

REPORT NUMBER: 208-2360529-TEST

**VEHICLE SAFETY COMPLIANCE TESTING
FOR
FMVSS 208, OCCUPANT CRASH PROTECTION
FMVSS 212, WINDSHIELD MOUNTING
FMVSS 219, WINDSHIELD INTRUSION (PARTIAL)
FMVSS 305, ELECTROLYTE SPILLAGE & ELECTRICAL SHOCK PROTECTION**

**GENERAL MOTORS LLC
2024 CHEVROLET SILVERADO EV
NHTSA NO.: C20240101**

**PREPARED BY:
MGA RESEARCH CORPORATION
5000 WARREN ROAD
BURLINGTON, WI 53105**



TEST DATES: OCTOBER 24, 2024 – MAY 8, 2025

FINAL REPORT DATE: JULY 14, 2025

FINAL REPORT

**PREPARED FOR:
U.S. DEPARTMENT OF TRANSPORTATION
NATIONAL HIGHWAY TRAFFIC SAFETY ADMINISTRATION
ENFORCEMENT
OFFICE OF VEHICLE SAFETY COMPLIANCE
1200 NEW JERSEY AVENUE, S.E.
WASHINGTON, D.C. 20590**

This final test report was prepared for the U.S. Department of Transportation, National Highway Traffic Safety Administration, in response to Contract Number 693JJ919D000012.

This publication is distributed by the U.S. Department of Transportation, National Highway Traffic Safety Administration, in the interest of information exchange. The opinions, findings and conclusions expressed in this publication are those of the author(s) and not necessarily those of the Department of Transportation or the National Highway Traffic Safety Administration. The United States Government assumes no liability for its contents or use thereof. If trade or manufacturers' names or products are mentioned it is only because they are considered essential to the object of the publication and should not be construed as an endorsement. The United States Government does not endorse products or manufacturers.

Prepared by:  Date: July 14, 2025
Jose Galvez, Project Engineer

Reviewed by:  Date: July 14, 2025
David Winkelbauer, Facility Director

FINAL REPORT ACCEPTED BY OVSC:

Accepted By: 
COR

Acceptance Date: July 14, 2025

Technical Report Documentation Page

<p>1. <i>Report No.</i> 208-2360529-TEST</p>	<p>2. <i>Government Accession No.</i></p>	<p>3. <i>Recipient's Catalog No.</i></p>	
<p>4. <i>Title and Subtitle</i> Final Report of FMVSS 208 Compliance Testing of a 2024 Chevrolet Silverado EV NHTSA No.: C20240101</p>		<p>5. <i>Report Date</i> July 14, 2025</p>	
		<p>6. <i>Performing Organization Code</i> MGA</p>	
<p>7. <i>Author(s)</i> Jose Galvez, Project Engineer</p>		<p>8. <i>Performing Organization Report No.</i> 208-2360529-TEST</p>	
<p>9. <i>Performing Organization Name and Address</i> MGA Research Corporation 5000 Warren Road Burlington, WI 53105</p>		<p>10. <i>Work Unit No.</i></p>	
		<p>11. <i>Contract or Grant No.</i> 693JJ919D000012</p>	
<p>12. <i>Sponsoring Agency Name and Address</i> U.S. Department of Transportation National Highway Traffic Safety Administration Enforcement Office of Vehicle Safety Compliance Mail Code: NEF-240 1200 New Jersey Avenue, S.E. Washington, D.C. 20590</p>		<p>13. <i>Type of Report and Period Covered</i> 10/24/24- 5/8/25</p>	
		<p>14. <i>Sponsoring Agency Code</i> NEF-240</p>	
<p>15. <i>Supplementary Notes</i></p>			
<p>16. <i>Abstract</i> Compliance tests were conducted on the subject 2024 Chevrolet Silverado EV in accordance with the specifications of the Office of Vehicle Safety Compliance Test Procedure No. TP208-14. Test failures identified were as follows: TEST FAILURES: None</p>			
<p>17. <i>Key Words</i> 40 kmph Vehicle Safety Compliance Testing FMVSS 208, "Occupant Crash Protection" FMVSS 212, "Windshield Mounting" FMVSS 219, (partial), "Windshield Zone Intrusion" FMVSS 305, "Electrolyte Spillage & Electrical Shock Protection"</p>		<p>18. <i>Distribution Statement</i> Copies of this report are available from the following: U.S. Department of Transportation National Highway Traffic Safety Administration Technical Information Services (TIS), Mail Code: NIO-120 1200 New Jersey Avenue, S.E. Washington, D.C. 20590 Phone: 202-366-2588</p>	
<p>19. <i>Security Classif. (of this report)</i> Unclassified</p>	<p>20. <i>Security Classif. (of this page)</i> Unclassified</p>	<p>21. <i>No. of Pages</i> 271</p>	<p>22. <i>Price</i></p>

TABLE OF CONTENTS

<u>Section</u>		<u>Page No</u>
1	Purpose of Compliance Tests	1
2	Tests Performed	2
3	Injury Result Summary for FMVSS 208 Tests	4
4	Discussion of Tests (if applicable)	5
5	Test Data Sheets	6
<u>Data Sheet</u>		
1	COTR Vehicle Work Order	7
2	Report of Vehicle Condition	12
3	Certification Label and Tire Placard Information	14
4	Rear Seating Position Seat Belts	15
5	Air Bag Labels	16
6	FMVSS 208 Readiness Indicator	23
7	Passenger Air Bag Manual Cut-Off Device	24
8	Lap Belt Lockability	27
9	FMVSS 208 Seat Belt Warning System Check	40
10	Belt Contact Force	41
11	Latch Plate Access	51
12	Seat Belt Retraction	56
13	Seat Belt Guides and Hardware	62
15	H-Point Determination for 50 th Percentile Male Dummy	67
16	Air Bag Suppression Telltale	77
17	Suppression Test Using 12-Month CRABI Dummy	78
18	Suppression Test Using Newborn Infant Dummy	88
32	Vehicle Weight, Fuel Tank, and Attitude Data	89
33	Vehicle Accelerometer Locations and Measurements	93
34	Photographic Targets	96
35	Camera Locations	101
36	Dummy Positioning	107

<u>Data Sheet</u>		<u>Page No</u>
37	Dummy Measurements	112
38	Crash Test	115
40	Accident Investigation Measurements	117
41	Windshield Mounting (FMVSS 212)	119
42	Windshield Zone Intrusion (FMVSS 219)	121
1-5	Electrolyte Spillage and Electrical Shock Protection (FMVSS 305)	123
<u>Appendix</u>		
A	Crash Test Data	A-1
B	Crash Test Photographs	B-1
C	Suppression Photographs	C-1
D	Instrumentation Calibration	D-1
E	Notice of Test Failure (If Applicable)	E-1

SECTION 1
PURPOSE OF COMPLIANCE TESTS

This Federal Motor Vehicle Safety Standard 208 compliance test is part of a program conducted for the National Highway Traffic Safety Administration (NHTSA) by MGA Research Corporation (MGA) under Contract No.: 693JJ919D000012. The purpose of this test was to determine whether the subject vehicle, a 2024 Chevrolet Silverado EV, NHTSA No.: C20240101, meets certain performance requirements of FMVSS 208, "Occupant Crash Protection"; FMVSS 212, "Windshield Mounting"; FMVSS 219, "Windshield Zone Intrusion"; and FMVSS 305, "Electric Powered Vehicles: Electrolyte Spillage and Electrical Shock Protection." The compliance test was conducted in accordance with OVSC Laboratory Test Procedure No.: TP208-14 dated April 16, 2008.

SECTION 2
TESTS PERFORMED

Test Vehicle: 2024 Chevrolet Silverado EV
Test Program: FMVSS 208 Compliance

NHTSA No.: C20240101
Test Dates: 10/24/24 - 5/8/25

The following checked items indicate the tests that were performed:

- | | | |
|-------------------------------------|-----|---|
| <input checked="" type="checkbox"/> | 1. | Rear seating position seat belts |
| <input checked="" type="checkbox"/> | 2. | Air bag labels (S4.5.1) |
| <input checked="" type="checkbox"/> | 3. | Readiness indicator (S4.5.2) |
| <input checked="" type="checkbox"/> | 4. | Passenger air bag manual cut-off device (S4.5.4) |
| <input checked="" type="checkbox"/> | 5. | Lap belt lockability (S7.1.1.5) |
| <input checked="" type="checkbox"/> | 6. | Seat belt warning system (S7.3) |
| <input checked="" type="checkbox"/> | 7. | Seat belt contact force (S7.4.3) |
| <input checked="" type="checkbox"/> | 8. | Seat belt latch plate access (S7.4.4) |
| <input checked="" type="checkbox"/> | 9. | Seat belt retraction (S7.4.5) |
| <input checked="" type="checkbox"/> | 10. | Seat belt guides and hardware (S7.4.6) |
| <input checked="" type="checkbox"/> | 11. | Air bag suppression telltale (S19.2.2) |
| <input checked="" type="checkbox"/> | 12. | Suppression tests with 12-month-old CRABI dummy (Part 572, Subpart R) |
| <input checked="" type="checkbox"/> | 13. | Suppression tests with Newborn infant (Part 572, Subpart K) |
| <input type="checkbox"/> | 14. | Suppression tests with 3-year-old dummy (Part 572, Subpart P) |
| <input type="checkbox"/> | 15. | Suppression tests with 6-year-old dummy (Part 572, Subpart N) |
| <input checked="" type="checkbox"/> | 16. | Test of Reactivation of the passenger air bag system with an unbelted 5 th percentile female dummy |
| <input type="checkbox"/> | 17. | Low risk deployment test with 12-month-old dummy (Part 572, Subpart R) |
| <input type="checkbox"/> | 18. | Low risk deployment test with 3-year-old dummy (Part 572, Subpart P) |
| <input type="checkbox"/> | 19. | Low risk deployment test with 6-year-old dummy (Part 572, Subpart N) |
| <input type="checkbox"/> | 20. | Low risk deployment test with 5 th female dummy (Part 572, Subpart O) |
| <input checked="" type="checkbox"/> | 21. | Impact Tests |
| <input type="checkbox"/> | | Frontal Oblique |
| <input type="checkbox"/> | | Belted 50 th male dummy driver and passenger (0 to 48 kmph) (S5.1.1(a)) |
| <input type="checkbox"/> | | Unbelted 50 th male dummy driver and passenger (0 to 48 kmph) (S5.1.2(a)(1)) |
| <input type="checkbox"/> | | Unbelted 50 th male dummy driver and passenger (32 to 40 kmph) (S5.1.2(a)(1) or S5.1.2(b)) |
| <input checked="" type="checkbox"/> | | Frontal 0° |
| <input type="checkbox"/> | | Belted 50 th male dummy driver (0 to 48 kmph) (S5.1.1.(b)(1) or S5.1.1(a)) |
| <input type="checkbox"/> | | Belted 50 th male dummy passenger (0 to 48 kmph) (S5.1.1.(b)(1) or S5.1.1(a)) |
| <input type="checkbox"/> | | Belted 5 th female dummy driver (0 to 48 kmph) (S16.1(a)) |
| <input type="checkbox"/> | | Belted 5 th female dummy passenger (0 to 48 kmph) (S16.1(a)) |
| <input type="checkbox"/> | | Belted 50 th male dummy driver and passenger (0 to 56 kmph) (S5.1.1.(b)(2)) |
| <input type="checkbox"/> | | Unbelted 50 th male dummy driver and passenger (0 to 48 kmph) (S5.1.2(a) (1)) |
| <input checked="" type="checkbox"/> | | Unbelted 50 th male dummy driver (32 to 40 kmph) (S5.1.2.(a)(2) or S5.1.2(b)) |
| <input checked="" type="checkbox"/> | | Unbelted 50 th male dummy passenger (32 to 40 kmph) (S5.1.2.(a)(2) or S5.1.2(b)) |
| <input type="checkbox"/> | | Unbelted 5 th female dummy driver (32 to 40 kmph) (S16.1(b)) |
| <input type="checkbox"/> | | Unbelted 5 th female dummy passenger (32 to 40 kmph) (S16.1(b)) |
| <input type="checkbox"/> | | 40% Offset 0° Belted 5 th female dummy driver and passenger (0 to 40 kmph) (S18.1) |
| <input type="checkbox"/> | 22. | FMVSS 204 Indicant Test |
| <input checked="" type="checkbox"/> | 23. | FMVSS 212 Indicant Test |
| <input checked="" type="checkbox"/> | 24. | FMVSS 219 Indicant Test |
| <input type="checkbox"/> | 25. | FMVSS 301 Frontal Indicant Test |
| <input checked="" type="checkbox"/> | 26. | FMVSS 305 Frontal Indicant Test |

For the crash tests, the vehicle was instrumented with 8 accelerometers. The data from the vehicle and dummies were sampled at 10,000 samples per second and processed as specified in SAE J211/1 MAR95 and FMVSS 208, S4.13.

The dynamic tests were recorded using high-speed digital video.

The vehicle appears to meet all of the performance requirements to which it was tested.

SECTION 3

INJURY RESULT SUMMARY FOR FMVSS 208 TESTS

Test Vehicle: 2024 Chevrolet Silverado EV
 Test Program: FMVSS 208 Compliance

NHTSA No.: C20240101
 Test Dates: 5/8/25

40 kmph Frontal Crash

Impact Angle:	0°			
Belted Dummies:		Yes	X	No

Speed Range:		0 to 40 kmph	X	32 to 40 kmph
		0 to 48 kmph		0 to 56 kmph

Test Speed (kmph):	39.2	Test Weight (kg):	3948.6
--------------------	------	-------------------	--------

Driver Dummy:		5 th female	X	50 th male
Passenger Dummy:		5 th female	X	50 th male

50th Percentile Male Frontal Crash Test

Vehicles certified to S5.1.1(b)(1), S5.1.1(b)(2), S5.1.2(a)(2), or S5.1.2(b)

Injury Criteria	Max. Allowable Injury Assessment Values	Driver	Passenger
HIC15	700	74	68
N _{te}	1.0	0.1	0.1
N _{tf}	1.0	0.3	0.2
N _{ce}	1.0	0.2	0.1
N _{cf}	1.0	0.1	0.3
Neck Tension	4170 N	866	1070
Neck Compression	4000 N	605	514
Chest g	60 g	41	33
Chest Displacement	63 mm	21	6
Left Femur	10,000 N	7653	8195
Right Femur	10,000 N	7384	5808

SECTION 4
DISCUSSION OF TESTS

Test Vehicle: 2024 Chevrolet Silverado EV
Test Program: FMVSS 208 Compliance

NHTSA No.: C20240101
Test Dates: 10/24/24 - 5/8/25

A blanket and visor were not used in the suppression testing because they did not affect the sensing system used on the vehicle.

The 2024 Chevrolet Silverado EV(C20240101) was tested to FMVSS 305 in conjunction with the FMVSS 208 frontal impact. The test was performed in accordance with the specifications of the Office of Vehicle Safety Compliance (OVSC) Test Procedures TP-305-01 to determine compliance to the requirements of Federal Motor Vehicle Safety Standards (FMVSS) 305, "Electric Powered Vehicles: Electrolyte Spillage and Electrical Shock Protection".

Based on the test results, the 2024 Chevrolet Silverado EV(C20240101) appears to meet the requirements of FMVSS 305 testing.

SECTION 5
TEST DATA SHEETS

Test Vehicle: 2024 Chevrolet Silverado EV
Test Program: FMVSS 208 Compliance

NHTSA No.: C20240101
Test Dates: 10/24/24 - 5/8/25

DATA SHEET 1
COTR VEHICLE WORK ORDER

Test Vehicle: 2024 Chevrolet Silverado EV
Test Program: FMVSS 208 Compliance

NHTSA No.: C20240101
Test Dates: 10/24/24 - 5/8/25

COTR Signature: Syed Rahaman

Test to be performed for this vehicle are checked below:

- | | |
|-------------------------------------|--|
| <input checked="" type="checkbox"/> | 1. Rear Seating Position Seat Belts |
| <input checked="" type="checkbox"/> | 2. Air Bag Labels (S4.5.1) |
| <input checked="" type="checkbox"/> | 3. Readiness Indicator (S4.5.2) |
| <input checked="" type="checkbox"/> | 4. Passenger Air Bag Manual Cut-off Device (S4.5.4) |
| <input checked="" type="checkbox"/> | 5. Lap Belt Lockability (S7.1.1.5) |
| <input checked="" type="checkbox"/> | 6. Seat Belt Warning System (S7.3) |
| <input checked="" type="checkbox"/> | 7. Seat Belt Contact Force (S7.4.3) |
| <input checked="" type="checkbox"/> | 8. Seat Belt Latch Plate Access (S7.4.4) |
| <input checked="" type="checkbox"/> | 9. Seat Belt Retraction (S7.4.5) |
| <input checked="" type="checkbox"/> | 10. Seat Belt Guides and Hardware (S7.4.6) |
| <input checked="" type="checkbox"/> | 11. Air bag suppression telltale (S19.2.2) |
| <input checked="" type="checkbox"/> | 12. Suppression tests with 12-month-old CRABI dummy (Part 572, Subpart R) using the following indicated child restraints (mid-height seat position): |

Section B – Rear Facing (unbelted and belted rear facing, unbelted forward facing)

<input type="checkbox"/>	Century Smart Fit 4543	<input type="checkbox"/>	Full Rearward	<input type="checkbox"/>	Mid Position	<input type="checkbox"/>	Full Forward
<input checked="" type="checkbox"/>	Cosco Arriva 22-013	<input checked="" type="checkbox"/>	Full Rearward	<input checked="" type="checkbox"/>	Mid Position	<input checked="" type="checkbox"/>	Full Forward
<input type="checkbox"/>	Evenflo Discovery Adjust Right 212	<input type="checkbox"/>	Full Rearward	<input type="checkbox"/>	Mid Position	<input type="checkbox"/>	Full Forward
<input type="checkbox"/>	Graco Infant 8457	<input type="checkbox"/>	Full Rearward	<input type="checkbox"/>	Mid Position	<input type="checkbox"/>	Full Forward
<input checked="" type="checkbox"/>	Graco Snugride	<input checked="" type="checkbox"/>	Full Rearward	<input checked="" type="checkbox"/>	Mid Position	<input checked="" type="checkbox"/>	Full Forward
<input checked="" type="checkbox"/>	Peg Perego Viaggio	<input checked="" type="checkbox"/>	Full Rearward	<input checked="" type="checkbox"/>	Mid Position	<input checked="" type="checkbox"/>	Full Forward

Section C – Convertible (unbelted and belted rear facing, unbelted and belted forward facing)

- | | | | | | | | |
|-------------------------------------|--|-------------------------------------|---------------|-------------------------------------|--------------|-------------------------------------|--------------|
| <input checked="" type="checkbox"/> | Britax Roundabout E9L02 | <input checked="" type="checkbox"/> | Full Rearward | <input checked="" type="checkbox"/> | Mid Position | <input checked="" type="checkbox"/> | Full Forward |
| <input type="checkbox"/> | Cosco High Back Booster 22-209 | <input type="checkbox"/> | Full Rearward | <input type="checkbox"/> | Mid Position | <input type="checkbox"/> | Full Forward |
| <input checked="" type="checkbox"/> | Cosco Summit Deluxe 22-262 | <input checked="" type="checkbox"/> | Full Rearward | <input checked="" type="checkbox"/> | Mid Position | <input checked="" type="checkbox"/> | Full Forward |
| <input type="checkbox"/> | Cosco Touriva 02519 | <input type="checkbox"/> | Full Rearward | <input type="checkbox"/> | Mid Position | <input type="checkbox"/> | Full Forward |
| <input type="checkbox"/> | Evenflo Generations 352 | <input type="checkbox"/> | Full Rearward | <input type="checkbox"/> | Mid Position | <input type="checkbox"/> | Full Forward |
| <input type="checkbox"/> | Evenflo Medallion 254 | <input type="checkbox"/> | Full Rearward | <input type="checkbox"/> | Mid Position | <input type="checkbox"/> | Full Forward |
| <input checked="" type="checkbox"/> | Evenflo Tribute V 379 | <input checked="" type="checkbox"/> | Full Rearward | <input checked="" type="checkbox"/> | Mid Position | <input checked="" type="checkbox"/> | Full Forward |
| <input type="checkbox"/> | Graco ComfortSport | <input type="checkbox"/> | Full Rearward | <input type="checkbox"/> | Mid Position | <input type="checkbox"/> | Full Forward |
| <input type="checkbox"/> | Graco Platinum Cargo | <input type="checkbox"/> | Full Rearward | <input type="checkbox"/> | Mid Position | <input type="checkbox"/> | Full Forward |
| <input checked="" type="checkbox"/> | Graco Safeseat Step 2 | <input checked="" type="checkbox"/> | Full Rearward | <input checked="" type="checkbox"/> | Mid Position | <input checked="" type="checkbox"/> | Full Forward |
| <input checked="" type="checkbox"/> | 13. Suppression tests with newborn infant (Part 572, Subpart K) using the following indicated child restraints (mid-height seat position). | | | | | | |

Section A – Car Bed (Belted)

<input checked="" type="checkbox"/>	Angel Guard Angel Ride	<input checked="" type="checkbox"/>	Full Rearward	<input checked="" type="checkbox"/>	Mid Position	<input checked="" type="checkbox"/>	Full Forward
-------------------------------------	------------------------	-------------------------------------	---------------	-------------------------------------	--------------	-------------------------------------	--------------

14. Suppression tests with 3-year-old dummy (Part 572, Subpart P) using the following indicated child restraints where a child restraint is required (mid-height seat position):

Section C – Convertible (Belted forward-facing)

Britax Roundabout E9L02	Full Rearward	Mid Position	Full Forward
Cosco High Back Booster 22-209	Full Rearward	Mid Position	Full Forward
Cosco Touriva 02519	Full Rearward	Mid Position	Full Forward
Evenflo Generations 352	Full Rearward	Mid Position	Full Forward
Evenflo Medallion 254	Full Rearward	Mid Position	Full Forward
Evenflo Tribute V 379	Full Rearward	Mid Position	Full Forward
Graco ComfortSport	Full Rearward	Mid Position	Full Forward
Graco Platinum Cargo	Full Rearward	Mid Position	Full Forward
Graco Safeseat Step 2	Full Rearward	Mid Position	Full Forward

Section D – Toddler/Belt Positioning Booster (Belted)

Britax Roadster 9004	Full Rearward	Mid Position	Full Forward
Cosco High Back Booster 22-262	Full Rearward	Mid Position	Full Forward
Evenflo Generations 352	Full Rearward	Mid Position	Full Forward
Evenflo Right Fit 245	Full Rearward	Mid Position	Full Forward
Graco Platinum Cargo	Full Rearward	Mid Position	Full Forward

15. Suppression tests with representative 3-year-old child using the following indicated child restraints where a child restraint is required (mid-height position).

(Appendix H, Data Sheet 19H and 20H)

Section C – Convertible (Belted forward-facing)

Britax Roundabout E9L02	Full Rearward	Mid Position	Full Forward
Cosco High Back Booster 22-209	Full Rearward	Mid Position	Full Forward
Cosco Summit Deluxe 22-262	Full Rearward	Mid Position	Full Forward
Cosco Touriva 02519	Full Rearward	Mid Position	Full Forward
Evenflo Generations 352	Full Rearward	Mid Position	Full Forward
Evenflo Medallion 254	Full Rearward	Mid Position	Full Forward
Evenflo Tribute V 379	Full Rearward	Mid Position	Full Forward
Graco ComfortSport	Full Rearward	Mid Position	Full Forward
Graco Platinum Cargo	Full Rearward	Mid Position	Full Forward
Graco Safeseat Step 2	Full Rearward	Mid Position	Full Forward

Section D – Toddler/Belt Positioning Booster (Belted)

Britax Roadster 9004	Full Rearward	Mid Position	Full Forward
Cosco High Back Booster 22-209	Full Rearward	Mid Position	Full Forward
Evenflo Right Fit 245	Full Rearward	Mid Position	Full Forward

16. Suppression tests with 3-year-old dummy (Part 572, Subpart P) in the following positions (mid-height seat position):
- Sitting on seat with back against seat back (S22.2.2.1)
 - Full Rearward Mid Position Full Forward
 - Sitting on seat with back against reclined seat back (S22.2.2.2)
 - Full Rearward Mid Position Full Forward
 - Sitting on seat with back not against seat back (S22.2.2.3)
 - Full Rearward Mid Position Full Forward
 - Sitting on seat edge, spine vertical, hands by the child's side (S22.2.2.4)
 - Full Rearward Mid Position Full Forward
 - Standing on seat, facing forward (S22.2.2.5)
 - Full Rearward Mid Position Full Forward
 - Kneeling on seat facing forward (S22.2.2.6)
 - Full Rearward Mid Position Full Forward
 - Kneeling on seat facing rearward (S22.2.2.7)
 - Full Rearward Mid Position Full Forward
 - Lying on seat (S22.2.2.8)
 - Full Rearward Mid Position Full Forward
17. Suppression tests with representative 3-year-old child in the following positions (mid-height seat position):
- Sitting on seat with back against seat back (S22.2.2.1)
 - Full Rearward Mid Position Full Forward
 - Sitting on seat with back against reclined seat back (S22.2.2.2)
 - Full Rearward Mid Position Full Forward
 - Sitting on seat with back not against seat back (S22.2.2.3)
 - Full Rearward Mid Position Full Forward
 - Sitting on seat edge, spine vertical, hands by the child's side (S22.2.2.4)
 - Full Rearward Mid Position Full Forward
 - Standing on seat, facing forward (S22.2.2.5)
 - Full Rearward Mid Position Full Forward
 - Kneeling on seat facing forward (S22.2.2.6)
 - Full Rearward Mid Position Full Forward
 - Kneeling on seat facing rearward (S22.2.2.7)
 - Full Rearward Mid Position Full Forward
 - Lying on seat (S22.2.2.8)
 - Full Rearward Mid Position Full Forward
18. Suppression tests with 6-year-old dummy (Part 572, Subpart N) using the following indicated child restraints where a child restraint is required (mid-height seat position):
- Section D
- | | | | |
|---|--|---------------------------------------|---------------------------------------|
| <input type="checkbox"/> Britax Roadster 9004 | <input type="checkbox"/> Full Rearward | <input type="checkbox"/> Mid Position | <input type="checkbox"/> Full Forward |
| <input type="checkbox"/> Cosco High Back Booster 22-209 | <input type="checkbox"/> Full Rearward | <input type="checkbox"/> Mid Position | <input type="checkbox"/> Full Forward |
| <input type="checkbox"/> Cosco Summit Deluxe 22-262 | <input type="checkbox"/> Full Rearward | <input type="checkbox"/> Mid Position | <input type="checkbox"/> Full Forward |
| <input type="checkbox"/> Evenflo Generations 352 | <input type="checkbox"/> Full Rearward | <input type="checkbox"/> Mid Position | <input type="checkbox"/> Full Forward |
| <input type="checkbox"/> Evenflo Right Fit 245 | <input type="checkbox"/> Full Rearward | <input type="checkbox"/> Mid Position | <input type="checkbox"/> Full Forward |
| <input type="checkbox"/> Graco Platinum Cargo | <input type="checkbox"/> Full Rearward | <input type="checkbox"/> Mid Position | <input type="checkbox"/> Full Forward |

19. Suppression tests with representative 6-year-old child using the following indicated child restraints where a child restraint is required (mid-height seat position):
- Section D
- | | | | | | | | |
|--------------------------|--------------------------------|--------------------------|---------------|--------------------------|--------------|--------------------------|--------------|
| <input type="checkbox"/> | Britax Roadster 9004 | <input type="checkbox"/> | Full Rearward | <input type="checkbox"/> | Mid Position | <input type="checkbox"/> | Full Forward |
| <input type="checkbox"/> | Cosco High Back Booster 22-209 | <input type="checkbox"/> | Full Rearward | <input type="checkbox"/> | Mid Position | <input type="checkbox"/> | Full Forward |
| <input type="checkbox"/> | Cosco Summit Deluxe 22-262 | <input type="checkbox"/> | Full Rearward | <input type="checkbox"/> | Mid Position | <input type="checkbox"/> | Full Forward |
| <input type="checkbox"/> | Evenflo Generations 352 | <input type="checkbox"/> | Full Rearward | <input type="checkbox"/> | Mid Position | <input type="checkbox"/> | Full Forward |
| <input type="checkbox"/> | Evenflo Right Fit 245 | <input type="checkbox"/> | Full Rearward | <input type="checkbox"/> | Mid Position | <input type="checkbox"/> | Full Forward |
| <input type="checkbox"/> | Graco Platinum Cargo | <input type="checkbox"/> | Full Rearward | <input type="checkbox"/> | Mid Position | <input type="checkbox"/> | Full Forward |
20. Suppression tests with 6-year-old dummy (Part 572, Subpart N) in the following positions (mid-height seat position):
- | | | | | | | | |
|--------------------------|--|--------------------------|---------------|--------------------------|--------------|--------------------------|--------------|
| <input type="checkbox"/> | Sitting on seat with back against seat back (S22.2.2.1) | <input type="checkbox"/> | Full Rearward | <input type="checkbox"/> | Mid Position | <input type="checkbox"/> | Full Forward |
| <input type="checkbox"/> | Sitting on seat with back against reclined seat back (S22.2.2.2) | <input type="checkbox"/> | Full Rearward | <input type="checkbox"/> | Mid Position | <input type="checkbox"/> | Full Forward |
| <input type="checkbox"/> | Sitting on seat edge, spine vertical, hands by the child's side (S22.2.2.4) | <input type="checkbox"/> | Full Rearward | <input type="checkbox"/> | Mid Position | <input type="checkbox"/> | Full Forward |
| <input type="checkbox"/> | Sitting back in the seat and leaning on the right front passenger door (S24.2.3) | <input type="checkbox"/> | Full Rearward | <input type="checkbox"/> | Mid Position | <input type="checkbox"/> | Full Forward |
21. Suppression tests with representative 6-year-old child in the following positions (mid-height seat position):
- | | | | | | | | |
|--------------------------|--|--------------------------|---------------|--------------------------|--------------|--------------------------|--------------|
| <input type="checkbox"/> | Sitting on seat with back against seat back (S22.2.2.1) | <input type="checkbox"/> | Full Rearward | <input type="checkbox"/> | Mid Position | <input type="checkbox"/> | Full Forward |
| <input type="checkbox"/> | Sitting on seat with back against reclined seat back (S22.2.2.2) | <input type="checkbox"/> | Full Rearward | <input type="checkbox"/> | Mid Position | <input type="checkbox"/> | Full Forward |
| <input type="checkbox"/> | Sitting on seat edge, spine vertical, hands by the child's side (S22.2.2.4) | <input type="checkbox"/> | Full Rearward | <input type="checkbox"/> | Mid Position | <input type="checkbox"/> | Full Forward |
| <input type="checkbox"/> | Sitting back in the seat and leaning on the right front passenger door (S24.2.3) | <input type="checkbox"/> | Full Rearward | <input type="checkbox"/> | Mid Position | <input type="checkbox"/> | Full Forward |
22. Test of Reactivation of the Passenger Air Bag System with an Unbelted 5th percentile female dummy (S20.3, 22.3, S24.3) (mid-height seat position). Perform this test after the following suppression tests: After each restraint.
23. Test of Reactivation of the Passenger Air Bag System with a representative 5th percentile female (S20.3, 22.3, S24.3) (mid-height seat position). Perform this test after the following suppression tests: After each restraint.
24. Low risk deployment test with 12-month-old dummy (Part 572, Subpart R) using the following indicated child restraints (full forward, mid-height seat position)(S20.4):
- Section B
- | | |
|--------------------------|------------------------------------|
| <input type="checkbox"/> | Century Smart Fit 4543 |
| <input type="checkbox"/> | Cosco Arriva 22-013 |
| <input type="checkbox"/> | Evenflo Discovery Adjust Right 212 |
| <input type="checkbox"/> | Graco Infant 8457 |
| <input type="checkbox"/> | Graco Snugride |
| <input type="checkbox"/> | Peg Perego Viaggio |
- Section C
- | | |
|--------------------------|-------------------------|
| <input type="checkbox"/> | Britax Roundabout E9L02 |
| <input type="checkbox"/> | Cosco Touriva 02519 |
| <input type="checkbox"/> | Evenflo Medallion 254 |
| <input type="checkbox"/> | Evenflo Tribute V 379 |
| <input type="checkbox"/> | Graco ComfortSport |

25. Low risk deployment test with 3-year-old dummy (Part 572, Subpart P) in the following positions:
 Position 1 (rearmost, lowest seat position)
 Position 2 (mid-height seat position)
26. Low risk deployment test with 6-year-old dummy (Part 572, Subpart N) in the following positions:
 Position 1 (rearmost, lowest seat position)
 Position 2 (mid-height seat position)
27. Low risk deployment test with 5th female dummy (Part 572, Subpart O) in the following positions:
 Position 1 (mid-height seat position)
 Position 2 (mid-height seat position)
28. Impact Tests
- | <input type="checkbox"/> | Frontal Oblique | Impact Angle: | Test Speed: |
|-------------------------------------|-------------------------------------|---|-------------|
| <input type="checkbox"/> | <input type="checkbox"/> | Belted 50 th male dummy driver and passenger (0 to 48 kmph) (S5.1.1(a)) | |
| <input type="checkbox"/> | <input type="checkbox"/> | Unbelted 50 th male dummy driver and passenger (0 to 48 kmph) (S5.1.2(a)(1)) | |
| <input type="checkbox"/> | <input type="checkbox"/> | Unbelted 50 th male dummy driver and passenger (32 to 40 kmph) (S5.1.2(a)(2) or S5.1.2(b)) | |
| <input checked="" type="checkbox"/> | <input checked="" type="checkbox"/> | Frontal 0° – Test Speed: 39.2 kmph | |
| <input type="checkbox"/> | <input type="checkbox"/> | Belted 50 th male dummy driver (0 to 48 kmph) (S5.1.1.(b)(1) or S5.1.1(a)) | |
| <input type="checkbox"/> | <input type="checkbox"/> | Belted 50 th male dummy passenger (0 to 48 kmph) (S5.1.1.(b)(1) or S5.1.1(a)) | |
| <input type="checkbox"/> | <input type="checkbox"/> | Belted 5 th female dummy driver (0 to 48 kmph) (S16.1(a)(1)) | |
| <input type="checkbox"/> | <input type="checkbox"/> | Belted 5 th female dummy passenger (0 to 48 kmph) (S16.1(a)(1)) | |
| <input type="checkbox"/> | <input type="checkbox"/> | Belted 5 th female dummy driver and passenger (0 to 56 kmph) (S16.1(a)(2)) | |
| <input type="checkbox"/> | <input type="checkbox"/> | Belted 50 th male dummy driver and passenger (0 to 56 kmph) (S5.1.1.(b)(2)) | |
| <input type="checkbox"/> | <input type="checkbox"/> | Unbelted 50 th male dummy driver and passenger (0 to 48 kmph) (S5.1.2(a) (1)) | |
| <input checked="" type="checkbox"/> | <input checked="" type="checkbox"/> | Unbelted 50 th male dummy driver (32 to 40 kmph) (S5.1.2.(a)(2) or S5.1.2(b)) | |
| <input checked="" type="checkbox"/> | <input checked="" type="checkbox"/> | Unbelted 50 th male dummy passenger (32 to 40 kmph) (S5.1.2.(a)(2) or S5.1.2(b)) | |
| <input type="checkbox"/> | <input type="checkbox"/> | Unbelted 5 th female dummy driver (32 to 40 kmph) (S16.1(b)) | |
| <input type="checkbox"/> | <input type="checkbox"/> | Unbelted 5 th female dummy passenger (32 to 40 kmph) (S16.1(b)) | |
| <input type="checkbox"/> | <input type="checkbox"/> | 40% Offset 0° Belted 5 th female dummy driver and passenger (0 to 40 kmph) (S18.1) Test Speed: | |
29. FMVSS 204 Indicant Test
30. FMVSS 212 Indicant Test
31. FMVSS 219 Indicant Test
32. FMVSS 301 Frontal Indicant Test
33. FMVSS 305 Frontal Indicant Test

DATA SHEET 2
REPORT OF VEHICLE CONDITION

Test Vehicle: 2024 Chevrolet Silverado EV NHTSA No.: C20240101
Test Program: FMVSS 208 Compliance Test Dates: 10/24/24 - 5/8/25

CONTRACT NO.: 693JJ919D000012 Date: 5/15/25

FROM (Lab and rep name): MGA Research Corporation

TO: NHTSA, OVSC, NVS-220

PURPOSE: () Initial Receipt () Received via Transfer (X) Present vehicle condition

MODEL YEAR/MAKE/MODEL/BODY STYLE: 2024 / Chevrolet / Silverado EV / Truck

MANUFACTURE DATE: 05/24

NHTSA NO. C20240101 GVWR: 4532 kg (9990 lbs)

BODY COLOR: Summit White GAWR (Fr): 2404 kg (5300 lbs)

VIN: 1GC10UED7RU206395 GAWR (Rr): 2608 kg (5750 lbs)

ODOMETER READINGS: ARRIVAL (miles): 1431 DATE: 10/10/2024

COMPLETION (miles): 1438 DATE: 5/8/2025

PURCHASE PRICE: (\$) 75,445

DEALER'S NAME: Ray Chevrolet

39 N Rte 12 Fox Lake, IL 60020-1222

- A. All options listed on window sticker are present on the test vehicle:
 Yes No
- B. Tires and wheel rims are new and the same as listed: Yes No
- C. There are no dents or other interior or exterior flaws: Yes No
- D. The vehicle has been properly prepared and is in running condition:
 Yes No
- E. Keyless remote is available and working: Yes No
- F. The glove box contains an owner's manual, warranty document, consumer information, and extra set of keys: Yes No
- G. Proper fuel filler cap is supplied on the test vehicle: Yes No
- H. Using permanent marker, identify vehicle with NHTSA number and FMVSS test type(s) on roof line above driver door or for school buses, place a placard with NHTSA number inside the windshield and to the exterior front and rear side of bus:
 Yes No
- I. Place vehicle in storage area: Yes No
- J. Inspect the vehicle's interior and exterior, including all windows, seats, doors, etc. to confirm that each system is complete and functional per the manufacturer's specifications. Any damage, misadjustment, or other unusual condition that could influence the test program or test results shall be recorded. Report any abnormal condition to the NHTSA COTR before beginning any test:
 Vehicle OK Conditions reported below in comment section

Identify the letter above to which any of the following comments apply.

Comments: _____

REPORT OF VEHICLE CONDITION AT THE COMPLETION OF TESTING

LIST OF FMVSS TESTS PERFORMED BY THIS LAB: FMVSS 208, 212, 219, 305

VEHICLE: 2024 Chevrolet Silverado EV

NHTSA NO.: C20240101

REMARKS:

Equipment that is no longer on the test vehicle as noted on previous page:

Bed Cover & Spare Tire Tools

Explanation for equipment removal:

Components removed for instrumentation installation and to meet target weight.

Test Vehicle Condition:

25 mph frontal impact damage– front suspension & structure damaged, hood & front quarter panels damaged, air bags deployed

RECORDED BY: Jose Galvez

DATE: 5/15/25

APPROVED BY: David Winkelbauer

DATE: 5/15/25

#####

RELEASE OF TEST VEHICLE

The vehicle described above is released from MGA to be delivered to:

Date:

Time:

Odometer:

Lab Rep's Signature:

Title:

Carrier/Customer Rep:

Date:

DATA SHEET 3

CERTIFICATION LABEL AND TIRE PLACARD INFORMATION

Test Vehicle: 2024 Chevrolet Silverado EV
 Test Program: FMVSS 208 Compliance
 Test Technician: Chad Williams

NHTSA No.: C20240101
 Test Date: 5/8/25

Certification Label (Part 567)	
Manufacturer:	General Motors LLC
Date of Manufacture:	05/24
VIN:	1GC10UED7RU206395
Vehicle Certified As (Pass. Car/MPV/Truck/Bus):	Truck
Front Axle GVWR:	2404 kg (5300 lbs)
Rear Axle GVWR:	2606 kg (5750 lbs)
Total GVWR:	4532 kg (9990 lbs)

Tire Placard for Motor Vehicles with GVWR of 10,000 lb or Less and Passenger Cars (571.110)	
Vehicle Capacity Weight:	804 kg (1772 lbs)
Designated Seating Capacity Front:	2
Designated Seating Capacity Rear:	3
Total Designated Seating Capacity:	5
Recommended Cold Tire Inflation Pressure Front:	420 kpa (61 psi)
Recommended Cold Tire Inflation Pressure Rear:	420 kpa (61 psi)
Recommended Tire Size:	Front: 265/70R18 Rear: 265/70R18
Tire Size on Vehicle:	Front: 265/70R18 Rear: 265/70R18

Signature: *Chad Williams* Date: 5/8/25

DATA SHEET 4
REAR SEATING POSITION SEAT BELTS

Test Vehicle: 2024 Chevrolet Silverado EV
Test Program: FMVSS 208 Compliance
Test Technician: Jose Galvez

NHTSA No.: C20240101
Test Date: 10/24/24

	Yes	No
Do all rear seating positions have Type 2 seat belts?	X	

If NO, describe the seat belt installed, the seat location, and any other information about the seat that would explain why a Type 2 seat belt was not installed.

REMARKS:

Signature: 

Date: 10/24/24

DATA SHEET 5
AIR BAG LABELS (S4.5.1)

Test Vehicle: 2024 Chevrolet Silverado EV
 Test Program: FMVSS 208 Compliance
 Test Technician: Jose Galvez

NHTSA No.: C20240101
 Test Date: 10/24/24

1. Air Bag Maintenance Label and Owner's Manual Instructions: (S4.5.1(a))
- 1.1 Does the manufacturer recommend periodic maintenance or replacement of the air bag?
 Yes (Go to 1.2)
 No (Go to 2)
- 1.2 Does the vehicle have a label specifying air bag maintenance or replacement?
 Yes – Pass
 No – Fail
- 1.3 Does the label contain one of the following?
 Yes – Pass
 No – Fail
- Check applicable schedule:
 Schedule on label specifies month and year (Record date_____)
 Schedule on label specifies vehicle mileage (Record mileage_____)
 Schedule on label specifies interval measured from date on certification label
 (Record interval_____)
- 1.4 Is the label permanently affixed within the passenger compartment such that it cannot be removed without destroying or defacing the label or vehicle part? (3/19/01 legal interpretation to Todd Mitchell)
 Yes – Pass
 No – Fail
- 1.5 Is the label lettered in English?
 Yes – Pass
 No – Fail
- 1.6 Is the label in block capitals and numerals?
 Yes – Pass
 No – Fail
- 1.7 Are the letters and numerals at least 3/32 inches high?
 Yes – Pass
 No – Fail
- 1.8 Does the owner's manual set forth the recommended schedule for maintenance or replacement?
2. Does the owner's manual: (S4.5.1(f))
- 2.1 Include a description of the vehicle's air bag system in an easily understandable format?
 Yes – Pass
 No – Fail
- 2.2 Include a statement that the vehicle is equipped with an air bag and a lap/shoulder belt at the front outboard seating position?
 Yes – Pass
 No – Fail
- 2.3 Include a statement that the air bag is a supplemental restraint at the front outboard seating position?
 Yes – Pass
 No – Fail

- 2.4 Emphasize that all occupants, including the driver, should always wear their seat belts whether or not an air bag is also provided at their seating positions to minimize the risk of severe injury or death in the event of a crash?
 Yes – Pass
 No – Fail
- 2.5 Provide any necessary precautions regarding the proper positioning of occupants, including children, at seating positions equipped with air bags to ensure maximum safety protection for those occupants?
 Yes – Pass
 No – Fail
- 2.6 Explain that no objects should be placed over or near the air bag on the steering wheel or on the instrument panel, because any such objects could cause harm if the vehicle is in a crash severe enough to cause the air bag to inflate?
 Yes – Pass
 No – Fail
- 2.7 Is the vehicle certified to meet the requirements of S14.5, S15, S17, S19, S21, S23, and S25? (Obtain answer to this question from the COTR) (S4.5.1(f)(2))
 Yes – (Go to 2.7.1)
 No – (Go to 3.)
- 2.7.1 Explain the proper functioning of the advanced air bag system? (S4.5.1(f)(2))
 Yes – Pass
 No – Fail
- 2.7.2 Provide a summary of the actions that may affect the proper functioning of the system? (S4.5.1(f)(2))
 Yes – Pass
 No – Fail
- 2.7.3 Present and explain the main components of the advanced passenger air bag system? (S4.5.1(f)(2)(i))
 Yes – Pass
 No – Fail
- 2.7.4 Explain how the components function together as part of the advanced passenger air bag system? (S4.5.1(f)(2)(ii))
 Yes – Pass
 No – Fail
- 2.7.5 Contain the basic requirements for proper operation, including an explanation of the actions that may affect the proper functioning of the system? (S4.5.1(f)(2)(iii))
 Yes – Pass
 No – Fail
- 2.7.6 Is the vehicle certified to the requirements of S19.2, S21.2, or 23.2 (automatic suppression)?
 Yes, continue with 2.7.6
 No, go to 2.7.7
- 2.7.6.1 Contain a complete description of the passenger air bag suppression system installed in the vehicle, including a discussion of any suppression zone? (S4.5.1(f)(2)(iv))
 Yes – Pass
 No – Fail
- 2.7.6.2 Discuss the telltale light, specifying its location in the vehicle and explaining when the light is illuminated?
 Yes – Pass
 No – Fail
- 2.7.7 Explain the interaction of the advanced passenger air bag system with other vehicle components, such as seat belts, seats or other components? (S4.5.1(f)(2)(v))
 Yes – Pass
 No – Fail

- 2.7.8 Summarize the expected outcomes when child restraint systems, children and small teenagers or adults are both properly and improperly positioned in the passenger seat, including cautionary advice against improper placement of child restraint systems? (S4.5.1(f)(2)(vi))
- Yes – Pass
 No – Fail
- 2.7.9 Provide information on how to contact the vehicle manufacturer concerning modifications for persons with disabilities that may affect the advanced air bag system? (S4.5.1(f)(2)(vii))
- Yes – Pass
 No – Fail
3. Sun Visor Air Bag Warning Label (S4.5.1(b)): Vehicles certified to meet the requirements of S19, S21 and S23. (S4.5.1(b)(3))
- 3.1 Is the label permanently affixed (including permanent marking on the visor material or molding into the visor material) to either side of the sun visor at each front outboard seating position such that it cannot be removed without destroying or defacing the label or the sun visor? (S4.5.1(b)(3)) (3/19/01 legal interpretation to Todd Mitchell)
- Driver Side, Yes – Pass
 Driver Side, No – Fail
 Passenger Side, Yes – Pass
 Passenger Side, No – Fail
- 3.2 Does the label conform in content to the label shown in Figure 11 at each front outboard seating position? (S4.5.1(b)(2)) **(Vehicles without back seats or the back seat is too small to accommodate a rear-facing child restraint may omit the statement: “Never put a rear-facing child seat in the front.” (S4.5.1(b)(3)(v)))**



Figure 11. Sun Visor Label Visible when Visor is in Down Position.



Figure 6b. Sun Visor Label Visible When Visor is in Down Position.

- Driver Side, Yes – Pass
 Driver Side, No – Fail
 Passenger Side, Yes – Pass
 Passenger Side, No – Fail

- 3.3 Is the label heading area yellow with the word "WARNING" and the alert symbol in black? (S4.5.1(b)(3)(i))
- Driver Side, Yes – Pass
 - Driver Side, No – Fail
 - Passenger Side, Yes – Pass
 - Passenger Side, No – Fail
- 3.4 Is the message area white with black text? (S4.5.1(b)(3)(ii))
- Driver Side, Yes – Pass
 - Driver Side, No – Fail
 - Passenger Side, Yes – Pass
 - Passenger Side, No – Fail
- 3.5 Is the message area at least 30 cm²? (S4.5.1(b)(3)(ii))
- The message area consists of the total label area minus the yellow heading area and the pictogram. The pictogram is enclosed on the left side and bottom by the edge of the label. The top edge of the pictogram area is defined by a horizontal line midway between the uppermost edge of the pictogram and the lowermost edge of the text. The right side of the pictogram is defined by a vertical line midway between the rightmost edge of the pictogram and the left most edge of the text, including any bullets. (See 5/6/03 interpretation to Gerald Plante on behalf of Subaru)**
- Driver Side: Length 88 mm, Width 35 mm
 Passenger Side: Length 88 mm, Width 35 mm
 Driver actual message area 30.8 cm²
 Passenger actual message area 30.8 cm²
- Driver Side, Yes – Pass
 - Driver Side, No – Fail
 - Passenger Side, Yes – Pass
 - Passenger Side, No – Fail
- 3.6 Is the pictogram black on a white background? (S4.5.1(b)(3)(iii))
- Driver Side, Yes – Pass
 - Driver Side, No – Fail
 - Passenger Side, Yes – Pass
 - Passenger Side, No – Fail
- 3.7 Is the pictogram at least 30 mm in length? (S4.5.1(b)(3)(iii))
- Driver side: Length: 32 mm
 Passenger side: Length: 32 mm
- Driver Side, Yes – Pass
 - Driver Side, No – Fail
 - Passenger Side, Yes – Pass
 - Passenger Side, No – Fail
- 3.8 Is the same side of the sun visor that contains the air bag warning label free of other information with the exception of the air bag maintenance label and/or the rollover–warning label? (S4.5.1(b)(5)(i))
- Driver Side, Yes – Pass
 - Driver Side, No – Fail
 - Passenger Side, Yes – Pass
 - Passenger Side, No – Fail
- 3.9 Is the sun visor free of other information about air bags or the need to wear seat belts with the exception of the air bag alert label and/or the rollover–warning label? (S4.5.1(b)(5)(ii))
- Driver Side, Yes – Pass
 - Driver Side, No – Fail
 - Passenger Side, Yes – Pass
 - Passenger Side, No – Fail

- 3.10 Does the driver side visor contain a rollover–warning label on the same side of the visor as the air bag warning label?
 ___ Yes (go to 3.10.1)
 No (go to 4., skipping 3.10.1 through 3.10.3)
- 3.10.1 Are both the rollover–warning label and the air bag warning label surrounded by a continuous solid–lined border?
 ___ Yes (go to 3.10.2 and skip 3.10.3)
 ___ No (go to 3.10.3 and skip 3.10.2)
- 3.10.2 Is the shortest distance from the border of the rollover label to the border of the air bag warning label at least 1 cm? (575.105 (d)(1)(iv)(B))
 _____ actual distance
 ___ Yes–Pass ___ **No–FAIL**
- 3.10.3 Is the shortest distance from any of the lettering or graphics on the rollover–warning label to any of the lettering or graphics of the air bag warning label at least 3 cm? (575.105 (d)(1)(iv)(A))
 _____ actual distance
 ___ Yes–Pass ___ **No–FAIL**
4. Air Bag Alert Label (S4.5.1(c) (A “Rollover Warning Label” or “Rollover Alert Label” may be on the same side of the driver’s sun visor as the “Air Bag Alert Label.” 575.105(d))
- 4.1 Is the Sun Visor Warning Label visible when the sun visor is in the stowed position?
 If yes for driver and passenger, go to 5.
 Driver Side, Yes
 Driver Side, No
 Passenger Side, Yes
 Passenger Side, No
- 4.2 Is the air bag alert label permanently affixed (including permanent marking on the visor material or molding into the visor material) to the sun visor at each front outboard seating position such that it cannot be removed without destroying or defacing the label or the sun visor? (S4.5.1(c)) (3/19/01 legal interpretation to Todd Mitchell)
 Driver Side, Yes – Pass
 Driver Side, No – Fail
 Passenger Side, Yes – Pass
 Passenger Side, No – Fail
- 4.3 Is the air bag alert label visible when the visor is in the stowed position? (S4.5.1(c))
 Driver Side, Yes – Pass
 Driver Side, No – Fail
 Passenger Side, Yes – Pass
 Passenger Side, No – Fail

4.4 Does the label conform in content to the label shown in Figure 6C? (S4.5.1(c))

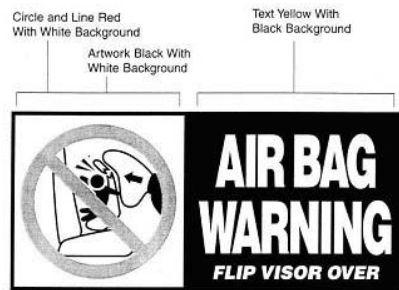

Figure 6c. Sun Visor Label Visible When Visor is in Up Position.

- Driver Side, Yes – Pass
- Driver Side, No – Fail
- Passenger Side, Yes – Pass
- Passenger Side, No – Fail

4.5 Is the message area black with yellow text? (S4.5.1(c)(1))

- Driver Side, Yes – Pass
- Driver Side, No – Fail
- Passenger Side, Yes – Pass
- Passenger Side, No – Fail

4.6 Is the message area at least 20 cm²? (S4.5.1(c)(1)) **The message area consists of the black part of the label.**

Driver Side: Length _____, Width _____

Passenger Side: Length _____, Width _____

Actual message area _____ cm²

- Driver Side, Yes – Pass
- Driver Side, No – Fail
- Passenger Side, Yes – Pass
- Passenger Side, No – Fail

4.7 Is the pictogram black with a red circle and slash on a white background? (S4.5.1(c)(2))

- Driver Side, Yes – Pass
- Driver Side, No – Fail
- Passenger Side, Yes – Pass
- Passenger Side, No – Fail

4.8 Is the pictogram at least 20 mm in diameter? (S4.5.1(c)(2))

Driver Side: Diameter _____mm

Passenger Side: Diameter _____mm

- Driver Side, Yes – Pass
- Driver Side, No – Fail
- Passenger Side, Yes – Pass
- Passenger Side, No – Fail

5. Label on the Dashboard: Vehicles certified to meet the requirements of S19, S21 and S23?

5.1 Does the vehicle have a label on the dash or steering wheel hub? (S4.5.1(e)(3))

Yes – Pass

No – Fail

5.2 Is the label clearly visible from all front seating positions? (S4.5.1(e)(3))

Yes – Pass

No – Fail

- 5.3 Does the label conform in content to the label shown in Figure 12? (S4.5.1(e)(3)) **Vehicles without back seats may omit the statement: “The back seat is the safest place for children.” Vehicles without back seats or too small to accommodate a rear-facing child restraint consistent with S4.5.4.1 as determined in DATA SHEET 7 may omit the statement “Never put a rear-facing child seat in the front.” (S4.5.1(e)(3)(iii))**

- Yes – Pass
 No – Fail

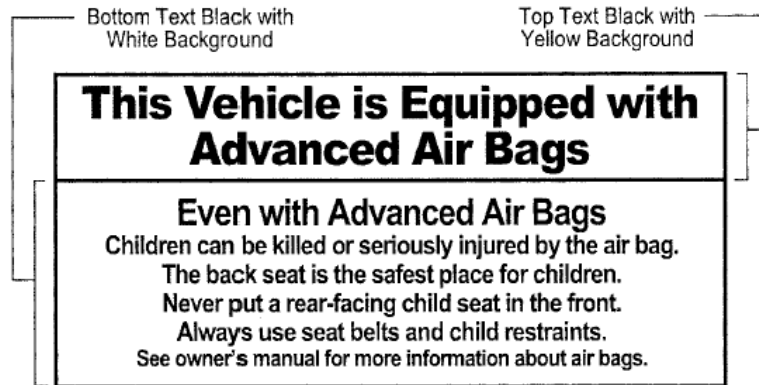

Figure 12. Removable Label on Dash.

- 5.4 Is the heading area yellow with black text? (S4.5.1(e)(3)(i))

- Yes – Pass
 No – Fail

- 5.5 Is the message white with black text? (S4.5.1(e)(3)(ii))

- Yes – Pass
 No – Fail

- 5.6 Is the message area at least 30 cm²? (S4.5.1(e)(3)(ii)) **The message area consists of the total label area minus the yellow heading area. (See 5/6/03 interpretation to Gerald Plante on behalf of Subaru)**

Length 103 mm, Width 48 mm

Actual message area 49.4 cm²

- Yes – Pass
 No – Fail

I certify that I have read and performed each instruction.

Signature: *Jose Galvez*

Date: 10/24/24

DATA SHEET 6
FMVSS 208 READINESS INDICATOR (S4.5.2)

Test Vehicle: 2024 Chevrolet Silverado EV
Test Program: FMVSS 208 Compliance
Test Technician: Jose Galvez

NHTSA No.: C20240101
Test Date: 10/24/24

An occupant restraint system that deploys in the event of a crash shall have a monitoring system with a readiness indicator. A totally mechanical system is exempt from this requirement. (11/8/94 legal interpretation to Lawrence F. Hennegerger on behalf of Breed)

1. Is the system totally mechanical? **(If Yes, this Data Sheet is complete).**
 Yes
 No
2. Describe the location of the readiness indicator: *Instrument Cluster*
3. Is the readiness indicator clearly visible to the driver?
 Yes – Pass
 No – Fail
4. Is a list of the elements in the occupant restraint system, being monitored by the readiness indicator, provided on a label or in the owner’s manual?
 Yes – Pass
 No – Fail
5. Does the vehicle have an on–off switch for the passenger air bag?
 If Yes (go to 6)
 If No (this form is complete)
6. Is the air bag readiness indicator off when the passenger air bag switch is in the off position?
 Yes – Pass
 No – Fail

REMARKS:

I certify that I have read and performed each instruction.

Signature: 

Date: 10/24/24

DATA SHEET 7

PASSENGER AIR BAG MANUAL CUT-OFF DEVICE (S4.5.4)

Test Vehicle: 2024 Chevrolet Silverado EV
Test Program: FMVSS 208 Compliance
Test Technician: Jose Galvez

NHTSA No.: C20240101
Test Date: 10/24/24

- 1. Is the vehicle equipped with an on-off switch that deactivates the air bag installed at the right front outboard seating position?
2. Does the vehicle have any forward-facing rear designated seating positions? (S4.5.4.1(a))
3. Verification there is room for a child restraint in the rear seat behind the driver's seat. (S4.5.4.1(b))
3.1 Using all the controls that affect the fore-aft movement of the seat, move the seat to the rearmost position. Mark this position.
3.2 Using all the controls that affect the fore-aft movement of the seat, move the seat to the foremost position. Mark this position.
3.3 Move the seat to the middle of the foremost and rearmost positions. (S8.1.2)
3.4 If the driver's seat height is adjustable, use all the controls that affect height to put it in the lowest position while maintaining the middle fore-aft position. (S8.1.2)
3.5 Position the driver's seat adjustable lumbar supports so that the lumbar support is in its lowest, retracted or deflated adjustment position. (S8.1.3)
3.6 The driver's seat back angle, if adjustable, is set at the manufacturer's nominal design riding position for a 50th percentile adult male in the manner specified by the manufacturer. (S4.5.4.1(b) and S8.1.3)
3.7 Is the driver seat a bucket seat?
3.7.1 Bucket seats:
3.7.1.1 Locate and mark a vertical Plane B through the longitudinal centerline of the driver's seat cushion. The longitudinal centerline of a bucket seat cushion is determined at SgRP. (S16.3.1.10) (S4.5.4.1(b)(1))
3.7.1.2 Locate the longitudinal horizontal line in plane B that is tangent to the highest point of the rear seat cushion behind the driver's seat. Measure along this line from the front of the seat back of the rear seat to the rear of the seat back of the driver's seat.
3.7.2 Bench seats (including split bench seats):
3.7.2.1 Locate and mark a vertical Plane B through the center of the steering wheel parallel to the vehicle longitudinal centerline. (S4.5.4.1(b)(2))

- 3.7.2.2 Locate the longitudinal horizontal line in plane B that is tangent to the highest point of the rear seat cushion. Measure along this line from the front of the seat back of the rear seat to the rear of the seat back of the front seat.
 ____ mm distance
 ____ less than 720 mm – Pass
 ____ more than 720 mm – **FAIL**
 Go to 4
4. Does the device turn the air bag on and off using the vehicle's ignition key? (S4.5.4.2)
 Yes – Pass
 No – Fail
5. Is the on-off device separate from the ignition switch? (S4.5.4.2)
 Yes – Pass
 No – Fail
6. Is there a telltale light that comes on when the passenger air bag is turned off? (S4.5.4.2)
 Yes – Pass
 No – Fail
7. Telltale light (S4.5.4.3)
- 7.1 Is the light yellow? (S4.5.4.3(a))
 Yes – Pass
 No – Fail
- 7.2 Are the words "PASSENGER AIR BAG OFF" or "PASS AIR BAG OFF" (S4.5.4.3(b))
 7.2.1 on the telltale?
 Yes – Pass, go to 7.3
 No – go to 7.2.2
- 7.2.2 within 25 mm of the telltale?
 Measurement from the edge of the telltale (mm):
 Yes – Pass
 No – Fail
- 7.3 Does the telltale remain illuminated while the air bag is turned off? (S4.5.4.3c)
 (Leave the air bag off for 5 minutes.)
 Yes – Pass
 No – Fail
- 7.4 Is the telltale illuminated while the air bag is turned on? (S4.5.4.3(d))
 Yes – Fail
 No – Pass
- 7.5 Is the telltale combined with the air bag readiness indicator? (S4.5.4.3(e))
 Yes – Fail
 No – Pass
8. Owner's Manual
- 8.1 Does the owner's manual contain complete instructions on the operation of the on-off switch? (S4.5.4.4(a))
 Yes – Pass
 No – Fail

DATA SHEET 8
LAP BELT LOCKABILITY

**Passenger cars, trucks, buses, and multipurpose passenger
Vehicles with a GVWR of 10,000 pounds or less. (S7.1.1.5)**

Test Vehicle: 2024 Chevrolet Silverado EV NHTSA No.: C20240101
 Test Program: FMVSS 208 Compliance Test Date: 10/24/24
 Test Technician: Jose Galvez

Complete one of these forms for **each** designated seating position that can be adjusted to forward-facing or that is a forward-facing seat, other than the driver's seat (S7.1.1.5(a), **and** that has seat belt retractors that are not solely automatic locking retractors. (S7.1.1.5(c))

DESIGNATED SEATING POSITION:	Front Passenger
------------------------------	-----------------

- | | | |
|-------------------------------------|-----|---|
| <input type="checkbox"/> | | N/A – No retractor is at this position |
| <input type="checkbox"/> | | N/A – The retractor is an automatic locking retractor ONLY |
| <input checked="" type="checkbox"/> | 1. | Record test fore-aft seat position: AFT
(S7.1.1.5(c)(1)) (Any position is acceptable) |
| <input checked="" type="checkbox"/> | 2. | Does the lap belt portion of the seat belt in the forward-facing seat or seat that can be adjusted to forward-facing consist of a locking device that does NOT have to be attached by the vehicle user to the seat belt webbing, retractor, or any other part of the vehicle. (S7.1.1.5(a)) |
| | | <input checked="" type="checkbox"/> Yes – Pass |
| | | <input type="checkbox"/> No – Fail |
| <input checked="" type="checkbox"/> | 3. | Does the lap belt portion of the seat belt in the forward-facing seat or seat that can be adjusted to forward-facing consist of a locking device that does NOT require inverting, twisting or deforming of the belt webbing. (S7.1.1.5(a)) |
| | | <input checked="" type="checkbox"/> Yes – Pass |
| | | <input type="checkbox"/> No – Fail |
| <input checked="" type="checkbox"/> | 4. | Place any adjustable seat belt anchorage in the lowest adjustment position. |
| | | <input type="checkbox"/> N/A The anchorage is not adjustable. |
| <input checked="" type="checkbox"/> | 5. | Buckle the seat belt. (S7.1.1.5(c)(1)) |
| <input checked="" type="checkbox"/> | 6. | Locate a reference point A on the seat belt buckle. (S7.1.1.5(c)(2)) |
| <input checked="" type="checkbox"/> | 7. | Locate a reference point B on the attachment hardware or retractor assembly at the other end of the lap belt or lap belt portion of the seat belt assembly. (S7.1.1.5(c)(2)) |
| <input checked="" type="checkbox"/> | 8. | Does the vehicle user need to take some action to activate the locking feature on the lap belt portion of the seat belt in any forward-facing seat or seat that can be adjusted to forward-facing? |
| | | <input checked="" type="checkbox"/> Yes (go to 8.1) |
| | | <input type="checkbox"/> No (go to 9) |
| <input checked="" type="checkbox"/> | 8.1 | Does the vehicle owner's manual include a description in words and/or diagrams describing how to activate the locking feature so that the seat belt assembly can tightly secure a child restraint system and how to deactivate the locking feature to remove the child restraint system. (S7.1.1.5(b)) |
| | | <input checked="" type="checkbox"/> Yes – Pass |
| | | <input type="checkbox"/> No – Fail |
| <input checked="" type="checkbox"/> | 9. | Adjust the lap belt or lap belt portion of the seat belt assembly according to any procedures recommended in the vehicle owner's manual to activate any locking feature so that the webbing between points A and B is at the maximum length allowed by the belt system. (S7.1.1.5(c)(2) & S7.1.1.5(c)(1)) |

10. Measure and record the distance between points A and B along the longitudinal centerline of the webbing for the lap belt or lap belt portion of the seat belt assembly. (S7.1.1.5(c)(2))
- Measured distance between A and B (inches): 60
11. Readjust the belt system so that the webbing between points A and B is at ½ the maximum length of the webbing. (S7.1.1.5(c)(3))
12. To the lap belt or lap belt portion of the seat belt assembly, apply a preload of 10 pounds using the webbing tension pull device in Figure 5. Apply the load in a vertical plane parallel to the longitudinal axis of the vehicle and passing through the seating reference point of the designated seating position. Apply the preload in a horizontal direction toward the front of the vehicle with a force application angle of not less than 5 degrees nor more than 15 degrees above the horizontal. (S7.1.1.5(c)(4))
- Measured force application angle: 10° (spec. 5 – 15 degrees)
13. Measure the length between points A and B along the longitudinal centerline of the webbing while the preload is being applied. (S7.1.1.5(c)(4))
- Measured distance between A and B: 25 inches
14. Increase the load to 50 pounds at a rate of no more than 50 pounds per second. Attain the load in not more than 5 seconds. (If webbing sensitive emergency locking retractors are installed as part of the lap belt or lap belt portion of the seat belt assembly, apply the load at a rate less than the threshold value for lock-up specified by the manufacturer.) Maintain the load for at least 5 seconds. Measure and record the distance between points A and B along the longitudinal centerline of the webbing. (S7.1.1.5(c)(5))
Record onset rate: 15 lb/sec (spec. 10 to 50 lb/sec) (S7.1.1.5(c)(5))
Measured distance between A and B: 25 inches (S7.1.1.5(c)(6))
15. Let the seat belt webbing retract to its minimum length with the seat belt still buckled.
16. To the lap belt or lap belt portion of the seat belt assembly, apply a preload of 10 pounds using the webbing tension pull device in Figure 5. Apply the load in a vertical plane parallel to the longitudinal axis of the vehicle and passing through the seating reference point of the designated seating position. Apply the preload in a horizontal direction toward the front of the vehicle with a force application angle of not less than 5 degrees nor more than 15 degrees above the horizontal. (S7.1.1.5(c)(4))
Measured force application angle: 10° (spec. 5 – 15 degrees)
17. Measure the length between points A and B along the longitudinal centerline of the webbing while the preload is being applied. (S7.1.1.5(c)(4))
Measured distance between A and B: 10 inches
18. Increase the load to 50 pounds at a rate of no more than 50 pounds per second. Attain the load in not more than 5 seconds. (If webbing sensitive emergency locking retractors are installed as part of the lap belt or lap belt portion of the seat belt assembly, apply the load at a rate less than the threshold value for lock-up specified by the manufacturer.) Maintain the load for at least 5 seconds. Measure and record the distance between points A and B along the longitudinal centerline of the webbing. (S7.1.1.5(c)(5))
Record onset rate: 15 lb/sec (spec. 10 to 50 lb/sec) (S7.1.1.5(c)(5))
Measured distance between A and B: 10 inches (S7.1.1.5(c)(6))
19. Subtract the measurement in 13 from the measurement in 14 and the measurement in 17 from the measurement in 18. Is the difference 2 inches or less for both? (S7.1.1.5(c)(7))
- $14 - 13 = \underline{25 - 25 = 0}$ inch;
- $18 - 17 = \underline{10 - 10 = 0}$ inch
- Yes – Pass
- No – Fail

20. Subtract the measurement in 14 from the measurement in 10 and the measurement in 18 from the measurement in 10. Is the difference 3 inches or more for both?
(S7.1.1.5(c)(8))

$10-14 = 60 - 25 = 35$ inches;

$10-18 = 60 - 10 = 50$ inches;

Yes – Pass

No – Fail

REMARKS:

Signature: *Jose Galvez*

Date: 10/24/24

I certify that I have read and performed each instruction.

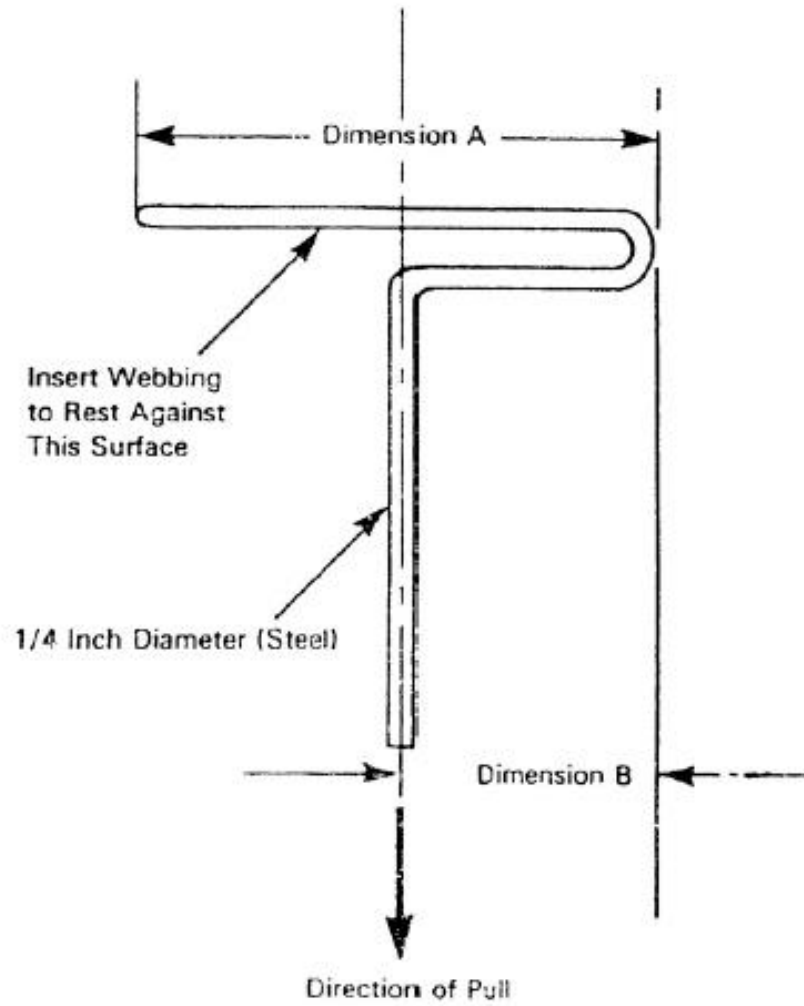

Dimension A - Width of Webbing Plus 1/2 Inch

Dimension B - 1/2 of Dimension A

Figure 5. - Webbing Tension Pull Device

DATA SHEET 8
LAP BELT LOCKABILITY

**Passenger cars, trucks, buses, and multipurpose passenger
Vehicles with a GVWR of 10,000 pounds or less. (S7.1.1.5)**

Test Vehicle: 2024 Chevrolet Silverado EV
Test Program: FMVSS 208 Compliance
Test Technician: Jose Galvez

NHTSA No.: C20240101
Test Date: 10/24/24

Complete one of these forms for **each** designated seating position that can be adjusted to forward-facing or that is a forward-facing seat, other than the driver's seat (S7.1.1.5(a), **and** that has seat belt retractors that are not solely automatic locking retractors. (S7.1.1.5(c))

DESIGNATED SEATING POSITION:	Left Rear Passenger
------------------------------	---------------------

- | | | |
|-------------------------------------|-----|---|
| <input type="checkbox"/> | | N/A – No retractor is at this position |
| <input type="checkbox"/> | | N/A – The retractor is an automatic locking retractor ONLY |
| <input checked="" type="checkbox"/> | 1. | Record test fore-aft seat position: FIXED
(S7.1.1.5(c)(1)) (Any position is acceptable) |
| <input checked="" type="checkbox"/> | 2. | Does the lap belt portion of the seat belt in the forward-facing seat or seat that can be adjusted to forward-facing consist of a locking device that does NOT have to be attached by the vehicle user to the seat belt webbing, retractor, or any other part of the vehicle. (S7.1.1.5(a)) |
| | | <input checked="" type="checkbox"/> Yes – Pass |
| | | <input type="checkbox"/> No – Fail |
| <input checked="" type="checkbox"/> | 3. | Does the lap belt portion of the seat belt in the forward-facing seat or seat that can be adjusted to forward-facing consist of a locking device that does NOT require inverting, twisting or deforming of the belt webbing. (S7.1.1.5(a)) |
| | | <input checked="" type="checkbox"/> Yes – Pass |
| | | <input type="checkbox"/> No – Fail |
| <input checked="" type="checkbox"/> | 4. | Place any adjustable seat belt anchorage in the lowest adjustment position. |
| | | <input checked="" type="checkbox"/> N/A The anchorage is not adjustable. |
| <input checked="" type="checkbox"/> | 5. | Buckle the seat belt. (S7.1.1.5(c)(1)) |
| <input checked="" type="checkbox"/> | 6. | Locate a reference point A on the seat belt buckle. (S7.1.1.5(c)(2)) |
| <input checked="" type="checkbox"/> | 7. | Locate a reference point B on the attachment hardware or retractor assembly at the other end of the lap belt or lap belt portion of the seat belt assembly. (S7.1.1.5(c)(2)) |
| <input checked="" type="checkbox"/> | 8. | Does the vehicle user need to take some action to activate the locking feature on the lap belt portion of the seat belt in any forward-facing seat or seat that can be adjusted to forward-facing? |
| | | <input checked="" type="checkbox"/> Yes (go to 8.1) |
| | | <input type="checkbox"/> No (go to 9) |
| <input checked="" type="checkbox"/> | 8.1 | Does the vehicle owner's manual include a description in words and/or diagrams describing how to activate the locking feature so that the seat belt assembly can tightly secure a child restraint system and how to deactivate the locking feature to remove the child restraint system. (S7.1.1.5(b)) |
| | | <input checked="" type="checkbox"/> Yes – Pass |
| | | <input type="checkbox"/> No – Fail |
| <input checked="" type="checkbox"/> | 9. | Adjust the lap belt or lap belt portion of the seat belt assembly according to any procedures recommended in the vehicle owner's manual to activate any locking feature so that the webbing between points A and B is at the maximum length allowed by the belt system. (S7.1.1.5(c)(2) & S7.1.1.5(c)(1)) |

10. Measure and record the distance between points A and B along the longitudinal centerline of the webbing for the lap belt or lap belt portion of the seat belt assembly. (S7.1.1.5(c)(2))
- Measured distance between A and B (inches): 52
11. Readjust the belt system so that the webbing between points A and B is at ½ the maximum length of the webbing. (S7.1.1.5(c)(3))
12. To the lap belt or lap belt portion of the seat belt assembly, apply a preload of 10 pounds using the webbing tension pull device in Figure 5. Apply the load in a vertical plane parallel to the longitudinal axis of the vehicle and passing through the seating reference point of the designated seating position. Apply the preload in a horizontal direction toward the front of the vehicle with a force application angle of not less than 5 degrees nor more than 15 degrees above the horizontal. (S7.1.1.5(c)(4))
- Measured force application angle: 10° (spec. 5 – 15 degrees)
13. Measure the length between points A and B along the longitudinal centerline of the webbing while the preload is being applied. (S7.1.1.5(c)(4))
- Measured distance between A and B: 22 ½ inches
14. Increase the load to 50 pounds at a rate of no more than 50 pounds per second. Attain the load in not more than 5 seconds. (If webbing sensitive emergency locking retractors are installed as part of the lap belt or lap belt portion of the seat belt assembly, apply the load at a rate less than the threshold value for lock-up specified by the manufacturer.) Maintain the load for at least 5 seconds. Measure and record the distance between points A and B along the longitudinal centerline of the webbing. (S7.1.1.5(c)(5))
- Record onset rate: 15 lb/sec (spec. 10 to 50 lb/sec) (S7.1.1.5(c)(5))
- Measured distance between A and B: 22 5/8 inches (S7.1.1.5(c)(6))
15. Let the seat belt webbing retract to its minimum length with the seat belt still buckled.
16. To the lap belt or lap belt portion of the seat belt assembly, apply a preload of 10 pounds using the webbing tension pull device in Figure 5. Apply the load in a vertical plane parallel to the longitudinal axis of the vehicle and passing through the seating reference point of the designated seating position. Apply the preload in a horizontal direction toward the front of the vehicle with a force application angle of not less than 5 degrees nor more than 15 degrees above the horizontal. (S7.1.1.5(c)(4))
- Measured force application angle: 10° (spec. 5 – 15 degrees)
17. Measure the length between points A and B along the longitudinal centerline of the webbing while the preload is being applied. (S7.1.1.5(c)(4))
- Measured distance between A and B: 11 inches
18. Increase the load to 50 pounds at a rate of no more than 50 pounds per second. Attain the load in not more than 5 seconds. (If webbing sensitive emergency locking retractors are installed as part of the lap belt or lap belt portion of the seat belt assembly, apply the load at a rate less than the threshold value for lock-up specified by the manufacturer.) Maintain the load for at least 5 seconds. Measure and record the distance between points A and B along the longitudinal centerline of the webbing. (S7.1.1.5(c)(5))
- Record onset rate: 15 lb/sec (spec. 10 to 50 lb/sec) (S7.1.1.5(c)(5))
- Measured distance between A and B: 11 1/8 inches (S7.1.1.5(c)(6))
19. Subtract the measurement in 13 from the measurement in 14 and the measurement in 17 from the measurement in 18. Is the difference 2 inches or less for both? (S7.1.1.5(c)(7))
- $14 - 13 = 22 \frac{5}{8} - 22 \frac{1}{2} = \frac{1}{8}$ inch;
- $18 - 17 = 11 \frac{1}{8} - 11 = \frac{1}{8}$ inch
- Yes – Pass
- No – Fail

20. Subtract the measurement in 14 from the measurement in 10 and the measurement in 18 from the measurement in 10. Is the difference 3 inches or more for both?
(S7.1.1.5(c)(8))

$10-14 = \underline{52 - 22 \frac{5}{8} = 29 \frac{3}{8}}$ inches;

$10-18 = \underline{52 - 11 \frac{1}{8} = 40 \frac{7}{8}}$ inches

Yes – Pass

No – Fail

REMARKS:

Signature: 

Date: 10/24/24

I certify that I have read and performed each instruction.

DATA SHEET 8
LAP BELT LOCKABILITY

**Passenger cars, trucks, buses, and multipurpose passenger
Vehicles with a GVWR of 10,000 pounds or less. (S7.1.1.5)**

Test Vehicle: 2024 Chevrolet Silverado EV
Test Program: FMVSS 208 Compliance
Test Technician: Jose Galvez

NHTSA No.: C20240101
Test Date: 10/24/24

Complete one of these forms for **each** designated seating position that can be adjusted to forward-facing or that is a forward-facing seat, other than the driver's seat (S7.1.1.5(a), **and** that has seat belt retractors that are not solely automatic locking retractors. (S7.1.1.5(c))

DESIGNATED SEATING POSITION:	Center Rear Passenger
------------------------------	-----------------------

- | | | |
|-------------------------------------|-----|---|
| <input type="checkbox"/> | | N/A – No retractor is at this position |
| <input type="checkbox"/> | | N/A – The retractor is an automatic locking retractor ONLY |
| <input checked="" type="checkbox"/> | 1. | Record test fore-aft seat position: FIXED
(S7.1.1.5(c)(1)) (Any position is acceptable) |
| <input checked="" type="checkbox"/> | 2. | Does the lap belt portion of the seat belt in the forward-facing seat or seat that can be adjusted to forward-facing consist of a locking device that does NOT have to be attached by the vehicle user to the seat belt webbing, retractor, or any other part of the vehicle. (S7.1.1.5(a)) |
| | | <input checked="" type="checkbox"/> Yes – Pass |
| | | <input type="checkbox"/> No – Fail |
| <input checked="" type="checkbox"/> | 3. | Does the lap belt portion of the seat belt in the forward-facing seat or seat that can be adjusted to forward-facing consist of a locking device that does NOT require inverting, twisting or deforming of the belt webbing. (S7.1.1.5(a)) |
| | | <input checked="" type="checkbox"/> Yes – Pass |
| | | <input type="checkbox"/> No – Fail |
| <input checked="" type="checkbox"/> | 4. | Place any adjustable seat belt anchorage in the lowest adjustment position. |
| | | <input checked="" type="checkbox"/> N/A The anchorage is not adjustable. |
| <input checked="" type="checkbox"/> | 5. | Buckle the seat belt. (S7.1.1.5(c)(1)) |
| <input checked="" type="checkbox"/> | 6. | Locate a reference point A on the seat belt buckle. (S7.1.1.5(c)(2)) |
| <input checked="" type="checkbox"/> | 7. | Locate a reference point B on the attachment hardware or retractor assembly at the other end of the lap belt or lap belt portion of the seat belt assembly. (S7.1.1.5(c)(2)) |
| <input checked="" type="checkbox"/> | 8. | Does the vehicle user need to take some action to activate the locking feature on the lap belt portion of the seat belt in any forward-facing seat or seat that can be adjusted to forward-facing? |
| | | <input checked="" type="checkbox"/> Yes (go to 8.1) |
| | | <input type="checkbox"/> No (go to 9) |
| <input checked="" type="checkbox"/> | 8.1 | Does the vehicle owner's manual include a description in words and/or diagrams describing how to activate the locking feature so that the seat belt assembly can tightly secure a child restraint system and how to deactivate the locking feature to remove the child restraint system. (S7.1.1.5(b)) |
| | | <input checked="" type="checkbox"/> Yes – Pass |
| | | <input type="checkbox"/> No – Fail |
| <input checked="" type="checkbox"/> | 9. | Adjust the lap belt or lap belt portion of the seat belt assembly according to any procedures recommended in the vehicle owner's manual to activate any locking feature so that the webbing between points A and B is at the maximum length allowed by the belt system. (S7.1.1.5(c)(2) & S7.1.1.5(c)(1)) |

10. Measure and record the distance between points A and B along the longitudinal centerline of the webbing for the lap belt or lap belt portion of the seat belt assembly. (S7.1.1.5(c)(2))
- Measured distance between A and B (inches): 58 1/2
11. Readjust the belt system so that the webbing between points A and B is at 1/2 the maximum length of the webbing. (S7.1.1.5(c)(3))
12. To the lap belt or lap belt portion of the seat belt assembly, apply a preload of 10 pounds using the webbing tension pull device in Figure 5. Apply the load in a vertical plane parallel to the longitudinal axis of the vehicle and passing through the seating reference point of the designated seating position. Apply the preload in a horizontal direction toward the front of the vehicle with a force application angle of not less than 5 degrees nor more than 15 degrees above the horizontal. (S7.1.1.5(c)(4))
- Measured force application angle: 10° (spec. 5 – 15 degrees)
13. Measure the length between points A and B along the longitudinal centerline of the webbing while the preload is being applied. (S7.1.1.5(c)(4))
- Measured distance between A and B: 29 inches
14. Increase the load to 50 pounds at a rate of no more than 50 pounds per second. Attain the load in not more than 5 seconds. (If webbing sensitive emergency locking retractors are installed as part of the lap belt or lap belt portion of the seat belt assembly, apply the load at a rate less than the threshold value for lock-up specified by the manufacturer.) Maintain the load for at least 5 seconds. Measure and record the distance between points A and B along the longitudinal centerline of the webbing. (S7.1.1.5(c)(5))
Record onset rate: 15 lb/sec (spec. 10 to 50 lb/sec) (S7.1.1.5(c)(5))
Measured distance between A and B: 29 1/8 inches (S7.1.1.5(c)(6))
15. Let the seat belt webbing retract to its minimum length with the seat belt still buckled.
16. To the lap belt or lap belt portion of the seat belt assembly, apply a preload of 10 pounds using the webbing tension pull device in Figure 5. Apply the load in a vertical plane parallel to the longitudinal axis of the vehicle and passing through the seating reference point of the designated seating position. Apply the preload in a horizontal direction toward the front of the vehicle with a force application angle of not less than 5 degrees nor more than 15 degrees above the horizontal. (S7.1.1.5(c)(4))
Measured force application angle: 10° (spec. 5 – 15 degrees)
17. Measure the length between points A and B along the longitudinal centerline of the webbing while the preload is being applied. (S7.1.1.5(c)(4))
Measured distance between A and B: 8 3/4 inches
18. Increase the load to 50 pounds at a rate of no more than 50 pounds per second. Attain the load in not more than 5 seconds. (If webbing sensitive emergency locking retractors are installed as part of the lap belt or lap belt portion of the seat belt assembly, apply the load at a rate less than the threshold value for lock-up specified by the manufacturer.) Maintain the load for at least 5 seconds. Measure and record the distance between points A and B along the longitudinal centerline of the webbing. (S7.1.1.5(c)(5))
Record onset rate: 15 lb/sec (spec. 10 to 50 lb/sec) (S7.1.1.5(c)(5))
Measured distance between A and B: 8 7/8 inches (S7.1.1.5(c)(6))
19. Subtract the measurement in 13 from the measurement in 14 and the measurement in 17 from the measurement in 18. Is the difference 2 inches or less for both? (S7.1.1.5(c)(7))
- $14 - 13 = 29 \frac{1}{8} - 29 = \frac{1}{8}$ inch;
- $18 - 17 = 8 \frac{7}{8} - 8 \frac{3}{4} = \frac{1}{8}$ inch
- Yes – Pass
- No – Fail

20. Subtract the measurement in 14 from the measurement in 10 and the measurement in 18 from the measurement in 10. Is the difference 3 inches or more for both?

(S7.1.1.5(c)(8))

$10-14 = 58 \frac{1}{2} - 29 \frac{1}{8} = 29 \frac{5}{8}$ inches;

$10-18 = 58 \frac{1}{2} - 8 \frac{7}{8} = 49 \frac{5}{8}$ inches

Yes – Pass

No – Fail

REMARKS:

Signature: *Jose Galvez*

Date: 10/24/24

I certify that I have read and performed each instruction.

DATA SHEET 8
LAP BELT LOCKABILITY

**Passenger cars, trucks, buses, and multipurpose passenger
Vehicles with a GVWR of 10,000 pounds or less. (S7.1.1.5)**

Test Vehicle: 2024 Chevrolet Silverado EV
Test Program: FMVSS 208 Compliance
Test Technician: Jose Galvez

NHTSA No.: C20240101
Test Date: 10/24/24

Complete one of these forms for **each** designated seating position that can be adjusted to forward-facing or that is a forward-facing seat, other than the driver's seat (S7.1.1.5(a), **and** that has seat belt retractors that are not solely automatic locking retractors. (S7.1.1.5(c))

DESIGNATED SEATING POSITION:	Right Rear Passenger
------------------------------	----------------------

- | | | |
|-------------------------------------|-----|---|
| <input type="checkbox"/> | | N/A – No retractor is at this position |
| <input type="checkbox"/> | | N/A – The retractor is an automatic locking retractor ONLY |
| <input checked="" type="checkbox"/> | 1. | Record test fore-aft seat position: FIXED
(S7.1.1.5(c)(1)) (Any position is acceptable) |
| <input checked="" type="checkbox"/> | 2. | Does the lap belt portion of the seat belt in the forward-facing seat or seat that can be adjusted to forward-facing consist of a locking device that does NOT have to be attached by the vehicle user to the seat belt webbing, retractor, or any other part of the vehicle. (S7.1.1.5(a)) |
| | | <input checked="" type="checkbox"/> Yes – Pass |
| | | <input type="checkbox"/> No – Fail |
| <input checked="" type="checkbox"/> | 3. | Does the lap belt portion of the seat belt in the forward-facing seat or seat that can be adjusted to forward-facing consist of a locking device that does NOT require inverting, twisting or deforming of the belt webbing. (S7.1.1.5(a)) |
| | | <input checked="" type="checkbox"/> Yes – Pass |
| | | <input type="checkbox"/> No – Fail |
| <input checked="" type="checkbox"/> | 4. | Place any adjustable seat belt anchorage in the lowest adjustment position. |
| | | <input checked="" type="checkbox"/> N/A The anchorage is not adjustable. |
| <input checked="" type="checkbox"/> | 5. | Buckle the seat belt. (S7.1.1.5(c)(1)) |
| <input checked="" type="checkbox"/> | 6. | Locate a reference point A on the seat belt buckle. (S7.1.1.5(c)(2)) |
| <input checked="" type="checkbox"/> | 7. | Locate a reference point B on the attachment hardware or retractor assembly at the other end of the lap belt or lap belt portion of the seat belt assembly. (S7.1.1.5(c)(2)) |
| <input checked="" type="checkbox"/> | 8. | Does the vehicle user need to take some action to activate the locking feature on the lap belt portion of the seat belt in any forward-facing seat or seat that can be adjusted to forward-facing? |
| | | <input checked="" type="checkbox"/> Yes (go to 8.1) |
| | | <input type="checkbox"/> No (go to 9) |
| <input checked="" type="checkbox"/> | 8.1 | Does the vehicle owner's manual include a description in words and/or diagrams describing how to activate the locking feature so that the seat belt assembly can tightly secure a child restraint system and how to deactivate the locking feature to remove the child restraint system. (S7.1.1.5(b)) |
| | | <input checked="" type="checkbox"/> Yes – Pass |
| | | <input type="checkbox"/> No – Fail |
| <input checked="" type="checkbox"/> | 9. | Adjust the lap belt or lap belt portion of the seat belt assembly according to any procedures recommended in the vehicle owner's manual to activate any locking feature so that the webbing between points A and B is at the maximum length allowed by the belt system. (S7.1.1.5(c)(2) & S7.1.1.5(c)(1)) |

10. Measure and record the distance between points A and B along the longitudinal centerline of the webbing for the lap belt or lap belt portion of the seat belt assembly. (S7.1.1.5(c)(2))
- Measured distance between A and B (inches): 51 ¼
11. Readjust the belt system so that the webbing between points A and B is at ½ the maximum length of the webbing. (S7.1.1.5(c)(3))
12. To the lap belt or lap belt portion of the seat belt assembly, apply a preload of 10 pounds using the webbing tension pull device in Figure 5. Apply the load in a vertical plane parallel to the longitudinal axis of the vehicle and passing through the seating reference point of the designated seating position. Apply the preload in a horizontal direction toward the front of the vehicle with a force application angle of not less than 5 degrees nor more than 15 degrees above the horizontal. (S7.1.1.5(c)(4))
- Measured force application angle: 10° (spec. 5 – 15 degrees)
13. Measure the length between points A and B along the longitudinal centerline of the webbing while the preload is being applied. (S7.1.1.5(c)(4))
- Measured distance between A and B: 23 inches
14. Increase the load to 50 pounds at a rate of no more than 50 pounds per second. Attain the load in not more than 5 seconds. (If webbing sensitive emergency locking retractors are installed as part of the lap belt or lap belt portion of the seat belt assembly, apply the load at a rate less than the threshold value for lock-up specified by the manufacturer.) Maintain the load for at least 5 seconds. Measure and record the distance between points A and B along the longitudinal centerline of the webbing. (S7.1.1.5(c)(5))
- Record onset rate: 15 lb/sec (spec. 10 to 50 lb/sec) (S7.1.1.5(c)(5))
- Measured distance between A and B: 23 1/8 inches (S7.1.1.5(c)(6))
15. Let the seat belt webbing retract to its minimum length with the seat belt still buckled.
16. To the lap belt or lap belt portion of the seat belt assembly, apply a preload of 10 pounds using the webbing tension pull device in Figure 5. Apply the load in a vertical plane parallel to the longitudinal axis of the vehicle and passing through the seating reference point of the designated seating position. Apply the preload in a horizontal direction toward the front of the vehicle with a force application angle of not less than 5 degrees nor more than 15 degrees above the horizontal. (S7.1.1.5(c)(4))
- Measured force application angle: 10° (spec. 5 – 15 degrees)
17. Measure the length between points A and B along the longitudinal centerline of the webbing while the preload is being applied. (S7.1.1.5(c)(4))
- Measured distance between A and B: 14 ½ inches
18. Increase the load to 50 pounds at a rate of no more than 50 pounds per second. Attain the load in not more than 5 seconds. (If webbing sensitive emergency locking retractors are installed as part of the lap belt or lap belt portion of the seat belt assembly, apply the load at a rate less than the threshold value for lock-up specified by the manufacturer.) Maintain the load for at least 5 seconds. Measure and record the distance between points A and B along the longitudinal centerline of the webbing. (S7.1.1.5(c)(5))
- Record onset rate: 15 lb/sec (spec. 10 to 50 lb/sec) (S7.1.1.5(c)(5))
- Measured distance between A and B: 14 5/8 inches (S7.1.1.5(c)(6))
19. Subtract the measurement in 13 from the measurement in 14 and the measurement in 17 from the measurement in 18. Is the difference 2 inches or less for both? (S7.1.1.5(c)(7))

$14 - 13 = 23 \frac{1}{8} - 23 = \frac{1}{8}$ inch;

$18 - 17 = 14 \frac{5}{8} - 14 \frac{1}{2} = \frac{1}{8}$ inch

- Yes – Pass
- No – Fail

20. Subtract the measurement in 14 from the measurement in 10 and the measurement in 18 from the measurement in 10. Is the difference 3 inches or more for both?

(S7.1.1.5(c)(8))

$10-14 = 51 \frac{1}{4} - 23 \frac{1}{8} = 28 \frac{1}{8}$ inches;

$10-18 = 51 \frac{1}{4} - 14 \frac{5}{8} = 46 \frac{5}{8}$ inches

Yes – Pass

No – Fail

REMARKS:

Signature: 

Date: 10/24/24

I certify that I have read and performed each instruction.

DATA SHEET 9

FMVSS 208 SEAT BELT WARNING SYSTEM CHECK (S7.3)



Test Vehicle: 2024 Chevrolet Silverado EV
 Test Program: FMVSS 208 Compliance
 Test Technician: Jose Galvez

NHTSA No.: C20240101
 Test Date: 10/24/24

- 1. The occupant is in the driver's seat.
- 2. The seat belt is in the stowed position.
- 3. The key is in the "on" or "start" position.
- 4. The time duration of the audible signal beginning with key "on" or "start" is 5 seconds.
- 5. The occupant is in the driver's seat.
- 6. The seat belt is in the stowed position.
- 7. The key is in the "on" or "start" position.
- 8. The time duration of the warning light beginning with key "on" or "start" is Stays On seconds.
- 9. The occupant is in the driver's seat.
- 10. The seat belt is in the latched position and with at least 4 inches of belt webbing extended.
- 11. The key is in the "on" or "start" position.
- 12. The time duration of the warning light beginning with key "on" or "start" is 0 seconds.
- 13. Complete the following table with the data from 4, 8, and 12 to determine which option is used.

		Warning light	Warning light specification	Audible signal	Audible signal specification*
S7.3 (a)(1)	Belt stowed & key on or start	Item 8: <u>Stays On</u>	60 seconds minimum	Item 4: <u>5</u>	4 to 8 seconds
S7.3 (a)(2)	Belt latched & key on or start	Item 12: <u>0</u>	4 to 8 seconds		
	Belt stowed & key on or start	Item 8: <u>Stays On</u>	4 to 8 seconds	Item 4: <u>5</u>	4 to 8 seconds

* 49 USCS @ 30124 does NOT allow an audible signal to operate for more than 8 seconds. A voluntary audible signal after the 4 to 8 second required signal may be provided. It must be differentiated from the required signal (5/25/2001 legal interpretation to Longacre and Associates).

- 14. The seat belt warning system meets the requirements of (manufacturers may comply with either section).
 - S7.3 (a)(1)
 - S7.3 (a)(2)
 - FAIL – Does NOT meet the requirements of either option.
- 15. Note wording of visual warning: (S7.3(a)(1) and S7.3(a)(2))
 - Fasten Seat Belts
 - Fasten Belts
 - Symbol 101 –  or 
 - FAIL – Does not use any of the above wording or symbol.

REMARKS:

I certify that I have read and performed each instruction.

Signature: 

Date: 10/24/24

DATA SHEET 10
BELT CONTACT FORCE (S7.4.3)

Test Vehicle: 2024 Chevrolet Silverado EV
 Test Program: FMVSS 208 Compliance
 Test Technician: Jose Galvez

NHTSA No.: C20240101
 Test Date: 10/24/24

Test all Type 2 seat belts other than those in walk-in van-type vehicles and those at front outboard designated seating positions in passenger cars. Complete a form for each applicable seat belt.

DESIGNATED SEATING POSITION:	Left Front Driver
------------------------------	-------------------

- | | | |
|-------------------------------------|----|---|
| <input checked="" type="checkbox"/> | 1. | Does the vehicle incorporate a webbing tension-relieving device? |
| | | <input type="checkbox"/> Yes (this form is complete) |
| | | <input checked="" type="checkbox"/> No (continue with this check sheet) |
- | | | |
|-------------------------------------|----|---|
| <input checked="" type="checkbox"/> | 2. | Position the seat's adjustable lumbar supports so that the lumbar support is in its lowest, retracted or deflated adjustment position. (S8.1.3) |
| | | <input checked="" type="checkbox"/> N/A – No lumbar adjustment |
- | | | |
|-------------------------------------|----|---|
| <input checked="" type="checkbox"/> | 3. | Position any adjustable parts of the seat that provide additional support so that they are in the lowest or most open adjustment position. (S16.2.10.2) |
| | | <input checked="" type="checkbox"/> N/A – No additional support adjustment |
- | | | |
|-------------------------------------|----|---|
| <input checked="" type="checkbox"/> | 4. | Is the fore-aft position of the seat adjustable? |
| | | <input type="checkbox"/> No – go to 5 |
| | | <input checked="" type="checkbox"/> Yes – go to 4.1 |
- | | | |
|-------------------------------------|-----|---|
| <input checked="" type="checkbox"/> | 4.1 | Use all the seat controls that have any effect on the fore-aft movement of the seat to move the seat cushion to the rearmost position. Mark this position. (8/31/95 legal interpretation to Hogan and Hartson) |
|-------------------------------------|-----|---|
- | | | |
|-------------------------------------|-----|--|
| <input checked="" type="checkbox"/> | 4.2 | Use all the seat controls that have any effects on the fore-aft movement of the seat to move the seat cushion to the foremost position. Mark this position. (8/31/95 legal interpretation to Hogan and Hartson) |
|-------------------------------------|-----|--|
- | | | |
|-------------------------------------|-----|---|
| <input checked="" type="checkbox"/> | 4.3 | Mark each fore-aft position so that there is a visual indication when the seat is at a particular position. For manual seats, mark each detent. For power seats, mark only the rearmost, middle and foremost positions. Label three of the positions with the following: F for foremost, M for mid-position (if there is no mid-position, label the closest adjustment position to the rear of the mid-point), and R for rearmost. Determine the mid fore-aft seat position based on the foremost and rearmost positions determined in items 4.1 and 4.2. (8/31/95 legal interpretation to Hogan and Hartson) |
|-------------------------------------|-----|---|
- | | | |
|-------------------------------------|-----|------------------------------------|
| <input checked="" type="checkbox"/> | 4.4 | Move the seat to the mid position. |
|-------------------------------------|-----|------------------------------------|
- | | | |
|-------------------------------------|-----|--|
| <input checked="" type="checkbox"/> | 4.5 | While maintaining the mid position, move the seat to its lowest position. For seats with adjustable seat cushions, use the manufacturer's recommended seat cushion angle for determining the lowest height position. |
|-------------------------------------|-----|--|
- | | | |
|-------------------------------------|----|--|
| <input checked="" type="checkbox"/> | 5. | Is the seat back angle adjustable? |
| | | <input type="checkbox"/> No- go to 6 |
| | | <input checked="" type="checkbox"/> Yes- go to 5.1 |
- | | | |
|-------------------------------------|-----|---|
| <input checked="" type="checkbox"/> | 5.1 | Set and mark seat back angle, if adjustable, at the manufacturer's nominal design riding position for a 50 th percentile adult male in the manner specified by the manufacturer. |
| | | <input type="checkbox"/> N/A – No seat back angle adjustment |
| | | <input checked="" type="checkbox"/> Manufacturer's design seat back angle: <u>-11.6° on Head Rest Post</u> |
| | | <input checked="" type="checkbox"/> Tested seat back angle: <u>-11.6° on Head Rest Post</u> |

DATA SHEET 10
BELT CONTACT FORCE (S7.4.3)

Test Vehicle: 2024 Chevrolet Silverado EV
Test Program: FMVSS 208 Compliance
Test Technician: Jose Galvez

NHTSA No.: C20240101
Test Date: 10/24/24

Test all Type 2 seat belts other than those in walk-in van-type vehicles and those at front outboard designated seating positions in passenger cars. Complete a form for each applicable seat belt.

DESIGNATED SEATING POSITION: **Right Front Passenger**

1. Does the vehicle incorporate a webbing tension-relieving device?
 Yes (this form is complete)
 No (continue with this check sheet)
2. Position the seat's adjustable lumbar supports so that the lumbar support is in its lowest, retracted or deflated adjustment position. (S8.1.3)
 N/A – No lumbar adjustment
3. Position any adjustable parts of the seat that provide additional support so that they are in the lowest or most open adjustment position. (S16.2.10.2)
 N/A – No additional support adjustment
4. Is the fore-aft position of the seat adjustable?
 No – go to 5
 Yes – go to 4.1
- 4.1 Use all the seat controls that have any affect on the fore-aft movement of the seat to move the seat cushion to the rearmost position. **Mark** this position. (8/31/95 legal interpretation to Hogan and Hartson)
- 4.2 Use all the seat controls that have any affects on the fore-aft movement of the seat to move the seat cushion to the foremost position. **Mark** this position. (8/31/95 legal interpretation to Hogan and Hartson)
- 4.3 **Mark** each fore-aft position so that there is a visual indication when the seat is at a particular position. For manual seats, **mark** each detent. For power seats, mark only the rearmost, middle and foremost positions. Label three of the positions with the following: F for foremost, M for mid-position (if there is no mid-position, label the closest adjustment position to the rear of the mid-point), and R for rearmost. Determine the mid fore-aft seat position based on the foremost and rearmost positions determined in items 4.1 and 4.2. (8/31/95 legal interpretation to Hogan and Hartson)
- 4.4 Move the seat to the mid position.
- 4.5 While maintaining the mid position, move the seat to its lowest position. For seats with adjustable seat cushions, use the manufacturer's recommended seat cushion angle for determining the lowest height position.
5. Is the seat back angle adjustable?
 No- go to 6
 Yes- go to 5.1
- 5.1 Set and mark seat back angle, if adjustable, at the manufacturer's nominal design riding position for a 50th percentile adult male in the manner specified by the manufacturer.
 N/A – No seat back angle adjustment
 Manufacturer's design seat back angle: -11.6° on Head Rest Post
 Tested seat back angle: -11.6° on Head Rest Post

6. Is the seat a bucket seat?
 Yes, go to 6.1 and skip 6.2
 No, go to 6.2 and skip 6.1
- 6.1 Bucket seats:
 Locate and mark the longitudinal centerline of the seat cushion. The intersection of the vertical longitudinal plane that passes through the SgRP and the seat cushion upper surface determines the longitudinal centerline of a bucket seat cushion. (S10.4.1.2 and S16.3.1.10)
- 6.2 Bench seats (complete ONLY the one that is applicable to the seat being tested):
- 6.2.1 Driver Seat
 Locate and **mark** the longitudinal line on the seat cushion that marks the intersection of the vertical longitudinal plane through the centerline of the steering wheel and the seat cushion upper surface. (S10.4.1.1)
- 6.2.2 Front Outboard Passenger Seat
 Locate and **mark** the longitudinal centerline of the passenger seat cushion. The longitudinal centerline is the same distance from the longitudinal centerline of the vehicle as the center of the steering wheel. (S10.4.1.1)
 Record the distance from the longitudinal centerline of the vehicle to the center of the steering wheel. _____
 Record the distance from the longitudinal centerline of the vehicle to the longitudinal centerline of the seat cushion. _____
- 6.2.3 Rear designated seating positions
 Locate and **mark** the longitudinal centerline of the seat cushion. The intersection of the vertical longitudinal plane that passes through the SgRP and the seat cushion upper surface determines the longitudinal centerline.
7. Position the test dummies according to dummy position placement instructions in Appendix F. **Complete the Appendix F check sheets, but include them in the test report ONLY if there is a test failure.**
8. Fasten the seat belt latch.
9. Pull either 12 inches of belt webbing or the maximum available amount of belt webbing, whichever is less, from the retractor and then release it, allowing the belt webbing to return to the dummy's chest.
10. Locate the point where the centerline of the upper torso belt webbing crosses the midsagittal line on the dummy's chest. At that point pull the belt webbing out 3 inches from the dummy's chest and release until it is within one inch from the dummy's chest. (S10.8) Using a force measuring gage with a full scale range of no more than 1.5 pounds, measure the contact force perpendicular to the dummy's chest exerted by the belt webbing.
 Contact Force (lb): **0.6**
 0.0 to 0.7 pounds – Pass
 Greater than 0.7 pounds - FAIL

REMARKS:

Signature: Joe Gabrey

Date: 10/24/24

I certify that I have read and performed each instruction.

DATA SHEET 10
BELT CONTACT FORCE (S7.4.3)

Test Vehicle: 2024 Chevrolet Silverado EV
 Test Program: FMVSS 208 Compliance
 Test Technician: Jose Galvez

NHTSA No.: C20240101
 Test Date: 10/24/24

Test all Type 2 seat belts other than those in walk-in van-type vehicles and those at front outboard designated seating positions in passenger cars. Complete a form for each applicable seat belt.

DESIGNATED SEATING POSITION:	Left Rear Passenger
------------------------------	---------------------

- | | | |
|-------------------------------------|----|---|
| <input checked="" type="checkbox"/> | 1. | Does the vehicle incorporate a webbing tension-relieving device? |
| | | <input type="checkbox"/> Yes (this form is complete) |
| | | <input checked="" type="checkbox"/> No (continue with this check sheet) |
- | | | |
|-------------------------------------|----|---|
| <input checked="" type="checkbox"/> | 2. | Position the seat's adjustable lumbar supports so that the lumbar support is in its lowest, retracted or deflated adjustment position. (S8.1.3) |
| | | <input checked="" type="checkbox"/> N/A – No lumbar adjustment |
- | | | |
|-------------------------------------|----|---|
| <input checked="" type="checkbox"/> | 3. | Position any adjustable parts of the seat that provide additional support so that they are in the lowest or most open adjustment position. (S16.2.10.2) |
| | | <input checked="" type="checkbox"/> N/A – No additional support adjustment |
- | | | |
|-------------------------------------|----|--|
| <input checked="" type="checkbox"/> | 4. | Is the fore-aft position of the seat adjustable? |
| | | <input checked="" type="checkbox"/> No – go to 5 |
| | | <input type="checkbox"/> Yes – go to 4.1 |
- | | | |
|--------------------------|-----|---|
| <input type="checkbox"/> | 4.1 | Use all the seat controls that have any affect on the fore-aft movement of the seat to move the seat cushion to the rearmost position. Mark this position. (8/31/95 legal interpretation to Hogan and Hartson) |
|--------------------------|-----|---|
- | | | |
|--------------------------|-----|--|
| <input type="checkbox"/> | 4.2 | Use all the seat controls that have any affects on the fore-aft movement of the seat to move the seat cushion to the foremost position. Mark this position. (8/31/95 legal interpretation to Hogan and Hartson) |
|--------------------------|-----|--|
- | | | |
|--------------------------|-----|---|
| <input type="checkbox"/> | 4.3 | Mark each fore-aft position so that there is a visual indication when the seat is at a particular position. For manual seats, mark each detent. For power seats, mark only the rearmost, middle and foremost positions. Label three of the positions with the following: F for foremost, M for mid-position (if there is no mid-position, label the closest adjustment position to the rear of the mid-point), and R for rearmost. Determine the mid fore-aft seat position based on the foremost and rearmost positions determined in items 4.1 and 4.2. (8/31/95 legal interpretation to Hogan and Hartson) |
|--------------------------|-----|---|
- | | | |
|--------------------------|-----|------------------------------------|
| <input type="checkbox"/> | 4.4 | Move the seat to the mid position. |
|--------------------------|-----|------------------------------------|
- | | | |
|--------------------------|-----|--|
| <input type="checkbox"/> | 4.5 | While maintaining the mid position, move the seat to its lowest position. For seats with adjustable seat cushions, use the manufacturer's recommended seat cushion angle for determining the lowest height position. |
|--------------------------|-----|--|
- | | | |
|-------------------------------------|----|---|
| <input checked="" type="checkbox"/> | 5. | Is the seat back angle adjustable? |
| | | <input checked="" type="checkbox"/> No– go to 6 |
| | | <input type="checkbox"/> Yes– go to 5.1 |
- | | | |
|--------------------------|-----|---|
| <input type="checkbox"/> | 5.1 | Set and mark seat back angle, if adjustable, at the manufacturer's nominal design riding position for a 50 th percentile adult male in the manner specified by the manufacturer. |
| | | <input type="checkbox"/> N/A – No seat back angle adjustment |
| | | <input type="checkbox"/> Manufacturer's design seat back angle: _____ |
| | | <input type="checkbox"/> Tested seat back angle: _____ |

6. Is the seat a bucket seat?
 Yes, go to 6.1 and skip 6.2
 No, go to 6.2 and skip 6.1
- 6.1 Bucket seats:
 Locate and mark the longitudinal centerline of the seat cushion. The intersection of the vertical longitudinal plane that passes through the SgRP and the seat cushion upper surface determines the longitudinal centerline of a bucket seat cushion. (S10.4.1.2 and S16.3.1.10)
- 6.2 Bench seats (complete ONLY the one that is applicable to the seat being tested):
- 6.2.1 Driver Seat
 Locate and **mark** the longitudinal line on the seat cushion that marks the intersection of the vertical longitudinal plane through the centerline of the steering wheel and the seat cushion upper surface. (S10.4.1.1)
- 6.2.2 Front Outboard Passenger Seat
 Locate and **mark** the longitudinal centerline of the passenger seat cushion. The longitudinal centerline is the same distance from the longitudinal centerline of the vehicle as the center of the steering wheel. (S10.4.1.1)
 Record the distance from the longitudinal centerline of the vehicle to the center of the steering wheel. _____
 Record the distance from the longitudinal centerline of the vehicle to the longitudinal centerline of the seat cushion. _____
- 6.2.3 Rear designated seating positions
 Locate and **mark** the longitudinal centerline of the seat cushion. The intersection of the vertical longitudinal plane that passes through the SgRP and the seat cushion upper surface determines the longitudinal centerline.
7. Position the test dummies according to dummy position placement instructions in Appendix F. **Complete the Appendix F check sheets, but include them in the test report ONLY if there is a test failure.**
8. Fasten the seat belt latch.
9. Pull either 12 inches of belt webbing or the maximum available amount of belt webbing, whichever is less, from the retractor and then release it, allowing the belt webbing to return to the dummy's chest.
10. Locate the point where the centerline of the upper torso belt webbing crosses the midsagittal line on the dummy's chest. At that point pull the belt webbing out 3 inches from the dummy's chest and release until it is within one inch from the dummy's chest. (S10.8) Using a force measuring gage with a full scale range of no more than 1.5 pounds, measure the contact force perpendicular to the dummy's chest exerted by the belt webbing.
 Contact Force (lb): **0.5**
 0.0 to 0.7 pounds – Pass
 Greater than 0.7 pounds – FAIL

REMARKS:

Signature: 

Date: 10/24/24

I certify that I have read and performed each instruction.

DATA SHEET 10
BELT CONTACT FORCE (S7.4.3)

Test Vehicle: 2024 Chevrolet Silverado EV
 Test Program: FMVSS 208 Compliance
 Test Technician: Jose Galvez

NHTSA No.: C20240101
 Test Date: 10/24/24

Test all Type 2 seat belts other than those in walk-in van-type vehicles and those at front outboard designated seating positions in passenger cars. Complete a form for each applicable seat belt.

DESIGNATED SEATING POSITION:	Center Rear Passenger
------------------------------	-----------------------

- | | | |
|-------------------------------------|----|---|
| <input checked="" type="checkbox"/> | 1. | Does the vehicle incorporate a webbing tension-relieving device? |
| | | <input type="checkbox"/> Yes (this form is complete) |
| | | <input checked="" type="checkbox"/> No (continue with this check sheet) |
- | | | |
|-------------------------------------|----|---|
| <input checked="" type="checkbox"/> | 2. | Position the seat's adjustable lumbar supports so that the lumbar support is in its lowest, retracted or deflated adjustment position. (S8.1.3) |
| | | <input checked="" type="checkbox"/> N/A – No lumbar adjustment |
- | | | |
|-------------------------------------|----|---|
| <input checked="" type="checkbox"/> | 3. | Position any adjustable parts of the seat that provide additional support so that they are in the lowest or most open adjustment position. (S16.2.10.2) |
| | | <input checked="" type="checkbox"/> N/A – No additional support adjustment |
- | | | |
|-------------------------------------|----|--|
| <input checked="" type="checkbox"/> | 4. | Is the fore-aft position of the seat adjustable? |
| | | <input checked="" type="checkbox"/> No – go to 5 |
| | | <input type="checkbox"/> Yes – go to 4.1 |
- | | | |
|--------------------------|-----|---|
| <input type="checkbox"/> | 4.1 | Use all the seat controls that have any affect on the fore-aft movement of the seat to move the seat cushion to the rearmost position. Mark this position. (8/31/95 legal interpretation to Hogan and Hartson) |
|--------------------------|-----|---|
- | | | |
|--------------------------|-----|--|
| <input type="checkbox"/> | 4.2 | Use all the seat controls that have any affects on the fore-aft movement of the seat to move the seat cushion to the foremost position. Mark this position. (8/31/95 legal interpretation to Hogan and Hartson) |
|--------------------------|-----|--|
- | | | |
|--------------------------|-----|---|
| <input type="checkbox"/> | 4.3 | Mark each fore-aft position so that there is a visual indication when the seat is at a particular position. For manual seats, mark each detent. For power seats, mark only the rearmost, middle and foremost positions. Label three of the positions with the following: F for foremost, M for mid-position (if there is no mid-position, label the closest adjustment position to the rear of the mid-point), and R for rearmost. Determine the mid fore-aft seat position based on the foremost and rearmost positions determined in items 4.1 and 4.2. (8/31/95 legal interpretation to Hogan and Hartson) |
|--------------------------|-----|---|
- | | | |
|--------------------------|-----|------------------------------------|
| <input type="checkbox"/> | 4.4 | Move the seat to the mid position. |
|--------------------------|-----|------------------------------------|
- | | | |
|--------------------------|-----|--|
| <input type="checkbox"/> | 4.5 | While maintaining the mid position, move the seat to its lowest position. For seats with adjustable seat cushions, use the manufacturer's recommended seat cushion angle for determining the lowest height position. |
|--------------------------|-----|--|
- | | | |
|-------------------------------------|----|---|
| <input checked="" type="checkbox"/> | 5. | Is the seat back angle adjustable? |
| | | <input checked="" type="checkbox"/> No– go to 6 |
| | | <input type="checkbox"/> Yes– go to 5.1 |
- | | | |
|--------------------------|-----|---|
| <input type="checkbox"/> | 5.1 | Set and mark seat back angle, if adjustable, at the manufacturer's nominal design riding position for a 50 th percentile adult male in the manner specified by the manufacturer. |
| | | <input type="checkbox"/> N/A – No seat back angle adjustment |
| | | <input type="checkbox"/> Manufacturer's design seat back angle: _____ |
| | | <input type="checkbox"/> Tested seat back angle: _____ |

6. Is the seat a bucket seat?
 Yes, go to 6.1 and skip 6.2
 No, go to 6.2 and skip 6.1
- 6.1 Bucket seats:
 Locate and mark the longitudinal centerline of the seat cushion. The intersection of the vertical longitudinal plane that passes through the SgRP and the seat cushion upper surface determines the longitudinal centerline of a bucket seat cushion. (S10.4.1.2 and S16.3.1.10)
- 6.2 Bench seats (complete ONLY the one that is applicable to the seat being tested):
- 6.2.1 Driver Seat
 Locate and **mark** the longitudinal line on the seat cushion that marks the intersection of the vertical longitudinal plane through the centerline of the steering wheel and the seat cushion upper surface. (S10.4.1.1)
- 6.2.2 Front Outboard Passenger Seat
 Locate and **mark** the longitudinal centerline of the passenger seat cushion. The longitudinal centerline is the same distance from the longitudinal centerline of the vehicle as the center of the steering wheel. (S10.4.1.1)
 Record the distance from the longitudinal centerline of the vehicle to the center of the steering wheel. _____
 Record the distance from the longitudinal centerline of the vehicle to the longitudinal centerline of the seat cushion. _____
- 6.2.3 Rear designated seating positions
 Locate and **mark** the longitudinal centerline of the seat cushion. The intersection of the vertical longitudinal plane that passes through the SgRP and the seat cushion upper surface determines the longitudinal centerline.
7. Position the test dummies according to dummy position placement instructions in Appendix F. **Complete the Appendix F check sheets, but include them in the test report ONLY if there is a test failure.**
8. Fasten the seat belt latch.
9. Pull either 12 inches of belt webbing or the maximum available amount of belt webbing, whichever is less, from the retractor and then release it, allowing the belt webbing to return to the dummy's chest.
10. Locate the point where the centerline of the upper torso belt webbing crosses the midsagittal line on the dummy's chest. At that point pull the belt webbing out 3 inches from the dummy's chest and release until it is within one inch from the dummy's chest. (S10.8) Using a force measuring gage with a full scale range of no more than 1.5 pounds, measure the contact force perpendicular to the dummy's chest exerted by the belt webbing.
 Contact Force (lb): **0.6**
 0.0 to 0.7 pounds – Pass
 Greater than 0.7 pounds – FAIL

REMARKS:

Signature: Jose Galvez

Date: 10/24/24

I certify that I have read and performed each instruction.

DATA SHEET 10
BELT CONTACT FORCE (S7.4.3)

Test Vehicle: 2024 Chevrolet Silverado EV
 Test Program: FMVSS 208 Compliance
 Test Technician: Jose Galvez

NHTSA No.: C20240101
 Test Date: 10/24/24

Test all Type 2 seat belts other than those in walk-in van-type vehicles and those at front outboard designated seating positions in passenger cars. Complete a form for each applicable seat belt.

DESIGNATED SEATING POSITION:	Right Rear Passenger
------------------------------	----------------------

- | | | |
|-------------------------------------|----|---|
| <input checked="" type="checkbox"/> | 1. | Does the vehicle incorporate a webbing tension-relieving device? |
| | | <input type="checkbox"/> Yes (this form is complete) |
| | | <input checked="" type="checkbox"/> No (continue with this check sheet) |
- | | | |
|-------------------------------------|----|---|
| <input checked="" type="checkbox"/> | 2. | Position the seat's adjustable lumbar supports so that the lumbar support is in its lowest, retracted or deflated adjustment position. (S8.1.3) |
| | | <input checked="" type="checkbox"/> N/A – No lumbar adjustment |
- | | | |
|-------------------------------------|----|---|
| <input checked="" type="checkbox"/> | 3. | Position any adjustable parts of the seat that provide additional support so that they are in the lowest or most open adjustment position. (S16.2.10.2) |
| | | <input checked="" type="checkbox"/> N/A – No additional support adjustment |
- | | | |
|-------------------------------------|----|--|
| <input checked="" type="checkbox"/> | 4. | Is the fore-aft position of the seat adjustable? |
| | | <input checked="" type="checkbox"/> No – go to 5 |
| | | <input type="checkbox"/> Yes – go to 4.1 |
- | | | |
|--------------------------|-----|---|
| <input type="checkbox"/> | 4.1 | Use all the seat controls that have any affect on the fore-aft movement of the seat to move the seat cushion to the rearmost position. Mark this position. (8/31/95 legal interpretation to Hogan and Hartson) |
|--------------------------|-----|---|
- | | | |
|--------------------------|-----|--|
| <input type="checkbox"/> | 4.2 | Use all the seat controls that have any affects on the fore-aft movement of the seat to move the seat cushion to the foremost position. Mark this position. (8/31/95 legal interpretation to Hogan and Hartson) |
|--------------------------|-----|--|
- | | | |
|--------------------------|-----|---|
| <input type="checkbox"/> | 4.3 | Mark each fore-aft position so that there is a visual indication when the seat is at a particular position. For manual seats, mark each detent. For power seats, mark only the rearmost, middle and foremost positions. Label three of the positions with the following: F for foremost, M for mid-position (if there is no mid-position, label the closest adjustment position to the rear of the mid-point), and R for rearmost. Determine the mid fore-aft seat position based on the foremost and rearmost positions determined in items 4.1 and 4.2. (8/31/95 legal interpretation to Hogan and Hartson) |
|--------------------------|-----|---|
- | | | |
|--------------------------|-----|------------------------------------|
| <input type="checkbox"/> | 4.4 | Move the seat to the mid position. |
|--------------------------|-----|------------------------------------|
- | | | |
|--------------------------|-----|--|
| <input type="checkbox"/> | 4.5 | While maintaining the mid position, move the seat to its lowest position. For seats with adjustable seat cushions, use the manufacturer's recommended seat cushion angle for determining the lowest height position. |
|--------------------------|-----|--|
- | | | |
|-------------------------------------|----|---|
| <input checked="" type="checkbox"/> | 5. | Is the seat back angle adjustable? |
| | | <input checked="" type="checkbox"/> No– go to 6 |
| | | <input type="checkbox"/> Yes– go to 5.1 |
- | | | |
|--------------------------|-----|---|
| <input type="checkbox"/> | 5.1 | Set and mark seat back angle, if adjustable, at the manufacturer's nominal design riding position for a 50 th percentile adult male in the manner specified by the manufacturer. |
| | | <input type="checkbox"/> N/A – No seat back angle adjustment |
| | | <input type="checkbox"/> Manufacturer's design seat back angle: _____ |
| | | <input type="checkbox"/> Tested seat back angle: _____ |

6. Is the seat a bucket seat?
 Yes, go to 6.1 and skip 6.2
 No, go to 6.2 and skip 6.1
- 6.1 Bucket seats:
 Locate and mark the longitudinal centerline of the seat cushion. The intersection of the vertical longitudinal plane that passes through the SgRP and the seat cushion upper surface determines the longitudinal centerline of a bucket seat cushion. (S10.4.1.2 and S16.3.1.10)
- 6.2 Bench seats (complete ONLY the one that is applicable to the seat being tested):
- 6.2.1 Driver Seat
 Locate and **mark** the longitudinal line on the seat cushion that marks the intersection of the vertical longitudinal plane through the centerline of the steering wheel and the seat cushion upper surface. (S10.4.1.1)
- 6.2.2 Front Outboard Passenger Seat
 Locate and **mark** the longitudinal centerline of the passenger seat cushion. The longitudinal centerline is the same distance from the longitudinal centerline of the vehicle as the center of the steering wheel. (S10.4.1.1)
 Record the distance from the longitudinal centerline of the vehicle to the center of the steering wheel. _____
 Record the distance from the longitudinal centerline of the vehicle to the longitudinal centerline of the seat cushion. _____
- 6.2.3 Rear designated seating positions
 Locate and **mark** the longitudinal centerline of the seat cushion. The intersection of the vertical longitudinal plane that passes through the SgRP and the seat cushion upper surface determines the longitudinal centerline.
7. Position the test dummies according to dummy position placement instructions in Appendix F. **Complete the Appendix F check sheets, but include them in the test report ONLY if there is a test failure.**
8. Fasten the seat belt latch.
9. Pull either 12 inches of belt webbing or the maximum available amount of belt webbing, whichever is less, from the retractor and then release it, allowing the belt webbing to return to the dummy's chest.
10. Locate the point where the centerline of the upper torso belt webbing crosses the midsagittal line on the dummy's chest. At that point pull the belt webbing out 3 inches from the dummy's chest and release until it is within one inch from the dummy's chest. (S10.8) Using a force measuring gage with a full scale range of no more than 1.5 pounds, measure the contact force perpendicular to the dummy's chest exerted by the belt webbing.
 Contact Force (lb): **0.5**
 0.0 to 0.7 pounds – Pass
 Greater than 0.7 pounds – FAIL

REMARKS:

Signature: Jose Galvez

Date: 10/24/24

I certify that I have read and performed each instruction.

DATA SHEET 11
LATCH PLATE ACCESS (S7.4.4)

Test Vehicle: 2024 Chevrolet Silverado EV
 Test Program: FMVSS 208 Compliance
 Test Technician: Jose Galvez

NHTSA No.: C20240101
 Test Date: 10/24/24

Test all front outboard seat belts other than those in walk-in van-type vehicles and those at front outboard designated seating positions in passenger cars. Complete a form for each applicable seat belt.

DESIGNATED SEATING POSITION:	Left Front Driver
-------------------------------------	--------------------------

- | | |
|-------------------------------------|--|
| <input checked="" type="checkbox"/> | 1. Position the seat's adjustable lumbar supports so that the lumbar support is in its lowest, retracted or deflated adjustment position. (S8.1.3) |
| | <input checked="" type="checkbox"/> N/A – No lumbar adjustment |
- | | |
|-------------------------------------|--|
| <input checked="" type="checkbox"/> | 2. Position any adjustable parts of the seat that provide additional support so that they are in the lowest or most open adjustment position. (S16.2.10.2) |
| | <input checked="" type="checkbox"/> N/A – No additional support adjustment |
- | | |
|-------------------------------------|---|
| <input checked="" type="checkbox"/> | 3. Is the fore-aft position of the seat adjustable? |
| | <input type="checkbox"/> No – go to 4 |
| | <input checked="" type="checkbox"/> Yes – go to 3.1 |
- | | |
|-------------------------------------|---|
| <input checked="" type="checkbox"/> | 3.1 Use all the seat controls that have any affect on the fore-aft movement of the seat to move the seat cushion to the rearmost position. Mark this position. (8/31/95 legal interpretation to Hogan and Hartson) |
|-------------------------------------|---|
- | | |
|-------------------------------------|---|
| <input checked="" type="checkbox"/> | 3.2 While maintaining the forward most position, move the seat to its lowest position. For seats with adjustable seat cushions, use the manufacturer's recommended seat cushion angle for determining the lowest height position. |
|-------------------------------------|---|
- | | |
|-------------------------------------|--|
| <input checked="" type="checkbox"/> | 4. Is the seat back angle adjustable? |
| | <input type="checkbox"/> No- go to 5 |
| | <input checked="" type="checkbox"/> Yes- go to 4.1 |
- | | |
|-------------------------------------|---|
| <input checked="" type="checkbox"/> | 4.1 Set and mark seat back angle, if adjustable, at the manufacturer's nominal design riding position for a 50th percentile adult male in the manner specified by the manufacturer. |
| | <input type="checkbox"/> N/A – No seat back angle adjustment |
| | <input checked="" type="checkbox"/> Manufacturer's design seat back angle: <u>-11.6° on Head Rest Post</u> |
| | <input checked="" type="checkbox"/> Tested seat back angle: <u>-11.6° on Head Rest Post</u> |
- | | |
|-------------------------------------|---|
| <input checked="" type="checkbox"/> | 5. Is the seat a bucket seat? |
| | <input checked="" type="checkbox"/> Yes, go to 5.1 and skip 5.2 |
| | <input type="checkbox"/> No, go to 5.2 and skip 5.1 |
- | | |
|-------------------------------------|--|
| <input checked="" type="checkbox"/> | 5.1 Bucket seats:
Locate and mark the longitudinal centerline of the seat cushion. The intersection of the vertical longitudinal plane that passes through the SgRP and the seat cushion upper surface determines the longitudinal centerline of a bucket seat cushion. (S10.4.1.2 and S16.3.1.10) |
|-------------------------------------|--|
- | | |
|--------------------------|---|
| <input type="checkbox"/> | 5.2 Bench seats (complete ONLY the one that is applicable to the seat being tested): |
| <input type="checkbox"/> | 5.2.1 Driver Seat
Locate and mark the longitudinal line on the seat cushion that marks the intersection of the vertical longitudinal plane through the centerline of the steering wheel and the seat cushion upper surface. (S10.4.1.1) |

- 5.2.2 Front Outboard Passenger Seat
 Locate and **mark** the longitudinal centerline of the passenger seat cushion.
 The longitudinal centerline is the same distance from the longitudinal centerline of the vehicle as the center of the steering wheel. (S10.4.1.1)
- Record the distance from the longitudinal centerline of the vehicle to the center of the steering wheel. _____
- Record the distance from the longitudinal centerline of the vehicle to the longitudinal centerline of the seat cushion. _____
6. Position the test dummy using the procedures in Appendix F. (Some modifications to the positioning procedure may need to be made because the seat is in the forward most position. Note on the Appendix F positioning check sheet any deviations necessary to position the Part 572, Subpart E dummy). **Complete the Appendix F check sheets, but include them in the test report ONLY if there is a test failure.**
7. Position the adjustable seat belt anchorage in the manufacturer's nominal design position for a 50th percentile adult male occupant.
8. Attach the inboard reach string to the base of the head following the instructions on Figure 3.
9. Attach the outboard reach string to the torso sheath following the instructions on Figure 3.
10. Place the latch plate in the stowed position.
11. Extend the inboard reach string in front of the dummy and then backward and outboard to the latch plate to generate arcs of the reach envelope of the test dummy's arms. Is the latch plate within the reach envelope?
- Yes – Pass
 No
12. Extend the outboard reach string in front of the dummy and then backward and outboard to the latch plate to generate arcs of the reach envelope of the test dummy's arms. Is the latch plate within the reach envelope?
- Yes – Pass
 No
13. Is the latch plate within the inboard (item 11) or outboard (item 12) reach envelope?
- Yes – Pass
 No – Fail
14. Using the clearance test block, specified in Figure 4, is there sufficient clearance between the vehicle seat and the side of vehicle interior to allow the test block to move unhindered to the latch plate or buckle?
- Yes – Pass
 No – Fail

REMARKS:

Signature: Jose Galvez Date: 10/24/24

I certify that I have read and performed each instruction.

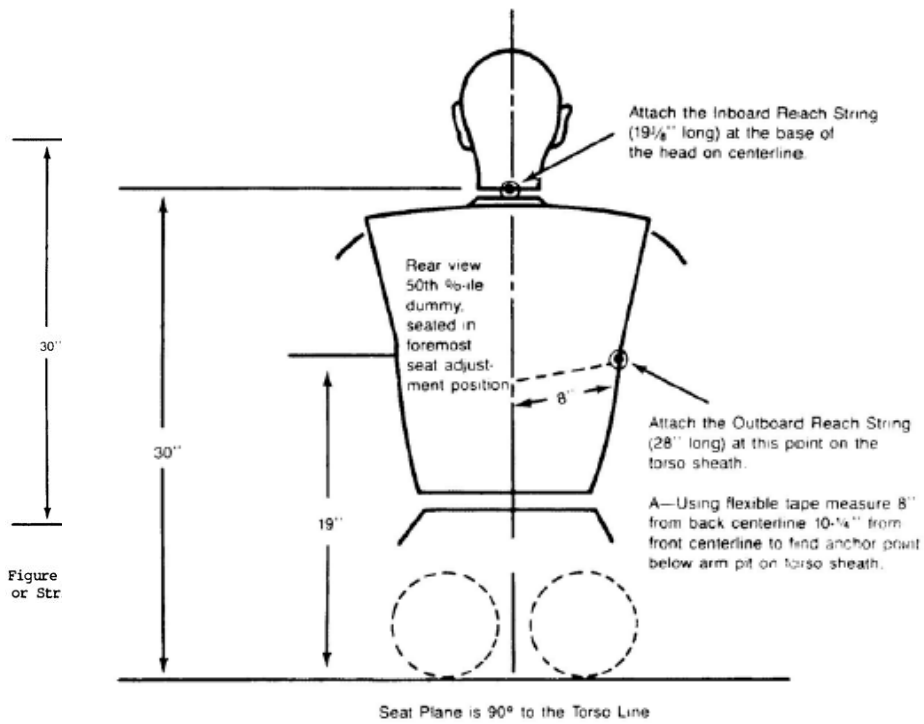

Figure 3. Location of Anchoring Points for Latchplate Reach Limiting Chains or Strings to Test for Latchplate Accessibility Using Subpart E Test Device

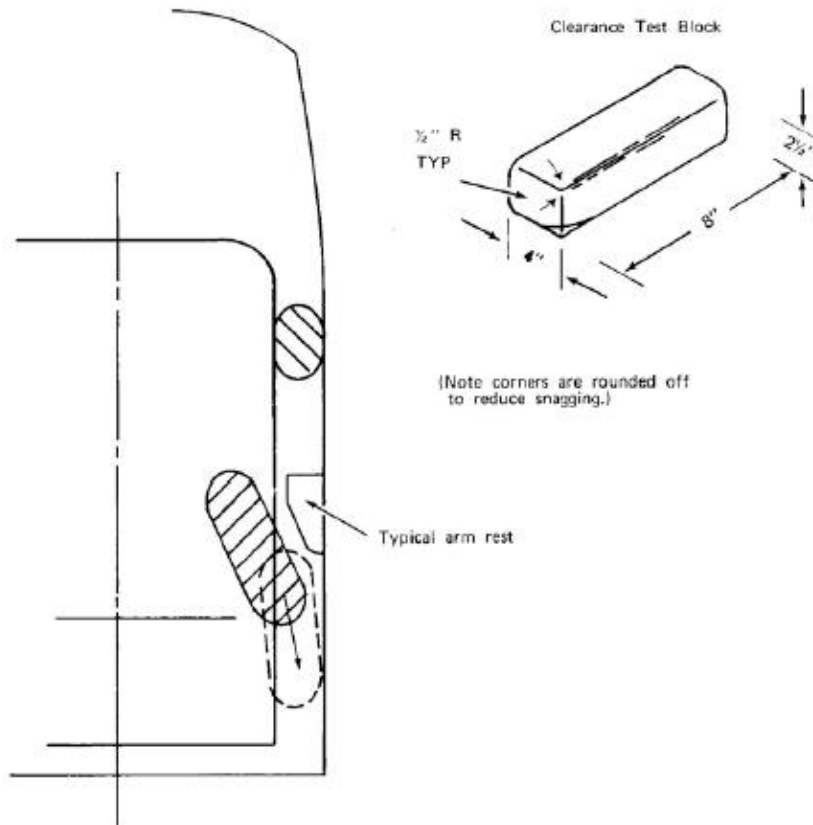

Figure 4—USE OF CLEARANCE TEST BLOCK TO DETERMINE HAND/ARM ACCESS

DATA SHEET 11
LATCH PLATE ACCESS (S7.4.4)

Test Vehicle: 2024 Chevrolet Silverado EV
 Test Program: FMVSS 208 Compliance
 Test Technician: Jose Galvez

NHTSA No.: C20240101
 Test Date: 10/24/24

Test all front outboard seat belts other than those in walk-in van-type vehicles and those at front outboard designated seating positions in passenger cars. Complete a form for each applicable seat belt.

DESIGNATED SEATING POSITION:	Right Front Passenger
------------------------------	-----------------------

- | | |
|-------------------------------------|--|
| <input checked="" type="checkbox"/> | 1. Position the seat's adjustable lumbar supports so that the lumbar support is in its lowest, retracted or deflated adjustment position. (S8.1.3) |
| | <input checked="" type="checkbox"/> N/A – No lumbar adjustment |
- | | |
|-------------------------------------|--|
| <input checked="" type="checkbox"/> | 2. Position any adjustable parts of the seat that provide additional support so that they are in the lowest or most open adjustment position. (S16.2.10.2) |
| | <input checked="" type="checkbox"/> N/A – No additional support adjustment |
- | | |
|-------------------------------------|---|
| <input checked="" type="checkbox"/> | 3. Is the fore-aft position of the seat adjustable? |
| | <input type="checkbox"/> No – go to 4 |
| | <input checked="" type="checkbox"/> Yes – go to 3.1 |
- | | |
|-------------------------------------|---|
| <input checked="" type="checkbox"/> | 3.1 Use all the seat controls that have any affect on the fore-aft movement of the seat to move the seat cushion to the rearmost position. Mark this position. (8/31/95 legal interpretation to Hogan and Hartson) |
|-------------------------------------|---|
- | | |
|-------------------------------------|---|
| <input checked="" type="checkbox"/> | 3.2 While maintaining the forward most position, move the seat to its lowest position. For seats with adjustable seat cushions, use the manufacturer's recommended seat cushion angle for determining the lowest height position. |
|-------------------------------------|---|
- | | |
|-------------------------------------|--|
| <input checked="" type="checkbox"/> | 4. Is the seat back angle adjustable? |
| | <input type="checkbox"/> No- go to 5 |
| | <input checked="" type="checkbox"/> Yes- go to 4.1 |
- | | |
|-------------------------------------|---|
| <input checked="" type="checkbox"/> | 4.1 Set and mark seat back angle, if adjustable, at the manufacturer's nominal design riding position for a 50th percentile adult male in the manner specified by the manufacturer. |
| | <input type="checkbox"/> N/A – No seat back angle adjustment |
| | <input checked="" type="checkbox"/> Manufacturer's design seat back angle: <u>-11.6° on Head Rest Post</u> |
| | <input checked="" type="checkbox"/> Tested seat back angle: <u>-11.6° on Head Rest Post</u> |
- | | |
|-------------------------------------|---|
| <input checked="" type="checkbox"/> | 5. Is the seat a bucket seat? |
| | <input checked="" type="checkbox"/> Yes, go to 5.1 and skip 5.2 |
| | <input type="checkbox"/> No, go to 5.2 and skip 5.1 |
- | | |
|-------------------------------------|--|
| <input checked="" type="checkbox"/> | 5.1 Bucket seats:
Locate and mark the longitudinal centerline of the seat cushion. The intersection of the vertical longitudinal plane that passes through the SgRP and the seat cushion upper surface determines the longitudinal centerline of a bucket seat cushion. (S10.4.1.2 and S16.3.1.10) |
|-------------------------------------|--|
- | | |
|--------------------------|---|
| <input type="checkbox"/> | 5.2 Bench seats (complete ONLY the one that is applicable to the seat being tested): |
| <input type="checkbox"/> | 5.2.1 Driver Seat
Locate and mark the longitudinal line on the seat cushion that marks the intersection of the vertical longitudinal plane through the centerline of the steering wheel and the seat cushion upper surface. (S10.4.1.1) |

- 5.2.2 Front Outboard Passenger Seat
 Locate and **mark** the longitudinal centerline of the passenger seat cushion.
 The longitudinal centerline is the same distance from the longitudinal centerline of the vehicle as the center of the steering wheel. (S10.4.1.1)
- Record the distance from the longitudinal centerline of the vehicle to the center of the steering wheel. _____
- Record the distance from the longitudinal centerline of the vehicle to the longitudinal centerline of the seat cushion. _____
6. Position the test dummy using the procedures in Appendix F. (Some modifications to the positioning procedure may need to be made because the seat is in the forward most position. Note on the Appendix F positioning check sheet any deviations necessary to position the Part 572, Subpart E dummy). **Complete the Appendix F check sheets, but include them in the test report ONLY if there is a test failure.**
7. Position the adjustable seat belt anchorage in the manufacturer's nominal design position for a 50th percentile adult male occupant.
8. Attach the inboard reach string to the base of the head following the instructions on Figure 3.
9. Attach the outboard reach string to the torso sheath following the instructions on Figure 3.
10. Place the latch plate in the stowed position.
11. Extend the inboard reach string in front of the dummy and then backward and outboard to the latch plate to generate arcs of the reach envelope of the test dummy's arms. Is the latch plate within the reach envelope?
- Yes – Pass
 No
12. Extend the outboard reach string in front of the dummy and then backward and outboard to the latch plate to generate arcs of the reach envelope of the test dummy's arms. Is the latch plate within the reach envelope?
- Yes – Pass
 No
13. Is the latch plate within the inboard (item 11) or outboard (item 12) reach envelope?
- Yes – Pass
 No – Fail
14. Using the clearance test block, specified in Figure 4, is there sufficient clearance between the vehicle seat and the side of vehicle interior to allow the test block to move unhindered to the latch plate or buckle?
- Yes – Pass
 No – Fail

REMARKS:

Signature: Jose Galvez Date: 10/24/24

I certify that I have read and performed each instruction.

DATA SHEET 12
SEAT BELT RETRACTION (S7.4.5)

Test Vehicle: 2024 Chevrolet Silverado EV
 Test Program: FMVSS 208 Compliance
 Test Technician: Jose Galvez

NHTSA No.: C20240101
 Test Date: 10/24/24

Test all front outboard seat belts, except those in walk-in van-type vehicles and those at front outboard designated seating positions in passenger cars. Complete a form for each applicable seat belt.

DESIGNATED SEATING POSITION:	Left Front Driver
------------------------------	-------------------

- | | |
|-------------------------------------|--|
| <input checked="" type="checkbox"/> | 1. Is the vehicle a passenger car or walk-in van-type vehicle? |
| | <input type="checkbox"/> Yes, this form is complete |
| | <input checked="" type="checkbox"/> No |
- | | |
|-------------------------------------|--|
| <input checked="" type="checkbox"/> | 2. Position the seat's adjustable lumbar supports so that the lumbar support is in its lowest, retracted or deflated adjustment position. (S8.1.3) |
| | <input checked="" type="checkbox"/> N/A – No lumbar adjustment |
- | | |
|-------------------------------------|--|
| <input checked="" type="checkbox"/> | 3. Position any adjustable parts of the seat that provide additional support so that they are in the lowest or most open adjustment position. (S16.2.10.2) |
| | <input checked="" type="checkbox"/> N/A – No additional support adjustment |
- | | |
|-------------------------------------|---|
| <input checked="" type="checkbox"/> | 4. Is the fore-aft position of the seat adjustable? |
| | <input type="checkbox"/> No – go to 5 |
| | <input checked="" type="checkbox"/> Yes – go to 4.1 |
- | | |
|-------------------------------------|---|
| <input checked="" type="checkbox"/> | 4.1 Use all the seat controls that have any affect on the fore-aft movement of the seat to move the seat cushion to the rearmost position. Mark this position. (8/31/95 legal interpretation to Hogan and Hartson) |
|-------------------------------------|---|
- | | |
|-------------------------------------|--|
| <input checked="" type="checkbox"/> | 4.2 Use all the seat controls that have any affects on the fore-aft movement of the seat to move the seat cushion to the foremost position. Mark this position. (8/31/95 legal interpretation to Hogan and Hartson) |
|-------------------------------------|--|
- | | |
|-------------------------------------|---|
| <input checked="" type="checkbox"/> | 4.3 Mark each fore-aft position so that there is a visual indication when the seat is at a particular position. For manual seats, mark each detent. For power seats, mark only the rearmost, middle and foremost positions. Label three of the positions with the following: F for foremost, M for mid-position (if there is no mid-position, label the closest adjustment position to the rear of the mid-point), and R for rearmost. Determine the mid fore-aft seat position based on the foremost and rearmost positions determined in items 4.1 and 4.2. (8/31/95 legal interpretation to Hogan and Hartson) |
|-------------------------------------|---|
- | | |
|-------------------------------------|--|
| <input checked="" type="checkbox"/> | 4.4 Move the seat to the mid position. |
|-------------------------------------|--|
- | | |
|-------------------------------------|--|
| <input checked="" type="checkbox"/> | 4.5 While maintaining the mid position, move the seat to its lowest position. For seats with adjustable seat cushions, use the manufacturer's recommended seat cushion angle for determining the lowest height position. |
|-------------------------------------|--|
- | | |
|-------------------------------------|--|
| <input checked="" type="checkbox"/> | 5. Is the seat back angle adjustable? |
| | <input type="checkbox"/> No- go to 6 |
| | <input checked="" type="checkbox"/> Yes- go to 5.1 |
- | | |
|-------------------------------------|---|
| <input checked="" type="checkbox"/> | 5.1 Set and mark seat back angle, if adjustable, at the manufacturer's nominal design riding position for a 50th percentile adult male in the manner specified by the manufacturer. |
| | <input type="checkbox"/> N/A – No seat back angle adjustment |
| | <input checked="" type="checkbox"/> Manufacturer's design seat back angle: <u>-11.6° on Head Rest Post</u> |
| | <input checked="" type="checkbox"/> Tested seat back angle: <u>-11.6° on Head Rest Post</u> |

6. Is the seat a bucket seat?
 Yes, go to 6.1 and skip 6.2
 No, go to 6.2 and skip 6.1
- 6.1 Bucket Seats:
 Locate and **mark** the longitudinal centerline of the seat cushion. The intersection of the vertical longitudinal plane that passes through the SgRP and the seat cushion upper surface determines the longitudinal centerline of a bucket seat cushion. (S10.4.1.2 and S16.3.1.10)
- 6.2 Bench seats (complete ONLY the one that is applicable to the seat being tested):
- 6.2. Driver Seat
- 1 Locate and **mark** the longitudinal line on the seat cushion that marks the intersection of the vertical longitudinal plane through the centerline of the steering wheel and the seat cushion upper surface. (S10.4.1.1)
- 6.2. Front Outboard Passenger Seat
- 2 Locate and **mark** the longitudinal centerline of the passenger seat cushion. The longitudinal centerline is the same distance from the longitudinal centerline of the vehicle as the center of the steering wheel. (S10.4.1.1)
- Record the distance from the longitudinal centerline of the vehicle to the center of the steering wheel. _____
- Record the distance from the longitudinal centerline of the vehicle to the longitudinal centerline of the seat cushion. _____
7. Position the Part 572 Subpart E test dummy according to dummy position placement instructions in Appendix F. **Complete the Appendix F check sheets, but include them in the test report ONLY if there is a test failure.**
8. Fasten the seat belt around the dummy.
9. Remove all slack from the lap belt portion. (S10.9)
10. Pull the upper torso webbing out of the retractor and allow it to retract; repeat this four times. (S10.9)
11. Apply a 2 to 4 pound tension load to the lap belt. (S10.9)
- Pound load applied: 3 lbs.**
12. Is the belt system equipped with a tension relieving device?
 Yes, continue
 No, go to 14
13. Introduce the maximum amount of slack into the upper torso belt that is recommended by the vehicle manufacturer in the vehicle owner's manual. (S10.9).
14. Check the statement that applies to this test vehicle:
- 14.1 The torso and lap belt webbing of the seat belt system automatically retracts to a stowed position when the adjacent vehicle door is in an open position and the seat belt latch plate is released.
 Yes – Pass go to 15
 No – go to 14.2
- 14.2 The torso and lap belt webbing of the seat belt system automatically retracts when the seat belt latch plate is released.
 Yes – Pass go to 15
 No – go to 14.3
- 14.3 Neither 14.1 nor 14.2 apply – Fail
15. With the webbing and hardware in the stowed position are the webbing and hardware prevented from being pinched when the door is closed?
 Yes – Pass
 No – Fail

16. If this test vehicle has an open body (without doors) and has a belt system with a tension relieving device, does the belt system fully retract when the tension-relieving device is deactivated?

N/A – Not an open body vehicle

Yes – Pass

No – Fail

REMARKS:

Signature: 

Date: 10/24/24

I certify that I have read and performed each instruction.

DATA SHEET 12
SEAT BELT RETRACTION (S7.4.5)

Test Vehicle: 2024 Chevrolet Silverado EV
 Test Program: FMVSS 208 Compliance
 Test Technician: Jose Galvez

NHTSA No.: C20240101
 Test Date: 10/24/24

Test all front outboard seat belts, except those in walk-in van-type vehicles and those at front outboard designated seating positions in passenger cars. Complete a form for each applicable seat belt.

DESIGNATED SEATING POSITION:	Right Front Passenger
------------------------------	-----------------------

- | | |
|-------------------------------------|---|
| <input checked="" type="checkbox"/> | 1. Is the vehicle a passenger car or walk-in van-type vehicle? |
| | <input type="checkbox"/> Yes, this form is complete
<input checked="" type="checkbox"/> No |
- | | |
|-------------------------------------|--|
| <input checked="" type="checkbox"/> | 2. Position the seat's adjustable lumbar supports so that the lumbar support is in its lowest, retracted or deflated adjustment position. (S8.1.3) |
| | <input checked="" type="checkbox"/> N/A – No lumbar adjustment |
- | | |
|-------------------------------------|--|
| <input checked="" type="checkbox"/> | 3. Position any adjustable parts of the seat that provide additional support so that they are in the lowest or most open adjustment position. (S16.2.10.2) |
| | <input checked="" type="checkbox"/> N/A – No additional support adjustment |
- | | |
|-------------------------------------|--|
| <input checked="" type="checkbox"/> | 4. Is the fore-aft position of the seat adjustable? |
| | <input type="checkbox"/> No – go to 5
<input checked="" type="checkbox"/> Yes – go to 4.1 |
- | | |
|-------------------------------------|---|
| <input checked="" type="checkbox"/> | 4.1 Use all the seat controls that have any affect on the fore-aft movement of the seat to move the seat cushion to the rearmost position. Mark this position. (8/31/95 legal interpretation to Hogan and Hartson) |
|-------------------------------------|---|
- | | |
|-------------------------------------|--|
| <input checked="" type="checkbox"/> | 4.2 Use all the seat controls that have any affects on the fore-aft movement of the seat to move the seat cushion to the foremost position. Mark this position. (8/31/95 legal interpretation to Hogan and Hartson) |
|-------------------------------------|--|
- | | |
|-------------------------------------|---|
| <input checked="" type="checkbox"/> | 4.3 Mark each fore-aft position so that there is a visual indication when the seat is at a particular position. For manual seats, mark each detent. For power seats, mark only the rearmost, middle and foremost positions. Label three of the positions with the following: F for foremost, M for mid-position (if there is no mid-position, label the closest adjustment position to the rear of the mid-point), and R for rearmost. Determine the mid fore-aft seat position based on the foremost and rearmost positions determined in items 4.1 and 4.2. (8/31/95 legal interpretation to Hogan and Hartson) |
|-------------------------------------|---|
- | | |
|-------------------------------------|--|
| <input checked="" type="checkbox"/> | 4.4 Move the seat to the mid position. |
|-------------------------------------|--|
- | | |
|-------------------------------------|--|
| <input checked="" type="checkbox"/> | 4.5 While maintaining the mid position, move the seat to its lowest position. For seats with adjustable seat cushions, use the manufacturer's recommended seat cushion angle for determining the lowest height position. |
|-------------------------------------|--|
- | | |
|-------------------------------------|--|
| <input checked="" type="checkbox"/> | 5. Is the seat back angle adjustable? |
| | <input type="checkbox"/> No- go to 6
<input checked="" type="checkbox"/> Yes- go to 5.1 |
- | | |
|-------------------------------------|---|
| <input checked="" type="checkbox"/> | 5.1 Set and mark seat back angle, if adjustable, at the manufacturer's nominal design riding position for a 50th percentile adult male in the manner specified by the manufacturer. |
| | <input type="checkbox"/> N/A – No seat back angle adjustment
<input checked="" type="checkbox"/> Manufacturer's design seat back angle: <u>-11.6° on Head Rest Post</u>
<input checked="" type="checkbox"/> Tested seat back angle: <u>-11.6° on Head Rest Post</u> |

6. Is the seat a bucket seat?
 Yes, go to 6.1 and skip 6.2
 No, go to 6.2 and skip 6.1
- 6.1 Bucket Seats:
 Locate and **mark** the longitudinal centerline of the seat cushion. The intersection of the vertical longitudinal plane that passes through the SgRP and the seat cushion upper surface determines the longitudinal centerline of a bucket seat cushion. (S10.4.1.2 and S16.3.1.10)
- 6.2 Bench seats (complete ONLY the one that is applicable to the seat being tested):
- 6.2. Driver Seat
- 1 Locate and **mark** the longitudinal line on the seat cushion that marks the intersection of the vertical longitudinal plane through the centerline of the steering wheel and the seat cushion upper surface. (S10.4.1.1)
- 6.2. Front Outboard Passenger Seat
- 2 Locate and **mark** the longitudinal centerline of the passenger seat cushion. The longitudinal centerline is the same distance from the longitudinal centerline of the vehicle as the center of the steering wheel. (S10.4.1.1)
- Record the distance from the longitudinal centerline of the vehicle to the center of the steering wheel. _____
- Record the distance from the longitudinal centerline of the vehicle to the longitudinal centerline of the seat cushion. _____
7. Position the Part 572 Subpart E test dummy according to dummy position placement instructions in Appendix F. **Complete the Appendix F check sheets, but include them in the test report ONLY if there is a test failure.**
8. Fasten the seat belt around the dummy.
9. Remove all slack from the lap belt portion. (S10.9)
10. Pull the upper torso webbing out of the retractor and allow it to retract; repeat this four times. (S10.9)
11. Apply a 2 to 4 pound tension load to the lap belt. (S10.9)
Pound load applied: 3 lbs.
12. Is the belt system equipped with a tension relieving device?
 Yes, continue
 No, go to 14
13. Introduce the maximum amount of slack into the upper torso belt that is recommended by the vehicle manufacturer in the vehicle owner's manual. (S10.9).
14. Check the statement that applies to this test vehicle:
- 14.1 The torso and lap belt webbing of the seat belt system automatically retracts to a stowed position when the adjacent vehicle door is in an open position and the seat belt latch plate is released.
 Yes – Pass go to 15
 No – go to 14.2
- 14.2 The torso and lap belt webbing of the seat belt system automatically retracts when the seat belt latch plate is released.
 Yes – Pass go to 15
 No – go to 14.3
- 14.3 Neither 14.1 nor 14.2 apply – Fail
15. With the webbing and hardware in the stowed position are the webbing and hardware prevented from being pinched when the door is closed?
 Yes – Pass
 No – Fail

16. If this test vehicle has an open body (without doors) and has a belt system with a tension relieving device, does the belt system fully retract when the tension-relieving device is deactivated?

N/A – Not an open body vehicle

Yes – Pass

No – Fail

REMARKS:

Signature:  Date: 10/24/24

I certify that I have read and performed each instruction.

DATA SHEET 13

SEAT BELT GUIDES AND HARDWARE (S7.4.6)

Test Vehicle: 2024 Chevrolet Silverado EV
Test Program: FMVSS 208 Compliance
Test Technician: Jose Galvez

NHTSA No.: C20240101
Test Date: 10/24/24

Test seat belts except those in walk-in van-type vehicles and those at front outboard designated seating positions in passenger cars. Complete a form for each applicable seat belt.

DESIGNATED SEATING POSITION: Left Front Driver

- 1. Is the seat cushion movable so that the seat back serves a function other than seating? (S7.4.6.1(b))
2. Is the seat removable? (S7.4.6.1(b))
3. Is the seat movable so that the space formerly occupied by the seat can be used for a secondary function? (S7.4.6.1(b))
4. Is the webbing designed to pass through the seat cushion or between the seat cushion and seat back? (S7.4.6.1(a))
5. Does one of the following three parts, the seat belt latch plate, the buckle, or the seat belt webbing, stay on top of or above the seat cushion under normal conditions...? (S7.4.6.1(a))
6. Are the remaining two seat belt parts accessible under normal conditions?
7. The buckle and latch plate do not pass through the guides or conduits provided and fall behind the seat when the belt is completely retracted or, if the belt is nonretractable, the belt is unlatched. (S7.4.6.2)
8. The buckle and latch plate do not pass through the guides or conduits provided and fall behind the seat when the seat is moved to any position to which it is designed to be adjusted. (S7.4.6.2)
9. The buckle and latch plate do not pass through the guides or conduits provided and fall behind the seat when the seat back, if foldable, is folded forward as far as possible and then moved backward into position. (S7.4.6.2)
10. Is the inboard receptacle end of the seat belt assembly, installed in the front outboard designated seating position, accessible with the center armrest in any position to which it can be adjusted (without moving the armrest)? (S7.4.6.2)

REMARKS:

Signature: Jose Galvez

Date: 10/24/24

I certify that I have read and performed each instruction.

DATA SHEET 13

SEAT BELT GUIDES AND HARDWARE (S7.4.6)

Test Vehicle: 2024 Chevrolet Silverado EV
Test Program: FMVSS 208 Compliance
Test Technician: Jose Galvez

NHTSA No.: C20240101
Test Date: 10/24/24

Test seat belts except those in walk-in van-type vehicles and those at front outboard designated seating positions in passenger cars. Complete a form for each applicable seat belt.

DESIGNATED SEATING POSITION: Right Front Passenger

- 1. Is the seat cushion movable so that the seat back serves a function other than seating? (S7.4.6.1(b))
2. Is the seat removable? (S7.4.6.1(b))
3. Is the seat movable so that the space formerly occupied by the seat can be used for a secondary function? (S7.4.6.1(b))
4. Is the webbing designed to pass through the seat cushion or between the seat cushion and seat back? (S7.4.6.1(a))
5. Does one of the following three parts, the seat belt latch plate, the buckle, or the seat belt webbing, stay on top of or above the seat cushion under normal conditions...? (S7.4.6.1(a))
6. Are the remaining two seat belt parts accessible under normal conditions?
7. The buckle and latch plate do not pass through the guides or conduits provided and fall behind the seat when the belt is completely retracted or, if the belt is nonretractable, the belt is unlatched. (S7.4.6.2)
8. The buckle and latch plate do not pass through the guides or conduits provided and fall behind the seat when the seat is moved to any position to which it is designed to be adjusted. (S7.4.6.2)
9. The buckle and latch plate do not pass through the guides or conduits provided and fall behind the seat when the seat back, if foldable, is folded forward as far as possible and then moved backward into position. (S7.4.6.2)
10. Is the inboard receptacle end of the seat belt assembly, installed in the front outboard designated seating position, accessible with the center armrest in any position to which it can be adjusted (without moving the armrest)? (S7.4.6.2)

REMARKS:

Signature: Jose Galvez

Date: 10/24/24

I certify that I have read and performed each instruction.

DATA SHEET 13

SEAT BELT GUIDES AND HARDWARE (S7.4.6)

Test Vehicle: 2024 Chevrolet Silverado EV
Test Program: FMVSS 208 Compliance
Test Technician: Jose Galvez

NHTSA No.: C20240101
Test Date: 10/24/24

Test seat belts except those in walk-in van-type vehicles and those at front outboard designated seating positions in passenger cars. Complete a form for each applicable seat belt.

DESIGNATED SEATING POSITION: Left Rear Passenger

- 1. Is the seat cushion movable so that the seat back serves a function other than seating? (S7.4.6.1(b))
2. Is the seat removable? (S7.4.6.1(b))
3. Is the seat movable so that the space formerly occupied by the seat can be used for a secondary function? (S7.4.6.1(b))
4. Is the webbing designed to pass through the seat cushion or between the seat cushion and seat back? (S7.4.6.1(a))
5. Does one of the following three parts, the seat belt latch plate, the buckle, or the seat belt webbing, stay on top of or above the seat cushion under normal conditions...? (S7.4.6.1(a))
6. Are the remaining two seat belt parts accessible under normal conditions?
7. The buckle and latch plate do not pass through the guides or conduits provided and fall behind the seat when the belt is completely retracted or, if the belt is nonretractable, the belt is unlatched. (S7.4.6.2)
8. The buckle and latch plate do not pass through the guides or conduits provided and fall behind the seat when the seat is moved to any position to which it is designed to be adjusted. (S7.4.6.2)
9. The buckle and latch plate do not pass through the guides or conduits provided and fall behind the seat when the seat back, if foldable, is folded forward as far as possible and then moved backward into position. (S7.4.6.2)
10. Is the inboard receptacle end of the seat belt assembly, installed in the front outboard designated seating position, accessible with the center armrest in any position to which it can be adjusted (without moving the armrest)? (S7.4.6.2)

REMARKS:

Signature: Jose Galvez

Date: 10/24/24

I certify that I have read and performed each instruction.

DATA SHEET 13

SEAT BELT GUIDES AND HARDWARE (S7.4.6)

Test Vehicle: 2024 Chevrolet Silverado EV
 Test Program: FMVSS 208 Compliance
 Test Technician: Jose Galvez

NHTSA No.: C20240101
 Test Date: 10/24/24

Test seat belts except those in walk-in van-type vehicles and those at front outboard designated seating positions in passenger cars. Complete a form for each applicable seat belt.

DESIGNATED SEATING POSITION: **Center Rear Passenger**

- | | | | | | |
|-------------------------------------|--|-----|--|--|---|
| <input checked="" type="checkbox"/> | | 1. | Is the seat cushion movable so that the seat back serves a function other than seating? (S7.4.6.1(b)) | <input type="checkbox"/> Yes, this form is complete | <input checked="" type="checkbox"/> No, go to 2 |
| <input checked="" type="checkbox"/> | | 2. | Is the seat removable? (S7.4.6.1(b)) | <input type="checkbox"/> Yes, this form is complete | <input checked="" type="checkbox"/> No, go to 3 |
| <input checked="" type="checkbox"/> | | 3. | Is the seat movable so that the space formerly occupied by the seat can be used for a secondary function? (S7.4.6.1(b)) | <input checked="" type="checkbox"/> Yes, this form is complete | <input type="checkbox"/> No, go to 4 |
| <input type="checkbox"/> | | 4. | Is the webbing designed to pass through the seat cushion or between the seat cushion and seat back? (S7.4.6.1(a)) | <input type="checkbox"/> Yes, go to 5 | <input type="checkbox"/> No, this form is complete |
| <input type="checkbox"/> | | 5. | Does one of the following three parts, the seat belt latch plate, the buckle, or the seat belt webbing, stay on top of or above the seat cushion under normal conditions (i.e., conditions other than when belt hardware is intentionally pushed behind the seat by a vehicle occupant)? (S7.4.6.1(a)) | <input type="checkbox"/> Yes – Pass | <input type="checkbox"/> No – Fail |
| | | | Identify the part(s) on top or above the seat. | <input type="checkbox"/> Seat belt latch plate | <input type="checkbox"/> Buckle <input type="checkbox"/> Seat belt webbing |
| <input type="checkbox"/> | | 6. | Are the remaining two seat belt parts accessible under normal conditions? | <input type="checkbox"/> Yes – Pass | <input type="checkbox"/> No – Fail |
| <input type="checkbox"/> | | 7. | The buckle and latch plate do not pass through the guides or conduits provided and fall behind the seat when the belt is completely retracted or, if the belt is nonretractable, the belt is unlatched. (S7.4.6.2) | <input type="checkbox"/> Yes – Pass | <input type="checkbox"/> No – Fail |
| <input type="checkbox"/> | | 8. | The buckle and latch plate do not pass through the guides or conduits provided and fall behind the seat when the seat is moved to any position to which it is designed to be adjusted. (S7.4.6.2) | <input type="checkbox"/> Yes – Pass | <input type="checkbox"/> No – Fail |
| <input type="checkbox"/> | | 9. | The buckle and latch plate do not pass through the guides or conduits provided and fall behind the seat when the seat back, if foldable, is folded forward as far as possible and then moved backward into position. (S7.4.6.2) | <input type="checkbox"/> Yes – Pass | <input type="checkbox"/> No – Fail |
| <input type="checkbox"/> | | 10. | Is the inboard receptacle end of the seat belt assembly, installed in the front outboard designated seating position, accessible with the center armrest in any position to which it can be adjusted (without moving the armrest)? (S7.4.6.2) | <input type="checkbox"/> Yes – Pass | <input type="checkbox"/> No – Fail <input type="checkbox"/> N/A – Rear seat |

REMARKS:

Signature: *Jose Galvez*

Date: 10/24/24

I certify that I have read and performed each instruction.

DATA SHEET 13

SEAT BELT GUIDES AND HARDWARE (S7.4.6)

Test Vehicle: 2024 Chevrolet Silverado EV
Test Program: FMVSS 208 Compliance
Test Technician: Jose Galvez

NHTSA No.: C20240101
Test Date: 10/24/24

Test seat belts except those in walk-in van-type vehicles and those at front outboard designated seating positions in passenger cars. Complete a form for each applicable seat belt.

DESIGNATED SEATING POSITION: Right Rear Passenger

- 1. Is the seat cushion movable so that the seat back serves a function other than seating? (S7.4.6.1(b))
2. Is the seat removable? (S7.4.6.1(b))
3. Is the seat movable so that the space formerly occupied by the seat can be used for a secondary function? (S7.4.6.1(b))
4. Is the webbing designed to pass through the seat cushion or between the seat cushion and seat back? (S7.4.6.1(a))
5. Does one of the following three parts, the seat belt latch plate, the buckle, or the seat belt webbing, stay on top of or above the seat cushion under normal conditions...? (S7.4.6.1(a))
6. Are the remaining two seat belt parts accessible under normal conditions?
7. The buckle and latch plate do not pass through the guides or conduits provided and fall behind the seat when the belt is completely retracted or, if the belt is nonretractable, the belt is unlatched. (S7.4.6.2)
8. The buckle and latch plate do not pass through the guides or conduits provided and fall behind the seat when the seat is moved to any position to which it is designed to be adjusted. (S7.4.6.2)
9. The buckle and latch plate do not pass through the guides or conduits provided and fall behind the seat when the seat back, if foldable, is folded forward as far as possible and then moved backward into position. (S7.4.6.2)
10. Is the inboard receptacle end of the seat belt assembly, installed in the front outboard designated seating position, accessible with the center armrest in any position to which it can be adjusted (without moving the armrest)? (S7.4.6.2)

REMARKS:

Signature: Jose Galvez

Date: 10/24/24

I certify that I have read and performed each instruction.

DATA SHEET 15

H-POINT DETERMINATION FOR 50TH PERCENTILE MALE DUMMY

Test Vehicle: 2024 Chevrolet Silverado EV
Test Program: FMVSS 208 Compliance
Test Technician: Dane Wieting

NHTSA No.: C20240101
Test Date: 5/8/25

Driver Designated Seating Position Passenger Designated Seating Position

1. Position the seat's adjustable lumbar supports so that the lumbar support is in its lowest, retracted or deflated adjustment position. (S8.1.3)
 N/A – No lumbar adjustment
2. Position any adjustable parts of the seat that provide additional support so that they are in the lowest or most open adjustment position. (S16.2.10.2)
 N/A – No additional support adjustment
3. Use all the seat controls that have any affect on the fore–aft movement of the seat to move the seat cushion to the rearmost position. **Mark** this position. (8/31/95 legal interpretation to Hogan and Hartson)
4. Use all the seat controls that have any affect on the fore–aft movement of the seat to move the seat cushion to the foremost position. **Mark** this position. (8/31/95 legal interpretation to Hogan and Hartson)
5. **Mark** each fore–aft position so that there is a visual indication when the seat is at a particular position. For manual seats, **mark** each detent. For power seats, **mark** only the rearmost, middle, and foremost positions. Label three of the positions with the following: F for foremost, M for mid–position (if there is no mid–position, label the closest adjustment position to the rear of the mid–point), and R for rearmost. Determine the mid fore–aft seat position based on the foremost and rearmost positions determined in items 3 and 4. (8/31/95 legal interpretation to Hogan and Hartson)
6. Move the seat to the mid position.
7. While maintaining the mid position, move the seat to its lowest position. **Mark** the height position. For seats with adjustable seat cushions, use the manufacturer's recommended seat cushion angle for determining the lowest height position.
8. Visually **mark** the seat back angle, if adjustable, at the manufacturer's nominal design riding position for a **50th percentile adult male** in the manner specified by the manufacturer.
 N/A – No seat back angle adjustment
Manufacturer's design seat back angle -11.6° on Head Rest Post
9. Is the seat a bucket seat?
 Yes, go to 10 and skip 11
 No, go to 11 and skip 10
10. Bucket seats:
Locate and **mark** for future reference the longitudinal centerline of the seat cushion. The intersection of the vertical longitudinal plane that passes through the SgRP and the seat cushion upper surface determines the longitudinal centerline of a bucket seat cushion. (S10.4.1.2 and S16.3.1.10)

11. Bench seats (complete ONLY the one that is applicable to the seat being marked):

11.1 Driver Seat

Locate and **mark** for future reference the longitudinal line on the seat cushion that marks the intersection of the vertical longitudinal plane through the centerline of the steering wheel and the seat cushion upper surface. (S10.4.1.1)

11.2 Passenger Seat

Locate and **mark** for future reference the longitudinal centerline of the passenger seat cushion. The longitudinal centerline is the same distance from the longitudinal centerline of the vehicle as the center of the steering wheel. (S10.4.1.1)

Record the distance from the longitudinal centerline of the vehicle to the center of the steering wheel. _____

Record the distance from the longitudinal centerline of the vehicle to the longitudinal centerline of the seat cushion. _____

12. Place a 910 mm² piece of muslin cotton cloth over the seat area. (The muslin cloth shall be comparable to 48 threads/in² and density of 2.85 lb/yd.) Tuck the muslin cloth in a sufficient amount to prevent hammocking of the material.

13. Place the seat and back assembly of the H-Point machine at the centerline of the seat as determined in item 10 or 11.

14. Install the lower leg, and foot segments.

15. Set the length of the lower leg segment at 16.3 inches and the length of the thigh bar at 15.8 inches.

16. Leg and foot placement.

16.1 Driver Designated Seating Position.

16.1.1 Insert the pin so that the foot angle is never less than 87 degrees.

16.1.2 Place the right foot on the undepressed accelerator pedal with the sole of the foot on the pedal and the heel as far forward as allowable. Do not place the heel on the toe board.

16.1.3 Adjust the left leg to be the same distance from H-point machine centerline as the right leg.

16.1.4 With the T-bar level, place the left foot on the toe board with the rearmost point of the heel resting on the floor pan as close as possible to the point of intersection of the planes described by the toe board and the floor pan and not on the wheel well projection. If the foot cannot be positioned on the toe board, set it on the floor pan.

Foot on toe board.

Foot on floor pan.

16.2 Passenger Designated Seating Position.

16.2.1 Insert the pin so that the foot angle is never less than 87 degrees.

16.2.2 Space the lower legs 10.6 inches apart, equally spaced about the centerline of the H-point machine.

- 16.2.3 With the T–bar level, place the left foot on the toe board with the rearmost point of the heel resting on the floor pan as close as possible to the point of intersection of the planes described by the toe board and the floor pan and not on the wheel well projection. If the foot cannot be positioned on the toe board, set it on the floor pan.
 Foot on toe board.
 Foot on floor pan.
- 16.2.4 With the T–bar level, place the right foot on the toe board with the rearmost point of the heel resting on the floor pan as close as possible to the point of intersection of the planes described by the toe board and the floor pan and not on the wheel well projection. If the foot cannot be positioned on the toe board, set it on the floor pan.
 Foot on toe board.
 Foot on floor pan.
17. Apply the lower leg weights.
18. Apply the thigh weights.
19. Tilt the back pan forward against the forward stop and draw the H–point machine away from the seatback using the T–bar.
20. Repositioning the back pan.
- 20.1 Allow the H–point machine to slide rearward until a forward horizontal restraining load on the T–bar is no longer required due to the seat pan contacting the seat back.
 The seat pan does not slide rearward. Go to 20.2
- 20.2 Slide the H–point machine rearward by a horizontal rearward load applied at the T–bar until the seat pan contacts the seat back.
21. Apply a 10 kg load at the intersection of the hip angle quadrant and the T–bar housing along a line from the above intersection to a point just above the thigh bar housing.
22. Again apply a 10 kg load at the intersection of the hip angle quadrant and the T–bar housing along a line from the above intersection to a point just above the thigh bar housing.
23. Carefully return the back pan to the seat back.
24. Install the right and left buttock weights.
25. Install the eight torso weights alternately the installation between right and left.
26. Tilt the back pan forward until the stop is contacted.
27. Rock the H–point from side to side over a 10 degree arc (5 degrees to each side of the vertical centerline) for three complete cycles. Restrain the T–bar during rocking so that the seat pan does not change position. Minimize any inadvertent exterior loads applied in a vertical or fore–aft direction. The feet are free to move during this rocking motion.
28. Without applying a forward or lateral load lift the right foot off the floor the minimum amount necessary until no additional forward foot movement is obtained.
29. Lower the right foot until the heel is in contact with the floor pan and the ball of the foot is in contact with the floor, toe board, or undepressed accelerator pedal.

- X 30. Without applying a forward or lateral load lift the left foot off the floor the minimum amount necessary until no additional forward foot movement is obtained.
- X 31. Lower the left foot until the heel is in contact with the floor pan and the ball of the foot is in contact with the floor or toe board.
- X 32. Is the seat pan level?
 Yes. Go to 34
 No. Go to 33
33. Apply a sufficient lateral load to the top of the seatback pan to level the H–point machine seat pan on the seat.
- X 34. Holding the T–bar to prevent the H–point from sliding forward on the seat cushion, return the seatback pan to the seatback.
- X 35. Holding the T–bar to prevent the H–point from sliding forward on the seat cushion, apply sufficient rearward force perpendicular to the back angle bar just above the torso weights to increase the hip angle 3 degrees. Minimize the exterior downward or side forces applied to the H–point machine. Release the force. Repeat this step until the hip angle readout is identical. Complete as many force applications as necessary and record the results in the following table:

Force Application	Hip Angle
1	105
2	106
3	106
4	
5	

- X 36. Is the H–point machine level?
 Yes, go to 37.
 No, relevel. Go back to item 26 and repeat using a new data sheet.

X37. Record the H-point location.
Describe and mark the measuring reference point.

Driver H-Point	
HP to Floor Z	340
HP to Hinge X	785
HP to Sill Y	286
HP to Striker X	220
HP to Dash X	539
HP to Header Z	834

H-Point Machine	
Left Knee	127
Right Knee	129
Left Foot Angle	100°
Right Foot Angle	90°
Left Leg	87
Right Leg	155
Hip Angle	106°
Back Angle	25°

Signature:  Date: 5/8/25

I certify that I have read and performed each instruction.

DATA SHEET 15

H-POINT DETERMINATION FOR 50TH PERCENTILE MALE DUMMY

Test Vehicle: 2024 Chevrolet Silverado EV
Test Program: FMVSS 208 Compliance
Test Technician: Dane Wieting

NHTSA No.: C20240101
Test Date: 5/8/25

Driver Designated Seating Position Passenger Designated Seating Position

1. Position the seat's adjustable lumbar supports so that the lumbar support is in its lowest, retracted or deflated adjustment position. (S8.1.3)
 N/A – No lumbar adjustment
2. Position any adjustable parts of the seat that provide additional support so that they are in the lowest or most open adjustment position. (S16.2.10.2)
 N/A – No additional support adjustment
3. Use all the seat controls that have any affect on the fore–aft movement of the seat to move the seat cushion to the rearmost position. **Mark** this position. (8/31/95 legal interpretation to Hogan and Hartson)
4. Use all the seat controls that have any affect on the fore–aft movement of the seat to move the seat cushion to the foremost position. **Mark** this position. (8/31/95 legal interpretation to Hogan and Hartson)
5. **Mark** each fore–aft position so that there is a visual indication when the seat is at a particular position. For manual seats, **mark** each detent. For power seats, **mark** only the rearmost, middle, and foremost positions. Label three of the positions with the following: F for foremost, M for mid–position (if there is no mid–position, label the closest adjustment position to the rear of the mid–point), and R for rearmost. Determine the mid fore–aft seat position based on the foremost and rearmost positions determined in items 3 and 4. (8/31/95 legal interpretation to Hogan and Hartson)
6. Move the seat to the mid position.
7. While maintaining the mid position, move the seat to its lowest position. **Mark** the height position. For seats with adjustable seat cushions, use the manufacturer's recommended seat cushion angle for determining the lowest height position.
8. Visually **mark** the seat back angle, if adjustable, at the manufacturer's nominal design riding position for a **50th percentile adult male** in the manner specified by the manufacturer.
 N/A – No seat back angle adjustment
Manufacturer's design seat back angle -11.6° on Head Rest Post
9. Is the seat a bucket seat?
 Yes, go to 10 and skip 11
 No, go to 11 and skip 10
10. Bucket seats:
Locate and **mark** for future reference the longitudinal centerline of the seat cushion. The intersection of the vertical longitudinal plane that passes through the SgRP and the seat cushion upper surface determines the longitudinal centerline of a bucket seat cushion. (S10.4.1.2 and S16.3.1.10)

11. Bench seats (complete ONLY the one that is applicable to the seat being marked):

11.1 Driver Seat

Locate and **mark** for future reference the longitudinal line on the seat cushion that marks the intersection of the vertical longitudinal plane through the centerline of the steering wheel and the seat cushion upper surface. (S10.4.1.1)

11.2 Passenger Seat

Locate and **mark** for future reference the longitudinal centerline of the passenger seat cushion. The longitudinal centerline is the same distance from the longitudinal centerline of the vehicle as the center of the steering wheel. (S10.4.1.1)

Record the distance from the longitudinal centerline of the vehicle to the center of the steering wheel. _____

Record the distance from the longitudinal centerline of the vehicle to the longitudinal centerline of the seat cushion. _____

12. Place a 910 mm² piece of muslin cotton cloth over the seat area. (The muslin cloth shall be comparable to 48 threads/in² and density of 2.85 lb/yd.) Tuck the muslin cloth in a sufficient amount to prevent hammocking of the material.

13. Place the seat and back assembly of the H-Point machine at the centerline of the seat as determined in item 10 or 11.

14. Install the lower leg, and foot segments.

15. Set the length of the lower leg segment at 16.3 inches and the length of the thigh bar at 15.8 inches.

16. Leg and foot placement.

16.1 Driver Designated Seating Position.

16.1.1 Insert the pin so that the foot angle is never less than 87 degrees.

16.1.2 Place the right foot on the undepressed accelerator pedal with the sole of the foot on the pedal and the heel as far forward as allowable. Do not place the heel on the toe board.

16.1.3 Adjust the left leg to be the same distance from H-point machine centerline as the right leg.

16.1.4 With the T-bar level, place the left foot on the toe board with the rearmost point of the heel resting on the floor pan as close as possible to the point of intersection of the planes described by the toe board and the floor pan and not on the wheel well projection. If the foot cannot be positioned on the toe board, set it on the floor pan.

Foot on toe board.

Foot on floor pan.

16.2 Passenger Designated Seating Position.

16.2.1 Insert the pin so that the foot angle is never less than 87 degrees.

16.2.2 Space the lower legs 10.6 inches apart, equally spaced about the centerline of the H-point machine.

- X 16.2.3 With the T–bar level, place the left foot on the toe board with the rearmost point of the heel resting on the floor pan as close as possible to the point of intersection of the planes described by the toe board and the floor pan and not on the wheel well projection. If the foot cannot be positioned on the toe board, set it on the floor pan.
- Foot on toe board.
 - Foot on floor pan.
- X 16.2.4 With the T–bar level, place the right foot on the toe board with the rearmost point of the heel resting on the floor pan as close as possible to the point of intersection of the planes described by the toe board and the floor pan and not on the wheel well projection. If the foot cannot be positioned on the toe board, set it on the floor pan.
- Foot on toe board.
 - Foot on floor pan.
- X 17. Apply the lower leg weights.
- X 18. Apply the thigh weights.
- X 19. Tilt the back pan forward against the forward stop and draw the H–point machine away from the seatback using the T–bar.
- X 20. Repositioning the back pan.
- X 20.1 Allow the H–point machine to slide rearward until a forward horizontal restraining load on the T–bar is no longer required due to the seat pan contacting the seat back.
- The seat pan does not slide rearward. Go to 20.2
- 20.2 Slide the H–point machine rearward by a horizontal rearward load applied at the T–bar until the seat pan contacts the seat back.
- X 21. Apply a 10 kg load at the intersection of the hip angle quadrant and the T–bar housing along a line from the above intersection to a point just above the thigh bar housing.
- X 22. Again apply a 10 kg load at the intersection of the hip angle quadrant and the T–bar housing along a line from the above intersection to a point just above the thigh bar housing.
- X 23. Carefully return the back pan to the seat back.
- X 24. Install the right and left buttock weights.
- X 25. Install the eight torso weights alternately the installation between right and left.
- X 26. Tilt the back pan forward until the stop is contacted.
- X 27. Rock the H–point from side to side over a 10 degree arc (5 degrees to each side of the vertical centerline) for three complete cycles. Restrain the T–bar during rocking so that the seat pan does not change position. Minimize any inadvertent exterior loads applied in a vertical or fore–aft direction. The feet are free to move during this rocking motion.
- X 28. Without applying a forward or lateral load lift the right foot off the floor the minimum amount necessary until no additional forward foot movement is obtained.
- X 29. Lower the right foot until the heel is in contact with the floor pan and the ball of the foot is in contact with the floor, toe board, or undepressed accelerator pedal.

- X 30. Without applying a forward or lateral load lift the left foot off the floor the minimum Amount necessary until no additional forward foot movement is obtained.
- X 31. Lower the left foot until the heel is in contact with the floor pan and the ball of the foot is In contact with the floor or toe board.
- X 32. Is the seat pan level?
 Yes. Go to 34
 No. Go to 33
33. Apply a sufficient lateral load to the top of the seatback pan to level the H–point machine seat pan on the seat.
- X 34. Holding the T–bar to prevent the H–point from sliding forward on the seat cushion, return the seatback pan to the seatback.
- X 35. Holding the T–bar to prevent the H–point from sliding forward on the seat cushion, apply sufficient rearward force perpendicular to the back angle bar just above the torso weights to increase the hip angle 3 degrees. Minimize the exterior downward or side forces applied to the H–point machine. Release the force. Repeat this step until the hip angle readout is identical. Complete as many force applications as necessary and record the results in the following table:

Force Application	Hip Angle
1	104
2	105
3	105
4	
5	

- X 36. Is the H–point machine level?
 Yes, go to 37.
 No, relevel. Go back to item 26 and repeat using a new data sheet.

X37. Record the H-point location.
Describe and mark the measuring reference point.

Passenger H-Point	
HP to Floor Z	336
HP to Hinge X	792
HP to Sill Y	284
HP to Striker X	214
HP to Dash X	544
HP to Header Z	839

H-Point Machine	
Left Knee	127
Right Knee	127
Left Foot Angle	110°
Right Foot Angle	111°
Left Leg	125
Right Leg	125
Hip Angle	105°
Back Angle	25°

Signature:  Date: 5/8/25

I certify that I have read and performed each instruction.

DATA SHEET 16

AIR BAG SUPPRESSION TELLTALE (S19.2.2)

Test Vehicle: 2024 Chevrolet Silverado EV
Test Program: FMVSS 208 Compliance
Test Technician: Jose Galvez

NHTSA No.: C20240101
Test Date: 10/28/24

- 1. Is the vehicle certified to any suppression performance standards of FMVSS 208?
 Yes – go to 2
 No – this form is complete
- 2. Does telltale emit yellow light when the air bag is suppressed? (S19.2.2 (a))
 Yes – Pass **___ NO – FAIL**
- 3. Are the words “PASSENGER AIR BAG OFF” or “PASS AIR BAG OFF” (S19.2.2 (b))
 3.1 on the telltale? (S19.2.2 (b))
 Yes – Pass, go to 4
 No – go to 3.2
- 3.2 Within 25 mm of the telltale? (S19.2.2 (b)) mm from the edge of the telltale light
 Yes – Pass **___ NO – FAIL**
- 4. Is the telltale separate from the air bag readiness indicator? (S19.2.2(c))
 Yes – Pass **___ NO – FAIL**
- 5. Is the telltale within the interior of the vehicle? (S19.2.2 (d))
 Yes – Pass **___ NO – FAIL**
- 6. Is the telltale forward of and above the design H–point of both the driver’s and the front outboard passenger’s seat when the seats are in their forwardmost seating positions? (S19.2.2 (d))
 Yes – Pass **___ NO – FAIL**
- 7. Is the telltale away from surfaces that can be used for temporary or permanent storage of objects that could obscure the telltale from either the driver’s or front outboard passenger’s view? (S19.2.2 (d))
 Yes – Pass **___ NO – FAIL**
- 8. Is the telltale located so that it is not obscured from the driver or front outboard passenger by a rear–facing child restraint in Appendix A installed in the front outboard passenger seat? (S19.2.2 (d))
 Yes – Pass **___ NO – FAIL**
- 9. Is the telltale visible or recognizable during the night? (S19.2.2 (e))
 Yes – Pass **___ NO – FAIL**
- 10. Is the telltale visible or recognizable during the day? (S19.2.2 (e))
 Yes – Pass **___ NO – FAIL**
- 11. If there is a visibility adjustment, do all the adjustment levels make the telltale visible and recognizable? (S19.2.2 (g))
 N/A–No visibility adjustment
 Yes – Pass **___ NO – FAIL**
- 12. Does the telltale remain illuminated while the air bag is suppressed? (S19.2.2 (h)) (Leave the air bag suppressed for 5 minutes.)
 Yes – Pass **___ NO – FAIL**
- 13. Is the telltale off while the air bag is activated? (S19.2.2 (h)) (Leave the air bag activated for 5 minutes.)
 Yes – Pass **___ NO – FAIL**

Signature: 

Date: 10/28/24

I certify that I have read and performed each instruction

DATA SHEET 17 SUMMARY

Suppression Test Using 12–Month–Old CRABI Dummy (Part 572, Subpart R)
Section B Rear Facing CRS

NHTSA NO.:	C20240101	TEST DATE:	10/28/24
LABORATORY:	MGA	TECHNICIAN:	JG
DUMMY TYPE:	12 Month Old	DUMMY SERIAL NO.:	062

CHILD RESTRAINT NAME:	Cosco
CHILD RESTRAINT MODEL:	Arriva 22–049 (same as model 22–013)
DATE OF MANUFACTURE:	8–20–2008

Base: On Off N/A–Restraint does not have a removable base

Manufacturer’s design seat back angle: -11.6° on Head Rest Post
 Tested seat back angle: -11.6° on Head Rest Post
 Manufacturer’s specified anchorage position: 0 of 3; Upper-most defined as 0
 Tested anchorage position: 0 of 3; Upper-most defined as 0

A blanket and visor were not used in the suppression testing because they did not affect the weight sensing system used on the vehicle.

Test Summary

Seat Belt	Seat Slide	Cinch Load (N)	Result
Belted Rear Facing	Forward 12*	133	Suppressed
	Middle	132	Suppressed
	Rearward	128	Suppressed
Unbelted Rear Facing	Forward	N/A	Won't Fit
	Middle	N/A	Suppressed
	Rearward	N/A	Suppressed
Unbelted Forward Facing	Forward 11*	N/A	Suppressed
	Middle	N/A	Suppressed
	Rearward	N/A	Suppressed

* The CRS would not fit in this Forward Slide position. If there is a number in the Seat Slide column, it indicates the fore-aft position with respect to the foremost position. (1 = Full Forward; 27 = Full Rearward; 27 Total Detents)

DATA SHEET 17 SUMMARY

Suppression Test Using 12-Month-Old CRABI Dummy (Part 572, Subpart R) Section B Rear Facing CRS

NHTSA NO.:	C20240101	TEST DATE:	10/28/24
LABORATORY:	MGA	TECHNICIAN:	JG
DUMMY TYPE:	12 Month Old	DUMMY SERIAL NO.:	062

CHILD RESTRAINT NAME:	Cosco
CHILD RESTRAINT MODEL:	Arriva 22-049 (same as model 22-013)
DATE OF MANUFACTURE:	8-20-2008

Base: On Off N/A—Restraint does not have a removable base

Manufacturer's design seat back angle: -11.6° on Head Rest Post
 Tested seat back angle: -11.6° on Head Rest Post
 Manufacturer's specified anchorage position: 0 of 3; Upper-most defined as 0
 Tested anchorage position: 0 of 3; Upper-most defined as 0

A blanket and visor were not used in the suppression testing because they did not affect the weight sensing system used on the vehicle.

Test Summary

Seat Belt	Seat Slide	Cinch Load (N)	Result
Belted Rear Facing	Forward 9*	132	Suppressed
	Middle	130	Suppressed
	Rearward	131	Suppressed
Unbelted Rear Facing	Forward	N/A	Won't Fit
	Middle 15*	N/A	Suppressed
	Rearward	N/A	Suppressed
Unbelted Forward Facing	Forward	N/A	Won't Fit
	Middle	N/A	Suppressed
	Rearward	N/A	Suppressed

* The CRS would not fit in this Forward or Middle Slide position. If there is a number in the Seat Slide column, it indicates the fore-aft position with respect to the foremost position. (1 = Full Forward; 27 = Full Rearward; 27 Total Detents)

Successful unbelted 5th percentile Female Dummy reactivation was performed with the seat in the Rearward position. (SN 506)

DATA SHEET 17 SUMMARY

Suppression Test Using 12-Month-Old CRABI Dummy (Part 572, Subpart R)
Section B Rear Facing CRS

NHTSA NO.:	C20240101	TEST DATE:	10/28/24
LABORATORY:	MGA	TECHNICIAN:	JG
DUMMY TYPE:	12 Month Old	DUMMY SERIAL NO.:	062

CHILD RESTRAINT NAME:	Graco
CHILD RESTRAINT MODEL:	Snugride
DATE OF MANUFACTURE:	5-24-2007

Base: On Off N/A—Restraint does not have a removable base

Manufacturer's design seat back angle: -11.6° on Head Rest Post
 Tested seat back angle: -11.6° on Head Rest Post
 Manufacturer's specified anchorage position: 0 of 3; Upper-most defined as 0
 Tested anchorage position: 0 of 3; Upper-most defined as 0

A blanket and visor were not used in the suppression testing because they did not affect the weight sensing system used on the vehicle.

Test Summary

Seat Belt	Seat Slide	Cinch Load (N)	Result
Belted Rear Facing	Forward 10*	130	Suppressed
	Middle	133	Suppressed
	Rearward	131	Suppressed
Unbelted Rear Facing	Forward 12*	N/A	Suppressed
	Middle	N/A	Suppressed
	Rearward	N/A	Suppressed
Unbelted Forward Facing	Forward 2*	N/A	Suppressed
	Middle	N/A	Suppressed
	Rearward	N/A	Suppressed

* The CRS would not fit in this Forward Slide position. If there is a number in the Seat Slide column, it indicates the fore-aft position with respect to the foremost position. (1 = Full Forward; 27 = Full Rearward; 27 Total Detents)

DATA SHEET 17 SUMMARY

Suppression Test Using 12-Month-Old CRABI Dummy (Part 572, Subpart R) Section B Rear Facing CRS

NHTSA NO.:	C20240101	TEST DATE:	10/28/24
LABORATORY:	MGA	TECHNICIAN:	JG
DUMMY TYPE:	12 Month Old	DUMMY SERIAL NO.:	062

CHILD RESTRAINT NAME:	Graco
CHILD RESTRAINT MODEL:	Snugride
DATE OF MANUFACTURE:	5-24-2007

Base: __On X Off __N/A--Restraint does not have a removable base

Manufacturer's design seat back angle: -11.6° on Head Rest Post
 Tested seat back angle: -11.6° on Head Rest Post
 Manufacturer's specified anchorage position: 0 of 3; Upper-most defined as 0
 Tested anchorage position: 0 of 3; Upper-most defined as 0

A blanket and visor were not used in the suppression testing because they did not affect the weight sensing system used on the vehicle.

Test Summary

Seat Belt	Seat Slide	Cinch Load (N)	Result
Belted Rear Facing	Forward 5*	129	Suppressed
	Middle	132	Suppressed
	Rearward	133	Suppressed
Unbelted Rear Facing	Forward 9*	N/A	Suppressed
	Middle	N/A	Suppressed
	Rearward	N/A	Suppressed
Unbelted Forward Facing	Forward 7*	N/A	Suppressed
	Middle	N/A	Suppressed
	Rearward	N/A	Suppressed

* The CRS would not fit in this Forward Slide position. If there is a number in the Seat Slide column, it indicates the fore-aft position with respect to the foremost position. (1 = Full Forward; 27 = Full Rearward; 27 Total Detents)

Successful unbelted 5th percentile Female Dummy reactivation was performed with the seat in the Middle position. (SN 506)

DATA SHEET 17 SUMMARY

Suppression Test Using 12-Month-Old CRABI Dummy (Part 572, Subpart R)
Section B Rear Facing CRS

NHTSA NO.:	C20240101	TEST DATE:	10/28/24
LABORATORY:	MGA	TECHNICIAN:	JG
DUMMY TYPE:	12 Month Old	DUMMY SERIAL NO.:	062

CHILD RESTRAINT NAME:	Peg Perego
CHILD RESTRAINT MODEL:	Primo Viaggio
DATE OF MANUFACTURE:	8-27-2007

Base: On Off N/A—Restraint does not have a removable base

Manufacturer's design seat back angle: -11.6° on Head Rest Post
 Tested seat back angle: -11.6° on Head Rest Post
 Manufacturer's specified anchorage position: 0 of 3; Upper-most defined as 0
 Tested anchorage position: 0 of 3; Upper-most defined as 0

A blanket and visor were not used in the suppression testing because they did not affect the weight sensing system used on the vehicle.

Test Summary

Seat Belt	Seat Slide	Cinch Load (N)	Result
Belted Rear Facing	Forward 2*	133	Suppressed
	Middle	132	Suppressed
	Rearward	133	Suppressed
Unbelted Rear Facing	Forward 3*	N/A	Suppressed
	Middle	N/A	Suppressed
	Rearward	N/A	Suppressed
Unbelted Forward Facing	Forward 2*	N/A	Suppressed
	Middle	N/A	Suppressed
	Rearward	N/A	Suppressed

* The CRS would not fit in this Forward Slide position. If there is a number in the Seat Slide column, it indicates the fore-aft position with respect to the foremost position. (1 = Full Forward; 27 = Full Rearward; 27 Total Detents)

DATA SHEET 17 SUMMARY

Suppression Test Using 12-Month-Old CRABI Dummy (Part 572, Subpart R) Section B Rear Facing CRS

NHTSA NO.:	C20240101	TEST DATE:	10/28/24
LABORATORY:	MGA	TECHNICIAN:	JG
DUMMY TYPE:	12 Month Old	DUMMY SERIAL NO.:	062

CHILD RESTRAINT NAME:	Peg Perego
CHILD RESTRAINT MODEL:	Primo Viaggio
DATE OF MANUFACTURE:	8-27-2007

Base: __On Off __N/A--Restraint does not have a removable base

Manufacturer's design seat back angle: -11.6° on Head Rest Post
 Tested seat back angle: -11.6° on Head Rest Post
 Manufacturer's specified anchorage position: 0 of 3; Upper-most defined as 0
 Tested anchorage position: 0 of 3; Upper-most defined as 0

A blanket and visor were not used in the suppression testing because they did not affect the weight sensing system used on the vehicle.

Test Summary

Seat Belt	Seat Slide	Cinch Load (N)	Result
Belted Rear Facing	Forward 2*	130	Suppressed
	Middle	129	Suppressed
	Rearward	133	Suppressed
Unbelted Rear Facing	Forward 6*	N/A	Suppressed
	Middle	N/A	Suppressed
	Rearward	N/A	Suppressed
Unbelted Forward Facing	Forward 3*	N/A	Suppressed
	Middle	N/A	Suppressed
	Rearward	N/A	Suppressed

* The CRS would not fit in this Forward Slide position. If there is a number in the Seat Slide column, it indicates the fore-aft position with respect to the foremost position. (1 = Full Forward; 27 = Full Rearward; 27 Total Detents)

Successful unbelted 5th percentile Female Dummy reactivation was performed with the seat in the Middle position. (SN 506)

DATA SHEET 17 SUMMARY

Suppression Test Using 12-Month-Old CRABI Dummy (Part 572, Subpart R)
Section C Forward Facing Convertible CRS

NHTSA NO.:	C20240101	TEST DATE:	10/28/24
LABORATORY:	MGA	TECHNICIAN:	JG
DUMMY TYPE:	12 Month Old	DUMMY SERIAL NO.:	062

CHILD RESTRAINT NAME:	Britax
CHILD RESTRAINT MODEL:	Roundabout E9L02
DATE OF MANUFACTURE:	7-2-2008

Base: __On __Off _X_ N/A—Restraint does not have a removable base

Manufacturer's design seat back angle: -11.6° on Head Rest Post
 Tested seat back angle: -11.6° on Head Rest Post
 Manufacturer's specified anchorage position: 0 of 3; Upper-most defined as 0
 Tested anchorage position: 0 of 3; Upper-most defined as 0

A blanket was not used in the suppression testing because it did not affect the weight sensing system used on the vehicle.

Test Summary

Seat Belt	Seat Slide	Cinch Load (N)	Result
Belted Forward Facing	Forward	128	Suppressed
	Middle	133	Suppressed
	Rearward	131	Suppressed
Unbelted Forward Facing	Forward	N/A	Suppressed
	Middle	N/A	Suppressed
	Rearward	N/A	Suppressed
Belted Rear Facing	Forward	132	Suppressed
	Middle	133	Suppressed
	Rearward	131	Suppressed
Unbelted Rear Facing	Forward	N/A	Suppressed
	Middle	N/A	Suppressed
	Rearward	N/A	Suppressed

Successful unbelted 5th percentile Female Dummy reactivation was performed with the seat in the Forward position. (SN 506)

DATA SHEET 17 SUMMARY

Suppression Test Using 12–Month–Old CRABI Dummy (Part 572, Subpart R)
Section C Forward Facing Convertible CRS

NHTSA NO.:	C20240101	TEST DATE:	10/28/24
LABORATORY:	MGA	TECHNICIAN:	JG
DUMMY TYPE:	12 Month Old	DUMMY SERIAL NO.:	062

CHILD RESTRAINT NAME:	Cosco
CHILD RESTRAINT MODEL:	Summit Deluxe High Back Booster 22-262
DATE OF MANUFACTURE:	8-9-2007

Base: __On __Off _X_ N/A–Restraint does not have a removable base

Manufacturer’s design seat back angle: -11.6° on Head Rest Post
 Tested seat back angle: -11.6° on Head Rest Post
 Manufacturer’s specified anchorage position: 0 of 3; Upper-most defined as 0
 Tested anchorage position: 0 of 3; Upper-most defined as 0

A blanket was not used in the suppression testing because it did not affect the weight sensing system used on the vehicle.

Test Summary

Seat Belt	Seat Slide	Cinch Load (N)	Result
Belted Forward Facing	Forward	131	Suppressed
	Middle	132	Suppressed
	Rearward	129	Suppressed
Unbelted Forward Facing	Forward	N/A	Suppressed
	Middle	N/A	Suppressed
	Rearward	N/A	Suppressed
Unbelted Rear Facing	Forward 10*	N/A	Suppressed
	Middle	N/A	Suppressed
	Rearward	N/A	Suppressed

* The CRS would not fit in this Forward Slide position. If there is a number in the Seat Slide column, it indicates the fore-aft position with respect to the foremost position. (1 = Full Forward; 27 = Full Rearward; 27 Total Detents)

Successful unbelted 5th percentile Female Dummy reactivation was performed with the seat in the Rearward position. (SN 506)

The Cosco Summit Deluxe 22-262 does not have a rear facing belt path.

DATA SHEET 17 SUMMARY

Suppression Test Using 12-Month-Old CRABI Dummy (Part 572, Subpart R)
Section C Forward Facing Convertible CRS

NHTSA NO.:	C20240101	TEST DATE:	10/28/24
LABORATORY:	MGA	TECHNICIAN:	JG
DUMMY TYPE:	12 Month Old	DUMMY SERIAL NO.:	062

CHILD RESTRAINT NAME:	Evenflo
CHILD RESTRAINT MODEL:	Tribute V 379
DATE OF MANUFACTURE:	6-20-2008

Base: On Off N/A—Restraint does not have a removable base

Manufacturer's design seat back angle: -11.6° on Head Rest Post
 Tested seat back angle: -11.6° on Head Rest Post
 Manufacturer's specified anchorage position: 0 of 3; Upper-most defined as 0
 Tested anchorage position: 0 of 3; Upper-most defined as 0

A blanket was not used in the suppression testing because it did not affect the weight sensing system used on the vehicle.

Test Summary

Seat Belt	Seat Slide	Cinch Load (N)	Result
Belted Forward Facing	Forward	130	Suppressed
	Middle	130	Suppressed
	Rearward	127	Suppressed
Unbelted Forward Facing	Forward	N/A	Suppressed
	Middle	N/A	Suppressed
	Rearward	N/A	Suppressed
Belted Rear Facing	Forward	128	Suppressed
	Middle	132	Suppressed
	Rearward	129	Suppressed
Unbelted Rear Facing	Forward 2*	N/A	Suppressed
	Middle	N/A	Suppressed
	Rearward	N/A	Suppressed

* The CRS would not fit in this Forward Slide position. If there is a number in the Seat Slide column, it indicates the fore-aft position with respect to the foremost position. (1 = Full Forward; 27 = Full Rearward; 27 Total Detents)

Successful unbelted 5th percentile Female Dummy reactivation was performed with the seat in the Rearward position. (SN 506)

DATA SHEET 17 SUMMARY

Suppression Test Using 12-Month-Old CRABI Dummy (Part 572, Subpart R)
Section C Forward Facing Convertible CRS

NHTSA NO.:	C20240101	TEST DATE:	10/28/24
LABORATORY:	MGA	TECHNICIAN:	JG
DUMMY TYPE:	12 Month Old	DUMMY SERIAL NO.:	062

CHILD RESTRAINT NAME:	Graco
CHILD RESTRAINT MODEL:	Toddler SafeSeat Step 2
DATE OF MANUFACTURE:	5-24-2007

Base: __On __Off _X_ N/A—Restraint does not have a removable base

Manufacturer's design seat back angle: -11.6° on Head Rest Post
 Tested seat back angle: -11.6° on Head Rest Post
 Manufacturer's specified anchorage position: 0 of 3; Upper-most defined as 0
 Tested anchorage position: 0 of 3; Upper-most defined as 0

A blanket was not used in the suppression testing because it did not affect the weight sensing system used on the vehicle.

Test Summary

Seat Belt	Seat Slide	Cinch Load (N)	Result
Belted Forward Facing	Forward	131	Suppressed
	Middle	133	Suppressed
	Rearward	133	Suppressed
Unbelted Forward Facing	Forward	N/A	Suppressed
	Middle	N/A	Suppressed
	Rearward	N/A	Suppressed
Unbelted Rear Facing	Forward 6*	N/A	Suppressed
	Middle	N/A	Suppressed
	Rearward	N/A	Suppressed

* The CRS would not fit in this Forward Slide position. If there is a number in the Seat Slide column, it indicates the fore-aft position with respect to the foremost position. (1 = Full Forward; 27 = Full Rearward; 27 Total Detents)

Successful unbelted 5th percentile Female Dummy reactivation was performed with the seat in the Rearward position. (SN 506)

The Graco Toddler SafeSeat Step 2 does not have a rear facing belt path.

DATA SHEET 18 SUMMARY

Suppression Test Using Newborn Infant Dummy (Part 572, Subpart K)
Section A Car Bed

NHTSA NO.:	C20240101	TEST DATE:	10/28/24
LABORATORY:	MGA	TECHNICIAN:	JG
DUMMY TYPE:	Newborn Infant	DUMMY SERIAL NO.:	003

CAR BED NAME:	Angel Guard
CAR BED MODEL:	Angel Ride
DATE OF MANUFACTURE:	4-15-2008

Base: On Off N/A—Restraint does not have a removable base
 (A car bed with a removable base shall be treated as two separate models, i.e. this form and test procedure will be completed with the base on and then repeated on a new form with the base off.)

Manufacturer’s design seat back angle: -11.6° on Head Rest Post
 Tested seat back angle: -11.6° on Head Rest Post
 Manufacturer’s specified anchorage position: 0 of 3; Upper-most defined as 0
 Tested anchorage position: 0 of 3; Upper-most defined as 0

A blanket and visor were not used in the suppression testing because they did not affect the weight sensing system used on the vehicle.

Test Summary

Seat Belt	Seat Slide	Result
Belted	Forward	Suppressed
	Middle	Suppressed
	Rearward	Suppressed

Successful unbelted 5th percentile Female Dummy reactivation was performed with the seat in the Forward position. (SN 506)

DATA SHEET 32

VEHICLE WEIGHT, FUEL TANK, AND ATTITUDE DATA

Test Vehicle: 2024 Chevrolet Silverado EV
 Test Program: FMVSS 208 Compliance
 Test Technician: Chad Williams

NHTSA No.: C20240101
 Test Date: 5/8/25

IMPACT ANGLE:	0°					
BELTED DUMMIES (YES/NO):	NO					
TEST SPEED:	X	32 to 56 kmph		0 to 48 kmph		0 to 56 kmph
DRIVER DUMMY:			5 th female	X		50 th male
PASSENGER DUMMY:			5 th female	X		50 th male

- NA 1. Fill the transmission with transmission fluid to the satisfactory range.
- NA 2. Drain fuel from vehicle.
- NA 3. Run the engine until fuel remaining in the fuel delivery system is used and the engine stops.
- NA 4. Record the useable fuel tank capacity supplied by the COTR.
Useable Fuel Tank Capacity supplied by COTR: Not Applicable Electric Vehicle
- NA 5. Record the fuel tank capacity supplied in the owner's manual.
Useable Fuel Tank Capacity in owner's manual: Not Applicable Electric Vehicle
- NA 6. Using purple dyed Stoddard solvent having the physical and chemical properties of Type 1 solvent or cleaning fluid, Table 1, ASTM Standard D484-71, "Standard Specifications for Hydrocarbon Dry-cleaning Solvents," or gasoline, fill the fuel tank.
Amount Added: Not Applicable Electric Vehicle
- X 7. Fill the coolant system to capacity.
- NA 8. Fill the engine with motor oil to the Max. mark on the dip stick.
- X 9. Fill the brake reservoir with brake fluid to its normal level.
- X 10. Fill the windshield washer reservoir to capacity.
- X 11. Inflate the tires to the tire pressure on the tire placard. If no tire placard is available, inflate the tires to the recommended pressure in the owner's manual.

Tire placard pressure:	RF:	61 psi	LF:	61 psi	RR:	61 psi	LR:	61 psi
Owner's manual pressure:	RF:	61 psi	LF:	61 psi	RR:	61 psi	LR:	61 psi
Actual inflated pressure:	RF:	61 psi	LF:	61 psi	RR:	61 psi	LR:	61 psi

- X 12. Record the vehicle weight at each wheel to determine the unloaded vehicle weight (UVW), i.e. "as delivered" weight).

Right Front (kg):	955.3	Right Rear (kg):	877.2
Left Front (kg):	959.8	Left Rear (kg):	873.2
Total Front (kg):	1915.1	Total Rear (kg):	1750.4
% Total Weight:	52.2	% Total Weight:	47.8
UVW = TOTAL FRONT PLUS TOTAL REAR (KG):	3665.5		

- X 13. UVW Test Vehicle Attitude: (All dimensions in millimeters)
- X 13.1 Mark a point on the vehicle above the center of each wheel.
- X 13.2 Place the vehicle on a level surface.
- X 13.3 Measure perpendicular to the level surface to the 4 points marked on the body and record the measurements.

RF:	942	LF:	947	RR:	986	LR:	990
-----	-----	-----	-----	-----	-----	-----	-----

14. Calculate the Rated Cargo and Luggage Weight (RCLW): 464 kg
- 14.1 Does the vehicle have the vehicle capacity weight (VCW) on the certification label or tire placard?
- Yes, go to 14.3
- No, go to 14.2
- 14.2 VCW = Gross Vehicle Weight - UVW
- VCW = _____ - _____ = _____
- 14.3 VCW = 804 kg (1772 lbs)
- 14.4 Does the certification or tire placard contain the Designated Seating Capacity (DSC)?
- Yes, go to 14.6
- No, go to 14.5 and skip 14.6
- 14.5 DSC = Total number of seat belt assemblies = _____
- 14.6 DSC = 5
- 14.7 RCLW = VCW - (68 kg x DSC) = 804 kg - (68 kg x 5) = 464 kg
- 14.8 Is the vehicle certified as a truck, MPV or bus (see the certification label on the door jamb)?
- Yes, if the calculated RCLW is greater than 136 kg, use 136 kg as the RCLW. (S8.1.1)
- No, use the RCLW calculated in 14.7
15. Fully Loaded Weight (100% fuel fill): 3957.7 kg
- 15.1 Place the appropriate test dummy in both front outboard seating positions.
- Driver: ___ 5th female 50th male
- Passenger: ___ 5th female 50th male
- 15.2 Load the vehicle with the RCLW from 14.7 or 14.8 whichever is applicable.
- 15.3 Place the RCLW in the cargo area. Center the load over the longitudinal centerline of the vehicle. (S8.1.1 (d))
- 15.4 Record the vehicle weight at each wheel to determine the Fully Loaded Weight.
- | | | | |
|---|--------|------------------|--------|
| Right Front (kg): | 991.6 | Right Rear (kg): | 987.0 |
| Left Front (kg): | 991.6 | Left Rear (kg): | 987.5 |
| Total Front (kg): | 1983.2 | Total Rear (kg): | 1974.5 |
| % Total Weight: | 50.1 | % Total Weight: | 49.9 |
| % GVW | 53.1 | % GVW | 57.6 |
| (% GVW = Axle GVW divided by Vehicle GVW) | | | |
| Fully Loaded Weight = Total Front Plus Total Rear (kg): | | | 3957.7 |
16. Fully Loaded Test Vehicle Attitude: (All dimensions in millimeters)
- 16.1 Place the vehicle on a level surface.
- 16.2 Measure perpendicular to the level surface to the 4 points marked on the body (see 13.1 above) and record the measurements.
- | | | | | | | | |
|-----|-----|-----|-----|-----|-----|-----|-----|
| RF: | 941 | LF: | 947 | RR: | 971 | LR: | 976 |
|-----|-----|-----|-----|-----|-----|-----|-----|
17. Drain the fuel system.

NA 18. Using purple dyed Stoddard solvent having the physical and chemical properties of Type 1 solvent or cleaning fluid, Table 1, ASTM Standard D484-71, "Standard Specifications for Hydrocarbon Dry-cleaning Solvents," fill the fuel tank to 92 - 94 percent of useable capacity.

NA Fuel tank capacity x .94 = 0 liters (0 gallons) Not Applicable Electric Vehicle

NA Amount added: 0 liters (0 gallons) Not Applicable Electric Vehicle

NA 19. Crank the engine to fill the fuel delivery system with Stoddard solvent.

X 20. Calculate the test weight range.

X 20.1 Calculated Weight = UVW (see 12 above) + RCLW (see 14 above) + 2x(dummy weight)

$$\underline{3957.5 \text{ kg} = 3665.5 \text{ kg} + 136 \text{ kg} + 156.0 \text{ kg}}$$

X 20.2 Test Weight Range = Calculated Weight (- 4.5 kg, - 9 kg.)

$$\text{Max. Test Weight} = \text{Calculated Test Weight} - 4.5 \text{ kg} = \underline{3953.0 \text{ kg}}$$

$$\text{Min. Test Weight} = \text{Calculated Test Weight} - 9 \text{ kg} = \underline{3948.5 \text{ kg}}$$

X 21. Remove the RCLW from the cargo area.

X 22. Drain transmission fluid, engine coolant, motor oil, and windshield washer fluid from the test vehicle so that Stoddard solvent leakage from the fuel system will be evident.

X 23. Vehicle Components Removed For Weight Reduction:

Bed Cover & Spare Tire Tools

X 24. Secure the equipment and ballast in the load carrying area and distribute it, as nearly as possible, to obtain the proportion of axle weight indicated by the gross axle weight ratings and center it over the longitudinal centerline of the vehicle.

X 25. If necessary, add ballast to achieve the actual test weight.

N/A

X Weight of Ballast: 95.3 kg

X 26. Ballast, including test equipment, must be contained so that it will not shift during the impact event or interfere with data collection or interfere with high-speed film recordings or affect the structural integrity of the vehicle or do anything else to affect test results. Care must be taken to assure that any attachment hardware added to the vehicle is not in the vicinity of the fuel tank or lines.

X 27. Record the vehicle weight at each wheel to determine the actual test weight.

Right Front (kg):	989.3	Right Rear (kg):	980.7
Left Front (kg):	991.6	Left Rear (kg):	987.0
Total Front (kg):	1980.9	Total Rear (kg):	1967.7
% Total Weight:	50.2	% Total Weight:	49.8
% GVW	53.1	% GVW	57.6
(% GVW = Axle GVW divided by Vehicle GVW)			
TOTAL FRONT PLUS TOTAL REAR (kg):			3948.6

X 28. Is the test weight between the Max. Weight and the Min. Weight (See 20.2)?

X Yes

No, explain why not.

X 29. Test Weight Vehicle Attitude: (all dimensions in millimeters)

X 29.1 Place the vehicle on a level surface.

X 29.2 Measure perpendicular to the level surface to the 4 points marked on the body (see 13 above) and record the measurements.

RF:	942	LF:	947	RR:	972	LR:	977
-----	-----	-----	-----	-----	-----	-----	-----

- 30. Summary of test attitude
- 30.1 AS DELIVERED:

RF:	942	LF:	947	RR:	986	LR:	990
-----	-----	-----	-----	-----	-----	-----	-----

AS TESTED:

RF:	942	LF:	947	RR:	972	LR:	977
-----	-----	-----	-----	-----	-----	-----	-----

FULLY LOADED:

RF:	941	LF:	947	RR:	971	LR:	976
-----	-----	-----	-----	-----	-----	-----	-----

- 30.2 Is the “as tested” test attitude equal to or between the “fully loaded” and “as delivered” attitude?

- Yes
- No, explain why not.

REMARKS:

Signature: Chad Wilkin Date: 5/8/25

I certify that I have read and performed each instruction.

DATA SHEET 33

VEHICLE ACCELEROMETER LOCATION AND MEASUREMENT

Test Vehicle: 2024 Chevrolet Silverado EV
 Test Program: FMVSS 208 Compliance
 Test Technician: Chad Williams

NHTSA No.: C20240101
 Test Date: 5/8/25

IMPACT ANGLE:	0° Frontal					
BELTED DUMMIES (YES/NO):	NO					
TEST SPEED:	X	32 to 40 kmph		0 to 48 kmph		0 to 56 kmph
DRIVER DUMMY:			5 th female	X		50 th male
PASSENGER DUMMY:			5 th female	X		50 th male

- 1. Find the location where the vertical plane parallel to the longitudinal centerline of the vehicle and through the center of the left front outboard seating position intersects the left rear seat cross member. Install an accelerometer at this intersection on the rear seat cross member to record x-direction accelerations. Record the location on the following chart.
- 2. Find the location where the vertical plane parallel to the longitudinal centerline of the vehicle and through the center of the right front outboard seating position intersects the right rear seat cross member. Install an accelerometer at this intersection on the rear seat cross member to record x-direction accelerations. Record the location on the following chart.
- 3. Find the location where a vertical plane through the longitudinal centerline of the vehicle and a vertical transverse plane through the center of the two wheels on opposite sides of the engine intersect at the top of the engine. Install an accelerometer at this intersection to record x-direction accelerations. Record the location on the following chart.
- 4. Find the location where a vertical plane through the longitudinal centerline of the vehicle and a vertical transverse plane through the center of the two wheels on opposite sides of the engine intersect the bottom of the engine. Install an accelerometer at this intersection to record x-direction accelerations. Record the location on the following chart.
- 5. Install an accelerometer on the right front brake caliper to record x-direction accelerations. Record the location on the following chart.
- 6. Find the location where a vertical plane through the longitudinal centerline of the vehicle intersects the top of the instrument panel. Install an accelerometer at this intersection to record x-direction accelerations. Record the location on the following chart.
- 7. Install an accelerometer on the left front brake caliper to record x-direction accelerations. Record the location on the following chart.
- 8. Find the location where a vertical plane through the longitudinal centerline of the vehicle intersects the floor of the trunk. Install an accelerometer on the trunk floor at this intersection to record z-direction accelerations. Record the location on the following chart.

REMARKS:

I certify that I have read and performed each instruction.

Signature: Chad Williams

Date: 5/8/25

VEHICLE ACCELEROMETER LOCATION AND DATA SUMMARY

CENTERLINE OF FRONT WHEELS

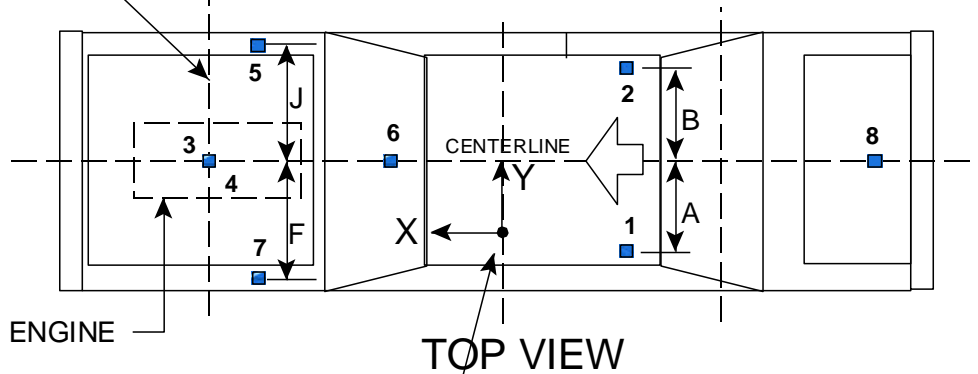

TOP VIEW

ACCELEROMETER COORDINATE SYSTEM (POSITIVE DIRECTION SHOWN)

REAR SEAT CUSHION ASSY. FRONT ATTACHMENT BRACKET SUPPORT

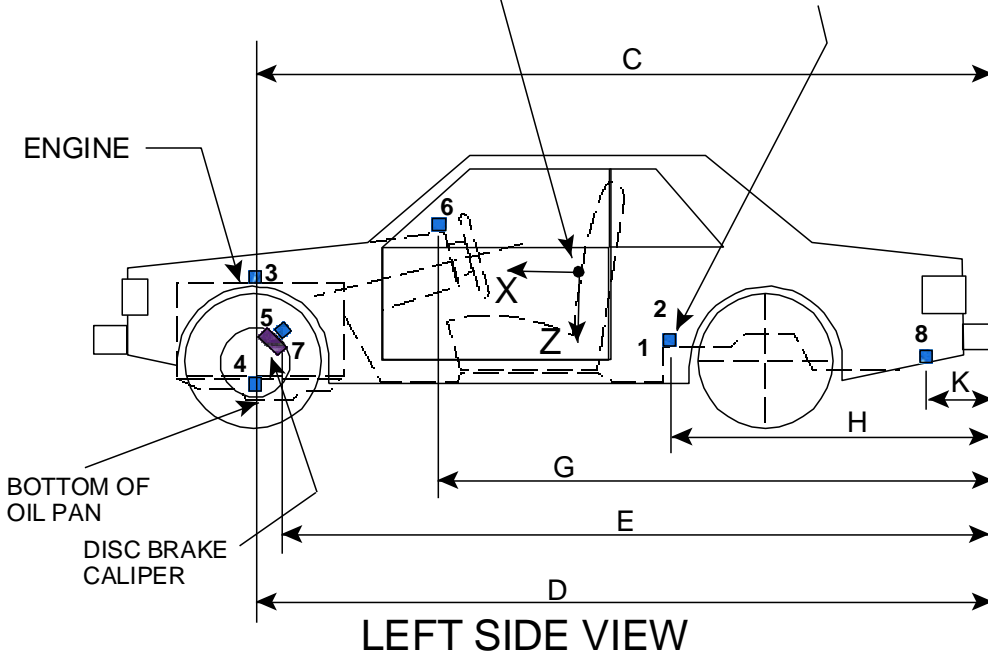

LEFT SIDE VIEW

Dimensions Corresponding To The Letters "A" Through "K" (Excluding "I") Are Recorded In The Table On The Following Page.

Accelerometers Corresponding To The Numbers 1 Through 8 Are Specified On The Preceding Page.

VEHICLE ACCELEROMETER LOCATION AND MEASUREMENTS

<u>DIMENSION</u>	<u>LENGTH (mm)</u>	
<u>PRETEST VALUES</u>		
<u>A</u> (LH Rear Seat Xmbr)	438	
<u>B</u> (RH Rear Seat Xmbr)	438	
<u>C</u> (Engine Top)	4831	
<u>D</u> (Engine Bottom)	4885	
<u>E</u> (Caliper)	Right Side: 4844	Left Side: 4844
<u>F</u> (Left Caliper)	710	
<u>G</u> (IP)	4129	
<u>H</u> (Seat)	2141	
<u>J</u> (Right Caliper)	710	
<u>K</u> (Trunk)	1232	
<u>POST TEST VALUES</u>		
<u>A</u> (LH Rear Seat Xmbr)	438	
<u>B</u> (RH Rear Seat Xmbr)	438	
<u>C</u> (Engine Top)	4735	
<u>D</u> (Engine Bottom)	4743	
<u>E</u> (Caliper)	Right Side: 4766	Left Side: 4793
<u>F</u> (Left Caliper)	708	
<u>G</u> (IP)	4017	
<u>H</u> (Seat)	2141	
<u>J</u> (Right Caliper)	706	
<u>K</u> (Trunk)	1232	

DATA SHEET 34
PHOTOGRAPHIC TARGETS

Test Vehicle: 2024 Chevrolet Silverado EV
 Test Program: FMVSS 208 Compliance
 Test Technician: Chad Williams

NHTSA No.: C20240101
 Test Date: 5/8/25

IMPACT ANGLE:	0° Frontal			
BELTED DUMMIES (YES/NO):	NO			
TEST SPEED:	X	32 to 40 kmph		0 to 48 kmph
DRIVER DUMMY:		5 th female	X	50 th male
PASSENGER DUMMY:		5 th female	X	50 th male

- 1. **FMVSS 208 vehicle targeting requirements** (See Figures 28A and 28B)
- 1.1 Targets A1 and A2 are on flat rectangular panels.
- 1.2 Three circular targets at least 90 mm in diameter and with black and yellow quadrants are mounted at the front on the outboard sides of A1 and A2. The center of each circular target is 100 mm from the one next to it.
- 1.3 Distance between targets (mm): 100 mm
- 1.3 Three circular targets at least 90 mm in diameter and with black and yellow quadrants are mounted at the back on the outboard sides of on A1 and A2. The center of each circular target is 100 mm from the one next to it.
- 1.4 Distance between targets (mm): 100 mm
- 1.4 The distance between the first circular target at the front of A1 and A2 and the last circular target at the back of A1 and A2 is at least 915 mm.
- 1.5 Distance between the first and last circular targets (mm): 915 mm
- 1.5 Firmly fix target A1 on the vehicle roof in the vertical longitudinal plane that is coincident with the midsagittal plane of the driver dummy.
- 1.6 Firmly fix target A2 on the vehicle roof in the vertical longitudinal plane that is coincident with the midsagittal plane of the passenger dummy.
- 1.7 Two circular targets (C1 and C2) at least 90 mm in diameter and with black and yellow quadrants are mounted on the outside of the driver door. The centers of each circular target are at least 610 mm apart.
- 1.8 Distance between targets (mm): 610 mm
- 1.8 Two circular targets (C1 and C2) at least 90 mm in diameter and with black and yellow quadrants are mounted on the outside of the passenger door. The centers of each circular target are at least 610 mm apart.
- 1.9 Distance between targets (mm): 610 mm
- 1.9 Place tape with squares having alternating colors on the top portion of the steering wheel.
- 1.10 Chalk the bottom portion of the steering wheel.
- 1.11 Is this an offset test?
- Yes, continue with this section**
- No, go to 2.**
- 1.12 Measure the width of the vehicle.
Vehicle width (mm):
- 1.13 Find the centerline of the vehicle. ($\frac{1}{2}$ of the vehicle width)
- 1.14 Find the line parallel to the centerline of the vehicle and 0.1 x vehicle width from the centerline of the vehicle.
- 1.15 Apply 25 mm wide tape with alternating black and yellow squares parallel to and on each side of the line found in 1.14. The edge of each tape shall be 50 mm from the line found in 1.14. The tape shall extend from the bottom of the bumper to the front edge of the windshield. (Figure 28D)

2. **Barrier Targeting**
- 2.1 Fix two stationary targets D1 and D2 to the barrier as shown in the Figure 28A. One target is in the vertical longitudinal plane that is coincident with the midsagittal plane of the driver dummy. The other is in the vertical longitudinal plane that is coincident with the midsagittal plane of the passenger dummy.
- 2.2 Targets D1 and D2 are on a rectangular panel.
- 2.3 Three circular targets at least 90 mm in diameter and with black and yellow quadrants are mounted on the sides of the rectangular panel away from the longitudinal centerline of the vehicle. The center of each circular target is 100 mm from the one next to it.
- Distance between circular targets on D1 (mm): 100 mm
- Distance between circular targets on D2 (mm): 100 mm
3. **FMVSS 208 Dummy Targeting Requirements**
- 3.1 Place a circular target with black and yellow quadrants on both sides of the driver dummy head as close as possible to the center of gravity of the head in the x and z direction (relative to the measuring directions of the accelerometers).
- 3.2 Place a circular target with black and yellow quadrants on both sides of the passenger dummy head as close as possible to the center of gravity of the head in the x and z direction (relative to the measuring directions of the accelerometers).
- 3.3 Place a circular target with black and yellow quadrants on the outboard shoulder of the driver dummy. Place the target as high up on the arm as possible at the intersection of the arm and shoulder. The sleeve of the shirt on the dummy may be cut to make the target visible, but do not remove any material.
- 3.4 Place a circular target with black and yellow quadrants on the outboard shoulder of the passenger dummy. Place the target as high up on the arm as possible at the intersection of the arm and shoulder. The sleeve of the shirt on the dummy may be cut to make the target visible, but do not remove any material.
4. **FMVSS 204 Targeting Requirements**
- 4.1 Is an FMVSS 204 indicant test ordered on the "COTR Vehicle Work Order?"
- Yes, continue with this form.
- No, this form is complete.
- 4.2 Resection panel (Figure 28C)
- 4.2.1 The panel deviates no more than 6 mm from perfect flatness when suspended vertically
- 4.2.2 The 8 targets on the panel are circular targets at least 90 mm in diameter and with black and yellow quadrants.
- 4.2.3 The center of each of the 4 outer targets are placed within 1 mm of the corners of a square measuring 914 mm on each side.
- 4.2.4 Locate another square with 228 mm sides and with the center of this square coincident with the center of the 914 mm square.
- 4.2.5 The center of the 4 inner targets are placed at the midpoints of each of the 228 mm sides.
- 4.3 Place a circular target at least 90 mm in diameter and with black and yellow quadrants on a material (cardboard, metal, etc.) that can be taped to the top of the steering column.
- 4.4 Tape the target from 4.3 to the top of the steering column in a manner that does not interfere with the movement of the steering column in a crash.

REMARKS:

Signature: Clad Wilkin

Date: 5/8/25

I certify that I have read and performed each instruction.

REFERENCE PHOTO TARGETS

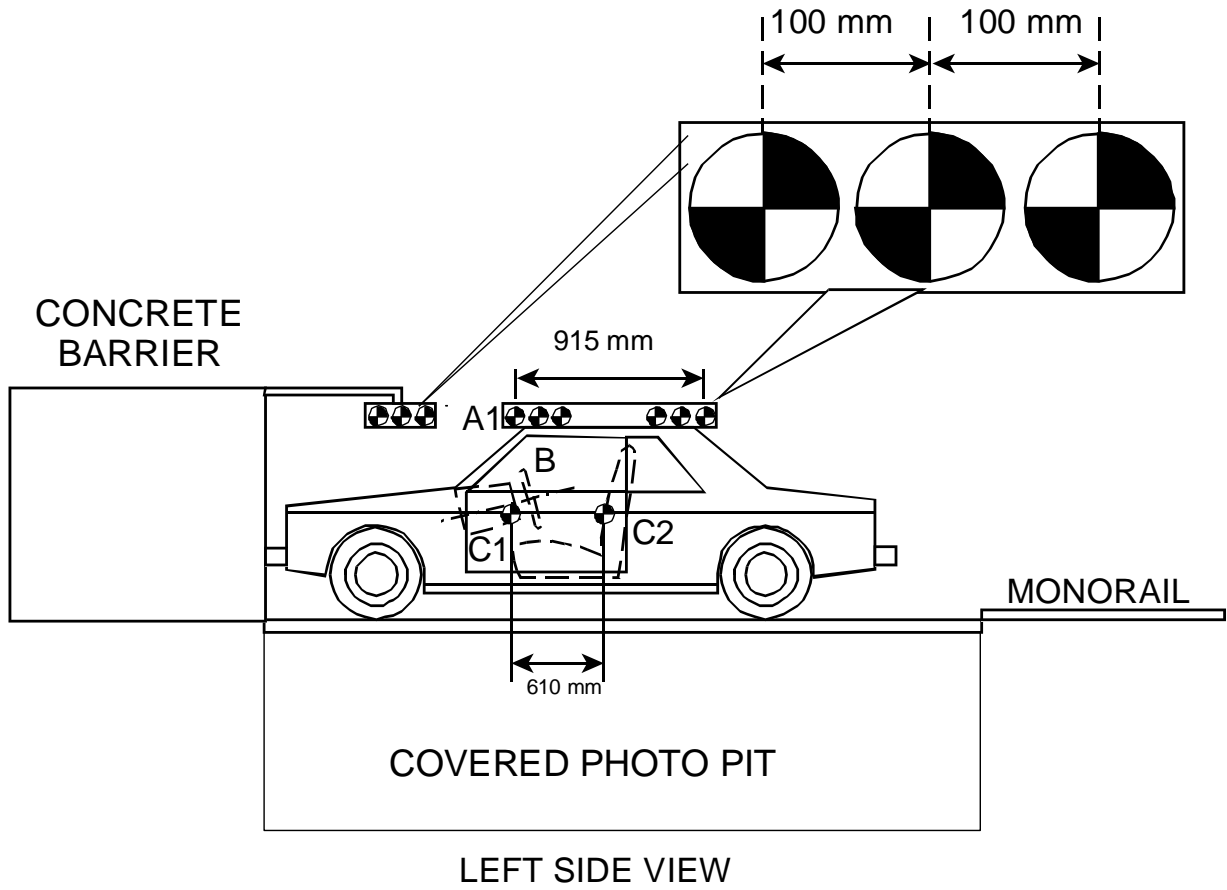

RESECTION PANEL TARGETING ALIGNMENT

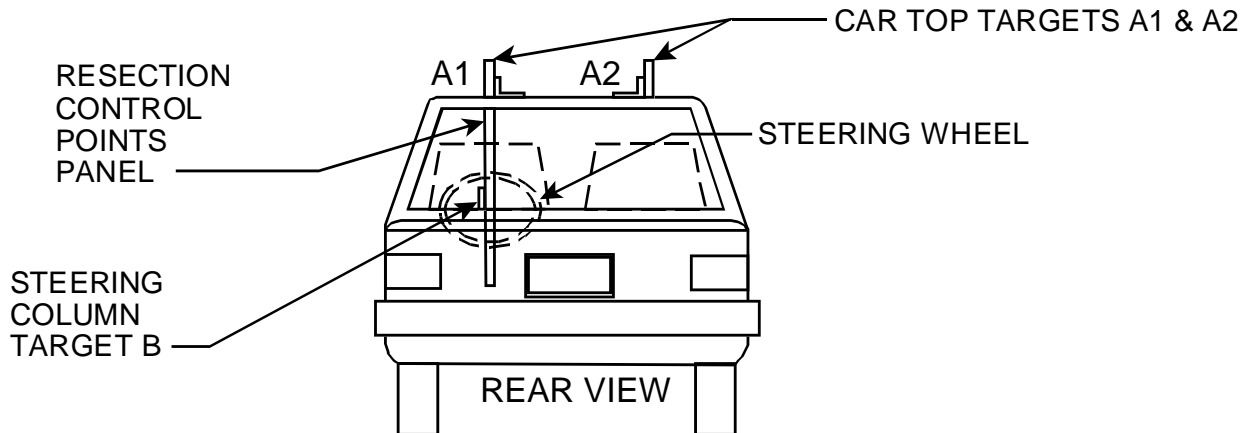

TEST RUN STEERING COLUMN CAMERA VIEW OF TYPICAL TIME ZERO VEHICLE POSITION

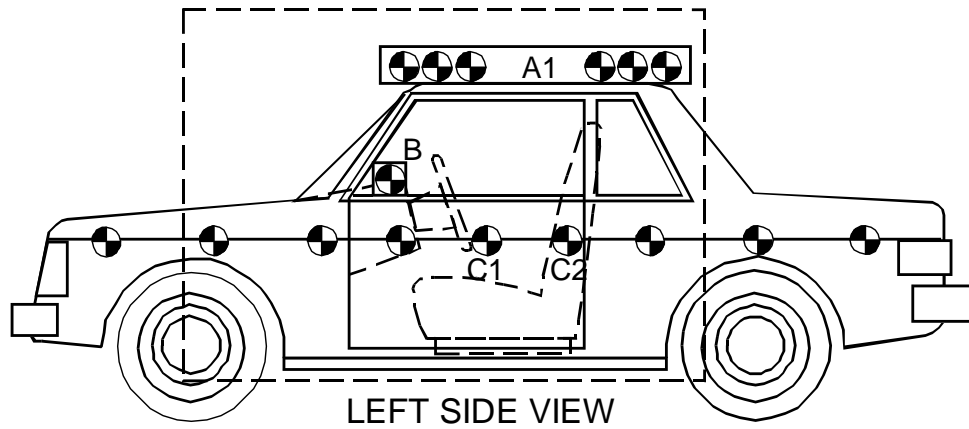

PRE-RUN STEERING COLUMN HIGH SPEED CAMERA VIEW

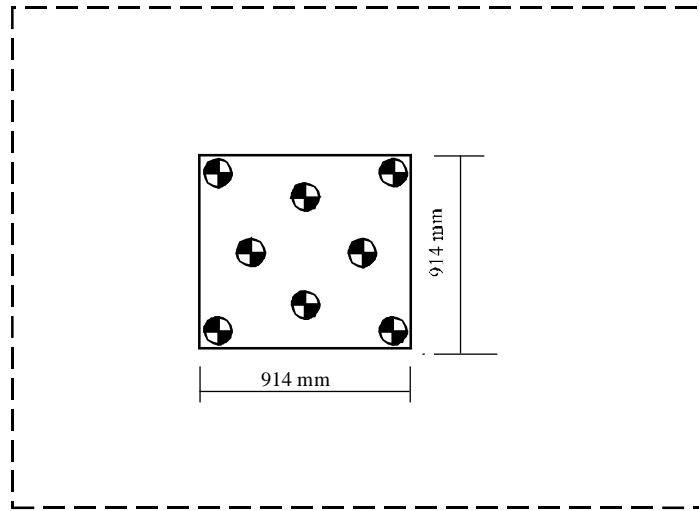

LEFT SIDE VIEW

DATA SHEET 35
CAMERA LOCATIONS

Test Vehicle: 2024 Chevrolet Silverado EV
Test Program: FMVSS 208 Compliance

NHTSA No.: C20240101
Test Date: 5/8/25
Time: 10:23 AM

CAMERA NO.	VIEW	CAMERA POSITIONS (mm) *			LENS (mm)	SPEED (fps)
		X	Y	Z		
1	Real Time Left Side View				13	24
2	Left Side View (Barrier face to front seat backs)	1450	-5890	1530	24	1000
3	Left Side View (Driver)	1830	-7160	2340	50	1000
4	Left Side View (B-post aimed toward center of steering wheel)	7480	-5860	2300	75	1000
5	Left Side View (Steering Column)	1100	-5600	1250	50	1000
6	Left Side View (Steering Column)	1050	-5530	800	50	1000
7	Right Side View (Overall)	2780	6450	1510	16	1000
8	Right Side View (Passenger)	1850	7000	2290	50	1000
9	Right Side View (Angle)	7680	5460	2360	75	1000
10	Right Side View (Front door)	1350	5990	1550	24	1000
11	Front View Windshield	110	0	2310	11	1000
12	Front View Driver	50	-370	2230	25	1000
13	Front View Passenger	50	370	2230	25	1000
14	Overhead Barrier Impact View	3100	0	6820	11	1000
15	Pit Camera Engine View	1060	0	-3340	24	1000
16	Pit Camera Fuel Tank View	3450	0	-3340	24	1000

***COORDINATES:**

- +X – forward of impact plane
- +Y – right of monorail centerline
- +Z – above ground level

CAMERA POSITIONS FOR FMVSS 208

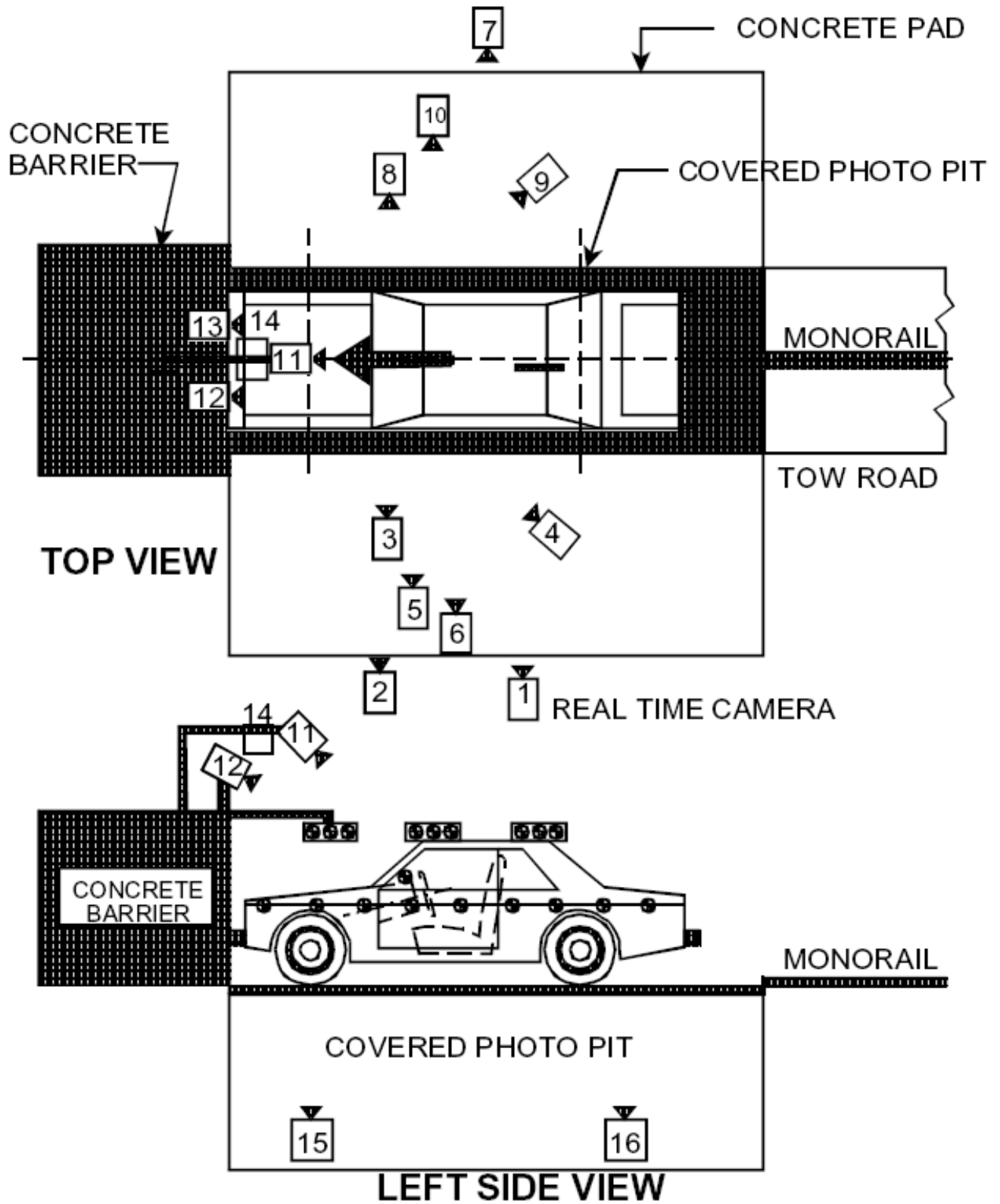

DATA SHEET 36

APPENDIX F

DUMMY POSITIONING PROCEDURES FOR DRIVER TEST DUMMY CONFORMING TO SUBPART E OF PART 572

Test Vehicle: 2024 Chevrolet Silverado EV
 Test Program: FMVSS 208 Compliance
 Test Technician: Dane Wieting

NHTSA No.: C20240101
 Test Date: 5/8/25

IMPACT ANGLE:	0° Frontal					
BELTED DUMMIES (YES/NO):	NO					
TEST SPEED:	X	32 to 40 kmph		0 to 48 kmph		0 to 56 kmph
DRIVER DUMMY:			5 th female	X		50 th male
PASSENGER DUMMY:			5 th female	X		50 th male

- X 1. Position the seat’s adjustable lumbar supports so that the lumbar support is in its lowest, retracted or deflated adjustment position. (S8.1.3)
X N/A – No lumbar adjustment

- X 2. Position any adjustable parts of the seat that provide additional support so that they are in the lowest or most open adjustment position. (S16.2.10.2)
X N/A – No additional support adjustment

- X 3. Use all the seat controls that have any affect on the fore–aft movement of the seat to move the seat cushion to the rearmost position. **Mark** this position. (8/31/95 legal interpretation to Hogan and Hartson)

- X 4. Use all the seat controls that have any affect on the fore–aft movement of the seat to move the seat cushion to the foremost position. **Mark** this position. (8/31/95 legal interpretation to Hogan and Hartson)

- X 5. **Mark** each fore–aft position so that there is a visual indication when the seat is at a particular position. For manual seats, **mark** each detent. For power seats, **mark** only the rearmost, middle, and foremost positions. Label three of the positions with the following: F for foremost, M for mid–position (if there is no mid–position, label the closest adjustment position to the rear of the mid–point), and R for rearmost. Determine the mid fore–aft seat position based on the foremost and rearmost positions determined in items 3 and 4. (8/31/95 legal interpretation to Hogan and Hartson)

- X 6. Move the seat to the mid position.

- X 7. While maintaining the mid position, move the seat to its lowest position. **Mark** the height position. For seats with adjustable seat cushions, use the manufacturer’s recommended seat cushion angle for determining the lowest height position.
X N/A– No cushion angle adjustment
 Manufacturer’s seat cushion angle: _____
 Tested seat cushion angle: _____

- X 8. Visually **mark** the seat back angle, if adjustable, at the manufacturer’s nominal design riding position for a **50th percentile adult male** in the manner specified by the manufacturer.
 N/A – No seat back angle adjustment
 Manufacturer’s design seat back angle: -11.6° on Head Rest Post
 Tested seat back angle: -12.1° on Head Rest Post

9. Is the seat a bucket seat?
 Yes, go to 10 and skip 11
 No, go to 11 and skip 10
10. Bucket seats:
Locate and **mark** the longitudinal centerline of the seat cushion. The intersection of the vertical longitudinal plane that passes through the SgRP and the seat cushion upper surface determines the longitudinal centerline of a bucket seat cushion. (S10.4.1.2 and S16.3.1.10)
11. Bench seats:
Locate and **mark** the longitudinal line on the seat cushion that marks the intersection of the vertical longitudinal plane through the centerline of the steering wheel and the seat cushion upper surface. (S10.4.1.1)
12. If adjustable, set the head restraint at the full up position. (S8.1.3) If there are adjustments other than vertical, adjust them as recommended by the manufacturer.
 N/A – No head restraint adjustment
13. Place any adjustable seat belt anchorages at the vehicle manufacturer's nominal design position for a 50th percentile adult male occupant (S8.1.3)
 N/A – No adjustable upper seat belt anchorage
Manufacturer's specified anchorage position: Unbelted Test
Tested anchorage position: Unbelted Test
14. Place adjustable pedals in the full forward position.
 N/A – the pedals are not adjustable.
15. Is the steering wheel adjustable up and down and/or in and out?
 Yes – go to 16
 No – go to 19
16. Find and **mark** each up and down position. Label three of the positions with the following: H for highest, M for mid–position (if there is no mid–position, label the next lowest adjustment position), and L for lowest.
 N/A – steering wheel is not adjustable up and down
17. Find and **mark** each in and out position. Label three of the positions with the following: F for foremost, M for mid–position (if there is no mid–position, label the next rearmost adjustment position), and R for rearmost.
 N/A – steering wheel is not adjustable in and out.
18. Set the steering wheel hub at the geometric center of the full range of driving positions including any telescoping positions.
19. Place the dummy in the seat such that the midsagittal plane is coincident with the longitudinal seat cushion markings as determined in item 10 or 11 and the upper torso rests against the seat back. (S10.4.1.1 & S10.4.1.2)
20. Rest the thighs on the seat cushion. (S10.5)

21. Position the H-point of the dummy within 0.5 inch of the vertical dimension and 0.5 inch of the horizontal dimension of a point 0.25 inch below the H-point determined in Data Sheet 15. (S10.4.2.1) Then measure the pelvic angle with respect to the horizontal using the pelvic angle gage. Adjust the dummy position until these three measurements are within the specifications. (S10.4.2.1 and S10.4.2.2)

0.2" horizontal inches from the point 0.25 below the determined H-point (0.5" max.) (S10.4.2.1)

0.17" vertical inches from the point 0.25 below the determined H-point (0.5" max.) (S10.4.2.1)

22.9° pelvic angle (20° to 25°)

22. Is the head level within $\pm 0.5^\circ$? (S10.1)

Yes, go to 23

No, go to 22.1

22.1 Adjust the position of the H-point. (S10.1)

22.2 Is the head level within $\pm 0.5^\circ$? (S10.1)

Yes, record the following, then go to 23. No, go to 22.3

horizontal inches from the point 0.25 below the determined H-point (0.5 inch max.) (S10.4.2.1)

vertical inches from the point 0.25 below the determined H-point (0.5 inch max.) (S10.4.2.1)

pelvic angle (20° to 25°) (S10.4.2.2)

22.3 Adjust the pelvic angle. (S10.1)

22.4 Is the head level within $\pm 0.5^\circ$? (S10.1)

Yes, record the following, then go to 23. No, go to 22.5

horizontal inches from the point 0.25 below the determined H-point (0.5" max.) (S10.4.2.1)

vertical inches from the point 0.25 below the determined H-point (0.5" max.) (S10.4.2.1)

pelvic angle (20° to 25°)

22.5 Adjust the neck bracket of the dummy the minimum amount necessary from the nonadjusted "0" setting until the head is level within $\pm 0.5^\circ$. (S10.1) Record the following, then go to 23.

horizontal inches from the point 0.25 below the determined H-point (0.5" max.) (S10.4.2.1)

vertical inches from the point 0.25 below the determined H-point (0.5" max.) (S10.4.2.1)

° pelvic angle (20° to 25°)

23. Set the distance between the outboard knee clevis flange surfaces at 10.6 inches.

10.6" measured distance (10.6 inches) (S10.5)

24. Can the right foot be placed on the accelerator?

Yes, go to 24.1 and skip 24.2

No, go to 24.2

24.1. To the extent practicable keep the right thigh and the leg in a vertical plane (S10.5) while resting the foot on the undepressed accelerator pedal with the rearmost point of the heel on the floor pan in the plane of the pedal. (S10.6.1.1)

24.2 Initially set the foot perpendicular to the leg and then place it as far forward as possible in the direction of the pedal centerline with the rearmost point of the heel resting on the floor pan. (S10.6.1.1)

24.2.1 Move the adjustable pedal to its most rearward position or until the right foot is flat on the pedal, whichever occurs first. (S10.6.1.1)

N/A – the accelerator pedal is not adjustable

25. Does the vehicle have a foot rest?

Yes, go to 25.1

No, go to 25.2

25.1 With the left thigh and leg in a vertical plane, place the left foot on the foot rest with the heel resting on the floor pan. (S10.6.1.2)

25.1.1 Is the left foot elevated above the right foot?

Yes, go to 25.2 and position the foot off the foot rest

No, go to 26

25.2 Check the ONLY one of the following that applies

The left foot reaches the toeboard without adjusting the foot or leg. To the extent practicable keep the left thigh and the leg in a vertical longitudinal plane (S10.5) and place the foot on the toeboard, skip 25.3 (S10.6.1.2)

The left foot reaches the toeboard but contacts the brake or clutch pedal and must be rotated to avoid pedal contact. To the extent practicable keep the left thigh and the leg in a vertical longitudinal plane (S10.5) and place the foot on the toeboard. The foot was rotated about the leg to avoid pedal contact, skip 25.3 (S10.6.1.2)

The left foot reaches the toeboard but contacts the brake or clutch pedal and the foot and leg must be rotated to avoid pedal contact. To the extent practicable keep the left thigh and the leg in a vertical longitudinal plane (S10.5) and place the foot on the toeboard. The foot was rotated about the leg and the leg was rotated outboard about the hip the minimum distance necessary to avoid pedal contact, skip 12.3 (S10.6.1.2)

N/A – the foot does not reach the toeboard, go to 25.3

25.3 Check the ONLY one of the following that applies

The left foot did not contact the brake or clutch pedal. To the extent practicable keep the left thigh and the leg in a vertical longitudinal plane (S10.5). Set the foot perpendicular to the leg and place it as far forward as possible with the heel resting on the floor pan. (S10.6.1.2)

The left foot did contact the brake or clutch pedal and the foot was rotated to avoid contact. To the extent practicable keep the left thigh and the leg in a vertical longitudinal plane (S10.5). Set the foot perpendicular to the leg and place it as far forward as possible with the heel resting on the floor pan and rotate the foot the minimum amount to avoid pedal contact. (S10.6.1.2)

The left foot did contact the brake or clutch pedal and the foot was rotated about the leg and the leg was rotated outboard about the hip the minimum distance necessary to avoid pedal contact. Set the foot perpendicular to the leg and place it as far forward as possible with the heel resting on the floor pan and rotate the foot about the leg and the thigh and leg outboard about the hip the minimum distance necessary to avoid pedal contact. (S10.6.1.2)

26. Place the right upper arm adjacent to the torso with the centerline as close to a vertical plane as possible. (S10.2.1)

27. Is the driver seat belt used for this test?

Yes, continue

No, go to 28

27.1 Fasten the seat belt around the dummy.

27.2 Remove all slack from the lap belt portion. (S10.9)

27.3 Pull the upper torso webbing out of the retractor and allow it to retract; repeat this four times. (S10.9)

27.4 Apply a 2 to 4 pound tension load to the lap belt. (S10.9)

pound load applied

27.5 Is the belt system equipped with a tension-relieving device?

Yes, continue

No, go to 28

27.6 Introduce the maximum amount of slack into the upper torso bet that is recommended by the vehicle manufacturer in the vehicle owner's manual. (S10.9).

28. Place the left upper arm adjacent to the torso with the centerline as close to a vertical plane as possible. (S10.2.1)

29. Place the right hand with the palm in contact with the steering wheel at the rim's horizontal centerline and with the thumb over the steering wheel. (S10.3.1)

30. Place the left hand with the palm in contact with the steering wheel at the rim's horizontal centerline and with the thumb over the steering wheel. (S10.3.1)

31. Tape the thumb of each hand to the steering wheel by using masking tape with a width of 0.25 inch. The length of the tape shall only be enough to go around the thumb and steering wheel one time.

Signature:  Date: 5/8/25

I certify that I have read and performed each instruction.

DATA SHEET 36
APPENDIX F
DUMMY POSITIONING PROCEDURES FOR PASSENGER TEST DUMMY
CONFORMING TO SUBPART E OF PART 572

Test Vehicle: 2024 Chevrolet Silverado EV
 Test Program: FMVSS 208 Compliance
 Test Technician: Dane Wieting

NHTSA No.: C20240101
 Test Date: 5/8/25

IMPACT ANGLE:	0° Frontal					
BELTED DUMMIES (YES/NO):	NO					
TEST SPEED:	X	32 to 40 kmph		0 to 48 kmph		0 to 56 kmph
DRIVER DUMMY:			5 th female	X		50 th male
PASSENGER DUMMY:			5 th female	X		50 th male

- X 1. The seat is a bench seat for which the adjustments have already been made for the driver and there are no independent adjustments that can be made for the passenger. Go to 12.
X N/A– the passenger seat adjusts independently of the driver seat.
- X 2. Position the seat’s adjustable lumbar supports so that the lumbar support is in its lowest, retracted or deflated adjustment position. (S8.1.3)
X N/A – No lumbar adjustment
- X 3. Position any adjustable parts of the seat that provide additional support so that they are in the lowest or most open adjustment position. (S16.2.10.2)
X N/A – No additional support adjustment
- X 4. Use all the seat controls that have any affect on the fore–aft movement of the seat to move the seat cushion to the rearmost position. **Mark** this position. (8/31/95 legal interpretation to Hogan and Hartson)
- X 5. Use all the seat controls that have any affect on the fore–aft movement of the seat to move the seat cushion to the foremost position. **Mark** this position. (8/31/95 legal interpretation to Hogan and Hartson)
- X 6. **Mark** each fore–aft position so that there is a visual indication when the seat is at a particular position. For manual seats, **mark** each detent. For power seats, **mark** only the rearmost, middle, and foremost positions. Label three of the positions with the following: F for foremost, M for mid–position (if there is no mid–position, label the closest adjustment position to the rear of the mid–point), and R for rearmost. Determine the mid fore–aft seat position based on the foremost and rearmost positions determined in items 3 and 4. (8/31/95 legal interpretation to Hogan and Hartson)
- X 7. Move the seat to the mid position.
- X 8. While maintaining the mid position, move the seat to its lowest position. **Mark** the height position. For seats with adjustable seat cushions, use the manufacturer’s recommended seat cushion angle for determining the lowest height position.
X N/A– No cushion angle adjustment
 Manufacturers seat cushion angle:
 Tested seat cushion angle:

9. Visually **mark** the seat back angle, if adjustable, at the manufacturer's nominal design riding position for a **50th percentile adult male** in the manner specified by the manufacturer.
___ N/A – No seat back angle adjustment
Manufacturer's design seat back angle: -11.6° on Head Rest Post
Tested seat back angle: -12.1° on Head Rest Post
10. Is the seat a bucket seat?
 Yes, go to 11 and skip 12
___ No, go to 12 and skip 11
11. Bucket seats:
Locate and **mark** for future reference the longitudinal centerline of the seat cushion. The intersection of the vertical longitudinal plane that passes through the SgRP and the seat cushion upper surface determines the longitudinal centerline of a bucket seat cushion. (S10.4.1.2 and S16.3.1.10)
- ___ 12. Bench seats:
Locate and **mark** for future reference the longitudinal centerline of the passenger seat cushion. The longitudinal centerline is the same distance from the longitudinal centerline of the vehicle as the center of the steering wheel. (S10.4.1.1)
Record the distance from the longitudinal centerline of the vehicle to the center of the steering wheel. _____
Record the distance from the longitudinal centerline of the vehicle to the longitudinal centerline of the seat cushion. _____
13. If adjustable, set the head restraint at the full up position. (S8.1.3) If there are adjustments other than vertical, adjust them as recommended by the manufacturer.
___ N/A – No head restraint adjustment
14. Place any adjustable seat belt anchorages at the vehicle manufacturer's nominal design position for a 50th percentile adult male occupant (S8.1.3)
___ N/A – No adjustable upper seat belt anchorage
Manufacturer's specified anchorage position: Unbelted Test
Tested anchorage position: Unbelted Test
15. Place the dummy in the seat such that the midsagittal plane is coincident with the longitudinal seat cushion markings as determined in item 11 or 12 and the upper torso rests against the seat back. (S10.4.1.1 & S10.4.1.2)
16. Rest the thighs on the seat cushion. (S10.5)
17. Position the H-point of the dummy within 0.5 inch of the vertical dimension and 0.5 inch of the horizontal dimension of a point 0.25 inch below the H-point determined by using the equipment and procedures specified in SAE J826 (APR 1980). (S10.4.2.1) Then measure the pelvic angle with respect to the horizontal using the pelvic angle gage. Adjust the dummy position until these three measurements are within the specifications. (S10.4.2.1 and S10.4.2.2)
0.0" horizontal inches from the point 0.25 below the determined H-point (0.5" max.) (S10.4.2.1)
0.18" vertical inches from the point 0.25 below the determined H-point (0.5" max.) (S10.4.2.1)
24.2° pelvic angle (20° to 25°)
18. Is the head level within $\pm 0.5^\circ$? (S10.1)
 Yes, go to 19

- ___ No, go to 18.1
- ___18.1 Adjust the position of the H–point. (S10.1 and S10.4.2.1)
- ___18.2 Is the head level within $\pm 0.5^\circ$? (S10.1)
- ___ Yes, record the following, then go to 19. ___ No, go to 18.3
- ___ horizontal inches from the point 0.25 below the determined H–point (0.5” max.) (S10.4.2.1)
- ___ vertical inches from the point 0.25 below the determined H–point (0.5” max.) (S10.4.2.1)
- ___ pelvic angle (20° to 25°)(S10.4.2.2)
- ___18.3 Adjust the pelvic angle. (S10.1)
- ___18.4 Is the head level within $\pm 0.5^\circ$? (S10.1)
- ___ Yes, record the following, then go to 19. ___ No, go to 18.5
- ___ horizontal inches from the point 0.25 below the determined H–point (0.5” max.) (S10.4.2.1)
- ___ vertical inches from the point 0.25 below the determined H–point (0.5” max.) (S10.4.2.1)
- ___ pelvic angle (20° to 25°)(S10.4.2.2)
- ___18.5 Adjust the neck bracket of the dummy the minimum amount necessary from the nonadjusted “0” setting until the head is level within $\pm 0.5^\circ$. (S10.1) Record the following, then go to 19. Adjusted Neck Bracket 4 Notches Rearward
- ___” horizontal inches from the point 0.25 below the determined H–point (0.5” max.) (S10.4.2.1)
- ___” vertical inches from the point 0.25 below the determined H–point (0.5” max.) (S10.4.2.1)
- ___° pelvic angle (20° to 25°)
- X 19. Set the distance between the outboard knee clevis flange surfaces at 10.6 inches.
- 10.6” measured distance (10.6 inches) (S10.5)
- X 20. Check the only one of the following that applies:
- ___ To the extent practicable keep the left thigh and leg in a vertical plane and the right thigh and leg in a vertical plane, place the feet on the toeboard with the heels resting on the floor pan as close as possible to the intersection of the floor pan and toeboard.
- X The feet cannot be placed flat on the toeboard. To the extent practicable keep the left thigh and leg in a vertical plane and the right thigh and leg in a vertical plane, set the feet perpendicular to the legs and place them as far forward as possible with the heels resting on the floor pan.
- ___ The vehicle has a wheelhouse projection. To the extent practicable keep the left thigh and leg in a vertical plane and the right thigh and leg in a vertical plane, set the feet perpendicular to the legs and place them as far forward as possible with the heels resting on the floor pan. Do not set the feet on the wheelhouse projection.
- ___ The vehicle has a wheelhouse projection and the feet cannot be placed on the toeboard. To the extent practicable keep the left thigh and leg in a vertical plane and the right thigh and leg in a vertical plane, set the feet perpendicular to the legs and place them as far forward as possible with the heel resting on the floor pan. Do not set the feet on the wheelhouse projection.
- X 21. Place the left upper arm in contact with the seat back and side of the torso. (S10.2.2)

DATA SHEET 37

DUMMY MEASUREMENTS

Test Vehicle: 2024 Chevrolet Silverado EV
 Test Program: FMVSS 208 Compliance
 Test Technician: Dane Wieting

NHTSA No.: C20240101
 Test Date: 5/8/25

DUMMY MEASUREMENTS FOR FRONT SEAT OCCUPANTS

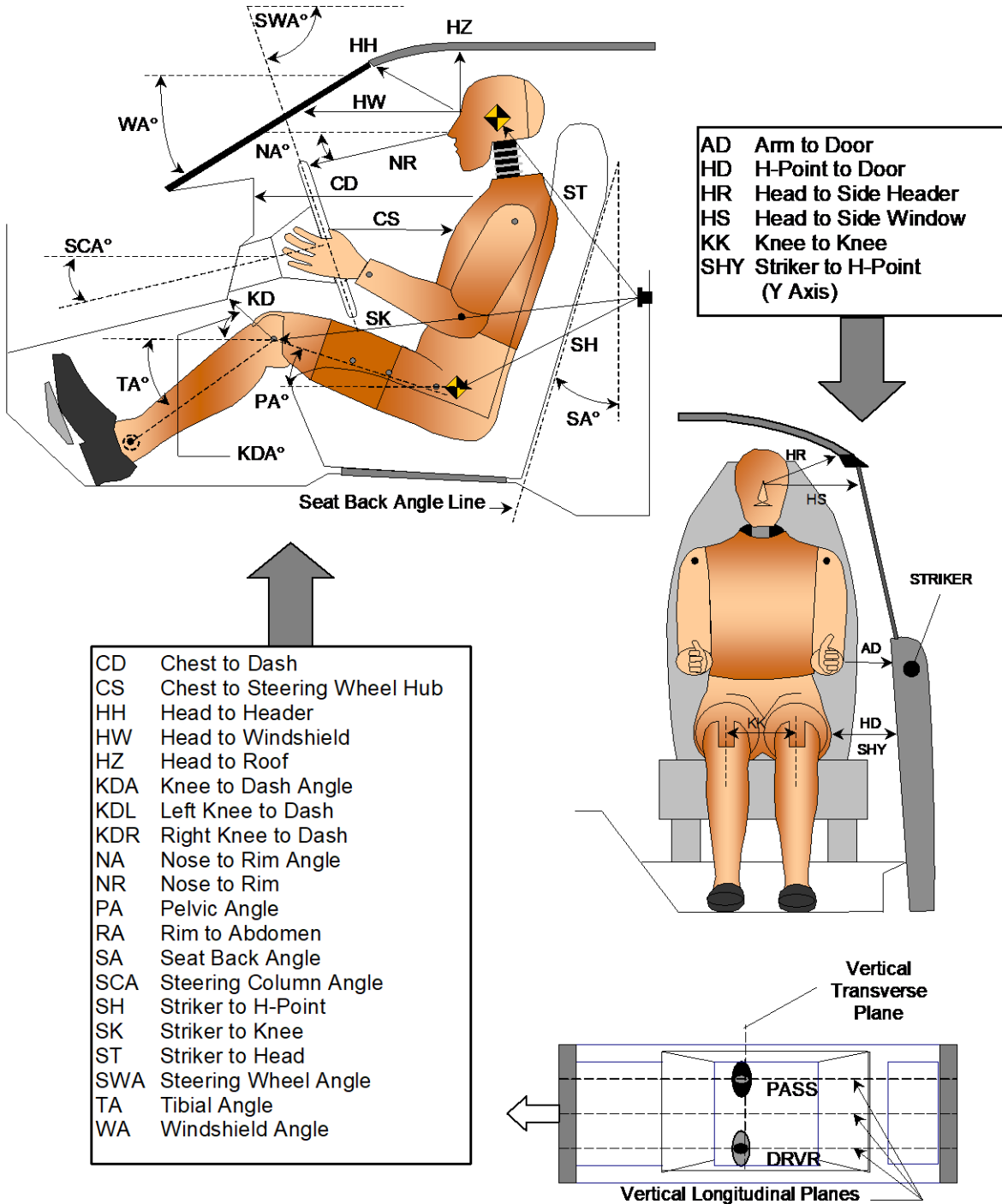

TEST DUMMY POSITION MEASUREMENTS

Code	Measurement Description	Driver SN 401		Passenger SN 403	
		Length (mm)	Angle (°)	Length (mm)	Angle (°)
WA	Windshield Angle		28.5		
SWA	Steering Wheel Angle		67.7		
SCA	Steering Column Angle		22.3		
SA	Seat Back Angle (On Headrest Post)		-12.1		-12.1
HZ	Head to Roof (Z)	247		260	
HH	Head to Header	510	16.6	498	24.2
HW	Head to Windshield	802	0.0	823	0.0
HR	Head to Side Header (Y)	240		251	
NR	Nose to Rim	455	11.9		
CD	Chest to Dash	657		582	
CS	Chest to Steering Hub	371	10.4		
RA	Rim to Abdomen	244	0.0		
KDL	Left Knee to Dash	182	28.7	188	
KDR	Right Knee to Dash	169		186	28.6
PA	Pelvic Angle		22.9		24.2
TA	Tibia Angle		51.4		47.7
KK	Knee to Knee (Y)	362		270	
SK	Striker to Knee	588	93.6	603	92.0
ST	Striker to Head	561	9.3	550	9.7
SH	Striker to H-Point	214	125.6	222	119.2
SHY	Striker to H-Point (Y)	289		281	
HS	Head to Side Window	340		342	
HD	H-Point to Door (Y)	158		159	
AD	Arm to Door (Y)	150		65	
AA	Ankle to Ankle	378		206	

SEAT BELT POSITIONING DATA

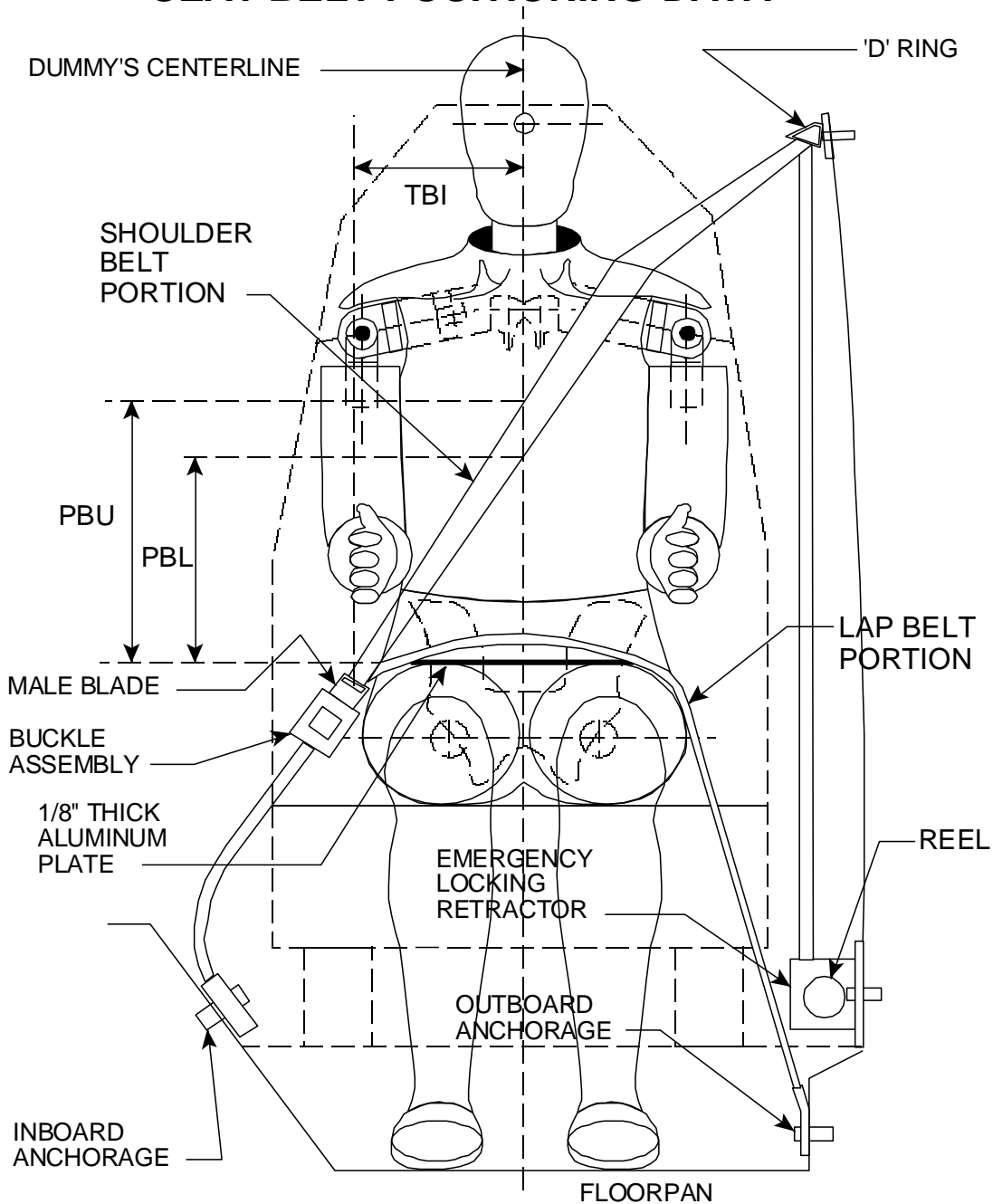

FRONT VIEW OF DUMMY

SEAT BELT POSITIONING MEASUREMENTS

Measurement Description	Units	Driver	Passenger
PBU – Top surface of reference to belt upper edge	mm	N/A	N/A
PBL – Top surface of reference to belt lower edge	mm	N/A	N/A

DATA SHEET 38

CRASH TEST

Test Vehicle: 2024 Chevrolet Silverado EV
 Test Program: FMVSS 208 Compliance
 Test Technician: Chad Williams

NHTSA No.: C20240101
 Test Date: 5/8/25

IMPACT ANGLE:	0° Frontal			
BELTED DUMMIES (YES/NO):	NO			
TEST SPEED:	X	32 to 40 kmph		0 to 48 kmph
				0 to 56 kmph
DRIVER DUMMY:		5 th female	X	50 th male
PASSENGER DUMMY:		5 th female	X	50 th male

- 1. Vehicle underbody painted.
- 2. The speed measuring devices are in place and functioning.
- 3. The speed measuring devices are 1.5 m from the barrier (spec. 1.5 m) and 30 cm from the barrier (spec. is 30 cm).
- 4. Convertible top is in the closed position.
 - N/A, not a convertible.
- 5. Instrumentation and wires are placed so motion of dummies during impact is not affected.
- 6. Tires inflated to pressure on tire placard or if it does not have a tire placard because it is not a passenger car, then inflated to the tire pressure specified in the owner information.
 - 420 kpa front left tire 420 kpa specified on tire placard or in owner information
 - 420 kpa front right tire 420 kpa specified on tire placard or in owner information
 - 420 kpa rear left tire 420 kpa specified on tire placard or in owner information
 - 420 kpa rear right tire 420 kpa specified on tire placard or in owner information
- 7. Time zero contacts on barrier in place.
- 8. Pre test zero and shunt calibration adjustments performed and recorded.
- 9. Dummy temperature meets requirements of section 12.2 of the test procedure.
- 10. Vehicle hood closed and latched.
- 11. Transmission placed in neutral.
- 12. Parking brake off.
- 13. Are the heads still level?
 - Yes, go to 14
 - No, Adjust dummy so that head is at the angle recorded in the Appendix F or G data sheets and then continue.
- 14. Ignition in the ON position.
- 15. Doors closed and latched but not locked.
- 16. Post test zero and shunt calibration checks performed and recorded.
- 17. Actual test speed: 39.2 kmph
- 18. Vehicle rebound from the barrier: 38 cm
- 19. Describe whether the doors open after the test and what method is used to open the doors.
 - Left Front Door: Door remained closed and latched; Door opened without tools.
 - Right Front Door: Door remained closed and latched; Door opened without tools.
 - Left Rear Door: Door remained closed and latched; Door opened without tools.
 - Right Rear Door: Door remained closed and latched; Door opened without tools.

20. Describe the contact points of the dummy with the interior of the vehicle.
- Driver Dummy: Head to Air Bag, Windshield, Visor; Chest to Air Bag; Knees to Knee Bolster
 - Passenger Dummy: Head to Air Bag, Visor; Chest to Air Bag; Knees to Glovebox

REMARKS:

Signature: Chad Willis Date: 5/8/25

I certify that I have read and performed each instruction.

DATA SHEET 40
ACCIDENT INVESTIGATION MEASUREMENTS

Test Vehicle: 2024 Chevrolet Silverado EV
 Test Program: FMVSS 208 Compliance
 Test Technician: Chad Williams

NHTSA No.: C20240101
 Test Date: 5/8/25

IMPACT ANGLE:	0° Frontal					
BELTED DUMMIES (YES/NO):	NO					
TEST SPEED:	X	32 to 40 kmph		0 to 48 kmph		0 to 56 kmph
DRIVER DUMMY:			5 th female	X		50 th male
PASSENGER DUMMY:			5 th female	X		50 th male

Vehicle Year/Make/Model/Body Style:	2024 Chevrolet Silverado EV Truck
VIN:	1GC10UED7RU206395
Wheelbase:	3704 mm
Build Date:	05/24
Vehicle Size Category:	6
Test Weight:	3948.6 kg
Front Overhang:	939 mm
Overall Width:	2036 mm
Overall Length Center:	5926 mm

Accelerometer Data	
Location:	As per measurements on Data Sheet 33
Linearity:	>99.9%

Integration Algorithm:	Trapezoidal
Vehicle Impact Speed:	39.2 kmph
Time of Separation:	124.4 ms
Velocity Change:	44.1 kmph

CRUSH PROFILE

Collision Deformation Classification: 12FDEW1
 Midpoint of Damage: Vehicle Longitudinal Centerline
 Damage Region Length (mm): 1412
 Impact Mode: Frontal Barrier

No.	Measurement Description	Units	Pre-Test	Post-Test	Difference
C1	Crush zone 1 at left side	mm	5799	5544	255
C2	Crush zone 2 at left side	mm	5882	5547	335
C3	Crush zone 3 at left side	mm	5926	5561	365
C4	Crush zone 4 at right side	mm	5926	5538	388
C5	Crush zone 5 at right side	mm	5882	5486	396
C6	Crush zone 6 at right side	mm	5799	5370	429

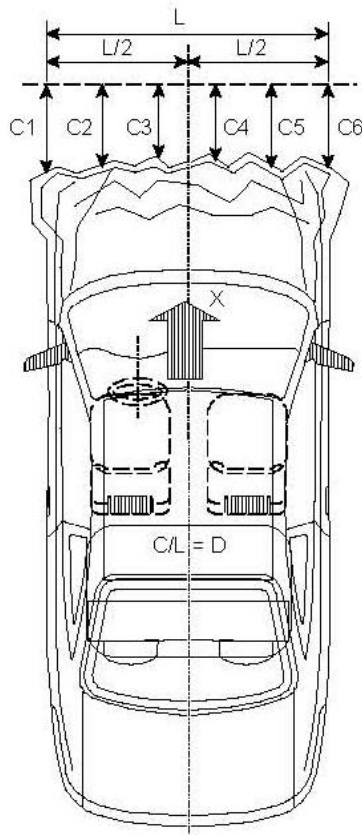

REMARKS:

Signature: Chad Wilkin

Date: 5/8/25

I certify that I have read and performed each instruction.

DATA SHEET 41
WINDSHIELD MOUNTING (FMVSS 212)

Test Vehicle: 2024 Chevrolet Silverado EV
 Test Program: FMVSS 208 Compliance
 Test Technician: Chad Williams

NHTSA No.: C20240101
 Test Date: 5/8/25

IMPACT ANGLE:	0° Frontal					
BELTED DUMMIES (YES/NO):	NO					
TEST SPEED:	<input checked="" type="checkbox"/>	32 to 40 kmph	<input type="checkbox"/>	0 to 48 kmph	<input type="checkbox"/>	0 to 56 kmph
DRIVER DUMMY:			5 th female	<input checked="" type="checkbox"/>	50 th male	
PASSENGER DUMMY:			5 th female	<input checked="" type="checkbox"/>	50 th male	

1. Pre-Crash
- 1.1 Describe from visual inspection how the windshield is mounted and describe any trim material.
- Retained with glue and plastic trim
- 1.2 Mark the longitudinal centerline of the windshield.
- 1.3 Measure pre-crash A, B, and C for the left side and record in the chart below.
- 1.4 Measure pre-crash C, D, and E for the right side and record in the chart below.
- 1.5 Measure from the edge of the retainer or molding to the edge of the windshield.
- Dimension G (mm): 6 mm
2. Post Crash
- 2.1 Can a single thickness of copier type paper (as small a piece as necessary) slide between the windshield and the vehicle body?
- No – Pass. Skip to the table of measurements, complete it by repeating the pre-crash measurements in the post crash column, and calculate the retention percentage, which will be 100%.
- Yes, go to 2.2
- 2.2 Visibly mark the beginning and end of the portions of the periphery where the paper slides between the windshield and the vehicle body.
- 2.3 Measure and record post-crash A, B, C, D, E, and F such that the measurements do not include any of the parts of the windshield where the paper slides between the windshield and the vehicle body.
- 2.4 Calculate and record the percent retention for the right and left side of the windshield.
- 2.5 Is total right side percent retention less than 50%?
- Yes, Fail
- No, Pass
- 2.6 Is total left side percent retention less than 50%?
- Yes, Fail
- No, Pass

WINDSHIELD RETENTION MEASUREMENTS

	Dimension	Pre-Crash (mm)	Post-Crash (mm)	Percent Retention (Post-Test ÷ Pre-Crash)
Left Side	A	666	666	100%
	B	532	532	100%
	C	829	829	100%
	Total	2027	2027	100%
Right Side	D	666	666	100%
	E	532	532	100%
	F	829	829	100%
	Total	2027	2027	100%

Indicate area of mounting failure: NONE

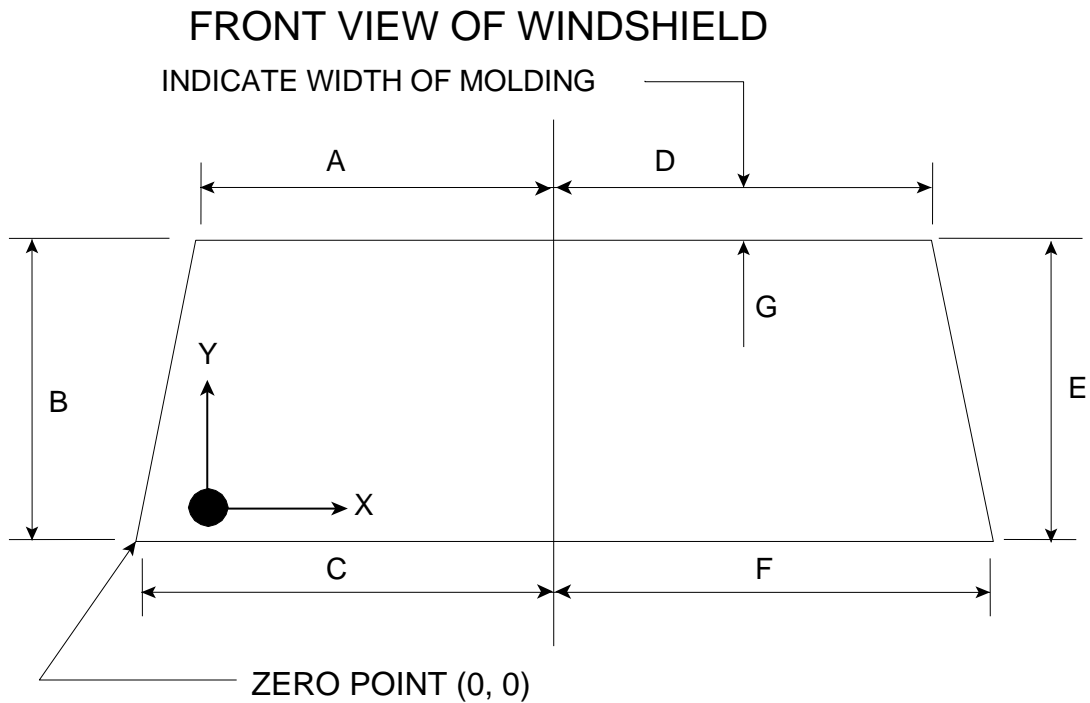

REMARKS:

Signature: Clad Wilkin

Date: 5/8/25

I certify that I have read and performed each instruction.

DATA SHEET 42
WINDSHIELD ZONE INTRUSION (FMVSS 219)

Test Vehicle: 2024 Chevrolet Silverado EV
 Test Program: FMVSS 208 Compliance
 Test Technician: Chad Williams

NHTSA No.: C20240101
 Test Date: 5/8/25

IMPACT ANGLE:	0° Frontal			
BELTED DUMMIES (YES/NO):	NO			
TEST SPEED:	X	32 to 40 kmph		0 to 56 kmph
DRIVER DUMMY:		5 th female	X	50 th male
PASSENGER DUMMY:		5 th female	X	50 th male

This standard specifies limits for the displacement of vehicle components into the windshield area during a frontal barrier impact test at any speed up to and including 48 kmph.

- X 1. Place a 165 mm diameter rigid sphere, with a mass of 6.8 kg on the instrument panel so that it is simultaneously touching the instrument panel and the windshield. (571.219 S6.1(a))
- X 2. Roll the sphere from one side of the windshield to the other while marking on the windshield where the sphere contacts the windshield. (571.219 S6.1(b))
- X 3. From the outermost contactable points on the windshield draw a horizontal line to the edges of the windshield. (571.219 S6.1(b))
- X 4. Draw a line on the inner surface of the windshield that is 13 mm below the line determined in items 2 and 3.
- X 5. After the crash test, record any points where a part of the exterior of the vehicle has marked, penetrated, or broken the windshield.

Provide all dimensions necessary to reproduce the protected area.

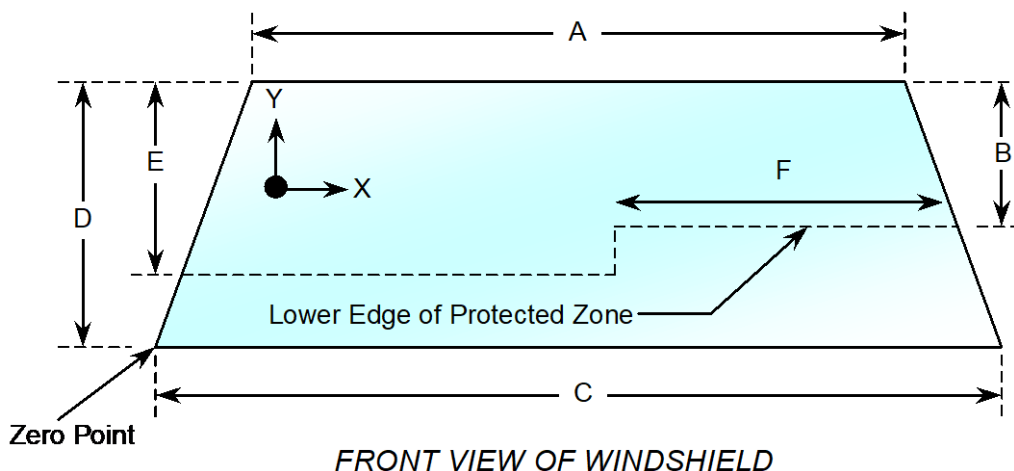

WINDSHIELD DIMENSIONS

Item	Units	Value
A	mm	1332
B	mm	522
C	mm	1658
D	mm	868
E	mm	532
F	mm	575

AREA OF PROTECTED ZONE FAILURES:

- B. Provide coordinates of the area that the protected zone was penetrated more than 0.25 inches by a vehicle component other than one which is normally in contact with the windshield.

X	Y
NONE	

- C. Provide coordinates of the area beneath the protected zone template that the inner surface of the windshield was penetrated by a vehicle component.

X	Y
NONE	

REMARKS:

I certify that I have read and performed each instruction.

Signature: Clad Wilkin

Date: 5/8/25

FMVSS 305
ELECTRIC POWERED VEHICLES: ELECTROLYTE
SPILLAGE AND ELECTRICAL SHOCK PROTECTION

This electric vehicle, a 2024 Chevrolet Silverado EV (NHTSA No. C20240101), in conjunction with the FMVSS 208, was tested to FMVSS 305.

The test was performed in accordance with the specifications of the Office of Vehicle Safety Compliance (OVSC) Test Procedures TP-305-01 to determine compliance to the requirements of Federal Motor Vehicle Safety Standards (FMVSS) 305, "Electric Powered Vehicles: Electrolyte Spillage and Electrical Shock Protection".

Based on the test results, the 2024 Chevrolet Silverado EV appears to meet the partial requirements of FMVSS 305 testing.

If a measured voltage was zero and resulted in a division by zero "Zero Volts" was reported. This condition is considered being compliant as stated in TP-305-01 12.4 F.

The following data sheets document the results of the FMVSS 305 test.

DATA SHEET 1
ELECTRIC VEHICLE PROPULSION SYSTEM

Test Vehicle: 2024 Chevrolet Silverado EV
 Test Program: FMVSS 208 Compliance
 Test Technician: Dane Wieting

NHTSA No.: C20240101
 Test Date: 5/8/25

VEHICLE PROPULSION SYSTEM

Type of Electric Vehicle (Electric/Hybrid):	Electric
Propulsion Battery Type:	Lithium Ion
Nominal Voltage (V):	24 module= 350V or 20 module= 292V
Physical Location of Automatic Propulsion Battery Disconnect:	Inside the traction battery
Auxiliary Battery Type:	12V AGM

DATA SHEET 2

**ELECTRIC ENERGY STORAGE CONVERSION / DEVICE SYSTEM DATA
(COTR SUPPLIED DATA)**

Electrolyte Fluid Type:	Newtonian Fluid	
Electrolyte Fluid Specific Gravity:	1.203 g/cm ³	
Electrolyte Kinematic Viscosity (centistokes):	3.9235 ⁻⁶ m ² /s	
Electrolyte Fluid Color:	Clear	
Electric Energy Storage/Conversion System Coolant Type, Color, Specific Gravity (if applicable):	Pink/Pale Orange	
Location of Battery Modules:	<input type="checkbox"/>	Inside Passenger Compartment
	<input checked="" type="checkbox"/>	Outside Passenger Compartment
	The high voltage battery is mounted on the underside of the vehicle.	
Electric Energy Storage/Conversion System State of Charge:	<input checked="" type="checkbox"/>	Maximum State of Charge
	<input type="checkbox"/>	Range of Normal Operating Voltage
Maximum	403V or 336V	
Test Voltage - No less than 95% of maximum State of Charge:		
Range of Normal Operating Voltage:		
Test Voltage – Within Normal Operative Voltage Range:		
Test Vehicle Equipped with Electrical Isolation Monitoring	Not Stated	

VEHICLE CHASSIS GROUND POINT(S) LOCATION(S)

Details of Vehicle Chassis Ground Point(s) & Location(s)	The Body Structure was used as Vehicle Ground
--	---

ELECTRIC ENERGY STORAGE/CONVERSION TEST POINTS

Details of Electric Energy Storage/Conversion System Test Points:	Downstream Voltage At The Positive and Negative Terminals Of The Electronic Supply Unit Assembly
---	--

DATA SHEET 3

PRE-IMPACT ELECTRIC ISOLATION MEASUREMENTS & CALCULATIONS

Test Vehicle: 2024 Chevrolet Silverado EV
Test Program: FMVSS 208 Compliance
Test Technician: Dane Wieting

NHTSA No.: C20240101
Test Date: 5/8/25

VOLTMETER INFORMATION

Make:	Fluke
Model:	177
Serial Number:	62100018
Internal Impedance Value (MΩ):	50 MΩ
Resolution (V):	.001 Volts
Last Calibration Date:	07/18/2024

ELECTRIC ENERGY STORAGE/CONVERSION SYSTEM VOLTAGE

Measurement shall be made with Energy Storage/Conversion System connected to the vehicle propulsion system, and the vehicle in the “ready-to-drive” (propulsion system energized) position.

If voltage measurement is not at the voltage or within the normal operating voltage range specified by the manufacturer, the battery must be charged.

Vb (V):	330.6
---------	-------

ELECTRIC ENERGY STORAGE/CONVERSION SYSTEM TO VEHICLE CHASSIS

Vehicle chassis point(s) determined and supplied to contractor by COTR.

V1 (V):	160.0
V2 (V):	164.1

ELECTRIC ENERGY STORAGE / CONVERSION SYSTEM TO VEHICLE CHASSIS ACROSS RESISTOR

The known resistance R_o (in ohms) should be approximately 500 times the normal operating voltage of the vehicle (in volts) per SAE J1766.

R_o (Ω):	226,100 Ω
------------	-----------

V1 (V) Pre-Impact:	160.0
V2 (V) Pre-Impact:	164.1

DATA SHEET 3 (CONTINUED)

PRE-IMPACT ELECTRICAL ISOLATION MEASUREMENTS & CALCULATIONS

ELECTRICAL ISOLATION MEASUREMENT

Note: If measured voltage is zero and results in a division by zero, record "Zero Volts". This "zero voltage" condition is considered as being compliant.

V1' (V):	51.3
$R_{i1} = R_o (1 + V_2/V_1) [(V_1 - V_1')/V_1']$	
Ri1 (Ω):	970,447
V2' (V):	50.0
$R_{i2} = R_0 (1 + V_1/V_2) [(V_2 - V_2')/V_2']$	
Ri2 (Ω):	1,019,029
Ri = The lesser of Ri1 and Ri2	
Ri Pre-Test (Ω):	970,447
Ri/Vb (Ω/V):	2,935
Minimum Electrical Isolation Value is 500 Ω/V	

Note: Measurements completed within 15 minutes prior to impact.

Is the measured Electrical Isolation Value:	Yes, Pass	No, Fail
≥500 Ω/V without electrical isolation monitoring	X	
≥100 Ω/V with electrical isolation monitoring		

**DATA SHEET 4
POST-IMPACT DATA**

Test Vehicle: 2024 Chevrolet Silverado EV
 Test Program: FMVSS 208 Compliance
 Test Technician: Dane Wieting

NHTSA No.: C20240101
 Test Date: 5/8/25

VOLTMETER INFORMATION

Make:	Fluke
Model:	177
Serial Number:	62100018
Internal Impedance Value (MΩ):	50 MΩ
Nominal Propulsion Battery Voltage (Vb) (V):	330.6 V
Resolution (V):	.001 Volts
NOTE: Record V1, V2, V1', V2' voltage measurements at a minimum of 5 seconds after impact.	

**ELECTRIC ENERGY STORAGE/CONVERSION SYSTEM
VOLTAGE LOCATION OF MEASUREMENT**

Measurement is made from the side of the automatic disconnect connected to the electric powertrain.

Vb (V):	1.7
---------	-----

ELECTRIC ENERGY STORAGE/CONVERSION SYSTEM VOLTAGE

V1 =	2.8	V	Impact Time:	0	Minutes	42	s
V2 =	1.0	V	Impact Time:	0	Minutes	45	s
V1' =	0.7	V	Impact Time:	0	Minutes	50	s
V2' =	0.3	V	Impact Time:	0	Minutes	56	s

ELECTRICAL ISOLATION MEASUREMENT

Note: If measured voltage is zero and results in a division by zero, record "Zero Volts". This "zero voltage" condition is considered as being compliant.

$Ri1 = Ro (1 + V2/V1) [(V1-V1')/V1']$							
Ri1 =	920,550	Ω	Impact Time:	1	Minutes	2	s
$Ri2 = Ro (1 + V1/V2) [(V2-V2')/V2']$							
Ri2 =	2,004,753	Ω	Impact Time:	1	Minutes	10	s
Ri = The lesser of Ri1 and Ri2							
Ri =	920,550	Ω	Impact Time:	1	Minutes	16	s
Ri/Vb = electrical Isolation Value/Nominal Battery Voltage							
Minimum Electrical Value is 500 Ω/V							
Ri/Vb =	541,500	Ω/V	Impact Time:	1	Minutes	25	s

Is the measured Electrical Isolation Value:	Yes, Pass	No, Fail
≥500 Ω/V without electrical isolation monitoring	X	
≥100 Ω/V with electrical isolation monitoring		

DATA SHEET 4 (CONTINUED)

POST-IMPACT DATA

ELECTRIC ENERGY STORAGE/CONVERSION DEVICE

	Inside Passenger Compartment	Outside Passenger Compartment
Location of Electric Energy Storage/Conversion Device:		X

	Yes, Pass	No, Fail
All Components of Electrical Energy Storage/Conversion Device remained attached to the vehicle with at least one mounting location.	X	

Describe Electric Energy Storage/Conversion Device movement within the passenger compartment [Supply photographs as appropriate]:
No Movement

	Yes, Fail	No, Pass
Has the Electric Energy Storage/Conversion Device moved within the passenger compartment?		X

Describe intrusion of an outside Electric Energy Storage/Conversion Device into the passenger compartment [Supply photographs as appropriate]:
No Movement

	Yes, Fail	No, Pass
Has an outside Electric Energy Storage/Conversion Device intruded into the passenger compartment?		X

	Yes, Fail	No, Pass
Is Electric Energy Storage/Conversion Device electrolyte spillage visible in the passenger compartment?		X

DATA SHEET 5
STATIC ROLLOVER TEST DATA

Test Vehicle: 2024 Chevrolet Silverado EV
 Test Program: FMVSS 208 Compliance
 Test Technician: Dane Wieting

NHTSA No.: C20240101
 Test Date: 5/8/25

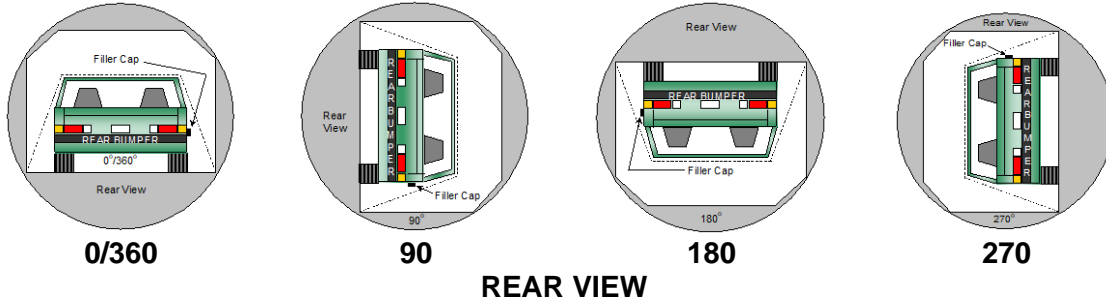

**DETERMINATION OF ELECTRIC ENERGY STORAGE / CONVERSION DEVICE
ELECTROLYTE COLLECTION TIME PERIOD**

Rollover Stage	Rotation Time (spec. 1-3 min)				FMVSS 301 Hold Time		Total Time				Next Whole Minute Interval	
0° - 90°	1	minutes	31	seconds	5	minutes	6	minutes	31	seconds	7	minutes
90° - 180°	1	minutes	38	seconds	5	minutes	6	minutes	38	seconds	7	minutes
180° - 270°	1	minutes	32	seconds	5	minutes	6	minutes	32	seconds	7	minutes
270° - 360°	1	minutes	28	seconds	5	minutes	6	minutes	28	seconds	7	minutes

**ACTUAL TEST VEHICLE ELECTRIC ENERGY STORAGE/CONVERSION DEVICE
ELECTROLYTE SPILLAGE**

Rollover Stage	Electric Energy Storage/Conversion Device Electrolyte Spillage (L)	Spillage Location
0° to 90°	0	Not Applicable
90° to 180°	0	Not Applicable
180° to 270°	0	Not Applicable
270° to 360°	0	Not Applicable

Total Spillage: 0 L

	Yes, Fail	No, Pass
Is the total spillage of Electric Energy Storage/Conversion Device electrolyte greater than 5.0 Liters?		X
Is Electric Energy Storage/Conversion Device electrolyte spillage visible in the passenger compartment?		X

DATA SHEET 5 (CONTINUED)
STATIC ROLLOVER TEST DATA

VOLTMETER INFORMATION

Make:	Fluke
Model:	177
Serial Number:	62100018
Internal Impedance Value (MΩ):	50 MΩ
Nominal Electric Energy Storage/Conversion Device Voltage (Vb) (V):	330.6 V

Record V1, V2, V1', V2' voltage measurements at the start of each successive increment of 90°, 180°, 270°, and 360° of the static rollover test.

ELECTRICAL ISOLATION MEASUREMENT

V1 =	2.8	V	0°	Time:		Minutes		s
V1 =	2.8	V	90°	Time:	2	Minutes	23	s
V1 =	2.8	V	180°	Time:	3	Minutes	05	s
V1 =	2.8	V	270°	Time:	2	Minutes	33	s
V1 =	2.8	V	360°	Time:	2	Minutes	20	s
V2 =	1.0	V	0°	Time:		Minutes		s
V2 =	1.0	V	90°	Time:	2	Minutes	27	s
V2 =	1.0	V	180°	Time:	3	Minutes	08	s
V2 =	1.0	V	270°	Time:	3	Minutes	37	s
V2 =	1.0	V	360°	Time:	3	Minutes	24	s
V1' =	0.7	V	0°	Time:		Minutes		s
V1' =	1.0	V	90°	Time:	3	Minutes	31	s
V1' =	0.7	V	180°	Time:	3	Minutes	11	s
V1' =	0.7	V	270°	Time:	3	Minutes	41	s
V1' =	0.7	V	360°	Time:	3	Minutes	29	s
V2' =	0.4	V	0°	Time:		Minutes		s
V2' =	0.4	V	90°	Time:	3	Minutes	34	s
V2' =	0.3	V	180°	Time:	3	Minutes	15	s
V2' =	0.3	V	270°	Time:	3	Minutes	44	s
V2' =	0.4	V	360°	Time:	3	Minutes	34	s
Vb =	1.7	V	0°	Time:		Minutes		s
Vb =	1.7	V	90°	Time:	3	Minutes	20	s
Vb =	1.7	V	180°	Time:	3	Minutes	00	s
Vb =	1.7	V	270°	Time:	3	Minutes	30	s
Vb =	1.7	V	360°	Time:	3	Minutes	17	s

DATA SHEET 5 (CONTINUED)
STATIC ROLLOVER TEST DATA

ELECTRICAL ISOLATION CALCULATION

Note: If measured voltage is zero and results in a division by zero, record "Zero Volts". This "zero voltage" condition is considered as being compliant.

$R_{i1} = R_o (1 + V_2/V_1) [(V_1 - V_1')/V_1']$								
Ri1 =	920,550	Ω	0°	Time:		Minutes		s
Ri1 =	552,330	Ω	90°	Time:	2	Minutes	37	s
Ri1 =	920,550	Ω	180°	Time:	2	Minutes	18	s
Ri1 =	920,550	Ω	270°	Time:	2	Minutes	48	s
Ri1 =	920,550	Ω	360°	Time:	2	Minutes	20	s
$R_{i2} = R_o (1 + V_1/V_2) [(V_2 - V_2')/V_2']$								
Ri2 =	1,288,770	Ω	0°	Time:		Minutes		s
Ri2 =	1,288,770	Ω	90°	Time:	2	Minutes	40	s
Ri2 =	2,004,753	Ω	180°	Time:	2	Minutes	20	s
Ri2 =	2,004,753	Ω	270°	Time:	2	Minutes	52	s
Ri2 =	1,288,770	Ω	360°	Time:	2	Minutes	24	s
Ri = The lesser of Ri1 and Ri2								
Ri =	920,550	Ω	0°	Time:		Minutes		s
Ri =	552,330	Ω	90°	Time:	2	Minutes	43	s
Ri =	920,550	Ω	180°	Time:	2	Minutes	24	s
Ri =	920,550	Ω	270°	Time:	2	Minutes	55	s
Ri =	920,550	Ω	360°	Time:	2	Minutes	28	s
Ri/Vb = Electrical Isolation Value/Nominal Battery Voltage Minimum Electrical Isolation Value is 500 Ω /V								
Ri/Vb =	541,500	Ω/V	0°	Time:		Minutes		s
Ri/Vb =	324,900	Ω/V	90°	Time:	2	Minutes	47	s
Ri/Vb =	541,500	Ω/V	180°	Time:	2	Minutes	28	s
Ri/Vb =	541,500	Ω/V	270°	Time:	2	Minutes	59	s
Ri/Vb =	541,500	Ω/V	360°	Time:	2	Minutes	31	s

Is the measured Electrical Isolation Value:	Yes, Pass	No, Fail
≥500 Ω/V without electrical isolation monitoring	X	
≥100 Ω/V with electrical isolation monitoring		

APPENDIX A

CRASH TEST DATA

TABLE OF DATA PLOTS

		<u>Page No.</u>
Figure No. 1.	Driver Head X Acceleration vs. Time	A-1
Figure No. 2.	Driver Head Y Acceleration vs. Time	A-1
Figure No. 3.	Driver Head Z Acceleration vs. Time	A-1
Figure No. 4.	Driver Head Resultant Acceleration vs. Time	A-1
Figure No. 5.	Driver Head X Velocity vs. Time	A-2
Figure No. 6.	Driver Head Y Velocity vs. Time	A-2
Figure No. 7.	Driver Head Z Velocity vs. Time	A-2
Figure No. 8.	Driver Neck Force X vs. Time	A-3
Figure No. 9.	Driver Neck Force Y vs. Time	A-3
Figure No. 10.	Driver Neck Force Z vs. Time	A-3
Figure No. 11.	Driver Neck Force Resultant vs. Time	A-3
Figure No. 12.	Driver Neck Moment X vs. Time	A-4
Figure No. 13.	Driver Neck Moment Y vs. Time	A-4
Figure No. 14.	Driver Neck Moment Z vs. Time	A-4
Figure No. 15.	Driver Neck Moment Resultant vs. Time	A-4
Figure No. 16.	Driver Chest X Acceleration vs. Time	A-5
Figure No. 17.	Driver Chest Y Acceleration vs. Time	A-5
Figure No. 18.	Driver Chest Z Acceleration vs. Time	A-5
Figure No. 19.	Driver Chest Resultant Acceleration vs. Time	A-5
Figure No. 20.	Driver Chest X Velocity vs. Time	A-6
Figure No. 21.	Driver Chest Y Velocity vs. Time	A-6
Figure No. 22.	Driver Chest Z Velocity vs. Time	A-6
Figure No. 23.	Driver Chest Displacement vs. Time	A-6
Figure No. 24.	Driver Left Femur Force vs. Time	A-7
Figure No. 25.	Driver Right Femur Force vs. Time	A-7
Figure No. 26.	Passenger Head X Acceleration vs. Time	A-8
Figure No. 27.	Passenger Head Y Acceleration vs. Time	A-8
Figure No. 28.	Passenger Head Z Acceleration vs. Time	A-8
Figure No. 29.	Passenger Head Resultant Acceleration vs. Time	A-8
Figure No. 30.	Passenger Head X Velocity vs. Time	A-9

	<u>Page No.</u>	
Figure No. 31.	Passenger Head Y Velocity vs. Time	A-9
Figure No. 32.	Passenger Head Z Velocity vs. Time	A-9
Figure No. 33.	Passenger Neck Force X vs. Time	A-10
Figure No. 34.	Passenger Neck Force Y vs. Time	A-10
Figure No. 35.	Passenger Neck Force Z vs. Time	A-10
Figure No. 36.	Passenger Neck Force Resultant vs. Time	A-10
Figure No. 37.	Passenger Neck Moment X vs. Time	A-11
Figure No. 38.	Passenger Neck Moment Y vs. Time	A-11
Figure No. 39.	Passenger Neck Moment Z vs. Time	A-11
Figure No. 40.	Passenger Neck Moment Resultant vs. Time	A-11
Figure No. 41.	Passenger Chest X Acceleration vs. Time	A-12
Figure No. 42.	Passenger Chest Y Acceleration vs. Time	A-12
Figure No. 43.	Passenger Chest Z Acceleration vs. Time	A-12
Figure No. 44.	Passenger Chest Resultant Acceleration vs. Time	A-12
Figure No. 45.	Passenger Chest X Velocity vs. Time	A-13
Figure No. 46.	Passenger Chest Y Velocity vs. Time	A-13
Figure No. 47.	Passenger Chest Z Velocity vs. Time	A-13
Figure No. 48.	Passenger Chest Displacement vs. Time	A-13
Figure No. 49.	Passenger Left Femur Force vs. Time	A-14
Figure No. 50.	Passenger Right Femur Force vs. Time	A-14
Figure No. 51.	Driver Nij (N_{TF}) vs. Time	A-15
Figure No. 52.	Driver Nij (N_{TE}) vs. Time	A-15
Figure No. 53.	Driver Nij (N_{CF}) vs. Time	A-15
Figure No. 54.	Driver Nij (N_{CE}) vs. Time	A-15
Figure No. 55.	Passenger Nij (N_{TF}) vs. Time	A-16
Figure No. 56.	Passenger Nij (N_{TE}) vs. Time	A-16
Figure No. 57.	Passenger Nij (N_{CF}) vs. Time	A-16
Figure No. 58.	Passenger Nij (N_{CE}) vs. Time	A-16
Figure No. 59.	Driver Occipital Condyle Moment vs. Time	A-17
Figure No. 60.	Passenger Occipital Condyle Moment vs. Time	A-17
Figure No. 61.	Left Rear Seat Crossmember X Acceleration vs. Time	A-18
Figure No. 62.	Left Rear Seat Crossmember X Velocity vs. Time	A-18
Figure No. 63.	Right Rear Seat Crossmember X Acceleration vs. Time	A-18
Figure No. 64.	Right Rear Seat Crossmember X Velocity vs. Time	A-18
Figure No. 65.	Top of Engine X Acceleration vs. Time	A-19

		<u>Page No.</u>
Figure No. 66.	Top of Engine X Velocity vs. Time	A-19
Figure No. 67.	Bottom of Engine X Acceleration vs. Time	A-19
Figure No. 68.	Bottom of Engine X Velocity vs. Time	A-19
Figure No. 69.	Left Brake Caliper X Acceleration vs. Time	A-20
Figure No. 70.	Left Brake Caliper X Velocity vs. Time	A-20
Figure No. 71.	Right Brake Caliper X Acceleration vs. Time	A-20
Figure No. 72.	Right Brake Caliper X Velocity vs. Time	A-20
Figure No. 73.	Instrument Panel X Acceleration vs. Time	A-21
Figure No. 74.	Instrument Panel X Velocity vs. Time	A-21
Figure No. 75.	Trunk Z Acceleration vs. Time	A-21
Figure No. 76.	Trunk Z Velocity vs. Time	A-21

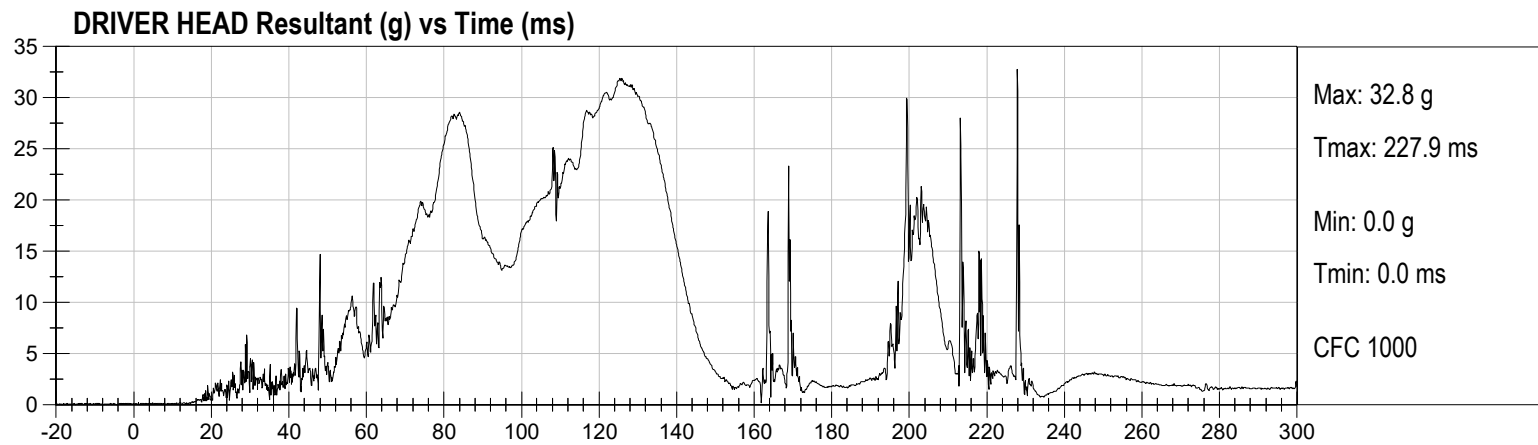
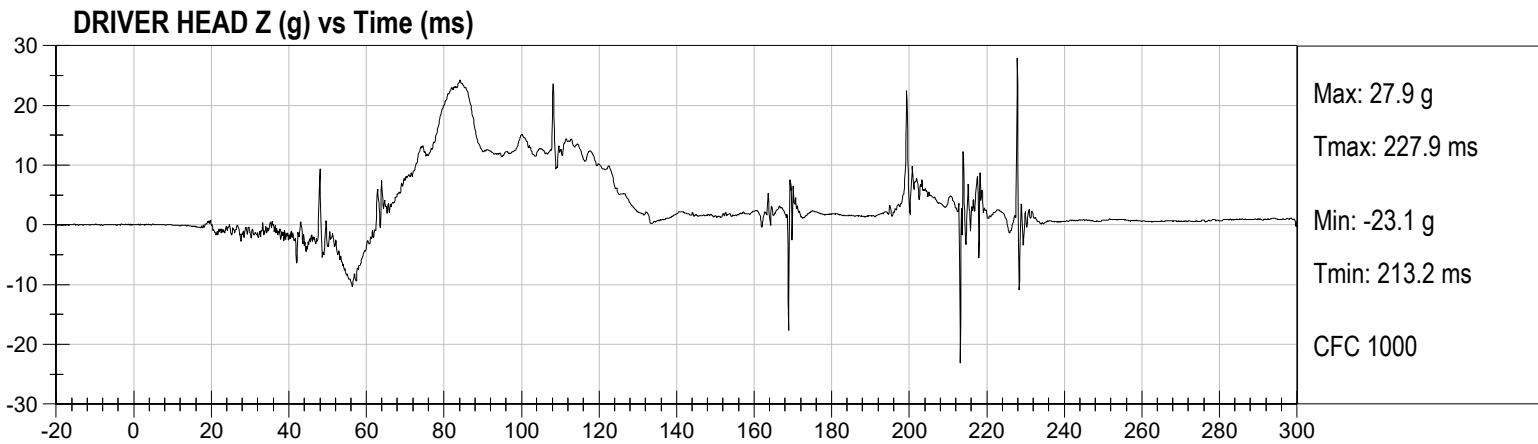
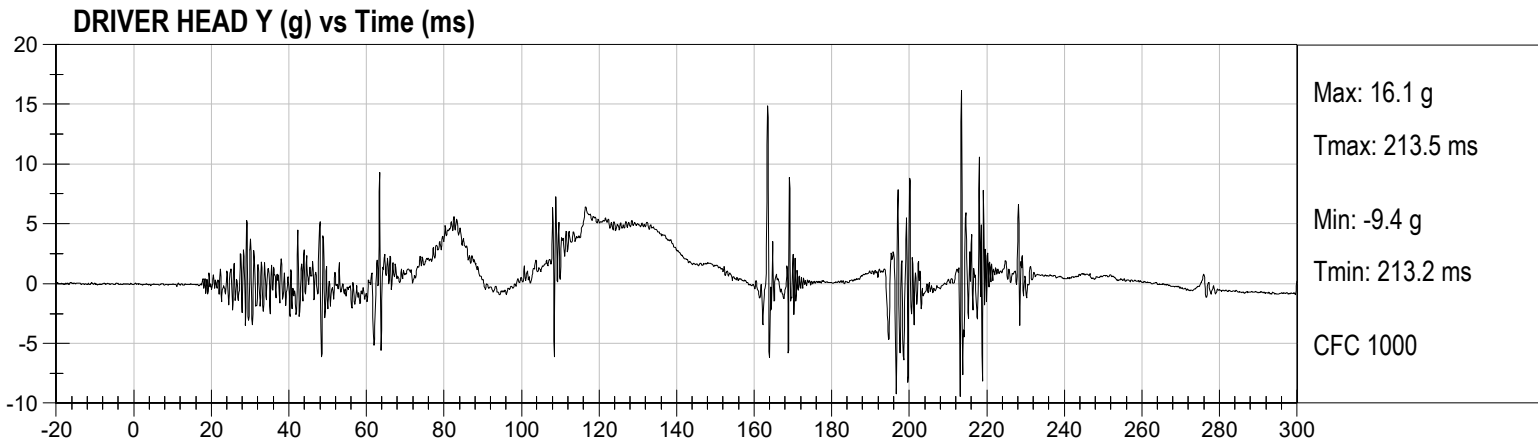
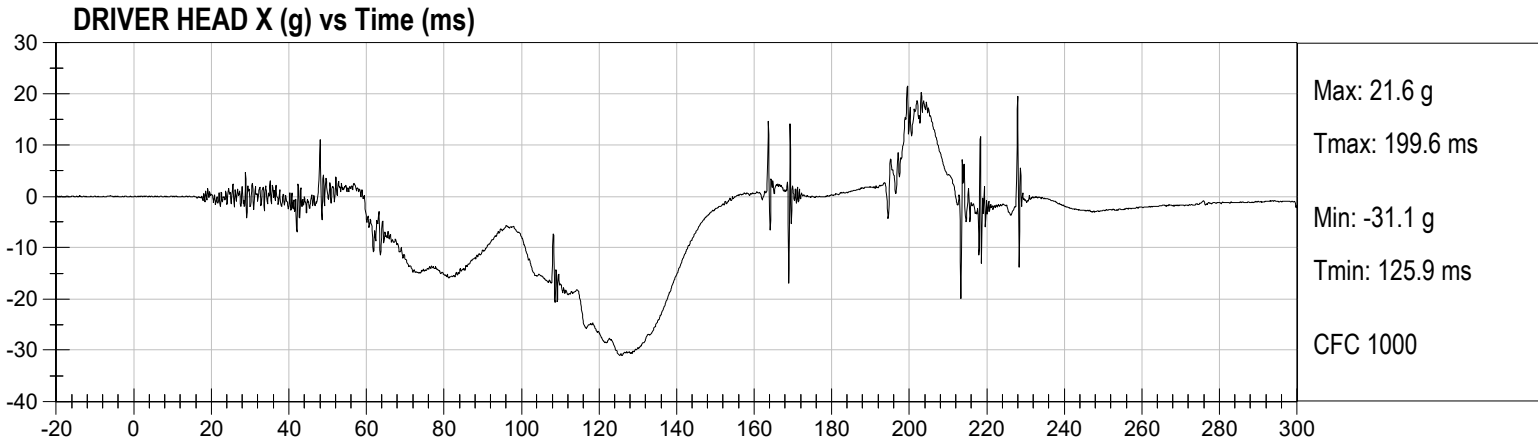

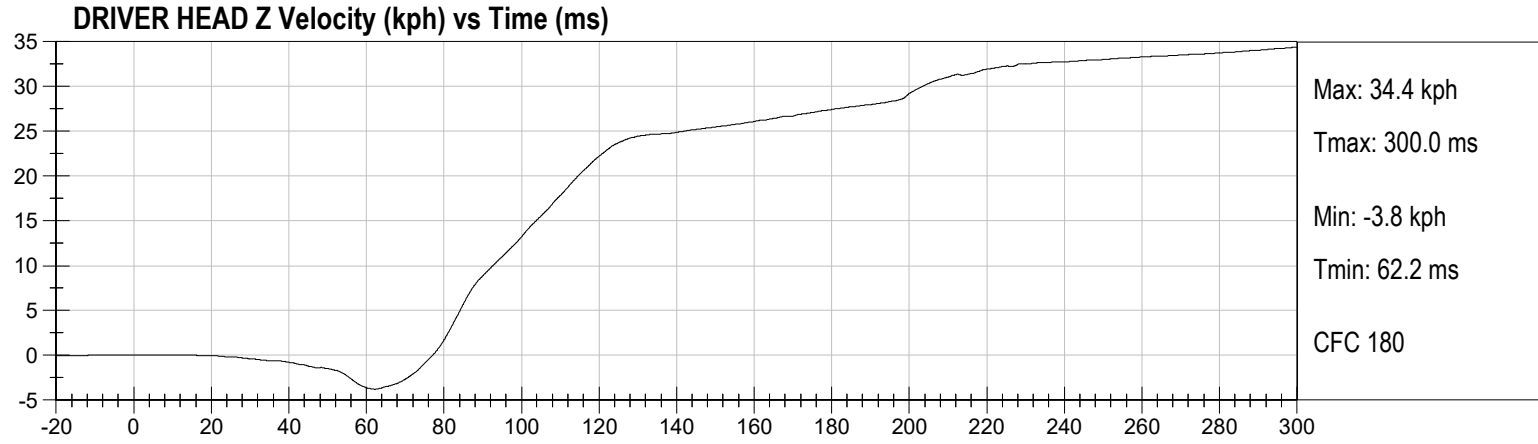
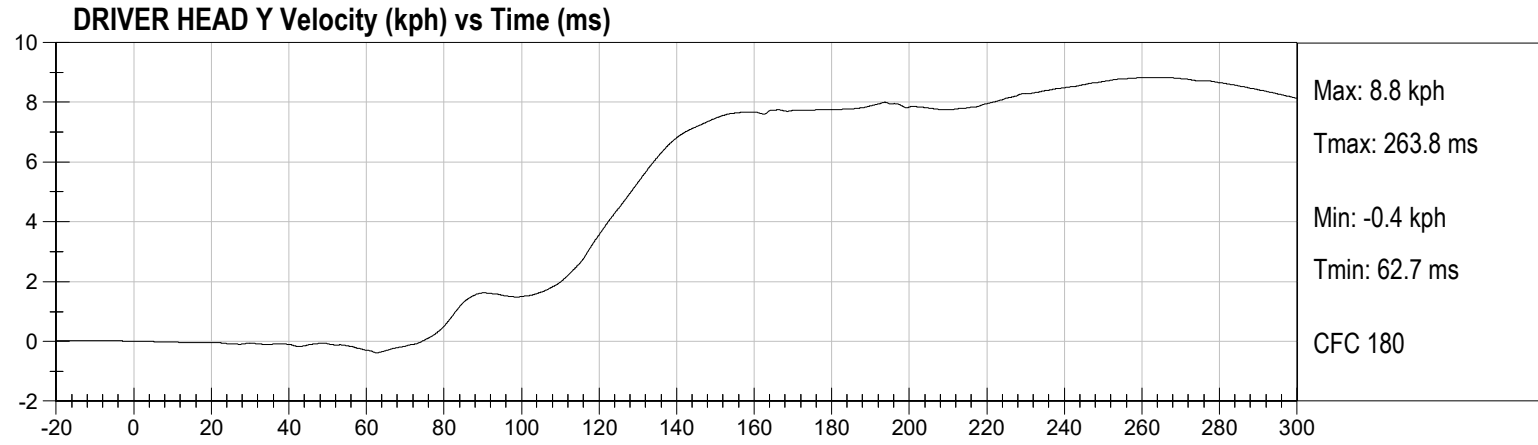
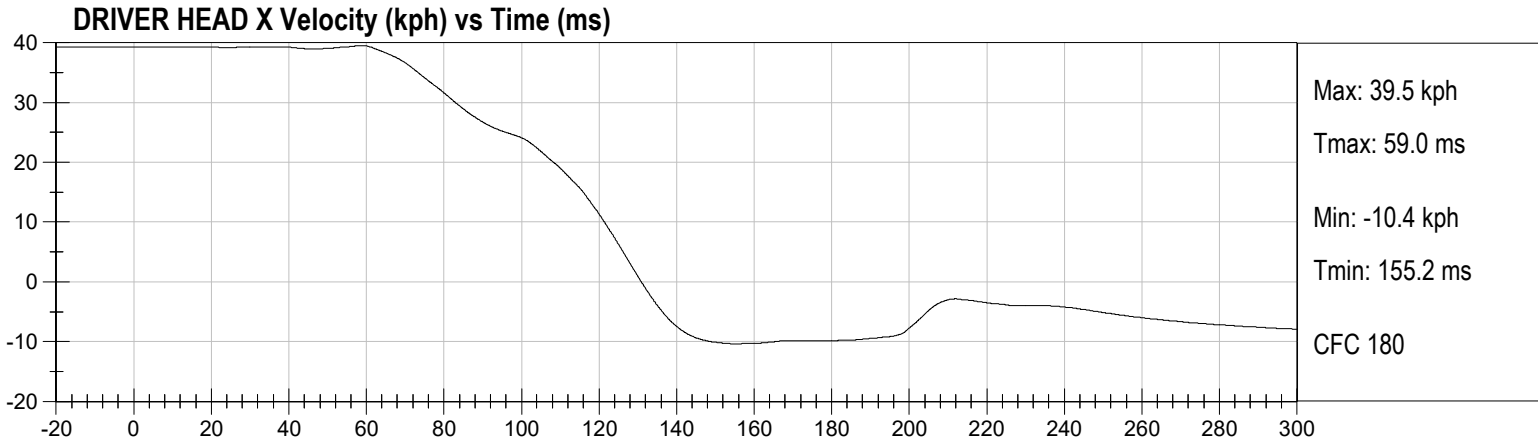

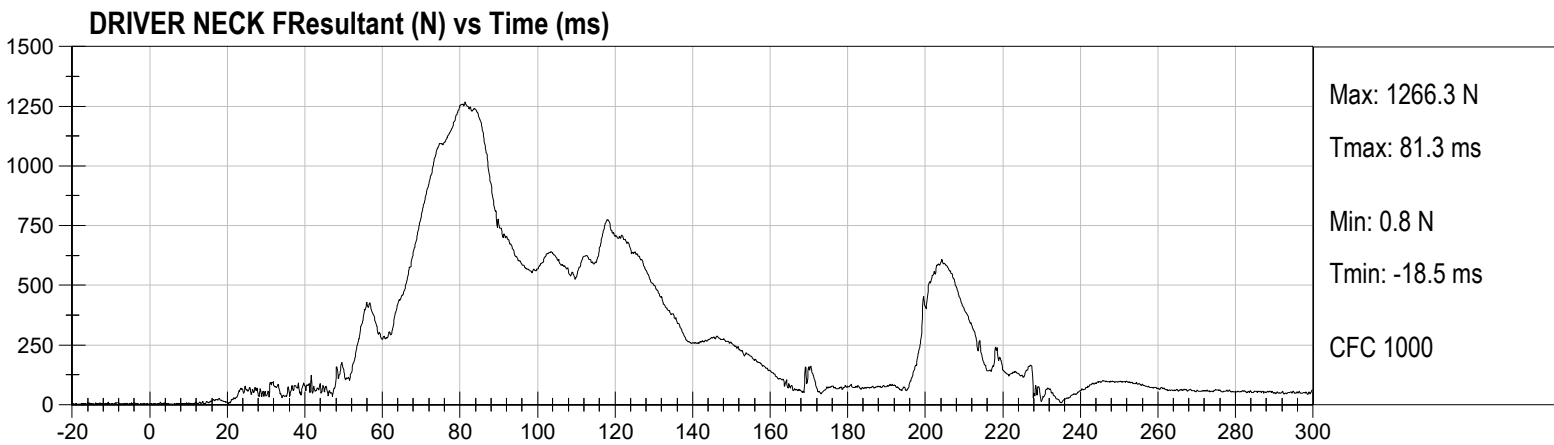
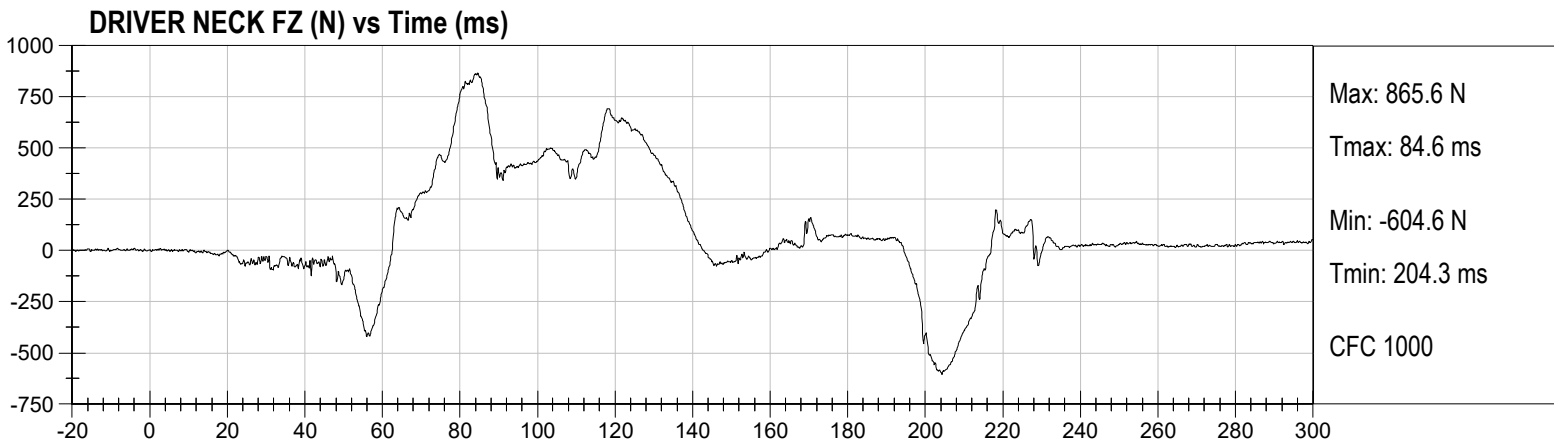
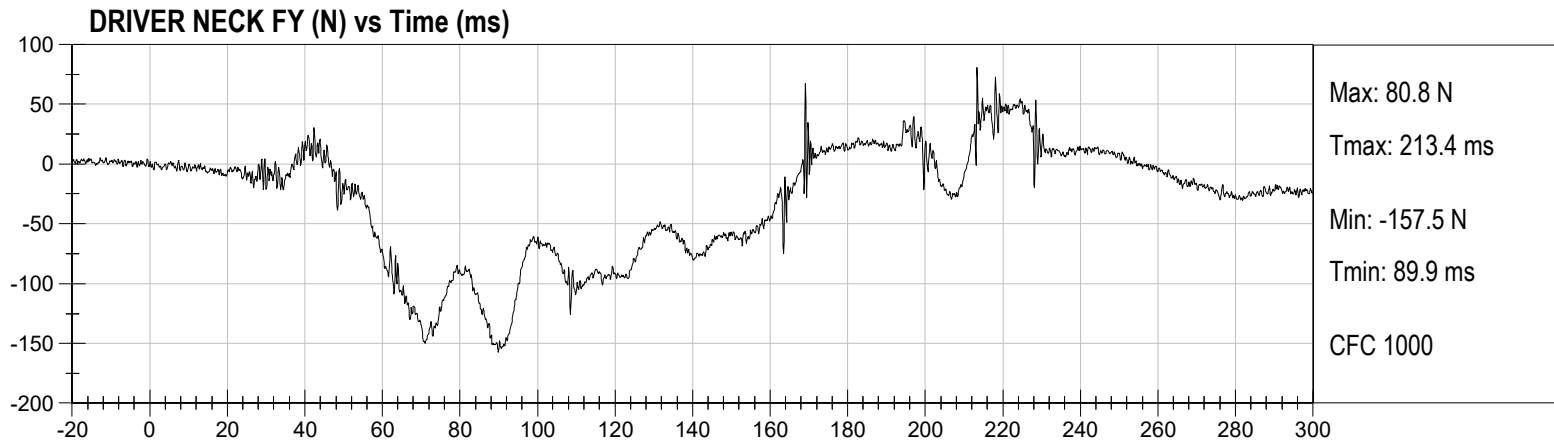
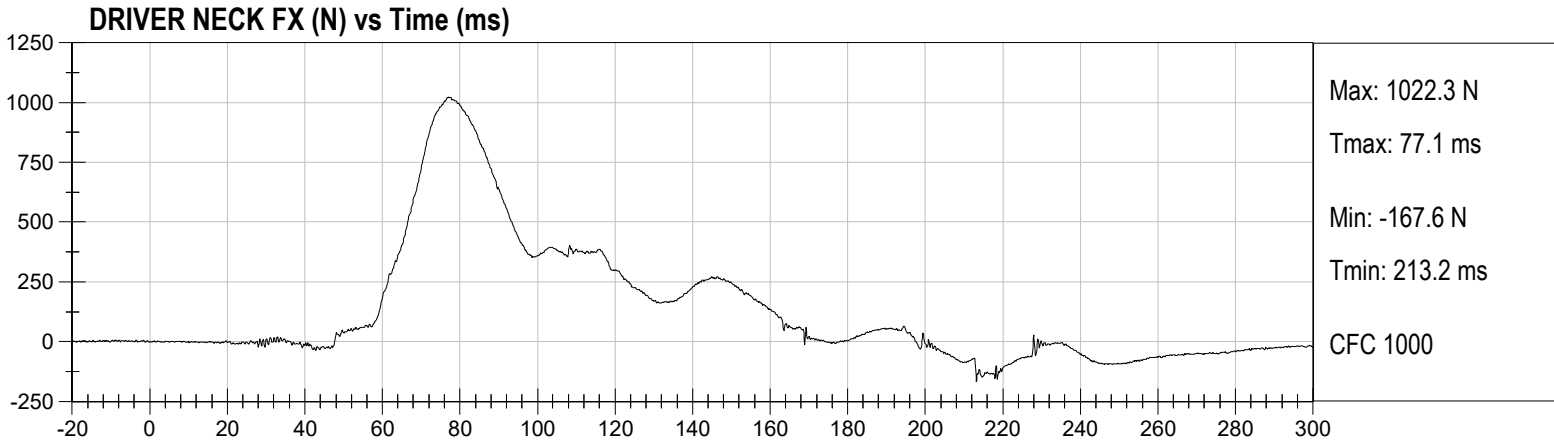

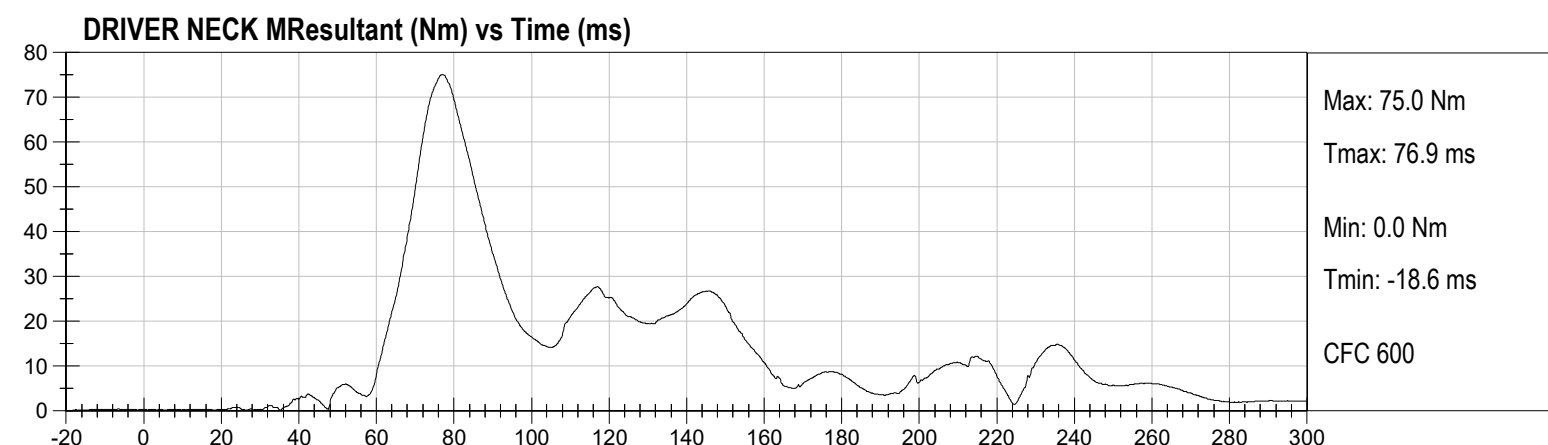
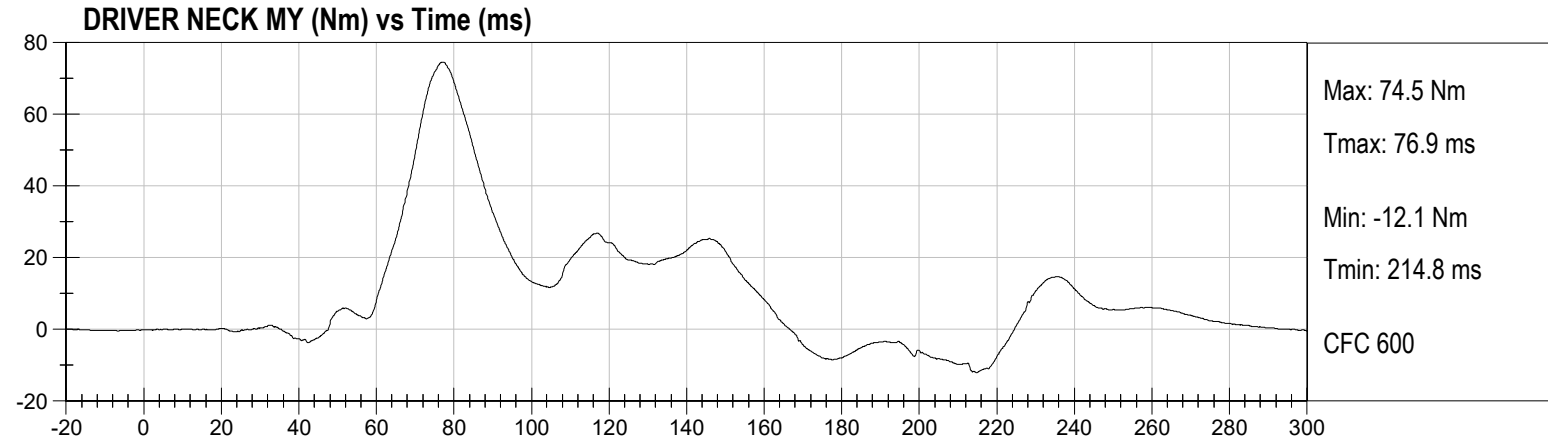
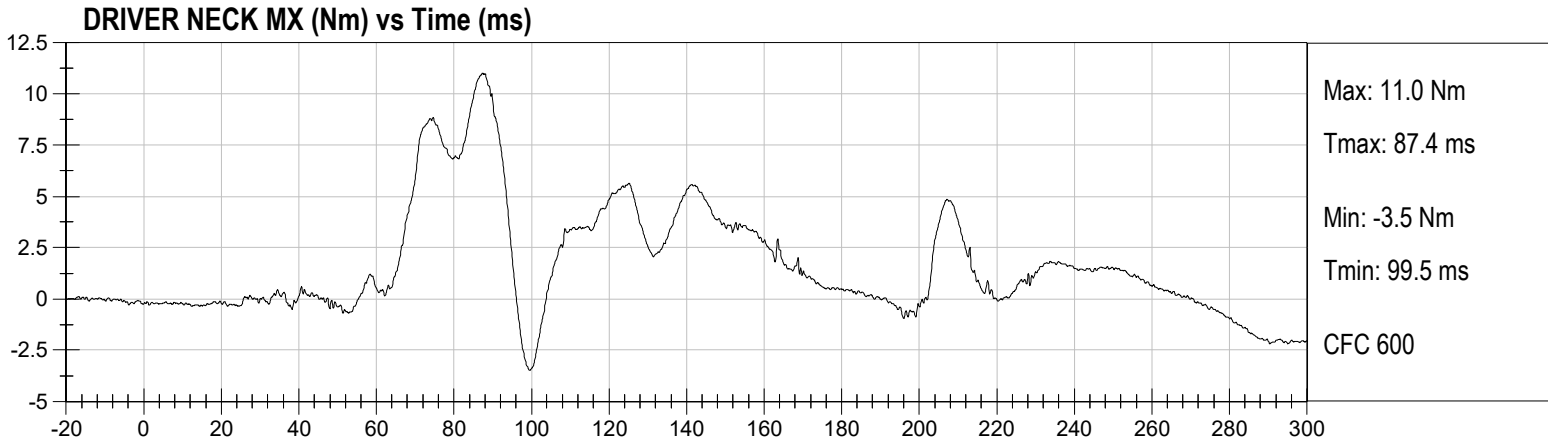

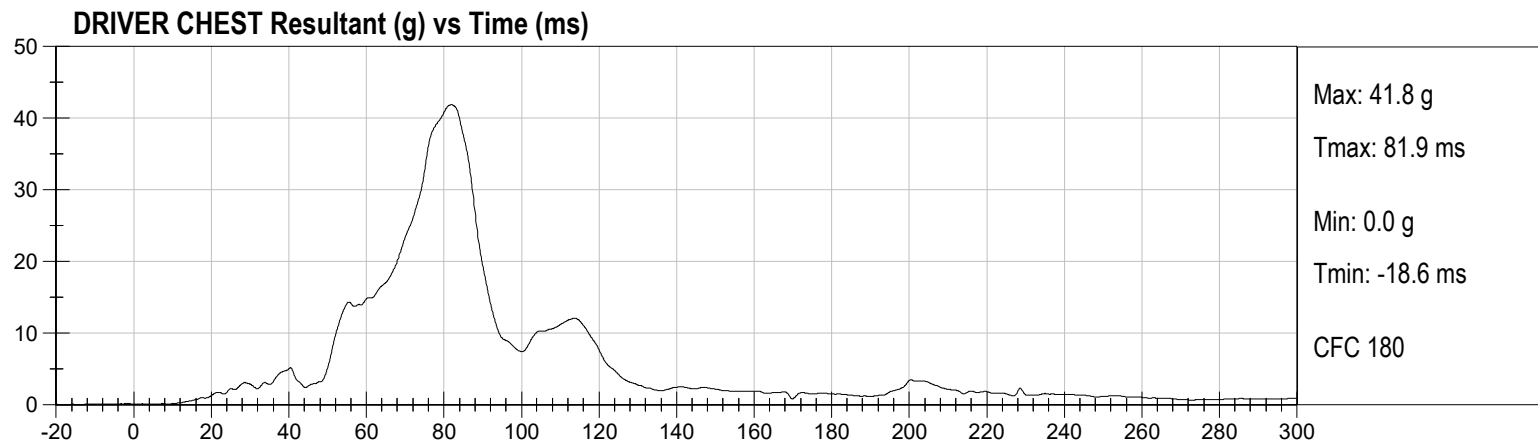
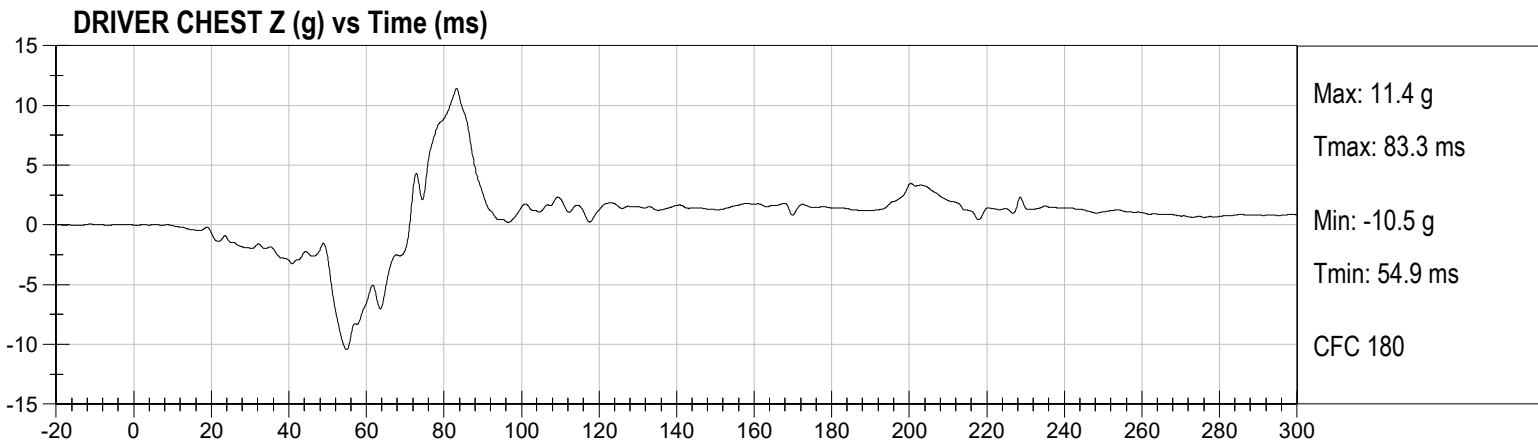
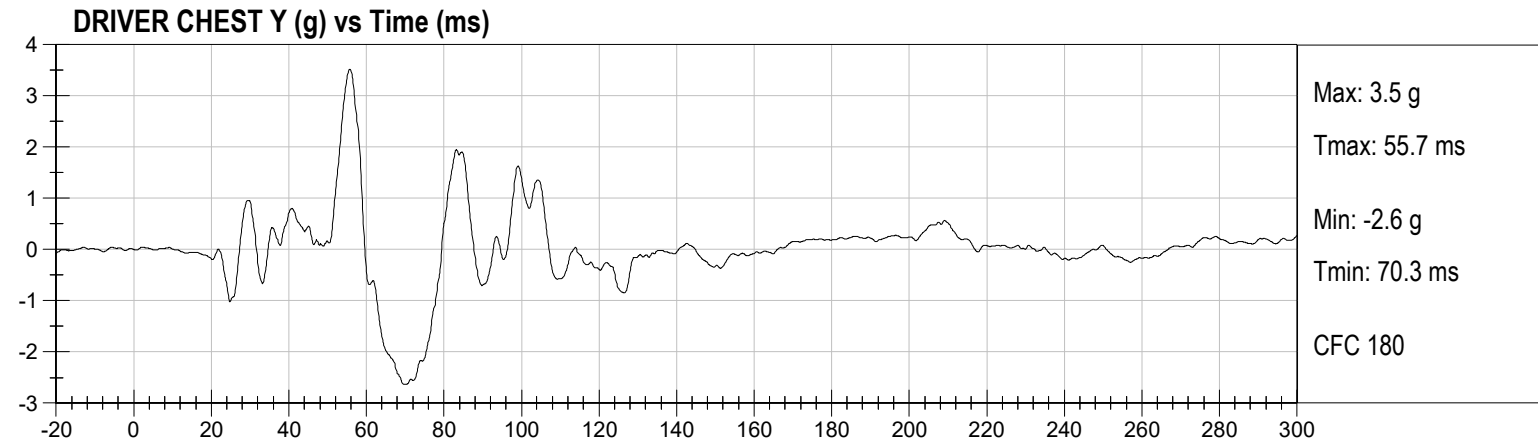
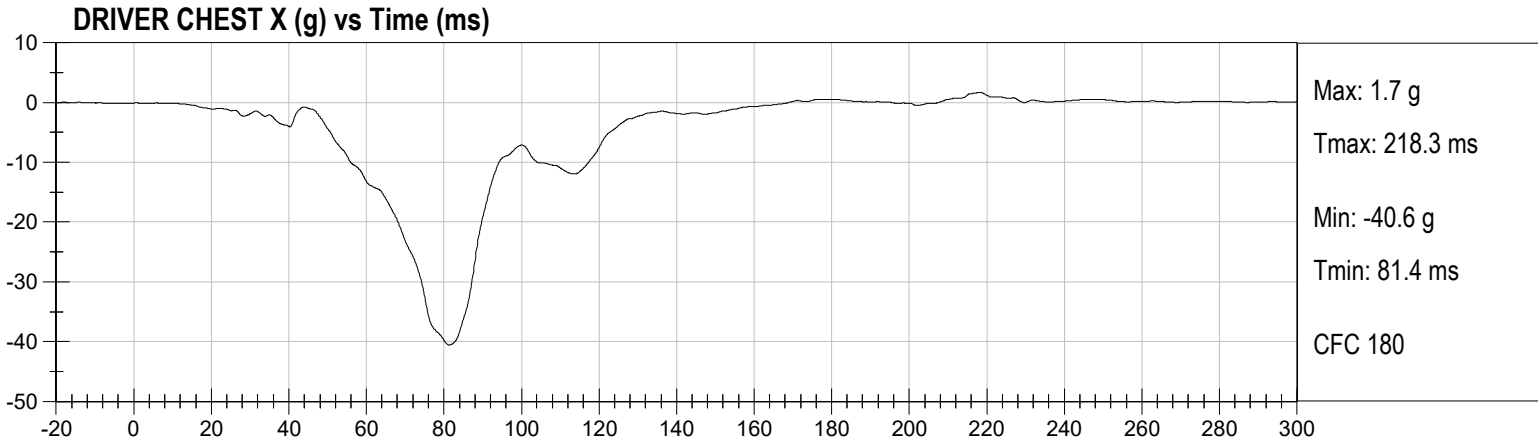

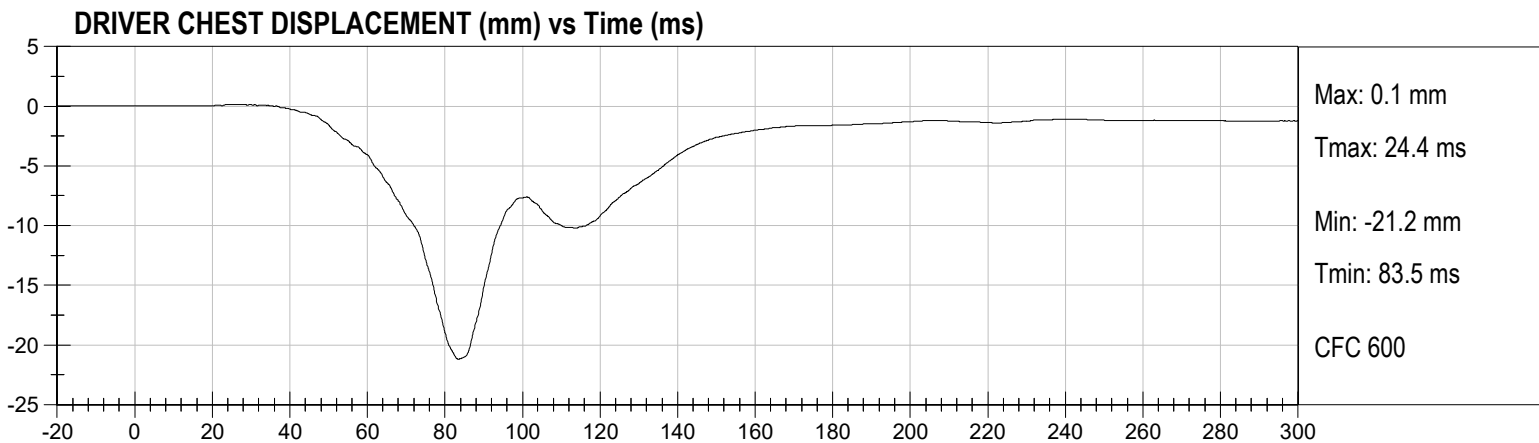
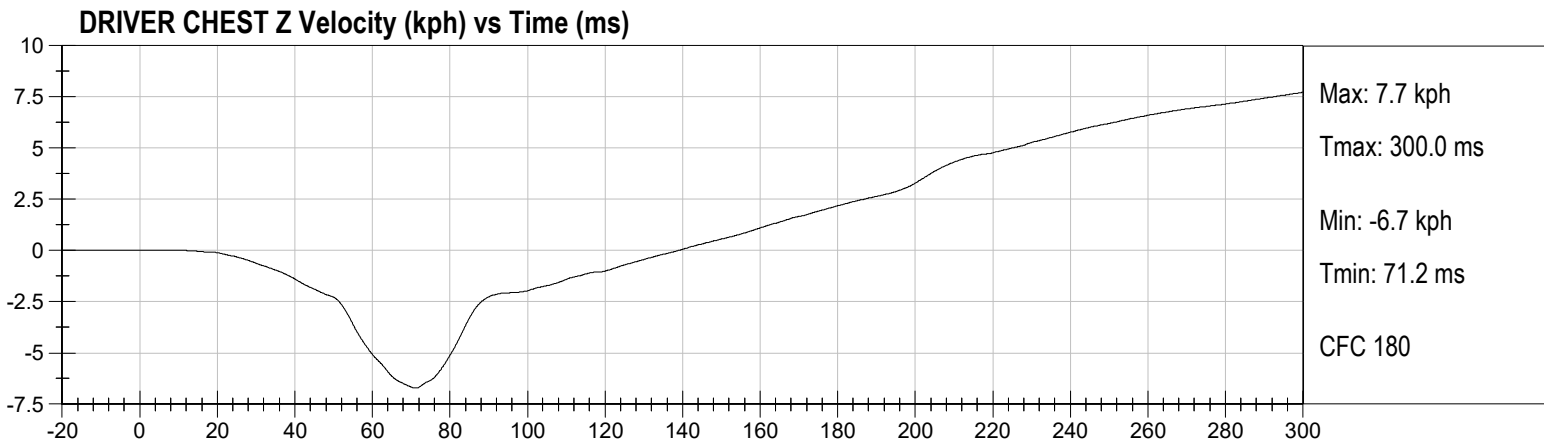
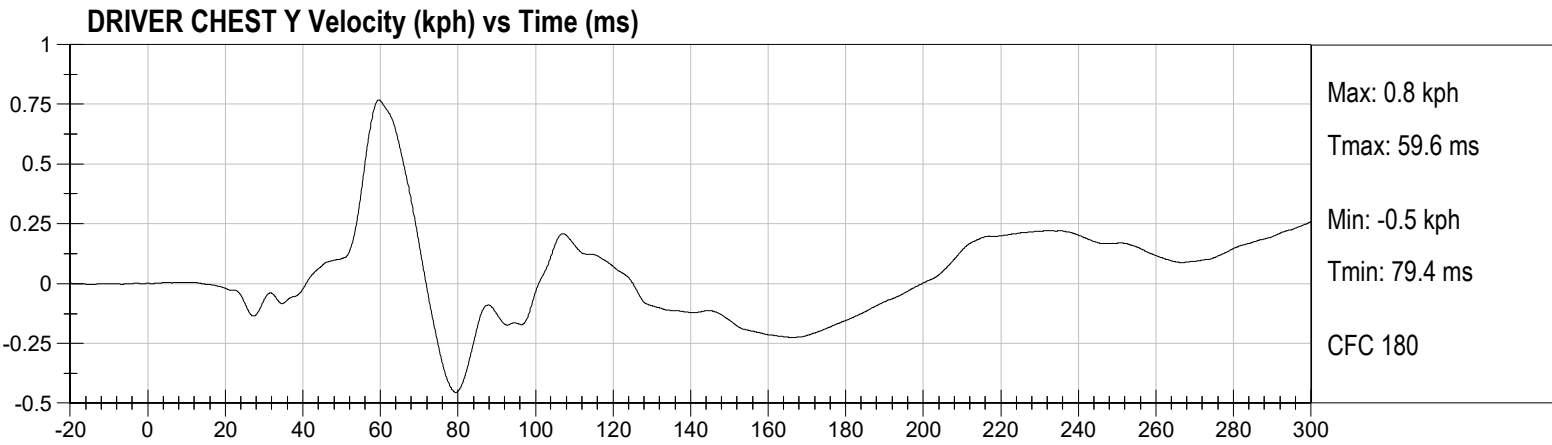
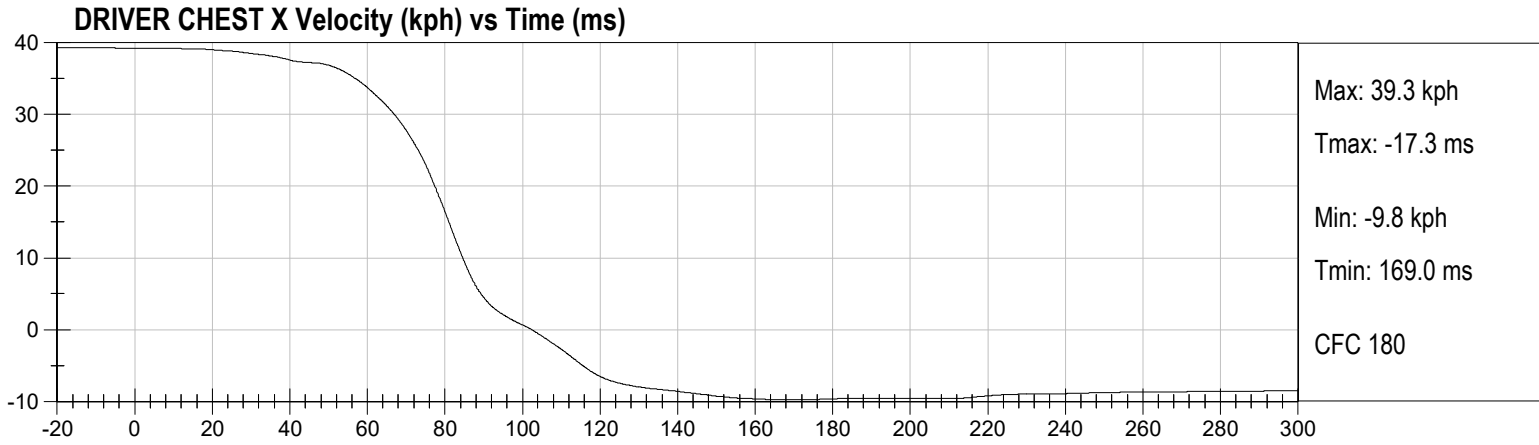

DRIVER LEFT FEMUR (N) vs Time (ms)

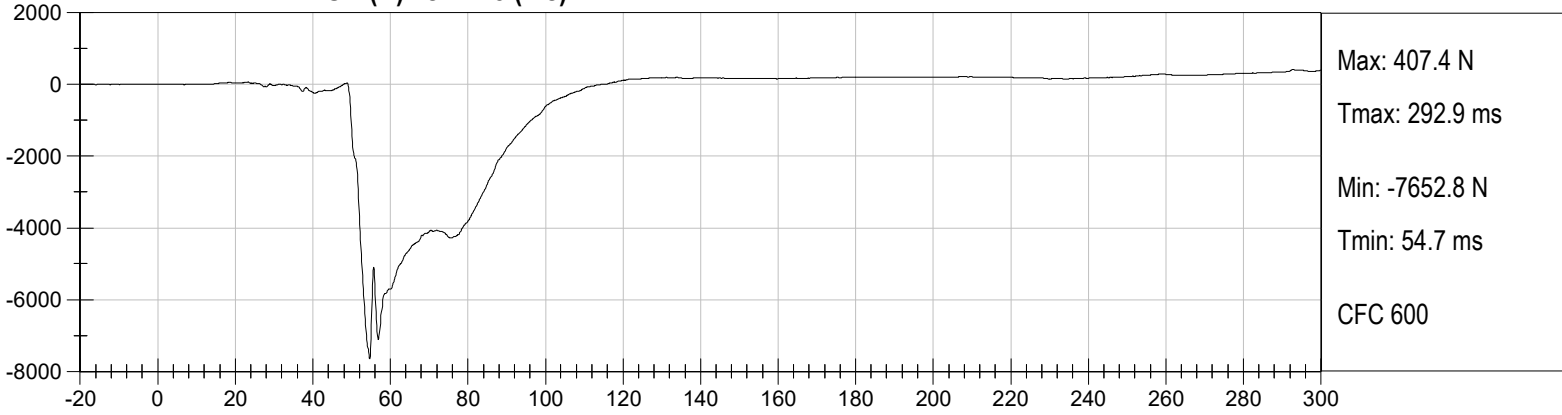

DRIVER RIGHT FEMUR (N) vs Time (ms)

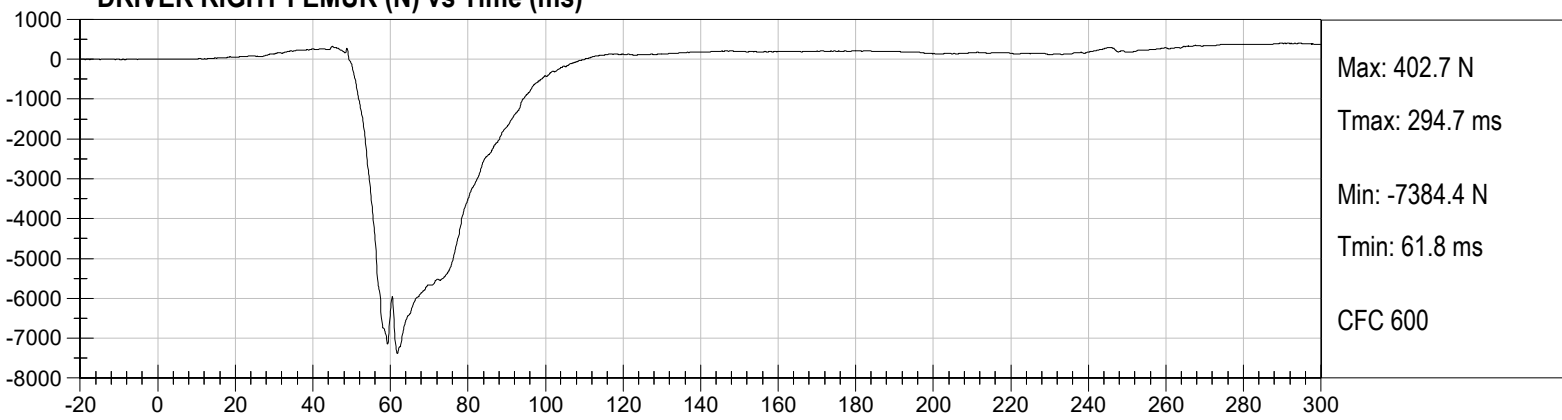

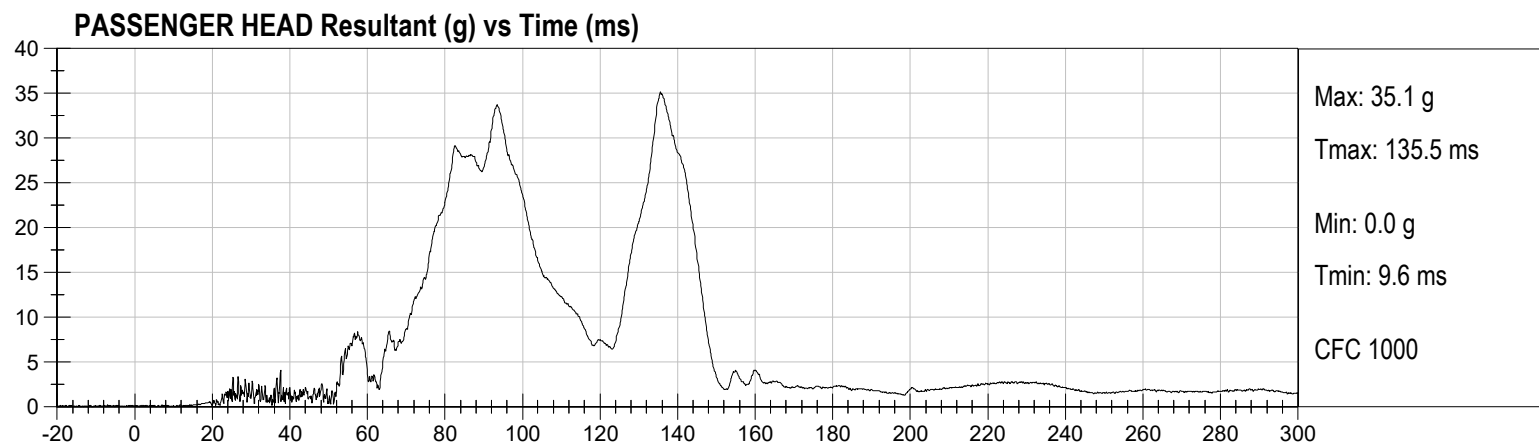
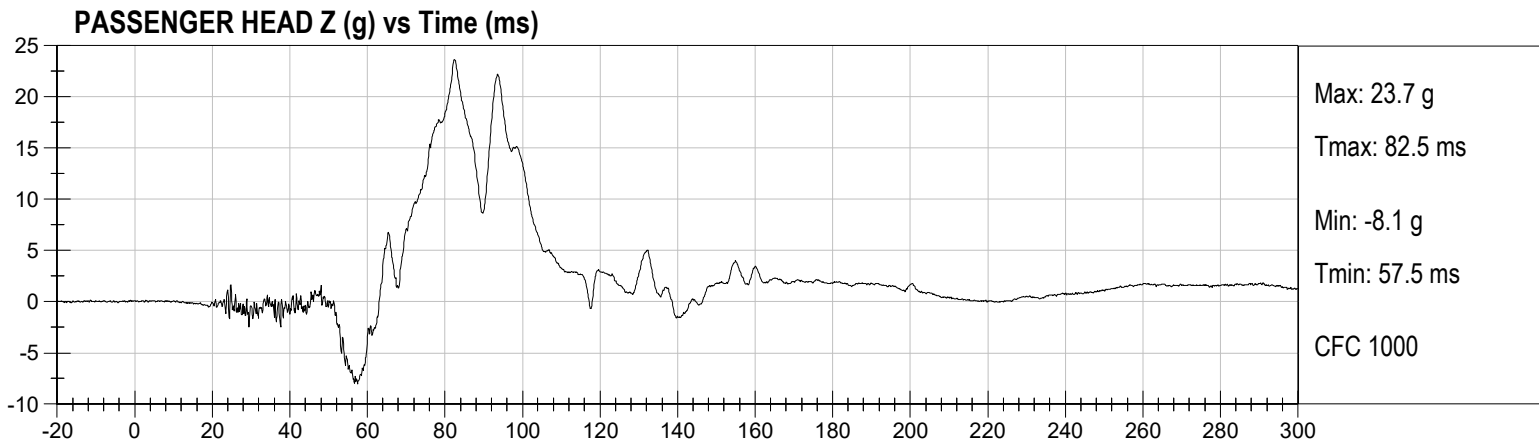
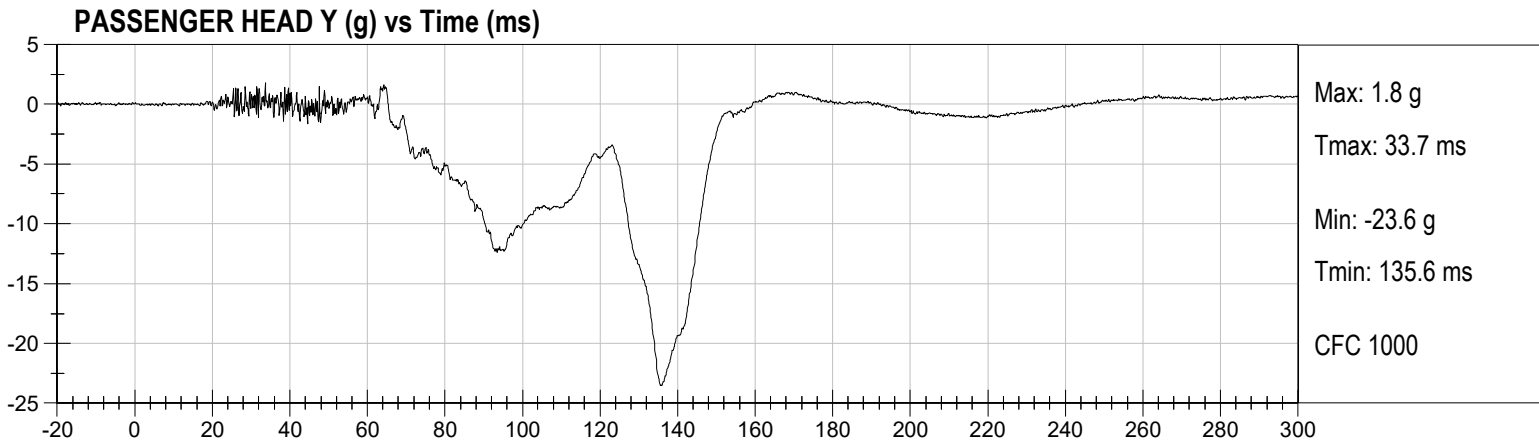
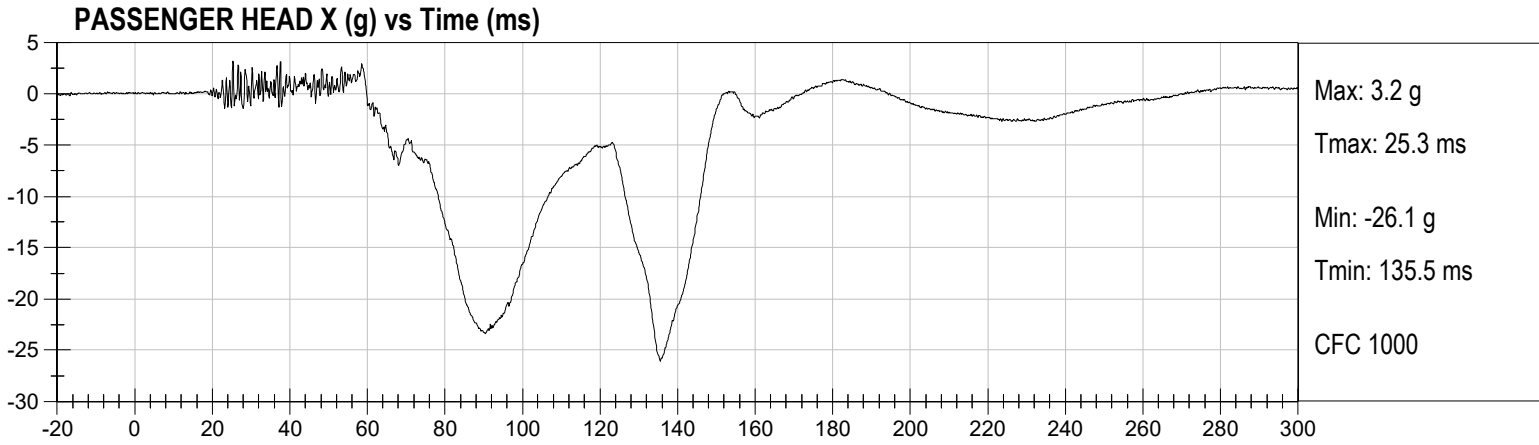

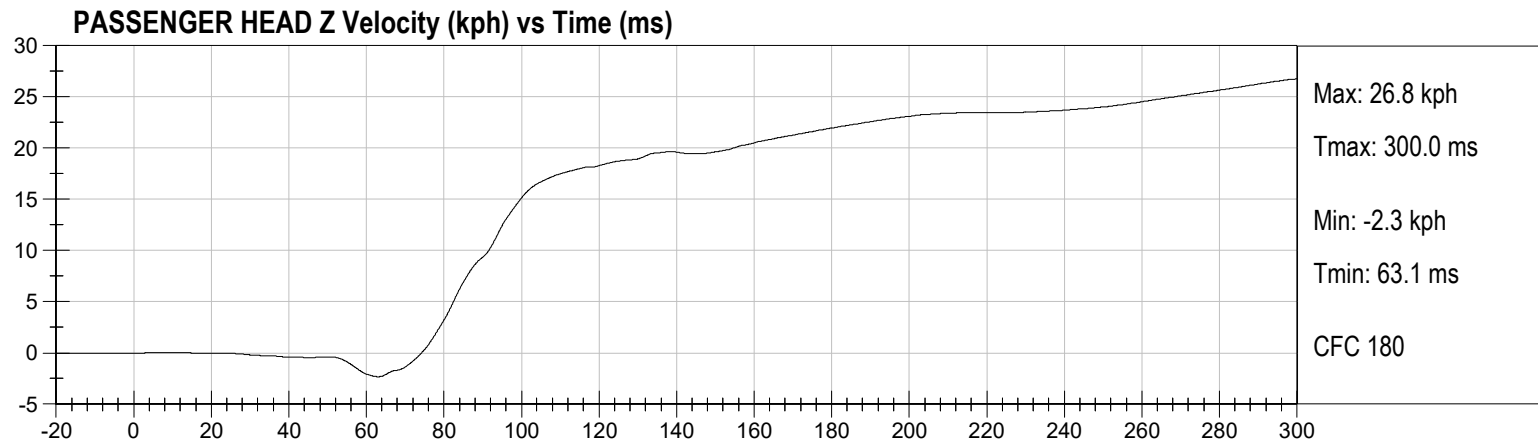
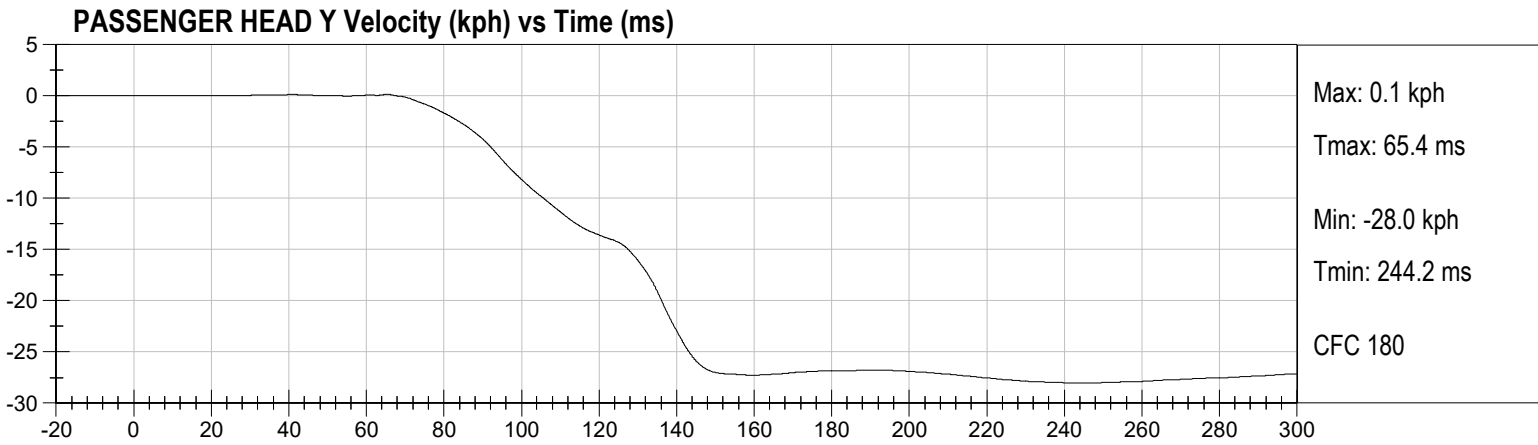
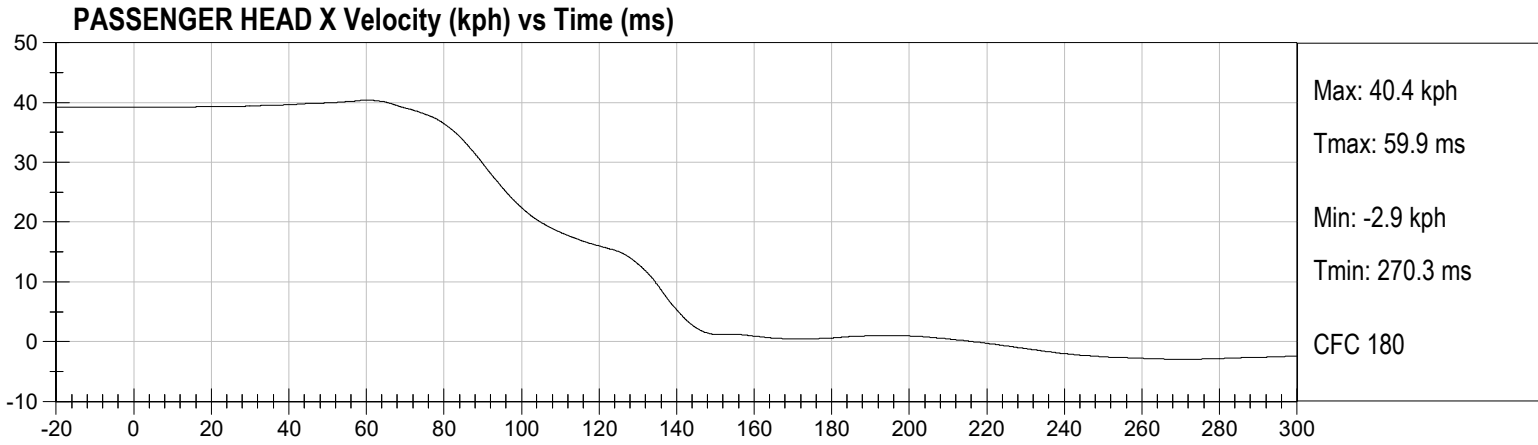

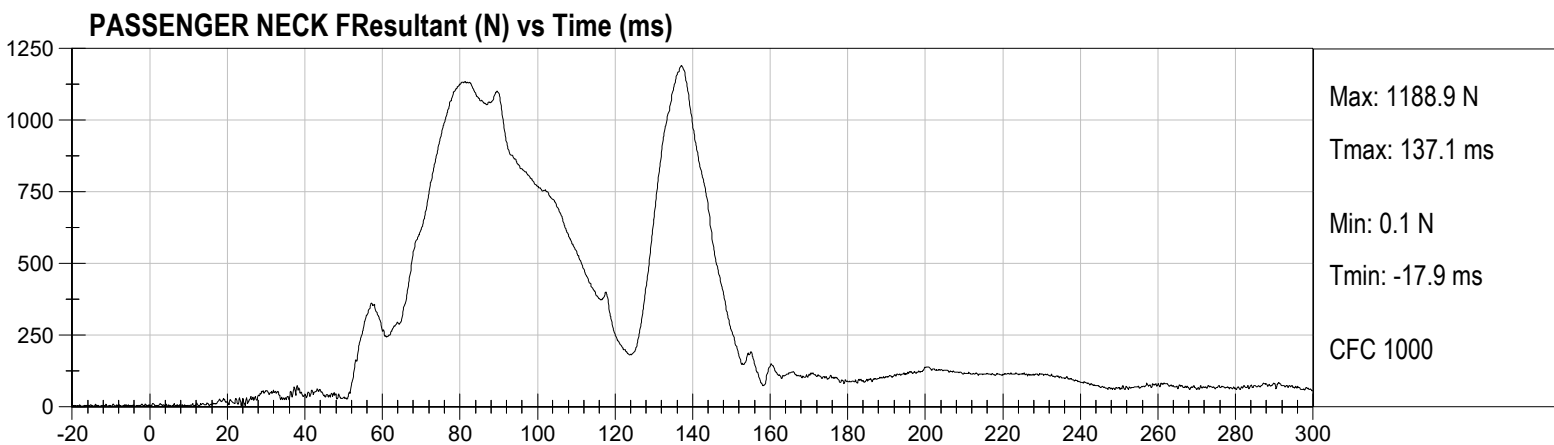
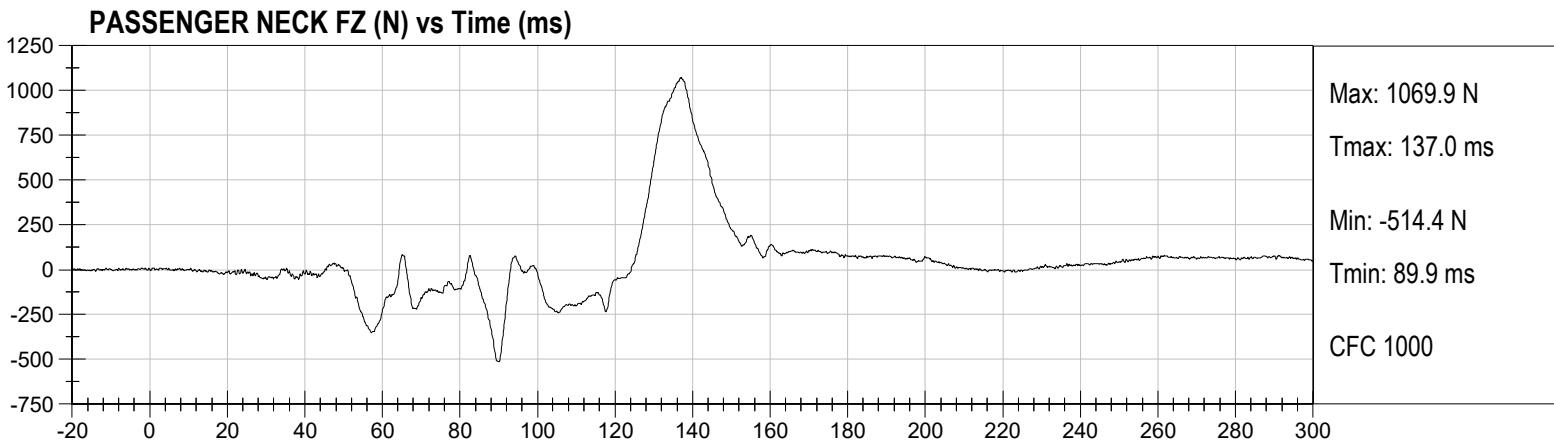
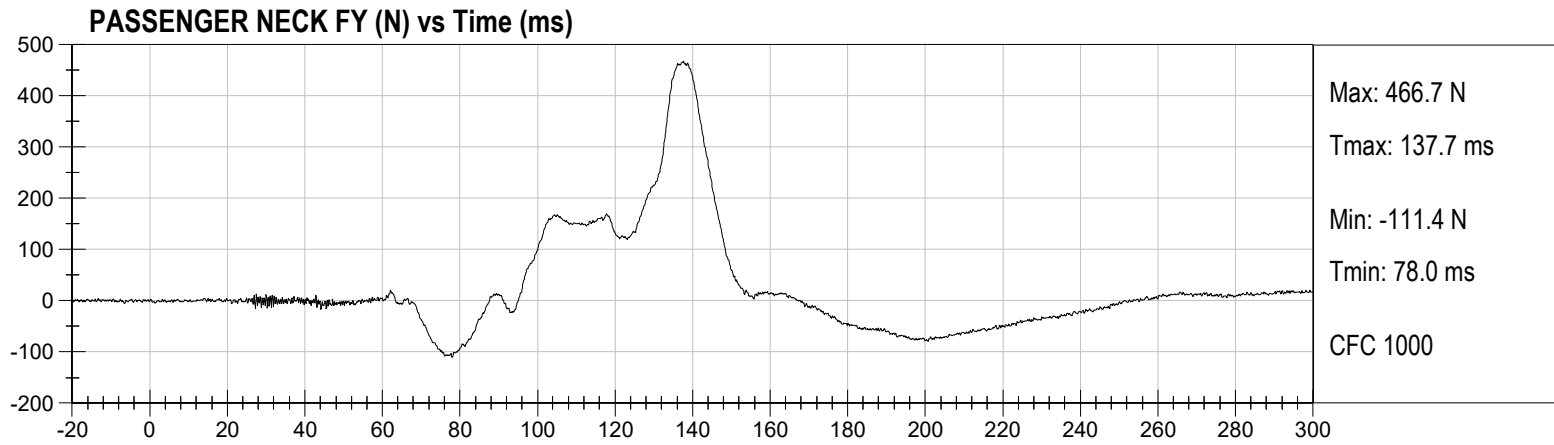
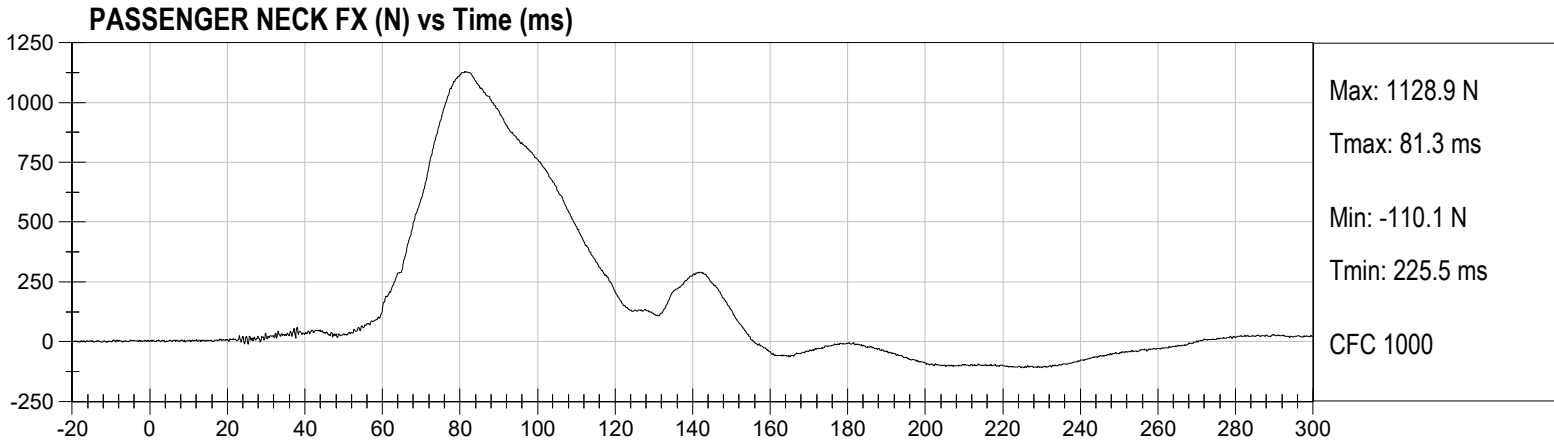

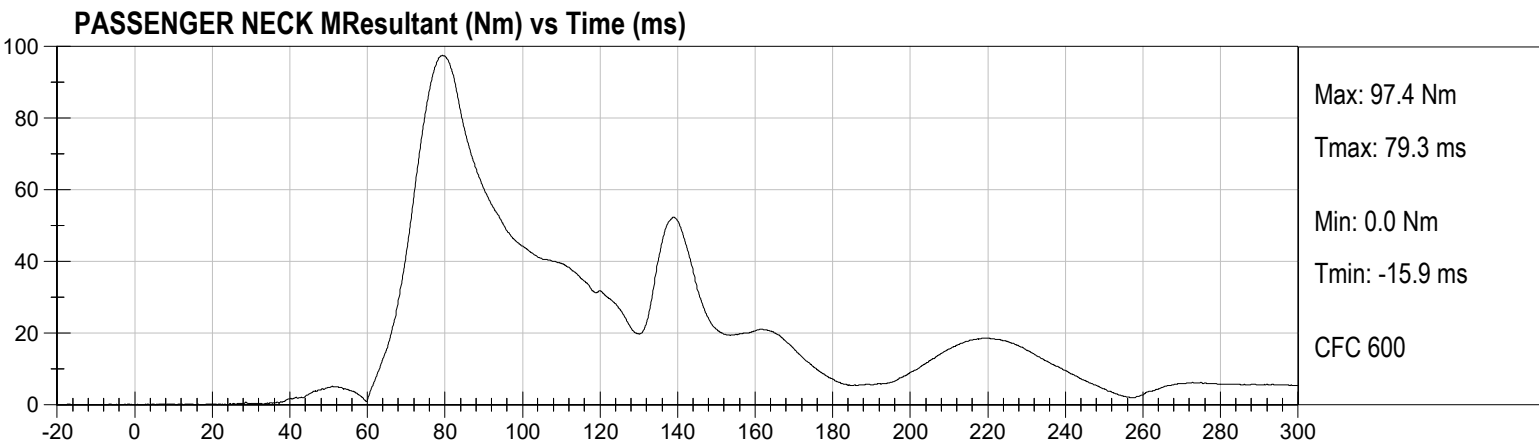
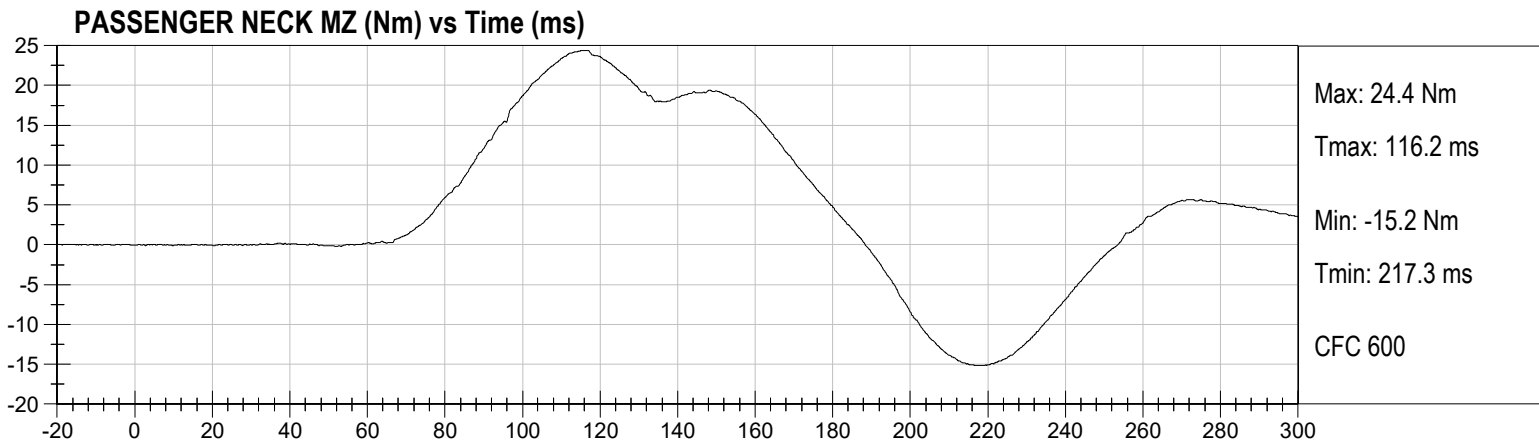
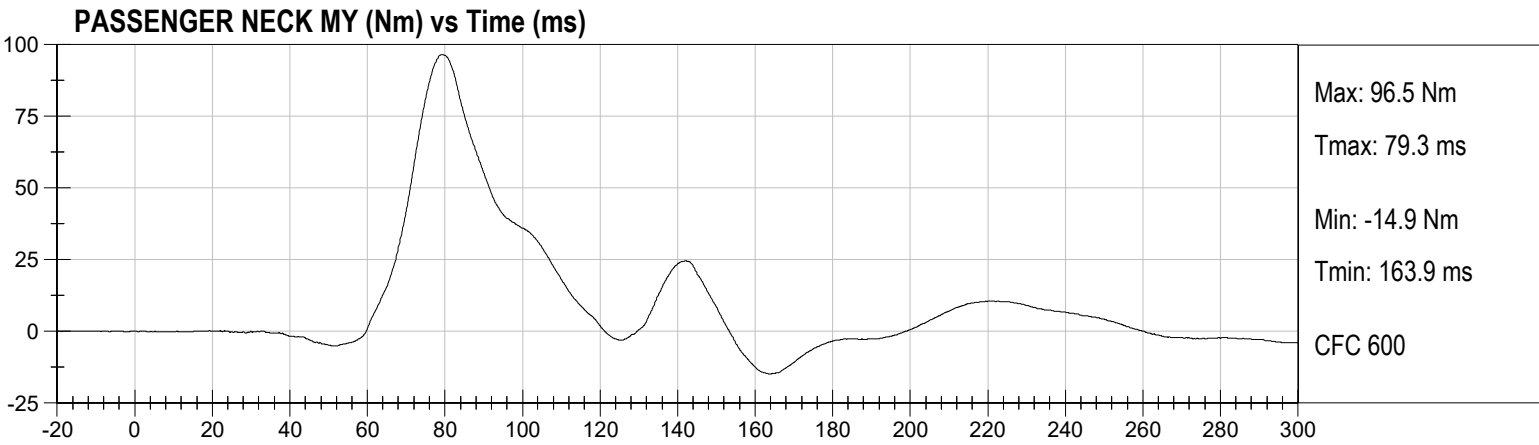
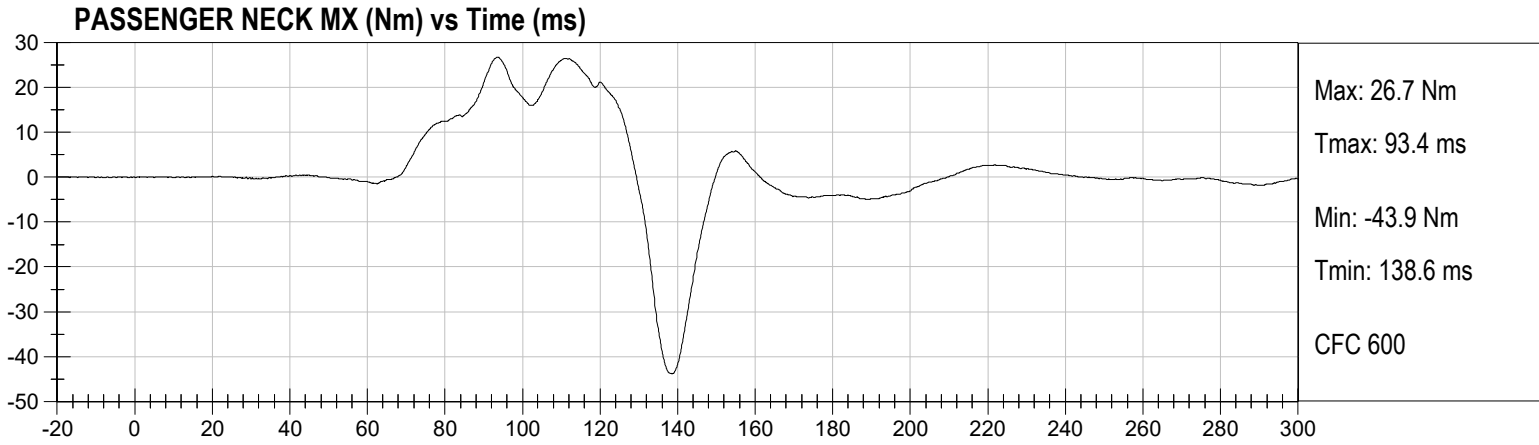

PASSENGER CHEST X (g) vs Time (ms)

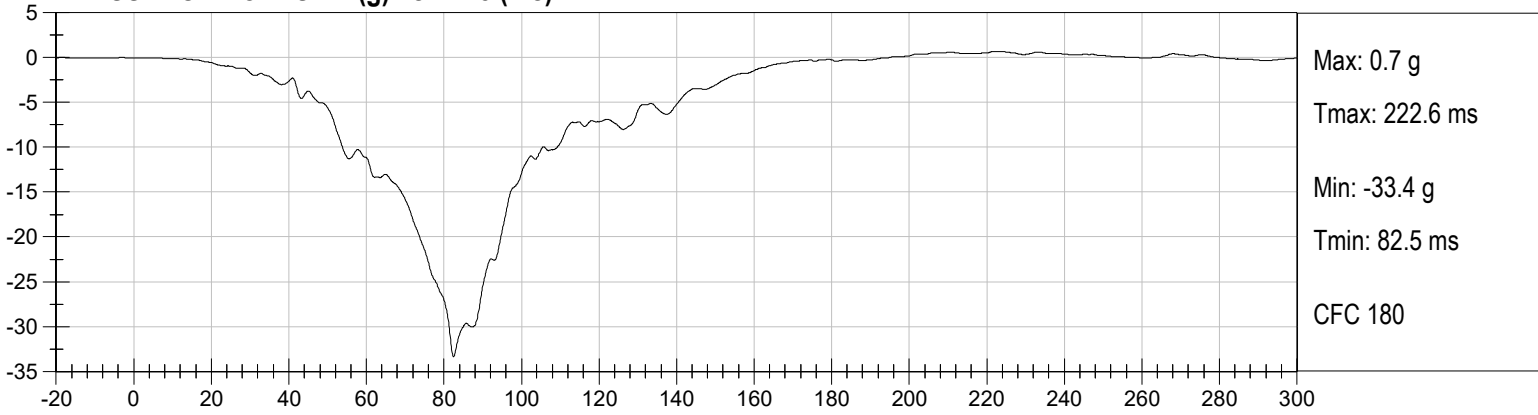

PASSENGER CHEST Y (g) vs Time (ms)

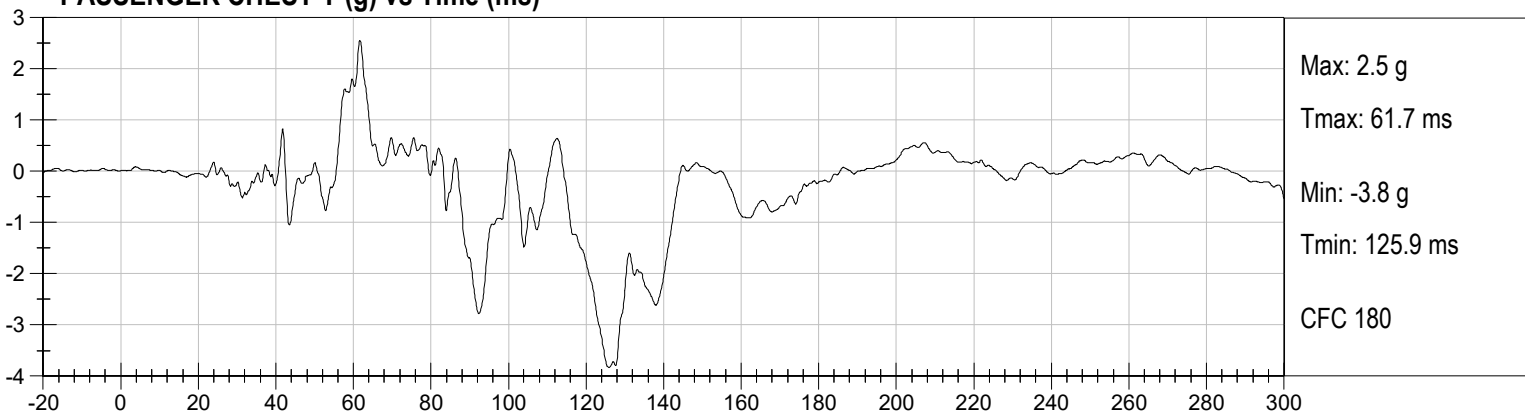

PASSENGER CHEST Z (g) vs Time (ms)

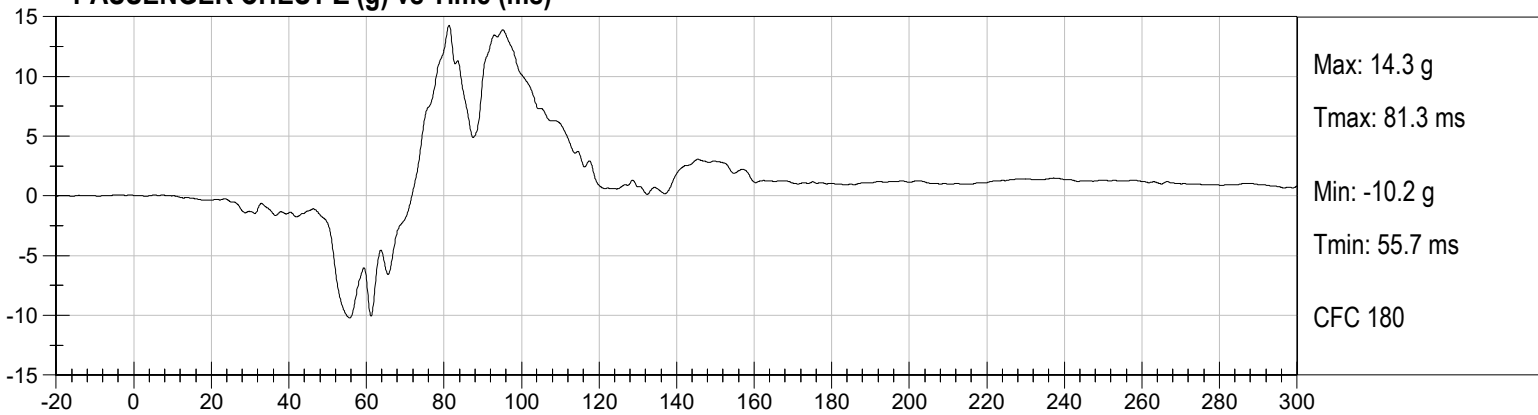

PASSENGER CHEST Resultant (g) vs Time (ms)

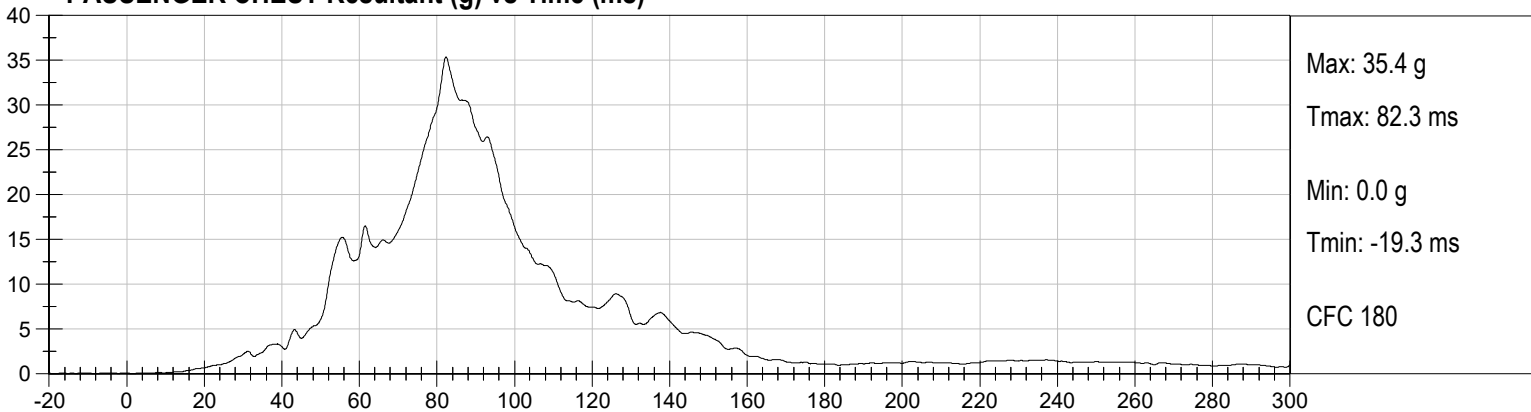

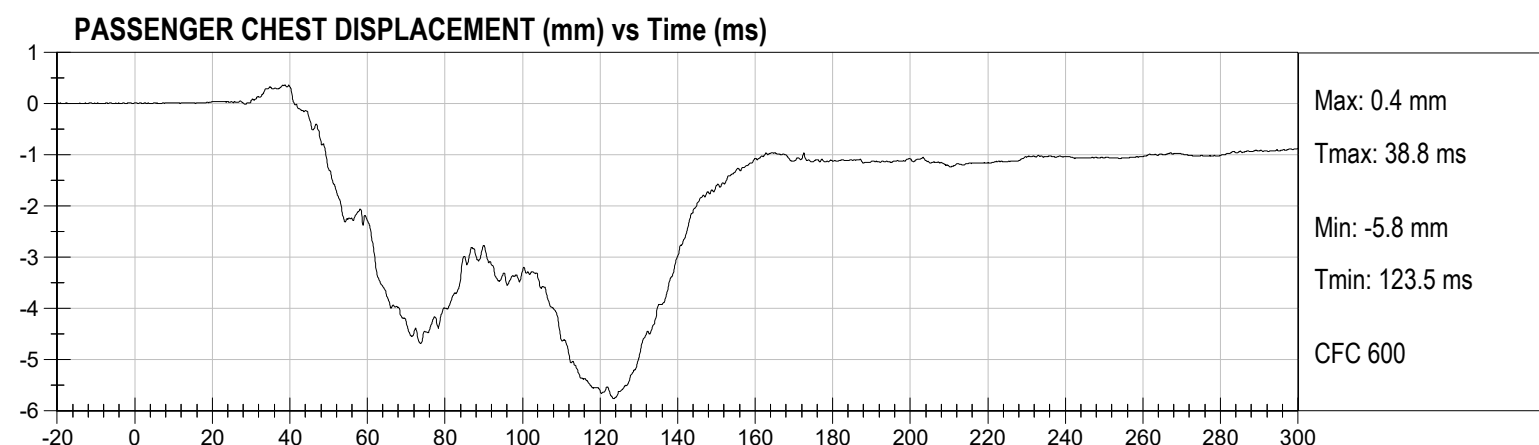
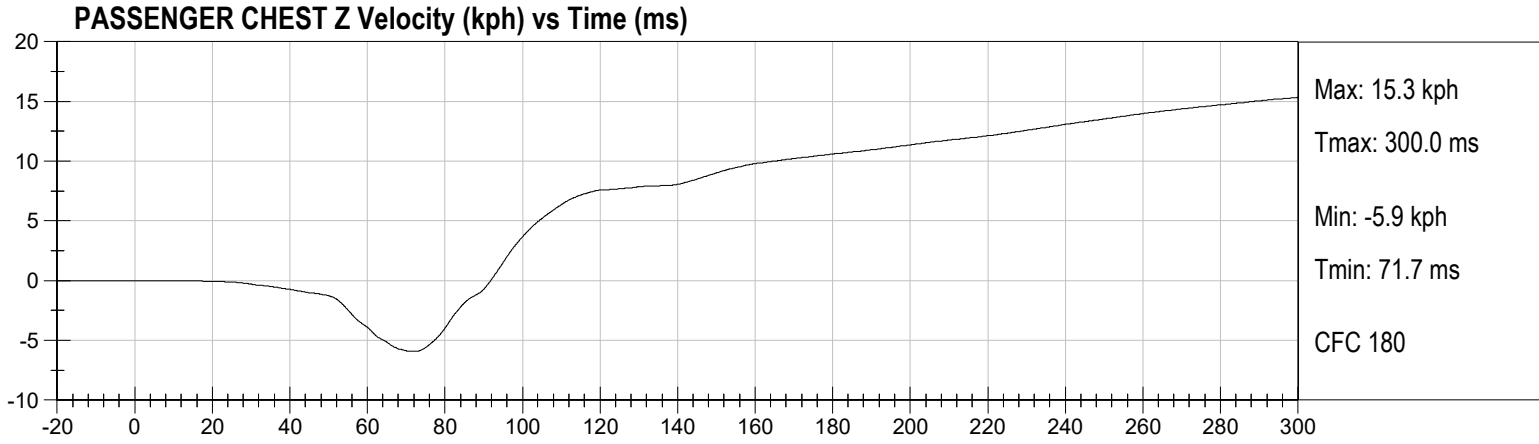
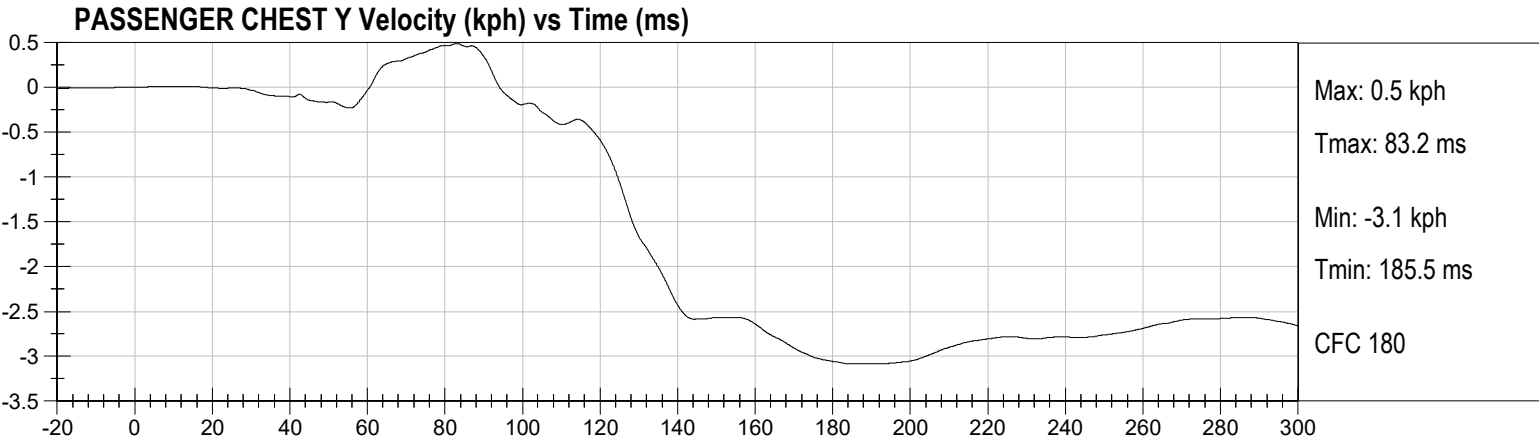
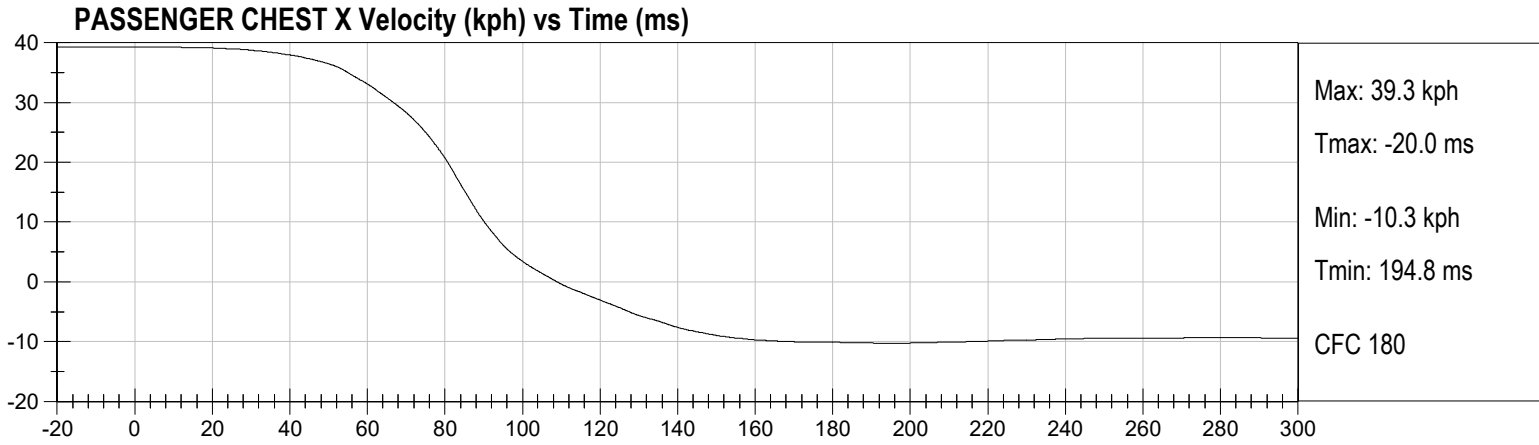

PASSENGER LEFT FEMUR (N) vs Time (ms)

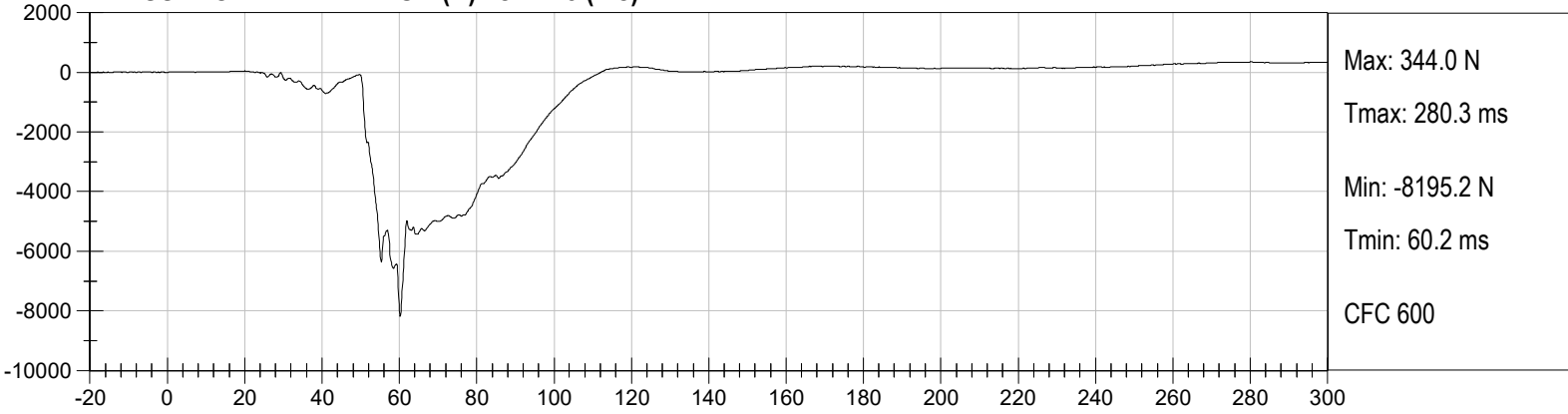

PASSENGER RIGHT FEMUR (N) vs Time (ms)

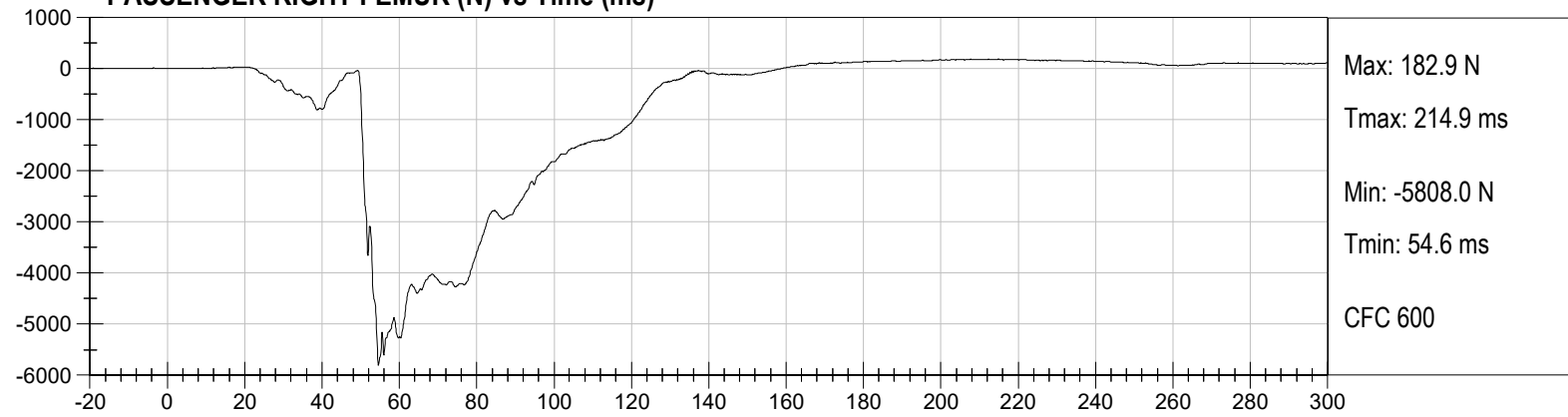

DRIVER Nij (NTF) () vs Time (ms)

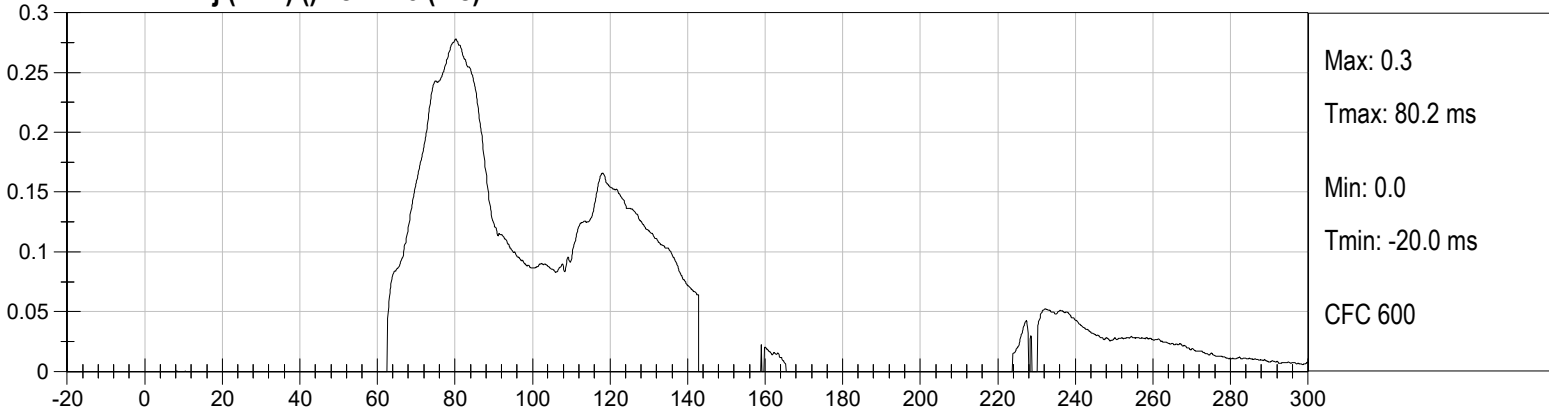

DRIVER Nij (NTE) () vs Time (ms)

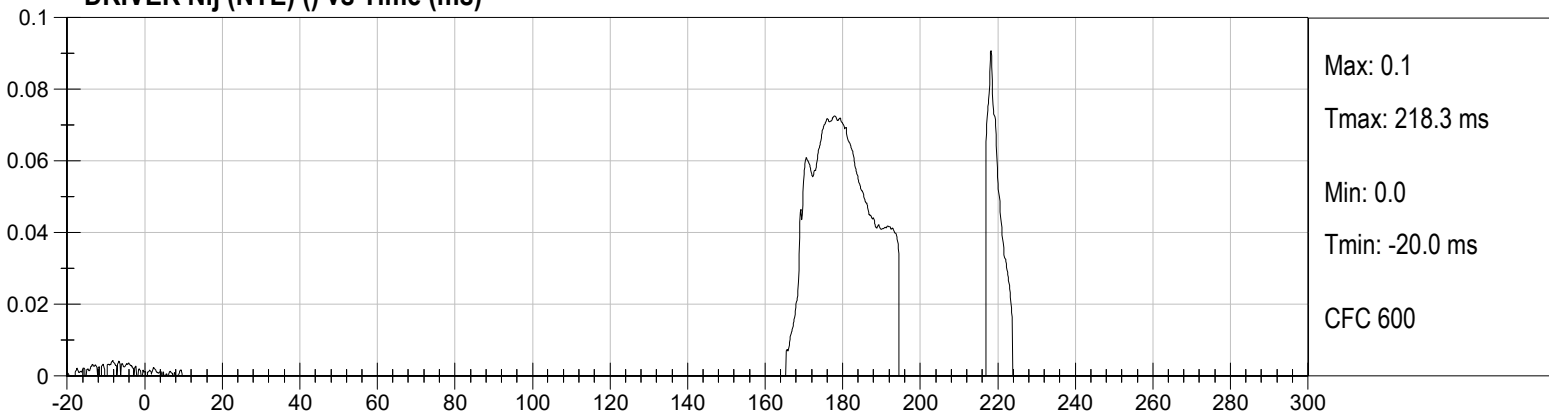

DRIVER Nij (NCF) () vs Time (ms)

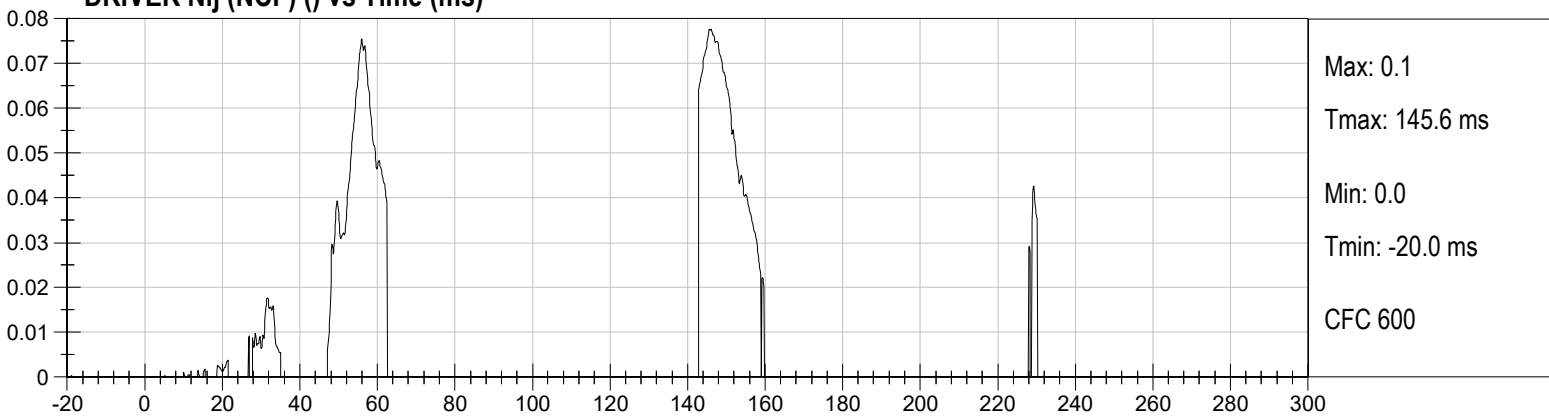

DRIVER Nij (NCE) () vs Time (ms)

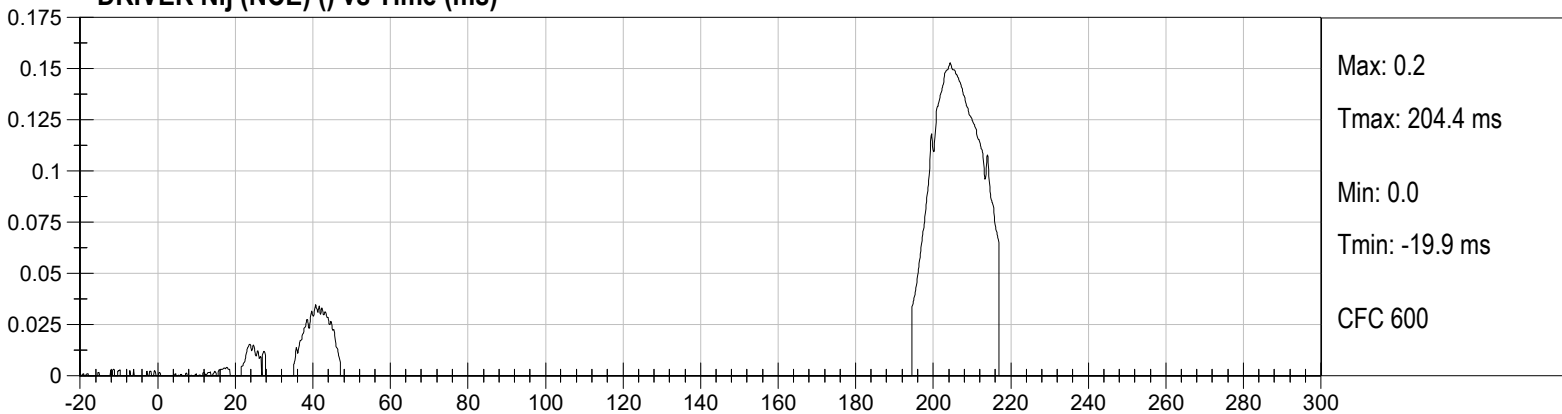

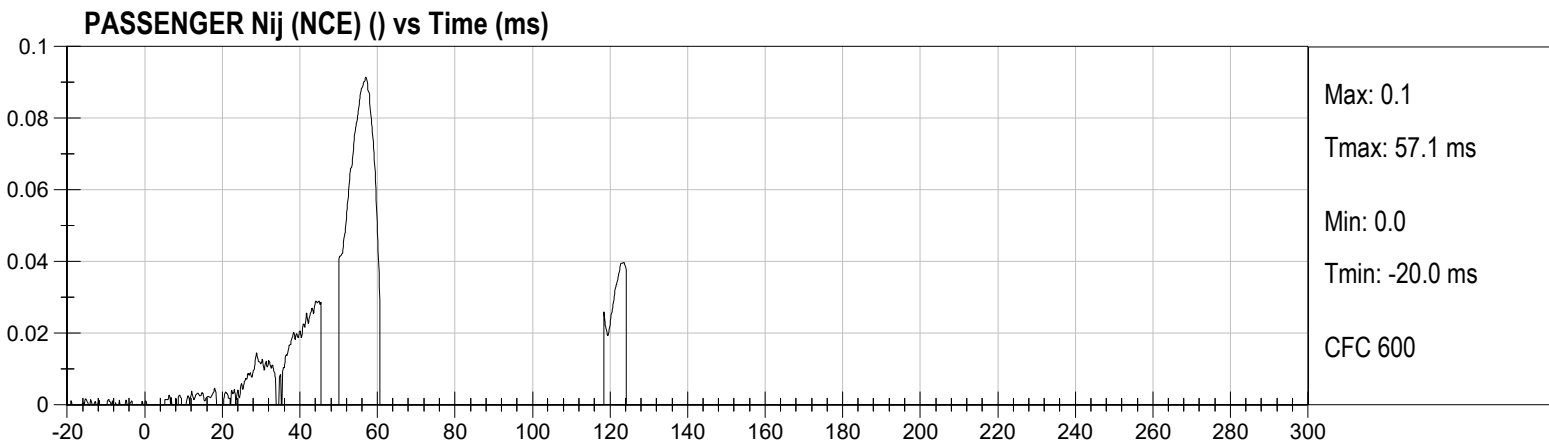
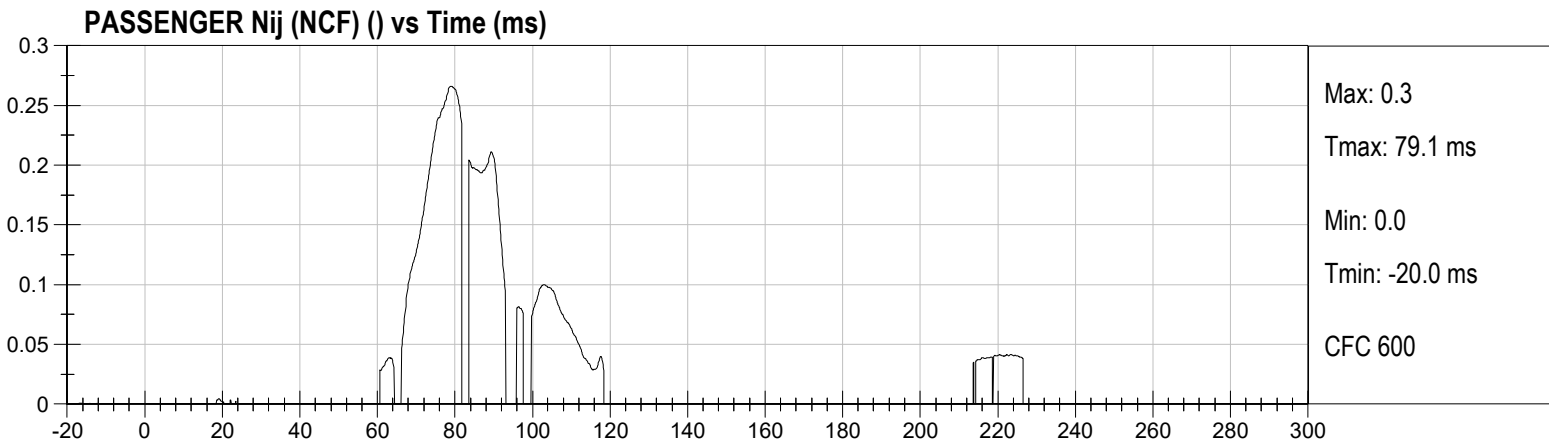
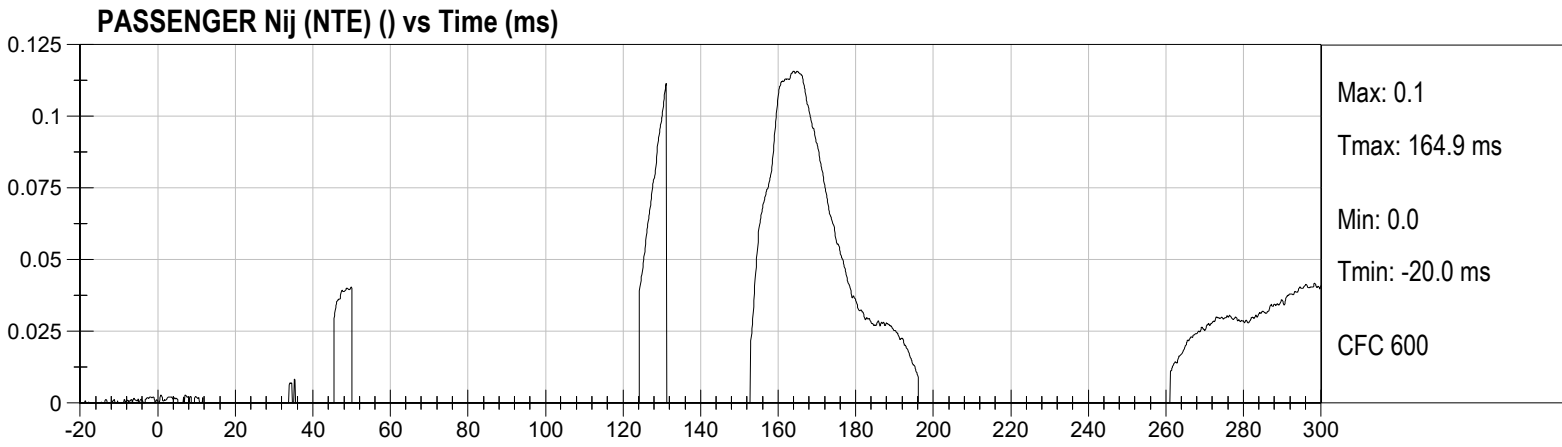
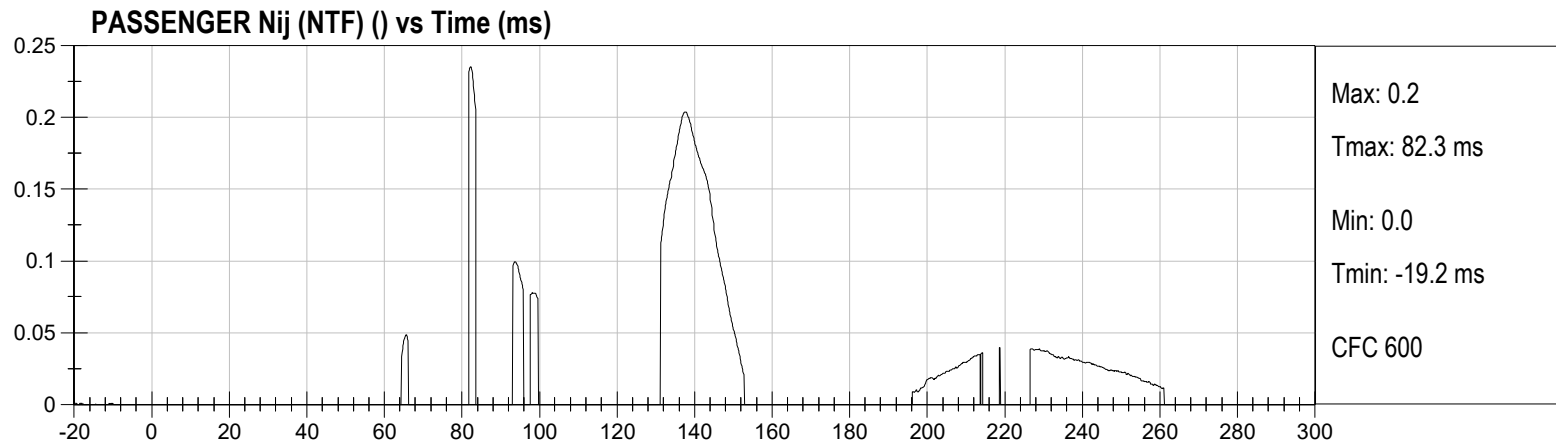

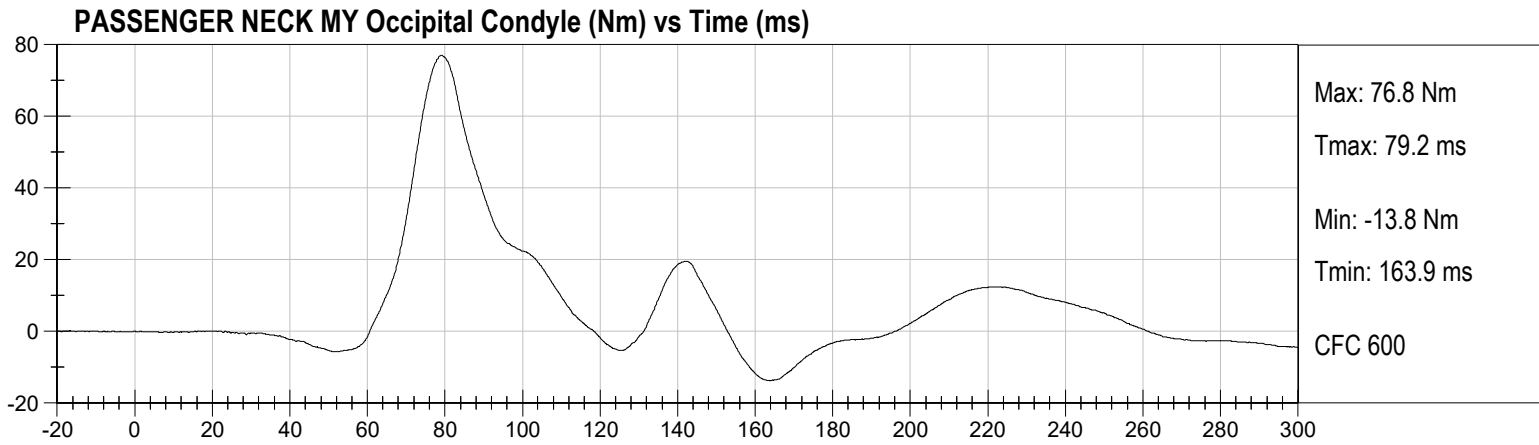
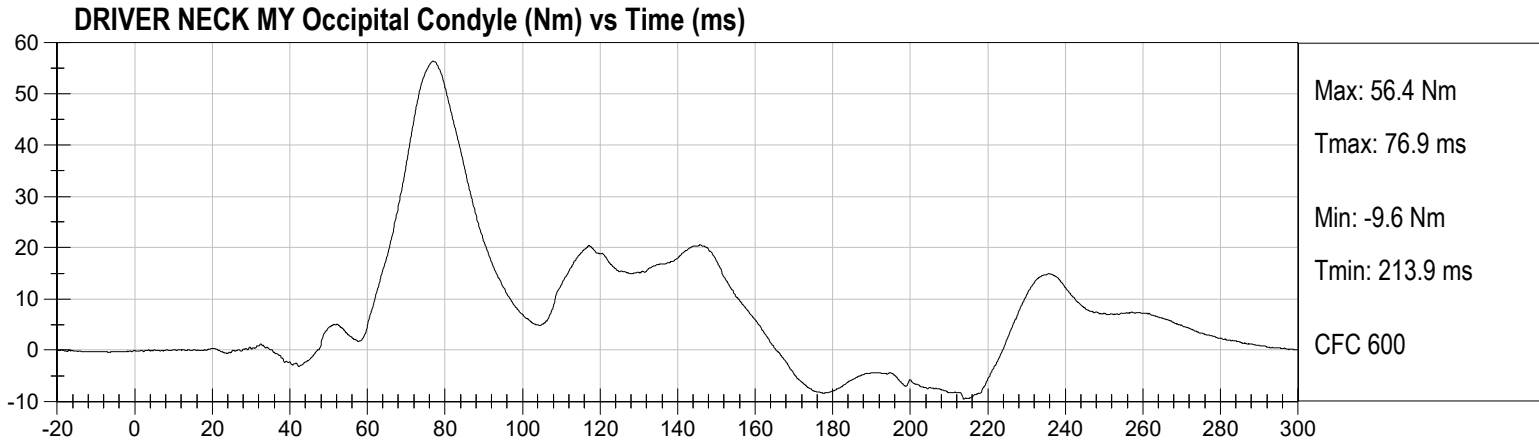

LEFT REAR SEAT CROSSMEMBER X (g) vs Time (ms)

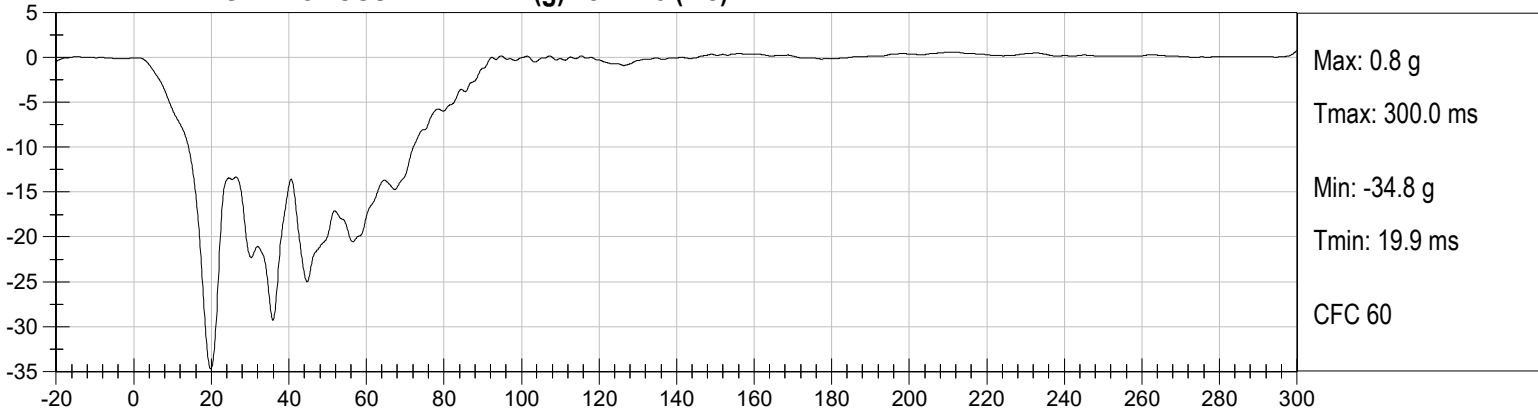

LEFT REAR SEAT CROSSMEMBER X Velocity (kph) vs Time (ms)

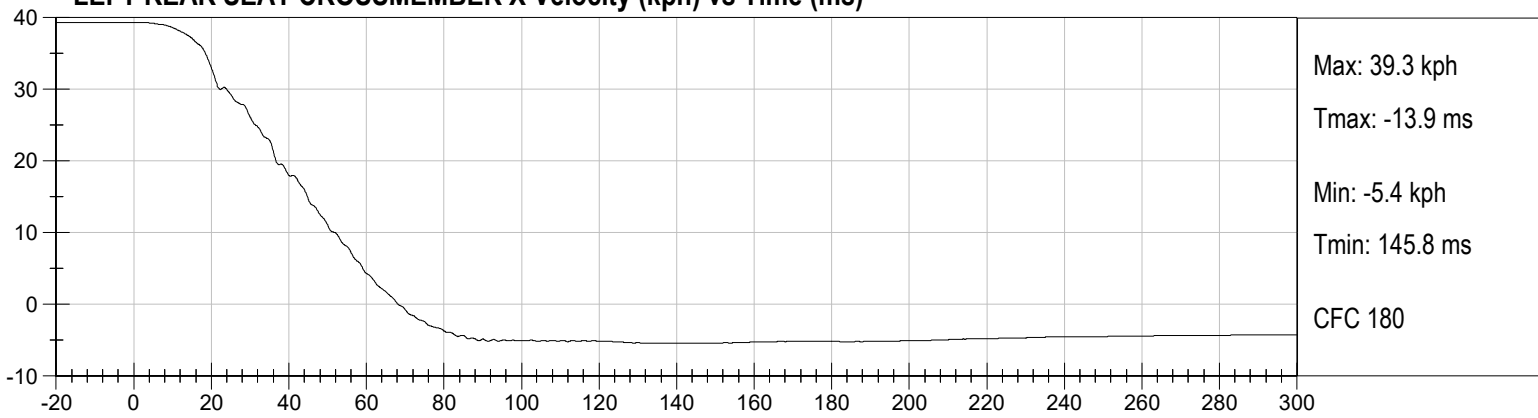

RIGHT REAR SEAT CROSSMEMBER X (g) vs Time (ms)

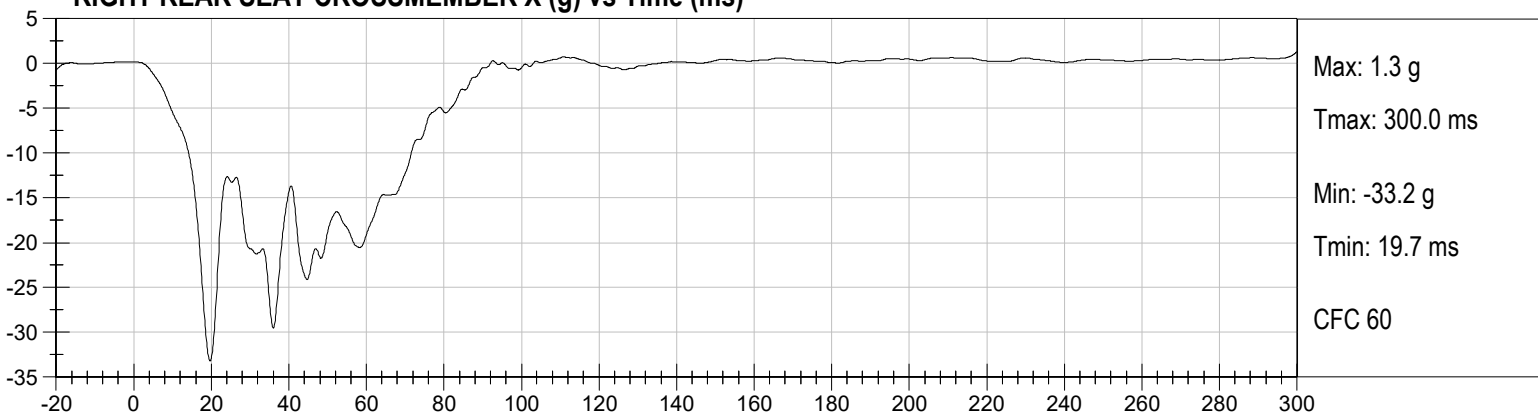

RIGHT REAR SEAT CROSSMEMBER X Velocity (kph) vs Time (ms)

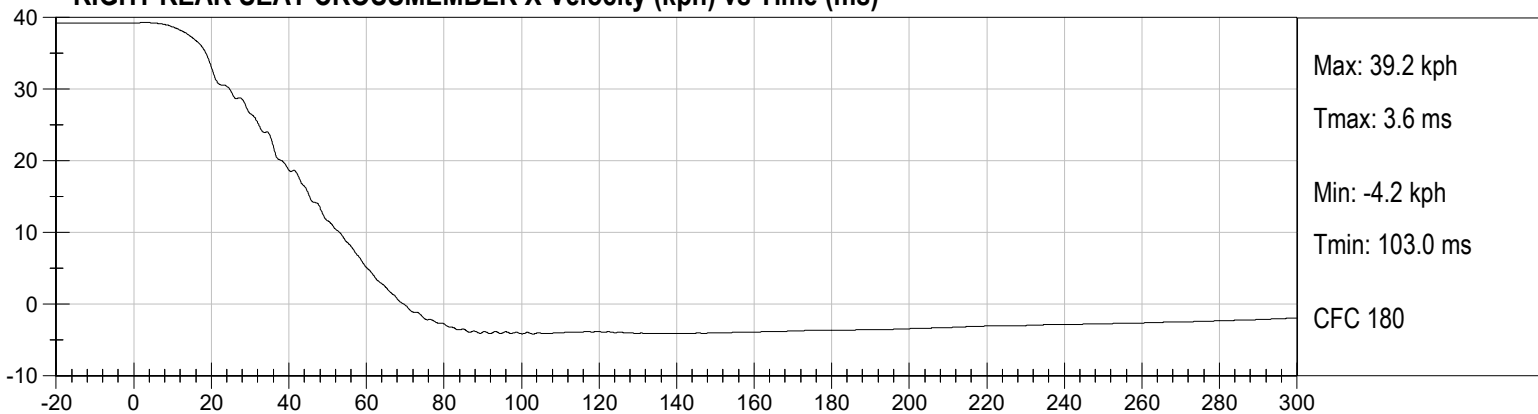

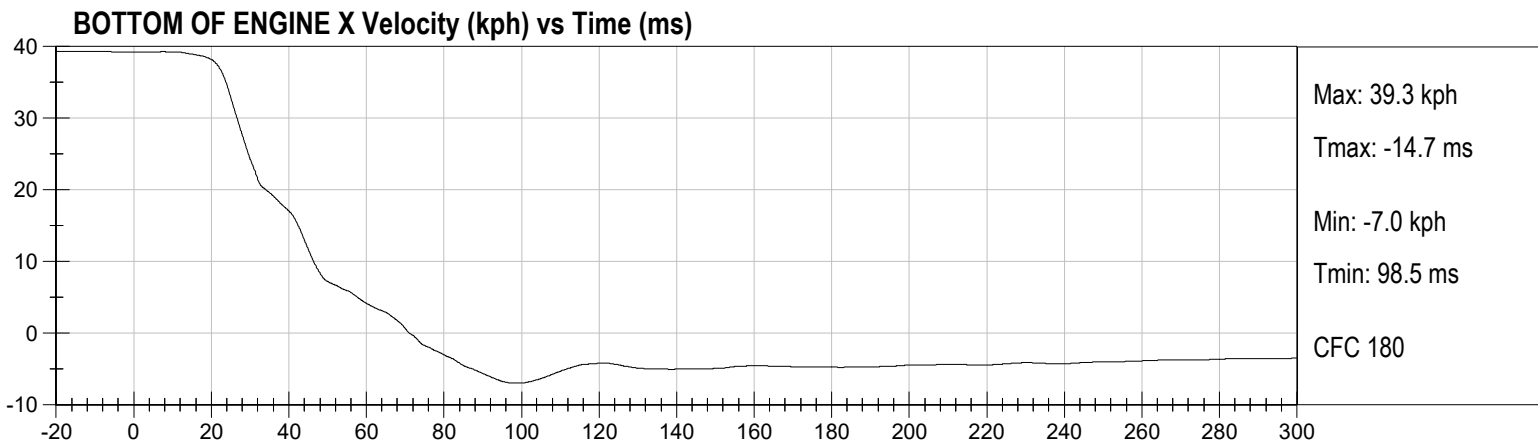
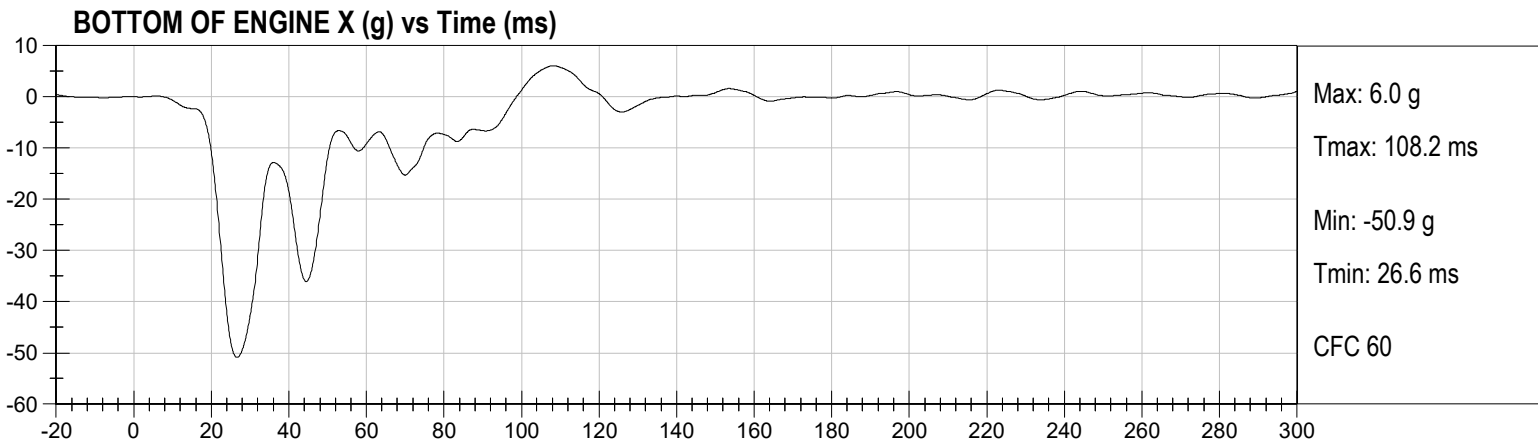
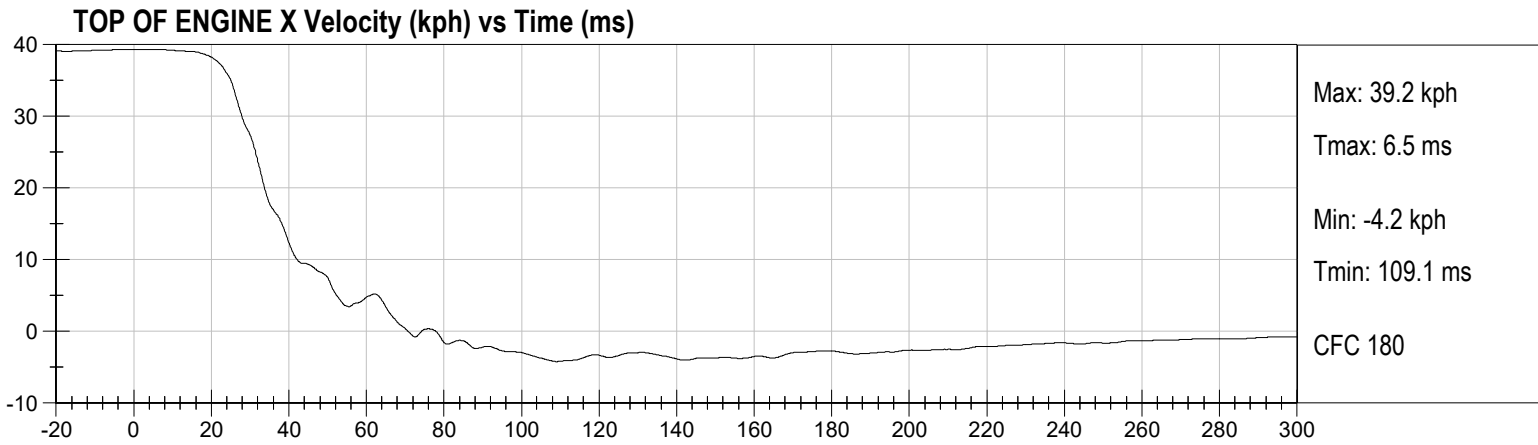
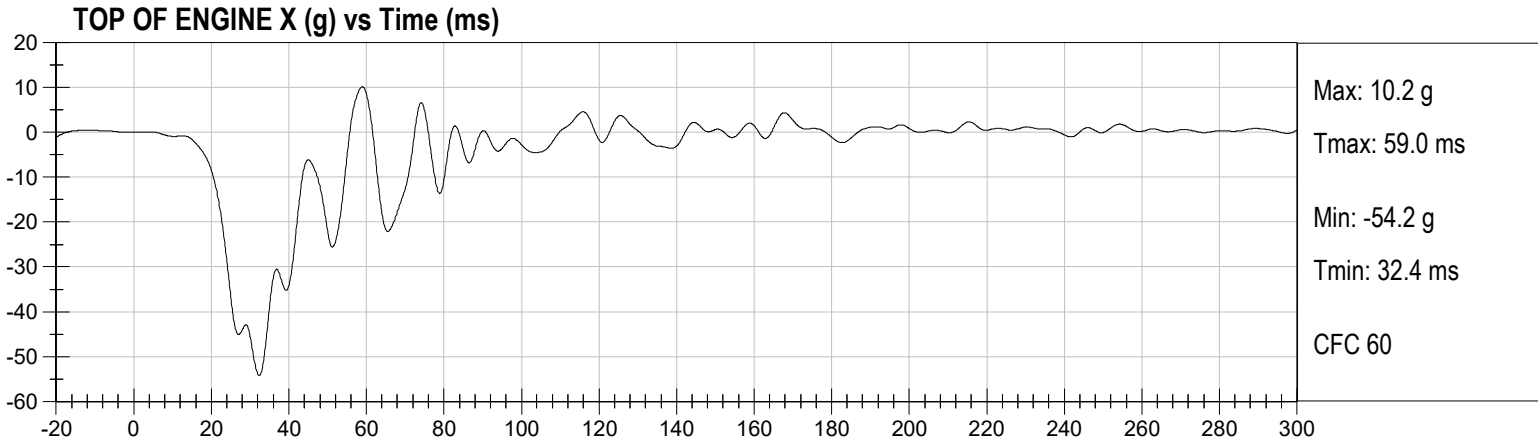

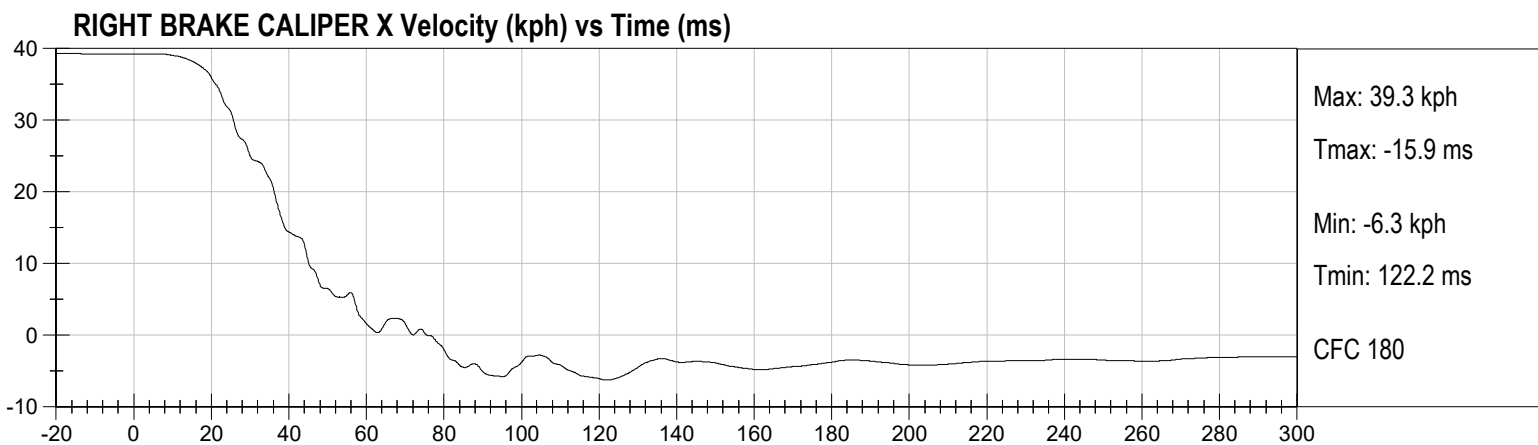
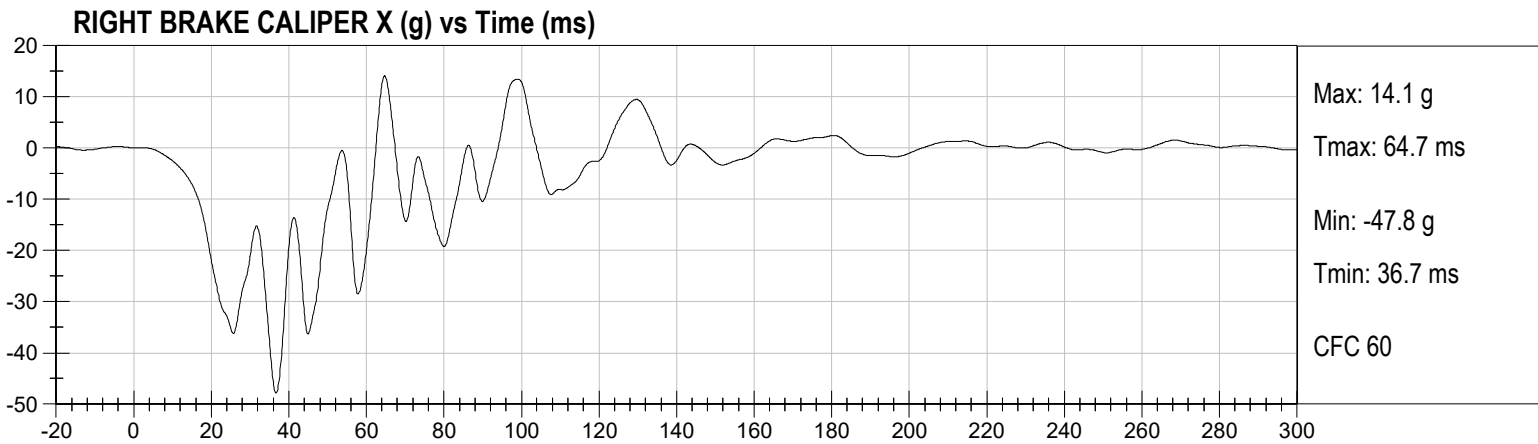
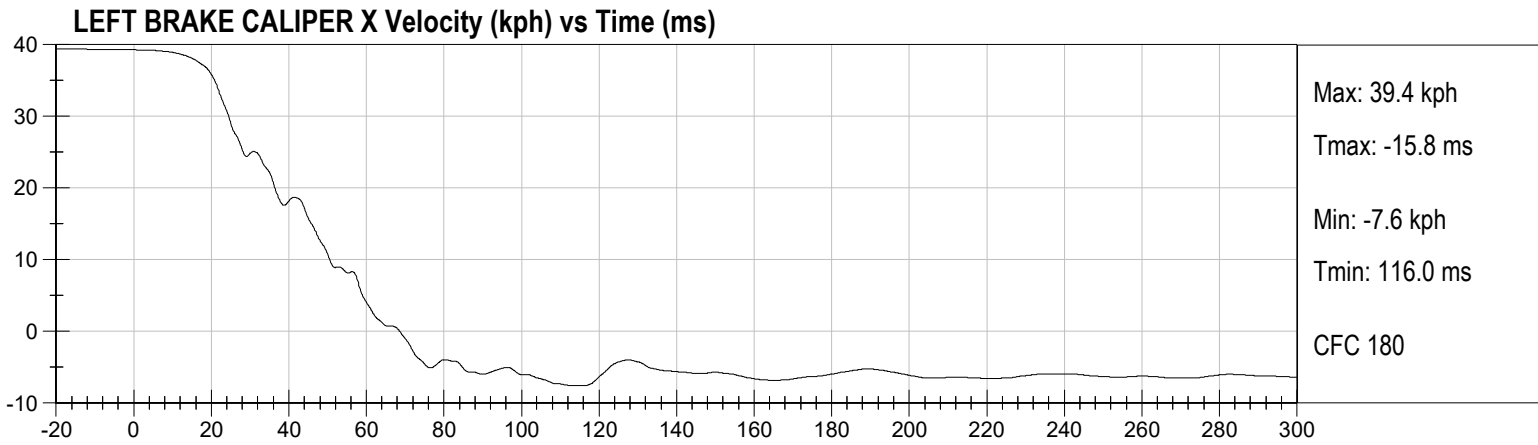
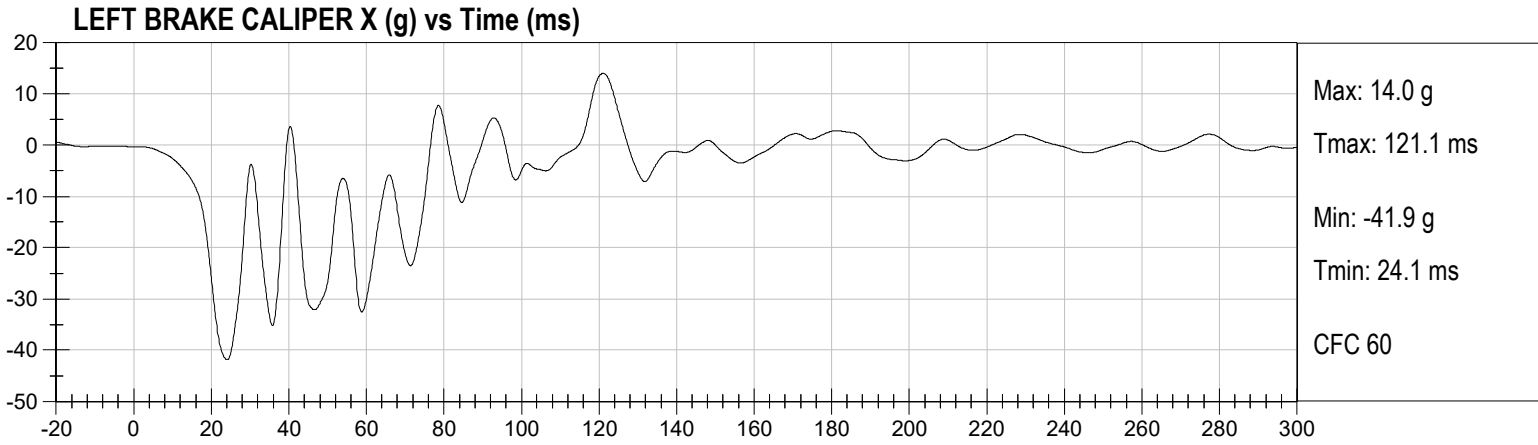

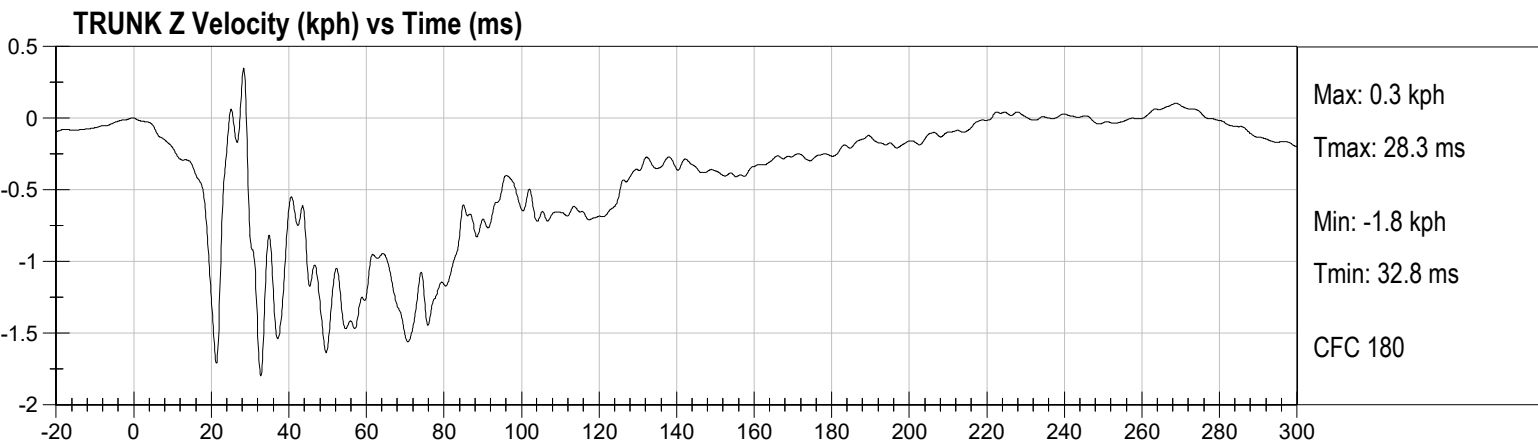
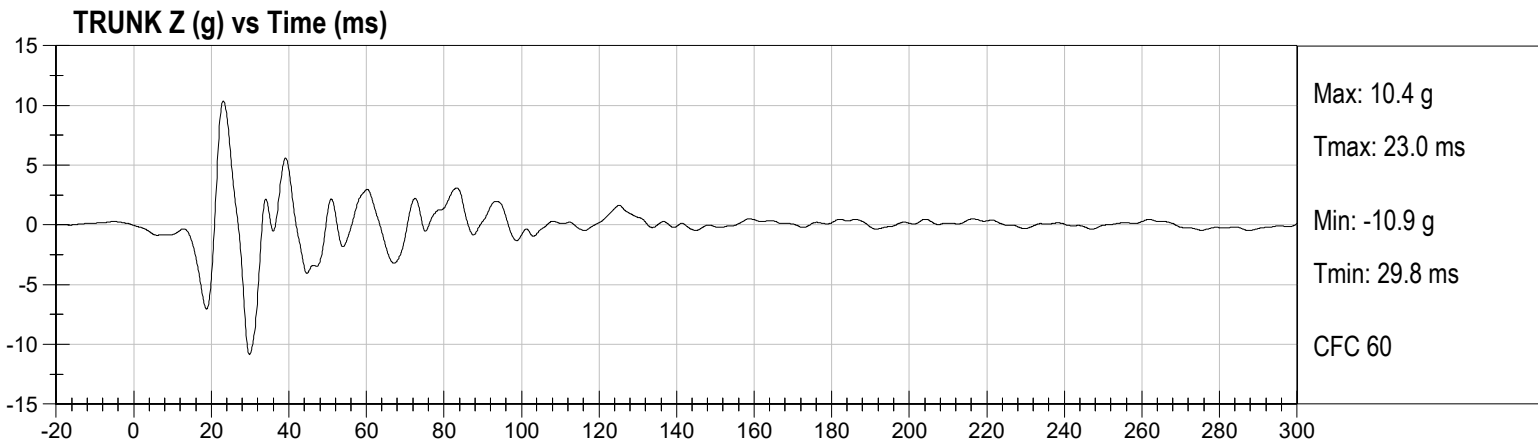
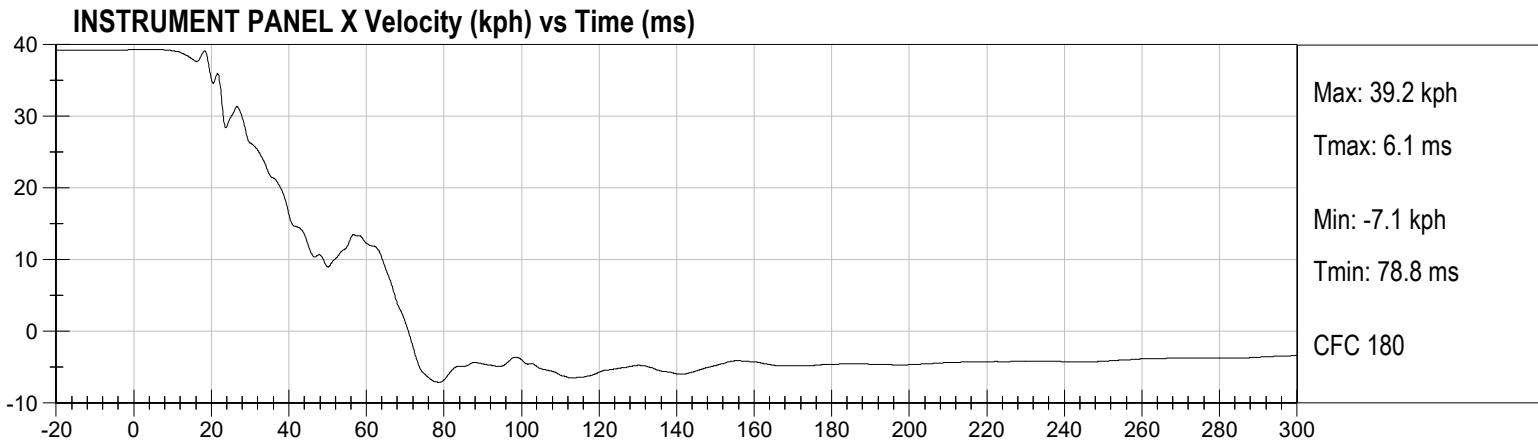
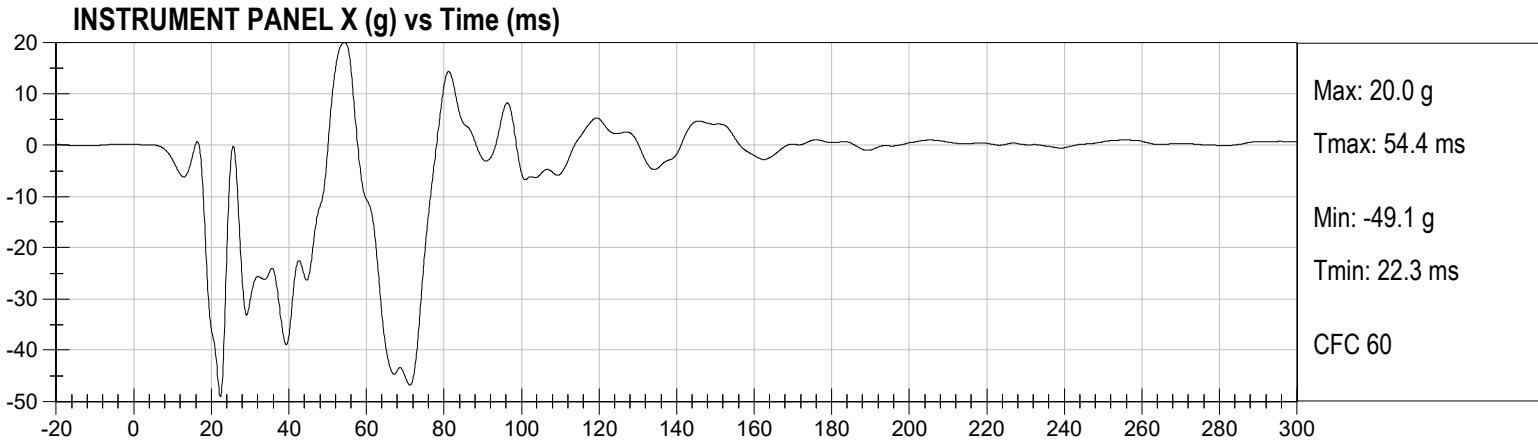

APPENDIX B

CRASH TEST PHOTOGRAPHS

TABLE OF PHOTOGRAPHS

	<u>Page No.</u>
Photo No. 1. Vehicle Certification Label	B-1
Photo No. 2. Tire Placard	B-2
Photo No. 3. Pre-Test Front View of Test Vehicle	B-3
Photo No. 4. Post-Test Front View of Test Vehicle	B-4
Photo No. 5. Pre-Test Left Side View of Test Vehicle	B-5
Photo No. 6. Post-Test Left Side View of Test Vehicle	B-6
Photo No. 7. Pre-Test Right Side View of Test Vehicle	B-7
Photo No. 8. Post-Test Right Side View of Test Vehicle	B-8
Photo No. 9. Pre-Test Left Front Three-Quarter View of Test Vehicle	B-9
Photo No. 10. Post-Test Left Front Three-Quarter View of Test Vehicle	B-10
Photo No. 11. Pre-Test Right Front Three-Quarter View of Test Vehicle	B-11
Photo No. 12. Post-Test Right Front Three-Quarter View of Test Vehicle	B-12
Photo No. 13. Pre-Test Right Rear Three-Quarter View of Test Vehicle	B-13
Photo No. 14. Post-Test Right Rear Three-Quarter View of Test Vehicle	B-14
Photo No. 15. Pre-Test Left Rear Three-Quarter View of Test Vehicle	B-15
Photo No. 16. Post-Test Left Rear Three-Quarter View of Test Vehicle	B-16
Photo No. 17. Pre-Test Rear View of Test Vehicle	B-17
Photo No. 18. Post-Test Rear View of Test Vehicle	B-18
Photo No. 19. Pre-Test Windshield View	B-19
Photo No. 20. Post-Test Windshield View	B-20
Photo No. 21. Pre-Test Front Compartment View	B-21
Photo No. 22. Post-Test Front Compartment View	B-22
Photo No. 23. Pre-Test Charging Port View	B-23
Photo No. 24. Post-Test Charging Port View	B-24
Photo No. 25. Pre-Test Front Underbody View	B-25
Photo No. 26. Post-Test Front Underbody View	B-26
Photo No. 27. Pre-Test Mid Underbody View	B-27
Photo No. 28. Post-Test Mid Underbody View	B-28
Photo No. 29. Pre-Test Mid Rear Underbody View	B-29
Photo No. 30. Post-Test Mid Rear Underbody View	B-30
Photo No. 31. Pre-Test Rear Underbody View	B-31
Photo No. 32. Post-Test Rear Underbody View	B-32
Photo No. 33. Pre-Test Driver Dummy Front View (head position)	B-33

	<u>Page No.</u>
Photo No. 34. Post-Test Driver Dummy Front View (head position)	B-34
Photo No. 35. Pre-Test Driver Dummy Position Left Side View	B-35
Photo No. 36. Post-Test Driver Dummy Position Left Side View	B-36
Photo No. 37. Pre-Test Driver Dummy Position Left Side View (door open)	B-37
Photo No. 38. Post-Test Driver Dummy Position Left Side View (door open)	B-38
Photo No. 39. Pre-Test Driver Dummy Seat Position	B-39
Photo No. 40. Post-Test Driver Dummy Seat Position	B-40
Photo No. 41. Pre-Test Driver Dummy Feet Position	B-41
Photo No. 42. Post-Test Driver Dummy Feet Position	B-42
Photo No. 43. Pre-Test Driver Side Knee Bolster View	B-43
Photo No. 44. Post-Test Driver Side Knee Bolster View	B-44
Photo No. 45. Post-Test Driver Dummy Airbag Contact	B-45
Photo No. 46. Post-Test Driver Dummy Knee Contact	B-46
Photo No. 47. Post-Test Driver Dummy Head Contact (windshield)	B-47
Photo No. 48. Post-Test Driver Dummy Head Contact (visor)	B-48
Photo No. 49. Pre-Test Passenger Dummy Front View (head position)	B-49
Photo No. 50. Post-Test Passenger Dummy Front View (head position)	B-50
Photo No. 51. Pre-Test Passenger Dummy Position Right Side View	B-51
Photo No. 52. Post-Test Passenger Dummy Position Right Side View	B-52
Photo No. 53. Pre-Test Passenger Dummy Position Right Side View (door open)	B-53
Photo No. 54. Post-Test Passenger Dummy Position Right Side View (door open)	B-54
Photo No. 55. Pre-Test Passenger Dummy Seat Position	B-55
Photo No. 56. Post-Test Passenger Dummy Seat Position	B-56
Photo No. 57. Pre-Test Passenger Dummy Feet Position	B-57
Photo No. 58. Post-Test Passenger Dummy Feet Position	B-58
Photo No. 59. Pre-Test Passenger Side Knee Bolster View	B-59
Photo No. 60. Post-Test Passenger Side Knee Bolster View	B-60
Photo No. 61. Post-Test Passenger Dummy Airbag Contact	B-61
Photo No. 62. Post-Test Passenger Dummy Knee Contact	B-62
Photo No. 63. Post-Test Passenger Dummy Head Contact (visor)	B-63
Photo No. 64. Rollover 90 Degrees	B-64
Photo No. 65. Rollover 180 Degrees	B-65
Photo No. 66. Rollover 270 Degrees	B-66
Photo No. 67. Rollover 360 Degrees	B-67
Photo No. 68. Temperature Plot	B-68
Photo No. 69. Pre-Test Manual High Voltage Service Disconnect in Place	B-69
Photo No. 70. Pre-Test Manual Service Disconnect Removed	B-70

		<u>Page No.</u>
Photo No. 71.	Pre-Test Voltage Monitoring Leads Attached to Electric Energy Storage System	B-71
Photo No. 72.	Pre-Test View of Installed Isolation Interface Port	B-72
Photo No. 73.	Post-Test View of Installed Isolation Interface Port	B-73

 MFD BY GENERAL MOTORS LLC

05/24

GVWR 4532 KG
 9990 LB

GAWR FRT 2404 KG
 5300 LB

GAWR RR 2608 KG
 5750 LB

THIS VEHICLE CONFORMS TO ALL
 APPLICABLE U.S. FEDERAL MOTOR
 VEHICLE SAFETY STANDARDS IN EFFECT
 ON THE DATE OF MANUFACTURE
 SHOWN ABOVE.

1GC10UED7RU206395

TYPE: TRUCK

MODEL: 75CT35843

TIRE SIZE
 FRT LT265/70R18ES
 RR LT265/70R18ES
 SPA LT225/65R18FS

RIM
 18X8.5J
 18X8.5J
 18X8J

8624



Photo No. 1. Vehicle Certification Label

1GC10UED7RU206395

TIRE AND LOADING INFORMATION

SEATING CAPACITY: TOTAL 5 FRONT 2 REAR 3

The combined weight of occupants and cargo must never exceed 804 kg or 1772 lbs.

TIRE	ORIGINAL SIZE	COLD TIRE PRESSURE
FRONT	LT265/70R18ES	420 kPa, 61 PSI
REAR	LT265/70R18ES	420 kPa, 61 PSI
SPARE	LT225/65R18FS	650 kPa, 94 PSI

SEE OWNER'S MANUAL FOR ADDITIONAL INFORMATION



Photo No. 2. Tire Placard



Photo No. 3. Pre-Test Front View of Test Vehicle



Photo No. 4. Post-Test Front View of Test Vehicle



Photo No. 5. Pre-Test Left Side View of Test Vehicle



Photo No. 6. Post-Test Left Side View of Test Vehicle



Photo No. 7. Pre-Test Right Side View of Test Vehicle



Photo No. 8. Post-Test Right Side View of Test Vehicle



Photo No. 9. Pre-Test Left Front Three-Quarter View of Test Vehicle



Photo No. 11. Pre-Test Right Front Three-Quarter View of Test Vehicle



Photo No. 12. Post-Test Right Front Three-Quarter View of Test Vehicle



Photo No. 14. Post-Test Right Rear Three-Quarter View of Test Vehicle



Photo No. 15. Pre-Test Left Rear Three-Quarter View of Test Vehicle



Photo No. 16. Post-Test Left Rear Three-Quarter View of Test Vehicle



Photo No. 17. Pre-Test Rear View of Test Vehicle



Photo No. 18. Post-Test Rear View of Test Vehicle

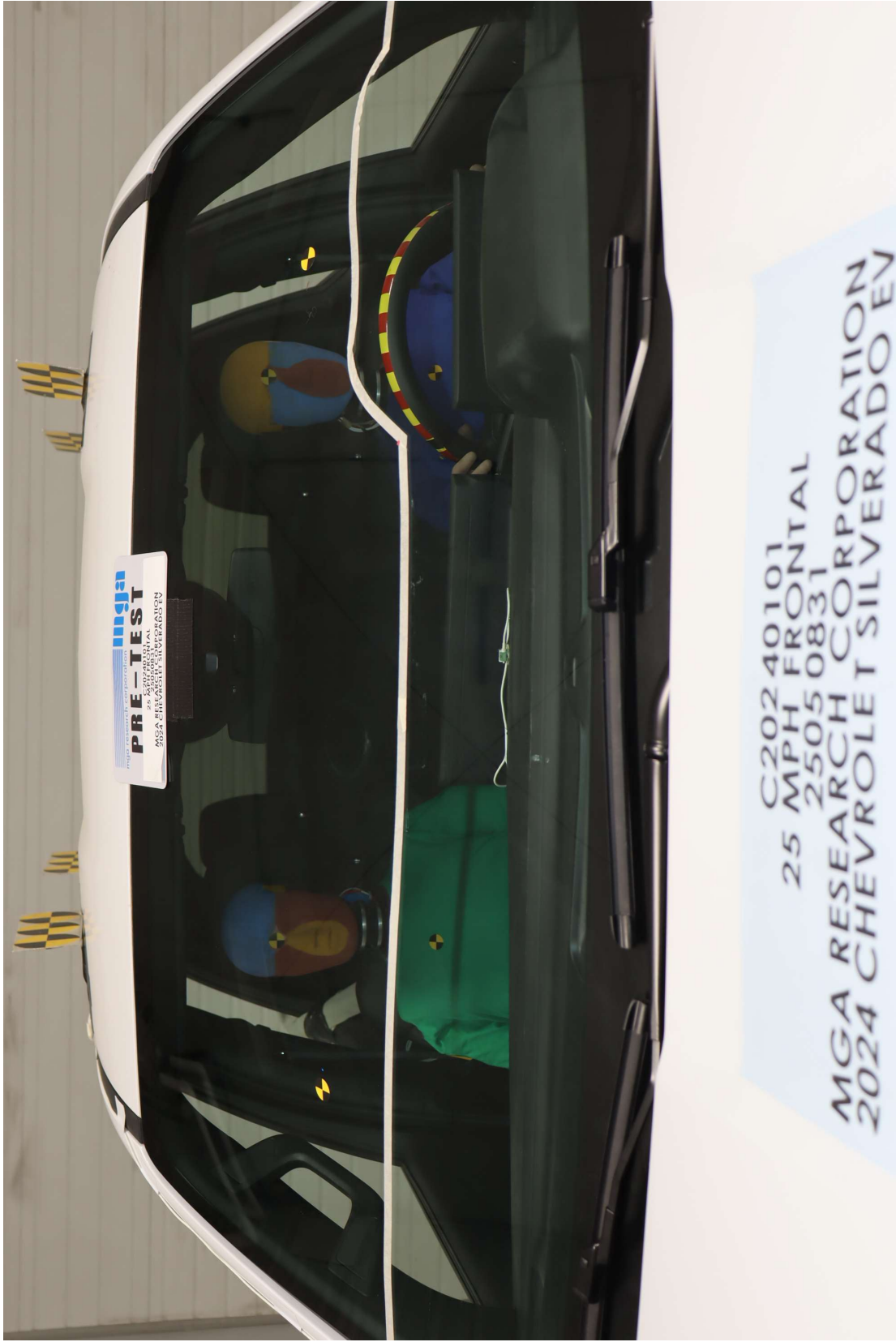

Photo No. 19. Pre-Test Windshield View



Photo No. 20. Post-Test Windshield View



Photo No. 21. Pre-Test Front Compartment View



Photo No. 22. Post-Test Front Compartment View



Photo No. 23. Pre-Test Charging Port View



Photo No. 24. Post-Test Charging Port View

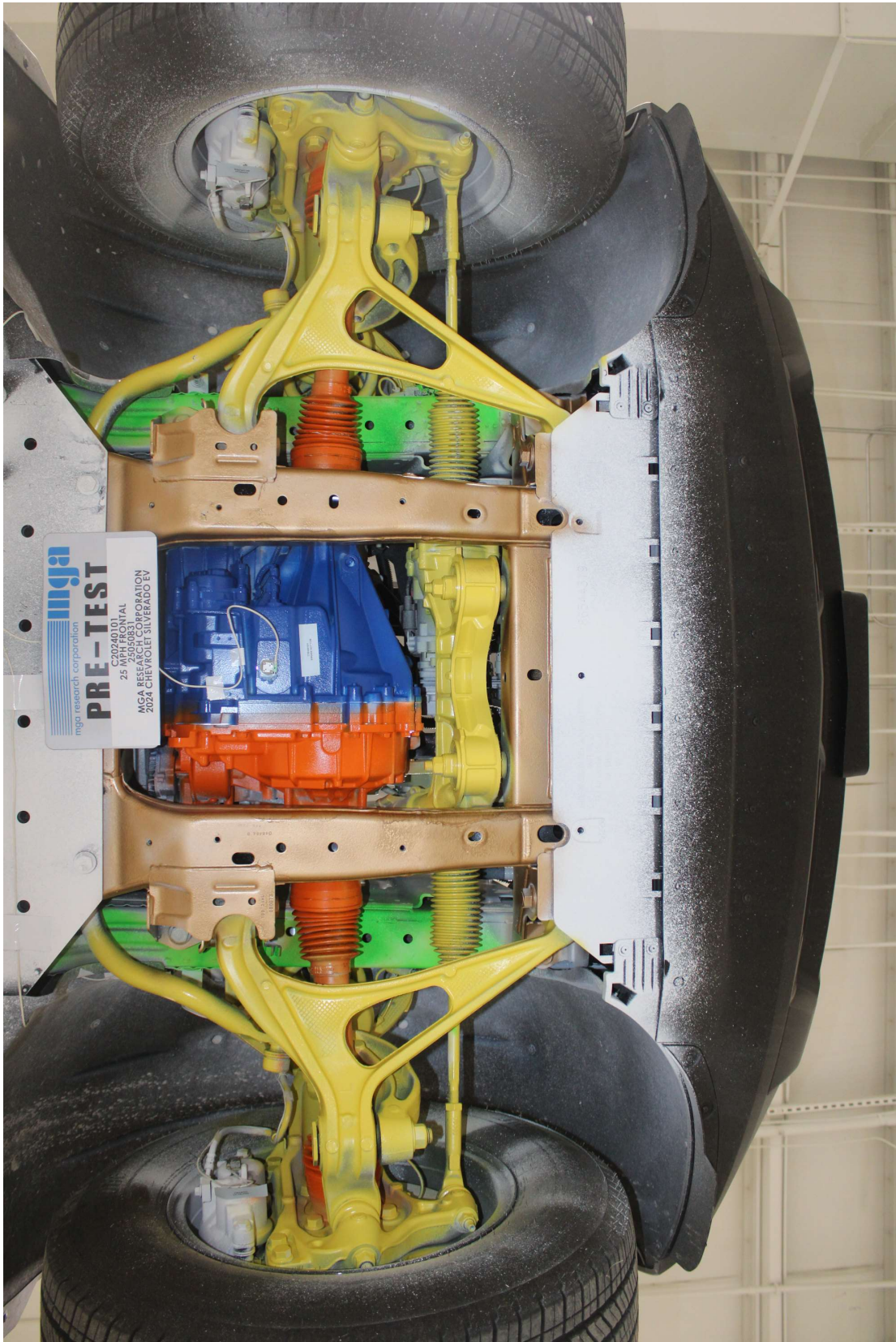

Photo No. 25. Pre-Test Front Underbody View



Photo No. 26. Post-Test Front Underbody View

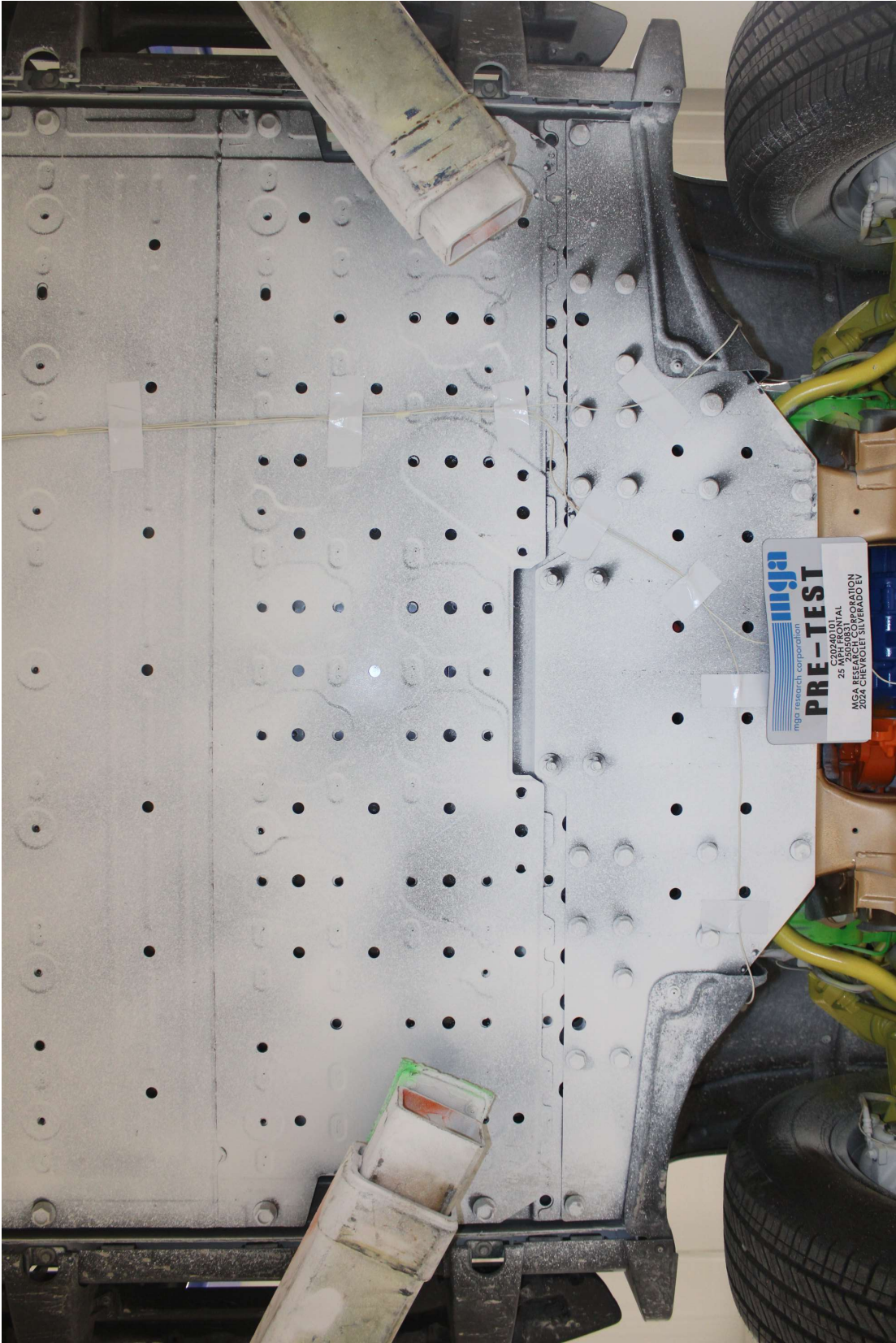

Photo No. 27. Pre-Test Mid Underbody View



Photo No. 28. Post-Test Mid Underbody View

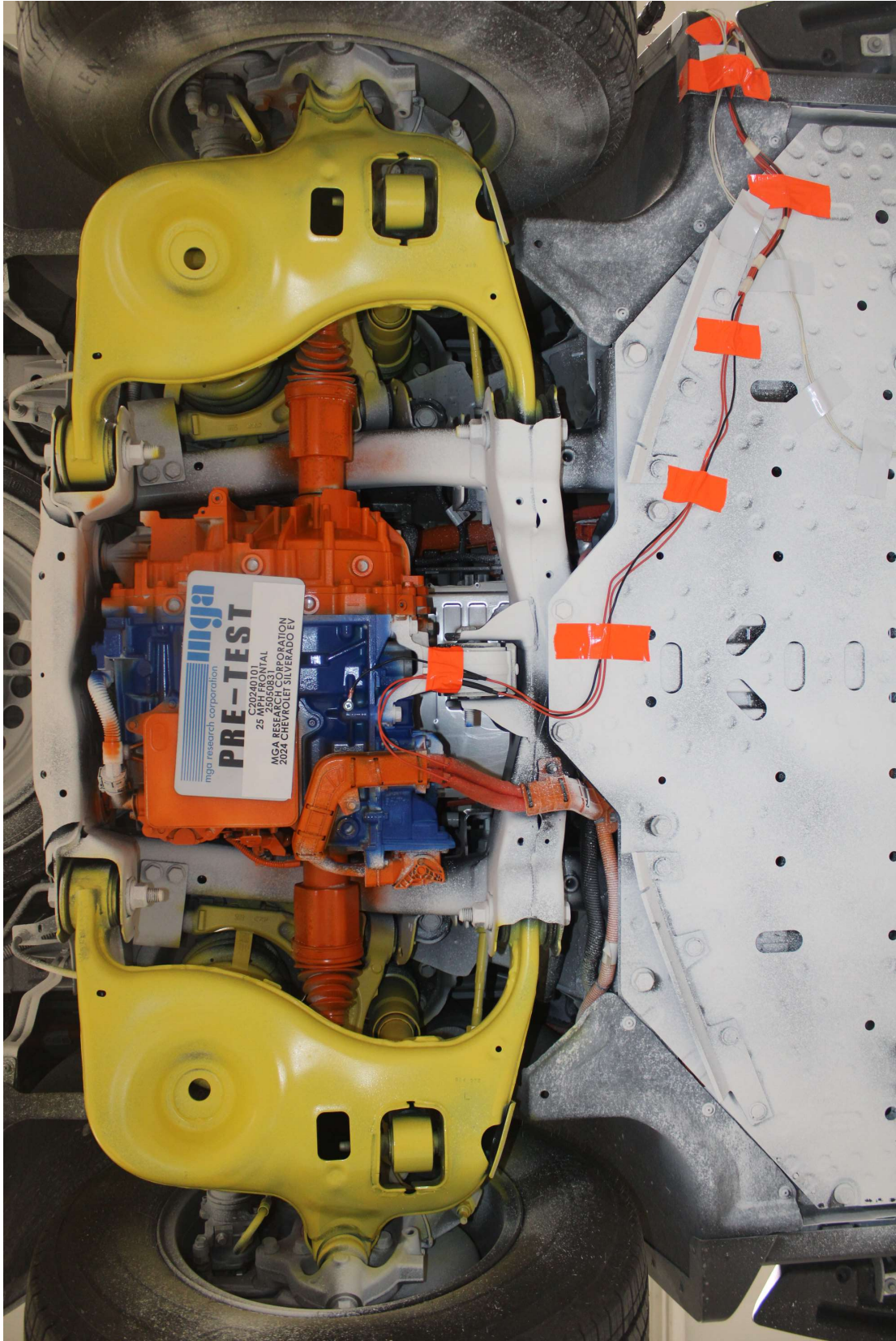

Photo No. 29. Pre-Test Mid Rear Underbody View

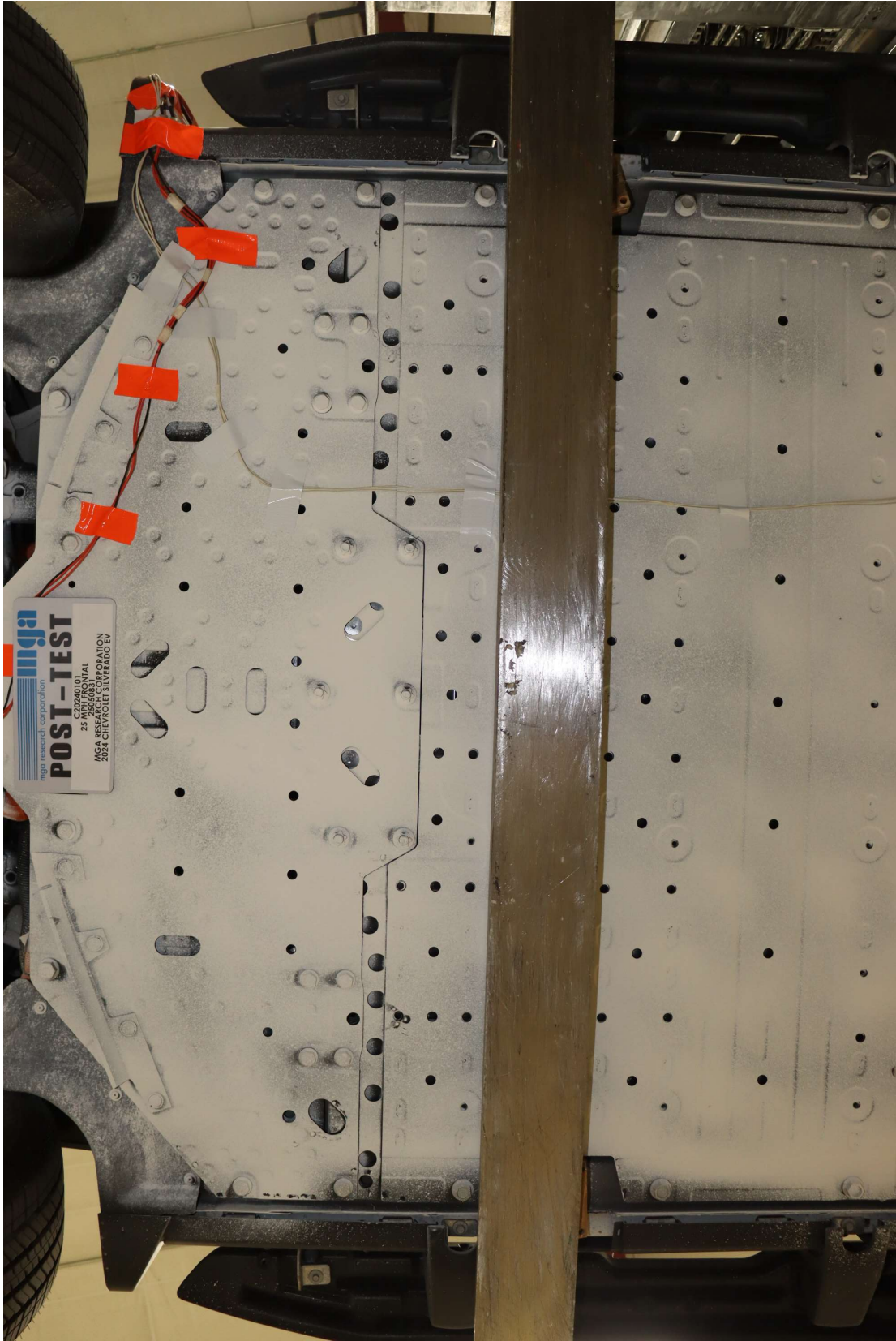

Photo No. 30. Post-Test Mid Rear Underbody View

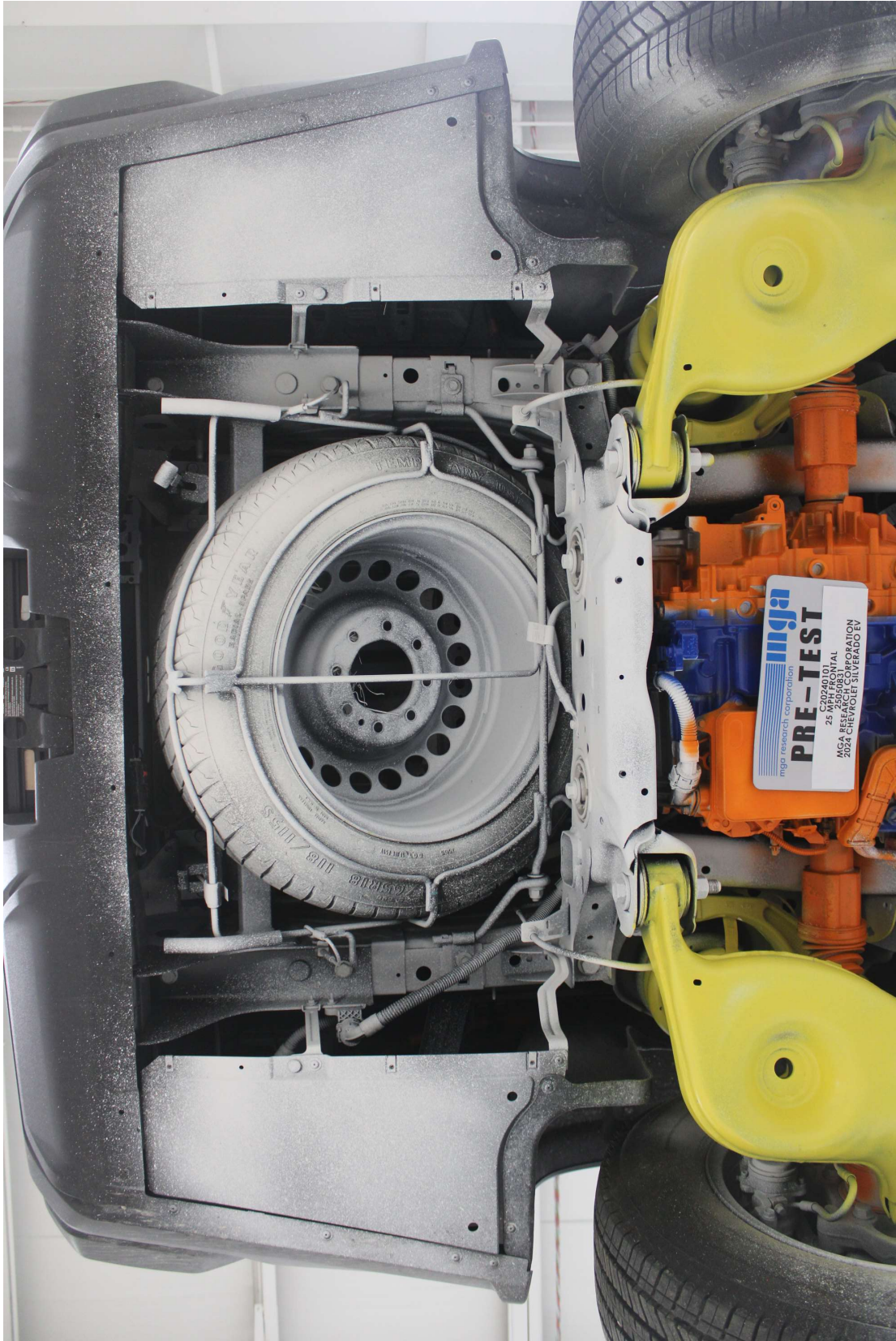

Photo No. 31. Pre-Test Rear Underbody View

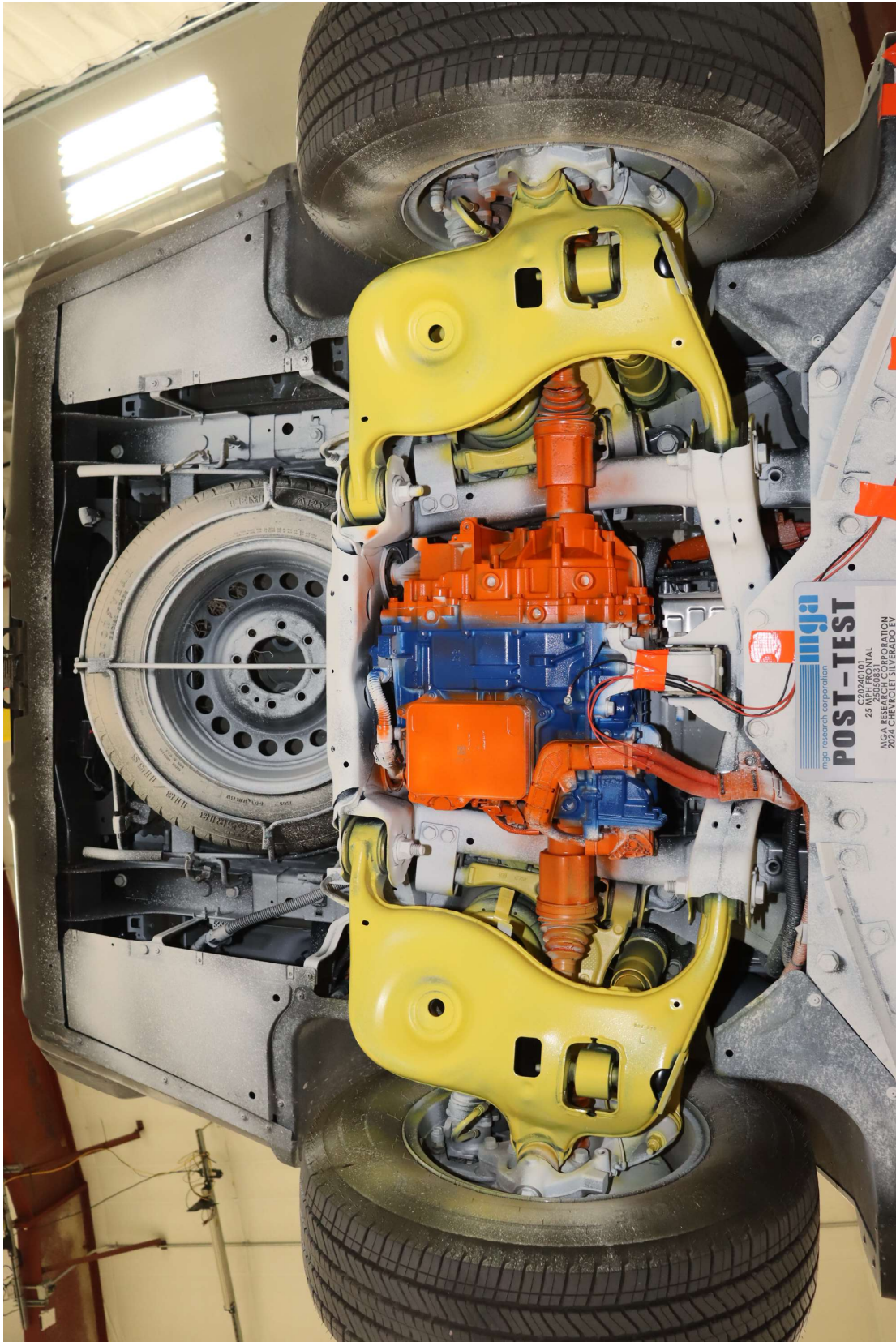

Photo No. 32. Post-Test Rear Underbody View



Photo No. 33. Pre-Test Driver Dummy Front View (head position)



Photo No. 34. Post-Test Driver Dummy Front View (head position)



Photo No. 35. Pre-Test Driver Dummy Position Left Side View



Photo No. 36. Post-Test Driver Dummy Position Left Side View



Photo No. 37. Pre-Test Driver Dummy Position Left Side View (door open)



Photo No. 38. Post-Test Driver Dummy Position Left Side View (door open)



Photo No. 39. Pre-Test Driver Dummy Seat Position



Photo No. 40. Post-Test Driver Dummy Seat Position



Photo No. 41. Pre-Test Driver Dummy Feet Position



Photo No. 42. Post-Test Driver Dummy Feet Position



Photo No. 43. Pre-Test Driver Side Knee Bolster View



Photo No. 44. Post-Test Driver Side Knee Bolster View



Photo No. 45. Post-Test Driver Dummy Airbag Contact



Photo No. 46. Post-Test Driver Dummy Knee Contact

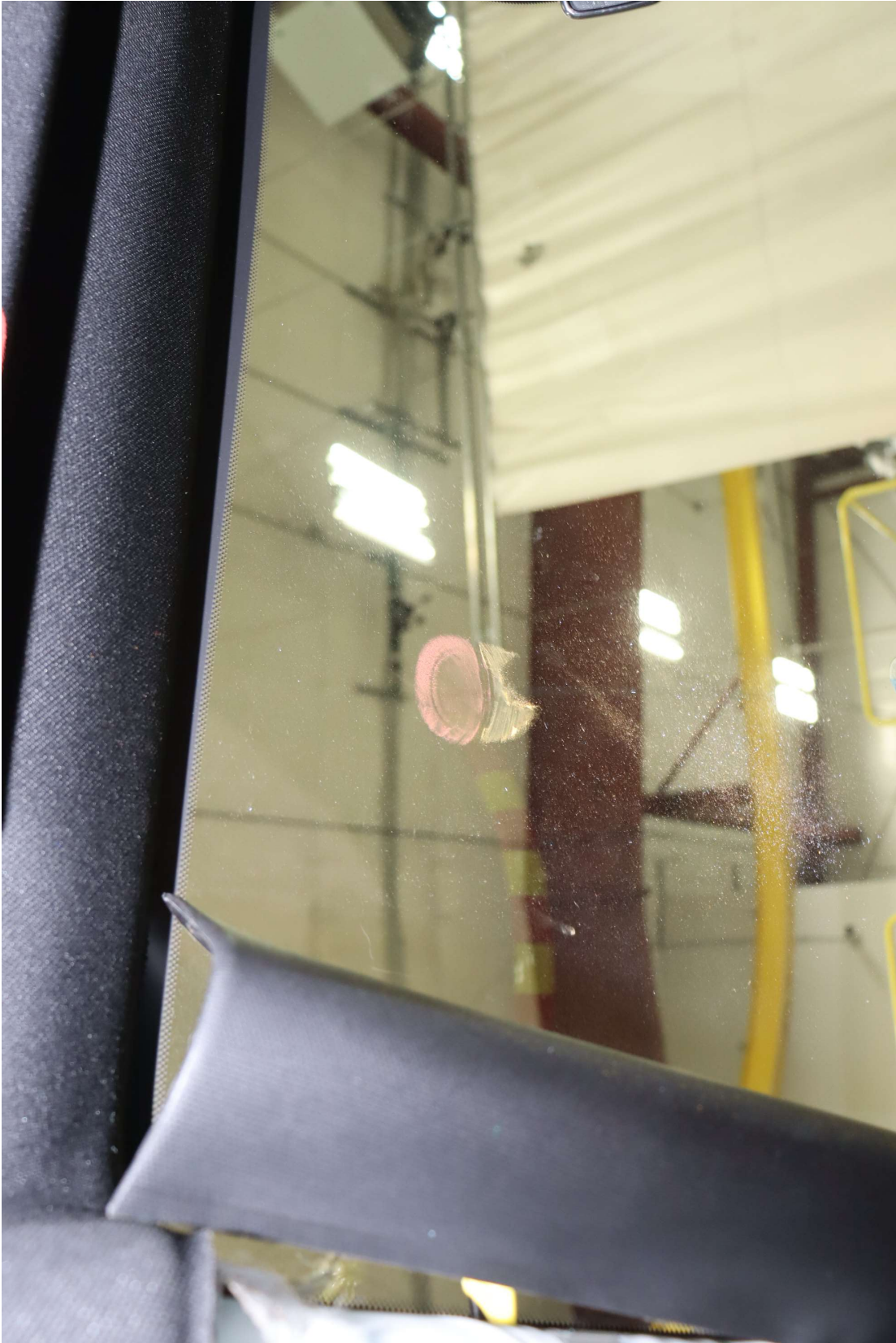

Photo No. 47. Post-Test Driver Dummy Head Contact (windshield)



Photo No. 49. Pre-Test Passenger Dummy Front View (head position)



Photo No. 50. Post-Test Passenger Dummy Front View (head position)



Photo No. 51. Pre-Test Passenger Dummy Position Right Side View



Photo No. 52. Post-Test Passenger Dummy Position Right Side View



Photo No. 53. Pre-Test Passenger Dummy Position Right Side View (door open)



Photo No. 54. Post-Test Passenger Dummy Position Right Side View (door open)



Photo No. 55. Pre-Test Passenger Dummy Seat Position



Photo No. 56. Post-Test Passenger Dummy Seat Position



Photo No. 57. Pre-Test Passenger Dummy Feet Position



Photo No. 58. Post-Test Passenger Dummy Feet Position



Photo No. 59. Pre-Test Passenger Side Knee Bolster View



Photo No. 60. Post-Test Passenger Side Knee Bolster View



Photo No. 61. Post-Test Passenger Dummy Airbag Contact



Photo No. 62. Post-Test Passenger Dummy Knee Contact



Photo No. 63. Post-Test Passenger Dummy Head Contact (visor)

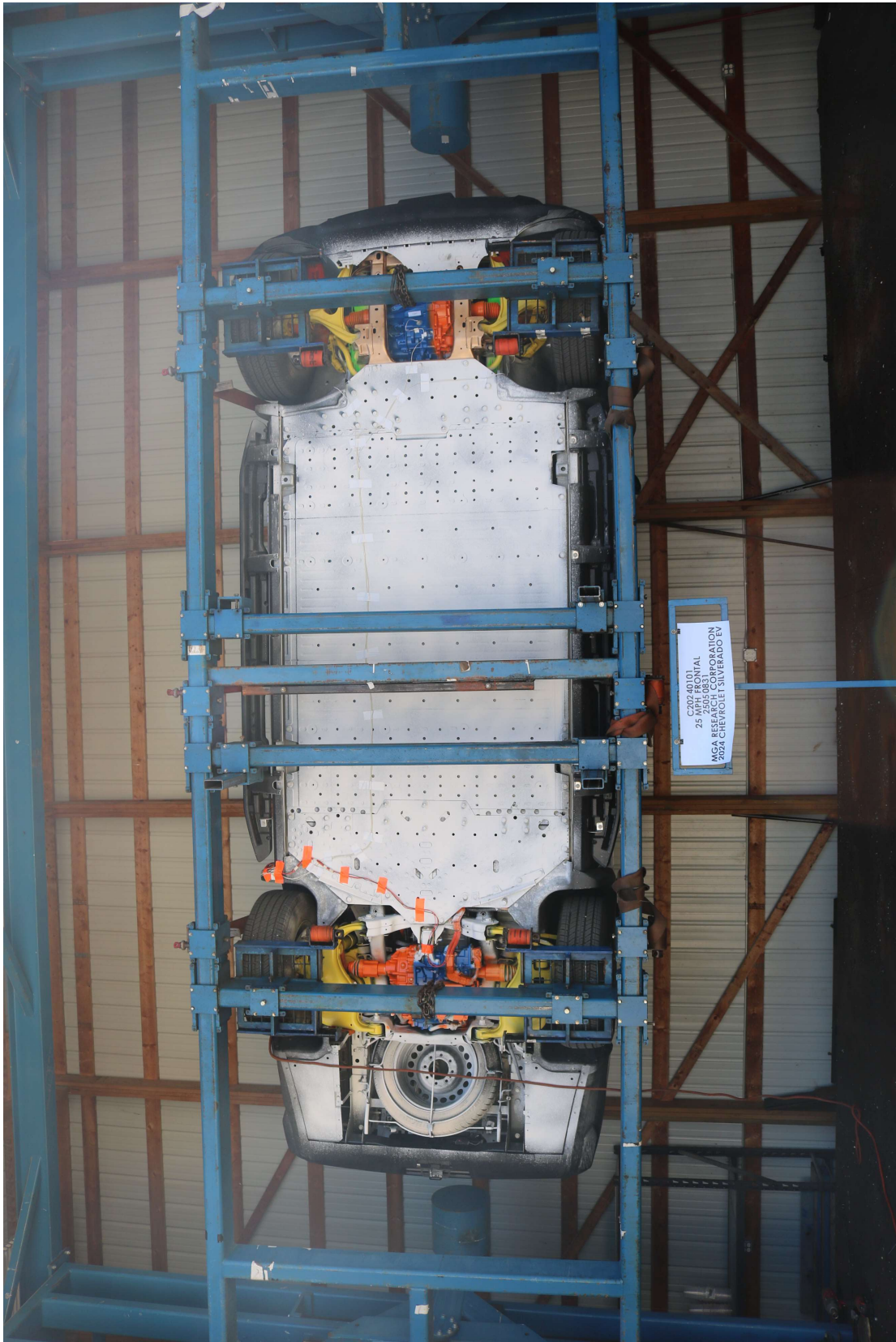

Photo No. 64. Rollover 90 Degrees



Photo No. 65. Rollover 180 Degrees



Photo No. 66. Rollover 270 Degrees



Photo No. 67. Rollover 360 Degrees

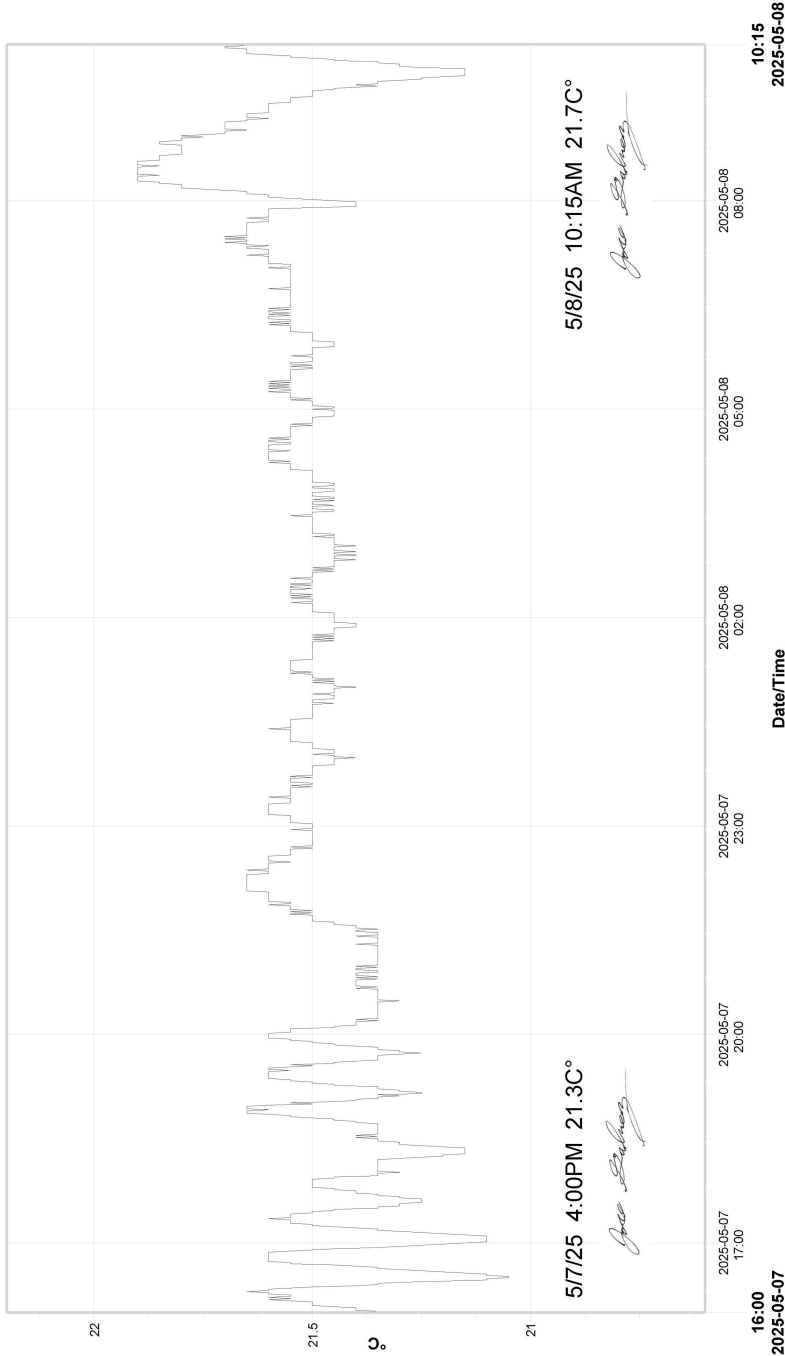

Report Summary Statistics			
#	Location	Zone	Units
1	VSC Start Room A - Temp (1038)	viewLinc/VSC (1037)	°C

Photo No. 68. Temperature Plot



Photo No. 69. Pre-Test Manual Service Disconnect in Place

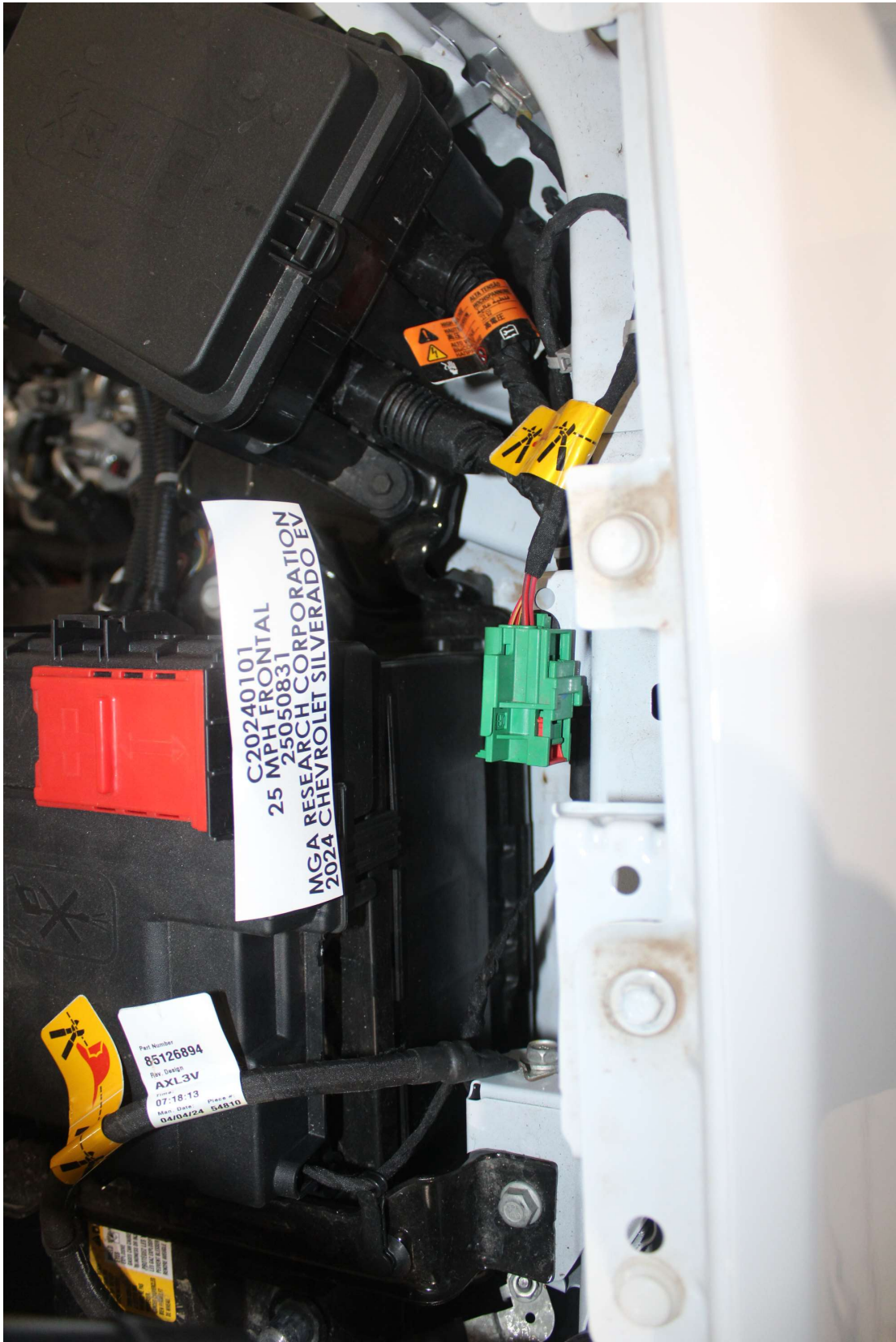

C20240101
25 MPH FRONTAL
25050831
MGA RESEARCH CORPORATION
2024 CHEVROLET SILVERADO EV

Part Number
85126894
Rev. Design
AXL3V
07-18-13
Man. Date Part #
04/04/24 54810

Photo No. 70. Pre-Test Manual Service Disconnect Removed

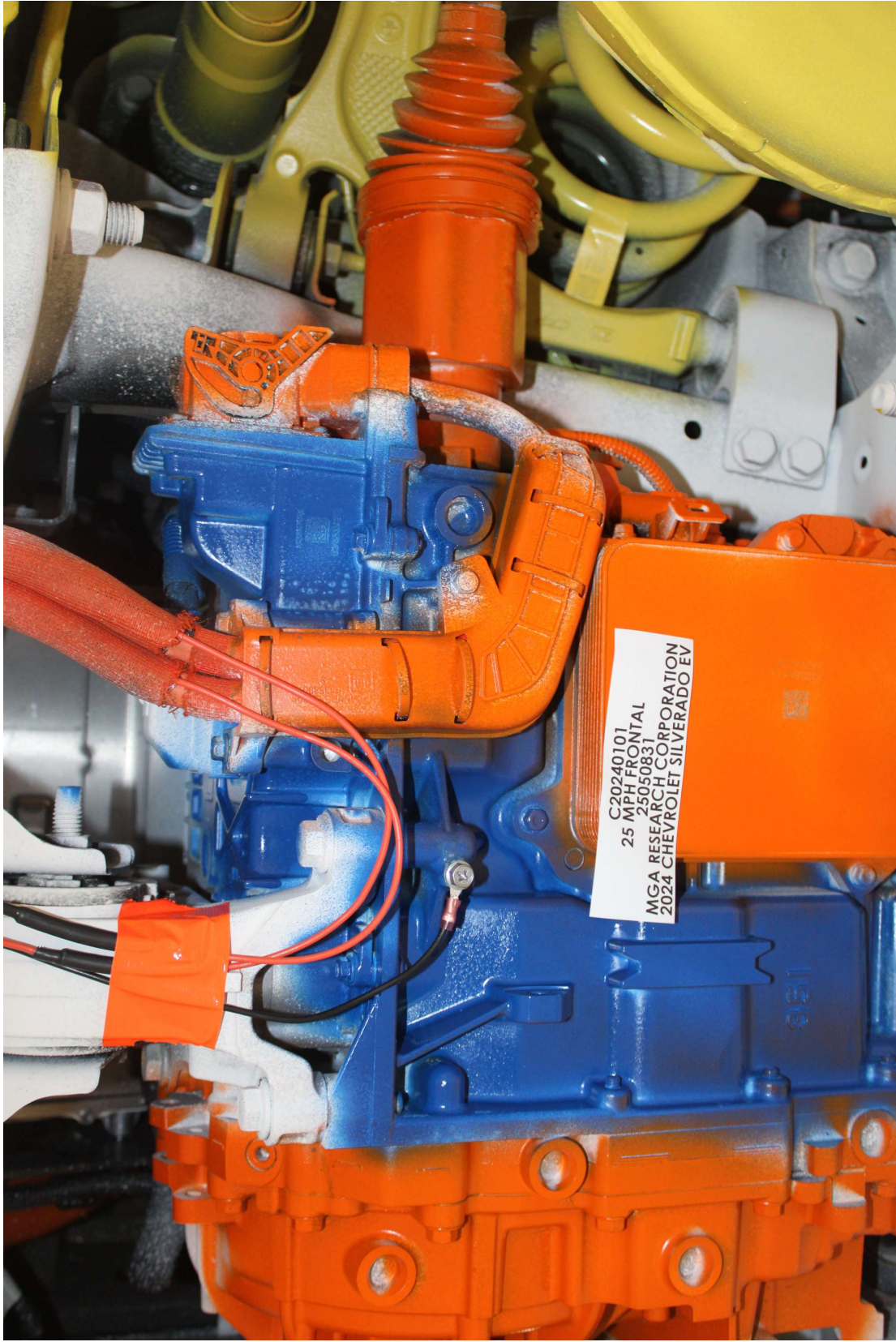

Photo No. 71. Pre-Test Voltage Monitoring Leads Attached to Electric Energy Storage System



Photo No. 72. Pre-Test View of Installed Isolation Interface Port

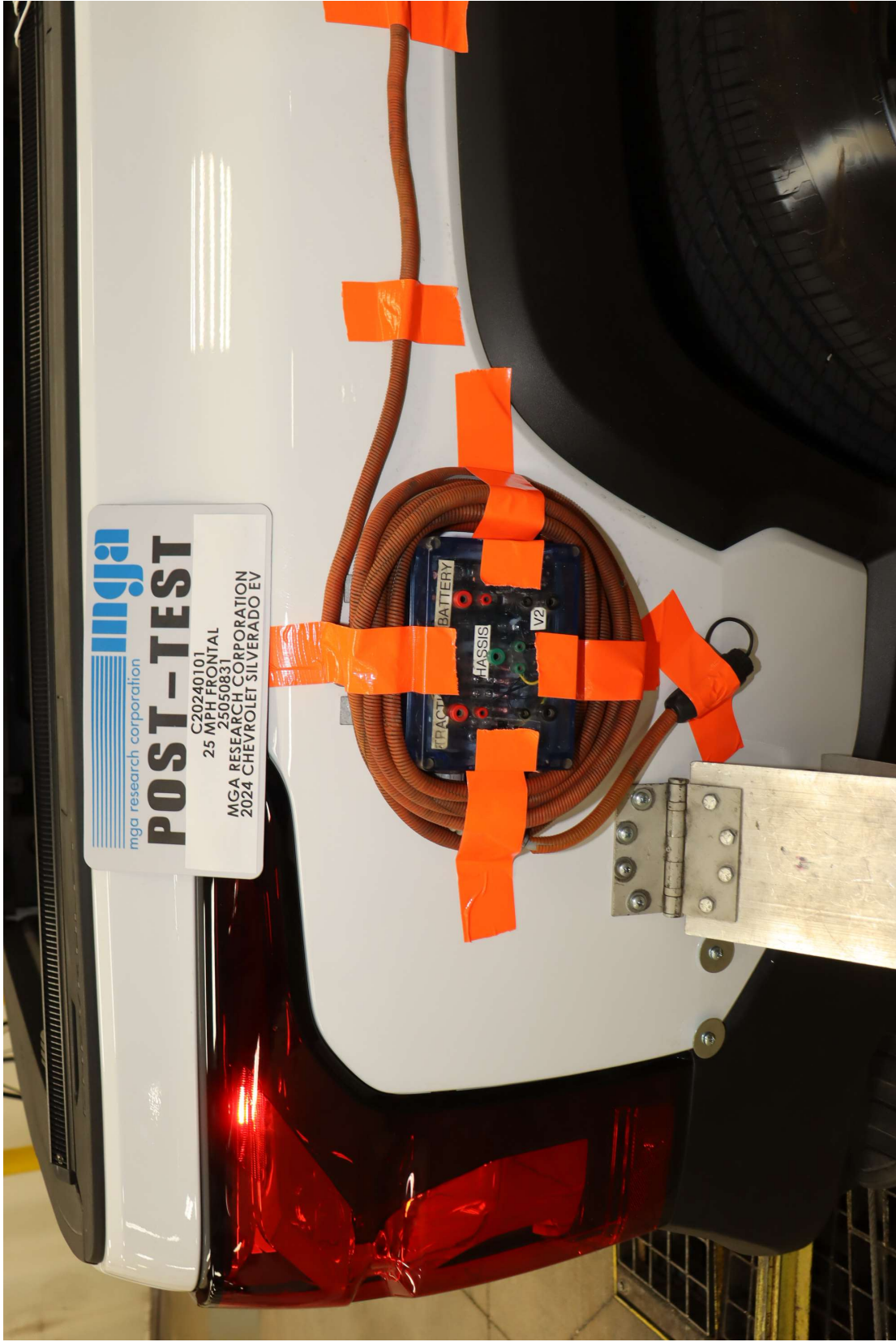

Photo No. 73. Post-Test View of Installed Isolation Interface Port

APPENDIX C
SUPPRESSION PHOTOGRAPHS

TABLE OF PHOTOGRAPHS

	<u>Page #</u>	
Photo No. 1.	Angel Guard Angel Ride Car Bed Belted, Forward Seat Track	C-1
Photo No. 2.	Angel Guard Angel Ride Car Bed Belted, Middle Seat Track	C-1
Photo No. 3.	Angel Guard Angel Ride Car Bed Belted, Rearward Seat Track	C-1
Photo No. 4.	Unbelted 5 th Percentile Female Dummy Reactivation, Forward Seat Track	C-1
Photo No. 5.	Cosco Arriva W/Base, Belted, Rear Facing, Forward Seat Track	C-2
Photo No. 6.	Cosco Arriva W/Base, Belted, Rear Facing, Middle Seat Track	C-2
Photo No. 7.	Cosco Arriva W/Base, Belted, Rear Facing, Rearward Seat Track	C-2
Photo No. 8.	Cosco Arriva W/Base, Unbelted, Rear Facing, Middle Seat Track	C-2
Photo No. 9.	Cosco Arriva W/Base, Unbelted, Rear Facing, Rearward Seat Track	C-3
Photo No. 10.	Cosco Arriva W/Base, Unbelted, Forward Facing, Forward Seat Track	C-3
Photo No. 11.	Cosco Arriva W/Base, Unbelted, Forward Facing, Middle Seat Track	C-3
Photo No. 12.	Cosco Arriva W/Base, Unbelted, Forward Facing, Rearward Seat Track	C-3
Photo No. 13.	Cosco Arriva W/Out Base, Belted, Rear Facing, Forward Seat Track	C-4
Photo No. 14.	Cosco Arriva W/Out Base, Belted, Rear Facing, Middle Seat Track	C-4
Photo No. 15.	Cosco Arriva W/Out Base, Belted, Rear Facing, Rearward Seat Track	C-4
Photo No. 16.	Cosco Arriva W/Out Base, Unbelted, Rear Facing, Middle Seat Track	C-4
Photo No. 17.	Cosco Arriva W/Out Base, Unbelted, Rear Facing, Rearward Seat Track	C-5
Photo No. 18.	Cosco Arriva W/Out Base, Unbelted, Forward Facing, Middle Seat Track	C-5
Photo No. 19.	Cosco Arriva W/Out Base, Unbelted, Forward Facing, Rearward Seat Track	C-5
Photo No. 20.	Unbelted 5 th Percentile Female Dummy Reactivation, Rearward Seat Track	C-5
Photo No. 21.	Graco Snugride W/Base, Belted, Rear Facing, Forward Seat Track	C-6
Photo No. 22.	Graco Snugride W/Base, Belted, Rear Facing, Middle Seat Track	C-6
Photo No. 23.	Graco Snugride W/Base, Belted, Rear Facing, Rearward Seat Track	C-6
Photo No. 24.	Graco Snugride W/Base, Unbelted, Rear Facing, Forward Seat Track	C-6
Photo No. 25.	Graco Snugride W/Base, Unbelted, Rear Facing, Middle Seat Track	C-7
Photo No. 26.	Graco Snugride W/Base, Unbelted, Rear Facing, Rearward Seat Track	C-7
Photo No. 27.	Graco Snugride W/Base, Unbelted, Forward Facing, Forward Seat Track	C-7
Photo No. 28.	Graco Snugride W/Base, Unbelted, Forward Facing, Middle Seat Track	C-7
Photo No. 29.	Graco Snugride W/Base, Unbelted, Forward Facing, Rearward Seat Track	C-8
Photo No. 30.	Graco Snugride W/Out Base, Belted, Rear Facing, Forward Seat Track	C-8
Photo No. 31.	Graco Snugride W/Out Base, Belted, Rear Facing, Middle Seat Track	C-8
Photo No. 32.	Graco Snugride W/Out Base, Belted, Rear Facing, Rearward Seat Track	C-8
Photo No. 33.	Graco Snugride W/Out Base, Unbelted, Rear Facing, Forward Seat Track	C-9

	<u>Page #</u>	
Photo No. 34.	Graco Snugride W/Out Base, Unbelted, Rear Facing, Middle Seat Track	C-9
Photo No. 35.	Graco Snugride W/Out Base, Unbelted, Rear Facing, Rearward Seat Track	C-9
Photo No. 36.	Graco Snugride W/Out Base, Unbelted, Forward Facing, Forward Seat Track	C-9
Photo No. 37.	Graco Snugride W/Out Base, Unbelted, Forward Facing, Middle Seat Track	C-10
Photo No. 38.	Graco Snugride W/Out Base, Unbelted, Forward Facing, Rearward Seat Track	C-10
Photo No. 39.	Unbelted 5 th Percentile Female Dummy Reactivation, Middle Seat Track	C-10
Photo No. 40.	Peg Perego Viaggio W/Base, Belted, Rear Facing, Forward Seat Track	C-11
Photo No. 41.	Peg Perego Viaggio W/Base, Belted, Rear Facing, Middle Seat Track	C-11
Photo No. 42.	Peg Perego Viaggio W/Base, Belted, Rear Facing, Rearward Seat Track	C-11
Photo No. 43.	Peg Perego Viaggio W/Base, Unbelted, Rear Facing, Forward Seat Track	C-11
Photo No. 44.	Peg Perego Viaggio W/Base, Unbelted, Rear Facing, Middle Seat Track	C-12
Photo No. 45.	Peg Perego Viaggio W/Base, Unbelted, Rear Facing, Rearward Seat Track	C-12
Photo No. 46.	Peg Perego Viaggio W/Base, Unbelted, Forward Facing, Forward Seat Track	C-12
Photo No. 47.	Peg Perego Viaggio W/Base, Unbelted, Forward Facing, Middle Seat Track	C-12
Photo No. 48.	Peg Perego Viaggio W/Base, Unbelted, Forward Facing, Rearward Seat Track	C-13
Photo No. 49.	Peg Perego Viaggio W/Out Base, Belted, Rear Facing, Forward Seat Track	C-13
Photo No. 50.	Peg Perego Viaggio W/Out Base, Belted, Rear Facing, Middle Seat Track	C-13
Photo No. 51.	Peg Perego Viaggio W/Out Base, Belted, Rear Facing, Rearward Seat Track	C-13
Photo No. 52.	Peg Perego Viaggio W/Out Base, Unbelted, Rear Facing, Forward Seat Track	C-14
Photo No. 53.	Peg Perego Viaggio W/Out Base, Unbelted, Rear Facing, Middle Seat Track	C-14
Photo No. 54.	Peg Perego Viaggio W/Out Base, Unbelted, Rear Facing, Rearward Seat Track	C-14
Photo No. 55.	Peg Perego Viaggio W/Out Base, Unbelted, Forward Facing, Forward Seat Track	C-14
Photo No. 56.	Peg Perego Viaggio W/Out Base, Unbelted, Forward Facing, Middle Seat Track	C-15
Photo No. 57.	Peg Perego Viaggio W/Out Base, Unbelted, Forward Facing, Rearward Seat Track	C-15
Photo No. 58.	Unbelted 5 th Percentile Female Dummy Reactivation, Middle Seat Track	C-15
Photo No. 59.	Britax Roundabout Forward Facing Belted, Forward Seat Track	C-16
Photo No. 60.	Britax Roundabout Forward Facing Belted, Middle Seat Track	C-16
Photo No. 61.	Britax Roundabout Forward Facing Belted, Rearward Seat Track	C-16
Photo No. 62.	Britax Roundabout Forward Facing Unbelted, Forward Seat Track	C-16
Photo No. 63.	Britax Roundabout Forward Facing Unbelted, Middle Seat Track	C-17
Photo No. 64.	Britax Roundabout Forward Facing Unbelted, Rearward Seat Track	C-17
Photo No. 65.	Britax Roundabout Rear Facing Belted, Forward Seat Track	C-17
Photo No. 66.	Britax Roundabout Rear Facing Belted, Middle Seat Track	C-17
Photo No. 67.	Britax Roundabout Rear Facing Belted, Rearward Seat Track	C-18
Photo No. 68.	Britax Roundabout Rear Facing Unbelted, Forward Seat Track	C-18
Photo No. 69.	Britax Roundabout Rear Facing Unbelted, Middle Seat Track	C-18
Photo No. 70.	Britax Roundabout Rear Facing Unbelted, Rearward Seat Track	C-18

	<u>Page #</u>	
Photo No. 71.	Unbelted 5 th Percentile Female Dummy Reactivation, Forward Seat Track	C-19
Photo No. 72.	Cosco Summit Deluxe Forward Facing Belted, Forward Seat Track	C-20
Photo No. 73.	Cosco Summit Deluxe Forward Facing Belted, Middle Seat Track	C-20
Photo No. 74.	Cosco Summit Deluxe Forward Facing Belted, Rearward Seat Track	C-20
Photo No. 75.	Cosco Summit Deluxe Forward Facing Unbelted, Forward Seat Track	C-20
Photo No. 76.	Cosco Summit Deluxe Forward Facing Unbelted, Middle Seat Track	C-21
Photo No. 77.	Cosco Summit Deluxe Forward Facing Unbelted, Rearward Seat Track	C-21
Photo No. 78.	Cosco Summit Deluxe Rear Facing Unbelted, Forward Seat Track	C-21
Photo No. 79.	Cosco Summit Deluxe Rear Facing Unbelted, Middle Seat Track	C-21
Photo No. 80.	Cosco Summit Deluxe Rear Facing Unbelted, Rearward Seat Track	C-22
Photo No. 81.	Unbelted 5 th Percentile Female Dummy Reactivation, Rearward Seat Track	C-22
Photo No. 82.	Evenflo Tribute Forward Facing Belted, Forward Seat Track	C-23
Photo No. 83.	Evenflo Tribute Forward Facing Belted, Middle Seat Track	C-23
Photo No. 84.	Evenflo Tribute Forward Facing Belted, Rearward Seat Track	C-23
Photo No. 85.	Evenflo Tribute Forward Facing Unbelted, Forward Seat Track	C-23
Photo No. 86.	Evenflo Tribute Forward Facing Unbelted, Middle Seat Track	C-24
Photo No. 87.	Evenflo Tribute Forward Facing Unbelted, Rearward Seat Track	C-24
Photo No. 88.	Evenflo Tribute Rear Facing Belted, Forward Seat Track	C-24
Photo No. 89.	Evenflo Tribute Rear Facing Belted, Middle Seat Track	C-24
Photo No. 90.	Evenflo Tribute Rear Facing Belted, Rearward Seat Track	C-25
Photo No. 91.	Evenflo Tribute Rear Facing Unbelted, Forward Seat Track	C-25
Photo No. 92.	Evenflo Tribute Rear Facing Unbelted, Middle Seat Track	C-25
Photo No. 93.	Evenflo Tribute Rear Facing Unbelted, Rearward Seat Track	C-25
Photo No. 94.	Unbelted 5 th Percentile Female Dummy Reactivation, Rearward Seat Track	C-26
Photo No. 95.	Graco Toddler SafeSeat Step 2 Forward Facing Belted, Forward Seat Track	C-27
Photo No. 96.	Graco Toddler SafeSeat Step 2 Forward Facing Belted, Middle Seat Track	C-27
Photo No. 97.	Graco Toddler SafeSeat Step 2 Forward Facing Belted, Rearward Seat Track	C-27
Photo No. 98.	Graco Toddler SafeSeat Step 2 Forward Facing Unbelted, Forward Seat Track	C-27
Photo No. 99.	Graco Toddler SafeSeat Step 2 Forward Facing Unbelted, Middle Seat Track	C-28
Photo No. 100.	Graco Toddler SafeSeat Step 2 Forward Facing Unbelted, Rearward Seat Track	C-28
Photo No. 101.	Graco Toddler SafeSeat Step 2 Rear Facing Unbelted, Forward Seat Track	C-28
Photo No. 102.	Graco Toddler SafeSeat Step 2 Rear Facing Unbelted, Middle Seat Track	C-28
Photo No. 103.	Graco Toddler SafeSeat Step 2 Rear Facing Unbelted, Rearward Seat Track	C-29
Photo No. 104.	Unbelted 5 th Percentile Female Dummy Reactivation, Middle Seat Track	C-29



Angel Guard Angel Ride Car Bed Belted, Forward Seat Track



Angel Guard Angel Ride Car Bed Belted, Middle Seat Track



Angel Guard Angel Ride Car Bed Belted, Rearward Seat Track



Unbelleted 5th Percentile Female Dummy Reactivation, Forward Seat Track



Cosco Arriva WBase, Belted, Rear Facing, Forward Seat Track



Cosco Arriva WBase, Belted, Rear Facing, Middle Seat Track



Cosco Arriva WBase, Belted, Rear Facing, Rearward Seat Track



Cosco Arriva WBase, Unbelted, Rear Facing, Middle Seat Track



Cosco Arriva WBase, Unbelleted, Rear Facing, Rearward Seat Track



Cosco Arriva WBase, Unbelleted, Forward Facing, Forward Seat Track



Cosco Arriva WBase, Unbelleted, Forward Facing, Middle Seat Track



Cosco Arriva WBase, Unbelleted, Forward Facing, Rearward Seat Track



Cosco Arriva WOut Base, Belted, Rear Facing, Forward Seat Track



Cosco Arriva WOut Base, Belted, Rear Facing, Middle Seat Track



Cosco Arriva WOut Base, Belted, Rear Facing, Rearward Seat Track



Cosco Arriva WOut Base, Unbelted, Rear Facing, Middle Seat Track



Cosco Arriva W/Out Base, Unbelted, Rear Facing, Rearward Seat Track



Cosco Arriva W/Out Base, Unbelted, Forward Facing, Middle Seat Track



Cosco Arriva W/Out Base, Unbelted, Forward Facing, Rearward Seat Track



Unbelted 5th Percentile Female Dummy Reactivation, Rearward Seat Track



Graco Snugride WBBase, Belted, Rear Facing, Forward Seat Track



Graco Snugride WBBase, Belted, Rear Facing, Middle Seat Track



Graco Snugride WBBase, Belted, Rear Facing, Rearward Seat Track



Graco Snugride WBBase, Unbelted, Rear Facing, Forward Seat Track



Graco Snugride WBase, Unbelted, Rear Facing, Middle Seat Track



Graco Snugride WBase, Unbelted, Rear Facing, Rearward Seat Track



Graco Snugride WBase, Unbelted, Forward Facing, Forward Seat Track



Graco Snugride WBase, Unbelted, Forward Facing, Middle Seat Track



Graco Snugride WB Base, Unbelled, Forward Facing, Rearward Seat Track



Graco Snugride WOut Base, Belted, Rear Facing, Forward Seat Track



Graco Snugride WOut Base, Belted, Rear Facing, Middle Seat Track



Graco Snugride WOut Base, Belted, Rear Facing, Rearward Seat Track



Graco Snugride WOut Base, Unbelted, Rear Facing, Forward Seat Track



Graco Snugride WOut Base, Unbelted, Rear Facing, Middle Seat Track



Graco Snugride WOut Base, Unbelted, Rear Facing, Rearward Seat Track



Graco Snugride WOut Base, Unbelted, Forward Facing, Forward Seat Track



Graco Snugride WOut Base, Unbelleted, Forward Facing, Middle Seat Track



Graco Snugride WOut Base, Unbelleted, Forward Facing, Rearward Seat Track



Unbelleted 5th Percentile Female Dummy Reactivation, Middle Seat Track



Peg Perego Viaggio WBBase, Belted, Rear Facing, Forward Seat Track



Peg Perego Viaggio WBBase, Belted, Rear Facing, Middle Seat Track



Peg Perego Viaggio WBBase, Belted, Rear Facing, Rearward Seat Track



Peg Perego Viaggio WBBase, Unbelted, Rear Facing, Forward Seat Track



Peg Perego Viaggio WBase, Unbeltoned, Rear Facing, Middle Seat Track



Peg Perego Viaggio WBase, Unbeltoned, Rear Facing, Rearward Seat Track



Peg Perego Viaggio WBase, Unbeltoned, Forward Facing, Forward Seat Track



Peg Perego Viaggio WBase, Unbeltoned, Forward Facing, Middle Seat Track



Peg Perego Viaggio WBase, Unbelted, Forward Facing, Rearward Seat Track



Peg Perego Viaggio WOut Base, Belted, Rear Facing, Forward Seat Track



Peg Perego Viaggio WOut Base, Belted, Rear Facing, Middle Seat Track



Peg Perego Viaggio WOut Base, Belted, Rear Facing, Rearward Seat Track



Peg Perego Viaggio WOut Base, Unbelleted, Rear Facing, Forward Seat Track



Peg Perego Viaggio WOut Base, Unbelleted, Rear Facing, Middle Seat Track



Peg Perego Viaggio WOut Base, Unbelleted, Rear Facing, Rearward Seat Track



Peg Perego Viaggio WOut Base, Unbelleted, Forward Facing, Forward Seat Track



Peg Perego Viaggio WOut Base, Unbelted, Forward Facing, Middle Seat Track



Peg Perego Viaggio WOut Base, Unbelted, Forward Facing, Rearward Seat Track



Unbelted 5th Percentile Female Dummy Reactivation, Middle Seat Track



Britax Roundabout Forward Facing Belted, Forward Seat Track



Britax Roundabout Forward Facing Belted, Middle Seat Track



Britax Roundabout Forward Facing Belted, Rearward Seat Track



Britax Roundabout Forward Facing Unbelted, Forward Seat Track



Britax Roundabout Forward Facing Unbelted, Middle Seat Track



Britax Roundabout Forward Facing Unbelted, Rearward Seat Track



Britax Roundabout Rear Facing Belted, Forward Seat Track



Britax Roundabout Rear Facing Belted, Middle Seat Track



Britax Roundabout Rear Facing Belted, Rearward Seat Track



Britax Roundabout Rear Facing Unbelleted, Forward Seat Track



Britax Roundabout Rear Facing Unbelleted, Middle Seat Track



Britax Roundabout Rear Facing Unbelleted, Rearward Seat Track



Unbelted 5th Percentile Female Dummy Reactivation, Forward Seat Track



Cosco Summit Deluxe Forward Facing Belted, Forward Seat Track



Cosco Summit Deluxe Forward Facing Belted, Middle Seat Track



Cosco Summit Deluxe Forward Facing Belted, Rearward Seat Track



Cosco Summit Deluxe Forward Facing Unbelted, Forward Seat Track



Cosco Summit Deluxe Forward Facing Unbelted, Middle Seat Track



Cosco Summit Deluxe Forward Facing Unbelted, Rearward Seat Track



Cosco Summit Deluxe Rear Facing Unbelted, Forward Seat Track



Cosco Summit Deluxe Rear Facing Unbelted, Middle Seat Track



Cosco Summit Deluxe Rear Facing Unbelted, Rearward Seat Track



Unbelted 5th Percentile Female Dummy Reactivation, Rearward Seat Track



Evenflo Tribute Forward Facing Belted, Forward Seat Track



Evenflo Tribute Forward Facing Belted, Middle Seat Track



Evenflo Tribute Forward Facing Belted, Rearward Seat Track



Evenflo Tribute Forward Facing Unbelted, Forward Seat Track



Evenflo Tribute Forward Facing Unbelted, Middle Seat Track



Evenflo Tribute Forward Facing Unbelted, Rearward Seat Track



Evenflo Tribute Rear Facing Belted, Forward Seat Track



Evenflo Tribute Rear Facing Belted, Middle Seat Track



Evenflo Tribute Rear Facing Belted, Rearward Seat Track



Evenflo Tribute Rear Facing Unbelted, Forward Seat Track



Evenflo Tribute Rear Facing Unbelted, Middle Seat Track



Evenflo Tribute Rear Facing Unbelted, Rearward Seat Track



Unbelted 5th Percentile Female Dummy Reactivation, Rearward Seat Track



Graco Toddler SafeSeat Step 2 Forward Facing Belted, Forward Seat Track



Graco Toddler SafeSeat Step 2 Forward Facing Belted, Middle Seat Track



Graco Toddler SafeSeat Step 2 Forward Facing Belted, Rearward Seat Track



Graco Toddler SafeSeat Step 2 Forward Facing Unbelted, Forward Seat Track



Graco Toddler SafeSeat Step 2 Forward Facing Unbelted, Middle Seat Track



Graco Toddler SafeSeat Step 2 Forward Facing Unbelted, Rearward Seat Track



Graco Toddler SafeSeat Step 2 Rear Facing Unbelted, Forward Seat Track



Graco Toddler SafeSeat Step 2 Rear Facing Unbelted, Middle Seat Track



Graco Toddler SafeSeat Step 2 Rear Facing Unbelted, Rearward Seat Track



Unbelted 5th Percentile Female Dummy Reactivation, Middle Seat Track

APPENDIX D

INSTRUMENTATION CALIBRATION

INSTRUMENTS FOR DRIVER DUMMY NO.: 401

	SERIAL NO.	MANUFACTURER	CALIBRATION DATE
Head X	AL6Y2	Endevco	4/14/25
Head Y	C19386	Endevco	5/7/25
Head Z	C18384	Endevco	5/7/25
Neck Load Cell	N252	Denton	2/15/25
Chest X	AGH70	Endevco	4/14/25
Chest Y	AGH55	Endevco	4/14/25
Chest Z	AGH72	Endevco	4/14/25
Chest Displacement	401	Humanetics	4/14/25
Left Femur Load Cell	F2027	Denton	4/14/25
Right Femur Load Cell	F2026	Denton	4/14/25

INSTRUMENTS FOR PASSENGER DUMMY NO.: 403

	SERIAL NO.	MANUFACTURER	CALIBRATION DATE
Head X	AH5D9	Endevco	4/14/25
Head Y	AGH74	Endevco	4/14/25
Head Z	C19307	Endevco	4/14/25
Neck Load Cell	N1206	Denton	11/18/24
Chest X	AH5J3	Endevco	4/14/25
Chest Y	C16675	Endevco	5/7/25
Chest Z	C12885	Endevco	4/14/25
Chest Displacement	403	Humanetics	4/14/25
Left Femur Load Cell	F3138	Humanetics	4/14/25
Right Femur Load Cell	F3137	Humanetics	4/14/25

VEHICLE INSTRUMENTS

	SERIAL NO.	MANUFACTURER	CALIBRATION DATE
Left Rear Seat Crossmember X	T43781	Endevco	4/16/25
Right Rear Seat Crossmember X	T42383	Endevco	4/7/25
Top of Engine X	T43399	Endevco	4/16/25
Bottom of Engine X	T42775	Endevco	3/21/25
Left Brake Caliper X	T44151	Endevco	4/11/25
Right Brake Caliper X	T43446	Endevco	4/10/25
Instrument Panel X	T42311	Endevco	4/7/25
Trunk Z	T42814	Endevco	4/16/25