

**REPORT NUMBER: 214D-CAL-24-008**

**SAFETY COMPLIANCE TESTING FOR FMVSS 214  
SIDE IMPACT PROTECTION**

**Mitsubishi Motors (Thailand) CO., LTD.  
2024 Mitsubishi Mirage G4  
4 Door Sedan**

**NHTSA No: C20245603**

**PREPARED BY:  
CALSPAN CORPORATION  
P.O. BOX 400  
BUFFALO, NEW YORK 14225**



**November 5, 2024**

**FINAL REPORT**

**PREPARED FOR:  
U.S. DEPARTMENT OF TRANSPORTATION  
NATIONAL HIGHWAY TRAFFIC SAFETY ADMINISTRATION  
ENFORCEMENT  
OFFICE OF VEHICLE SAFETY COMPLIANCE  
1200 NEW JERSEY AVE. S.E.  
WEST Bldg. (NEF-240)  
WASHINGTON, D.C. 20590**

This final test report was prepared for the U.S. Department of Transportation, National Highway Traffic Safety Administration, in response to Contract Number 693JJ923D000043.

This publication is distributed by the U.S. Department of Transportation, National Highway Traffic Safety Administration, in the interest of information exchange. The opinions, findings and conclusions expressed in this publication are those of the author(s) and not necessarily those of the Department of Transportation or the National Highway Traffic Safety Administration. The United States Government assumes no liability for its contents or use thereof.

If trade or manufacturers' names or products are mentioned it is only because they are considered essential to the object of the publication and should not be construed as an endorsement. The United States Government does not endorse products or manufacturers.

Prepared by: *Alexander Rudniski*  
Alexander Rudniski, Test Engineer

Date: November 5, 2024

Approved by: *Vanessa Hansen*  
Vanessa Hansen, Operations Manager

Date: November 5, 2024

**FINAL REPORT ACCEPTANCE BY OVSC:**

*James A. Jones*

Accepted by \_\_\_\_\_

Date: 11-5-2024

**TECHNICAL REPORT DOCUMENTATION PAGE**

<b>1. Report No.</b> 214D-CAL-24-008	<b>2. Government Accession No.</b>	<b>3. Recipient's Catalog No.</b>
<b>4. Title and Subtitle</b> Final Report of 214D Compliance Test Side Impact Protection Testing of 2024 Mitsubishi Mirage G4 4 Door Sedan NHTSA No.: C20245603		<b>5. Report Date</b> November 5, 2024
<b>7. Author(s)</b> Alexander Rudniski, Test Engineer Vanessa Hansen, Operations Manager		<b>6. Performing Organization Code</b> CAL
<b>9. Performing Organization Name and Address</b> Calspan Corporation Transportation Test Operation P.O. Box 400 Buffalo, New York 14225		<b>8. Performing Organization Report No.</b> CAL-DOT-2024-008
<b>12. Sponsoring Agency Name and Address</b> U.S. Department of Transportation National Highway Traffic Safety Administration Enforcement Office of Vehicle Safety Compliance 1200 New Jersey Ave., SE, Room W43-304 Washington, D.C. 20590		<b>10. Work Unit No.</b>
		<b>11. Contract or Grant No.</b> 693JJ923D000043
		<b>13. Type of Report and Period Covered:</b> Final Test Report, October 14, 2024 - November 5, 2024
		<b>14. Sponsoring Agency Code</b> NEF-240

**15. Supplementary Notes**

**16. Abstract**  
A 48/24 kph 90° Impact (Moving Deformable Barrier) Compliance Tests was conducted on the subject 2024 Mitsubishi Mirage G4 4 Door Sedan in accordance with the specifications of the Office of Vehicle Safety Compliance Test Procedure No. TP-214D-09 for the determination of FMVSS No. 214 Side Impact Protection compliance. This test was conducted at Calspan Corporation's Transportation Test Operations facility in Buffalo, New York on October 14, 2024.

The impact velocity of the Moving Deformable Barrier (MDB) was 53.04 kph, and the ambient temperature at the struck side (driver side) of the target vehicle at the time of impact was 21°C. The target vehicle post test maximum crush was 175 mm at level 2. The test vehicle's occupant performance is as follows:

Measurement Description	Driver ATD (ES-2re)		
	Units	IARV	Result
Head Injury Criteria (HIC <sub>36</sub> )	N/A	1000	156.742
Maximum Rib Deflection	mm	44	14.821
Sum of Abdominal Forces	N	2500	545.785
Pubic Symphysis Force	N	6000	2234.251

Measurement Description	Passenger ATD (SID-IIs)		
	Units	IARV	Result
Head Injury Criteria (HIC <sub>36</sub> )	N/A	1000	468.871
Lower Spine Resultant Acceleration	G	82	61.934
Sum of Acetabular and iliac forces	N	5525	2206.362

The two doors on the struck side of the vehicle did not separate from the body at the hinges or latches and the opposite doors did not open during the side impact event.

<b>17. Key Words</b> Compliance Testing Side Impact Protection MDB ES-2re SID-IIs	<b>18. Distribution Statement</b> Copies of this report are available from: National Highway Traffic Safety Administration Technical Information Services (TIS) Room E12-100 East Bldg. 1200 New Jersey Ave. Washington, D.C. 20590 Telephone No. (202) 366-2588
--	---

<b>19. Security Class. (of this report)</b> UNCLASSIFIED	<b>20. Security Class. (of this page)</b> UNCLASSIFIED	<b>21. No. of Pages</b> 175	<b>22. Price</b>
---	---	--------------------------------	------------------

## TABLE OF CONTENTS

<u>Section</u>		<u>Page</u>
1	Purpose and Summary of the Test	1-1
2	Occupant and Vehicle Information	2-1
 <u>Data Sheet</u>		 <u>Page</u>
1	Test Vehicle Information and Options	2-2
2	General Test and Vehicle Parameter Data	2-4
3	Seat and Seat Belt Adjustment Data	2-5
4	Fuel Systems and Steering Wheel Position Data	2-6
5	Dummy Longitudinal Clearance Dimensions	2-7
6	Dummy Lateral Clearance Dimensions	2-8
7	High Speed Camera Locations	2-9
8	Test Vehicle Accelerometer Locations	2-10
9	Test Vehicle Accelerometer Data Summary	2-11
10	MDB Accelerometer Locations and Data Summary	2-12
11	MDB Summary of Results	2-13
12	Dummy Injury Response Data for ES-2re	2-14
13	Dummy Injury Response Data for SID-IIs	2-15
14	Post Test Observations	2-16
15	Vehicle Pre-test and Post-test Measurements	2-17
16	Exterior Crush Measurements	2-18
17	Vehicle Exterior Crush Profiles	2-19
18	Exterior Static Crush for Impactor Face	2-21
19	Temperature and Humidity Trace	2-22
 <u>Appendix</u>		 <u>Page</u>
I	Photographs	I-1
II	ES-2re Dummy Response Data	II-1
III	SID-IIs Dummy Response Data	III-1
IV	Vehicle and MDB Accelerometer Response Data	IV-1
V	ES-2re Performance Calibration Test Data	V-1
VI	SID-IIs Performance Calibration Test Data	VI-1
VII	Test Equipment and Instrumentation Calibration	VII-1

## **SECTION 1 PURPOSE AND SUMMARY OF TEST**

### PURPOSE

This moving deformable barrier side impact test was conducted as part of the MY 2024 214 Side Impact Protection Compliance Test Program, sponsored by the National Highway Traffic Safety Administration (NHTSA), under Contract No. 693JJ923D000043. The purpose of this test was to evaluate side impact protection in a 2024 Mitsubishi Mirage G4 4 Door Sedan. The side impact test was conducted in accordance with the Office of Vehicle Safety Compliance's Laboratory Test Procedure, TP-214D-09 dated September 2012.

### SUMMARY

A 2024 Mitsubishi Mirage G4 4 Door Sedan was impacted on the left side by a Moving Deformable Barrier (MDB) which was moving forward in a 27° crabbed position to the tow road guidance system at a velocity of 53.04 kph. The target vehicle was stationary and was positioned at an angle of 63° to the line of forward motion. The side impact test was conducted by the Calspan Corporation's Transportation Test Operations Center in Buffalo, New York on October 14, 2024. Pre-test and post test photographs of the test vehicle, the MDB and test dummies are included in this report.

Test dummies were placed in both the driver and left rear designated seating positions according to instructions specified in the OVSC Test Procedure data September 2012. The side impact event was documented by 9 high speed cameras and two real time cameras. Camera locations and other pertinent camera information are included in this report.

The ES2re male dummy was instrumented with triaxial accelerometer packs located in the head, three rib displacement transducers located in the chest, three load cells located in the abdomen and a load cell located in the pubic symphysis.

The SID-1Is female dummy was instrumented with triaxial accelerometer packs located in the head and the spine and load cells located in the pubic symphysis and acetabulum. A summary of each dummy's configuration and performance verification test data has been included in this report along with the dummy response traces.

Injury readings for the dummies were recorded as follows:

**INJURY READINGS**

<b>ES-2re Injury Criteria</b>	<b>Units</b>	<b>Max. Allowable IARV</b>	<b>Measured Value</b>	<b>Pass/Fail</b>
HIC		1000	156.742	Pass
Upper Rib Deflection	mm	44	9.067	Pass
Mid Rib Deflection	mm		7.418	Pass
Lower Rib Deflection	mm		14.821	Pass
Abdominal Load (front)	N		61.448	
Abdominal Load (mid)	N		173.809	
Abdominal Load (rear)	N		316.027	
Total Abdomen Force	N	2500	545.785	Pass
Pubic Symphysis Force	N	6000	2234.251	Pass

<b>SID-IIs Injury Criteria</b>	<b>Units</b>	<b>Max. Allowable IARV</b>	<b>Measured Value</b>	<b>Pass/Fail</b>
HIC		1000	468.871	Pass
Lower Spine Resultant Acceleration	g	82	61.934	Pass
Acetabular Force	N		1962.654	
Iliac Force	N		478.427	
Sum of Acetabular & Iliac	N	5525	2206.362	Pass

## SECTION 2

### OCCUPANT AND VEHICLE INFORMATION

This section contains information reporting for the following Data Sheets:

<u>Data Sheet</u>		<u>Page</u>
1	Test Vehicle Information and Options	2-2
2	General Test and Vehicle Parameter Data	2-4
3	Seat and Seat Belt Adjustment Data	2-5
4	Fuel Systems and Steering Wheel Position Data	2-6
5	Dummy Longitudinal Clearance Dimensions	2-7
6	Dummy Lateral Clearance Dimensions	2-8
7	High Speed Camera Locations	2-9
8	Test Vehicle Accelerometer Locations	2-10
9	Test Vehicle Accelerometer Data Summary	2-11
10	MDB Accelerometer Locations and Data Summary	2-12
11	MDB Summary of Results	2-13
12	Dummy Injury Response Data for ES-2re	2-14
13	Dummy Injury Response Data for SID-IIs	2-15
14	Post Test Observations	2-16
15	Vehicle Pre-test and Post-test Measurements	2-17
16	Exterior Crush Measurements	2-18
17	Vehicle Exterior Crush Profiles	2-19
18	Exterior Static Crush for Impactor Face	2-21
19	Temperature and Humidity Trace	2-22

**DATA SHEET NO. 1  
TEST VEHICLE INFORMATION AND OPTIONS**

Test Vehicle: 2024 Mitsubishi Mirage G4 4 Door Sedan  
 Test Facility: Calspan

NHTSA No.: C20245603  
 Test Date: 10/14/2024

**TEST VEHICLE INFORMATION AND OPTIONS**

Make	Mitsubishi	Anti-Lock Brakes (ABS)	Yes
Model	Mirage G4	All-Wheel Drive (AWD)	No
Body Style	Passenger Car	Traction Control System (TCS)	Yes
VIN	ML32FUFJ3RHF08420	Electric Stability Control (ECS)	Yes
Body Color	Wine Red Metallic	Side Curtain Airbags	Yes
Engine Displacement (L)	1.2	Torso Airbags – Front Seats	Yes
Type/No. Cylinders	I3	Torso Airbags – Rear Seats	No
Engine Placement	Transverse	Combination/Head Torso Bag	No
Transmission Type	Automatic	Pelvic Airbag – Front Seats	No
Transmission Speeds	CVT	Pelvis Airbag – Rear Seats	No
Overdrive	Yes	Knee Airbag – Driver	Yes
Final Drive	Front Wheel Drive	Knee Airbag – Front Passenger	No
Odometer Reading (km/mi)	20 mi	Seat Belt Pretensioners – Front Seats	Yes
		Seat Belt Pretensioners – Rear Seats	No
		Seat Belt Load Limiter – Front Seats	Yes
		Seat Belt Load Limiter – Rear Seats	No
		Tire Pressure Monitoring System (TPMS)	Yes
		Tilt Steering Wheel	Yes
		Automatic Door Locks (ADL)	Yes
		Power Window Auto-reverse	No
		Power Seats	No

**DATA FROM CERTIFICATION LABEL**

Manufactured By	Mitsubishi Motors (Thailand) CO. LTD.	GVWR (kg)	1410
Date of Manufacture	JAN 2024	GAWR Front (kg)	730
Vehicle Type	Passenger Car	GAWR Rear (kg)	690

**VEHICLE SEATING AND CAPACITY WEIGHT DATA**

Measured Parameter	Front	Rear	Third	Total
Type of Seats (Bench or Bucket)	Bench	Split Bench	N/A	
Designated Seating Capacity (DSC)	2	3	N/A	5
Capacity Weight (VCW) (kg)				375

## DATA SHEET NO. 2 VEHICLE TIRE INFORMATION

Test Vehicle: 2024 Mitsubishi Mirage G4 4 Door Sedan  
 Test Facility: Calspan

NHTSA No.: C20245603  
 Test Date: 10/14/2024

### VEHICLE TIRE INFORMATION

*Collected for year, make, model, & VIN, all items circled in red, tire manufacturer and tire name.*

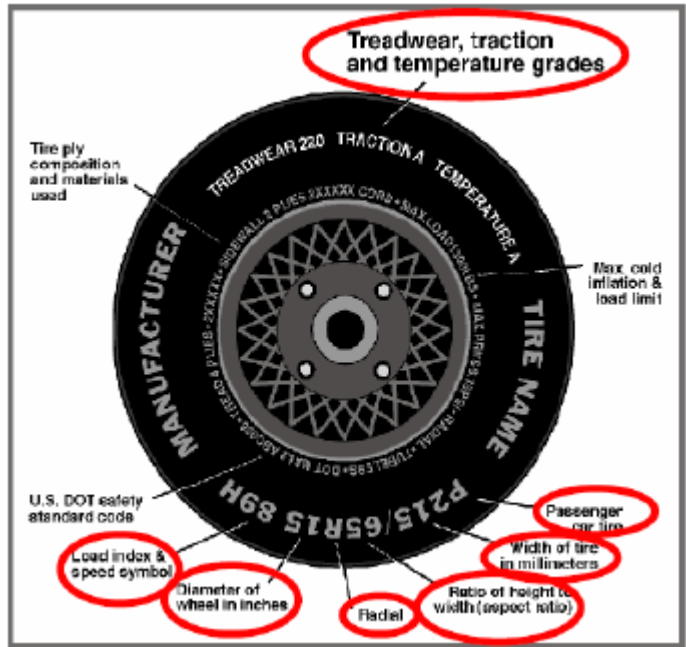

### TIRE SIDEWALL INFORMATION

Tire Placard	Front	Rear
Recommended Cold Pressure (kPa)	270	270
Recommended Tire Size	165/65R14	165/65R14
Tire Sidewall	<b>Front</b>	<b>Rear</b>
Maximum Tire Pressure (kPa)	350	350
Tire Size on Vehicle	165/65R14	165/65R14
Tire Manufacturer Model	Falken	Falken
Tire Name	Sincera	Sincera
Tire Type	All Season	All Season
Tire Width	165	165
Aspect Ratio	65	65
Radial	Yes	Yes
Wheel Diameter	14"	14"
Load Index/Speed Symbol	79S	79S
Treadwear	320	320
Traction Grade	B	B
Temperature Grade	B	B

**DATA SHEET NO. 3  
GENERAL TEST AND VEHICLE PARAMETER DATA**

Test Vehicle: 2024 Mitsubishi Mirage G4 4 Door Sedan  
 Test Facility: Calspan

NHTSA No.: C20245603  
 Test Date: 10/14/2024

**TIRE PRESSURES**

	Units	LF	RF	LR	RR
As Delivered	kPa	200	200	200	200
As Tested	kPa	270	270	270	270

**TEST VEHICLE AXLE WEIGHTS**

	Units	As Delivered (UVW)			Fully Loaded			As Tested		
		Front	Rear	Total	Front	Rear	Total	Front	Rear	Total
Left	kg	296	206.5		335	291		326	281	
Right	kg	283.5	195		300	230		307	227	
Ratio	%	59.1	40.9		54.9	45.1		55.4	44.6	
Totals	kg	579.5	401.5	981	635	521	1156	633	508	1141

**TEST VEHICLE TARGET WEIGHT (TVTW) CALCULATION**

Measured Parameter	Units	Value	
As Delivered Weight (UVW)	kg	981	(A)
Weight of 2 P572 ATDs	kg	131	(B)
Rated Cargo / Luggage Weight (RCLW)	kg	34.8	(C)
Calculated Vehicle Target Weight (TVTW)	kg	1146.8	(A+B+C)

**TEST VEHICLE ATTITUDES AND CG**

Wheel Opening Location	Distance (grd to ref. point above wheel opening in mm)		Difference (mm)	Meets Requirement**
	Fully Loaded	As Tested		
Left Front	618	628	10	Yes
Right Front	637	634	3	Yes
Left Rear	599	608	9	Yes
Right Rear	622	615	7	Yes

\*\*\* The "As Tested" vehicle attitude measurements must be equal to or within  $\pm 10$ mm of the "Fully Loaded" vehicle attitude measurements at each wheel well. Indicate "Yes" or "No" for "Meets Requirements".

**CALCULATION OF VERTICAL IMPACT REFERENCE LINE**

Measured Parameter	Units	Distance (mm)	Met Requirement
Test Vehicle Wheelbase	mm	2552	
Target Vertical Impact Reference Line Aft of Front Axle	mm	336	
Actual Impact Point Location (fore-aft, above - below)		+7 / -13	Yes

Note: Fore or above the target impact point is positive (+). Aft or below the target impact point is negative (-)

**WEIGHT OF BALLAST AND VEHICLE COMPONENTS REMOVED TO MEET TVTW**

Component Description	Weight (kg)
Trunk Carpeting & Spare Tire	16
Head Lights & Tail Lights & Rear Center Armrest	6
Front & Rear Bumper	10.5
Mirror, Hub Caps, Door Panels & Windows	10
Ballast (if any)	0

**DATA SHEET NO. 3 (Continued)**  
**SEAT AND SEAT BELT ANCHORAGE ADJUSTMENT DATA**

Test Vehicle: 2024 Mitsubishi Mirage G4 4 Door Sedan  
 Test Facility: Calspan

NHTSA No.: C20245603  
 Test Date: 10/14/2024

**SEAT BACK ANGLE ADJUSTMENT**

The driver's seat back is positioned to the manufacturer's designated design angle. The front center and front passenger's seat backs are positioned in a similar manner as the driver's seat back. The struck side rear seat back is positioned such that the dummy's head is level. The rear center and non-struck side rear outboard seat backs are positioned in a similar manner as the struck-side rear seat back.

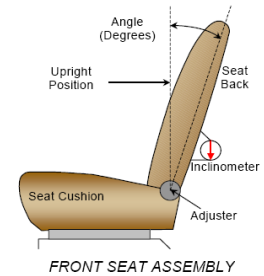

Seat	Total Seat Back Angle Range		Test Position from Most Upright	
	Degrees	Detents*	Degrees	Detents*
Driver Seat w/Seated Dummy	61.2	26 (0-25)	15.0	4
Passenger w/Seated Dummy	62.1	26 (0-25)	15.7	4
Rear Seat	Fixed	Fixed	Fixed	Fixed

**SEAT POSITIONING**

The driver's seat, front center seat (if applicable), and right front passenger's seat should be set to the mid-track, lowest, mid-angle position. The struck-side rear passenger's seat, rear center seat, and non-struck side rear passengers' seats should be set to the rear-most, lowest, mid-angle position.

**SEAT HEIGHT AND ANGLE**

Seat	As Tested SCRL Angle (Mid) (°)	As Tested SCRP Height (mm)	SCR P Height Position	SCR P Height (mm)		
				Rearmost	Mid-Fore / Aft	Forward-Most
Driver Seat	11.9	10.3	Max	-	-	-
			Mid	-	-	-
			Min	2.5	10.3	18.85
Front Passenger Seat	Fixed	Fixed	Max	-	-	-
			Mid	-	-	-
			Min	-	-	-

**SEAT FORE / AFT POSITION**

Seat	Total Fore / Aft Travel		Test Position from Forward most Position	
	mm	Detents*	mm	Detents*
Driver Seat	228	24 (0-23)	119	12
Front Passenger Seat	228	24 (0-23)	119	12
Rear Seat	Fixed	Fixed	Fixed	Fixed

**SEAT BELT ANCHORAGE ADJUSTMENT**

Seat	Total # of Positions	Placed in Position #
Driver Seat	4 (0-3)	Uppermost

**HEAD RESTRAINT ADJUSTMENT**

Seat	Total # of Positions	Placed in Position #
Driver Seat	5 (0-4)	Uppermost

**DATA SHEET NO. 4**  
**FUEL SYSTEMS AND STEERING WHEEL POSITION DATA**

Test Vehicle: 2024 Mitsubishi Mirage G4 4 Door Sedan  
 Test Facility: Calspan

NHTSA No.: C20245603  
 Test Date: 10/14/2024

**STEERING COLUMN ADJUSTMENT**

*Steering wheel and column adjustments are made so that the steering wheel hub is at the center of its geometric locus it describes when it moves through its full range of motion.*

	Degrees	Fore / Aft Position (mm)
Lowermost – Position 1	23.0	
Geometric Center – Position 2	24.6	
Uppermost – Position 3	26.2	
Telescoping Steering Wheel Travel		Fixed
Test Position	24.6	Fixed

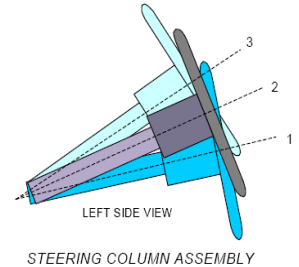

**FUEL PUMP**

*Describe the fuel pump type, details about how it operates, and the location of the fuel filler neck.*

The vehicle is equipped with an electric fuel pump.  
The fuel filler neck is on the left side of the vehicle.  
The pump creates positive pressure in the fuel lines, pushing the gasoline to the engine. See form 1 for more information.

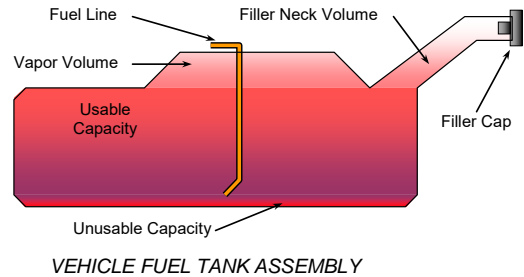

**FUEL TANK CAPACITY DATA**

Description	Liters
Usable Capacity - see Form No. 1	34.8
Usable Capacity - see Owner's Manual	34.8
92-94% of Usable Capacity	32.0 – 32.7
Actual Amount of Solvent Used in Test	32.4

**DATA SHEET NO. 5**  
**DUMMY LONGITUDINAL CLEARANCE DIMENSIONS**

Test Vehicle: 2024 Mitsubishi Mirage G4 4 Door Sedan  
Test Facility: Calspan

NHTSA No.: C20245603  
Test Date: 10/14/2024

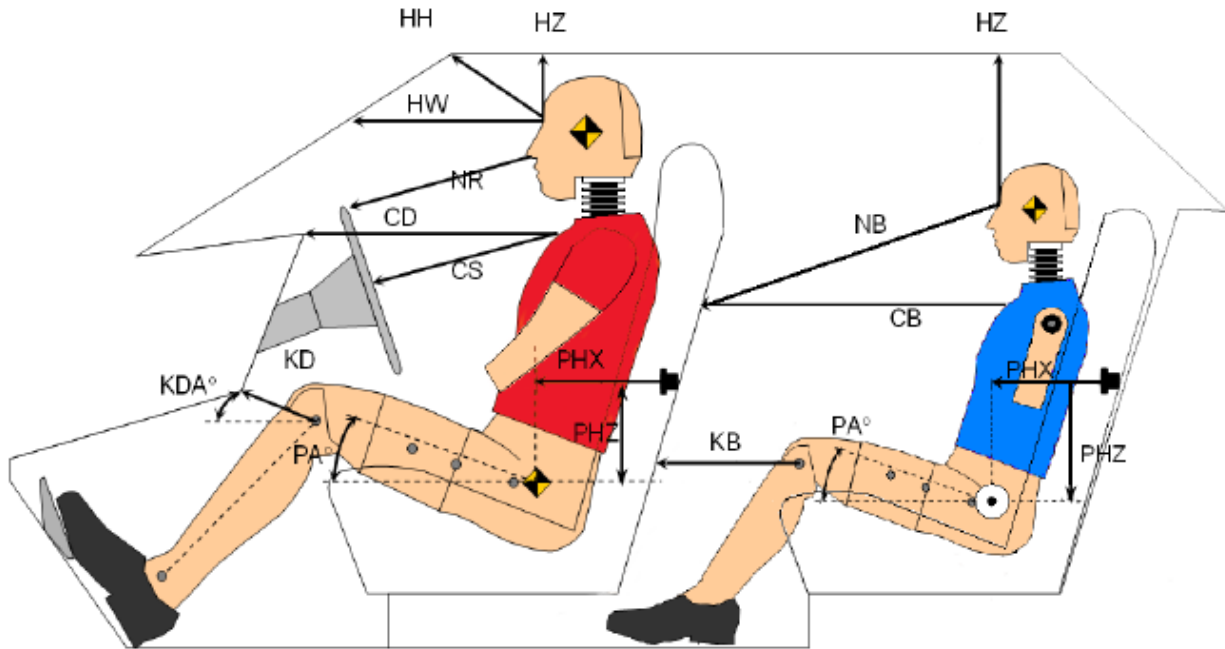

**DUMMY LONGITUDINAL CLEARANCE DIMENSION INFORMATION**

Driver Code	Pass. Code	Description	ES2-re		SID-IIs	
			Length (mm)	Angle	Length (mm)	Angle
HH		Header to Header	383			
HW		Header to Windshield	537			
HZ	HZ	Head to Roof Liner	43		264	
NR	NB	Nose to Rim/Seat Back	433		606	
CD	CB	Chest to Dash/Seat Back	562		637	
CS		Chest to Steering Wheel	370			
KD(L)/KDA(L)°	KB(L)/KBA(L)°	Left Knee to Dash/Seat Back	149	28.6	333	12.5
KD(R)/KDA(R)°	KB(R)/KBA(R)°	Right Knee to Dash/Seat Back	209	15.8	330	18.2
PAX°	PAX°	Pelvic Tilt Angle (X-Axis)		23.3		20.6
PAY°	PAY°	Pelvic Tilt Angle (Y-Axis)				0.3
PHX	PHX	Hip Point to Striker (X-Axis)	201		224	
PHZ	PHZ	Hip Point to Striker (Z-Axis)	124		223	

**DATA SHEET NO. 6  
DUMMY LATERAL CLEARANCE DIMENSIONS**

Test Vehicle: 2024 Mitsubishi Mirage G4 4 Door Sedan  
 Test Facility: Calspan

NHTSA No.: C20245603  
 Test Date: 10/14/2024

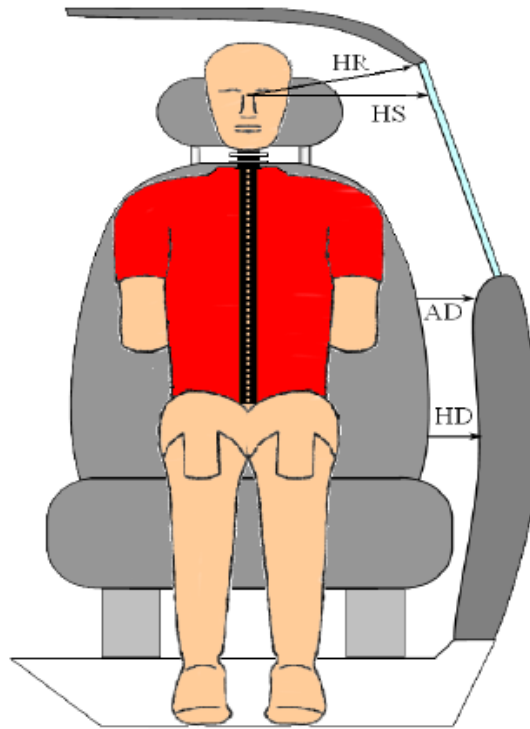

*FRONT VIEW OF DUMMY*

**DUMMY LATERAL CLEARANCE DIMENSION INFORMATION**

Code	Measurement Description	Units	Front Occupant	Rear Occupant
HR	Head To Side Header	mm	197	218
HS	Head to Side Window	mm	321	353
AD	Arm to Door	mm	82	119
HD	Hip Point to Door	mm	125	159

**DATA SHEET NO. 7  
LOCATION OF CAMERAS**

Test Vehicle: 2024 Mitsubishi Mirage G4 4 Door Sedan  
 Test Facility: Calspan

NHTSA No.: C20245603  
 Test Date: 10/14/2024

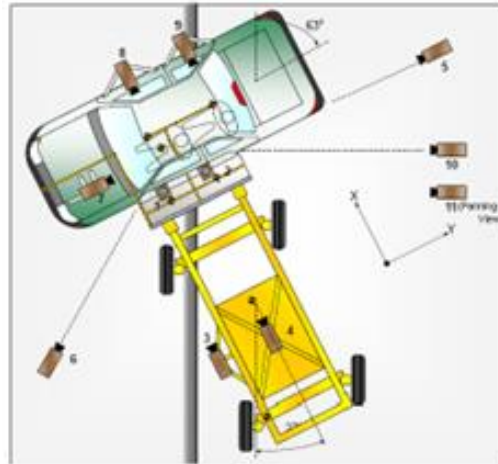

**CAMERA LOCATIONS AND DATA**

No.	Camera View	Coordinates (mm)			Lens Length (mm)	Operating Frame Rate (fps)
		X	Y	Z		
1	Overhead Overall	0	369	-9220	12.5	1000
2	Overhead Close-up	0	0	-9220	25	1000
3	Impact Point Close-up				25	1000
4	Centerline of Impact (MDB)				8	1000
5	Right Side View	471	7458	-1528	28	1000
6	Left Side View	-3431	-5279	-1469	24	1000
7	Front Seat Occupant-Frontal View (OB)				25	1000
8	Front Seat Occupant-Side View (OB)				12.5	1000
9	Rear Passenger-Side View (OB)				12.5	1000
10	Real-time Coverage				Zoom	60

Notes: Reference: Impact Point projected to Ground  
 +X = To Front of MDB, +Y = To Right of MDB, +Z = Down

**DATA SHEET NO. 8  
TEST VEHICLE ACCELEROMETER LOCATIONS**

Test Vehicle: 2024 Mitsubishi Mirage G4 4 Door Sedan  
 Test Facility: Calspan

NHTSA No.: C20245603  
 Test Date: 10/14/2024

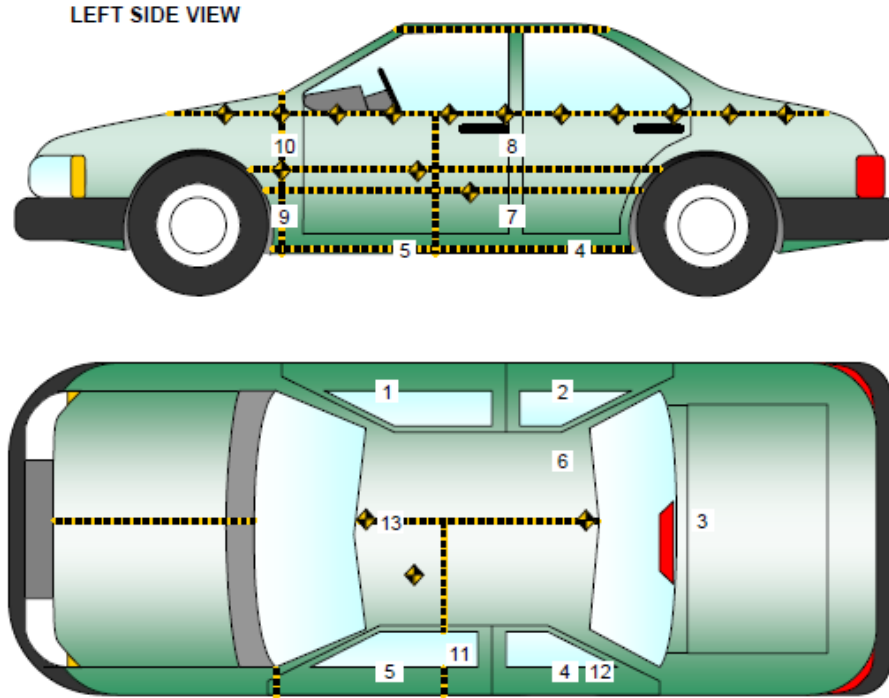

**TEST VEHICLE ACCELEROMETER LOCATIONS**

No.	Accelerometer Location	Coordinates (mm)		
		X	Y	Z
1	Left (or Rt.) Sill at Front Seat	2737	604	228
2	Left (or Rt.) Sill at Rear Seat	1839	599	218
3	Rear Floorpan Above Axle	951	-24	211
4	Left (or Rt.) Sill at Rear Door	1869	-588	247
5	Left (or Rt.) Sill at Front Door	2820	-598	239
6	Left (or Rt.) Rear Occ. Compartment	2083	343	300
7	Left (or Rt.) B-Post Lower	2093	-607	-25
8	Left (or Rt.) B-Post Middle	2034	-609	-433
9	Left (or Rt.) A-Post Lower	3159	-576	43
10	Left (or Rt.) A-Post Middle	3051	-588	-473
11	Front Seat Track	2305	-482	156
12	Rear Seat Track or Structure	1513	-607	132
13	Vehicle CG	1951	10	207

Reference: X – Rear surface of vehicle (+ forward)  
 Y – Vehicle centerline (+ to right)  
 Z – Ground plane (+ down)

**DATA SHEET NO. 9**  
**TEST VEHICLE ACCELEROMETER DATA SUMMARY**

Test Vehicle: 2024 Mitsubishi Mirage G4 4 Door Sedan  
 Test Facility: Calspan

NHTSA No.: C20245603  
 Test Date: 10/14/2024

Loc No.	Description	Axes	Units	Peak Values (g's)			
				Max	Time (ms)	Max	Time (ms)
1	Left (or Rt.) Sill at Front Seat	X	g	4.61	23.15	-4.81	14.75
		Y	g	26.56	6.30	-4.57	85.40
		Z	g	8.65	62.65	-12.77	12.80
		Resultant		27.39	6.45	0.01	-32.60
2	Left (or Rt.) Sill at Rear Seat	X	g	6.19	20.40	-8.29	27.65
		Y	g	29.70	32.00	-5.04	85.45
		Z	g	8.00	61.65	-28.97	19.55
		Resultant		30.37	19.60	0.03	-22.60
3	Rear Floorpan Above Axle	X	g	11.10	48.15	-10.69	27.00
		Y	g	29.93	31.25	-4.00	85.30
		Z	g	20.82	39.35	-34.05	35.10
		Resultant		43.35	35.10	0.01	-25.65
4	Left (or Rt.) Sill at Rear Door	Y	g	164.84	12.40	-199.51	23.10
5	Left (or Rt.) Sill at Front Door	Y	g	104.01	9.05	-85.86	24.80
6	Left (or Rt.) Rear Occ. Compartment	Y	g	26.76	6.20	-5.07	85.90
7	Left (or Rt.) B-Post Lower	Y	g	214.37	4.70	-110.65	14.75
8	Left (or Rt.) B-Post Middle	Y	g	198.65	5.35	-172.98	12.30
9	Left (or Rt.) A-Post Lower	Y	g	142.91	20.30	-132.69	26.30
10	Left (or Rt.) A-Post Middle	Y	g	52.38	16.10	-31.08	125.40
11	Front Seat Track	Y	g	84.11	12.00	-17.59	24.20
12	Rear Seat Track or Structure	Y	g	120.59	4.80	-82.09	16.50
13	Vehicle CG	X	g	3.67	51.65	-9.55	28.10
		Y	g	24.51	19.85	-4.47	85.35
		Z	g	13.97	30.35	-18.07	11.80
		Resultant		26.87	28.60	0.01	-42.10

**DATA SHEET NO. 10**  
**MDB ACCELEROMETER LOCATION DATA SUMMARY**

Test Vehicle: 2024 Mitsubishi Mirage G4 4 Door Sedan  
 Test Facility: Calspan

NHTSA No.: C20245603  
 Test Date: 10/14/2024

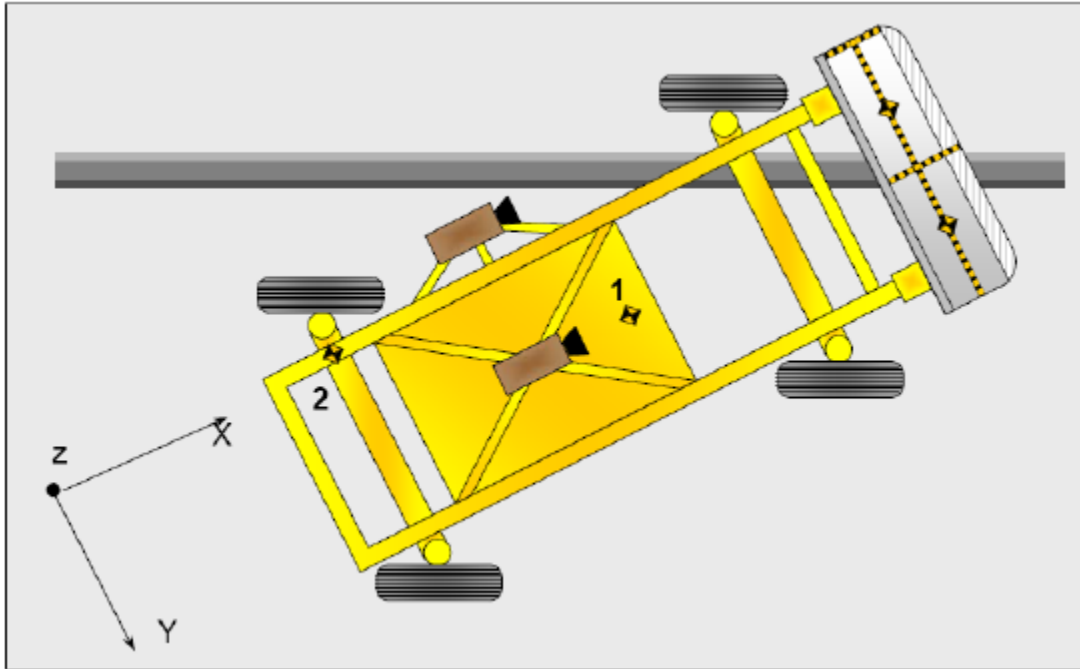

Loc No.	Description	Axes	Units	Peak Values (g's)			
				Max	Time (ms)	Max	Time (ms)
1	MDB CG	X	g	1.37	78.95	-16.94	33.60
		Y	g	2.39	53.90	-8.76	37.45
		Z	g	15.88	51.75	-10.85	45.40
		Resultant		19.13	38.20	0.03	-28.35
2	MDB Rear	X	g	1.32	179.80	-20.27	30.60
		Y	g	2.47	41.85	-2.43	52.35

**DATA SHEET NO. 11  
MDB SUMMARY OF RESULTS**

Test Vehicle: 2024 Mitsubishi Mirage G4 4 Door Sedan  
 Test Facility: Calspan

NHTSA No.: C20245603  
 Test Date: 10/14/2024

**MDB SPECIFICATIONS**

Measurement Description	Requirement	Value
Overall Width of Framework Carriage	1241 – 1261	1,250
Overall Length Including Honeycomb Frame	4140 – 3990	4,120
Wheelbase of Framework Carriage	2566 – 2616	2,600
CG Location Aft of Front Axle		1,120
MDB Front Axle Weight		764
MDB Rear Axle Weight		594
MDB Total Weight	1356.5 – 1365.5	1358

**SPEED AND ANGLE AT IMPACT DATA**

Measured Parameter	Units	Requirement	Value
Trap No. 1 Velocity (Primary)	km/h	52.1 to 53.7	53.04
Trap No. 2 Velocity (Redundant)	km/h	52.1 to 53.7	53.01
MDB CL to Target Vehicle CL	degrees	88.5 to 91.5	90.0

**MAXIMUM STATIC CRUSH OF HONEYCOMB IMPACT FACE**

Vertical Location			From Centerline		Maximum Crush (mm)
Row	Description	Height (mm)	Distance (mm)	Direction	
A	Center of Bumper	432	800	Right	69
B	Top of Bumper	533	800	Right	37
C	Mid-Level	686	800	Left	30
D	Top of Stack	813	800	Left	55

**IMPACT POINT LOCATION DATA**

Measured Parameter	Units	Tolerance	Value
Horizontal Offset (+ forward / - rearward)	mm	+/- 50 of Intended Impact Point	+7
Vertical Offset (- down / + up)	mm	+/- 20 of Intended Impact Point	-13

**DATA SHEET NO. 12**  
**DUMMY INJURY RESPONSE DATA**  
**(Subpart U, ES-2re)**

Test Vehicle: 2024 Mitsubishi Mirage G4 4 Door Sedan  
 Test Facility: Calspan

NHTSA No.: C20245603  
 Test Date: 10/14/2024

**Dummy Serial No. DG5348**

Description	Axes	Positive Direction		Negative Direction	
		Max	Time (ms)	Max	Time (ms)
<b>HEAD ACCELERATION (g)</b>					
Longitudinal	X	3.83	147.20	-23.22	59.25
Lateral	Y	37.25	50.70	-7.67	134.95
Vertical	Z	12.38	15.55	-10.02	56.85
Resultant	N/A	39.49	51.00		
HIC36 (t1, t2)	N/A	156.74		t1 = 36.90	t2 = 65.95
<b>THORAX DEFLECTION (mm)</b>					
Upper Rib	Y	9.07	57.00	-1.96	16.85
Middle Rib	Y	7.42	32.90	-1.34	72.85
Lower Rib	Y	14.82	34.55	-1.73	68.55
<b>ABDOMINAL FORCES (N)</b>					
Front	Y	61.45	33.00	-22.03	14.55
Middle	Y	173.81	49.60	-8.83	99.75
Rear	Y	316.03	31.85	-0.78	-38.80
SUM	N/A	545.78	32.80		
<b>PELVIS FORCES (N)</b>					
Pubic Symphysis	Y	119.04	119.00	-2234.25	46.25

Reference: Positive Direction    -    Longitudinal                    (X) = forward  
    -    Lateral                                (Y) = to right  
    -    Vertical                                (Z) = down



**DATA SHEET NO. 14  
POST-TEST OBSERVATIONS**

Test Vehicle: 2024 Mitsubishi Mirage G4 4 Door Sedan  
 Test Facility: Calspan

NHTSA No.: C20245603  
 Test Date: 10/14/2024

**TEST DUMMY INFORMATION AND CONTACT POINTS**

Dummy Body Part	Front Occupant	Rear Occupant
Head Contact	Curtain Airbag, Headliner & Headrest	Curtain Airbag, Headliner & Center Seat
Upper Torso Contact	Torso/Pelvis Airbag	Door Panel
Lower Torso Contact	Torso/Pelvis Airbag	Door Panel
Left Knee Contact	Door Panel	Door Panel
Right Knee Contact	Left Knee	Left Knee

**POST-TEST DOOR PERFORMANCE**

Description	Front	Rear
Left Side Doors	Jammed	Jammed
Right Side Doors	Closed & Operational	Closed & Operational
Hatch and Other Doors		Closed & Operational
Seat Movement	None	None
Seatback Failure	None	None

\*Note: Description for door opening must be specific with the following three categories: Remained closed and operational, opened/unlatched during the crash, or jammed shut. Sometimes the door is jammed and unlatched. If the door cannot be opened, then note the door as jammed shut. If open, measurement must be taken for the width of the door opening (mm).

**POST-TEST STRUCTURAL OBSERVATIONS**

Critical Areas of Performance	Observations and Conclusions
Pillar Performance	A-Pillar, B-Pillar & C-Pillar Buckled
Sill Separation	None
Windshield Damage	None
Side Window Damage	Rear struck side window shattered during impact
Other Notable Effects	None

**SUPPLEMENTAL RESTRAINT SYSTEM INFORMATION**

Restraint Type	Front Occupant		Rear Occupant	
	Installed	Deployed	Installed	Deployed
Frontal Airbag	Yes	No		
Side Torso Airbag	Yes	Yes	No	N/A
Head Airbag	No	N/A	No	N/A
Curtain Airbag	Yes	Yes	Yes	Yes
Seat Belt Pretensioner	Yes	Yes	No	N/A
Other				

**DATA SHEET NO. 15**  
**VEHICLE PRE TEST AND POST TEST MEASUREMENTS**

Test Vehicle: 2024 Mitsubishi Mirage G4 4 Door Sedan  
Test Facility: Calspan

NHTSA No.: C20245603  
Test Date: 10/14/2024

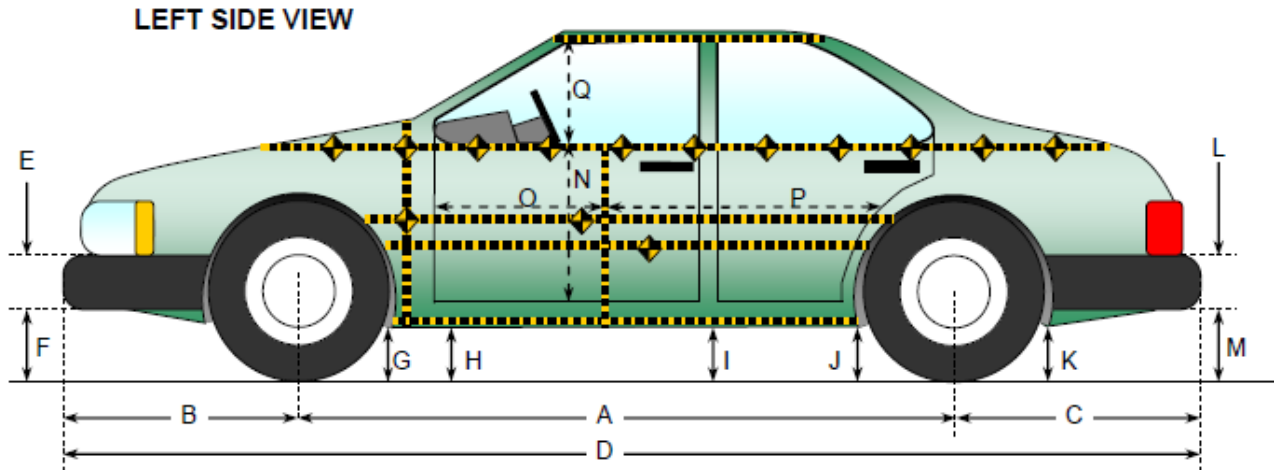

**VEHICLE PRE- AND POST-TEST MEASUREMENT INFORMATION**

Code	Description	Pre-Test	Post-Test	Difference
A	Vehicle Wheelbase	2552	2527	-25
B	Front Axle to FSOV	798	839	41
C	Rear Axle to RSOV	956	955	-1
D	Total Length at Centerline	4303	4321	18
E	Front Bumper Thickness	95	95	0
F	Front Bumper Bottom to Ground	428	432	4
G	Sill Height at Front Wheel Well	204	182	-22
H	Sill Height at Front Door Leading Edge	208	195	-13
I	Sill Height at B-Pillar	208	248	40
J1	Sill Height at Rear Wheel Well	201	210	9
J2	Pinch Weld Height at Rear Wheel Well	180	202	22
K	Sill Height Aft of Rear Wheel Well	247	257	10
L	Rear Bumper Thickness	80	80	0
M	Rear Bumper Bottom to Ground	382	384	2
N	Sill Height to Bottom of Front Window Sill	722	654	-68
O	Front Door Leading Edge to Impact CL	765	750	-15
P	Rear Door Trailing Edge to Impact CL	1267	1250	-17
Q	Front Window Opening	413	412	-1
R	Right Side Length	4191	4215	24
S	Left Side Length	4185	4209	24
T	Vehicle Width at B-Pillars	1643	1448	-195

**DATA SHEET NO. 16**  
**TEST VEHICLE EXTERIOR CRUSH MEASUREMENTS**

Test Vehicle: 2024 Mitsubishi Mirage G4 4 Door Sedan  
Test Facility: Calspan

NHTSA No.: C20245603  
Test Date: 10/14/2024

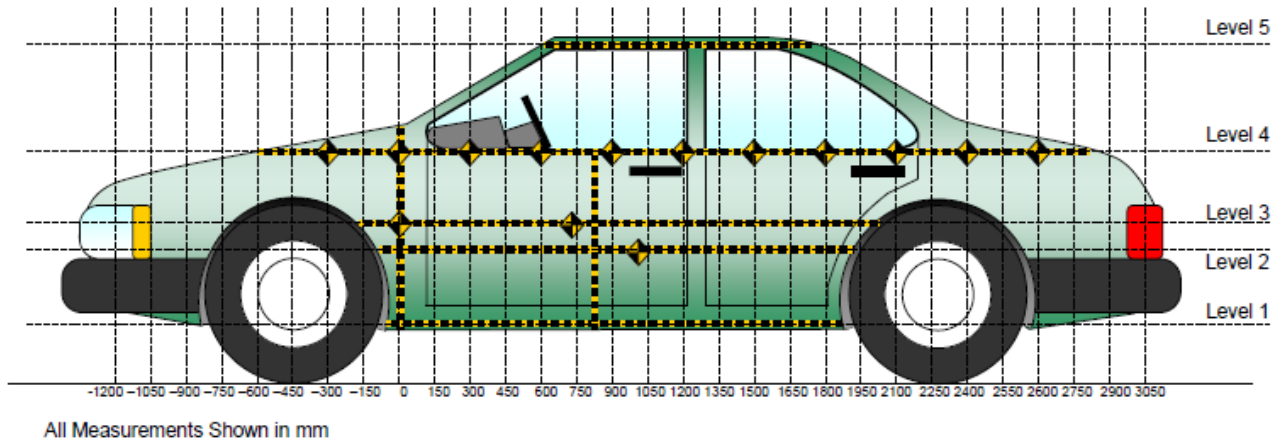

**MAXIMUM EXTERIOR CRUSH MEASUREMENTS**

Level	Measurement Description	Units	Height Above Ground	Maximum Exterior Static Crush	Distance from Impact
1	Sill Top	mm	266	72	300
2	Occupant Hip Point	mm	611	175	900
3	Mid - Door	mm	661	163	300
4	Window Sill	mm	908	136	1500
5	Window Top	mm	1435	5	1200

**NOTE:** The above measurements should be taken along the vertical impact reference line. Vehicle measurements forward of the vertical impact reference line are negative.

**DATA SHEET NO. 17**  
**VEHICLE EXTERIOR CRUSH MEASUREMENTS**

Test Vehicle: 2024 Mitsubishi Mirage G4 4 Door Sedan  
Test Facility: Calspan

NHTSA No.: C20245603  
Test Date: 10/14/2024

**EXTERIOR CRUSH MEASUREMENTS AT EACH LEVEL**

	Pre-Test					Post-Test					Difference				
	1	2	3	4	5	1	2	3	4	5	1	2	3	4	5
-900															
-750															
-600															
-450															
-300			832	753				831	753				1	0	
-150		833	828	761			828	821	752			5	7	9	
0		820	820	767			800	794	748			20	26	19	
150	779	814	812	773		763	674	675	709		16	140	137	64	
300	777	817	816	780		705	646	653	694		72	171	163	86	
450	777	819	820	787		708	655	661	684		69	164	159	103	
600	776	821	822	795		712	654	665	674		64	167	157	121	
750	775	821	823	801	576	712	649	667	672	580	63	172	156	129	-4
900	773	821	823	806	590	710	646	666	675	591	63	175	157	131	-1
1050	771	819	822	807	590	708	648	666	679	588	63	171	156	128	2
1200	769	818	821	807	586	710	651	669	686	581	59	167	152	121	5
1350	766	816	819	806	581	711	677	680	676	579	55	139	139	130	2
1500	764	814	817	803	574	709	693	688	667	576	55	121	129	136	-2
1650	764	814	817	798	567	706	710	703	681	573	58	104	114	117	-6
1800	763	817	818	796	545	718	721	730	723	556	45	96	88	73	-11
1950		833	829	793			826	813	760			7	16	33	
2100		836	836	791			797	801	811			39	35	-20	
2250			835	786				824	791				11	-5	
2400			830	780				832	795				-2	-15	
2550			813	772				819	797				-6	-25	
2700															
2850															
3000															

**NOTE:** Pre-test measurements are taken when the vehicle is in the "As Tested" weight condition.  
Vehicle measurements forward of the vertical impact reference line are negative.  
The crush profile grid is established prior to test based on an estimated impact point.

**DATA SHEET NO. 17**  
**TEST VEHICLE EXTERIOR CRUSH MEASUREMENTS (CONTINUED)**

Test Vehicle: 2024 Mitsubishi Mirage G4 4 Door Sedan  
 Test Facility: Calspan

NHTSA No.: C20245603  
 Test Date: 10/14/2024

**Vehicle Exterior Crush Measurements - Visual Representation**

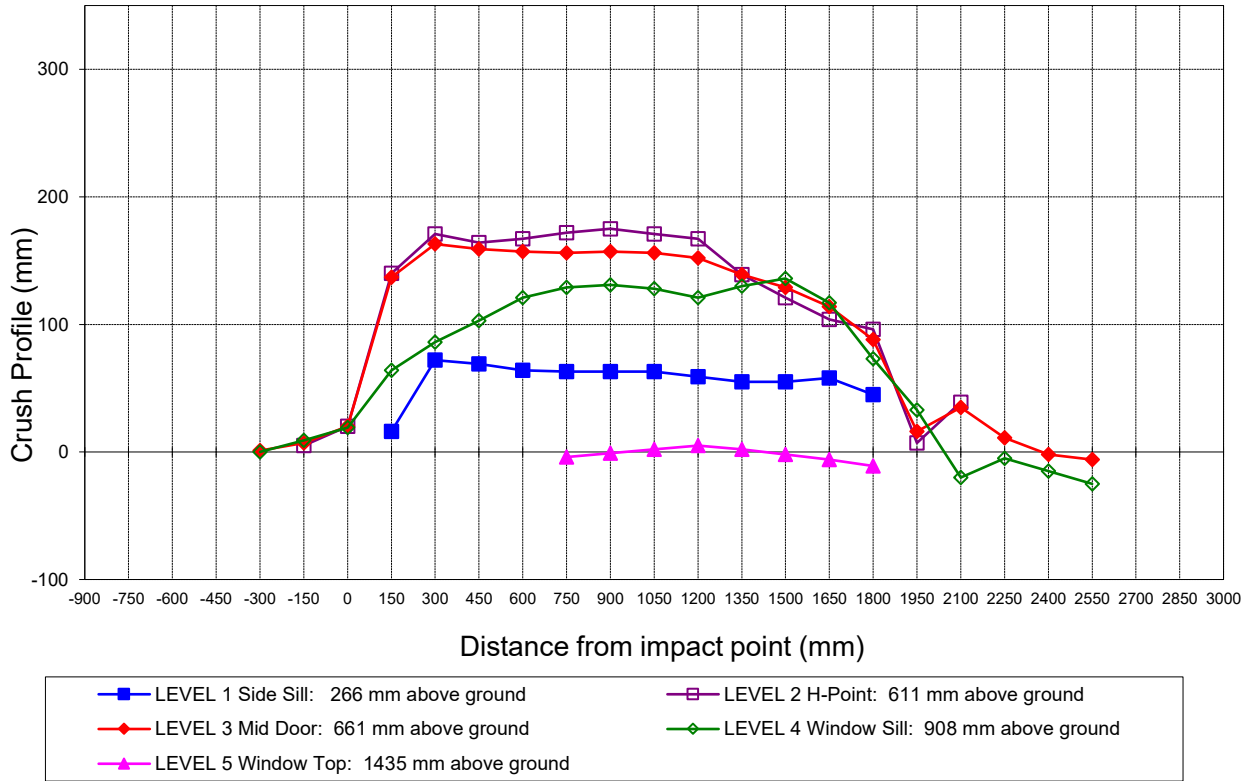

**DATA SHEET NO. 18**  
**TEST VEHICLE EXTERIOR CRUSH MEASUREMENTS (CONTINUED)**

Test Vehicle: 2024 Mitsubishi Mirage G4 4 Door Sedan  
 Test Facility: Calspan

NHTSA No.: C20245603  
 Test Date: 10/14/2024

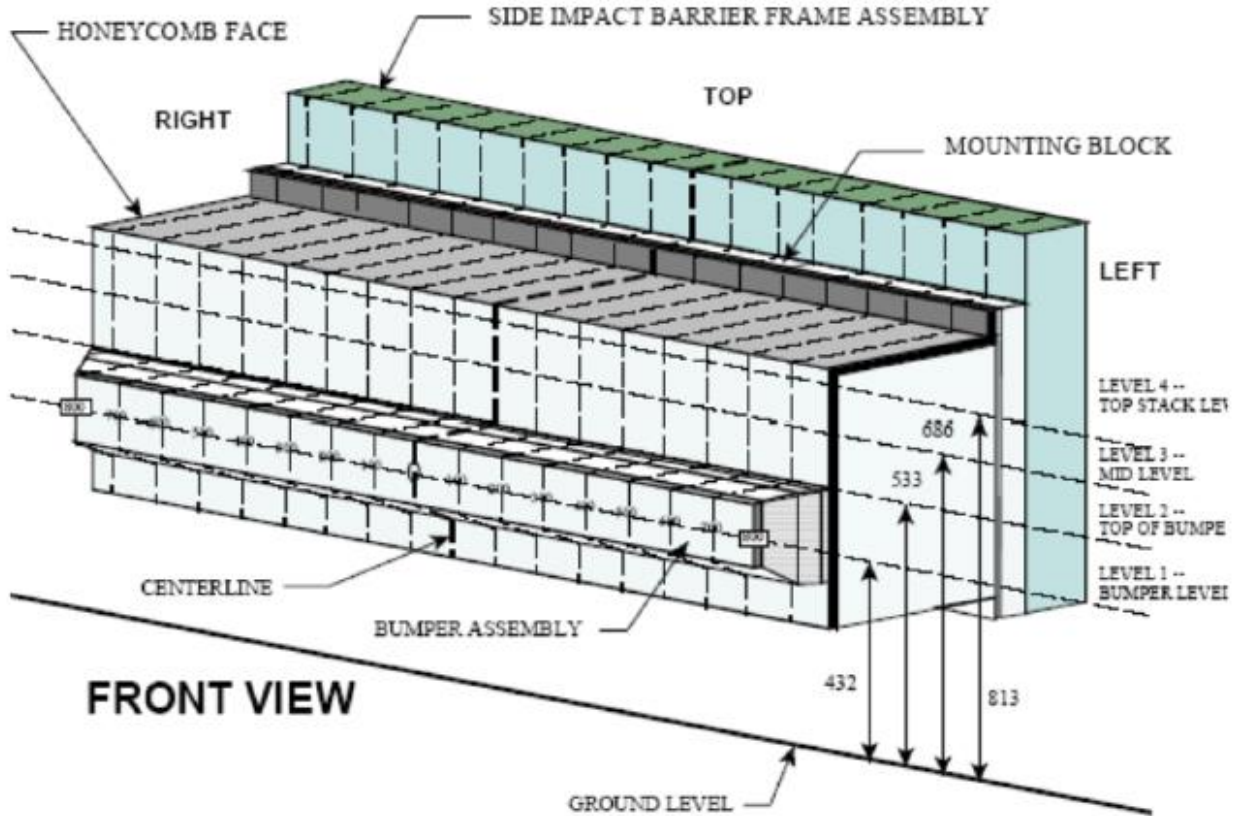

NOTE: Dimensions are shown in millimeters, mm

**DEFORMABLE BARRIER STATIC CRUSH**

Stack Level	Distance Right of Center								C/L	Distance Left of Center							
	800	700	600	500	400	300	200	100		0	100	200	300	400	500	600	700
1	69	67	58	57	55	54	53	54	52	50	47	46	46	45	45	48	64
2	37	33	30	30	27	27	26	25	22	20	18	16	16	14	14	14	21
3	4	-4	-3	-1	1	3	13	19	4	1	1	1	2	4	6	8	30
4	13	-11	-11	-9	-5	7	28	18	5	0	0	1	3	6	11	22	55

Reference:  
 +X = Forward  
 +Y = To Right  
 +Z = Down

**DATA SHEET NO. 19**  
**DUMMY / VEHICLE TEMPERATURE AND HUMIDITY STABILIZATION DATA**

Test Vehicle: 2024 Mitsubishi Mirage G4 4 Door Sedan  
Test Facility: Calspan

NHTSA No.: C20245603  
Test Date: 10/14/2024

***Temperature and Humidity Stabilization Chart / Data for Dummies and Test Vehicle***

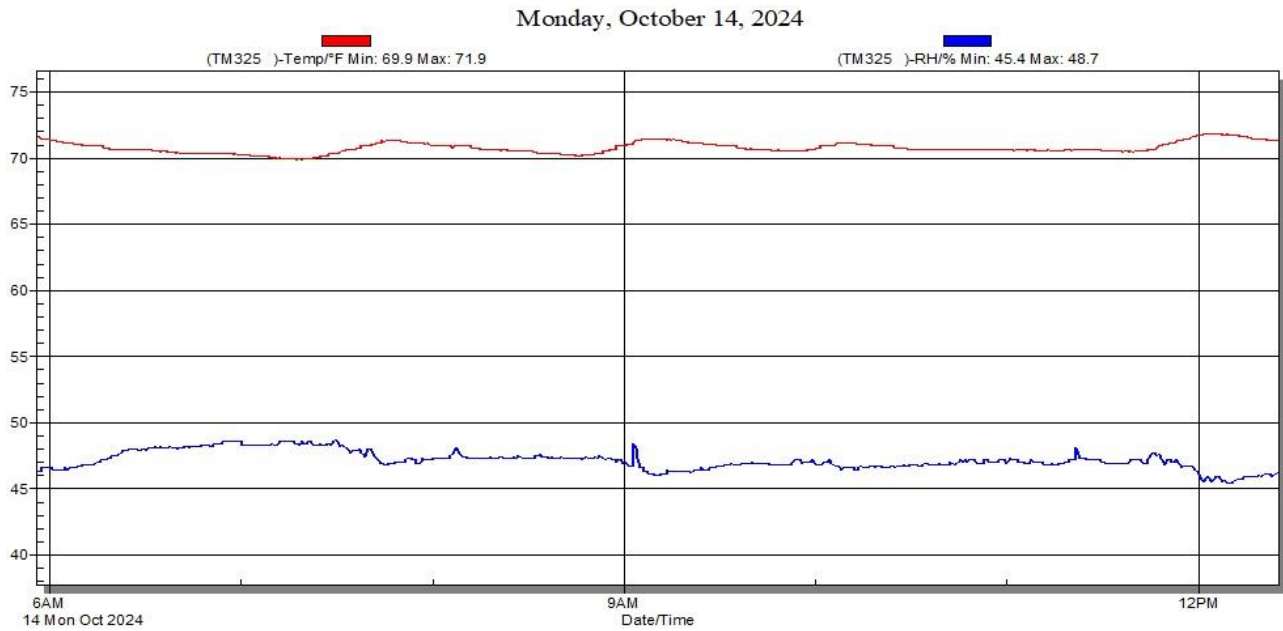

**APPENDIX I**  
**PHOTOGRAPHS**

## TABLE OF PHOTOGRAPHS

Fig.	Description	Page
1	Pre-Test Frontal View of Test Vehicle	I-3
2	Post-Test Frontal View of Test Vehicle	I-3
3	Pre-Test Rear View of Test Vehicle	I-4
4	Post-Test Rear View of Test Vehicle	I-4
5	Pre-Test Impacted Side View of Test Vehicle	I-5
6	Post-Test Impacted Side View of Test Vehicle	I-5
7	Pre-Test Frontal View of Impactor Face	I-6
8	Post-Test Frontal View of Impactor Face	I-6
9	Pre-Test Left Side View of Impactor Face	I-7
10	Post-Test Left Side View of Impactor Face	I-7
11	Pre-Test Right Side View of Impactor Face	I-8
12	Post-Test Right Side View of Impactor Face	I-8
13	Pre-Test Top View of Impactor Face	I-9
14	Post-Test Top View of Impactor Face	I-9
15	Pre-Test Overhead View of MDB Positioned Against Impact Side of Test Vehicle at Impact Location	I-10
16	Post-Test Overhead View of the MDB and Test Vehicle	I-10
17	Pre-Test Front ES2-re in Final Seating Position (Door Open)	I-11
18	Pre-Test Front ES2-re in Final Seating Position (Door Closed)	I-11
19	Pre-Test Front ES2-re – Opposite Side View	I-12
20	Post-Test Front ES2-re – Opposite Side View	I-12
21	Pre-Test Rear SID in Final Seating Position (Door Open)	I-13
22	Pre-Test Rear SID in Final Seating Position (Door Closed)	I-13
23	Pre-Test Rear SID – Opposite Side View	I-14
24	Post-Test Rear SID – Opposite Side View	I-14
25	T (0) – Impact Event	I-15
26	Post-Test Close-up View of Impact Point Target	I-15
27	Close-up View of Vehicle’s Certification Label	I-16
28	Post-Test Front Seat Occupant Area Showing Head & Torso Contact Regions	I-16
29	Post-Test Rear Seat Occupant Area Showing Head & Torso Contact Regions	I-17
30	Close-up View of Vehicle’s Tire Placard	I-17



**Figure A-1: Pre-Test Frontal View of Test Vehicle**



**Figure A-2: Post-Test Frontal View of Test Vehicle**



**Figure A-3: Pre-Test Rear View of Test Vehicle**



**Figure A-4: Post-Test Rear View of Test Vehicle**



**Figure A-5: Pre-Test Impacted Side View of Test Vehicle**



**Figure A-6: Post-Test Impacted Side View of Test Vehicle**

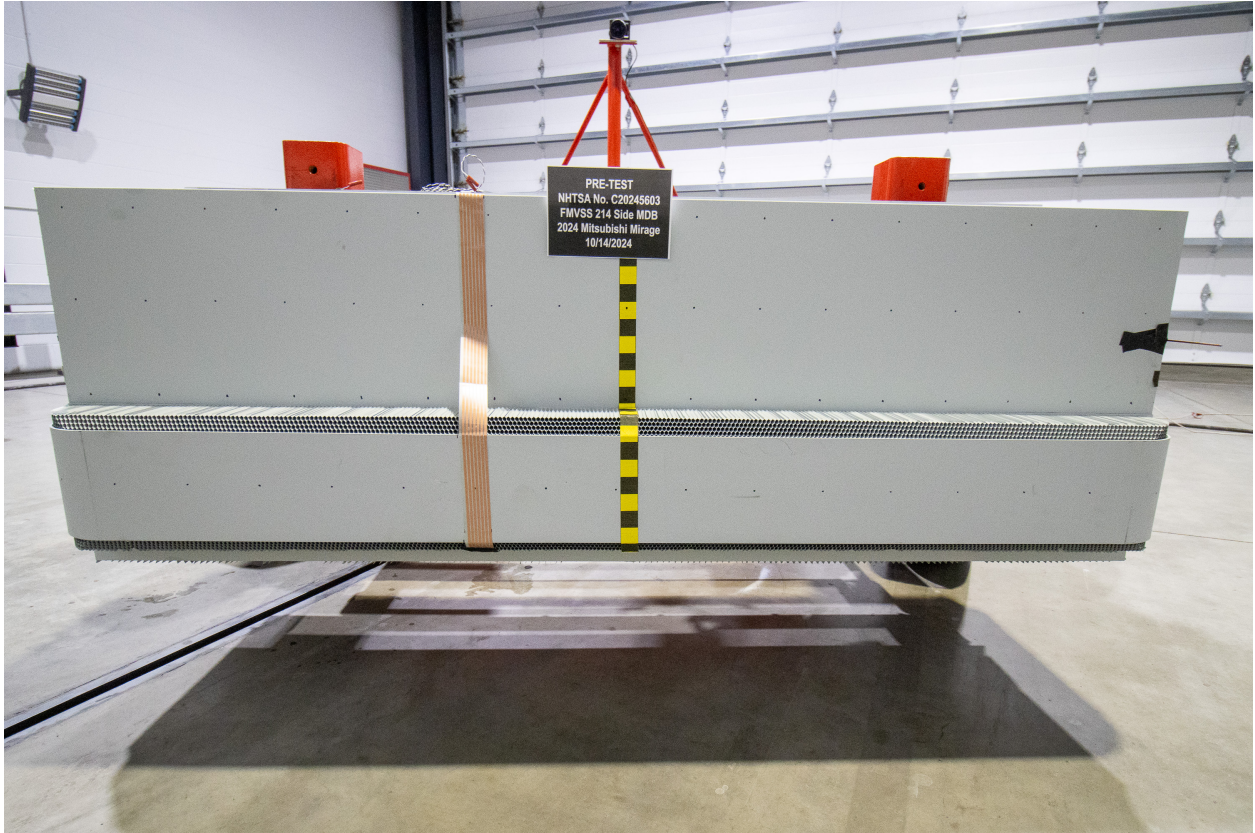

**Figure A-7: Pre-Test Frontal View of Impactor Face**



**Figure A-8: Post-Test Frontal View of Impactor Face**



**Figure A-9: Pre-Test Left Side View of Impactor Face**



**Figure A-10: Post-Test Left Side View of Impactor Face**



**Figure A-11: Pre-Test Right Side View of Impactor Face**



**Figure A-12: Post-Test Right Side View of Impactor Face**



**Figure A-13: Pre-Test Top View of Impactor Face**



**Figure A-14: Post-Test Top View of Impactor Face**



**Figure A-15: Pre-Test Overhead View of MDB Positioned Against Impact Side of Test Vehicle at Impact Location**

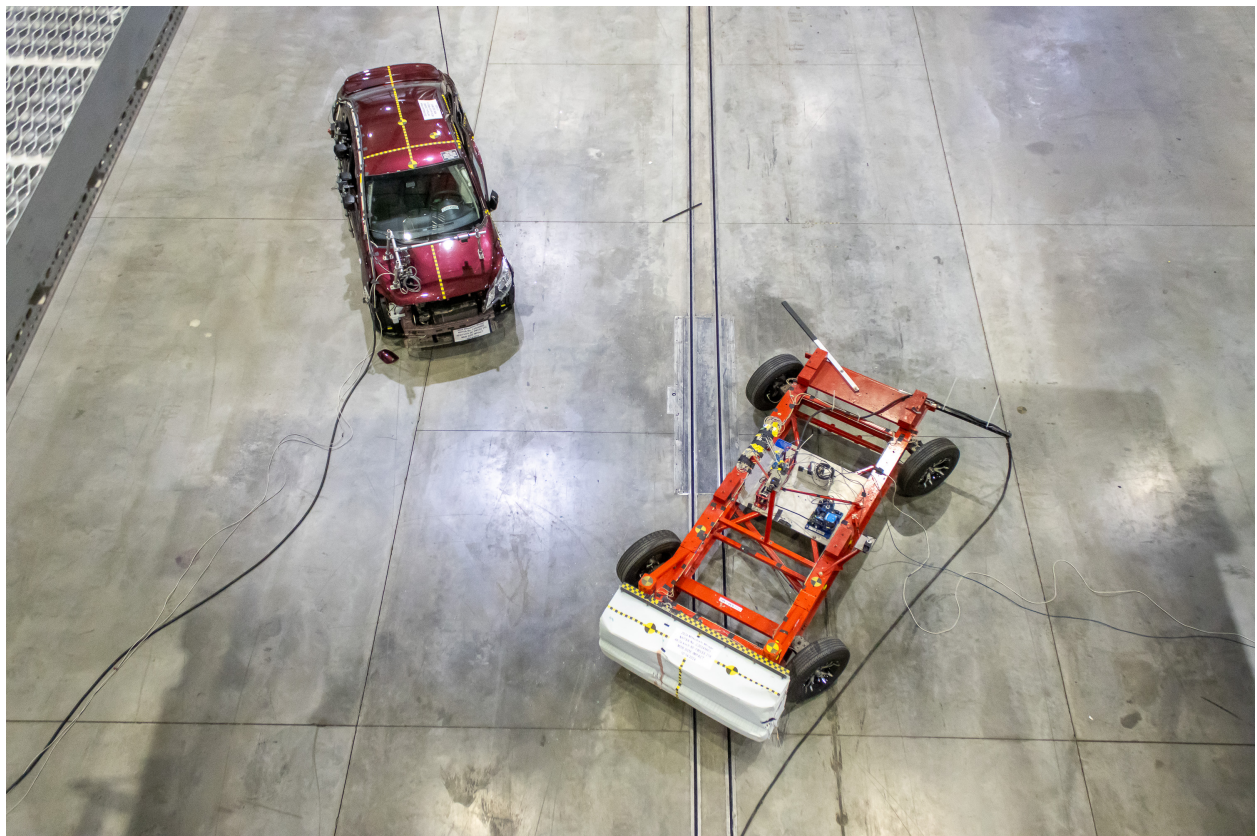

**Figure A-16: Post-Test Overhead View of the MDB and Test Vehicle**



**Figure A-17: Pre-Test Front ES2-re in Final Seating Position (Door Open)**



**Figure A-18: Pre-Test Front ES2-re in Final Seating Position (Door Closed)**



**Figure A-19: Pre-Test Front ES2-re - Opposite Side View**



**Figure A-20: Post-Test Front ES2-re - Opposite Side View**



**Figure A-21: Pre-Test Rear SID in Final Seating Position (Door Open)**



**Figure A-22: Pre-Test Rear SID in Final Seating Position (Door Closed)**



**Figure A-23: Pre-Test Rear SID - Opposite Side View**



**Figure A-24: Post-Test Rear SID - Opposite Side View**



Figure A-25: T (0) - Impact Event



Figure A-26: Post-Test Close-up View of Impact Point Target



Figure A-27: Close-up View of Vehicle's Certification Label



Figure A-28: Post-Test Front Seat Occupant Area Showing Head & Torso Contact Regions



Figure A-29: Post-Test Rear Seat Occupant Area Showing Head & Torso Contact Regions

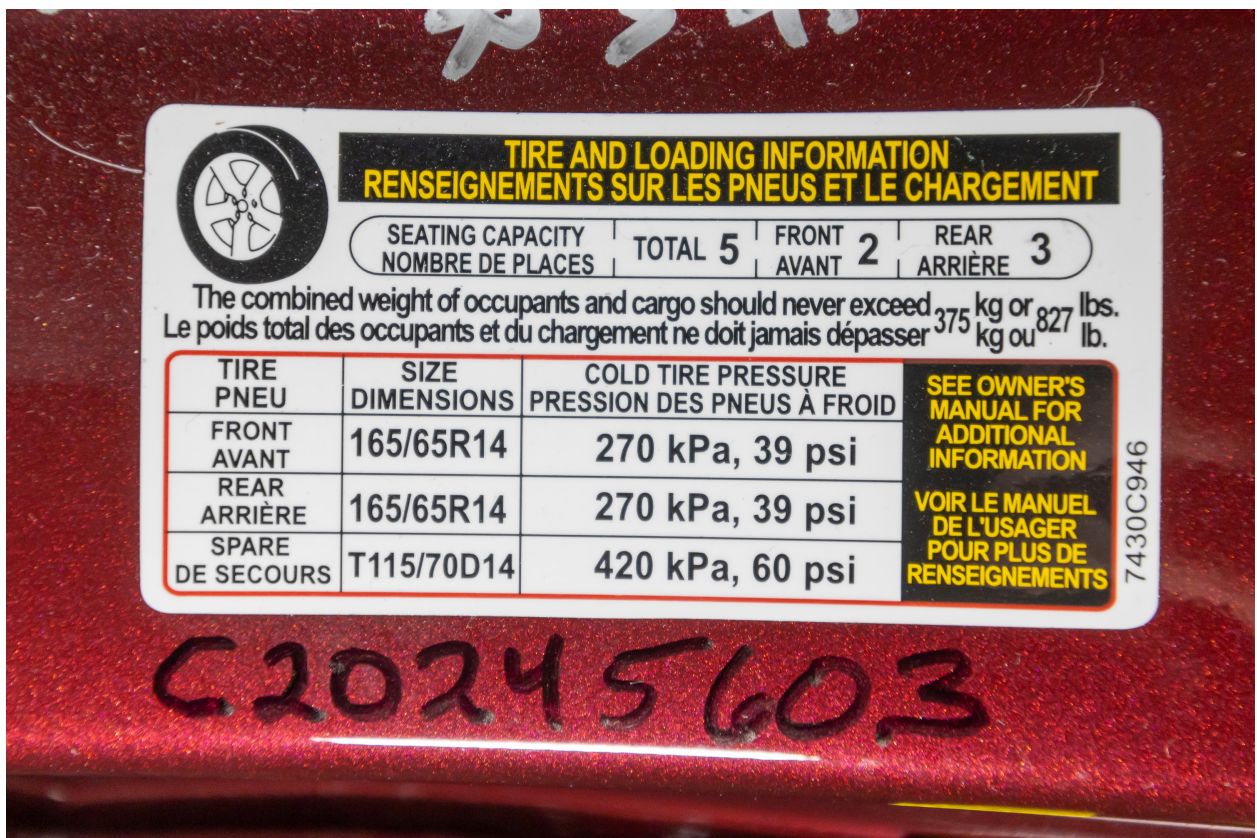

Figure A-30: Close-up View of Vehicle's Tire Placard

**APPENDIX II**  
**ES-2re DUMMY RESPONSE DATA TRACES**

## Table of Data Plots

No.	Description	Page
1	ES-2re Head (X) Acceleration vs. Time	II-3
2	ES-2re Head (Y) Acceleration vs. Time	II-3
3	ES-2re Head (Z) Acceleration vs. Time	II-3
4	ES-2re Head Resultant Acceleration vs. Time	II-3
5	ES-2re Head (X) Velocity vs. Time	II-4
6	ES-2re Head (Y) Velocity vs. Time	II-4
7	ES-2re Head (Z) Velocity vs. Time	II-4
8	ES-2re Upper Thorax Rib Deflection Rate vs. Time	II-4
9	ES-2re Upper Thorax Rib Deflection (Y) vs. Time	II-5
10	ES-2re Middle Thorax Rib Deflection Rate vs. Time	II-5
11	ES-2re Middle Thorax Rib Deflection (Y) vs. Time	II-5
12	ES-2re Lower Thorax Rib Deflection Rate vs. Time	II-5
13	ES-2re Lower Thorax Rib Deflection (Y) vs. Time	II-6
14	ES-2re Front Abdomen Force (Y) vs. Time	II-6
15	ES-2re Middle Abdomen Force (Y) vs. Time	II-6
16	ES-2re Rear Abdomen Force (Y) vs. Time	II-6
17	ES-2re Sum of Abdomen Forces vs. Time	II-7
18	ES-2re Pubic Symphysis Force (Y) vs. Time	II-7

ACCELERATION [g's]

ES-2re Head (X) Acceleration vs. Time

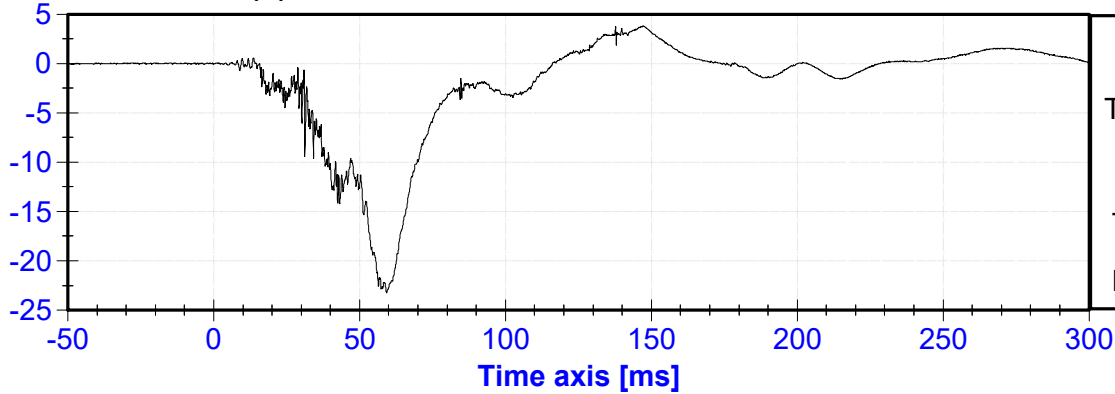

ACCELERATION [g's]

ES-2re Head (Y) Acceleration vs. Time

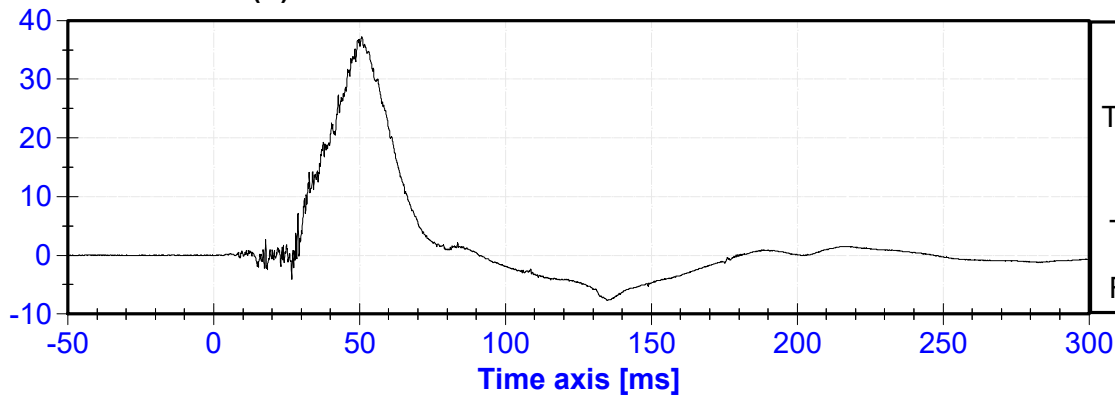

ACCELERATION [g's]

ES-2re Head (Z) Acceleration vs. Time

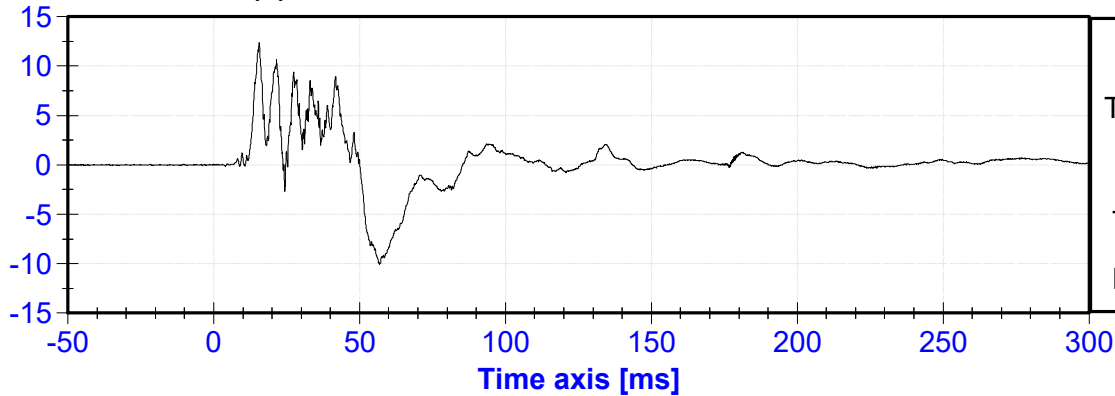

ACCELERATION [g's]

ES-2re Head Resultant Acceleration vs. Time

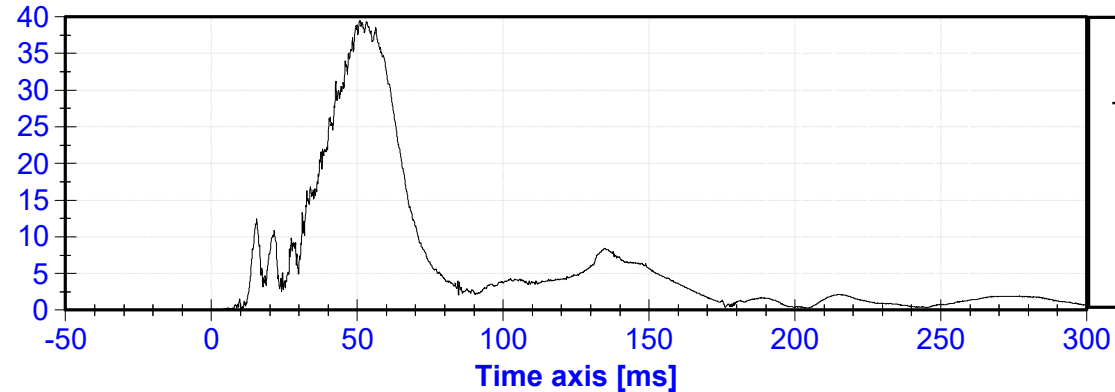

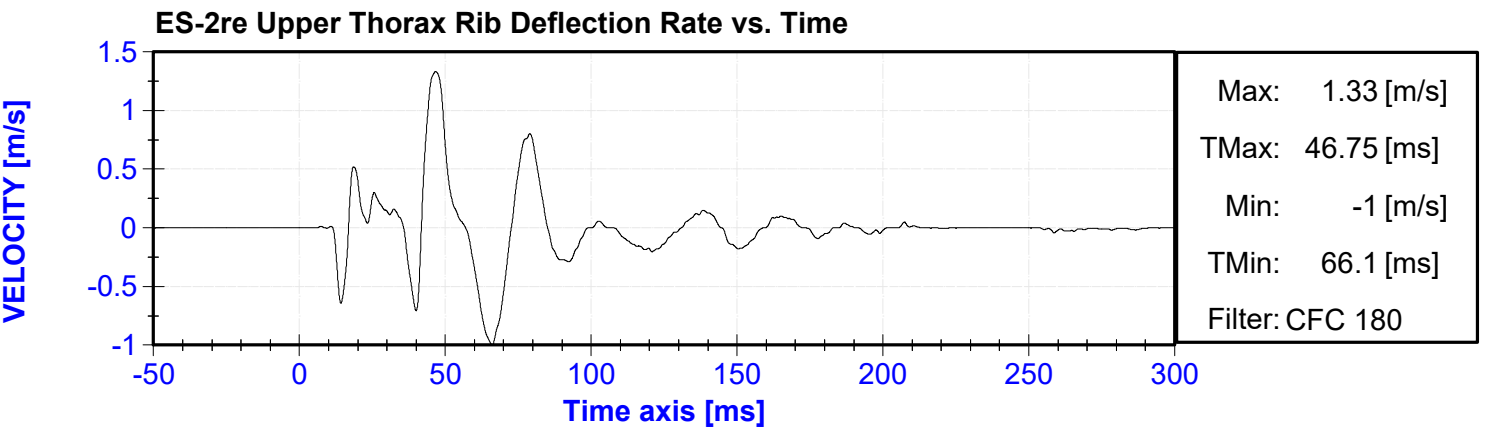
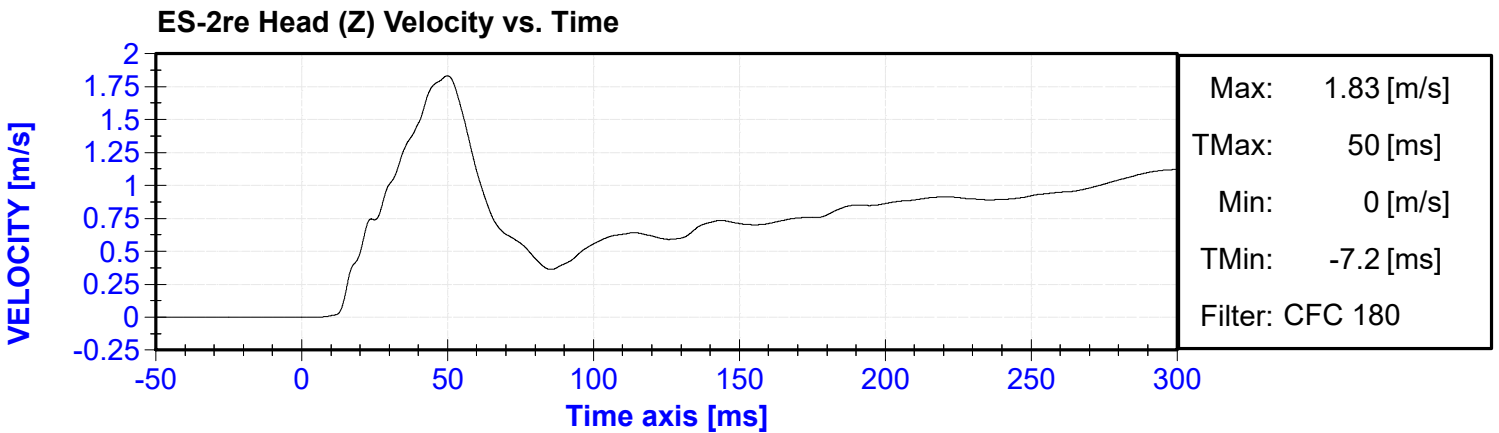
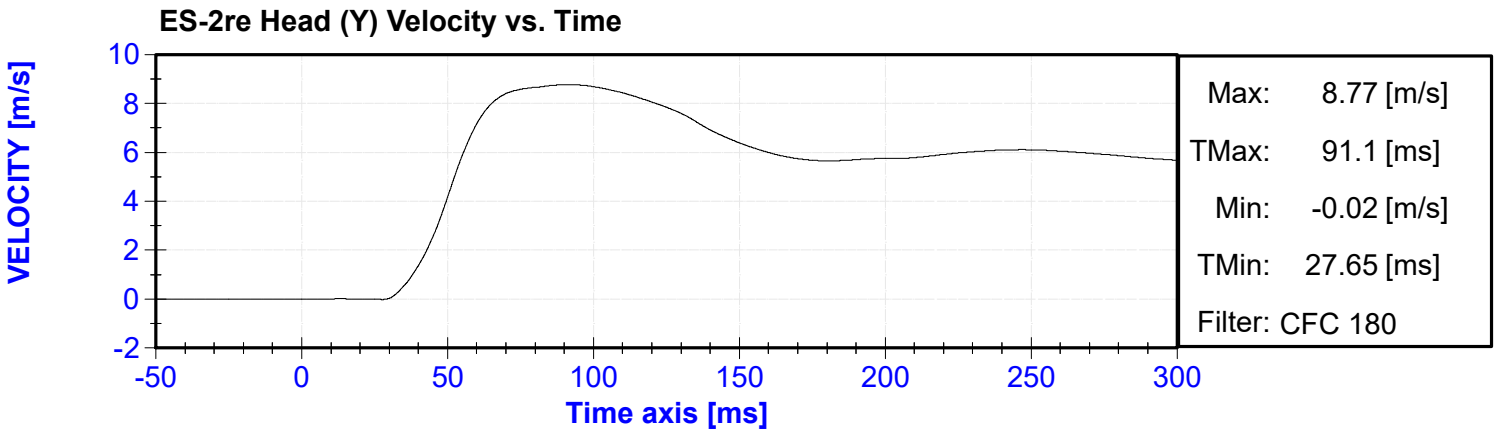
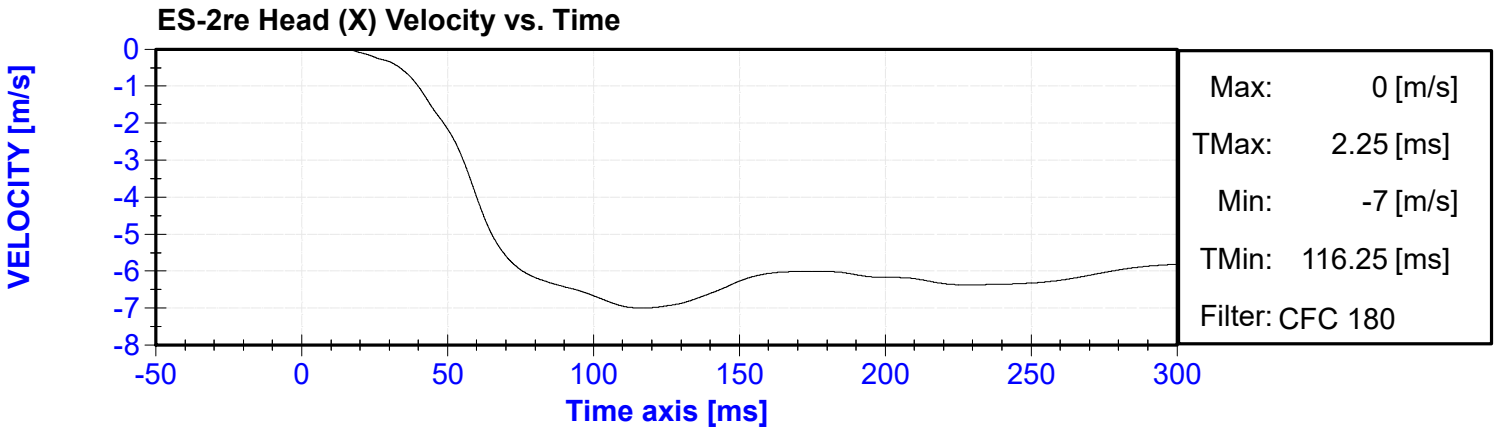

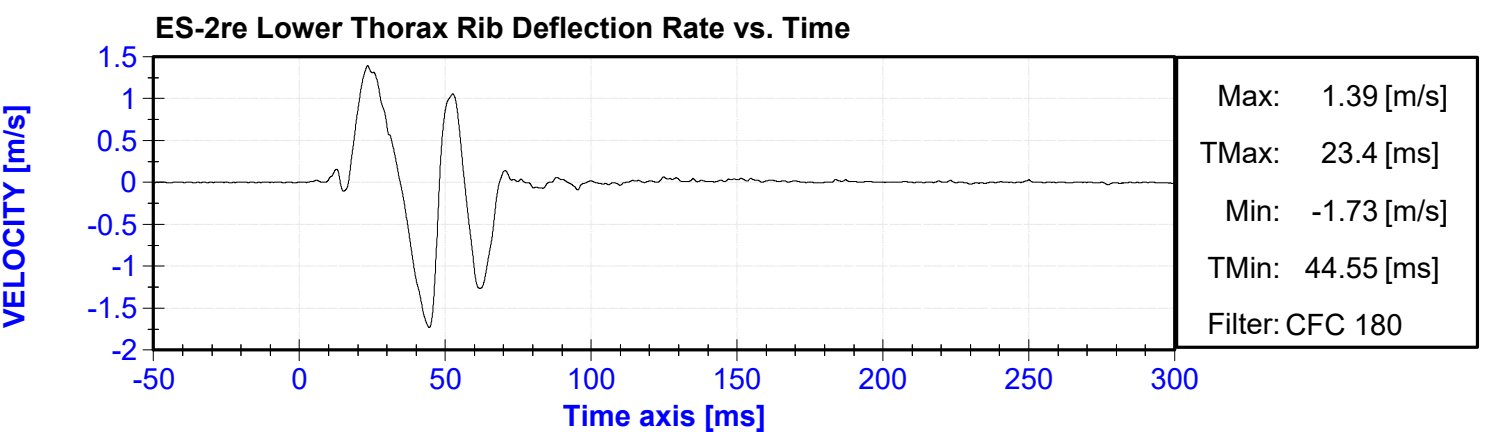
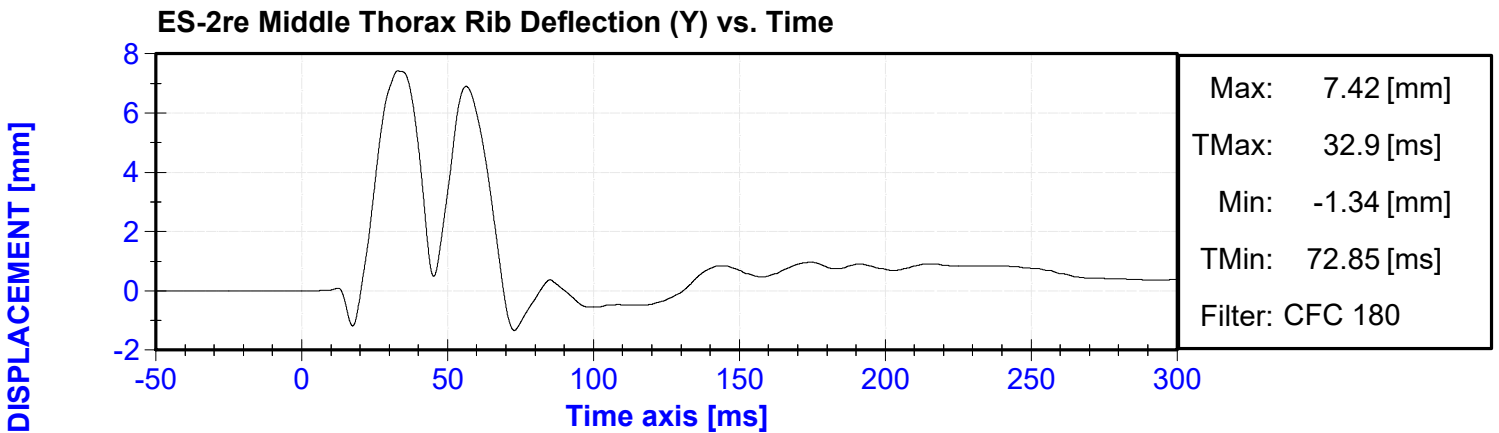
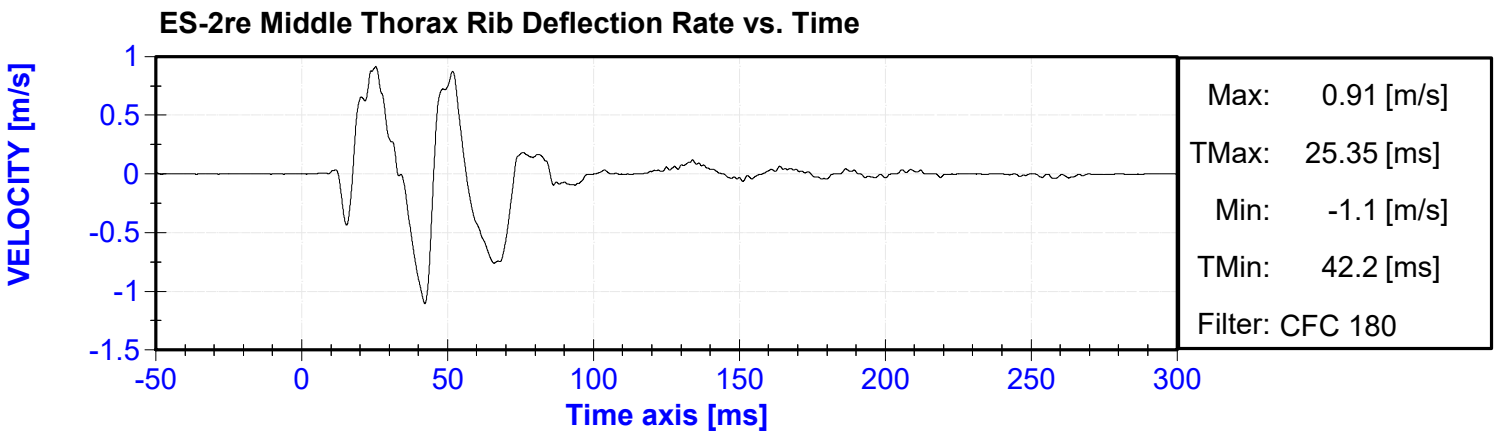
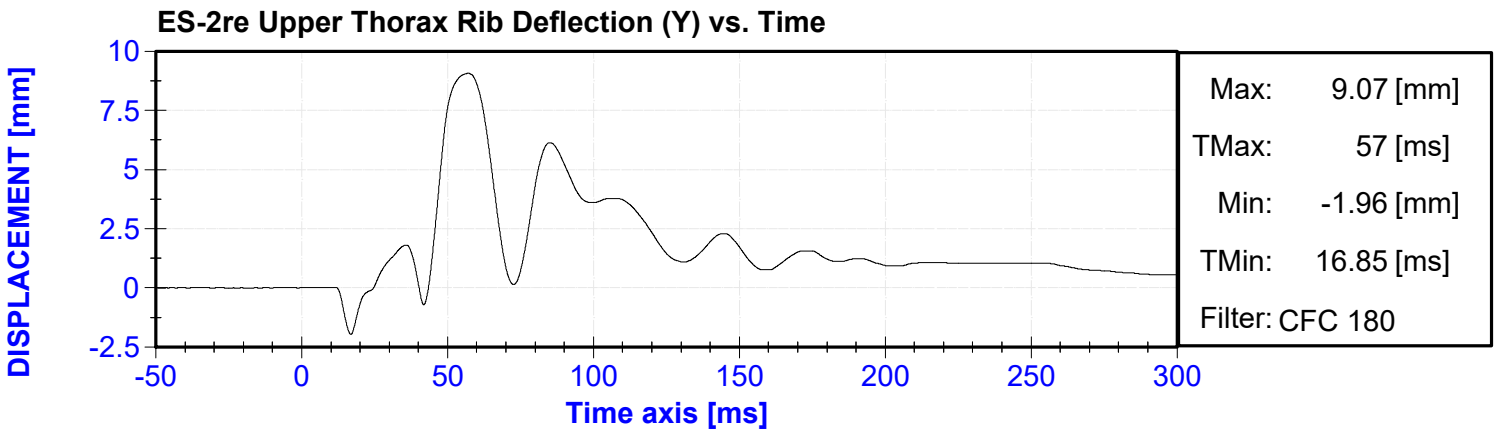

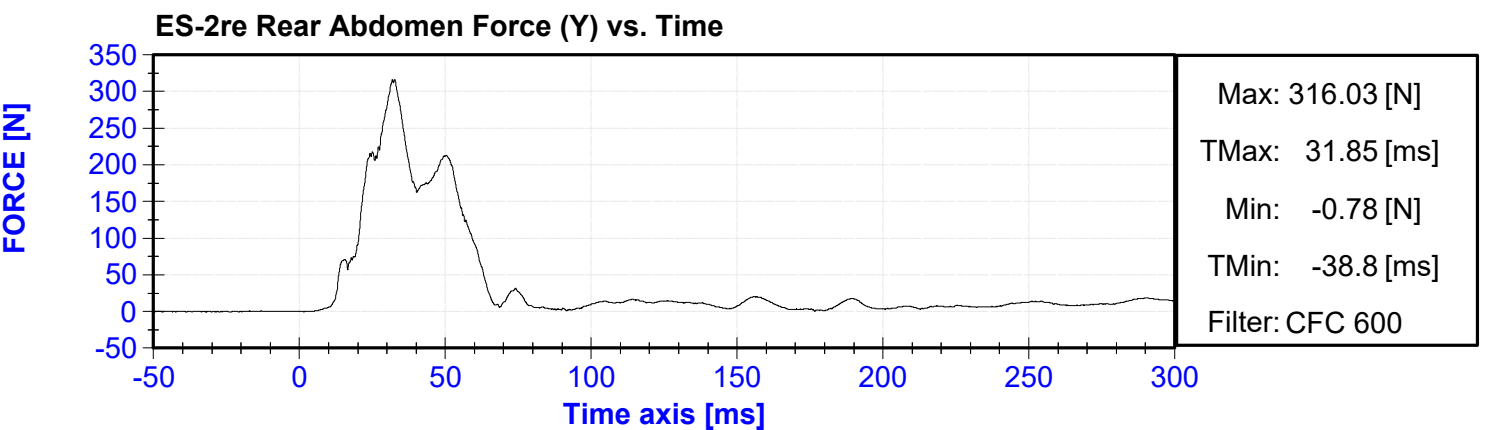
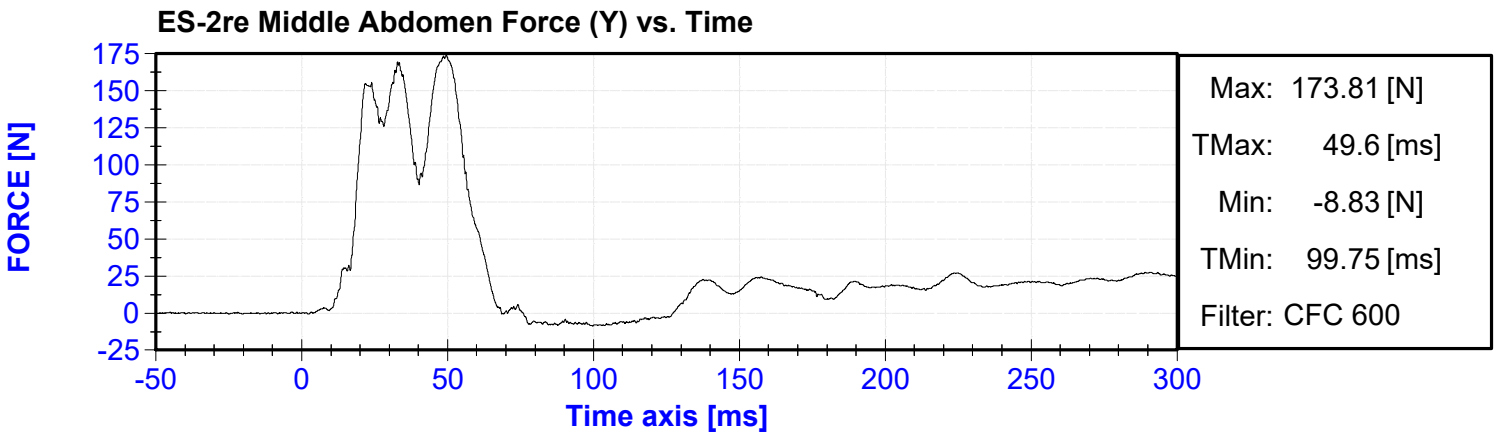
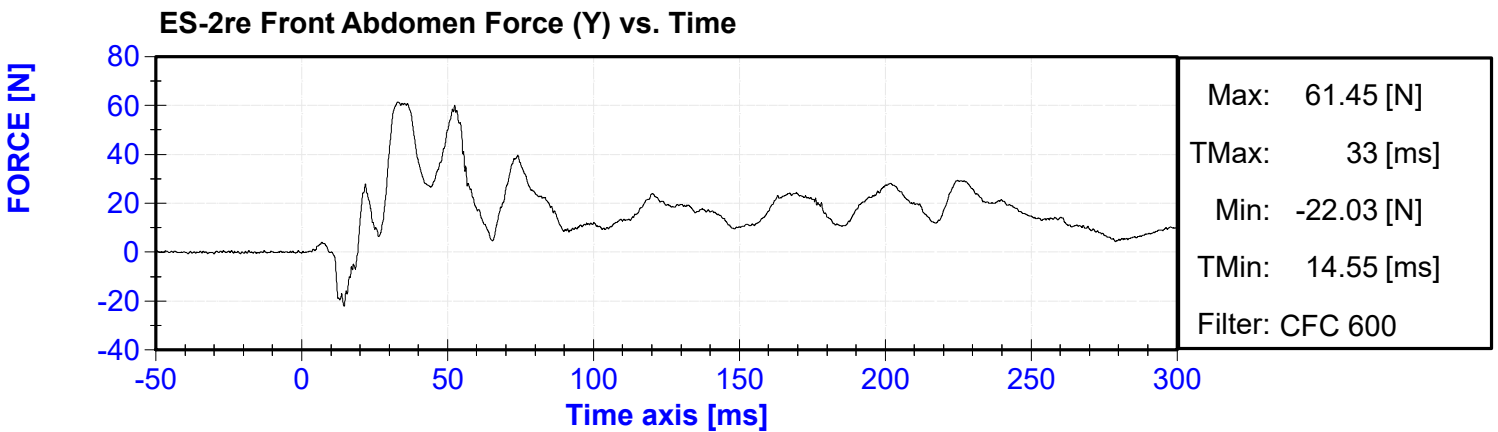
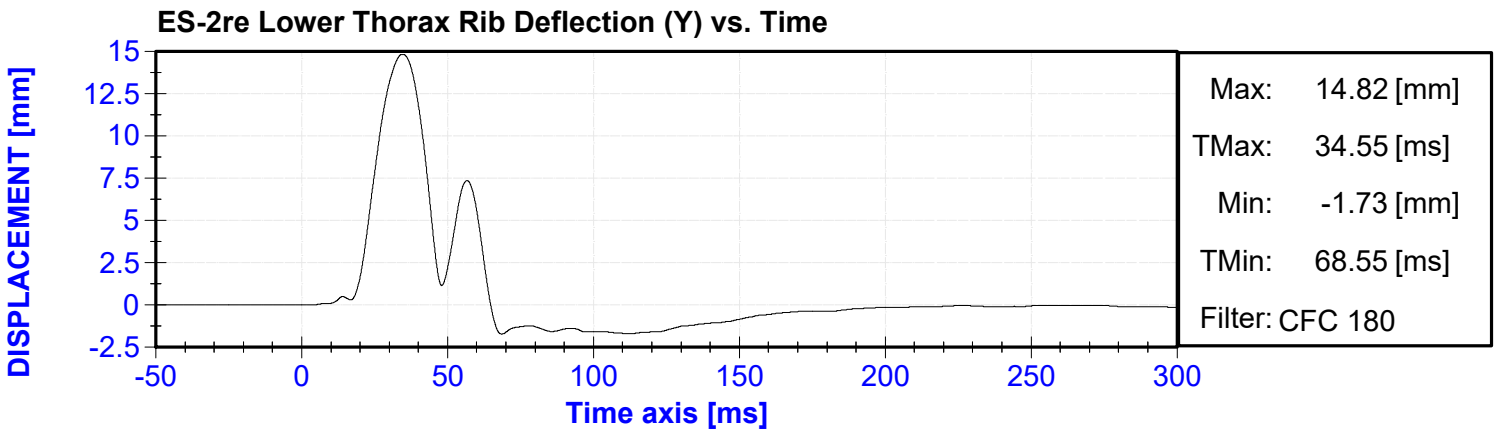

ES-2re Sum of Abdomen Forces vs. Time

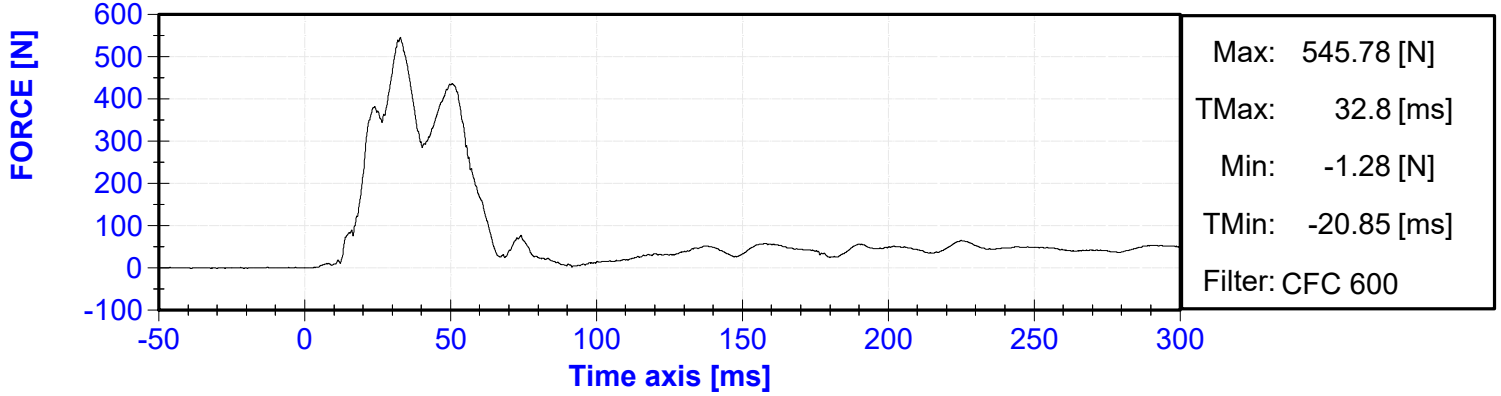

ES-2re Pubic Symphysis Force (Y) vs. Time

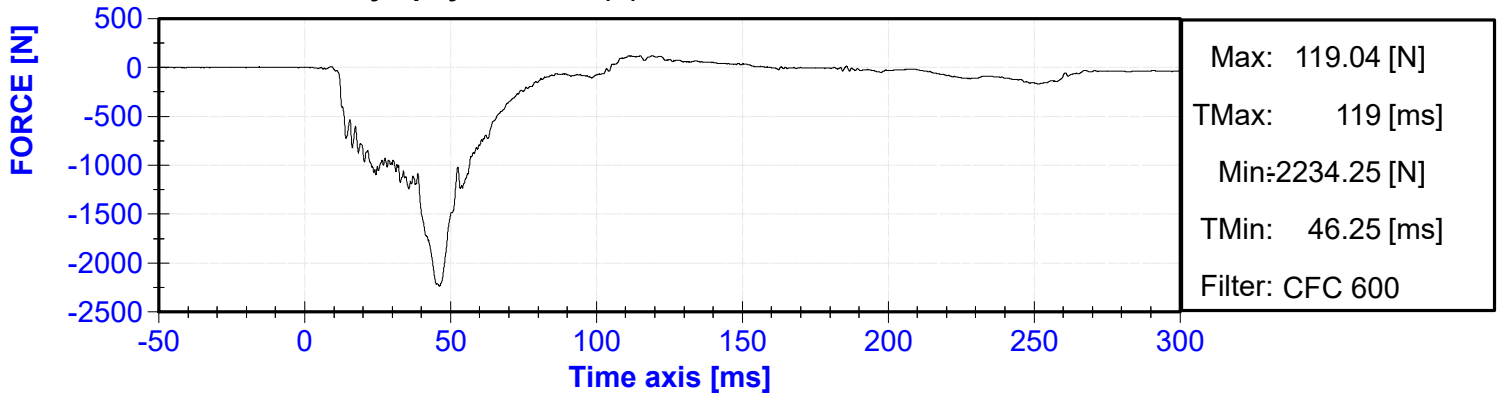

**APPENDIX III**  
**SID-II's DUMMY RESPONSE DATA TRACES**

## Table of Data Plots

No.	Description	Page
1	SID-IIs Head (X) Acceleration vs. Time	III-3
2	SID-IIs Head (Y) Acceleration vs. Time	III-3
3	SID-IIs Head (Z) Acceleration vs. Time	III-3
4	SID-IIs Head Resultant Acceleration vs. Time	III-3
5	SID-IIs Head (X) Velocity vs. Time	III-4
6	SID-IIs Head (Y) Velocity vs. Time	III-4
7	SID-IIs Head (Z) Velocity vs. Time	III-4
8	SID-IIs Lower Spine X Acceleration vs. Time	III-4
9	SID-IIs Lower Spine Y Acceleration vs. Time	III-5
10	SID-IIs Lower Spine Z Acceleration vs. Time	III-5
11	SID-IIs Lower Spine Resultant Acceleration vs. Time	III-5
12	SID-IIs Lower Spine X Velocity vs. Time	III-5
13	SID-IIs Lower Spine Y Velocity vs. Time	III-6
14	SID-IIs Lower Spine Z Velocity vs. Time	III-6
15	SID-IIs Acetabulum Force vs. Time	III-6
16	SID-IIs Iliac Force vs. Time	III-6
17	SID-IIs Sum of Iliac and Acetabulum Forces vs. Time	III-7

ACCELERATION [g's]

SID-Ils Head (X) Acceleration vs. Time

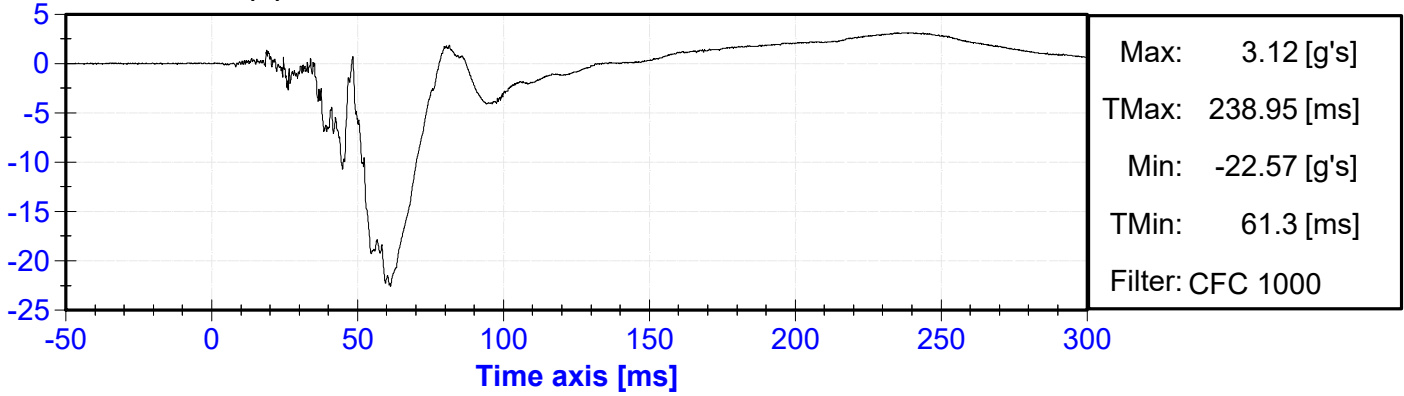

ACCELERATION [g's]

SID-Ils Head (Y) Acceleration vs. Time

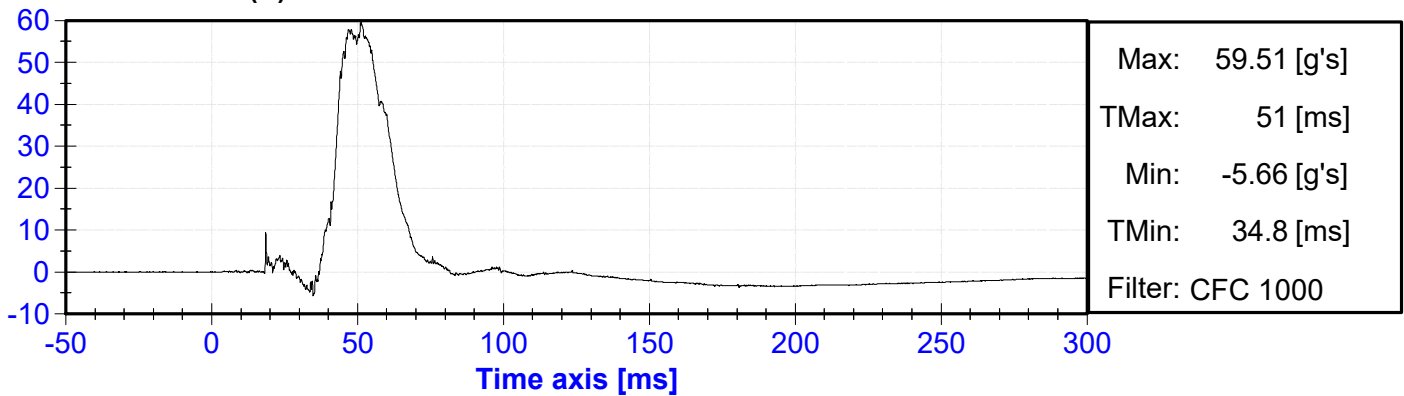

ACCELERATION [g's]

SID-Ils Head (Z) Acceleration vs. Time

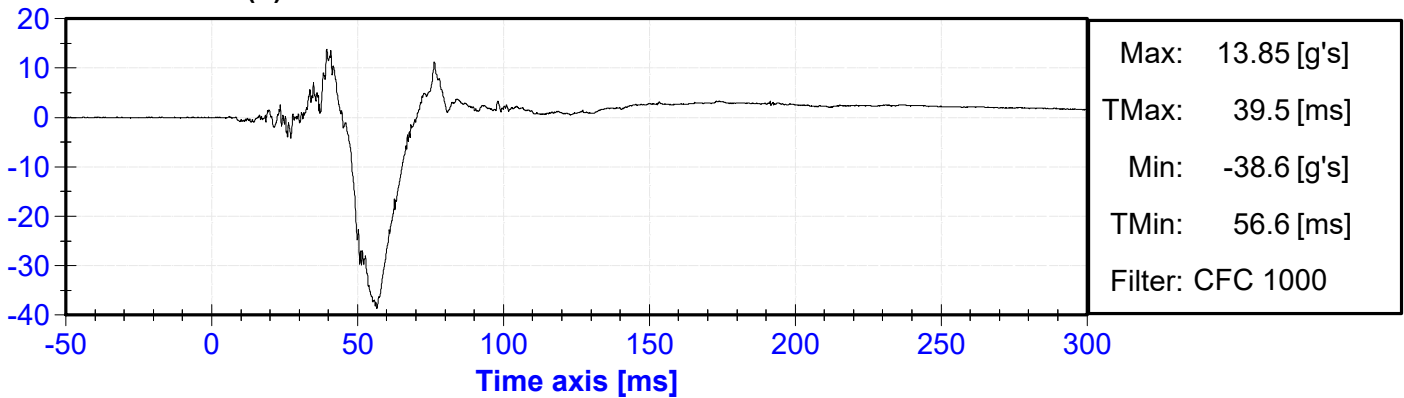

ACCELERATION [g's]

SID-Ils Head Resultant Acceleration vs. Time

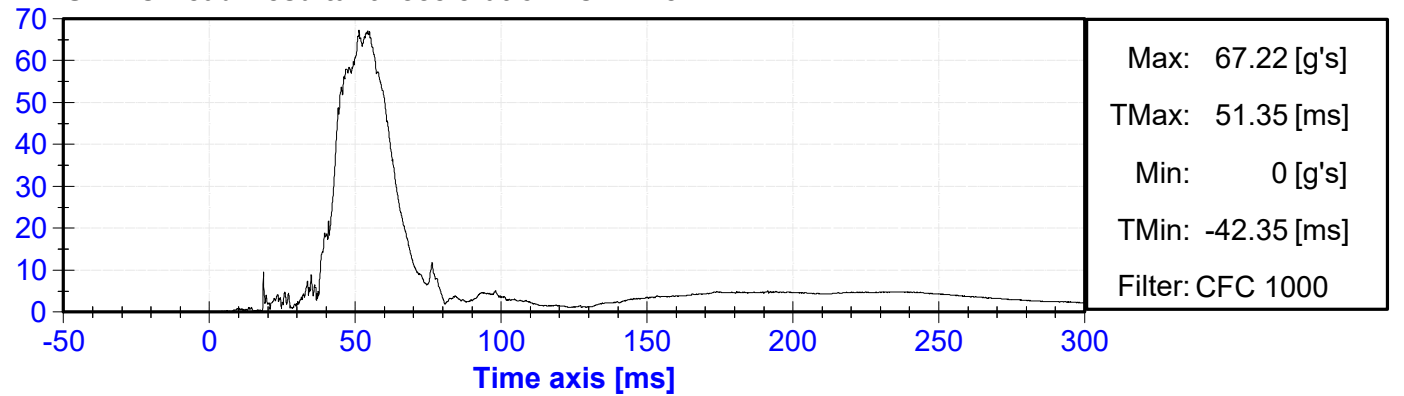

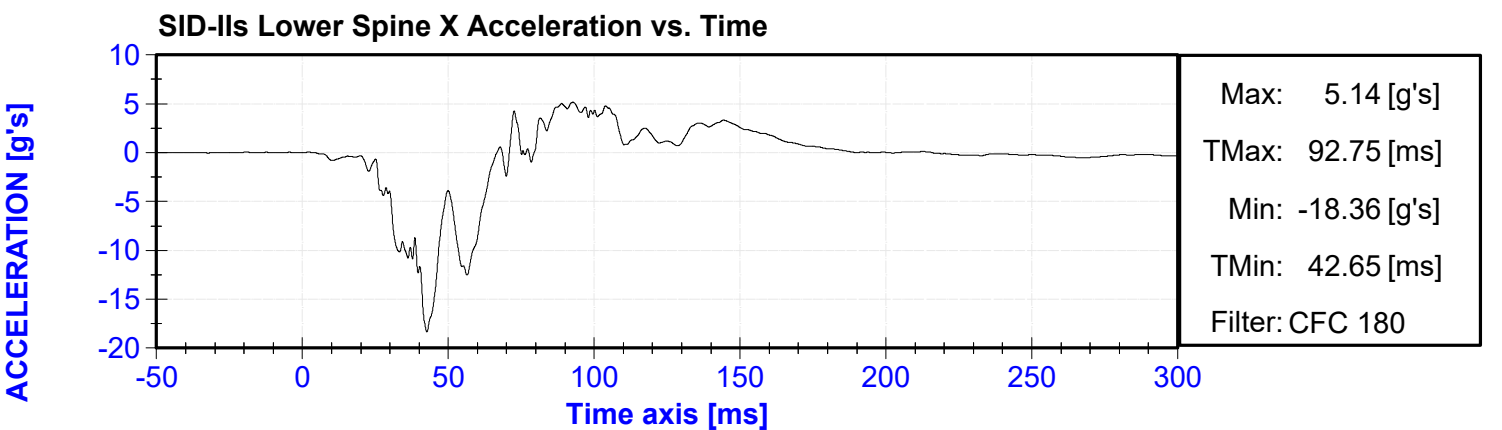
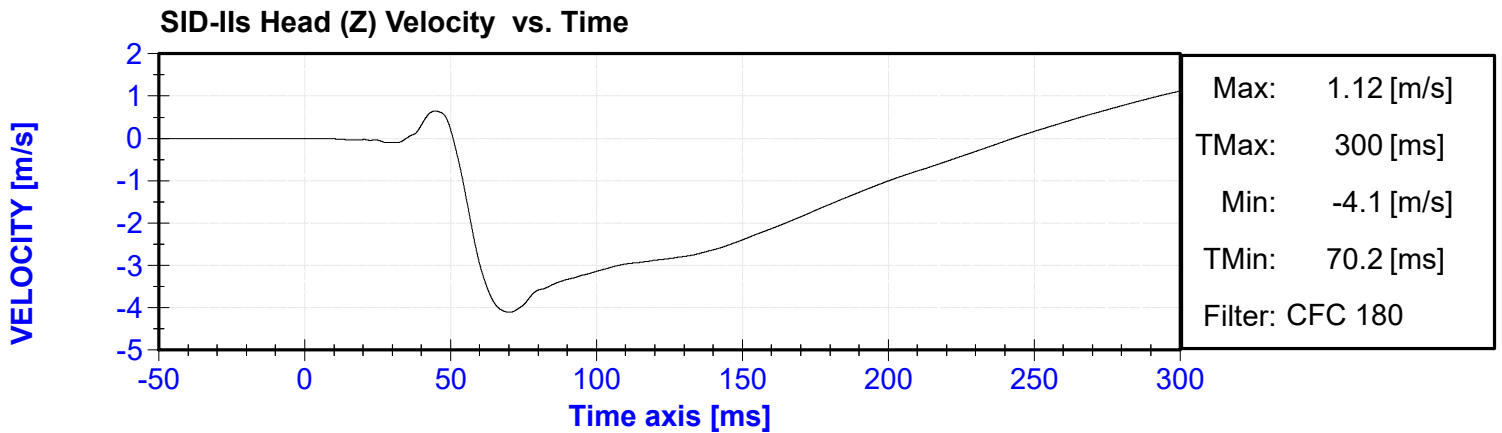
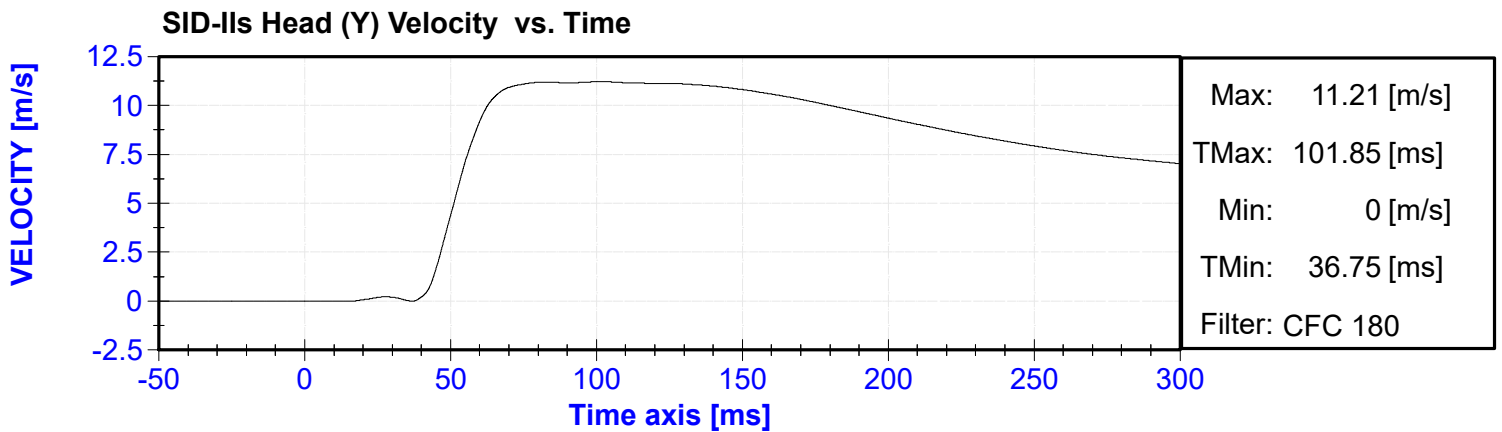
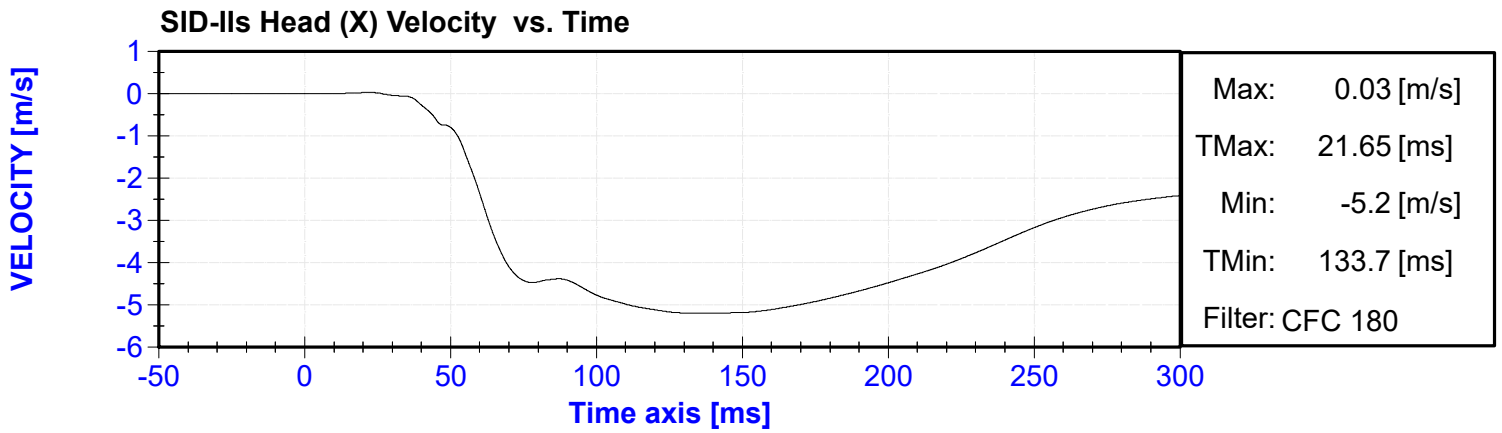

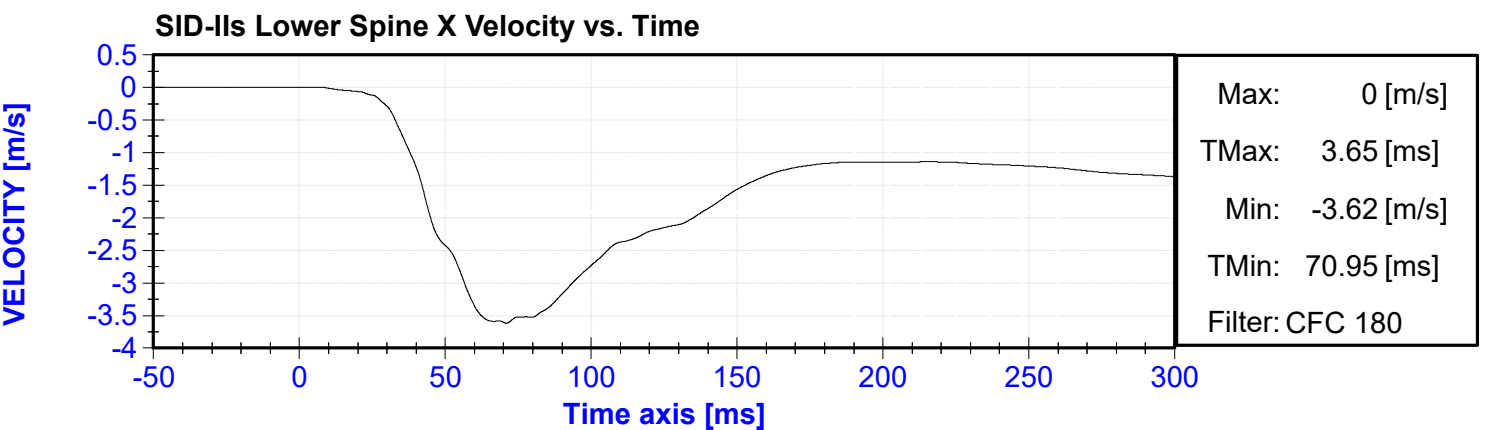
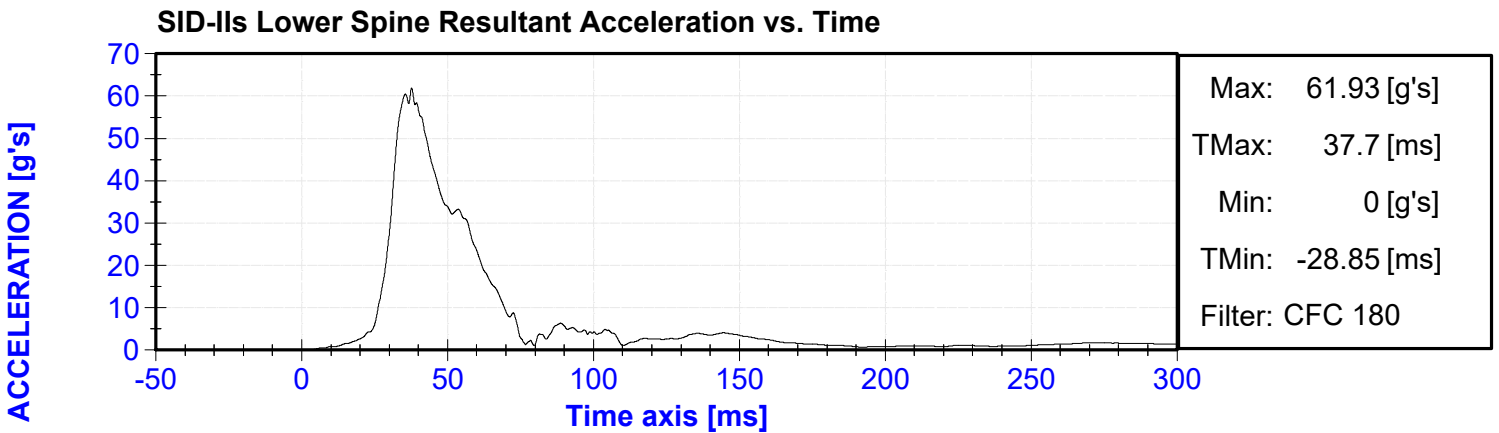
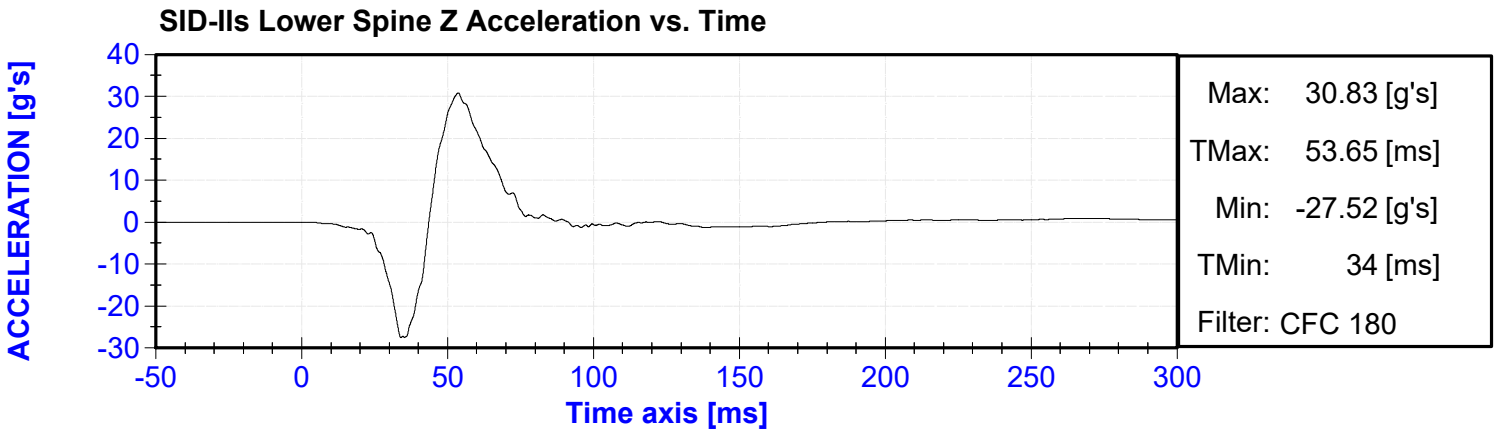
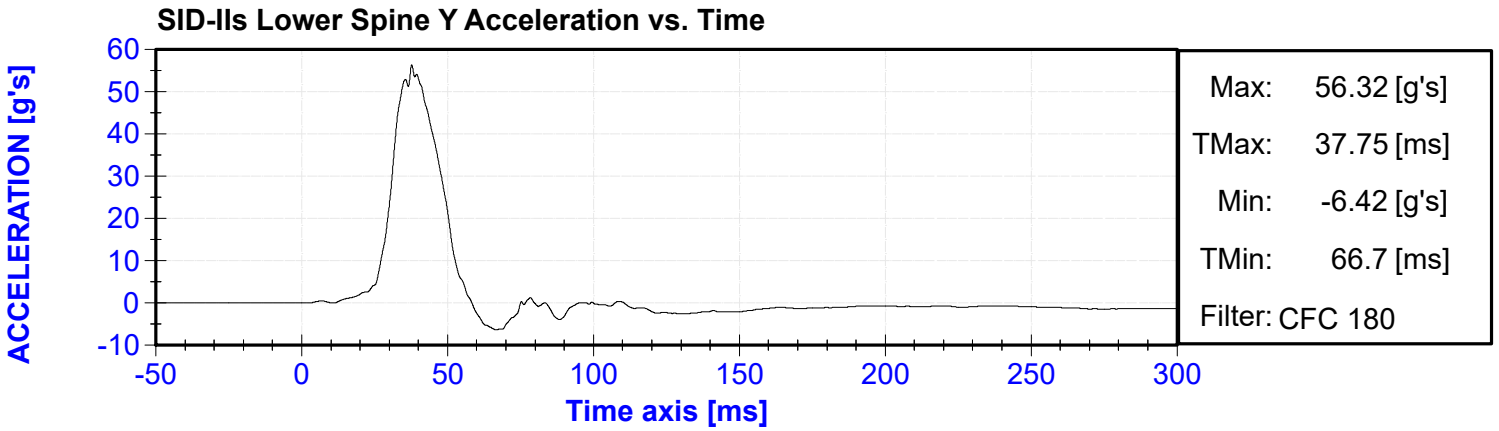

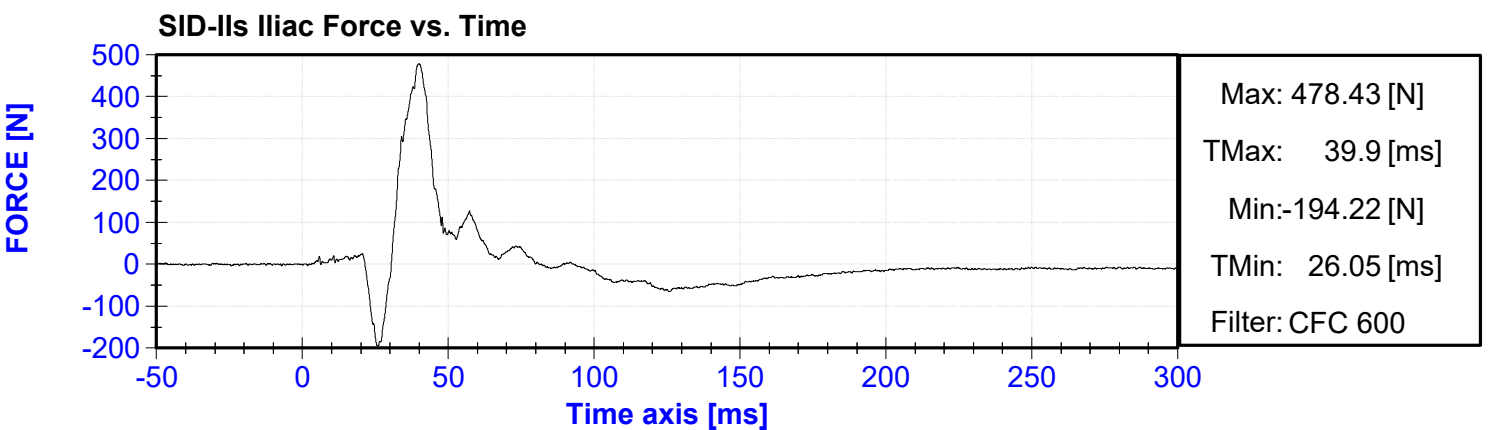
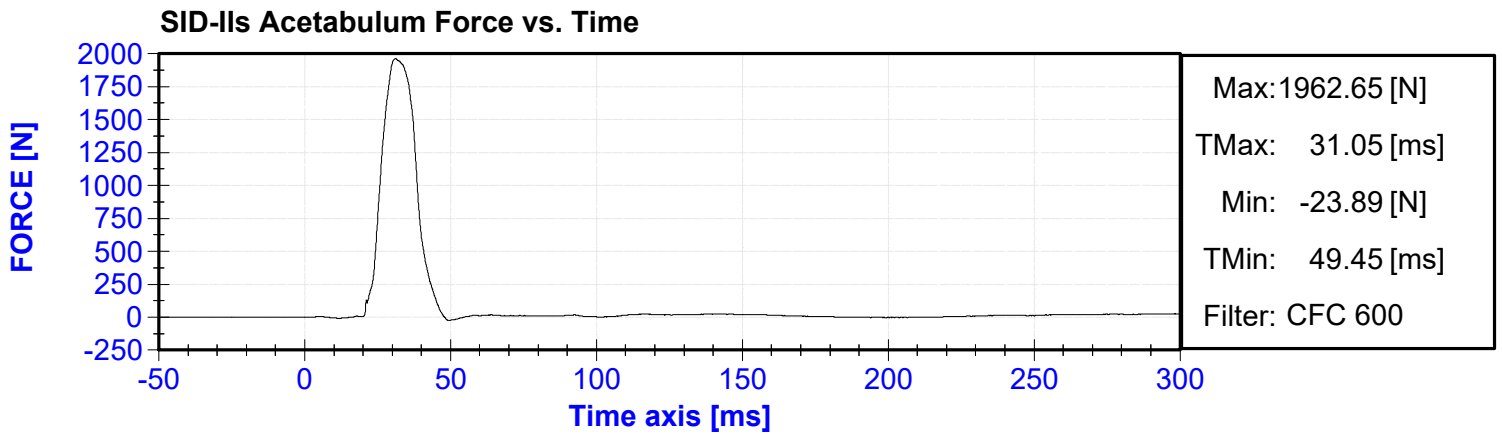
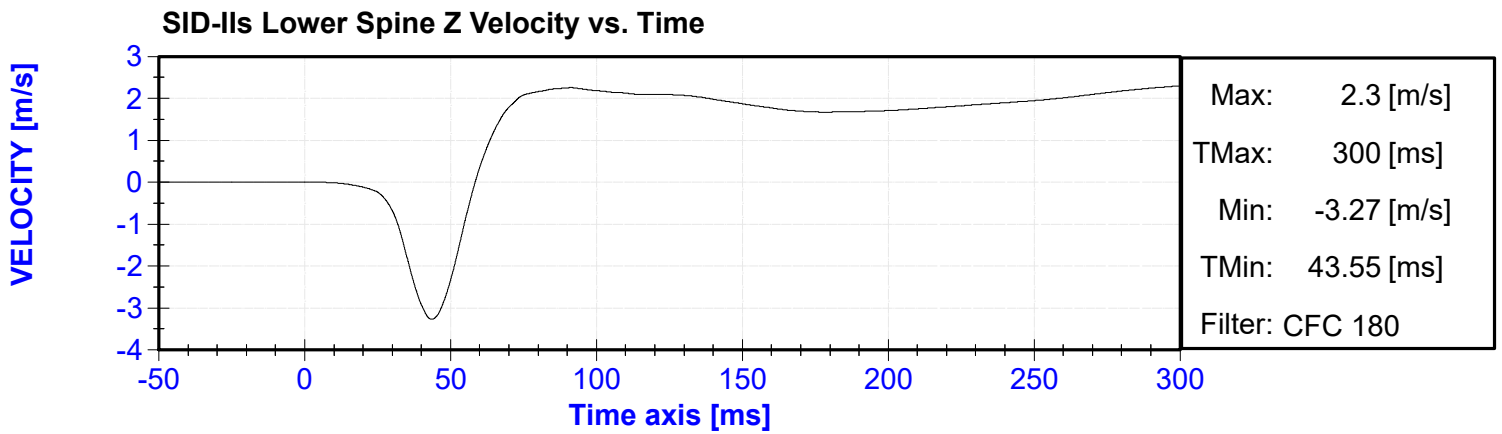
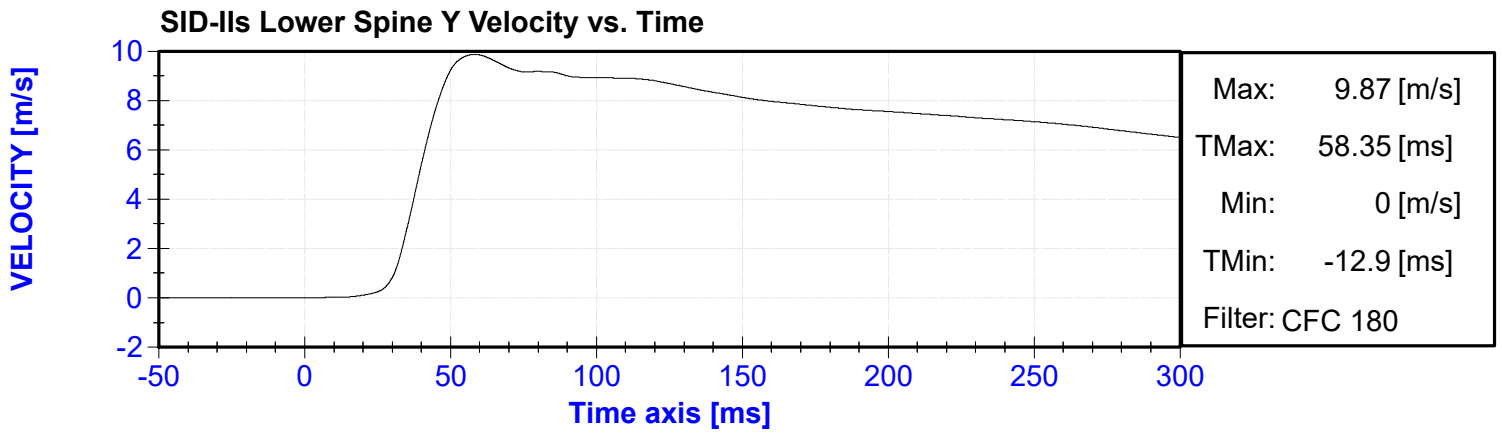

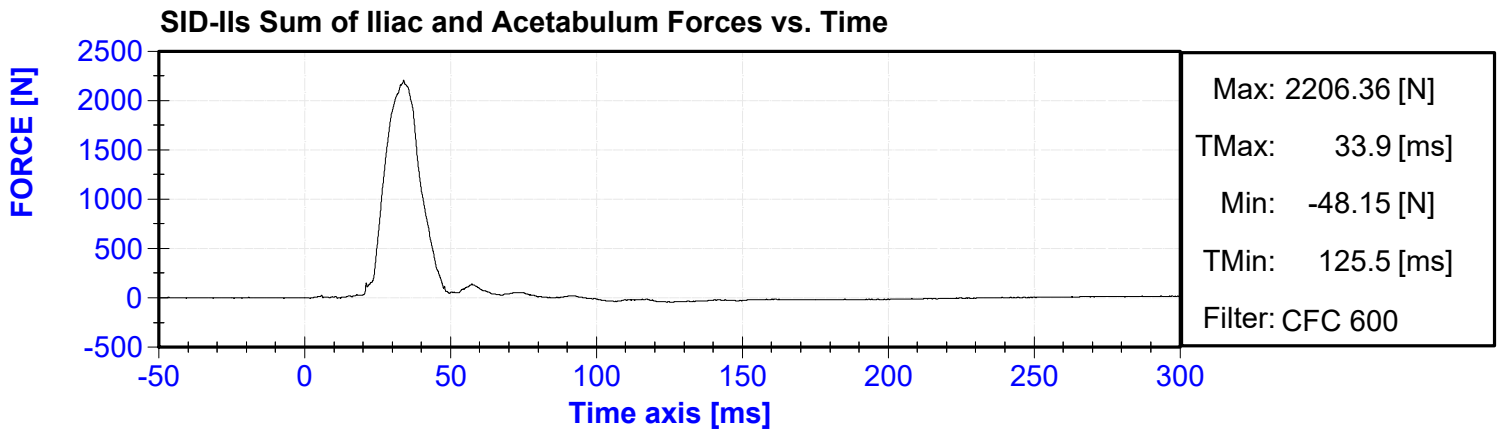

**APPENDIX IV  
VEHICLE AND MDB ACCELEROMETER RESPONSE  
DATA**

## Table of Data Plots

No.	Description	Page
1	Right Sill at Front Seat (X) Acceleration vs. Time	IV-4
2	Right Sill at Front Seat (X) Velocity vs. Time	IV-4
3	Right Sill at Front Seat (Y) Acceleration vs. Time	IV-4
4	Right Sill at Front Seat (Y) Velocity vs. Time	IV-4
5	Right Sill at Front Seat (Z) Acceleration vs. Time	IV-5
6	Right Sill at Front Seat (Z) Velocity vs. Time	IV-5
7	Right Sill at Front Seat Resultant vs. Time	IV-5
8	Right Sill at Rear Seat (X) Acceleration vs. Time	IV-5
9	Right Sill at Rear Seat (X) Velocity vs. Time	IV-6
10	Right Sill at Rear Seat (Y) Acceleration vs. Time	IV-6
11	Right Sill at Rear Seat (Y) Velocity vs. Time	IV-6
12	Right Sill at Rear Seat (Z) Acceleration vs. Time	IV-6
13	Right Sill at Rear Seat (Z) Velocity vs. Time	IV-7
14	Right Sill at Rear Seat Resultant Acceleration vs. Time	IV-7
15	Rear Floorpan Above Axle (X) Acceleration vs. Time	IV-7
16	Rear Floorpan Above Axle (X) Velocity vs. Time	IV-7
17	Rear Floorpan Above Axle (Y) Acceleration vs. Time	IV-8
18	Rear Floorpan Above Axle (Y) Velocity vs. Time	IV-8
19	Rear Floorpan Above Axle (Z) Acceleration vs. Time	IV-8
20	Rear Floorpan Above Axle (Z) Velocity vs. Time	IV-8
21	Rear Floorpan Above Axle Resultant Acceleration vs. Time	IV-9
22	Left Sill at Rear Door (Y) Acceleration vs. Time	IV-9
23	Left Sill at Rear Door (Y) Velocity vs. Time	IV-9
24	Left Sill at Front Door (Y) Acceleration vs. Time.	IV-9
25	Left Sill at Front Door (Y) Velocity vs. Time	IV-10
26	Right Rear Occ. Compartment(Y) Acceleration vs. Time	IV-10
27	Right Rear Occ. Compartment(Y) Velocity vs. Time	IV-10
28	Left B-Post Lower (Y) Acceleration vs. Time	IV-10
29	Left B-Post Lower (Y) Velocity vs. Time	IV-11
30	Left B-Post Middle (Y) Acceleration vs. Time	IV-11
31	Left B-Post Middle (Y) Velocity vs. Time	IV-11
32	Left A-Post Lower( Y) Acceleration vs. Time	IV-11
33	Left A-Post Lower( Y) Velocity vs. Time	IV-12
34	Left A-Post Middle (Y) Acceleration vs. Time	IV-12
35	Left A-Post Middle (Y) Velocity vs. Time	IV-12
36	Front Seat Track (Y) Acceleration vs. Time	IV-12
37	Front Seat Track (Y) Velocity vs. Time	IV-13
38	Rear Seat Track or Structure (Y) Acceleration vs. Time	IV-13
39	Rear Seat Track or Structure (Y) Velocity vs. Time	IV-13
40	Vehicle CG (X) Acceleration vs. Time	IV-13
41	Vehicle CG (X) Velocity vs. Time	IV-14
42	Vehicle CG (Y) Acceleration vs. Time	IV-14
43	Vehicle CG (Y) Velocity vs. Time	IV-14
44	Vehicle CG (Z) Acceleration vs. Time	IV-14
45	Vehicle CG (Z) Velocity vs. Time	IV-15
46	Vehicle CG Resultant Acceleration vs. Time	IV-15
47	MDB Center of Gravity (X) Acceleration vs. Time	IV-15
48	MDB Center of Gravity (X) Velocity vs. Time	IV-15
49	MDB Center of Gravity (Y) Acceleration vs. Time	IV-16
50	MDB Center of Gravity (Y) Velocity vs. Time	IV-16
51	MDB Center of Gravity (Z) Acceleration vs. Time	IV-16
52	MDB Center of Gravity (Z) Velocity vs. Time	IV-16

53	MDB Center of Gravity Resultant Acceleration vs. Time	IV-17
54	MDB Rear (X) Acceleration vs. Time	IV-17
55	MDB Rear (X) Velocity vs. Time	IV-17
56	MDB Rear (Y) Acceleration vs. Time	IV-17
57	MDB Rear (Y) Velocity vs. Time	IV-18

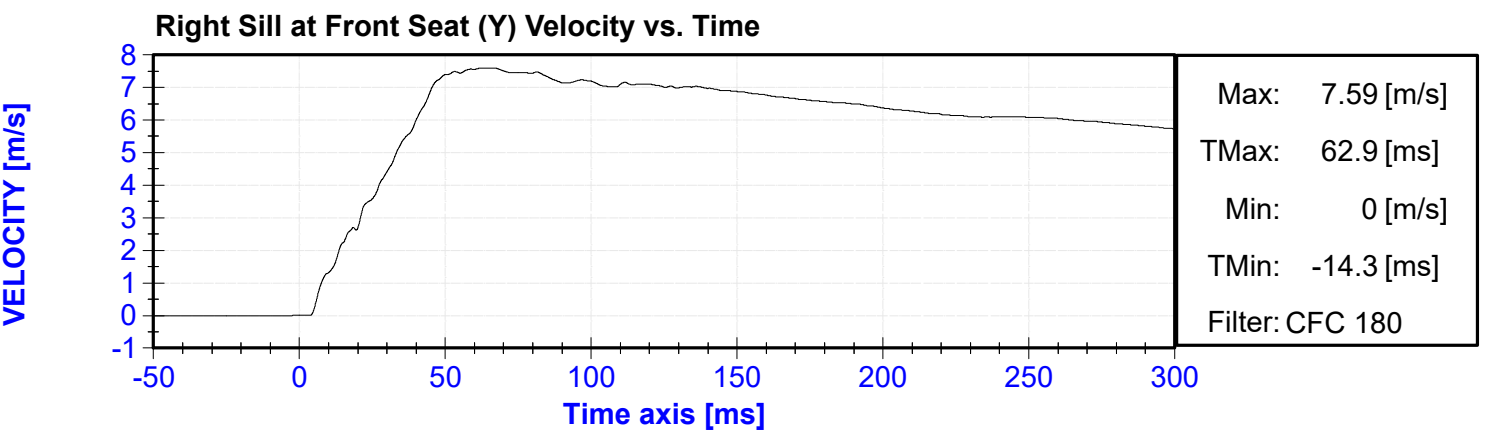
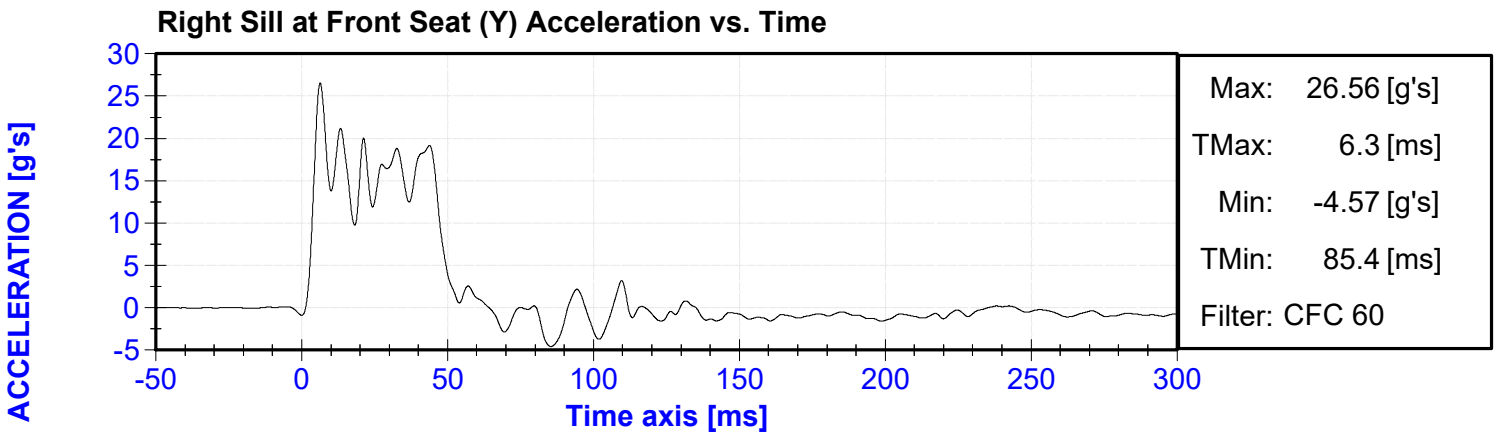
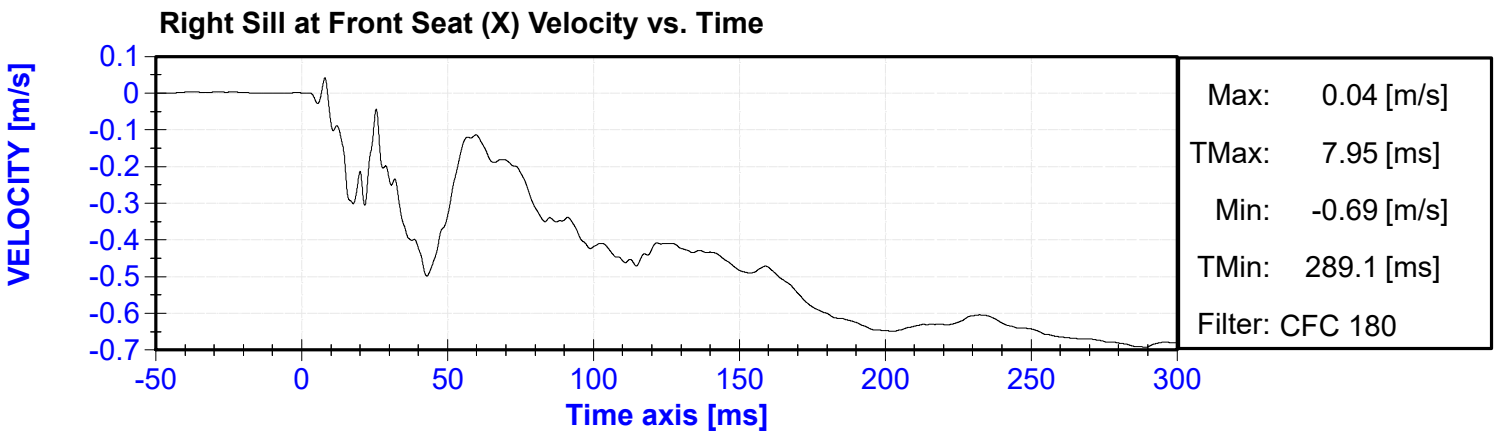
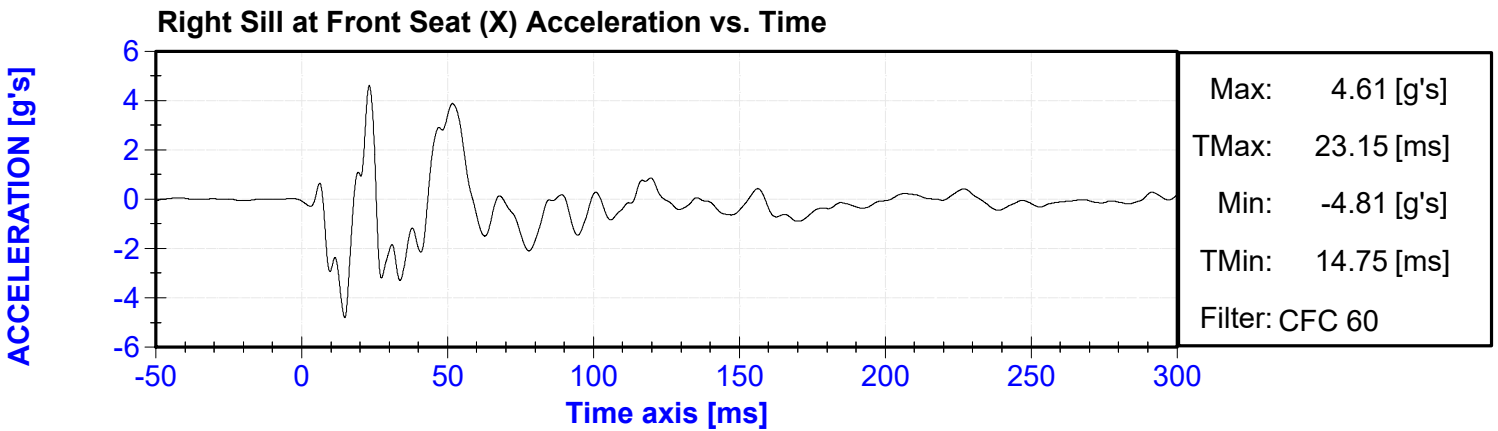

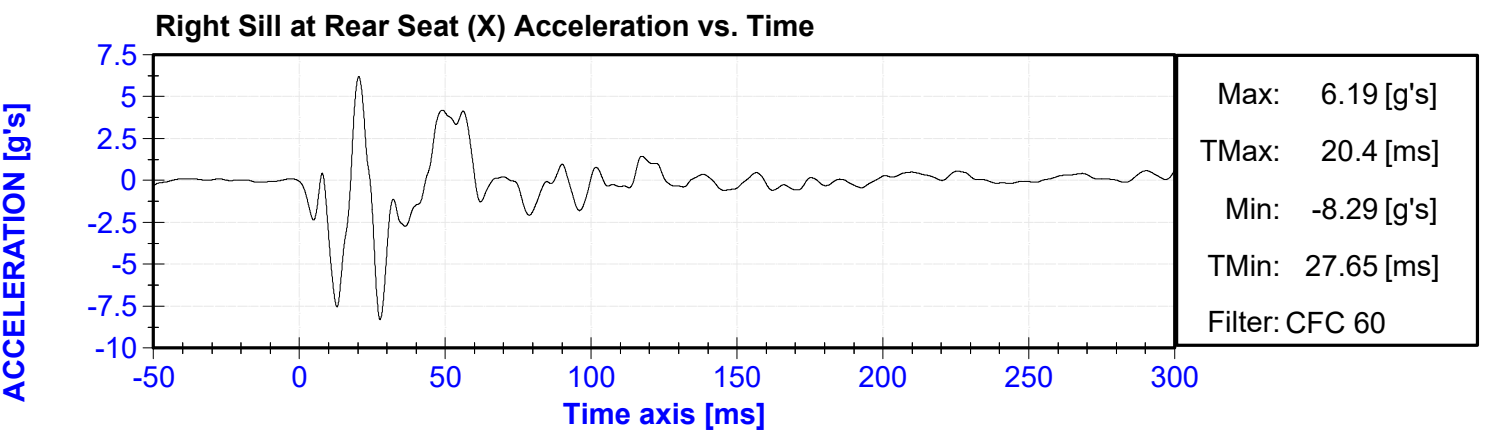
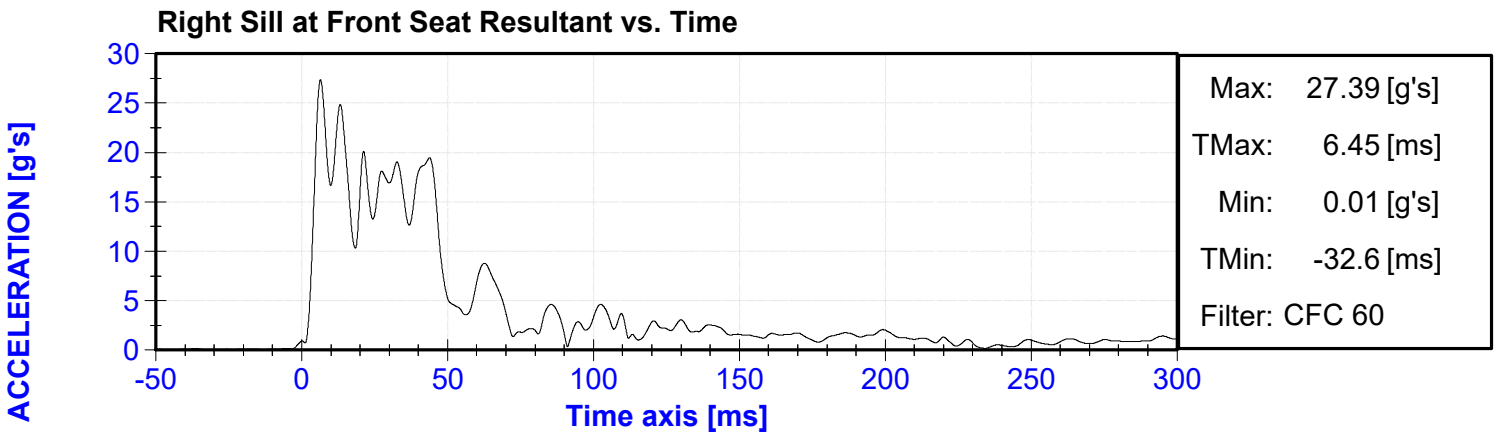
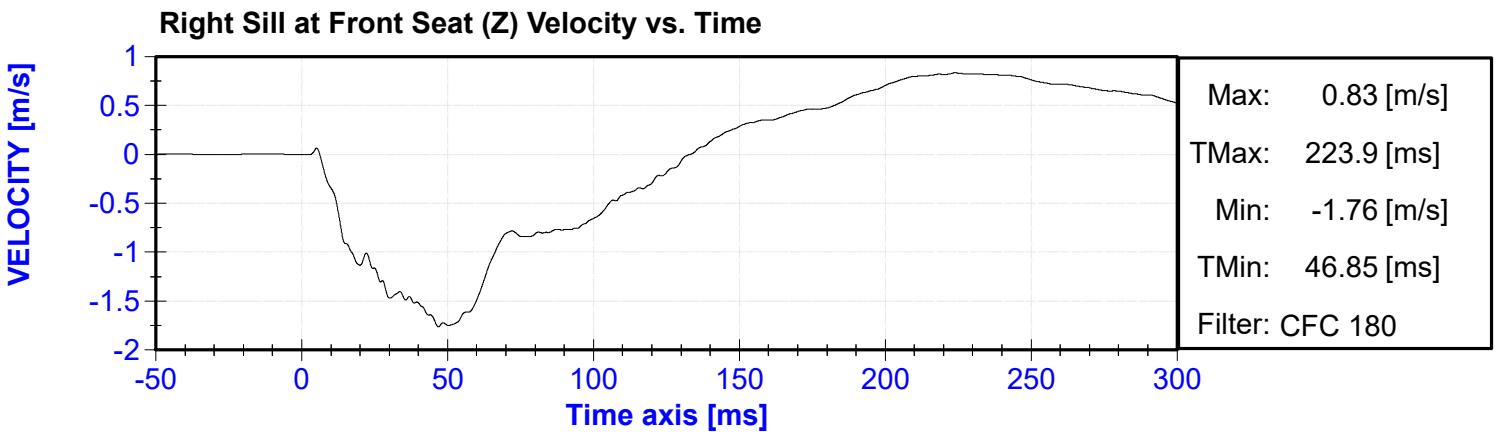
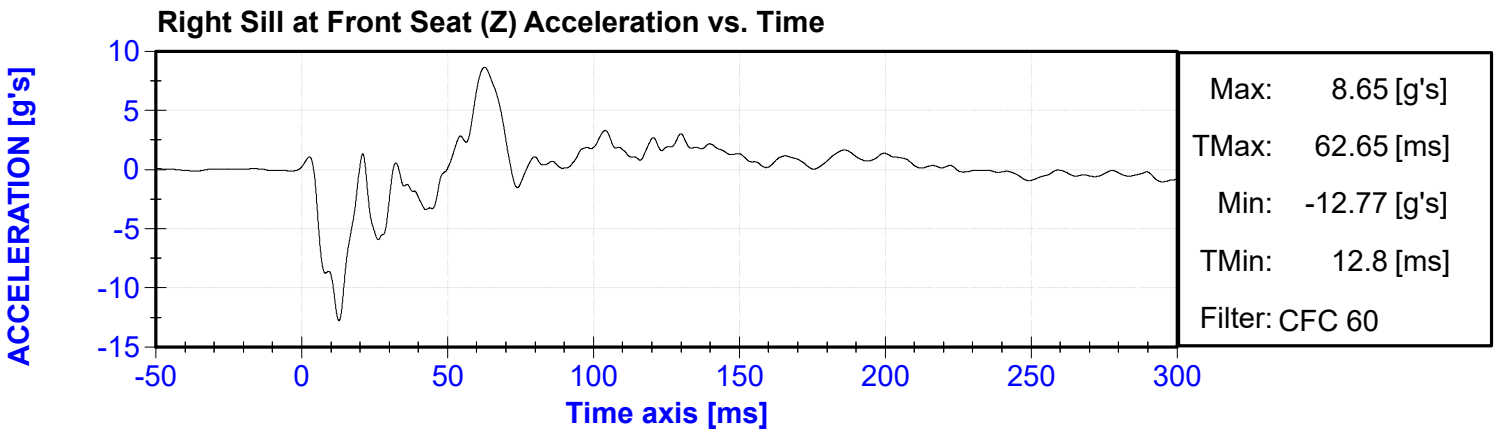

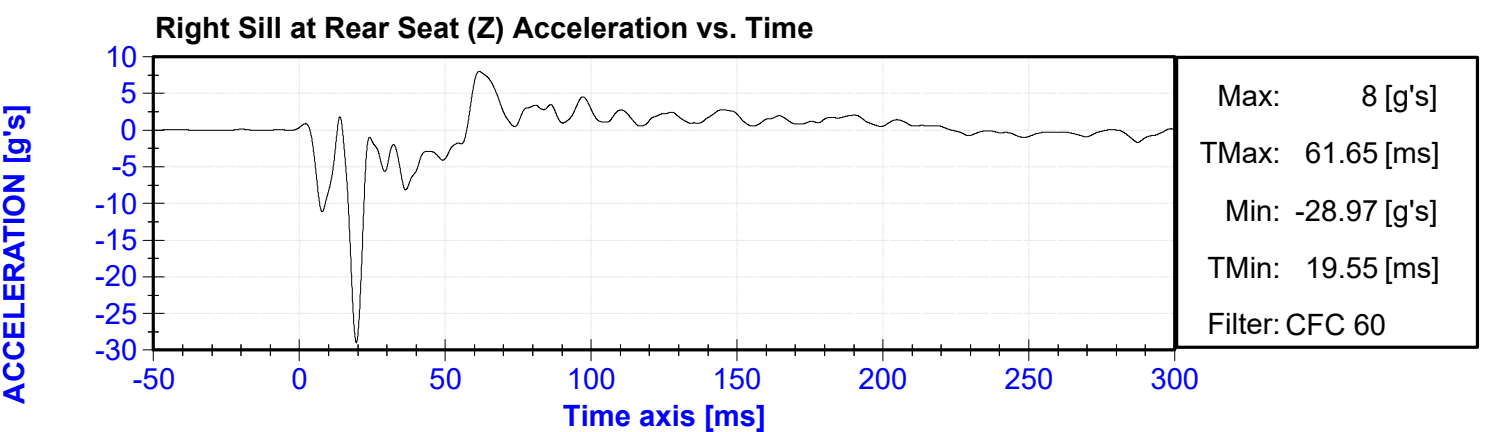
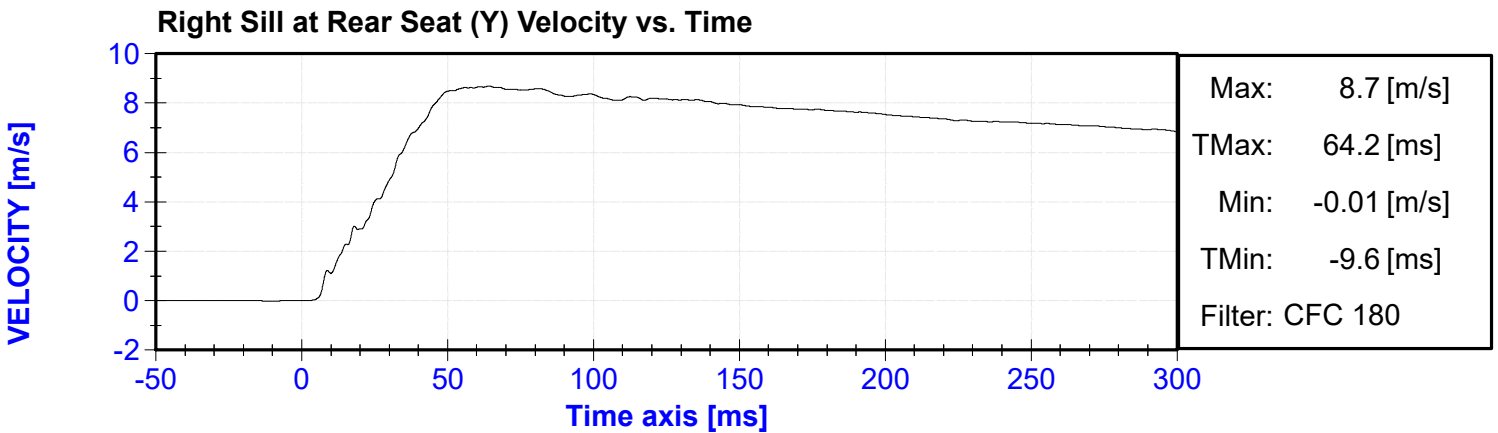
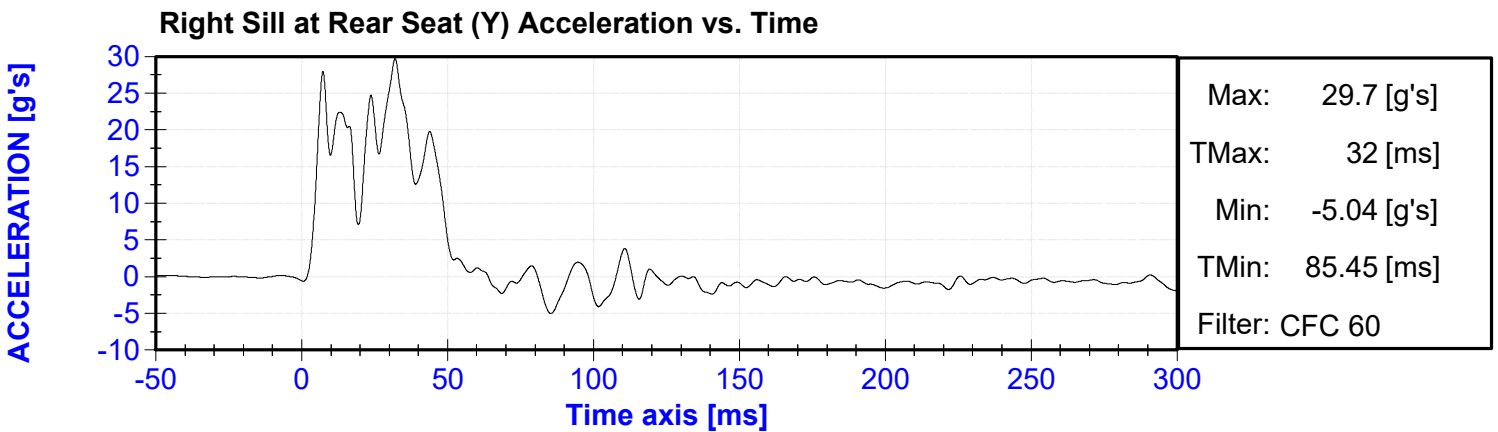
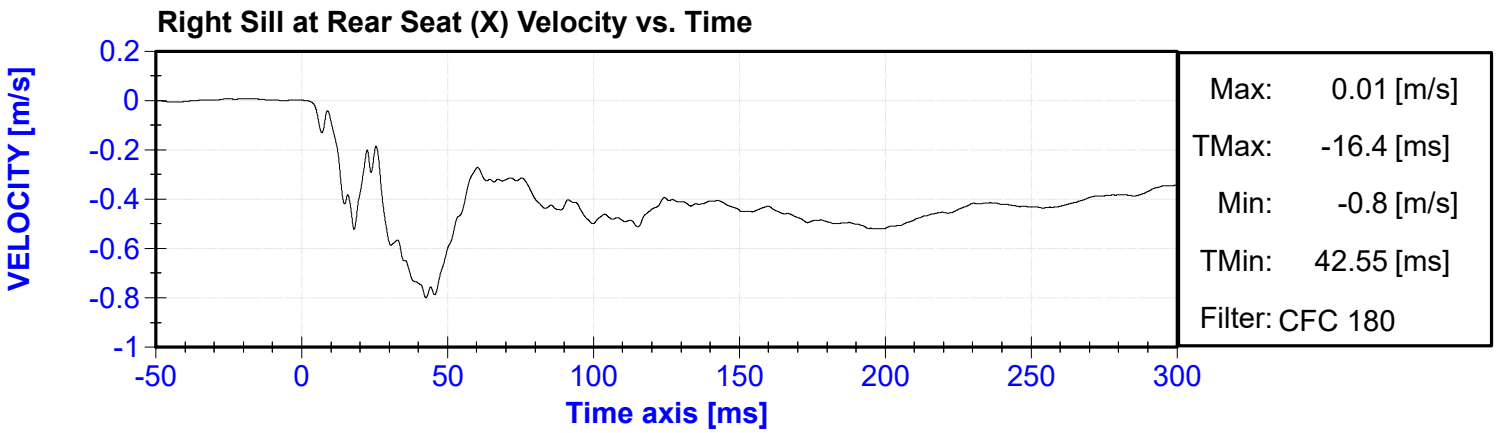

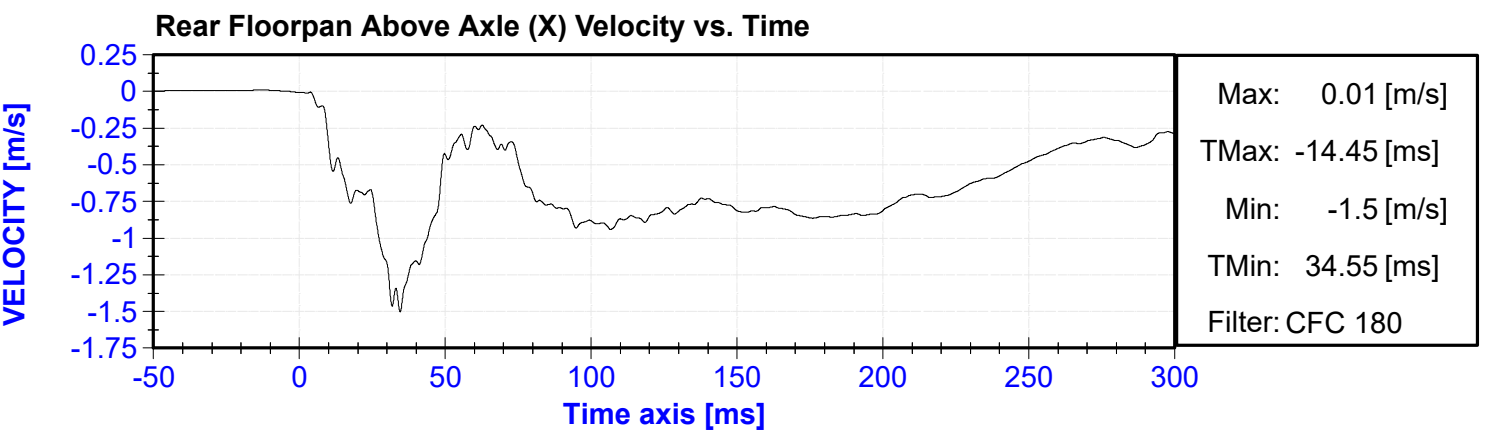
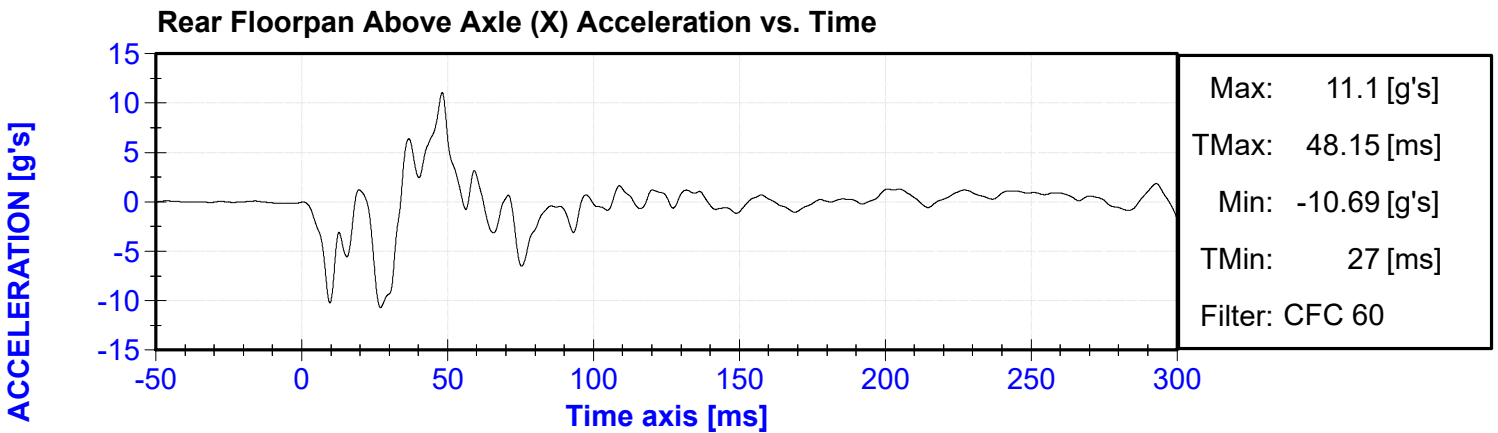
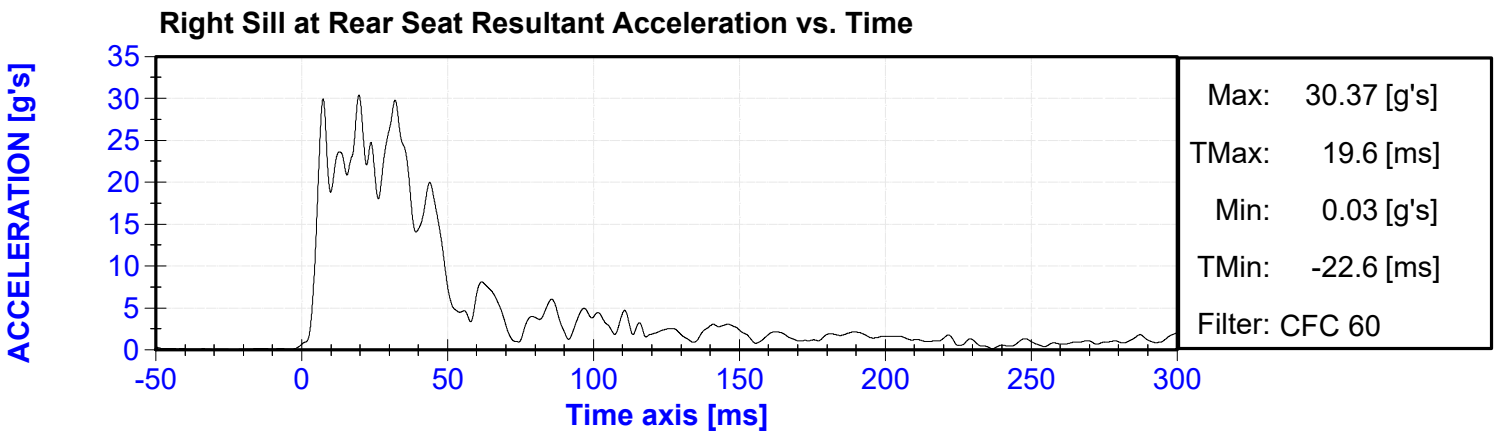
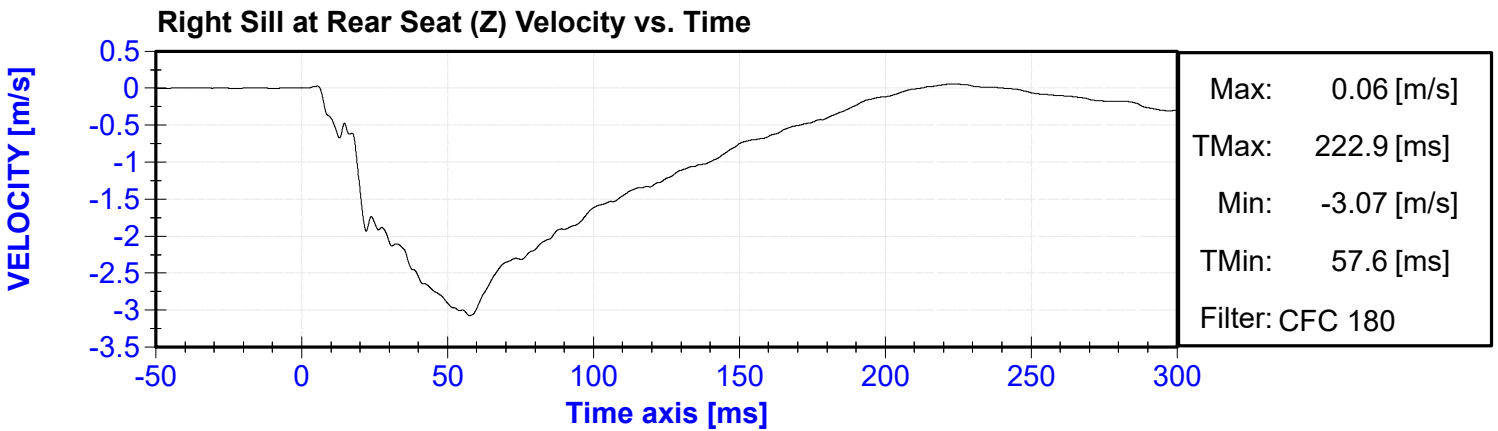

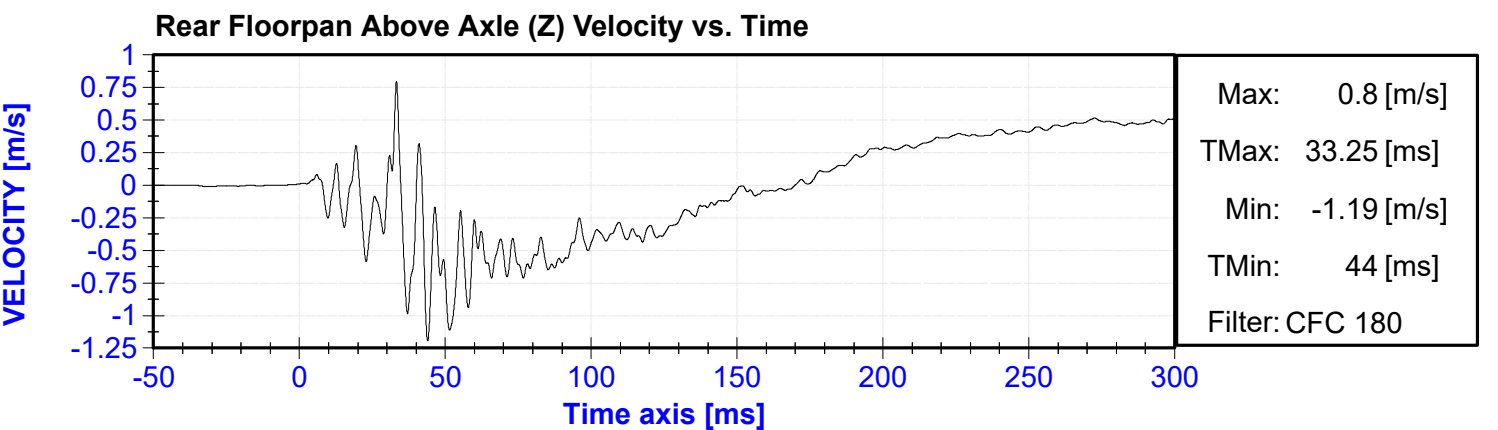
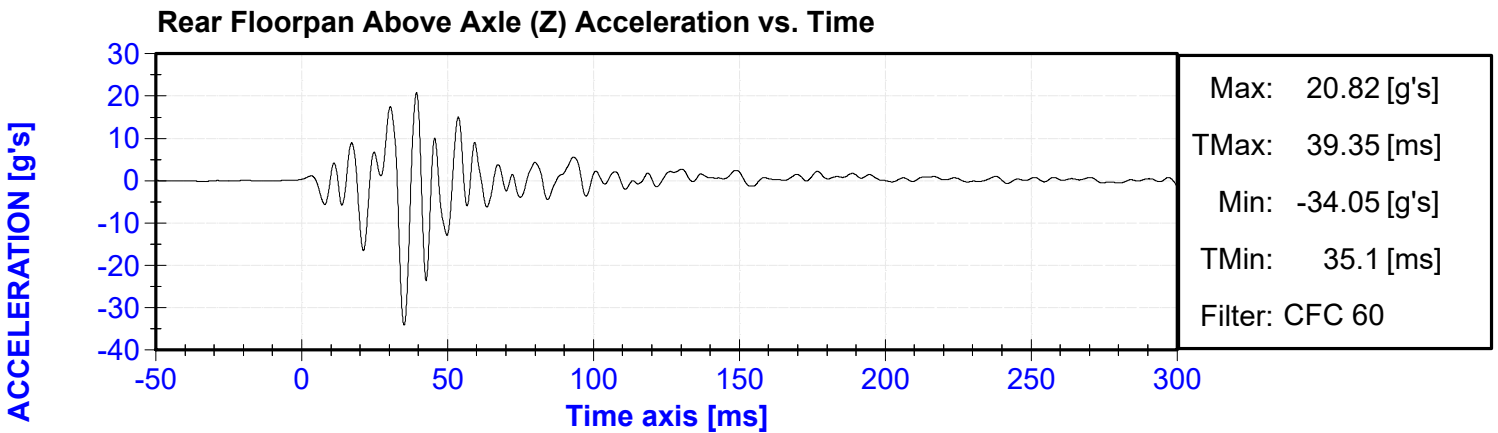
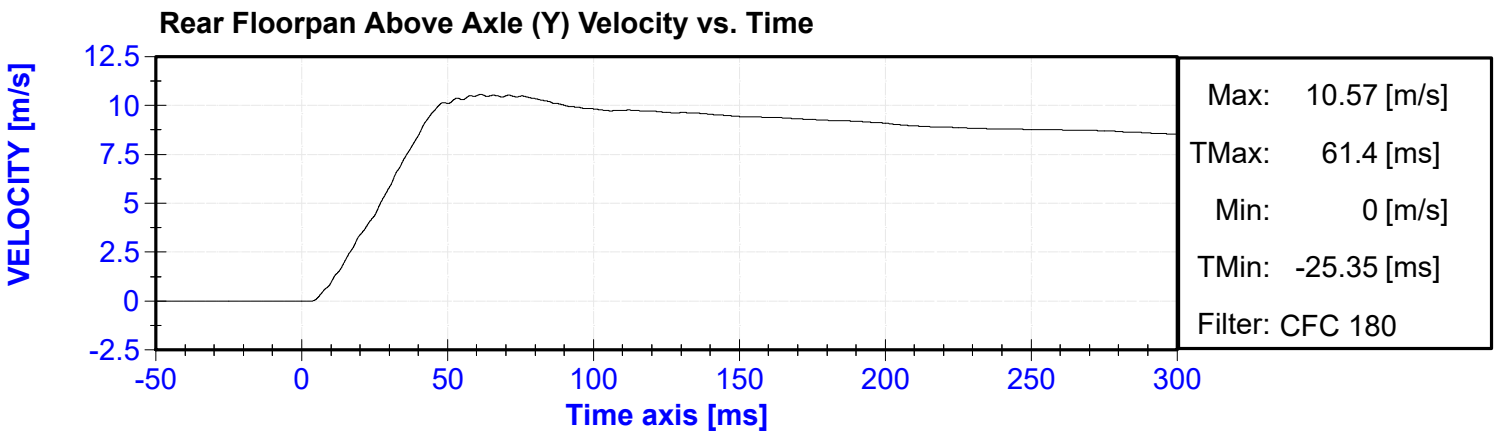
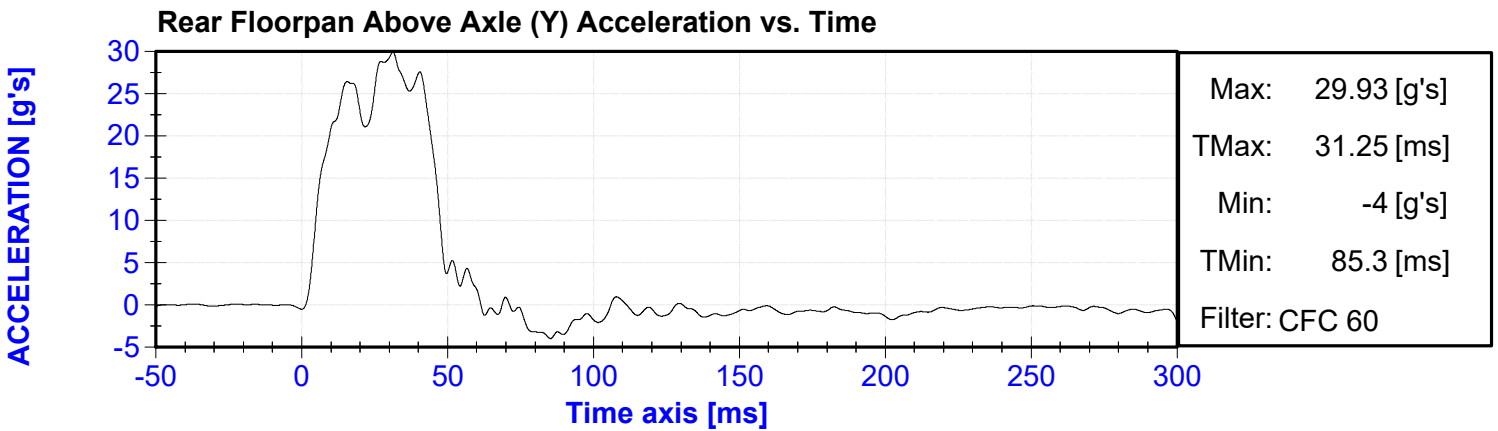

Rear Floorpan Above Axle Resultant Acceleration vs. Time

ACCELERATION [g's]

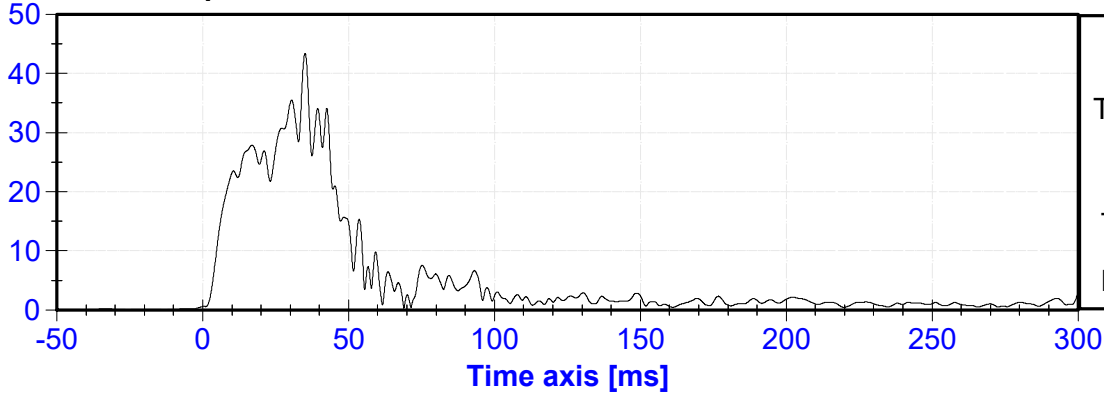

Exceeded calibration range at 29.2 ms

Left Sill at Rear Door (Y) Acceleration vs. Time

ACCELERATION [g's]

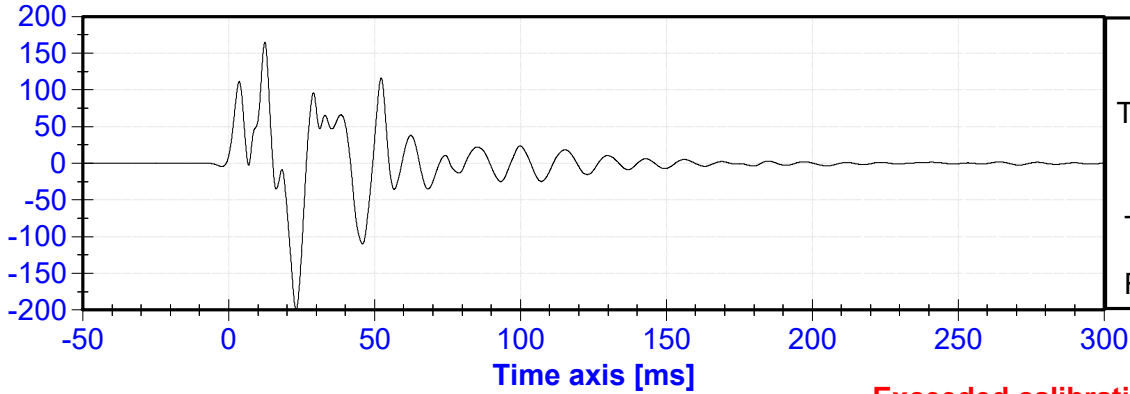

Exceeded calibration range at 29.2 ms

Left Sill at Rear Door (Y) Velocity vs. Time

VELOCITY [m/s]

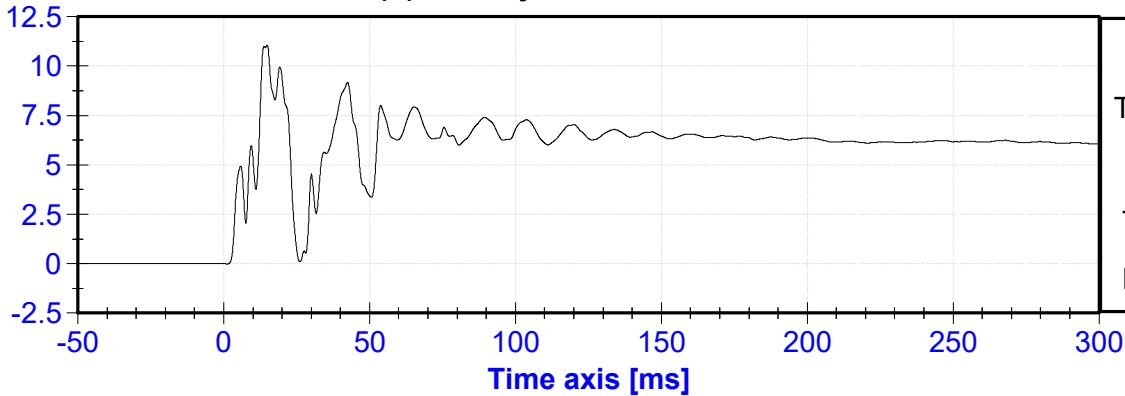

Exceeded calibration range at 18.8 ms

Left Sill at Front Door (Y) Acceleration vs. Time.

ACCELERATION [g's]

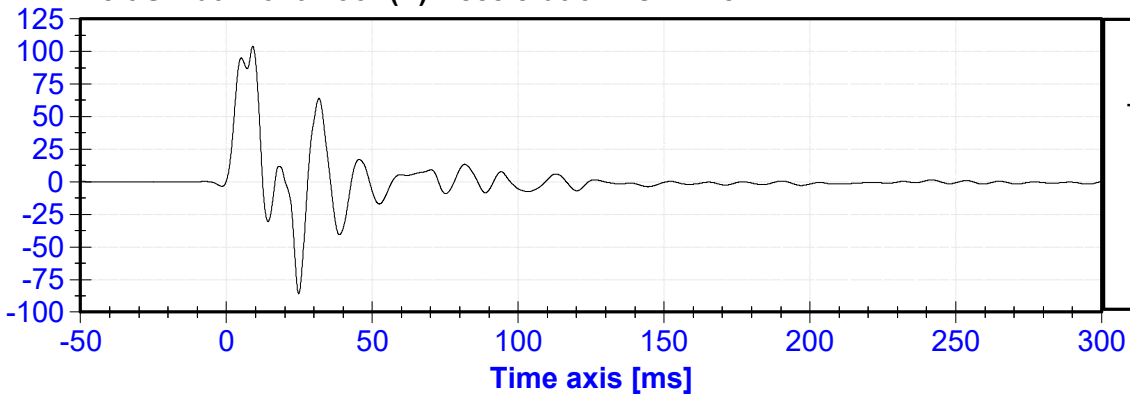

Exceeded calibration range at 18.8 ms

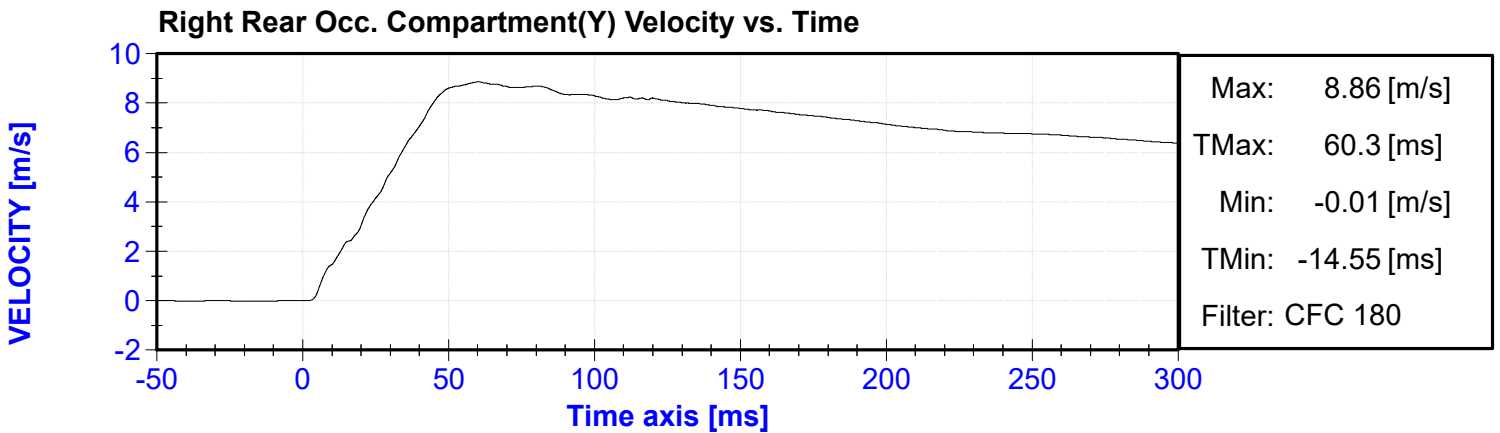
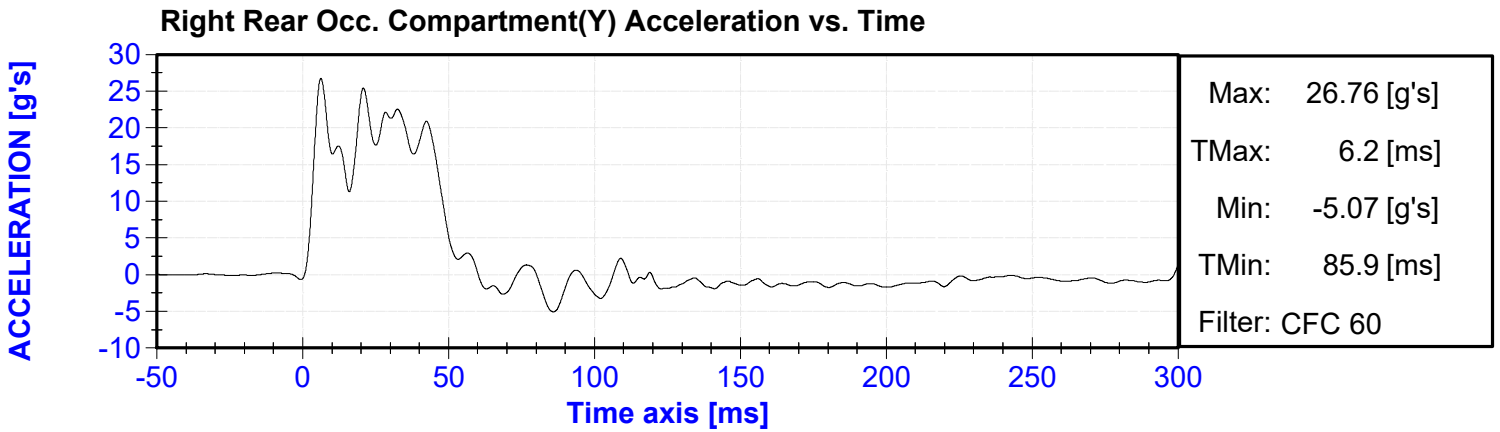
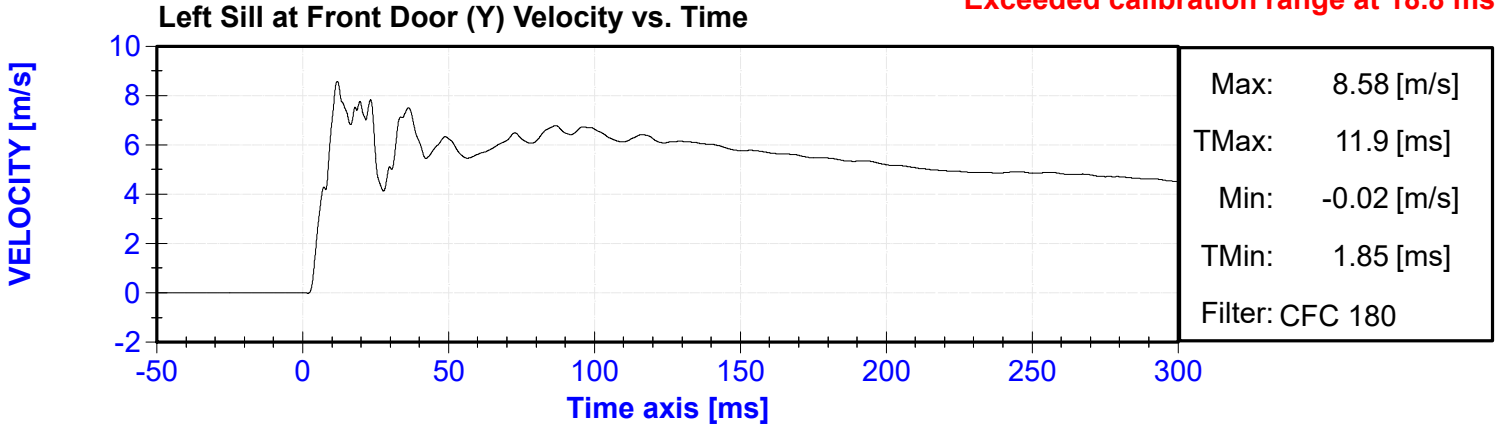

Exceeded calibration range and saturated at 8.8 ms 16.2 ms

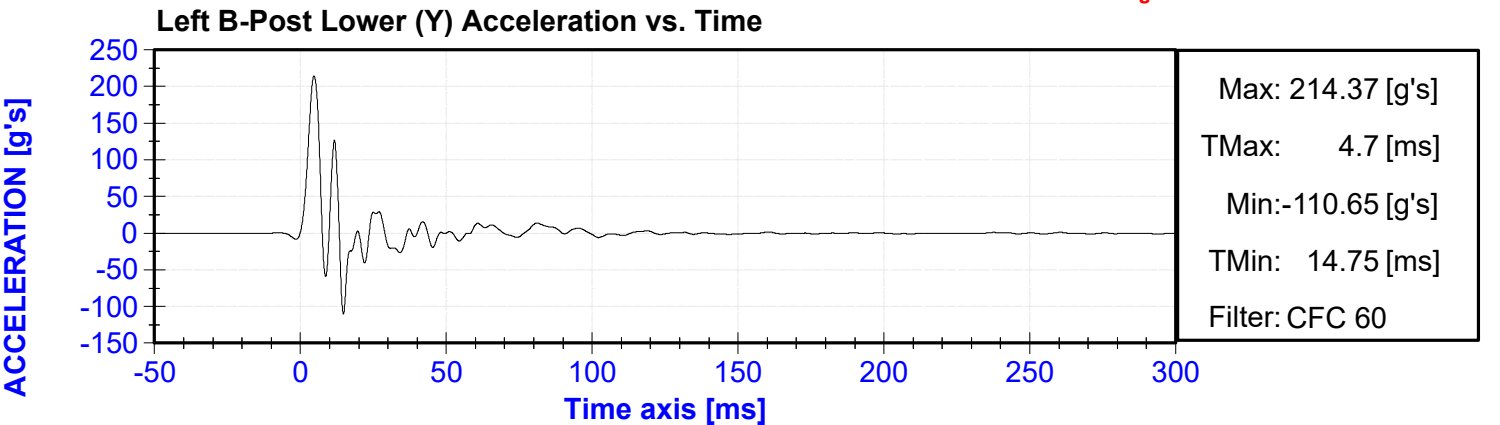

Exceeded calibration range and saturated at 8.8 ms 16.2 ms

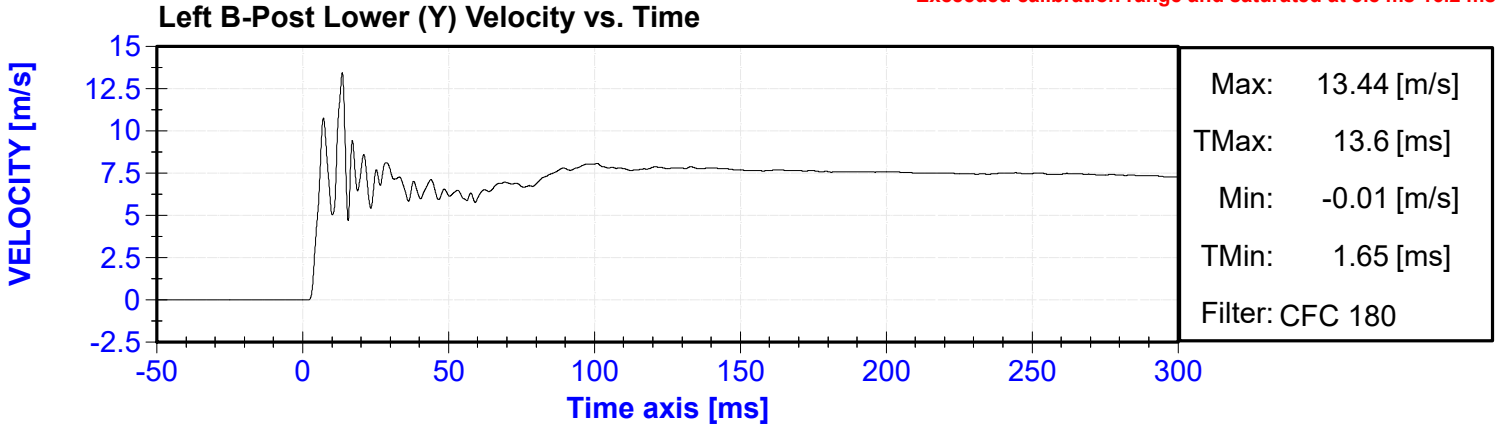

Exceeded calibration range and saturated at 10.6 ms

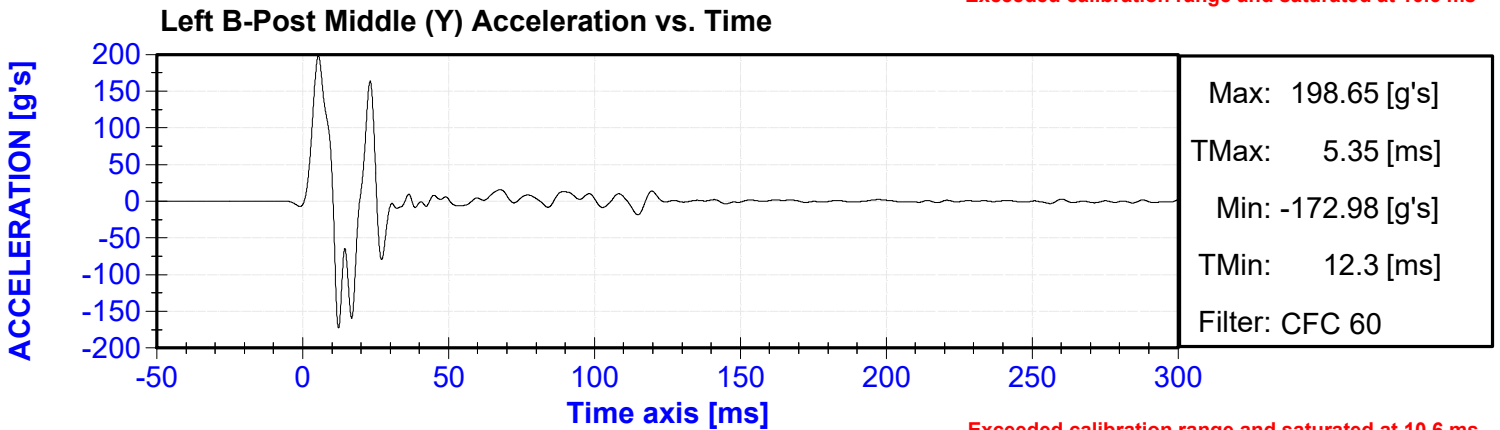

Exceeded calibration range and saturated at 10.6 ms

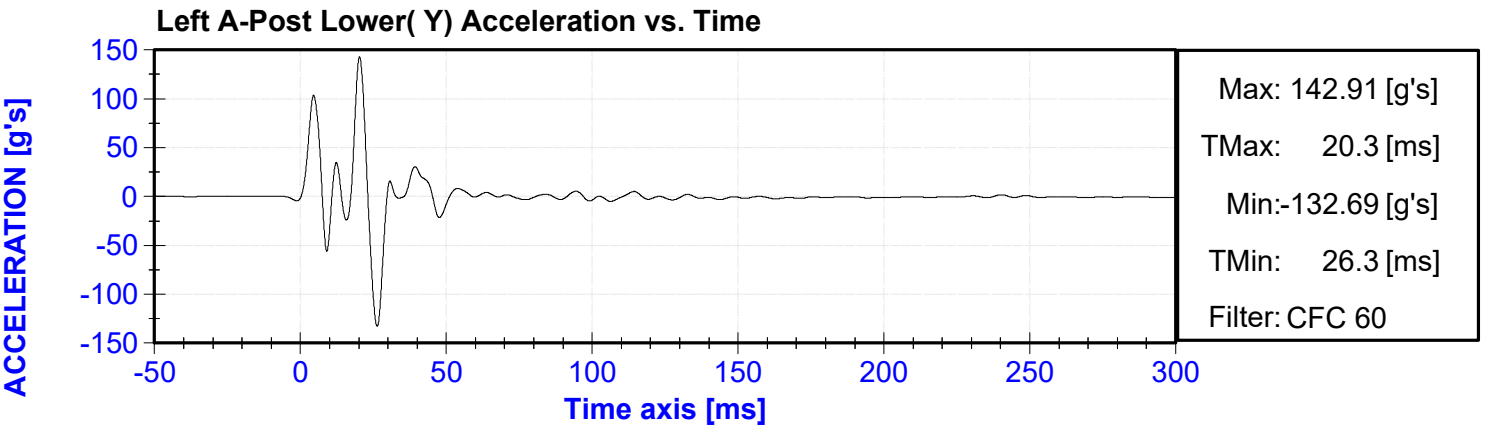
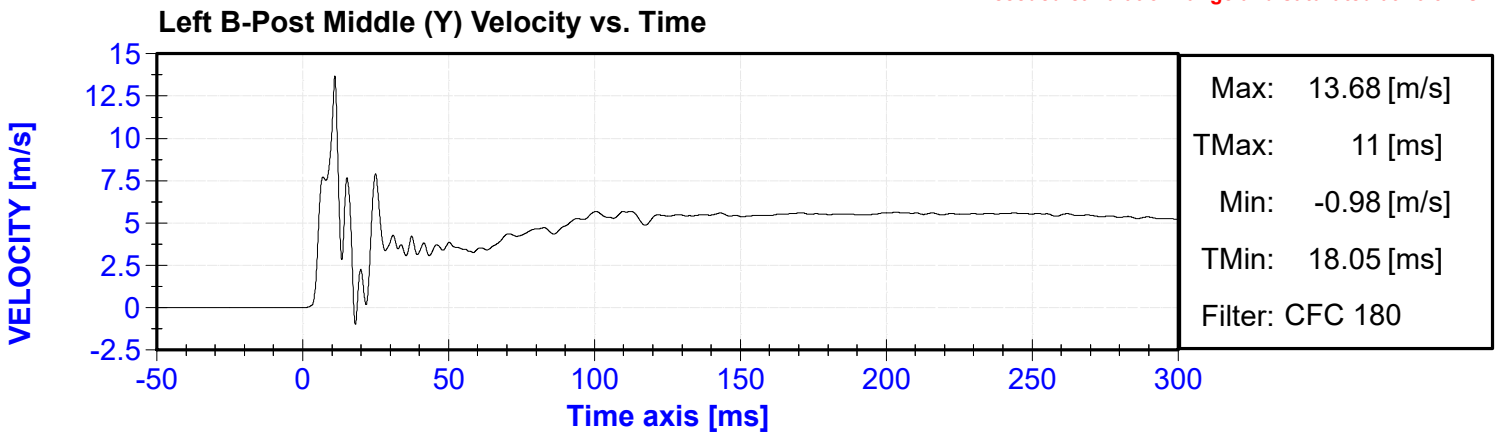

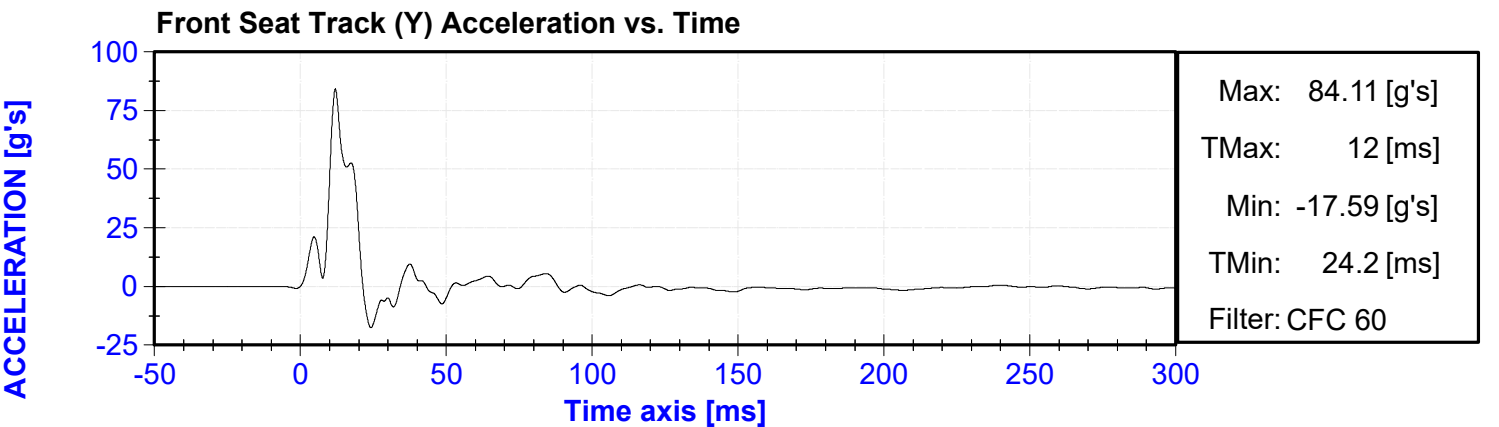
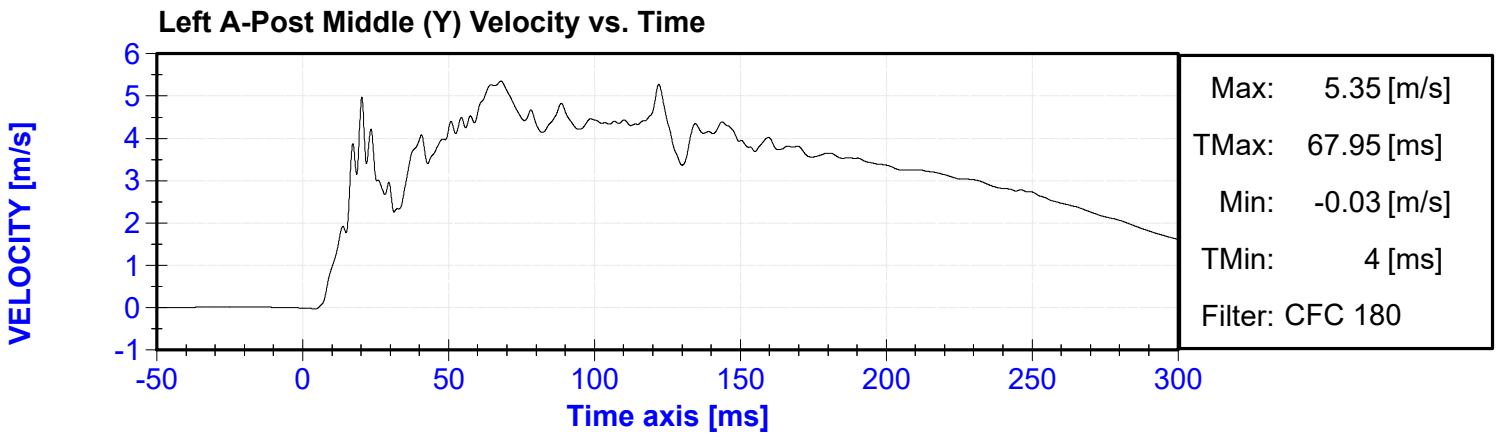
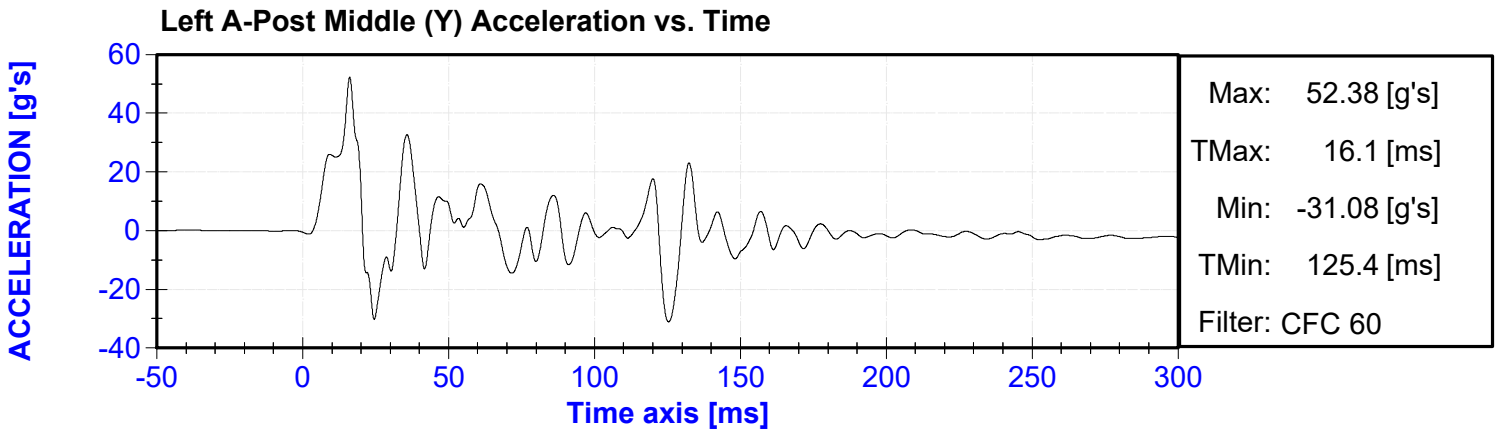
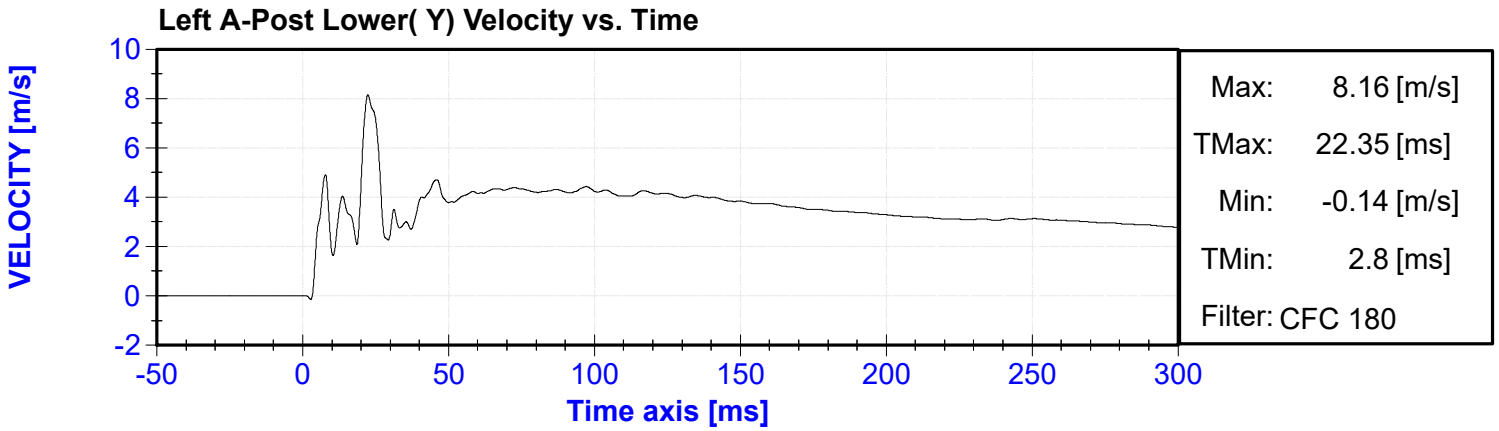

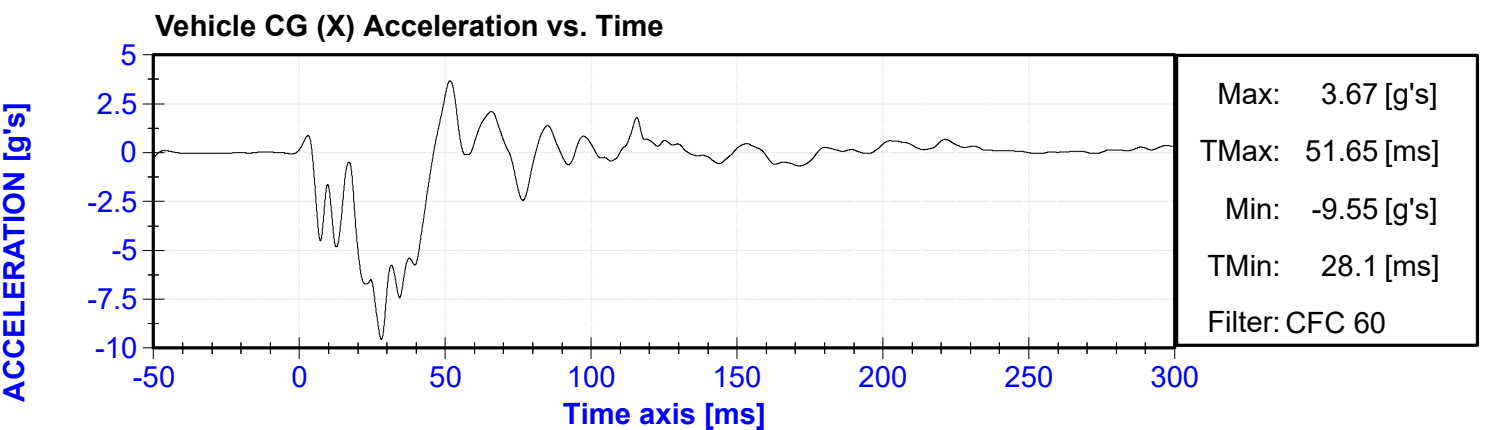
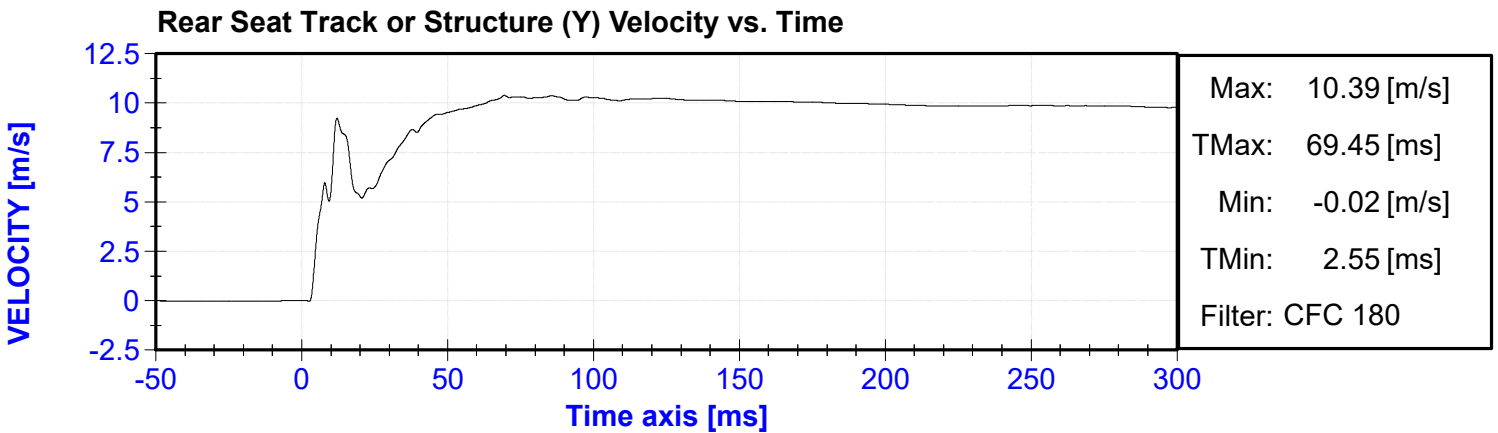
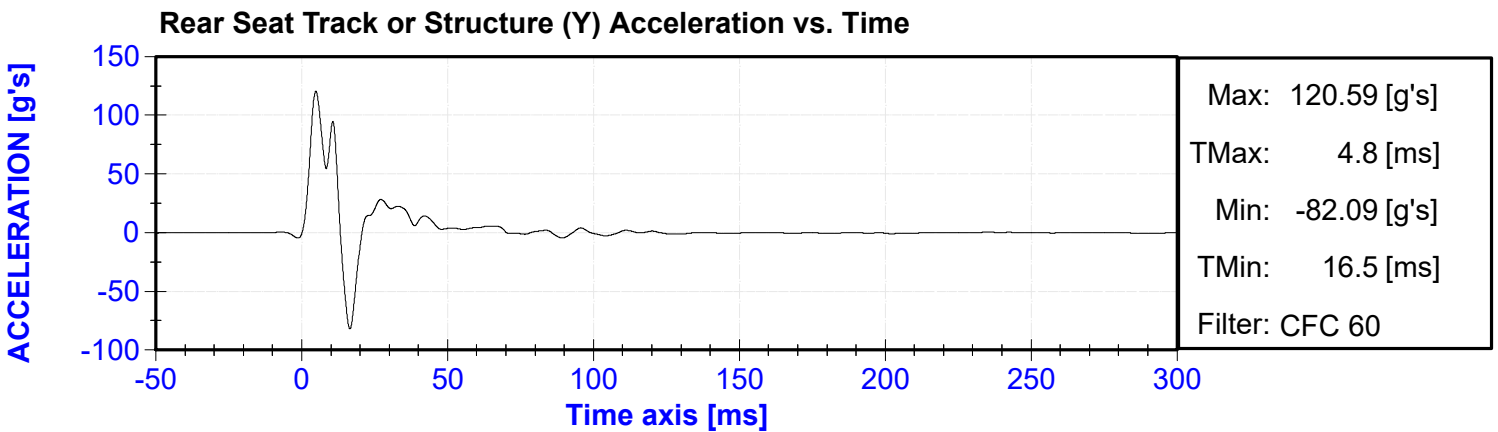
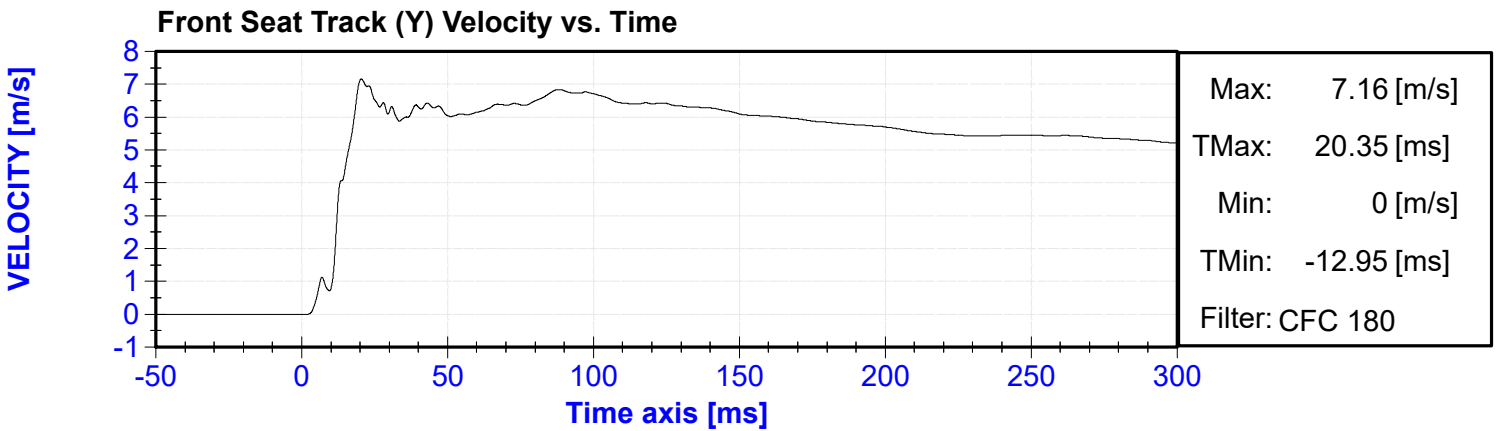

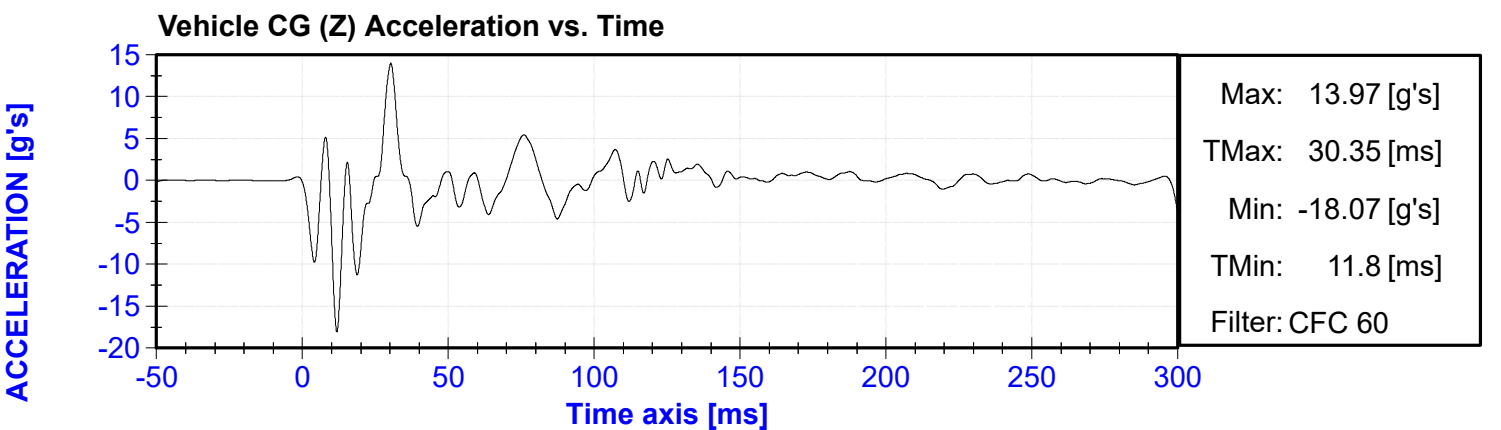
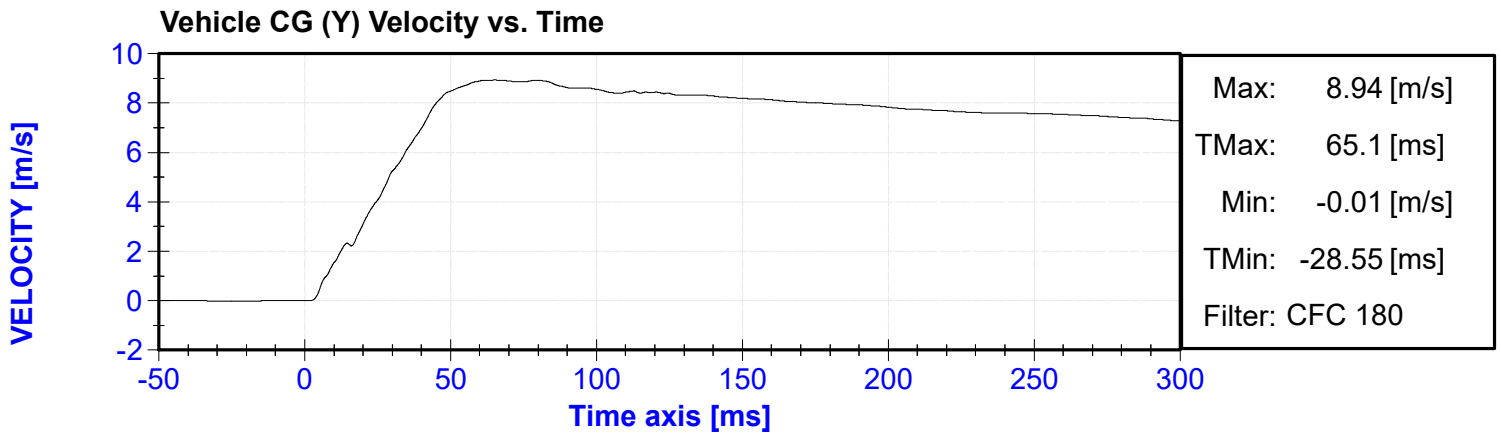
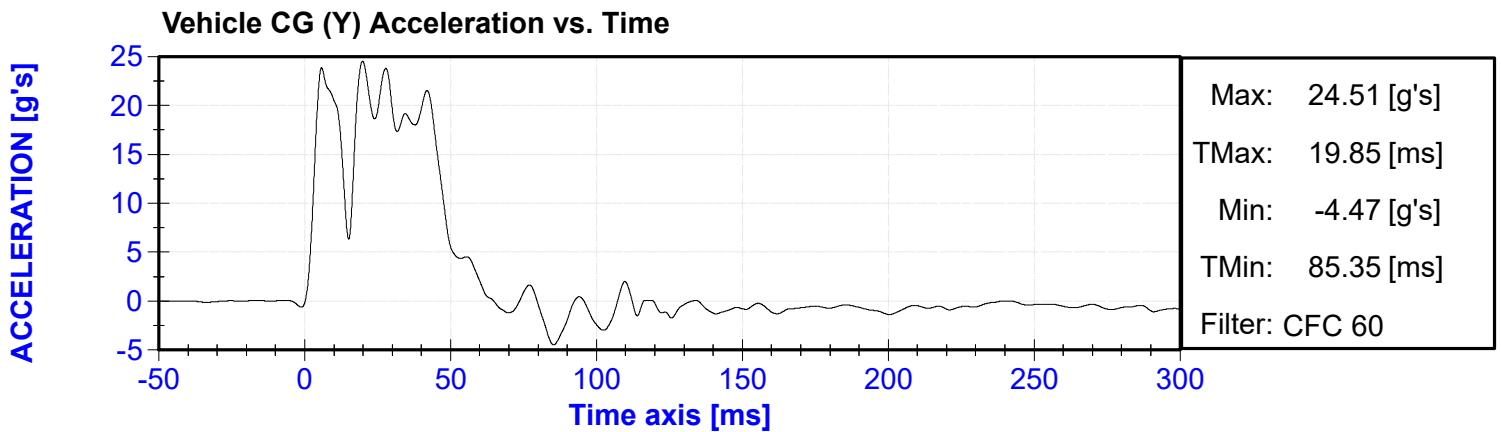
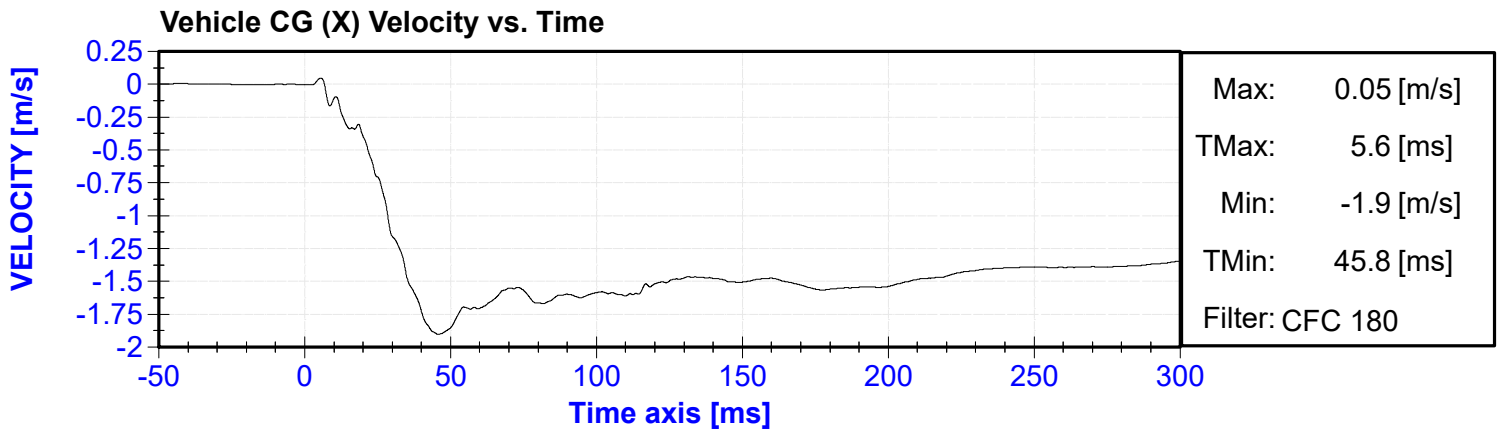

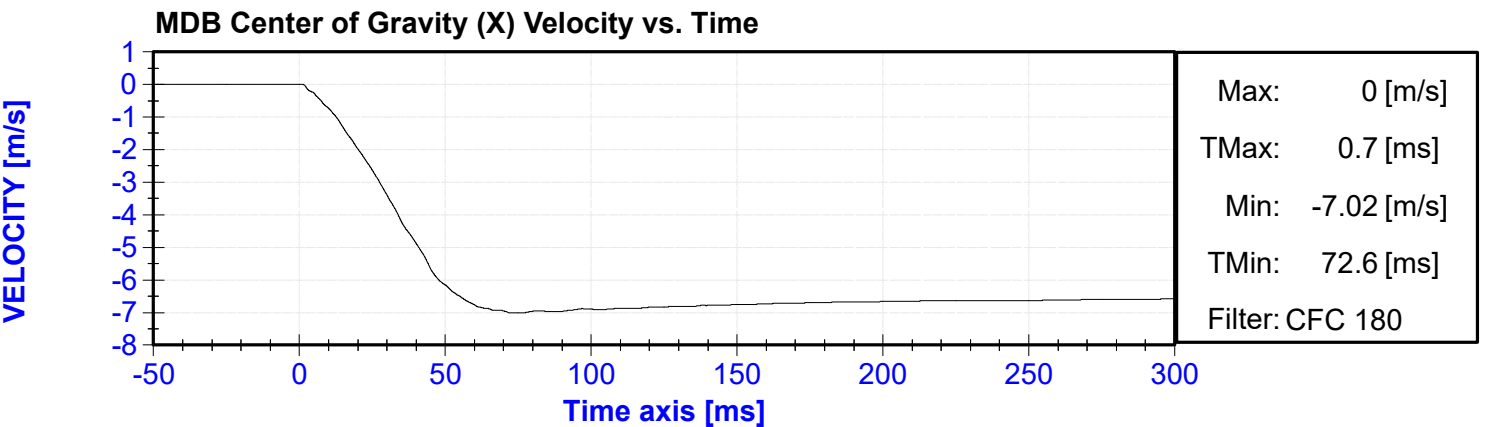
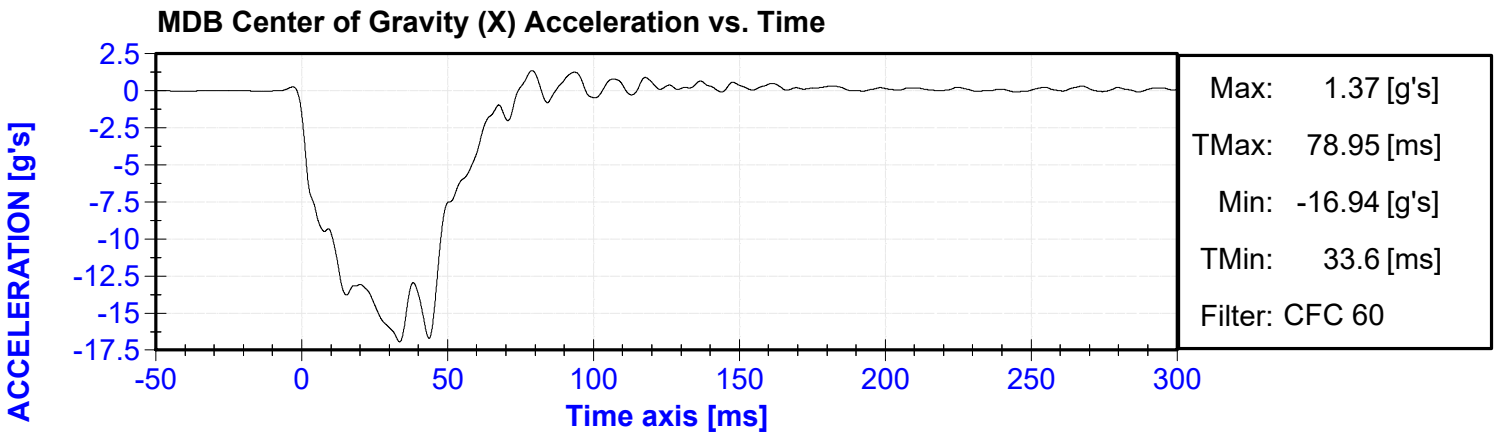
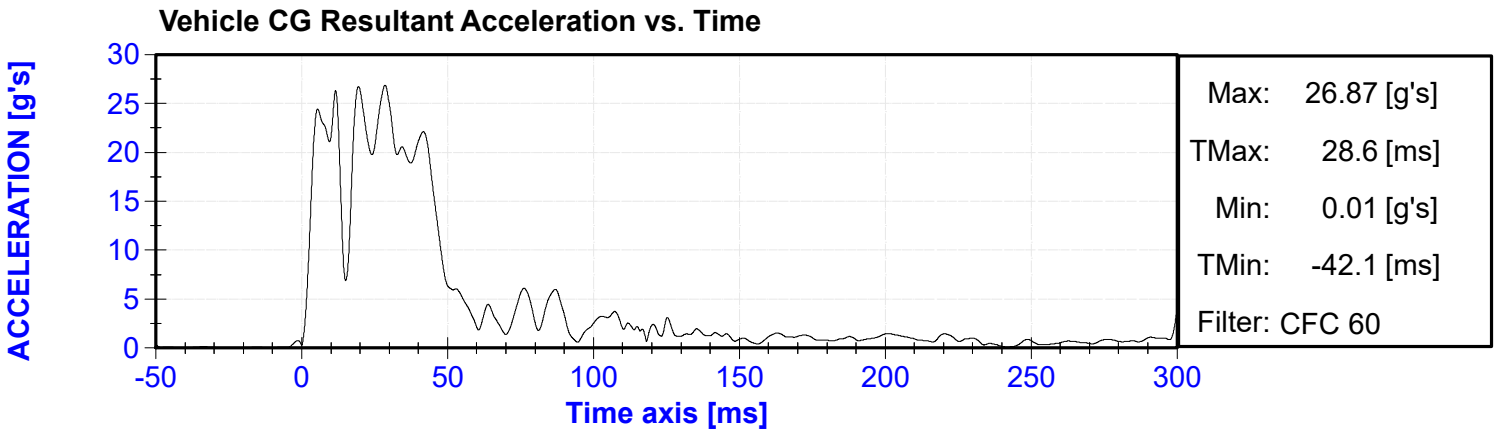
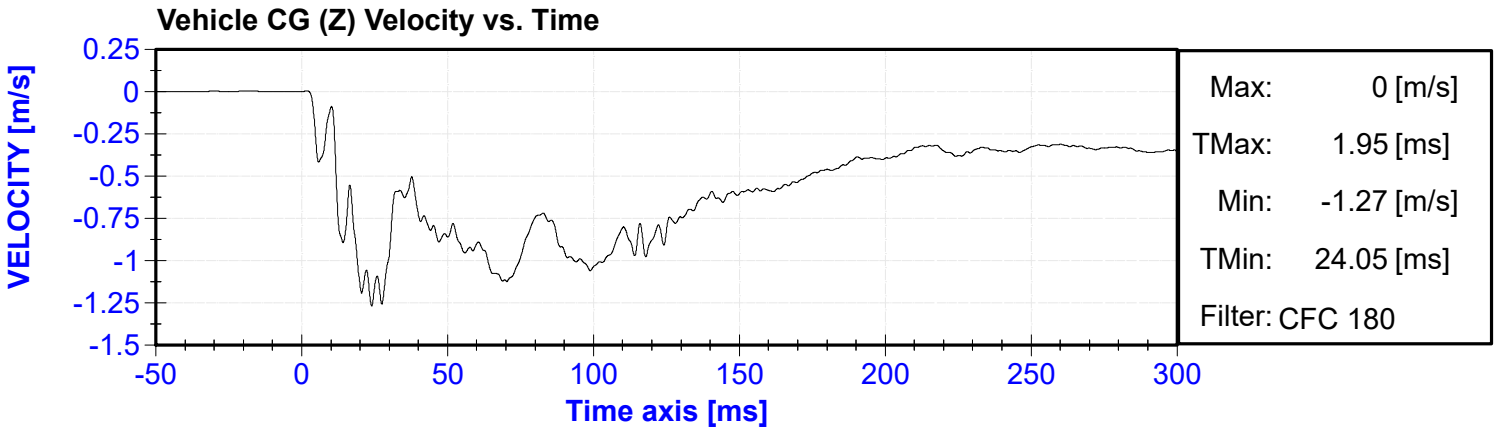

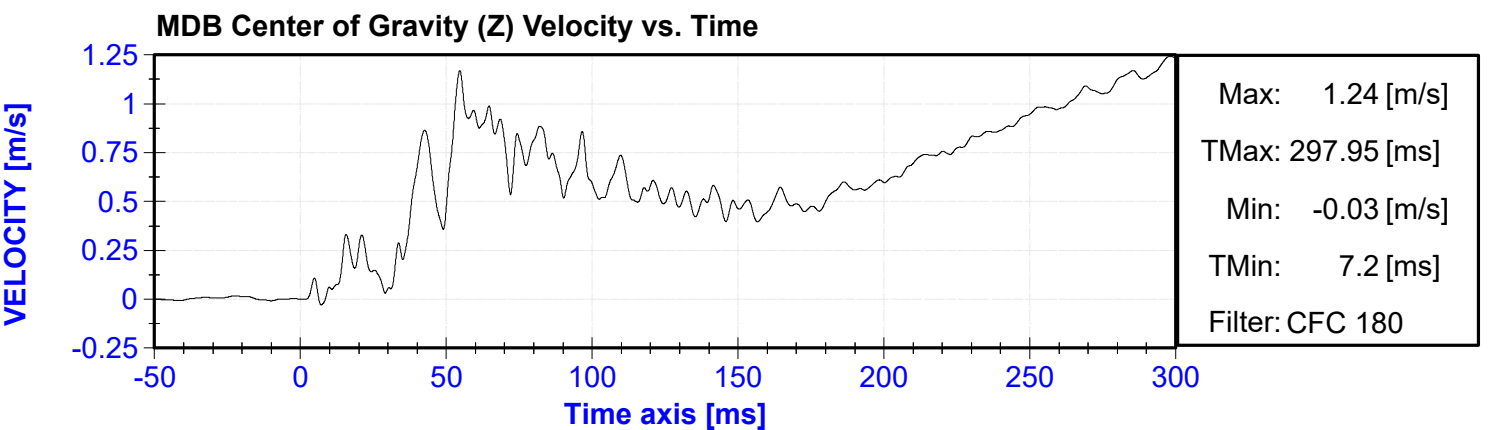
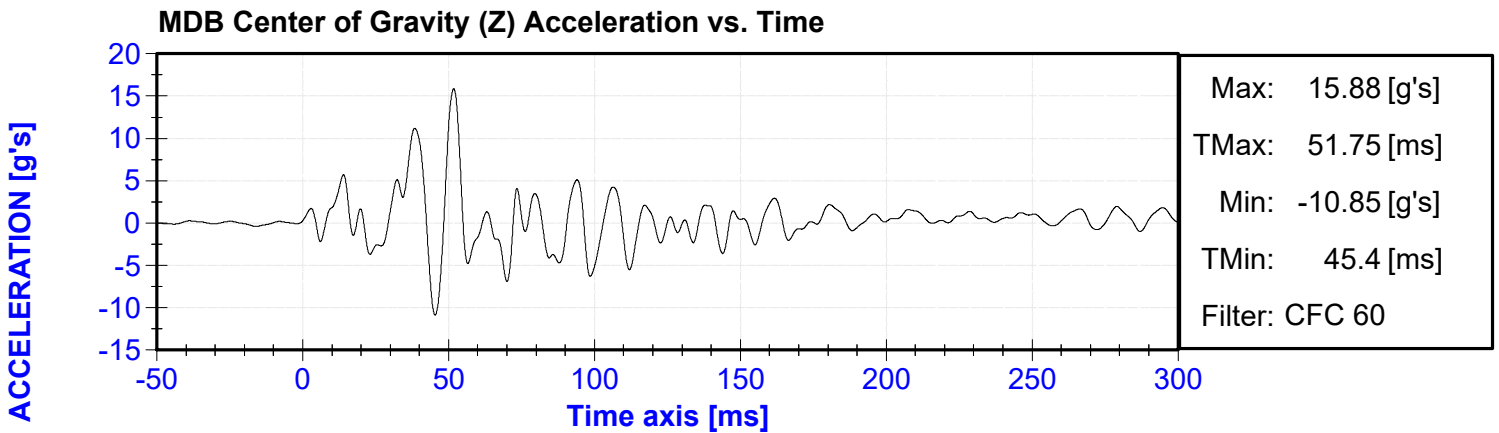
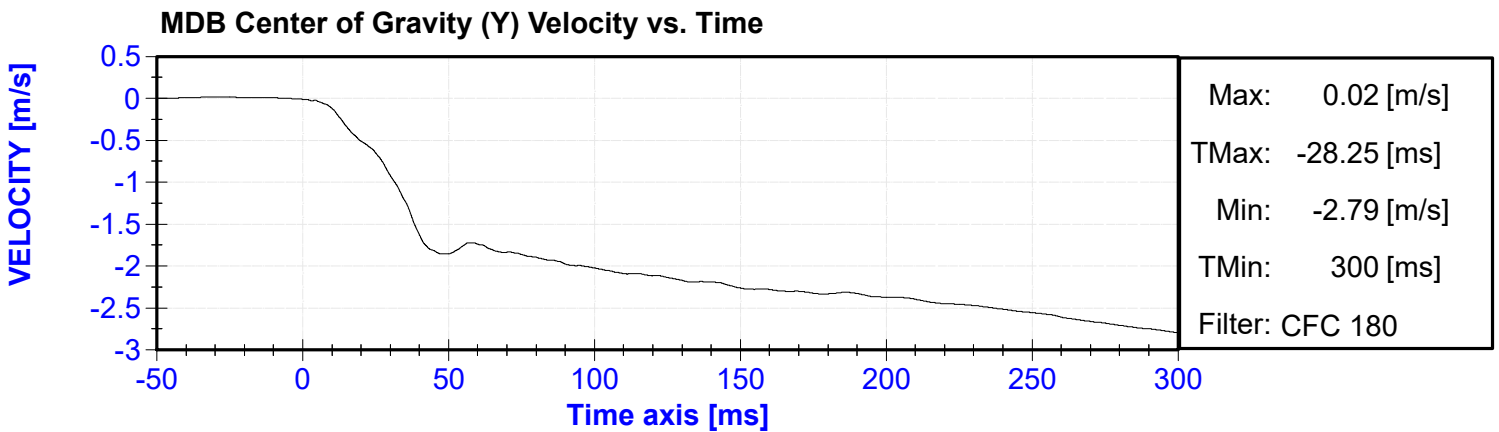
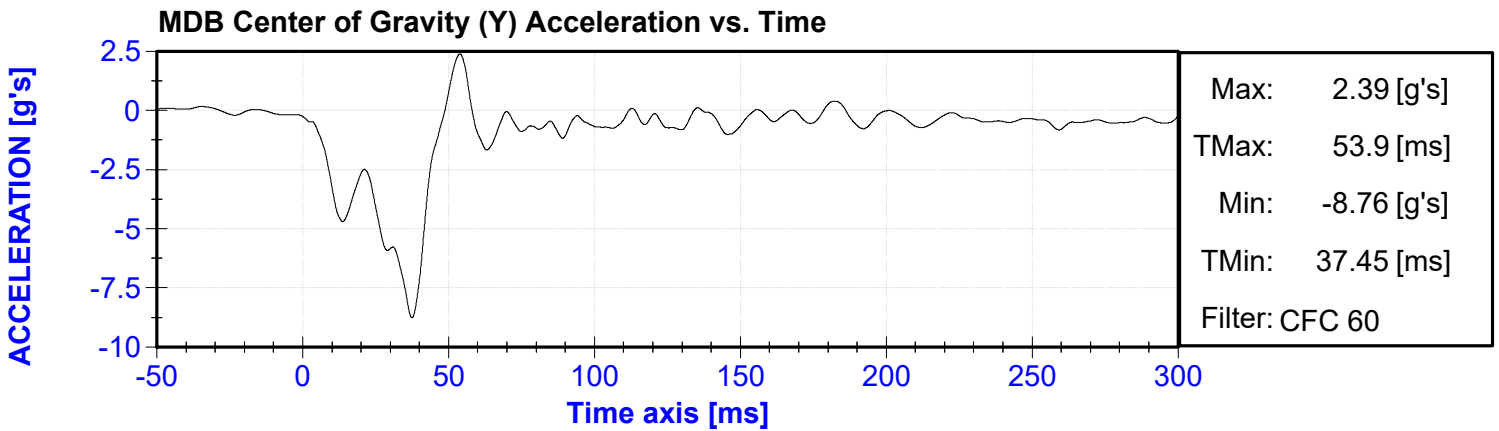

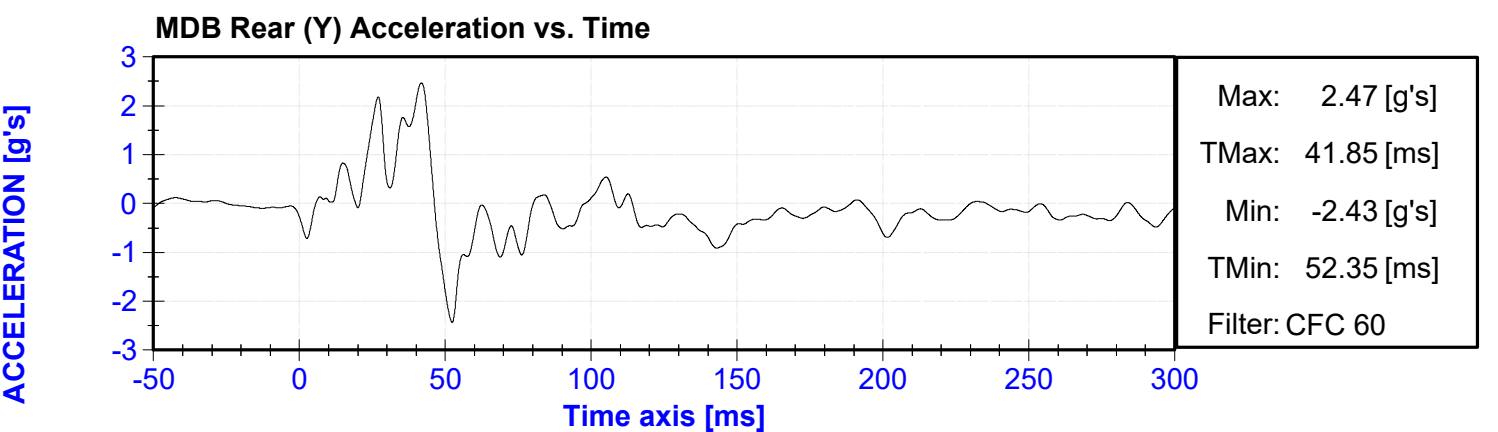
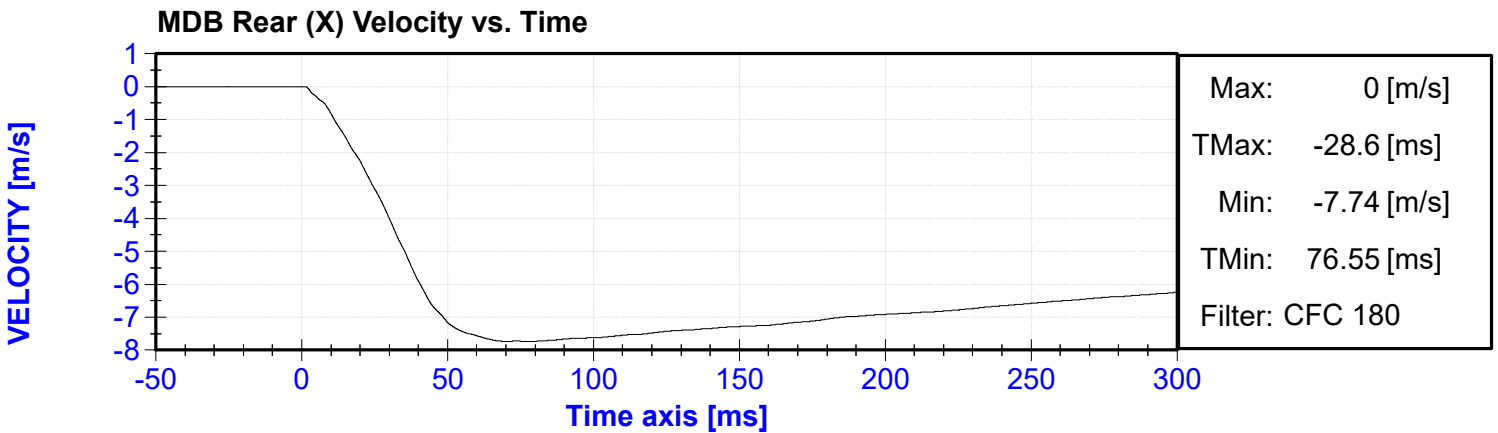
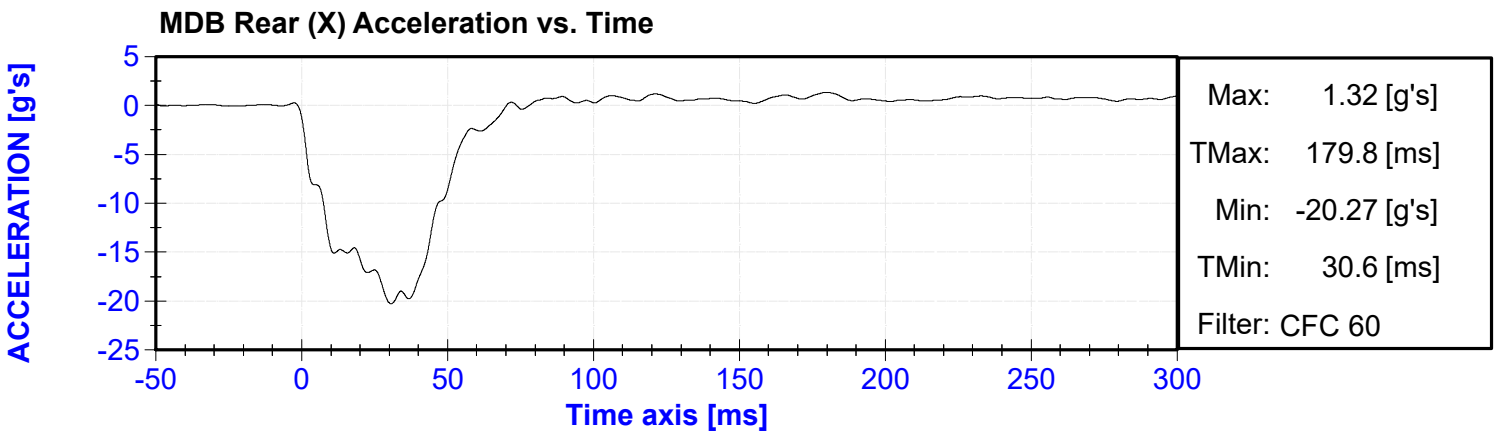
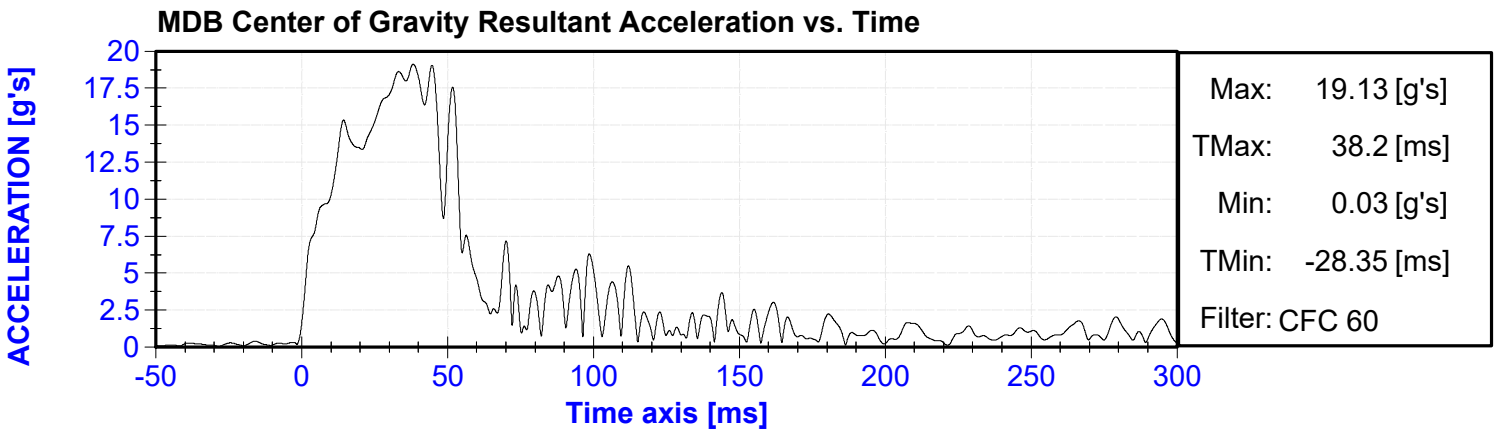

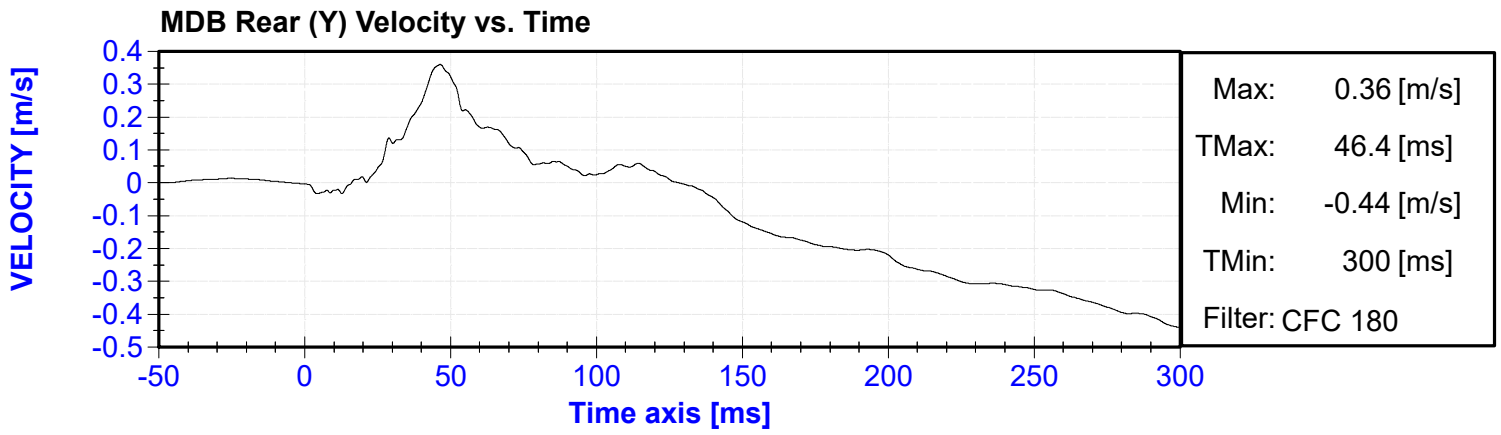

**APPENDIX V**

**PRE-TEST  
ES-2re PERFORMANCE CALIBRATION TEST DATA**

External Measurements - EuroSID-2re

Technician: J. Rios

Date: 09/06/2024

Dummy Serial Number: DG5348

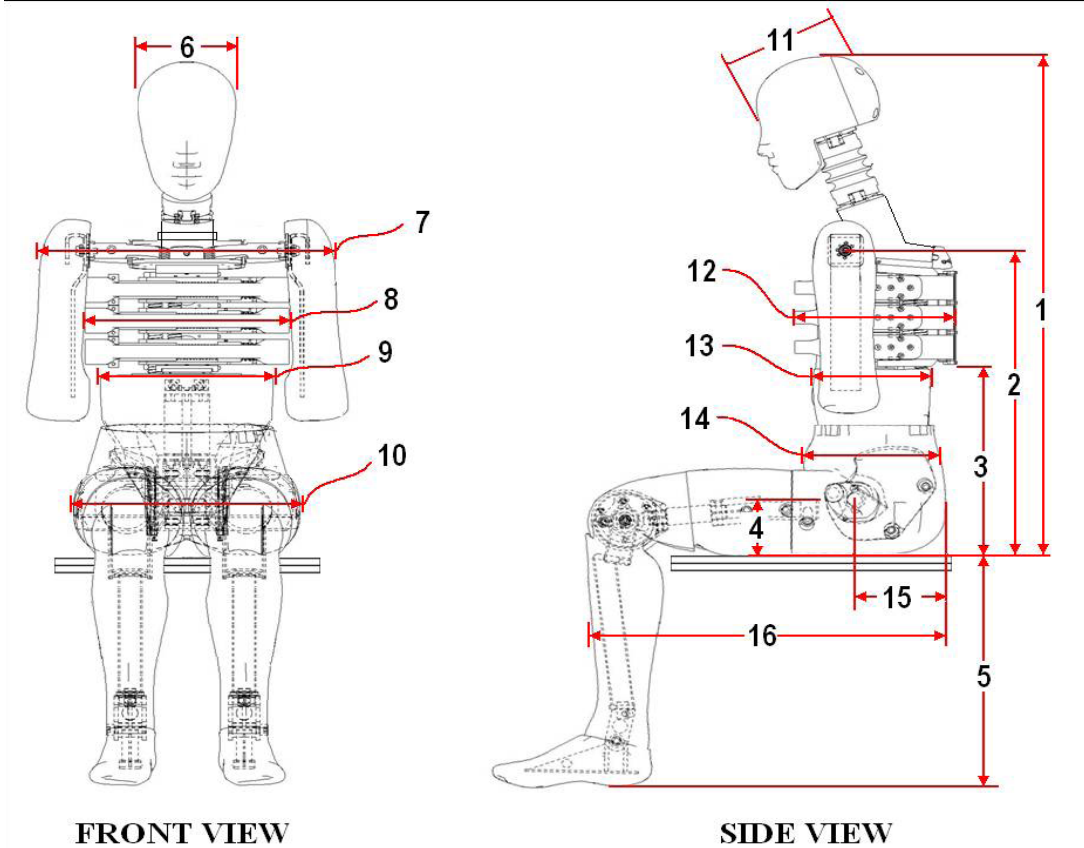

Dim. No.	Description	Specification (mm)		Result (mm)	Pass/Fail
1	Sitting Height	900	918	908	Pass
2	Seat to Shoulder Joint	558	572	565	Pass
3	Seat to Lower Face of Thoracic Spine Box	346	356	352	Pass
4	Seat to Hip Joint (center of bolt)	97	103	102	Pass
5	Sole to Seat, Sitting	333	451	411	Pass
6	Head Width	152	158	154	Pass
7	Shoulder/Arm Width	461	479	468	Pass
8	Thorax Width	322	332	326	Pass
9	Abdomen Width	273	287	280	Pass
10	Pelvis Lap Width	359	373	365	Pass
11	Head Depth	196	206	201	Pass
12	Thorax Depth	262	272	267	Pass
13	Abdomen Depth	194	204	199	Pass
14	Pelvis Depth	235	245	241	Pass
15	Back of Buttocks to Hip Joint (center of bolt)	150	160	153	Pass
16	Back of Buttocks to Front Knee	597	615	605	Pass

ATD Manufacturer	FTSS	Test Technician	J.Kinderman
ATD Serial Number	DG5348	Laboratory Supervisor	C. Mantell

**Results**

Test Parameter	Minimum Specification	Maximum Specification	Unit	Result	Pass/Fail
Temperature	20.6	22.2	°C	20.8	Pass
Humidity	10	70	%	55	Pass
Resultant Acceleration	125	155	g's	148.2	Pass
Oscillation	0	15	%	1.67	Pass
Fore-Aft Acceleration	-15	15	g's	3.0	Pass

**Transducer Calibrations**

Channel	Manufacturer	Serial Number	Calibration Date	Calibration Due Date
X Accelerometer	Endevco	18613	7/30/2024	1/26/2025
Y Accelerometer	Endevco	18472	7/30/2024	1/26/2025
Z Accelerometer	Endevco	18663	7/30/2024	1/26/2025

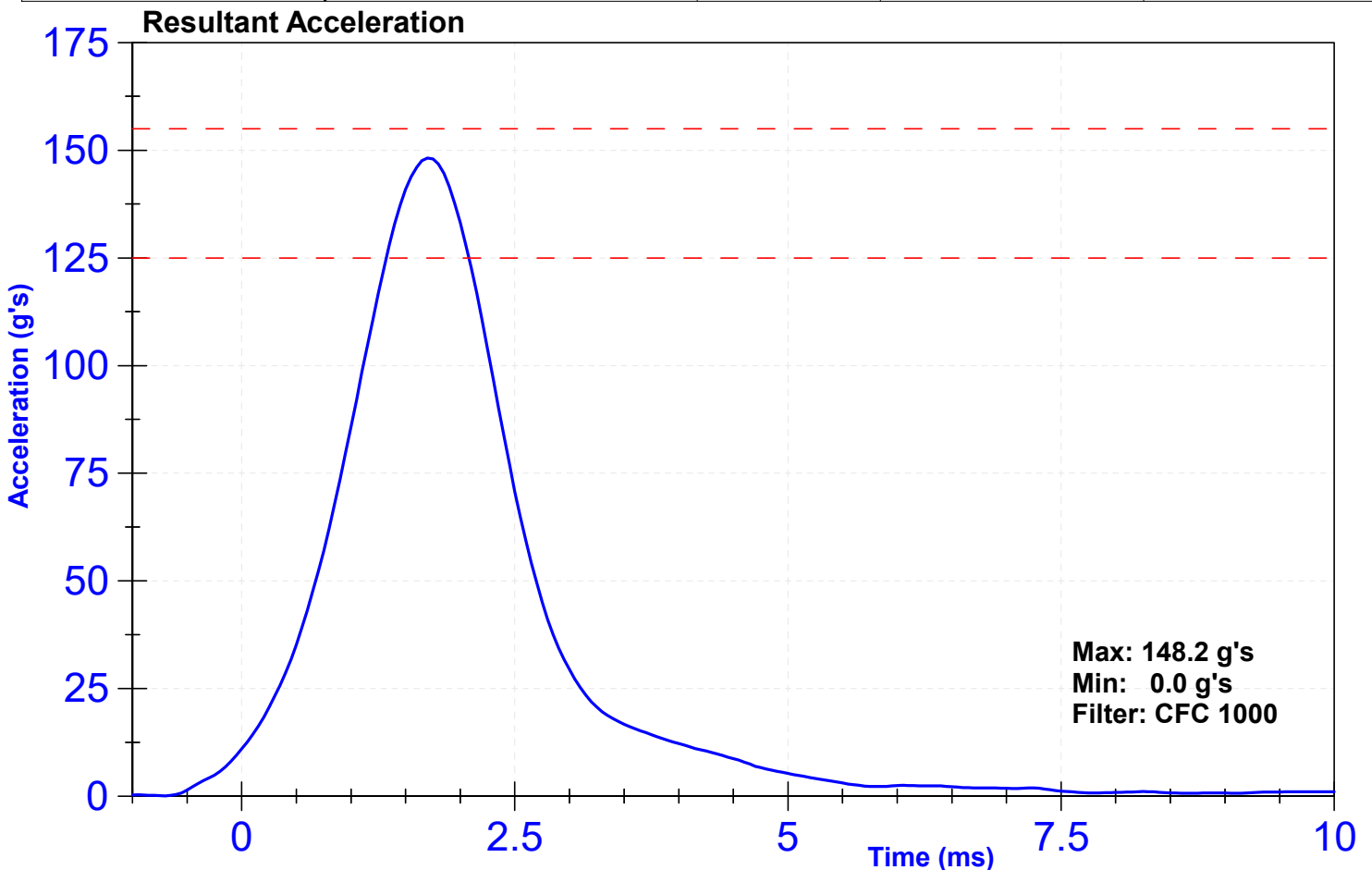

Head CG X Acceleration

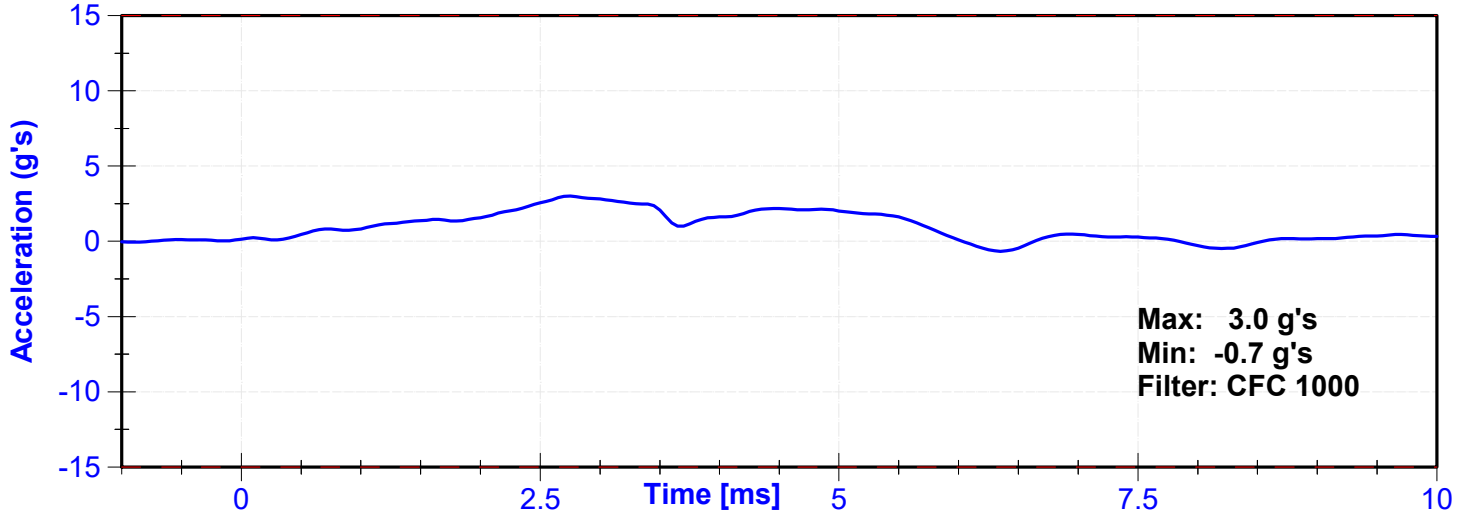

Head CG Y Acceleration

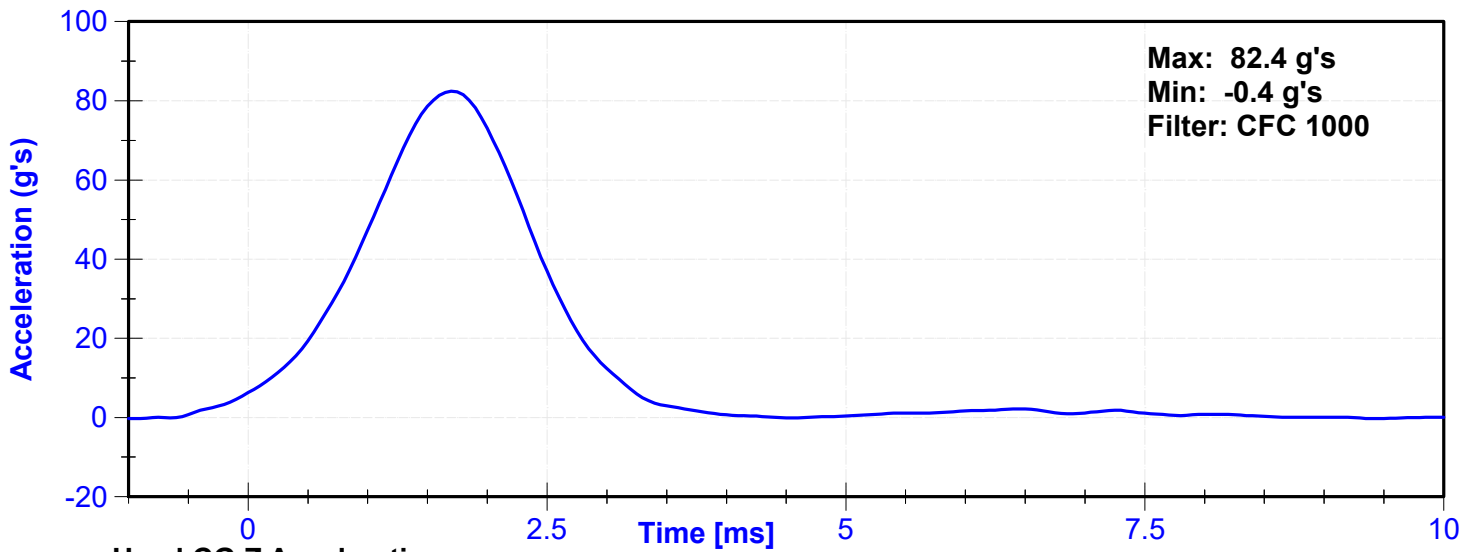

Head CG Z Acceleration

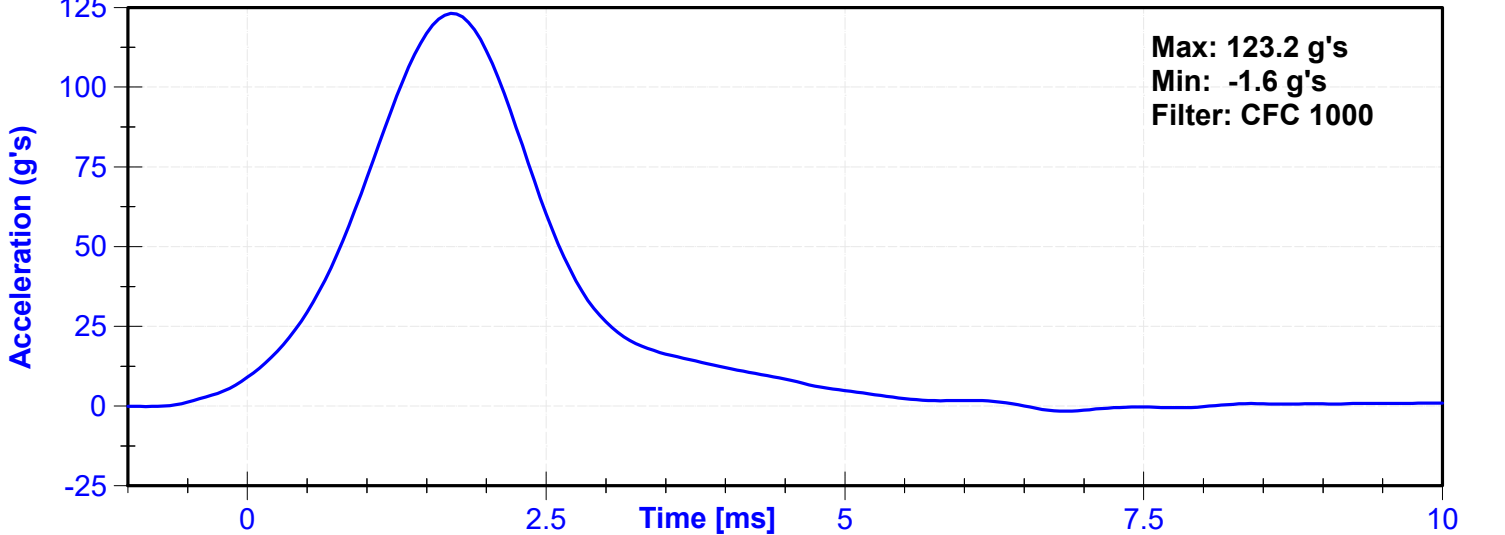

ATD Manufacturer	FTSS	Test Technician	J.Kinderman
ATD Serial Number	DG5348	Laboratory Supervisor	C. Mantell

**Results**

Test Parameter	Minimum Specification	Maximum Specification	Unit	Result	Pass/Fail
Temperature	20.6	22.2	°C	21.0	Pass
Humidity	10	70	%	53.0	Pass
Velocity	3.3	3.5	m/s	3.43	Pass
Lateral Neck Rotation	49	59	deg	49.2	Pass
Time at Maximum Rotation	54	66	ms	54.9	Pass
Time of Rotation Decay from Maximum	53	88	ms	57.3	Pass
Pendulum Velocity Overall Corridor	Lower Boundary <sup>1</sup>	Upper Boundary <sup>2</sup>	m/s	See Plot <sup>3</sup>	Pass

**Transducer Calibrations**

Channel	Manufacturer	Serial Number	Calibration Date	Calibration Due Date
Pendulum Accelerometer	Endevco	C16650	10/31/2023	10/30/2024
Front Pendulum Potentiometer	Sfernice	2247	12/5/2023	12/4/2024
Headform Potentiometer	Sfernice	095	9/29/2023	9/28/2024

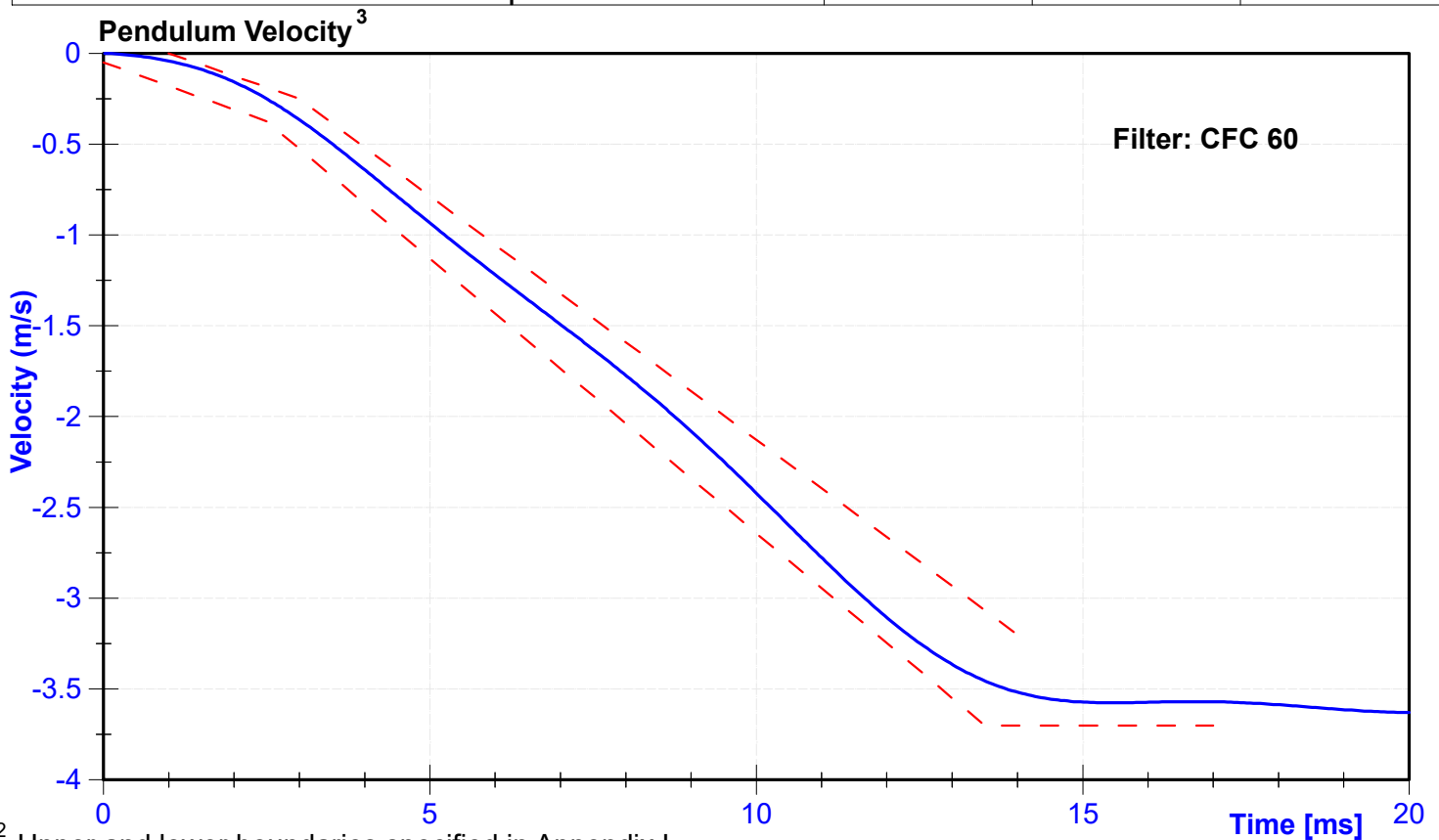

<sup>1,2</sup> Upper and lower boundaries specified in Appendix I

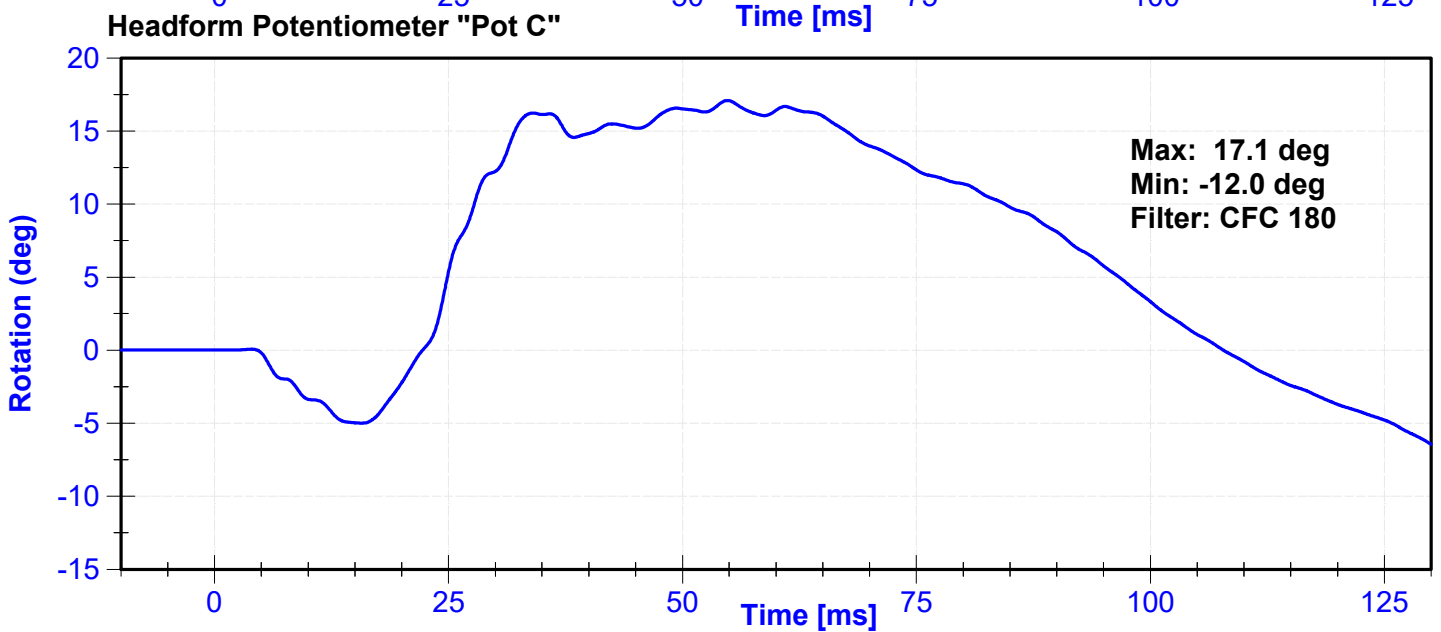
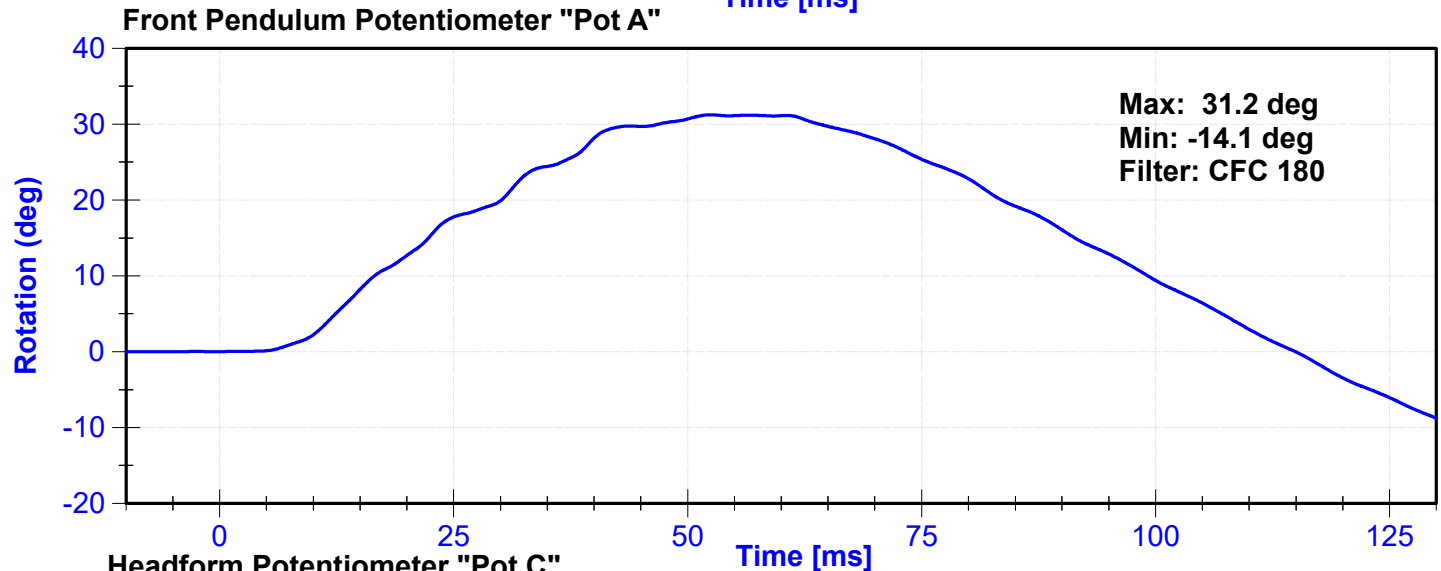
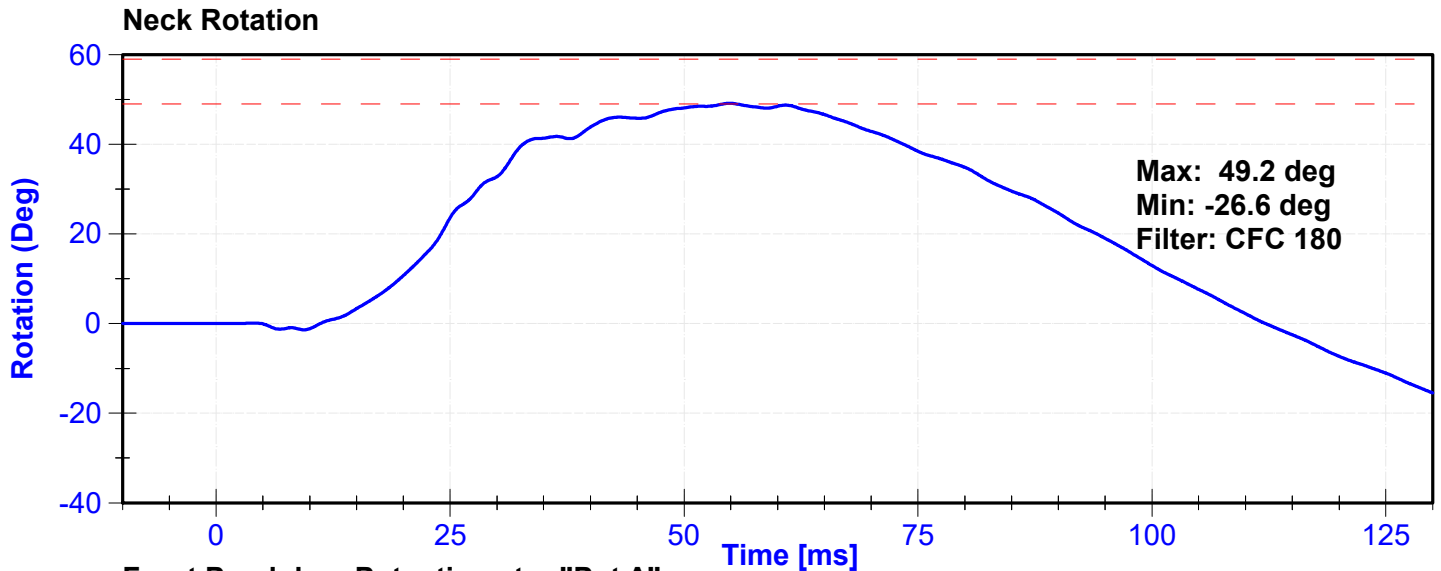

## Appendix I

<sup>2</sup> Upper Boundary Corridor		<sup>1</sup> Lower Boundary Corridor	
Time (ms)	Velocity (m/s)	Time (ms)	Velocity (m/s)
1.0	0.00	0.0	-0.05
3.0	-0.25	2.5	-0.375
14.0	-3.20	13.5	-3.7
		17.0	-3.7

ATD Manufacturer	FTSS	Test Technician	J.Kinderman
ATD Serial Number	DG5348	Laboratory Supervisor	C. Mantell

**Results**

Test Parameter	Minimum Specification	Maximum Specification	Unit	Result	Pass/Fail
Temperature	20.6	22.2	°C	21.0	Pass
Humidity	10	70	%	45	Pass
Velocity	4.2	4.4	m/s	4.28	Pass
Probe Acceleration	7.5	10.5	g's	9.69	Pass

**Transducer Calibrations**

Channel	Manufacturer	Serial Number	Calibration Date	Calibration Due Date
Probe Accelerometer	Endevco	18587	11/20/2023	11/19/2024

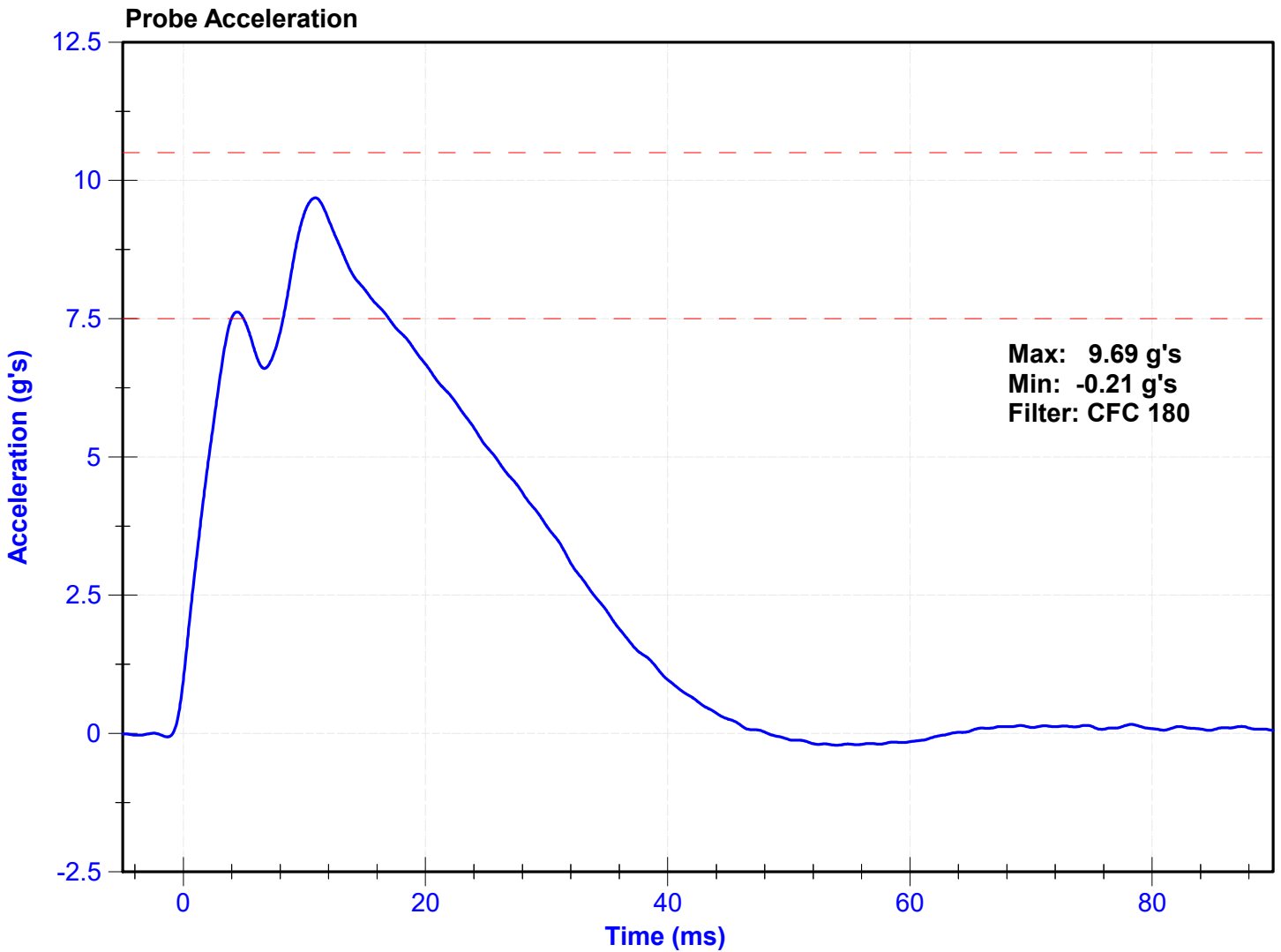

ATD Manufacturer	FTSS	Test Technician	J.Kinderman
ATD Serial Number	DG5348	Laboratory Supervisor	C. Mantell

**Results**

Test Parameter	Minimum Specification	Maximum Specification	Unit	Result	Pass/Fail
Temperature	20.6	22.2	°C	20.7	Pass
Humidity	10	70	%	47	Pass
Rib Displacement	46	51	mm	48.9	Pass

**Transducer Calibrations**

Channel	Manufacturer	Serial Number	Calibration Date	Calibration Due Date
Rib Potentiometer	Honeywell	268GFE	7/30/2024	1/28/2025

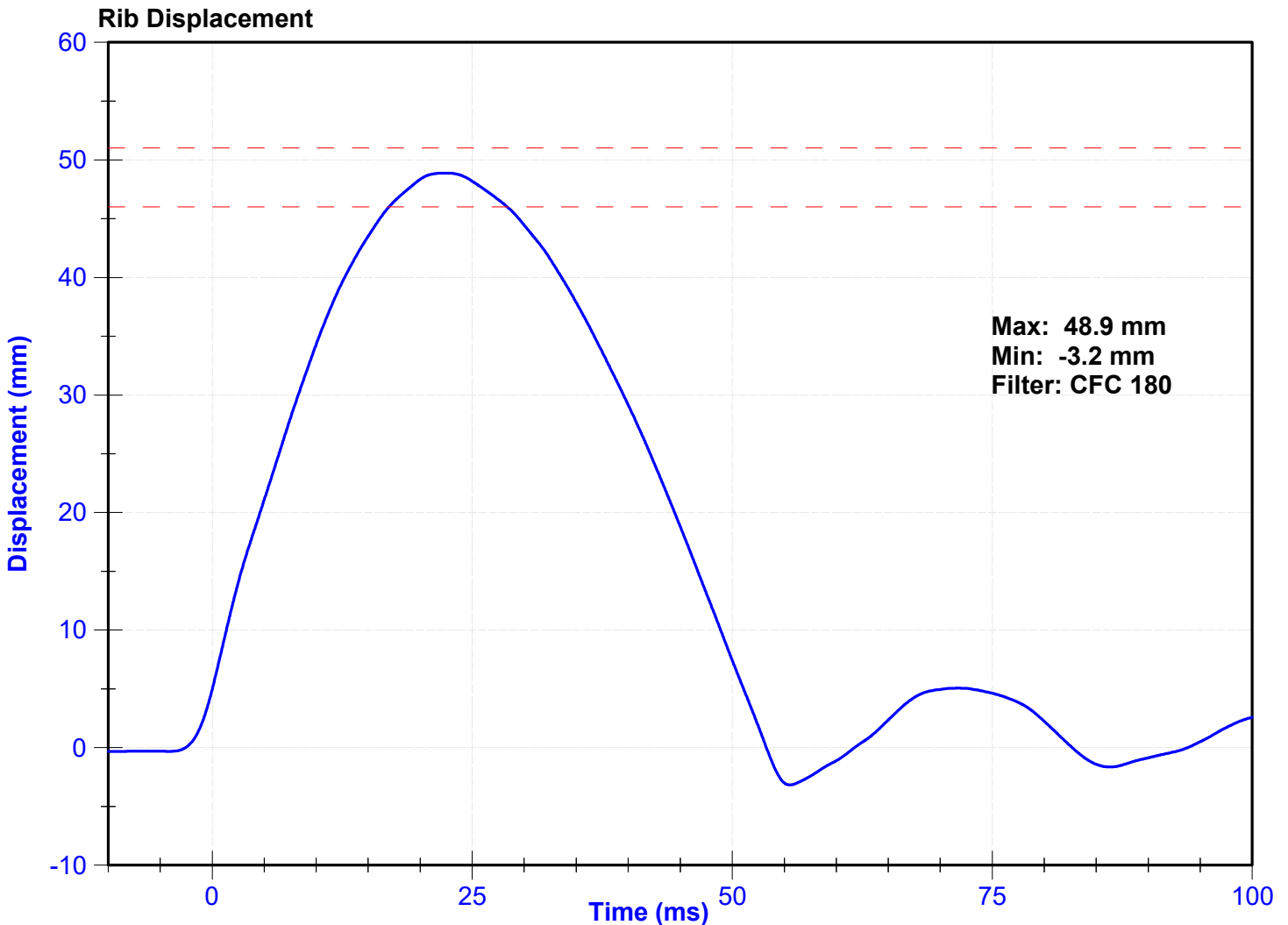

ATD Manufacturer	FTSS	Test Technician	J.Kinderman
ATD Serial Number	DG5348	Laboratory Supervisor	C. Mantell

**Results**

Test Parameter	Minimum Specification	Maximum Specification	Unit	Result	Pass/Fail
Temperature	20.6	22.2	°C	20.7	Pass
Humidity	10	70	%	47	Pass
Rib Displacement	36	40	mm	39.0	Pass

**Transducer Calibrations**

Channel	Manufacturer	Serial Number	Calibration Date	Calibration Due Date
Rib Potentiometer	Honeywell	268GFE	7/30/2024	1/28/2025

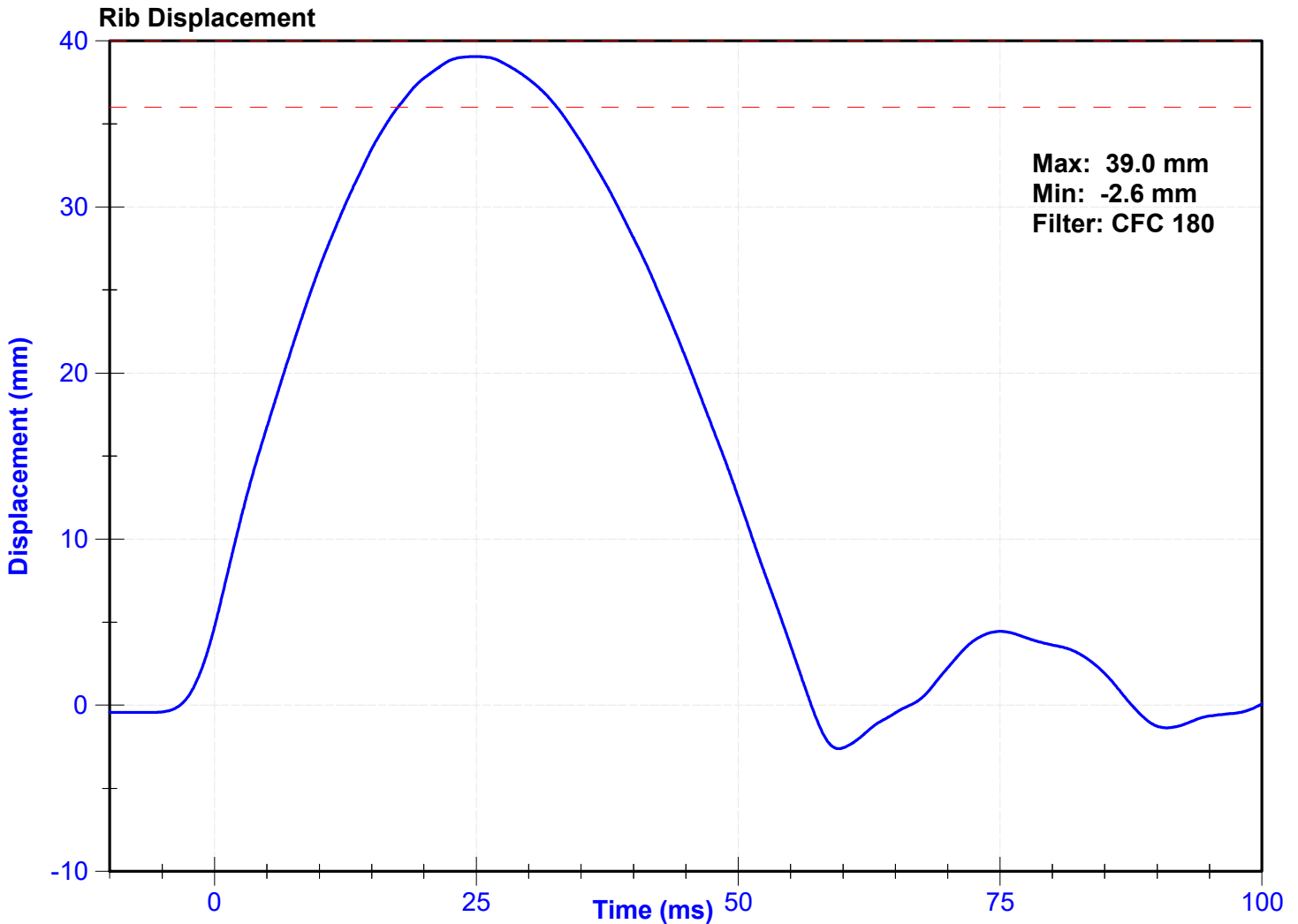

ATD Manufacturer	FTSS	Test Technician	J.Kinderman
ATD Serial Number	DG5348	Laboratory Supervisor	C. Mantell

**Results**

Test Parameter	Minimum Specification	Maximum Specification	Unit	Result	Pass/Fail
Temperature	20.6	22.2	°C	20.7	Pass
Humidity	10	70	%	47	Pass
Rib Displacement	46	51	mm	48.8	Pass

**Transducer Calibrations**

Channel	Manufacturer	Serial Number	Calibration Date	Calibration Due Date
Rib Potentiometer	Honeywell	269GFE	7/30/2024	1/28/2025

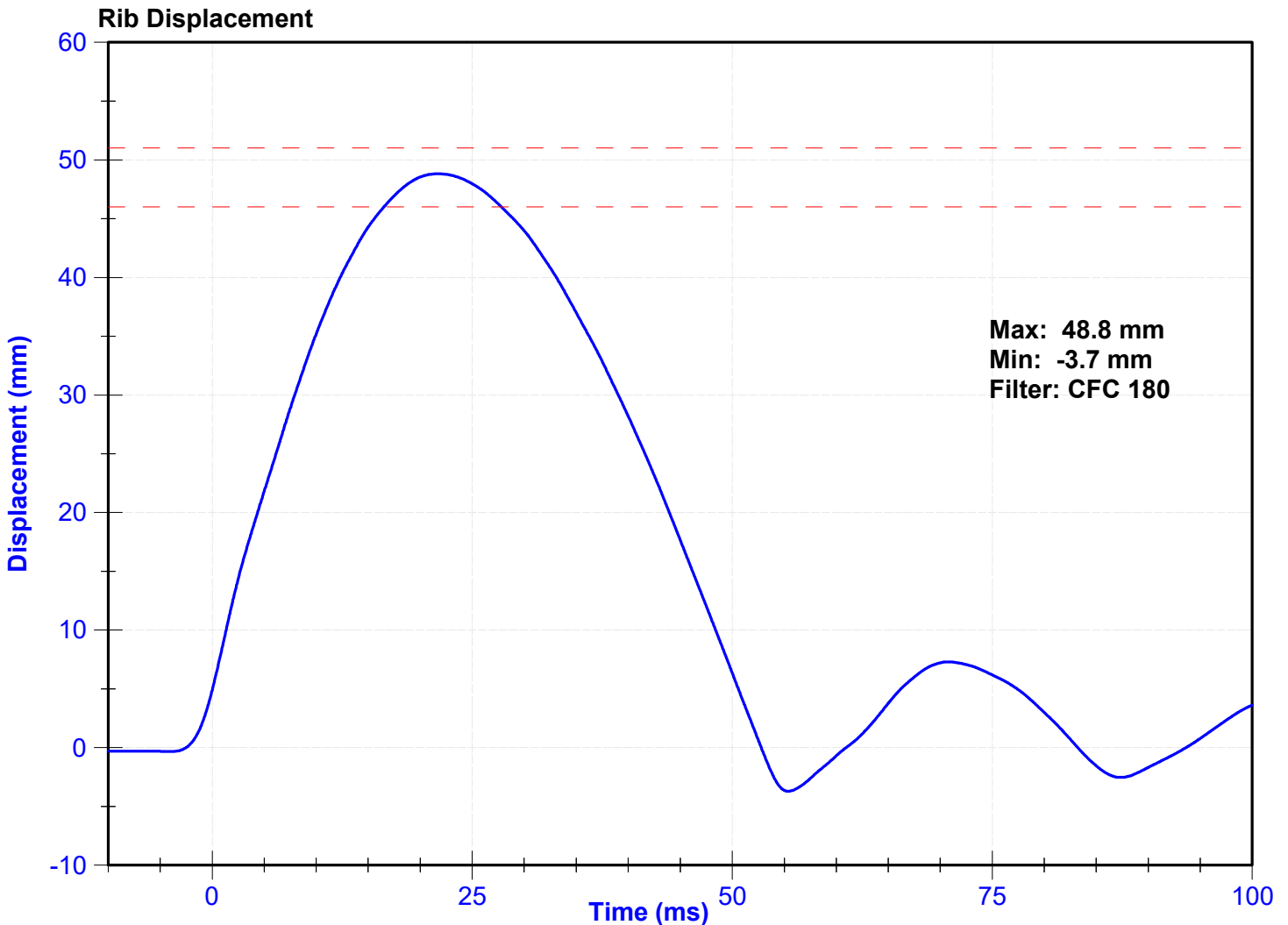

ATD Manufacturer	FTSS	Test Technician	J.Kinderman
ATD Serial Number	DG5348	Laboratory Supervisor	C. Mantell

**Results**

Test Parameter	Minimum Specification	Maximum Specification	Unit	Result	Pass/Fail
Temperature	20.6	22.2	°C	20.7	Pass
Humidity	10	70	%	47	Pass
Rib Displacement	36	40	mm	39.6	Pass

**Transducer Calibrations**

Channel	Manufacturer	Serial Number	Calibration Date	Calibration Due Date
Rib Potentiometer	Honeywell	269GFE	7/30/2024	1/28/2025

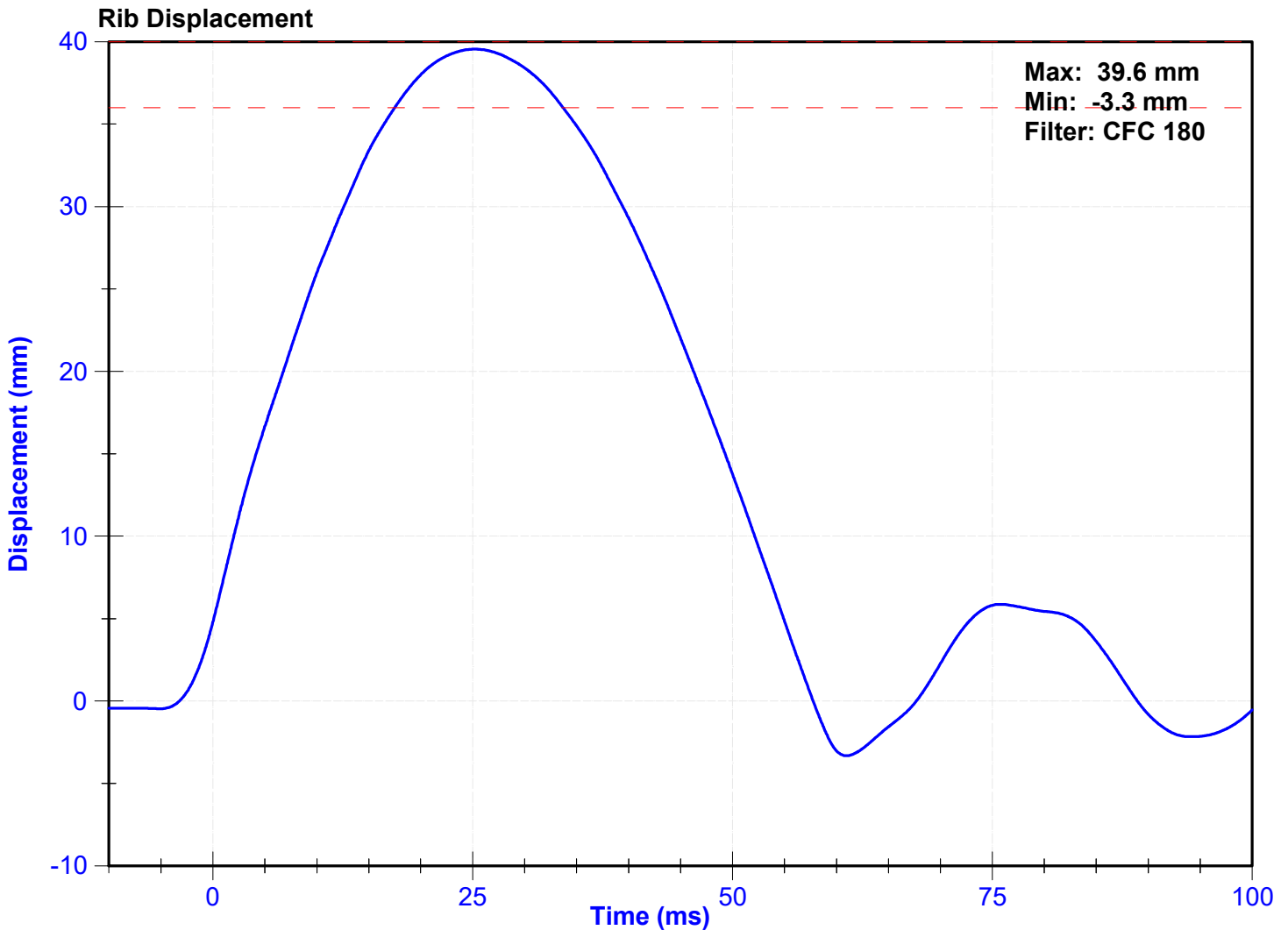

ATD Manufacturer	FTSS	Test Technician	J.Kinderman
ATD Serial Number	DG5348	Laboratory Supervisor	C. Mantell

**Results**

Test Parameter	Minimum Specification	Maximum Specification	Unit	Result	Pass/Fail
Temperature	20.6	22.2	°C	20.7	Pass
Humidity	10	70	%	47	Pass
Rib Displacement	46	51	mm	48.5	Pass

**Transducer Calibrations**

Channel	Manufacturer	Serial Number	Calibration Date	Calibration Due Date
Rib Potentiometer	Honeywell	270GFE	7/30/2024	1/28/2025

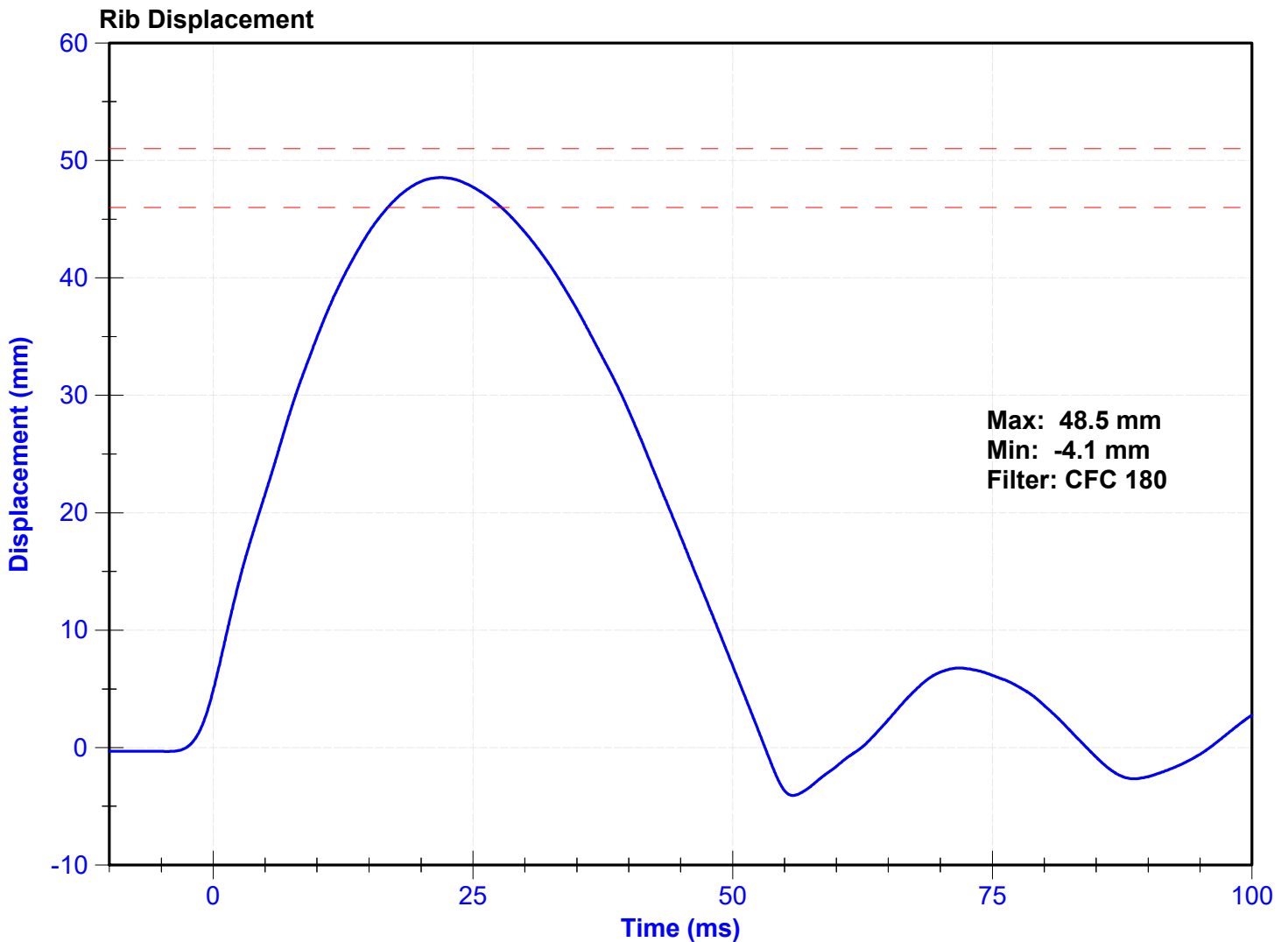

ATD Manufacturer	FTSS	Test Technician	J.Kinderman
ATD Serial Number	DG5348	Laboratory Supervisor	C. Mantell

**Results**

Test Parameter	Minimum Specification	Maximum Specification	Unit	Result	Pass/Fail
Temperature	20.6	22.2	°C	20.7	Pass
Humidity	10	70	%	47	Pass
Rib Displacement	36	40	mm	39.4	Pass

**Transducer Calibrations**

Channel	Manufacturer	Serial Number	Calibration Date	Calibration Due Date
Rib Potentiometer	Honeywell	270GFE	7/30/2024	1/28/2025

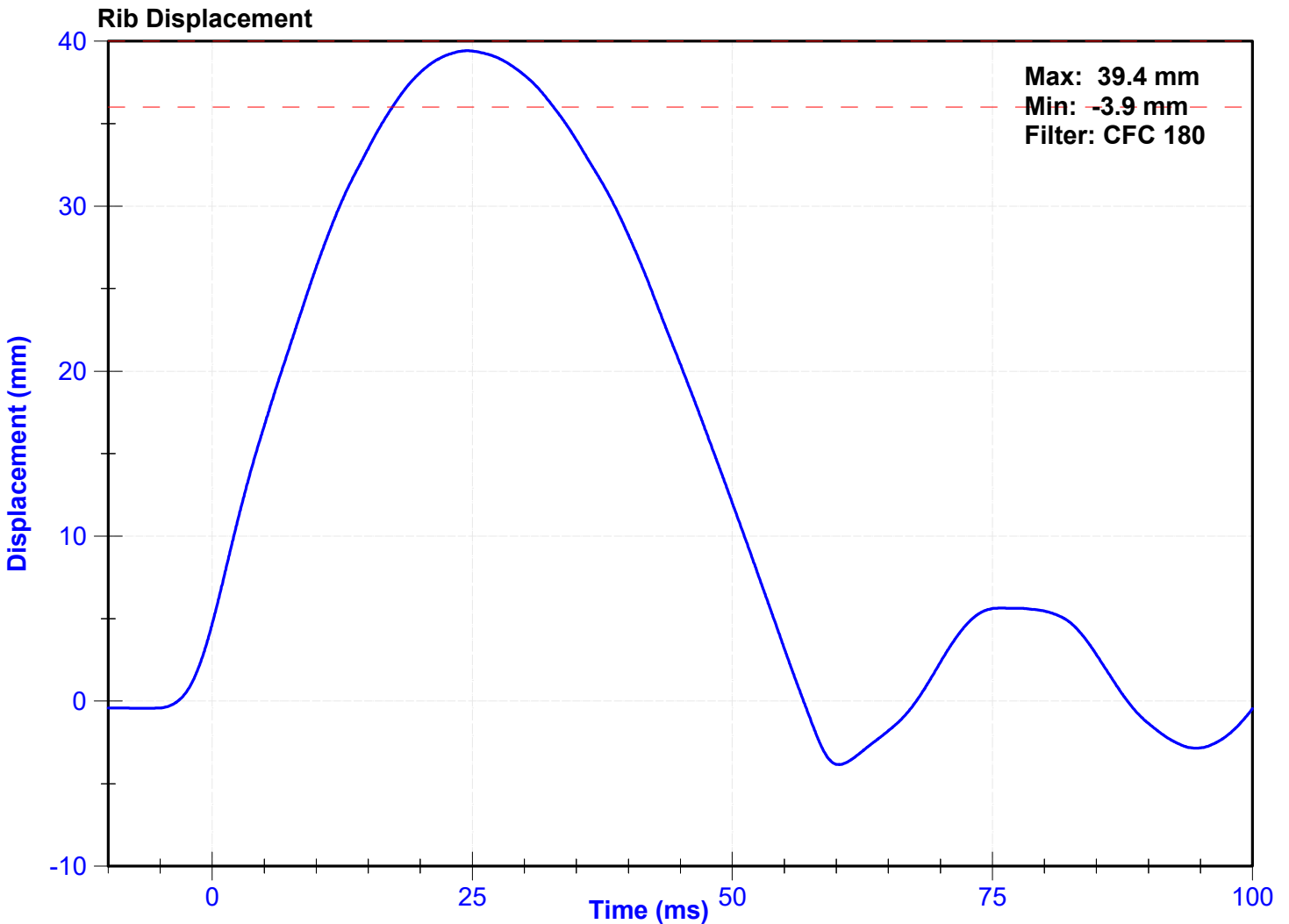

ATD Manufacturer	FTSS	Test Technician	J.Kinderman
ATD Serial Number	DG5348	Laboratory Supervisor	C. Mantell

**Results**

Test Parameter	Minimum Specification	Maximum Specification	Unit	Result	Pass/Fail
Temperature	20.6	22.2	°C	21.0	Pass
Humidity	10	70	%	45	Pass
Velocity	5.4	5.6	m/s	5.54	Pass
Resistive Force after 6ms	5100	6200	N	6094.6	Pass
Upper Thorax Rib Deflection	34	41	mm	39.1	Pass
Mid Thorax Rib Deflection	37	45	mm	42.0	Pass
Lower Thorax Rib Deflection	37	44	mm	40.4	Pass

**Transducer Calibrations**

Channel	Manufacturer	Serial Number	Calibration Date	Calibration Due Date
Probe Accelerometer	Endevco	18587	11/20/2023	11/19/2024
Upper Thorax Rib Potentiometer	Honeywell	268GFE	7/30/2024	1/28/2025
Middle Thorax Rib Potentiometer	Honeywell	269GFE	7/30/2024	1/28/2025
Lower Thorax Rib Potentiometer	Honeywell	270GFE	7/30/2024	1/28/2025

**Probe Acceleration**

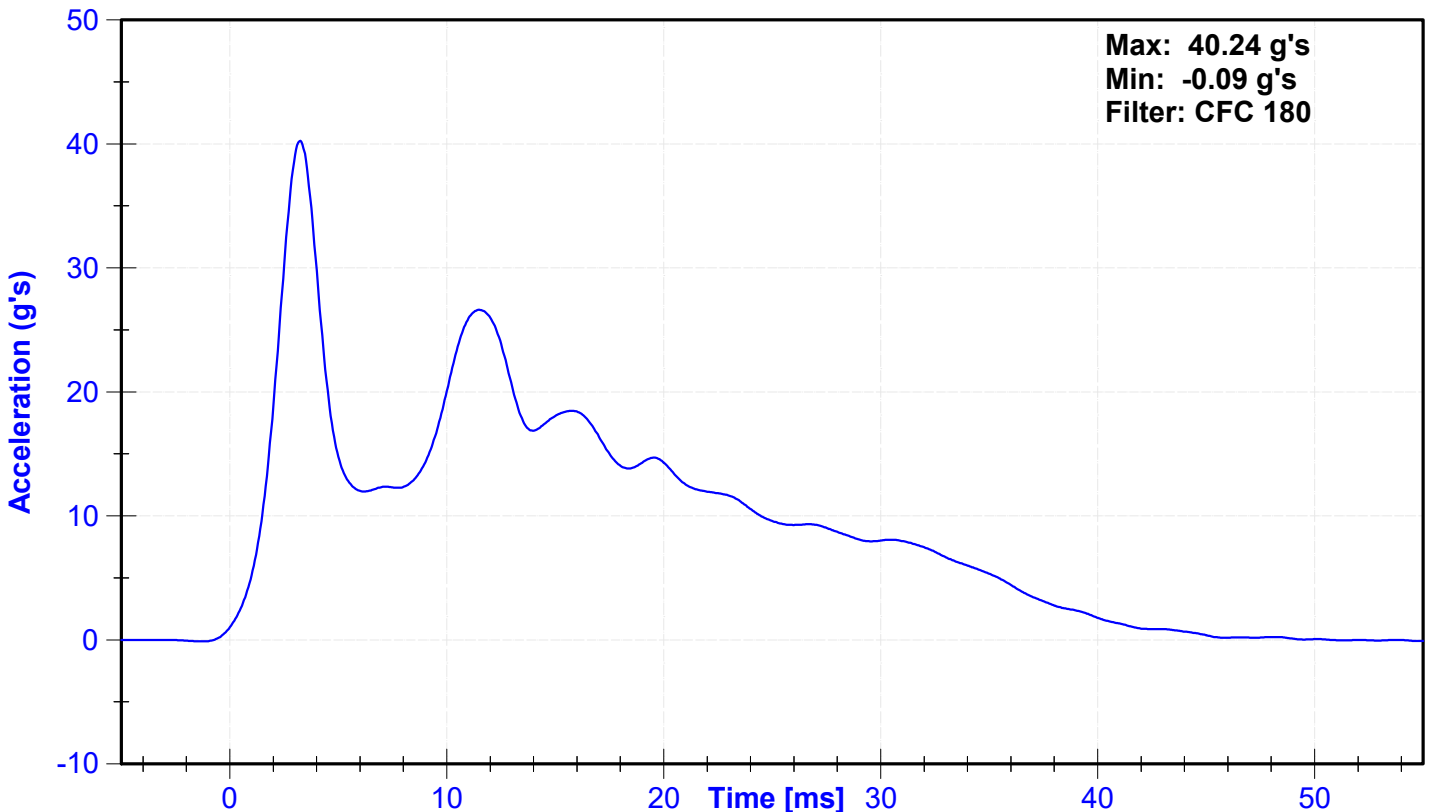

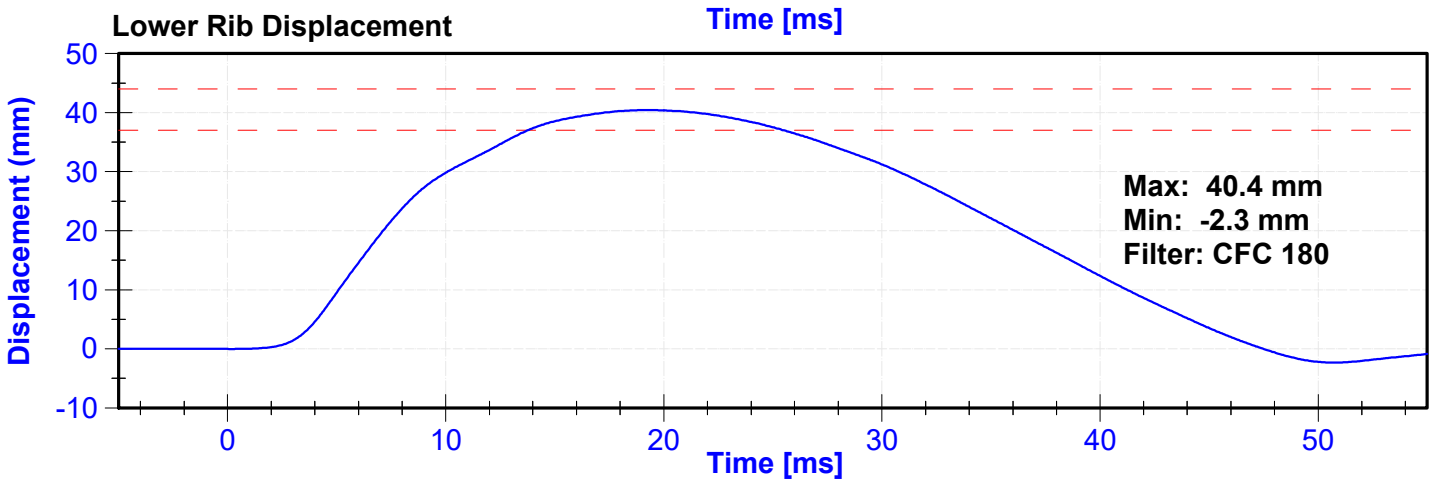
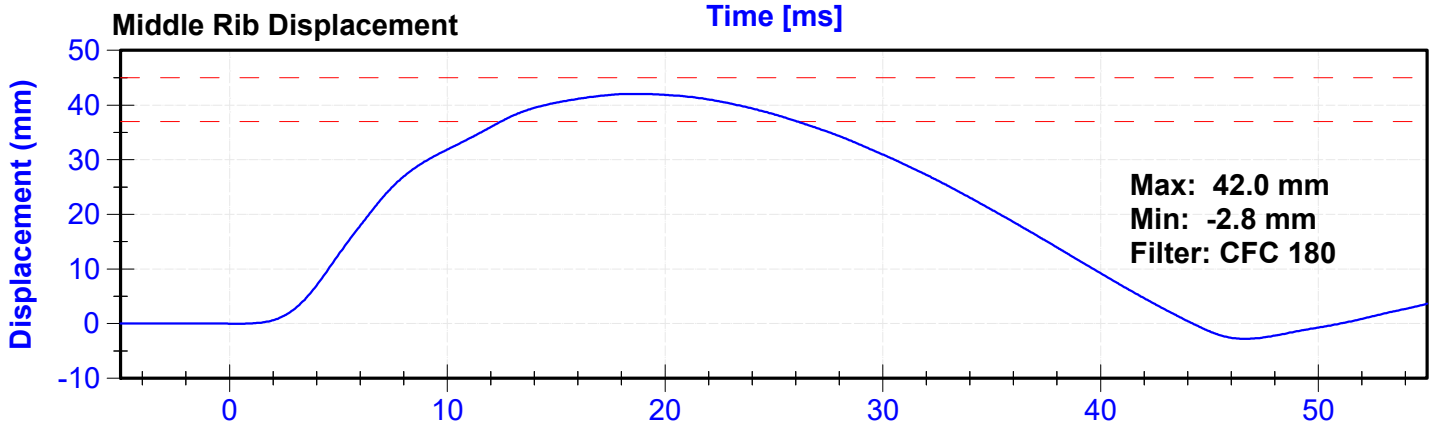
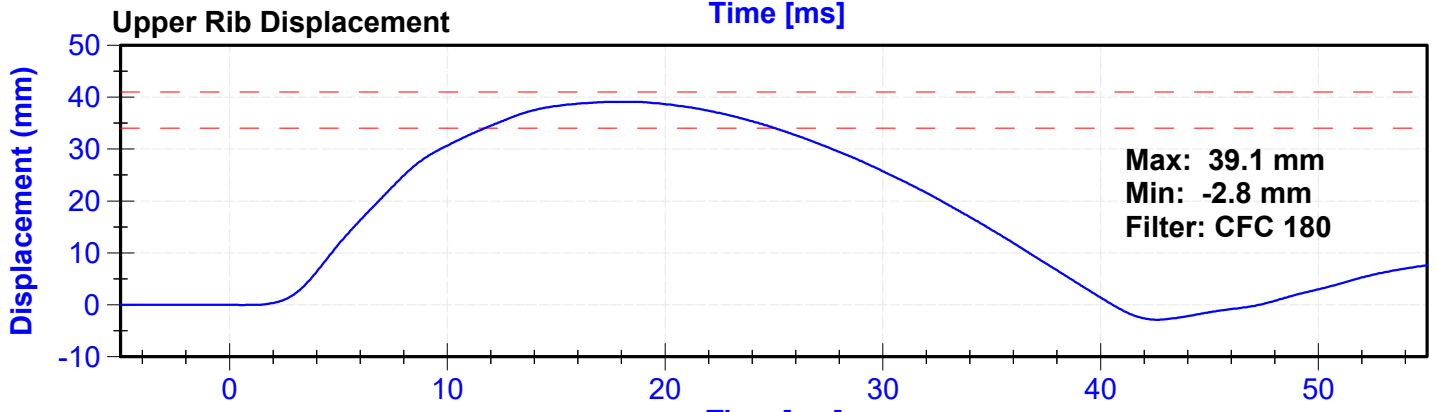
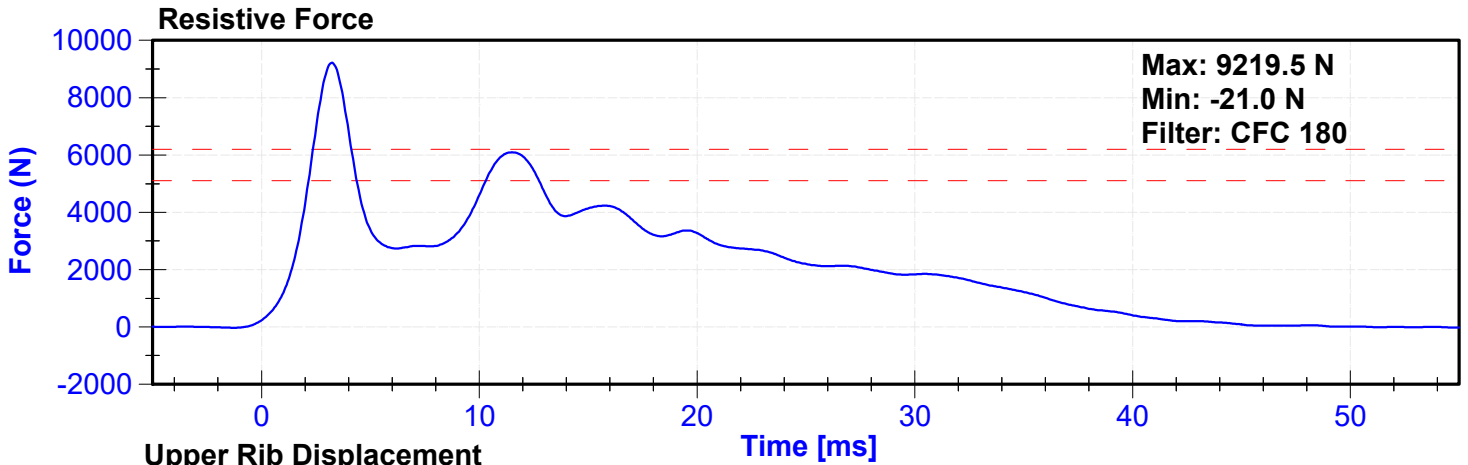

ATD Manufacturer	FTSS	Test Technician	J.Kinderman
ATD Serial Number	DG5348	Laboratory Supervisor	C. Mantell

**Results**

Test Parameter	Minimum Specification	Maximum Specification	Unit	Result	Pass/Fail
Temperature	20.6	22.2	°C	21.0	Pass
Humidity	10	70	%	45	Pass
Velocity	3.9	4.1	m/s	4.01	Pass
Combined Abdomen Force	2200	2700	N	2309.8	Pass
Time at Peak Abdomen Force	10.0	12.3	ms	11.50	Pass
Resistive Probe Force	4000	4800	N	4654.8	Pass
Time at Peak Resistive Force	10.6	13.0	ms	11.25	Pass

**Transducer Calibrations**

Channel	Manufacturer	Serial Number	Calibration Date	Calibration Due Date
Pendulum Accelerometer	Endevco	18587	11/20/2023	11/19/2024
Front Abdomen Load Cell	Denton	DM5846	5/22/2024	5/22/2025
Middle Abdomen Load Cell	Denton	1529	5/22/2024	5/22/2025
Rear Abdomen Load Cell	Denton	1533	5/22/2024	5/22/2025

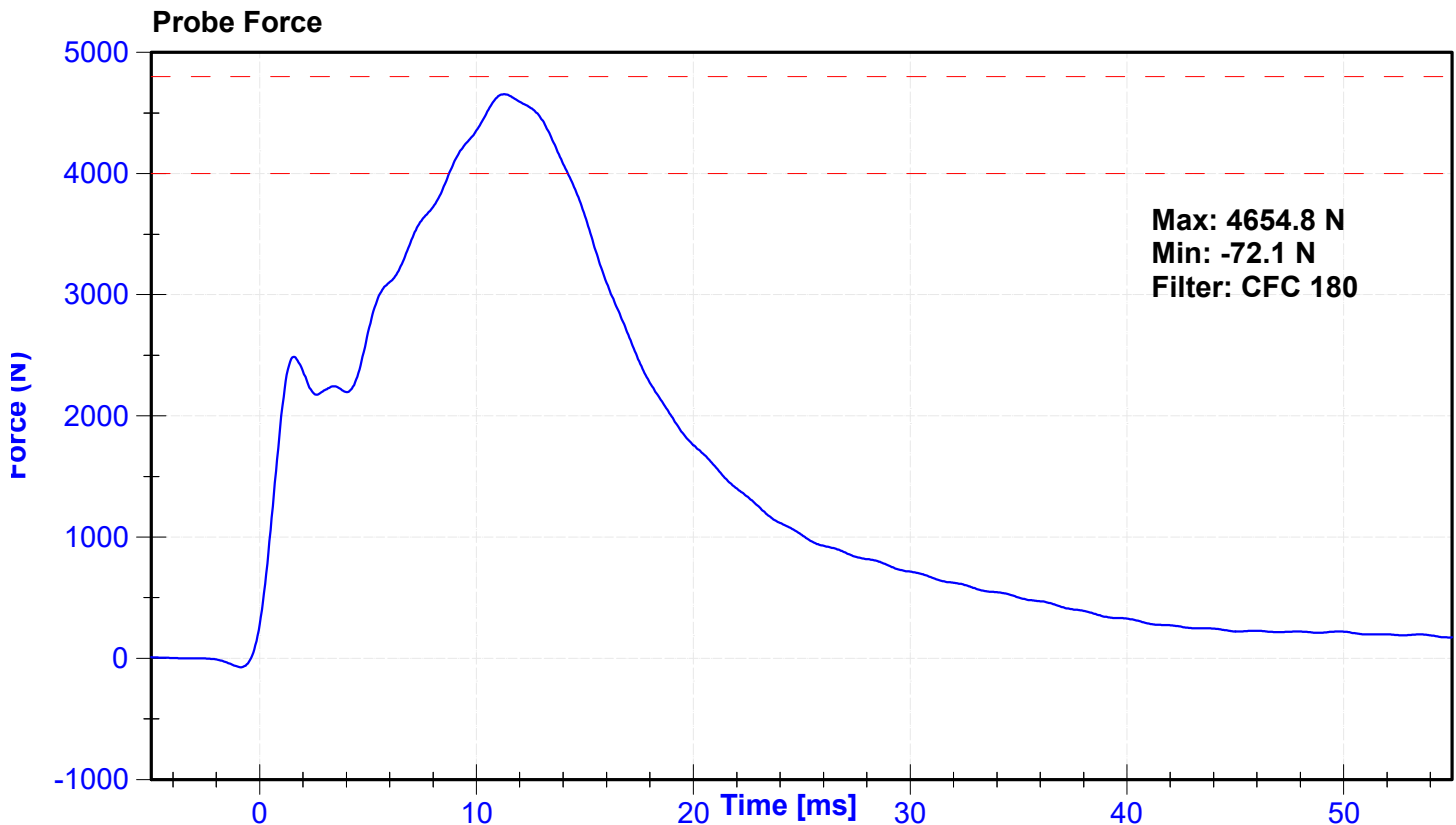

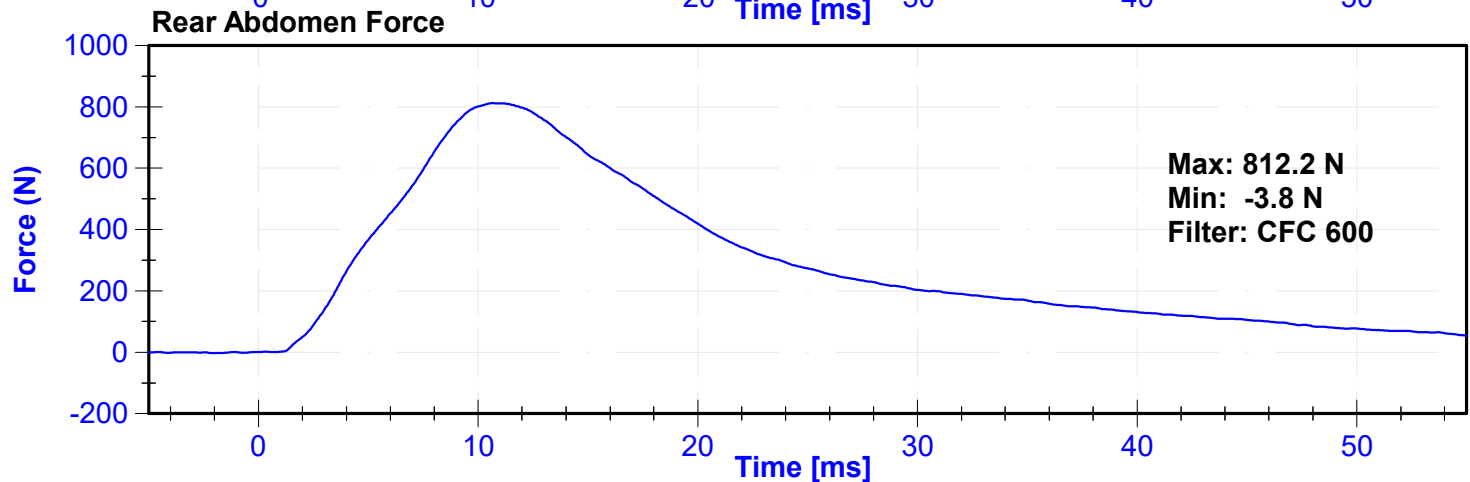
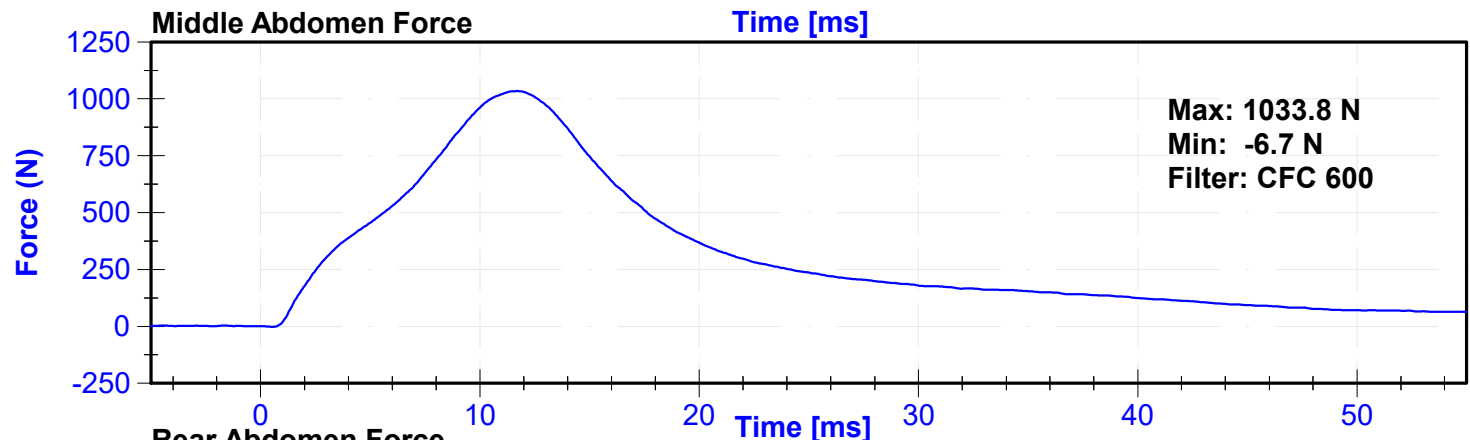
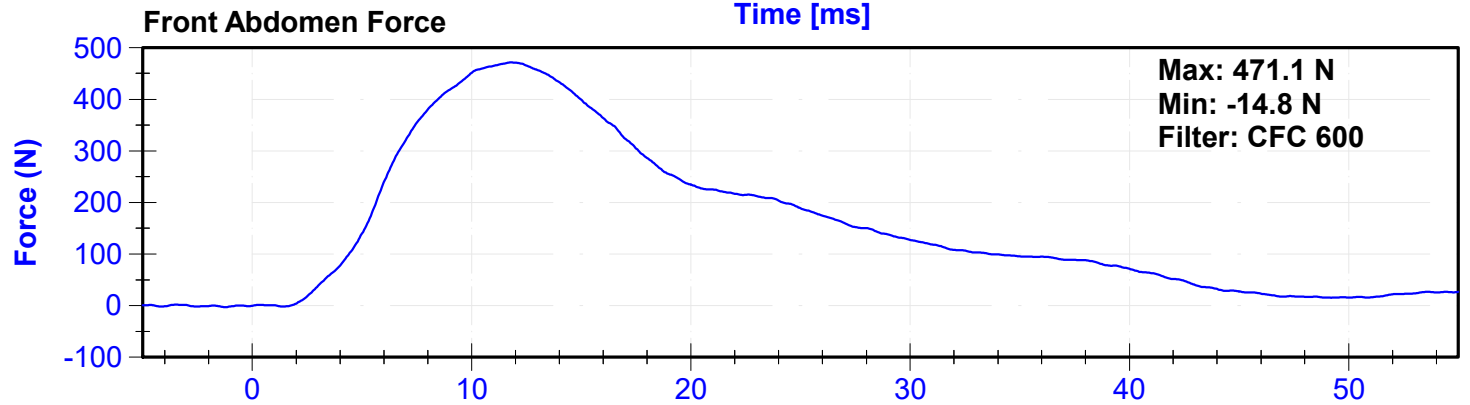
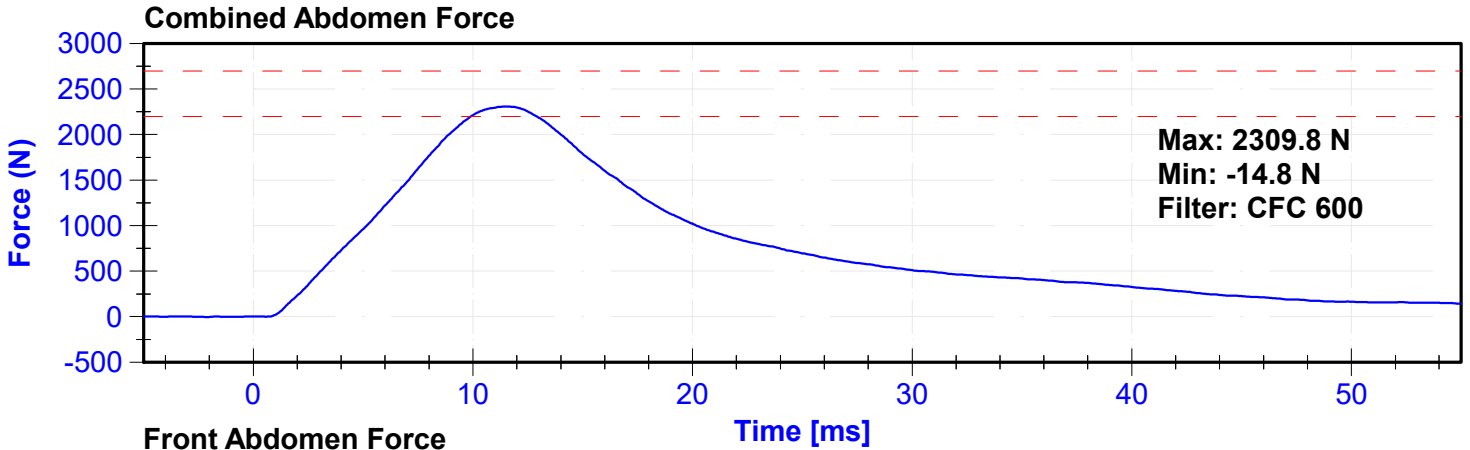

ATD Manufacturer	FTSS	Test Technician	J.Kinderman
ATD Serial Number	DG5348	Laboratory Supervisor	C. Mantell

**Results**

Test Parameter	Minimum Specification	Maximum Specification	Unit	Result	Pass/Fail
Temperature	20.6	22.2	°C	21.0	Pass
Humidity	10	70	%	53.0	Pass
Velocity	5.95	6.15	m/s	6.110	Pass
Lateral Spine Rotation	45	55	deg	45.3	Pass
Time at Maximum Rotation	39	53	ms	46.2	Pass
Time of Decay to Zero Degrees	37	57	ms	37.1	Pass
Pendulum Velocity Overall Corridor	Lower Boundary <sup>1</sup>	Upper Boundary <sup>2</sup>	m/s	See Plot <sup>3</sup>	Pass

**Transducer Calibrations**

Channel	Manufacturer	Serial Number	Calibration Date	Calibration Due Date
Pendulum Accelerometer	Endevco	C16650	10/31/2023	10/30/2024
Pendulum "A" Potentiometer	Sfernice	2247	12/5/2023	12/4/2024
Condyle "B" Potentiometer	Sfernice	095	9/29/2023	9/28/2024

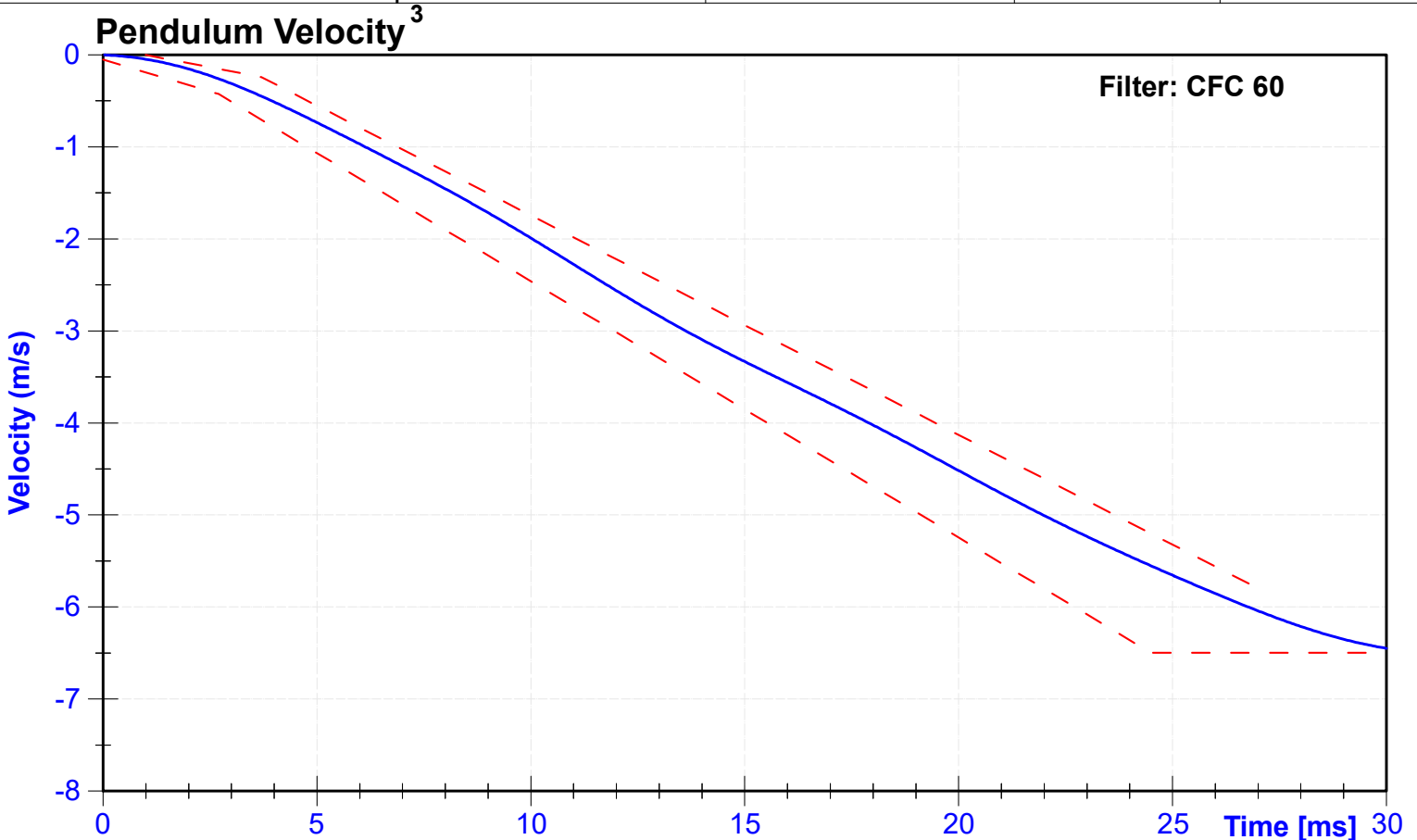

<sup>1,2</sup> Upper and lower boundaries specified in Appendix I

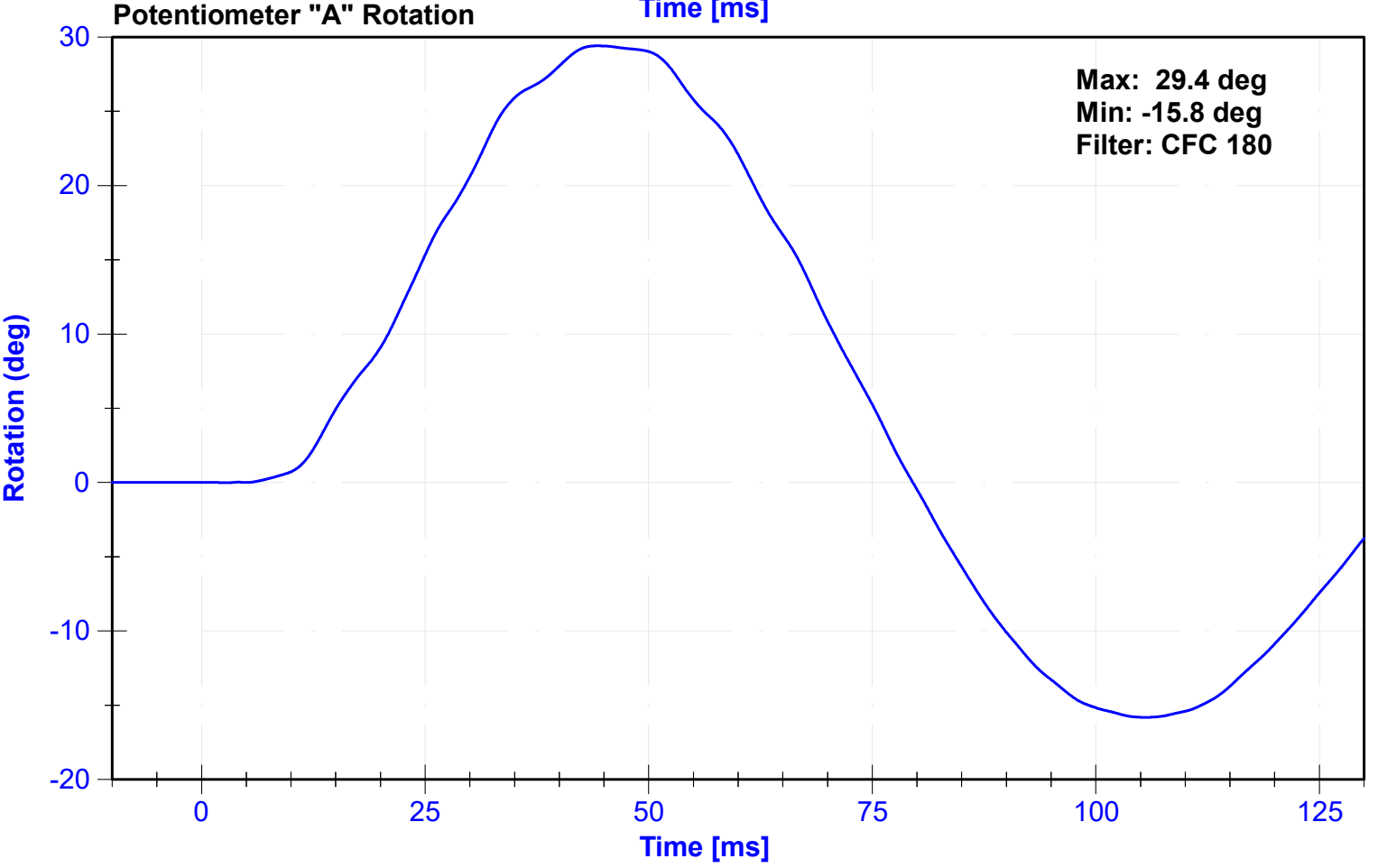
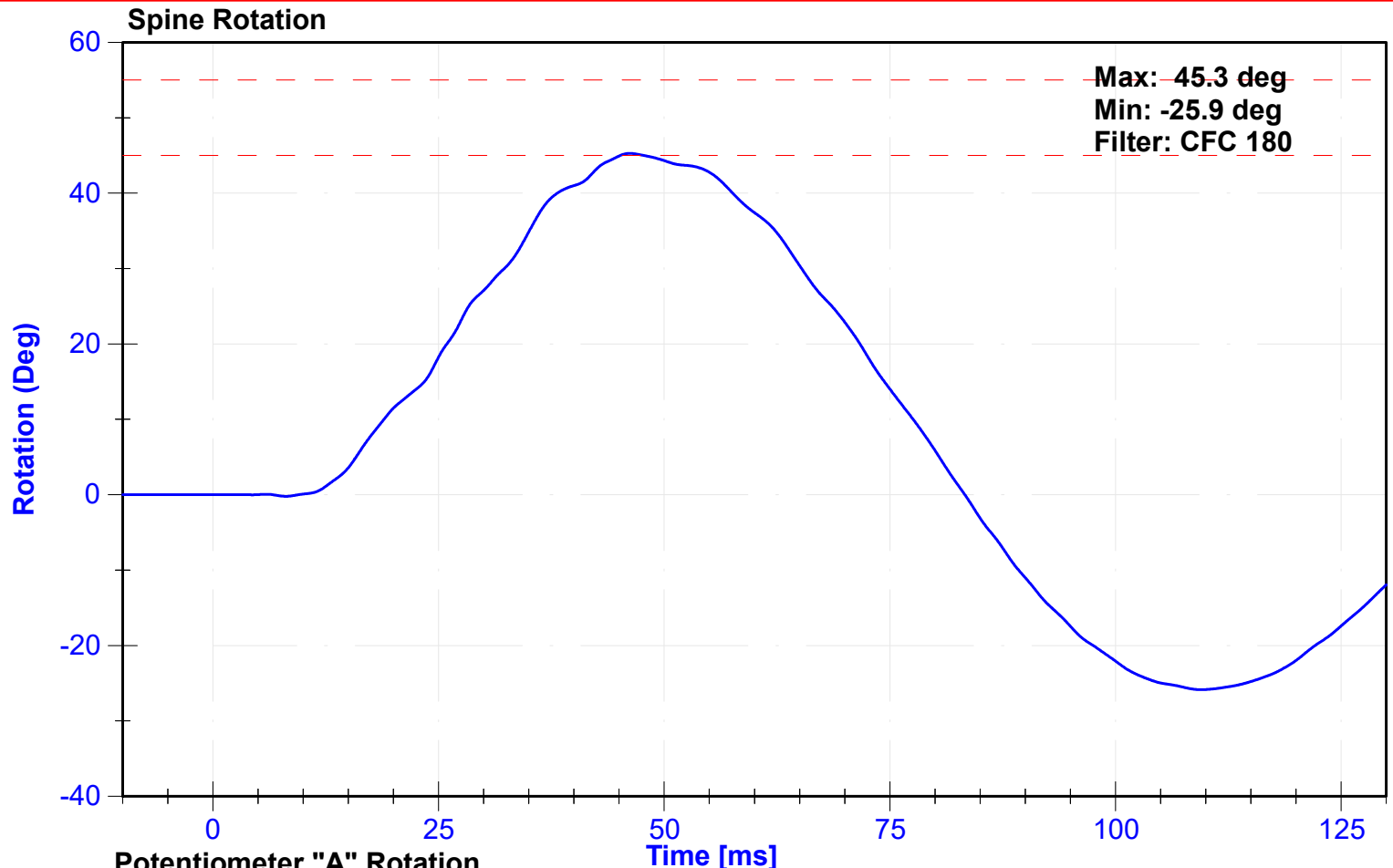

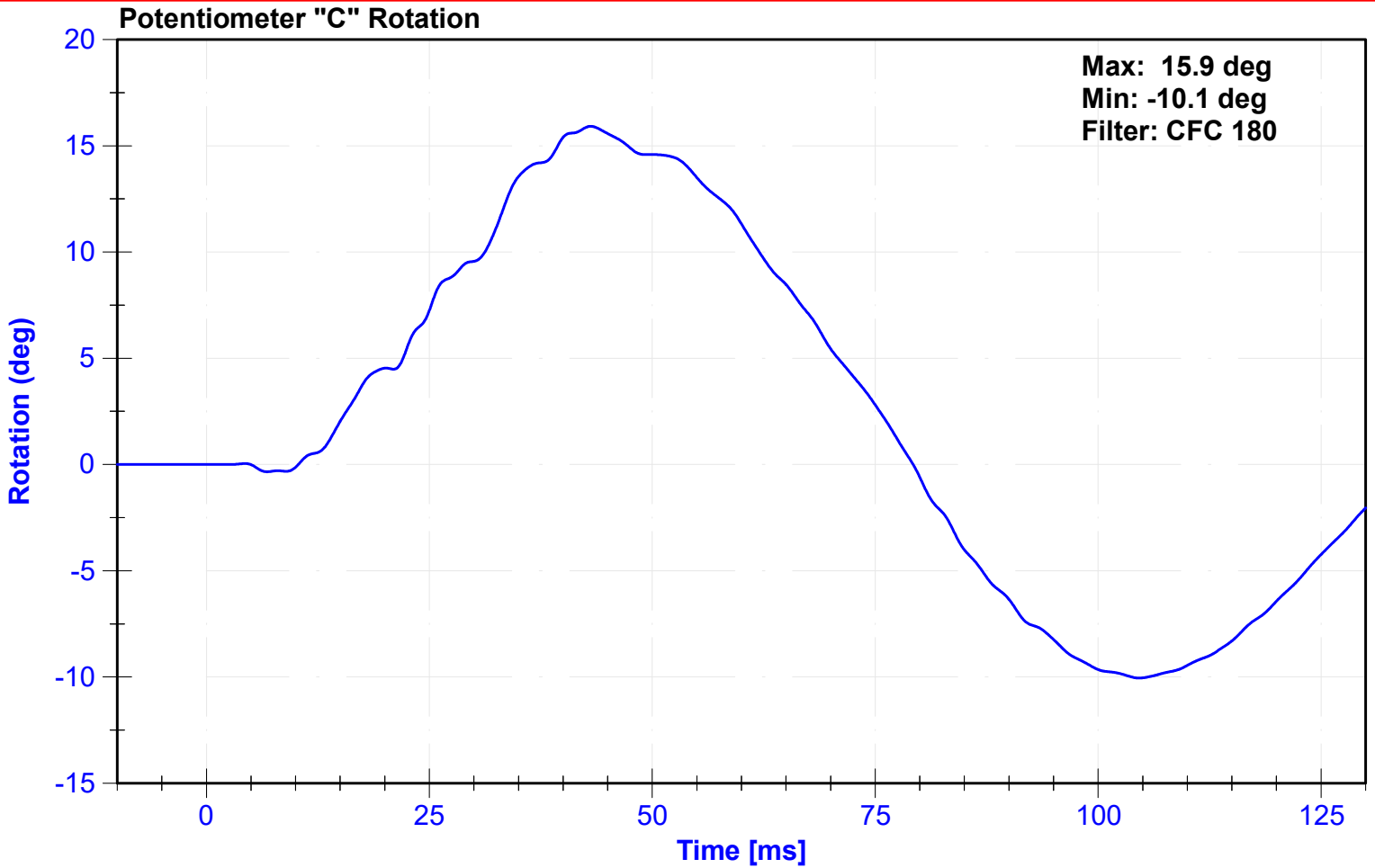

## Appendix I

<sup>2</sup> Upper Boundary Corridor		<sup>1</sup> Lower Boundary Corridor	
Time (ms)	Velocity (m/s)	Time (ms)	Velocity (m/s)
1.0	0.00	0.0	-0.05
3.7	-0.24	2.7	-0.425
27.0	-5.80	24.5	-6.5
		30.0	-6.5

ATD Manufacturer	FTSS	Test Technician	J.Kinderman
ATD Serial Number	DG5348	Laboratory Supervisor	C. Mantell

**Results**

Test Parameter	Minimum Specification	Maximum Specification	Unit	Result	Pass/Fail
Temperature	20.6	22.2	°C	21.0	Pass
Humidity	10	70	%	45	Pass
Velocity	4.2	4.4	m/s	4.28	Pass
Resistive Force	4700	5400	N	4981.8	Pass
Time at Peak Resistive Force	11.8	16.1	ms	13.05	Pass
Pubic Force	-1590	-1230	N	-1466.9	Pass
Time at Peak Pubic Force	12.2	17.0	ms	14.10	Pass

**Transducer Calibrations**

Channel	Manufacturer	Serial Number	Calibration Date	Calibration Due Date
Pendulum Accelerometer	Endevco	18587	11/20/2023	11/19/2024
Pubic Load Cell	Denton	459-FY	7/12/2024	7/12/2025

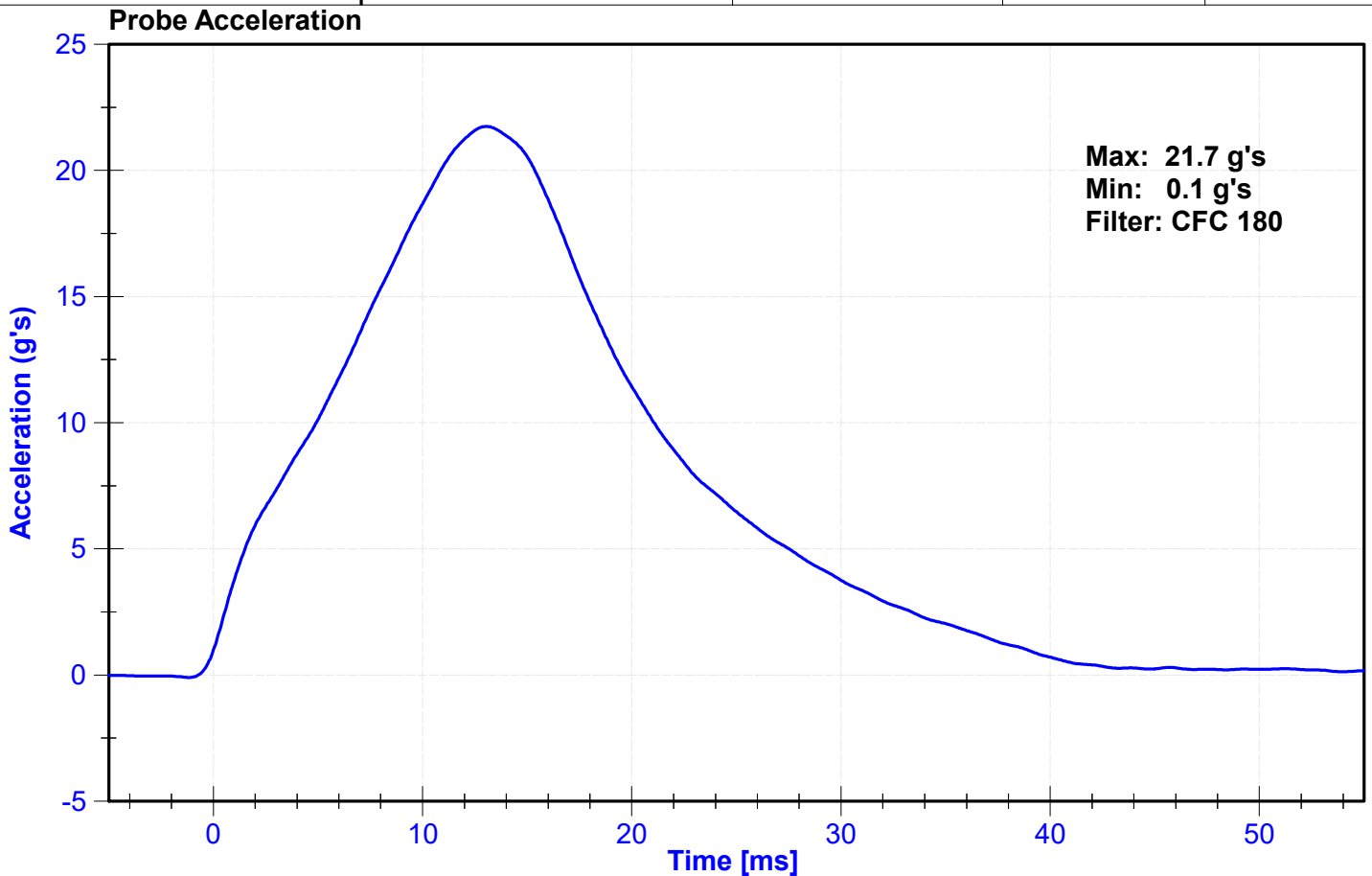

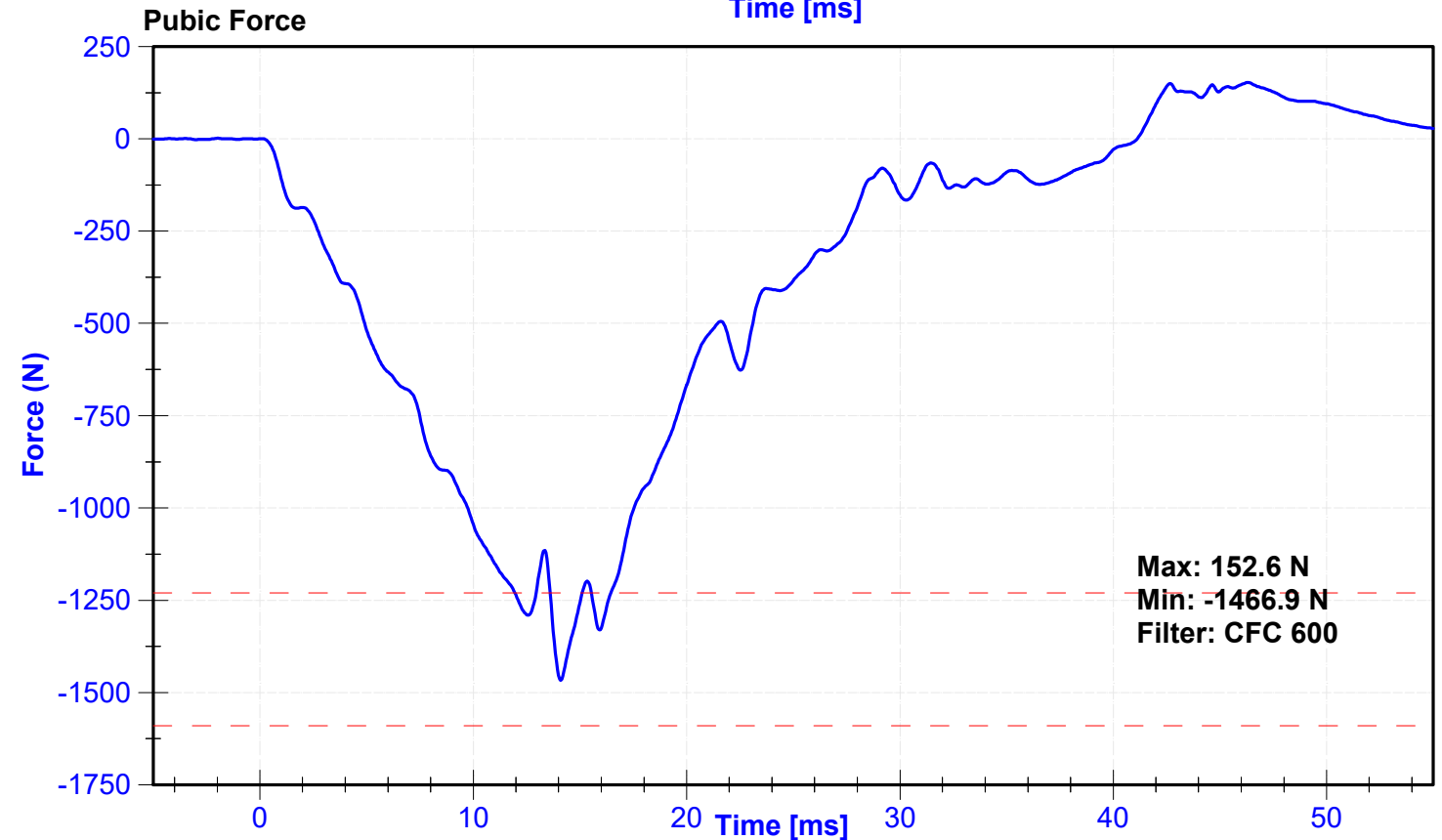
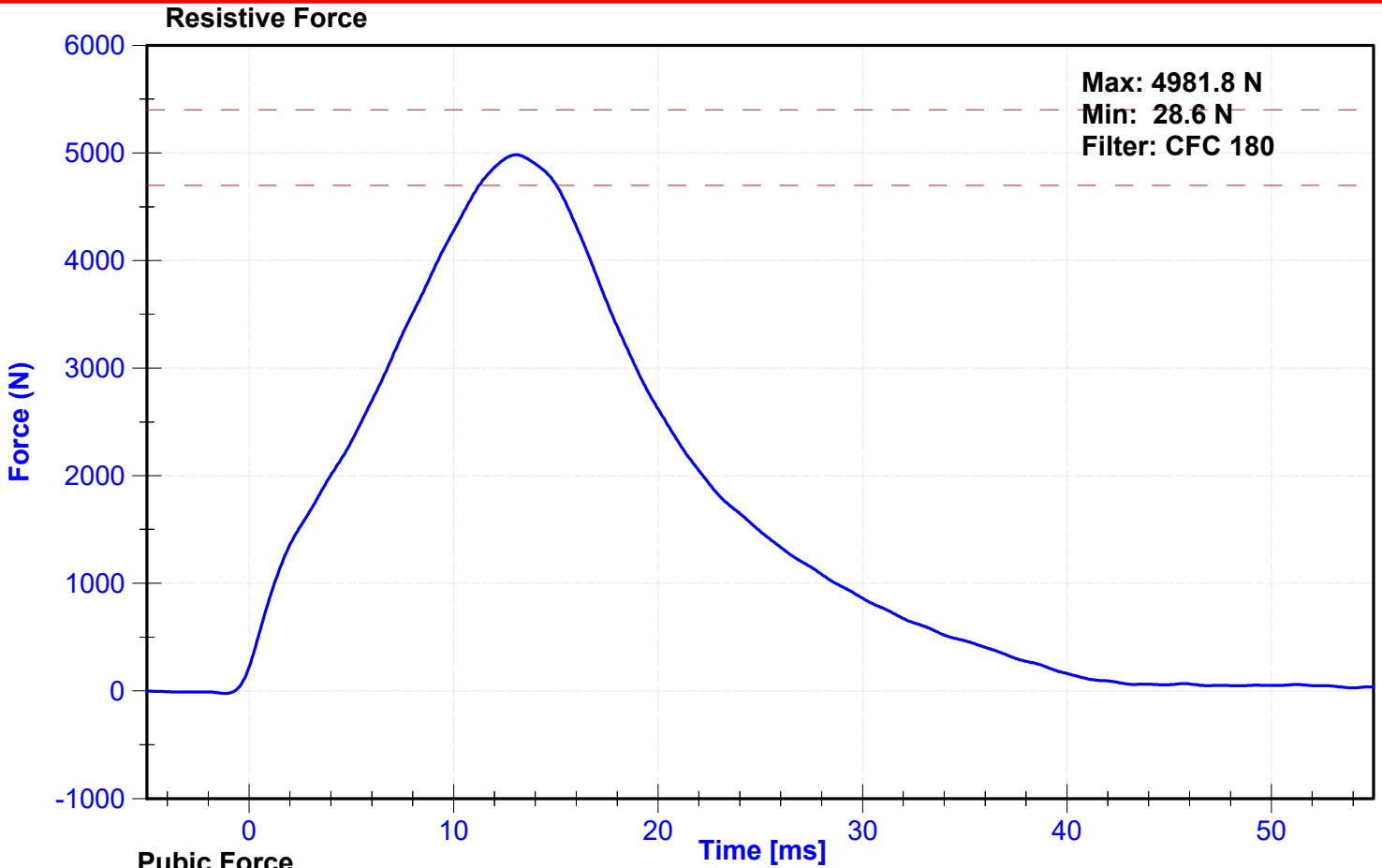

**POST-TEST  
ES-2re PERFORMANCE CALIBRATION TEST DATA**

External Measurements - EuroSID-2re

Technician: J. Rios

Date: 10/23/2024

Dummy Serial Number: DG5348

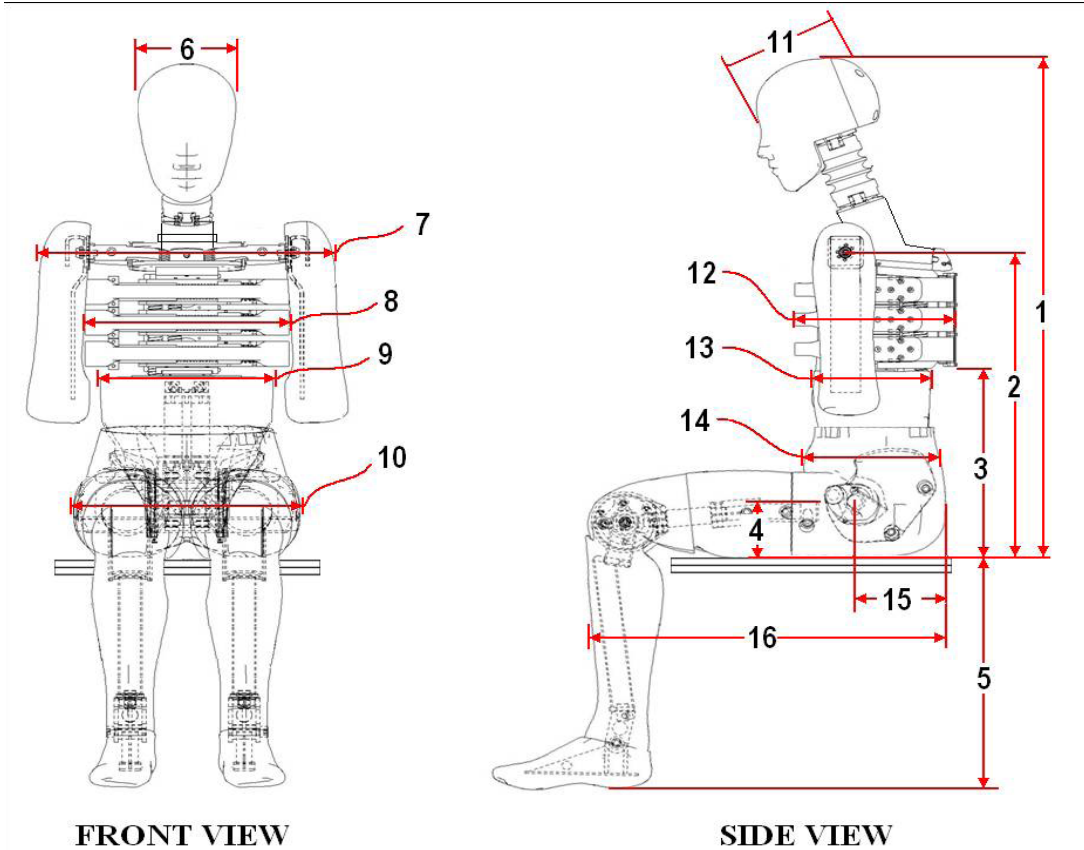

Dim. No.	Description	Specification (mm)		Result (mm)	Pass/Fail
1	Sitting Height	900	918	902	Pass
2	Seat to Shoulder Joint	558	572	561	Pass
3	Seat to Lower Face of Thoracic Spine Box	346	356	352	Pass
4	Seat to Hip Joint (center of bolt)	97	103	99	Pass
5	Sole to Seat, Sitting	333	451	405	Pass
6	Head Width	152	158	154	Pass
7	Shoulder/Arm Width	461	479	469	Pass
8	Thorax Width	322	332	326	Pass
9	Abdomen Width	273	287	277	Pass
10	Pelvis Lap Width	359	373	368	Pass
11	Head Depth	196	206	201	Pass
12	Thorax Depth	262	272	266	Pass
13	Abdomen Depth	194	204	200	Pass
14	Pelvis Depth	235	245	239	Pass
15	Back of Buttocks to Hip Joint (center of bolt)	150	160	153	Pass
16	Back of Buttocks to Front Knee	597	615	604	Pass

ATD Manufacturer	FTSS	Test Technician	J.Kinderman
ATD Serial Number	DG5348	Laboratory Supervisor	C. Mantell

**Results**

Test Parameter	Minimum Specification	Maximum Specification	Unit	Result	Pass/Fail
Temperature	20.6	22.2	°C	21.1	Pass
Humidity	10	70	%	40	Pass
Resultant Acceleration	125	155	g's	141.7	Pass
Oscillation	0	15	%	2.63	Pass
Fore-Aft Acceleration	-15	15	g's	8.1	Pass

**Transducer Calibrations**

Channel	Manufacturer	Serial Number	Calibration Date	Calibration Due Date
X Accelerometer	Endevco	18613	7/30/2024	1/26/2025
Y Accelerometer	Endevco	18472	7/30/2024	1/26/2025
Z Accelerometer	Endevco	18663	7/30/2024	1/26/2025

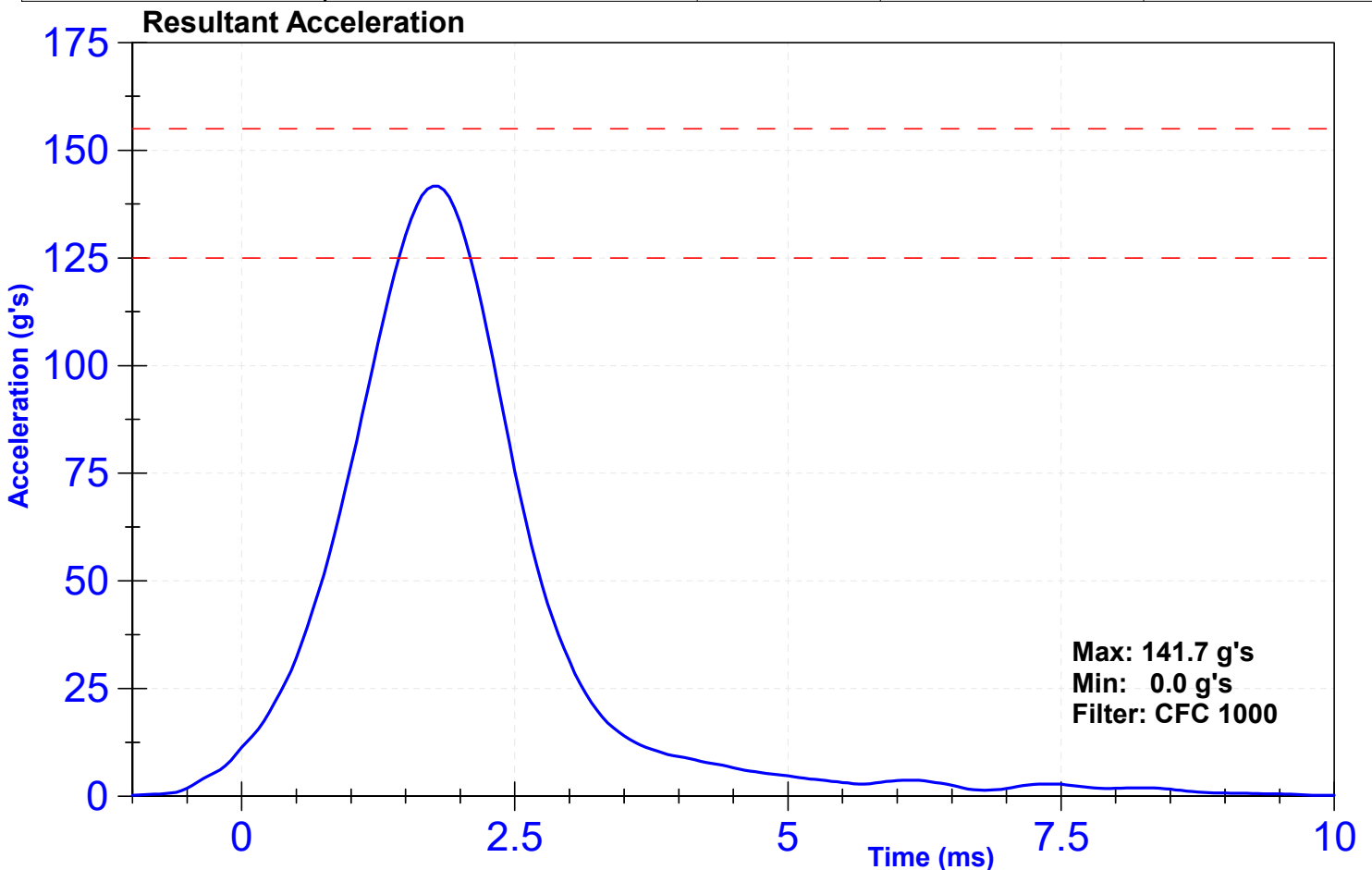

Head CG X Acceleration

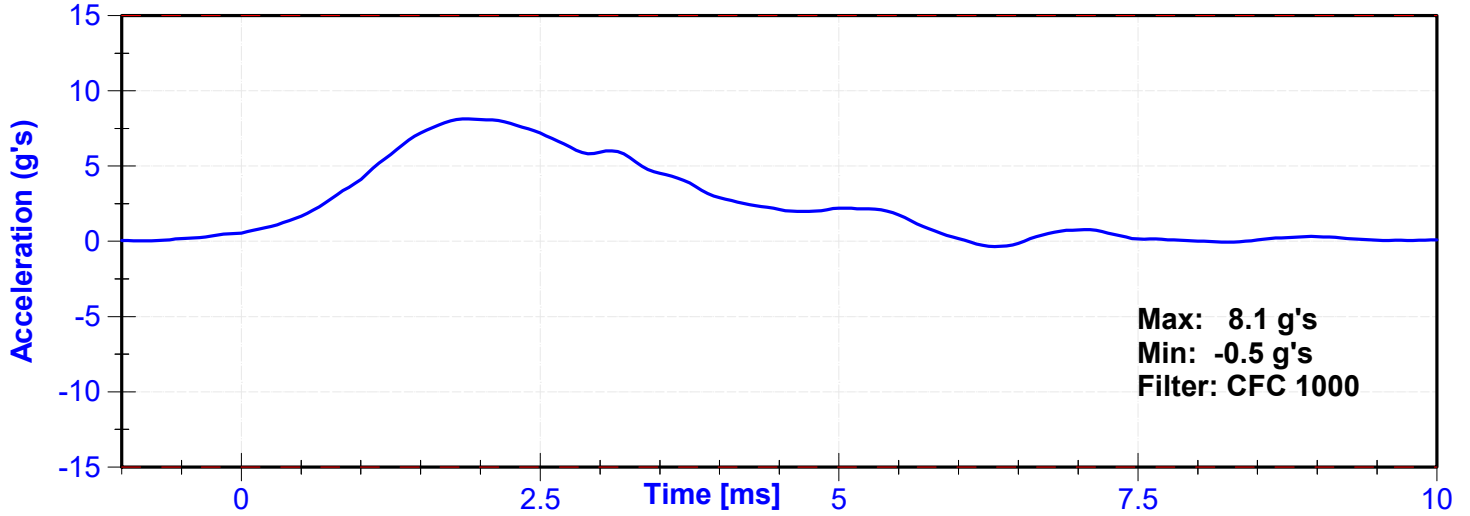

Head CG Y Acceleration

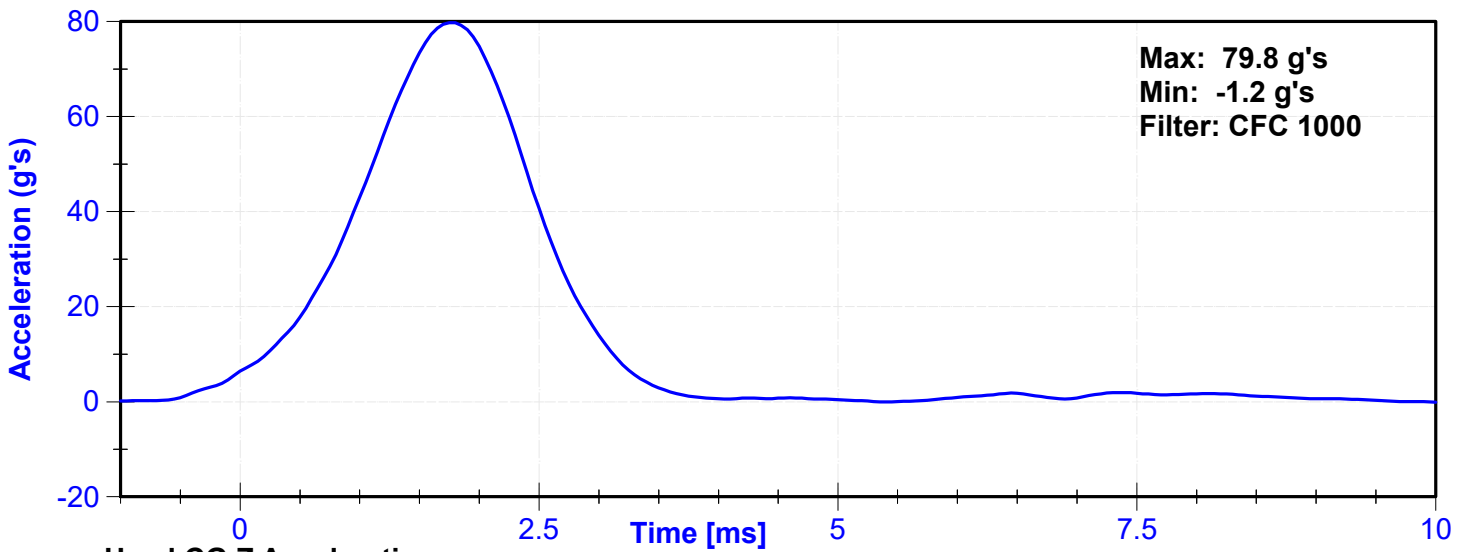

Head CG Z Acceleration

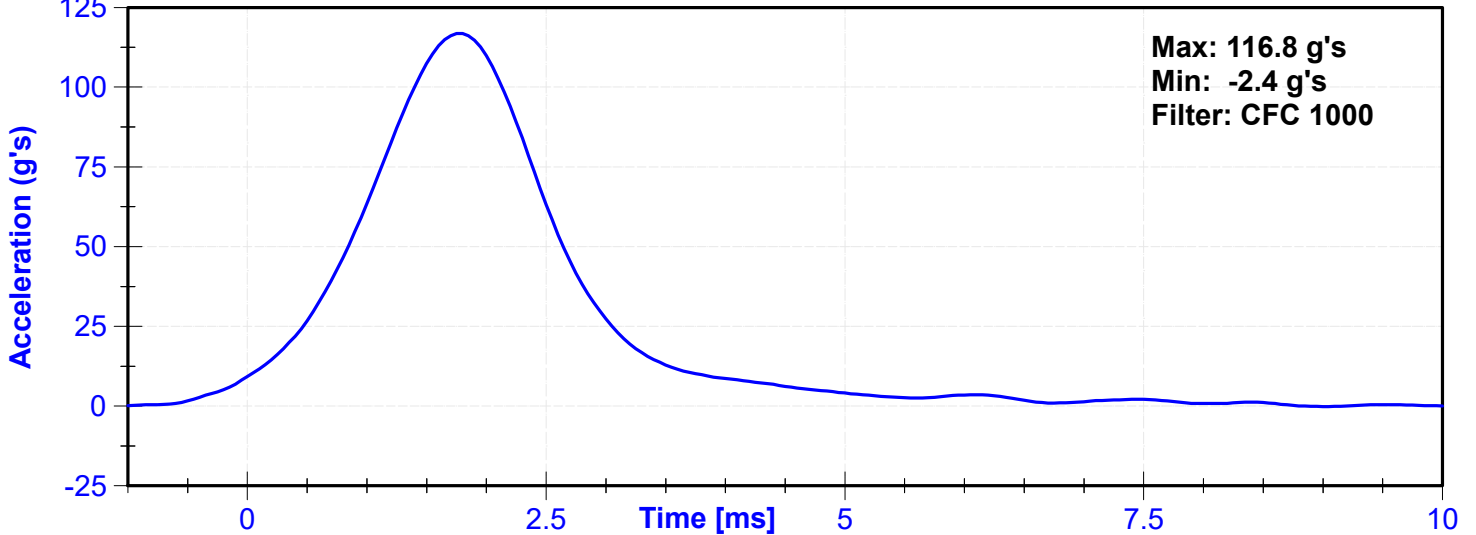

ATD Manufacturer	FTSS	Test Technician	J. Kinderman
ATD Serial Number	DG5348	Laboratory Supervisor	C. Mantell

**Results**

Test Parameter	Minimum Specification	Maximum Specification	Unit	Result	Pass/Fail
Temperature	20.6	22.2	°C	21.1	Pass
Humidity	10	70	%	40	Pass
Velocity	3.3	3.5	m/s	3.44	Pass
Lateral Neck Rotation	49	59	deg	49.4	Pass
Time at Maximum Rotation	54	66	ms	55.7	Pass
Time of Rotation Decay from Maximum	53	88	ms	55.9	Pass
Pendulum Velocity Overall Corridor	Lower Boundary <sup>1</sup>	Upper Boundary <sup>2</sup>	m/s	See Plot <sup>3</sup>	Pass

**Transducer Calibrations**

Channel	Manufacturer	Serial Number	Calibration Date	Calibration Due Date
Pendulum Accelerometer	Endevco	C16503	4/29/2024	10/26/2024
Front Pendulum Potentiometer	Sfernice	2247	9/13/2024	9/13/2025
Headform Potentiometer	Sfernice	095	9/13/2024	9/13/2025

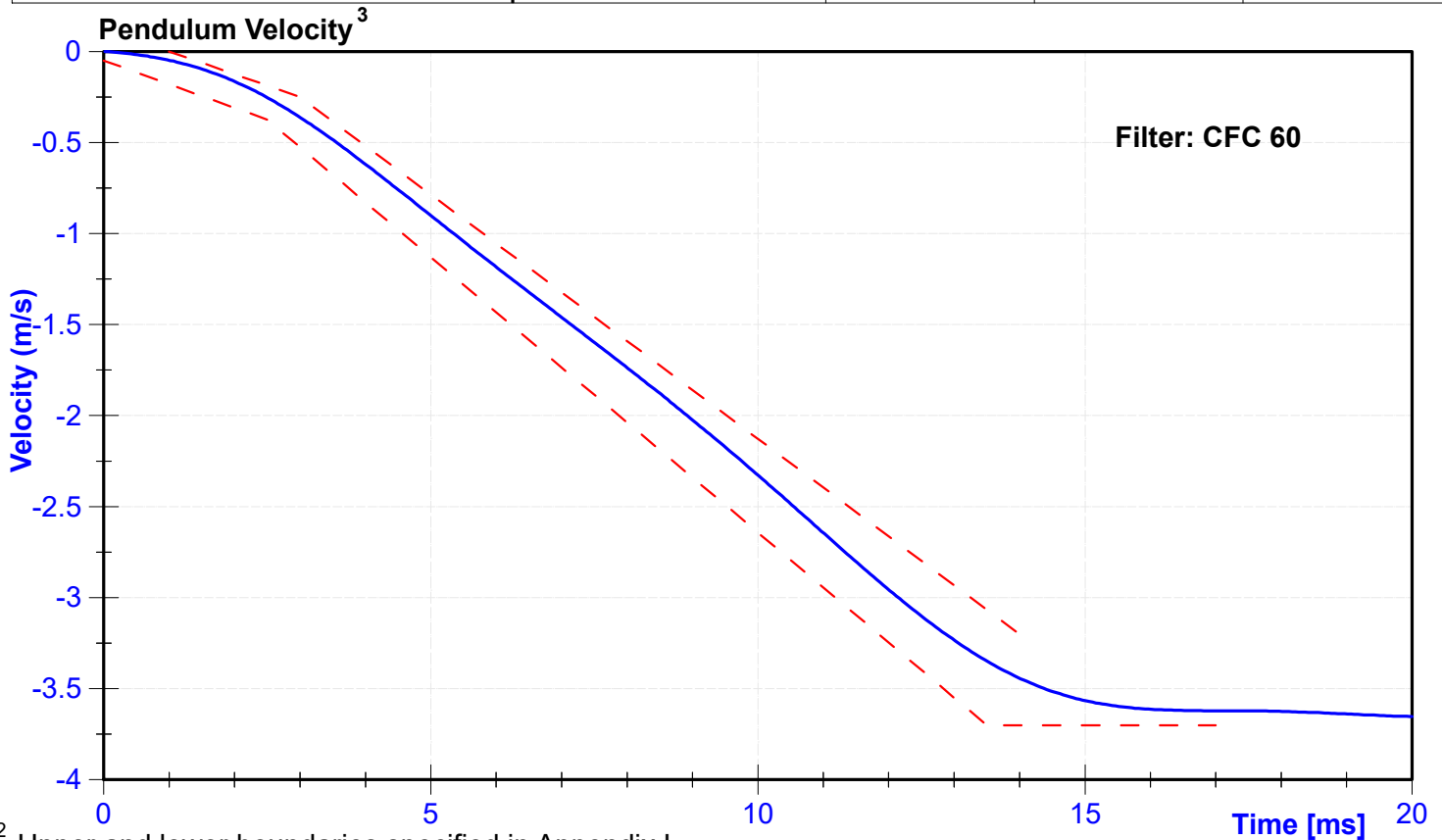

<sup>1,2</sup> Upper and lower boundaries specified in Appendix I

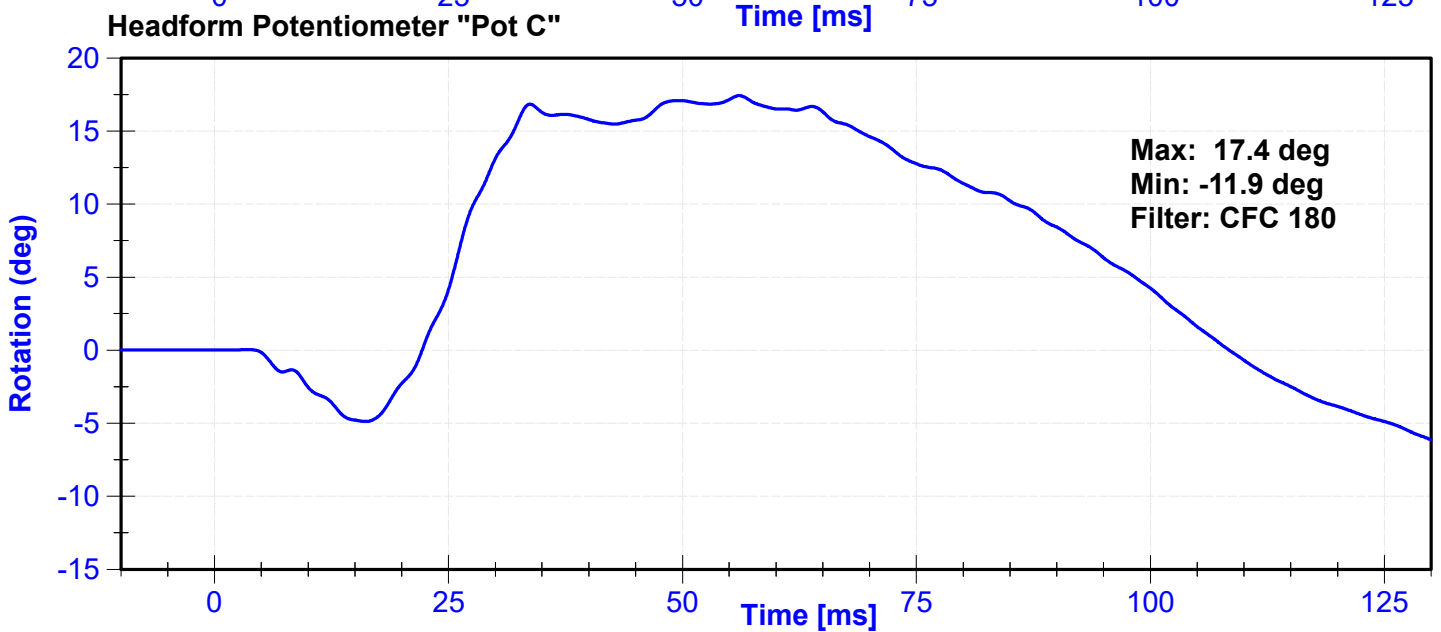
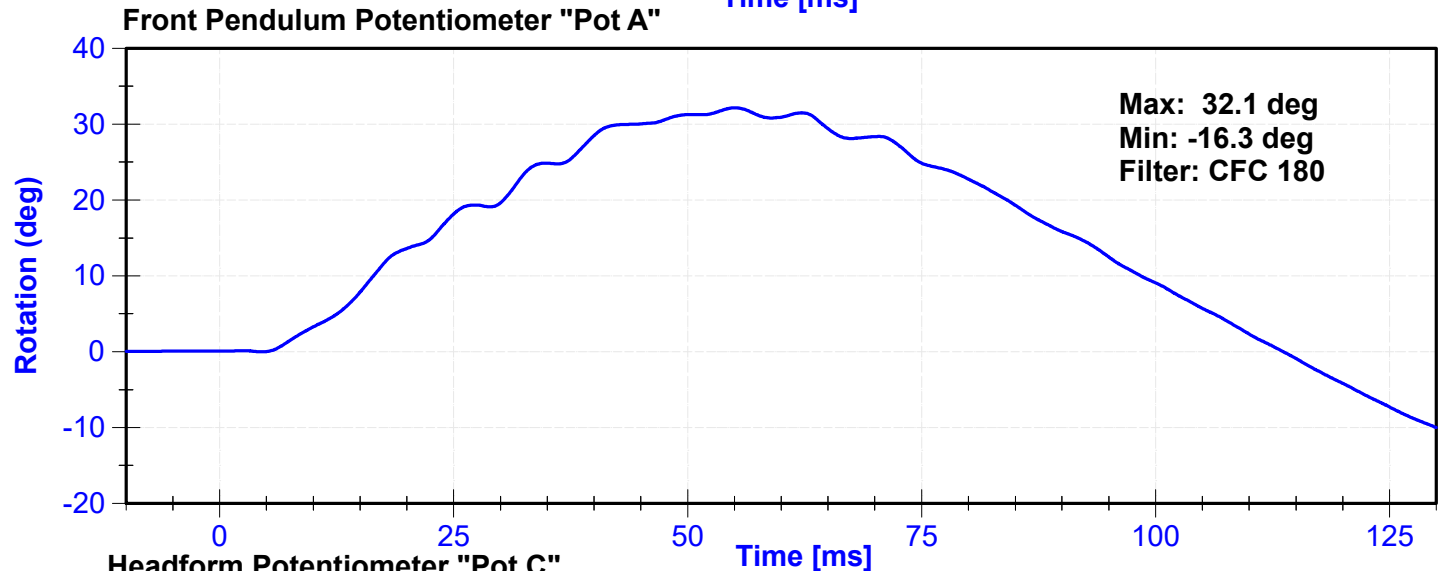
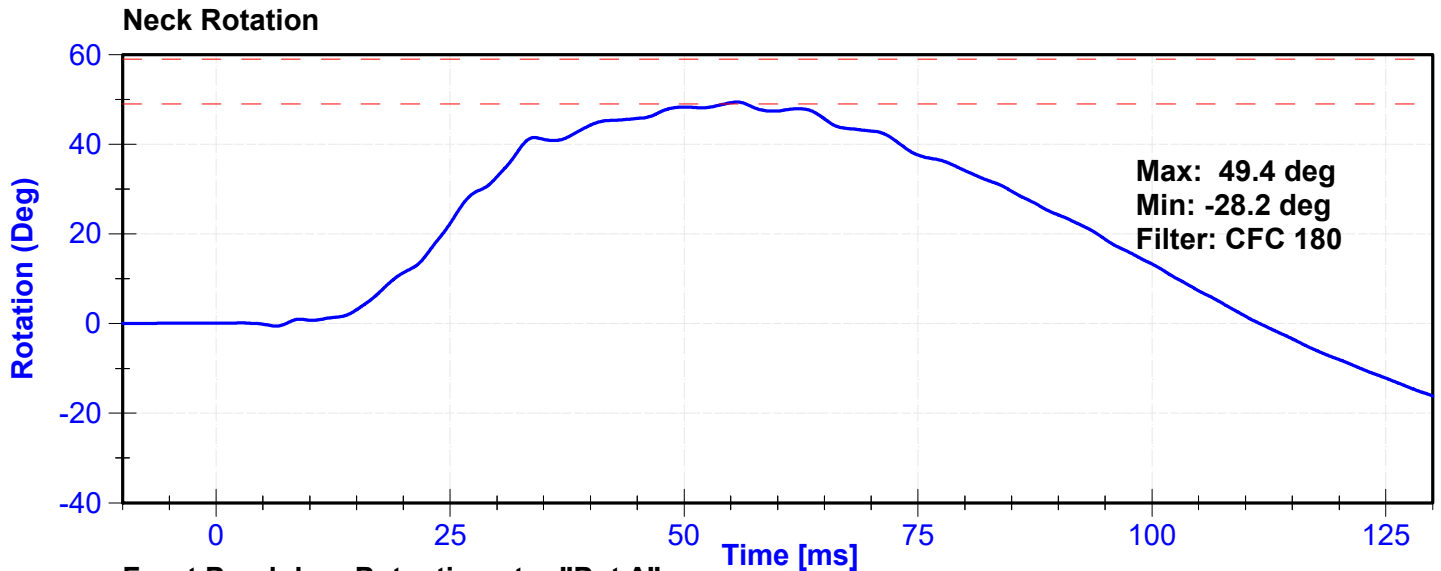

## Appendix I

<sup>2</sup> Upper Boundary Corridor		<sup>1</sup> Lower Boundary Corridor	
Time (ms)	Velocity (m/s)	Time (ms)	Velocity (m/s)
1.0	0.00	0.0	-0.05
3.0	-0.25	2.5	-0.375
14.0	-3.20	13.5	-3.7
		17.0	-3.7

ATD Manufacturer	FTSS	Test Technician	J.Kinderman
ATD Serial Number	DG5348	Laboratory Supervisor	C. Mantell

**Results**

Test Parameter	Minimum Specification	Maximum Specification	Unit	Result	Pass/Fail
Temperature	20.6	22.2	°C	21.1	Pass
Humidity	10	70	%	40	Pass
Velocity	4.2	4.4	m/s	4.29	Pass
Probe Acceleration	7.5	10.5	g's	10.04	Pass

**Transducer Calibrations**

Channel	Manufacturer	Serial Number	Calibration Date	Calibration Due Date
Probe Accelerometer	Endevco	18599	9/13/2024	3/12/2025

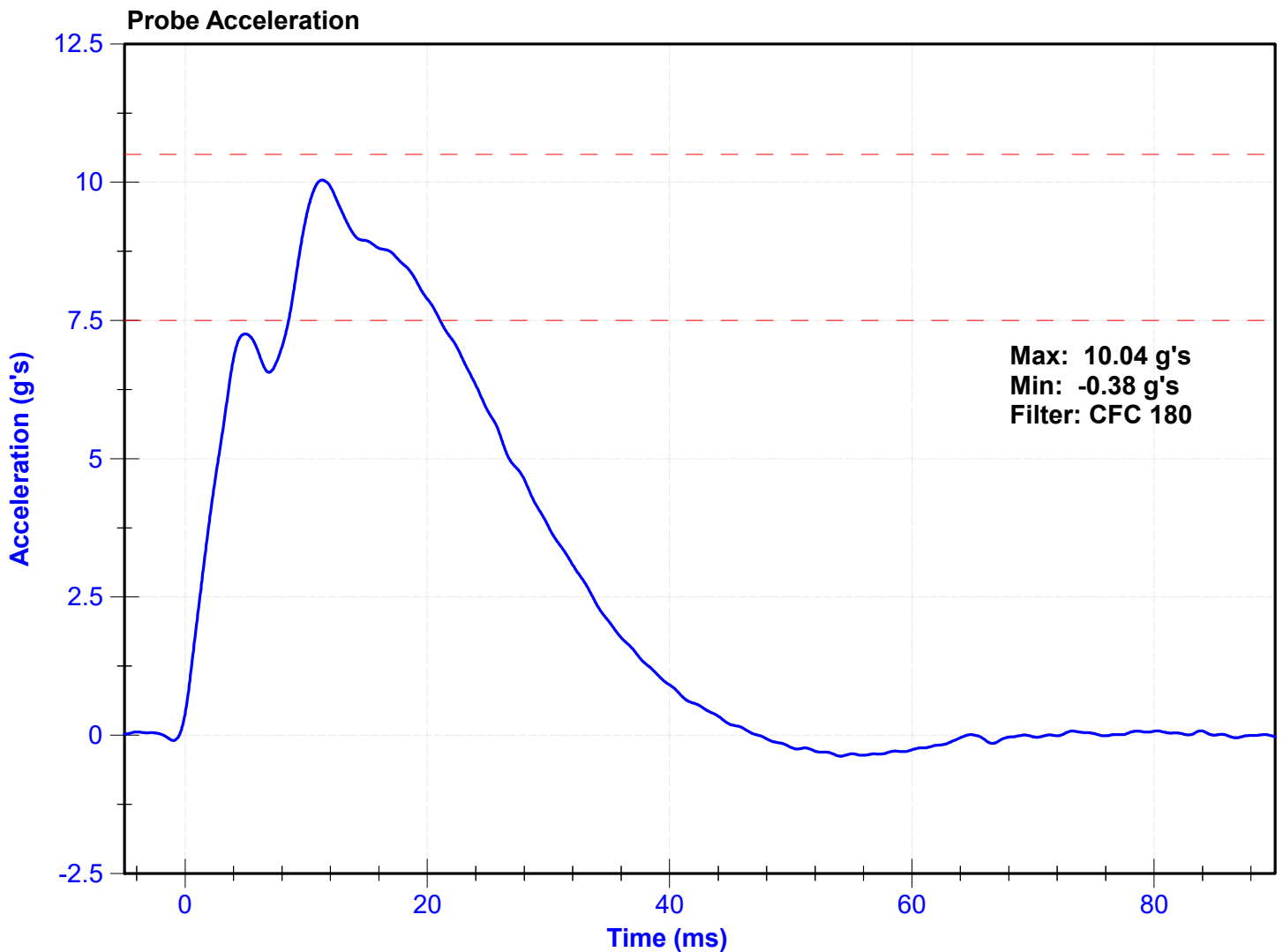

ATD Manufacturer	FTSS	Test Technician	J.Kinderman
ATD Serial Number	DG5348	Laboratory Supervisor	C. Mantell

**Results**

Test Parameter	Minimum Specification	Maximum Specification	Unit	Result	Pass/Fail
Temperature	20.6	22.2	°C	21.1	Pass
Humidity	10	70	%	40	Pass
Rib Displacement	46	51	mm	49.2	Pass

**Transducer Calibrations**

Channel	Manufacturer	Serial Number	Calibration Date	Calibration Due Date
Rib Potentiometer	Honeywell	268GFE	7/30/2024	1/28/2025

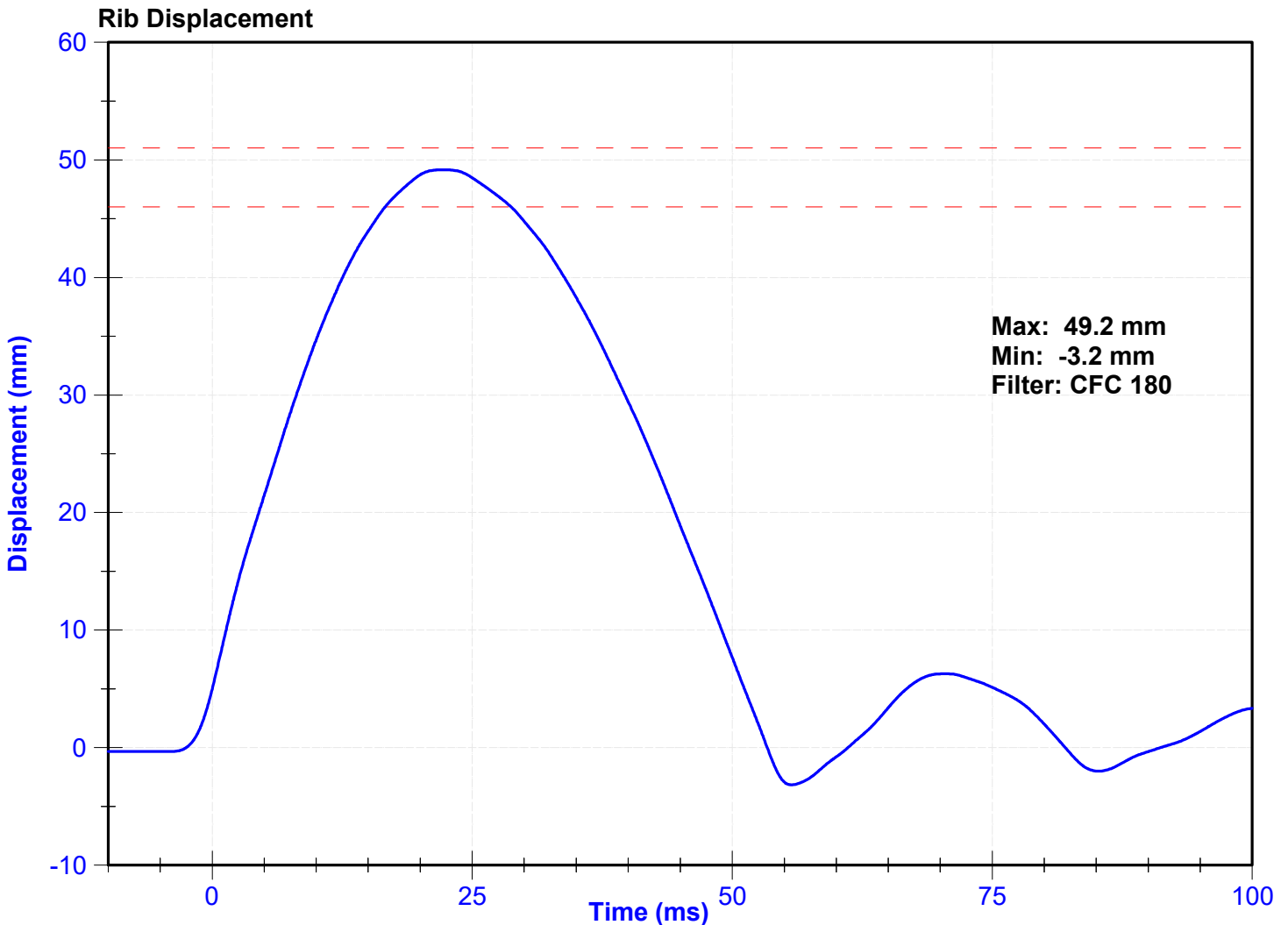

ATD Manufacturer	FTSS	Test Technician	J.Kinderman
ATD Serial Number	DG5348	Laboratory Supervisor	C. Mantell

**Results**

Test Parameter	Minimum Specification	Maximum Specification	Unit	Result	Pass/Fail
Temperature	20.6	22.2	°C	21.1	Pass
Humidity	10	70	%	40	Pass
Rib Displacement	36	40	mm	38.8	Pass

**Transducer Calibrations**

Channel	Manufacturer	Serial Number	Calibration Date	Calibration Due Date
Rib Potentiometer	Honeywell	268GFE	7/30/2024	1/28/2025

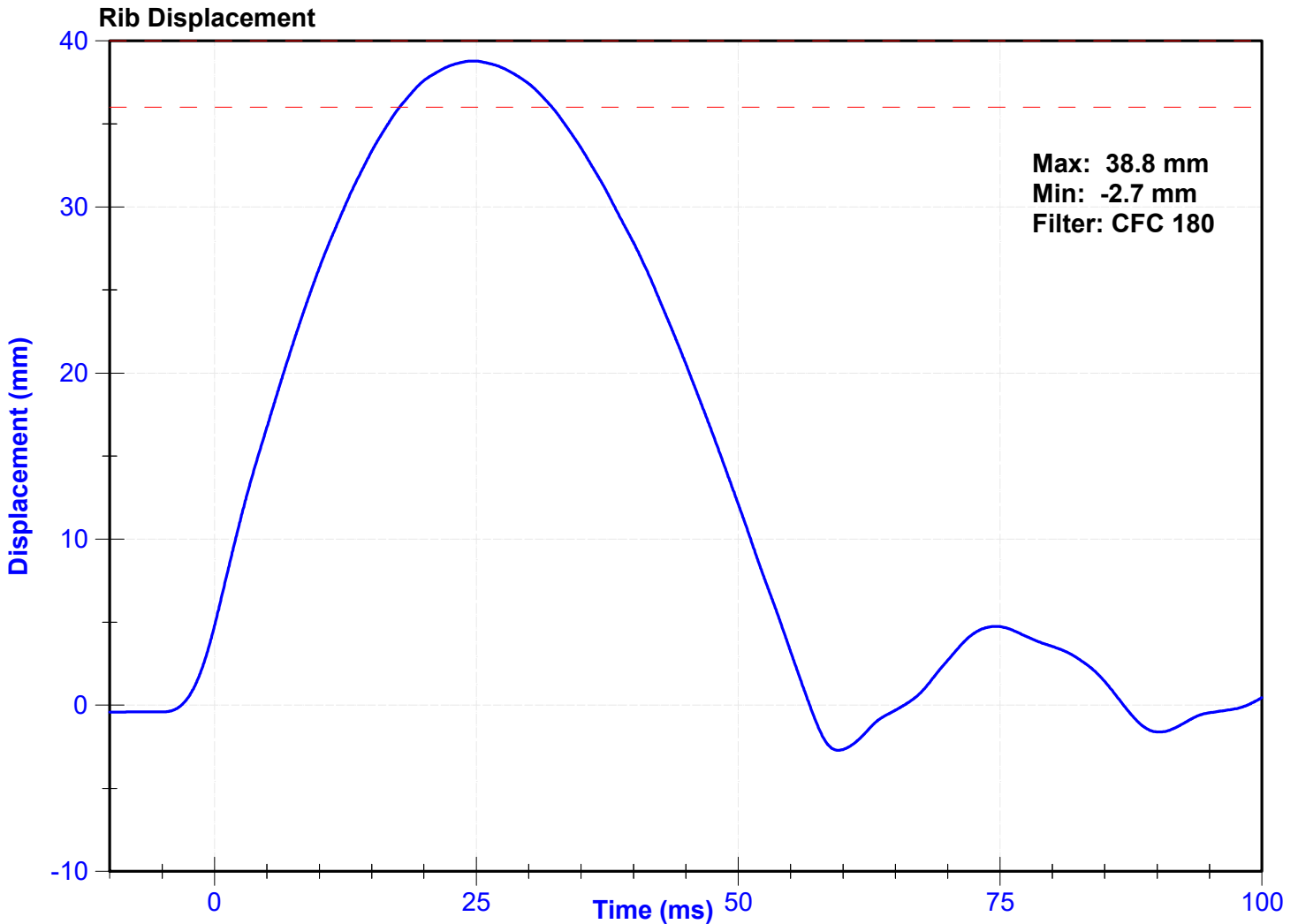

ATD Manufacturer	FTSS	Test Technician	J.Kinderman
ATD Serial Number	DG5348	Laboratory Supervisor	C. Mantell

**Results**

Test Parameter	Minimum Specification	Maximum Specification	Unit	Result	Pass/Fail
Temperature	20.6	22.2	°C	21.1	Pass
Humidity	10	70	%	40	Pass
Rib Displacement	46	51	mm	49.1	Pass

**Transducer Calibrations**

Channel	Manufacturer	Serial Number	Calibration Date	Calibration Due Date
Rib Potentiometer	Honeywell	269GFE	7/30/2024	1/28/2025

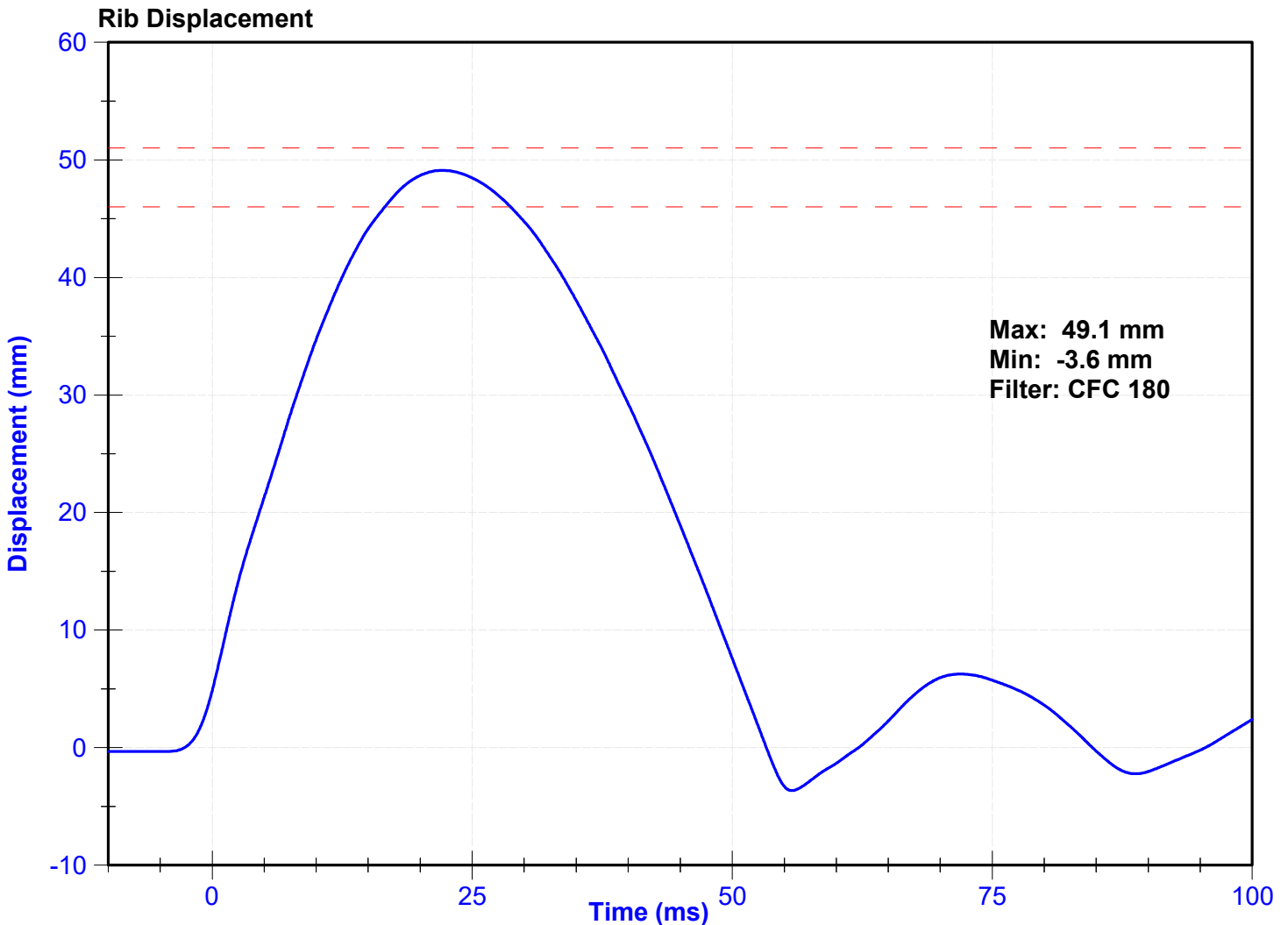

ATD Manufacturer	FTSS	Test Technician	J.Kinderman
ATD Serial Number	DG5348	Laboratory Supervisor	C. Mantell

**Results**

Test Parameter	Minimum Specification	Maximum Specification	Unit	Result	Pass/Fail
Temperature	20.6	22.2	°C	21.1	Pass
Humidity	10	70	%	40	Pass
Rib Displacement	36	40	mm	39.5	Pass

**Transducer Calibrations**

Channel	Manufacturer	Serial Number	Calibration Date	Calibration Due Date
Rib Potentiometer	Honeywell	269GFE	7/30/2024	1/28/2025

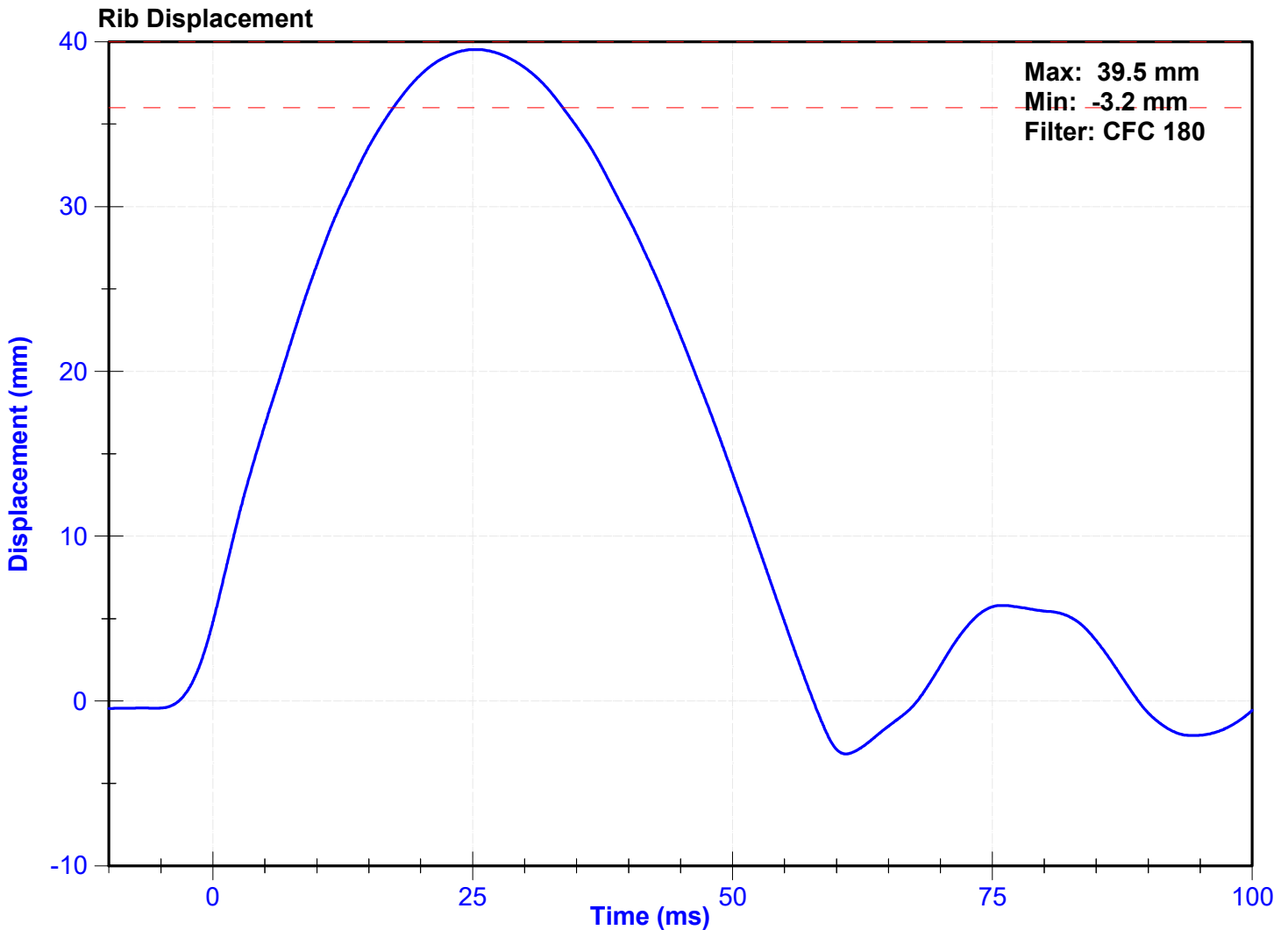

ATD Manufacturer	FTSS	Test Technician	J.Kinderman
ATD Serial Number	DG5348	Laboratory Supervisor	C. Mantell

**Results**

Test Parameter	Minimum Specification	Maximum Specification	Unit	Result	Pass/Fail
Temperature	20.6	22.2	°C	21.1	Pass
Humidity	10	70	%	40	Pass
Rib Displacement	46	51	mm	48.5	Pass

**Transducer Calibrations**

Channel	Manufacturer	Serial Number	Calibration Date	Calibration Due Date
Rib Potentiometer	Honeywell	270GFE	7/30/2024	1/28/2025

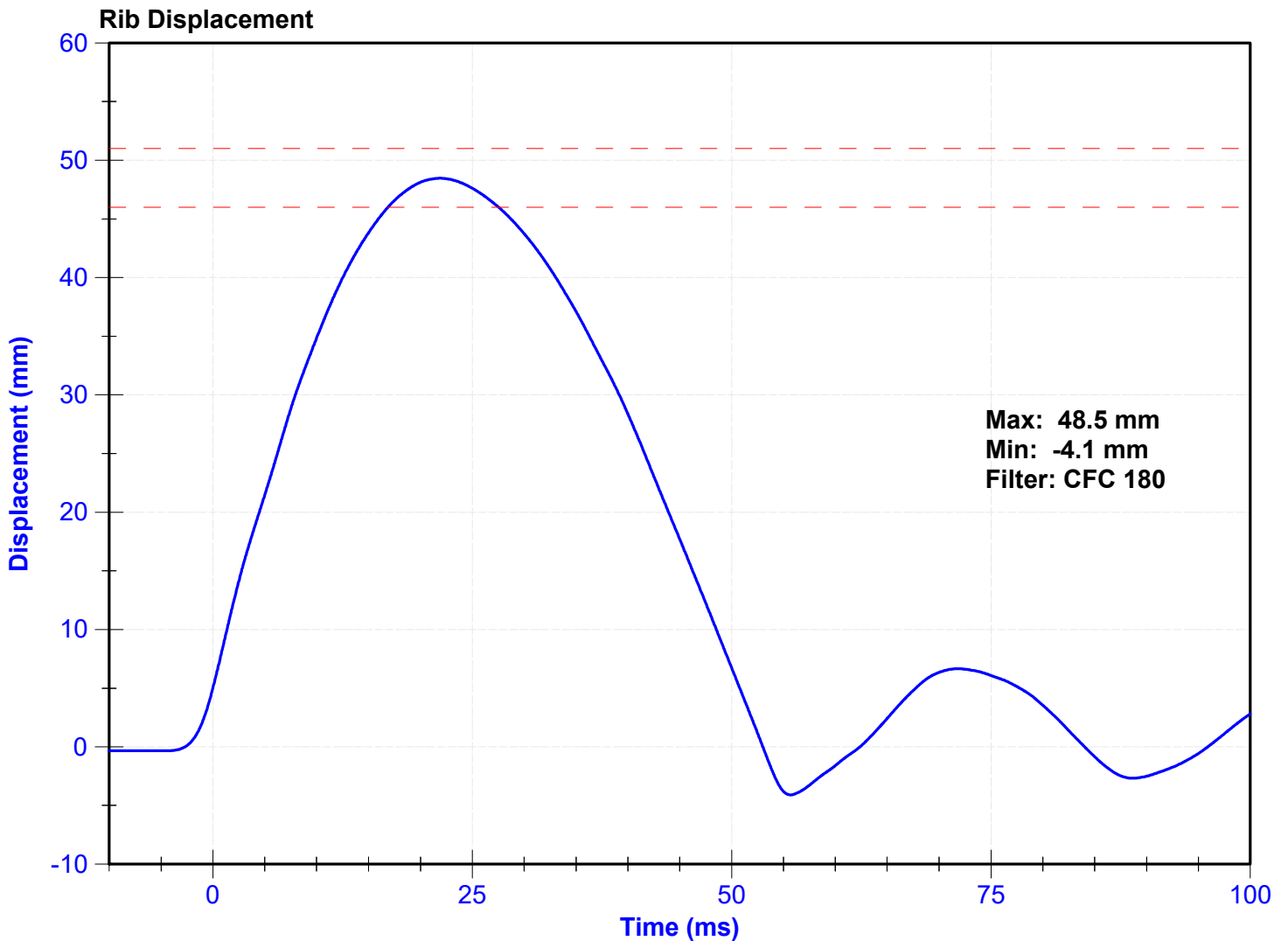

ATD Manufacturer	FTSS	Test Technician	J.Kinderman
ATD Serial Number	DG5348	Laboratory Supervisor	C. Mantell

**Results**

Test Parameter	Minimum Specification	Maximum Specification	Unit	Result	Pass/Fail
Temperature	20.6	22.2	°C	21.1	Pass
Humidity	10	70	%	40	Pass
Rib Displacement	36	40	mm	39.4	Pass

**Transducer Calibrations**

Channel	Manufacturer	Serial Number	Calibration Date	Calibration Due Date
Rib Potentiometer	Honeywell	270GFE	7/30/2024	1/28/2025

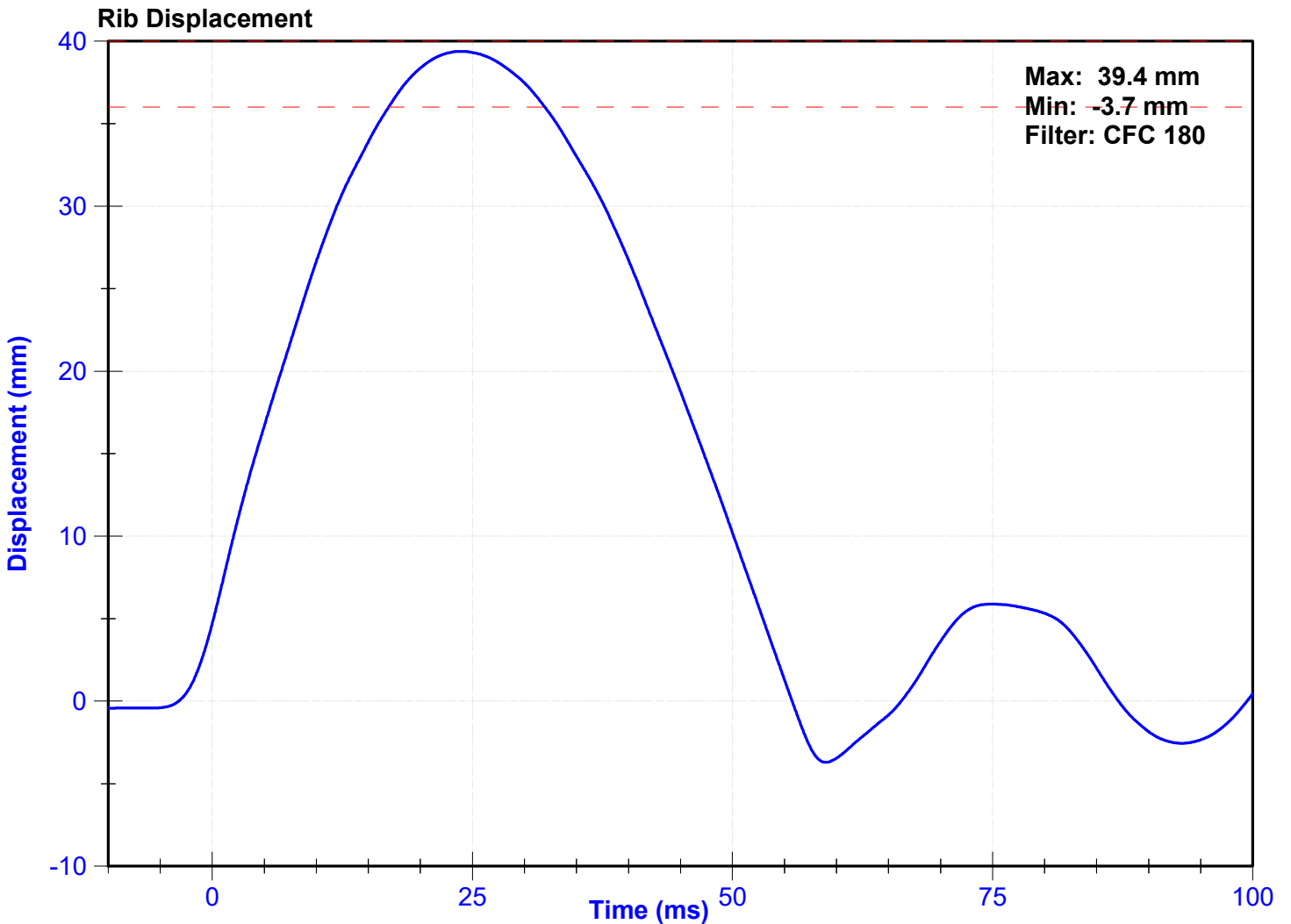

ATD Manufacturer	FTSS	Test Technician	J.Kinderman
ATD Serial Number	DG5348	Laboratory Supervisor	C. Mantell

**Results**

Test Parameter	Minimum Specification	Maximum Specification	Unit	Result	Pass/Fail
Temperature	20.6	22.2	°C	21.1	Pass
Humidity	10	70	%	40	Pass
Velocity	5.4	5.6	m/s	5.53	Pass
Resistive Force after 6ms	5100	6200	N	6192.9	Pass
Upper Thorax Rib Deflection	34	41	mm	38.4	Pass
Mid Thorax Rib Deflection	37	45	mm	40.8	Pass
Lower Thorax Rib Deflection	37	44	mm	39.3	Pass

**Transducer Calibrations**

Channel	Manufacturer	Serial Number	Calibration Date	Calibration Due Date
Probe Accelerometer	Endevco	18599	9/13/2024	3/12/2025
Upper Thorax Rib Potentiometer	Honeywell	268GFE	7/30/2024	1/28/2025
Middle Thorax Rib Potentiometer	Honeywell	269GFE	7/30/2024	1/28/2025
Lower Thorax Rib Potentiometer	Honeywell	270GFE	7/30/2024	1/28/2025

**Probe Acceleration**

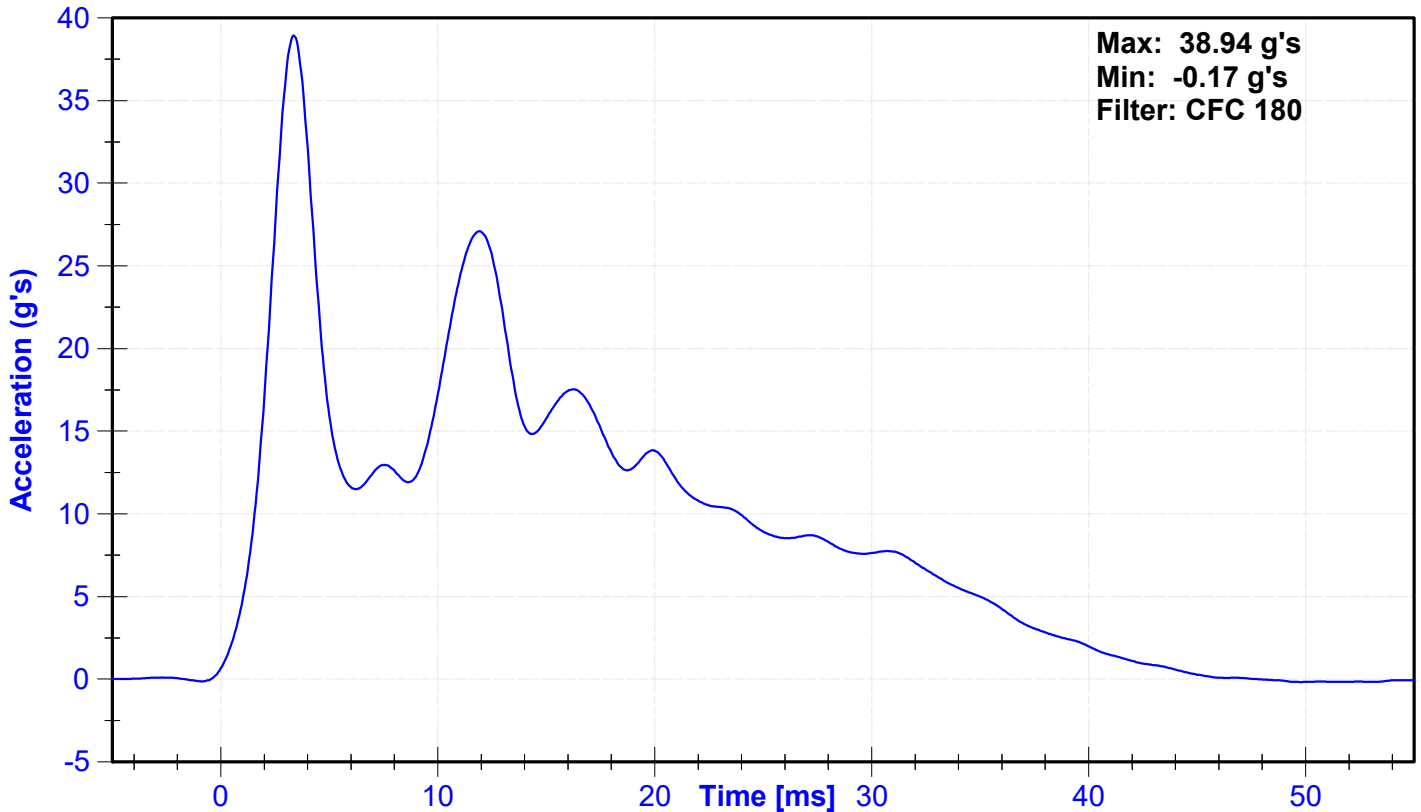

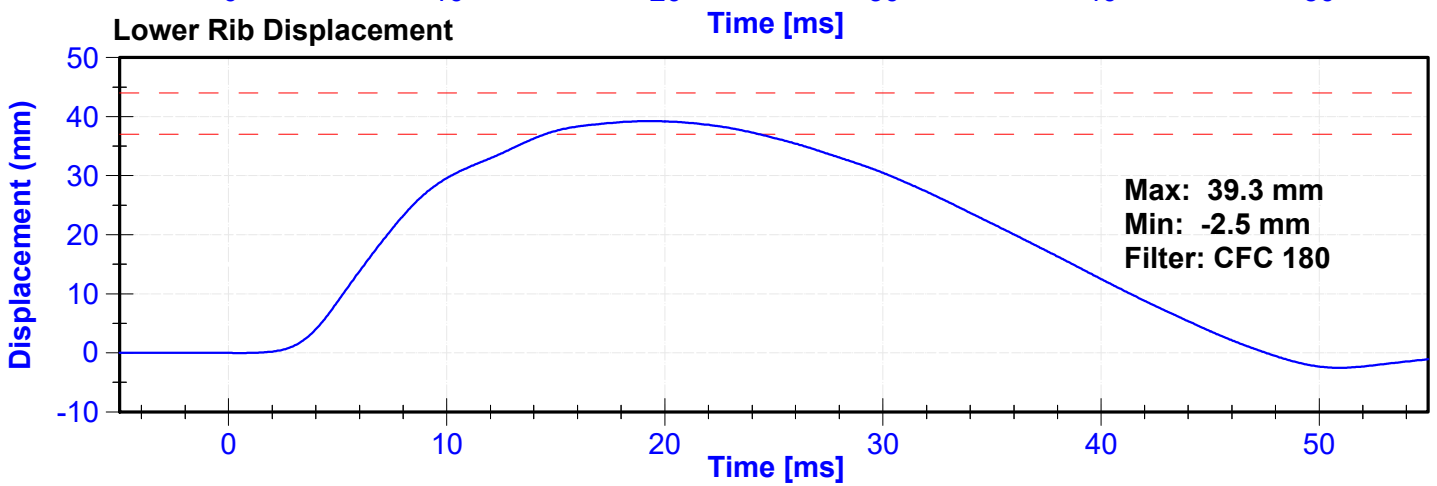
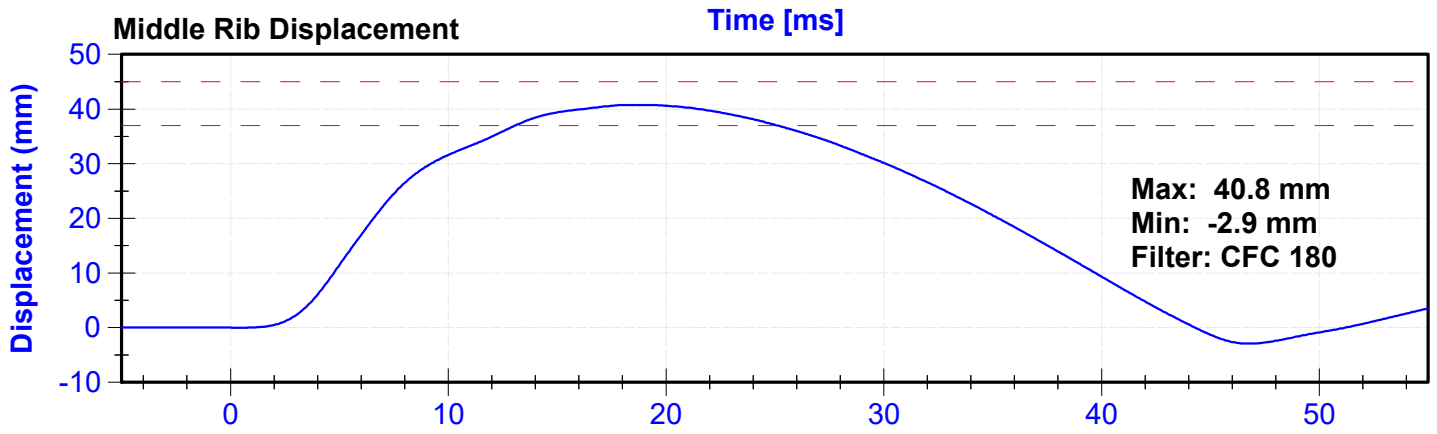
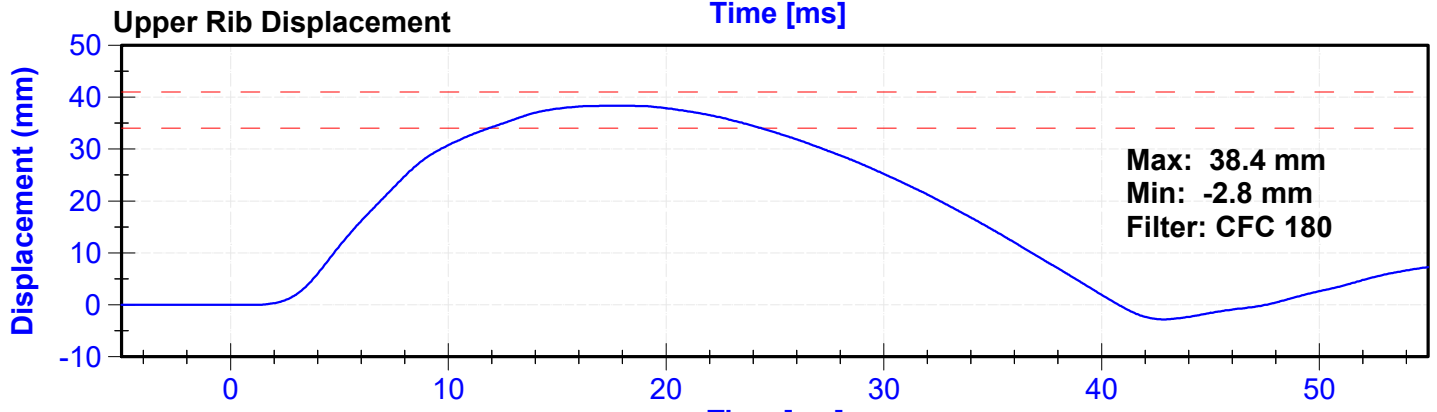
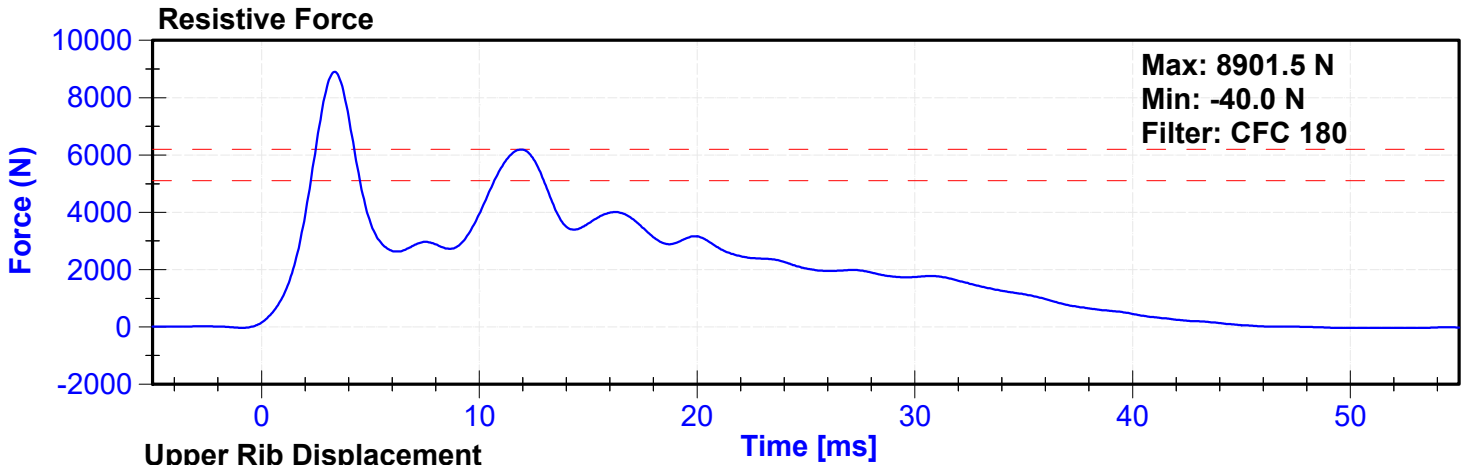

ATD Manufacturer	FTSS	Test Technician	J.Kinderman
ATD Serial Number	DG5348	Laboratory Supervisor	C. Mantell

**Results**

Test Parameter	Minimum Specification	Maximum Specification	Unit	Result	Pass/Fail
Temperature	20.6	22.2	°C	21.1	Pass
Humidity	10	70	%	40	Pass
Velocity	3.9	4.1	m/s	4.01	Pass
Combined Abdomen Force	2200	2700	N	2295.1	Pass
Time at Peak Abdomen Force	10.0	12.3	ms	11.50	Pass
Resistive Probe Force	4000	4800	N	4271.4	Pass
Time at Peak Resistive Force	10.6	13.0	ms	11.20	Pass

**Transducer Calibrations**

Channel	Manufacturer	Serial Number	Calibration Date	Calibration Due Date
Pendulum Accelerometer	Endevco	18599	9/13/2024	3/12/2025
Front Abdomen Load Cell	Denton	DM5846	5/22/2024	5/22/2025
Middle Abdomen Load Cell	Denton	1529	5/22/2024	5/22/2025
Rear Abdomen Load Cell	Denton	1533	5/22/2024	5/22/2025

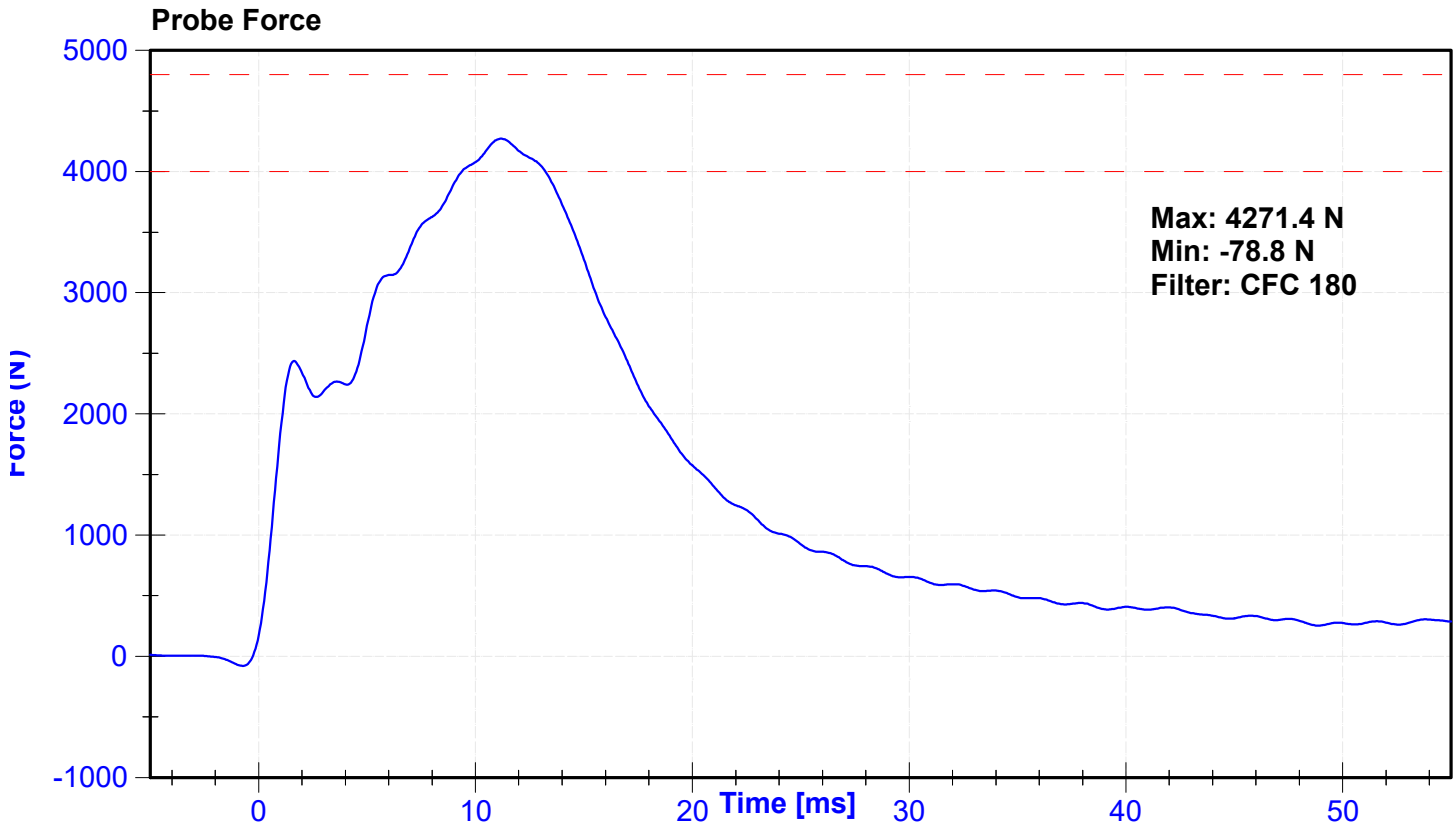

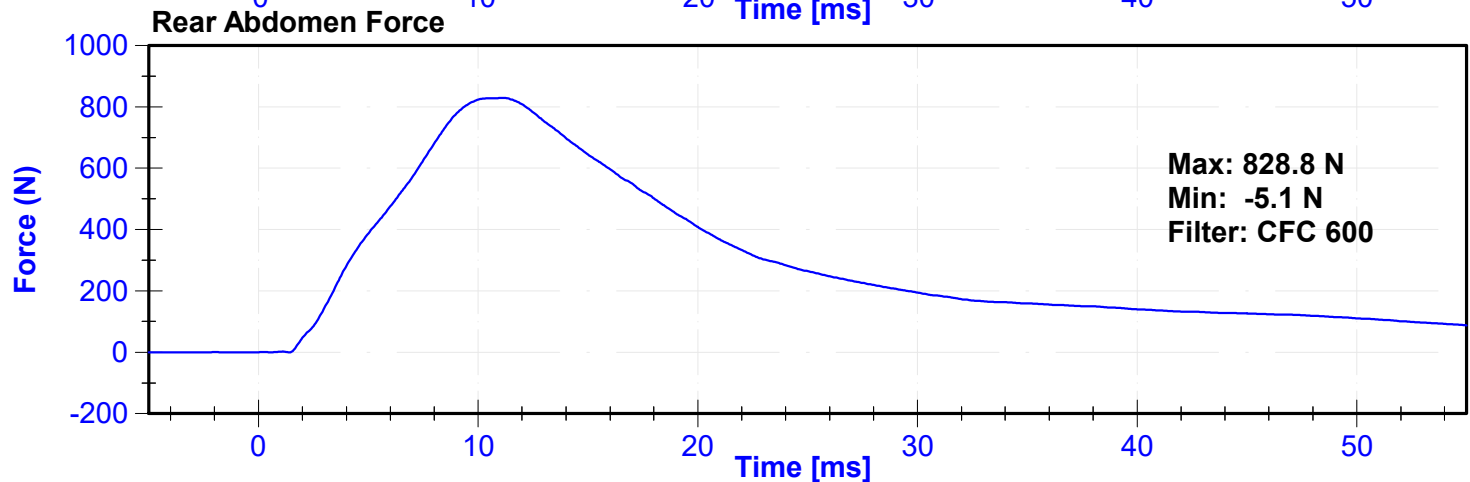
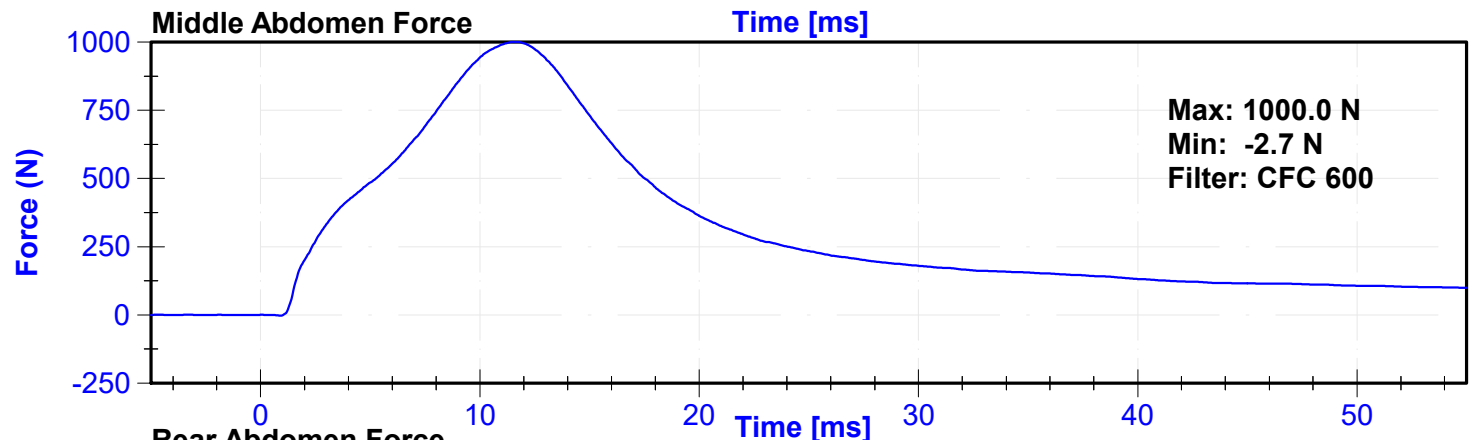
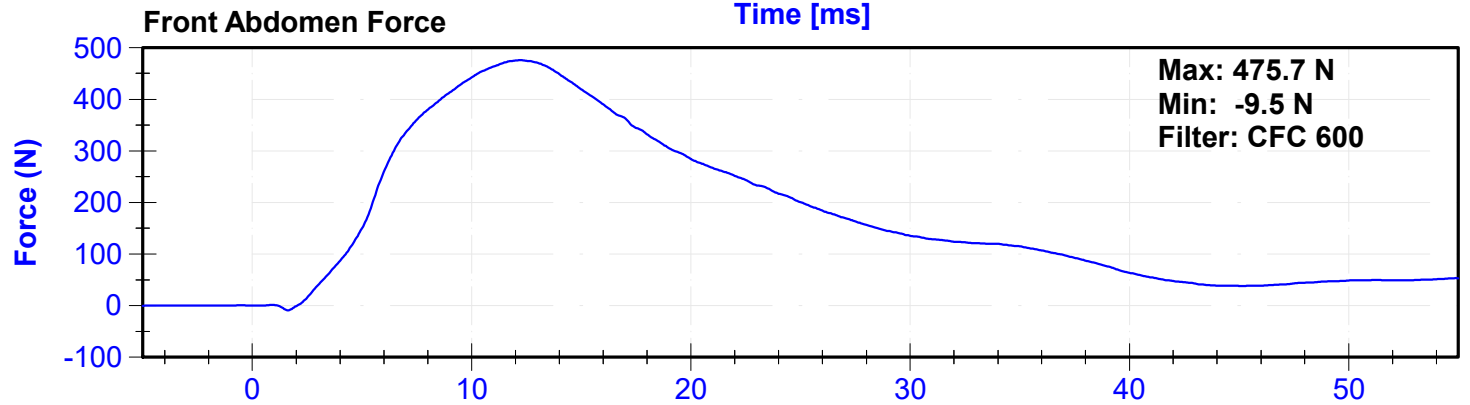
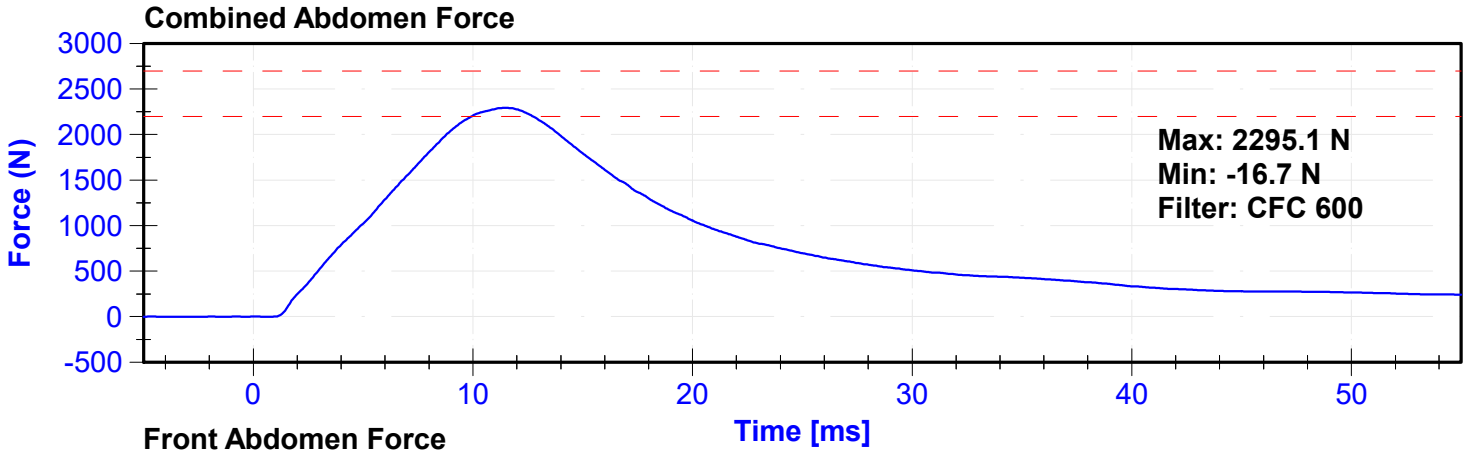

ATD Manufacturer	FTSS	Test Technician	J. Kinderman
ATD Serial Number	DG5348	Laboratory Supervisor	C. Mantell

**Results**

Test Parameter	Minimum Specification	Maximum Specification	Unit	Result	Pass/Fail
Temperature	20.6	22.2	°C	21.1	Pass
Humidity	10	70	%	40	Pass
Velocity	5.95	6.15	m/s	6.105	Pass
Lateral Spine Rotation	45	55	deg	46.6	Pass
Time at Maximum Rotation	39	53	ms	43.8	Pass
Time of Decay to Zero Degrees	37	57	ms	37.4	Pass
Pendulum Velocity Overall Corridor	Lower Boundary <sup>1</sup>	Upper Boundary <sup>2</sup>	m/s	See Plot <sup>3</sup>	Pass

**Transducer Calibrations**

Channel	Manufacturer	Serial Number	Calibration Date	Calibration Due Date
Pendulum Accelerometer	Endevco	C16503	4/29/2024	10/26/2024
Pendulum "A" Potentiometer	Sfernice	2247	9/13/2024	9/13/2025
Condyle "B" Potentiometer	Sfernice	095	9/13/2024	9/13/2025

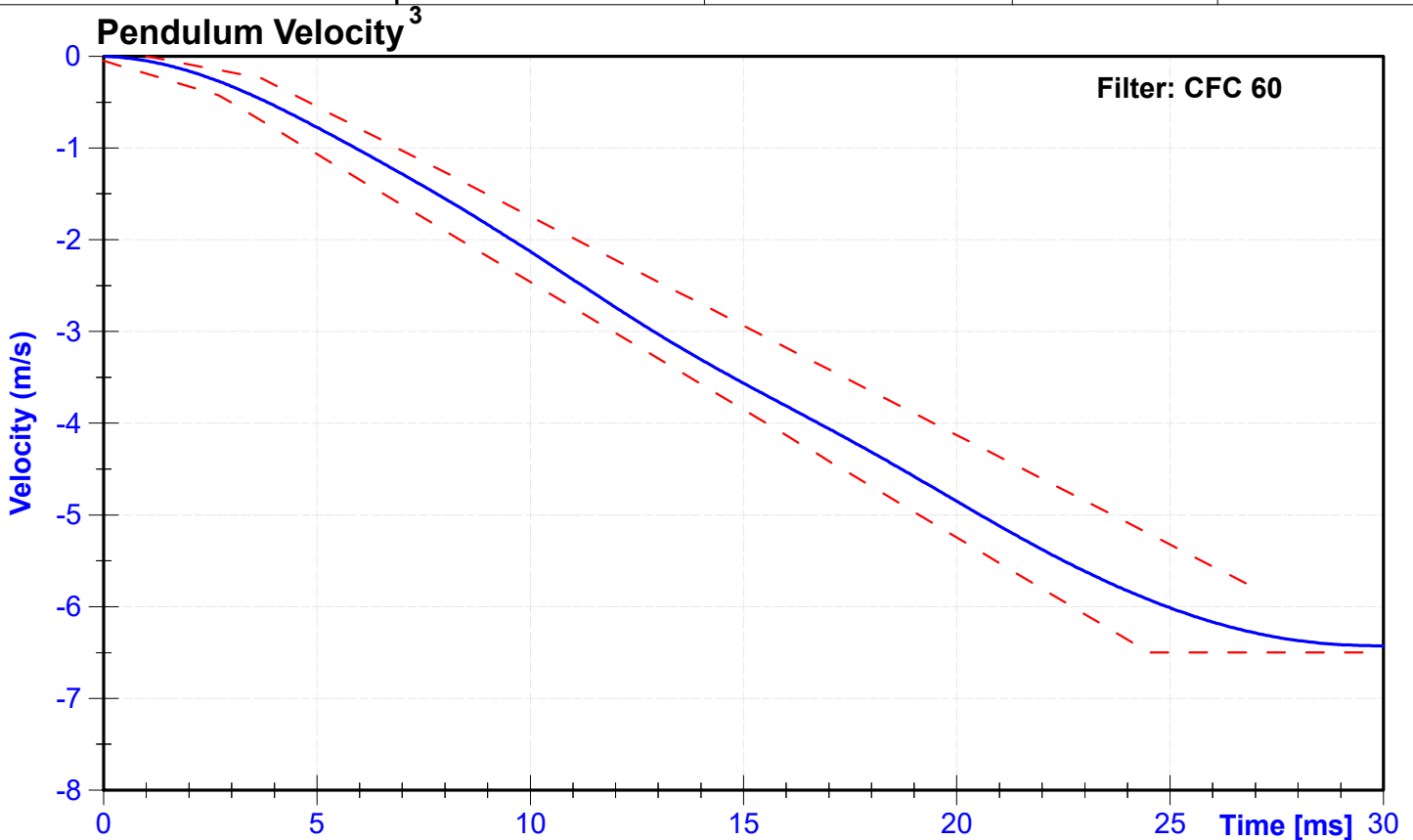

<sup>1,2</sup> Upper and lower boundaries specified in Appendix I

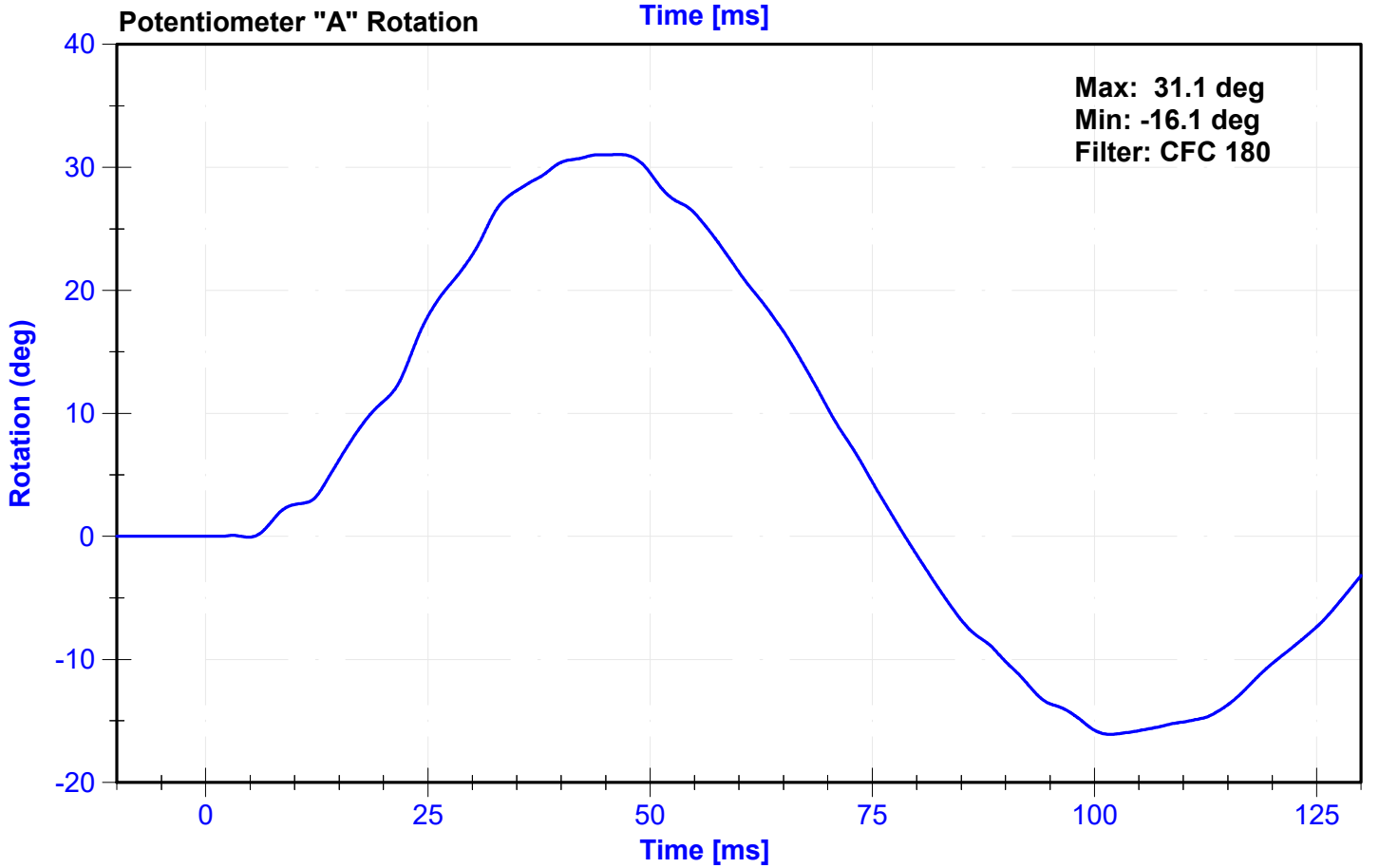
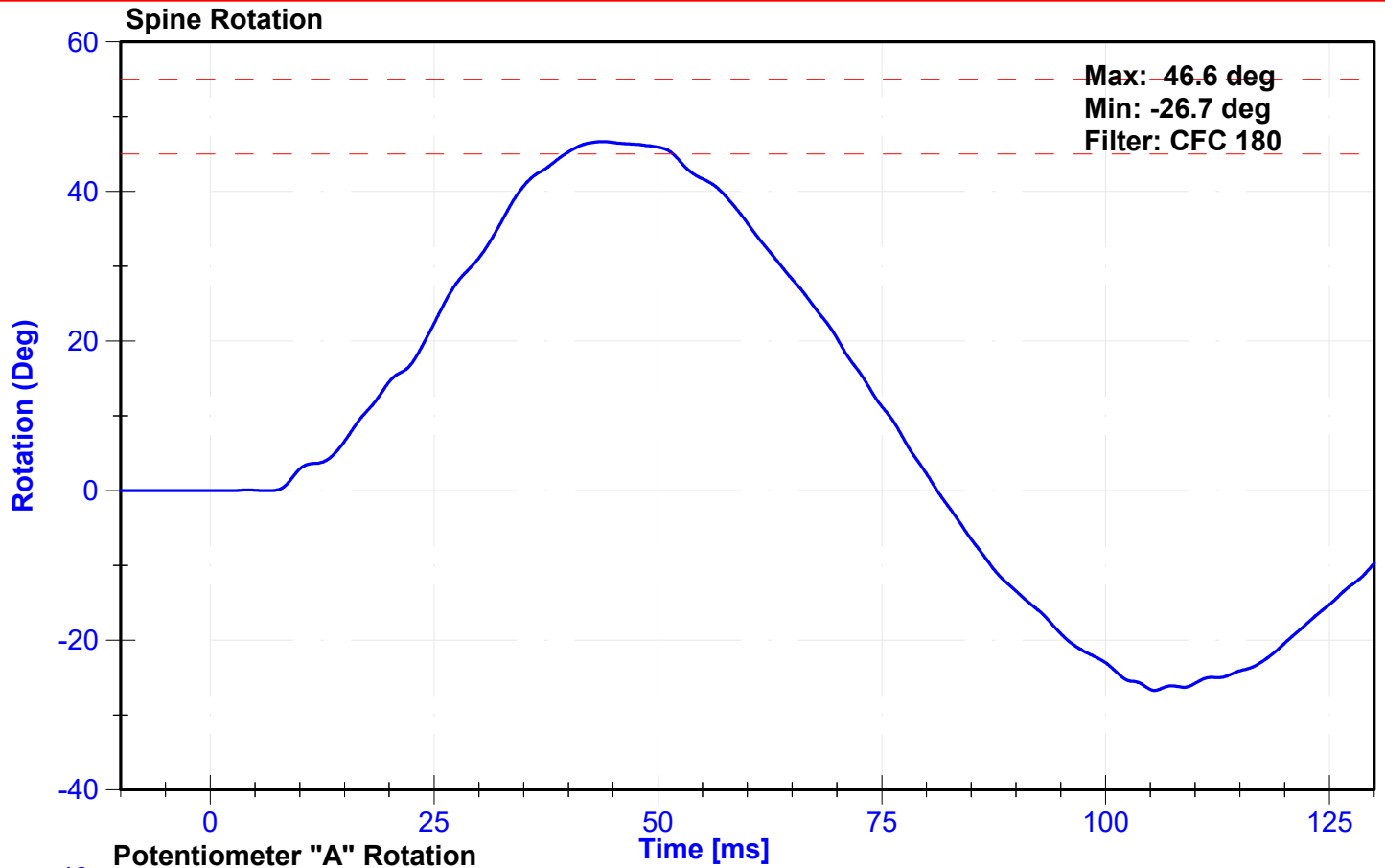

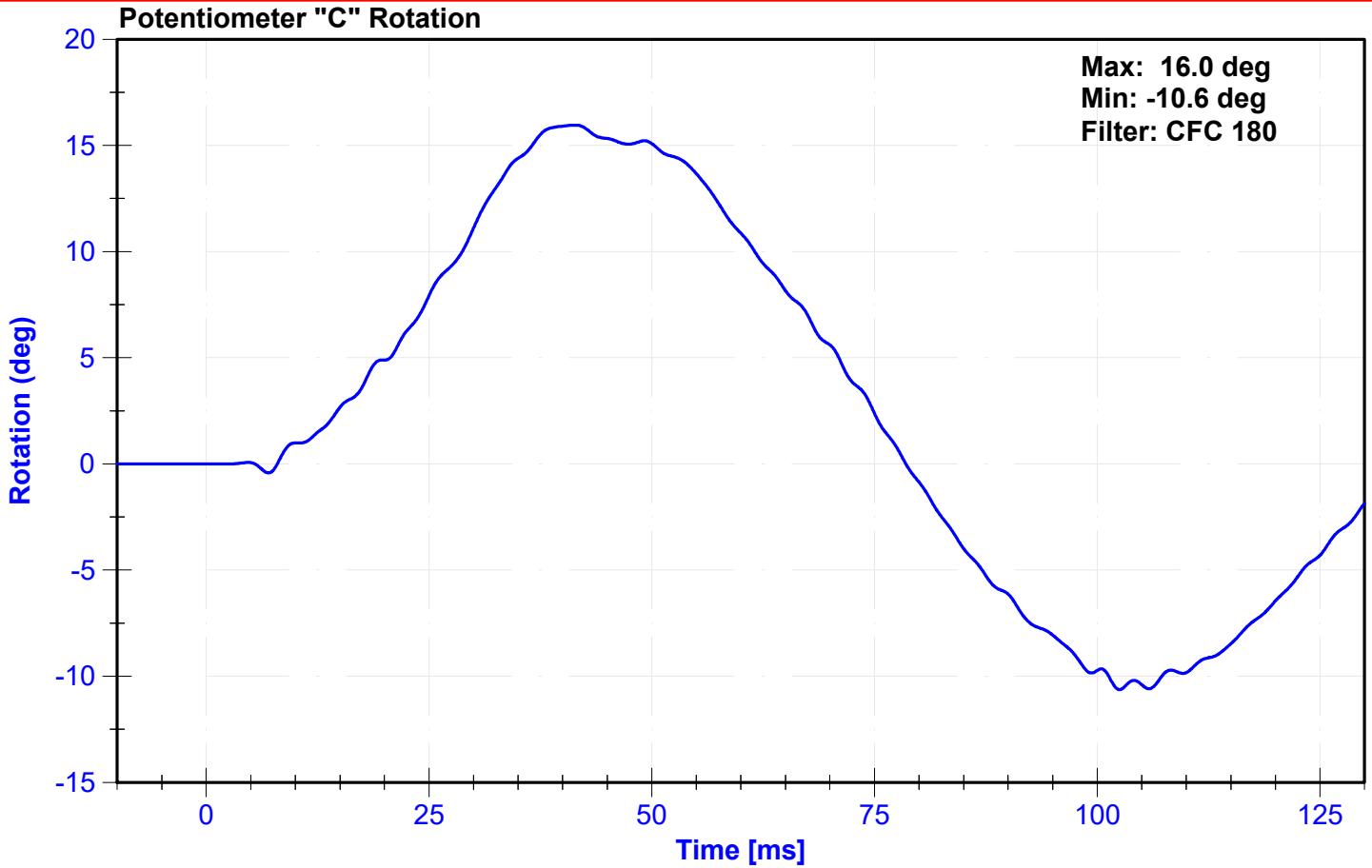

## Appendix I

<sup>2</sup> Upper Boundary Corridor		<sup>1</sup> Lower Boundary Corridor	
Time (ms)	Velocity (m/s)	Time (ms)	Velocity (m/s)
1.0	0.00	0.0	-0.05
3.7	-0.24	2.7	-0.425
27.0	-5.80	24.5	-6.5
		30.0	-6.5

ATD Manufacturer	FTSS	Test Technician	J.Kinderman
ATD Serial Number	DG5348	Laboratory Supervisor	C. Mantell

**Results**

Test Parameter	Minimum Specification	Maximum Specification	Unit	Result	Pass/Fail
Temperature	20.6	22.2	°C	21.1	Pass
Humidity	10	70	%	40	Pass
Velocity	4.2	4.4	m/s	4.28	Pass
Resistive Force	4700	5400	N	4905.2	Pass
Time at Peak Resistive Force	11.8	16.1	ms	13.25	Pass
Pubic Force	-1590	-1230	N	-1296.6	Pass
Time at Peak Pubic Force	12.2	17.0	ms	14.80	Pass

**Transducer Calibrations**

Channel	Manufacturer	Serial Number	Calibration Date	Calibration Due Date
Pendulum Accelerometer	Endevco	18599	9/13/2024	3/12/2025
Pubic Load Cell	Denton	459-FY	7/12/2024	7/12/2025

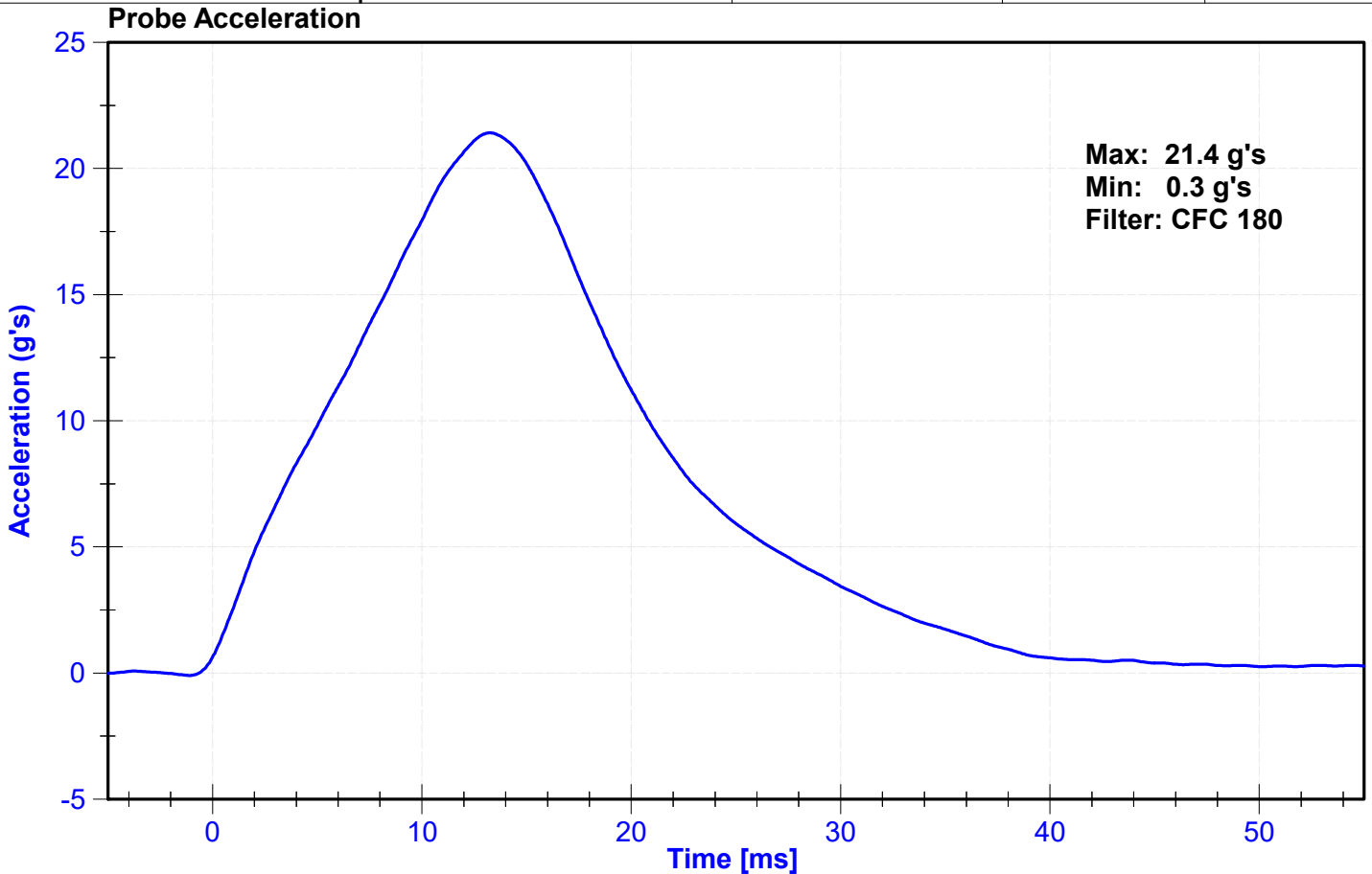

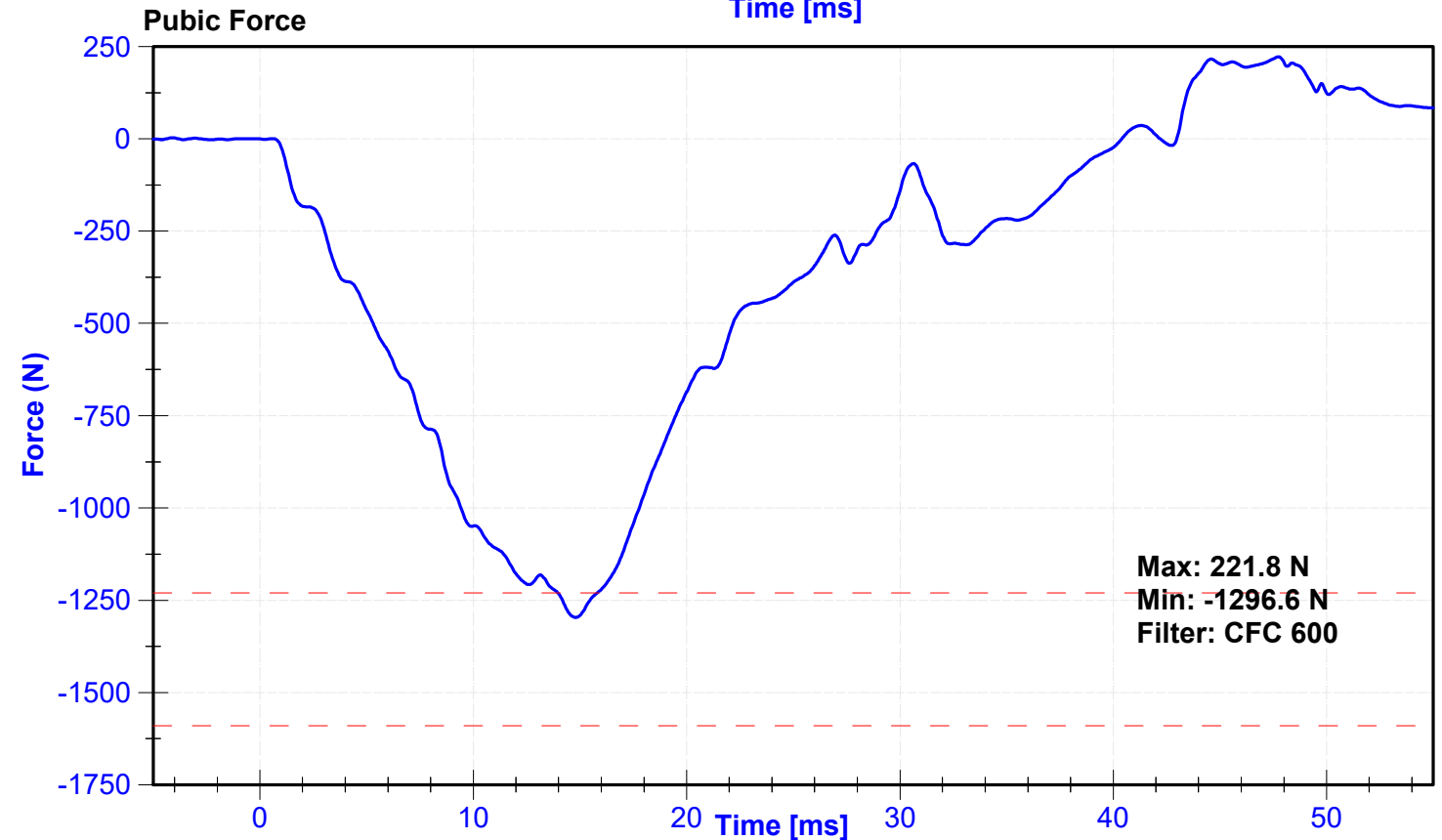
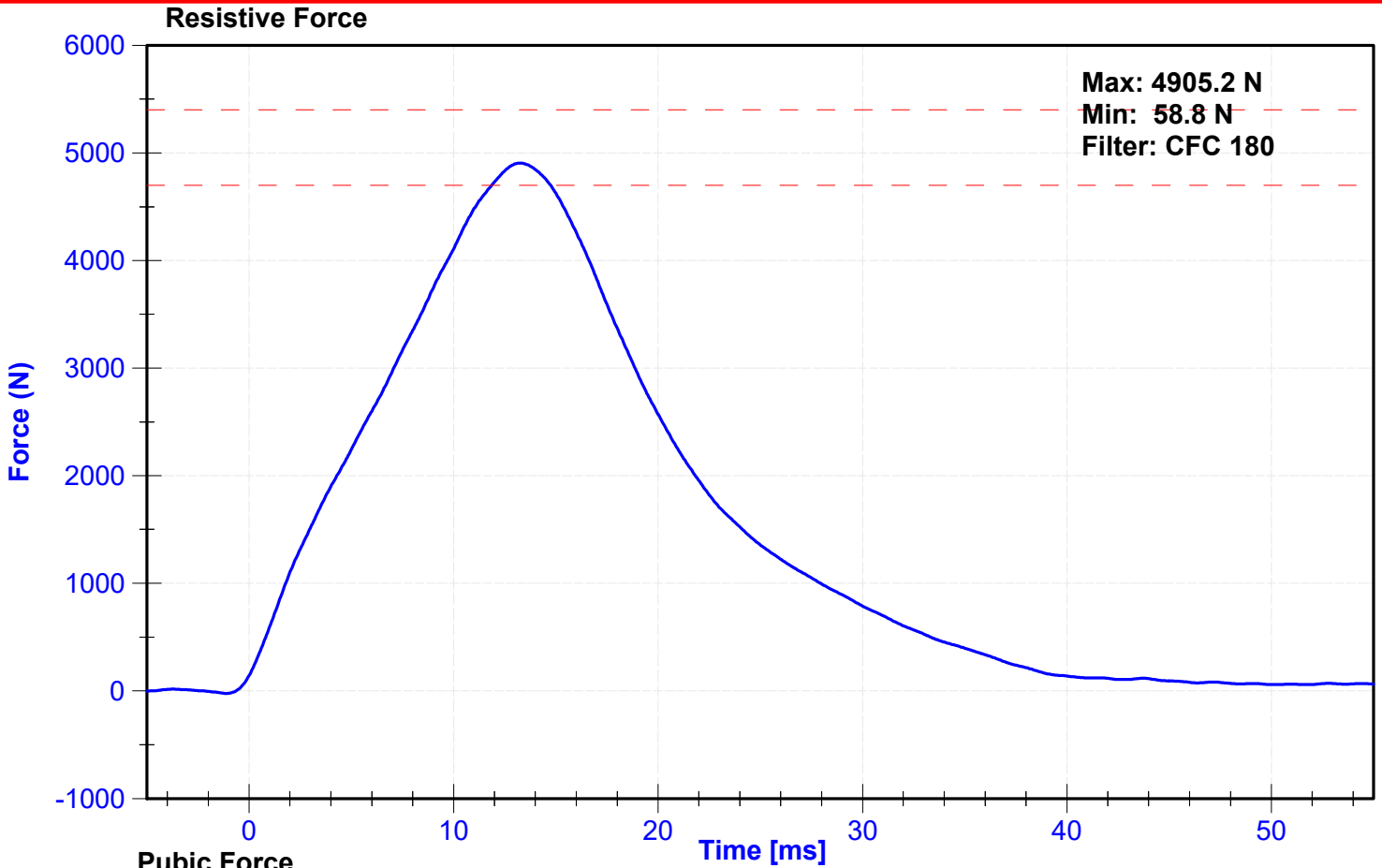

**APPENDIX VI**  
**SID-Its PERFORMANCE CALIBRATION TEST DATA**

**PRE-TEST  
SID-IIs PERFORMANCE CALIBRATION TEST DATA**



External Measurements - SID-IIs

Technician: J. Rios

Date: 09/04/2024

Dummy Serial Number: 261

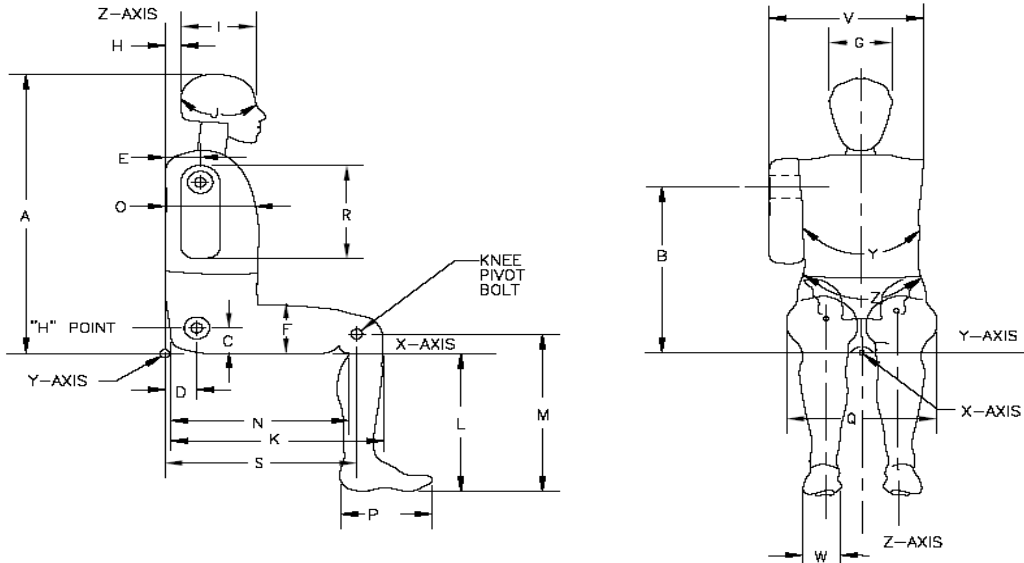

Symbol	Description	Specification (mm)		Result (mm)	Pass/Fail
A	Sitting Height	772	788	780	Pass
B	Shoulder Pivot Height	437	453	450	Pass
C	H-point Height	79	89	84	Pass
D	H-point from seatback	141	151	144	Pass
E	Shoulder Pivot from Backline	97	107	104	Pass
F	Thigh Clearance	119	135	127	Pass
G	Head Breadth	140	148	144	Pass
H	Head Back from Backline	40	46	43	Pass
I	Head Depth	178	188	180	Pass
J	Head Circumference	541	551	549	Pass
K	Buttock to Knee Length	514	540	522	Pass
L	Popliteal Height	343	369	349	Pass
M	Knee Pivot to floor height	392	409	398	Pass
N	Buttock Popliteal Length	416	442	422	Pass
O	Chest Depth w/o jacket	195	211	206	Pass
P	Foot Length	216	232	219	Pass
Q	Hip Breadth (w/pelvic plugs)	313	323	317	Pass
R	Arm Length	249	259	250	Pass
S	Knee Joint to seatback	477	493	479	Pass
V	Shoulder Width	341	357	346	Pass
W	Foot Width	78	94	85	Pass
Y	Chest Circumference w/jacket	851	881	868	Pass
Z	Waist Circumference	761	791	777	Pass

ATD Manufacturer	FTSS	Test Technician	J. Rios
ATD Serial Number	261	Laboratory Supervisor	C .Mantell

**Results**

Test Parameter	Minimum Specification	Maximum Specification	Unit	Result	Pass/Fail
Temperature	20.6	22.2	°C	20.7	Pass
Humidity	10	70	%	57	Pass
Resultant Acceleration	115	137	g's	135.4	Pass
Oscillation	0	15	%	1.9	Pass
Fore-Aft Acceleration	-15	15	g's	4.2	Pass

**Transducer Calibrations**

Channel	Manufacturer	Serial Number	Calibratio Date	Calibratio Due Date
X Accelerometer	Endevco	P68067	5/15/2024	11/11/2024
Y Accelerometer	Endevco	P18567	5/15/2024	11/11/2024
Z Accelerometer	Endevco	P49163	5/15/2024	11/11/2024

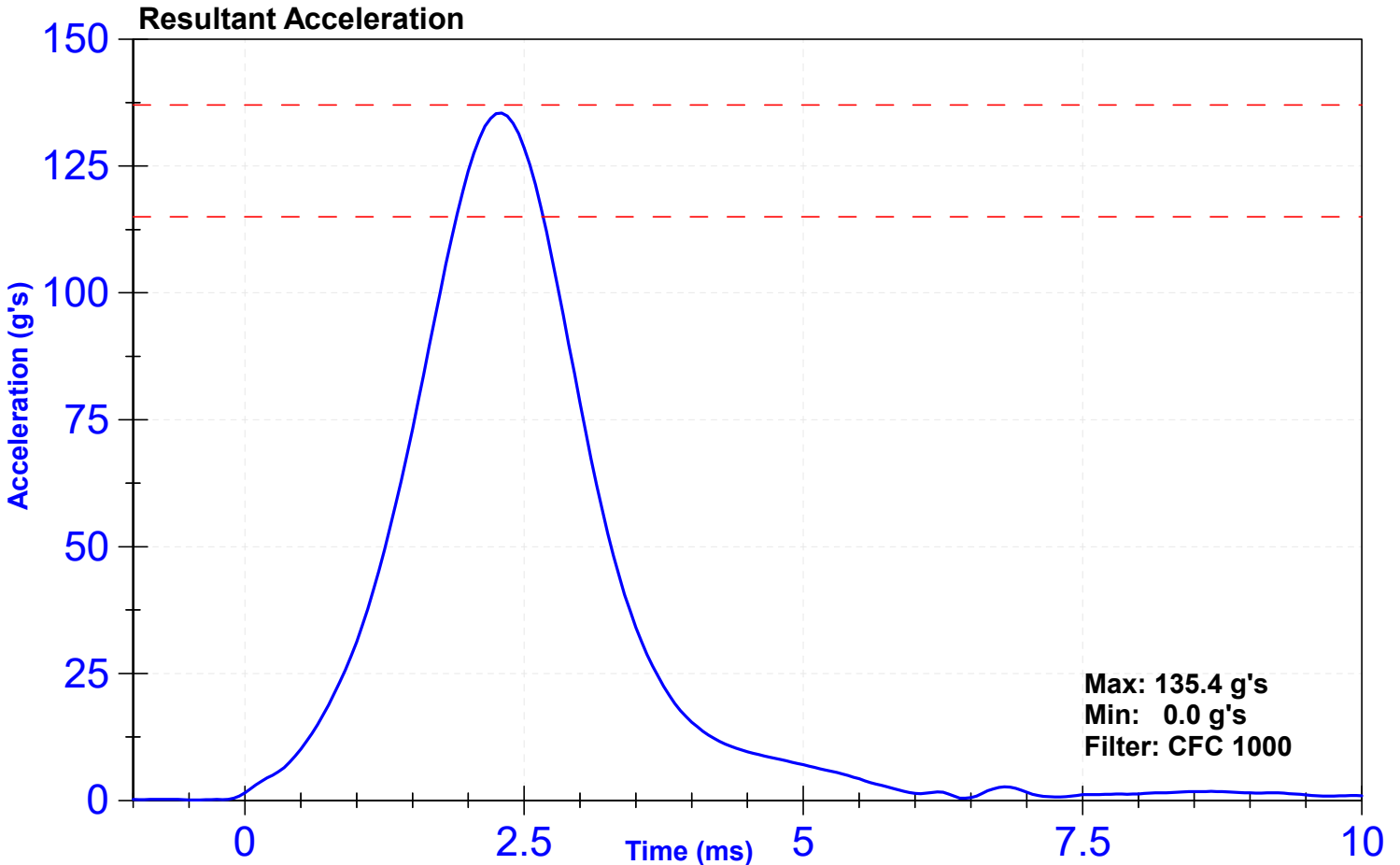

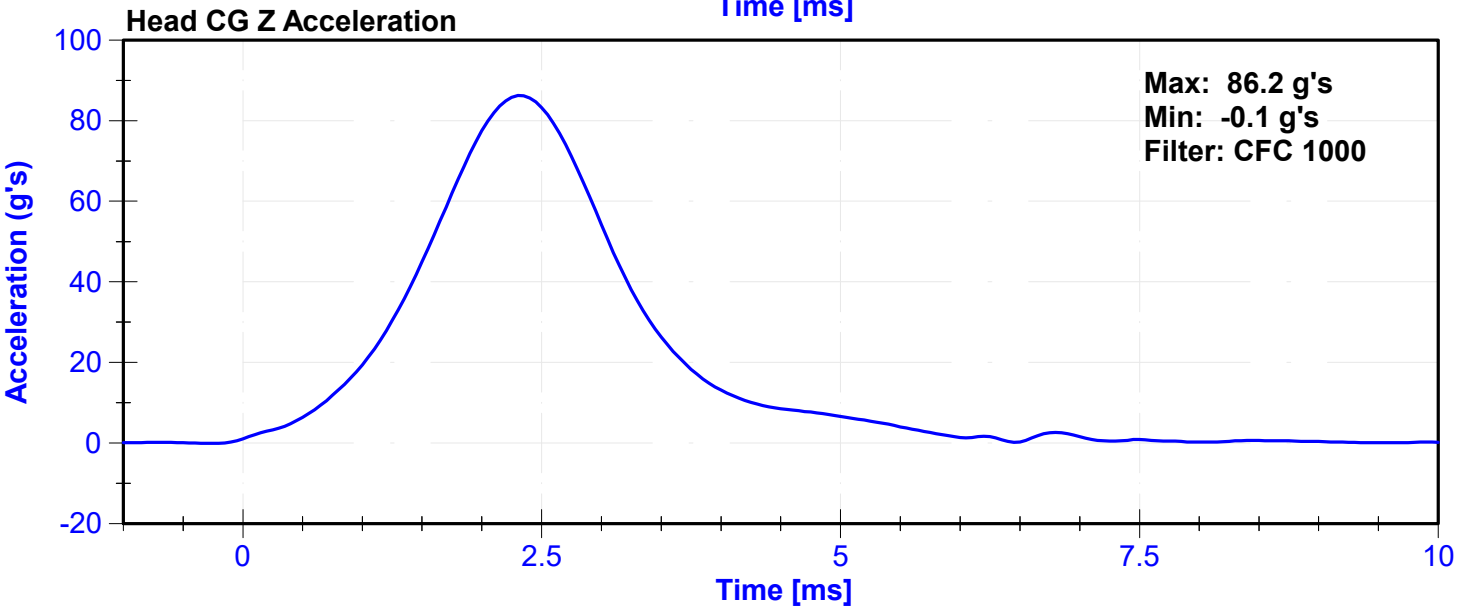
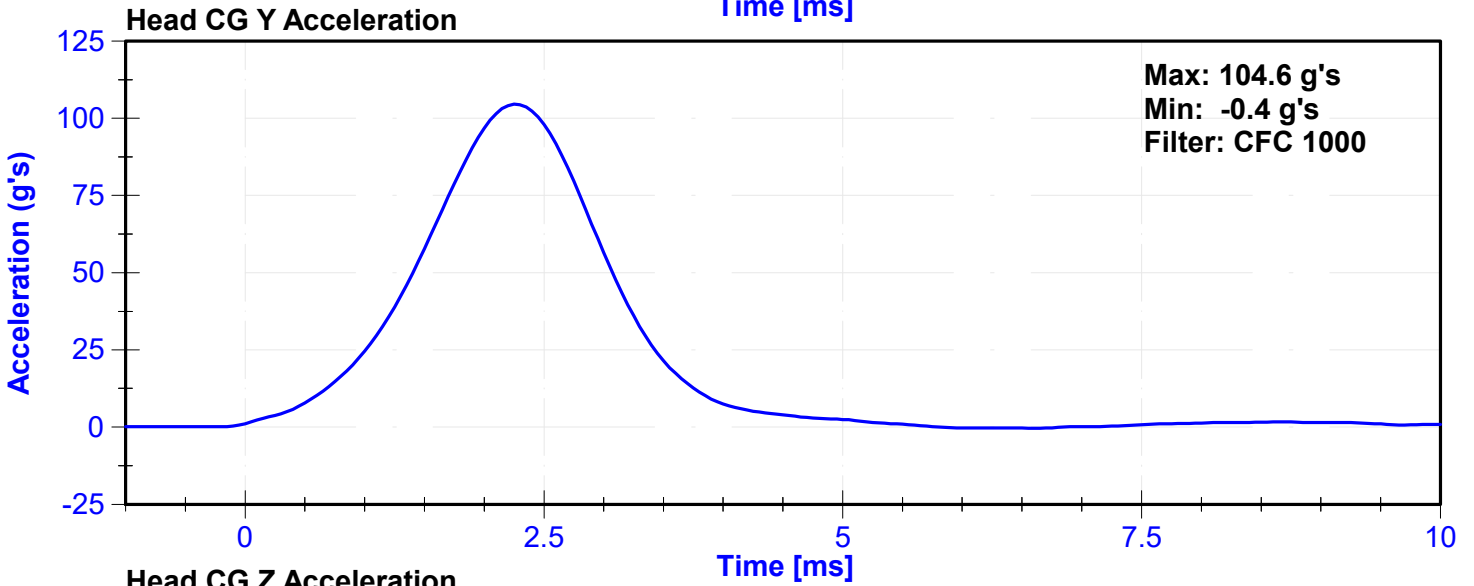
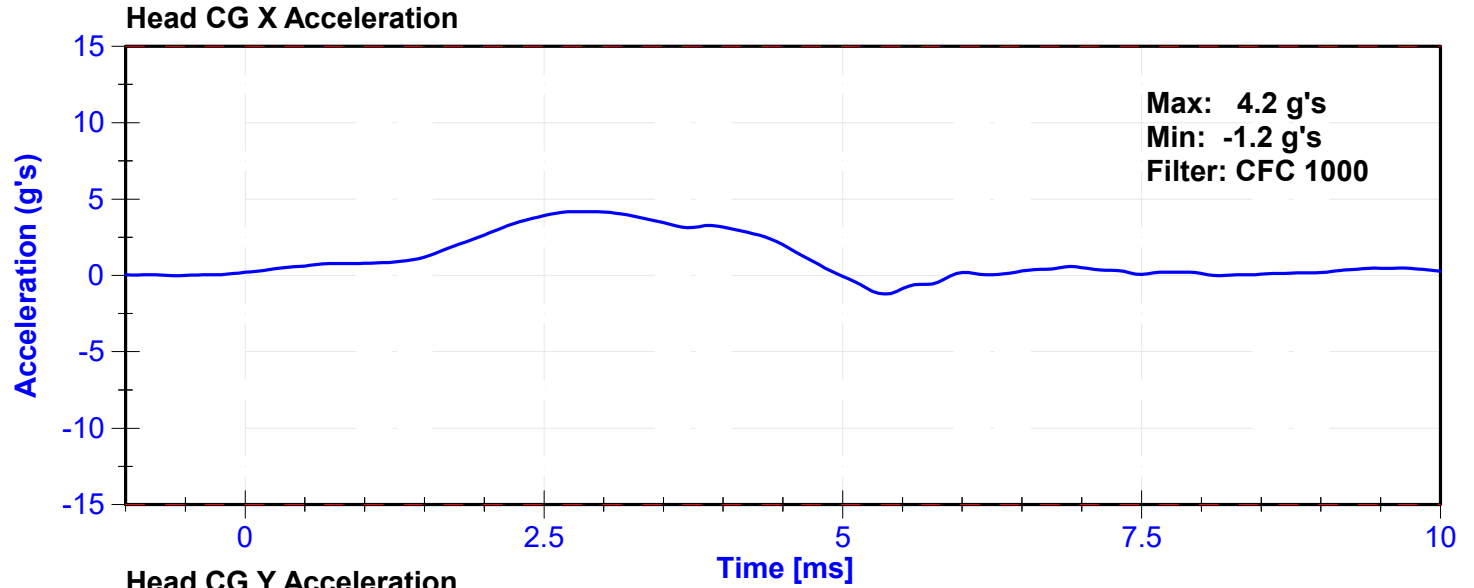

ATD Manufacturer	FTSS	Test Technician	J. Rios
ATD Serial Number	261	Laboratory Supervisor	C. Mantell

**Results**

Test Parameter	Minimum Specification	Maximum Specification	Unit	Result	Pass/Fail
Temperature	20.6	22.2	°C	21.0	Pass
Humidity	10	70	%	58	Pass
Velocity	5.51	5.63	m/s	5.533	Pass
Pendulum Impulse at 10ms	2.2	2.8	m/s	2.28	Pass
Pendulum Impulse at 15ms	3.3	4.1	m/s	3.46	Pass
Pendulum Impulse at 20ms	4.4	5.4	m/s	4.71	Pass
Pendulum Impulse at 25ms	5.4	6.1	m/s	5.66	Pass
Pendulum Impulse from 25 to 100ms	5.5	6.2	m/s	5.97	Pass
Neck Rotation	71	81	deg	71.0	Pass
Time at Maximum Rotation	50	70	ms	70.0	Pass
Moment about the OC	36	44	Nm	42.9	Pass
Moment Decay to 0 Nm	102	126	ms	112.1	Pass

**Transducer Calibrations**

Channel	Manufacturer	Serial Number	Calibration Date	Calibration Due Date
Pendulum Accelerometer	Endevco	7231C-750	4/29/2024	10/26/2024
Pendulum Potentiometer	Servo	4961	10/2/2023	10/1/2024
Condyle Potentiometer	Servo	DS185	10/2/2023	10/1/2024
Upper Neck Load Cell	Denton	1716A_2187-FY	12/5/2023	12/4/2024

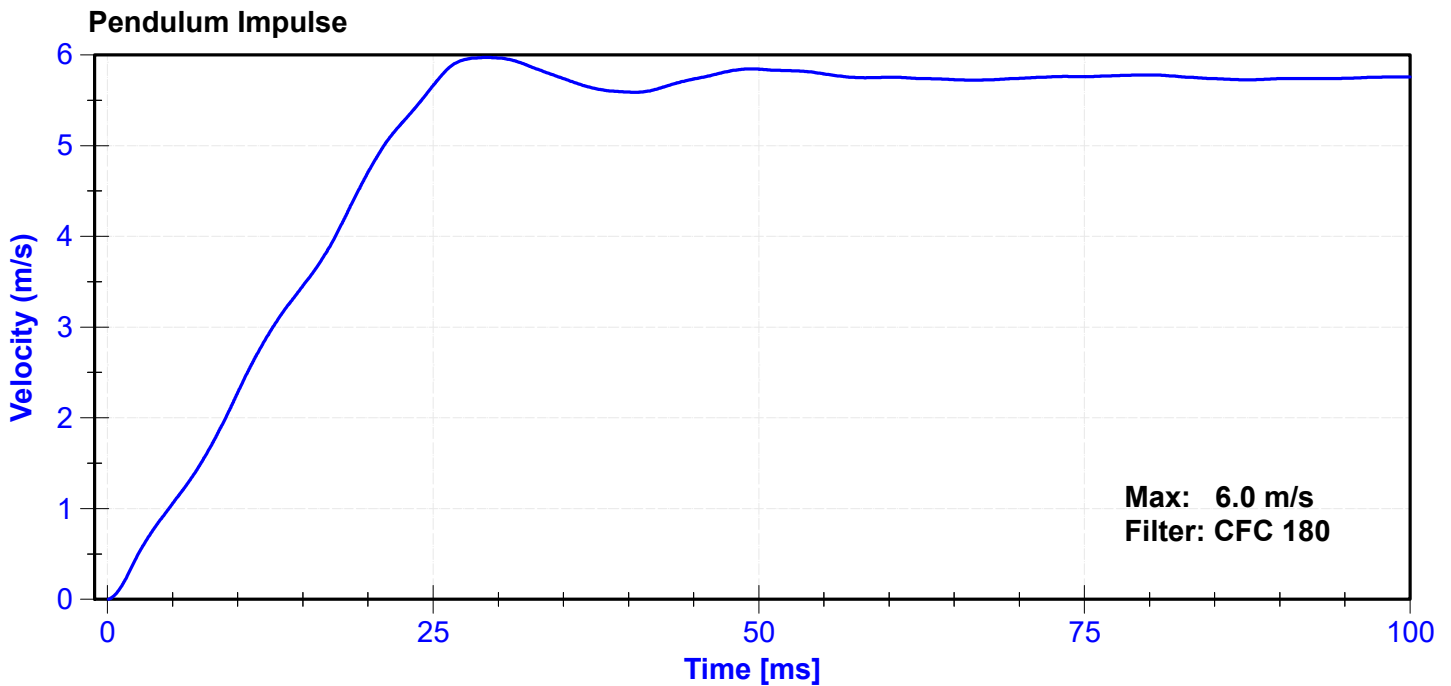

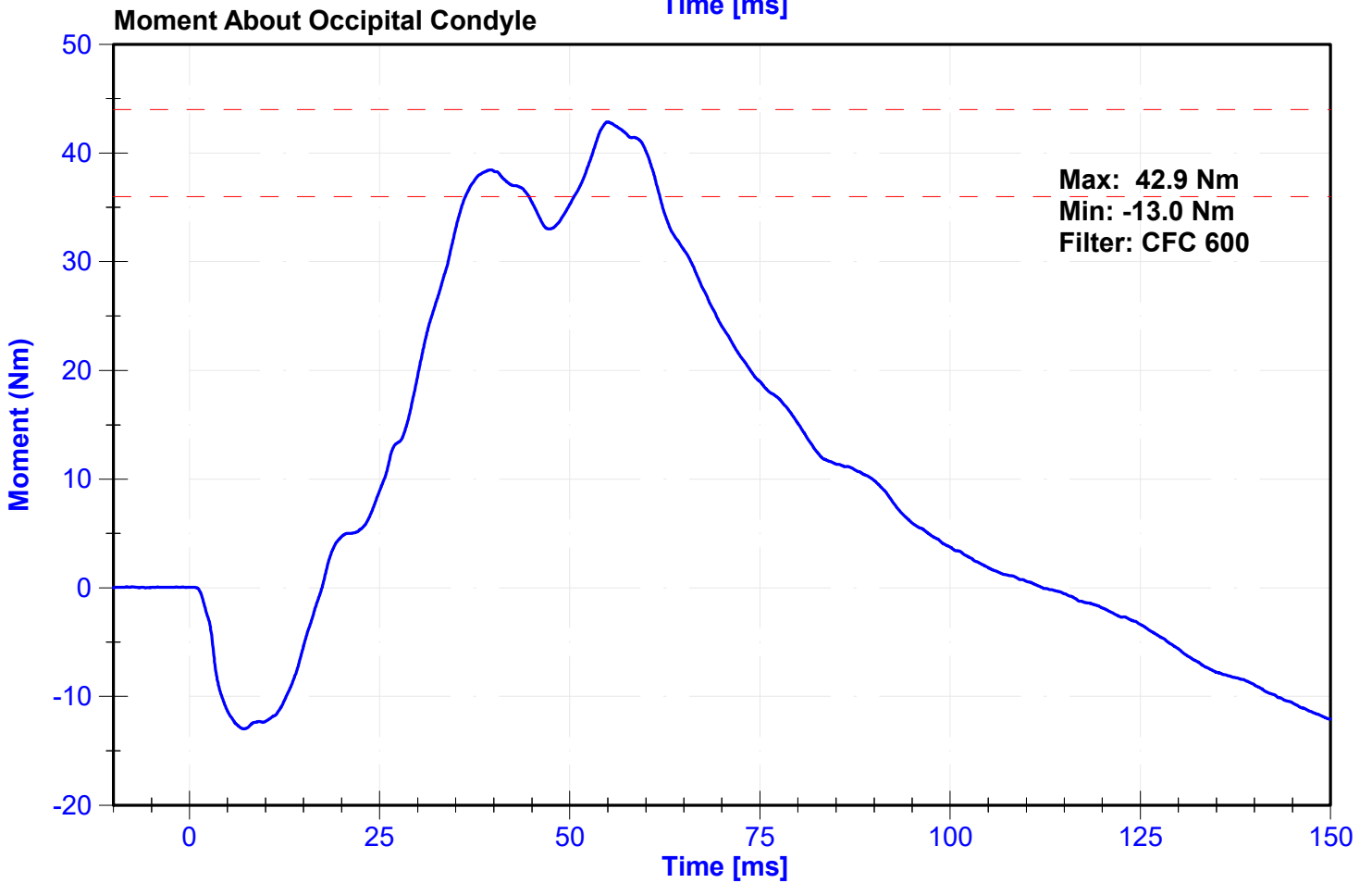
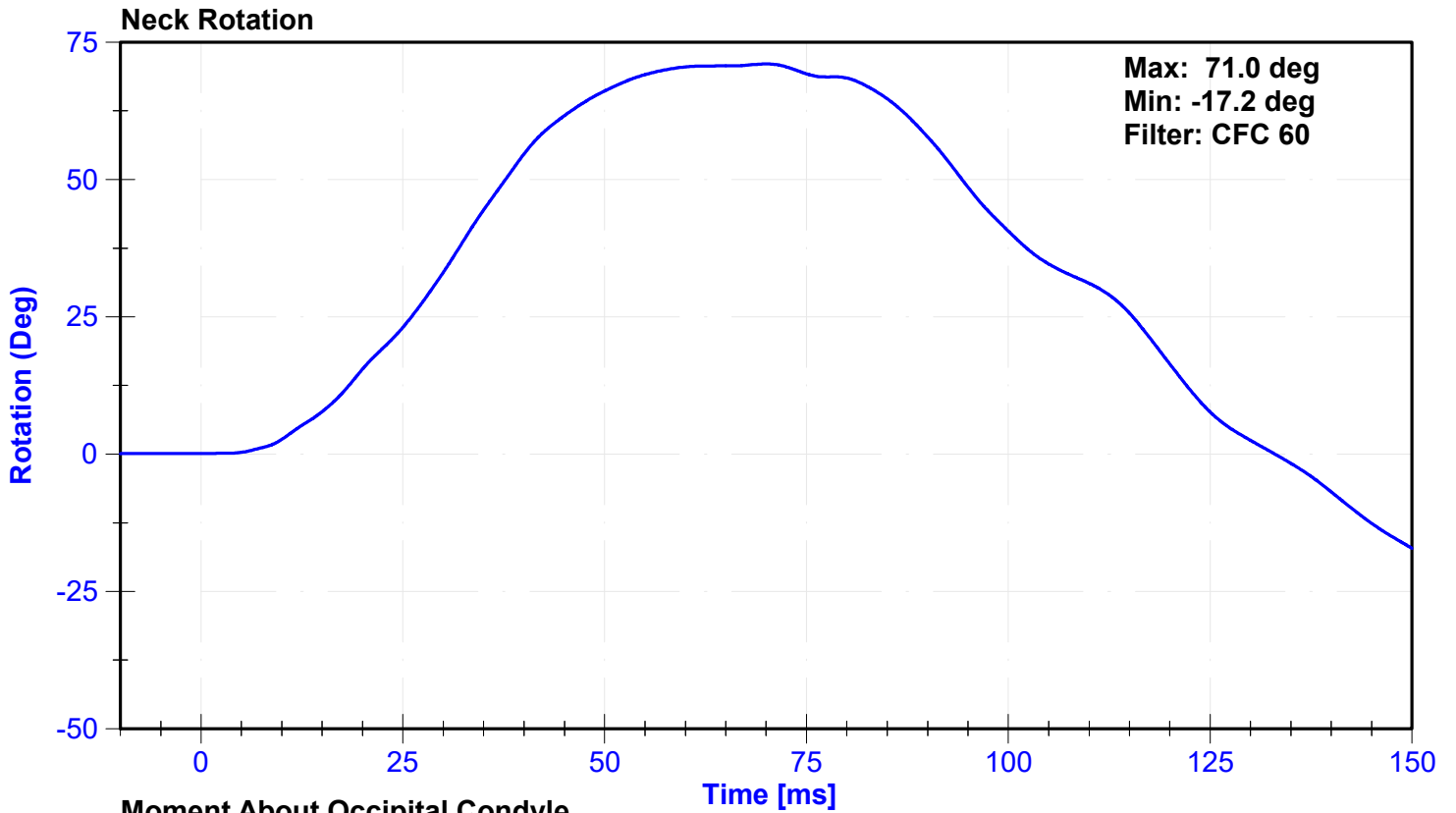

ATD Manufacturer	FTSS	Test Technician	J. Rios
ATD Serial Number	261	Laboratory Supervisor	C. Mantell

**Results**

Test Parameter	Minimum Specification	Maximum Specification	Unit	Result	Pass/Fail
Temperature	20.6	22.2	°C	20.9	Pass
Humidity	10	70	%	45	Pass
Velocity	4.2	4.4	m/s	4.30	Pass
Probe Acceleration	13	18	g's	16.4	Pass
Shoulder Deflection	28	37	mm	29.6	Pass
Lateral Upper Spine Acceleration	17	22	g's	20.3	Pass

**Transducer Calibrations**

Channel	Manufacturer	Serial Number	Calibration Date	Calibration Due Date
Pendulum Accelerometer	Endevco	18527	8/2/2024	1/29/2025
Shoulder Potentiometer	Servo	572GFE	5/16/2024	11/14/2024
Upper Spine Y Accelerometer	Endevco	P94678	5/15/2024	11/11/2024

**Probe Acceleration**

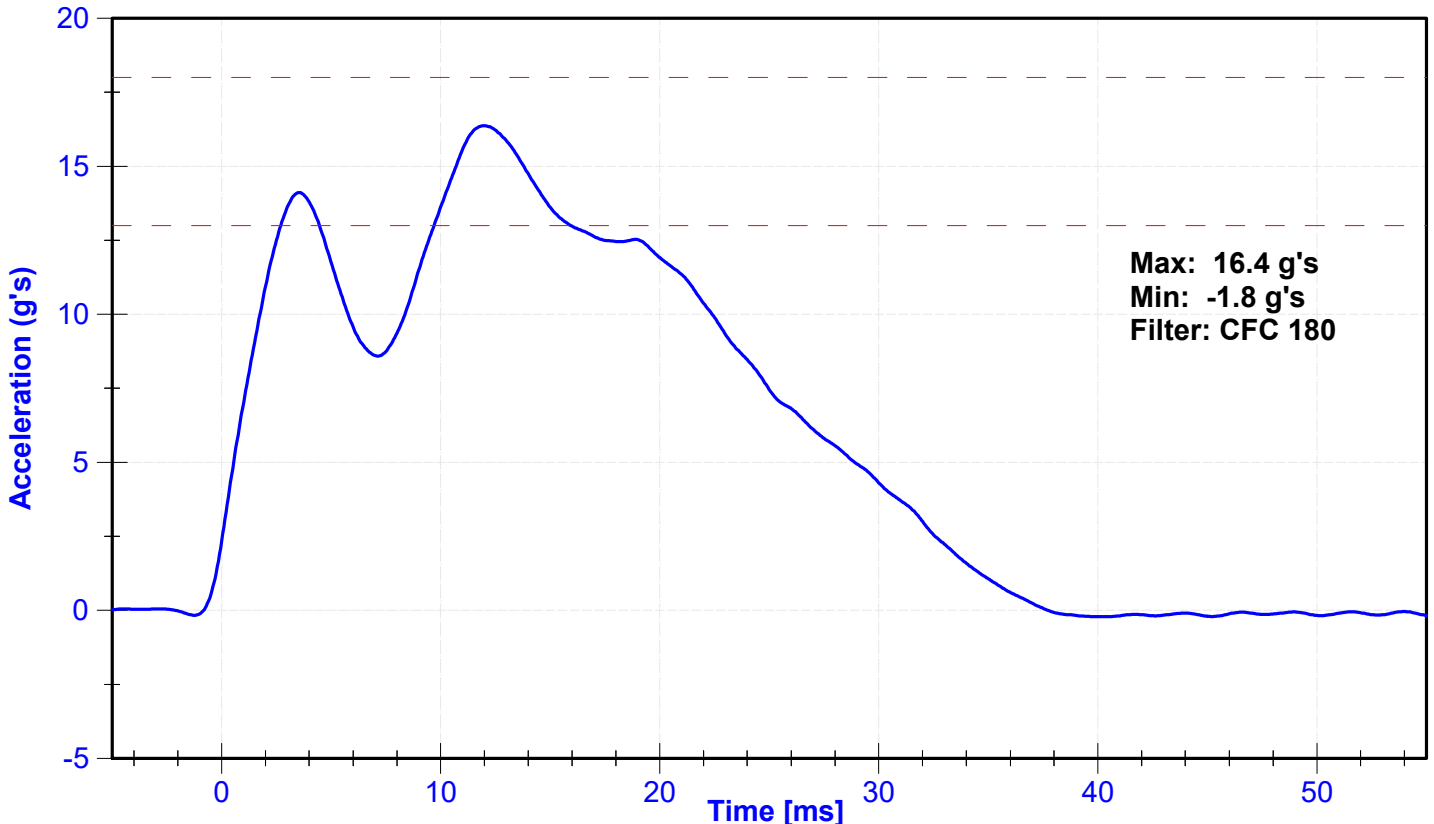

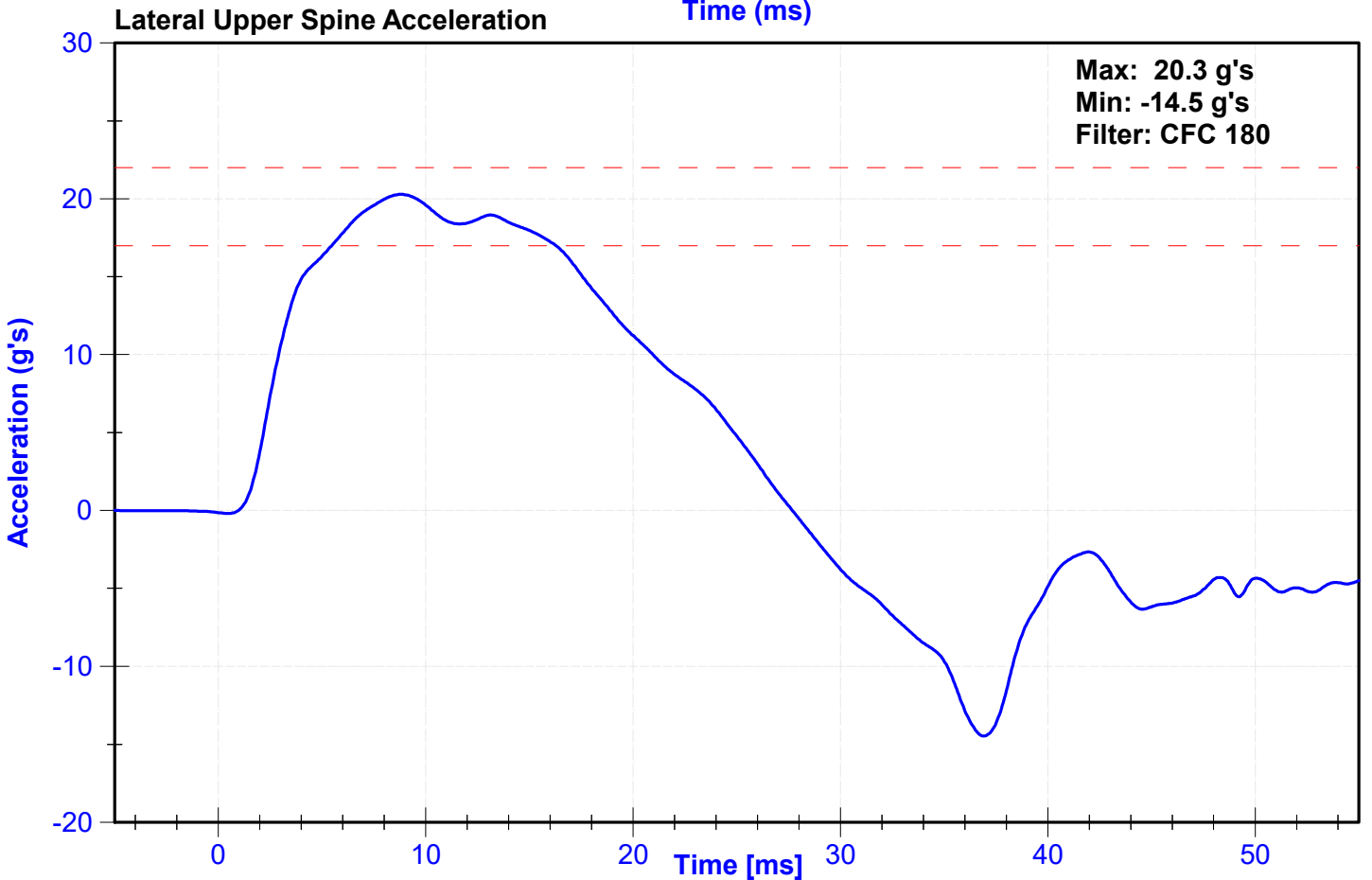
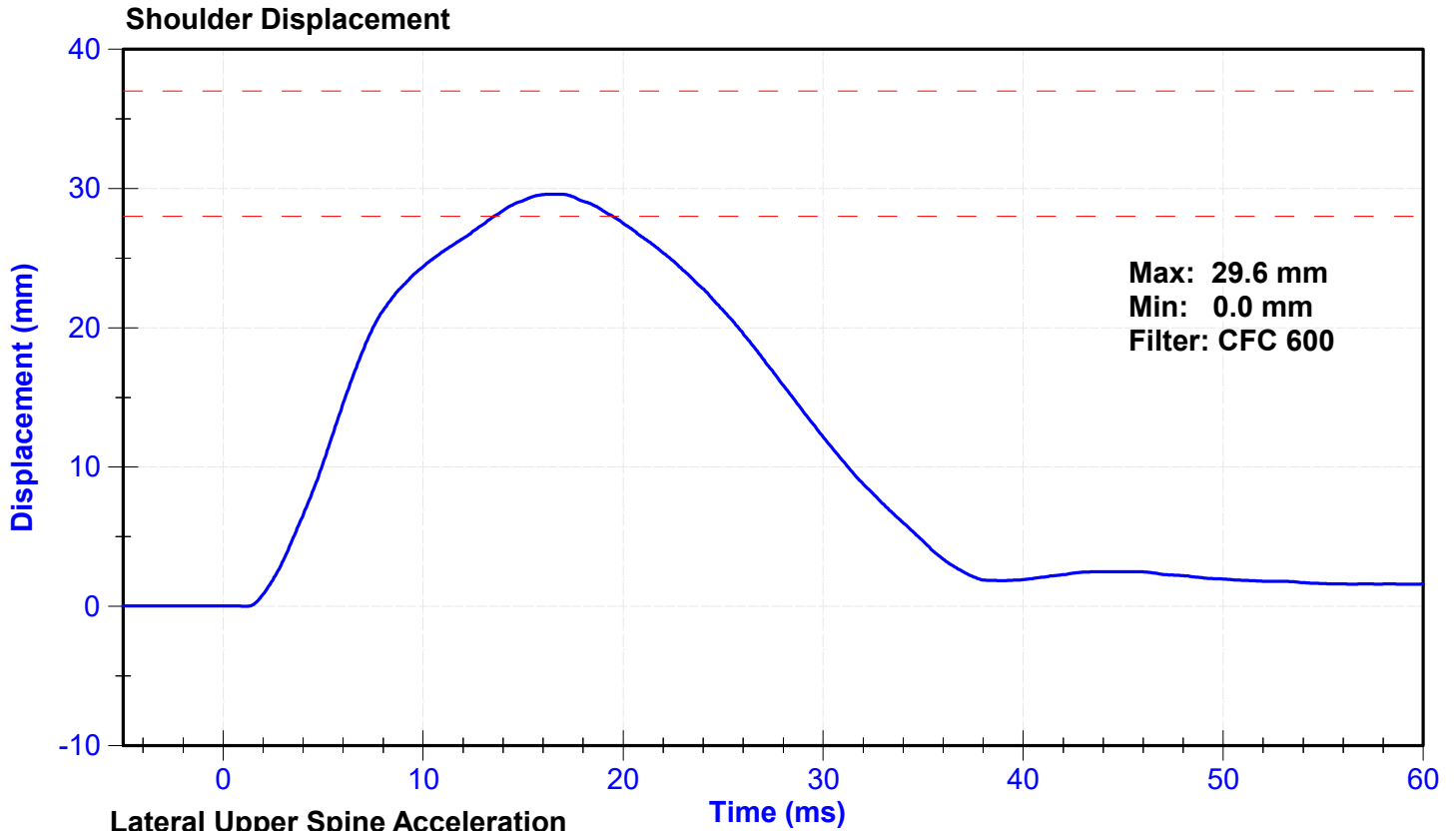

ATD Manufacturer	FTSS	Test Technician	J. Rios
ATD Serial Number	261	Laboratory Supervisor	C. Mantell

**Results**

Test Parameter	Minimum Specification	Maximum Specification	Unit	Result	Pass/Fail
Temperature	20.6	22.2	°C	20.9	Pass
Humidity	10	70	%	45	Pass
Velocity	6.6	6.8	m/s	6.67	Pass
Probe Acceleration after 5 ms	30	36	g's	33.1	Pass
Lateral Upper Spine Acceleration	34	43	g's	41.2	Pass
Lateral Lower Spine Acceleration	29	37	g's	33.2	Pass
Shoulder Deflection	31	40	mm	34.4	Pass
Upper Thorax Rib Deflection	25	32	mm	26.0	Pass
Mid Thorax Rib Deflection	30	36	mm	30.1	Pass
Lower Thorax Rib Deflection	32	38	mm	32.1	Pass

**Transducer Calibrations**

Channel	Manufacturer	Serial Number	Calibration Date	Calibration Due Date
Pendulum Accelerometer	Endevco	18527	8/2/2024	1/29/2025
Upper Spine T1 Y Accelerometer	Endevco	P94678	5/15/2024	11/11/2024
Upper Spine T12 Y Accelerometer	Endevco	P58744	5/15/2024	11/11/2024
Shoulder Potentiometer	Servo	572GFE	5/16/2024	11/14/2024
Upper Thorax Rib Potentiometer	Servo	062GFE	5/16/2024	11/14/2024
Middle Thorax Rib Potentiometer	Servo	528GFE	5/16/2024	11/14/2024
Lower Thorax Rib Potentiometer	Servo	513GFE	5/16/2024	11/14/2024

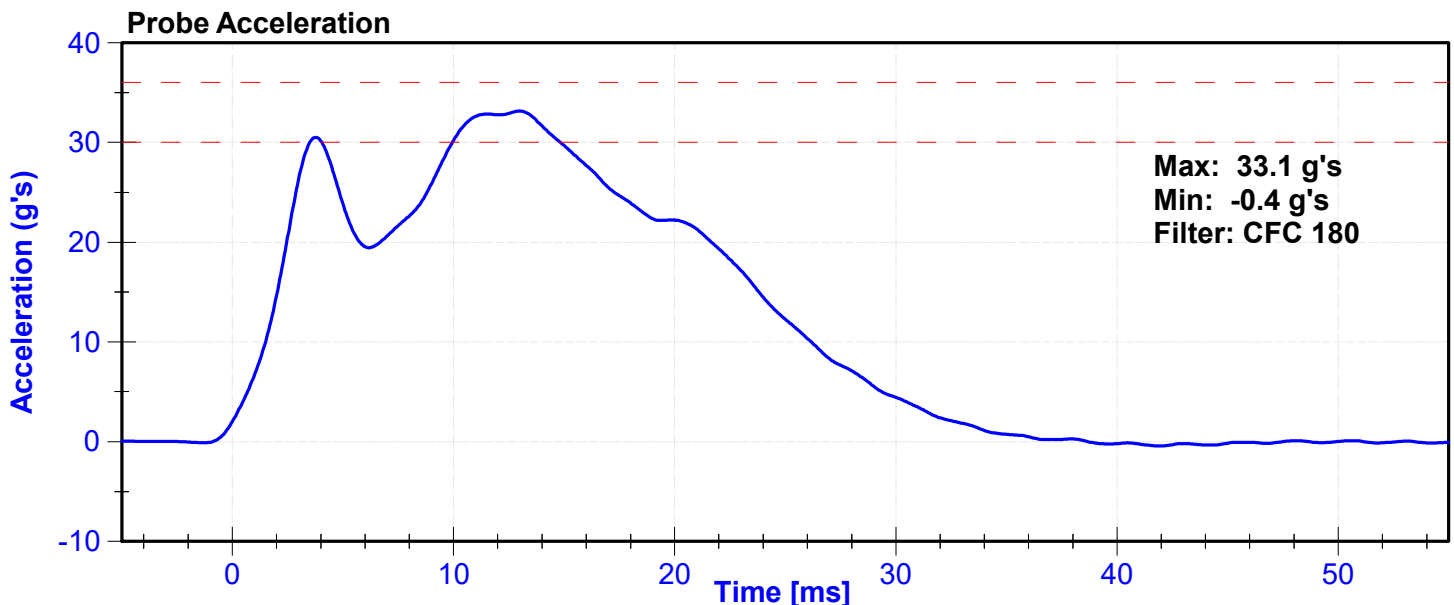

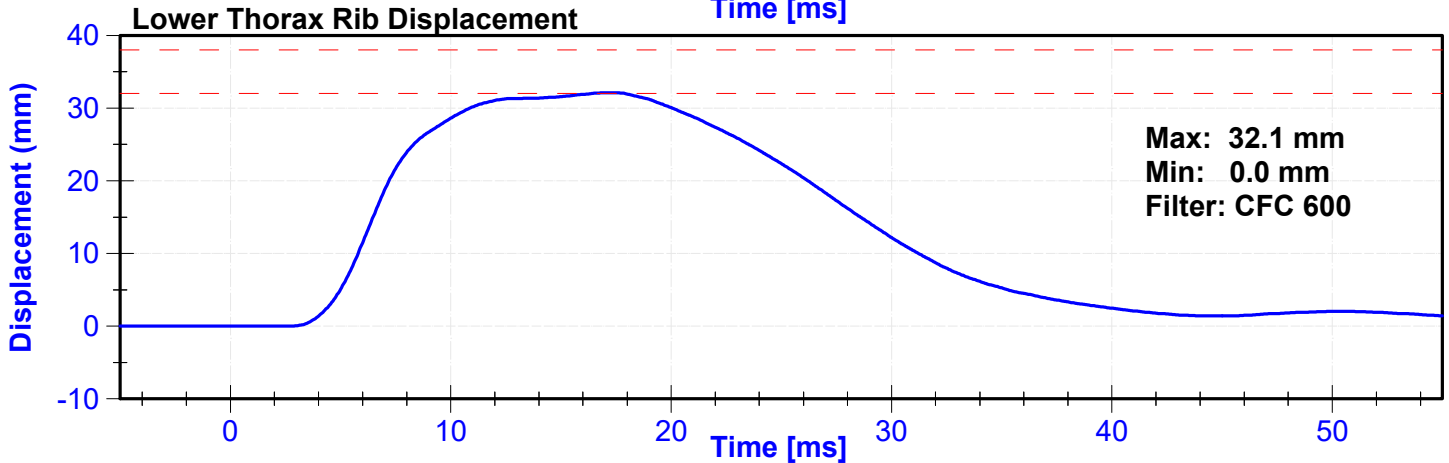
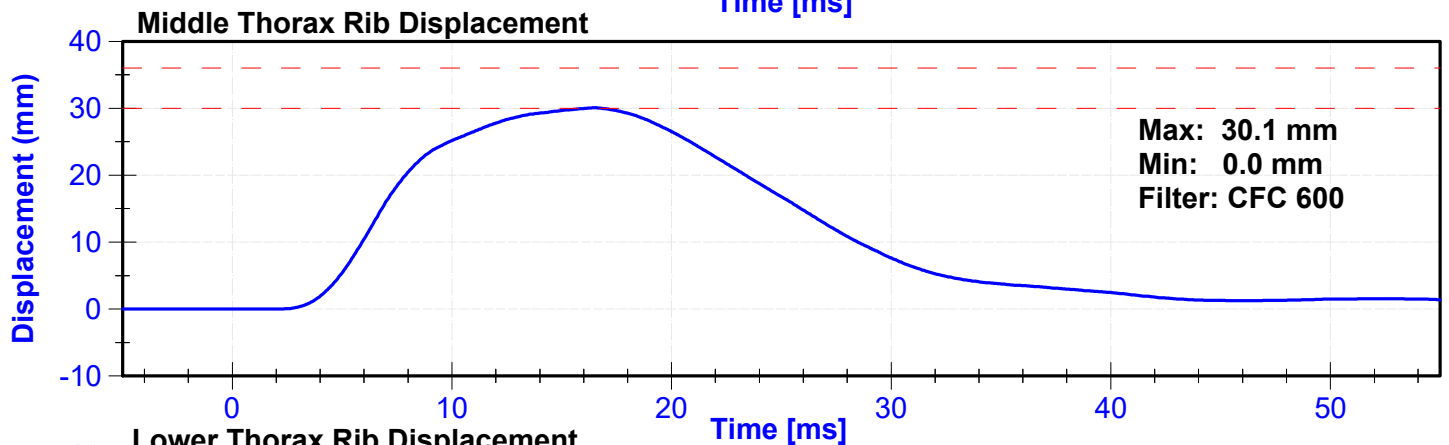
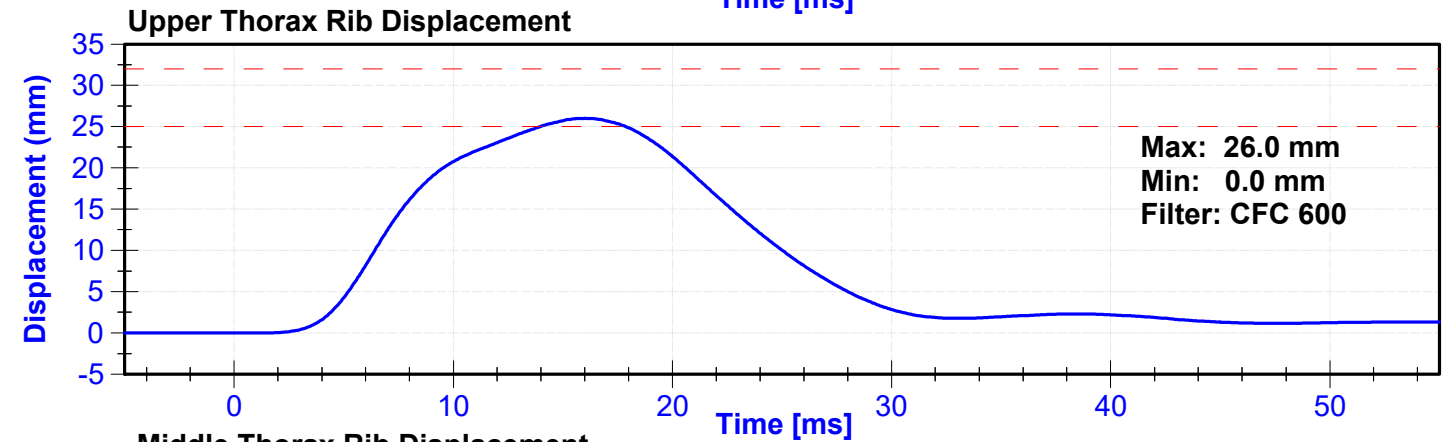
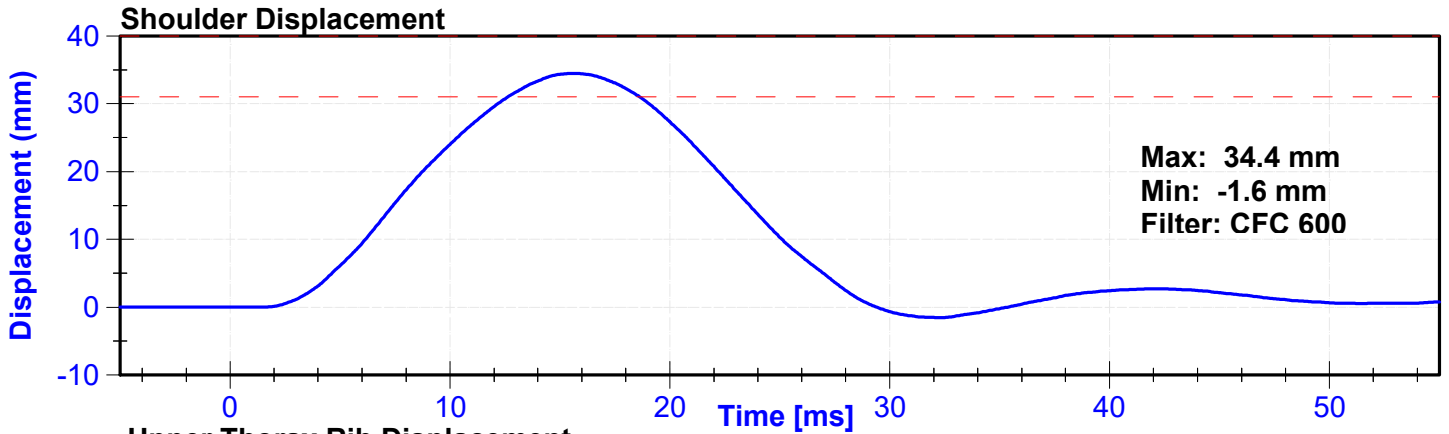

### Lateral Upper Spine Acceleration

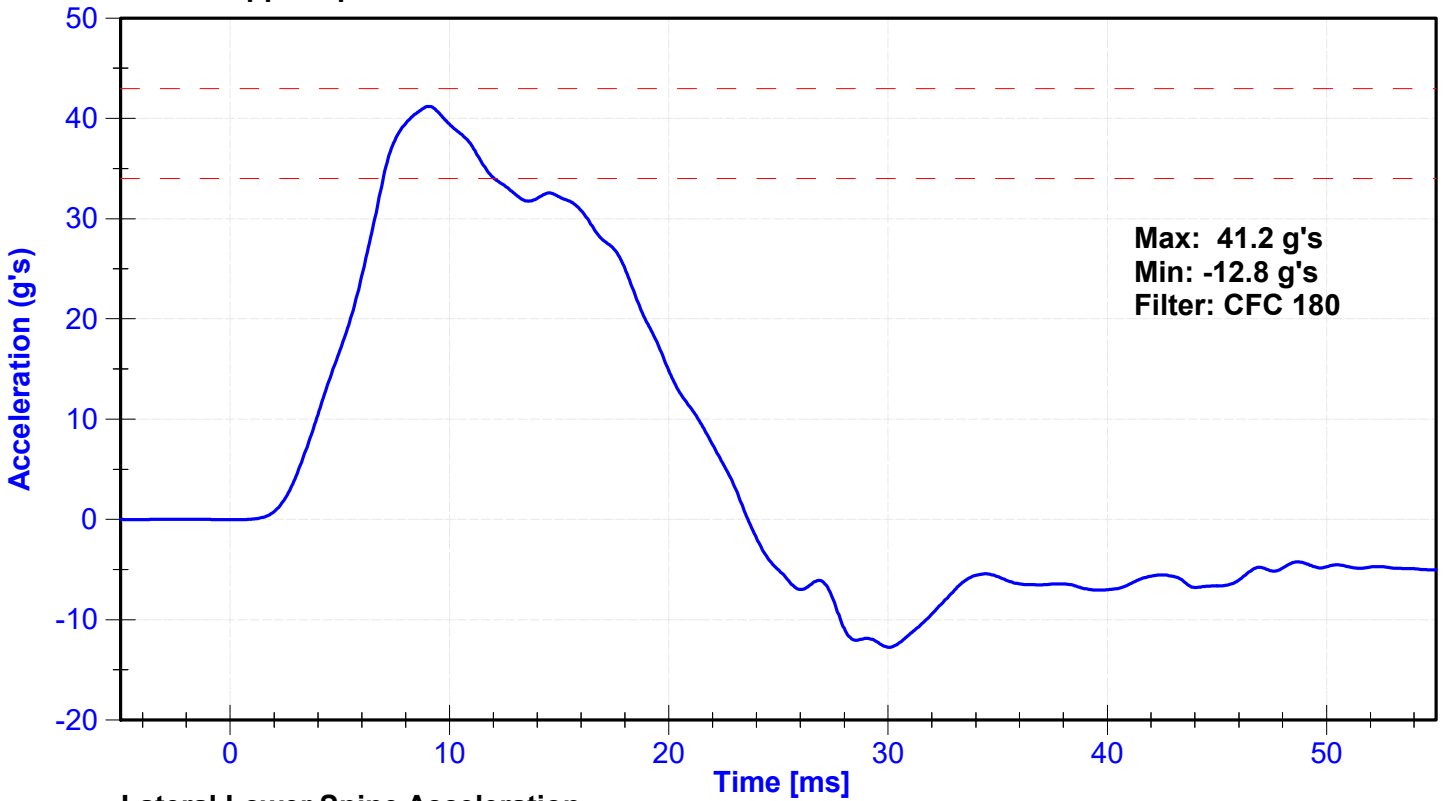

### Lateral Lower Spine Acceleration

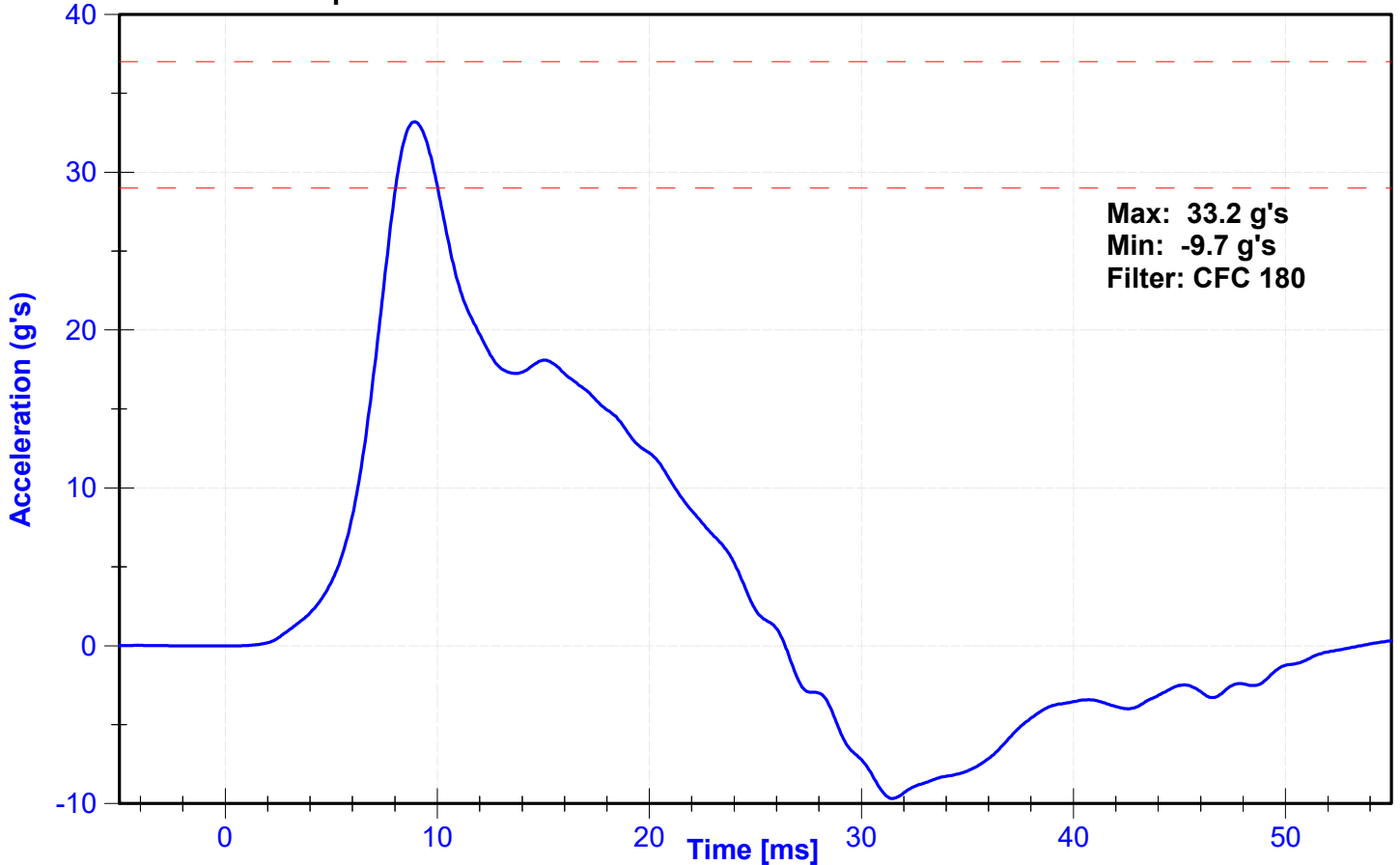

ATD Manufacturer	FTSS	Test Technician	J. Rios
ATD Serial Number	261	Laboratory Supervisor	C. Mantell

**Results**

Test Parameter	Minimum Specification	Maximum Specification	Unit	Result	Pass/Fail
Temperature	20.6	22.2	°C	20.9	Pass
Humidity	10	70	%	45	Pass
Velocity	4.2	4.4	m/s	4.20	Pass
Probe Acceleration	14	18	g's	16.5	Pass
Lateral Upper Spine Acceleration	13	17	g's	15.5	Pass
Lateral Lower Spine Acceleration	7	11	g's	8.9	Pass
Upper Thorax Rib Deflection	32	40	mm	35.4	Pass
Middle Thorax Rib Deflection	39	45	mm	39.1	Pass
Lower Thorax Rib Deflection	35	43	mm	35.0	Pass

**Transducer Calibrations**

Channel	Manufacturer	Serial Number	Calibration Date	Calibration Due Date
Pendulum Accelerometer	Endevco	18527	8/2/2024	1/29/2025
Upper Spine Y Accelerometer	Endevco	P94678	5/15/2024	11/11/2024
Lower Spine Y Accelerometer	Endevco	P58744	5/15/2024	11/11/2024
Upper Thorax Rib Potentiometer	Servo	062GFE	5/16/2024	11/14/2024
Middle Thorax Rib Potentiometer	Servo	528GFE	5/16/2024	11/14/2024
Lower Thorax Rib Potentiometer	Servo	513GFE	5/16/2024	11/14/2024

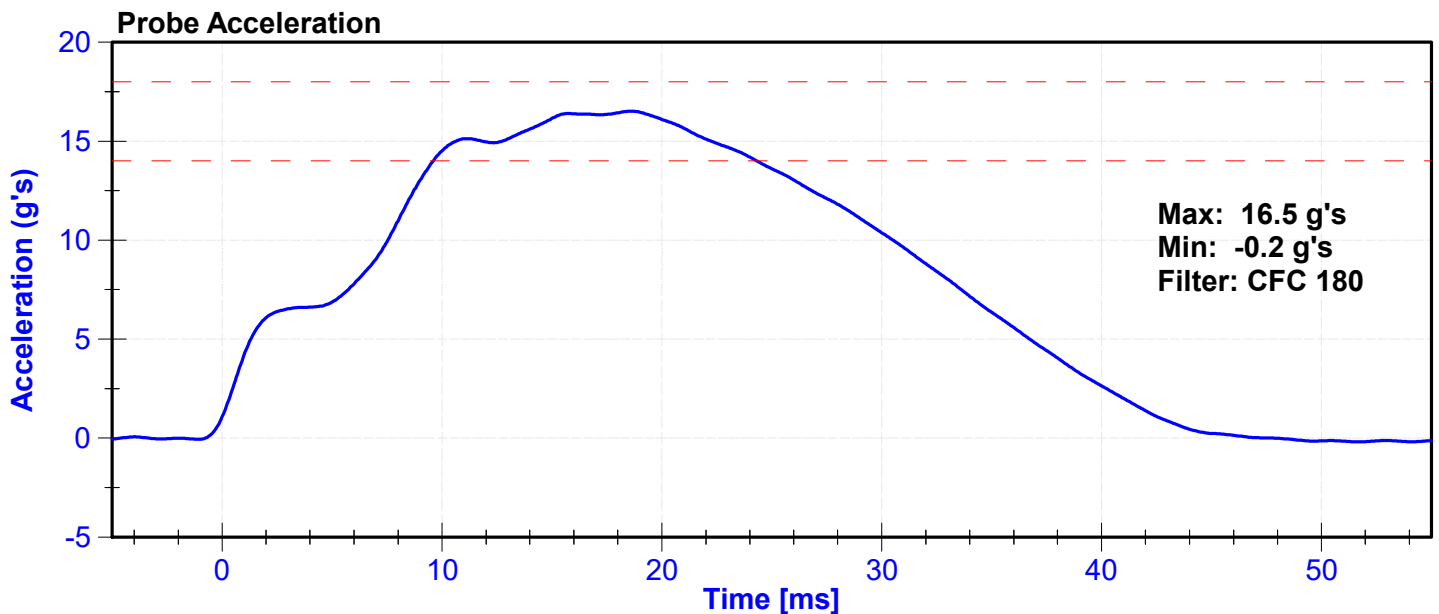

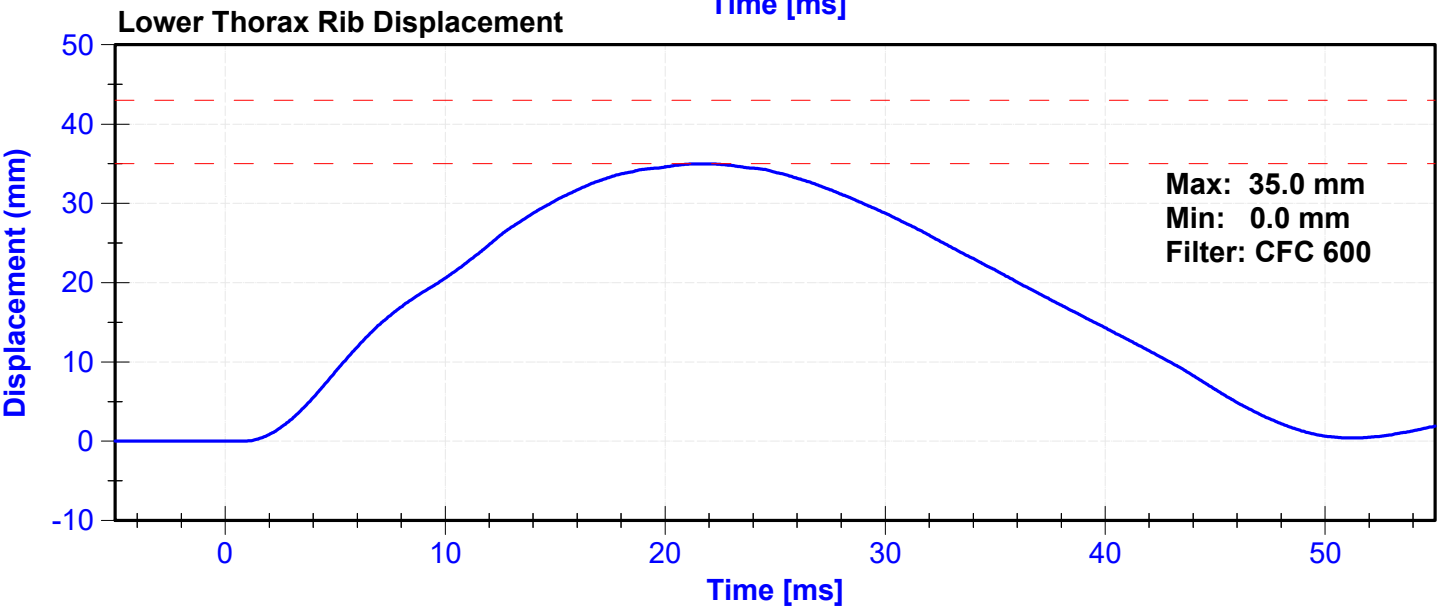
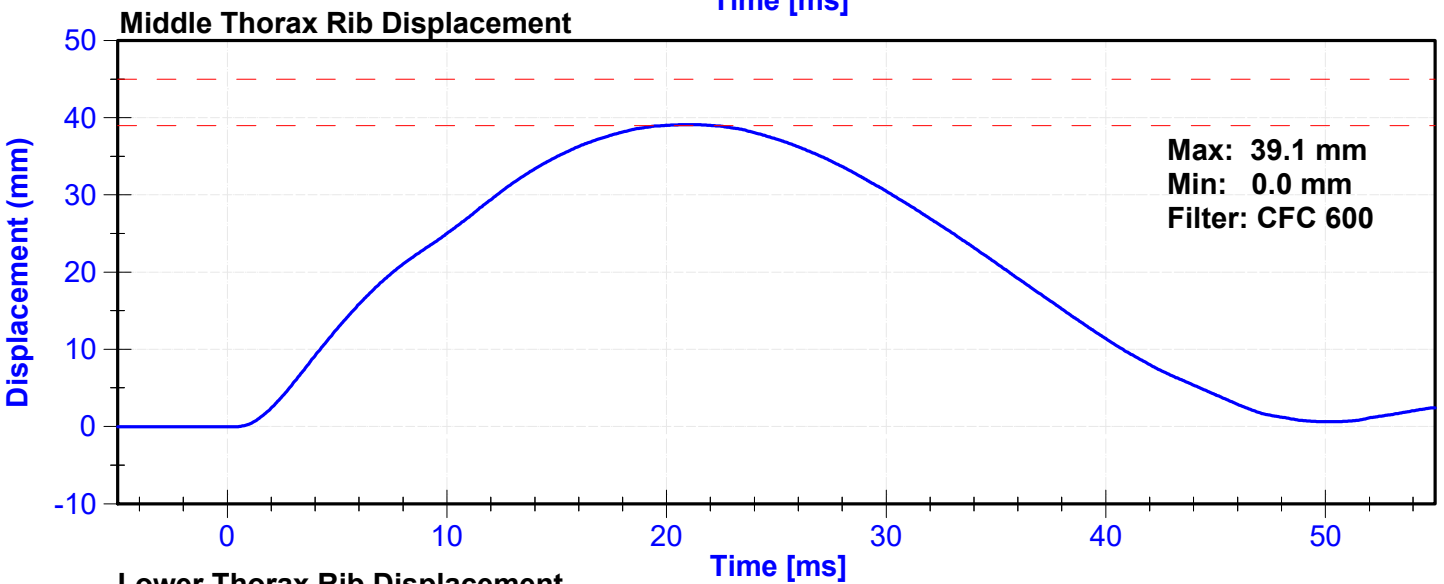
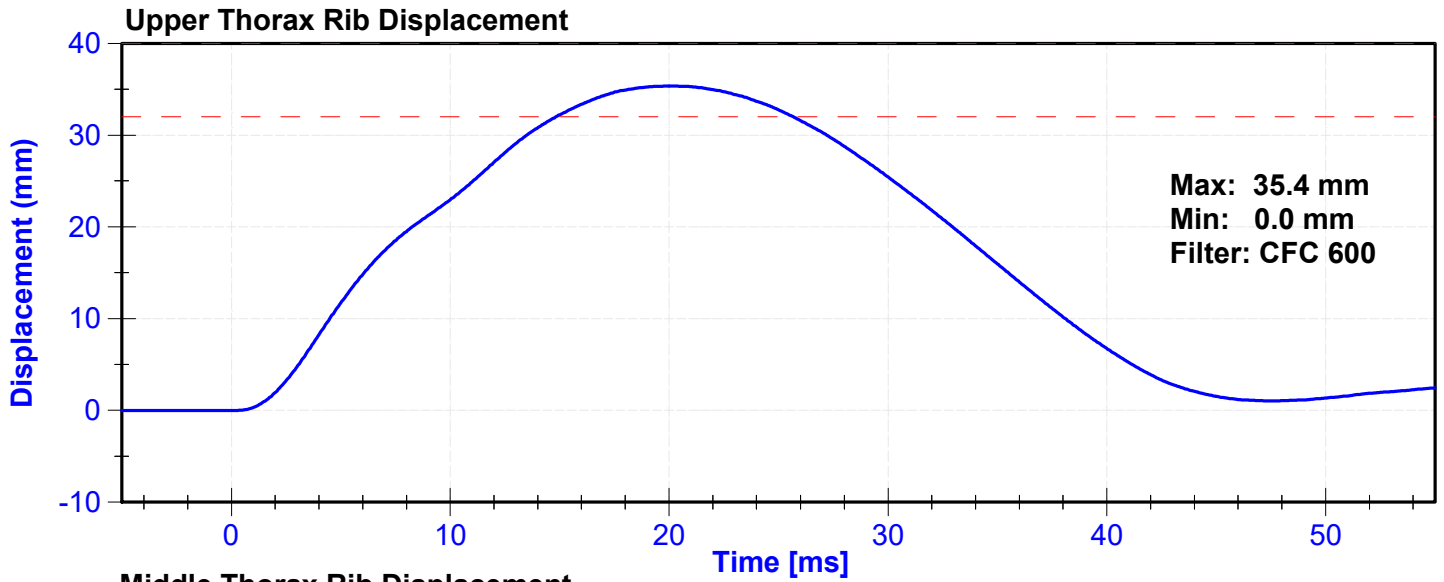

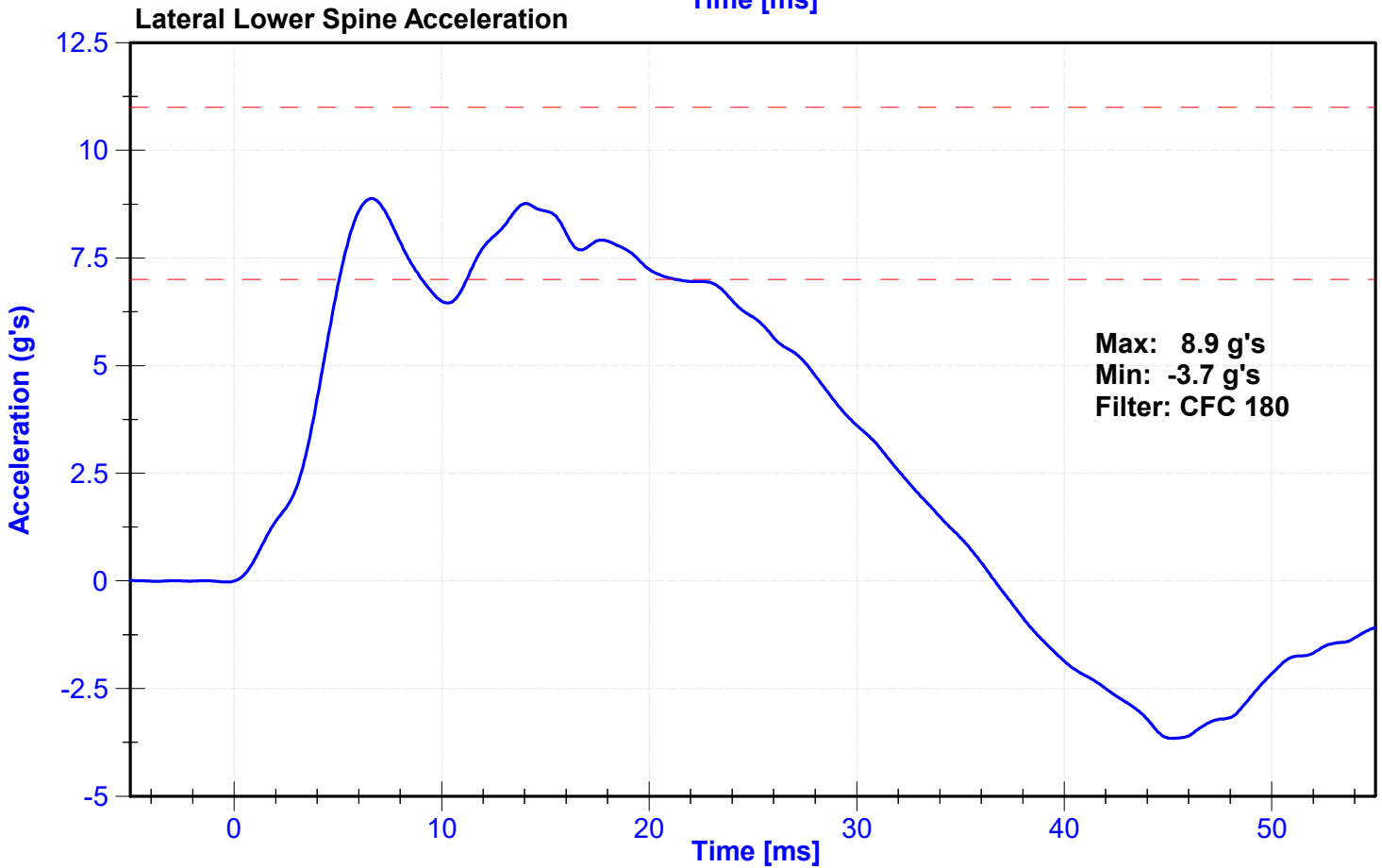
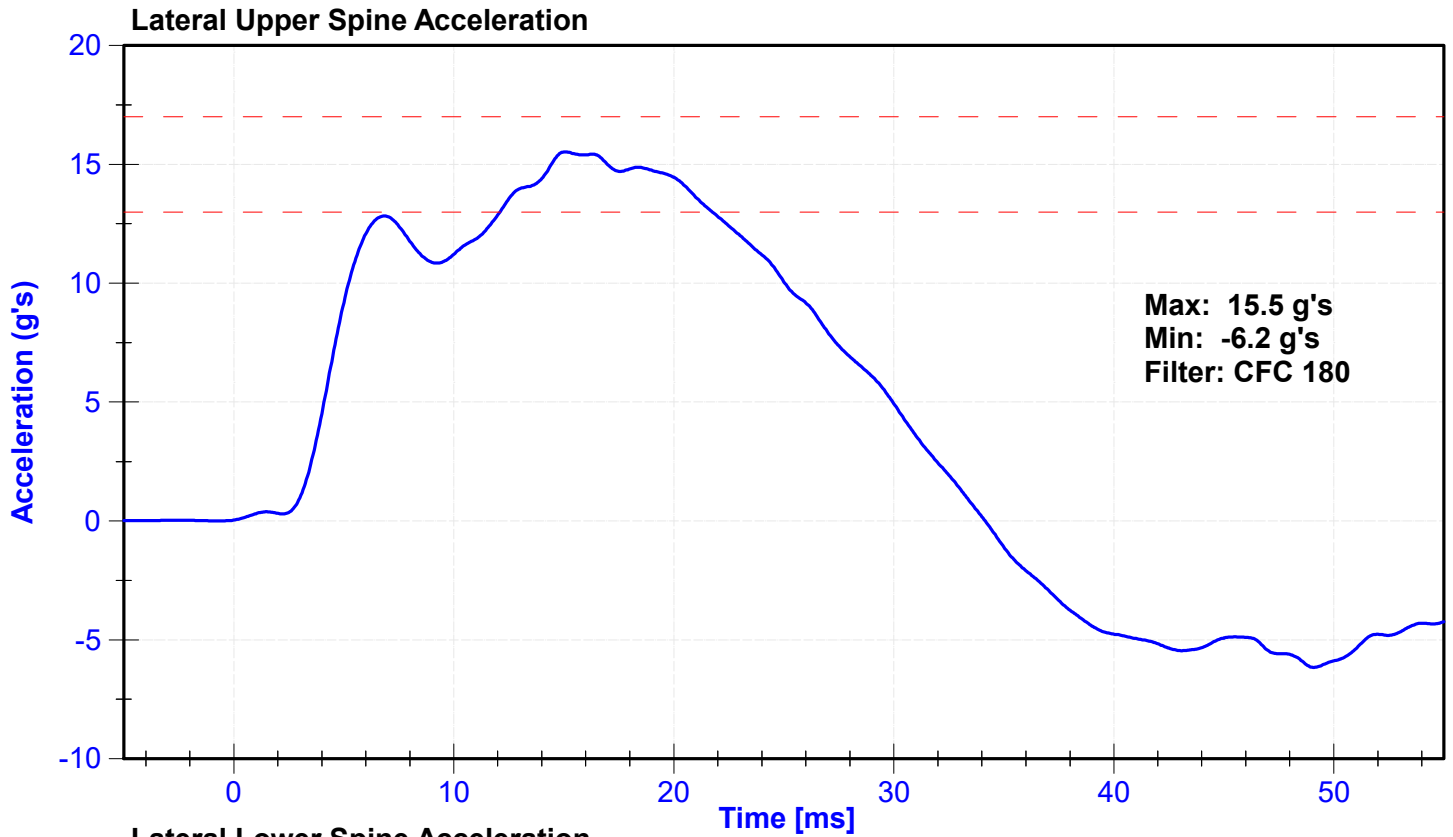

ATD Manufacturer	FTSS	Test Technician	J. Rios
ATD Serial Number	261	Laboratory Supervisor	C. Mantell

**Results**

Test Parameter	Minimum Specification	Maximum Specification	Unit	Result	Pass/Fail
Temperature	20.6	22.2	°C	20.9	Pass
Humidity	10	70	%	45	Pass
Velocity	4.2	4.4	m/s	4.29	Pass
Probe Acceleration	12	16	g's	13.9	Pass
Lateral Lower Spine Acceleration	9	14	g's	9.8	Pass
Upper Abdomen Rib Deflection	36	47	mm	38.1	Pass
Lower Abdomen Rib Deflection	33	44	mm	43.8	Pass

**Transducer Calibrations**

Channel	Manufacturer	Serial Number	Calibration Date	Calibration Due Date
Probe Accelerometer	Endevco	18527	8/2/2024	1/29/2025
Lower Spine Y Accelerometer	Endevco	P58744	5/15/2024	11/11/2024
Upper Abdomen Rib Potentiometer	Servo	342GFE	5/16/2024	11/14/2024
Lower Abdomen Rib Potentiometer	Servo	512GFE	5/16/2024	11/14/2024

**Probe Acceleration**

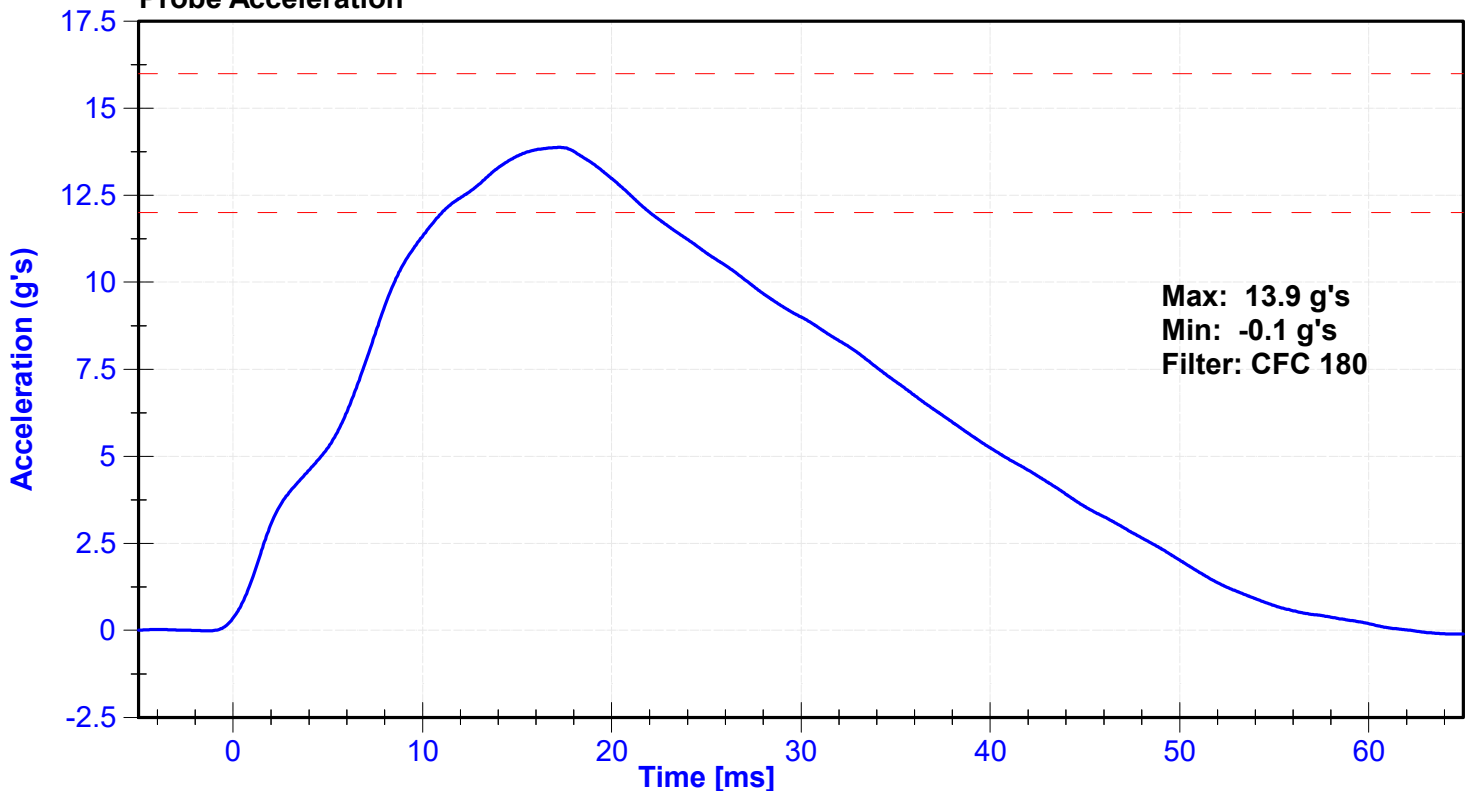

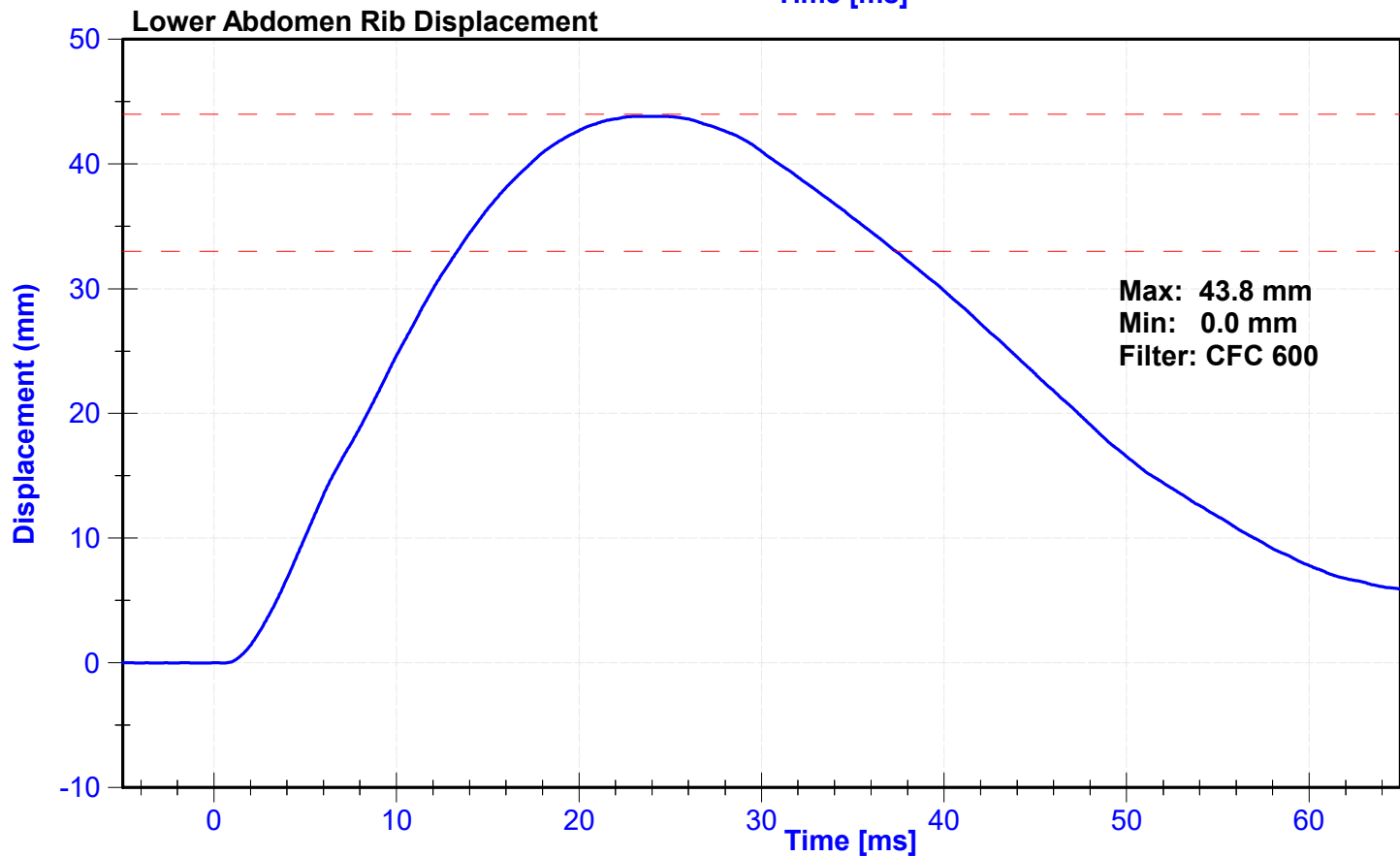
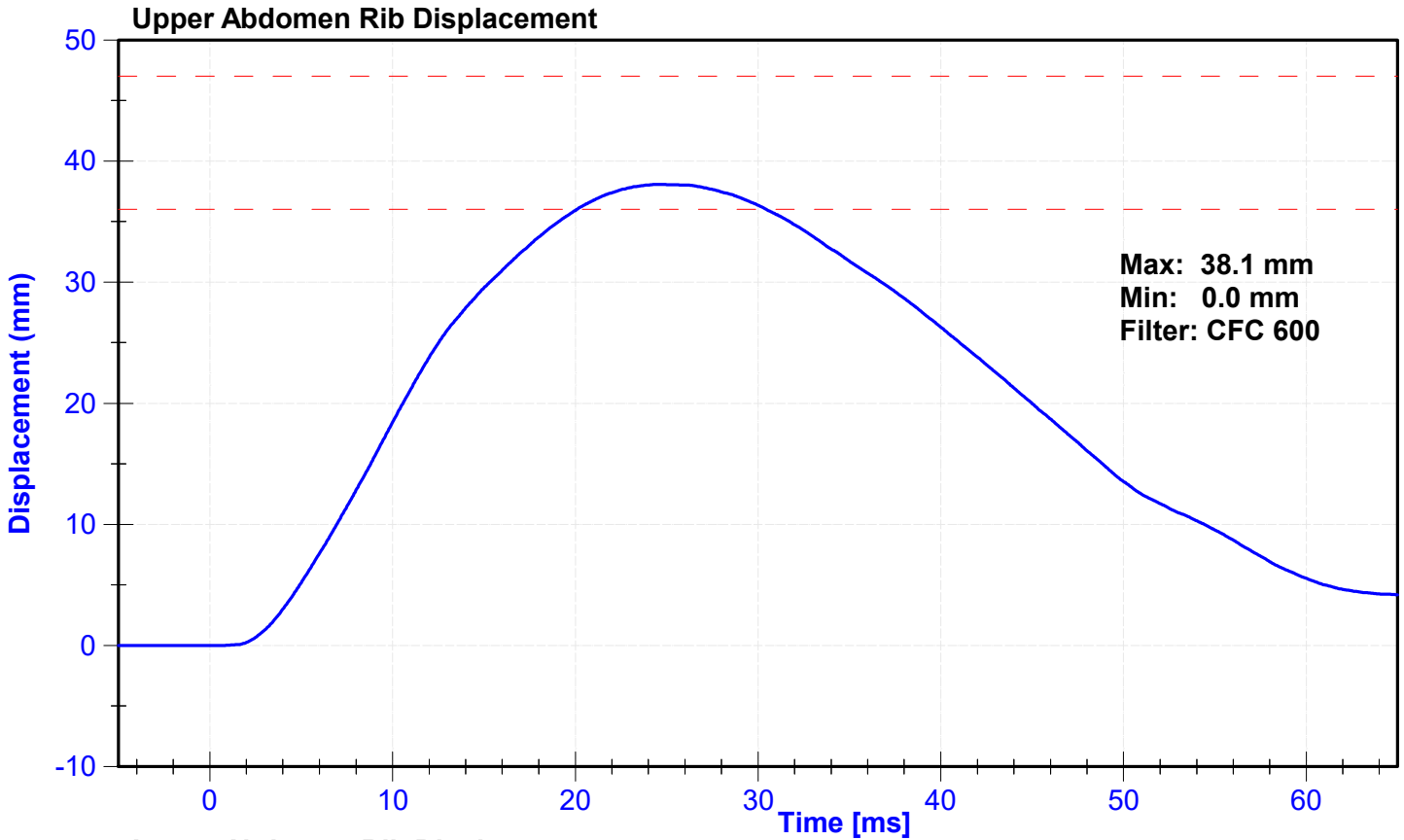

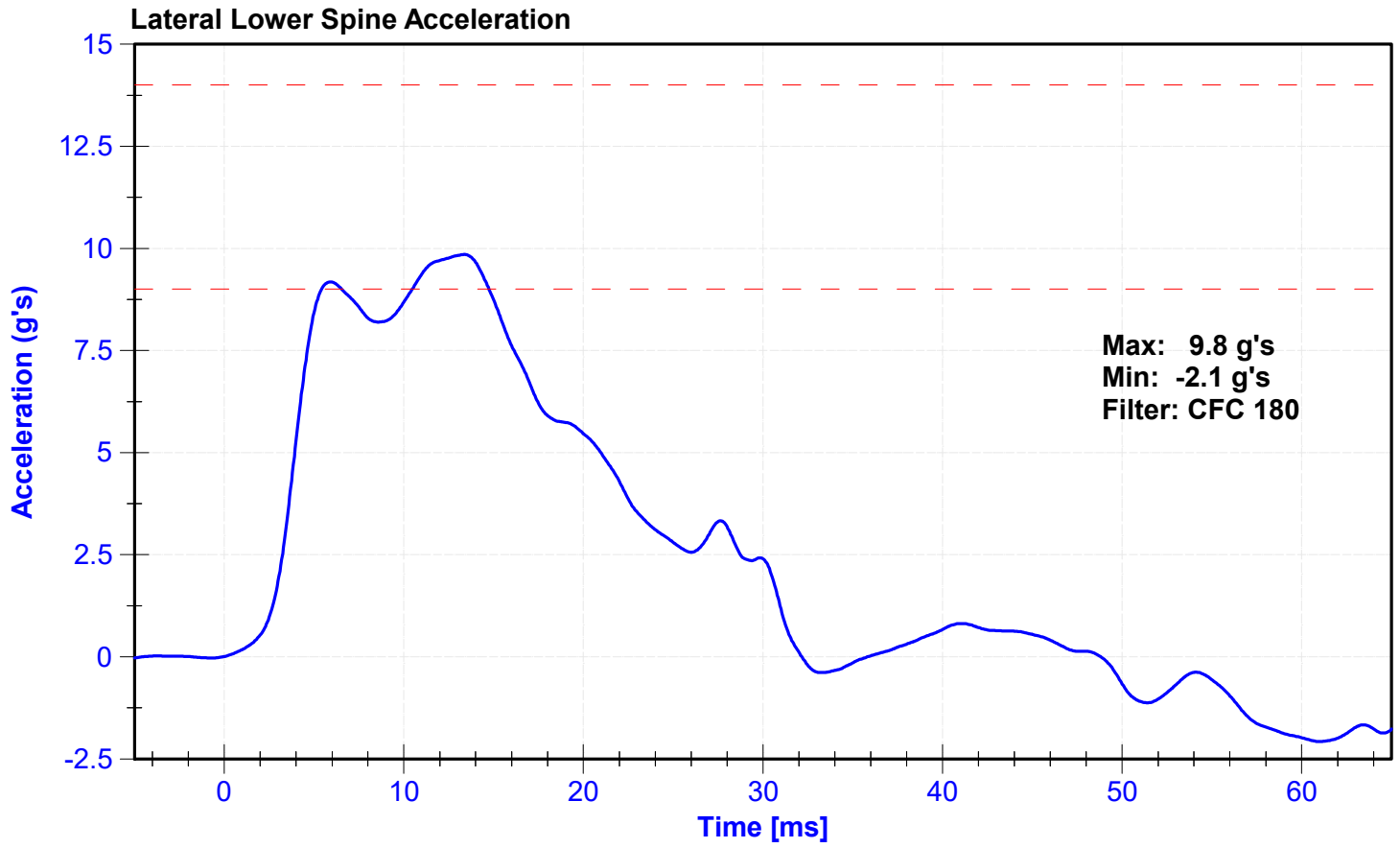

ATD Manufacturer	FTSS	Test Technician	J. Rios
ATD Serial Number	261	Laboratory Supervisor	C. Mantell

**Results**

Test Parameter	Minimum Specification	Maximum Specification	Unit	Result	Pass/Fail
Temperature	20.6	22.2	°C	20.9	Pass
Humidity	10	70	%	45	Pass
Velocity	6.6	6.8	m/s	6.67	Pass
Probe Acceleration	38	47	g's	46.8	Pass
Lateral Pelvis Acceleration after 6ms	34	42	g's	39.2	Pass
Acetabulum Force	3600	4300	N	4073.2	Pass

**Transducer Calibrations**

Channel	Manufacturer	Serial Number	Calibration Date	Calibration Due Date
Pendulum Accelerometer	Endevco	18527	8/2/2024	1/29/2025
Pelvis Y Accelerometer	Endevco	T29392	5/15/2024	11/11/2024
Acetabulum Load Cell	FTSS	236-FY	12/5/2023	12/4/2024
Certification Plug	SACO			N/A
Crash Test Plug	SACO			N/A

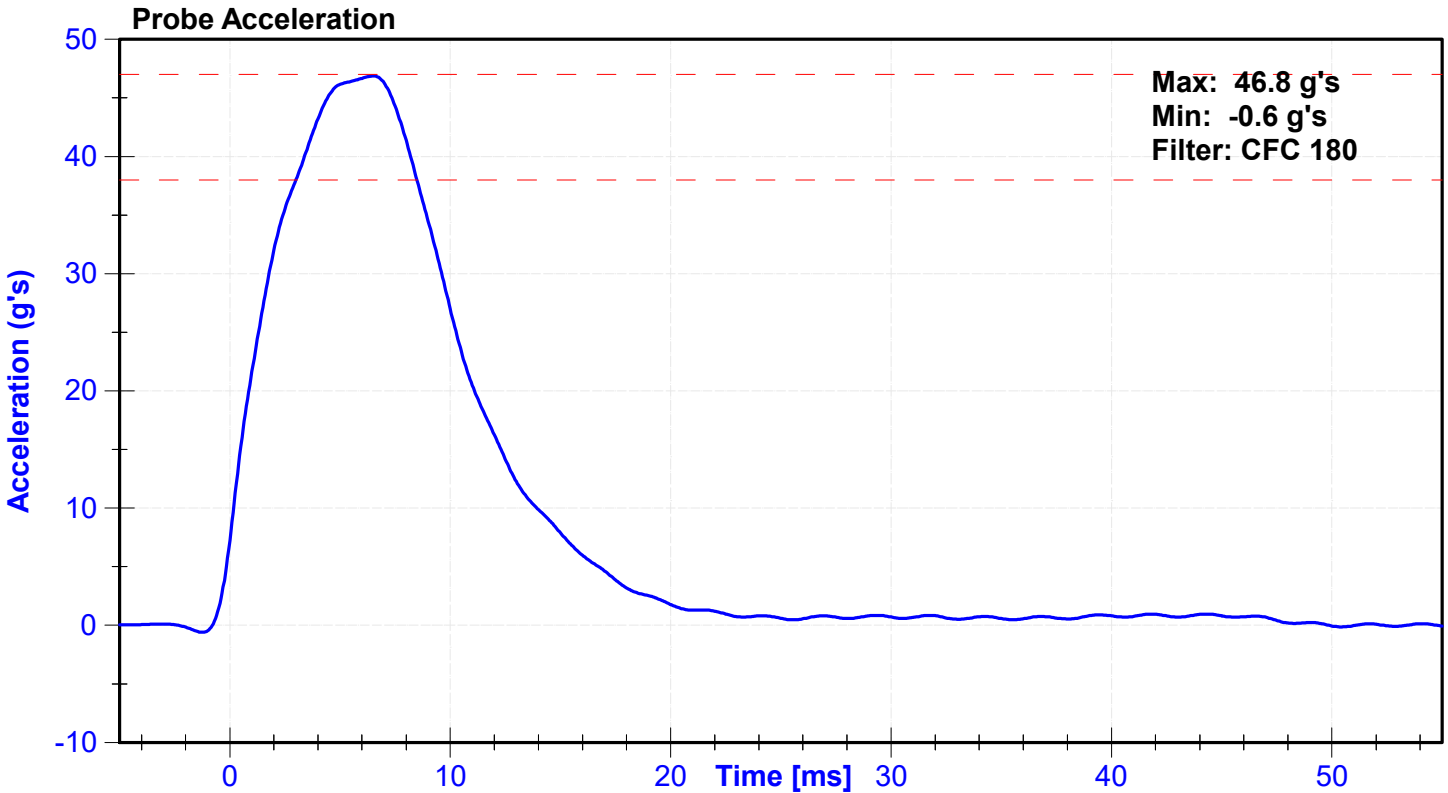

### Lateral Pelvis Acceleration

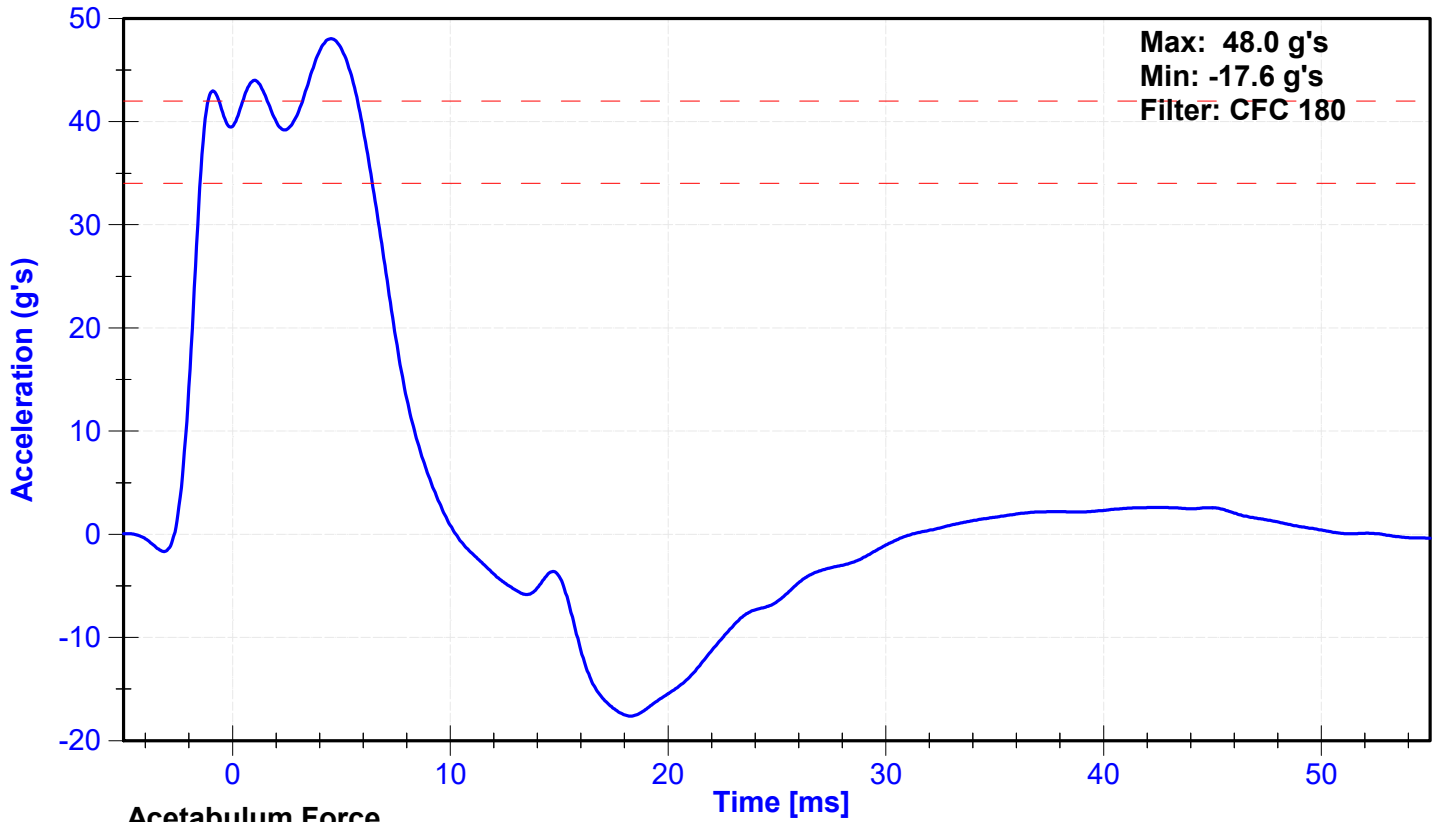

### Acetabulum Force

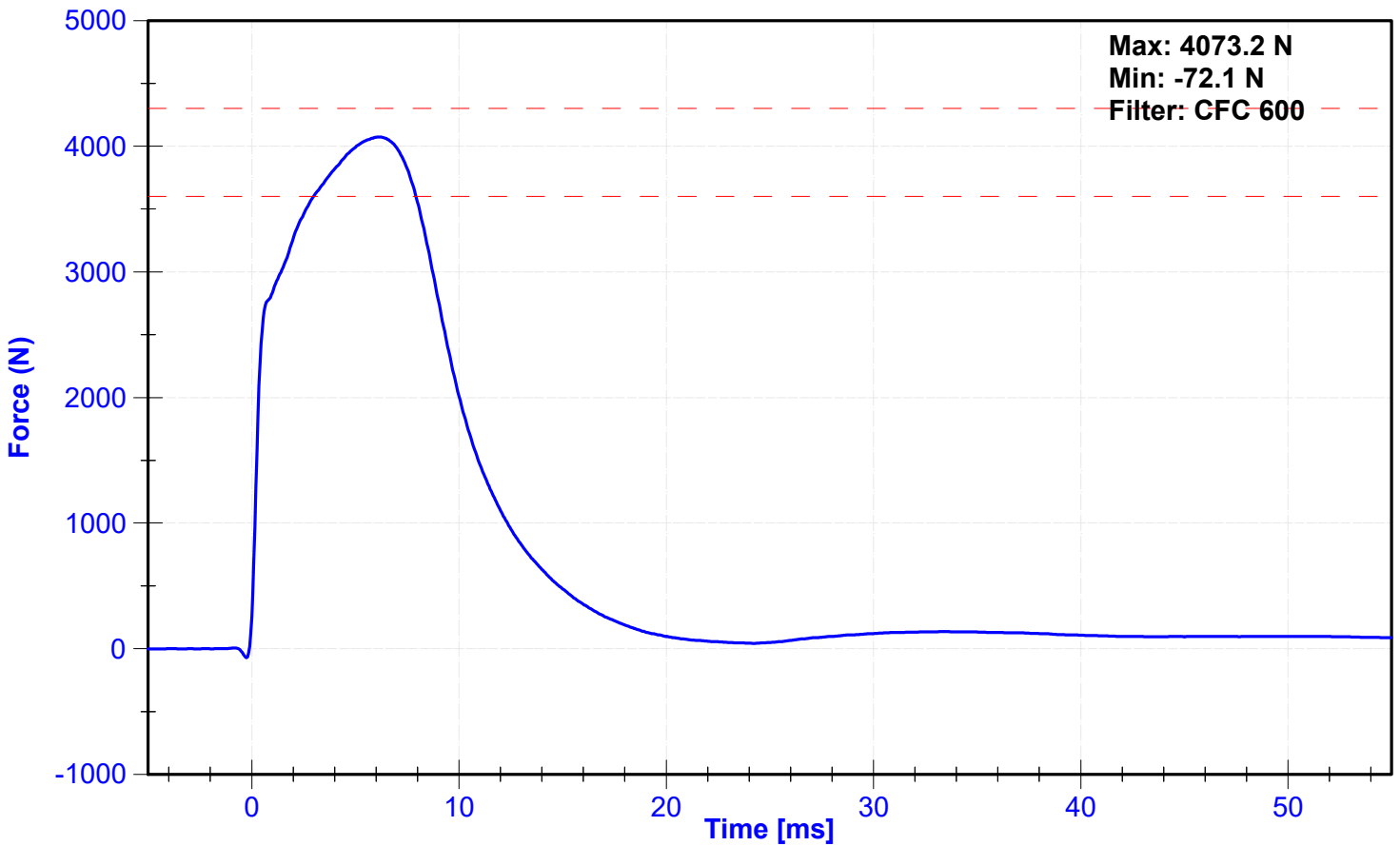



**SID-IIs Pelvis Plug Certification Test**

Plug S/N 15767

Test Number 20667

Report Number 20721

Test Date 10/15/2021 7:49:56 AM

	Test Results	Spec Min	Spec Max
Force @ 0.5 mm (N)	281	50	600
Force @ 1.5 mm (N)	1,177	850	1,400
Force @ 2.5 mm (N)	1,509	1,306	1,618
Force @ 3.0 mm (N)	1,567	1,361	1,673

Testing Machine STM-20 5965542  
 Load Cell S/N (FI360947), Units (LBS) 1000  
 Crosshead Speed ( mm / min ) or Rate 12.7  
 Extension or Position Measured by XHD\_100 ( XHD100 )

Notes: 261 NON IMPACT 9/4/24

Force (-N) vs Extension (-mm)

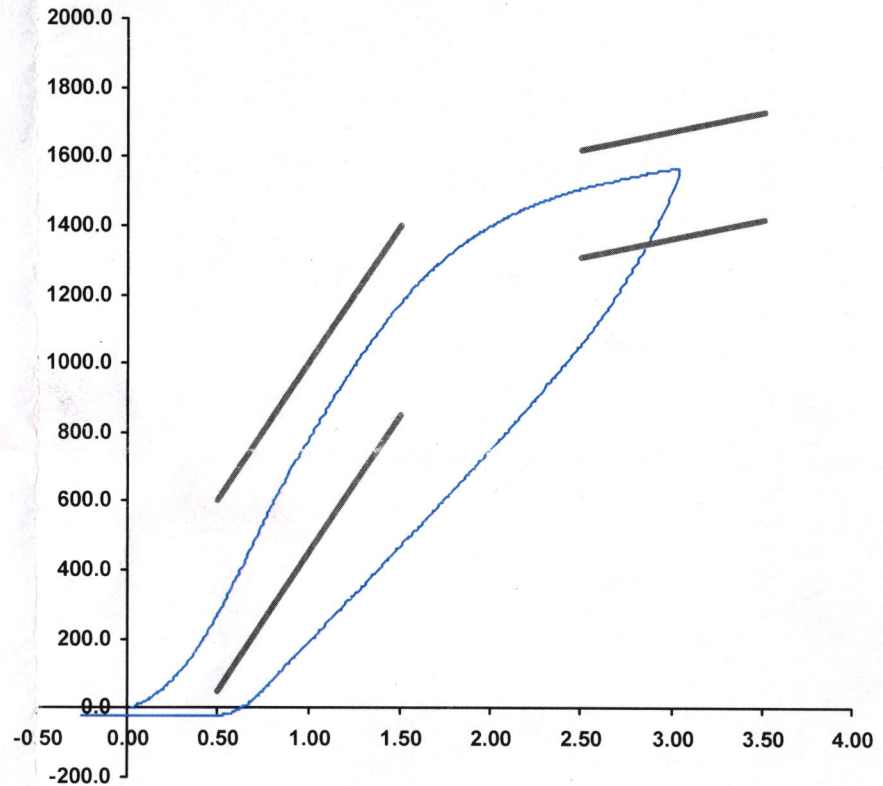

Operator \_\_\_\_\_  
 Part Number 180-4450

Template No 107 15-Oct-21  
 SACO Research

By: DC Date: 10/15/21



**SID-IIs Pelvis Plug Certification Test**

Plug S/N 15799

Test Number 20699

Report Number 20753

Test Date 10/15/2021 8:53:22 AM

	<u>Test Results</u>	<u>Spec Min</u>	<u>Spec Max</u>
Force @ 0.5 mm (N)	270	50	600
Force @ 1.5 mm (N)	1,148	850	1,400
Force @ 2.5 mm (N)	1,458	1,306	1,618
Force @ 3.0 mm (N)	1,514	1,361	1,673

Testing Machine STM-20 5965542  
 Load Cell S/N (FI360947), Units (LBS ) 1000  
 Crosshead Speed ( mm / min ) or Rate 12.7  
 Extension or Position Measured by XHD\_100 ( XHD100 )

Notes: 261 IMPACT 10/14/21

Force (-N) vs Extension (-mm)

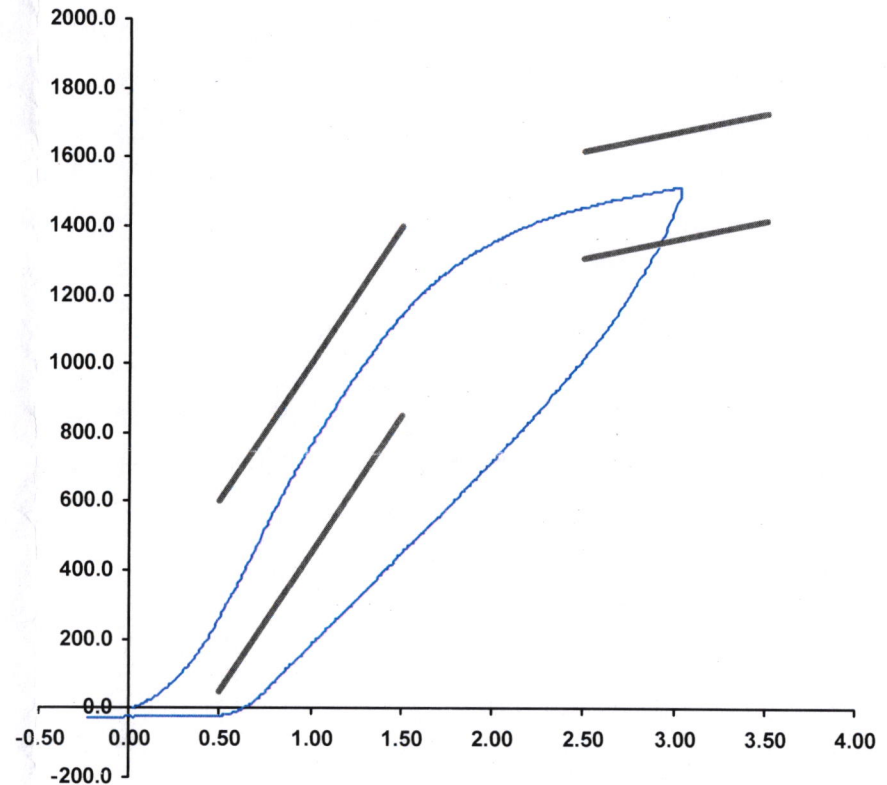

Operator \_\_\_\_\_  
 Part Number 180-4450

Template No 107 15-Oct-21  
 SACO Research

By: DC Date: 10/15/21



**SID-IIs Pelvis Plug Certification Test**

Plug S/N 14165

Test Number 14203

Report Number 14248

Test Date 6/28/2020 12:36:33 PM

	<u>Test Results</u>	<u>Spec Min</u>	<u>Spec Max</u>
Force @ 0.5 mm (N)	323.57	50.00	600.00
Force @ 1.5 mm (N)	1,143.76	850.00	1,400.00
Force @ 2.5 mm (N)	1,380.36	1,306.00	1,618.00
Force @ 3.0 mm (N)	1,425.93	1,361.00	1,673.00

Testing Machine STM-20 5965542  
 Load Cell S/N (FI360947), Units (LBS) 1000  
 Crosshead Speed ( mm / min ) or Rate 12.7  
 Extension or Position Measured by XHD\_100 ( XHD100 )

Notes: EE 261 CERT 9/11/24

Force (-N) vs Extension (-mm)

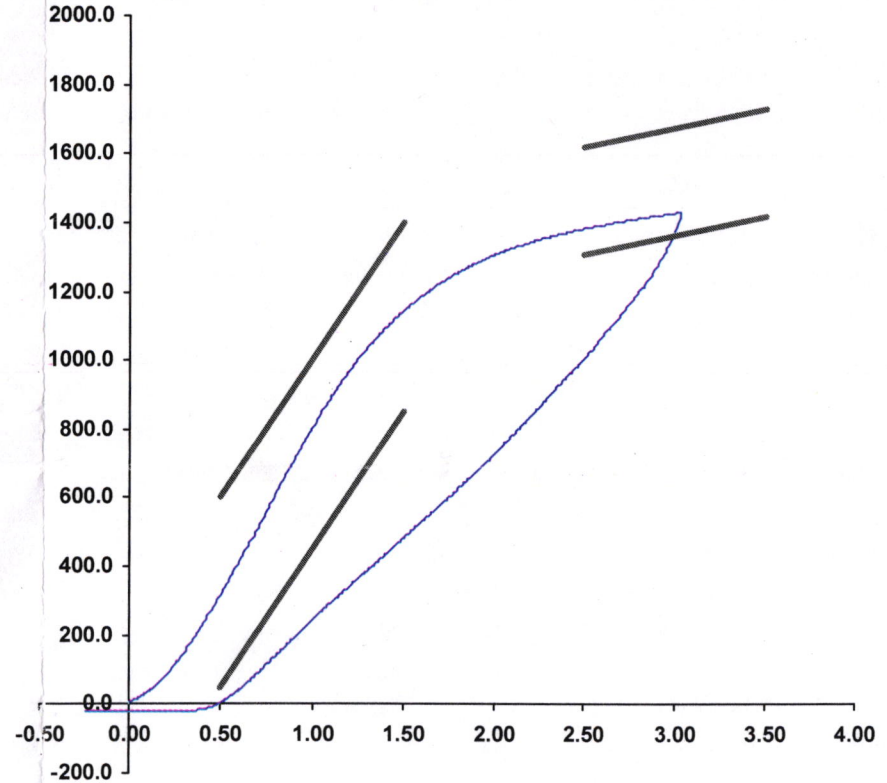

Operator \_\_\_\_\_  
 Part Number 180-4450

Template No 107 28-Jun-20  
 SACO Research

By: D.C. Date: 6-28-2020

ATD Manufacturer	FTSS	Test Technician	J. Rios
ATD Serial Number	261	Laboratory Supervisor	C. Mantell

**Results**

Test Parameter	Minimum Specification	Maximum Specification	Unit	Result	Pass/Fail
Temperature	20.6	22.2	°C	20.9	Pass
Humidity	10	70	%	45	Pass
Velocity	4.2	4.4	m/s	4.28	Pass
Probe Acceleration	36	45	g's	37.1	Pass
Lateral Pelvis Acceleration	28	39	g's	28.0	Pass
Iliac Force	4100	5100	N	4128.9	Pass

**Transducer Calibrations**

Channel	Manufacturer	Serial Number	Calibration Date	Calibration Due Date
Pendulum Accelerometer	Endevco	18527	8/2/2024	1/29/2025
Pelvis Y Accelerometer	Endevco	T29392	5/15/2024	11/11/2024
Iliac Load Cell	Denton	290-FY	12/5/2023	12/4/2024

**Probe Acceleration**

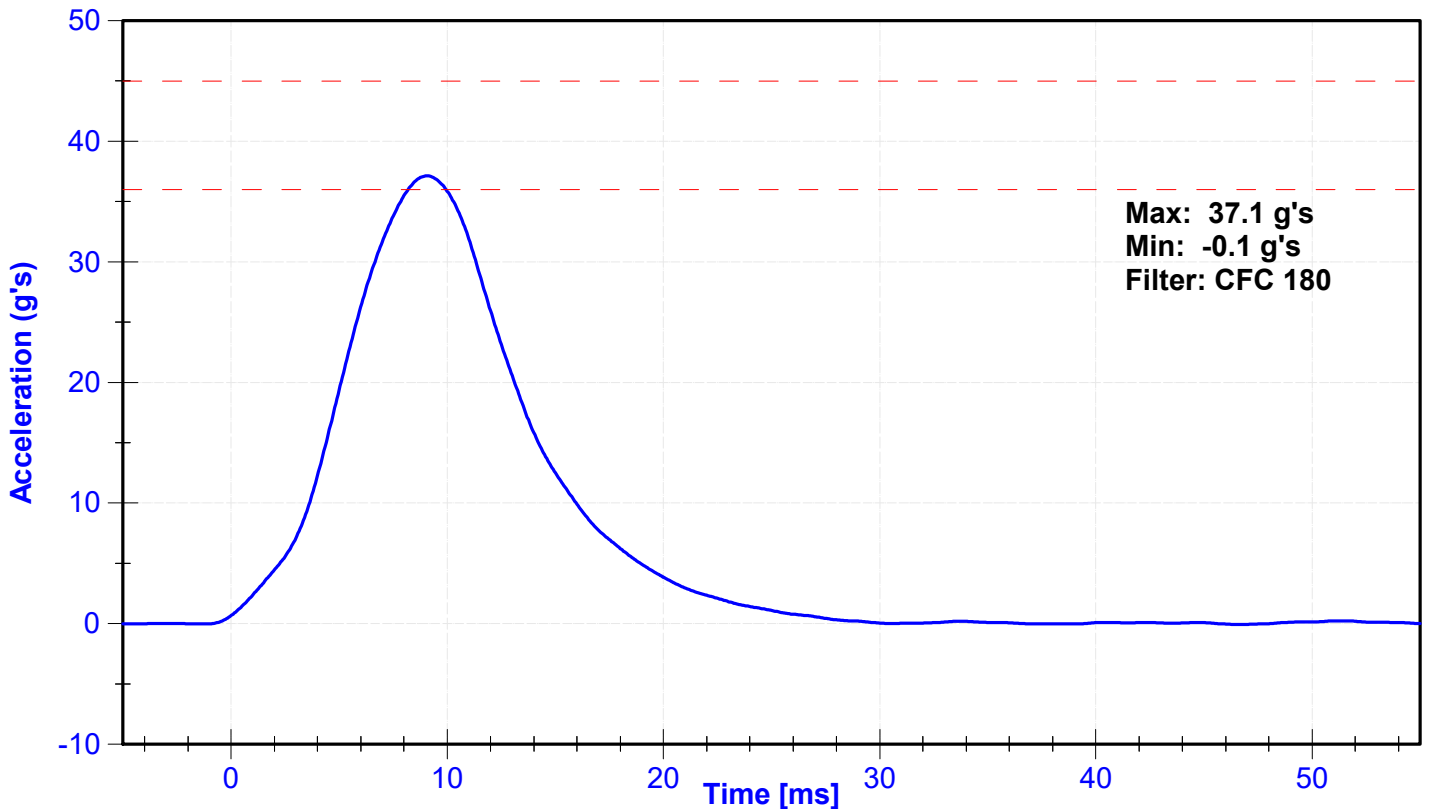

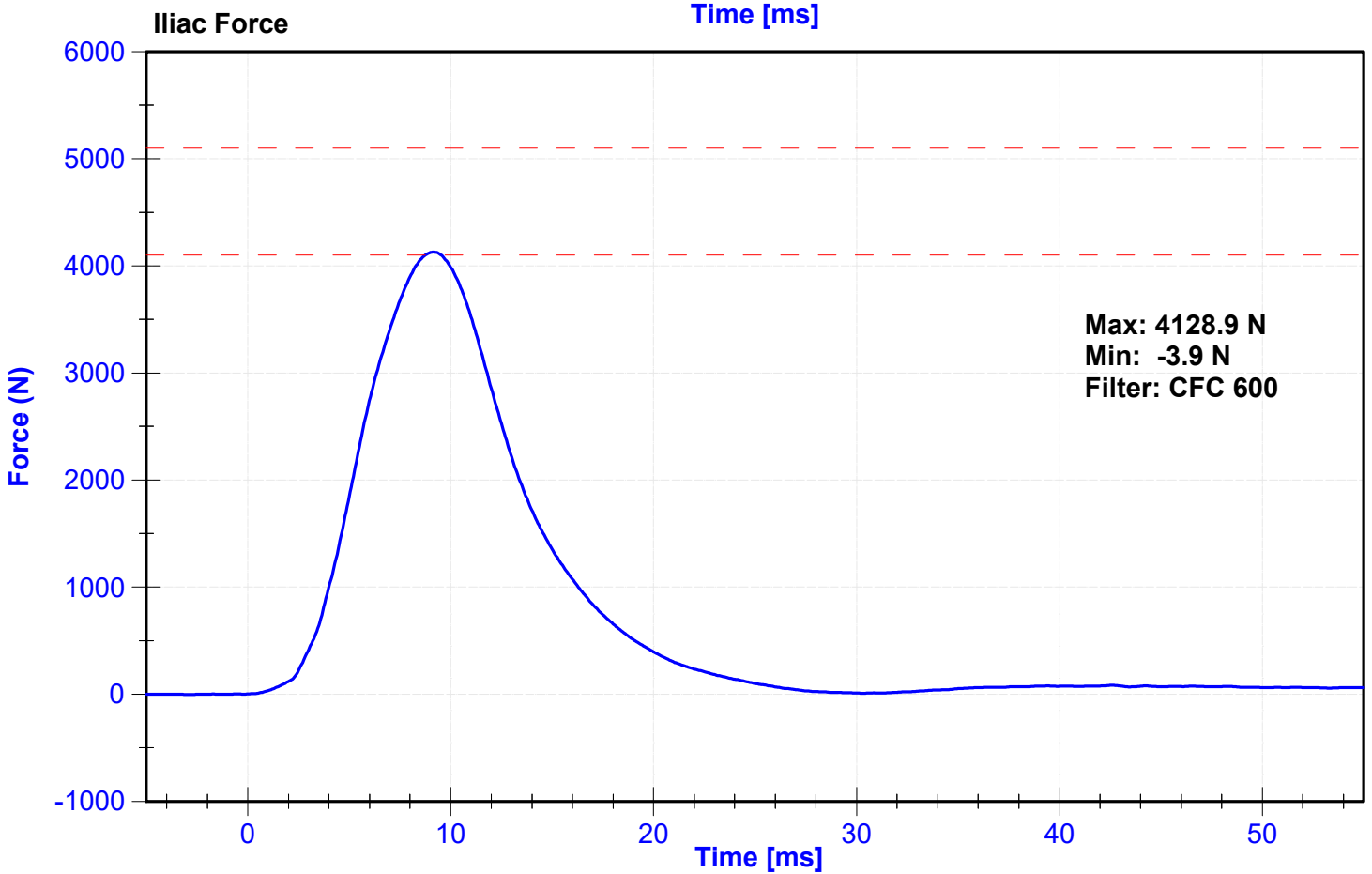
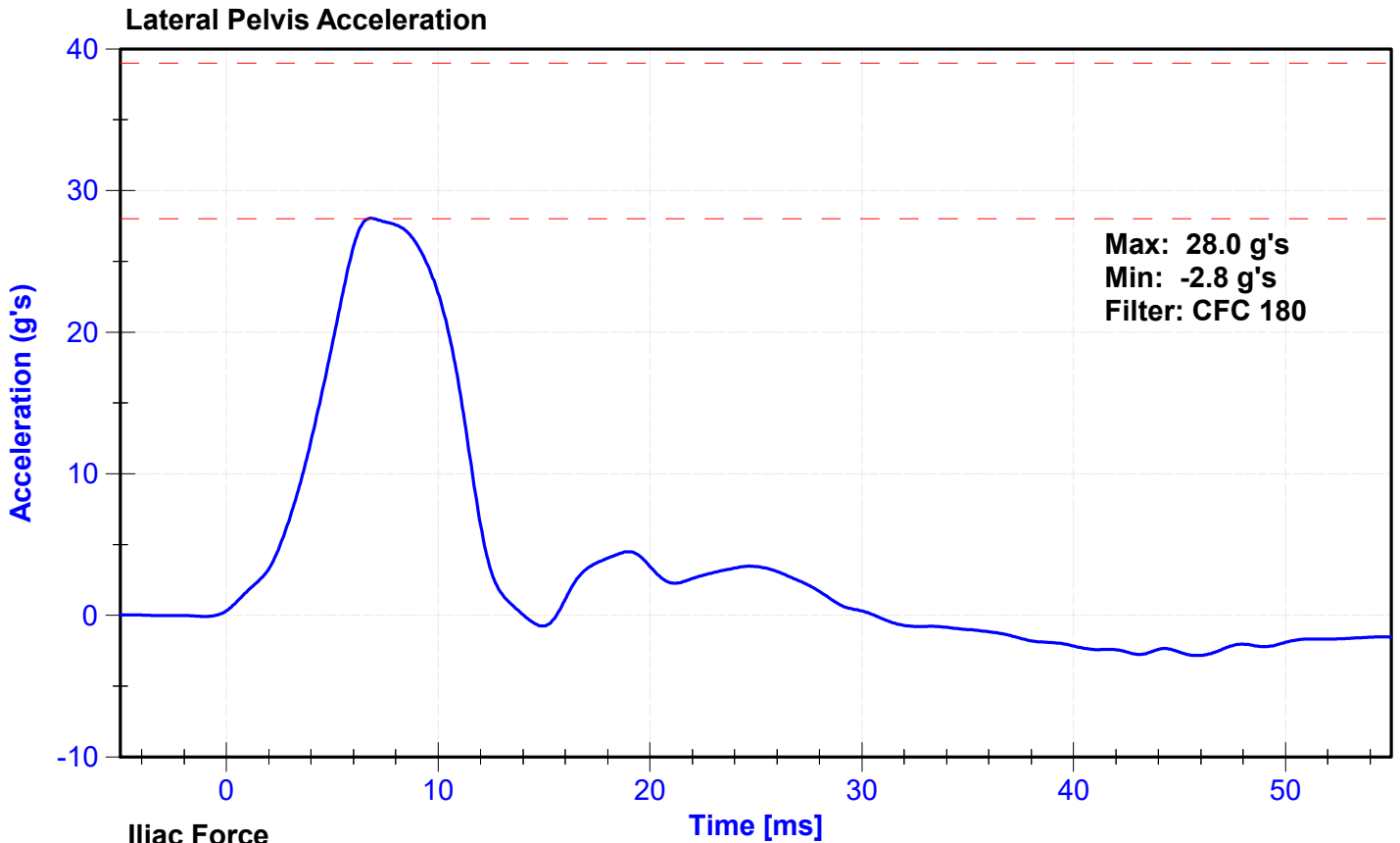

**POST-TEST  
SID-IIs PERFORMANCE CALIBRATION TEST DATA**



External Measurements - SID-IIs

Technician: J. Rios

Date: 10/22/2024

Dummy Serial Number: 261

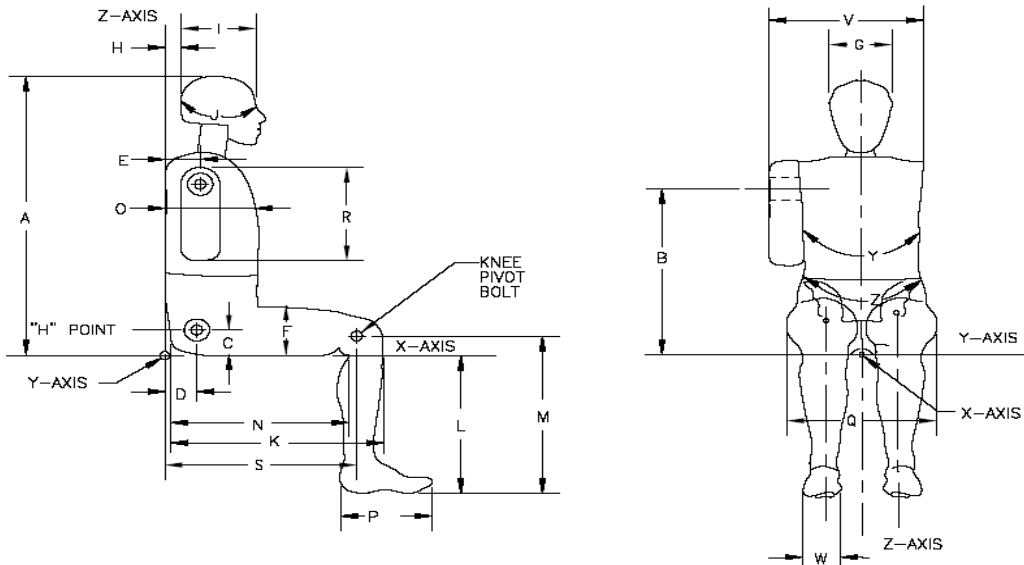

Symbol	Description	Specification (mm)		Result (mm)	Pass/Fail
A	Sitting Height	772	788	781	Pass
B	Shoulder Pivot Height	437	453	450	Pass
C	H-point Height	79	89	85	Pass
D	H-point from seatback	141	151	144	Pass
E	Shoulder Pivot from Backline	97	107	103	Pass
F	Thigh Clearance	119	135	127	Pass
G	Head Breadth	140	148	146	Pass
H	Head Back from Backline	40	46	43	Pass
I	Head Depth	178	188	182	Pass
J	Head Circumference	541	551	549	Pass
K	Buttock to Knee Length	514	540	524	Pass
L	Popliteal Height	343	369	349	Pass
M	Knee Pivot to floor height	392	409	397	Pass
N	Buttock Popliteal Length	416	442	422	Pass
O	Chest Depth w/o jacket	195	211	205	Pass
P	Foot Length	216	232	219	Pass
Q	Hip Breadth (w/pelvic plugs)	313	323	315	Pass
R	Arm Length	249	259	250	Pass
S	Knee Joint to seatback	477	493	480	Pass
V	Shoulder Width	341	357	346	Pass
W	Foot Width	78	94	85	Pass
Y	Chest Circumference w/jacket	851	881	858	Pass
Z	Waist Circumference	761	791	779	Pass

ATD Manufacturer	FTSS	Test Technician	K. Konieczny
ATD Serial Number	261	Laboratory Supervisor	C .Mantell

**Results**

Test Parameter	Minimum Specification	Maximum Specification	Unit	Result	Pass/Fail
Temperature	20.6	22.2	°C	21.3	Pass
Humidity	10	70	%	40	Pass
Resultant Acceleration	115	137	g's	124.2	Pass
Oscillation	0	15	%	1.2	Pass
Fore-Aft Acceleration	-15	15	g's	2.6	Pass

**Transducer Calibrations**

Channel	Manufacturer	Serial Number	Calibratio Date	Calibratio Due Date
X Accelerometer	Endevco	P68067	5/15/2024	11/11/2024
Y Accelerometer	Endevco	P18567	5/15/2024	11/11/2024
Z Accelerometer	Endevco	P49163	5/15/2024	11/11/2024

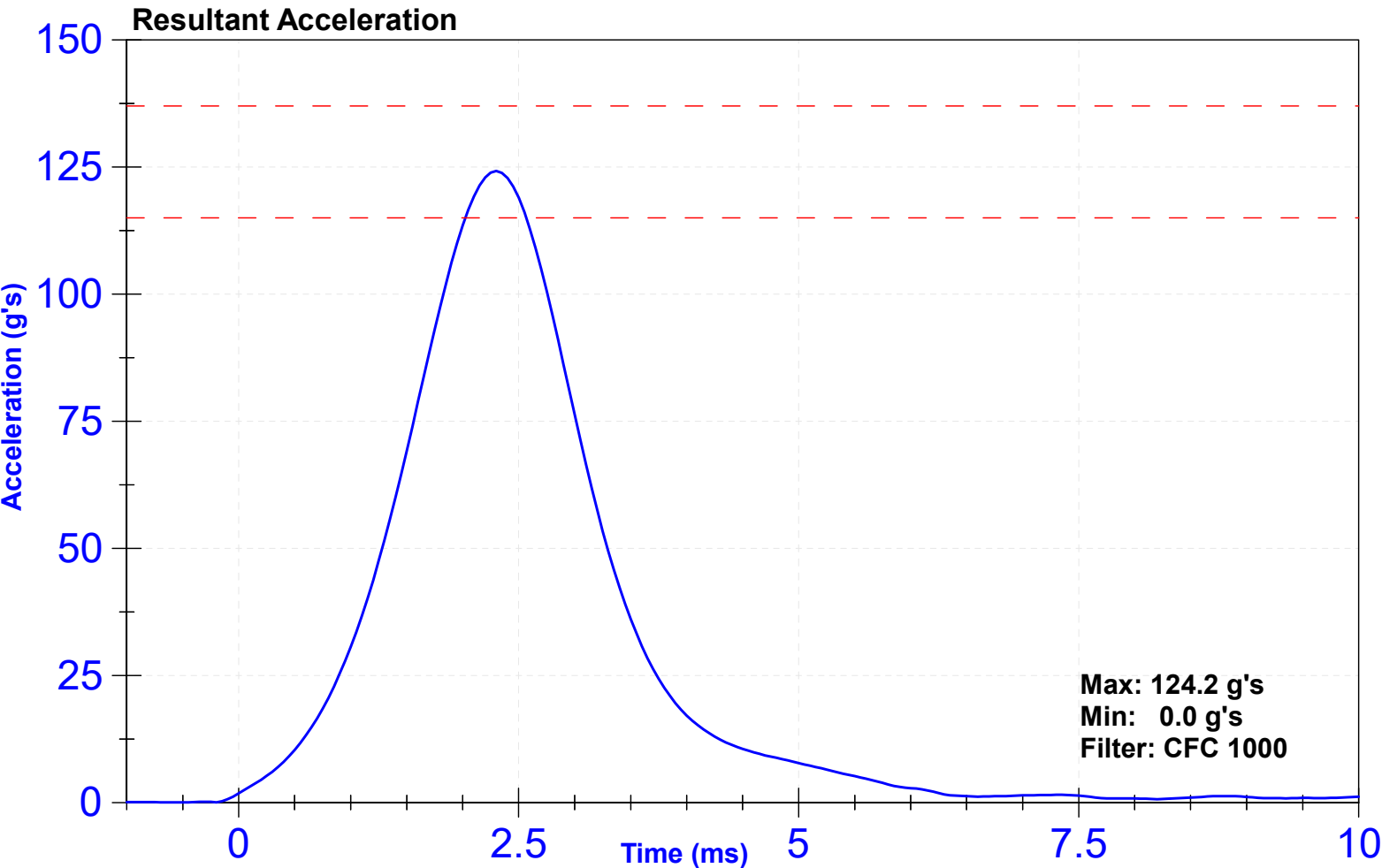

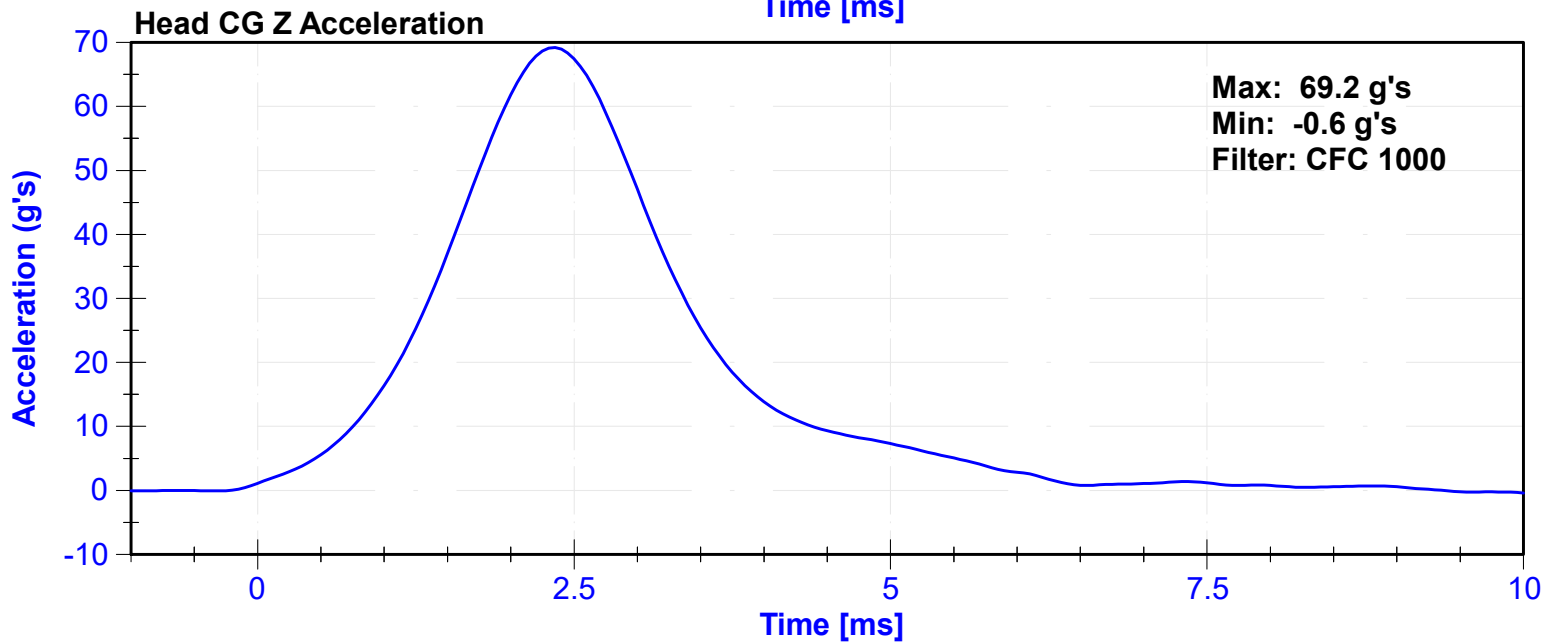
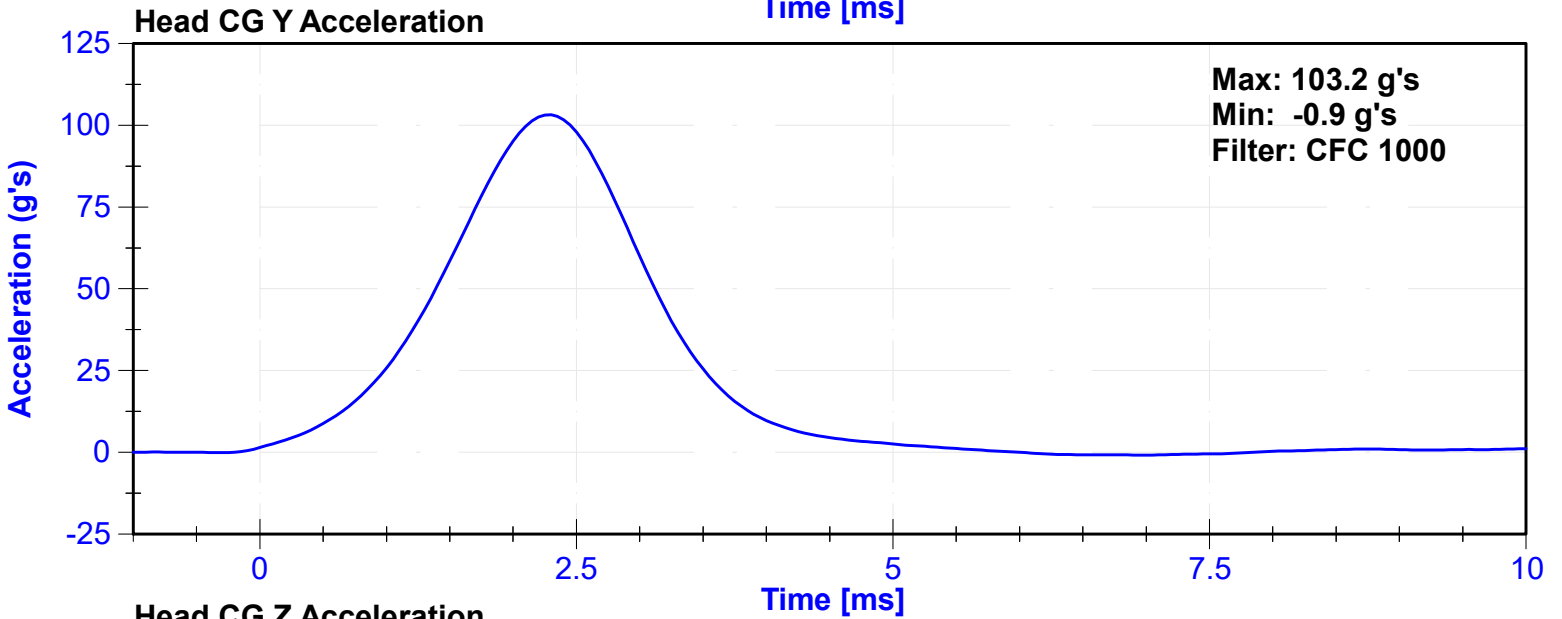
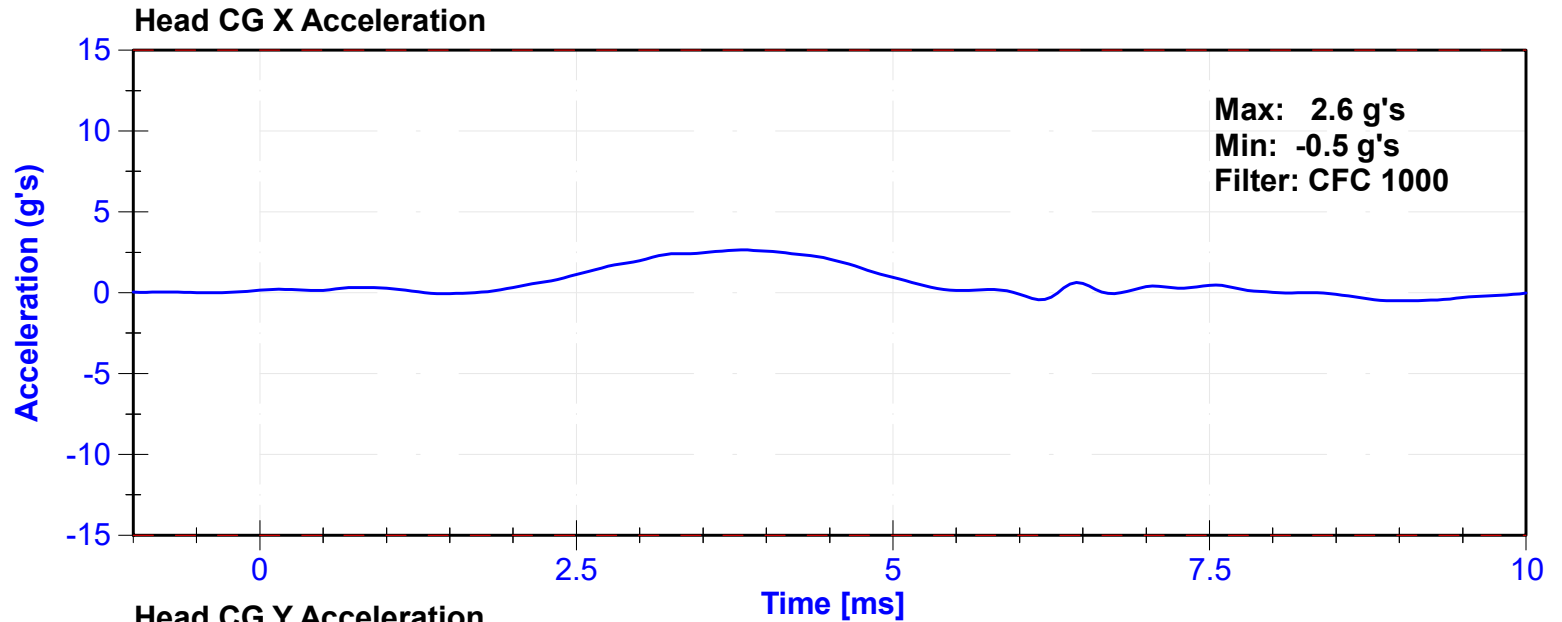

ATD Manufacturer	FTSS	Test Technician	J. Rios
ATD Serial Number	261	Laboratory Supervisor	C. Mantell

**Results**

Test Parameter	Minimum Specification	Maximum Specification	Unit	Result	Pass/Fail
Temperature	20.6	22.2	°C	21.1	Pass
Humidity	10	70	%	35	Pass
Velocity	5.51	5.63	m/s	5.542	Pass
Pendulum Impulse at 10ms	2.2	2.8	m/s	2.35	Pass
Pendulum Impulse at 15ms	3.3	4.1	m/s	3.62	Pass
Pendulum Impulse at 20ms	4.4	5.4	m/s	4.92	Pass
Pendulum Impulse at 25ms	5.4	6.1	m/s	5.80	Pass
Pendulum Impulse from 25 to 100ms	5.5	6.2	m/s	5.89	Pass
Neck Rotation	71	81	deg	74.4	Pass
Time at Maximum Rotation	50	70	ms	60.5	Pass
Moment about the OC	36	44	Nm	43.9	Pass
Moment Decay to 0 Nm	102	126	ms	116.3	Pass

**Transducer Calibrations**

Channel	Manufacturer	Serial Number	Calibration Date	Calibration Due Date
Pendulum Accelerometer	Endevco	7231C-750	4/29/2024	10/26/2024
Pendulum Potentiometer	Servo	4961	9/23/2024	9/23/2025
Condyle Potentiometer	Servo	DS185	9/23/2024	9/23/2025
Upper Neck Load Cell	Denton	1716A_2187-FY	12/5/2023	12/4/2024

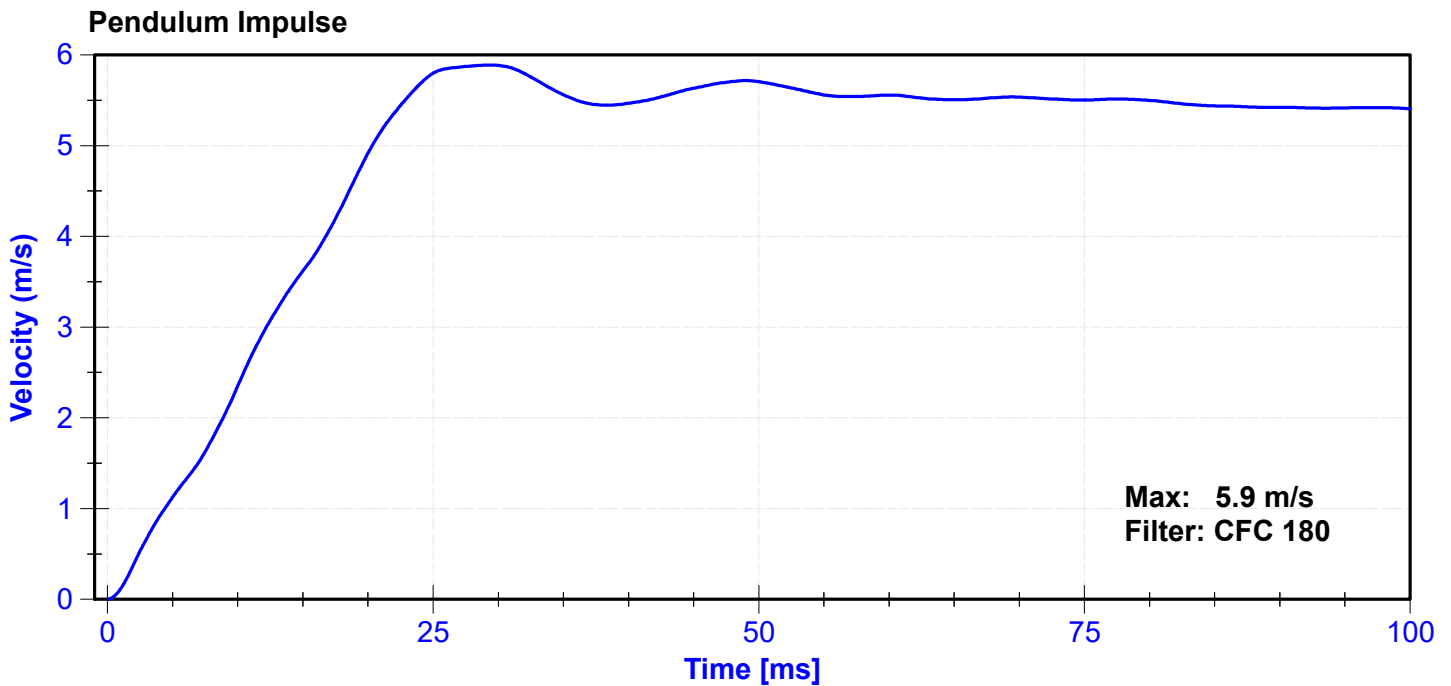

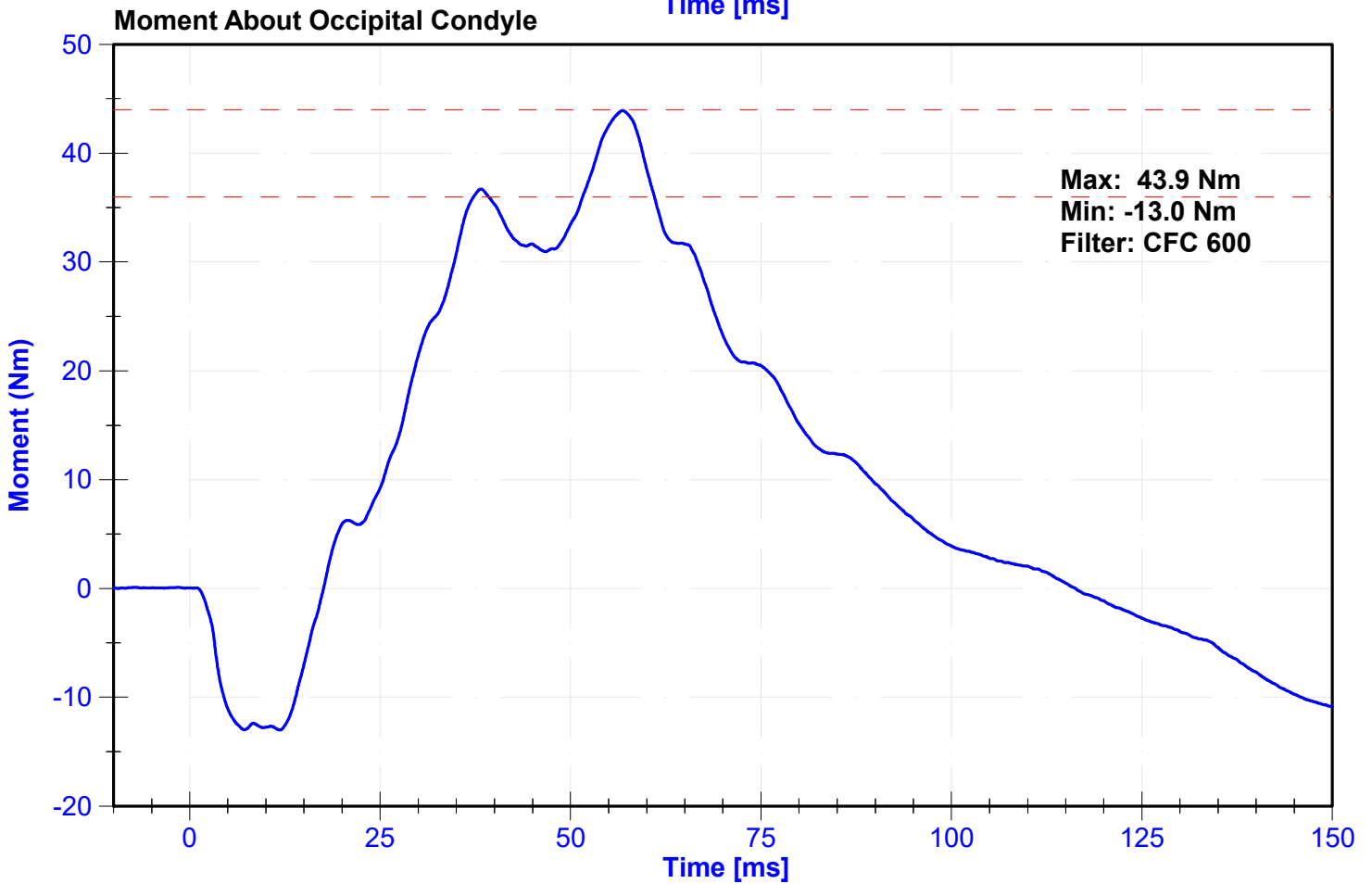
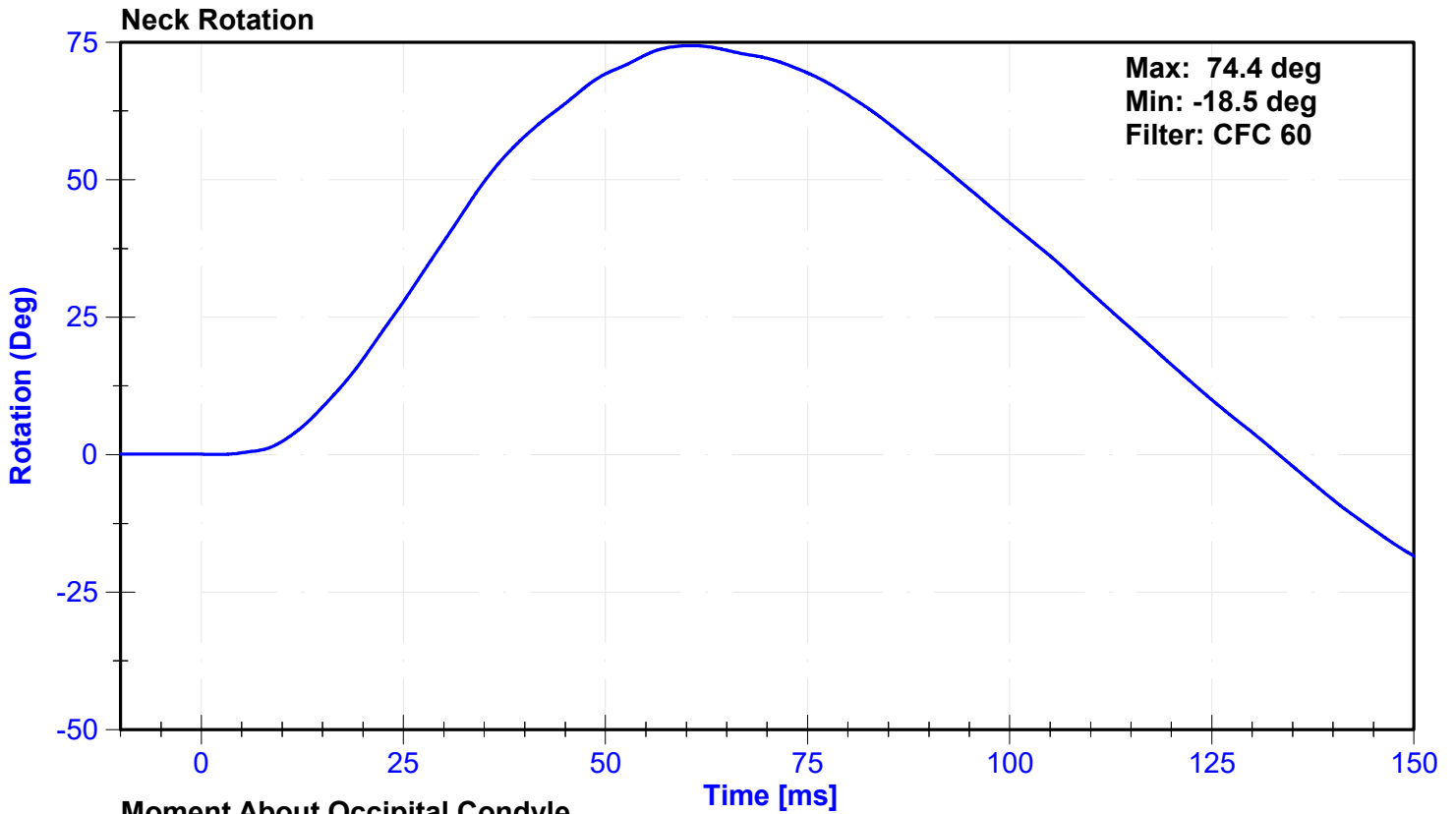

ATD Manufacturer	FTSS	Test Technician	J. Rios
ATD Serial Number	261	Laboratory Supervisor	C. Mantell

**Results**

Test Parameter	Minimum Specification	Maximum Specification	Unit	Result	Pass/Fail
Temperature	20.6	22.2	°C	21.2	Pass
Humidity	10	70	%	35	Pass
Velocity	4.2	4.4	m/s	4.28	Pass
Probe Acceleration	13	18	g's	18.0	Pass
Shoulder Deflection	28	37	mm	30.0	Pass
Lateral Upper Spine Acceleration	17	22	g's	19.9	Pass

**Transducer Calibrations**

Channel	Manufacturer	Serial Number	Calibration Date	Calibration Due Date
Pendulum Accelerometer	Endevco	18527	8/2/2024	1/29/2025
Shoulder Potentiometer	Servo	572GFE	5/16/2024	11/14/2024
Upper Spine Y Accelerometer	Endevco	P94678	5/15/2024	11/11/2024

**Probe Acceleration**

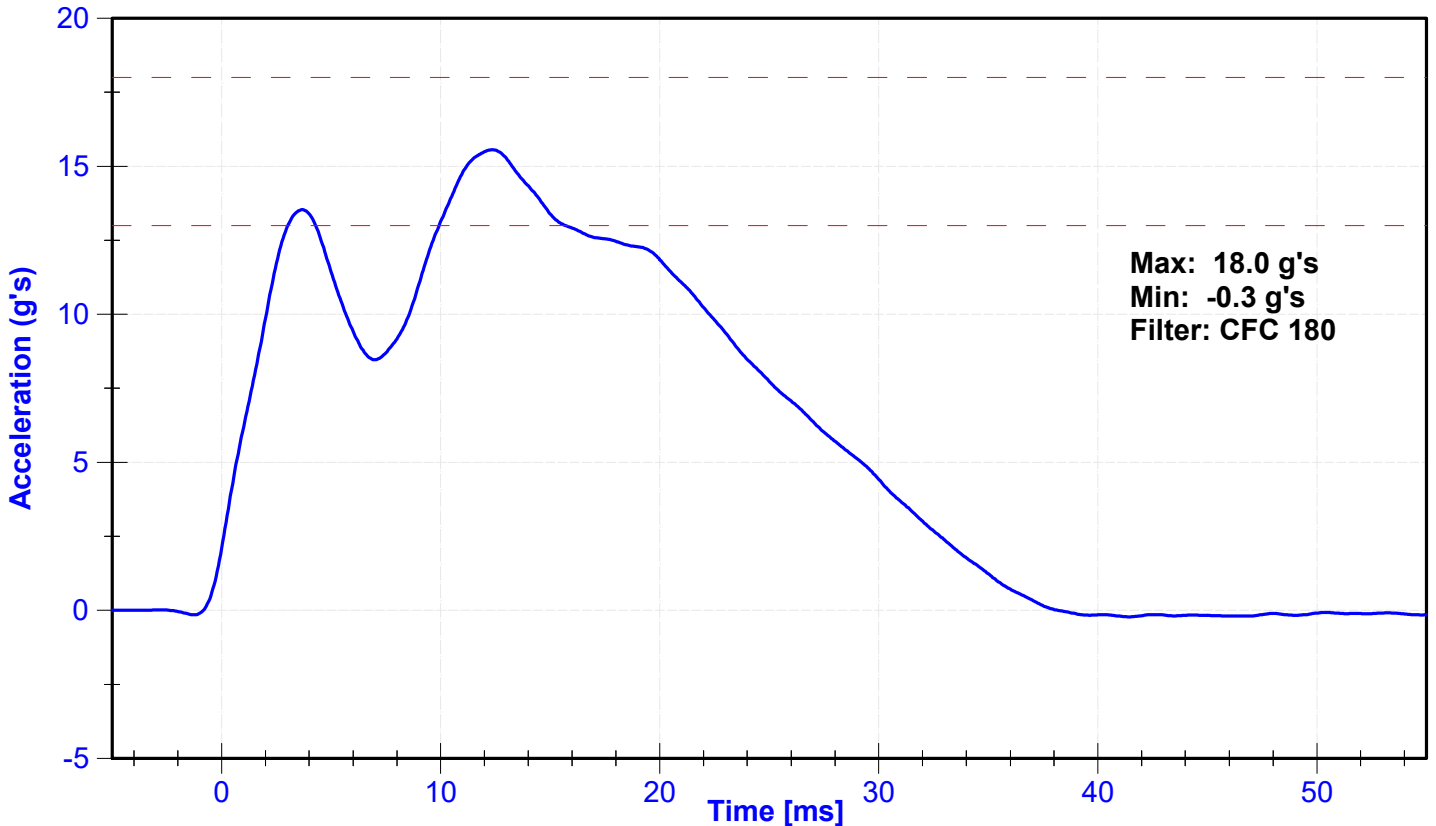

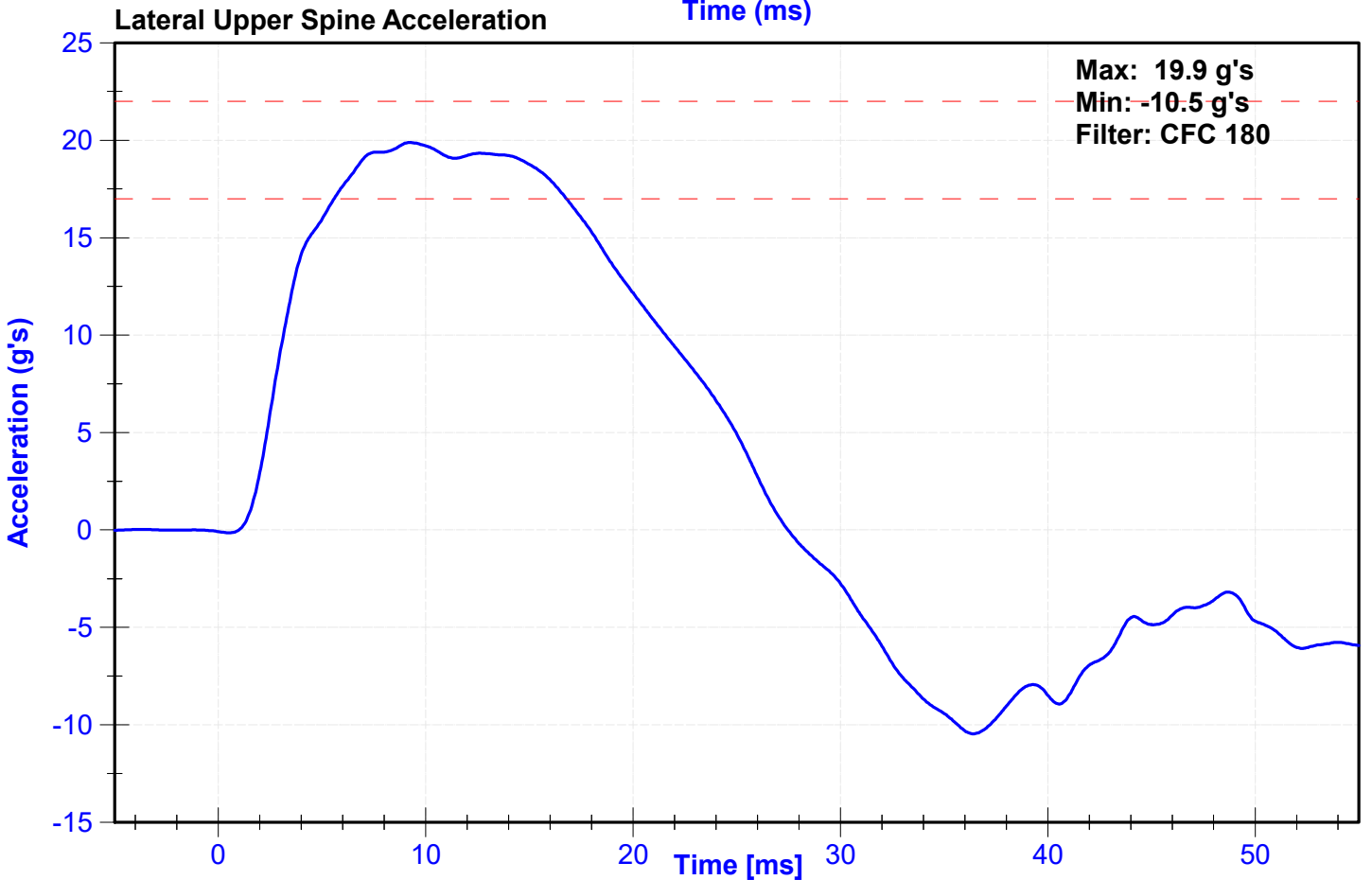
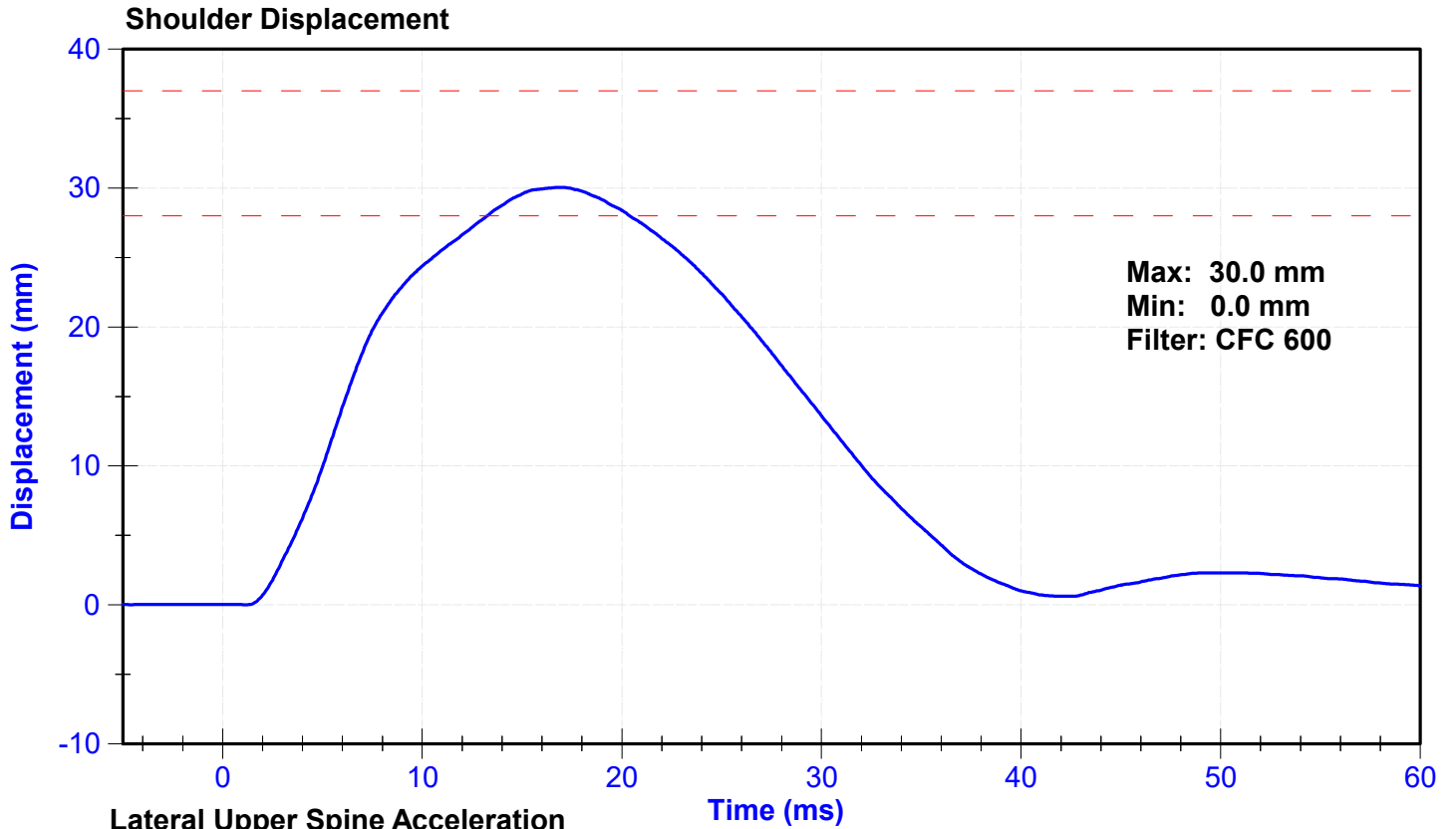

ATD Manufacturer	FTSS	Test Technician	J. Rios
ATD Serial Number	261	Laboratory Supervisor	C. Mantell

**Results**

Test Parameter	Minimum Specification	Maximum Specification	Unit	Result	Pass/Fail
Temperature	20.6	22.2	°C	21.2	Pass
Humidity	10	70	%	35	Pass
Velocity	6.6	6.8	m/s	6.66	Pass
Probe Acceleration after 5 ms	30	36	g's	32.7	Pass
Lateral Upper Spine Acceleration	34	43	g's	40.8	Pass
Lateral Lower Spine Acceleration	29	37	g's	33.0	Pass
Shoulder Deflection	31	40	mm	33.7	Pass
Upper Thorax Rib Deflection	25	32	mm	25.9	Pass
Mid Thorax Rib Deflection	30	36	mm	30.0	Pass
Lower Thorax Rib Deflection	32	38	mm	32.6	Pass

**Transducer Calibrations**

Channel	Manufacturer	Serial Number	Calibration Date	Calibration Due Date
Pendulum Accelerometer	Endevco	18527	8/2/2024	1/29/2025
Upper Spine T1 Y Accelerometer	Endevco	P94678	5/15/2024	11/11/2024
Upper Spine T12 Y Accelerometer	Endevco	P58744	5/15/2024	11/11/2024
Shoulder Potentiometer	Servo	572GFE	5/16/2024	11/14/2024
Upper Thorax Rib Potentiometer	Servo	062GFE	5/16/2024	11/14/2024
Middle Thorax Rib Potentiometer	Servo	528GFE	5/16/2024	11/14/2024
Lower Thorax Rib Potentiometer	Servo	513GFE	5/16/2024	11/14/2024

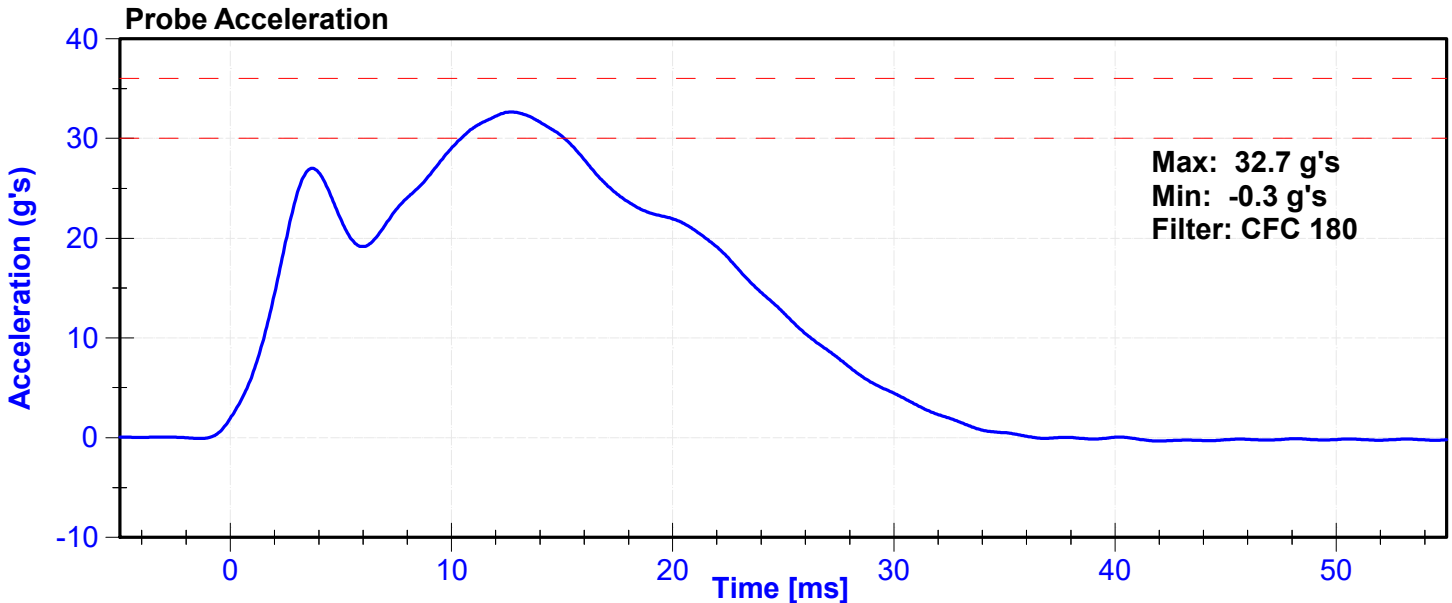

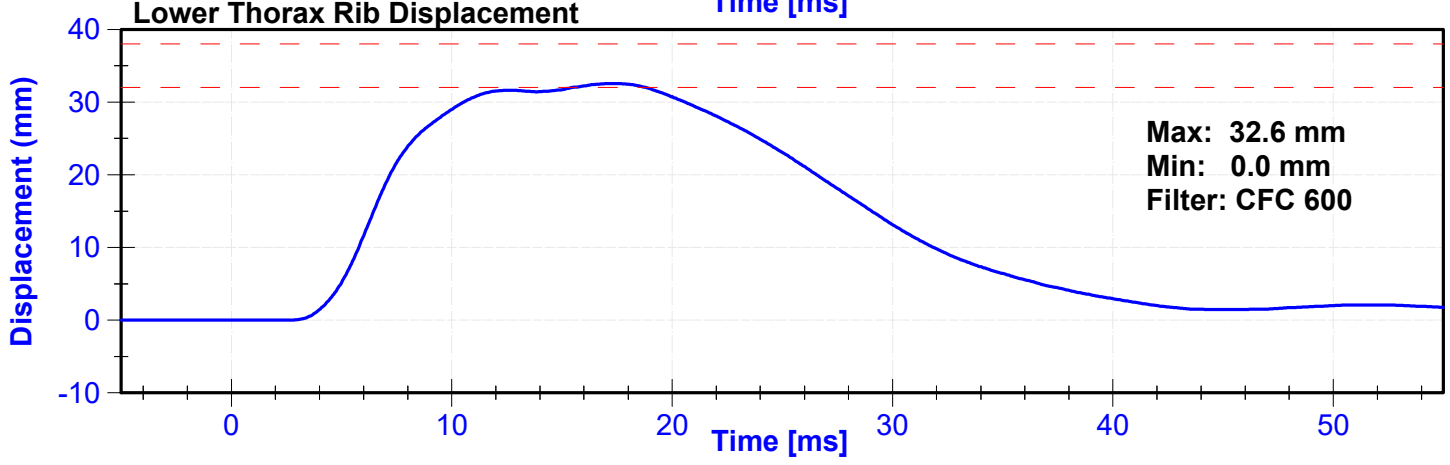
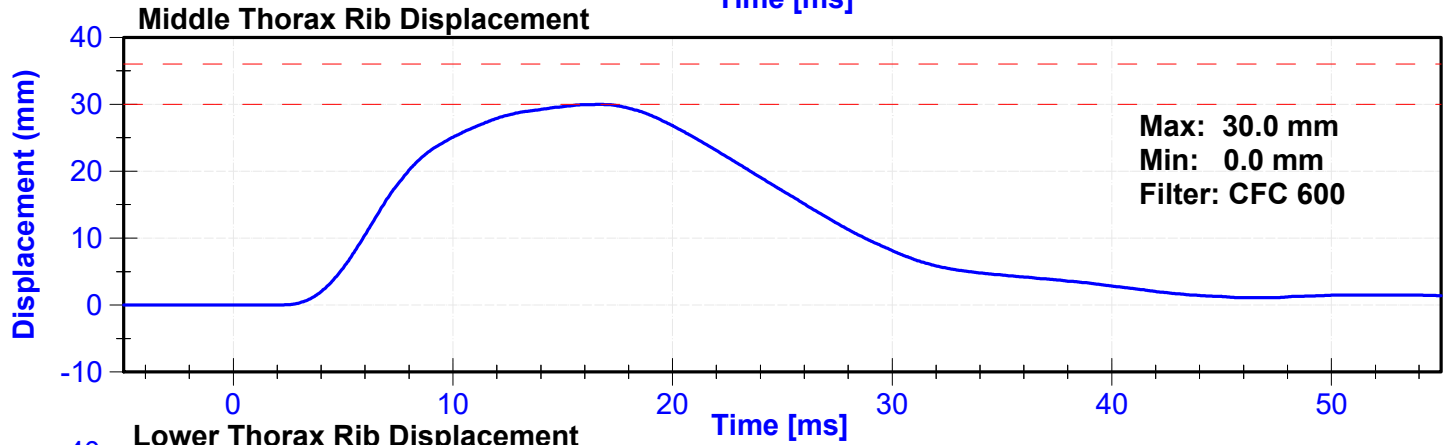
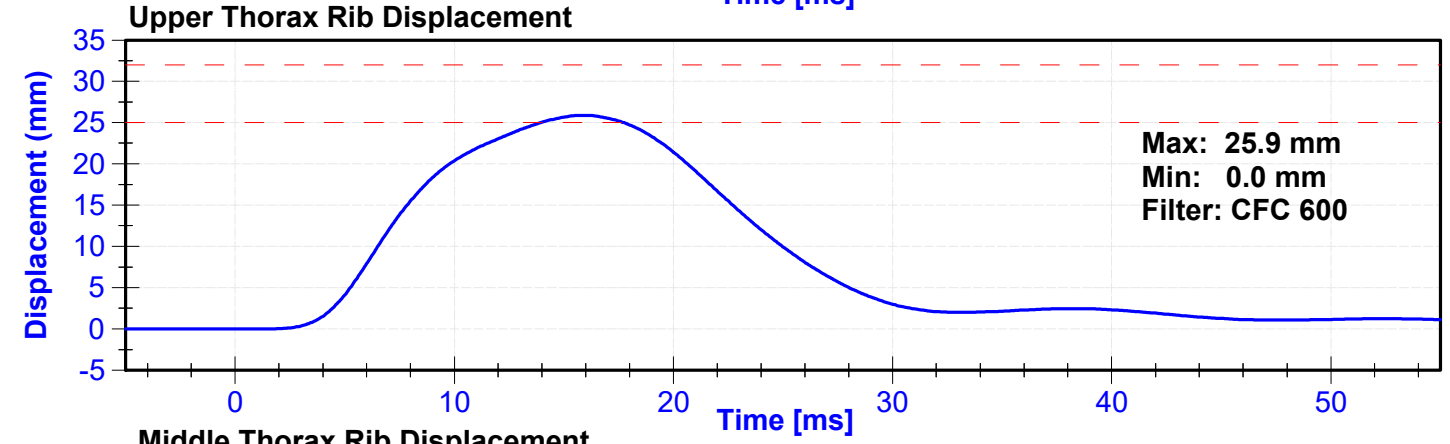
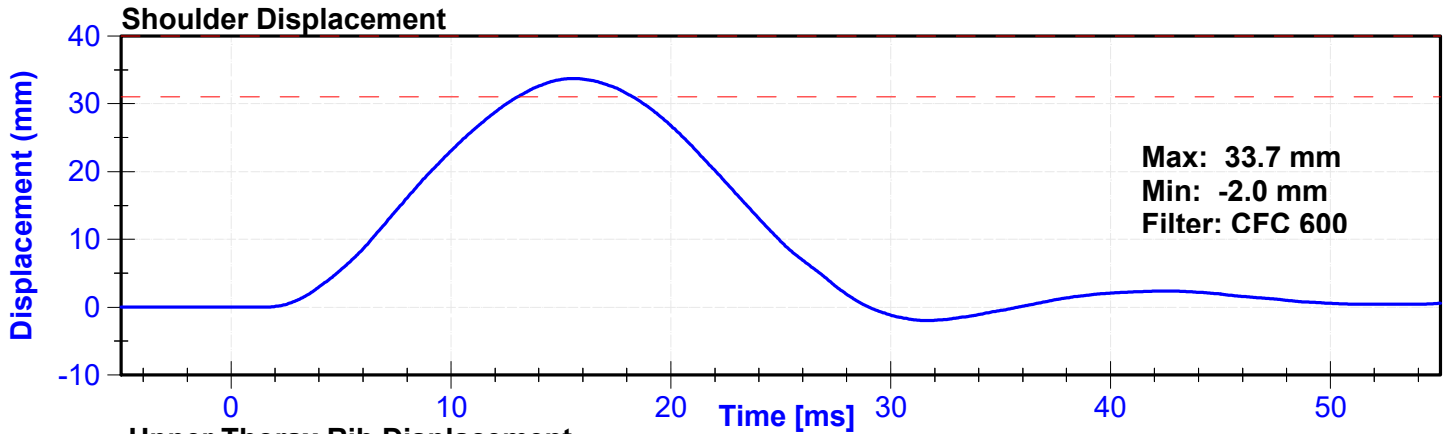

### Lateral Upper Spine Acceleration

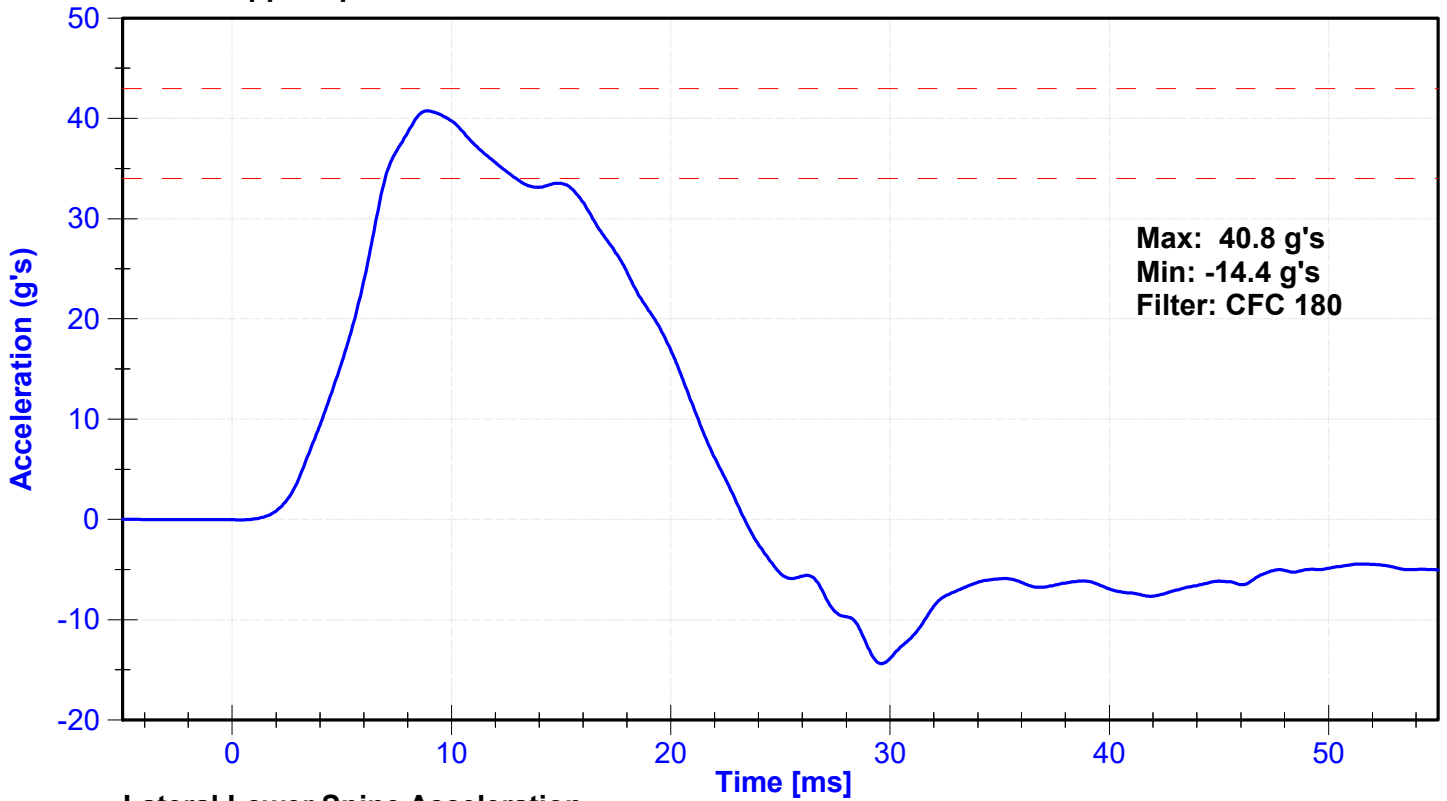

### Lateral Lower Spine Acceleration

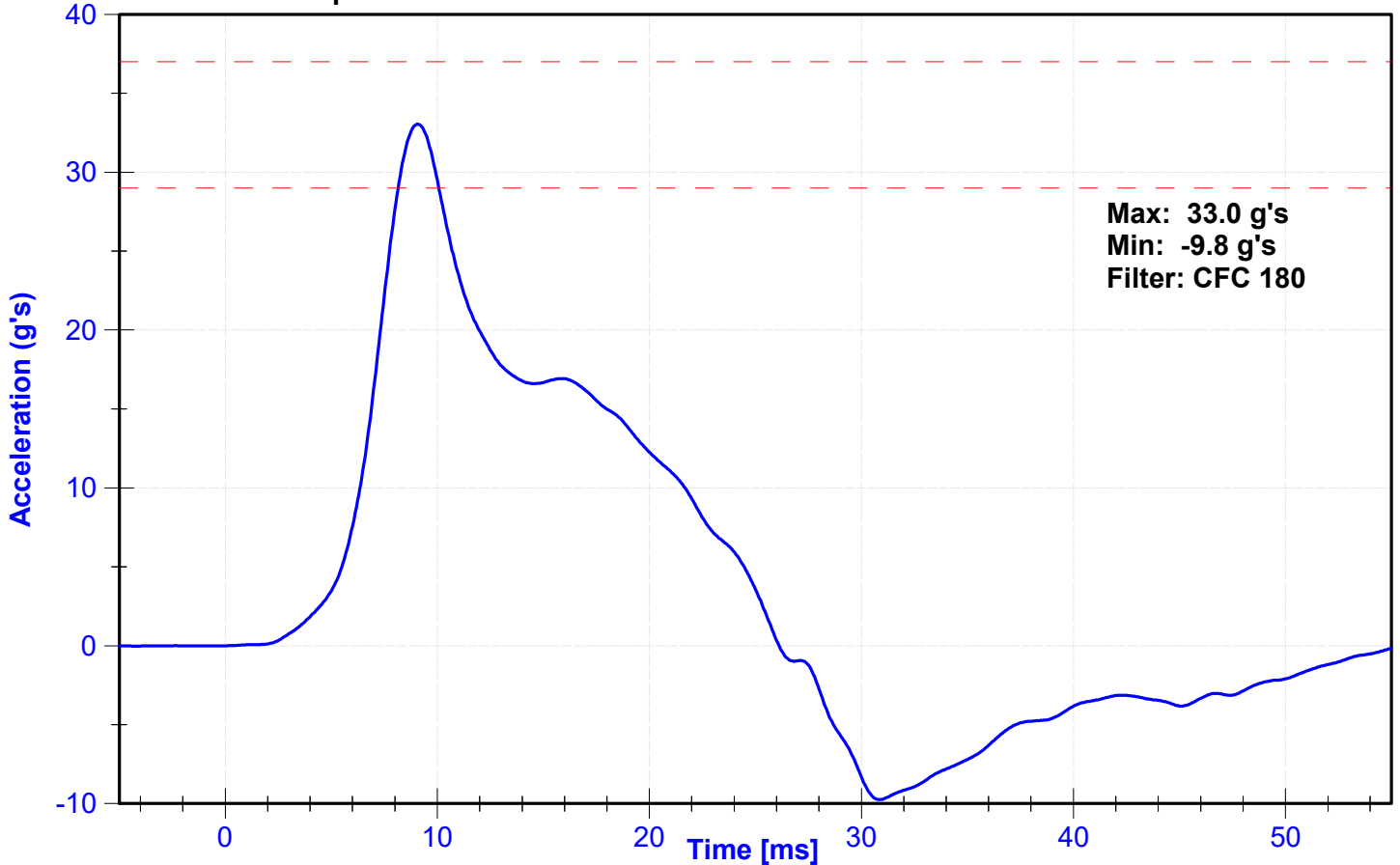

ATD Manufacturer	FTSS	Test Technician	J. Rios
ATD Serial Number	261	Laboratory Supervisor	C. Mantell

**Results**

Test Parameter	Minimum Specification	Maximum Specification	Unit	Result	Pass/Fail
Temperature	20.6	22.2	°C	21.2	Pass
Humidity	10	70	%	35	Pass
Velocity	4.2	4.4	m/s	4.28	Pass
Probe Acceleration	14	18	g's	17.3	Pass
Lateral Upper Spine Acceleration	13	17	g's	16.0	Pass
Lateral Lower Spine Acceleration	7	11	g's	10.2	Pass
Upper Thorax Rib Deflection	32	40	mm	32.1	Pass
Middle Thorax Rib Deflection	39	45	mm	39.2	Pass
Lower Thorax Rib Deflection	35	43	mm	37.5	Pass

**Transducer Calibrations**

Channel	Manufacturer	Serial Number	Calibration Date	Calibration Due Date
Pendulum Accelerometer	Endevco	18527	8/2/2024	1/29/2025
Upper Spine Y Accelerometer	Endevco	P94678	5/15/2024	11/11/2024
Lower Spine Y Accelerometer	Endevco	P58744	5/15/2024	11/11/2024
Upper Thorax Rib Potentiometer	Servo	062GFE	5/16/2024	11/14/2024
Middle Thorax Rib Potentiometer	Servo	528GFE	5/16/2024	11/14/2024
Lower Thorax Rib Potentiometer	Servo	513GFE	5/16/2024	11/14/2024

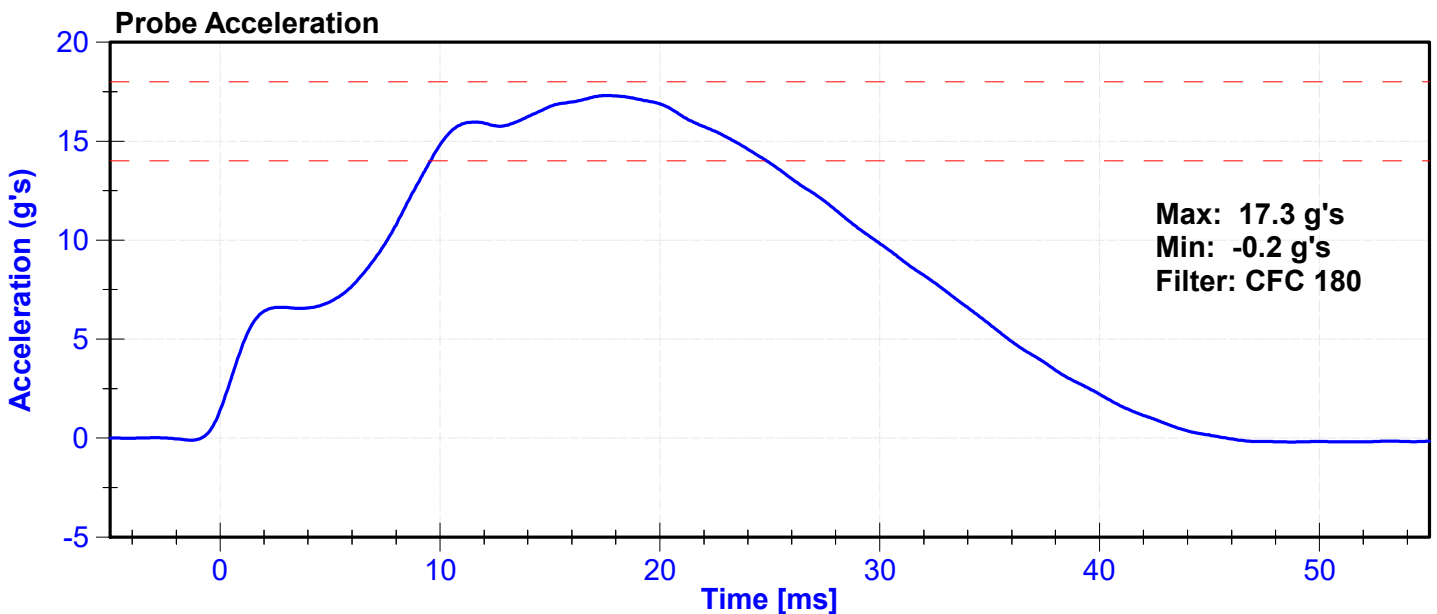

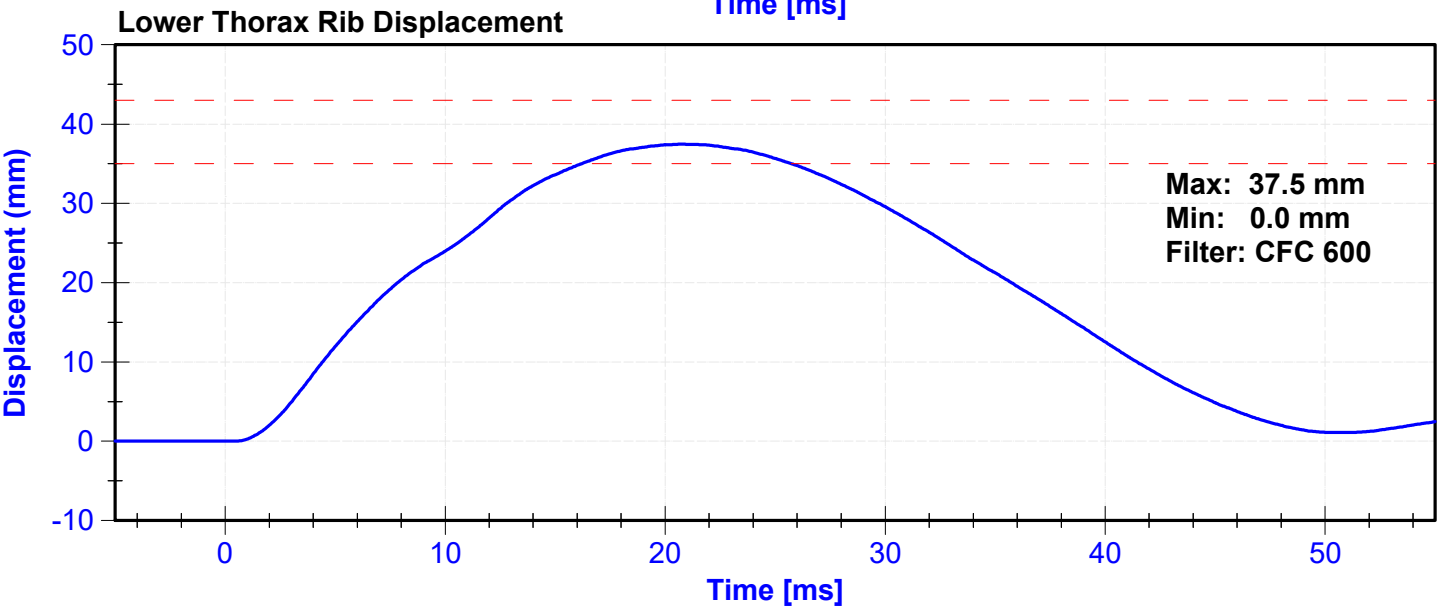
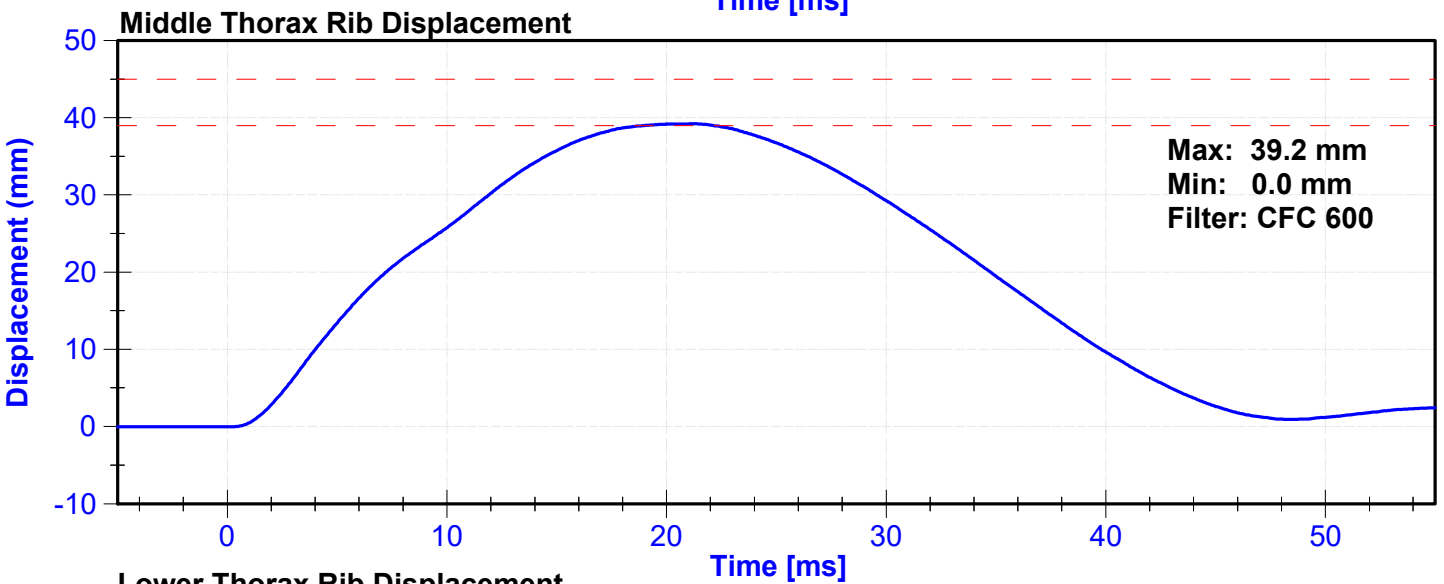
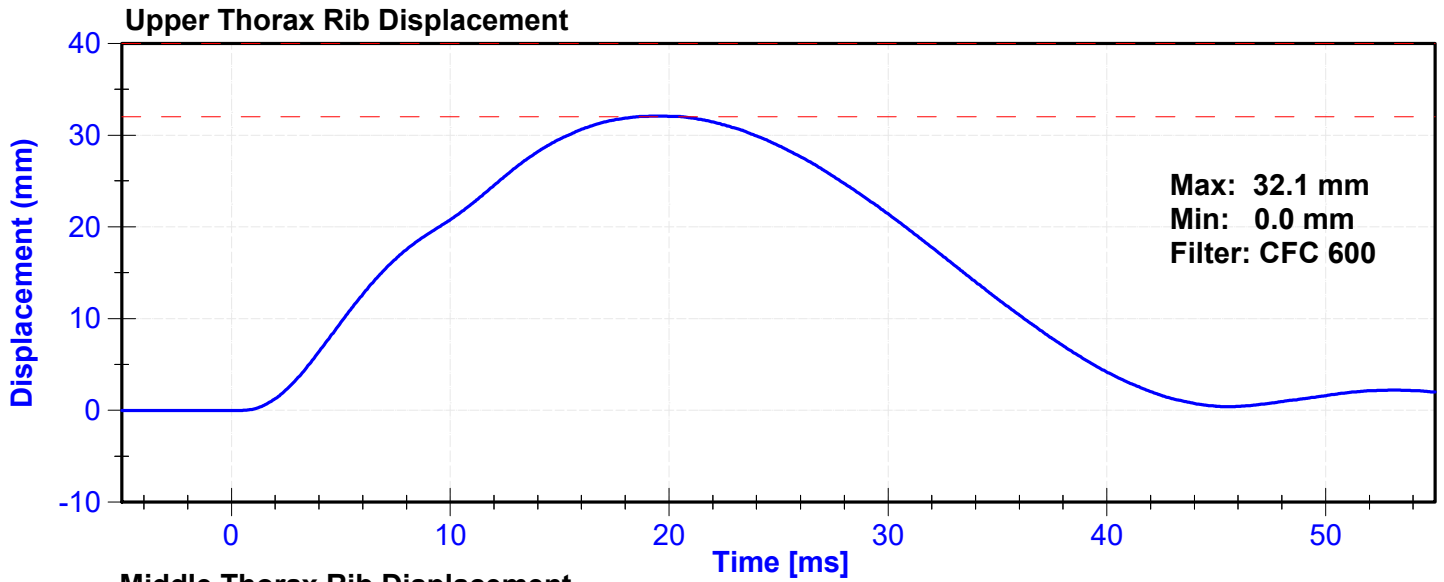

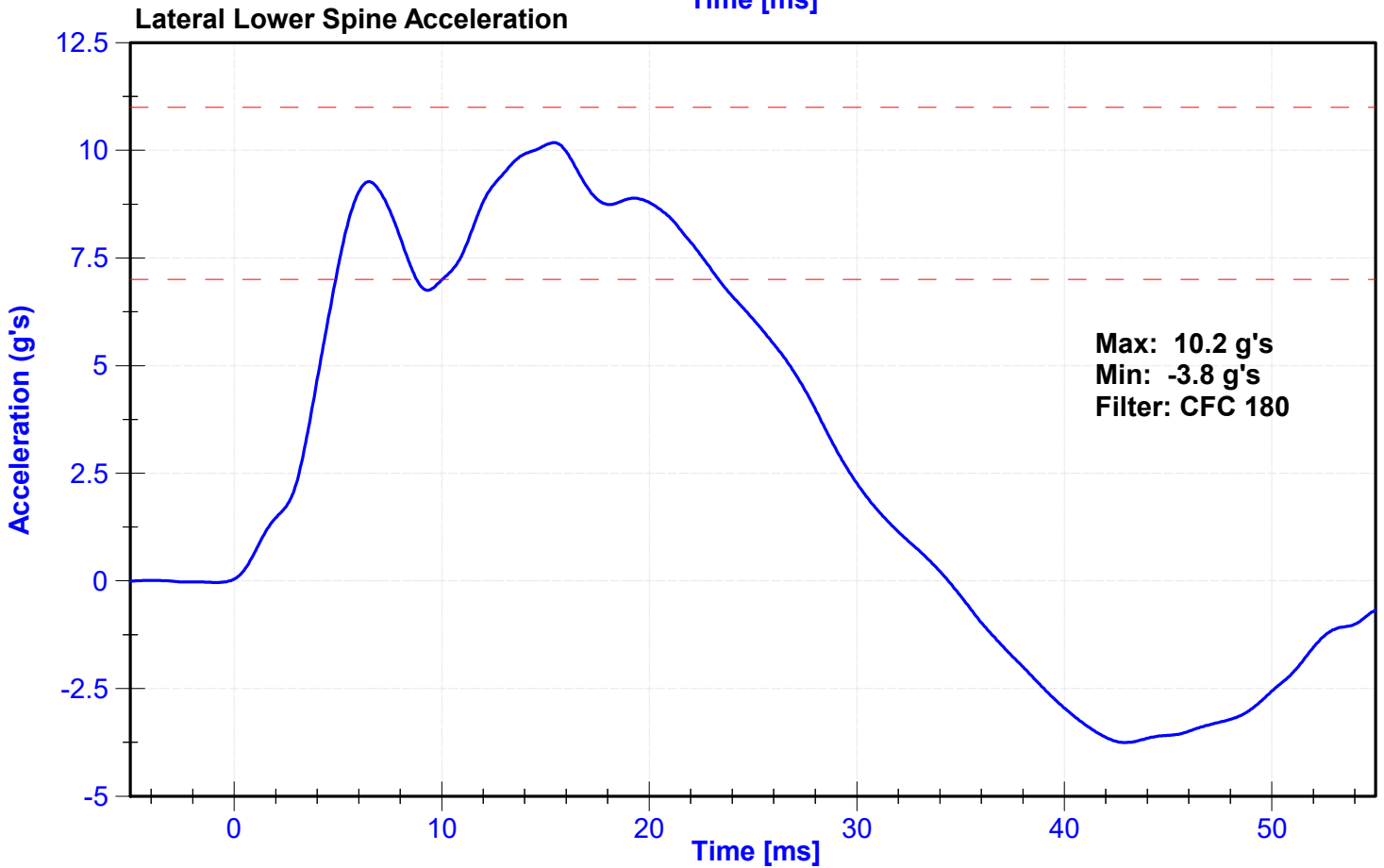
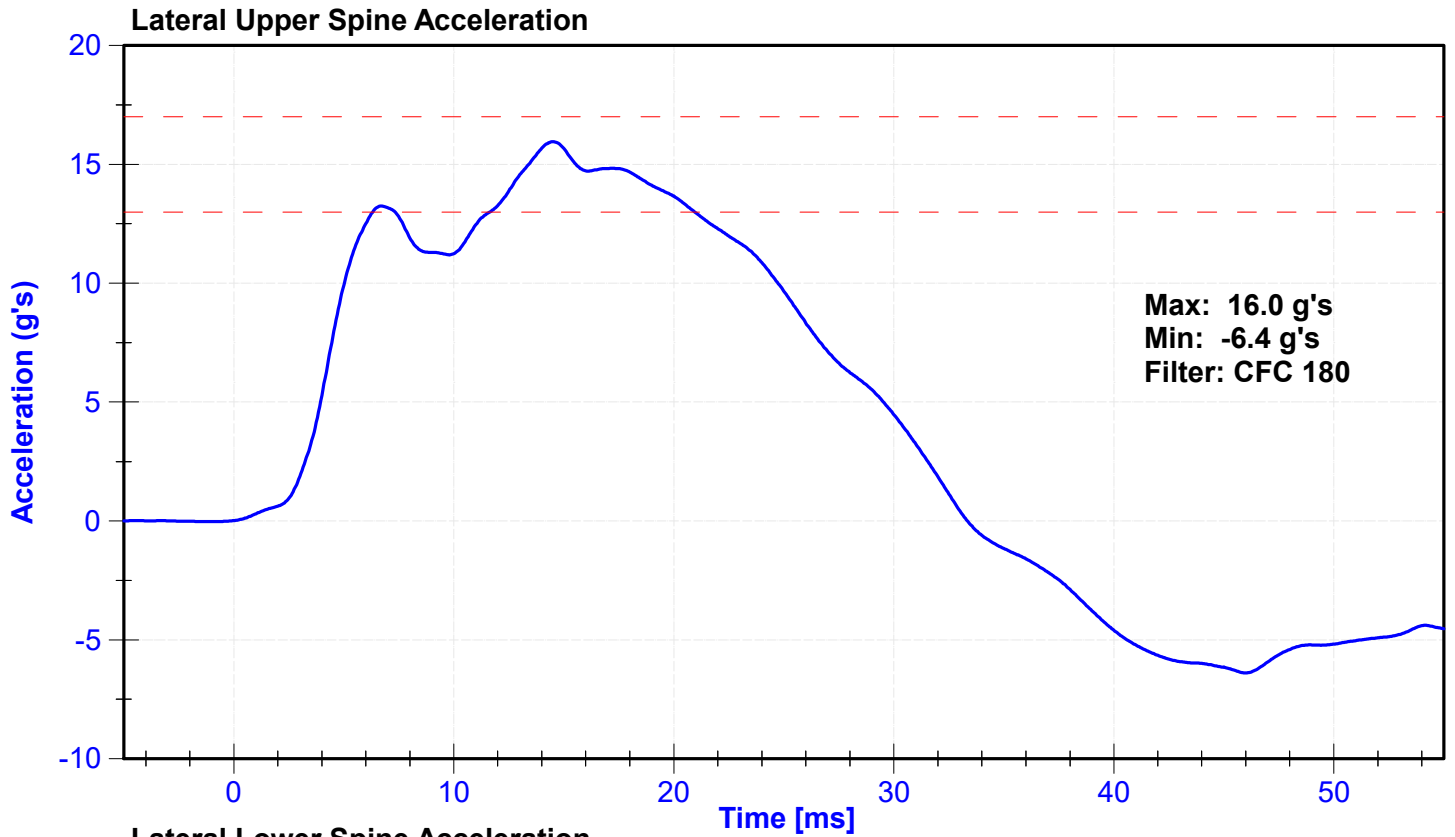

ATD Manufacturer	FTSS	Test Technician	J. Rios
ATD Serial Number	261	Laboratory Supervisor	C. Mantell

**Results**

Test Parameter	Minimum Specification	Maximum Specification	Unit	Result	Pass/Fail
Temperature	20.6	22.2	°C	21.2	Pass
Humidity	10	70	%	35	Pass
Velocity	4.2	4.4	m/s	4.28	Pass
Probe Acceleration	12	16	g's	14.2	Pass
Lateral Lower Spine Acceleration	9	14	g's	10.5	Pass
Upper Abdomen Rib Deflection	36	47	mm	42.1	Pass
Lower Abdomen Rib Deflection	33	44	mm	39.4	Pass

**Transducer Calibrations**

Channel	Manufacturer	Serial Number	Calibration Date	Calibration Due Date
Probe Accelerometer	Endevco	18527	8/2/2024	1/29/2025
Lower Spine Y Accelerometer	Endevco	P58744	5/15/2024	11/11/2024
Upper Abdomen Rib Potentiometer	Servo	342GFE	5/16/2024	11/14/2024
Lower Abdomen Rib Potentiometer	Servo	512GFE	5/16/2024	11/14/2024

**Probe Acceleration**

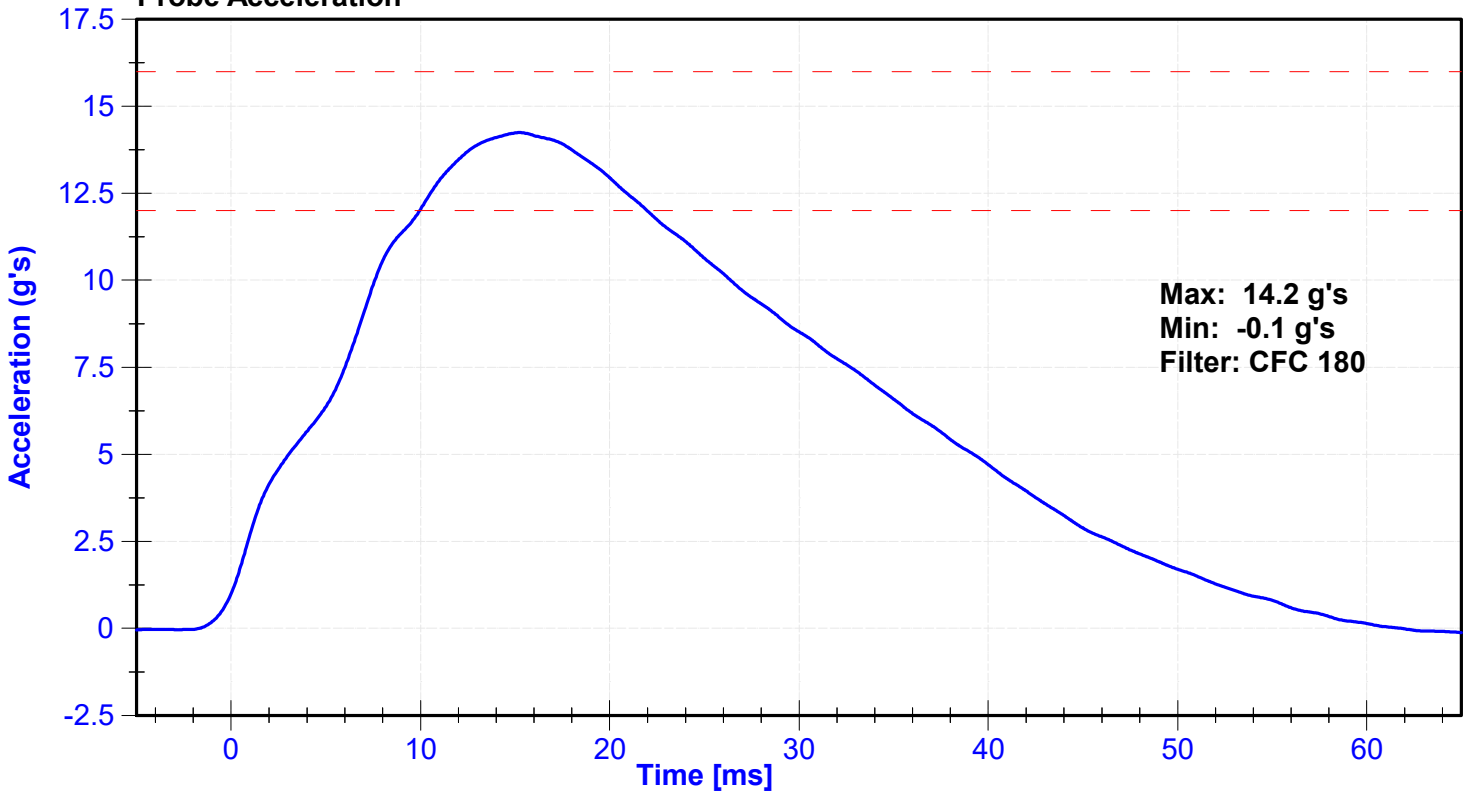

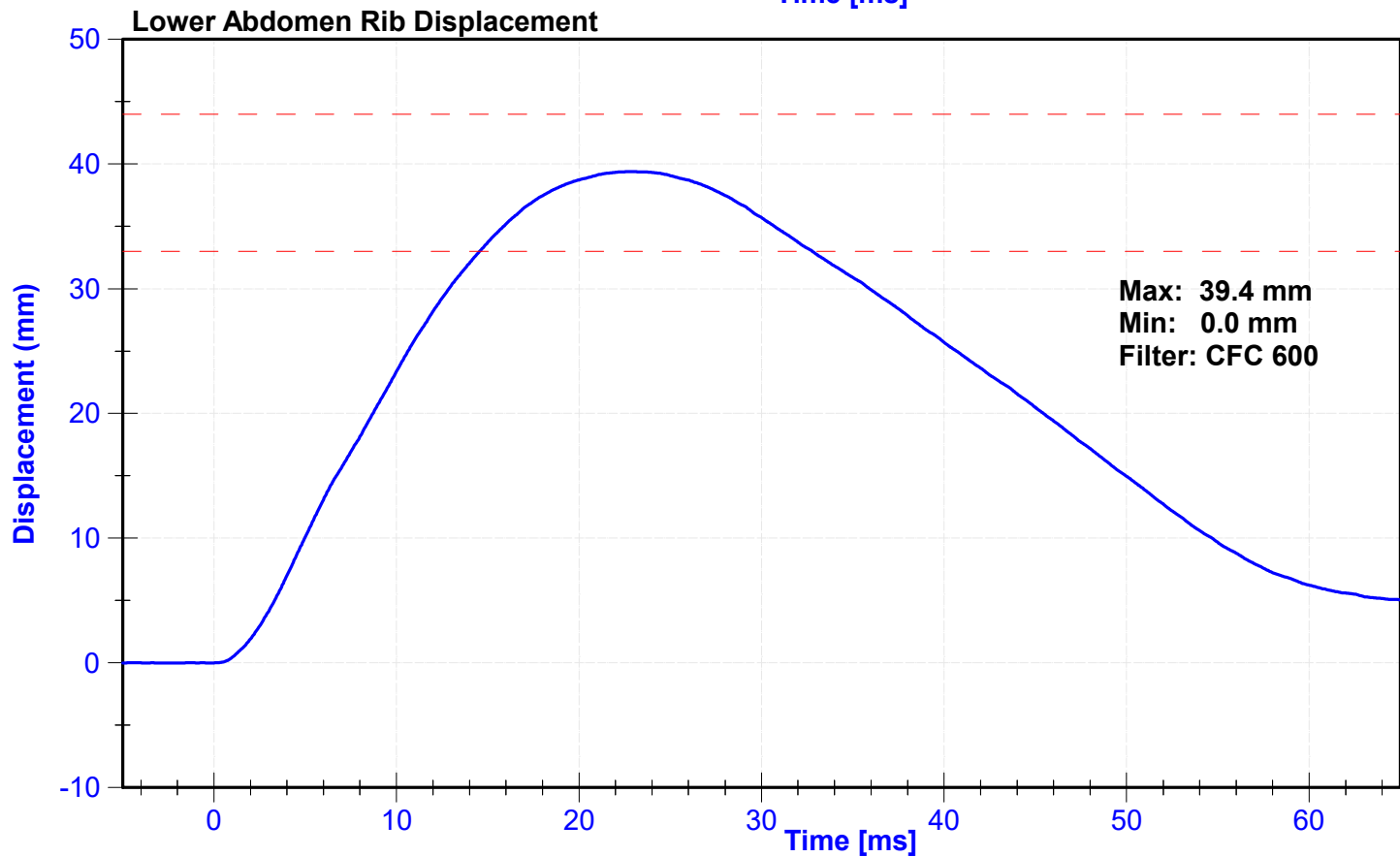
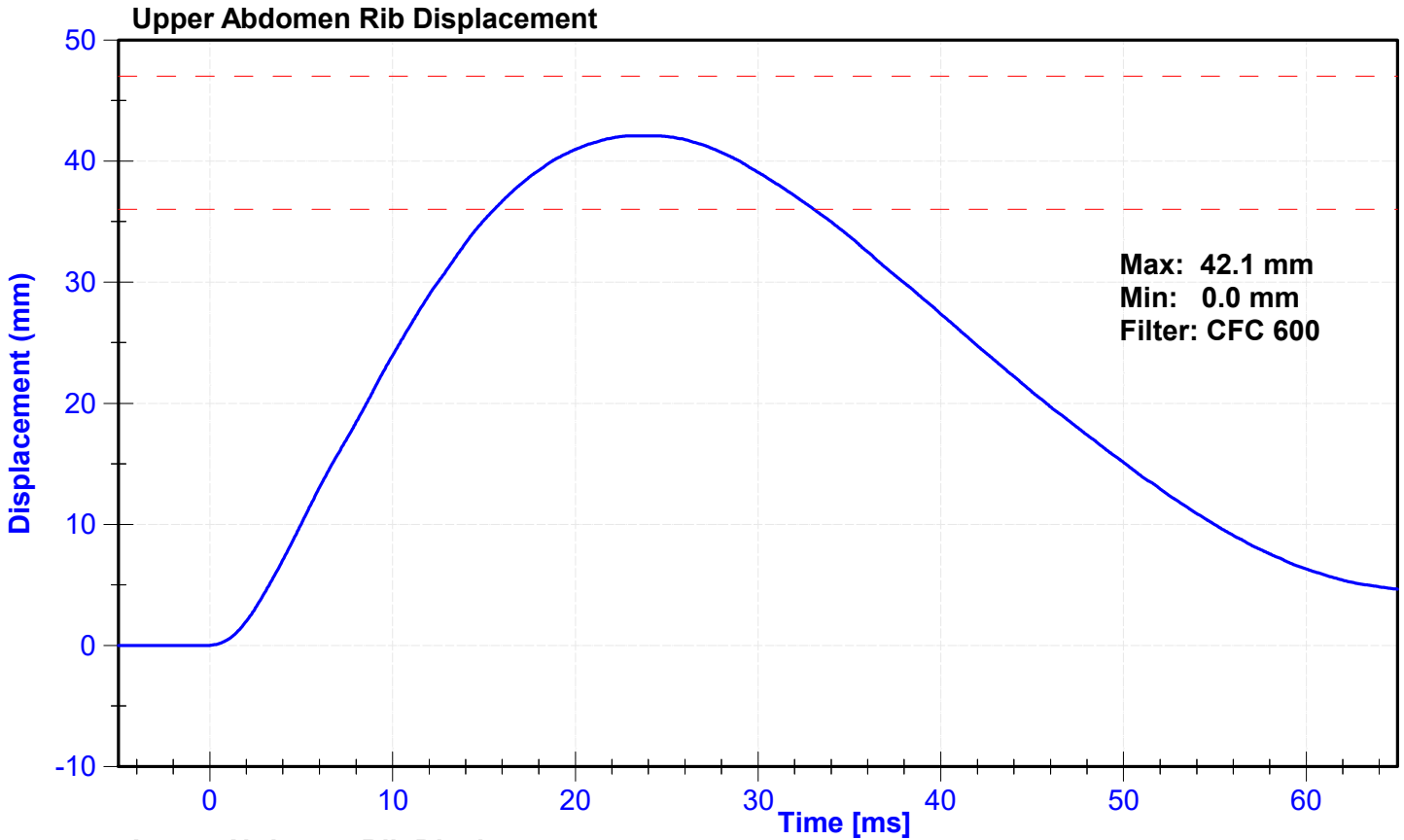

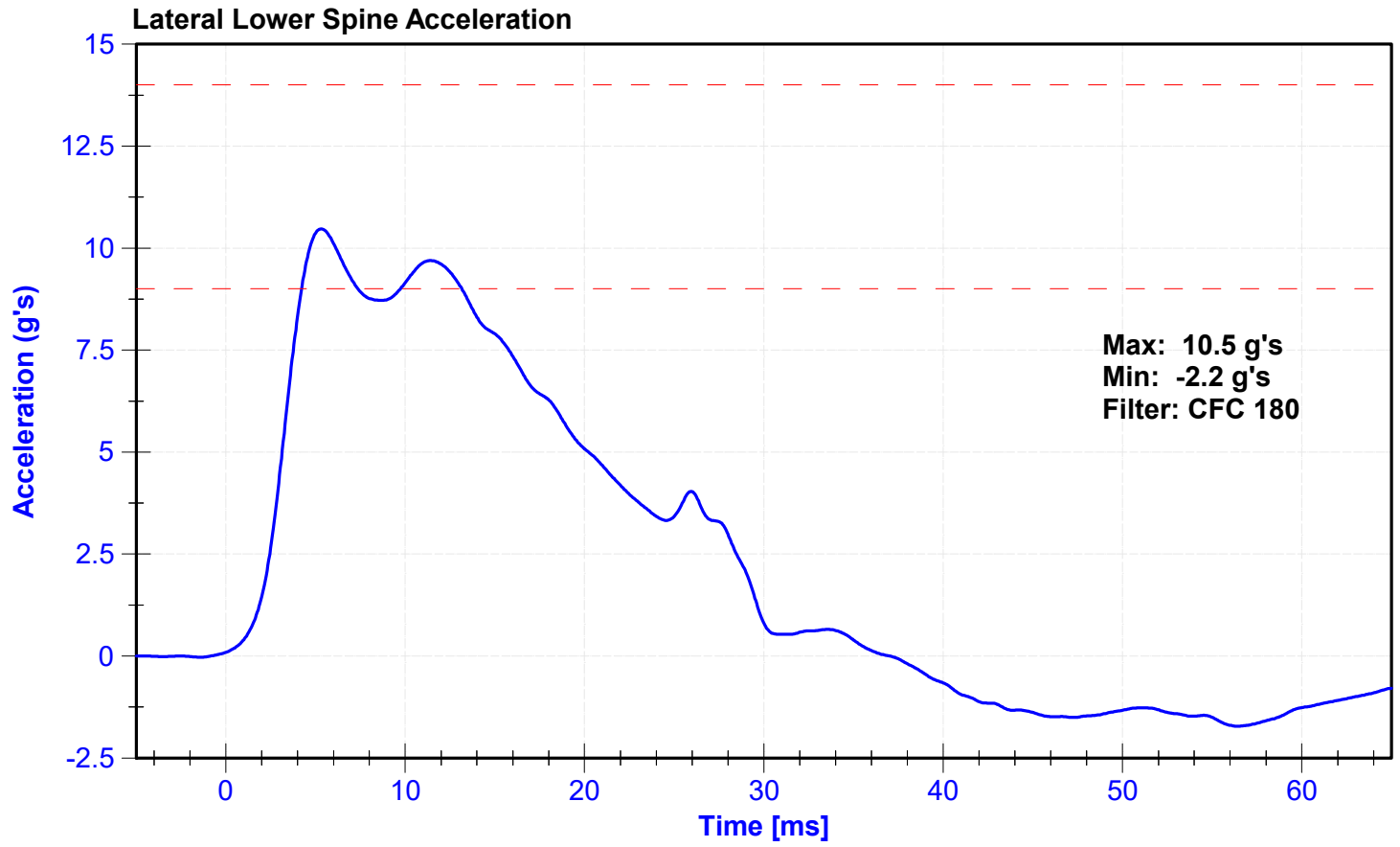

ATD Manufacturer	FTSS	Test Technician	J. Rios
ATD Serial Number	261	Laboratory Supervisor	C. Mantell

**Results**

Test Parameter	Minimum Specification	Maximum Specification	Unit	Result	Pass/Fail
Temperature	20.6	22.2	°C	21.2	Pass
Humidity	10	70	%	35	Pass
Velocity	6.6	6.8	m/s	6.66	Pass
Probe Acceleration	38	47	g's	46.4	Pass
Lateral Pelvis Acceleration after 6ms	34	42	g's	38.0	Pass
Acetabulum Force	3600	4300	N	3906.3	Pass

**Transducer Calibrations**

Channel	Manufacturer	Serial Number	Calibration Date	Calibration Due Date
Pendulum Accelerometer	Endevco	18527	8/2/2024	1/29/2025
Pelvis Y Accelerometer	Endevco	T29392	5/15/2024	11/11/2024
Acetabulum Load Cell	FTSS	236-FY	12/5/2023	12/4/2024
Certification Plug	SACO			N/A
Crash Test Plug	SACO			N/A

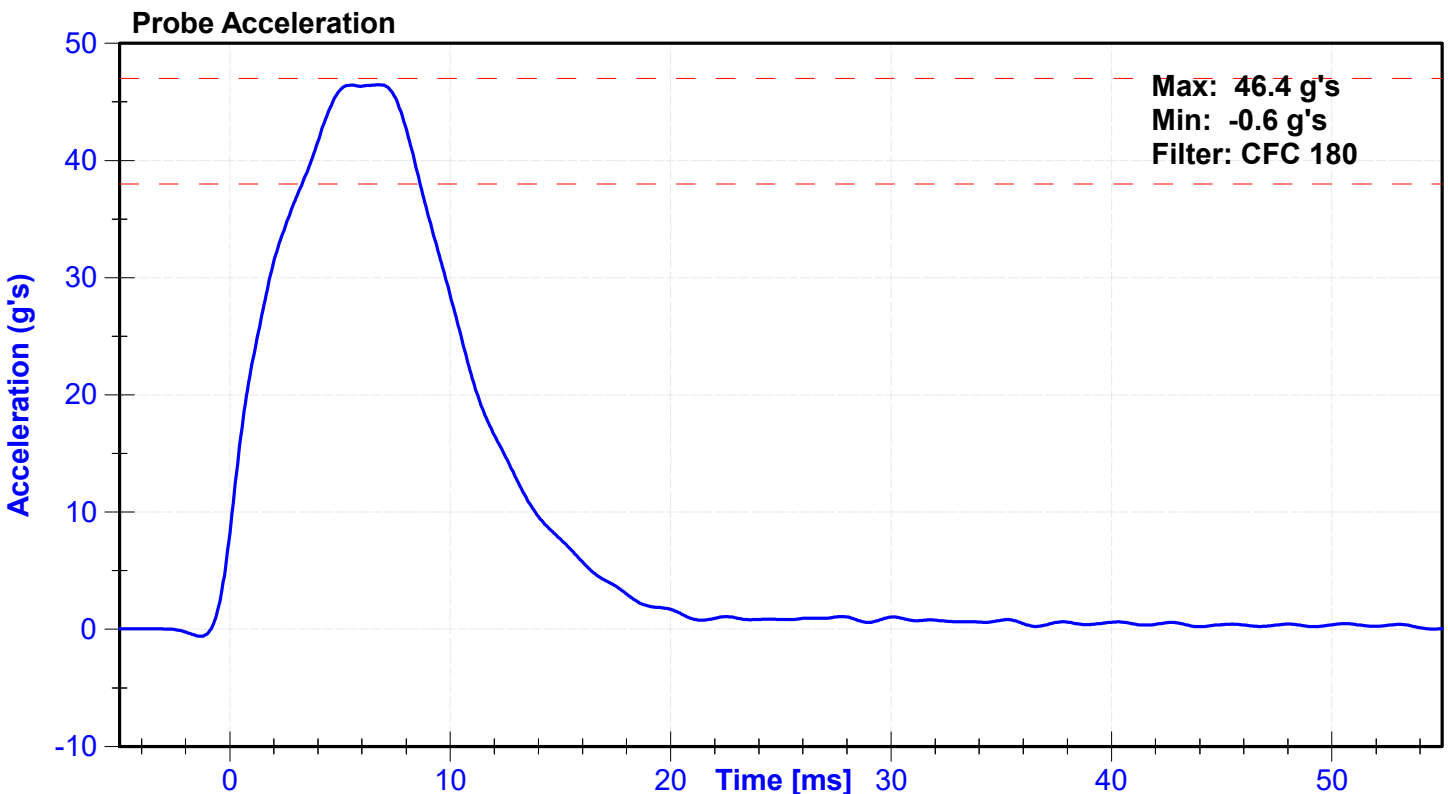

Lateral Pelvis Acceleration

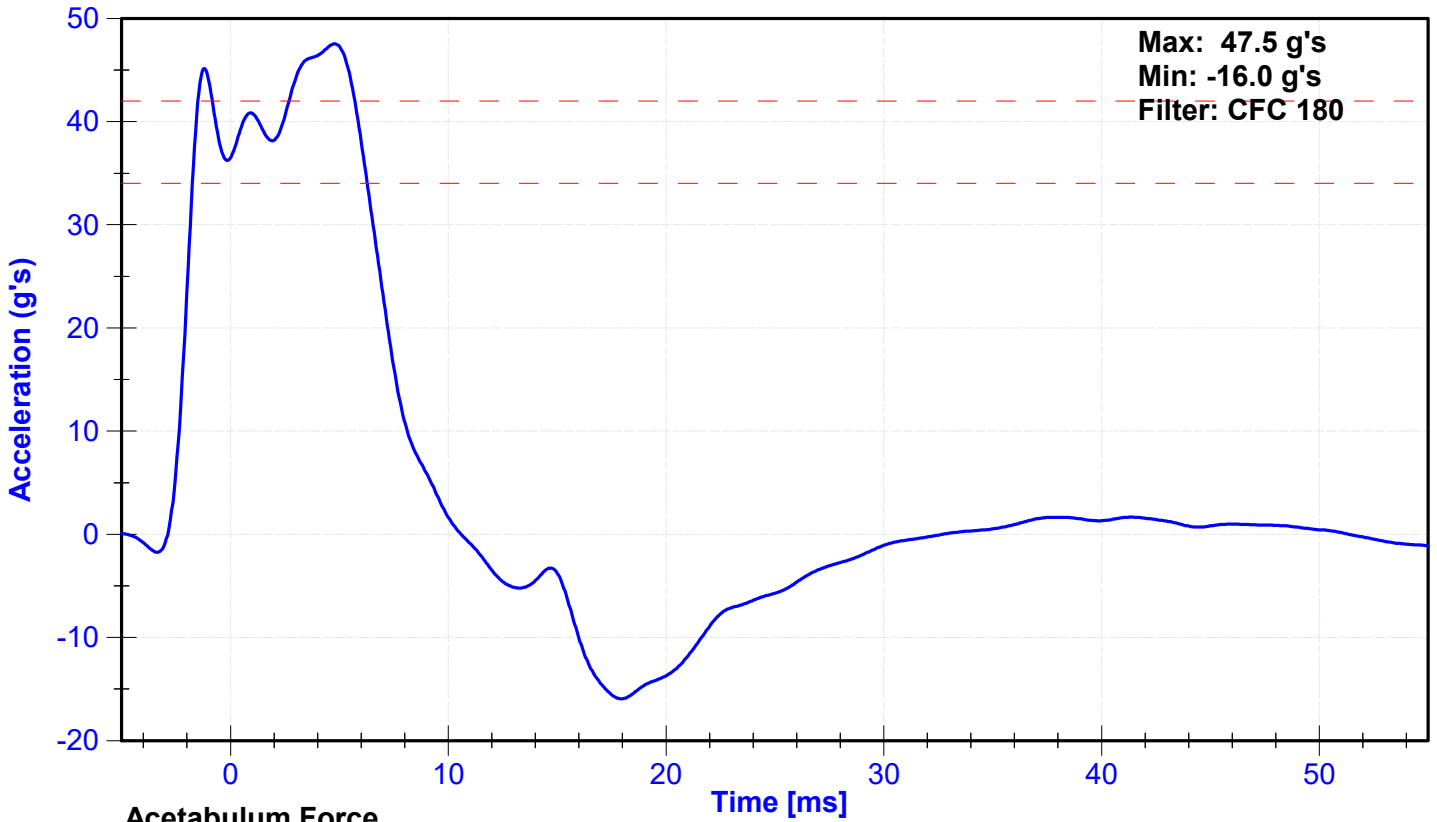

Acetabulum Force

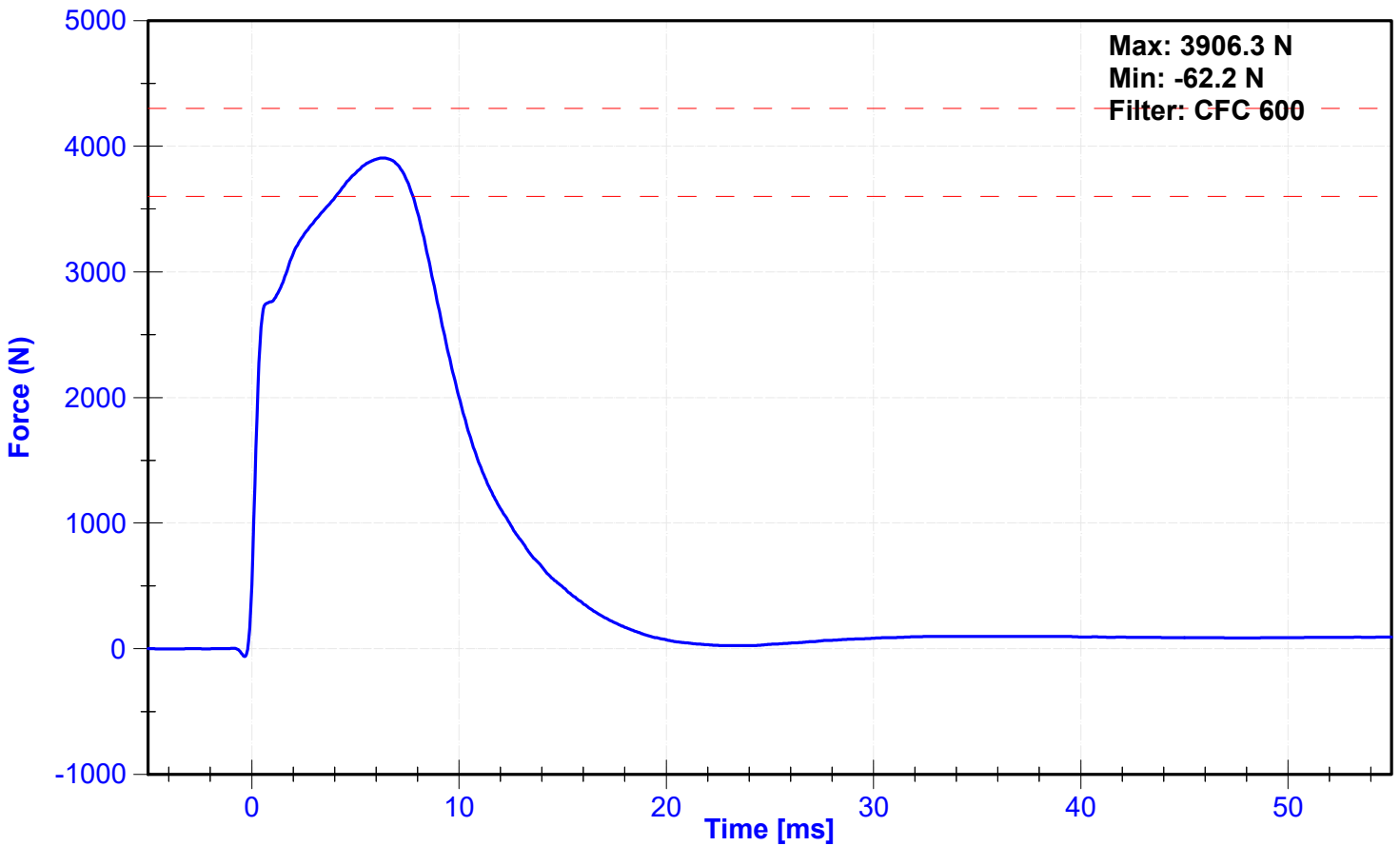



**SID-IIs Pelvis Plug Certification Test**

Plug S/N 16672

Test Number 23472

Report Number 23529

Test Date 7/22/2022 10:09:51 AM

	Test Results	Spec Min	Spec Max
Force @ 0.5 mm (N)	296	50	600
Force @ 1.5 mm (N)	1,144	850	1,400
Force @ 2.5 mm (N)	1,428	1,306	1,618
Force @ 3.0 mm (N)	1,466	1,361	1,673

Testing Machine STM-20 5965542  
 Load Cell S/N (FI360947), Units (LBS) 1000  
 Crosshead Speed ( mm / min ) or Rate 12.7  
 Extension or Position Measured by XHD\_100 ( XHD100 )

Notes:  
 Cert Plug 10-22-24 261

Force (-N) vs Extension (-mm)

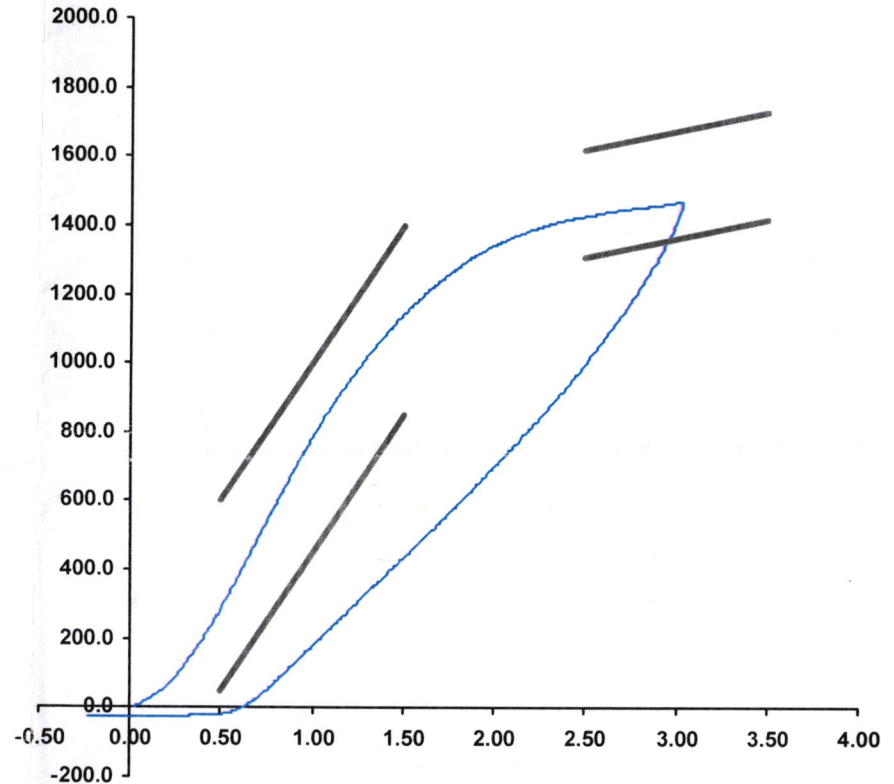

Operator

Part Number 180-4450

Template No 107 22-Jul-22  
 SACO Research

By : DC Date : 7/22/22

SACO Research 41735 Elm St, #401 Murrieta, CA 92562 Tel 310-694-2082 FAX



**SID-IIs Pelvis Plug Certification Test**

Plug S/N 16671

Test Number 23471

Report Number 23528

Test Date 7/22/2022 10:06:55 AM

	Test Results	Spec Min	Spec Max
Force @ 0.5 mm (N)	313	50	600
Force @ 1.5 mm (N)	1,177	850	1,400
Force @ 2.5 mm (N)	1,464	1,306	1,618
Force @ 3.0 mm (N)	1,500	1,361	1,673

Testing Machine STM-20 5965542  
 Load Cell S/N (FI360947), Units (LBS) 1000  
 Crosshead Speed ( mm / min ) or Rate 12.7  
 Extension or Position Measured by XHD\_100 (XHD100)

Notes:  
 Impact Plug 10-22-24 261

Force (-N) vs Extension (-mm)

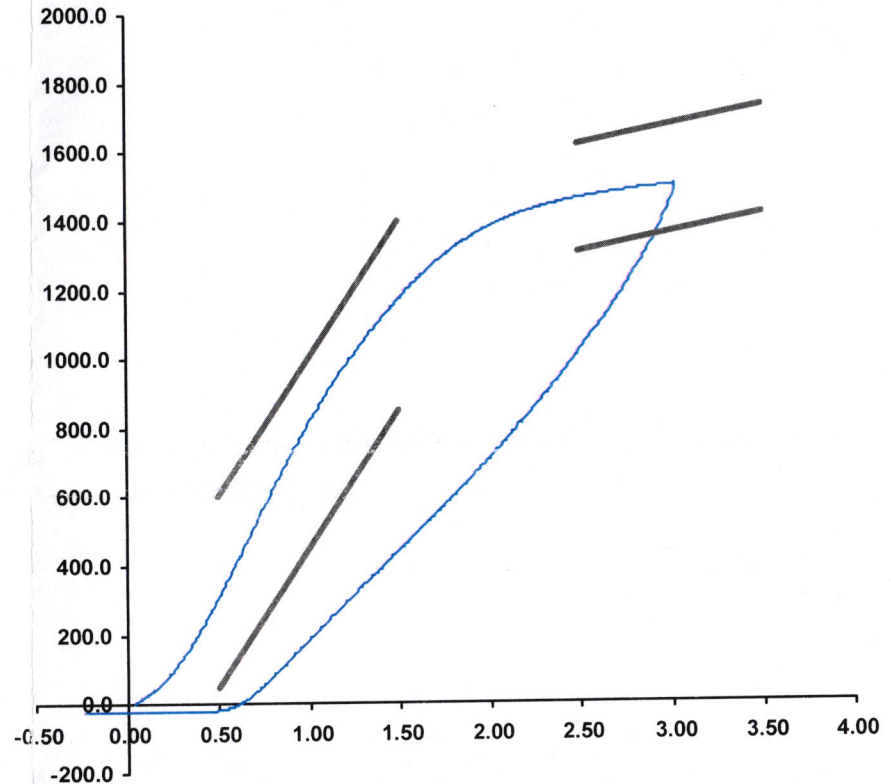

Operator

Part Number 180-4450

Template No 107 22-Jul-22

SACO Research

By: DC Date: 7/22/22



**SID-IIs Pelvis Plug Certification Test**

Plug S/N 16674

Test Number 23474

Report Number 23531

Test Date 7/22/2022 10:13:49 AM

	Test Results	Spec Min	Spec Max
Force @ 0.5 mm (N)	309	50	600
Force @ 1.5 mm (N)	1,185	850	1,400
Force @ 2.5 mm (N)	1,468	1,306	1,618
Force @ 3.0 mm (N)	1,503	1,361	1,673

Testing Machine STM-20 5965542  
 Load Cell S/N (FI360947), Units (LBS ) 1000  
 Crosshead Speed ( mm / min ) or Rate 12.7  
 Extension or Position Measured by XHD\_100 ( XHD100 )

Notes:  
 NON IMPACT 10-22-24 261

Force (-N) vs Extension (-mm)

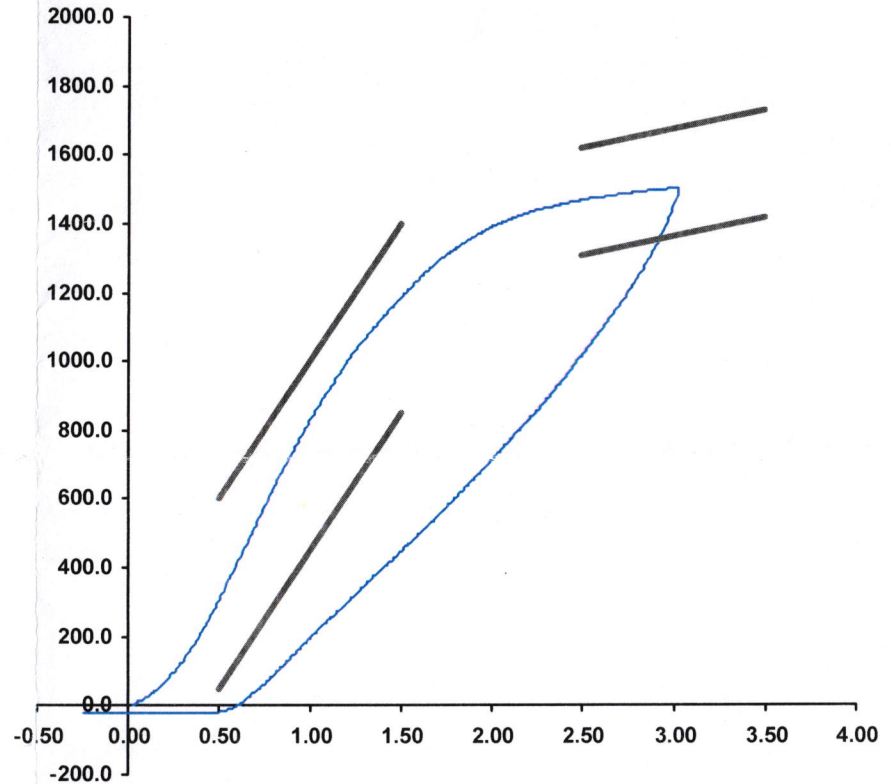

Operator  
 Part Number 180-4450

Template No 107 22-Jul-22  
 SACO Research

By : DC Date : 7/22/22

ATD Manufacturer	FTSS	Test Technician	J. Rios
ATD Serial Number	261	Laboratory Supervisor	C. Mantell

**Results**

Test Parameter	Minimum Specification	Maximum Specification	Unit	Result	Pass/Fail
Temperature	20.6	22.2	°C	21.2	Pass
Humidity	10	70	%	35	Pass
Velocity	4.2	4.4	m/s	4.29	Pass
Probe Acceleration	36	45	g's	37.8	Pass
Lateral Pelvis Acceleration	28	39	g's	28.1	Pass
Iliac Force	4100	5100	N	4201.3	Pass

**Transducer Calibrations**

Channel	Manufacturer	Serial Number	Calibration Date	Calibration Due Date
Pendulum Accelerometer	Endevco	18527	8/2/2024	1/29/2025
Pelvis Y Accelerometer	Endevco	T29392	5/15/2024	11/11/2024
Iliac Load Cell	Denton	290-FY	12/5/2023	12/4/2024

**Probe Acceleration**

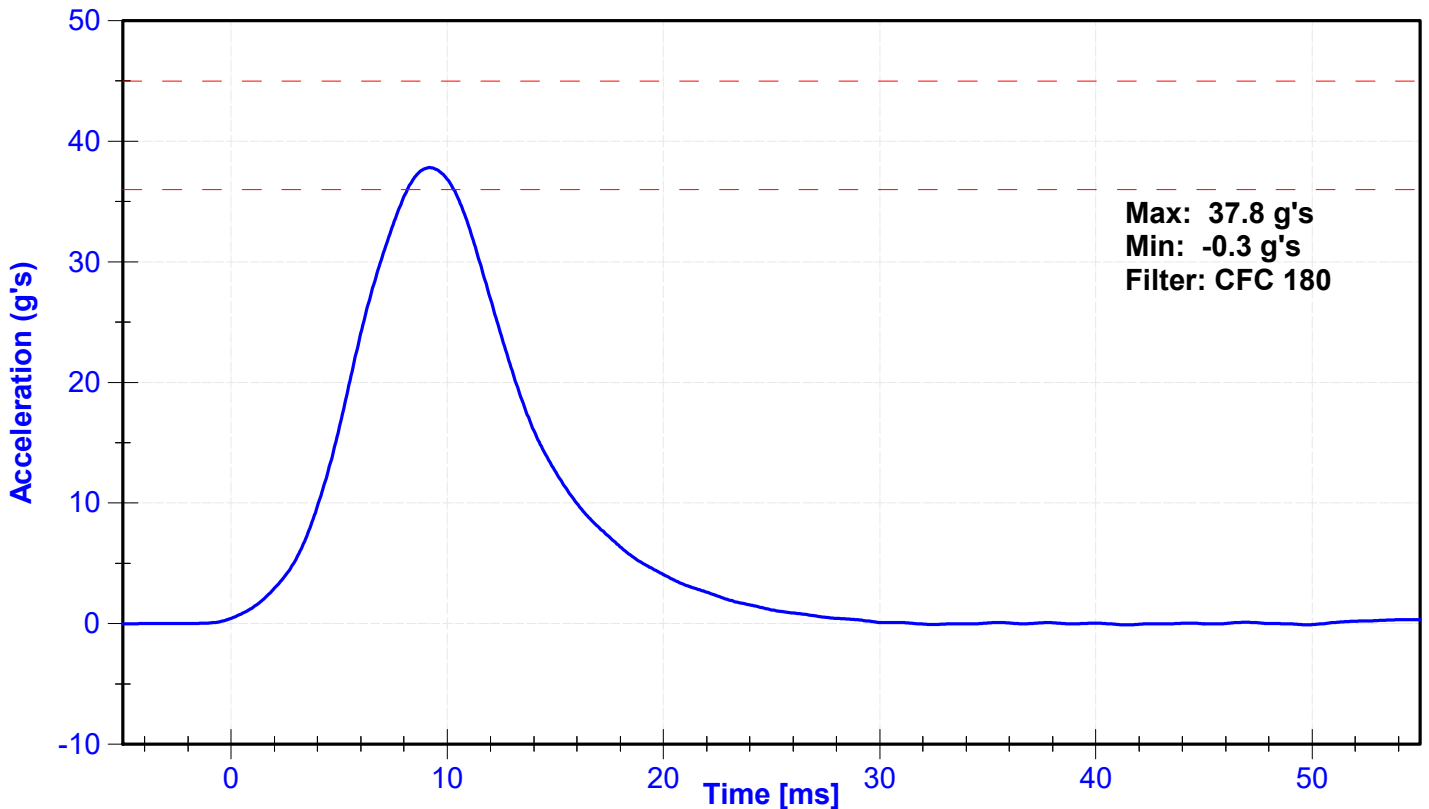

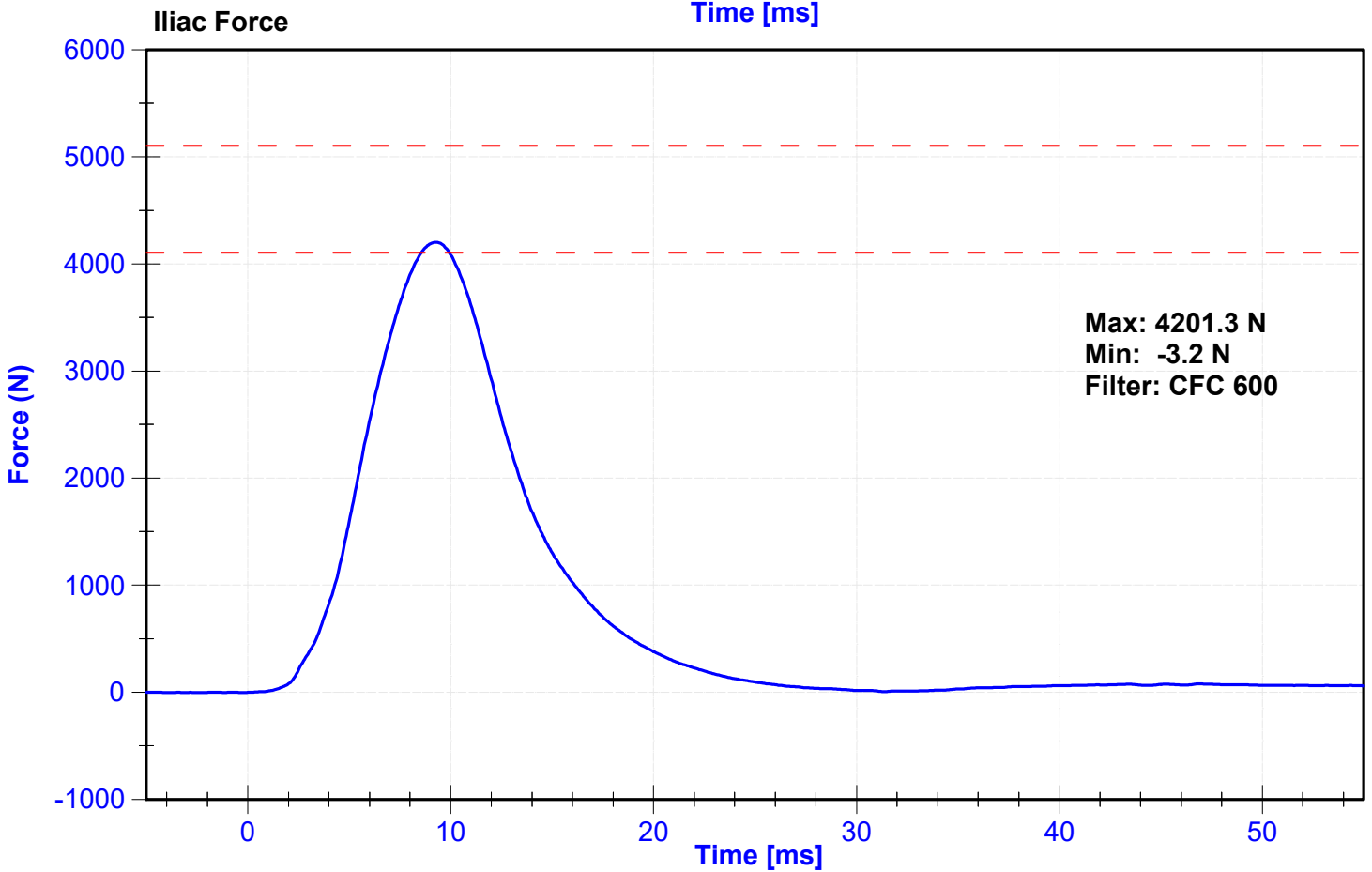
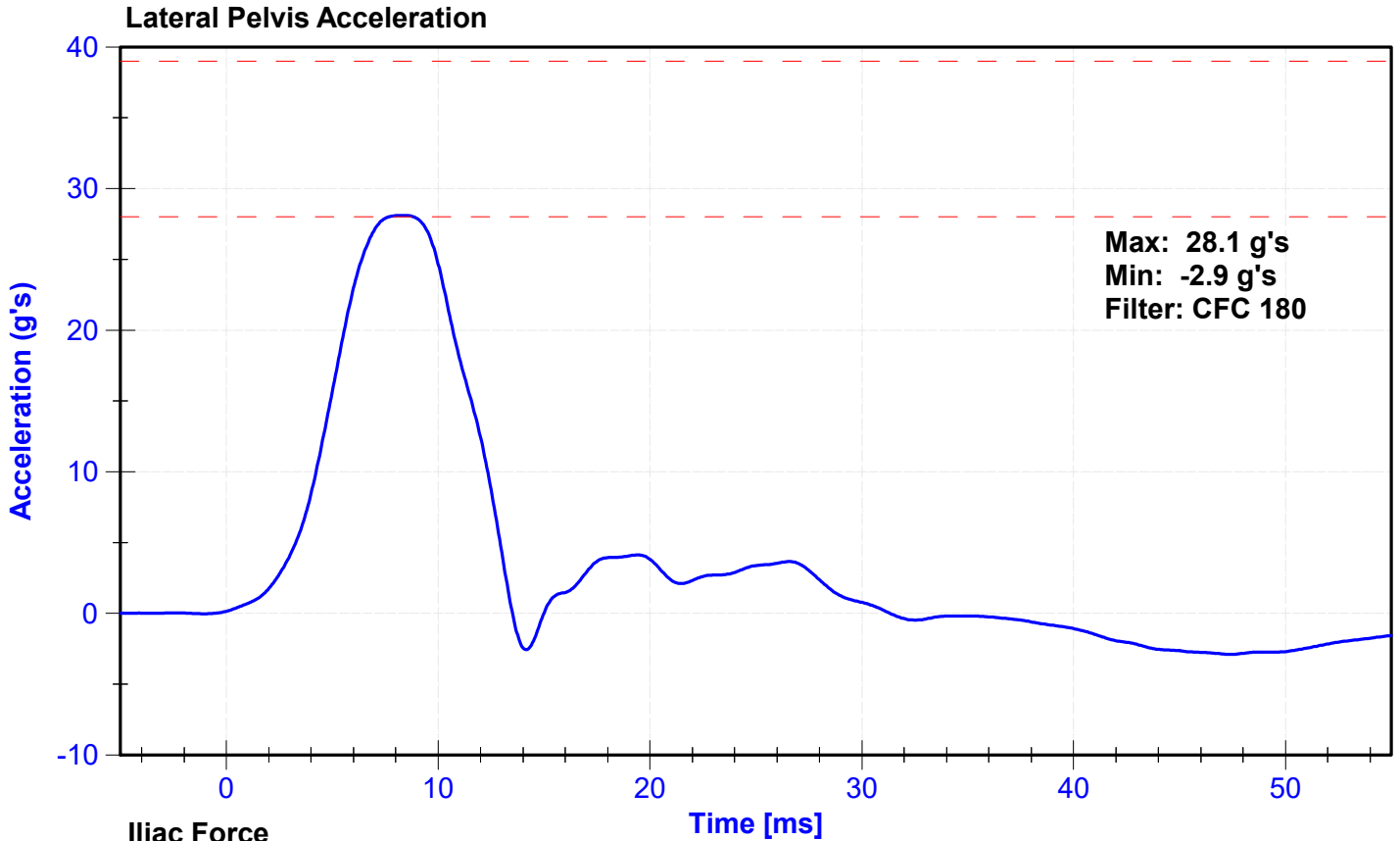

**APPENDIX VII**

**TEST EQUIPMENT AND INSTRUMENTATION CALIBRATION**

**TABLE 1 – Dummy Instrumentation (ES-2re)**

			ES-2re S/N DG5348		
			Serial Number	Manufacturer	Calibration Date
Head Accelerometers	Primary	X	18613	Endevco	07/30/2024
		Y	18472	Endevco	07/30/2024
		Z	18663	Endevco	07/30/2024
	Redundant	X	18666	Endevco	07/30/2024
		Y	18664	Endevco	07/30/2024
		Z	18675	Endevco	07/30/2024
Thorax Rib Displacement Potentiometers	Upper	Y	268GFE	Honeywell	07/30/2024
	Middle	Y	269GFE	Honeywell	07/30/2024
	Lower	Y	270GFE	Honeywell	07/30/2024
Abdomen Load Cells	Forward	Y	DM5846	Denton	05/22/2024
	Middle	Y	1529	Denton	05/22/2024
	Rear	Y	1533	Denton	05/22/2024
Lower Spine Accelerometers (T12)		X	T30049	Endevco	07/30/2024
		Y	18573	Endevco	07/30/2024
		Z	18657	Endevco	07/30/2024
Pubic Symphysis Load Cell		Y	459-FY	Denton	07/12/2024

**TABLE 2 – Dummy Instrumentation (SID-IIs)**

			SID-IIs S/N 261			
			Serial Number	Manufacturer	Calibration Date	
Head Accelerometers	Primary	X	P68067	Endevco	05/15/2024	
		Y	P18567	Endevco	05/15/2024	
		Z	P49163	Endevco	05/15/2024	
	Redundant	X	T26041	Endevco	05/15/2024	
		Y	T22409	Endevco	05/15/2024	
		Z	T26086	Endevco	05/15/2024	
Displacement Potentiometers	Thoracic Rib	Upper	Y	062GFE	Servo	05/16/2024
		Middle	Y	528GFE	Servo	05/16/2024
		Lower	Y	513GFE	Servo	05/16/2024
	Abdominal Rib	Upper	Y	342GFE	Servo	05/16/2024
		Lower	Y	512GFE	Servo	05/16/2024
Lower Spine Accelerometers (T12)		X	T22340	Endevco	05/15/2024	
		Y	P58744	Endevco	05/15/2024	
		Z	T22124	Endevco	05/15/2024	
Acetabulum Load Cell		Y	236-FY	FTSS	12/05/2023	
Iliac Wing Load Cell		Y	290-FY	Denton	12/05/2023	
Pelvis Plug (struck side)			15799	SACO	10/15/2021	
Pelvis Plug (non-struck side)			15767	SACO	10/15/2021	

**TABLE 3 – Vehicle Instrumentation**

Vehicle Instrumentation			Serial Number	Manufacturer	Calibration Date
1	Vehicle Center of Gravity	X	G23838	Endevco	07/18/2024
	Vehicle Center of Gravity	Y	G23843	Endevco	07/18/2024
	Vehicle Center of Gravity	Z	G23855	Endevco	07/18/2024
2	Right Sill at Front Seat	X	G21412	Endevco	07/16/2024
	Right Sill at Front Seat	Y	G22233	Endevco	07/16/2024
	Right Sill at Front Seat	Z	A398644	Measurement Specialties	07/16/2024
3	Right Sill at Rear Seat	X	A262047	Measurement Specialties	05/10/2024
	Right Sill at Rear Seat	Y	A290929	Measurement Specialties	05/10/2024
	Right Sill at Rear Seat	Z	A399976	Measurement Specialties	05/10/2024
4	Left Sill at Front Door	Y	G25875	Endevco	06/04/2024
5	Left Sill at Rear Door	Y	G26001	Endevco	07/18/2024
6	Left A-Post Lower	Y	G26000	Endevco	07/18/2024
7	Left A-Post Middle	Y	G25973	Endevco	07/18/2024
8	Left B-Post Lower	Y	G25972	Endevco	07/18/2024
9	Left B-Post Middle	Y	G25969	Endevco	07/18/2024
10	Front Seat Track	Y	G25994	Endevco	07/18/2024
11	Rear Seat Track or Structure	Y	A280993	Measurement Specialties	06/13/2024
12	Right Rear Occ. Compartment	Y	A284324	Measurement Specialties	05/31/2024
13	Rear Floorpan Above Axle	X	A399966	Measurement Specialties	07/26/2024
	Rear Floorpan Above Axle	Y	A399967	Measurement Specialties	07/26/2024
	Rear Floorpan Above Axle	Z	A399978	Measurement Specialties	07/26/2024

**TABLE 4 – MDB Instrumentation**

MDB Instrumentation		Serial Number	Manufacturer	Calibration Date
Vehicle CG Acceleration vs. Time	X	A374299	Measurement Specialties	08/01/2024
Vehicle CG Acceleration vs. Time	Y	A399983	Measurement Specialties	08/01/2024
Vehicle CG Velocity vs. Time	Y	Calculated	Measurement Specialties	08/01/2024
Vehicle CG Acceleration vs. Time	Z	G23881	Endevco	08/01/2024
Vehicle CG Velocity vs. Time	Z	Calculated	Endevco	08/01/2024
Vehicle CG Resultant Acceleration vs. Time	R	Calculated	Measurement Specialties	08/01/2024