

REPORT NUMBER: 214D-CAL-23-003

**SAFETY COMPLIANCE TESTING FOR FMVSS 214
SIDE IMPACT PROTECTION
MDB TEST**

**Volvo Car Corporation
2023 Volvo XC40 Recharge Twin
SUV**

NHTSA No: C20235901

**PREPARED BY:
CALSPAN CORPORATION
P.O. BOX 400
BUFFALO, NEW YORK 14225**



January 19, 2023

FINAL REPORT

**PREPARED FOR:
U.S. DEPARTMENT OF TRANSPORTATION
NATIONAL HIGHWAY TRAFFIC SAFETY ADMINISTRATION
ENFORCEMENT
OFFICE OF VEHICLE SAFETY COMPLIANCE
1200 NEW JERSEY AVE. S.E.
WEST Bldg. (NVS-220)
WASHINGTON, D.C. 20590**

This final test report was prepared for the U.S. Department of Transportation, National Highway Traffic Safety Administration, in response to Contract Number DTNH22-17-D-00078.

This publication is distributed by the U.S. Department of Transportation, National Highway Traffic Safety Administration, in the interest of information exchange. The opinions, findings and conclusions expressed in this publication are those of the author(s) and not necessarily those of the Department of Transportation or the National Highway Traffic Safety Administration. The United States Government assumes no liability for its contents or use thereof.

If trade or manufacturers' names or products are mentioned it is only because they are considered essential to the object of the publication and should not be construed as an endorsement. The United States Government does not endorse products or manufacturers.

Prepared by: Alexander Rudniski
Alexander Rudniski, Test Engineer

Date: January 19, 2023

Approved by: Vanessa Hansen
Vanessa Hansen, Operations Manager

Date: January 19, 2023

FINAL REPORT ACCEPTANCE BY OVSC:

Accepted by

Date: _____

TECHNICAL REPORT DOCUMENTATION PAGE

1. Report No. 214D-CAL-23-003	2. Government Accession No.	3. Recipient's Catalog No.																								
4. Title and Subtitle Final Report of 214D Compliance Test Side Impact Protection Testing of 2023 Volvo XC40 Recharge Twin NHTSA No.: C20235901		5. Report Date January 19, 2023																								
		6. Performing Organization Code CAL																								
7. Author(s) Matthew Pronko, Test Engineer Vanessa Hansen, Operations Manager		8. Performing Organization Report No. CAL-DOT-2023-003																								
9. Performing Organization Name and Address Calspan Corporation Transportation Test Operation P.O. Box 400 Buffalo, New York 14225		10. Work Unit No.																								
		11. Contract or Grant No. DTNH22-17-D-00078																								
12. Sponsoring Agency Name and Address U.S. Department of Transportation National Highway Traffic Safety Administration Enforcement Office of Vehicle Safety Compliance 1200 New Jersey Ave., SE, Room W43-503 Washington, D.C. 20590		13. Type of Report and Period Covered: Final Test Report, December 20, 2022 - January 19, 2023																								
		14. Sponsoring Agency Code NVS-220																								
15. Supplementary Notes																										
16. Abstract <p>A 48/24 kph 90° Impact (Moving Deformable Barrier) Compliance Tests was conducted on the subject 2023 Volvo XC40 Recharge Twin four door sedan in accordance with the specifications of the Office of Vehicle Safety Compliance Test Procedure No. TP-214D-09 for the determination of FMVSS No. 214 Side Impact Protection compliance. The test was conducted at Calspan Corporation's Transportation Test Operations facility in Buffalo, New York on December 20, 2022.</p> <p>The impact velocity of the Moving Deformable Barrier (MDB) was 52.9 kph, and the ambient temperature at the struck side (driver side) of the target vehicle at the time of impact was 21°C. The target vehicle post test maximum crush was 202 mm at level 2. The test vehicle's occupant performance is as follows:</p>																										
<table border="1" style="width: 100%; border-collapse: collapse;"> <thead> <tr> <th rowspan="2" style="width: 55%;">Measurement Description</th> <th colspan="3" style="text-align: center;">Driver ATD (ES-2re)</th> </tr> <tr> <th style="width: 10%;">Units</th> <th style="width: 10%;">IARV</th> <th style="width: 10%;">Result</th> </tr> </thead> <tbody> <tr> <td>Head Injury Criteria (HIC₃₆)</td> <td>N/A</td> <td>1000</td> <td style="text-align: right;">38.377</td> </tr> <tr> <td>Maximum Rib Deflection</td> <td>mm</td> <td>44</td> <td style="text-align: right;">13.236</td> </tr> <tr> <td>Sum of Abdominal Forces</td> <td>N</td> <td>2500</td> <td style="text-align: right;">420.400</td> </tr> <tr> <td>Pubic Symphysis Force</td> <td>N</td> <td>6000</td> <td style="text-align: right;">680.370</td> </tr> </tbody> </table>				Measurement Description	Driver ATD (ES-2re)			Units	IARV	Result	Head Injury Criteria (HIC ₃₆)	N/A	1000	38.377	Maximum Rib Deflection	mm	44	13.236	Sum of Abdominal Forces	N	2500	420.400	Pubic Symphysis Force	N	6000	680.370
Measurement Description	Driver ATD (ES-2re)																									
	Units	IARV	Result																							
Head Injury Criteria (HIC ₃₆)	N/A	1000	38.377																							
Maximum Rib Deflection	mm	44	13.236																							
Sum of Abdominal Forces	N	2500	420.400																							
Pubic Symphysis Force	N	6000	680.370																							
<table border="1" style="width: 100%; border-collapse: collapse;"> <thead> <tr> <th rowspan="2" style="width: 55%;">Measurement Description</th> <th colspan="3" style="text-align: center;">Passenger ATD (SID-IIs)</th> </tr> <tr> <th style="width: 10%;">Units</th> <th style="width: 10%;">IARV</th> <th style="width: 10%;">Result</th> </tr> </thead> <tbody> <tr> <td>Head Injury Criteria (HIC₃₆)</td> <td>N/A</td> <td>1000</td> <td style="text-align: right;">23.288</td> </tr> <tr> <td>Lower Spine Resultant Acceleration</td> <td>G</td> <td>82</td> <td style="text-align: right;">38.683</td> </tr> <tr> <td>Sum of Acetabular and iliac forces</td> <td>N</td> <td>5525</td> <td style="text-align: right;">2066.256</td> </tr> </tbody> </table>				Measurement Description	Passenger ATD (SID-IIs)			Units	IARV	Result	Head Injury Criteria (HIC ₃₆)	N/A	1000	23.288	Lower Spine Resultant Acceleration	G	82	38.683	Sum of Acetabular and iliac forces	N	5525	2066.256				
Measurement Description	Passenger ATD (SID-IIs)																									
	Units	IARV	Result																							
Head Injury Criteria (HIC ₃₆)	N/A	1000	23.288																							
Lower Spine Resultant Acceleration	G	82	38.683																							
Sum of Acetabular and iliac forces	N	5525	2066.256																							
<p>The two doors on the struck side of the vehicle did not separate from the body at the hinges or latches and the opposite doors did not open during the side impact event.</p>																										
17. Key Words Compliance Testing Side Impact Protection MDB ES-2re SID-IIs		18. Distribution Statement Copies of this report are available from: National Highway Traffic Safety Administration Technical Information Services (TIS) Room E12-100 East Bldg. 1200 New Jersey Ave. Washington, D.C. 20590 Telephone No. (202) 366-2588																								
19. Security Class. (of this report) UNCLASSIFIED	20. Security Class. (of this page) UNCLASSIFIED	21. No. of Pages 291	22. Price																							

TABLE OF CONTENTS

<u>Section</u>		<u>Page</u>
1	Purpose and Summary of the Test	1-1
2	Occupant and Vehicle Information	2-1
 <u>Data Sheet</u>		 <u>Page</u>
1	Test Vehicle Information and Options	2-2
2	Vehicle Tire Information	2-4
3	General Test and Vehicle Parameter Data	2-3
4	Seat and Seat Belt Adjustment Data	2-5
5	Fuel Systems and Steering Wheel Position Data	2-6
6	Dummy Longitudinal Clearance Dimensions	2-7
7	Dummy Lateral Clearance Dimensions	2-8
8	Location of Cameras	2-9
9	Test Vehicle Accelerometer Locations	2-10
10	Test Vehicle Accelerometer Data Summary	2-11
11	MDB Accelerometer Locations and Data Summary	2-12
12	MDB Summary of Results	2-13
13	Dummy Injury Response Data for ES-2re	2-14
14	Dummy Injury Response Data for SID-IIs	2-15
15	Post Test Observations	2-16
16	Vehicle Pre test and Post test Measurements	2-17
17	Exterior Crush Measurements	2-18
18	Vehicle Exterior Crush Profiles	2-19
19	Exterior Static Crush for Impactor Face	2-21
20	Temperature and Humidity Trace	2-22
 <u>Appendix</u>		 <u>Page</u>
I	Photographs	I-1
II	ES-2re Dummy Response Data	II-1
III	SID-IIs Dummy Response Data	III-1
IV	Vehicle and MDB Accelerometer Response Data	IV-1
V	ES-2re Performance Calibration Test Data	V-1
VI	SID-IIs Performance Calibration Test Data	VI-1
VII	Test Equipment and Instrumentation Calibration	VII-1
VIII	Check Sheets	V-III-1

SECTION 1 PURPOSE AND SUMMARY OF TEST

PURPOSE

This moving deformable barrier side impact test was conducted as part of the MY 2023 214 Side Impact Protection Compliance Test Program, sponsored by the National Highway Traffic Safety Administration (NHTSA), under Contract No. DTNH22-17-D-00078. The purpose of this test was to evaluate side impact protection in a 2023 Volvo XC40 Recharge Twin SUV. The side impact test was conducted in accordance with the Office of Vehicle Safety Compliance's Laboratory Test Procedure, TP-214D-09 dated September 2012.

SUMMARY

A 2023 Volvo XC40 Recharge Twin SUV was impacted on the left side by a Moving Deformable Barrier (MDB) which was moving forward in a 27° crabbed position to the tow road guidance system at a velocity of 52.76 kph (32.78 mph). The target vehicle was stationary and was positioned at an angle of 63° to the line of forward motion. The side impact test was conducted by the Calspan Corporation's Transportation Test Operations Center in Buffalo, New York on December 20, 2022. Pre-test and post test photographs of the test vehicle, the MDB and test dummies are included in this report.

Test dummies were placed in both the driver and left rear designated seating positions according to instructions specified in the OVSC Test Procedure data September 2012. The side impact event was documented by 9 high speed cameras and two real time camera. Camera locations and other pertinent camera information are included in this report.

The ES2re male dummy was instrumented with triaxial accelerometer packs located in the head, three rib displacement transducers located in the chest, three load cells located in the abdomen and a load cell located in the pubic symphysis.

The SID-1Is female dummy was instrumented with triaxial accelerometer packs located in the head and the spine and load cells located in the pubic symphysis and acetabulum. A summary of each dummy's configuration and performance verification test data has been included in this report along with the dummy response traces.

Injury readings for the dummies were recorded as follows:

INJURY READINGS

ES-2re Injury Criteria	Units	Max. Allowable IARV	Measured Value	Pass/Fail
HIC		1000	38.377	Pass
Upper Rib Deflection	mm	44	8.155	Pass
Mid Rib Deflection	mm		10.223	Pass
Lower Rib Deflection	mm		13.236	Pass
Abdominal Load (front)	N		89.128	
Abdominal Load (mid)	N		167.797	
Abdominal Load (rear)	N		205.902	
Sum of Abdomen Forces	N	2500	420.400	Pass
Pubic Symphysis	N	6000	680.370	Pass

SID-IIs Injury Criteria	Units	Max. Allowable IARV	Measured Value	Pass/Fail
HIC		1000	23.288	Pass
Max Spine Acceleration	g	82	38.683	Pass
Acetabular	N		2036.851	Pass
Iliac	N		346.085	Pass
Sum of Acetabular & Iliac	N	5525	2066.256	Pass

SECTION 2

OCCUPANT AND VEHICLE INFORMATION

This section contains information reporting for the following Data Sheets:

<u>Data Sheet</u>		<u>Page</u>
1	Test Vehicle Information and Options	2-2
2	Vehicle Tire Information	2-4
3	General Test and Vehicle Parameter Data	2-3
4	Seat and Seat Belt Adjustment Data	2-5
5	Fuel Systems and Steering Wheel Position Data	2-6
6	Dummy Longitudinal Clearance Dimensions	2-7
7	Dummy Lateral Clearance Dimensions	2-8
8	Location of Cameras	2-9
9	Test Vehicle Accelerometer Locations	2-10
10	Test Vehicle Accelerometer Data Summary	2-11
11	MDB Accelerometer Locations and Data Summary	2-12
12	MDB Summary of Results	2-13
13	Dummy Injury Response Data for ES-2re	2-14
14	Dummy Injury Response Data for SID-IIs	2-15
15	Post Test Observations	2-16
16	Vehicle Pre test and Post test Measurements	2-17
17	Exterior Crush Measurements	2-18
18	Vehicle Exterior Crush Profiles	2-19
19	Exterior Static Crush for Impactor Face	2-21
20	Temperature and Humidity Trace	2-22

**DATA SHEET NO. 1
TEST VEHICLE INFORMATION AND OPTIONS**

Test Vehicle: 2023 Volvo XC40 Recharge Twin SUV
 Test Facility: Calspan

NHTSA No.: C20235901
 Test Date: 12/20/2022

TEST VEHICLE INFORMATION AND OPTIONS

Make	Volvo	Anti-Lock Brakes (ABS)	Yes
Model	XC40 Recharge Twin	All-Wheel Drive (AWD)	Yes
Body Style	SUV	Traction Control System (TCS)	Yes
VIN	YV4ED3UM1P2963963	Electric Stability Control (ECS)	Yes
Body Color	Silver	Side Curtain Airbags	Yes
Engine Displacement (L)	N/A	Torso Airbags – Front Seats	Yes
Type/No. Cylinders	N/A	Torso Airbags – Rear Seats	No
Engine Placement	Transverse	Combination/Head Torso Bag	No
Transmission Type	Automatic	Pelvic Airbag – Front Seats	No
Transmission Speeds	Direct Drive	Pelvis Airbag – Rear Seats	No
Overdrive	N/A	Knee Airbag – Driver	Yes
Final Drive	All Wheel Drive	Knee Airbag – Front Passenger	No
Odometer Reading (km/mi)	7 miles	Seat Belt Pretensioners – Front Seats	Yes
		Seat Belt Pretensioners – Rear Seats	Yes
		Seat Belt Load Limiter – Front Seats	Yes
		Seat Belt Load Limiter – Rear Seats	Yes
		Tire Pressure Monitoring System (TPMS)	Yes
		Tilt Steering Wheel	Yes
		Automatic Door Locks (ADL)	Yes
		Power Window Auto-reverse	No
		Power Seats	Yes

DATA FROM CERTIFICATION LABEL

Manufactured By	Volvo Car Corporation	GVWR (kg)	2649
Date of Manufacture	09/22	GAWR Front (kg)	1309
Vehicle Type	MPV	GAWR Rear (kg)	1451

VEHICLE SEATING AND CAPACITY WEIGHT DATA

Measured Parameter	Front	Rear	Third	Total
Type of Seats (Bench or Bucket)	Bucket	Bench	N/A	
Designated Seating Capacity (DSC)	2	3	N/A	5
Capacity Weight (VCW) (kg)				435

**DATA SHEET NO. 2
VEHICLE TIRE INFORMATION**

Test Vehicle: 2023 Volvo XC40 Recharge Twin SUV
 Test Facility: Calspan

NHTSA No.: C20235901
 Test Date: 12/20/2022

VEHICLE TIRE INFORMATION

Collected for year, make, model, & VIN, all items circled in red, tire manufacturer and tire name.

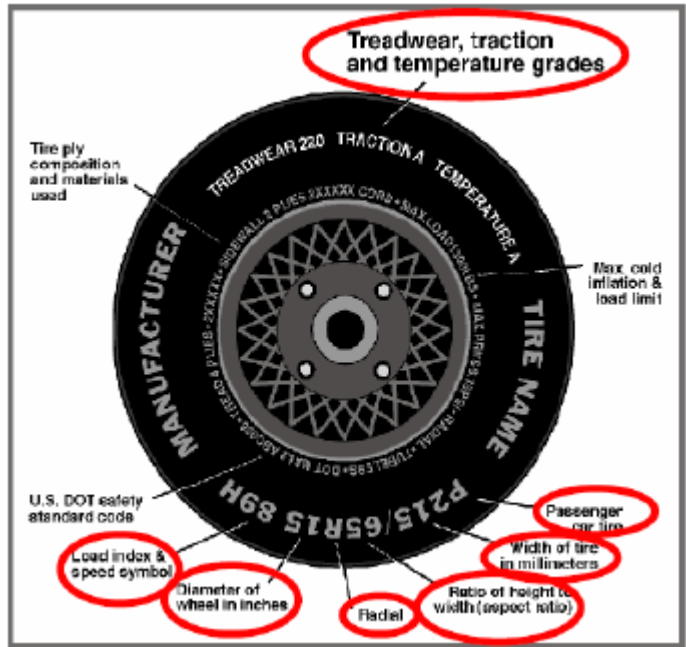

TIRE SIDEWALL INFORMATION

Tire Placard	Front	Rear
Recommended Cold Pressure (kPa)	280	290
Recommended Tire Size	235/45R20	255/40R20
Tire Sidewall	Front	Rear
Maximum Tire Pressure (kPa)	340	340
Tire Size on Vehicle	235/45R20	255/40R20
Tire Manufacturer Model	Pirelli	Pirelli
Tire Name	Scorpion Zero A/S	Scorpion Zero A/S
Tire Type	All Season	All Season
Tire Width	235	255
Aspect Ratio	45	40
Radial	Yes	Yes
Wheel Diameter	20"	20"
Load Index/Speed Symbol	100H	100H
Treadwear	500	500
Traction Grade	A	A
Temperature Grade	A	A

**DATA SHEET NO. 3
GENERAL TEST AND VEHICLE PARAMETER DATA**

Test Vehicle: 2023 Volvo XC40 Recharge Twin SUV
 Test Facility: Calspan

NHTSA No.: C20235901
 Test Date: 12/20/2022

TIRE PRESSURES

	Units	LF	RF	LR	RR
As Delivered	kPa	275	270	285	287
As Tested	kPa	280	280	290	290

TEST VEHICLE AXLE WEIGHTS

	Units	As Delivered (UVW)			Fully Loaded			As Tested		
		Front	Rear	Total	Front	Rear	Total	Front	Rear	Total
Left	kg	554	542		585	657		585	641	
Right	kg	569	519		589	583		584	593	
Ratio	%	51.4	48.6		48.6	51.4		48.6	51.4	
Totals	kg	1123	1061	2184	1174	1240	2414	1169	1234	2403

TEST VEHICLE TARGET WEIGHT (TVTW) CALCULATION

Measured Parameter	Units	Value	
As Delivered Weight (UVW)	kg	2184	(A)
Weight of 2 P572 ATDs	kg	131	(B)
Rated Cargo / Luggage Weight (RCLW)	kg	94.8	(C)
Calculated Vehicle Target Weight (TVTW)	kg	2409.8	(A+B+C)

TEST VEHICLE ATTITUDES AND CG

Wheel Opening Location	Distance (grd to ref. point above wheel opening in mm)		Difference (mm)	Meets Requirement**
	Fully Loaded	As Tested		
Left Front	831	834	3	Yes
Right Front	834	835	1	Yes
Left Rear	844	845	1	Yes
Right Rear	846	850	4	Yes

*** The "As Tested" vehicle attitude measurements must be equal to or within ± 10 mm of the "Fully Loaded" vehicle attitude measurements at each wheel well. Indicate "Yes" or "No" for "Meets Requirements".

MDB IMPACT POINT DATA

Measured Parameter	Distance (mm)	Met Requirement
Test Vehicle Wheelbase	2703	
Target Vertical Impact Reference Line Aft of Front Axle	411	Yes
Actual Impact Point Location (fore-aft, above - below)	+7 / -2	Yes

Note: Fore or above the target impact point is positive (+). Aft or below the target impact point is negative (-)

WEIGHT OF BALLAST AND VEHICLE COMPONENTS REMOVED TO MEET TVTW

Component Description	Weight (kg)
Non-Struck Rear Passenger Door Trim/Components	8
Trunk Carpeting & Jack	19
Ballast (if any)	56.7

**DATA SHEET NO. 4
SEAT AND SEAT BELT ANCHORAGE ADJUSTMENT DATA**

Test Vehicle: 2023 Volvo XC40 Recharge Twin SUV
 Test Facility: Calspan

NHTSA No.: C20235901
 Test Date: 12/20/2022

SEAT BACK ANGLE ADJUSTMENT

The driver's seat back is positioned to the manufacturer's designated design angle. The front center and front passenger's seat backs are positioned in a similar manner as the driver's seat back. The struck side rear seat back is positioned such that the dummy's head is level. The rear center and non-struck side rear outboard seat backs are positioned in a similar manner as the struck-side rear seat back.

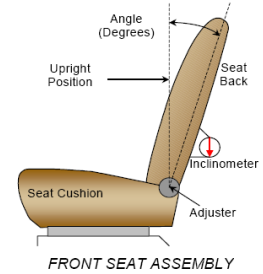

Seat	Total Seat Back Angle Range		Test Position from Most Upright	
	Degrees	Detents*	Degrees	Detents*
Driver Seat w/Seated Dummy	71.5	Power	19.8	Power
Passenger w/Seated Dummy	71.2	Power	19.9	Power

SEAT POSITIONING

The driver's seat, front center seat (if applicable), and right front passenger's seat should be set to the mid-track, lowest, mid-angle position. The struck-side rear passenger's seat, rear center seat, and non-struck side rear passengers' seats should be set to the rear-most, lowest, mid-angle position.

SEAT HEIGHT AND ANGLE

Seat	As Tested SCRL Angle (Mid) (°)	As Tested SCRP Height (mm)	SCRP Height Position	SCRP Height (mm)		
				Rearmost	Mid-Fore / Aft	Forward-Most
Driver Seat	15.9	10	Max	53	63	69
			Mid	28	36	42
			Min	4	10	15
Front Passenger Seat	14.8	8	Max	54	60	67
			Mid	28	34	41
			Min	3	8	16

SEAT FORE / AFT POSITION

Seat	Total Fore / Aft Travel		Test Position from Forward most Position	
	mm	Detents*	mm	Detents*
Driver Seat	331	Power	188	Power
Front Passenger Seat	334	Power	191	Power

SEAT BELT ANCHORAGE ADJUSTMENT

Seat	Total # of Positions	Placed in Position #
Driver Seat	4 (0-3)	0 - Uppermost
Rear Passenger Seat	Fixed	Fixed

HEAD RESTRAINT ADJUSTMENT

Seat	Total # of Positions	Placed in Position #
Driver Seat	2 (0-1)	Uppermost
Rear Passenger Seat	Fixed	Fixed

DATA SHEET NO. 5
FUEL SYSTEMS AND STEERING WHEEL POSITION DATA

Test Vehicle: 2023 Volvo XC40 Recharge Twin SUV
 Test Facility: Calspan

NHTSA No.: C20235901
 Test Date: 12/20/2022

STEERING COLUMN ADJUSTMENT

Steering wheel and column adjustments are made so that the steering wheel hub is at the center of its geometric locus it describes when it moves through its full range of motion.

	Degrees	Fore / Aft Position (mm)
Lowermost – Position 1	18.7	
Geometric Center – Position 2	22.2	
Uppermost – Position 3	25.7	
Telescoping Steering Wheel Travel		50
Test Position	22.2	25

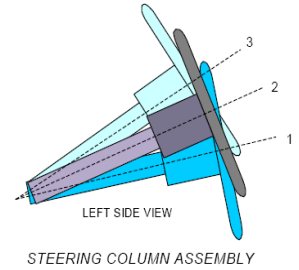

FUEL PUMP

Describe the fuel pump type, details about how it operates, and the location of the fuel filler neck.

The vehicle is equipped with charge port located on the left rear of the vehicle.

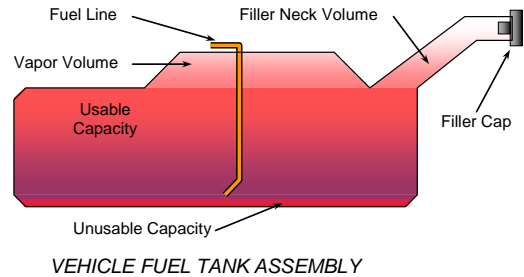

FUEL TANK CAPACITY DATA

Description	Liters
Usable Capacity - see Form No. 1	N/A
Usable Capacity - see Owner's Manual	N/A
92-94% of Usable Capacity	N/A
Actual Amount of Solvent Used in Test	Full Electric

**DATA SHEET NO. 6
DUMMY LONGITUDINAL CLEARANCE DIMENSIONS**

Test Vehicle: 2023 Volvo XC40 Recharge Twin SUV
 Test Facility: Calspan

NHTSA No.: C20235901
 Test Date: 12/20/2022

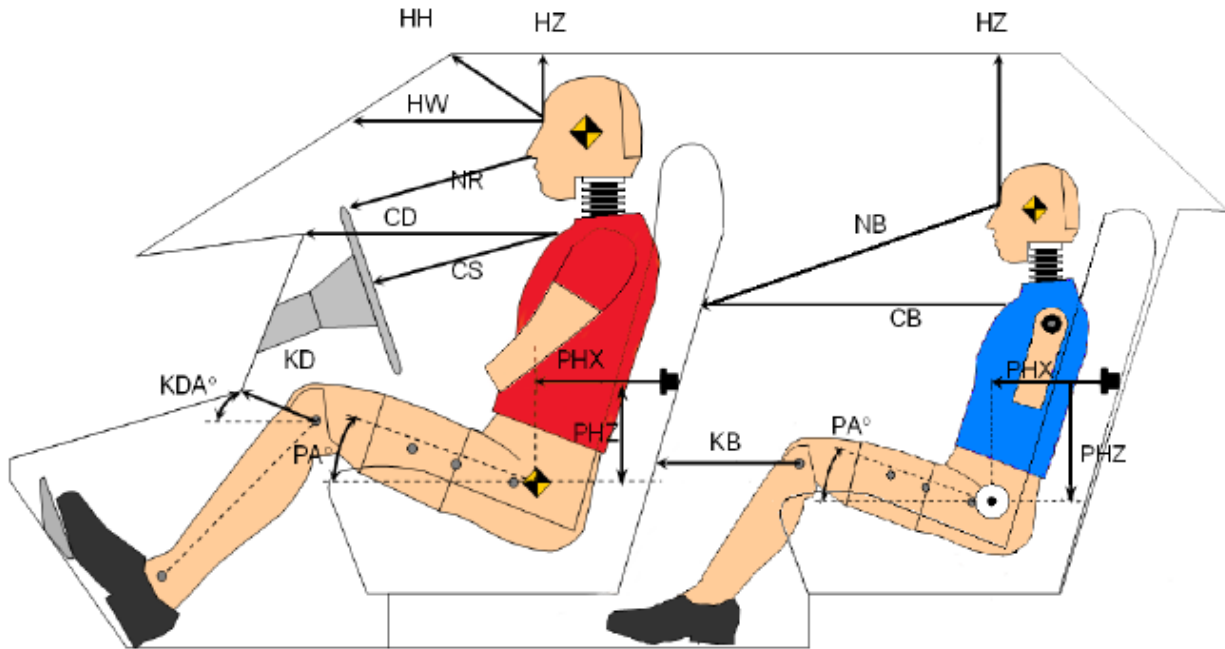

DUMMY LONGITUDINAL CLEARANCE DIMENSION INFORMATION

Driver Code	Pass. Code	Description	ES2-re		SID-IIs	
			Length (mm)	Angle	Length (mm)	Angle
HH		Header to Header	405			
HW		Header to Windshield	646			
HZ	HZ	Head to Roof Liner	163		310	
NR	NB	Nose to Rim/Seat Back	503		530	
CD	CB	Chest to Dash/Seat Back	607		523	
CS		Chest to Steering Wheel	409			
KD(L)/KDA(L)°	KB(L)/KBA(L)°	Left Knee to Dash/Seat Back	203	39.4	260	10.8
KD(R)/KDA(R)°	KB(R)/KBA(R)°	Right Knee to Dash/Seat Back	151	54.3	259	13.4
PA°	PA°	Pelvic Tilt Angle (X-Axis)		26.9		20.0
PA°	PA°	Pelvic Tilt Angle (Y-Axis)		0.1		0.3
PHX	PHX	Hip Point to Striker (X-Axis)	185		201	
PHZ	PHZ	Hip Point to Striker (Z-Axis)	133		245	

**DATA SHEET NO. 7
DUMMY LATERAL CLEARANCE DIMENSIONS**

Test Vehicle: 2023 Volvo XC40 Recharge Twin SUV
 Test Facility: Calspan

NHTSA No.: C20235901
 Test Date: 12/20/2022

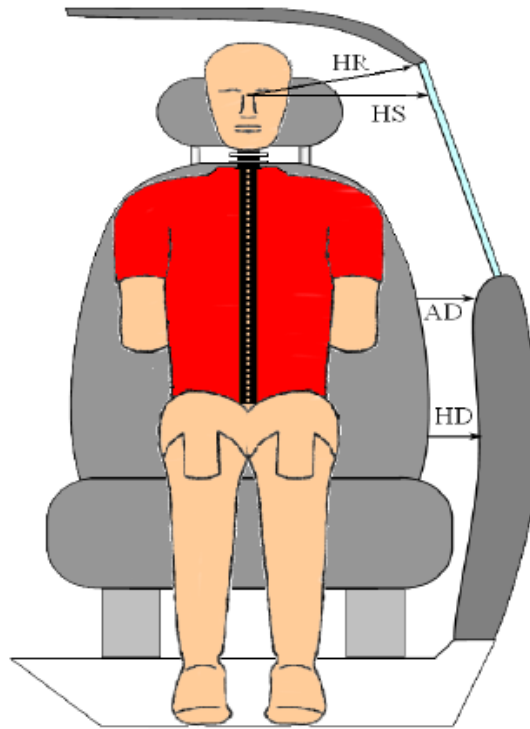

FRONT VIEW OF DUMMY

DUMMY LATERAL CLEARANCE DIMENSION INFORMATION

Code	Measurement Description	Units	Front Occupant	Rear Occupant
HR	Head To Side Header	mm	198	272
HS	Head to Side Window	mm	350	390
AD	Arm to Door	mm	105	160
HD	Hip Point to Door	mm	228	195

**DATA SHEET NO. 8
LOCATION OF CAMERAS**

Test Vehicle: 2023 Volvo XC40 Recharge Twin SUV
 Test Facility: Calspan

NHTSA No.: C20235901
 Test Date: 12/20/2022

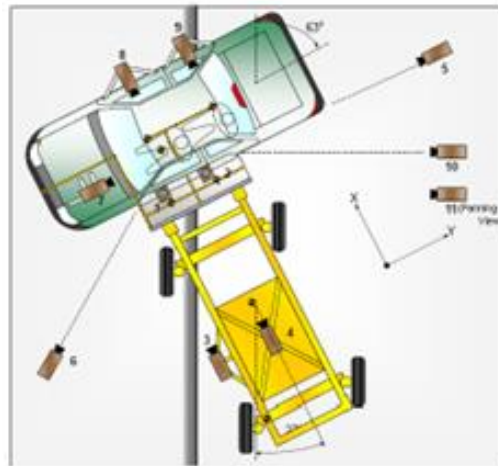

CAMERA LOCATIONS AND DATA

No.	Camera View	Coordinates (mm)			Lens Length (mm)	Operating Frame Rate (fps)
		X	Y	Z		
1	Overhead Overall	0	313	-8419	12.5	1000
2	Overhead Close-up	0	0	-8510	28	1000
3	Impact Point Close-up				25	1000
4	Centerline of Impact (MDB)				8	1000
5	Right Side View	0	10709	-1501	28	1000
6	Left Side View	-4609	-6454	-1532	28	1000
7	Front Seat Occupant-Frontal View (OB)				25	1000
8	Front Seat Occupant-Side View (OB)				12.5	1000
9	Rear Passenger-Side View (OB)				12.5	1000
10	Real-time Coverage				Zoom	60

Notes: Reference: Impact Point projected to Ground
 +X = To Front of MDB, +Y = To Right of MDB, +Z = Down

**DATA SHEET NO. 9
TEST VEHICLE ACCELEROMETER LOCATIONS**

Test Vehicle: 2023 Volvo XC40 Recharge Twin SUV
 Test Facility: Calspan

NHTSA No.: C20235901
 Test Date: 12/20/2022

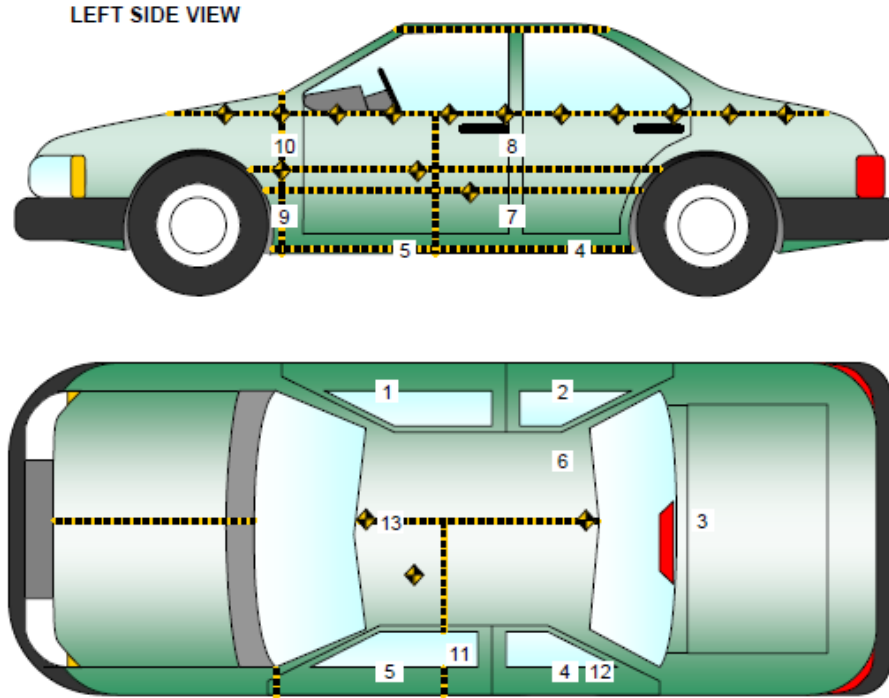

TEST VEHICLE ACCELEROMETER LOCATIONS

No.	Accelerometer Location	Coordinates (mm)		
		X	Y	Z
1	Left (or Rt.) Sill at Front Seat	2686	625	436
2	Left (or Rt.) Sill at Rear Seat	1837	654	443
3	Rear Floorpan Above Axle	878	16	652
4	Left (or Rt.) Sill at Rear Door	1759	-652	435
5	Left (or Rt.) Sill at Front Door	2822	-620	421
6	Left (or Rt.) Rear Occ. Compartment	1871	256	326
7	Left (or Rt.) B-Post Lower	2005	-670	506
8	Left (or Rt.) B-Post Middle	1928	-676	1106
9	Left (or Rt.) A-Post Lower	3035	-602	598
10	Left (or Rt.) A-Post Middle	2928	-659	1149
11	Front Seat Track	2372	-547	503
12	Rear Seat Track or Structure	1727	-343	485
13	Vehicle CG	2354	-6	778

Reference: X – Rear surface of vehicle (+ forward)
 Y – Vehicle centerline (+ to right)
 Z – Ground plane (+ down)

DATA SHEET NO. 10
TEST VEHICLE ACCELEROMETER DATA SUMMARY

Test Vehicle: 2023 Volvo XC40 Recharge Twin SUV
 Test Facility: Calspan

NHTSA No.: C20235901
 Test Date: 12/20/2022

Loc No.	Description	Axes	Units	Peak Values (g's)			
				Max	Time (ms)	Max	Time (ms)
1	Left (or Rt.) Sill at Front Seat	X	g	1.29	300.00	-3.29	22.30
		Y	g	13.93	18.95	-1.82	142.35
		Z	g	6.00	17.35	-11.98	21.75
		Resultant		15.80	21.40	0.03	-29.10
2	Left (or Rt.) Sill at Rear Seat	X	g	1.47	58.45	-5.06	20.20
		Y	g	15.25	19.25	-1.81	133.30
		Z	g	5.80	25.85	-8.99	21.25
		Resultant		16.81	20.55	0.03	-14.40
3	Rear Floorpan Above Axle	X	g	8.25	13.90	-10.20	17.90
		Y	g	14.56	42.60	-1.73	95.80
		Z	g	15.48	21.65	-7.08	49.20
		Resultant		19.69	21.65	0.02	-33.30
4	Left (or Rt.) Sill at Rear Door	Y	g	117.92	18.95	-68.11	30.65
5	Left (or Rt.) Sill at Front Door	Y	g	75.53	8.85	-127.69	12.35
6	Left (or Rt.) Rear Occ. Compartment	Y	g	17.60	15.30	-1.62	90.95
7	Left (or Rt.) B-Post Lower	Y	g	103.16	8.65	-109.40	13.15
8	Left (or Rt.) B-Post Middle	Y	g	168.83	11.65	-107.44	14.95
9	Left (or Rt.) A-Post Lower	Y	g	61.69	16.70	-53.74	20.90
10	Left (or Rt.) A-Post Middle	Y	g	40.56	24.05	-29.94	18.80
11	Front Seat Track	Y	g	32.66	10.60	-26.17	13.90
12	Rear Seat Track or Structure	Y	g	21.92	9.20	-5.40	12.60
13	Vehicle CG	X	g	3.46	36.30	-8.15	19.95
		Y	g	20.53	18.35	-14.93	224.85
		Z	g	9.75	15.40	-4.61	11.45
		Resultant		23.45	18.35	0.01	-33.70

DATA SHEET NO. 11
MDB ACCELEROMETER LOCATION DATA SUMMARY

Test Vehicle: 2023 Volvo XC40 Recharge Twin SUV
 Test Facility: Calspan

NHTSA No.: C20235901
 Test Date: 12/20/2022

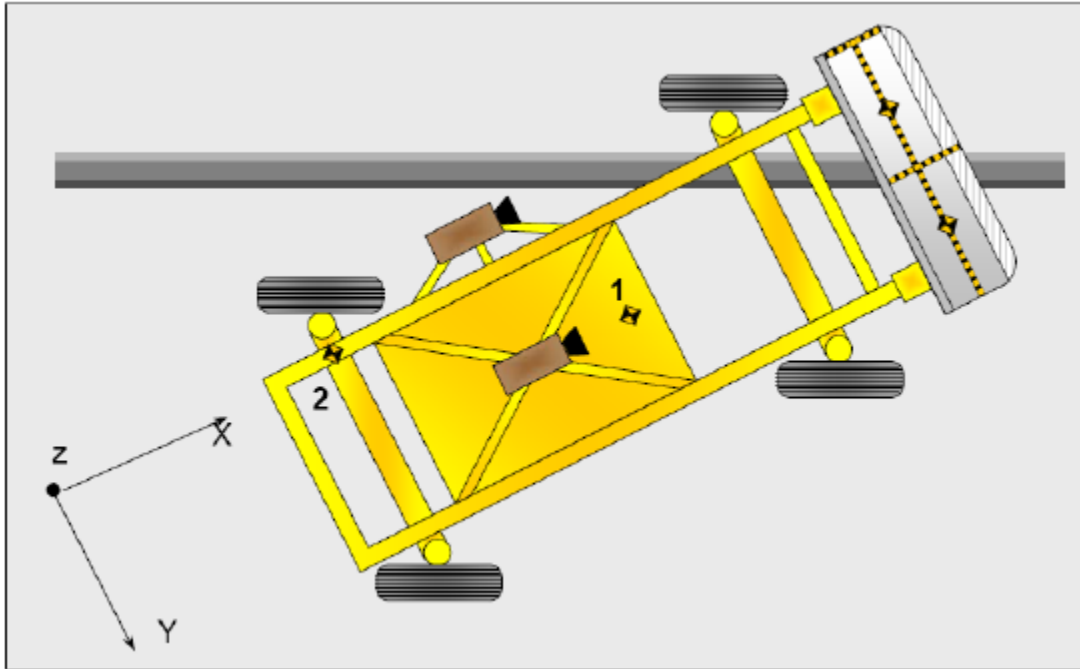

Loc No.	Description	Axes	Units	Peak Values (g's)			
				Max	Time (ms)	Max	Time (ms)
1	MDB CG	X	g	0.90	137.75	-20.93	44.90
		Y	g	0.89	107.95	-6.71	33.95
		Z	g	15.87	54.15	-11.80	29.65
		Resultant		24.62	34.00	0.04	-45.25
2	MDB Rear	X	g	1.63	144.50	-24.78	36.00
		Y	g	4.73	24.90	-3.16	62.80

**DATA SHEET NO. 12
MDB SUMMARY OF RESULTS**

Test Vehicle: 2023 Volvo XC40 Recharge Twin SUV
 Test Facility: Calspan

NHTSA No.: C20235901
 Test Date: 12/20/2022

MDB SPECIFICATIONS

Measurement Description	Requirement	Value
Overall Width of Framework Carriage	1241 – 1261	1,250
Overall Length Including Honeycomb Frame	4140 – 3990	4,120
Wheelbase of Framework Carriage	2566 – 2616	2,600
CG Location Aft of Front Axle		1,120
MDB Front Axle Weight		764
MDB Rear Axle Weight		594
MDB Total Weight	1356.5 – 1365.5	1358

SPEED AND ANGLE AT IMPACT DATA

Measured Parameter	Units	Requirement	Value
Trap No. 1 Velocity (Primary)	km/h	52.10 to 53.70	52.76
Trap No. 2 Velocity (Redundant)	km/h	52.10 to 53.70	52.80
MDB CL to Target Vehicle CL	degrees	88.5 to 91.5	90.0

MAXIMUM STATIC CRUSH OF HONEYCOMB IMPACT FACE

Vertical Location			From Centerline		Maximum Crush (mm)
Row	Description	Height (mm)	Distance (mm)	Direction	
A	Center of Bumper	432	300	Right	208
B	Top of Bumper	533	800	Left	119
C	Mid-Level	686	800	Left	135
D	Top of Stack	813	800	Left	173

IMPACT POINT LOCATION DATA

Measured Parameter	Units	Tolerance	Value
Horizontal Offset (+ forward / - rearward)	mm	+/- 50 of Intended Impact Point	+7
Vertical Offset (+ down / - up)	mm	+/- 20 of Intended Impact Point	-2

**DATA SHEET NO. 13
DUMMY INJURY RESPONSE DATA
(Subpart U, ES-2re)**

Test Vehicle: 2023 Volvo XC40 Recharge Twin SUV
 Test Facility: Calspan

NHTSA No.: C20235901
 Test Date: 12/20/2022

Dummy Serial No. D037

Description	Axes	Positive Direction		Negative Direction	
		MAX	TIME (ms)	MAX	TIME (ms)
HEAD ACCELERATION (g)					
Longitudinal	X	4.59	125.05	-7.28	44.60
Lateral	Y	19.32	51.45	-5.26	87.65
Vertical	Z	7.39	22.55	-4.93	72.15
Resultant	N/A	20.53	47.05		
HIC36 (t1, t2)	N/A	38.38		t1 = 33.90	t2 = 66.40
THORAX DEFLECTION (mm)					
Upper Rib	Y	8.15	46.80	-1.32	19.90
Middle Rib	Y	10.22	45.70	-0.23	300.00
Lower Rib	Y	13.24	44.55	-0.22	300.00
ABDOMINAL FORCES (N)					
Front	Y	89.13	21.45	-20.75	12.30
Middle	Y	167.80	24.90	-8.83	285.10
Rear	Y	205.90	16.40	-4.77	-8.95
SUM	N/A	420.40	30.75		
PELVIS FORCES (N)					
Pubic Symphysis	Y	376.13	214.55	-680.37	64.80

Reference: Positive Direction - Longitudinal (X) = forward
 - Lateral (Y) = to right
 - Vertical (Z) = down

DATA SHEET NO. 14
DUMMY INJURY RESPONSE DATA
(Subpart V, SIDIs)

Test Vehicle: 2023 Volvo XC40 Recharge Twin SUV
 Test Facility: Calspan

NHTSA No.: C20235901
 Test Date: 12/20/2022

Dummy Serial No. 261

Description	Axes	Positive Direction		Negative Direction	
		MAX	TIME (ms)	MAX	TIME (ms)
HEAD ACCELERATION (g)					
Longitudinal	X	1.85	191.75	-6.94	15.80
Lateral	Y	16.17	70.40	-5.37	201.60
Vertical	Z	13.64	69.75	-3.70	55.10
Resultant	N/A	21.60	70.10		
HIC36 (t1, t2)	N/A	23.29		t1 = 64.65	t2 = 100.65
LOWER SPINE (g)					
Longitudinal	X	8.22	60.10	-16.99	15.45
Lateral	Y	34.32	59.55	-7.10	13.60
Vertical	Z	6.35	14.65	-16.78	61.40
Resultant	N/A	38.68	60.10	0.01	-11.00
PELVIS FORCES (N)					
Acetabular	Y	2036.85	52.70	-33.66	132.90
Iliac	Y	346.09	46.35	-124.74	74.35

Reference: Positive Direction - Longitudinal (X) = forward
 - Lateral (Y) = to right
 - Vertical (Z) = down

**DATA SHEET NO. 14
POST-TEST OBSERVATIONS**

Test Vehicle: 2023 Volvo XC40 Recharge Twin SUV
 Test Facility: Calspan

NHTSA No.: C20235901
 Test Date: 12/20/2022

TEST DUMMY INFORMATION AND CONTACT POINTS

Dummy Body Part	Front Occupant	Rear Occupant
Head Contact	Curtain Airbag, Side Header, Head Restraint	Curtain Airbag & Head Restraint
Upper Torso Contact	Torso/Pelvis Airbag & Seat Back	C-Pillar Trim & Passenger Door
Lower Torso Contact	Seat Back	C-Pillar Trim
Left Knee Contact	Driver Door Trim	Passenger Door
Right Knee Contact	Left Knee	Left Knee

POST-TEST DOOR PERFORMANCE

Description	Front	Rear
Left Side Doors	Jammed Shut	Jammed Shut
Right Side Doors	Closed & Operational	Closed & Operational
Hatch and Other Doors	Closed & Operational	
Seat Movement	None	None
Seatback Failure	No	No

*Note: Description for door opening must be specific with the following three categories: Remained closed and operational, opened/unlatched during the crash, or jammed shut. Sometimes the door is jammed and unlatched. If the door cannot be opened, then note the door as jammed shut. If open, measurement must be taken for the width of the door opening (mm).

POST-TEST STRUCTURAL OBSERVATIONS

Critical Areas of Performance	Observations and Conclusions
Pillar Performance	A-Pillar, B-Pillar and C-Pillar Buckled
Sill Separation	None
Windshield Damage	None
Side Window Damage	None
Other Notable Effects	None

SUPPLEMENTAL RESTRAINT SYSTEM INFORMATION

Restraint Type	Front Occupant		Rear Occupant	
	Installed	Deployed	Installed	Deployed
Frontal Airbag	Yes	No	No	N/A
Side Torso Airbag	Yes	Yes	No	N/A
Head Airbag	No	N/A	No	N/A
Curtain Airbag	Yes	Yes	Yes	Yes
Seat Belt Pretensioner	Yes	Yes	Yes	Yes
Other				

DATA SHEET NO. 16
VEHICLE PRE TEST AND POST TEST MEASUREMENTS

Test Vehicle: 2023 Volvo XC40 Recharge Twin SUV
Test Facility: Calspan

NHTSA No.: C20235901
Test Date: 12/20/2022

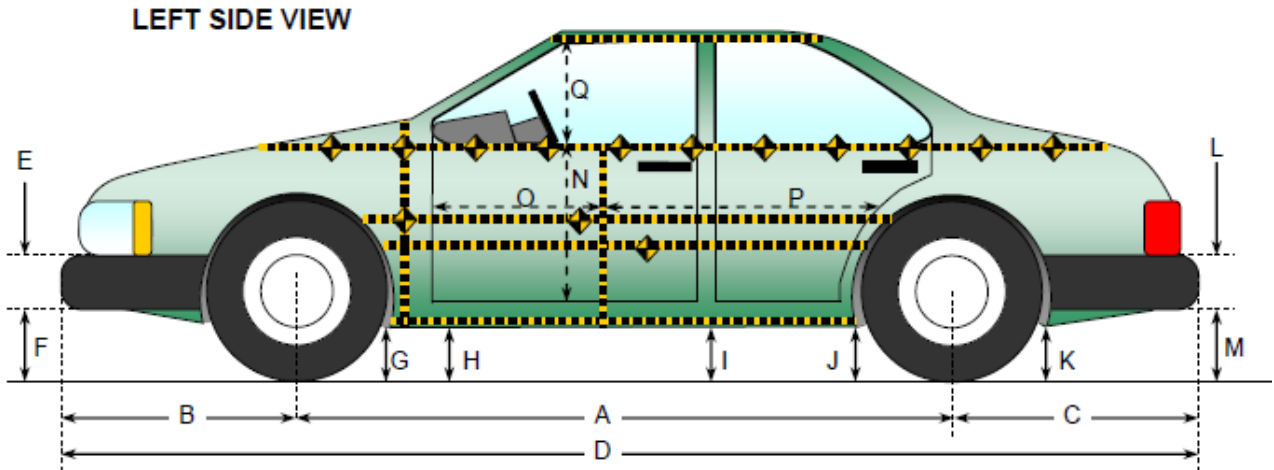

VEHICLE PRE- AND POST-TEST MEASUREMENT INFORMATION

Code	Description	Pre-Test	Post-Test	Difference
A	Vehicle Wheelbase	2703	2721	19
B	Front Axle to FSOV	867	850	-17
C	Rear Axle to RSOV	860	858	-2
D	Total Length at Centerline	4429	4430	0
E	Front Bumper Thickness	120	120	0
F	Front Bumper Bottom to Ground	504	509	5
G	Sill Height at Front Wheel Well	208	210	2
H	Sill Height at Front Door Leading Edge	219	229	10
I	Sill Height at B-Pillar	217	215	-2
J1	Sill Height at Rear Wheel Well	193	202	9
J2	Pinch Weld Height at Rear Wheel Well	241	248	7
K	Sill Height Aft of Rear Wheel Well	285	301	16
L	Rear Bumper Thickness	135	135	0
M	Rear Bumper Bottom to Ground	391	398	7
N	Sill Height to Bottom of Front Window Sill	866	818	-48
O	Front Door Leading Edge to Impact CL	730	731	1
P	Rear Door Trailing Edge to Impact CL	1334	1287	-47
Q	Front Window Opening	434	456	22
R	Right Side Length	4306	4308	2
S	Left Side Length	4304	4301	-3
T	Vehicle Width at B-Pillars	1840	1699	-141

DATA SHEET NO. 17
TEST VEHICLE EXTERIOR CRUSH MEASUREMENTS

Test Vehicle: 2023 Volvo XC40 Recharge Twin SUV
 Test Facility: Calspan

NHTSA No.: C20235901
 Test Date: 12/20/2022

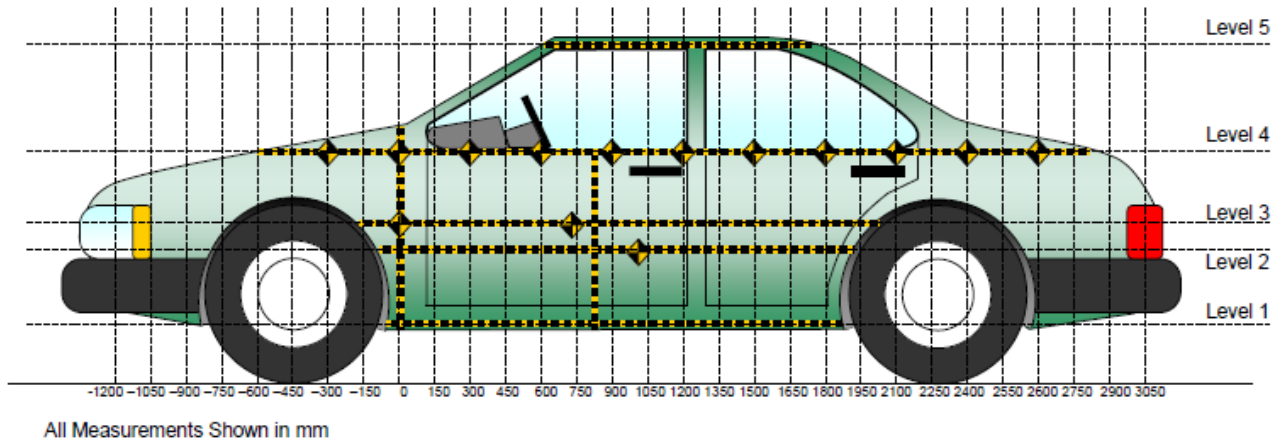

MAXIMUM EXTERIOR CRUSH MEASUREMENTS

Level	Measurement Description	Units	Height Above Ground	Maximum Exterior Static Crush	Distance from Impact
1	Sill Top	mm	344	73	1200
2	Occupant Hip Point	mm	674	202	1650
3	Mid - Door	mm	736	201	1650
4	Window Sill	mm	1088	46	1200
5	Window Top	mm	1583	12	2100

NOTE: The above measurements should be taken along the vertical impact reference line. Vehicle measurements forward of the vertical impact reference line are negative.

DATA SHEET NO. 18
VEHICLE EXTERIOR CRUSH MEASUREMENTS

Test Vehicle: 2023 Volvo XC40 Recharge Twin SUV
Test Facility: Calspan

NHTSA No.: C20235901
Test Date: 12/20/2022

EXTERIOR CRUSH MEASUREMENTS AT EACH LEVEL

	Pre-Test					Post-Test					Difference				
	1	2	3	4	5	1	2	3	4	5	1	2	3	4	5
-900															
-750															
-600															
-450															
-300															
-150			930	765				916	763				14	2	
0		928	928	792			897	896	789			31	32	3	
150	881	910	910	814		875	823	840	817		6	87	70	-3	
300	872	903	907	832		862	769	774	833		10	134	133	-1	
450	876	904	909	844		855	775	766	842		21	129	143	2	
600	880	905	910	854		848	757	747	850		32	148	163	4	
750	883	906	911	861		842	737	736	854		41	169	175	7	
900	884	906	911	868		836	741	738	857		48	165	173	11	
1050	885	904	910	871	592	830	774	760	856	588	55	130	150	15	4
1200	883	900	908	873	604	810	771	759	827	601	73	129	149	46	3
1350	880	896	905	874	611	817	738	763	832	608	63	158	142	42	3
1500	874	896	902	873	613	815	724	712	846	610	59	172	190	27	3
1650	863	904	906	870	612	813	702	705	860	609	50	202	201	10	3
1800	872	925	922	868	606	837	773	769	875	604	35	152	153	-7	2
1950		933	936	869	588		915	910	892	596		18	26	-23	-8
2100				871	599				906	587				-35	12
2250				871	573				859	573				12	0
2400				869					862					7	
2550															
2700															
2850															
3000															

NOTE: Pre-test measurements are taken when the vehicle is in the "As Tested" weight condition. Vehicle measurements forward of the vertical impact reference line are negative. The crush profile grid is established prior to test based on an estimated impact point.

DATA SHEET NO. 18 (CONTINUED)
TEST VEHICLE EXTERIOR CRUSH MEASUREMENTS

Test Vehicle: 2023 Volvo XC40 Recharge Twin SUV
 Test Facility: Calspan

NHTSA No.: C20235901
 Test Date: 12/20/2022

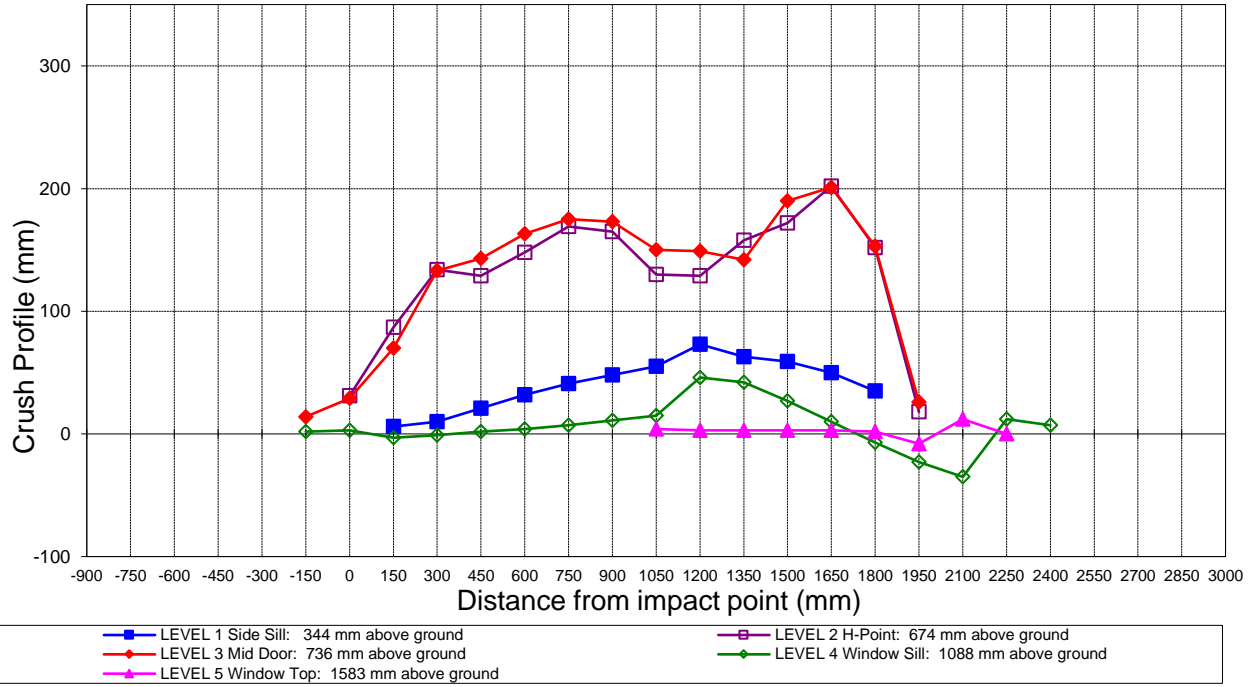

Vehicle Exterior Crush Measurements - Visual Representation

DATA SHEET NO. 19
EXTERIOR STATIC CRUSH FOR IMPACTOR FACE

Test Vehicle: 2023 Volvo XC40 Recharge Twin SUV
 Test Facility: Calspan

NHTSA No.: C20235901
 Test Date: 12/20/2022

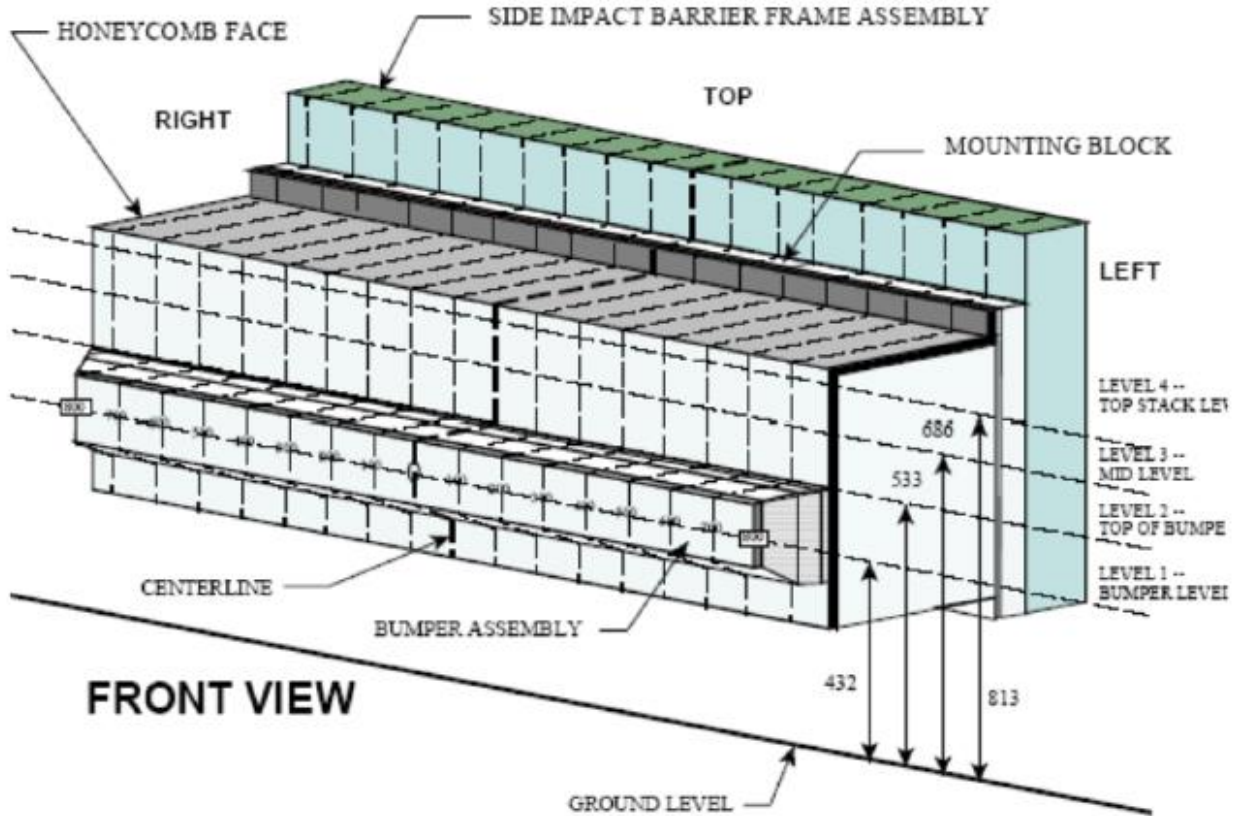

NOTE: Dimensions are shown in millimeters, mm

DEFORMABLE BARRIER STATIC CRUSH

Stack Level	Distance Right of Center								C/L	Distance Left of Center							
	800	700	600	500	400	300	200	100		0	100	200	300	400	500	600	700
1	189	192	193	194	196	208	195	194	194	193	192	192	191	191	191	193	190
2	103	103	106	107	107	104	105	104	101	99	99	97	97	95	96	97	119
3	31	20	30	45	45	75	91	71	49	30	32	41	55	59	64	91	135
4	42	36	33	47	86	111	112	85	67	59	56	56	61	66	86	128	173

Reference:
 +X = Forward
 +Y = To Right
 +Z = Down

DATA SHEET NO. 20
DUMMY / VEHICLE TEMPERATURE AND HUMIDITY STABILIZATION DATA

Test Vehicle: 2023 Volvo XC40 Recharge Twin SUV
Test Facility: Calspan

NHTSA No.: C20235901
Test Date: 12/20/2022

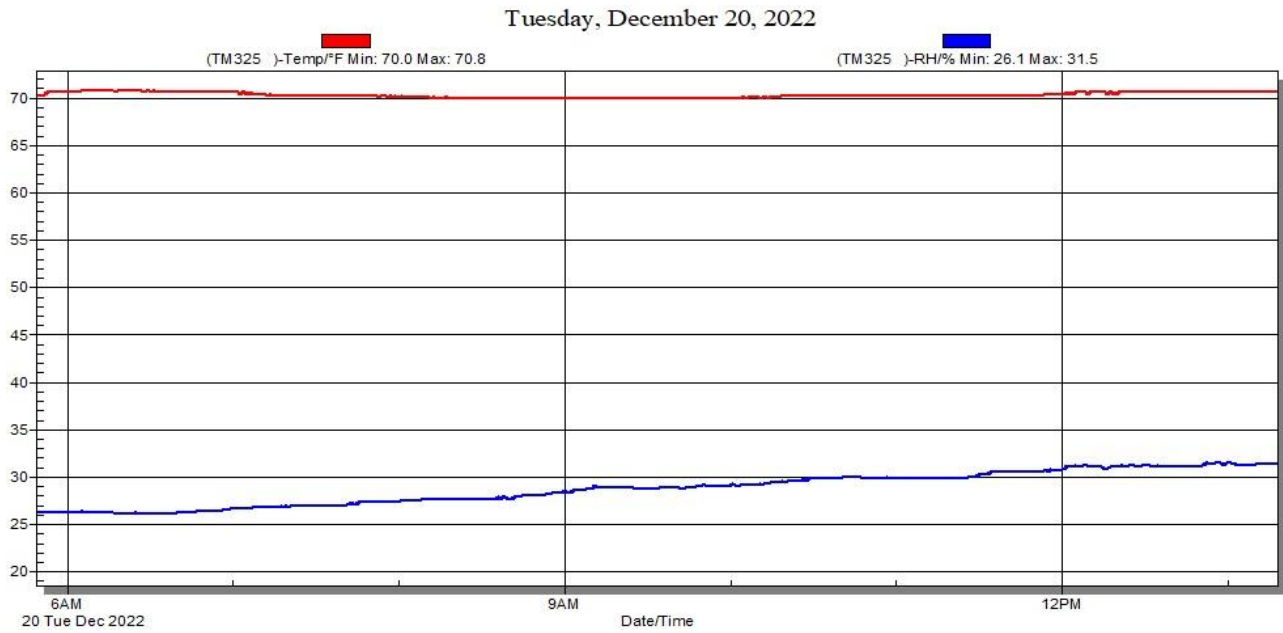

Temperature and Humidity Stabilization Chart / Data for Dummies and Test Vehicle

APPENDIX I
PHOTOGRAPHS

Note: Photographs depict placards that include the test number "C20235805".
This Side MDB test number was "C20235901". Disregard the error.

TABLE OF PHOTOGRAPHS

Fig.	Description	Page
1	Pre-Test Frontal View of Test Vehicle	I-3
2	Post-Test Frontal View of Test Vehicle	I-3
3	Pre-Test Rear View of Test Vehicle	I-4
4	Post-Test Rear View of Test Vehicle	I-4
5	Pre-Test Impacted Side View of Test Vehicle	I-5
6	Post-Test Impacted Side View of Test Vehicle	I-5
7	Pre-Test Frontal View of Impactor Face	I-6
8	Post-Test Frontal View of Impactor Face	I-6
9	Pre-Test Left Side View of Impactor Face	I-7
10	Post-Test Left Side View of Impactor Face	I-7
11	Pre-Test Right Side View of Impactor Face	I-8
12	Post-Test Right Side View of Impactor Face	I-8
13	Pre-Test Top View of Impactor Face	I-9
14	Post-Test Top View of Impactor Face	I-9
15	Pre-Test Overhead View of MDB Positioned Against Impact Side of Test Vehicle at Impact Location	I-10
16	Post-Test Overhead View of the MDB and Test Vehicle	I-10
17	Pre-Test Front ES2-re in Final Seating Position (Door Open)	I-11
18	Pre-Test Front ES2-re in Final Seating Position (Door Closed)	I-11
19	Pre-Test Front ES2-re – Opposite Side View	I-12
20	Post-Test Front ES2-re – Opposite Side View	I-12
21	Pre-Test Rear SID in Final Seating Position (Door Open)	I-13
22	Pre-Test Rear SID in Final Seating Position (Door Closed)	I-13
23	Pre-Test Rear SID – Opposite Side View	I-14
24	Post-Test Rear SID – Opposite Side View	I-14
25	T (0) – Impact Event	I-15
26	Post-Test Close-up View of Impact Point Target	I-15
27	Close-up View of Vehicle's Certification Label	I-16
28	Post-Test Front Seat Occupant Area Showing Head & Torso Contact Regions	I-16
29	Post-Test Rear Seat Occupant Area Showing Head & Torso Contact Regions	I-17
30	Close-up View of Vehicle's Tire Placard	I-17



Figure A-1: Pre-Test Frontal View of Test Vehicle



Figure A-2: Post-Test Frontal View of Test Vehicle



Figure A-3: Pre-Test Rear View of Test Vehicle



Figure A-4: Post-Test Rear View of Test Vehicle



Figure A-5: Pre-Test Impacted Side View of Test Vehicle



Figure A-6: Post-Test Impacted Side View of Test Vehicle



Figure A-7: Pre-Test Frontal View of Impactor Face



Figure A-8: Post-Test Frontal View of Impactor Face



Figure A-9: Pre-Test Left Side View of Impactor Face



Figure A-10: Post-Test Left Side View of Impactor Face



Figure A-11: Pre-Test Right Side View of Impactor Face



Figure A-12: Post-Test Right Side View of Impactor Face



Figure A-13: Pre-Test Top View of Impactor Face



Figure A-14: Post-Test Top View of Impactor Face

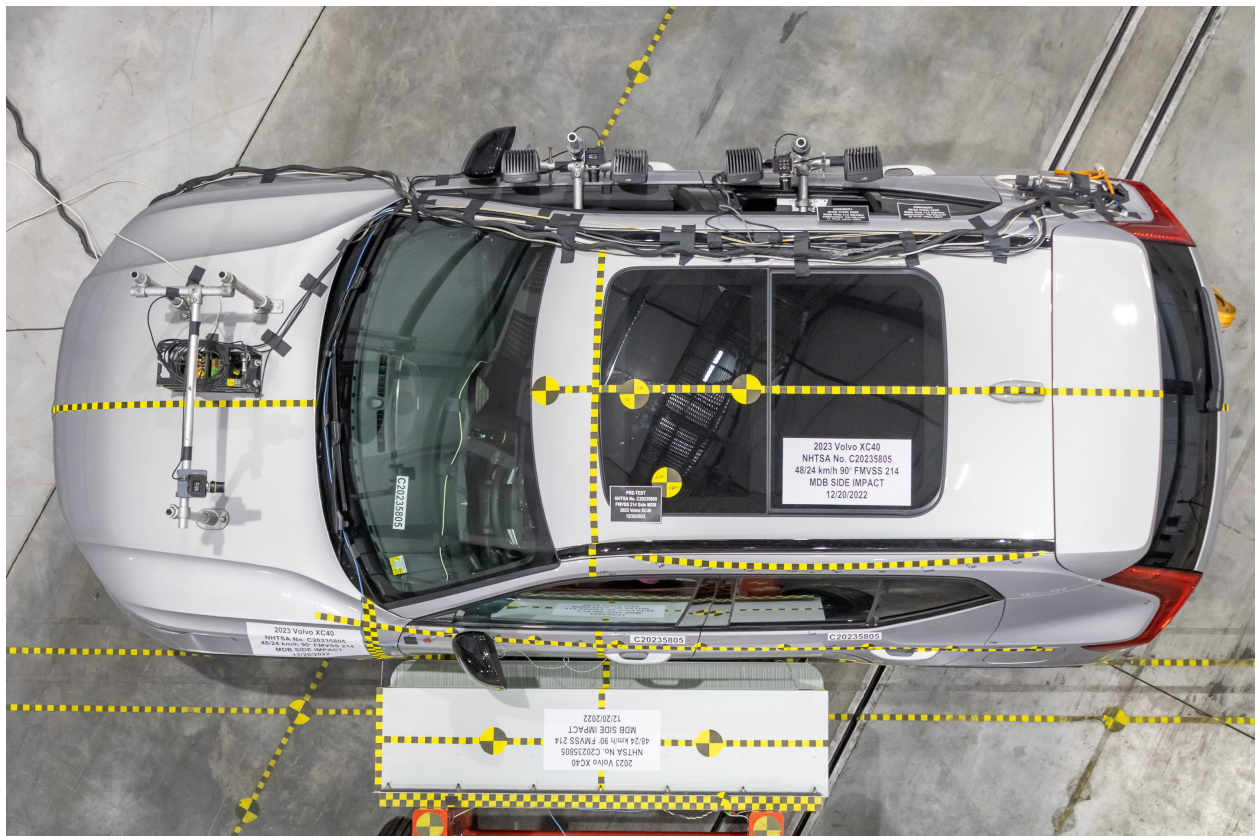

Figure A-15: Pre-Test Overhead View of MDB Positioned Against Impact Side of Test Vehicle at Impact Location

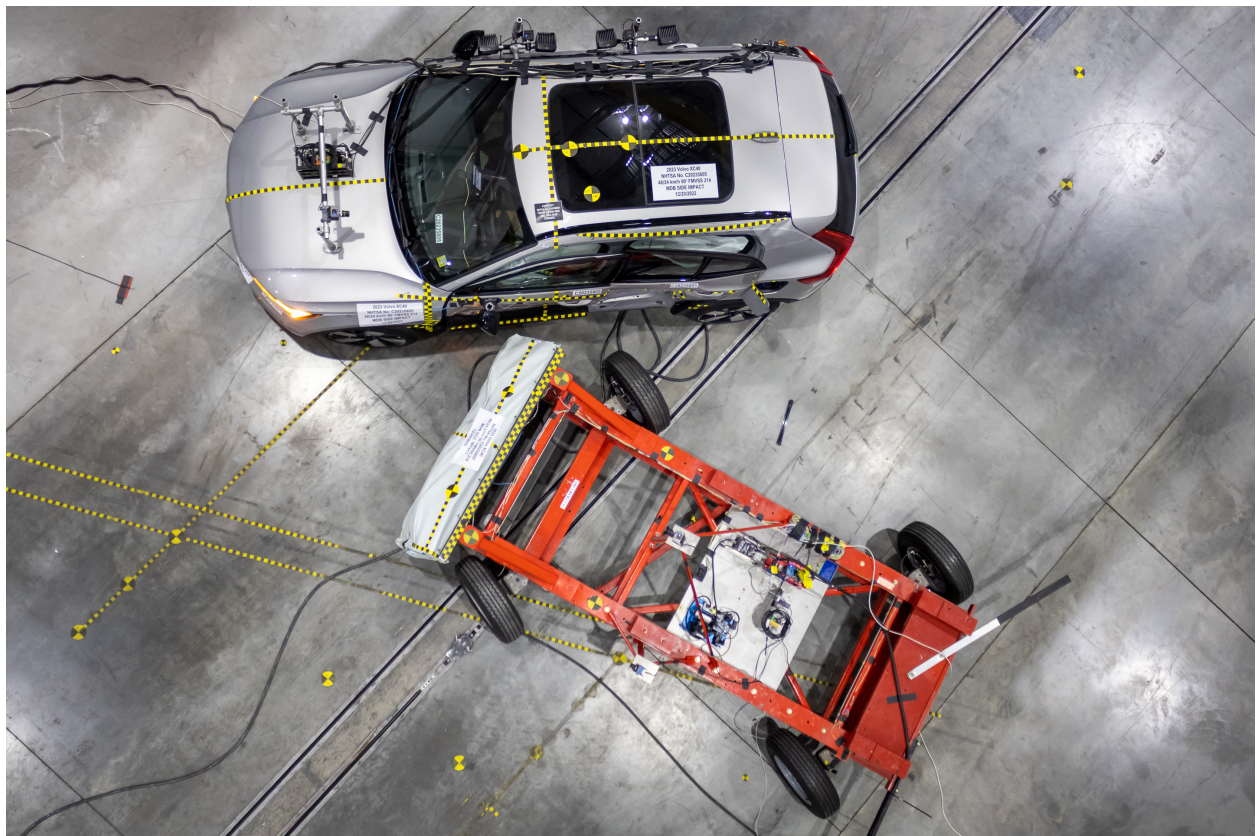

Figure A-16: Post-Test Overhead View of the MDB and Test Vehicle



Figure A-17: Pre-Test Front ES2-re in Final Seating Position (Door Open)



Figure A-18: Pre-Test Front ES2-re in Final Seating Position (Door Closed)



Figure A-19: Pre-Test Front ES2-re - Opposite Side View



Figure A-20: Post-Test Front ES2-re - Opposite Side View



Figure A-21: Pre-Test Rear SID in Final Seating Position (Door Open)



Figure A-22: Pre-Test Rear SID in Final Seating Position (Door Closed)



Figure A-23: Pre-Test Rear SID - Opposite Side View



Figure A-24: Post-Test Rear SID - Opposite Side View



Figure A-25: T (0) - Impact Event



Figure A-26: Post-Test Close-up View of Impact Point Target



Figure A-27: Close-up View of Vehicle's Certification Label



Figure A-28: Post-Test Front Seat Occupant Area Showing Head & Torso Contact Regions



Figure A-29: Post-Test Rear Seat Occupant Area Showing Head & Torso Contact Regions



Figure A-30: Close-up View of Vehicle's Tire Placard

APPENDIX II
ES-2re DUMMY RESPONSE DATA TRACES

Table of Data Plots

No.	Description	Page
1	ES-2re Head (X) Acceleration vs. Time	II-3
2	ES-2re Head (Y) Acceleration vs. Time	II-3
3	ES-2re Head (Z) Acceleration vs. Time	II-3
4	ES-2re Head Resultant Acceleration vs. Time	II-3
5	ES-2re Head (X) Velocity vs. Time	II-4
6	ES-2re Head (Y) Velocity vs. Time	II-4
7	ES-2re Head (Z) Velocity vs. Time	II-4
8	ES-2re Upper Thorax Rib Deflection Rate vs. Time	II-4
9	ES-2re Upper Thorax Rib Deflection (Y) vs. Time	II-5
10	ES-2re Middle Thorax Rib Deflection Rate vs. Time	II-5
11	ES-2re Middle Thorax Rib Deflection (Y) vs. Time	II-5
12	ES-2re Lower Thorax Rib Deflection Rate vs. Time	II-5
13	ES-2re Lower Thorax Rib Deflection (Y) vs. Time	II-6
14	ES-2re Front Abdomen Force (Y) vs. Time	II-6
15	ES-2re Middle Abdomen Force (Y) vs. Time	II-6
16	ES-2re Rear Abdomen Force (Y) vs. Time	II-6
17	ES-2re Sum of Abdomen Forces vs. Time	II-7
18	ES-2re Pubic Symphysis Force (Y) vs. Time	II-7

ES-2re Head (X) Acceleration vs. Time

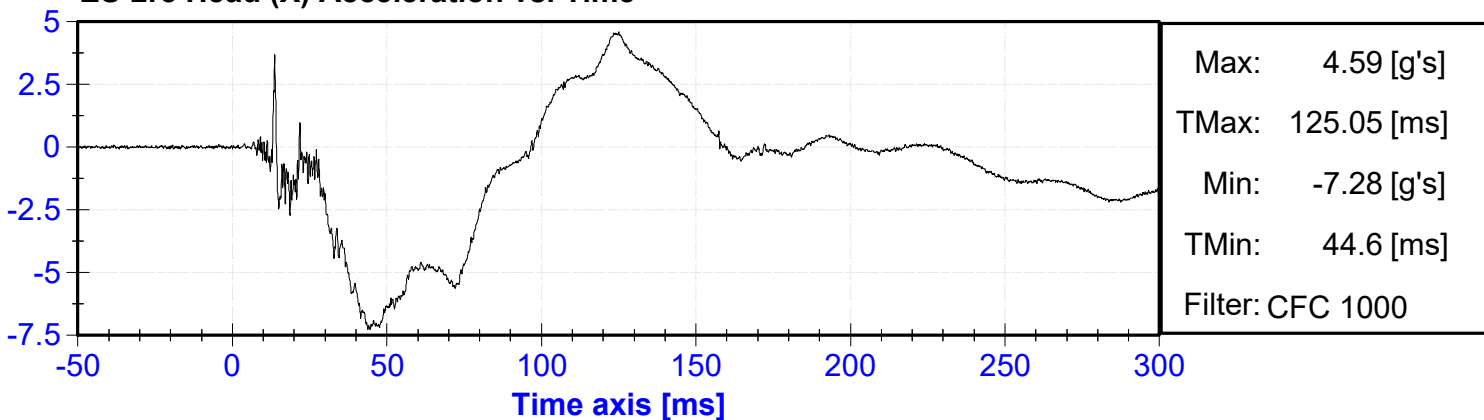

ES-2re Head (Y) Acceleration vs. Time

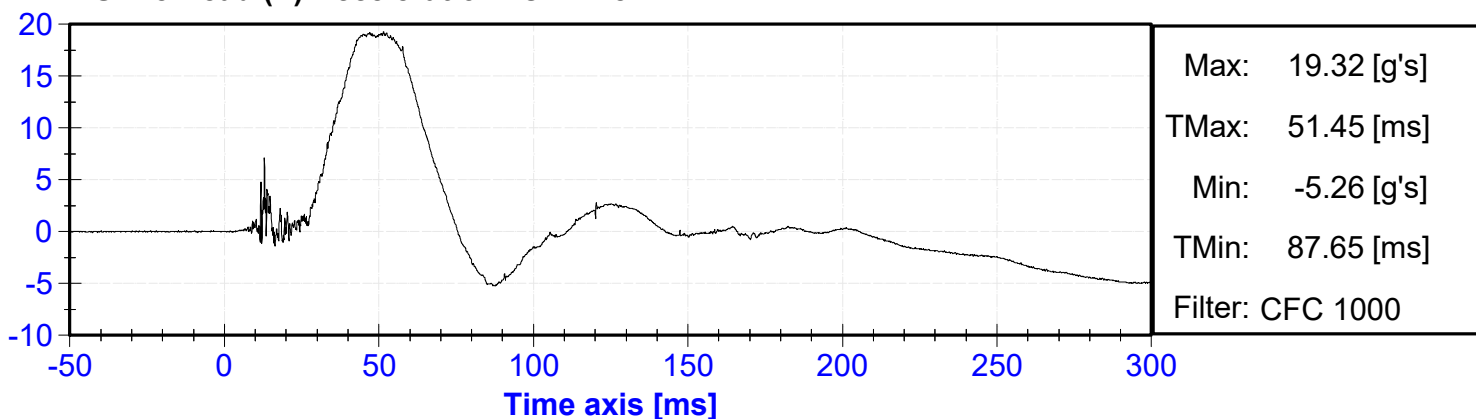

ES-2re Head (Z) Acceleration vs. Time

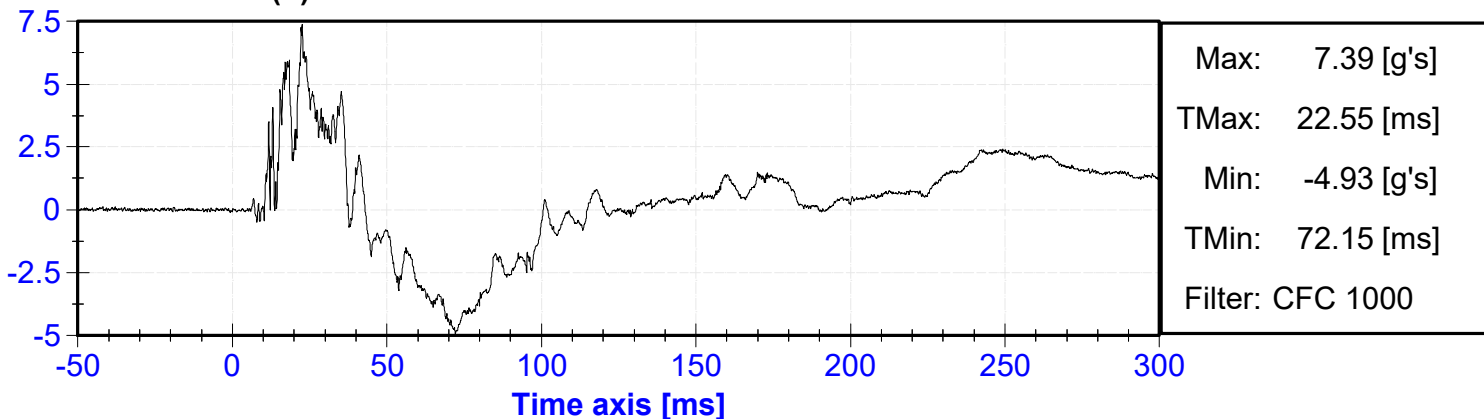

ES-2re Head Resultant Acceleration vs. Time

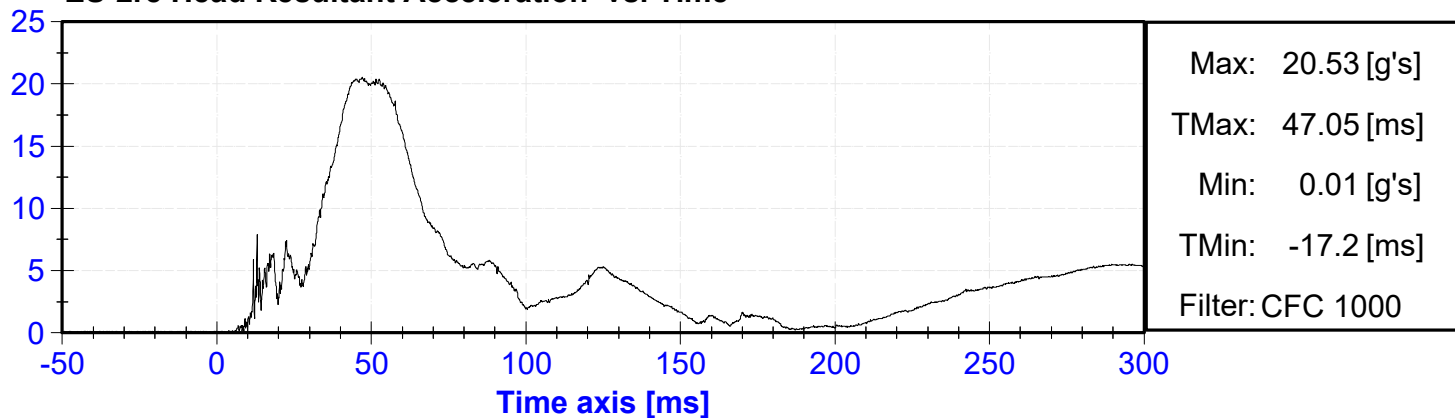

ES-2re Head (X) Velocity vs. Time

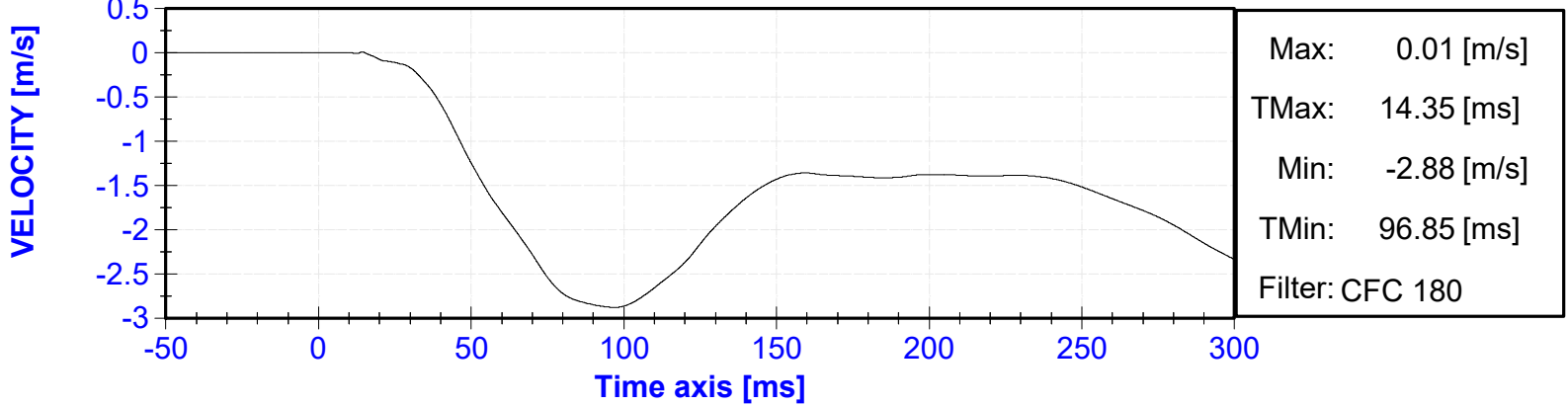

ES-2re Head (Y) Velocity vs. Time

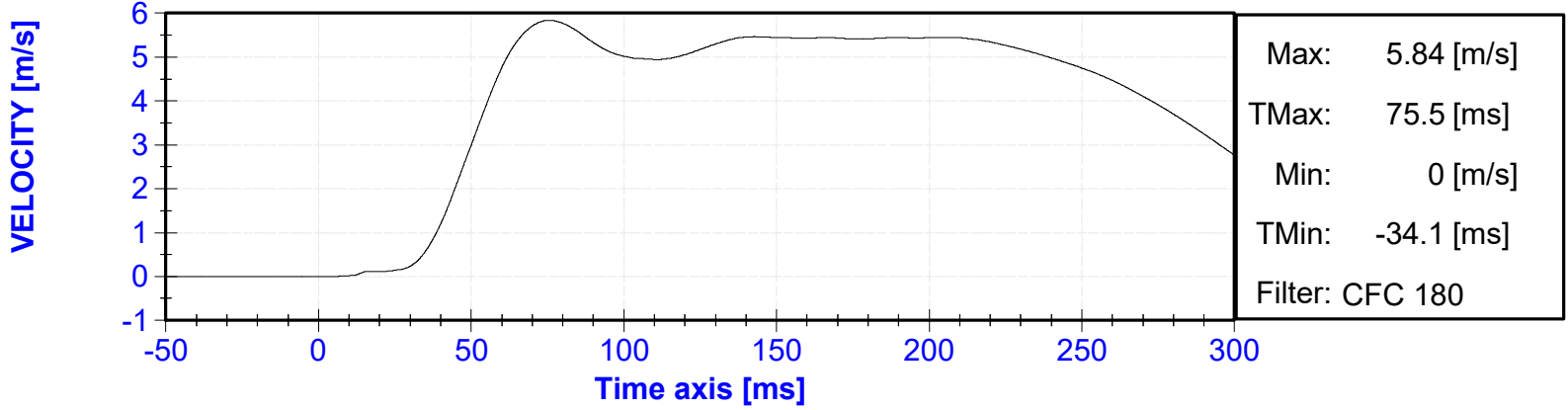

ES-2re Head (Z) Velocity vs. Time

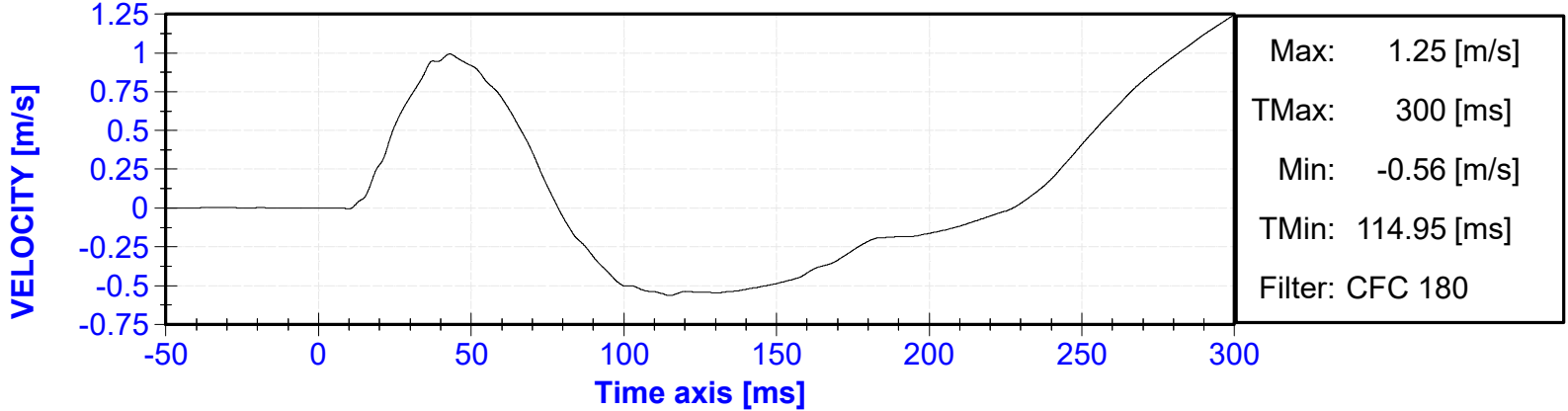

ES-2re Upper Thorax Rib Deflection Rate vs. Time

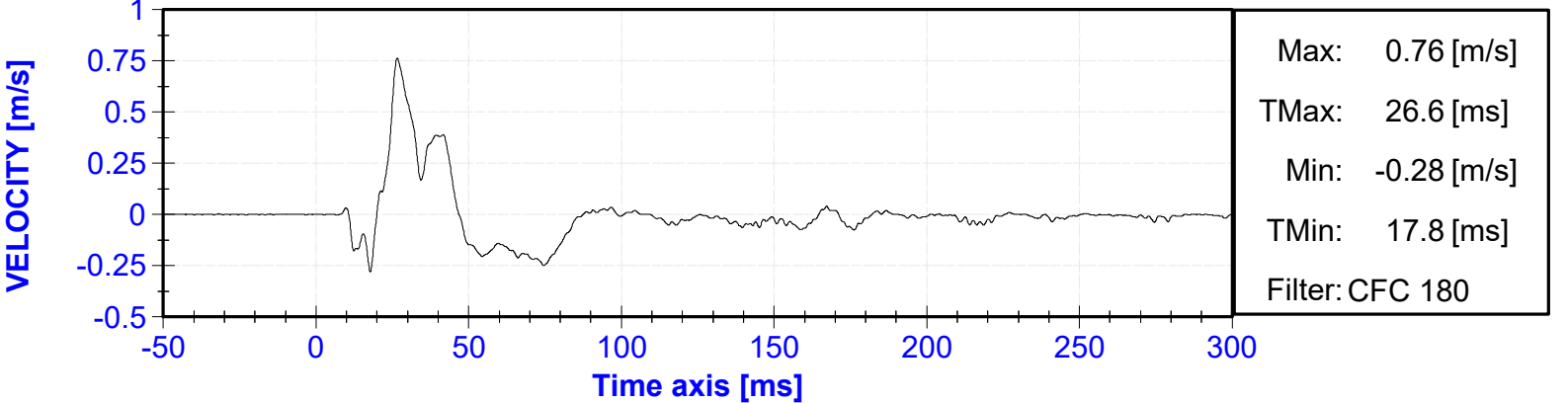

ES-2re Upper Thorax Rib Deflection (Y) vs. Time

DISPLACEMENT [mm]

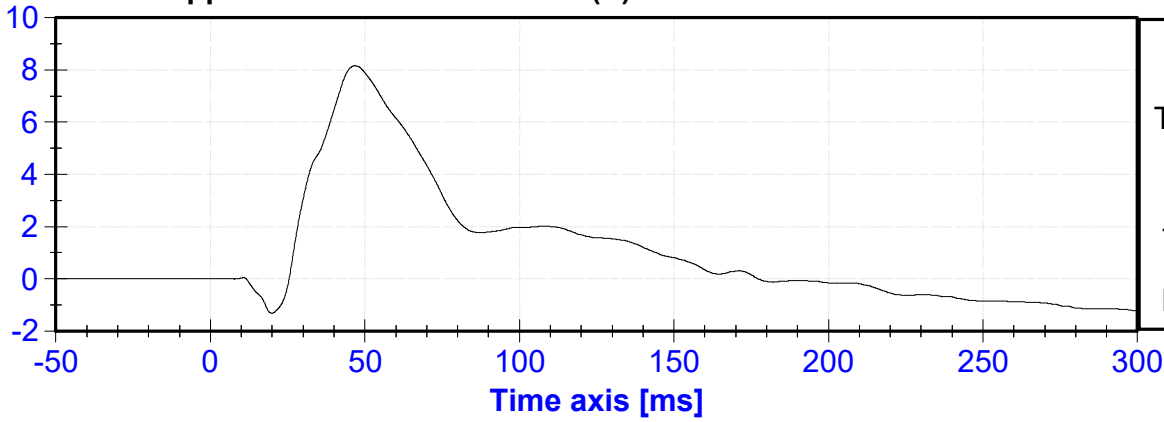

ES-2re Middle Thorax Rib Deflection Rate vs. Time

VELOCITY [m/s]

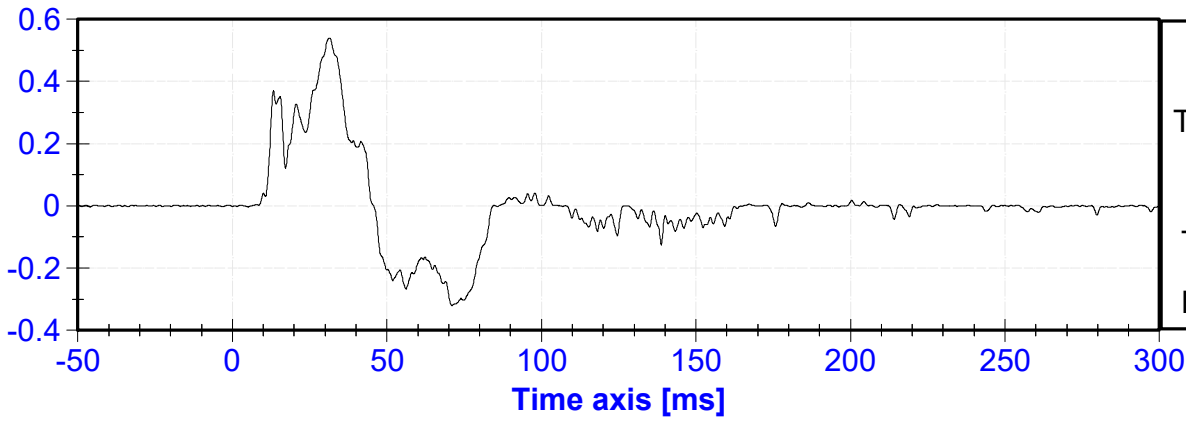

ES-2re Middle Thorax Rib Deflection (Y) vs. Time

DISPLACEMENT [mm]

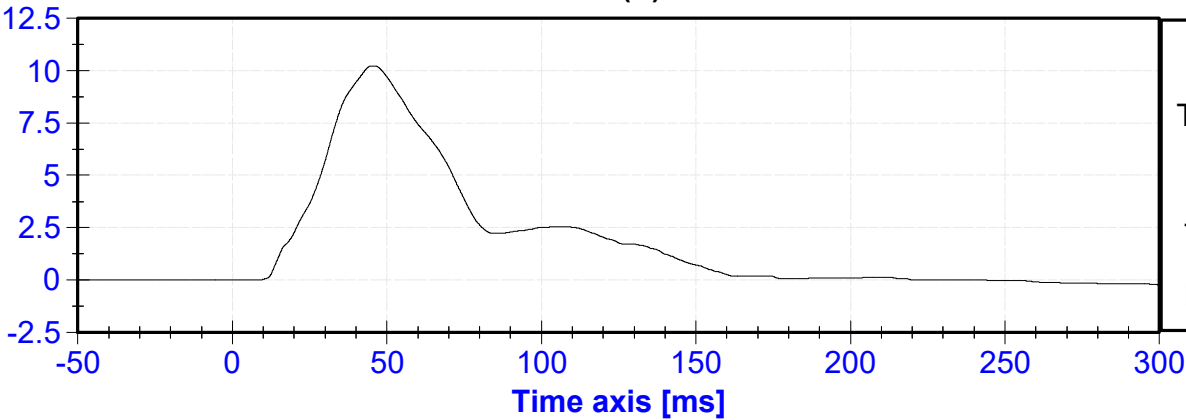

ES-2re Lower Thorax Rib Deflection Rate vs. Time

VELOCITY [m/s]

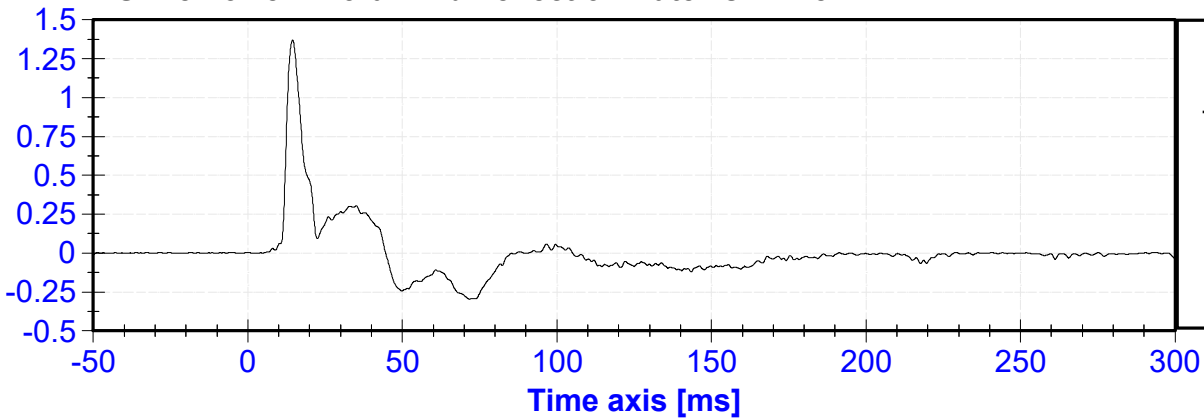

ES-2re Lower Thorax Rib Deflection (Y) vs. Time

DISPLACEMENT [mm]

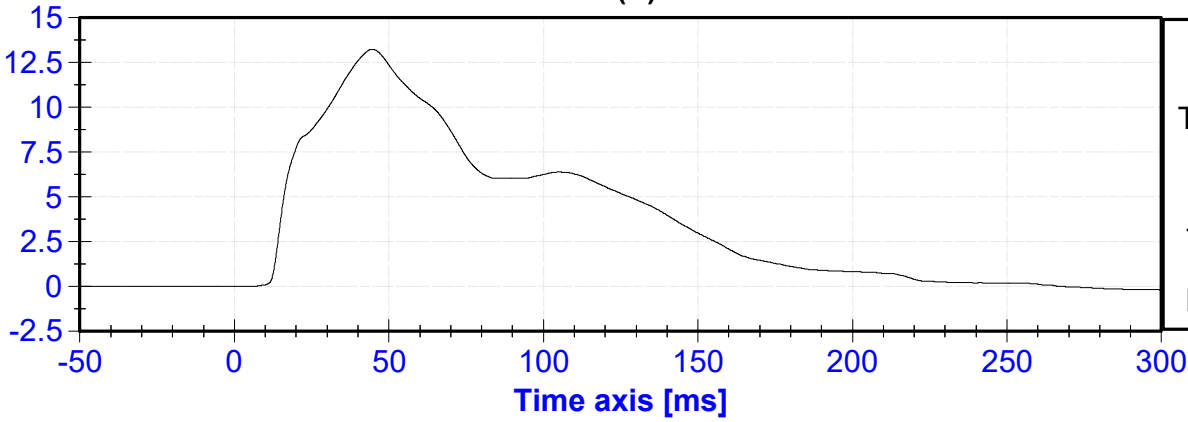

ES-2re Front Abdomen Force (Y) vs. Time

FORCE [N]

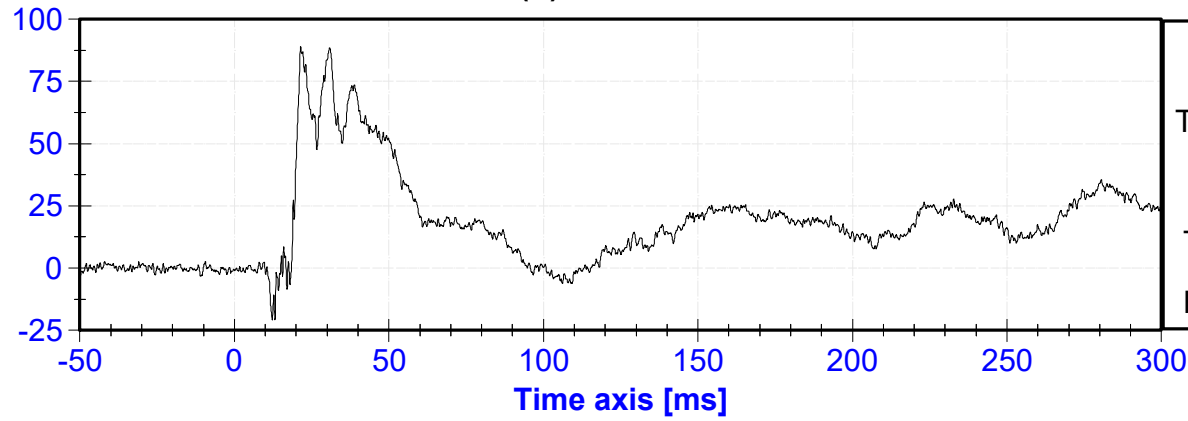

ES-2re Middle Abdomen Force (Y) vs. Time

FORCE [N]

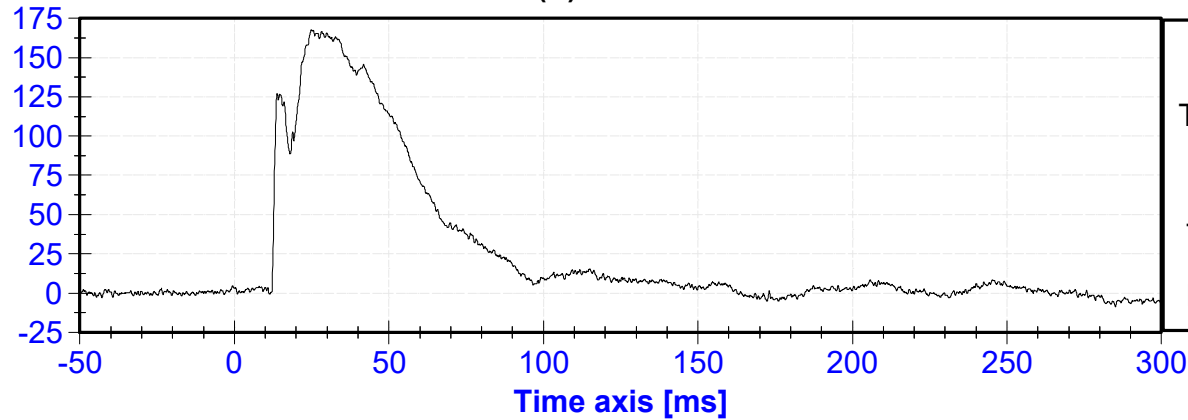

ES-2re Rear Abdomen Force (Y) vs. Time

FORCE [N]

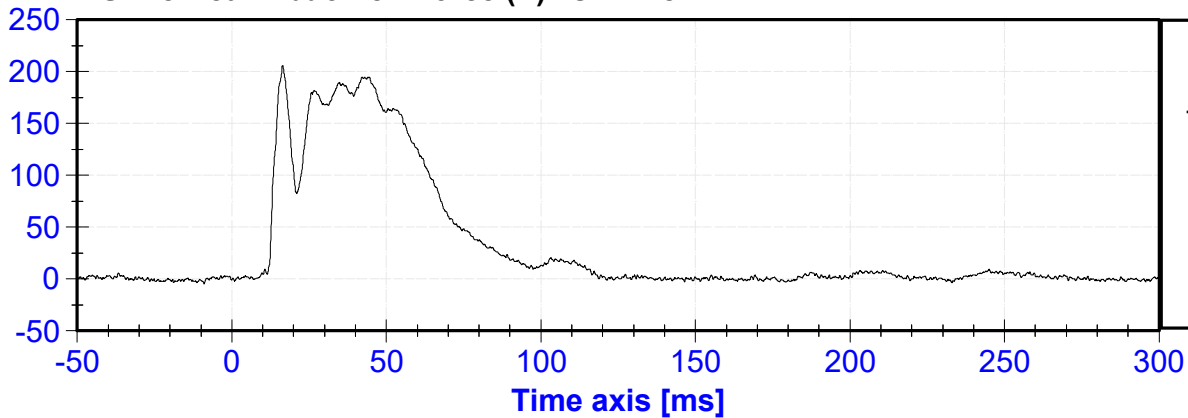

ES-2re Sum of Abdomen Forces vs. Time

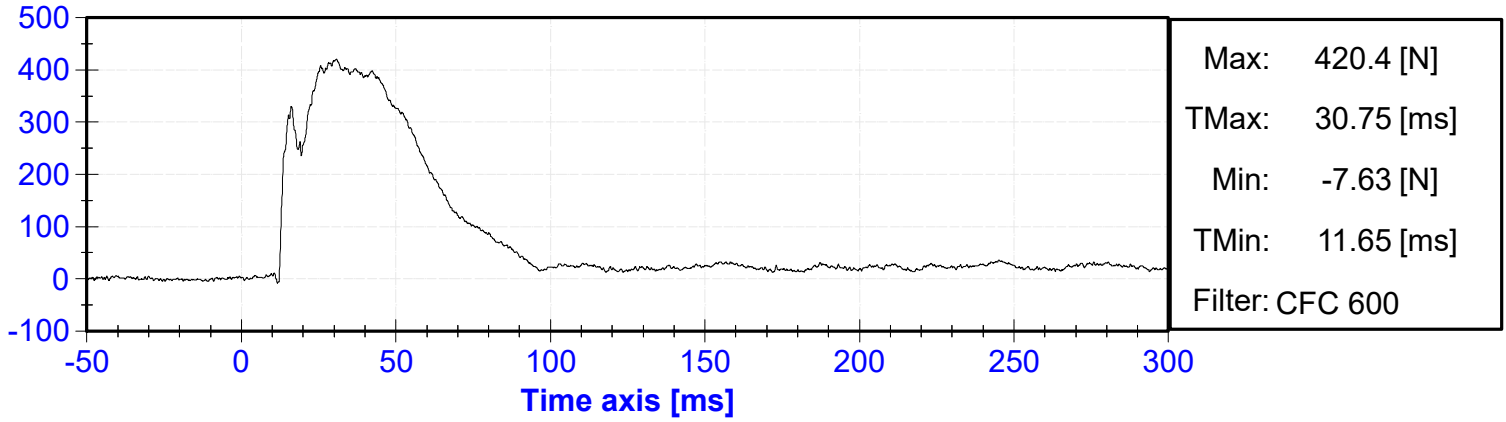

ES-2re Pubic Symphysis Force (Y) vs. Time

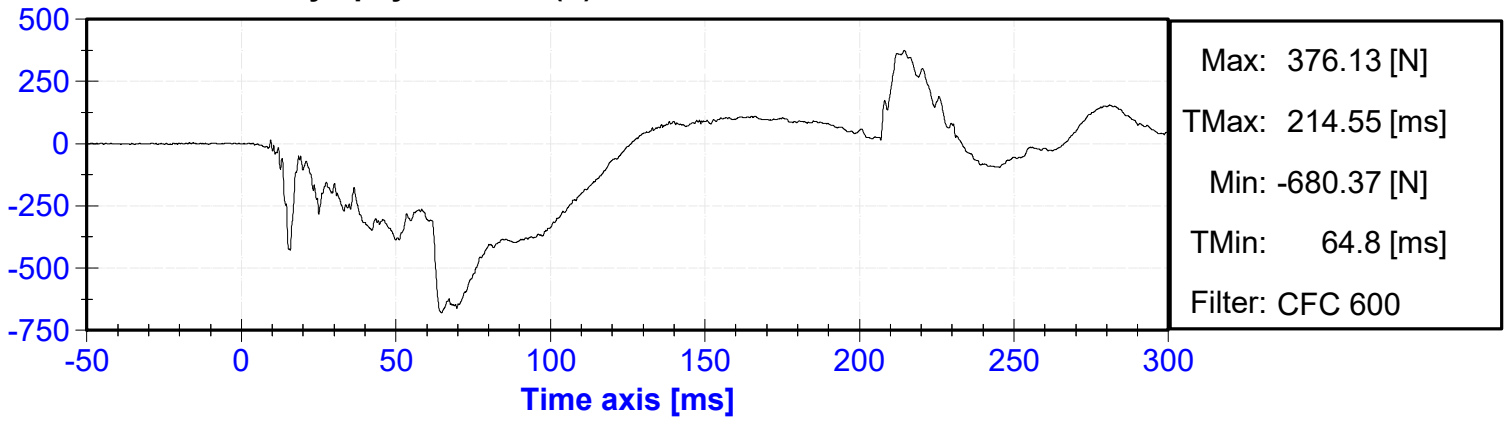

APPENDIX III
SID-IIs DUMMY RESPONSE DATA

Table of Data Plots

No.	Description	Page
1	SID-IIs Head (X) Acceleration vs. Time	III-3
2	SID-IIs Head (Y) Acceleration vs. Time	III-3
3	SID-IIs Head (Z) Acceleration vs. Time	III-3
4	SID-IIs Head Resultant Acceleration vs. Time	III-3
5	SID-IIs Head (X) Velocity vs. Time	III-4
6	SID-IIs Head (Y) Velocity vs. Time	III-4
7	SID-IIs Head (Z) Velocity vs. Time	III-4
8	SID-IIs Lower Spine X Acceleration vs. Time	III-4
9	SID-IIs Lower Spine Y Acceleration vs. Time	III-5
10	SID-IIs Lower Spine Z Acceleration vs. Time	III-5
11	SID-IIs Lower Spine Resultant Acceleration vs. Time	III-5
12	SID-IIs Lower Spine X Velocity vs. Time	III-5
13	SID-IIs Lower Spine Y Velocity vs. Time	III-6
14	SID-IIs Lower Spine Z Velocity vs. Time	III-6
15	SID-IIs Acetabulum Force vs. Time	III-6
16	SID-IIs Iliac Force vs. Time	III-6
17	SID-IIs Sum of Iliac and Acetabulum Forces vs. Time	III-7

ACCELERATION [g's]

SID-IIs Head (X) Acceleration vs. Time

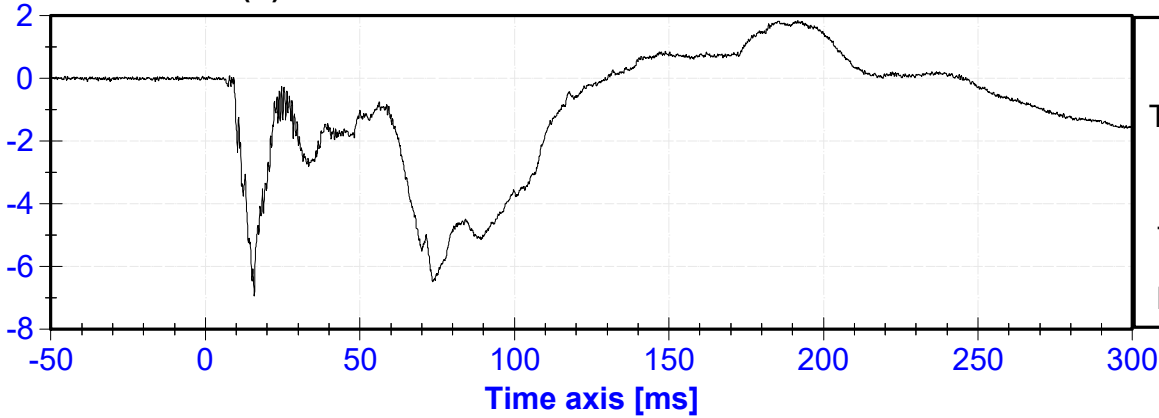

ACCELERATION [g's]

SID-IIs Head (Y) Acceleration vs. Time

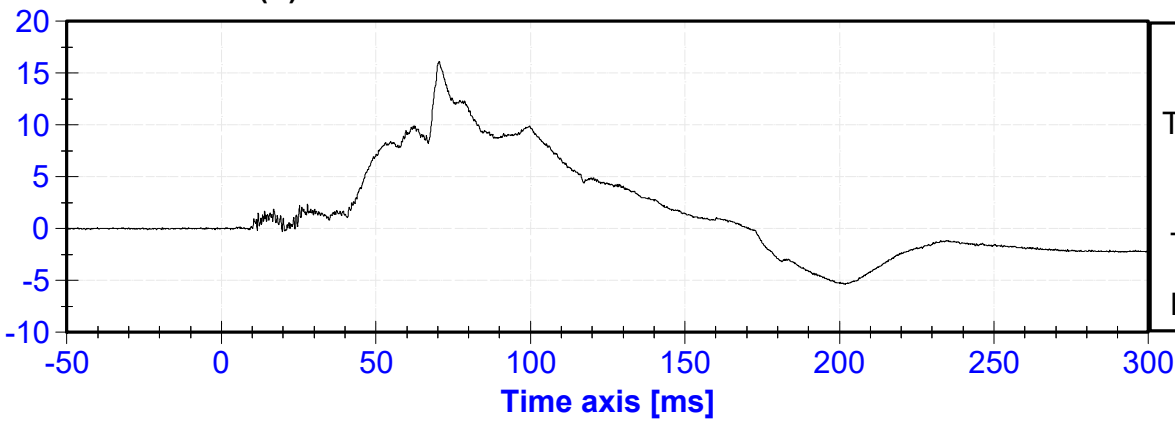

ACCELERATION [g's]

SID-IIs Head (Z) Acceleration vs. Time

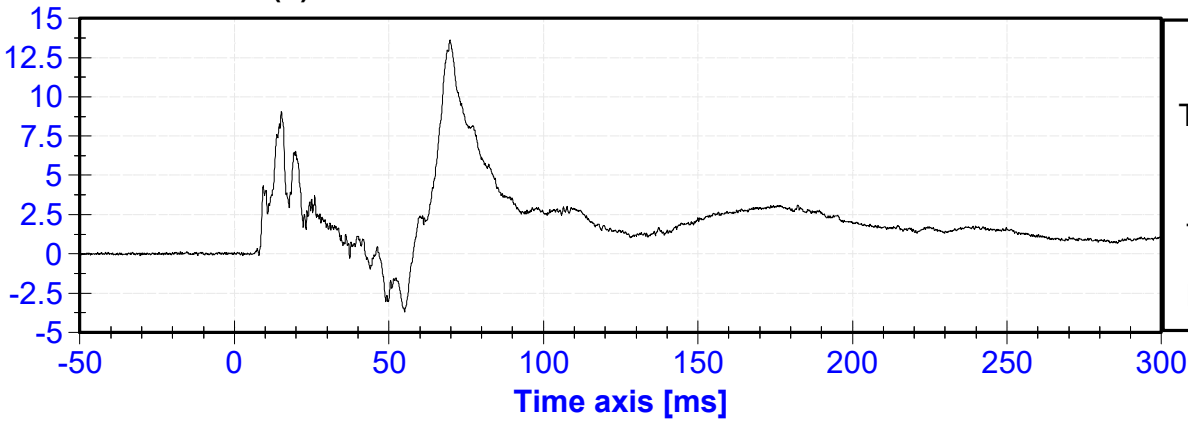

ACCELERATION [g's]

SID-IIs Head Resultant Acceleration vs. Time

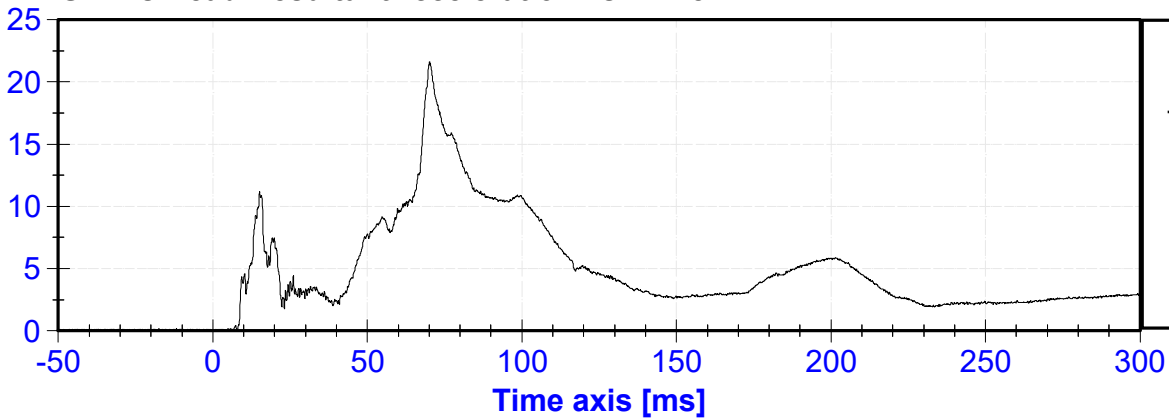

VELOCITY [m/s]

SID-Ils Head (X) Velocity vs. Time

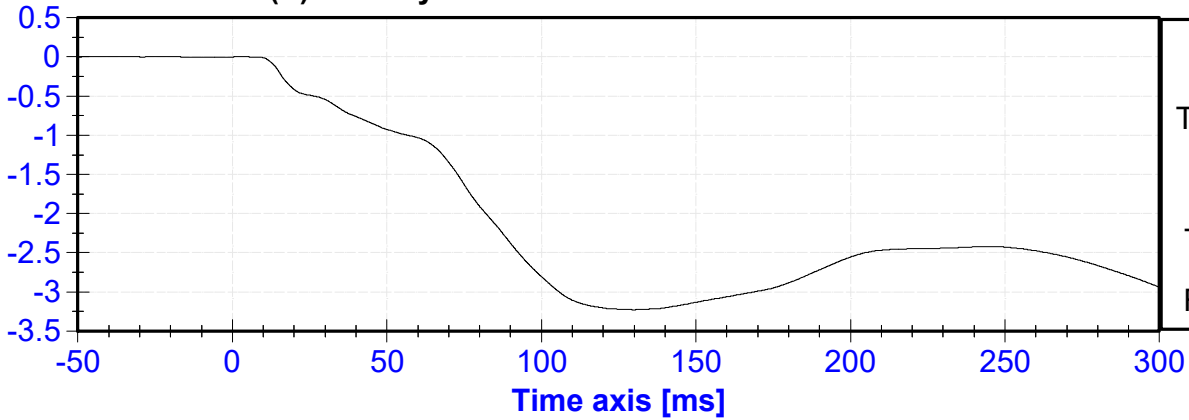

VELOCITY [m/s]

SID-Ils Head (Y) Velocity vs. Time

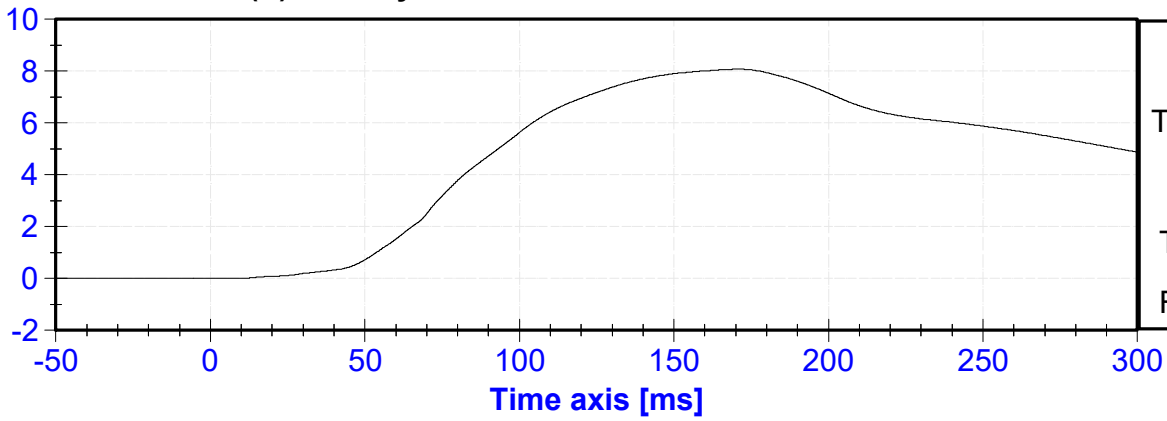

VELOCITY [m/s]

SID-Ils Head (Z) Velocity vs. Time

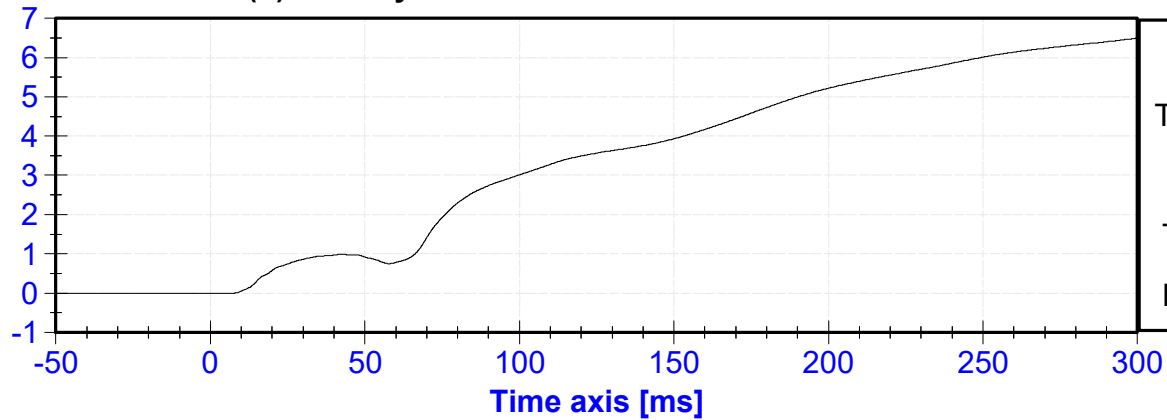

ACCELERATION [g's]

SID-Ils Lower Spine X Acceleration vs. Time

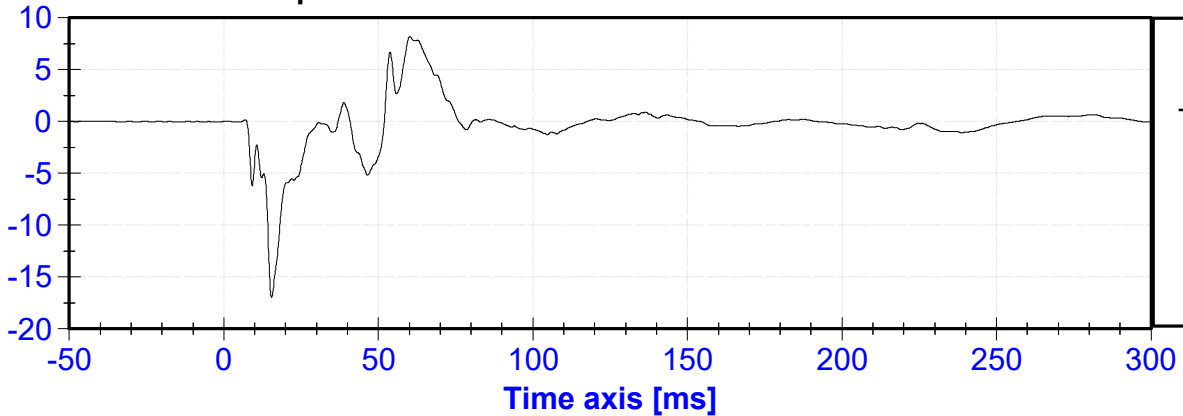

SID-IIs Lower Spine Y Acceleration vs. Time

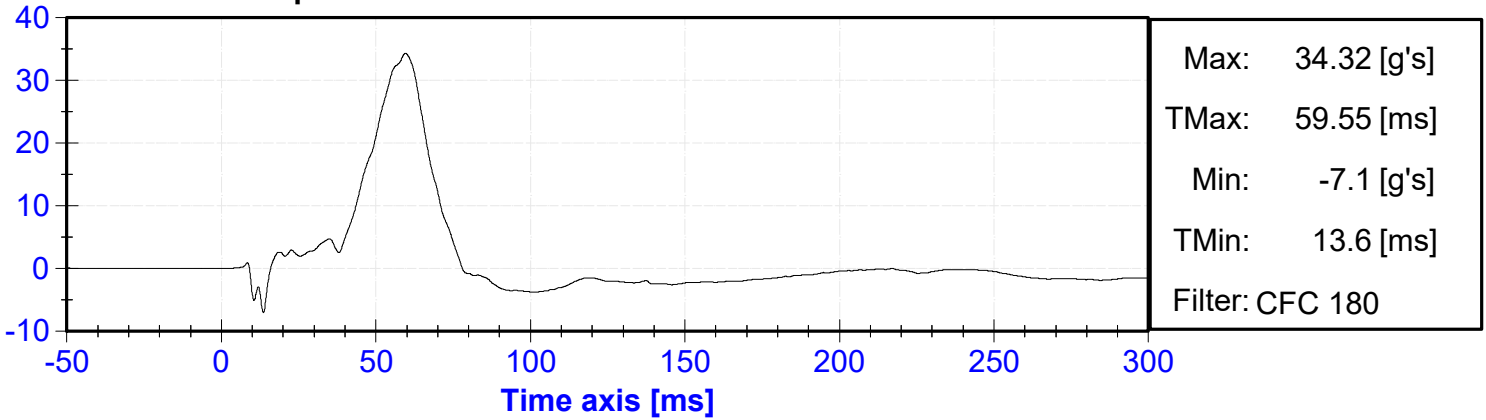

SID-IIs Lower Spine Z Acceleration vs. Time

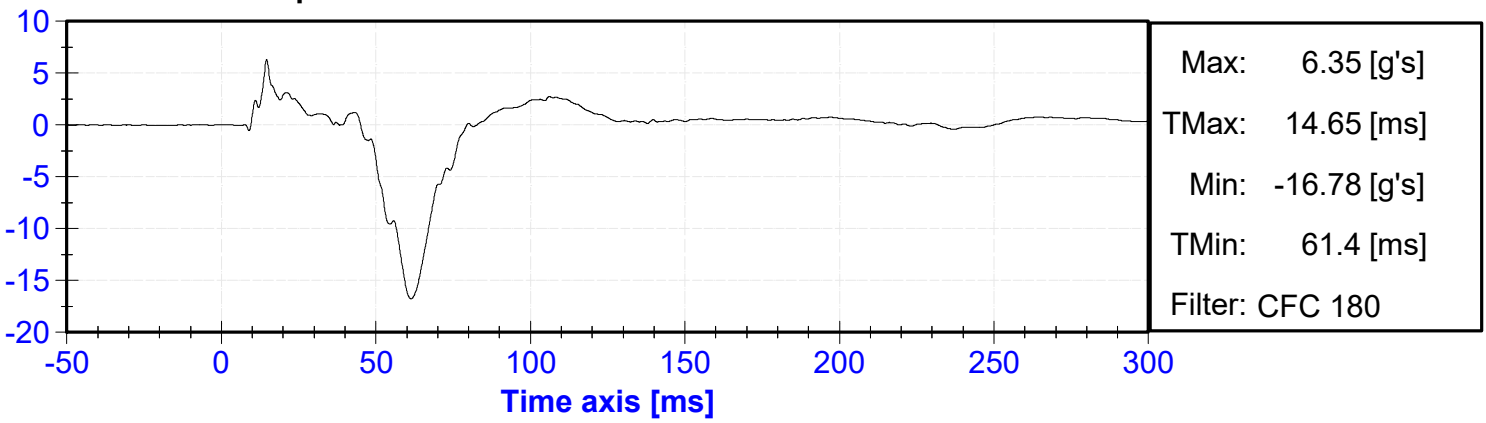

SID-IIs Lower Spine Resultant Acceleration vs. Time

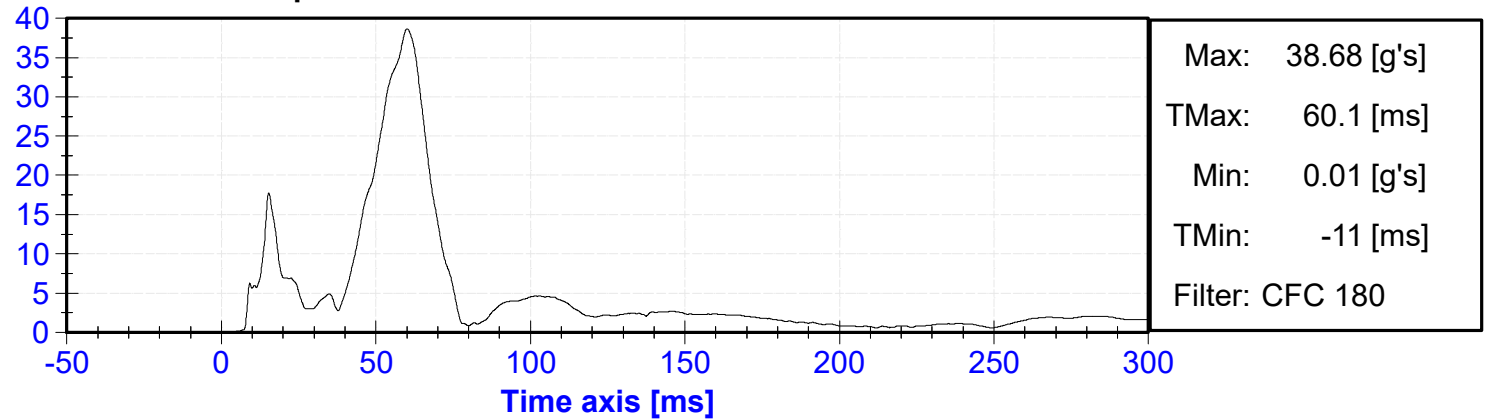

SID-IIs Lower Spine X Velocity vs. Time

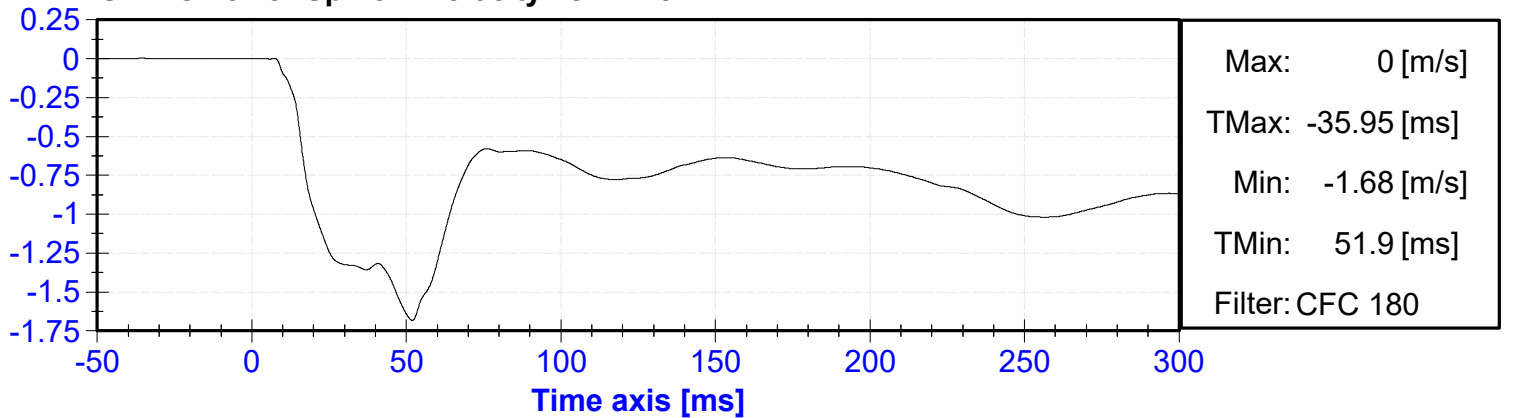

SID-Ils Lower Spine Y Velocity vs. Time

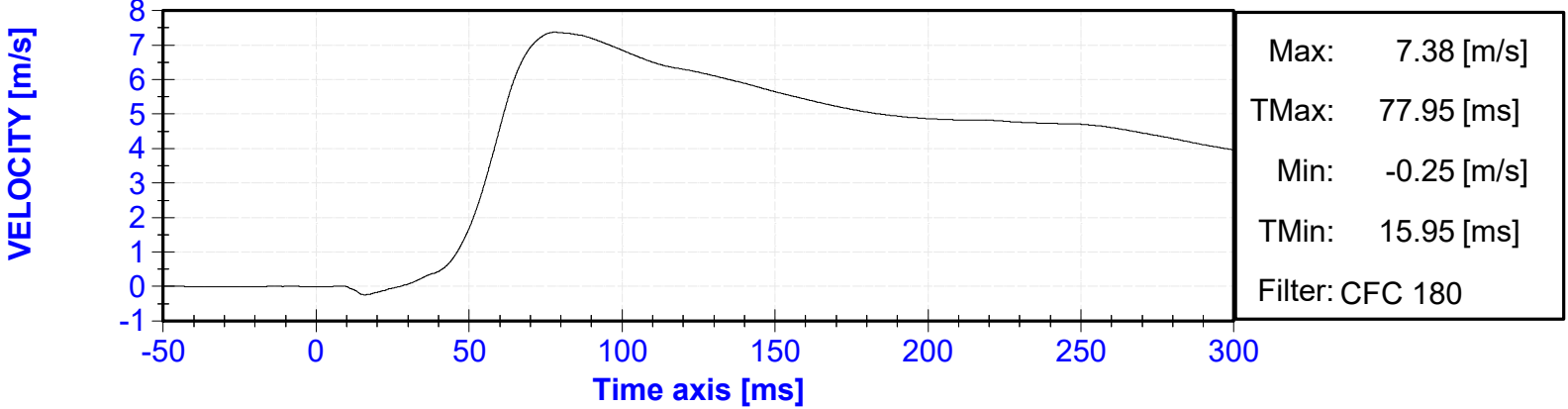

SID-Ils Lower Spine Z Velocity vs. Time

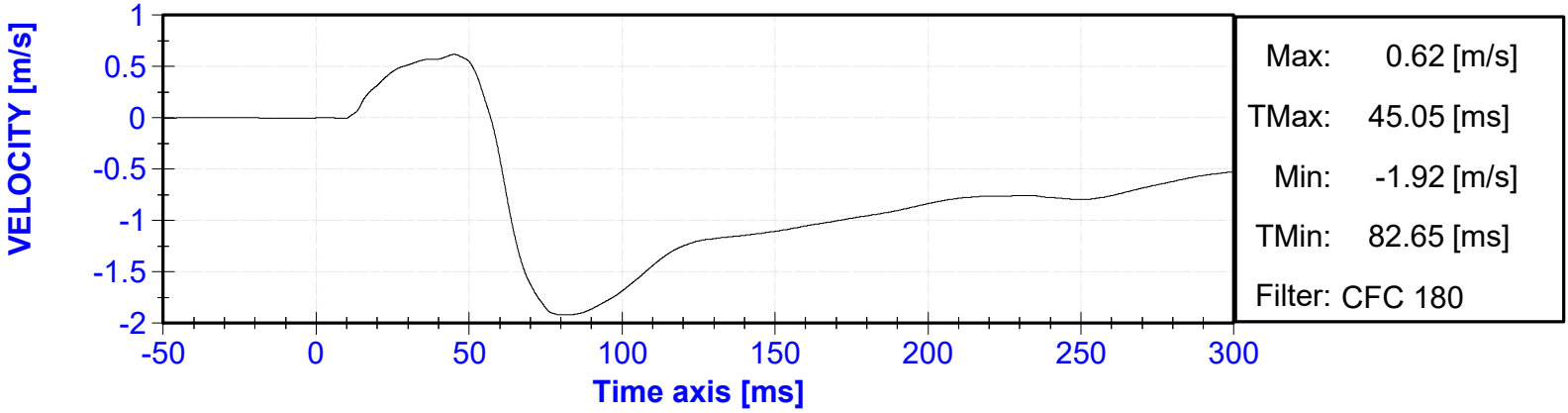

SID-Ils Acetabulum Force vs. Time

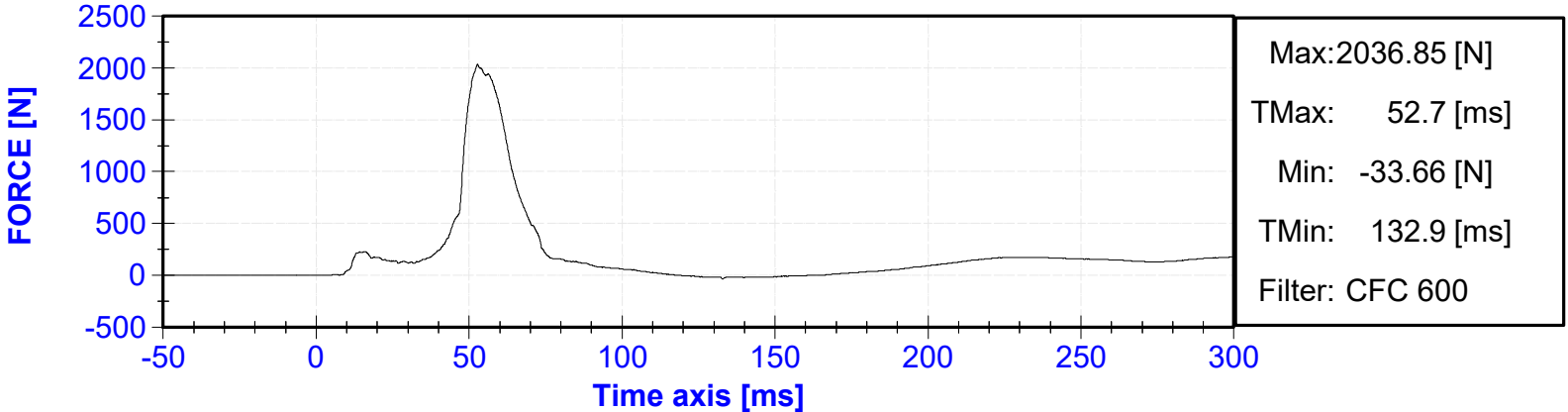

SID-Ils Iliac Force vs. Time

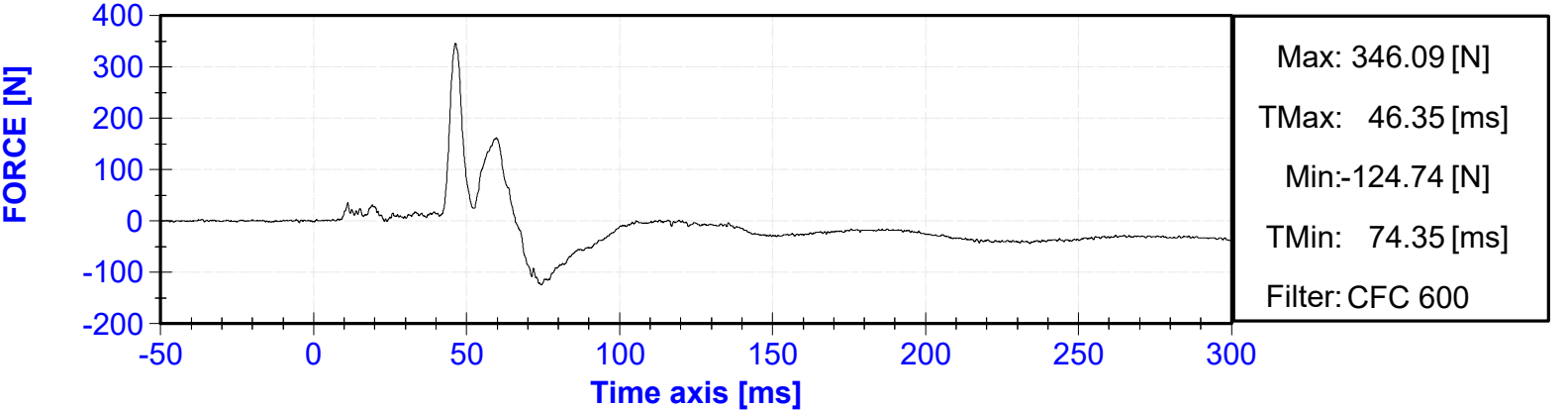

SID-IIs Sum of Iliac and Acetabulum Forces vs. Time

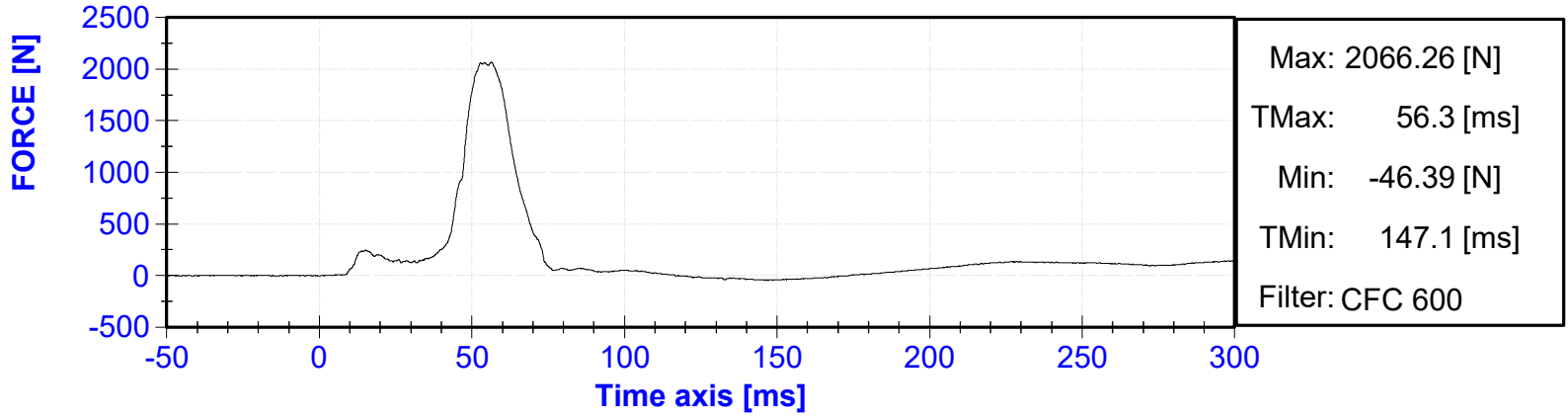

**APPENDIX IV
VEHICLE AND MDB ACCELEROMETER RESPONSE
DATA**

Table of Data Plots

No.	Description	Page
1	Right Sill at Front Seat (X) Acceleration vs. Time	IV-4
2	Right Sill at Front Seat (X) Velocity vs. Time	IV-4
3	Right Sill at Front Seat (Y) Acceleration vs. Time	IV-4
4	Right Sill at Front Seat (Y) Velocity vs. Time	IV-4
5	Right Sill at Front Seat (Z) Acceleration vs. Time	IV-5
6	Right Sill at Front Seat (Z) Velocity vs. Time	IV-5
7	Right Sill at Front Seat Resultant vs. Time	IV-5
8	Right Sill at Rear Seat (X) Acceleration vs. Time	IV-5
9	Right Sill at Rear Seat (X) Velocity vs. Time	IV-6
10	Right Sill at Rear Seat (Y) Acceleration vs. Time	IV-6
11	Right Sill at Rear Seat (Y) Velocity vs. Time	IV-6
12	Right Sill at Rear Seat (Z) Acceleration vs. Time	IV-6
13	Right Sill at Rear Seat (Z) Velocity vs. Time	IV-7
14	Right Sill at Rear Seat Resultant Acceleration vs. Time	IV-7
15	Rear Floorpan Above Axle (X) Acceleration vs. Time	IV-7
16	Rear Floorpan Above Axle (X) Velocity vs. Time	IV-7
17	Rear Floorpan Above Axle (Y) Acceleration vs. Time	IV-8
18	Rear Floorpan Above Axle (Y) Velocity vs. Time	IV-8
19	Rear Floorpan Above Axle (Z) Acceleration vs. Time	IV-8
20	Rear Floorpan Above Axle (Z) Velocity vs. Time	IV-8
21	Rear Floorpan Above Axle Resultant Acceleration vs. Time	IV-9
22	Left Sill at Rear Door (Y) Acceleration vs. Time	IV-9
23	Left Sill at Rear Door (Y) Velocity vs. Time	IV-9
24	Left Sill at Front Door (Y) Acceleration vs. Time.	IV-9
25	Left Sill at Front Door (Y) Velocity vs. Time	IV-10
26	Right Rear Occ. Compartment(Y) Acceleration vs. Time	IV-10
27	Right Rear Occ. Compartment(Y) Velocity vs. Time	IV-10
28	Left B-Post Lower (Y) Acceleration vs. Time	IV-10
29	Left B-Post Lower (Y) Velocity vs. Time	IV-11
30	Left B-Post Middle (Y) Acceleration vs. Time	IV-11
31	Left B-Post Middle (Y) Velocity vs. Time	IV-11
32	Left A-Post Lower(Y) Acceleration vs. Time	IV-11
33	Left A-Post Lower(Y) Velocity vs. Time	IV-12
34	Left A-Post Middle (Y) Acceleration vs. Time	IV-12
35	Left A-Post Middle (Y) Velocity vs. Time	IV-12
36	Front Seat Track (Y) Acceleration vs. Time	IV-12
37	Front Seat Track (Y) Velocity vs. Time	IV-13
38	Rear Seat Track or Structure (Y) Acceleration vs. Time	IV-13
39	Rear Seat Track or Structure (Y) Velocity vs. Time	IV-13
40	Vehicle CG (X) Acceleration vs. Time	IV-13
41	Vehicle CG (X) Velocity vs. Time	IV-14
42	Vehicle CG (Y) Acceleration vs. Time	IV-14
43	Vehicle CG (Y) Velocity vs. Time	IV-14
44	Vehicle CG (Z) Acceleration vs. Time	IV-14
45	Vehicle CG (Z) Velocity vs. Time	IV-15
46	Vehicle CG Resultant Acceleration vs. Time	IV-15
47	MDB Center of Gravity (X) Acceleration vs. Time	IV-15
48	MDB Center of Gravity (X) Velocity vs. Time	IV-15
49	MDB Center of Gravity (Y) Acceleration vs. Time	IV-16
50	MDB Center of Gravity (Y) Velocity vs. Time	IV-16
51	MDB Center of Gravity (Z) Acceleration vs. Time	IV-16
52	MDB Center of Gravity (Z) Velocity vs. Time	IV-16

53	MDB Center of Gravity Resultant Acceleration vs. Time	IV-17
54	MDB Rear (X) Acceleration vs. Time	IV-17
55	MDB Rear (X) Velocity vs. Time	IV-17
56	MDB Rear (Y) Acceleration vs. Time	IV-17
57	MDB Rear (Y) Velocity vs. Time	IV-18

Right Sill at Front Seat (X) Acceleration vs. Time

ACCELERATION [g's]

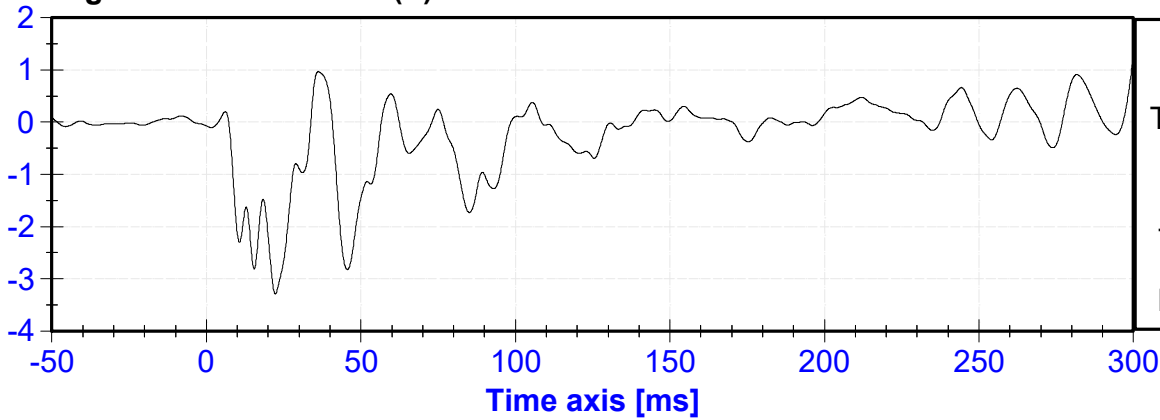

Right Sill at Front Seat (X) Velocity vs. Time

VELOCITY [m/s]

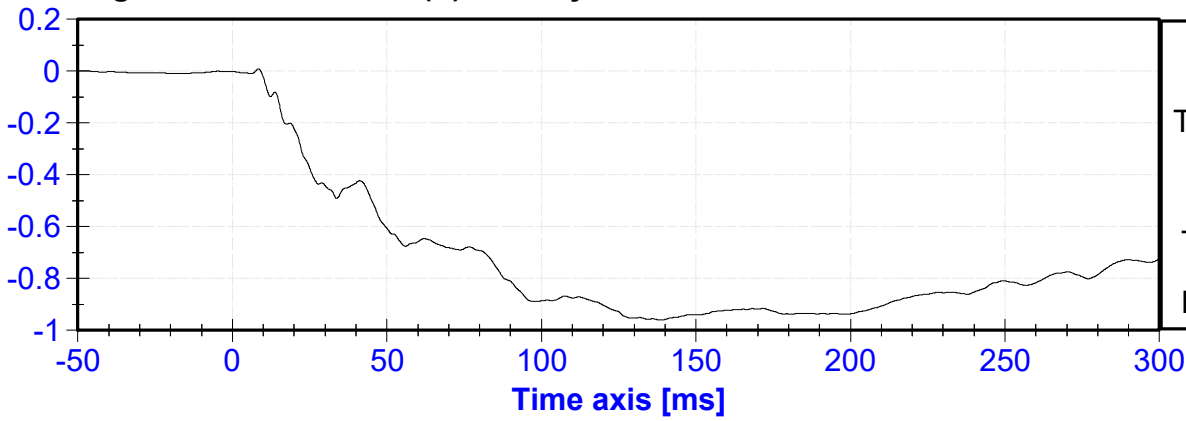

Right Sill at Front Seat (Y) Acceleration vs. Time

ACCELERATION [g's]

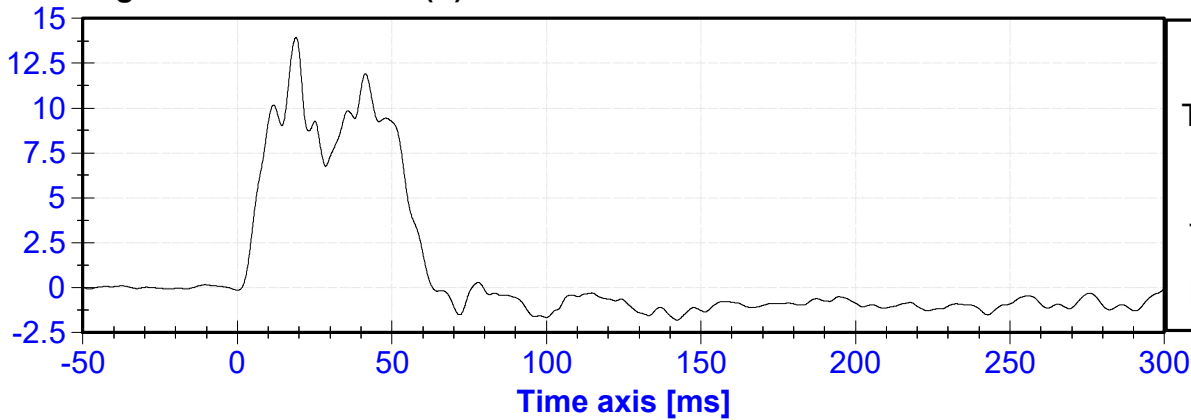

Right Sill at Front Seat (Y) Velocity vs. Time

VELOCITY [m/s]

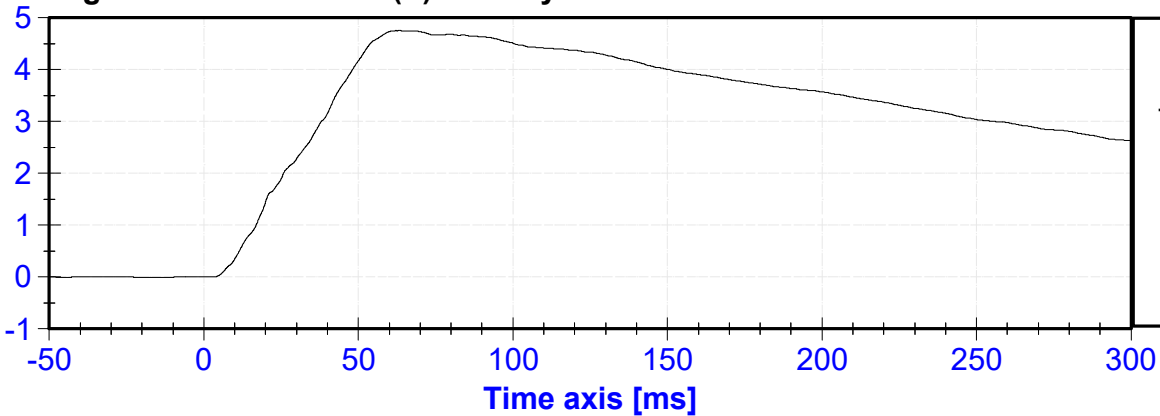

Right Sill at Front Seat (Z) Acceleration vs. Time

ACCELERATION [g's]

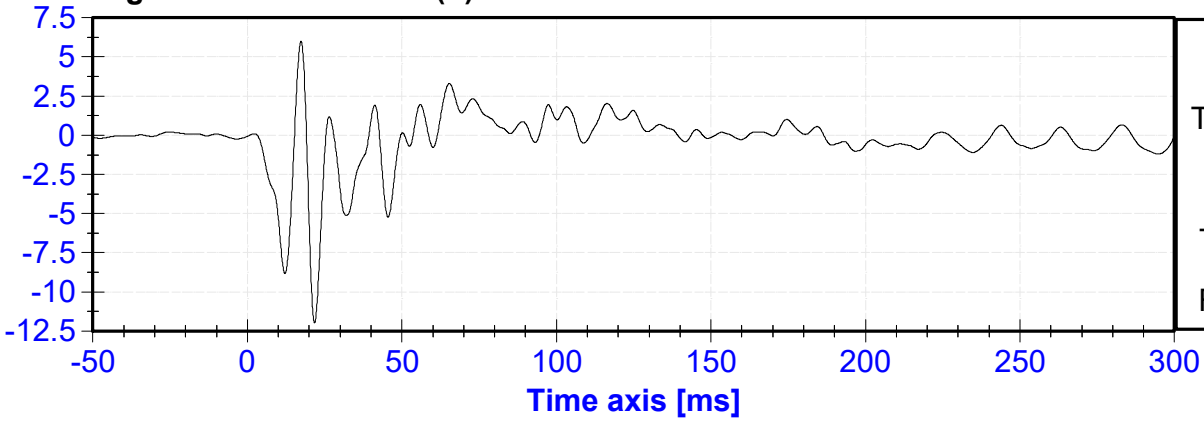

Right Sill at Front Seat (Z) Velocity vs. Time

VELOCITY [m/s]

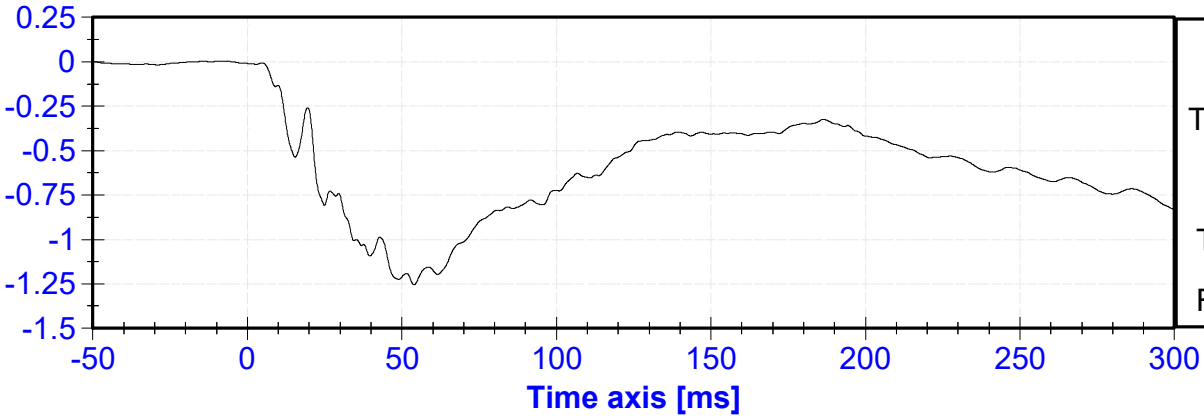

Right Sill at Front Seat Resultant vs. Time

ACCELERATION [g's]

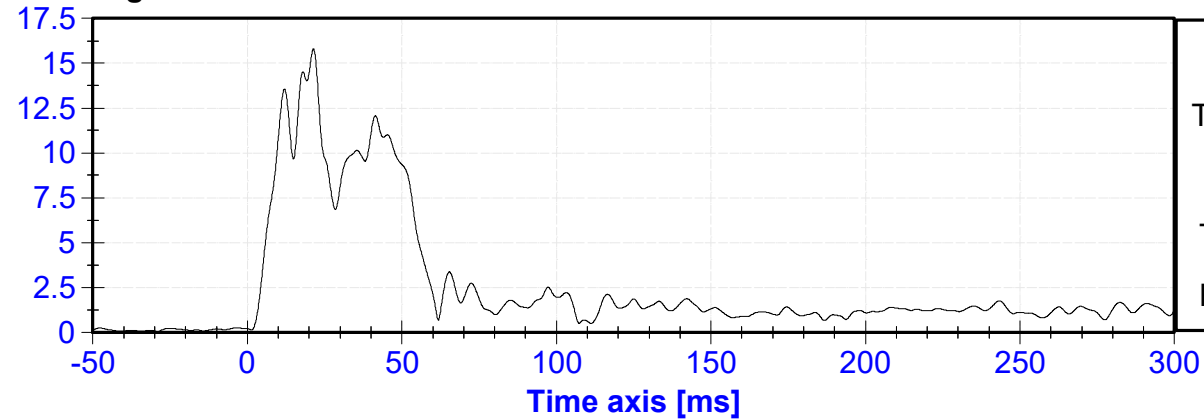

Right Sill at Rear Seat (X) Acceleration vs. Time

ACCELERATION [g's]

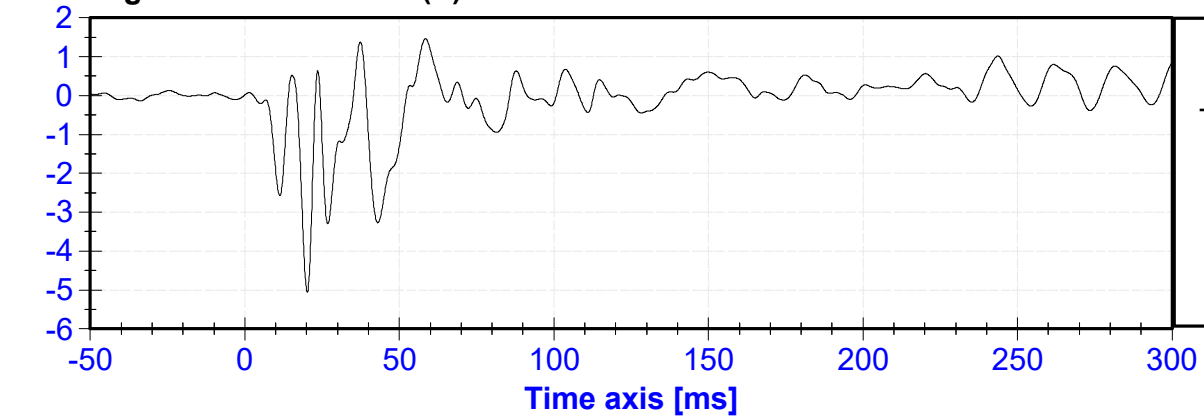

Right Sill at Rear Seat (X) Velocity vs. Time

VELOCITY [m/s]

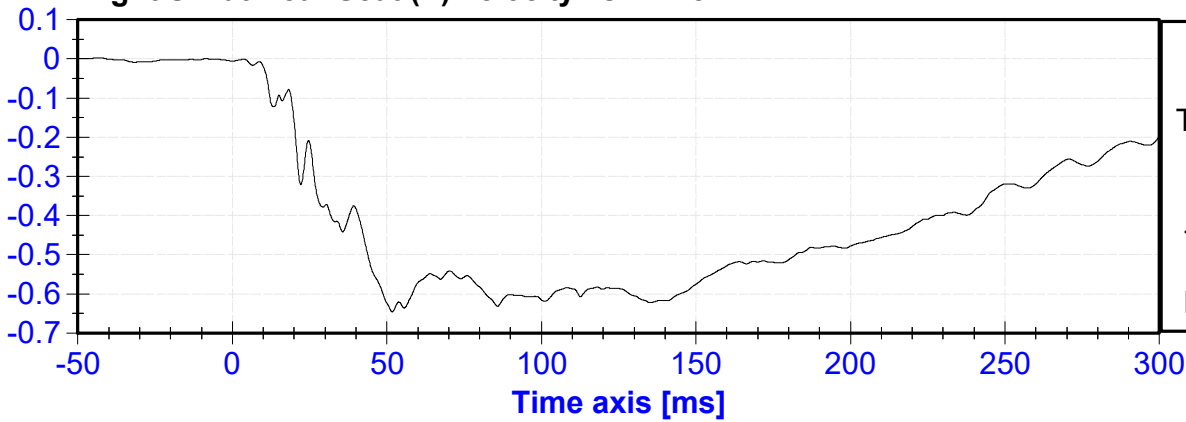

Right Sill at Rear Seat (Y) Acceleration vs. Time

ACCELERATION [g's]

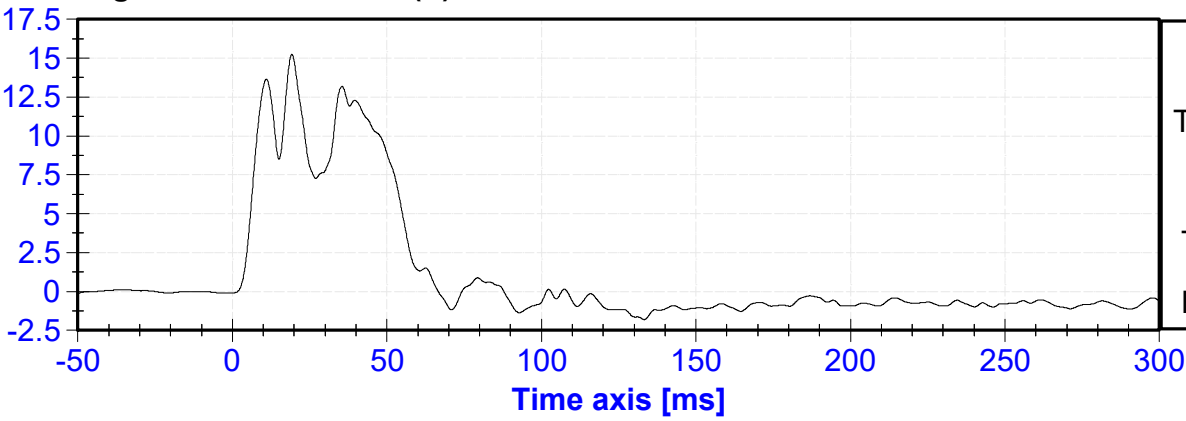

Right Sill at Rear Seat (Y) Velocity vs. Time

VELOCITY [m/s]

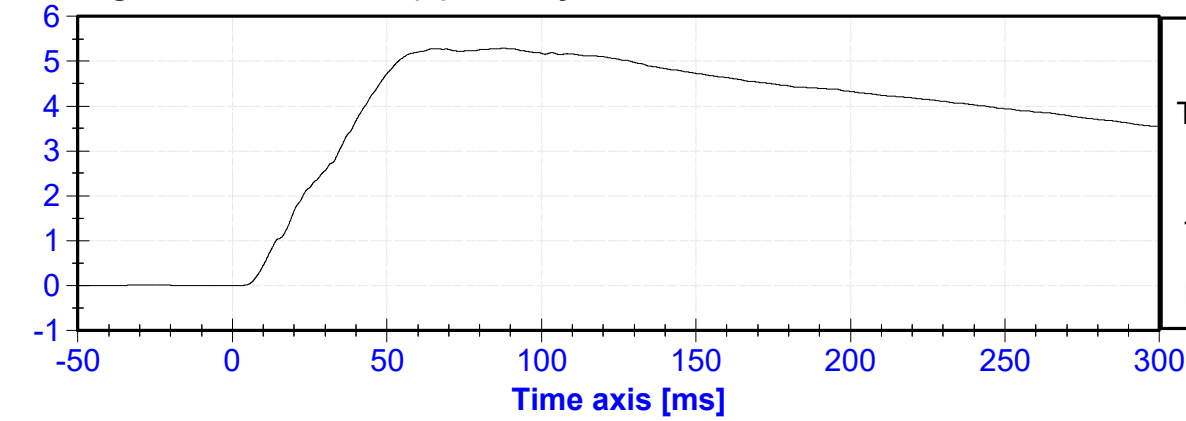

Right Sill at Rear Seat (Z) Acceleration vs. Time

ACCELERATION [g's]

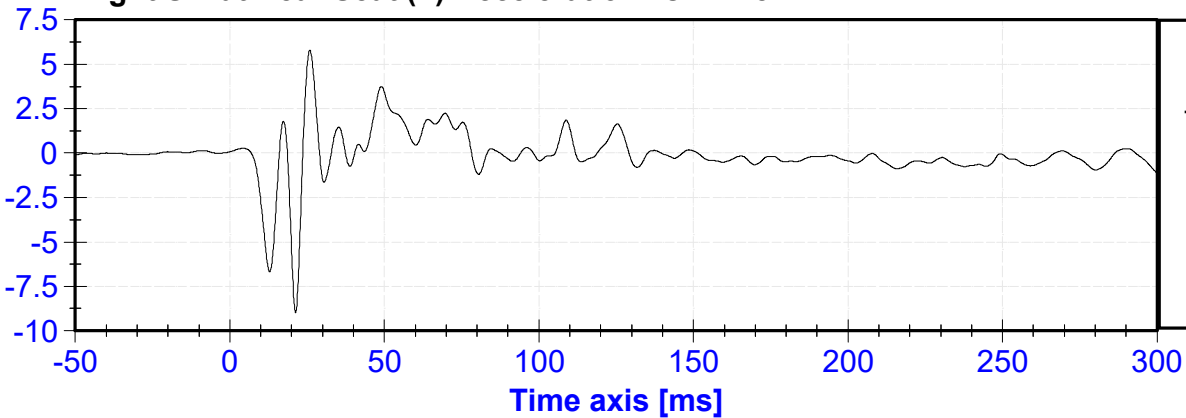

VELOCITY [m/s]

Right Sill at Rear Seat (Z) Velocity vs. Time

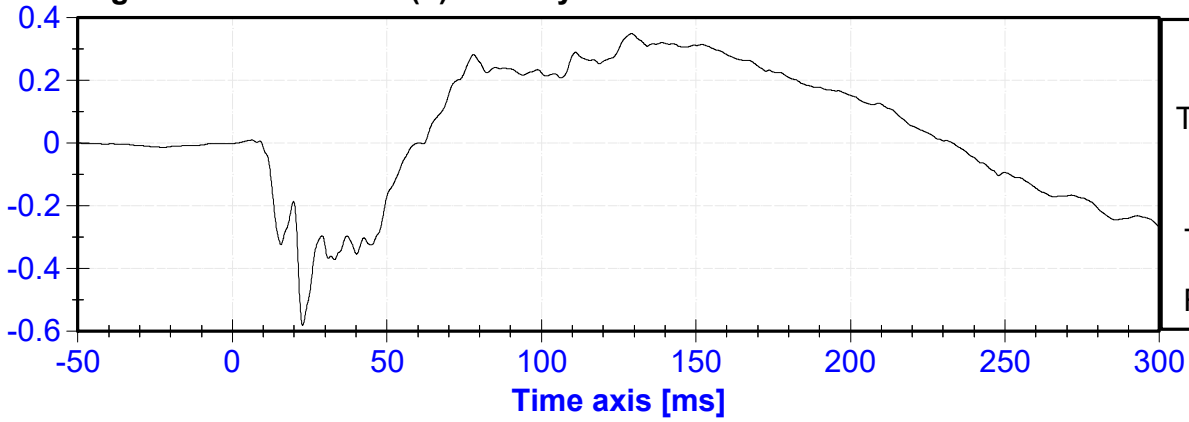

ACCELERATION [g's]

Right Sill at Rear Seat Resultant Acceleration vs. Time

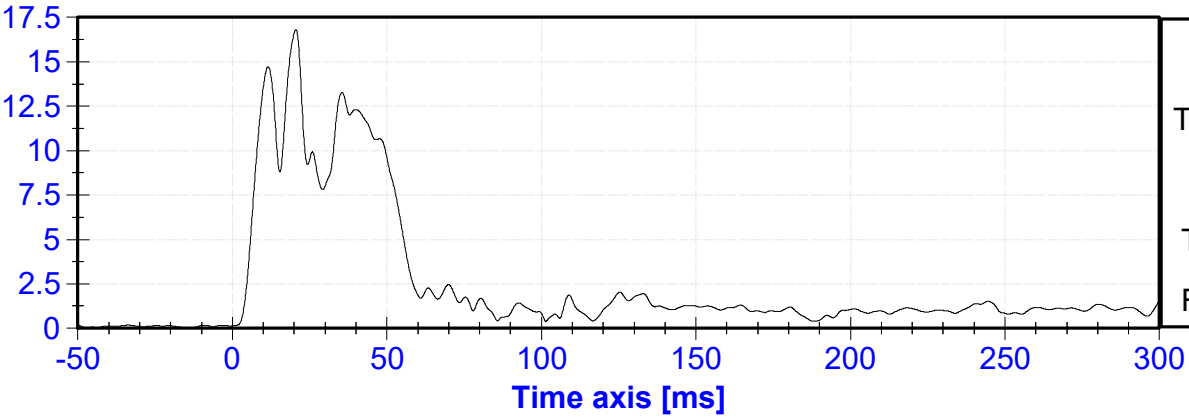

ACCELERATION [g's]

Rear Floorpan Above Axle (X) Acceleration vs. Time

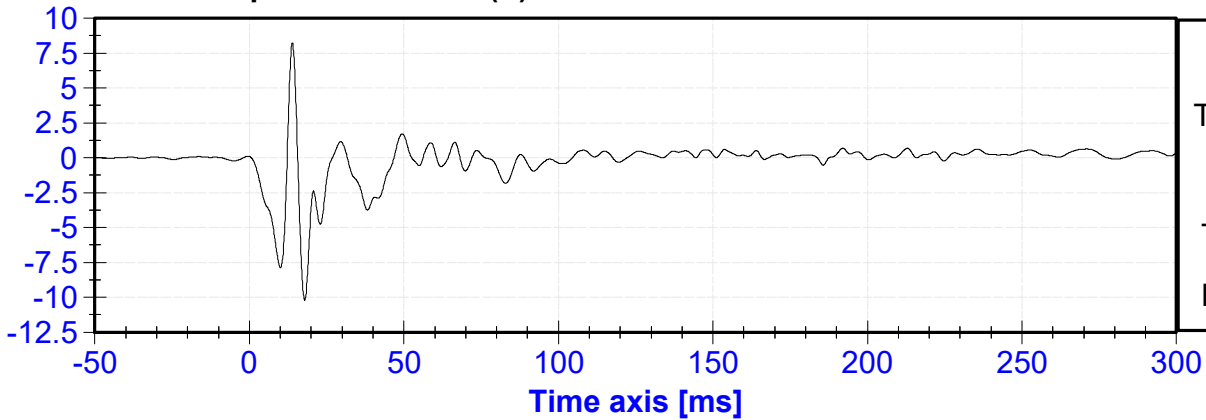

VELOCITY [m/s]

Rear Floorpan Above Axle (X) Velocity vs. Time

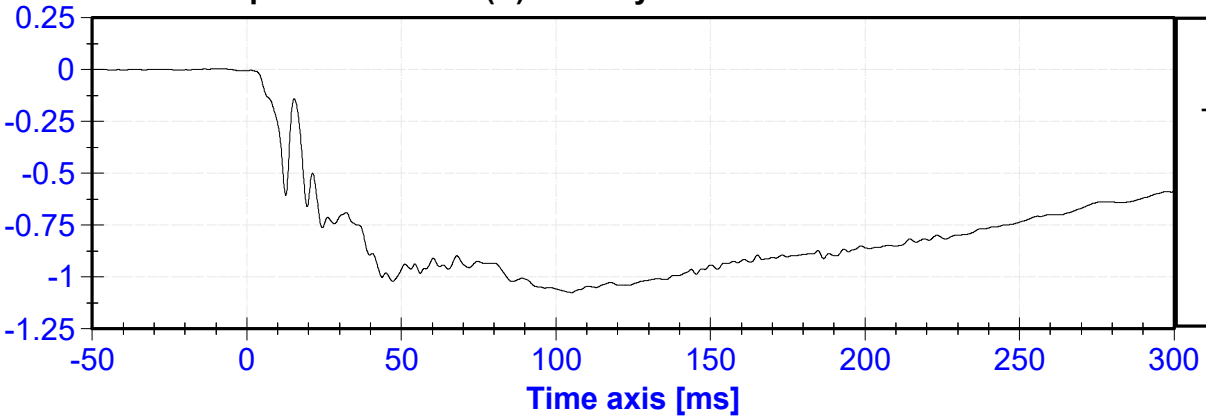

Rear Floorpan Above Axle (Y) Acceleration vs. Time

ACCELERATION [g's]

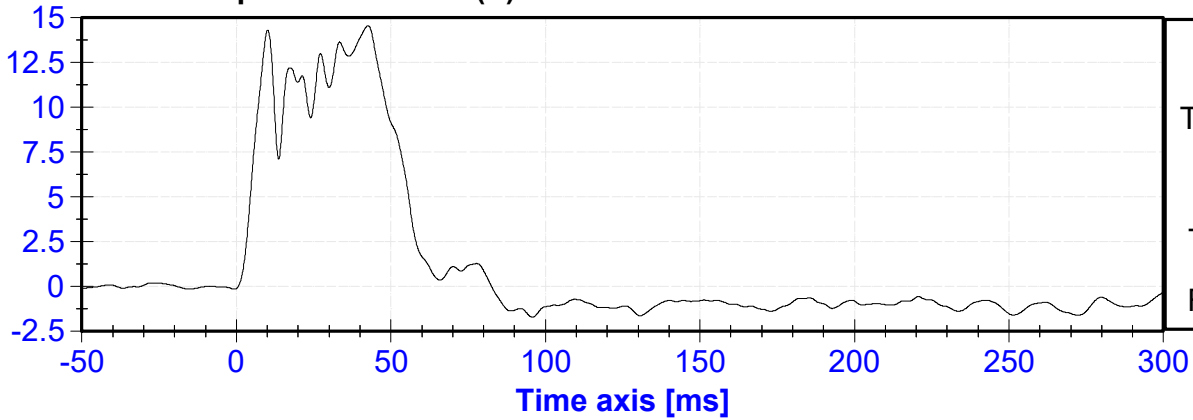

Rear Floorpan Above Axle (Y) Velocity vs. Time

VELOCITY [m/s]

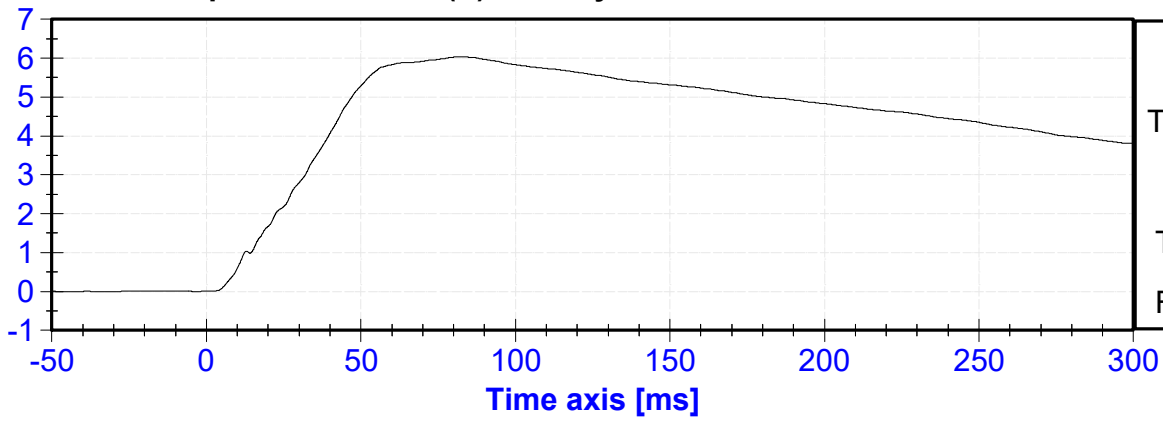

Rear Floorpan Above Axle (Z) Acceleration vs. Time

ACCELERATION [g's]

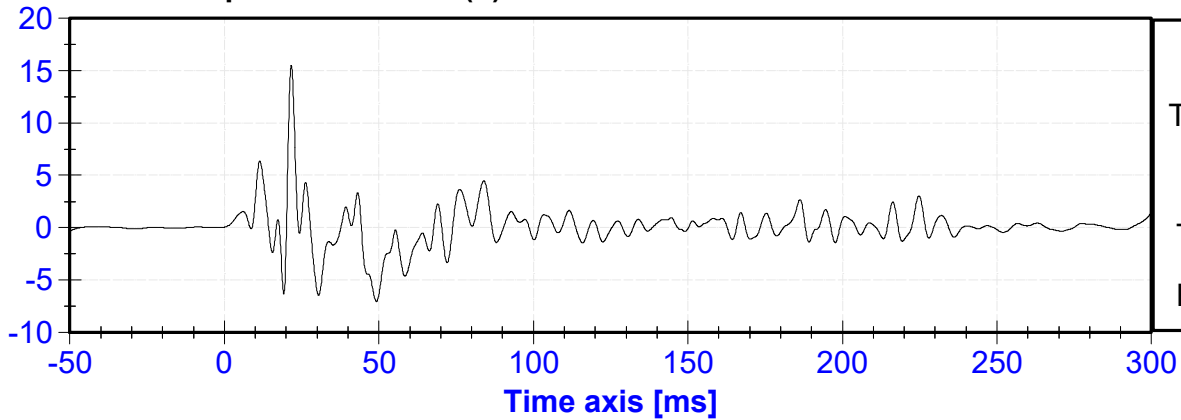

Rear Floorpan Above Axle (Z) Velocity vs. Time

VELOCITY [m/s]

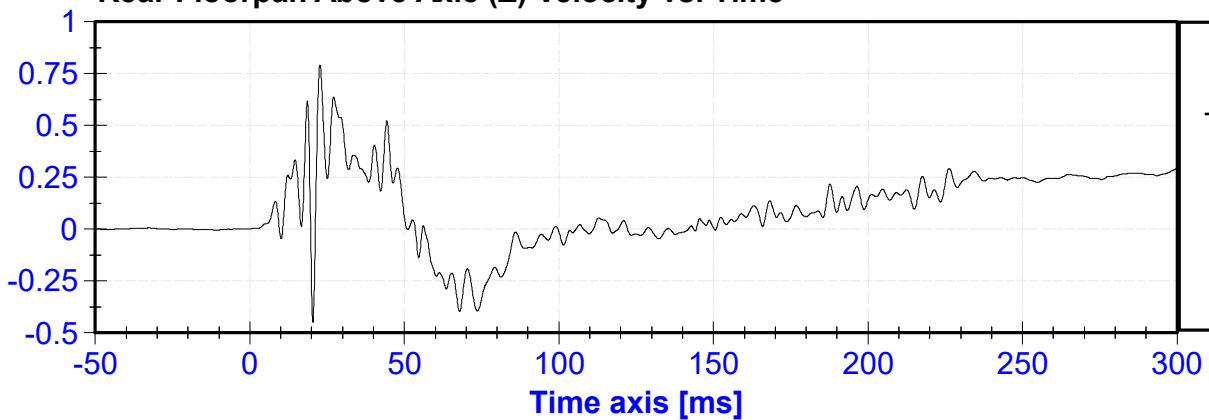

Rear Floorpan Above Axle Resultant Acceleration vs. Time

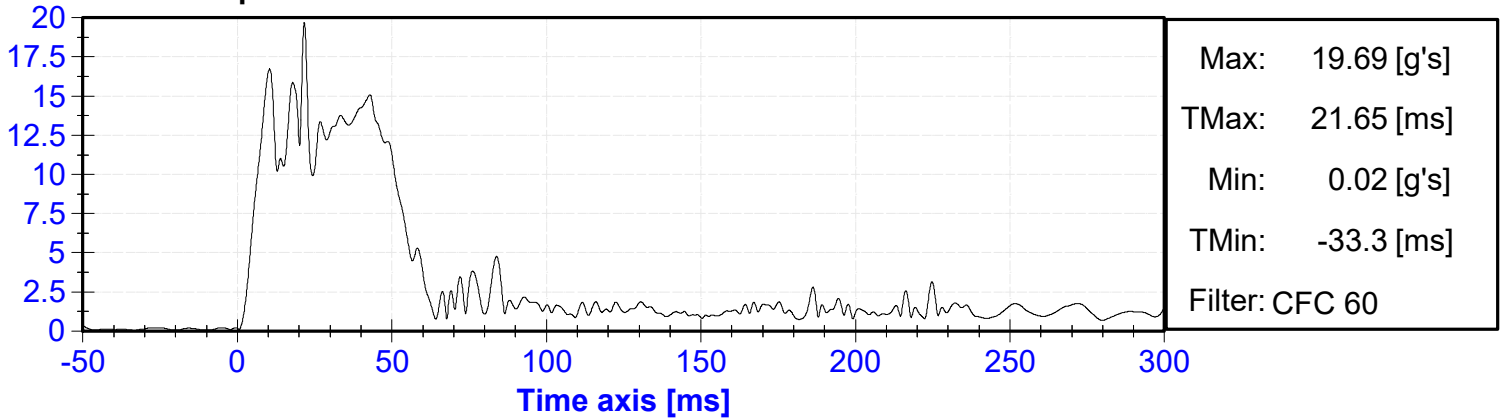

Exceeded calibration range at 15.5 ms

Left Sill at Rear Door (Y) Acceleration vs. Time

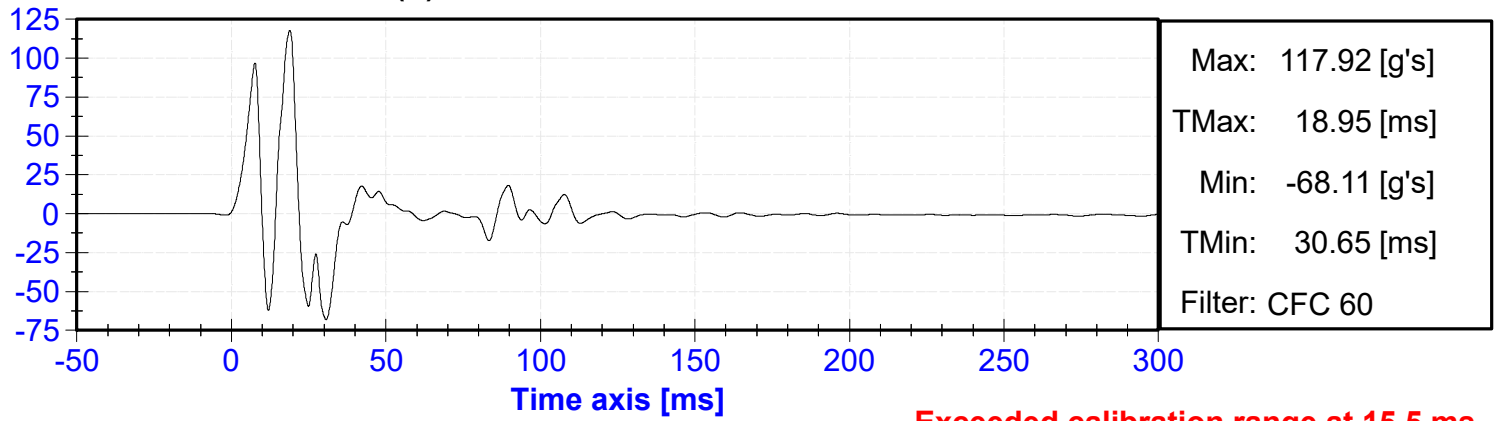

Exceeded calibration range at 15.5 ms

Left Sill at Rear Door (Y) Velocity vs. Time

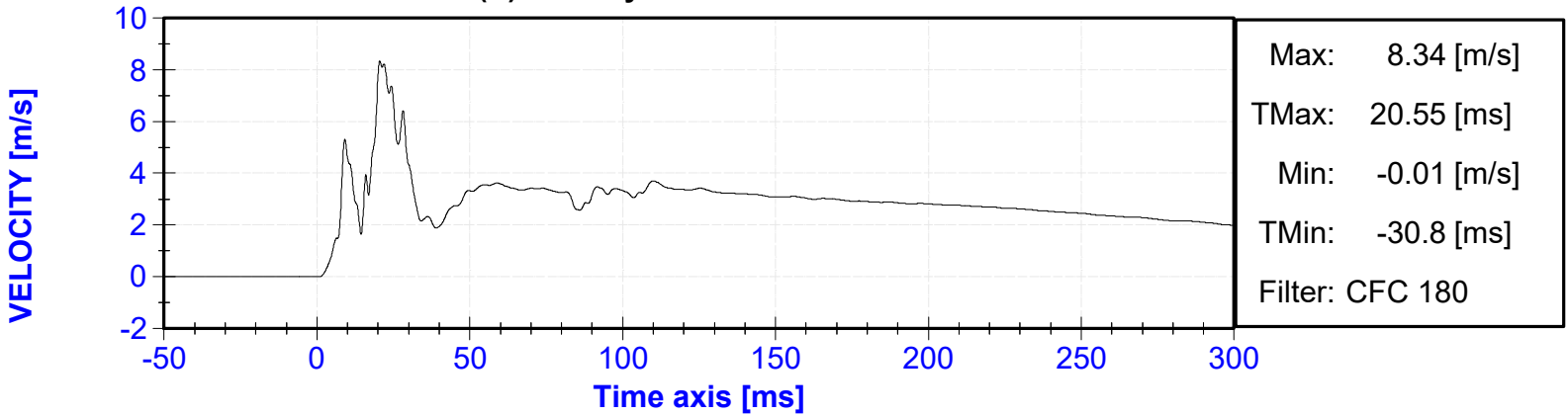

Left Sill at Front Door (Y) Acceleration vs. Time.

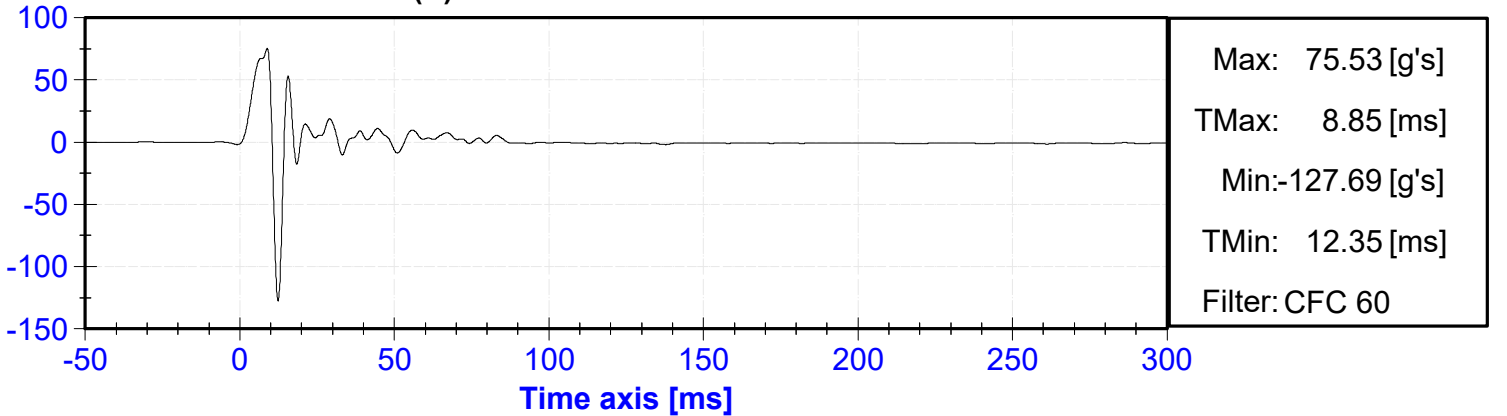

Left Sill at Front Door (Y) Velocity vs. Time

VELOCITY [m/s]

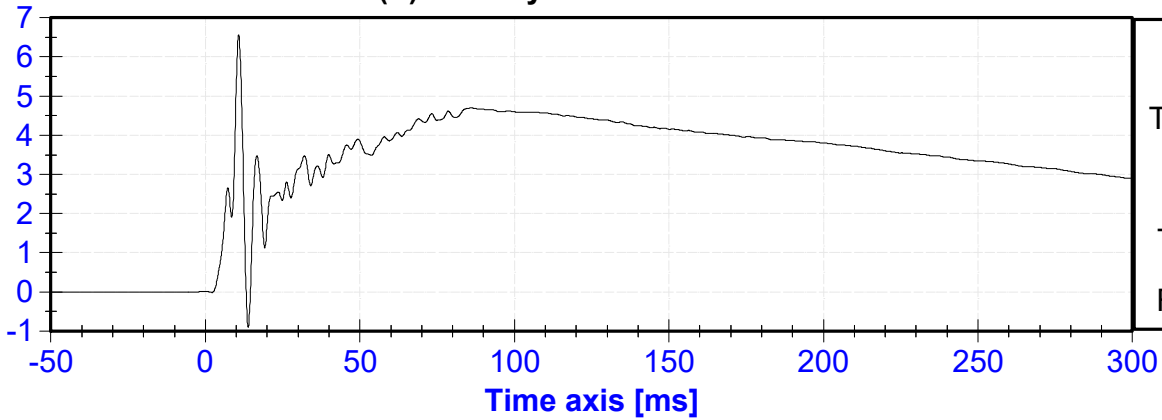

Right Rear Occ. Compartment(Y) Acceleration vs. Time

ACCELERATION [g's]

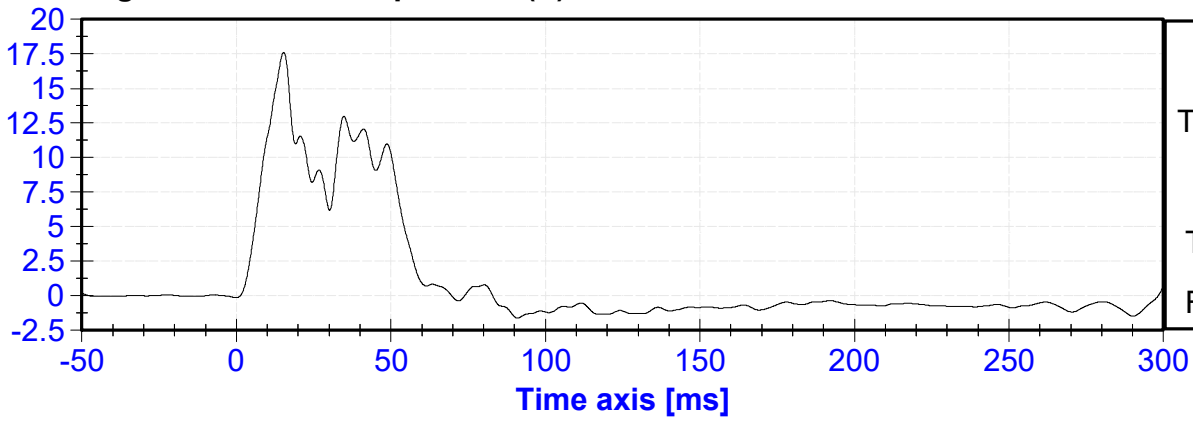

Right Rear Occ. Compartment(Y) Velocity vs. Time

VELOCITY [m/s]

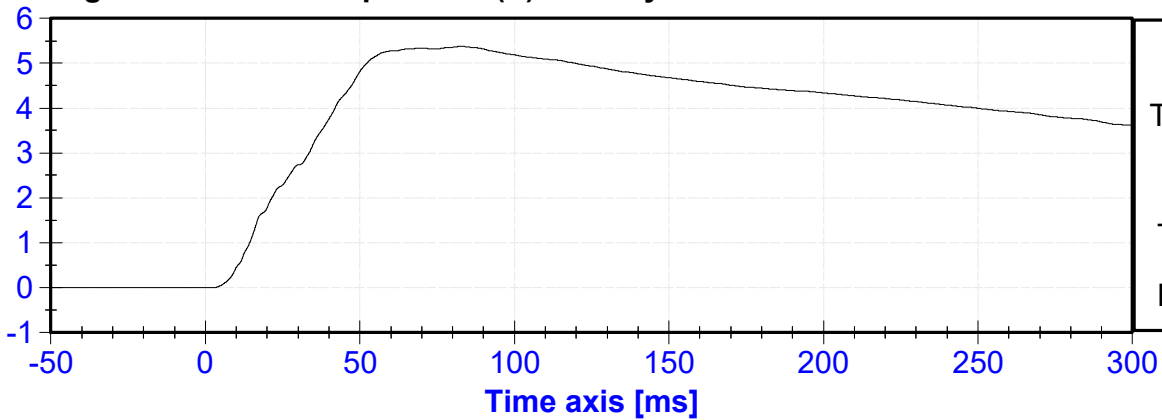

Exceeded calibration range at 11.1 ms

Left B-Post Lower (Y) Acceleration vs. Time

ACCELERATION [g's]

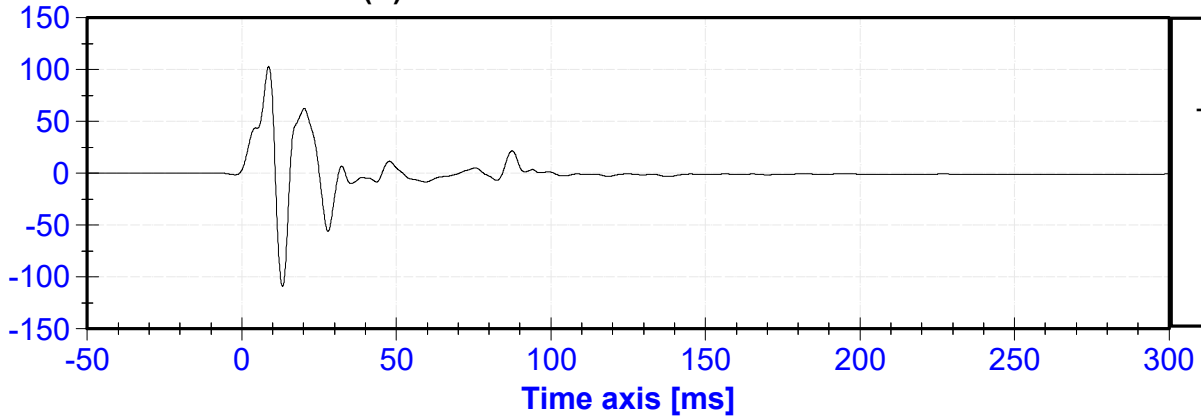

Exceeded calibration range at 11.1 ms

Left B-Post Lower (Y) Velocity vs. Time

VELOCITY [m/s]

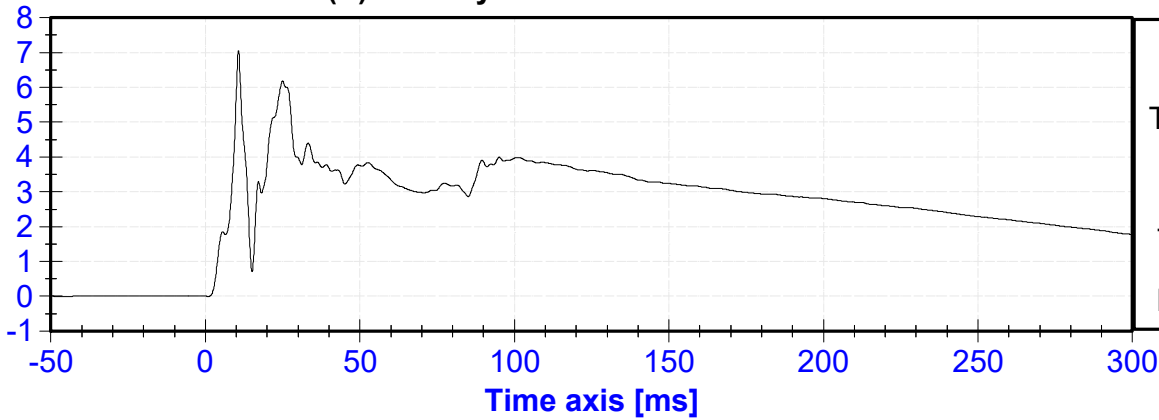

Exceeded calibration range and saturated at 10.5 ms

Left B-Post Middle (Y) Acceleration vs. Time

ACCELERATION [g's]

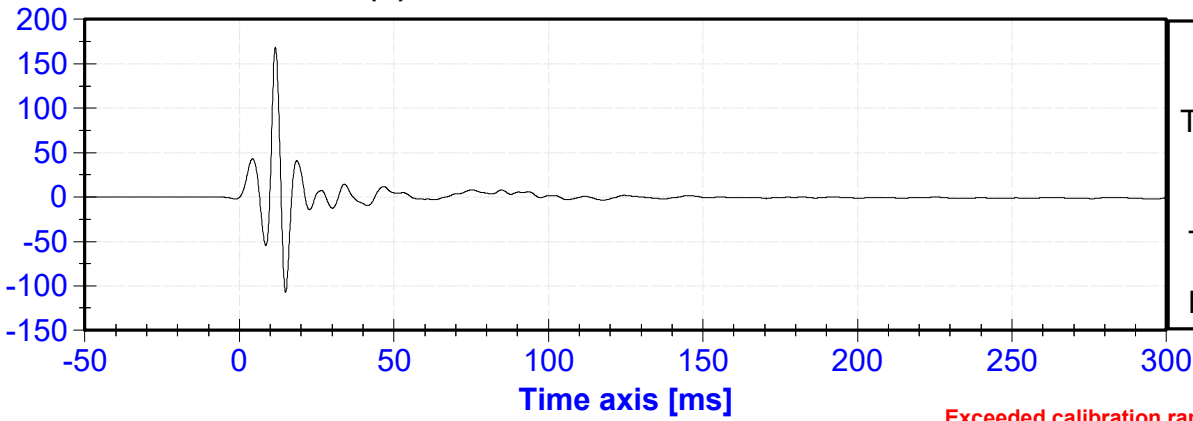

Exceeded calibration range and saturated at 10.5 ms

Left B-Post Middle (Y) Velocity vs. Time

VELOCITY [m/s]

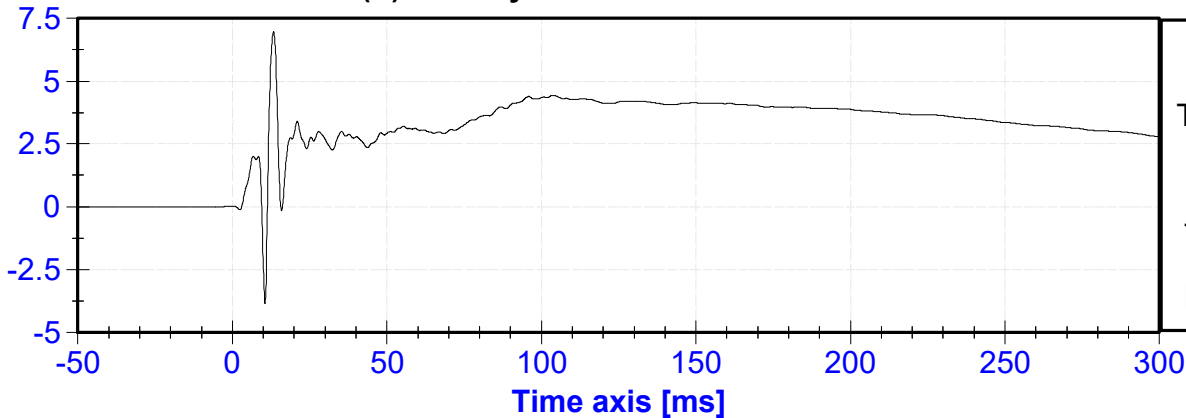

Left A-Post Lower (Y) Acceleration vs. Time

ACCELERATION [g's]

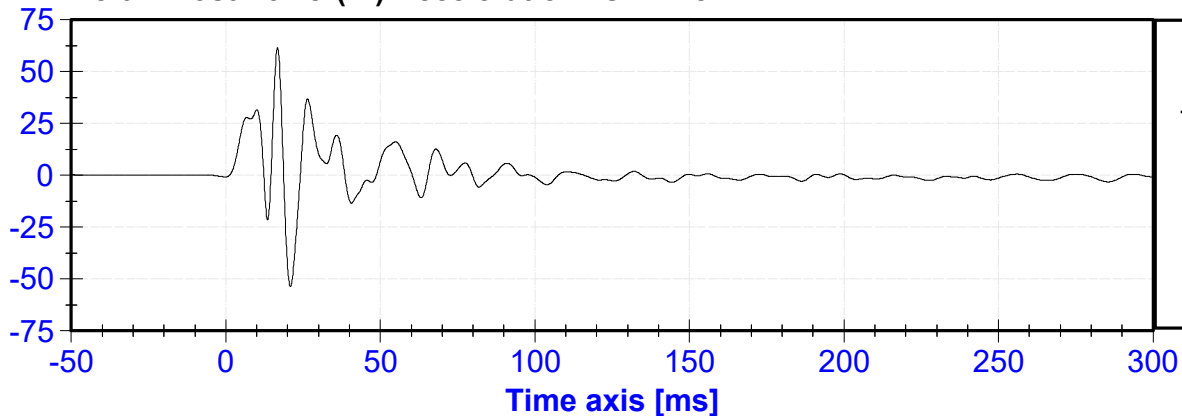

VELOCITY [m/s]

Left A-Post Lower (Y) Velocity vs. Time

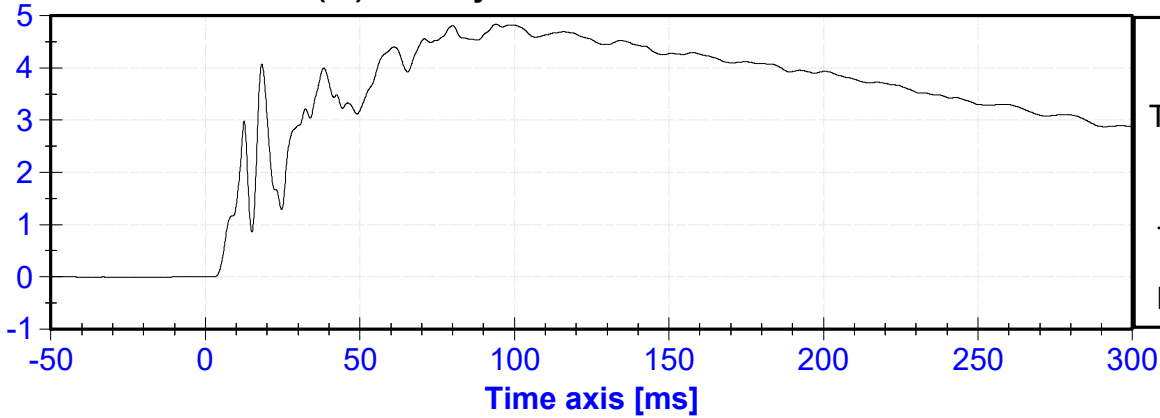

Max:	4.84 [m/s]
TMax:	94 [ms]
Min:	0 [m/s]
TMin:	-25.65 [ms]
Filter:	CFC 180

ACCELERATION [g's]

Left A-Post Middle (Y) Acceleration vs. Time

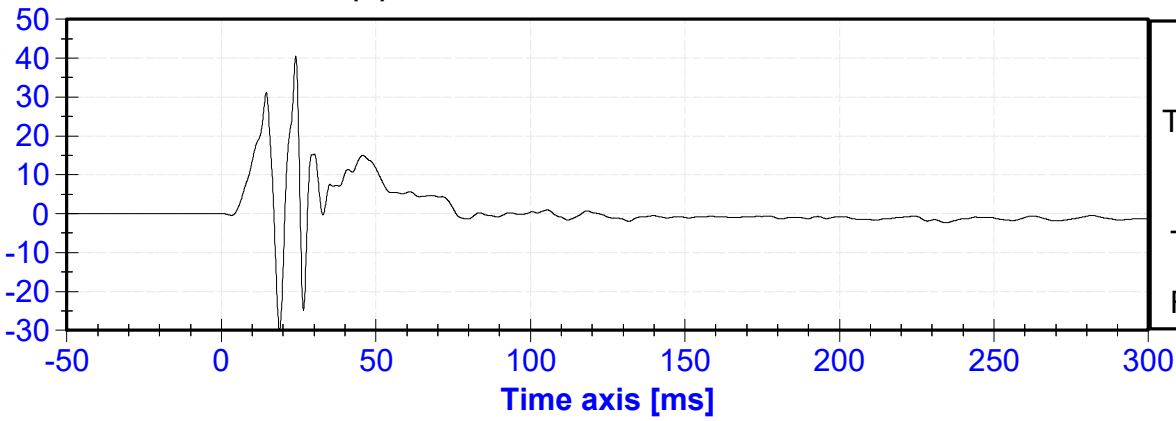

Max:	40.56 [g's]
TMax:	24.05 [ms]
Min:	-29.94 [g's]
TMin:	18.8 [ms]
Filter:	CFC 60

VELOCITY [m/s]

Left A-Post Middle (Y) Velocity vs. Time

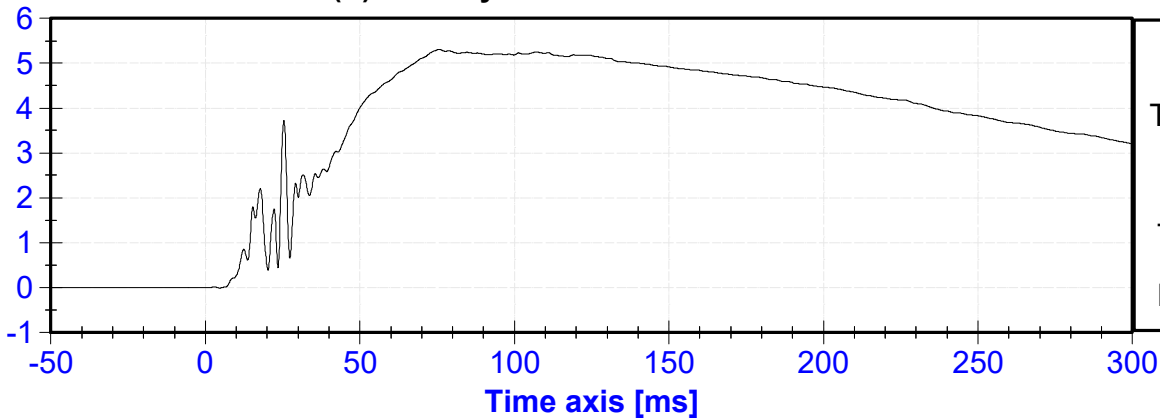

Max:	5.3 [m/s]
TMax:	75.6 [ms]
Min:	-0.02 [m/s]
TMin:	4.65 [ms]
Filter:	CFC 180

ACCELERATION [g's]

Front Seat Track (Y) Acceleration vs. Time

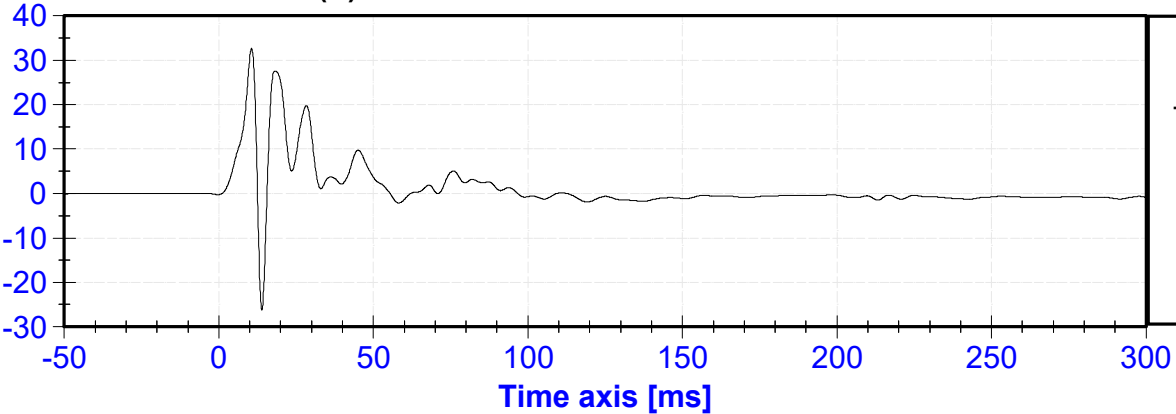

Max:	32.66 [g's]
TMax:	10.6 [ms]
Min:	-26.17 [g's]
TMin:	13.9 [ms]
Filter:	CFC 60

VELOCITY [m/s]

Front Seat Track (Y) Velocity vs. Time

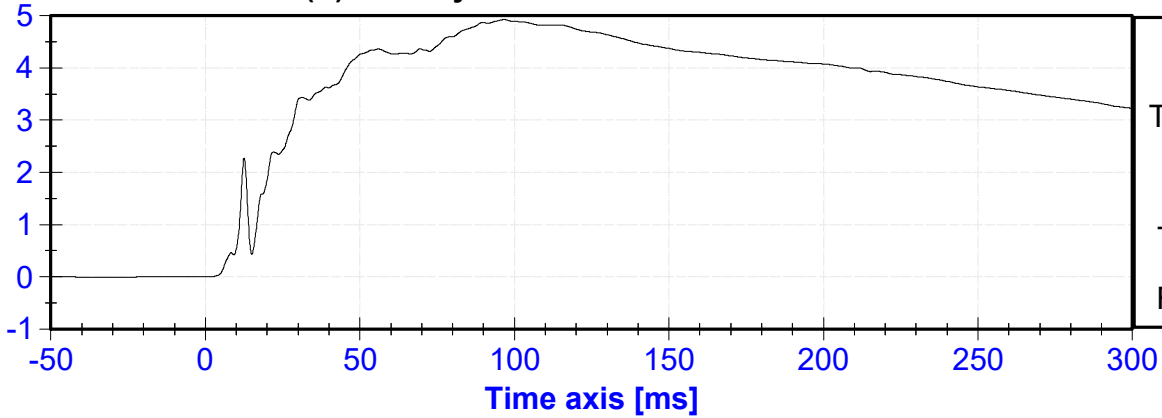

ACCELERATION [g's]

Rear Seat Track or Structure (Y) Acceleration vs. Time

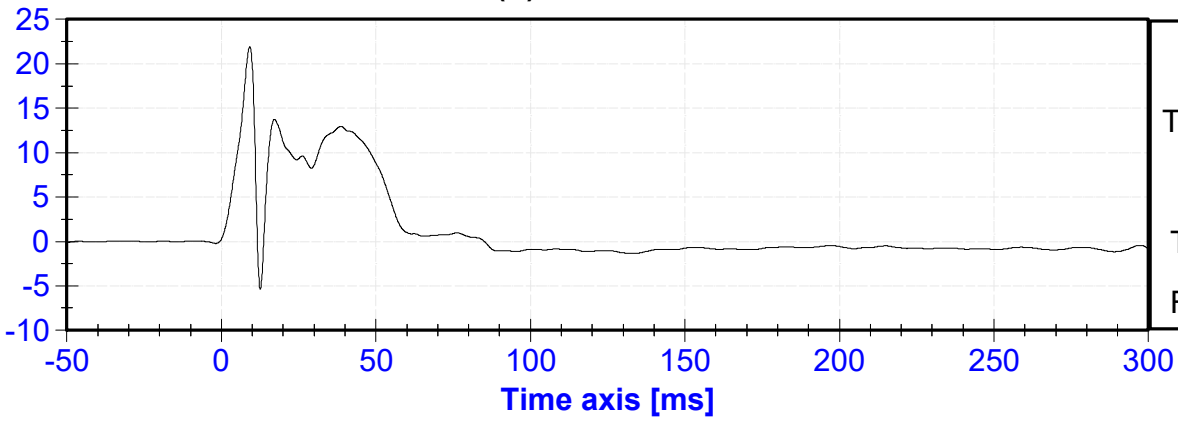

VELOCITY [m/s]

Rear Seat Track or Structure (Y) Velocity vs. Time

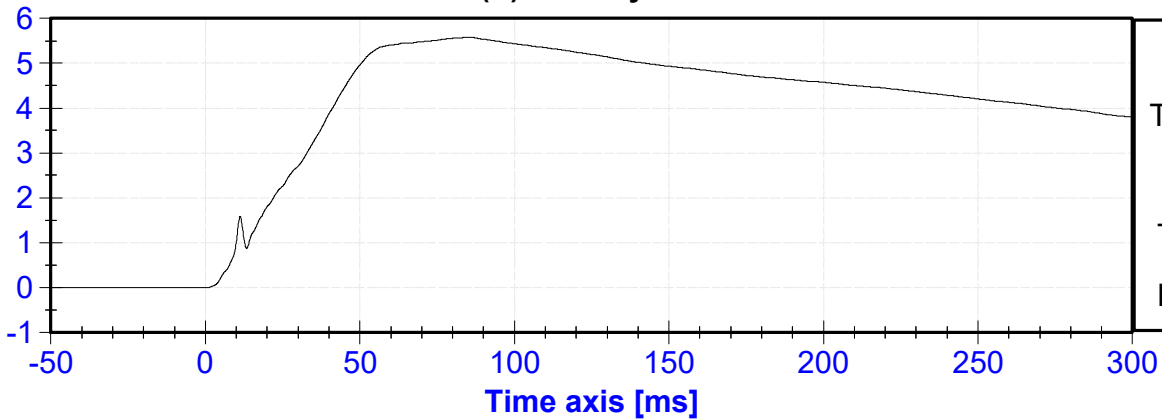

ACCELERATION [g's]

Vehicle CG (X) Acceleration vs. Time

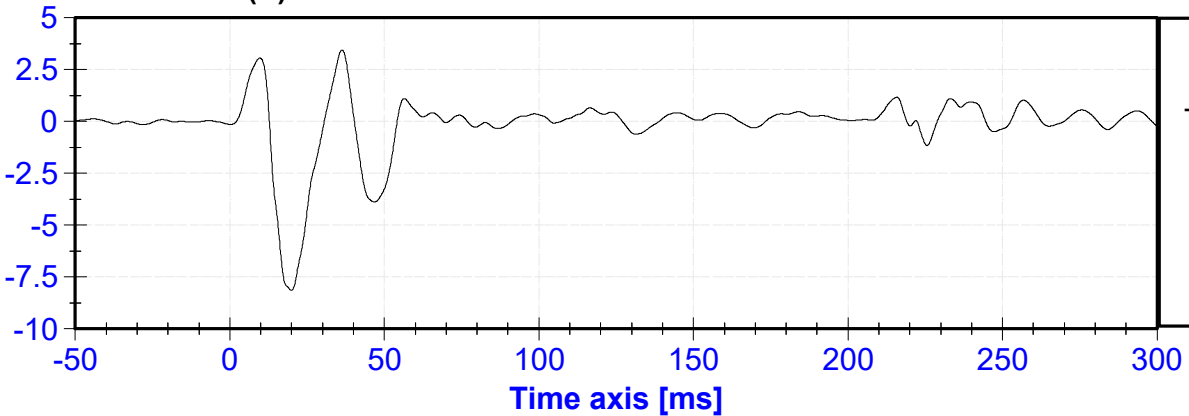

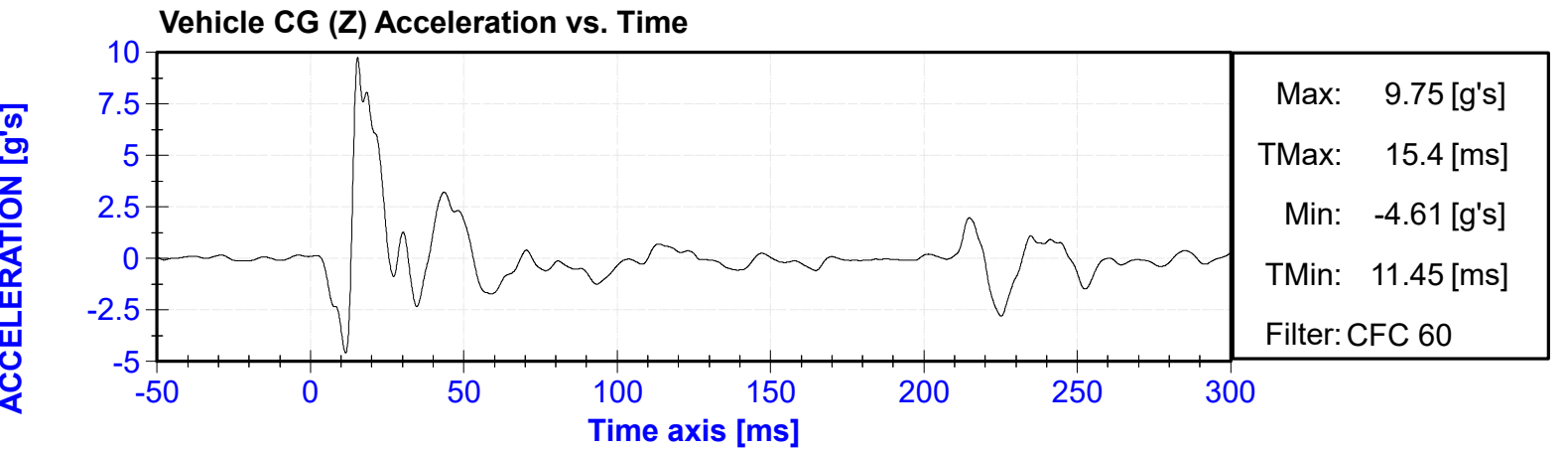
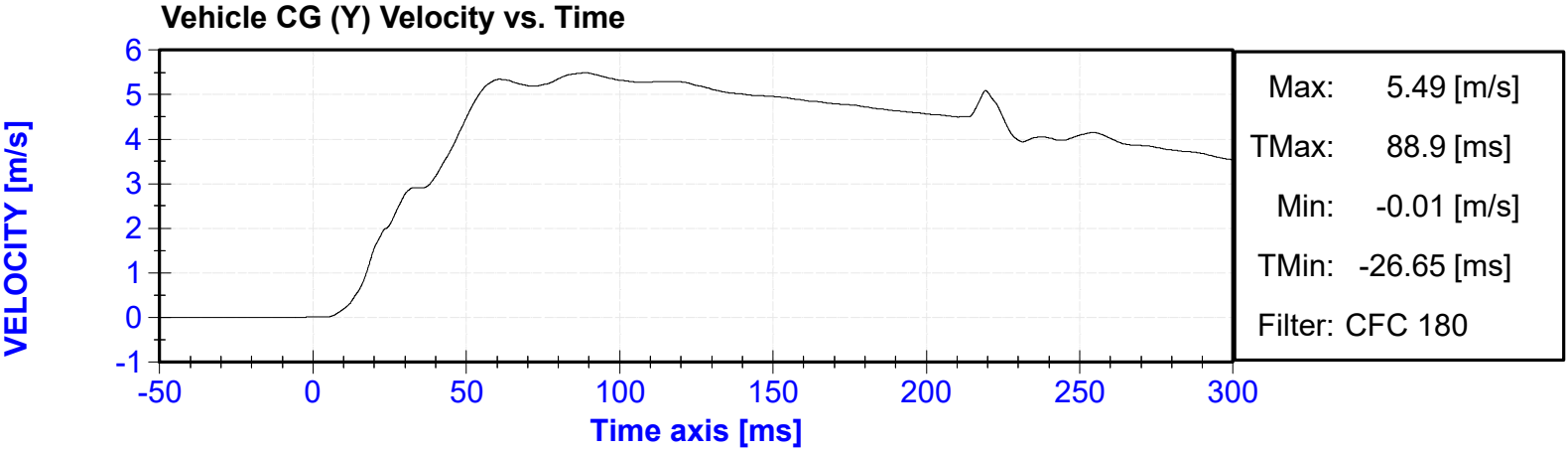
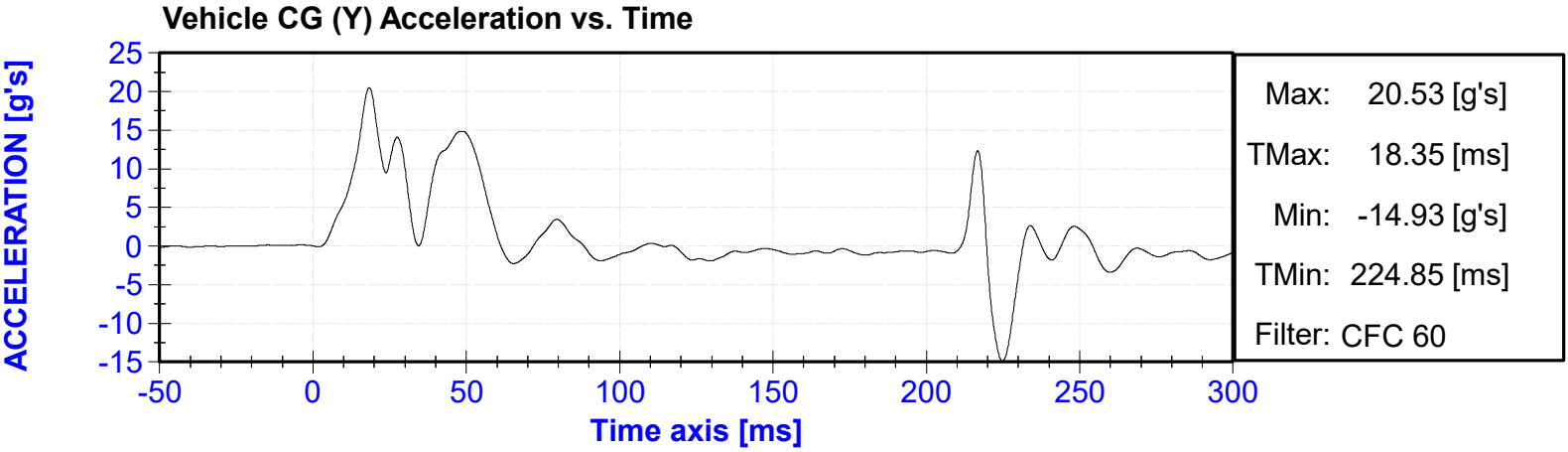
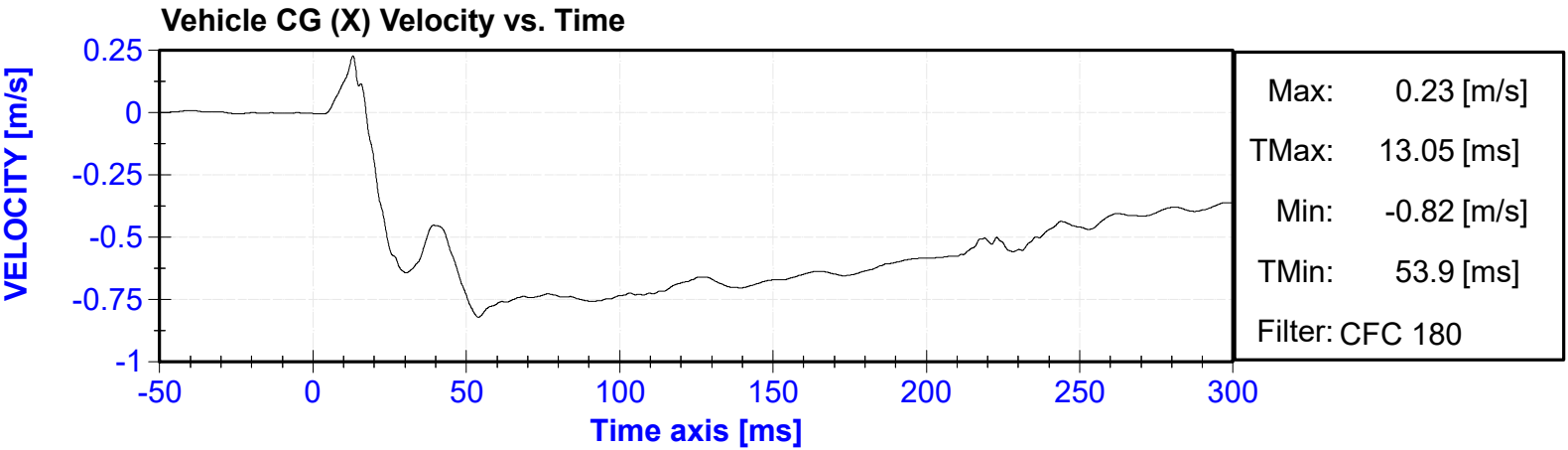

Vehicle CG (Z) Velocity vs. Time

VELOCITY [m/s]

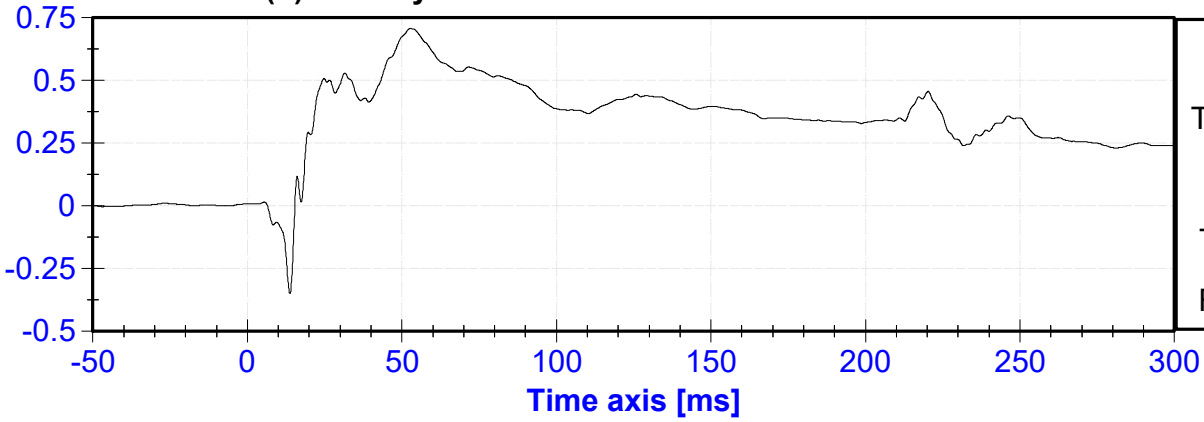

Vehicle CG Resultant Acceleration vs. Time

ACCELERATION [g's]

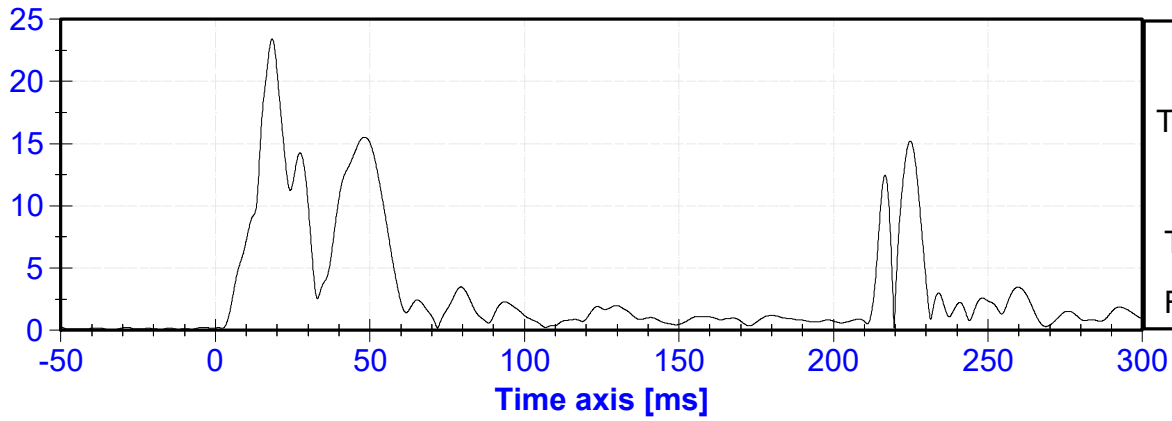

MDB Center of Gravity (X) Acceleration vs. Time

ACCELERATION [g's]

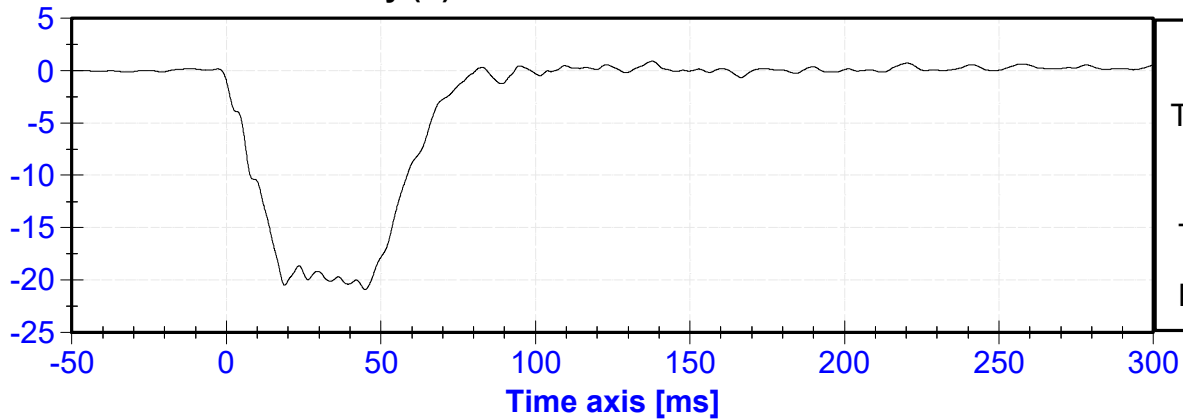

MDB Center of Gravity (X) Velocity vs. Time

VELOCITY [m/s]

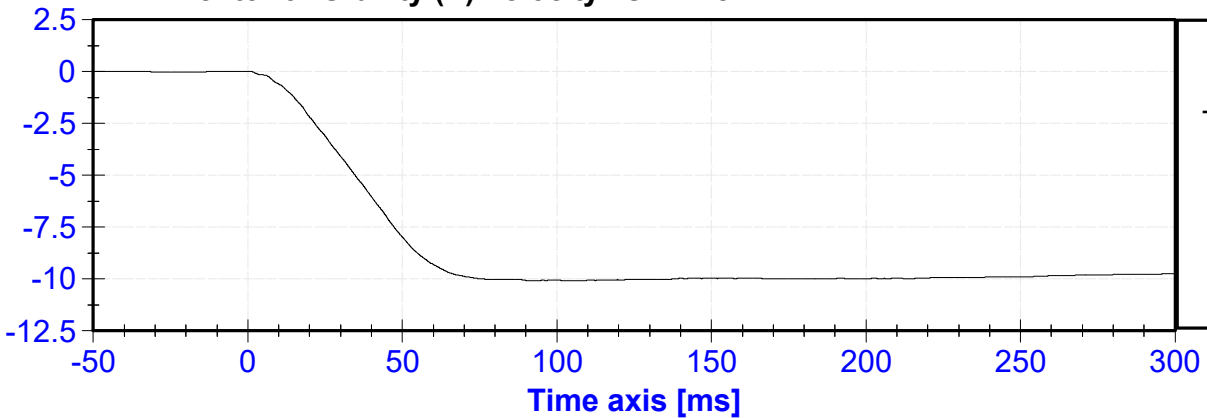

MDB Center of Gravity (Y) Acceleration vs. Time

ACCELERATION [g's]

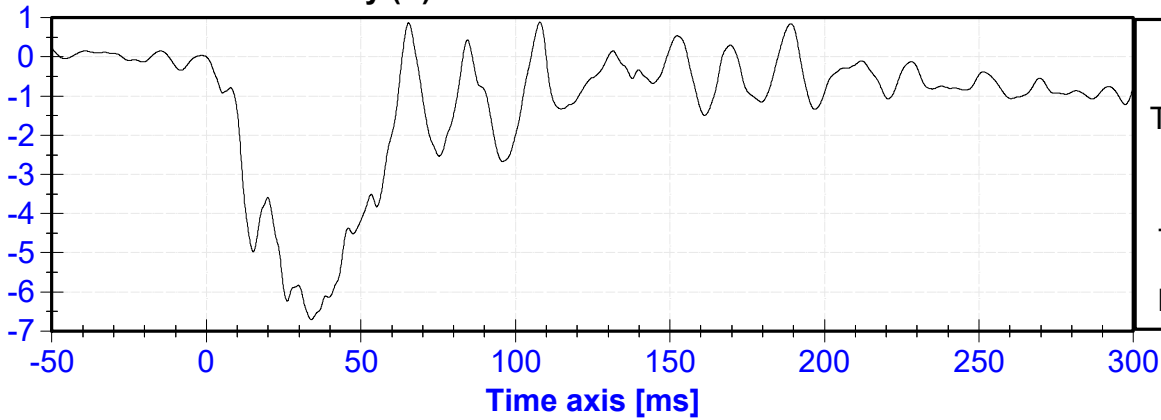

MDB Center of Gravity (Y) Velocity vs. Time

VELOCITY [m/s]

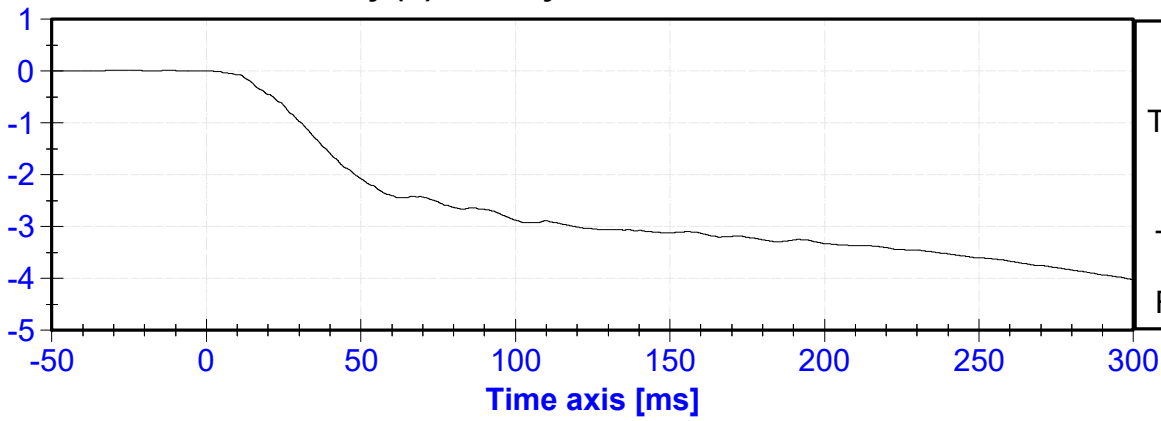

MDB Center of Gravity (Z) Acceleration vs. Time

ACCELERATION [g's]

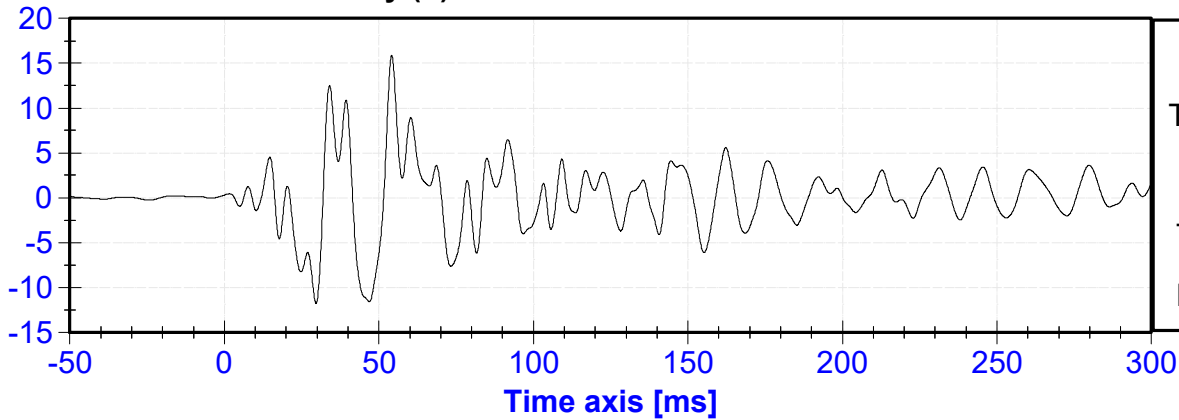

MDB Center of Gravity (Z) Velocity vs. Time

VELOCITY [m/s]

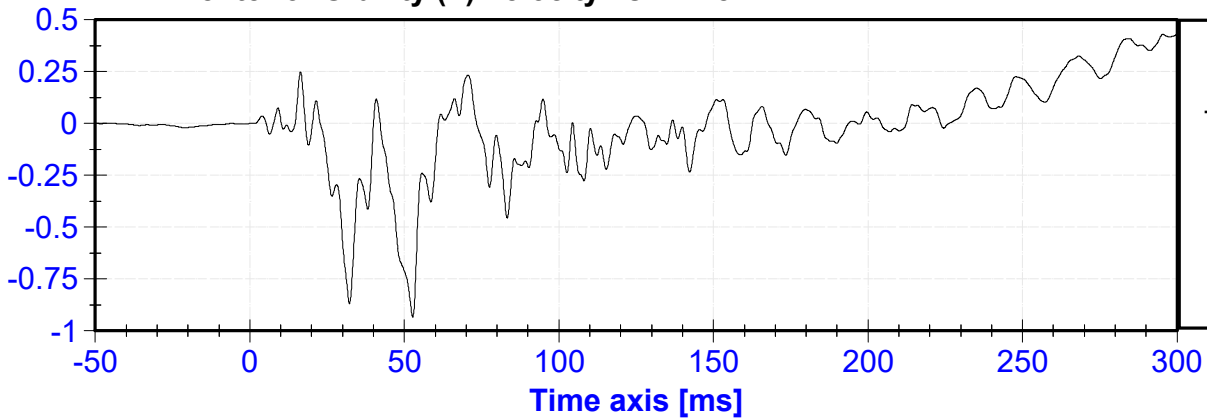

MDB Center of Gravity Resultant Acceleration vs. Time

ACCELERATION [g's]

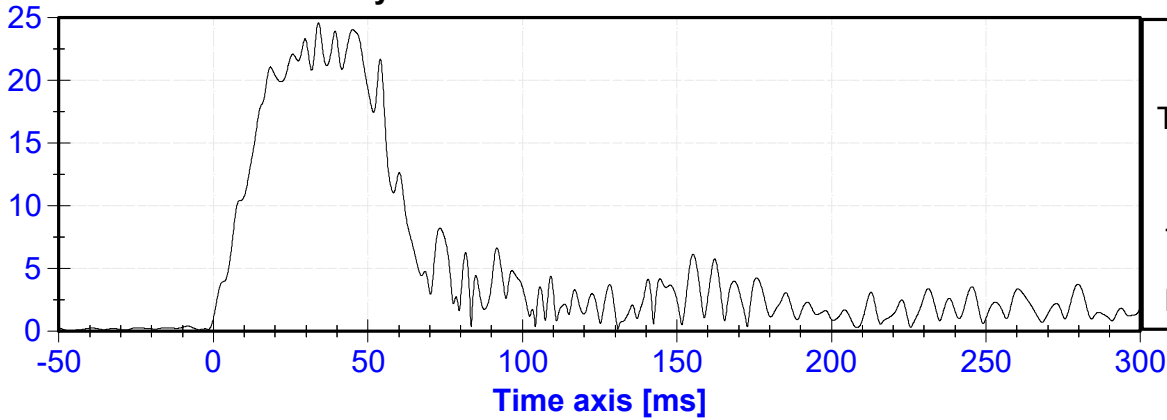

MDB Rear (X) Acceleration vs. Time

ACCELERATION [g's]

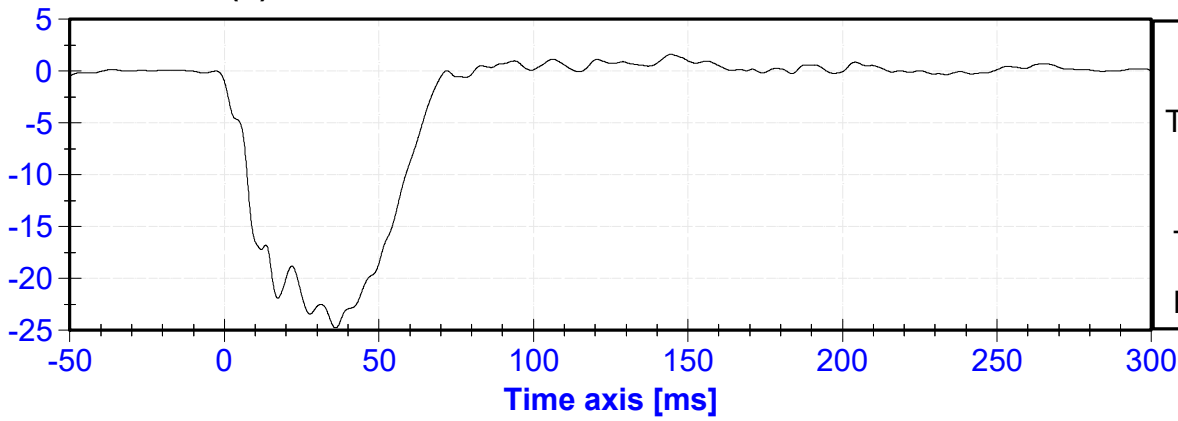

MDB Rear (X) Velocity vs. Time

VELOCITY [m/s]

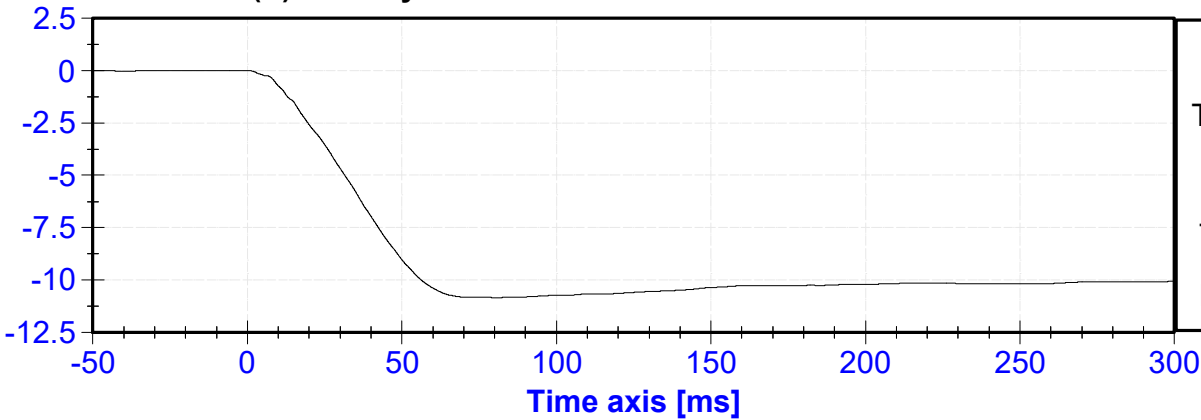

MDB Rear (Y) Acceleration vs. Time

ACCELERATION [g's]

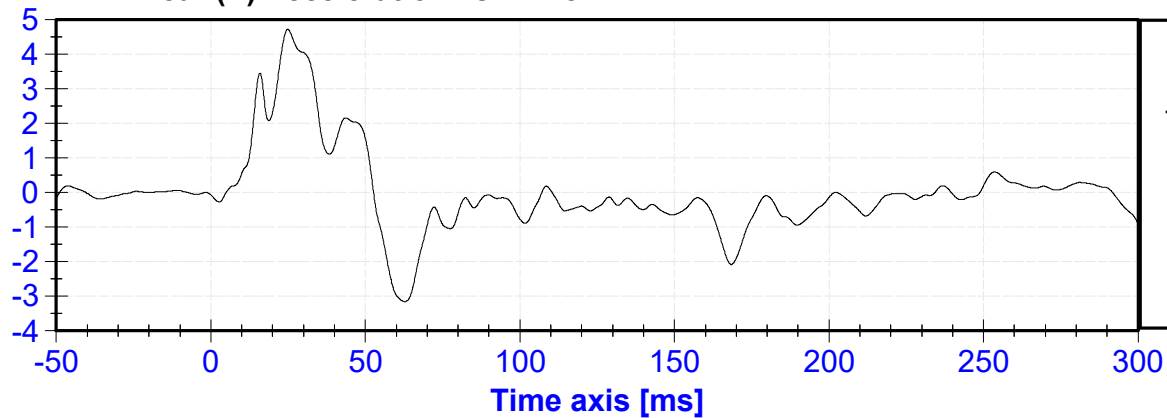

MDB Rear (Y) Velocity vs. Time

VELOCITY [m/s]

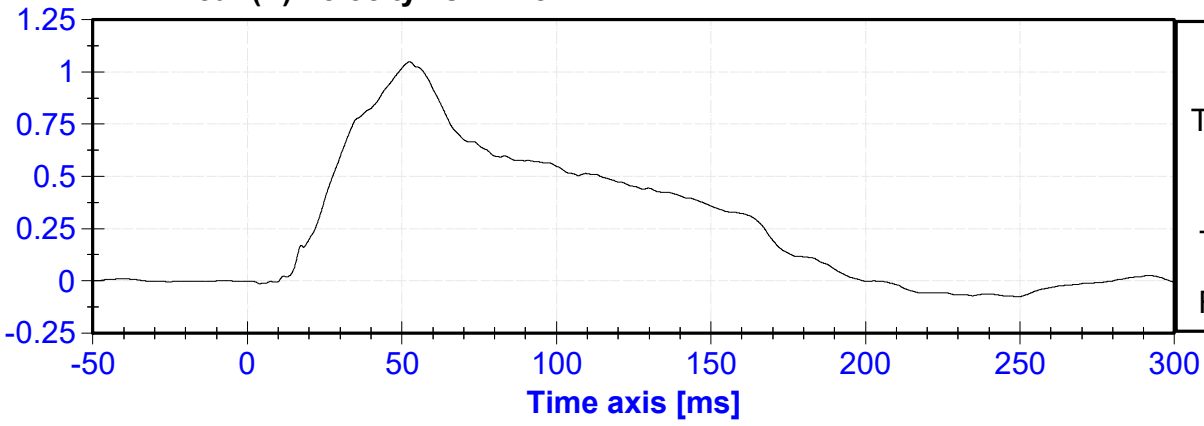

APPENDIX V

**PRE-TEST
ES-2re PERFORMANCE CALIBRATION TEST DATA**

External Measurements - EuroSID-2re

Technician: K. Brogan

Date: 12/15/2022

Dummy Serial Number: D037

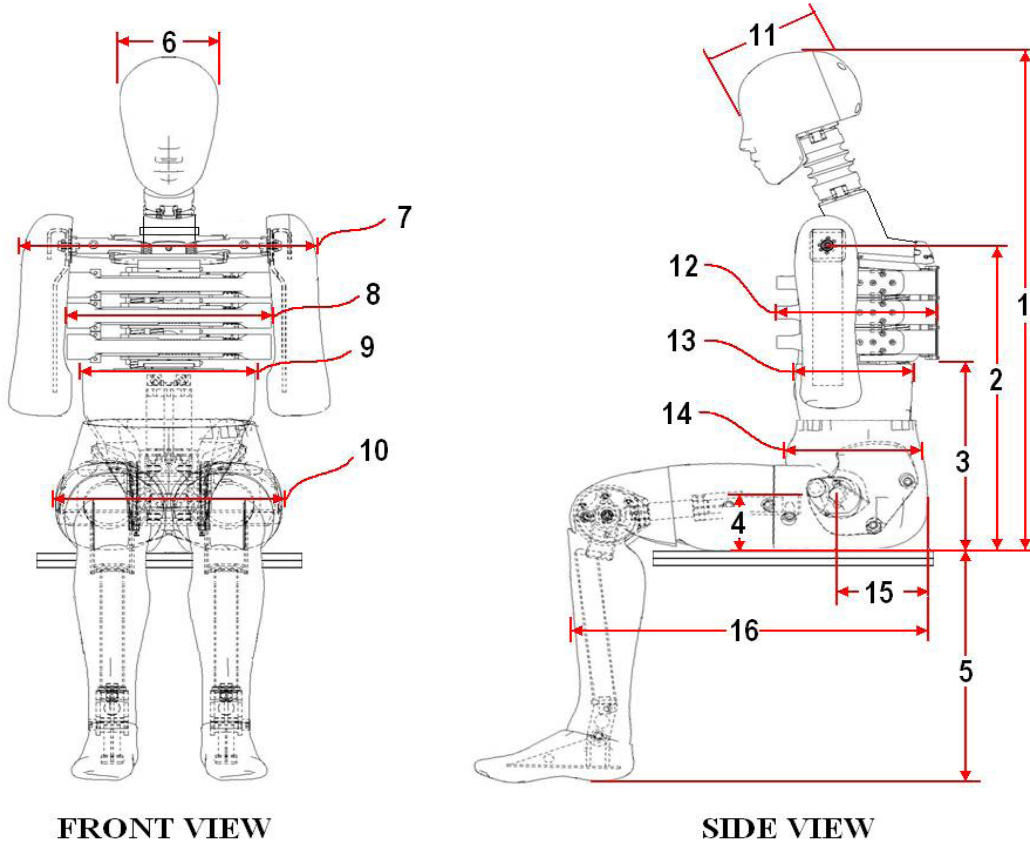

Dim. No.	Description	Specification (mm)		Result (mm)	Pass/Fail
1	Sitting Height	900	918	912	Pass
2	Seat to Shoulder Joint	558	572	564	Pass
3	Seat to Lower Face of Thoracic Spine Box	346	356	353	Pass
4	Seat to Hip Joint (center of bolt)	97	103	101	Pass
5	Sole to Seat, Sitting	333	451	422	Pass
6	Head Width	152	158	155	Pass
7	Shoulder/Arm Width	461	479	471	Pass
8	Thorax Width	322	332	330	Pass
9	Abdomen Width	273	287	281	Pass
10	Pelvis Lap Width	359	373	365	Pass
11	Head Depth	196	206	197	Pass
12	Thorax Depth	262	272	268	Pass
13	Abdomen Depth	194	204	201	Pass
14	Pelvis Depth	235	245	241	Pass
15	Back of Buttocks to Hip Joint (center of bolt)	150	160	153	Pass
16	Back of Buttocks to Front Knee	597	615	609	Pass

ATD Manufacturer	Denton	Test Technician	D. Sakona
ATD Serial Number	D037	Laboratory Supervisor	C. Mantell

Results

Test Parameter	Minimum Specification	Maximum Specification	Unit	Result	Pass/Fail
Temperature	20.6	22.2	°C	21.1	Pass
Humidity	10	70	%	18.5	Pass
Resultant Acceleration	125	155	g's	143.9	Pass
Oscillation	0	15	%	1.68	Pass
Fore-Aft Acceleration	-15	15	g's	8.8	Pass

Transducer Calibrations

Channel	Manufacturer	Serial Number	Calibration Date	Calibration Due Date
X Accelerometer	Endevco	T21724	9/6/2022	3/5/2023
Y Accelerometer	Endevco	T22281	9/6/2022	3/5/2023
Z Accelerometer	Endevco	T26050	9/9/2022	3/8/2023

Resultant Acceleration

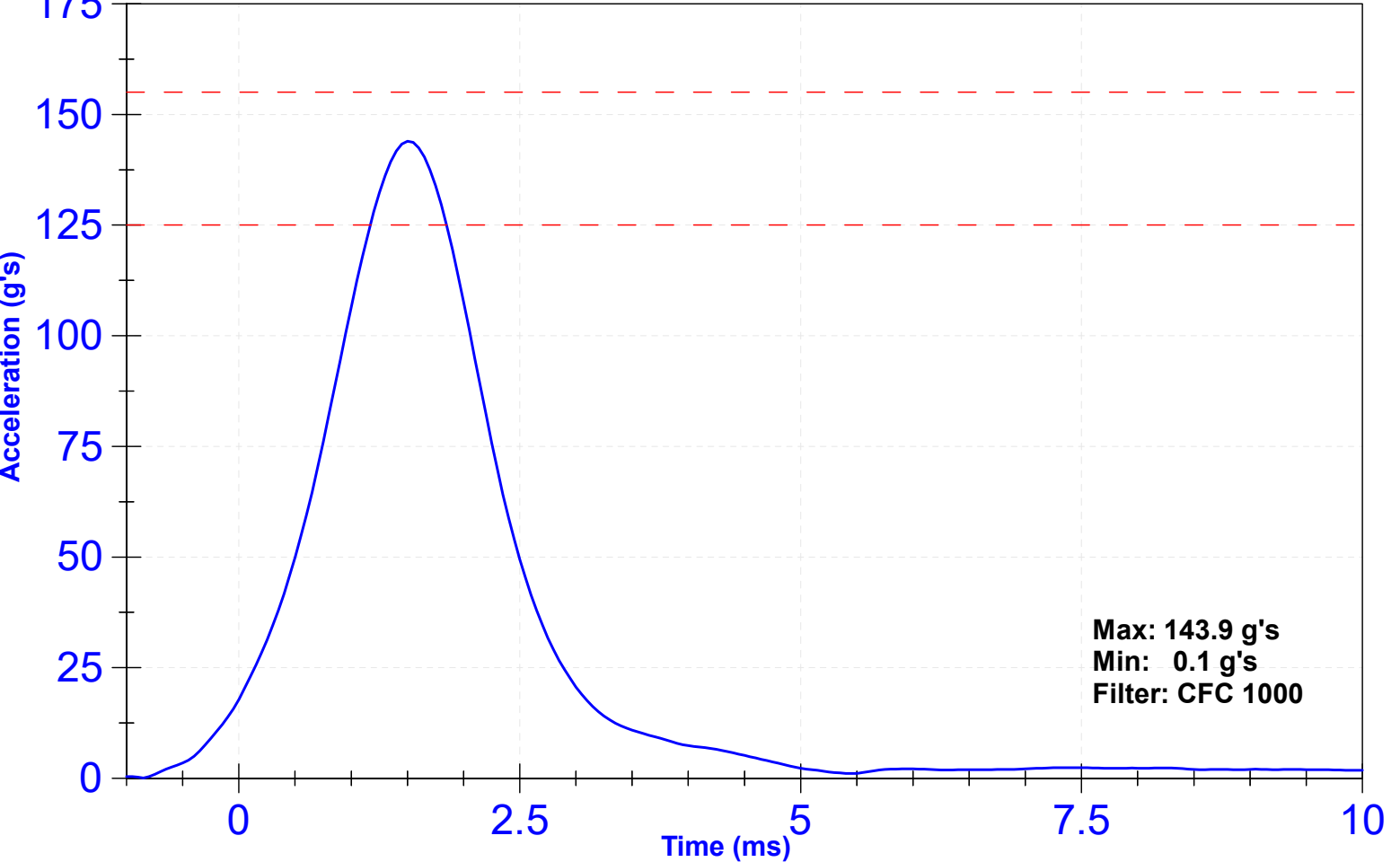

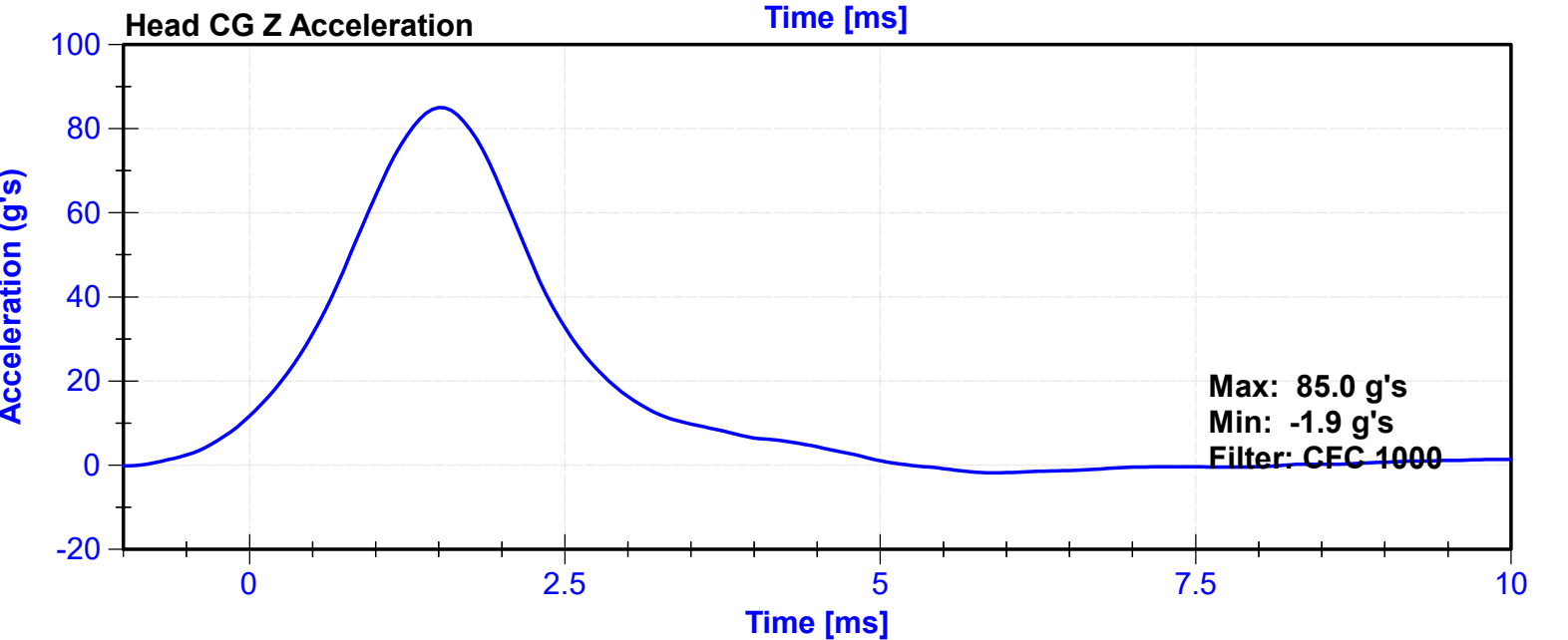
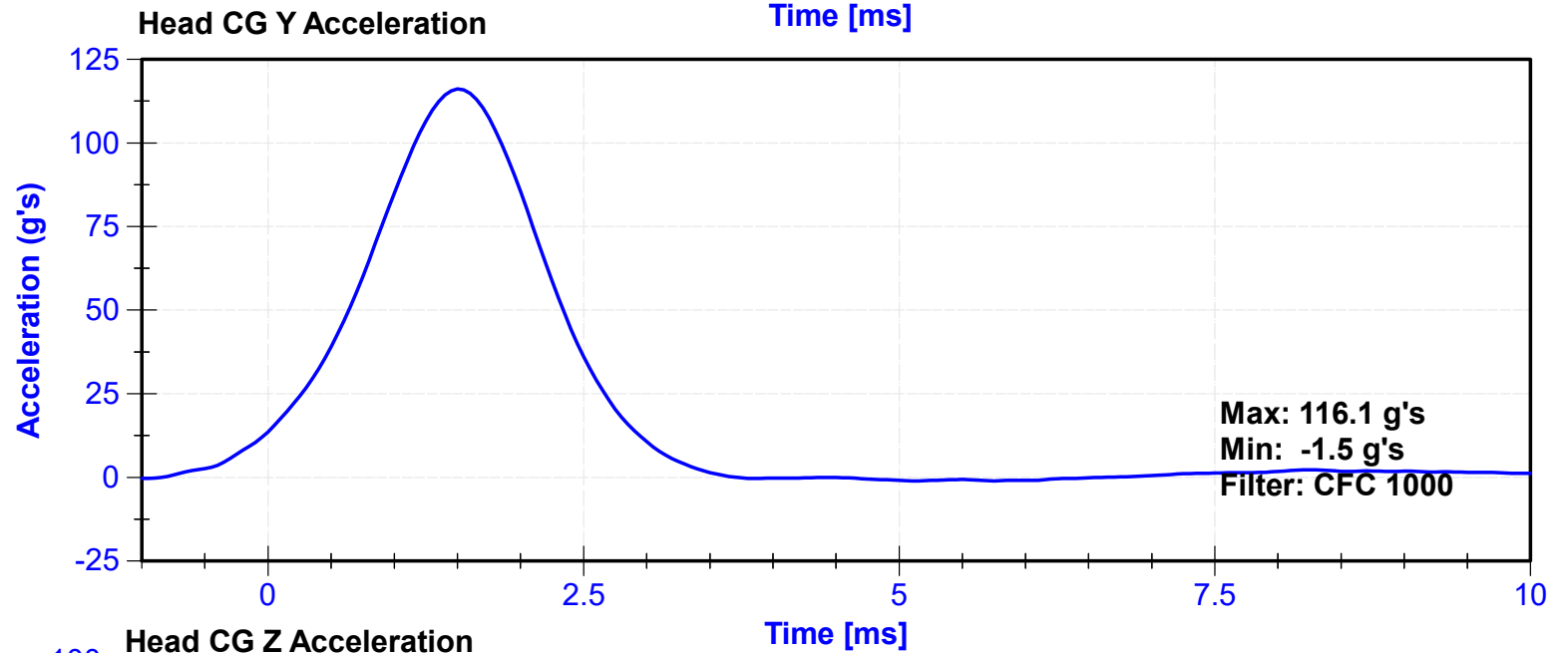
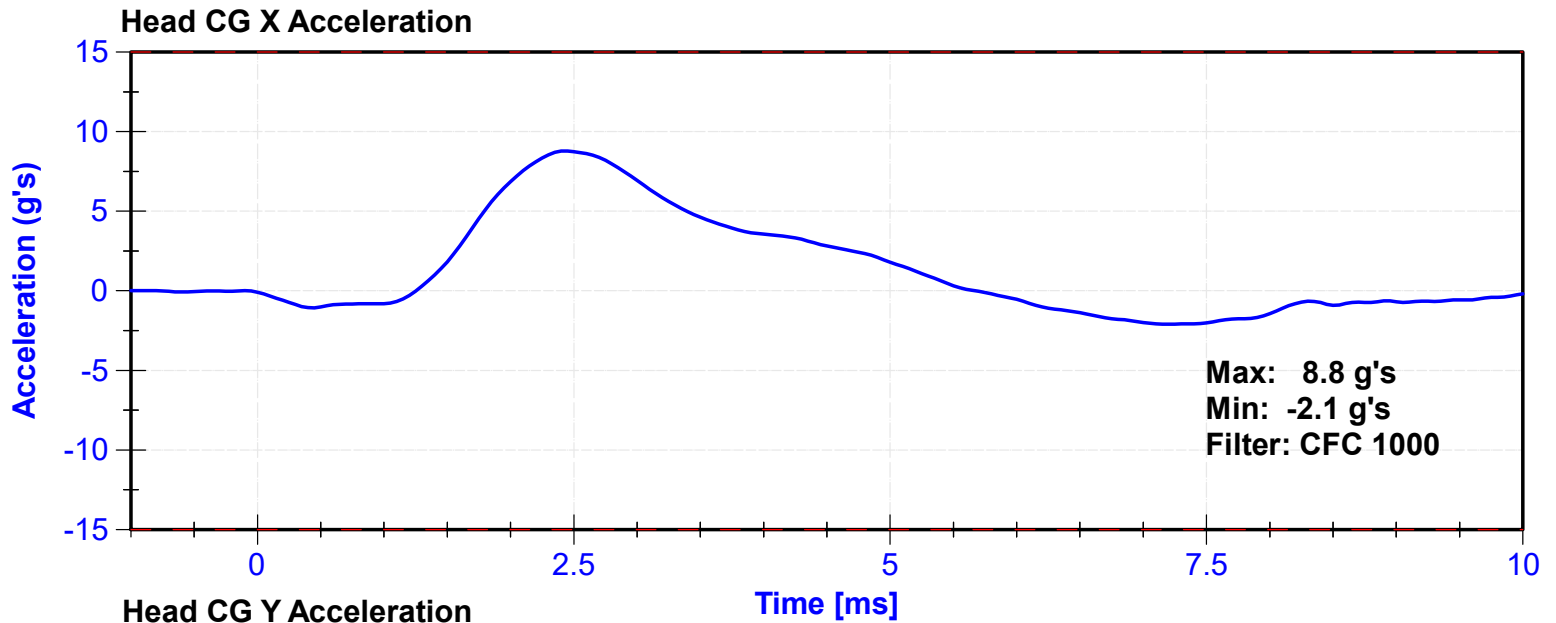

ATD Manufacturer	Denton	Test Technician	D. Kroll
ATD Serial Number	D037	Laboratory Supervisor	C. Mantell

Results

Test Parameter	Minimum Specification	Maximum Specification	Unit	Result	Pass/Fail
Temperature	20.6	22.2	°C	21.0	Pass
Humidity	10	70	%	25.8	Pass
Velocity	3.3	3.5	m/s	3.39	Pass
Lateral Neck Rotation	49	59	deg	53.3	Pass
Time at Maximum Rotation	54	66	ms	61.0	Pass
Time of Rotation Decay from Maximum	53	88	ms	55.8	Pass
Pendulum Velocity Overall Corridor	Lower Boundary ¹	Upper Boundary ²	m/s	See Plot ³	Pass

Transducer Calibrations

Channel	Manufacturer	Serial Number	Calibration Date	Calibration Due Date
Pendulum Accelerometer	Endevco	C16503	10/26/2022	10/26/2023
Front Pendulum Potentiometer	Sfernice	094	10/5/2022	10/5/2023
Headform Potentiometer	Sfernice	095	10/5/2022	10/5/2023

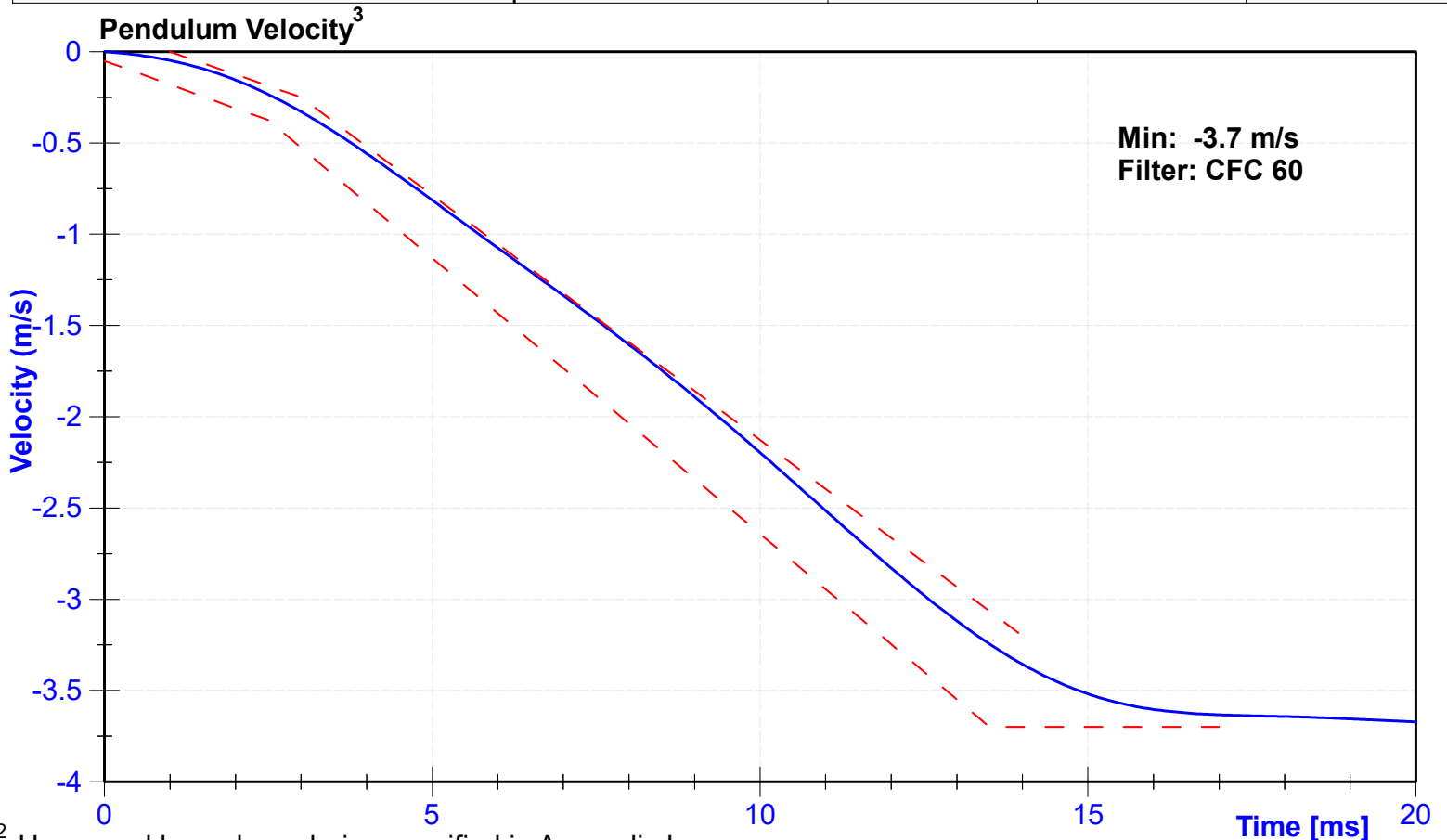

^{1,2} Upper and lower boundaries specified in Appendix I

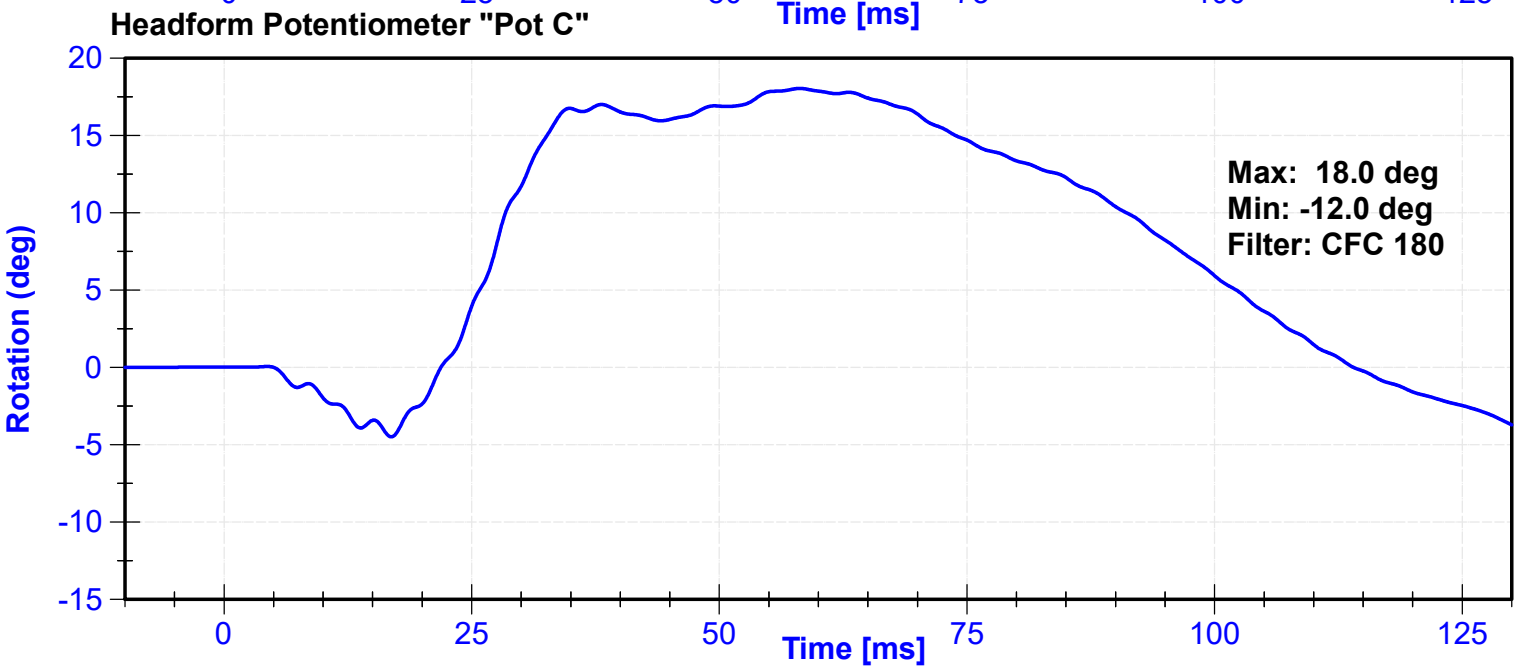
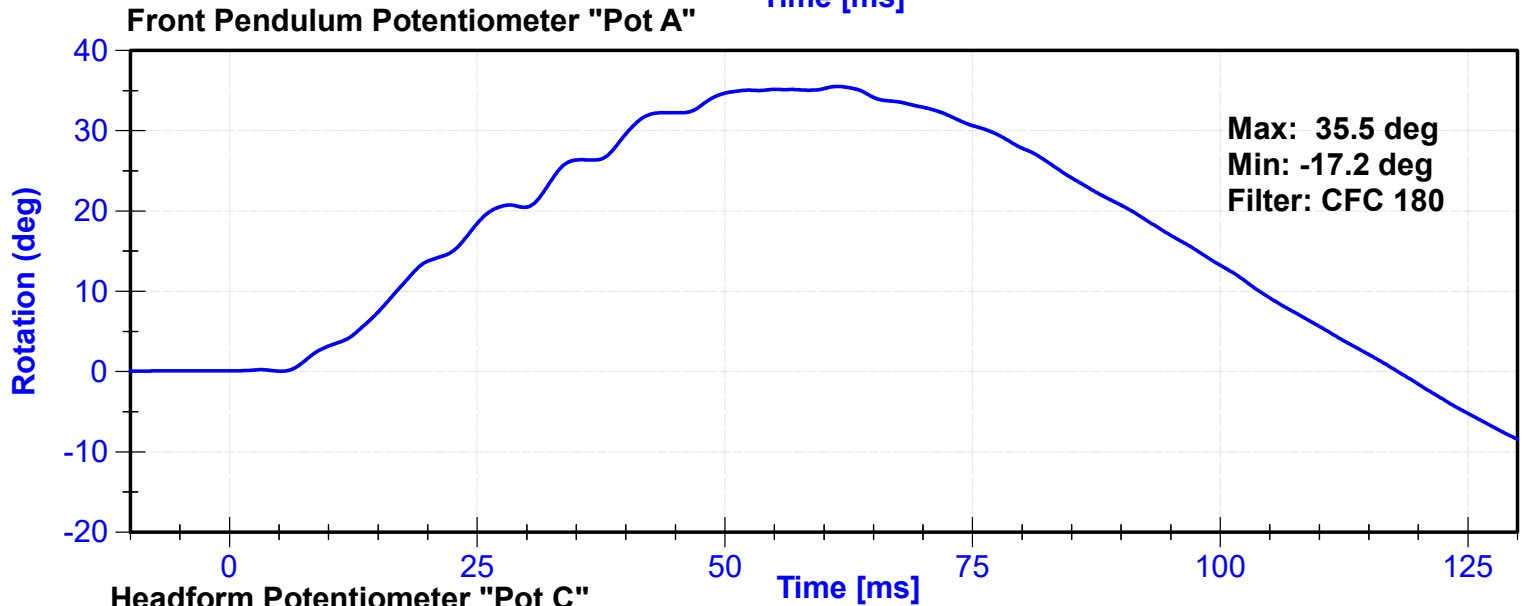
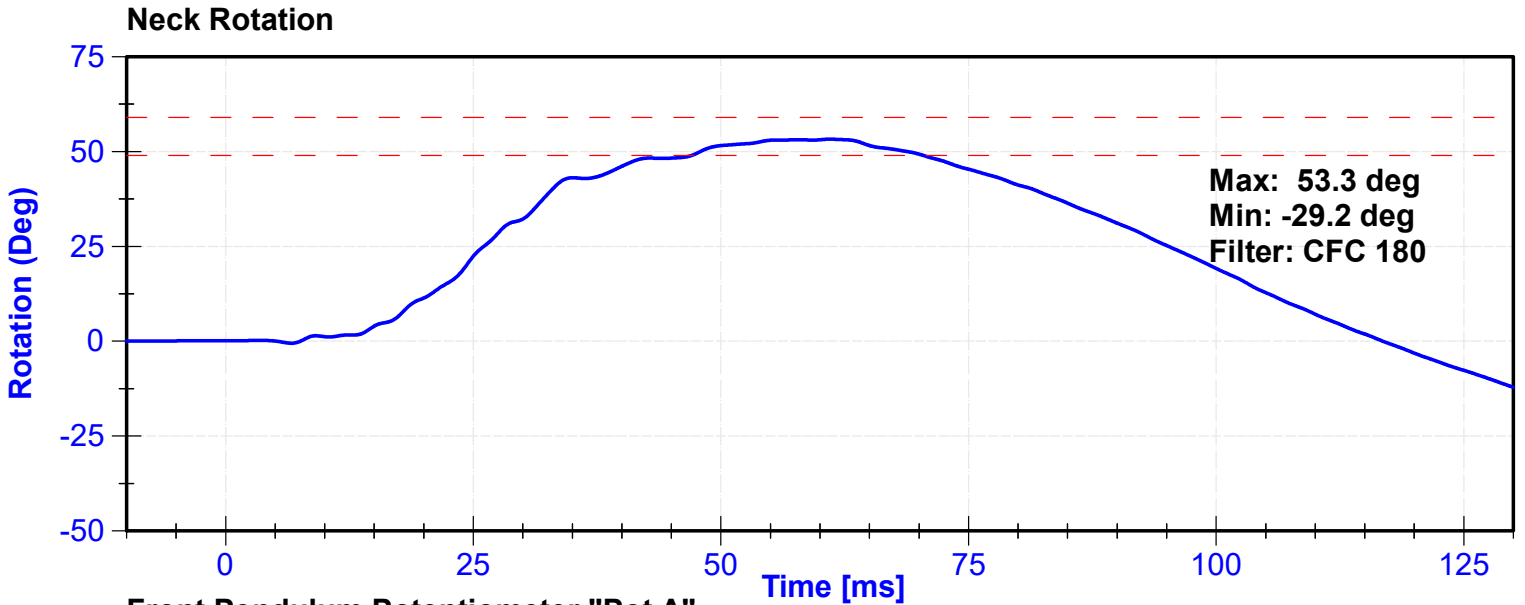

Appendix I

² Upper Boundary Corridor		¹ Lower Boundary Corridor	
Time (ms)	Velocity (m/s)	Time (ms)	Velocity (m/s)
1.0	0.00	0.0	-0.05
3.0	-0.25	2.5	-0.375
14.0	-3.20	13.5	-3.7
		17.0	-3.7

ATD Manufacturer	Denton	Test Technician	Z.Schneider
ATD Serial Number	D037	Laboratory Supervisor	C. Mantell

Results

Test Parameter	Minimum Specification	Maximum Specification	Unit	Result	Pass/Fail
Temperature	20.6	22.2	°C	21	Pass
Humidity	10	70	%	30	Pass
Velocity	4.2	4.4	m/s	4.35	Pass
Probe Acceleration	7.5	10.5	g's	8.06	Pass

Transducer Calibrations

Channel	Manufacturer	Serial Number	Calibration Date	Calibration Due Date
Probe Accelerometer	Endevco	P51736	10/25/2022	4/23/2023

Probe Acceleration

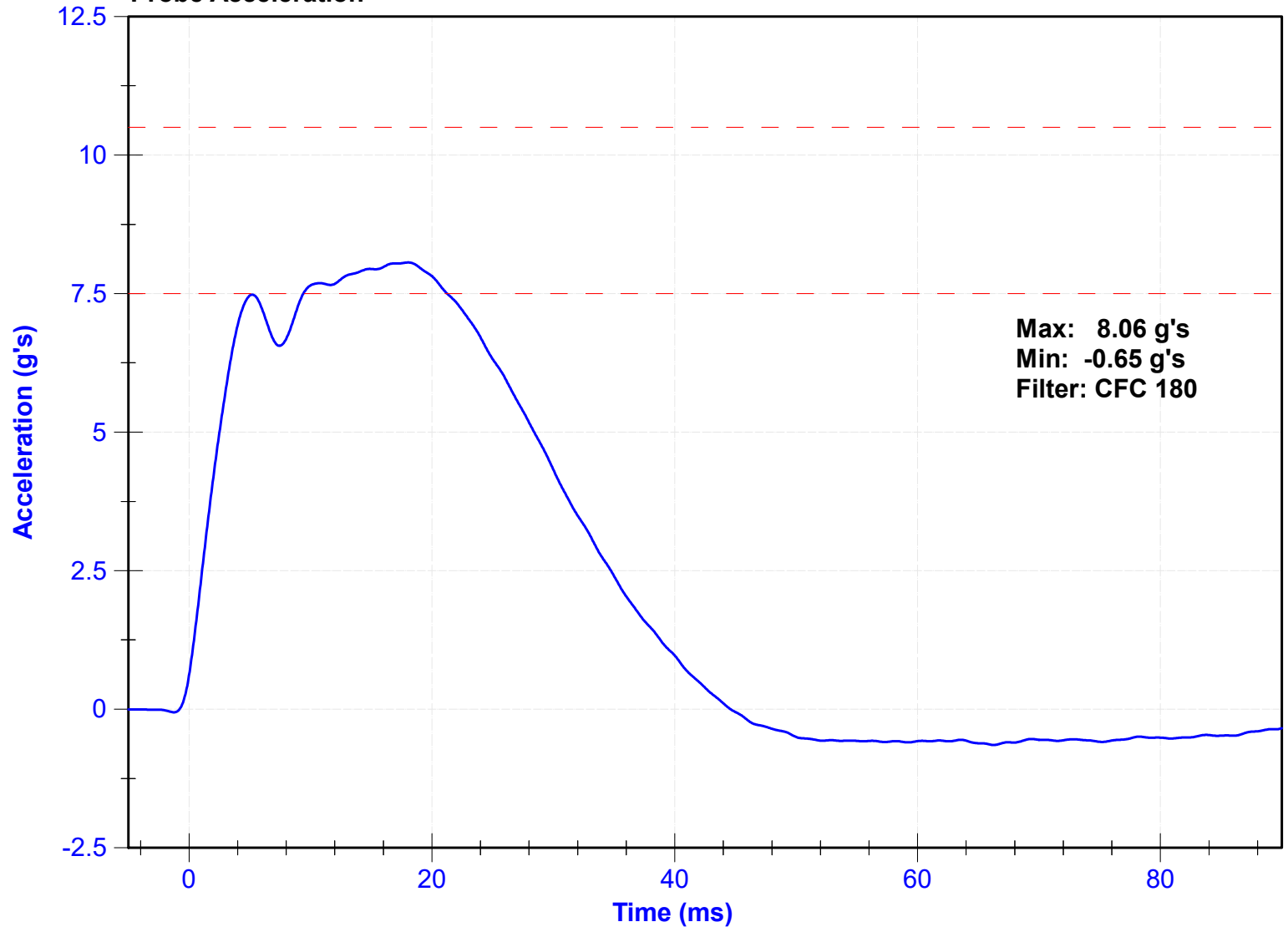

ATD Manufacturer	Denton	Test Technician	D. Sakona
ATD Serial Number	D037	Laboratory Supervisor	C. Mantell

Results

Test Parameter	Minimum Specification	Maximum Specification	Unit	Result	Pass/Fail
Temperature	20.6	22.2	°C	21.1	Pass
Humidity	10	70	%	18.5	Pass
Rib Displacement	36	40	mm	38.5	Pass

Transducer Calibrations

Channel	Manufacturer	Serial Number	Calibration Date	Calibration Due Date
Rib Potentiometer	Honeywell	DS-0552-01	9/7/2022	3/8/2023

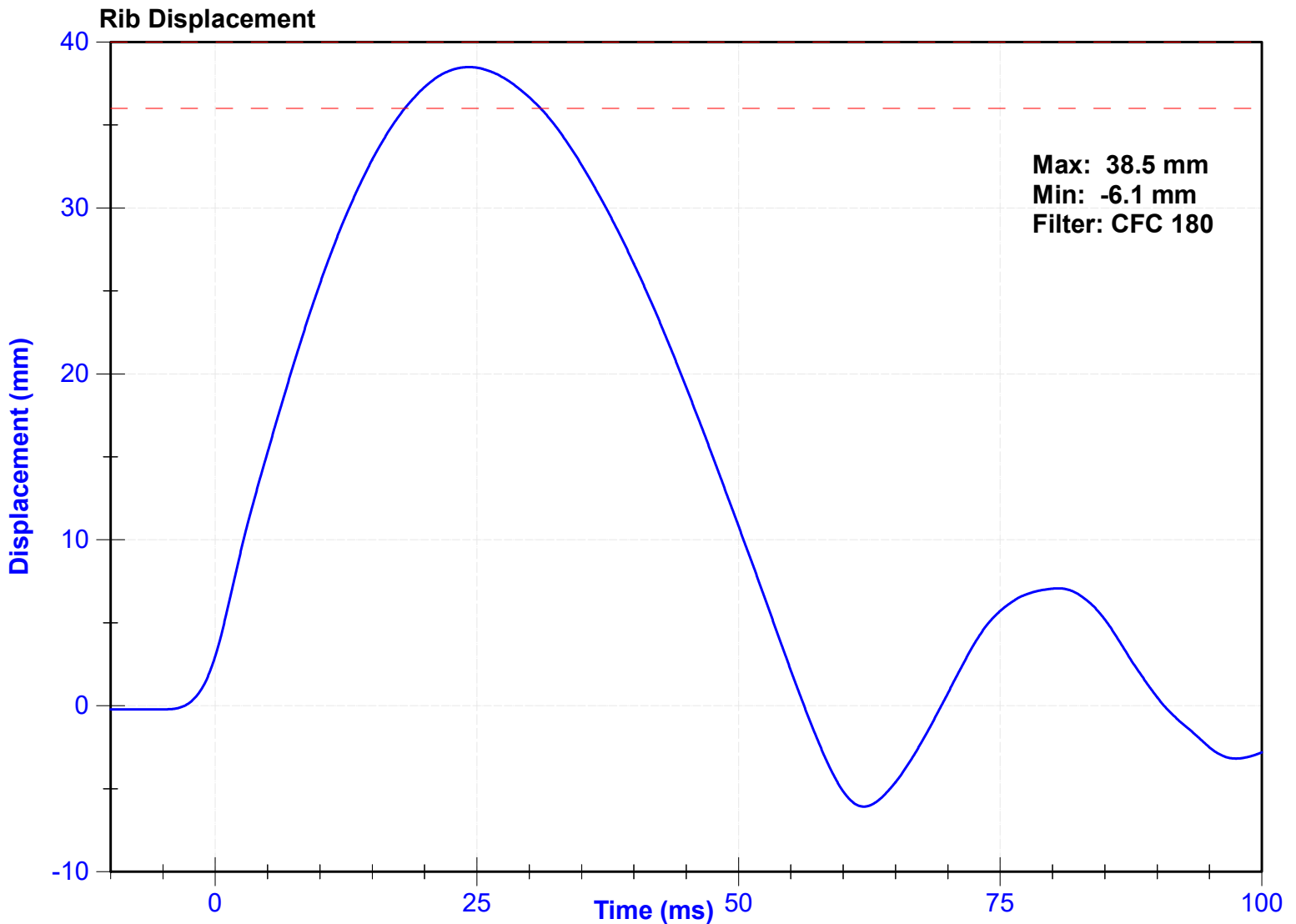

ATD Manufacturer	Denton	Test Technician	D. Sakona
ATD Serial Number	D037	Laboratory Supervisor	C. Mantell

Results

Test Parameter	Minimum Specification	Maximum Specification	Unit	Result	Pass/Fail
Temperature	20.6	22.2	°C	21.1	Pass
Humidity	10	70	%	18.5	Pass
Rib Displacement	46	51	mm	48.9	Pass

Transducer Calibrations

Channel	Manufacturer	Serial Number	Calibration Date	Calibration Due Date
Rib Potentiometer	Honeywell	DS-0552-01	9/7/2022	3/8/2023

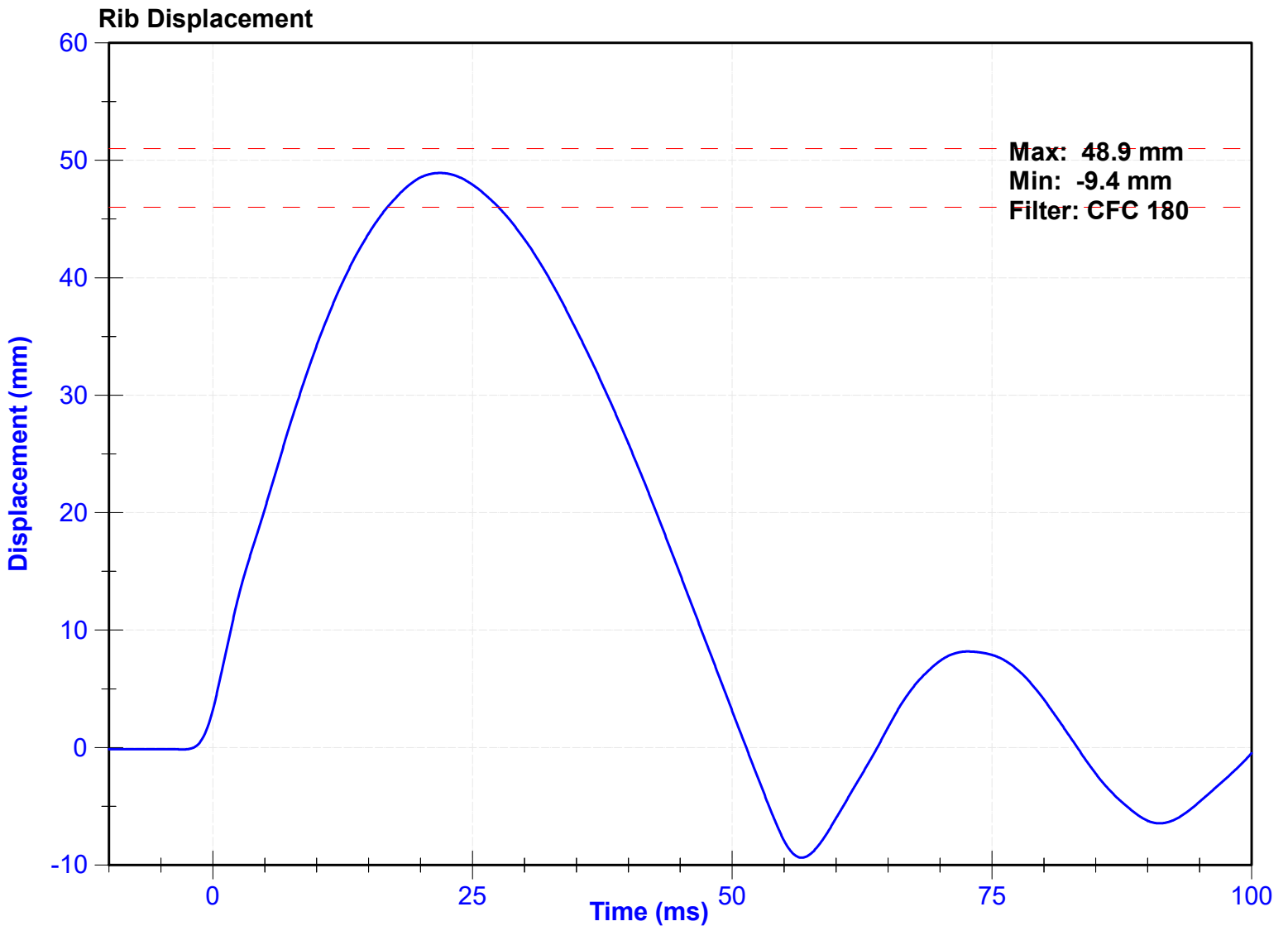

ATD Manufacturer	Denton	Test Technician	D. Sakona
ATD Serial Number	D037	Laboratory Supervisor	C. Mantell

Results

Test Parameter	Minimum Specification	Maximum Specification	Unit	Result	Pass/Fail
Temperature	20.6	22.2	°C	21.1	Pass
Humidity	10	70	%	18.5	Pass
Rib Displacement	36	40	mm	38.2	Pass

Transducer Calibrations

Channel	Manufacturer	Serial Number	Calibration Date	Calibration Due Date
Rib Potentiometer	Honeywell	DS-807	9/7/2022	3/8/2023

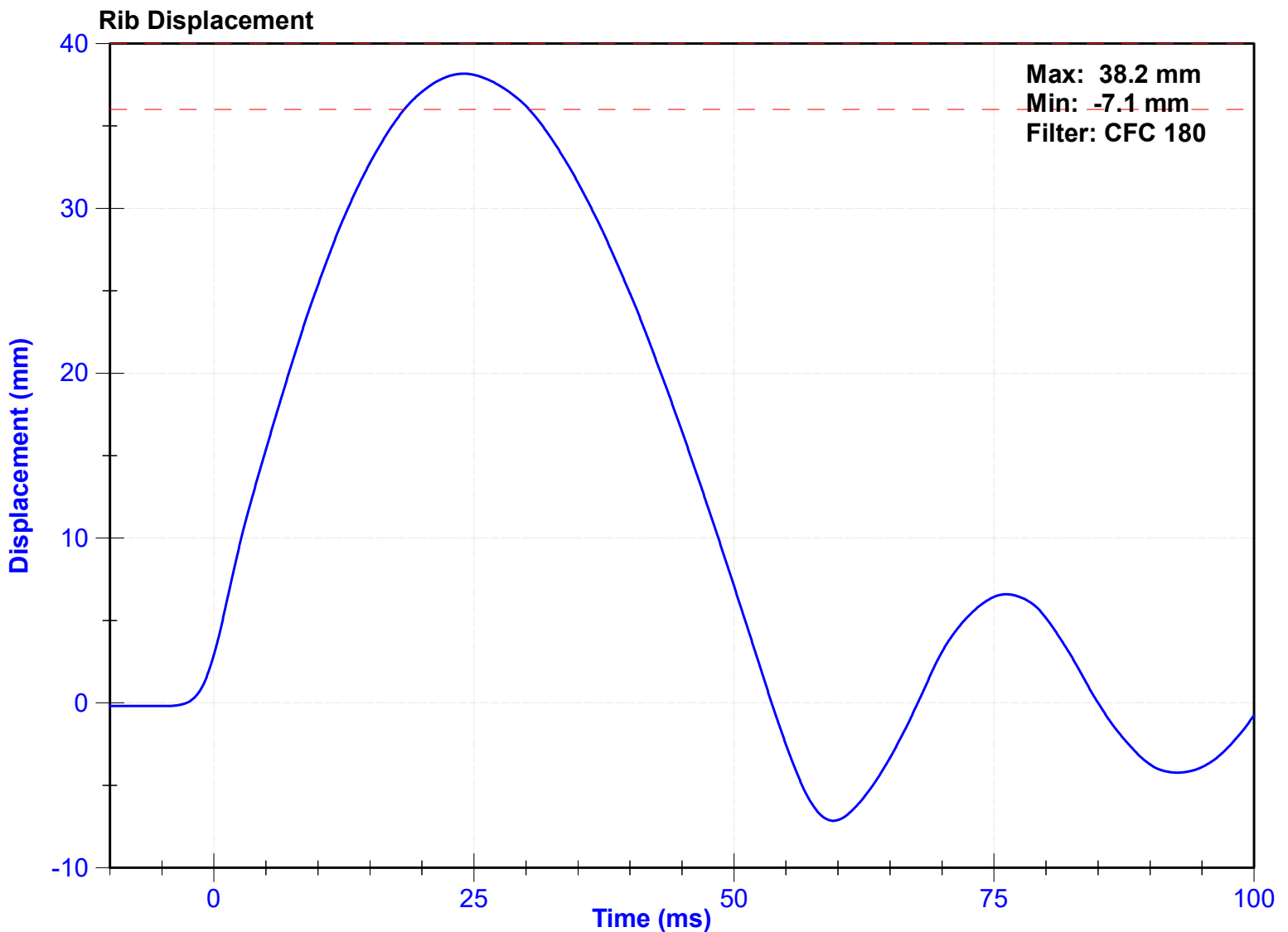

ATD Manufacturer	Denton	Test Technician	D. Sakona
ATD Serial Number	D037	Laboratory Supervisor	C. Mantell

Results

Test Parameter	Minimum Specification	Maximum Specification	Unit	Result	Pass/Fail
Temperature	20.6	22.2	°C	21.1	Pass
Humidity	10	70	%	18.5	Pass
Rib Displacement	46	51	mm	49.1	Pass

Transducer Calibrations

Channel	Manufacturer	Serial Number	Calibration Date	Calibration Due Date
Rib Potentiometer	Honeywell	DS-807	9/7/2022	3/8/2023

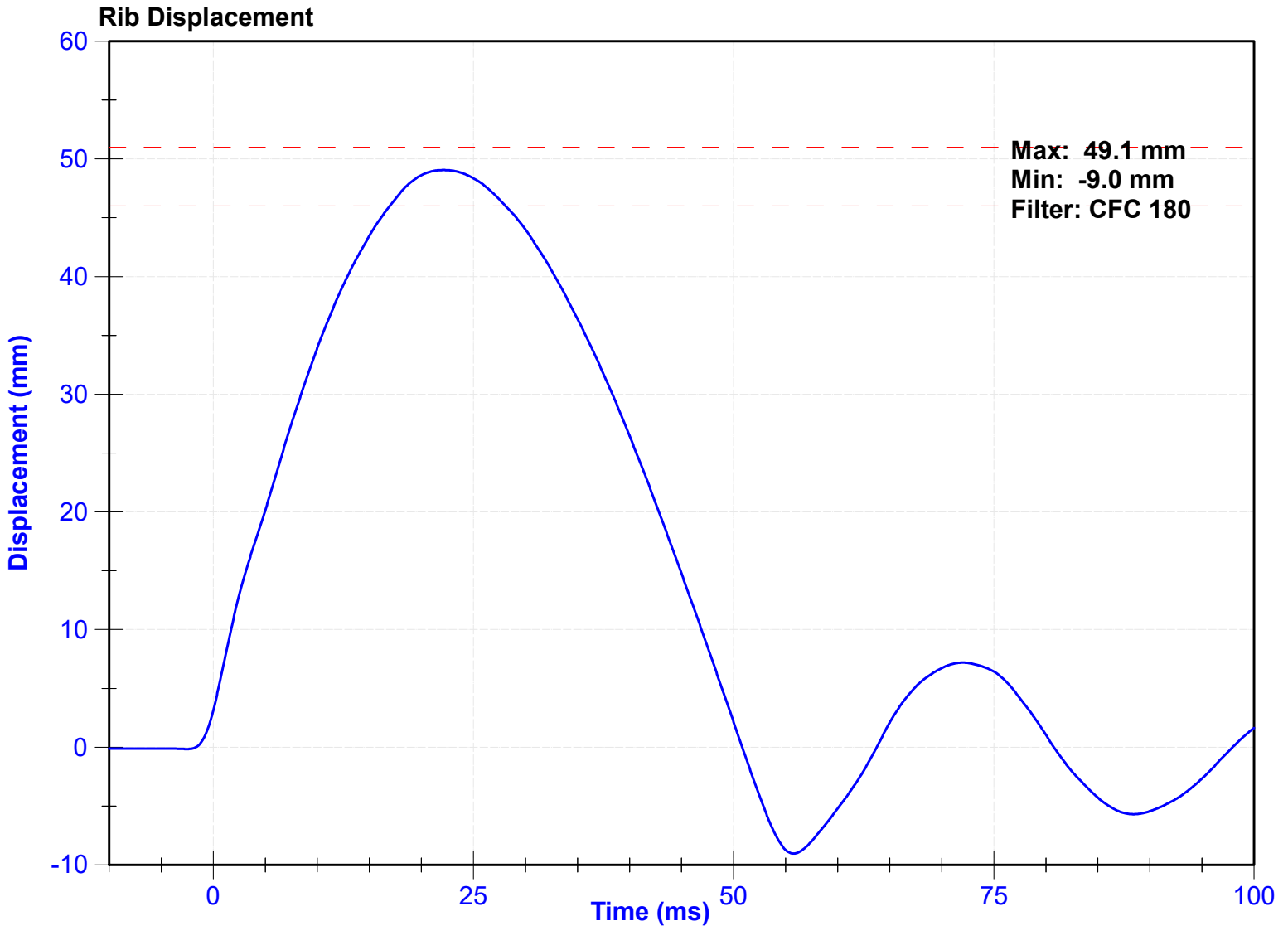

ATD Manufacturer	Denton	Test Technician	D. Sakona
ATD Serial Number	D037	Laboratory Supervisor	C. Mantell

Results

Test Parameter	Minimum Specification	Maximum Specification	Unit	Result	Pass/Fail
Temperature	20.6	22.2	°C	21.1	Pass
Humidity	10	70	%	18.5	Pass
Rib Displacement	36	40	mm	37.8	Pass

Transducer Calibrations

Channel	Manufacturer	Serial Number	Calibration Date	Calibration Due Date
Rib Potentiometer	Honeywell	DS-0552-03	9/7/2022	3/8/2023

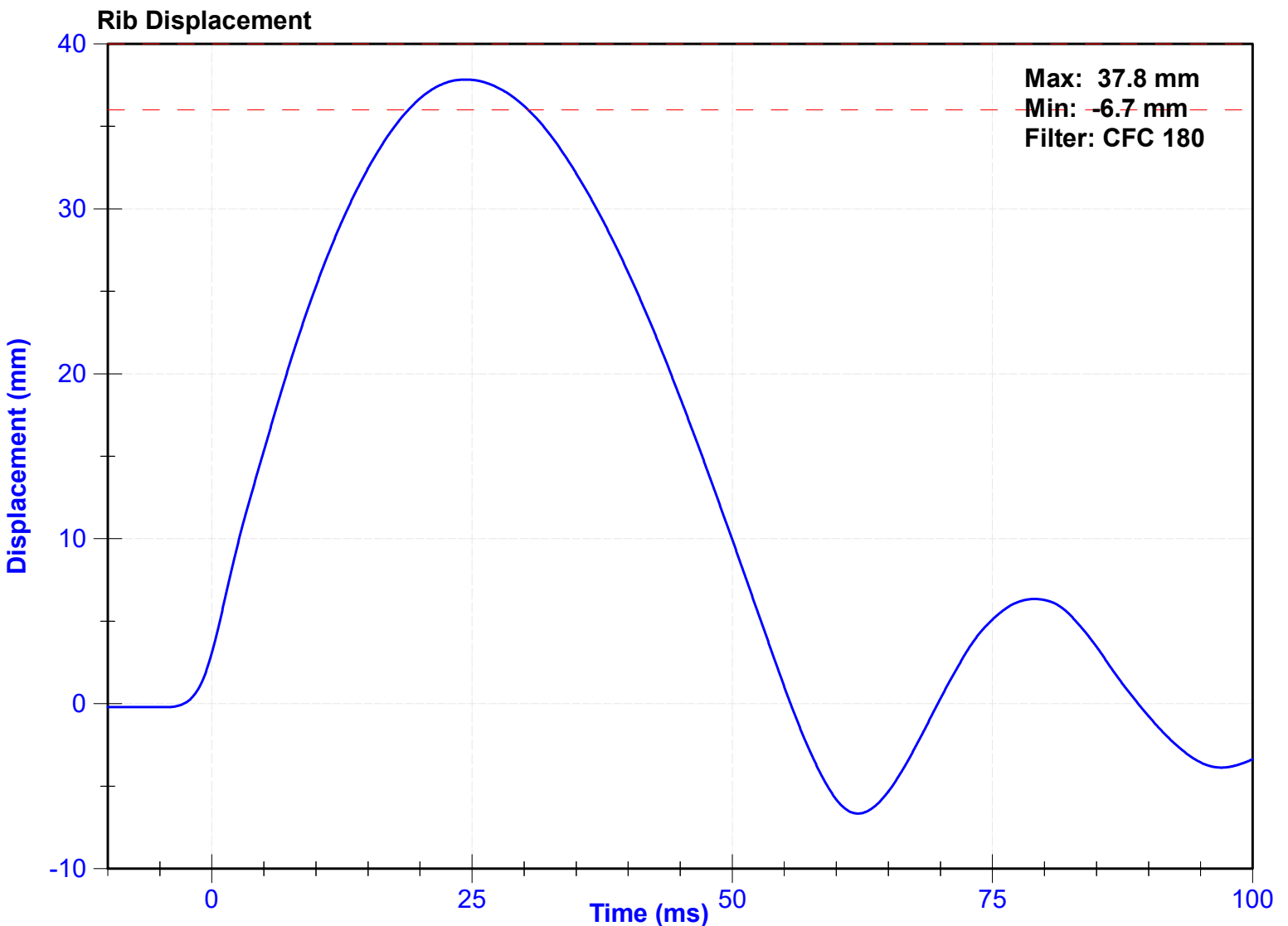

ATD Manufacturer	Denton	Test Technician	D. Sakona
ATD Serial Number	D037	Laboratory Supervisor	C. Mantell

Results

Test Parameter	Minimum Specification	Maximum Specification	Unit	Result	Pass/Fail
Temperature	20.6	22.2	°C	21.1	Pass
Humidity	10	70	%	18.5	Pass
Rib Displacement	46	51	mm	49.0	Pass

Transducer Calibrations

Channel	Manufacturer	Serial Number	Calibration Date	Calibration Due Date
Rib Potentiometer	Honeywell	DS-0552-03	9/7/2022	3/8/2023

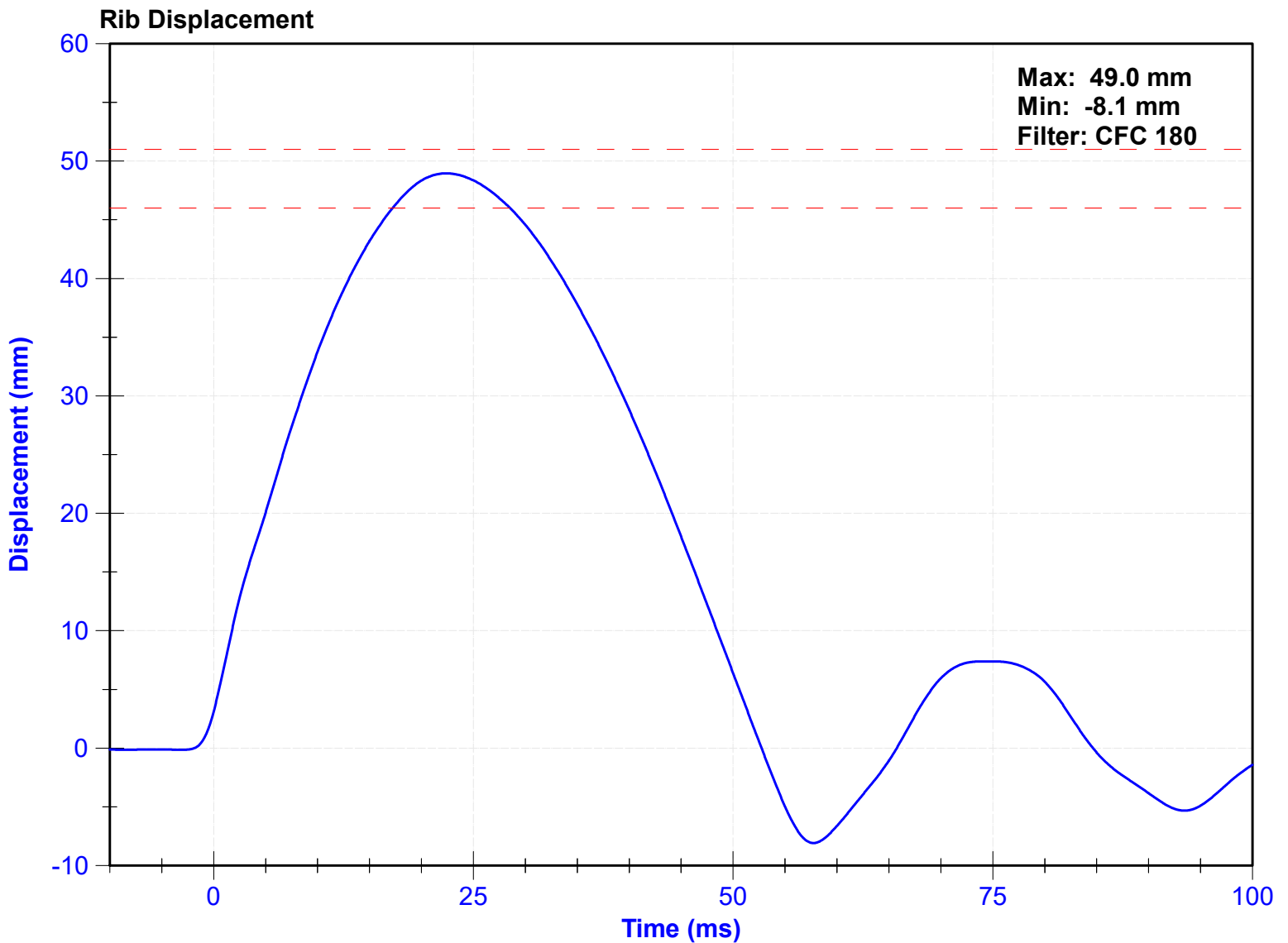

ATD Manufacturer	Denton	Test Technician	Z.Schneider
ATD Serial Number	D037	Laboratory Supervisor	C. Mantell

Results

Test Parameter	Minimum Specification	Maximum Specification	Unit	Result	Pass/Fail
Temperature	20.6	22.2	°C	21	Pass
Humidity	10	70	%	30	Pass
Velocity	5.4	5.6	m/s	5.52	Pass
Resistive Force after 6ms	5100	6200	N	6032.7	Pass
Upper Thorax Rib Deflection	34	41	mm	36.5	Pass
Mid Thorax Rib Deflection	37	45	mm	39.3	Pass
Lower Thorax Rib Deflection	37	44	mm	40.1	Pass

Transducer Calibrations

Channel	Manufacturer	Serial Number	Calibration Date	Calibration Due Date
Probe Accelerometer	Endevco	P51736	10/25/2022	4/23/2023
Upper Thorax Rib Potentiometer	Honeywell	DS-0552-01	9/7/2022	3/8/2023
Middle Thorax Rib Potentiometer	Honeywell	DS-807	9/7/2022	3/8/2023
Lower Thorax Rib Potentiometer	Honeywell	DS-0552-03	9/7/2022	3/8/2023

Probe Acceleration

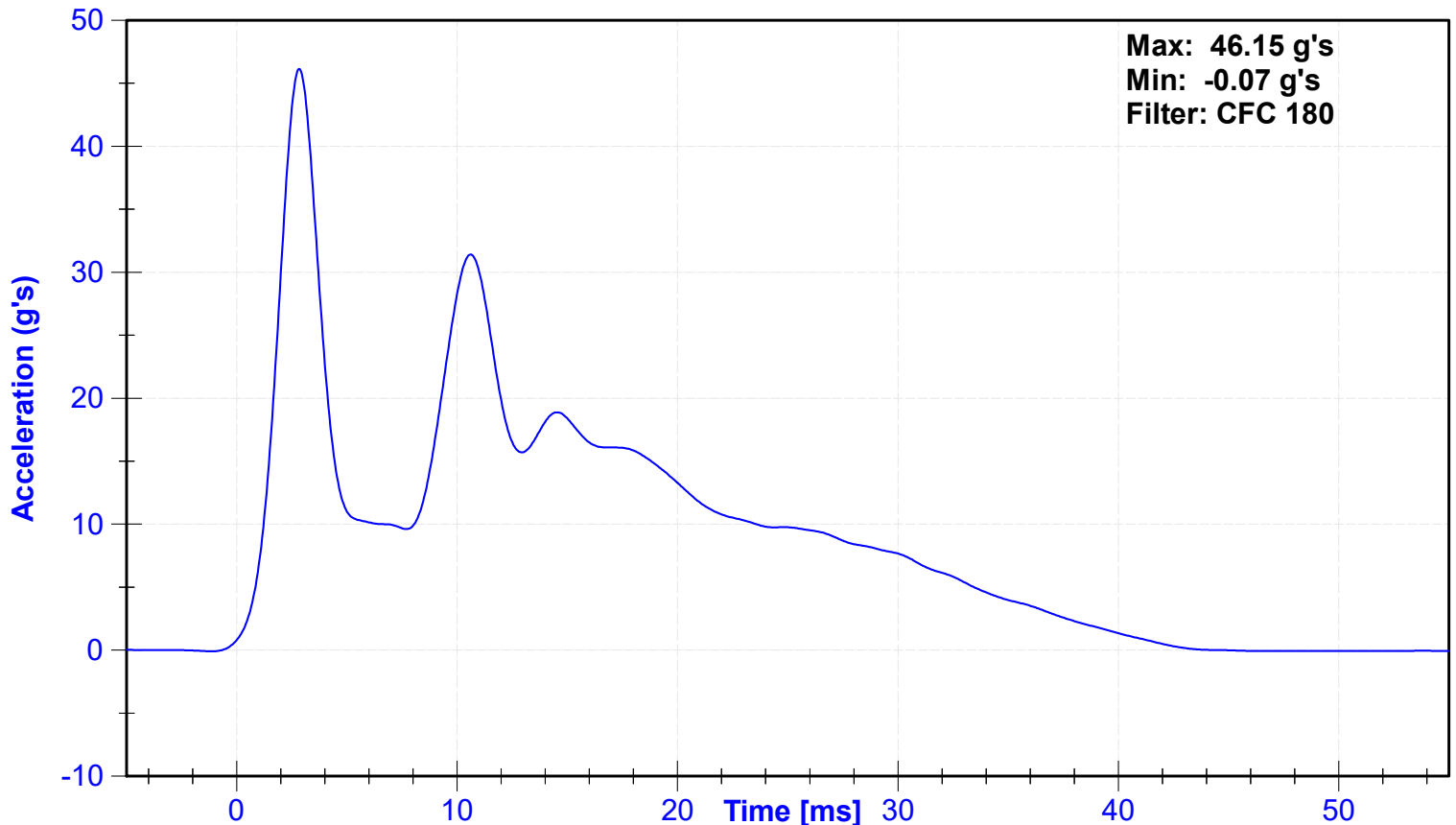

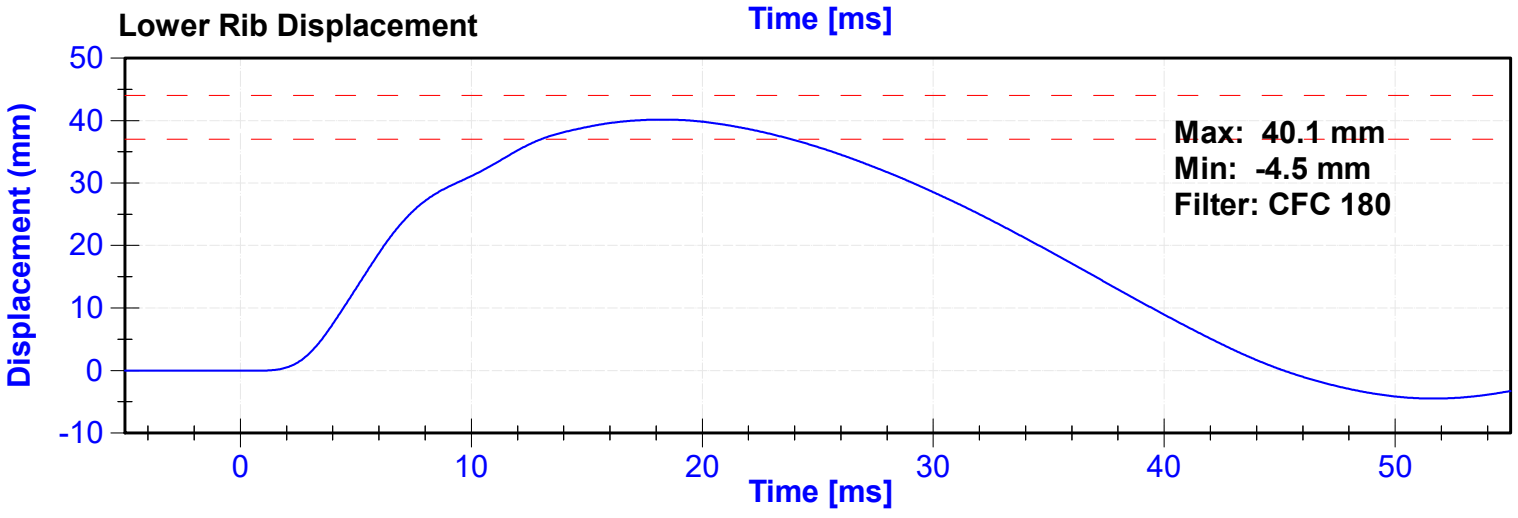
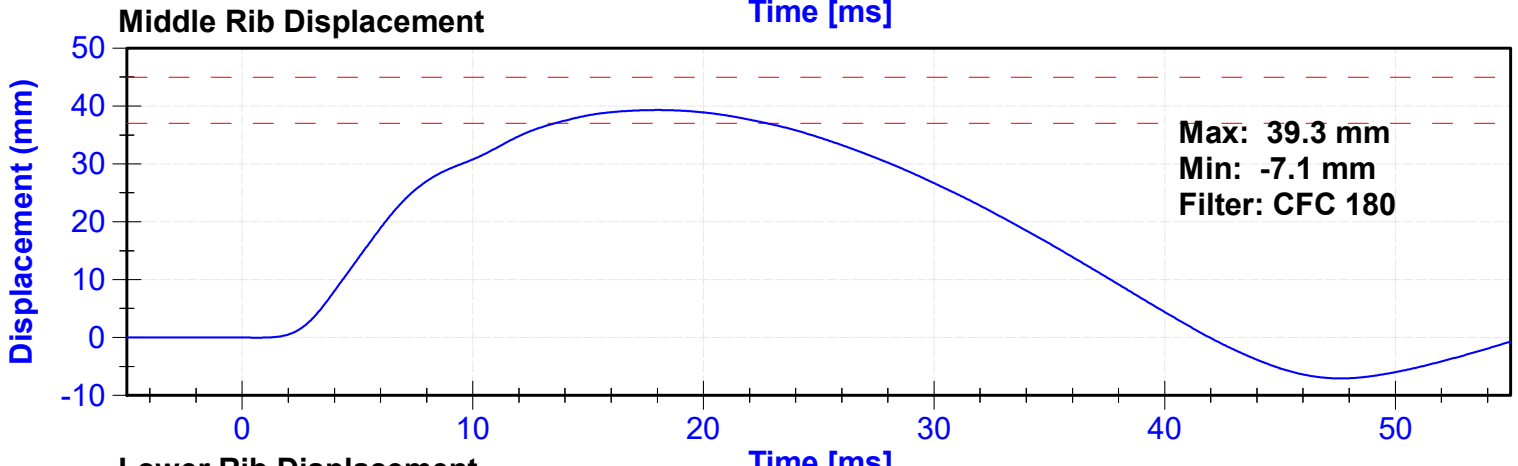
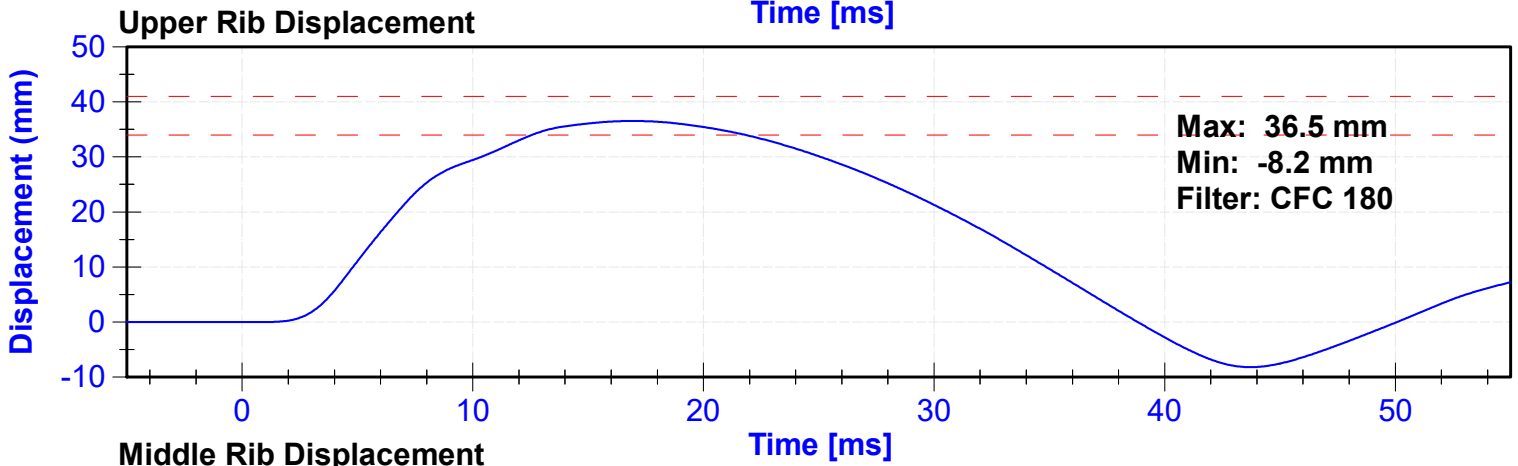
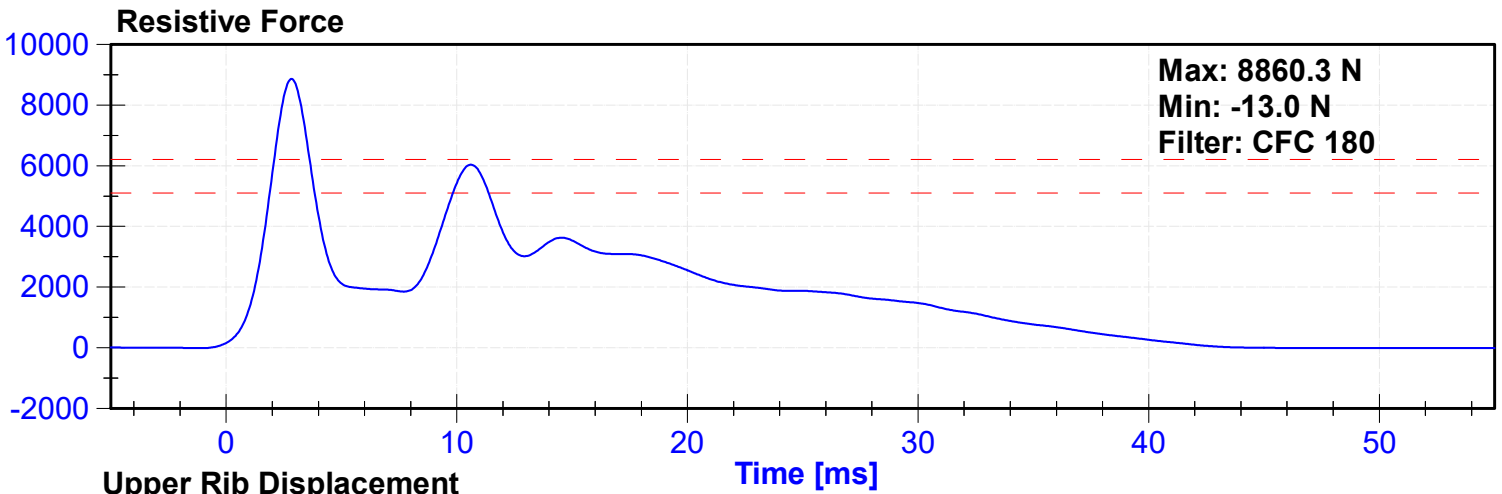

ATD Manufacturer	Denton	Test Technician	Z.Schneider
ATD Serial Number	D037	Laboratory Supervisor	C. Mantell

Results

Test Parameter	Minimum Specification	Maximum Specification	Unit	Result	Pass/Fail
Temperature	20.6	22.2	°C	21	Pass
Humidity	10	70	%	30	Pass
Velocity	3.9	4.1	m/s	4.04	Pass
Combined Abdomen Force	2200	2700	N	2343.4	Pass
Time at Peak Abdomen Force	10.0	12.3	ms	10.35	Pass
Resistive Probe Force	4000	4800	N	4489.1	Pass
Time at Peak Resistive Force	10.6	13.0	ms	10.80	Pass

Transducer Calibrations

Channel	Manufacturer	Serial Number	Calibration Date	Calibration Due Date
Pendulum Accelerometer	Endevco	P51736	10/25/2022	4/23/2023
Front Abdomen Load Cell	Denton	1440	8/12/2022	8/12/2023
Middle Abdomen Load Cell	Denton	1525	8/12/2022	8/12/2023
Rear Abdomen Load Cell	Denton	1528	8/12/2022	8/12/2023

Probe Force

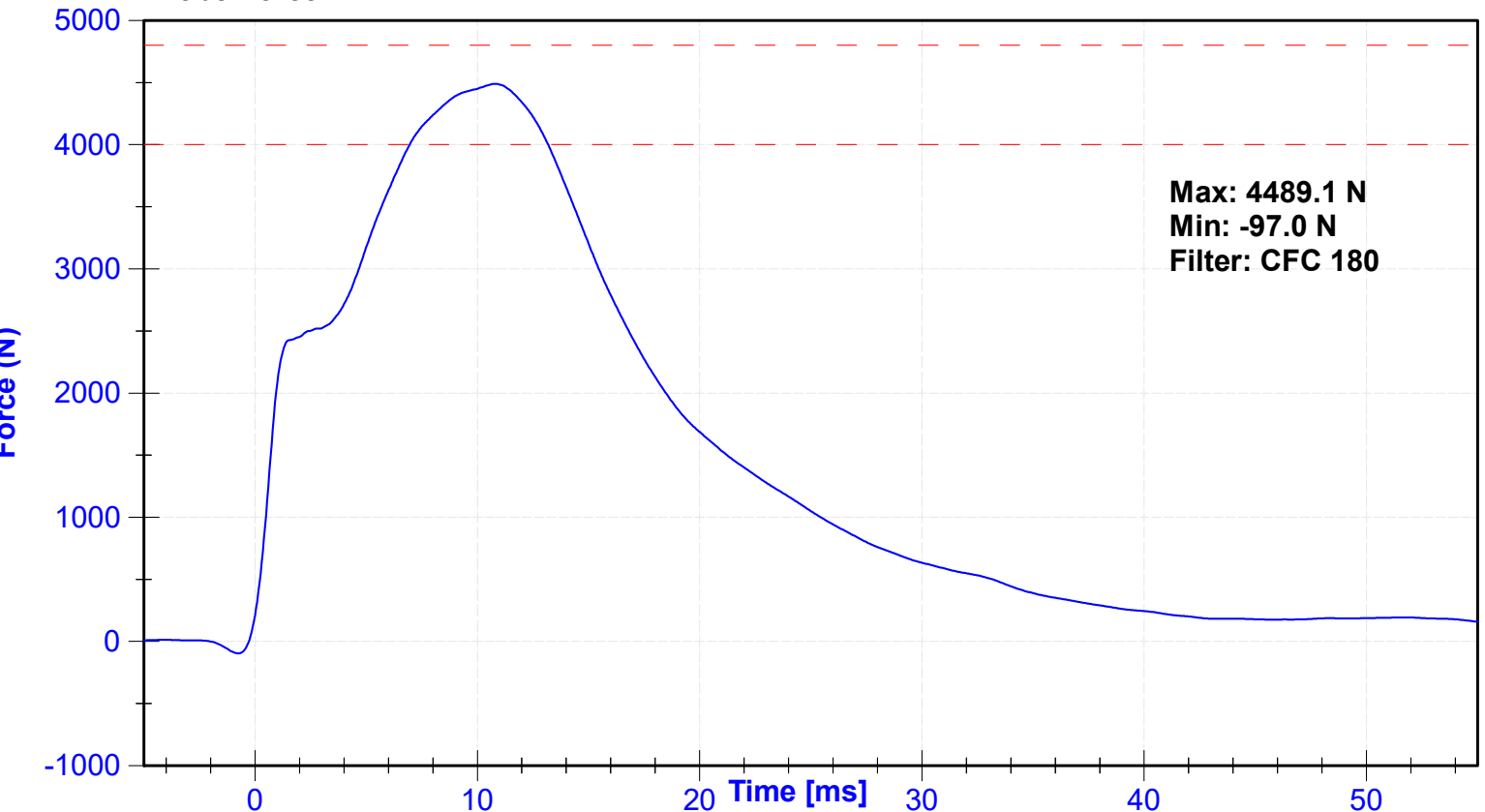

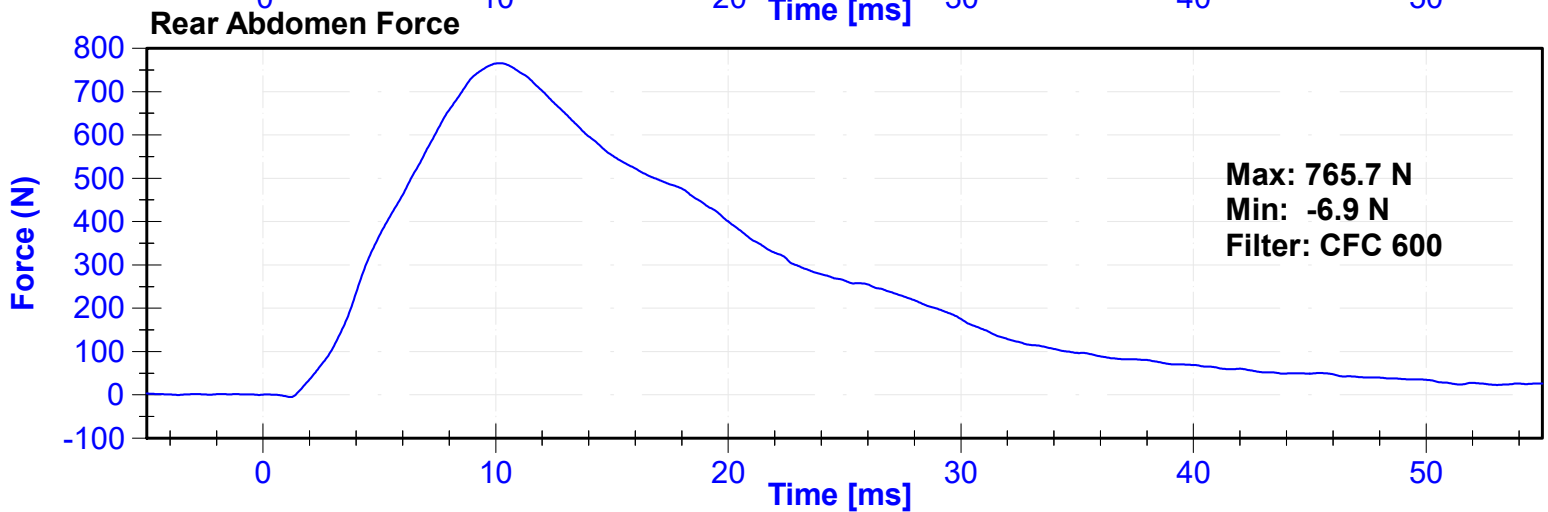
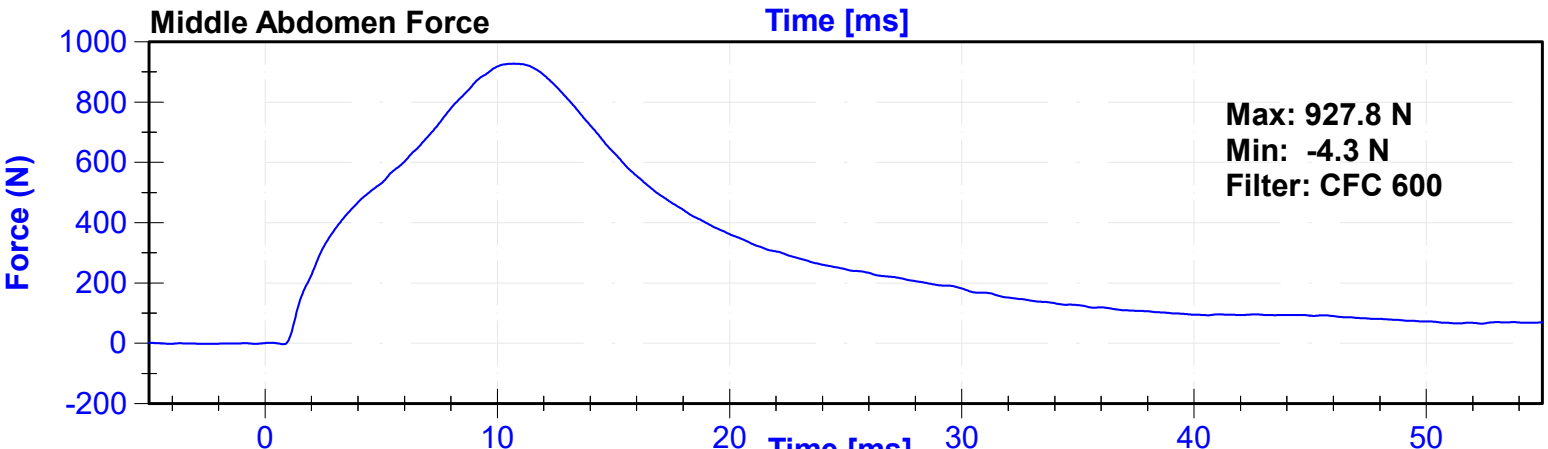
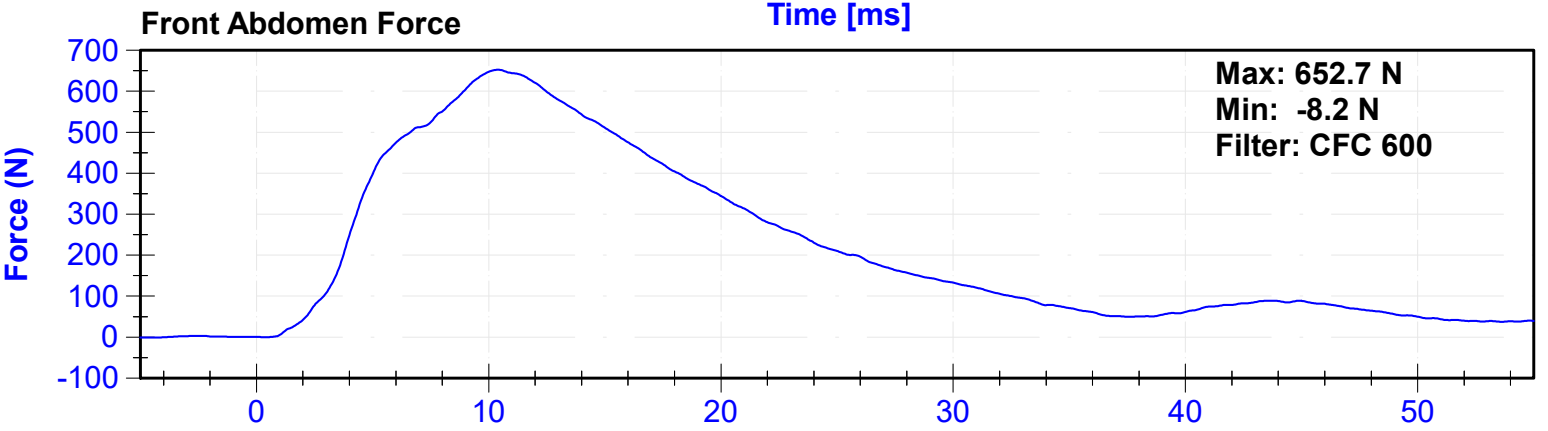
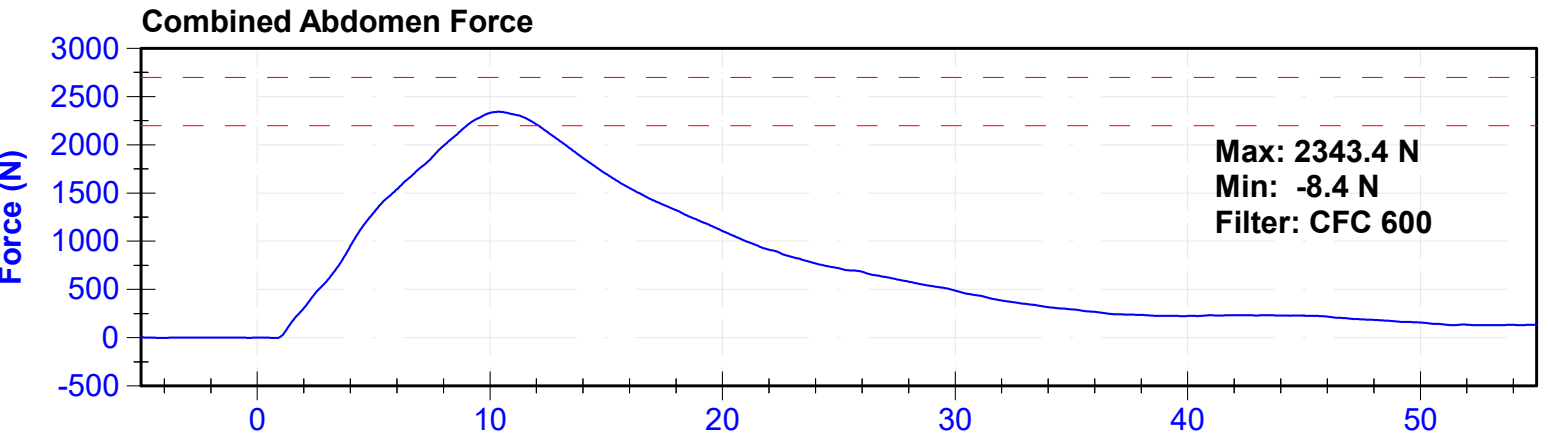

ATD Manufacturer	Denton	Test Technician	D. Kroll
ATD Serial Number	D037	Laboratory Supervisor	C. Mantell

Results

Test Parameter	Minimum Specification	Maximum Specification	Unit	Result	Pass/Fail
Temperature	20.6	22.2	°C	21.0	Pass
Humidity	10	70	%	25.8	Pass
Velocity	5.95	6.15	m/s	6.005	Pass
Lateral Spine Rotation	45	55	deg	50.2	Pass
Time at Maximum Rotation	39	53	ms	46.1	Pass
Time of Decay to Zero Degrees	37	57	ms	39.0	Pass
Pendulum Velocity Overall Corridor	Lower Boundary ¹	Upper Boundary ²	m/s	See Plot ³	Pass

Transducer Calibrations

Channel	Manufacturer	Serial Number	Calibration Date	Calibration Due Date
Pendulum Accelerometer	Endevco	C16503	10/26/2022	10/26/2023
Pendulum "A" Potentiometer	Sfernice	094	10/5/2022	10/5/2023
Condyle "B" Potentiometer	Sfernice	095	10/5/2022	10/5/2023

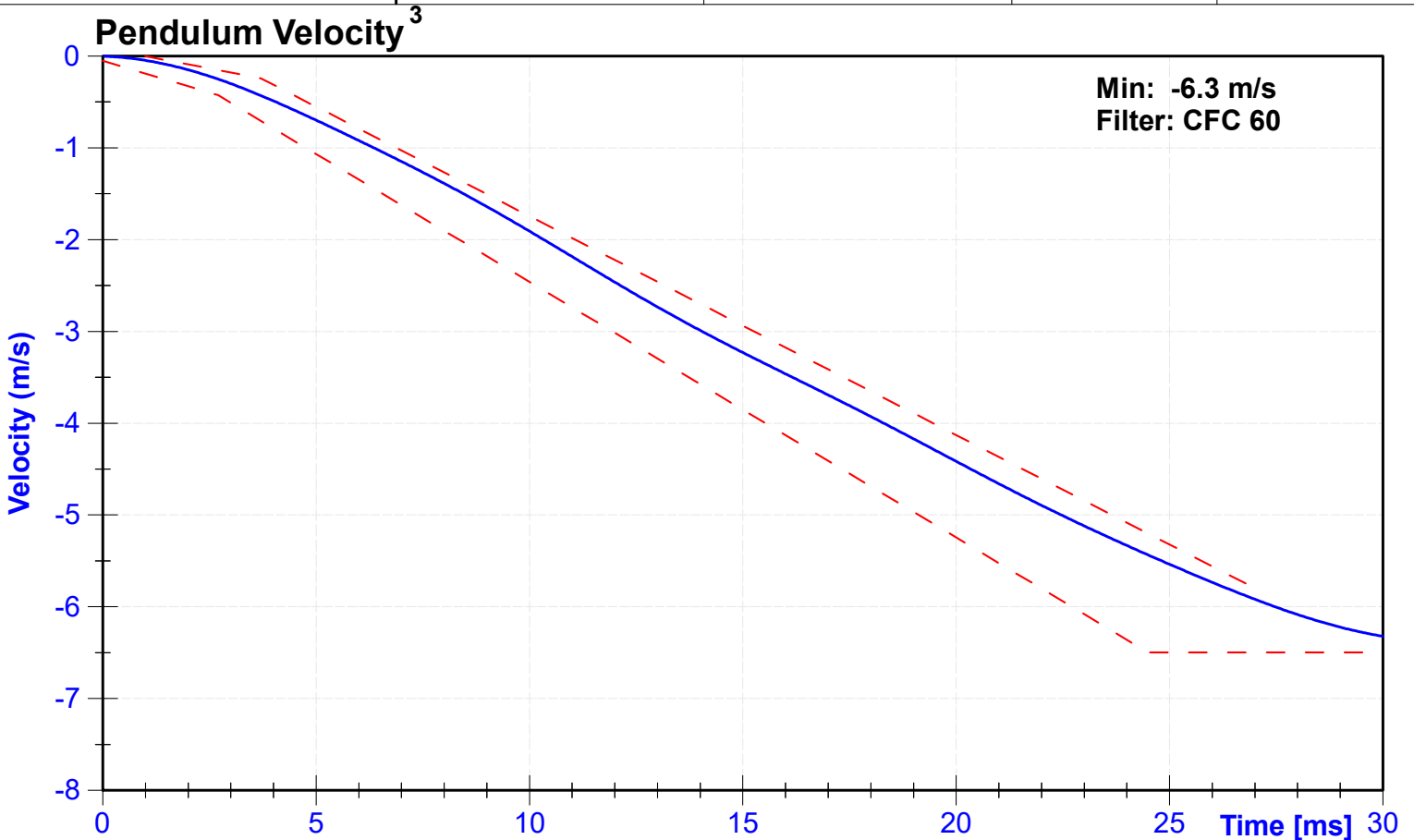

^{1,2} Upper and lower boundaries specified in Appendix I V-19

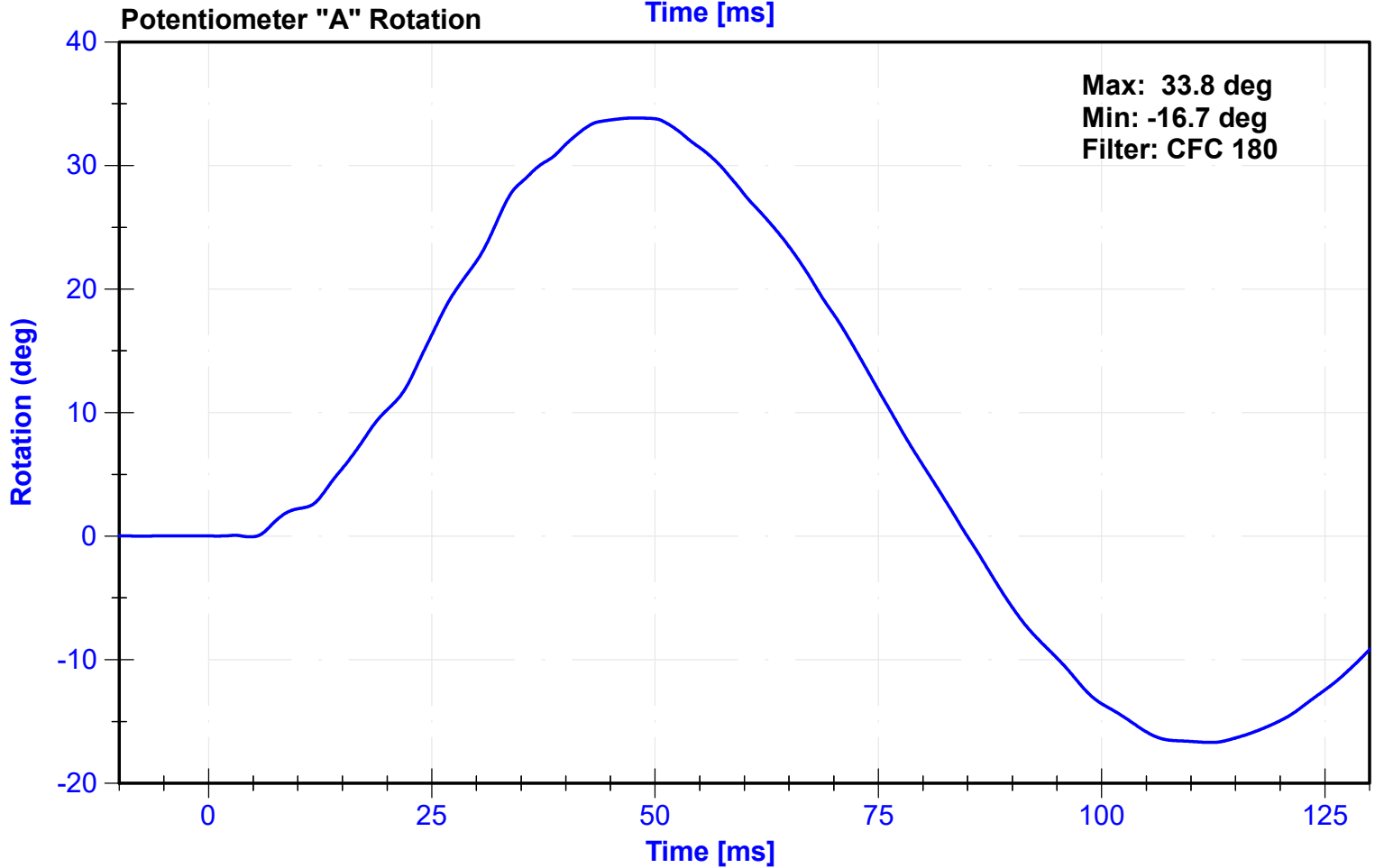
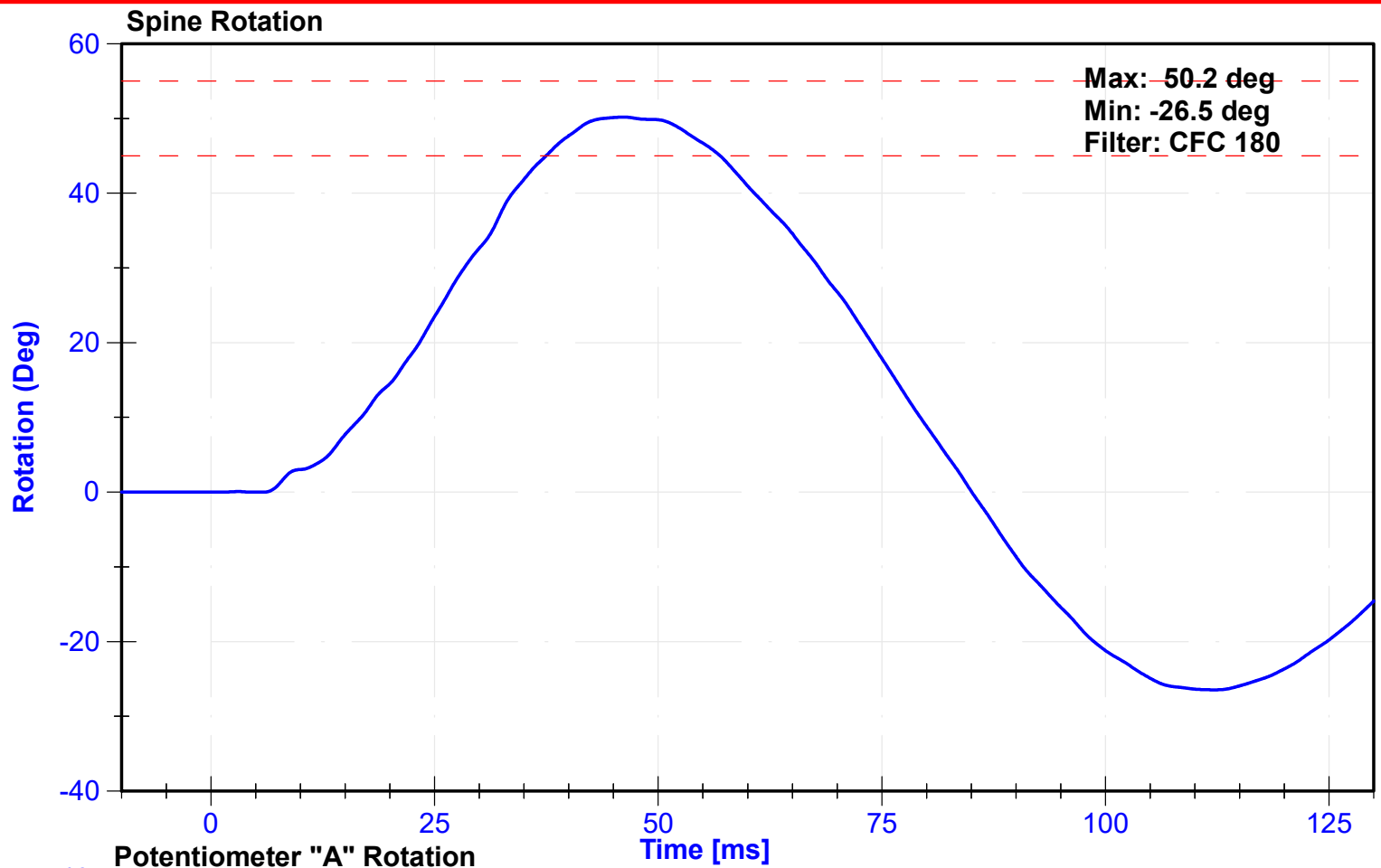

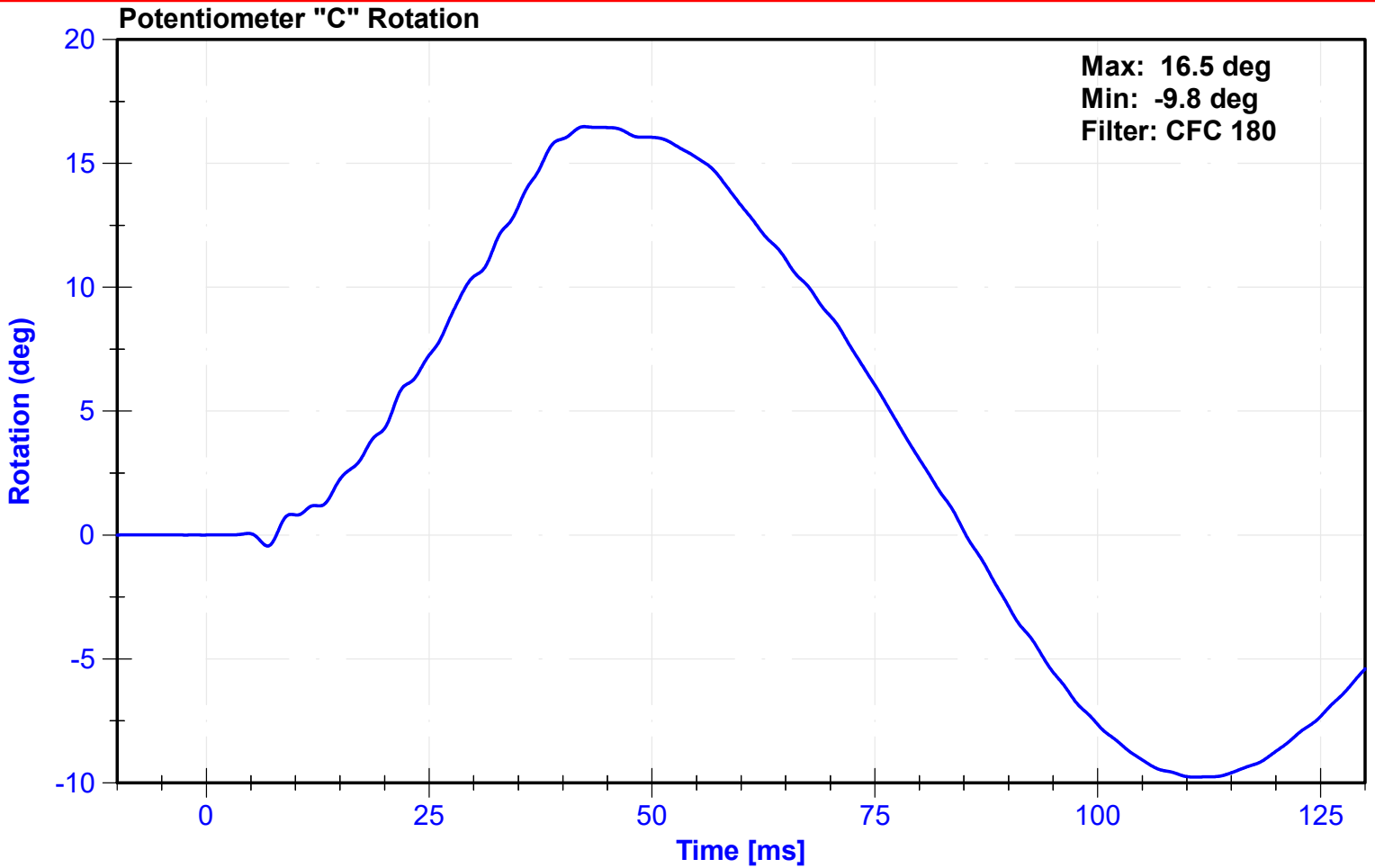

Appendix I

² Upper Boundary Corridor		¹ Lower Boundary Corridor	
Time (ms)	Velocity (m/s)	Time (ms)	Velocity (m/s)
1.0	0.00	0.0	-0.05
3.7	-0.24	2.7	-0.425
27.0	-5.80	24.5	-6.5
		30.0	-6.5

ATD Manufacturer	Denton	Test Technician	Z.Schneider
ATD Serial Number	D037	Laboratory Supervisor	C. Mantell

Results

Test Parameter	Minimum Specification	Maximum Specification	Unit	Result	Pass/Fail
Temperature	20.6	22.2	°C	21	Pass
Humidity	10	70	%	30	Pass
Velocity	4.2	4.4	m/s	4.29	Pass
Resistive Force	4700	5400	N	4837.3	Pass
Time at Peak Resistive Force	11.8	16.1	ms	15.35	Pass
Pubic Force	-1590	-1230	N	-1438.4	Pass
Time at Peak Pubic Force	12.2	17.0	ms	15.15	Pass

Transducer Calibrations

Channel	Manufacturer	Serial Number	Calibration Date	Calibration Due Date
Pendulum Accelerometer	Endevco	P51736	10/25/2022	4/23/2023
Pubic Load Cell	Denton	456-FY	8/12/2022	8/12/2023

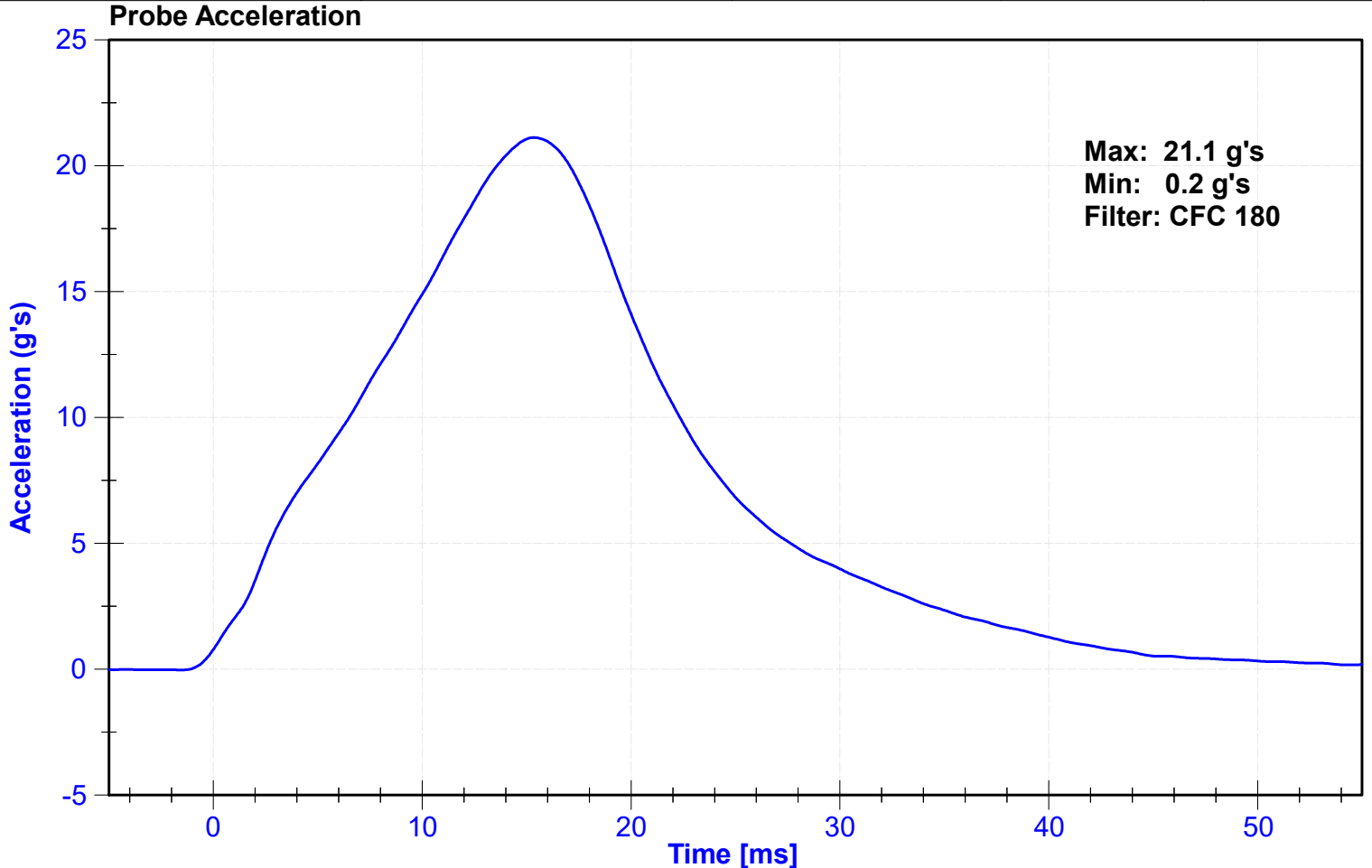

Resistive Force

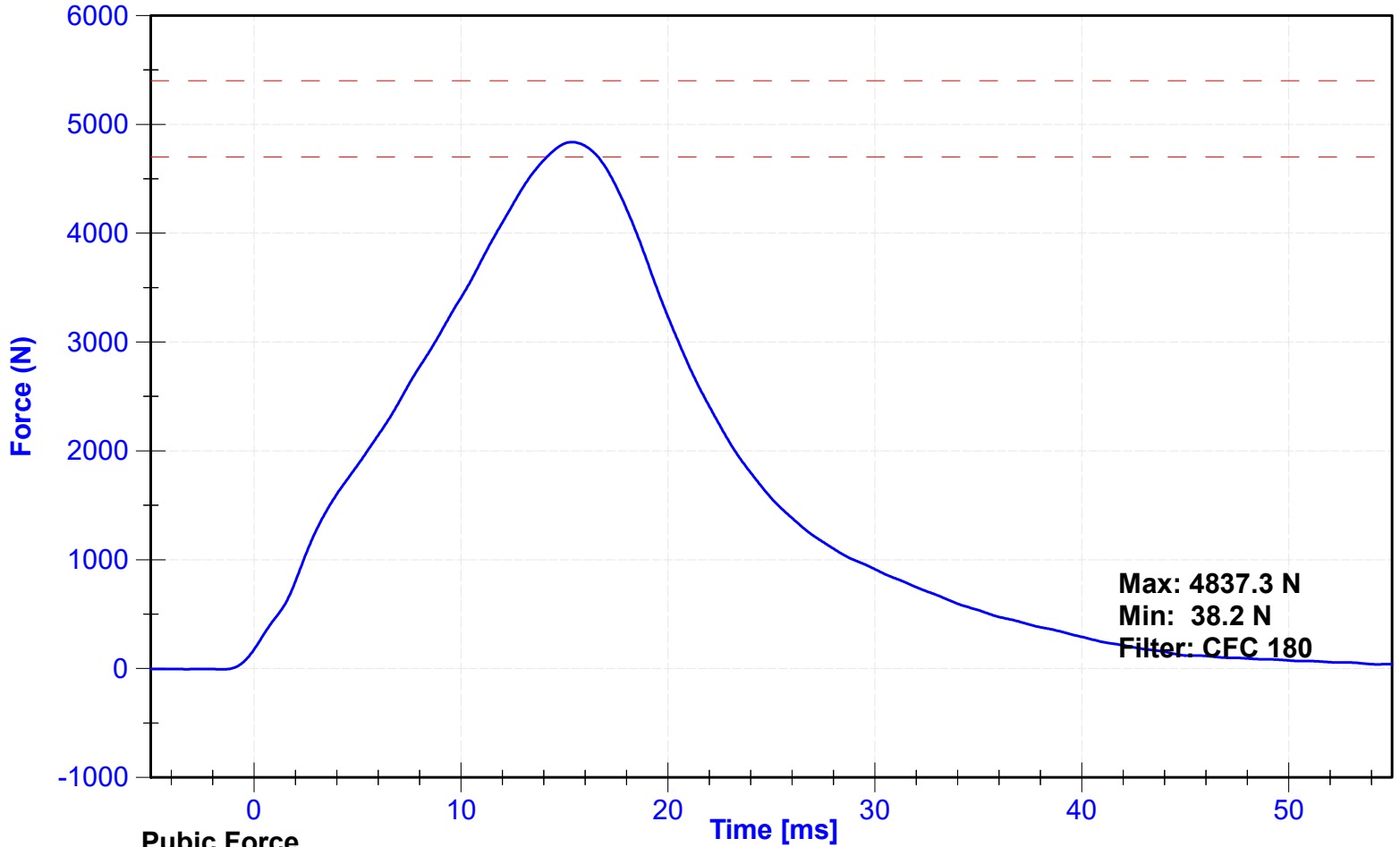

Pubic Force

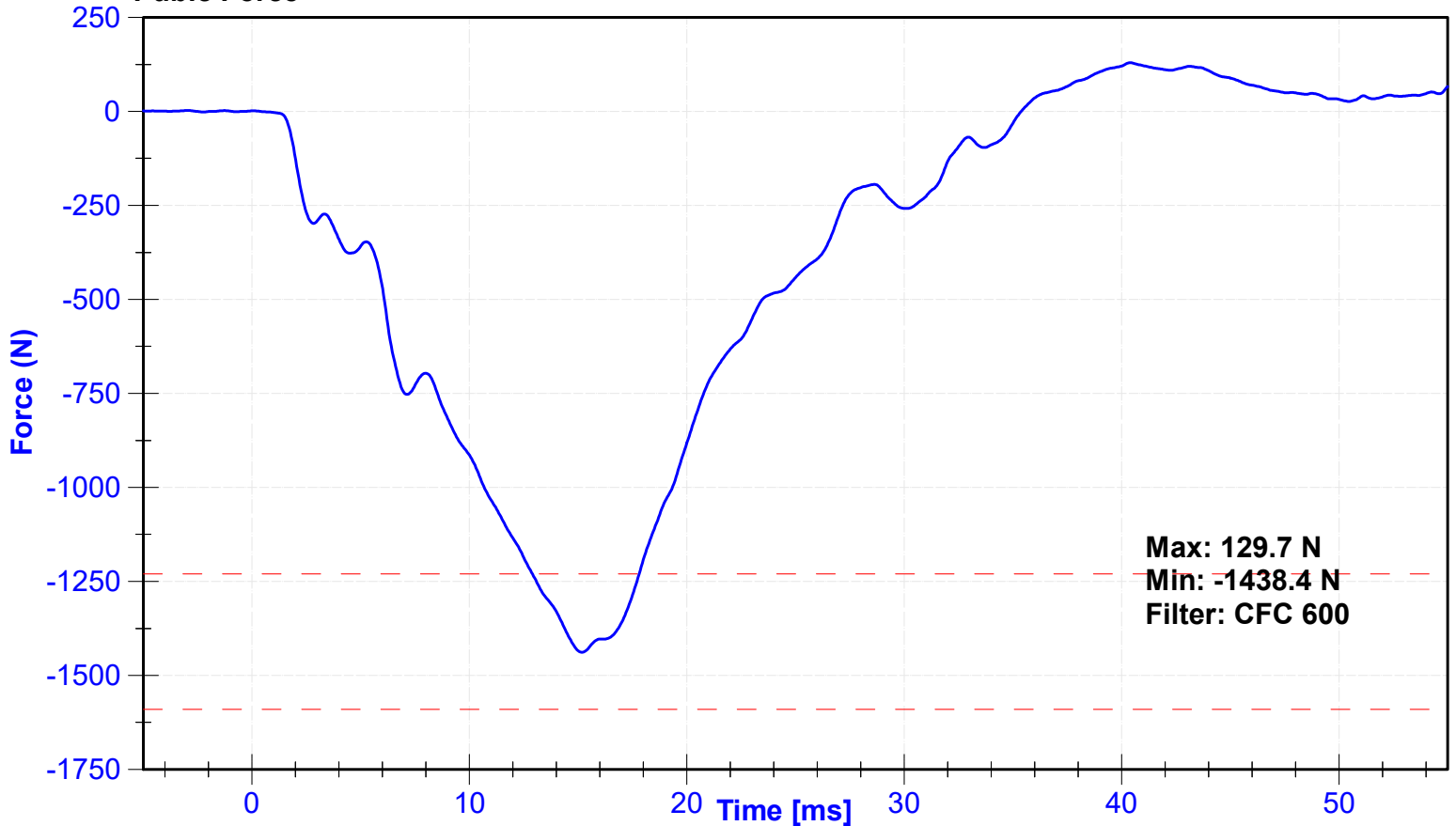

**POST-TEST
ES-2re PERFORMANCE CALIBRATION TEST DATA**

External Measurements - EuroSID-2re

Technician: K. Brogan

Date: 12/21/2022

Dummy Serial Number: D037

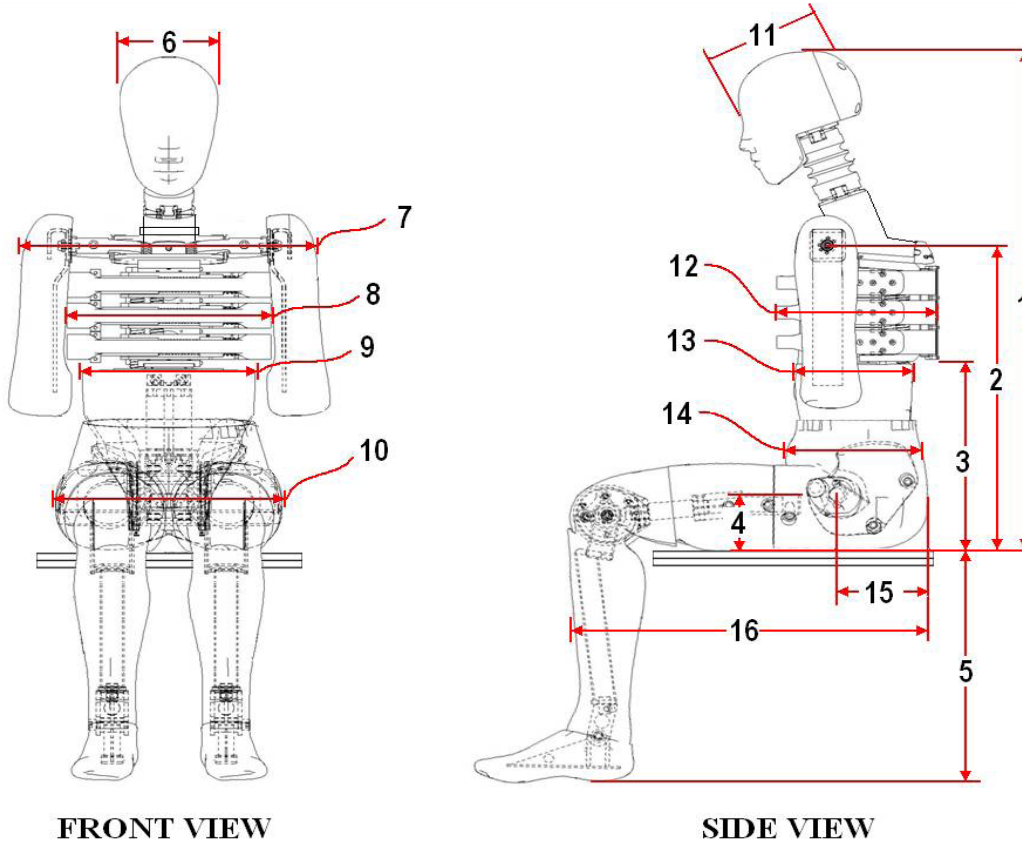

Dim. No.	Description	Specification (mm)		Result (mm)	Pass/Fail
1	Sitting Height	900	918	913	Pass
2	Seat to Shoulder Joint	558	572	567	Pass
3	Seat to Lower Face of Thoracic Spine Box	346	356	353	Pass
4	Seat to Hip Joint (center of bolt)	97	103	101	Pass
5	Sole to Seat, Sitting	333	451	422	Pass
6	Head Width	152	158	154	Pass
7	Shoulder/Arm Width	461	479	471	Pass
8	Thorax Width	322	332	330	Pass
9	Abdomen Width	273	287	279	Pass
10	Pelvis Lap Width	359	373	365	Pass
11	Head Depth	196	206	197	Pass
12	Thorax Depth	262	272	268	Pass
13	Abdomen Depth	194	204	200	Pass
14	Pelvis Depth	235	245	241	Pass
15	Back of Buttocks to Hip Joint (center of bolt)	150	160	153	Pass
16	Back of Buttocks to Front Knee	597	615	610	Pass

ATD Manufacturer	Denton	Test Technician	D. Sakona
ATD Serial Number	D037	Laboratory Supervisor	C. Mantell

Results

Test Parameter	Minimum Specification	Maximum Specification	Unit	Result	Pass/Fail
Temperature	20.6	22.2	°C	20.8	Pass
Humidity	10	70	%	20.5	Pass
Resultant Acceleration	125	155	g's	135.0	Pass
Oscillation	0	15	%	2.12	Pass
Fore-Aft Acceleration	-15	15	g's	8.6	Pass

Transducer Calibrations

Channel	Manufacturer	Serial Number	Calibration Date	Calibration Due Date
X Accelerometer	Endevco	T21724	9/6/2022	3/5/2023
Y Accelerometer	Endevco	T22281	9/6/2022	3/5/2023
Z Accelerometer	Endevco	T26050	9/9/2022	3/8/2023

Resultant Acceleration

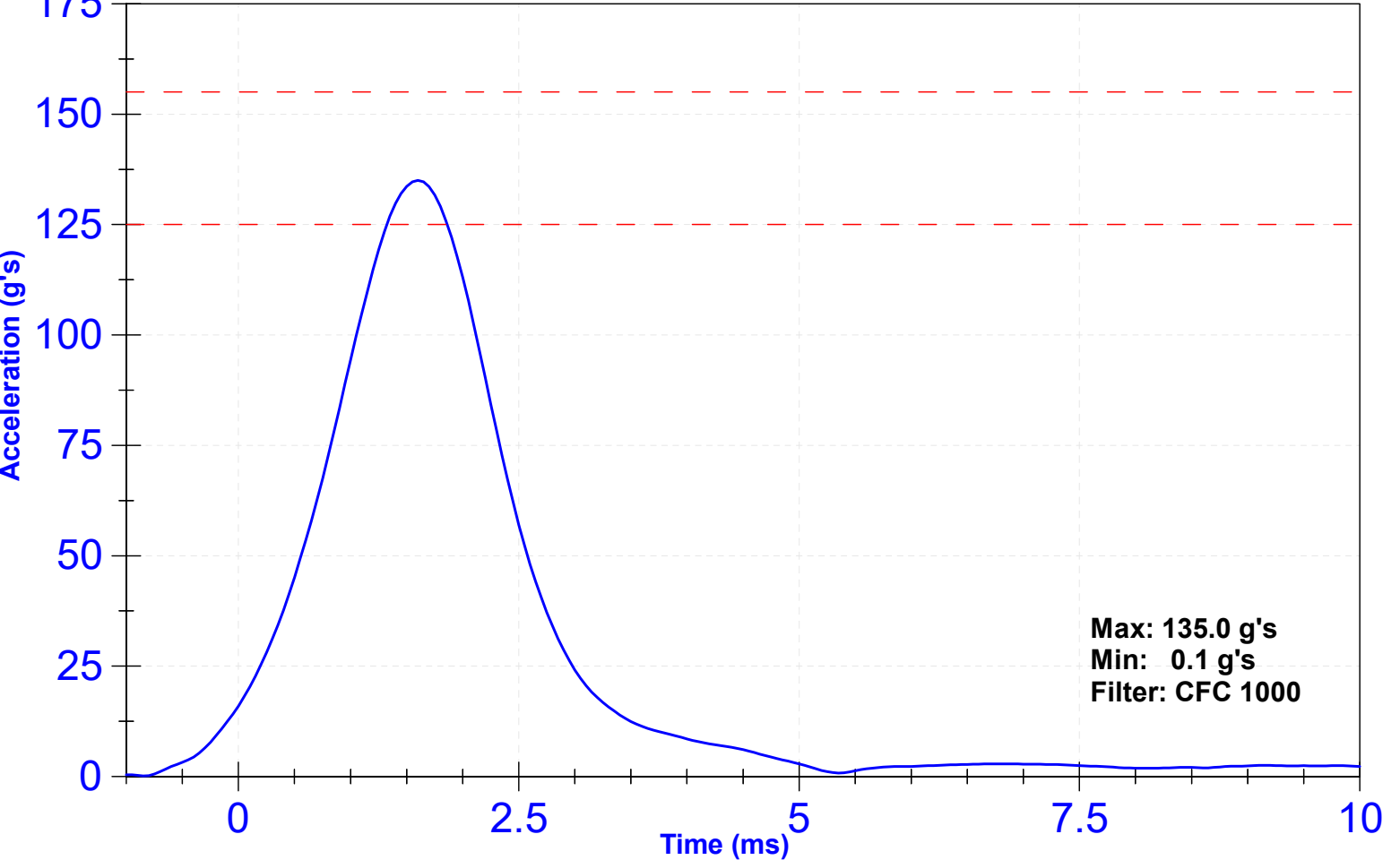

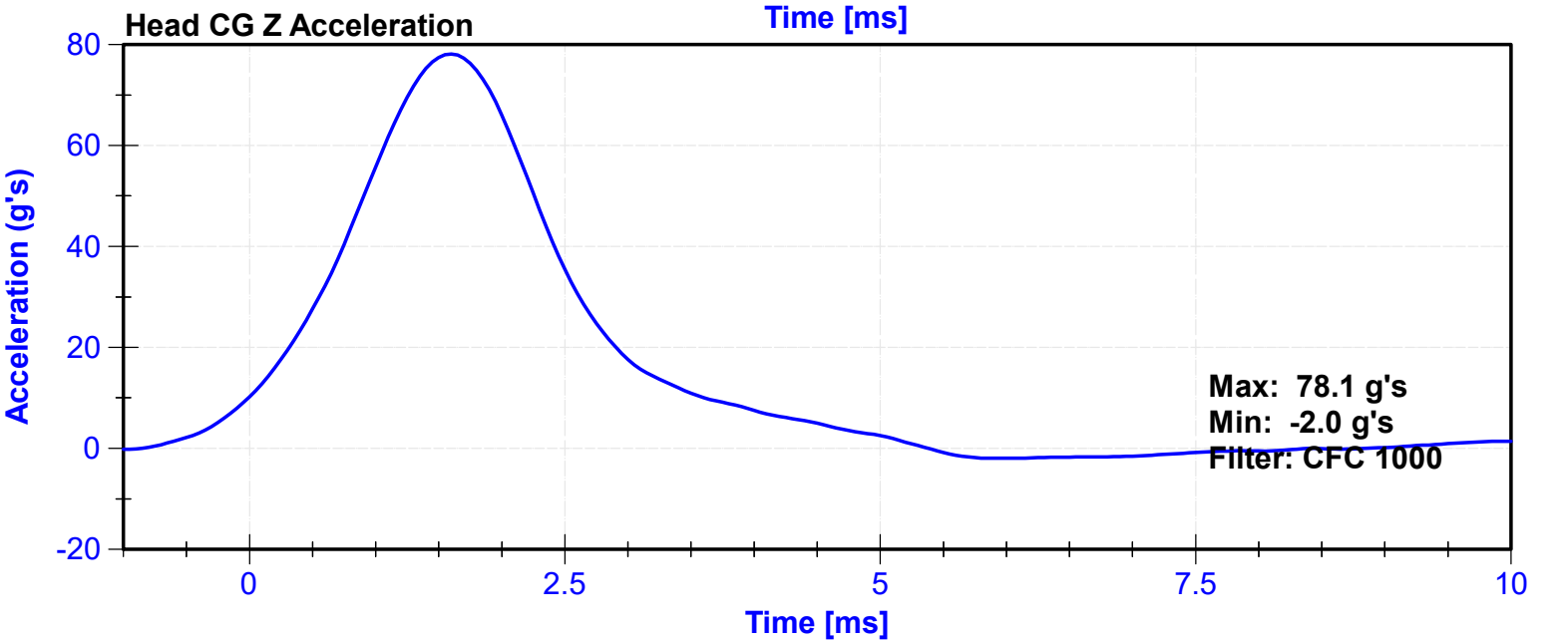
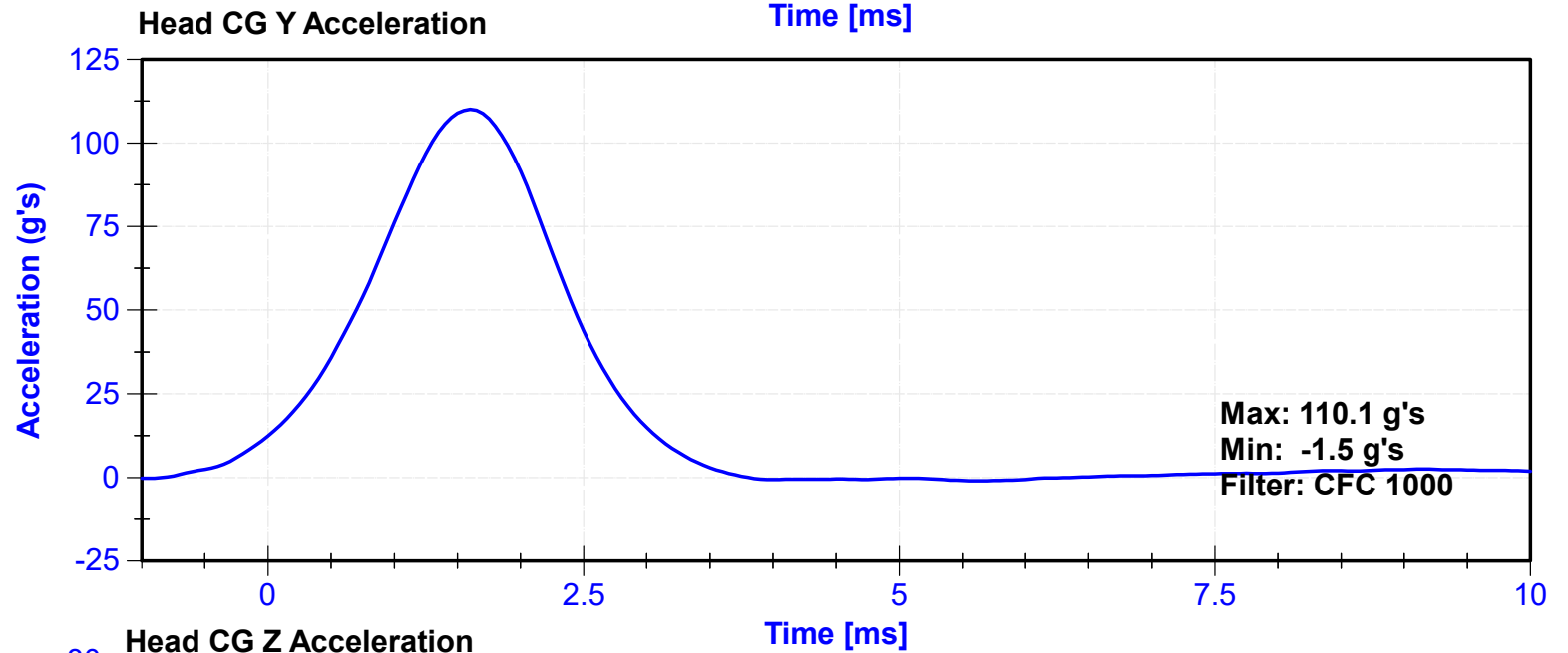
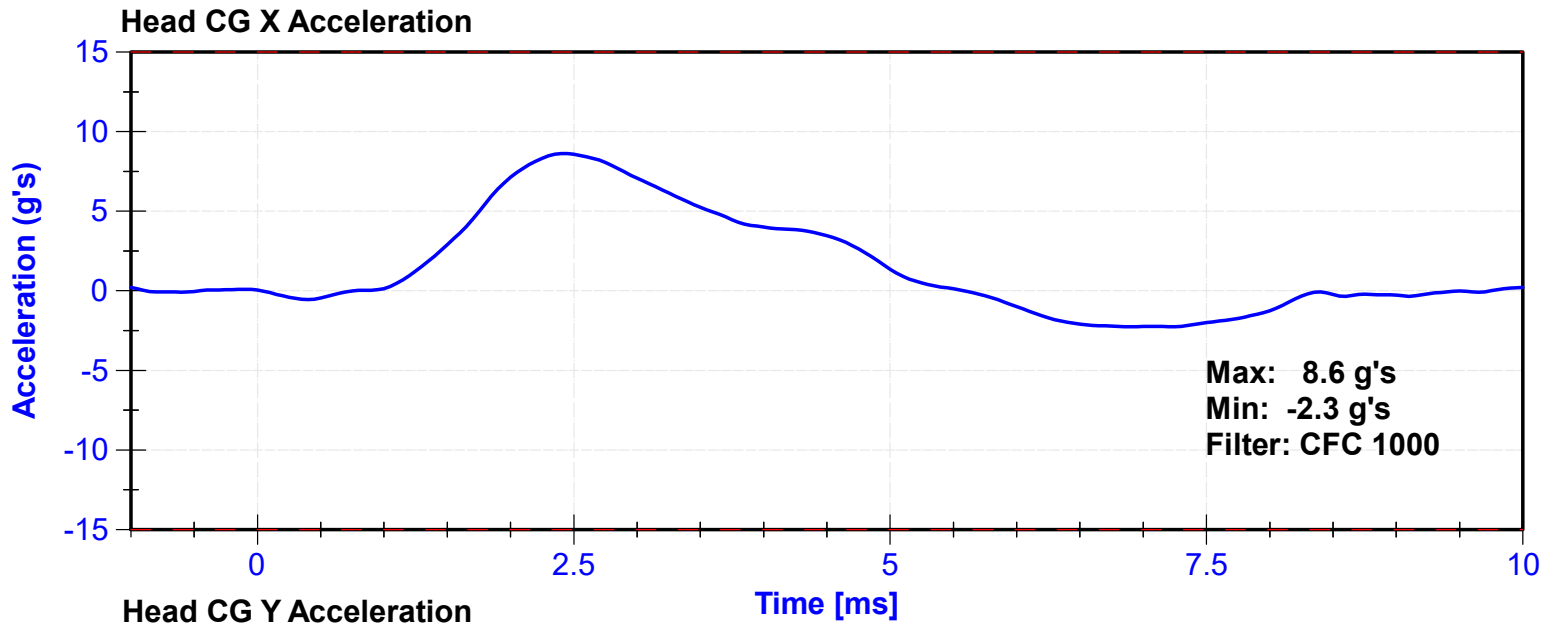

ATD Manufacturer	Denton	Test Technician	Z.Schneider
ATD Serial Number	F033	Laboratory Supervisor	C. Mantell

Results

Test Parameter	Minimum Specification	Maximum Specification	Unit	Result	Pass/Fail
Temperature	20.6	22.2	°C	21.0	Pass
Humidity	10	70	%	21	Pass
Velocity	3.3	3.5	m/s	3.42	Pass
Lateral Neck Rotation	49	59	deg	54.8	Pass
Time at Maximum Rotation	54	66	ms	57.4	Pass
Time of Rotation Decay from Maximum	53	88	ms	57.0	Pass
Pendulum Velocity Overall Corridor	Lower Boundary ¹	Upper Boundary ²	m/s	See Plot ³	Pass

Transducer Calibrations

Channel	Manufacturer	Serial Number	Calibration Date	Calibration Due Date
Pendulum Accelerometer	Endevco	C16503	10/26/2022	10/26/2023
Front Pendulum Potentiometer	Sfernice	094	10/5/2022	10/5/2023
Headform Potentiometer	Sfernice	095	10/5/2022	10/5/2023

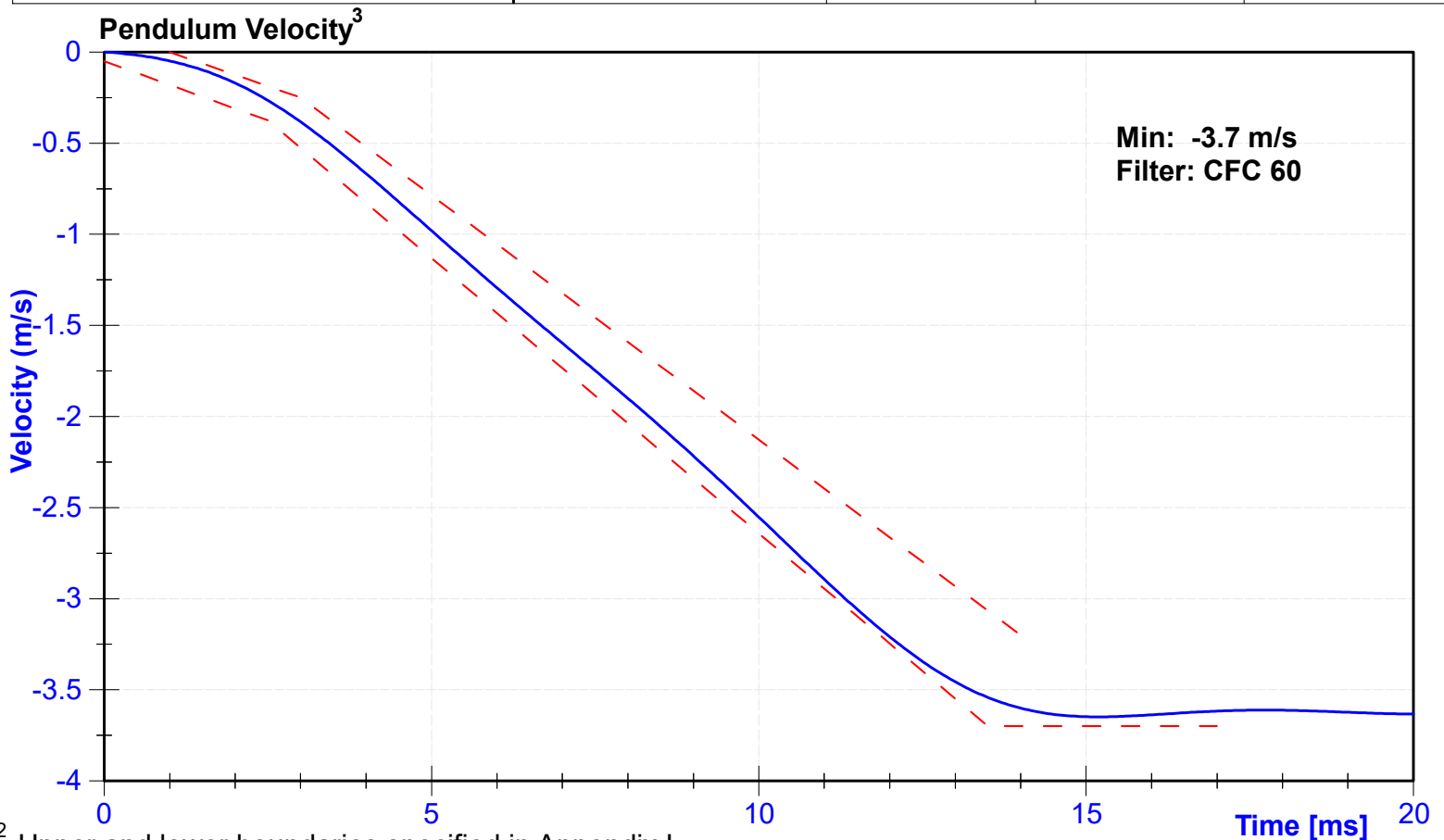

^{1,2} Upper and lower boundaries specified in Appendix I

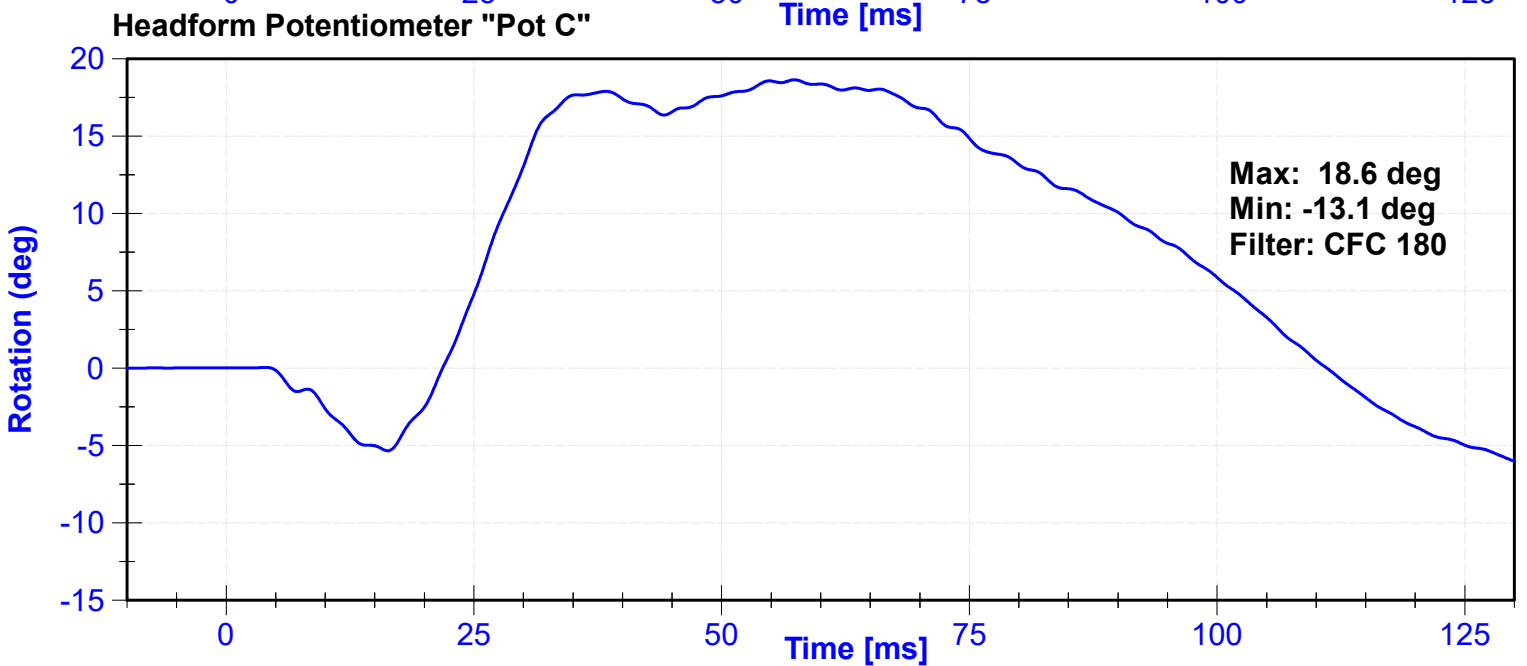
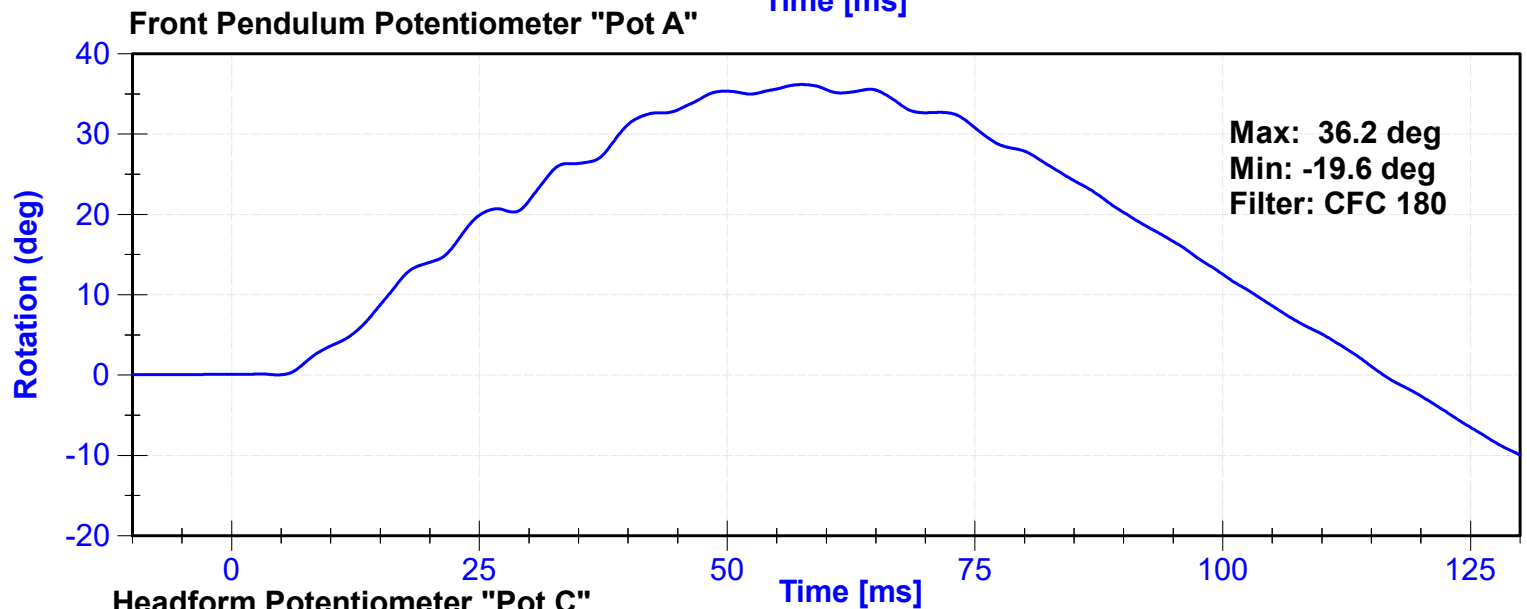
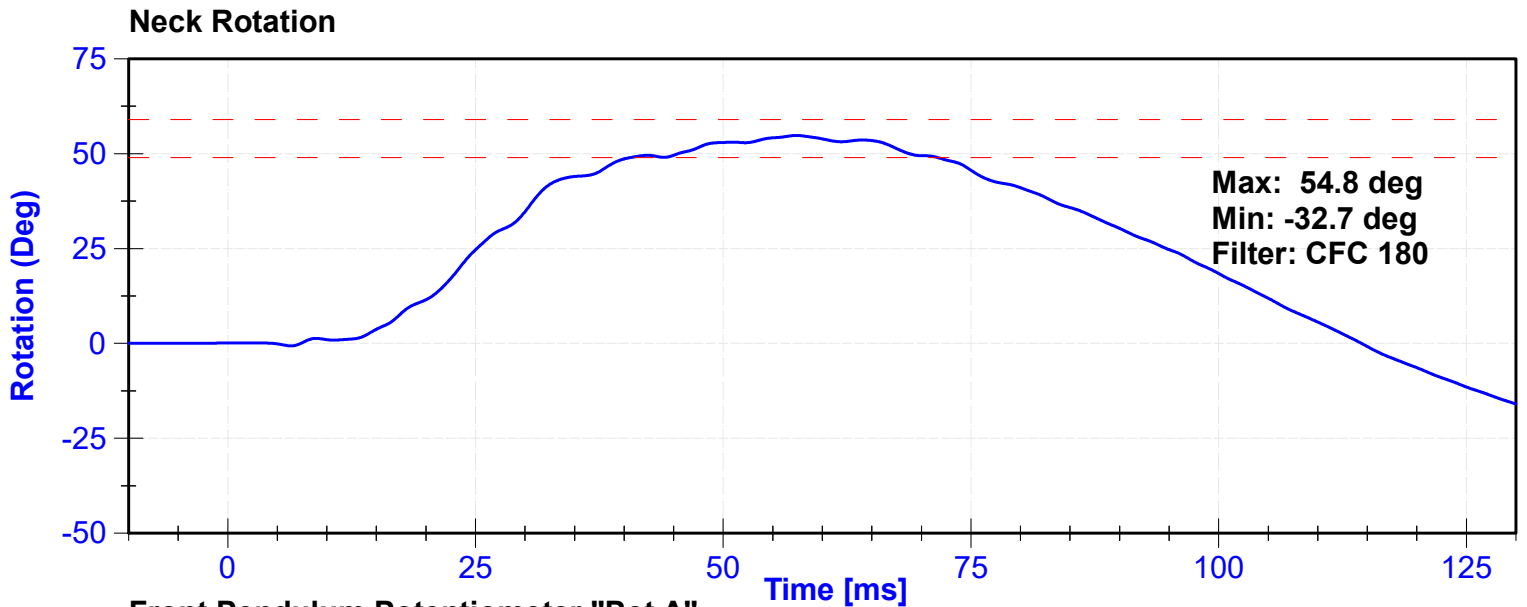

Appendix I

² Upper Boundary Corridor		¹ Lower Boundary Corridor	
Time (ms)	Velocity (m/s)	Time (ms)	Velocity (m/s)
1.0	0.00	0.0	-0.05
3.0	-0.25	2.5	-0.375
14.0	-3.20	13.5	-3.7
		17.0	-3.7

ATD Manufacturer	Denton	Test Technician	Z.Schneider
ATD Serial Number	D037	Laboratory Supervisor	C. Mantell

Results

Test Parameter	Minimum Specification	Maximum Specification	Unit	Result	Pass/Fail
Temperature	20.6	22.2	°C	21	Pass
Humidity	10	70	%	21	Pass
Velocity	4.2	4.4	m/s	4.35	Pass
Probe Acceleration	7.5	10.5	g's	7.91	Pass

Transducer Calibrations

Channel	Manufacturer	Serial Number	Calibration Date	Calibration Due Date
Probe Accelerometer	Endevco	18494	11/5/2022	5/4/2023

Probe Acceleration

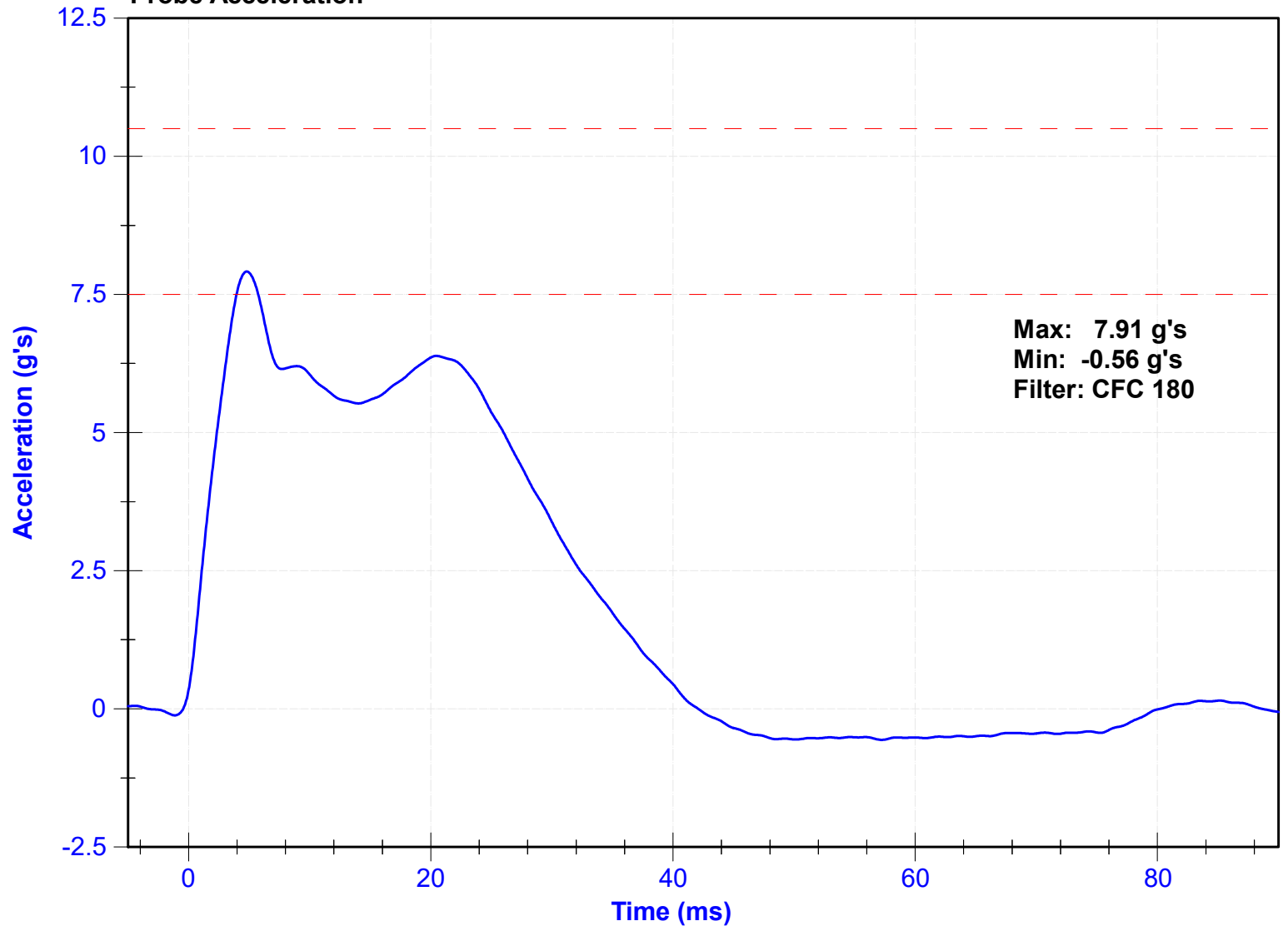

ATD Manufacturer	Denton	Test Technician	D. Sakona
ATD Serial Number	D037	Laboratory Supervisor	C. Mantell

Results

Test Parameter	Minimum Specification	Maximum Specification	Unit	Result	Pass/Fail
Temperature	20.6	22.2	°C	20.8	Pass
Humidity	10	70	%	20.5	Pass
Rib Displacement	36	40	mm	37.7	Pass

Transducer Calibrations

Channel	Manufacturer	Serial Number	Calibration Date	Calibration Due Date
Rib Potentiometer	Honeywell	DS-0552-01	9/7/2022	3/8/2023

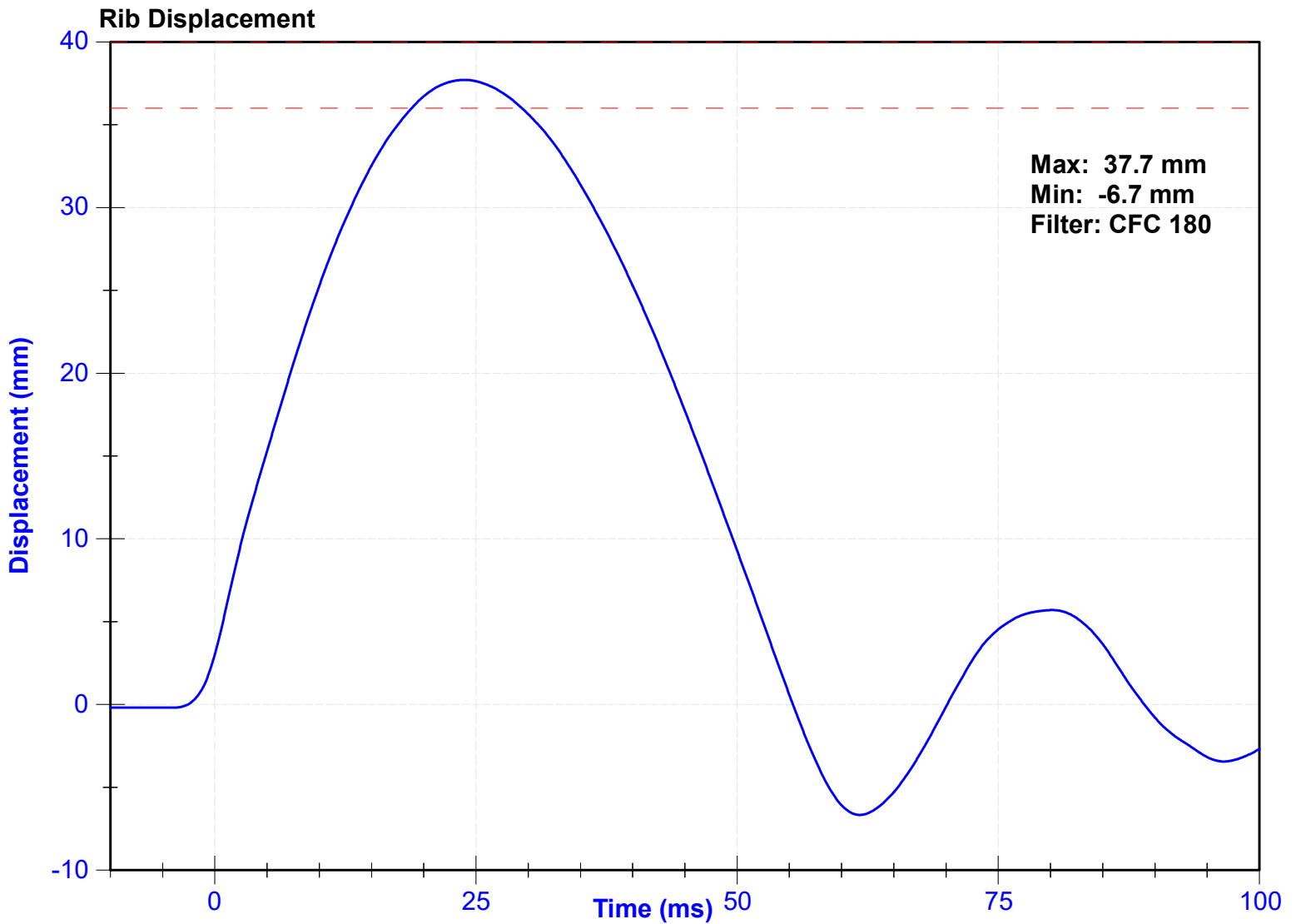

ATD Manufacturer	Denton	Test Technician	D. Sakona
ATD Serial Number	D037	Laboratory Supervisor	C. Mantell

Results

Test Parameter	Minimum Specification	Maximum Specification	Unit	Result	Pass/Fail
Temperature	20.6	22.2	°C	20.8	Pass
Humidity	10	70	%	20.5	Pass
Rib Displacement	46	51	mm	48.5	Pass

Transducer Calibrations

Channel	Manufacturer	Serial Number	Calibration Date	Calibration Due Date
Rib Potentiometer	Honeywell	DS-0552-01	9/7/2022	3/8/2023

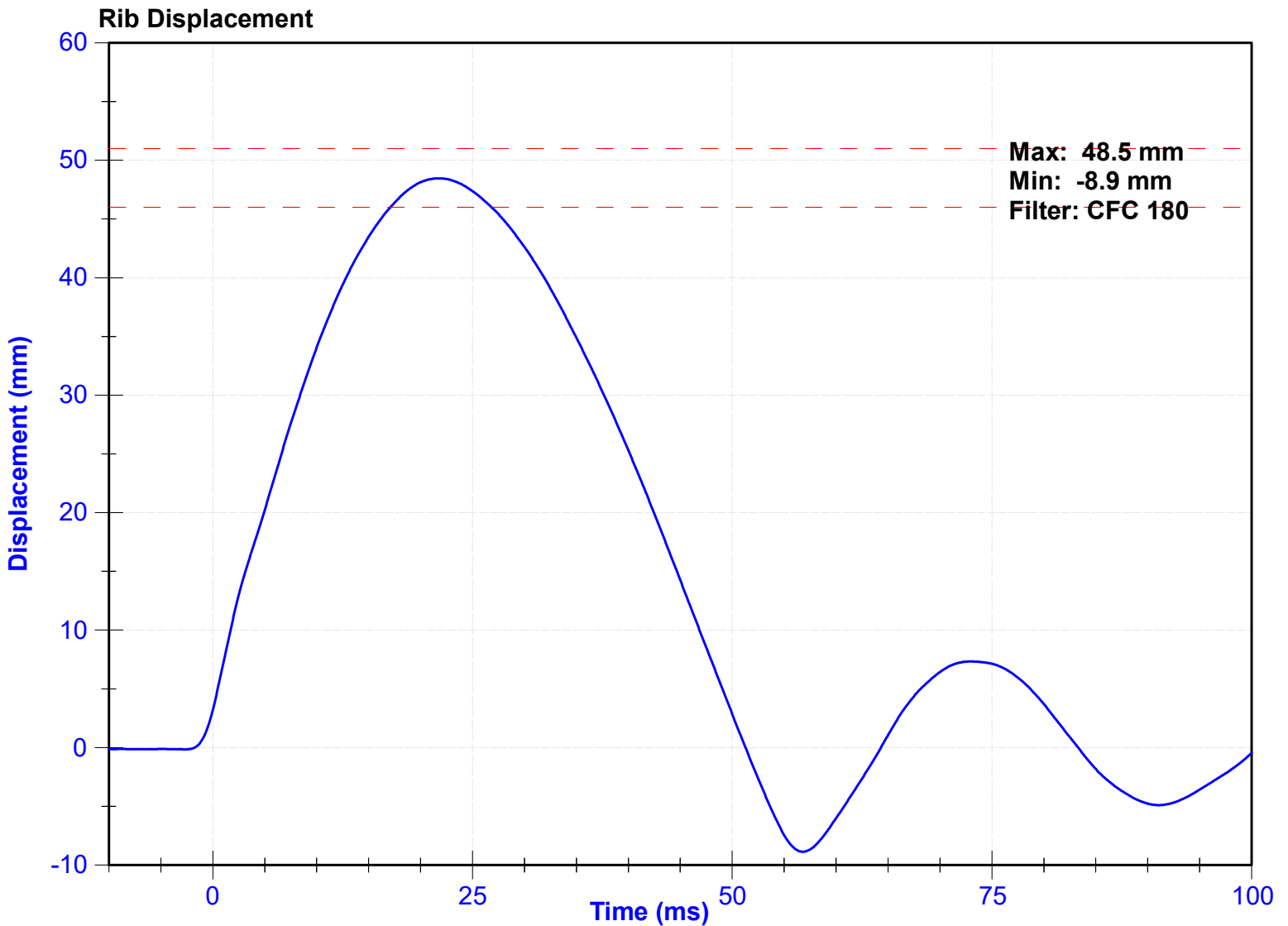

ATD Manufacturer	Denton	Test Technician	D. Sakona
ATD Serial Number	D037	Laboratory Supervisor	C. Mantell

Results

Test Parameter	Minimum Specification	Maximum Specification	Unit	Result	Pass/Fail
Temperature	20.6	22.2	°C	20.8	Pass
Humidity	10	70	%	20.5	Pass
Rib Displacement	36	40	mm	38.2	Pass

Transducer Calibrations

Channel	Manufacturer	Serial Number	Calibration Date	Calibration Due Date
Rib Potentiometer	Honeywell	DS-807	9/7/2022	3/8/2023

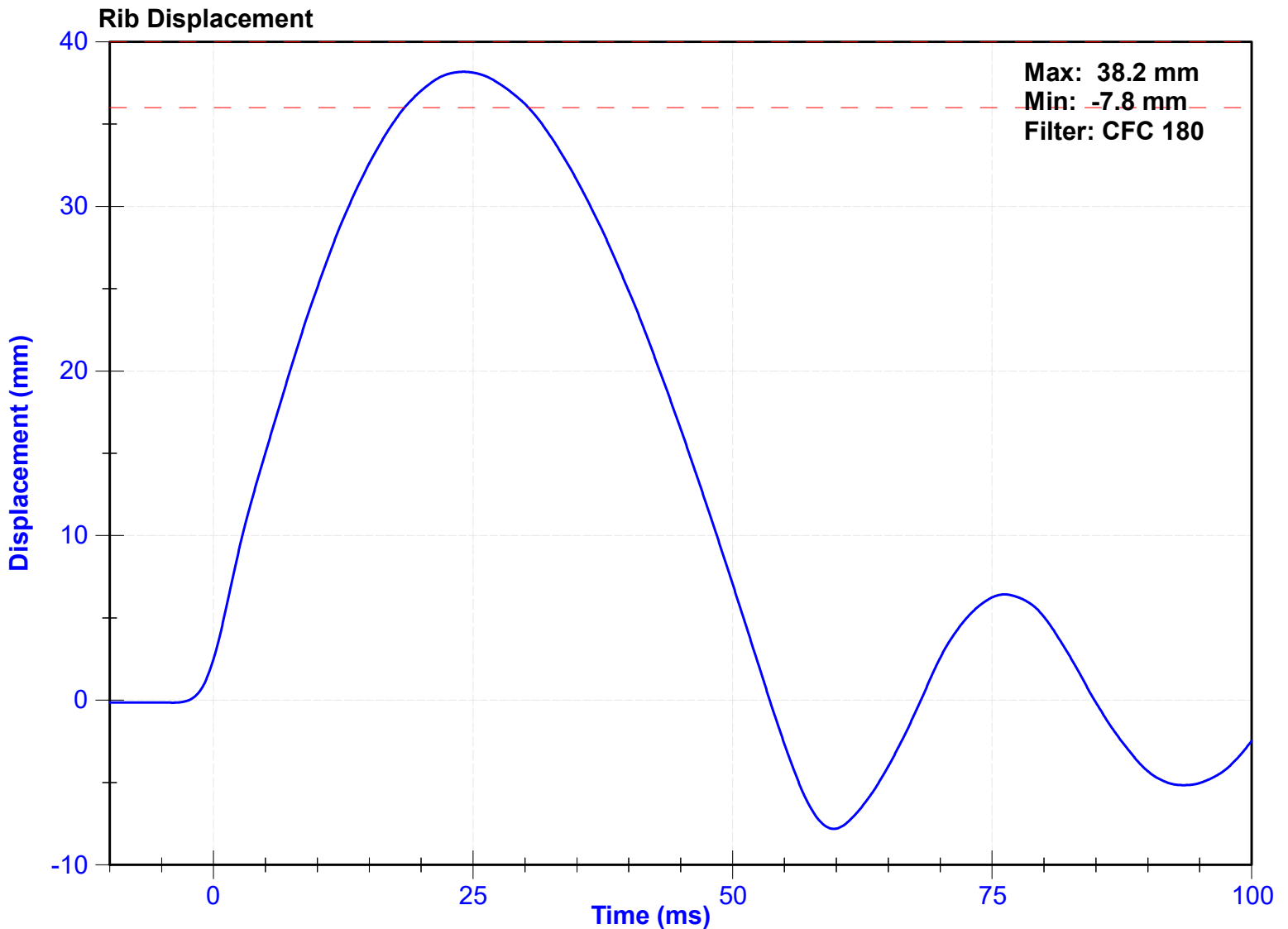

ATD Manufacturer	Denton	Test Technician	D. Sakona
ATD Serial Number	D037	Laboratory Supervisor	C. Mantell

Results

Test Parameter	Minimum Specification	Maximum Specification	Unit	Result	Pass/Fail
Temperature	20.6	22.2	°C	20.8	Pass
Humidity	10	70	%	20.5	Pass
Rib Displacement	46	51	mm	49.2	Pass

Transducer Calibrations

Channel	Manufacturer	Serial Number	Calibration Date	Calibration Due Date
Rib Potentiometer	Honeywell	DS-807	9/7/2022	3/8/2023

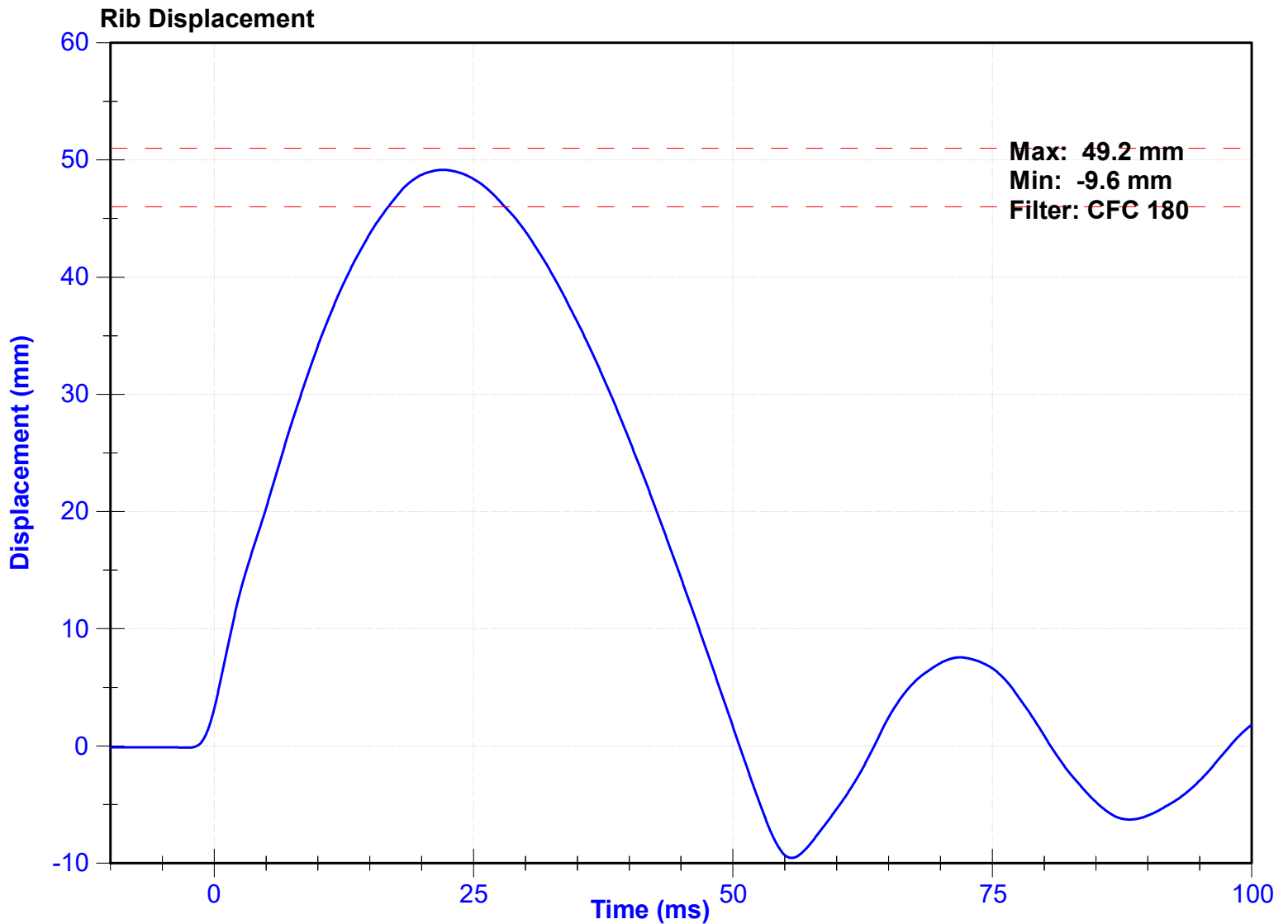

ATD Manufacturer	Denton	Test Technician	D. Sakona
ATD Serial Number	D037	Laboratory Supervisor	C. Mantell

Results

Test Parameter	Minimum Specification	Maximum Specification	Unit	Result	Pass/Fail
Temperature	20.6	22.2	°C	20.8	Pass
Humidity	10	70	%	20.5	Pass
Rib Displacement	36	40	mm	38.5	Pass

Transducer Calibrations

Channel	Manufacturer	Serial Number	Calibration Date	Calibration Due Date
Rib Potentiometer	Honeywell	DS-0552-03	9/7/2022	3/8/2023

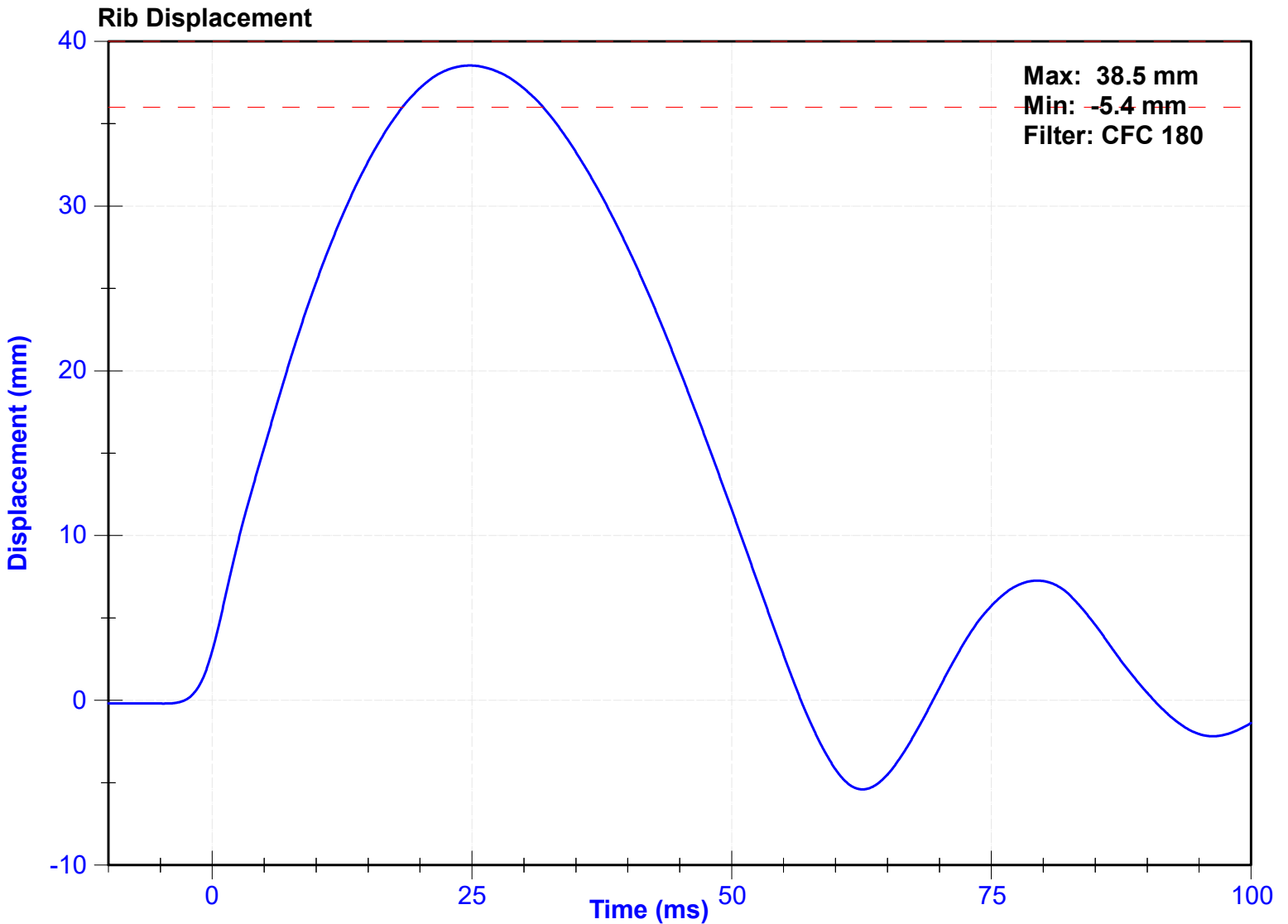

ATD Manufacturer	Denton	Test Technician	D. Sakona
ATD Serial Number	D037	Laboratory Supervisor	C. Mantell

Results

Test Parameter	Minimum Specification	Maximum Specification	Unit	Result	Pass/Fail
Temperature	20.6	22.2	°C	20.8	Pass
Humidity	10	70	%	20.5	Pass
Rib Displacement	46	51	mm	49.0	Pass

Transducer Calibrations

Channel	Manufacturer	Serial Number	Calibration Date	Calibration Due Date
Rib Potentiometer	Honeywell	DS-0552-03	9/7/2022	3/8/2023

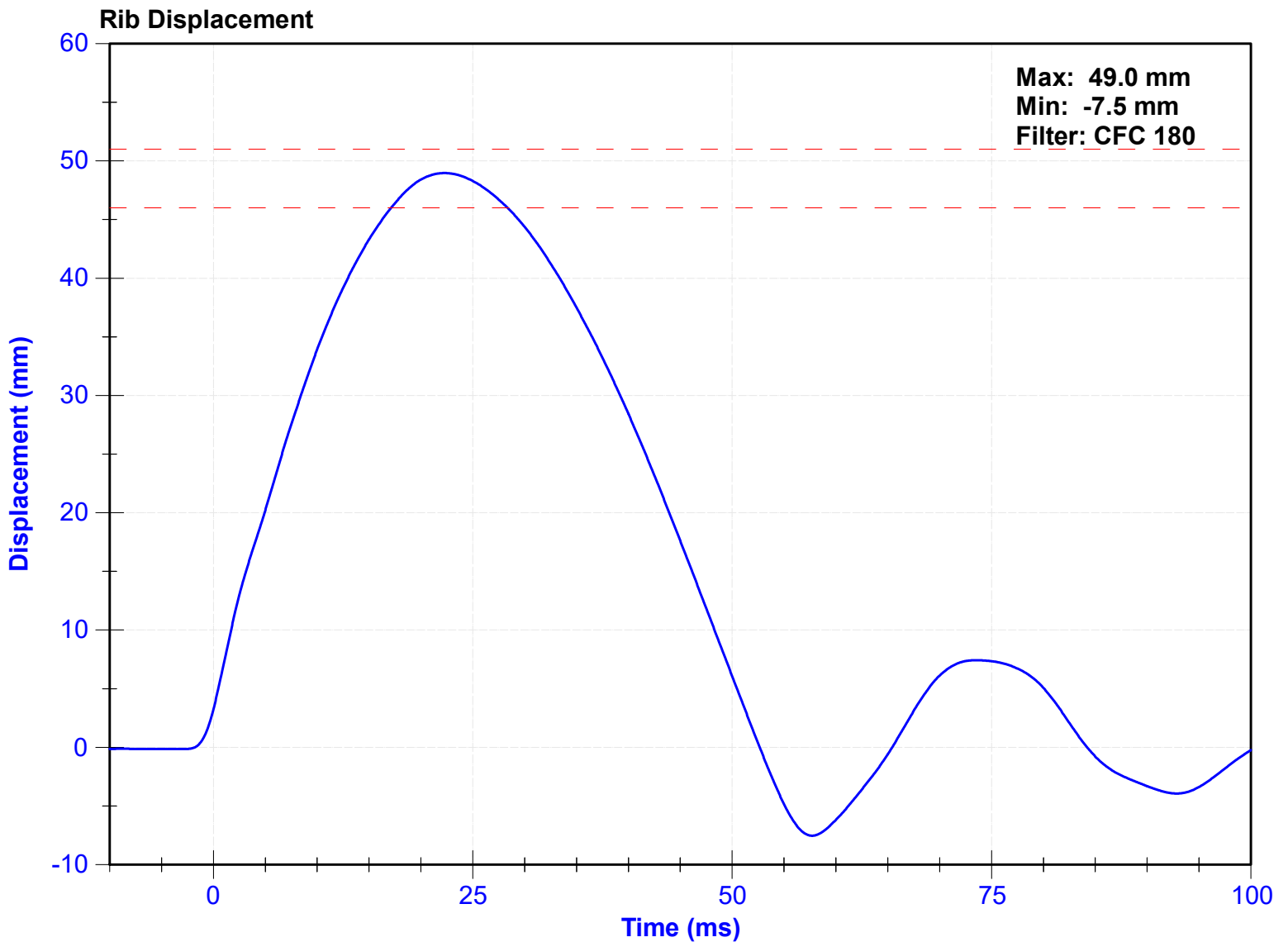

ATD Manufacturer	Denton	Test Technician	Z.Schneider
ATD Serial Number	D037	Laboratory Supervisor	C. Mantell

Results

Test Parameter	Minimum Specification	Maximum Specification	Unit	Result	Pass/Fail
Temperature	20.6	22.2	°C	21	Pass
Humidity	10	70	%	21	Pass
Velocity	5.4	5.6	m/s	5.50	Pass
Resistive Force after 6ms	5100	6200	N	6135.7	Pass
Upper Thorax Rib Deflection	34	41	mm	38.1	Pass
Mid Thorax Rib Deflection	37	45	mm	40.6	Pass
Lower Thorax Rib Deflection	37	44	mm	41.8	Pass

Transducer Calibrations

Channel	Manufacturer	Serial Number	Calibration Date	Calibration Due Date
Probe Accelerometer	Endevco	18494	11/5/2022	5/4/2023
Upper Thorax Rib Potentiometer	Honeywell	DS-0552-01	9/7/2022	3/8/2023
Middle Thorax Rib Potentiometer	Honeywell	DS-807	9/7/2022	3/8/2023
Lower Thorax Rib Potentiometer	Honeywell	DS-0552-03	9/7/2022	3/8/2023

Probe Acceleration

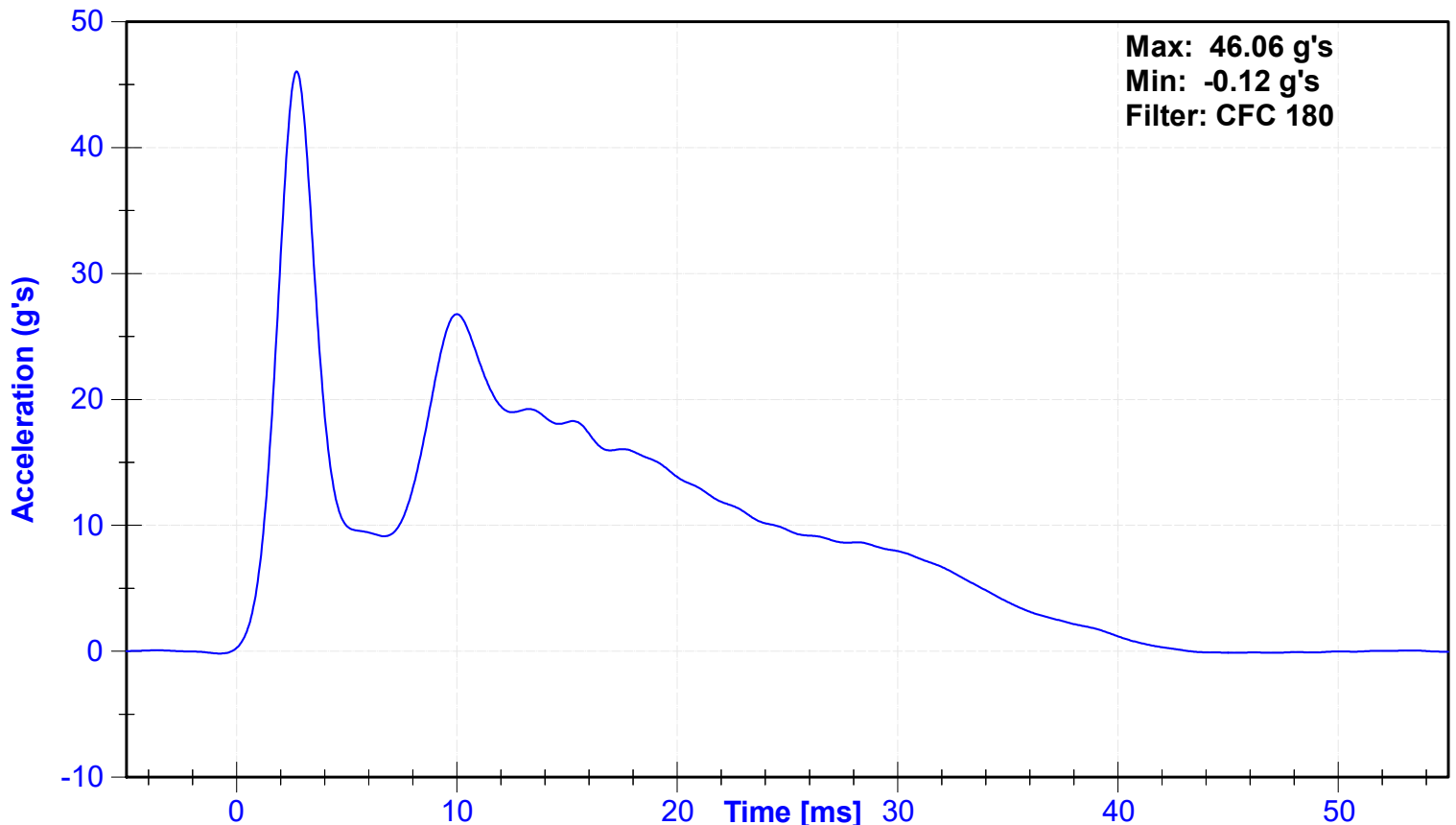

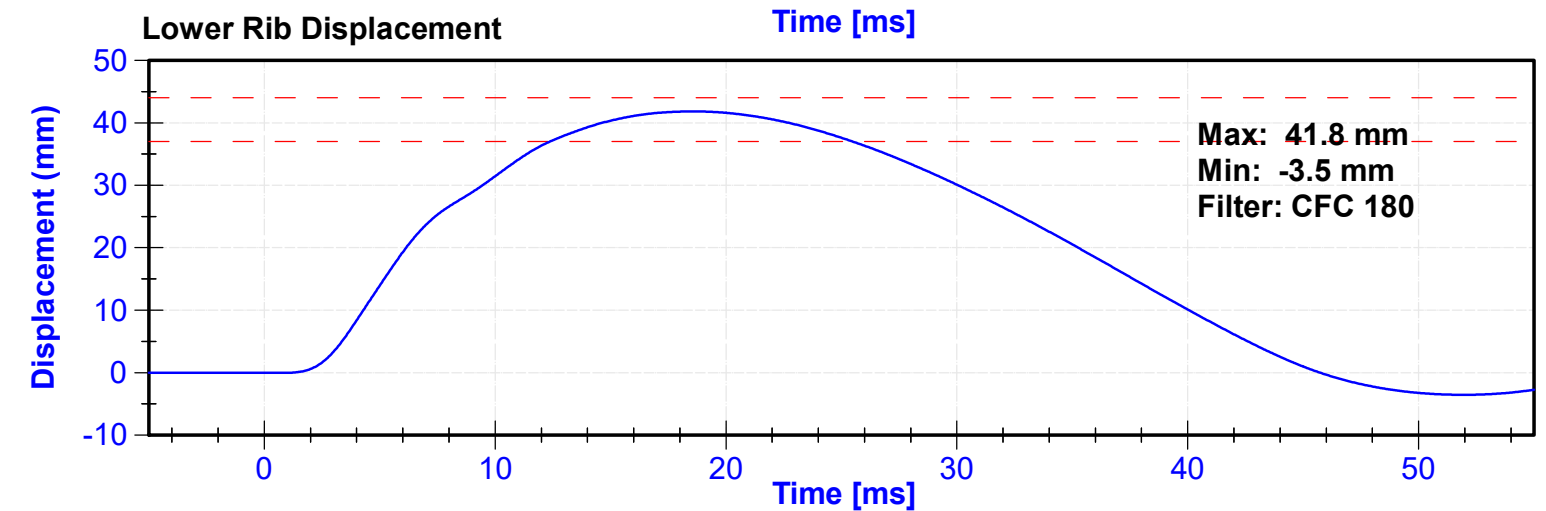
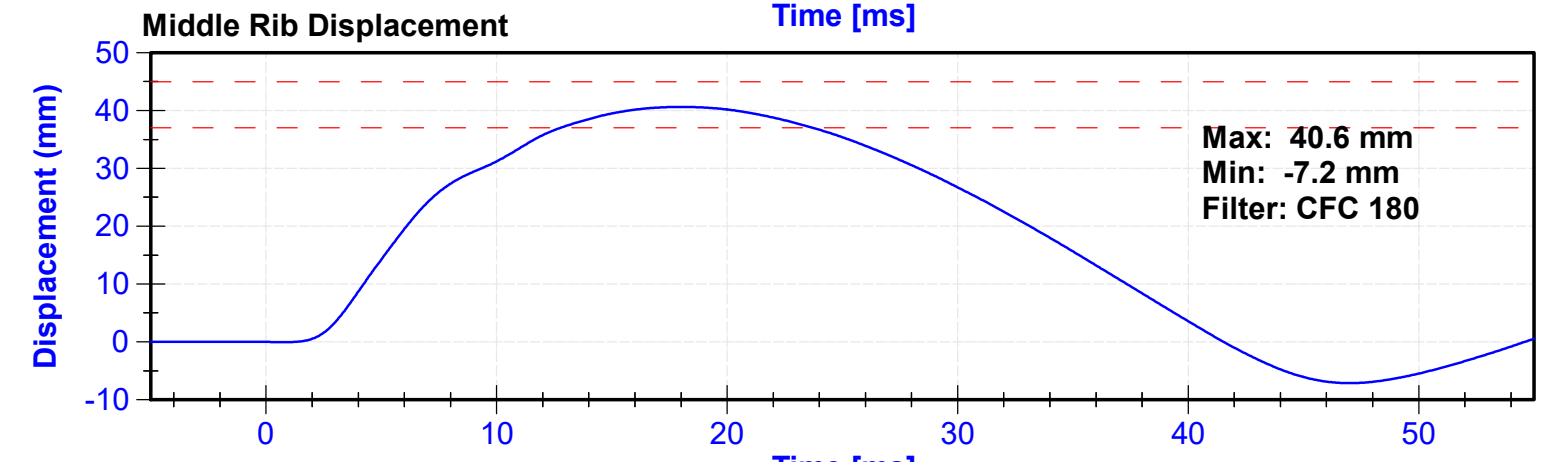
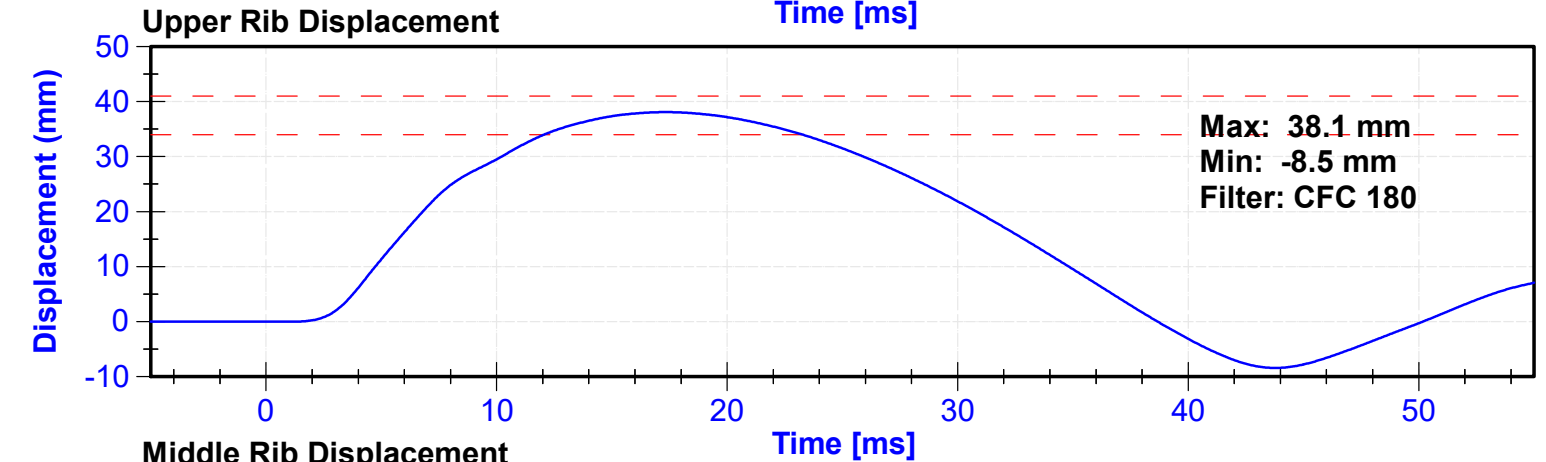
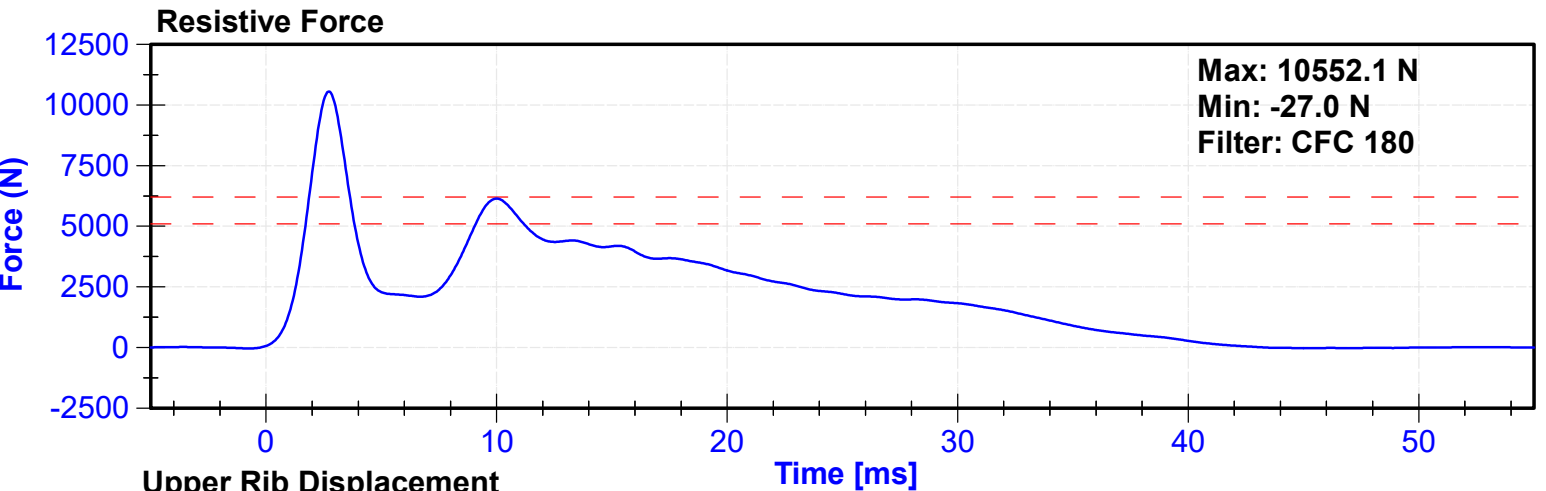

ATD Manufacturer	Denton	Test Technician	Z.Schneider
ATD Serial Number	D037	Laboratory Supervisor	C. Mantell

Results

Test Parameter	Minimum Specification	Maximum Specification	Unit	Result	Pass/Fail
Temperature	20.6	22.2	°C	21	Pass
Humidity	10	70	%	21	Pass
Velocity	3.9	4.1	m/s	4.01	Pass
Combined Abdomen Force	2200	2700	N	2278.4	Pass
Time at Peak Abdomen Force	10.0	12.3	ms	10.80	Pass
Resistive Probe Force	4000	4800	N	4388.4	Pass
Time at Peak Resistive Force	10.6	13.0	ms	11.05	Pass

Transducer Calibrations

Channel	Manufacturer	Serial Number	Calibration Date	Calibration Due Date
Pendulum Accelerometer	Endevco	18494	11/5/2022	5/4/2023
Front Abdomen Load Cell	Denton	1440	8/12/2022	8/12/2023
Middle Abdomen Load Cell	Denton	1525	8/12/2022	8/12/2023
Rear Abdomen Load Cell	Denton	1528	8/12/2022	8/12/2023

Probe Force

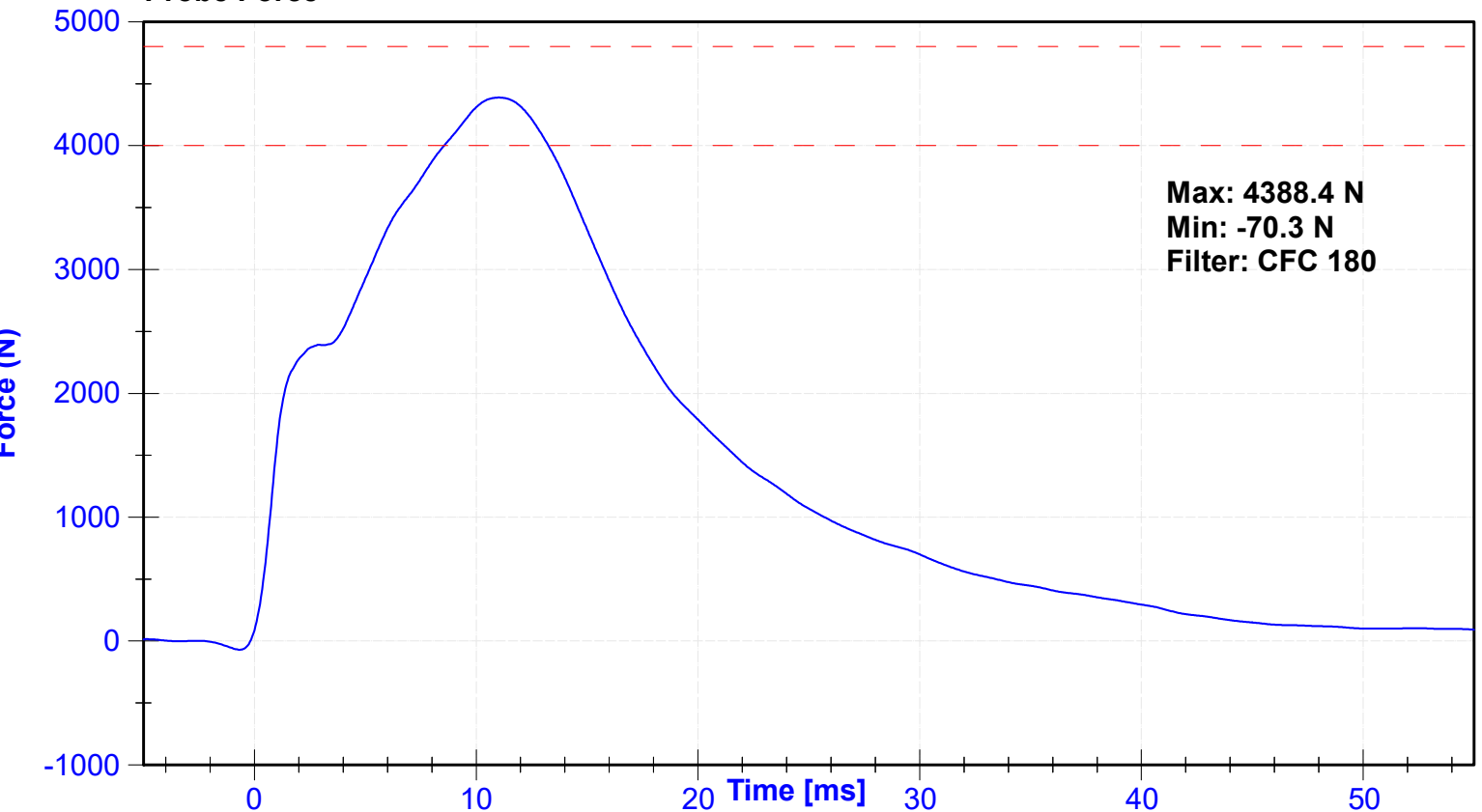

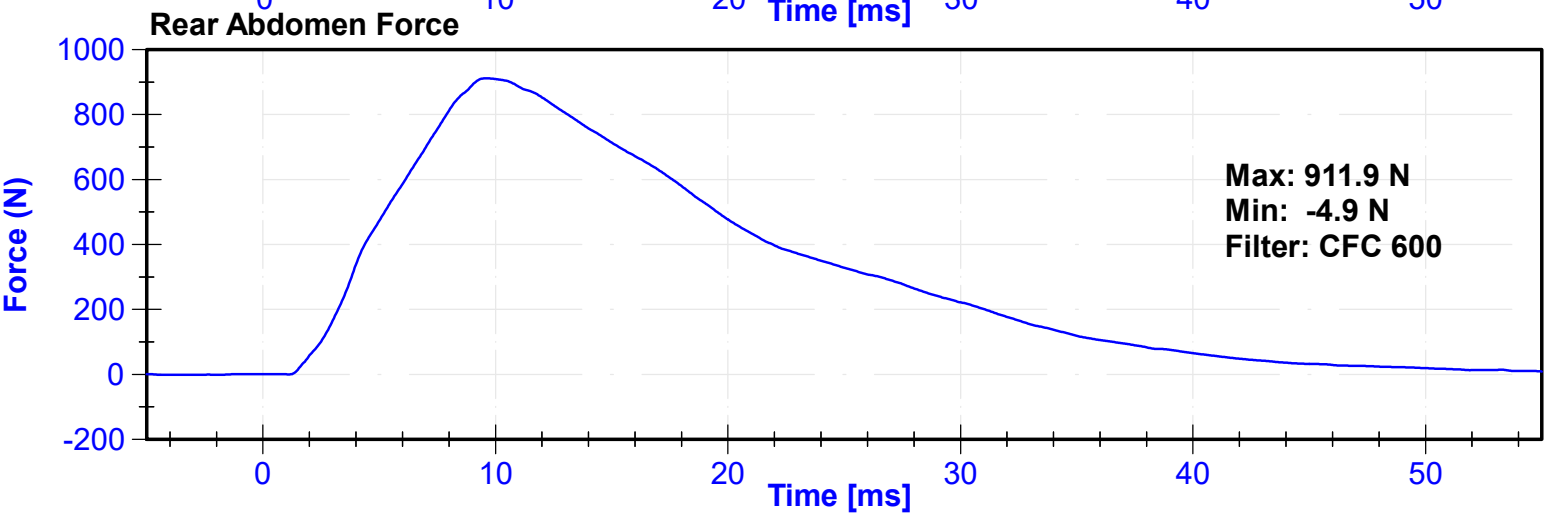
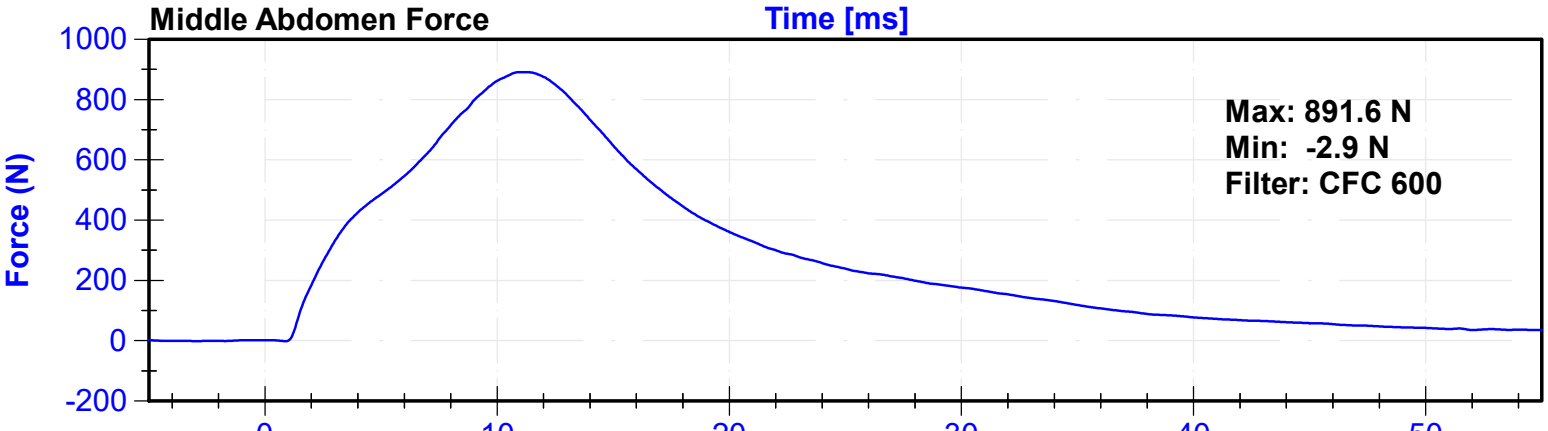
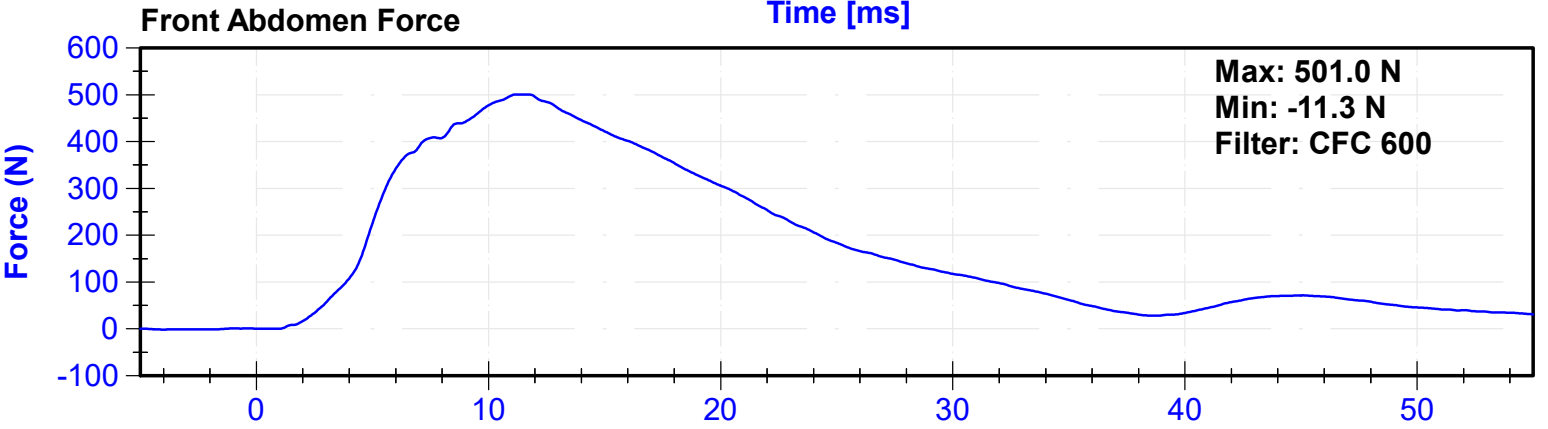
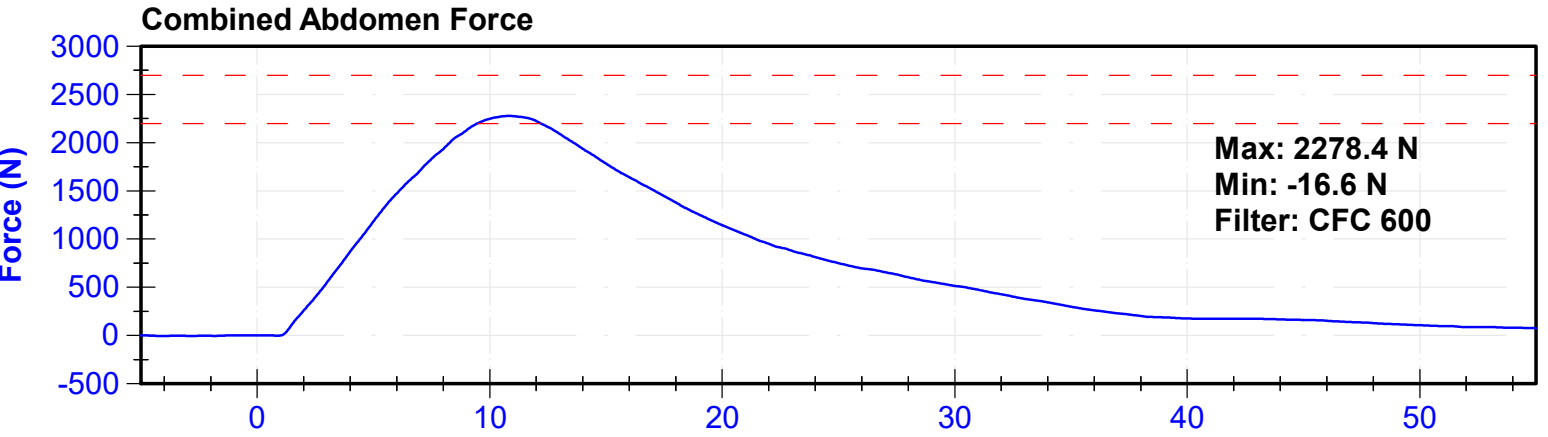

ATD Manufacturer	Denton	Test Technician	Z.Schneider
ATD Serial Number	F033	Laboratory Supervisor	C. Mantell

Results

Test Parameter	Minimum Specification	Maximum Specification	Unit	Result	Pass/Fail
Temperature	20.6	22.2	°C	21.0	Pass
Humidity	10	70	%	21	Pass
Velocity	5.95	6.15	m/s	6.029	Pass
Lateral Spine Rotation	45	55	deg	53.8	Pass
Time at Maximum Rotation	39	53	ms	48.7	Pass
Time of Decay to Zero Degrees	37	57	ms	39.4	Pass
Pendulum Velocity Overall Corridor	Lower Boundary ¹	Upper Boundary ²	m/s	See Plot ³	Pass

Transducer Calibrations

Channel	Manufacturer	Serial Number	Calibration Date	Calibration Due Date
Pendulum Accelerometer	Endevco	C16503	10/26/2022	10/26/2023
Pendulum "A" Potentiometer	Sfernice	094	10/5/2022	10/5/2023
Condyle "B" Potentiometer	Sfernice	095	10/5/2022	10/5/2023

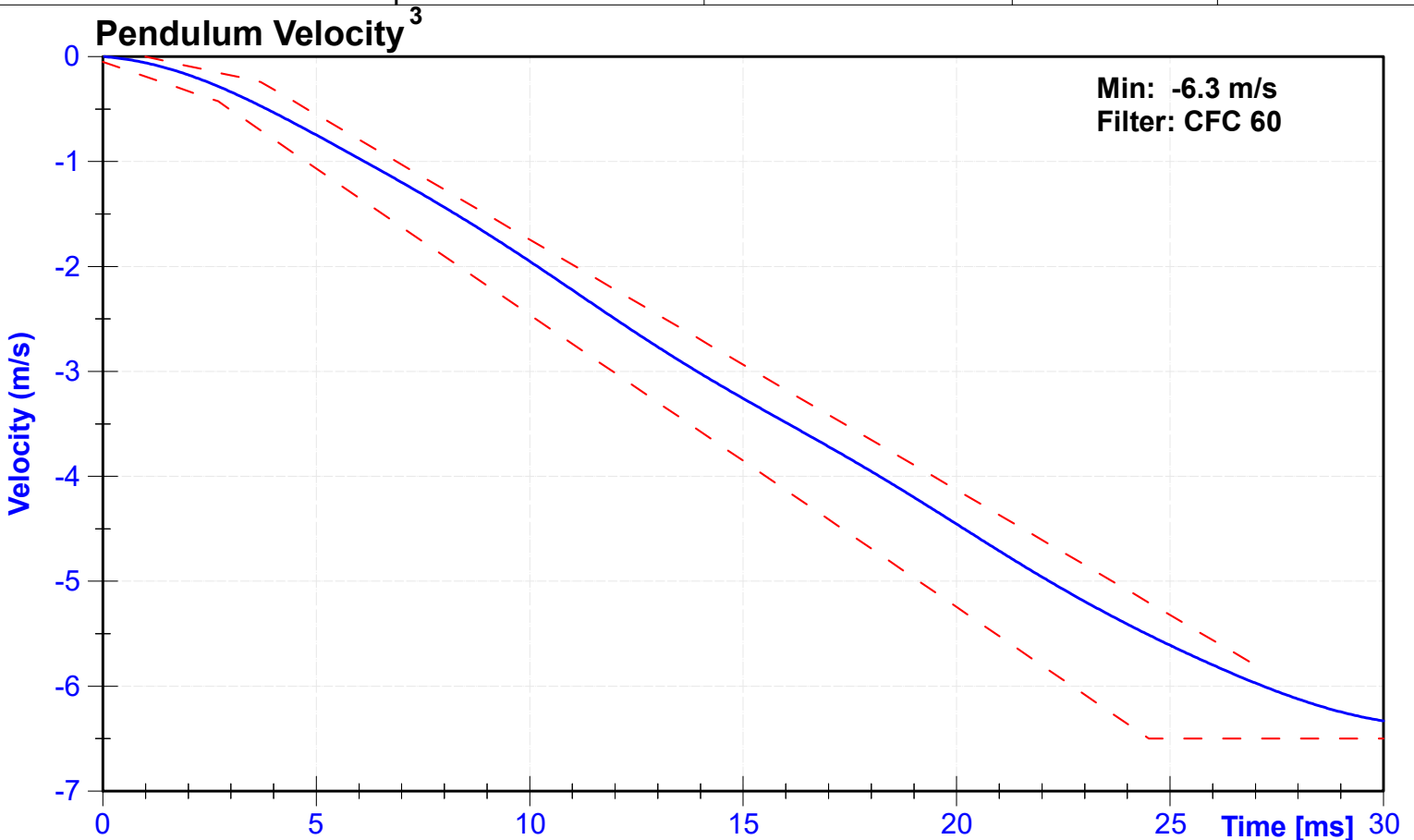

^{1,2} Upper and lower boundaries specified in Appendix I V-41

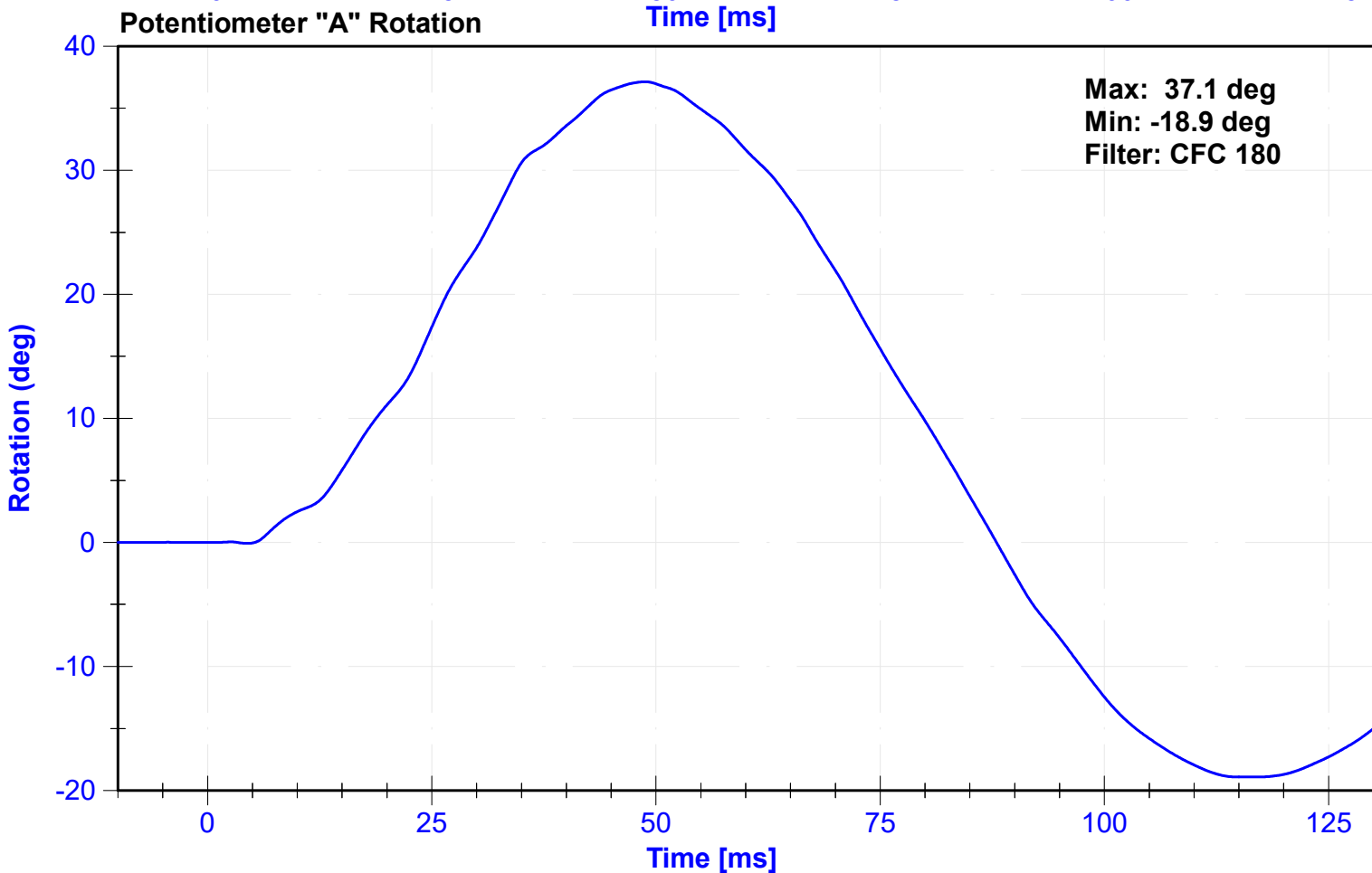
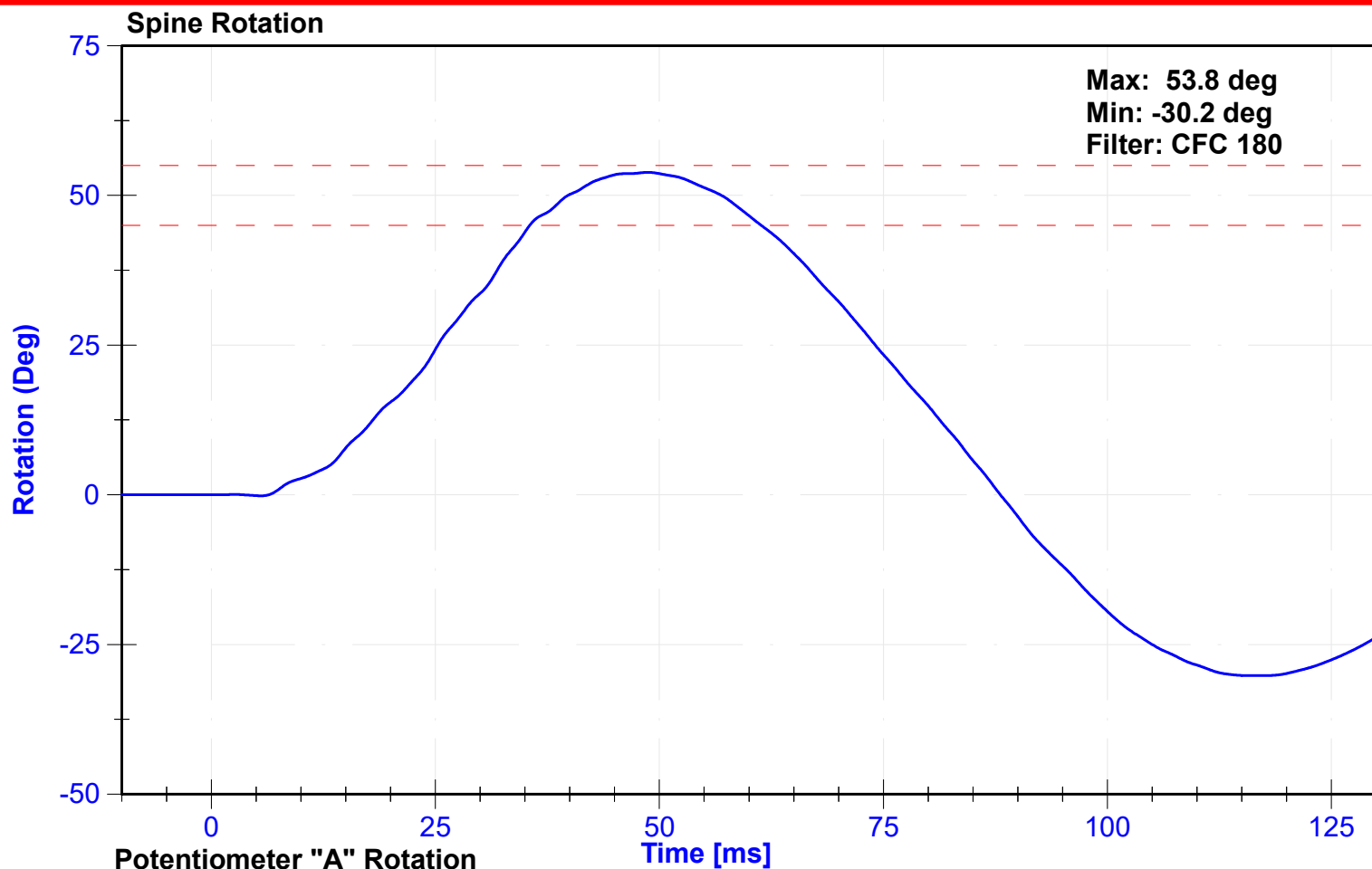

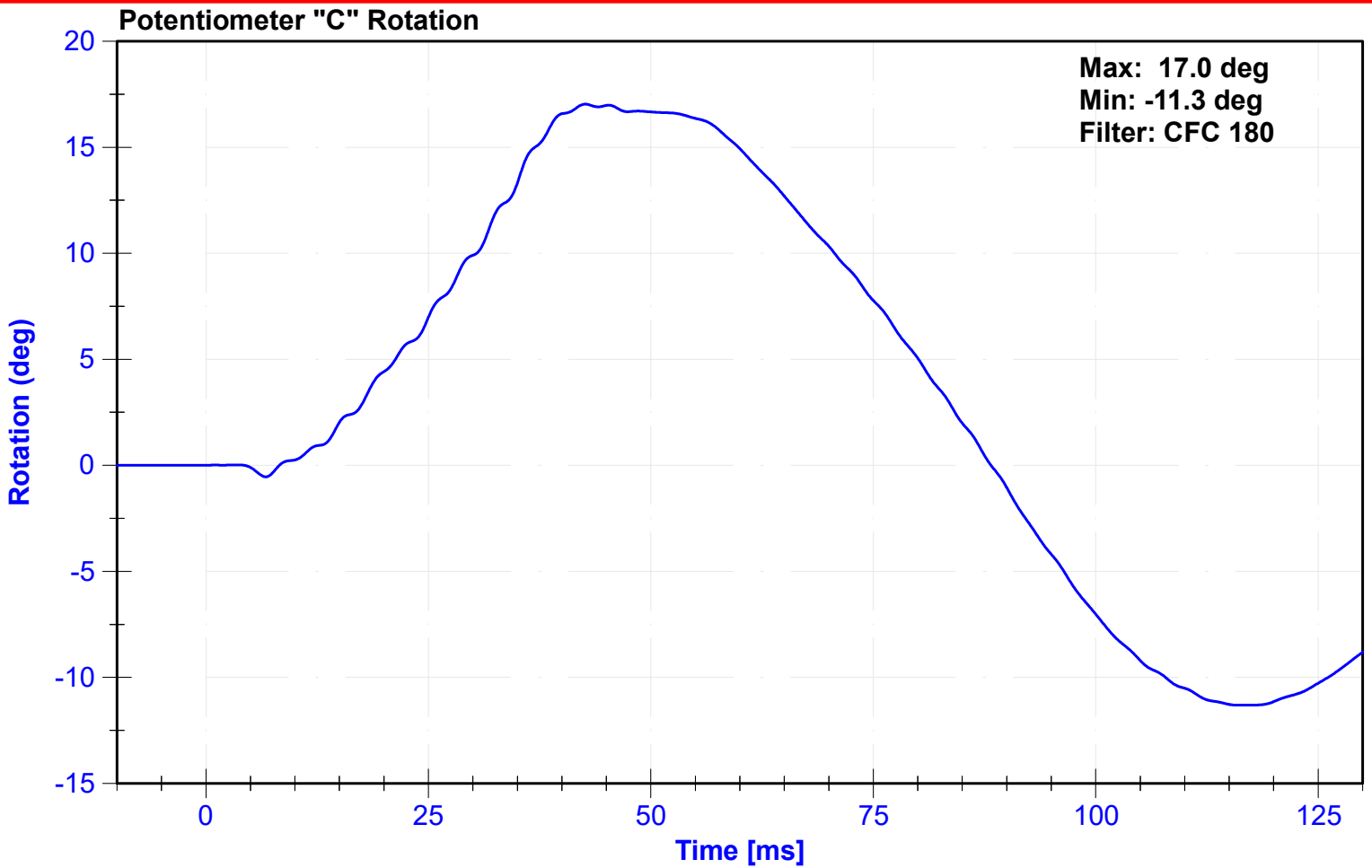

Appendix I

² Upper Boundary Corridor		¹ Lower Boundary Corridor	
Time (ms)	Velocity (m/s)	Time (ms)	Velocity (m/s)
1.0	0.00	0.0	-0.05
3.7	-0.24	2.7	-0.425
27.0	-5.80	24.5	-6.5
		30.0	-6.5

ATD Manufacturer	Denton	Test Technician	Z.Schneider
ATD Serial Number	D037	Laboratory Supervisor	C. Mantell

Results

Test Parameter	Minimum Specification	Maximum Specification	Unit	Result	Pass/Fail
Temperature	20.6	22.2	°C	21	Pass
Humidity	10	70	%	21	Pass
Velocity	4.2	4.4	m/s	4.29	Pass
Resistive Force	4700	5400	N	4984.7	Pass
Time at Peak Resistive Force	11.8	16.1	ms	14.75	Pass
Pubic Force	-1590	-1230	N	-1453.3	Pass
Time at Peak Pubic Force	12.2	17.0	ms	14.85	Pass

Transducer Calibrations

Channel	Manufacturer	Serial Number	Calibration Date	Calibration Due Date
Pendulum Accelerometer	Endevco	18494	11/5/2022	5/4/2023
Pubic Load Cell	Denton	456-FY	8/12/2022	8/12/2023

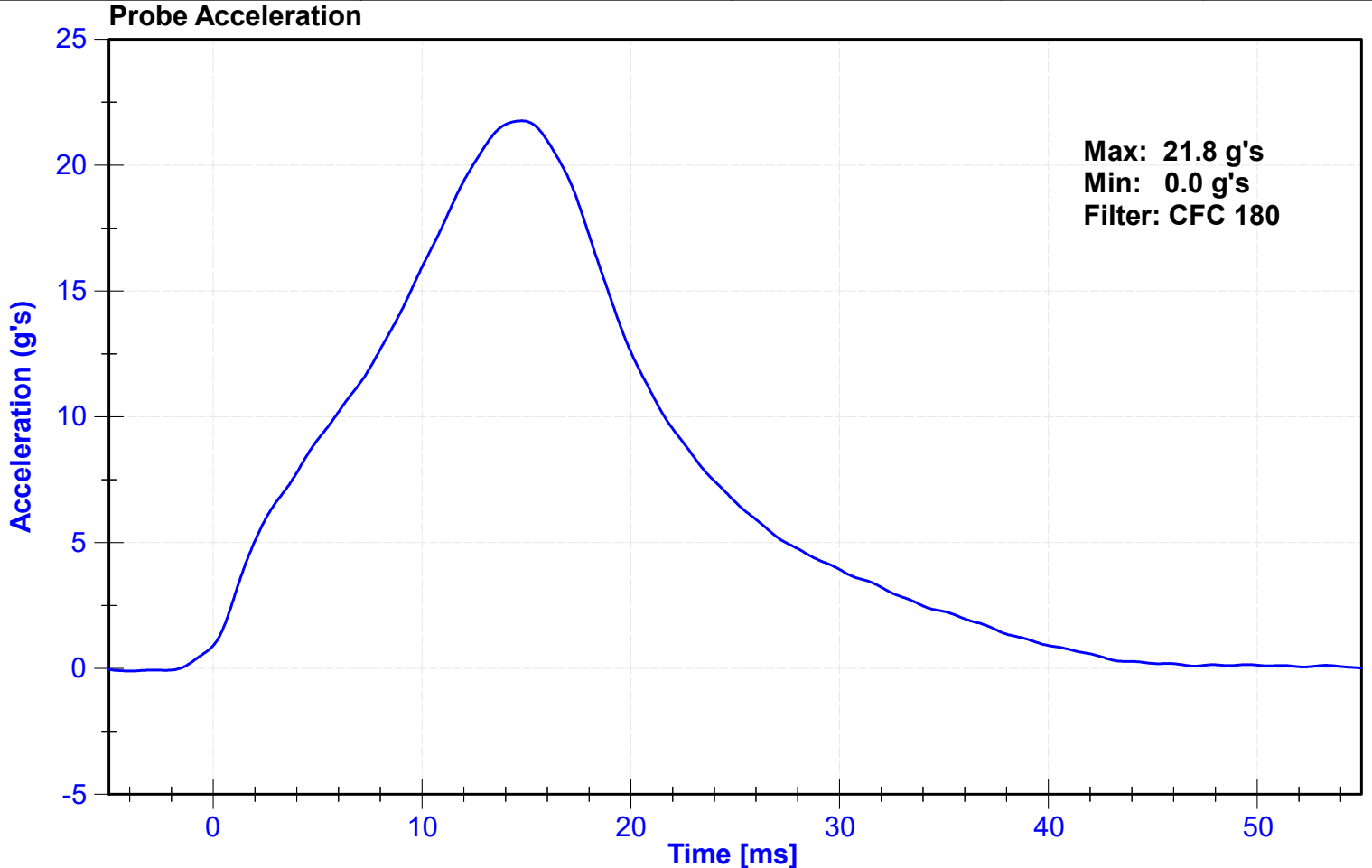

Resistive Force

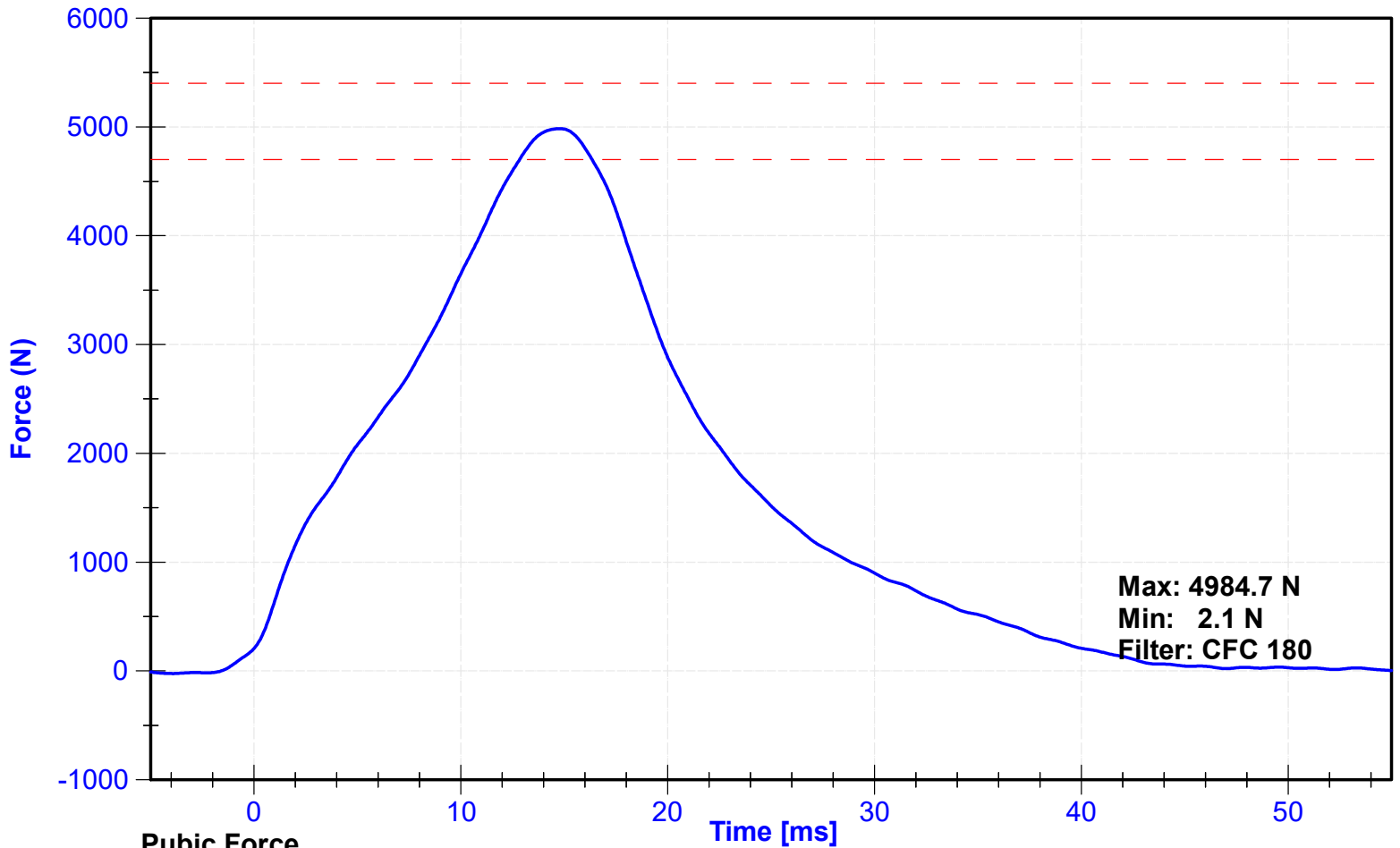

Pubic Force

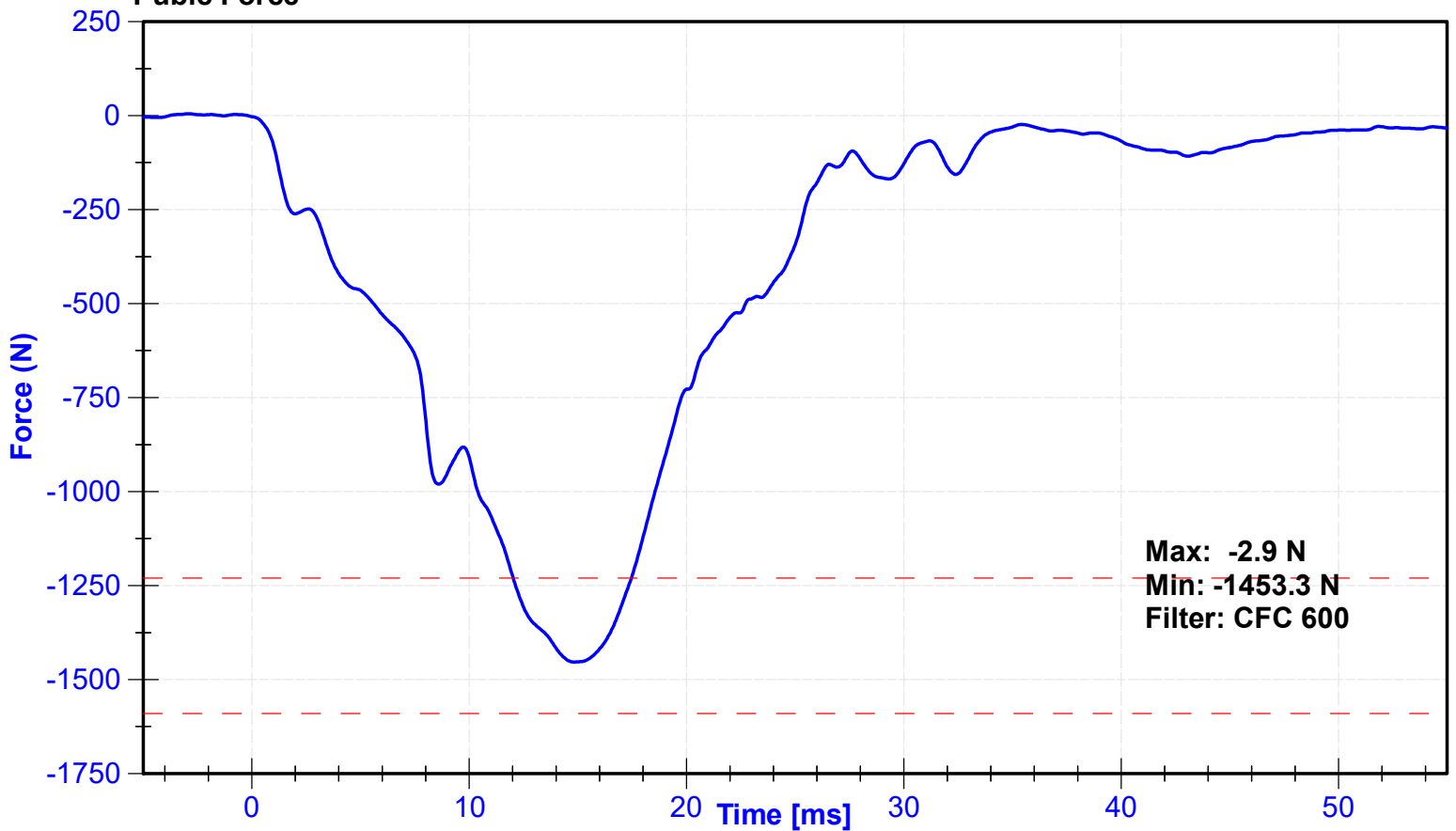

APPENDIX VI
SID-Its PERFORMANCE CALIBRATION TEST DATA

**PRE-TEST
SID-IIs PERFORMANCE CALIBRATION TEST DATA**



External Measurements - SID-IIs

Technician: K. Brogan

Date: 12/14/2022

Dummy Serial Number: 261

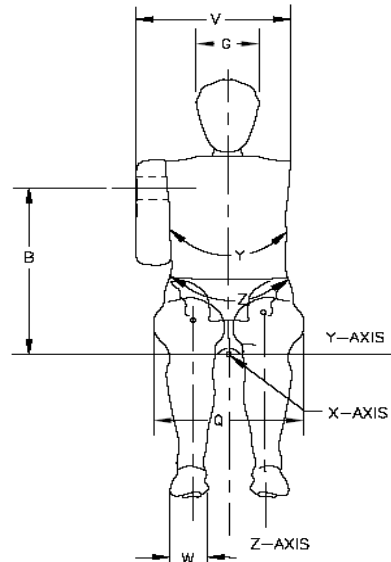
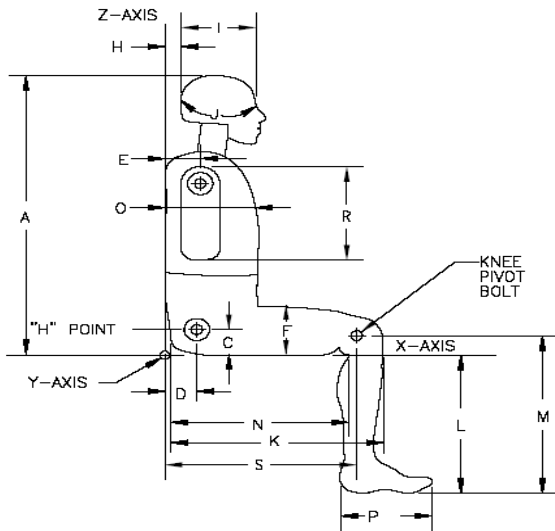

Symbol	Description	Specification (mm)		Result (mm)	Pass/Fail
A	Sitting Height	772	788	785	Pass
B	Shoulder Pivot Height	437	453	445	Pass
C	H-point Height	79	89	84	Pass
D	H-point from seatback	141	151	145	Pass
E	Shoulder Pivot from Backline	97	107	100	Pass
F	Thigh Clearance	119	135	129	Pass
G	Head Breadth	140	148	145	Pass
H	Head Back from Backline	40	46	43	Pass
I	Head Depth	178	188	181	Pass
J	Head Circumference	541	551	543	Pass
K	Buttock to Knee Length	514	540	531	Pass
L	Popliteal Height	343	369	358	Pass
M	Knee Pivot to floor height	392	409	401	Pass
N	Buttock Popliteal Length	416	442	433	Pass
O	Chest Depth w/o jacket	195	211	206	Pass
P	Foot Length	216	232	223	Pass
Q	Hip Breadth (w/pelvic plugs)	313	323	318	Pass
R	Arm Length	249	259	254	Pass
S	Knee Joint to seatback	477	493	489	Pass
V	Shoulder Width	341	357	351	Pass
W	Foot Width	78	94	84	Pass
Y	Chest Circumference w/jacket	851	881	873	Pass
Z	Waist Circumference	761	791	782	Pass

ATD Manufacturer	FTSS	Test Technician	D. Sakona
ATD Serial Number	261	Laboratory Supervisor	K. Brogan

Results

Test Parameter	Minimum Specification	Maximum Specification	Unit	Result	Pass/Fail
Temperature	20.6	22.2	°C	21.1	Pass
Humidity	10	70	%	18.5	Pass
Resultant Acceleration	115	137	g's	130.3	Pass
Oscillation	0	15	%	1.5	Pass
Fore-Aft Acceleration	-15	15	g's	-7.7	Pass

Transducer Calibrations

Channel	Manufacturer	Serial Number	Calibratio Date	Calibratio Due Date
X Accelerometer	Endevco	P68067	10/26/2022	4/24/2023
Y Accelerometer	Endevco	P18567	10/25/2022	4/23/2023
Z Accelerometer	Endevco	P49163	10/25/2022	4/23/2023

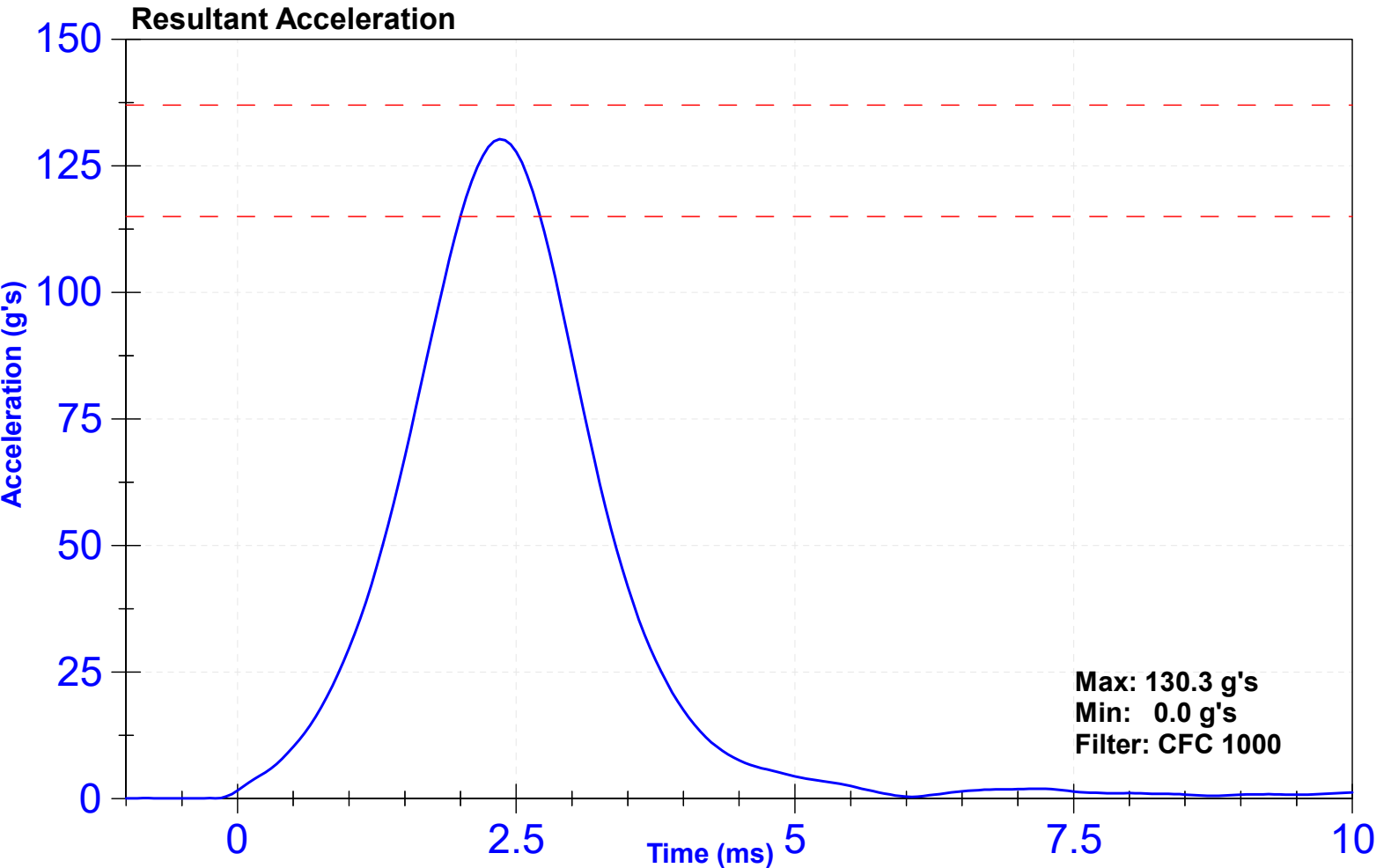

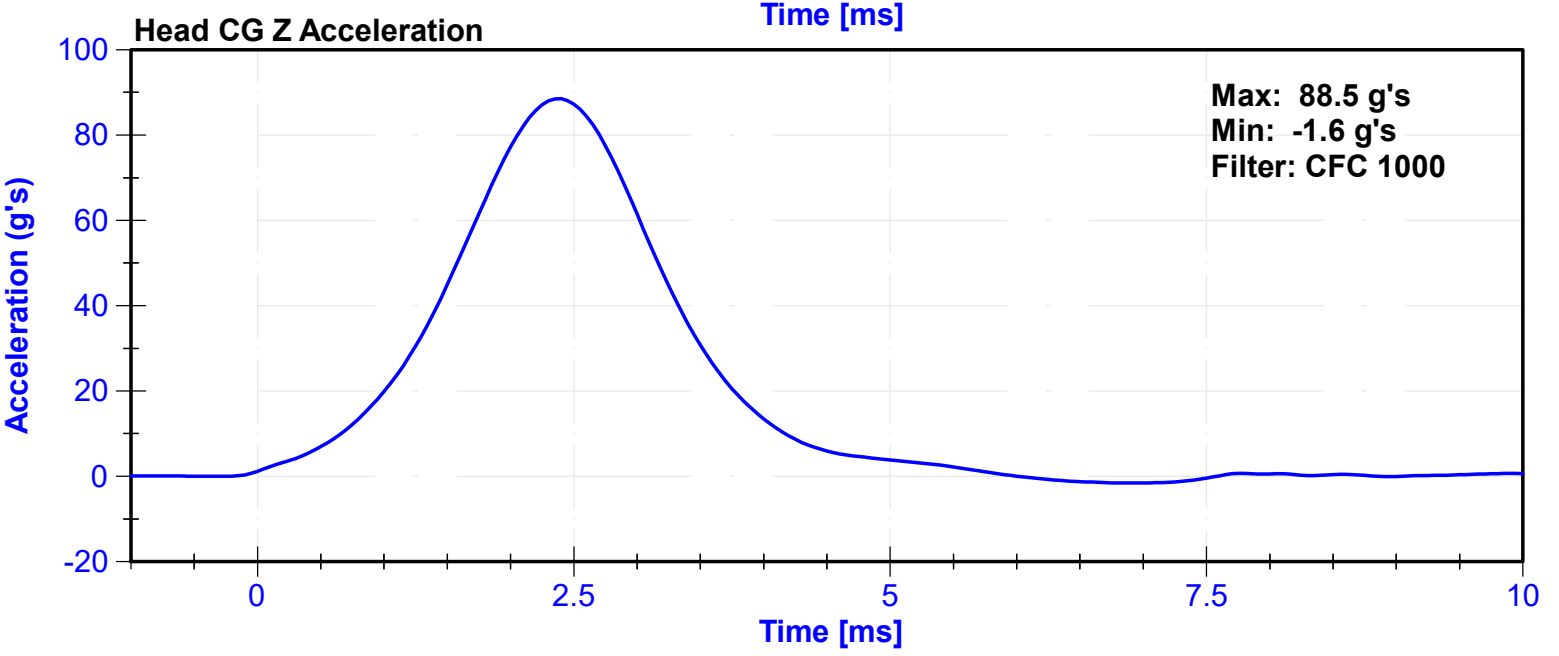
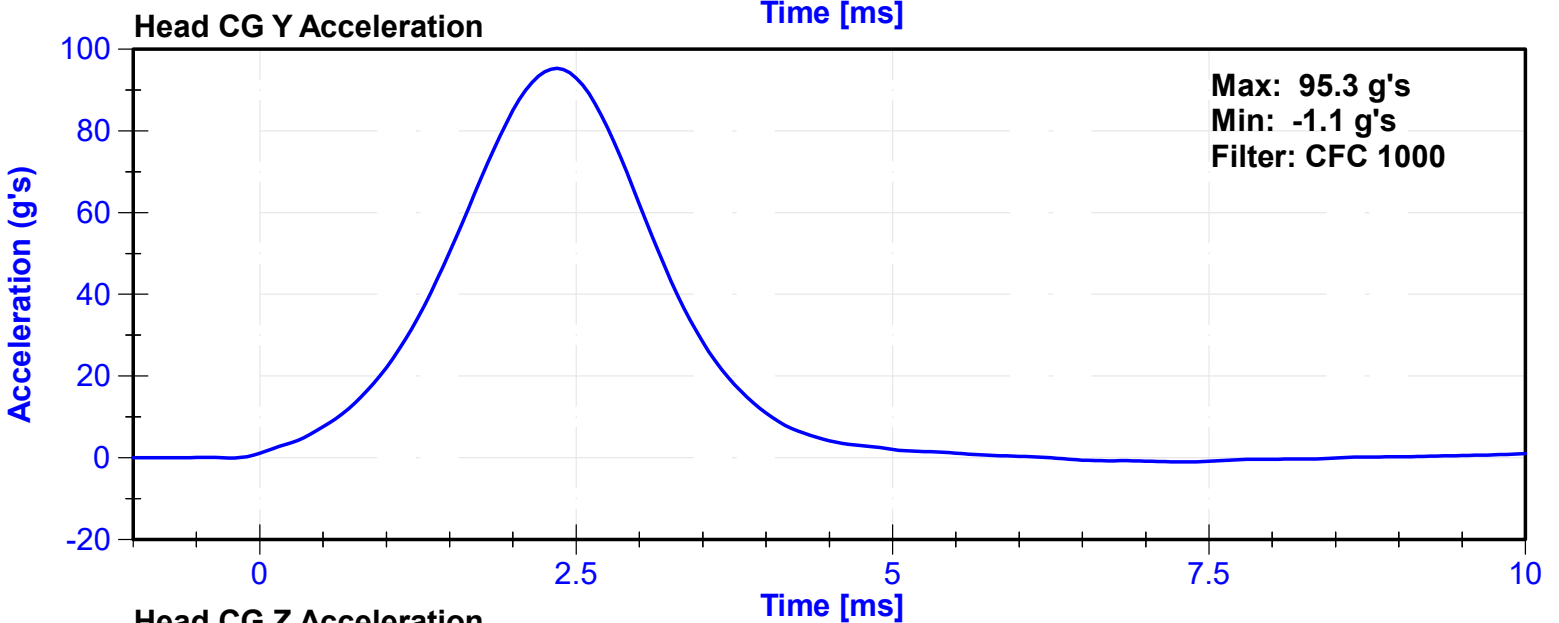
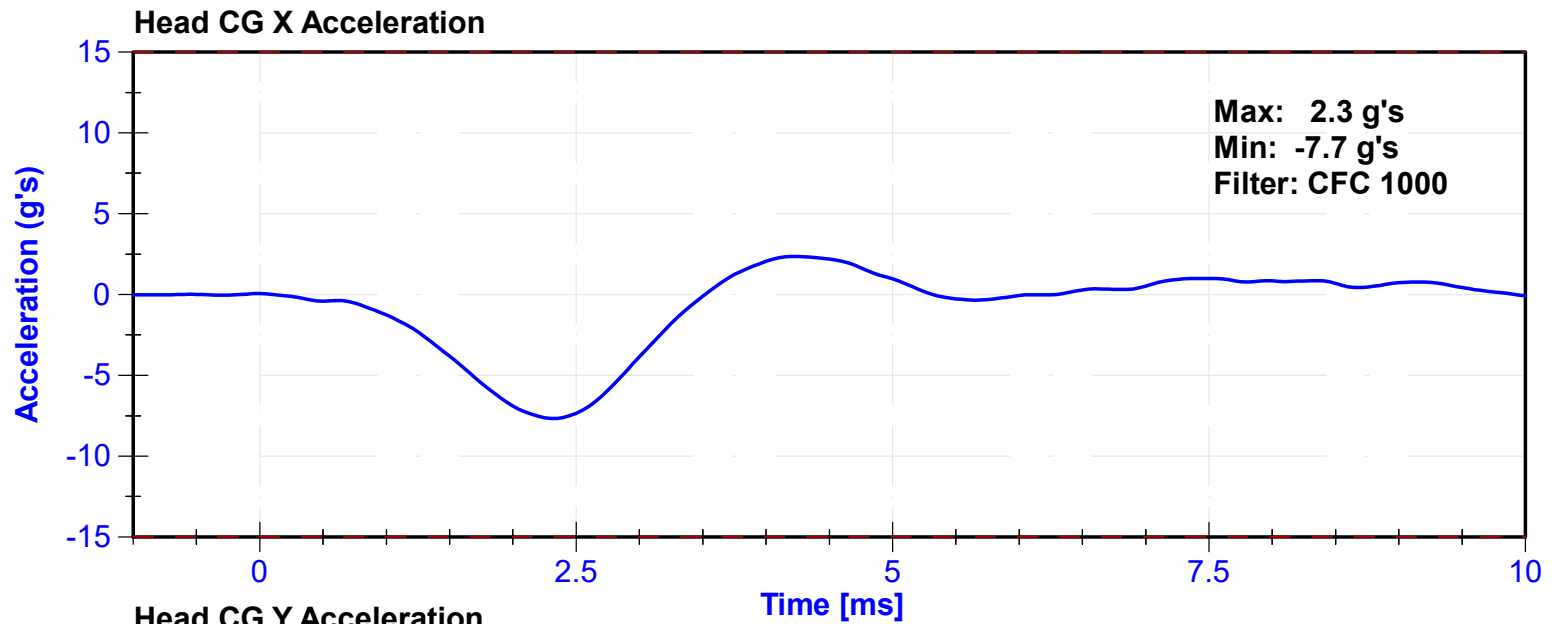

ATD Manufacturer	FTSS	Test Technician	D. Sakona
ATD Serial Number	261	Laboratory Supervisor	C. Mantell

Results

Test Parameter	Minimum Specification	Maximum Specification	Unit	Result	Pass/Fail
Temperature	20.6	22.2	°C	20.8	Pass
Humidity	10	70	%	22.5	Pass
Velocity	5.51	5.63	m/s	5.546	Pass
Pendulum Impulse at 10ms	2.2	2.8	m/s	2.24	Pass
Pendulum Impulse at 15ms	3.3	4.1	m/s	3.39	Pass
Pendulum Impulse at 20ms	4.4	5.4	m/s	4.56	Pass
Pendulum Impulse at 25ms	5.4	6.1	m/s	5.47	Pass
Pendulum Impulse from 25 to 100ms	5.5	6.2	m/s	5.94	Pass
Neck Rotation	71	81	deg	71.0	Pass
Time at Maximum Rotation	50	70	ms	59.4	Pass
Moment about the OC	36	44	Nm	43.4	Pass
Moment Decay to 0 Nm	102	126	ms	111.8	Pass

Transducer Calibrations

Channel	Manufacturer	Serial Number	Calibration Date	Calibration Due Date
Pendulum Accelerometer	Endevco	7231C-750	10/26/2022	10/26/2023
Pendulum Potentiometer	Servo	4961	11/11/2022	11/11/2023
Condyle Potentiometer	Servo	DS185	11/11/2022	11/11/2023
Upper Neck Load Cell	Humanetics	1716A_1872-FY	6/13/2022	6/13/2023

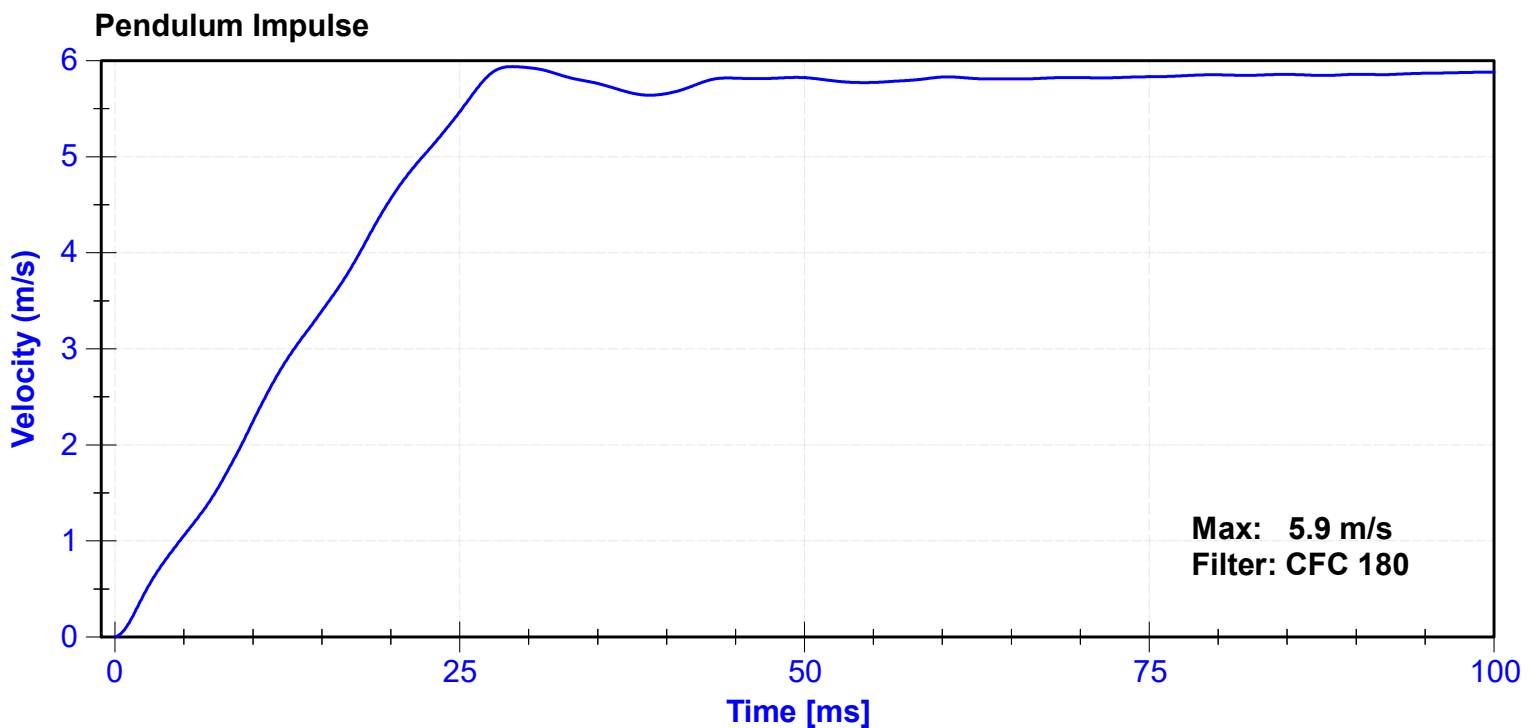

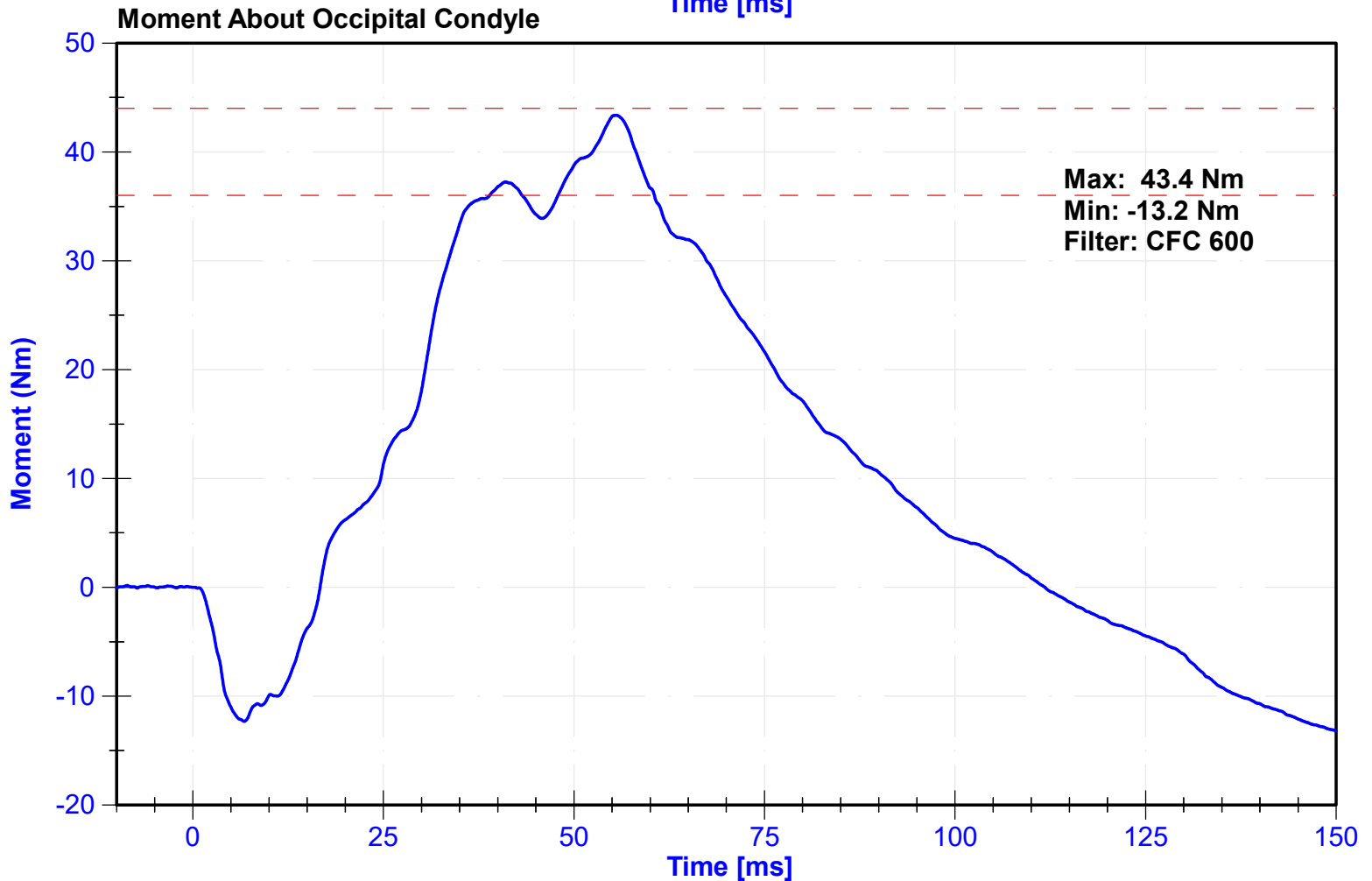
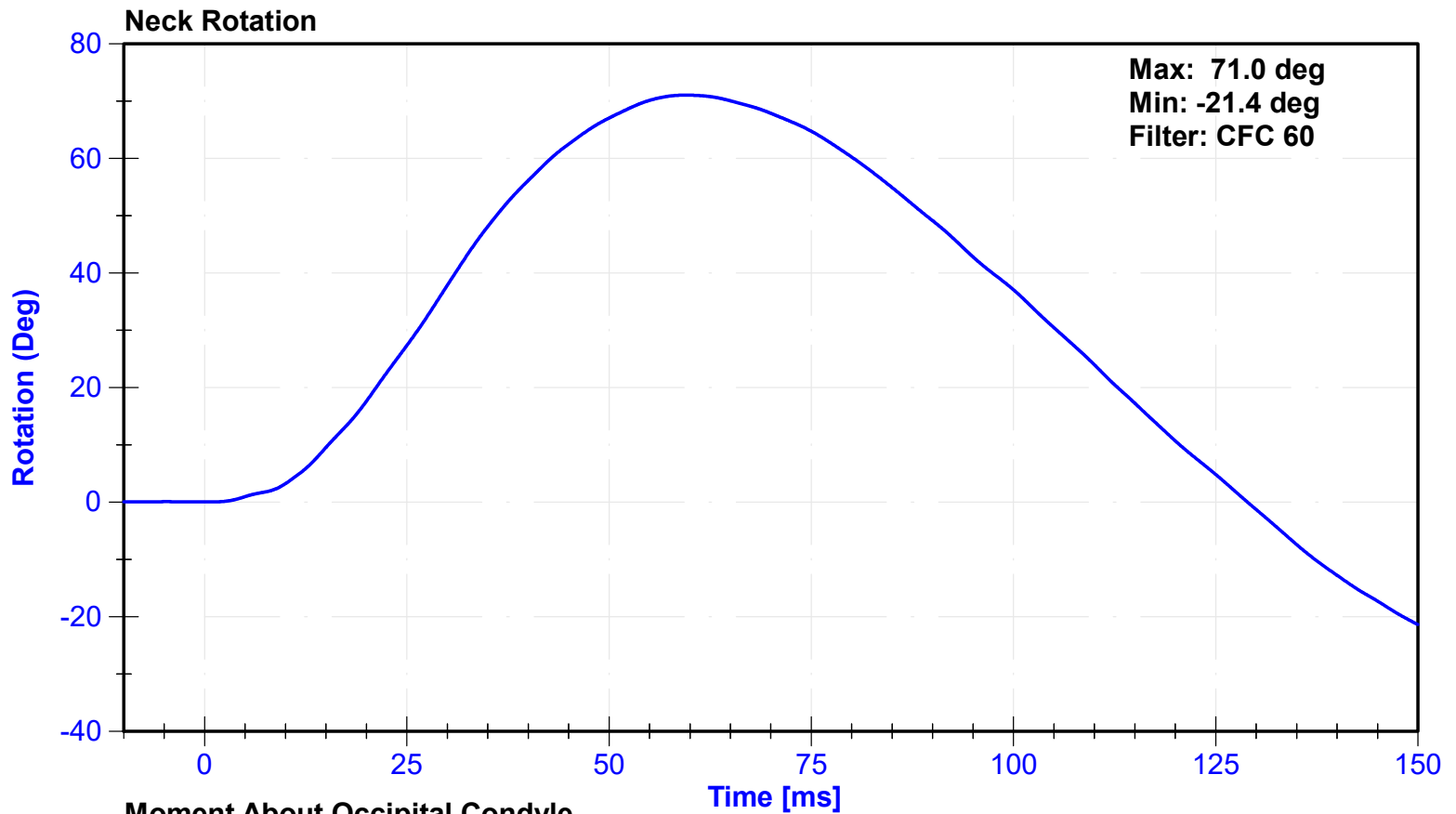

ATD Manufacturer	FTSS	Test Technician	D. Sakona
ATD Serial Number	261	Laboratory Supervisor	K. Brogan

Results

Test Parameter	Minimum Specification	Maximum Specification	Unit	Result	Pass/Fail
Temperature	20.6	22.2	°C	20.8	Pass
Humidity	10	70	%	22.5	Pass
Velocity	4.2	4.4	m/s	4.30	Pass
Probe Acceleration	13	18	g's	16.1	Pass
Shoulder Deflection	28	37	mm	32.1	Pass
Lateral Upper Spine Acceleration	17	22	g's	19.6	Pass

Transducer Calibrations

Channel	Manufacturer	Serial Number	Calibration Date	Calibration Due Date
Pendulum Accelerometer	Endevco	P51736	10/25/2022	4/23/2023
Shoulder Potentiometer	Servo	572GFE	11/1/2022	5/2/2023
Upper Spine Y Accelerometer	Endevco	P18688	10/25/2022	4/23/2023

Probe Acceleration

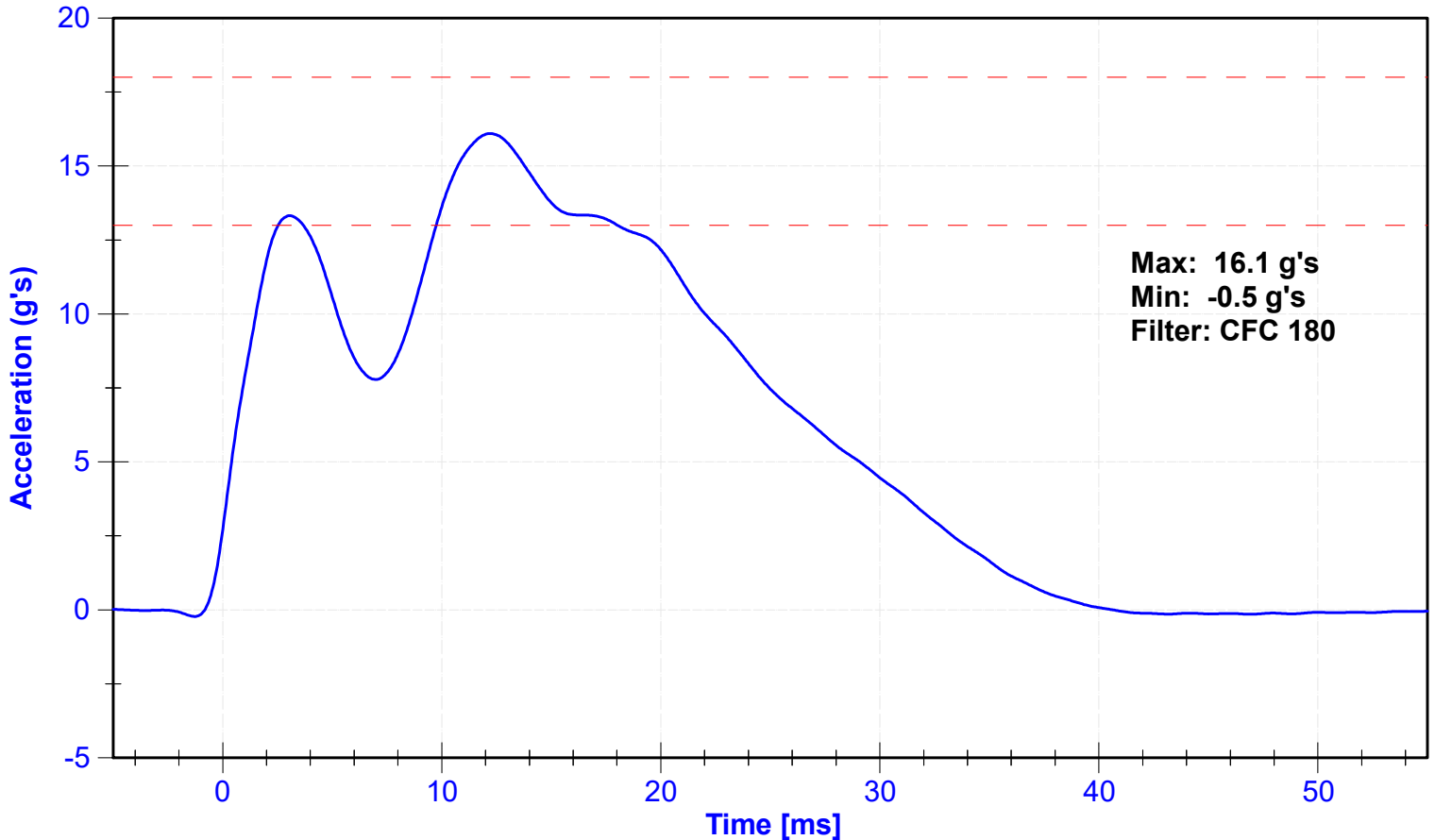

Shoulder Displacement

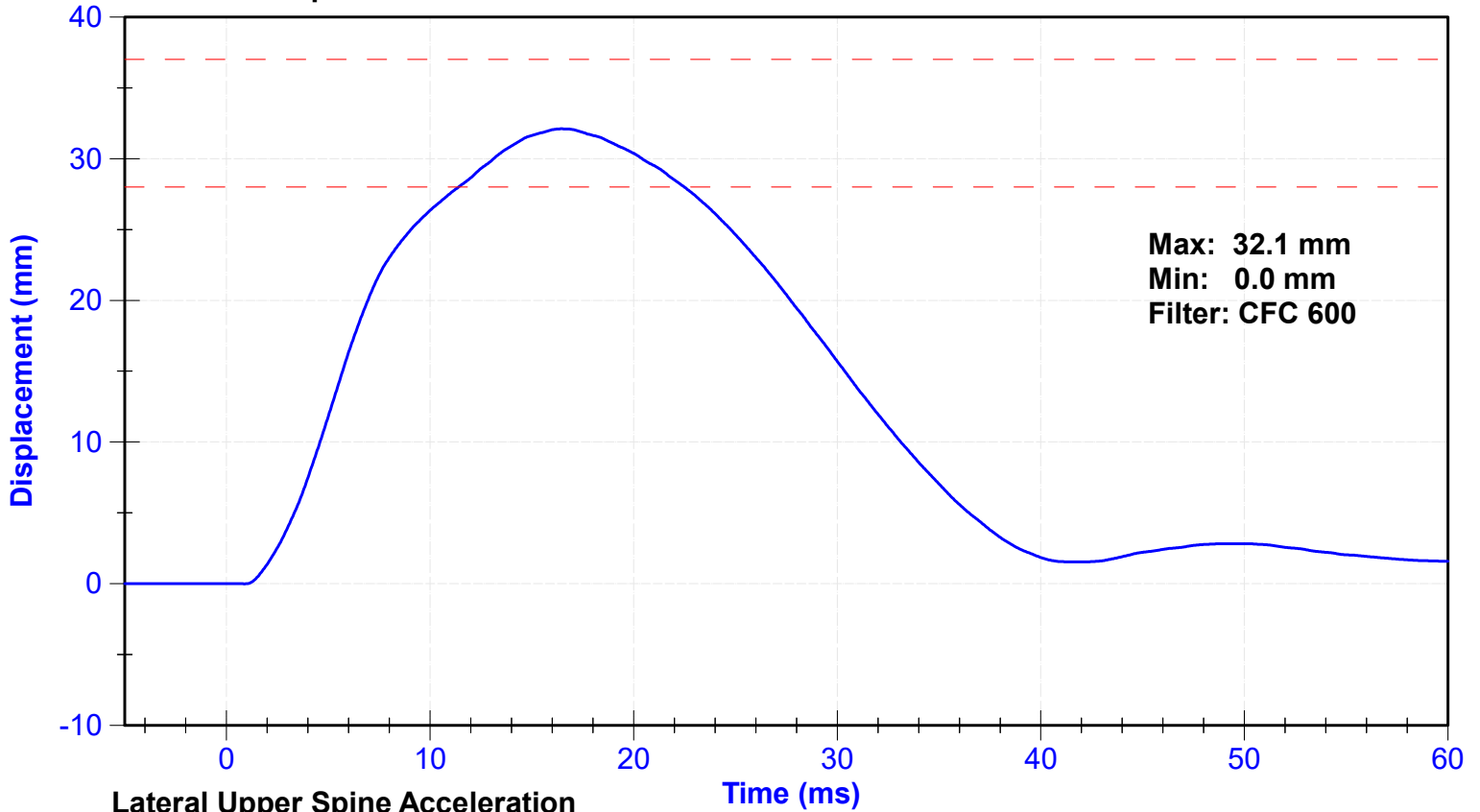

Lateral Upper Spine Acceleration

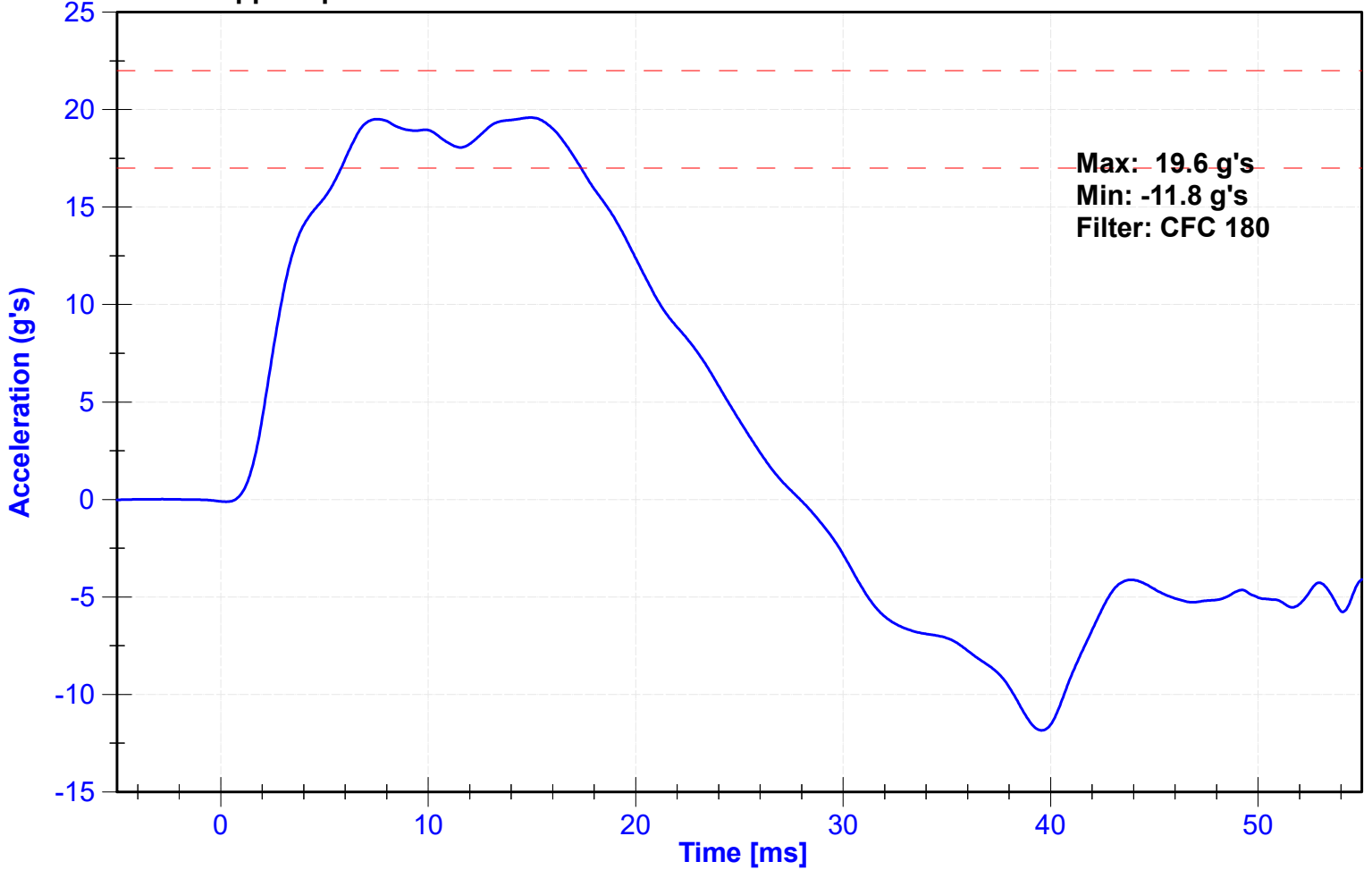

ATD Manufacturer	FTSS	Test Technician	D. Sakona
ATD Serial Number	261	Laboratory Supervisor	K. Brogan

Results

Test Parameter	Minimum Specification	Maximum Specification	Unit	Result	Pass/Fail
Temperature	20.6	22.2	°C	20.8	Pass
Humidity	10	70	%	22.5	Pass
Velocity	6.6	6.8	m/s	6.65	Pass
Probe Acceleration after 5 ms	30	36	g's	32.9	Pass
Lateral Upper Spine Acceleration	34	43	g's	40.8	Pass
Lateral Lower Spine Acceleration	29	37	g's	30.6	Pass
Shoulder Deflection	31	40	mm	34.8	Pass
Upper Thorax Rib Deflection	25	32	mm	27.7	Pass
Mid Thorax Rib Deflection	30	36	mm	31.0	Pass
Lower Thorax Rib Deflection	32	38	mm	33.3	Pass

Transducer Calibrations

Channel	Manufacturer	Serial Number	Calibration Date	Calibration Due Date
Pendulum Accelerometer	Endevco	P51736	10/25/2022	4/23/2023
Upper Spine T1 Y Accelerometer	Endevco	P18688	10/25/2022	4/23/2023
Upper Spine T12 Y Accelerometer	Endevco	P58744	10/25/2022	4/23/2023
Shoulder Potentiometer	Servo	572GFE	11/1/2022	5/2/2023
Upper Thorax Rib Potentiometer	Servo	062GFE	11/1/2022	5/2/2023
Middle Thorax Rib Potentiometer	Servo	528GFE	11/1/2022	5/2/2023
Lower Thorax Rib Potentiometer	Servo	513GFE	11/1/2022	5/2/2023

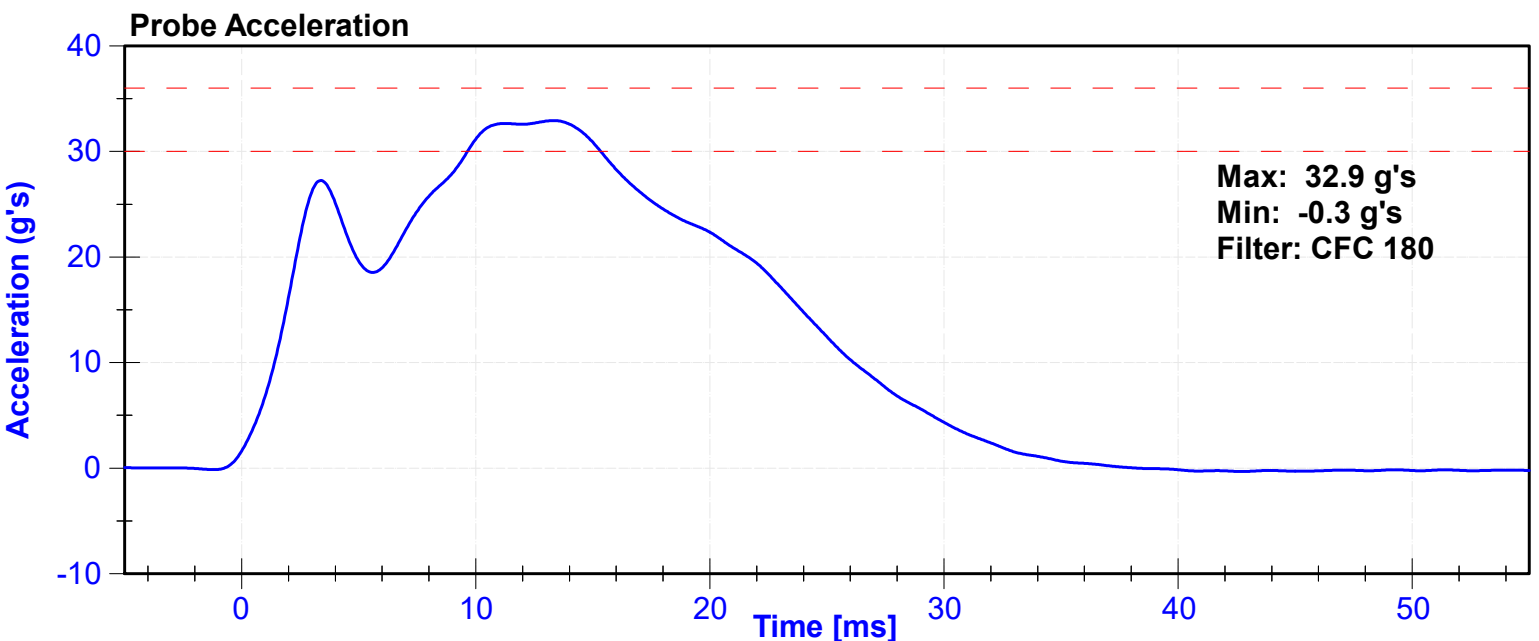

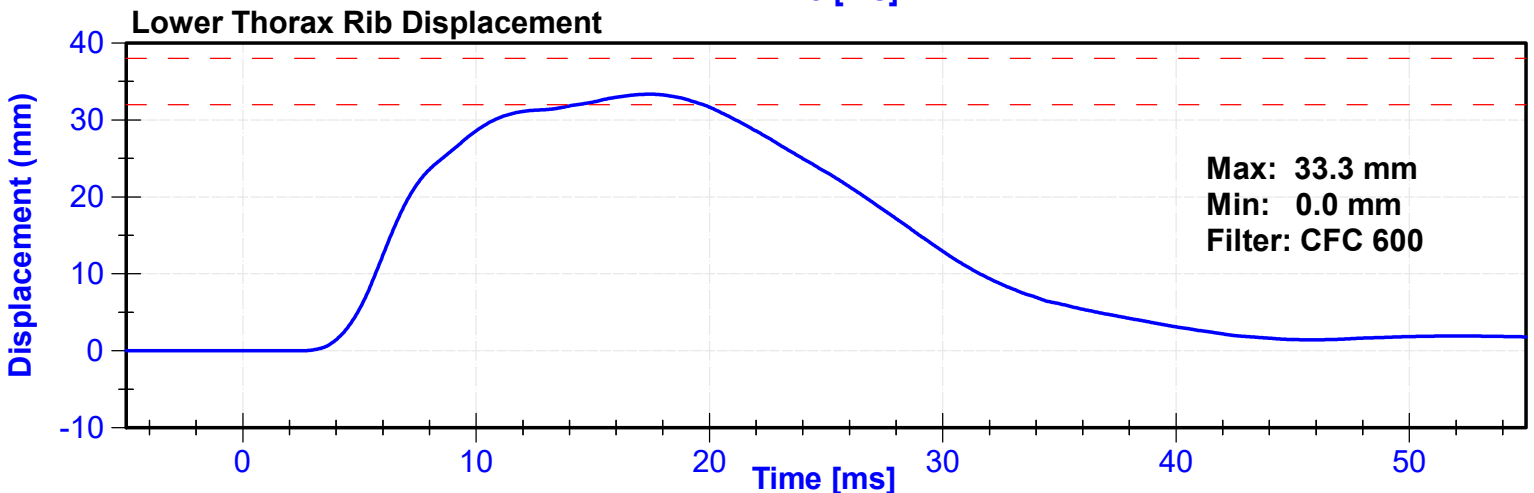
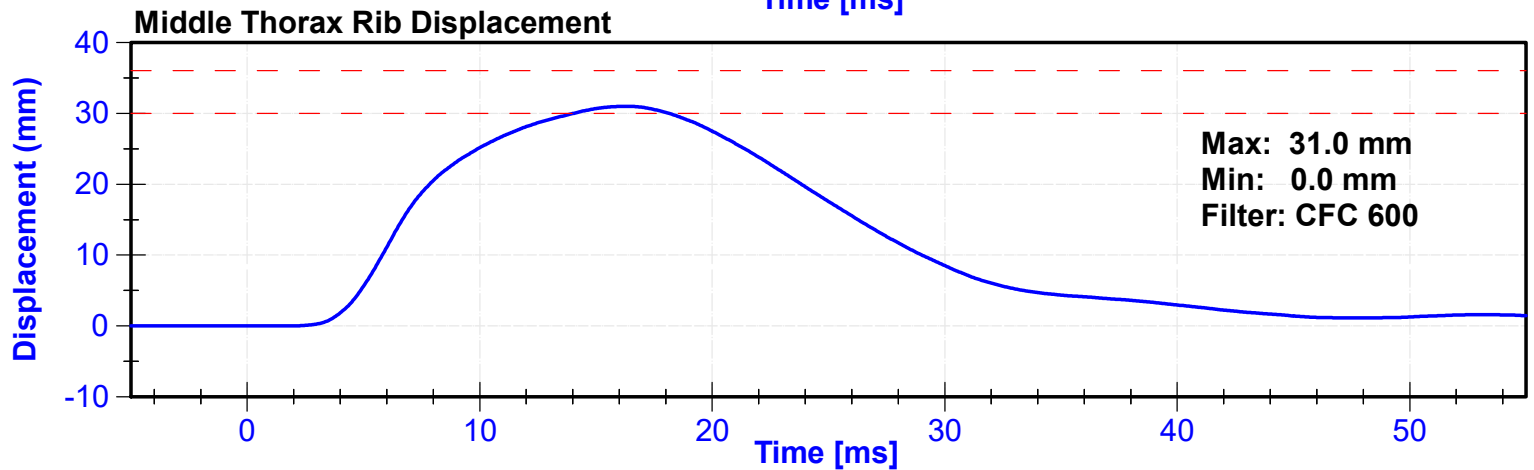
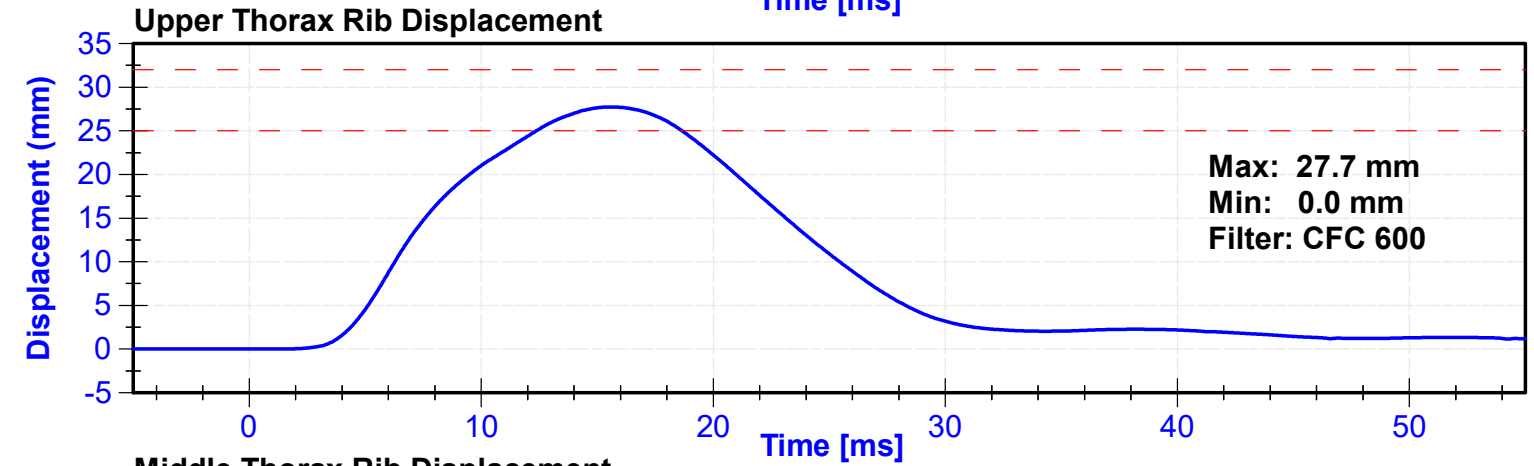
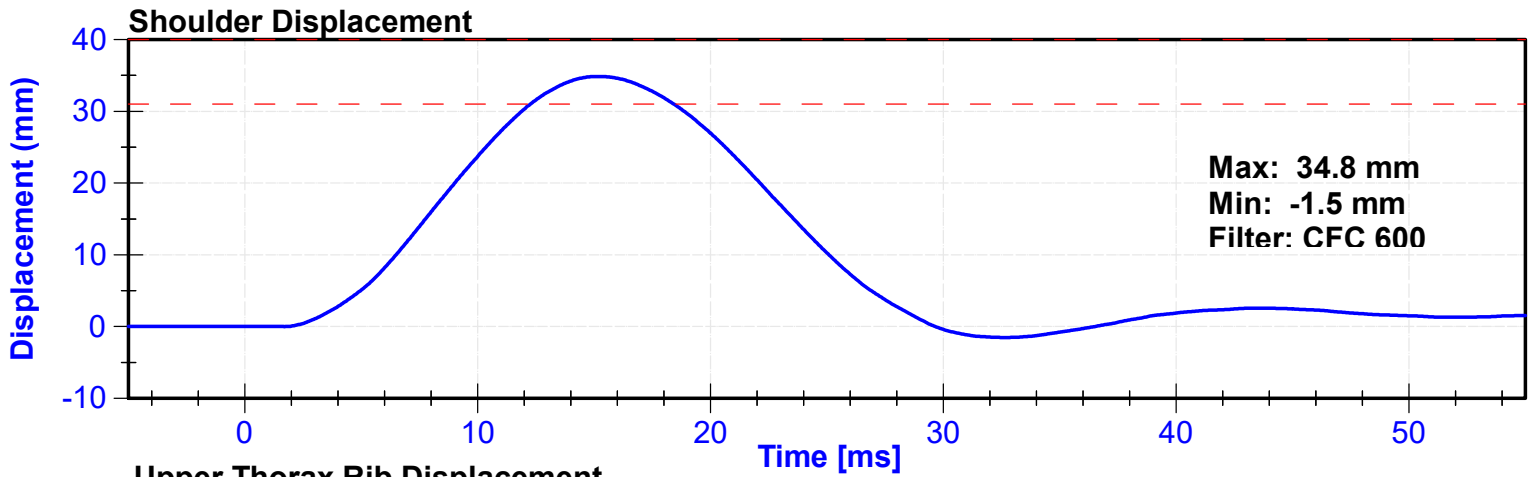

Lateral Upper Spine Acceleration

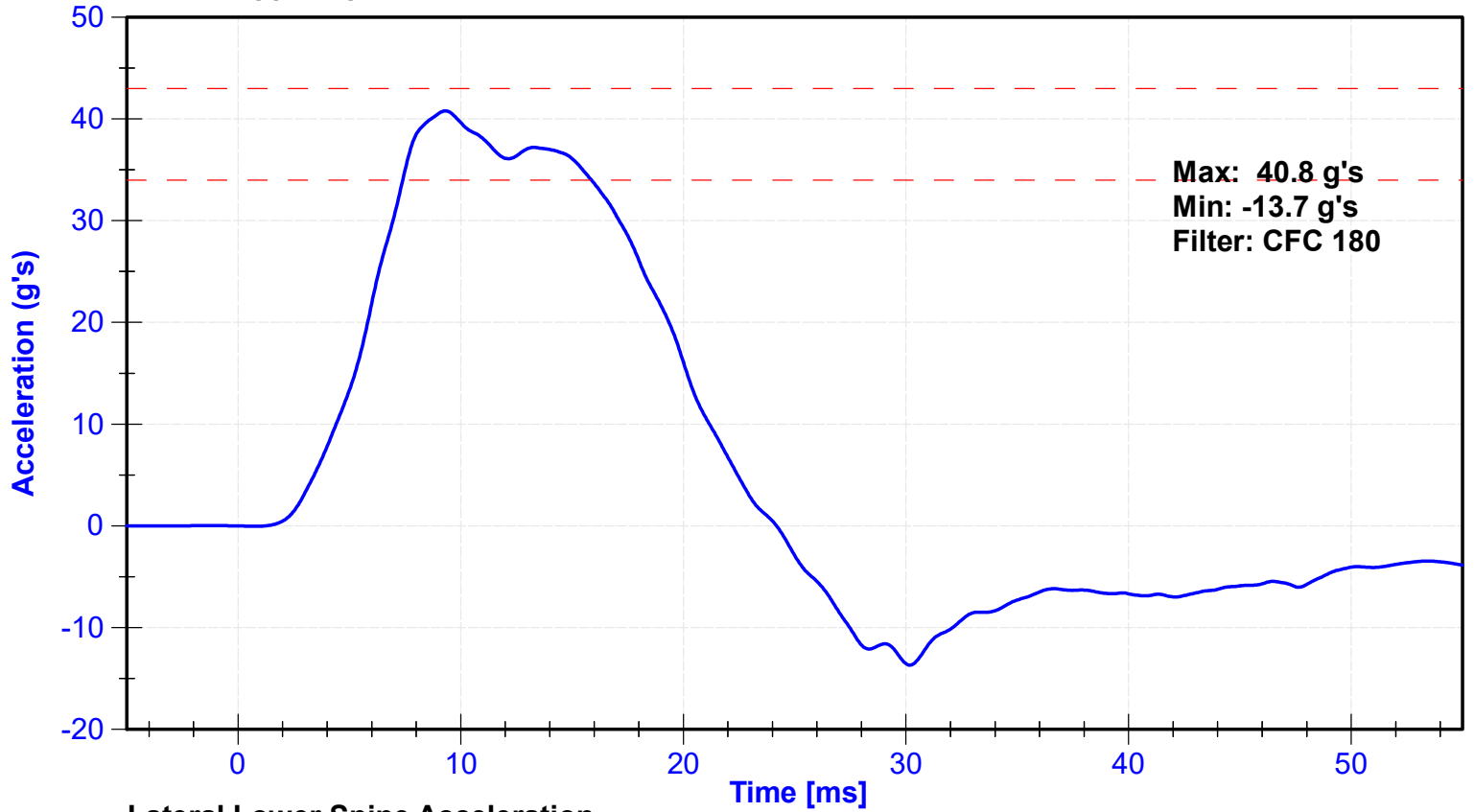

Lateral Lower Spine Acceleration

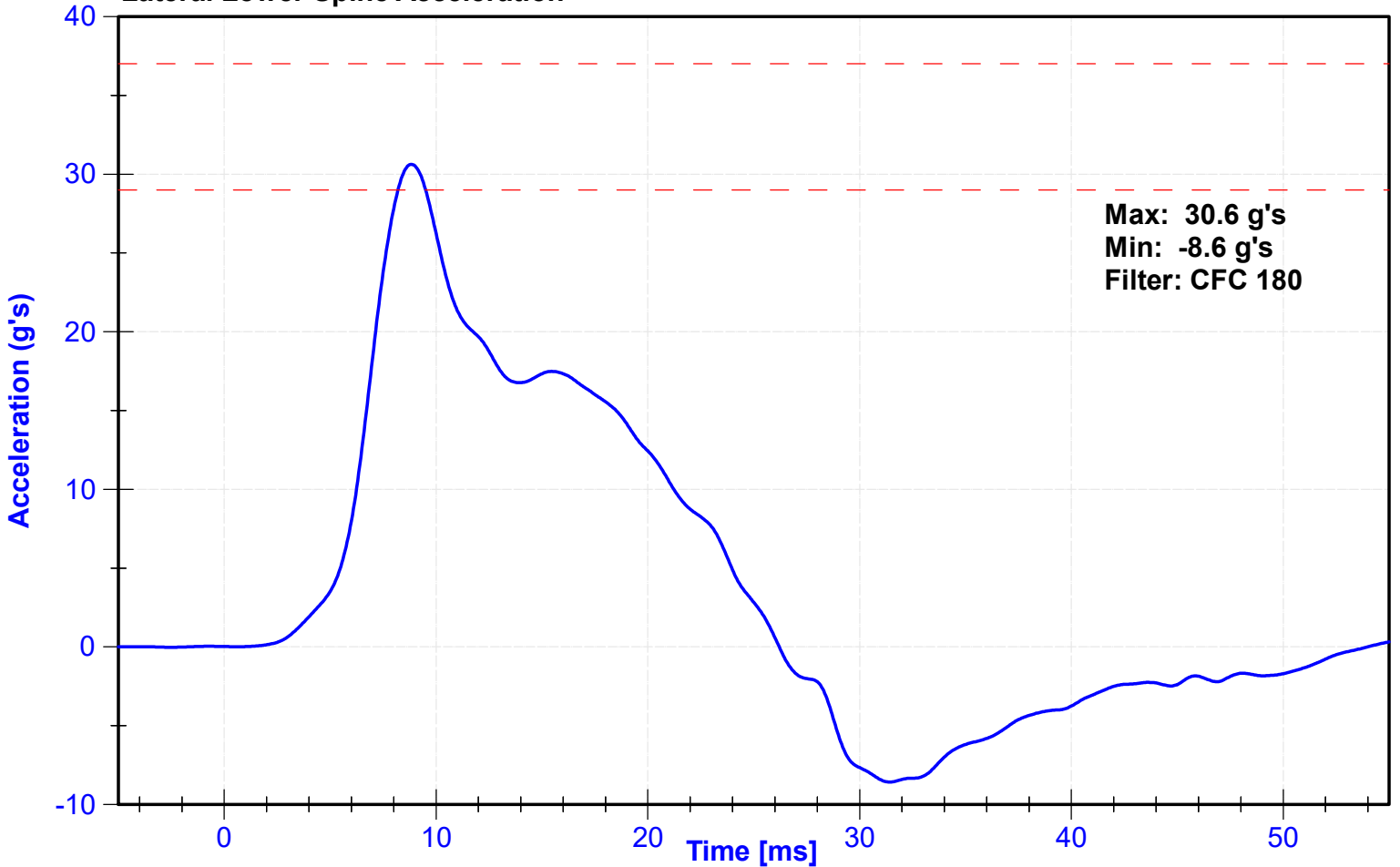

ATD Manufacturer	FTSS	Test Technician	D. Sakona
ATD Serial Number	261	Laboratory Supervisor	K. Brogan

Results

Test Parameter	Minimum Specification	Maximum Specification	Unit	Result	Pass/Fail
Temperature	20.6	22.2	°C	20.8	Pass
Humidity	10	70	%	22.5	Pass
Velocity	4.2	4.4	m/s	4.34	Pass
Probe Acceleration	14	18	g's	17.6	Pass
Lateral Upper Spine Acceleration	13	17	g's	16.8	Pass
Lateral Lower Spine Acceleration	7	11	g's	9.7	Pass
Upper Thorax Rib Deflection	32	40	mm	32.5	Pass
Middle Thorax Rib Deflection	39	45	mm	39.6	Pass
Lower Thorax Rib Deflection	35	43	mm	37.8	Pass

Transducer Calibrations

Channel	Manufacturer	Serial Number	Calibration Date	Calibration Due Date
Pendulum Accelerometer	Endevco	P51736	10/25/2022	4/23/2023
Upper Spine Y Accelerometer	Endevco	P18688	10/25/2022	4/23/2023
Lower Spine Y Accelerometer	Endevco	P58744	10/25/2022	4/23/2023
Upper Thorax Rib Potentiometer	Servo	062GFE	11/1/2022	5/2/2023
Middle Thorax Rib Potentiometer	Servo	528GFE	11/1/2022	5/2/2023
Lower Thorax Rib Potentiometer	Servo	513GFE	11/1/2022	5/2/2023

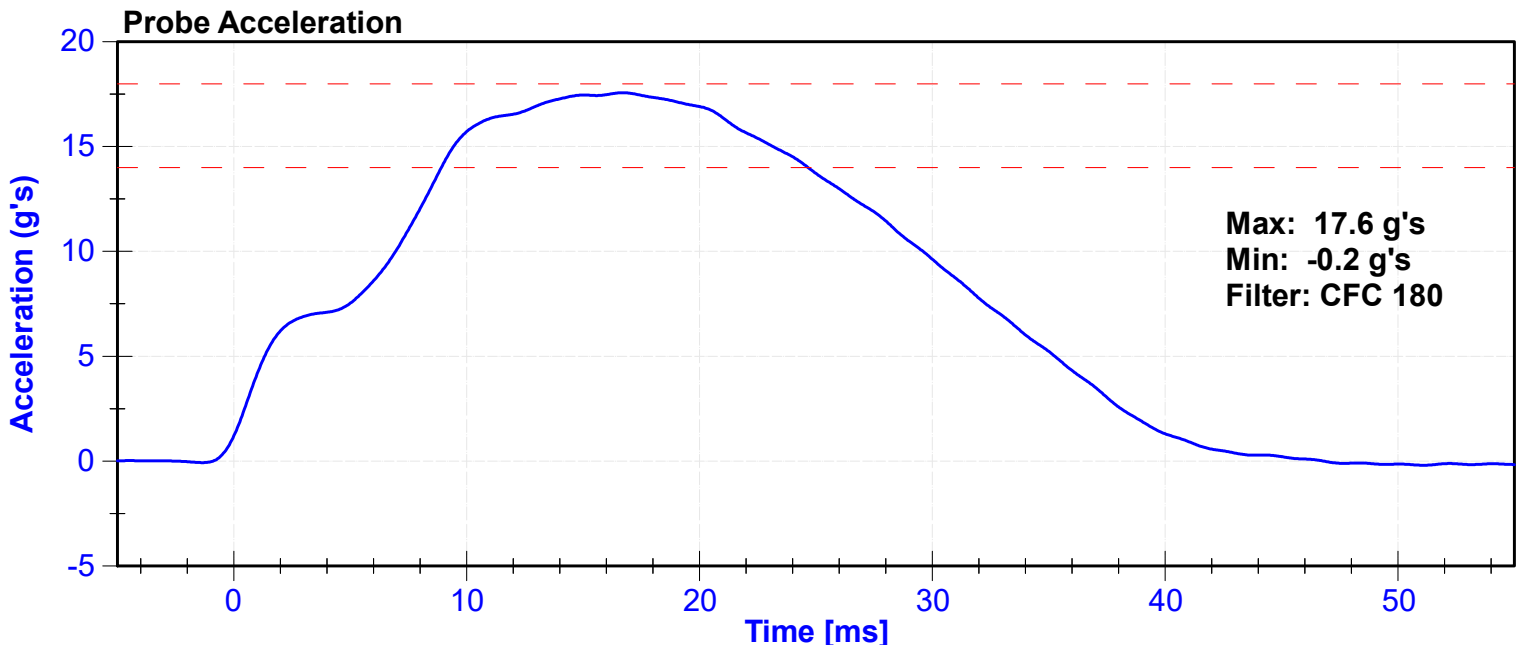

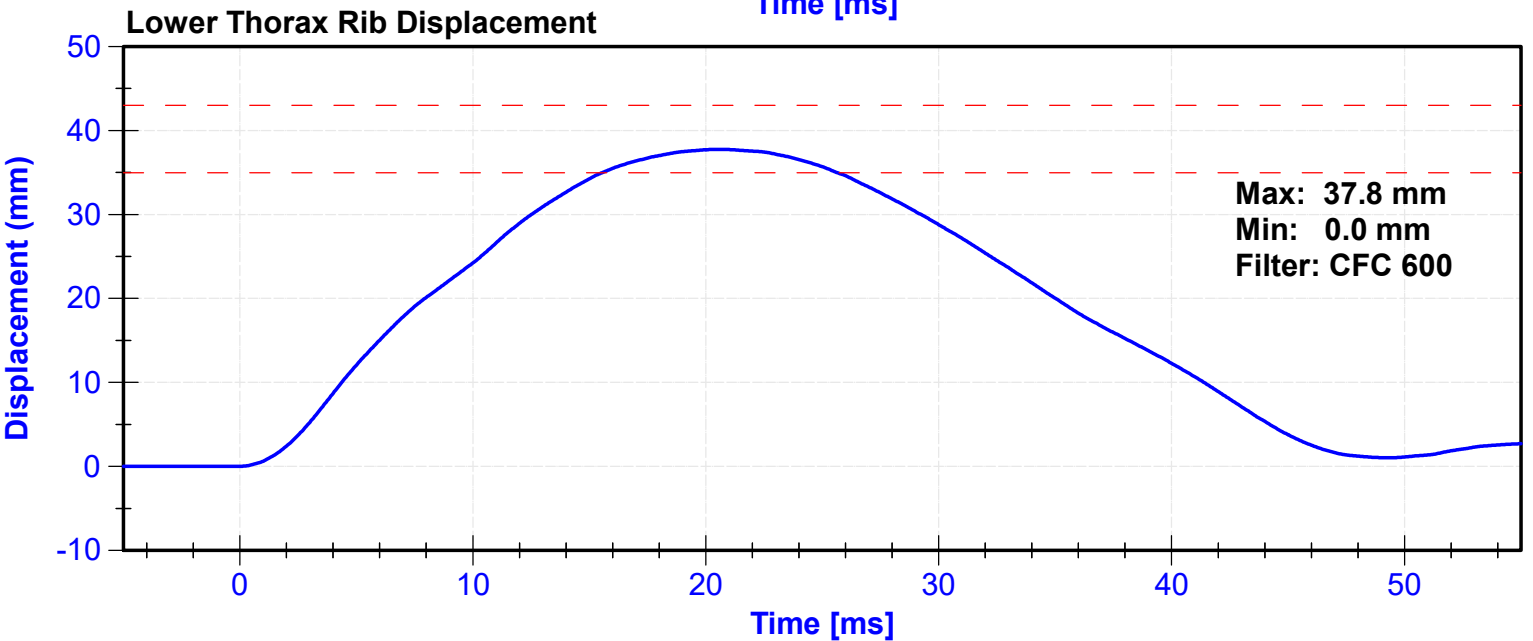
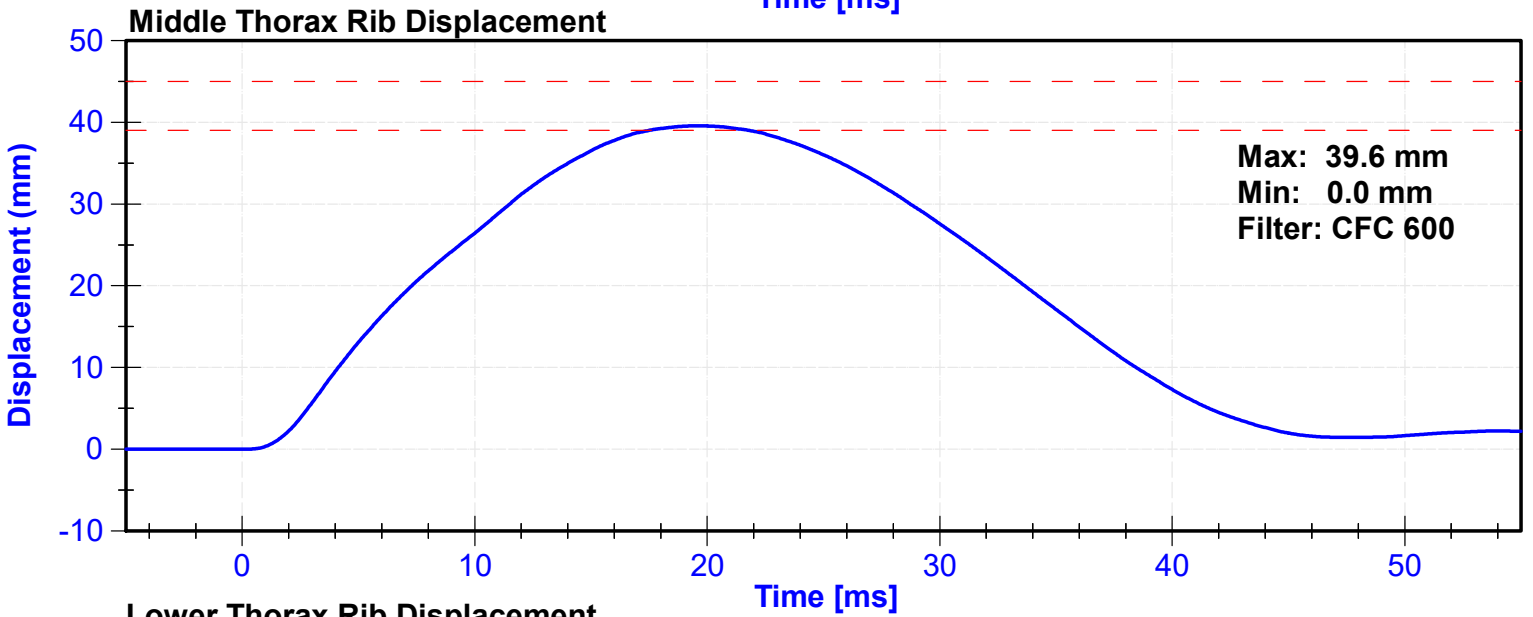
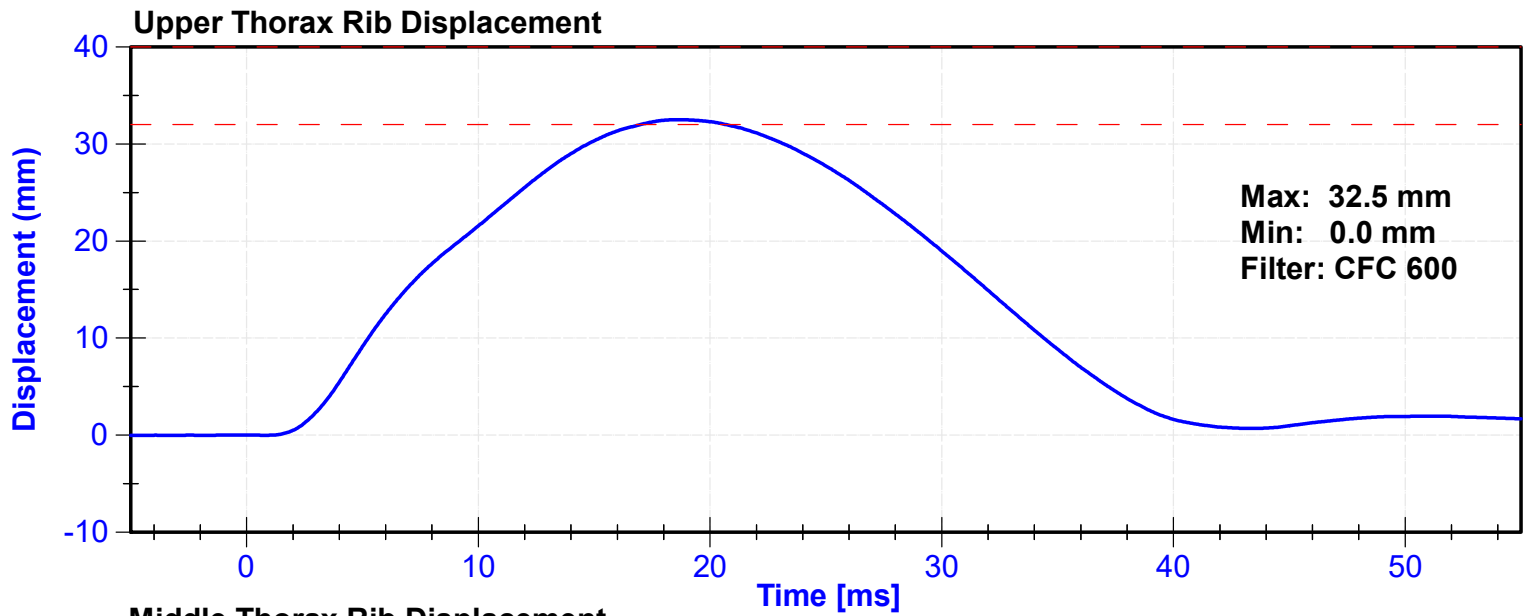

Lateral Upper Spine Acceleration

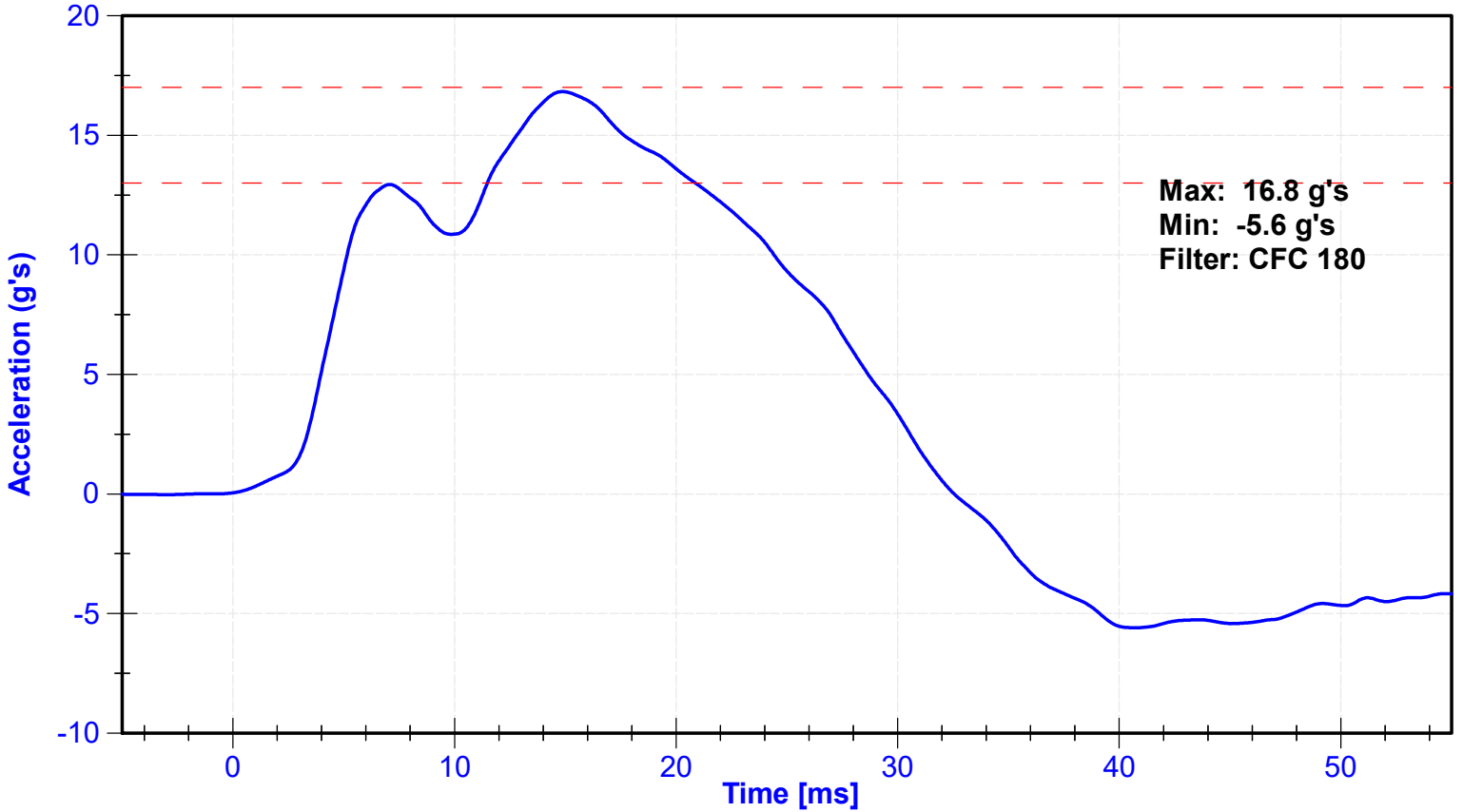

Lateral Lower Spine Acceleration

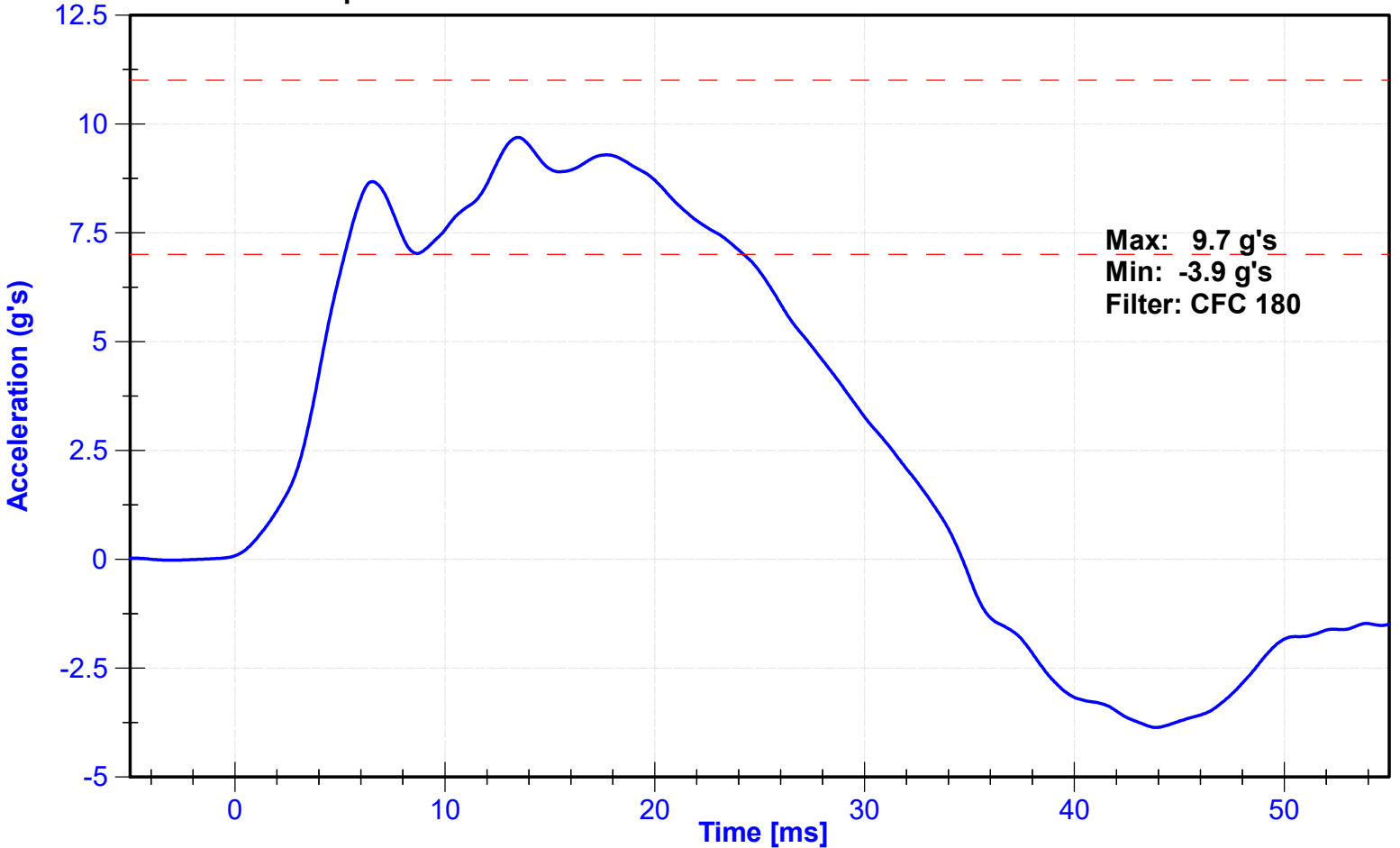

ATD Manufacturer	FTSS	Test Technician	D. Sakona
ATD Serial Number	261	Laboratory Supervisor	K. Brogan

Results

Test Parameter	Minimum Specification	Maximum Specification	Unit	Result	Pass/Fail
Temperature	20.6	22.2	°C	20.8	Pass
Humidity	10	70	%	22.5	Pass
Velocity	4.2	4.4	m/s	4.31	Pass
Probe Acceleration	12	16	g's	14.9	Pass
Lateral Lower Spine Acceleration	9	14	g's	10.8	Pass
Upper Abdomen Rib Deflection	36	47	mm	39.9	Pass
Lower Abdomen Rib Deflection	33	44	mm	40.7	Pass

Transducer Calibrations

Channel	Manufacturer	Serial Number	Calibration Date	Calibration Due Date
Probe Accelerometer	Endevco	P51736	10/25/2022	4/23/2023
Lower Spine Y Accelerometer	Endevco	P58744	10/25/2022	4/23/2023
Upper Abdomen Rib Potentiometer	Servo	342GFE	11/1/2022	5/2/2023
Lower Abdomen Rib Potentiometer	Servo	512GFE	11/1/2022	5/2/2023

Probe Acceleration

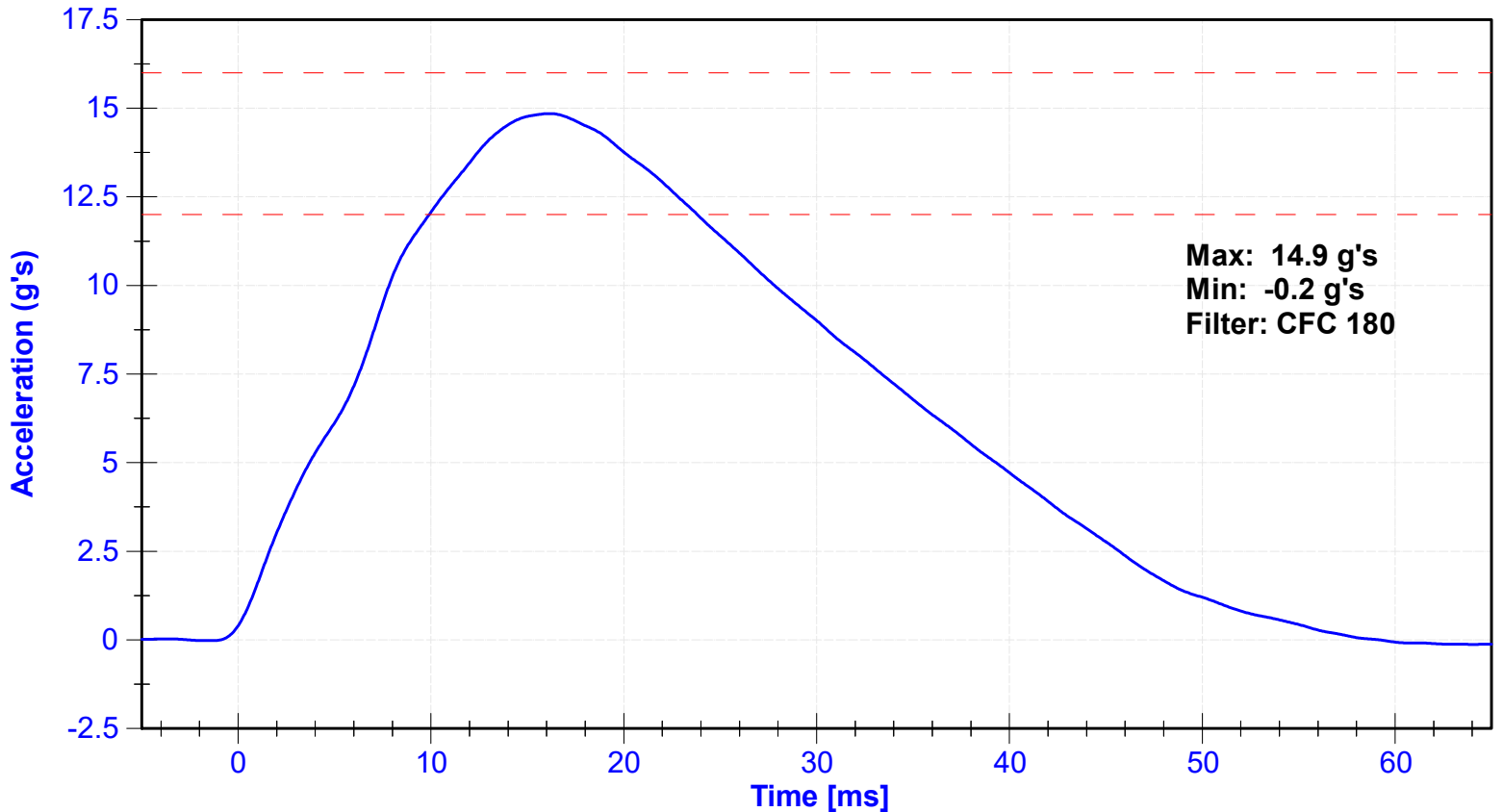

Upper Abdomen Rib Displacement

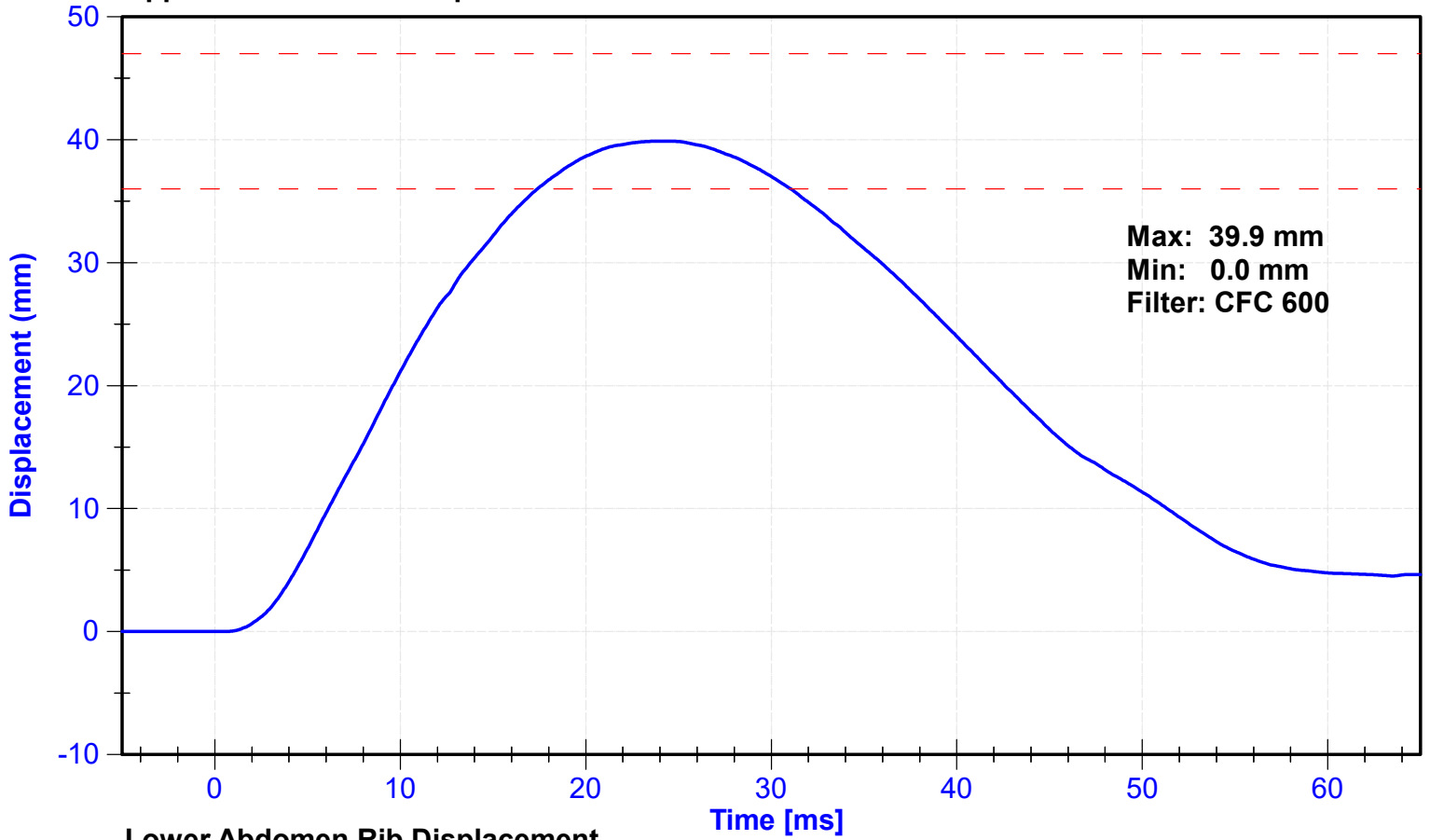

Lower Abdomen Rib Displacement

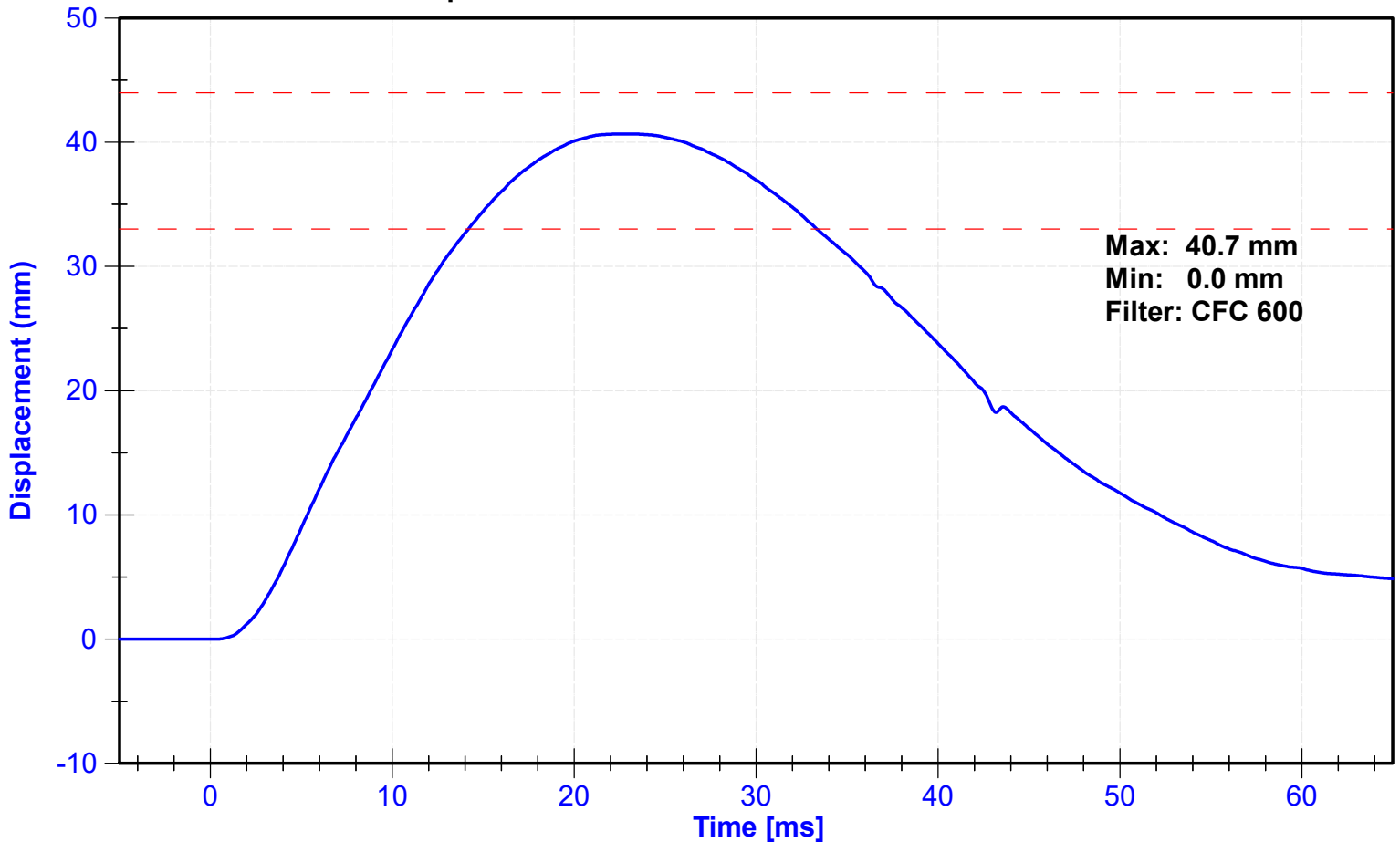

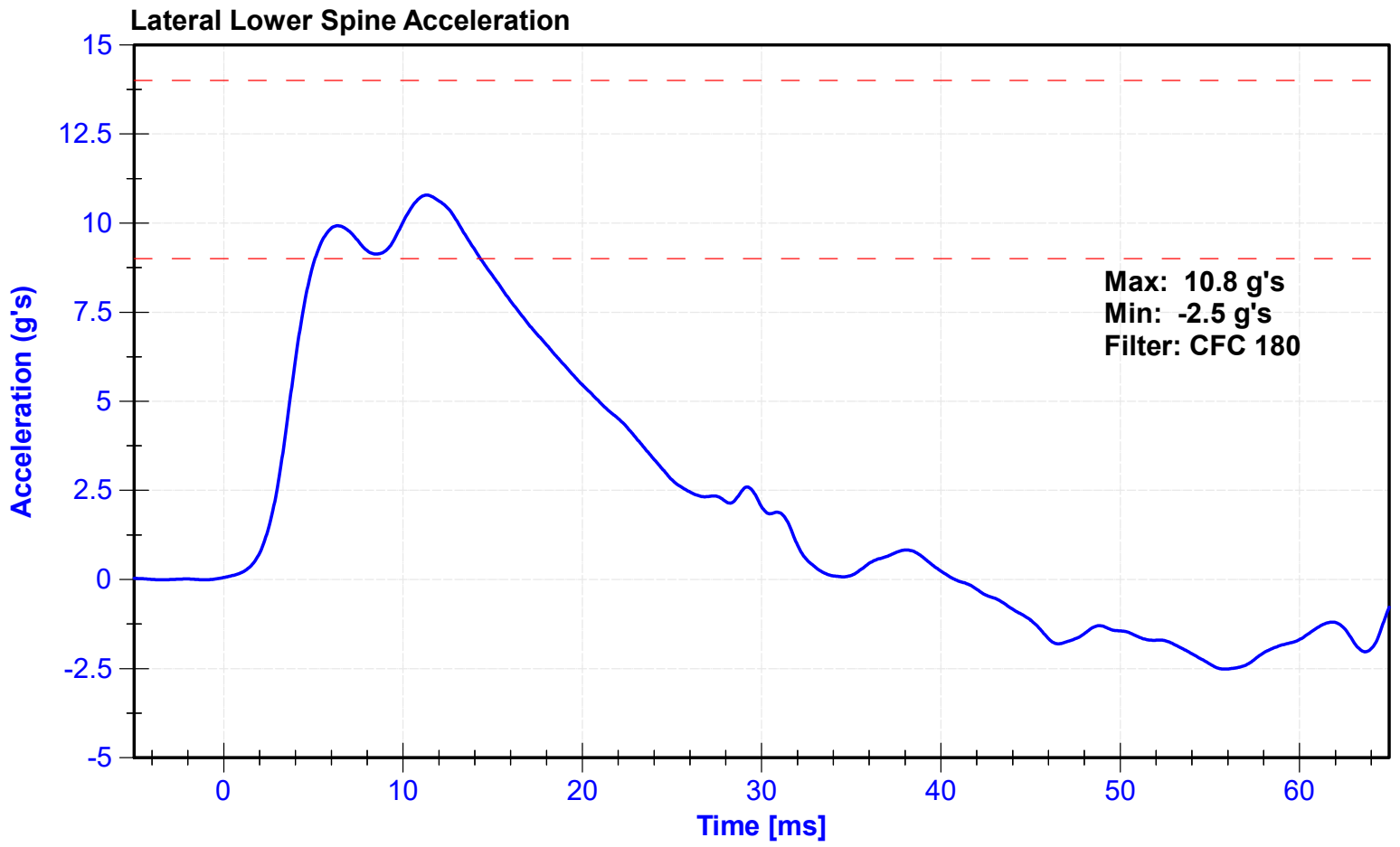

ATD Manufacturer	FTSS	Test Technician	D. Sakona
ATD Serial Number	261	Laboratory Supervisor	K. Brogan

Results

Test Parameter	Minimum Specification	Maximum Specification	Unit	Result	Pass/Fail
Temperature	20.6	22.2	°C	20.8	Pass
Humidity	10	70	%	22.5	Pass
Velocity	6.6	6.8	m/s	6.63	Pass
Probe Acceleration	38	47	g's	46.3	Pass
Lateral Pelvis Acceleration after 6ms	34	42	g's	41.3	Pass
Acetabulum Force	3600	4300	N	3977.3	Pass

Transducer Calibrations

Channel	Manufacturer	Serial Number	Calibration Date	Calibration Due Date
Pendulum Accelerometer	Endevco	P51736	10/25/2022	4/23/2023
Pelvis Y Accelerometer	Endevco	P94678	10/25/2022	4/23/2023
Acetabulum Load Cell	Denton	275-FY	8/11/2022	8/11/2023
Certification Plug	SACO			N/A
Crash Test Plug	SACO			N/A

Probe Acceleration

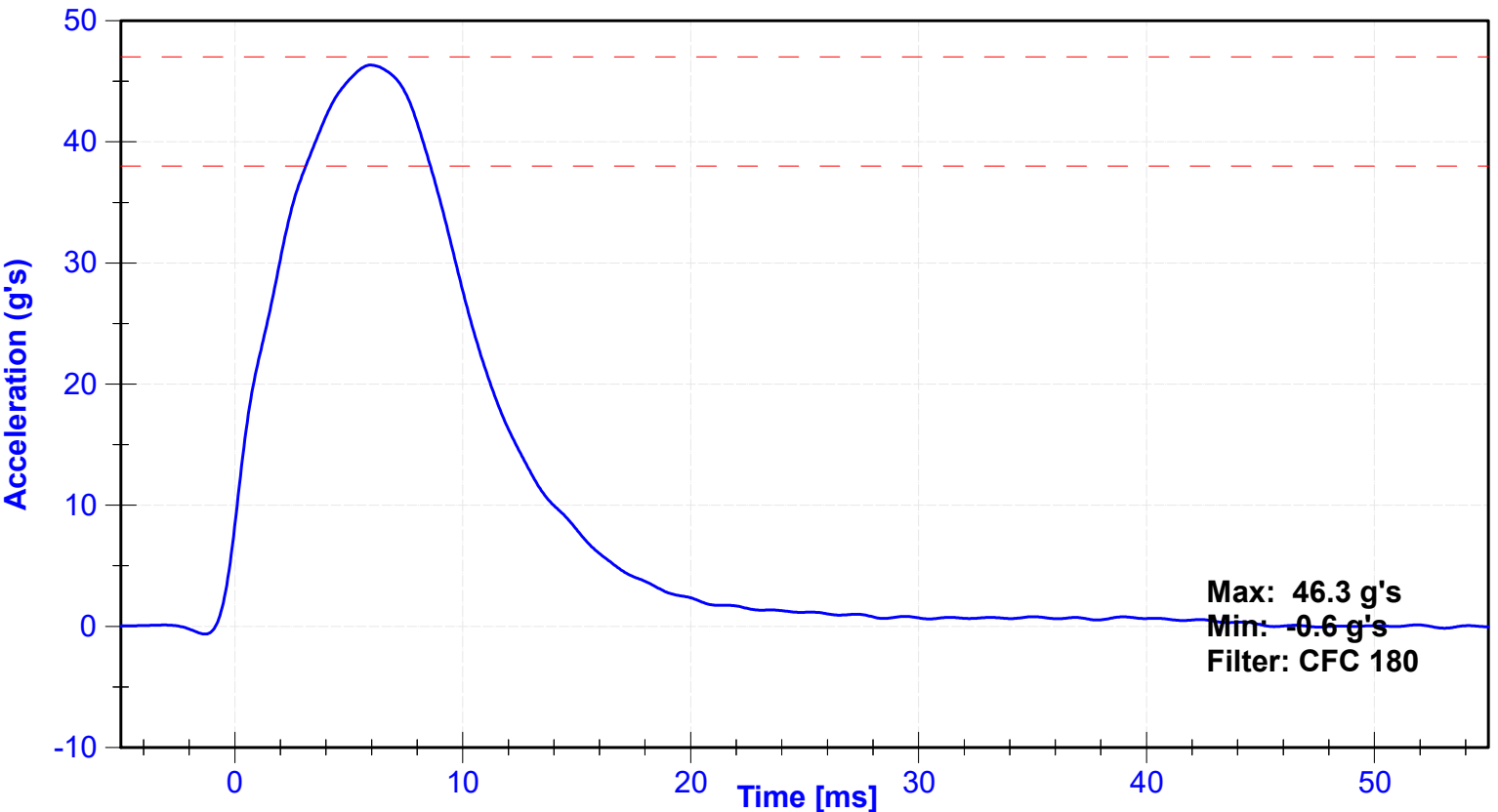

Lateral Pelvis Acceleration

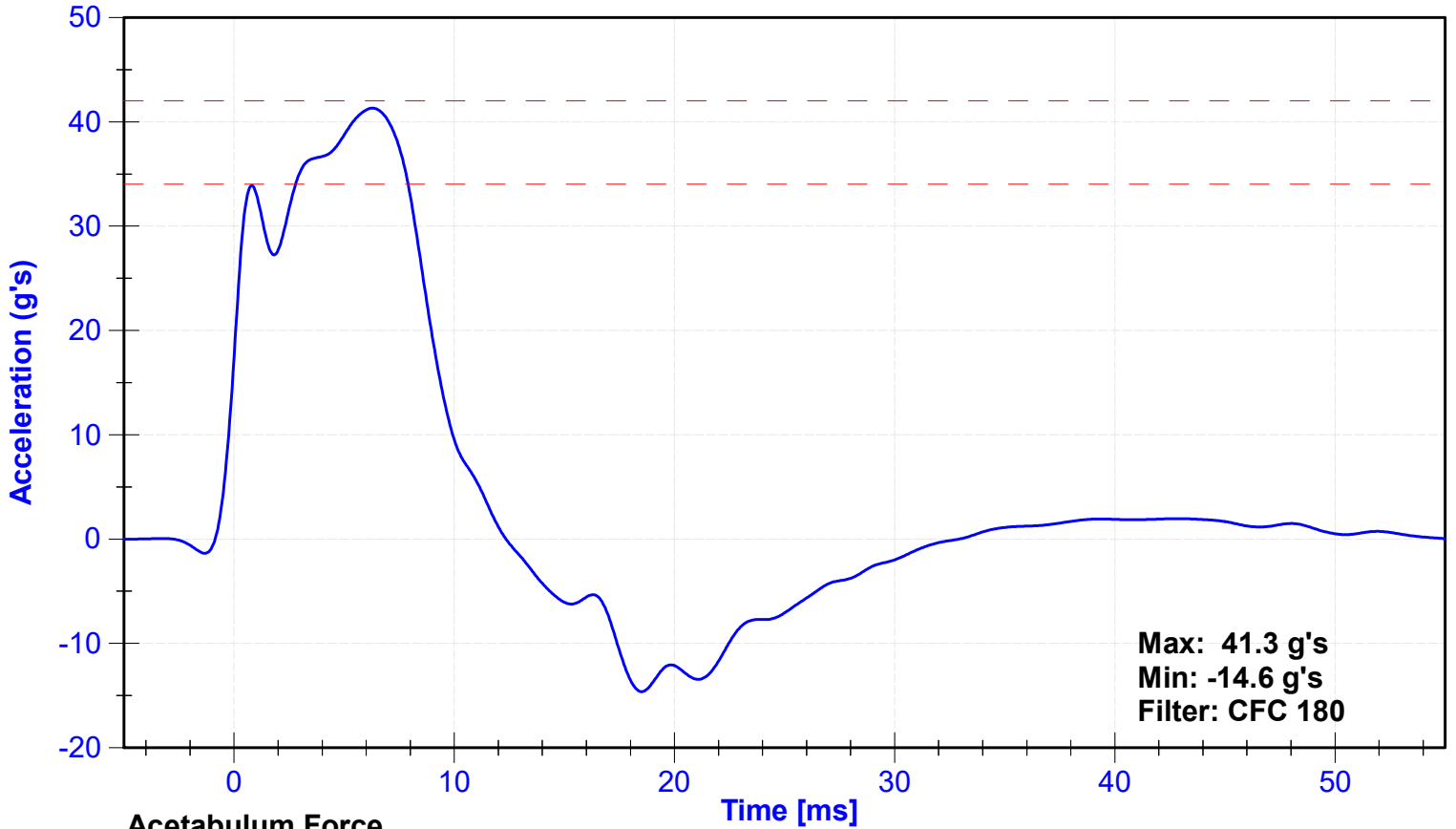

Acetabulum Force

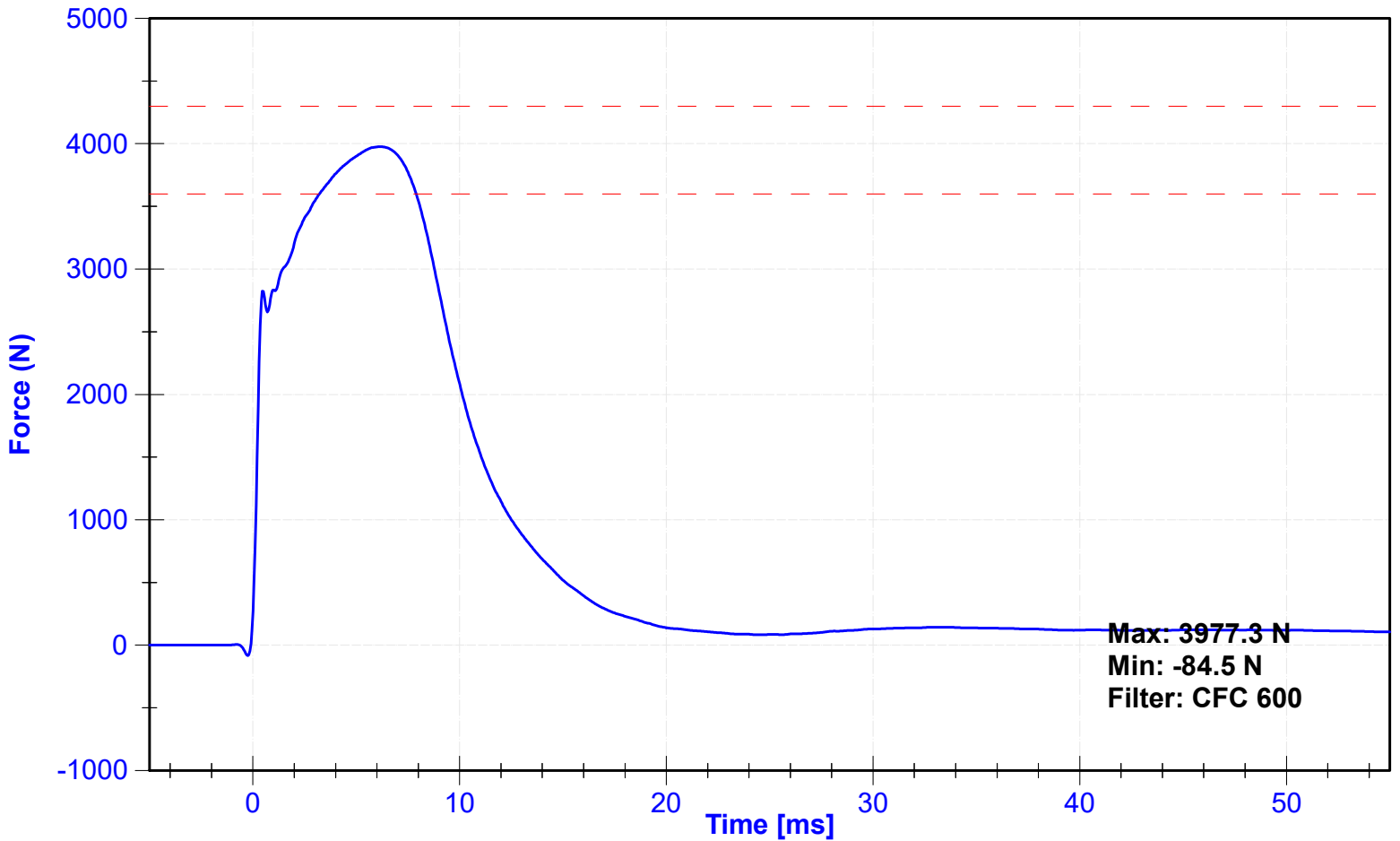



SID-IIs Pelvis Plug Certification Test

Plug S/N 15192

Test Number 17908

Report Number 17957

Test Date 3/8/2021 12:47:09 PM

	Test Results	Spec Min	Spec Max
Force @ 0.5 mm (N)	361	50	600
Force @ 1.5 mm (N)	1,189	850	1,400
Force @ 2.5 mm (N)	1,426	1,306	1,618
Force @ 3.0 mm (N)	1,475	1,361	1,673

Testing Machine STM-20 5965542
 Load Cell S/N (FI360947), Units (LBS) 1000
 Crosshead Speed (mm / min) or Rate 12.7
 Extension or Position Measured by XHD_100 (XHD100)

Notes:

*Cent 12/15/22
 attempt 2*

Force (-N) vs Extension (-mm)

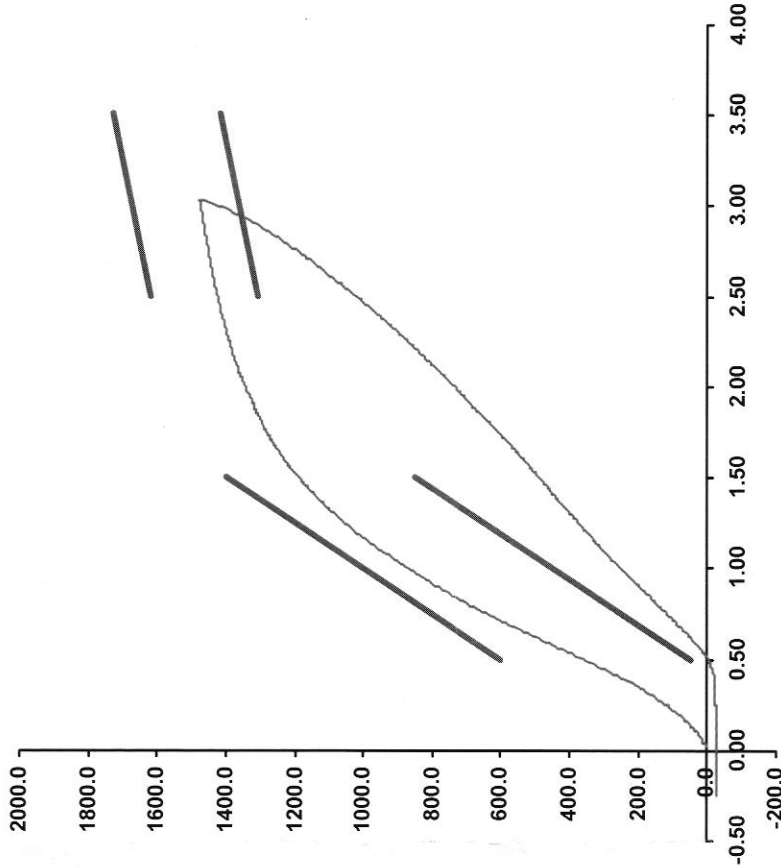

Operator _____

Part Number 180-4450

Template No 107 08-Mar-21

SACO Research

By: *DC* Date: *3/8/2021*



SID-IIs Pelvis Plug Certification Test

Plug S/N 15456

Test Number 20117

Report Number 20171

Test Date 9/9/2021 10:56:27 AM

Crash Plug

Test Results	Spec Min	Spec Max
Force @ 0.5 mm (N)	50	600
Force @ 1.5 mm (N)	850	1,400
Force @ 2.5 mm (N)	1,306	1,618
Force @ 3.0 mm (N)	1,361	1,673

Testing Machine STM-20 5965542

Load Cell S/N (F1360947), Units (LBS) 1000

Preload Value (-N) 22.24

Crosshead Speed (mm / min) or Rate 12.7

Extension or Position Measured by XHD_100 (XHD100)

Notes:

Force (-N) vs Extension (-mm)

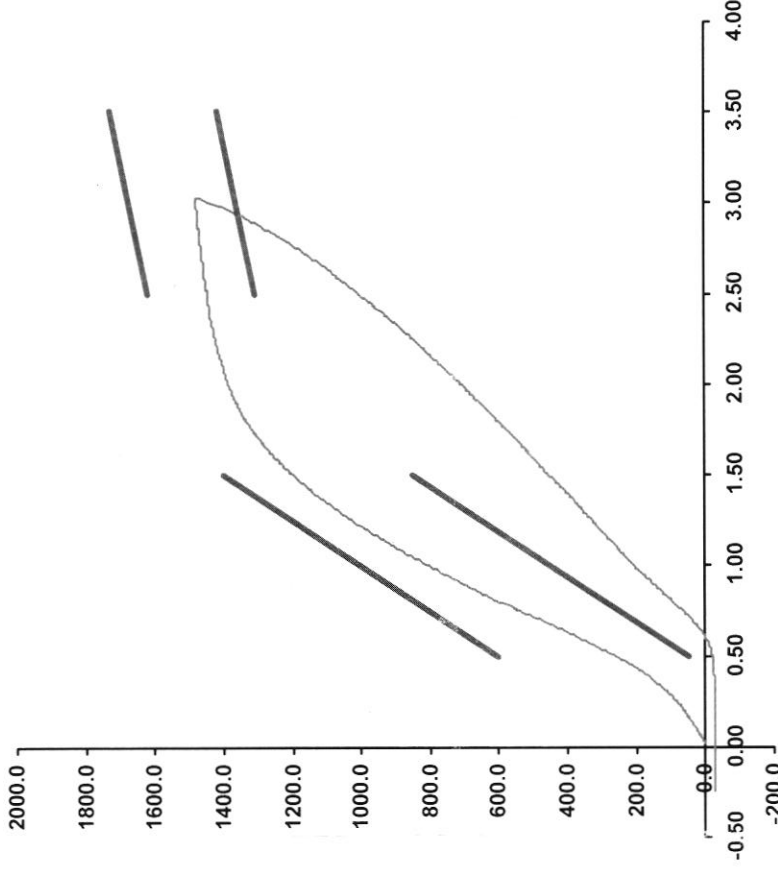

Operator _____

Part Number 180-4450

By: DC Date: 9/9/2021



SID-Ils Pelvis Plug Certification Test

Plug S/N 15011
 Test Number 17592
 Report Number 17639
 Test Date 2/5/2021 9:05:17 AM

Test Results	Spec Min	Spec Max
Force @ 0.5 mm (N)	50	600
Force @ 1.5 mm (N)	850	1,400
Force @ 2.5 mm (N)	1,306	1,618
Force @ 3.0 mm (N)	1,361	1,673

Testing Machine STM-20 5965542
 Load Cell S/N (F1360947), Units (LBS) 1000
 Crosshead Speed (mm / min) 12.7
 Extension or Position Measured by XHD_100 (XHD100)

Notes:

Non-Impact Plug

Force (-N) vs Extension (-mm)

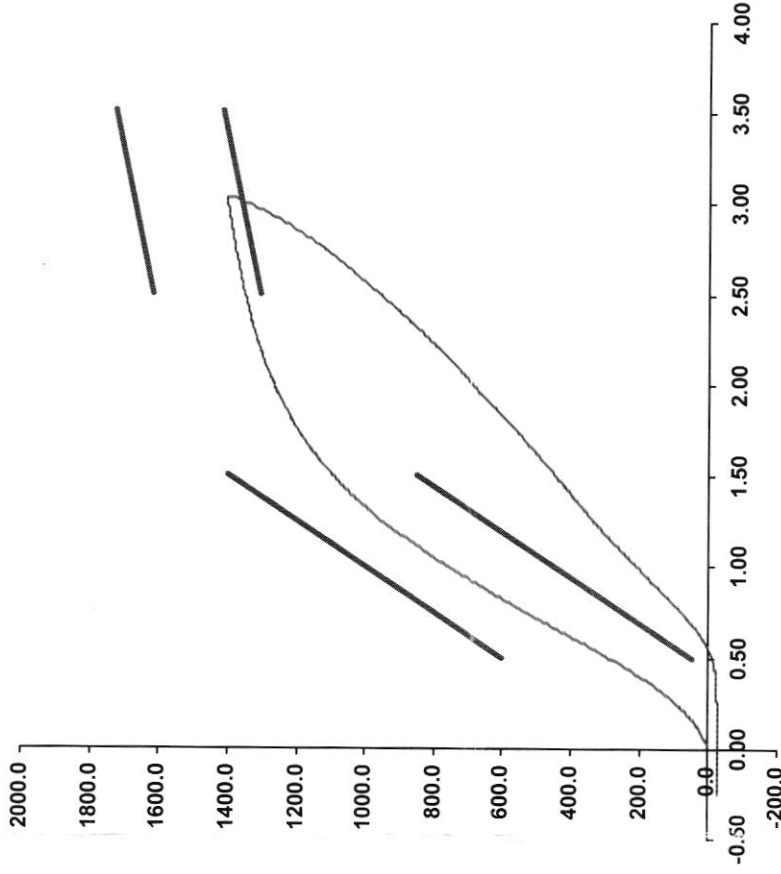

Operator
 Part Number 180-4450

Template No 107 05-Feb-21
 SACO Research

By: DC Date: 2/5/2021
 SACO Research 41735 Elm St, #401 Murrieta, CA 92562 Tel 310-694-2082 FAX

ATD Manufacturer	FTSS	Test Technician	Z.Schneider
ATD Serial Number	261	Laboratory Supervisor	K. Brogan

Results

Test Parameter	Minimum Specification	Maximum Specification	Unit	Result	Pass/Fail
Temperature	20.6	22.2	°C	21.5	Pass
Humidity	10	70	%	20	Pass
Velocity	4.2	4.4	m/s	4.37	Pass
Probe Acceleration	36	45	g's	38.4	Pass
Lateral Pelvis Acceleration	28	39	g's	28.4	Pass
Iliac Force	4100	5100	N	4264.0	Pass

Transducer Calibrations

Channel	Manufacturer	Serial Number	Calibration Date	Calibration Due Date
Pendulum Accelerometer	Endevco	P51736	10/25/2022	4/23/2023
Pelvis Y Accelerometer	Endevco	P94678	10/25/2022	4/23/2023
Iliac Load Cell	Denton	279-FY	8/11/2022	8/11/2023

Probe Acceleration

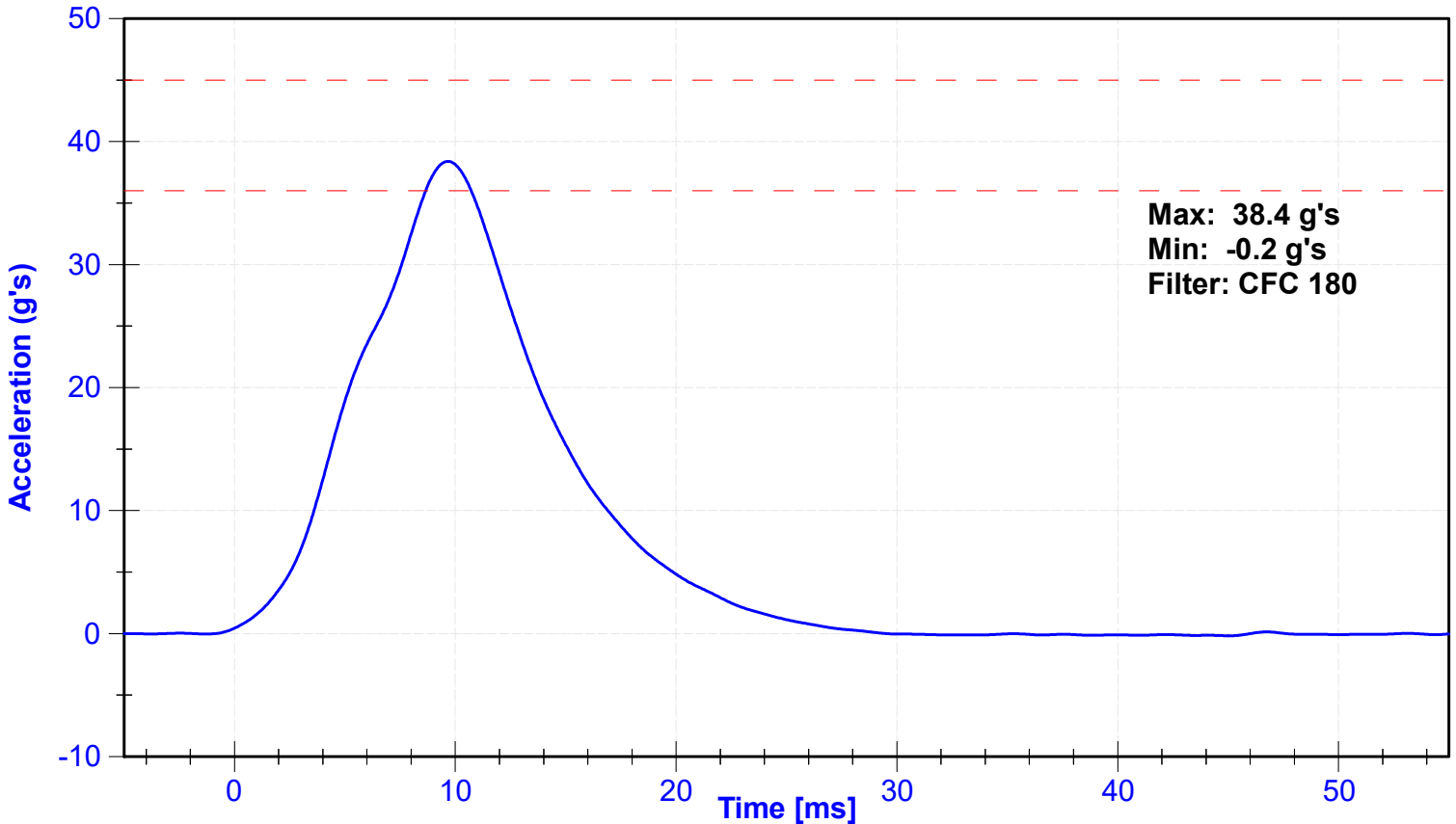

Lateral Pelvis Acceleration

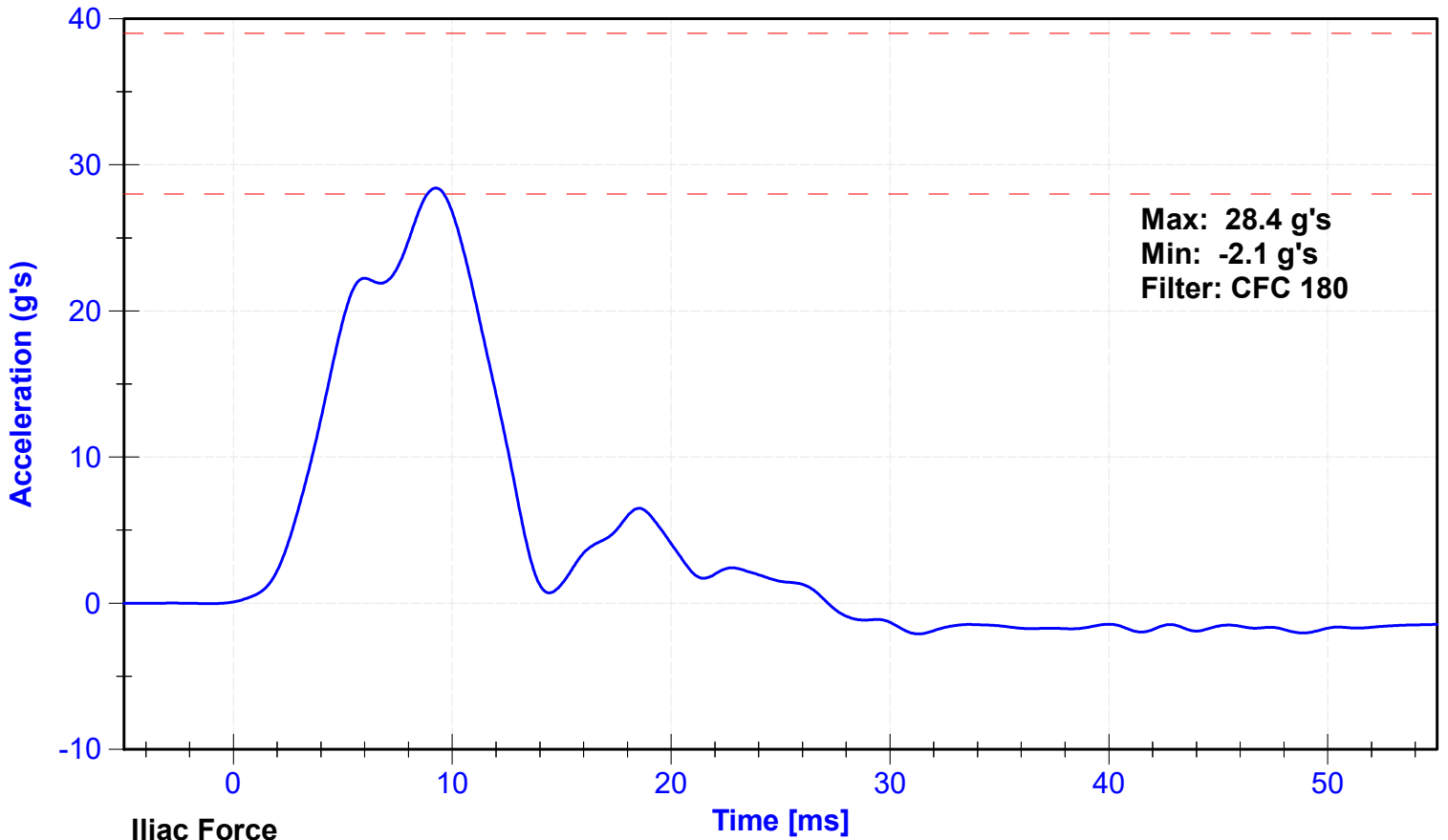

Iliac Force

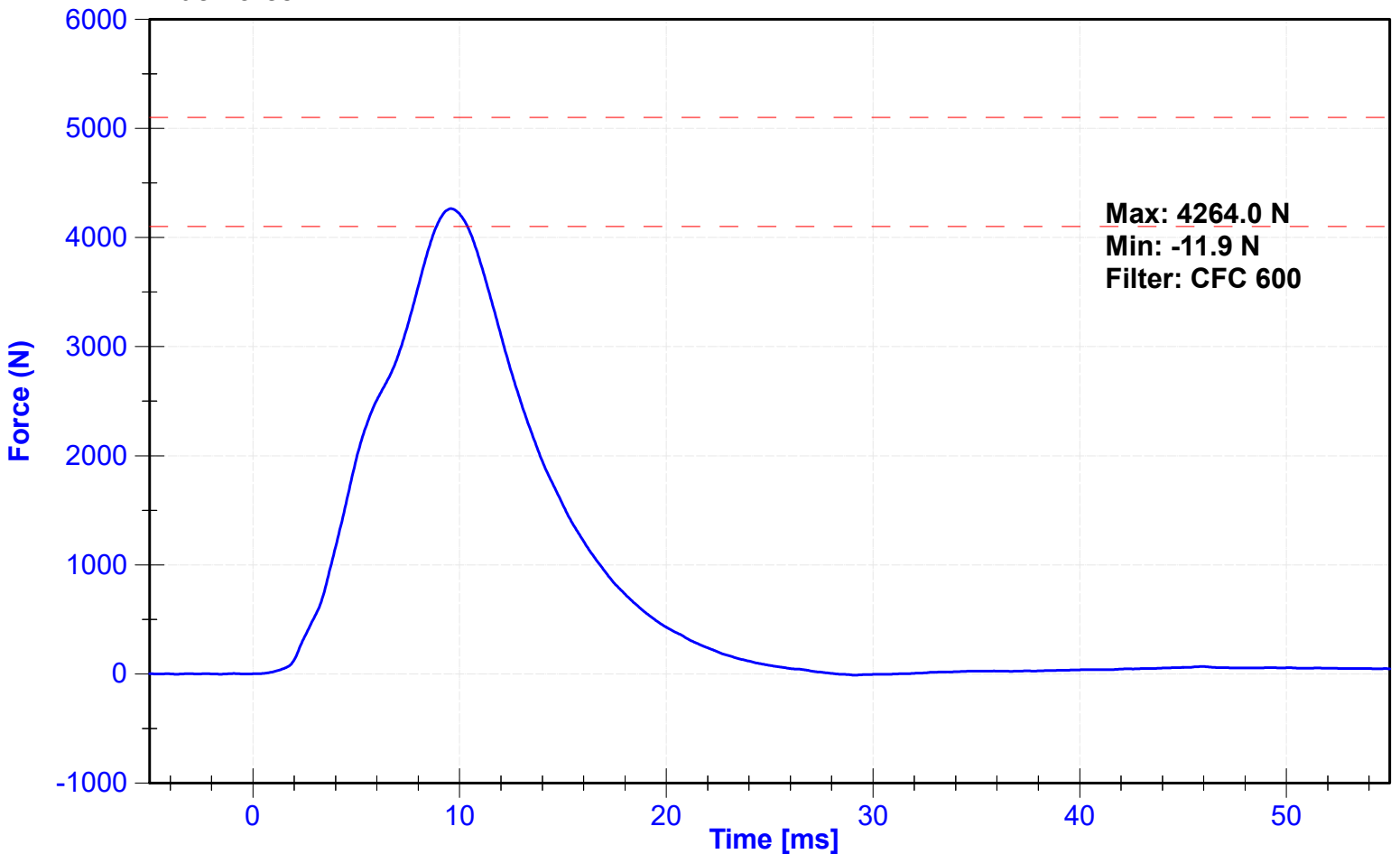

**POST-TEST
SID-IIs PERFORMANCE CALIBRATION TEST DATA**



External Measurements - SID-IIs

Technician: K. Brogan

Date: 12/20/2022

Dummy Serial Number: 261

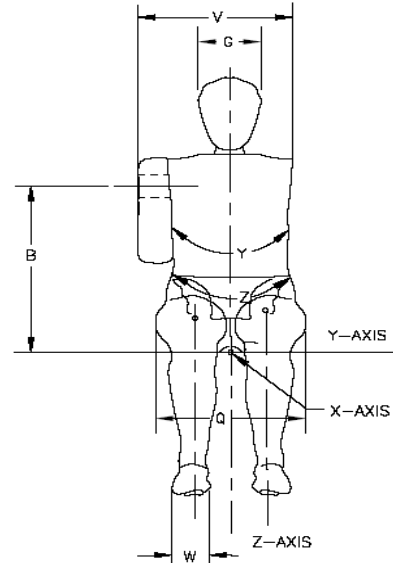
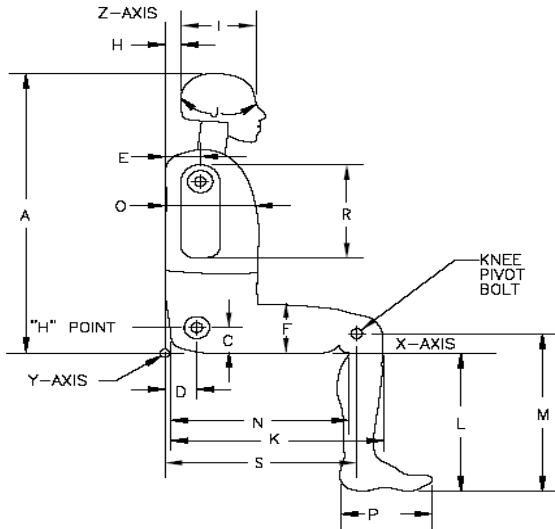

Symbol	Description	Specification (mm)		Result (mm)	Pass/Fail
A	Sitting Height	772	788	783	Pass
B	Shoulder Pivot Height	437	453	445	Pass
C	H-point Height	79	89	84	Pass
D	H-point from seatback	141	151	145	Pass
E	Shoulder Pivot from Backline	97	107	101	Pass
F	Thigh Clearance	119	135	129	Pass
G	Head Breadth	140	148	143	Pass
H	Head Back from Backline	40	46	43	Pass
I	Head Depth	178	188	181	Pass
J	Head Circumference	541	551	547	Pass
K	Buttock to Knee Length	514	540	531	Pass
L	Popliteal Height	343	369	358	Pass
M	Knee Pivot to floor height	392	409	401	Pass
N	Buttock Popliteal Length	416	442	438	Pass
O	Chest Depth w/o jacket	195	211	206	Pass
P	Foot Length	216	232	223	Pass
Q	Hip Breadth (w/pelvic plugs)	313	323	318	Pass
R	Arm Length	249	259	254	Pass
S	Knee Joint to seatback	477	493	485	Pass
V	Shoulder Width	341	357	351	Pass
W	Foot Width	78	94	84	Pass
Y	Chest Circumference w/jacket	851	881	873	Pass
Z	Waist Circumference	761	791	782	Pass

ATD Manufacturer	FTSS	Test Technician	Z. Schneider
ATD Serial Number	261	Laboratory Supervisor	C. Mantell

Results

Test Parameter	Minimum Specification	Maximum Specification	Unit	Result	Pass/Fail
Temperature	20.6	22.2	°C	21	Pass
Humidity	10	70	%	21	Pass
Resultant Acceleration	115	137	g's	124.3	Pass
Oscillation	0	15	%	1.9	Pass
Fore-Aft Acceleration	-15	15	g's	8.4	Pass

Transducer Calibrations

Channel	Manufacturer	Serial Number	Calibratio Date	Calibratio Due Date
X Accelerometer	Endevco	P68067	10/26/2022	4/24/2023
Y Accelerometer	Endevco	P18567	10/25/2022	4/23/2023
Z Accelerometer	Endevco	P49163	10/25/2022	4/23/2023

Resultant Acceleration

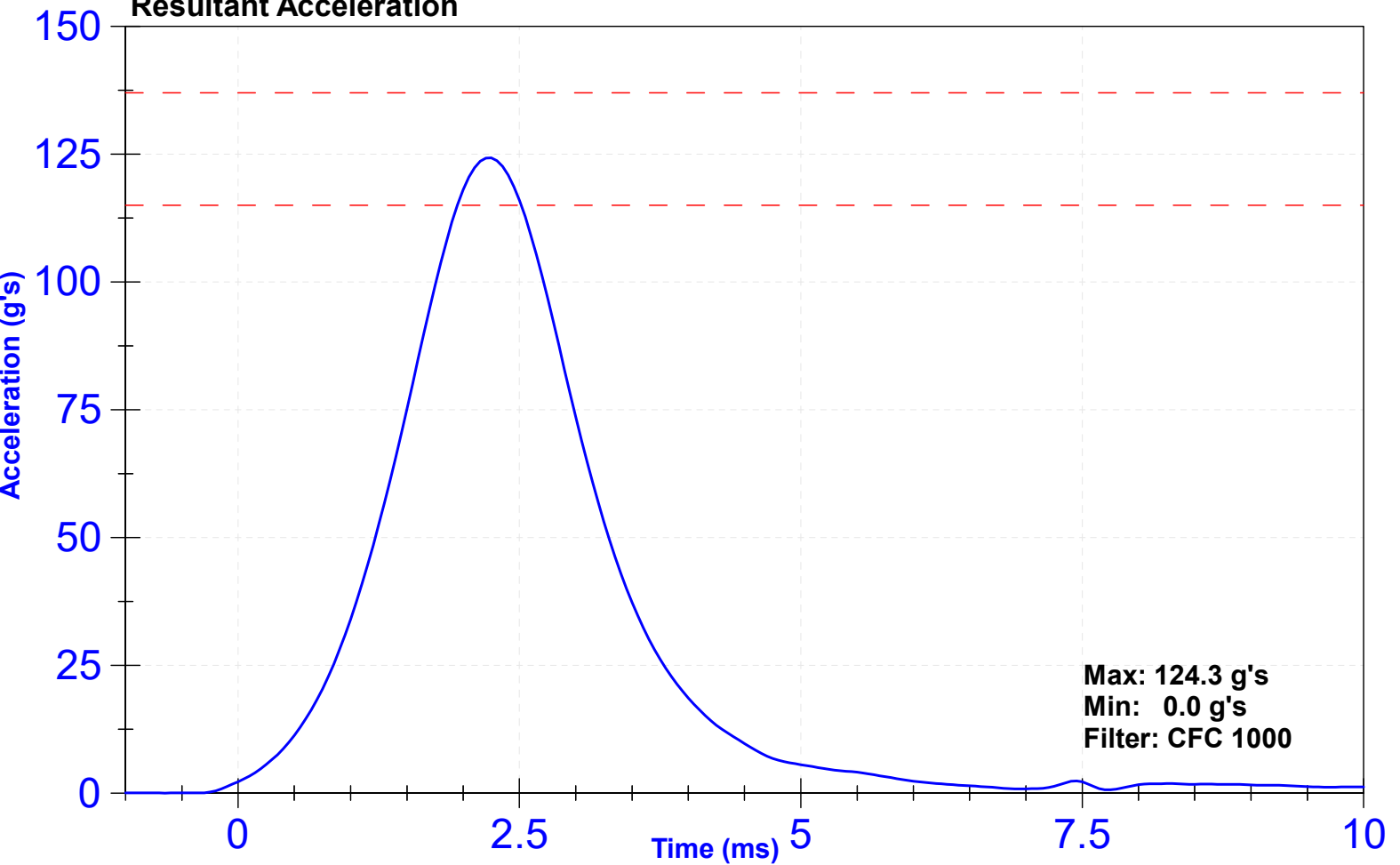

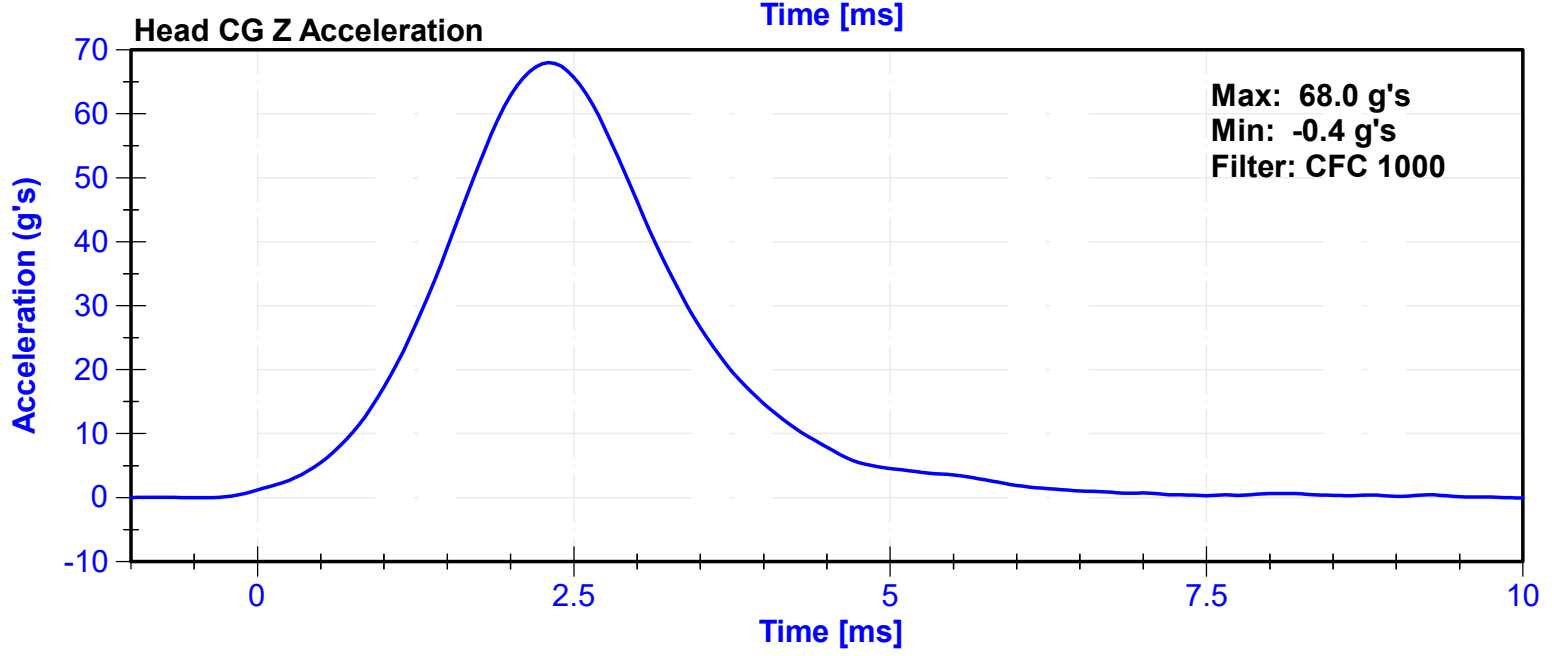
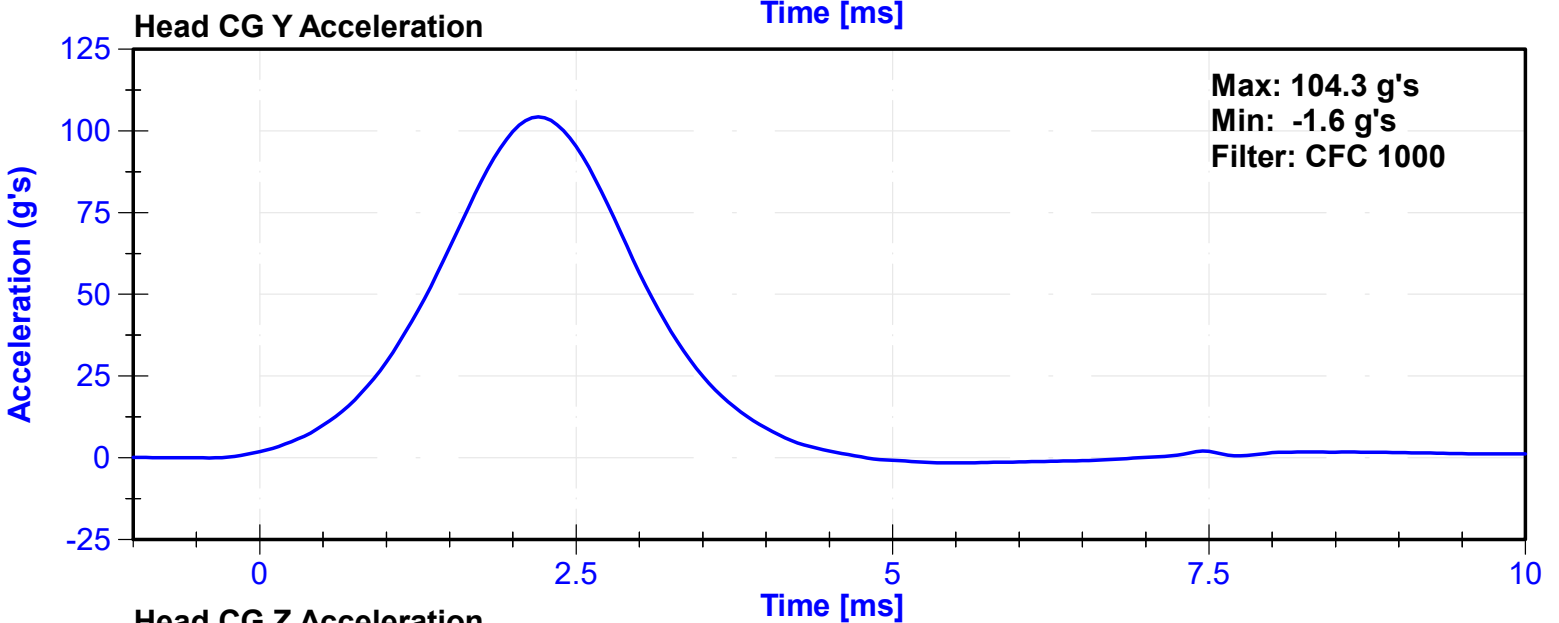
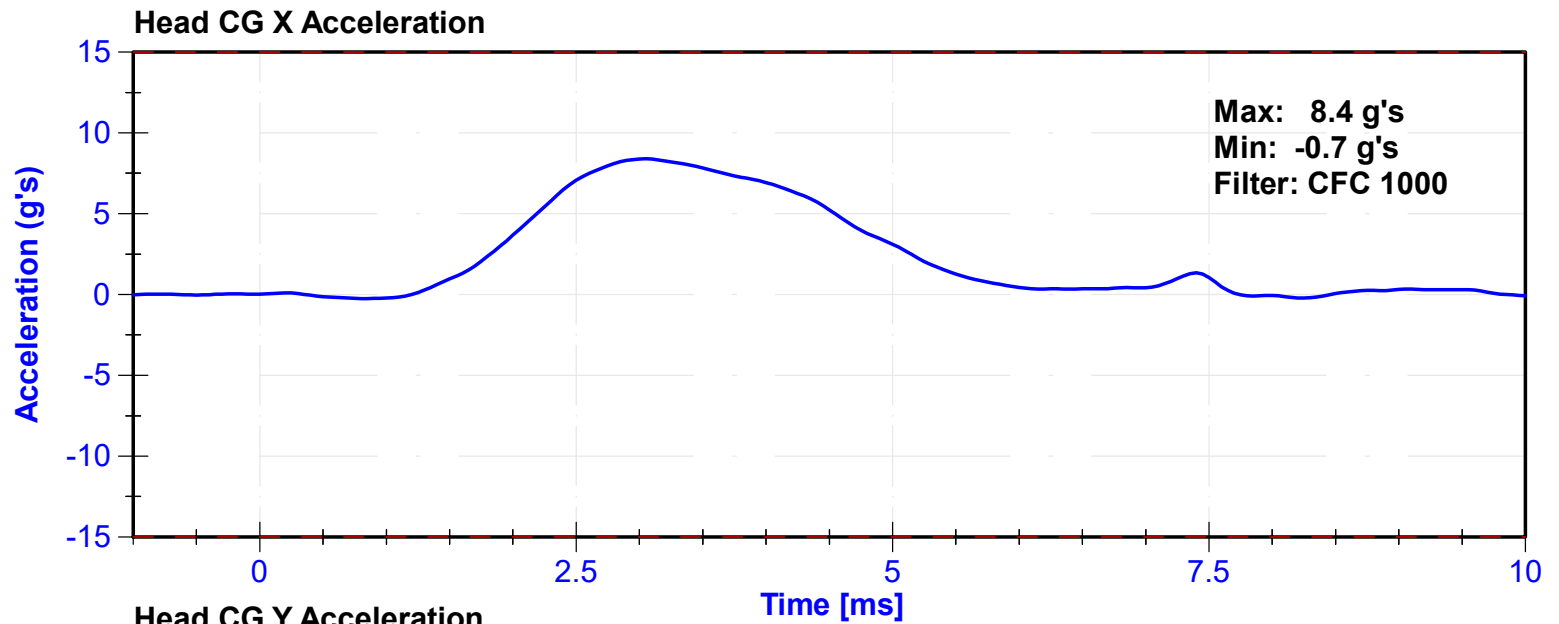

ATD Manufacturer	FTSS	Test Technician	D. Sakona
ATD Serial Number	261	Laboratory Supervisor	C. Mantell

Results

Test Parameter	Minimum Specification	Maximum Specification	Unit	Result	Pass/Fail
Temperature	20.6	22.2	°C	20.8	Pass
Humidity	10	70	%	22.5	Pass
Velocity	5.51	5.63	m/s	5.536	Pass
Pendulum Impulse at 10ms	2.2	2.8	m/s	2.29	Pass
Pendulum Impulse at 15ms	3.3	4.1	m/s	3.44	Pass
Pendulum Impulse at 20ms	4.4	5.4	m/s	4.65	Pass
Pendulum Impulse at 25ms	5.4	6.1	m/s	5.61	Pass
Pendulum Impulse from 25 to 100ms	5.5	6.2	m/s	5.93	Pass
Neck Rotation	71	81	deg	71.6	Pass
Time at Maximum Rotation	50	70	ms	59.4	Pass
Moment about the OC	36	44	Nm	43.0	Pass
Moment Decay to 0 Nm	102	126	ms	113.2	Pass

Transducer Calibrations

Channel	Manufacturer	Serial Number	Calibration Date	Calibration Due Date
Pendulum Accelerometer	Endevco	7231C-750	10/26/2022	10/26/2023
Pendulum Potentiometer	Servo	4961	11/11/2022	11/11/2023
Condyle Potentiometer	Servo	DS185	11/11/2022	11/11/2023
Upper Neck Load Cell	Humanetics	1716A_1872-FY	6/13/2022	6/13/2023

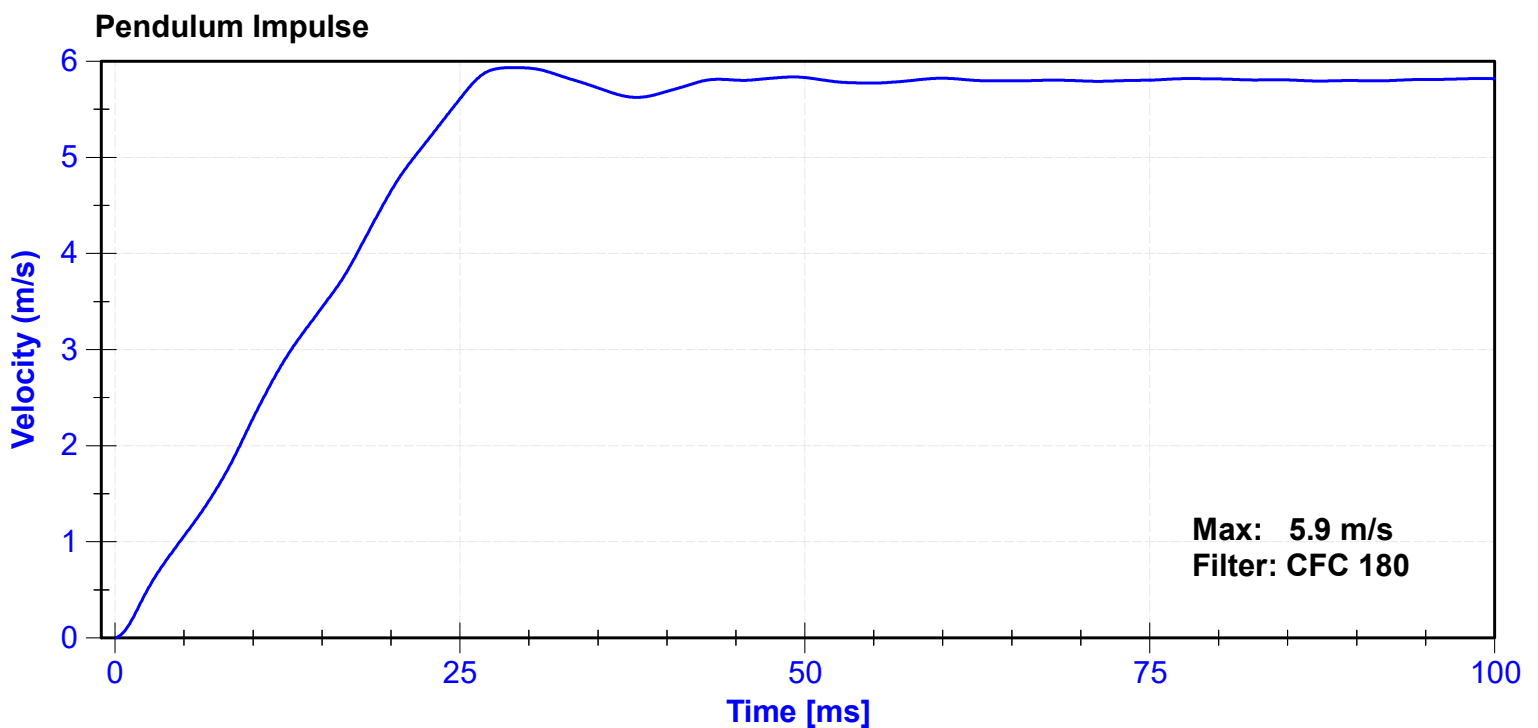

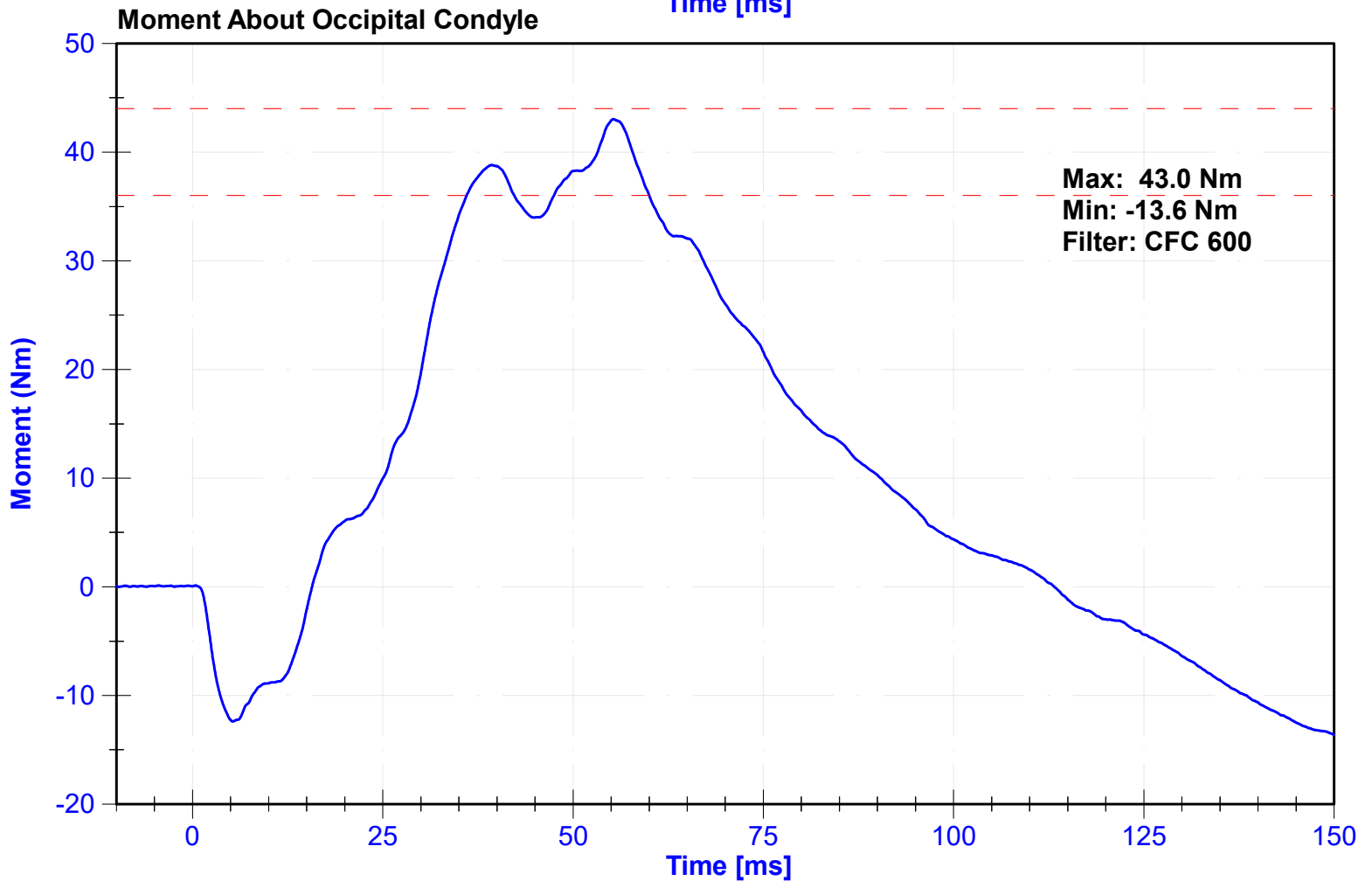
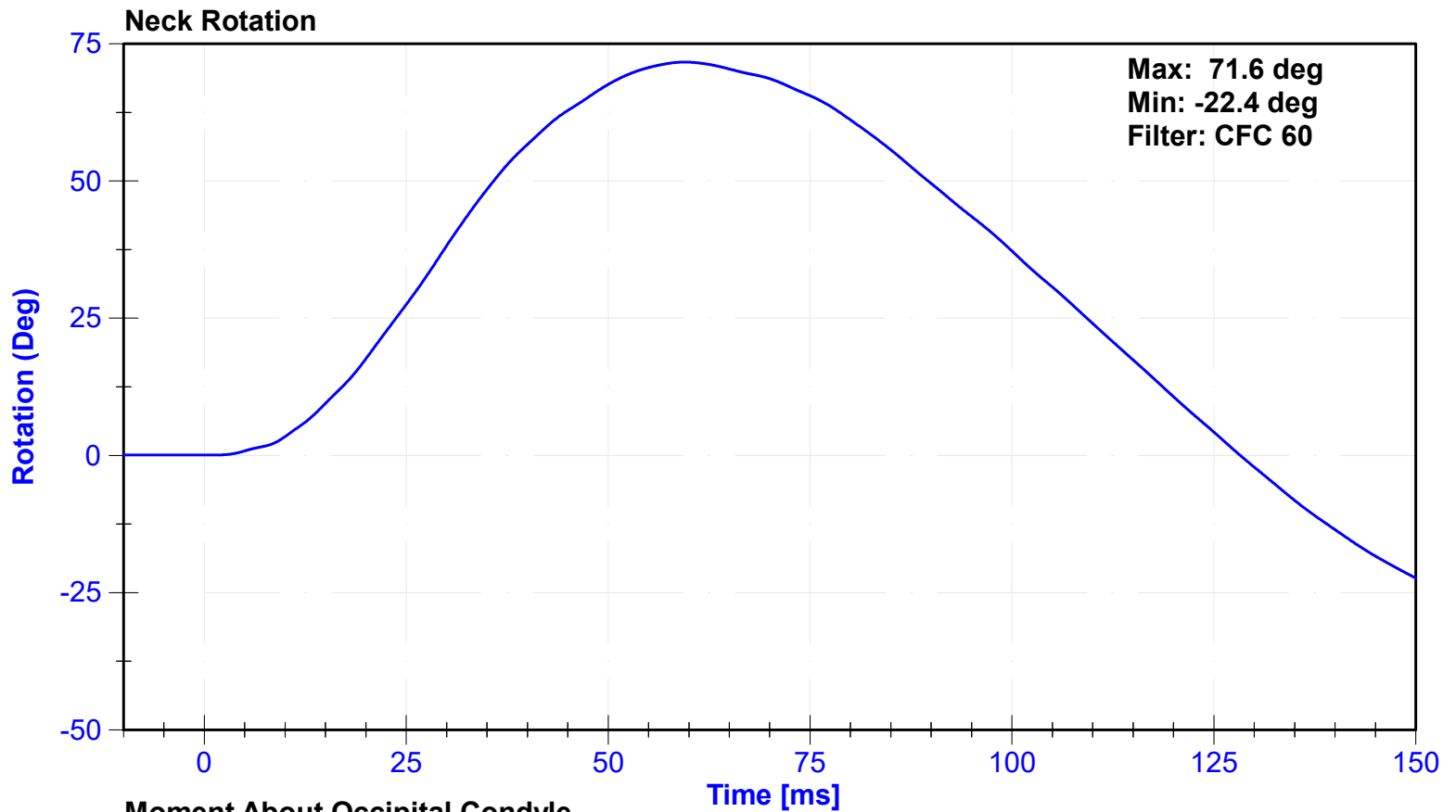

ATD Manufacturer	FTSS	Test Technician	D. Sakona
ATD Serial Number	261	Laboratory Supervisor	K. Brogan

Results

Test Parameter	Minimum Specification	Maximum Specification	Unit	Result	Pass/Fail
Temperature	20.6	22.2	°C	20.8	Pass
Humidity	10	70	%	22.5	Pass
Velocity	4.2	4.4	m/s	4.29	Pass
Probe Acceleration	13	18	g's	15.6	Pass
Shoulder Deflection	28	37	mm	33.0	Pass
Lateral Upper Spine Acceleration	17	22	g's	19.5	Pass

Transducer Calibrations

Channel	Manufacturer	Serial Number	Calibration Date	Calibration Due Date
Pendulum Accelerometer	Endevco	P51736	10/25/2022	4/23/2023
Shoulder Potentiometer	Servo	572GFE	11/1/2022	5/2/2023
Upper Spine Y Accelerometer	Endevco	P18688	10/25/2022	4/23/2023

Probe Acceleration

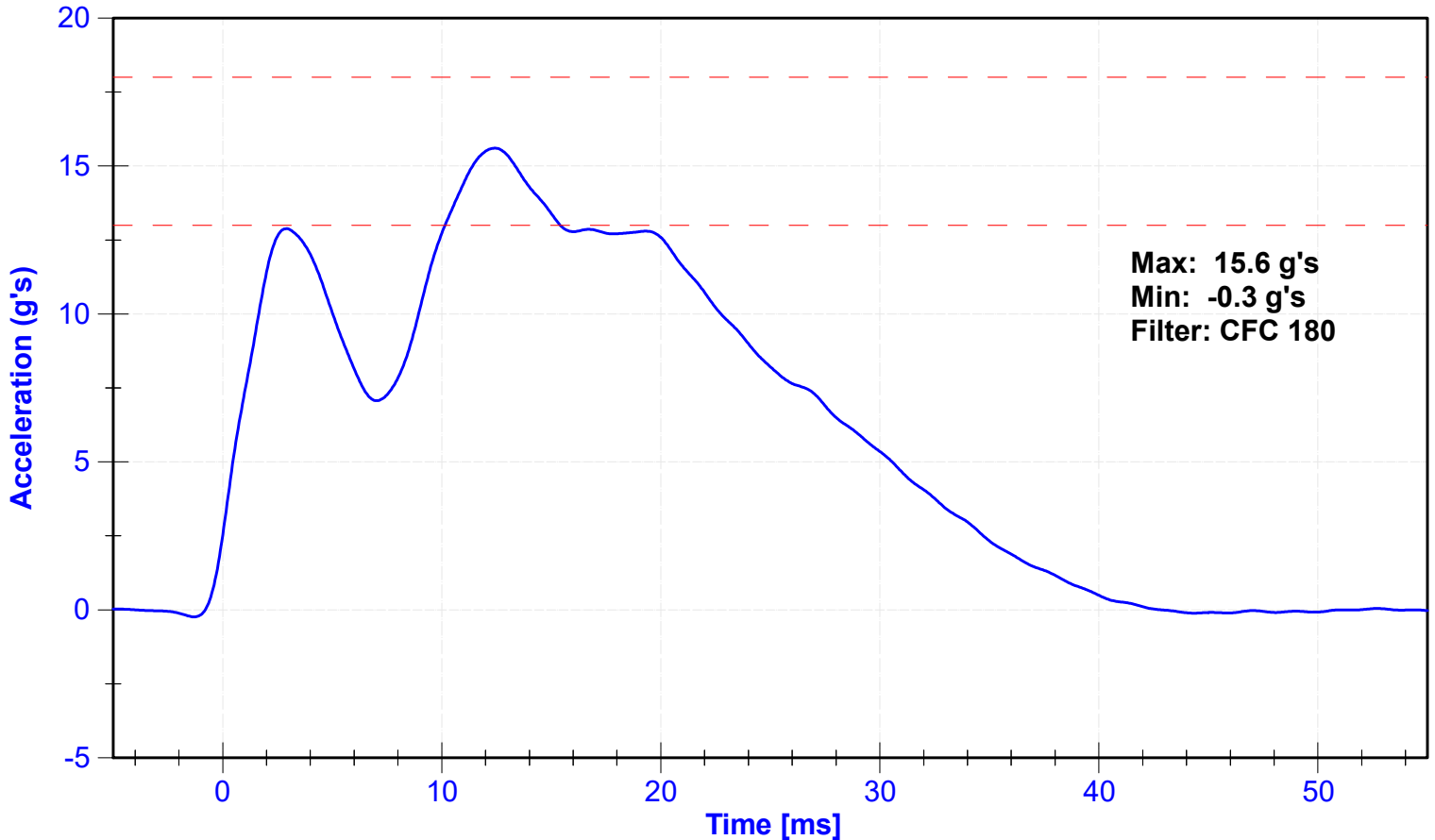

Shoulder Displacement

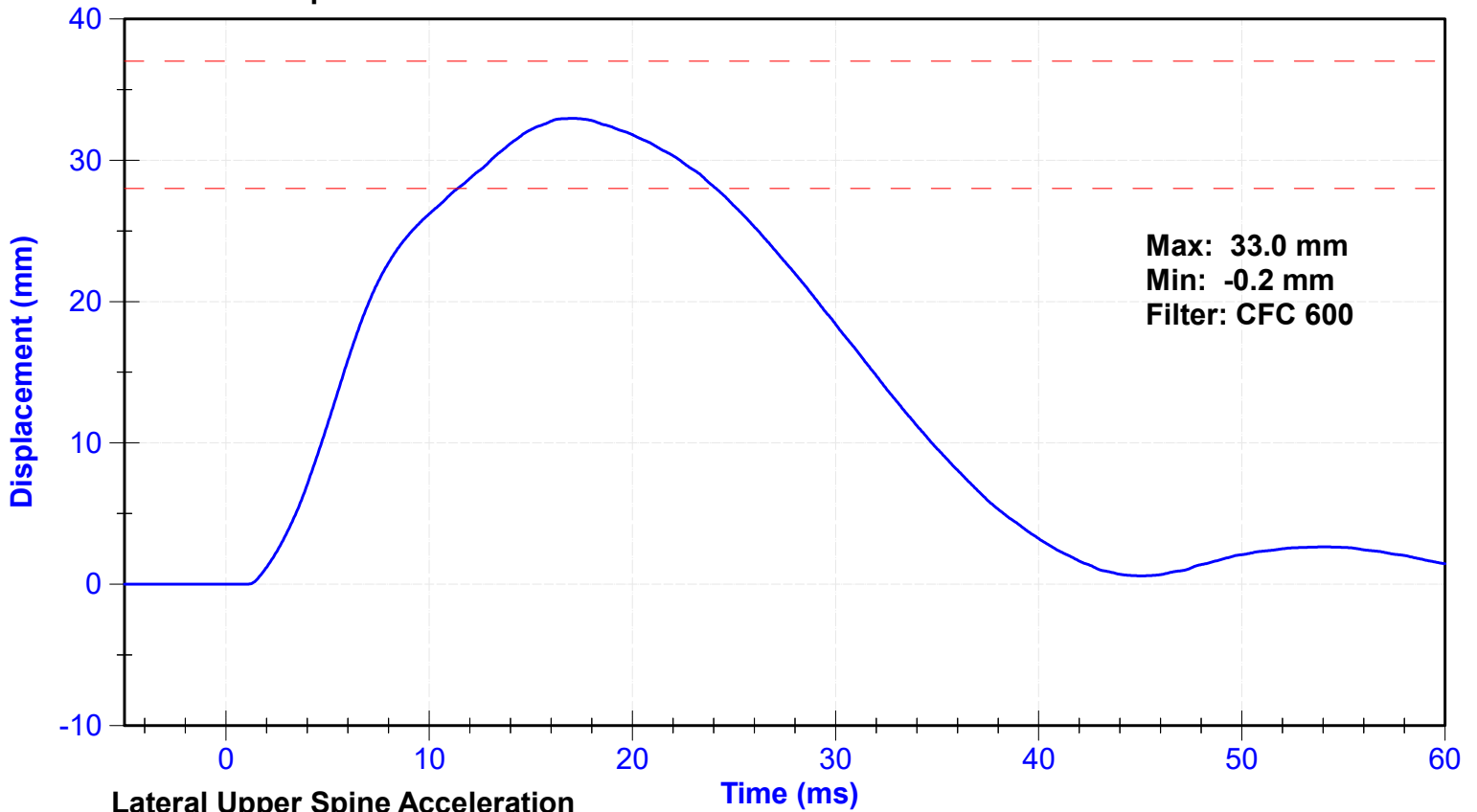

Lateral Upper Spine Acceleration

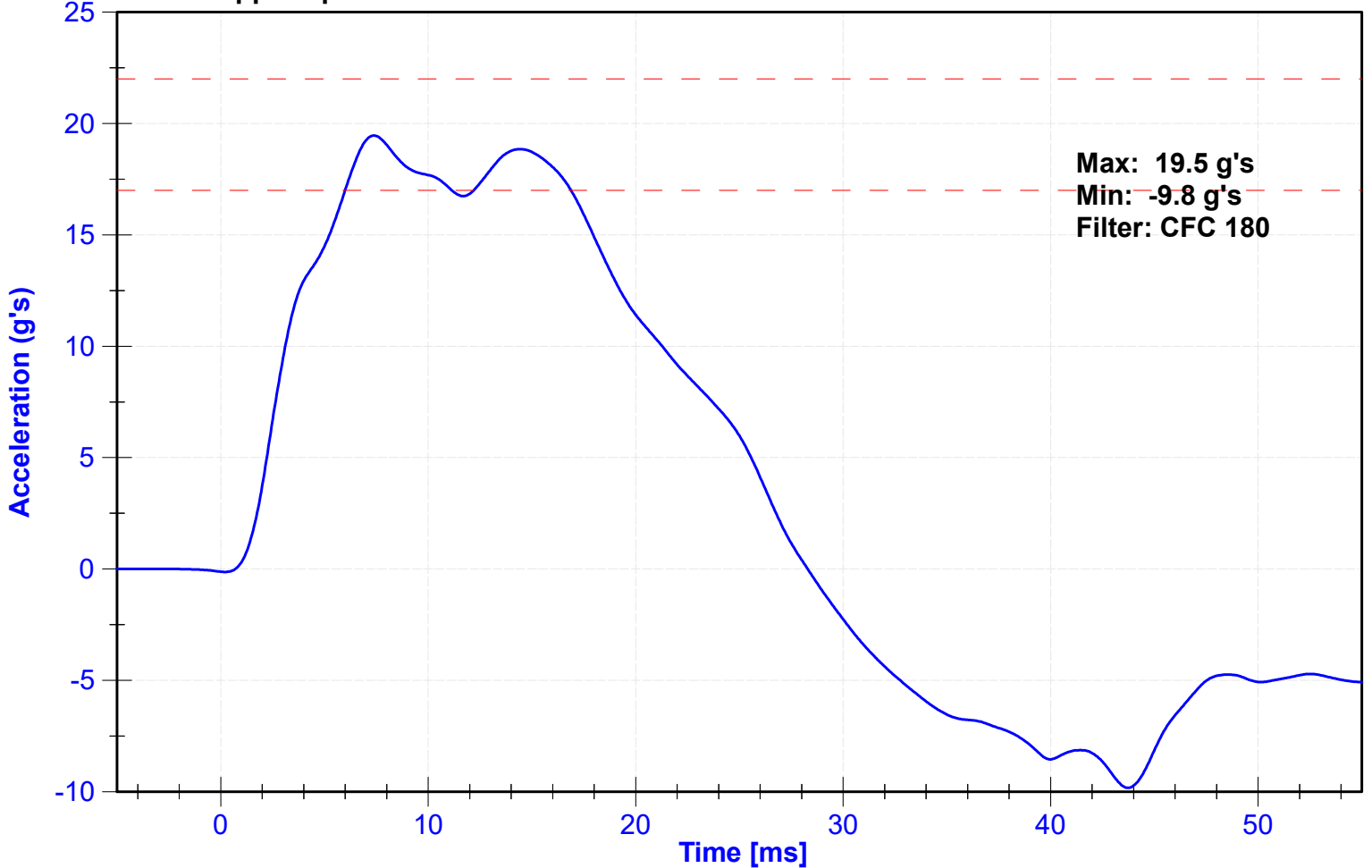

ATD Manufacturer	FTSS	Test Technician	D. Sakona
ATD Serial Number	261	Laboratory Supervisor	K. Brogan

Results

Test Parameter	Minimum Specification	Maximum Specification	Unit	Result	Pass/Fail
Temperature	20.6	22.2	°C	20.8	Pass
Humidity	10	70	%	22.5	Pass
Velocity	6.6	6.8	m/s	6.66	Pass
Probe Acceleration after 5 ms	30	36	g's	32.9	Pass
Lateral Upper Spine Acceleration	34	43	g's	39.8	Pass
Lateral Lower Spine Acceleration	29	37	g's	31.3	Pass
Shoulder Deflection	31	40	mm	34.7	Pass
Upper Thorax Rib Deflection	25	32	mm	28.2	Pass
Mid Thorax Rib Deflection	30	36	mm	31.8	Pass
Lower Thorax Rib Deflection	32	38	mm	34.1	Pass

Transducer Calibrations

Channel	Manufacturer	Serial Number	Calibration Date	Calibration Due Date
Pendulum Accelerometer	Endevco	P51736	10/25/2022	4/23/2023
Upper Spine T1 Y Accelerometer	Endevco	P18688	10/25/2022	4/23/2023
Upper Spine T12 Y Accelerometer	Endevco	P58744	10/25/2022	4/23/2023
Shoulder Potentiometer	Servo	572GFE	11/1/2022	5/2/2023
Upper Thorax Rib Potentiometer	Servo	062GFE	11/1/2022	5/2/2023
Middle Thorax Rib Potentiometer	Servo	528GFE	11/1/2022	5/2/2023
Lower Thorax Rib Potentiometer	Servo	513GFE	11/1/2022	5/2/2023

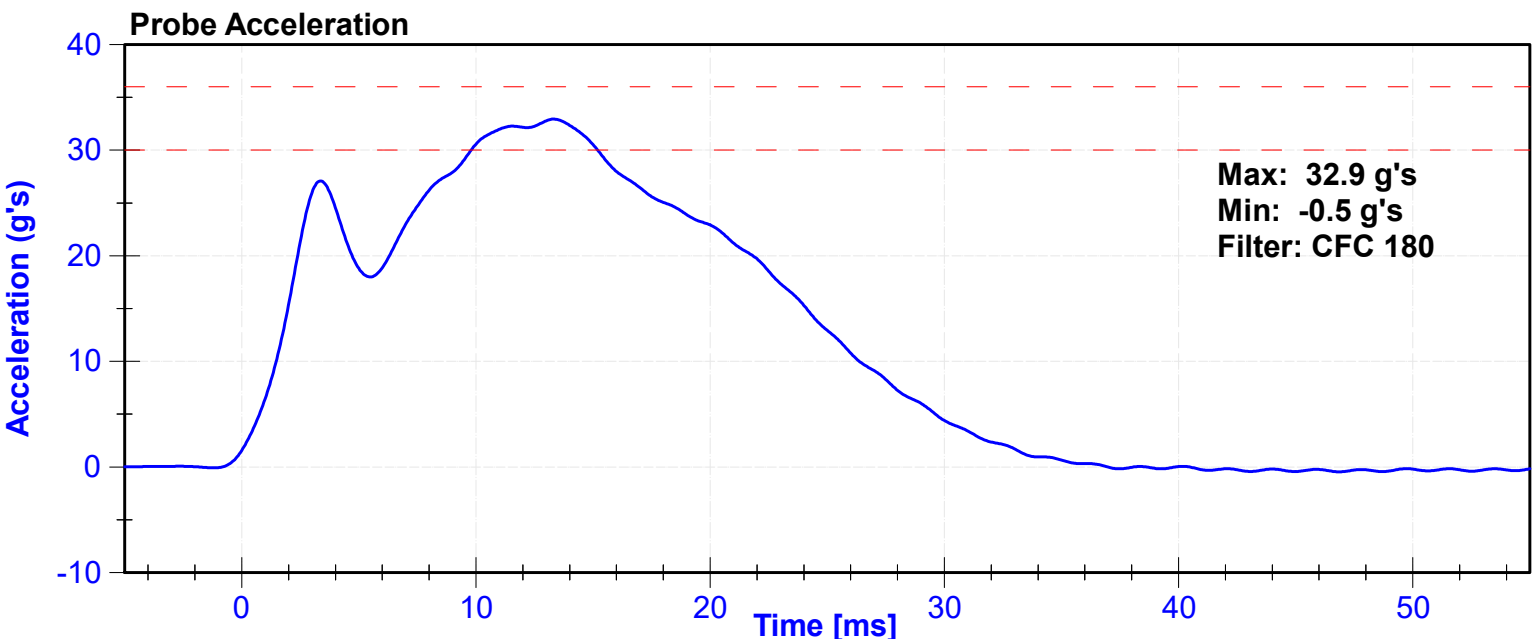

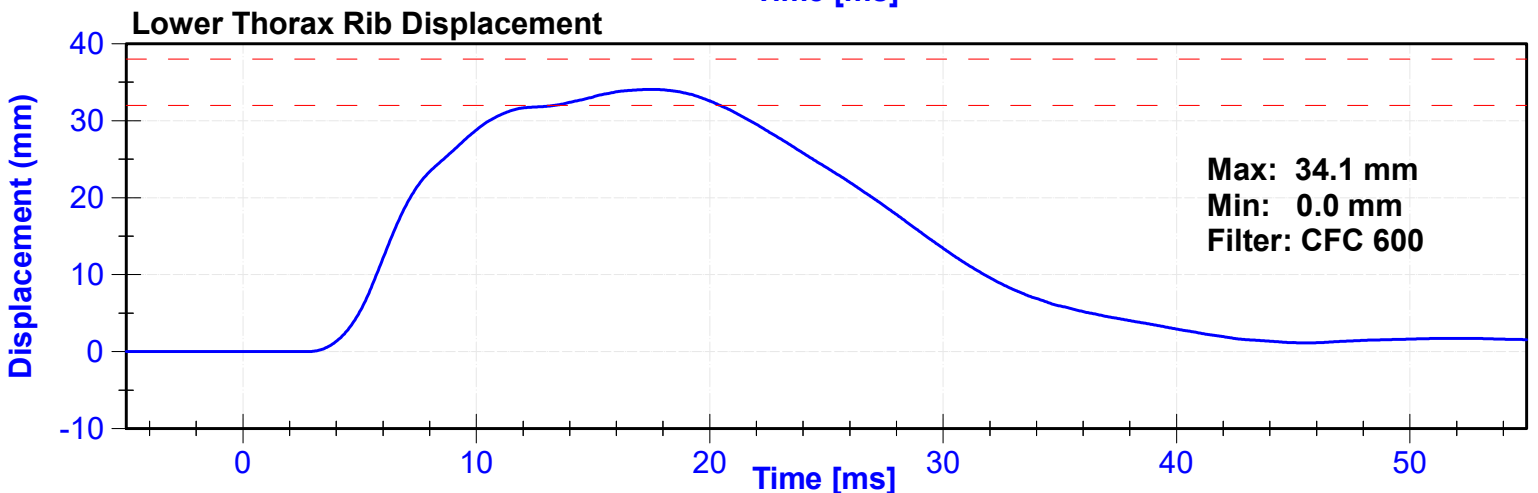
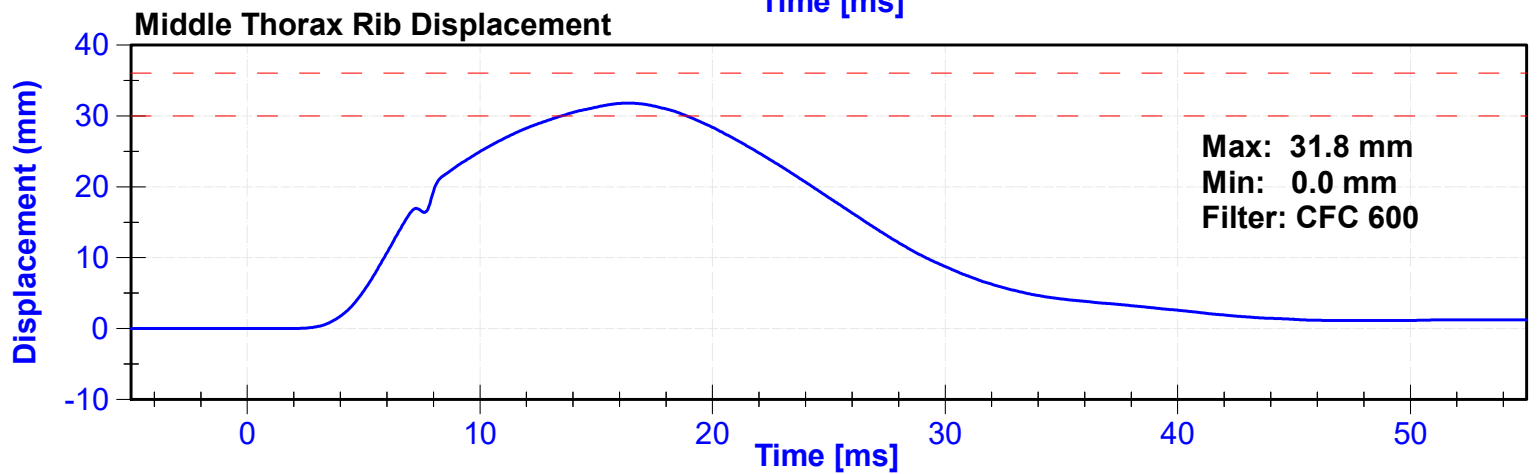
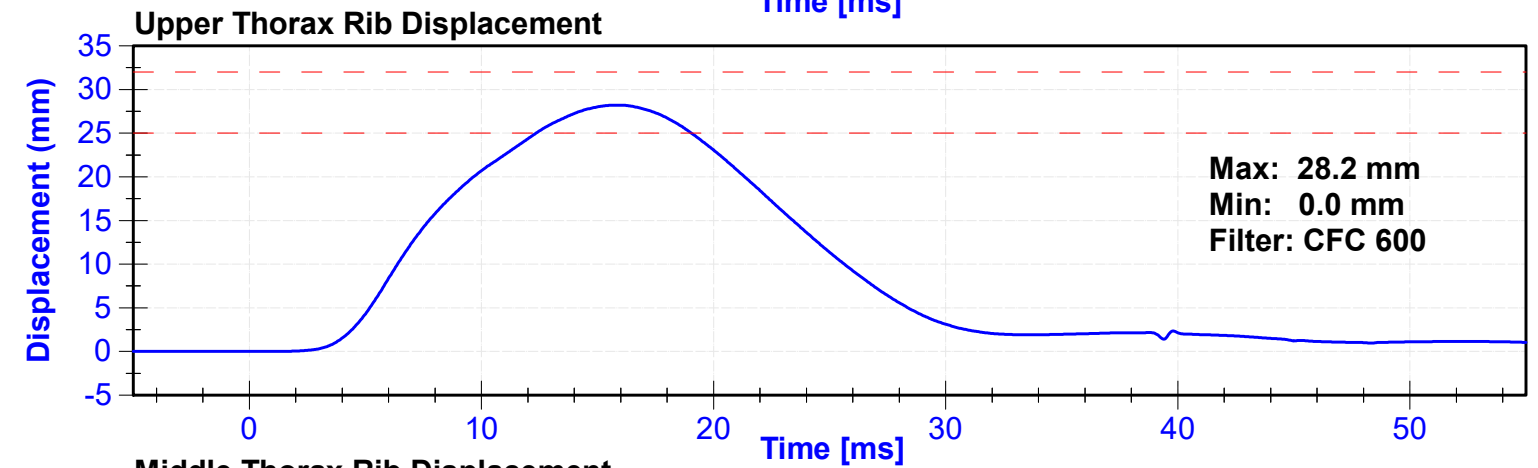
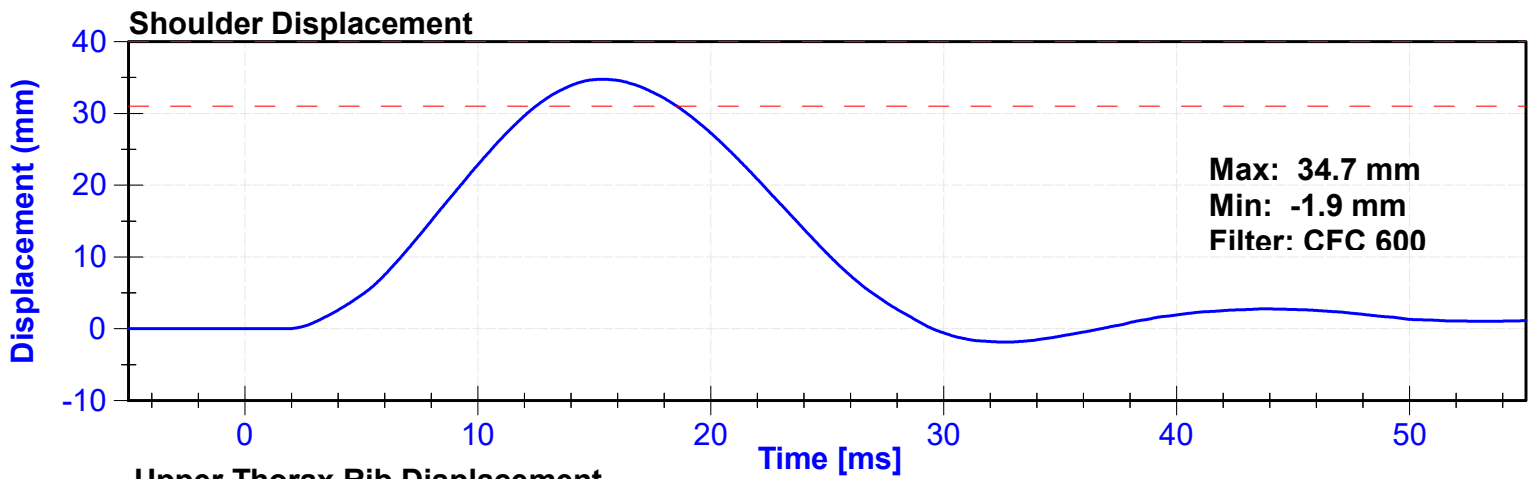

Lateral Upper Spine Acceleration

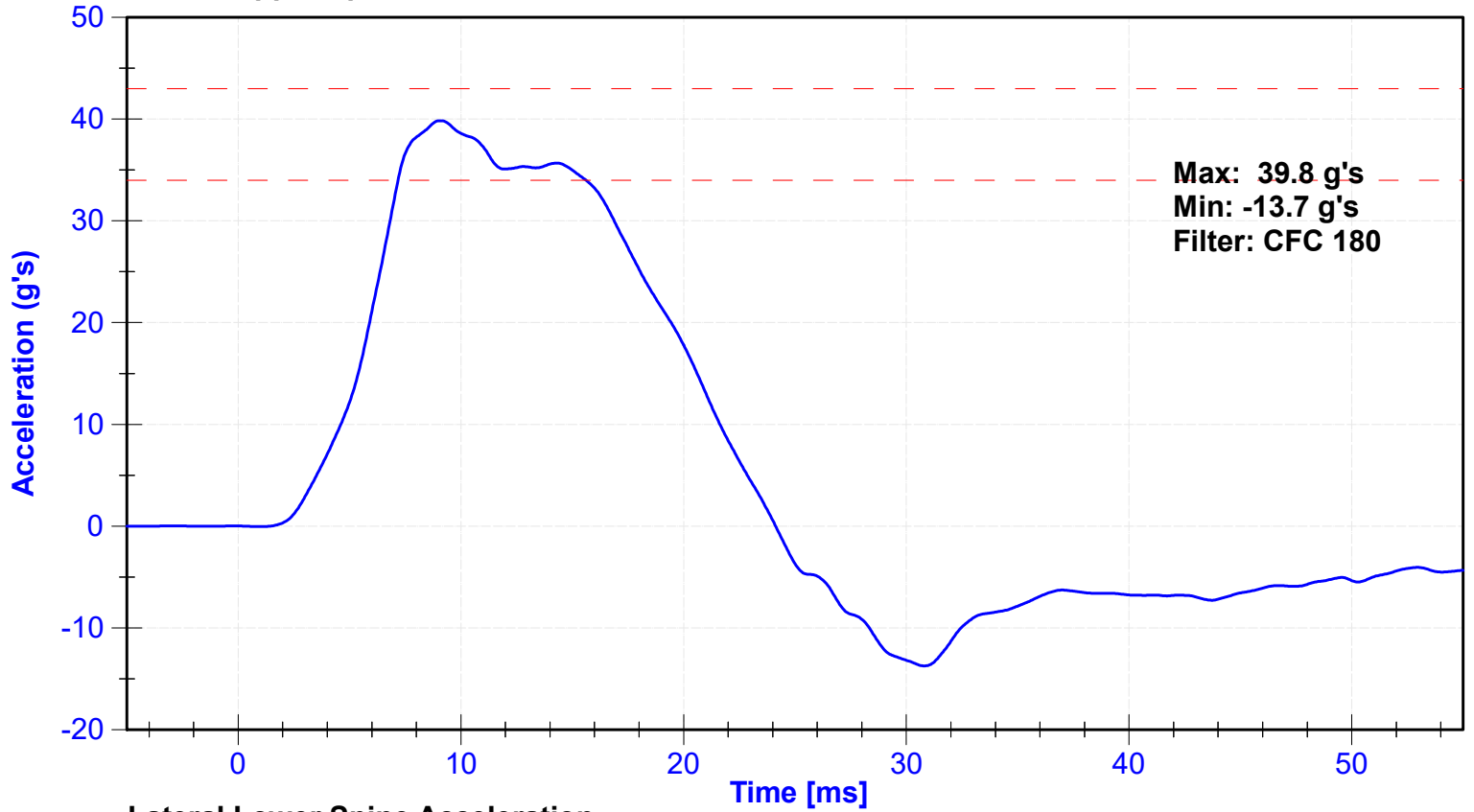

Lateral Lower Spine Acceleration

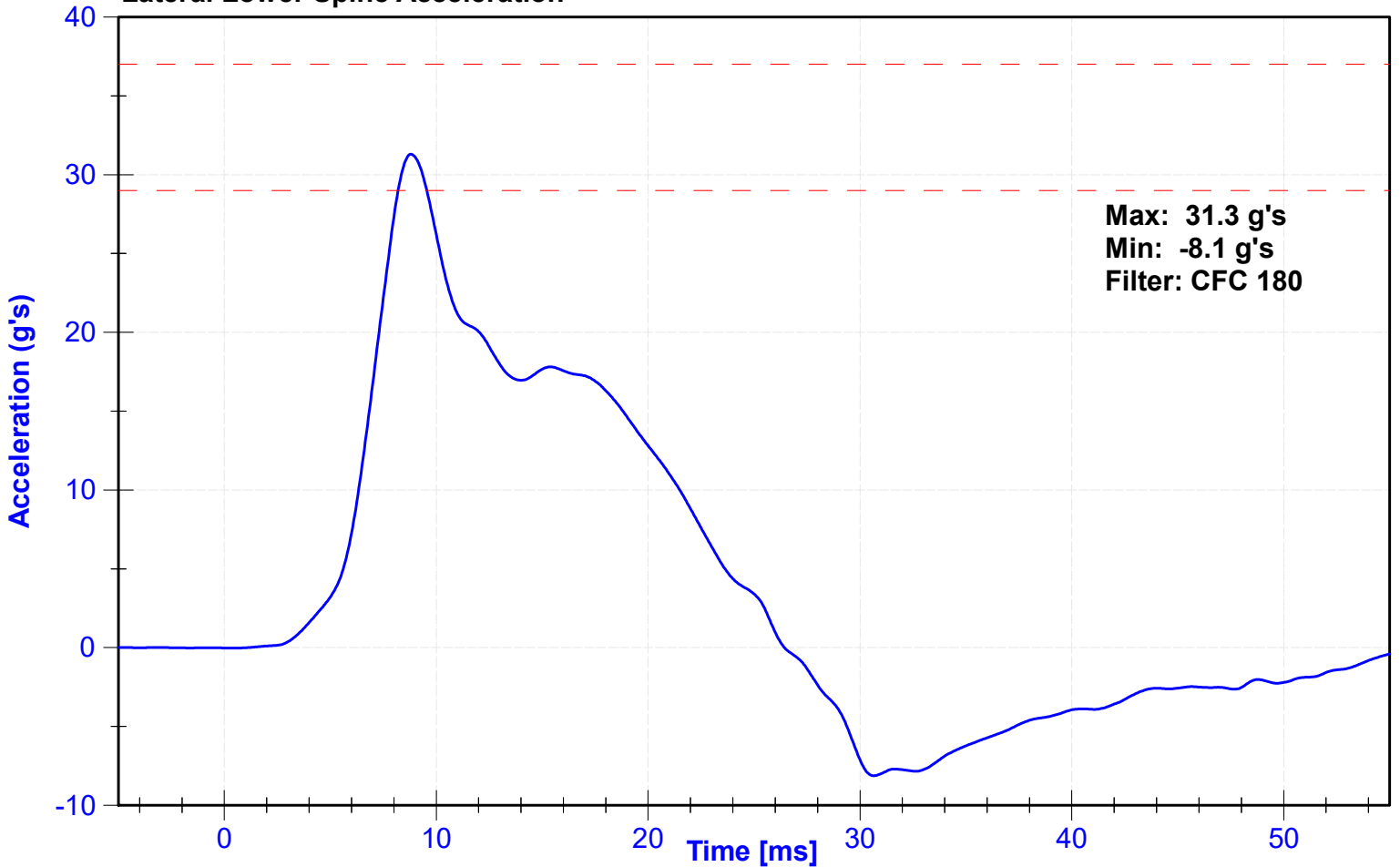

ATD Manufacturer	FTSS	Test Technician	D. Sakona
ATD Serial Number	261	Laboratory Supervisor	K. Brogan

Results

Test Parameter	Minimum Specification	Maximum Specification	Unit	Result	Pass/Fail
Temperature	20.6	22.2	°C	20.8	Pass
Humidity	10	70	%	22.5	Pass
Velocity	4.2	4.4	m/s	4.34	Pass
Probe Acceleration	14	18	g's	17.6	Pass
Lateral Upper Spine Acceleration	13	17	g's	16.8	Pass
Lateral Lower Spine Acceleration	7	11	g's	10.4	Pass
Upper Thorax Rib Deflection	32	40	mm	34.6	Pass
Middle Thorax Rib Deflection	39	45	mm	39.9	Pass
Lower Thorax Rib Deflection	35	43	mm	37.3	Pass

Transducer Calibrations

Channel	Manufacturer	Serial Number	Calibration Date	Calibration Due Date
Pendulum Accelerometer	Endevco	P51736	10/25/2022	4/23/2023
Upper Spine Y Accelerometer	Endevco	P18688	10/25/2022	4/23/2023
Lower Spine Y Accelerometer	Endevco	P58744	10/25/2022	4/23/2023
Upper Thorax Rib Potentiometer	Servo	062GFE	11/1/2022	5/2/2023
Middle Thorax Rib Potentiometer	Servo	528GFE	11/1/2022	5/2/2023
Lower Thorax Rib Potentiometer	Servo	513GFE	11/1/2022	5/2/2023

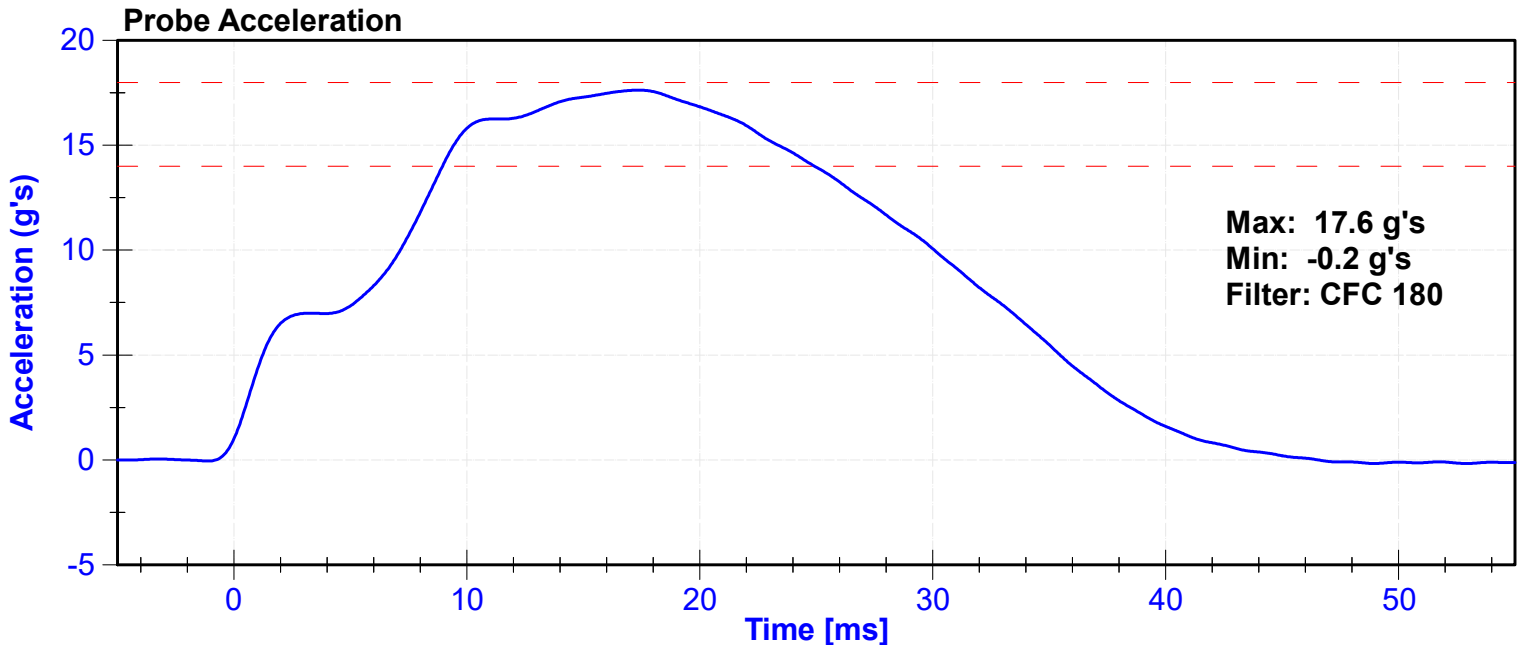

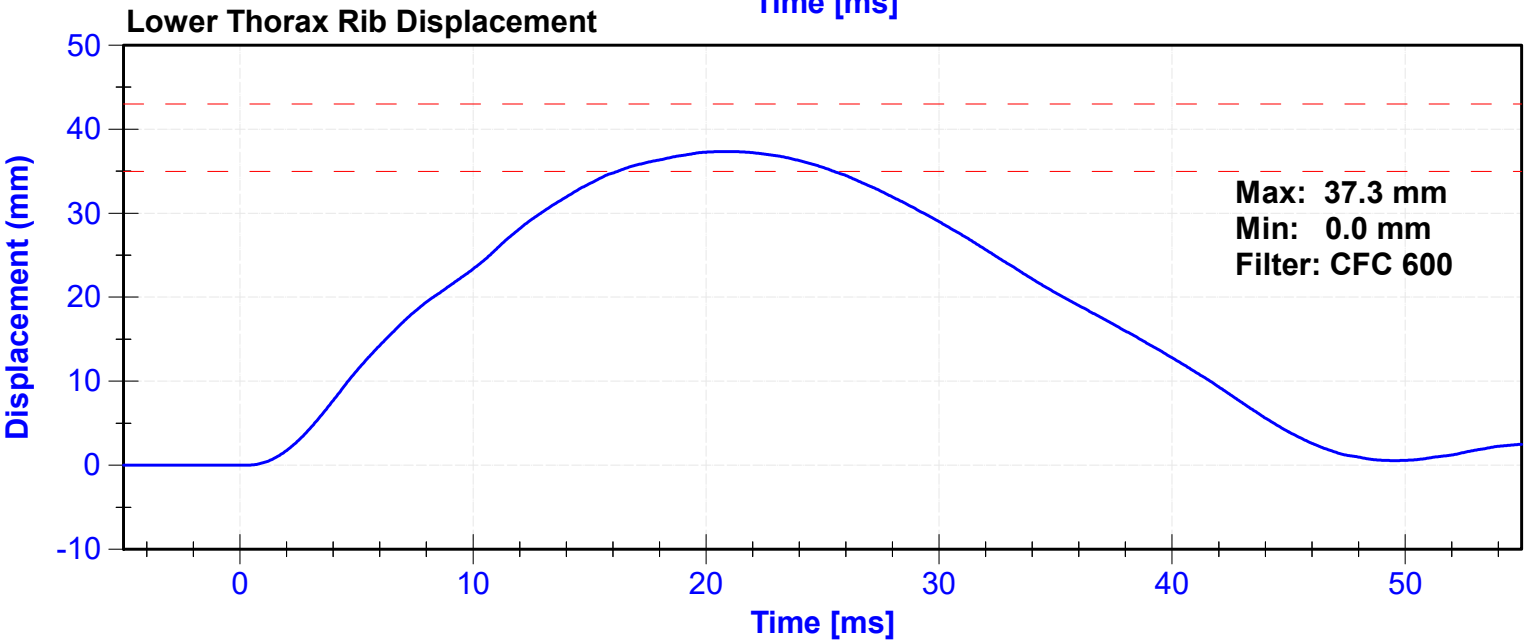
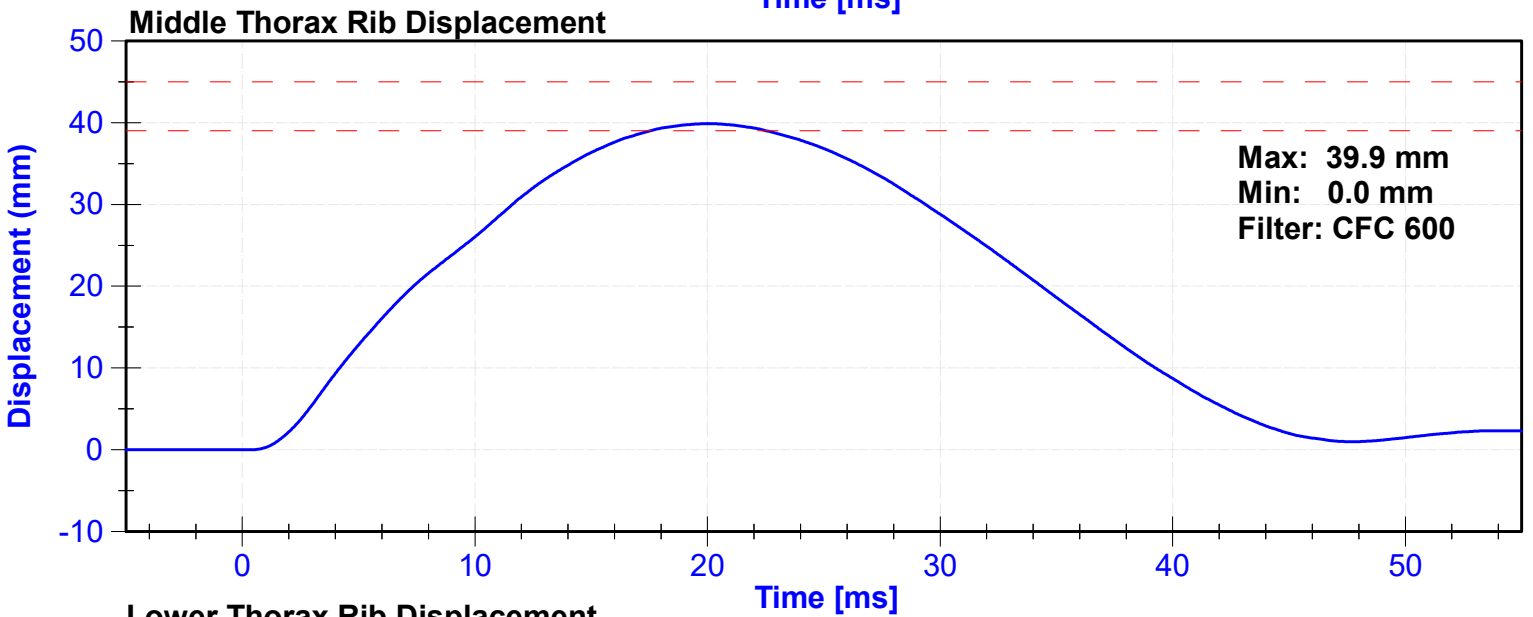
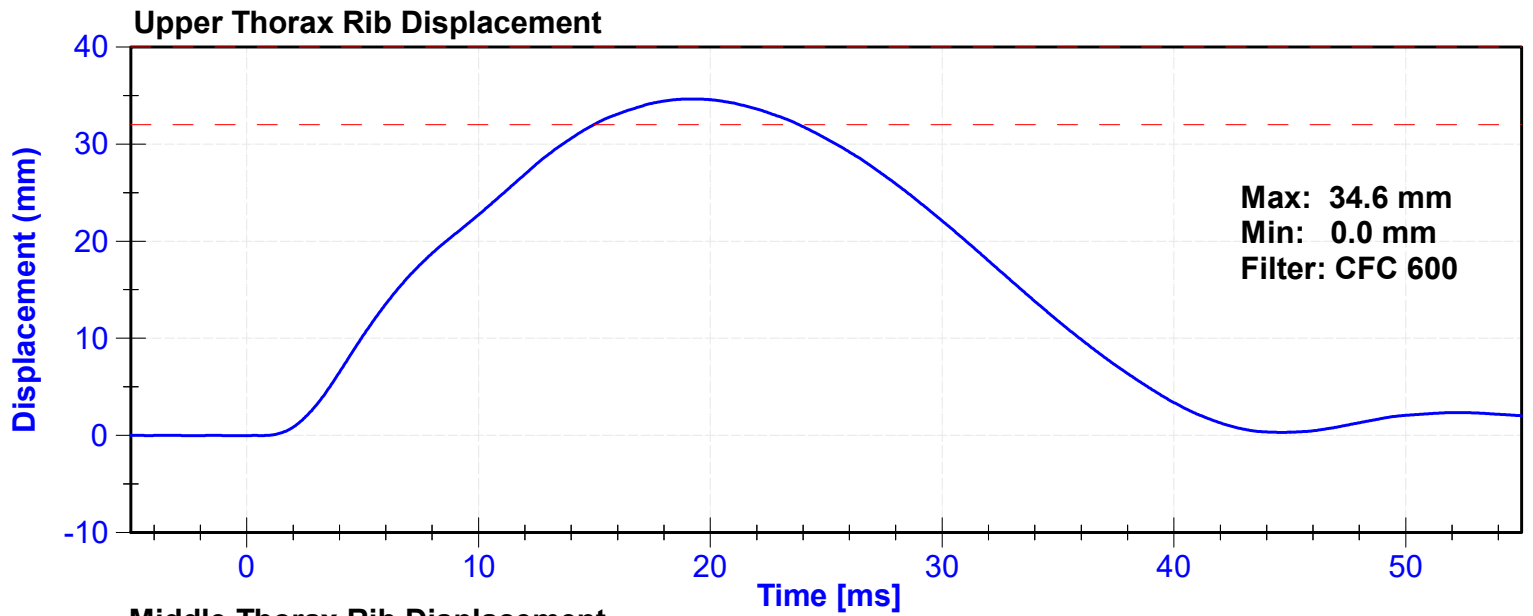

Lateral Upper Spine Acceleration

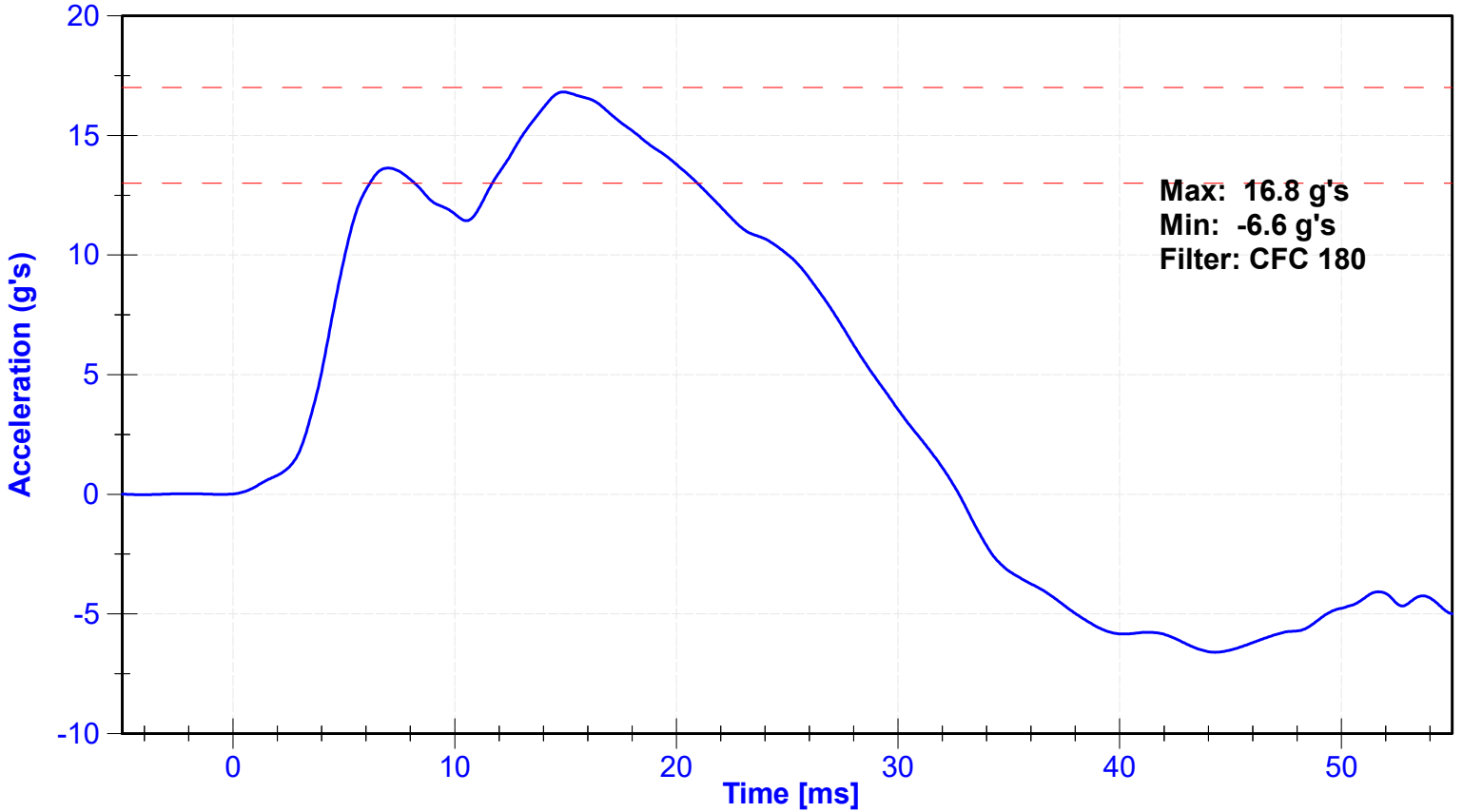

Lateral Lower Spine Acceleration

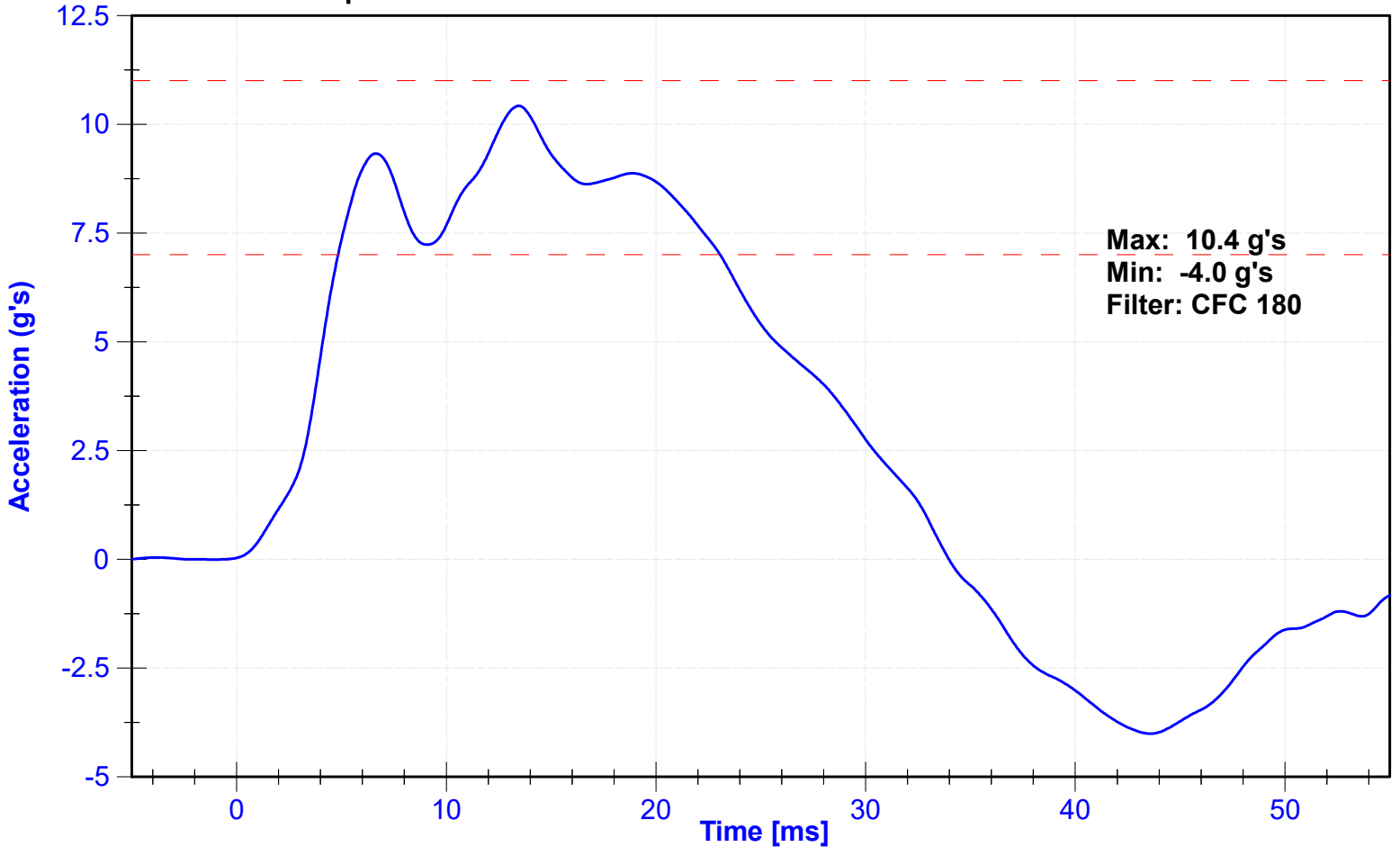

ATD Manufacturer	FTSS	Test Technician	D. Sakona
ATD Serial Number	261	Laboratory Supervisor	K. Brogan

Results

Test Parameter	Minimum Specification	Maximum Specification	Unit	Result	Pass/Fail
Temperature	20.6	22.2	°C	20.8	Pass
Humidity	10	70	%	22.5	Pass
Velocity	4.2	4.4	m/s	4.31	Pass
Probe Acceleration	12	16	g's	14.9	Pass
Lateral Lower Spine Acceleration	9	14	g's	10.6	Pass
Upper Abdomen Rib Deflection	36	47	mm	39.9	Pass
Lower Abdomen Rib Deflection	33	44	mm	34.8	Pass

Transducer Calibrations

Channel	Manufacturer	Serial Number	Calibration Date	Calibration Due Date
Probe Accelerometer	Endevco	P51736	10/25/2022	4/23/2023
Lower Spine Y Accelerometer	Endevco	P58744	10/25/2022	4/23/2023
Upper Abdomen Rib Potentiometer	Servo	342GFE	11/1/2022	5/2/2023
Lower Abdomen Rib Potentiometer	Servo	512GFE	11/1/2022	5/2/2023

Probe Acceleration

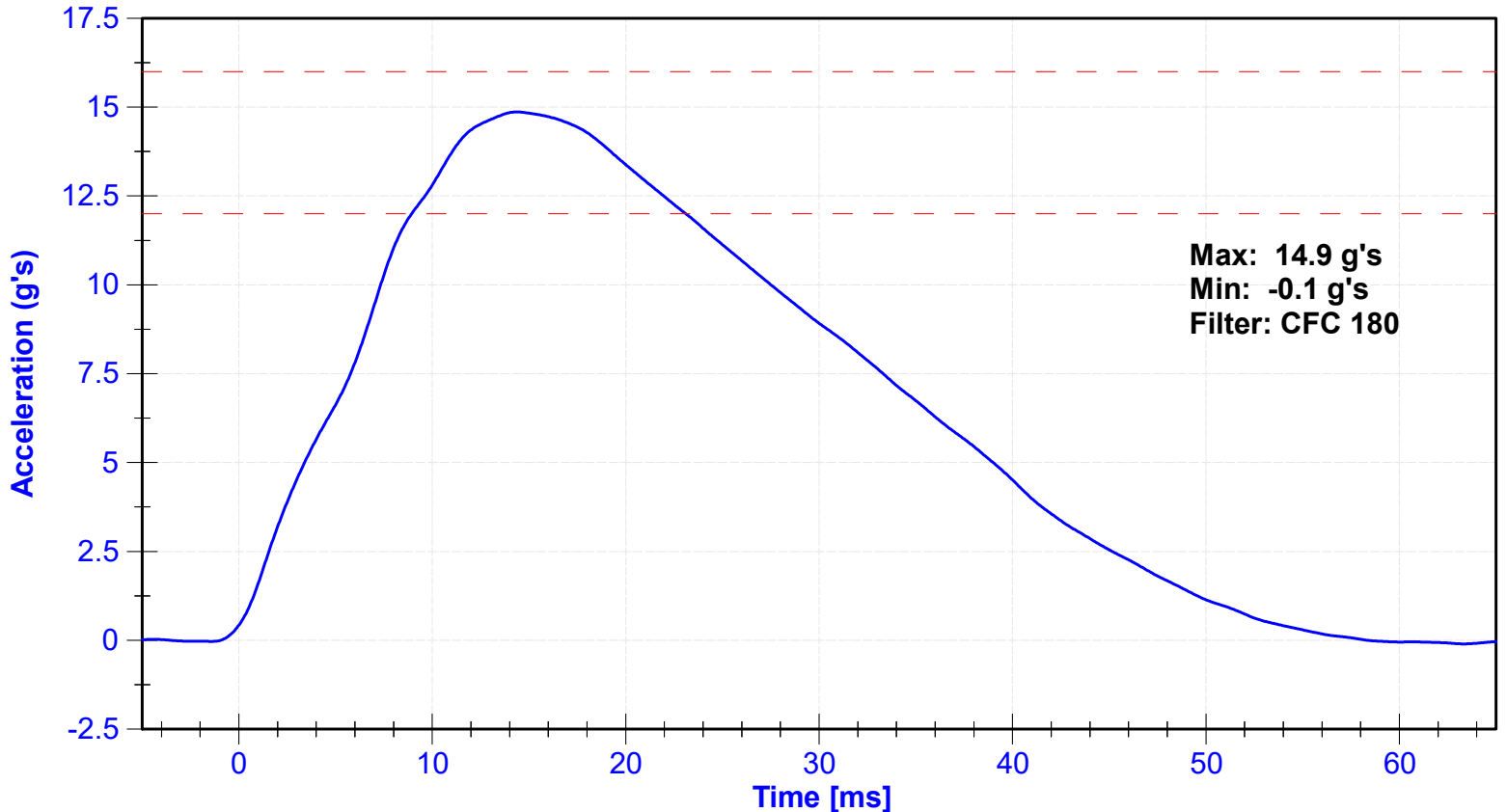

Upper Abdomen Rib Displacement

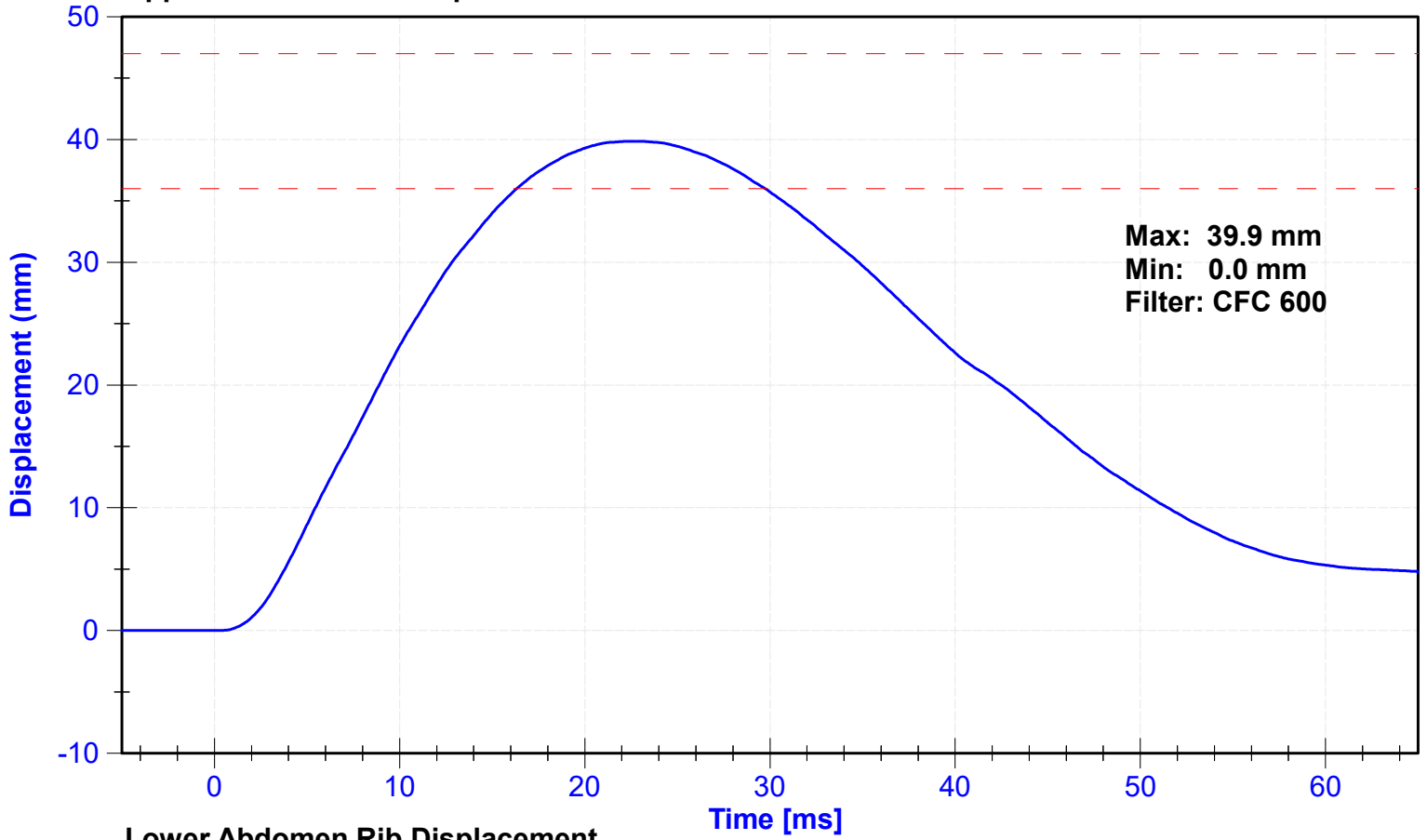

Lower Abdomen Rib Displacement

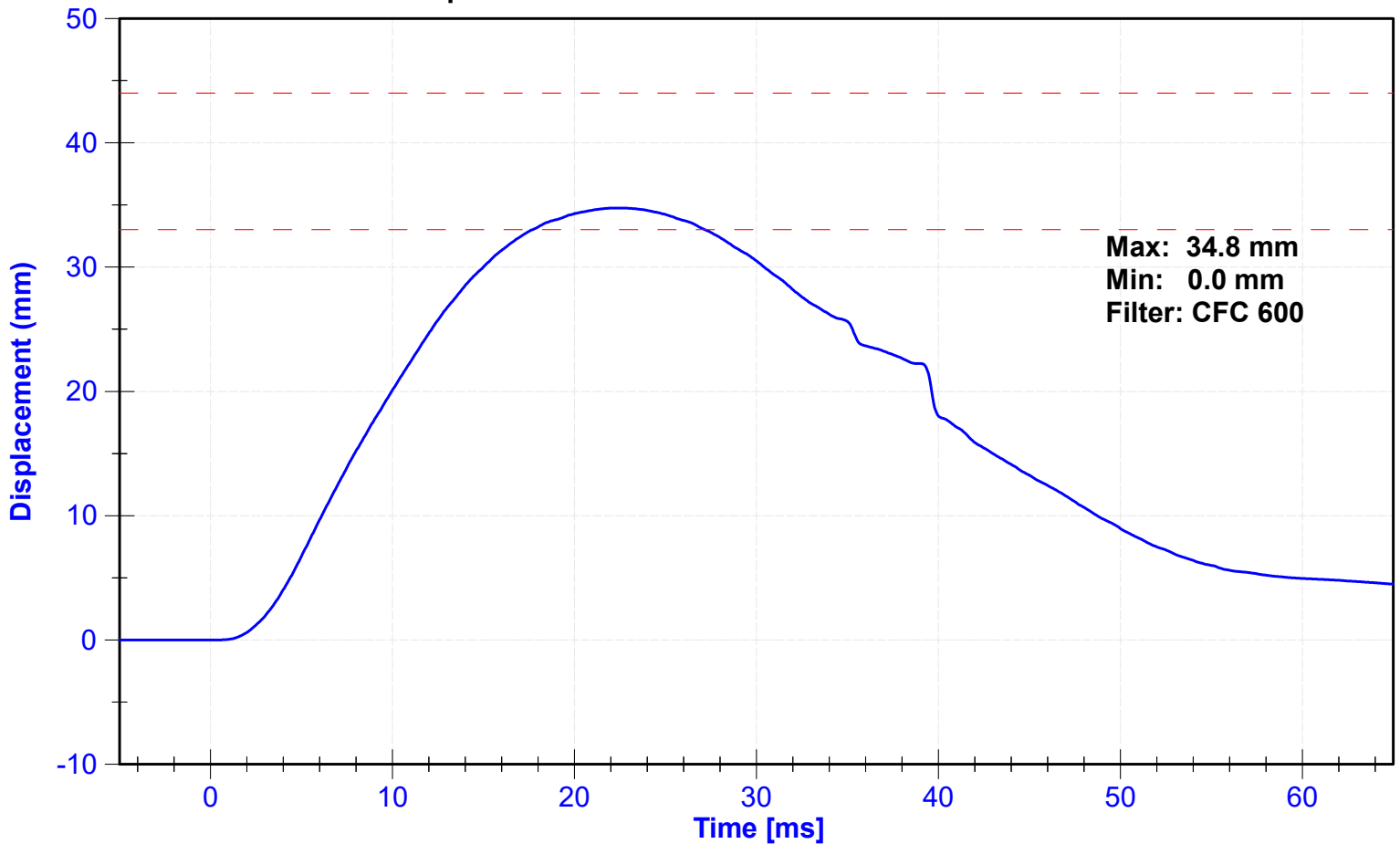

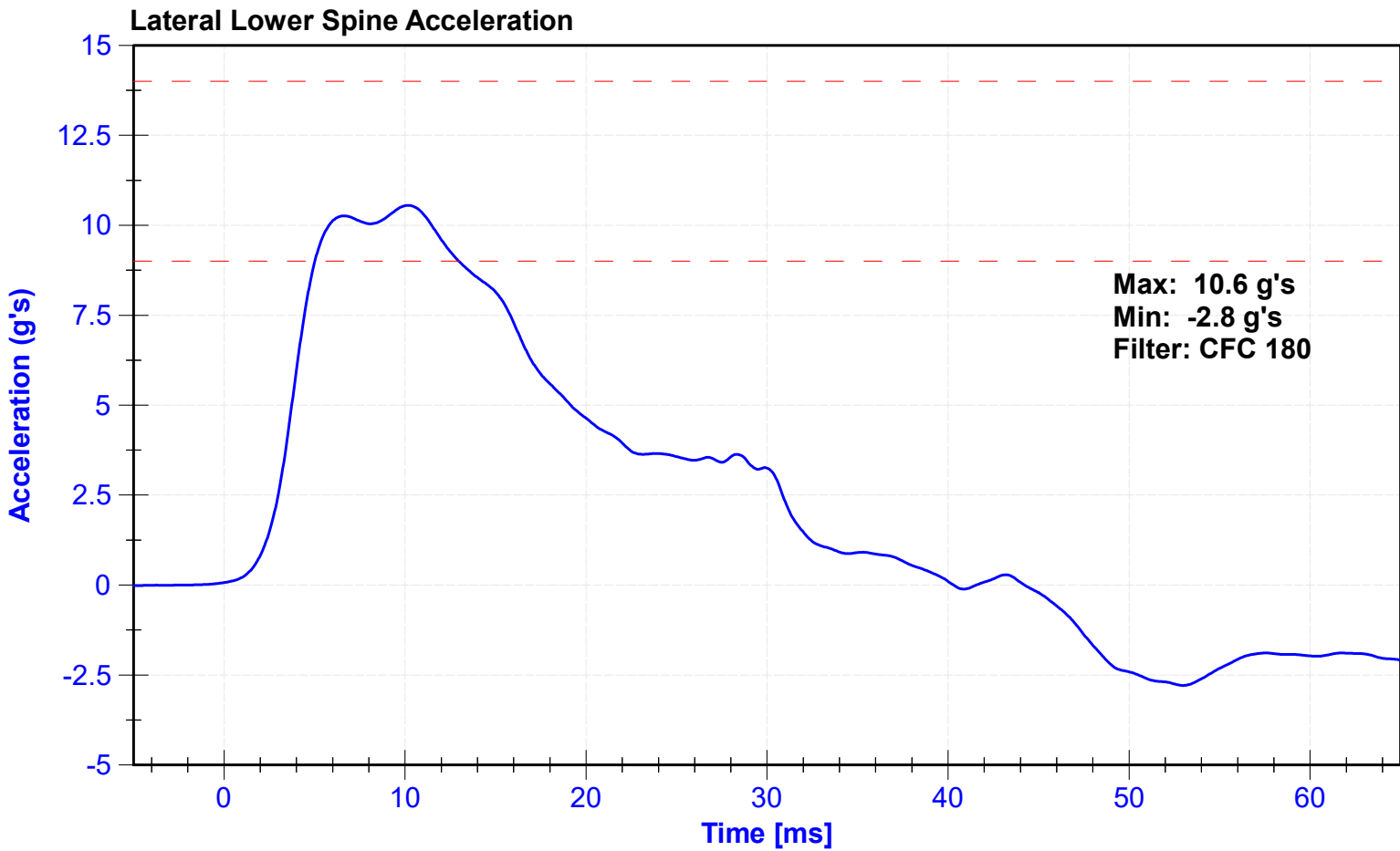

ATD Manufacturer	FTSS	Test Technician	D. Sakona
ATD Serial Number	261	Laboratory Supervisor	K. Brogan

Results

Test Parameter	Minimum Specification	Maximum Specification	Unit	Result	Pass/Fail
Temperature	20.6	22.2	°C	20.8	Pass
Humidity	10	70	%	22.5	Pass
Velocity	6.6	6.8	m/s	6.62	Pass
Probe Acceleration	38	47	g's	46.5	Pass
Lateral Pelvis Acceleration after 6ms	34	42	g's	41.1	Pass
Acetabulum Force	3600	4300	N	4004.1	Pass

Transducer Calibrations

Channel	Manufacturer	Serial Number	Calibration Date	Calibration Due Date
Pendulum Accelerometer	Endevco	P51736	10/25/2022	4/23/2023
Pelvis Y Accelerometer	Endevco	P94678	10/25/2022	4/23/2023
Acetabulum Load Cell	Denton	275-FY	8/11/2022	8/11/2023
Certification Plug	SACO			N/A
Crash Test Plug	SACO			N/A

Probe Acceleration

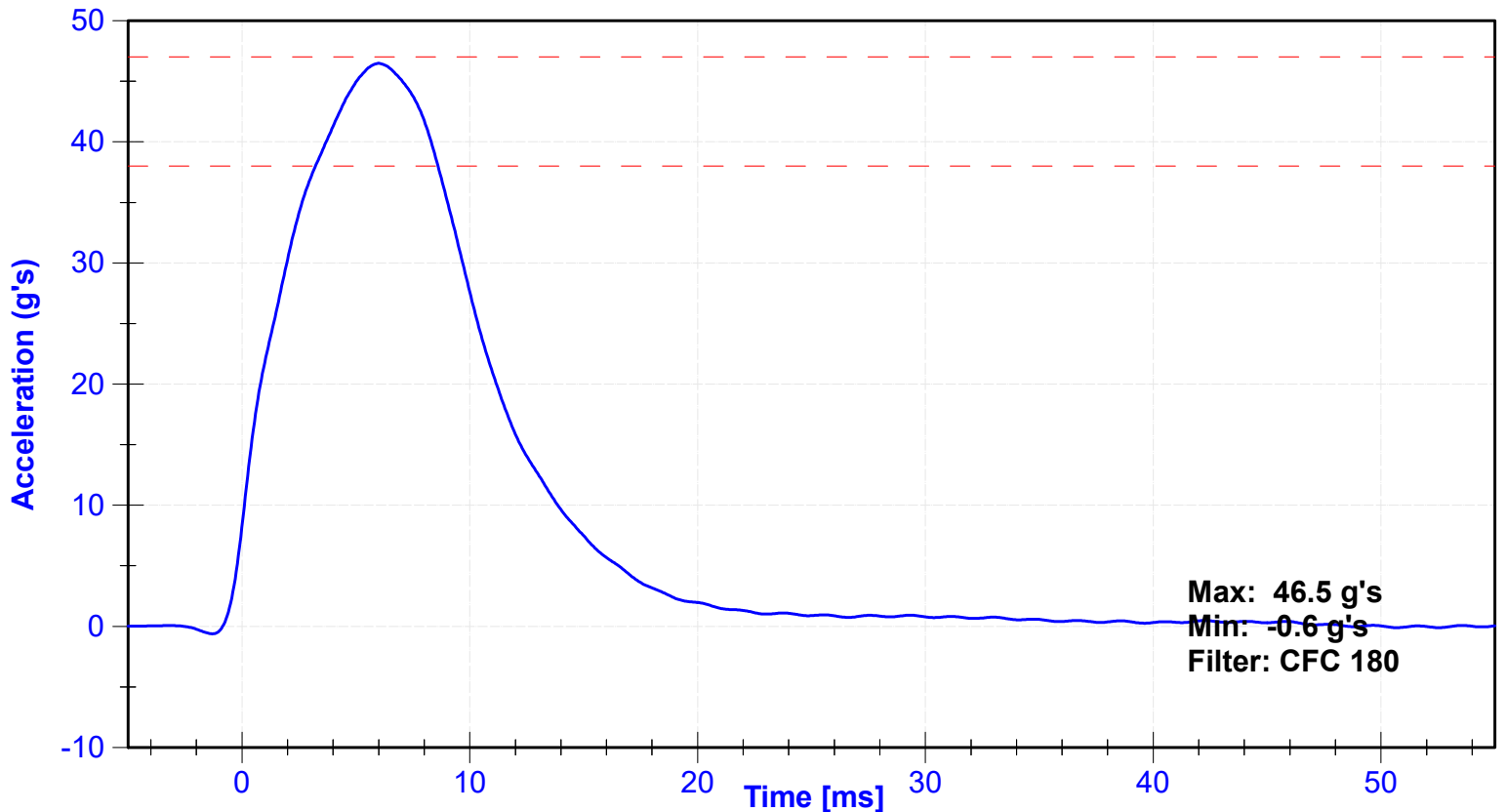

Lateral Pelvis Acceleration

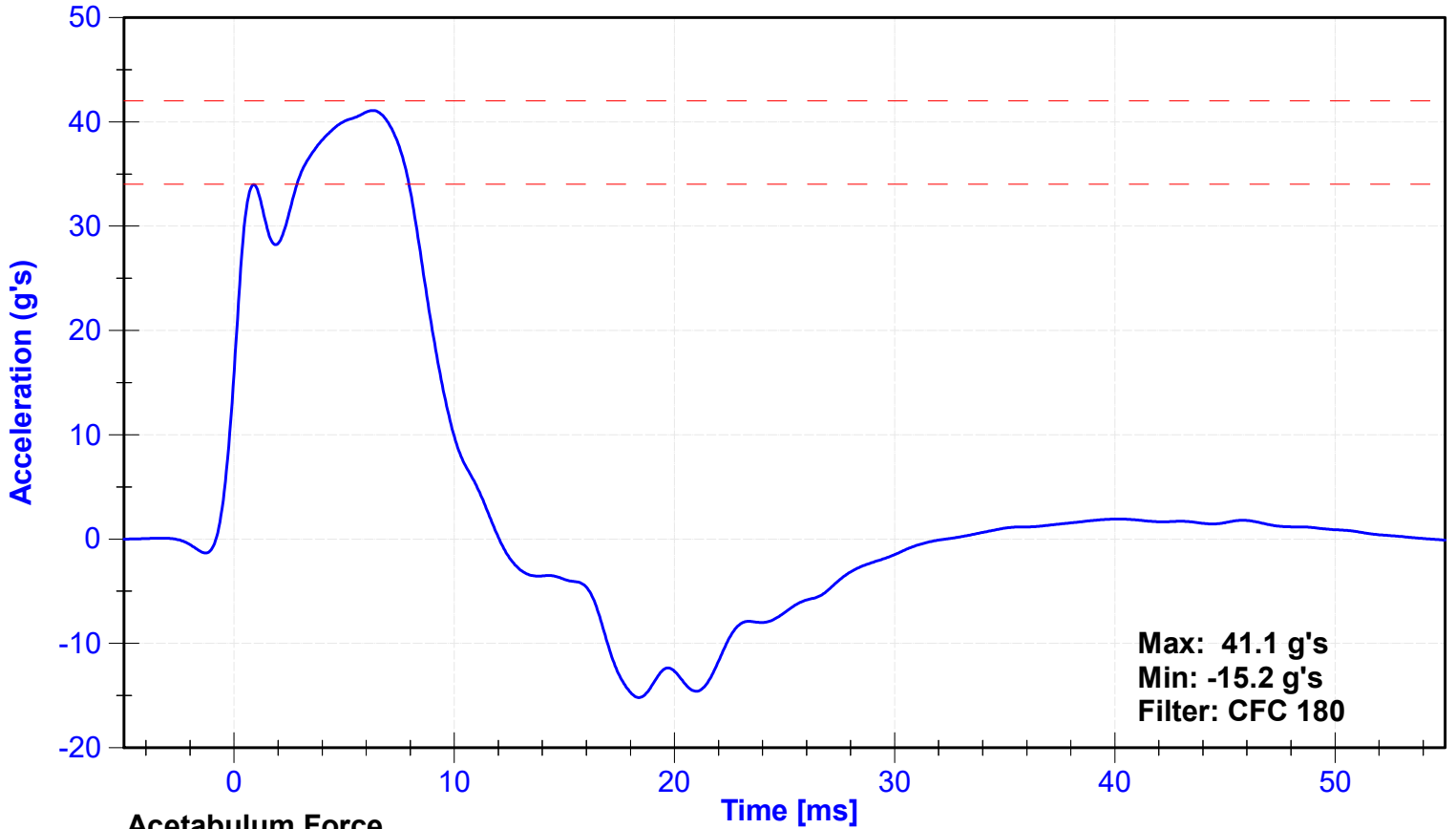

Acetabulum Force

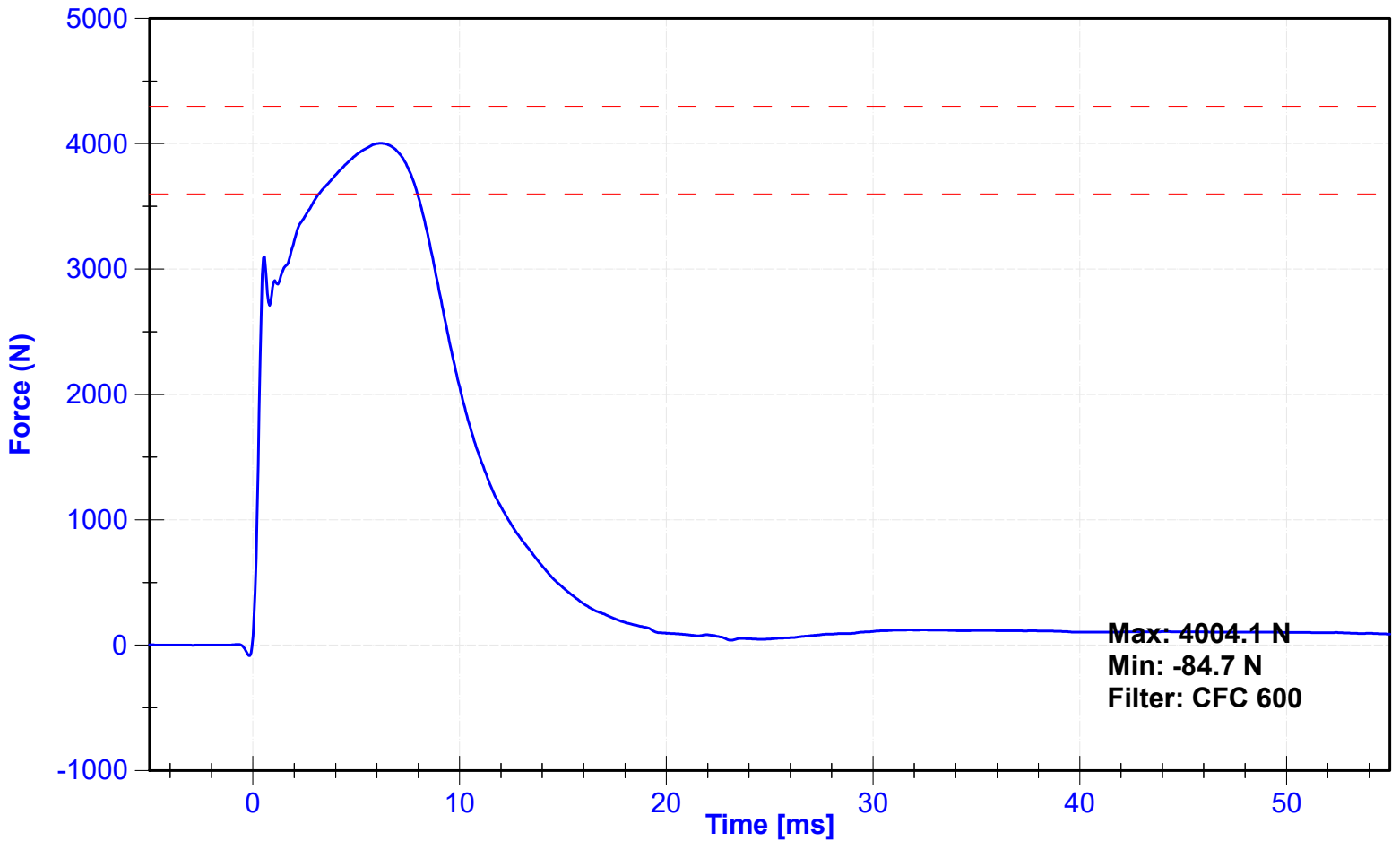



CERT 2

SID-IIs Pelvis Plug Certification Test

Force (-N) vs Extension (-mm)

Plug S/N 15238

Test Number 17989

Report Number 18038

Test Date 3/10/2021 1:06:41 PM

	Test Results	Spec Min	Spec Max
Force @ 0.5 mm (N)	340	50	600
Force @ 1.5 mm (N)	1,169	850	1,400
Force @ 2.5 mm (N)	1,419	1,306	1,618
Force @ 3.0 mm (N)	1,472	1,361	1,673

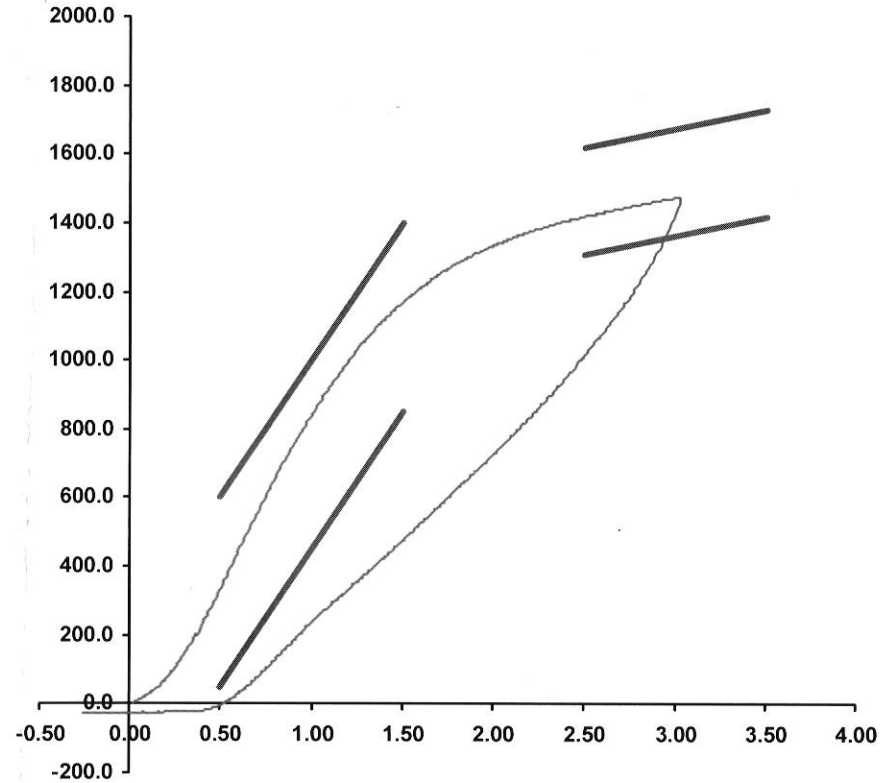

Testing Machine STM-20 5965542
 Load Cell S/N (FI360947), Units (LBS) 1000
 Crosshead Speed (mm / min) or Rate 12.7
 Extension or Position Measured by XHD_100 (XHD100)

Notes:

Operator _____
 Part Number 180-4450

Template No 107 10-Mar-21
 SACO Research

By : DC Date : 3/10/2021



Crash

SID-IIs Pelvis Plug Certification Test

Plug S/N 15364

Test Number 19711

Report Number 19763

Test Date 7/20/2021 1:02:43 PM

	Test Results	Spec Min	Spec Max
Force @ 0.5 mm (N)	353	50	600
Force @ 1.5 mm (N)	1,248	850	1,400
Force @ 2.5 mm (N)	1,470	1,306	1,618
Force @ 3.0 mm (N)	1,497	1,361	1,673

Testing Machine STM-20 5965542
 Load Cell S/N (FI360947), Units (LBS) 1000
 Crosshead Speed (mm / min) or Rate 12.7
 Extension or Position Measured by XHD_100 (XHD100)

Notes:

Force (-N) vs Extension (-mm)

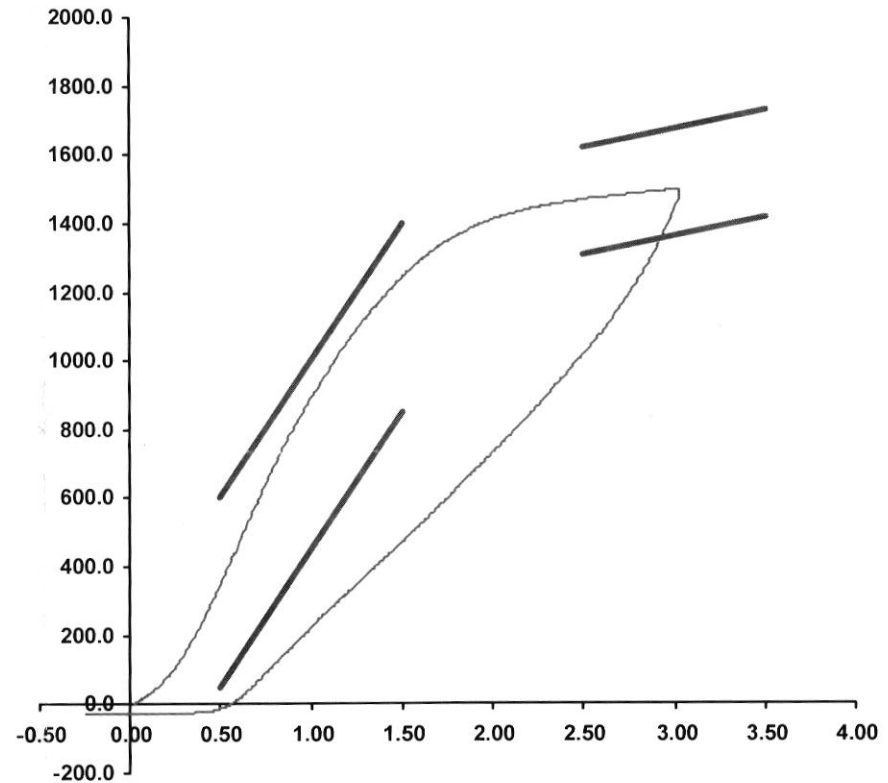

Operator
 Part Number 180-4450

Template No 107 20-Jul-21
 SACO Research

By: DC Date: 7/21/2021



Non - Impact

SID-IIs Pelvis Plug Certification Test

Force (-N) vs Extension (-mm)

Plug S/N 15202

Test Number 17918

Report Number 17967

Test Date 3/8/2021 1:30:53 PM

	Test Results	Spec Min	Spec Max
Force @ 0.5 mm (N)	351	50	600
Force @ 1.5 mm (N)	1,186	850	1,400
Force @ 2.5 mm (N)	1,432	1,306	1,618
Force @ 3.0 mm (N)	1,481	1,361	1,673

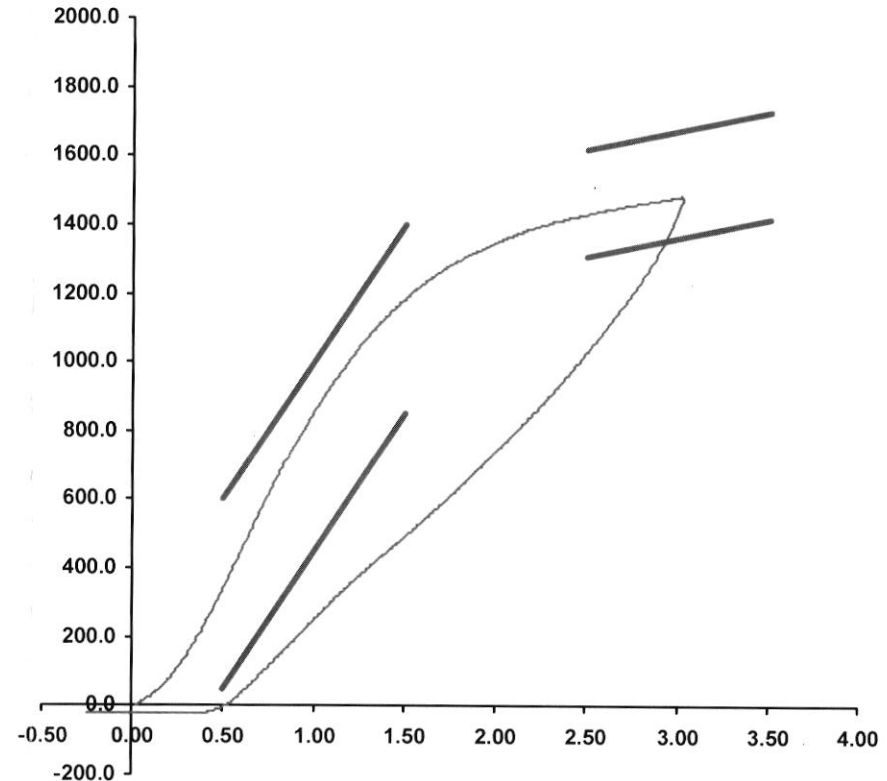

Testing Machine STM-20 5965542
 Load Cell S/N (FI360947), Units (LBS) 1000
 Crosshead Speed (mm / min) or Rate 12.7
 Extension or Position Measured by XHD_100 (XHD100)

Notes:

Operator
 Part Number 180-4450

Template No 107 08-Mar-21
 SACO Research

By : DC Date : 3/8/2021

ATD Manufacturer	FTSS	Test Technician	D. Sakona
ATD Serial Number	261	Laboratory Supervisor	K. Brogan

Results

Test Parameter	Minimum Specification	Maximum Specification	Unit	Result	Pass/Fail
Temperature	20.6	22.2	°C	20.8	Pass
Humidity	10	70	%	22.5	Pass
Velocity	4.2	4.4	m/s	4.40	Pass
Probe Acceleration	36	45	g's	42.5	Pass
Lateral Pelvis Acceleration	28	39	g's	31.5	Pass
Iliac Force	4100	5100	N	4635.4	Pass

Transducer Calibrations

Channel	Manufacturer	Serial Number	Calibration Date	Calibration Due Date
Pendulum Accelerometer	Endevco	P51736	10/25/2022	4/23/2023
Pelvis Y Accelerometer	Endevco	P94678	10/25/2022	4/23/2023
Iliac Load Cell	Denton	279-FY	8/11/2022	8/11/2023

Probe Acceleration

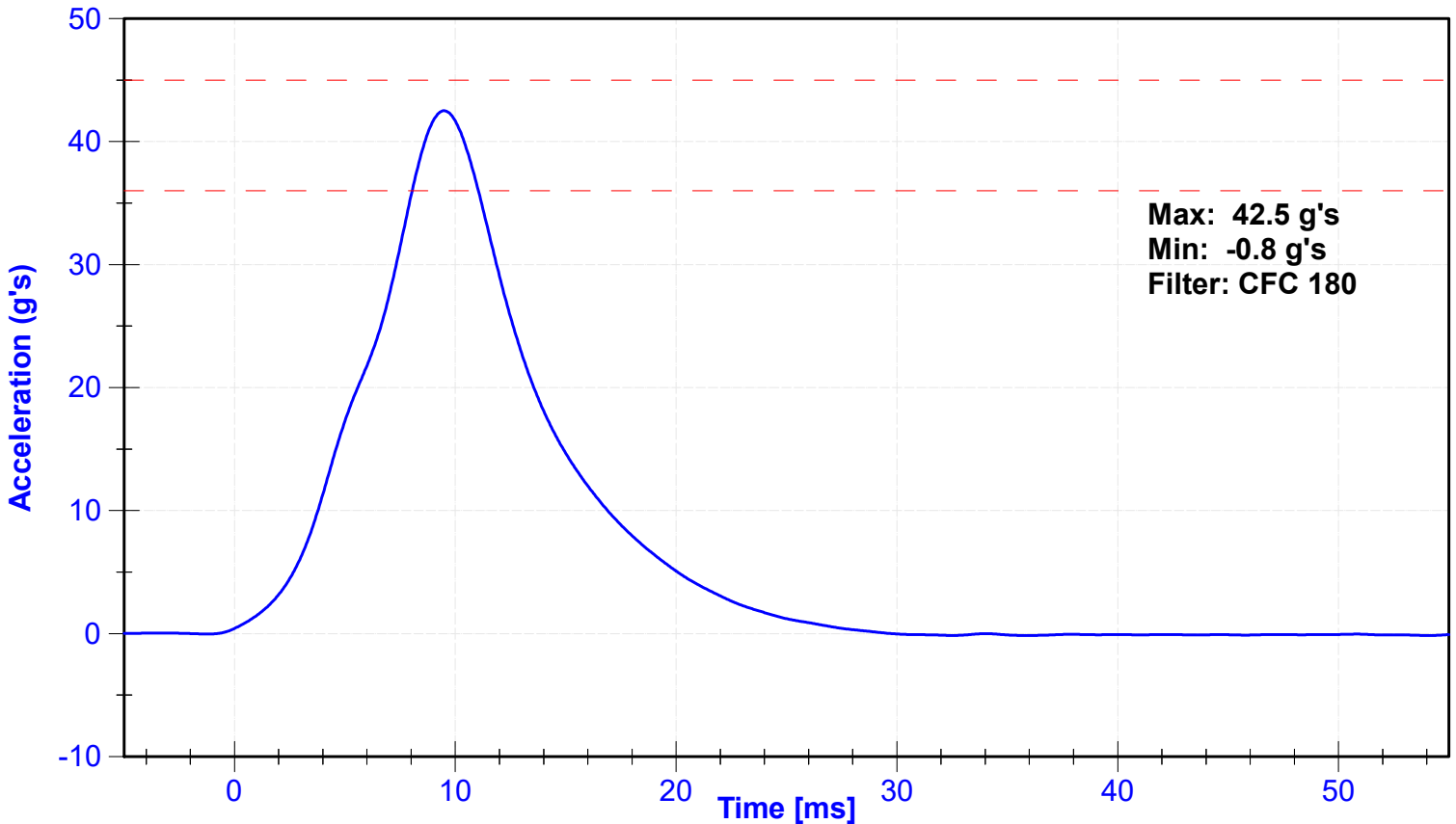

Lateral Pelvis Acceleration

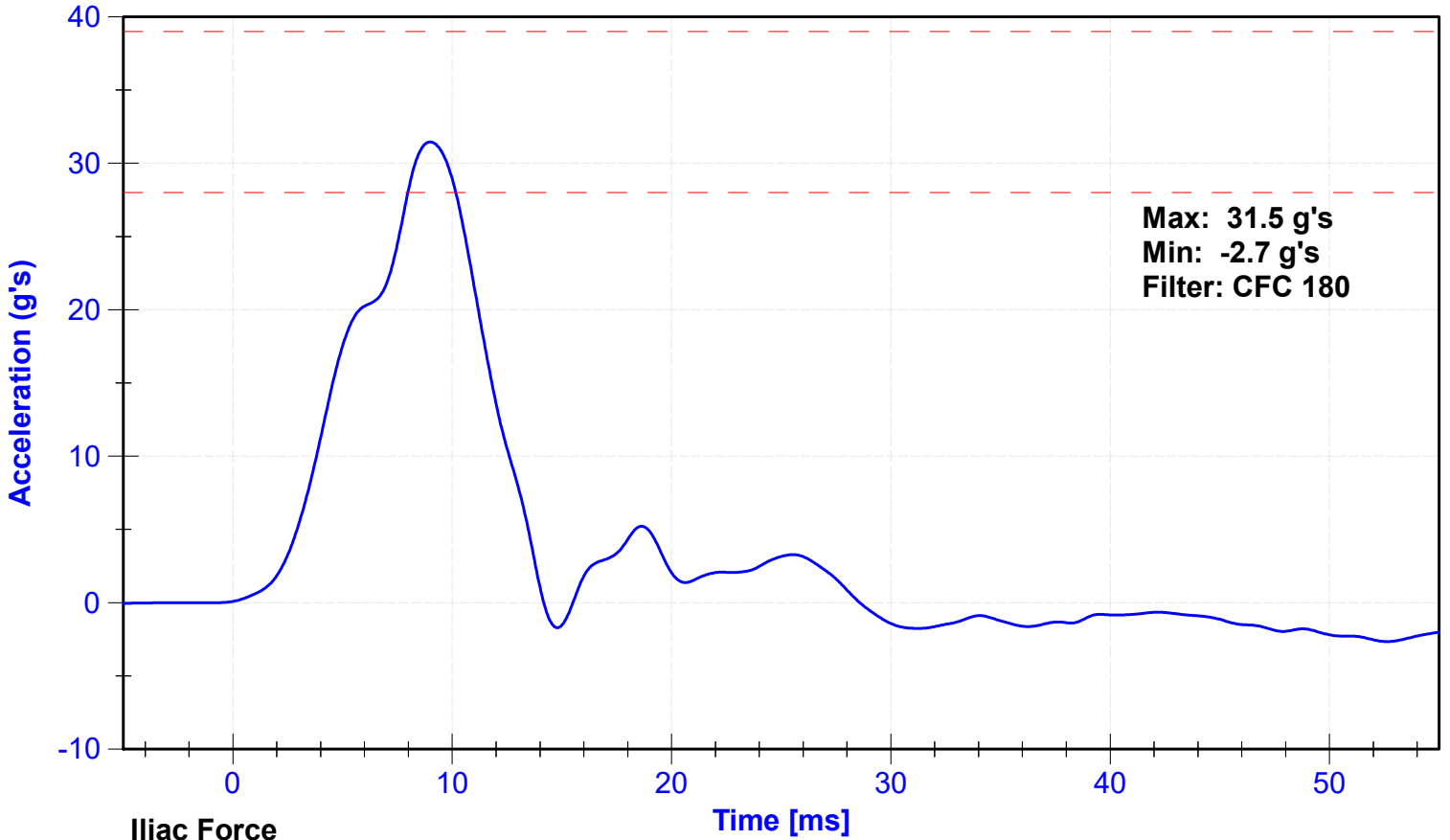

Iliac Force

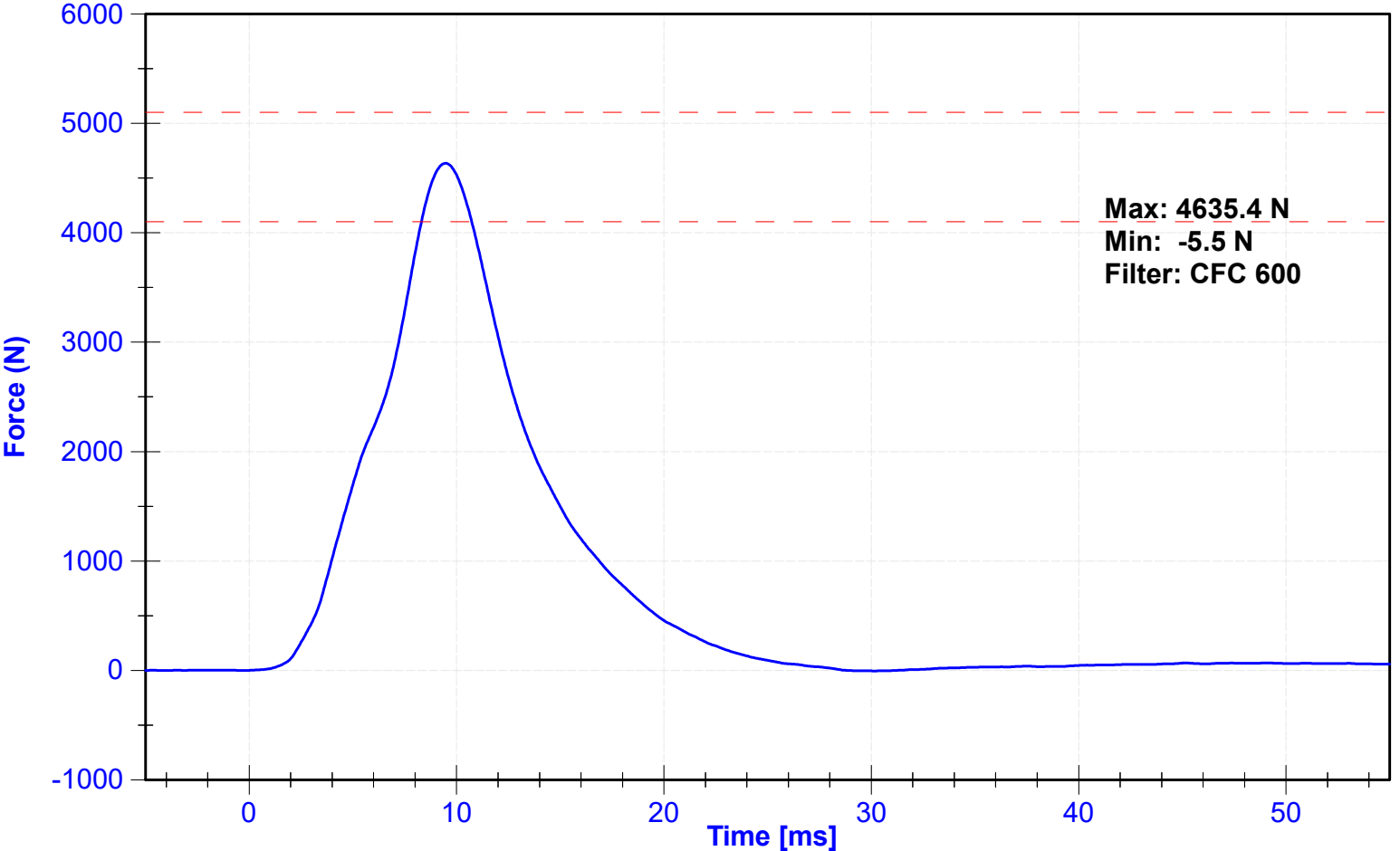

APPENDIX VII

TEST EQUIPMENT AND INSTRUMENTATION CALIBRATION

TABLE 1 – Dummy Instrumentation (ES-2re)

			ES-2re S/N: D037		
			Serial Number	Manufacturer	Calibration Date
Head Accelerometers	Primary	X	T21724	Endevco	9/6/2022
		Y	T22281	Endevco	9/6/2022
		Z	T26050	Endevco	9/9/2022
	Redundant	X	T21682	Endevco	9/6/2022
		Y	T25989	Endevco	9/9/2022
		Z	T25864	Endevco	9/6/2022
Thorax Rib Displacement Potentiometers	Upper	Y	DS-0552-01	Honeywell	9/7/2022
	Middle	Y	DS-807	Honeywell	9/7/2022
	Lower	Y	DS-0552-03	Honeywell	9/7/2022
Abdomen Load Cells	Forward	Y	1440	Denton	8/12/2022
	Middle	Y	1525	Denton	8/12/2022
	Rear	Y	1528	Denton	8/12/2022
Lower Spine Accelerometers (T12)		X	P71278	Endevco	9/6/2022
		Y	P71276	Endevco	9/6/2022
		Z	T23573	Endevco	9/6/2022
Pubic Symphysis Load Cell		Y	3096JFL-456-FY	Denton	8/12/2022

TABLE 2 – Dummy Instrumentation (SID-IIs)

			SID-IIs S/N: 261			
			Serial Number	Manufacturer	Calibration Date	
Head Accelerometers	Primary	X	P68067	Endevco	10/26/2022	
		Y	P18567	Endevco	10/25/2022	
		Z	P49163	Endevco	10/25/2022	
	Redundant	X	T26041	Endevco	10/25/2022	
		Y	T22409	Endevco	10/25/2022	
		Z	T26086	Endevco	10/25/2022	
Displacement Potentiometers	Thoracic Rib	Upper	Y	062GFE	Servo	11/1/2022
		Middle	Y	528GFE	Servo	11/1/2022
		Lower	Y	513GFE	Servo	11/1/2022
	Abdominal Rib	Upper	Y	342GFE	Servo	11/1/2022
		Lower	Y	512GFE	Servo	11/1/2022
Lower Spine Accelerometers (T12)		X	T22340	Endevco	10/25/2022	
		Y	P58744	Endevco	10/25/2022	
		Z	T22124	Endevco	10/25/2022	
Acetabulum Load Cell		Y	275-FY	Denton	8/11/2022	
Iliac Wing Load Cell		Y	279-FY	Denton	8/11/2022	
Pelvis Plug (struck side)			15456	SACO	12/14/2022	
Pelvis Plug (non-struck side)			15011	SACO	12/14/2022	

TABLE 3 – Vehicle Instrumentation

Vehicle Instrumentation			Serial Number	Manufacturer	Calibration Date
1	Vehicle Center of Gravity	X	A413580	Measurement Specialties	11/8/2022
	Vehicle Center of Gravity	Y	A413581	Measurement Specialties	11/8/2022
	Vehicle Center of Gravity	Z	A413590	Measurement Specialties	11/8/2022
2	Right Sill at Front Seat	X	A280190	Measurement Specialties	8/18/2022
	Right Sill at Front Seat	Y	A280887	Measurement Specialties	8/18/2022
	Right Sill at Front Seat	Z	A315843	Measurement Specialties	8/18/2022
3	Right Sill at Rear Seat	X	A405589	Measurement Specialties	7/25/2022
	Right Sill at Rear Seat	Y	A405599	Measurement Specialties	7/25/2022
	Right Sill at Rear Seat	Z	A405602	Measurement Specialties	7/25/2022
4	Left Sill at Front Door	Y	G22614	Endevco	11/2/2022
5	Left Sill at Rear Door	Y	G22586	Endevco	10/22/2022
6	Left A-Post Lower	Y	G22617	Endevco	11/2/2022
7	Left A-Post Middle	Y	G22585	Endevco	10/22/2022
8	Left B-Post Lower	Y	G22593	Endevco	10/22/2022
9	Left B-Post Middle	Y	G22591	Endevco	10/22/2022
10	Front Seat Track	Y	G22590	Endevco	10/22/2022
11	Rear Seat Track or Structure	Y	G22583	Endevco	10/22/2022
12	Right Rear Occ. Compartment	Y	G22594	Endevco	10/22/2022
13	Engine Block	X	A280971	Measurement Specialties	11/14/2022
	Engine Block	Y	A396614	Measurement Specialties	11/14/2022
14	Rear Floorpan Above Axle	X	A274237	Measurement Specialties	9/28/2022
	Rear Floorpan Above Axle	Y	A284366	Measurement Specialties	9/28/2022
	Rear Floorpan Above Axle	Z	A413616	Measurement Specialties	9/28/2022

TABLE 4 – MDB Instrumentation

MDB Instrumentation		Serial Number	Manufacturer	Calibration Date
Vehicle CG Acceleration vs. Time	X	A398663	Measurement Specialties	11/15/2022
Vehicle CG Acceleration vs. Time	Y	A413569	Measurement Specialties	11/15/2022
Vehicle CG Velocity vs. Time	Y	Calculated	Calculated	Calculated
Vehicle CG Acceleration vs. Time	Z	A413574	Measurement Specialties	11/15/2022
Vehicle CG Velocity vs. Time	Z	Calculated	Calculated	Calculated
Vehicle CG Resultant Acceleration vs. Time	R	Calculated	Calculated	Calculated

APPENDIX VIII
CHECK SHEETS



Federal Motor Vehicle Safety Standards

Work Instructions: FMVSS 214

Side Impact Moving Deformable Barrier Test

W/305 Roll

Work Instructions Aligned with U.S. D.O.T. National Highway Traffic Safety Administration's
Laboratory Test Procedure for FMVSS 214:
Side Impact Moving Deformable Barrier

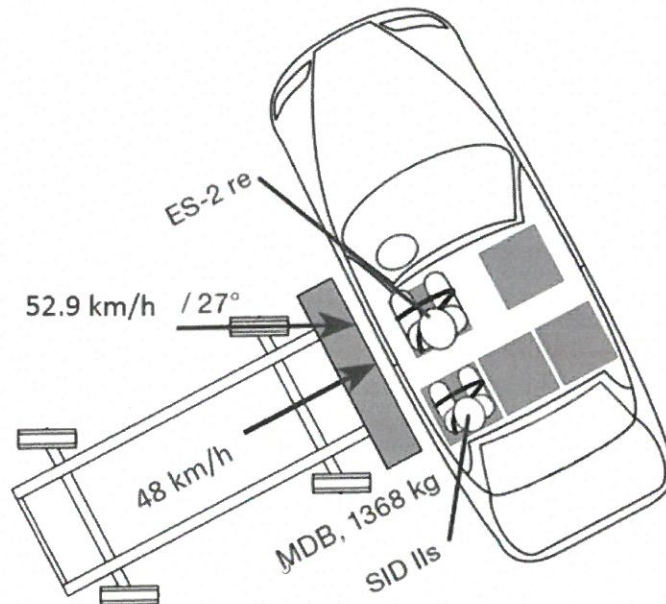

Customer:

JCRSH-00006 – HV Battery!

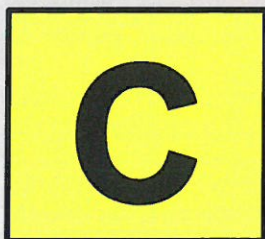

C20235805

VIN: YV4ED3UM1P2963963

DTNH-22-17D-00078

Lead Test Engineer: Vanessa Hansen

Table of Contents

Project Set-up	4
Vehicle Inspection	5
Incoming Vehicle Checklist:	6
Vehicle Condition Checklist:.....	7
General Vehicle Data:.....	9
Attitudes, Weights, Mechanical Prep & Electrical Connections	12
Weight - As Delivered Condition:	13
Attitude - As Delivered Condition:	17
CG - As Delivered Condition:	18
Weight – Fully Loaded Condition:	19
Attitude - Fully Loaded Condition:	20
CG - Fully Loaded Condition:.....	21
Drain Fuel and Paint Vehicle:.....	22
Mechanical Preparation:	24
Onboard Camera Installation:	28
Seat Positioning, Seat Setting, H-Point & Targeting	30
1 st Row Seat Positioning – Reference Marks:	31
2 nd Row Seat Positioning – Reference Marks:	37
H-Point Left Front Seat (Position 1):	43
1 st Row Seat Positioning – Setting Seats	45
2 nd Row Seat Positioning – Setting Seats	46
Setting Steering Wheel & Seat Belt Adjustment	47
Photographic Tape & Measurements	49
Pre-Test Measurements:	52
Vehicle Instrumentation	56
Instrumentation Installation:	57
Onboard Test Equipment Installation:	59
Verification of Vehicle, ATD & Facility Readiness	60
Weight – As Tested Condition:.....	61
CG – As Tested Condition:	63
Vehicle Verification:	64
Install Honeycomb	65
MDB Photographic Targets and Tape:	66
Align Vehicle & MDB.....	67
High Speed Camera Set-Up.....	69
Camera Set-up:	70
Camera Location - Data Sheet:.....	75
Camera Control Software.....	76
Test Set-up & Execution.....	77

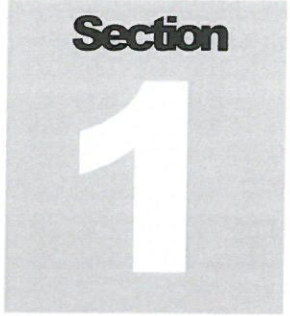

Data Acquisition Software Setup:.....	78
Pre-Test Photos & Video Prior to Seating:	79
Positioning SID-IIs in Rear Left Position:.....	80
Positioning ES-2re Male in Driver Position.....	82
Dummy Measurement:.....	84
Inch Tape, Cables & Chalking:.....	88
Attitude - As Tested Condition:	89
Pre-Test Photos:.....	90
Pre-Test Video:.....	91
Review Post-Test Assignments with Staff:	92
Verify Vehicle & Set-Up / Go / No-Go:	93
OEM Inspection of Set-up:	95
Tow System & DAS Checklist:	96
Impact Speed:.....	97
Impact Location:	98
Post-Test Observations – Vehicle As Is	99
Post-Test Hand Measurements	100
Post-Test Photos – Vehicle As Is:.....	101
Post-Test Video:	102
Post-Test Photos:	103
Post-Test Observations – Doors Open:.....	104
Post-Test Data Checklist:.....	106
Critical Results:.....	107
Notify Customer – Test Executed:.....	109
Post Test Measurements	110
Post-Test Exterior Static Crush for Impactor Face	112
Conversions:.....	113
Revision History:.....	114



Section
1

Project Set-up

Instruction: Insert Engineer's Checklist, Customer's Statement of Work or Test Request after this tab.

-  Inserted Completed Engineer's Checklist.
-  Inserted Customer's SOW / Test Request.
-  Inserted Copy of the Form 1.

Section
2

Vehicle Inspection

Instruction: Complete the checked task:



Fully Complete the Following Section.

The Following Section Does Not Need to be Completed.

Incoming Vehicle Checklist:

Performed by:	MP	Date:	12/8/22
---------------	----	-------	---------

Complete the following fields:

Dealer	Maguire Volvo
Date vehicle arrived:	12/7/2022
Model Year	2023
Make	VOLVO
Model	XC40 ReCharge Twin

Verify the following and place a checkmark in the appropriate box. Any variances must be reported to the Technical Director within 2 working days of the vehicle's arrival:

Yes No

- All options listed on the 'window sticker' are present on the test vehicle.
- Tires and wheel rims are the same as listed.
- There are no dents or other interior or exterior flaws.
- The vehicle has been properly prepared and is in running condition.
- The glove box contains an owner's manual, warranty document, consumer information, and extra set of keys.
- Proper fuel filler cap is supplied on the test vehicle.
- Spare tire, jack, lug wrench and tool kit (if applicable) is located in the vehicle cargo area.
- The odometer reflects that the vehicle has been driven less than or equal to 200 miles.
- The VIN (vehicle identification number) matches the number supplied by NHTSA.
- Vehicle is equipped / matches description provided by NHTSA.
- Vehicle warning lights (i.e. check engine, SRS, etc.) are not illuminated.
- Floor mats come with vehicle (front and rear). Verify with window sticker.
- Is vehicle a hybrid or full electric vehicle that requires FMVSS 305?

Vehicle Condition Checklist:

Performed by: MP Date: 12/8/2022

Complete the following fields:

Make	Volvo
Model	XC40
Body Style	SUV
Vin	YV4ED3UM1P2963963
Body Color	Silver
Engine Disp (liters)	N/A
Number of Cylinders	N/A
Engine Placement	transverse
Transmission Type	Automatic
Transmission Speeds	Direct Drive
Overdrive	N/A
Final Drive	AWD
Odometer Reading	7 miles

Anti-lock Brakes (ABS)	Y
All-Wheel Drive (AWD)	Y
Traction Control System (TCS)	Y
Electronic Stability Control (ECS)	Y
Side Curtain Airbags	Y
Torso Airbag – Front Seats	Y
Torso Airbag – Rear Seats	N
Combination/Head Torso Bag	N
Pelvic Airbag – Front Seats	N
Pelvic Airbag – Rear Seats	N
Knee Airbag – Driver	Y
Knee Airbag – Front Passenger	N
Seat Belt Pretensioners – Front Seats	Y
Seat Belt Pretensioners – Rear Seats	N Y
Seat Belt Load Limiters – Front Seats	Y
Seat Belt Load Limiters – Rear Seats	N Y
Tire Pressure Monitoring System (TPMS)	Y
Tilt Steering Wheel	Y
Automatic Door Locks (ADL)	Y
Power Window Auto-reverse	N
Power Seats	Y

Yes No

N/A 1 Does owner's manual provide instructions to turn off automatic door locks?

¹ These items are in addition to the Form 1 Report of Vehicle Condition and are required for The Data Sheet No. 1 General Test and Vehicle Parameters.

Tinted Glass	Y
Power Brakes	Y
Front Disc	Y
Rear Disc	Y
Bucket Seats	Y
Air Conditioning	Y

Am/FM CD	Y
Power Windows	Y
Other	—

Take the following photographs (Refer to the sample photo set if necessary):

Initial:

- Close-up view of Vehicle's Tire Placard Label (No. 30)
- Close up view of Vehicle's Certification Label (No. 27)
- Front View
- Left Front $\frac{3}{4}$ View
- Left Side View
- Left Rear $\frac{3}{4}$ View
- Rear View
- Right Rear $\frac{3}{4}$ View
- Right Side View
- Right Front $\frac{3}{4}$ View
- Monroney Label



General Vehicle Data:

Performed by: MP Date: 12/8/2022

Yes No

N/A Does owner's manual provide instructions to turn off automatic door locks?

Data from Certification Label

Manufactured By	<u>Volvo Car Corporation</u>	GVWR	<u>2649</u>	kg
Date of Manufacture	<u>09/22</u>	GAWR Front	<u>1309</u>	kg
Vehicle Type	<u>MPV</u>	GAWR Rear	<u>1451</u>	kg

Vehicle Seating and Weight Capacity Data

	Front	Rear	Third	Total
Designated Seating Capacity (DSC)	<u>2</u>	<u>3</u>	<u>0</u>	<u>5</u>
Vehicle Capacity Weight (VCW)				(A) <u>435</u> kg
DSC x 68.04 kg				(B) <u>340.2</u> kg
Load Reduction				(C) <u>—</u> kg
Rated Cargo and Luggage Weight (RCLW)				(A-B-C) <u>94.8</u> kg

Vehicle Seat Type (Check one of the following)

Seating Location	Type of Seat Pan				Type of Seat Back		
	Bucket	Bench	Split Bench	Contoured	Fixed	Adjustable w/Lever	Adjustable w/Knob
Front Seat	<u>X</u>						<u>X</u>
Rear or Second Row Seat			<u>X</u>				
Third Row Seat	<u>N/A</u>						

Please list other pertinent Optional Equipment below:

N/A

Tire Placard Information	Front	Rear
Recommended Cold Tire Pressure (kPa)	280	290
Recommended Tire Size	235/45R20	255/40R20

Tire Sidewall Information	Front	Rear
Maximum Tire Pressure (kPa)	340	340
Tire Size on Vehicle	235/45R20	255/40R20
Tire Manufacturer Model	Pirelli	Pirelli
Tire Name	Scorpion Zero A/S	Scorpion Zero A/S
Tire Type	W All season	W All season
Tire Width	235	255
Aspect Ratio	45	40
Radial	Yes	Yes
Wheel Diameter	20	20
Load Index/Speed Symbol	100H	100H
Tread Wear	500	500
Traction Grade	A	A
Temperature Grade	A	A

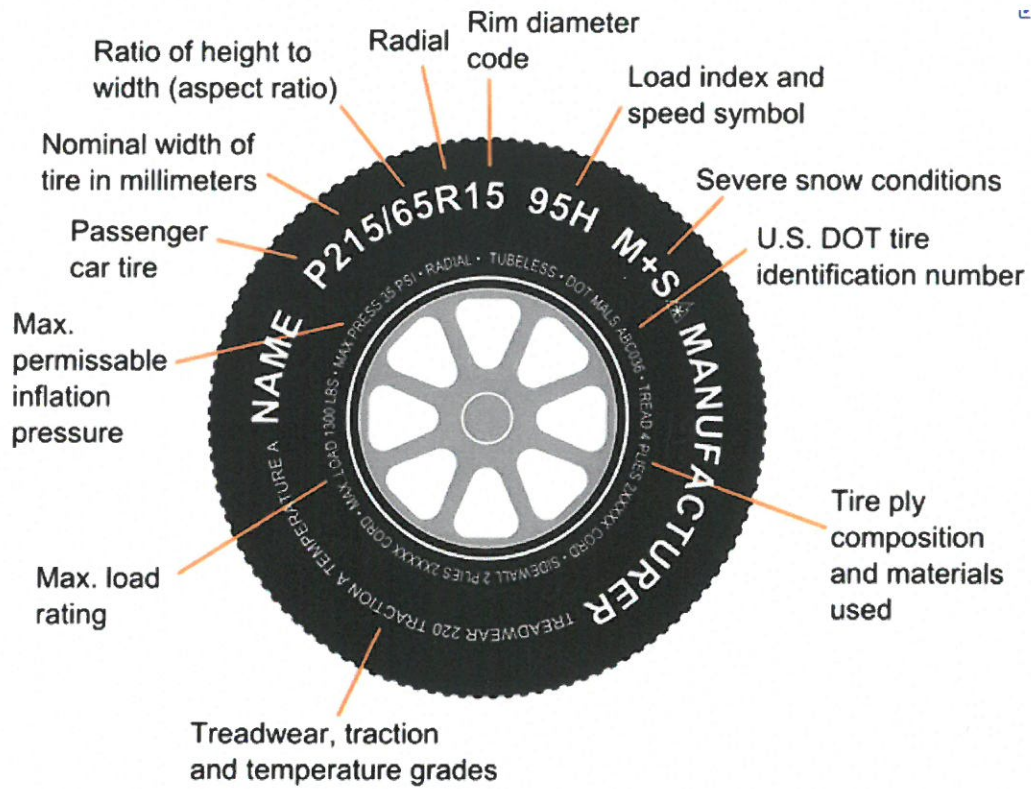

Section
3

Attitudes, Weights, Mechanical Prep & Electrical Connections

Weight - As Delivered Condition:

Performed by:

Jake Lambert

Date:

12-9-22

Initial:

Drain the fuel from the fuel tank.

Run engine until all fuel remaining in the fuel delivery system is used and engine stops.

Describe the fuel pump type, details about how it operates and the location of the fuel filler neck in the space provided below.

[Handwritten notes area with diagonal lines]

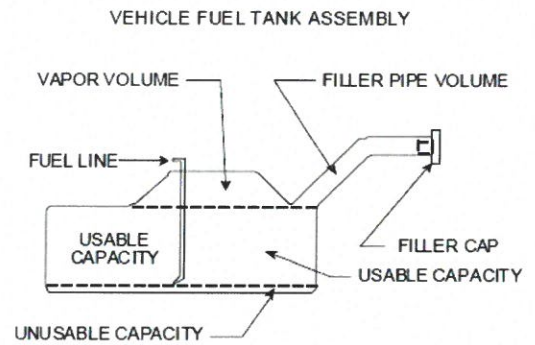

Yes No

Is the vehicle equipped with an electric fuel pump?

If yes, does the pump normally operate when the vehicle's electrical system is activated?

Initial:

- Record the usable fuel tank capacity of both standard and optional (if applicable) fuel tanks in the space provided below as stated in the supplied FORM1.
- Record the fuel tank capacity of both standard and optional (if applicable) fuel tanks as supplied in the owner's manual in the space provided below.
- Calculate 1/3 of the usable capacity of the tank(s) (as supplied on Form 1) and record the calculated value in the space provided below.
- Calculate 93% of the usable capacity of the fuel tank(s) and record the calculated value in the space provided below.
- Using gasoline, fill the fuel tank to 100% of the usable capacity as supplied on Form 1.
- Record the amount of fuel added for the "As Delivered" weight condition in the space provided below.

Note: Stoddard solvent shall be free of debris. It is considered debris-free only if upon filtering with a 10 micron filter, no solid debris is retained on the filter media or in any conduit, container or vessel upstream from the filter paper (e.g. debris is not allowed to be present in the funnel, pump or container).

Fuel Tank Capacity Data

Usable Capacity of "Standard Tank" (see Form No. 1)	<input checked="" type="checkbox"/>	liters
Usable Capacity of "Optional Tank" (see Form No. 1)	<input checked="" type="checkbox"/>	liters
Usable Capacity of Standard Tank (see Owner's Manual)	<input checked="" type="checkbox"/>	liters
Usable Capacity of Optional Tank (see Owner's Manual)	<input checked="" type="checkbox"/>	liters
1/3 of Usable Capacity	<input checked="" type="checkbox"/>	liters
93% of Usable Capacity	<input checked="" type="checkbox"/>	liters
Gasoline to Achieve 100% of Capacity (As Delivered)	<input checked="" type="checkbox"/>	Electric liters

Initial:

- NA Crank the engine to fill the fuel delivery system with gasoline
- JL Fill the coolant system to capacity.
- NA Fill the engine with motor oil to the maximum mark on the dip stick.
- NA Fill the transmission with transmission fluid to full capacity.
- JL Fill the brake reservoir with brake fluid to its normal level.
- JL Fill the windshield washer reservoir to capacity.
- JL Inflate the tires to the cold tire pressure indicated on the tire placard. If no tire placard is available, inflate the tires to the recommended pressure in the owner's manual and record the pressure for each tire in the space provided below.

	Units	LF	RF	LR	RR
As Delivered	kpa	275	270	285	287
Tire Placard	kpa	280	280	290	290
Owner's Manual	kpa	280	280	290	290
Tire Pressure Gage Unique Identifier:					

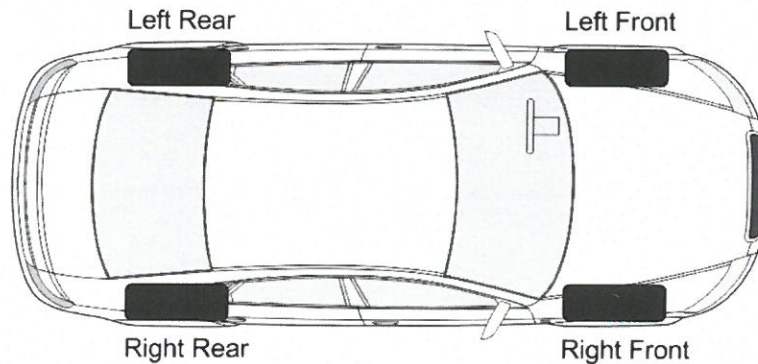

Initial:

SL

Weigh the vehicle at each wheel and add the weights together to determine the "As Delivered" (or "Unloaded Vehicle") weight.

SL

Record the weight measurements and Weight Scale's Unique Identifier in the space provided below.

		As Delivered (UVW)		
	Units	Front Axle	Rear Axle	Total
Left	kg	554	542	$W_{Left} = 1,096$
Right	kg	569	519	$W_{Right} = 1,088$
Ratio	%	51.4	48.6	
Totals	kg	$W_F = 1,123$	$W_R = 1,061$	2,184
Weight Scale Unique Identifier:		400323		

Initial:

SL

Calculate the Rated Cargo and Luggage Weight (RCLW) and record this value in the space provided below. For trucks, MPV's or Buses - **if the RCLW calculated is greater than 136 kg, use 136 kg as the RCLW.**

SL

Calculate the Test Vehicle Target Weight by adding the "As Delivered" weight, the RCLW, and the weight of the fully instrumented dummies in the space provided below.

Rated Cargo and Luggage Weight Calculation	Units	Value	
Vehicle Capacity Weight (VCW - From Vehicle Placard)	kg	435	(A)
Reduced Load Capacity (if Applicable)	kg	—	(B)
Designated Seating Capacity (DSC - From Vehicle Placard)		5	(C)
Rated Cargo and Luggage Weight (RCLW)	kg	94.8	$(C \times 68.04 \text{ kg}) - (A-B)$
Is the RCLW > 136 kg? If yes use 136 kg as RCLW	kg	No	
Target Test Weight Calculation	Units	Value	
Total As Delivered Weight (UVW = Unloaded Vehicle Wgt.)	kg	2,184	(A)
Actual Weight of 1 – ES-2re ATD & 1 – SID-IIs ATD (Ask ATD Lab for specific ATD Weight)	kg	131	(B)
Rated Cargo / Luggage Weight (RCLW)	kg	94.8	(C)
Calculated Vehicle Target Weight (TVTW)	kg	2,409.8	(A+B+C)
Target Test Weight (min):	kg	2,400.8	$(A+B+C) - 9.0 \text{ kg}$
Target Test Weight (max):	kg	2,405.3	$(A+B+C) - 4.5 \text{ kg}$

OP

Attitude - As Delivered Condition:

Performed by:	Jake Lambert	Date:	12-9-22
---------------	--------------	-------	---------

Note: Do not lift the vehicle off the ground until the attitude measurements have been taken.

Initial:

- JL** With the vehicle in the "As Delivered" weight condition, place it on a flat, level surface.
- JL** Place transmission in neutral. Note: If the vehicle has an Auto-Leveling, the ignition must be set to the "on" position. If the vehicle is equipped with a self-adjusting hydraulic system, contact the COTR for further guidance on attitude measurements.
- JL** Exercise the suspension by rolling the vehicle forward and rearward approximately 4 to 6 feet. Repeat this step three to four additional times.
- JL** Mark a point on each vehicle body above the center of each wheel.
- JL** Measure the perpendicular distance from the level surface to the four (4) points marked on the vehicle and record each.

Vehicle Attitudes	Units	LF	RF	LR	RR
As Delivered	mm	842	839	867	862
Tape Measure Unique Identifier:		NA			

CG - As Delivered Condition:

Performed by:

JH

Date:

12/19/22

Initial:

JH

Measure and record the vehicle distances and copy the weights from the previous section in the space provided below in order to calculate the vehicle CG aft of the front axle.

Center of Gravity Calculation:

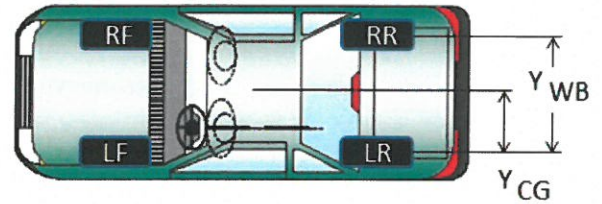
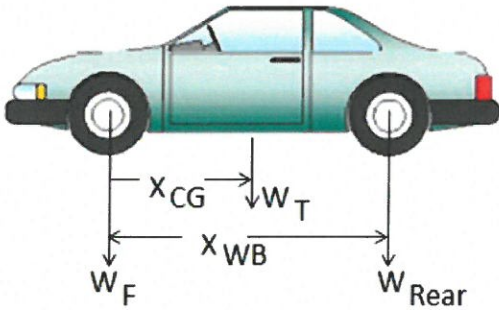

$$X_{CG} = \frac{X_{WB} \times W_{Rear}}{W_{Total}}$$

(From Front Axle)

$$Y_{CG} = \frac{Y_{WB} \times W_{Right}}{W_{Total}}$$

(From Left Wheel Centerline)

$$X_{CG} = \frac{X_{WB} \times W_{Rear}}{W_{Total}}$$

1313 mm = 2703 mm x 1061 kg

2184 kg

W_{Total}

$$Y_{CG} = \frac{Y_{WB} \times W_{Right}}{W_{Total}}$$

1605 mm = 1605 mm (x 1088)

2184 kg

W_{Total}

Test Vehicle Center of Gravity (CG)

	Units	As Delivered	
Vehicle CG (Aft of Front Axle)	mm	<i>1313</i>	X _{CG}
Vehicle CG (Left (+) / Right (-) from Longitudinal Centerline)	mm	<i>3</i>	Y _{CG}

Attitude - Fully Loaded Condition:

Performed by:	Sage Lambert	Date:	12-9-22
---------------	--------------	-------	---------

Initial:

- SL With the vehicle in the "Fully Loaded" weight condition, place it on a flat, level surface.
- Note: If the vehicle has an Auto-Leveling, the ignition must be set to the "on" position. If the vehicle is equipped with a self-adjusting hydraulic system, contact the COTR for further guidance on attitude measurements.
- SL Exercise the suspension by rolling the vehicle forward and rearward approximately 4 to 6 feet. Repeat this step three to four additional times.
- SL Measure the perpendicular distance from the level surface to the four (4) points previously marked on the vehicle and record each in the space provided below.
- SL Record the Unique Identifier of the inclinometer used to complete these measurements in the space provided below.

Vehicle Attitudes	Units	LF	RF	LR	RR
Fully Loaded	mm	831	834	844	846
Tape Measure Unique Identifier:		NA			

CG - Fully Loaded Condition:

Performed by: Date: 12/19

Initial:

Measure and record the vehicle distances and copy the weights from the previous section in the space provided below in order to calculate the vehicle CG aft of the front axle and left (+) / right (-) from the longitudinal centerline.

Center of Gravity Calculation:

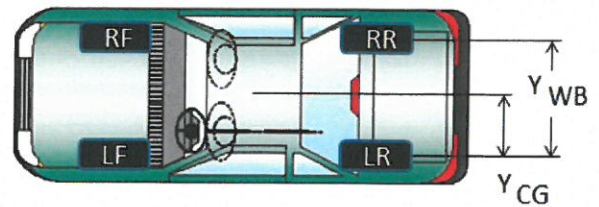
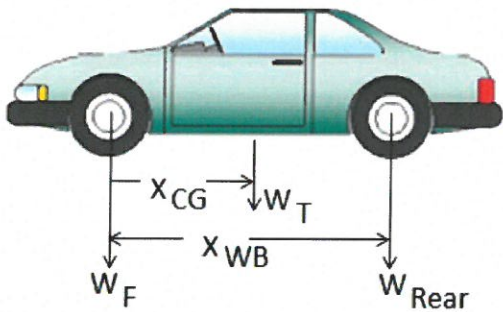

$$X_{CG} = \frac{X_{WB} \times W_{Rear}}{W_{Total}}$$

(From Front Axle)

$$Y_{CG} = \frac{Y_{WB} \times W_{Right}}{W_{Total}}$$

(From Left Wheel Centerline)

$$X_{CG} = \frac{X_{WB} \times W_{Rear}}{W_{Total}}$$

1388 mm = $\frac{2703 \text{ mm} \times 1240 \text{ kg}}{2414 \text{ kg}}$

$$Y_{CG} = \frac{Y_{WB} \times W_{Right}}{W_{Total}}$$

1605 mm = $\frac{1605 \text{ mm} \times 1172 \text{ kg}}{2414 \text{ kg}}$

Test Vehicle Center of Gravity (CG)

	Units	As Delivered	RP
Vehicle CG (Aft of Front Axle)	mm	1388	X _{CG}
Vehicle CG (Left (+) / Right (-) from Longitudinal Centerline)	mm	23.5	Y _{CG}

Drain Fuel and Paint Vehicle:

Performed by:	Jake Lambert	Date:	12-9-22
---------------	--------------	-------	---------

Initial:

- JL Remove the ballast weight (RCLW) from the cargo area.
- NA Drain the fuel tank. Use caution when draining the fuel. Do not damage or remove any fuel system components.
- NA Using purple dyed Stoddard solvent fill the tank to 93 % ($\pm 1\%$) of the usable capacity as supplied on Form 1 found in a previous section.
- NA Record this amount of Stoddard solvent in the space provided below along with the Unique Identifier of the meter used to conduct this task.
- NA Record this amount on the inside of the fuel filler lid.

Actual Amount of Solvent Used in Test	N/A \rightarrow EV	liters
Pump Meter Unique Identifier	N/A \rightarrow EV	

Yes No

Is the Actual Amount of Solvent Used in the test equal to 93% \pm 1% of the Usable Capacity stated in on Form No. 1?

Initial:

- JL Disable all side airbags on the non-struck side of the vehicle per manufacturer's instructions. If manufacturer will be here for the test confirm that the manufacturer has disabled these airbags prior to conducting the test.
- NA Disable vehicle Daytime Running Lights (if equipped).
- JL Remove horn fuse.
- NA Tape off interior airbag covers, instrument cluster, transmission gear selector, and airbag cut-off switch (if equipped).
- JL Paint vehicle interior surfaces such as the instrument panel, A-post trim panels, door trim panels, console, etc., with flat white paint. Note: Do not paint points marked on dash if they are present before painting. Note: The air bag indicator light on the dash shall NOT be painted so as to be visible prior to testing. Also be sure not to paint over passenger air bag indicator light.
- JL Black out mirrors.
- JL Place driver and passenger front windows in the fully open position. Place all other windows and vents in the fully closed position unless otherwise specified by the COTR.
- JL Adjustable cowl tops or other adjustable panels in front of the windshield should be placed in the position used under normal operation during inclement weather.

- NA Evacuate refrigerant.
- NA Tap brakes for abort.
- NA Drain the engine oil *
- NA Drain the transmission fluid *
- NA Drain the transfer case (4WD) *
- NA Drain the engine coolant *
- JL Drain the windshield washer fluid *
- NA Drain the power steering fluid *
- LA DR Connect 305 monitoring and make sure engineer takes required 305 photos
- AR Install 305 tow hook to rear of vehicle

*Note: Ensure that no fluids are leaking from the vehicle after being drained. Seal any leaks before vehicle is transported to the test track.

Mechanical Preparation:

Performed by: Jake Lambert Date: 12-12-22

Initial:

JL

Remove trunk carpeting, spare tire and jack (in trunk). Note: Per the NHTSA procedure, the spare tire, rear radio speakers, interior door trim and windows on the non-struck side, outboard mirrors on non-struck side taillights and rear bumper can be removed – IF NECESSARY. Refer to the Form 1 for a list of components that the manufacturer will allowed to be removed from the vehicle.

Equipment that is no longer on the test vehicle:

Description	Weight	
Trunk carpeting	16	kg
Spare tire	—	kg
Jack	3.0	kg
Rear speaker	—	kg
Tail light	—	kg
rear window passenger and int panel	8	kg

Description	Weight	
N/A	N/A	kg
↓	↓	kg
		kg
		kg
		kg
		kg

Weight Scale Unique Identifier: 070705

Explanation for equipment removal:

removed trunk carpeting for in Strumentation plate and window for side camera

Initial:		Description	Qty.
SL	1	Trunk Release NOT FOR REAR. Cut trunk release cable inside of vehicle and route outside to rear deck lid.	1
SL	2	Hood Release NOT FOR FRONTAL. Cut hood release cable near fender and tape to bumper.	1
SL	3	Instrumentation Plate Install instrumentation plate in trunk. Note location of all fuel components and use caution when drilling holes.	1
N/A	4	Abort Package Install abort package on instrumentation plate leading to rear brakes. Verify no leaks.	0
N/A	5	Roof Camera Mount Interior T-Bar, stay clear of side curtain air bags when drilling.	0
SL	6	Side Door Camera Mount	2
SL	7	Hood Camera Mount	1
N/A	8	Toe Pan Camera Mount Place seat in test position. Install toe pan camera in corresponding footwell area as far back as possible. Check for fuel lines before drilling.	0
SL	9	LED Light On the camera mount, attach (2) LED lights to either side of each camera (2 in total).	3
N/A	10	Remote Battery and Cable Route remote battery cable over the vehicle on the non-struck side to the monitor box. Not needed for AGM type battery.	0
SL	11	Battery Monitor Box Mount the battery monitor box to the right rear corner / non-struck corner.	1
	12	Umbilical Hangar	1

N/A		Attach the umbilical hanger to rear quarter panel on same side as umbilical	
N/A	13	Air Bag Monitor	0
		As per test request, connect inductive pickup to corresponding airbag positive (+) wire.	
N/A	14	Overhead Target Bar	0
		Refer to Vehicle Targeting section	
JL	15	Trigger	2
		Tape (2) triggers centered on the front hood and run cables to the truck / cargo area. Leave 2 feet of cable slack on hood.	
	16	Flash Unit	0
N/A		Attach flash units.	
	17	LED Light Box	1
BG		Mount one LED Light box to the instrumentation plate.	
BG	18	Camera Network Box	1
		Mount on instrumentation plate or rear floor pan depending on camera placement. Only 1 cable per camera, no extensions.	
	19	Breakout Box / Hub	1
SK		Mount Breakout Box hub to instrumentation plate.	
SK	20	DAU (KI/MINI)	3
		Mount (3) DAUs to the instrumentation plate.	

N/A	21	Wireless Antenna Mount (1) wireless antenna within the trunk / cargo compartment.	1
N/A	22	Speed Trap Bar Fasten speed trap bar to rear bumper of vehicle, opposite side of umbilical. (395 mm minimum height)	0
	23	25ft Camera Cable	3
BG	24	IDT Camera Mount (2) IDT cameras to the onboard camera mounts.	3
N/A	25	GoPro Camera	0
N/A	26	Seat Belt Displacement Sensor Screw displacement sensor bracket to corresponding pillar in line with seat belt at thorax height as per dummy placement	0
N/A	27	Seat Belt Load Cell (See Form 1) - Place (2) seat belt load cells on the front driver's seat. Place (2) seat belt load cells on the front passenger seat.	0

Onboard Camera Installation:

Performed by:

BG

Date:

12/26/22

BG

Install Camera Hub with Power & Trigger Cables

BG

Install On-Board Camera's & Cables to Mounts

BG

Check to make sure all required camera views are met. If not readjust camera mounts until all required views are met. (See photo references below)

BG

Verify the Battery is fully charged

BG

Install On-Board Lights Battery Box & ensure all light cables reach the box. If they do not install extension cables.

BG

Tie down all wiring related to the cameras and lights

BG

Pin all onboard cameras & camera bars to stabilize images during the impact.

High speed camera and light mounts photo reference:

High speed camera (1000 fps): Camera #7 – Onboard Dummy Front View and two LED lights to capture the following field of view:



High speed camera (1000 fps): Camera #8 – Onboard Dummy Side View and two LED lights to capture the following field of view:



High speed camera (1000 fps): Camera #9 – Onboard Dummy Rear Passenger Side View and two LED lights to capture the following field of view:



Section

4

Seat Positioning, Seat Setting, H- Point & Targeting

DB n/a DB

3. Position additional supports

Position any adjustable parts of the seat that provide additional support so that they are in the lowest or most open adjustment position.

N/A, No additional support adjustment

DB DB

4. Position leg supports

Position an additional leg support system in its rearmost position.

N/A, No additional support adjustment

DB DB

5.2.1. Position head restraint

Using any adjustment of the head restraint, position it to its highest position.

DB DB

5.2.2. Using any adjustment of the head restraint, position it to the full forward position. If it rotates, rotate it such that the head restraint extends as far forward as possible. Record the position of the head restraint in the space below.

N/A – The test vehicle is equipped with automatically adjusting head restraints or there is no head restraint adjustment.

Head Restraint Adjustment

Total # of Positions

Placed in Position #

Driver Seat

2 H0

DB n/a

6. Mark the longitudinal centerline of the seat

6.1 Driver's seat:

If adjustable, place the seat back in its most vertical (upright) position. For bucket seats, locate and **mark** for reference the intersection of a vertical longitudinal plane that passes through the SgRP and the seat cushion upper surface, seat back and head restraint. For bench seats, draw a line along the intersection of a vertical longitudinal plane that passes through the centerline of the steering wheel and the seat cushion upper surface, seat back and head restraint.

DB DB

7. Mark the range of seat travel

Prior to marking the seat, move the seat through its full range of motion using all available controls. Separately, operate each control to determine whether it moves the seat and/or seat cushion primarily in the fore-aft or up-down directions.

Seat Fore/Aft Positioning	Total Fore/Aft Travel	Placed in Position #
Driver	331	188 from F ₀
Front Passenger Seat	334	191 from F ₀

Front Center Seat	n/a	n/a
-------------------	-----	-----

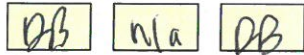

7.1 Mark a point (seat cushion reference point - **SCR**P) on the side of the seat cushion that is between 150 mm and 250 mm from the front edge of the seat cushion. For seat cushions that move up and down independently from the seat housing, mark the point on the side of the cushion in an area that will not be obscured by the seat housing when the seat cushion is at its lowest height position.

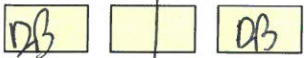

7.2 Draw a horizontal line (seat cushion reference line - **SCR**L) through the **SCR**P.

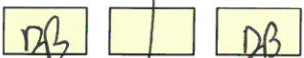

7.3 Use only the controls that primarily move the seat in the fore-aft direction to move the **SCR**P to the rearmost position.

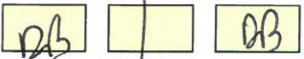

7.4 If the seat cushion adjusts fore-aft, independent of the seat back, use only the controls that primarily move the seat cushion in the fore-aft direction to move the **SCR**P to the rearmost position.



N/A No independent fore-aft seat cushion adjustment

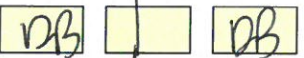

7.5 Use any part of any control, other than the parts just used for fore-aft positioning, to determine the range of angles of the **SCR**L and to set the **SCR**L at mid-angle. Record the maximum, minimum and midangles in the table below;

SCR	Max	Min	Mid
Driver Seat	21.2	10.6	15.9
Front Passenger Seat	20.4	9.2	14.8
Front Center Seat	n/a	n/a	n/a

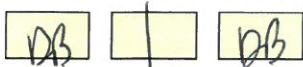

7.6 If the seat and/or seat cushion height is adjustable, use any part of any control other than the parts which primarily move the seat or seat cushion fore-aft, to put the **SCR**P in its lowest position with the **SCR**L angle at the mid-angle found in 7.5.



N/A No independent fore-aft seat cushion adjustment

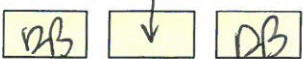

7.7 Use only the controls that primarily move the seat in the fore-aft direction to verify the seat is in the rearmost position.

DB n/a DB

7.8 Use only the controls that primarily move the seat in the fore-aft direction to **mark** the fore-aft seat positions. **Mark** each position so that there is a visual indication when the seat is at a particular position. For manual seats, move the seat forward one detent at a time and **mark** each detent. For power seats, **mark** only the rearmost, middle, and foremost positions. Label three of the positions with the following: F for foremost, M for mid-position (if there is no mid-position, label the closest adjustment position to the rear of the mid-point), and R for rearmost.

DB [] DB

7.9 Use only the controls that primarily move the seat in the fore-aft direction to move the **SCRIP** to the rearmost position.

DB [] DB

7.10 Use any part of any control, other than the parts which primarily move the seat or seat cushion fore-aft, to find the maximum, minimum, and middle height of the **SCRIP** with the **SCRL** at the mid-angle determined in 7.5 by measuring from the **SCRIP** to a reference point on the floor pan or sill. Record the maximum, minimum and middle heights on the table below.



N/A No independent fore-aft seat cushion adjustment

DB [] DB

7.11 Use only the controls that primarily move the seat and/or seat cushion in the fore-aft direction to place the **SCRIP** at the mid-fore-aft position.

DB [] DB

7.12 Use any part of any control, other than the parts which primarily move the seat or seat cushion fore-aft, to find the maximum, minimum, and middle height of the **SCRIP** with the **SCRL** at the mid-angle determined in 7.5 by measuring from the **SCRIP** to a reference point on the floor pan or sill. Record the maximum, minimum and middle heights on the table below.

DB [] DB

7.13 Use only the controls that primarily move the seat in the fore-aft direction to place the **SCRIP** at the full forward position.

DB [v] DB

7.14 Use any part of any control, other than the parts which primarily move the seat or seat cushion fore-aft, to find and visually **mark** the maximum, minimum, and middle height of the **SCRIP** with the **SCRL** at the midangle determined in 7.5 by measuring from the **SCRIP** to a reference point on the floor pan or sill. Record the maximum, minimum and middle heights and SCRL mid-angle on the table below.

Seat	SCRL Mid-Angle (7.5)	SCR Height Position	SCR Height (mm)		
			Rearmost (7.10) ^{DB}	Mid-fore/aft (7.12) ^{DB}	Full forward (7.14) ^{DB}
Driver Seat	15.9	Max	54 ⁴⁵³	60 ⁶³	67 ⁶⁹
		Mid	28 ²⁸	34 ³⁶	41 ⁴²
		Min	3 ⁴	8 ¹⁰	16 ¹⁵
Front Passenger Seat	14.8	Max	54	60	67
		Mid	28	34	41
		Min	3	8	16
Front Center Seat	n/a	Max	n/a	n/a	n/a
		Mid	↓	↓	↓
		Min	↓	↓	↓

DB n/a DB

8. For adjustable seat backs, position the seat back at the foremost stop. Mark each position of adjustment from the foremost to rearmost stops so that there is a visual indication when the seat back is at a particular position.

For manually adjustable seat backs (with detents), move the seat back rearward one detent at a time and mark each detent. Label the rearmost, middle, and foremost positions with the measured detent. If no middle detent exists, label the next most-rearward detent to the middle position.

For power seat backs (no detents), move the seat back rearward one degree at a time and mark each angle. Angles should be measured at the location on the seat (head restraint, seat back, plastic trim, etc.) as indicated by the manufacturer on Form No. 1. Label the rearmost, middle, and foremost positions with the measured angle.

Record the range of angles in degrees and detents in the space provided below. Visually mark and label for future reference the rear seat back angle, if adjustable, as provided by the manufacturer on Form No. 1 for the 50th percentile (ES-2re) male dummy in a Side MDB test.

Seat	Total Seat Back Angle Range		Test Position from Most Upright	
	Degrees	Detents *	Degree	Detent *
Driver Seat w/ Seated Dummy	71.5 30+ DB	n/a	19.8	n/a
Front Passenger Seat	71.2 30+	n/a	19.9	n/a
Front Center Seat	n/a	n/a	n/a	n/a

DB n/a DB

8. Mark the seat belt upper anchorage positions

Mark for reference each vertical position of a manually adjustable seat belt upper anchorage.

Mark and label each position with the following: H for highest, M"X" for mid-positions (where "X" stands for 1, 2, 3, etc. and 1 is used for the highest mid-position), and L for lowest.



N/A No independent fore-aft seat cushion adjustment

DB 9. Mark the steering wheel position

Is the steering wheel adjustable up and down and/or in and out?



Yes, go to 9.1



No - Check Sheet completed.

DB 9.1 Find and **mark** for future reference each up and down position. Label three of the positions with the following: H for highest, M for mid-position (if there is no mid-position, label the next lowest adjustment position), and L for lowest.



N/A steering wheel is not adjustable up and down

DB 9.2 Find and **mark** for future reference each -in- and -out- position. Label three of the positions with the following: F for foremost, M for mid-position (if there is no mid-position, label the next rearmost adjustment position), and R for rearmost.

2nd Row Seat Positioning – Reference Marks:

Performed by:	Drew Baginski	Date:	12/9/22
Tape Measure Unique Identifier:	400602		
Inclinometer Unique Identifier:	400774		

Instructions: In this section there are three sets of check marks. The first row corresponds with the rear struck side seat (left rear seat P4), the second row corresponds with the rear center seat (P6) and the third row corresponds with the rear outboard passenger seat (P3).

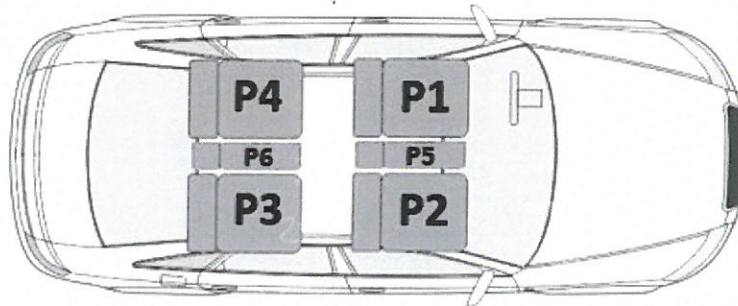

Setting the Seats - Driver, Front Center, and Front Passenger Seats

Set the driver, front center (if applicable), and front passenger seats accordingly:

Initial Settings -----

Initial:

DB 1. Determine the Seat Type

Visually inspect the front seats to determine its type (i.e., bucket or bench).

Struck Side Rear Passenger Seat:	Bench <input checked="" type="checkbox"/>	Bucket <input type="checkbox"/>
Non-Struck Side Passenger Seat:	Bench <input checked="" type="checkbox"/>	Bucket <input type="checkbox"/>
Rear Center Seat:	Bench <input checked="" type="checkbox"/>	Bucket <input type="checkbox"/>

P4	P6	P3
DB	DB	DB

2. Position lumbar supports

Position the seat's adjustable lumbar supports to the lowest, retracted or deflated adjustment positions.

DB N/A, No lumbar adjustment

DB DB DB

3. Position additional supports

Position any adjustable parts of the seat that provide additional support so that they are in the lowest or most open adjustment position.

DB N/A, No additional support adjustment

DB DB DB

4. Position leg supports

Position an additional leg support system in its rearmost position.

DB N/A, No additional support adjustment

DB DB DB

5.2.1. Position head restraint

Does the adjustable head restraint have a non-use position as defined by FMVSS No. 202a?

DB DB DB

Yes - Set the head restraint to the lowest position using the procedure described by the manufacturer. Record position in table below. Go to step 6.

No – go to step 5.1.2

Head Restraint Adjustment	Total # of Positions	Placed in Position #
Rear Passenger Seat	1 (FIXED)	1

DB DB DB

5.1.2. Using any adjustment of the head restraint, position it to its lowest position.

DB DB DB

5.1.3 Using any adjustment of the head restraint, position it to the full forward position. If it rotates, rotate it such that the head restraint extends as far forward as possible.

DB N/A – The test vehicle is equipped with automatically adjusting head restraints or there is no head restraint adjustment.

DB DB DB

6. Mark the longitudinal centerline of the seat

DB ^{Passenger} **6.1 Driver's seat:**

If adjustable, place the seat back in its most vertical (upright) position. For bucket seats, locate and **mark** for reference the intersection of a vertical longitudinal plane that passes through the SgRP and the seat cushion upper surface, seat back and head restraint. For bench seats, draw a line along the intersection of a vertical longitudinal plane that passes through the centerline of the steering wheel and the seat cushion upper surface, seat back and head restraint.

DB DB DB

7. Mark the range of seat travel

Prior to marking the seat, move the seat through its full range of motion using all available controls. Separately, operate each control to determine whether it moves the seat and/or seat cushion primarily in the fore-aft or up-down directions.

Seat Fore/Aft Positioning	Total Fore/Aft Travel	Placed in Position #
Struck Side Rear Seat	Fixed	Fixed
Non-Struck Side Rear Seat	Fixed	Fixed
Rear Center Seat	Fixed	Fixed

DB DB DB

7.1 Mark a point (seat cushion reference point - **SCRCP**) on the side of the seat cushion that is between 150 mm and 250 mm from the front edge of the seat cushion. For seat cushions that move up and down independently from the seat housing, mark the point on the side of the cushion in an area that will not be obscured by the seat housing when the seat cushion is at its lowest height position.

DB DB DB

7.2 Draw a horizontal line (seat cushion reference line - **SCRL**) through the **SCRCP**.

DB DB DB

7.3 Use only the controls that primarily move the seat in the fore-aft direction to move the **SCRCP** to the rearmost position.

DB DB DB

7.4 If the seat cushion adjusts fore-aft, independent of the seat back, use only the controls that primarily move the seat cushion in the fore-aft direction to move the **SCRCP** to the rearmost position.

N/A No independent fore-aft seat cushion adjustment

DB DB DB

7.5 Use any part of any control, other than the parts just used for fore-aft positioning, to determine the range of angles of the **SCRL** and to set the **SCRL** at mid-angle. Record the maximum, minimum and midangles in the table below;

SCRL°	Max	Min	Mid
Struck Side Rear Seat	FIXED	FIXED	FIXED
Non-Struck Side Rear Seat	↓	↓	↓
Rear Center Seat	↓	↓	↓

DB DB DB
(Fixed Seat)

7.6 If the seat and/or seat cushion height is adjustable, use any part of any control other than the parts which primarily move the seat or seat cushion fore-aft, to put the **SCR**P in its lowest position with the **SCRL** angle at the mid-angle found in 7.5.

DB

N/A No independent fore-aft seat cushion adjustment

DB DB DB

7.7 Use only the controls that primarily move the seat in the fore-aft direction to verify the seat is in the rearmost position.

DB DB DB

7.8 Use only the controls that primarily move the seat in the fore-aft direction to **mark** the fore-aft seat positions. **Mark** each position so that there is a visual indication when the seat is at a particular position. For manual seats, move the seat forward one detent at a time and **mark** each detent. For power seats, **mark** only the rearmost, middle, and foremost positions. Label three of the positions with the following: F for foremost, M for mid-position (if there is no mid-position, label the closest adjustment position to the rear of the mid-point), and R for rearmost.

DB DB DB

7.9 Use only the controls that primarily move the seat in the fore-aft direction to move the **SCR**P to the rearmost position.

DB DB DB

7.10 Use any part of any control, other than the parts which primarily move the seat or seat cushion fore-aft, to find the maximum, minimum, and middle height of the **SCR**P with the **SCRL** at the mid-angle determined in 7.5 by measuring from the **SCR**P to a reference point on the floor pan or sill. Record the maximum, minimum and middle heights on the table below.

DB

N/A No independent fore-aft seat cushion adjustment

DB DB DB

7.11 Use only the controls that primarily move the seat and/or seat cushion in the fore-aft direction to place the **SCR**P at the mid-fore-aft position.

DB DB DB

7.12 Use any part of any control, other than the parts which primarily move the seat or seat cushion fore-aft, to find the maximum, minimum, and middle height of the **SCR**P with the **SCRL** at the mid-angle determined in 7.5 by measuring from the **SCR**P to a reference point on the floor pan or sill. Record the maximum, minimum and middle heights on the table below.

DB DB DB

7.13 Use only the controls that primarily move the seat in the fore-aft direction to place the **SCR**P at the full forward position.

DB DB DB

7.14 Use any part of any control, other than the parts which primarily move the seat or seat cushion fore-aft, to find and visually **mark** the maximum, minimum, and middle height of the **SCR**P with the **SCRL** at the midangle determined in 7.5 by measuring from the **SCR**P to a reference point on the floor pan or sill. Record the maximum, minimum and middle heights and **SCRL** mid-angle on the table below.

Seat	SCRL Mid-Angle (7.5)	SCR Height Position	SCR Height (mm)		
			Rearmost (7.10)	Mid-fore/aft (7.12)	Full forward (7.14)
Struck Side Rear Seat	NOT Adjustable ↓	Max	N/A	N/A	N/A
		Mid	↓	↓	↓
		Min	↓	↓	↓
Non-Struck Side Rear Seat	↓	Max	↓	↓	↓
		Mid	↓	↓	↓
		Min	↓	↓	↓
Rear Center Seat	↓	Max	↓	↓	↓
		Mid	↓	↓	↓
		Min	↓	↓	↓

DB DB DB

(FIXED)

8. For adjustable seat backs, position the seat back at the foremost stop. Mark each position of adjustment from the foremost to rearmost stops so that there is a visual indication when the seat back is at a particular position.

For manually adjustable seat backs (with detents), move the seat back rearward one detent at a time and mark each detent. Label the rearmost, middle, and foremost positions with the measured detent. If no middle detent exists, label the next most-rearward detent to the middle position.

For power seat backs (no detents), move the seat back rearward one degree at a time and mark each angle. Angles should be measured at the location on the seat (head restraint, seat back, plastic trim, etc.) as indicated by the manufacturer on Form No. 1. Label the rearmost, middle, and foremost positions with the measured angle.

Record the range of angles in degrees and detents in the space provided below. Visually mark and label for future reference the rear seat back angle, if adjustable, as provided by the manufacturer on Form No. 1 for the 5th percentile (SID-IIs) female dummy in a Side MDB test.

Seat	Total Seat Back Angle Range		Test Position from Most Upright	
	Degrees	Detents *	Degree	Detent *
Struck Side Rear Seat	FIXED	FIXED	FIXED	FIXED
Non-Struck Side Rear Seat	↓	↓	↓	↓
Rear Center Seat	↓	↓	↓	↓

DB DB DB

9. Mark the seat belt upper anchorage positions

Mark for reference each vertical position of a manually adjustable seat belt upper anchorage.

Mark and label each position with the following: H for highest, M"X" for mid-positions (where "X" stands for 1, 2, 3, etc. and 1 is used for the highest mid-position), and L for lowest.

DB

N/A No independent fore-aft seat cushion adjustment

DB

10. Mark the steering wheel position

Is the steering wheel adjustable up and down and/or in and out?

DB

Yes, go to 9.1

No - Check Sheet completed.

DB

10.1 Find and **mark** for future reference each up and down position. Label three of the positions with the following: H for highest, M for mid-position (if there is no mid-position, label the next lowest adjustment position), and L for lowest.

N/A steering wheel is not adjustable up and down

DB

10.2 Find and **mark** for future reference each -in- and -out- position. Label three of the positions with the following: F for foremost, M for mid-position (if there is no mid-position, label the next rearmost adjustment position), and R for rearmost.

H-Point Left Front Seat (Position 1):

Performed by:

Drew Bagmski

Date:

12/9/22

Initial:

DB

Place a piece of muslin cloth over seat area.

DB

Place H-point machine in center of seat. Note: If vehicle is a bench seat, then the center is aligned with the center of the steering column. For the passenger seat, the center is found by placing the machine the same distance outboard from the vehicle centerline as for the driver seat. If the seat is a bucket, place the H-point machine on the seat centerline.

DB

Attach leg assemblies. T-bar parallel to ground and perpendicular to vehicle centerline. T-bar set at 15.8, legs set at 16.3 for 50th percentile.

DB

Position right driver's foot on un-depressed accelerator pedal. Insert pin in right foot to ensure angle is not less than 87 degrees. Sole on pedal and heel as far forward as possible. Left knee is placed same distance from H-point machine centerline as right knee.

DB

Position knees 254 mm apart. Place feet as far forward as possible.

DB

Apply lower leg and thigh weights.

DB

Tilt back pan forward. Pull T-bar forward then release to allow machine to slide back into seat.

DB

Apply a 22 pound rearward load at the intersection of hip angle and T-bar. Apply load twice.

DB

Return back plane to seat back.

DB

Prevent H-point machine from sliding forward for the rest of the procedure.

DB

Install buttock and torso weights.

DB

Move back plane forward and rock 3 times over a 10 degree arc.

DB

Lift each leg and allow it to fall into place. Make sure seat pan is level (i.e. no roll) and return back pan to seat back.

DB

Apply force to the back pan to either: (1) Increase hip angle 3 degrees. (2) Maximum of 15 pounds.

DB

Record H-Point Machine Torso Angle in the space provided below.

DB

Record H-Point Machine Hip Point location in the space provided below.

DB

Place H-point target sticker on outside of vehicle door.

H-Point Machine Torso Angle	25.5 degrees
H-Point Machine Hip Angle	99 degrees
Seatback Angle (Headrest Post)	19.3 degrees
Hip Point: X (fore/aft of striker)	188.377 mm
Z (above/below striker)	142.452 mm

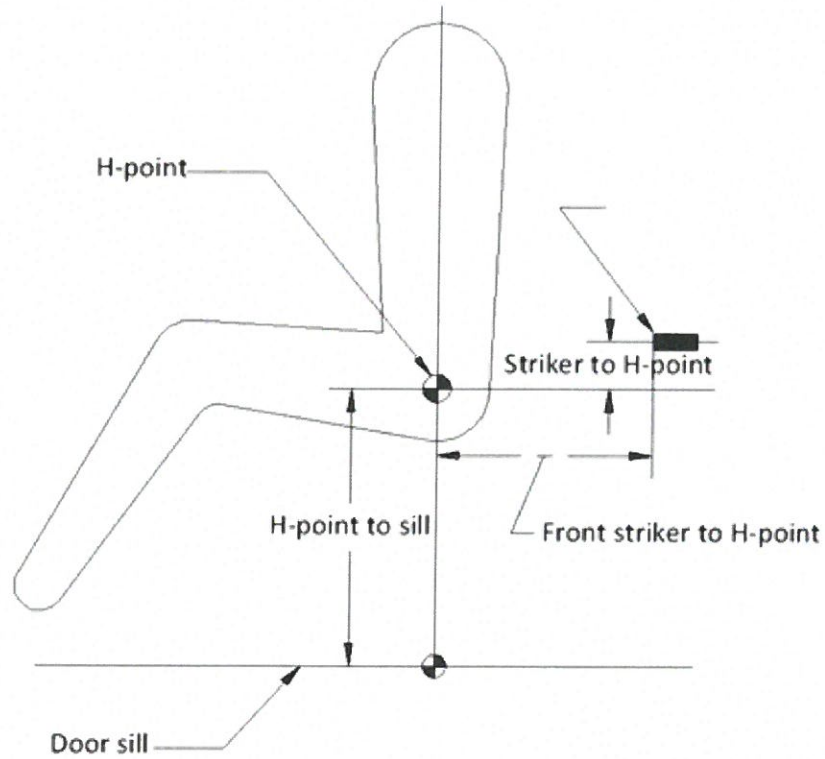

1st Row Seat Positioning – Setting Seats

Performed by:	Drew Baginski	Date:	12/9/22
Tape Measure Unique Identifier:	400602		
Inclinometer Unique Identifier:	400774		

Instructions: In this section there are three sets of check marks. The first row corresponds with the front driver seat (P1), the second row corresponds with the front center seat (P5) and the third row corresponds with the front passenger seat (P2).

Setting the Seats - Driver, Front Center, and Front Passenger Seats

Set the driver, front center (if applicable), and front passenger seats accordingly:

Initial:

P1	P5	P2
DB	n/a	DB

1. Set the seat for a (ES-2re) test dummy

Using the reference marks on the seat, set the seat in the mid fore-aft, lowest height at mid seat cushion angle position as follows;

DB		DB
----	--	----

1.1 Using the control that primarily moves the seat fore and aft, move the **SCR**P to the mid-travel (i.e., mid-fore aft) position.

DB		DB
----	--	----

1.2 If the seat or seat cushion height is adjustable, other than by the controls that primarily move the seat or seat cushion fore and aft set the height of the **SCR**P to the minimum height, with the **SCR**L set as closely as possible to the mid-angle.

DB		DB
----	--	----

1.3 Set the seat back angle at the manufacturer's nominal design riding position for a 50th percentile adult male in the manner specified by the manufacturer. If the position is not specified, set the seat back at the first detent rearward of 25° from vertical.

Seat Back Angle 20.0 °

N/A The seat back does not adjust.

DB	✓	DB
----	---	----

Using any adjustment of the head restraint, position it to its highest position. Using any adjustment of the head restraint, position it to the full forward position.

2nd Row Seat Positioning – Setting Seats

Performed by:	Draw Bagmster	Date:	12/9/22
Tape Measure Unique Identifier:			
Inclinometer Unique Identifier:			

Instructions: In this section there are three sets of check marks. The first row corresponds with the rear struck side seat (left rear seat P4), the second row corresponds with the rear center seat (P6) and the third row corresponds with the rear outboard passenger seat (P3).

Setting the Seats - Rear Struck Side Seat, Rear Center, and Rear Outboard Seats

Using the reference marks determined in the previous section, set the seats accordingly for a SID-IIs ATD:

Set the seat at rearmost fore/aft position, lowest height at mid-angle.

Initial:

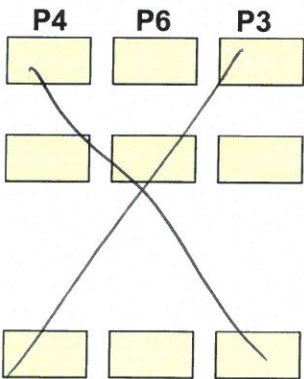

FIXED SEATS

- 1.1 Using the control that primarily moves the seat fore and aft, move the **SCR**P to the rearmost position.
 - N/A The seat is not adjustable.
- 1.2 If the seat or seat cushion height is adjustable, other than by the controls that primarily move the seat or seat cushion fore and aft, set the height of the **SCR**P to the lowest height, with the **SCR**L set as closely as possible to the mid-angle.
 - N/A The seat back does not adjust.
- 1.3 Fully recline the seat back
 - N/A The seat back does not adjust.

Setting Steering Wheel & Seat Belt Adjustment

Performed by:	Drew Baginski	Date:	12/9/22
Tape Measure Unique Identifier:	400602		
Inclinometer Unique Identifier:	400774		

Setting Steering Wheel, Seat Belt Anchorages, Belt Guides, etc.

Steering Wheel Adjustment - If the steering wheel is adjustable up and down and/or in and out complete the following steps to set the final steering wheel location:

Initial:

DB 11. Set the steering wheel to the mid-position

Use the markings to position the steering wheel hub at the geometric center of full range of driving positions including any telescoping positions or if applicable, the next lowest detent position. Complete the following table

N/A steering wheel does not adjust.

Steering Column Adjustment

Steering wheel and column adjustments are made so that the steering wheel hub is at the center of its geometric locus it describes when it moves through its full range of motion.

	Degrees	Fore / Aft Position (mm)
Lowermost, Position No. 1	18.7	
Geometric Center, Position No. 2	22.2	
Uppermost, Position No. 3	25.7	
Telescoping Steering Wheel Travel		50
Test Position	22.2	25

Reference distance from ceiling to center of steering wheel. Mark point in ceiling.	450 mm	<p>LEFT SIDE VIEW</p>
Reference distance from front of dash to steering wheel. Mark points on dash and steering wheel.	130 mm	

Adjustable Seat Belt Anchorages

Initial:

DB

Place adjustable seat belt anchorages in the nominal adjustment position in accordance with the manufacturer's data on Form No. 1 for a 50th percentile (ES-2re) male adult occupant and a 5th percentile (SID-IIs) female adult occupant.

Note the position of the seat belt anchorages in the space provided below.

	Total # of Positions	Placed in Position #
Driver Seat	4	Ho
Rear Passenger Seat	1	1

✓

Seat Belt Guides: Usage of seat belt guides should be set in accordance with instructions included in the vehicle owner's manual or in Form No. 1.

Photographic Tape & Measurements

Performed by:	Draw Baginski	Date:	12/9/22
---------------	---------------	-------	---------

Initial:

DB Align the left edge of 25 mm (1 inch) wide yellow/black checkerboard tape along the vertical impact reference line as defined below. Reference illustrations can be found on the next page.

For passenger vehicles

Test Vehicle Wheelbase Length	Vertical Impact Reference Line Location
Less than or equal to 2,896 mm	940 mm +/- 5 mm forward of wheelbase centerline
Greater than 2,896 mm	508 mm +/- 5 mm rearward of front axle centerline

- Excel: Center = 1249.684
 - 12.5
 = 1236.584
 (edge)

For multipurpose vehicles, sport utility vehicles, light trucks and vans:

Test Vehicle Wheelbase Length	Vertical Impact Reference Line Location
Less than or equal to 2,489 mm	305 mm +/- 5 mm rearward of front axle centerline
Greater than 2,489 mm but less than 2,896 mm	940 mm +/- 5 mm forward of wheelbase centerline
Greater than 2,896 mm	508 mm +/- 5 mm rearward of front axle centerline

IRL = 411.1
 from front axle

Note: For different wheelbase versions of the same model vehicle, the vertical impact reference line may be determined by the following procedure:

- Select the shortest wheelbase version of the same model and locate the vertical impact reference line as described above.
- Measure the distance between the SgRP and the vertical impact reference line.
- Maintain the same distance between the seating reference point and the vertical impact reference line for the version being tested as that distance between the seating reference point and vertical impact reference line for the shortest wheelbase version.

DB Measure the distance from the front axle to the edge of the tape used to denote the vertical impact reference line and record the measurement in the space provided below.

Impact Point Location:	Units	Value
Vehicle Wheel Base	mm	2702.168
Wheelbase Midpoint	dx mm	1351 from axle
Vertical Impact Reference Line Location (Taken from above table) If Wheel Base is greater than 2,896 mm than use 508 mm	mm	940
Vertical Impact Reference Line (Aft of Front Axle) (Intended Impact Point)	mm	411.100

DB Place 25 mm (1 inch) wide yellow/black checkerboard tape shall be placed on the vehicle such that when the barrier is properly aligned with the test for impact, the tape coincides with the vertical centerline of the barrier's impact face. See below figures.

The tape should be extended across the roof of the vehicle (90° angle to the test vehicle longitudinal centerline) to provide a reference for the overhead camera coverage.

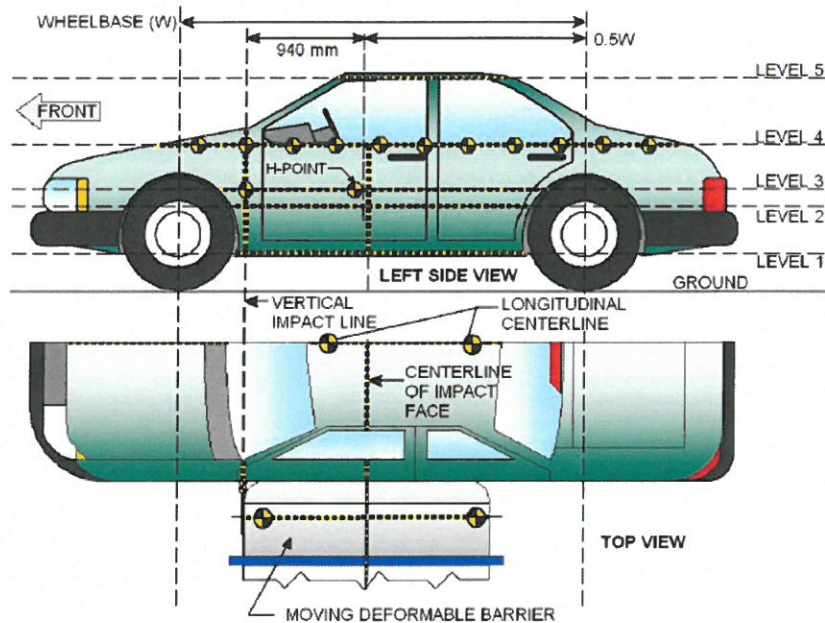

DB Affix 25 mm (1 inch) wide yellow/black checkerboard tape horizontally along the impact side of the test vehicle at LEVEL 1 – Top of side sill: Affix tape along the door sill from the front to the rear wheel-wells.

DB Affix 25 mm (1 inch) wide yellow/black checkerboard tape horizontally along the impact side of the test vehicle at LEVEL 2 – Occupant Hip Point: Project the location of the driver dummy's hip point laterally through the door to its exterior panel. Affix tape to the side body panels so that the tape intersects the hip point.

DB Affix 25 mm (1 inch) wide yellow/black checkerboard tape horizontally along the impact side of the test vehicle at LEVEL 3 – Mid-door: Measure the height of the front door body panel at two different locations that are at least 600 mm apart. Take the average of the two measurements. Mark this point on the exterior door panel. Affix tape to the side body panels so that the tape intersects this point.

DB Affix 25 mm (1 inch) wide yellow/black checkerboard tape horizontally along the impact side of the test vehicle at LEVEL 4 – Window sill: Affix tape just below the front door window sill.

DB Affix 25 mm (1 inch) wide yellow/black checkerboard tape horizontally along the impact side of the test vehicle at LEVEL 5 – Top of window: Affix tape just above the top of the front door window.

Note: The following measurements should be taken along the vertical impact reference line. Vehicle measurements forward of the vertical impact reference line are negative. All measurements are in millimeters (mm). Pre-test measurements are taken when the vehicle is in the "As Tested" weight condition. The crush profile grid is established prior to the test based on an estimated impact point.

Affix Targets to the Struck side of the Test Vehicle

Initial:

- DB** Place a 50 mm (2 inch) diameter target on the vehicle at mid-door height and along the left edge of the vertical impact reference line. The tip of the welding rod will be located in the center of the target.
- DB** Affix targets, labeled appropriately (if applicable) to the front door or side panel to denote the hip pivot center of the test driver dummy. Use a 100 mm (4 inch) diameter target and label with "HP".
- DB** Affix targets, labeled appropriately (if applicable), along LEVEL 4, window sill tape line, at every 300 mm. Use 50 mm (2 inch) diameter targets.
- DB** Affix 25 mm (1 inch) wide checkerboard tape on the hood and roof along the longitudinal centerline of the entire vehicle (excluding glazing surfaces).
- DB** Affix two (4-inch) diameter targets approximately 700mm apart on the roof's longitudinal centerline.

If the vehicle has a sunroof, do not affix any targets to any glazing. Maximize the distance between the targets assuring that the targets only lie on the roof's body panel.

Roof Target Dia. 100 mm

Distance between target centers: 698 mm

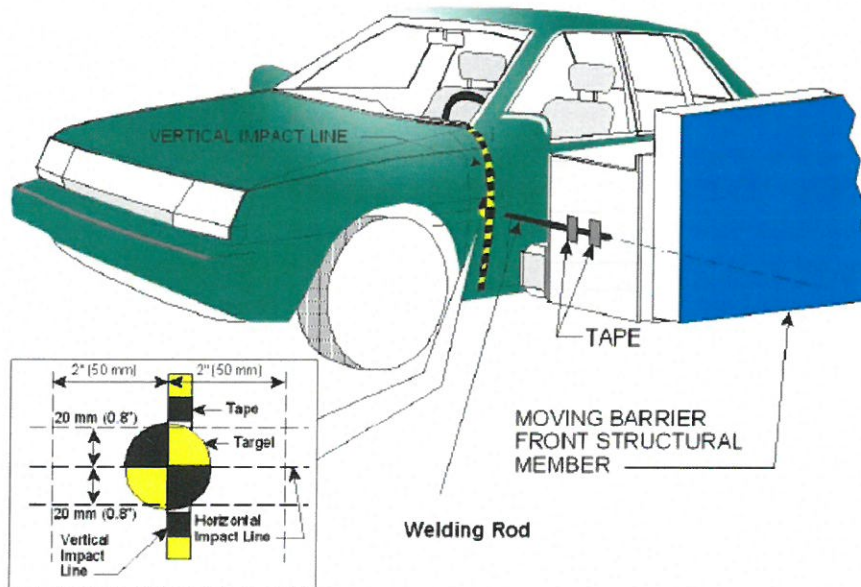

Pre-Test Measurements:

Performed by:

Drew Baginski

Date:

12/9/22

Instructions: Read through the following instruction PRIOR to measuring the following locations using the FARO arm.

Vehicle Coordinate System:

- X – Rear Surface of Vehicle (+ forward)
- Y – Vehicle Centerline (+ to right)
- Z – Ground Plane (+ down)

Exterior Vehicle Measurements:

FARO Unique Identifier:

136257

Initial:



Review the below illustrations.

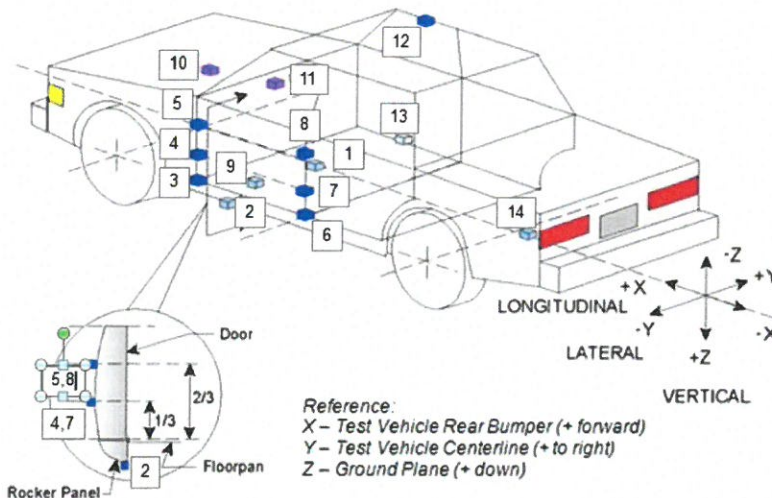
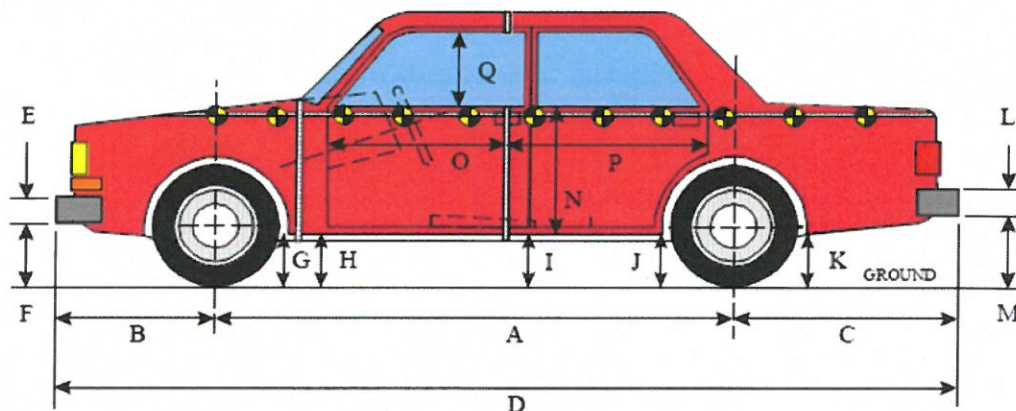

Initial:

Confirm vehicle is in the "As Tested" configuration.

Establish a fixed reference plane that is perpendicular to the vehicle's longitudinal centerline.

Ground Plane Reference Points -----

Initial:

DB

Gplane - Ground Plane Reference Points Left, Front, Right and Rear.

Wheelbase / Vehicle Length -----

Initial:

DB

LFW - Left Front Wheel.

DB

LRW - Left Rear Wheel.

DB

RFW - Right Front Wheel.

DB

RRW - Right Rear Wheel.

DB

RFRONT - Right Front (X19)

DB

CFRONT - Center of Front (X1)

DB

LFRONT - Left Front (X20)

DB

RREAR - Right Rear

DB

CREAR - Center of Rear

DB

LREAR - Left Rear

DB

NUP - N Upper Point

DB

NLOW - N Lower Point

DB

OFRNT - O Front Point

DB

OPMID - O Rear Point / P Front Point

DB

PREAR - P Rear Point

DB

QUP - Front Window Opening – Take uppermost point on front window to obtain window vertical distance measurement

DB

QLOW – Front Window Opening – Take lowermost point on front window to obtain window vertical distance movement

DB

RBPW - Right B Pillar Point (*Taken at vertical tangency point*)

DB

LBPW - Left B Pillar Point (*Taken at vertical tangency point*)

Vehicle Floor Pan Measurements / P1 Floor Pan / Interior -----

Initial:

DB P1 STRIKER – Center of P1 Striker Bolt

Vehicle Floor Pan Measurements / P2 Floor Pan / Interior -----

Initial:

DB P2 STRIKER – Center of P2 Striker Bolt

Crush Measurements (Previously Taken in Vehicle & Photographic Targets Section)-----

Initial:

DB C1 - Vehicle Crush Measurement #1 – Sill Top

DB C2 - Vehicle Crush Measurement #2 – Occupant Hip Point

DB C3 - Vehicle Crush Measurement #3 – Mid Door

DB C4 - Vehicle Crush Measurement #4 – Window Sill

DB C5 - Vehicle Crush Measurement #5 – Window Top

Accelerometer Measurements-----

Initial:

DB ACC 1 – Right Front Sill

DB ACC 2 – Right Rear Sill

DB ACC 3 – Rear Floor Pan

DB ACC 4 – Left Rear Sill

DB ACC 5 – Left Front Sill

DB ACC 6 – Right Rear Occupant Compartment

DB ACC 7 – Left B-Pillar Low

DB ACC 8 – Left B-Pillar Mid

DB ACC 9 – Left A-Pillar Low

DB ACC 10 – Left A-Pillar Middle

DB ACC 11 – Front Seat Track

DB ACC 12 – Rear Seat Track

DB ACC 13 – Vehicle CG

DB ACC 14 – Engine Top

Hand Measurements-----

Initial:

AR	Hand measure	E	Front Bumper Thickness - (The vertical height of the front bumper fascia)	120 mm
AR	Hand measure	F	Front Bumper Bottom to Ground - (Vertical distance from ground to the bottom of the front bumper fascia)	504 mm
AR	Hand measure	G	Sill Height at Front Wheel Well - (Vertical distance from ground to the sill at the front wheel well opening)	208 mm
AR	Hand measure	H	Sill Height at Front Door Leading Edge - (Vertical distance from ground to the sill at the front door seam)	219 mm
AR	Hand measure	I	Sill Height at B-Pillar - (Vertical distance from ground to the sill in line with the front door striker or B-pillar if no striker exists)	217 mm
AR	Hand measure	J1	Sill Height at Rear Wheel Well - (Vertical distance from ground to the sill at the rear wheel well opening)	193 mm
AR	Hand measure	J2	Pinch Weld Height at Rear Wheel Well - (Vertical distance from ground to the pinch weld at the rear wheel well opening)	241 mm
AR	Hand measure	K	Sill Height Aft of Rear Wheel Well - (Vertical distance from ground to the vehicle sheet body at the rear of the rear tire's wheel well)	285 mm
AR	Hand measure	L	Thickness or height of rear bumper at center.	135 mm
AR	Hand measure	M	Distance from bottom of bumper to ground at center.	391 mm
Tape Measure Unique Identifier Used to conduct measurements				—

Initial:

AB Record the following information below (needed to generate the QuickLook).

Wheelbase Left Side	2702.168 mm
Wheelbase Right Side	2703.287 mm
Vehicle Width at B-Pillar	1840.236 mm
Vehicle Length Left Side	4304.014 mm
Vehicle Length Center	4429.474 mm
Vehicle Length Right Side	4305.780 mm

Section
5

Vehicle Instrumentation

Instrumentation Installation:

Performed by:	Will Brock	Date:	12-15-22
---------------	------------	-------	----------

Note: It is the Technician's responsibility to verify that all instrumentation and associated wiring is in good working condition and calibrated.

Initial:

- WB Review the customer's test request or statement of work for the list of desired instrumentation.
- WB Create Calspan Excel channel request.
- WB Generate photo placards.
- WB Verify that the placards match the desired instrumentation list.
- WB Print and cut out photo placards.
- WB Acquire instrumentation, verify functionality, that it has been calibrated and that its calibration has not expired or is within two weeks of needing to be calibrated.
- WB Install instrumentation in the following locations using two-face tape, hot melt or screws as appropriate. Use single accelerometers that have been pre-assembled as dual or tri-packs as appropriate). Then take a close-up photo of the installed instrumentation and corresponding photo placard followed by an overall photo. See Figure 5 below for vehicle accelerometer locations.

Install	Photo Close	Photo Overall	
---------	----------------	------------------	--

- | | | | |
|-------------------------------------|-------------------------------------|-------------------------------------|---|
| <input checked="" type="checkbox"/> | <input checked="" type="checkbox"/> | <input checked="" type="checkbox"/> | <i>Right Sill @ Front Seat</i> – Triaxial accelerometer mounted on the opposite side to the impacted side sill at the front seat to provide Ax, Ay and Az data: ACC 1 – Location 1. |
| <input checked="" type="checkbox"/> | <input checked="" type="checkbox"/> | <input checked="" type="checkbox"/> | <i>Right Sill @ Rear Seat</i> – Triaxial accelerometer mounted on the opposite side to the impacted side sill at the rear seat to provide Ax, Ay and Az data: ACC 2 – Location 2. |
| <input checked="" type="checkbox"/> | <input checked="" type="checkbox"/> | <input checked="" type="checkbox"/> | <i>Rear Floor Pan Above Axle</i> – Triaxial accelerometer mounted on the rear floor pan above the axle to provide Ax, Ay and Az data: ACC 3 - Location 3. |
| <input checked="" type="checkbox"/> | <input checked="" type="checkbox"/> | <input checked="" type="checkbox"/> | <i>Left Sill @ Rear Door</i> – Uniaxial accelerometer mounted on the impacted side sill in line longitudinally with the center of the widest portion of the front door and located under the sill inward of pinch welds to provide Ay data: ACC 4 – Location 4. |
| <input checked="" type="checkbox"/> | <input checked="" type="checkbox"/> | <input checked="" type="checkbox"/> | <i>Left Sill @ Front Door</i> – Uniaxial accelerometer mounted on the impacted side sill in line longitudinally with the center of the widest portion of the rear door and located under the sill inward of pinch welds to provide Ay data: ACC 5 – Location 5. |

- Right Rear Occupant Compartment* – Uniaxial accelerometer mounted in the rear occupant compartment to provide Ay data: ACC 6 – Location 6.
- Left B-Post Lower* – Uniaxial accelerometer mounted on the impacted lower B-Pillar (located 1/3 the distance from the floor to the bottom of the door's window opening) to provide Ay data: ACC 7 – Location 7.
- Left B-Post Middle* – Uniaxial accelerometer mounted on the impacted middle A-Pillar (located 2/3 the distance from the floor to the bottom of the doors window opening) to provide Ay data: ACC 8 – Location 8.
- Left A-Post Lower* – Uniaxial accelerometer mounted on the impacted lower A-Pillar (located 1/3 the distance from the floor to the bottom of the doors window opening) to provide Ay data: ACC 9 – Location 9.
- Left A-Post Middle* – Uniaxial accelerometer mounted on the impacted middle A-Pillar (located 2/3 the distance from the floor to the bottom of the doors window opening) to provide Ay data: ACC 10 – Location 10.
- Front Seat Track* – Uniaxial accelerometer mounted on the front seat track nearest the impacted door and approximately aligned with the driver hip point to provide Ay data: ACC 11 – Location 11.
- Rear Seat Track or Structure* – Uniaxial accelerometer mounted on the rear seat structure (if easily accessible) nearest the impacted door and approximately aligned with the dummy's hip pivot point to provide Ay data: ACC 12 – Location 12.
- Vehicle CG* – One triaxial accelerometer mounted to the floorpan at the longitudinal and lateral location of the vehicle CG to measure accelerations in the x, y, and z directions: ACC 13 - Location 13.

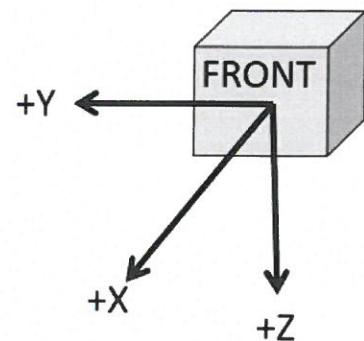
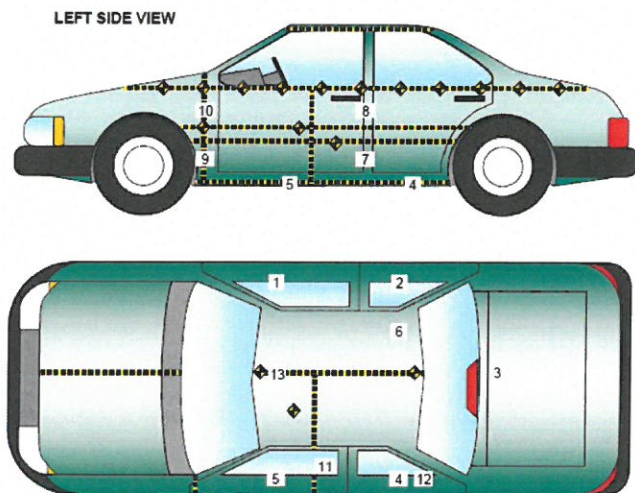

Onboard Test Equipment Installation:

Performed by:	SIC	Date:	12/20/22
---------------	-----	-------	----------

Note: It is the Technician's responsibility to verify that all instrumentation and associated wiring is in good working condition and calibrated. Verify that all DAU's calibration has not expired. This section MUST be completed prior to installation to prevent unnecessary delays.

Initial:

- SIC Inspect cables for damage prior to installation.
- SIC When installing any instrumentation cables, leave slack for strain relief.
 - SIC Connect 4³ DAU's in series with crash link cables, starting with breakout box.
 - SIC Plug in all accelerometer LEMO connectors into DAU's, ensuring a tight fit. Verify lock engaged.
 - SIC Plug in battery monitor cable, ensuring a tight fit. Verify lock engaged.
 - SIC Connect 2 trigger BNC connectors into breakout box.
 - SIC Connect WIFI to Ki-Hub interface.
 - SIC Connect abort to breakout box power wire.
 - TB Connect LED light LEMO connector to battery box.
 - TB Connect trigger 1 port to camera in port using corresponding cable.
- SIC Check functionality of SRS light.

Section
6

Verification of Vehicle, ATD & Facility Readiness

Instruction: Insert ATD and Facility checklists after this tab.



Inserted ATD Checklist.



Inserted Facility Checklist.



Inserted MDB Checklist.

Weight – As Tested Condition:

Performed by: Eric Cornell + Jeff Weisberg Date: 12-14-2022

Initial:

JW Load the appropriate dummies (with umbilical cord) into the appropriate seating position.
(Ask ATD Lab for specific ATD Weight)

EC Reference weight: Driver 178.6 lbs.

EC Reference weight: Left Rear Passenger 110.2 lbs.

JW Weigh the vehicle at each wheel and add the weights to determine the “As Tested” weight.

EC Record the weight measurements and scale unique identifier in the space provided below.

EC Verify that the “As Tested” weight is within the Target Test Weight (min) and Target Test Weight (max) determined in the Weight – As Delivered section.

Note: Adjust the weight of the test vehicle by either adding ballast or removing vehicle components in accordance with the manufacturer’s data provided by the COTR on Form No. 1. If the calculated Test Vehicle Target Weight is exceeded immediately contact the Technical Director.

EC Record the weight of any added ballast in the space provided on the next page.

EC Record any vehicle components that were removed and their associated total weight in the space provided on the next page.

EC Check to make sure the “As Tested” weight is similar to the “Fully Loaded” weight distribution

EC Record the Unique Identifier of the weight scales used to weigh the vehicle in the box below.

Weight Scales Unique Identifier 070705

	Units	As Tested		Total
		Front Axle	Rear Axle	
Left	kg	<u>585</u>	<u>641</u>	$W_{Left} = $ <u>1226</u>
Right	kg	<u>584</u>	<u>593</u>	$W_{Right} = $ <u>1177</u>
Ratio	%	<u>48.6</u>	<u>51.4</u>	
Totals	kg	$W_F = $ <u>1169</u>	$W_R = $ <u>1234</u>	<u>2403</u>

Target Test Weight Minimum	<u>2400.8</u> kg
Target Test Weight Maximum	<u>2405.3</u> kg

Weight of ballast added to meet TWTW

Description	Weight
Ballast	56.7 kg

Yes No

Does the measured As Tested Vehicle Weight lie within the required weight range (i.e. Calculated Test Vehicle Weight -4.5 kg to -9.0 kg)?

If no, indicate in the space provided below the equipment that was removed and its associated weight to meet this requirement.

Equipment that was removed to meet test weight:

NIA

Explanation for equipment removal: ²

NIA

Vehicle components removed to meet TWTW

Description	Weight
NIA	kg
	kg
	kg

CG – As Tested Condition:

Performed by: QP Date: 12/19

Initial:

QP

Measure and record the vehicle distances and copy the weights from the previous section in the space provided below in order to calculate the vehicle CG aft of the front axle and left (+) / right (-) from the longitudinal centerline.

Center of Gravity Calculation:

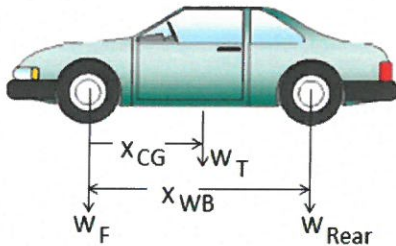

$$X_{CG} = \frac{X_{WB} \times W_{Rear}}{W_{Total}}$$

(From Front Axle)

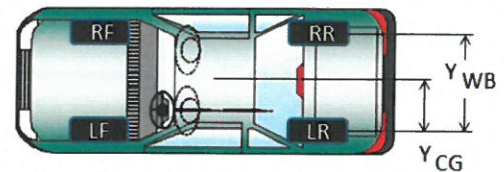

$$Y_{CG} = \frac{Y_{WB} \times W_{Right}}{W_{Total}}$$

(From Left Wheel Centerline)

$$X_{CG} = \frac{X_{WB} \times W_{Rear}}{W_{Total}}$$

824 mm = $\frac{2703 \text{ mm} \times 1234 \text{ kg}}{2403 \text{ kg}}$

$$Y_{CG} = \frac{Y_{WB} \times W_{Right}}{W_{Total}}$$

1605 mm = $\frac{1605 \text{ mm} \times 1177 \text{ kg}}{2403 \text{ kg}}$

Test Vehicle Center of Gravity (CG)	Units	As Tested	
Vehicle CG (Aft of Front Axle)	mm	824	1388 X _{CG} QP
Vehicle CG (Left (+) / Right (-) from Longitudinal Centerline)	mm	16.5	Y _{CG}

Vehicle Verification:

Engineer's Name:	AR	Date:	12/20/22
------------------	----	-------	----------

Complete the following steps before transporting the vehicle to the Crash Hall.

Initial:

- AR Review and verify that all prior sections of this workbook have been completed.
- VJ Review all Pre-Test photos for content, field of view, clarity and exposure.
- AR Conduct a visual inspection of the vehicle to verify that it has been properly prepared. Note: For OEM's verify that the vehicle reflects the customer's statement of work or test request.
- VJ Verify that the SRS light is not illuminated.
- AR Verify Non-struck side airbags have been disabled.
- AR Verify battery voltage is sufficient without charger – Wait 1 minute.
 - 12 Volt or HEV State of Charge
- AR Verify that the vehicle has the proper instrumentation.
- AR Verify that ATD is ready and have the proper instrumentation. Verify tilt sensor is installed in ES-2re.
- AR Electric vehicle SOC check. 100% 8:30 AM 12/20
- VJ Verify that placards have been placed on vehicle and contain up-to-date information.
 - VH Affix large placards to vehicle.
 - VJ Verify that small photograph placards are in test binder with vehicle.

Install Honeycomb

Performed by:	TR	Date:	12/20/22
---------------	----	-------	----------

Instructions: Read through the following instruction PRIOR to measuring the following locations. See reference images on next page.

Exterior MDB Measurements:

The maximum static crush of the MDB's honeycomb face shall be measured pre-test in the longitudinal direction at the following vertical installation height locations (see **Figure 14 Below**):

- (1) Center of Bumper Level = **432 mm** above ground level
- (2) Top of Bumper Level = **533 mm** above ground level
- (3) Mid Level = **686 mm** above ground level
- (4) Top-Stack Level = **813 mm** above ground level

Pre-test measurements are taken (from a reference plane perpendicular to and 1,000 mm from the MDB's longitudinal centerline) across the barrier face at 100 mm intervals at each of the four levels specified.

Initial:







- Take Level 1 measurements every 100 mm (i.e. L1 800ROC to L1 800LOC) – Center of Bumper Level
- Take Level 2 measurements every 100 mm (i.e. L2 800ROC to L2 800LOC) – Top of Bumper Level
- Take Level 3 measurements every 100 mm (i.e. L3 800ROC to L3 800LOC) – Mid Level
- Take Level 4 measurements every 100 mm (i.e. L4 800ROC to L4 800LOC) – Top-Stack Level

MDB Photographic Targets and Tape:

Performed by:	TP	Date:	12/20/22
---------------	----	-------	----------

See reference images on next page.

Initial:

-  Place 25 mm (1 inch) wide yellow/black checkerboard tape along the top of the honeycomb barrier face centerline.
-  Place 25 mm (1 inch) wide yellow/black checkerboard tape along front of the honeycomb barrier face centerline.
-  Place 25 mm (1 inch) wide yellow/black checkerboard tape along the top of the left edge of the honeycomb barrier face, to align with the vertical impact reference line of the test vehicle.
-  Place 25 mm (1 inch) wide yellow/black checkerboard tape along the front of the left edge of the honeycomb barrier face, to align with the vertical impact reference line of the test vehicle.
-  Place two [102 mm diameter (4")] targets on top of the barrier face 400 mm from the barrier centerline.
-  Verify [102 mm diameter (4")] photographic target on the MDB at the rear cross member accelerometer location on the left side of the frame.
-  Verify CG marker and other known location markers are visible and labeled on the MDB in the overhead view.

Align Vehicle & MDB

Performed by:	VIT	Date:	12/20/22
---------------	-----	-------	----------

Initial:

- QR Transport vehicle to South Crash Hall and attach battery charger.
- VA Place placards on vehicle.
- VA Verify that vehicle's tire pressures match the tire pressures listed on the tire placard. If a tire is low, add air and notify Test Engineer.

Tire Pressures	Units	LF	RF	LR	RR
As Tested	kpa	280	280	290	290

Initial:

- VA Position vehicle on the side impact pad along 27 degree line and align with MDB.

Note: When the MDB is properly positioned such that it is contacting the vehicle at the initial point of contact along struck side of the vehicle, strike a plane perpendicular to the ground that is coincident with the MDB impact face and is parallel to the vehicle's longitudinal centerline. Accordingly, this plane should form an angle of 63 degrees (± 0.5 degrees) with the direction of forward motion of the MDB.

- VA Mark the floor at this location. This line should extend past the front and rear of the vehicle when it is properly positioned.

- VA Hold vehicle in place with parking brake.
- VA Place automatic transmission in NEUTRAL, manual in SECOND gear
- AR Check if vehicle attitudes fall into test range. (If attitude is lower than fully loaded condition, vehicle wheels may need to be momentarily lifted off ground)
- AR Attach plumb bobs to center of front and rear vehicle bumpers.
- CA Mark cement beneath vehicle plumb bobs
- VA Re-attach battery charger to vehicle.
- VA Attach sharpened welding rod along the left side vertical surface of the honeycomb barrier in the horizontal plane level with the mid-door of the test vehicle (Level 3 target). Welding rod shall be positioned and attached with duct tape so as to contact the test vehicle body sheet metal during pre-test setup when MDB is positioned against the side of the test vehicle. The tip should be located in the center of the target.

Continued on next page.

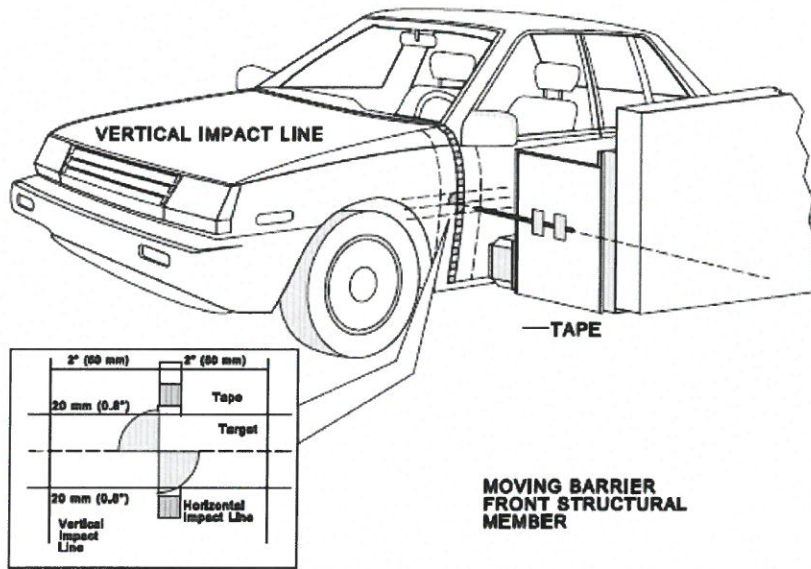

Initial:

VH Place inch tape on barrier sides at H-point level

MA Measure and record the vertical height of level 3 impact targets

Left Side: MA mm

VH Check speed trap and barrier release distance

VH Locate camera trigger on floor

VH Confirm welding rod will not contact trigger first.

VH Inspect and take the necessary steps so that the Crash Hall is neat, clean, and arranged in an orderly manner.

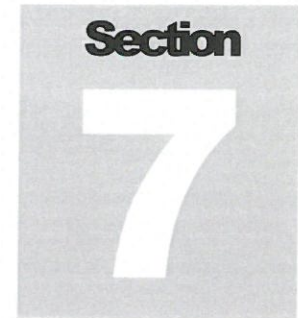

High Speed Camera Set-Up

Camera Set-up:

Performed by: TB Date: 12/20/2022

General Requirements:

High-speed digital cameras that operate at a minimum speed of 1000 frames per second (fps) for at least 10 ms before the vehicle contacts the barrier and for at least 300 ms after the vehicle contacts the barrier.

Glare or lights showing on any glass area (closed windows or vents) must be minimized so that views of the dummies during the test are visible for video analysis.

A time zero (T(0)) impact event marker (flash or strobe unit) to indicate when the test vehicle contacts the barrier must be present in each high speed video camera view.

The test laboratory's name or logo shall not appear in any high-speed videos. Note that for the real time, the test laboratory's name shall only appear in the documentary real-time video as part of the title frame.

Locate the following cameras and set field of view:

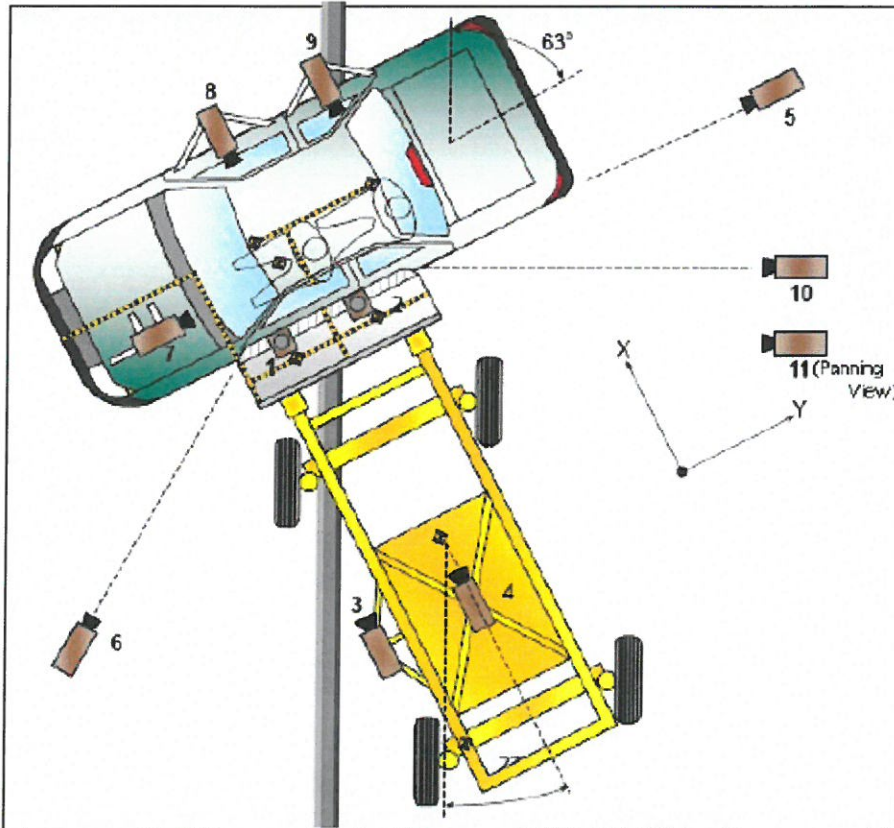

Camera 1: Overhead Wide View: High-Speed overhead camera to view target vehicle dynamics and positioned directly above the impact plane between the target vehicle and the MDB.

- TB Establish field of view (FOV); start w/ **12.5 mm** lens.
- TB Confirm placards & strobe are in FOV.
- TB Focus camera
- TB Record Camera's Unique Identifier:
10-1018-1000

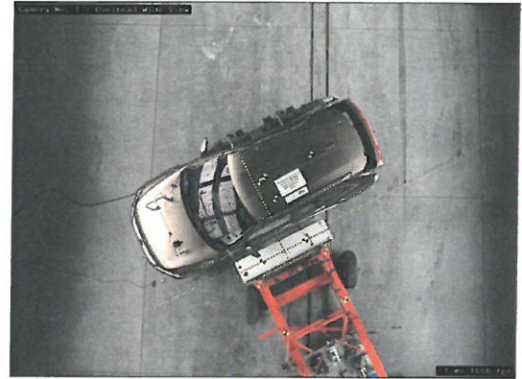

Camera 2: Overhead Close-Up View: A high-speed overhead camera to provide close-up view of the impact plane (should include view of photograph targets on centerline of test vehicle and photograph targets on top of MDB barrier face) and positioned adjacent to Camera No.1.

- TB Establish field of view (FOV); start w/ **24 mm** lens.
- TB Confirm placards & strobe are in FOV.
- TB Focus camera
- TB Record Camera's Unique Identifier:
10-0517-0014

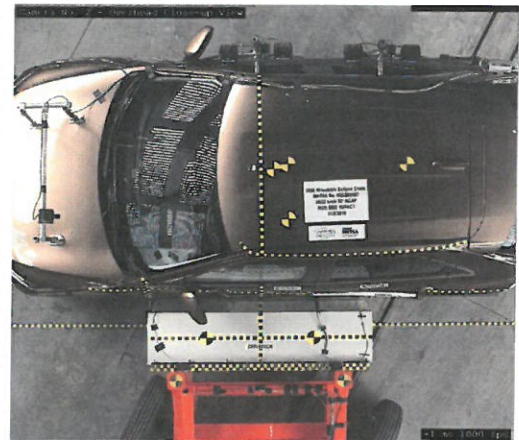

Camera 3: Impact Point: A high-speed digital camera positioned along the impactor's face left vertical edge to cover target vehicle impact point during side impact event. The initial contact between the tip of the welding rod and test vehicle

Shall be recorded by Camera No. 3.

- TB Establish field of view (FOV); start w/ **25 mm** lens.
- TB Confirm placards & strobe are in FOV.
- TB Focus camera
- TB Record Camera's Unique Identifier:
10-1018-1011

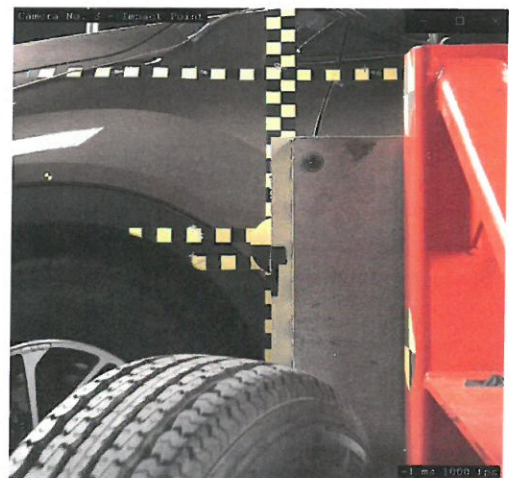

Camera 4: Struck-Side View at Impact: A high-speed digital camera, positioned on MDB's centerline to view struck side of test vehicle during the side impact event.

- TB Establish field of view (FOV); start w/ **8** mm lens.
- TB Confirm placards & strobe are in FOV.
- TB Focus camera
- TB Record Camera's Unique Identifier:
10-1018-0993

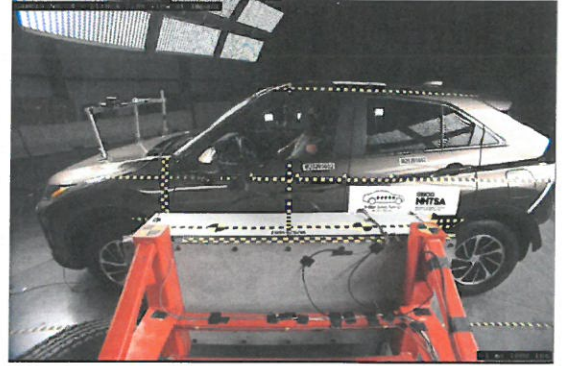

Camera 5: Rear Impact View of Struck Side: A high-speed right side view camera to cover both the MDB and the target vehicle during the side impact event.

- TB Establish field of view (FOV); start w/ **28** mm lens.
- TB Confirm placards & strobe are in FOV.
- TB Focus camera
- TB Record Camera's Unique Identifier:
10-1018-1015



Camera 6: Front Oblique Impact View of Struck Side: A high-speed left side view camera to cover the motion of the target vehicle after impact.

- TB Establish field of view (FOV); start w/ **24** mm lens.
- TB Confirm placards & strobe are in FOV.
- TB Focus camera
- TB Record Camera's Unique Identifier:
10-1018-7010



Camera 7: Driver Dummy Front View (Onboard): A high-speed camera to provide front view of the front dummy through the vehicles windshield from above the engine compartment. (Should be sufficiently raised above the hood structure and positioned such that it shows not only curtain air bag deployment in relation to the dummy's head, but also torso air bag deployment in relation to the dummy's chest, if applicable.)

- TB Establish field of view (FOV); start w/ 25 mm lens.
- TB Confirm placards & strobe are in FOV.
- TB Focus camera
- TB Record Camera's Unique Identifier:
10-1118-1033
- TB Verify all mounts and piping have been pinned and secured.



Camera 8: Driver Dummy Side View (Onboard): A high-speed camera to view across the test vehicle's occupant compartment to record the lateral motion of the front dummy during and after side impact.

- TB Establish field of view (FOV); start w/ 12.5 mm lens.
- TB Confirm placards & strobe are in FOV.
- TB Focus camera
- TB Record Camera's Unique Identifier:
10-1118-1034
- TB Verify all mounts and piping have been pinned and secured.

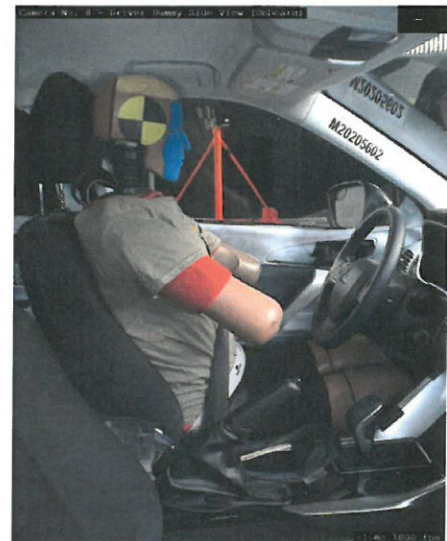

Camera 9: Rear Passenger Dummy Side View (Onboard): A high-speed camera to view across the test vehicle's occupant compartment to record the lateral motion of the rear dummy during and after side impact.

- TB Establish field of view (FOV); start w/ 12.5 mm lens.
- TB Confirm placards & strobe are in FOV.
- TB Focus camera
- TB Record Camera's Unique Identifier:
10-1218-1044
- TB Verify all mounts and piping have been pinned and secured.



Camera 11: Real-Time Pan View of Impact: Real-time (24-30 fps) camera to provide the following pre-test, test, and post-test coverage.

- TB Establish field of view (FOV).
- TB Confirm placards & strobe are in FOV.
- TB Focus camera (Focus on ATD's and not placards)
- TB Record Camera's Unique Identifier:
Panasonic 7



Camera Location - Data Sheet:

Performed by: TB Date: 12/20/2022

Camera Locations:

No.	Camera View	Location			Lens (mm)	Operating Frame Rate
		X (mm)	Y (mm)	Z (mm)		
1	Overhead Overall	0	313	-8419	12.5	1000
2	Overhead Close-Up	0	0	-8510	28	1000
3	Impact Point Close-up (MDB)				25	1000
4	Centerline of Impact (MDB)				8	1000
5	Right Side View	0	10709	-1501	28	1000
6	Left Side View	-4609	-6454	-1532	28	1000
7	Front Seat Occupant – Frontal View (OB)				25	1000
8	Front Seat Occupant – Side View (OB)				12.5	1000
9	Rear Passenger – Side View (OB)				12.5	1000
10	Real Time Coverage				Variable	30
Measuring Device Unique Identifier:		Fluke 416D				

*COORDINATES

Specifically, the X and Y coordinates shall reference the designated impact point on the target vehicle's struck side and the Z coordinate shall reference the ground (+X = forward of impact, +Y = right of impact, +Z = Down). The coordinate system shall be aligned with the test vehicle's struck side.

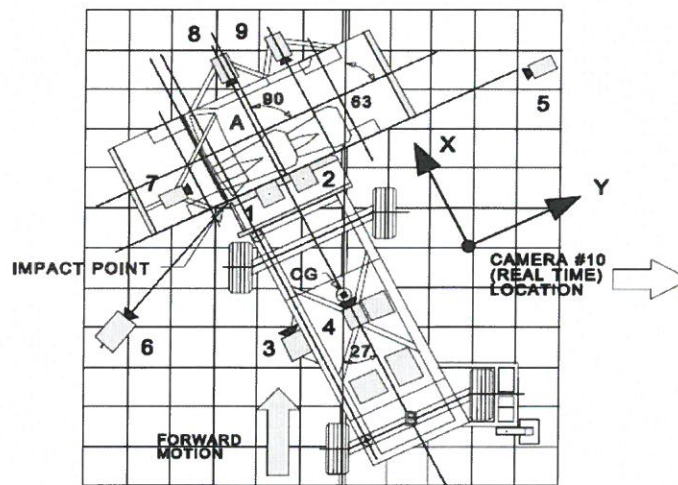

Camera Control Software

Performed by:	TB	Date:	12/20/2022
---------------	----	-------	------------

Instructions: Verify the following software settings and functions are correct

Initial:

- TB Appropriate software exposure settings (determined during exposure setup with overhead lights on)
- TB Color balance and check corrections (performed during exposure setup with overhead lights on)
- TB Pre and post-trigger recorded frames – minimum 10 pre-trigger, 300 post-trigger
- TB Record mode is 'circular', trigger configuration is 'SWC'
- TB Trigger checks are performed and all cameras trigger properly
- TB Auto download is activated and set to download to correct file path on control PC
- TB After all configuration settings are set, camera configuration is saved
- TB Download to SD card on camera

Section
8

Test Set-up & Execution

Data Acquisition Software Setup:

Performed by:

SIC

Date:

12/20/22

Initial:

SIC

Verify signals from critical channels are operational and reasonable BEFORE installing ATD.

Yes No

SIC

Verify firing of airbag(s) with customer, or monitoring and confirm timing pretensions.

SIC

Load the Crash Test Plan.

SIC

Verify Test Plan has been reviewed by process engineer and customer.

Process Engineer
Approval:

DM

Date:

12/19/22

SIC

Place copy of Test Plan after this page for reference.

SIC

Verify dummies are attached to data acquisition boxes and are grounded.

SIC

Verify crash link cables are installed.

SIC

Verify communication cables are attached to the vehicle.

SIC

Verify wireless box is communicating with DAU's

SIC

Verify KT interface shows 30-36 volts at the vehicle.

Record Vehicle 1 Voltage 30

Record Vehicle 2 Voltage: 30

SIC

Verify KT data channels CAC's and polarities.

SIC

Add the ES-2re, SID-IIs, Vehicle, and Mobile Deformable Barrier assemblies to the Signals tab.

SIC

Verify vehicle is communicating with DAU's.

SIC

Verify mobile deformable barrier is communicating with DAU's.

SIC

Select Auto-ID from the Signals tab and verify there are no transducers identified.

SIC

Perform electrical check on Signals tab and verify there are no errors.

Record Number of Channels: _____

SIC

Perform electrical check on Samplers tab and verify there are no errors.

SIC

Record Vehicle DAU Serial Numbers: OTS _____

SIC

Record Mobile Deformable Barrier DAU Serial Number: OTS

SIC

Perform electrical check on Triggers tab to test the trigger and verify there are no errors.

SIC

Tie down umbilicals and verify adequate cable slack.

Pre-Test Photos & Video Prior to Seating:

Performed by: JH Date: 12-20-22

Note: Clear and properly focused digital still photographs in .jpg format with a minimum dots-per-inch (DPI) of 180 shall be taken. A vehicle information placard placed parallel with the camera, identifying the test vehicle model as well as the barrier and NHTSA number, along with an indication of whether the photo was taken pre-test shall appear in each photograph and be legible. All photographs must be in landscape view / orientation. Glare or light from any illuminated or reflective surface shall be minimized while taking photographs. Reference sample photo set.

Initial: JB **Video of MDB:**
Overhead View of MDB

Initial: JH **Photos of Vehicle against Barrier:**
No. 15 – Pretest Overhead View of MDB Positioned Against Impact Side of Test Vehicle at Impact Location.
JH Move MDB back from vehicle and then take below photos and real time video.

Initial: JH **Photos of MDB:**
JH No. 7 – Pretest Frontal View of Impactor Face
JH No. 13 – Pretest Top View of Impactor Face
JH No. 9 – Pretest Left Side View of Impactor Face
JH No. 11 – Pretest Right Side View of Impactor Face

Initial: JB **Video of MDB**
JB Left side view of MDB
JB Right side view of MDB
JB Front view of MDB

Initial: JH **Vehicle Surrounds**
JH No. 1 – Pretest Frontal View of Test Vehicle
JH No. 5 – Pretest Impacted Side View of Test Vehicle
JH No. 3 – Pretest Rear View of Test Vehicle

Initial: JH Move MDB to start position, attach tow and abort cables and check onboard abort.

Positioning SID-IIs in Rear Left Position:

Performed by:

VH

Date:

12/20/22

Initial:

VH

1. Set the seat at rearmost fore/aft position, lowest height at mid-angle

VH

1.1 Using the control that primarily moves the seat fore and aft, move the **SCR**P to the rearmost position.

VH

1.2 If the seat or seat cushion height is adjustable, other than by the controls that primarily move the seat or seat cushion fore and aft, set the height of the **SCR**P to the lowest height, with the **SCR**L set as closely as possible to the mid-angle.

VH

N/A The seat is not adjustable.

VH

1.3 Fully recline the seat back

VH

N/A The seat back does not adjust.

VH

3. Place the test dummy in the seat

Position the dummy in the seat such that the midsagittal plane is coincident with the longitudinal centerline markings on the seat cushion, seat back and head restraint. Place the dummy in the seat with the legs at an angle of 120° to the thighs. The calves should not be touching the seat cushion.

VH

4. Hold down the dummy's thighs and push rearward on the upper torso to maximize the pelvic angle.

VH

5. Set the angle between the legs and the thighs to 120°.

VH

6. Set the transverse distance between the centers of the front of the knees at 160 to 170 mm. (6.3 to 6.7 inches). Center the knee separation with respect to the longitudinal centerline markings of the seat cushion

VH

Record Knee Separation 165

VH

7. Push rearward on the dummy's knees until the pelvis contacts the seat back, or the backs of the calves contact the seat cushion, whichever occurs first.

X

Pelvis contacted seat back.

Calves contacted seat cushion.

VH

8. Gently rock the upper torso $\pm 5^\circ$ arc (approximately 51 mm (2 inches)) side-to-side three times.

VH

9. If needed, extend the legs until the feet do not contact the floor pan. The thighs should be resting on the seat cushion.

VH

10. With the feet perpendicular to the legs, place the heels on the floor pan. If a heel will not contact the floor pan, place it as close to the floor pan as possible.

VH

11. For vehicles without adjustable seat backs, adjust the lower neck bracket to level the head as much as possible. For vehicles with adjustable seat backs, while holding the thighs in place, rotate the seat back forward until the transverse instrumentation platform of the head is level to within $\pm 0.5^\circ$, making sure that the pelvis does not interfere with the seat bight.

4th detent

- VH 12. If it is not possible to orient the head level within $\pm 0.5^\circ$ minimize the angle.
- VH 13. Measure and set the dummy's pelvic angle using the pelvic angle gauge. The angle is set to $20.0^\circ \pm 2.5^\circ$. If this is not possible, adjust the pelvic angle as close to 20.0° as possible while keeping the transverse instrumentation platform of the head as level as possible. 20.8
- VH 14. Passenger foot positioning
- VH 14.1 Place the passenger's feet flat on the floor pan.
- VH 14.2 If the either foot does not contact the floor pan, place the foot parallel to the floor and place the leg as perpendicular to the thigh as possible.
- VH 15. **Passenger arm/hand positioning**
Place the rear dummy's upper arm such that the angle between the projection of the arm centerline on the midsagittal plane of the dummy and the thoracic spine centerline is $45^\circ \pm 5^\circ$.
- VH 16. **Seatbelt Placement**
Place the seatbelt around the test dummy and fasten latch.
- VH Belt in cabling / umbilicals

Positioning ES-2re Male in Driver Position

Performed by:

AR, VH

Date:

12/26/22

Initial:

AR 7. Place the test dummy in the seat

AR 7.1 Move the seat and seat back rearward as necessary to get the test dummy in the seat.

AR 7.2 Position the test dummy in the seat such that its plane of symmetry (i.e., mid-sagittal plane) is coincident with the longitudinal centerline marking on the seat cushion, seat back and head restraint.

AR 7.3 Bend the upper torso forward and then lay it back against the seat back. Push the shoulders of the dummy fully rearward.

AR 7.4 Remove the foam blocks from the pelvis flesh.

AR 7.5 Position the dummy so that it sits square and level in the seat.

AR 7.6 Repeat steps 1 thru 1.3 within "1st Row Seat Positioning – Setting Seats" to set the seat at the mid-fore aft position

AR 7.7 Maneuver the dummy's pelvis until the M3 hole on its back plate is within a circle with a radius of 10 mm round the H-point location (x,z) determined by the H-point machine.

AR 7.8 Position the pelvis of the dummy such that a horizontal (lateral) line passing through the dummy's hip pivot center is perpendicular to the longitudinal center plane of the seat.

AR 7.9 Measure the angle using the tilt angle sensor installed in the test dummy. Verify that the line through the dummy's hip pivot center is horizontal with a maximum inclination of $\pm 2^\circ$.

AR 7.10 Is the pelvis tilt angle within spec. $\pm 2^\circ$?

AR Yes - Record the tilt angle and measure and record the X and Z location of the dummy's hip pivot center on the chart below;

Dummy hip pivot center location	
Tilt Angle	27.5 °
X(fore/aft) of striker	185 (mm)
Z(above/below) striker	133 (mm)

-0.3° left

AR No, go back to step 7.2 and repeat steps to re-adjust the position of the test dummy.

AR Proper position cannot be achieved, contact COTR immediately.

AK 7.11.1 **Foot Placement - For test dummy placed in driver seating position**

AK 7.11.2 Without inducing pelvis or torso movement, place the right foot of the dummy on the un-pressed accelerator pedal with the heel resting as far forward as possible on the floor pan.

AK 7.11.3 Set the left foot perpendicular to the lower leg with the heel resting on the floor pan in the same lateral line as the right heel.

AK 7.11.4 If possible within these constraints, place the thighs of the dummy in contact with the seat cushion.

AK 7.12 **Arm Placement**

Place the dummy's upper arms such that the angle between the projection of the arm centerline on the mid-sagittal plane of the dummy and the torso reference line is $40^{\circ} \pm 5^{\circ}$.

AK 8. **Seatbelt Placement**

Place the seatbelt around the test dummy and fasten latch.

SK Belt in Cabling / umbilical's

AK Affix targets, labeled appropriately (if applicable) to the front door or side panel to denote the hip pivot center of the test driver and rear passenger dummy. Use a 100 mm (4 inch) diameter target and label with "HP".

Dummy Measurement:

Performed by:	VH, AR	Date:	12/20/20
---------------	--------	-------	----------

Initial:

AR Once the dummy is properly positioned, and the seat belt has been fastened over the dummy's chest, align a 150 mm (6-inch) segment of yellow/red checkerboard tape with the outboard edge of the shoulder belt portion of the seat belt such that it will be visible in Camera View No. 11.

VH Place a second 150 mm (6-inch) segment of yellow/red checkerboard tape on the dummy's chest such that it is aligned with the first segment that was placed along the outboard edge of the shoulder belt. The two checkerboard tape segments should be cut and positioned such that the colors for each square-inch section alternate on either side of the edge of the shoulder belt.

VH, AR Record the final position of the dummy after it is seated in the test vehicle by taking the measurements indicated on the next page (accurate to ± 3 mm).

Tape Measure Unique Identifier:

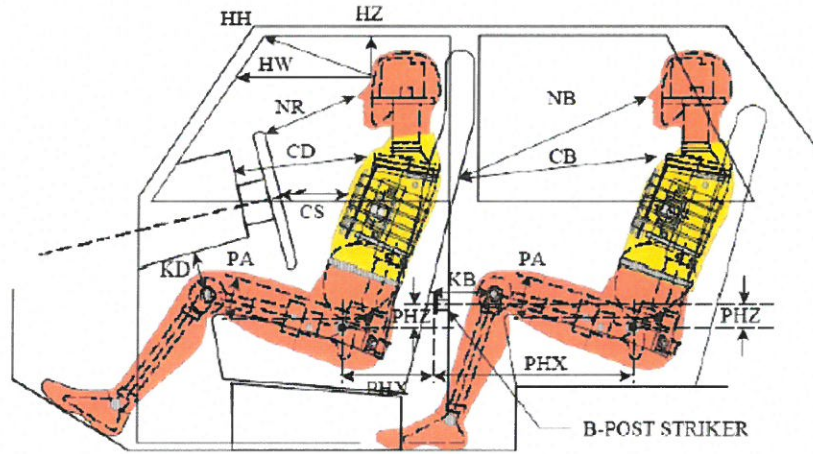

LEFT SIDE VIEW

NOTE: 2-DOOR VEHICLE SHOWN. REAR DUMMY PHX & PHZ MEASUREMENTS FOR A 4-DOOR VEHICLE WOULD USE THE C-POST STRIKER AS A REFERENCE POINT

HH HEAD TO HEADER – Measure the distance from the point where the dummy's nose meets his forehead (between the eyes) to the furthest point forward on the header.

HW HEAD TO WINDSHIELD – Measure the distance from the point where the dummy's nose meets his forehead (between the eyes) to a point on the windshield directly in front of it. Use a level or plumb-bob.

HZ HEAD TO ROOF LINER – Measure the distance from the point where the dummy's nose meets his forehead (between the eyes) to the point on the roof directly above it. Use a level or plumb-bob.

NR NOSE TO RIM – Measure the distance from the tip of the dummy's nose to the closest point on the top of the steering wheel rim.

CD CHEST TO DASHBOARD – Place a tape measure on the tip of the dummy's chin and rotate 125 mm of it downward toward the dummy to the point of contact on the transverse center of the dummy's chest. Mark this point with a 25 mm (1 inch) diameter target. Measure the distance from this point to the closest point on the dashboard either between the upper part of the steering wheel between the hub and the rim, or measure to the dashboard placing the tape measure above the rim, whichever is a shorter measurement.

CS CHEST TO STEERING WHEEL – Measure the distance from the center of the steering wheel hub to the dummy's chest. Use a level. Mark this location on the dummy's chest with a 25 mm (1 inch) diameter target.

KDL/KDR LEFT AND RIGHT KNEES TO DASHBOARD – Measure the distance from the center of the knee pivot bolt's outer surface to the closest point forward acquired by swinging the tape measure in continually larger arcs until it contacts the dashboard.

KDAL/KDAR KNEE TO DASHBOARD ANGLE – Using the line representing the length measurement of the knee to the dashboard above, measure the angle between that line and the horizontal.

PAX PELVIC TILT ANGLE (X) – Measure by inserting the pelvic angle gauge into the Hip Point gauging hole (actual pivot center of the dummy's torso and thighs) on the dummy and taking this angle with respect to the horizontal. Alternatively, record the pelvic tilt angle X measured by tilt sensors installed in the test dummy.

PAY PELVIC TILT ANGLE (Y) – Measure by inserting the pelvic angle gauge into the Hip Point gauging hole (actual pivot center of the dummy's torso and thighs) on the dummy and taking this angle with respect to the vertical. Alternatively, record the pelvic tilt angle Y measured by tilt sensors installed in the test dummy.

PHX HIP POINT TO STRIKER (X) – Locate a point on the front door striker and project this point (with a level) vertically downward. Measure the distance horizontally from the pivot center of the dummy's torso and thigh to the point it intersects with the level.

PHZ HIP POINT TO STRIKER (Z) – Locate a point on the front door striker and project this point (preferably, with a level) horizontally toward the pivot center of the dummy's torso and thigh. Measure the distance vertically from the pivot center of the dummy's torso and thigh to the point it intersects with the level.

Note: The B-pillar striker will be used as the reference point for PHX & PHZ measurements.

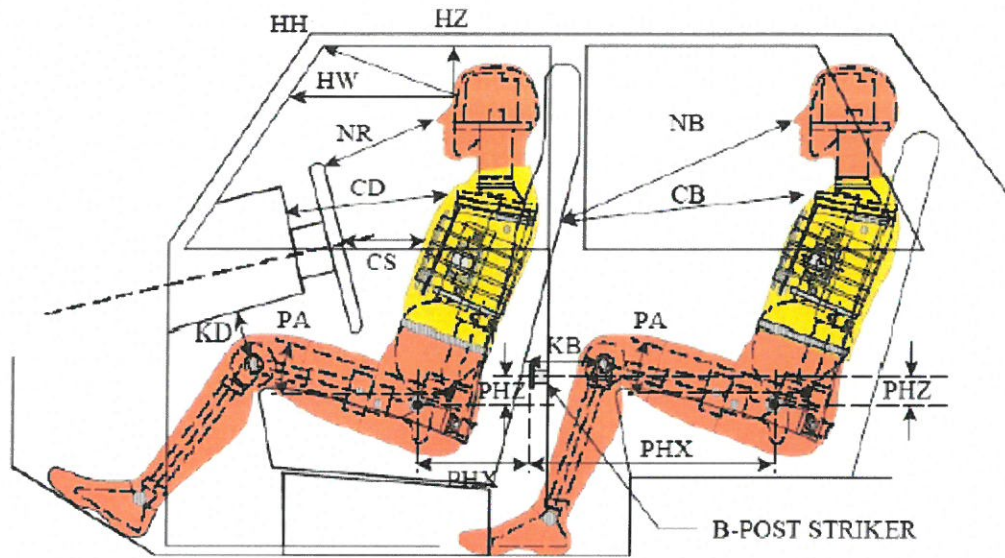

LEFT SIDE VIEW

NOTE: 2-DOOR VEHICLE SHOWN.
REAR DUMMY PHX & PHZ
MEASUREMENTS FOR A 4-DOOR
VEHICLE WOULD USE THE C-POST
STRIKER AS A REFERENCE POINT

Code	Measurement Description	ATD Driver Unique Identifier: <u>1037</u>		ATD Passenger Unique Identifier: <u>261</u>	
		Length (mm)	Angle (°)	Length (mm)	Angle (°)
HH	Header to Header	405			
HW	Head to Windshield	646			
HZ	Head to Roof Liner	163		310	
NR	Nose to Rim / Seat	503		530	
CD	Chest to Dashboard	607		523	
CS	Chest to Steering Wheel	409			
KDL/KDAL°	Left Knee to Dash	203	39.4	260	10.8
KDR/KDAR°	Right Knee to Dash	151	54.3	259	13.4
PAX°	Pelvic Tilt Angle (X-axis)		26.9		20.0
PAY°	Pelvic Tilt Angle (Y-axis)				0.3
PHX	Hip Point to Striker (X-Axis)	185		201	
PHZ	Hip Point to Striker (Z-axis)	133		245	

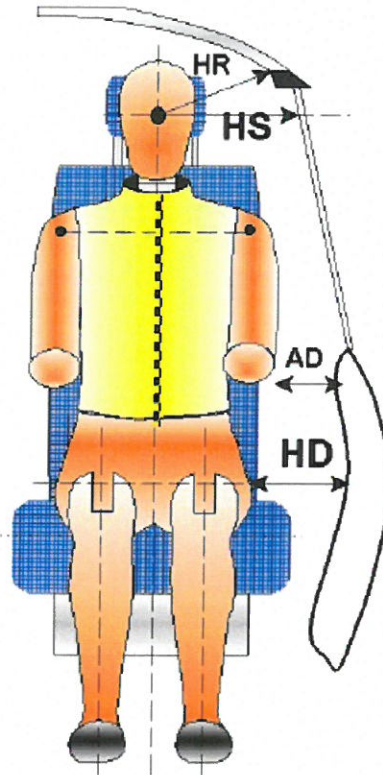

Code	Measurement Location	Units	Driver	Rear Passenger
HR	Head to Side Header	mm	198	272
HS	Head to Side Window	mm	350	390
AD	Arm to Door	mm	105	160
HD	Hip Point to Door	mm	228	195

HR HEAD TO SIDE HEADER – Measure the shortest distance from the point where the dummy's nose meets his forehead (between the eyes) to the side edge of the header just above the window frame, directly adjacent to the dummy.

HS HEAD TO SIDE WINDOW – Measure the distance horizontally from the point where the dummy's nose meets his forehead (between the eyes) to the outside of the side window. In order to take this measurement, roll the window down to the exact height that allows a level measurement. Use a level.

AD ARM TO DOOR – Measure the distance from the center of the bottom of the outboard arm segment where it meets the driver or passenger dummy's torso to the closest point on the door.

HD HIP POINT TO DOOR – Project a point horizontally from the pivot center of the dummy's torso and thigh, outward to the edge of the pelvis plug. Measure the distance horizontally from this point to the closest point on the door panel. Use a level.

Inch Tape, Cables & Chalking:

Performed by:	VH CH	Date:	12/20/22
---------------	-------	-------	----------

Initial:

sk Check cable routing. Take precaution to ensure that cable bundle is routed over the front seat armrest/console such that it allows sufficient slack and does not preclude or restrict dummy movement during impact. Duct tape may be used to secure the cable bundle to the front seat armrest/console to prevent cable damage, and to permanently set the necessary amount of slack.

sk Belt in cabling / umbilical's.

sk Zip tie down cabling in trunk.

VH Place inch tape on the dummy chest and shoulder belt in order to show the belt pretensioner deploy during the impact event.

VH, CH Chalk ATD(s)

Parts of the anthropomorphic testing devices shall be coated with colored chalk/water solutions to show contact points with the vehicle's interior, with their own components (such as head to knee contact), and with each other. The chalk/water solution shall be applied after final dummy positioning.

Note: Face chalk should extend below the chin.

Dummy Part	Driver
Face (Do not paint sides)	Blue
Top of Head (Stop painting at skull cap)	Yellow
Outer Side of Head	Green
Back of Head (skull cap)	Red
Outer Shoulder	Orange
Outer Hip	Red



Dummy Part	Color
Face	Blue
Top of Head	Yellow
Side of Head	Green
Back of Head	Red
Shoulder	Orange
Hip	Red

Attitude - As Tested Condition:

Performed by:	AR+CM	Date:	12/20/22
---------------	-------	-------	----------

Initial:

AR

With the vehicle in the "As Tested" weight condition, place it on a flat, level surface.

Note: If the vehicle has an Auto-Leveling, the ignition must be set to the "on" position. If the vehicle is equipped with a self-adjusting hydraulic system, contact the COTR for further guidance on attitude measurements.

AR

Verify that the "As Tested" vehicle attitude measurements are equal to or between the "As Delivered" and "Fully Loaded" vehicle attitude measurements. If any "As Tested" attitude measurements do not meet this requirement, adjust the load by shifting ballast, instrumentation, and/or cameras. If, after repeating these steps, any of the "As Tested" attitude measurements do not meet the requirement, contact the Technical Director.

Note: The "As Tested" vehicle attitude measurements **shall be taken within an hour of impact** to ensure the proper attitude is met.

Test Vehicle Attitudes and CG	Units	Fully Loaded	As Tested	Meets Requirements ***	
				Yes	No
Left Front	mm	831	834	✓	
Right Front	mm	834	835	✓	
Right Rear	mm	846	845	✓	
Left Rear	mm	844	850	✓	
Vehicle CG (Aft of Front Axle)	mm	1388			
Vehicle CG (Left+)/Right(-) from Longitudinal Centerline)	mm	23.5			

*** The "As Tested" vehicle attitude measurements must be equal to or within +/- 10 mm of the "Fully Loaded" vehicle attitude measurements at each wheel well.

Pre-Test Photos:

Performed by:

JH

Date:

12-20

Note: Clear and properly focused digital still photographs in .jpg format with a minimum dots-per-inch (DPI) of 180 shall be taken. A vehicle information placard placed parallel with the camera, identifying the test vehicle model as well as the barrier and NHTSA number, along with an indication of whether the photo was taken pre-test shall appear in each photograph and be legible. All photographs must be in landscape view / orientation. Glare or light from any illuminated or reflective surface shall be minimized while taking photographs. Reference sample photo set!

Initial: Photos With Driver Positioned in Vehicle

JH

No. 17 – Pretest Front SID in Final Seating Position (Door Open)

JH

No. 18 – Pretest Front SID in Final Seating Position (Door Closed)

JH

No. 19 – Pretest Front SID – Opposite Side View

JH

No. *21 – Pretest Rear SID in Final Seating Position (Door Open)

JH

No. 22. – Pretest Rear SID in Final Seating Position (Door Closed)

JH

No. 23. – Pretest Rear SID – Opposite Side View

* - Applies to vehicles with 4 or more side doors

Pre-Test Video:

Performed by:

TB

Date:

12/20/22

A real-time camera (24-30 fps) shall be used to document the pre-test and post-test condition of the test vehicle in addition to the pre-test and post-test positions of the test dummies, including, but not limited to, the placement of the lap and shoulder belts. Particular attention must be exercised to fully document the proper closing of all vehicle doors, including any rear hatchback or tailgate.

Initial: Videos of Vehicle

TB Impact side view of vehicle

TB Rear view of vehicle

TB Non-impact side view of vehicle

TB Front view of vehicle

TB View of gas cap being attached to filler pipe

Initial: Videos of Dummy Position (including, placement of lap and shoulder belt on the dummy)

TB Side View of ES-2re in front seat (struck-side door open)

TB Side view of SID-IIs in rear seat (struck-side door open)

TB Side view of ES-2re in front seat (doors closed)

TB Side view of SID-IIs in rear seat (doors closed)

Review Post-Test Assignments with Staff:

Performed by:	VH+AR	Date:	12/20/22
---------------	-------	-------	----------

Initial:

VH

Review with the Staff their post-impact order of events and assignments.

While the Test Engineer is taking post-test photos, the following personnel need to be completing the following tasks. During this time, please make sure customers are staying in the observation room and that each one of you stay clear in order not to be photographed. Furthermore, no instrumentation or equipment shall be removed from the test vehicle at this time. Assignments are as follows:

- Camera Personnel – Need to be downloading high speed video and verifying that acceptable video was captured by all cameras.
- Data Personnel – Need to download all instrumentation data and identify questionable and lost channels.
- Facility Personnel – Need to have equipment in hand to capture any Stoddard leaks.

Once the Test Engineer has informed the Staff that post-test photos have been taken. Assignments are as follows:

- Camera Personnel – Check and document any type of equipment damage. If video was lost or is of poor quality, inspect equipment and identify root cause. Please document all findings.
- Data Personnel – For any questionable and lost channels, inspect cabling and instrumentation to identify root cause. Please document findings.
- Facility Personnel – Clean up impact area.

Verify Vehicle & Set-Up / Go / No-Go:

Performed by:	VH	Date:	12/20/22
---------------	----	-------	----------

Initial:

- VH Review workbook for completeness
- VH Remove head level from ATD
- VH Verify plumb bobs have been removed from vehicle
- VH Verify Non-struck side airbags have been disabled
- VH Seat Belt Guides – Usage of seat belt guides should be in accords with instructions included in the vehicle owner’s manual or in Form No. 1.
- VH Adjustable Armrests – Place any adjustable armrest in the retracted position.
- VH Accelerator Pedal – If the vehicle has an adjustable accelerator pedal, adjust it to the full forward position.
- VH Doors – Place all doors (including a hatchback or tailgate) in the fully closed and latched position. Check instrument panel telltales just prior to the test to ensure that all doors and hatches are closed. **In all instances, all side doors should be unlocked pre-test.**
- VH Door Locks – Verify that the locks on *all side doors* are unlocked.
- VH Floor Mats - If the vehicle is equipped with optional all-weather (rubber) floor mats, remove them from prior to test. If the vehicle is equipped with carpeted floor mats, or if all-weather floor mats are standard equipment, place them in their proper locations prior to test.
- VH Windows - Verify that the driver and passenger front windows are in the fully closed position. Verify that all other windows and vents in the fully closed position unless otherwise specified by the COTR.
- VH Transmission Engagement:
 1. Manual Transmission – Place manual transmissions in neutral.
 2. Automatic Transmission – Place automatic transmissions in neutral.
- VH Parking Brake Engagement – Engage the parking brake.
- VH Verify speed traps are reset. (Primary and Secondary)
- VH Confirm fuel collectors are ready at the barrier.
- VH Escort customer to Observation Room – explain to them that they need to stay in the Observation Room until the Test Engineer comes to get them (at minimum, until after the post-test photos have been taken).
- VH Verify tow skate attached to tow hooks (visual inspection).

Run in Park
approved by
NHTSA + OEM

- N/A Disconnect battery charger. Verify vehicle battery power is sufficient without charger on (wait 1 minute then should have at least 12.75 volts and stable).
- VH Turn real time cameras on.
- VH Verify cameras are Armed and ready.
- VH Ignition Switch –
Place the key in the ignition and switch it to the “ON” position and have SRS light observed by visitor. Check to ensure that the “Airbag Readiness Indicator” shows the airbag system as being functional. If it is a PUSH start vehicle, test must be conducted in 5 min from “Key on”.
- VH If there is any delay over 5 minutes, verify SRS light is still OK.
- VH Verify tow operator has completed their checklist.
- VH Verify impact speed.

Initial:

- VH Trigger Check
- VH Abort Check.
- VH Speed Trap Check
- VH Verify Speed Trap Location
- VH Safety Check
- VH Reviewed all sections of this binder for completeness.
- VH Facility Ready for Test

<input checked="" type="radio"/>	READY for test	Date:	12/20/22
<input type="radio"/>	NOT READY to be tested		

<input type="radio"/>	Corrections made now READY for test	Date:	
<input type="radio"/>	NOT READY for test		

OEM Inspection of Set-up:

Performed by:	VIA	Date:	12/20/22
---------------	-----	-------	----------

Initial:

- Setup real time cameras on both sides of vehicle [Lens must be pointed toward ATD].
- Turn on cameras and start recording.
- Get OEM and notify them that they have 35 minutes to inspect dummy positioning.
- Escort OEM to conference room immediately after dummy positioning inspection.

Tow System & DAS Checklist:

Tow Engineer's Name:	Dave	Today's Date:	12/20/22
DAS Engineer's Name:	Steve	Today's Date:	12/20/22

Reference VERF Drive Operation Steps:

Please place copy of associated documentation following this page.

Reference VERF DAS Operation Steps:

Please place copy of associated documentation following this page.

Note Speed Requirement: 52.9 kph ± 0.8 kph

Impact Speed:

Performed by:	CH + TB	Date:	12/20/22
---------------	---------	-------	----------

Initial:

WX Remind the DAS operator to look over the Quick Look to determine whether data is near its limits or not. If yes, the operator should look at the traces (i.e. spike or wave form). If a redundant exists, the redundant data should be reviewed to determine whether its traces are the same or different. If it is determined that something is not right with the primary, the operator should use the redundant in the Quick Look and to include a note in the comments section that the redundant was used.

CH Immediately after impact, record the time of impact in the space provided below.

TB Photograph speed trap read-out and record values in the space provided below.

Time of Impact:

11:05 AM

Vehicle Speed Trap Readout (Primary):

52.76	kph	Primary
-------	-----	---------

52.80	kph	Redundant
-------	-----	-----------

Trap Location (from barrier)	mm	close
------------------------------	----	-------

Speed Trap Unique Identifier:	400432
-------------------------------	--------

Vehicle Speed Trap Readout (Secondary):

52.77	kph	Primary
-------	-----	---------

52.83	kph	Redundant
-------	-----	-----------

Trap Location (from barrier)	mm	away
------------------------------	----	------

Speed Trap Unique Identifier:	4009169
-------------------------------	---------

Impact Location:

Performed by: VH+CH Date: 12/20/22

Initial:

VH

With the vehicle in the "As Tested" weight condition, place it on a flat, level surface.

Impact Location:

404 mm Actual impact point (aft of front axle)

7 mm to Right (Left) (Circle One) – must be within ± 50 mm (+ Forward / - Rearward)

2 mm Up / (Down) (Circle One) – must be within ± 20 mm (+ Up / - Down)

Looking at the impacted target, draw / indicate the location of the impact on this illustration:

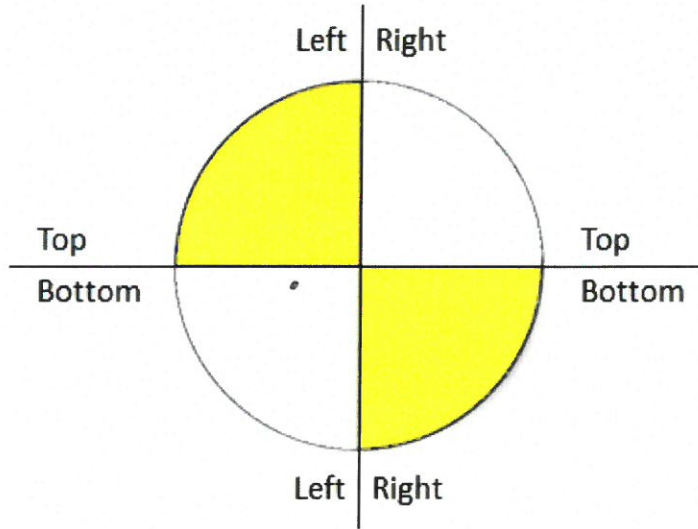

+/- 50 mm Horizontal ("+" = Forward, "-" = Rearward)

+/- 20 mm Vertical ("+" = Down, "-" = Up)

Post-Test Observations – Vehicle As Is

Performed by: CH + AR Date: 12/20/22

Instructions: Please completely fill in the below tables. If unsure, take additional photographs and please include any observations. Be as descriptive as possible.

Dummy Contact Location	Driver	Rear Passenger
Face Contact	None	None
Top of Head Contact	Curtain AB, headliner	Curtain AB
Left Side of Head Contact	Curtain AB, headliner	Curtain AB
Back of Head Contact	headrest	headrest
Left Shoulder Contact	torso pelvis AB Curtain AB, B-pillar trim	door panel
Upper Torso Contact	torso pelvis AB, seat bolster	C-pillar trim, door panel
Lower Torso Contact	torso pelvis AB seat bolster	C-pillar trim
Left Knee Contact	door panel	door panel
Left Hip Contact	torso pelvis AB, seat pan side	door panel

Supplemental Restraint System	Struck Side Driver		Non-Struck Side Rear Passenger	
	Mounted	Deployed	Mounted	Deployed
Frontal airbag	Y	N		
Knee airbag	Y	N		
Side airbag 1 – Curtain Airbag	Y	Y	Y	Y
Side airbag 2 – Torso Airbag	N/A No	No	N	N
Side airbag 3 – Torso / Pelvis Airbag	Y	Y	N	N
Seat belt pretensioner	Y	Y	Y	Y
Seat belt load limiter	Y	Y	Y	Y
Other – Seat Cushion Airbag	N	N	N	N

Post-Test Hand Measurements

Performed by:

AR + CH

Date:

12/20/22

Note: All measurements must be taken in the As Tested Condition (Fully loaded with instrumentation & ATD)

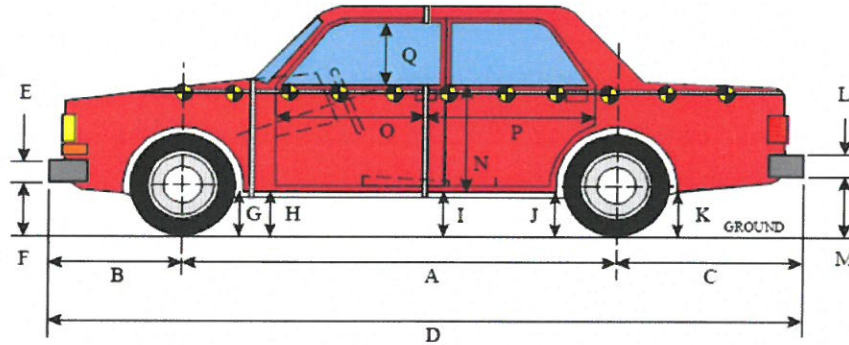
Initial:

AR	Hand measure	E	Front Bumper Thickness - (The vertical height of the front bumper fascia)	120	mm
AR	Hand measure	F	Front Bumper Bottom to Ground - (Vertical distance from ground to the bottom of the front bumper fascia)	509	mm
AR	Hand measure	G	Sill Height at Front Wheel Well - (Vertical distance from ground to the sill at the front wheel well opening)	210	mm
AR	Hand measure	H	Sill Height at Front Door Leading Edge - (Vertical distance from ground to the sill at the front door seam)	229	mm
AR	Hand measure	I	Sill Height at B-Pillar - (Vertical distance from ground to the sill in line with the front door striker or B-pillar if no striker exists)	215	mm
AR	Hand measure	J1	Sill Height at Rear Wheel Well - (Vertical distance from ground to the sill at the rear wheel well opening)	202	mm
AR	Hand measure	J2	Pinch Weld Height at Rear Wheel Well - (Vertical distance from ground to the pinch weld at the rear wheel well opening)	248	mm
AR	Hand measure	K	Sill Height Aft of Rear Wheel Well - (Vertical distance from ground to the vehicle sheet body at the rear of the rear tire's wheel well)	301	mm
AR	Hand measure	L	Thickness or height of rear bumper at center.	135	mm
AR	Hand measure	M	Distance from bottom of bumper to ground at center.	398	mm

Tape Measure Unique Identifier Used to conduct measurements

Post-Test Photos – Vehicle As Is:

Performed by:	JH	Date:	12/20/22
---------------	----	-------	----------

Note: Clear and properly focused digital still photographs in .jpg format with a minimum dots-per-inch (DPI) of 180 shall be taken. A vehicle information placard placed parallel with the camera, identifying the test vehicle model as well as the MDB and NHTSA number, along with an indication of whether the photo was taken post-test shall appear in each photograph and be legible. All photographs must be in landscape view / orientation. Glare or light from any illuminated or reflective surface shall be minimized while taking photographs.

Initial: Vehicle

- JH No. 2 – Post test Frontal View of Test Vehicle
- JH No. 6 – Post test Impacted Side View of Test Vehicle
- JH No. 4 – Post test Rear View of Test Vehicle
- JH No. 16 – Post test Overhead View of the MDB and Test Vehicle
- JH No. 25 – Post-Test T(0) – Impact Event
- JH No. 26 – Post test Close-up View of Impact Point Target

Initial: Photos of MDB

- JH No. 8 – Post test Frontal View of Impactor Face
- JH No. 14 – Post test Top View of Impactor Face
- JH No. 10 – Post test Left Side View of Impactor Face
- JH No. 12 – Post test Right Side View of Impactor Face

Initial: With Dummy's Positioned in Vehicle

- JH No. 20 – Post test Front SID – Opposite Side View
- JH No. 24 – Post test Rear SID – Opposite Side View

Post-Test Video:

Performed by:

TB

Date:

12/20/22

A real-time camera (24-30 fps) shall be used to document the pre-test and post-test condition of the test vehicle in addition to the pre-test and post-test positions of the test dummies, including, but not limited to, the placement of the lap and shoulder belts. Particular attention must be exercised to fully document the proper closing of all vehicle doors, including any rear hatchback or tailgate.

Initial: MDB

- TB View of MDB and vehicle – front of vehicle
- TB View of MDB and vehicle – rear of vehicle
- TB View of MDB and vehicle – ¼ front
- TB View of MDB and vehicle – ¼ rear
- TB View of MDB and vehicle – parallel to impact door

Initial: Vehicle

- TB View of impact point – close-up
- TB View of impacted side (vehicle removed)
- TB View of front of car
- TB View of rear of car
- TB View of inside front door (dummy removed)
- TB View of inside rear door (dummy removed)
- TB Any other vehicle anomalies if applicable

Initial: Test Dummies

- TB View of front ES-2re – parallel to impact door
- TB View of rear SID-IIs – parallel to impact door
- TB View of front ES-2re – thru opposite window
- TB View of rear SID-IIs – thru opposite window

Post-Test Photos:

Performed by:

JA

Date:

12/20/22

Note: Clear and properly focused digital still photographs in .jpg format with a minimum dots-per-inch (DPI) of 180 shall be taken. A vehicle information placard placed parallel with the camera, identifying the test vehicle model as well as the barrier and NHTSA number, along with an indication of whether the photo was taken pre-test shall appear in each photograph and be legible. All photographs must be in landscape view / orientation. Glare or light from any illuminated or reflective surface shall be minimized while taking photographs. Reference sample photo set!

Initial: Photos With Dummy's Not in Vehicle

JA No. 28 – Post test Front Seat Occupant Area showing head and torso contact regions (Test dummy removed)

JA No. 29 – Post test Rear Seat Occupant Area showing head and torso contact regions (Test dummy removed)

Post-Test Observations – Doors Open:

Performed by: CH + AR Date: 12/20/22

Instructions: Please completely fill in the below tables. If unsure, take additional photographs and please include any observations and be descriptive as possible.

Doors

For each door, note whether: the door remained closed and operational, whether the door totally separated from the vehicle at the hinges or latches, the door disengaged from the latched position, the latch separated from the striker, the hinge components separated from each other, the latch or hinge systems pulled out of their anchorages, or the door was jammed shut. All applicable conditions should be noted. Video analysis should also be used to verify whether any door, including the rear hatch, opened during the impact event.

Initial:

CH

Inspect the door at the striker, if the door is open at the striker post, take measurements of the door opening at the location and record it in the space provided below.

CH

If there is a failure with any door, door component, or door opening, notify the Data Processing Engineer to include such information on the Quick Look Report.

Instructions: For the next two tables, indicate “Yes”, “No” or “N/A”

Post Test Door Performance	Struck Side		Non-Struck Side		Rear Hatch / Other Door
	Front	Rear	Front	Rear	
Remained closed and operational	No	No	Yes	Yes	Yes
Total separation from vehicle at hinges or latches	No	No	No	No	No
Latch or hinge systems pulled out of their anchorages	No	No	No	No	No
Latch separated from striker	No	No	No	No	No
Jammed shut	Yes	Yes	No	No	No
If door opened at striker, record width of opening at striker (mm)	N/A	N/A	N/A	N/A	N/A

Seat Movement and Structural Observations

In the space provided below, note any seat or seat back movement or disengagement. Also, note any structural observations pertaining to the pillars, sill, window, and windshield. In particular, describe the amount of deformation to the struck-side pillars and struck side sill. Note whether there was damage to the front windshield area and if so, where the damage occurred. A similar assessment should be made for the side windows. Any other notable effects from the impact should also be indicated.

Instructions: For the next two tables, indicate "Yes", "No" or "N/A"

Post Test Seat Performance	Struck Side		Non-Struck Side	
	Front	Rear	Front	Rear
Seat movement along seat track	NO	NO	NO	NO
Seat disengagement from floor pan	NO	NO	NO	NO
Seat back movement from initial position	NO	NO	NO	NO
Seat back collapse	NO	NO	NO	NO

Post Test Structural Observations	Observations and Conclusions
Pillar performance	A-pillar buckled, B-pillar & C-pillar buckled
Sill separation	None
Windshield damage	None
Side window damage	None
Other notable effects	None

Post-Test Data Checklist:

Performed by:

AR + CH

Date:

12/20/22

Initial:

AR

Confirm video has been downloaded.

AR

Confirm data has been downloaded.

VB

Download ATD / vehicle temperature data.

VB

Read and review Questionable Data Channel list.

VB

Remind staff not to remove equipment from vehicle until questionable channel list / questionable channels have been inspected.

VB

Inspect questionable instrumentation/cabling before removal from vehicle, take photos, and document damage.

VB

Tag damaged equipment and remove from service.

VB

Authorize equipment to be removed.

Critical Results:

Performed by:	VH	Date:	12/20/22
---------------	----	-------	----------

The following deliverables were met:

- Impact speed within 52.9 km/h \pm 0.8 km/h (32.9 mph \pm 0.5 mph).
- Impact angle within 27° \pm 1°
- Impact point within \pm 50 mm (Horizontal offset from the vertical impact line)

Driver ATD (ES-2re) Dummy Injury Data:

- Head – Head Injury Criterion (HIC) (36) may not exceed 1000.
 - Maximum Thoracic Rib Deflection – The sum of thoracic rib deflection may not exceed 44 mm.
 - Total Abdominal Force – The sum of abdominal forces may not exceed 2,500 N (562 lbf.).
 - Pubic Symphysis Force – The sum of pubic symphysis forces may not exceed 6,000 N (1349 lbf.).
- Notify customer if injury criteria limit is exceeded.

(Reference Table)

ES-2re Injury Criteria	Max. Allowable IARV
	Units
HIC	1000
Upper Rib Deflection (mm)	44 mm
Mid. Rib Deflection (mm)	
Lower Rib Deflection (mm)	
Abdominal Load (front) (N)	
Abdominal Load (mid) (N)	
Abdominal Load (rear) (N)	
Sum of Abdominal Forces (N)	
Pubic Symphysis (N)	6 kN

Passenger ATD (SID-IIs) Dummy Injury Data:

- VH Head – Head Injury Criterion (HIC) (36) may not exceed 1000.
 - VH Lower Spine – The resultant spine acceleration may not exceed 82 g.
 - VH Pelvis – The sum of the acetabular and iliac pelvic forces may not exceed 5,525 N (1,242 lbf.).
- Notify customer if injury criteria limit is exceeded.

(Reference Table)

SIDIIIs Injury Criteria	Max. Allowable IARV
HIC	1000
Max. Spine Acceleration (g)	82
Acetabular (N)	
Iliac (N)	
Sum of Acetabular and Iliac (N)	5525

* Proposed IARV

Door Opening Criteria:

- VH Any side door that is struck by the mdb shall not separate totally from the vehicle.
- VH Any door (including a rear hatchback or tailgate) that is not struck by the MDB must meet the following requirements:
 - The door shall not disengage from the latched position.
 - The latch shall not separate from the striker, and the hinge components shall not separate from each other or from their attachment to the vehicle.
 - Neither the latch nor the hinge systems of the door shall pull out of their anchorages.

Notify Customer – Test Executed:

Performed by:	VH + AR + CH	Date:	12/20/22
---------------	--------------	-------	----------

Informed COTR that test was conducted:

Initial:

<input type="checkbox"/>	Via e-mail	Date:	12/20/22
<input type="checkbox"/>	Via voice mail message		
<input checked="" type="checkbox"/>	Via live conversation		

TOM Comments:

Post Test Measurements

Performed by: AP Date: 12/21/22

Initial:

AP Measure using the FARO arm the vertical distance from ground to each level (top edge of the tapeline) along the vertical impact reference line.





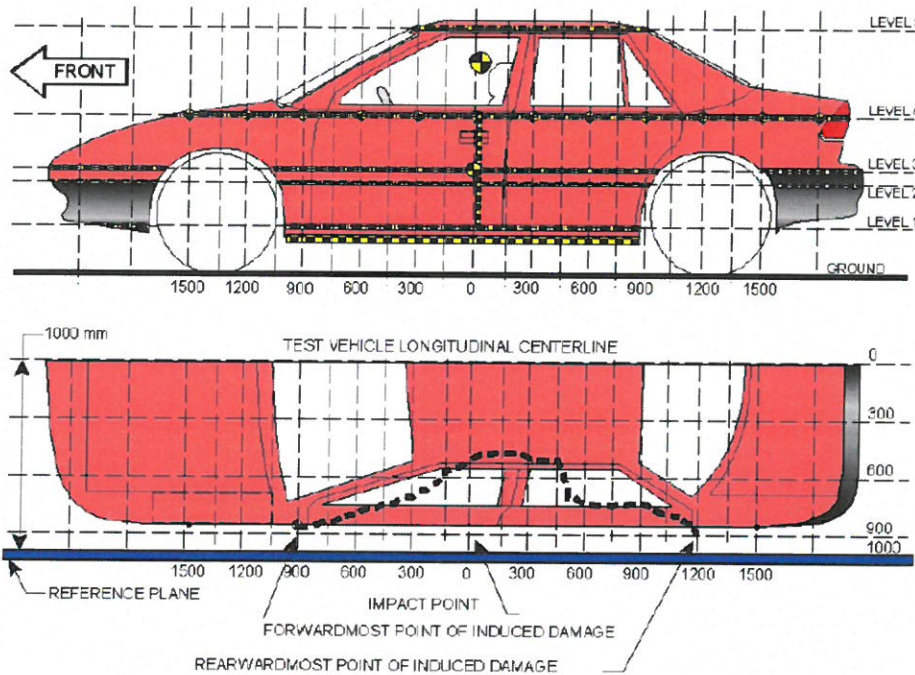













FARO Unique Identifier:

- AP Using the FARO arm, take Level 1 measurements every 150 mm (i.e. L1 900P to L1 2850P) - Top of side sill (top edge of the tapeline)
- AP Using the FARO arm, take Level 2 measurements every 150 mm (i.e. L2 900P to L2 2850P) - Occupant Hip Point (top edge of the tapeline)
- AP Using the FARO arm, take Level 3 measurements every 150 mm (i.e. L3 900P to L3 2850P) - Mid-door (top edge of the tapeline)
- AP Using the FARO arm, take Level 4 measurements every 150 mm (i.e. L4 900P to L4 2850P) - Window sill (top edge of the tapeline)
- AP Using the FARO arm, take Level 5 measurements every 150 mm (L5 900P to L5 2850P) - Top of window (top edge of the tapeline)



Left Side View – All measurements in (mm) with tolerance of +/- 3 mm

Initial:

-  LFW - Left Front Wheel.
-  LRW - Left Rear Wheel.
-  RFW - Right Front Wheel.
-  RRW - Right Rear Wheel.
-  RFRONT - Right Front (X19)
-  CFRONT - Center of Front (X1)
-  LFRONT - Left Front (X20)
-  RREAR - Right Rear
-  CREAM - Center of Rear
-  LREAR - Left Rear
-  NUP - N Upper Point
-  NLOW - N Lower Point
-  OFRNT - O Front Point
-  OPMID - O Rear Point / P Front Point
-  PREAR - P Rear Point
-  QUP - Front Window Opening – Take uppermost point on front window to obtain window vertical distance measurement
-  QLOW – Front Window Opening – Take lowermost point on front window to obtain window vertical distance movement
-  RBPW - Right B Pillar Point (*Taken at vertical tangency point*)
-  LBPW - Left B Pillar Point (*Taken at vertical tangency point*)

Vehicle Floor Pan Measurements / P1 Floor Pan / Interior -----

Initial:

-  P1 STRIKER – Center of P1 Striker Bolt

Vehicle Floor Pan Measurements / P2 Floor Pan / Interior -----

Initial:

-  P2 STRIKER – Center of P2 Striker Bolt

Post-Test Exterior Static Crush for Impactor Face

Performed by:

AP

Date:

12/22/22

Instructions: Read through the following instruction PRIOR to measuring the following locations using the FARO arm.

Exterior MDB Measurements:

FARO Unique Identifier:

The maximum static crush of the MDB's honeycomb face shall be measured post-test in the longitudinal direction at the following vertical locations (see **Figure 14 Below**):

- (1) Center of Bumper Level = **432** mm above ground level
- (2) Top of Bumper Level = **533** mm above ground level
- (3) Mid Level = **686** mm above ground level
- (4) Top-Stack Level = **813** mm above ground level

Post-test measurements are taken (from a reference plane perpendicular to and 1,000 mm from the MDB's longitudinal centerline) across the barrier face at 100 mm intervals at each of the four levels specified.

Initial:

- AP Using the FARO arm, take Level 1 measurements every 100 mm (i.e. L1 800ROC to L1 800LOC) – Center of Bumper Level
- AP Using the FARO arm, take Level 2 measurements every 100 mm (i.e. L2 800ROC to L2 800LOC) – Top of Bumper Level
- AP Using the FARO arm, take Level 3 measurements every 100 mm (i.e. L3 800ROC to L3 800LOC) – Mid Level
- AP Using the FARO arm, take Level 4 measurements every 100 mm (i.e. L4 800ROC to L4 800LOC) – Top-Stack Level

Conversions:

SI* (MODERN METRIC) CONVERSION FACTORS				
Table of APPROXIMATE CONVERSIONS TO SI UNITS				
Symbol	When You Know	Multiply By	To Find	Symbol
LENGTH				
in	inches	25.4	millimeters	mm
ft	feet	0.305	meters	m
yd	yards	0.914	meters	m
mi	miles	1.61	kilometers	km
AREA				
in ²	square inches	645.2	square millimeters	mm ²
ft ²	square feet	0.093	square meters	m ²
yd ²	square yards	0.836	square meters	m ²
ac	acres	0.405	hectares	ha
mi ²	square miles	2.59	square kilometers	km ²
VOLUME				
fl oz	fluid ounces	29.57	milliliters	mL
gal	gallons	3.785	liters	L
ft ³	cubic feet	0.028	cubic meters	m ³
yd ³	cubic yards	0.765	cubic meters	m ³
MASS				
oz	ounces	28.35	grams	g
lb	pounds	0.454	kilograms	kg
T	short tons (2000 lb)	0.907	megagrams (or "metric ton")	Mg (or "t")
TEMPERATURE				
°F	Fahrenheit	$5 \times (F-32) \div 9$ or $(F-32) \div 1.8$	Celsius	°C
ILLUMINATION				
fc	foot-candles	10.76	lux	lx
fl	foot-Lamberts	3.426	candela/m ²	cd/m ²
Force and Pressure or Stress				
lbf	poundforce	4.45	newtons	N
lbf/in ²	poundforce per square inch	6.89	kilopascals	kPa

Revision History:

Revision Level:	Revision Date:	Comments:
R00	7/7/2017	Initial Issue as Work Instruction Test Template.
R01	11/21/2019	Complete Rewrite.
R02	11/11/2022	Relocated various sections and procedures to better align with work flow. <ul style="list-style-type: none">• Added to Quality System, Security provisions added• Removed duplicate and not applicable steps/procedures• Increased details within various steps & procedures to improve clarity

Approved:



Edward Dutton, Crash Operations Manager

Date: 11/26/19