

REPORT NUMBER: 214P-CAL-23-003

**SAFETY COMPLIANCE TESTING FOR FMVSS 214
DYNAMIC SIDE IMPACT PROJECTION
RIGID POLE TEST**

**FORD MOTOR CO.
2023 Ford Maverick
4 Door Truck**

NHTSA No: C20230201

**PREPARED BY:
CALSPAN CORPORATION
P.O. BOX 400
BUFFALO, NEW YORK 14225**



March 24, 2023

FINAL REPORT

**PREPARED FOR:
U. S. DEPARTMENT OF TRANSPORTATION
NATIONAL HIGHWAY TRAFFIC SAFETY ADMINISTRATION
ENFORCEMENT
OFFICE OF SAFETY COMPLIANCE
1200 NEW JERSEY AVE. S.E.
WEST Bldg. (NVS-220)
WASHINGTON, D.C. 20590**

This final test report was prepared for the U.S. Department of Transportation, National Highway Traffic Administration, in response to Contract Number DTNH2217D00078.

This publication is distributed by the U.S. Department of Transportation, National Highway Traffic Safety Administration, in the interest of information exchange. The opinions, findings and conclusions expressed in this publication are those of the author(s) and not necessarily those of the Department of Transportation or the National Highway Traffic Safety Administration. The United States Government assumes no liability for its contents or use thereof.

If trade or manufacturers' names or products are mentioned, it is only because they are considered essential to the object of the publication and should not be construed as an endorsement. The United States Government does not endorse products or manufacturers.

Prepared by:  _____ Date: March 24, 2023
Quinn Porzio, Test Engineer

Approved by:  _____ Date: March 24, 2023
Matthew Pronko, Test Engineer

FINAL REPORT ACCEPTANCE BY OVSC:

Accepted by

Date: _____

TECHNICAL REPORT DOCUMENTATION PAGE

1. Report No. 214P-CAL-23-003		2. Government Accession No.		3. Recipient's Catalog No.																								
4. Title and Subtitle Final Report of 214P Compliance Test Side Impact Protection Testing of a 2023 Ford Maverick 4 Door Truck NHTSA No.: C20230201				5. Report Date March 24, 2023																								
				6. Performing Organization Code CAL																								
7. Author(s) Quinn Porzio, Test Engineer Matthew Pronko, Test Engineer				8. Performing Organization Report No. CAL-DOT-2023-003																								
9. Performing Organization Name and Address Calspan Corporation Transportation Test Operations P.O. Box 400 Buffalo, New York 14225				10. Work Unit No.																								
				11. Contract or Grant No. DTNH2217D00078																								
12. Sponsoring Agency Name and Address U.S. Department of Transportation National Highway Traffic Safety Administration Office of Vehicle Safety Compliance 1200 New Jersey Ave., SE, Room W43-304 Washington, D.C. 20590				13. Type of Report and Period Covered: Final Test Report March 2, 2023 - March 24, 2023																								
				14. Sponsoring Agency Code NEF-240																								
15. Supplementary Notes																												
16. Abstract A 31.00 km/h (19.3 mph), 285° oblique compliance test was conducted on the subject 2023 Ford Maverick 4 Door Truck in accordance with the specifications of the Office of Vehicle Safety Compliance TP-214P-01 for the determination of FMVSS No.214 Side Impact Protection compliance. This test was conducted at Calspan Corporation's Transportation Test Operations facility in Buffalo, New York on March 2, 2023. The impact velocity of the vehicle was 30.89 km/h, and the ambient temperature at the struck (passenger's) side of the target vehicle was 21°C. The target vehicle's maximum post-test static crush was 332 mm located at level 3. The test vehicle's occupant performance data is as follows:																												
<table border="1"> <thead> <tr> <th rowspan="2">Measurement Description</th> <th colspan="3">Front Passenger ATD (ES-2re)</th> </tr> <tr> <th>Units</th> <th>IARV</th> <th>Result</th> </tr> </thead> <tbody> <tr> <td>Head Injury Criteria (HIC36)</td> <td></td> <td>1000</td> <td>394.734</td> </tr> <tr> <td>Maximum Thoracic Rib Deflection</td> <td>mm</td> <td>44</td> <td>24.868</td> </tr> <tr> <td>Total Abdominal Force</td> <td>N</td> <td>2500</td> <td>1009.828</td> </tr> <tr> <td>Pubic Symphysis Force</td> <td>N</td> <td>6000</td> <td>1451.157</td> </tr> </tbody> </table>						Measurement Description	Front Passenger ATD (ES-2re)			Units	IARV	Result	Head Injury Criteria (HIC36)		1000	394.734	Maximum Thoracic Rib Deflection	mm	44	24.868	Total Abdominal Force	N	2500	1009.828	Pubic Symphysis Force	N	6000	1451.157
Measurement Description	Front Passenger ATD (ES-2re)																											
	Units	IARV	Result																									
Head Injury Criteria (HIC36)		1000	394.734																									
Maximum Thoracic Rib Deflection	mm	44	24.868																									
Total Abdominal Force	N	2500	1009.828																									
Pubic Symphysis Force	N	6000	1451.157																									
The two doors on the struck side of the vehicle did not separate from the body at the hinges or latches and the opposite doors did not open during the side impact event.																												
17. Key Words Compliance Testing Side Impact Protection Pole Test ES-2re SID-IIs				18. Distribution Statement Copies of this report are available from: National Highway Traffic Safety Administration Technical Information Services (TIS) Room E12-100 East Bldg. 1200 New Jersey Ave. Washington, D.C. 20590 Telephone No. (202) 366-2588																								
19. Security Class. (of this report) UNCLASSIFIED		20. Security Class. (of this page) UNCLASSIFIED		21. No. of Pages 109	22. Price																							

TABLE OF CONTENTS

<u>Section</u>		<u>Page</u>
1	Test Purpose and Summary of the Test	1-1
2	Occupant and Vehicle Information	2-1
 <u>Data Sheet</u>		 <u>Page</u>
1	Test Vehicle Information and Options	2-2
2	Vehicle Tire Information	2-3
3	General Test and Vehicle Parameter Data	2-4
4	Seat and Seat Belt Adjustment Data	2-5
5	Fuel Systems and Steering Wheel Position Data	2-6
6	Dummy Longitudinal Clearance Dimensions	2-7
7	Dummy Lateral Clearance Dimensions	2-8
8	Location of Cameras	2-9
9	Test Vehicle Accelerometer Location	2-10
10	Test Vehicle Accelerometer Data Summary	2-11
11	Dummy Injury Response Data	2-12
12	Post Test Observations	2-13
13	Vehicle Pre-test and Post-test Measurements	2-15
14	Exterior Crush Measurements	2-16
15	Vehicle Exterior Crush Profiles	2-17
16	Temperature and Humidity Trace	2-19
 <u>Appendix</u>		 <u>Page</u>
I	Photographs	I-1
II	Dummy Response Data	II-1
III	Vehicle and Dummy Response Data Plots	III-1
IV	Dummy Performance Calibration Test Data	IV-1
V	Test Equipment and Instrumentation Calibration	V-1

SECTION 1

PURPOSE AND SUMMARY OF TEST

PURPOSE

This side impact test was conducted as part of the FY 2023 FMVSS 214 Side Impact Protection Compliance Test Program, sponsored by the National Highway Traffic Safety Administration (NHTSA), under Contract No. DTNH2217D00078. The purpose of this test was to evaluate side impact protection in a 2023 Ford Maverick 4 Door Truck. The side impact test was conducted in accordance with the Office of Vehicle Safety Compliance's Laboratory Test Procedure, TP-214P-01 dated September 2012.

SUMMARY

A rigid pole side impact test was conducted on a 2023 Ford Maverick 4 Door Truck. The subject vehicle was towed into the rigid pole at an angle of 285° and a velocity of 30.89 km/h. The test was conducted by Calspan Corporation's Transportation Test Operations facility in Buffalo, New York on March 2, 2023. Pre-test and post-test photographs of the test vehicle and side impact dummy (ES2re) are included in Appendix I of this report.

One Part 572U (ES2re) dummy was placed in the front passenger designated seating position according to instructions specified in the TP-214P-01 Test Procedure, dated September 2012. The side impact event was documented by nine High Speed Cameras and one real time camera.

The ES2re male dummy was instrumented accordingly:

- Primary and redundant head CG tri-axial accelerometers
- Chest upper rib, middle rib, and lower rib y-axis displacement potentiometers
- Abdomen forward, middle, and rear y-axis load cells
- Lower spine (T12) tri-axial accelerometers
- Public symphysis y-axis load cell

Appendix II contains the dummy response data. Dummy configuration and performance verification data can be found in Appendix IV of this report. Appendix V identifies all serial numbers, manufacturers, and calibration dates for test equipment, dummy sensors, potentiometers, and load cells used to collect data during the test.

Injury readings for the ES2re dummy were recorded as follows:

INJURY READINGS

Measurement Description	Front Passenger ATD (ES2re)		
	Units	IARV	Result
Head Injury Criteria (HIC36)		1000	394.734
Upper Rib Deflection	mm	44	24.868
Mid Rib Deflection	mm	44	22.932
Lower Rib Deflection	mm	44	24.533
Abdominal Load (front)	N		315.709
Abdominal Load (mid)	N		301.728
Abdominal Load (rear)	N		421.620
Total Abdominal Force	N	2500	1009.828
Pubic Symphysis Force	N	6000	1451.157

SECTION 2

OCCUPANT AND VEHICLE INFORMATION

This section contains information reporting for the following Data Sheets:

<u>Data Sheet</u>		<u>Page</u>
1	Test Vehicle Information and Options	2-2
2	Vehicle Tire Information	2-3
3	General Test and Vehicle Parameter Data	2-4
4	Seat and Seat Belt Adjustment Data	2-5
5	Fuel Systems and Steering Wheel Position Data	2-6
6	Dummy Longitudinal Clearance Dimensions	2-7
7	Dummy Lateral Clearance Dimensions	2-8
8	Location of Cameras	2-9
9	Test Vehicle Accelerometer Location	2-10
10	Test Vehicle Accelerometer Summary	2-11
11	Dummy Injury Response Data	2-12
12	Post Test Observations	2-13
13	Vehicle Pre-test and Post-test Measurements	2-15
14	Exterior Crush Measurements	2-16
15	Vehicle Exterior Crush Profiles	2-17
16	Temperature and Humidity Trace	2-19

**DATA SHEET NO. 1
TEST VEHICLE INFORMATION AND OPTIONS**

Test Vehicle: 2023 Ford Maverick 4 Door Truck
 Test Facility: Calspan

NHTSA No.: C20230201
 Test Date: 03/02/2023

TEST VEHICLE INFORMATION AND OPTIONS

Make	Ford	Anti-Lock Brakes (ABS)	Yes
Model	Maverick	All-Wheel Drive (AWD)	Yes
Body Style	Four Door Truck	Traction Control System (TCS)	Yes
VIN	3FTTW8F98PRA03626	Electric Stability Control (ECS)	Yes
Body Color	Light Blue	Curtain Airbags	Yes
Engine Displacement (L)	2.0	Torso Airbags – Front Seats	Yes
Type / No. Cylinders	I4	Torso Airbags – Rear Seats	No
Engine Placement	Transverse	Combination/Head Torso Bag	No
Transmission Type	Automatic	Pelvic Airbag – Front Seats	No
Transmission Speeds	8-Speed	Pelvis Airbag – Rear Seats	No
Overdrive	Yes	Knee Airbag – Driver	Yes
Final Drive	All Wheel Drive	Knee Airbag – Front Passenger	No
Odometer Reading (mi)	10.3 miles	Seat Belt Pretensioners – Front Seats	Yes
		Seat Belt Pretensioners – Rear Seats	No
		Seat Belt Load Limiter – Front Seats	Yes
		Seat Belt Load Limiter – Rear Seats	No
		Tire Pressure Monitoring System (TPMS)	Yes
		Tilt Steering Wheel	Yes
		Automatic Door Locks (ADL)	Yes
		Power Window Auto-reverse	No
		Power Seats	No
		Other Safety Restraint	N/A

DATA FROM CERTIFICATION LABEL

Manufactured By	FORD MOTOR CO.	GVWR (kg)	2361
Date of Manufacture	12/22	GVWR Front (kg)	1218
Vehicle Type	Truck	GVWR Rear (kg)	1256

VEHICLE SEATING AND WEIGHT CAPACITY DATA

Measured Parameter	Front	Rear	Third	Total
Type of Seats (Bench or Bucket)	Bucket	Bench	N/A	
Designated Seating Capacity (DSC)	2	3	N/A	5
Capacity Weight (VCW) (kg)				670
Cargo Weight (RCLW) (kg)				136

**DATA SHEET NO. 2
VEHICLE TIRE INFORMATION**

Test Vehicle: 2023 Ford Maverick 4 Door Truck
 Test Facility: Calspan

NHTSA No.: C20230201
 Test Date: 03/02/2023

VEHICLE TIRE INFORMATION

Collected for year, make, model, & VIN, all items circled in red, tire manufacturer and tire name

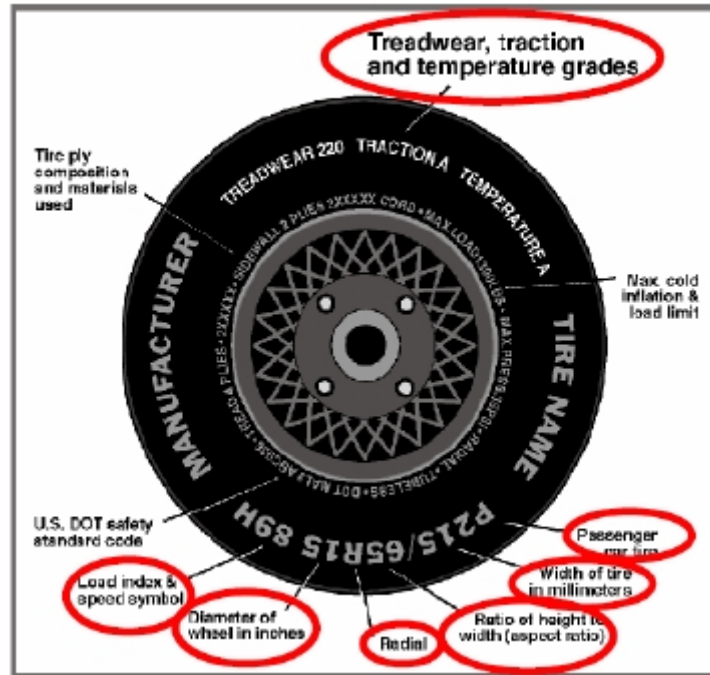

TIRE SIDEWALL INFORMATION

Tire Placard	Front	Rear
Recommended Cold Pressure (kPa)	240	240
Recommended Tire Size	225/65R17	225/65R17
Tire Sidewall	Front	Rear
Maximum Tire Pressure (kPa)	350	350
Tire Size on Vehicle	225/65R17	225/65R17
Tire Manufacturer Model	Continental	Continental
Tire Name	Pro Contact TX	Pro Contact TX
Tire Type	All Season	All Season
Tire Width	225	225
Aspect Ratio	65	65
Radial	Yes	Yes
Wheel Diameter	17"	17"
Load Index / Speed Symbol	102 H	102 H
Treadwear	500	500
Traction Grade	A	A
Temperature Grades	A	A

**DATA SHEET NO. 3
GENERAL TEST AND VEHICLE PARAMETER DATA**

Test Vehicle: 2023 Ford Maverick 4 Door Truck
 Test Facility: Calspan

NHTSA No.: C20230201
 Test Date: 03/02/2023

TIRE PRESSURES

	Units	LF	RF	LR	RR
As Delivered	kPa	295	298	290	288
Tire Placard	kPa	240	240	240	240

TEST VEHICLE AXLE WEIGHTS

	Units	As Delivered (UVW)			Fully Loaded			As Tested		
		Front	Rear	Total	Front	Rear	Total	Front	Rear	Total
Left	kg	491	363		514	427		531	430	
Right	kg	495	337		522	443		507	429	
Ratio	%	58.5	41.5		54.4	45.6		54.7	45.3	
Totals	kg	986	700	1686	1036	870	1906	1038	859	1897

TARGET TEST WEIGHT CALCULATION

Measured Parameter	Units	Value	
Total As Delivered Weight (UVW)	kg	1686	(A)
Weight of Test Dummy	kg	81	(B)
Rated Cargo / Luggage Weight (RCLW)	kg	136	(C)
Calculated Vehicle Target Weight (TVTW)	kg	1903	(A+B+C)

TEST VEHICLE ATTITUDES AND CG

Measurement Description	Units	As Delivered	Fully Loaded	As Tested
Driver Door Sill Angle	Deg	+ 0.30	+ 0.20	+ 0.30
Front Passenger Sill Angle	Deg	+ 0.05	+ 0.10	+ 0.10
Front Bumper-Line Angle	Deg	+ 0.10	+ 0.20	+ 0.10
Rear Bumper-Line Angle	Deg	+ 0.50	- 0.30	- 0.15

ND = Nose Down (-), NU = Nose Up (+), LD = Left Down (-), LU = Left Up (+)

CALCULATION OF VERTICAL IMPACT REFERENCE LINE

Measured Parameter	Units	Value
Test Vehicle Wheelbase	mm	3072
Vertical Impact Reference Line Aft of Front Axle	mm	1284

WEIGHT OF BALLAST AND VEHICLE COMPONENTS REMOVED TO MEET TVTW

Component Description	Weight (kg)
Spare Tire	23
Jack	3.5
Ballast (if any)	82

**DATA SHEET NO. 4
SEAT AND SEAT BELT ANCHORAGE ADJUSTMENT DATA**

Test Vehicle: 2023 Ford Maverick 4 Door Truck
 Test Facility: Calspan

NHTSA No.: C20230201
 Test Date: 03/02/2023

SEAT BACK ANGLE ADJUSTMENT

The driver and passenger seat backs are positioned to the manufacturer's designated angle provided in the Form 1.

	Units	Seat Back Angle
Driver Seat	Degree	2.8
Front Passenger Seat	Degree	3.0

*Measurement taken on outboard head rest post.

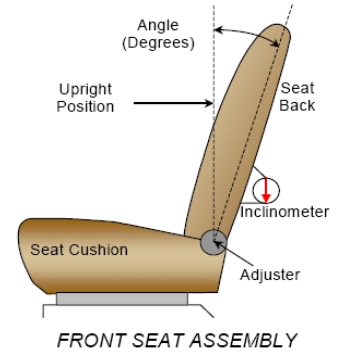

SEAT HEIGHT AND ANGLE

Seat	As Tested SCRL Angle (Mid) (°)	SCR P Height Position	SCR P Height (mm)		
			Rearmost	Mid-Fore / Aft	Forward-Most
Driver Seat	13.7	Max	-	-	-
		Mid	-	-	-
		Min	23	27	34
Front Passenger Seat	Fixed	Max			
		Mid			
		Min			

SEAT FORE / AFT POSITION

Seat	Total Fore / Aft Travel		Placed in Position #	
	mm	Detents	mm	Detents
Driver Seat	240	36 (0-35)	115	17
Front Passenger Seat	254	38 (0-37)	127	18

SEAT BELT ANCHORAGE ADJUSTMENT

Seat	Total # of Positions	Placed in Position #
Front Passenger Seat	4 (0-3)	0 - Uppermost

HEAD RESTRAINT ADJUSTMENT

Seat	Total # of Positions	Placed in Position #
Front Passenger Seat	3 (0-2)	0 - Uppermost

**DATA SHEET NO. 5
FUEL SYSTEMS AND STEERING WHEEL POSITION DATA**

Test Vehicle: 2023 Ford Maverick 4 Door Truck
 Test Facility: Calspan

NHTSA No.: C20230201
 Test Date: 03/02/2023

FUEL TANK CAPACITY

Description	Liters
Usable Capacity of (Form No.1)	62.5
Usable Capacity of (Owner's Manual)	62.5
92 - 94% of Usable Capacity	57.5 - 58.8
Actual Amount of Solvent Used in Test	58.0

FUEL PUMP

Describe the operation of the fuel pump.

The vehicle is equipped with an electric fuel pump. The fuel filler neck is on the left side of the vehicle. The pump creates positive pressure in the fuel lines, pushing the gasoline to the engine. See form 1 for more information.

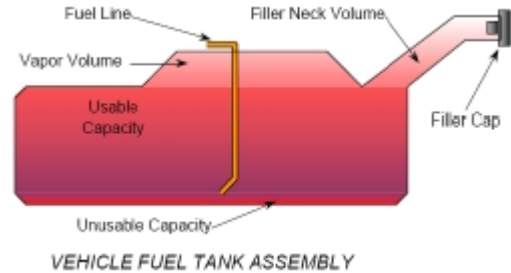

STEERING COLUMN POSITIONS

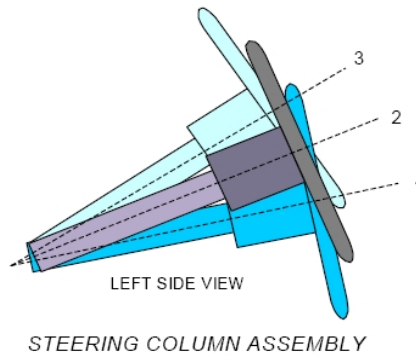

	Degrees	Fore / Aft Position (mm)
Lowermost - Position No. 1	24.3	
Geometric center - Position No. 2	26.4	
Uppermost - Position No. 3	28.5	
Telescoping Steering Wheel Travel		58
Test Position	26.4	29

**DATA SHEET NO. 6
DUMMY LONGITUDINAL CLEARANCE DIMENSIONS**

Test Vehicle: 2023 Ford Maverick 4 Door Truck
 Test Facility: Calspan

NHTSA No.: C20230201
 Test Date: 03/02/2023

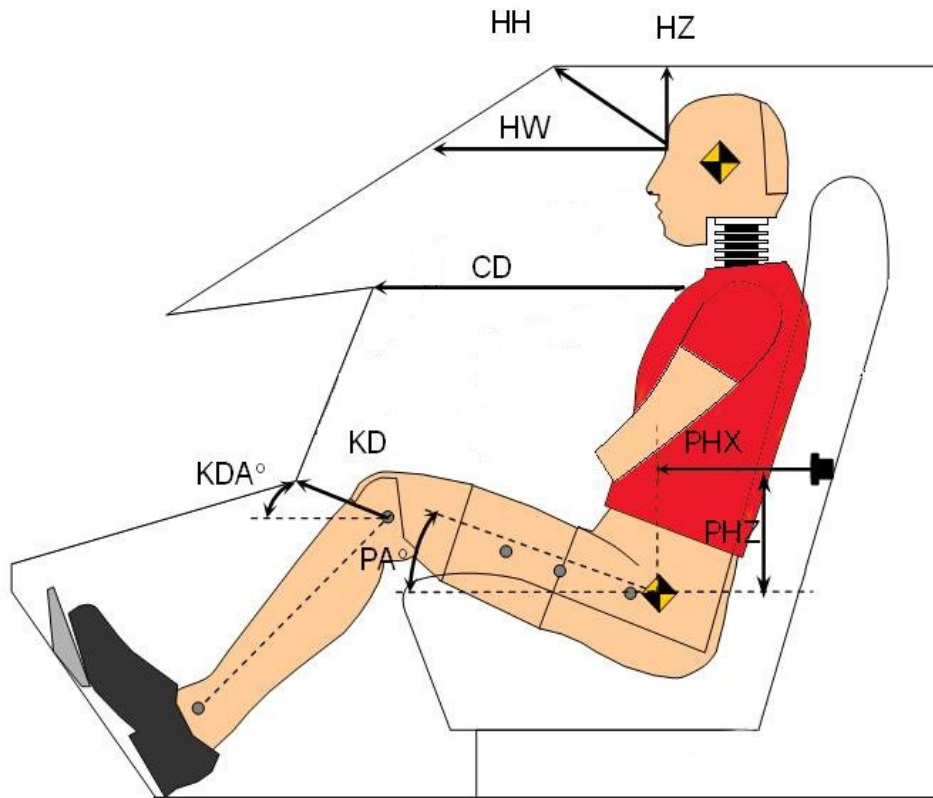

DUMMY LONGITUDINAL CLEARANCE DIMENSION INFORMATION

Driver Code	Description	Front Passenger	
		Length (mm)	Angle (°)
HH	Head to Header	431	
HW	Head to Windshield	624	
HZ	Head to Roof Liner	190	
NR	Nose to Dash	593	
CD	Chest to Dash	557	
KD(L) / KDA(L)°	Left Knee to Dash	180	21.4
KD(R) / KDA(R)°	Right Knee to Dash	190	27.8
PAX°	Pelvic Tilt Angle (X-Axis)		22.1
PAY°	Pelvic Tilt Angle (Y-Axis)		-0.1
PHX	Hip Point to Striker (X-Axis)	188	
PHZ	Hip Point to Striker (Z-Axis)	93	

**DATA SHEET NO. 7
DUMMY LATERAL CLEARANCE DIMENSIONS**

Test Vehicle: 2023 Ford Maverick 4 Door Truck
 Test Facility: Calspan

NHTSA No.: C20230201
 Test Date: 03/02/2023

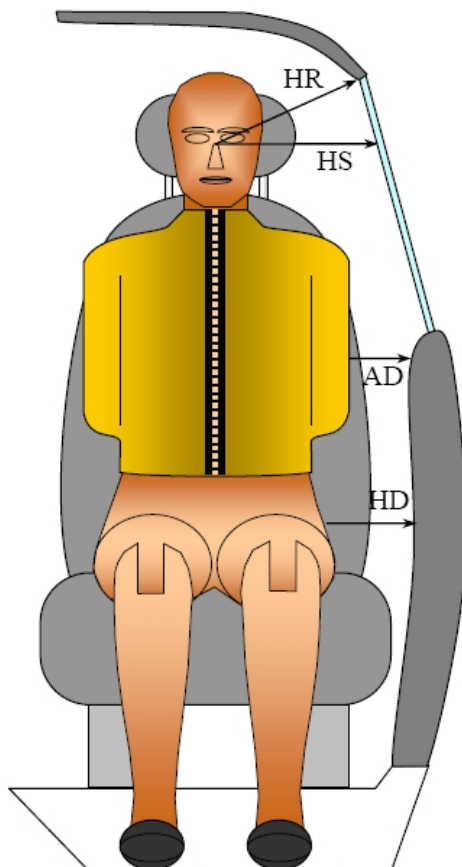

FRONT VIEW OF DUMMY

DUMMY LATERAL CLEARANCE DIMENSION INFORMATION

Code	Measurement Description	Units	Front Passenger
HR	Head to Side Header	mm	234
HS	Head to Side Window	mm	355
AD	Arm to Door	mm	72
HD	H-Point to Door	mm	142

**DATA SHEET NO. 8
LOCATION OF CAMERAS**

Test Vehicle: 2023 Ford Maverick 4 Door Truck
 Test Facility: Calspan

NHTSA No.: C20230201
 Test Date: 03/02/2023

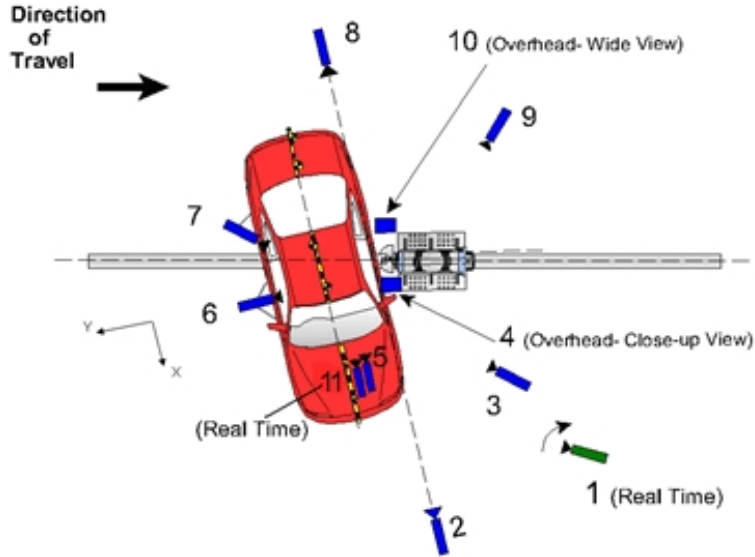

CAMERA LOCATIONS AND DATA

CAMERA LOCATIONS AND DATA

No.	Camera View	Coordinates (mm)			Lens Length (mm)	Operating Frame Rate (fps)
		X	Y	Z		
1	Real-time (24 - 30 fps) pan view of impact				Zoom	30
2	Front ground level - impact view	565	-8536	-1428	24	1000
3	Impact side 45° - forward pole view	1531	-5795	-1548	28	1000
4	Overhead Close-up view of impact	0	0	-9200	24	1000
5	Onboard - dummy front view				25	1000
6	Onboard - dummy side view				12.5	1000
7	Onboard - dummy rear oblique view				12.5	1000
8	Rear ground level - impact view	826	9003	-1458	24	1000
9	Impact side 45° - rearward pole view	3400	5416	-1576	28	1000
10	Overhead wide - view of impact	0	0	-9200	12.5	1000

Notes: Reference - From Point of Impact for X and Y; from Ground for Z
 +X = Forward of vehicle, +Y = Right of vehicle, +Z = Down
 * All measurements accurate to ± 6 mm. Vehicle is at a 75° angle to the rigid pole.

**DATA SHEET NO. 9
TEST VEHICLE ACCELEROMETER LOCATIONS**

Test Vehicle: 2023 Ford Maverick 4 Door Truck
 Test Facility: Calspan

NHTSA No.: C20230201
 Test Date: 03/02/2023

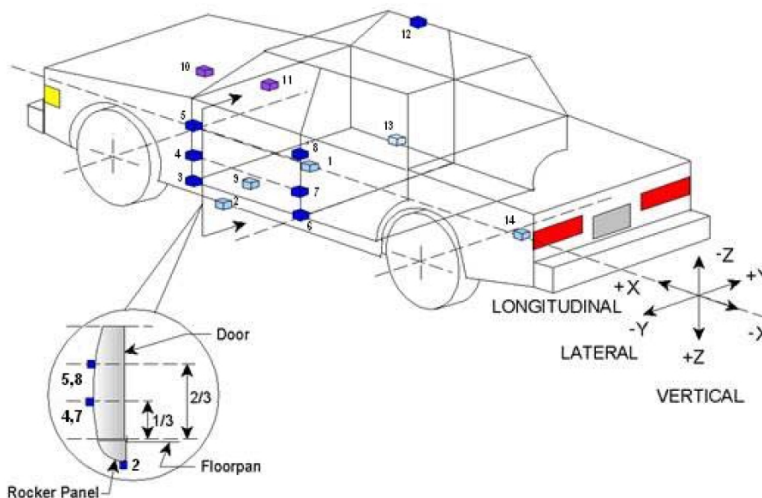

TEST VEHICLE ACCELEROMETER LOCATIONS

No.	Accelerometer Location	Coordinates (mm)		
		X	Y	Z
1	Vehicle CG	2958	3	-86
2	Left Floor Sill	3244	665	40
3	A-Pillar Sill	3577	651	40
4	A-Pillar Low	3701	644	-141
5	A-Pillar Mid	3636	671	-686
6	B-Pillar Sill	2612	648	64
7	B-Pillar Low	2689	691	-117
8	B-Pillar Mid	2635	681	-514
9	Seat	2941	-547	20
10	Engine	4394	212	-385
11	Firewall	4057	277	-415
12	Roof	2962	-665	-1133
13	Right Floor Sill	3300	-669	51
14	Rear Deck	1198	53	-249

Reference: X – Rear surface of vehicle (+ forward)
 Y – Vehicle centerline (+ to right)
 Z – Ground plane (+ down)

DATA SHEET NO. 10
TEST VEHICLE ACCELEROMETER DATA SUMMARY

Test Vehicle: 2023 Ford Maverick 4 Door Truck
 Test Facility: Calspan

NHTSA No.: C20230201
 Test Date: 03/02/2023

Loc. No	Description	Axes	Units	Positive Direction		Negative Direction	
				Max	Time (ms)	Max	Time (ms)
1	Vehicle CG	X	g	10.02	83.60	-15.03	49.50
	Vehicle CG	Y	g	48.41	46.60	-55.70	52.50
	Vehicle CG	Z	g	11.81	52.65	-13.37	57.55
	Vehicle CG Resultant	N/A	g	57.61	52.45	0.13	4.60
2	Floor Sill (Left)	Y	g	4.80	75.80	-20.78	72.45
3	A Pillar Sill	Y	g	32.31	37.35	-40.53	19.20
4	A Pillar Low	Y	g	6.83	23.40	-21.91	15.80
5	A Pillar Mid	Y	g	13.25	37.65	-23.48	40.50
6	B Pillar Sill	Y	g	57.33	45.40	-88.36	40.75
7	B Pillar Low	Y	g	63.62	23.40	-124.67	15.65
8	B Pillar Mid	Y	g	28.88	11.15	-87.20	17.60
9	Seat	Y	g	6.66	80.45	-21.68	48.00
10	Engine Top	X	g	12.28	121.05	-20.72	42.00
	Engine Top	Y	g	2.42	255.75	-12.86	93.80
11	Firewall	Y	g	1.00	300.00	-11.76	83.00
12	Roof	Y	g	12.74	39.45	-41.57	33.45
13	Floor Sill (Right)	Y	g	35.76	27.65	-54.14	15.45
14	Rear Deck	X	g	3.20	34.85	-6.61	79.70
	Rear Deck	Y	g	1.16	195.00	-12.07	35.45

DATA SHEET NO. 11
DUMMY INJURY RESPONSE DATA
(Subpart U, ES-2re)

Test Vehicle: 2023 Ford Maverick 4 Door Truck NHTSA No.: C20230201
 Test Facility: Calspan Test Date: 03/02/2023

Dummy Serial No. D037

Description	Axes	Positive Direction		Negative Direction	
		MAX	TIME (ms)	MAX	TIME (ms)
HEAD ACCELERATION (g)					
Longitudinal	X	7.33	142.20	-20.13	47.70
Lateral	Y	9.86	135.10	-54.55	48.95
Vertical	Z	15.61	41.30	-8.19	58.20
Resultant	N/A	57.85	49.15		
HIC36 (t1, t2)	N/A	394.73		t1 = 39.85	t2 = 66.25
THORAX DEFLECTION (mm)					
Upper Rib	Y	24.87	58.60	-7.36	25.45
Middle Rib	Y	22.93	52.25	-3.78	83.25
Lower Rib	Y	24.53	51.10	-3.12	83.65
ABDOMINAL FORCES (N)					
Front	Y	315.71	44.35	-22.47	17.70
Middle	Y	301.73	53.35	-12.47	201.45
Rear	Y	421.62	53.45	-11.48	134.50
SUM	N/A	1009.83	43.85		
PELVIS FORCES (N)					
Pubic Symphysis	Y	68.80	297.25	-1451.16	60.45

Reference: Positive Direction - Longitudinal (X) = forward
 - Lateral (Y) = to right
 - Vertical (Z) = down

**DATA SHEET NO. 12
POST-TEST OBSERVATIONS**

Test Vehicle: 2023 Ford Maverick 4 Door Truck
 Test Facility: Calspan

NHTSA No.: C20230201
 Test Date: 03/02/2023

IMPACT POINT DATA

Measured Parameter	Units	Value
Vertical Impact Ref Line - Aft of Front Axle, Intended Impact Pt	mm	1284
Actual Impact Point - Aft of Front Axle	mm	1297
Difference	mm	13

TEST DUMMY INFORMATION AND CONTACT POINTS

Dummy Body Part	Front Passenger Seat Dummy (ES2re)
Head Contact	Curtain Airbag, Side Header & Head Restraint
Upper Torso Contact	Torso/Pelvis Airbag & Seat Back
Lower Torso Contact	Torso/Pelvis Airbag & Seat Back
Left Knee Contact	Right Knee
Right Knee Contact	Passenger Door Trim

POST-TEST DOOR PERFORMANCE

Description	Struck Side		Non-Struck Side		Rear Hatch/Other
	Front	Rear	Front	Rear	
Remained Closed and Operational	No	No	Yes	Yes	Yes
Total Separation from Vehicle at Hinges or Latches	No	No	No	No	No
Latch or Hinge Systems Pulled Out of Their Anchorages	No	No	No	No	No
Disengaged from Latched Position	No	No	No	No	No
Latch Separated from Striker	No	No	No	No	No
Jammed Shut	Yes	Yes	No	No	No
If Door Opened at Striker, Width of Opening at Striker (mm)	0	0	0	0	0

POST-TEST SEAT PERFORMANCE

Description	Struck Side		Non-Struck Side	
	Front	Rear	Front	Rear
Seat Movement Along Seat Track	No	No	No	No
Seat Disengagement from Floor Pan	No	No	No	No

POST-TEST STRUCTURAL OBSERVATIONS

Critical Areas of Performance	Observations and Conclusions
Pillar Performance	A-Pillar, B-Pillar & C-Pillar buckled
Sill Separation	314 mm of sill separation along pinch weld at impact area
Windshield Damage	Cracked Throughout
Side Window Damage	Front Passenger Window Shattered Completely
Other Notable Effects	None

**DATA SHEET NO. 12 ... (CONTINUED)
POST-TEST OBSERVATIONS**

Test Vehicle: 2023 Ford Maverick 4 Door Truck
 Test Facility: Calspan

NHTSA No.: C20230201
 Test Date: 03/02/2023

SUPPLEMENTAL RESTRAINT SYSTEM INFORMATION

Restraint Type	Struck Side Front Occupant	
	Mounted	Deployed
Front Airbag	Yes	No
Knee Airbag	Yes	No
Curtain Airbag	Yes	Yes
Torso/Pelvis Airbag	Yes	Yes
Seat Belt Pretensioner	Yes	Yes
Seat Belt Load Limiter	Yes	Yes
Other	N/A	N/A

DATA SHEET NO. 13
VEHICLE PRE TEST AND POST TEST MEASUREMENTS

Test Vehicle: 2023 Ford Maverick 4 Door Truck
 Test Facility: Calspan

NHTSA No.: C20230201
 Test Date: 03/02/2023

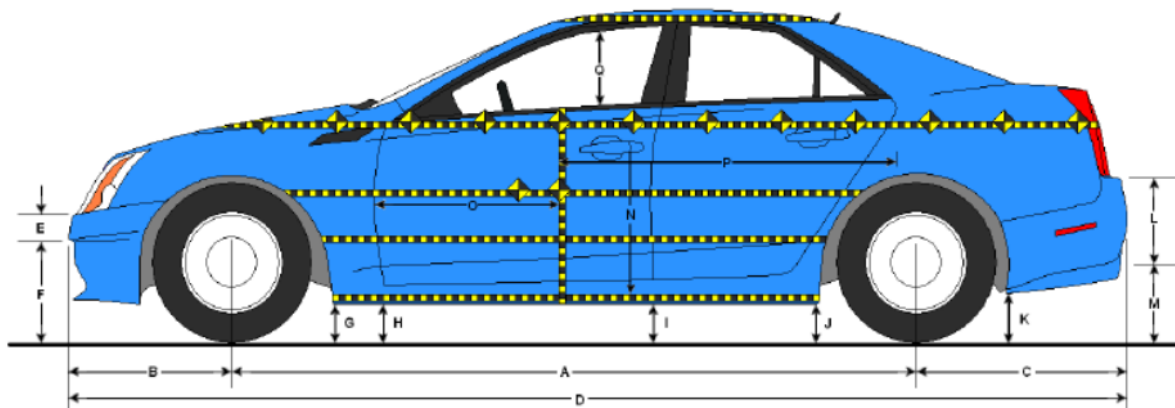

LEFT SIDE VIEW

VEHICLE PRE- AND POST-TEST MEASUREMENT INFORMATION

No.	Measurement Description	Pre-Test	Post-Test	Difference
A	Vehicle Wheelbase	3072	3089	-17
B	Front Axle to FSOV	869	822	47
C	Rear Axle to RSOV	1146	1141	4
D	Total Vehicle Length at Centerline	5087	5053	35
E	Front Bumper Thickness	110	110	0
F	Front Bumper Bottom to Ground	523	538	-15
G	Sill Height at Front Wheel Well	270	264	6
H	Sill Height at Front Door Leading Edge	269	262	7
I	Sill Height at B Pillar	284	261	23
J1	Sill Height at Rear Wheel Well	302	294	8
J2	Pinch Weld Height at Rear Wheel Well	272	271	1
K	Sill Height Aft of Rear Wheel Well	331	347	-16
L	Rear Bumper Thickness	95	95	0
M	Rear Bumper Bottom to Ground	473	476	-3
N	Sill Height to Window Bottom Sill	826	823	2
O	Front Door Leading Edge to Impact CL	769	689	80
P	Rear Door Trailing Edge to Impact CL	1158	1078	80
Q	Front Window Opening	452	440	12
R	Right Side Length	5024	4949	75
S	Left Side Length	5027	5014	13
T	Vehicle Width at B-Pillars	1818	1672	145

DATA SHEET NO. 14
TEST VEHICLE EXTERIOR CRUSH MEASUREMENTS

Test Vehicle: 2023 Ford Maverick 4 Door Truck
Test Facility: Calspan

NHTSA No.: C20230201
Test Date: 03/02/2023

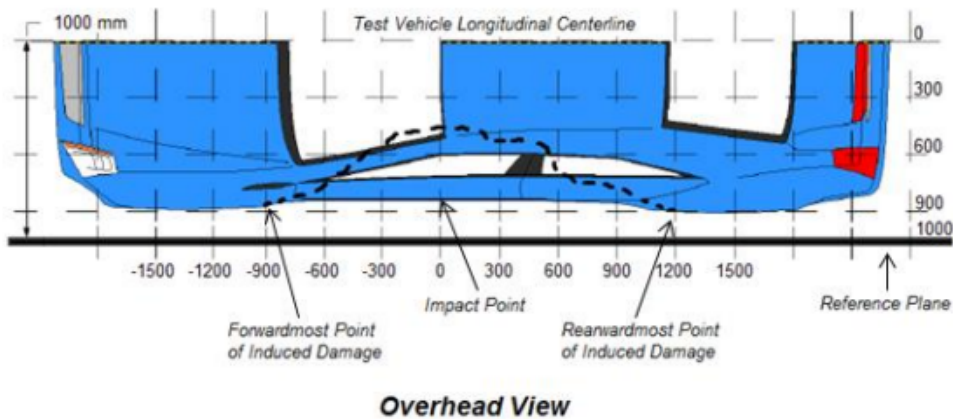
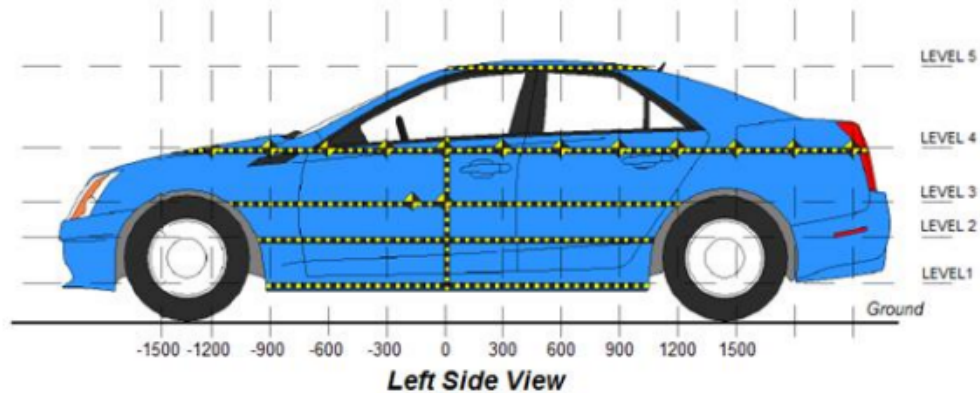

MAXIMUM EXTERIOR CRUSH MEASUREMENTS

Level	Measurement Description	Units	Height Above Ground	Maximum Exterior Static Crush	Distance from Impact
1	Sill Top	mm	424	270	0
2	Occupant H-Point	mm	713	329	0
3	Mid-Door	mm	767	332	0
4	Window Sill	mm	1073	310	0
5	Window Top	mm	1608	173	0

NOTE: The above measurements should be taken along the vertical impact reference line. Vehicle measurements forward of the vertical impact reference line are negative.

DATA SHEET NO. 14
VEHICLE EXTERIOR CRUSH MEASUREMENTS (CONTINUED)

Test Vehicle: 2023 Ford Maverick 4 Door Truck
 Test Facility: Calspan

NHTSA No.: C20230201
 Test Date: 03/02/2023

EXTERIOR CRUSH MEASUREMENTS AT EACH LEVEL

	Pre-Test					Post-Test					Difference				
	1	2	3	4	5	1	2	3	4	5	1	2	3	4	5
-1500				-867					-881					14	
-1350		-912	-912	-868			-942	-939	-880			30	27	12	
-1200	-872	-903	-904	-870		-939	-936	-933	-880		67	33	29	10	
-1050	-858	-901	-902	-873	-676	-893	-904	-903	-866	-665	35	3	1	-7	-11
-900	-850	-901	-903	-867	-676	-837	-872	-871	-833	-654	-13	-29	-32	-34	-22
-750	-852	-904	-905	-877	-676	-807	-843	-840	-813	-637	-45	-61	-65	-64	-39
-600	-855	-907	-907	-876	-675	-780	-817	-812	-783	-618	-75	-90	-95	-93	-57
-450	-858	-908	-909	-875	-674	-752	-791	-787	-752	-593	-106	-117	-122	-123	-81
-300	-860	-909	-910	-875	-671	-724	-770	-769	-721	-561	-136	-139	-141	-154	-110
-150	-861	-909	-910	-871	-668	-621	-605	-601	-591	-531	-240	-304	-309	-280	-137
0	-863	-908	-908	-869	-659	-593	-579	-576	-559	-486	-270	-329	-332	-310	-173
150	-863	-906	-907	-864		-684	-654	-655	-635		-179	-252	-252	-229	
300	-863	-905	-905	-856		-767	-735	-732	-706		-96	-170	-173	-150	
450	-865	-904	-904	-847		-813	-813	-805	-778		-52	-91	-99	-69	
600	-873	-904	-903	-842		-858	-878	-870	-836		-15	-26	-33	-6	
750	-889	-907	-906	-843		-915	-938	-934	-865		26	31	28	22	
900		-913	-916	-841			-935	-937	-864			22	21	23	
1050				-833					-867					34	
1200				-823					-866					43	
1350															
1500															

DATA SHEET NO. 14
TEST VEHICLE EXTERIOR CRUSH MEASUREMENTS (CONTINUED)

Test Vehicle: 2023 Ford Maverick 4 Door Truck
 Test Facility: Calspan

NHTSA No.: C20230201
 Test Date: 03/02/2023

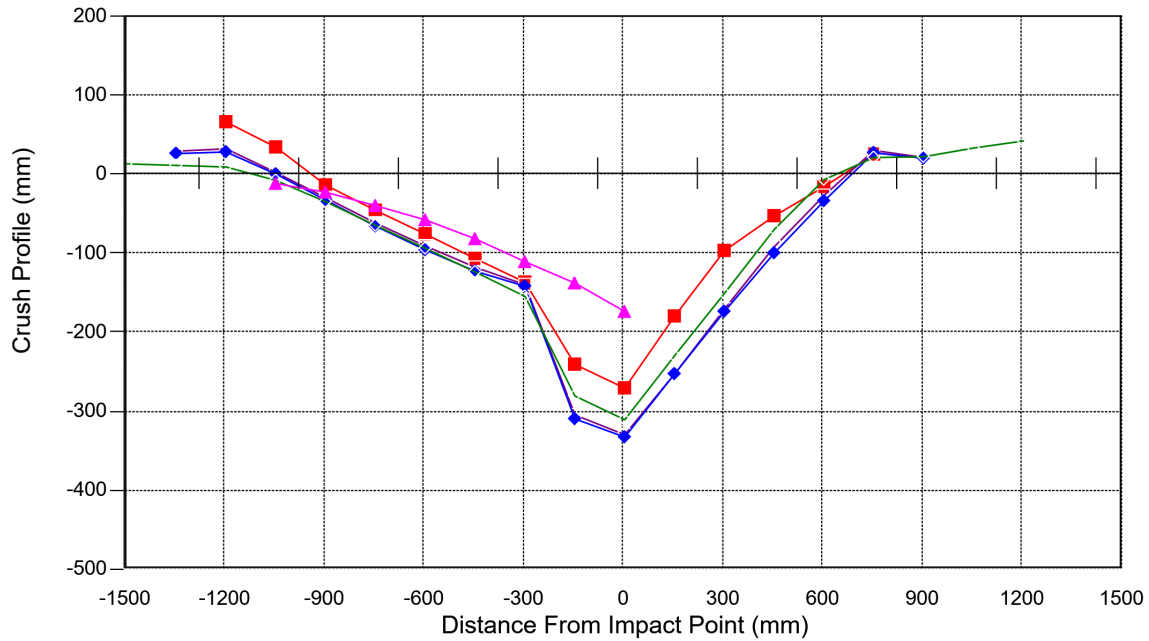

— LEVEL 1 Side Sill: 424 mm above ground	— LEVEL 2 H-Point: 713 mm above ground	— LEVEL 3 Mid Door: 767 mm above ground
— LEVEL 4 Window Sill: 1073 mm above ground	— LEVEL 5 Window Top: 1608 mm above ground	

Vehicle Exterior Crush Measurements - Visual Representation

DATA SHEET NO. 16
DUMMY / VEHICLE TEMPERATURE AND HUMIDITY STABILIZATION DATA

Test Vehicle: 2023 Ford Maverick 4 Door Truck
Test Facility: Calspan

NHTSA No.: C20230201
Test Date: 03/02/2023

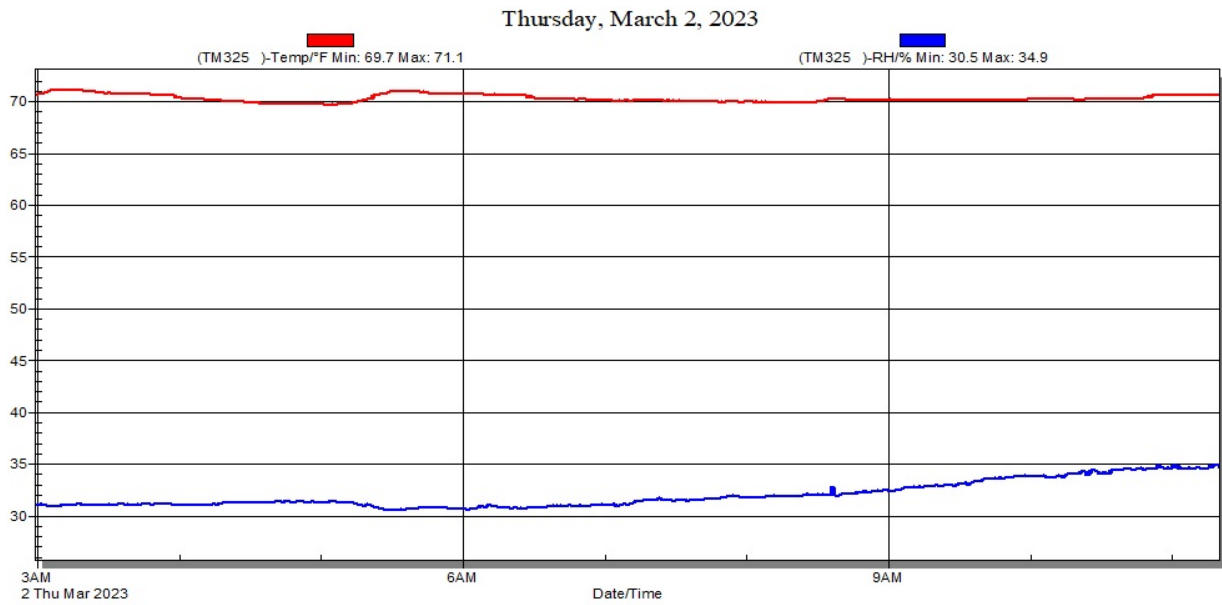

Temperature and Humidity Stabilization Chart/Data for Dummies and Test Vehicle

APPENDIX I
PHOTOGRAPHS

TABLE OF PHOTOGRAPHS

Fig.	Description	Page
1	Pre-Test Frontal View of Test Vehicle	I-3
2	Post Test Frontal View of Test Vehicle	I-3
3	Pre-Test Rear View of Test Vehicle	I-4
4	Post-Test Rear View of Test Vehicle	I-4
5	Pre-Test Impacted Side View of Test Vehicle	I-5
6	Post-Test Impacted Side View of Test Vehicle	I-5
7	Pre-Test Impacted Side $\frac{3}{4}$ Front View of Vehicle and Pole	I-6
8	Pre-Test Impacted Side $\frac{3}{4}$ Rear View of Vehicle and Pole	I-6
9	Pre-Test Overhead View of Test Vehicle	I-7
10	Post-Test Overhead View of Test Vehicle	I-7
11	Pre-Test Dummy Through Opposite Window	I-8
12	Post-Test Dummy Through Opposite Window	I-8
13	Pre-Test Close-Up of Dummy with Door Closed (Impact Side)	I-9
14	Post-Test Close-Up of Dummy with Door Closed (Impact Side)	I-9
15	Pre-Test Dummy with Door Open	I-10
16	Pre-Test Dummy Shoulder and Door Top View	I-10
17	Post-Test Dummy Shoulder and Door Top View	I-11
18	Pre-Test Interior of Front Door Closed (through opposite window)	I-11
19	Post-Test Interior of Front Door Showing Dummy Impact Locations	I-12
20	Impact Event	I-12
21	Post-Test Impact Zone Close-Up View	I-13
22	Post-Test $\frac{3}{4}$ Front View of Impact Zone	I-13
23	Post-Test $\frac{3}{4}$ Rear View of Impact Zone	I-14
24	Post-Test Close-Up View of Impact Point Target	I-14
25	Close-Up View of Vehicle's Certification Label	I-15
26	Close-Up View of Vehicle's Tire Placard Label	I-15

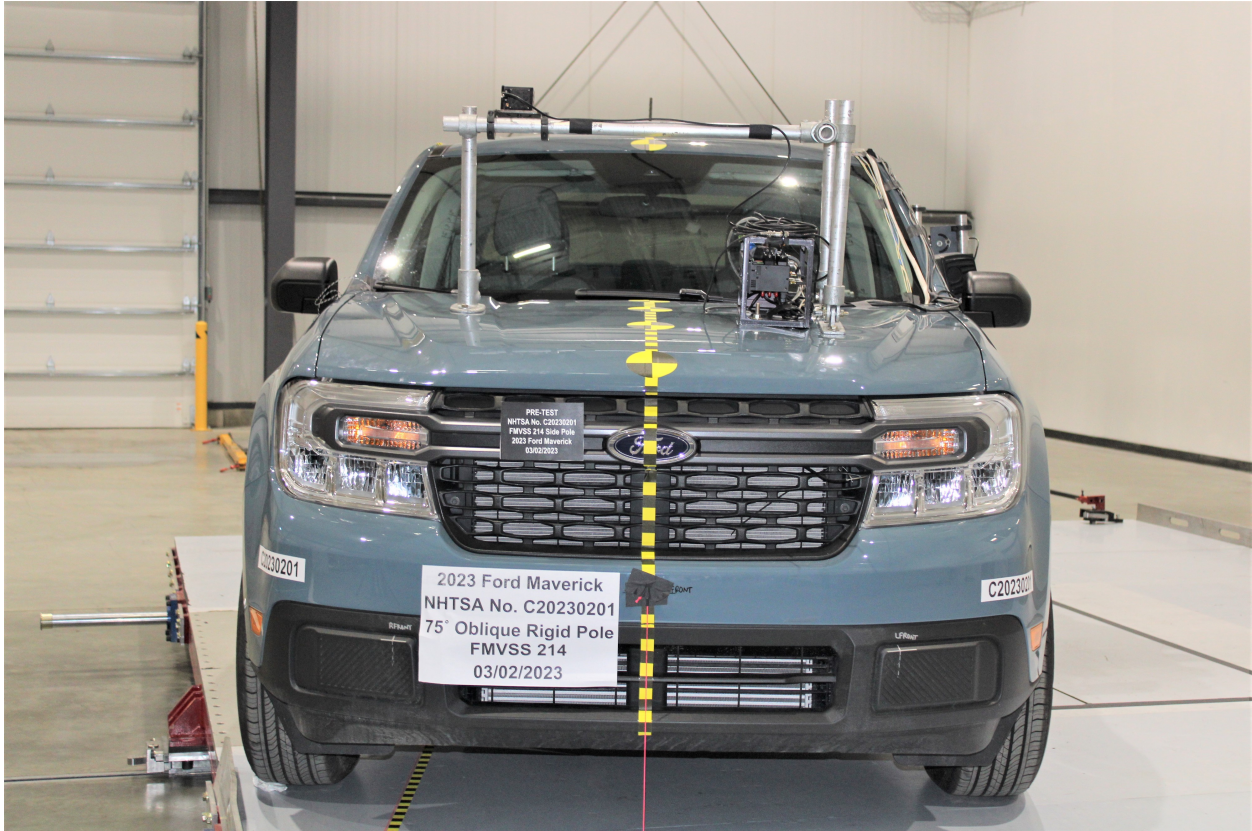

Figure A-1: Pre-Test Frontal View of Test Vehicle



Figure A-2: Post Test Frontal View of Test Vehicle

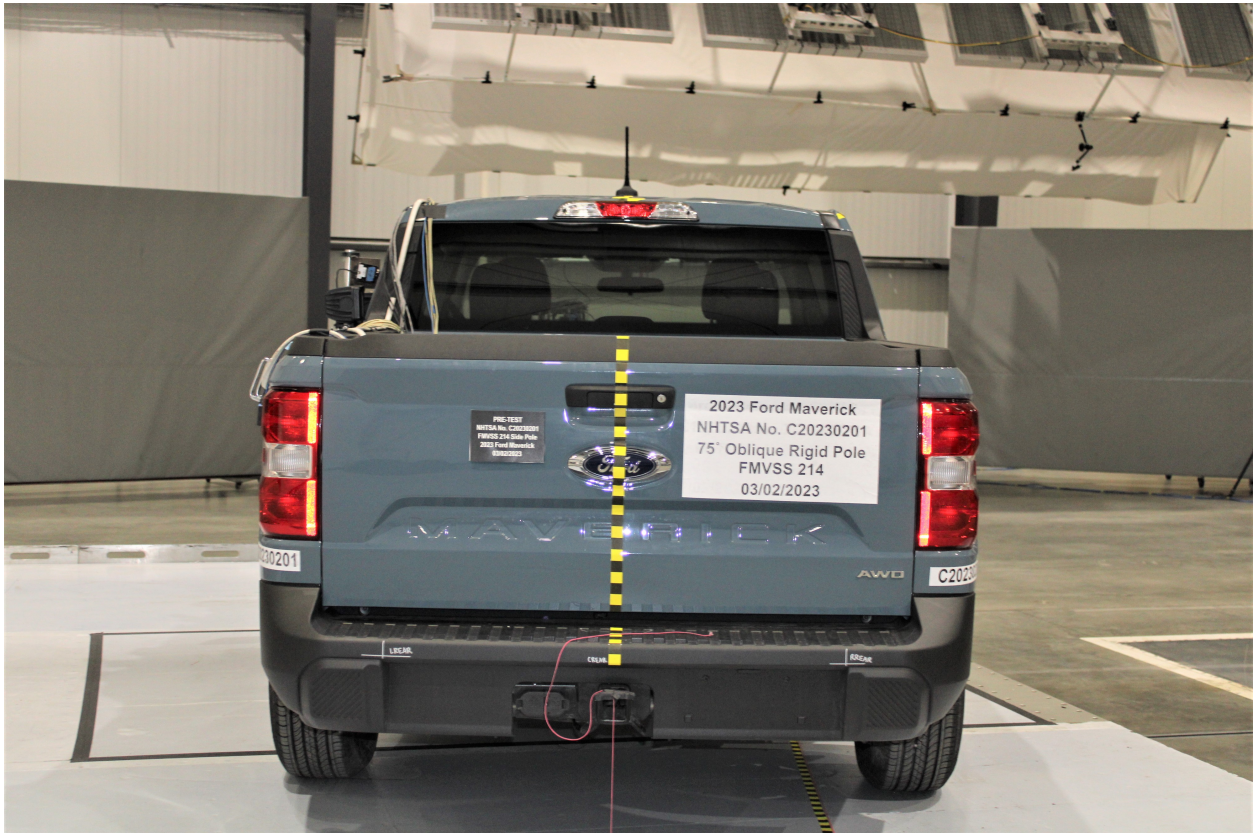

Figure A-3: Pre-Test Rear View of Test Vehicle



Figure A-4: Post-Test Rear View of Test Vehicle

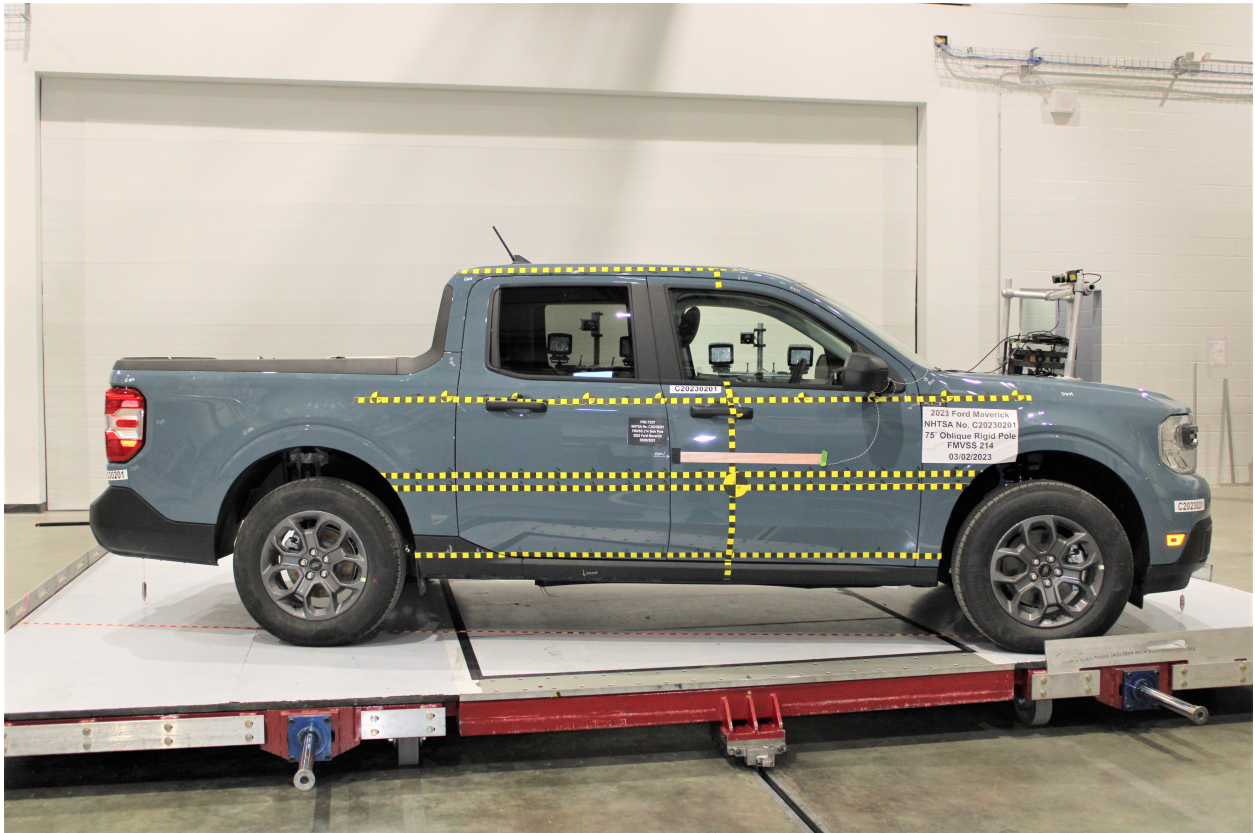

Figure A-5: Pre-Test Impacted Side View of Test Vehicle



Figure A-6: Post-Test Impacted Side View of Test Vehicle

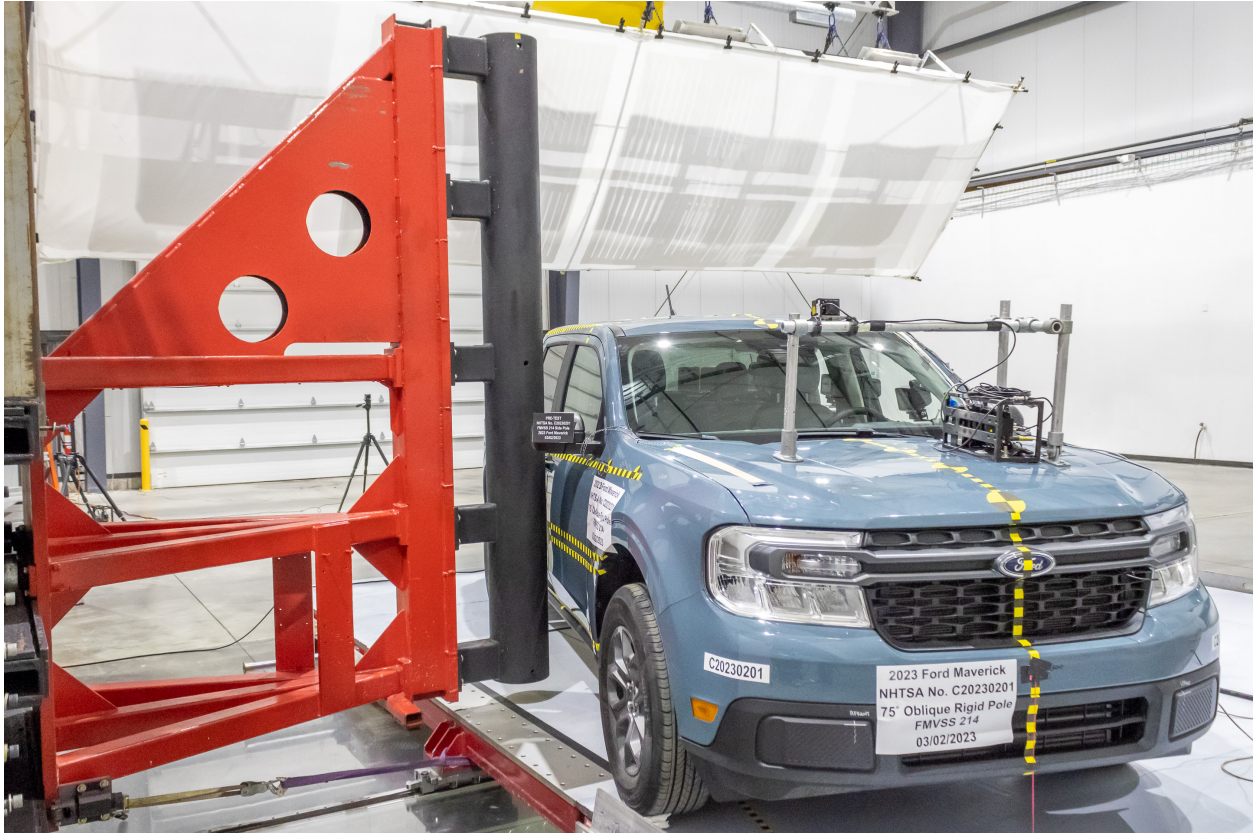

Figure A-7: Pre-Test Impacted Side $\frac{3}{4}$ Front View of Vehicle and Pole



Figure A-8: Pre-Test Impacted Side $\frac{3}{4}$ Rear View of Vehicle and Pole

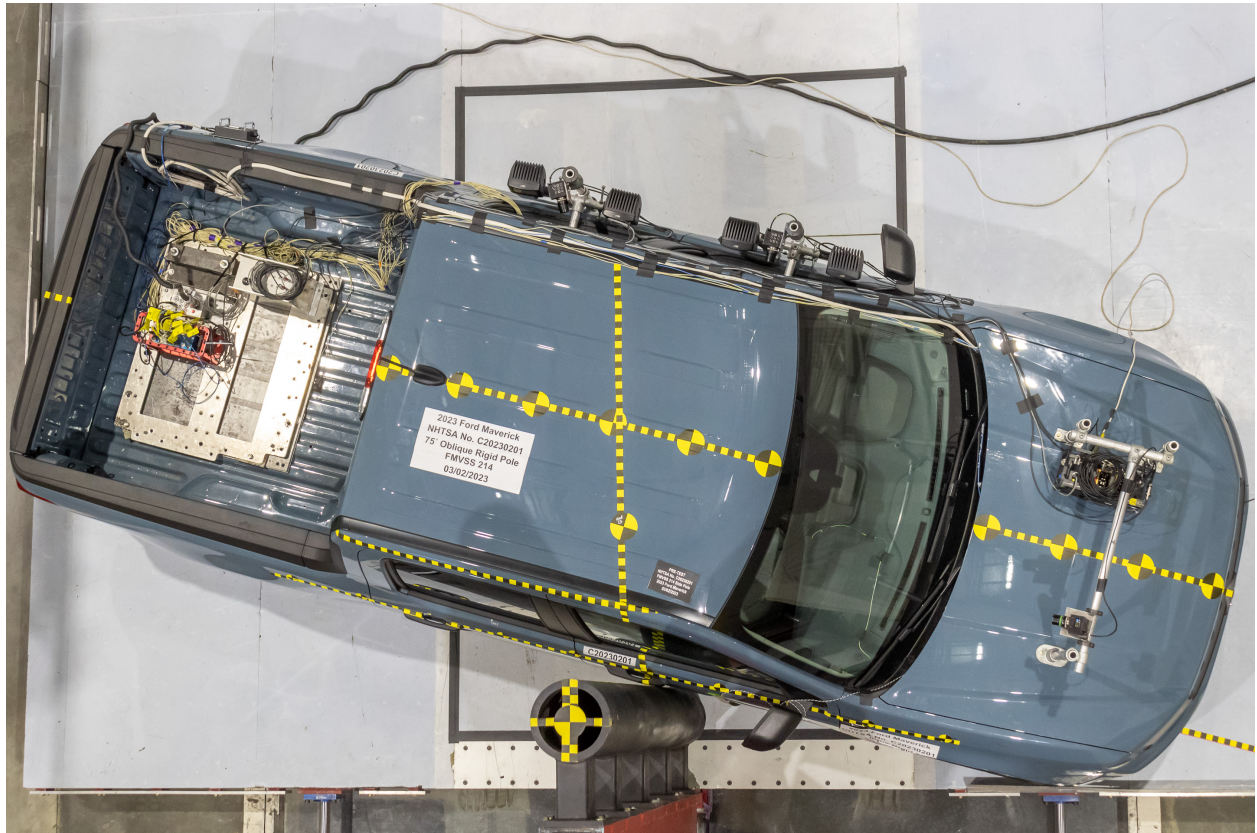

Figure A-9: Pre-Test Overhead View of Test Vehicle

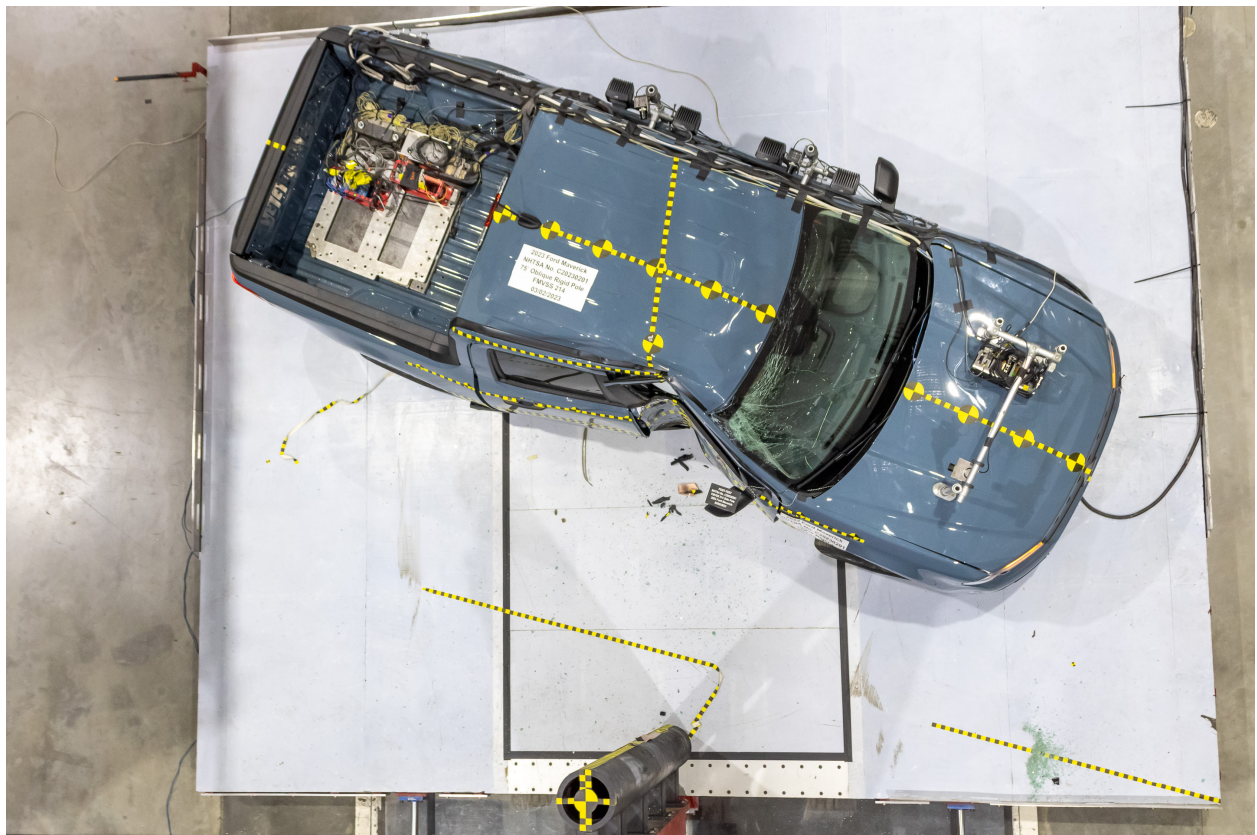

Figure A-10: Post-Test Overhead View of Test Vehicle



Figure A-11: Pre-Test Dummy Through Opposite Window



Figure A-12: Post-Test Dummy Through Opposite Window



Figure A-13: Pre-Test Close-Up of Dummy with Door Closed (Impact Side)



Figure A-14: Post-Test Close-Up of Dummy with Door Closed (Impact Side)



Figure A-15: Pre-Test Dummy with Door Open



Figure A-16: Pre-Test Dummy Shoulder and Door Top View



Figure A-17: Post-Test Dummy Shoulder and Door Top View



Figure A-18: Pre-Test Interior of Front Door Closed (through opposite window)



Figure A-19: Post-Test Interior of Front Door Showing Dummy Impact Locations



Figure A-20: Impact Event



Figure A-21: Post-Test Impact Zone Close-Up View



Figure A-22: Post-Test ¾ Front View of Impact Zone



Figure A-23: Post-Test $\frac{3}{4}$ Rear View of Impact Zone



Figure A-24: Post-Test Close-Up View of Impact Point Target

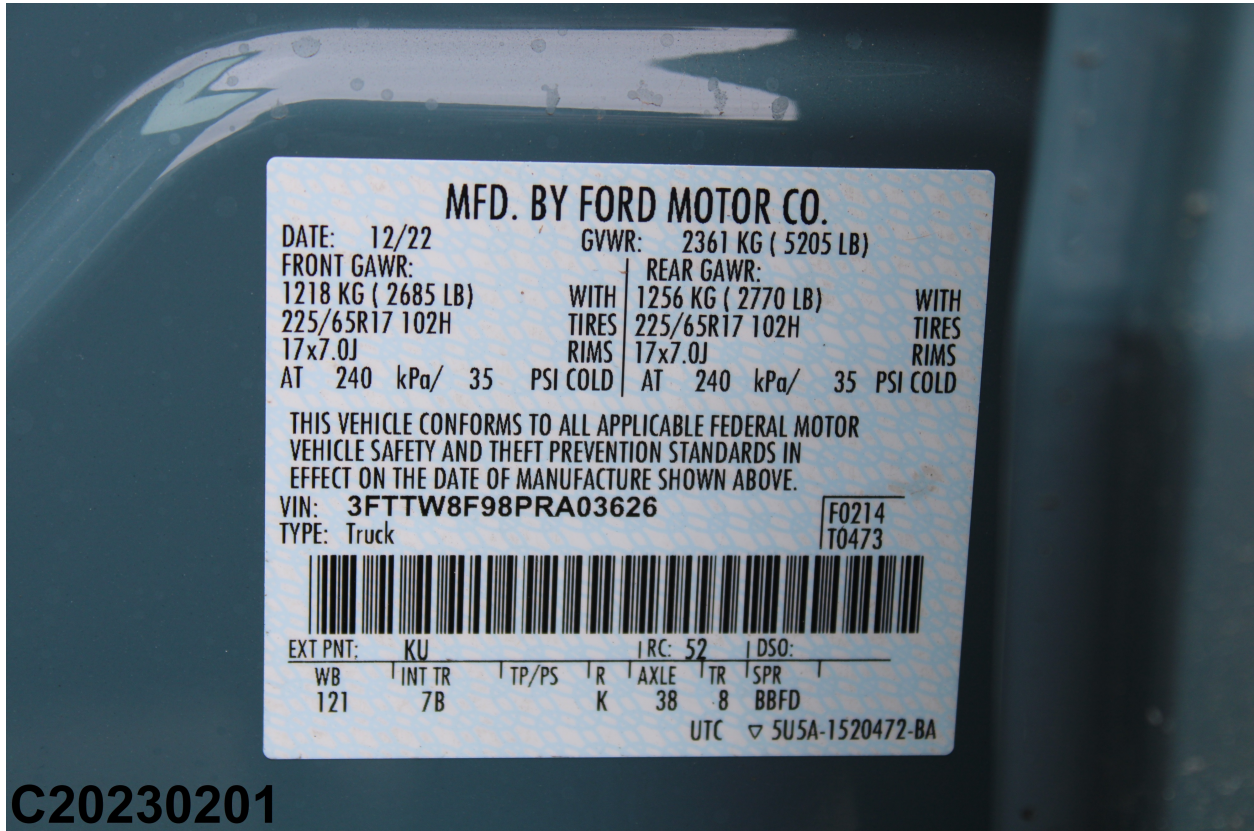

C20230201

Figure A-25: Close-Up View of Vehicle's Certification Label



C20230201

Figure A-26: Close-Up View of Vehicle's Tire Placard Label

APPENDIX II
ES-2re DUMMY RESPONSE DATA TRACES

Table of Data Plots

No.	Description	Page
1	ES-2re Head (X) Acceleration vs. Time	II-3
2	ES-2re Head (Y) Acceleration vs. Time	II-3
3	ES-2re Head (Z) Acceleration vs. Time	II-3
4	ES-2re Head Resultant Acceleration vs. Time	II-3
5	ES-2re Head (X) Velocity vs. Time	II-4
6	ES-2re Head (Y) Velocity vs. Time	II-4
7	ES-2re Head (Z) Velocity vs. Time	II-4
8	ES-2re Upper Thorax Rib Deflection Rate vs. Time	II-4
9	ES-2re Upper Thorax Rib Deflection (Y) vs. Time	II-5
10	ES-2re Middle Thorax Rib Deflection Rate vs. Time	II-5
11	ES-2re Lower Thorax Rib Deflection Rate vs. Time	II-5
12	ES-2re Middle Thorax Rib Deflection (Y) vs. Time	II-5
13	ES-2re Lower Thorax Rib Deflection (Y) vs. Time	II-6
14	ES-2re Front Abdomen Force (Y) vs. Time	II-6
15	ES-2re Middle Abdomen Force (Y) vs. Time	II-6
16	ES-2re Rear Abdomen Force (Y) vs. Time	II-6
17	ES-2re Sum of Abdomen Forces vs. Time	II-7
18	ES-2re Pubic Symphysis Force (Y) vs. Time	II-7

ES-2re Head (X) Acceleration vs. Time

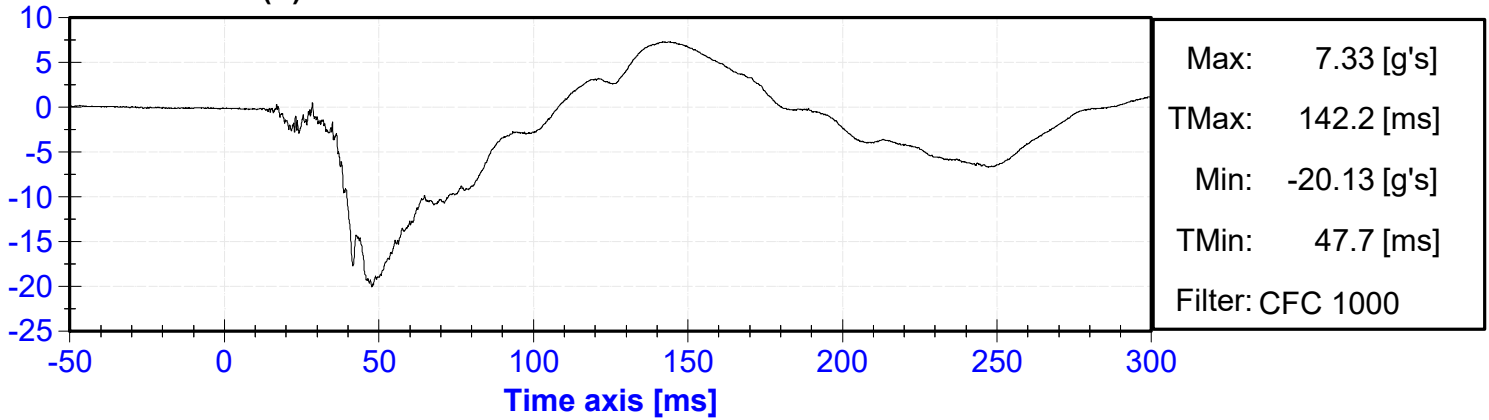

ES-2re Head (Y) Acceleration vs. Time

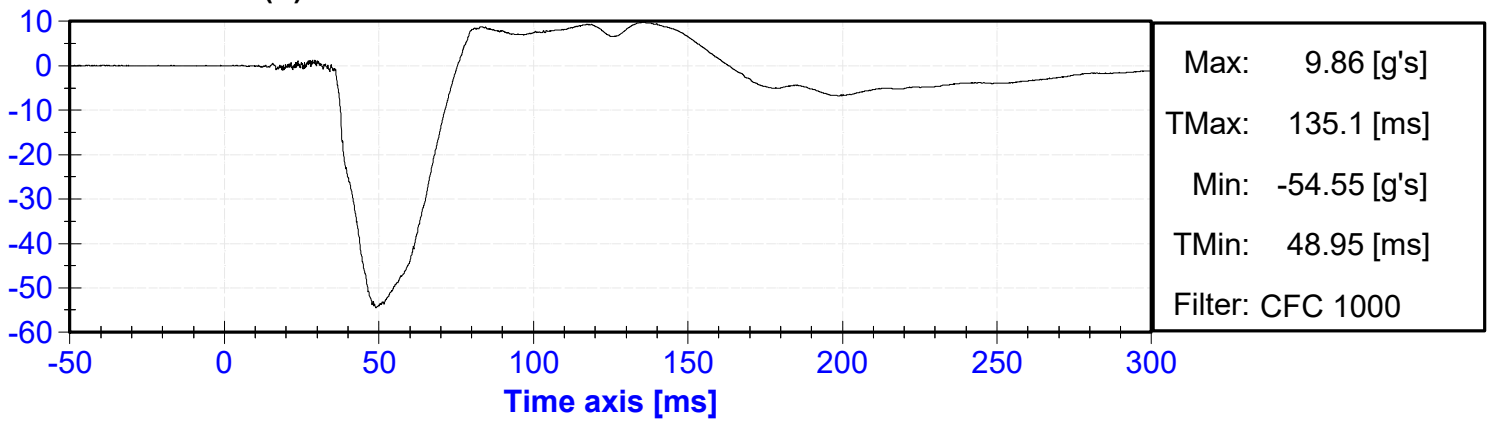

ES-2re Head (Z) Acceleration vs. Time

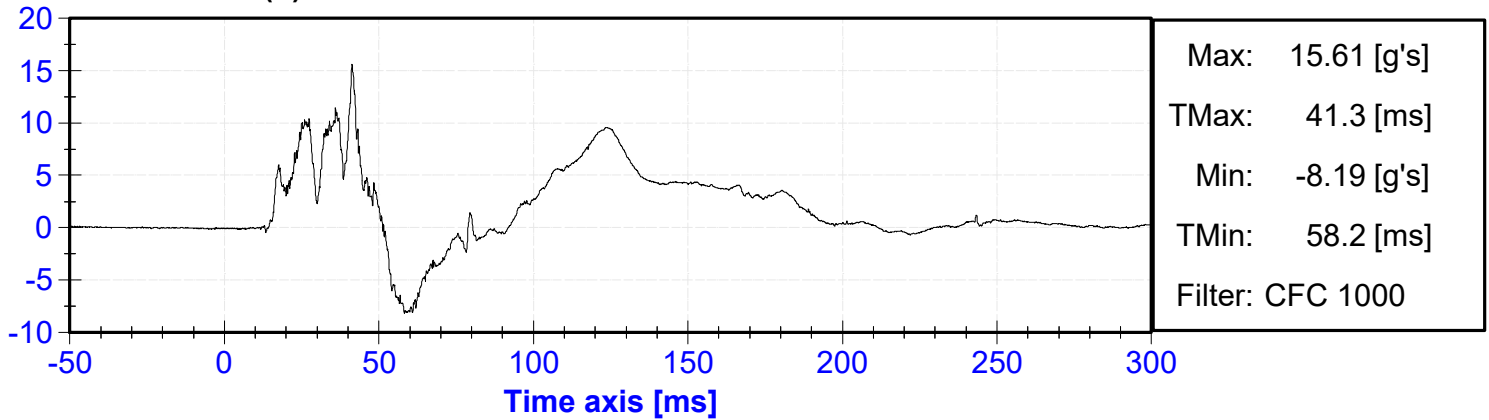

ES-2re Head Resultant Acceleration vs. Time

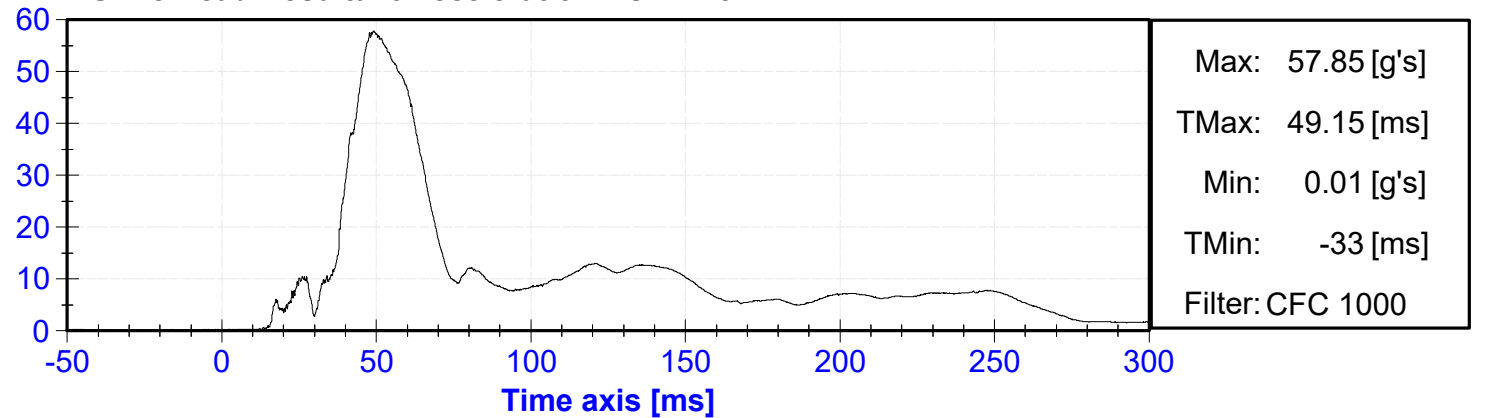

ES-2re Head (X) Velocity vs. Time

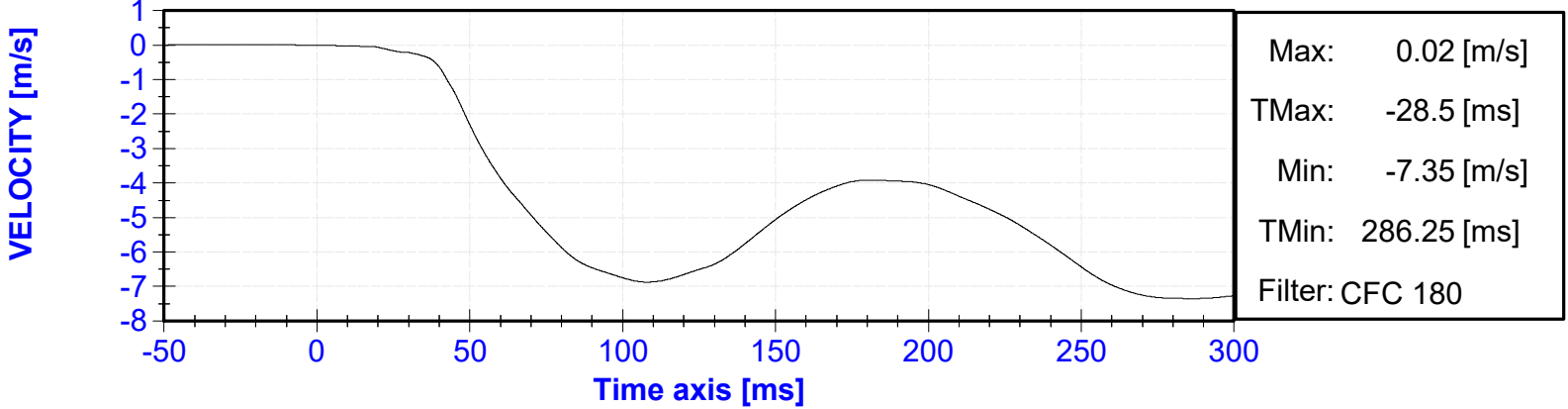

ES-2re Head (Y) Velocity vs. Time

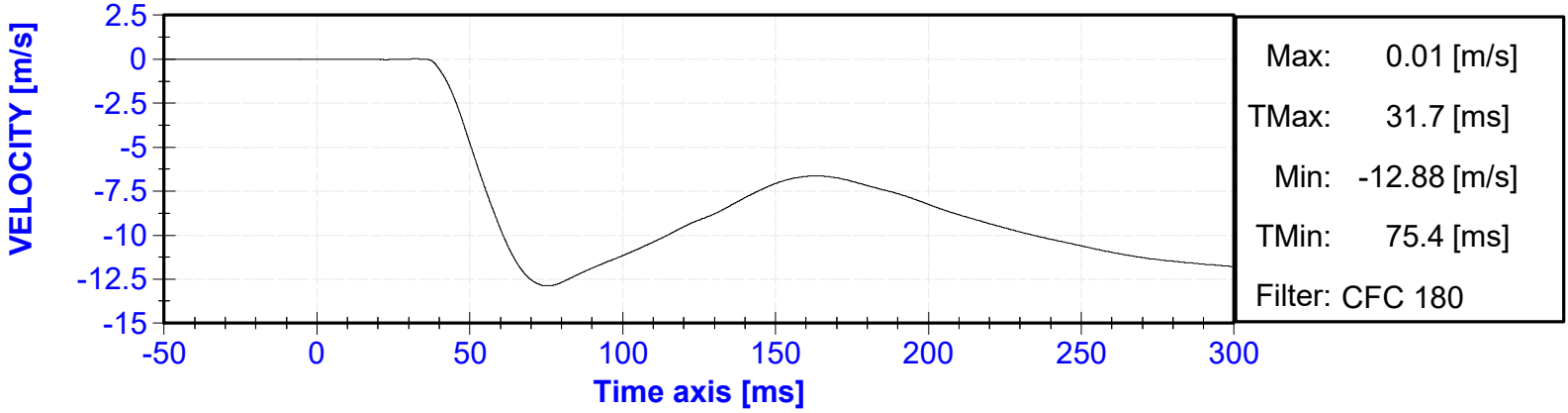

ES-2re Head (Z) Velocity vs. Time

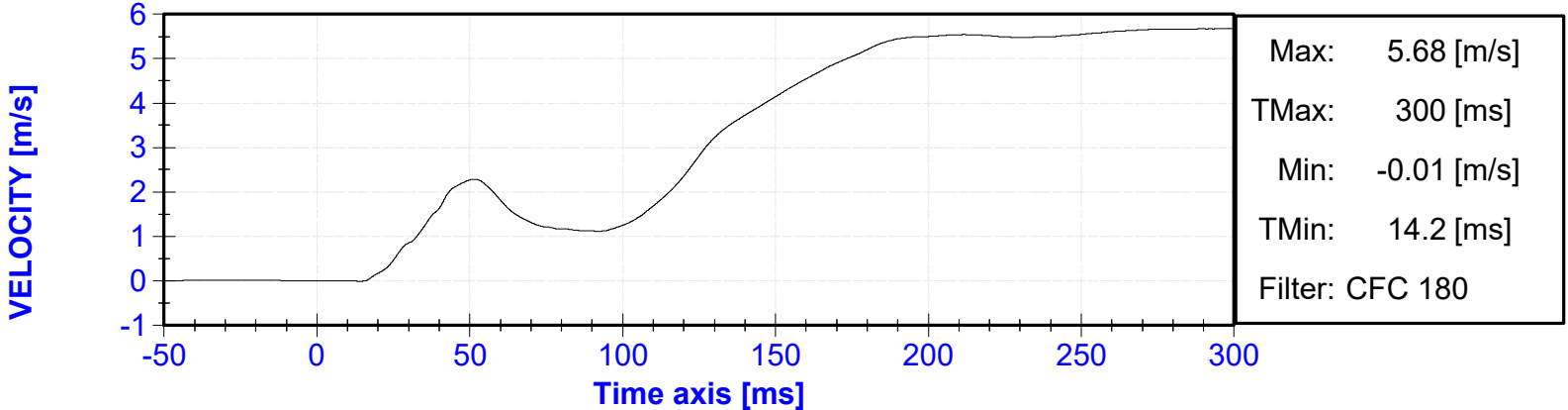

ES-2re Upper Thorax Rib Deflection Rate vs. Time

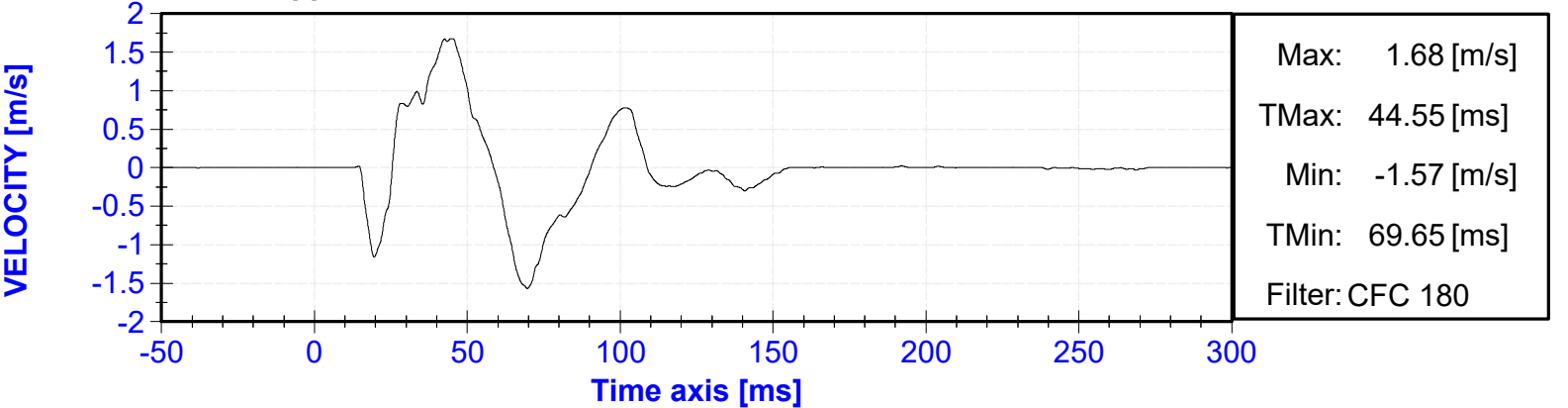

ES-2re Upper Thorax Rib Deflection (Y) vs. Time

DISPLACEMENT [mm]

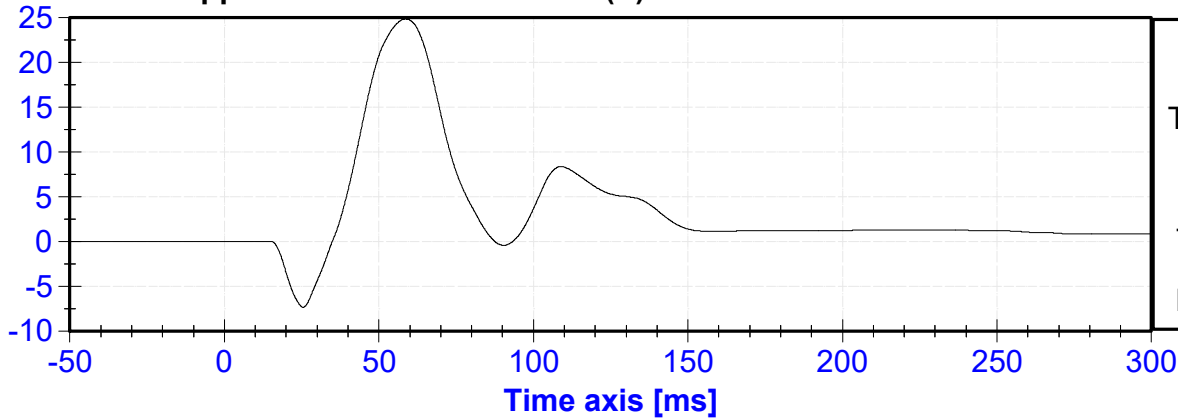

ES-2re Middle Thorax Rib Deflection Rate vs. Time

VELOCITY [m/s]

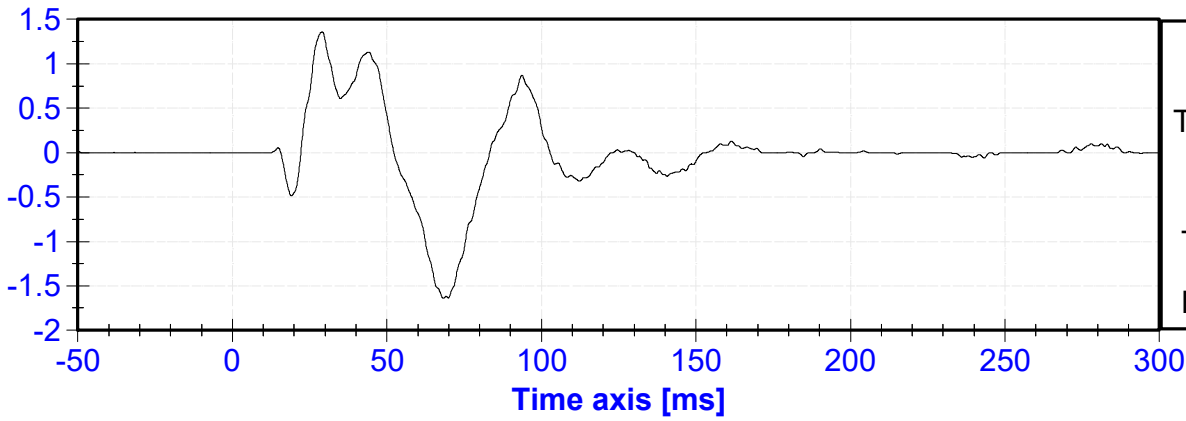

ES-2re Lower Thorax Rib Deflection Rate vs. Time

VELOCITY [m/s]

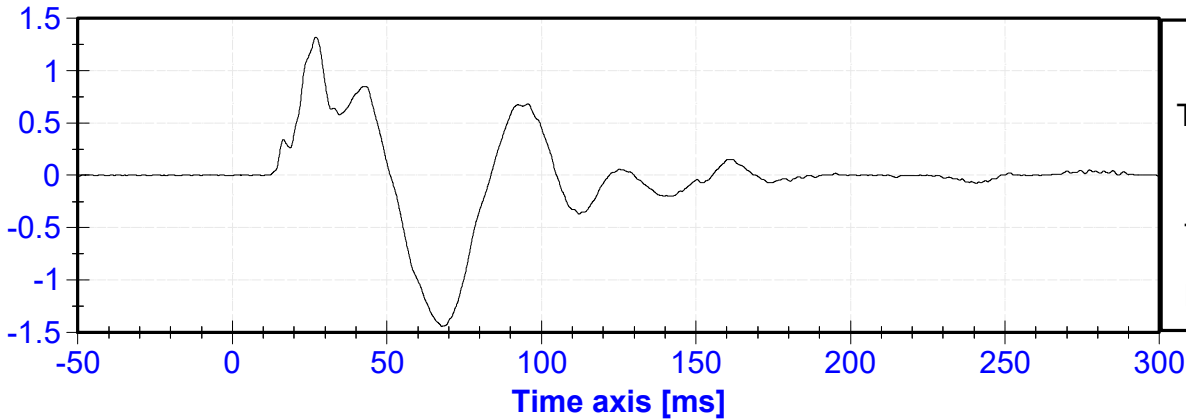

ES-2re Middle Thorax Rib Deflection (Y) vs. Time

DISPLACEMENT [mm]

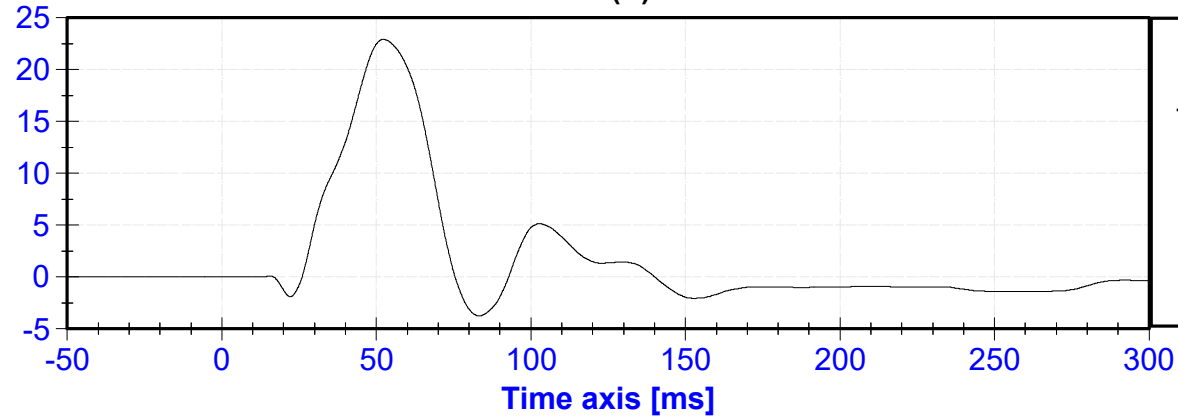

ES-2re Lower Thorax Rib Deflection (Y) vs. Time

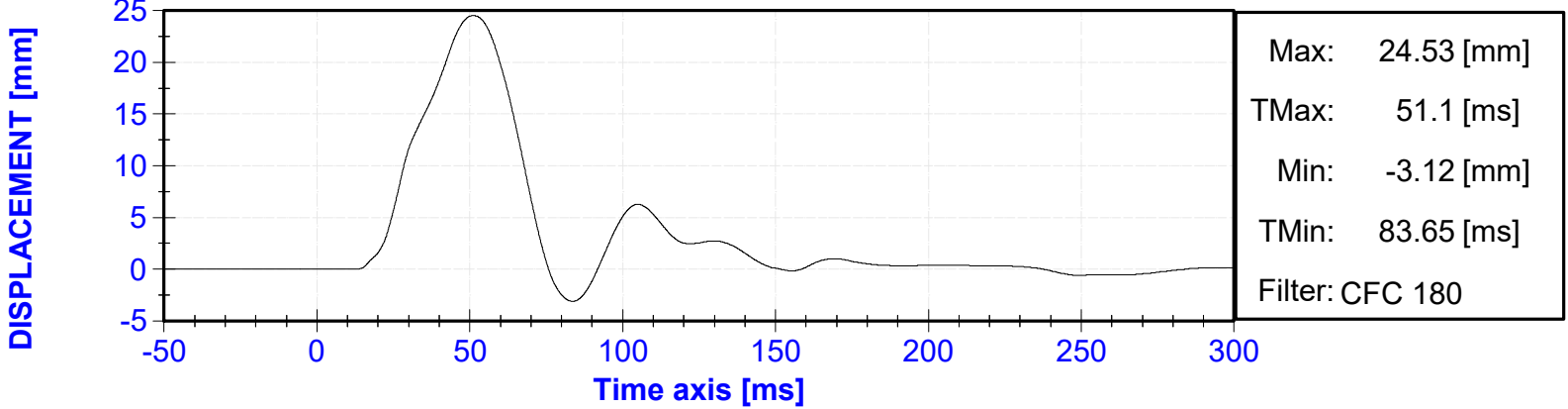

ES-2re Front Abdomen Force (Y) vs. Time

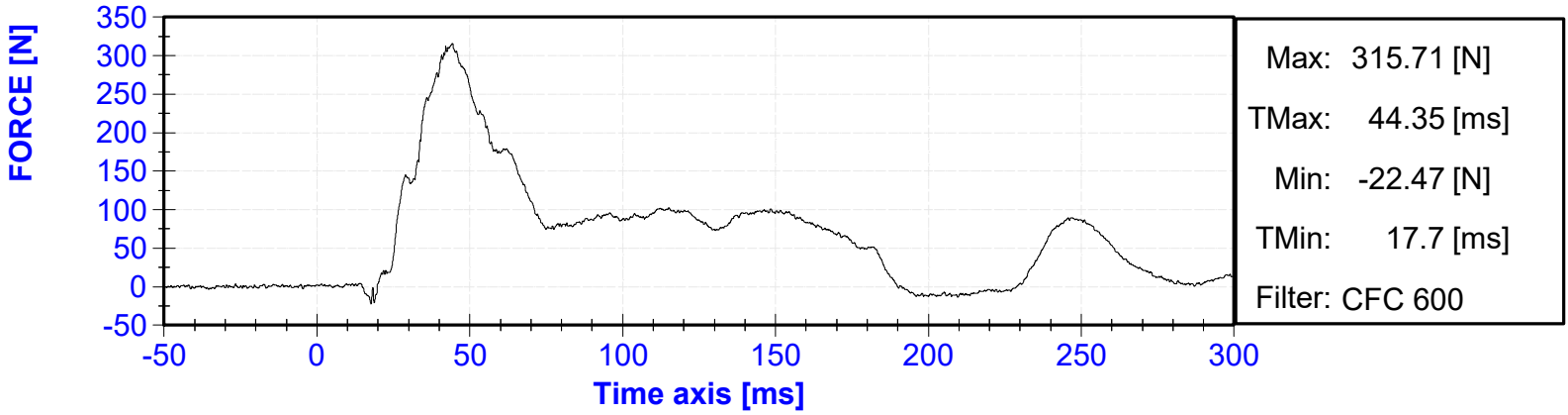

ES-2re Middle Abdomen Force (Y) vs. Time

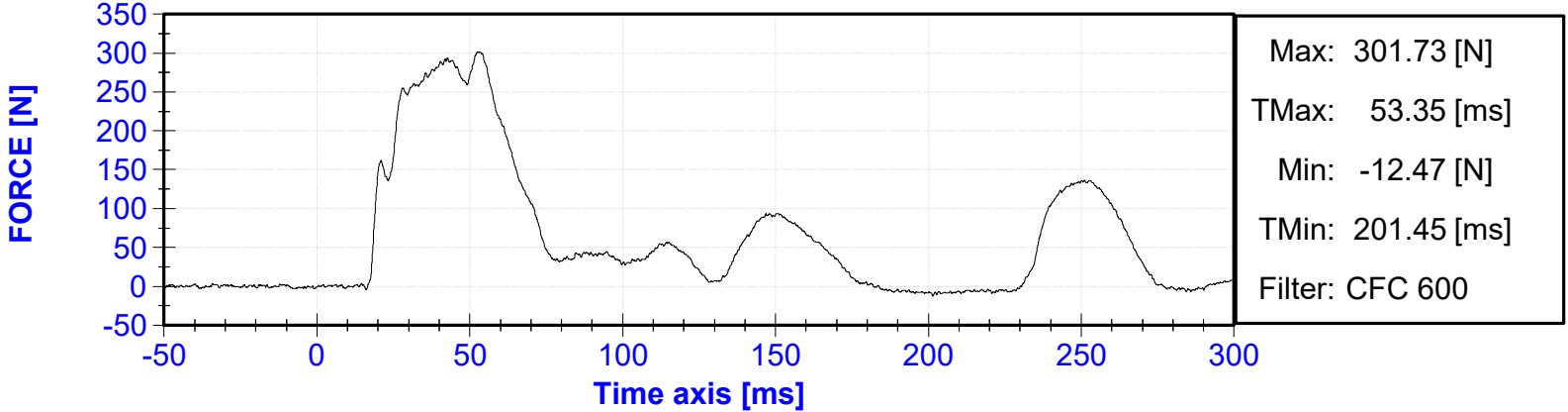

ES-2re Rear Abdomen Force (Y) vs. Time

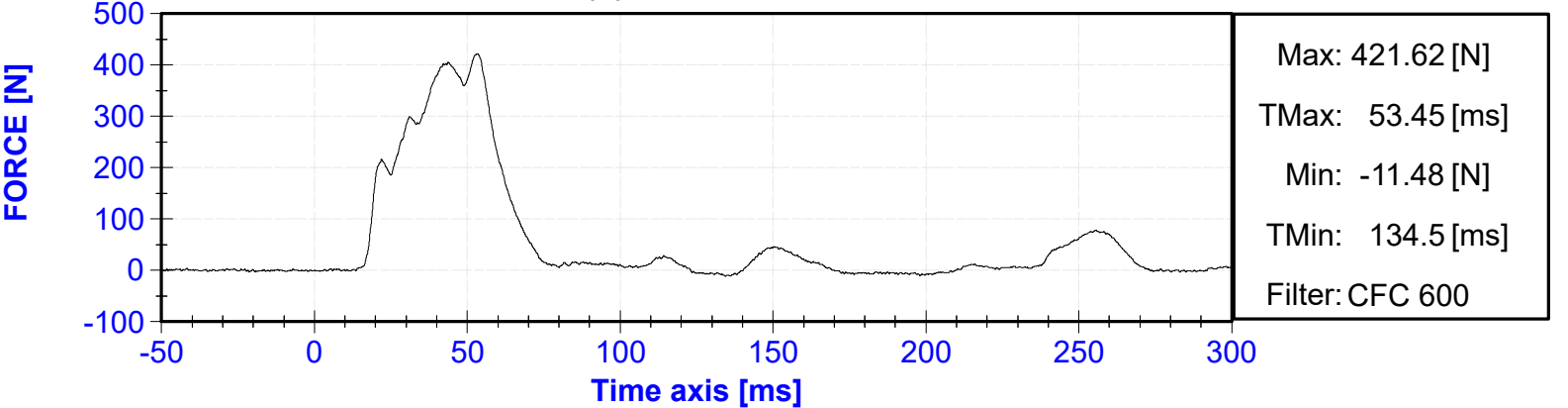

ES-2re Sum of Abdomen Forces vs. Time

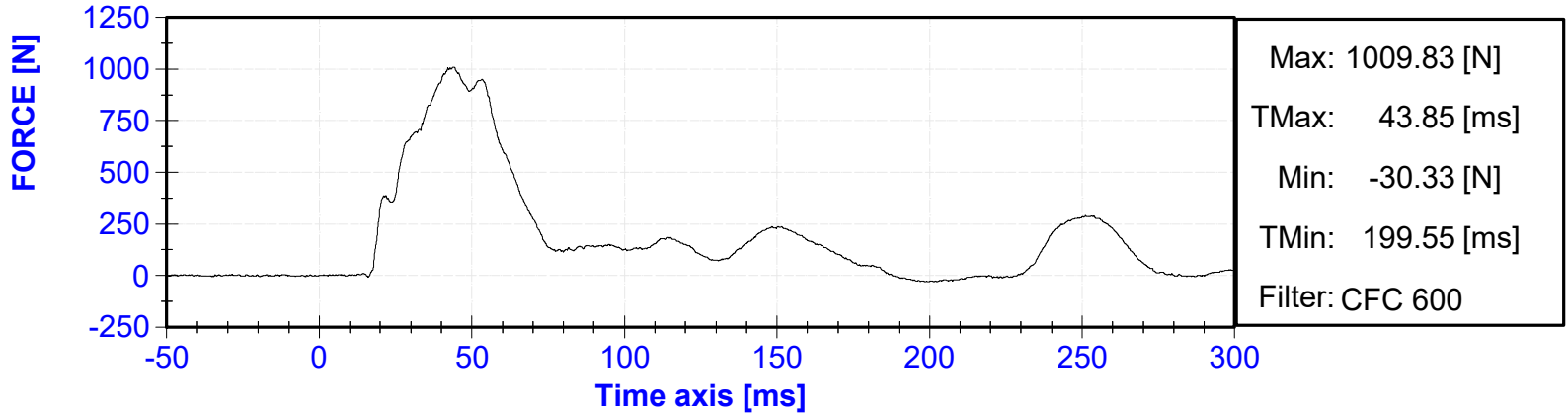

ES-2re Pubic Symphysis Force (Y) vs. Time

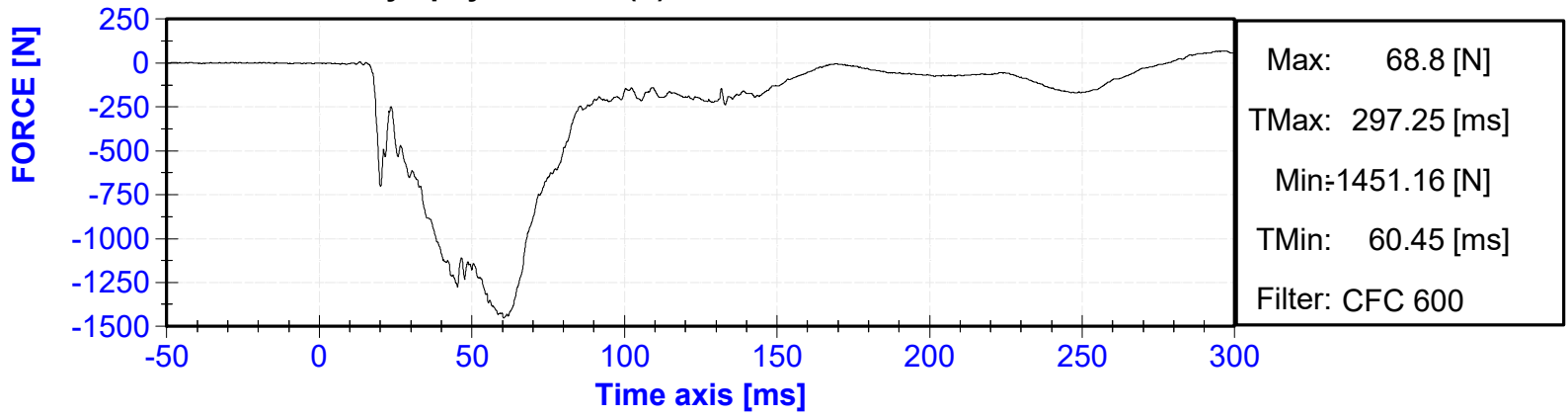

APPENDIX III
VEHICLE & DUMMY RESPONSE TRACES

Table of Data Plots

No.	Description	Page
1	Vehicle Center of Gravity (X) Acceleration vs. Time	III-3
2	Vehicle Center of Gravity (X) Velocity vs. Time	III-3
3	Vehicle Center of Gravity (Y) Acceleration vs. Time	III-3
4	Vehicle Center of Gravity (Y) Velocity vs. Time	III-3
5	Vehicle Center of Gravity (Z) Acceleration vs. Time	III-4
6	Vehicle Center of Gravity (Z) Velocity vs. Time	III-4
7	Vehicle Center of Gravity Resultant Acceleration vs. Time	III-4
8	Floor Sill – Impact Side (Y) Acceleration vs. Time	III-4
9	Floor Sill – Impact Side (Y) Velocity vs. Time	III-5
10	Floor Sill – Impact Side (Y) Displacement vs. Time	III-5
11	A-Pillar Sill (Y) Acceleration vs. Time	III-5
12	A-Pillar Sill (Y) Velocity vs. Time	III-5
13	A-Pillar Sill (Y) Displacement vs. Time	III-6
14	A-Pillar Low (Y) Acceleration vs. Time	III-6
15	A-Pillar Low (Y) Velocity vs. Time	III-6
16	A-Pillar Low (Y) Displacement vs. Time	III-6
17	A-Pillar Mid (Y) Acceleration vs. Time	III-7
18	A-Pillar Mid (Y) Velocity vs. Time	III-7
19	A-Pillar Mid (Y) Displacement vs. Time	III-7
20	B-Pillar Sill (Y) Acceleration vs. Time	III-7
21	B-Pillar Sill (Y) Velocity vs. Time	III-8
22	B-Pillar Sill (Y) Displacement vs. Time	III-8
23	B-Pillar Low (Y) Acceleration vs. Time	III-8
24	B-Pillar Low (Y) Velocity vs. Time	III-8
25	B-Pillar Low (Y) Displacement vs. Time	III-9
26	B-Pillar Mid (Y) Acceleration vs. Time	III-9
27	B-Pillar Mid (Y) Velocity vs. Time	III-9
28	B-Pillar Mid (Y) Displacement vs. Time	III-9
29	Seat (Y) Acceleration vs. Time	III-10
30	Seat (Y) Velocity vs. Time	III-10
31	Seat (Y) Displacement vs. Time	III-10
32	Engine (X) Acceleration vs. Time	III-10
33	Engine (X) Velocity vs. Time	III-11
34	Engine (Y) Acceleration vs. Time	III-11
35	Engine (Y) Velocity vs. Time	III-11
36	Firewall (Y) Acceleration vs. Time	III-11
37	Firewall (Y) Velocity vs. Time	III-12
38	Roof (Y) Acceleration vs. Time	III-12
39	Roof (Y) Velocity vs. Time	III-12
40	Floor Sill – Non Impact Side (Y) Acceleration vs. Time	III-12
41	Floor Sill – Non Impact Side (Y) Velocity vs. Time	III-13
42	Rear Deck (X) Acceleration vs. Time	III-13
43	Rear Deck (X) Velocity vs. Time	III-13
44	Rear Deck (Y) Acceleration vs. Time	III-13
45	Rear Deck (Y) Velocity vs. Time	III-14

Vehicle Center of Gravity (X) Acceleration vs. Time

ACCELERATION [g's]

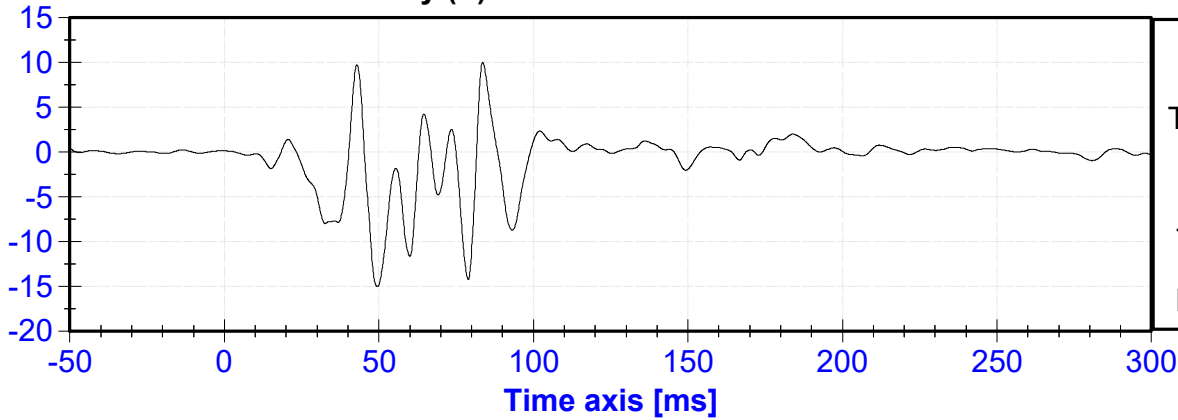

Vehicle Center of Gravity (X) Velocity vs. Time

VELOCITY [m/s]

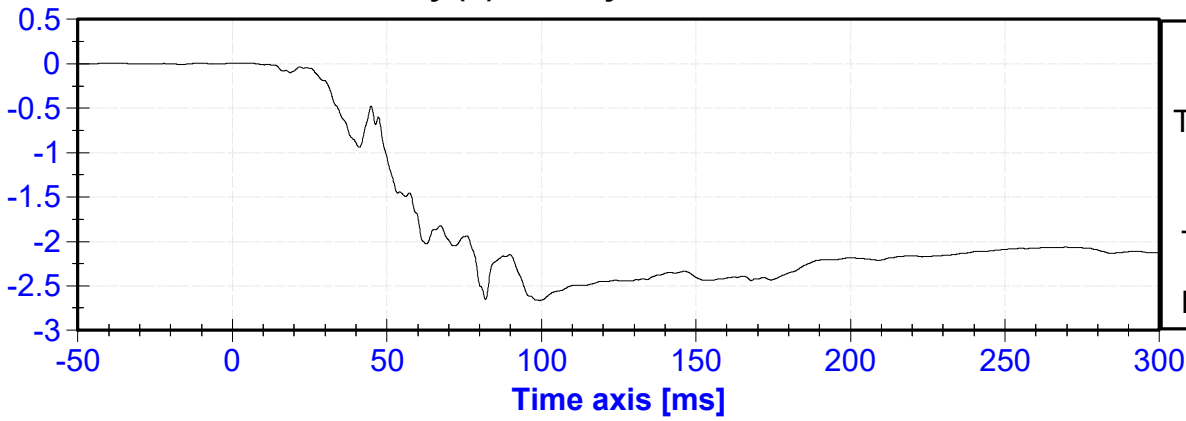

Vehicle Center of Gravity (Y) Acceleration vs. Time

ACCELERATION [g's]

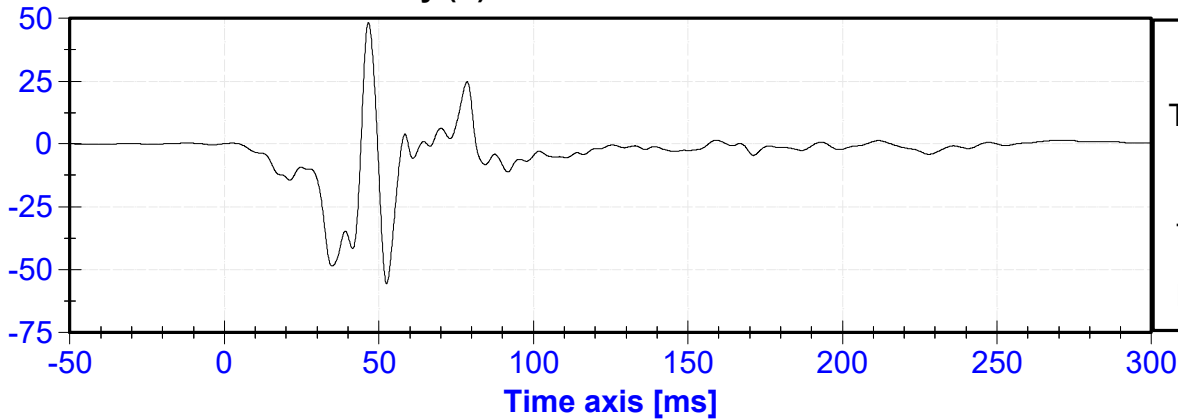

Vehicle Center of Gravity (Y) Velocity vs. Time

VELOCITY [m/s]

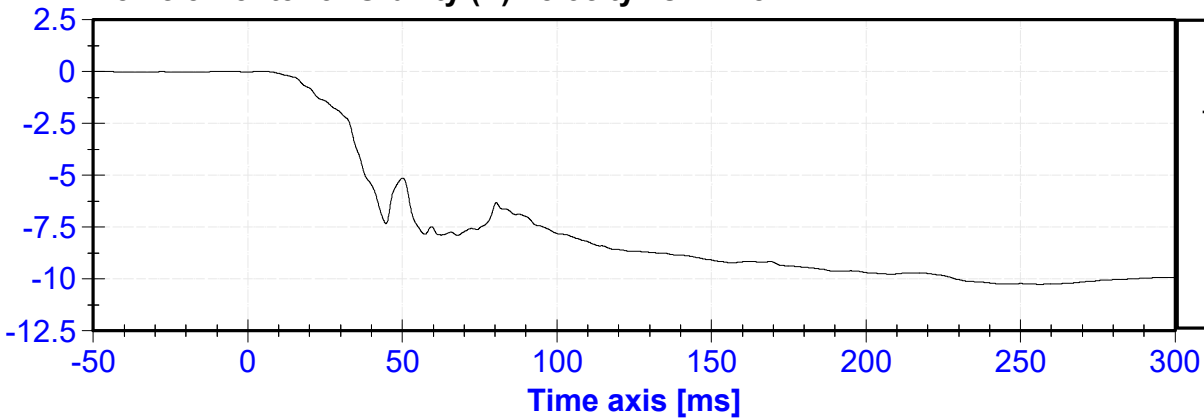

Vehicle Center of Gravity (Z) Acceleration vs. Time

ACCELERATION [g's]

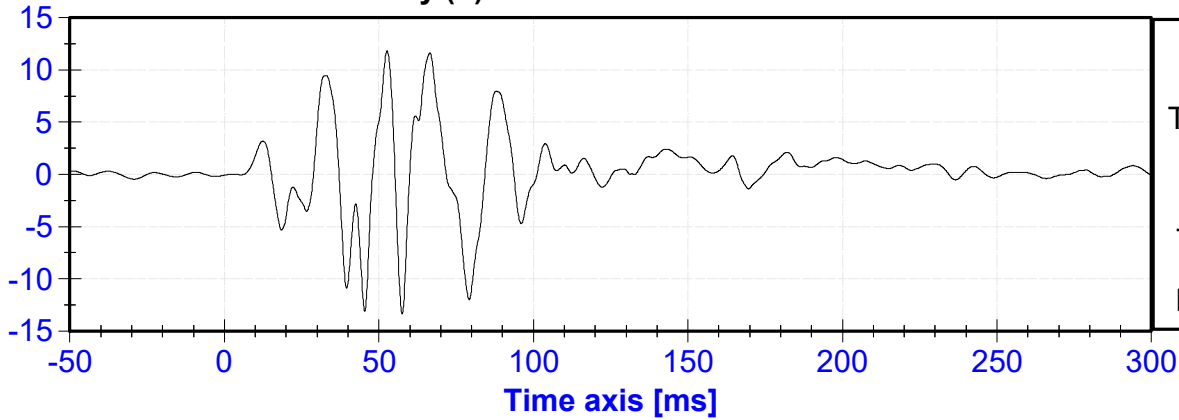

Vehicle Center of Gravity (Z) Velocity vs. Time

VELOCITY [m/s]

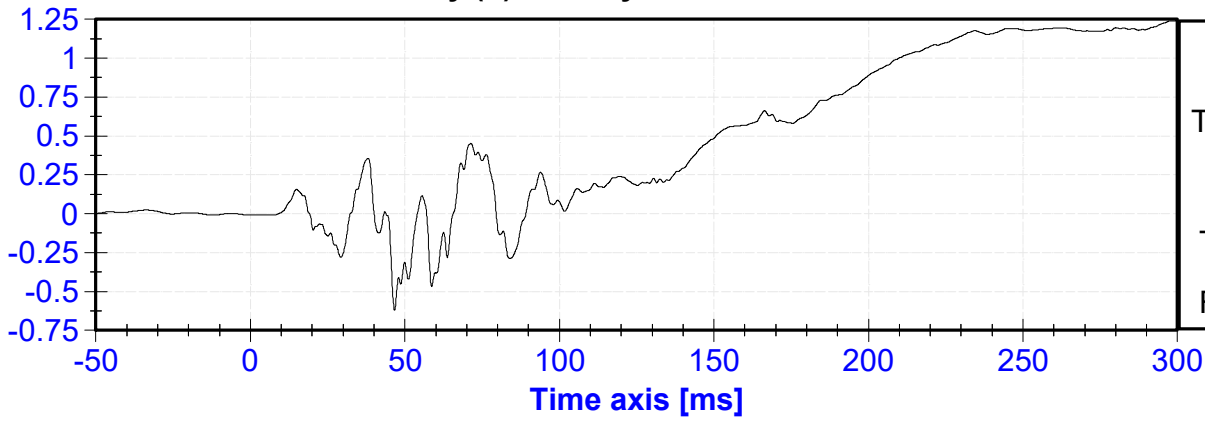

Vehicle Center of Gravity Resultant Acceleration vs. Time

ACCELERATION [g's]

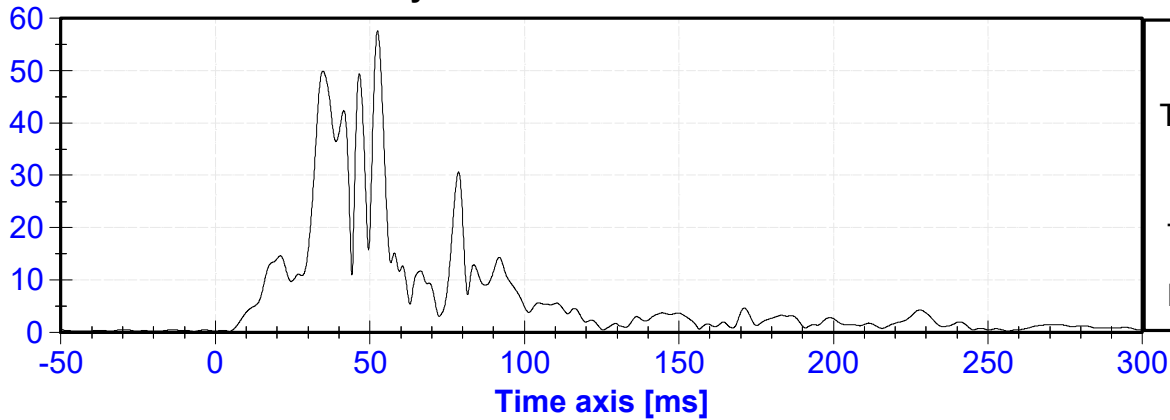

Floor Sill – Impact Side (Y) Acceleration vs. Time

ACCELERATION [g's]

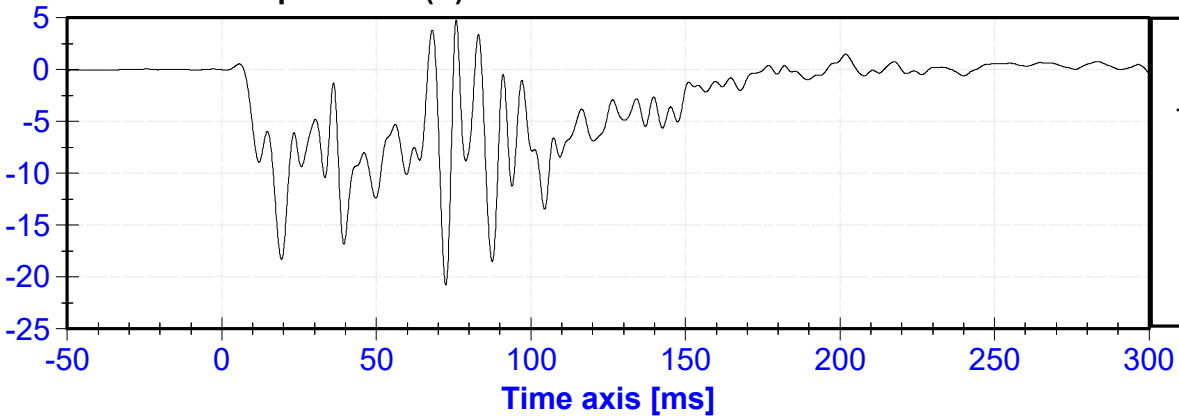

Floor Sill – Impact Side (Y) Velocity vs. Time

VELOCITY [m/s]

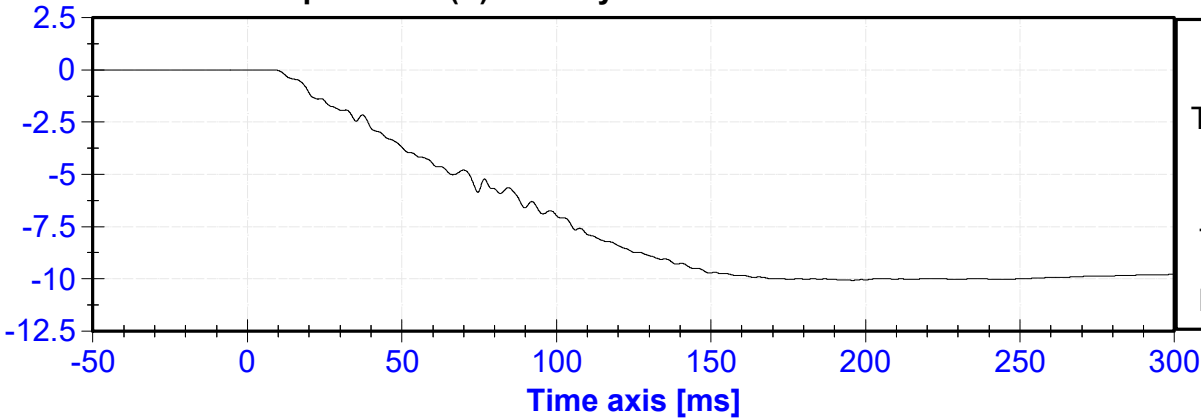

Max: 0.01 [m/s]
TMax: 8.05 [ms]
Min: -10.07 [m/s]
TMin: 195.9 [ms]
Filter: CFC 180

Floor Sill – Impact Side (Y) Displacement vs. Time

DISPLACEMENT [m]

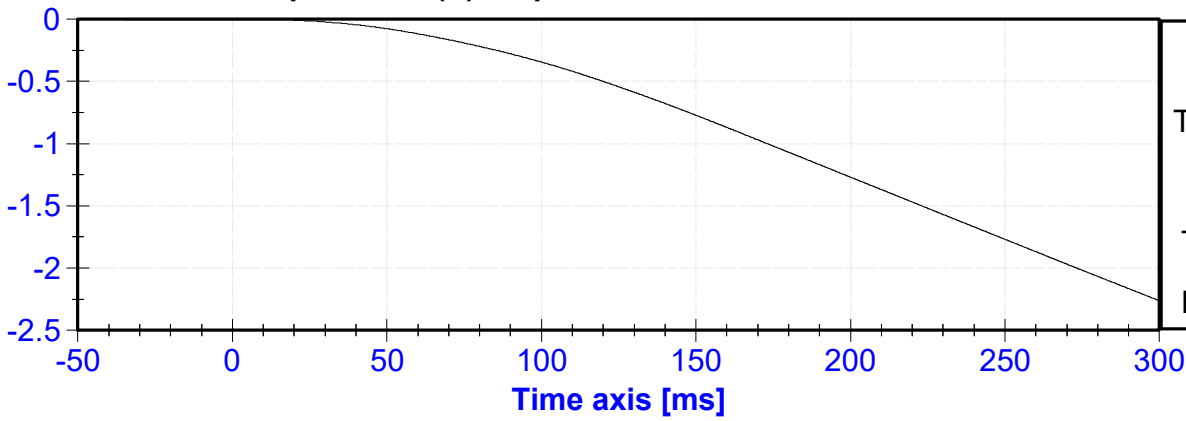

Max: 0 [m]
TMax: -46 [ms]
Min: -2.26 [m]
TMin: 300 [ms]
Filter: CFC 180

A-Pillar Sill (Y) Acceleration vs. Time

ACCELERATION [g's]

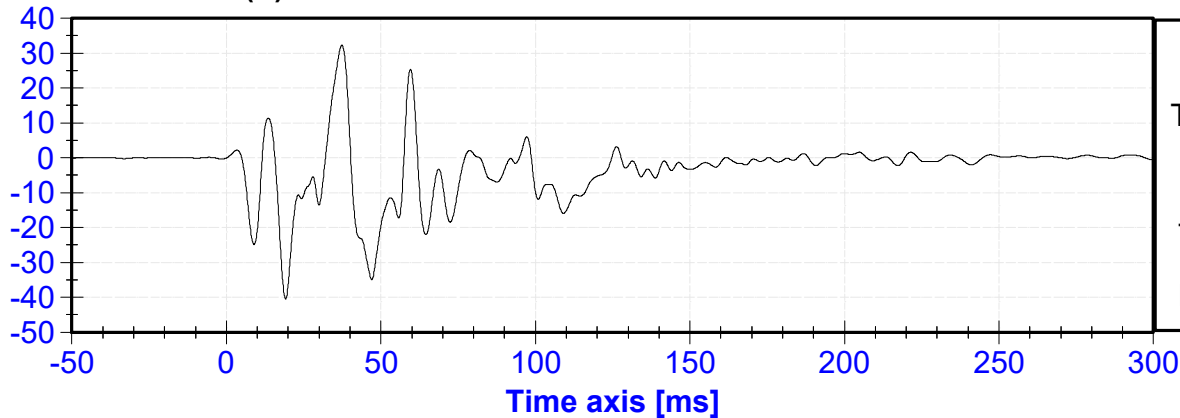

Max: 32.31 [g's]
TMax: 37.35 [ms]
Min: -40.53 [g's]
TMin: 19.2 [ms]
Filter: CFC 60

A-Pillar Sill (Y) Velocity vs. Time

VELOCITY [m/s]

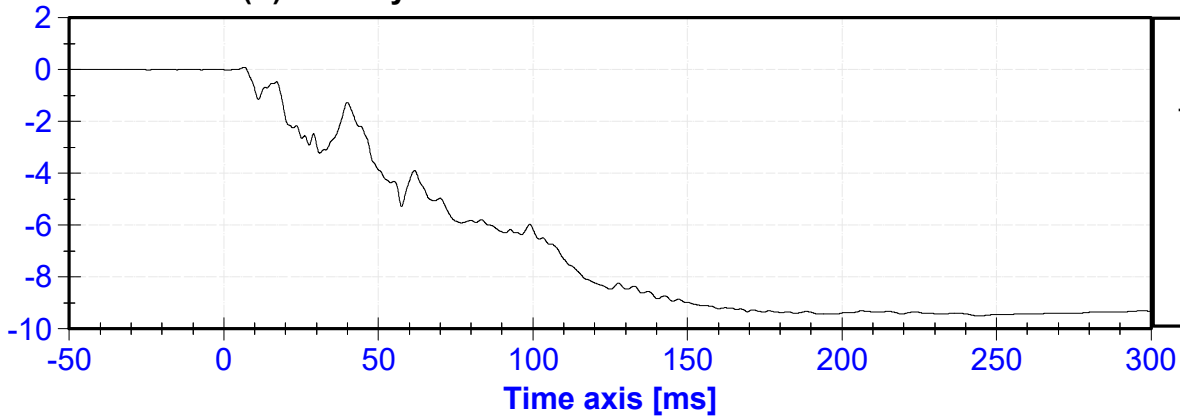

Max: 0.09 [m/s]
TMax: 6.6 [ms]
Min: -9.5 [m/s]
TMin: 244.4 [ms]
Filter: CFC 180

A-Pillar Sill (Y) Displacement vs. Time

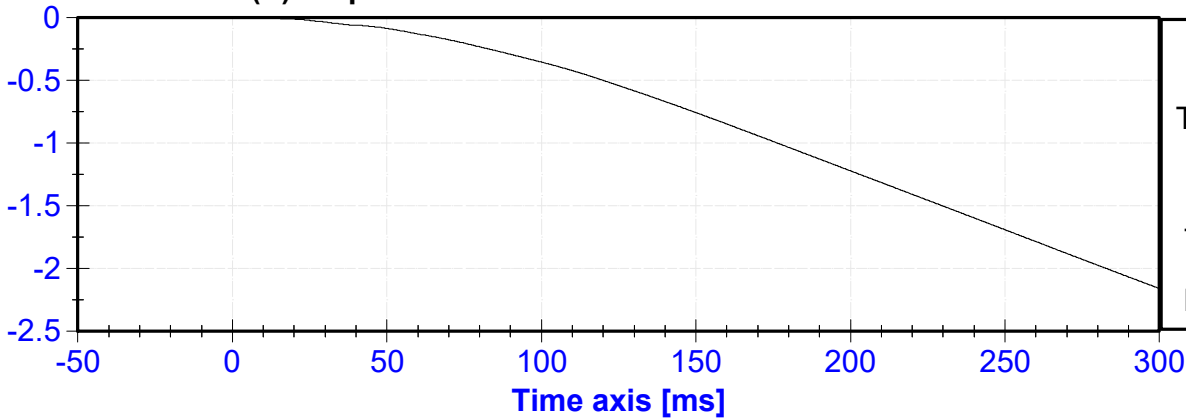

A-Pillar Low (Y) Acceleration vs. Time

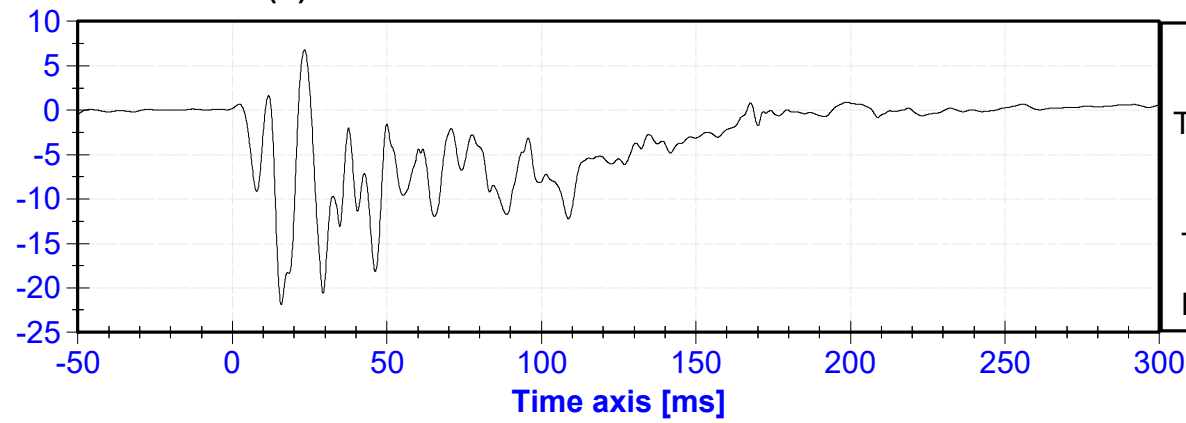

A-Pillar Low (Y) Velocity vs. Time

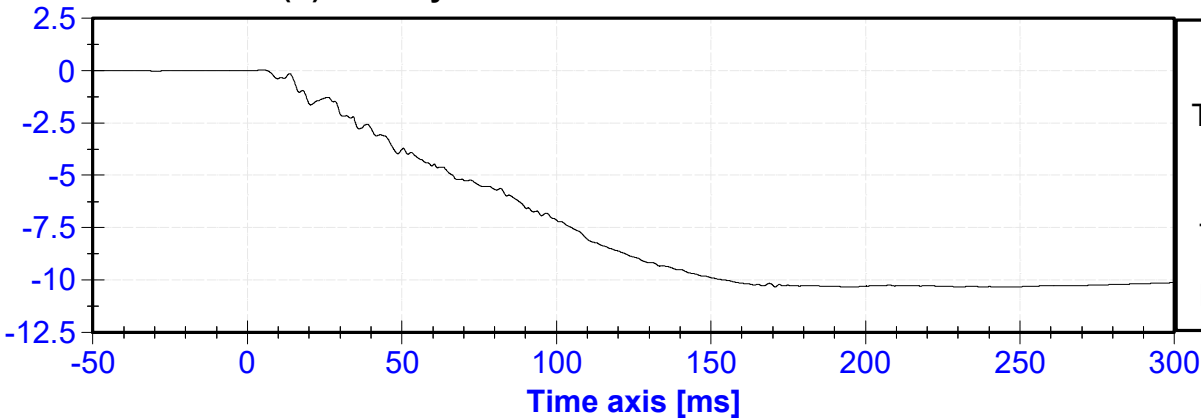

A-Pillar Low (Y) Displacement vs. Time

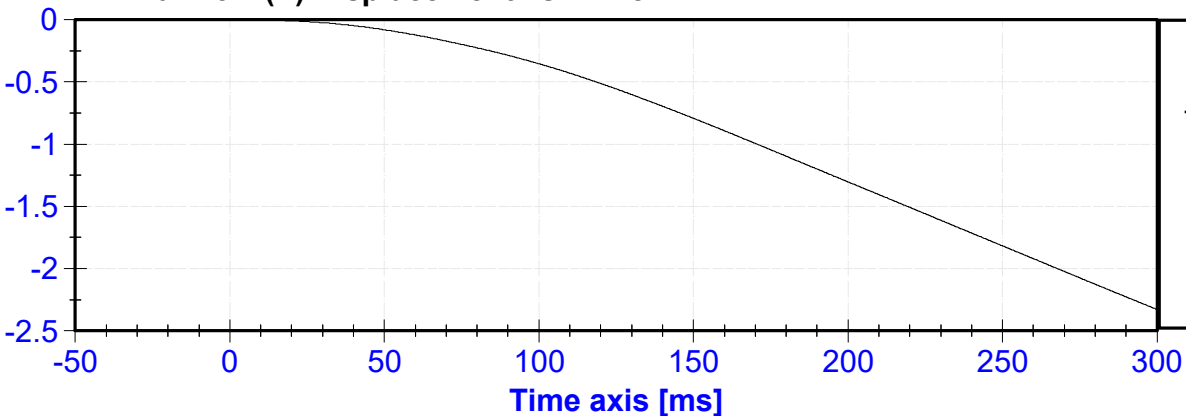

A-Pillar Mid (Y) Acceleration vs. Time

ACCELERATION [g's]

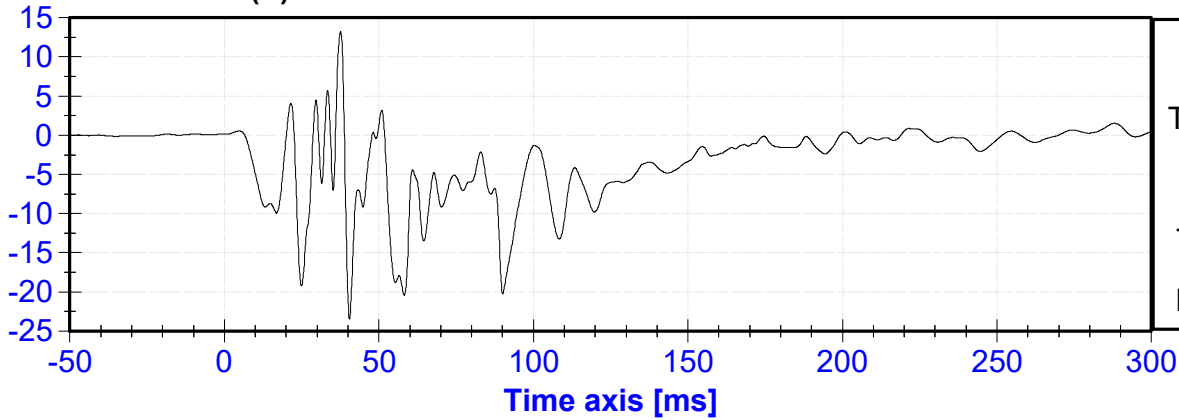

Max: 13.25 [g's]
TMax: 37.65 [ms]
Min: -23.48 [g's]
TMin: 40.5 [ms]
Filter: CFC 60

A-Pillar Mid (Y) Velocity vs. Time

VELOCITY [m/s]

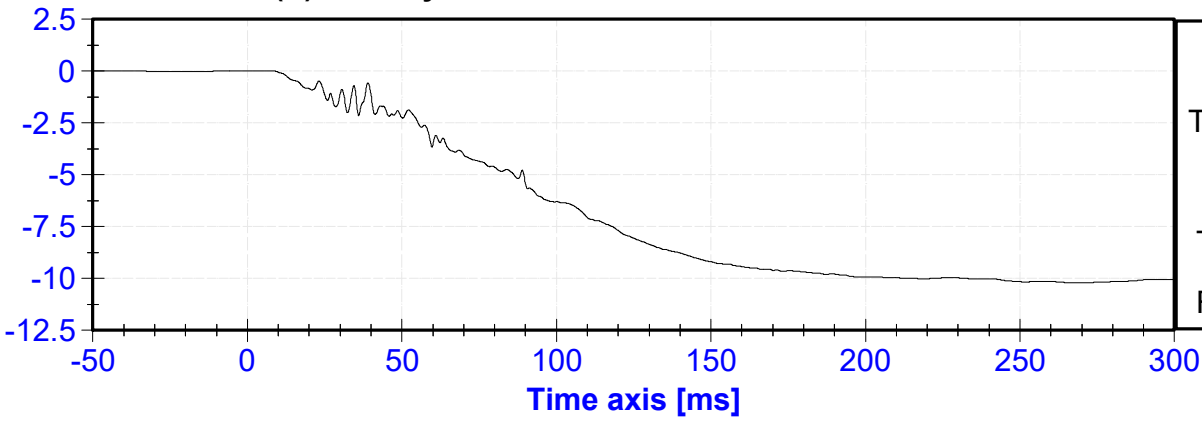

Max: 0.03 [m/s]
TMax: 7.4 [ms]
Min: -10.21 [m/s]
TMin: 270 [ms]
Filter: CFC 180

A-Pillar Mid (Y) Displacement vs. Time

DISPLACEMENT [m]

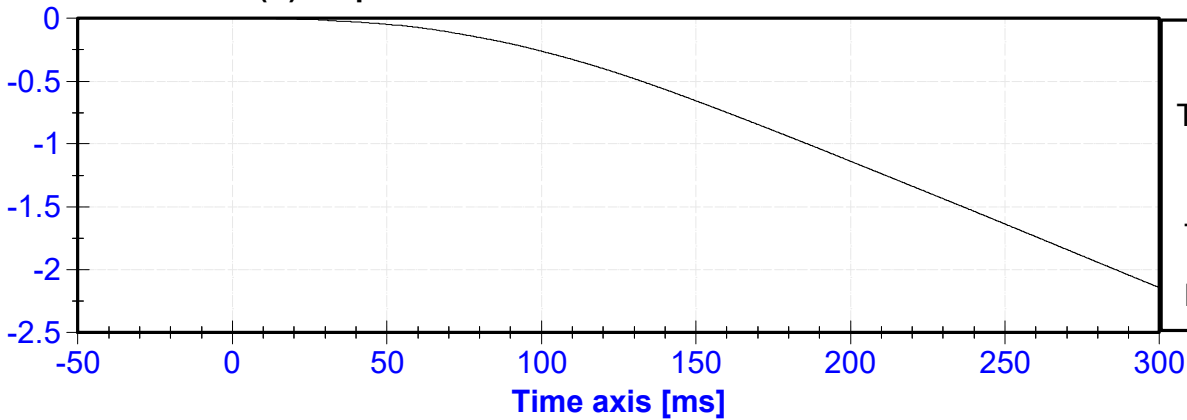

Max: 0 [m]
TMax: -37.2 [ms]
Min: -2.14 [m]
TMin: 300 [ms]
Filter: CFC 180

B-Pillar Sill (Y) Acceleration vs. Time

ACCELERATION [g's]

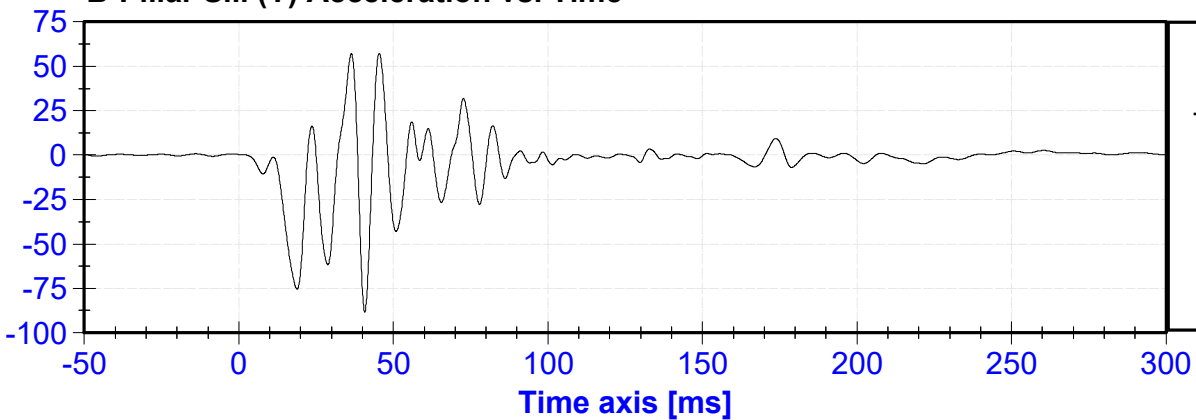

Max: 57.33 [g's]
TMax: 45.4 [ms]
Min: -88.36 [g's]
TMin: 40.75 [ms]
Filter: CFC 60

B-Pillar Sill (Y) Velocity vs. Time

VELOCITY [m/s]

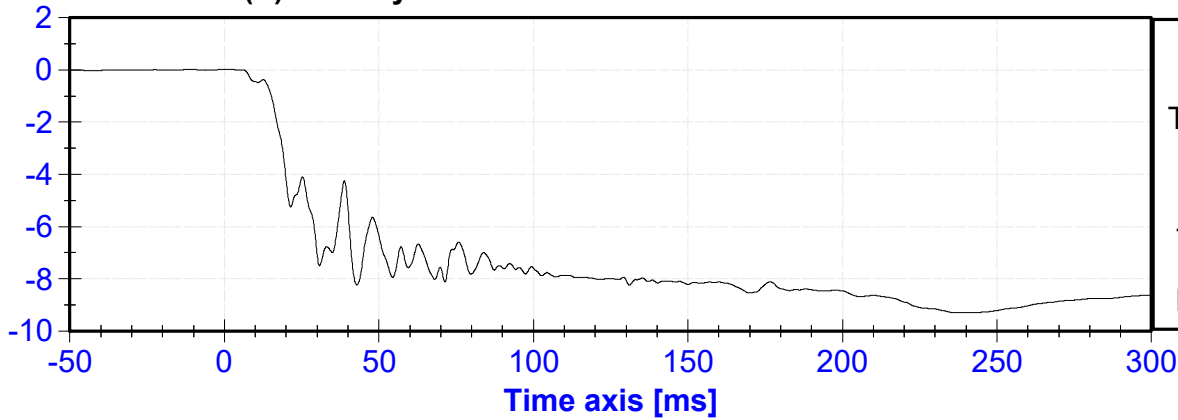

B-Pillar Sill (Y) Displacement vs. Time

DISPLACEMENT [m]

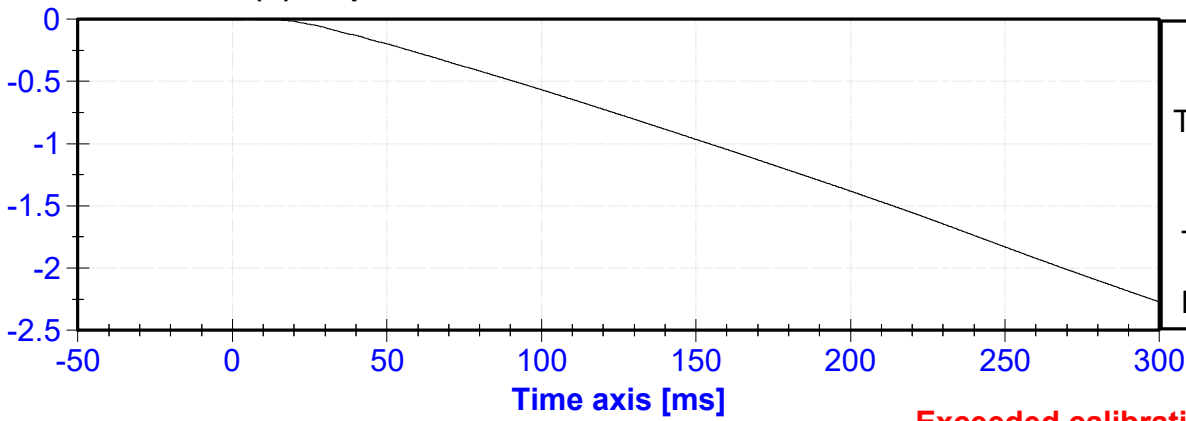

Exceeded calibration range at 23.2 ms

B-Pillar Low (Y) Acceleration vs. Time

ACCELERATION [g's]

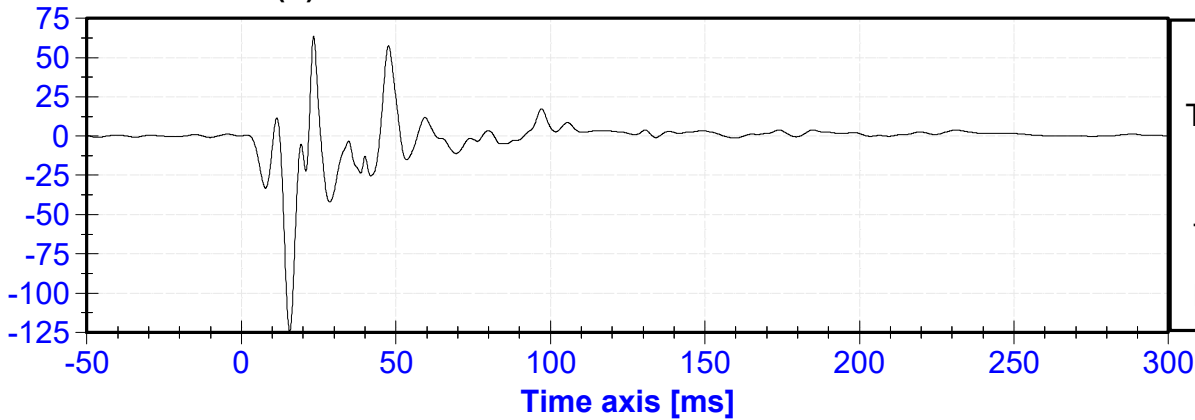

Exceeded calibration range at 23.2 ms

B-Pillar Low (Y) Velocity vs. Time

VELOCITY [m/s]

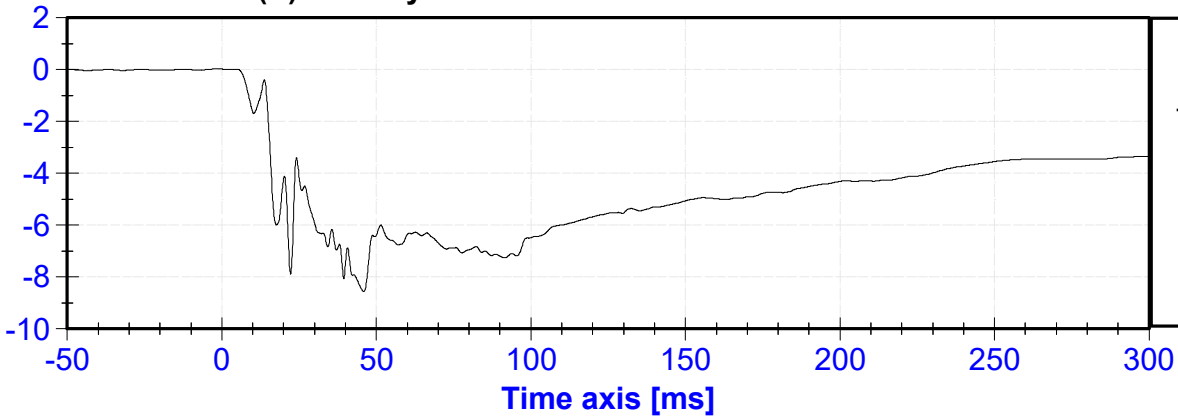

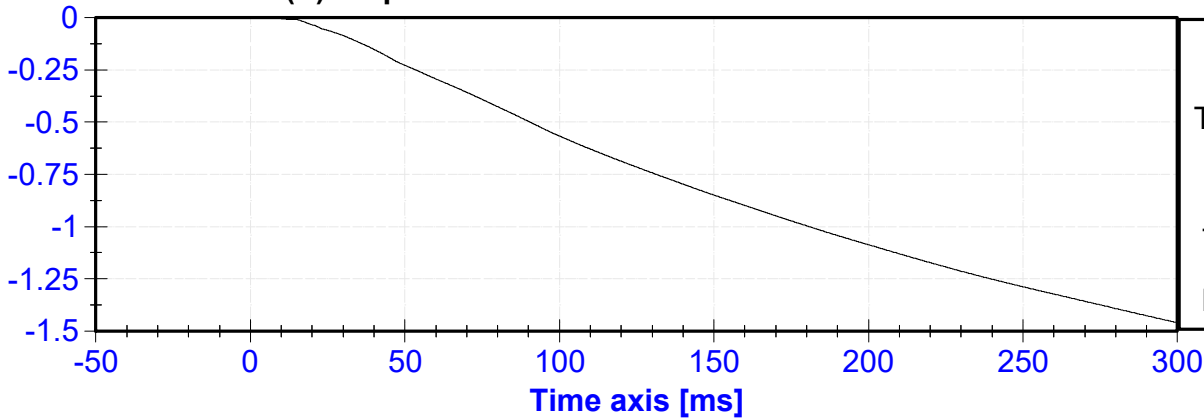
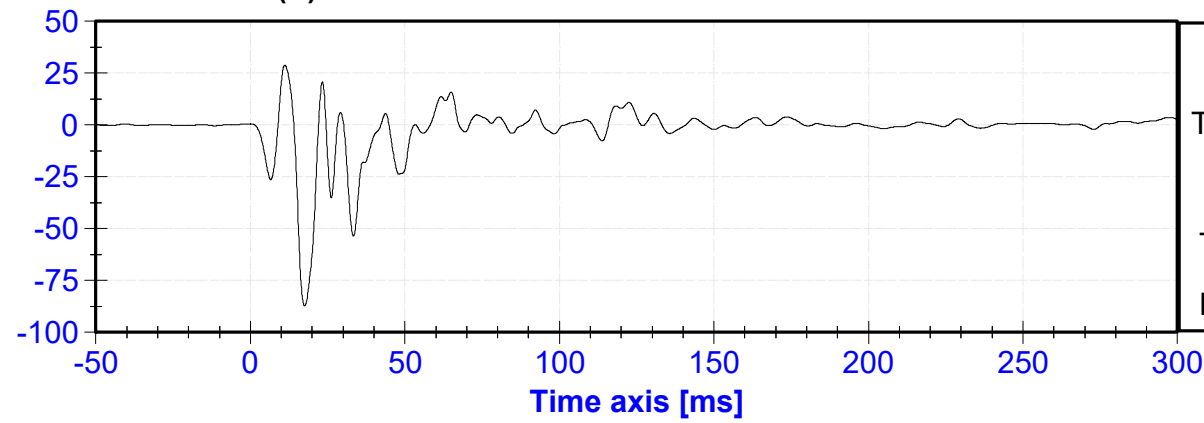
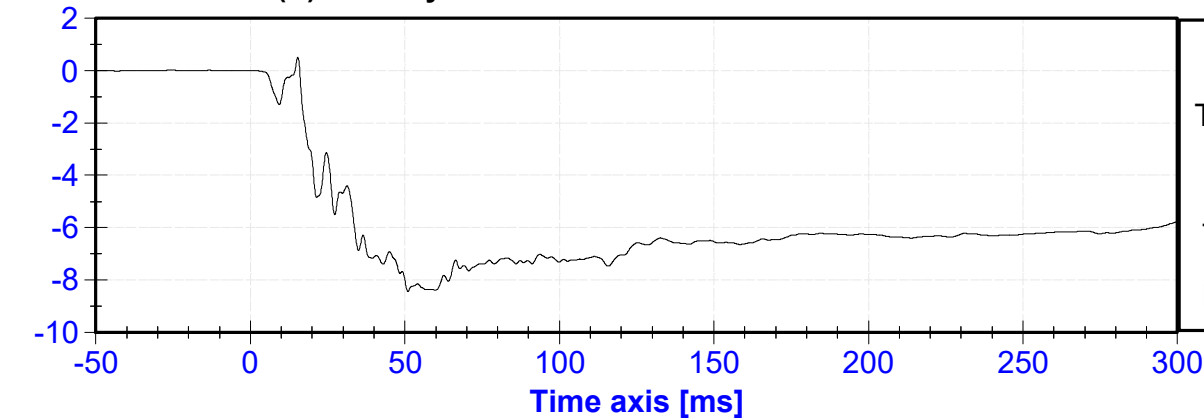
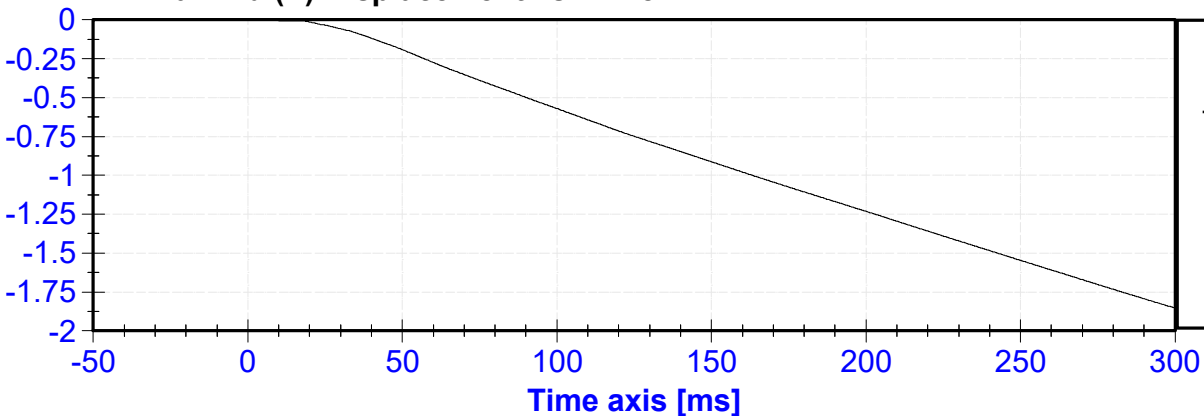
Exceeded calibration range at 23.2 ms**B-Pillar Low (Y) Displacement vs. Time****B-Pillar Mid (Y) Acceleration vs. Time****B-Pillar Mid (Y) Velocity vs. Time****B-Pillar Mid (Y) Displacement vs. Time**

Seat (Y) Acceleration vs. Time

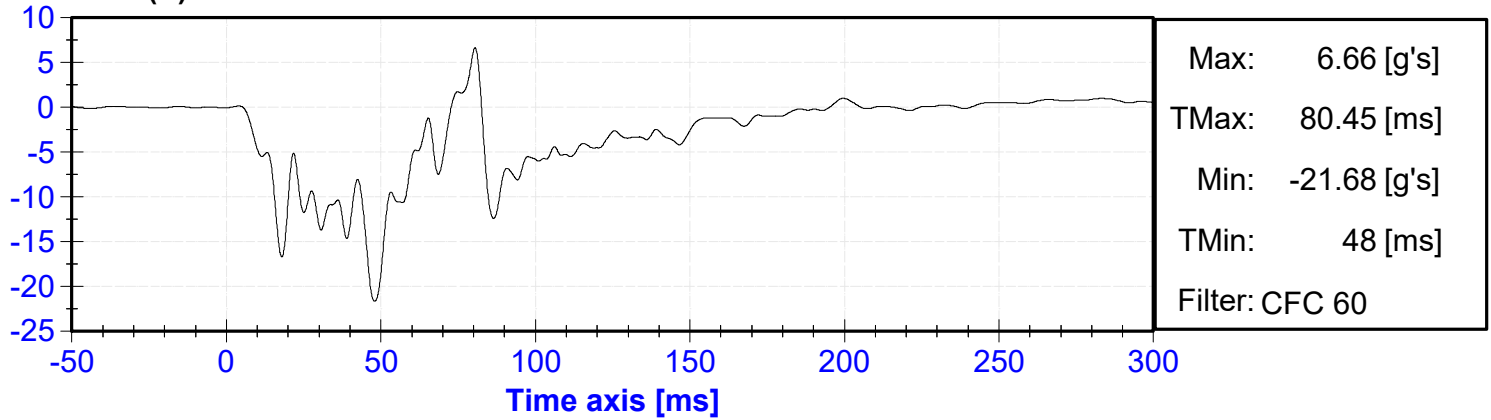

Seat (Y) Velocity vs. Time

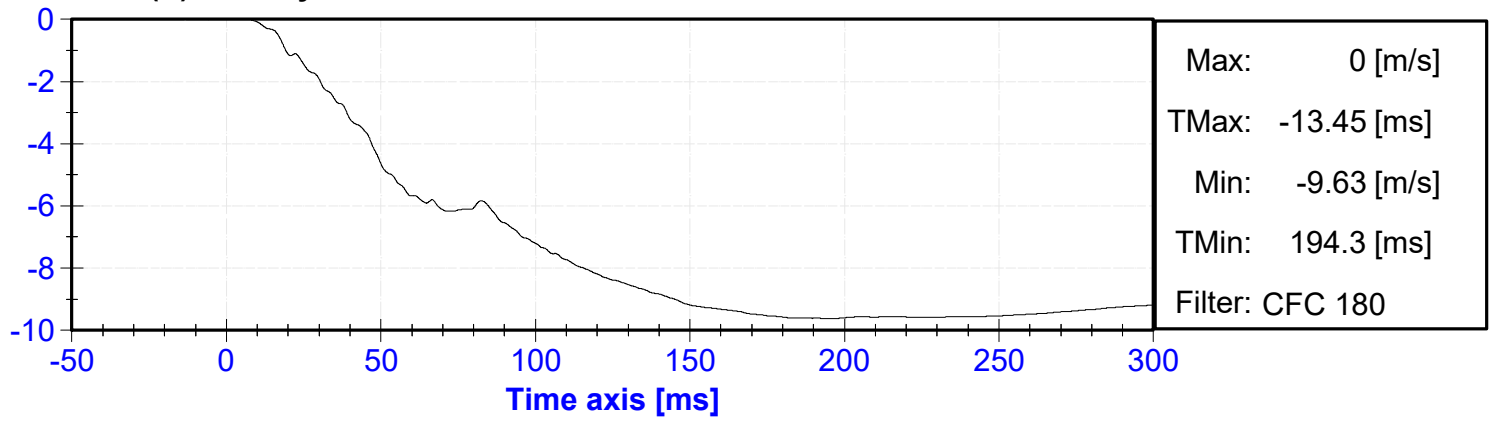

Seat (Y) Displacement vs. Time

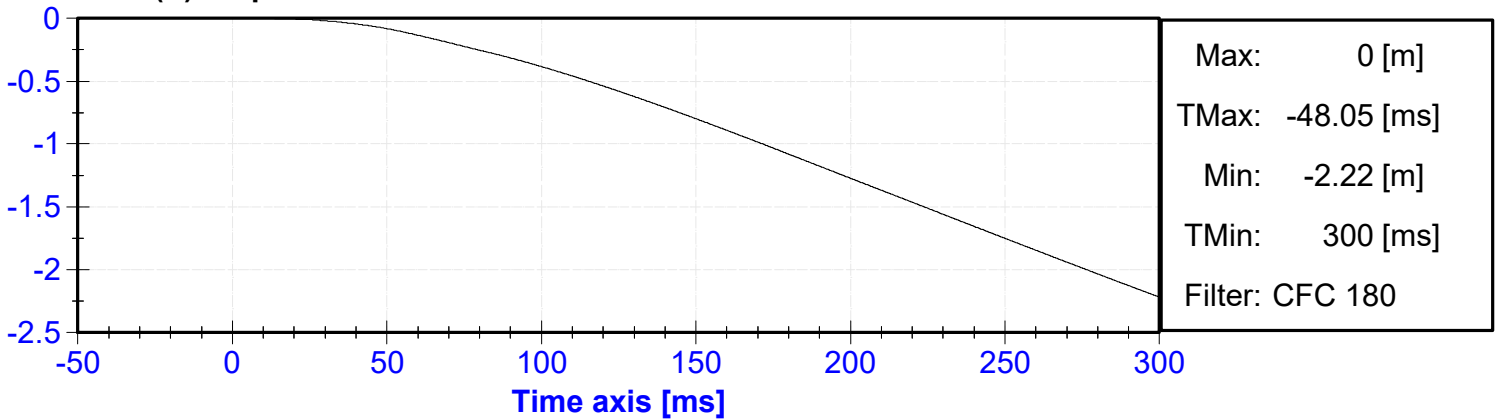

Engine (X) Acceleration vs. Time

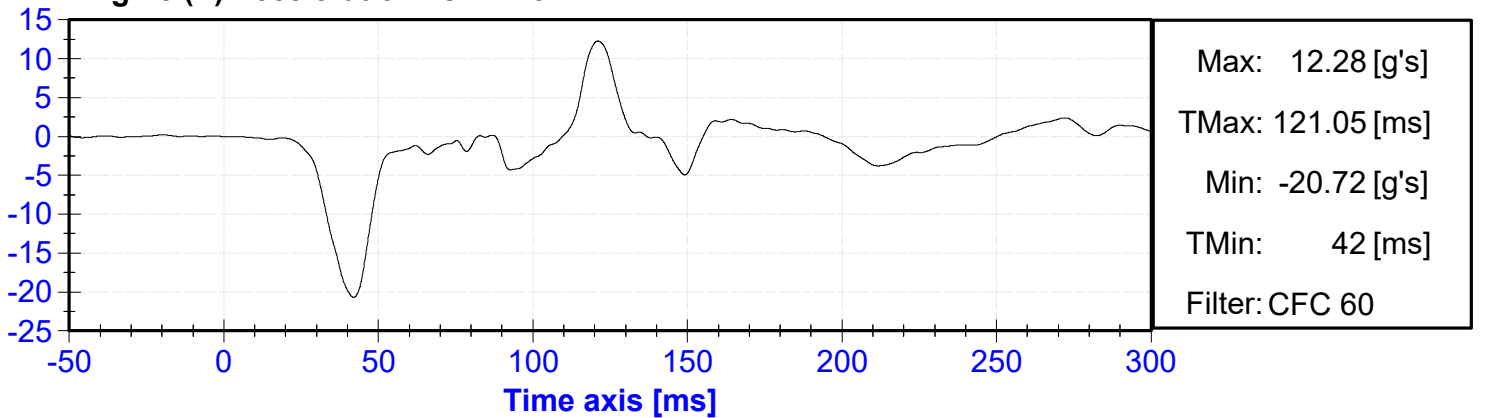

VELOCITY [m/s]

Engine (X) Velocity vs. Time

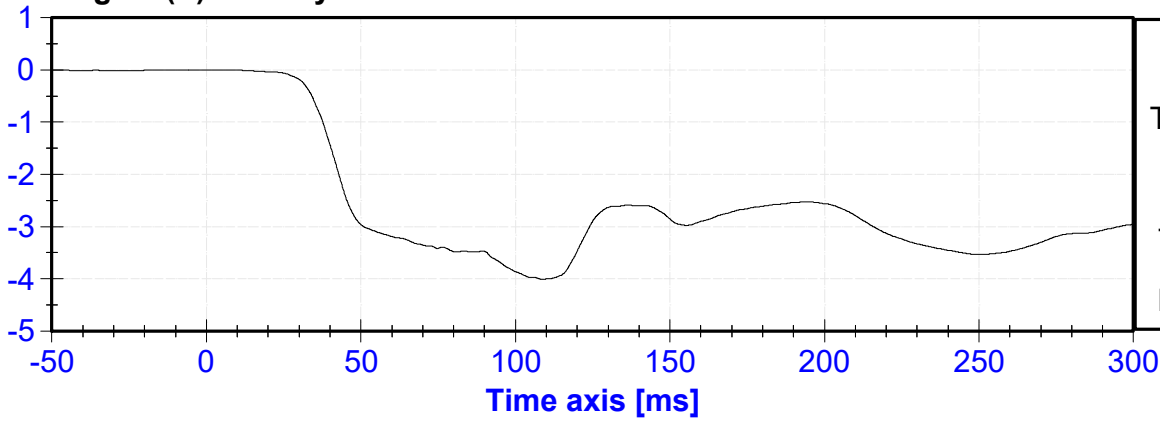

ACCELERATION [g's]

Engine (Y) Acceleration vs. Time

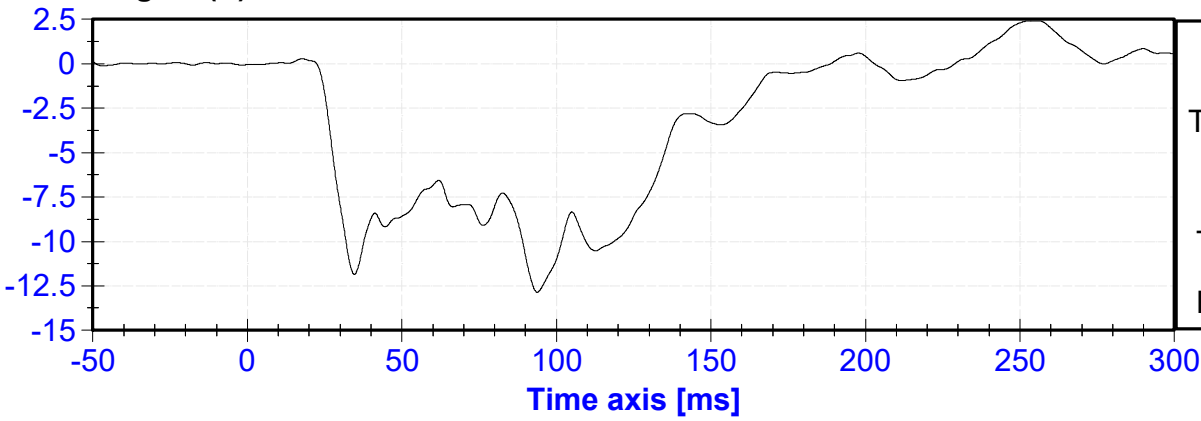

VELOCITY [m/s]

Engine (Y) Velocity vs. Time

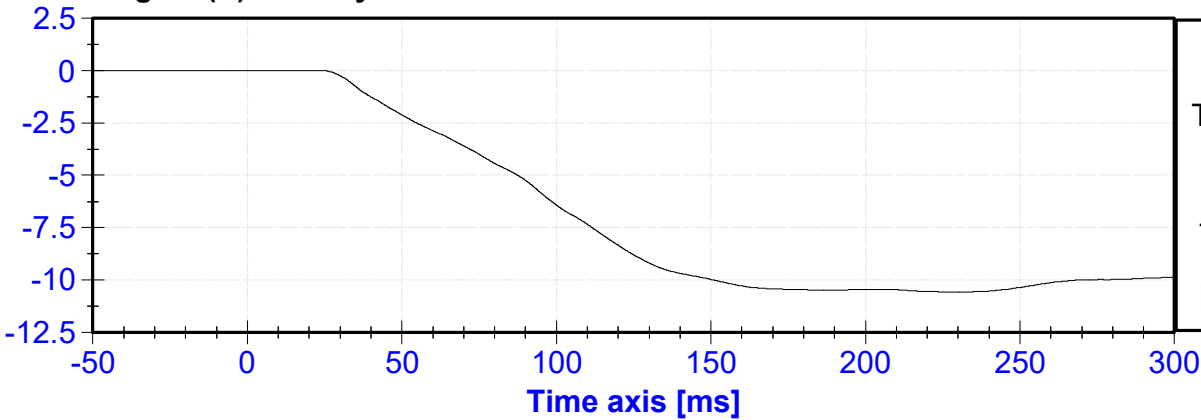

ACCELERATION [g's]

Firewall (Y) Acceleration vs. Time

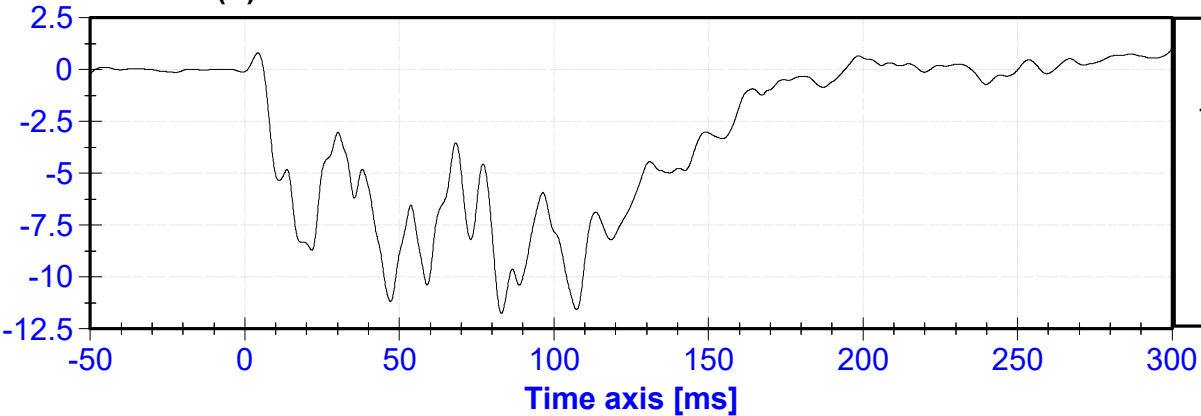

Firewall (Y) Velocity vs. Time

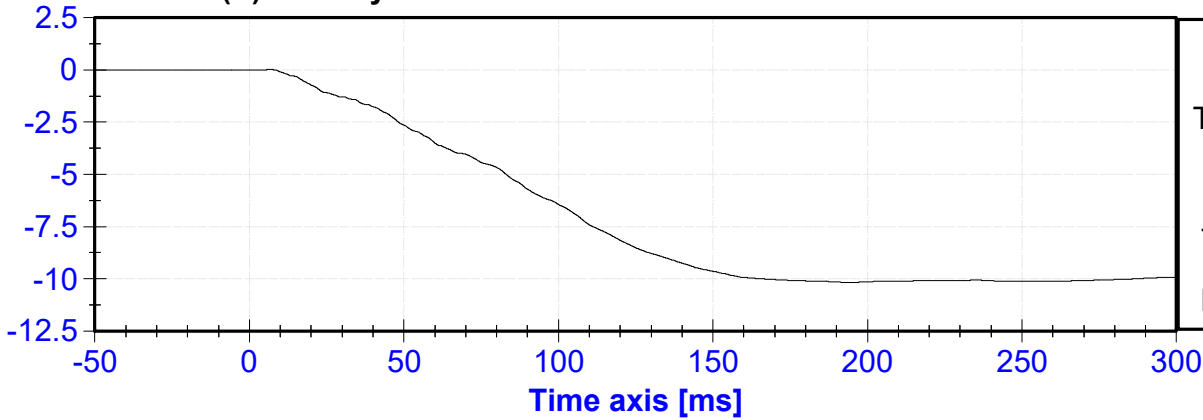

Roof (Y) Acceleration vs. Time

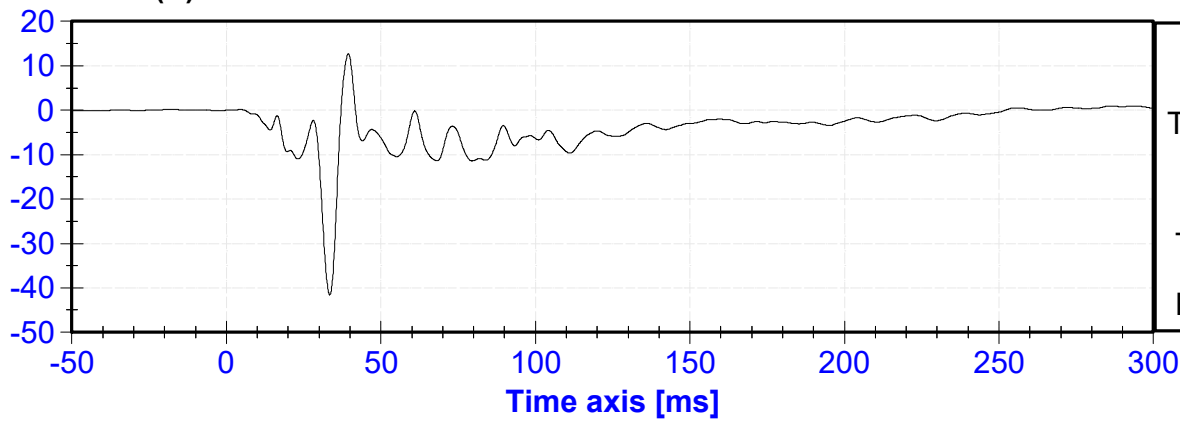

Roof (Y) Velocity vs. Time

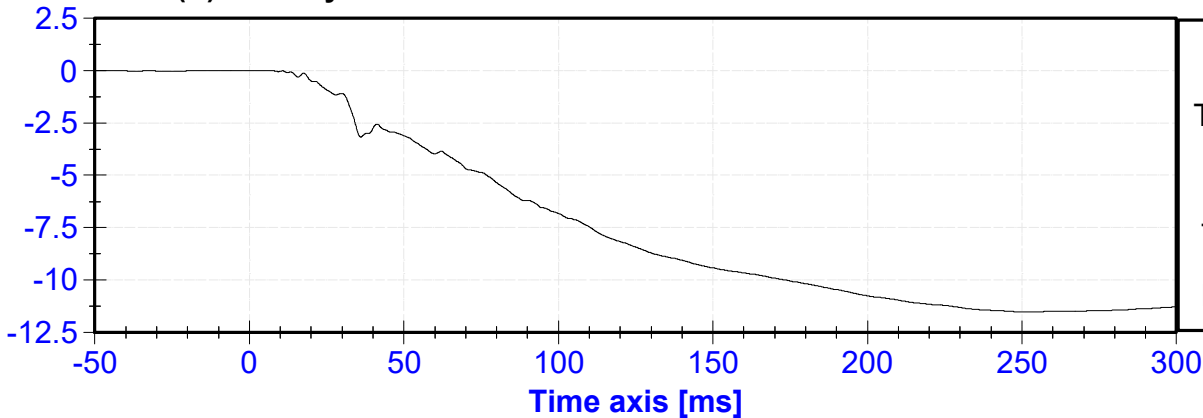

Floor Sill – Non Impact Side (Y) Acceleration vs. Time

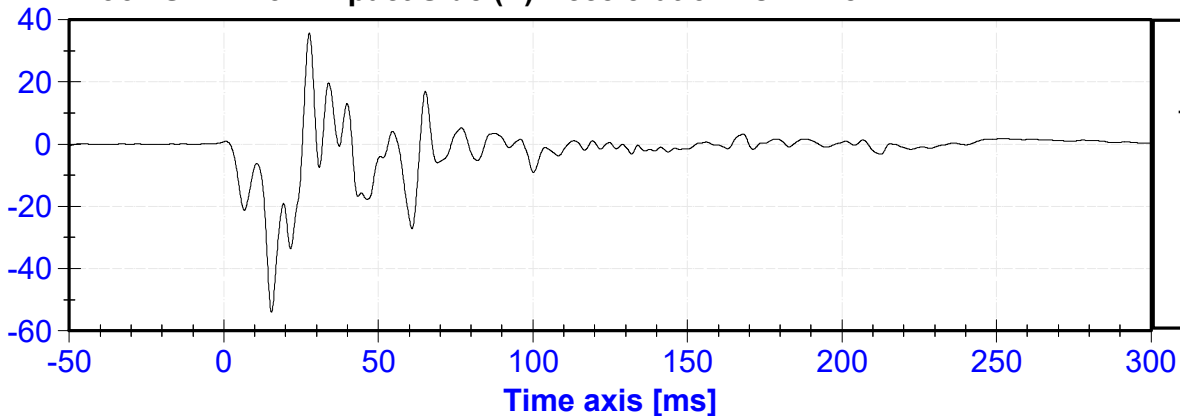

Floor Sill – Non Impact Side (Y) Velocity vs. Time

VELOCITY [m/s]

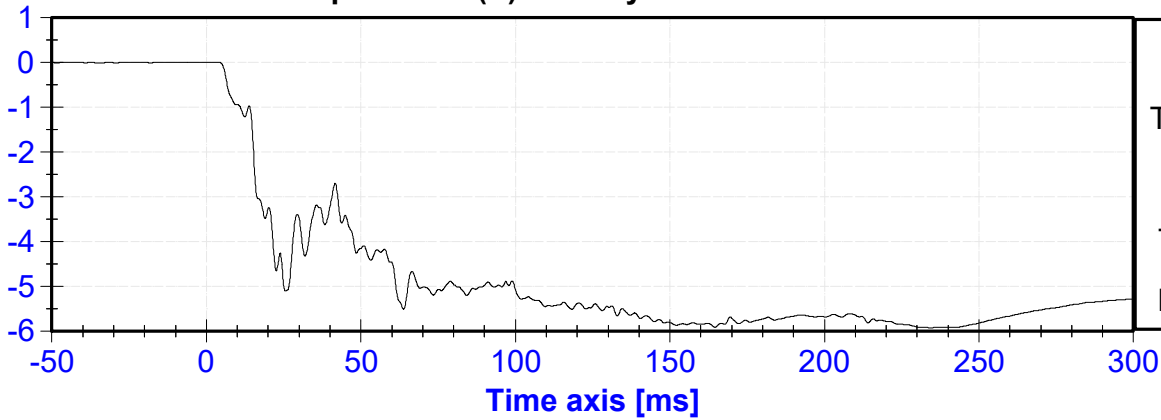

Rear Deck (X) Acceleration vs. Time

ACCELERATION [g's]

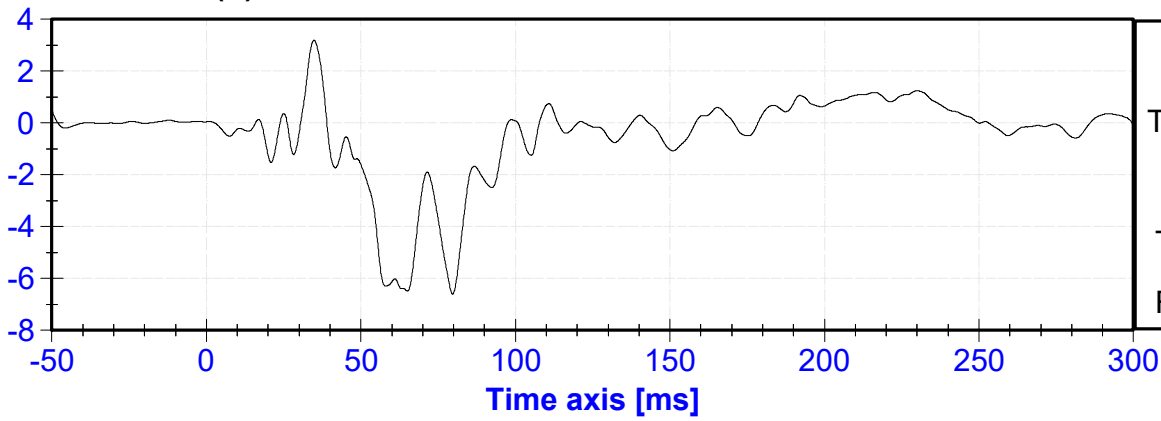

Rear Deck (X) Velocity vs. Time

VELOCITY [m/s]

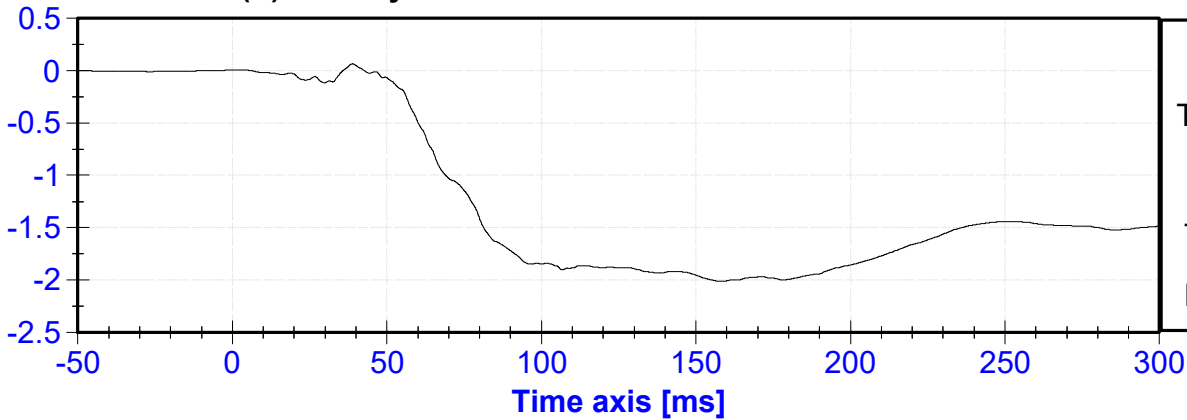

Rear Deck (Y) Acceleration vs. Time

ACCELERATION [g's]

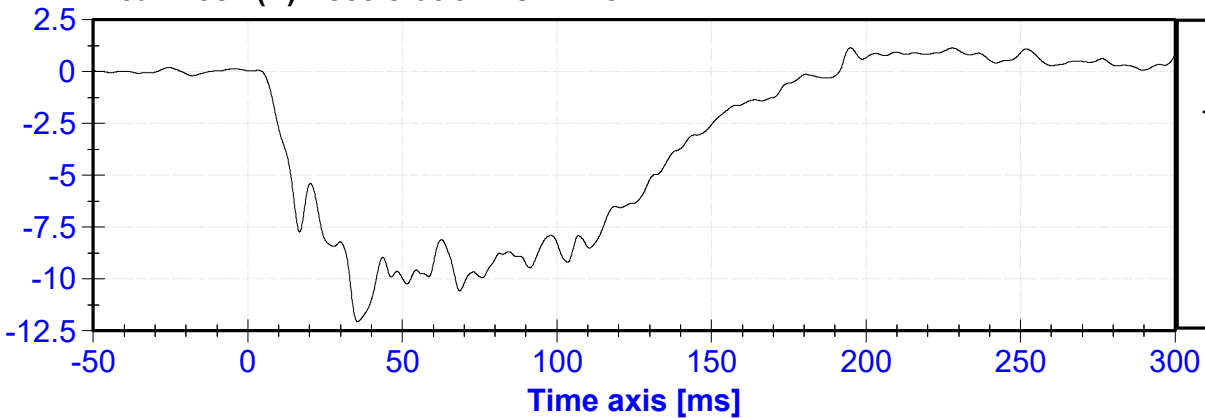

Rear Deck (Y) Velocity vs. Time

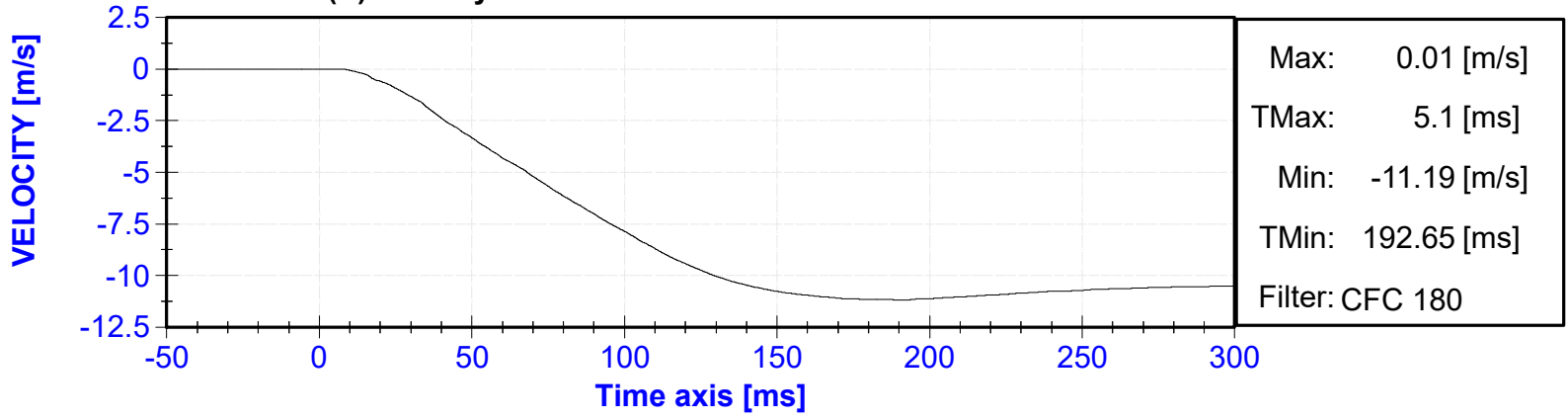

APPENDIX IV

PRE-TEST DUMMY PERFORMANCE CALIBRATION TEST DATA

(Subpart U, ES-2re)

External Measurements - EuroSID-2re

Technician: K. Brogan

Date: 02/28/2023

Dummy Serial Number: D037

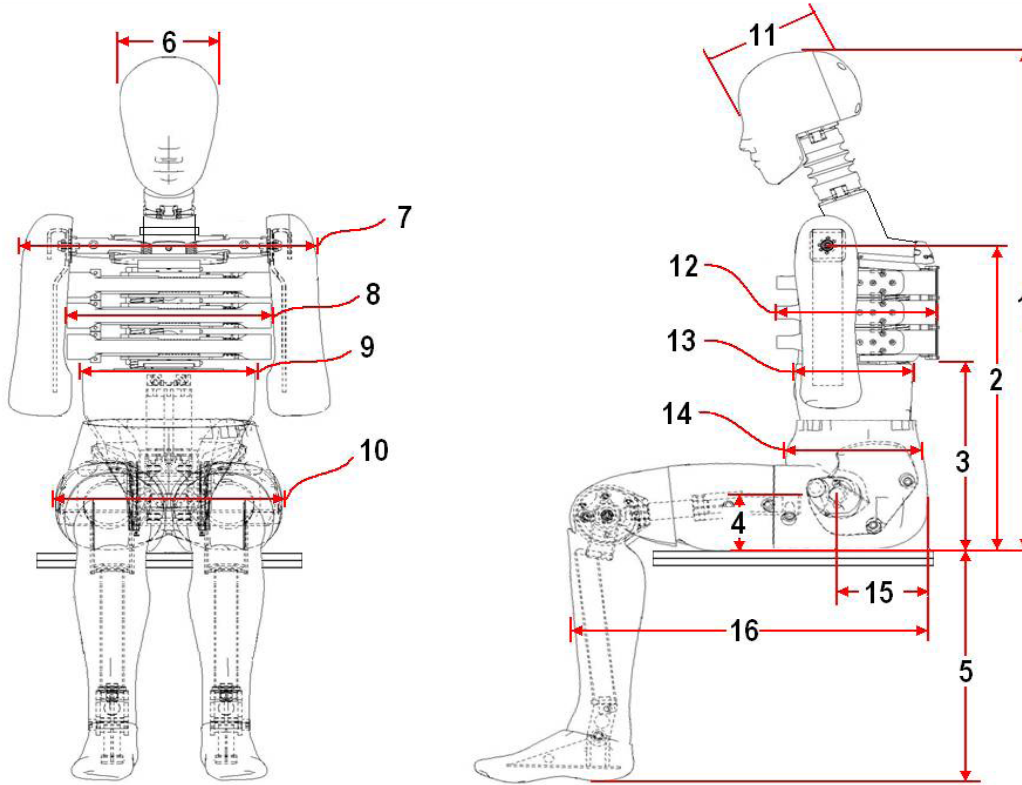

FRONT VIEW

SIDE VIEW

Dim. No.	Description	Specification (mm)		Result (mm)	Pass/Fail
1	Sitting Height	900	918	911	Pass
2	Seat to Shoulder Joint	558	572	564	Pass
3	Seat to Lower Face of Thoracic Spine Box	346	356	352	Pass
4	Seat to Hip Joint (center of bolt)	97	103	101	Pass
5	Sole to Seat, Sitting	333	451	421	Pass
6	Head Width	152	158	155	Pass
7	Shoulder/Arm Width	461	479	473	Pass
8	Thorax Width	322	332	330	Pass
9	Abdomen Width	273	287	280	Pass
10	Pelvis Lap Width	359	373	365	Pass
11	Head Depth	196	206	199	Pass
12	Thorax Depth	262	272	268	Pass
13	Abdomen Depth	194	204	200	Pass
14	Pelvis Depth	235	245	241	Pass
15	Back of Buttocks to Hip Joint (center of bolt)	150	160	153	Pass
16	Back of Buttocks to Front Knee	597	615	607	Pass

ATD Manufacturer	Denton	Test Technician	T. Roseman
ATD Serial Number	D037	Laboratory Supervisor	C. Mantell

Results

Test Parameter	Minimum Specification	Maximum Specification	Unit	Result	Pass/Fail
Temperature	20.6	22.2	°C	20.9	Pass
Humidity	10	70	%	15.3	Pass
Resultant Acceleration	125	155	g's	141.9	Pass
Oscillation	0	15	%	2.07	Pass
Fore-Aft Acceleration	-15	15	g's	6.7	Pass

Transducer Calibrations

Channel	Manufacturer	Serial Number	Calibration Date	Calibration Due Date
X Accelerometer	Endevco	T21724	2/27/2023	8/26/2023
Y Accelerometer	Endevco	T22281	2/27/2023	8/26/2023
Z Accelerometer	Endevco	T26050	2/27/2023	8/26/2023

Resultant Acceleration

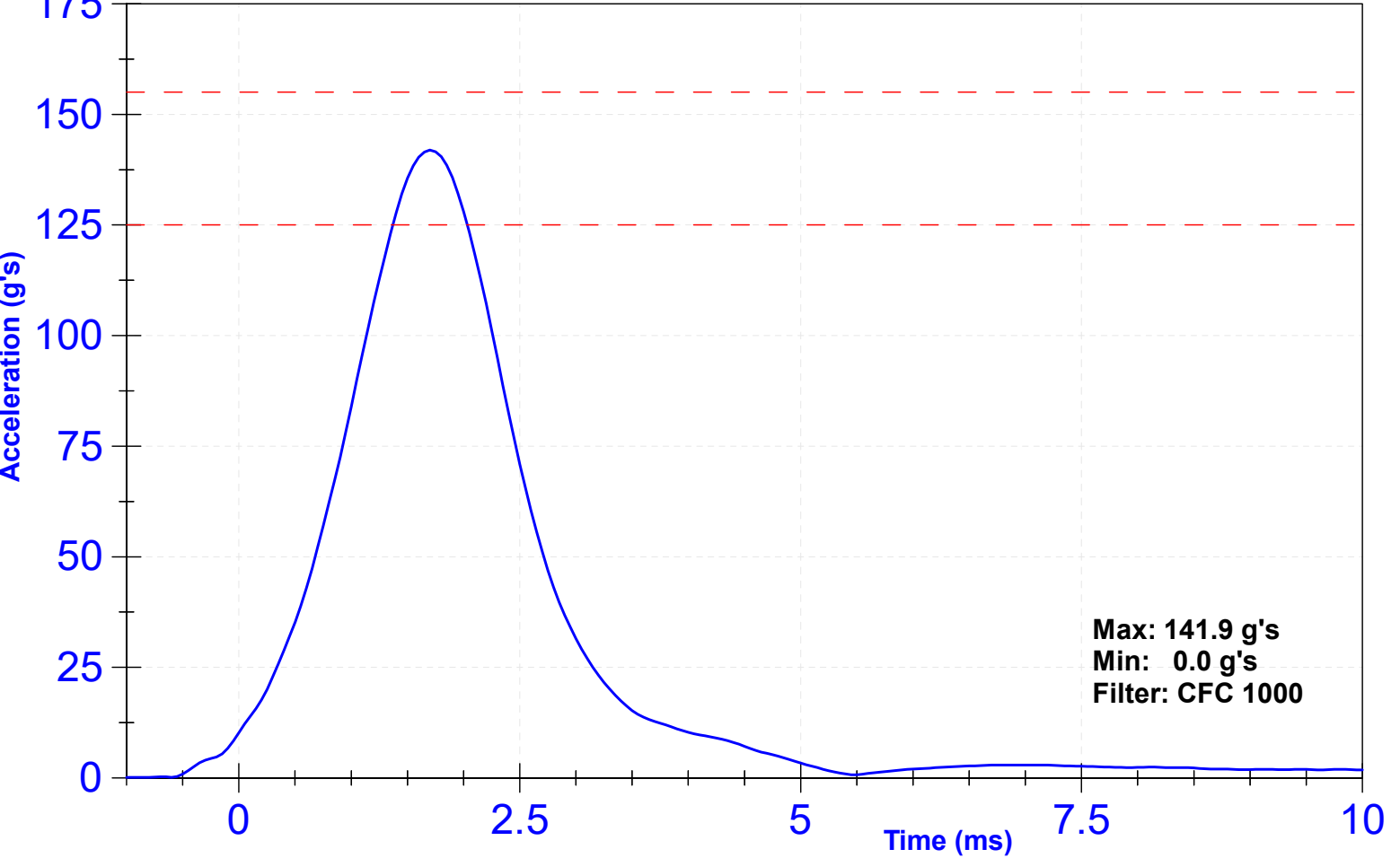

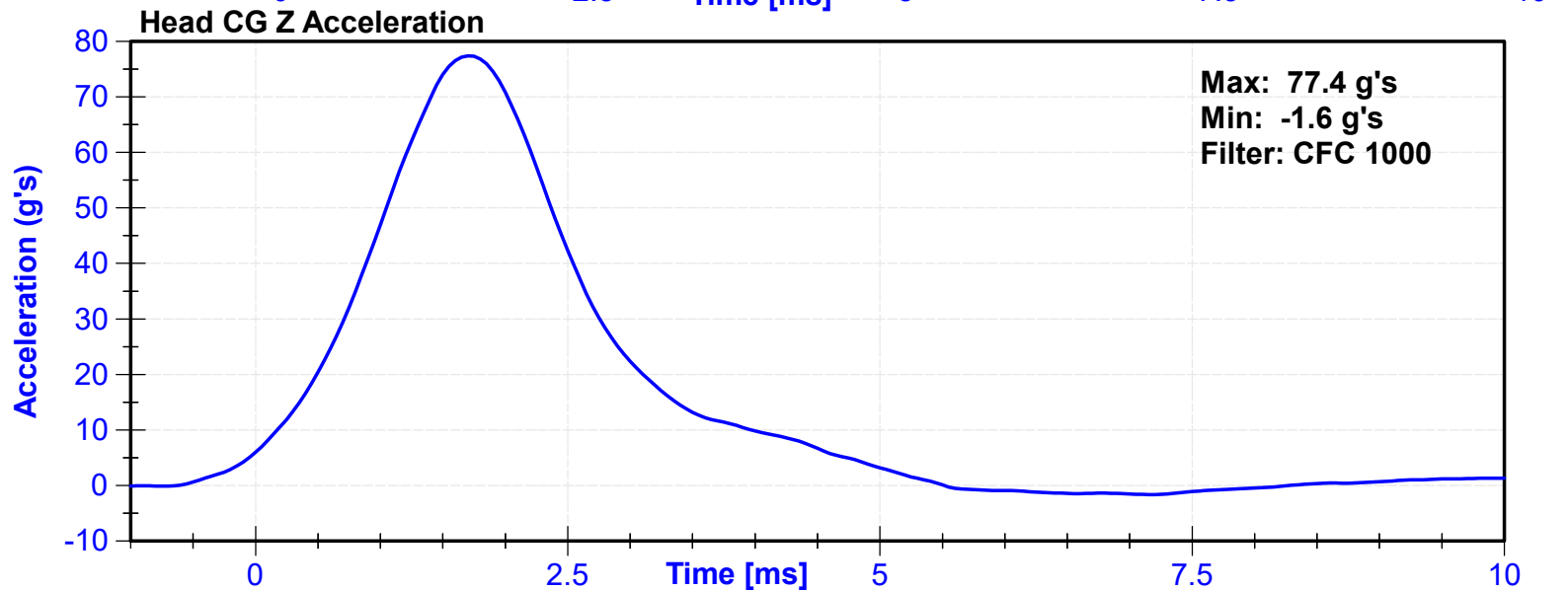
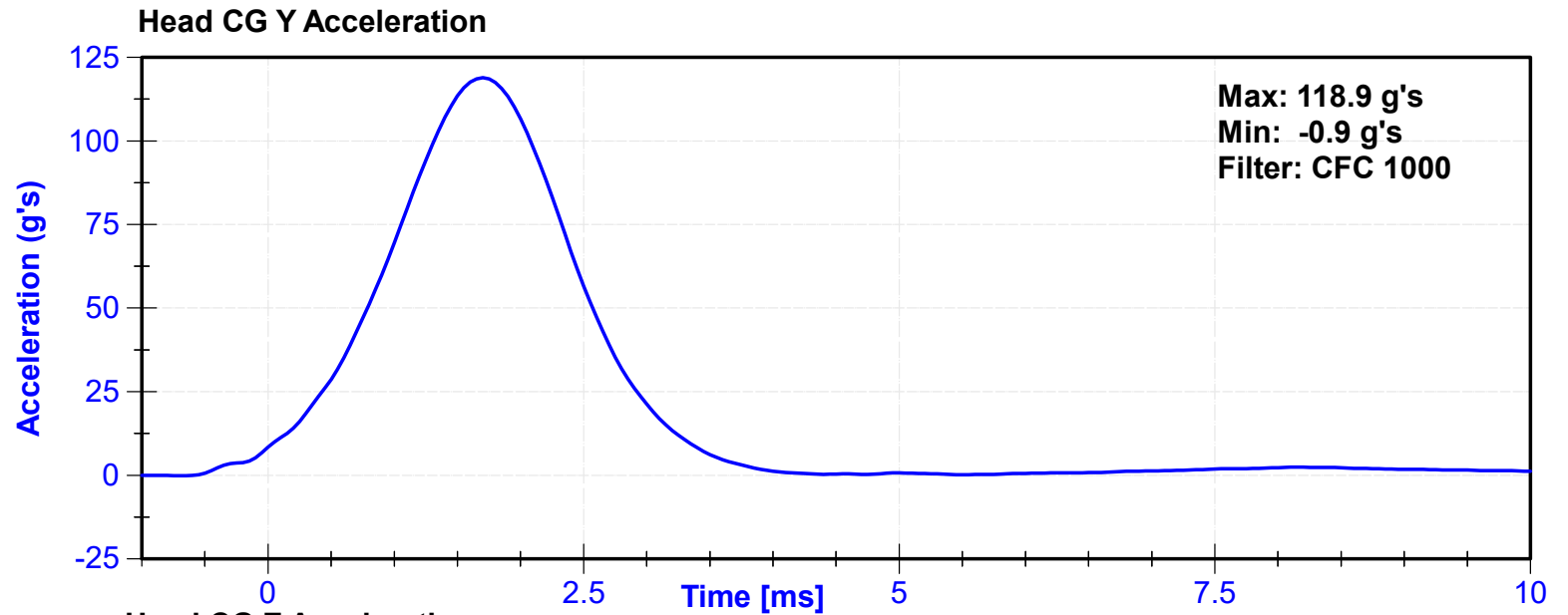
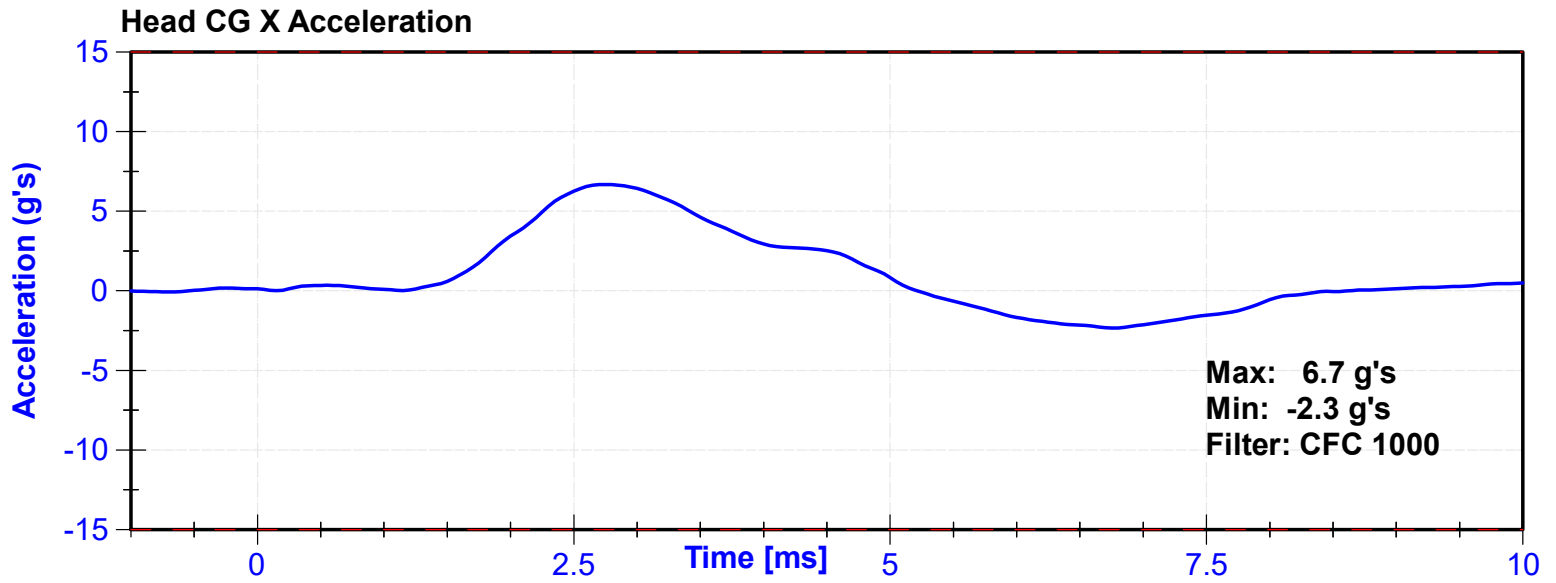

ATD Manufacturer	Denton	Test Technician	D. Sakona
ATD Serial Number	D037	Laboratory Supervisor	C. Mantell

Results

Test Parameter	Minimum Specification	Maximum Specification	Unit	Result	Pass/Fail
Temperature	20.6	22.2	°C	21.1	Pass
Humidity	10	70	%	25.5	Pass
Velocity	3.3	3.5	m/s	3.39	Pass
Lateral Neck Rotation	49	59	deg	54.7	Pass
Time at Maximum Rotation	54	66	ms	63.0	Pass
Time of Rotation Decay from Maximum	53	88	ms	54.6	Pass
Pendulum Velocity Overall Corridor	Lower Boundary ¹	Upper Boundary ²	m/s	See Plot ³	Pass

Transducer Calibrations

Channel	Manufacturer	Serial Number	Calibration Date	Calibration Due Date
Pendulum Accelerometer	Endevco	C16503	10/26/2022	10/26/2023
Front Pendulum Potentiometer	Sfernice	094	10/5/2022	10/5/2023
Headform Potentiometer	Sfernice	095	10/5/2022	10/5/2023

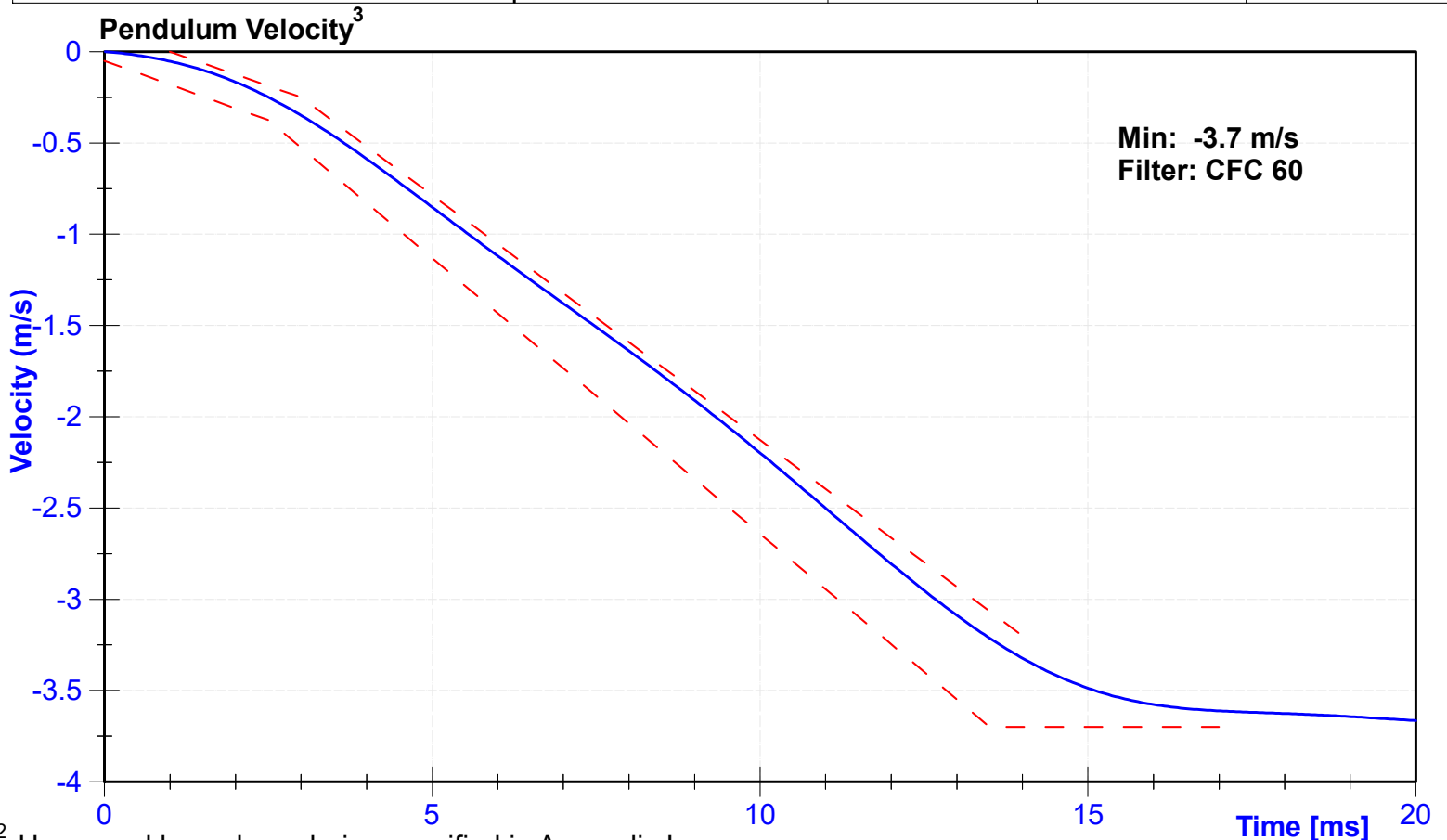

^{1,2} Upper and lower boundaries specified in Appendix I

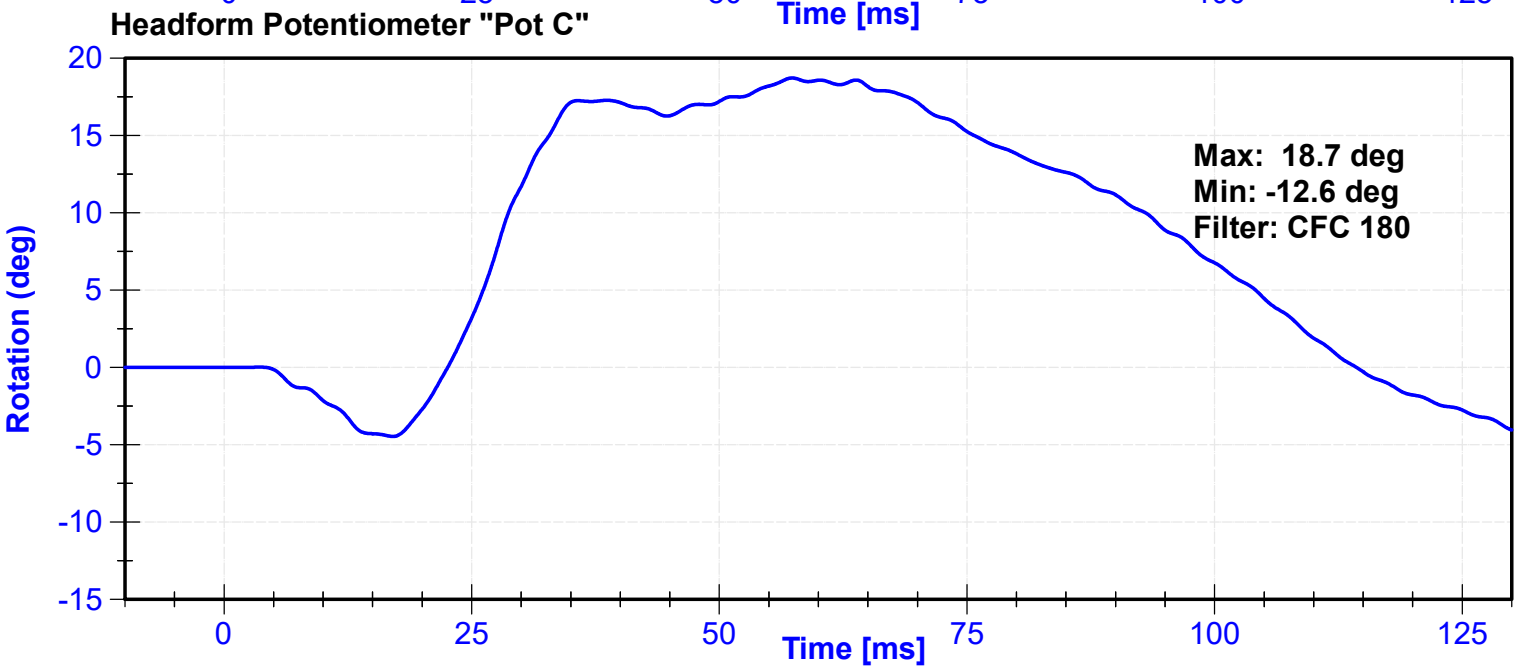
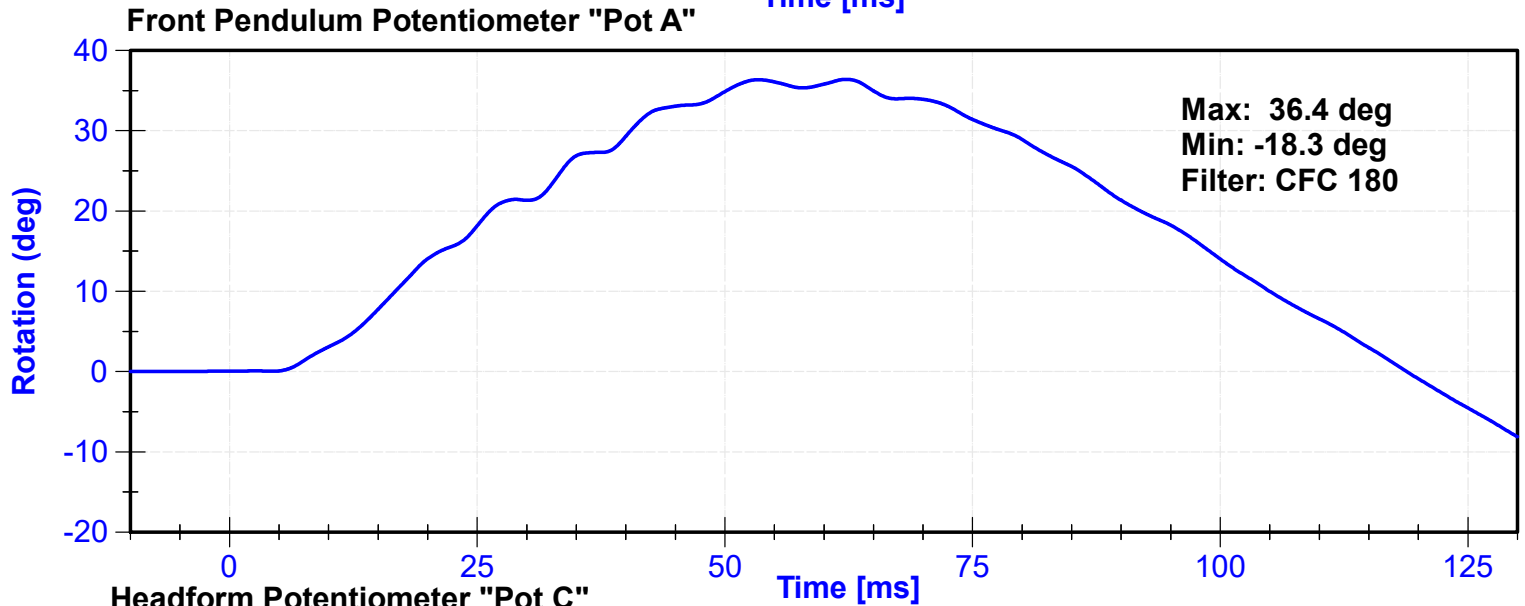
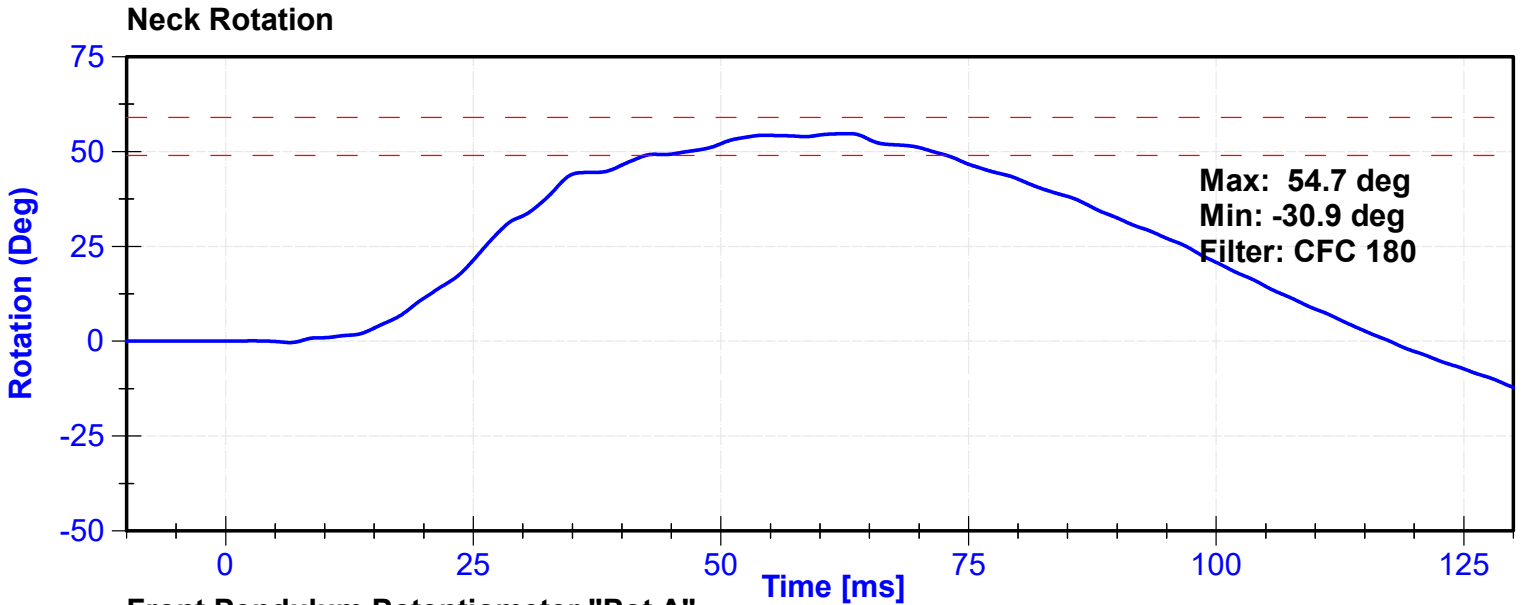

Appendix I

² Upper Boundary Corridor		¹ Lower Boundary Corridor	
Time (ms)	Velocity (m/s)	Time (ms)	Velocity (m/s)
1.0	0.00	0.0	-0.05
3.0	-0.25	2.5	-0.375
14.0	-3.20	13.5	-3.7
		17.0	-3.7

ATD Manufacturer	Denton	Test Technician	T. Roseman
ATD Serial Number	D037	Laboratory Supervisor	C. Mantell

Results

Test Parameter	Minimum Specification	Maximum Specification	Unit	Result	Pass/Fail
Temperature	20.6	22.2	°C	21.3	Pass
Humidity	10	70	%	19.0	Pass
Velocity	4.2	4.4	m/s	4.32	Pass
Probe Acceleration	7.5	10.5	g's	7.60	Pass

Transducer Calibrations

Channel	Manufacturer	Serial Number	Calibration Date	Calibration Due Date
Probe Accelerometer	Endevco	18546	11/19/2022	5/18/2023

Probe Acceleration

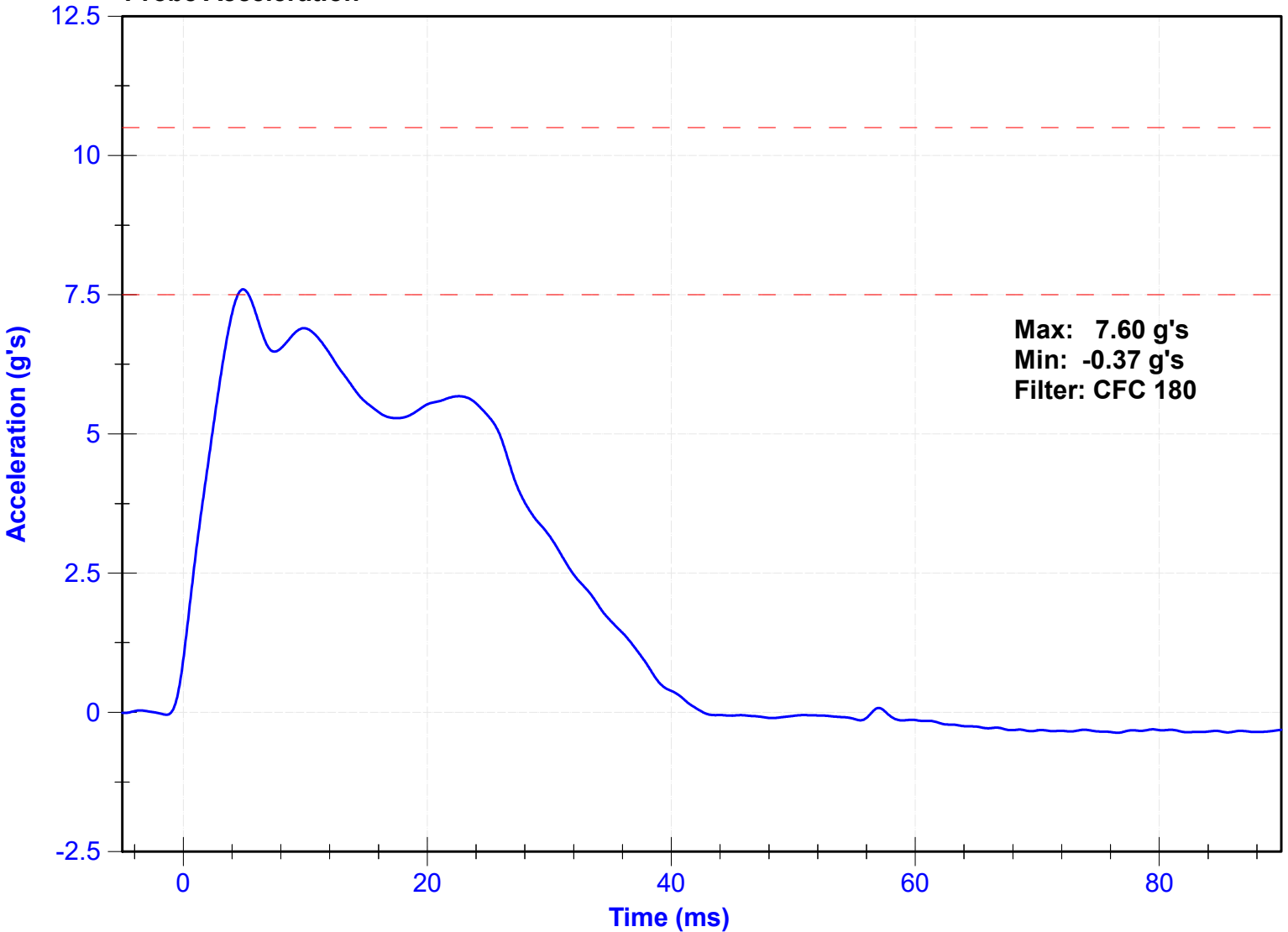

ATD Manufacturer	Denton	Test Technician	T. Roseman
ATD Serial Number	D037	Laboratory Supervisor	C. Mantell

Results

Test Parameter	Minimum Specification	Maximum Specification	Unit	Result	Pass/Fail
Temperature	20.6	22.2	°C	20.8	Pass
Humidity	10	70	%	20.5	Pass
Rib Displacement	46	51	mm	48.6	Pass

Transducer Calibrations

Channel	Manufacturer	Serial Number	Calibration Date	Calibration Due Date
Rib Potentiometer	Honeywell	DS-0552-01	2/27/2023	8/28/2023

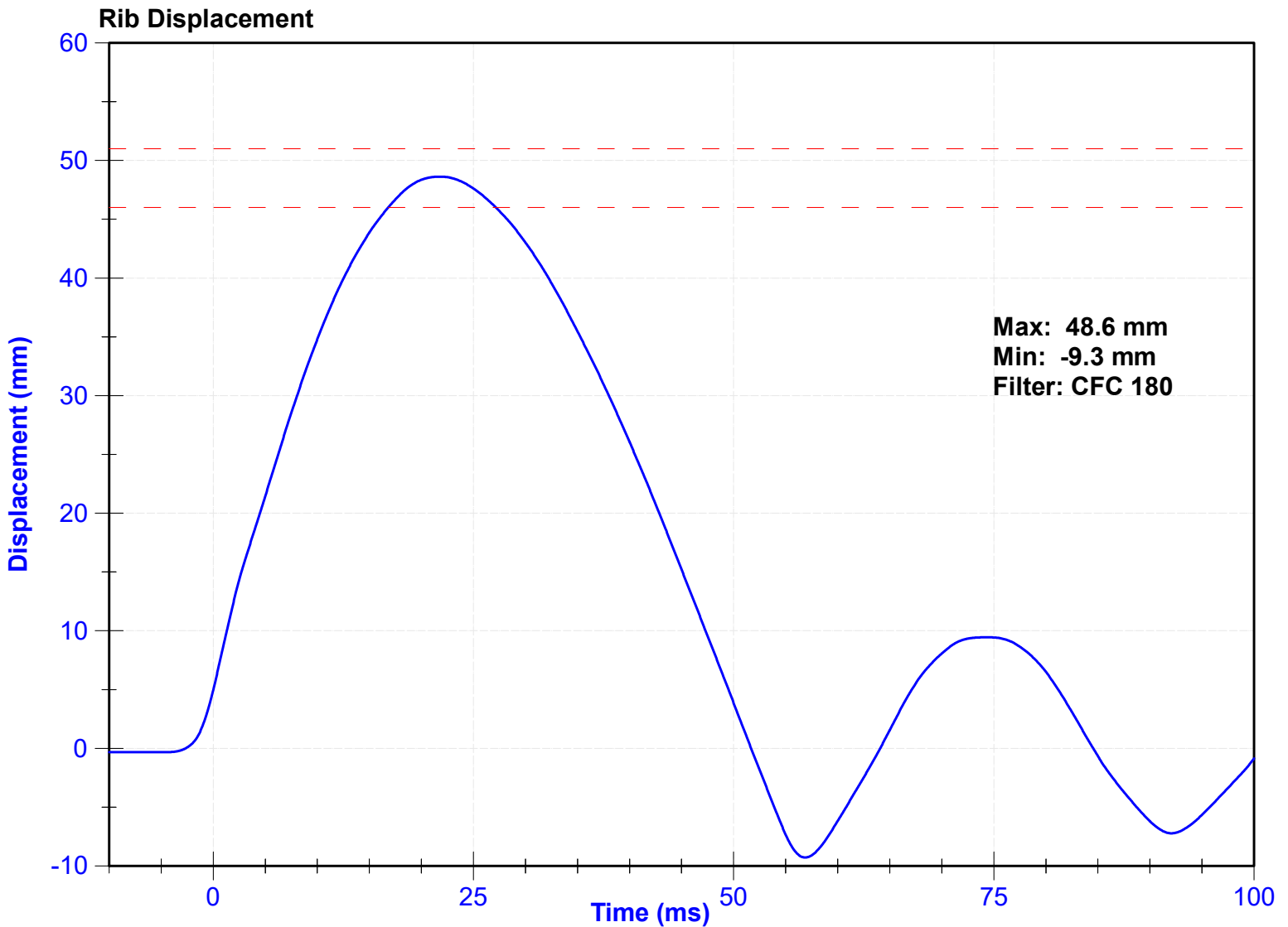

ATD Manufacturer	Denton	Test Technician	T. Roseman
ATD Serial Number	D037	Laboratory Supervisor	C. Mantell

Results

Test Parameter	Minimum Specification	Maximum Specification	Unit	Result	Pass/Fail
Temperature	20.6	22.2	°C	20.8	Pass
Humidity	10	70	%	20.5	Pass
Rib Displacement	36	40	mm	38.1	Pass

Transducer Calibrations

Channel	Manufacturer	Serial Number	Calibration Date	Calibration Due Date
Rib Potentiometer	Honeywell	DS-0552-01	2/27/2023	8/28/2023

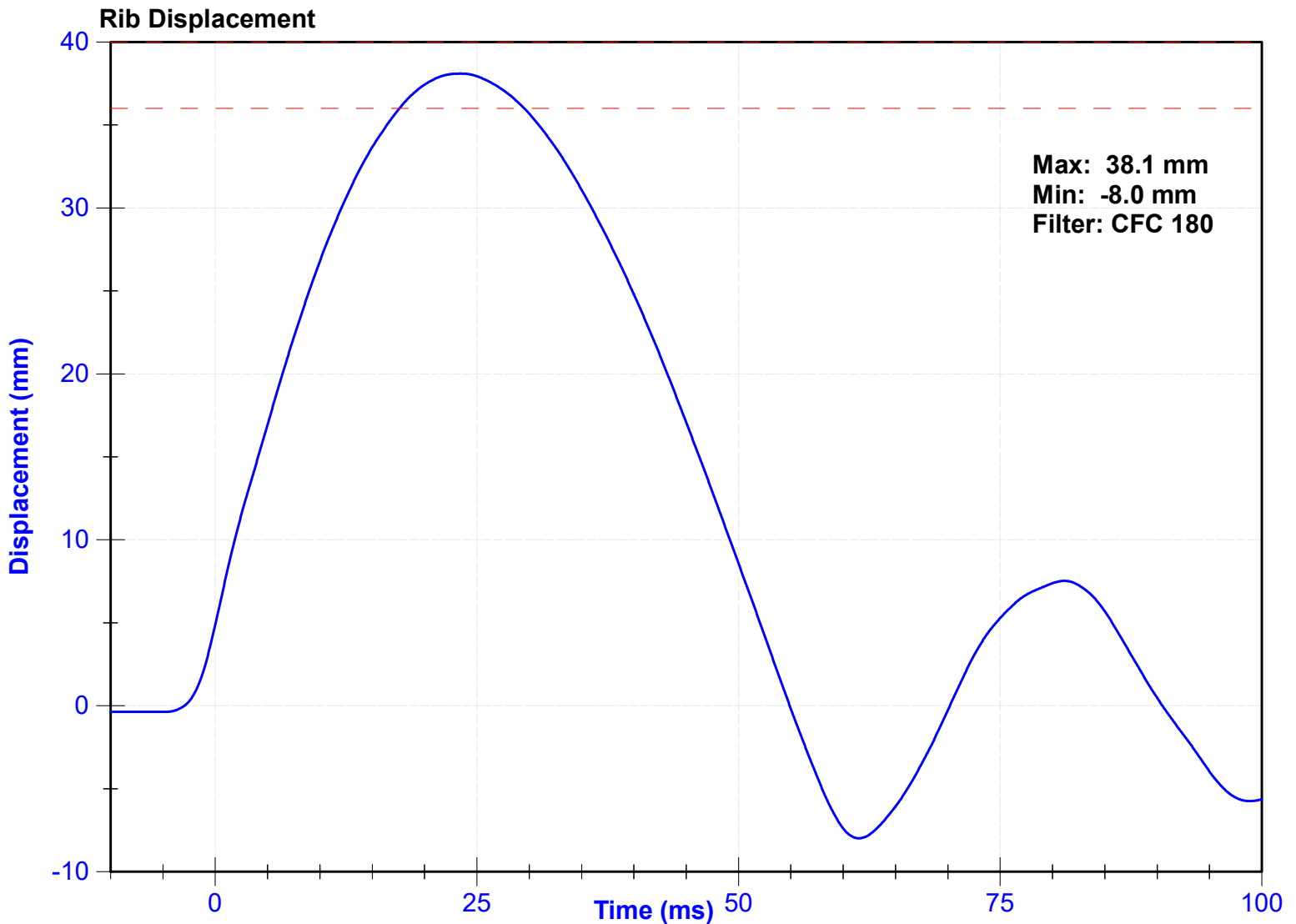

ATD Manufacturer	Denton	Test Technician	T. Roseman
ATD Serial Number	D037	Laboratory Supervisor	C. Mantell

Results

Test Parameter	Minimum Specification	Maximum Specification	Unit	Result	Pass/Fail
Temperature	20.6	22.2	°C	20.8	Pass
Humidity	10	70	%	20.5	Pass
Rib Displacement	46	51	mm	49.4	Pass

Transducer Calibrations

Channel	Manufacturer	Serial Number	Calibration Date	Calibration Due Date
Rib Potentiometer	Honeywell	DS-807	2/27/2023	8/28/2023

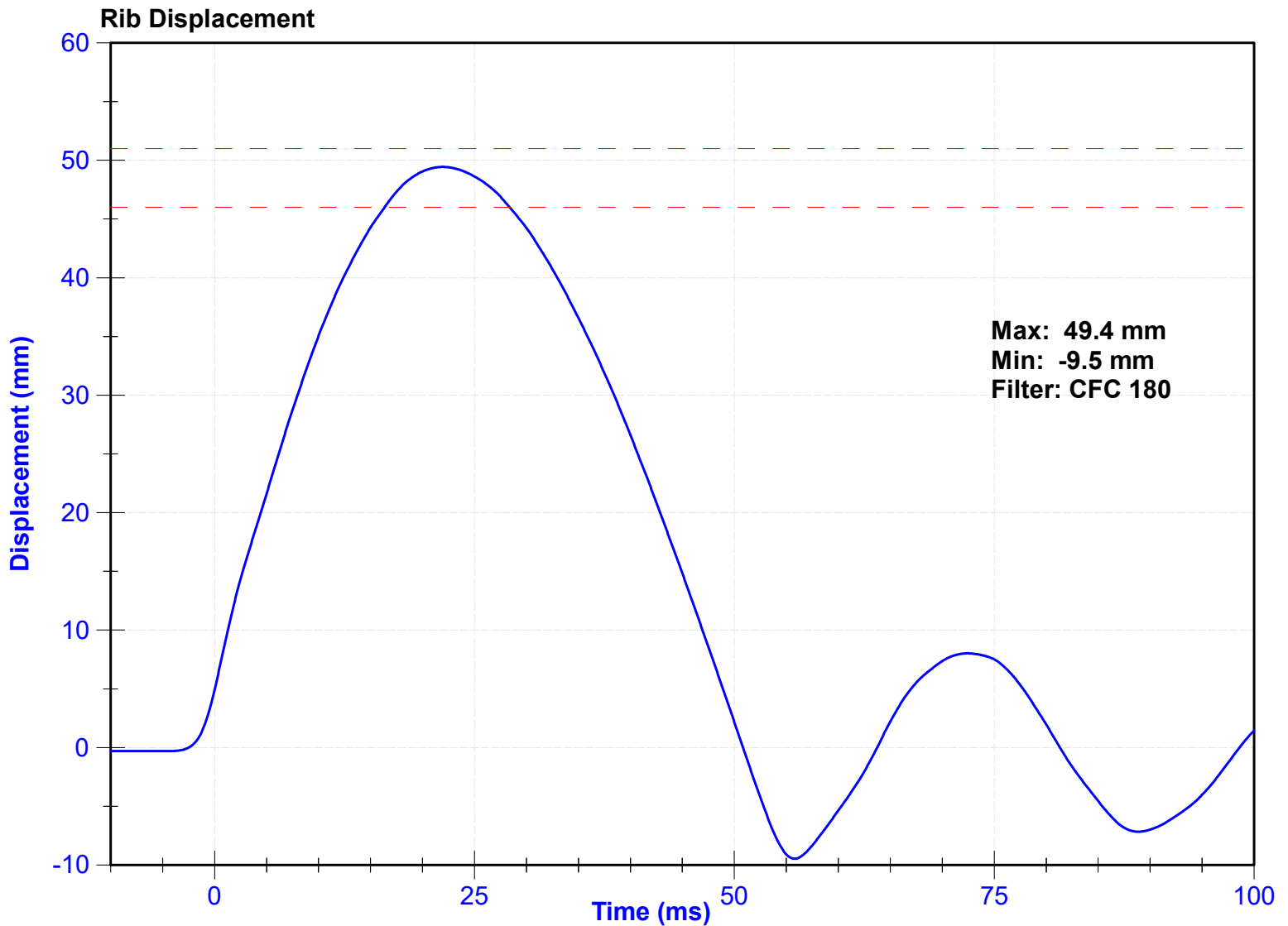

ATD Manufacturer	Denton	Test Technician	T. Roseman
ATD Serial Number	D037	Laboratory Supervisor	C. Mantell

Results

Test Parameter	Minimum Specification	Maximum Specification	Unit	Result	Pass/Fail
Temperature	20.6	22.2	°C	20.8	Pass
Humidity	10	70	%	20.5	Pass
Rib Displacement	36	40	mm	38.5	Pass

Transducer Calibrations

Channel	Manufacturer	Serial Number	Calibration Date	Calibration Due Date
Rib Potentiometer	Honeywell	DS-807	2/27/2023	8/28/2023

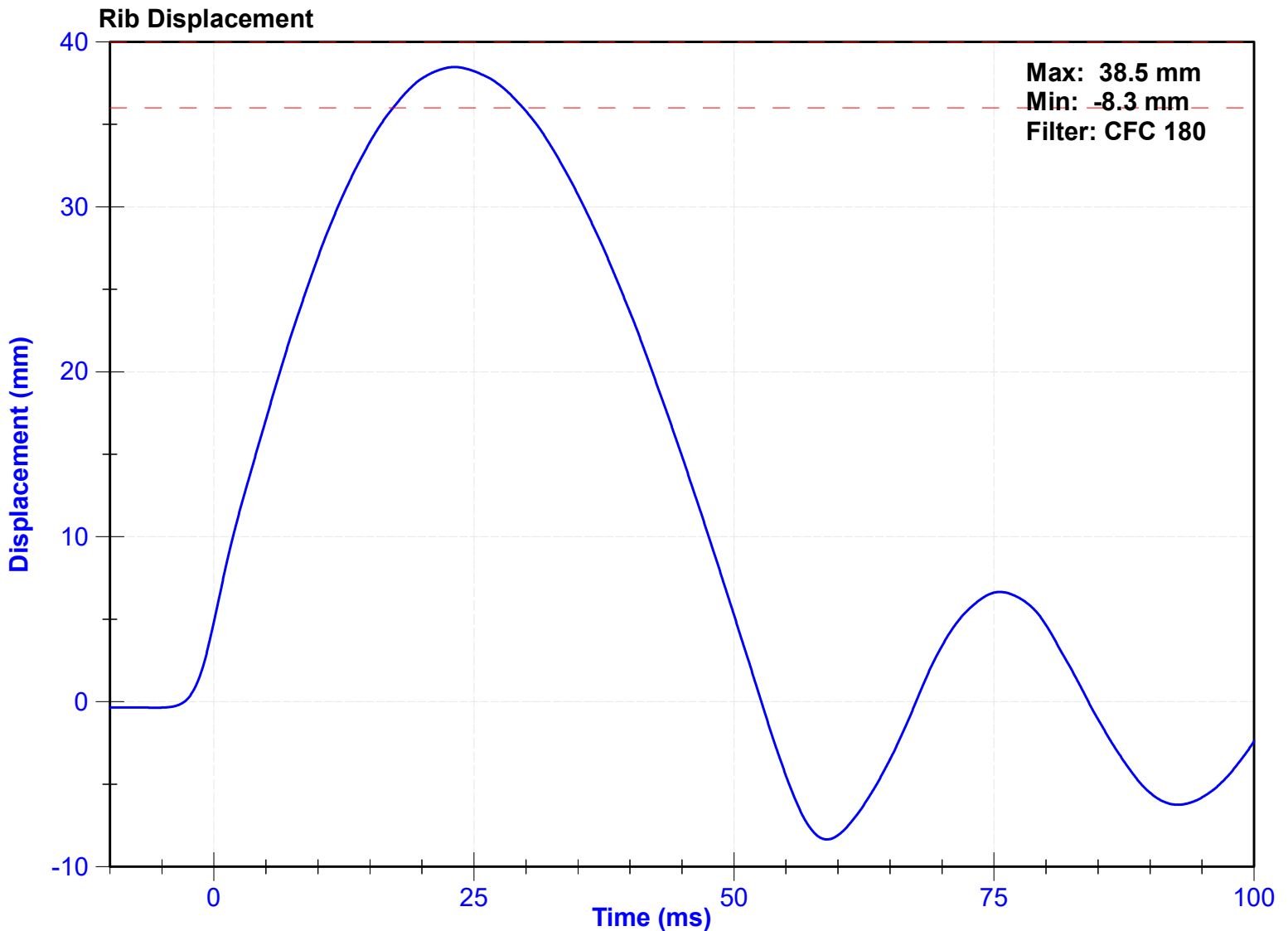

ATD Manufacturer	Denton	Test Technician	T. Roseman
ATD Serial Number	D037	Laboratory Supervisor	C. Mantell

Results

Test Parameter	Minimum Specification	Maximum Specification	Unit	Result	Pass/Fail
Temperature	20.6	22.2	°C	20.8	Pass
Humidity	10	70	%	20.5	Pass
Rib Displacement	46	51	mm	48.8	Pass

Transducer Calibrations

Channel	Manufacturer	Serial Number	Calibration Date	Calibration Due Date
Rib Potentiometer	Honeywell	DS-0552-03	2/27/2023	8/28/2023

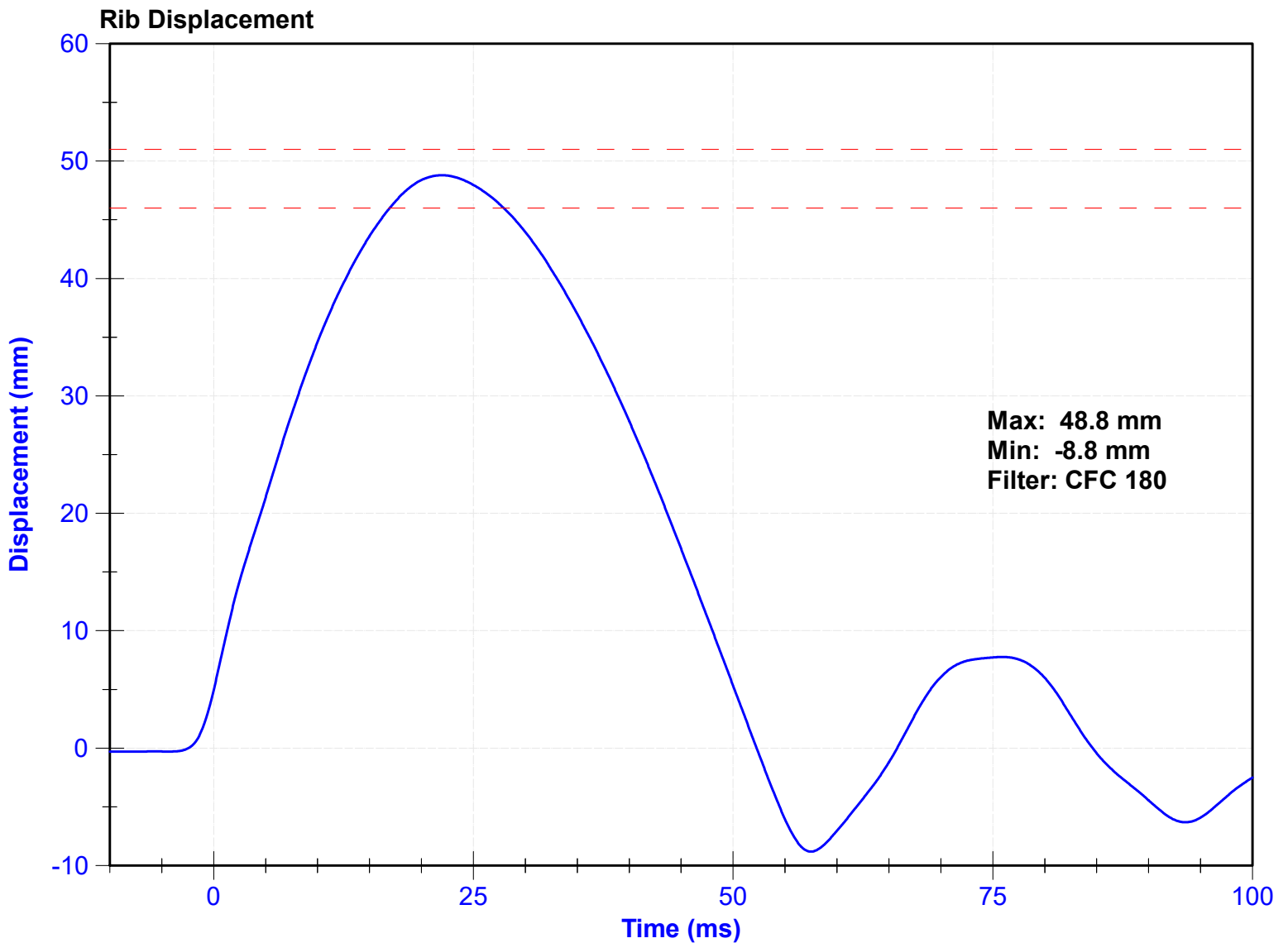

ATD Manufacturer	Denton	Test Technician	T. Roseman
ATD Serial Number	D037	Laboratory Supervisor	C. Mantell

Results

Test Parameter	Minimum Specification	Maximum Specification	Unit	Result	Pass/Fail
Temperature	20.6	22.2	°C	20.8	Pass
Humidity	10	70	%	20.5	Pass
Rib Displacement	36	40	mm	38.1	Pass

Transducer Calibrations

Channel	Manufacturer	Serial Number	Calibration Date	Calibration Due Date
Rib Potentiometer	Honeywell	DS-0552-03	2/27/2023	8/28/2023

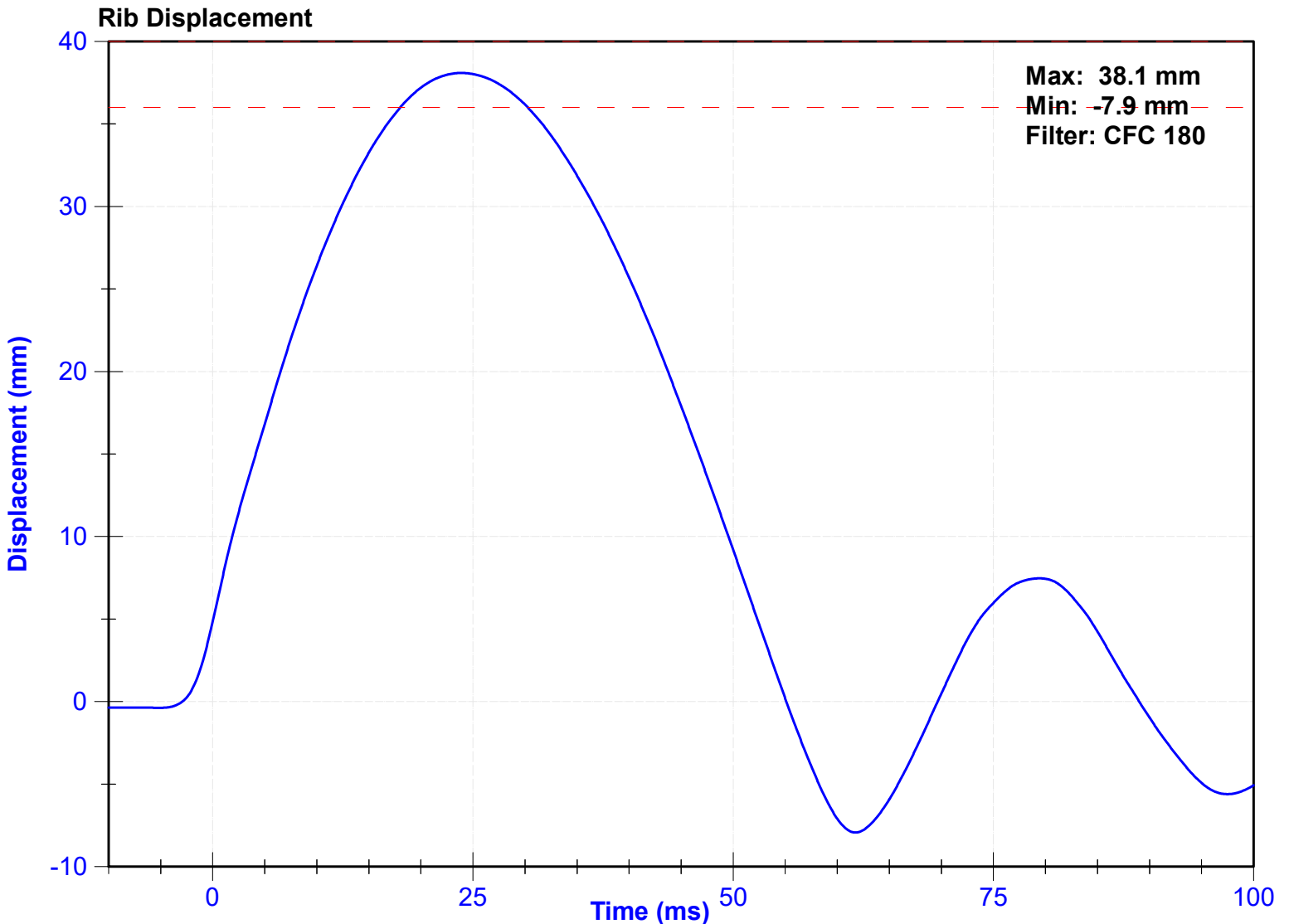

ATD Manufacturer	Denton	Test Technician	T. Roseman
ATD Serial Number	D037	Laboratory Supervisor	C. Mantell

Results

Test Parameter	Minimum Specification	Maximum Specification	Unit	Result	Pass/Fail
Temperature	20.6	22.2	°C	21.3	Pass
Humidity	10	70	%	19.0	Pass
Velocity	5.4	5.6	m/s	5.54	Pass
Resistive Force after 6ms	5100	6200	N	5907.5	Pass
Upper Thorax Rib Deflection	34	41	mm	39.5	Pass
Mid Thorax Rib Deflection	37	45	mm	41.7	Pass
Lower Thorax Rib Deflection	37	44	mm	42.2	Pass

Transducer Calibrations

Channel	Manufacturer	Serial Number	Calibration Date	Calibration Due Date
Probe Accelerometer	Endevco	18546	11/19/2022	5/18/2023
Upper Thorax Rib Potentiometer	Honeywell	DS-0552-01	2/27/2023	8/28/2023
Middle Thorax Rib Potentiometer	Honeywell	DS-807	2/27/2023	8/28/2023
Lower Thorax Rib Potentiometer	Honeywell	DS-0552-03	2/27/2023	8/28/2023

Probe Acceleration

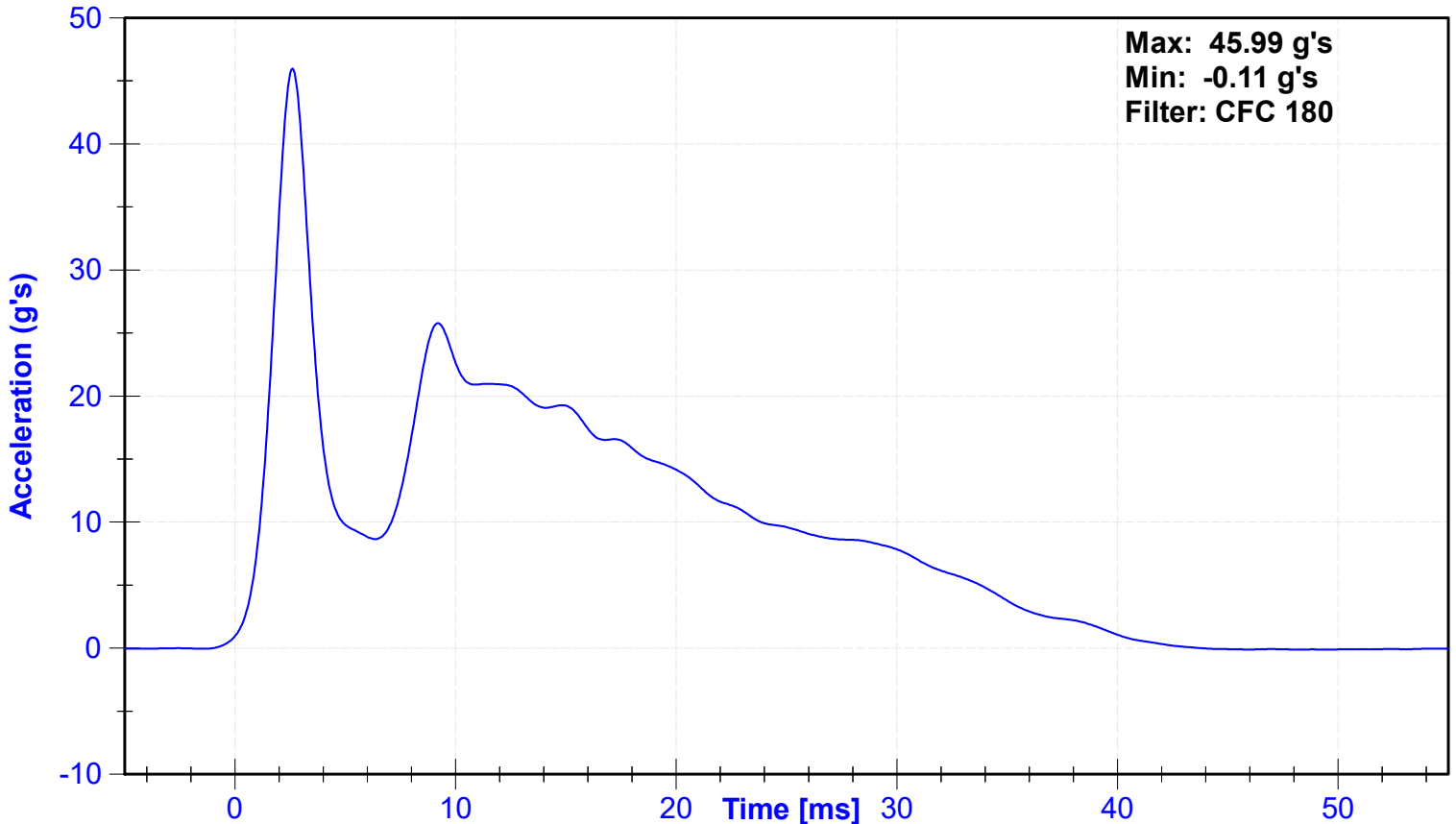

Resistive Force

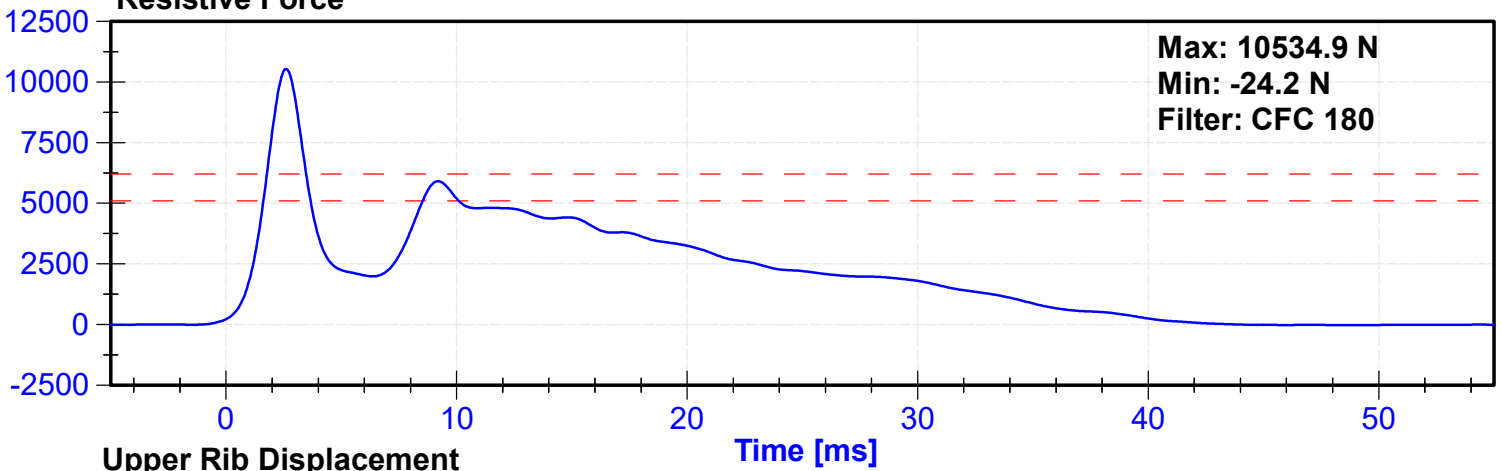

Upper Rib Displacement

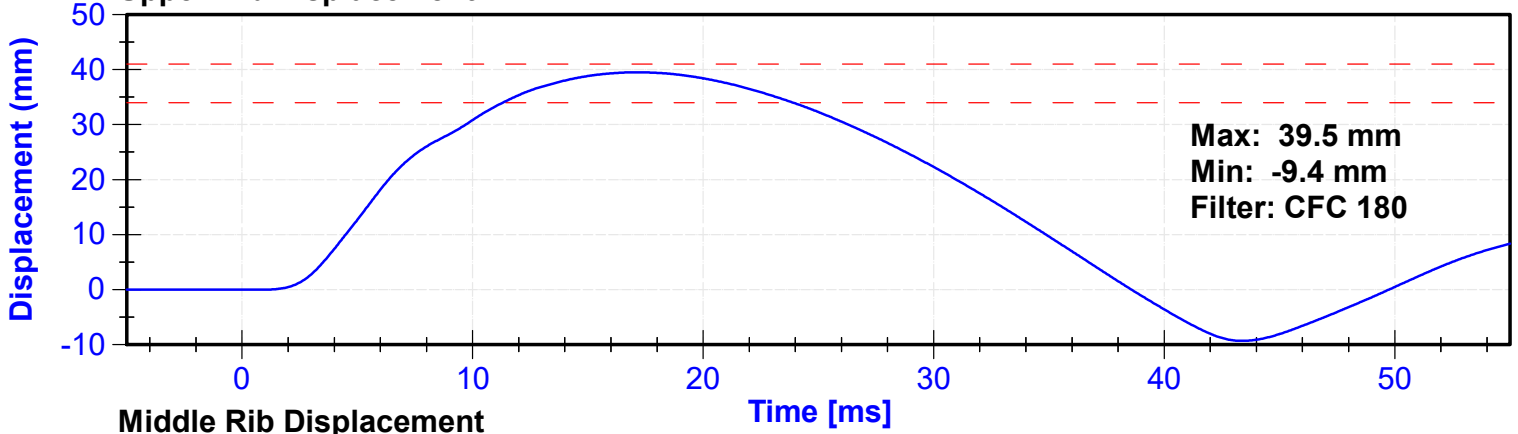

Middle Rib Displacement

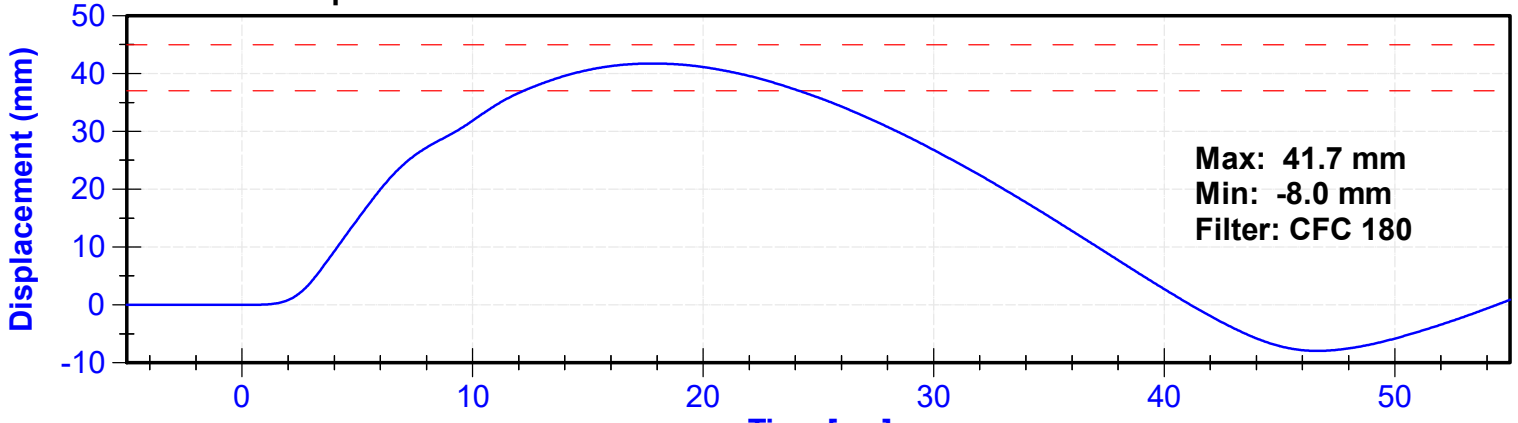

Lower Rib Displacement

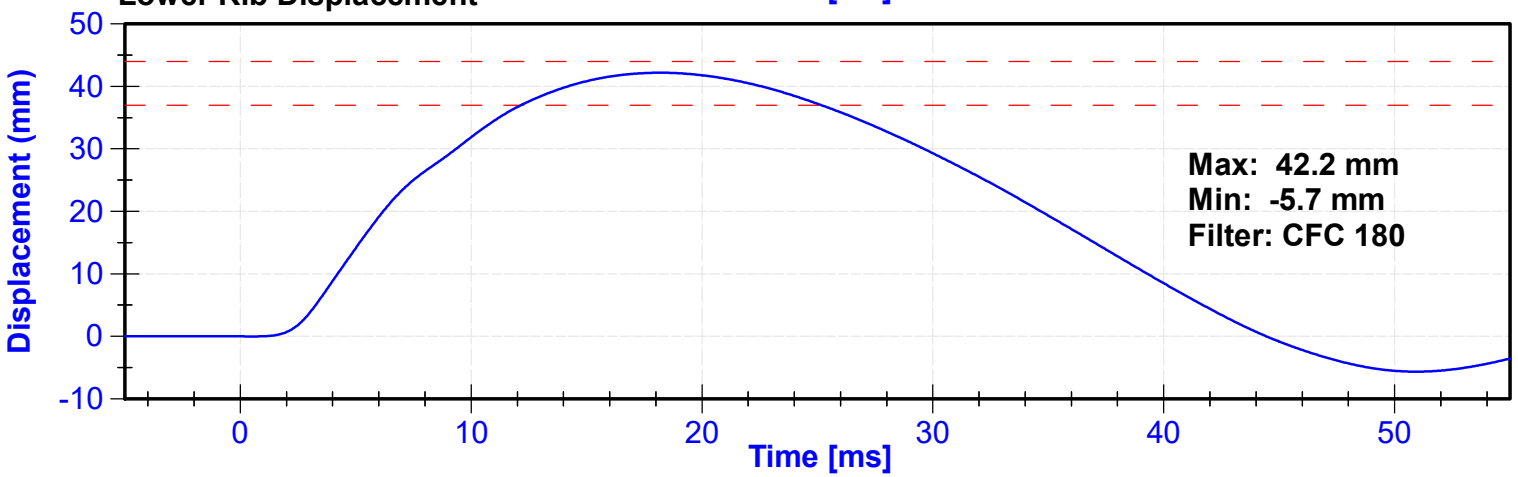

ATD Manufacturer	Denton	Test Technician	T. Roseman
ATD Serial Number	D037	Laboratory Supervisor	C. Mantell

Results

Test Parameter	Minimum Specification	Maximum Specification	Unit	Result	Pass/Fail
Temperature	20.6	22.2	°C	21.3	Pass
Humidity	10	70	%	19.0	Pass
Velocity	3.9	4.1	m/s	4.03	Pass
Combined Abdomen Force	2200	2700	N	2440.9	Pass
Time at Peak Abdomen Force	10.0	12.3	ms	11.25	Pass
Resistive Probe Force	4000	4800	N	4544.6	Pass
Time at Peak Resistive Force	10.6	13.0	ms	11.60	Pass

Transducer Calibrations

Channel	Manufacturer	Serial Number	Calibration Date	Calibration Due Date
Pendulum Accelerometer	Endevco	18546	11/19/2022	5/18/2023
Front Abdomen Load Cell	Denton	1440	8/12/2022	8/12/2023
Middle Abdomen Load Cell	Denton	1525	8/12/2022	8/12/2023
Rear Abdomen Load Cell	Denton	1528	8/12/2022	8/12/2023

Probe Force

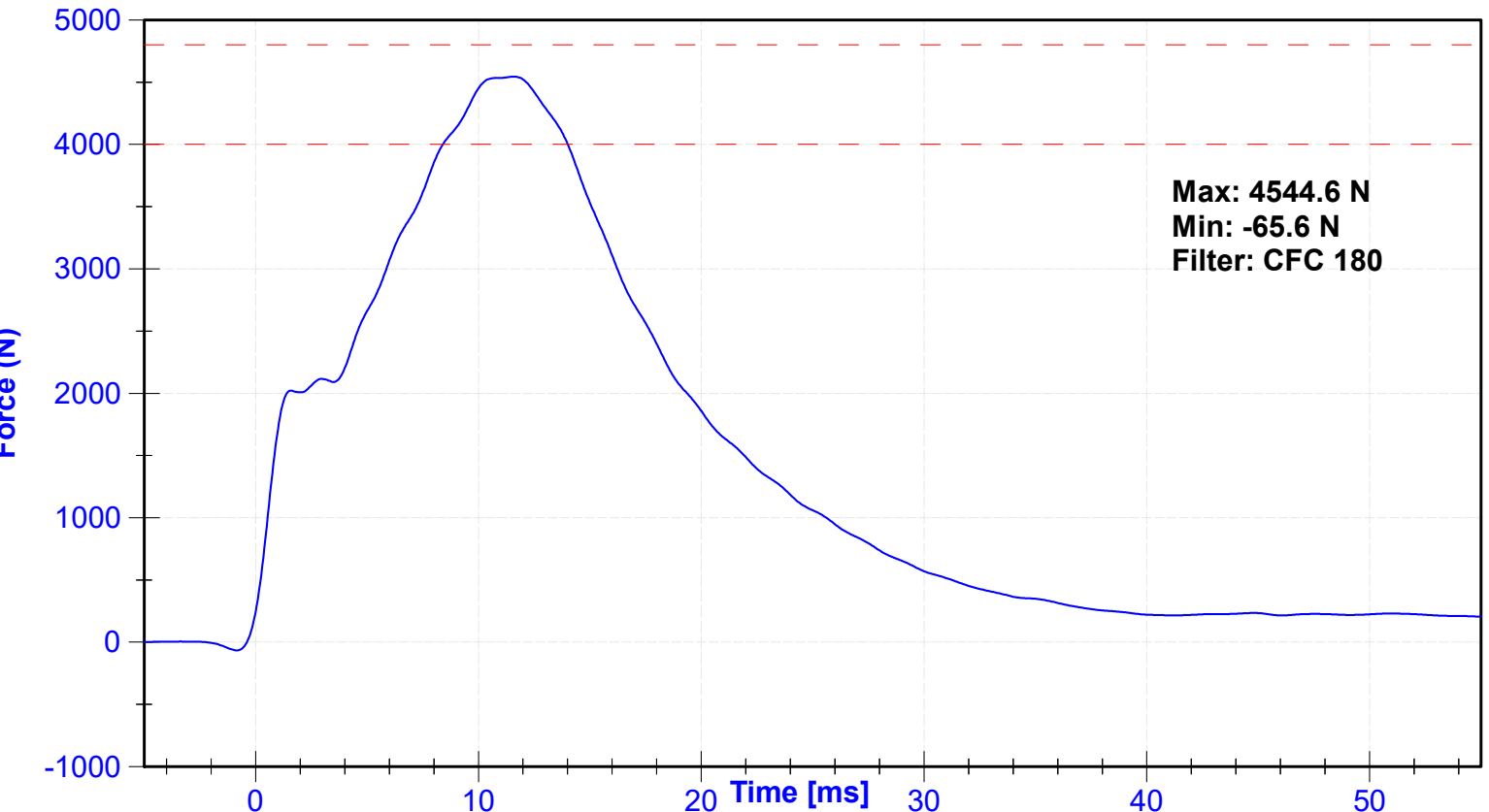

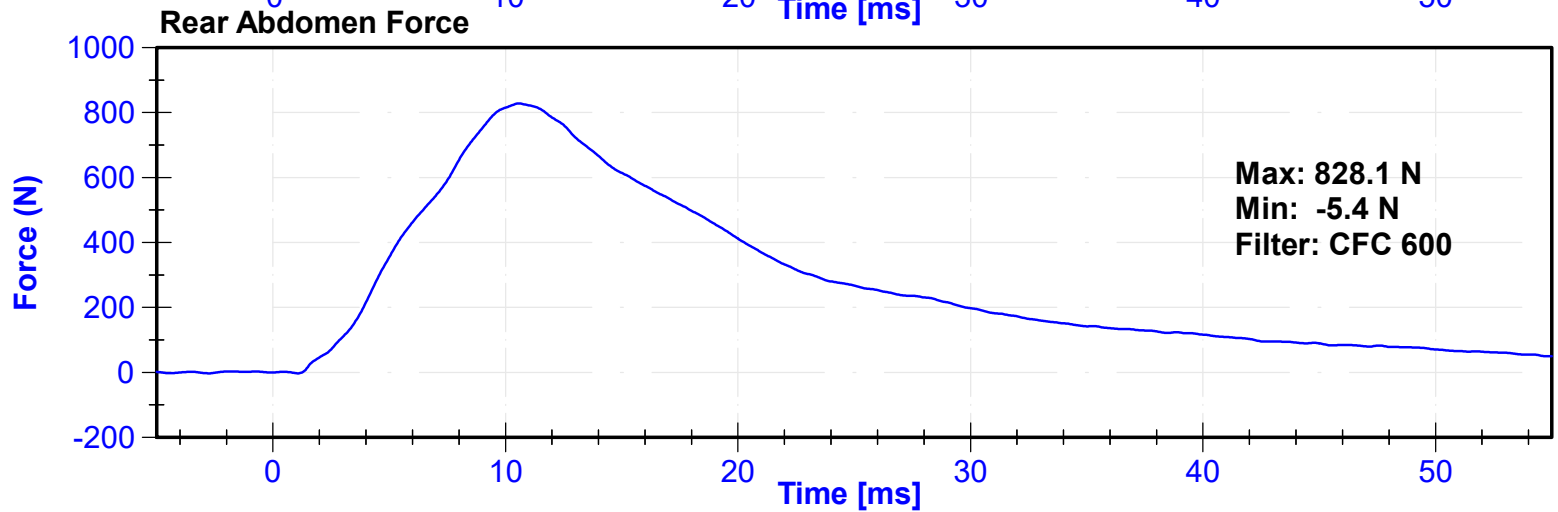
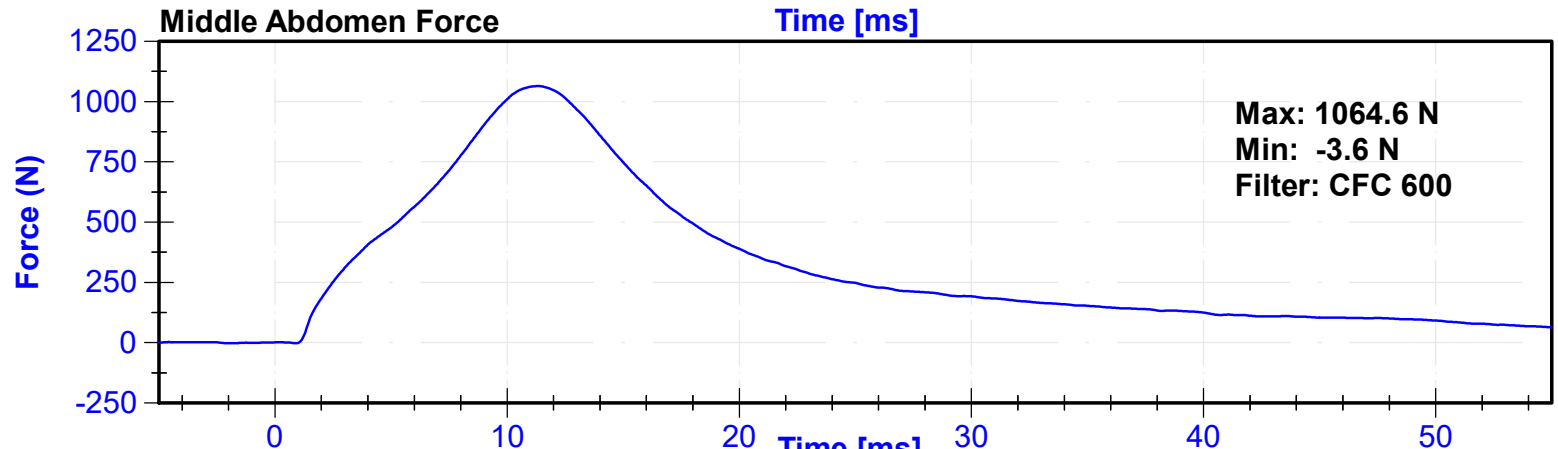
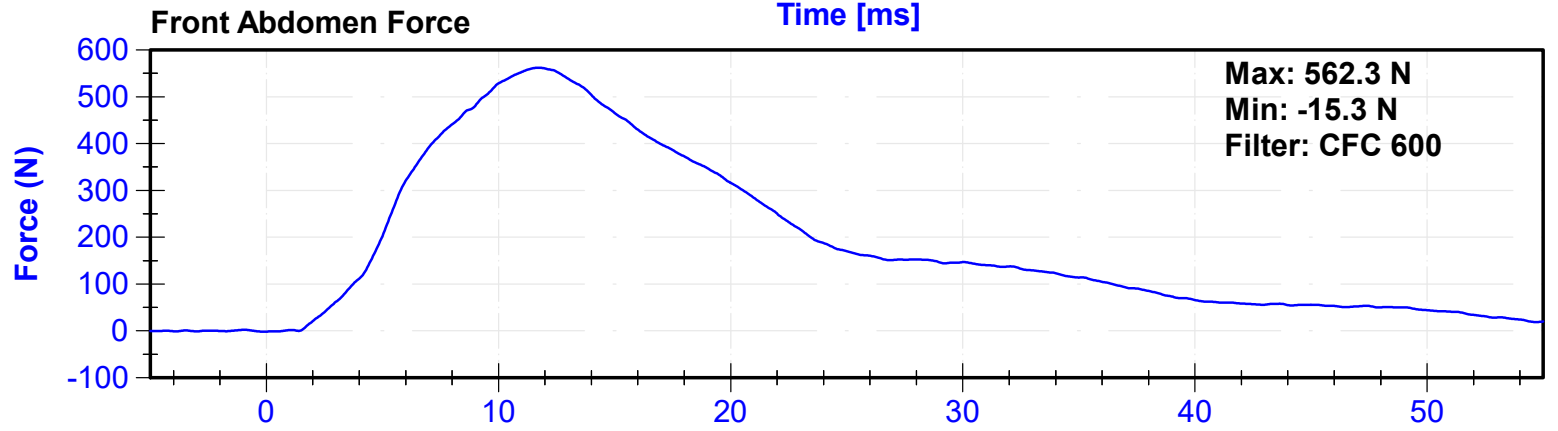
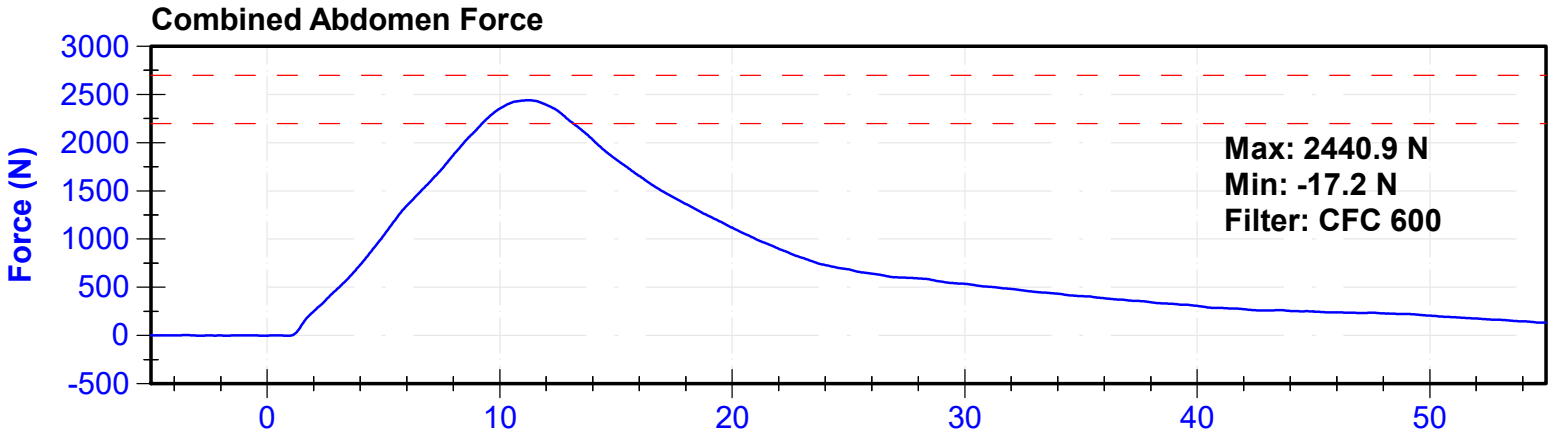

ATD Manufacturer	Denton	Test Technician	D. Sakona
ATD Serial Number	D037	Laboratory Supervisor	C. Mantell

Results

Test Parameter	Minimum Specification	Maximum Specification	Unit	Result	Pass/Fail
Temperature	20.6	22.2	°C	21.1	Pass
Humidity	10	70	%	25.5	Pass
Velocity	5.95	6.15	m/s	6.011	Pass
Lateral Spine Rotation	45	55	deg	50.0	Pass
Time at Maximum Rotation	39	53	ms	45.9	Pass
Time of Decay to Zero Degrees	37	57	ms	38.3	Pass
Pendulum Velocity Overall Corridor	Lower Boundary ¹	Upper Boundary ²	m/s	See Plot ³	Pass

Transducer Calibrations

Channel	Manufacturer	Serial Number	Calibration Date	Calibration Due Date
Pendulum Accelerometer	Endevco	C16503	10/26/2022	10/26/2023
Pendulum "A" Potentiometer	Sfernice	094	10/5/2022	10/5/2023
Condyle "B" Potentiometer	Sfernice	095	10/5/2022	10/5/2023

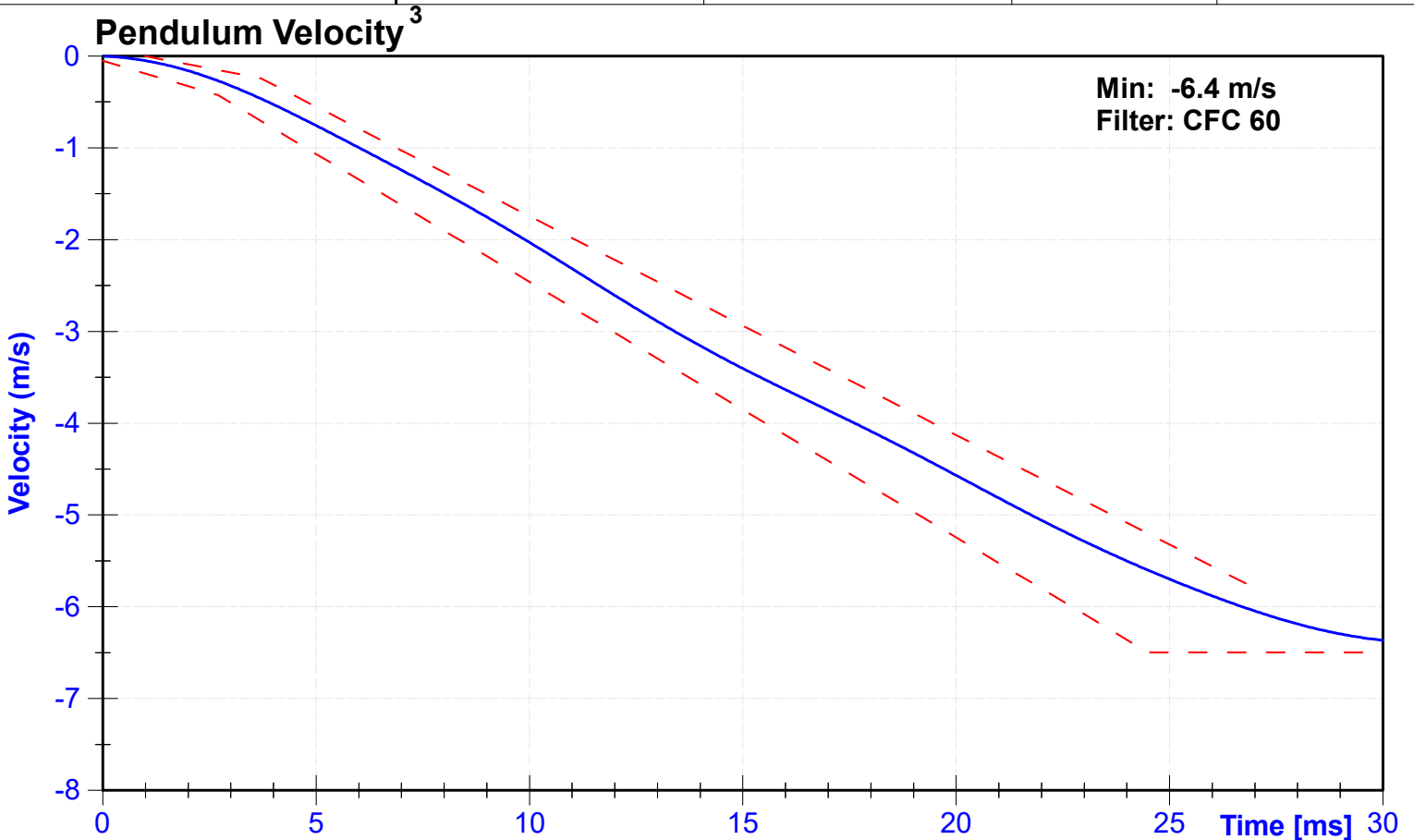

^{1,2} Upper and lower boundaries specified in Appendix I IV-19

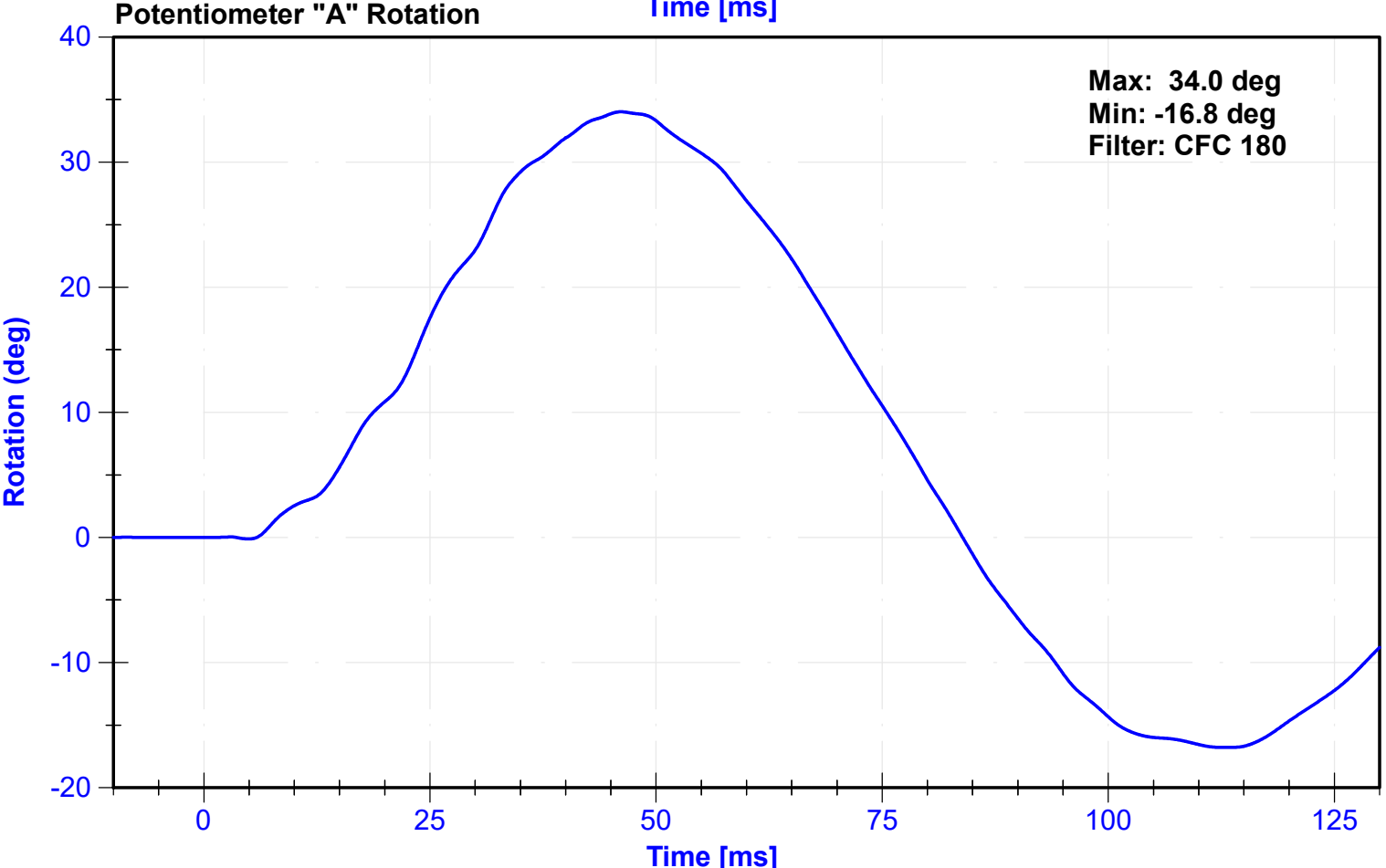
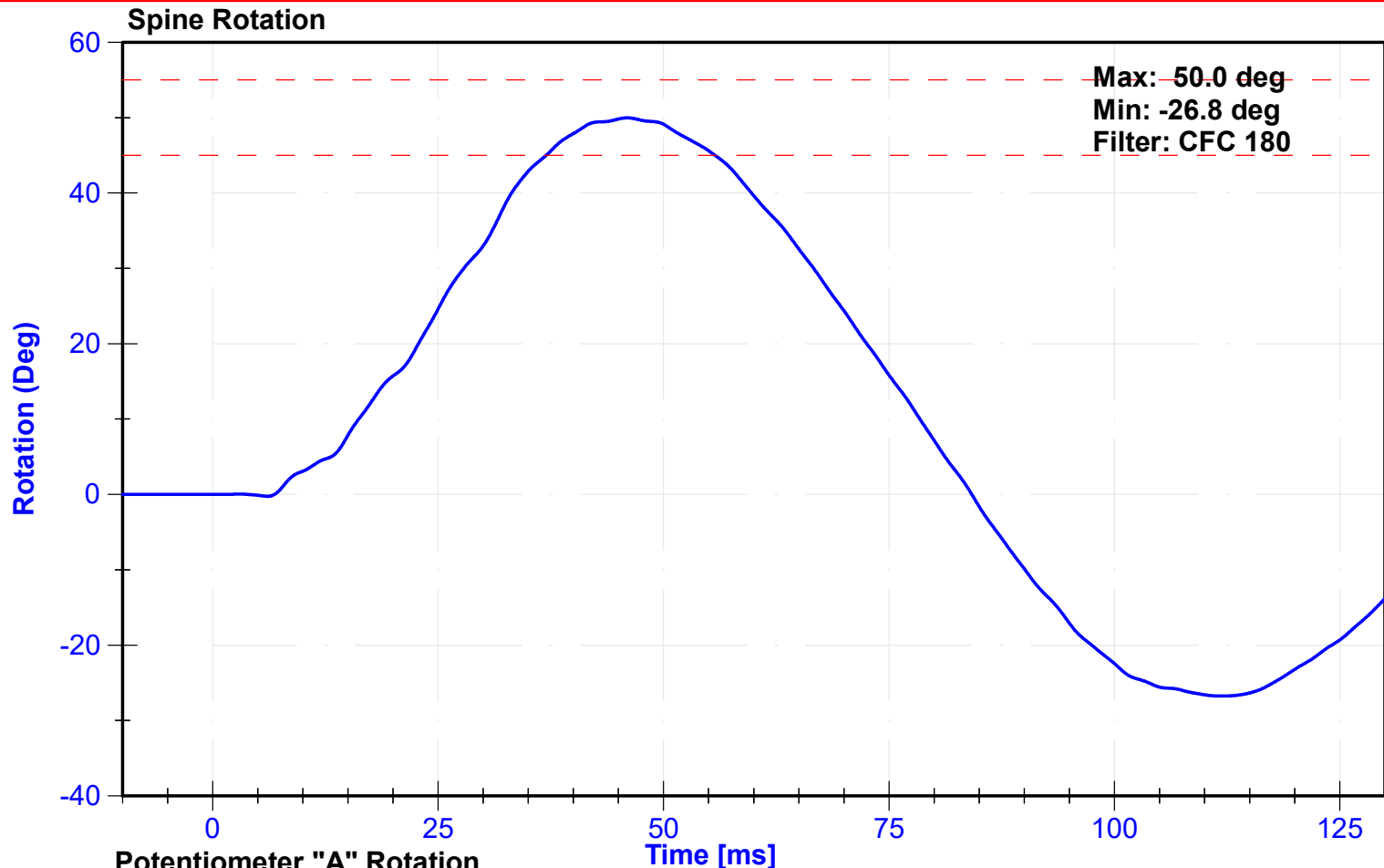

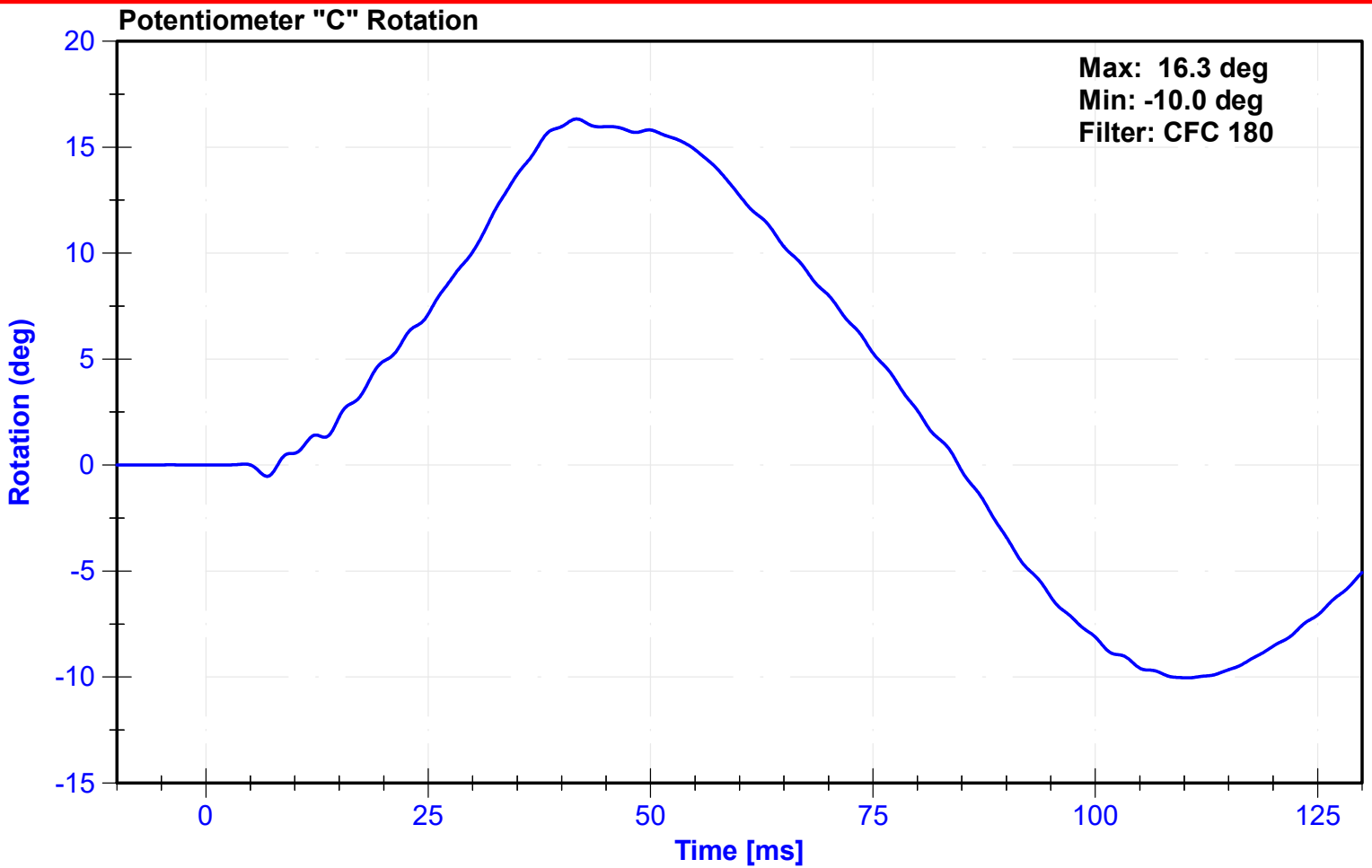

Appendix I

² Upper Boundary Corridor		¹ Lower Boundary Corridor	
Time (ms)	Velocity (m/s)	Time (ms)	Velocity (m/s)
1.0	0.00	0.0	-0.05
3.7	-0.24	2.7	-0.425
27.0	-5.80	24.5	-6.5
		30.0	-6.5

ATD Manufacturer	Denton	Test Technician	T. Roseman
ATD Serial Number	D037	Laboratory Supervisor	C. Mantell

Results

Test Parameter	Minimum Specification	Maximum Specification	Unit	Result	Pass/Fail
Temperature	20.6	22.2	°C	21.3	Pass
Humidity	10	70	%	19.0	Pass
Velocity	4.2	4.4	m/s	4.34	Pass
Resistive Force	4700	5400	N	4873.7	Pass
Time at Peak Resistive Force	11.8	16.1	ms	13.60	Pass
Pubic Force	-1590	-1230	N	-1368.4	Pass
Time at Peak Pubic Force	12.2	17.0	ms	13.50	Pass

Transducer Calibrations

Channel	Manufacturer	Serial Number	Calibration Date	Calibration Due Date
Pendulum Accelerometer	Endevco	18546	11/19/2022	5/18/2023
Pubic Load Cell	Denton		8/12/2022	8/12/2023

Probe Acceleration

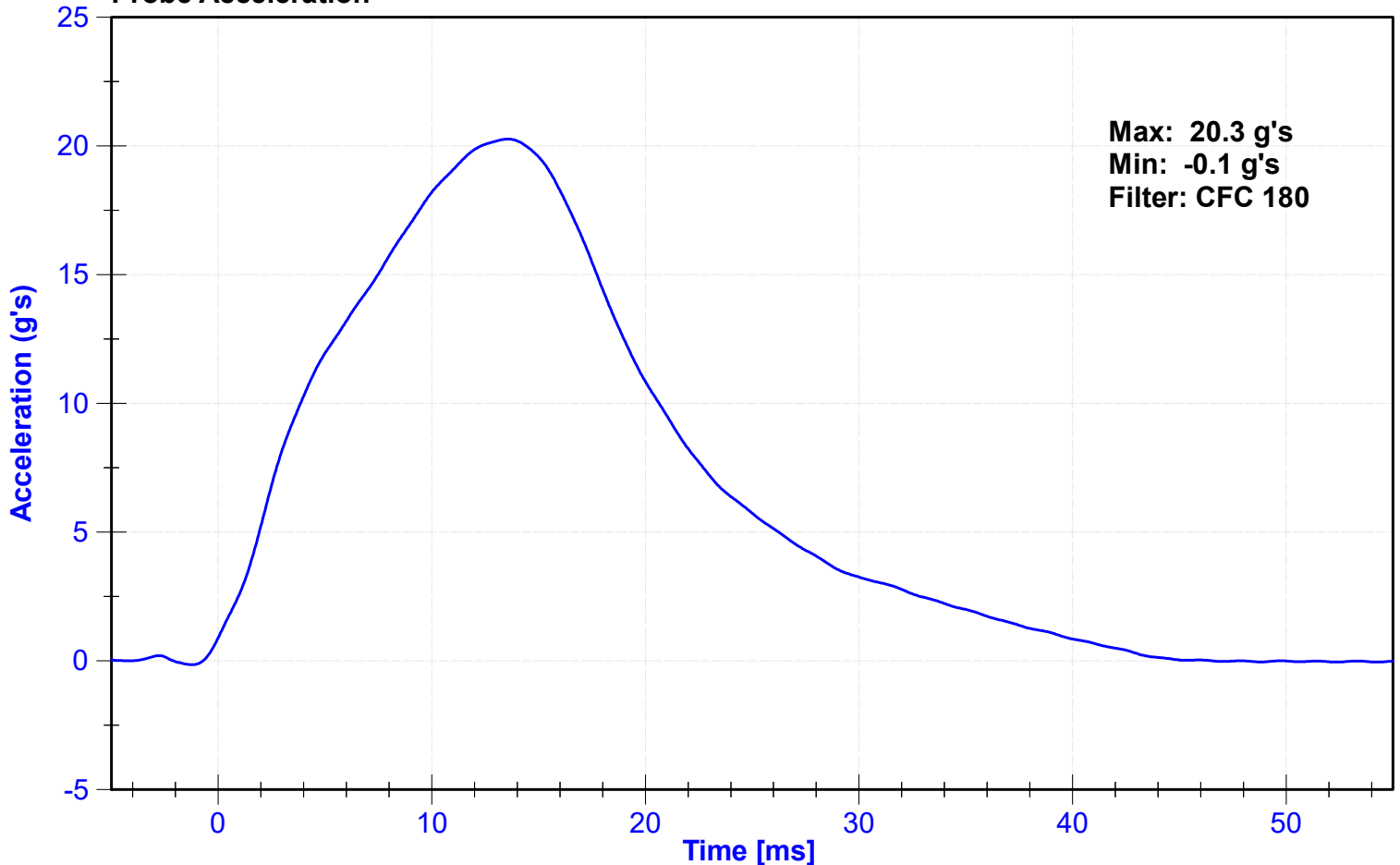

Resistive Force

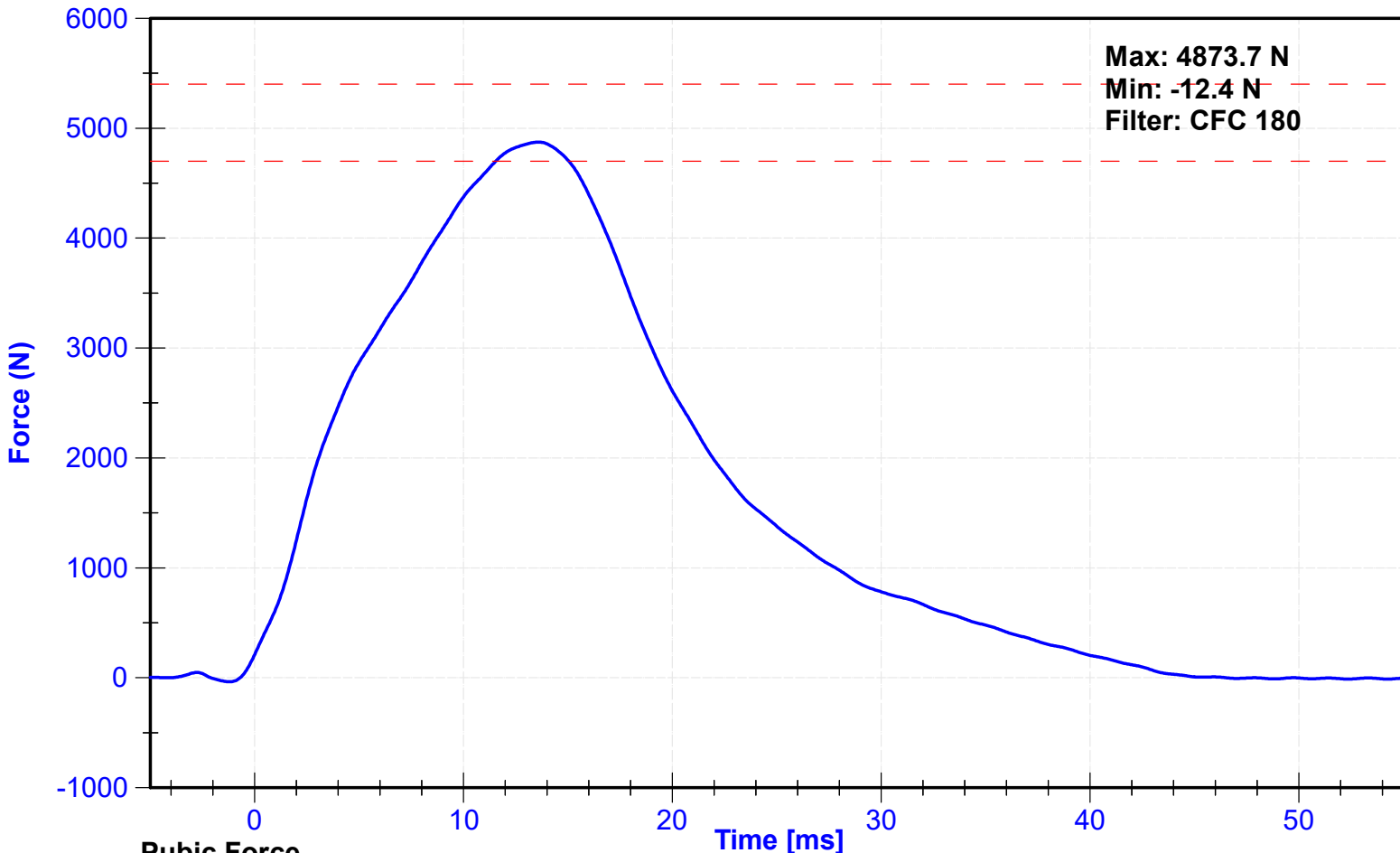

Pubic Force

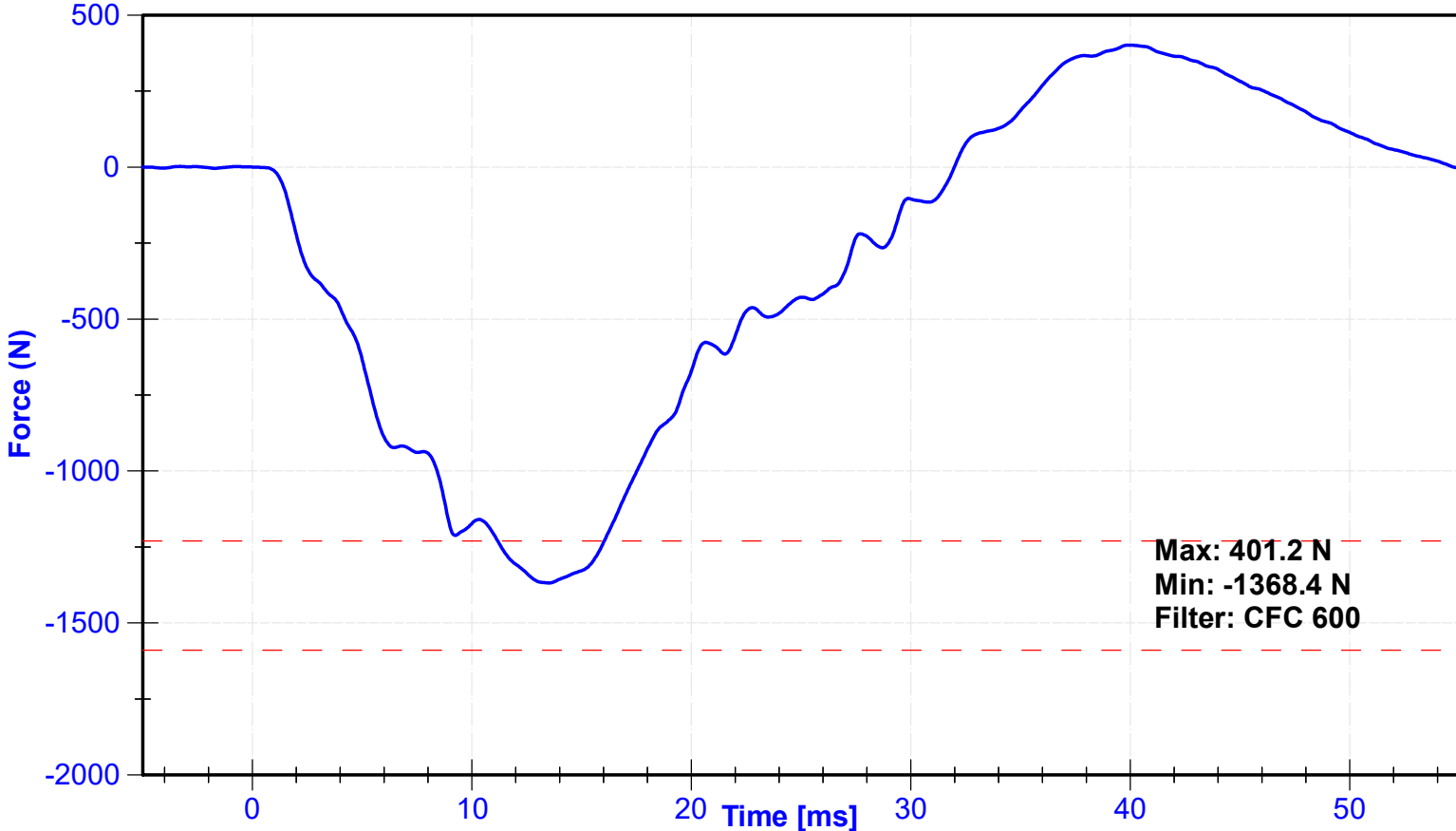

POST-TEST DUMMY PERFORMANCE CALIBRATION TEST DATA
(Subpart U, ES-2re)

External Measurements - EuroSID-2re

Technician: K. Brogan

Date: 03/07/2023

Dummy Serial Number: D037

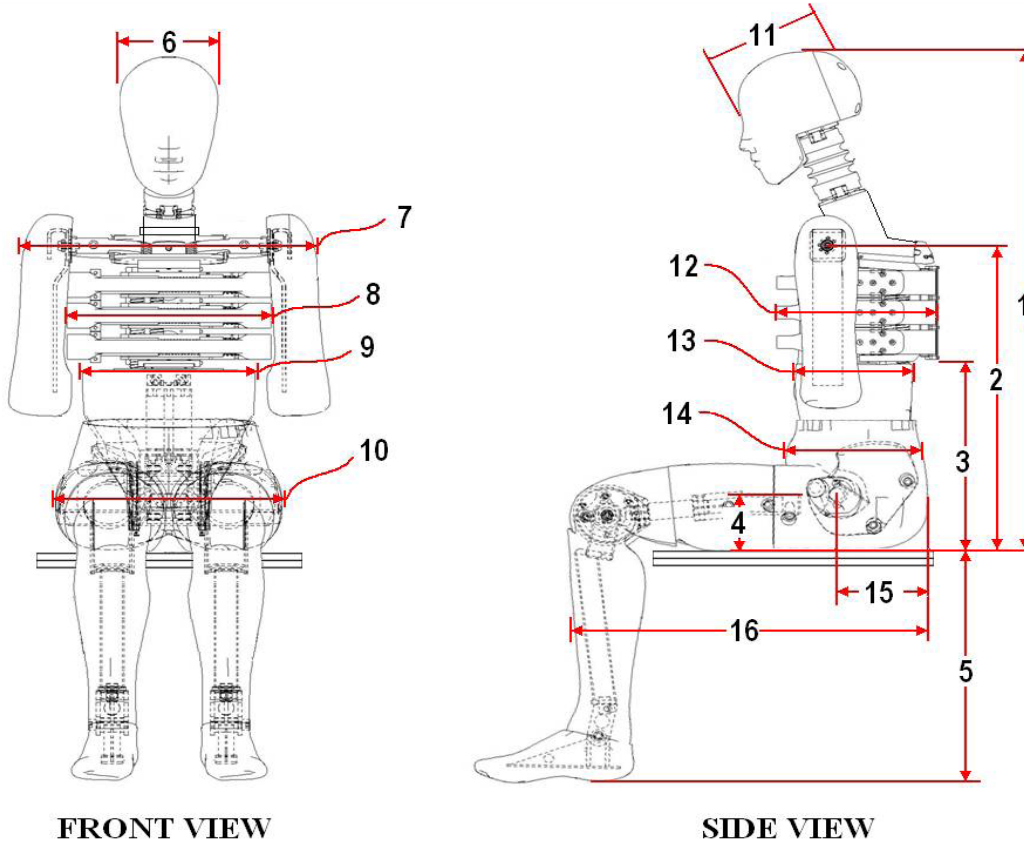

FRONT VIEW

SIDE VIEW

Dim. No.	Description	Specification (mm)		Result (mm)	Pass/Fail
1	Sitting Height	900	918	913	Pass
2	Seat to Shoulder Joint	558	572	564	Pass
3	Seat to Lower Face of Thoracic Spine Box	346	356	352	Pass
4	Seat to Hip Joint (center of bolt)	97	103	103	Pass
5	Sole to Seat, Sitting	333	451	421	Pass
6	Head Width	152	158	155	Pass
7	Shoulder/Arm Width	461	479	473	Pass
8	Thorax Width	322	332	330	Pass
9	Abdomen Width	273	287	280	Pass
10	Pelvis Lap Width	359	373	365	Pass
11	Head Depth	196	206	199	Pass
12	Thorax Depth	262	272	268	Pass
13	Abdomen Depth	194	204	200	Pass
14	Pelvis Depth	235	245	241	Pass
15	Back of Buttocks to Hip Joint (center of bolt)	150	160	153	Pass
16	Back of Buttocks to Front Knee	597	615	605	Pass

ATD Manufacturer	Denton	Test Technician	T. Roseman
ATD Serial Number	D037	Laboratory Supervisor	C. Mantell

Results

Test Parameter	Minimum Specification	Maximum Specification	Unit	Result	Pass/Fail
Temperature	20.6	22.2	°C	20.8	Pass
Humidity	10	70	%	20.5	Pass
Resultant Acceleration	125	155	g's	144.0	Pass
Oscillation	0	15	%	2.16	Pass
Fore-Aft Acceleration	-15	15	g's	7.8	Pass

Transducer Calibrations

Channel	Manufacturer	Serial Number	Calibration Date	Calibration Due Date
X Accelerometer	Endevco	T21724	2/27/2023	8/26/2023
Y Accelerometer	Endevco	T22281	2/27/2023	8/26/2023
Z Accelerometer	Endevco	T26050	2/27/2023	8/26/2023

Resultant Acceleration

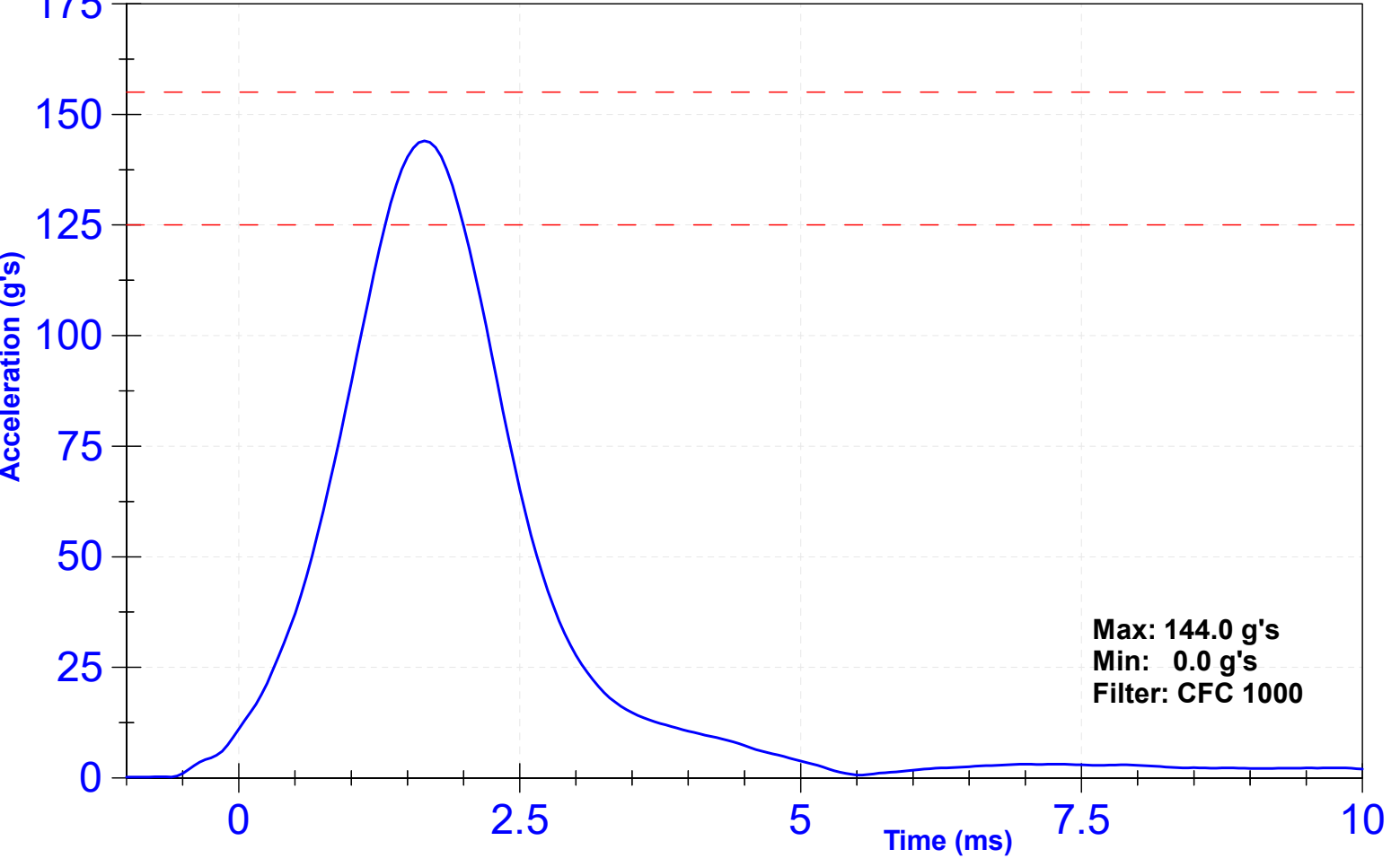

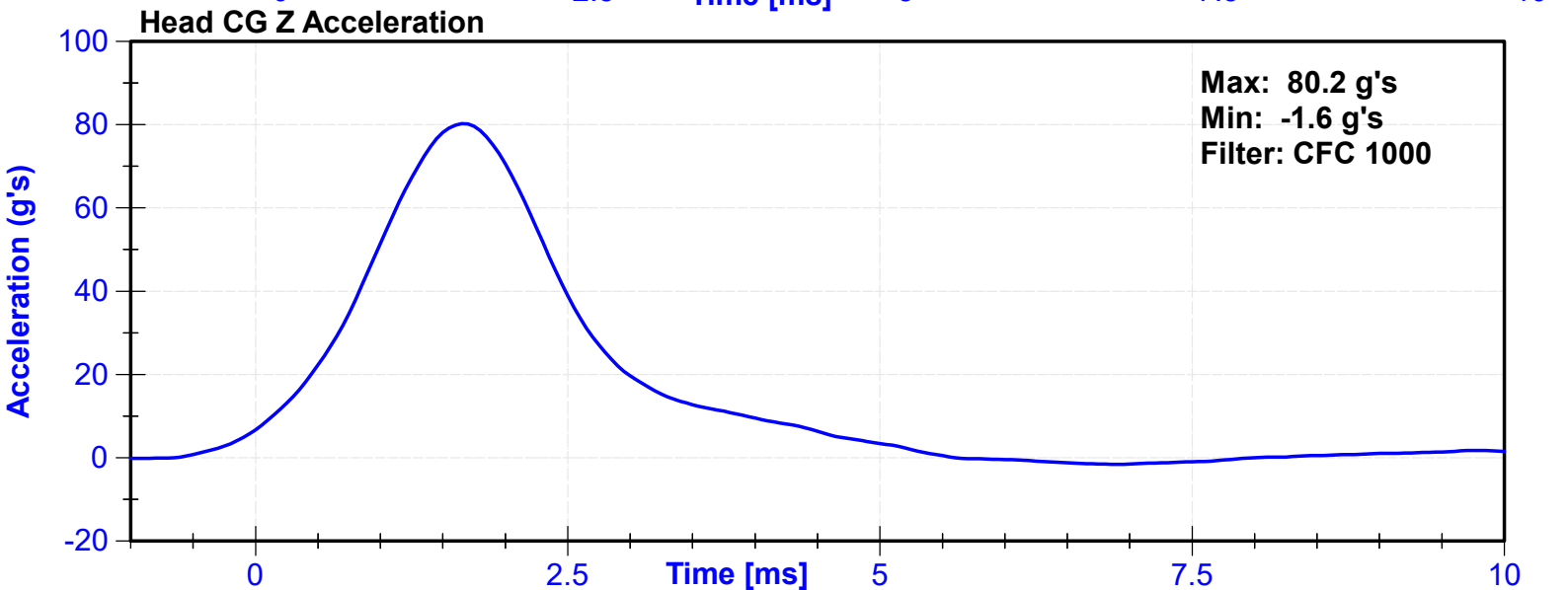
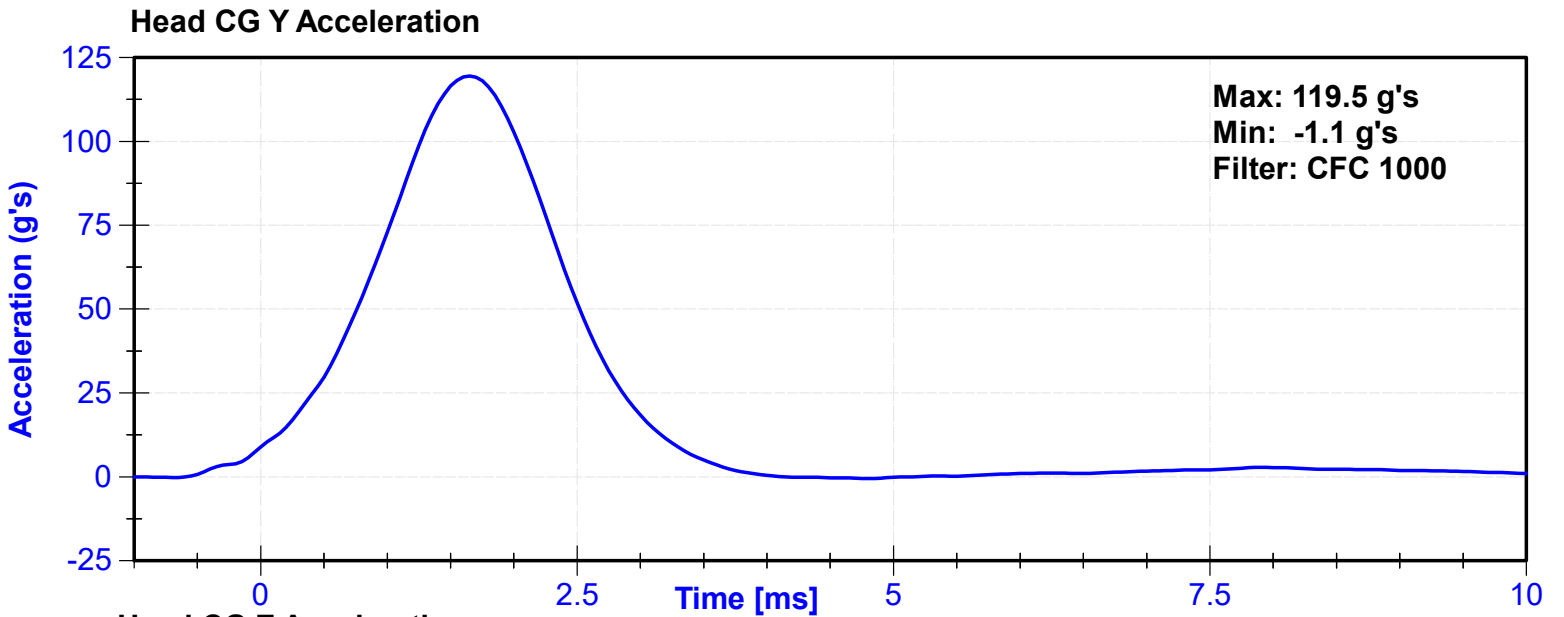
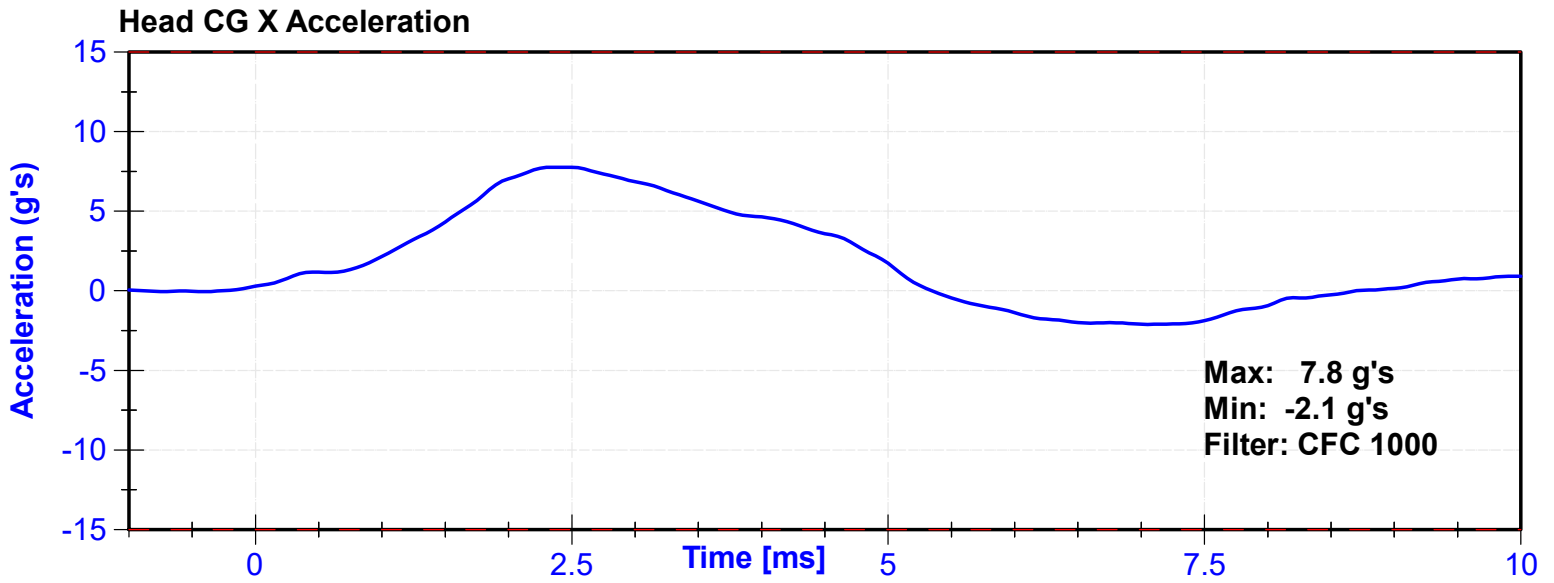

ATD Manufacturer	Denton	Test Technician	C. Mantell
ATD Serial Number	D037	Laboratory Supervisor	C. Mantell

Results

Test Parameter	Minimum Specification	Maximum Specification	Unit	Result	Pass/Fail
Temperature	20.6	22.2	°C	21.0	Pass
Humidity	10	70	%	23.4	Pass
Velocity	3.3	3.5	m/s	3.38	Pass
Lateral Neck Rotation	49	59	deg	54.6	Pass
Time at Maximum Rotation	54	66	ms	56.7	Pass
Time of Rotation Decay from Maximum	53	88	ms	58.5	Pass
Pendulum Velocity Overall Corridor	Lower Boundary ¹	Upper Boundary ²	m/s	See Plot ³	Pass

Transducer Calibrations

Channel	Manufacturer	Serial Number	Calibration Date	Calibration Due Date
Pendulum Accelerometer	Endevco	C16503	10/26/2022	10/26/2023
Front Pendulum Potentiometer	Sfernice	094	10/5/2022	10/5/2023
Headform Potentiometer	Sfernice	095	10/5/2022	10/5/2023

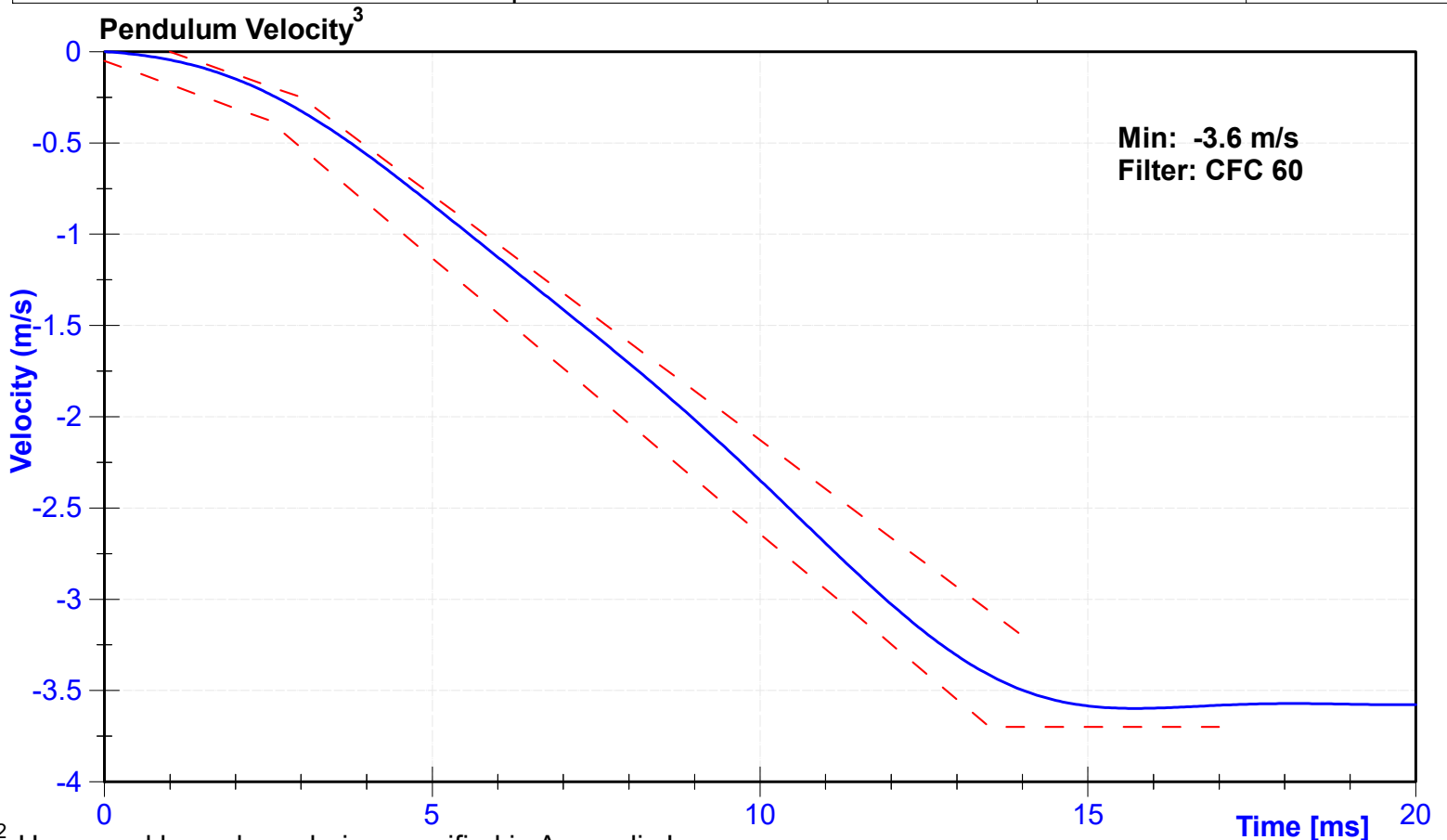

^{1,2} Upper and lower boundaries specified in Appendix I

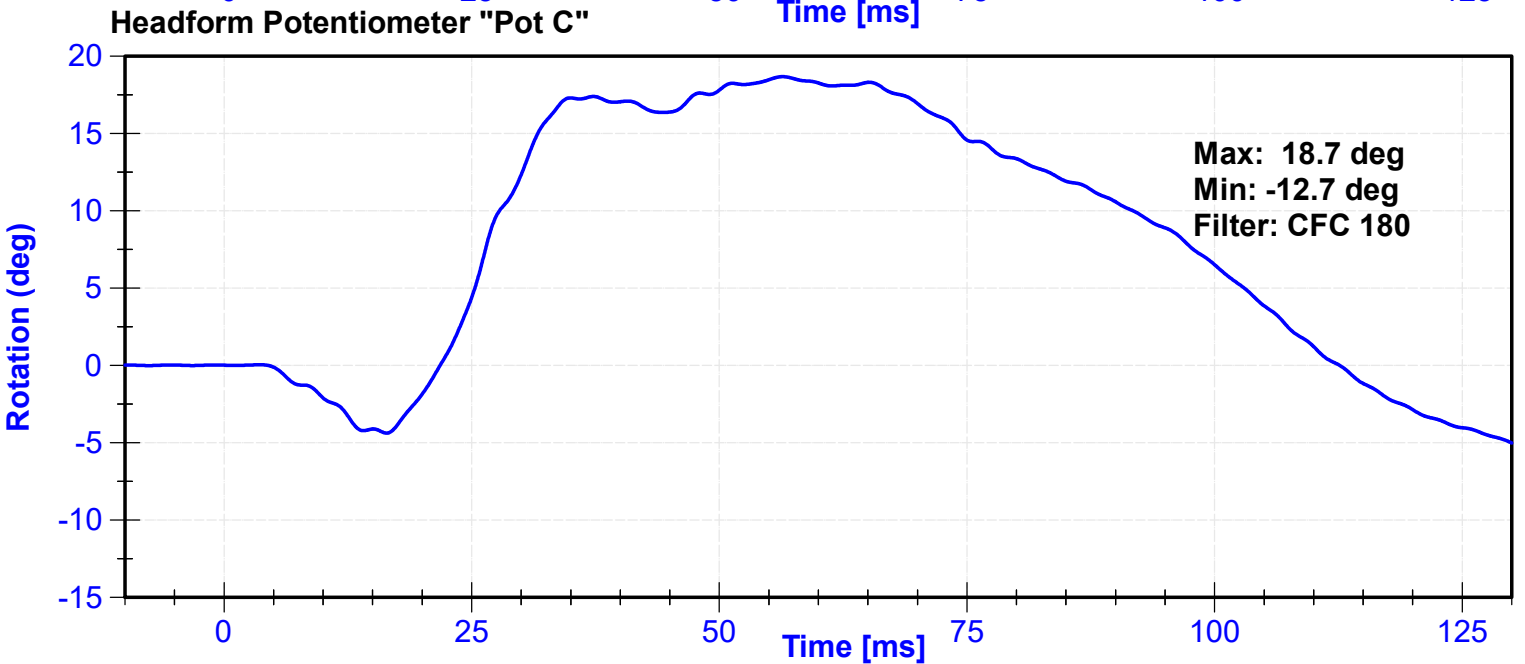
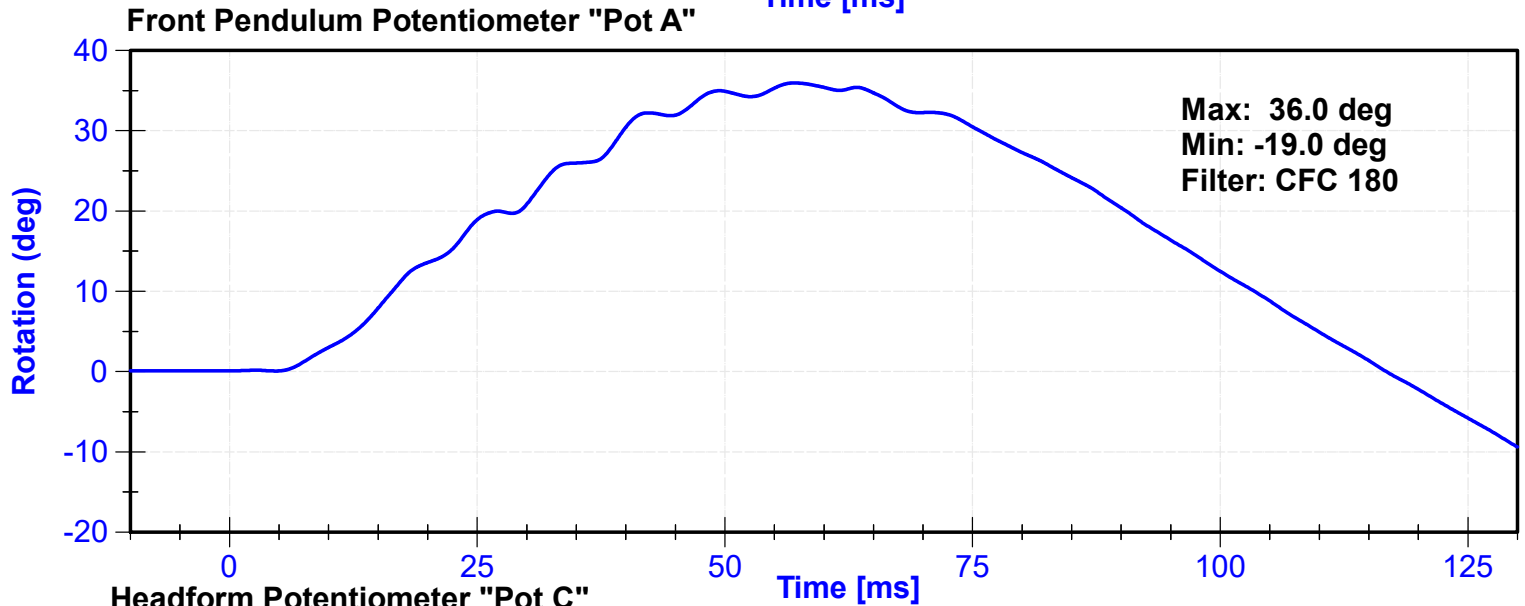
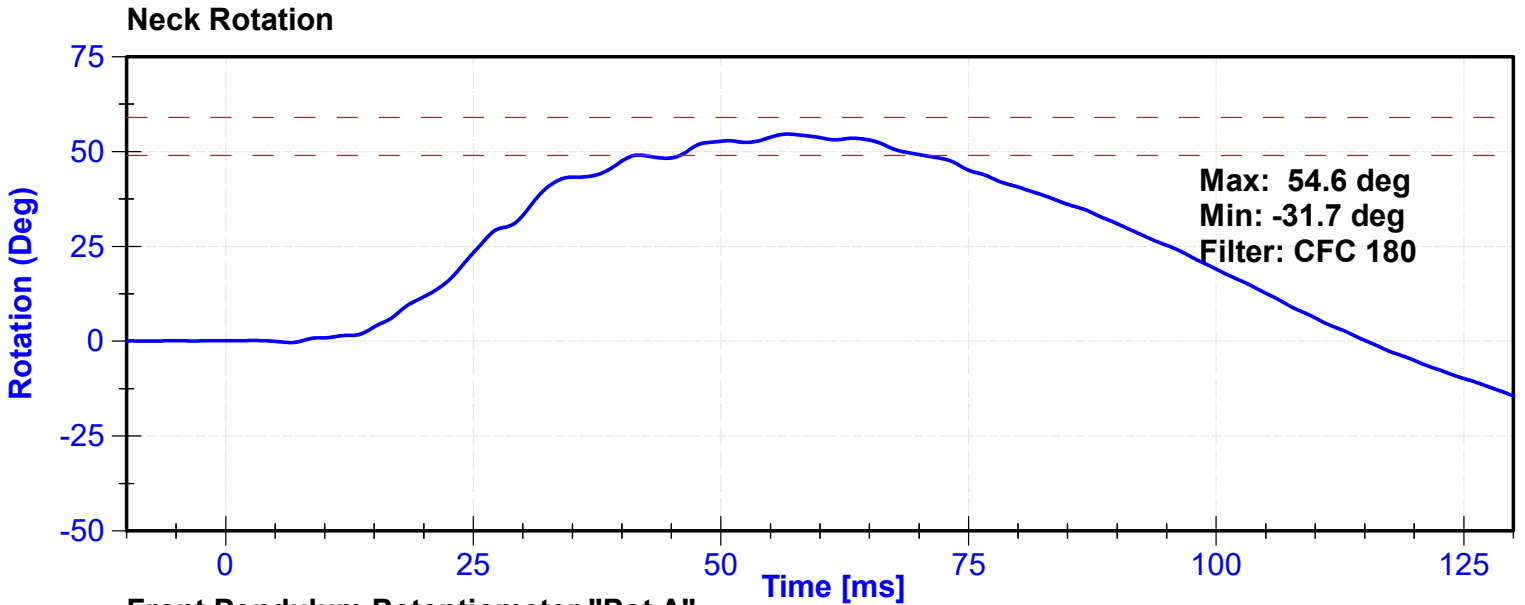

Appendix I

² Upper Boundary Corridor		¹ Lower Boundary Corridor	
Time (ms)	Velocity (m/s)	Time (ms)	Velocity (m/s)
1.0	0.00	0.0	-0.05
3.0	-0.25	2.5	-0.375
14.0	-3.20	13.5	-3.7
		17.0	-3.7

ATD Manufacturer	Denton	Test Technician	T. Roseman
ATD Serial Number	D037	Laboratory Supervisor	C. Mantell

Results

Test Parameter	Minimum Specification	Maximum Specification	Unit	Result	Pass/Fail
Temperature	20.6	22.2	°C	21.3	Pass
Humidity	10	70	%	19.0	Pass
Velocity	4.2	4.4	m/s	4.36	Pass
Probe Acceleration	7.5	10.5	g's	7.75	Pass

Transducer Calibrations

Channel	Manufacturer	Serial Number	Calibration Date	Calibration Due Date
Probe Accelerometer	Endevco	18546	11/19/2022	5/18/2023

Probe Acceleration

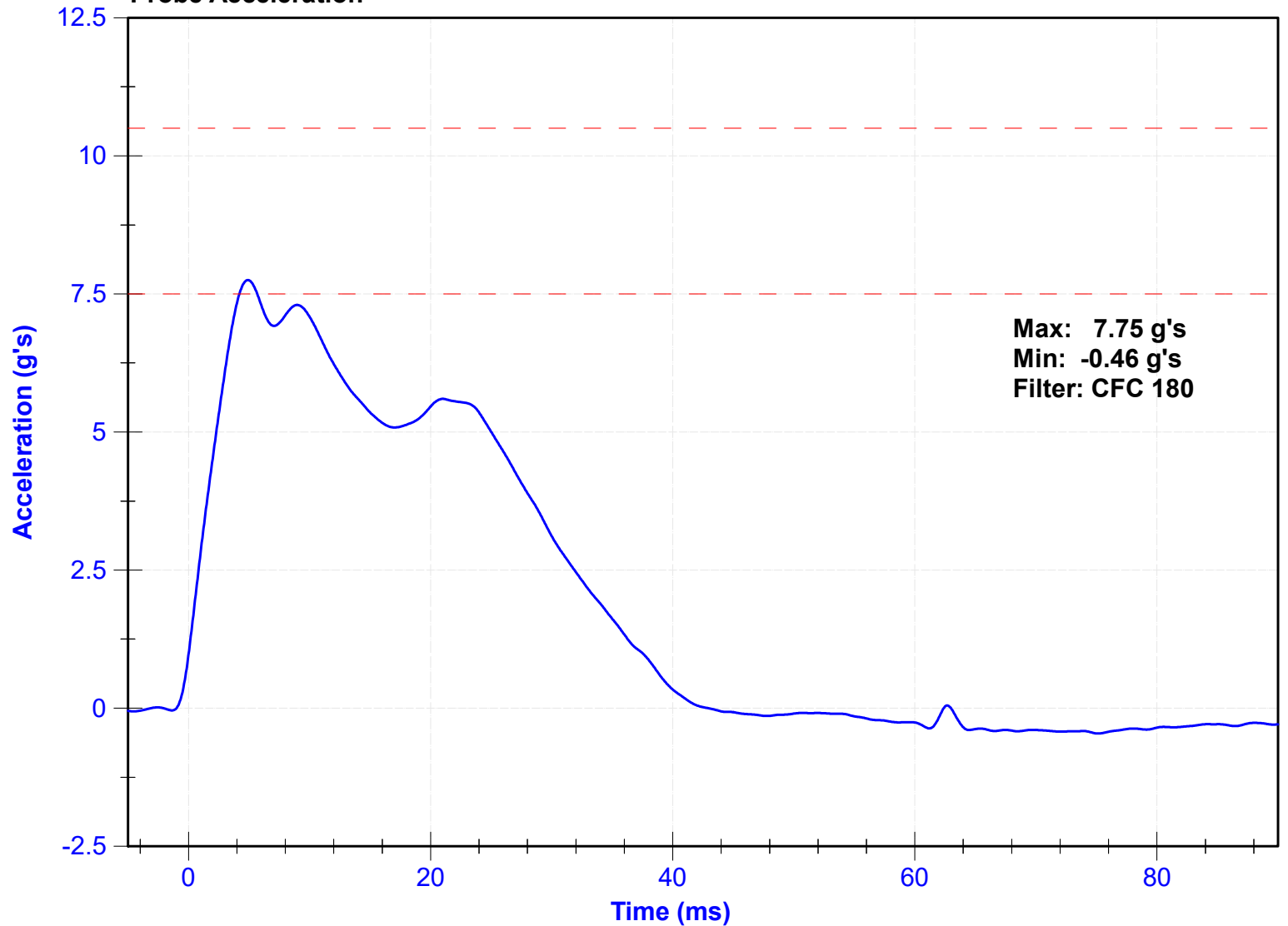

ATD Manufacturer	Denton	Test Technician	T. Roseman
ATD Serial Number	D037	Laboratory Supervisor	C. Mantell

Results

Test Parameter	Minimum Specification	Maximum Specification	Unit	Result	Pass/Fail
Temperature	20.6	22.2	°C	20.8	Pass
Humidity	10	70	%	20.5	Pass
Rib Displacement	36	40	mm	38.3	Pass

Transducer Calibrations

Channel	Manufacturer	Serial Number	Calibration Date	Calibration Due Date
Rib Potentiometer	Honeywell	DS-0552-01	2/27/2023	8/28/2023

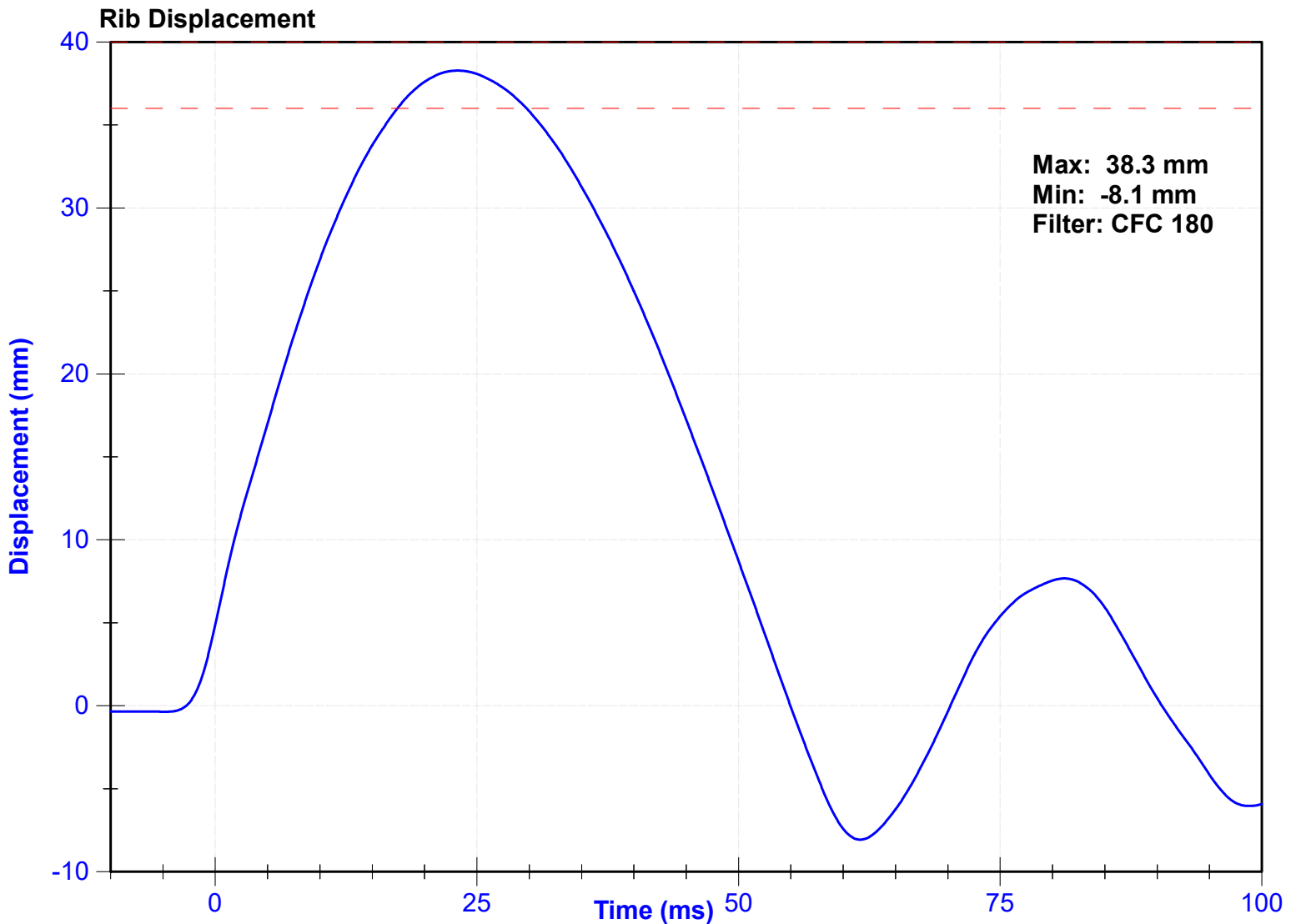

ATD Manufacturer	Denton	Test Technician	T. Roseman
ATD Serial Number	D037	Laboratory Supervisor	C. Mantell

Results

Test Parameter	Minimum Specification	Maximum Specification	Unit	Result	Pass/Fail
Temperature	20.6	22.2	°C	20.8	Pass
Humidity	10	70	%	20.5	Pass
Rib Displacement	46	51	mm	48.9	Pass

Transducer Calibrations

Channel	Manufacturer	Serial Number	Calibration Date	Calibration Due Date
Rib Potentiometer	Honeywell	DS-0552-01	2/27/2023	8/28/2023

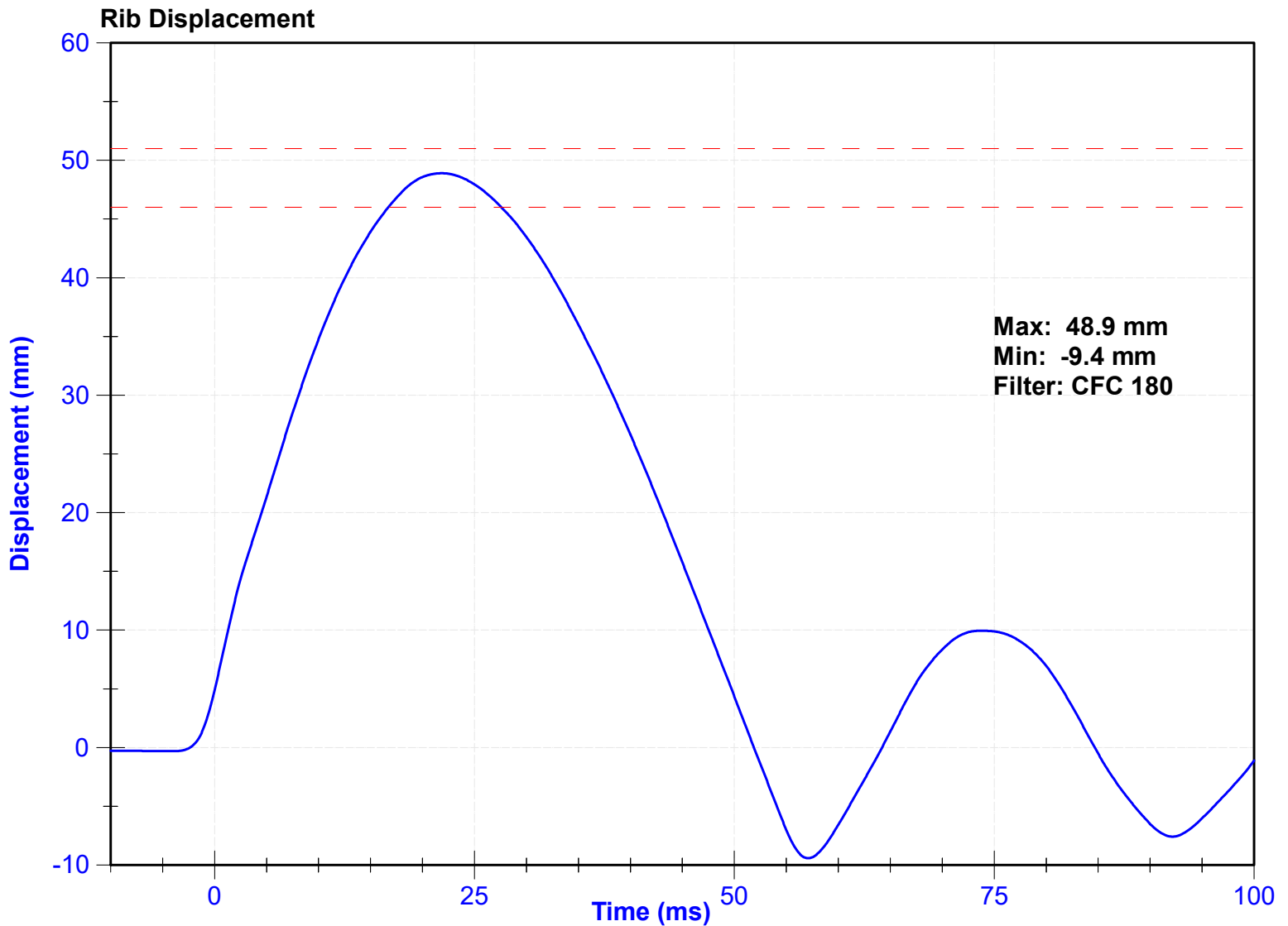

ATD Manufacturer	Denton	Test Technician	T. Roseman
ATD Serial Number	D037	Laboratory Supervisor	C. Mantell

Results

Test Parameter	Minimum Specification	Maximum Specification	Unit	Result	Pass/Fail
Temperature	20.6	22.2	°C	20.8	Pass
Humidity	10	70	%	20.5	Pass
Rib Displacement	36	40	mm	38.3	Pass

Transducer Calibrations

Channel	Manufacturer	Serial Number	Calibration Date	Calibration Due Date
Rib Potentiometer	Honeywell	DS-807	2/27/2023	8/28/2023

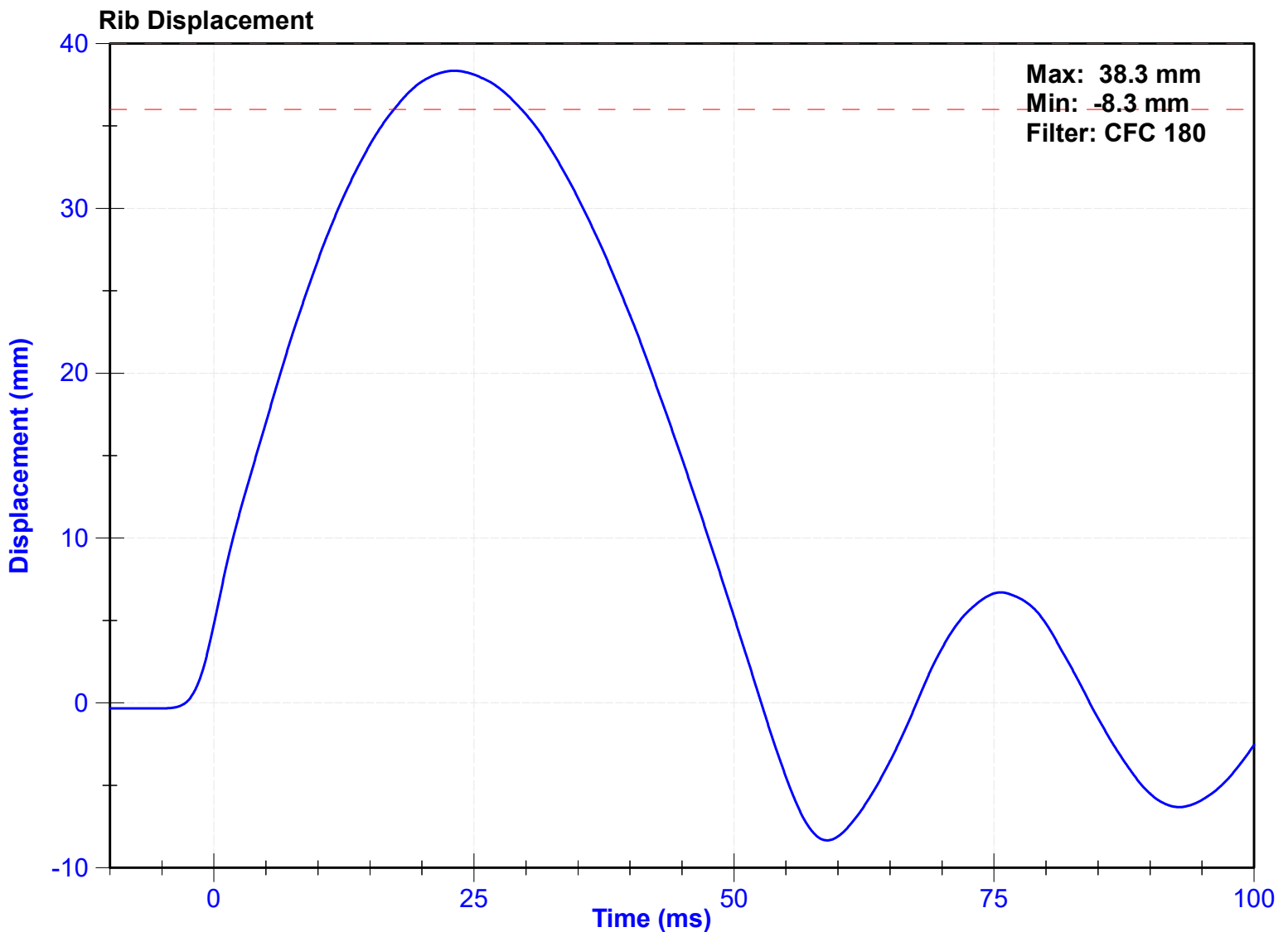

ATD Manufacturer	Denton	Test Technician	T. Roseman
ATD Serial Number	D037	Laboratory Supervisor	C. Mantell

Results

Test Parameter	Minimum Specification	Maximum Specification	Unit	Result	Pass/Fail
Temperature	20.6	22.2	°C	20.8	Pass
Humidity	10	70	%	20.5	Pass
Rib Displacement	46	51	mm	49.3	Pass

Transducer Calibrations

Channel	Manufacturer	Serial Number	Calibration Date	Calibration Due Date
Rib Potentiometer	Honeywell	DS-807	2/27/2023	8/28/2023

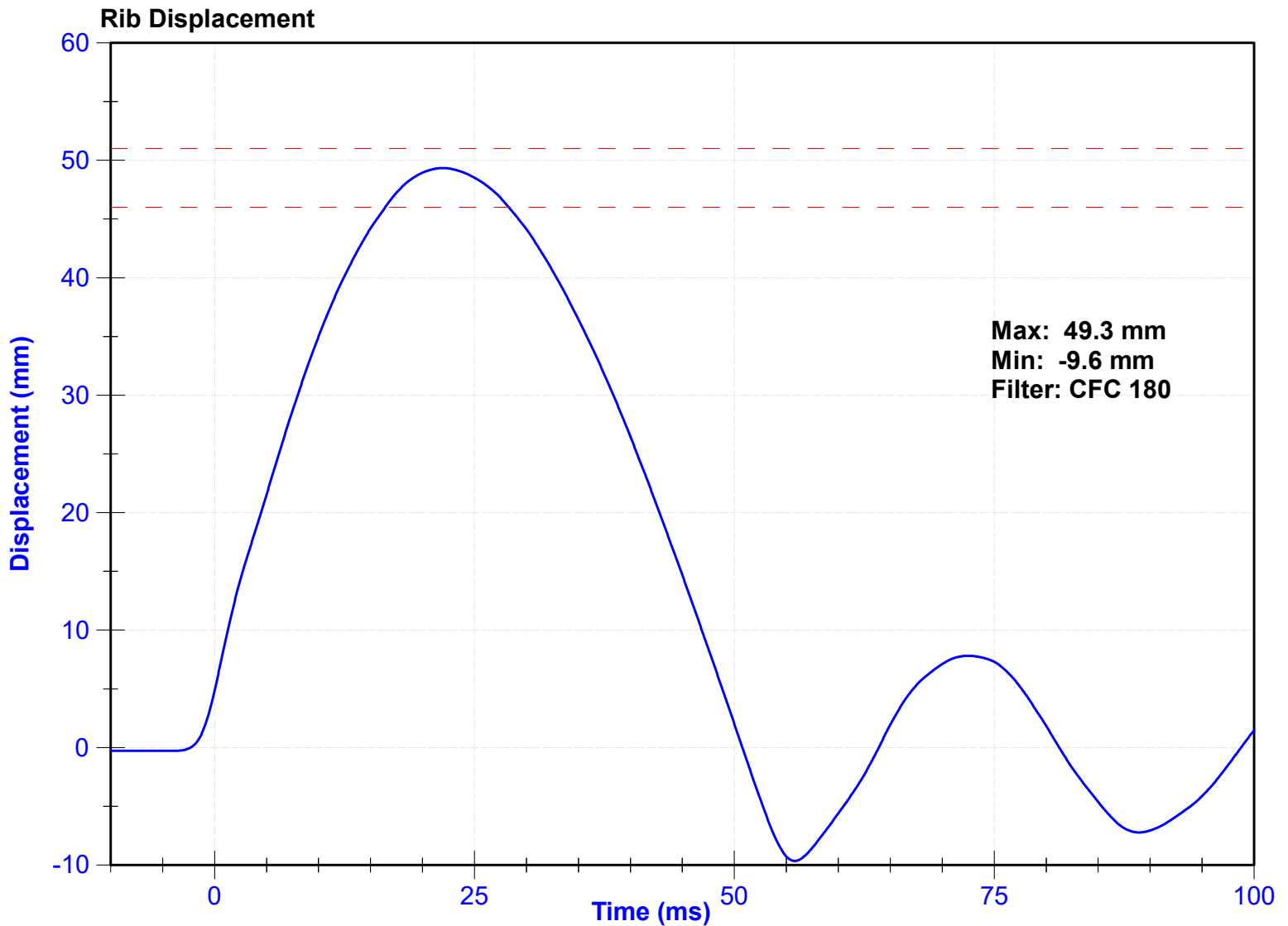

ATD Manufacturer	Denton	Test Technician	T. Roseman
ATD Serial Number	D037	Laboratory Supervisor	C. Mantell

Results

Test Parameter	Minimum Specification	Maximum Specification	Unit	Result	Pass/Fail
Temperature	20.6	22.2	°C	20.8	Pass
Humidity	10	70	%	20.5	Pass
Rib Displacement	36	40	mm	38.2	Pass

Transducer Calibrations

Channel	Manufacturer	Serial Number	Calibration Date	Calibration Due Date
Rib Potentiometer	Honeywell	DS-0552-03	2/27/2023	8/28/2023

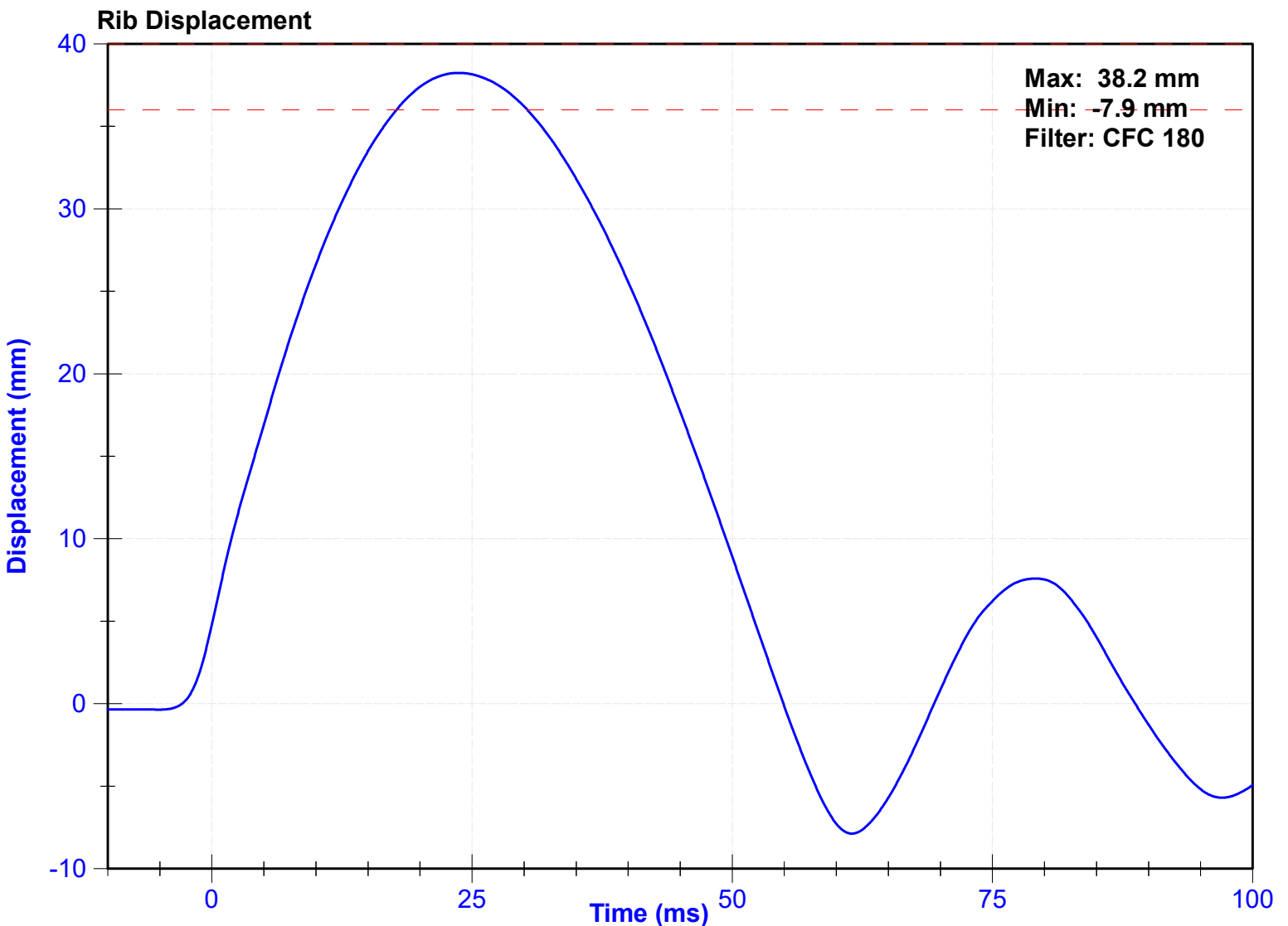

ATD Manufacturer	Denton	Test Technician	T. Roseman
ATD Serial Number	D037	Laboratory Supervisor	C. Mantell

Results

Test Parameter	Minimum Specification	Maximum Specification	Unit	Result	Pass/Fail
Temperature	20.6	22.2	°C	20.8	Pass
Humidity	10	70	%	20.5	Pass
Rib Displacement	46	51	mm	49.1	Pass

Transducer Calibrations

Channel	Manufacturer	Serial Number	Calibration Date	Calibration Due Date
Rib Potentiometer	Honeywell	DS-0552-03	2/27/2023	8/28/2023

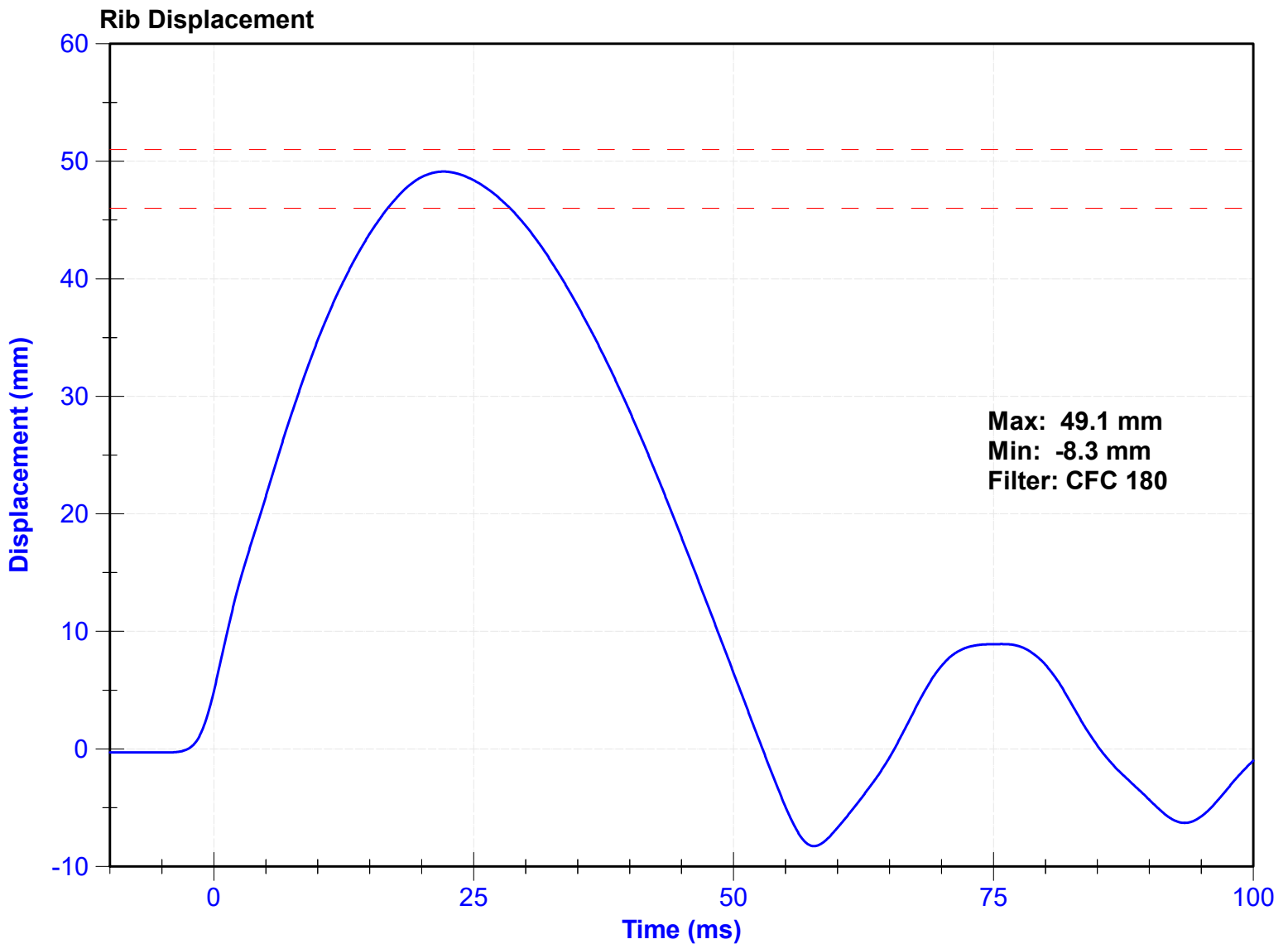

ATD Manufacturer	Denton	Test Technician	T. Roseman
ATD Serial Number	D037	Laboratory Supervisor	C. Mantell

Results

Test Parameter	Minimum Specification	Maximum Specification	Unit	Result	Pass/Fail
Temperature	20.6	22.2	°C	21.3	Pass
Humidity	10	70	%	19.0	Pass
Velocity	5.4	5.6	m/s	5.54	Pass
Resistive Force after 6ms	5100	6200	N	5763.5	Pass
Upper Thorax Rib Deflection	34	41	mm	39.1	Pass
Mid Thorax Rib Deflection	37	45	mm	42.0	Pass
Lower Thorax Rib Deflection	37	44	mm	42.5	Pass

Transducer Calibrations

Channel	Manufacturer	Serial Number	Calibration Date	Calibration Due Date
Probe Accelerometer	Endevco	18546	11/19/2022	5/18/2023
Upper Thorax Rib Potentiometer	Honeywell	DS-0552-01	2/27/2023	8/28/2023
Middle Thorax Rib Potentiometer	Honeywell	DS-807	2/27/2023	8/28/2023
Lower Thorax Rib Potentiometer	Honeywell	DS-0552-03	2/27/2023	8/28/2023

Probe Acceleration

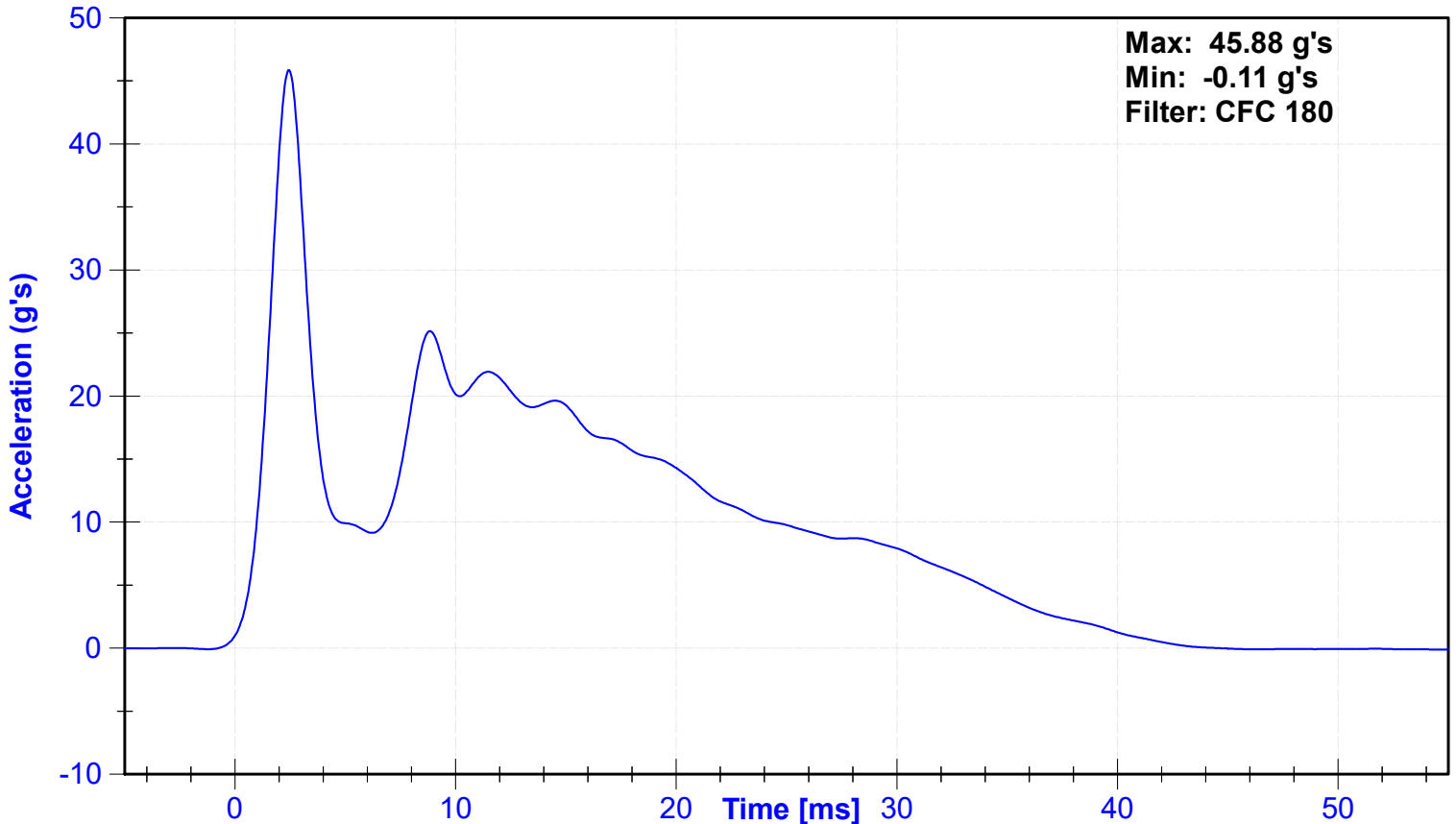

Resistive Force

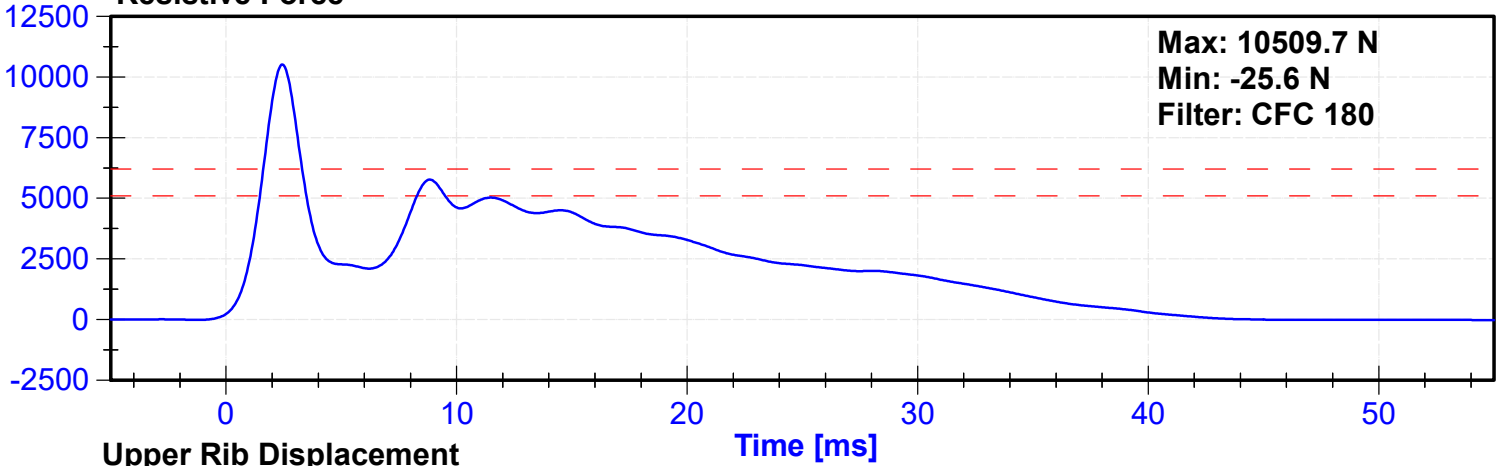

Upper Rib Displacement

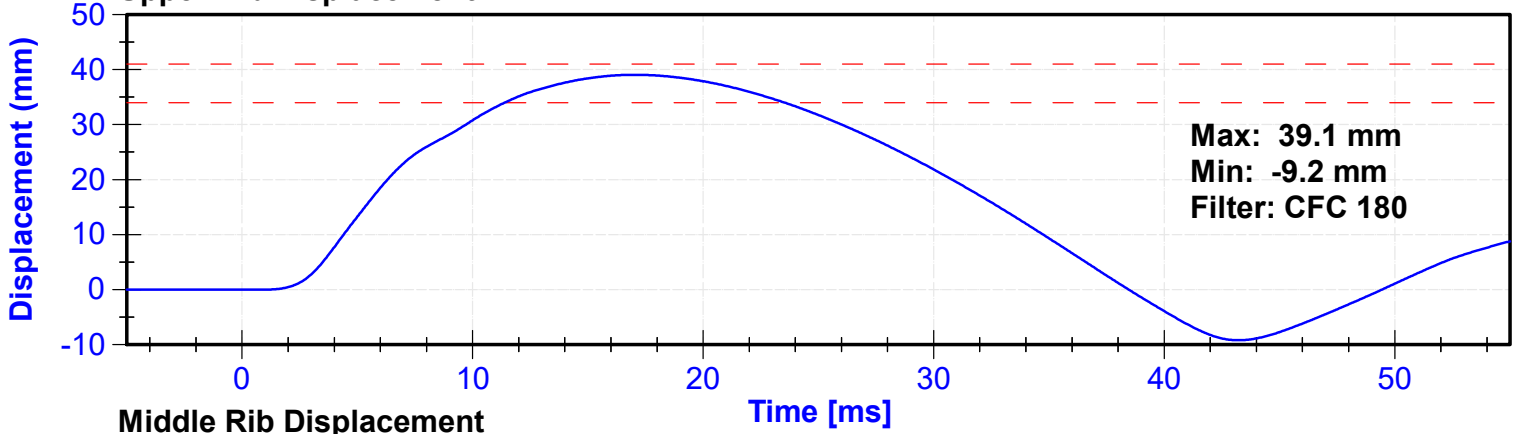

Middle Rib Displacement

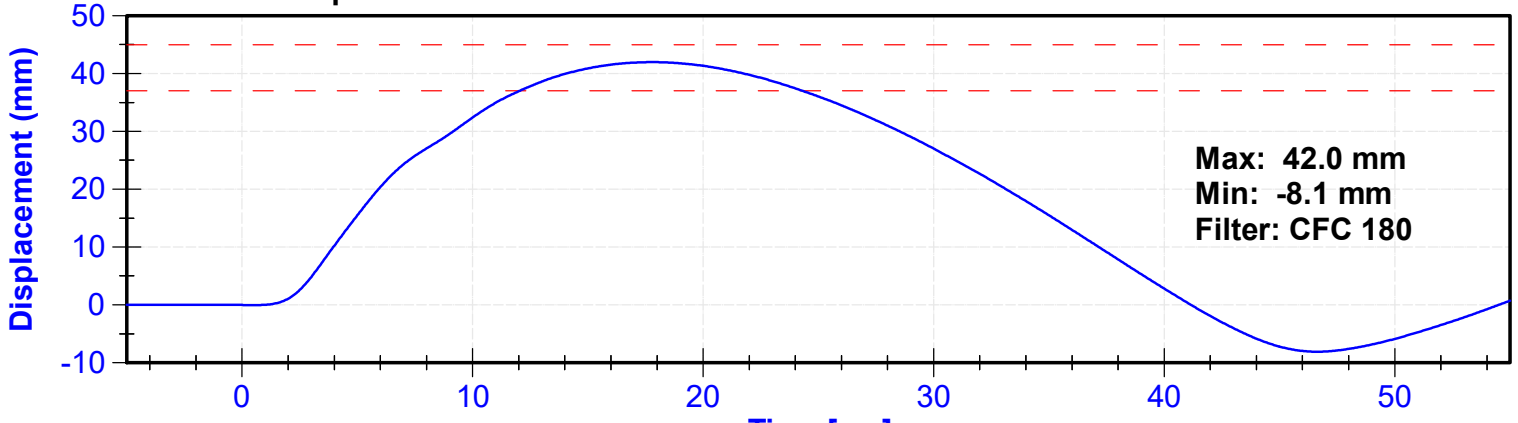

Lower Rib Displacement

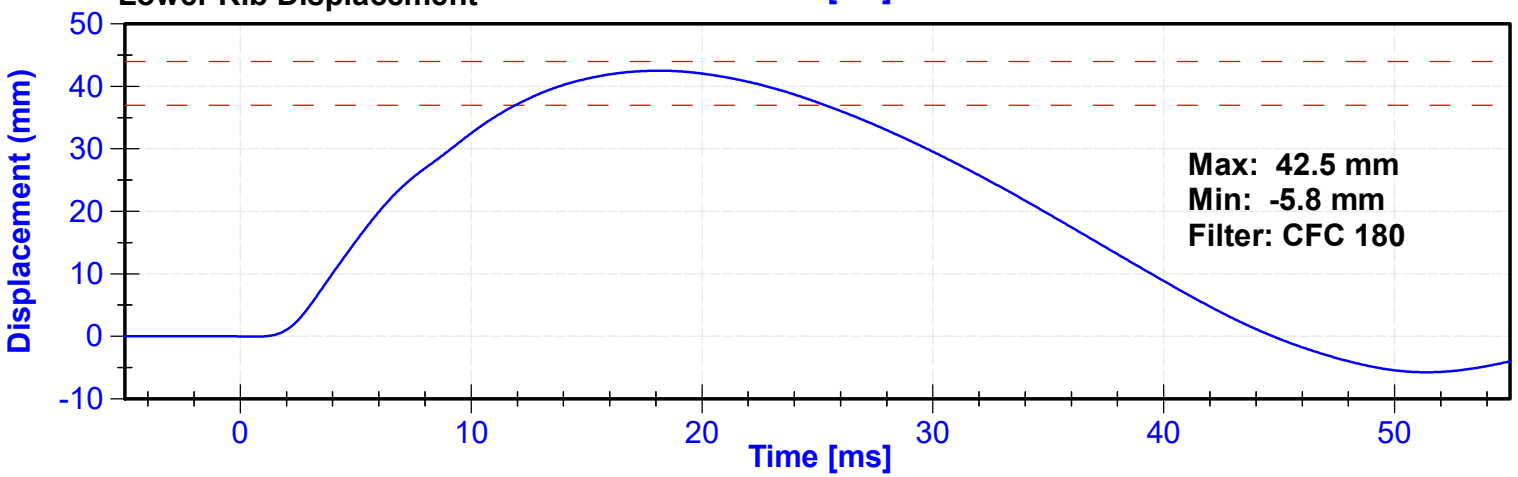

ATD Manufacturer	Denton	Test Technician	T. Roseman
ATD Serial Number	D037	Laboratory Supervisor	C. Mantell

Results

Test Parameter	Minimum Specification	Maximum Specification	Unit	Result	Pass/Fail
Temperature	20.6	22.2	°C	21.3	Pass
Humidity	10	70	%	19.0	Pass
Velocity	3.9	4.1	m/s	4.02	Pass
Combined Abdomen Force	2200	2700	N	2378.3	Pass
Time at Peak Abdomen Force	10.0	12.3	ms	10.85	Pass
Resistive Probe Force	4000	4800	N	4352.4	Pass
Time at Peak Resistive Force	10.6	13.0	ms	10.85	Pass

Transducer Calibrations

Channel	Manufacturer	Serial Number	Calibration Date	Calibration Due Date
Pendulum Accelerometer	Endevco	18546	11/19/2022	5/18/2023
Front Abdomen Load Cell	Denton	1440	8/12/2022	8/12/2023
Middle Abdomen Load Cell	Denton	1525	8/12/2022	8/12/2023
Rear Abdomen Load Cell	Denton	1528	8/12/2022	8/12/2023

Probe Force

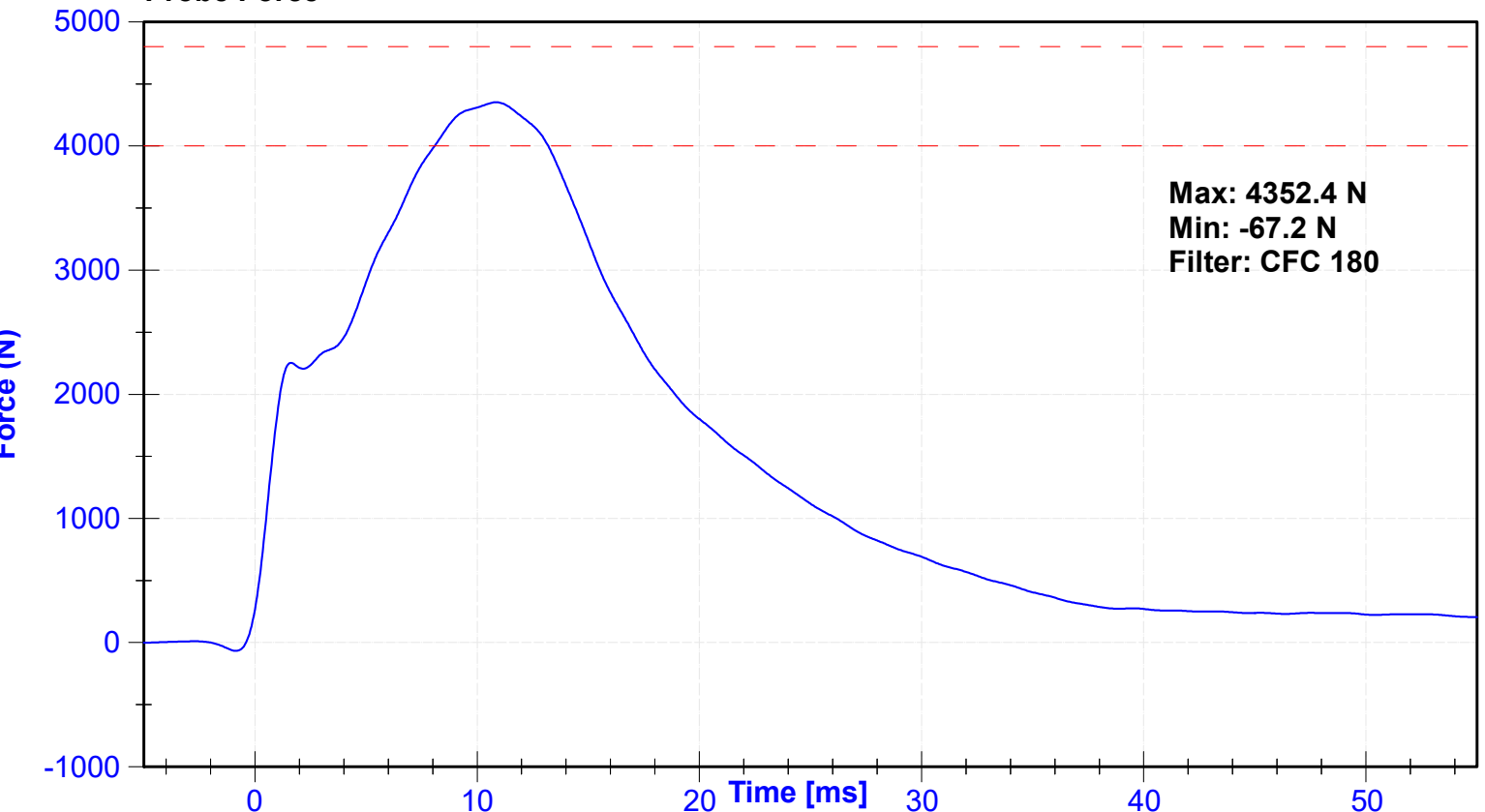

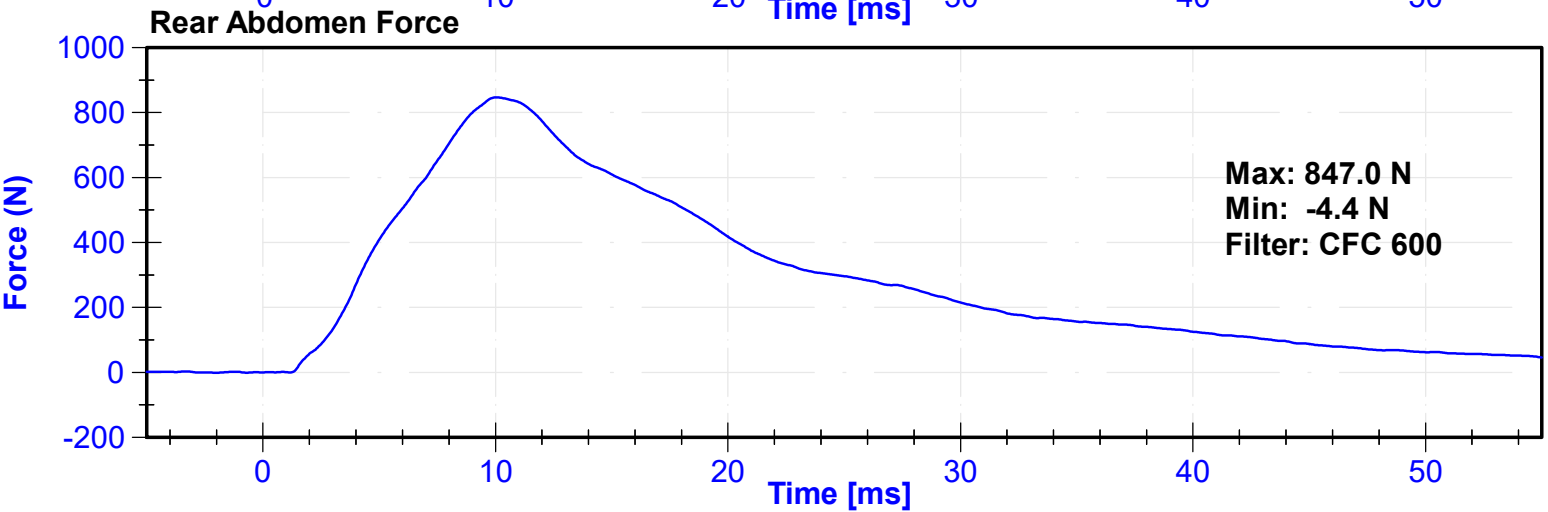
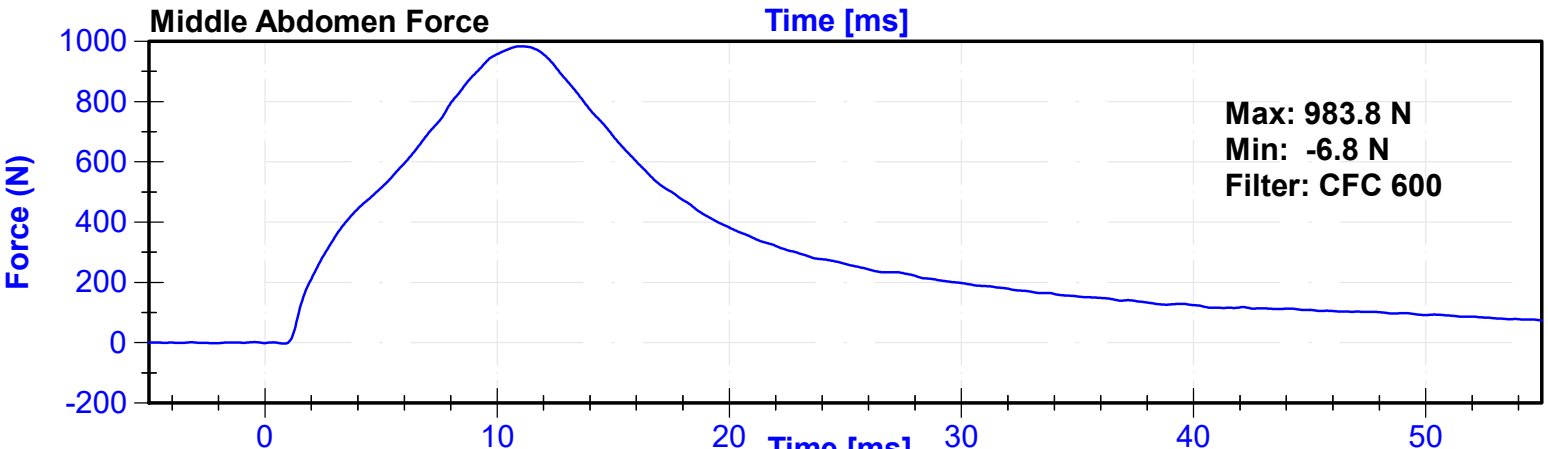
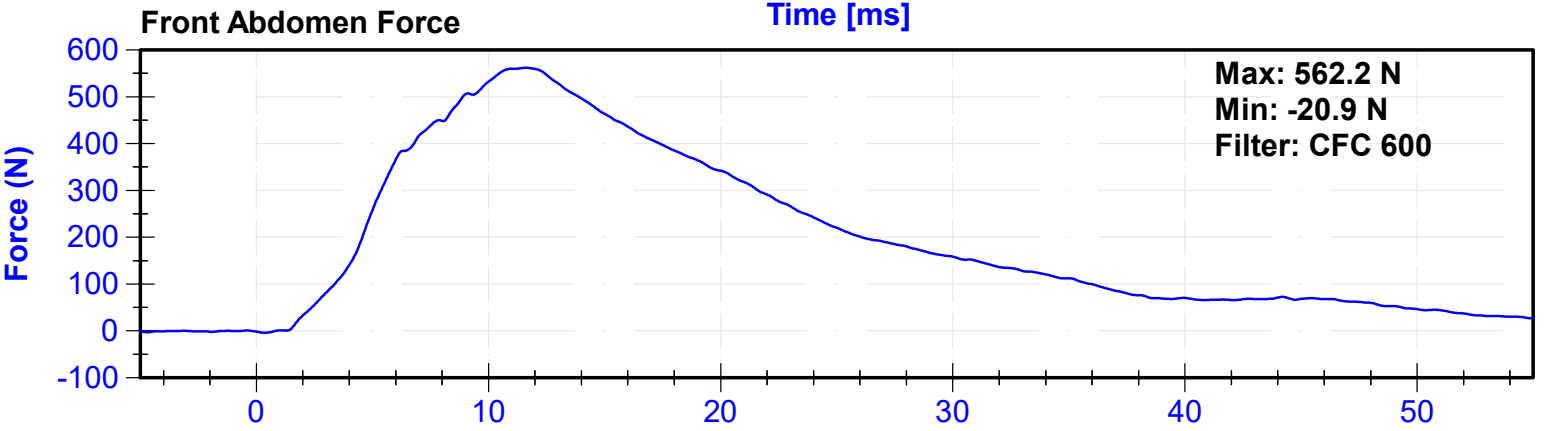
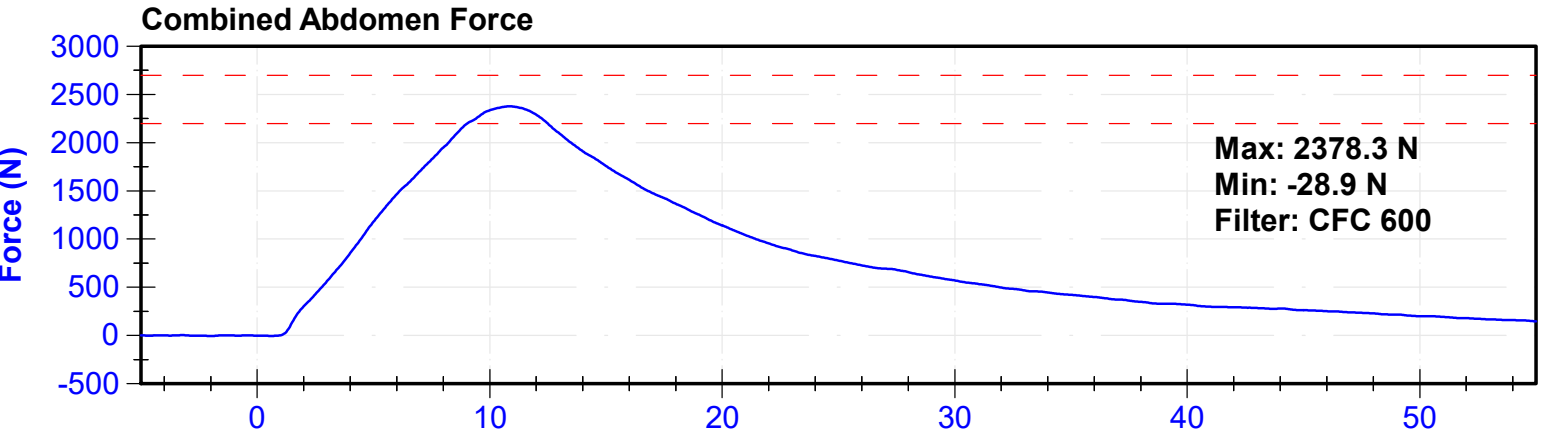

ATD Manufacturer	Denton	Test Technician	C. Mantell
ATD Serial Number	D037	Laboratory Supervisor	C. Mantell

Results

Test Parameter	Minimum Specification	Maximum Specification	Unit	Result	Pass/Fail
Temperature	20.6	22.2	°C	21.0	Pass
Humidity	10	70	%	23.4	Pass
Velocity	5.95	6.15	m/s	6.045	Pass
Lateral Spine Rotation	45	55	deg	55.0	Pass
Time at Maximum Rotation	39	53	ms	45.8	Pass
Time of Decay to Zero Degrees	37	57	ms	43.8	Pass
Pendulum Velocity Overall Corridor	Lower Boundary ¹	Upper Boundary ²	m/s	See Plot ³	Pass

Transducer Calibrations

Channel	Manufacturer	Serial Number	Calibration Date	Calibration Due Date
Pendulum Accelerometer	Endevco	C16503	10/26/2022	10/26/2023
Pendulum "A" Potentiometer	Sfernice	094	10/5/2022	10/5/2023
Condyle "B" Potentiometer	Sfernice	095	10/5/2022	10/5/2023

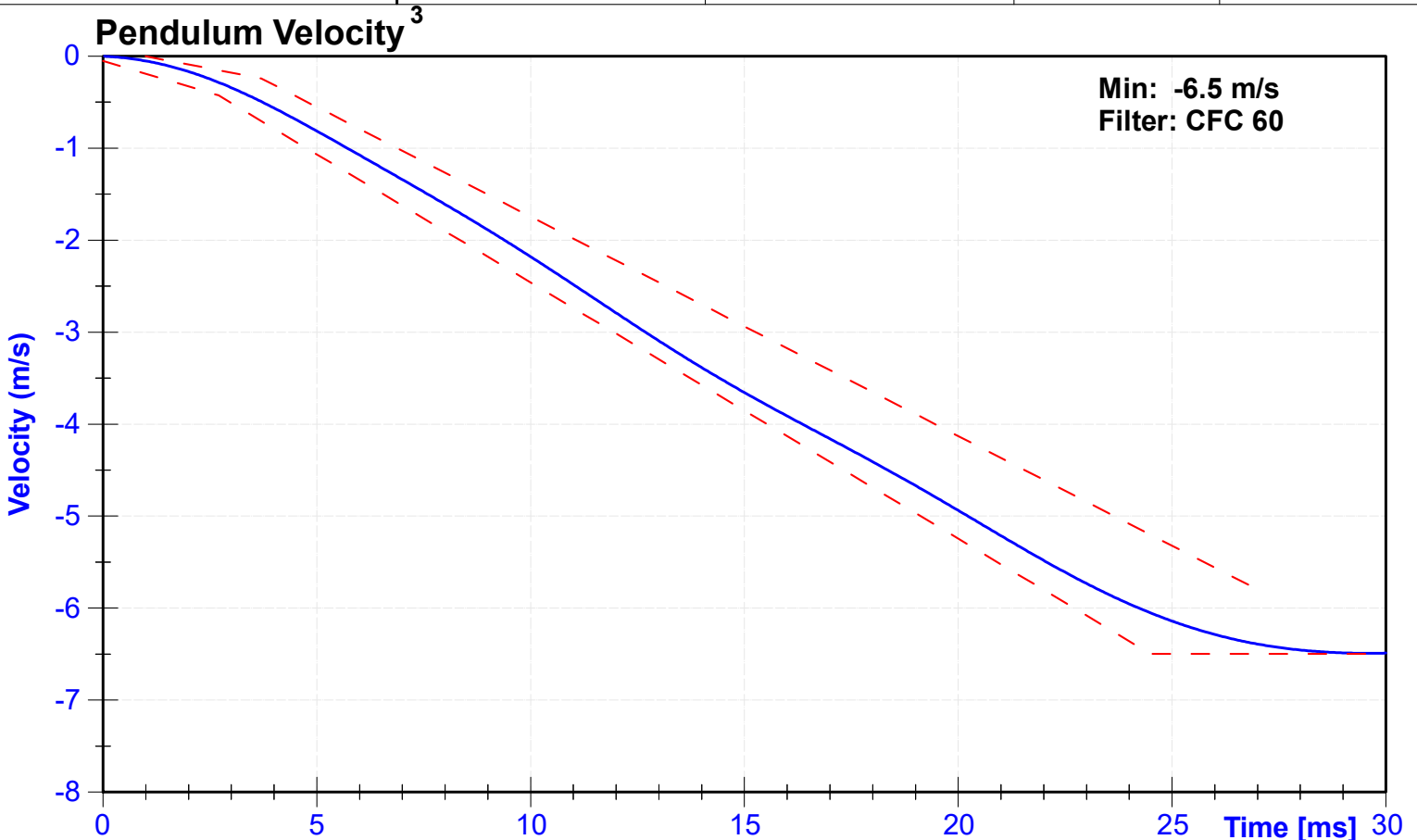

^{1,2} Upper and lower boundaries specified in Appendix I IV-42

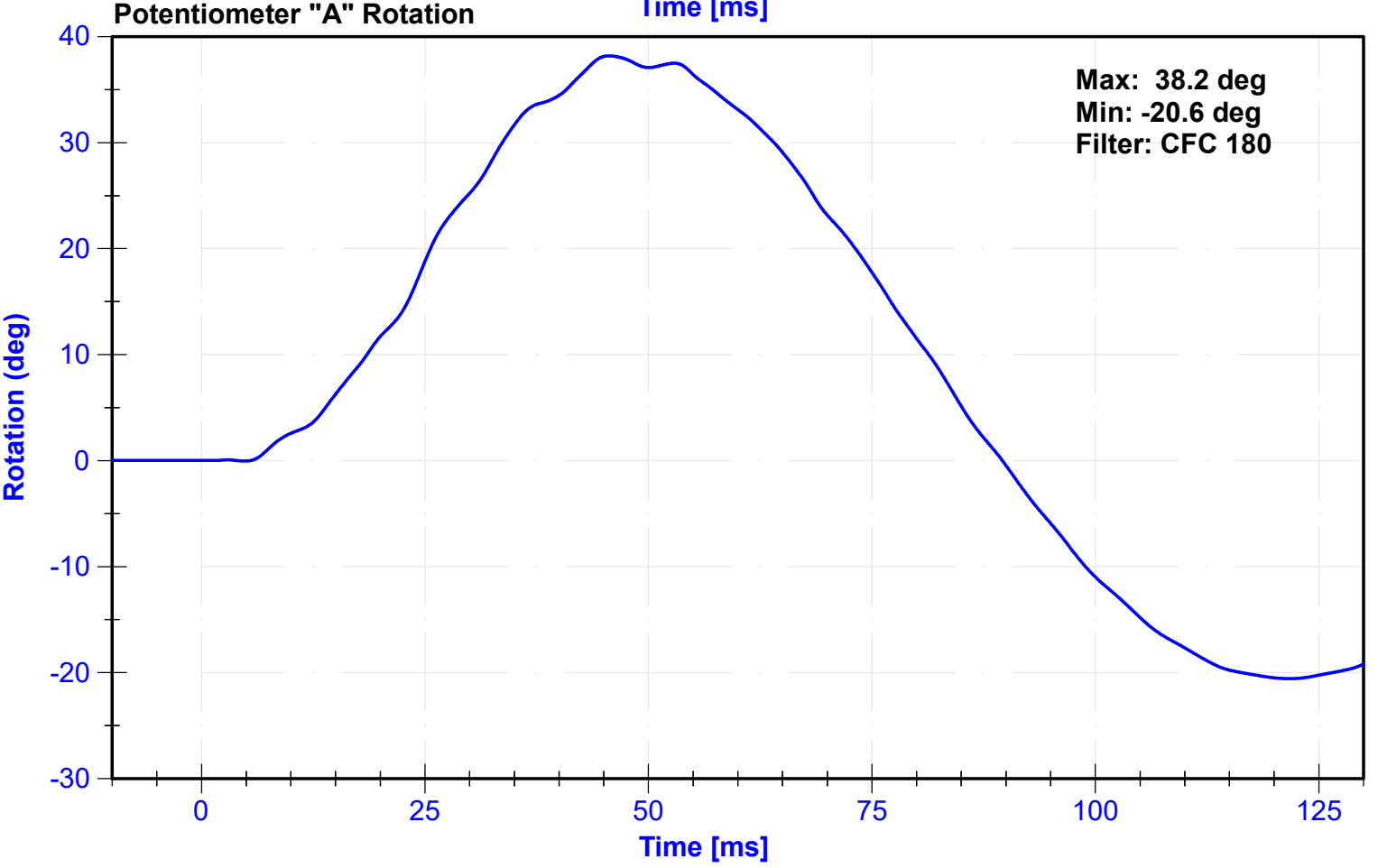
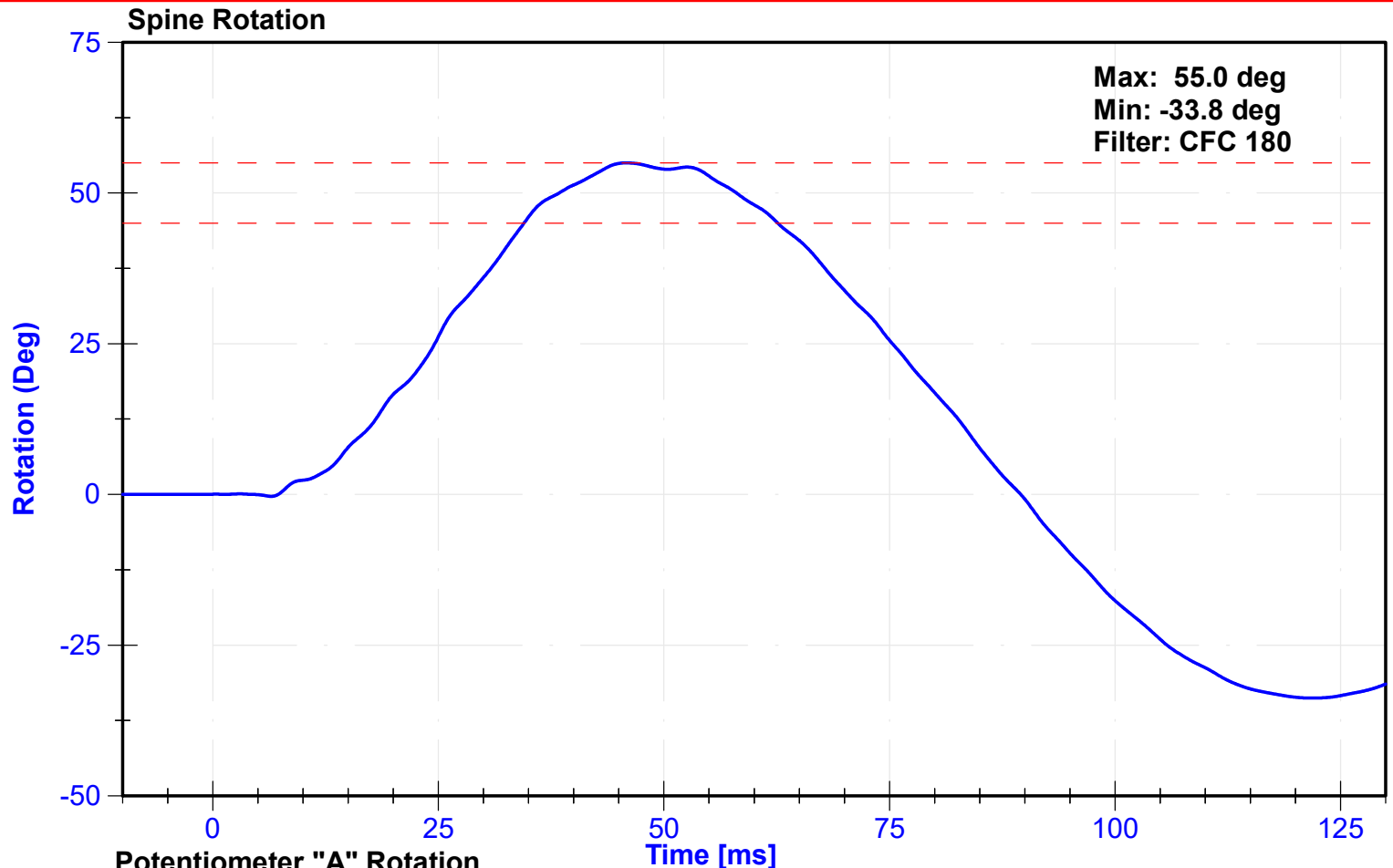

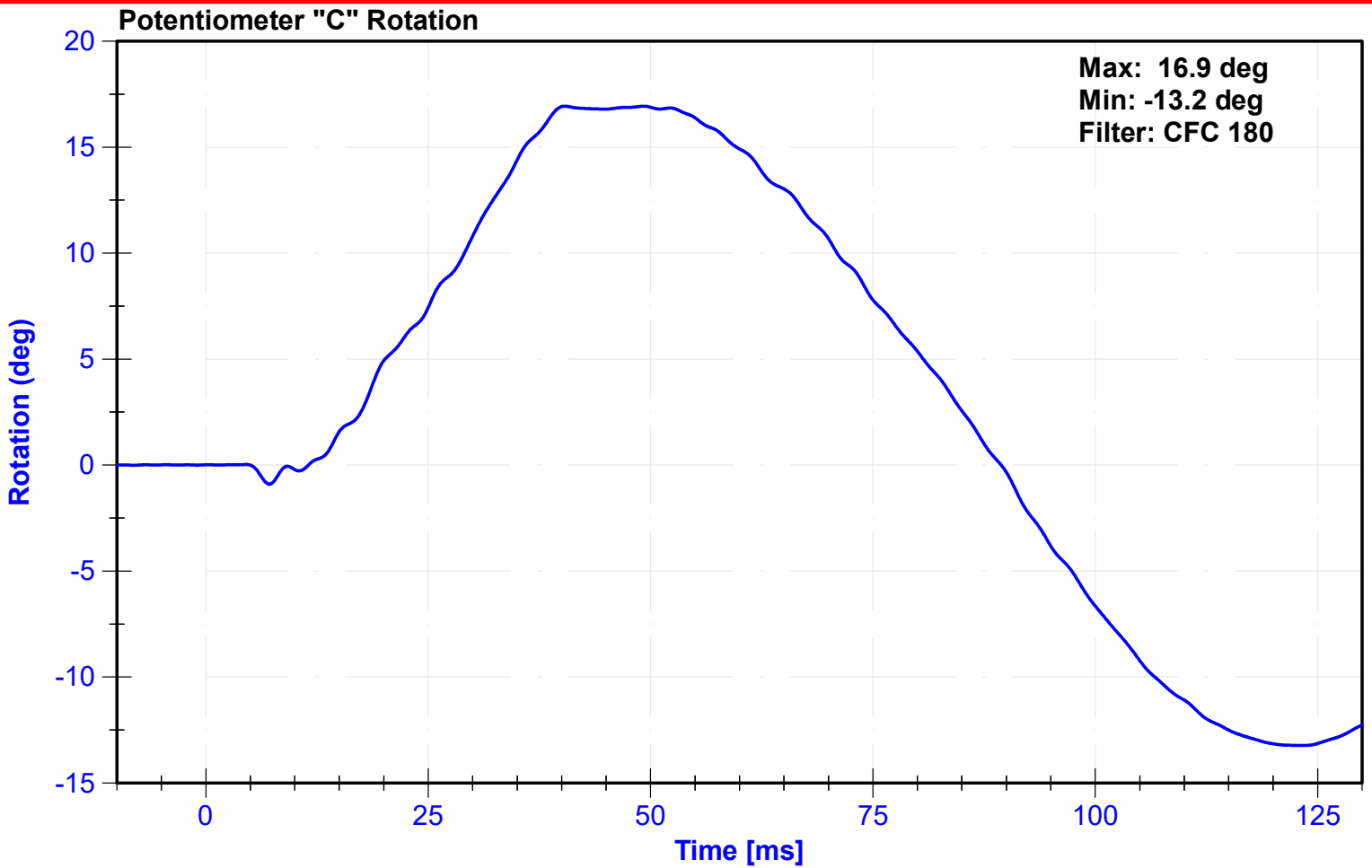

Appendix I

² Upper Boundary Corridor		¹ Lower Boundary Corridor	
Time (ms)	Velocity (m/s)	Time (ms)	Velocity (m/s)
1.0	0.00	0.0	-0.05
3.7	-0.24	2.7	-0.425
27.0	-5.80	24.5	-6.5
		30.0	-6.5

ATD Manufacturer	Denton	Test Technician	T. Roseman
ATD Serial Number	D037	Laboratory Supervisor	C. Mantell

Results

Test Parameter	Minimum Specification	Maximum Specification	Unit	Result	Pass/Fail
Temperature	20.6	22.2	°C	21.3	Pass
Humidity	10	70	%	19.0	Pass
Velocity	4.2	4.4	m/s	4.35	Pass
Resistive Force	4700	5400	N	4862.5	Pass
Time at Peak Resistive Force	11.8	16.1	ms	13.10	Pass
Pubic Force	-1590	-1230	N	-1405.9	Pass
Time at Peak Pubic Force	12.2	17.0	ms	13.60	Pass

Transducer Calibrations

Channel	Manufacturer	Serial Number	Calibration Date	Calibration Due Date
Pendulum Accelerometer	Endevco	18546	11/19/2022	5/18/2023
Pubic Load Cell	Denton	456-FY	8/12/2022	8/12/2023

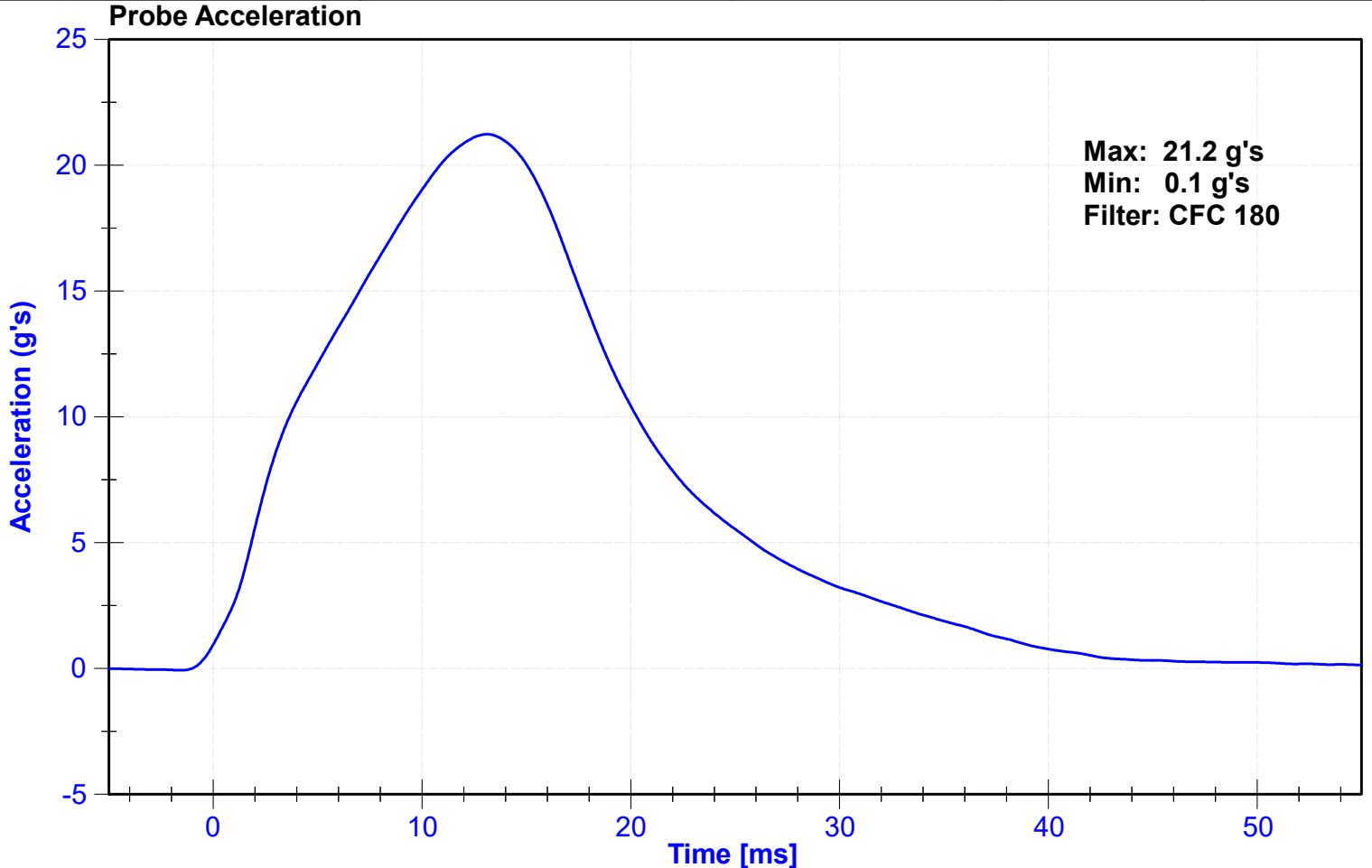

Resistive Force

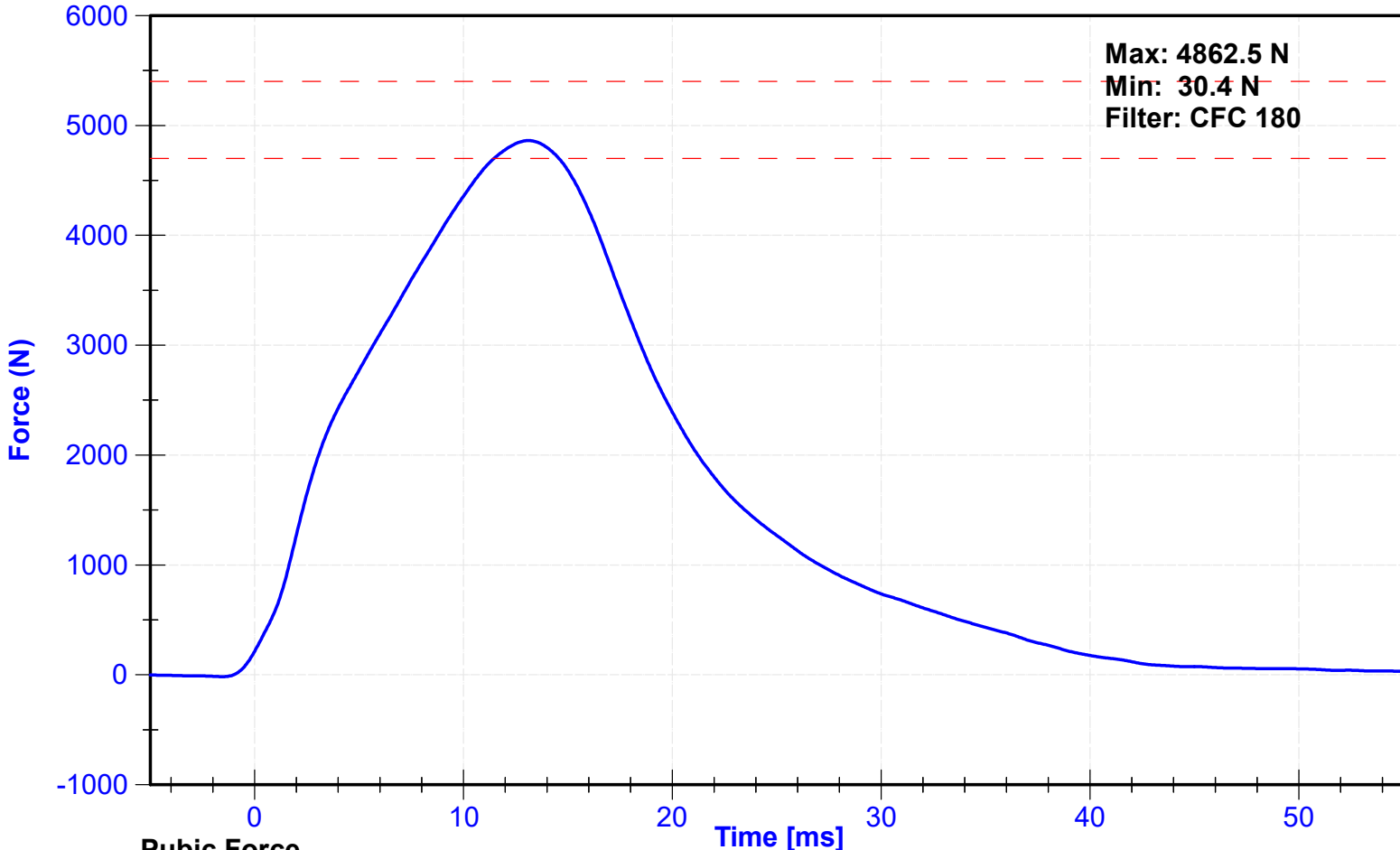

Pubic Force

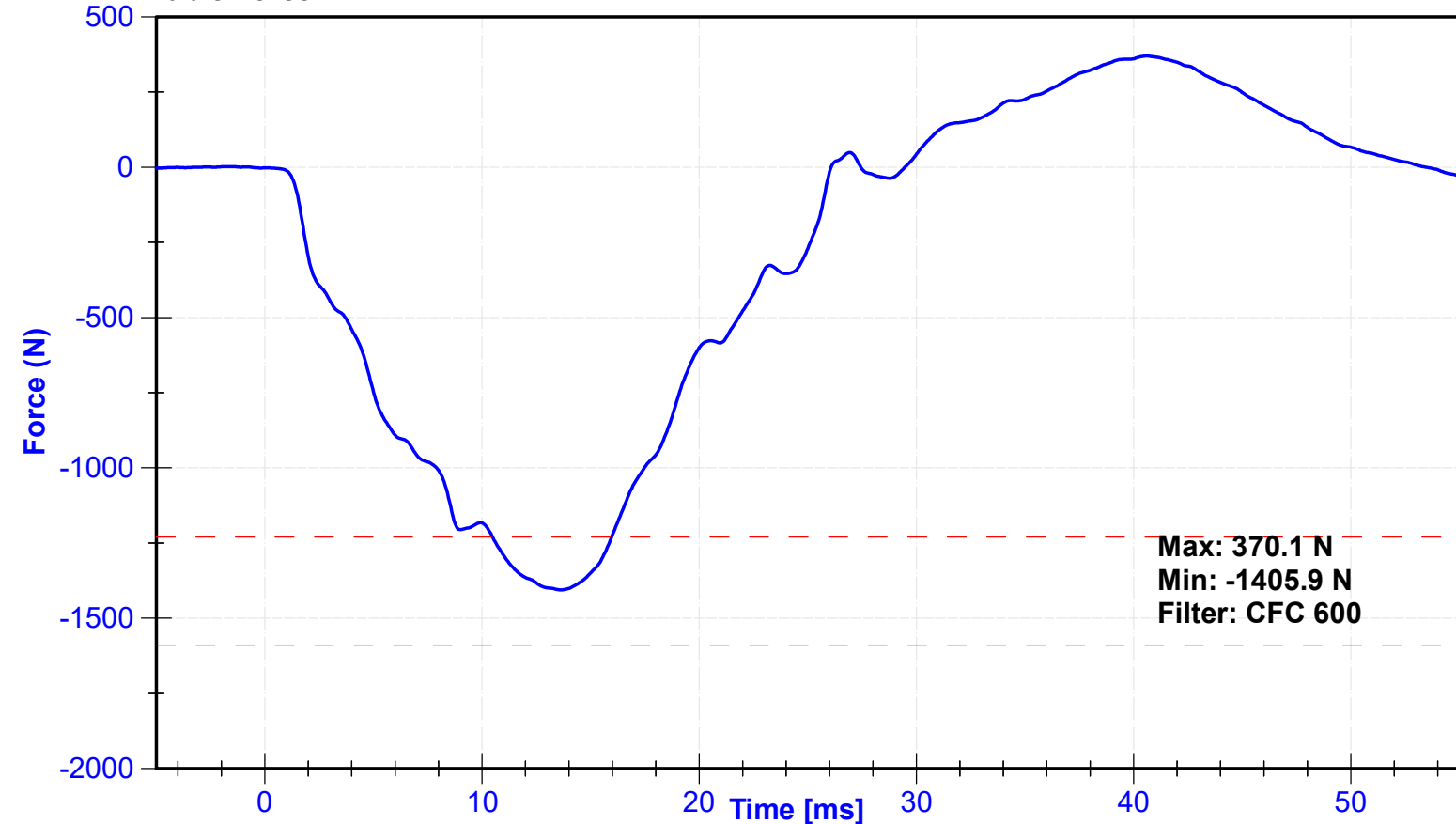

APPENDIX V

TEST EQUIPMENT AND INSTRUMENTATION CALIBRATION DATA

Table 1 – Dummy Instrumentation (ES-2re)

			ES-2re S/N: D037		
			Serial Number	Manufacturer	Calibration Date
Head Accelerometers	Primary	X	T21724	Endevco	2/27/2023
		Y	T22281	Endevco	2/27/2023
		Z	T26050	Endevco	2/27/2023
	Redundant	X	T21682	Endevco	2/27/2023
		Y	T25989	Endevco	2/27/2023
		Z	T25864	Endevco	2/27/2023
Thorax Rib Displacement Potentiometers	Upper	Y	DS-0552-01	Honeywell	2/27/2023
	Middle	Y	DS-807	Honeywell	2/27/2023
	Lower	Y	DS-0552-03	Honeywell	2/27/2023
Abdomen Load Cells	Forward	Y	1440	Denton	8/12/2022
	Middle	Y	1525	Denton	8/12/2022
	Rear	Y	1528	Denton	8/12/2022
Lower Spine Accelerometers (T12)		X	P71278	Endevco	2/27/2023
		Y	P71276	Endevco	2/27/2023
		Z	T23573	Endevco	2/27/2023
Pubic Symphysis Load Cell		Y	3096JFL-456-FY	Denton	8/12/2022

Table 2 – Vehicle Instrumentation

Vehicle Instrumentation		Serial Number	Manufacturer	Calibration Date
Vehicle Center of Gravity	X	A282710	Measurement Specialties	11/17/2022
Vehicle Center of Gravity	Y	A290918	Measurement Specialties	11/17/2022
Vehicle Center of Gravity	Z	A374322	Measurement Specialties	11/17/2022
Left Floor Sill	Y	G22637	Endevco	11/24/2022
A-Pillar Sill	Y	A374214	Measurement Specialties	1/12/2023
A-Pillar Low	Y	A431195	Measurement Specialties	1/6/2023
A-Pillar Mid	Y	A374314	Measurement Specialties	11/14/2022
B-Pillar Sill	Y	A315761	Measurement Specialties	10/10/2022
B-Pillar Low	Y	A372820	Measurement Specialties	11/30/2022
B-Pillar Mid	Y	A405588	Measurement Specialties	1/16/2023
Driver Seat	Y	G22204	Endevco	1/24/2023
Engine Top	X	A315714	Measurement Specialties	1/6/2023
Engine Top	Y	A373201	Measurement Specialties	1/6/2023
Firewall	Y	A373239	Measurement Specialties	11/17/2022
Right Roof	Y	A284277	Measurement Specialties	11/15/2022
Right Floor Sill	Y	A428014	Measurement Specialties	1/3/2023
Rear Floorpan	X	A400750	Measurement Specialties	11/3/2022
Rear Floorpan	Y	A413618	Measurement Specialties	11/3/2022