

REPORT NUMBER: NCAP-MGA-24-014

**NEW CAR ASSESSMENT PROGRAM (NCAP)
Frontal Barrier Impact Test**

**FORD MOTOR CO.
2024 Ford Mustang Mach-E eAWD 5-Door SUV
NHTSA No.: M20240208**

**MGA RESEARCH CORPORATION
5000 Warren Road
Burlington, WI 53105**



Test Date: May 31, 2024

Final Report Date: November 12, 2024

FINAL REPORT

**U.S. DEPARTMENT OF TRANSPORTATION
National Highway Traffic Safety Administration
Office of Crashworthiness Standards
1200 New Jersey Ave, SE
Washington, DC 20590**

This publication is distributed by the U.S. Department of Transportation, National Highway Traffic Safety Administration, in the interest of information exchange. The opinions, findings and conclusions expressed in this publication are those of the author(s) and not necessarily those of the Department of Transportation or the National Highway Traffic Safety Administration. The United States Government assumes no liability for its contents or use thereof.

If trade or manufacturers' names or products are mentioned, it is only because they are considered essential to the object of the publication and should not be construed as an endorsement. The United States Government does not endorse products or manufacturers.

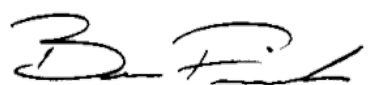
Prepared by: 
Ben Fischer, Program Manager

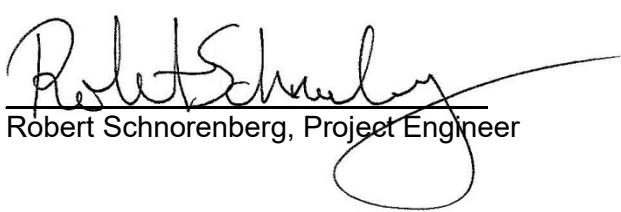
Approved by: 
Robert Schnorenberg, Project Engineer

Approval Date: November 12, 2024

FINAL REPORT ACCEPTANCE BY OCWS:

Division Chief, New Car Assessment Program
NHTSA, Office of Crashworthiness Standards

Date: _____

COTR, New Car Assessment Program
NHTSA, Office of Crashworthiness Standards

Date: _____

TECHNICAL REPORT DOCUMENTATION PAGE

1. Report No. NCAP-MGA-24-014	2. Government Accession No.	3. Recipient's Catalog No.																																																							
4. Title and Subtitle Final Report of New Car Assessment Program Frontal Impact Testing and FMVSS No. 305 Indicant Testing of a 2024 Ford Mustang Mach-E eAWD 5-Door SUV, NHTSA No.: M20240208		5. Report Date November 12, 2024		6. Performing Organization Code MGA																																																					
7. Author(s) Ben Fischer, Program Manager		8. Performing Organization Report No. NCAP-MGA-24-014																																																							
9. Performing Organization Name and Address MGA Research Corporation 5000 Warren Road Burlington, WI 53105		10. Work Unit No.																																																							
		11. Contract or Grant No. 693JJ919D000006																																																							
12. Sponsoring Agency Name and Address U.S. Department of Transportation National Highway Traffic Safety Administration Office of Crashworthiness Standards (NRM-110) 1200 New Jersey Ave, SE Washington, D.C. 20590		13. Type of Report and Period Covered Final Test Report May 31, 2024 to November 12, 2024																																																							
		14. Sponsoring Agency Code NRM-110																																																							
15. Supplementary Notes																																																									
16. Abstract A 56.3 km/h NCAP Frontal Rigid Barrier Impact Test was conducted on a 2024 Ford Mustang Mach-E eAWD 5-Door SUV in accordance with the specifications of the Office of Crashworthiness Standards Laboratory Procedure for NCAP Full Frontal Rigid Barrier Impact Testing. The test was conducted at MGA Research Corporation in Burlington, Wisconsin on May 31, 2024. The impact velocity of the vehicle was 56.46 km/h and the ambient temperature at the barrier face at the time of impact was 21.6°C. The target vehicle post-test maximum crush was 532 mm located to the left of the vehicle centerline. The test vehicle's performance was as follows:																																																									
<table border="1" style="width: 100%; border-collapse: collapse;"> <thead> <tr> <th rowspan="2">Measurement Description</th> <th rowspan="2">Units</th> <th colspan="2">Driver ATD</th> <th colspan="2">Passenger ATD</th> </tr> <tr> <th>Threshold</th> <th>Result</th> <th>Threshold</th> <th>Result</th> </tr> </thead> <tbody> <tr> <td>Head Injury Criteria (HIC₁₅)</td> <td></td> <td>700</td> <td>170.134</td> <td>700</td> <td>162.814</td> </tr> <tr> <td>Maximum Chest Compression</td> <td>mm</td> <td>63</td> <td>30.204</td> <td>52</td> <td>11.691</td> </tr> <tr> <td>Nij</td> <td></td> <td>1</td> <td>0.244</td> <td>1</td> <td>0.589</td> </tr> <tr> <td>Neck Tension</td> <td>N</td> <td>4170</td> <td>1028.717</td> <td>2620</td> <td>706.596</td> </tr> <tr> <td>Neck Compression</td> <td>N</td> <td>4000</td> <td>199.965</td> <td>2520</td> <td>292.052</td> </tr> <tr> <td>Left Femur Force</td> <td>N</td> <td>10008</td> <td>1569.090</td> <td>6805</td> <td>1145.226</td> </tr> <tr> <td>Right Femur Force</td> <td>N</td> <td>10008</td> <td>1797.866</td> <td>6805</td> <td>41.053</td> </tr> </tbody> </table>						Measurement Description	Units	Driver ATD		Passenger ATD		Threshold	Result	Threshold	Result	Head Injury Criteria (HIC ₁₅)		700	170.134	700	162.814	Maximum Chest Compression	mm	63	30.204	52	11.691	Nij		1	0.244	1	0.589	Neck Tension	N	4170	1028.717	2620	706.596	Neck Compression	N	4000	199.965	2520	292.052	Left Femur Force	N	10008	1569.090	6805	1145.226	Right Femur Force	N	10008	1797.866	6805	41.053
Measurement Description	Units	Driver ATD		Passenger ATD																																																					
		Threshold	Result	Threshold	Result																																																				
Head Injury Criteria (HIC ₁₅)		700	170.134	700	162.814																																																				
Maximum Chest Compression	mm	63	30.204	52	11.691																																																				
Nij		1	0.244	1	0.589																																																				
Neck Tension	N	4170	1028.717	2620	706.596																																																				
Neck Compression	N	4000	199.965	2520	292.052																																																				
Left Femur Force	N	10008	1569.090	6805	1145.226																																																				
Right Femur Force	N	10008	1797.866	6805	41.053																																																				
17. Key Words 56.3 km/h (35 mph) Full Frontal Rigid Barrier Impact Test New Car Assessment Program (NCAP)			18. Distribution Statement Copies of this report are available from: National Highway Traffic Safety Administration Technical Information Services Division 1200 New Jersey Ave, SE Washington, DC 20590																																																						
19. Security Classification of Report Unclassified	20. Security Classification of Page Unclassified	21. No. of Pages 209	22. Price																																																						

TABLE OF CONTENTS

<u>Section</u>		<u>Page No.</u>
1	Purpose and Summary of Test	1
2	Occupant and Vehicle Information / Data Sheets	3
<u>Data Sheet No.</u>		<u>Page No.</u>
1	General Test and Vehicle Parameter Data	4
2	Seat Adjustment, Fuel System, and Steering Wheel Data	8
3	Dummy Longitudinal Clearance Dimensions	10
4	Dummy Lateral Clearance Dimensions	11
5	Seat Belt Positioning Data	12
6	High-Speed Camera Locations and Data	13
7	Vehicle Accelerometer Locations	15
8	Photographic Reference Target Locations	16
9	Load Cell Locations on Fixed Barrier	17
10	Test Vehicle Summary of Results	18
11	Post-Test Observations	19
12	Vehicle Profile Measurements	20
13	Accident Investigation Division Data	22
14	Vehicle Intrusion Measurements	23
15	Summary of Indicant FMVSS No. 212 and FMVSS No. 219 (Partial) Data	25
16	FMVSS No. 301 Barrier Impact and Static Rollover Results	26
17	Dummy/Vehicle Temperature Stabilization Data	28
305-1	General Test and Vehicle Parameter Data for Indicant FMVSS No. 305 Testing	29
305-2	Pre-Impact Data for Indicant FMVSS No. 305 Testing	30
305-3	Pre-Impact Electrical Isolation Measurements and Calculations for Indicant FMVSS No. 305 Testing	31
305-4	Post-Impact Data for Indicant FMVSS No. 305 Testing	33
305-5	Static Rollover Test Data for Indicant FMVSS No. 305 Testing	36
<u>Appendix</u>		
A	Photographs	A
B	Dummy Response Data Traces	B
C	Dummy Qualification and Performance Verification	C
D	Test Equipment and Instrumentation Calibration	D

SECTION 1 PURPOSE AND SUMMARY OF TEST

PURPOSE

This 56.3 km/h frontal barrier impact test is part of the Vehicle Barrier Impact Testing Program sponsored by the National Highway Traffic Safety Administration (NHTSA) under contract number 693JJ919D000006. The purpose of this test was to obtain vehicle crashworthiness and occupant restraint system performance data for consumer information purposes.

The 56.3 km/h frontal barrier impact was conducted in accordance with the Office of Crashworthiness Standards Laboratory Procedure for NCAP Full Frontal Rigid Barrier Impact Testing.

SUMMARY

A load cell barrier consisting of 176 load cells was impacted by a 2024 Ford Mustang Mach-E eAWD 5-Door SUV at a velocity of 56.46 km/h. The test was performed at MGA Research Corporation on May 31, 2024. Pre-test and post-test photographs of the vehicle and dummies can be found in Appendix A.

Two (2) real-time cameras and sixteen (16) high-speed cameras were used to document the frontal barrier impact event. Camera locations and other pertinent camera information can be found in this report.

One Part 572E 50th percentile male anthropomorphic test device (ATD), was placed in the driver seating position and one Part 572O 5th percentile female test device (ATD) was placed in the right-front passenger seating position according to dummy placement instructions specified in the Laboratory Procedure for NCAP Full Frontal Rigid Barrier Impact Testing.

Both ATDs were fully instrumented with head, chest and pelvis tri-axial accelerometers, chest displacement potentiometers, upper neck transducers, right/left femur load cells, and lower leg instrumentation.

The driver (position 1) ATD (Serial No. 064) and the right-front passenger (position 2) ATD (Serial No. 142) were qualified previous to this test. Certification details, along with instrumentation calibration data, are found in Appendix C of this report.

The 278 channels of data were recorded on a data acquisition system. Appendix B contains the dummy response data traces.

There was 100 percent windshield retention and no intrusion into the protected zone of the windshield during the event. There was no Stoddard Solvent or battery electrolyte leakage and no loss of high-voltage battery isolation after the event or during any phase of the static rollover.

The maximum static crush of the vehicle was 532 mm located to the left of the vehicle centerline and both the driver and passenger side doors remained closed during the impact event and were operable after the impact.

The driver's visible contact points were as follows: The driver's head contacted the airbag. The driver's head also contacted the headrest. The driver's knees contacted the knee airbag.

The passenger's visible contact points were as follows: The passenger's head contacted the airbag. The passenger's head also contacted the headrest. The passenger's knees contacted the glove box.

The occupant data is summarized below:

ATD position	HIC₁₅	Nij	Neck Tension (N)	Neck Comp. (N)	3ms Chest Clip (g)	Chest Disp. (mm)	Left Femur (N)	Right Femur (N)
Driver (50 th)	170.134	0.244	1028.717	199.965	40.924	30.204	1569.090	1797.866
Passenger (5 th)	162.814	0.589	706.596	292.052	40.114	11.691	1145.226	41.053

The test data can be found on the NHTSA website at www.nhtsa.gov

TEST NOTES

None.

SECTION 2
OCCUPANT AND VEHICLE INFORMATION / DATA SHEETS

**DATA SHEET NO. 1
GENERAL TEST AND VEHICLE PARAMETER DATA**

Test Vehicle: 2024 Ford Mustang Mach-E eAWD 5-Door SUV
 Test Program: NCAP Frontal Barrier Impact Test

NHTSA No.: M20240208
 Test Date: 5/31/2024

TEST VEHICLE INFORMATION AND OPTIONS

NHTSA No.	M20240208	Traction Control System (TCS)	Yes
Model Year	2024	Power Steering	Yes
Make	Ford	Power Window Auto-Reverse	Yes
Model	Mustang Mach-E eAWD	Driver Frontal Airbag	Yes
Body Style	5-Door SUV	Driver Curtain Airbag	Yes
VIN	3FMTK1S55RMA04136	Driver Head/Torso Airbag	No
Body Color	Shadow Black	Driver Torso Airbag	No
Odometer (km/mi)	63 km / 39 mi	Driver Torso/Pelvis Airbag	Yes
Engine Displacement (L)		Driver Pelvis Airbag	No
Type/No. Cylinders	Electric	Driver Knee Airbag	Yes
Engine Placement	Lateral	Front Pass. Frontal Airbag	Yes
Transmission Type	Direct Drive	Front Pass. Curtain Airbag	Yes
Transmission Speeds		Front Pass. Head/Torso Airbag	No
Overdrive	No	Front Pass. Torso Airbag	No
Final Drive	AWD	Front Pass. Torso/Pelvis Airbag	Yes
Roof Rack	No	Front Pass. Pelvis Airbag	No
Sunroof/T-Top	No	Front Pass. Knee Airbag	No
Running Boards	No	Driver Pretensioner	Yes
Tilt Steering Wheel	Yes	Driver Load Limiter	Yes
Power Seats	Driver	Front Pass. Pretensioner	Yes
Anti-Lock Brakes (ABS)	Yes	Front Pass. Load Limiter	Yes
Automatic Door Locks (ADLs)	Yes	Other	N/A

Does owner's manual provide instructions to turn off automatic door locks?	No
--	----

DATA FROM CERTIFICATION LABEL

Manufactured By	FORD MOTOR CO.	GVWR (kg)	2640
		GAWR Front (kg)	1211
Date of Manufacture	01/24	GAWR Rear (kg)	1476

VEHICLE SEATING AND WEIGHT CAPACITY DATA

Measured Parameter	Front	Rear	Third	Total
Type of Seats	Bucket	Contoured		
Designated Seating Capacity (DSC)	2	3		5
Capacity Weight (VCW) (kg)				448
Cargo Weight (RCLW) (kg)				108

DATA SHEET NO. 1 (CONTINUED)
GENERAL TEST AND VEHICLE PARAMETER DATA

Test Vehicle: 2024 Ford Mustang Mach-E eAWD 5-Door SUV
 Test Program: NCAP Frontal Barrier Impact Test

NHTSA No.: M20240208
 Test Date: 5/31/2024

VEHICLE TIRE INFORMATION

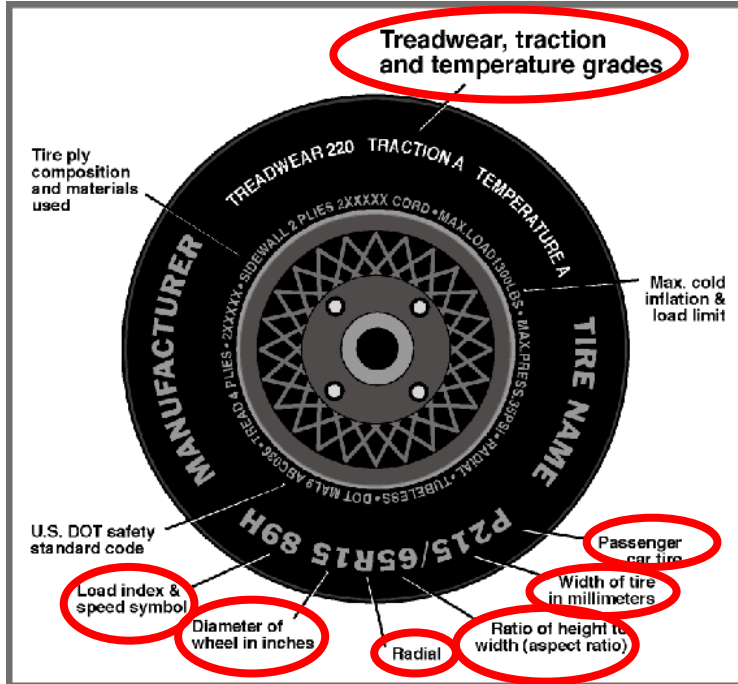

Measured Parameter	Front	Rear
Max. Tire Pressure (kPa)	340	340
Cold Pressure (kPa)	270	270
Recommended Tire Size	225/55R19	225/55R19
Tire Size on Vehicle	225/55R19	225/55R19
Tire Manufacturer	Michelin	Michelin
Tire Model	Primacy A/S	Primacy A/S
Treadwear	540	540
Traction	A	A
Temperature Grade	A	A
Tire Plies Sidewall	2 Polyester	2 Polyester
Tire Plies Body	2 Polyester, 1 Polyamide, 2 Steel	2 Polyester, 1 Polyamide, 2 Steel
Load Index/Speed Symbol	103H	103H
Tire Material	Rubber	Rubber
DOT Safety Code Left	1B9JN O O J X 4223	1B9JN O O J X 4223
DOT Safety Code Right	1B9JN O O J X 4223	1B9JN O O J X 4123

**DATA SHEET NO. 1 (CONTINUED)
GENERAL TEST AND VEHICLE PARAMETER DATA**

Test Vehicle: 2024 Ford Mustang Mach-E eAWD 5-Door SUV
Test Program: NCAP Frontal Barrier Impact Test

NHTSA No.: M20240208
Test Date: 5/31/2024

TEST VEHICLE WEIGHTS

	Units	As Delivered (UVW)			As Tested (ATW)		
		Front	Rear	Total	Front	Rear	Total
Left	kg	534.5	571.0		577.5	656.0	
Right	kg	531.0	547.0		568.0	624.5	
Ratio	%	48.8%	51.2%		47.2%	52.8%	
Totals	kg	1065.5	1118.0	2183.5	1145.5	1280.5	2426.0

TARGET TEST WEIGHT CALCULATION

Measured Parameter	Units	Value
Total Delivered Weight (UVW)	kg	2183.5
Weight of 1 P572E ATD & 1 P572O ATD	kg	141
Rated Cargo/Luggage Weight (RCLW)	kg	108
Calculated Test Vehicle Target Weight (TVTW)	kg	2432.5

TEST VEHICLE ATTITUDES AND CG

	Units	LF	RF	LR	RR	CG (aft of front axle)
As Delivered	mm	773	776	784	781	1529
As Tested	mm	764	762	763	770	1576
Post Test	mm	740	770	767	765	

GENERAL TEST VEHICLE DATA

Measurement Description	Units	Value
Total Vehicle Wheel Base	mm	2986
Total Vehicle Length at Left Side	mm	4533
Total Vehicle Length at Centerline	mm	4711
Total Vehicle Length at Right Side	mm	4543
Weight of Ballast in Cargo Area	kg	40
Weight of Vehicle Components Removed	kg	14
Amount of Stoddard Solvent in Fuel Tank	L	

List of components removed to meet test weight: None.

List of components removed for instrumentation, data box, and equipment installation: Cargo area carpet/trim/divider, jack and tools, underbody plastic, EV charging cable.

DATA SHEET NO. 1 (CONTINUED)
GENERAL TEST AND VEHICLE PARAMETER DATA

Test Vehicle: 2024 Ford Mustang Mach-E eAWD 5-Door SUV
 Test Program: NCAP Frontal Barrier Impact Test

NHTSA No.: M20240208
 Test Date: 5/31/2024

TARGET VEHICLE STRUCTURAL MEASUREMENT

	Elements	Pre-Test (mm)
1	Total Length	4711
2	Total Width	1836
3	Bumper Top Height	512
4	Bumper Bottom Height	400
5	Longitudinal Member Top Height	558
6	Distance between Longitudinal Members	808
7	Longitudinal Member Width	97
8	Engine Top Height	794
9	Engine Bottom Height	178
10	Engine and Gearbox Width	419
11	Front Bumper-Engine Distance	601
12	Front Shock Absorber Fixing Height	915
13	Bonnet Leading Edge Height	801
14	Front Shock Absorber Fixing Width	1209
15	Front Bumper – Front Axle Distance	732
16	Front Axle – A-Pillar Distance	719
17	A-Pillar – B-Pillar Distance	1022
18	B-Pillar – Rear Axle Distance	1245
19	B-Pillar – C-Pillar Distance	1221
20	Roof Sill Bottom Height	1334
21	Roof Sill Top Height	1388
22	Floor Sill Bottom Height	238
23	Floor Sill Top Height	412

**DATA SHEET NO. 2
SEAT ADJUSTMENT, FUEL SYSTEM, AND STEERING WHEEL DATA**

Test Vehicle: 2024 Ford Mustang Mach-E eAWD 5-Door SUV
 Test Program: NCAP Frontal Barrier Impact Test

NHTSA No.: M20240208
 Test Date: 5/31/2024

NOMINAL DESIGN RIDING POSITION

The driver seat back is positioned as close as possible to the manufacturer’s design angle. For the passenger seat back, seat back is adjusted following Appendix F, “Driver & Passenger Dummy Seating & Positioning Procedures” in the NCAP Test Procedure dated May 2018.

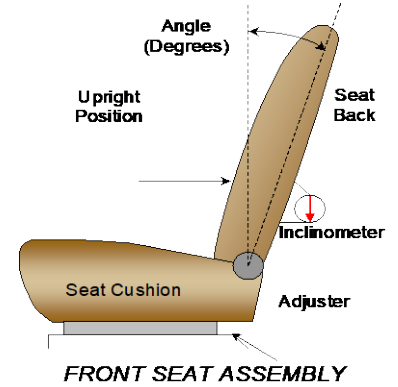

	Degrees
Driver Seat Back Angle	3.0° on outboard headrest post
Passenger Seat Back Angle	0.1° on outboard headrest post

SEAT FORE/AFT POSITIONS

The driver and passenger seat fore/aft positions are adjusted following Appendix F, “Driver & Passenger Dummy Seating & Positioning Procedures” in the NCAP Test Procedure dated May 2018.

	Total Fore/Aft Travel	Placed in Position #
Driver Seat	312 mm	156 mm
Passenger Seat	256 mm / 38 detents (1st as 1)	0 mm / 0th detent (1st as 0)

SEAT BELT UPPER ANCHORAGES

The seat belt upper anchorages are set following the manufacturer’s specified position as listed in Form 1.

	Total # of Positions	Placed in Position #
Driver Seat	4 (1st as 1)	0 (1st as 0)
Passenger Seat	4 (1st as 1)	0 (1st as 0)

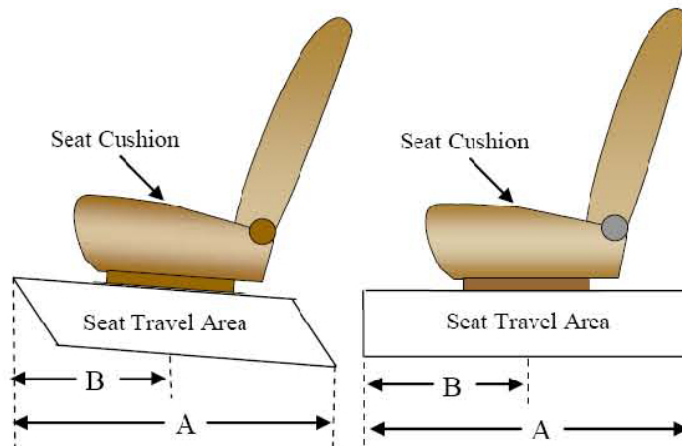

DATA SHEET NO. 2 (CONTINUED)
SEAT ADJUSTMENT, FUEL SYSTEM, AND STEERING WHEEL DATA

Test Vehicle: 2024 Ford Mustang Mach-E eAWD 5-Door SUV
 Test Program: NCAP Frontal Barrier Impact Test

NHTSA No.: M20240208
 Test Date: 5/31/2024

FUEL TANK CAPACITY DATA

	Liters
Usable Capacity of "Standard Tank"	
Usable Capacity of "Optional Tank"	
92-94% of Usable Capacity	
Actual Amount of Solvent used	
1/3 of Usable Capacity	

FUEL PUMP

Electric vehicle.

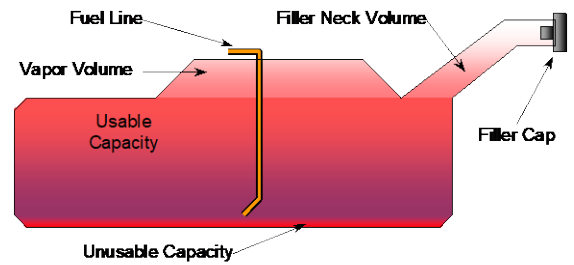

VEHICLE FUEL TANK ASSEMBLY

STEERING COLUMN ADJUSTMENT

Steering wheel and column adjustments are made so that the steering wheel hub is at the geometric center of the locus it describes when moved through its full range of motion. An aluminum plate is placed across the rim of the steering wheel, an inclinometer is placed on the plate and the angle is measured.

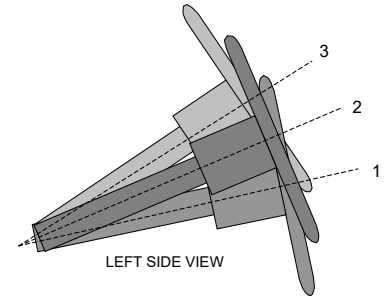

STEERING COLUMN ASSEMBLY

STEERING COLUMN POSITION

	Degrees	Fore/Aft Position (mm)
Lowermost Position 1	69.4	
Geometric Center Position 2	67.2	
Uppermost Position 3	65.0	
Telescoping Steering Wheel Travel		56
Test Position	67.2	28

DATA SHEET NO. 3
DUMMY LONGITUDINAL CLEARANCE DIMENSIONS

Test Vehicle: 2024 Ford Mustang Mach-E eAWD 5-Door SUV
Test Program: NCAP Frontal Barrier Impact Test

NHTSA No.: M20240208
Test Date: 5/31/2024

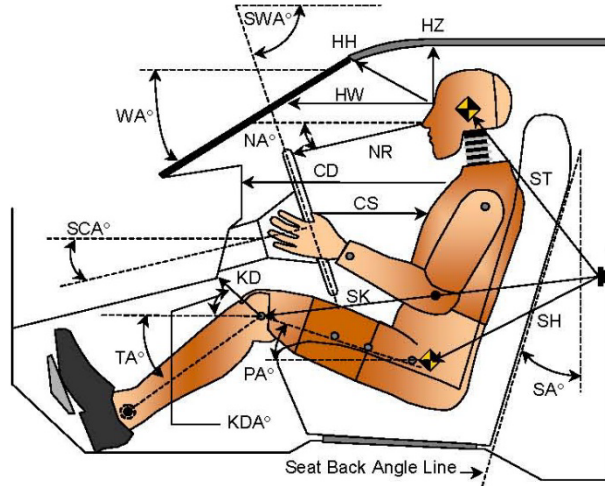

LEFT SIDE VIEW

Code	Measurement Description	Driver		Passenger	
		Length (mm)	Angle (°)	Length (mm)	Angle (°)
WA°	Windshield Angle		28.2		
SWA°	Steering Wheel Angle		67.2		
SCA°	Steering Column Angle		22.8		
SA°	Seat Back Angle		3.0		0.1
HZ	Head to Roof (Z)	202	90	211	90
HH	Head to Header	352	25.1	299	49.2
HW	Head to Windshield	656	0	664	0
NR	Nose to Rim	361	9.3		
CD	Chest to Dash	491		332	
CS	Chest to Steering Hub	280	1.6		
RA	Rim to Abdomen	170	0		
KDL	Left Knee to Dash	164	23.9	102	51.1
KDR	Right Knee to Dash	215	16.1	112	44.7
PA°	Pelvic Angle		24.5		21.9
TA°	Tibia Angle		39.2		36.1
SK	Striker to Knee	581	92.2	682	92.9
ST	Striker to Head	535	9.8	495	25.5
SH	Striker to H-Point	249	119.9	368	108.1

**DATA SHEET NO. 4
DUMMY LATERAL CLEARANCE DIMENSIONS**

Test Vehicle: 2024 Ford Mustang Mach-E eAWD 5-Door SUV
 Test Program: NCAP Frontal Barrier Impact Test

NHTSA No.: M20240208
 Test Date: 5/31/2024

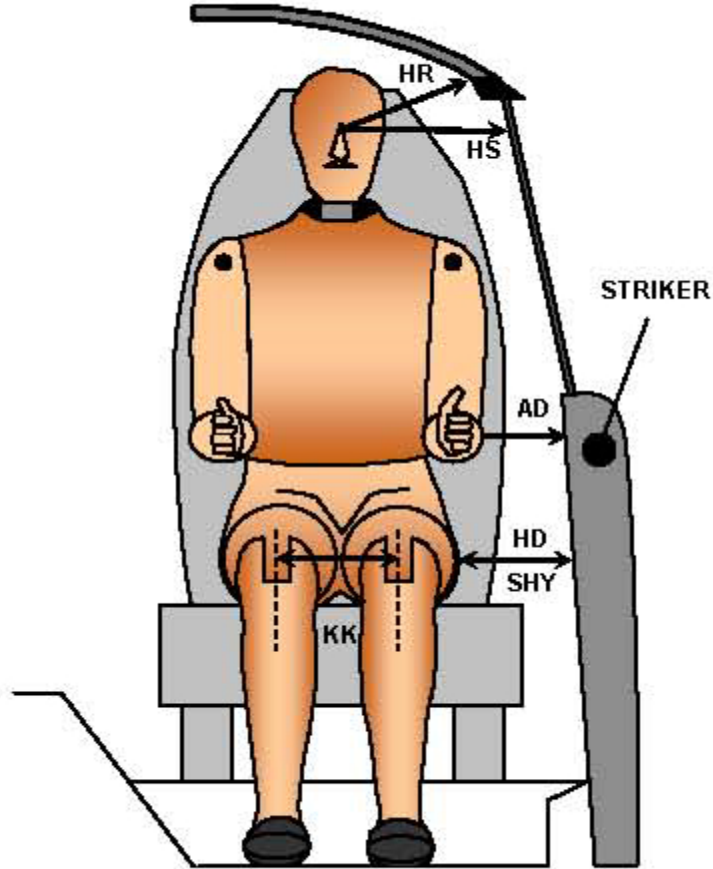

FRONT VIEW OF DUMMY

Code	Measurement Description	Units	Driver	Passenger
AD	Arm to Door	mm	142	86
HD	H-Point to Door	mm	141	169
HR	Head to Side Header	mm	221	282
HS	Head to Side Window	mm	342	371
KK	Knee to Knee	mm	353	234
SHY	Striker to H-Point (Y Direction)	mm	231	261
AA	Ankle to Ankle	mm	356	172

**DATA SHEET NO. 5
SEAT BELT POSITIONING DATA**

Test Vehicle: 2024 Ford Mustang Mach-E eAWD 5-Door SUV
 Test Program: NCAP Frontal Barrier Impact Test

NHTSA No.: M20240208
 Test Date: 5/31/2024

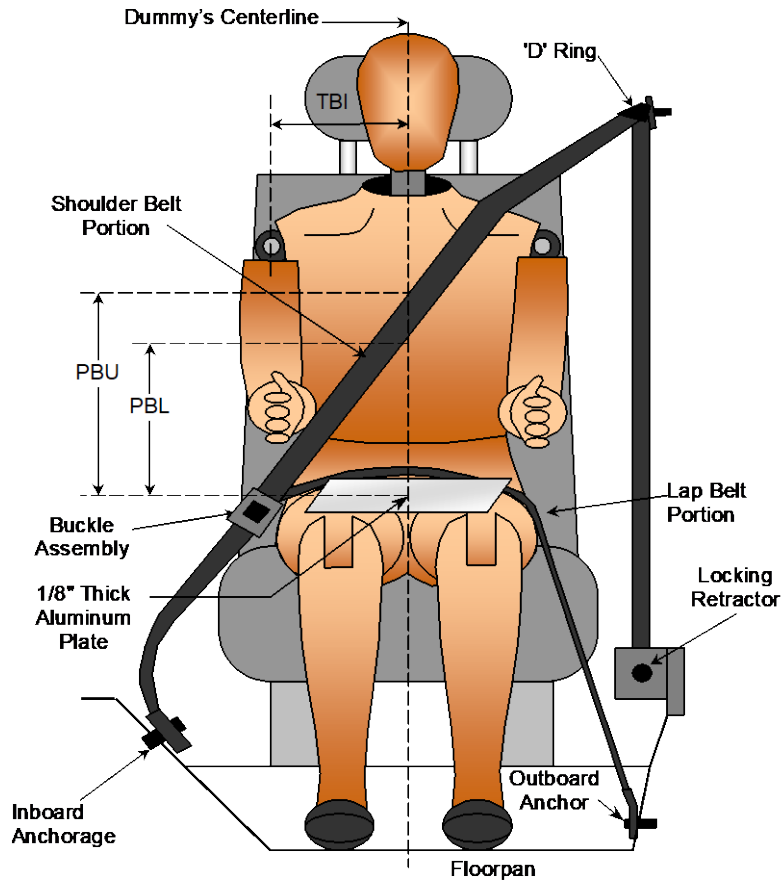

FRONT VIEW OF DUMMY

SEAT BELT POSITIONING MEASUREMENTS

Measurement Description	Units	Driver	Passenger
PBU - Top surface of reference to belt upper edge	mm	350	310
PBL - Top surface of reference to belt lower edge	mm	260	200

BELT LENGTH DATA

Measurement Description	Units	Driver	Passenger
Shoulder Belt Length as measured on ATD	mm	813	883
Lap Belt Length as measured on ATD	mm	643	671
Remainder of belt on reel	mm	324	331
Total Belt Length for Continuous Webbing Systems	mm	2380	2360

**DATA SHEET NO. 6
HIGH-SPEED CAMERA LOCATIONS AND DATA**

Test Vehicle: 2024 Ford Mustang Mach-E eAWD 5-Door SUV
Test Program: NCAP Frontal Barrier Impact Test

NHTSA No.: M20240208
Test Date: 5/31/2024

CAMERA POSITIONS FOR FRONTAL IMPACTS

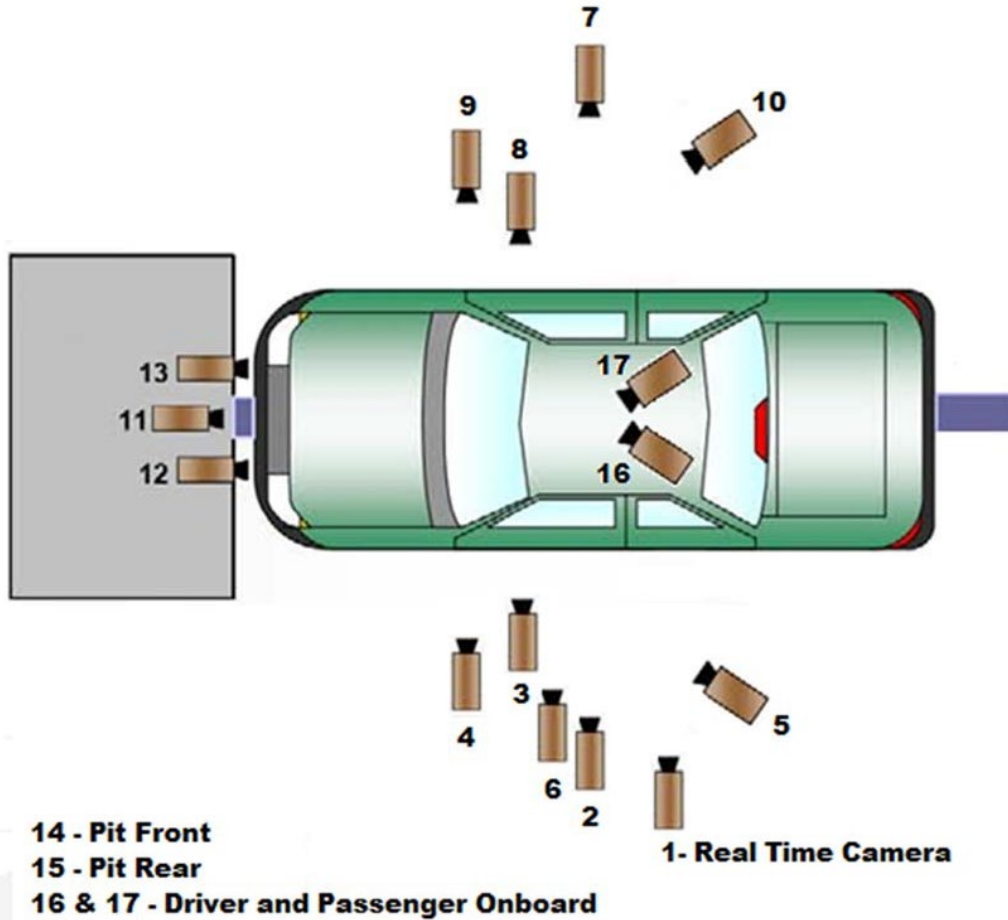

***Camera locations are approximate and not to scale*

DATA SHEET NO. 6 (CONTINUED)
HIGH-SPEED CAMERA LOCATIONS AND DATA

Test Vehicle: 2024 Ford Mustang Mach-E eAWD 5-Door SUV
 Test Program: NCAP Frontal Barrier Impact Test

NHTSA No.: M20240208
 Test Date: 5/31/2024

CAMERA LOCATIONS

No.	Camera View	Coordinates* (mm)			Lens (mm)	Speed (fps)
		X	Y	Z		
1	Real-Time Left Overall					30
2	Left Overall	-2275	-5900	-1350	12	1000
3	Driver Close-Up	-1850	-6840	-1830	50	1000
4	Left Front Half	-1325	-5870	-1300	24	1000
5	Left Angle	-7305	-5780	-2060	75	1000
6	Steering Column	-1100	-6140	-1240	50	1000
7	Right Overall	-1940	6060	-1475	12	1000
8	Passenger Close-Up	-1625	7065	-1865	50	1000
9	Right Front Half	-1105	5610	-1480	24	1000
10	Right Angle	-7385	5510	-2100	75	1000
11	Windshield	120	0	-2310	12	1000
12	Driver Windshield	200	-370	-2230	25	1000
13	Passenger Windshield	200	370	-2230	25	1000
14	Pit Front	-1110	0	3340	24	1000
15	Pit Rear	-3130	0	3340	24	1000
16	Driver Onboard				12	1000
17	Passenger Onboard				12	1000
18	Real-Time Pan View					30

*COORDINATES:

- +X = forward of impact plane
- +Y = right of monorail centerline
- +Z = below ground level

DATA SHEET NO. 7
VEHICLE ACCELEROMETER LOCATIONS

Test Vehicle: 2024 Ford Mustang Mach-E eAWD 5-Door SUV
Test Program: NCAP Frontal Barrier Impact Test

NHTSA No.: M20240208
Test Date: 5/31/2024

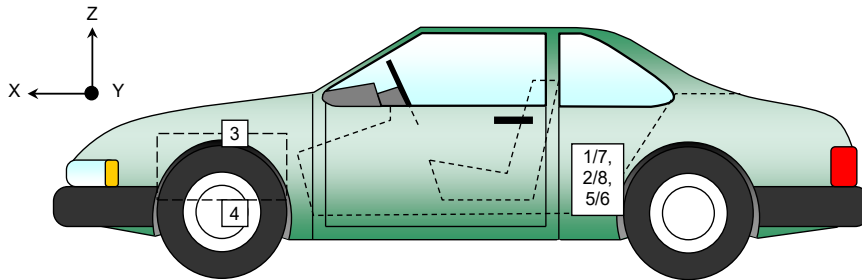
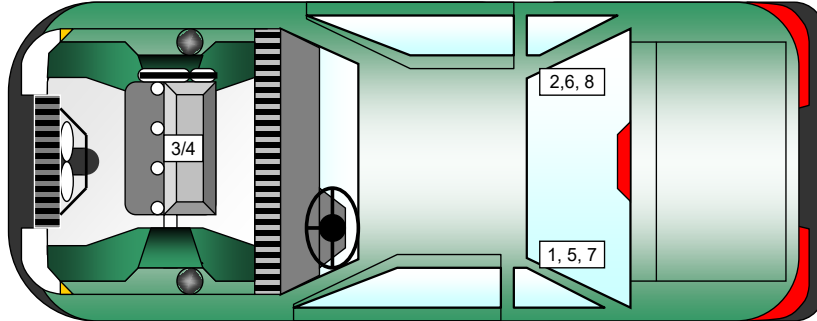

VEHICLE ACCELEROMETER PRE-TEST LOCATIONS

No.	Accelerometer Location	Measurements (mm)		
		X	Y	Z
1	Left Rear Crossmember Accelerometer – X Direction	1820	-355	-349
2	Right Rear Crossmember Accelerometer – X Direction	1814	434	-346
3	Engine Top X	3849	-16	-805
4	Engine Bottom X	3845	163	-211
5	Left Rear Crossmember Accelerometer – Z Direction	1820	-355	-349
6	Right Rear Crossmember Accelerometer – Z Direction	1814	434	-346
7	Left Rear Crossmember Accelerometer Redundant – X Direction	1820	-355	-349
8	Right Rear Crossmember Accelerometer Redundant – X Direction	1814	434	-346

Reference Points: X - Rear Surface of Vehicle (+ forward)
Y - Vehicle Centerline (+ to right)
Z - Ground Plane (+ down)

DATA SHEET NO. 8
PHOTOGRAPHIC REFERENCE TARGET LOCATIONS

Test Vehicle: 2024 Ford Mustang Mach-E eAWD 5-Door SUV
 Test Program: NCAP Frontal Barrier Impact Test

NHTSA No.: M20240208
 Test Date: 5/31/2024

Item	Value (mm)
A	379
B	918
C	2433
D	609
E	1669
F	189
G	
H	919
I	1391
J	957
K	961
L	1402
M	919
N	1404
O	962
P	952
Q	1393

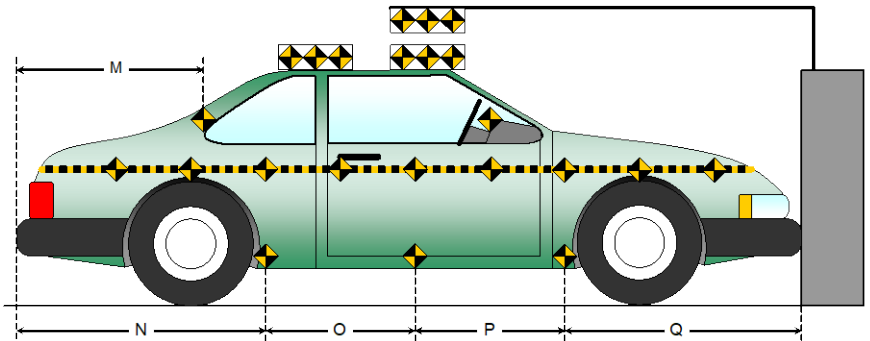
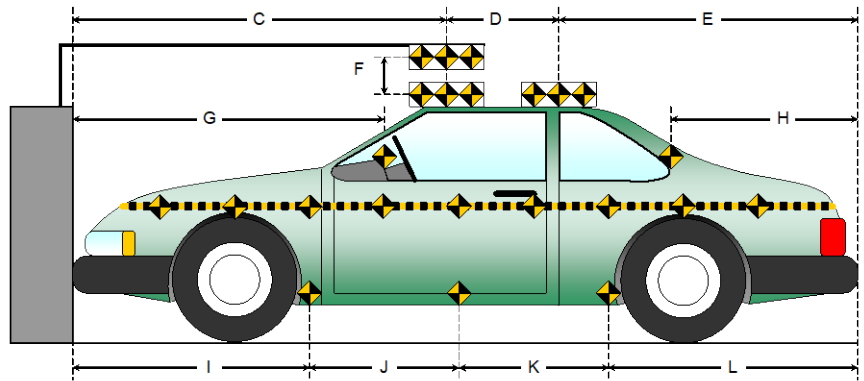
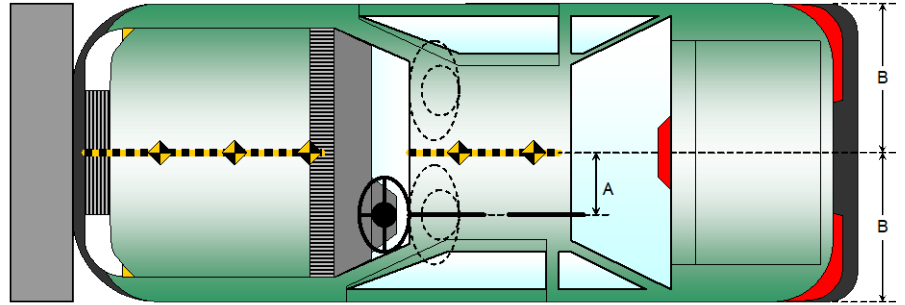

**DATA SHEET NO. 9
LOAD CELL LOCATIONS ON FIXED BARRIER**

Test Vehicle: 2024 Ford Mustang Mach-E eAWD 5-Door SUV
 Test Program: NCAP Frontal Barrier Impact Test

NHTSA No.: M20240208
 Test Date: 5/31/2024

ADVANCED RESEARCH LOAD CELL BARRIER

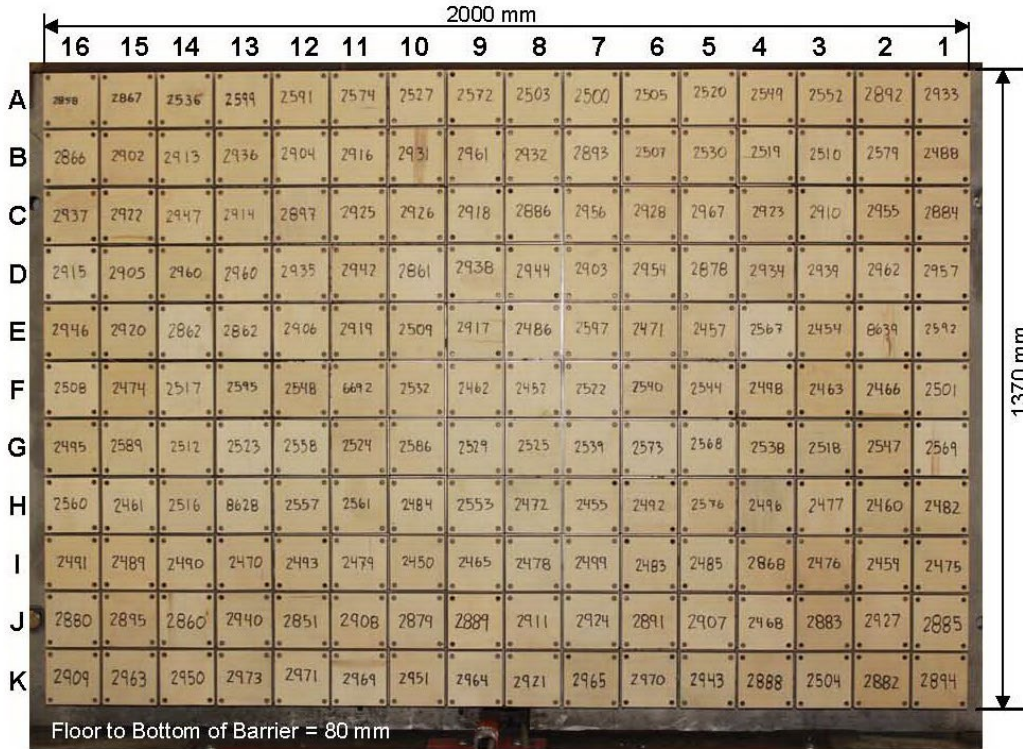

Photo for Reference Only

Centerline

A-16	A-15	A-14	A-13	A-12	A-11	A-10	A-09	A-08	A-07	A-06	A-05	A-04	A-03	A-02	A-01
B-16	B-15	B-14	B-13	B-12	B-11	B-10	B-09	B-08	B-07	B-06	B-05	B-04	B-03	B-02	B-01
C-16	C-15	C-14	C-13	C-12	C-11	C-10	C-09	C-08	C-07	C-06	C-05	C-04	C-03	C-02	C-01
D-16	D-15	D-14	D-13	D-12	D-11	D-10	D-09	D-08	D-07	D-06	D-05	D-04	D-03	D-02	D-01
E-16	E-15	E-14	E-13	E-12	E-11	E-10	E-09	E-08	E-07	E-06	E-05	E-04	E-03	E-02	E-01
F-16	F-15	F-14	F-13	F-12	F-11	F-10	F-09	F-08	F-07	F-06	F-05	F-04	F-03	F-02	F-01
G-16	G-15	G-14	G-13	G-12	G-11	G-10	G-09	G-08	G-07	G-06	G-05	G-04	G-03	G-02	G-01
H-16	H-15	H-14	H-13	H-12	H-11	H-10	H-09	H-08	H-07	H-06	H-05	H-04	H-03	H-02	H-01
I-16	I-15	I-14	I-13	I-12	I-11	I-10	I-09	I-08	I-07	I-06	I-05	I-04	I-03	I-02	I-01
J-16	J-15	J-14	J-13	J-12	J-11	J-10	J-09	J-08	J-07	J-06	J-05	J-04	J-03	J-02	J-01
K-16	K-15	K-14	K-13	K-12	K-11	K-10	K-09	K-08	K-07	K-06	K-05	K-04	K-03	K-02	K-01

Load Cells are 121 mm x 121 mm with a 7 mm gap in between each load cell.

DATA SHEET NO. 10
TEST VEHICLE SUMMARY OF RESULTS

Test Vehicle: 2024 Ford Mustang Mach-E eAWD 5-Door SUV
 Test Program: NCAP Frontal Barrier Impact Test

NHTSA No.: M20240208
 Test Date: 5/31/2024

INSTRUMENTATION

Instrumentation	Number of Channels Collected
Driver Dummy Data Channels	47
Passenger Dummy Data Channels	47
Vehicle Structure Accelerometers	8
Barrier Channels	176
Total	278

CAMERA COVERAGE

Type of Camera	Number Used in this Test
High-Speed Vehicle Onboard	2
High-Speed Offboard	15
Real-Time	2
Total	19

**DATA SHEET NO. 11
POST-TEST OBSERVATIONS**

Test Vehicle: 2024 Ford Mustang Mach-E eAWD 5-Door SUV
 Test Program: NCAP Frontal Barrier Impact Test

NHTSA No.: M20240208
 Test Date: 5/31/2024

TEST DUMMY INFORMATION AND CONTACT LOCATIONS

Description	Driver	Passenger
Dummy Type / Serial No.	HIII 50% / 064	HIII 5% / 142
Head Contact	Frontal Airbag, Headrest	Frontal Airbag, Headrest
Upper Torso Contact	Frontal Airbag	Frontal Airbag
Lower Torso Contact	None	None
Left Knee Contact	Knee Airbag	Glove Box
Right Knee Contact	Knee Airbag	Glove Box

DOOR OPENING, TRUNK OPENING, AND SEAT TRACK INFORMATION

Description	Driver	Passenger
Locked/Unlocked Doors	Doors were locked	Doors were locked
Front Door Opening	Remained closed and unlocked; opened without tools	Remained closed and unlocked; opened without tools
Rear Door Opening	Remained closed and unlocked; opened without tools	Remained closed and unlocked; opened without tools
Trunk/Hatch/Tailgate Opening	Remained closed; opened without tools	
Seat Track Shift (mm)	0	0
Seat Back Movement	None	None

OTHER VEHICLE POST-TEST OBSERVATIONS

Critical Areas of Performance	Observations and Conclusions
Windshield Damage	None
Window Damage	None
Other Notable Effects	LF/RF tires deflated after event, LR/RR doors could not

VEHICLE REBOUND FROM BARRIER

Measured Parameter	Units	Value
Left Side	mm	1070
Center	mm	1005
Right Side	mm	1045
Average	mm	1040

SUPPLEMENTAL RESTRAINT SYSTEM INFORMATION

Restraint Type	Driver		Passenger	
	Mounted	Deployed	Mounted	Deployed
Frontal Airbag	Yes	Yes	Yes	Yes
Curtain Side Airbag	Yes	No	Yes	No
Torso/Pelvis Side Airbag	Yes	No	Yes	No
Knee Airbag	Yes	Yes	No	
Seat Belt Pretensioner	Yes	Yes	Yes	Yes
Seat Belt Load Limiter	Yes		Yes	
Other				

DATA SHEET NO. 12 VEHICLE PROFILE MEASUREMENTS

Test Vehicle: 2024 Ford Mustang Mach-E eAWD 5-Door SUV
 Test Program: NCAP Frontal Barrier Impact Test

NHTSA No.: M20240208
 Test Date: 5/31/2024

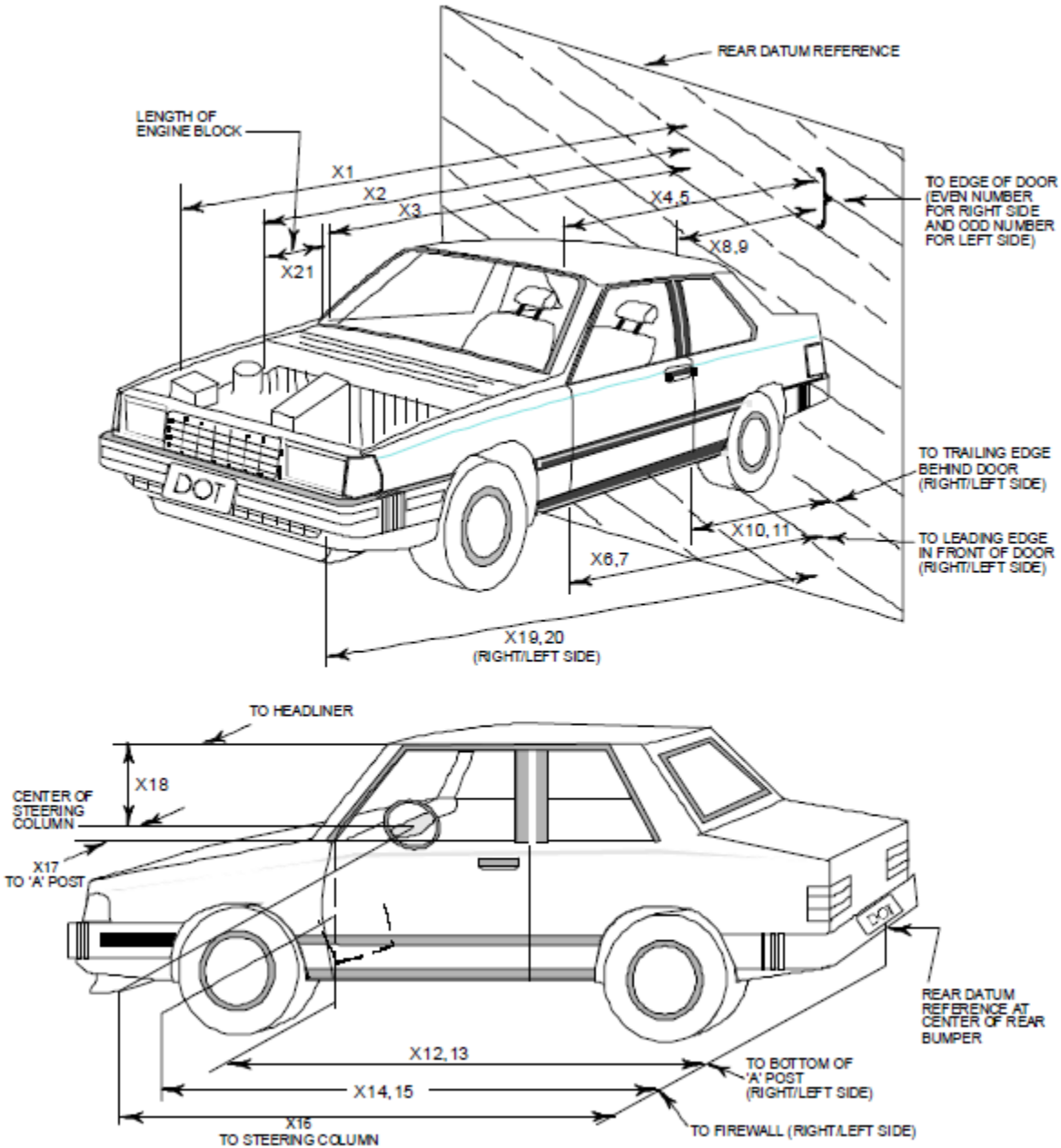

**DATA SHEET NO. 12 (CONTINUED)
VEHICLE PROFILE MEASUREMENTS**

Test Vehicle: 2024 Ford Mustang Mach-E eAWD 5-Door SUV
Test Program: NCAP Frontal Barrier Impact Test

NHTSA No.: M20240208
Test Date: 5/31/2024

No.	Measurement Description	Pre-Test	Post-Test	Change
1	Total Length of Vehicle at Centerline	4711	4184	-527
2	RSOV to Front of Engine	3976	3913	-63
3	RSOV to Firewall	3621	3630	9
4	RSOV to Upper Leading Edge of Right Door	3194	3193	-1
5	RSOV to Upper Leading Edge of Left Door	3193	3191	-2
6	RSOV to Lower Leading Edge of Right Door	3183	3182	-1
7	RSOV to Lower Leading Edge of Left Door	3183	3181	-2
8	RSOV to Upper Trailing Edge of Right Door	2049	2049	0
9	RSOV to Upper Trailing Edge of Left Door	2047	2045	-2
10	RSOV to Lower Trailing Edge of Right Door	2093	2092	-1
11	RSOV to Lower Trailing Edge of Left Door	2092	2089	-3
12	RSOV to Bottom of "A" Post of Right Side	3318	3315	-3
13	RSOV to Bottom of "A" Post of Left Side	3320	3317	-3
14	RSOV to Firewall, Right Side	3753	3740	-13
15	RSOV to Firewall, Left Side	3753	3738	-15
16	RSOV to Steering Column	2662	2720	58
17	Center of Steering Column to "A" Post	284	288	4
18	Center of Steering Column to Headliner	419	450	31
19	RSOV to Right Side of Front Bumper	4543	4170	-373
20	RSOV to Left Side of Front Bumper	4533	4164	-369
21	Length of Engine Block	187	187	0
RD	RSOV to Right Side of Dash Panel	2950	2951	1
CD	RSOV to Center of Dash Panel	2931	2930	-1
LD	RSOV to Left Side of Dash Panel	2948	2947	-1

All dimensions in mm

DATA SHEET NO. 13
ACCIDENT INVESTIGATION DIVISION DATA

Test Vehicle: 2024 Ford Mustang Mach-E eAWD 5-Door SUV
Test Program: NCAP Frontal Barrier Impact Test

NHTSA No.: M20240208
Test Date: 5/31/2024

VEHICLE INFORMATION

VIN:	<u>3FMTK1S55RMA04136</u>	Wheelbase (mm):	<u>2986</u>
Vehicle Size Category:	<u>MPV</u>	Test Weight (kg):	<u>2426.0</u>

ACCELEROMETER DATA

Accelerometer Locations:	<u>As per Data Sheet No. 7</u>
Cal. Procedure/Interval:	<u>MGA Procedure / 6 month</u>
Integration Algorithm:	<u>Trapezoidal</u>
Linearity:	<u>> 99%</u>
Impact Velocity (km/h):	<u>56.46</u>
Velocity Change (km/h):	<u>66.3</u>
Time of Separation (msec)	<u>91</u>

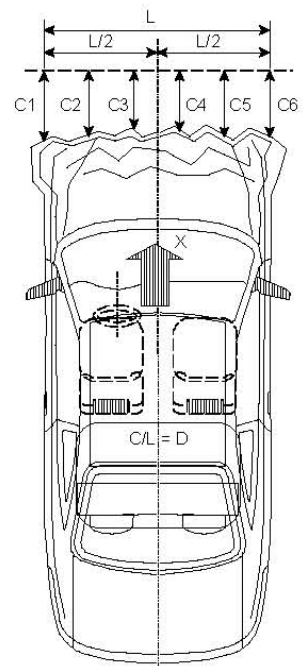

CRUSH PROFILE

Collision Deformation Classification:	<u>12FDEW3</u>
Midpoint of Damage:	<u>Centerline</u>
Damage Region Length (mm):	<u>1488</u>
Impact Mode:	<u>Frontal</u>

No.	Measurement Description	Units	Pre-Test	Post-Test	Exterior Crush
C1	Crush zone 1 at left side	mm	2467	2829	362
C2	Crush zone 2 at left side	mm	2346	2878	532
C3	Crush zone 3 at left side	mm	2301	2823	522
C4	Crush zone 4 at right side	mm	2300	2822	522
C5	Crush zone 5 at right side	mm	2330	2855	525
C6	Crush zone 6 at right side	mm	2457	2824	367
L	C1 TO C6	mm	1488	1507	-19

DATA SHEET NO. 14
VEHICLE INTRUSION MEASUREMENTS

Test Vehicle: 2024 Ford Mustang Mach-E eAWD 5-Door SUV
Test Program: NCAP Frontal Barrier Impact Test

NHTSA No.: M20240208
Test Date: 5/31/2024

DOOR OPENING WIDTH

Item	Description	Units	Pre-Test	Post-Test	Change
A	Left Side Upper	mm	1020	1020	0
B	Left Side Lower	mm	933	932	-1
D	Right Side Upper	mm	1020	1021	1
E	Right Side Lower	mm	925	926	1

WHEELBASE MEASUREMENTS

Item	Description	Units	Pre-Test	Post-Test	Change
C	Left Side Wheelbase	mm	2986	2930	-56
F	Right Side Wheelbase	mm	2985	2893	-92

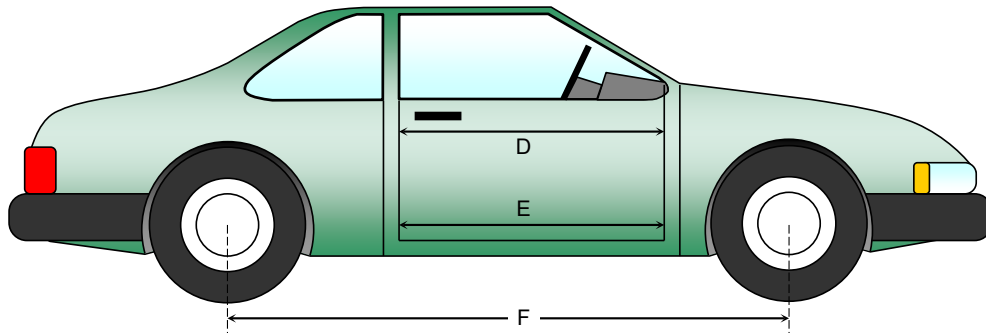
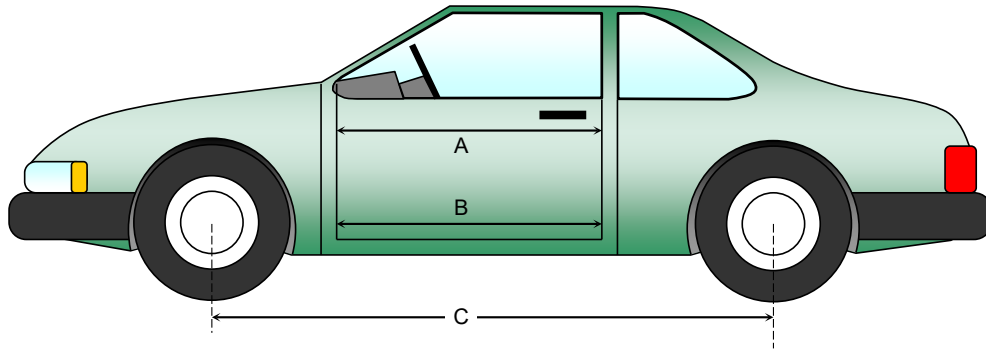

**DATA SHEET NO. 14 (CONTINUED)
VEHICLE INTRUSION MEASUREMENTS**

Test Vehicle: 2024 Ford Mustang Mach-E eAWD 5-Door SUV
 Test Program: NCAP Frontal Barrier Impact Test

NHTSA No.: M20240208
 Test Date: 5/31/2024

DRIVER COMPARTMENT INTRUSION

Item	Description	Units	Pre-Test	Post-Test	Change
AB	Door Opening (Inside Window Jam)	mm	737	736	-1
CX	Left Knee Bolster to X	mm	362	365	3
DX	Right Knee Bolster to X	mm	363	369	6
EX	Brake Pedal to X	mm	560	557	-3
FX	Foot Rest to X	mm	596	586	-10
GX	Center of Steering Column Wheel Hub to X	mm	53	115	62

X = Front of Seat Track (stationary)

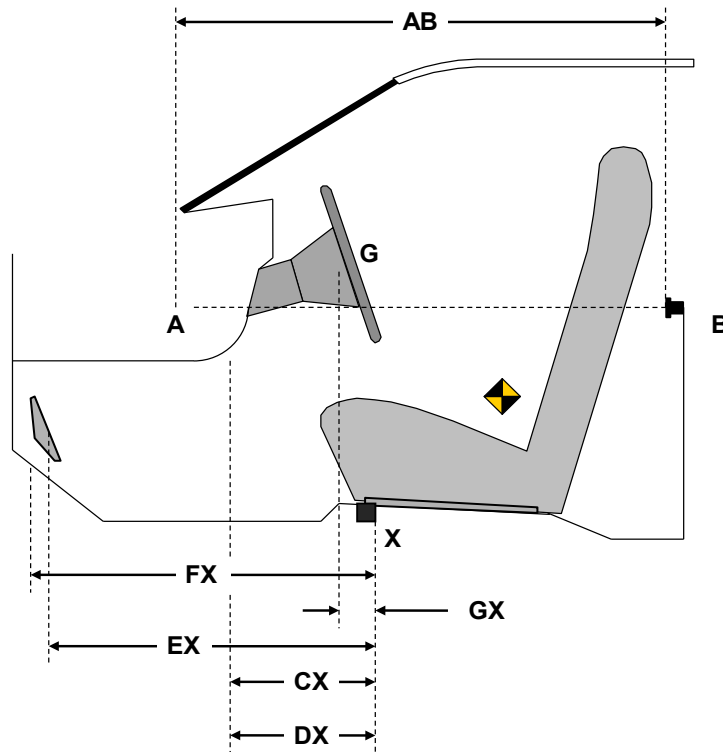

DRIVER COMPARTMENT

DATA SHEET NO. 15
SUMMARY OF FMVSS 212 AND FMVSS 219 (PARTIAL) DATA

Test Vehicle: 2024 Ford Mustang Mach-E eAWD 5-Door SUV
 Test Program: NCAP Frontal Barrier Impact Test

NHTSA No.: M20240208
 Test Date: 5/31/2024

WINDSHIELD MOUNTING DETAILS

Windshield glass is secured to the vehicle frame with a rubber trim and glue.

The standard requires that the post-test retention measurement be a minimum of 75 percent of the pre-test total periphery measurement for vehicles not equipped with occupant passive restraints and 50 percent for each side of the windshield for vehicles which are equipped with occupant passive restraints.

Temperature of windshield molding during test: 21.6°C.

WINDSHIELD PERIPHERY MEASUREMENTS

Measurement	Pre-Test (mm)	Post-Test (mm)	% of Retention
Left Side	2228	2228	100
Right Side	2228	2228	100
Total	4456	4456	100

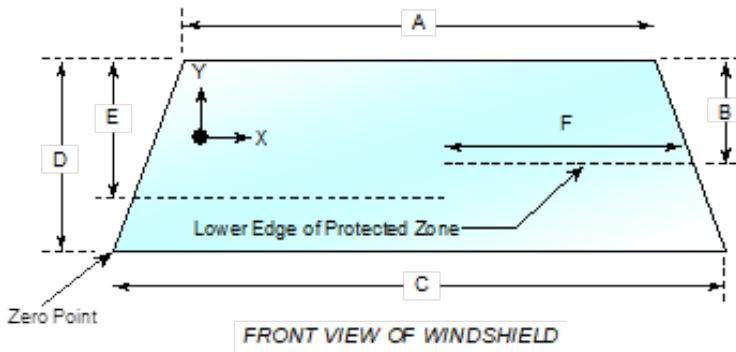

Item	Units	Value
A	mm	1286
B	mm	464
C	mm	1594
D	mm	788
E	mm	475
F	mm	696

AREA OF PROTECTED ZONE FAILURES

A. Provide coordinates of the area that the protected zone was penetrated more than 0.25 inches by a vehicle component other than one that is normally in contact with the windshield. **None**

X	Y

B. Provide coordinates of the area beneath the protected zone that the inner surface of the windshield was penetrated by a vehicle component. **None**

X	Y

DATA SHEET NO. 16
FMVSS 301 BARRIER IMPACT AND STATIC ROLLOVER

Test Vehicle: 2024 Ford Mustang Mach-E eAWD 5-Door SUV
 Test Program: NCAP Frontal Barrier Impact Test

NHTSA No.: M20240208
 Test Date: 5/31/2024

FMVSS 301 FUEL SYSTEM INTEGRITY POST IMPACT DATA

Temperature at Time of Impact: N/A

Test Time: N/A

- A. From impact until vehicle motion ceases: (Maximum Allowable = 1 ounce) N/A oz.
 B. For the 5 minute period after motion ceases: (Maximum Allowable = 5 ounces) N/A oz.
 C. For the following 25 minutes: (Maximum Allowable = 1 ounce / minute) N/A
 D. Spillage Details: N/A

FMVSS 301 STATIC ROLLOVER RESULTS

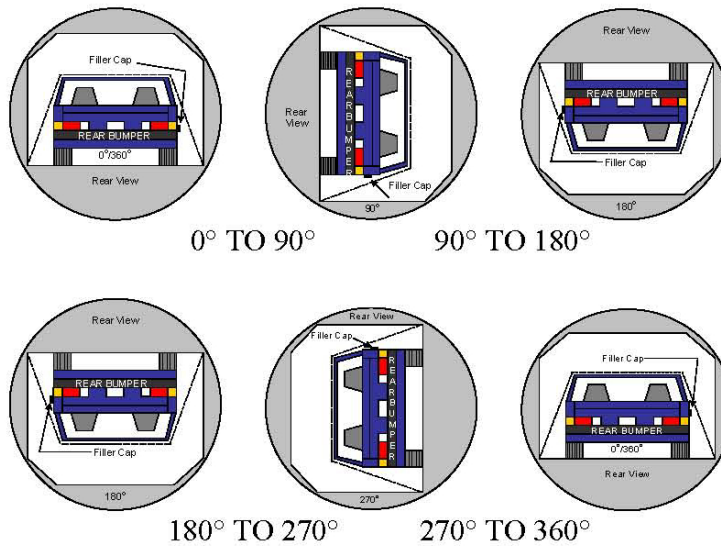

1. The specified fixture rollover rate for each 90° of rotation is 60 to 180 seconds.
2. The position hold time at each position is 300 seconds (minimum).
3. Details of Stoddard Solvent spillage: **None**

SOLVENT COLLECTION TIME TABLE IN SECONDS

Test Phase	Rotation Time	Hold Time	Total Time
0° to 90°			
90° to 180°			
180° to 270°			
270° to 360°			

DATA SHEET NO. 16 (CONTINUED)
FMVSS 301 BARRIER IMPACT AND STATIC ROLLOVER

Test Vehicle: 2024 Ford Mustang Mach-E eAWD 5-Door SUV
 Test Program: NCAP Frontal Barrier Impact Test

NHTSA No.: M20240208
 Test Date: 5/31/2024

FMVSS 301 SPILLAGE TABLE (UNITS IN OUNCES)

Test Phase	First 5 Minutes	Sixth Minute	Seventh Minute	Eight Minute
0° to 90°				
90° to 180°				
180° to 270°				
270° to 360°				

SOLVENT SPILLAGE LOCATION TABLE

Test Phase	Spillage Location
0° to 90°	
90° to 180°	
180° to 270°	
270° to 360°	

DATA SHEET NO. 17
DUMMY/VEHICLE TEMPERATURE STABILIZATION DATA

Test Vehicle: 2024 Ford Mustang Mach-E eAWD 5-Door SUV
 Test Program: NCAP Frontal Barrier Impact Test

NHTSA No.: M20240208
 Test Date: 5/31/2024

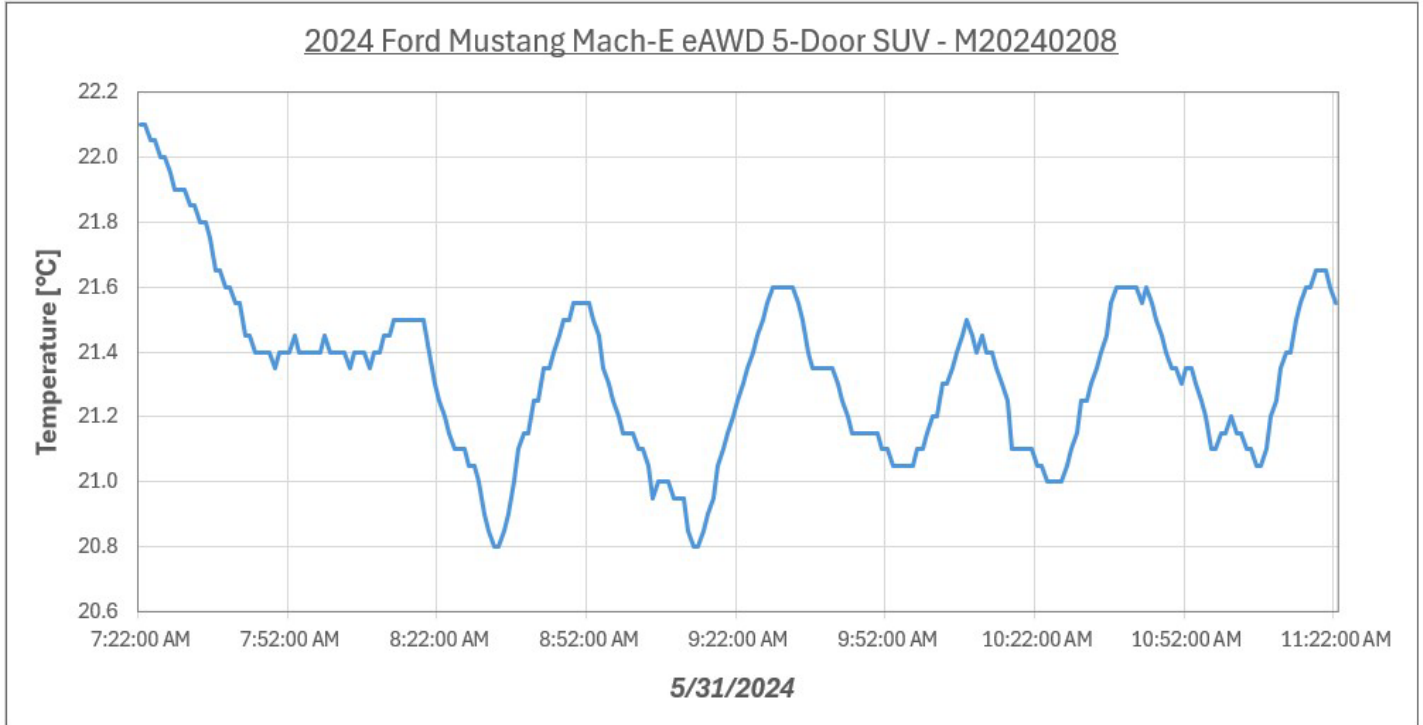

Serial #	Description	Maximum	Average	Minimum	Units
RFL100-U3731464	VSC Start Room A	22.1	21.3	20.8	°C

**DATA SHEET NO. 305-1
GENERAL TEST AND VEHICLE PARAMETER DATA
FOR INDICANT FMVSS NO. 305 TESTING**

Test Vehicle: 2024 Ford Mustang Mach-E eAWD 5-Door SUV
Test Program: NCAP Frontal Barrier Impact Test

NHTSA No.: M20240208
Test Date: 5/31/2024

ELECTRIC VEHICLE PROPULSION SYSTEM

	Units	Observations and Conclusions
Type of Electric Vehicle		Electric
Propulsion Battery Type		Lithium Ion
Nominal Voltage	V	348
Physical Location of Automatic Propulsion Battery Disconnect		The service disconnect is located under the hood on the LH side of the vehicle near the 12V battery.
Auxiliary Battery Type		12V Lead Acid Battery

PROPULSION BATTERY SYSTEM DATA

	Units	Observations and Conclusions
Electrolyte Fluid Type		LiPF6 + organic solvent
Electrolyte Fluid Specific Gravity	g/cm ³	1.168-1.184
Electrolyte Fluid Kinematic Viscosity	mPa*s	2.3-2.5
Electrolyte Fluid Color		Colorless
Propulsion Battery Coolant Type, Color, Specific Gravity (if applicable)		Ford Motorcraft Yellow Pre-Diluted
Location of Battery Modules		Inside Passenger Compartment
		X Outside Passenger Compartment
		The high-voltage battery is located on the underside of the vehicle.

PROPULSION BATTERY STATE OF CHARGE

<i>For all battery types:</i>	
Voltage range corresponding to useable energy of the battery:	
Minimum State of Charge	216 V
Maximum State of Charge	410 V
95% of Maximum State of Charge	389.5 V
Test Voltage - No less than 95% of maximum State of Charge	363.3 V*
<i>For batteries that are rechargeable ONLY by an energy source on the vehicle:</i>	
Voltage range corresponding to useable energy of the battery:	
Minimum State of Charge	
Maximum State of Charge	
Test Voltage – Maximum practicable State of Charge within Normal Operating Range	

*Vehicle indicated 100% State of Charge at time of test.

**DATA SHEET NO. 305-2
PRE-IMPACT DATA
FOR INDICANT FMVSS NO. 305 TESTING**

Test Vehicle: 2024 Ford Mustang Mach-E eAWD 5-Door SUV
 Test Program: NCAP Frontal Barrier Impact Test

NHTSA No.: M20240208
 Test Date: 5/31/2024

VEHICLE CHASSIS GROUND POINT(S) LOCATION(S)

Details of Vehicle Chassis Ground Point(s) & Location(s)	Rear drive motor casing
--	-------------------------

PROPULSION BATTERY SYSTEM

Details of Electric Energy Storage/Conversion System Test Points	Connected at + and – terminals inside battery pack Bussed Electrical Center (BEC)
Additional Comments	None

DATA SHEET NO. 305-3
PRE-IMPACT ELECTRICAL ISOLATION MEASUREMENTS AND CALCULATIONS
FOR INDICANT FMVSS NO. 305 TESTING

Test Vehicle: 2024 Ford Mustang Mach-E eAWD 5-Door SUV
 Test Program: NCAP Frontal Barrier Impact Test

NHTSA No.: M20240208
 Test Date: 5/31/2024

VOLTMETER INFORMATION

	Units	Observations and Conclusions
Make		Fluke
Model		177
Serial Number		62100018
Internal Impedance Value	MΩ	> 10 MΩ < 100 pF
Resolution	V	0.001
Last Calibration Date		7/14/2023

PROPULSION BATTERY VOLTAGE

Measurement shall be made with Energy Storage/Conversion System connected to the vehicle propulsion system, and the vehicle in the “ready-to-drive” (propulsion system energized) position.

NOTE: If voltage measurement is not at the voltage or within the normal operating voltage range specified by the manufacturer, the battery must be charged.

Vb	V	363.3
----	---	-------

ELECTRIC ISOLATION MEASUREMENTS
PROPULSION BATTERY TO VEHICLE CHASSIS

Vehicle chassis point(s) determined and supplied to contractor by COTR.

V1	V	105.3
V2	V	172.2

PROPULSION BATTERY TO VEHICLE CHASSIS ACROSS RESISTOR

The known resistance R_o (in ohms) should be approximately 500 times the normal operating voltage of the vehicle (in volts) per SAE J1766.

R_o	Ω	542,700
-------	---	---------

V1' Pre-Impact	V	68.0
V2' Pre-Impact	V	90.1

DATA SHEET NO. 305-3 (CONTINUED)
PRE-IMPACT ELECTRICAL ISOLATION MEASUREMENTS AND CALCULATIONS
FOR INDICANT FMVSS NO. 305 TESTING

Test Vehicle: 2024 Ford Mustang Mach-E eAWD 5-Door SUV
 Test Program: NCAP Frontal Barrier Impact Test

NHTSA No.: M20240208
 Test Date: 5/31/2024

ELECTRICAL ISOLATION CALCULATIONS

NOTE: If measured voltage is zero and results in a division by zero, record "Zero Volts".
 This "zero voltage" condition is considered as being compliant.

$R_{i1} = R_o (1 + V_2/V_1) [(V_1 - V_1')/V_1']$		
Ri1 Pre-Impact	Ω	784,503
$R_{i2} = R_o (1 + V_1/V_2) [(V_2 - V_2')/V_2']$		
Ri2 Pre-Impact	Ω	796,908
Ri = The lesser of Ri1 and Ri2		
Ri Pre-Impact	Ω	784,503
$R_i / V_b = \text{Electrical Isolation Value} / \text{Nominal Battery Voltage}$		
Ri / Vb Pre-Impact	Ω	2,159

NOTE: The minimum Electrical Isolation Value is 500 Ω/V.

	Yes	No (Fail)
Is the measured Electrical Isolation Value ≥ 500 Ω/V?	X	
Additional Comments	None	

**DATA SHEET NO. 305-4
POST-IMPACT DATA
FOR INDICANT FMVSS NO. 305 TESTING**

Test Vehicle: 2024 Ford Mustang Mach-E eAWD 5-Door SUV
 Test Program: NCAP Frontal Barrier Impact Test

NHTSA No.: M20240208
 Test Date: 5/31/2024

VOLTMETER INFORMATION

	Units	Observations and Conclusions
Make		Fluke
Model		177
Serial Number		62100018
Internal Impedance Value	MΩ	> 10 MΩ < 100 pF
Resolution	V	0.001
Last Calibration Date		7/14/2023

ELECTRICAL ISOLATION MEASUREMENTS

Vb Post-Impact	V	0.41
----------------	---	------

Measurement	Units	Value	Impact Time	Count	Minutes	Seconds
V1 Post-Impact	V	0.14		1	24	Seconds
V2 Post-Impact	V	0.13		1	27	Seconds
V1' Post-Impact	V	0.02		1	40	Seconds
V2' Post-Impact	V	0.03	1	32	Seconds	

Ro	Ω	542,700
----	---	---------

DATA SHEET NO. 305-4 (CONTINUED)
POST-IMPACT DATA
FOR INDICANT FMVSS NO. 305 TESTING

Test Vehicle: 2024 Ford Mustang Mach-E eAWD 5-Door SUV
 Test Program: NCAP Frontal Barrier Impact Test

NHTSA No.: M20240208
 Test Date: 5/31/2024

ELECTRICAL ISOLATION CALCULATIONS

NOTE: If measured voltage is zero and results in a division by zero, record "Zero Volts".
 This "zero voltage" condition is considered as being compliant.

$R_{i1} = R_o (1 + V_2/V_1) [(V_1 - V_1')/V_1']$							
Ri1 Post-Impact	Ω	6,279,814	Impact Time	1	Minutes	40	Seconds
$R_{i2} = R_o (1 + V_1/V_2) [(V_2 - V_2')/V_2']$							
Ri2 Post-Impact	Ω	3,757,154	Impact Time	1	Minutes	32	Seconds
Ri = The lesser of Ri1 and Ri2							
Ri Post-Impact	Ω	3,757,154	Impact Time	1	Minutes	32	Seconds
$R_i / V_b = \text{Electrical Isolation Value} / \text{Nominal Battery Voltage}$							
Ri / Vb Post-Impact	Ω	9,163,790	Impact Time	1	Minutes	32	Seconds

NOTE: The minimum Electrical Isolation Value is 500 Ω/V.

	Yes	No (Fail)
Is the measured Electrical Isolation Value ≥ 500 Ω/V?	X	
Additional Comments	None	

**DATA SHEET NO. 305-4 (CONTINUED)
POST-IMPACT DATA
FOR INDICANT FMVSS NO. 305 TESTING**

Test Vehicle: 2024 Ford Mustang Mach-E eAWD 5-Door SUV
 Test Program: NCAP Frontal Barrier Impact Test

NHTSA No.: M20240208
 Test Date: 5/31/2024

PROPULSION BATTERY SYSTEM COMPONENTS

Describe any Propulsion Battery Module movement within the passenger compartment [Supply photographs as appropriate]:
Not Applicable

	Yes (Fail)	No
Has the Propulsion Battery Module moved within the passenger compartment?		X

Describe intrusion of an outside Propulsion Battery Component into the passenger compartment [Supply photographs as appropriate]:
No Intrusion

	Yes (Fail)	No
Has an outside Propulsion Battery Component intruded into the passenger compartment?		X

	Yes (Fail)	No
Is the Propulsion Battery Electrolyte Spillage visible in the passenger compartment?		X

**DATA SHEET NO. 305-5
 STATIC ROLLOVER TEST DATA
 FOR INDICANT FMVSS NO. 305 TESTING**

Test Vehicle: 2024 Ford Mustang Mach-E eAWD 5-Door SUV
 Test Program: NCAP Frontal Barrier Impact Test

NHTSA No.: M20240208
 Test Date: 5/31/2024

PROPULSION BATTERY SYSTEM COMPONENTS

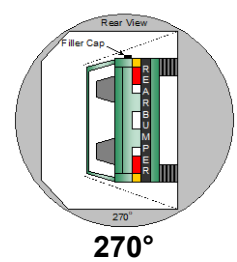
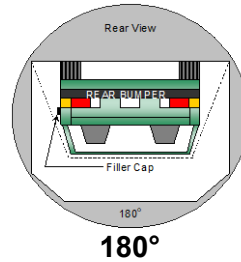
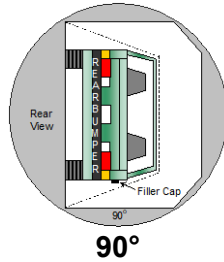
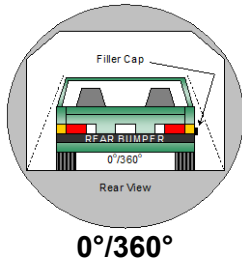

PROPULSION BATTERY ELECTROLYTE COLLECTION TIME PERIOD

Test Phase	Rotation Time (spec. 1-3 min)				FMVSS 301 Hold Time		Total Time				Next Whole Minute Interval	
	1	min	52	sec	5	min	6	min	52	sec	7	min
0° - 90°	1	min	52	sec	5	min	6	min	52	sec	7	min
90° - 180°	1	min	51	sec	5	min	6	min	51	sec	7	min
180° - 270°	1	min	47	sec	5	min	6	min	47	sec	7	min
270° - 360°	1	min	51	sec	5	min	6	min	51	sec	7	min

TEST VEHICLE PROPULSION BATTERY ELECTROLYTE SPILLAGE

NOTE: The maximum allowable Propulsion Battery Electrolyte Spillage is 5.0 Liters.

Test Phase	Propulsion Battery Electrolyte Spillage (L)	Spillage Location
0° to 90°	0	Not Applicable
90° to 180°	0	Not Applicable
180° to 270°	0	Not Applicable
270° to 360°	0	Not Applicable
Total Spillage	0	

	Yes (Fail)	No
Is the total Propulsion Battery Electrolyte Spillage greater than 5.0 Liters?		X
Is the Propulsion Battery Electrolyte Spillage visible in the passenger compartment?		X

DATA SHEET NO. 305-5 (CONTINUED)
STATIC ROLLOVER TEST DATA
FOR INDICANT FMVSS NO. 305 TESTING

Test Vehicle: 2024 Ford Mustang Mach-E eAWD 5-Door SUV
 Test Program: NCAP Frontal Barrier Impact Test

NHTSA No.: M20240208
 Test Date: 5/31/2024

VOLTMETER INFORMATION

	Units	Observations and Conclusions
Make		Fluke
Model		177
Serial Number		62100018
Internal Impedance Value	MΩ	> 10 MΩ < 100 pF
Resolution	V	0.001
Last Calibration Date		7/14/2023

ELECTRICAL ISOLATION MEASUREMENTS

Vb Post-Impact	V	0.41
Ro	Ω	542,700

Record V1, V2, V1', V2' voltage measurements at the start of each successive increment of 90°, 180°, 270°, and 360° of the static rollover test.

	Voltage	Units	Test Phase	Time			
V1	0.0	V	0°	min	48	sec	
	0.0		90°				3
	0.0		180°				3
	0.0		270°				2
	0.0		360°				3
V2	0.0	V	0°	min	51	sec	
	0.0		90°				3
	0.0		180°				3
	0.0		270°				2
	0.0		360°				3
V1'	0.0	V	0°	min	5	sec	
	0.0		90°				4
	0.0		180°				3
	0.0		270°				3
	0.0		360°				3
V2'	0.0	V	0°	min	55	sec	
	0.0		90°				3
	0.0		180°				3
	0.0		270°				3
	0.0		360°				3

DATA SHEET NO. 305-5 (CONTINUED)
STATIC ROLLOVER TEST DATA
FOR INDICANT FMVSS NO. 305 TESTING

Test Vehicle: 2024 Ford Mustang Mach-E eAWD 5-Door SUV
 Test Program: NCAP Frontal Barrier Impact Test

NHTSA No.: M20240208
 Test Date: 5/31/2024

ELECTRICAL ISOLATION CALCULATIONS

NOTE: If measured voltage is zero and results in a division by zero, record "Zero Volts".
 This "zero voltage" condition is considered as being compliant.

	Voltage	Units	Test Phase	Time			
$Ri1 = Ro (1 + V2/V1) [(V1-V1')/V1']$							
Ri1	Zero Volts	Ω	0°		min		sec
	Zero Volts		90°	4		5	
	Zero Volts		180°	3		28	
	Zero Volts		270°	3		12	
	Zero Volts		360°	3		41	
$Ri2 = Ro (1 + V1/V2) [(V2-V2')/V2']$							
Ri2	Zero Volts	Ω	0°		min		sec
	Zero Volts		90°	3		55	
	Zero Volts		180°	3		21	
	Zero Volts		270°	3		4	
	Zero Volts		360°	3		35	
$Ri = \text{The lesser of } Ri1 \text{ and } Ri2$							
Ri	Zero Volts	Ω	0°		min		sec
	Zero Volts		90°	3		55	
	Zero Volts		180°	3		21	
	Zero Volts		270°	3		4	
	Zero Volts		360°	3		35	
$Ri / Vb = \text{Electrical Isolation Value} / \text{Nominal Battery Voltage}$							
Ri / Vb	Zero Volts	Ω/V	0°		min		sec
	Zero Volts		90°	3		55	
	Zero Volts		180°	3		21	
	Zero Volts		270°	3		4	
	Zero Volts		360°	3		35	

NOTE: The minimum Electrical Isolation Value is 500 Ω/V.

	Yes	No (Fail)
Is the measured Electrical Isolation Value ≥ 500 Ω/V?	X	
Additional Comments	None	

**APPENDIX A
PHOTOGRAPHS**

TABLE OF PHOTOGRAPHS

		<u>Page No.</u>
Photo No. 001	Load Cell Location	A-1
Photo No. 002	Pre-Test Load Cell Wall	A-1
Photo No. 003	Post-Test Load Cell Wall	A-2
Photo No. 004	Manufacturer's Label	A-2
Photo No. 005	Tire Placard	A-3
Photo No. 006	2024 Ford Mustang Mach-E eAWD 5-Dr SUV Frontal As Delivered	A-3
Photo No. 007	Left Rear 3-4 View, As Received	A-4
Photo No. 008	Pre-Test Front View of Test Vehicle	A-4
Photo No. 009	Post-Test Front View of Test Vehicle	A-5
Photo No. 010	Pre-Test Left View of Test Vehicle	A-5
Photo No. 011	Post-Test Left View of Test Vehicle	A-6
Photo No. 012	Pre-Test Right View of Test Vehicle	A-6
Photo No. 013	Post-Test Right View of Test Vehicle	A-7
Photo No. 014	Pre-Test Right Front 3-4 View	A-7
Photo No. 015	Post-Test Right Front 3-4 View	A-8
Photo No. 016	Pre-Test Left Rear 3-4 View	A-8
Photo No. 017	Post-Test Left Rear 3-4 View	A-9
Photo No. 018	Pre-Test Windshield View	A-9
Photo No. 019	Post-Test Windshield View	A-10
Photo No. 020	Pre-Test Engine Compartment View	A-10
Photo No. 021	Post-Test Engine Compartment View	A-11
Photo No. 022	Pre-Test Fuel Filler Cap View	A-11
Photo No. 023	Post-Test Fuel Filler Cap View	A-12
Photo No. 024	Pre-Test Front Underbody View	A-12
Photo No. 025	Post-Test Front Underbody View	A-13
Photo No. 026	Pre-Test Rear Underbody View	A-13
Photo No. 027	Post-Test Rear Underbody View	A-14
Photo No. 028	Pre-Test Dummy Cable Routing	A-14
Photo No. 029	Post-Test Dummy Cable Routing	A-15

Photo No. 030	Pre-Test Driver Dummy Front View	A-15
Photo No. 031	Post-Test Driver Dummy Front View	A-16
Photo No. 032	Pre-Test Driver Dummy Window View	A-16
Photo No. 033	Post-Test Driver Dummy Window View	A-17
Photo No. 034	Pre-Test Driver Dummy and Vehicle Interior View	A-17
Photo No. 035	Post-Test Driver Dummy and Vehicle Interior View	A-18
Photo No. 036	Pre-Test Driver's Seat Fore-Aft Markings	A-18
Photo No. 037	Post-Test Driver's Seat Fore-Aft Markings	A-19
Photo No. 038	Pre-Test View of Belt Anchorage for Driver Dummy	A-19
Photo No. 039	Post-Test View of Belt Anchorage for Driver Dummy	A-20
Photo No. 040	Pre-Test View of Belt Buckle and Latch Plate for Driver Dummy	A-20
Photo No. 041	Post-Test View of Belt Buckle and Latch Plate for Driver Dummy	A-21
Photo No. 042	Pre-Test Driver Dummy Feet	A-21
Photo No. 043	Post-Test Driver Dummy Feet	A-22
Photo No. 044	Pre-Test Driver's Side Knee Bolster	A-22
Photo No. 045	Post-Test Driver's Side Knee Bolster	A-23
Photo No. 046	Pre-Test Driver's Side Floorpan	A-23
Photo No. 047	Post-Test Driver's Side Floorpan	A-24
Photo No. 048	Post-Test Driver Dummy Face	A-24
Photo No. 049	Post-Test Driver Dummy Contact with Airbag	A-25
Photo No. 050	Post-Test Driver Dummy Contact with Headrest	A-25
Photo No. 051	Pre-Test View of the Steering Wheel	A-26
Photo No. 052	Post-Test View of the Steering Wheel	A-26
Photo No. 053	Pre-Test Passenger Dummy Front View	A-27
Photo No. 054	Post-Test Passenger Dummy Front View	A-27
Photo No. 055	Pre-Test Passenger Dummy Window View	A-28
Photo No. 056	Post-Test Passenger Dummy Window View	A-28
Photo No. 057	Pre-Test Passenger Dummy and Vehicle Interior	A-29
Photo No. 058	Post-Test Passenger Dummy and Vehicle Interior	A-29
Photo No. 059	Pre-Test Passenger's Seat Fore-Aft Markings	A-30

Photo No. 060	Post-Test Passenger's Seat Fore-Aft Markings	A-30
Photo No. 061	Pre-Test View of Belt Anchorage for Passenger Dummy	A-31
Photo No. 062	Post-Test View of Belt Anchorage for Passenger Dummy	A-31
Photo No. 063	Pre-Test View of Belt Buckle and Latch Plate for Passenger Dummy	A-32
Photo No. 064	Post-Test View of Belt Buckle and Latch Plate for Passenger Dummy	A-32
Photo No. 065	Pre-Test Passenger Dummy Feet	A-33
Photo No. 066	Post-Test Passenger Dummy Feet	A-33
Photo No. 067	Pre-Test Passenger's Side Knee Bolster	A-34
Photo No. 068	Post-Test Passenger's Side Knee Bolster	A-34
Photo No. 069	Pre-Test Passenger's Side Floorpan	A-35
Photo No. 070	Post-Test Passenger's Side Floorpan	A-35
Photo No. 071	Post-Test Passenger Dummy Face	A-36
Photo No. 072	Post-Test Passenger Dummy Contact with Airbag	A-36
Photo No. 073	Post-Test Passenger Dummy Contact with Headrest	A-37
Photo No. 074	Photograph of Ballast Installed in Vehicle	A-37
Photo No. 075	Post-Test Stoddard Solvent Spillage Location View	A-38
Photo No. 076	Post-Test Speed Trap Read-Out	A-38
Photo No. 077	Vehicle at 0 Degree on Static Rollover Device	A-39
Photo No. 078	Vehicle at 90 Degrees on Static Rollover Device	A-39
Photo No. 079	Vehicle at 180 Degrees on Static Rollover Device	A-40
Photo No. 080	Vehicle at 270 Degrees on Static Rollover Device	A-40
Photo No. 081	Vehicle at 360 Degrees on Static Rollover Device	A-41
Photo No. 082	2024 Ford Mustang Mach-E eAWD 5-Dr SUV Frontal Impact Event	A-41
Photo No. 083	Monroney Label Photograph	A-42
Photo No. 305-01	Auxiliary Power Module Warning Label	A-42
Photo No. 305-02	Power Inverter Warning Label	A-43
Photo No. 305-03	First Responder Warning Label	A-43
Photo No. 305-04	First Responder Warning Location	A-44
Photo No. 305-05	Other Vehicle Label(s) Related to Electrical Propulsion System	A-44
Photo No. 305-06	Manual High Voltage Service Disconnect in Place	A-45

Photo No. 305-07	Manual High Voltage Service Disconnect Removed	A-45
Photo No. 305-08	Manual High Voltage Service Disconnect Removed	A-46
Photo No. 305-09	Pre-Impact View of Propulsion Battery	A-46
Photo No. 305-10	Post-Impact Front View of Propulsion Battery	A-47
Photo No. 305-11	Post-Impact Rear View of Propulsion Battery	A-47
Photo No. 305-12	Pre-Impact View of Battery Box(s) or Container(s) Which Holds Individual Battery Modules	A-48
Photo No. 305-13	Post-Impact View of Battery Box(s) or Container(s) Which Holds Individual Battery Modules	A-48
Photo No. 305-14	Pre-Impact View of Propulsion Battery Module(s)	A-49
Photo No. 305-15	Post-Impact View of Propulsion Battery Module(s)	A-49
Photo No. 305-16	Pre-Impact View of Electric Propulsion Drive	A-50
Photo No. 305-17	Post-Impact View of Electric Propulsion Drive	A-50
Photo No. 305-18	Pre-Impact View of High Voltage Interconnect(s)	A-51
Photo No. 305-19	Pre-Impact View Propulsion Battery Venting System(s)	A-51
Photo No. 305-20	Pre-Impact View of Other Visible Electric Propulsion Components	A-52
Photo No. 305-21	Pre-Impact View of Ground Lead Attached	A-52
Photo No. 305-22	Pre-Impact View of High Voltage Leads Attached	A-53
Photo No. 305-23	Pre-Impact Close-Up View of High Voltage Leads Attached	A-53
Photo No. 305-24	Pre-Impact View of Installed Test Interface Port	A-54
Photo No. 305-25	Post-Impact View of Installed Test Interface Port	A-54
Photo No. 305-26	Pre-Impact View of Other Test Devices	A-55
Photo No. 305-27	Post-Impact View of Other Test Devices	A-55
Photo No. 305-28	FMVSS No. 305 Static Rollover at 90 Degrees	A-56
Photo No. 305-29	FMVSS No. 305 Static Rollover at 180 Degrees	A-56
Photo No. 305-30	FMVSS No. 305 Static Rollover at 270 Degrees	A-57
Photo No. 305-31	FMVSS No. 305 Static Rollover at 360 Degrees	A-57
Photo No. 305-32	Pre-Impact View of the Vehicle Passenger Compartment Adjacent to Propulsion Battery	A-58
Photo No. 305-33	Post-Impact View of the Vehicle Passenger Compartment Adjacent to Propulsion Battery	A-58
Photo No. 305-34	Post-Impact Propulsion Battery System Mounting and/or Intrusion Failure(s)	A-59

Page No.

Photo No. 305-35	Post-Impact View of Battery Component Intrusion	A-59
Photo No. 305-36	Post-Impact View of Battery Module Movement or Retention Loss	A-60
Photo No. 305-37	Post-Impact View of Propulsion Battery Electrolyte Spillage Location	A-60
Photo No. 305-38	Post-Test View of Propulsion Battery Electrolyte Spillage Location	A-61

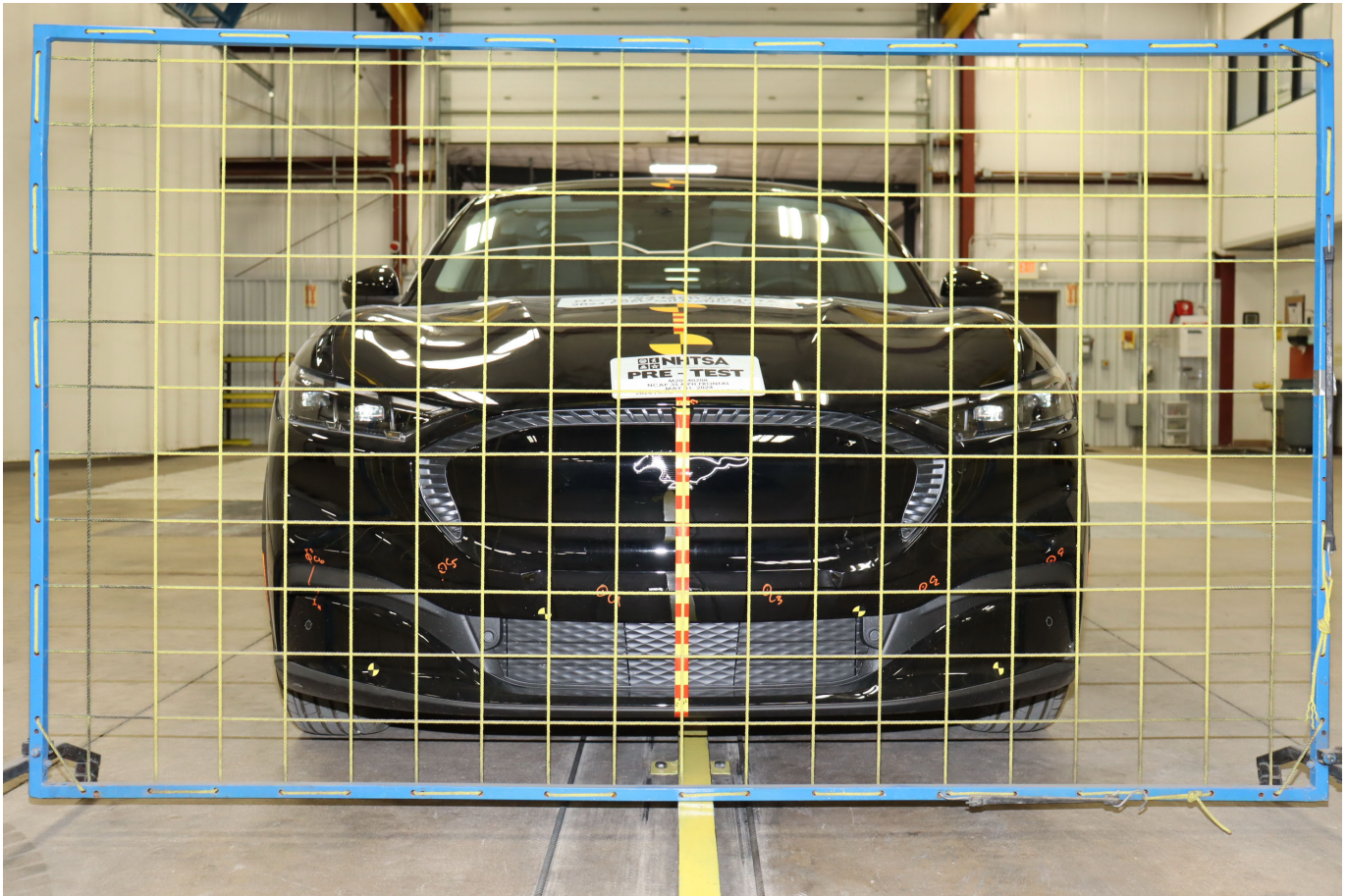

Photo No. 001 - Load Cell Location



Photo No. 002 - Pre-Test Load Cell Wall



Photo No. 003 - Post-Test Load Cell Wall



Photo No. 004 - Manufacturer's Label



Photo No. 005 - Tire Placard



Photo No. 006 - 2024 Ford Mustang Mach-E eAWD 5-Door SUV Frontal As Delivered



Photo No. 007 - Left Rear 3-4 View, As Received



Photo No. 008 - Pre-Test Front View of Test Vehicle



Photo No. 009 - Post-Test Front View of Test Vehicle



Photo No. 010 - Pre-Test Left View of Test Vehicle



Photo No. 011 - Post-Test Left View of Test Vehicle



Photo No. 012 - Pre-Test Right View of Test Vehicle



Photo No. 013 - Post-Test Right View of Test Vehicle



Photo No. 014 - Pre-Test Right Front 3-4 View



Photo No. 015 - Post-Test Right Front 3-4 View



Photo No. 016 - Pre-Test Left Rear 3-4 View



Photo No. 017 - Post-Test Left Rear 3-4 View



Photo No. 018 - Pre-Test Windshield View



Photo No. 019 - Post-Test Windshield View



Photo No. 020 - Pre-Test Engine Compartment View



Photo No. 021 - Post-Test Engine Compartment View

PHOTOGRAPH NOT APPLICABLE

Photo No. 022 - Pre-Test Fuel Filler Cap View

PHOTOGRAPH NOT APPLICABLE

Photo No. 023 - Post-Test Fuel Filler Cap View

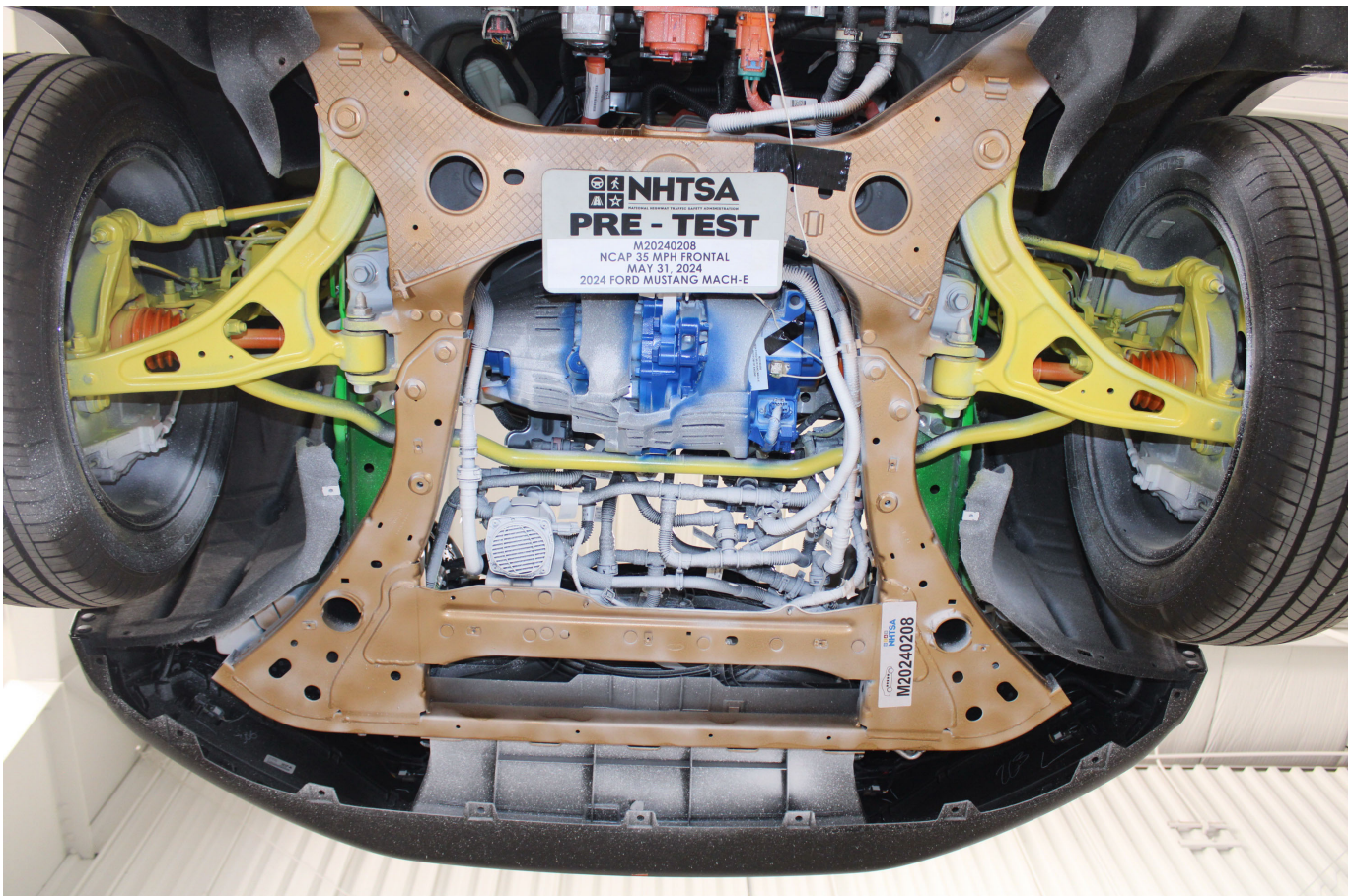

Photo No. 024 - Pre-Test Front Underbody View

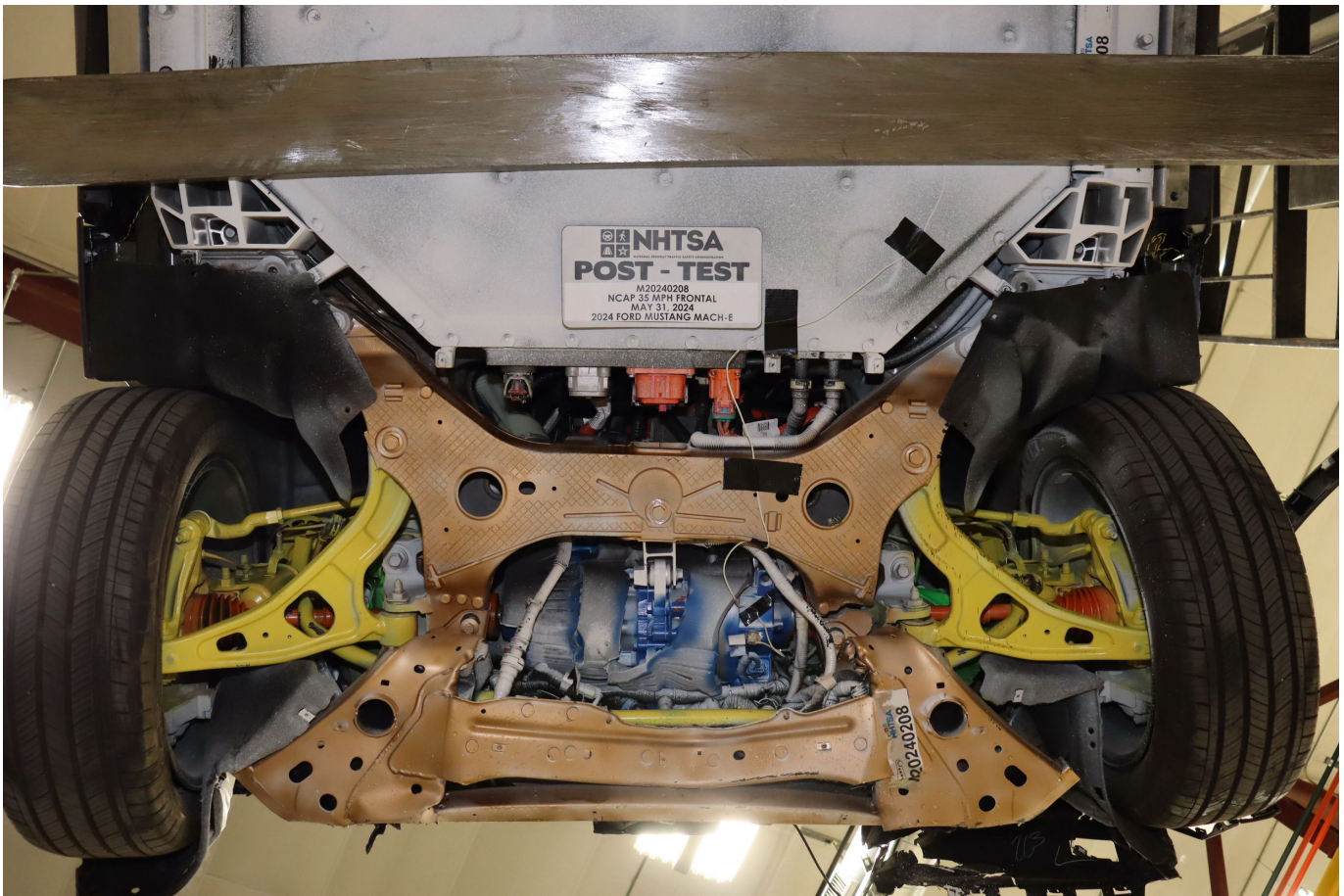

Photo No. 025 - Post-Test Front Underbody View

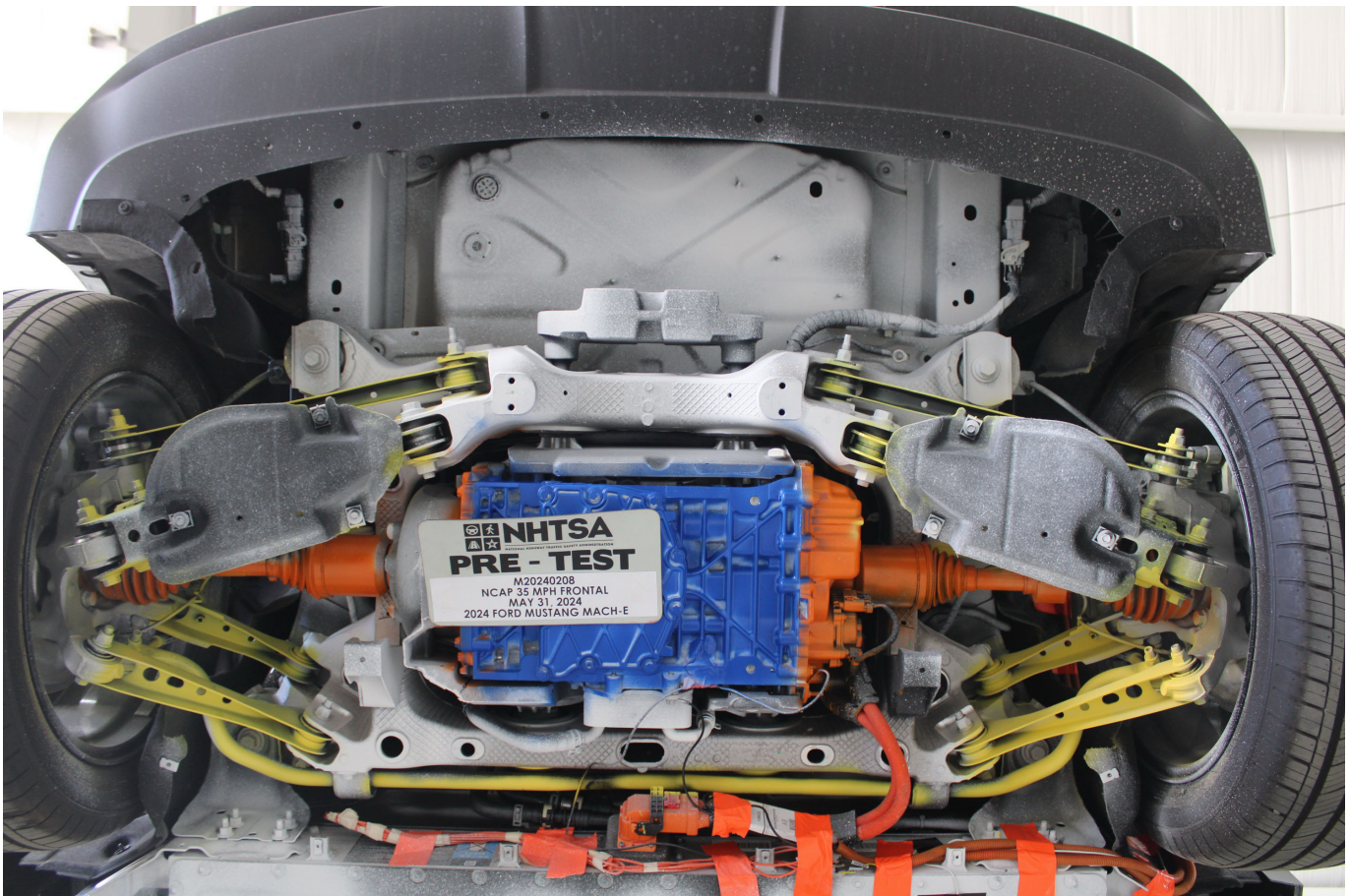

Photo No. 026 - Pre-Test Rear Underbody View

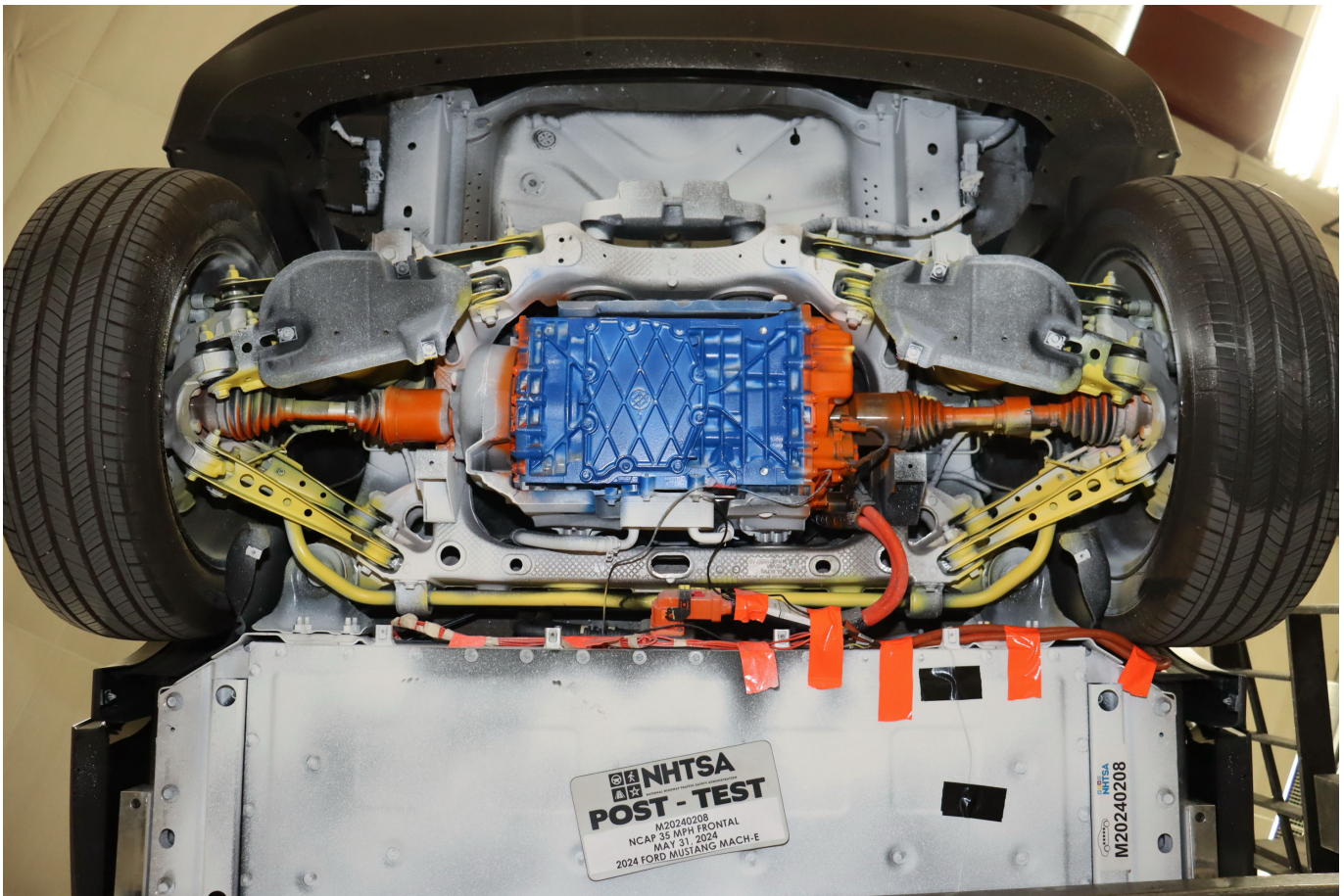

Photo No. 027 - Post-Test Rear Underbody View



Photo No. 028 - Pre-Test Dummy Cable Routing



Photo No. 029 - Post-Test Dummy Cable Routing



Photo No. 030 - Pre-Test Driver Dummy Front View



Photo No. 031 - Post-Test Driver Dummy Front View



Photo No. 032 - Pre-Test Driver Dummy Window View



Photo No. 033 - Post-Test Driver Dummy Window View



Photo No. 034 - Pre-Test Driver Dummy and Vehicle Interior View



Photo No. 035 - Post-Test Driver Dummy and Vehicle Interior View



Photo No. 036 - Pre-Test Driver's Seat Fore-Aft Markings



Photo No. 037 - Post-Test Driver's Seat Fore-Aft Markings



Photo No. 038 - Pre-Test View of Belt Anchorage for Driver Dummy



Photo No. 039 - Post-Test View of Belt Anchorage for Driver Dummy



Photo No. 040 - Pre-Test View of Belt Buckle and Latch Plate for Driver Dummy



Photo No. 041 - Post-Test View of Belt Buckle and Latch Plate for Driver Dummy



Photo No. 042 - Pre-Test Driver Dummy Feet



Photo No. 043 - Post-Test Driver Dummy Feet



Photo No. 044 - Pre-Test Driver's Side Knee Bolster



Photo No. 045 - Post-Test Driver's Side Knee Bolster



Photo No. 046 - Pre-Test Driver's Side Floorpan



Photo No. 047 - Post-Test Driver's Side Floorpan



Photo No. 048 - Post-Test Driver Dummy Face



Photo No. 049 - Post-Test Driver Dummy Contact with Airbag



Photo No. 050 - Post-Test Driver Dummy Contact with Headrest



Photo No. 051 - Pre-Test View of the Steering Wheel



Photo No. 052 - Post-Test View of the Steering Wheel



Photo No. 053 - Pre-Test Passenger Dummy Front View



Photo No. 054 - Post-Test Passenger Dummy Front View



Photo No. 055 - Pre-Test Passenger Dummy Window View



Photo No. 056 - Post-Test Passenger Dummy Window View



Photo No. 057 - Pre-Test Passenger Dummy and Vehicle Interior View



Photo No. 058 - Post-Test Passenger Dummy and Vehicle Interior View



Photo No. 059 - Pre-Test Passenger's Seat Fore-Aft Markings



Photo No. 060 - Post-Test Passenger's Seat Fore-Aft Markings



Photo No. 061 - Pre-Test View of Belt Anchorage for Passenger Dummy



Photo No. 062 - Post-Test View of Belt Anchorage for Passenger Dummy



Photo No. 063 - Pre-Test View of Belt Buckle and Latch Plate for Passenger Dummy



Photo No. 064 - Post-Test View of Belt Buckle and Latch Plate for Passenger Dummy



Photo No. 065 - Pre-Test Passenger Dummy Feet



Photo No. 066 - Post-Test Passenger Dummy Feet



Photo No. 067 - Pre-Test Passenger's Side Knee Bolster



Photo No. 068 - Post-Test Passenger's Side Knee Bolster



Photo No. 069 - Pre-Test Passenger's Side Floorpan



Photo No. 070 - Post-Test Passenger's Side Floorpan



Photo No. 071 - Post-Test Passenger Dummy Face

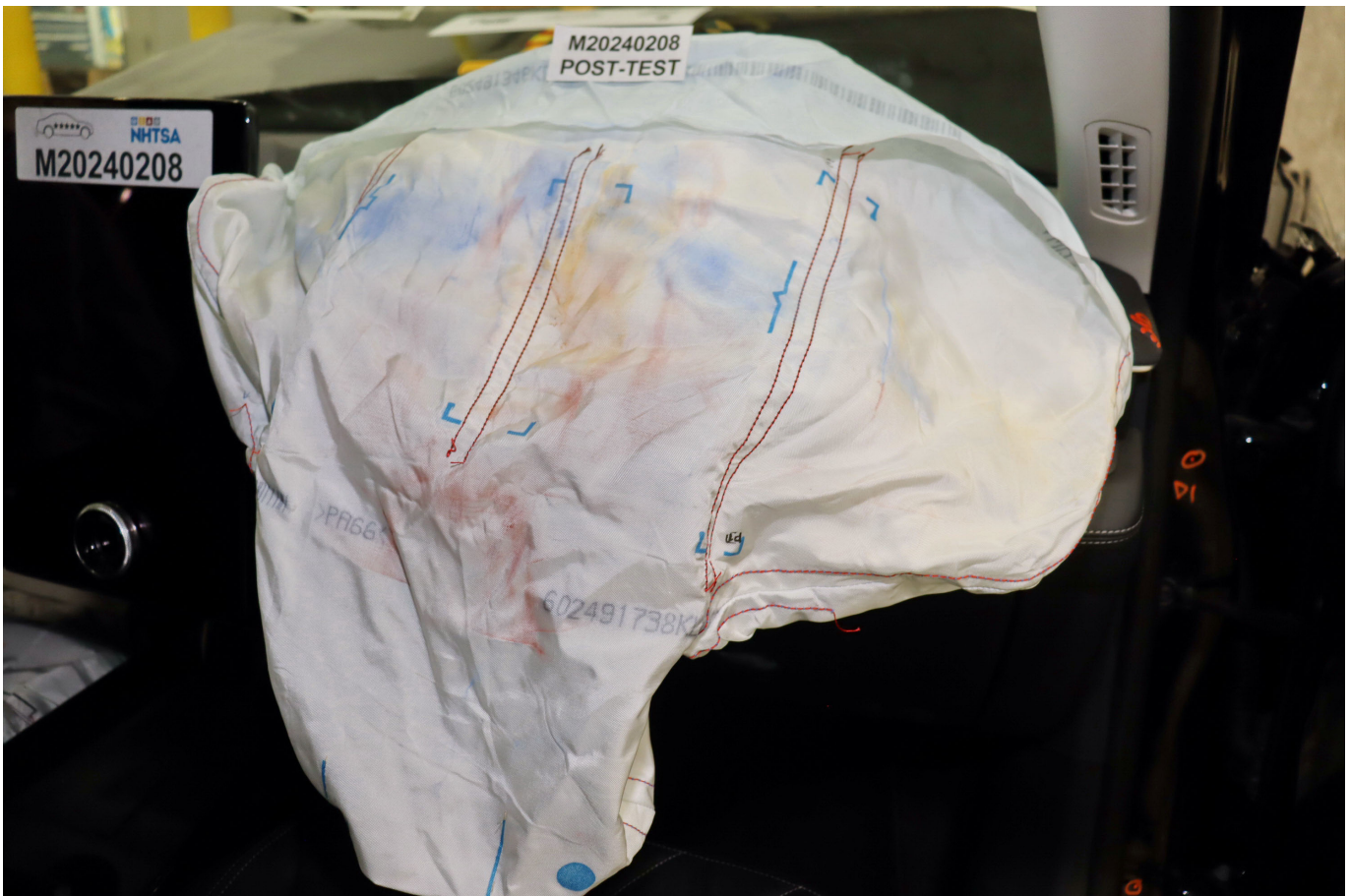

Photo No. 072 - Post-Test Passenger Dummy Contact with Airbag



Photo No. 073 - Post-Test Passenger Dummy Contact with Headrest

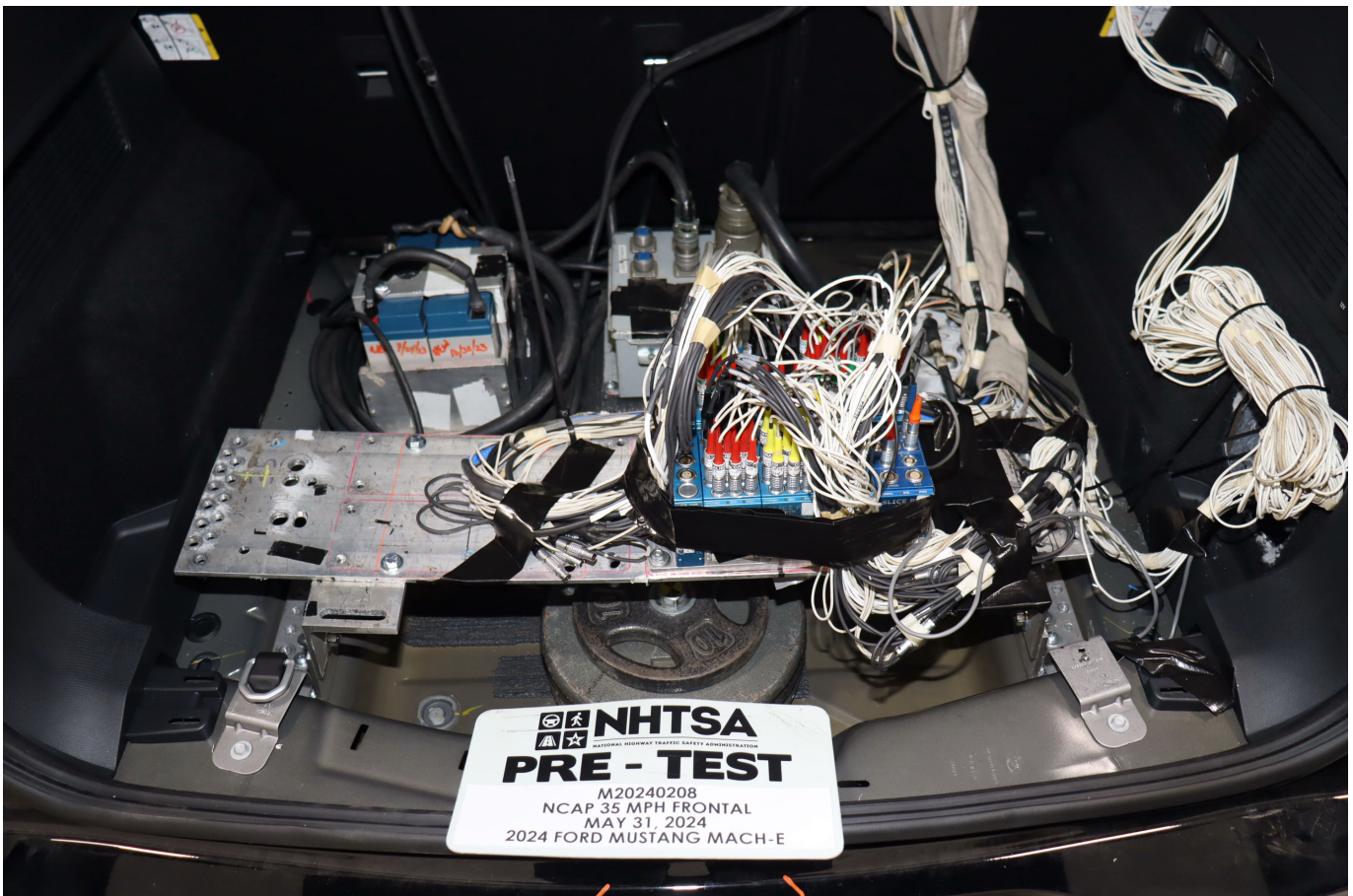

Photo No. 074 - Photograph of Ballast Installed in Vehicle

PHOTOGRAPH NOT APPLICABLE

Photo No. 075 - Post-Test Stoddard Solvent Spillage Location View



Photo No. 076 - Post-Test Speed Trap Read-Out



Photo No. 077 - Vehicle at 0 Degrees on Static Rollover Device

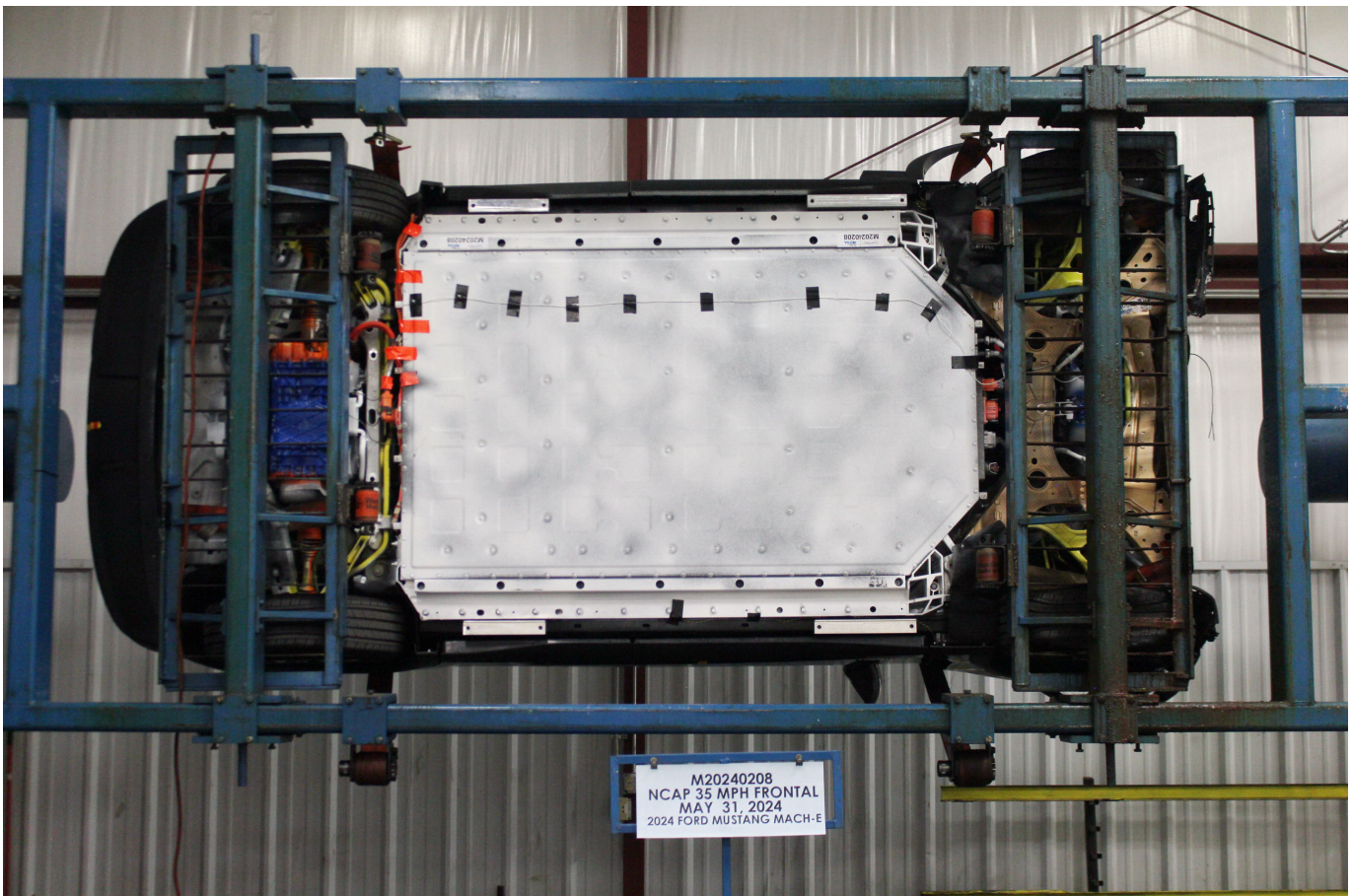

Photo No. 078 - Vehicle at 90 Degrees on Static Rollover Device



Photo No. 079 - Vehicle at 180 Degrees on Static Rollover Device



Photo No. 080 - Vehicle at 270 Degrees on Static Rollover Device



Photo No. 081 - Vehicle at 360 Degrees on Static Rollover Device



Photo No. 082 - 2024 Ford Mustang Mach-E eAWD 5-Door SUV Frontal Impact Event

VEHICLE DESCRIPTION
MUSTANG MACH-E **RM A04136**

2024 SELECT EAWD
 5-PASSENGER
 72KW USABLE STD LFP BATT
 SINGLE-SPEED TRANSMISSION

EXTERIOR
 SHADOW BLACK
 INTERIOR
 BLK ONYX ACTIVEX SEAT MTRL

ford.com

STANDARD EQUIPMENT INCLUDED AT NO EXTRA CHARGE

EXTERIOR • ACTIVE GRILLE SHUTTERS • E-LATCH - PUSH BUTTON OPEN • FRUNK - DRAINABLE • HEADLAMPS - WIPER ACTIVATED • HEADLAMPS-AUTO LED PROJECTOR • W/SIGNATURE LED LIGHTING • REAR SPOILER • TAILLAMPS-LED W/SEQUENTIAL TURN SIGNAL • WIPERS - RAIN-SENSING	INTERIOR • 10.2" DIGITAL INSTR CLSTR • 15.5" TOUCHSCREEN • 1 TOUCH UP/DOWN FRT/RR WIN • AUTO-DIM REARVIEW MIRROR • DUAL ILLUM VANITY MIRRORS • DUAL ZONE AUTO CLIMATE CTL • POWER DRIV SEAT - 8-WAY • POWERPOINTS - 12V • ROTARY GEAR SHIFT DIAL • SCUFF PLATE W/PONY GRAPHIC • SOFT VINYL WRAP-STEERING WHEEL W/MOUNTED CONTROLS • SPLIT FOLD REAR SEAT • TILT/TELESCOPE STR COLUMN	FUNCTIONAL • 11KW AC ONBOARD CHARGER • 360-DEGREE CAMERA • DRIVE MODES/ONE PEDAL DRV • FORDPASS™ CONNECT 4GWI-FI HOTSPOT TELEMATICS MODEM • INTELL ACCESS W/PUSH START • J1772 CCS COMBO CONNECTOR • PHONE AS A KEY • REGENERATIVE BRAKING SYS • SYNC®4A • UP TO 150KW DC CHRG CAPABL • WIRELESS CHARGING PAD	SAFETY/SECURITY • ADVANCED SECURITY PACK • ADVANCETRAC™ • ELCTR STABILITY/TRACN CTL • AIRBAG - DRIVER KNEE • AIRBAGS - DUAL STAGE FRONT • AIRBAGS - FRT/REAR SIDE • IMPACT & SIDE AIR CURTAIN • SOS POST-CRASH ALERT SYS™ • INDOV TIRE PRESS MONIT SYS • LATCH CHILD SAFETY SYSTEM
--	--	---	---

WARRANTY
 • 5YR/36,000 BUMPER / BUMPER
 • 5YR/60,000 POWERTRAIN
 • 5YR/60,000 ROADSIDE ASSIST
 • 8YR/100,000 HV BATT/COMPON

INCLUDED ON THIS VEHICLE EQUIPMENT GROUP 100A (MSRP)

OPTIONAL EQUIPMENT/OTHER

.225/55R19 A/S BSW TIRES	
BLUECRUISE EQUIP: 90DAY TRIAL COMFORT PACKAGE LITE	1,500.00
HEATED FRONT SEATS	
HEATED STEERING WHEEL	
MEMORY DR SEAT/SIDE MIRRORS	795.00
18" HIGH-GLOSS PTD BLK WHEEL	500.00
MOBILE POWER CORD	
FRONT LICENSE PLATE BRACKET	NO CHARGE

PRICE INFORMATION (MSRP)

BASE PRICE	\$43,495.00
TOTAL OPTIONS/OTHER	2,795.00
TOTAL VEHICLE & OPTIONS/OTHER DESTINATION & DELIVERY	46,290.00
	1,895.00

SALES TAX, TITLE, LICENSE, AND OTHER FEES

SALES TAX (MSRP)

TITLE (MSRP)

LICENSE (MSRP)

OTHER FEES (MSRP)

TOTAL MSRP \$48,185.00

SOLD TO
 Napleton Ford of Oak Lawn
 6100 W. 95th Street
 Oak Lawn IL 60453

RAMP ONE
 41D 001

RAMP TWO
 RA95

FINAL ASSEMBLY PLANT
 CUAUTTILAN

METHOD OF TRANSP.
 RAIL

ITEM #:
 41-C610 OT 2

SHIP TO (IF OTHER THAN SOLD TO)

SHIP THROUGH

Whether you decide to lease or finance your vehicle, you'll find the choices that are right for you. See your dealer for details or visit www.ford.com/finance.

1440 R 6B 2X 415 002721 03 26 24

EPA DOT Fuel Economy and Environment **Electric Vehicle**

Fuel Economy

91 **MPGe** Small SUV's range from 14 to 123 MPGe. The best vehicle rates 140 MPGe.

95 **88** **37**
 city highway kW-hrs per 100 miles

Driving Range
 When fully fueled, vehicle can travel about 230 miles
 Charge Time: 7.5 hours (240V)

You save \$5,500
 in fuel costs over 5 years compared to the average new vehicle.

Annual fuel cost \$850

Fuel Economy & Greenhouse Gas Rating (tailpipe only) **Smog Rating** (tailpipe only)

1 **9** **10** **1** **10**
 Best Best

This vehicle emits 0 grams CO₂ per mile. The best emits 0 grams per mile (tailpipe only). Does not include emissions from generating electricity. Learn more at fuelconomy.gov.

Actual results will vary for many reasons, including driving conditions and how you drive and maintain your vehicle. This average new vehicle gets 28 MPGe and costs \$9,750 to fuel over 5 years. Cost estimates are based on 15,000 miles per year at \$15 per kW-hr. MPGe is miles per gasoline gallon equivalent. Vehicle emissions are a significant cause of climate change and smog.

fuelconomy.gov
 Calculate personalized estimates and compare vehicles

GOVERNMENT 5-STAR SAFETY RATINGS

Overall Vehicle Score **Not Rated**
 Based on the combined ratings of frontal, side and rollover. Should ONLY be compared to other vehicles of similar size and weight.

Frontal Crash	Driver Passenger	Not Rated
Side Crash	Front seat	★★★★★
	Rear seat	★★★★★
Rollover		★★★★★

Star ratings range from 1 to 5 stars (★★★★★), with 5 being the highest. Source: National Highway Traffic Safety Administration (NHTSA). www.safercar.gov or 1-888-327-4236

EXHILARATION. ELECTRIFIED.

The FordPass Connect™ modem is active and sending vehicle data (e.g., diagnostics) to Ford. See in-vehicle Settings for connectivity options.

FordPass Connect™ service and FordPass™ App required for certain remote features (see App Terms for more information). Connected service and related feature functionality is subject to compatible AT&T network availability. Evolving technology / cellular networks may affect functionality and availability, or continued provision of some features, prohibiting them from functioning. Message and data rates may apply. See your local Ford website for our privacy policy.

FORD PROTECT™

Enlist on Ford Protect! The only extended service plan fully backed by Ford and honored at every Ford dealership in the U.S., Canada and Mexico. See your Ford dealer or visit www.FordOwner.com.

WARNING: Operating, servicing and maintaining a passenger vehicle, pickup truck, van, or off-road vehicle can expose you to chemicals including phthalates and lead, which are known to the State of California to cause cancer and birth defects or other reproductive harm. To minimize exposure, wear gloves or wash your hands frequently when servicing your vehicle. For more information go to www.P66Warnings.ca.gov/passenger-vehicle.

3FMTK1S55RMA04136

SCAN QR CODE OR TEXT 3F8M4D136 TO 48028

Map & Data rates may apply. Text HELP for help

www.ford.com/help/privacy-terms/

Photo No. 083 - Monroney Label Photograph

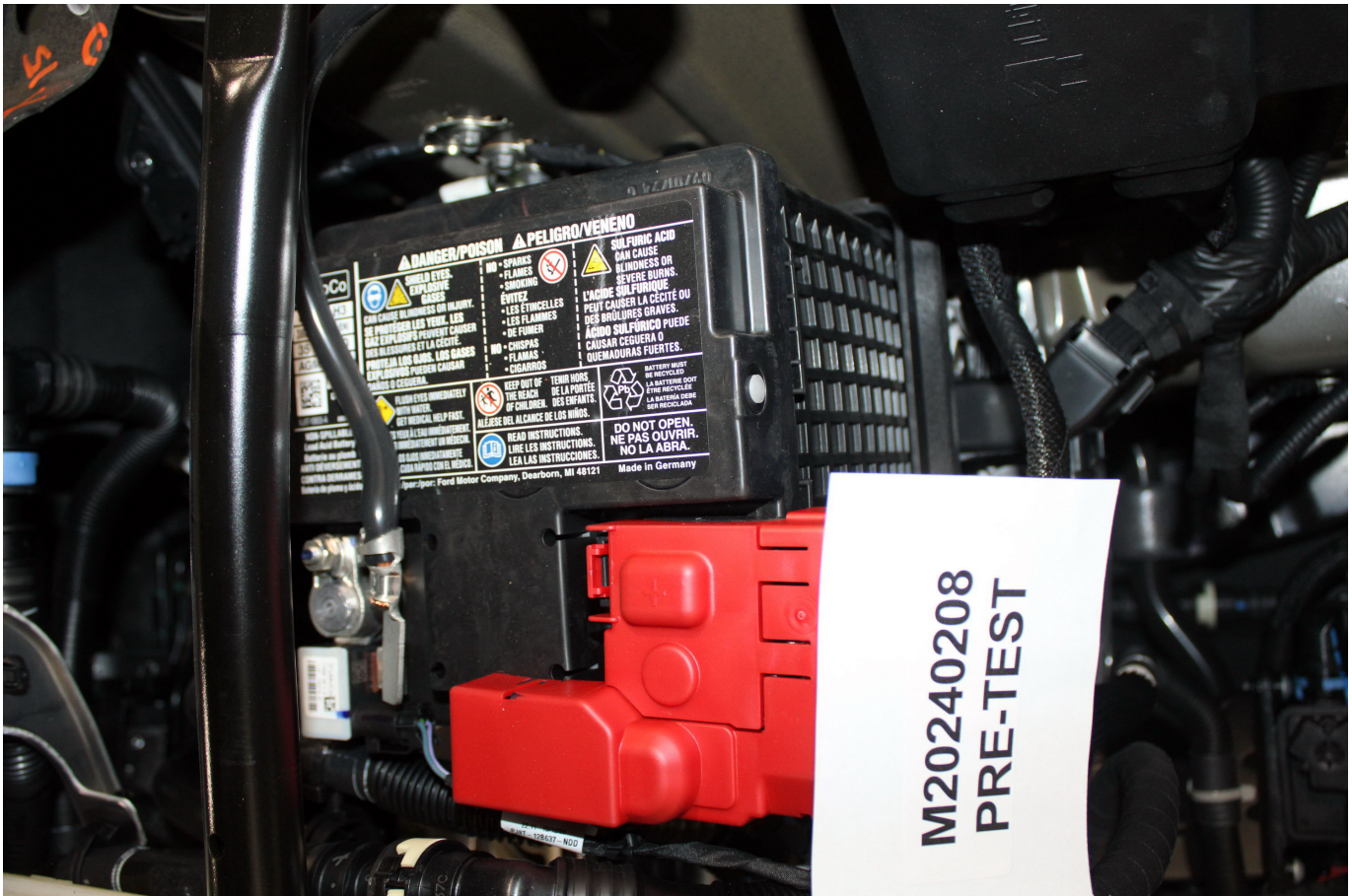

Photo No. 305-01 - Auxiliary Power Module Warning Label

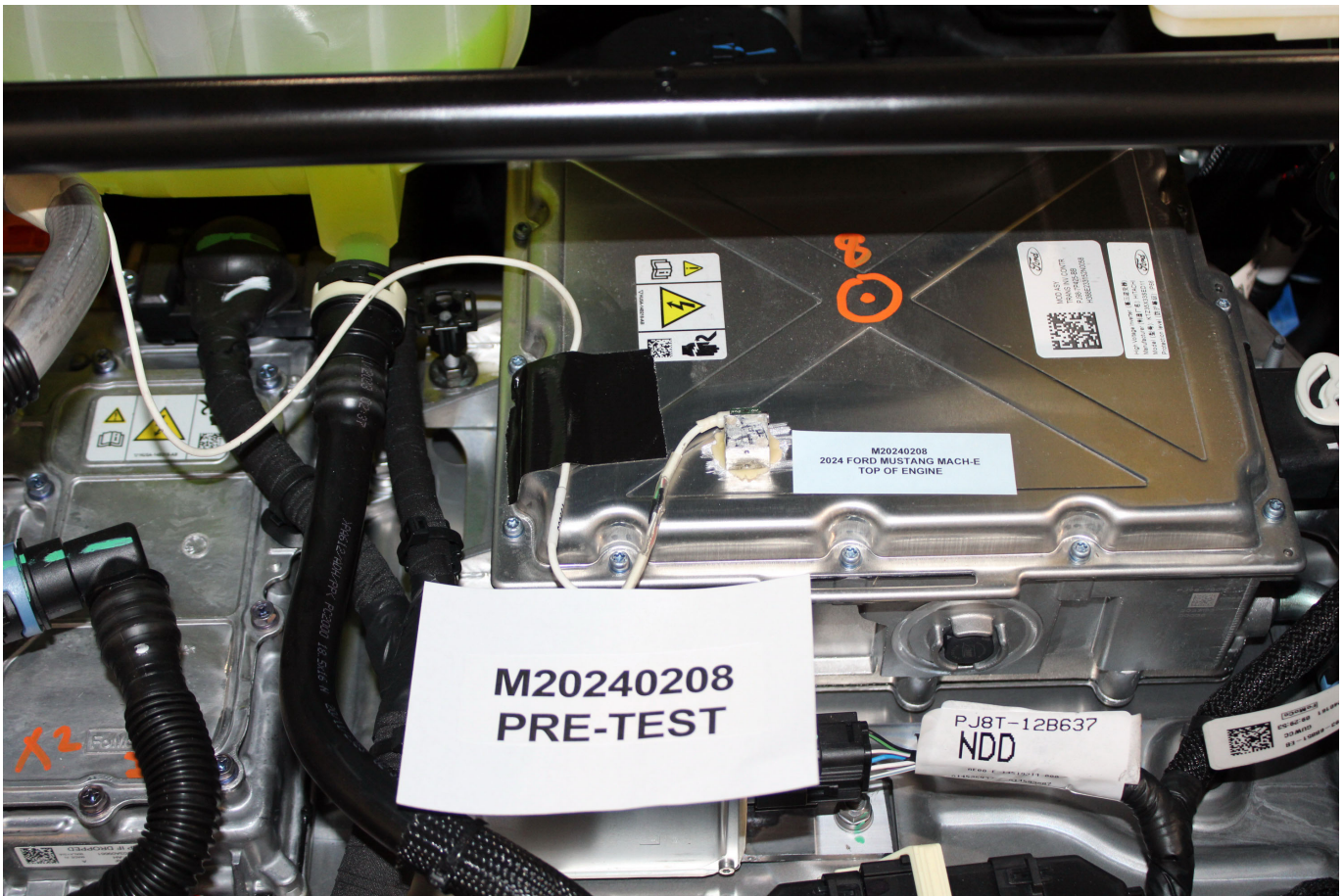

Photo No. 305-02 - Power Inverter Warning Label

PHOTOGRAPH NOT APPLICABLE

Photo No. 305-03 - First Responder Warning Label

PHOTOGRAPH NOT APPLICABLE

Photo No. 305-04 - First Responder Warning Location



Photo No. 305-05 - Other Vehicle Label(s) Related to Electrical Propulsion System

PHOTOGRAPH NOT APPLICABLE

Photo No. 305-06 - Manual High Voltage Service Disconnect in Place

PHOTOGRAPH NOT APPLICABLE

Photo No. 305-07 - Manual High Voltage Service Disconnect Removed

PHOTOGRAPH NOT APPLICABLE

Photo No. 305-08 - Manual High Voltage Service Disconnect Removed



Photo No. 305-09 - Pre-Impact View of Propulsion Battery



Photo No. 305-10 - Post-Impact Front View of Propulsion Battery



Photo No. 305-11 - Post-Impact Rear View of Propulsion Battery



Photo No. 305-12 - Pre-Impact View of Battery Box(s) or Container(s) Which Holds Individual Battery Modules

PHOTOGRAPH NOT AVAILABLE

Photo No. 305-13 - Post-Impact View of Battery Box(s) or Container(s) Which Holds Individual Battery Modules



Photo No. 305-14 - Pre-Impact View of Propulsion Battery Module(s)

PHOTOGRAPH NOT AVAILABLE

Photo No. 305-15 - Post-Impact View of Propulsion Battery Module(s)

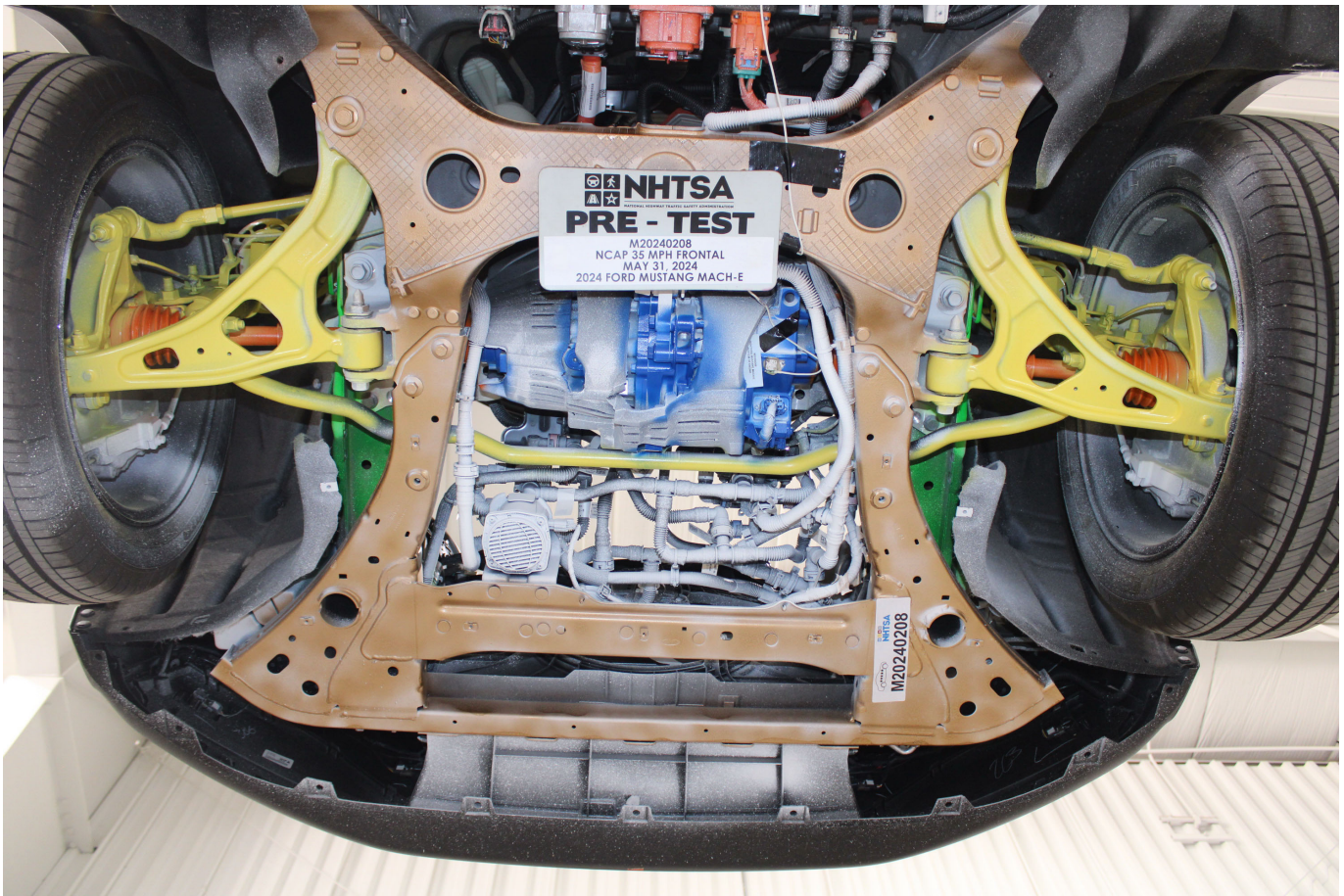

Photo No. 305-16 - Pre-Impact View of Electric Propulsion Drive

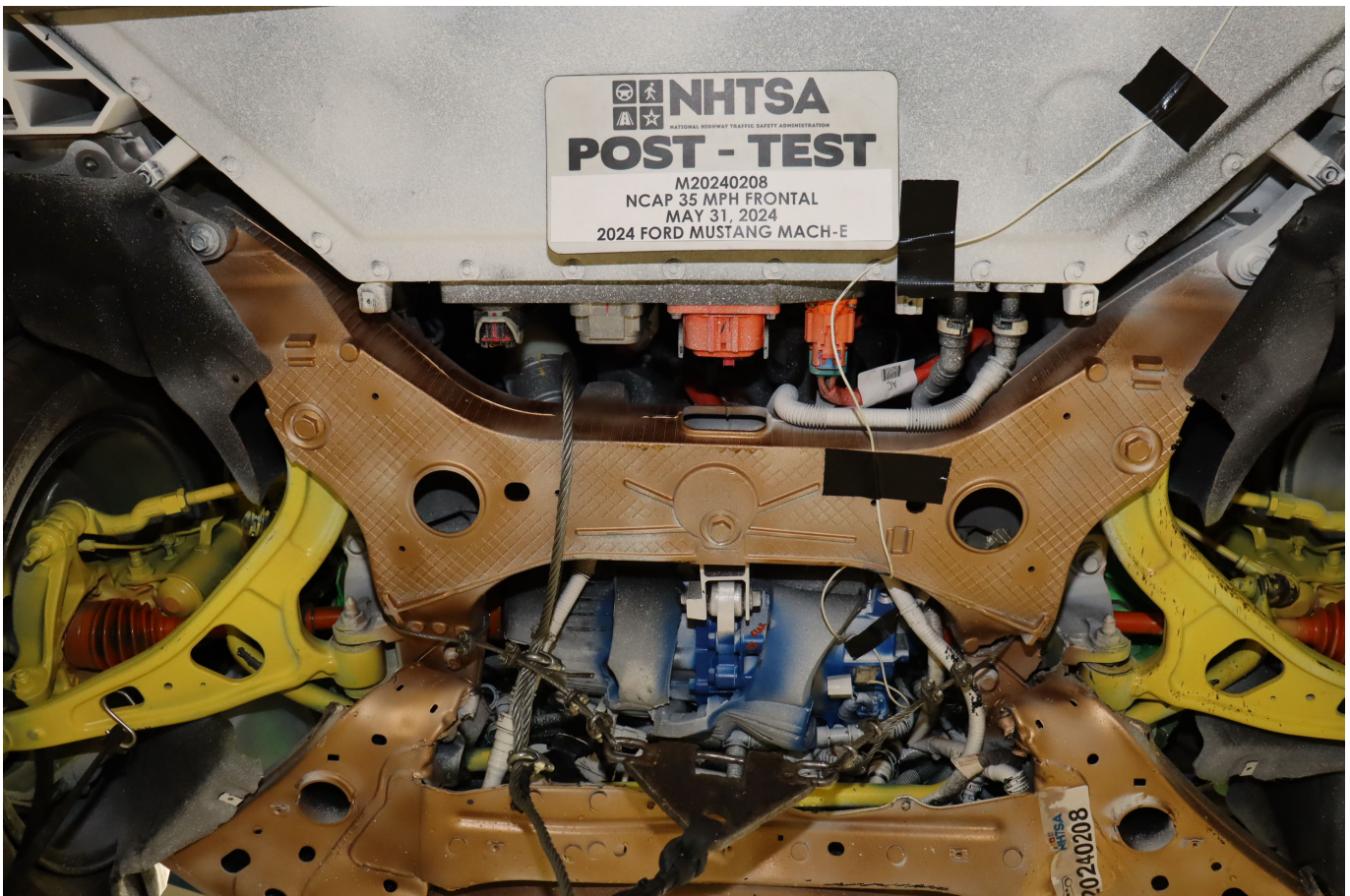

Photo No. 305-17 - Post-Impact View of Electric Propulsion Drive



Photo No. 305-18 - Pre-Impact View of High Voltage Interconnect(s)

PHOTOGRAPH NOT APPLICABLE

Photo No. 305-19 - Pre-Impact View Propulsion Battery Venting System(s)

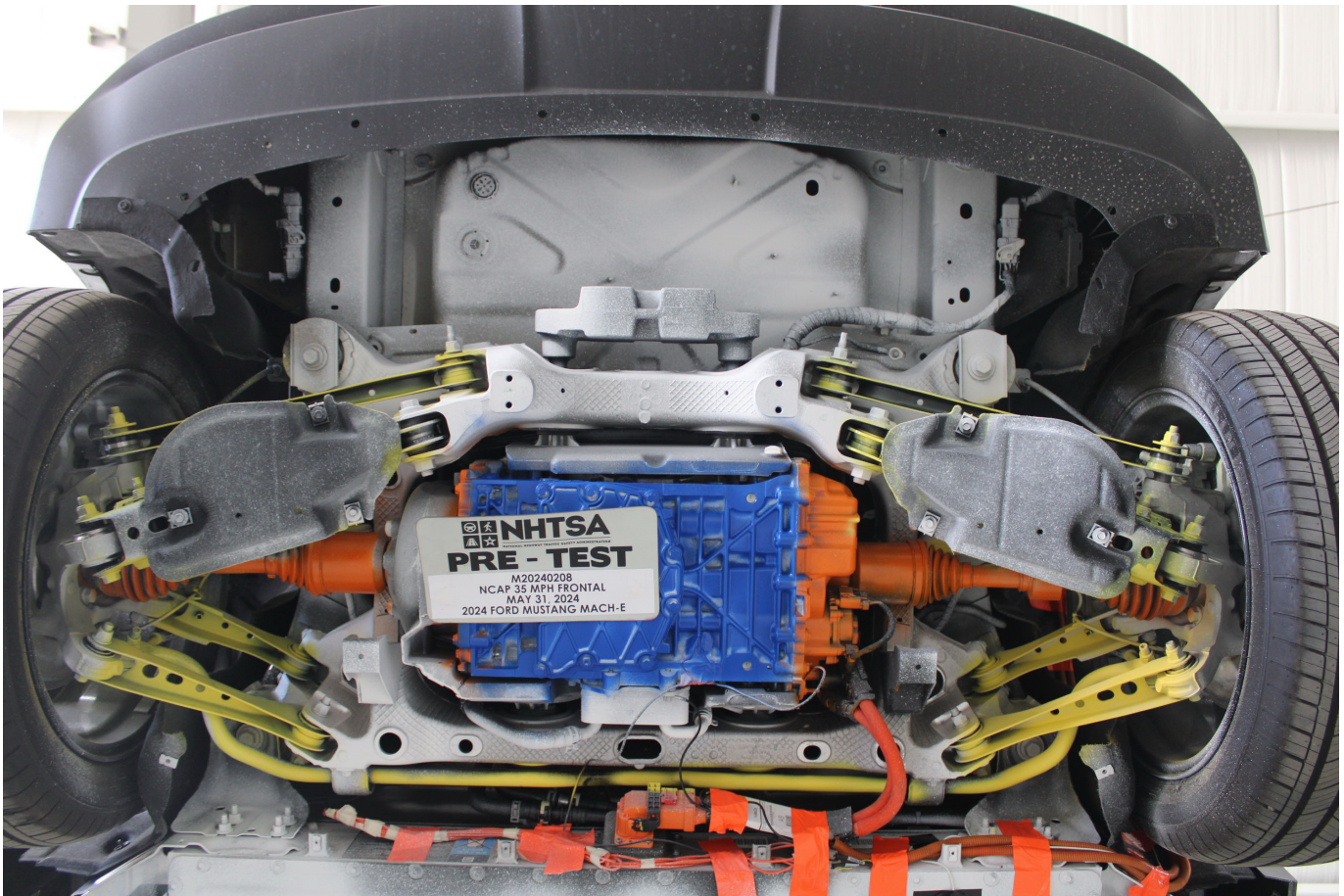

Photo No. 305-20 - Pre-Impact View of Other Visible Electric Propulsion Components

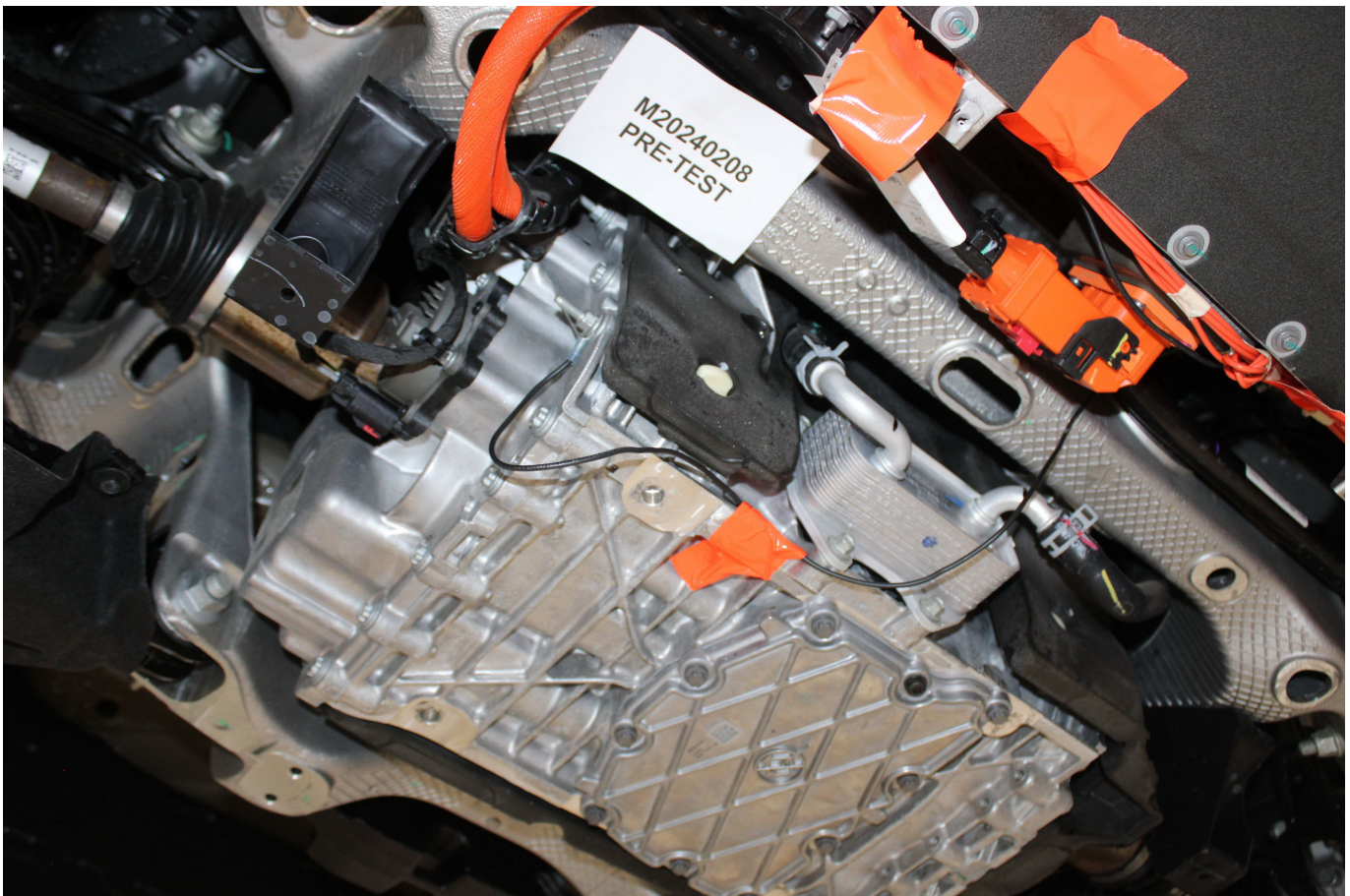

Photo No. 305-21 - Pre-Impact View of Ground Lead Attached



Photo No. 305-22 - Pre-Impact View of High Voltage Leads Attached

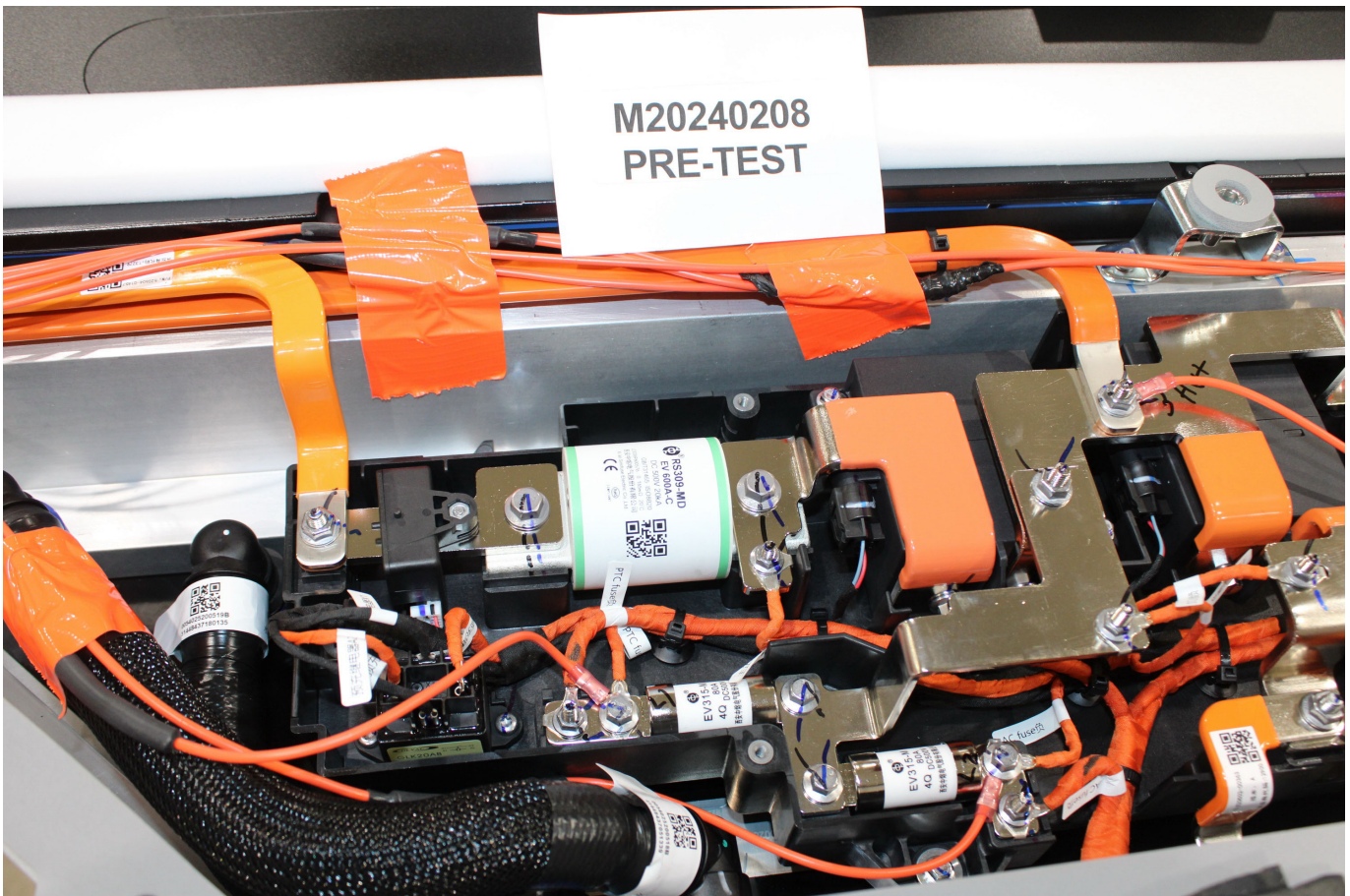

Photo No. 305-23 - Pre-Impact Close-Up View of High Voltage Leads Attached

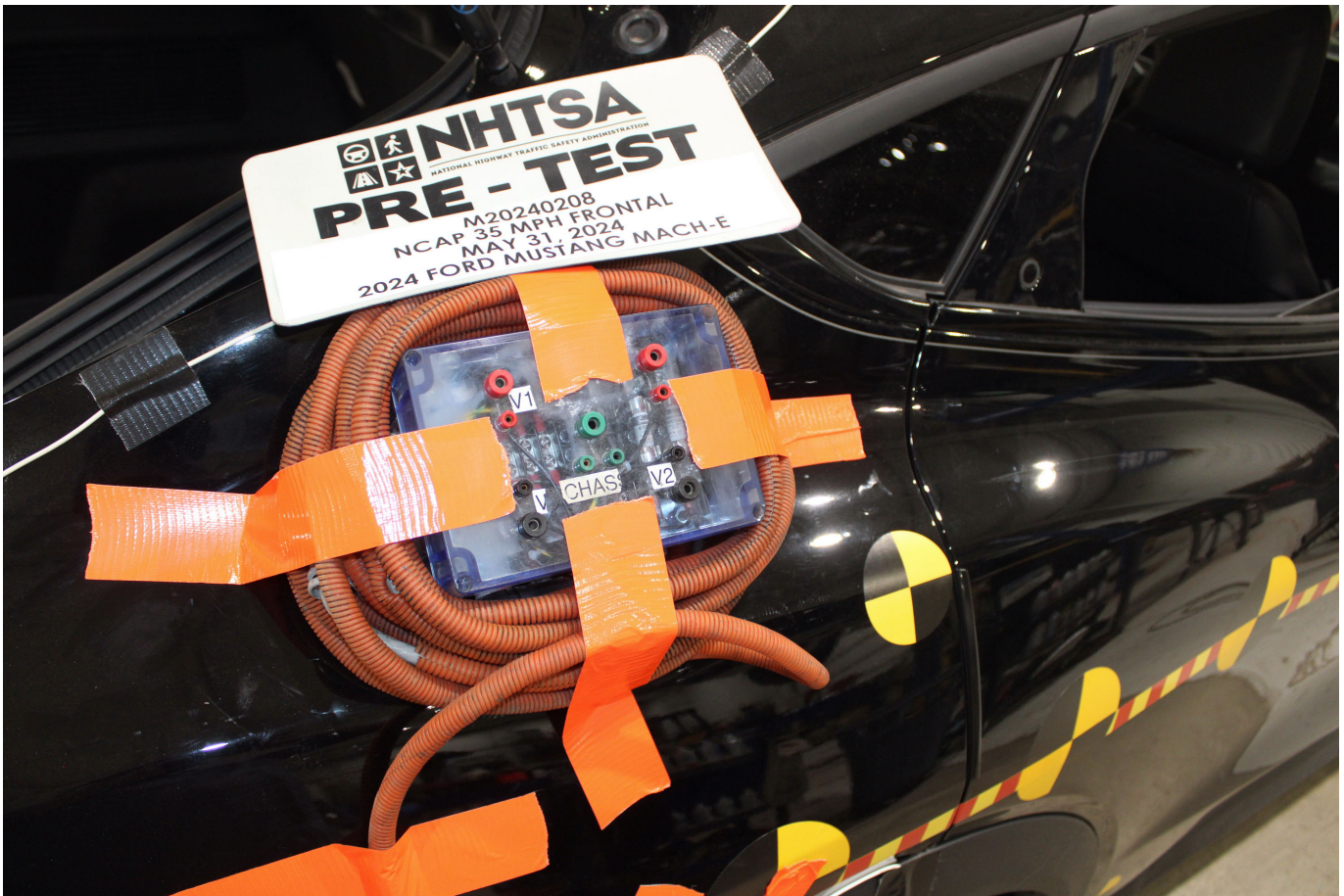

Photo No. 305-24 - Pre-Impact View of Installed Test Interface Port

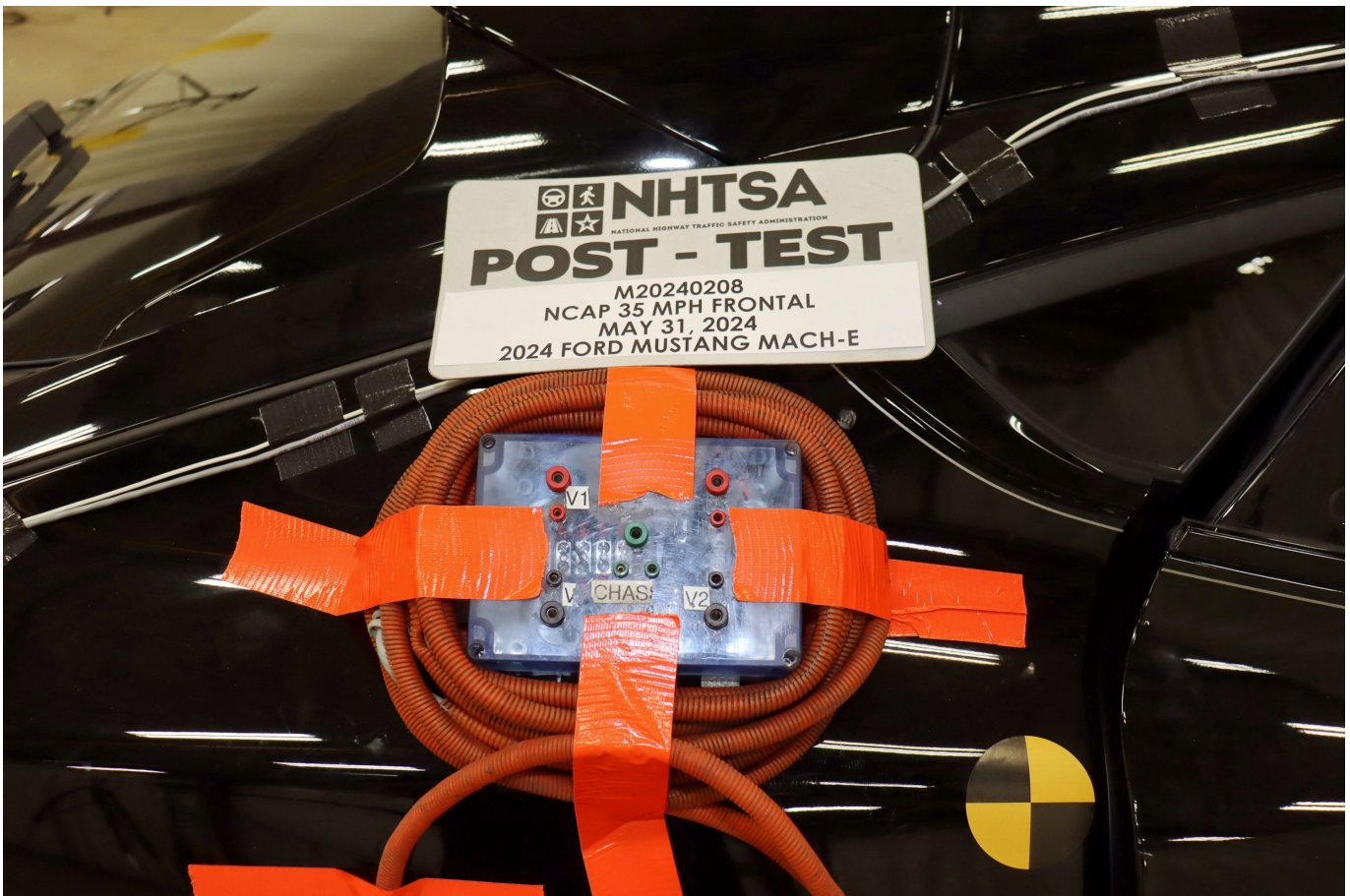

Photo No. 305-25 - Post-Impact View of Installed Test Interface Port



Photo No. 305-26 - Pre-Impact View of Other Test Devices



Photo No. 305-27 - Post-Impact View of Other Test Devices

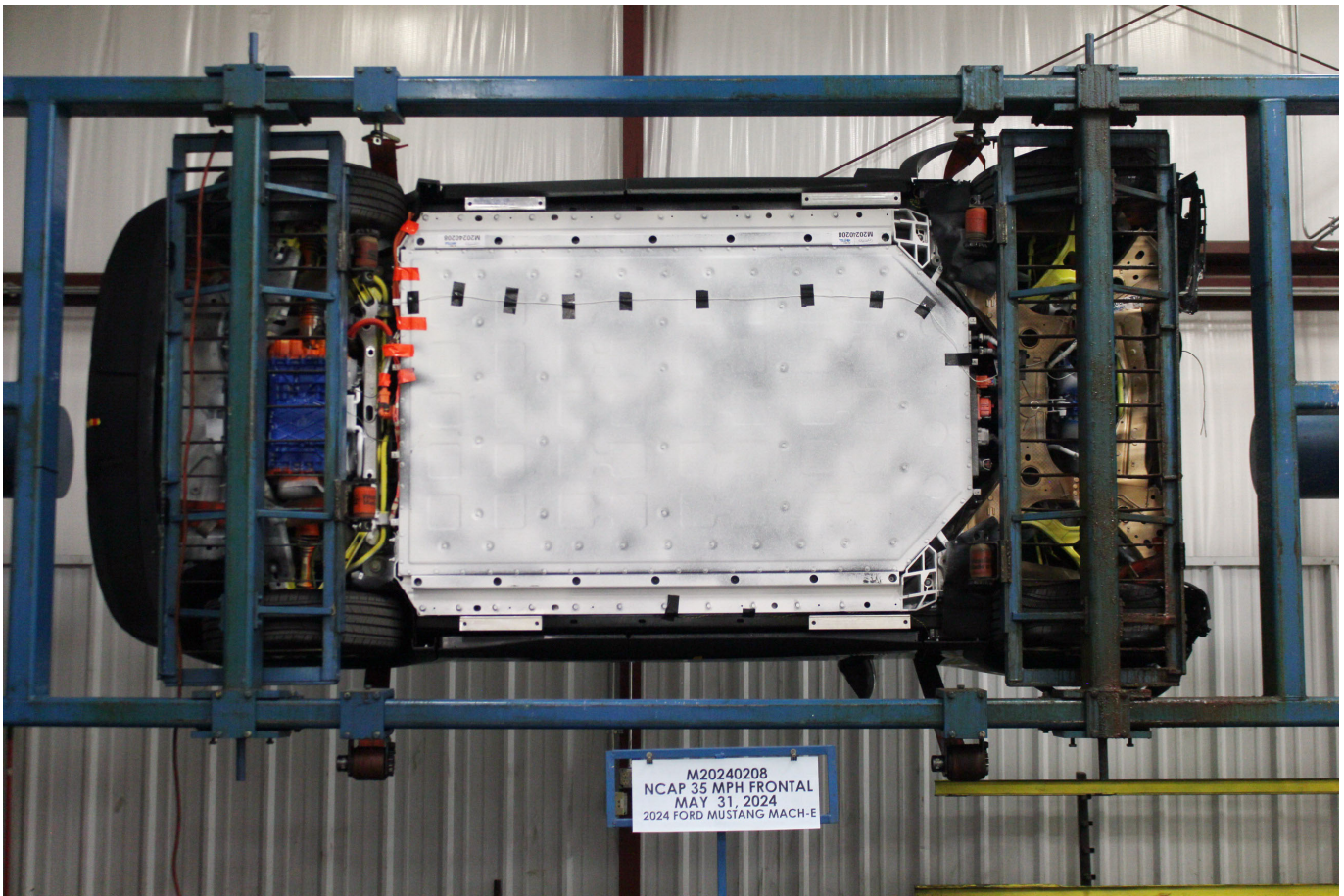

Photo No. 305-28 - FMVSS No. 305 Static Rollover at 90 Degrees



Photo No. 305-29 - FMVSS No. 305 Static Rollover at 180 Degrees



Photo No. 305-30 - FMVSS No. 305 Static Rollover at 270 Degrees



Photo No. 305-31 - FMVSS No. 305 Static Rollover at 360 Degrees



Photo No. 305-32 - Pre-Impact View of the Vehicle Passenger Compartment Adjacent to Propulsion Battery



Photo No. 305-33 - Post-Impact View of the Vehicle Passenger Compartment Adjacent to Propulsion Battery

PHOTOGRAPH NOT APPLICABLE

Photo No. 305-34 - Post-Impact Propulsion Battery System Mounting and-or Intrusion Failure(s)

PHOTOGRAPH NOT APPLICABLE

Photo No. 305-35 - Post-Impact View of Battery Component Intrusion

PHOTOGRAPH NOT APPLICABLE

Photo No. 305-36 - Post-Impact View of Battery Module Movement or Retention Loss

PHOTOGRAPH NOT APPLICABLE

Photo No. 305-37 - Post-Impact View of Propulsion Battery Electrolyte Spillage Location

PHOTOGRAPH NOT APPLICABLE

Photo No. 305-38 - Post-Test View of Propulsion Battery Electrolyte Spillage Location

APPENDIX B
DUMMY RESPONSE DATA TRACES

TABLE OF DATA PLOTS

Page No.

List of Data Plots Provided in the Test Report

Figure No. 1.	Driver Head X Acceleration vs. Time	B-1
Figure No. 2.	Driver Head Y Acceleration vs. Time	B-1
Figure No. 3.	Driver Head Z Acceleration vs. Time	B-1
Figure No. 4.	Driver Head Resultant Acceleration vs. Time	B-1
Figure No. 5.	Driver Chest Displacement vs. Time	B-2
Figure No. 6.	Driver Chest X Acceleration vs. Time	B-3
Figure No. 7.	Driver Chest Y Acceleration vs. Time	B-3
Figure No. 8.	Driver Chest Z Acceleration vs. Time	B-3
Figure No. 9.	Driver Chest Resultant Acceleration vs. Time	B-3
Figure No. 10.	Driver Neck Force X vs. Time	B-4
Figure No. 11.	Driver Neck Force Z vs. Time	B-4
Figure No. 12.	Driver Neck Moment Y vs. Time	B-4
Figure No. 13.	Driver Nij (NTF) vs. Time	B-5
Figure No. 14.	Driver Nij (NTE) vs. Time	B-5
Figure No. 15.	Driver Nij (NCF) vs. Time	B-5
Figure No. 16.	Driver Nij (NCE) vs. Time	B-5
Figure No. 17.	Driver Left Femur Force vs. Time	B-6
Figure No. 18.	Driver Right Femur Force vs. Time	B-6
Figure No. 19.	Passenger Head X Acceleration vs. Time	B-7
Figure No. 20.	Passenger Head Y Acceleration vs. Time	B-7
Figure No. 21.	Passenger Head Z Acceleration vs. Time	B-7
Figure No. 22.	Passenger Head Resultant Acceleration vs. Time	B-7
Figure No. 23.	Passenger Chest Displacement vs. Time	B-8
Figure No. 24.	Passenger Chest X Acceleration vs. Time	B-9
Figure No. 25.	Passenger Chest Y Acceleration vs. Time	B-9
Figure No. 26.	Passenger Chest Z Acceleration vs. Time	B-9
Figure No. 27.	Passenger Chest Resultant Z Acceleration vs. Time	B-9

	<u>Page No.</u>
Figure No. 28. Passenger Neck Force X vs. Time	B-10
Figure No. 29. Passenger Neck Force Z vs. Time	B-10
Figure No. 30. Passenger Neck Moment Y vs. Time	B-10
Figure No. 31. Passenger Nij (NTF) vs. Time	B-11
Figure No. 32. Passenger Nij (NTE) vs. Time	B-11
Figure No. 33. Passenger Nij (NCF) vs. Time	B-11
Figure No. 34. Passenger Nij (NCE) vs. Time	B-11
Figure No. 35. Passenger Left Femur Force vs. Time	B-12
Figure No. 36. Passenger Right Femur Force vs. Time	B-12

The following additional dummy and vehicle response data can be found in the R&D section of the NHTSA website at www.nhtsa.gov

Driver Head X Redundant
 Driver Head Y Redundant
 Driver Head Z Redundant
 Driver Head Angular Velocity X
 Driver Head Angular Velocity Y
 Driver Head Angular Velocity Z
 Driver Upper Neck Force Y
 Driver Upper Neck Moment X
 Driver Upper Neck Moment Z
 Driver Chest X Redundant
 Driver Chest Y Redundant
 Driver Chest Z Redundant
 Driver Pelvis X
 Driver Pelvis Y
 Driver Pelvis Z
 Driver Left Femur Redundant
 Driver Right Femur Redundant
 Driver Left Upper Tibia Moment X
 Driver Left Upper Tibia Moment Y

Driver Left Upper Tibia Force Z
Driver Left Lower Tibia Moment X
Driver Left Lower Tibia Moment Y
Driver Left Lower Tibia Force Z
Driver Right Upper Tibia Moment X
Driver Right Upper Tibia Moment Y
Driver Right Upper Tibia Force Z
Driver Right Lower Tibia Moment X
Driver Right Lower Tibia Moment Y
Driver Right Lower Tibia Force Z
Driver Left Foot Fore Z
Driver Left Foot Aft X
Driver Left Foot Aft Z
Driver Right Foot Fore Z
Driver Right Foot Aft X
Driver Right Foot Aft Z
Driver Lap Belt Force
Driver Shoulder Belt Force
Passenger Head X Redundant
Passenger Head Y Redundant
Passenger Head Z Redundant
Passenger Head Angular Velocity X
Passenger Head Angular Velocity Y
Passenger Head Angular Velocity Z
Passenger Upper Neck Force Y
Passenger Upper Neck Moment X
Passenger Upper Neck Moment Z
Passenger Chest X Redundant
Passenger Chest Y Redundant
Passenger Chest Z Redundant
Passenger Pelvis X
Passenger Pelvis Y

Passenger Pelvis Z
Passenger Left Femur Redundant
Passenger Right Femur Redundant
Passenger Left Upper Tibia Moment X
Passenger Left Upper Tibia Moment Y
Passenger Left Upper Tibia Force Z
Passenger Left Lower Tibia Moment X
Passenger Left Lower Tibia Moment Y
Passenger Left Lower Tibia Force Z
Passenger Right Upper Tibia Moment X
Passenger Right Upper Tibia Moment Y
Passenger Right Upper Tibia Force Z
Passenger Right Lower Tibia Moment X
Passenger Right Lower Tibia Moment Y
Passenger Right Lower Tibia Force Z
Passenger Left Foot Fore Z
Passenger Left Foot Aft X
Passenger Left Foot Aft Z
Passenger Right Foot Fore Z
Passenger Right Foot Aft X
Passenger Right Foot Aft Z
Passenger Lap Belt Force
Passenger Shoulder Belt Force
Left Rear Seat Crossmember X
Right Rear Seat Crossmember X
Vehicle Engine Top X
Vehicle Engine Bottom X
Left Rear Seat Crossmember Z
Right Rear Seat Crossmember Z
Left Rear Seat Crossmember Xr
Right Rear Seat Crossmember Xr
Advanced Research Load Cell Barrier – 528 channels

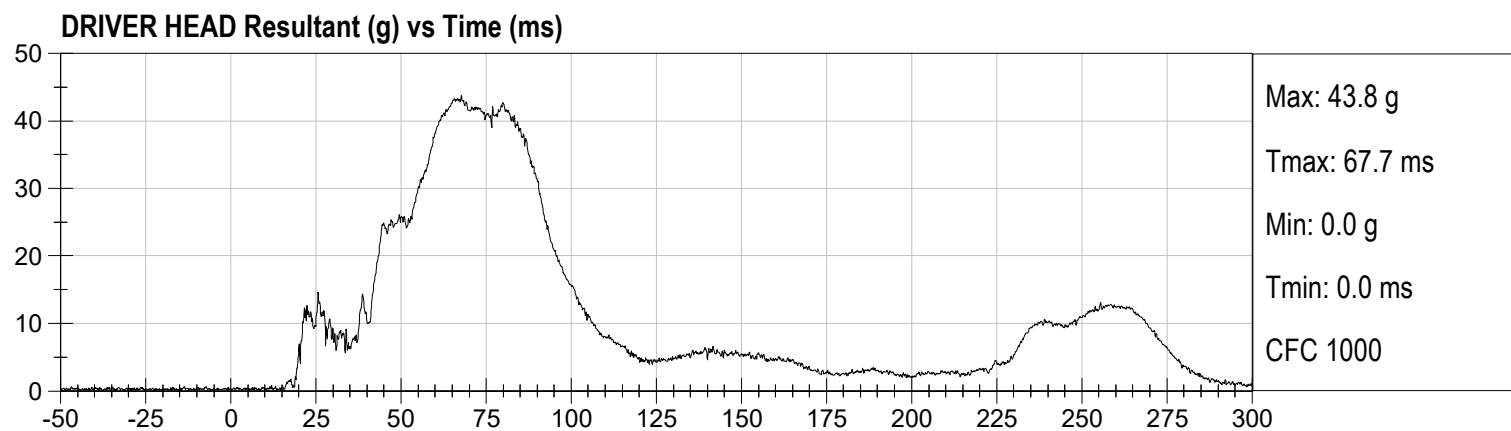
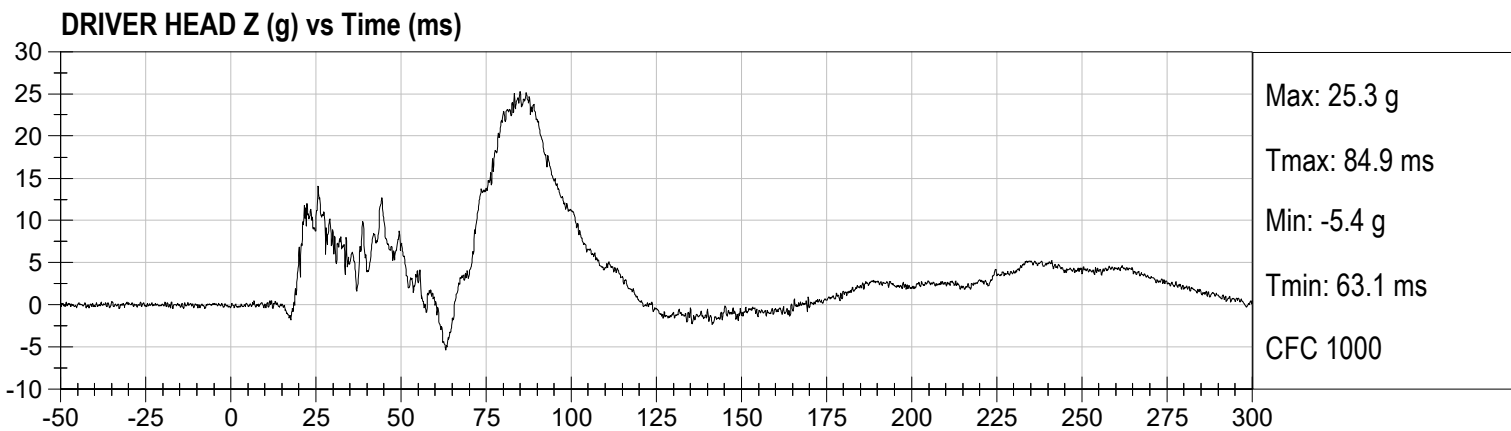
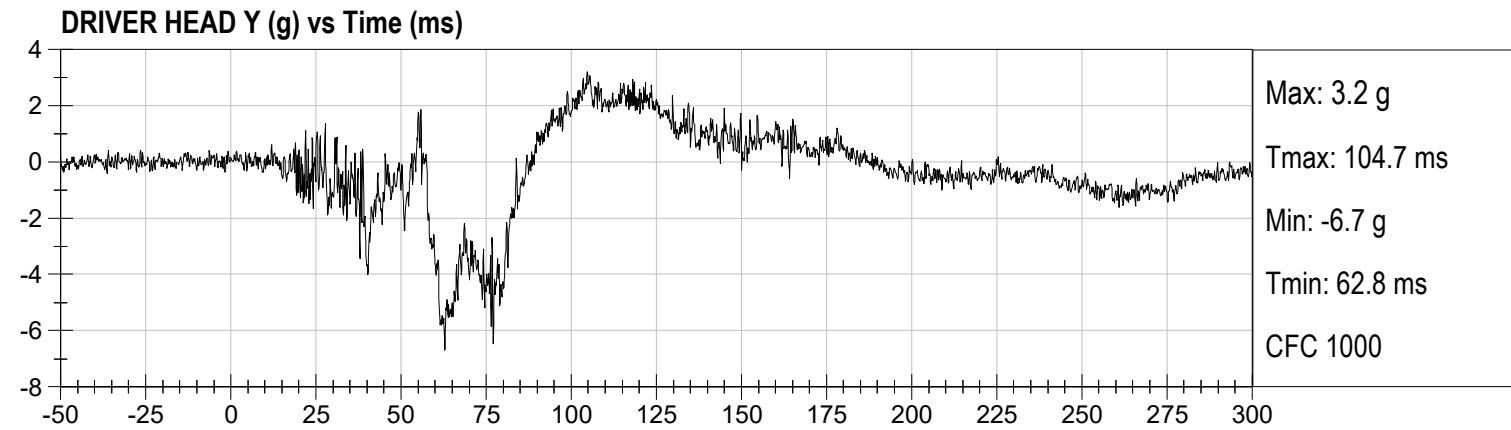
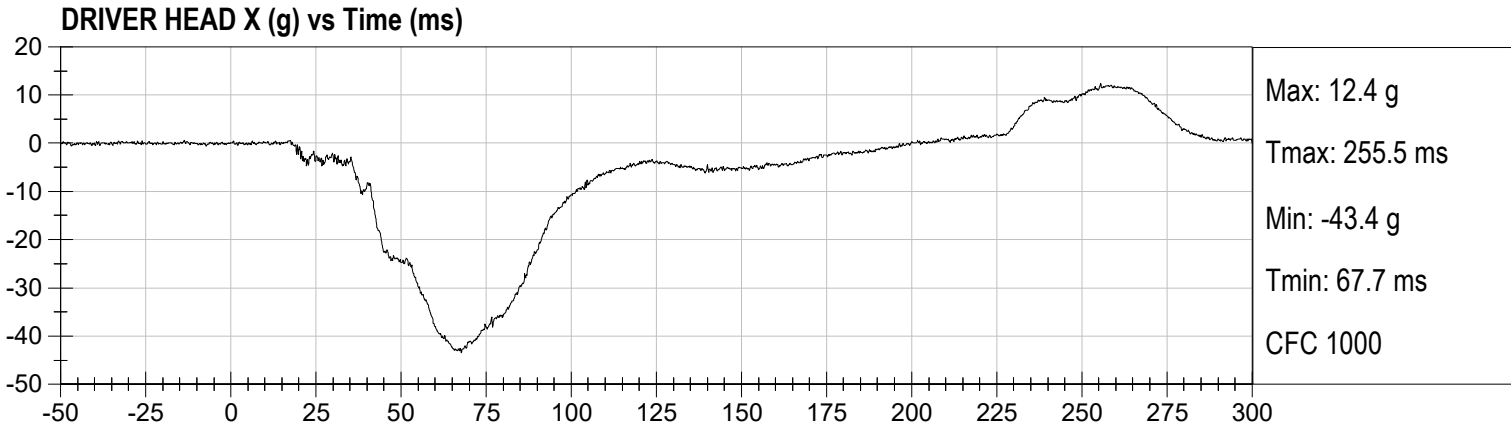

DRIVER CHEST DISPLACEMENT (mm) vs Time (ms)

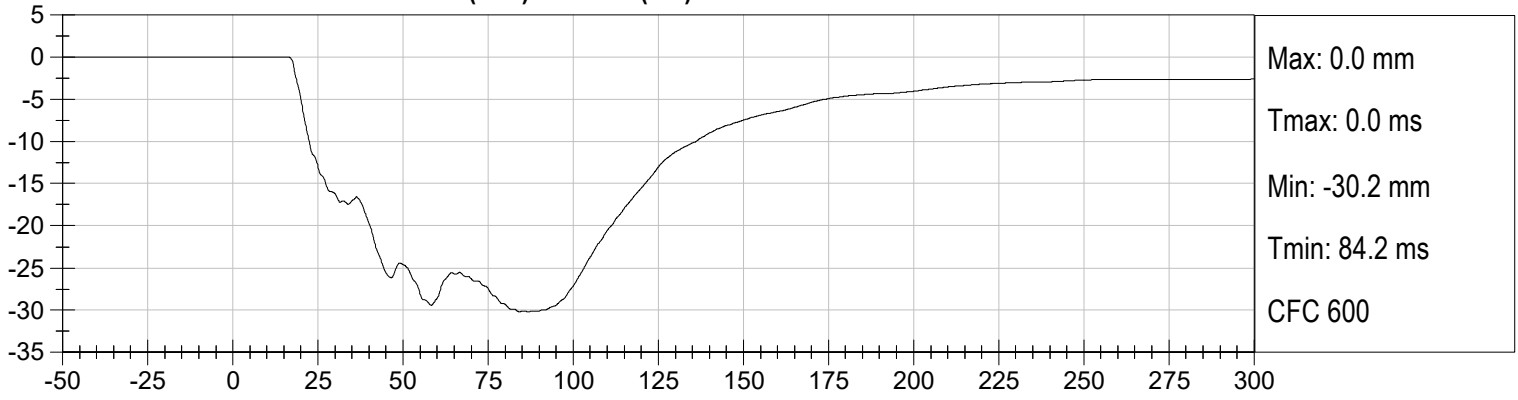

DRIVER CHEST X (g) vs Time (ms)

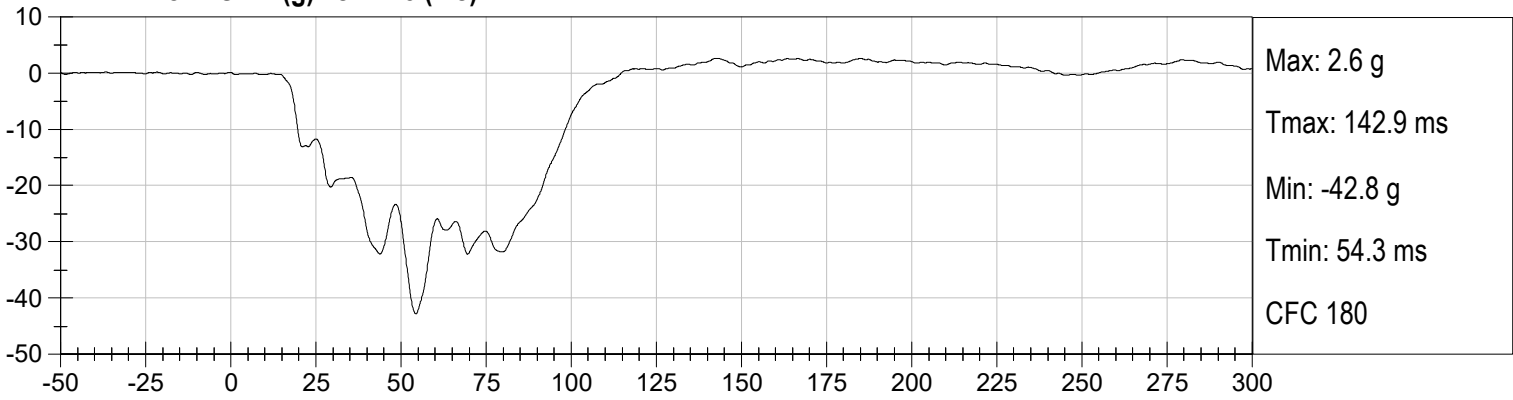

DRIVER CHEST Y (g) vs Time (ms)

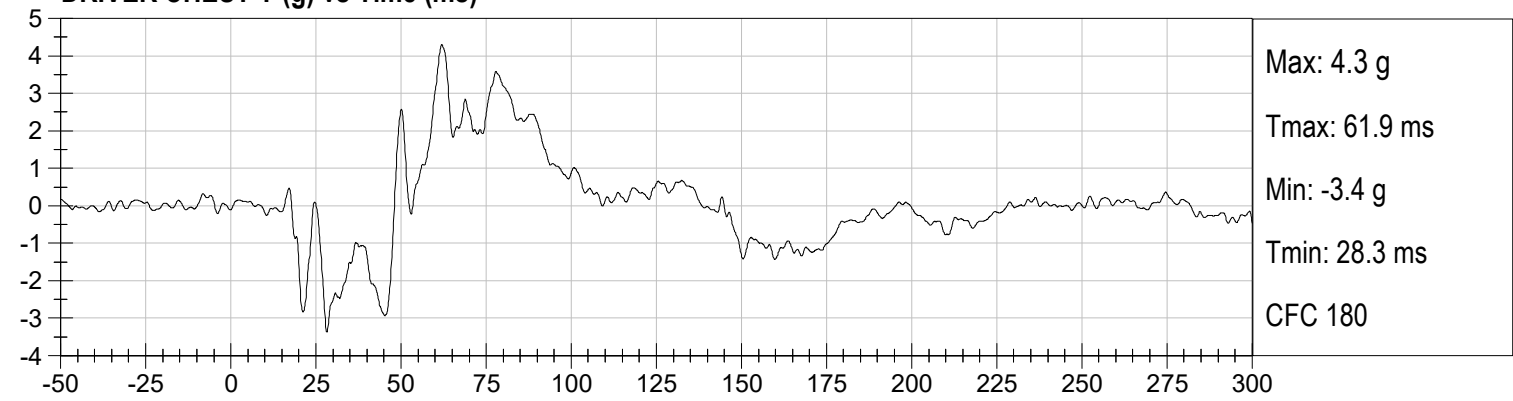

DRIVER CHEST Z (g) vs Time (ms)

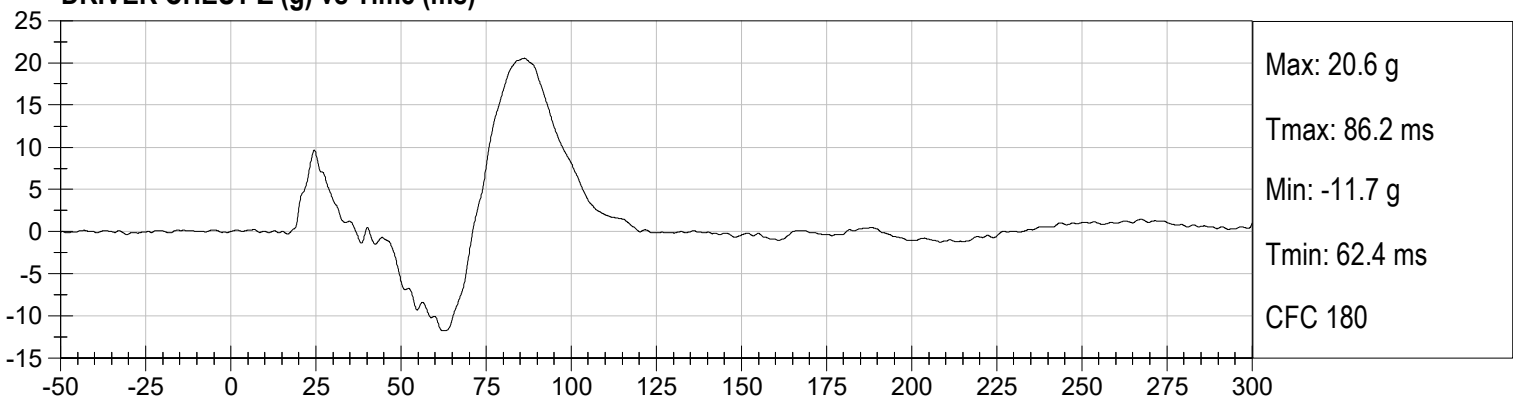

DRIVER CHEST Resultant (g) vs Time (ms)

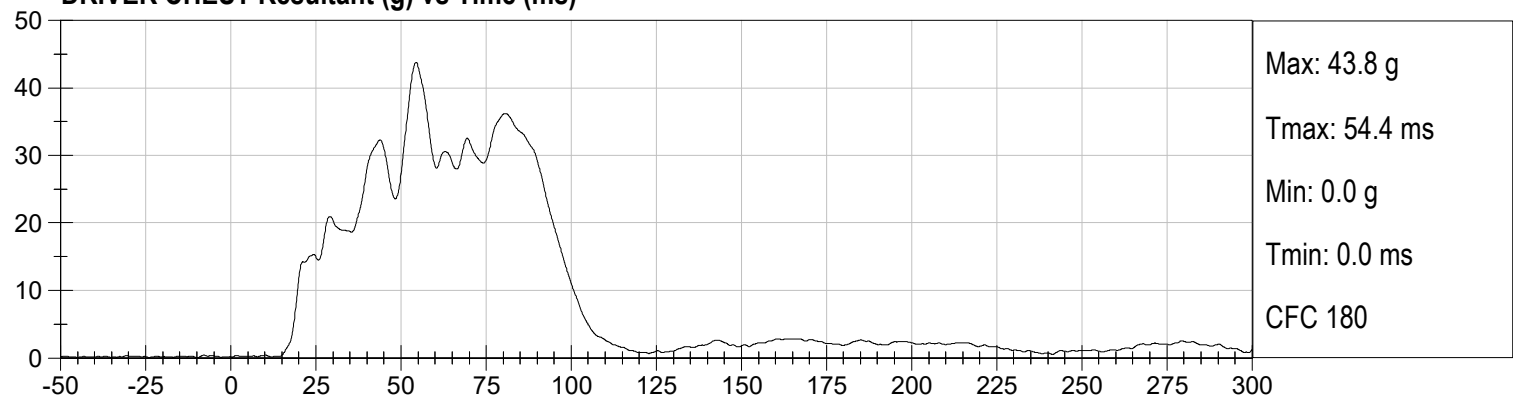

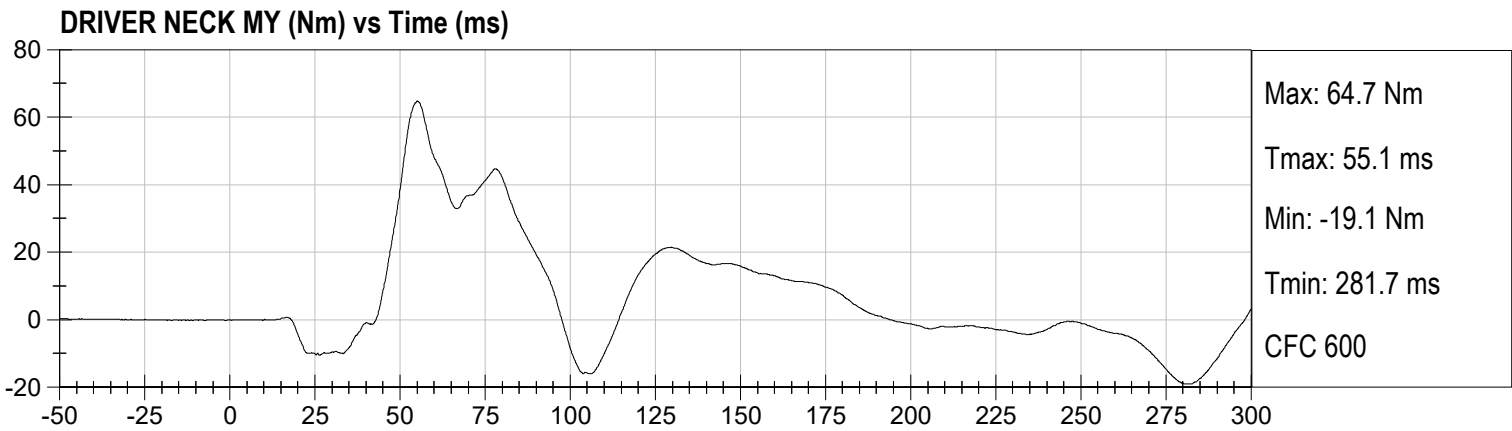
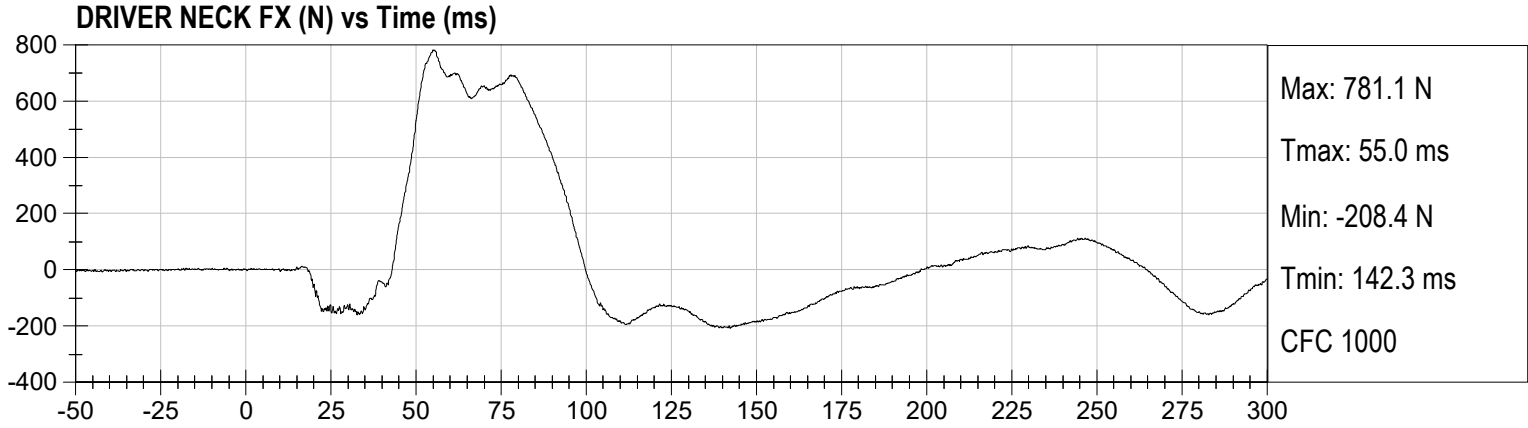

DRIVER Nij (NTF) vs Time (ms)

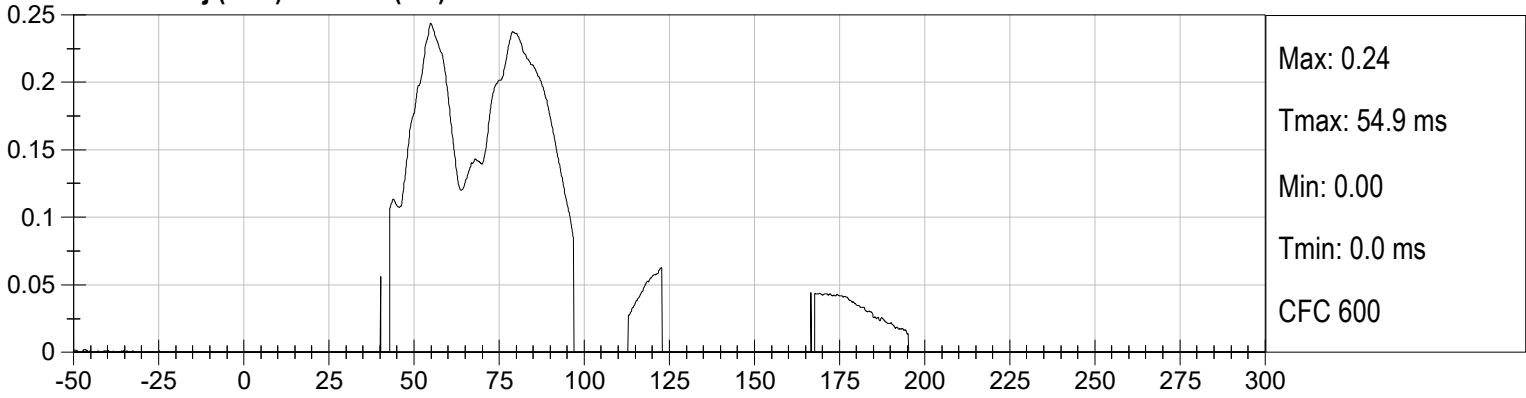

DRIVER Nij (NTE) vs Time (ms)

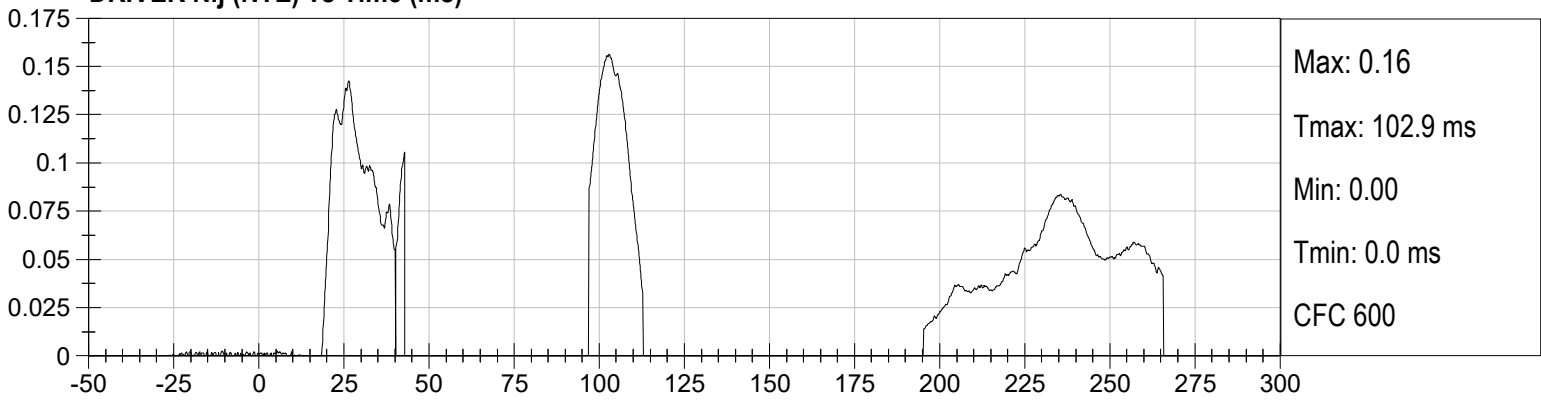

DRIVER Nij (NCF) vs Time (ms)

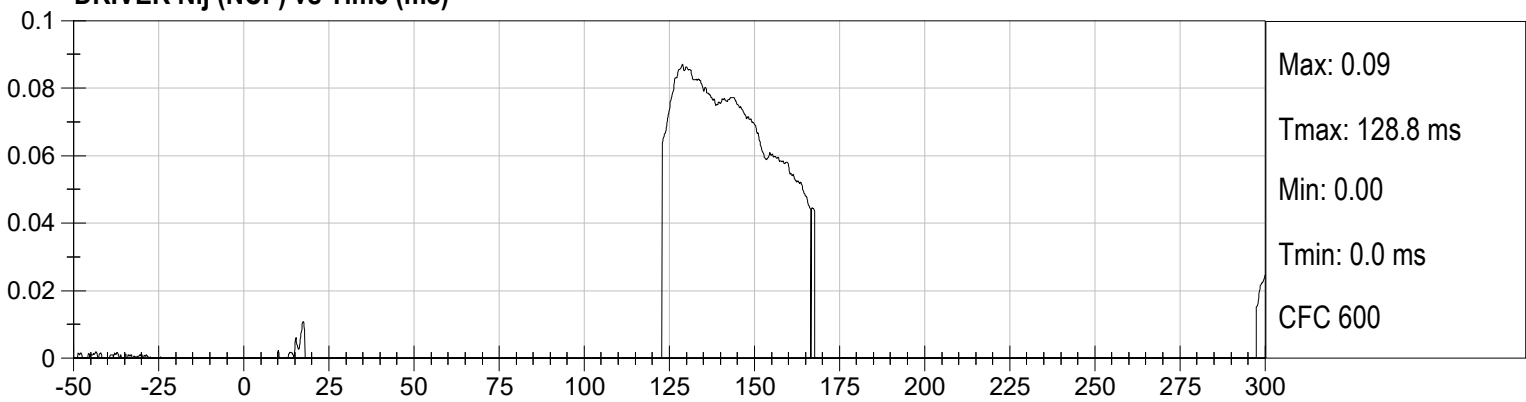

DRIVER Nij (NCE) vs Time (ms)

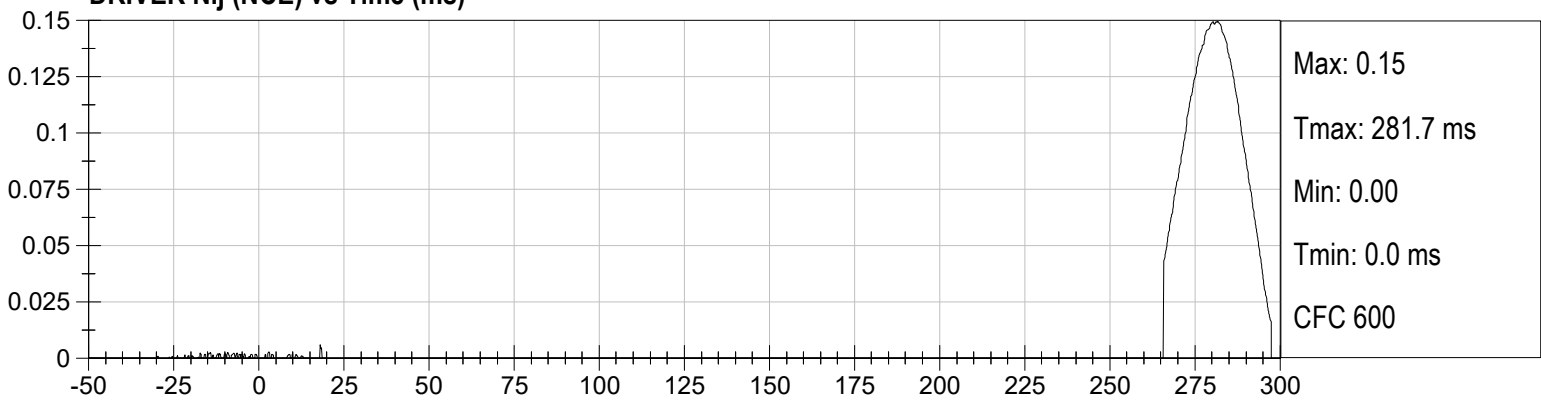

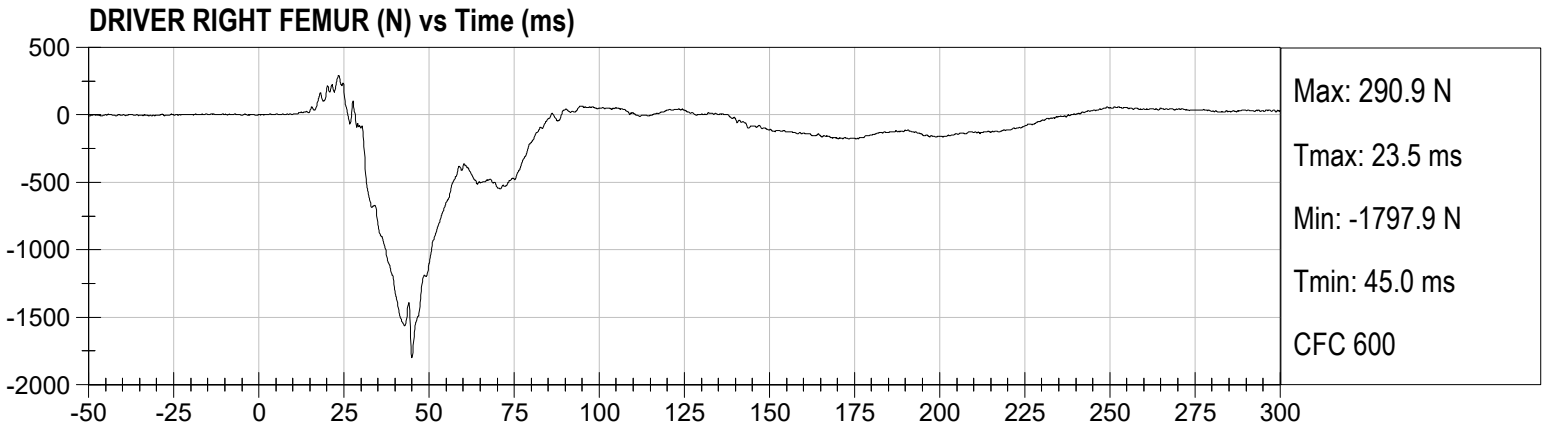
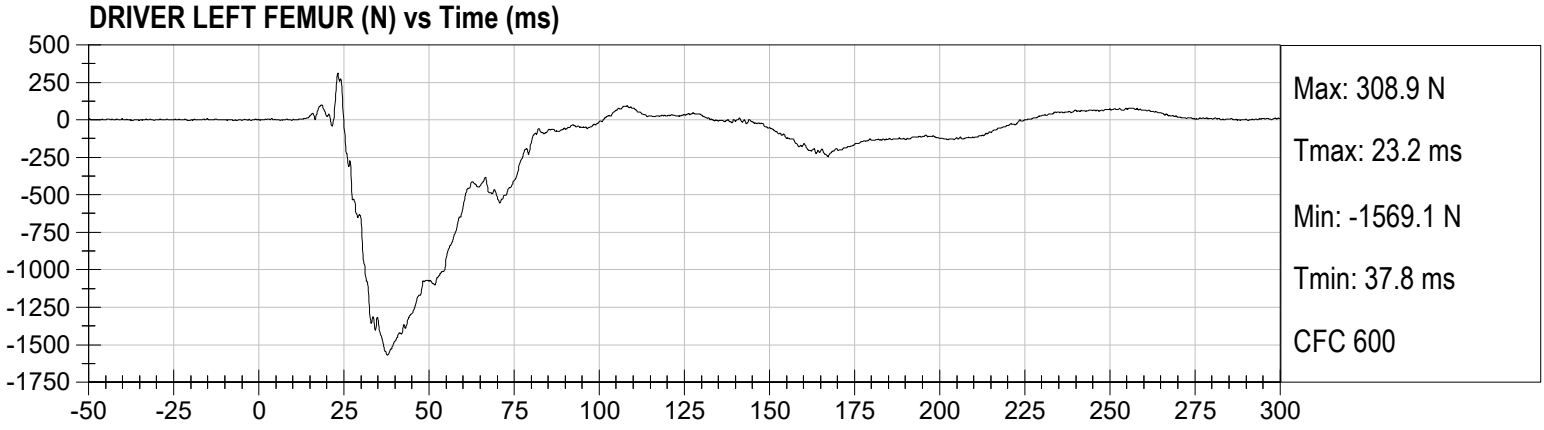

PASSENGER HEAD X (g) vs Time (ms)

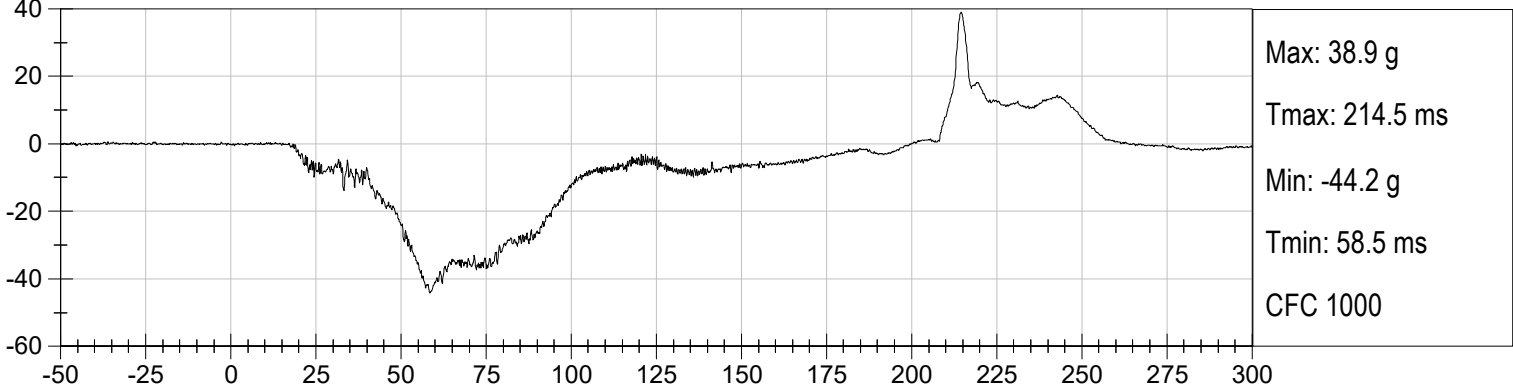

PASSENGER HEAD Y (g) vs Time (ms)

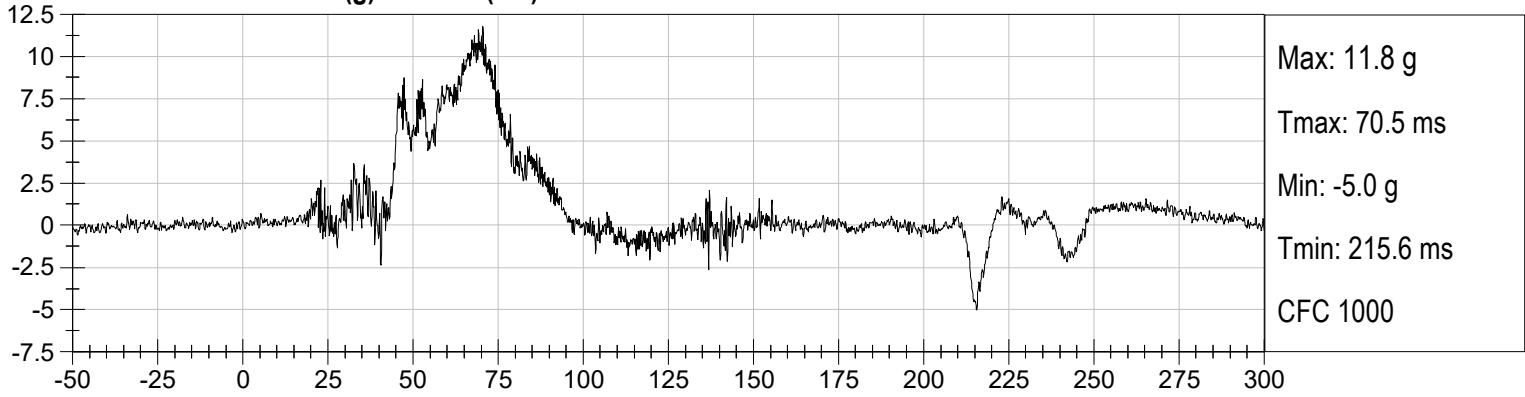

PASSENGER HEAD Z (g) vs Time (ms)

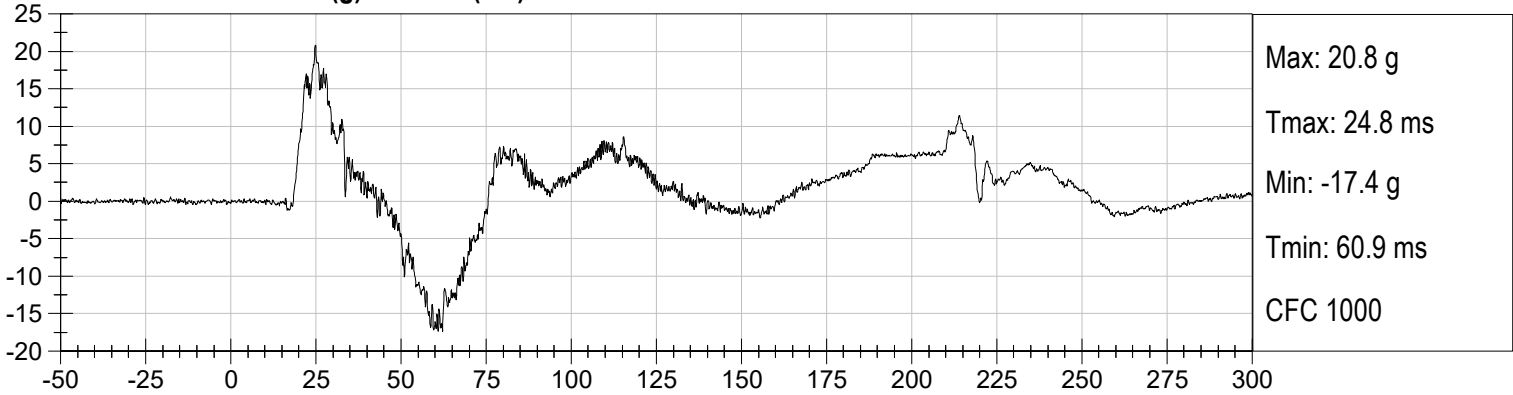

PASSENGER HEAD Resultant (g) vs Time (ms)

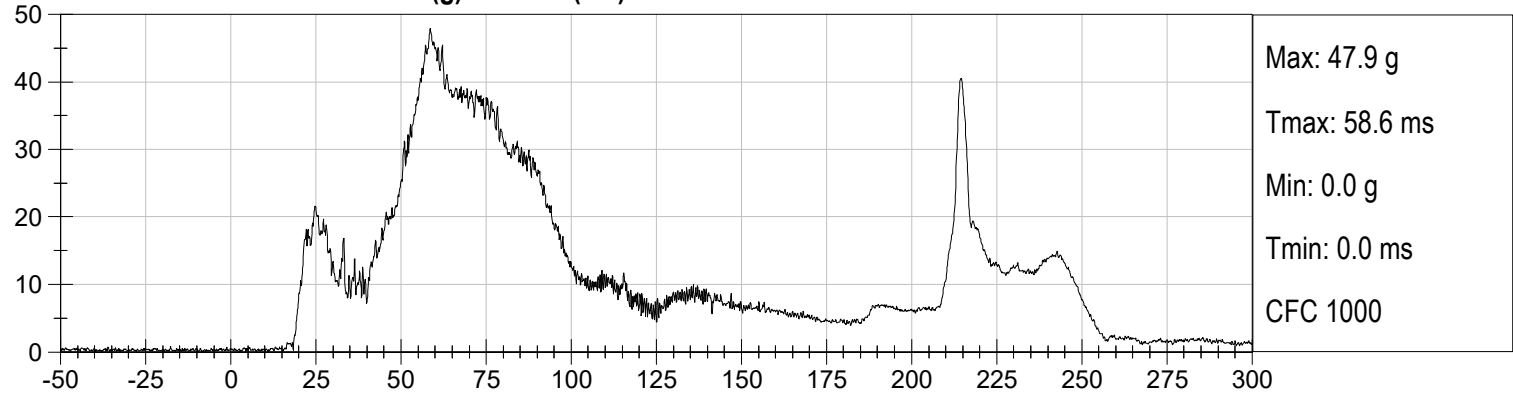

PASSENGER CHEST DISPLACEMENT (mm) vs Time (ms)

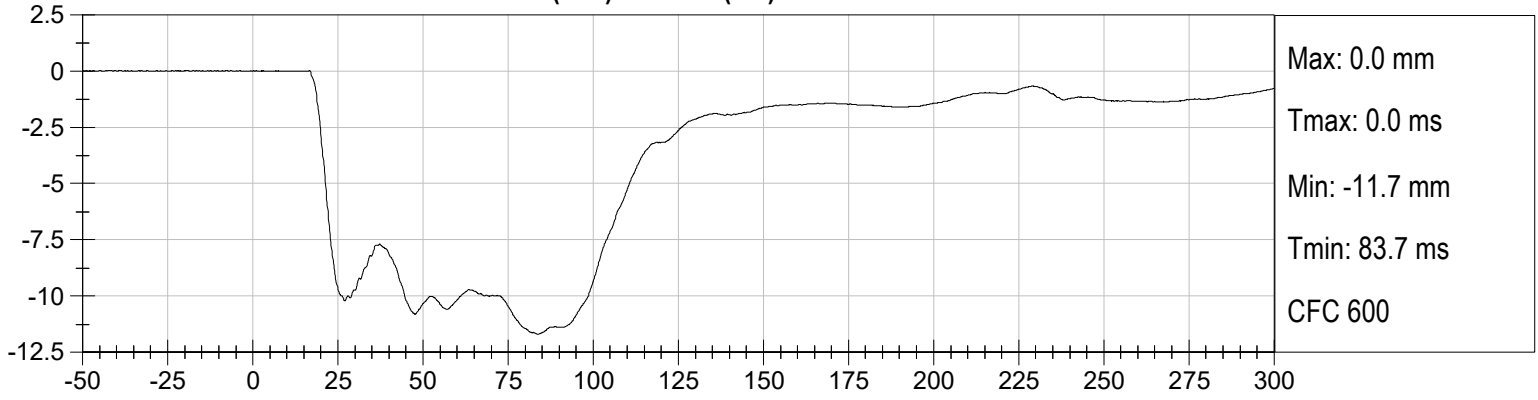

PASSENGER CHEST X (g) vs Time (ms)

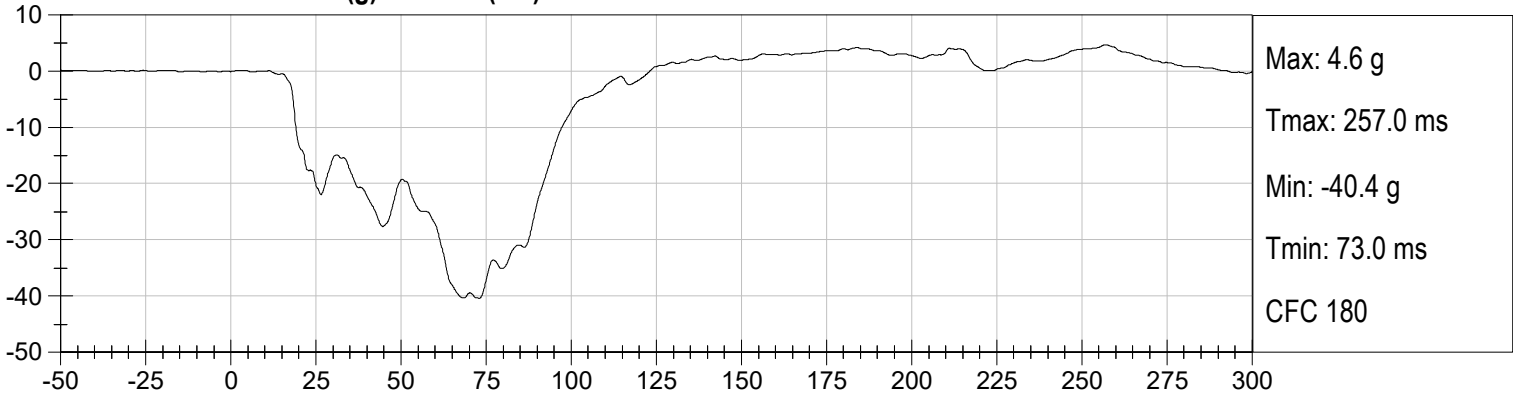

PASSENGER CHEST Y (g) vs Time (ms)

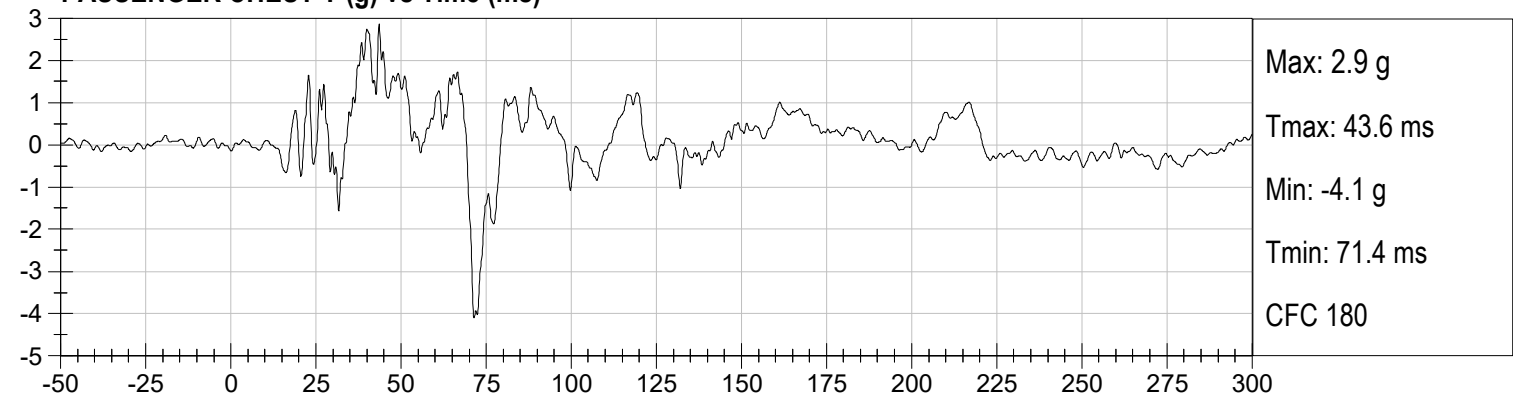

PASSENGER CHEST Z (g) vs Time (ms)

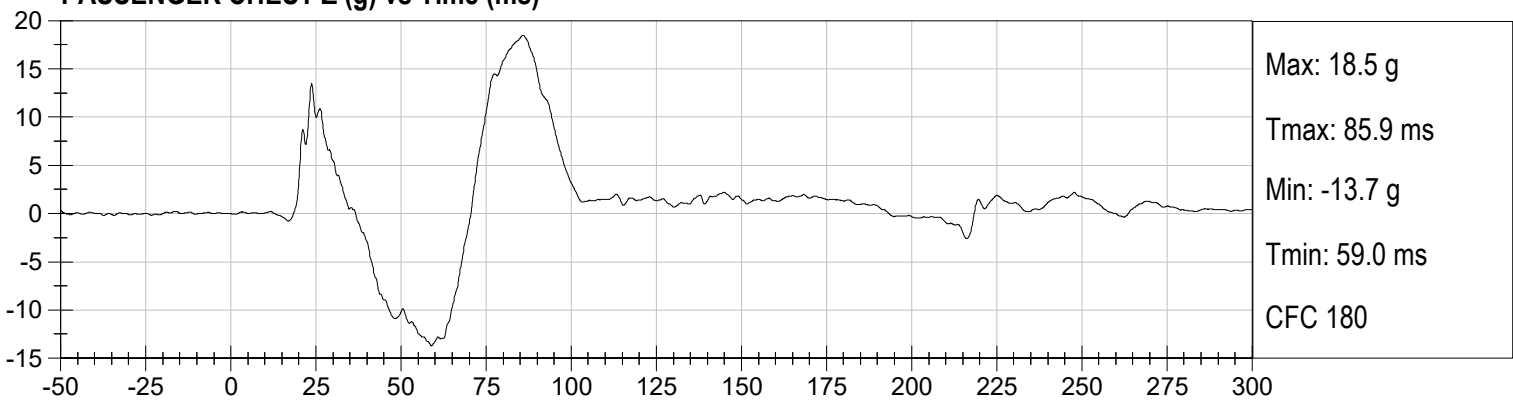

PASSENGER CHEST Resultant (g) vs Time (ms)

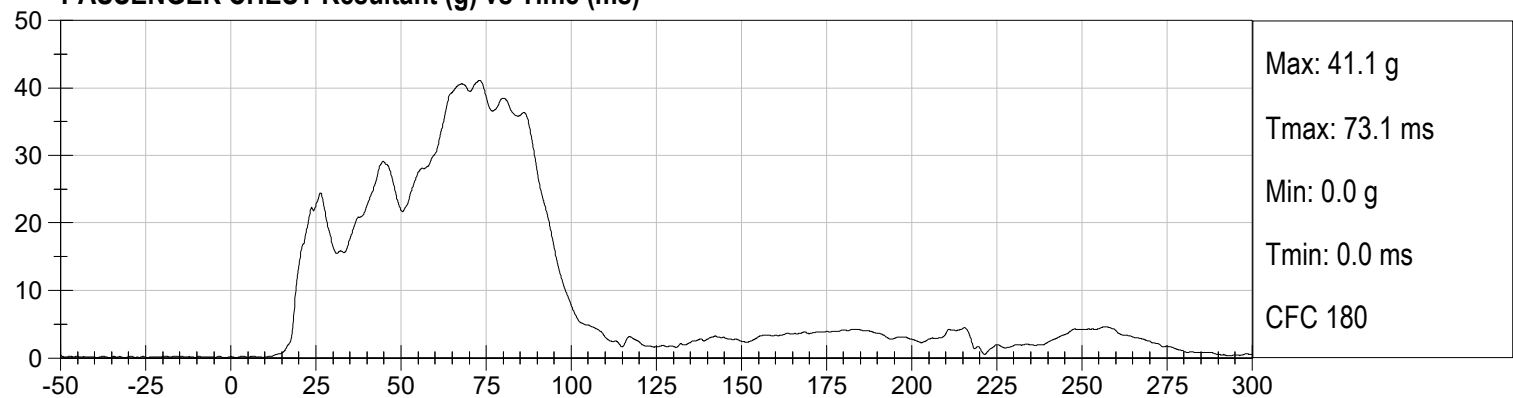

PASSENGER NECK FX (N) vs Time (ms)

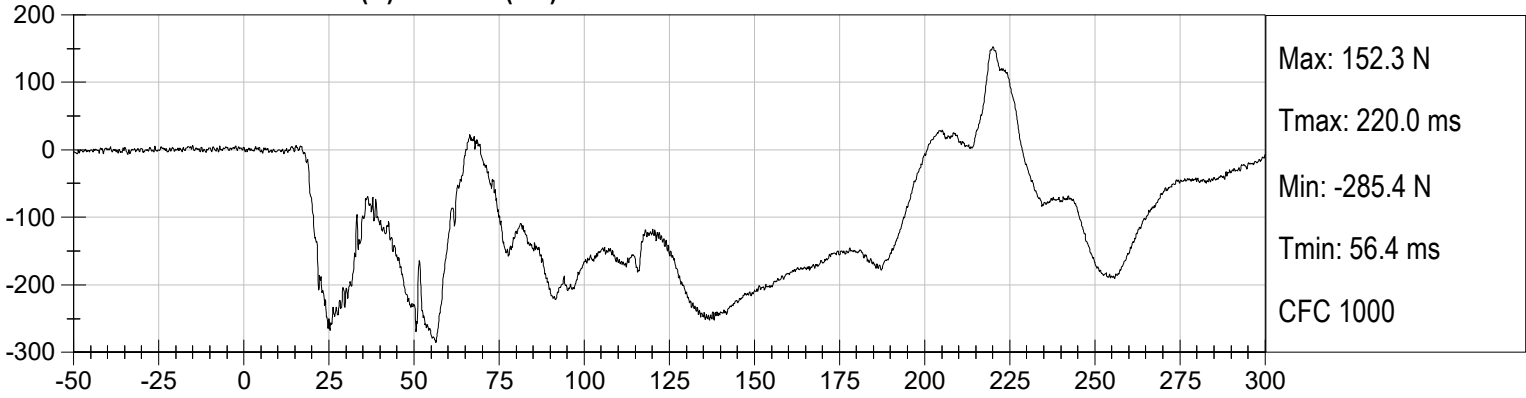

PASSENGER NECK FZ (N) vs Time (ms)

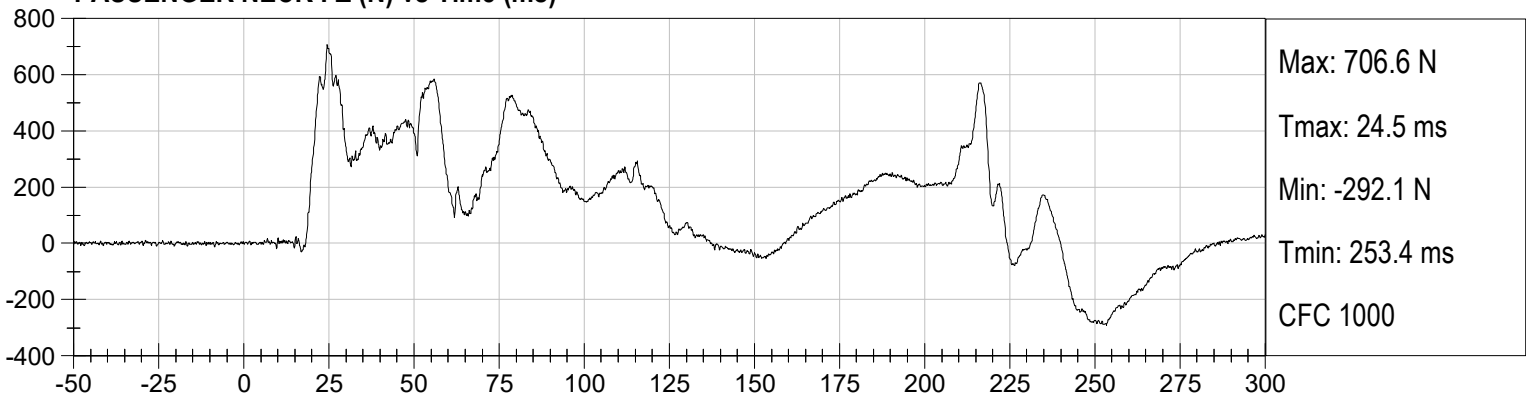

PASSENGER NECK MY (Nm) vs Time (ms)

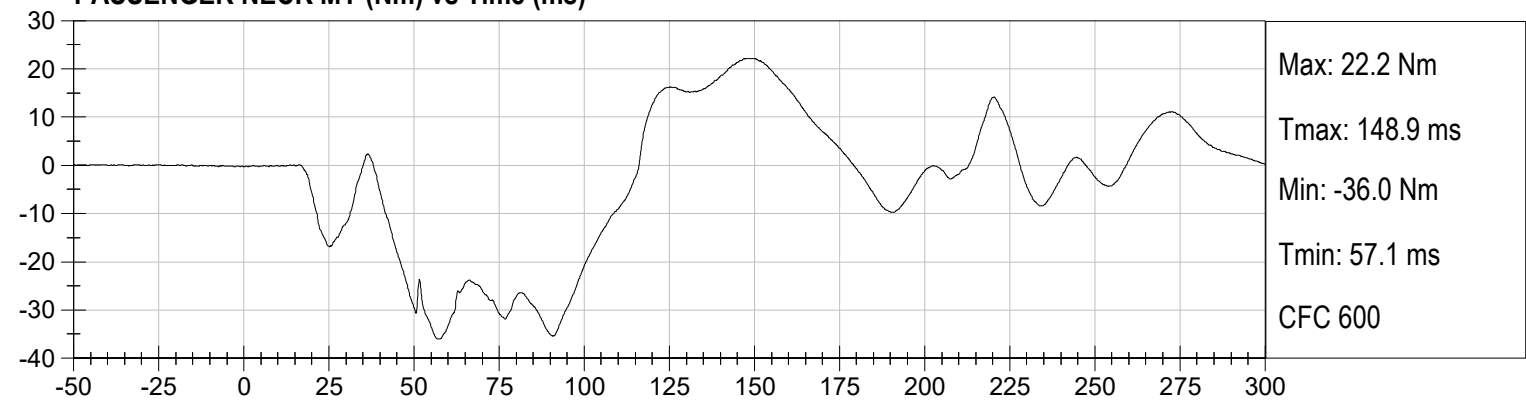

PASSENGER Nij (NTF) vs Time (ms)

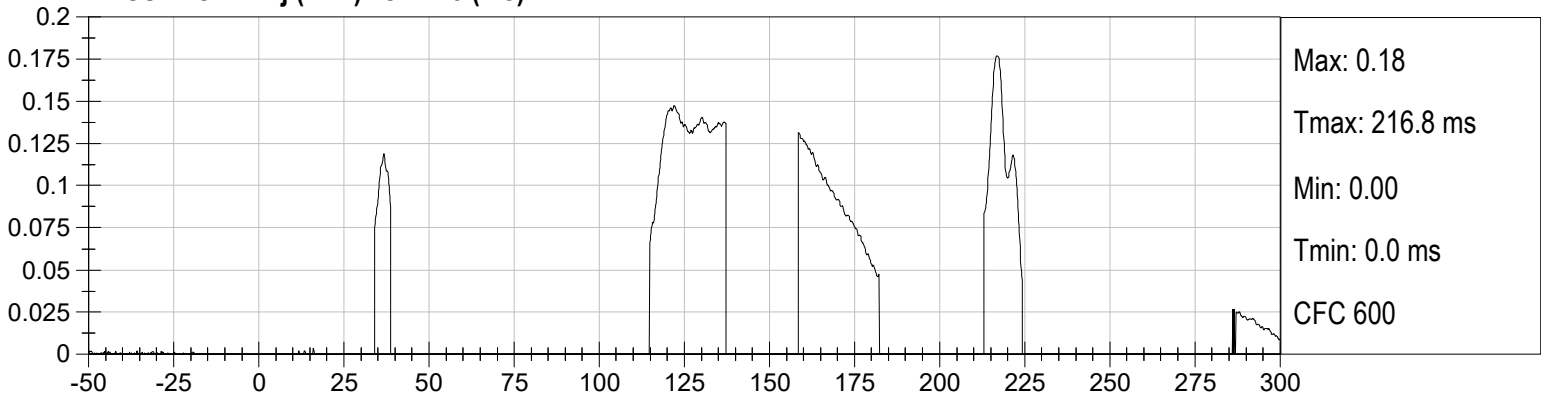

PASSENGER Nij (NTE) vs Time (ms)

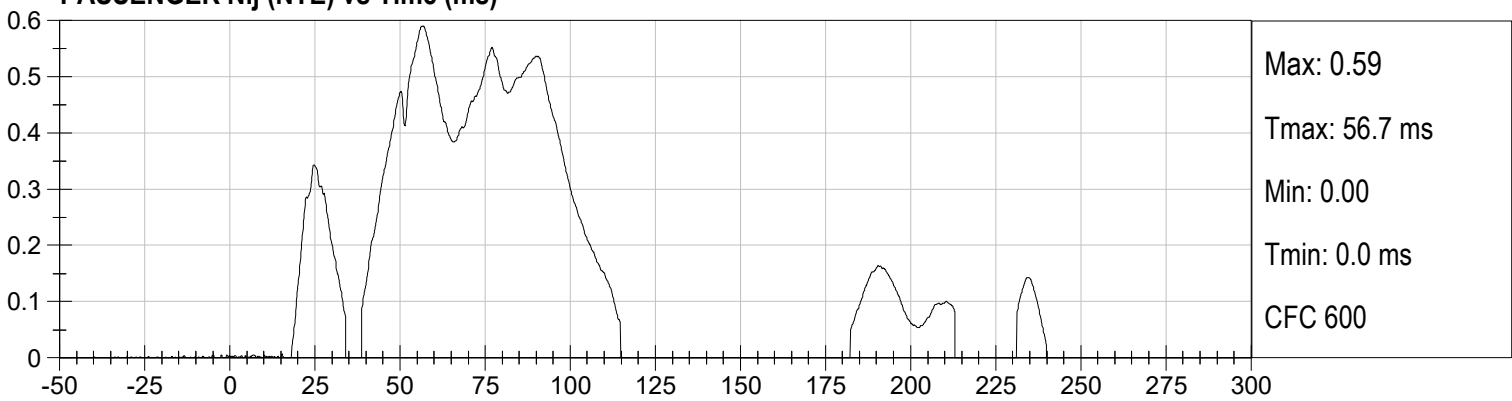

PASSENGER Nij (NCF) vs Time (ms)

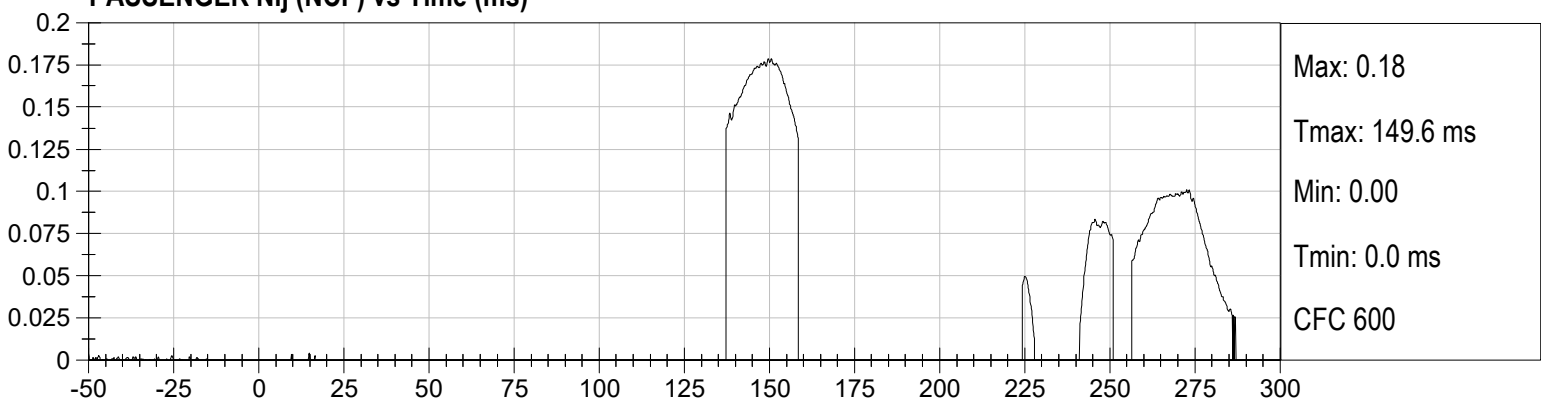

PASSENGER Nij (NCE) vs Time (ms)

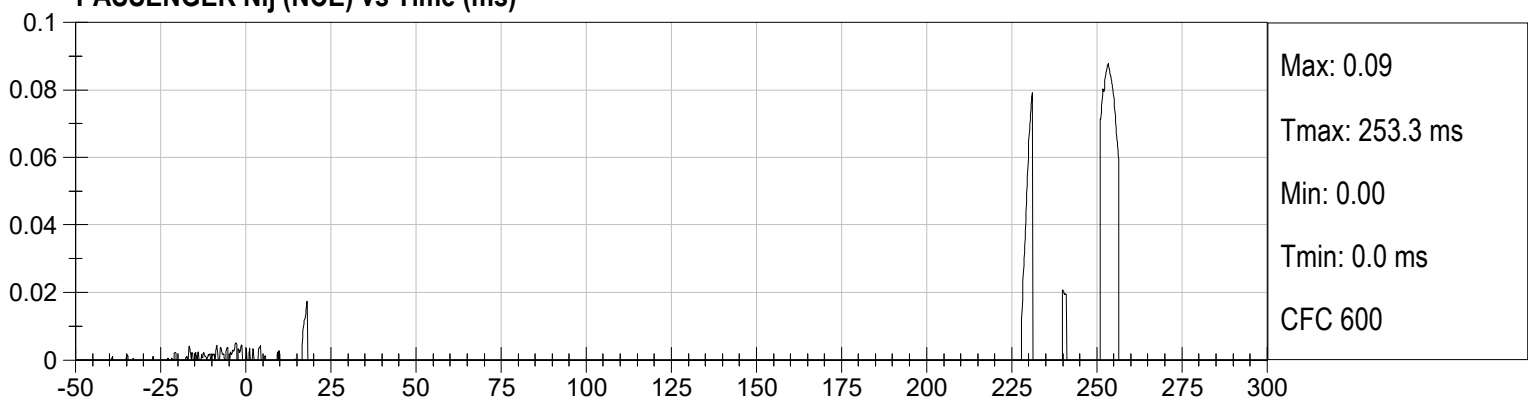

PASSENGER LEFT FEMUR (N) vs Time (ms)

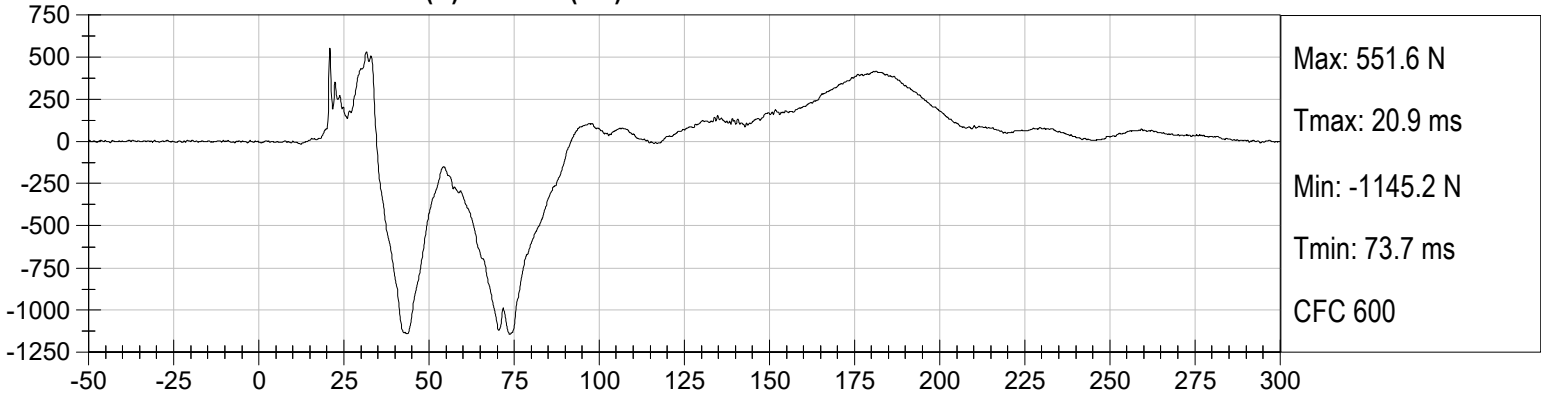

PASSENGER RIGHT FEMUR (N) vs Time (ms)

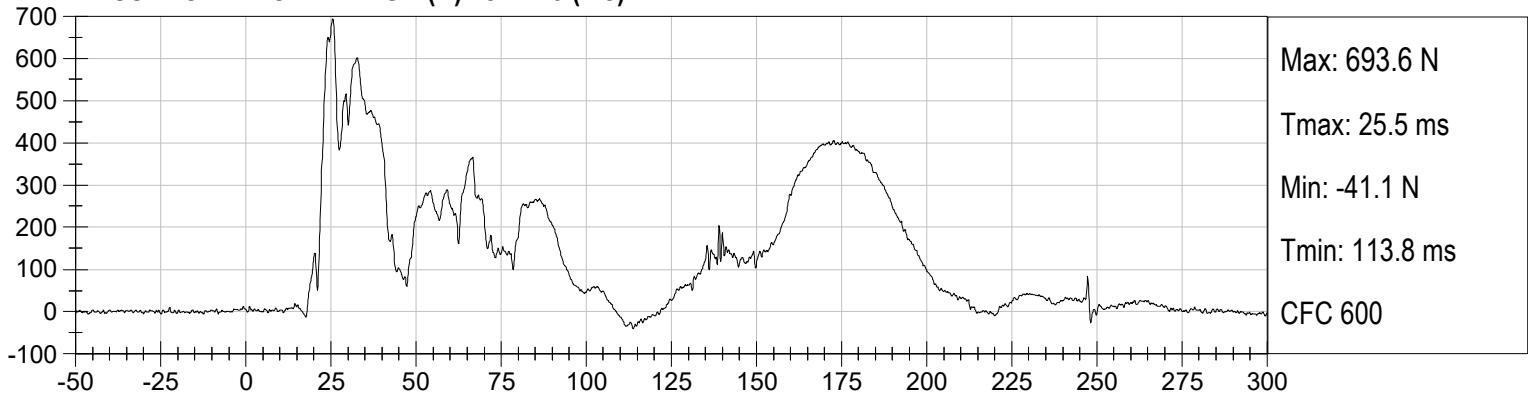

APPENDIX C
DUMMY QUALIFICATION AND PERFORMANCE VERIFICATION

QUALIFICATION TEST RESULTS

PRE-TEST

HYBRID III 50TH PERCENTILE MALE - DRIVER ATD

**Hybrid III 50th, External Measurements
SN: 064**

HYBRID III, PART 572, SUBPART E EXTERNAL DIMENSIONS				
DIMENSION	DESCRIPTION	DETAILS	ASSEMBLY DIMENSION (inches)	ACTUAL MEASUREMENT
A	TOTAL SITTING HEIGHT	Seat surface to highest point on top of the head.	34.6-35.0	34.71
B	SHOULDER PIVOT HEIGHT	Centerline of shoulder pivot bolt to the seat surface.	19.9-20.5	20.31
C	H-POINT HEIGHT	Reference	3.3-3.5	3.38
D	H-POINT LOCATION FROM BACKLINE	Reference	5.3-5.5	5.40
E	SHOULDER PIVOT FROM BACKLINE	Center of the shoulder clevis to the rear vertical surface of the fixture.	3.3-3.7	3.46
F	THIGH CLEARANCE	Measured at the highest point on the upper femur segment.	5.5-6.1	6.09
G	BACK OF ELBOW TO WRIST PIVOT	back of the elbow flesh to the wrist pivot in line with the elbow and wrist pivots	11.4-12.0	11.48
H	HEAD BACK TO BACKLINE	Back of Skull cap skin to seat rear vertical surface (Reference)	1.6-1.8	1.75
I	SHOULDER TO- ELBOW LENGTH	Measure from the highest point on top of the shoulder clevis to the lowest part of the flesh on the elbow in line with the elbow pivot bolt.	13.0-13.6	13.08
J	ELBOW REST HEIGHT	Measure from the flesh below the elbow pivot bolt to the seat surface.	7.5-8.3	8.13
K	BUTTOCK TO KNEE LENGTH	The forward most part of the knee flesh to the rear vertical surface of the fixture.	22.8-23.8	23.49
L	POPLITEAL HEIGHT	Seat surface to the plane of the horizontal plane of the bottom of the feet.	16.9-17.9	17.01
M	KNEE PIVOT HEIGHT	Centerline of knee pivot bolt to the horizontal plane of the bottom of the feet.	19.1-19.7	19.22
N	BUTTOCK POPLITEAL LENGTH	The rearmost surface of the lower leg to the same point on the rear surface of the buttocks used for dim. "K".	17.8-18.8	18.20

HYBRID III, SUBPART E EXTERIOR DIMENSIONS, continued				
DIMENSION	DESCRIPTION	DETAILS		ACTUAL MEASUREMENT
O	CHEST DEPTH WITHOUT JACKET	Measured 16.9-17.1 in. above seat surface	8.4-9.0	8.43
P	FOOT LENGTH	Tip of toe to rear of heel	9.9-10.5	10.33
V	SHOULDER BREADTH	Outside edges of right and left shoulder clevises	16.3-17.2	16.65
W	FOOT BREADTH	The widest part of the foot	3.6-4.2	3.94
Y	CHEST CIRCUMFERENCE (WITH CHEST JACKET)	Measured 16.9-17.1 in. above seat surface	38.2-39.4	39.25
Z	WAIST CIRCUMFERENCE	Measured 8.9-9.1 in. above seat surface	32.9-34.1	33.89
AA	REFERENCE LOCATION FOR MEASUREMENT OF CHEST CIRCUMFERENCE	Reference	16.9-17.1	17.00
BB	REFERENCE LOCATION FOR MEASUREMENT OF WAIST CIRCUMFERENCE	Reference	8.9-9.1	9.00

NOTE: THE H-POINT IS LOCATED 1.83 INCHES FORWARD AND 2.57 INCHES DOWN FROM THE CENTER OF THE PELVIS ANGLE REFERENCE HOLE.

MGA RESEARCH CORPORATION
HEAD DROP TEST
HYBRID III 50TH PERCENTILE MALE

ATD Serial No: 064

Test ID: D241261

Tested Parameter	Units	Specification	Result	Pass/Fail
Laboratory Temperature	deg C	18.9 to 25.6	21.4	Pass
Laboratory Relative Humidity	%	10 to 70	46	Pass
Peak Resultant Acceleration	G's	225 to 275	231	Pass
Peak Lateral Acceleration	G's	<= +/- 15.0	-4.8	Pass
Unimodal	N/A	Yes	Yes	Pass
Oscillations	N/A	within 10% of peak	Yes	Pass
Overall Test Results				Pass



 Laboratory Technician

05/24/2024

 Test Date

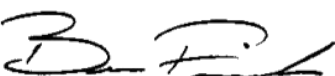

 Approved By

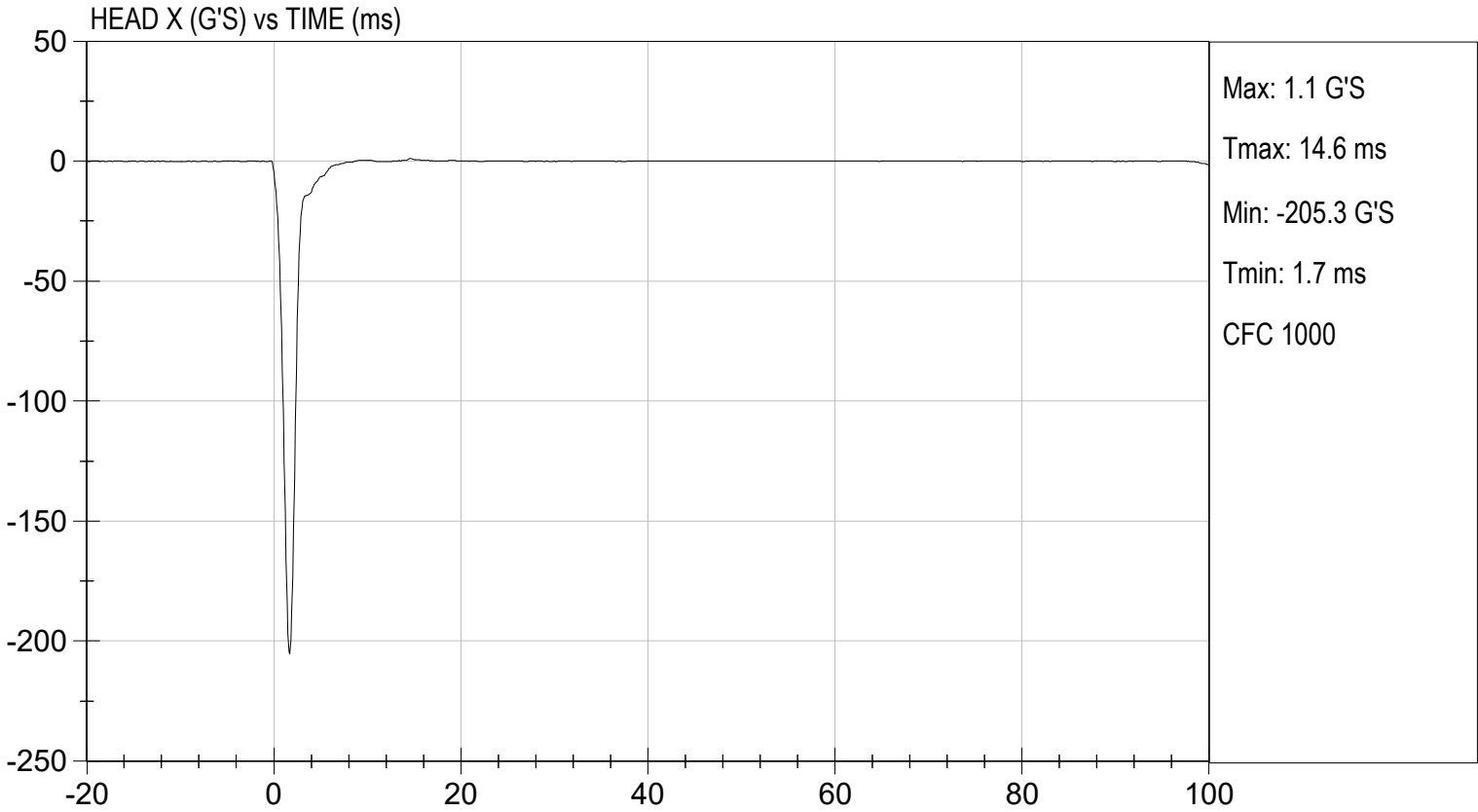
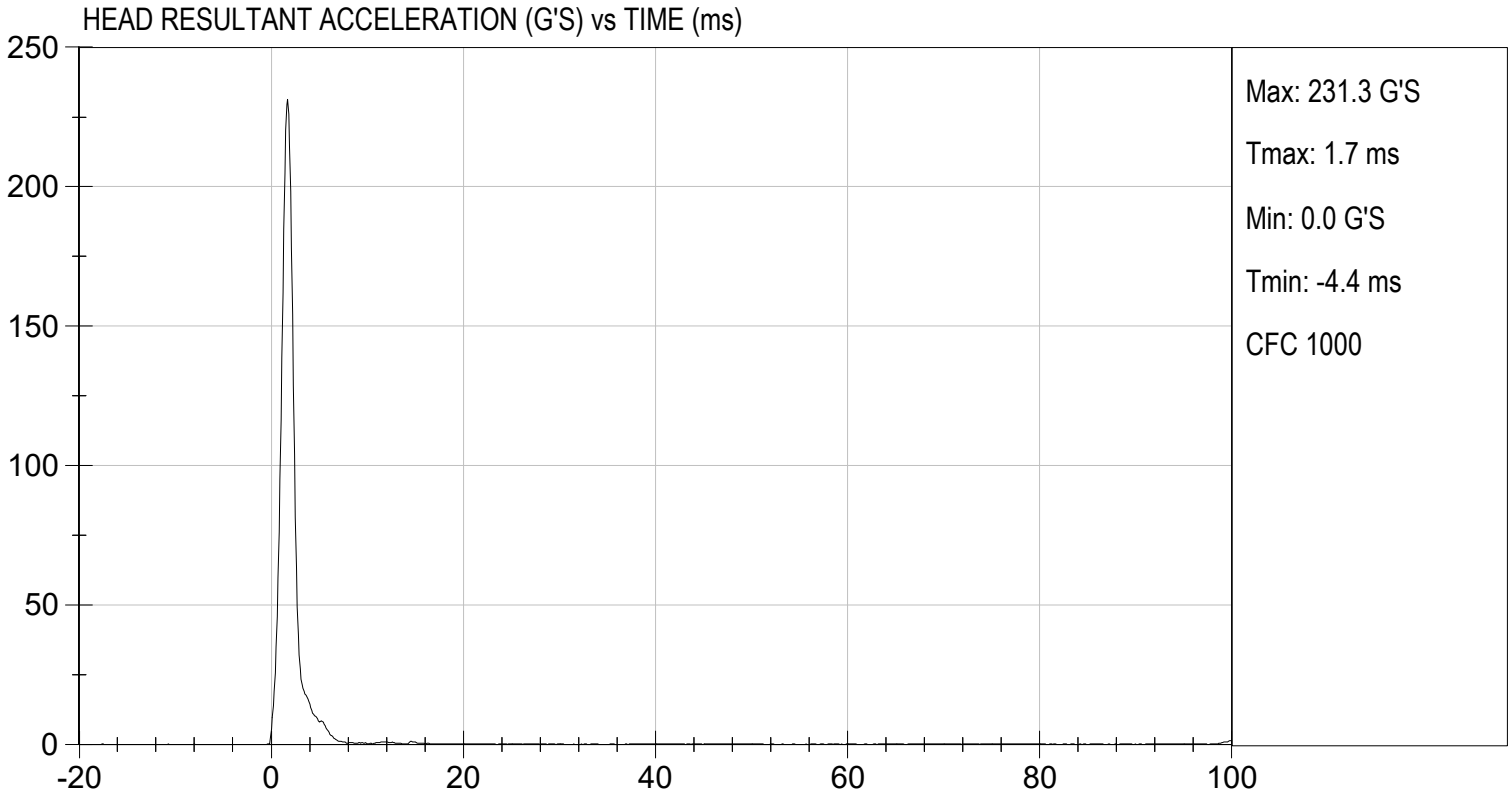

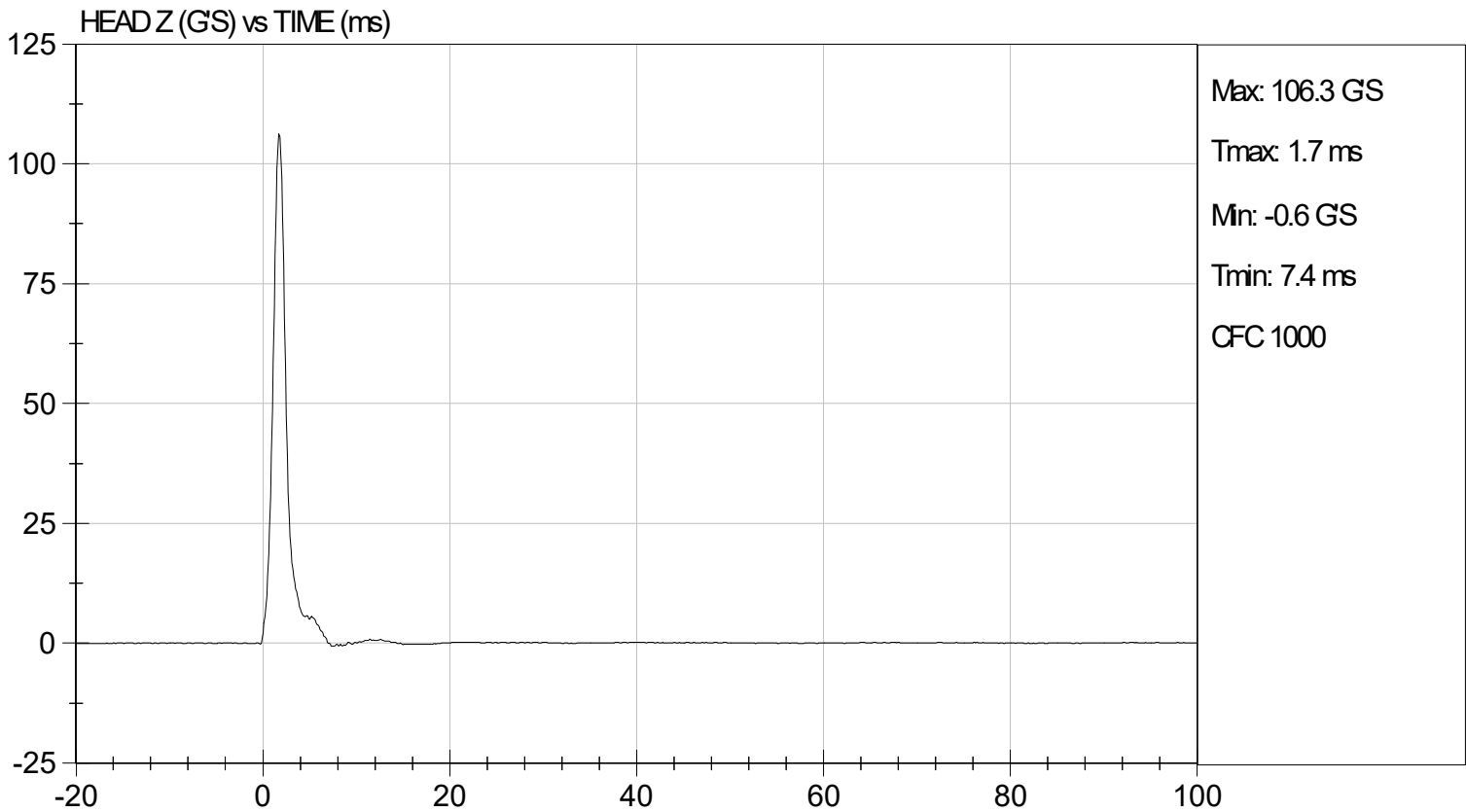
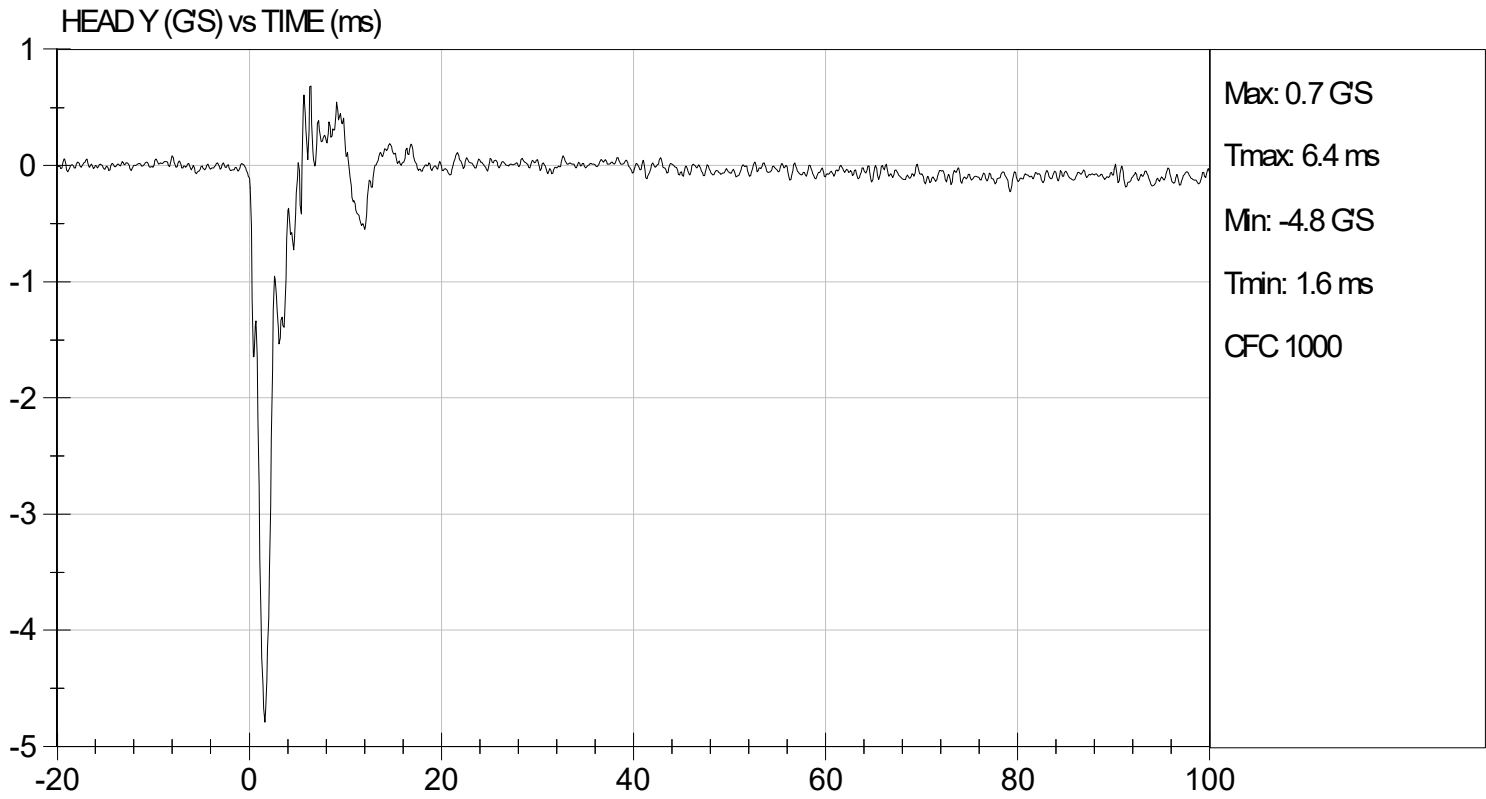

MGA RESEARCH CORPORATION
NECK FLEXION TEST
HYBRID III 50TH PERCENTILE MALE

ATD Serial No: 064

Test I.D.: D241262

Tested Parameter		Units	Specification	Result	Pass/Fail
Laboratory Temperature		deg C	20.6 to 22.2	21.3	Pass
Laboratory Relative Humidity		%	10 to 70	45	Pass
Pendulum Velocity		m/s	6.89 to 7.13	7.06	Pass
Pendulum Deceleration	10 ms	G's	22.50 to 27.50	23.17	Pass
	20 ms	G's	17.60 to 22.60	20.60	Pass
	30 ms	G's	12.50 to 18.50	16.93	Pass
Peak Pendulum Deceleration After 30 ms		G's	<= 29.0	17.3	Pass
Deceleration Decay Time to Cross 5 G's		ms	34.0 to 42.0	37.3	Pass
Maximum "D" Plane Rotation	Maximum	Deg	64.0 to 78.0	72.4	Pass
	Time	ms	57.0 to 64.0	60.8	Pass
"D" Plane Rotation Decay Time To Zero Crossing		ms	113.0 to 128.0	114.4	Pass
Moment About Occipital Condyle	Maximum	Nm	88.1 to 108.5	100.6	Pass
	Time	ms	47.0 to 58.0	49.3	Pass
Positive Moment Decay Time To Zero Crossing		ms	97.0 to 107.0	97.9	Pass
Overall Test Results					Pass

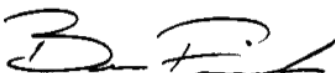

 Laboratory Technician

05/24/2024
 Test Date



 Approved By

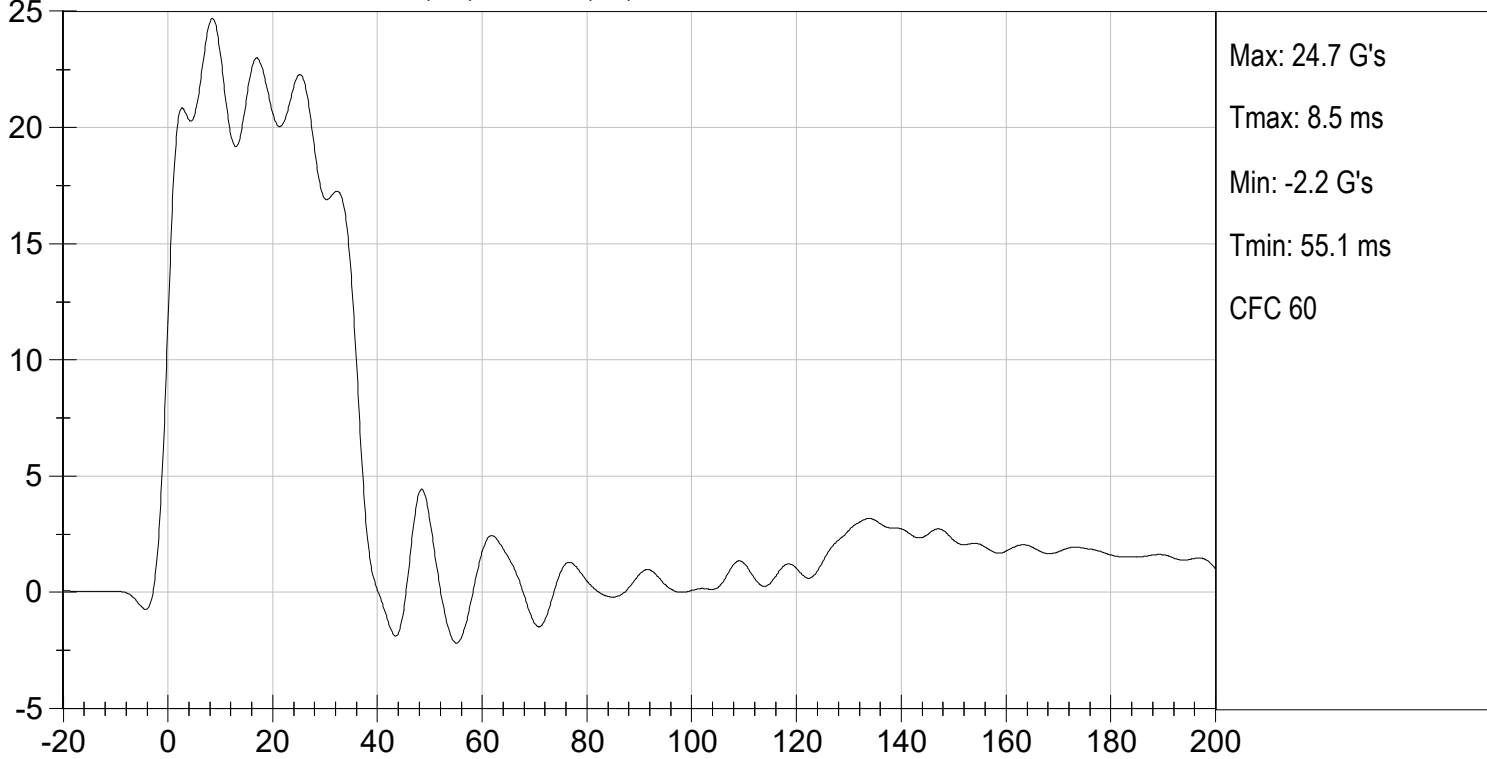

PENDULUM DECELERATION (G's) vs TIME (ms)

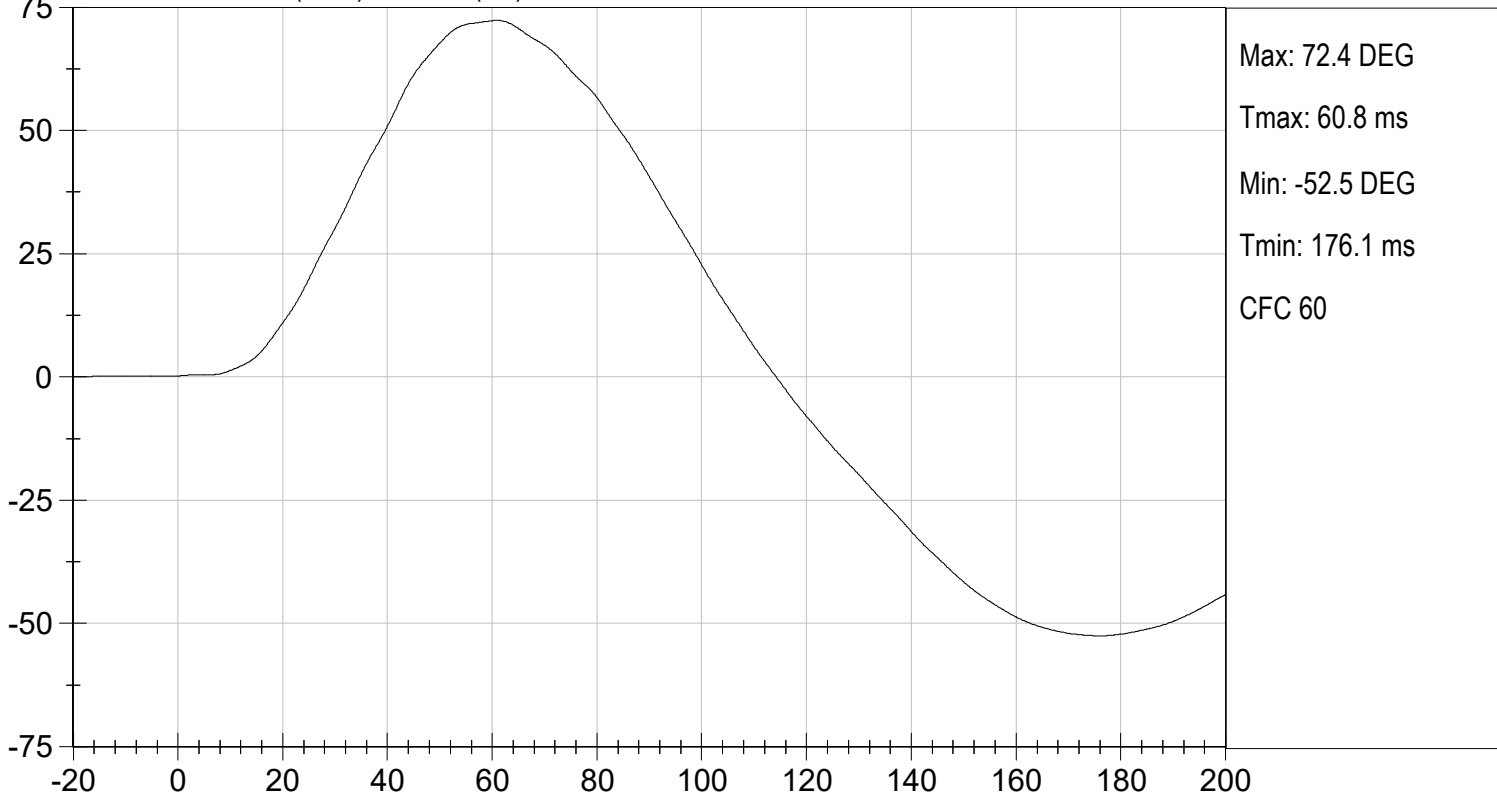

NECK ROTATION (DEG) vs TIME (ms)



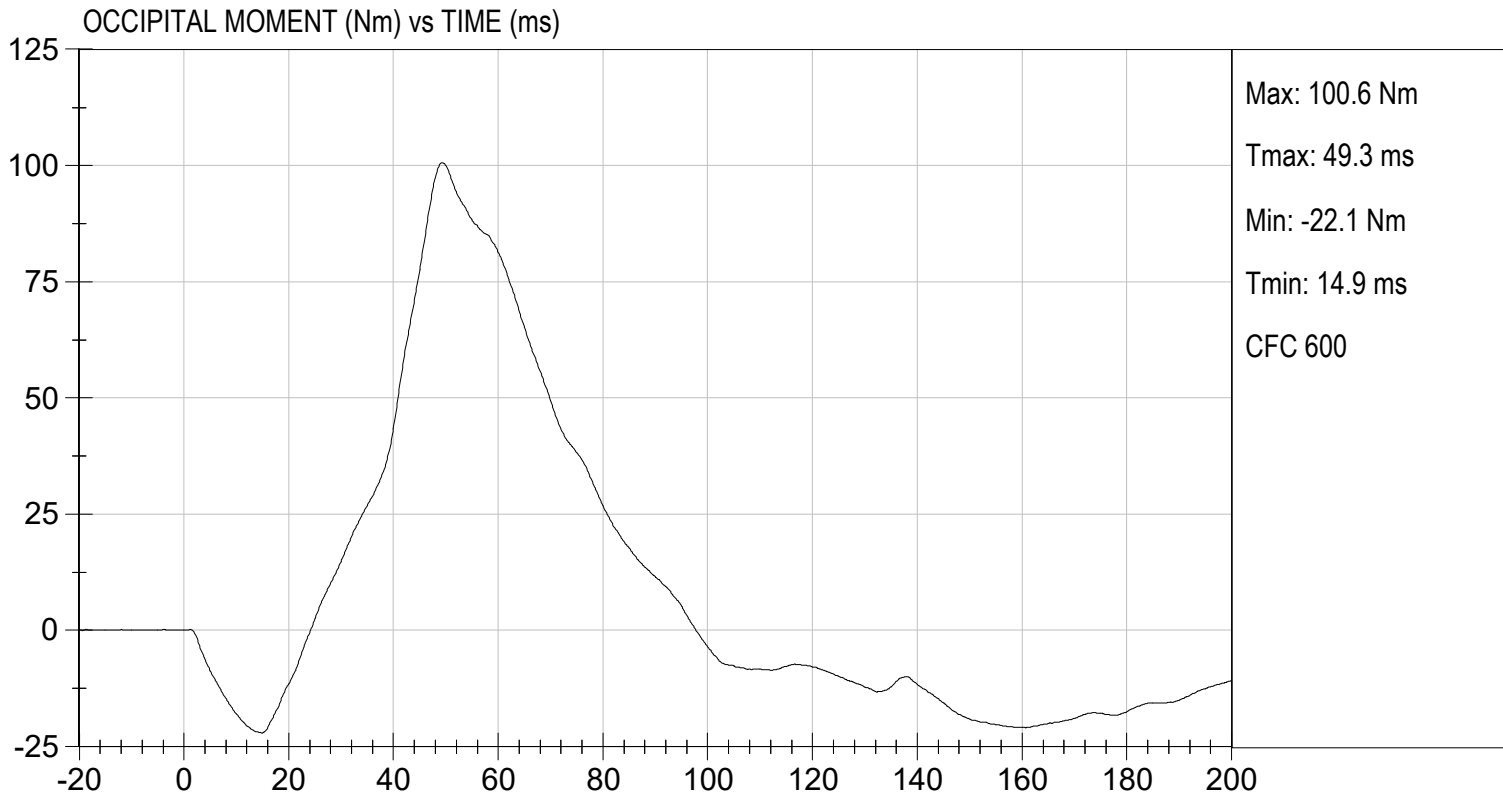

MGA RESEARCH CORPORATION
NECK EXTENSION TEST
HYBRID III 50TH PERCENTILE MALE

ATD Serial No: 064

Test I.D.: D241263

Tested Parameter		Units	Specification	Result	Pass/Fail
Laboratory Temperature		deg C	20.6 to 22.2	21.4	Pass
Laboratory Relative Humidity		%	10 to 70	45	Pass
Pendulum Velocity		m/s	5.95 to 6.19	6.05	Pass
Pendulum Deceleration	10 ms	G's	17.20 to 21.20	18.63	Pass
	20 ms	G's	14.00 to 19.00	17.02	Pass
	30 ms	G's	11.00 to 16.00	15.63	Pass
Peak Pendulum Deceleration After 30 ms		G's	<= 22.0	15.6	Pass
Deceleration Decay Time to Cross 5 G's		ms	38.0 to 46.0	39.7	Pass
Maximum "D" Plane Rotation	Maximum	Degrees	81.0 to 106.0	99.4	Pass
	Time	ms	72.0 to 82.0	76.8	Pass
"D" Plane Rotation Decay Time To Zero Crossing		ms	147.0 to 174.0	157.8	Pass
Moment About Occipital Condyle	Maximum	Nm	-52.9 to -79.9	-60.6	Pass
	Time	ms	65.0 to 79.0	74.5	Pass
Negative Moment Decay Time To Zero Crossing		ms	120.0 to 148.0	143.3	Pass
Overall Test Results					Pass

 Laboratory Technician

05/24/2024
 Test Date

 Approved By

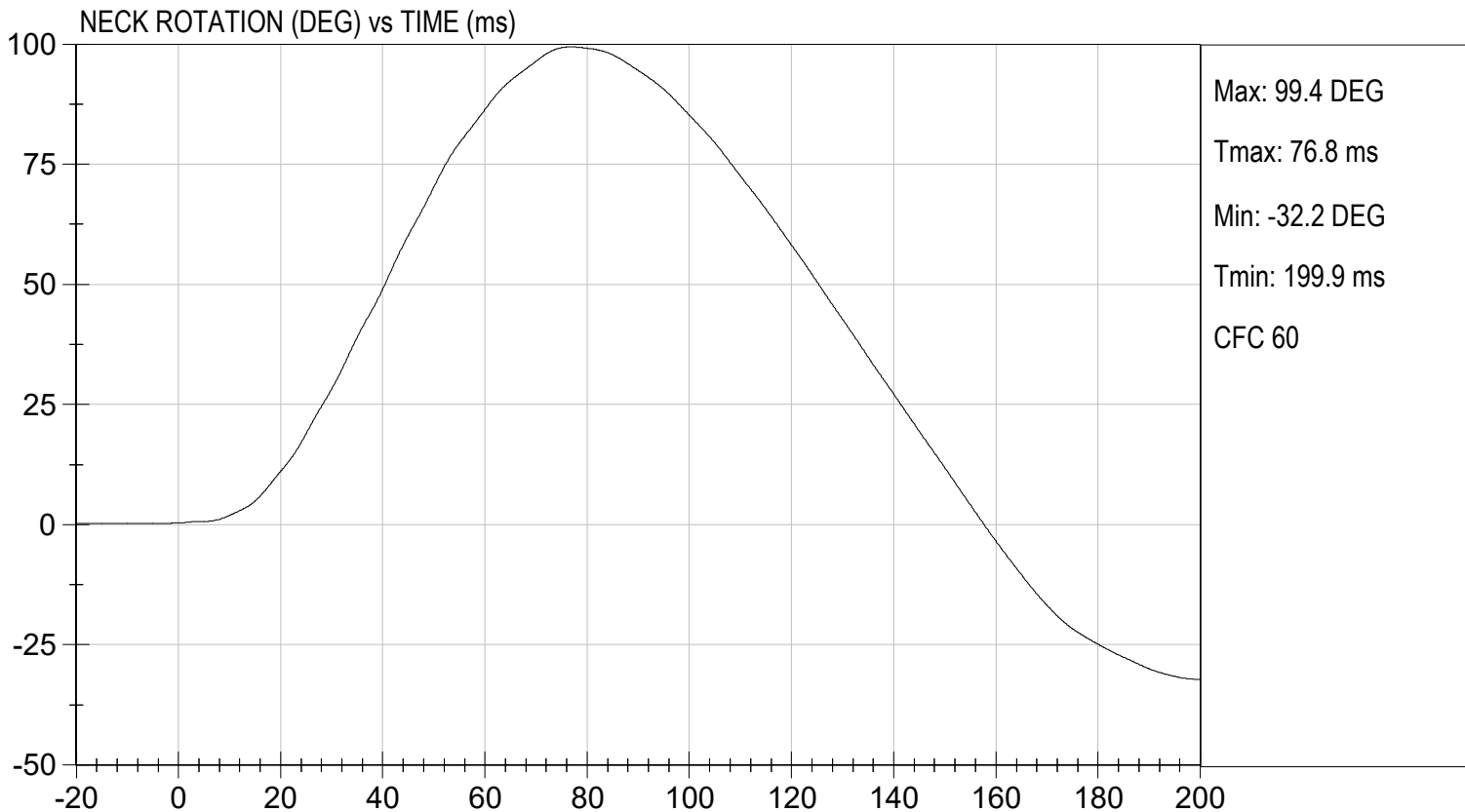
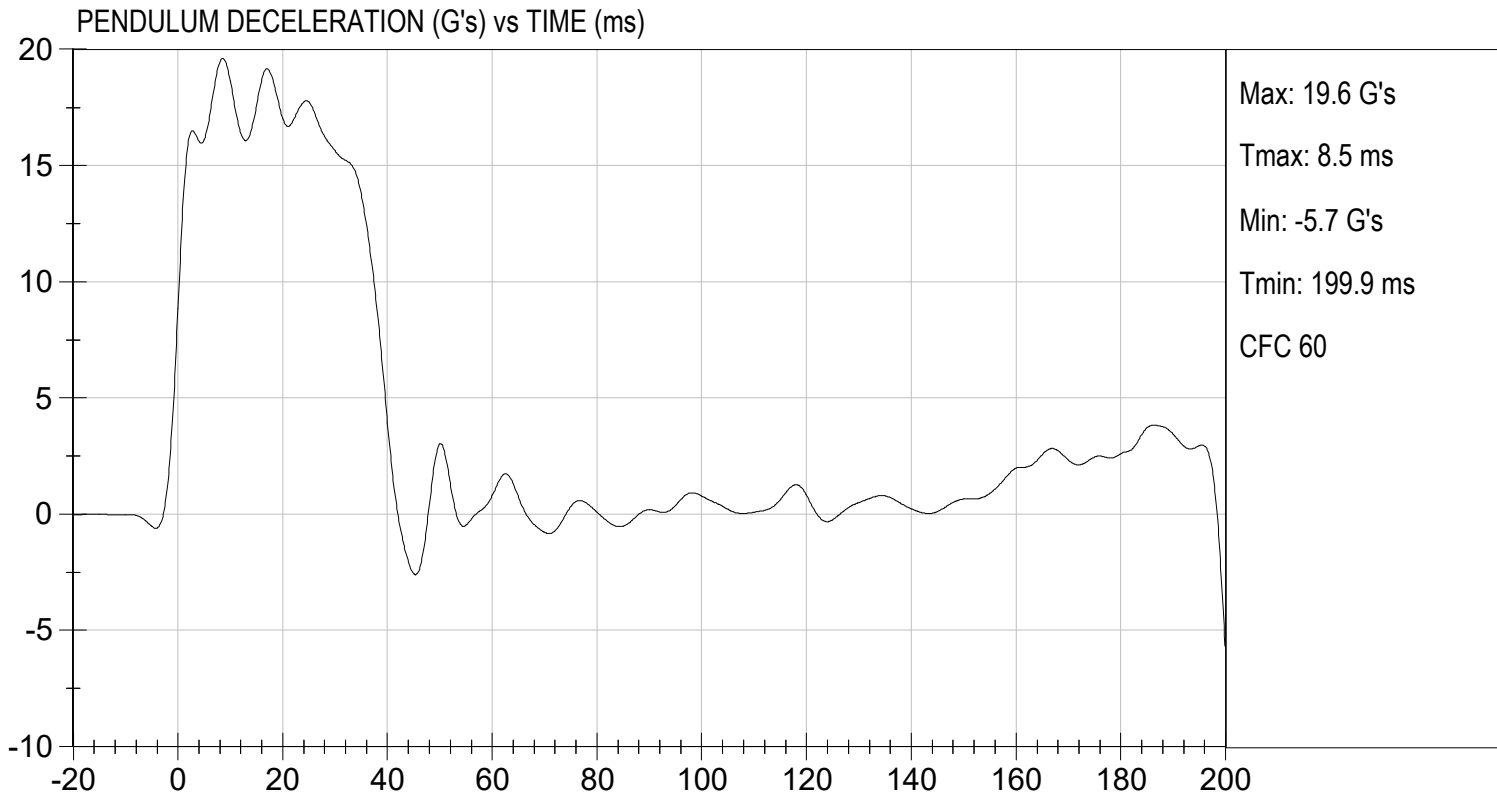



MGA RESEARCH CORPORATION
THORAX IMPACT
HYBRID III 50TH PERCENTILE MALE

ATD Serial No: 064

Test I.D.: D241264

Tested Parameter	Units	Specification	Result	Pass/Fail
Laboratory Temperature	deg C	20.6 to 22.2	21.3	Pass
Laboratory Relative Humidity	%	10 to 70	44	Pass
Probe Velocity	m/s	6.58 to 6.82	6.77	Pass
Peak Probe Force	N	5159 to 5893	5,425	Pass
Peak Sternum Displacement	cm	6.35 to 7.26	6.95	Pass
Internal Hysteresis	%	69 to 85	72	Pass
Overall Test Results				Pass

 Laboratory Technician

05/24/2024
 Test Date

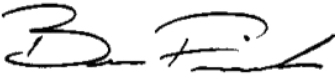
 Approved By

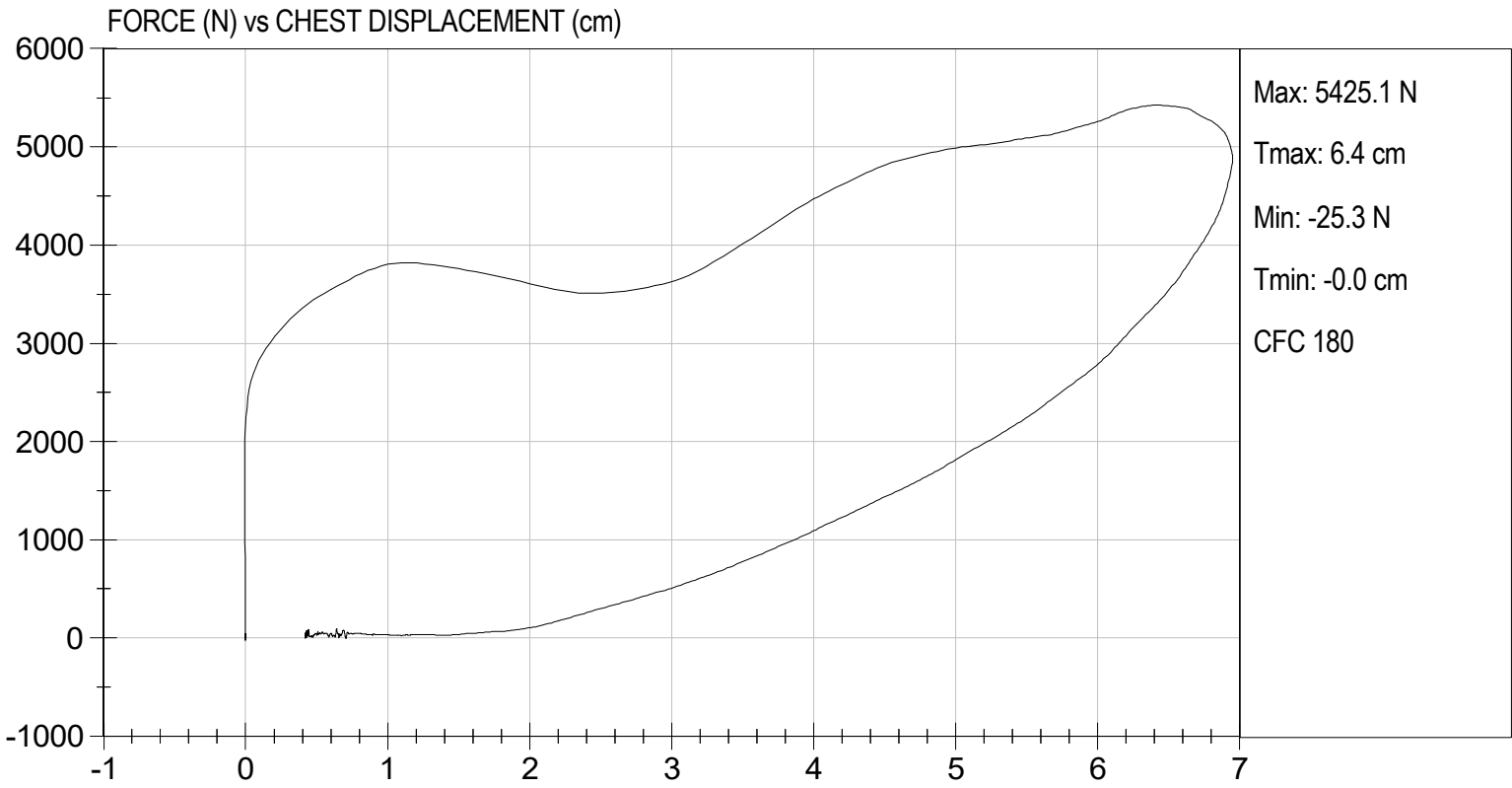

MGA RESEARCH CORPORATION
RIGHT KNEE IMPACT TEST
HYBRID III 50TH PERCENTILE MALE

ATD Serial No: 064

Test I.D: D241265

Tested Parameter	Units	Specification	Result	Pass/Fail
Laboratory Temperature	deg C	18.9 to 25.6	21.3	Pass
Laboratory Relative Humidity	%	10 to 70	44	Pass
Probe Velocity	m/s	2.07 to 2.13	2.10	Pass
Peak Probe Force	N	4715 to 5782	5,082	Pass
Overall Test Results				Pass



Laboratory Technician

05/24/2024

Test Date

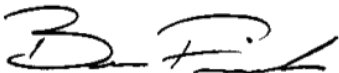

Approved By



TEST DESC: RIGHT KNEE
VELOCITY: 6.89 ft/s, 2.10 m/s

TEST DATE: 05/24/2024
TEST #: D241265

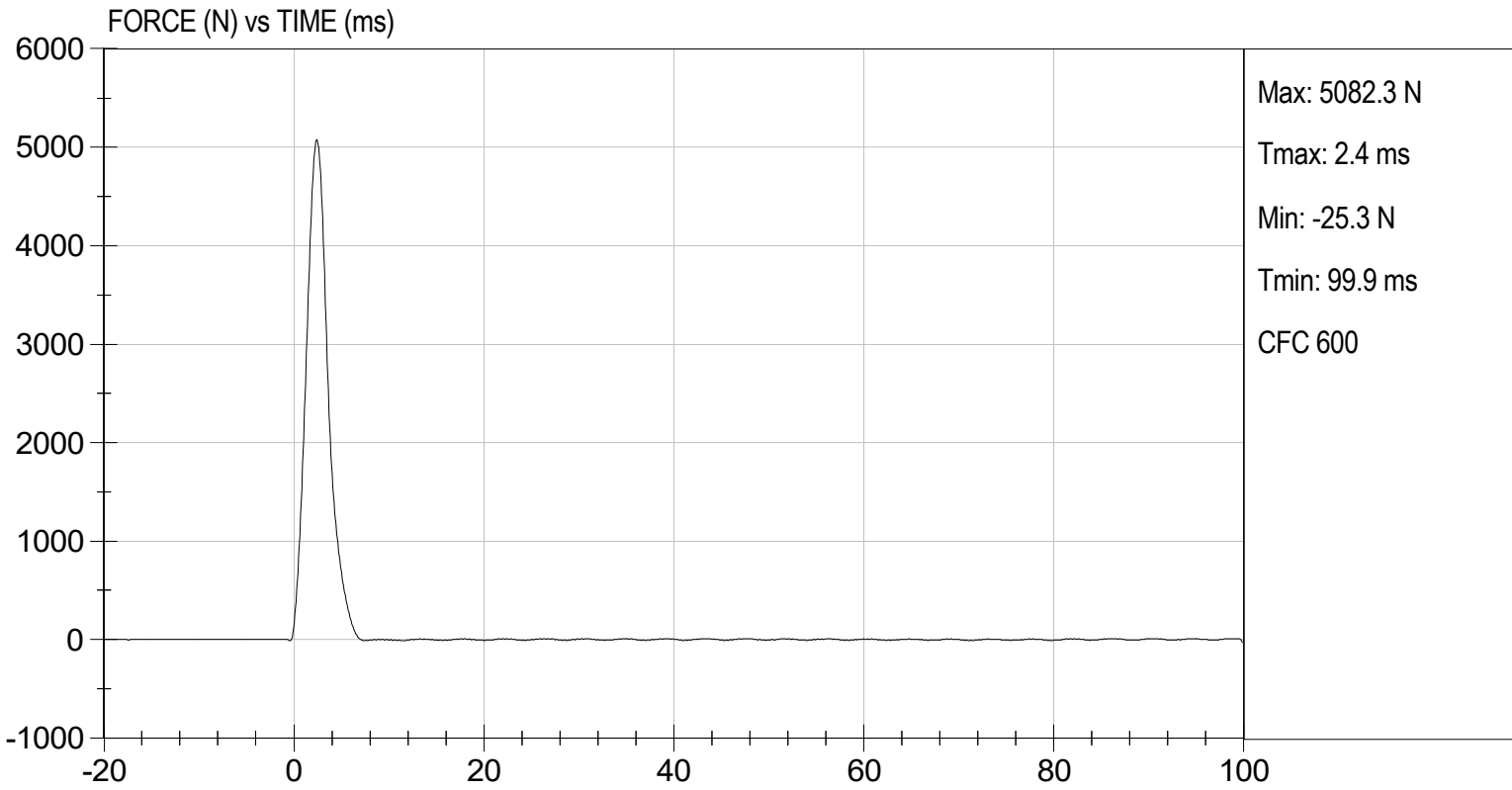

MGA RESEARCH CORPORATION
LEFT KNEE IMPACT TEST
HYBRID III 50TH PERCENTILE MALE

ATD Serial No: 064

Test I.D: D241266

Tested Parameter	Units	Specification	Result	Pass/Fail
Laboratory Temperature	deg C	18.9 to 25.6	21.3	Pass
Laboratory Relative Humidity	%	10 to 70	44	Pass
Probe Velocity	m/s	2.07 to 2.13	2.09	Pass
Peak Probe Force	N	4715 to 5782	4,953	Pass
Overall Test Results				Pass



Laboratory Technician

05/24/2024

Test Date

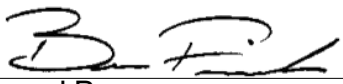

Approved By



TEST DESC: LEFT KNEE
VELOCITY: 6.86 ft/s, 2.09 m/s

TEST DATE: 05/24/2024
TEST #: D241266

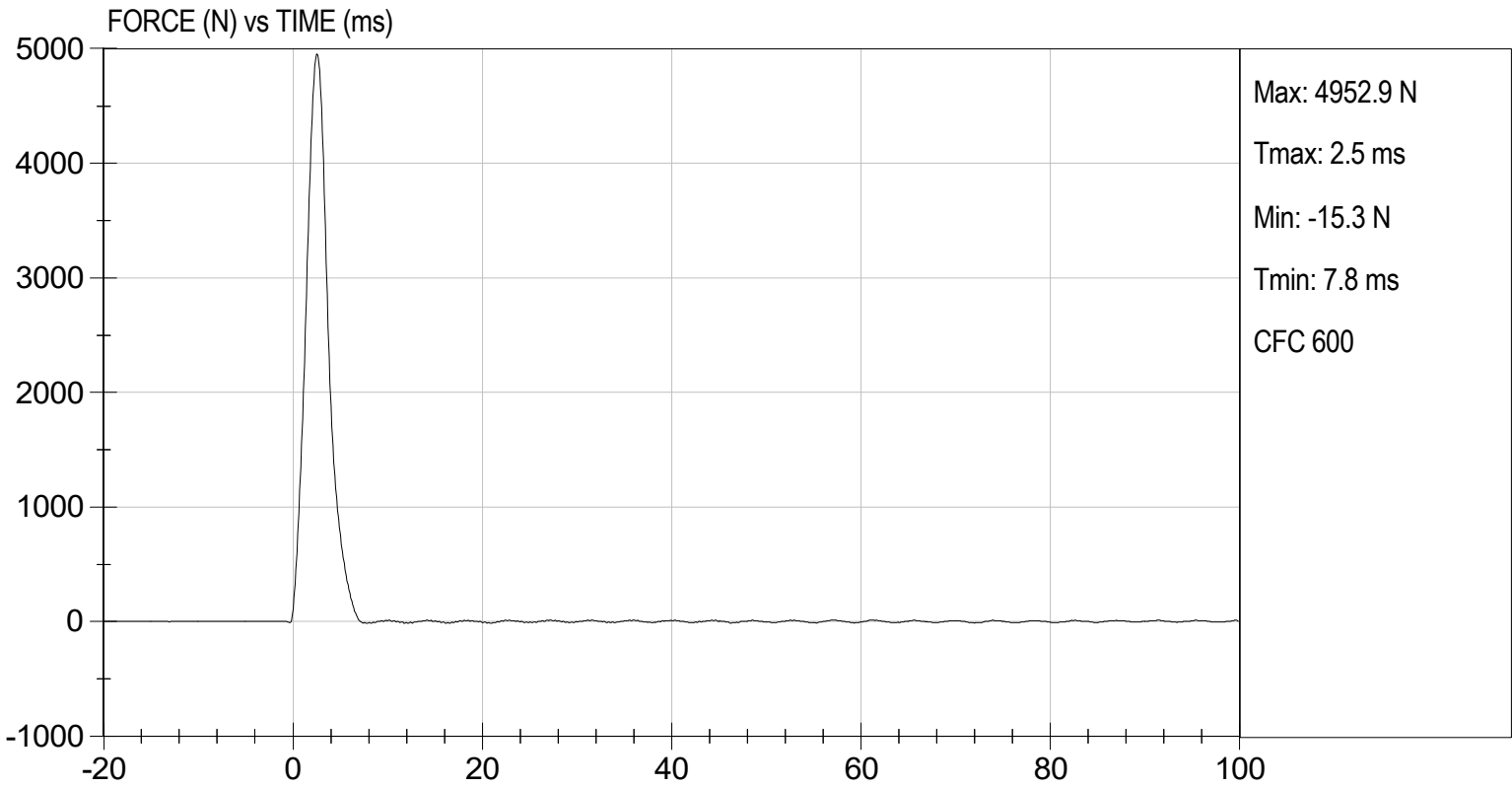

MGA RESEARCH CORPORATION
HIP-FEMUR FLEXION TEST
HYBRID III 50TH PERCENTILE MALE

ATD Serial No: 064

Test I.D: D241260

Tested Parameter	Units	Specification	Result		Pass/Fail
			Right	Left	
Laboratory Temperature	deg C	18.9 to 25.6	21.3	21.3	Pass
Laboratory Relative Humidity	%	10 to 70	45	45	Pass
Rotation Rate	deg/s	5.0 to 10.0	6.5	6.5	Pass
30 Degrees	Nm	94.9 Nm Max	84.9	82.9	Pass
150 ft-lbf / 203.4 Nm	Deg	40.0 to 50.0 Degree Max Rotation	47.5	47.1	Pass
Overall Test Results					Pass

 Laboratory Technician

05/24/2024
 Test Date

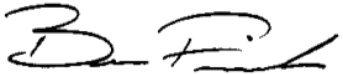
 Approved By

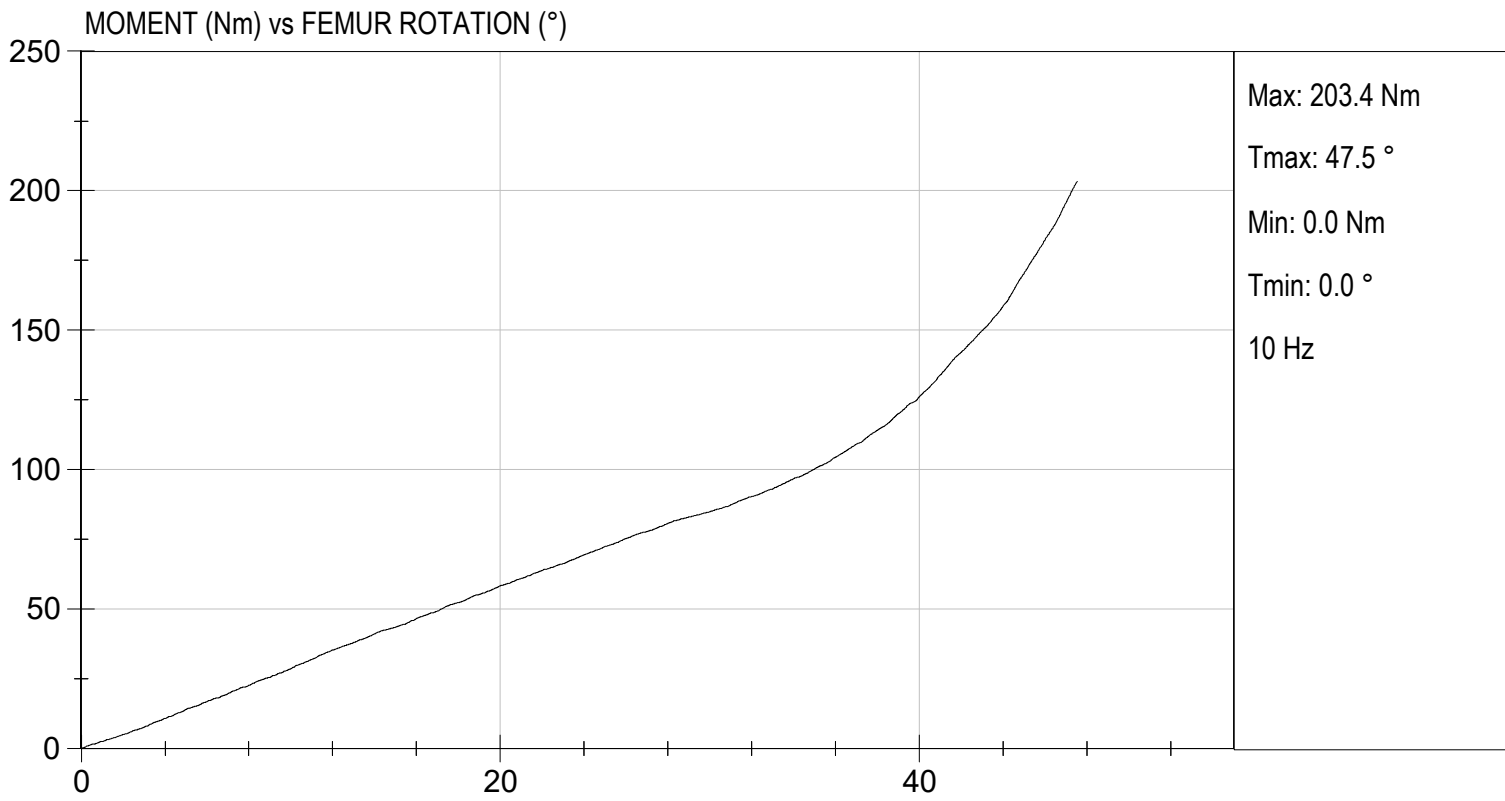

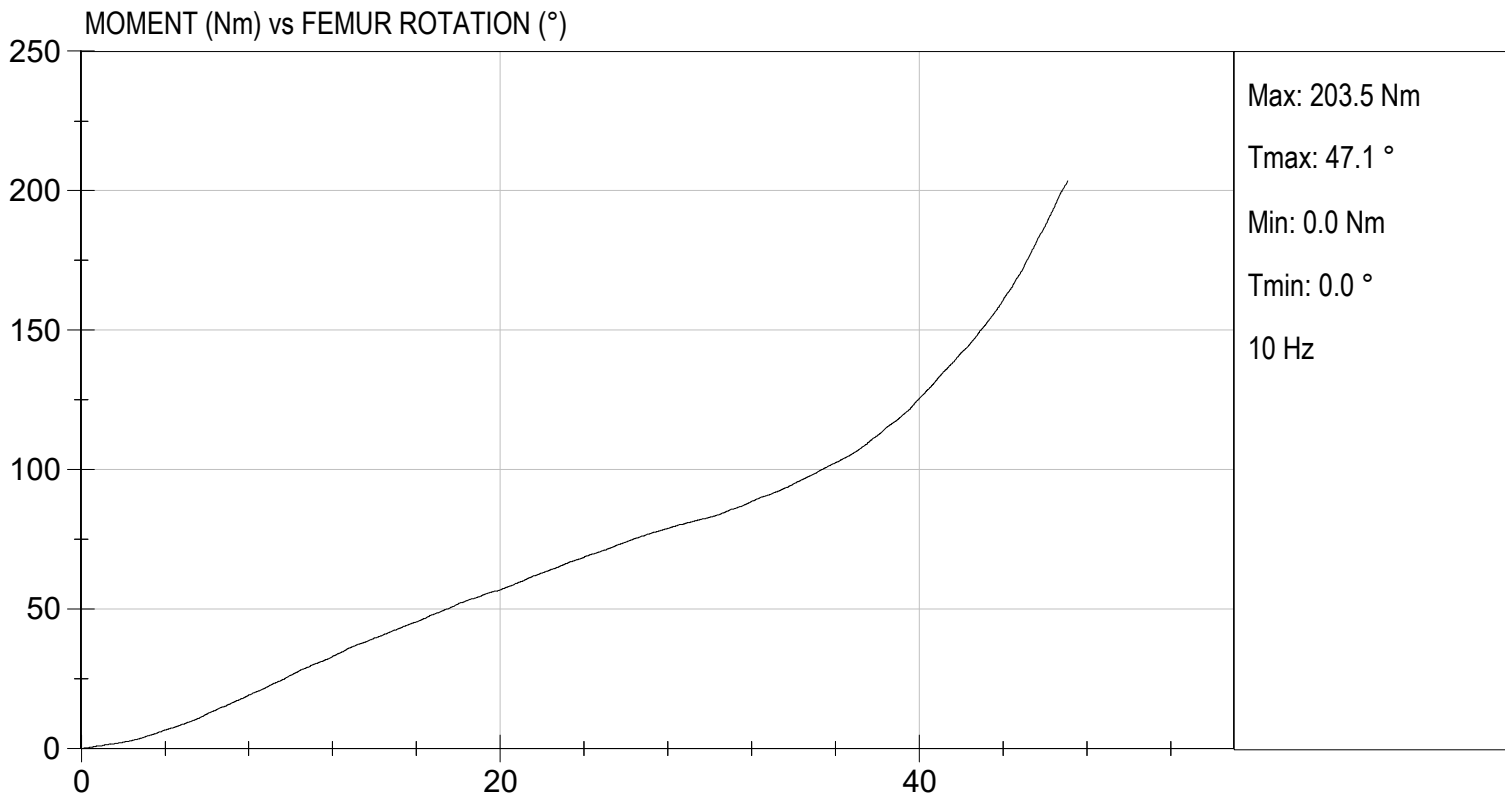

QUALIFICATION TEST RESULTS

POST-TEST

HYBRID III 50TH PERCENTILE MALE - DRIVER ATD

MGA RESEARCH CORPORATION
HEAD DROP TEST
HYBRID III 50TH PERCENTILE MALE

ATD Serial No: 064

Test ID: D241331

Tested Parameter	Units	Specification	Result	Pass/Fail
Laboratory Temperature	deg C	18.9 to 25.6	21.4	Pass
Laboratory Relative Humidity	%	10 to 70	46	Pass
Peak Resultant Acceleration	G's	225 to 275	231	Pass
Peak Lateral Acceleration	G's	<= +/- 15.0	-1.6	Pass
Unimodal	N/A	Yes	Yes	Pass
Oscillations	N/A	within 10% of peak	Yes	Pass
			Overall Test Results	Pass

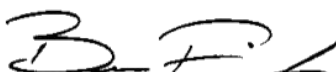

 Laboratory Technician

06/03/2024
 Test Date



 Approved By

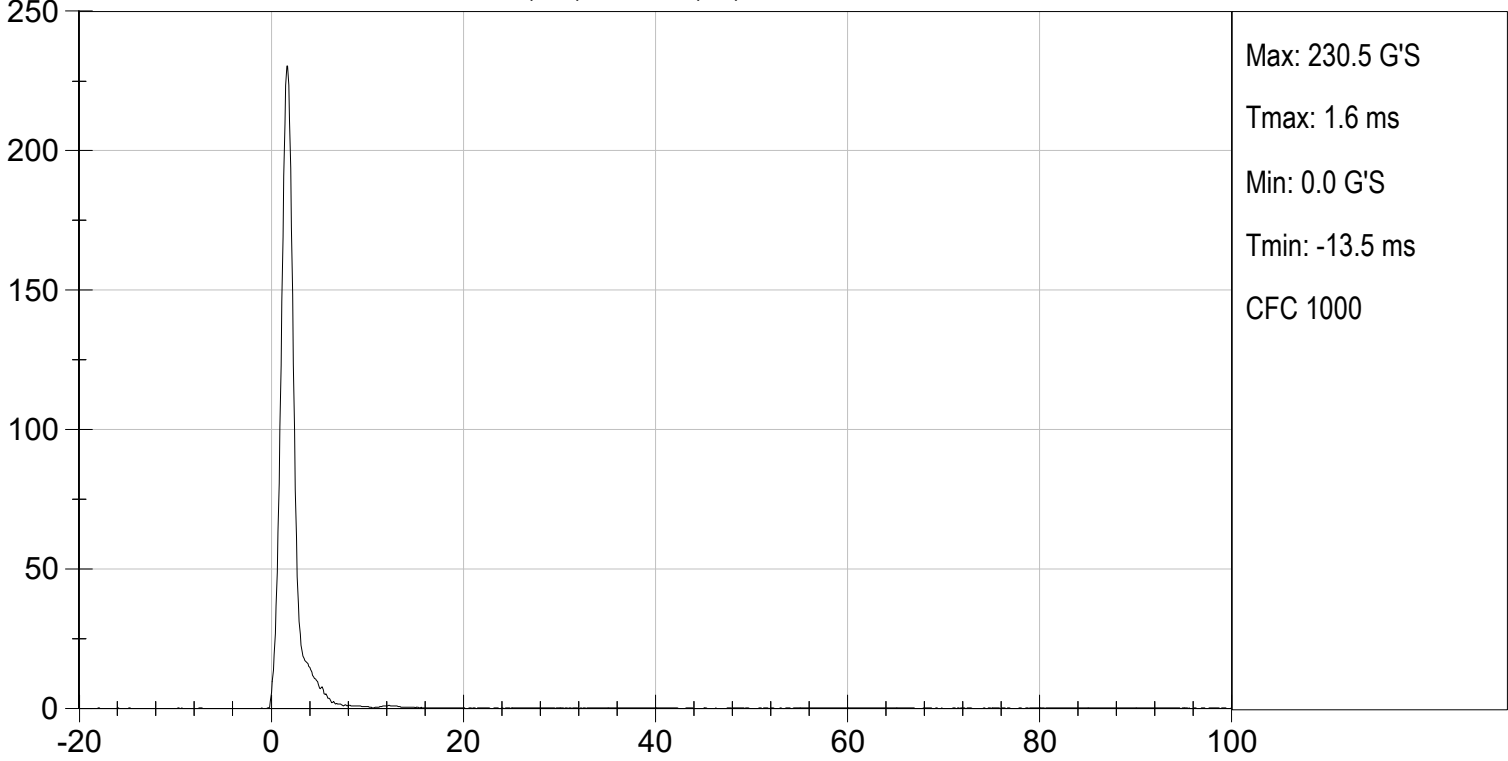

HEAD RESULTANT ACCELERATION (G'S) vs TIME (ms)

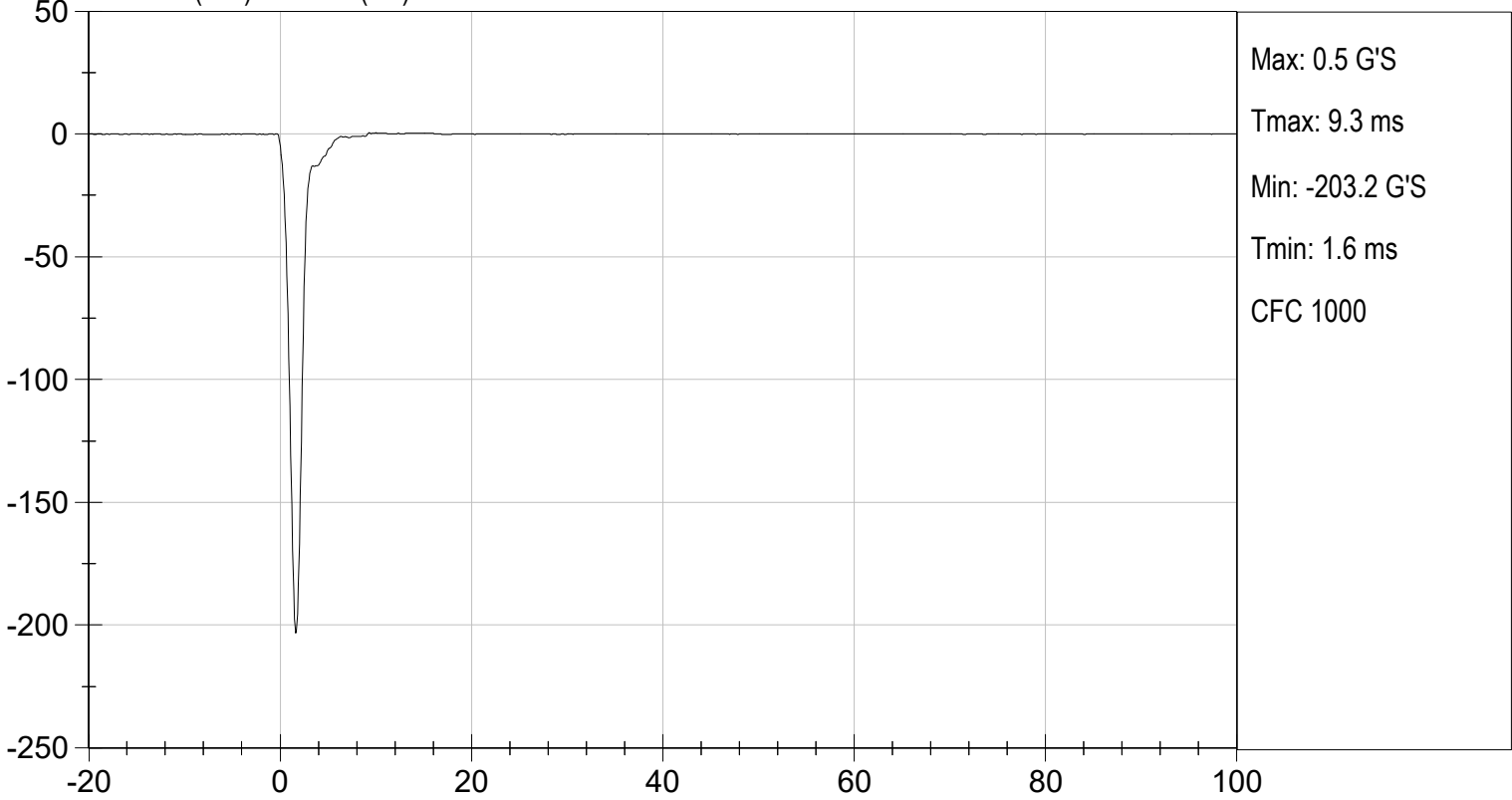

HEAD X (G'S) vs TIME (ms)



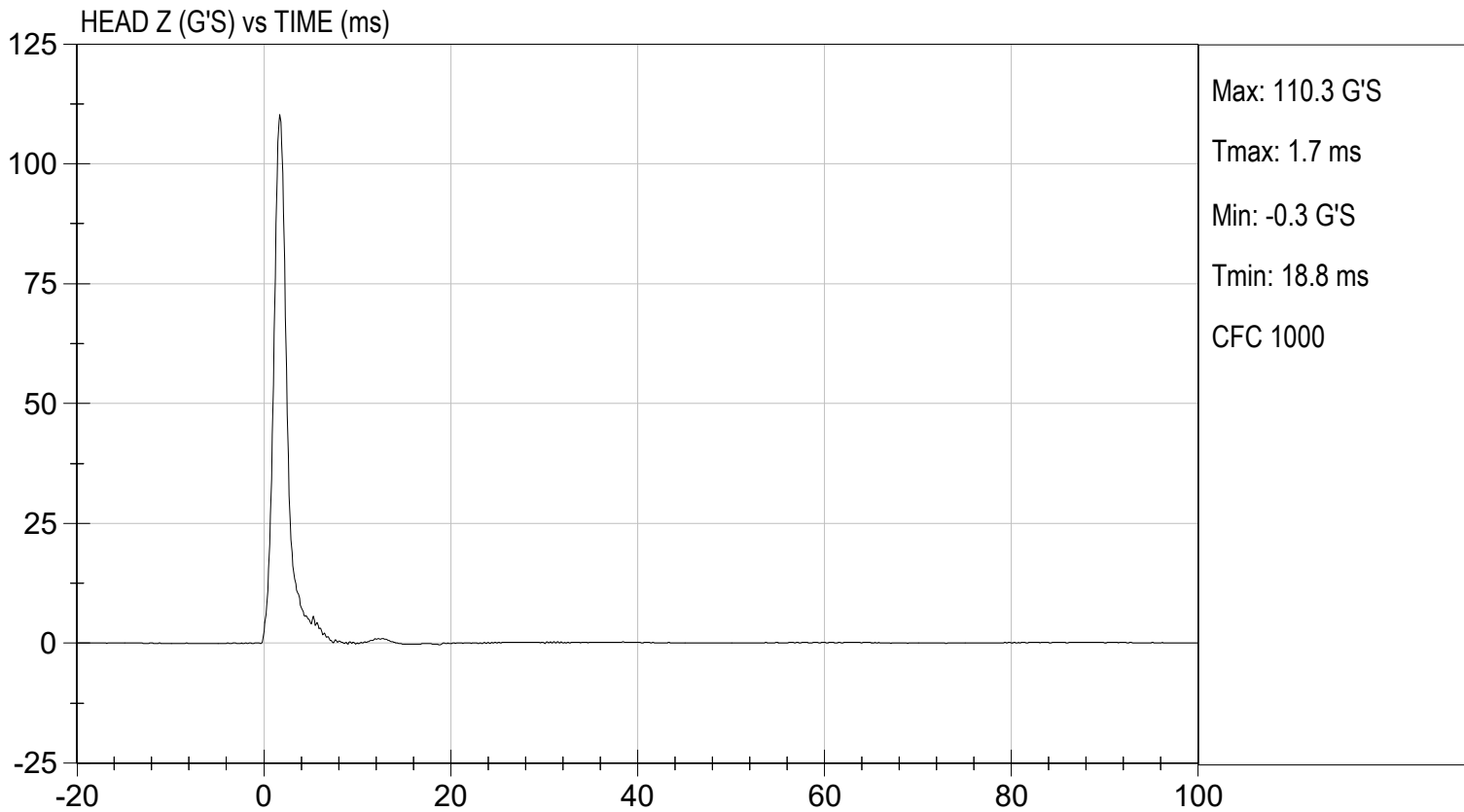
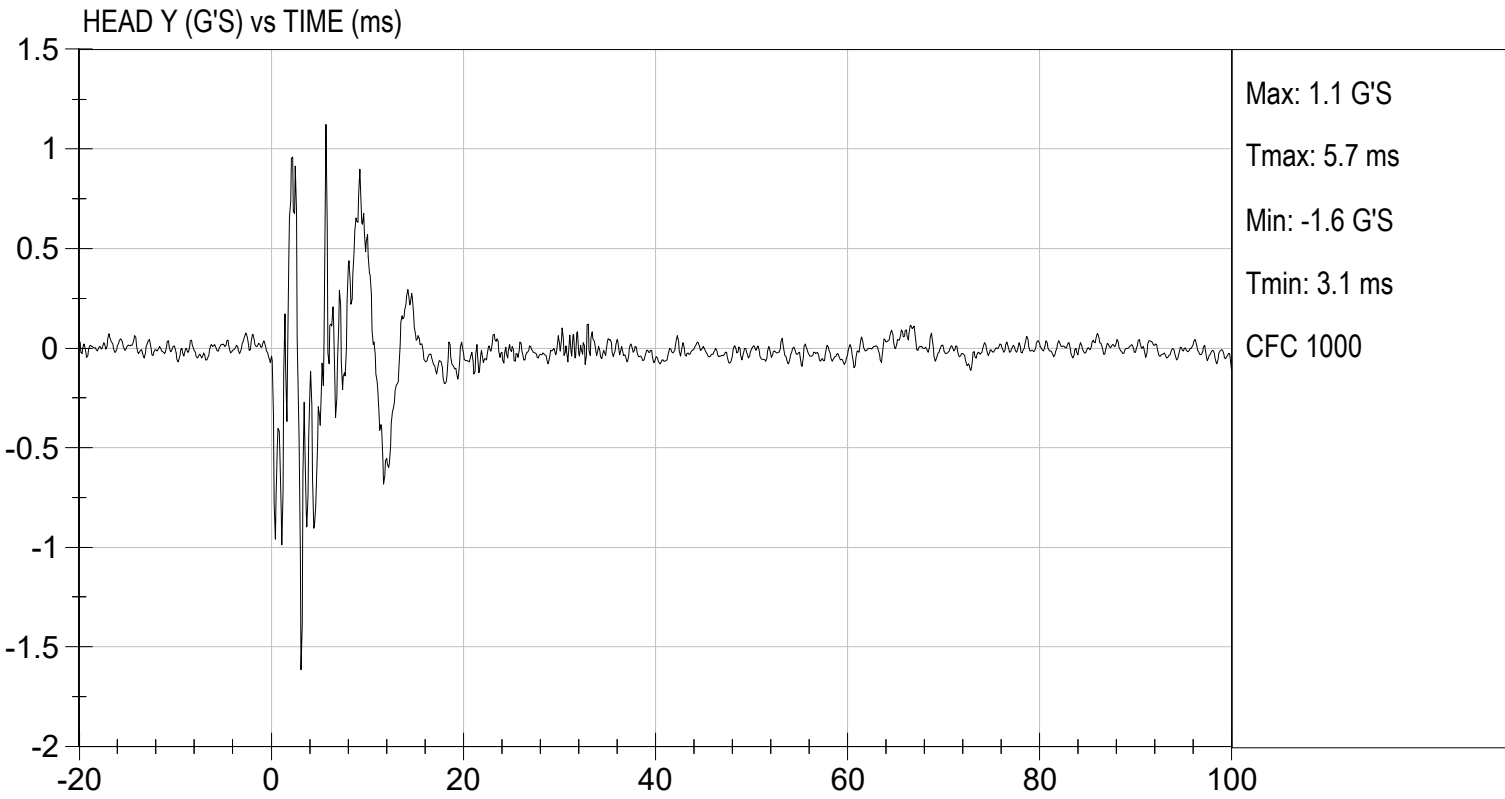

MGA RESEARCH CORPORATION
NECK FLEXION TEST
HYBRID III 50TH PERCENTILE MALE

ATD Serial No: 064

Test I.D.: D241332

Tested Parameter		Units	Specification	Result	Pass/Fail
Laboratory Temperature		deg C	20.6 to 22.2	21.4	Pass
Laboratory Relative Humidity		%	10 to 70	46	Pass
Pendulum Velocity		m/s	6.89 to 7.13	6.96	Pass
Pendulum Deceleration	10 ms	G's	22.50 to 27.50	23.91	Pass
	20 ms	G's	17.60 to 22.60	20.55	Pass
	30 ms	G's	12.50 to 18.50	16.59	Pass
Peak Pendulum Deceleration After 30 ms		G's	<= 29.0	16.6	Pass
Deceleration Decay Time to Cross 5 G's		ms	34.0 to 42.0	38.2	Pass
Maximum "D" Plane Rotation	Maximum	Deg	64.0 to 78.0	72.3	Pass
	Time	ms	57.0 to 64.0	60.7	Pass
"D" Plane Rotation Decay Time To Zero Crossing		ms	113.0 to 128.0	114.3	Pass
Moment About Occipital Condyle	Maximum	Nm	88.1 to 108.5	100.2	Pass
	Time	ms	47.0 to 58.0	50.1	Pass
Positive Moment Decay Time To Zero Crossing		ms	97.0 to 107.0	97.1	Pass
Overall Test Results					Pass

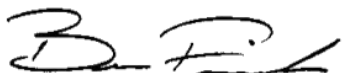

 Laboratory Technician

06/03/2024
 Test Date



 Approved By

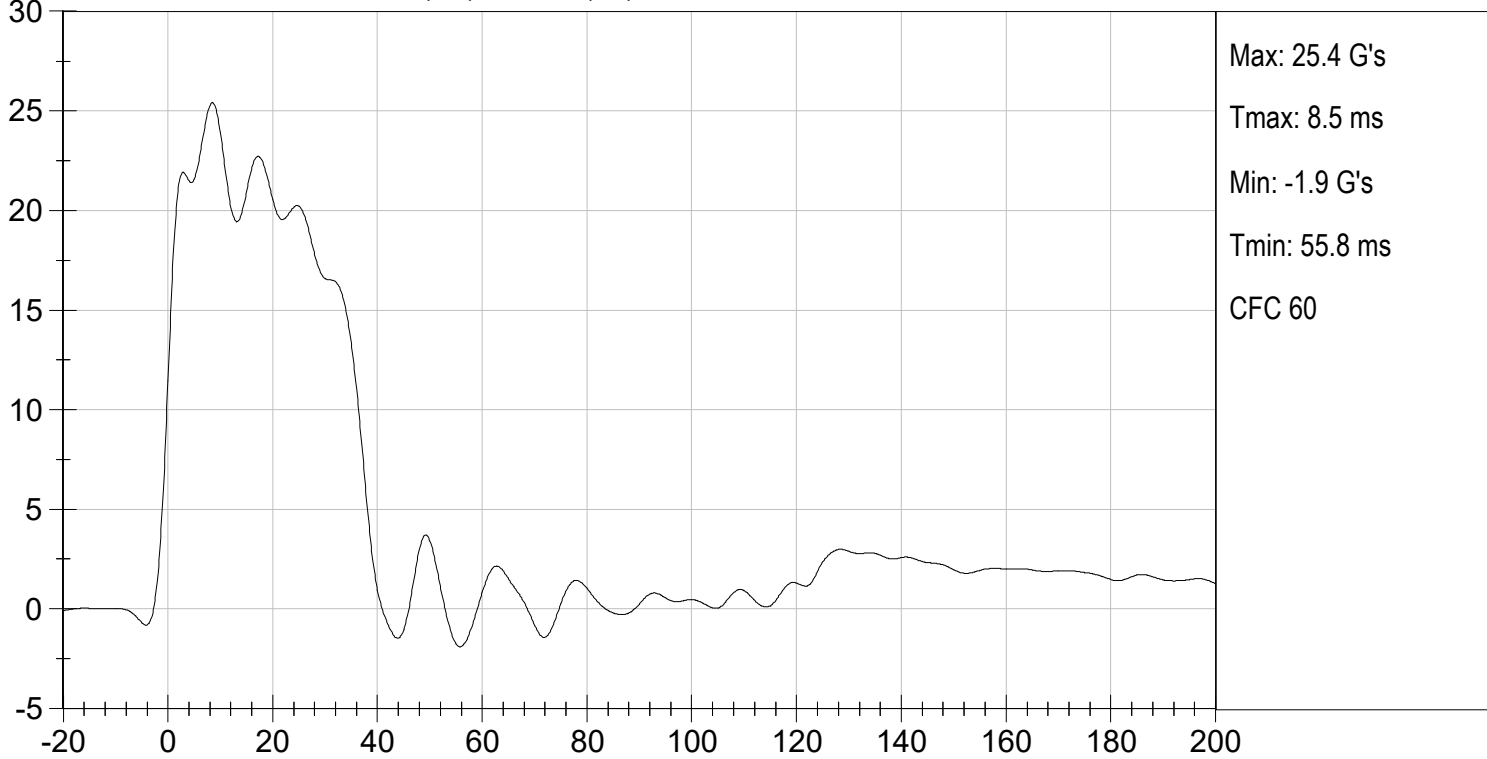

PENDULUM DECELERATION (G's) vs TIME (ms)

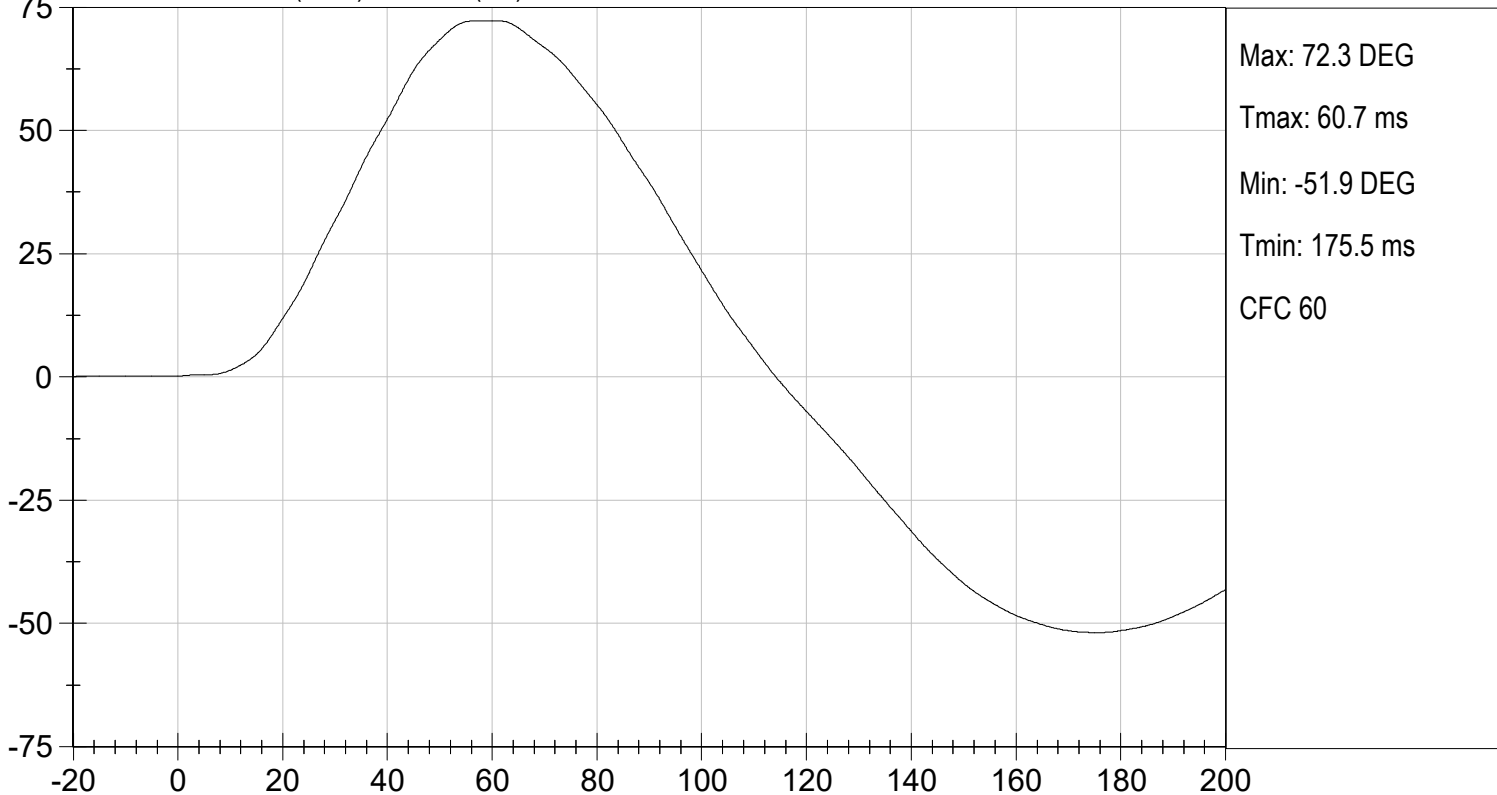

NECK ROTATION (DEG) vs TIME (ms)



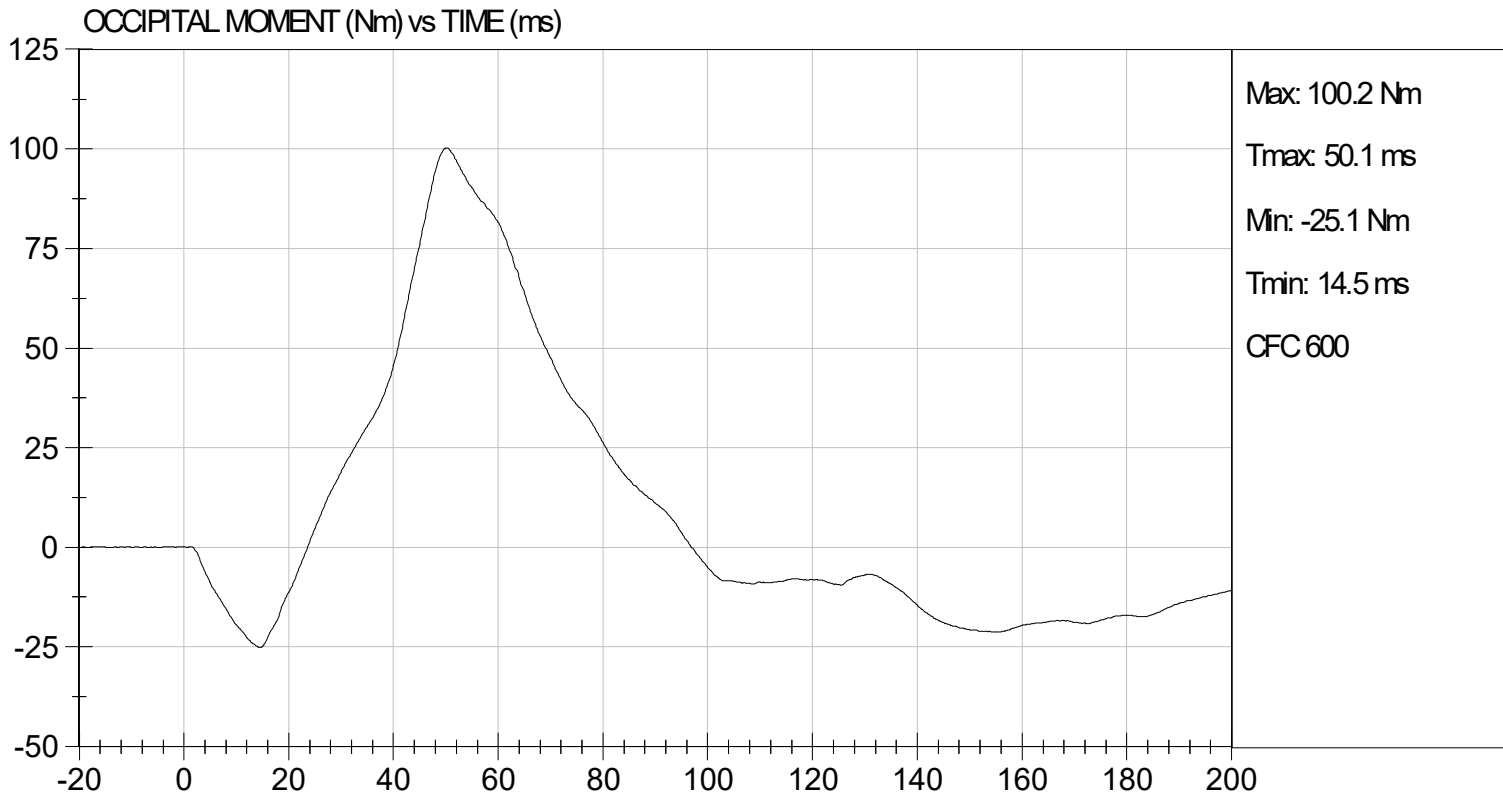

MGA RESEARCH CORPORATION
NECK EXTENSION TEST
HYBRID III 50TH PERCENTILE MALE

ATD Serial No: 064

Test I.D: D241333

Tested Parameter		Units	Specification	Result	Pass/Fail
Laboratory Temperature		deg C	20.6 to 22.2	21.4	Pass
Laboratory Relative Humidity		%	10 to 70	45	Pass
Pendulum Velocity		m/s	5.95 to 6.19	6.05	Pass
Pendulum Deceleration	10 ms	G's	17.20 to 21.20	17.88	Pass
	20 ms	G's	14.00 to 19.00	16.15	Pass
	30 ms	G's	11.00 to 16.00	15.90	Pass
Peak Pendulum Deceleration After 30 ms		G's	<= 22.0	15.9	Pass
Deceleration Decay Time to Cross 5 G's		ms	38.0 to 46.0	38.7	Pass
Maximum "D" Plane Rotation	Maximum	Degrees	81.0 to 106.0	99.5	Pass
	Time	ms	72.0 to 82.0	76.6	Pass
"D" Plane Rotation Decay Time To Zero Crossing		ms	147.0 to 174.0	157.6	Pass
Moment About Occipital Condyle	Maximum	Nm	-52.9 to -79.9	-63.2	Pass
	Time	ms	65.0 to 79.0	73.0	Pass
Negative Moment Decay Time To Zero Crossing		ms	120.0 to 148.0	143.6	Pass
Overall Test Results					Pass

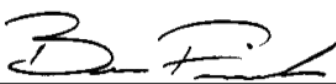

 Laboratory Technician

06/03/2024
 Test Date



 Approved By

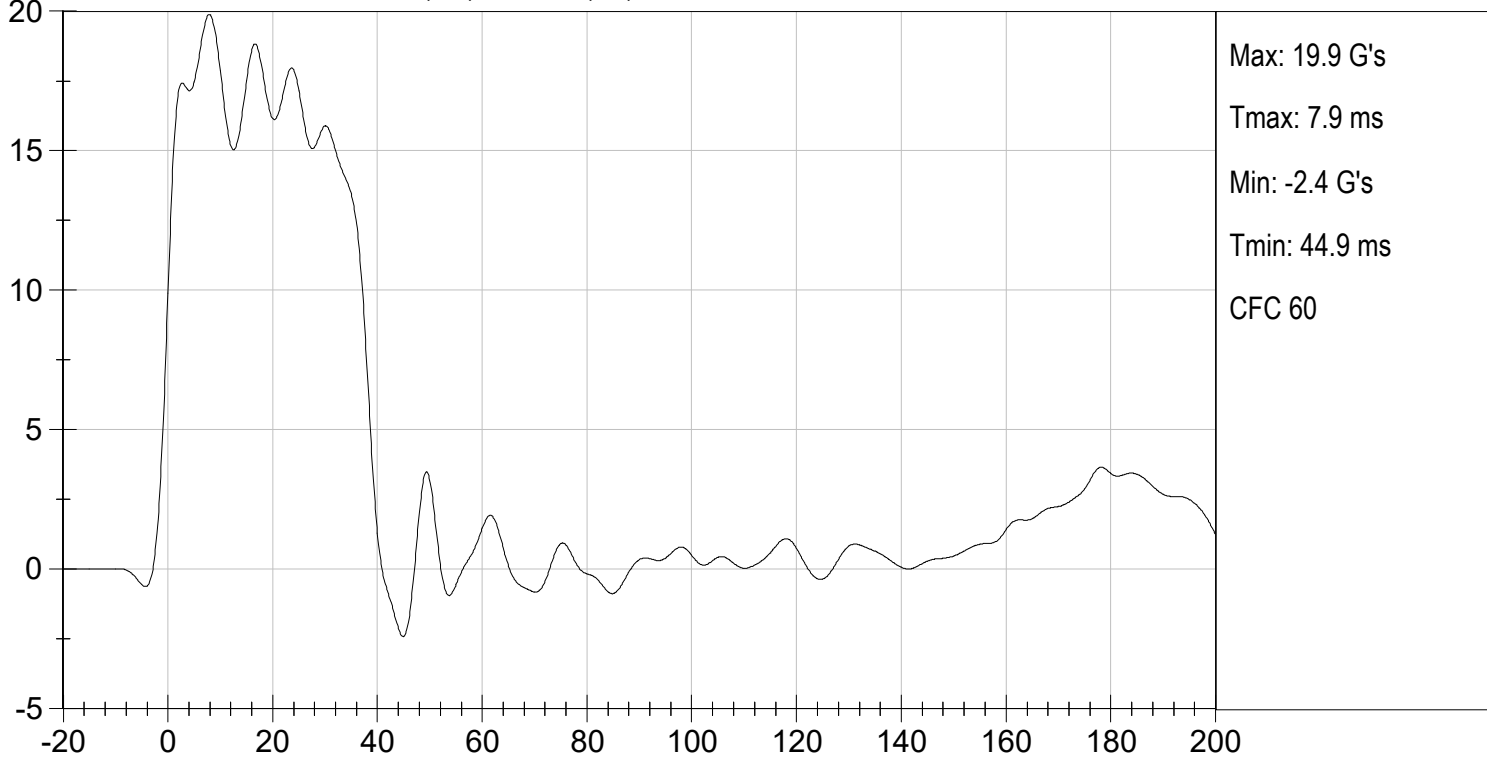

PENDULUM DECELERATION (G's) vs TIME (ms)

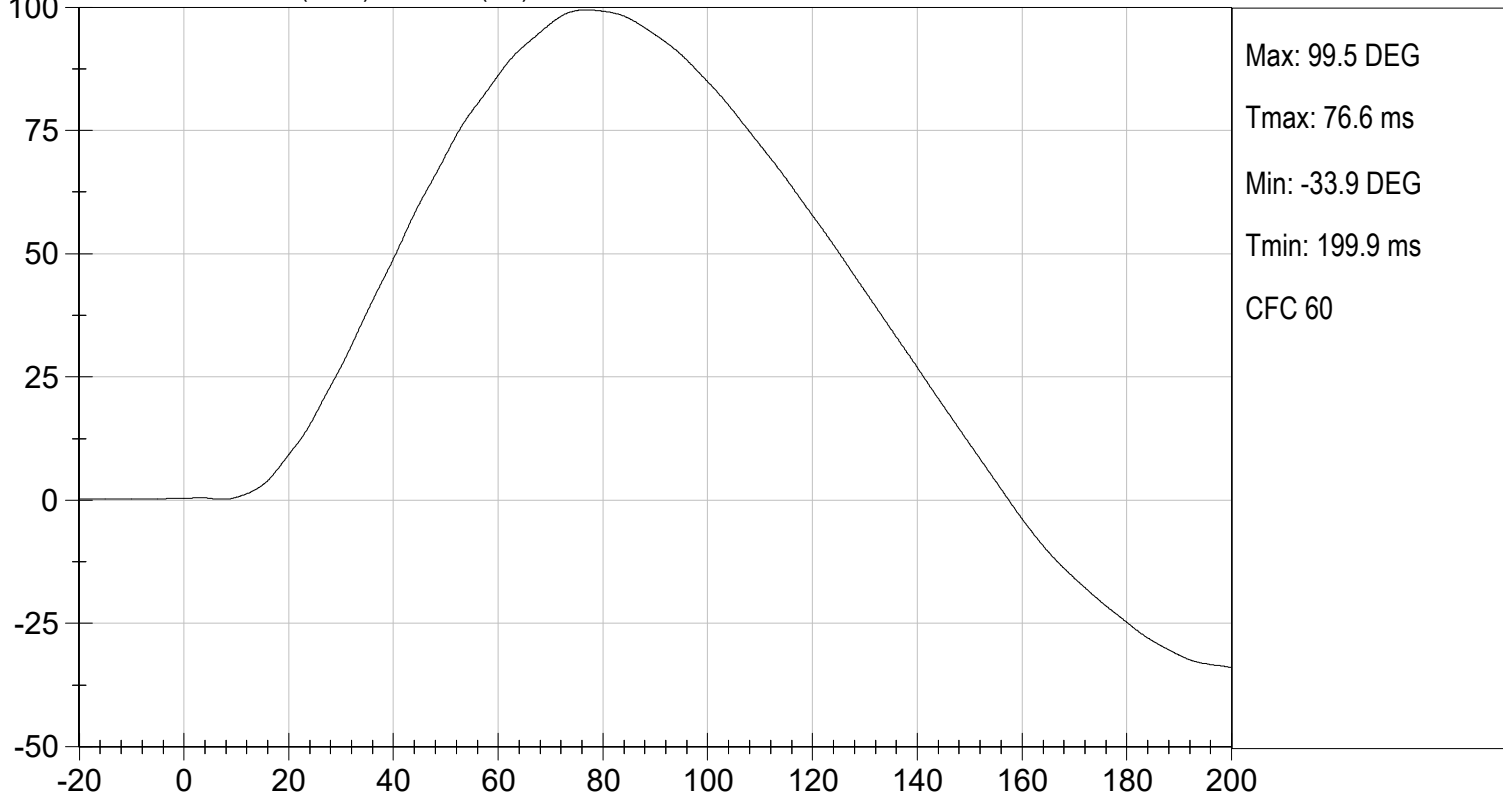

NECK ROTATION (DEG) vs TIME (ms)





MGA RESEARCH CORPORATION
THORAX IMPACT
HYBRID III 50TH PERCENTILE MALE

ATD Serial No: 064

Test I.D: D241334

Tested Parameter	Units	Specification	Result	Pass/Fail
Laboratory Temperature	deg C	20.6 to 22.2	21.4	Pass
Laboratory Relative Humidity	%	10 to 70	49	Pass
Probe Velocity	m/s	6.58 to 6.82	6.77	Pass
Peak Probe Force	N	5159 to 5893	5,279	Pass
Peak Sternum Displacement	cm	6.35 to 7.26	6.93	Pass
Internal Hysteresis	%	69 to 85	72	Pass
Overall Test Results				Pass

 Laboratory Technician

06/03/2024
 Test Date

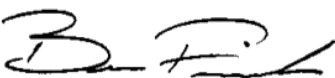
 Approved By

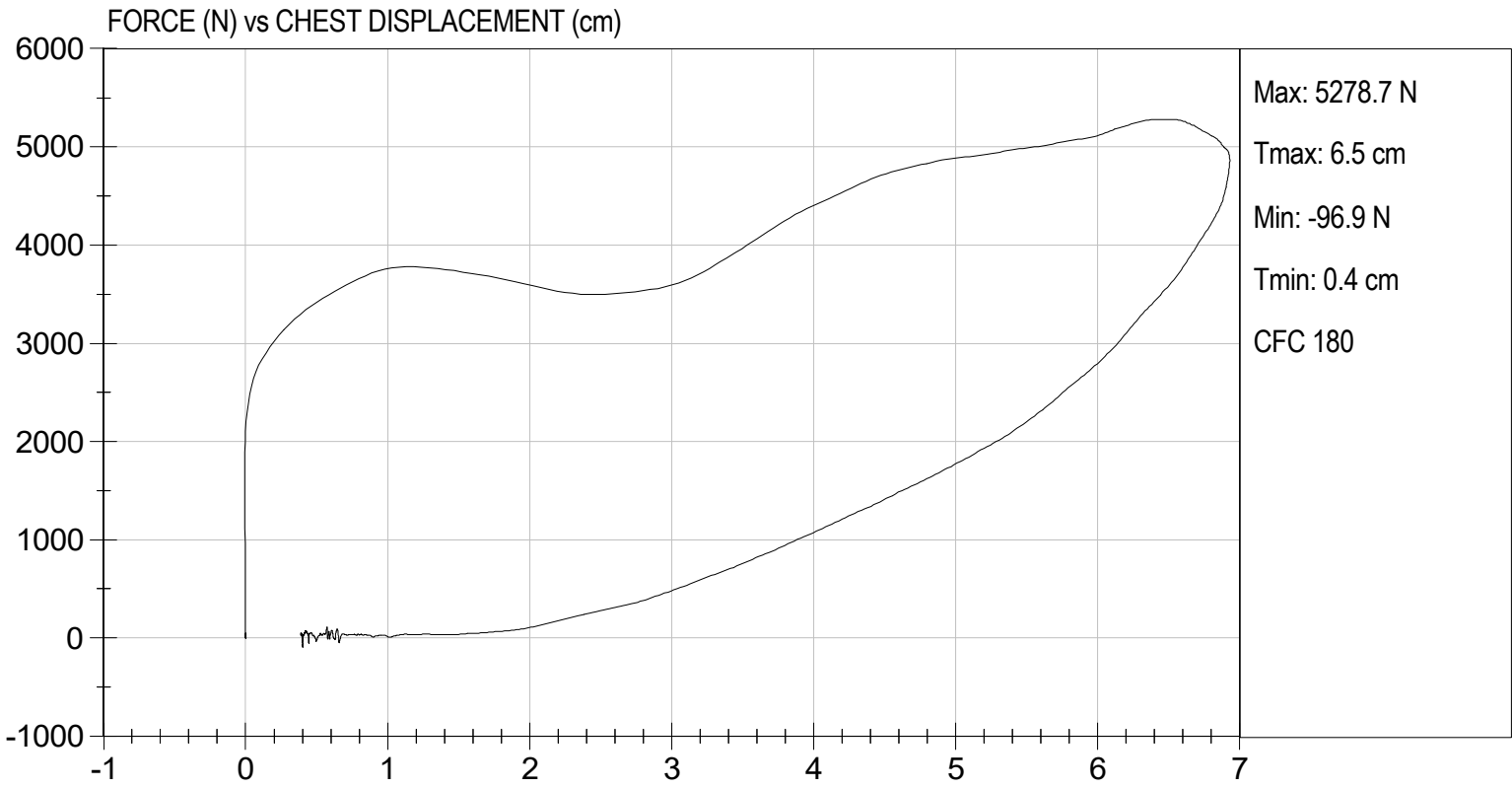

MGA RESEARCH CORPORATION
RIGHT KNEE IMPACT TEST
HYBRID III 50TH PERCENTILE MALE

ATD Serial No: 064

Test I.D: D241335

Tested Parameter	Units	Specification	Result	Pass/Fail
Laboratory Temperature	deg C	18.9 to 25.6	21.3	Pass
Laboratory Relative Humidity	%	10 to 70	48	Pass
Probe Velocity	m/s	2.07 to 2.13	2.08	Pass
Peak Probe Force	N	4715 to 5782	4,759	Pass
Overall Test Results				Pass



Laboratory Technician

06/03/2024

Test Date



Approved By

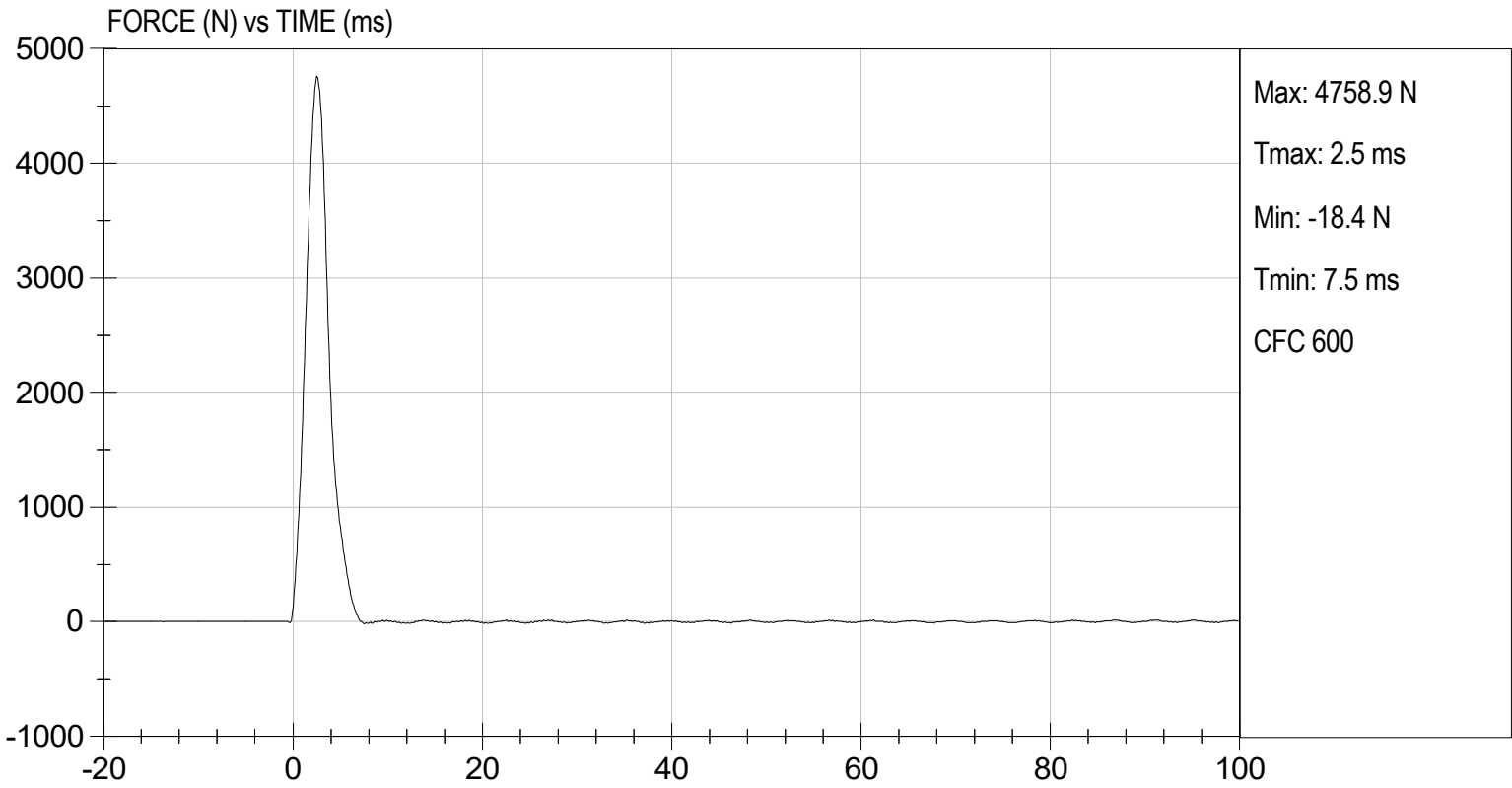

MGA RESEARCH CORPORATION
LEFT KNEE IMPACT TEST
HYBRID III 50TH PERCENTILE MALE

ATD Serial No: 064

Test I.D: D241336

Tested Parameter	Units	Specification	Result	Pass/Fail
Laboratory Temperature	deg C	18.9 to 25.6	21.3	Pass
Laboratory Relative Humidity	%	10 to 70	48	Pass
Probe Velocity	m/s	2.07 to 2.13	2.11	Pass
Peak Probe Force	N	4715 to 5782	5,179	Pass
Overall Test Results				Pass



Laboratory Technician

06/03/2024

Test Date

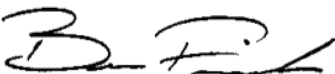

Approved By



TEST DESC: LEFT KNEE
VELOCITY: 6.92 ft/s, 2.11 m/s

TEST DATE: 06/03/2024
TEST #: D241336

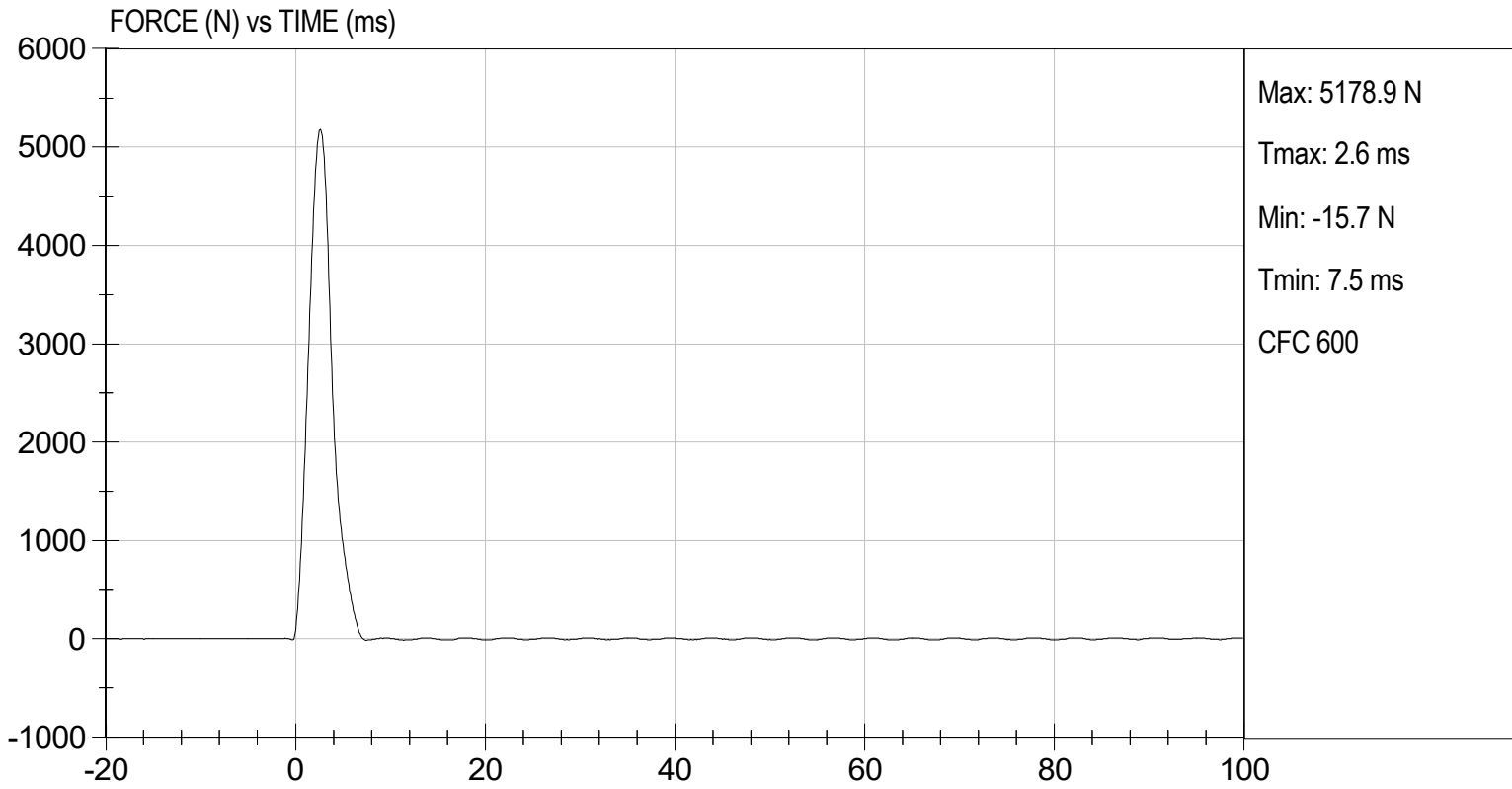

MGA RESEARCH CORPORATION
HIP-FEMUR FLEXION TEST
HYBRID III 50TH PERCENTILE MALE

ATD Serial No: 064

Test I.D: D241330

Tested Parameter	Units	Specification	Result		Pass/Fail
			Right	Left	
Laboratory Temperature	deg C	18.9 to 25.6	21.4	21.4	Pass
Laboratory Relative Humidity	%	10 to 70	45	45	Pass
Rotation Rate	deg/s	5.0 to 10.0	6.5	6.5	Pass
30 Degrees	Nm	94.9 Nm Max	82.3	83.1	Pass
150 ft-lbf / 203.4 Nm	Deg	40.0 to 50.0 Degree Max Rotation	48.1	47.2	Pass
Overall Test Results					Pass

 Laboratory Technician

06/03/2024
 Test Date

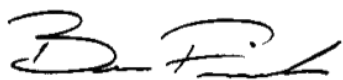
 Approved By

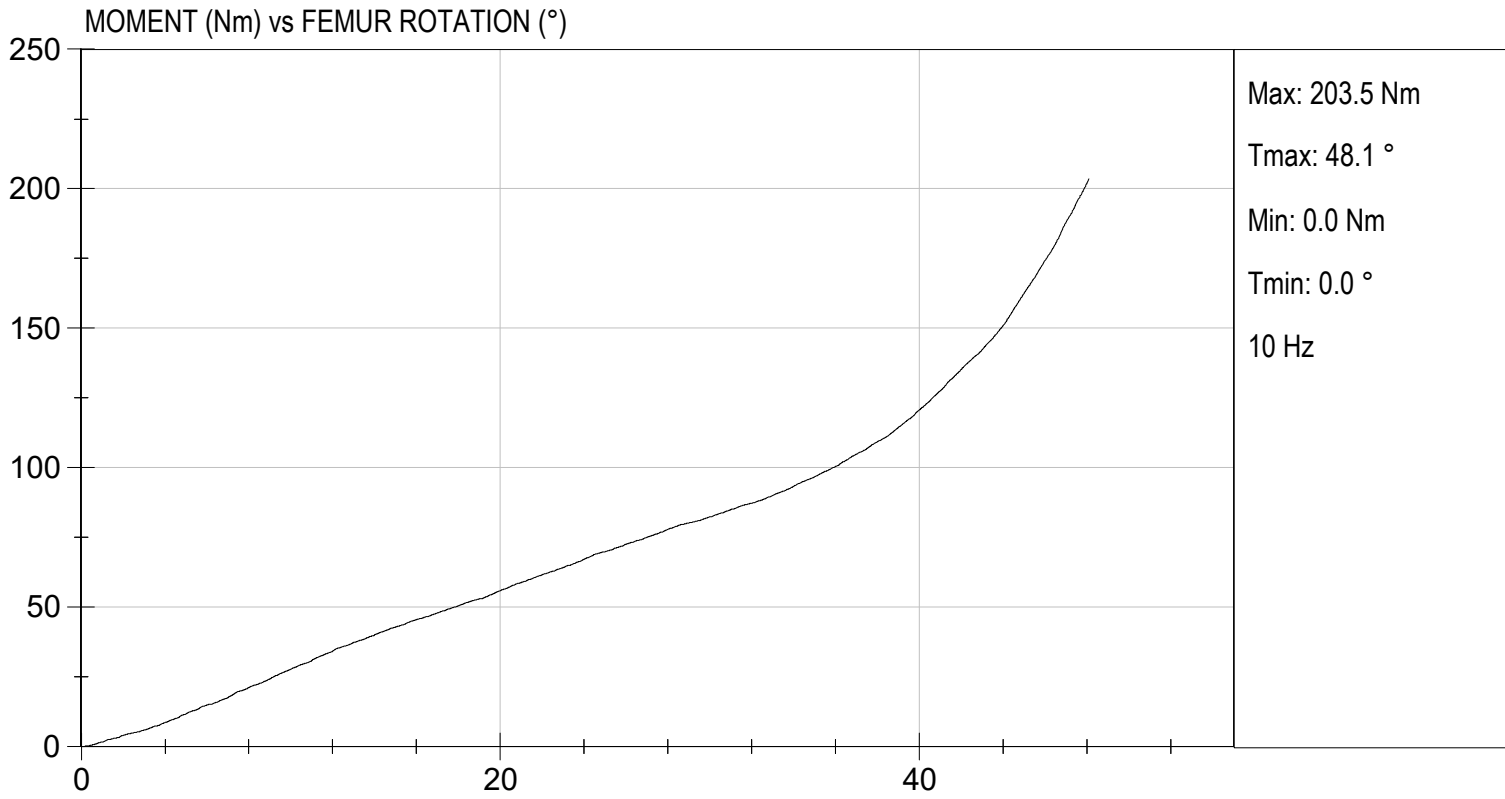

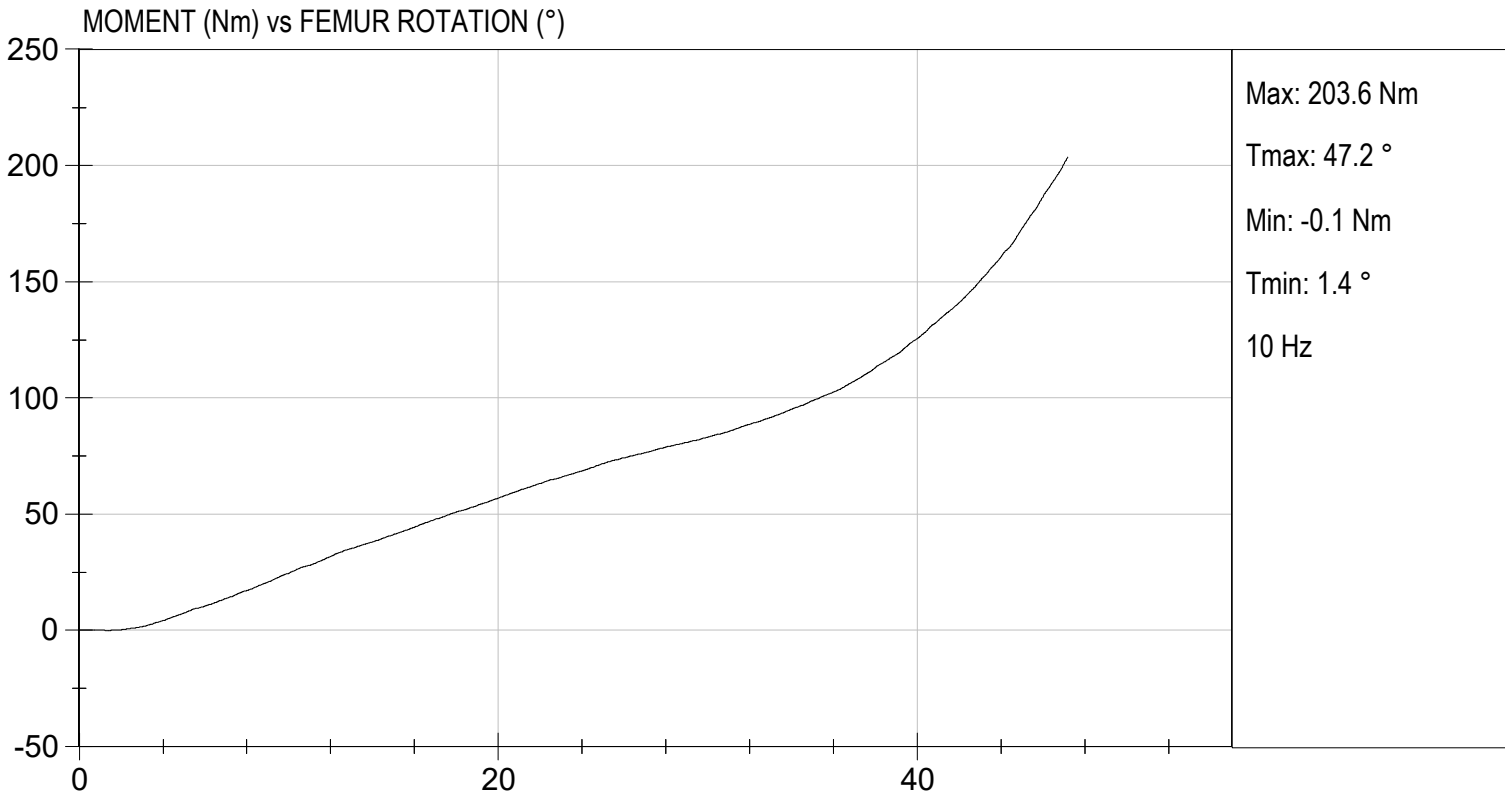

QUALIFICATION TEST RESULTS

PRE-TEST

HYBRID III 5TH PERCENTILE FEMALE - PASSENGER ATD

Hybrid III, 5th External Measurements
SN: 142

HYBRID III, PART 572, SUBPART O EXTERNAL DIMENSIONS				
DIMENSION	DESCRIPTION	DETAILS	ASSEMBLY DIMENSION (mm)	ACTUAL MEASUREMENT
A	TOTAL SITTING HEIGHT	Seat surface to highest point on top of the head.	774.7-800.1	775.0
B	SHOULDER PIVOT HEIGHT	Centerline of shoulder pivot bolt to the seat surface.	431.8-457.2	438.2
C	H-POINT HEIGHT	Reference	81.3-86.3	81.8
D	H-POINT LOCATION FROM BACKLINE	Reference	144.8-149.8	148.3
E	SHOULDER PIVOT FROM BACKLINE	Center of the shoulder clevis to the rear vertical surface of the fixture.	68.6-83.8	83.0
F	THIGH CLEARANCE	Measured at the highest point on the upper femur segment.	119.4-134.6	124.4
G	BACK OF ELBOW TO WRIST PIVOT	back of the elbow flesh to the wrist pivot in line with the elbow and wrist pivots	243.9-259.1	245.2
H	HEAD BACK TO BACKLINE	Back of Skull cap skin to seat rear vertical surface (Reference)	43.2-48.2	43.4
I	SHOULDER TO- ELBOW LENGTH	Measure from the highest point on top of the shoulder clevis to the lowest part of the flesh on the elbow in line with the elbow pivot bolt.	276.8-297.2	281.1
J	ELBOW REST HEIGHT	Measure from the flesh below the elbow pivot bolt to the seat surface.	182.8-203.2	197.2
K	BUTTOCK TO KNEE LENGTH	The forward most part of the knee flesh to the rear vertical surface of the fixture.	520.7-546.1	537.2
L	POPLITEAL HEIGHT	Seat surface to the plane of the horizontal plane of the bottom of the feet.	355.6-376	358.8
M	KNEE PIVOT HEIGHT	Centerline of knee pivot bolt to the horizontal plane of the bottom of the feet.	393.7-419.1	403.1
N	BUTTOCK POPLITEAL LENGTH	The rearmost surface of the lower leg to the same point on the rear surface of the buttocks used for dim. "K".	414-439.4	435.2

HYBRID III, SUBPART O EXTERNAL DIMENSIONS, continued				
DIMENSION	DESCRIPTION	DETAILS	ASSEMBLY DIMENSION (mm)	ACTUAL MEASUREMENT
O	CHEST DEPTH WITHOUT JACKET	Measured 304.8 ± 5.1 mm above seat surface	175.3-190.5	181.2
P	FOOT LENGTH	Tip of toe to rear of heel	218.5-233.7	227.3
Q	STANDING HEIGHT	(THEORETICAL)	1501.1	N/A
R	BUTTOCK TO KNEE PIVOT LENGTH	The rear surface of the buttocks to the knee pivot bolt	457.2-482.6	475.0
S	HEAD BREADTH	The widest part of the head	137.1-147.3	138.6
T	HEAD DEPTH	Back of the head to the forehead	177.8-188	181.0
U	HIP BREADTH	The widest part of the hip	299.7-314.9	308.4
V	SHOULDER BREADTH	Outside edges of right and left shoulder clevises	350.5-365.7	362.1
W	FOOT BREADTH	The widest part of the foot	78.8-94	82.8
X	HEAD CIRCUMFERENCE	Measured at the point as in dim. "T"	528.3-548.7	545.2
Y	CHEST CIRCUMFERENCE (WITH CHEST JACKET)	Measured 345.4 ± 12.7 mm above seat surface	850.9-881.3	870.7
Z	WAIST CIRCUMFERENCE	Measured 165.1 ± 5.1 mm above seat surface	759.5-789.9	779.9
AA	REFERENCE LOCATION FOR MEASUREMENT OF CHEST CIRCUMFERENCE	Reference	332.7-358.1	350.1
BB	REFERENCE LOCATION FOR MEASUREMENT OF WAIST CIRCUMFERENCE	Reference	160.1-170.2	170.0

MGA RESEARCH CORPORATION
HEAD DROP TEST
HYBRID III 5TH PERCENTILE

ATD Serial No: 142

Test ID: D241271

Tested Parameter	Units	Specification	Result	Pass/Fail
Laboratory Temperature	deg C	18.9 to 25.6	21.3	Pass
Laboratory Relative Humidity	%	10 to 70	45	Pass
Peak Resultant Acceleration	G's	250 to 300	277	Pass
Peak Lateral Acceleration	G's	<= +/- 15.0	5.0	Pass
Unimodal	N/A	Yes	Yes	Pass
Oscillations	N/A	within 10% of peak	Yes	Pass
Overall Test Results				Pass

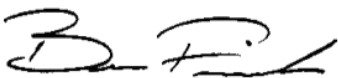

 Laboratory Technician

05/24/2024
 Test Date



 Approved By

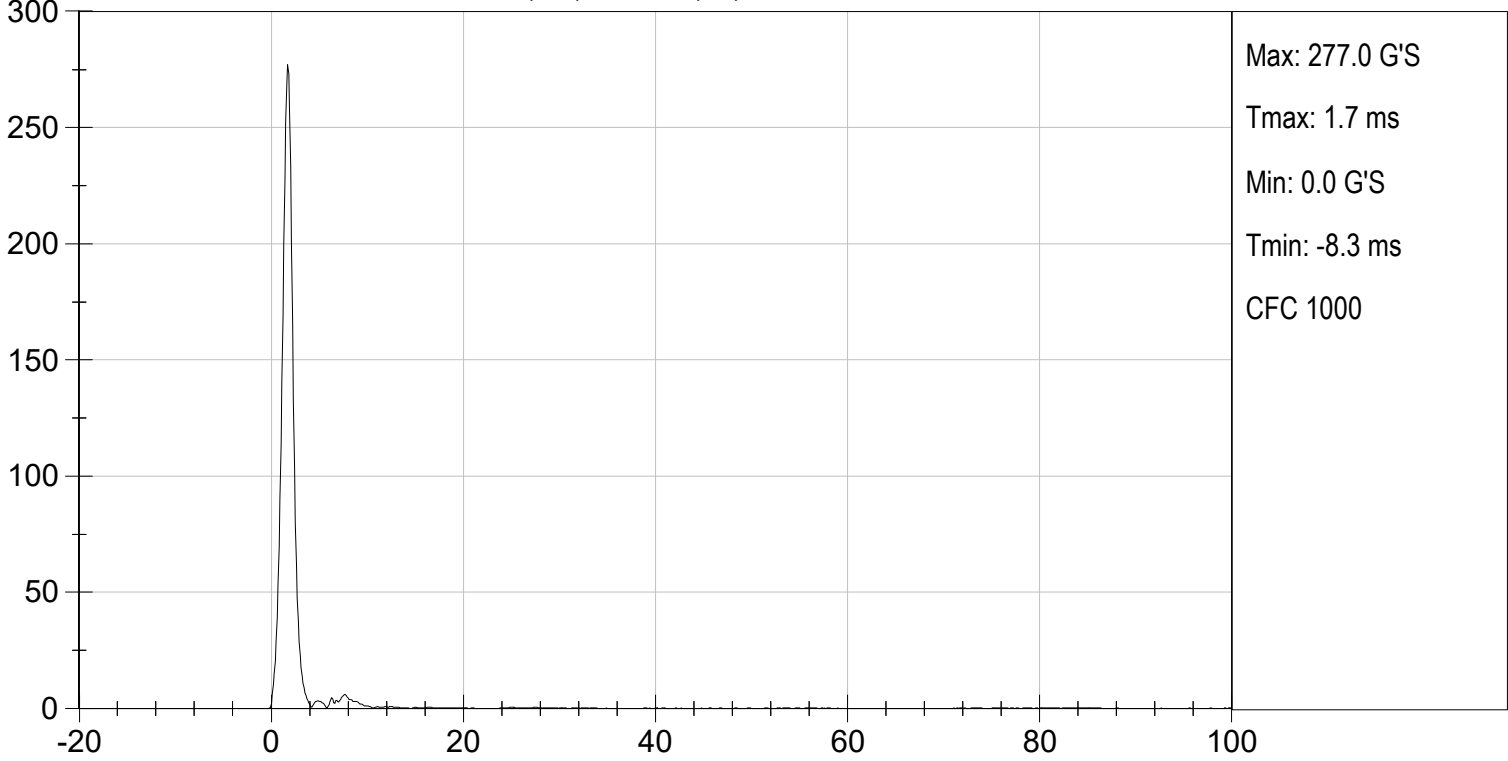

HEAD RESULTANT ACCELERATION (G'S) vs TIME (ms)

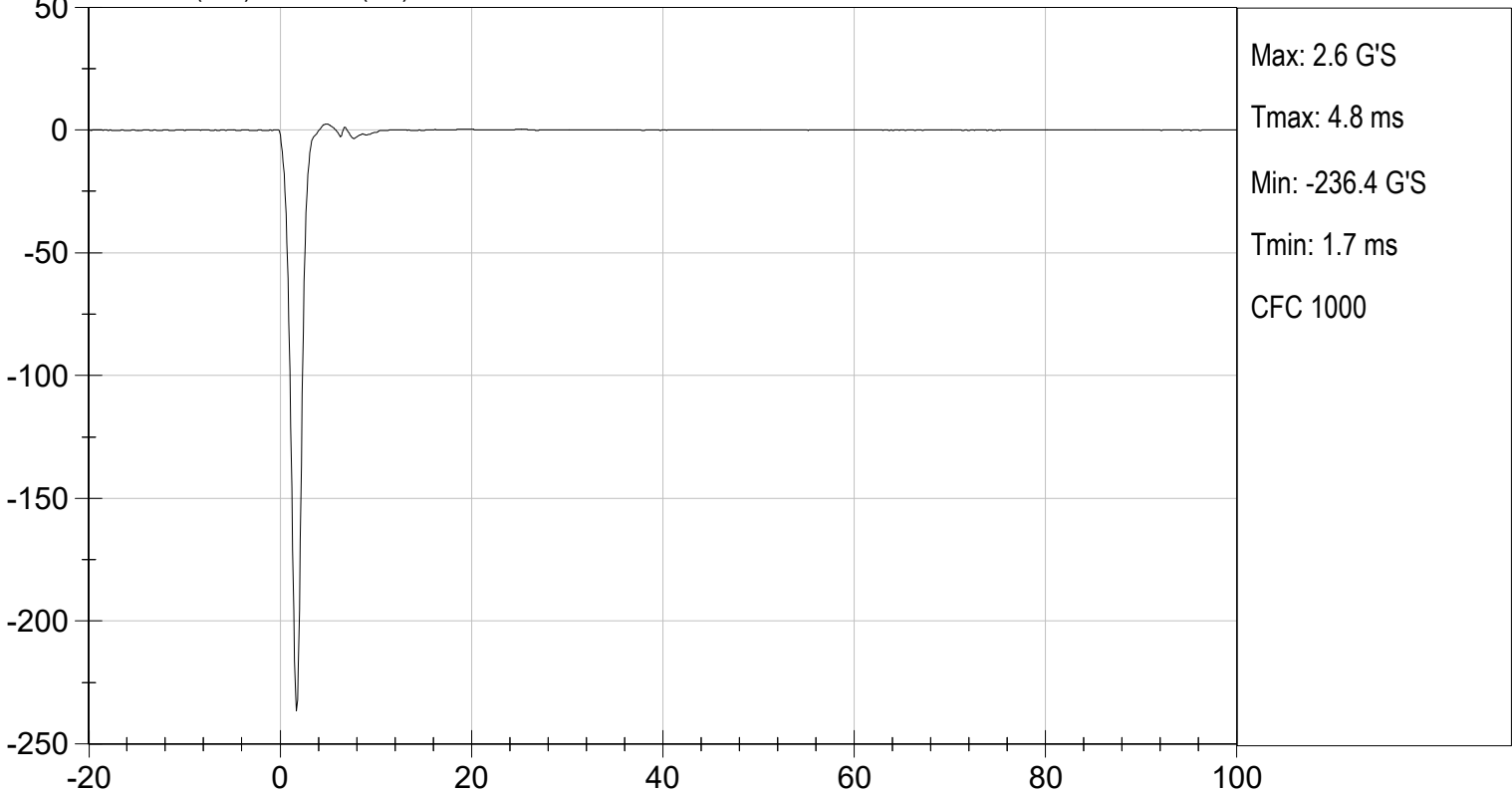

HEAD X (G'S) vs TIME (ms)



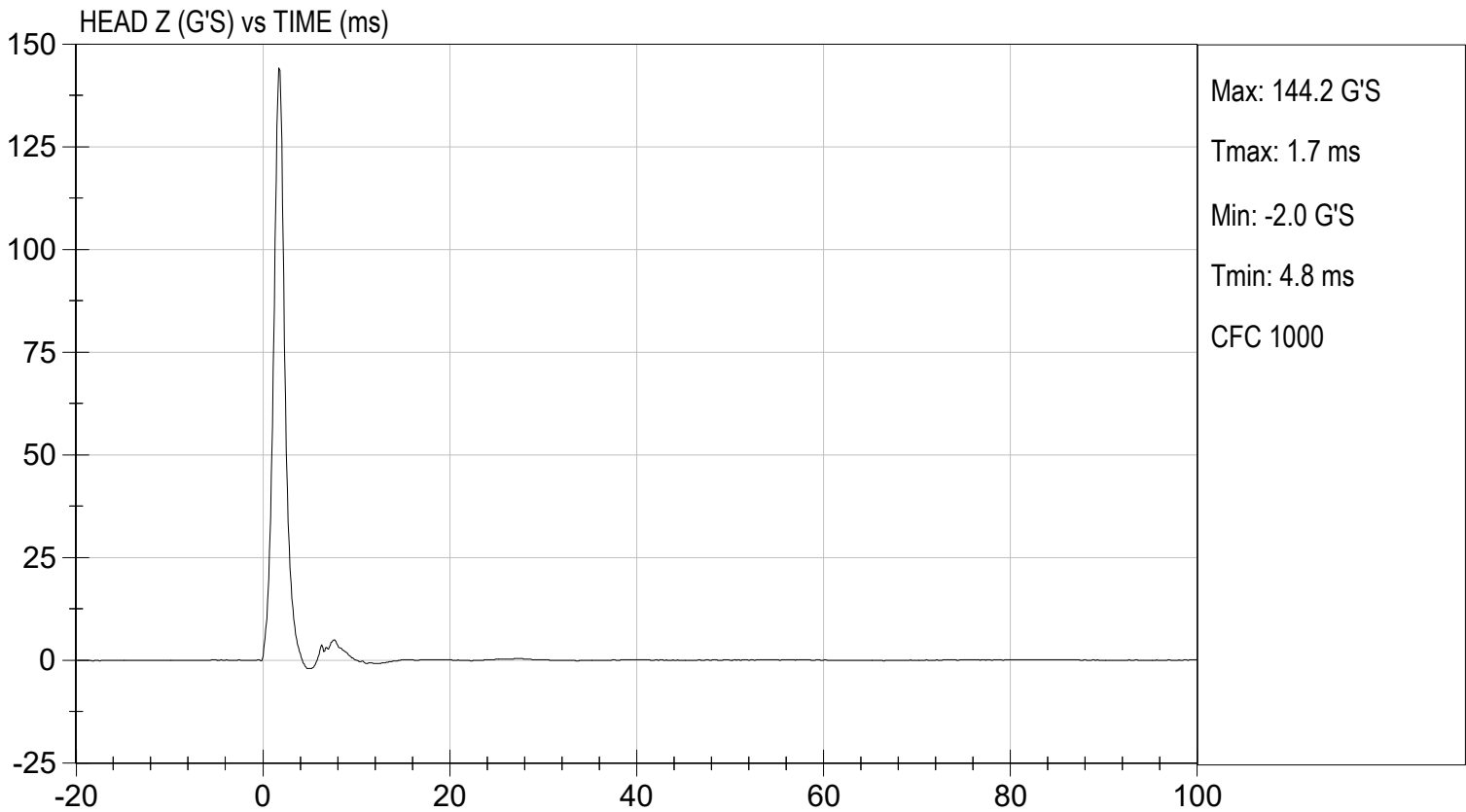
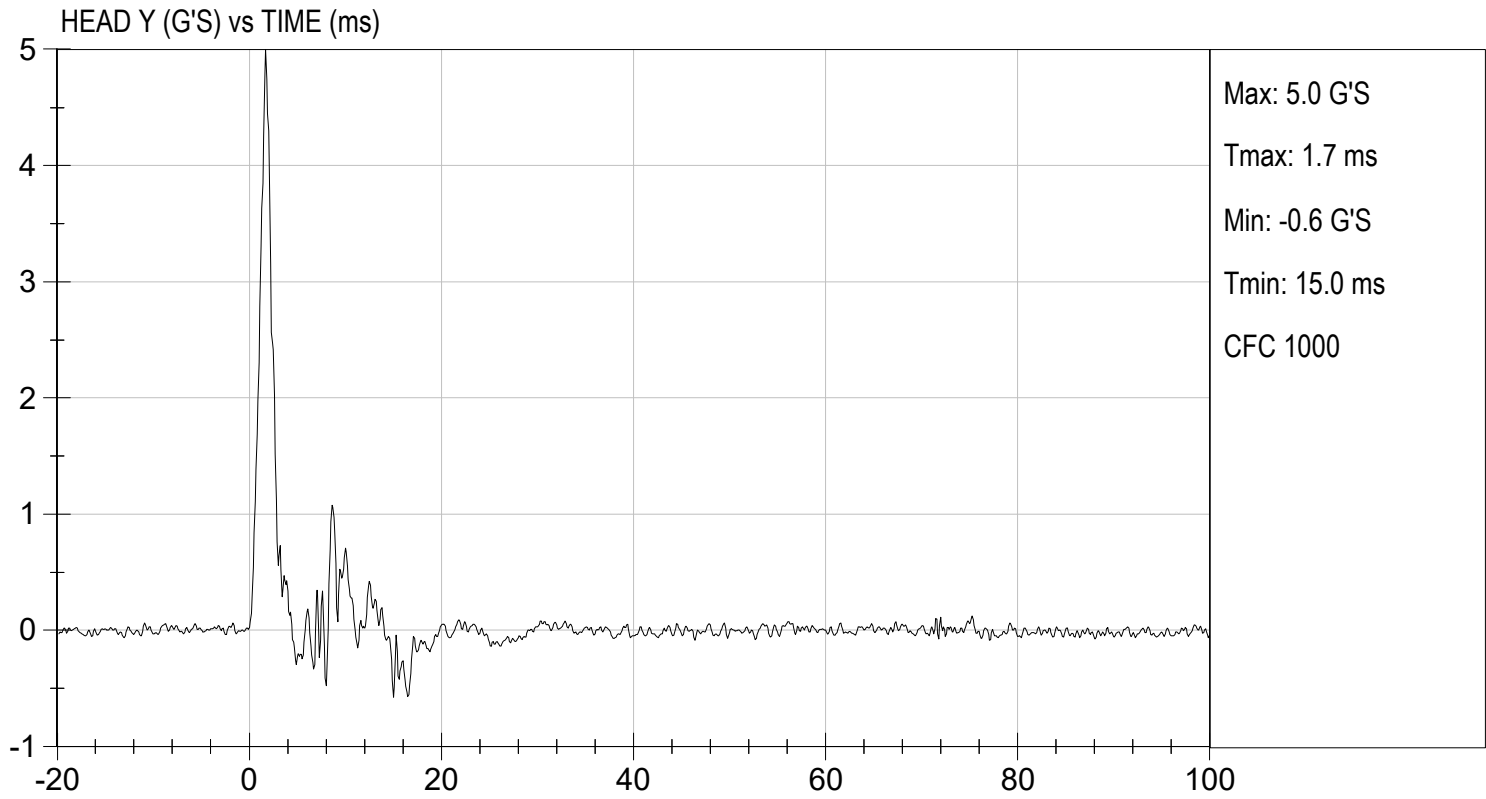

MGA RESEARCH CORPORATION

NECK FLEXION TEST

HYBRID III 5TH PERCENTILE

ATD Serial No: 142

Test I.D: D241272

Tested Parameter		Units	Specification	Result	Pass/Fail
Laboratory Temperature		deg C	20.6 to 22.2	21.3	Pass
Laboratory Relative Humidity		%	10 to 70	45	Pass
Pendulum Speed		m/s	6.89 to 7.13	7.06	Pass
Pendulum Velocity	10 ms	m/s	2.1 to 2.5	2.3	Pass
	20 ms	m/s	4.0 to 5.0	4.6	Pass
	30 ms	m/s	5.8 to 7.0	6.9	Pass
D Plane Rotation	Max	deg	77 to 91	80	Pass
Occipital Condyle Moment within Rotation Corridor		Nm	69 to 83	71	Pass
Positive Moment Time Curve Decay to 10 Nm		ms	80 to 100	85	Pass
Overall Results					Pass



 Laboratory Technician

05/24/2024

 Test Date

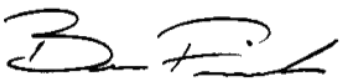

 Approved By



PENDULUM VELOCITY (m/s) vs TIME (ms)

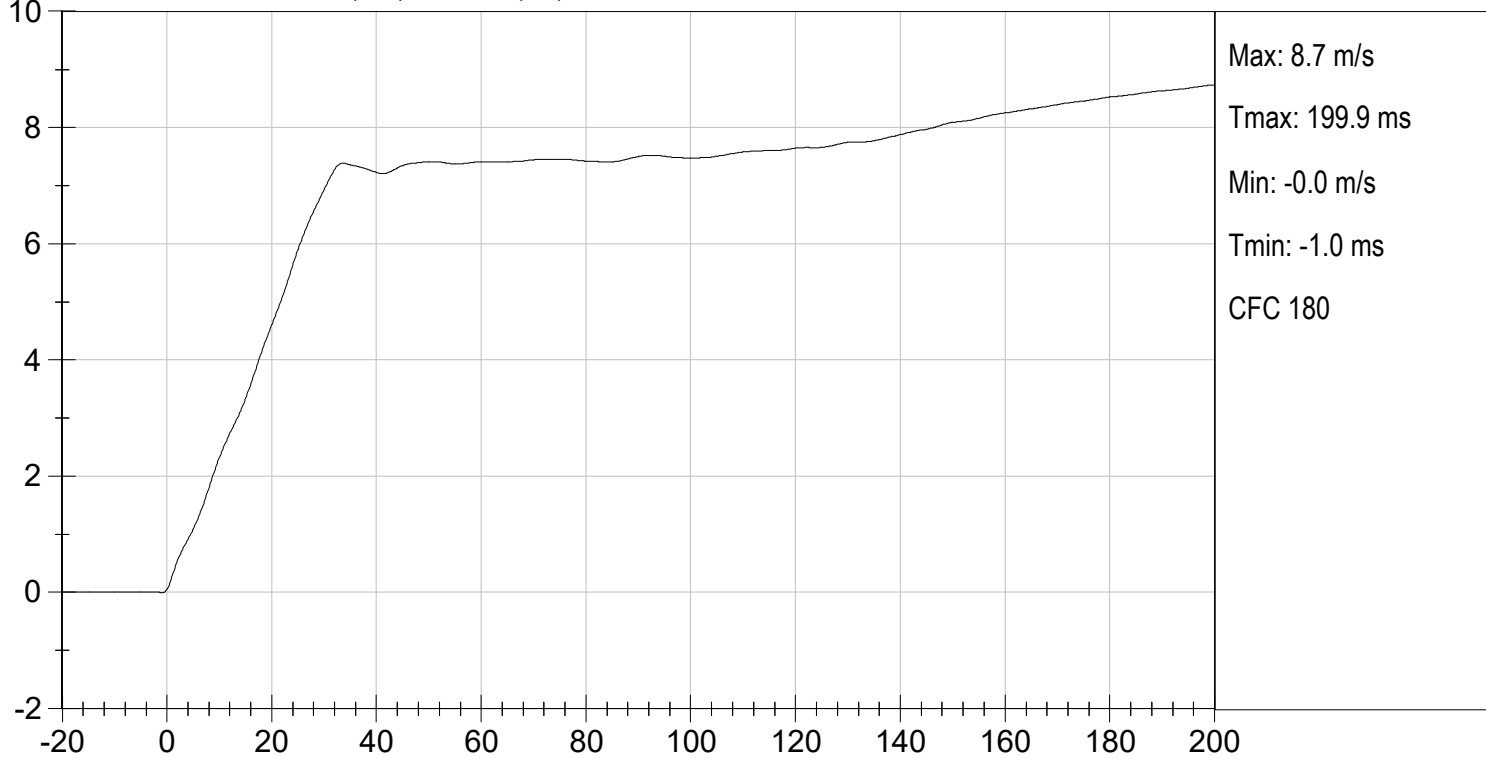

NECK ROTATION (DEG) vs TIME (ms)

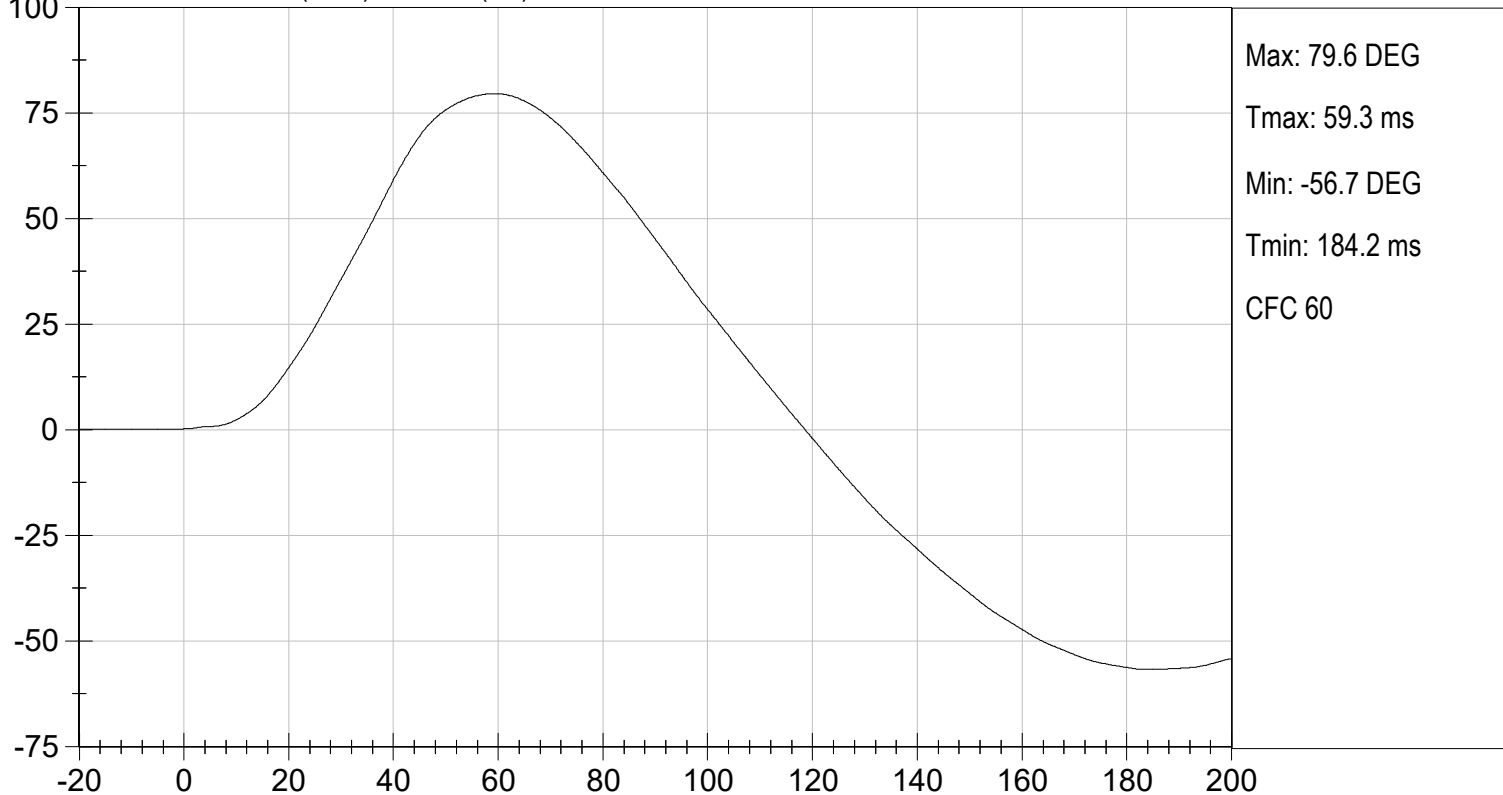

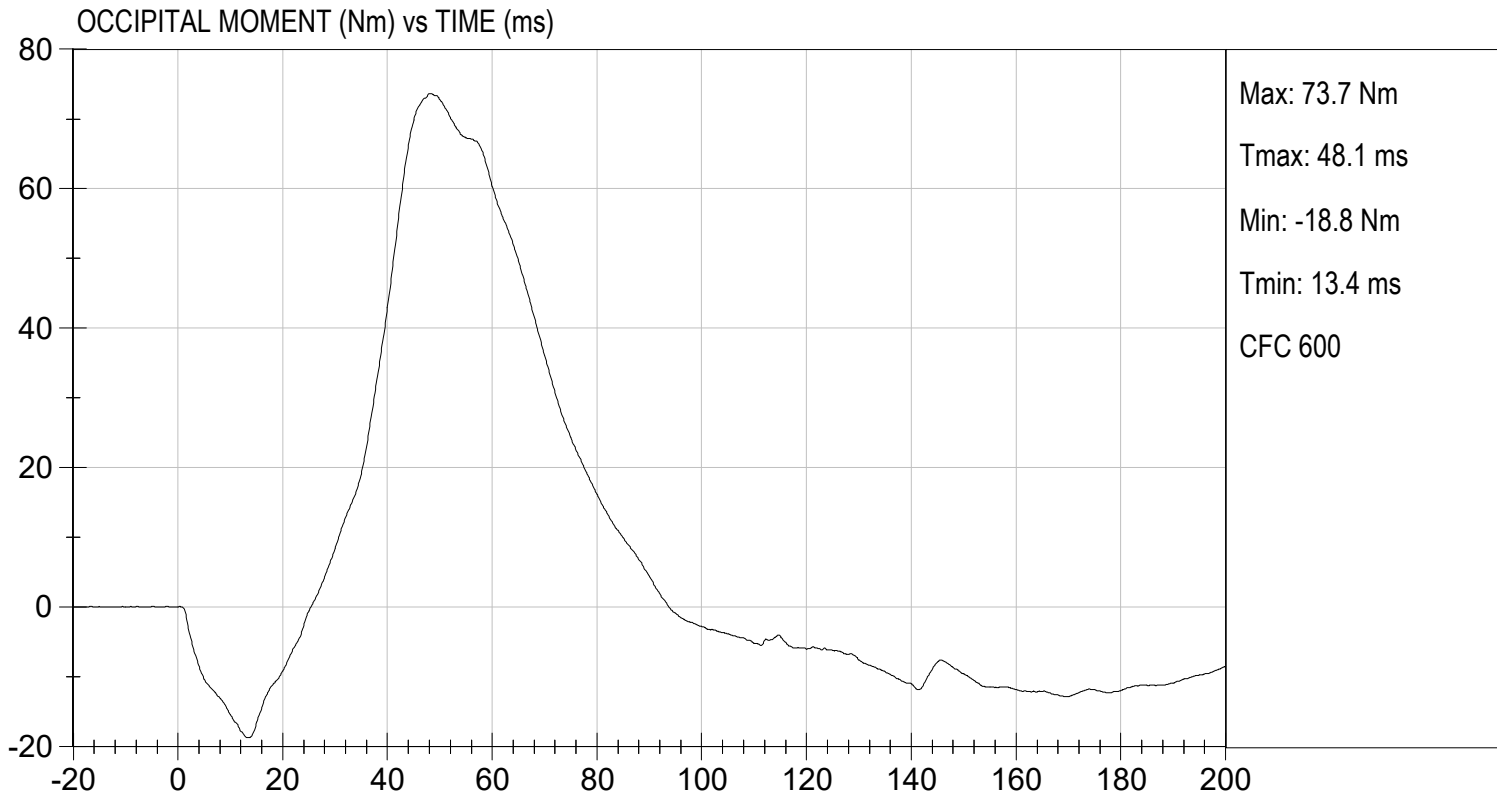

MGA RESEARCH CORPORATION
NECK EXTENSION TEST
HYBRID III 5TH PERCENTILE

ATD Serial No: 142

Test I.D.: D241273

Tested Parameter		Units	Specification	Result	Pass/Fail
Laboratory Temperature		deg C	20.6 to 22.2	21.4	Pass
Laboratory Relative Humidity		%	10 to 70	45	Pass
Pendulum Speed		m/s	5.95 to 6.19	6.12	Pass
Pendulum Velocity	10 ms	m/s	1.5 to 1.9	1.7	Pass
	20 ms	m/s	3.1 to 3.9	3.6	Pass
	30 ms	m/s	4.6 to 5.6	5.2	Pass
D Plane Rotation	Max	deg	99 to 114	109	Pass
Occipital Condyle Moment within Rotation Corridor		Nm	-65 to -53	-55	Pass
Negative Moment Time Curve Decay to -10 Nm		ms	94 to 114	111	Pass
Overall Results					Pass

 Laboratory Technician

05/24/2024
 Test Date

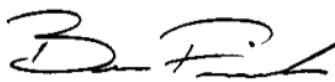
 Approved By

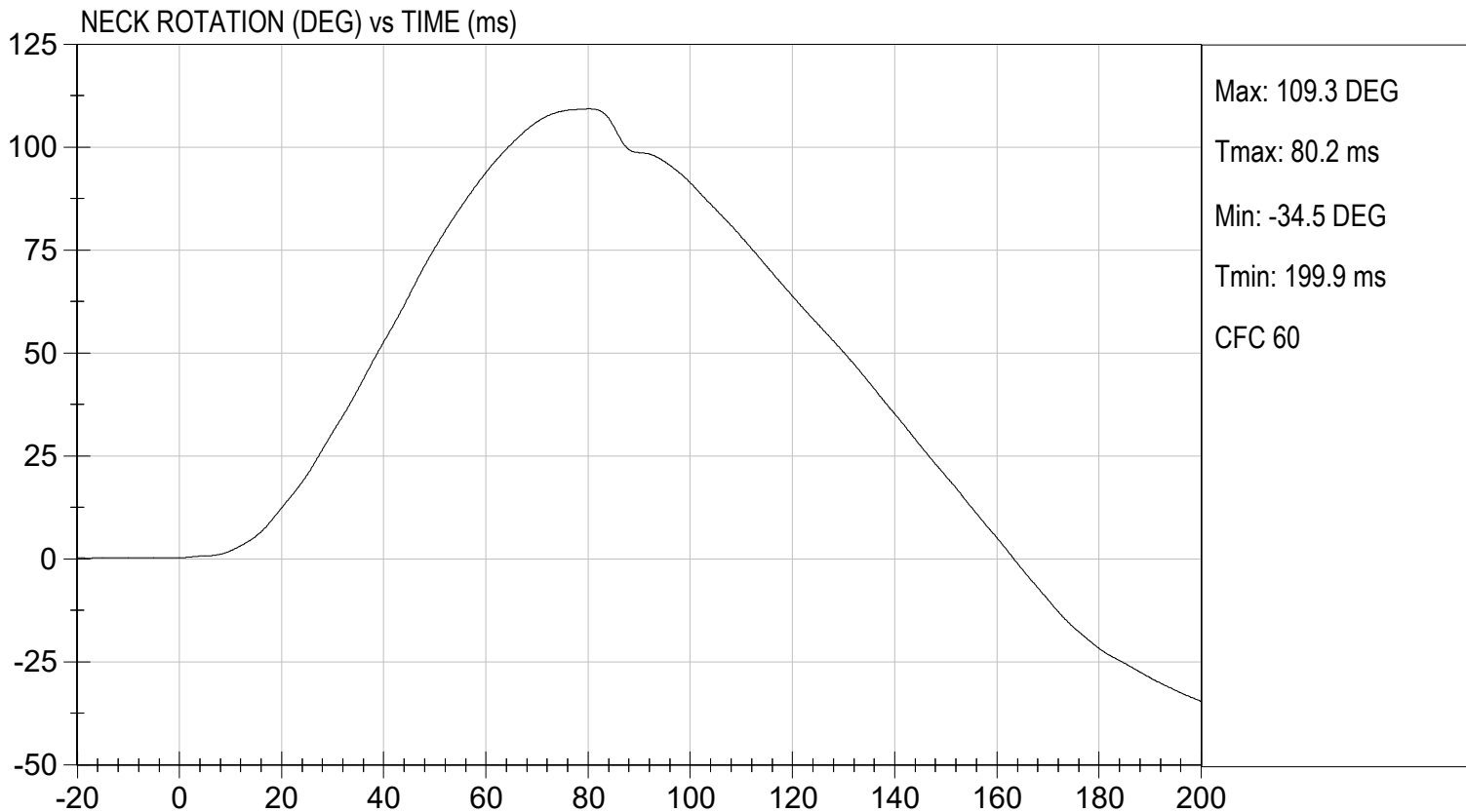
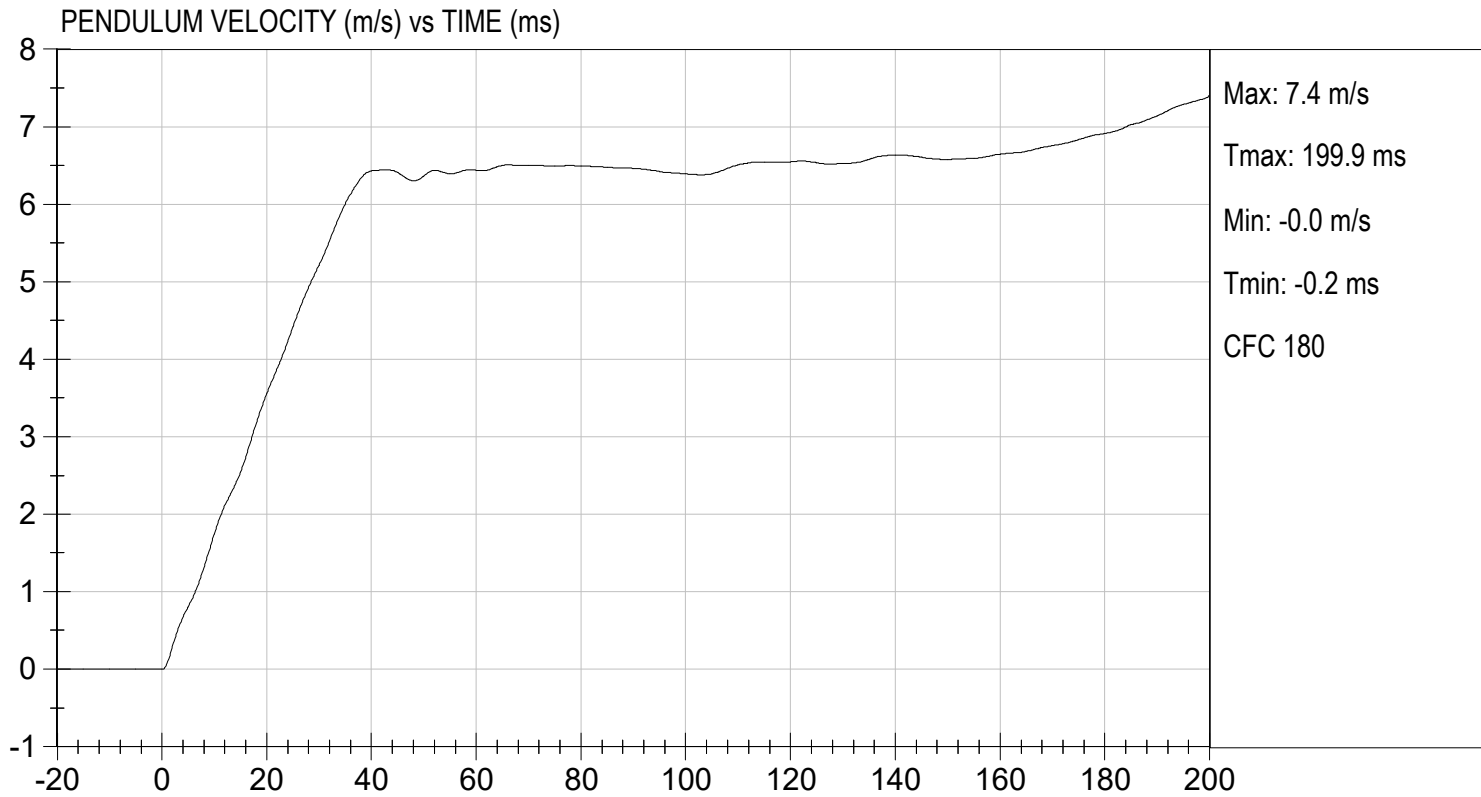

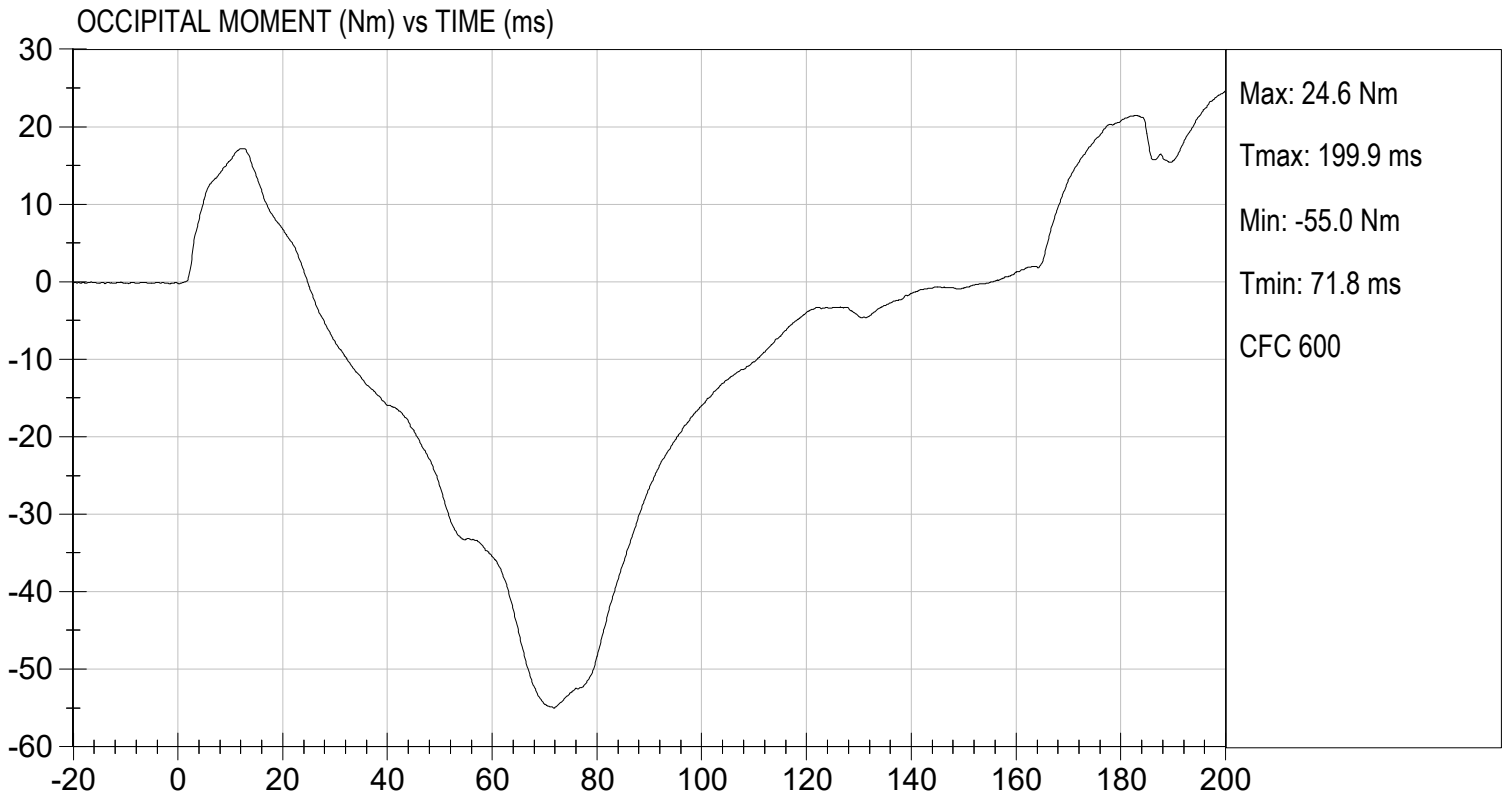

MGA RESEARCH CORPORATION

THORAX IMPACT

HYBRID III 5TH PERCENTILE

ATD Serial No: 142

Test I.D: D241274

Tested Parameter	Units	Specification	Result	Pass/Fail
Temperature	deg C	20.6 to 22.2	21.4	Pass
Relative Humidity	%	10 to 70	44	Pass
Probe Speed	m/s	6.59 to 6.83	6.77	Pass
Peak Deflection	mm	50 to 58	52	Pass
Peak Resistive Force w/in Deflection Corridor	N	3900 to 4400	4334	Pass
Internal Hysteresis	%	69 to 85	75	Pass
Peak Force 18 mm - 50 mm	N	<= 4600	4349	Pass
Overall Test Results				Pass

Laboratory Technician

05/24/2024
Test Date

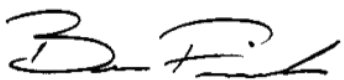
Approved By

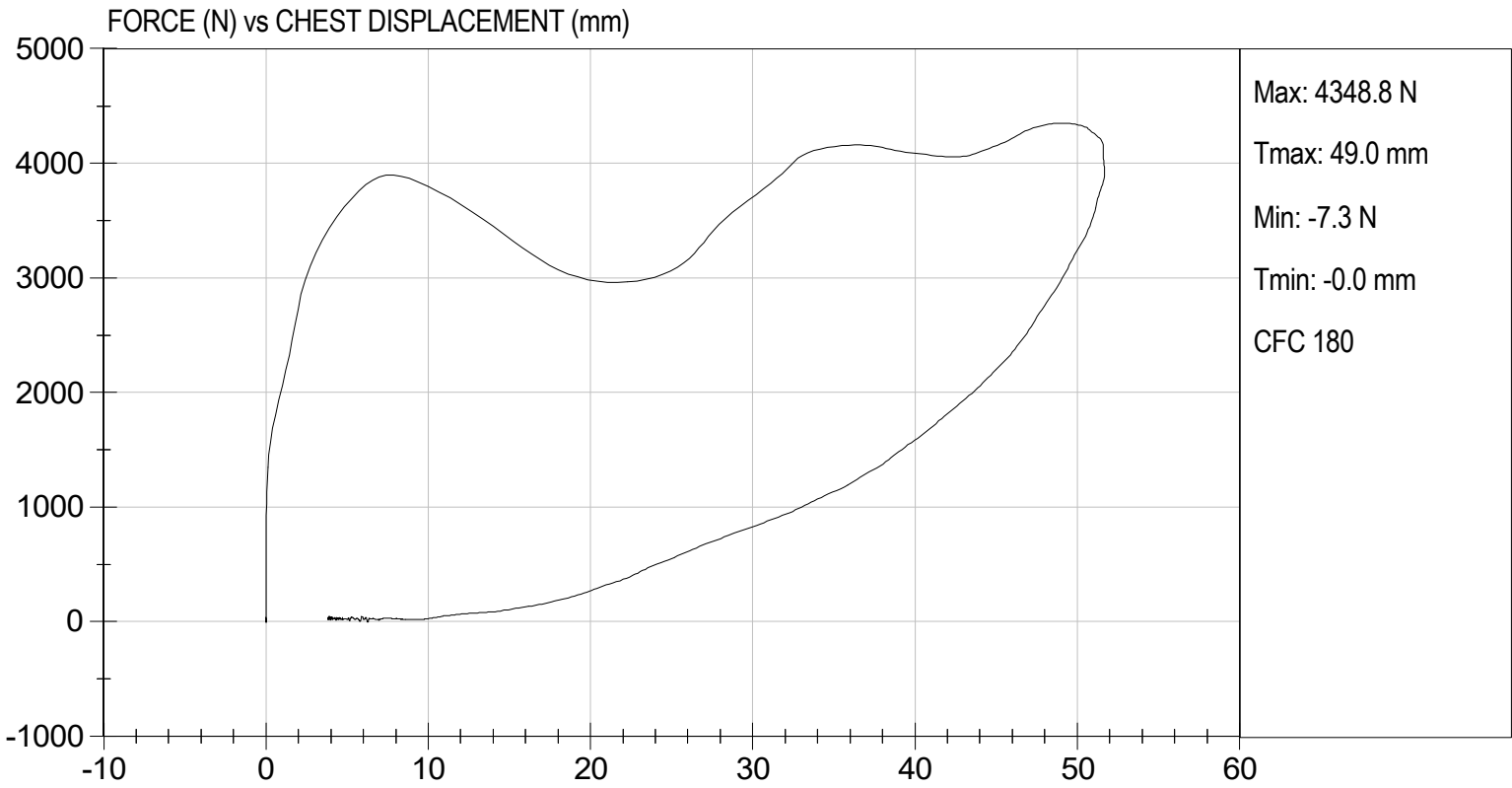

MGA RESEARCH CORPORATION
RIGHT KNEE IMPACT TEST
HYBRID III 5TH PERCENTILE

ATD Serial No: 142

Test I.D: D241275

Tested Parameter	Units	Specification	Result	Pass/Fail
Laboratory Temperature	deg C	18.9 to 25.6	21.3	Pass
Laboratory Relative Humidity	%	10 to 70	44	Pass
Probe Speed	m/s	2.07 to 2.13	2.10	Pass
Maximum Force	N	3450 to 4060	3750	Pass
			Overall Test Results	Pass



Laboratory Technician

05/24/2024

Test Date

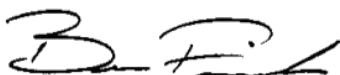

Approved By



TEST DESC: RIGHT KNEE
VELOCITY: 6.89 ft/s, 2.10 m/s

TEST DATE: 05/24/2024
TEST #: D241275

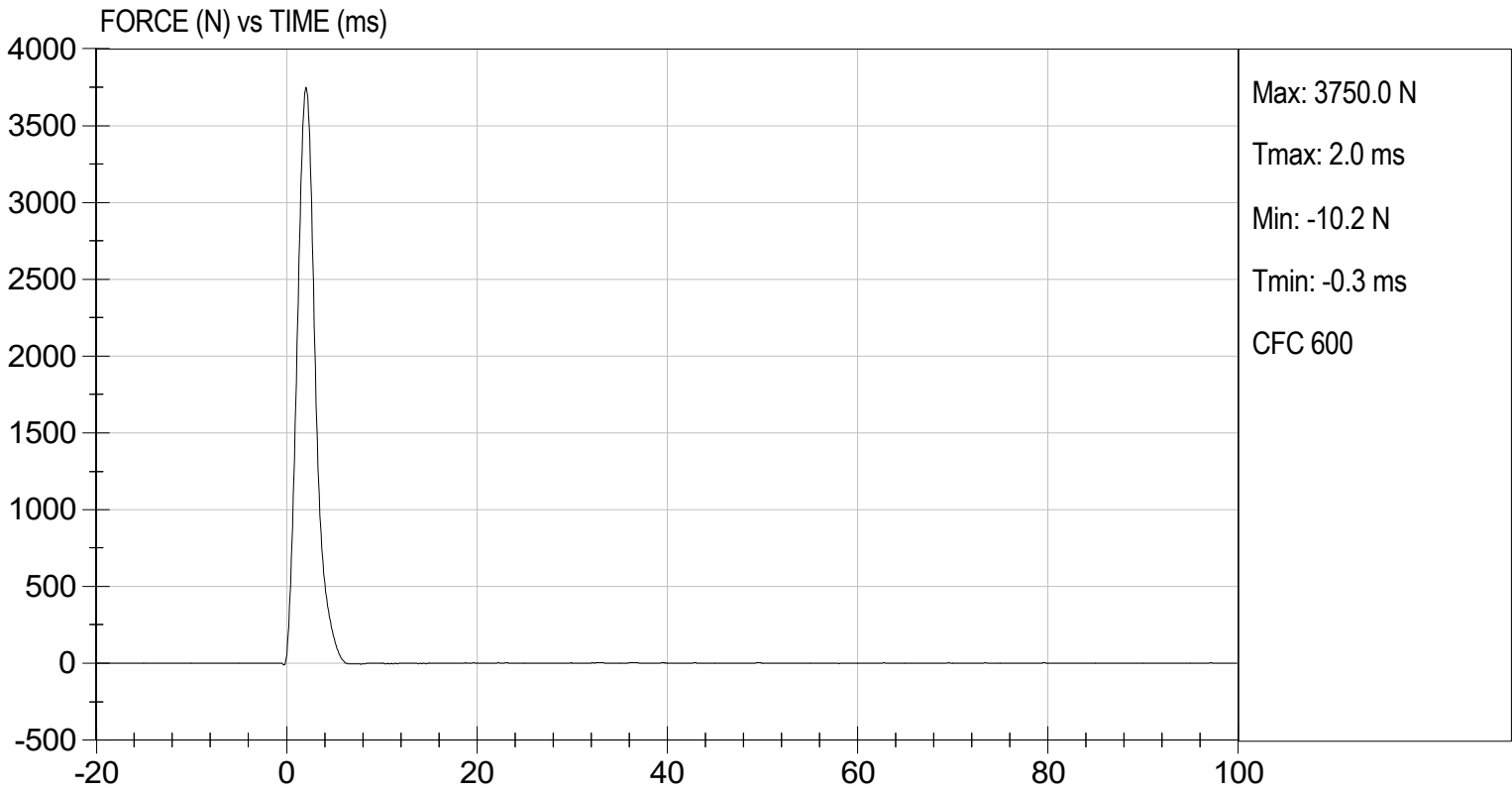

MGA RESEARCH CORPORATION

LEFT KNEE IMPACT TEST

HYBRID III 5TH PERCENTILE

ATD Serial No: 142

Test I.D: D241276

Tested Parameter	Units	Specification	Result	Pass/Fail
Laboratory Temperature	deg C	18.9 to 25.6	21.3	Pass
Laboratory Relative Humidity	%	10 to 70	44	Pass
Probe Speed	m/s	2.07 to 2.13	2.10	Pass
Maximum Force	N	3450 to 4060	3911	Pass
			Overall Test Results	Pass



Laboratory Technician

05/24/2024

Test Date

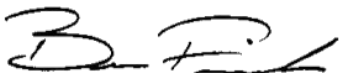

Approved By



TEST DESC: LEFT KNEE
VELOCITY: 6.89 ft/s, 2.10 m/s

TEST DATE: 05/24/2024
TEST #: D241276

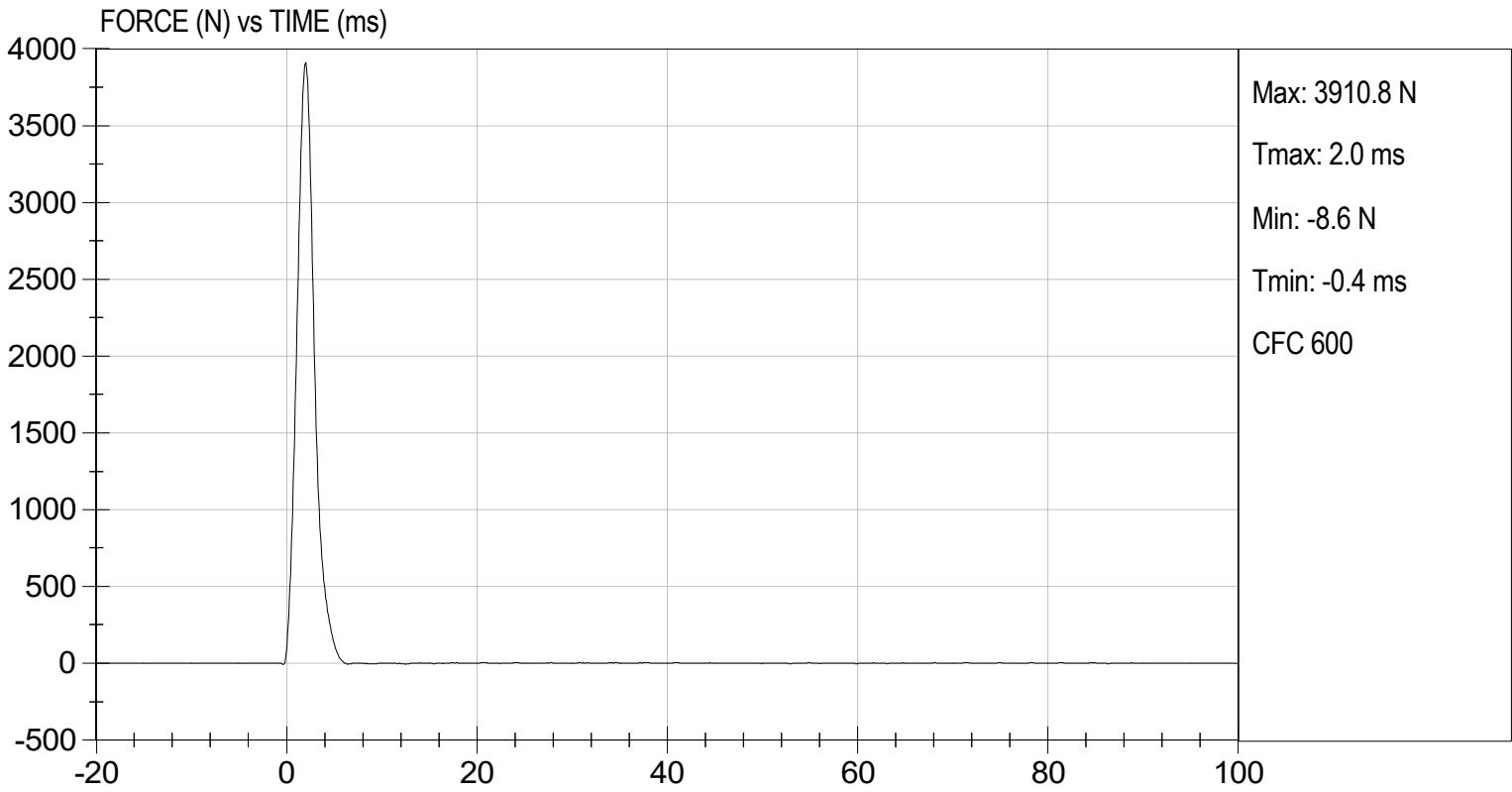

MGA RESEARCH CORPORATION

TORSO FLEXION TEST

HYBRID III 5TH PERCENTILE

ATD Serial No: 142

Test I.D: D241277

Tested Parameter	Units	Specification	Result	Pass/Fail
Laboratory Temperature	deg C	18.9 to 25.6	21.3	Pass
Laboratory Relative Humidity	%	10 to 70	45	Pass
Initial Angle	deg	0 to 20	18	Pass
Return Angle	deg	+/- 8	4	Pass
Force at 45 deg	N	320 to 390	374	Pass
Upper Torso Deflection Rate	deg/s	0.5 to 1.5	0.8	Pass
			Overall Result	Pass



Laboratory Technician

05/24/2024

Test Date

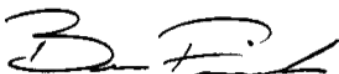

Approved By

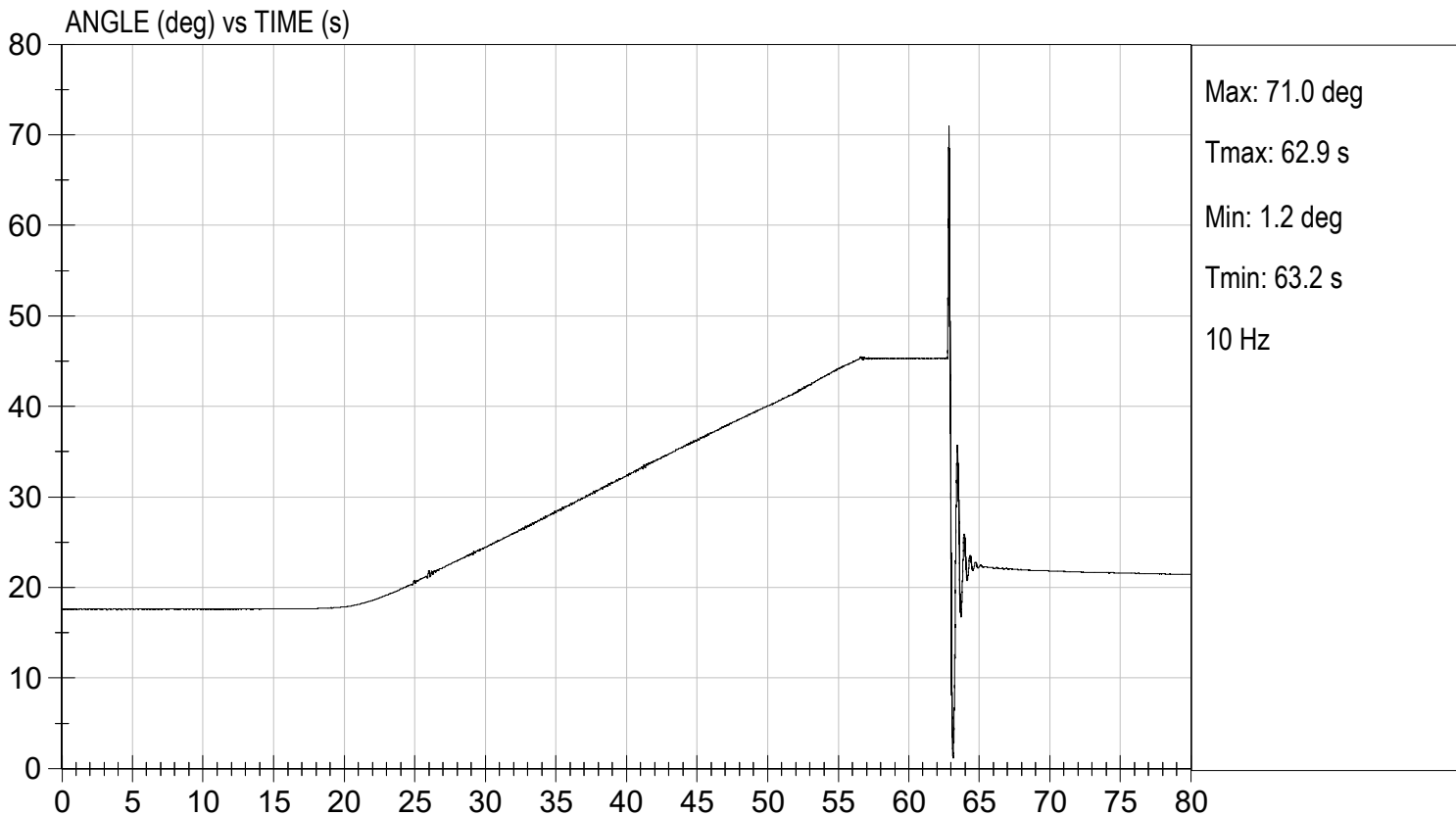
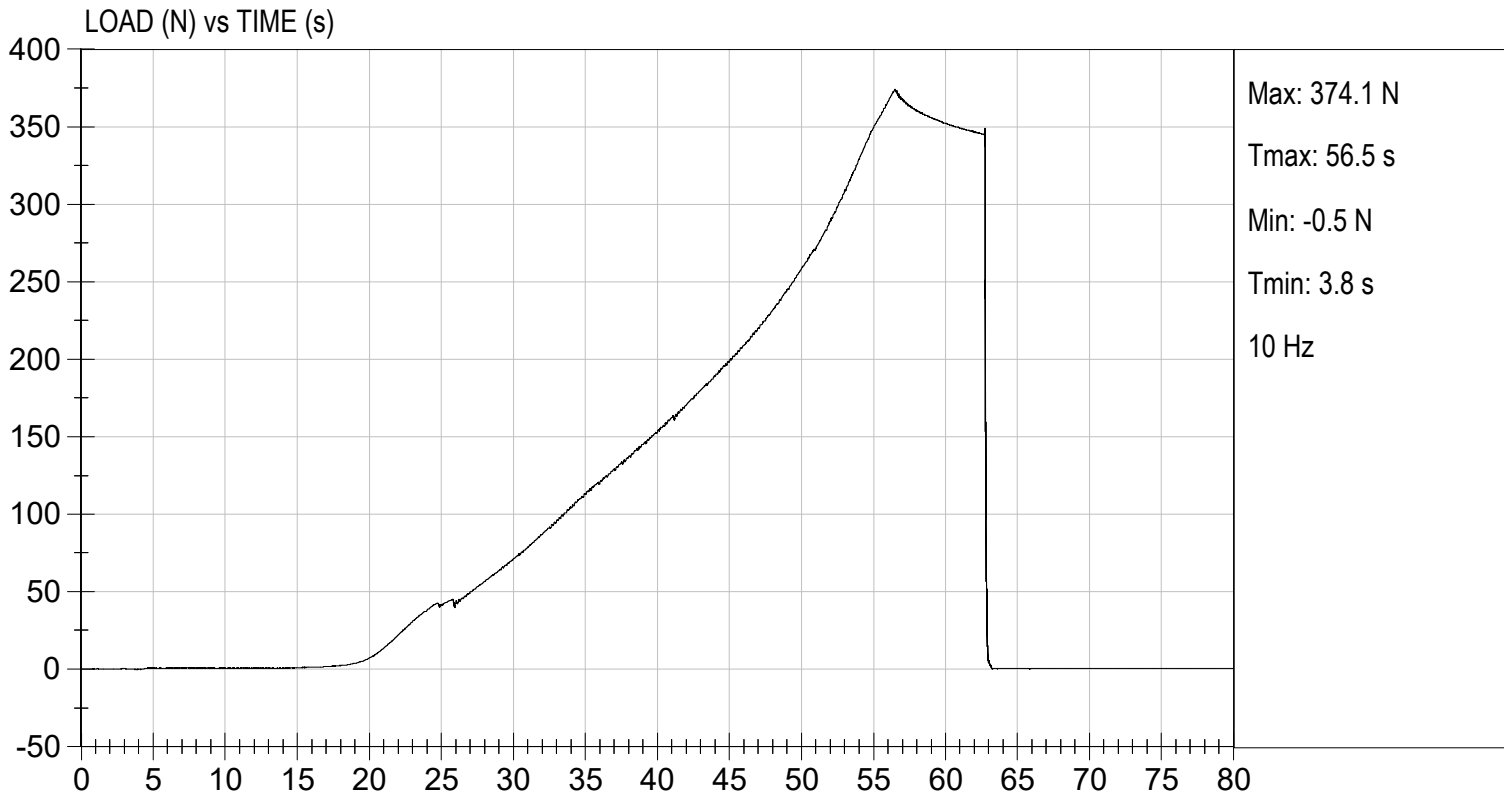

QUALIFICATION TEST RESULTS

POST-TEST

HYBRID III 5TH PERCENTILE FEMALE - PASSENGER ATD

MGA RESEARCH CORPORATION
HEAD DROP TEST
HYBRID III 5TH PERCENTILE

ATD Serial No: 142

Test ID: D241341

Tested Parameter	Units	Specification	Result	Pass/Fail
Laboratory Temperature	deg C	18.9 to 25.6	21.4	Pass
Laboratory Relative Humidity	%	10 to 70	46	Pass
Peak Resultant Acceleration	G's	250 to 300	286	Pass
Peak Lateral Acceleration	G's	<= +/- 15.0	5.6	Pass
Unimodal	N/A	Yes	Yes	Pass
Oscillations	N/A	within 10% of peak	Yes	Pass
Overall Test Results				Pass

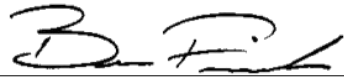

 Laboratory Technician

06/03/2024
 Test Date



 Approved By

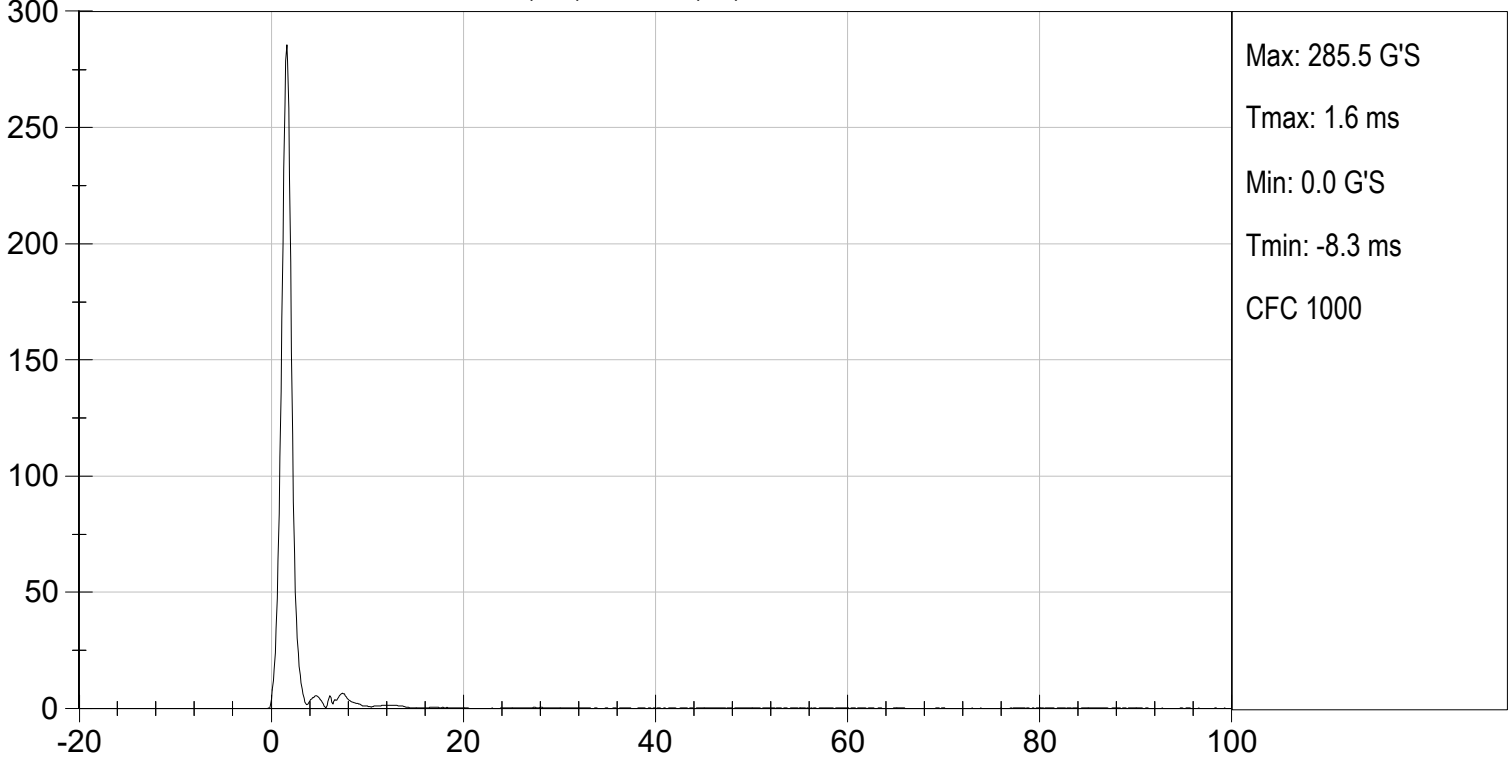

HEAD RESULTANT ACCELERATION (G'S) vs TIME (ms)

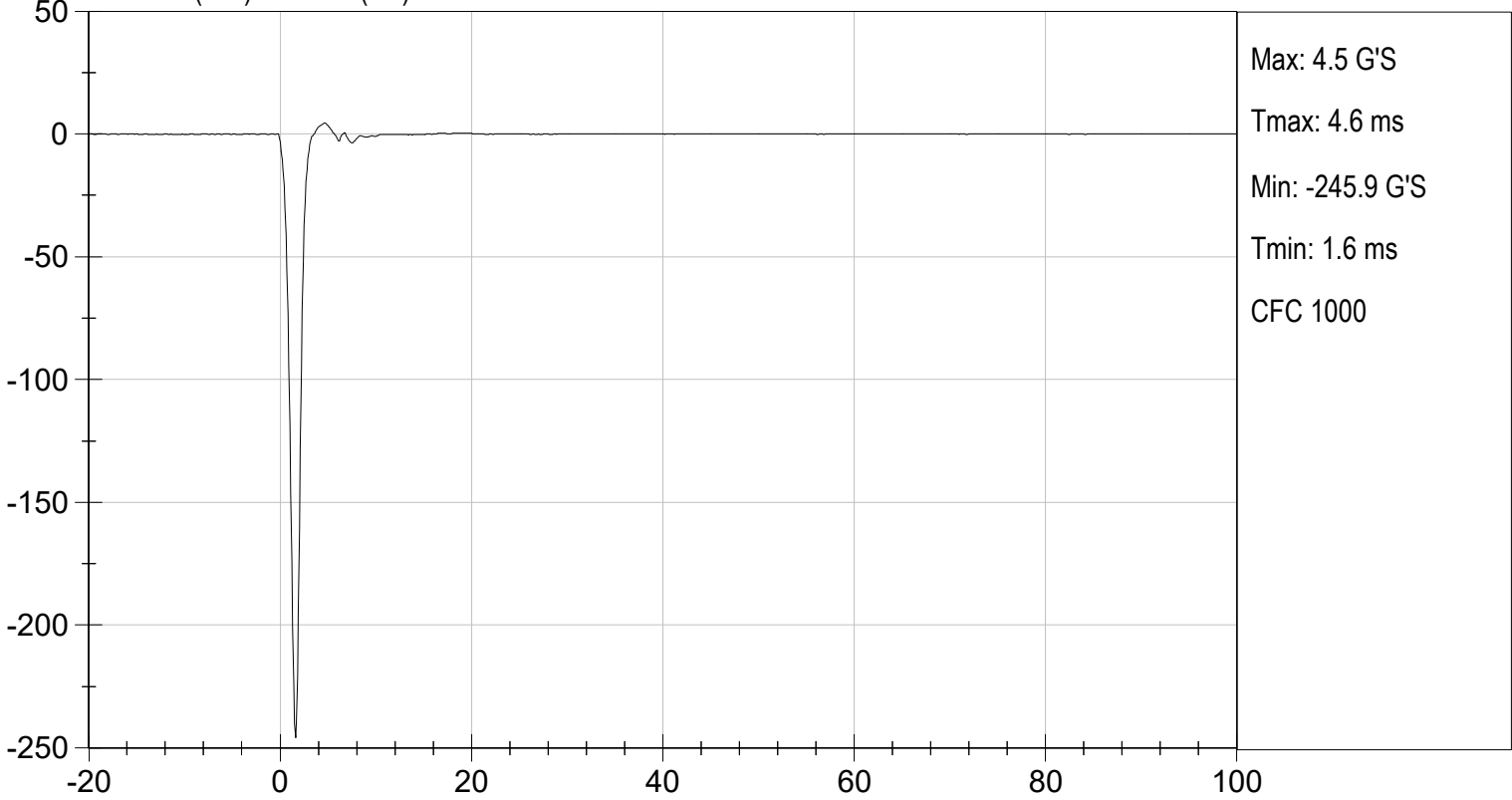

HEAD X (G'S) vs TIME (ms)



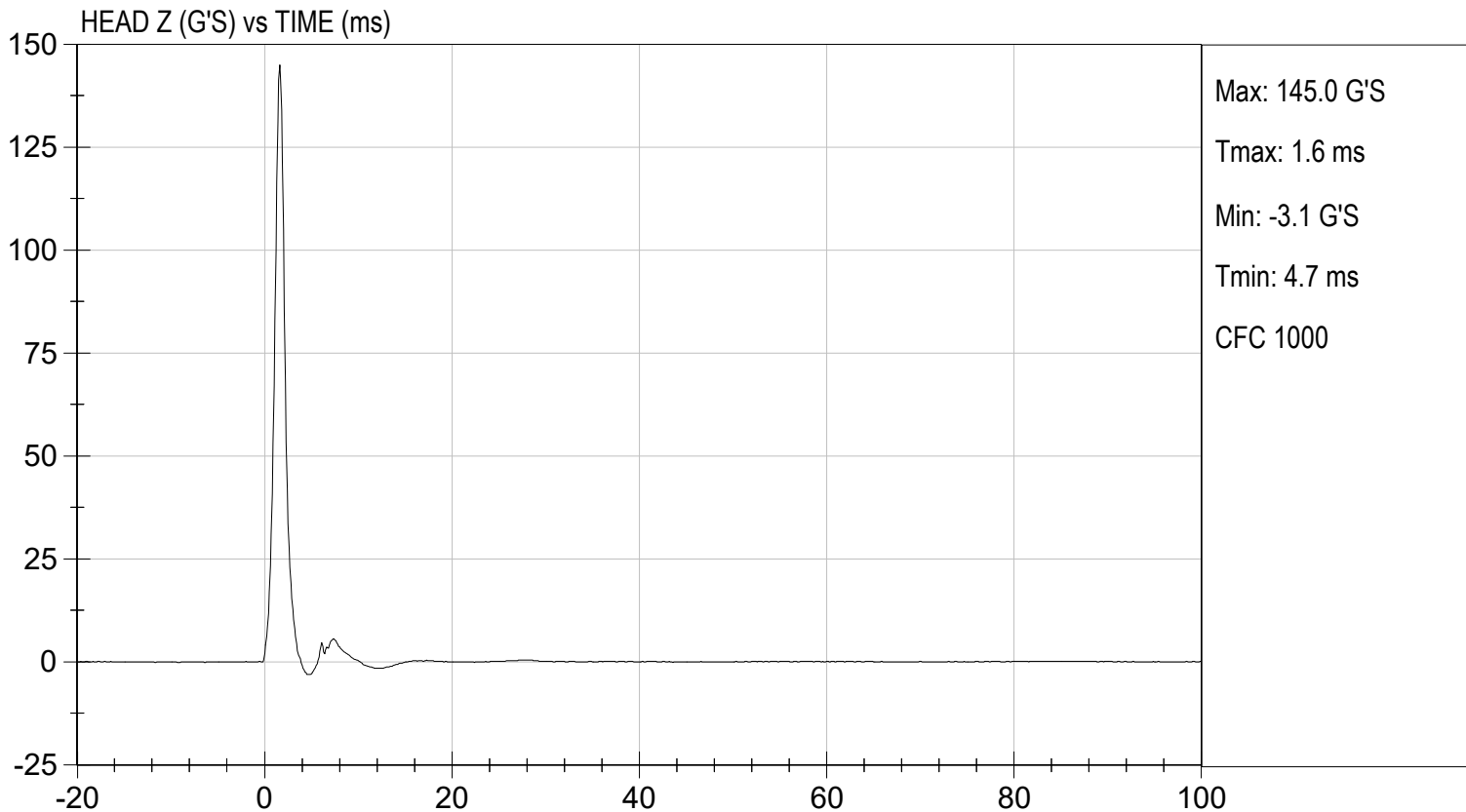
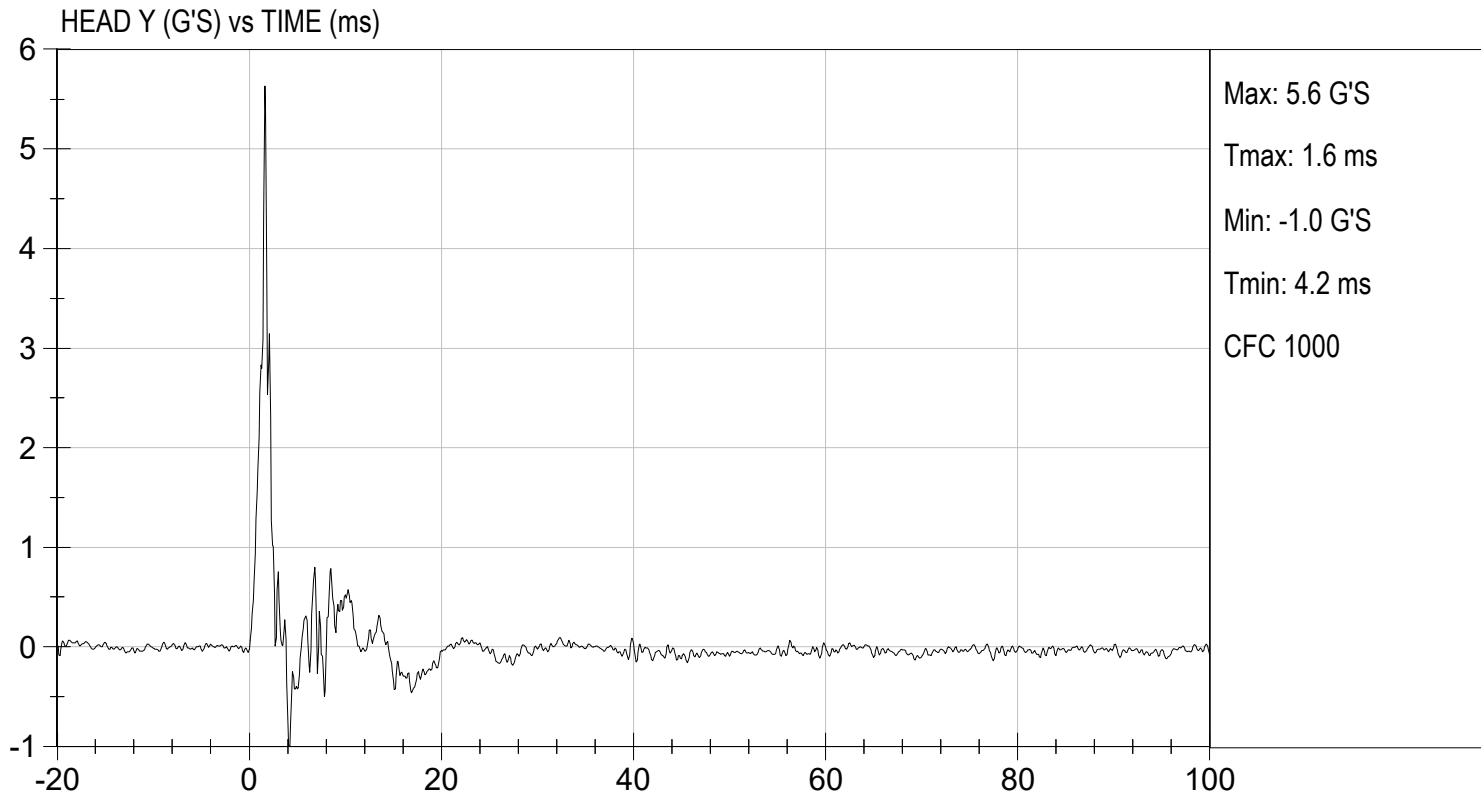

MGA RESEARCH CORPORATION

NECK FLEXION TEST

HYBRID III 5TH PERCENTILE

ATD Serial No: 142

Test I.D: D241342

Tested Parameter		Units	Specification	Result	Pass/Fail
Laboratory Temperature		deg C	20.6 to 22.2	21.4	Pass
Laboratory Relative Humidity		%	10 to 70	46	Pass
Pendulum Speed		m/s	6.89 to 7.13	7.06	Pass
Pendulum Velocity	10 ms	m/s	2.1 to 2.5	2.4	Pass
	20 ms	m/s	4.0 to 5.0	4.6	Pass
	30 ms	m/s	5.8 to 7.0	6.8	Pass
D Plane Rotation	Max	deg	77 to 91	79	Pass
Occipital Condyle Moment within Rotation Corridor		Nm	69 to 83	71	Pass
Positive Moment Time Curve Decay to 10 Nm		ms	80 to 100	85	Pass
Overall Results					Pass



 Laboratory Technician

06/03/2024

 Test Date

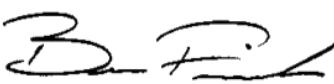

 Approved By



PENDULUM VELOCITY (m/s) vs TIME (ms)

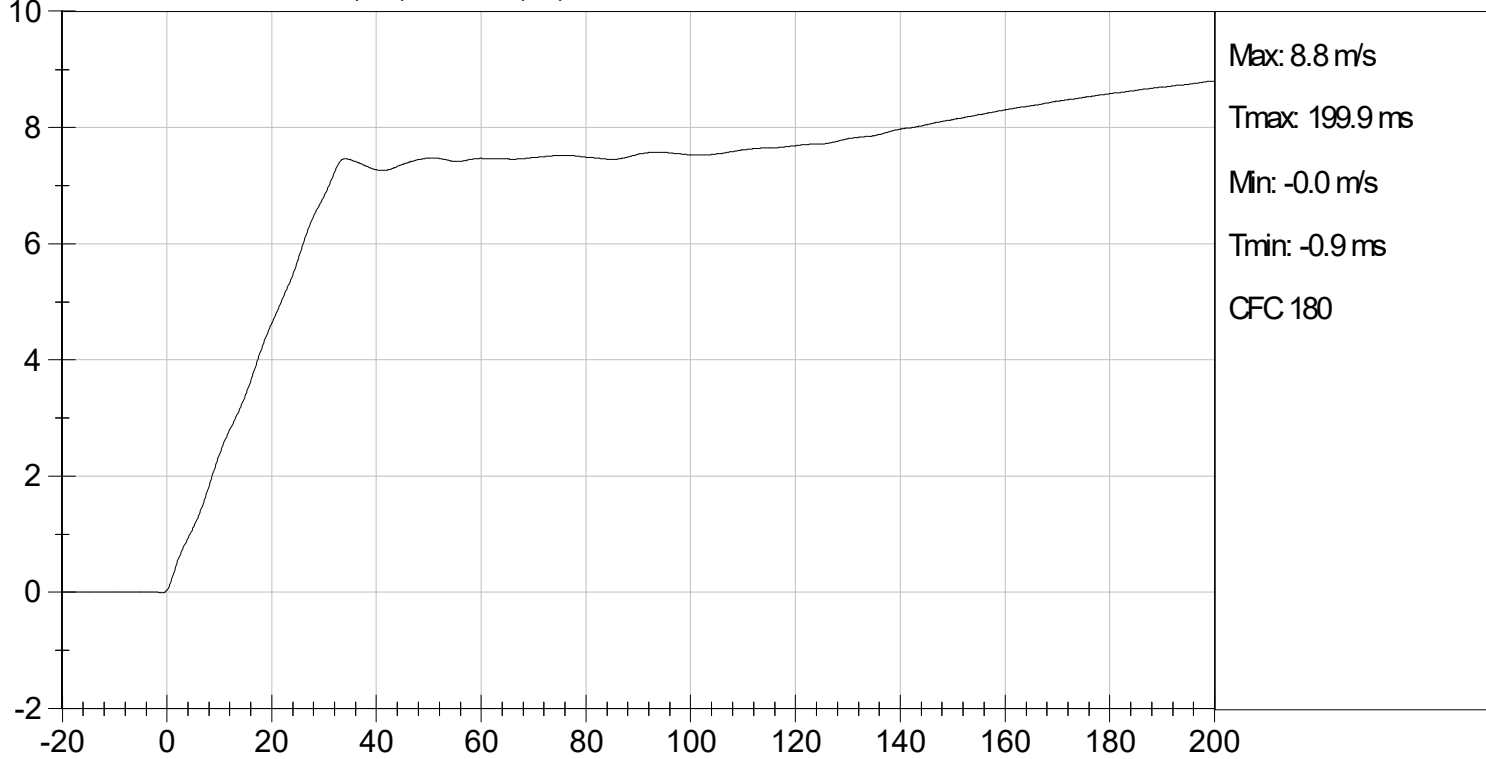

NECK ROTATION (DEG) vs TIME (ms)

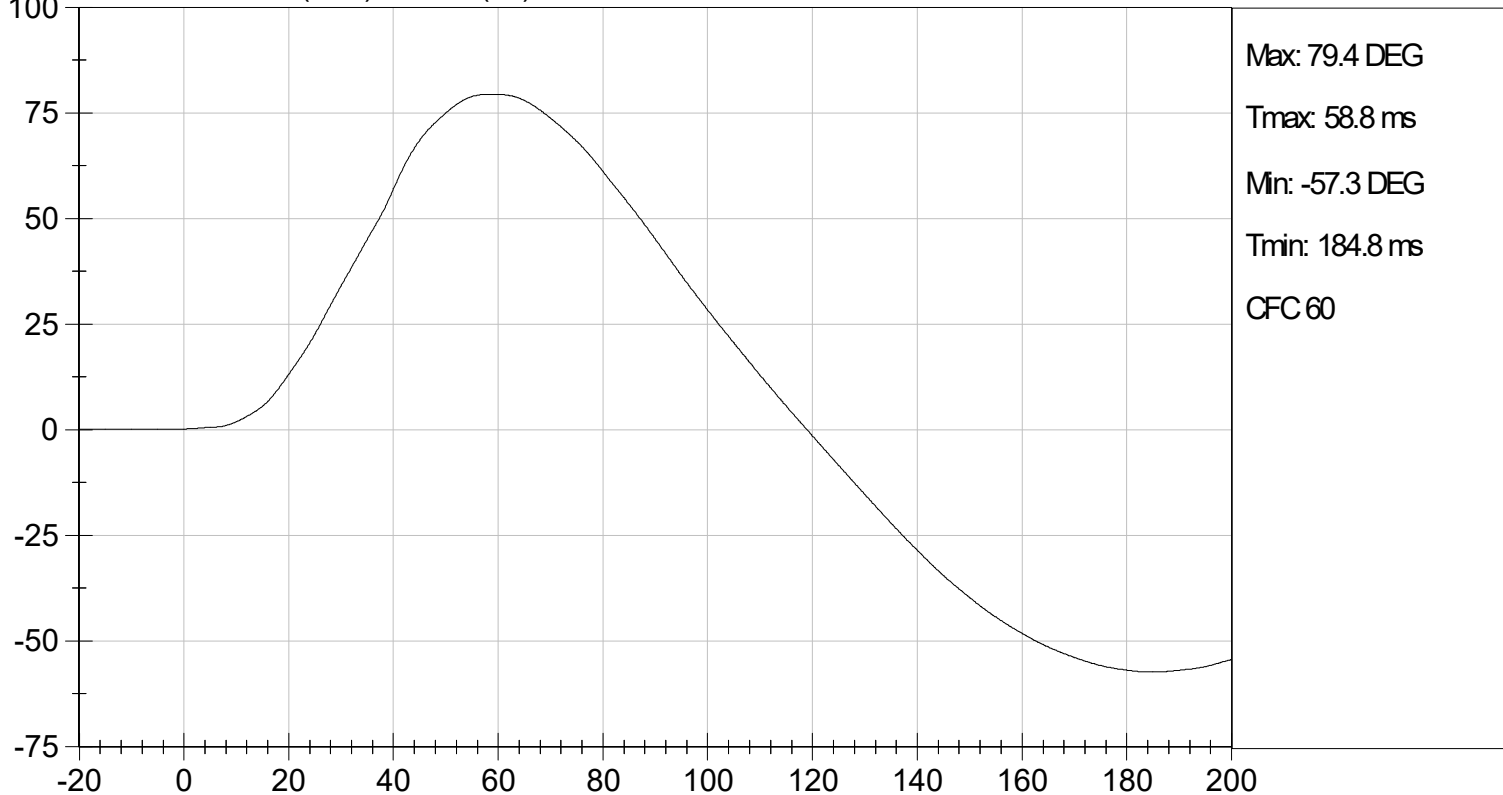

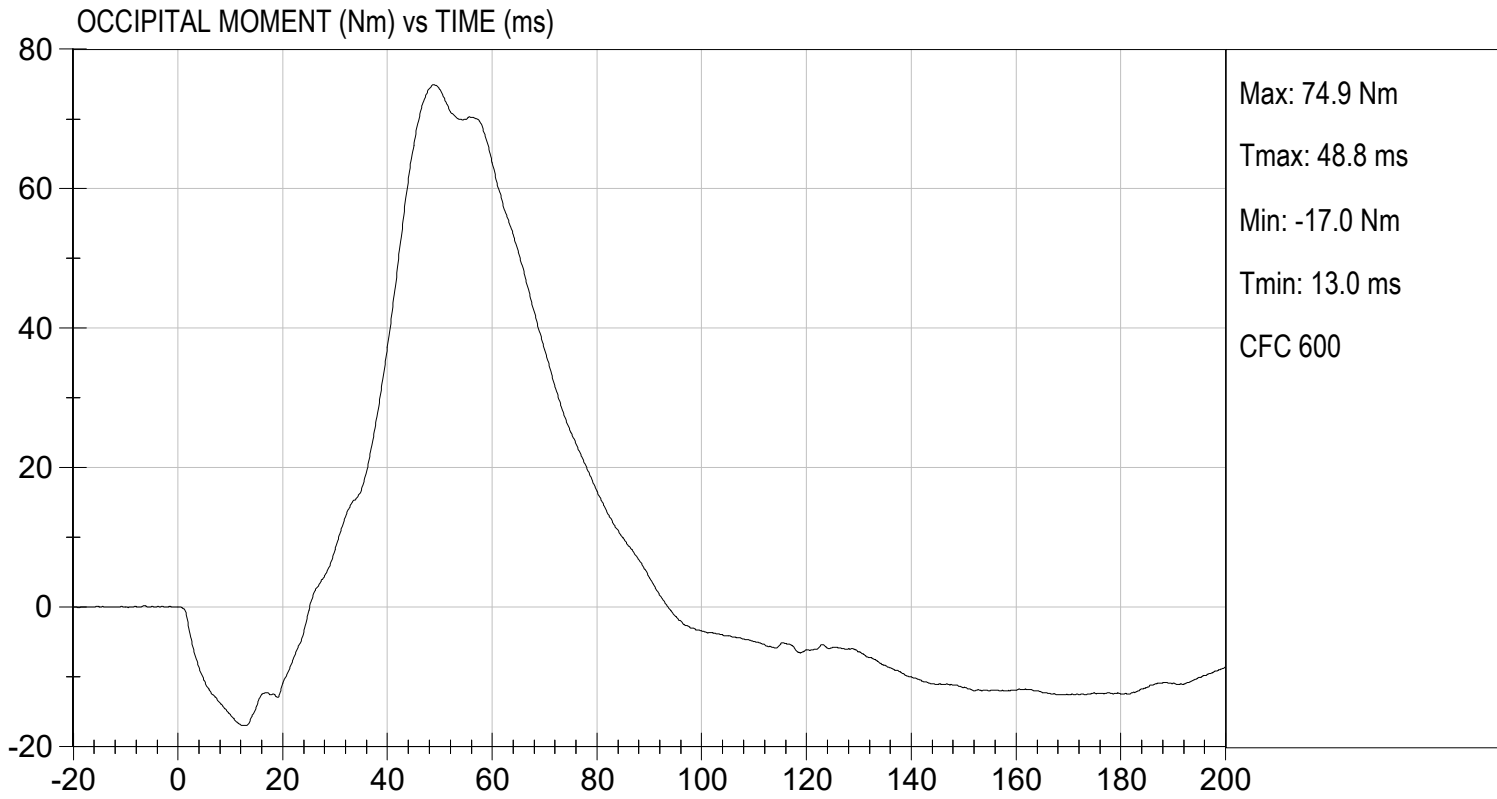

MGA RESEARCH CORPORATION
NECK EXTENSION TEST
HYBRID III 5TH PERCENTILE

ATD Serial No: 142

Test I.D: D241343

Tested Parameter		Units	Specification	Result	Pass/Fail
Laboratory Temperature		deg C	20.6 to 22.2	21.4	Pass
Laboratory Relative Humidity		%	10 to 70	46	Pass
Pendulum Speed		m/s	5.95 to 6.19	6.12	Pass
Pendulum Velocity	10 ms	m/s	1.5 to 1.9	1.8	Pass
	20 ms	m/s	3.1 to 3.9	3.7	Pass
	30 ms	m/s	4.6 to 5.6	5.4	Pass
D Plane Rotation	Max	deg	99 to 114	109	Pass
Occipital Condyle Moment within Rotation Corridor		Nm	-65 to -53	-54	Pass
Negative Moment Time Curve Decay to -10 Nm		ms	94 to 114	106	Pass
Overall Results					Pass

 Laboratory Technician

06/03/2024
 Test Date

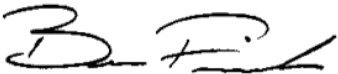
 Approved By

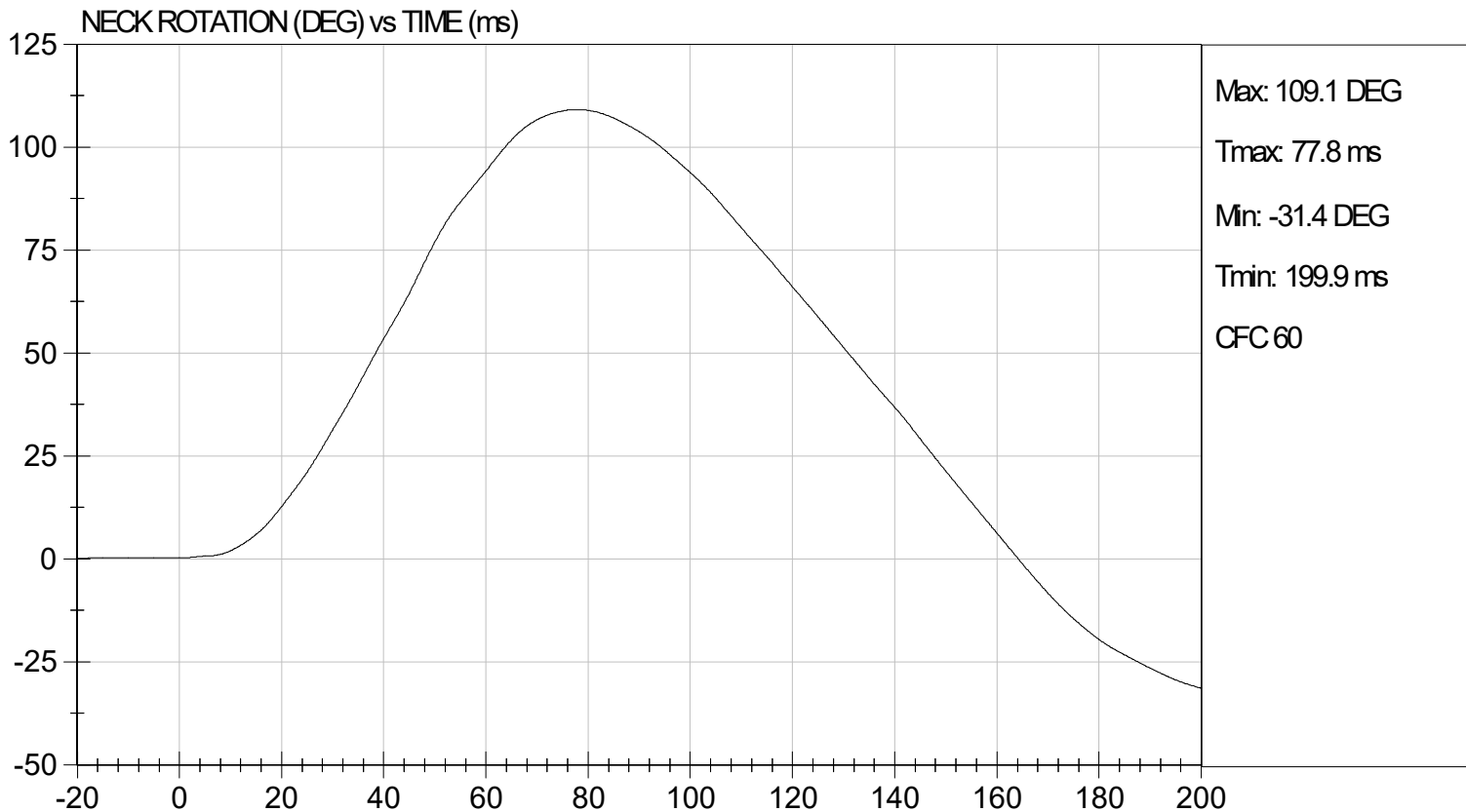
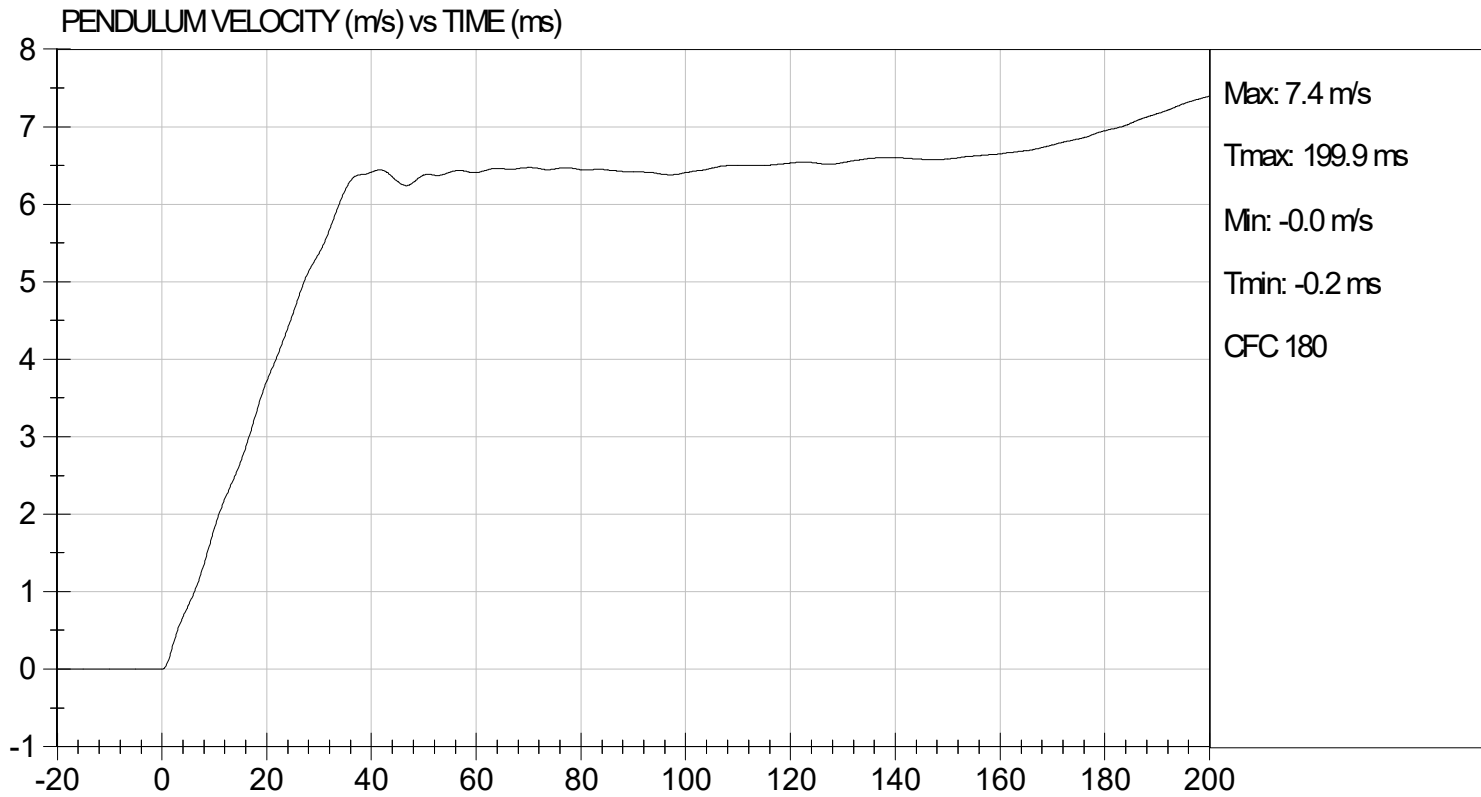

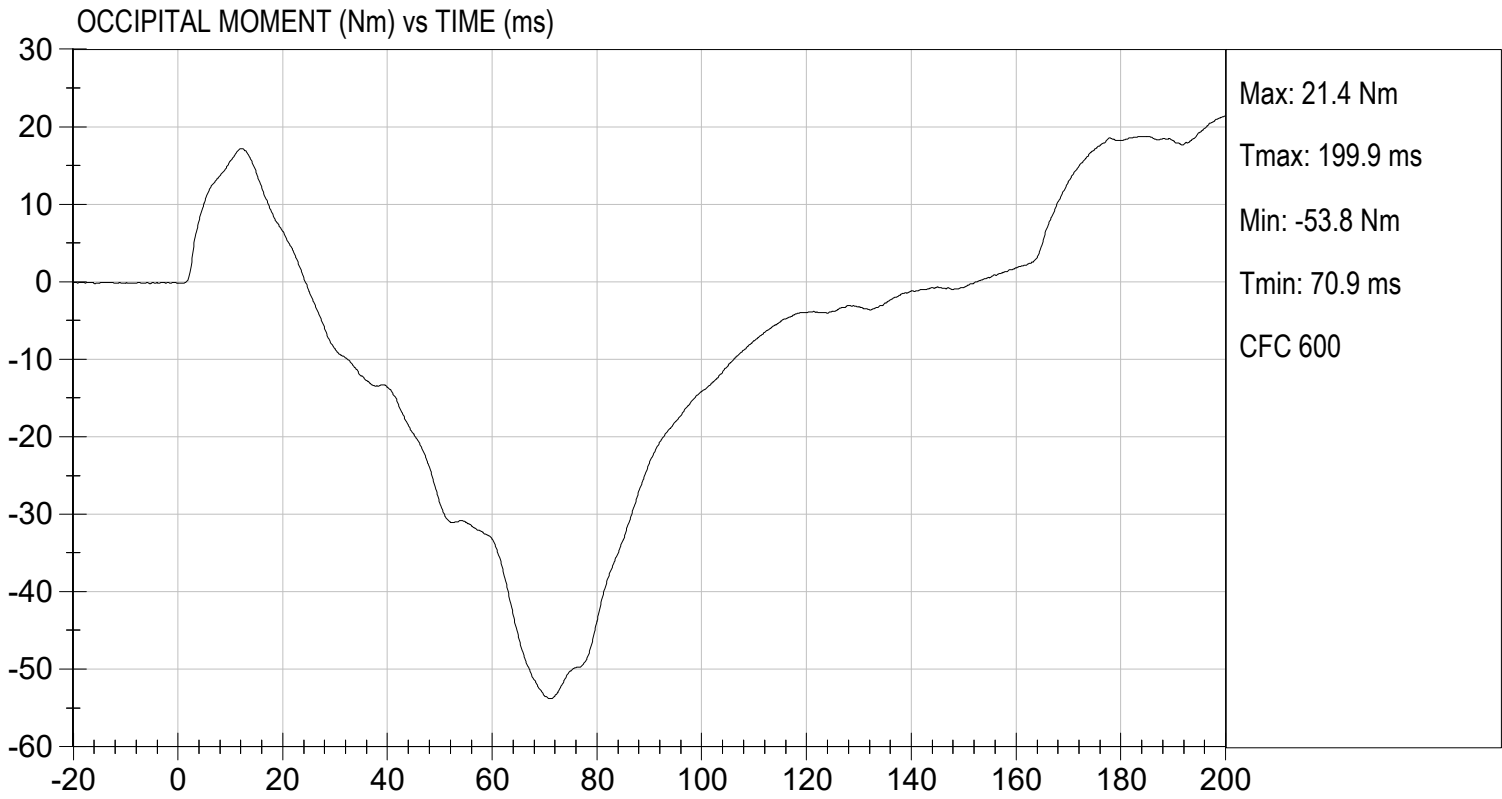

MGA RESEARCH CORPORATION
THORAX IMPACT
HYBRID III 5TH PERCENTILE

ATD Serial No: 142

Test I.D: D241344

Tested Parameter	Units	Specification	Result	Pass/Fail
Temperature	deg C	20.6 to 22.2	21.4	Pass
Relative Humidity	%	10 to 70	49	Pass
Probe Speed	m/s	6.59 to 6.83	6.77	Pass
Peak Deflection	mm	50 to 58	53	Pass
Peak Resistive Force w/in Deflection Corridor	N	3900 to 4400	4321	Pass
Internal Hysteresis	%	69 to 85	75	Pass
Peak Force 18 mm - 50 mm	N	<= 4600	4320	Pass
Overall Test Results				Pass

 Laboratory Technician

06/03/2024
 Test Date

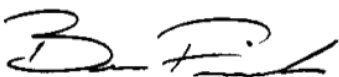
 Approved By

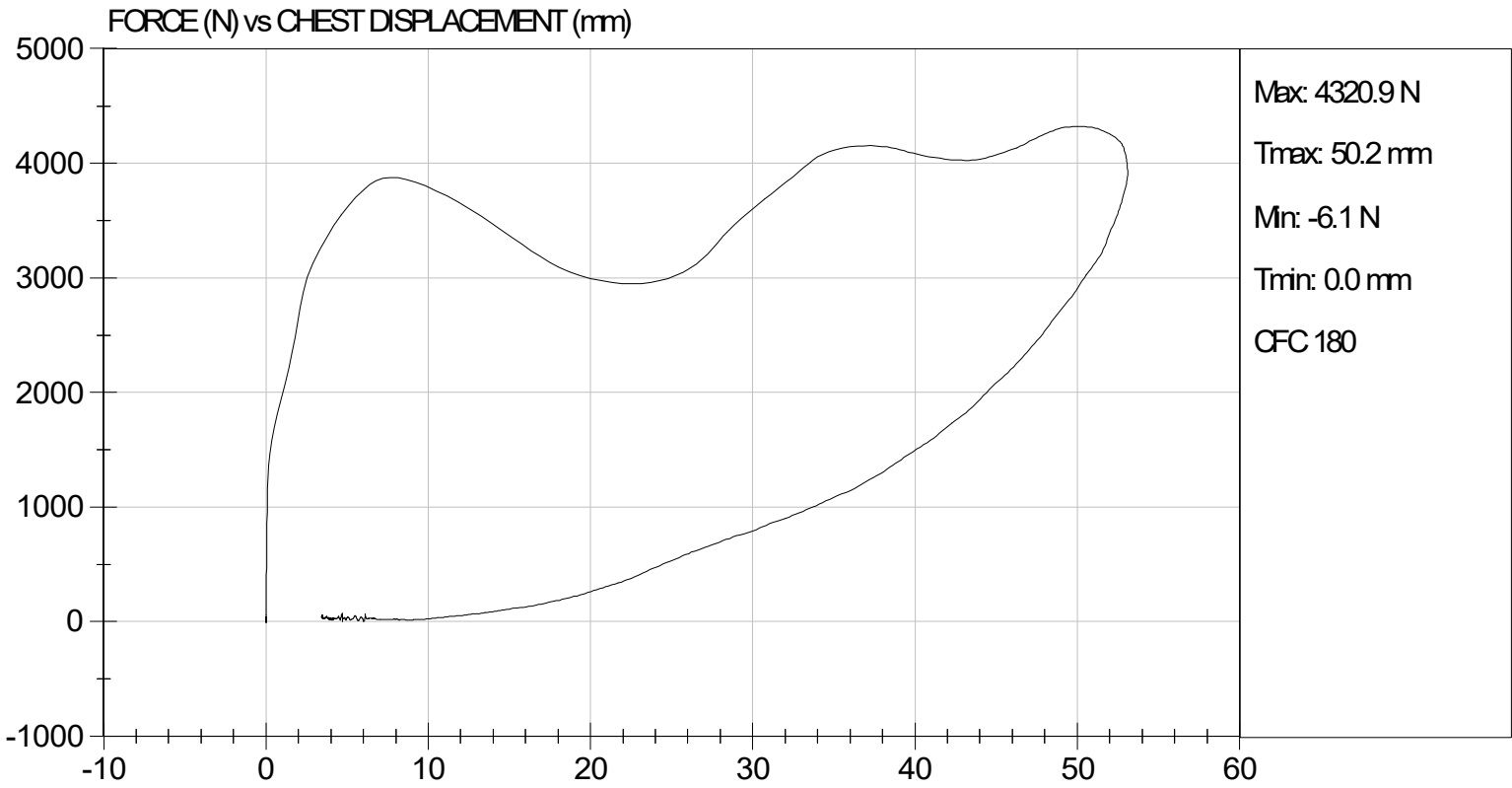

MGA RESEARCH CORPORATION
RIGHT KNEE IMPACT TEST
HYBRID III 5TH PERCENTILE

ATD Serial No: 142

Test I.D: D241345

Tested Parameter	Units	Specification	Result	Pass/Fail
Laboratory Temperature	deg C	18.9 to 25.6	21.4	Pass
Laboratory Relative Humidity	%	10 to 70	45	Pass
Probe Speed	m/s	2.07 to 2.13	2.09	Pass
Maximum Force	N	3450 to 4060	3789	Pass
			Overall Test Results	Pass

Laboratory Technician

06/03/2024
Test Date

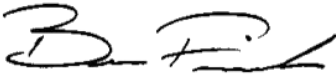
Approved By



TEST DESC: RIGHT KNEE
VELOCITY: 6.86 ft/s, 2.09 m/s

TEST DATE: 06/03/2024
TEST #: D241345

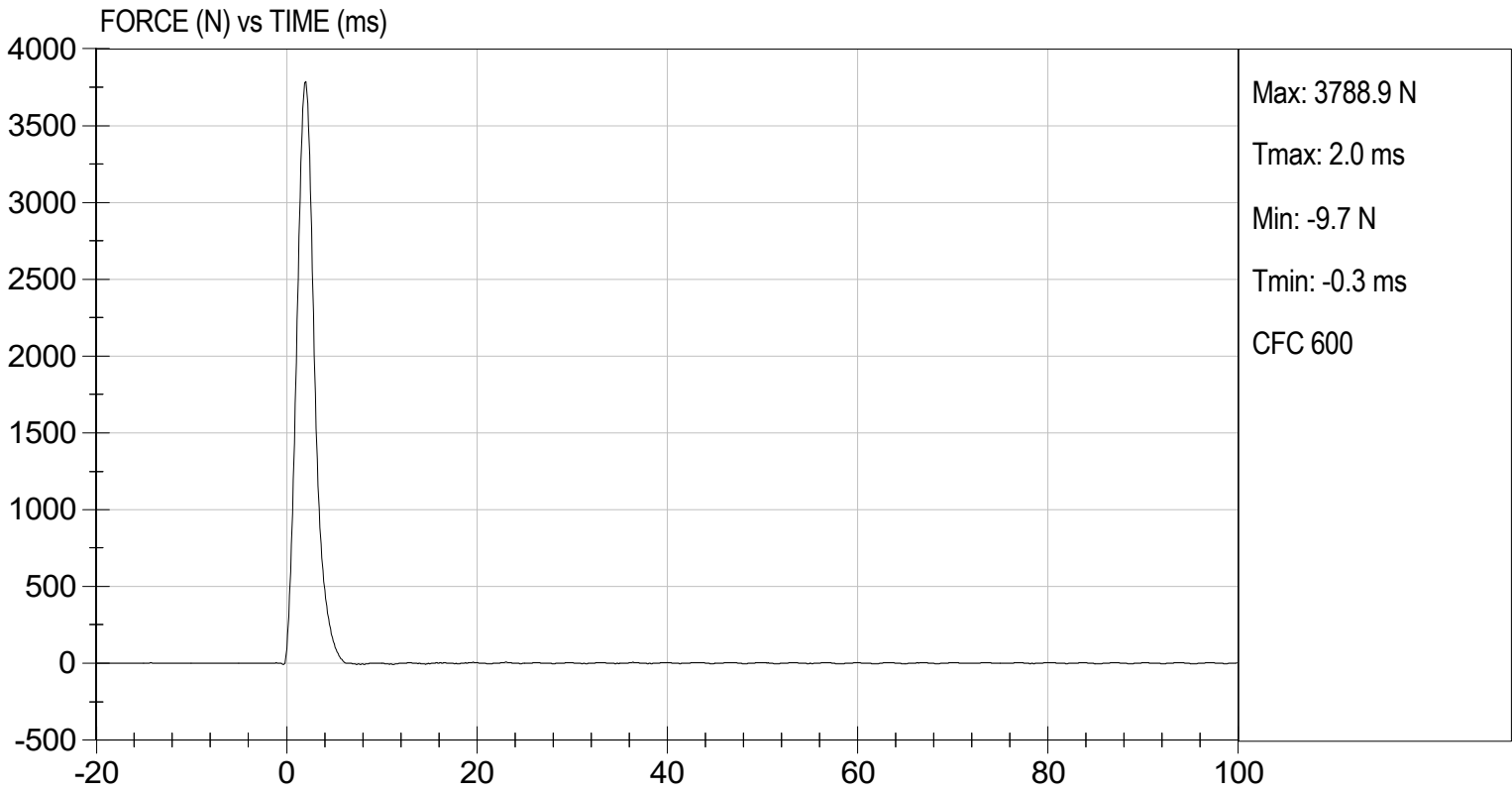

MGA RESEARCH CORPORATION

LEFT KNEE IMPACT TEST

HYBRID III 5TH PERCENTILE

ATD Serial No: 142

Test I.D: D241346

Tested Parameter	Units	Specification	Result	Pass/Fail
Laboratory Temperature	deg C	18.9 to 25.6	21.4	Pass
Laboratory Relative Humidity	%	10 to 70	45	Pass
Probe Speed	m/s	2.07 to 2.13	2.10	Pass
Maximum Force	N	3450 to 4060	3812	Pass
			Overall Test Results	Pass



Laboratory Technician

06/03/2024

Test Date

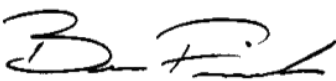

Approved By



TEST DESC: LEFT KNEE
VELOCITY: 6.89 ft/s, 2.10 m/s

TEST DATE: 06/03/2024
TEST #: D241346

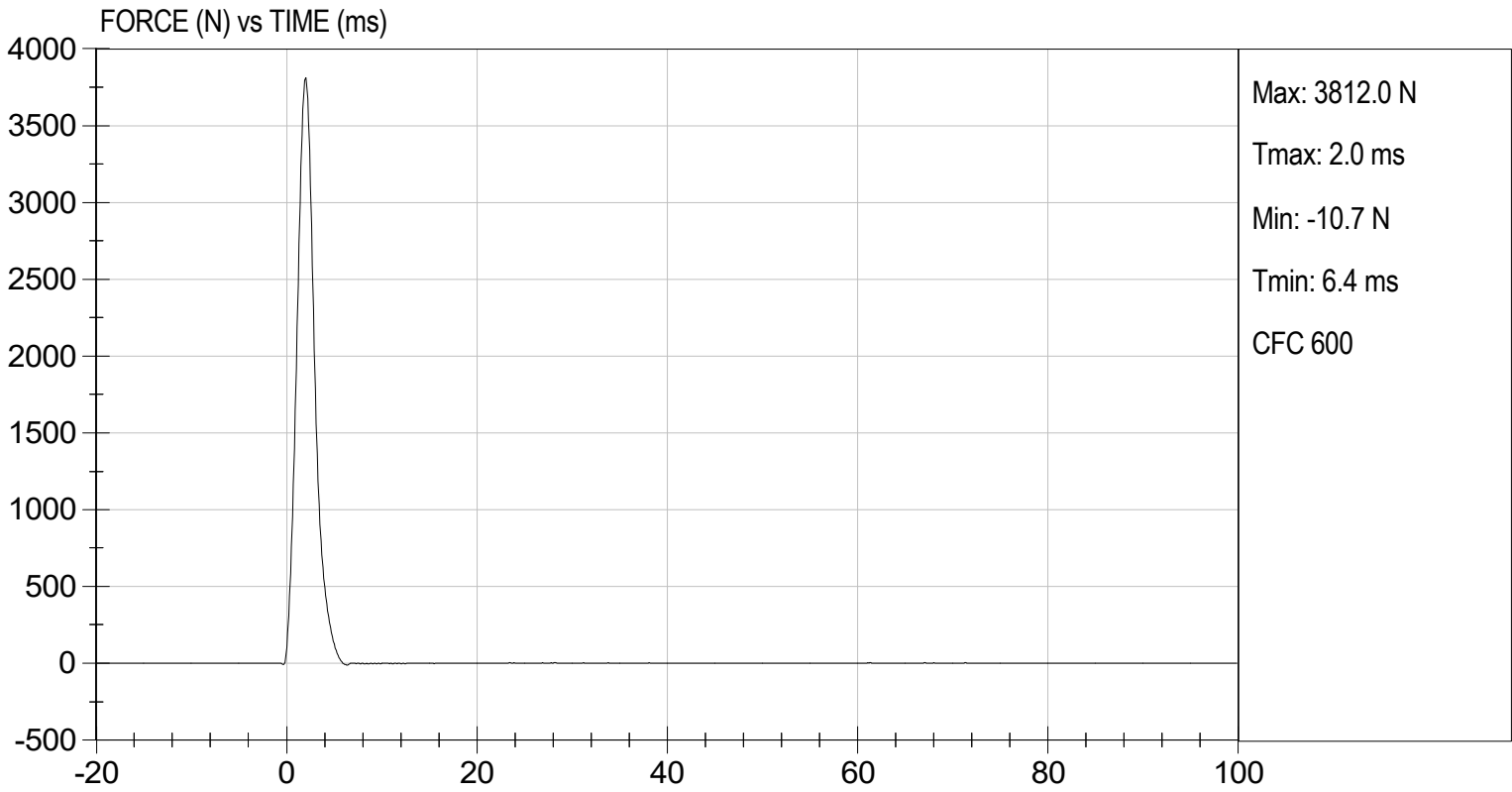

MGA RESEARCH CORPORATION

TORSO FLEXION TEST

HYBRID III 5TH PERCENTILE

ATD Serial No: 142

Test I.D: D241347

Tested Parameter	Units	Specification	Result	Pass/Fail
Laboratory Temperature	deg C	18.9 to 25.6	21.3	Pass
Laboratory Relative Humidity	%	10 to 70	46	Pass
Initial Angle	deg	0 to 20	16	Pass
Return Angle	deg	+/- 8	4	Pass
Force at 45 deg	N	320 to 390	381	Pass
Upper Torso Deflection Rate	deg/s	0.5 to 1.5	0.7	Pass
			Overall Result	Pass



Laboratory Technician

06/03/2024

Test Date

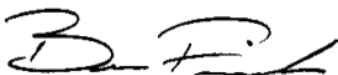

Approved By

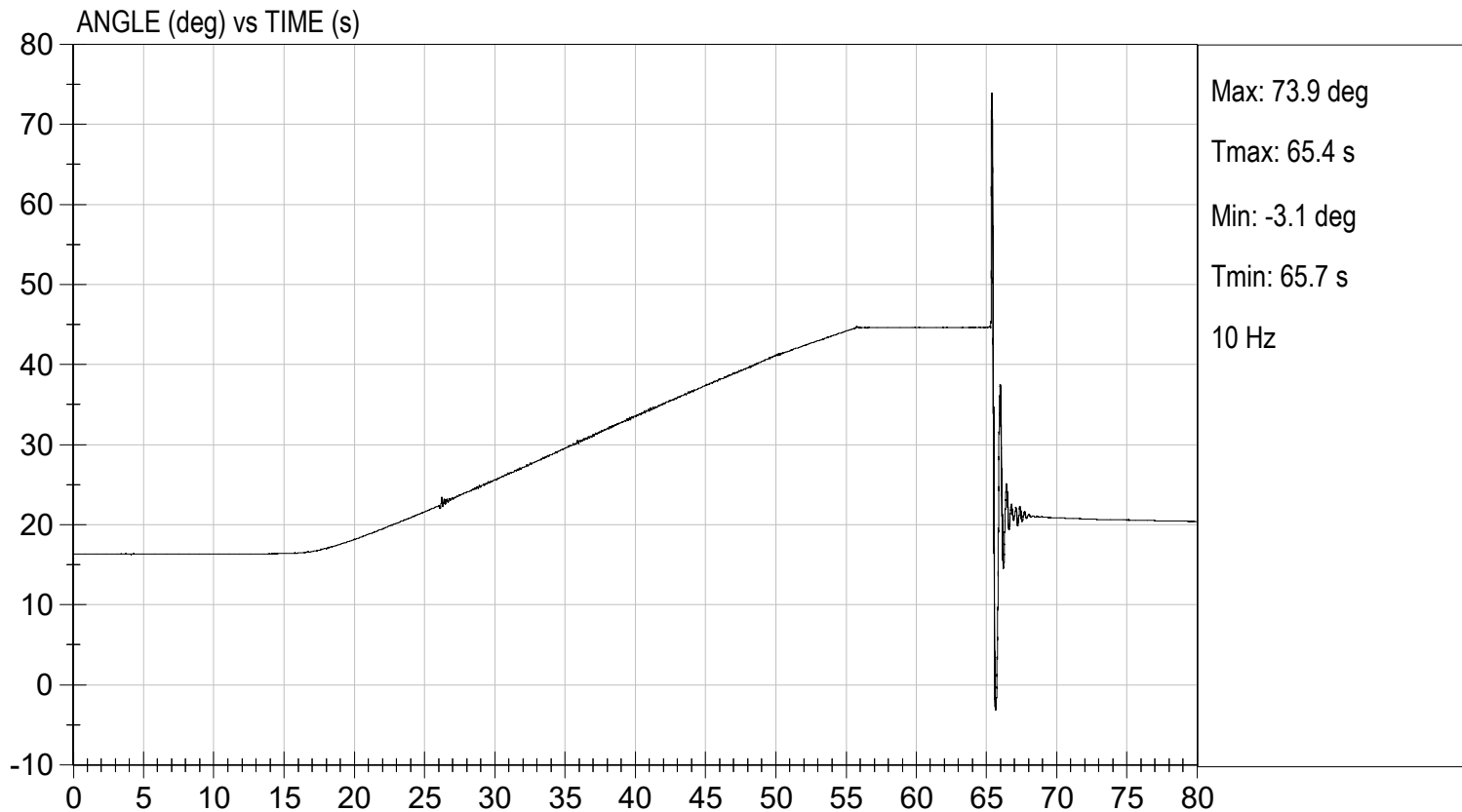
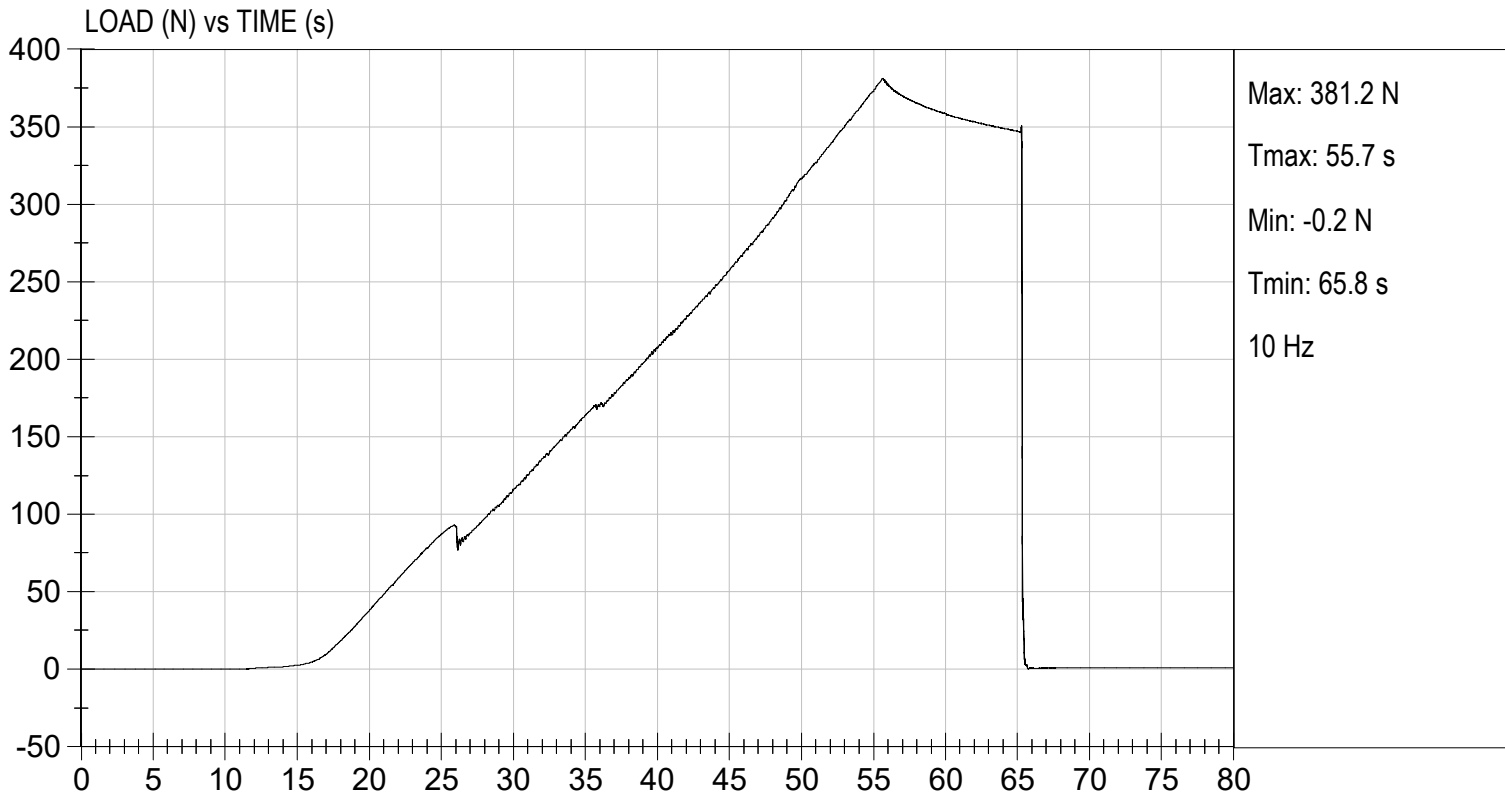

APPENDIX D
TEST EQUIPMENT AND INSTRUMENTATION CALIBRATION

TABLE 1 – DRIVER DUMMY INSTRUMENTATION

Instrument Location			Axis	Hybrid III 50 th S/N 064		
				Serial Number	Manufacturer	Calibration Date
Head Accelerometers	Primary	X		T30960	Endevco	05/23/2024
		Y		P79743	Endevco	05/23/2024
		Z		P79741	Endevco	05/23/2024
	Redundant	X		P79744	Endevco	05/23/2024
		Y		P94834	Endevco	05/23/2024
		Z		P94856	Endevco	05/23/2024
Head Angular Rate Sensors			X	ARS7325	DTS	11/17/2023
			Y	ARS7340	DTS	11/17/2023
			Z	ARS7354	DTS	11/17/2023
Upper Neck Load Cell			Fx, Fy, Fz Mx, My, Mz	NG1911	Denton	06/23/2023
Chest Accelerometers	Primary	X		P86793	Endevco	05/23/2024
		Y		P88348	Endevco	05/23/2024
		Z		P86792	Endevco	05/23/2024
	Redundant	X		P88667	Endevco	05/23/2024
		Y		P94109	Endevco	05/23/2024
		Z		P88666	Endevco	05/23/2024
Chest Potentiometer			X	064	Humanetics	05/23/2024
Pelvis Accelerometers			X	P97742	Endevco	05/23/2024
			Y	P96038	Endevco	05/23/2024
			Z	P95526	Endevco	05/23/2024
Femur Load Cells	Right	Primary	Z	FG121P	Denton	05/22/2024
		Redundant	Z	FG121R	Denton	05/22/2024
	Left	Primary	Z	FG122P	Denton	05/22/2024
		Redundant	Z	FG122R	Denton	05/22/2024
Tibia Load Cells	Right	Upper	Mx, My, Fz	TG408	Denton	11/28/2023
		Lower	Mx, My, Fz	AG116	Denton	11/28/2023
	Left	Upper	Mx, My, Fz	TG480	Denton	11/28/2023
		Lower	Mx, My, Fz	AG502	Denton	11/28/2023
Foot Accelerometers	Right	Rear	X	T22486	Endevco	05/23/2024
			Z	P97382	Endevco	05/23/2024
		Front	Z	P82120	Endevco	05/23/2024
	Left	Rear	X	T16468	Endevco	05/23/2024
			Z	T32154	Endevco	05/23/2024
		Front	Z	T32190	Endevco	05/23/2024
Seat Belt Load Cells		Lap				
		Shoulder				

TABLE 2 – FRONT PASSENGER DUMMY INSTRUMENTATION

Instrument Location			Axis	Hybrid III 5 th S/N 142		
				Serial Number	Manufacturer	Calibration Date
Head Accelerometers	Primary		X	P94799	Endevco	04/15/2024
			Y	P94800	Endevco	04/15/2024
			Z	P94801	Endevco	04/15/2024
	Redundant		X	P94802	Endevco	04/15/2024
			Y	P94803	Endevco	04/15/2024
			Z	P97377	Endevco	04/15/2024
Head Angular Rate Sensors			X	ARS7371	DTS	11/17/2023
			Y	ARS7357	DTS	11/17/2023
			Z	ARS7366	DTS	11/17/2023
Upper Neck Load Cell			Fx, Fy, Fz Mx, My, Mz	NG2203	Denton	01/22/2024
Chest Accelerometers	Primary		X	P88719	Endevco	04/15/2024
			Y	P94785	Endevco	04/15/2024
			Z	P94793	Endevco	04/15/2024
	Redundant		X	P95322	Endevco	04/15/2024
			Y	P95370	Endevco	04/15/2024
			Z	T30901	Endevco	04/15/2024
Chest Potentiometer			X	142	Humanetics	04/15/2024
Pelvis Accelerometers			X	P94798	Endevco	04/15/2024
			Y	P82646	Endevco	04/15/2024
			Z	P97705	Endevco	04/15/2024
Femur Load Cells	Right	Primary	Z	FG126P	Denton	04/15/2024
		Redundant	Z	FG126R	Denton	04/15/2024
	Left	Primary	Z	FG127P	Denton	04/15/2024
		Redundant	Z	FG127R	Denton	04/15/2024
Tibia Load Cells	Right	Upper	Mx, My, Fz	TG467	Denton	01/22/2024
		Lower	Mx, My, Fz	AG500	Denton	01/22/2024
	Left	Upper	Mx, My, Fz	TG478	Denton	01/22/2024
		Lower	Mx, My, Fz	AG491	Denton	01/22/2024
Foot Accelerometers	Right	Rear	X	P94795	Endevco	04/16/2024
			Z	P94796	Endevco	04/16/2024
		Front	Z	P94797	Endevco	04/16/2024
	Left	Rear	X	P83167	Endevco	04/16/2024
			Z	P83168	Endevco	04/16/2024
		Front	Z	P83169	Endevco	04/15/2024
Seat Belt Load Cells		Lap				
		Shoulder				

TABLE 3 – VEHICLE INSTRUMENTATION

Instrument Location			Axis	Serial Number	Manufacturer	Calibration Date
Crossmember / Rear Seat Accelerometers	Left	Primary	X	A405049	MSI	03/14/2024
			Z	T40726	Endevco	05/07/2024
		Redundant	X	A411432	MSI	03/15/2024
	Right	Primary	X	T39758	Endevco	01/03/2024
			Z	T39759	Endevco	01/03/2024
		Redundant	X	T39756	Endevco	01/03/2024
Engine Accelerometers		Top	X	T39088	Endevco	05/20/2024
		Bottom	X	T40101	Endevco	03/21/2024