

REPORT NUMBER: SINCAP-CAL-18-001

**NEW CAR ASSESSMENT PROGRAM (NCAP)
MOVING DEFORMABLE BARRIER SIDE IMPACT TEST**

**Subaru Corporation
2018 Subaru Crosstrek
Four Door Station Wagon**

NHTSA No: M20185503

**PREPARED BY:
CALSPAN CORPORATION
P.O. BOX 400
BUFFALO, NEW YORK 14225**



November 30, 2017

FINAL REPORT

**PREPARED FOR:
U.S. DEPARTMENT OF TRANSPORTATION
NATIONAL HIGHWAY TRAFFIC SAFETY ADMINISTRATION
OFFICE OF CRASHWORTHINESS STANDARDS
MAIL CODE: NRM-110
1200 NEW JERSEY AVE SE, ROOM W43-410
WASHINGTON, D.C. 20590**

This final test report was prepared for the U.S. Department of Transportation, National Highway Traffic Safety Administration, in response to Contract Number DTNH22-14-D-00352.

This publication is distributed by the U.S. Department of Transportation, National Highway Traffic Safety Administration, in the interest of information exchange. The opinions, findings and conclusions expressed in this publication are those of the author(s) and not necessarily those of the Department of Transportation or the National Highway Traffic Safety Administration. The United States Government assumes no liability for its contents or use thereof.

If trade or manufacturers' names or products are mentioned it is only because they are considered essential to the object of the publication and should not be construed as an endorsement. The United States Government does not endorse products or manufacturers.

Prepared by: Vanessa Hansen
Vanessa Hansen, Project Engineer

Date: November 30, 2017

Approved by: Edward Dutton
Edward Dutton, Test Engineer
Transportation Test Operations

Date: November 30, 2017

FINAL REPORT ACCEPTANCE BY OCWS:

Division Chief, New Car Assessment Program
NHTSA, Office of Crashworthiness Standards

Date: _____

COTR, New Car Assessment Program
NHTSA, Office of Crashworthiness Standards

Date: _____

TECHNICAL REPORT DOCUMENTATION PAGE

1. Report No. SINCAP-CAL-18-001	2. Government Accession No.	3. Recipient's Catalog No.																												
4. Title and Subtitle Final Report of New Car Assessment Program Side Impact MDB Testing of a 2018 Subaru Crosstrek four door station wagon NHTSA No.: M20185503		5. Report Date November 30, 2017																												
		6. Performing Organization Code CAL																												
Vanessa Hansen, Senior Test Engineer Edward Dutton, Operations Manager		8. Performing Organization Report No. CAL-DOT-2018-001																												
9. Performing Organization Name and Address Calspan Corporation Transportation Test Operations P.O. Box 400 Buffalo, New York 14225		10. Work Unit No.																												
		11. Contract or Grant No. DTNH22-14-D-00352																												
12. Sponsoring Agency Name and Address U.S. Department of Transportation National Highway Traffic Safety Administration Office of Crashworthiness Standards (NRM-110) 1200 New Jersey Ave., SE, Room W43-410 Washington, D.C. 20590		13. Type of Report and Period Covered: Final Test Report November 1, 2017 - November 30, 2017																												
		14. Sponsoring Agency Code NRM-110																												
15. Supplementary Notes																														
16. Abstract A 55/28, (61.90kph / 38.5 mph), 90° Moving Deformable Barrier NCAP Side Impact Test was conducted on the subject 2018 Subaru Crosstrek four door station wagon in accordance with the specifications of the Office of Crashworthiness Standards Test Procedure for the generation of consumer information on vehicle side crash protection. This test was conducted at Calspan Corporation's Transportation Test Operations facility in Buffalo, New York on November 1, 2017. The impact velocity of the Moving Deformable Barrier (MDB) was 61.93 km/h, and the ambient temperature at the struck (driver's) side of the target vehicle at the time of impact was 21°C. The target vehicle's maximum post-test static crush was 206mm located at level 3. The test vehicle's occupant performance data is as follows:																														
<table border="1" style="width: 100%; border-collapse: collapse;"> <thead> <tr> <th rowspan="2" style="width: 55%;">Measurement Description</th> <th colspan="3" style="text-align: center;">Driver ATD (ES-2re)</th> </tr> <tr> <th style="width: 10%;">Units</th> <th style="width: 10%;">IARV</th> <th style="width: 10%;">Result</th> </tr> </thead> <tbody> <tr> <td>Head Injury Criteria (HIC₃₆)</td> <td>N/A</td> <td>1000</td> <td style="background-color: yellow;">138.194</td> </tr> <tr> <td>Maximum Thoracic Rib Deflection</td> <td>mm</td> <td>44</td> <td style="background-color: yellow;">19.011</td> </tr> <tr> <td>Total Abdominal Force</td> <td>N</td> <td>2500</td> <td style="background-color: yellow;">871.052</td> </tr> <tr> <td>Pubic Symphysis Force</td> <td>N</td> <td>6000</td> <td style="background-color: yellow;">1541.005</td> </tr> </tbody> </table>				Measurement Description	Driver ATD (ES-2re)			Units	IARV	Result	Head Injury Criteria (HIC ₃₆)	N/A	1000	138.194	Maximum Thoracic Rib Deflection	mm	44	19.011	Total Abdominal Force	N	2500	871.052	Pubic Symphysis Force	N	6000	1541.005				
Measurement Description	Driver ATD (ES-2re)																													
	Units	IARV	Result																											
Head Injury Criteria (HIC ₃₆)	N/A	1000	138.194																											
Maximum Thoracic Rib Deflection	mm	44	19.011																											
Total Abdominal Force	N	2500	871.052																											
Pubic Symphysis Force	N	6000	1541.005																											
<table border="1" style="width: 100%; border-collapse: collapse;"> <thead> <tr> <th rowspan="2" style="width: 55%;">Measurement Description</th> <th colspan="3" style="text-align: center;">Passenger ATD (SID-IIs)</th> </tr> <tr> <th style="width: 10%;">Units</th> <th style="width: 10%;">IARV</th> <th style="width: 10%;">Result</th> </tr> </thead> <tbody> <tr> <td>Head Injury Criteria (HIC₃₆)</td> <td>N/A</td> <td>1000</td> <td style="background-color: yellow;">303.117</td> </tr> <tr> <td>Lower Spine Resultant Acceleration</td> <td>G</td> <td>82</td> <td style="background-color: yellow;">57.747</td> </tr> <tr> <td>Total Pelvic Force (sum of acetabular and iliac forces)</td> <td>N</td> <td>5525</td> <td style="background-color: yellow;">1904.208</td> </tr> <tr> <td>Maximum Thoracic Rib Deflection</td> <td>mm</td> <td>38*</td> <td style="background-color: yellow;">19.513</td> </tr> <tr> <td>Maximum Abdominal Rib Deflection</td> <td>mm</td> <td>45*</td> <td style="background-color: yellow;">18.862</td> </tr> </tbody> </table>				Measurement Description	Passenger ATD (SID-IIs)			Units	IARV	Result	Head Injury Criteria (HIC ₃₆)	N/A	1000	303.117	Lower Spine Resultant Acceleration	G	82	57.747	Total Pelvic Force (sum of acetabular and iliac forces)	N	5525	1904.208	Maximum Thoracic Rib Deflection	mm	38*	19.513	Maximum Abdominal Rib Deflection	mm	45*	18.862
Measurement Description	Passenger ATD (SID-IIs)																													
	Units	IARV	Result																											
Head Injury Criteria (HIC ₃₆)	N/A	1000	303.117																											
Lower Spine Resultant Acceleration	G	82	57.747																											
Total Pelvic Force (sum of acetabular and iliac forces)	N	5525	1904.208																											
Maximum Thoracic Rib Deflection	mm	38*	19.513																											
Maximum Abdominal Rib Deflection	mm	45*	18.862																											
<p>* Proposed IARV</p> <p>The two doors on the struck side of the vehicle did not separate from the body at the hinges or latches and the opposite doors did not open during the side impact event.</p>																														
17. Key Words New Car Assessment Program (NCAP) Side Impact MDB ES-2re SID-IIs		18. Distribution Statement Copies of this report are available from: National Highway Traffic Safety Administration Technical Information Services Division, NPO-411 1200 New Jersey Ave. SE Washington, D.C. 20590 e-mail: tis@nhtsa.dot.gov FAX: 202-493-2833																												
19. Security Class. (of this report) UNCLASSIFIED	20. Security Class. (of this page) UNCLASSIFIED	21. No. of Pages 188	22. Price																											

TABLE OF CONTENTS

<u>Section</u>		<u>Page</u>
1	Test Purpose and Procedure	1-1
2	Summary of Test Results	2-1
3	Occupant and Vehicle Information	3-1
 <u>Data Sheet</u>		 <u>Page</u>
1	General Test and Vehicle Parameter Data	3-2
2	Seat, Seat Belt, Steering Wheel Adjustment and Fuel System Data	3-6
3	Dummy Longitudinal Clearance Dimensions	3-11
4	Dummy Lateral Clearance Dimensions	3-12
5	Camera and Instrumentation Data	3-13
6	Test Vehicle Accelerometer Locations	3-14
7	MDB Accelerometer Locations	3-15
8	Post-Test Observations	3-16
9	MDB Summary of Results	3-18
10	Test Vehicle Profile Measurements	3-19
11	Test Vehicle Exterior Crush Measurements	3-20
12	MDB Exterior Static Crush Measurements	3-23
13	FMVSS No. 301 Static Rollover Results	3-24
14	Dummy/Vehicle Temperature and Humidity Stabilization Data	3-25
 <u>Appendix</u>		 <u>Page</u>
A	Photographs	A-1
B	Vehicle and Dummy Response Data Plots	B-1
C	Dummy Configuration and Performance Verification Data	C-1
D	Test Equipment and Instrumentation Calibration Data	D-1

SECTION 1

TEST PURPOSE AND PROCEDURE

This moving deformable barrier side impact test is part of the MY 2018 New Car Assessment Program Side Impact Test Program, sponsored by the National Highway Traffic Safety Administration (NHTSA), under contract number DTNH22-14-D-00352. The purpose of this test is to generate comparative side impact performance in a 2018 Subaru Crosstrek four door station wagon. The side impact test was conducted in accordance with the Office of Crashworthiness Standard's Laboratory Test Procedure dated October 2015.

SECTION 2

SUMMARY OF TEST RESULTS

A 2018 Subaru Crosstrek four door station wagon was impacted on the left (driver's) side by a Moving Deformable Barrier (MDB) which was moving forward in a 27° crabbed position to the tow road guidance system at a velocity of 61.93 km/h. The target vehicle was stationary and was positioned at an angle of 63° to the line of forward motion. The side impact test was conducted by the Calspan Corporation's Transportation Test Operations Center in Buffalo, New York on November 1, 2017. Pre-test and post-test photographs of the test vehicle, the MDB and the dummies (ES-2re and SID-IIs) are included in this report.

Dummies were placed in the driver and left rear designated seating positions according to instructions specified in the OCWS Side Impact Laboratory Test Procedure, dated October 2015. The side impact event was documented by 9 high-speed and 2 real-time cameras. Camera locations are included in this report.

The Dummies were instrumented in the following manner:

DRIVER ATD (ES-2re)

Primary and redundant head CG tri-axial accelerometers

Chest upper rib, middle rib, and lower rib y-axis displacement potentiometers

Abdomen forward, middle, and rear y-axis load cells

Lower spine (T12) tri-axial accelerometers

Public symphysis y-axis load cell

PASSENGER ATD (SID-IIs)

Primary and redundant head CG tri-axial accelerometers

Chest upper rib, middle rib, and lower rib y-axis displacement potentiometers

Abdomen upper rib and lower rib y-axis displacement potentiometers

Lower spine (T12) tri-axial accelerometers

Acetabulum and iliac wing y-axis load cells

Appendix B contains the vehicle and dummy response data. Dummy configuration and performance verification data can be found in APPENDIX C of this report. Appendix D of this report contains the test equipment and instrumentation calibration data.

DUMMY INJURY VALUES

Measurement Description	Driver ATD (ES-2re)		
	Units	Threshold	Result
Head Injury Criteria (HIC36)		1000	138.194
Maximum Thorax Rib Deflection	mm	44	19.011
Combined Abdominal Force	N	2500	871.052
Pubic Symphysis Force	N	6000	1541.005

Measurement Description	Passenger ATD (SID-IIs)		
	Units	Threshold	Result
Head Injury Criteria (HIC36)		1000	303.117
Lower Spine (T12) Resultant Acceleration	G	82	57.747
Total Pelvic Force (sum of acetabular and iliac forces)	N	5525	1904.208
Maximum Thoracic Rib Deflection	mm	38*	19.513
Maximum Abdominal Rib Deflection	mm	45*	18.862

*Proposed IARV

SUPPLEMENTAL RESTRAINT INFORMATION

Restraint Type	Left Front (Driver) Occupant Location 1		Left Rear (Passenger) Occupant Location 4	
	Mounted	Deployed	Mounted	Deployed
Frontal Airbag	Yes	No		
Knee Airbag	Yes	No		
Side Airbag 1 - Curtain	Yes	Yes	Yes	Yes
Side Airbag 2 – Torso/Pelvis Airbag	Yes	Yes	No	N/A
Seat Belt Pretensioner	Yes	Yes	No	N/A
Seat Belt Load Limiter	Yes	Yes	No	N/A
Other				

GENERAL COMMENTS:

1. P1 serial number – F034
2. P4 serial number – 300

Data Anomalies:

The following channel was questionable for

- Left B-Pillar Lower Y Acceleration, Exceeded calibration range at 10.7ms & 14.5ms
- Left B-Pillar Middle Y Acceleration, Exceeded calibration range & saturated at 10.2ms

SECTION 3
OCCUPANT AND VEHICLE INFORMATION

This section contains information reporting for the following Data Sheets:

Data Sheet No. 1 - General Test and Vehicle Parameter Data

Data Sheet No. 2 – Seat, Seat Belt, Steering Wheel Adjustment and Fuel System Data

Data Sheet No. 3 – Dummy Longitudinal Clearance Dimensions

Data Sheet No. 4 – Dummy Lateral Clearance Dimensions

Data Sheet No. 5 – Camera and Instrumentation Data

Data Sheet No. 6 – Test Vehicle Accelerometer Locations

Data Sheet No. 7 – MDB Accelerometer Locations

Data Sheet No. 8 – Post-Test Observations

Data Sheet No. 9 – MDB Summary of Results

Data Sheet No. 10 – Test Vehicle Profile Measurements

Data Sheet No. 11 – Test Vehicle Exterior Crush Measurements

Data Sheet No. 12 – MDB Exterior Static Crush Measurements

Data Sheet No. 13 – Vehicle and MDB Damage Profile Distances

Data Sheet No. 14 – FMVSS No. 301 Static Rollover Results

Data Sheet No. 15 – Dummy/Vehicle Temperature and Humidity Stabilization Data

**DATA SHEET NO. 1
GENERAL TEST AND VEHICLE PARAMETER DATA**

Test Vehicle: 2018 Subaru Crosstrek four door station wagon
 Test Program: NCAP Side MDB Impact Test

NHTSA No.: M20185503
 Test Date: 11/1/2017

TEST VEHICLE INFORMATION AND OPTIONS

NHTSA No.	M20185503
Model Year	2018
Make	Subaru
Model	Crosstrek
Body Style	Four Dr Station Wagon
VIN	JF2GTAAC3J9210580
Body Color	Light Blue
Odometer Reading (km/mi)	27 mi
Engine Displacement (L)	2.0
Type/No. Cylinders	I4
Engine Placement	Transverse
Transmission Type	Manual
Transmission Speeds	6-speed
Overdrive	Yes
Final Drive	All Wheel Drive
Roof Rack	No
Sunroof/T-Top	No
Running Boards	No
Tilt Steering Wheel	Yes
Power Seats	No
Anti-Lock Brakes (ABS)	Yes

Traction Control System (TCS)	Yes
Auto-Leveling System	No
Automatic Door Locks (ADL)	No
Power Window Auto-Reverse	No
Other Optional Feature	-
Driver Front Airbag	Yes
Driver Curtain Airbag	Yes
Driver Head/Torso Airbag	No
Driver Torso Airbag	No
Driver Torso/Pelvis Airbag	Yes
Driver Pelvis Airbag	No
Driver Knee Airbag	Yes
Rear Pass. Curtain Airbag	Yes
Rear Pass. Head/Torso Airbag	No
Rear Pass. Torso Airbag	No
Rear Pass. Torso/Pelvis Airbag	No
Rear Pass. Pelvis Airbag	No
Driver Seat Belt Pretensioners	Yes
Rear Pass. Seat Belt Pretensioners	No
Driver Load Limiter	Yes
Rear Pass. Load Limiter	No
Other Safety Restraint	-

Does owner's manual provide instructions to turn off automatic door locks?

N/A

DATA FROM CERTIFICATION LABEL

Manufactured By	Subaru Corporation
Date of Manufacture	07/17
Vehicle Type	MPV

GVWR (kg)	1970
GAWR Front (kg)	1010
GAWR Rear (kg)	1000

VEHICLE SEATING AND WEIGHT CAPACITY DATA

Measured Parameter	Front	Rear	Third	Total		
Designated Seating Capacity (DSC)	2	3	-	5		
Capacity Weight (VCW) (kg)					408	(A)
DSC X 68.04 kg					340.2	(B)
Cargo Weight (RCLW) (kg)					67.8	(A-B)

VEHICLE SEAT TYPE

Seating Location	Type of Seat Pan				Type of Seat Back		
	Bucket	Bench	Split Bench	Contoured	Fixed	Adjustable	
						W/ Lever	W/ Knob
Front Seat	X					X	
Rear or Second Row Seat			X		X		
Third Row seat							

DATA SHEET NO. 1 ... (CONTINUED)
GENERAL TEST AND VEHICLE PARAMETER DATA

Test Vehicle: 2018 Subaru Crosstrek four door station wagon
 Test Program: NCAP Side MDB Impact Test

NHTSA No.: M20185503
 Test Date: 11/1/2017

VEHICLE TIRE INFORMATION

Collected for year, make, model, & VIN, all items circled in red, tire manufacturer and tire name.

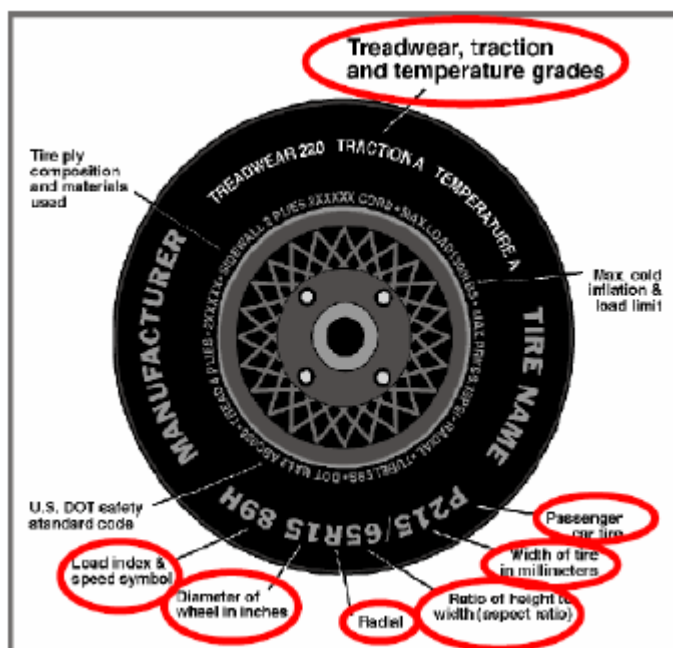

TIRE SIDEWALL INFORMATION

Measured Parameter	Front	Rear
Maximum Tire Pressure (kPa)	350	350
Cold Pressure (kPa)	230	220
Recommended Tire Size	P225/60R17	P225/60R17
Tire Size on Vehicle	P225/60R17	P225/60R17
Tire Manufacturer	Yokohama	Yokohama
Tire Model	Geolandar	Geolandar
Treadwear	320	320
Traction	B	B
Temperature Grade	A	A
Tire Plies Sidewall	2 Polyester	2 Polyester
Tire Plies Body	2 Polyester, 2 Steel	2 Polyester, 2 Steel
Load Index/Speed Symbol	98H	98H
Tire Material	Rubber	Rubber
DOT Safety Code Left	FDFCPE22717	FDFCPE22717
DOT Safety Code Right	FDFCPE22717	FDFCPE22717

DATA SHEET NO. 1 ... (CONTINUED)
GENERAL TEST AND VEHICLE PARAMETER DATA

Test Vehicle: 2018 Subaru Crosstrek four door station wagon
 Test Program: NCAP Side MDB Impact Test

NHTSA No.: M20185503
 Test Date: 11/1/2017

TIRE PRESSURES

	Units	LF	RF	LR	RR
As Delivered	kPa	262	264	258	258
Tire Placard	kPa	230	230	220	220
Owner's Manual	kPa	230	230	220	220
As Tested	kPa	230	230	220	220

MDB TIRE SPECIFICATIONS

	Units	Requirement	LF	RF	LR	RR
Tire Size		P205/75R15	P205/75R15	P205/75R15	P205/75R15	P205/75R15
Tire Pressure	kPa	200 ± 21	207	207	207	207

TEST VEHICLE WEIGHTS

	Units	As Delivered (UVW)			As Tested (ATW)			Fully Loaded		
		Front	Rear	Total	Front	Rear	Total	Front	Rear	Total
Left	kg	425	302		449	399		473	388	
Right	kg	396	301		417	353		406	363	
Ratio	%	58	42		54	46		54	46	
Totals	kg	821	603	1424	866	752	1618	879	751	1630

TARGET TEST WEIGHT CALCULATION

Measured Parameter	Units	Value	
Total Delivered Weight (UVW)	kg	1424	(A)
Sum of Actual Weight of 1 ES2re and 1 P572 ATD (SID-IIs)	kg	132	(B)
Rated Cargo / Luggage Weight (RCLW)	kg	67.8	(C)
Calculated Target Vehicle Test Weight (TVTW)	kg	1623.8	(A+B+C)

Does the measured As Test Vehicle Weight lie within the required weight range
 (i.e. Calculated Test Vehicle Target Weight – 4.5 kg to – 9 kg)? Yes No

TEST VEHICLE ATTITUDES AND CG

Measurement Description	Units	Fully Loaded	As Tested	Meets Requirement**
LF	mm	796	797	Yes
RF	mm	800	799	Yes
RR	mm	780	779	Yes
LR	mm	766	763	Yes
Vehicle CG (Aft of Front Axle)	mm	1230	1240	
Vehicle CG (Left+)/Right(-) from Longitudinal Centerline)	mm	44	38	

*** The "As Tested" vehicle attitude measurements must be equal to or within ± 10mm of the "Fully Loaded" vehicle attitude measurements at each wheel well. Indicate "Yes" or "No" for "Meets Requirements".

Test height adjustable suspension setting, if applicable: N/A

DATA SHEET NO. 1 ... (CONTINUED)
GENERAL TEST AND VEHICLE PARAMETER DATA

Test Vehicle: 2018 Subaru Crosstrek four door station wagon NHTSA No.: M20185503
Test Program: NCAP Side MDB Impact Test Test Date: 11/1/2017

WEIGHT OF BALLAST AND VEHICLE COMPONENTS REMOVED TO MEET TVTW

Component Description	Weight (kg)
Trunk Carpeting	10
Spare Tire	12
Jack	3
Tail Light	1
Passenger Side Windows	9
Ballast / Equipment Added	0

DATA SHEET NO. 2
SEAT, SEAT BELT, STEERING WHEEL ADJUSTMENT AND FUEL SYSTEM DATA

Test Vehicle: 2018 Subaru Crosstrek four door station wagon
 Test Program: NCAP Side MDB Impact Test

NHTSA No.: M20185503
 Test Date: 11/1/2017

SEAT POSITIONING

The driver's seat, front center seat (if applicable), and right front passenger's seat should be set to the mid-track, lowest, mid-angle position. The struck-side rear passenger's seat, rear center seat, and non-struck side rear passengers' seats should be set to the rear-most, lowest, mid-angle position.

SCRL ANGLE RANGE

Seat	SCRL (°)		
	Max	Min	Mid
Driver Seat	16.6	12.4	14.5
Front Passenger Seat	Not Adjustable		
Front Center Seat*			
Struck Side Rear Seat	Fixed	Fixed	Fixed
Non-Struck Side Rear Seat	Fixed	Fixed	Fixed
Rear Center Seat*	Fixed	Fixed	Fixed

**if applicable*

SEAT HEIGHT AND ANGLE

Seat	As Tested SCRL Angle (Mid) (°)	As Tested SCRP Height (mm)	SCRP Height Position	SCRP Height (mm)		
				Rearmost	Mid-Fore/Aft	Forward-Most
Driver Seat	14.5	24	Max	14	24	34
			Mid	14	24	34
			Min	14	24	34
Front Passenger Seat	Not Adjustable		Max	-	-	-
			Mid	-	-	-
			Min	-	-	-
Front Center Seat*	N/A	N/A	Max	-	-	-
			Mid	-	-	-
			Min	-	-	-
Struck Side Rear Seat	Fixed	Fixed	Max	-	-	-
			Mid	-	-	-
			Min	-	-	-
Non-Struck Side Rear Seat	Fixed	Fixed	Max	-	-	-
			Mid	-	-	-
			Min	-	-	-
Rear Center Seat*	Fixed	Fixed	Max	-	-	-
			Mid	-	-	-
			Min	-	-	-

**if applicable*

DATA SHEET NO. 2 ... (CONTINUED)
SEAT, SEAT BELT, STEERING WHEEL ADJUSTMENT AND FUEL SYSTEM DATA

Test Vehicle: 2018 Subaru Crosstrek four door station wagon
 Test Program: NCAP Side MDB Impact Test

NHTSA No.: M20185503
 Test Date: 11/1/2017

SEAT FORE / AFT POSITION

Seat	Total Fore / Aft Travel		Test Position from Forwardmost Position	
	mm	Detents*	mm	Detent*
Driver Seat	260	27 (0-26)	130	13
Front Passenger Seat	260	27 (0-26)	130	13
Front Center Seat*	N/A	N/A	N/A	N/A
Struck Side Rear Seat	FIXED	FIXED	FIXED	FIXED
Non-Struck Side Rear Seat	FIXED	FIXED	FIXED	FIXED
Rear Center Seat*	FIXED	FIXED	FIXED	FIXED

**if applicable*

SEAT BACK ANGLE ADJUSTMENT

The driver's seat back is positioned to the manufacturer's designated design angle. The front center and front passenger's seat backs are positioned in a similar manner as the driver's seat back. The struck side rear seat back is positioned such that the dummy's head is level. The rear center and non-struck side rear outboard seat backs are positioned in a similar manner as the struck-side rear seat back.

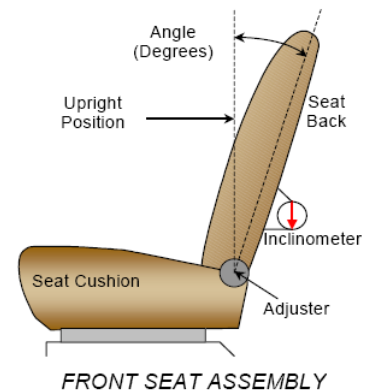

Seat	Total Seat Back Angle Range		Test Position from Most Upright	
	Degrees	Detents*	Degrees	Detents*
Driver Seat w/ Seated Dummy	-8.8 to 60.9	N/A	9.0	N/A
Front Passenger Seat	-9.0 to 61.4	N/A	9.2	N/A
Front Center Seat*	N/A	N/A	N/A	N/A
Struck Side Rear Seat w/ Seated Dummy	FIXED	FIXED	FIXED	FIXED
Non-Struck Side Rear Seat	FIXED	FIXED	FIXED	FIXED
Rear Center Seat*	FIXED	FIXED	FIXED	FIXED

**if applicable*

DATA SHEET NO. 2 ... (CONTINUED)
SEAT, SEAT BELT, STEERING WHEEL ADJUSTMENT AND FUEL SYSTEM DATA

Test Vehicle: 2018 Subaru Crosstrek four door station wagon
 Test Program: NCAP Side MDB Impact Test

NHTSA No.: M20185503
 Test Date: 11/1/2017

SEAT BELT ANCHORAGE ADJUSTMENT

Seat belt anchorages are adjusted in accordance with the information provided by the manufacturer on Form No. 1. For this test zero is defined as the uppermost position.

	Total # of Positions	Placed in Position #
Driver Seat	4	1
Rear Seat	Fixed	Fixed

HEAD RESTRAINT ADJUSTMENT

The driver's head restraint is adjusted to the highest and most full forward in-use position. The struck-side rear passenger's head restraint is adjusted to the lowest and most full forward in-use position.

	Total # of Positions	Placed in Position #
Driver Seat	3	0 - Uppermost
Rear Seat	1	1

STEERING COLUMN ADJUSTMENT

Steering wheel and column adjustments are made so that the steering wheel hub is at the center of its geometric locus it describes when it moves through its full range of motion.

	Degrees	Fore/Aft Position (mm)
Lowermost – Position 1	21.8	
Geometric Center – Position 2	23.6	
Uppermost – Position 3	25.5	
Telescoping Steering Wheel Travel		50
Test Position	23.6	25

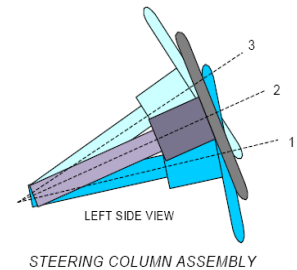

FUEL PUMP

Describe the fuel pump type, details about how it operates, and the location of the fuel filler neck.

The vehicle is equipped with an electric fuel pump. The fuel filler neck is on the right side of the vehicle. The pump creates positive pressure in the fuel lines, pushing the gasoline to the engine. See form 1 for more information.

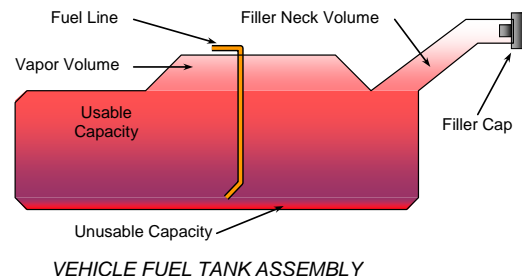

DATA SHEET NO. 2 ... (CONTINUED)
SEAT, SEAT BELT, STEERING WHEEL ADJUSTMENT AND FUEL SYSTEM DATA

Test Vehicle: 2018 Subaru Crosstrek four door station wagon NHTSA No.: M20185503
 Test Program: NCAP Side MDB Impact Test Test Date: 11/1/2017

FUEL TANK CAPACITY

	Liters
Usable Capacity of "Standard Tank" (see Form No. 1)	62.8
Usable Capacity of "Optional Tank" (see Form No. 1)	N/A
Usable Capacity of Standard Tank (see Owner's Manual)	62.8
Usable Capacity of Optional Tank (see Owner's Manual)	N/A
93% of Usable Capacity	58.4
Actual Amount of Solvent Used in Test	58.4
1/3 of Usable Capacity	20.9

Is the Actual Amount of Solvent Used in the test equal to 93% ± 1% of the Usable Capacity stated in Form No. 1? **Yes** **No**

**DATA SHEET NO. 3
DUMMY LONGITUDINAL CLEARANCE DIMENSIONS**

Test Vehicle: 2018 Subaru Crosstrek four door station wagon
 Test Program: NCAP Side MDB Impact Test

NHTSA No.: M20185503
 Test Date: 11/1/2017

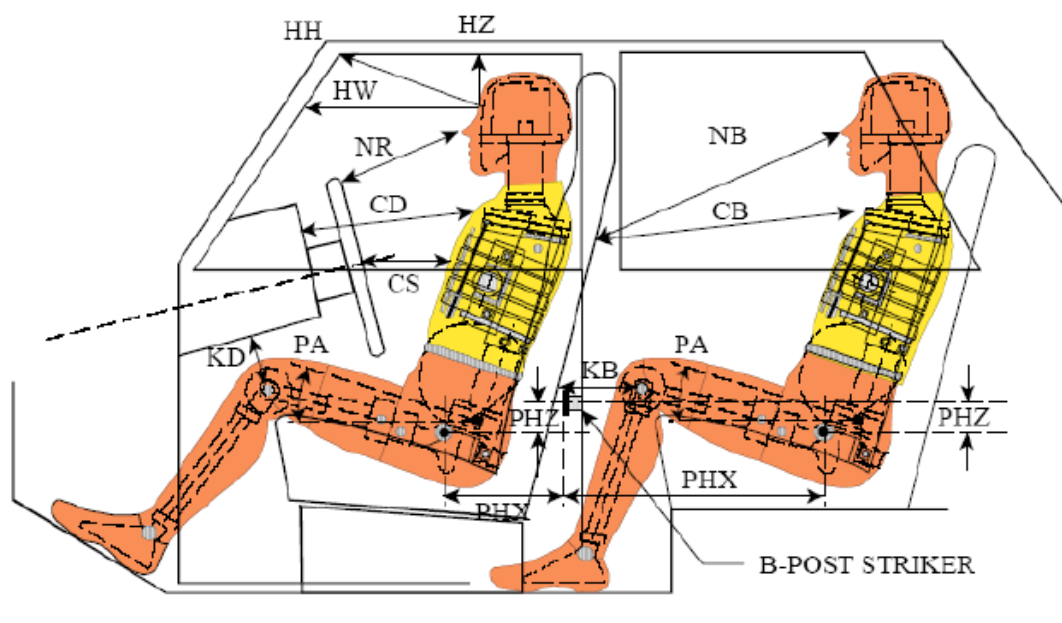

LEFT SIDE VIEW

NOTE: 2-DOOR VEHICLE SHOWN.
 REAR DUMMY PHX & PHZ
 MEASUREMENTS FOR A 4-DOOR
 VEHICLE WOULD USE THE C-POST
 STRIKER AS A REFERENCE POINT

DUMMY LONGITUDINAL CLEARANCE DIMENSION INFORMATION

Driver Code	Pass. Code	Description	Driver (Serial No. F034)		Passenger (Serial No.300)	
			Length (mm)	Angle	Length (mm)	Angle
HH		Header to Header	333			
HW		Header to Windshield	645			
HZ	HZ	Head to Roof Liner	177		270	
NR	NB	Nose to Rim/Seat Back	421		569	
CD	CB	Chest to Dash/Seat Back	562		568	
CS		Chest to Steering Wheel	324			
KD(L)/KDA(L)°	KB(L)/KBA(L)°	Left Knee to Dash/Seat Back	188	14.7	314	7.7
KD(R)/KDA(R)°	KB(R)/KBA(R)°	Right Knee to Dash/Seat Back	181	10	314	7.5
PAX°	PAX°	Pelvic Tilt Angle X		21.2		19.9
	PAY°	Pelvic Tilt Angle Y				0.3
PHX	PHX	Hip Point to Striker (X-Axis)	224		291	
PHZ	PHZ	Hip Point to Striker (Z-Axis)	206		305	

**DATA SHEET NO. 4
DUMMY LATERAL CLEARANCE DIMENSIONS**

Test Vehicle: 2018 Subaru Crosstrek four door station wagon
 Test Program: NCAP Side MDB Impact Test

NHTSA No.: M20185503
 Test Date: 11/1/2017

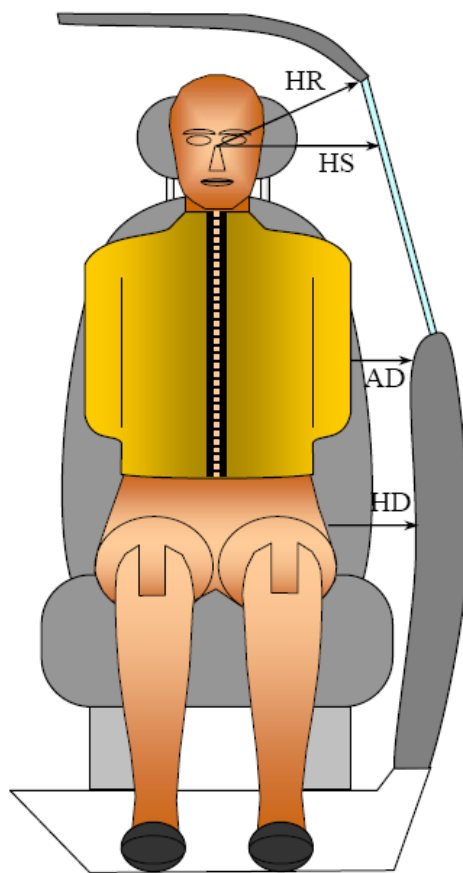

FRONT VIEW OF DUMMY

DUMMY LATERAL CLEARANCE DIMENSION INFORMATION

Code	Measurement Description	Units	Driver (Serial No. F034)	Passenger (Serial No. 300)
HR	Head to Side Header	mm	220	255
HS	Head to Side Window	mm	333	365
AD	Arm to Door	mm	126	178
HD	Hip Point to Door	mm	153	194

**DATA SHEET NO. 5
CAMERA AND INSTRUMENTATION DATA**

Test Vehicle: 2018 Subaru Crosstrek four door station wagon
 Test Program: NCAP Side MDB Impact Test

NHTSA No.: M20185503
 Test Date: 11/1/2017

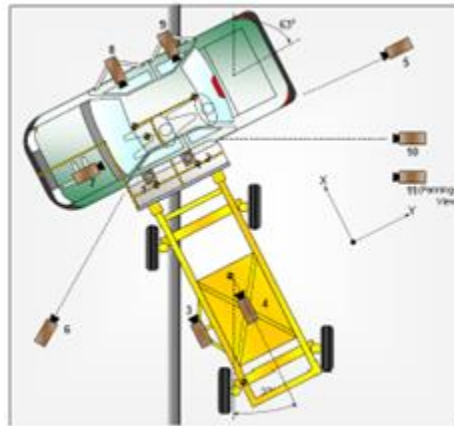

CAMERA LOCATIONS AND DATA

No.	Camera View	Coordinates (mm)			Lens Length (mm)	Operating Frame Rate (fps)
		X	Y	Z		
1	Overhead Overall	315	1085	-5305	14	1000
2	Overhead Close-up	0	890	-5305	28	1000
3	Left Impact Point (MDB)	-1470	0	-847	25	1000
4	Side Overall (MDB)	-1140	838	-1587	12.5	1000
5	Rear	0	9586	-1138	20	1000
6	Left Front	-2722	-4833	-1165	24	1000
7	Driver Front (OB)				25	1000
8	Driver Side (OB)				12.5	1000
9	Passenger Side (OB)				12.5	1000
10	Real-time Left Rear				Zoom	60
11	Real-time In run				Zoom	60

Notes: Reference: Impact Point projected to Ground
 +X = To Front of MDB, +Y = To Right of MDB, +Z = Down
 *All measurements accurate to ± 6 mm.

If applicable, explain why camera(s) did not operate as intended: All cameras operated normally

INSTRUMENTATION

Driver Dummy Channels	16
Passenger Dummy Channels	16
Vehicle Structure Accelerometers	23
MDB Accelerometers	7
Total	62

**DATA SHEET NO. 6
TEST VEHICLE ACCELEROMETER LOCATIONS**

Test Vehicle: 2018 Subaru Crosstrek four door station wagon
 Test Program: NCAP Side MDB Impact Test

NHTSA No.: M20185503
 Test Date: 11/1/2017

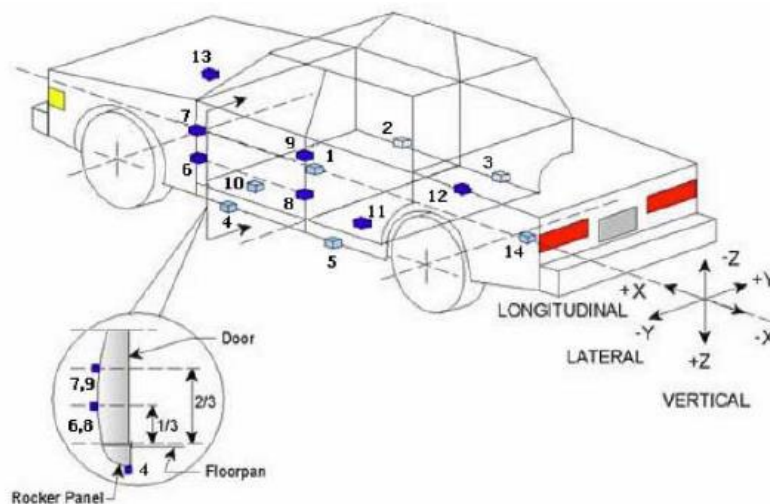

TEST VEHICLE ACCELEROMETER LOCATIONS

No.	Accelerometer Location	Coordinates (mm)		
		X	Y	Z
1	Vehicle CG	2505	97	21
2	Right Sill at Front Seat	2559	664	134
3	Right Sill at Rear Seat	1758	672	119
4	Left Sill at Front Door	2593	-669	151
5	Left Sill at Rear Door	1740	-666	141
6	A-Post Lower	3000	-645	-38
7	A-Post Middle	2984	-661	-545
8	B-Post Lower	1974	-683	-68
9	B-Post Middle	1922	-683	-347
10	Front Seat Track	2200	-562	127
11	Rear Seat Structure	1241	-562	4
12	Rt. Rear Occ. Compartment	1821	395	218
13	Engine Block	3720	79	-316
14	Rear Above Axle	993	1	-128

Reference: X – Rear surface of vehicle (+ forward)
 Y – Vehicle centerline (+ to right)
 Z – Ground plane (+ down)

DATA SHEET NO. 7
MDB ACCELEROMETER LOCATIONS

Test Vehicle: 2018 Subaru Crosstrek four door station wagon
 Test Program: NCAP Side MDB Impact Test

NHTSA No.: M20185503
 Test Date: 11/1/2017

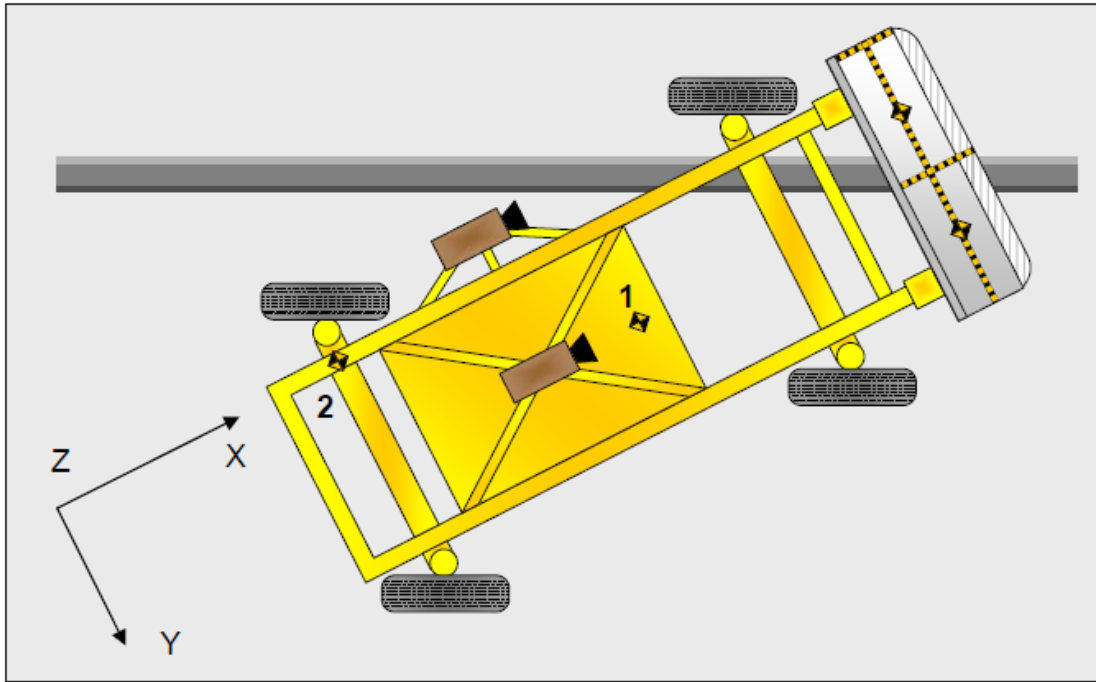

MDB ACCELEROMETER LOCATIONS

No.	Accelerometer Location	Coordinates (mm)		
		X	Y	Z
1	MDB CG	1859	0	-330
2	MDB Rear	386	-660	-660

*Reference: X – Face of MDB (+ forward)
 Y – MDB centerline (+ to right)
 Z – Ground plane (+ down)*

**DATA SHEET NO. 8
POST-TEST OBSERVATIONS**

Test Vehicle: 2018 Subaru Crosstrek four door station wagon
 Test Program: NCAP Side MDB Impact Test

NHTSA No.: M20185503
 Test Date: 11/1/2017

TEST DUMMY INFORMATION AND CONTACT POINTS

Dummy Body Part	Front Seat Dummy (ES-2re)	Rear Seat Dummy (SID-IIs)
Face	Curtain Airbag	Curtain Airbag
Top of Head	Side Headliner	Curtain Airbag & Side Headliner & Center Headrest
Left Side of Head	Curtain Airbag & Side Headliner	Curtain Airbag
Back of Head	Curtain Airbag, Side Headliner, Headrest	Curtain Airbag & Center Headrest
Left Shoulder	Curtain & Torso/Pelvis Airbag	Passenger Door
Upper Torso	Seatback & Torso/Pelvis Airbag	Passenger Door
Lower Torso	Seatback & Torso/Pelvis Airbag	Passenger Door
Left Hip	Torso/Pelvis Airbag	Seat pan & Passenger Door
Left Knee	Driver Door	Passenger Door

POST-TEST DOOR PERFORMANCE

Description	Struck Side		Non-Struck Side		Rear Hatch/ Other*
	Front	Rear	Front	Rear	
Remained Closed and Operational	No	No	Yes	Yes	Yes
Total Separation from Vehicle at Hinges or Latches	No	No	No	No	No
Latch or Hinge Systems Pulled Out of Their Anchorages	No	No	No	No	No
Disengaged from Latched Position	No	No	No	No	No
Latch Separated from Striker	No	No	No	No	No
Jammed Shut	Yes	Yes	No	No	No
If Door Opened at Striker, Width of Opening at Striker (mm)	0	0	0	0	0

*Tailgate opened during impact but is still operational.

POST-TEST SEAT PERFORMANCE

Description	Struck Side		Non-Struck Side	
	Front	Rear	Front	Rear
Seat Movement Along Seat Track	No	No	No	No
Seat Disengagement from Floor Pan	No	No	No	No
Seat Back Movement from Initial Position	No	No	No	No
Seat Back Collapse	No	No	No	No

POST-TEST STRUCTURAL OBSERVATIONS

Critical Areas of Performance	Observations and Conclusions
Pillar Performance	B-Pillar Buckled
Sill Separation	None
Windshield Damage	None
Side Window Damage	Rear Passenger Window Shattered
Other Notable Effects	None

**DATA SHEET NO. 8 ... (CONTINUED)
POST-TEST OBSERVATIONS**

Test Vehicle: 2018 Subaru Crosstrek four door station wagon
 Test Program: NCAP Side MDB Impact Test

NHTSA No.: M20185503
 Test Date: 11/1/2017

SUPPLEMENTAL RESTRAINT SYSTEM INFORMATION

Restraint Type	Struck Side Driver		Struck Side Rear Passenger	
	Mounted	Deployed	Mounted	Deployed
Frontal Airbag	Yes	No		
Knee Airbag	Yes	No		
Side Airbag 1 - Curtain	Yes	Yes	Yes	Yes
Side Airbag 2 - Torso/Pelvis Airbag	Yes	Yes	No	N/A
Seat Belt Pretensioner	Yes	Yes	No	N/A
Seat Belt Load Limiter	Yes	Yes	No	N/A
Other				

IMPACT POINT LOCATION DATA

Measured Parameter	Units	Tolerance	Value
Vehicle Wheel Base	mm		2669
Vertical Impact Reference Line (Aft of Front Axle - Intended Impact Point)	mm		394
Actual Impact Point (Aft of Frontal Axle)	mm		402
Horizontal Offset (+ forward / - rearward)	mm	+/- 50 of Intended Impact Point	-8
Vertical Offset (+ down / - up)	mm	+/- 20 of Intended Impact Point	-11

**DATA SHEET NO. 9
MDB SUMMARY OF RESULTS**

Test Vehicle: 2018 Subaru Crosstrek four door station wagon

NHTSA No.: M20185503

Test Program: NCAP Side MDB Impact Test

Test Date: 11/1/2017

MDB SPECIFICATIONS

Measurement Description	Length (mm)
Overall Width of Framework Carriage	1,250
Overall Length Including Honeycomb Frame	4,120
Wheelbase of Framework Carriage	2,600
CG Location of Front Axle	1,120

MDB WEIGHTS

	Units	Front Axle	Rear Axle	Total
Left	kg	392.5	297.5	690.0
Right	kg	386.0	291.5	677.5
Ratio	%	57.4%	42.6%	100.0%
Totals	kg	778.5	589.0	1367.5

SPEED AND ANGLE AT IMPACT DATA

Measured Parameter	Units	Requirement	Value
Trap No. 1 Velocity (Primary)	km/h	61.10 to 62.70	61.93
Trap No. 2 Velocity (Redundant)	km/h	61.10 to 62.70	61.79
MDB CL to Target Vehicle CL	degrees	88.5 to 91.5	90.0
MDB Forward Line of Motion to Target Vehicle CL	degrees	62.5 to 63.5	63.0
MDB Crabbed angle to MDB Forward Line of Motion	degrees	26.0 to 28.0	27.0

MAXIMUM STATIC CRUSH OF HONEYCOMB IMPACT FACE

Vertical Location			From Centerline		Maximum Crush (mm)
Row	Description	Height (mm)	Distance (mm)	Direction	
A	Center of Bumper	432	800	Left	208
B	Top of Bumper	533	800	Left	141
C	Mid-Level	686	800	Left	136
D	Top of Stack	813	800	Left	135

**DATA SHEET NO. 10
TEST VEHICLE PROFILE MEASUREMENTS**

Test Vehicle: 2018 Subaru Crosstrek four door station wagon

NHTSA No.: M20185503

Test Program: NCAP Side MDB Impact Test

Test Date: 11/1/2017

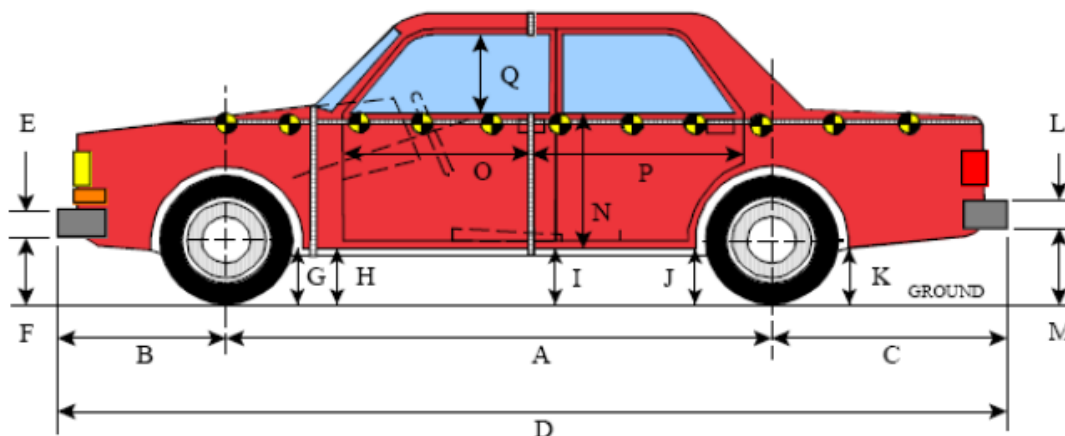

LEFT SIDE VIEW

All MEASUREMENTS IN (mm) WITH TOLERANCE OF ± 3 mm

VEHICLE PRE- AND POST-TEST MEASUREMENT INFORMATION

Code	Description	Pre-Test	Post-Test	Difference
A	Wheelbase	2669	2664	-5
B	Front Axle to FSOV	957	964	7
C	Rear Axle to RSOV	834	837	3
D	Total Length at Centerline	4463	4466	2
E	Front Bumper Thickness	100	100	0
F	Front Bumper Bottom to Ground	485	495	10
G	Sill Height at Front Wheel Well	264	276	12
H	Sill Height at Front Door Leading Edge	272	284	12
I	Sill Height at B Pillar	253	255	2
J1	Sill Height at Rear Wheel Well	261	270	9
J2	Pinch Weld Height at Rear Wheel Well	240	250	10
K	Sill Height Aft of Rear Wheel Well	292	297	5
L	Rear Bumper Thickness	170	170	0
M	Rear Bumper Bottom to Ground	500	500	0
N	Sill Height to Window Bottom of Front Window Sill	704	672	-32
O	Front Door Leading Edge to Impact CL	755	747	-8
P	Rear Door Trailing Edge to Impact CL	1381	1334	-47
Q	Front Window Opening	421	426	5
R	Right Side Length	4410	4414	4
S	Left Side Length	4409	4405	-4
T	Maximum Vehicle Width	1776	1637	-139

**DATA SHEET NO. 11
TEST VEHICLE EXTERIOR CRUSH MEASUREMENTS**

Test Vehicle: 2018 Subaru Crosstrek four door station wagon

NHTSA No.: M20185503

Test Program: NCAP Side MDB Impact Test

Test Date: 11/1/2017

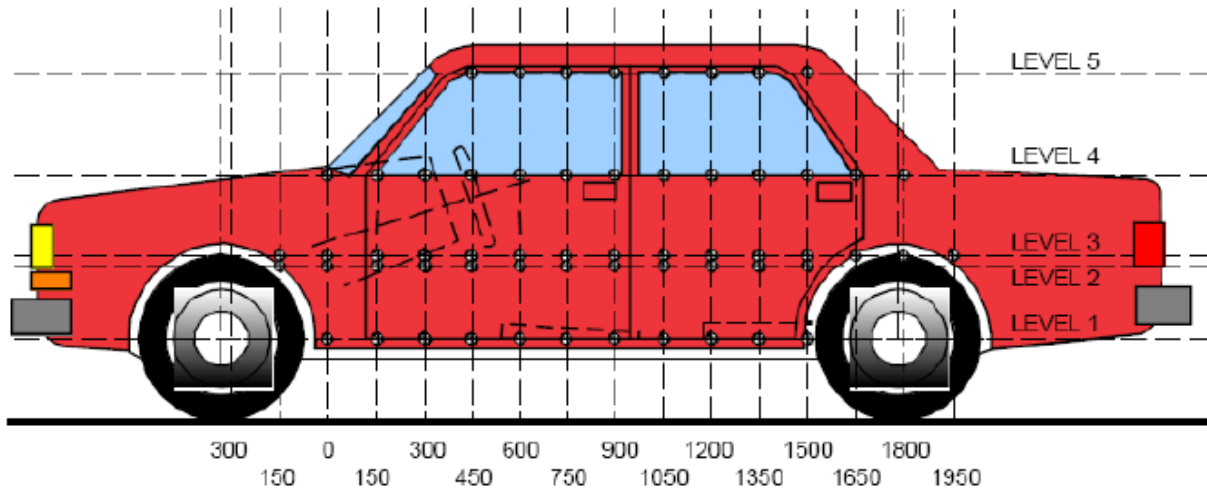

LEFT SIDE VIEW

MAXIMUM EXTERIOR CRUSH MEASUREMENTS

Level	Measurement Description	Units	Height Above Ground	Maximum Exterior Static Crush	Distance from Impact
1	Sill Top	mm	380	75	1050
2	Driver Hip Point	mm	628	186	1650
3	Mid-Door	mm	720	206	1650
4	Window Sill	mm	999	136	1650
5	Window Top	mm	1500	6	1350

*window top level bent outward from original position

NOTE: The above measurements should be taken along the vertical impact reference line. Vehicle measurements forward of the vertical impact reference line are negative.

DATA SHEET NO. 11 ... (CONTINUED)
TEST VEHICLE EXTERIOR CRUSH MEASUREMENTS

Test Vehicle: 2018 Subaru Crosstrek four door station wagon

NHTSA No.: M20185503

Test Program: NCAP Side MDB Impact Test

Test Date: 11/1/2017

EXTERIOR CRUSH MEASUREMENTS AT EACH LEVEL

	Pre-Test					Post-Test					Difference				
	1	2	3	4	5	1	2	3	4	5	1	2	3	4	5
-900															
-750															
-600															
-450															
-300				804					802					2	
-150			904	806				893	801				11	5	
0		899	899	808			876	867	798			23	32	10	
150	844	886	885	818		827	803	796	824		17	83	89	-6	
300	837	886	886	851		813	771	754	834		24	115	132	17	
450	834	886	888	843		799	758	732	803		35	128	156	40	
600	833	887	890	853		790	753	721	808		43	134	169	45	
750	830	887	890	861		758	752	715	809		72	135	175	52	
900	832	888	891	867	615	758	752	716	810	614	74	136	175	57	1
1050	836	887	891	866	618	761	755	723	805	614	75	132	168	61	4
1200	837	884	889	864	617	765	745	737	812	612	72	139	152	52	5
1350	837	881	886	862	617	764	712	702	779	611	73	169	184	83	6
1500	837	879	883	860	616	764	714	684	751	611	73	165	199	109	5
1650	850	879	883	858	615	779	693	677	722	610	71	186	206	136	5
1800	858	884	887	859	610	801	704	702	775	605	57	180	185	84	5
1950		901	892	873	601		853	799	833	597		48	93	40	4
2100				880	585				868	583				12	2
2250				865	552				843	550				22	2
2400				858					838					20	
2550															
2700															
2850															
3000															

NOTE: Pre-test measurements are taken when the vehicle is in the "As Tested" weight condition. Vehicle measurements forward of the vertical impact reference line are negative. The crush profile grid is established prior to test based on an estimated impact point.

DATA SHEET NO. 11 (CONTINUED)
TEST VEHICLE EXTERIOR CRUSH MEASUREMENTS

Test Vehicle: 2018 Subaru Crosstrek four door station wagon

NHTSA No.: M20185503

Test Program: NCAP Side MDB Impact Test

Test Date: 11/1/2017

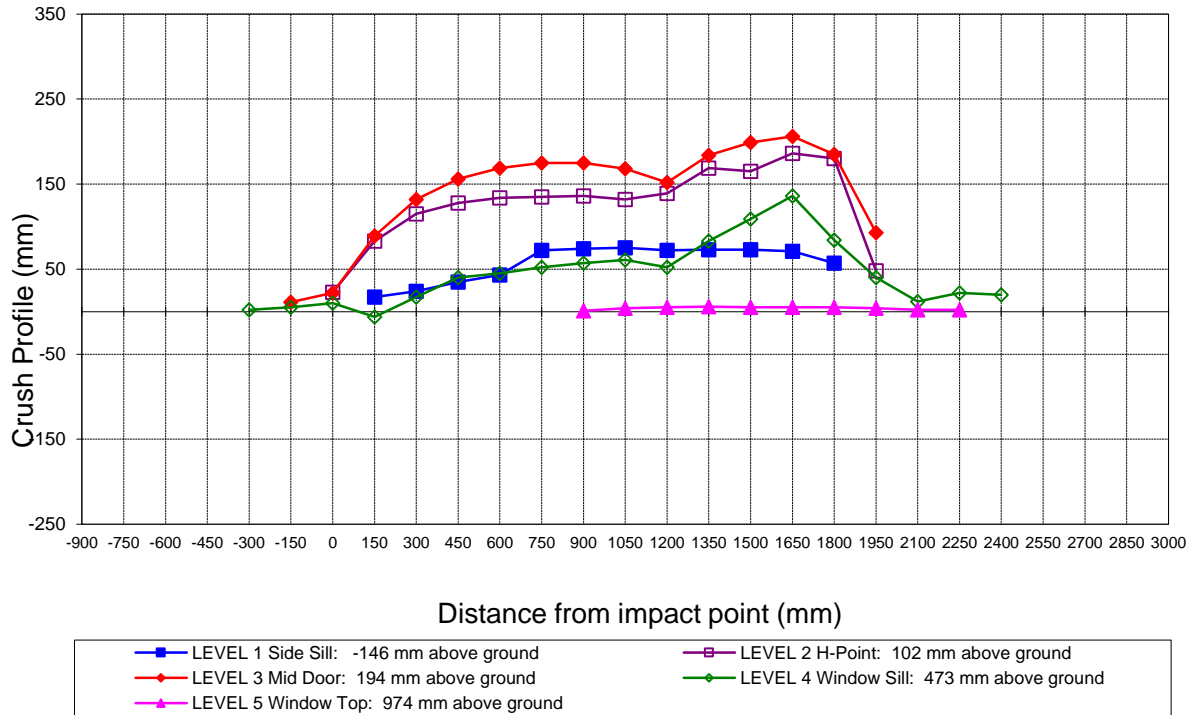

Vehicle Exterior Crush Measurements - Visual Representation

**DATA SHEET NO. 12
MDB EXTERIOR STATIC CRUSH MEASUREMENTS**

Test Vehicle: 2018 Subaru Crosstrek four door station wagon
 Test Program: NCAP Side MDB Impact Test

NHTSA No.: M20185503
 Test Date: 11/1/2017

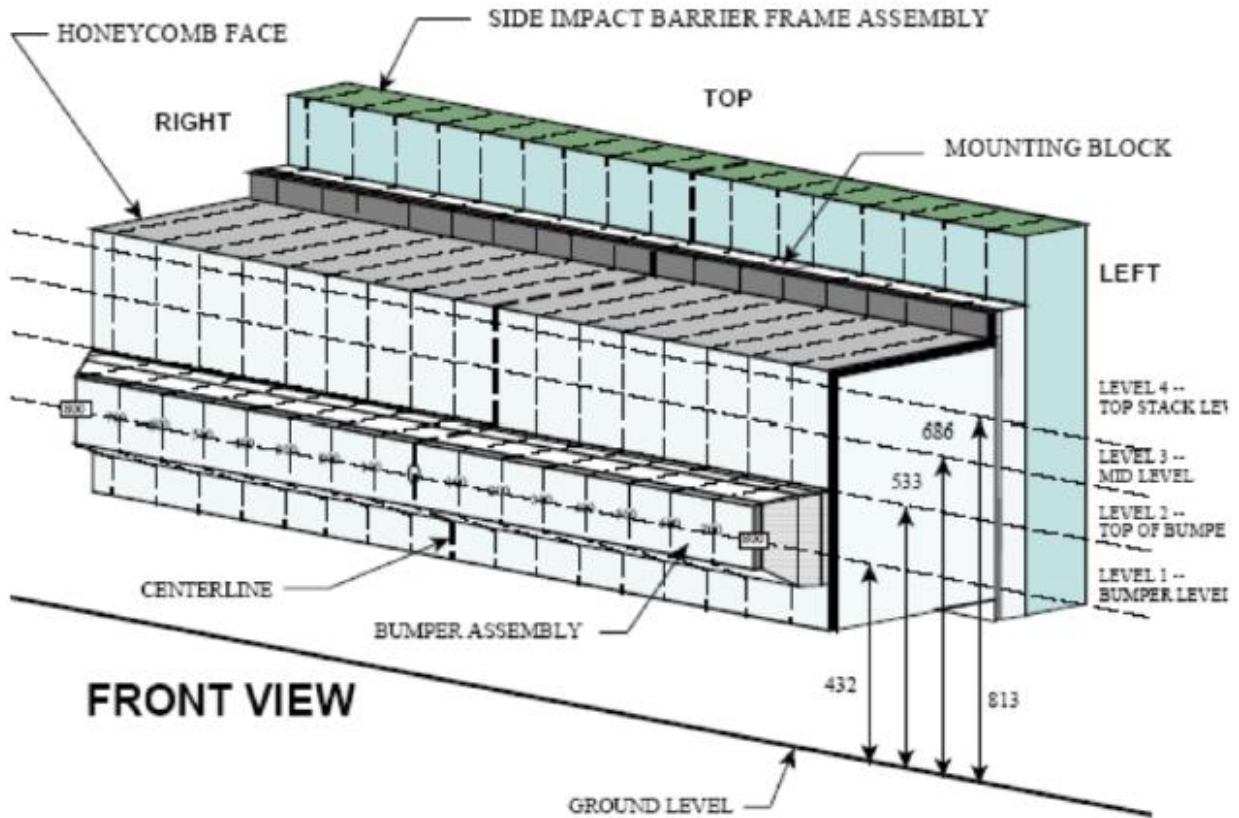

NOTE: Dimensions are shown in millimeters, mm

DEFORMABLE BARRIER STATIC CRUSH

Stack Level	Distance Right of Center								C/L	Distance Left of Center							
	800	700	600	500	400	300	200	100		0	100	200	300	400	500	600	700
1	196	194	186	183	183	183	182	182	182	181	181	181	181	181	183	193	208
2	121	122	118	117	116	112	109	102	114	113	110	110	111	110	112	117	141
3	46	31	29	35	46	68	72	57	48	41	38	36	41	51	69	93	136
4	59	25	18	25	41	73	94	78	65	62	62	64	71	72	84	100	135

DATA SHEET NO. 13
MDB EXTERIOR STATIC CRUSH MEASUREMENTS

Test Vehicle: 2018 Subaru Crosstrek four door station wagon
 Test Program: NCAP Side MDB Impact Test

NHTSA No.: M20185503
 Test Date: 11/1/2017

For guidance regarding damage profile distance measurements, please refer to the latest version of the *NHTSA Test Reference Guide, Volume 1: Vehicle Tests*.

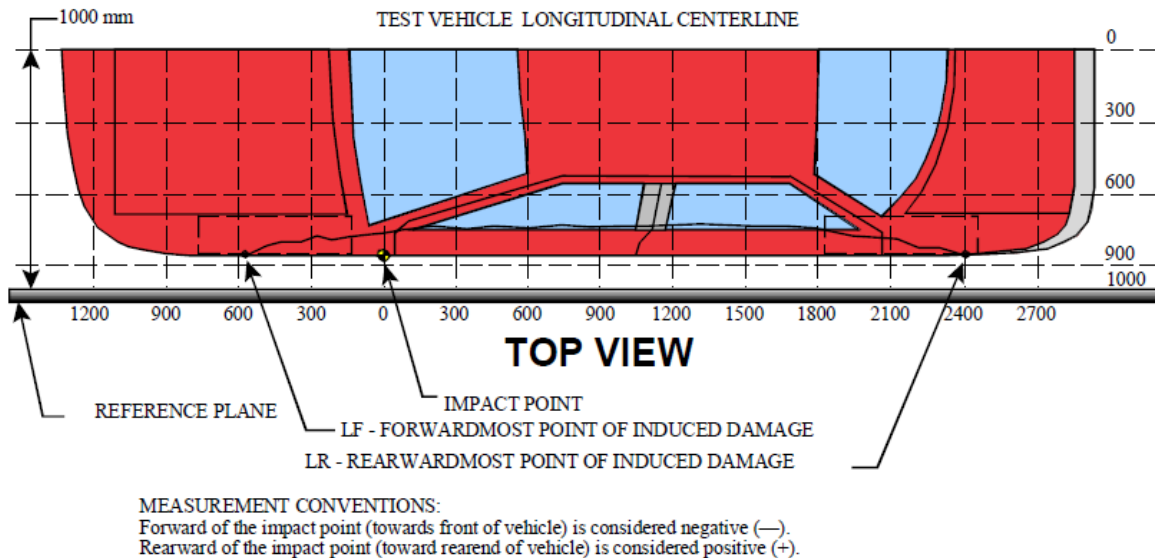

VEHICLE DAMAGE PROFILE DISTANCES

DPD	Distance From Impact Point (mm)	Level	Post-Test (mm)	Pre-Test (mm)	Crush (mm)
1	-150	3	107	96	11
2	270	3	238	114	124
3	690	3	283	110	173
4	1110	3	271	110	161
5	1530	3	317	117	200
6	1950	3	201	108	93

MDB DAMAGE PROFILE DISTANCES

DPD	Distance From Center of MDB	Level	Post-Test (mm)*
1	800 mm left of center	1	208
2	480 mm left of center	1	181
3	160 mm left of center	1	181
4	160 mm right of center	1	182
5	480 mm right of center	1	183
6	800 mm right of center	1	196

**DATA SHEET NO. 14
FMVSS NO. 301 STATIC ROLLOVER RESULTS**

Test Vehicle:	<u>2018 Subaru Crosstrek four door station wagon</u>	NHTSA No.:	<u>M20185503</u>
Test Program:	<u>NCAP Side MDB Impact Test</u>	Test Date:	<u>11/1/2017</u>
Test Time:	<u>10:55 AM</u>	Temperature:	<u>21°C</u>

- | | | |
|---|-----------------------------|-----|
| A. From impact until vehicle motion ceases:
(Maximum allowable is 1 oz.) | <u>0</u> | oz. |
| B. For the 5-minute period after motion ceases:
(Maximum allowable is 5 oz.) | <u>0</u> | oz. |
| C. For the following 25 minutes:
(Maximum allowable is 1 oz./minute) | <u>0</u> | oz. |
| D. Spillage Details: | <u>No Spillage Occurred</u> | |

FMVSS NO. 301 STATIC ROLLOVER DATA



ROLLOVER SOLVENT COLLECTION TIME TABLE IN SECONDS

Test Phase	Rotation Time	Hold Time	Total Time
0° to 90°	71	300	371
90° to 180°	66	300	366
180° to 270°	62	300	362
270° to 360°	69	300	369

FMVSS NO. 301 ROLLOVER SPILLAGE TABLE

Test Phase	First 5 Minutes	Sixth Minute	Seventh Minute	Eighth Minute
0° to 90°	0	0	0	
90° to 180°	0	0	0	
180° to 270°	0	0	0	
270° to 360°	0	0	0	

ROLLOVER SOLVENT SPILLAGE LOCATION TABLE

Test Phase	Spillage Location
0° to 90°	None
90° to 180°	None
180° to 270°	None
270° to 360°	None

DATA SHEET NO. 15
DUMMY/VEHICLE TEMPERATURE AND HUMIDITY STABILIZATION DATA

Test Vehicle: 2018 Subaru Crosstrek four door station wagon
Test Program: NCAP Side MDB Impact Test

NHTSA No.: M20185503
Test Date: 11/1/2017

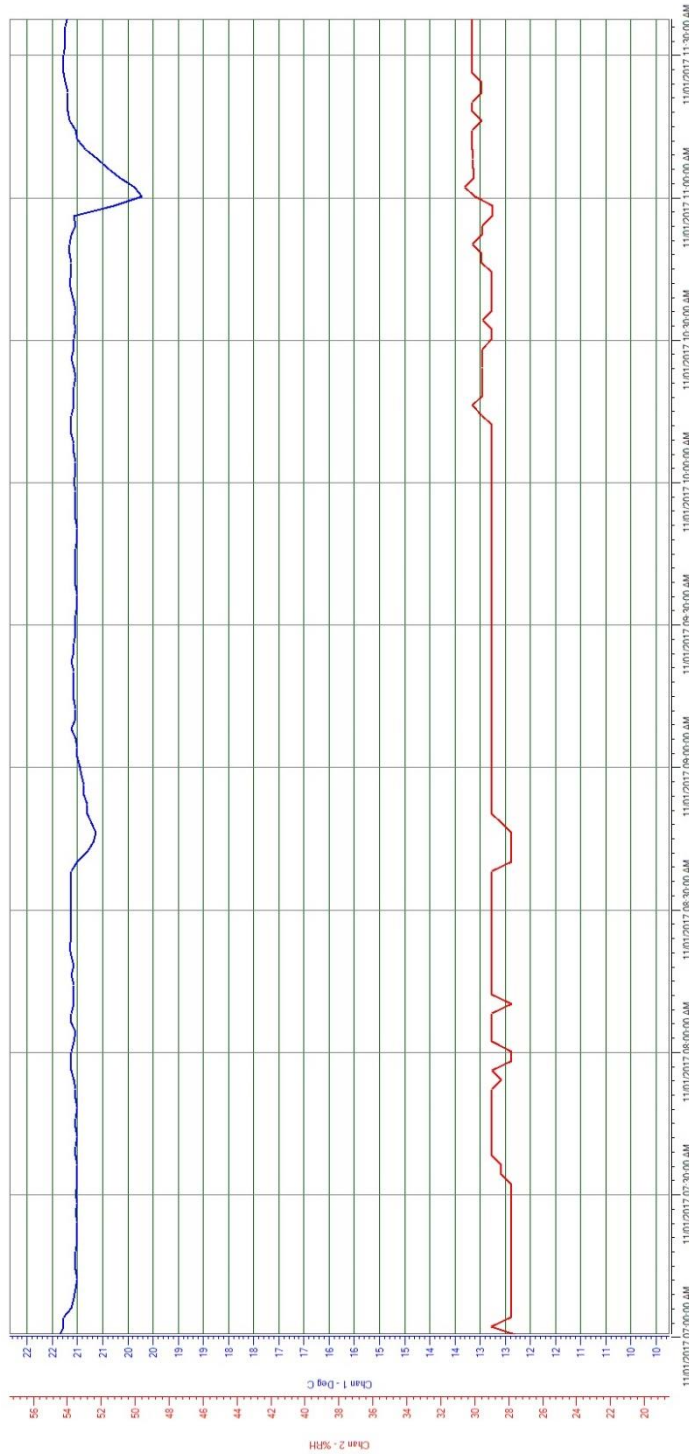

Temperature and Humidity Stabilization Chart/Data for Dummies and Test Vehicle

APPENDIX A
PHOTOGRAPHS

TABLE OF PHOTOGRAPHS

Fig.	Description	Page
1	As-Delivered Right Front 3/4 View of Test Vehicle	A-5
2	As-Delivered Left Rear 3/4 View of Test Vehicle	A-5
3	Pre-Test Frontal View of Test Vehicle	A-6
4	Post-Test Frontal View of Test Vehicle	A-6
5	Pre-Test Left Front 3/4 View of Test Vehicle	A-7
6	Post-Test Left Front 3/4 View of Test Vehicle	A-7
7	Pre-Test Left Side View of Test Vehicle	A-8
8	Post-Test Left Side View of Test Vehicle	A-8
9	Pre-Test Left Rear 3/4 View of Test Vehicle	A-9
10	Post-Test Left Rear 3/4 View of Test Vehicle	A-9
11	Pre-Test Rear View of Test Vehicle	A-10
12	Post-Test Rear Side View of Test Vehicle	A-10
13	Pre-Test Right Side View of Test Vehicle	A-11
14	Post-Test Right Side View of Test Vehicle	A-11
15	Pre-Test Overhead View of Test Area	A-12
16	Post-Test Overhead View of Test Area	A-12
17	Pre-Test Left Side View of MDB Positioned Against Side of Test Vehicle	A-13
18	Pre-Test Right Side View of MDB Positioned Against Side of Test Vehicle	A-13
19	Pre-Test Close-Up View of Impact Point Target	A-14
20	Post-Test Close-up View of Impact Point Target	A-14
21	Pre-Test Left Front Door Latch Close-Up	A-15
22	Post-Test Left Front Door Latch Close-Up	A-15
23	Pre-Test Left Rear Door Latch Close-Up	A-16
24	Post-Test Left Rear Door Latch Close-Up	A-16
25	Pre-Test Front Close-up View of Driver Dummy	A-17
26	Post-Test Front Close-up View of Driver Dummy	A-17
27	Pre-Test Left Side View of Driver Dummy Showing Belt and Chalking	A-18
28	Pre-Test Left Side View of Driver Dummy Shoulder and Door Top View	A-18
29	Post-Test Left Side View of Driver Dummy Shoulder and Door Top View	A-19
30	Pre-Test Frontal View of Driver Seat Back Prior to Dummy Positioning	A-19
31	Pre-Test Frontal View of Driver Dummy Head and Shoulders in Relation to Head Restraint	A-20
32	Pre-Test Frontal View of Driver Seat Pan Prior to Dummy Positioning	A-20
33	Pre-Test Overhead View of Driver Dummy Thighs on Seat Pan	A-21
34	Pre-Test Placement of Driver Dummy's Feet	A-21

Fig.	Description	Page
35	Pre-Test View of Belt Anchorage for Driver Dummy	A-22
36	Pre-Test Left Side View of Steering Wheel	A-22
37	View of Disengaged Parking Brake	A-23
38	Pre-Test View of Parking Brake	A-23
39	Pre-Test Close-Up Left Side View of Driver Seat Track	A-24
40	Pre-Test Close-Up Left Side View of Driver Seat Back	A-24
41	Pre-Test Close-Up View of Driver Seat Back or Head Restraint	A-25
42	Pre-Test Driver Dummy and Door Clearance View	A-25
43	Post-Test Driver Dummy and Door Clearance View	A-26
44	Pre-Test Right Side View of Driver Dummy and Front Seat of Occupant Compartment	A-26
45	Post-Test Right Side View of Driver Dummy and Front Seat of Occupant Compartment	A-27
46	Pre-Test Driver Inner Door Panel View	A-27
47	Post-Test Driver Inner Door Panel View	A-28
48	Post-Test Driver Dummy Close-Up Head Contact with Vehicle View	A-28
49	Post-Test Driver Dummy Close-Up Head Contact with Side Airbag View	A-29
50	Post-Test Driver Dummy Close-Up Torso Contact with Vehicle Interior View	A-29
51	Post-Test Driver Dummy Close-Up Torso Contact with Side Airbag View	A-30
52	Post-Test Driver Dummy Close-Up Pelvis Contact View	A-30
53	Post-Test Driver Dummy Close-Up Pelvis Contact with Side Airbag View	A-31
54	Post-Test Driver Dummy Close-Up Knee Contact View	A-31
55	Pre-Test Left Side View of Passenger Dummy Showing Belt and Chalking	A-32
56	Pre-Test Left Side View of Passenger Dummy Shoulder and Door Top View	A-32
57	Post-Test Left Side View of Passenger Dummy Shoulder and Door Top View	A-33
58	Pre-Test Frontal View of Rear Passenger Seat Back Prior to Dummy Positioning	A-33
59	Pre-Test Frontal View of Rear Passenger Dummy Head and Shoulders in Relation to Head Restraint	A-34
60	Pre-Test Overhead View of Rear Passenger Seat Pan Prior to Dummy Positioning	A-34
61	Pre-Test Overhead View of Rear Passenger Dummy Thighs on Seat Pan	A-35
62	Pre-Test View of Rear Passenger Dummy's Neck Showing Position of Adjustable Neck Bracket	A-35
63	Pre-Test View of Rear Passenger Dummy's Head Showing Dummy's Head is Level	A-36
64	Pre-Test Placement of Rear Passenger Dummy's Feet	A-36
65	Pre-Test View of Belt Anchorage for Rear Passenger Dummy	A-37
66	Pre-Test Close-Up Left Side View of Rear Passenger Seat Track	A-37
67	Pre-test Close-Up Left Side View of Rear Passenger Seat Back	A-38
68	Pre-Test Close-Up View of Rear Passenger Seat Back or Head Restraint	A-38

Fig.	Description	Page
69	Pre-Test Passenger Dummy and Door Clearance View	A-39
70	Post-Test Passenger Dummy and Door Clearance View	A-39
71	Pre-Test Right Side View of Rear Passenger Dummy and Rear Seat Occupant Compartment	A-40
72	Post-Test Right Side View of Rear Passenger Dummy and Rear Seat Occupant Compartment	A-40
73	Pre-Test Passenger Inner Door Panel View	A-41
74	Post-Test Passenger Inner Door Panel View	A-41
75	Post-Test Rear Passenger Dummy Close-Up Head Contact with Vehicle View	A-42
76	Post-Test Rear Passenger Dummy Close-Up Head Contact with Side Airbag View	A-42
77	Post-Test Rear Passenger Dummy Close-Up Torso Contact with Vehicle Interior View	A-43
78	Post-Test Rear Passenger Dummy Close-Up Torso Contact with Side Airbag View	A-43
79	Post-Test Rear Passenger Dummy Close-Up Pelvis Contact View	A-44
80	Post-Test Rear Passenger Dummy Close-Up Pelvis Contact with Side Airbag View	A-44
81	Post-Test Rear Passenger Dummy Close-Up Knee Contact View	A-45
82	Pre-Test View of Fuel Filler Cap or Fuel Filler Neck	A-45
83	Post-Test View of Fuel Filler Cap or Fuel Filler Neck	A-46
84	Pre-Test Front View of MDB Impactor Face	A-46
85	Post-Test Front View of MDB Impactor Face	A-47
86	Pre-Test Top View of MDB Impactor Face	A-47
87	Post-Test Top View of MDB Impactor Face	A-48
88	Pre-Test Left Side View of MDB Impactor Face	A-48
89	Post-Test Left Side View of MDB Impactor Face	A-49
90	Pre-Test Right Side View of MDB Impactor Face	A-49
91	Post-Test Right Side View of MDB Impactor Face	A-50
92	Close-Up View of Vehicle's Certification Label	A-50
93	Close-Up View of Vehicle's Tire Information Placard or Label	A-51
94	Pre-Test Ballast View	A-51
95	Post-Test Primary and Redundant Speed Trap Read-Out	A-52
96	FMVSS No. 301 Static Rollover 0 Degrees	A-52
97	FMVSS No. 301 Static Rollover 90 Degrees	A-53
98	FMVSS No. 301 Static Rollover 180 Degrees	A-53
99	FMVSS No. 301 Static Rollover 270 Degrees	A-54
100	FMVSS No. 301 Static Rollover 360 Degrees	A-54
101	Impact Event	A-55
102	Monroney Label	A-55
103	Driver Head Restraint Use and Adjustment Information from Vehicle Owner's Manual	A-56
104	Left Rear Passenger Head Restraint Use and Adjustment Information from Vehicle Owner's Manual	A-56



Figure A-1: As-Delivered Right Front 3/4 View of Test Vehicle



Figure A-2: As-Delivered Left Rear 3/4 View of Test Vehicle



Figure A-3: Pre-Test Frontal View of Test Vehicle



Figure A-4: Post-Test Frontal View of Test Vehicle



Figure A-5: Pre-Test Left Front ¾ View of Test Vehicle



Figure A-6: Post-Test Left Front ¾ View of Test Vehicle



Figure A-7: Pre-Test Left Side View of Test Vehicle



Figure A-8: Post-Test Left Side View of Test Vehicle



Figure A-9: Pre-Test Left Rear $\frac{3}{4}$ View of Test Vehicle



Figure A-10: Post-Test Left Rear $\frac{3}{4}$ View of Test Vehicle



Figure A-11: Pre-Test Rear View of Test Vehicle



Figure A-12: Post-Test Rear Side View of Test Vehicle



Figure A-13: Pre-Test Right Side View of Test Vehicle



Figure A-14: Post-Test Right Side View of Test Vehicle



Figure A-15: Pre-Test Overhead View of the Test Area

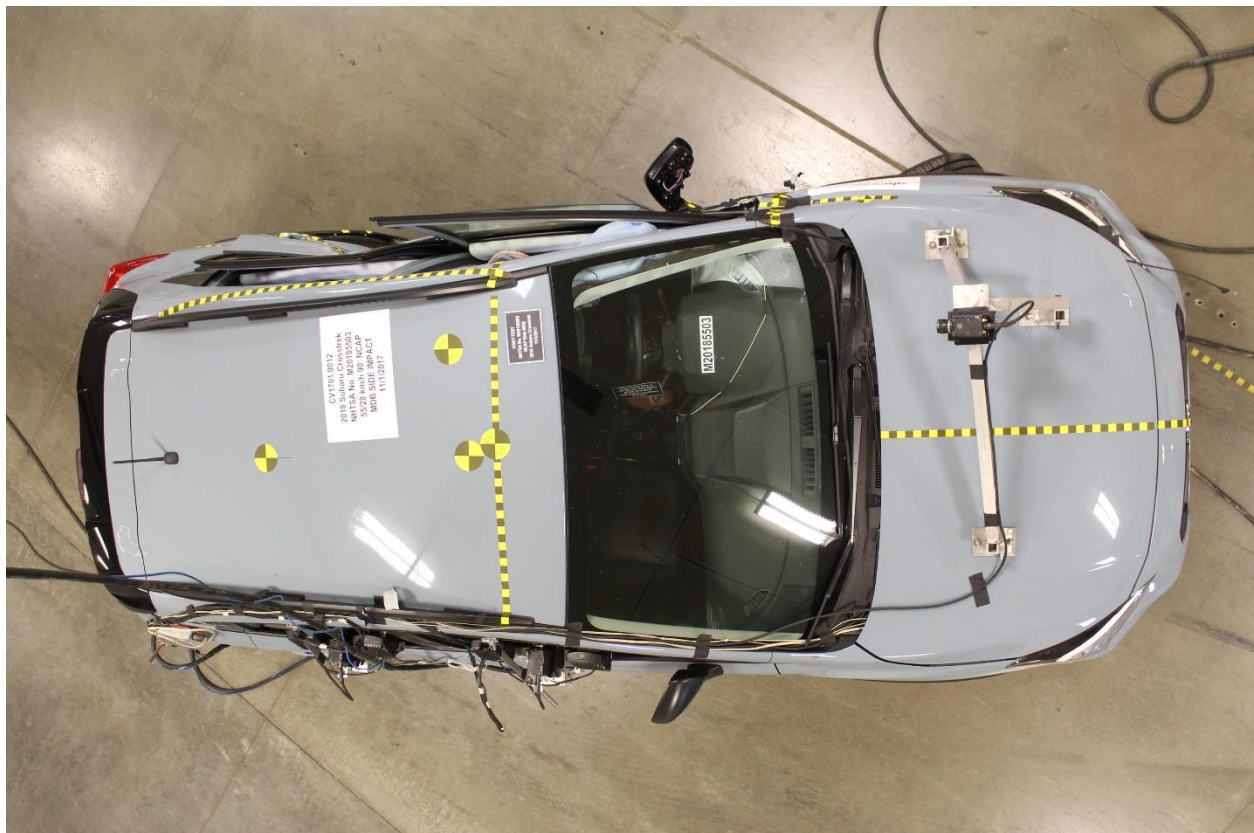

Figure A-16: Post-Test Overhead View of Test Area



Figure A-17: Pre-Test Left Side View of MDB Positioned Against Side of Test Vehicle



Figure A-18: Pre-Test Right Side View of MDB Positioned Against Side of Test Vehicle



Figure A-19: Pre-Test Close-up View of Impact Point Target



Figure A-20: Post-Test Close-up View of Impact Point Target

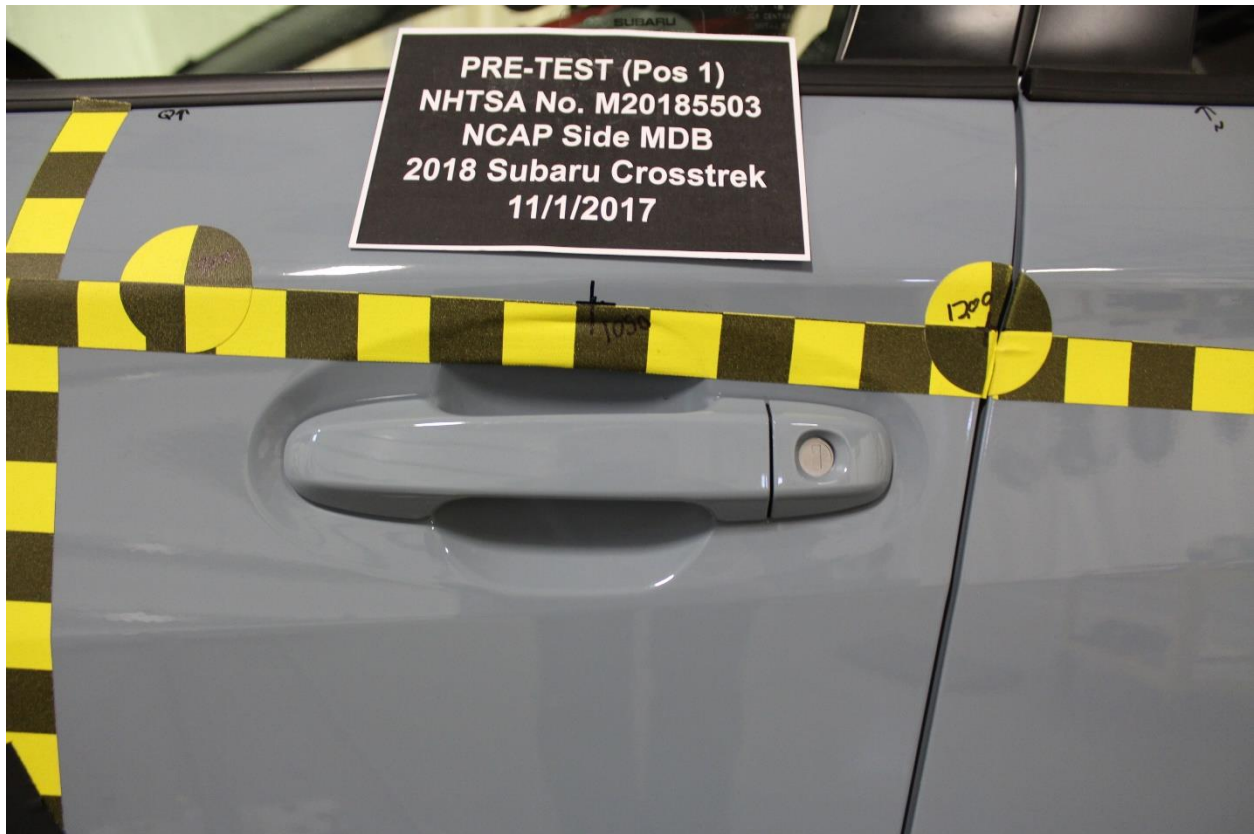

Figure A-21: Pre-Test Left Front Door Latch Close-Up

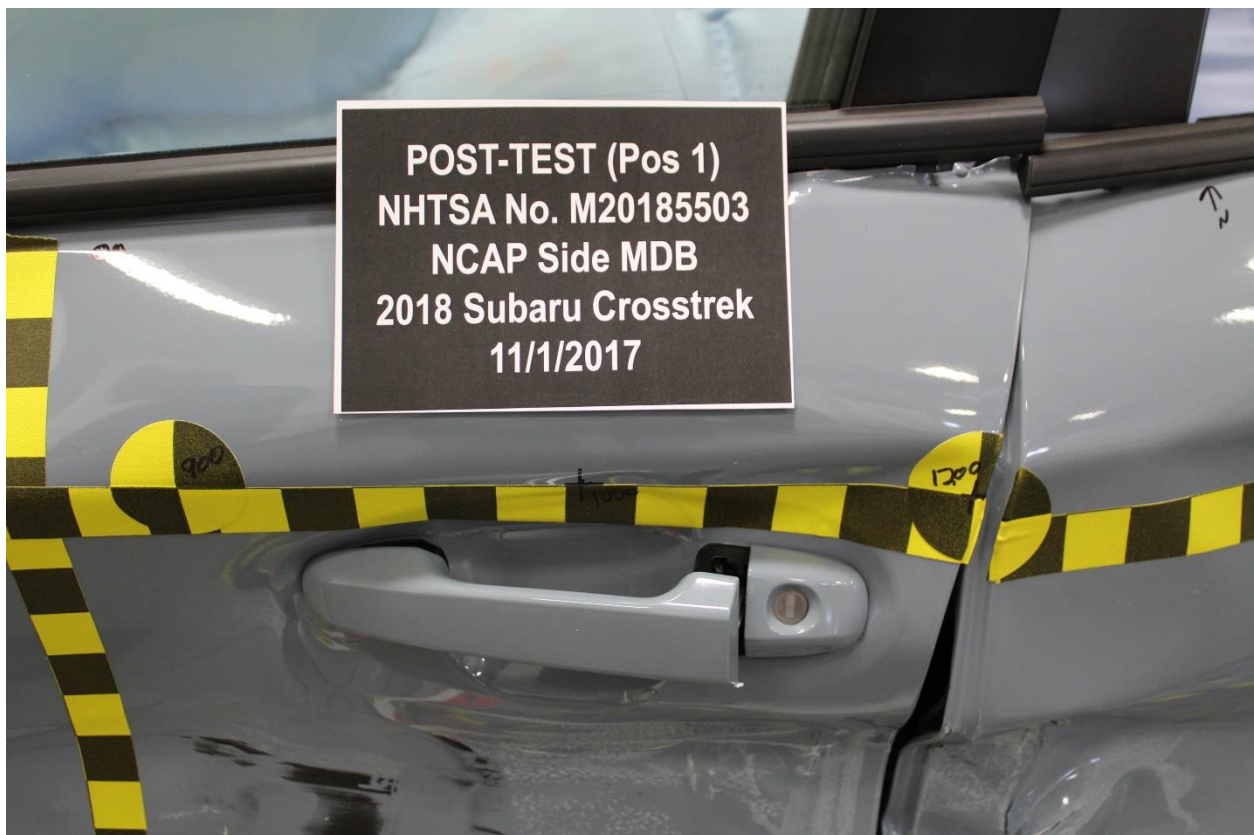

Figure A-22: Post-Test Left Front Door Latch Close-Up

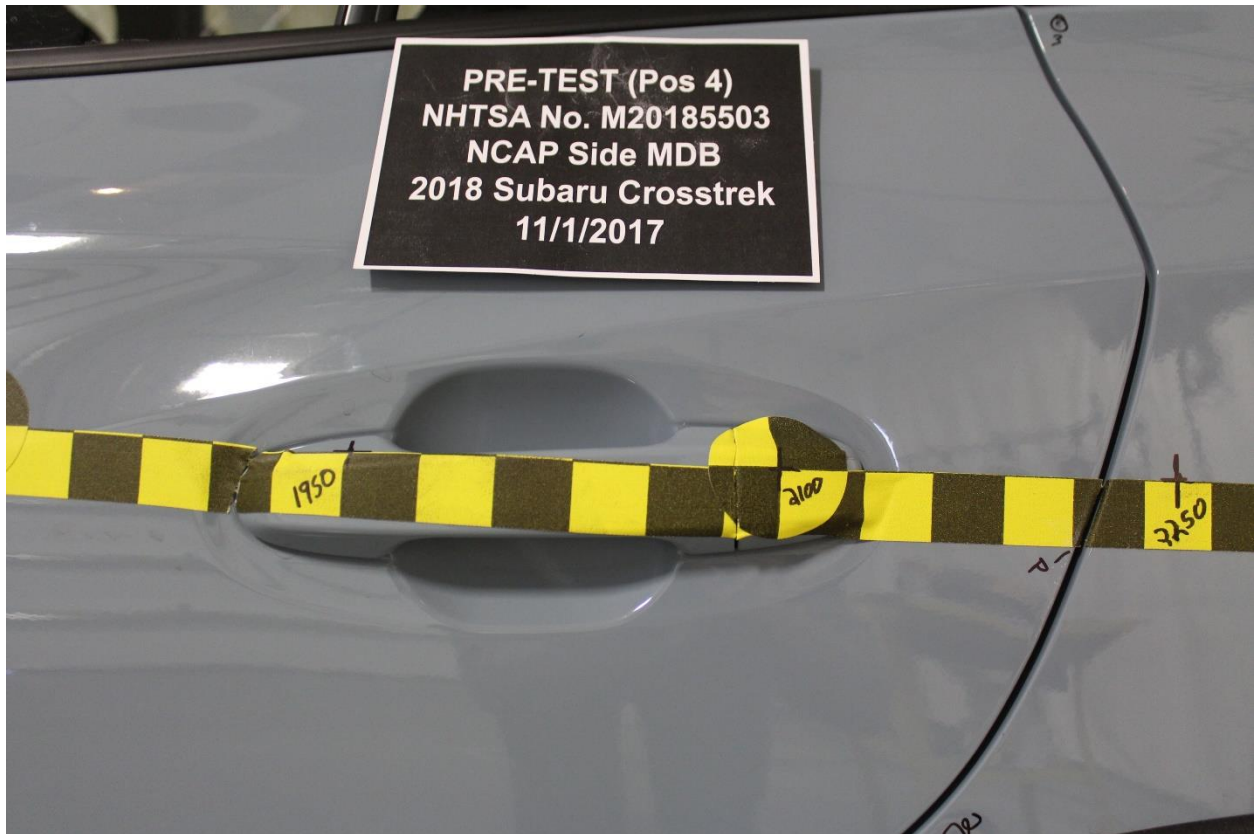

Figure A-23: Pre-Test Left Rear Door Latch Close-Up

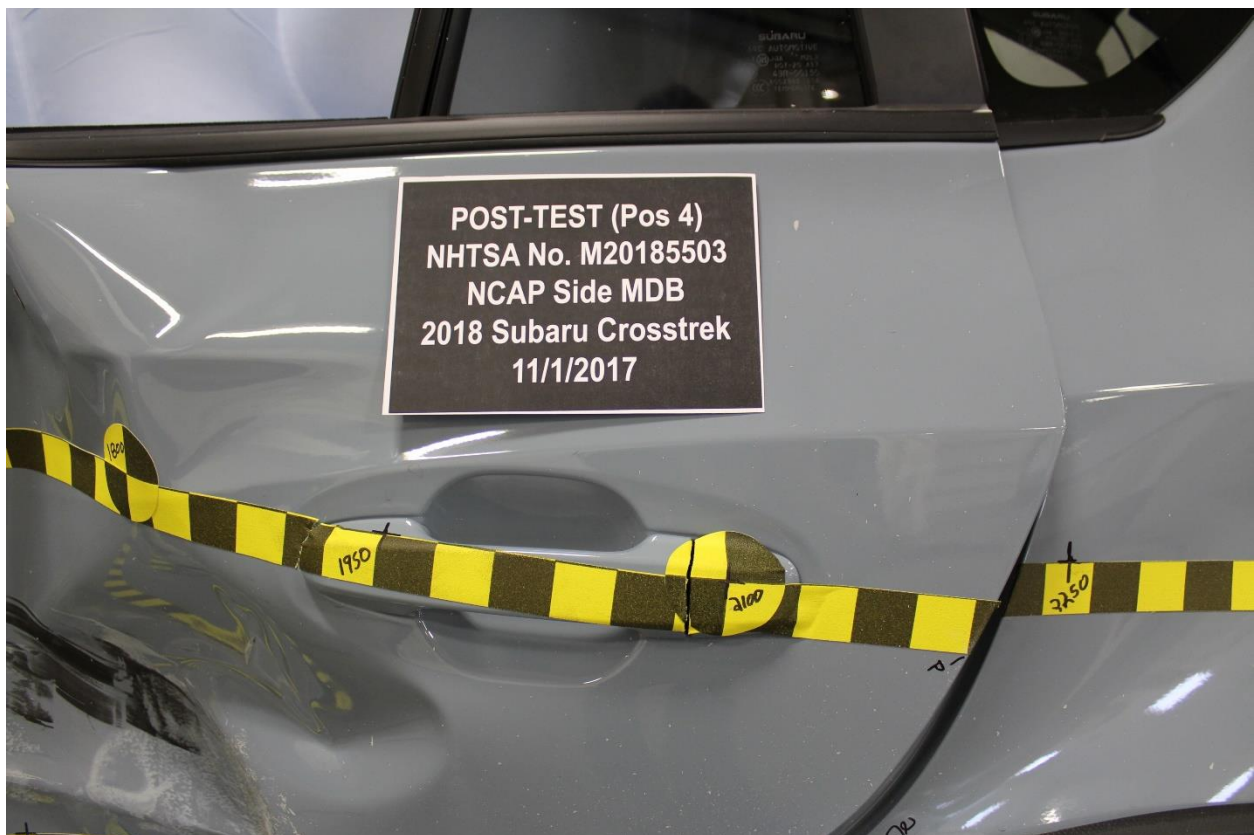

Figure A-24: Post-Test Left Rear Door Latch Close-Up



Figure A-25: Pre-Test Front Close-up View of Driver Dummy



Figure A-26: Post-Test Front Close-up View of Driver Dummy



Figure A-27: Pre-Test Left Side View of Driver Dummy Showing Belt and Chalking



Figure A-28: Pre-Test Left Side View of Driver Dummy Shoulder and Door Top View



Figure A-29: Post-Test Left Side View of Driver Dummy Shoulder and Door Top View



Figure A-30: Pre-Test Frontal View of Driver Seat Back Prior to Dummy Positioning

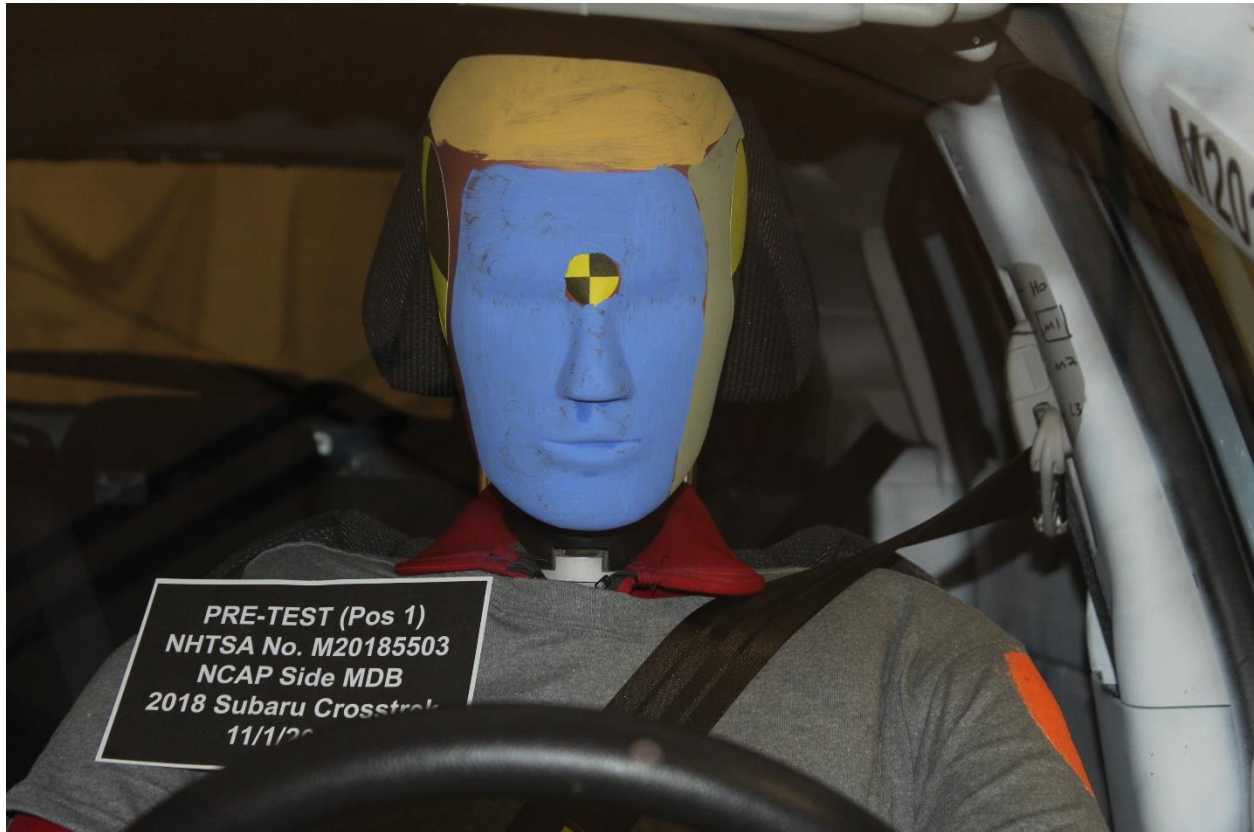

Figure A-31: Pre-Test Frontal View of Driver Dummy Head and Shoulders in Relation to Head Restraint



Figure A-32: Pre-Test Frontal View of Driver Seat Pan Prior to Dummy Positioning

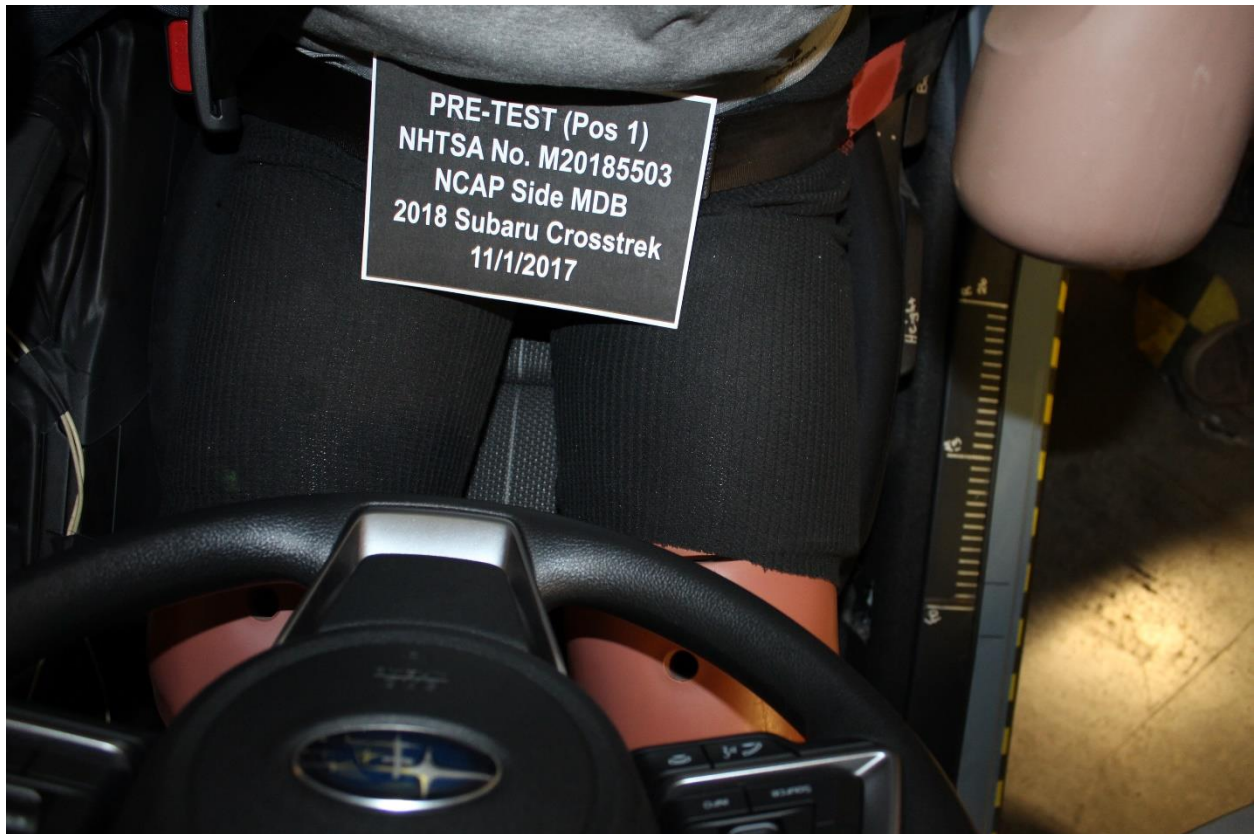

Figure A-33: Pre-Test Overhead View of Driver Dummy Thighs on Seat Pan



Figure A-34: Pre-Test Placement of Driver Dummy's Feet



Figure A-35: Pre-Test View of Belt Anchorage for Driver Dummy

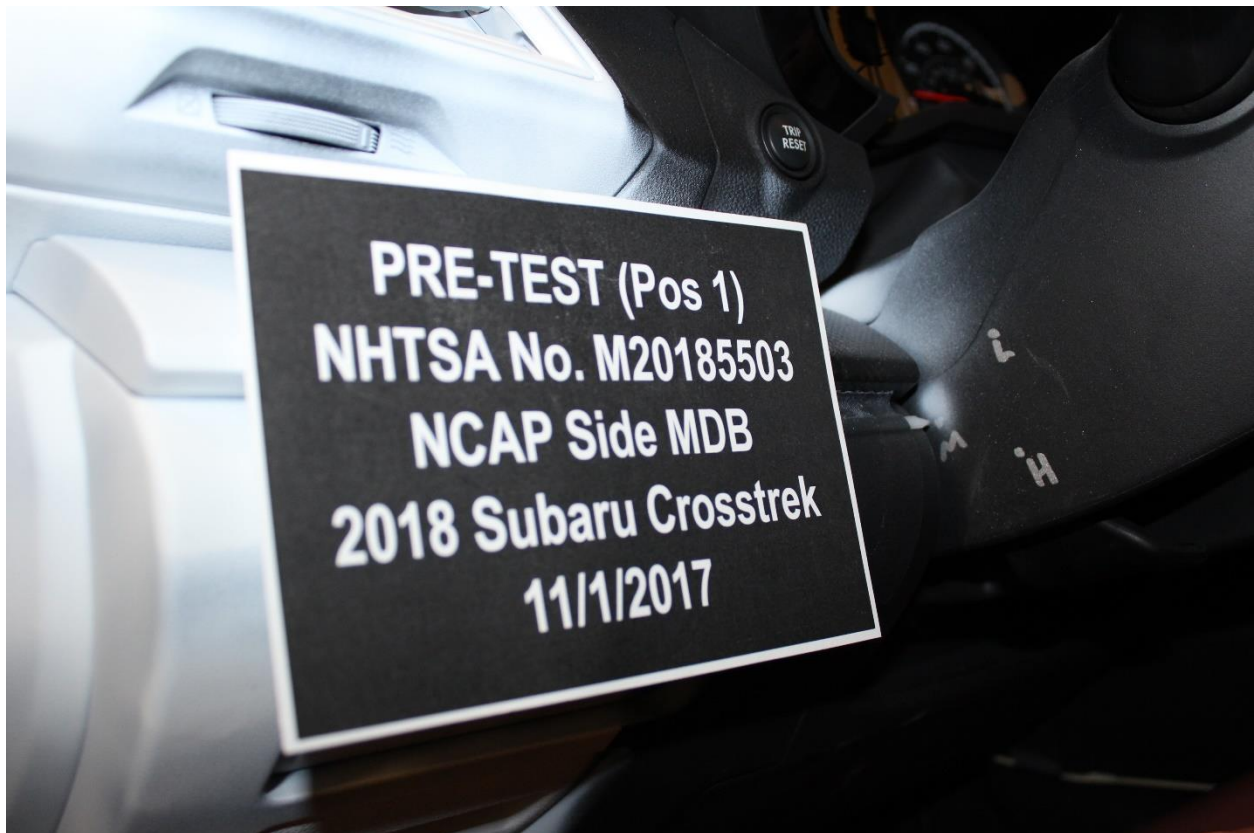

Figure A-36: Pre-Test Left Side View of Steering Wheel



Figure A-37: View of Disengaged Parking Brake



Figure A-38: Pre-Test View of Parking Brake



Figure A-39: Pre-test Close-Up Left Side View of Driver Seat Track

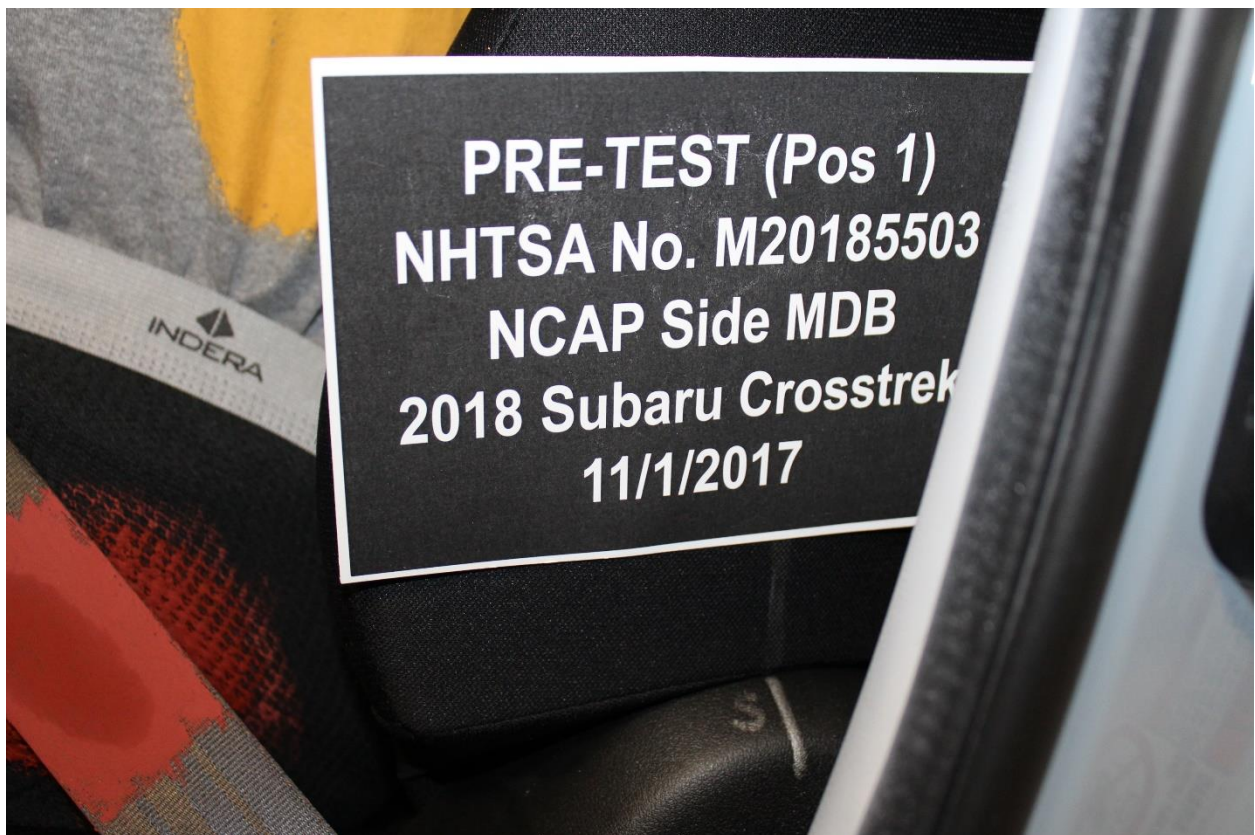

Figure A-40: Pre-Test Close-Up Left Side View of Driver Seat Back



Figure A-41: Pre-Test Close-Up View of Driver Seat Back or Head Restraint



Figure A-42: Pre-Test Driver Dummy and Door Clearance View



Figure A-43: Post-Test Driver Dummy and Door Clearance View



Figure A-44: Pre-Test Right Side View of Driver Dummy and Front Seat of Occupant Compartment



Figure A-45: Post-Test Right Side View of Driver Dummy and Front Seat of Occupant Compartment



Figure A-46: Pre-Test Driver Inner Door Panel View



Figure A-47: Post-Test Driver Inner Door Panel View



Figure A-48: Post-Test Driver Dummy Close-Up Head Contact with Vehicle View



Figure A-49: Post-Test Driver Dummy Close-Up Head Contact with Side Airbag View



Figure A-50: Post-Test Driver Dummy Close-Up Torso Contact with Vehicle Interior View



Figure A-51: Post-Test Driver Dummy Close-Up Torso Contact with Side Airbag View

Photo Not Applicable

Figure A-52: Post-Test Driver Dummy Close-Up Pelvis Contact View

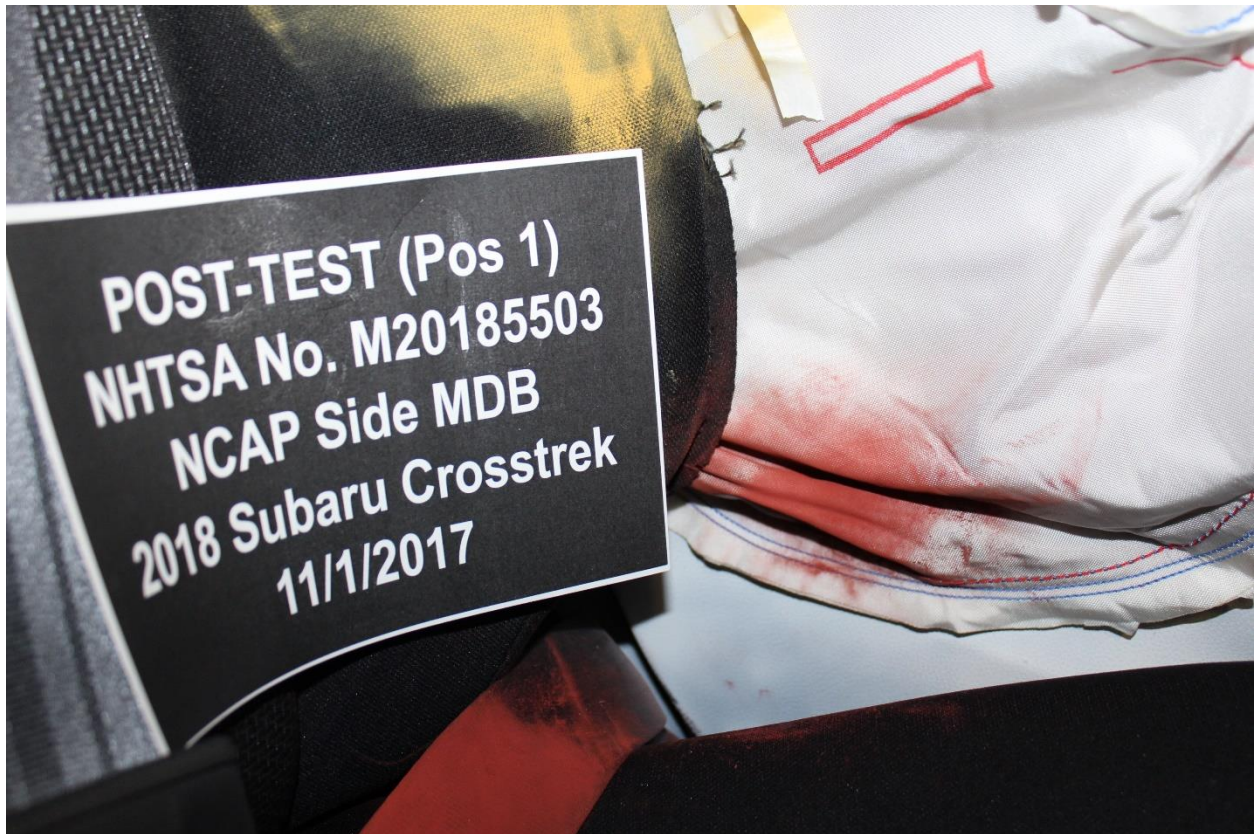

Figure A-53: Post-Test Driver Dummy Close-Up Pelvis Contact with Side Airbag View

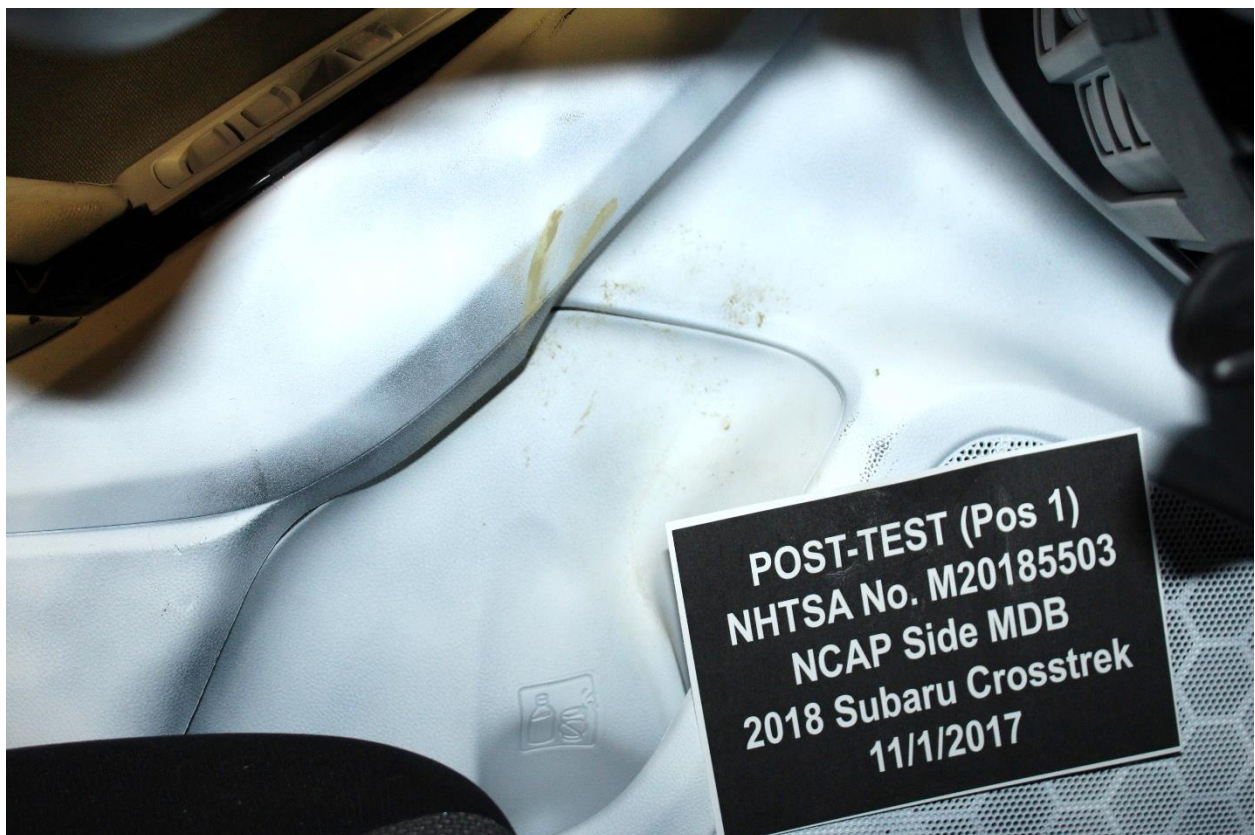

Figure A-54: Post-Test Driver Dummy Close-Up Knee Contact View



Figure A-55: Pre-Test Left Side View of Passenger Dummy Showing Belt and Chalking



Figure A-56: Pre-Test Left Side View of Passenger Dummy Shoulder and Door Top View



Figure A-57: Post-Test Left Side View of Passenger Dummy Shoulder and Door Top View



Figure A-58: Pre-Test Frontal View of Rear Passenger Seat Back Prior to Dummy Positioning

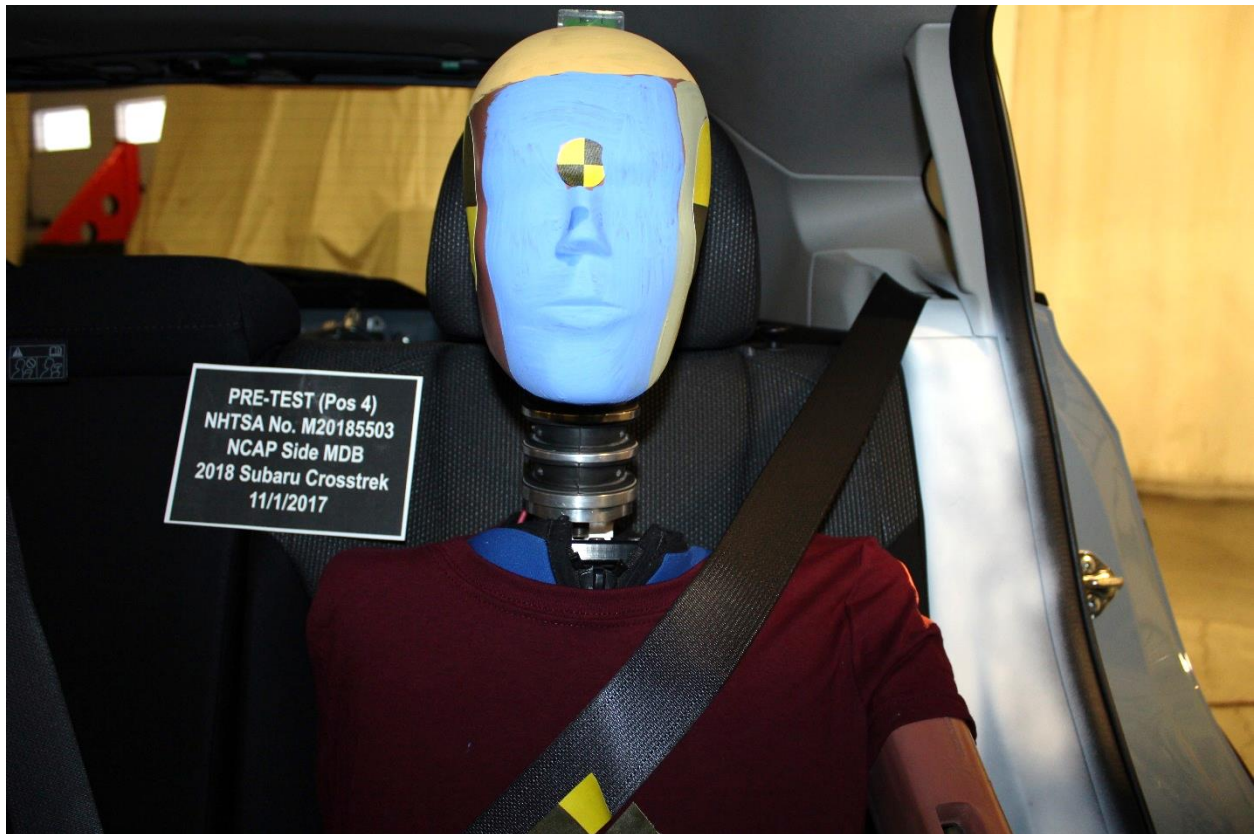

Figure A-59: Pre-Test Frontal View of Rear Passenger Dummy Head and Shoulders in Relation to Head Restraint



Figure A-60: Pre-Test Overhead View of Rear Passenger Seat Pan Prior to Dummy Positioning

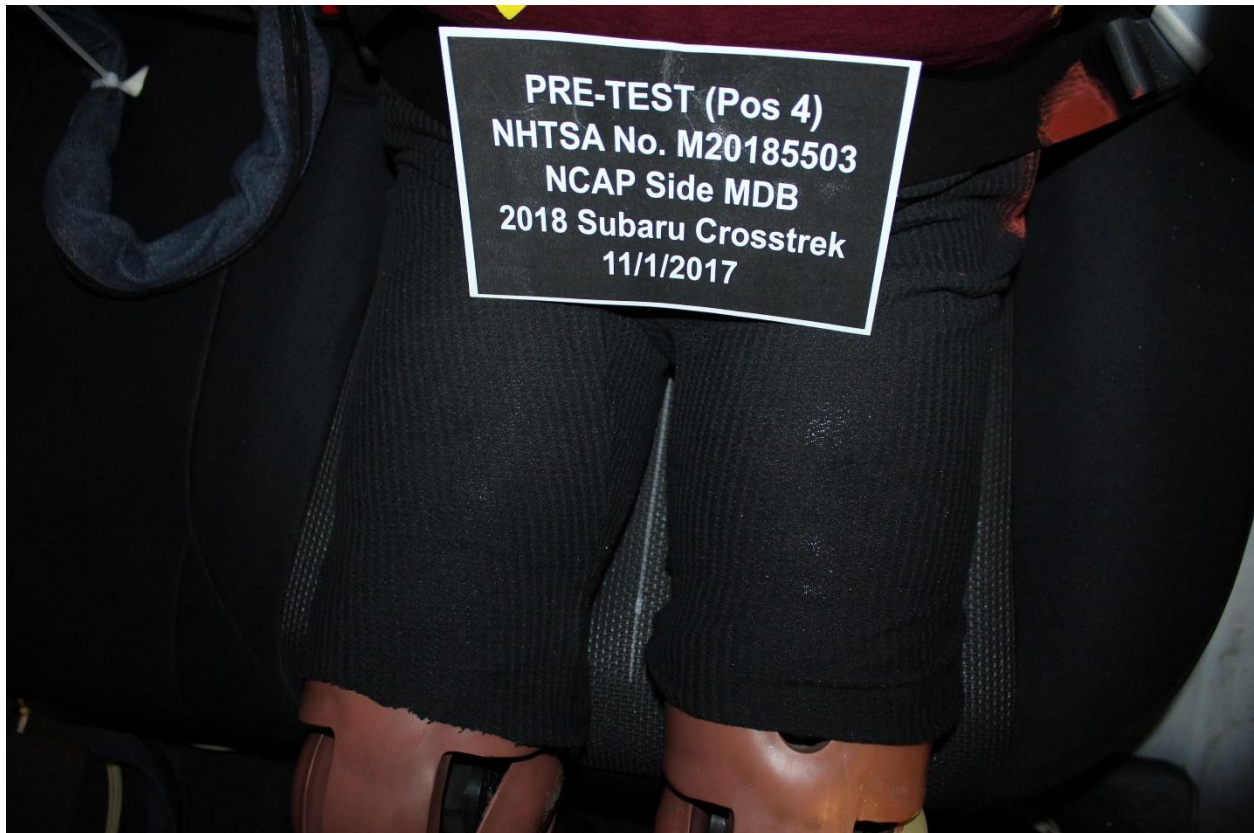

Figure A-61: Pre-Test Overhead View of Rear Passenger Dummy Thighs on Seat Pan



Figure A-62: Pre-Test View of Rear Passenger Dummy's Neck Showing Position of Adjustable Neck Bracket



Figure A-63: Pre-Test View of Rear Passenger Dummy's Head Showing Dummy's Head is Level



Figure A-64: Pre-Test Placement of Rear Passenger Dummy's Feet



Figure A-65: Pre-Test View of Belt Anchorage for Rear Passenger Dummy



Figure A-66: Pre-Test Close-Up Left Side View of Rear Passenger Seat Track



Figure A-67: Pre-Test Close-Up Left Side View of Rear Passenger Seat Back

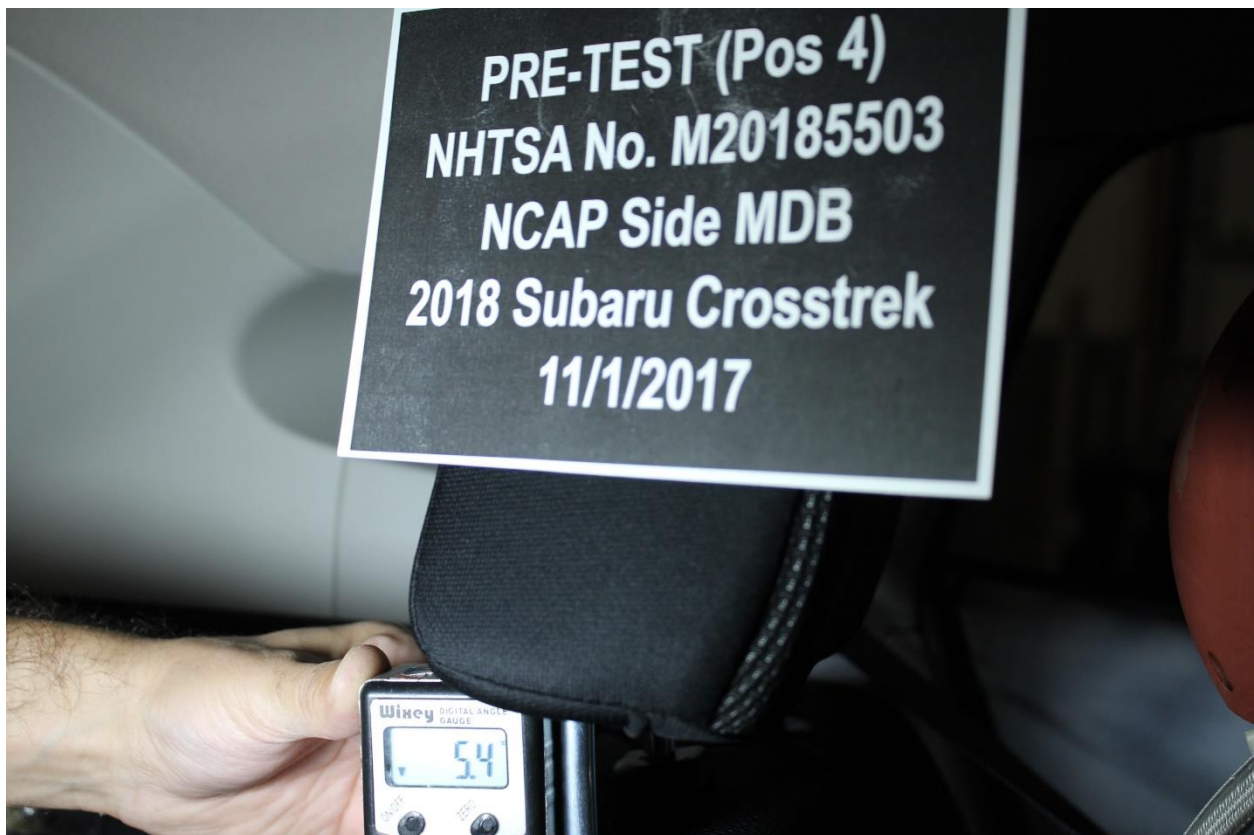

Figure A-68: Pre-Test Close-Up View of Rear Passenger Seat Back or Head Restraint



Figure A-69: Pre-Test Passenger Dummy and Door Clearance View



Figure A-70: Post-Test Passenger Dummy and Door Clearance View



Figure A-71: Pre-Test Right Side View of Rear Passenger Dummy and Rear Seat Occupant Compartment



Figure A-72: Post-Test Right Side View of Rear Passenger Dummy and Rear Seat Occupant Compartment



Figure A-73: Pre-Test Passenger Inner Door Panel View



Figure A-74: Post-Test Passenger Inner Door Panel View



Figure A-75: Post-Test Rear Passenger Dummy Close-Up Head Contact with Vehicle View



Figure A-76: Post-Test Rear Passenger Dummy Close-Up Head Contact with Side Airbag View



Figure A-77: Post-Test Rear Passenger Dummy Close-Up Torso Contact with Vehicle Interior View

Photo Not Applicable

Figure A-78: Post-Test Rear Passenger Dummy Close-Up Torso Contact with Side Airbag View



Figure A-79: Post-Test Rear Passenger Dummy Close-Up Pelvis Contact View

Photo Not Applicable

Figure A-80: Post-Test Rear Passenger Dummy Close-Up Pelvis Contact with Side Airbag View



Figure A-81: Post-Test Rear Passenger Dummy Close-Up Knee Contact View

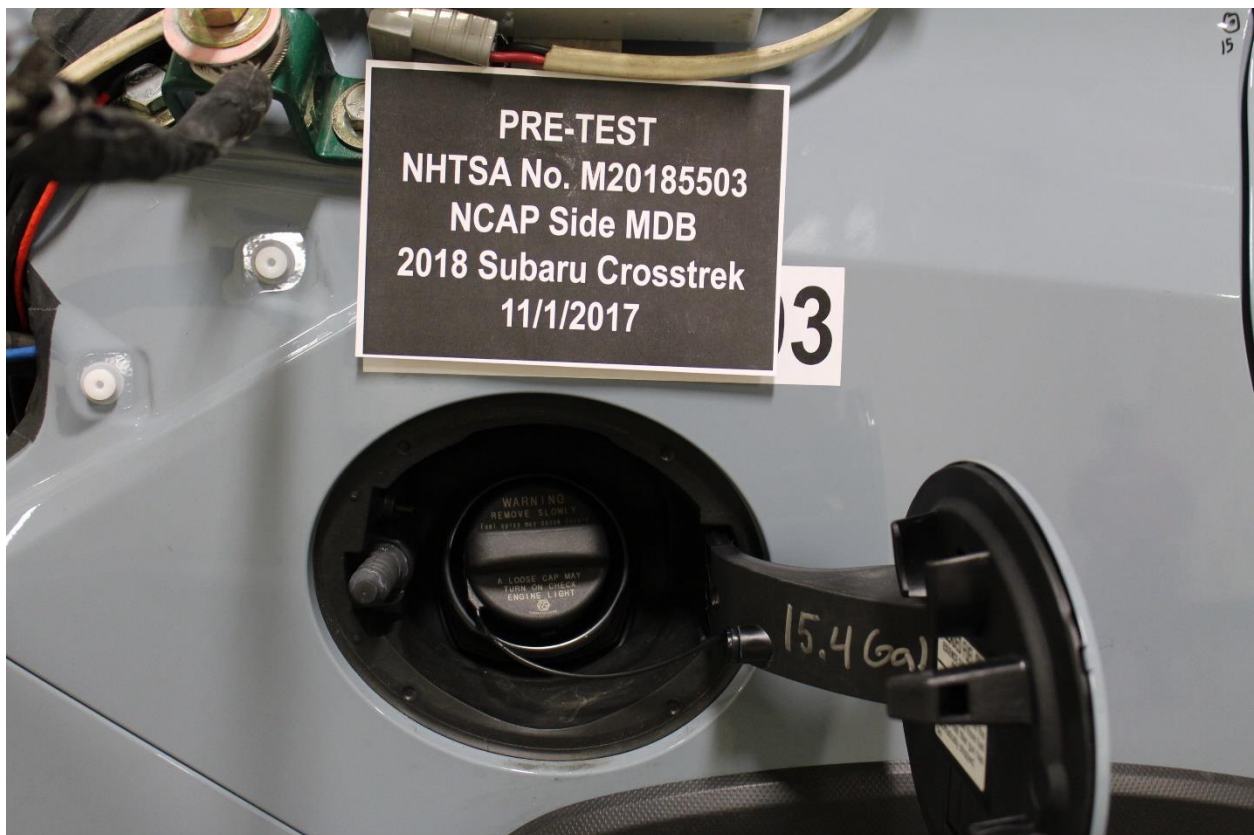

Figure A-82: Pre-Test View of Fuel Filler Cap or Fuel Filler Neck



Figure A-83: Post-Test View of Fuel Filler Cap or Fuel Filler Neck

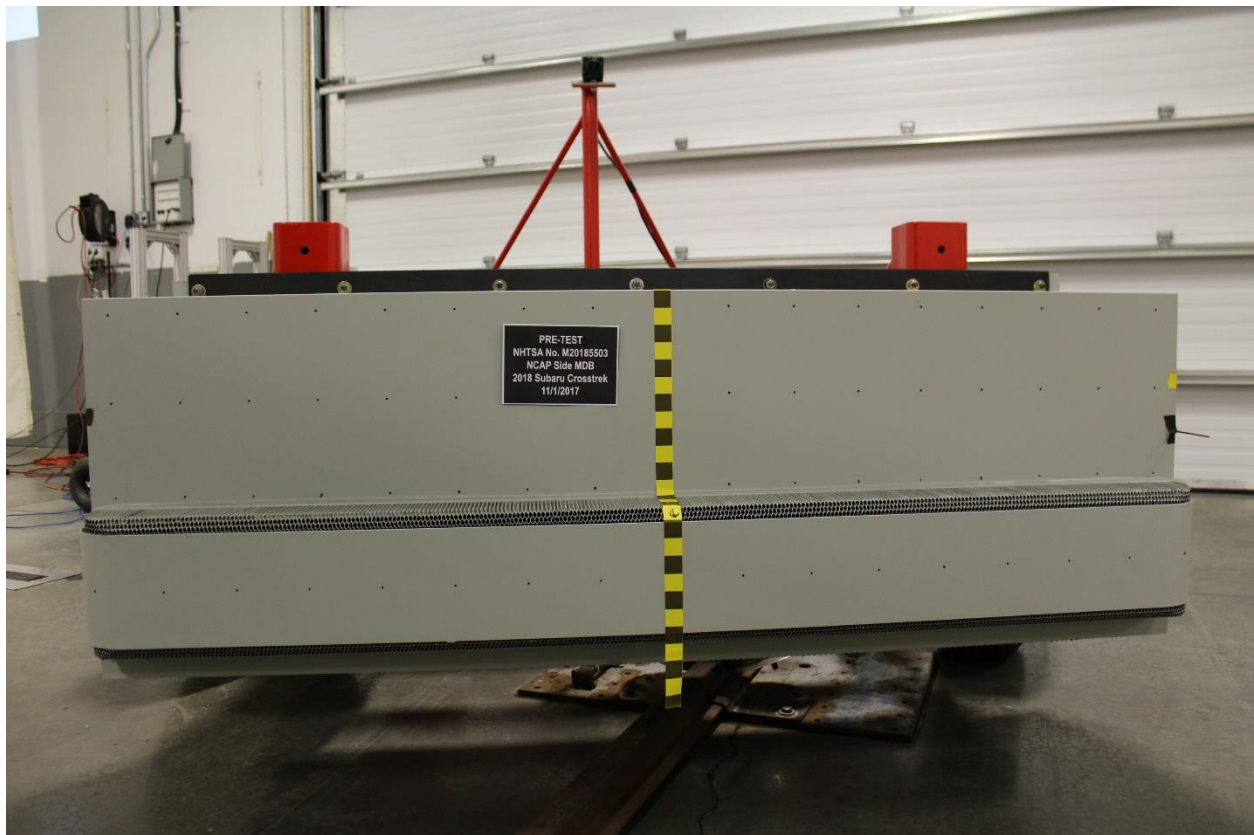

Figure A-84: Pre-Test Front View of MDB Impactor Face



Figure A-85: Post-Test Front View of MDB Impactor Face



Figure A-86: Pre-Test Top View of MDB Impactor Face



Figure A-87: Post-Test Top View of MDB Impactor Face



Figure A-88: Pre-Test Left Side View of MDB Impactor Face



Figure A-89: Post-Test Left Side View of MDB Impactor Face

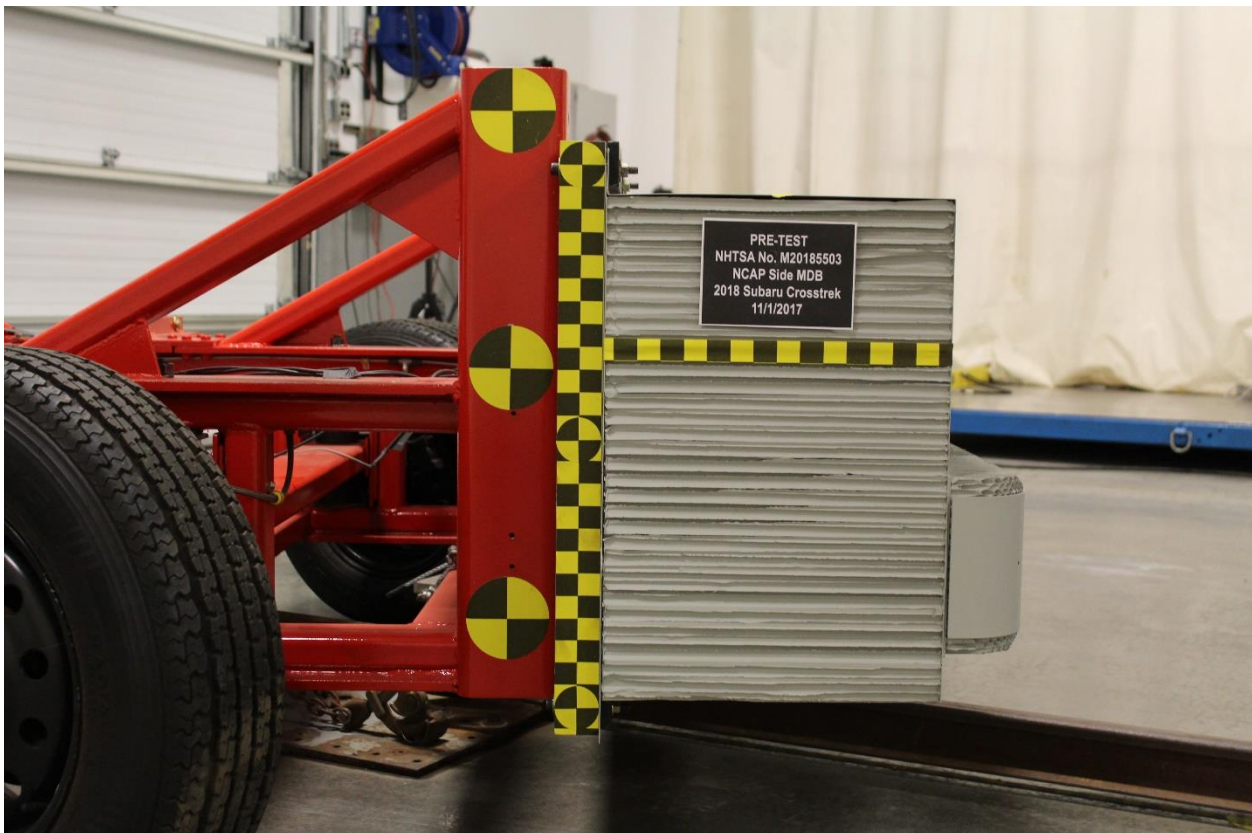

Figure A-90: Pre-Test Right Side View of MDB Impactor Face



Figure A-91: Post-Test Right Side View of MDB Impactor Face

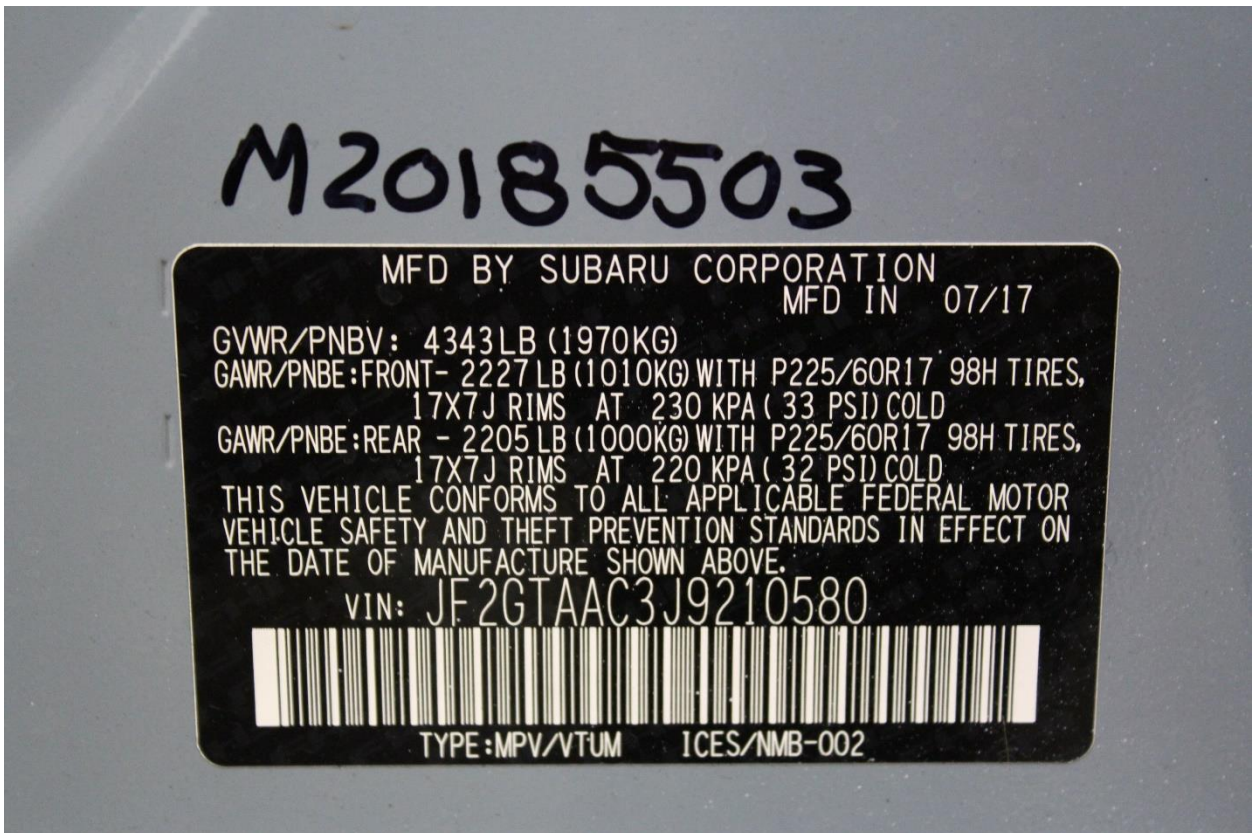

Figure A-92: Close-Up View of Vehicle's Certification Label

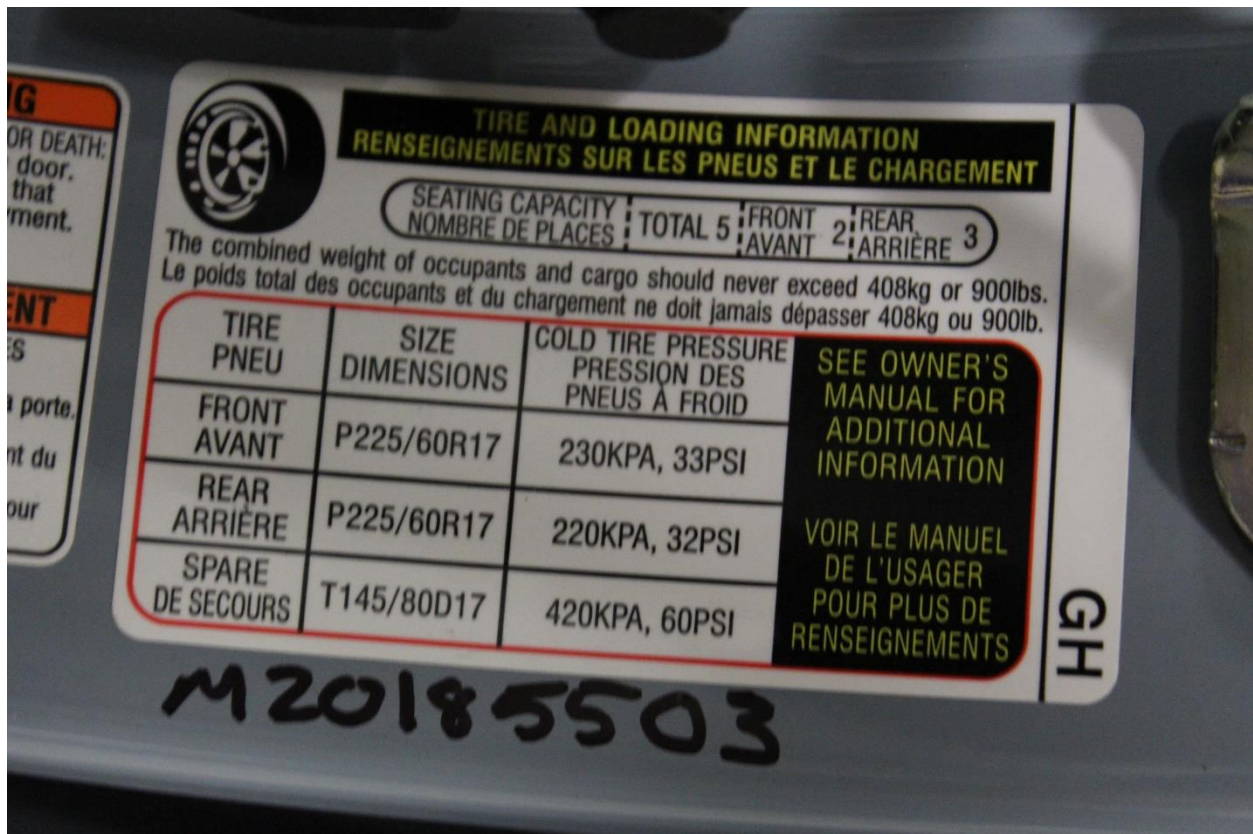

Figure A-93: Close-Up View of Vehicle's Tire Information Placard or Label

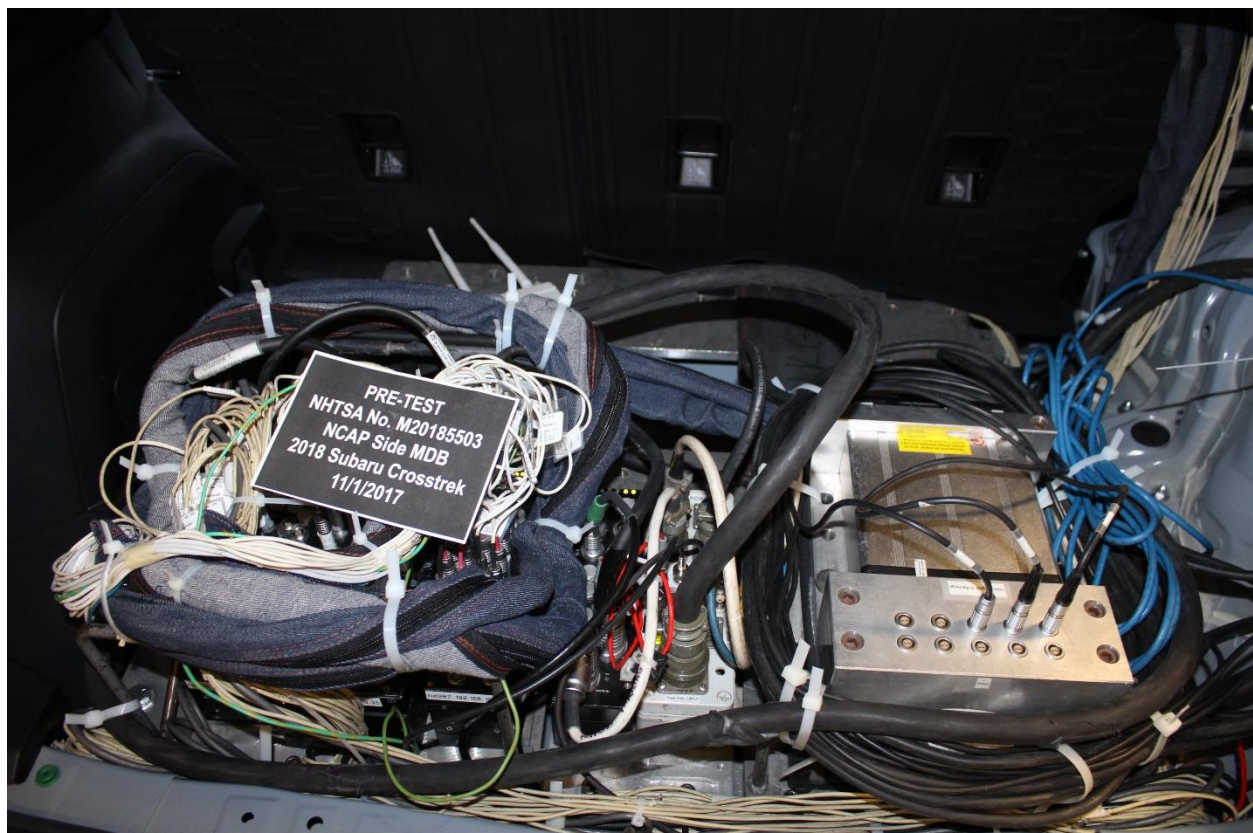

Figure A-94: Pre-Test Ballast View



Figure A-95: Post-Test Primary and Redundant Speed Trap Read-Out



Figure A-96: FMVSS No. 301 Static Rollover 0 Degrees



Figure A-97: FMVSS No. 301 Static Rollover 90 Degrees

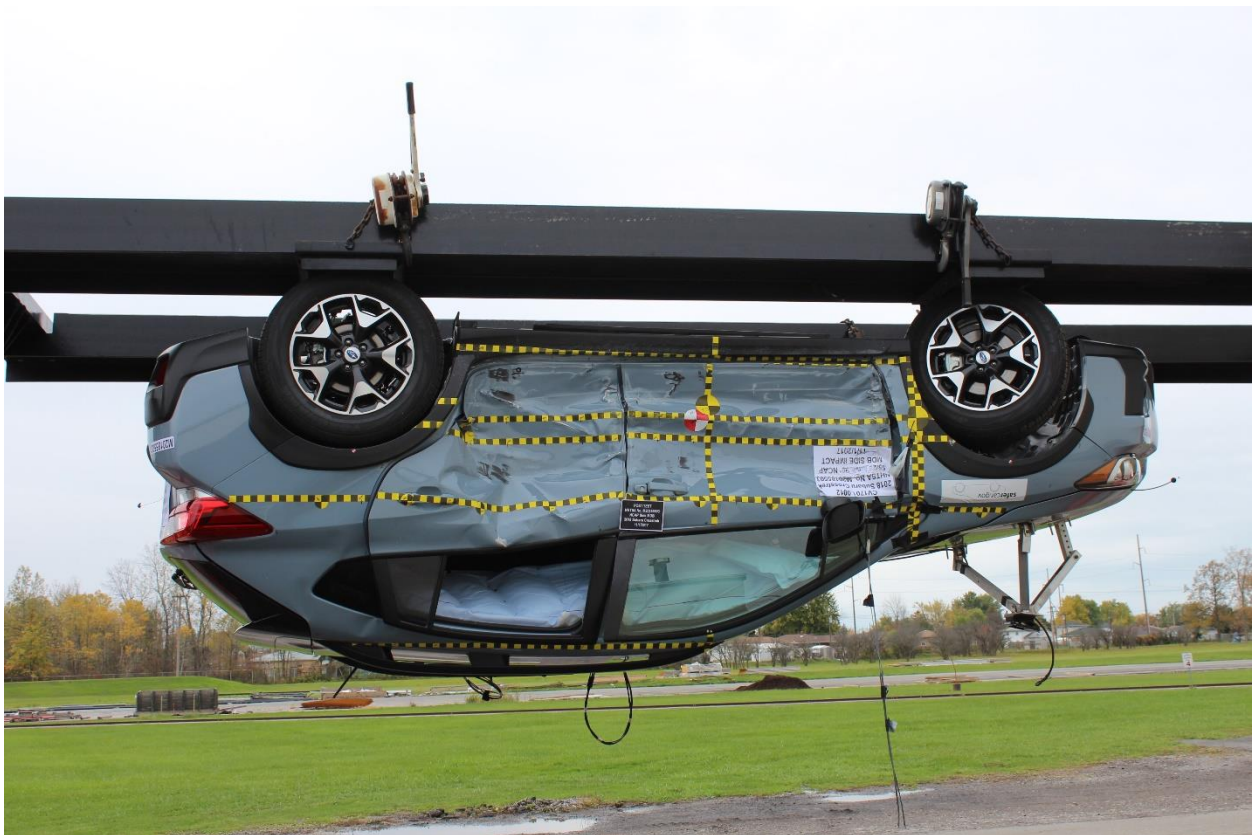

Figure A-98: FMVSS No. 301 Static Rollover 180 Degrees



Figure A-99: FMVSS No. 301 Static Rollover 270 Degrees



Figure A-100: FMVSS No. 301 Static Rollover 360 Degrees



Figure A-101: Impact Event

CROSSTREK VIN: JF2GTAAC3J9210580 Model/Code: 2018 SUBARU CROSSTREK 2.0I/JRA Port/Assembly: VANCOUVER WA Deliver by/Carrier: TRUCK / 601-601061		SHIP TO: 401289 KENOSHA SUBARU 7000 120TH AVE KENOSHA WI 53142	SOLD TO: 401289 KENOSHA SUBARU 7000 120TH AVE KENOSHA WI 53142										
GOVERNMENT 5-STAR SAFETY RATINGS Overall Vehicle Score Not Rated <small>Based on the combined ratings of frontal, side and rollover. Should ONLY be compared to other vehicles of similar size and weight.</small> <table border="1"> <tr> <td>Frontal Crash</td> <td>Driver Passenger</td> <td>Not Rated</td> </tr> <tr> <td>Side Crash</td> <td>Front seat Rear seat</td> <td>Not Rated</td> </tr> <tr> <td>Rollover</td> <td></td> <td>Not Rated</td> </tr> </table> <small>Star ratings range from 1 to 5 stars (★★★★★) with 5 being the highest. Source: National Highway Traffic Safety Administration (NHTSA). Based on the risk of injury in a single-vehicle crash.</small> www.safercar.gov or 1-888-927-4236		Frontal Crash	Driver Passenger	Not Rated	Side Crash	Front seat Rear seat	Not Rated	Rollover		Not Rated	Protect Your Investment! Subaru Added Security™ <small>The Only Extended Service Agreement Backed By Subaru</small> <ul style="list-style-type: none"> Protection designed to fit your driving needs, up to 7 years/100,000 miles of coverage Maintenance plans also available We use Genuine Subaru replacement parts - only the best We use technicians trained by Subaru - those who know your vehicle best Towing, rental and trip interruption benefits available Transferable to the next owner <small>Ask your sales representative for more details. Accept nothing less than Added Security!</small>		
Frontal Crash	Driver Passenger	Not Rated											
Side Crash	Front seat Rear seat	Not Rated											
Rollover		Not Rated											
EPA DOT Fuel Economy and Environment Fuel Economy Annual fuel cost \$1,450 <small>Actual results will vary for many reasons, including driving conditions and how you drive and maintain your vehicle. The average new vehicle gets 27 MPG and costs \$6,730 to fuel over 5 years. Cost estimates are based on 15,000 miles per year at \$2.60 per gallon. MPGe is miles per gallon equivalent. Vehicle emissions are a significant cause of climate change and smog.</small> fuelconomy.gov <small>Calculate personalized estimates and compare vehicles</small>		Gasoline Vehicle You spend \$500 more in fuel costs over 5 years <small>compared to the average new vehicle.</small> Annual fuel cost \$1,450 <small>This vehicle emits 353 grams CO2 per mile. The best emits 0 grams per mile (tailpipe only). Producing and distributing fuel also creates emissions. Learn more at fuelconomy.gov.</small>											
PARTS CONTENT INFORMATION FOR VEHICLES IN THIS CARLINE: U.S./CANADIAN PARTS CONTENT: 5% MAJOR SOURCES OF FOREIGN PARTS CONTENT: JAPAN: 90% FOR THIS VEHICLE: FINAL ASSEMBLY POINT: OTA, GUNMA, JAPAN COUNTRY OF ORIGIN: ENGINE: JAPAN TRANSMISSION: JAPAN <small>Note: Parts content does not include final assembly, distribution, or other non-parts costs.</small>		STANDARD EQUIPMENT SAFETY Symmetrical All-Wheel Drive (AWD) Vehicle Dynamics Control (VDC) Subaru Advanced Frontal Airbag System Driver's Side Knee Airbag Side-Curtain Airbags w/ Rollover Sensor Front Seat Side-Impact Airbags Whiplash Protection Front Seats 4-Wheel Disc Brakes with Brake Assist Anti-Lock Braking System (ABS) Electronic Brake-Force Distribution Brake Override System Safety Pedal System Anti-Theft Alarm & Immobilizer System Daytime Running Lights (DRL) Rear Vision Camera PERFORMANCE AND EXTERIOR 2.0L Horizontally-Opposed DOHC Engine 6-Speed Manual Transmission Four-Wheel Independent Suspension 17-Inch Aluminum-Alloy Wheels Variable Intermittent Windshield Wipers Electric Power-Assisted Steering Folding Exterior Mirrors Roof Rails COMFORT, CONVENIENCE & INTERIOR Air Conditioning with Air Filtration System 6.5" STARLINK Multimedia Audio System STARLINK Smartphone Connectivity USB Port with iPod & iPhone Connectivity Bluetooth Hands-Free Phone Connectivity Tilt/Telescopic Steering Wheel w/Bluetooth & Audio Switches Cruise Control Power Door Locks and Dual Power Mirrors Remote Keyless Entry System Power Windows w/ Driver's and Front Passenger Auto Up/Down 60/40 Split Fold-Down Rear Seatback Multi-Function Trip Computer Dual Map Lights Height Adjustable Driver's Seat LIMITED WARRANTY/ROADSIDE ASSISTANCE 3 Years / 36,000 Miles Basic 5 Years / 60,000 Miles Powertrain 5 Yrs/Unlimited Mileage Rust Perforation 3 Yrs / 36,000 24/7 Roadside Assistance See Owner Info Kit/Warranty For Details											
Destination and Delivery \$915.00 Total Suggested Retail Price \$23,146.00		<small>This is a registered trademark of Apple Inc. iPhone/iOS is a registered trademark of Apple Intellectual Property, Inc. Bluetooth is a registered trademark of Bluetooth SIG, Inc. Toyota is a registered trademark of Toyota Motor Sales, U.S.A., Inc. Ford is a registered trademark of Ford Motor Company. TORO is a registered trademark of TORO Industries, Inc.</small>											

Figure A-102: Monroney Label

fold down in the event of sudden braking, or objects may move out from the cargo area, which could cause serious injury or death.

■ Head restraints

WARNING
The front seat head restraints are designed to be installed into the front seats only. The rear seat head restraints are designed to be installed into the rear seats only. Do not attempt to install the front seat head restraints into the rear seats, or the rear seat head restraints into the front seats.

NOTE

It is possible to adjust the angle of the front seat head restraints only. When installing the front seat head restraints, make sure that the angle of the head restraints can be adjusted.

▼ Front seats

Both the driver's seat and the front passenger's seat are equipped with head restraints. Both head restraints are adjustable in the following ways.

▼ Height adjustment

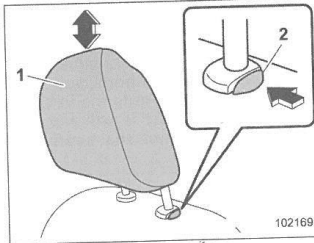

- 1) Head restraint
- 2) Release button

To raise:

Pull the head restraint up.

To lower:

Push the head restraint down while pressing the release button on the top of the seatback.

To remove:

While pressing the release button, pull out the head restraint.

To install:

Install the head restraint into the holes that are located on the top of the seatback until the head restraint locks. Press and hold the release button to lower the head restraint.

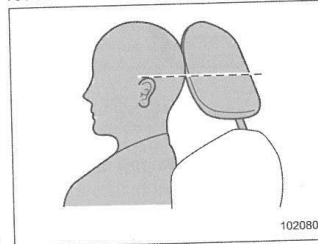

Each head restraint should be adjusted so that the center of the head restraint is closest to the top of the occupant's ears.

NOTE

When the head restraint cannot be pulled out or installed due to insufficient clearance between the head restraint and the roof, tilt the seat and then perform the installation and removal tasks.

Figure A-103: Driver Head Restraint Use and Adjustment Information from Vehicle Owner's Manual

▼ Angle adjustment

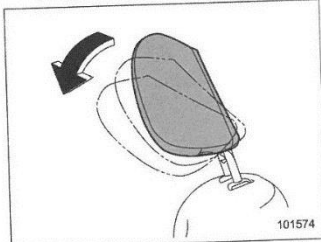

The angle of the head restraint can be adjusted in several steps. While maintaining a suitable driving posture, adjust the head restraint to a position where the back of your head is as close to the head restraint as possible.

To tilt:

Tilt the head restraint by hand to the preferred position. A click will be audible when the head restraint is locked.

To return:

Tilt the head restraint once as far forward as it can go. The head restraint will automatically return to the fully upright position. Then, adjust the head restraint again to the preferred angle.

▼ Rear seats

Both the rear window side seats and the rear center seat are equipped with head restraints.

▼ Rear windows side seating position

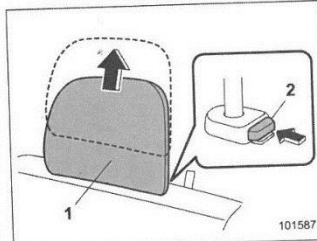

- 1) Head restraint
- 2) Release button

To remove:

While pressing the release button, pull out the head restraint.

To install:

Install the head restraint into the holes that are located on the top of the seatback until the head restraint locks. Press and hold the release button to lower the head restraint.

After installing the head restraint, make sure it is securely locked.

▼ Rear center seating position

CAUTION
The head restraint is not intended to be used at the retracted position. Before sitting on the seat, raise the head restraint to the extended position.

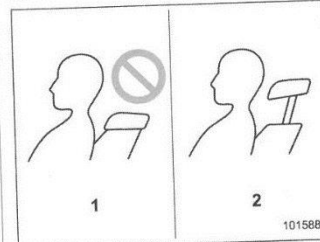

- 1) Incorrect (retracted position)
- 2) Correct (extended position)

- CONTINUED -

Figure A-104: Left Rear Passenger Head Restraint Use and Adjustment Information from Vehicle Owner's Manual-Rear Restraints Not Adjustable

APPENDIX B

VEHICLE AND DUMMY RESPONSE DATA PLOTS

TABLE OF DATA PLOTS

Driver & Passenger Dummy Instrumentation Plots

Fig.	Description	Page
1	Driver Head Acceleration (X) Primary vs. Time	B-5
2	Driver Head Acceleration (Y) Primary vs. Time	B-5
3	Driver Head Acceleration (Z) Primary vs. Time	B-5
4	Driver Head Resultant Acceleration Primary vs. Time	B-5
5	Driver Upper Thorax Rib Deflection (Y) vs. Time	B-6
6	Driver Middle Thorax Rib Deflection (Y) vs. Time	B-6
7	Driver Lower Thorax Rib Deflection (Y) vs. Time	B-6
8	Driver Thorax Rib Deflection Maximum vs. Time	B-6
9	Driver Anterior Abdominal Force (Y) vs. Time	B-7
10	Driver Middle Abdominal Force (Y) vs. Time	B-7
11	Driver Posterior Abdominal Force (Y) vs. Time	B-7
12	Driver Total Abdominal Force (Y) vs. Time	B-7
13	Driver Pubic Symphysis Force (Y) vs. Time	B-8
14	Passenger Head Acceleration (X) vs. Time Primary	B-8
15	Passenger Head Acceleration (Y) vs. Time Primary	B-8
16	Passenger Head Acceleration (Z) vs. Time Primary	B-8
17	Passenger Head Resultant Acceleration Primary vs. Time	B-9
18	Passenger Lower Spine T12 Acceleration (X) vs. Time	B-9
19	Passenger Lower Spine T12 Acceleration (Y) vs. Time	B-9
20	Passenger Lower Spine T12 Acceleration (Z) vs. Time	B-9
21	Passenger Lower Spine T12 Resultant Acceleration vs. Time	B-10
22	Passenger Iliac Force on Impact Side (Y) vs. Time	B-10
23	Passenger Acetabulum Force on Impact Side (Y) vs. Time	B-10
24	Passenger Total Pelvic Force on Impact Side (Y) vs. Time	B-10

The following additional data for this test can be obtained from the Research and Development section of the NHTSA website. The website can be found at www.NHTSA.dot.gov.

Additional Driver & Passenger Dummy Instrumentation Data

Driver Lower Spine T12 Acceleration (X)
Driver Lower Spine T12 Acceleration (Y)
Driver Lower Spine T12 Acceleration (Z)
Passenger Upper Thorax Rib Deflection (Y)
Passenger Middle Thorax Rib Deflection (Y)
Passenger Lower Thorax Rib Deflection (Y)
Passenger Upper Abdomen Rib Deflection (Y)
Passenger Lower Abdomen Rib Deflection (Y)
Driver Head Acceleration Redundant (X)
Driver Head Acceleration Redundant (Y)
Driver Head Acceleration Redundant (Z)
Passenger Head Acceleration Redundant (X)
Passenger Head Acceleration Redundant (Y)
Passenger Head Acceleration Redundant (Z)

Vehicle Instrumentation Data

Vehicle Center of Gravity Acceleration (X)
Vehicle Center of Gravity Acceleration (Y)
Vehicle Center of Gravity Acceleration (Z)
Right Side Sill at Front Seat Acceleration (X)
Right Side Sill at Front Seat Acceleration (Y)
Right Side Sill at Front Seat Acceleration (Z)
Right Side Sill at Rear Seat Acceleration (X)
Right Side Sill at Rear Seat Acceleration (Y)
Right Side Sill at Rear Seat Acceleration (Z)
Left Side Sill at Front Seat Acceleration (Y)
Left Side Sill at Rear Seat Acceleration (Y)
Lower A-Post Acceleration (Y)
Middle A-Post Acceleration (Y)
Lower B-Post Acceleration (Y)
Middle B-Post Acceleration (Y)
Front Seat Track Acceleration (Y)
Rear Seat Structure Acceleration (Y)
Right Rear Occupant Compartment Acceleration (Y)
Engine Block (X)
Engine Block (Y)
Rear Floorpan Above Axle Acceleration (X)
Rear Floorpan Above Axle Acceleration (Y)
Rear Floorpan Above Axle Acceleration (Z)

MDB Instrumentation Data

MDB Center of Gravity Acceleration (X)
MDB Center of Gravity Acceleration (Y)
MDB Center of Gravity Acceleration (Z)
MDB Rear Acceleration (X)
MDB Rear Acceleration (Y)
Left MDB Contact Switch
Right MDB Contact Switch

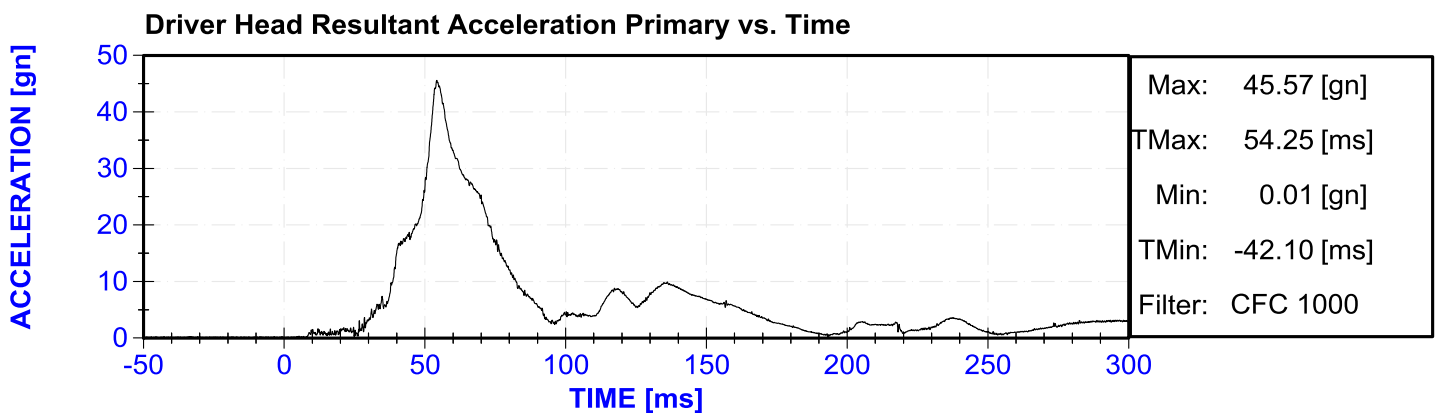
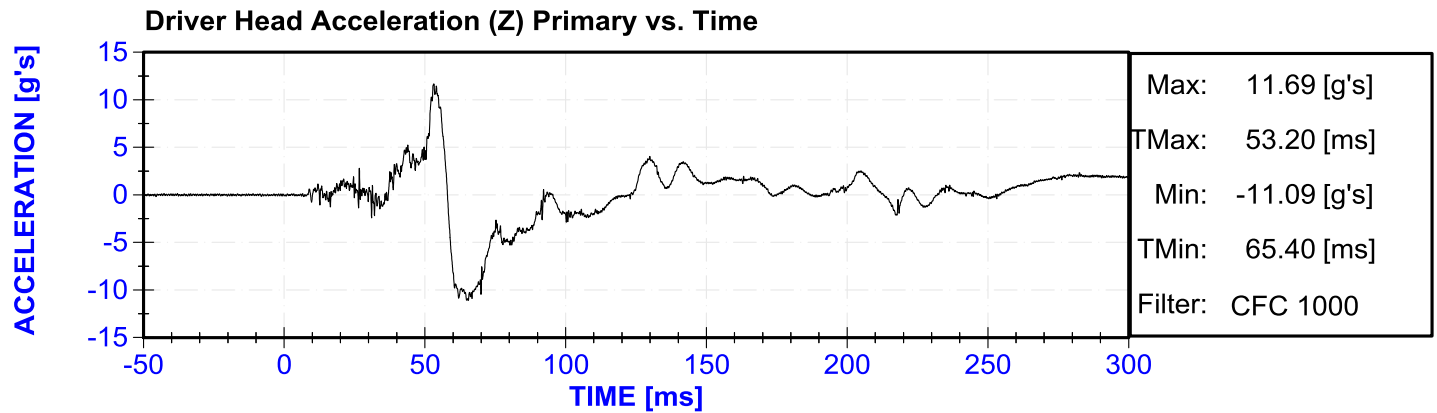
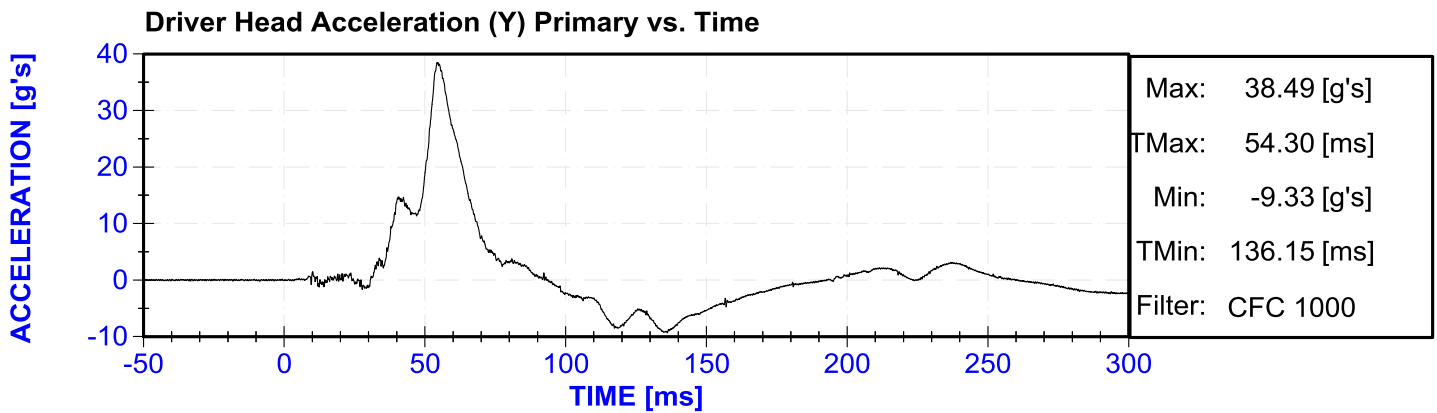
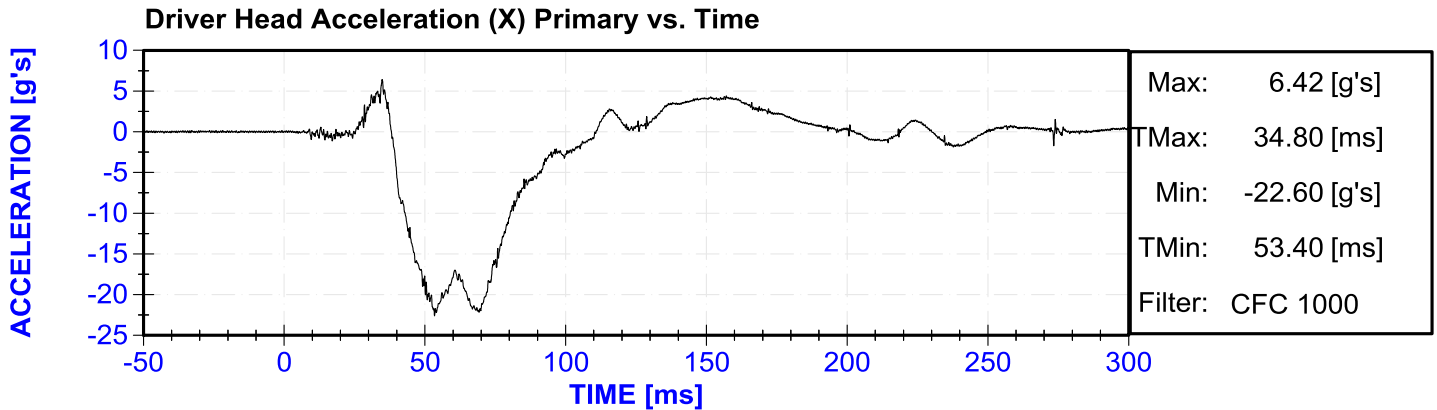

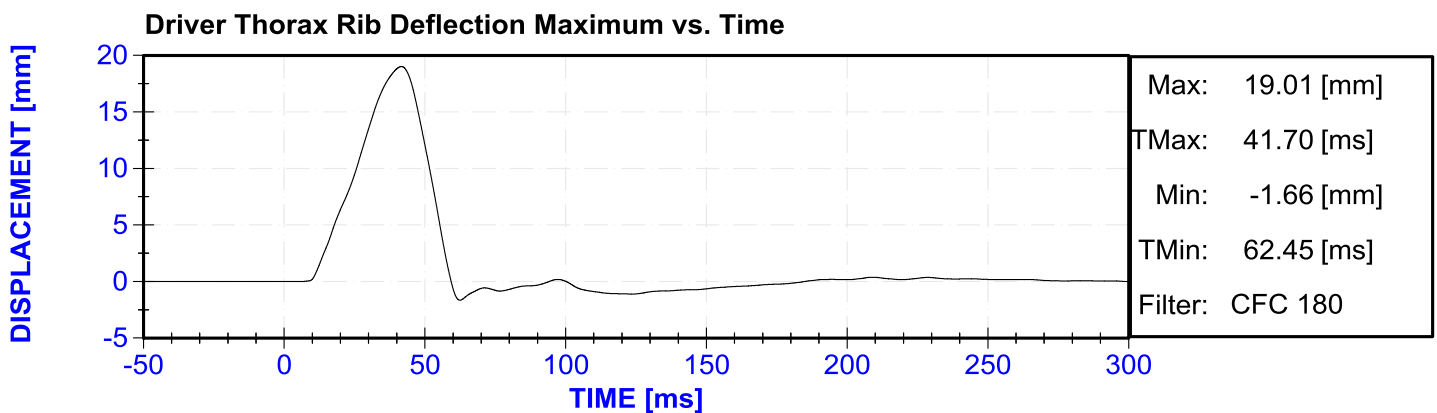
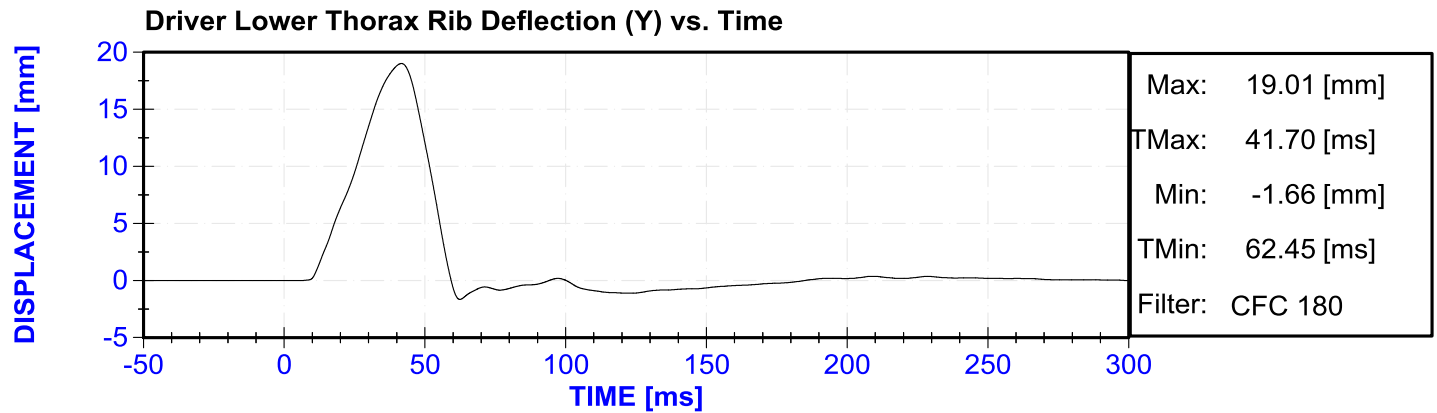
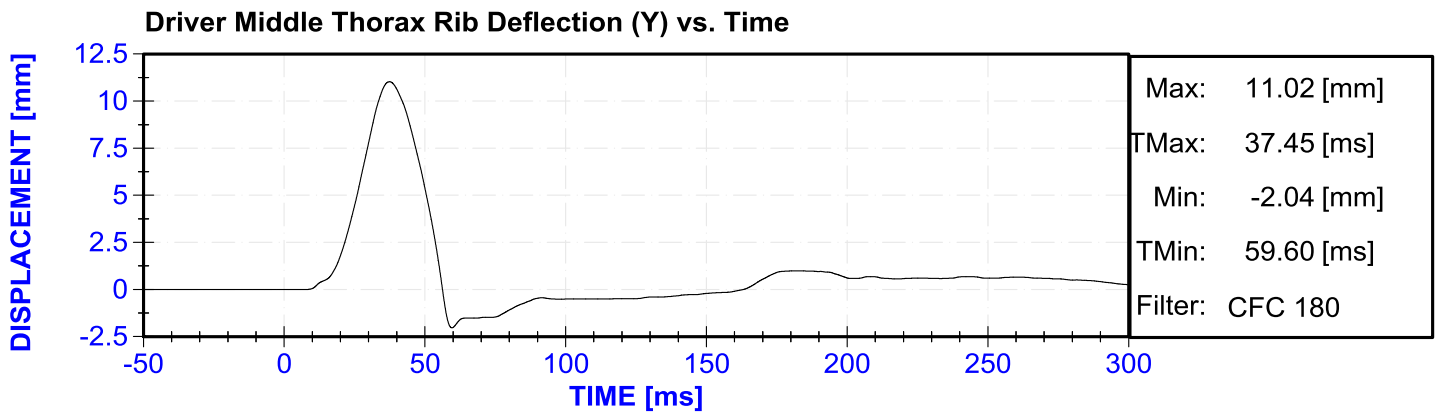
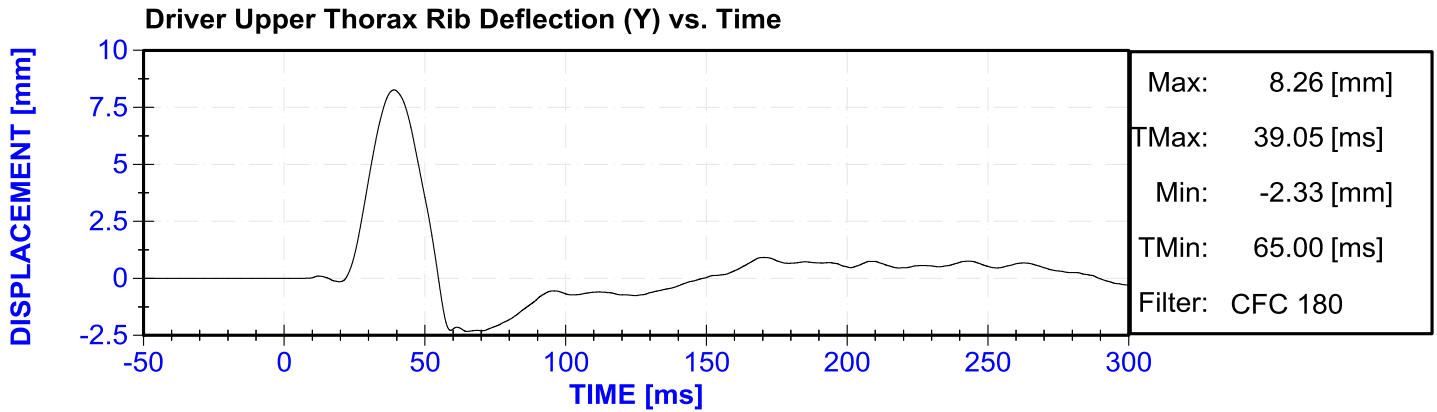

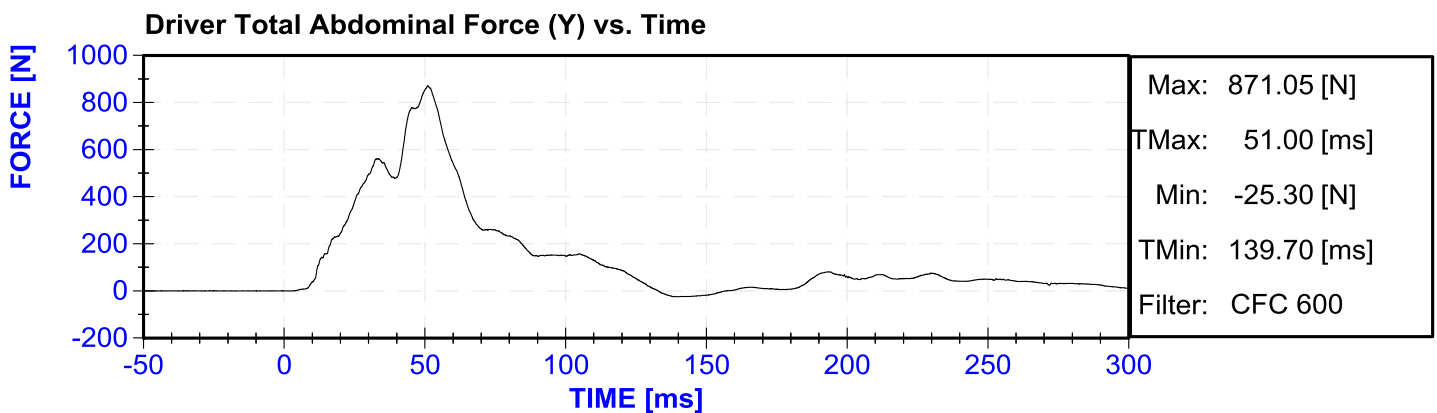
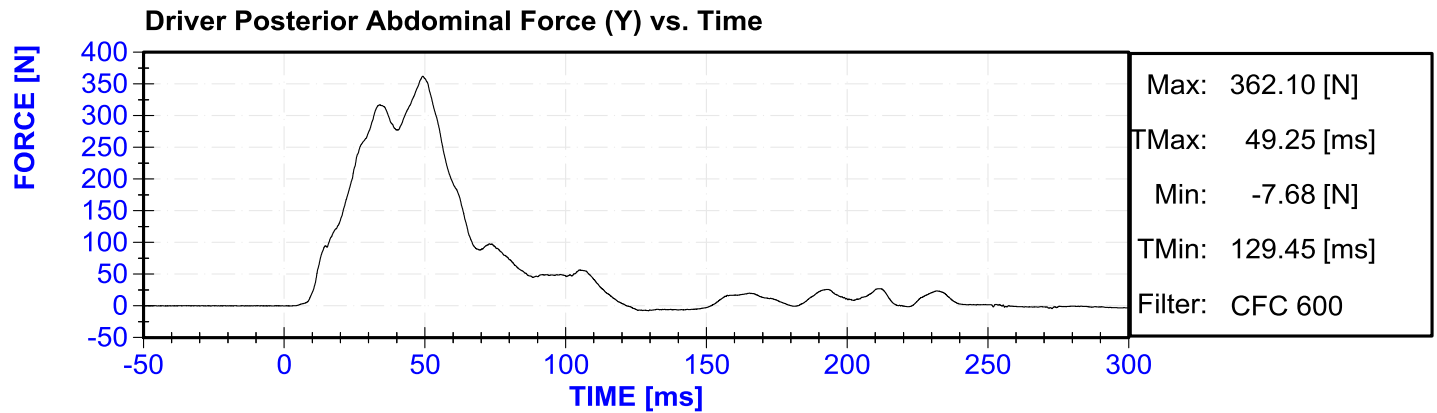
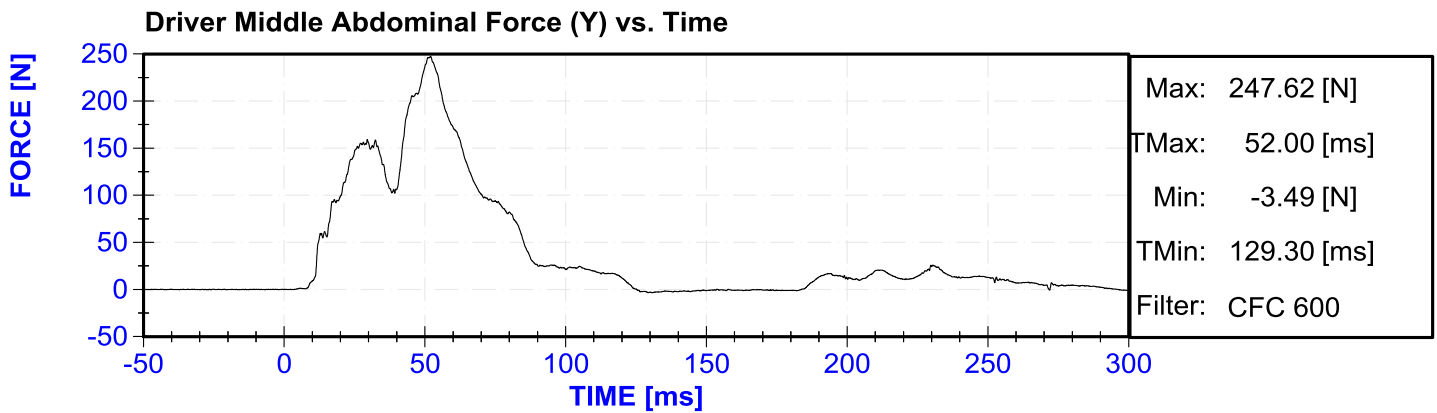
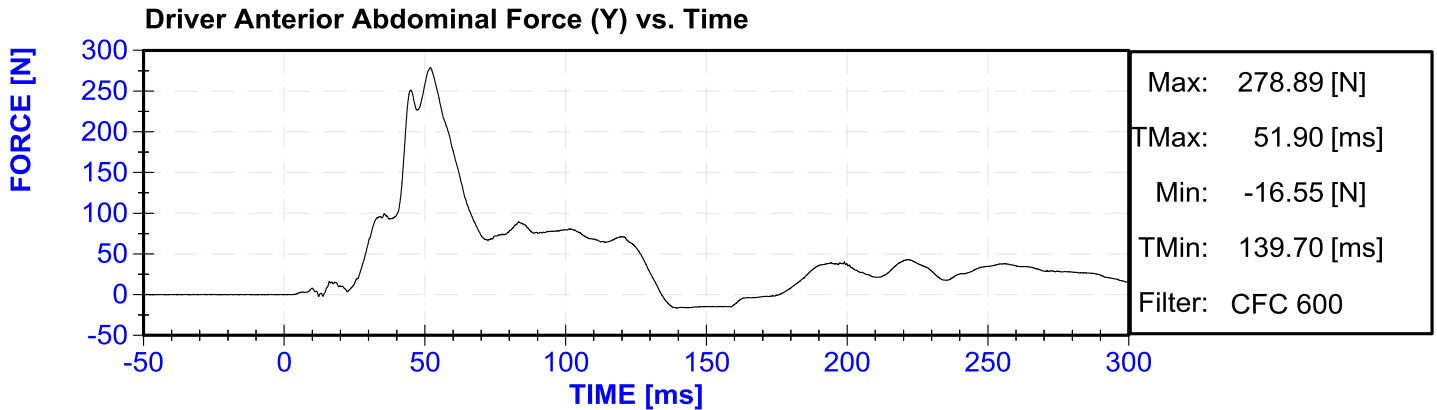

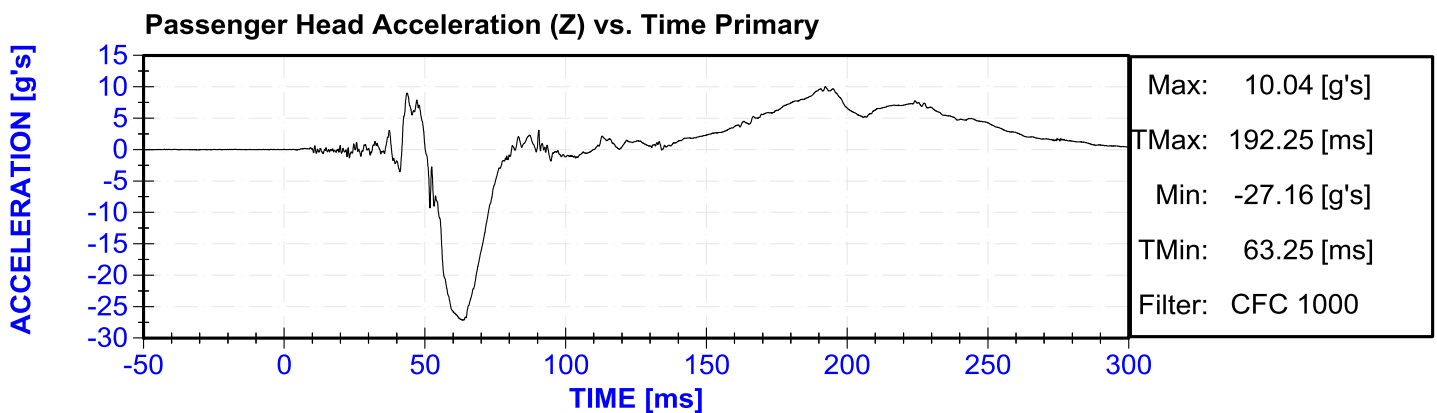
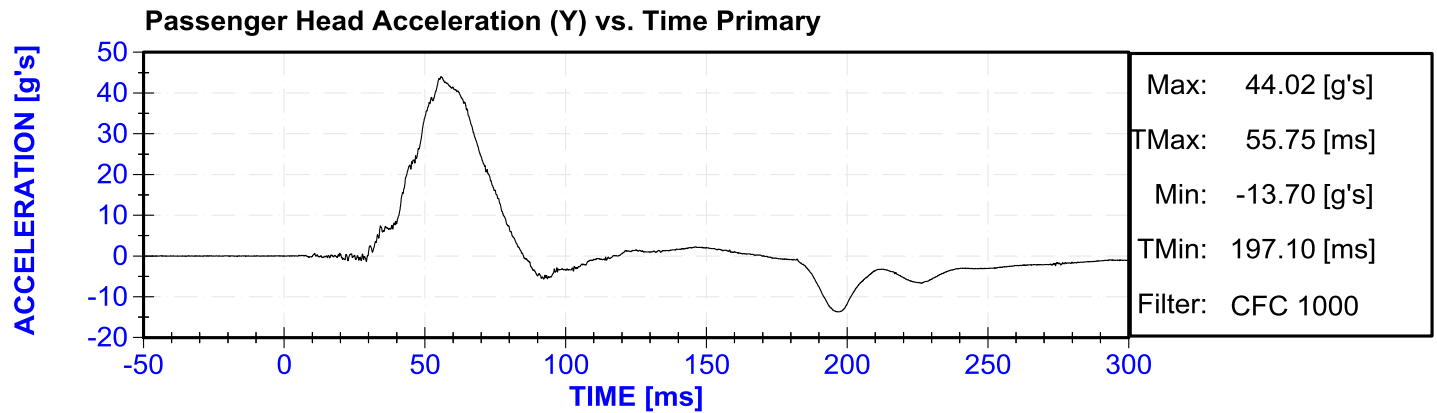
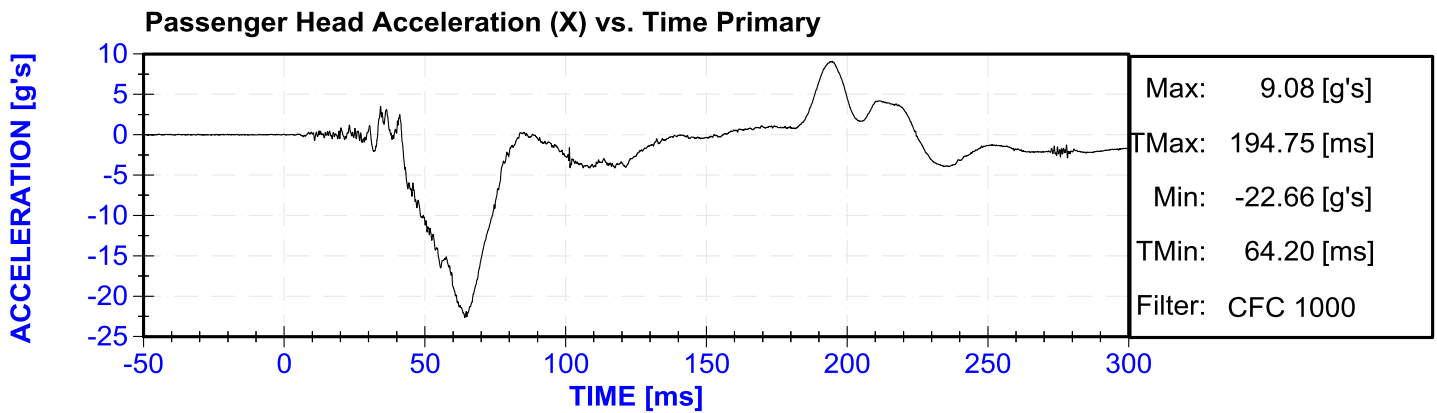
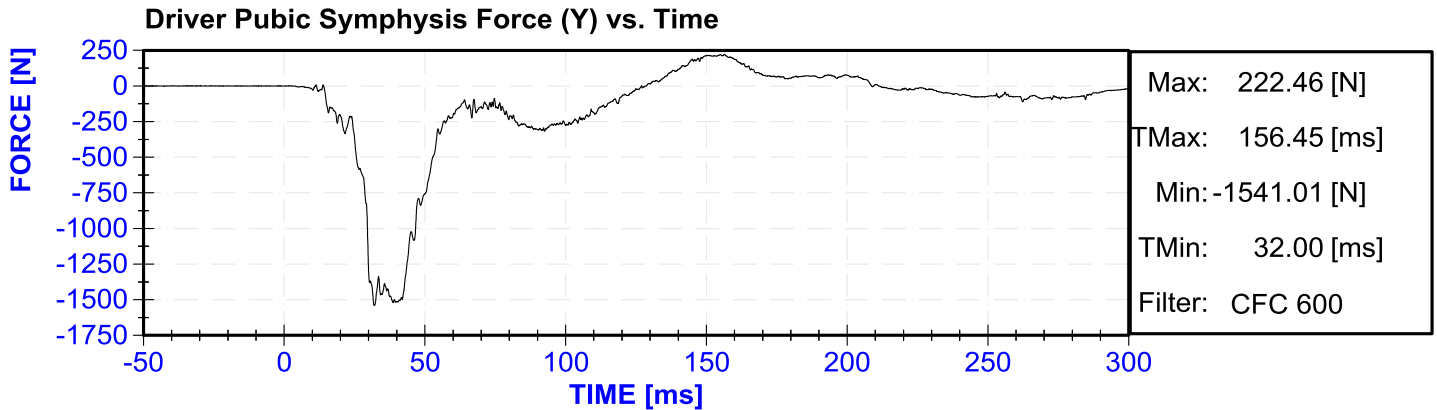

Passenger Head Resultant Acceleration Primary vs. Time

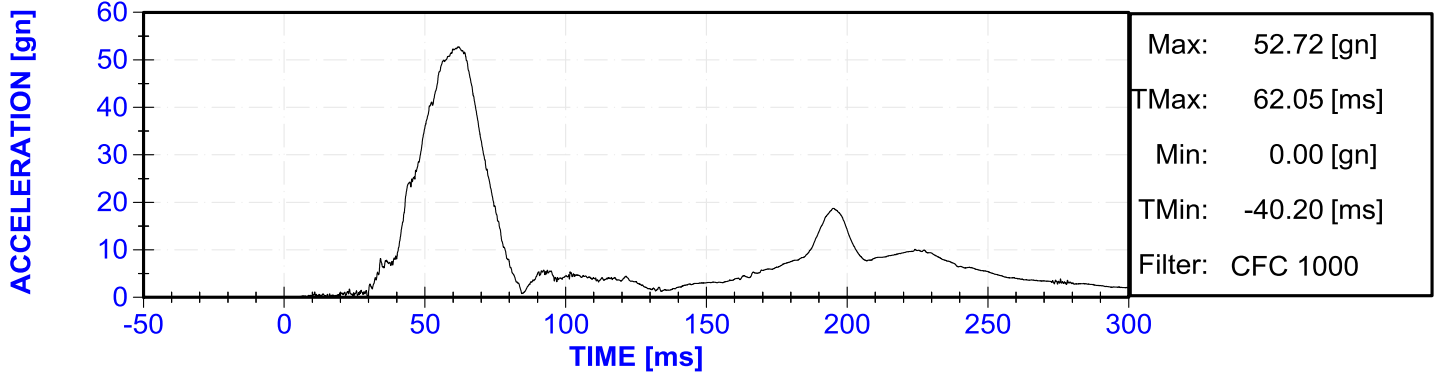

Passenger Lower Spine T12 Acceleration (X) vs. Time

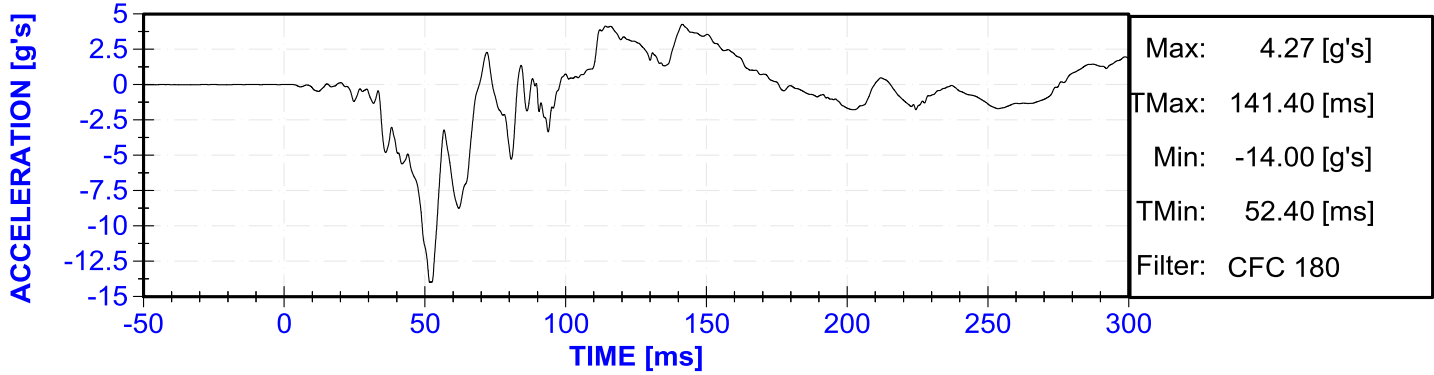

Passenger Lower Spine T12 Acceleration (Y) vs. Time

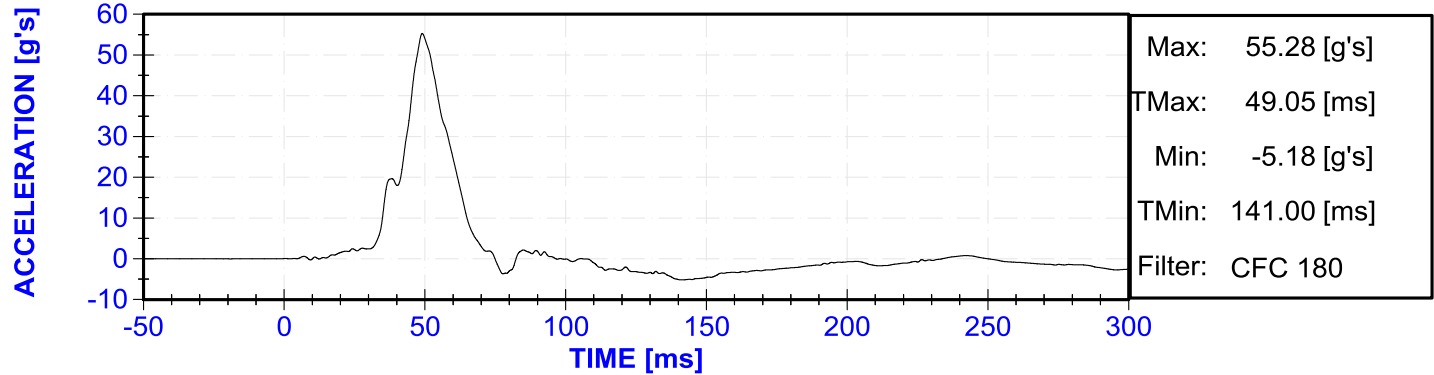

Passenger Lower Spine T12 Acceleration (Z) vs. Time

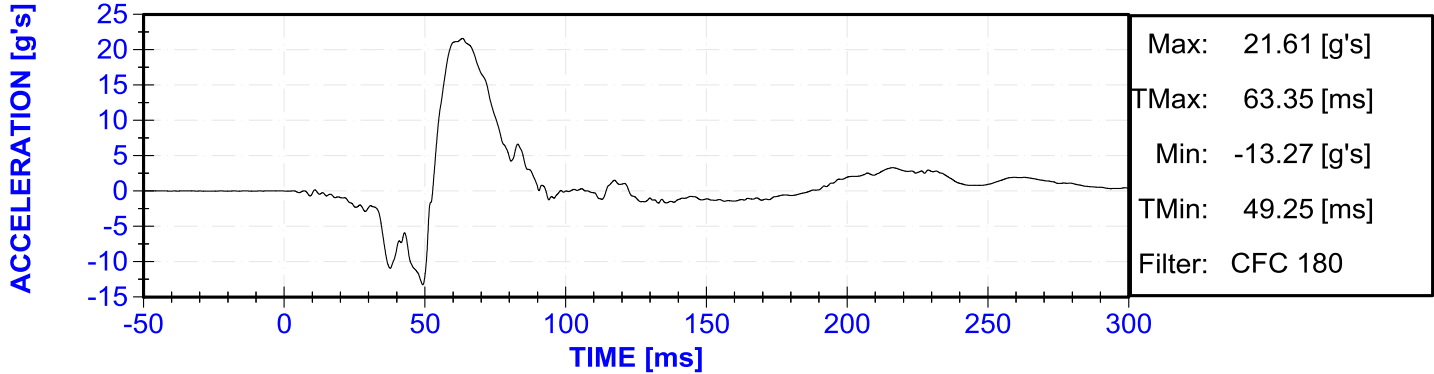

Passenger Lower Spine T12 Resultant Acceleration vs. Time

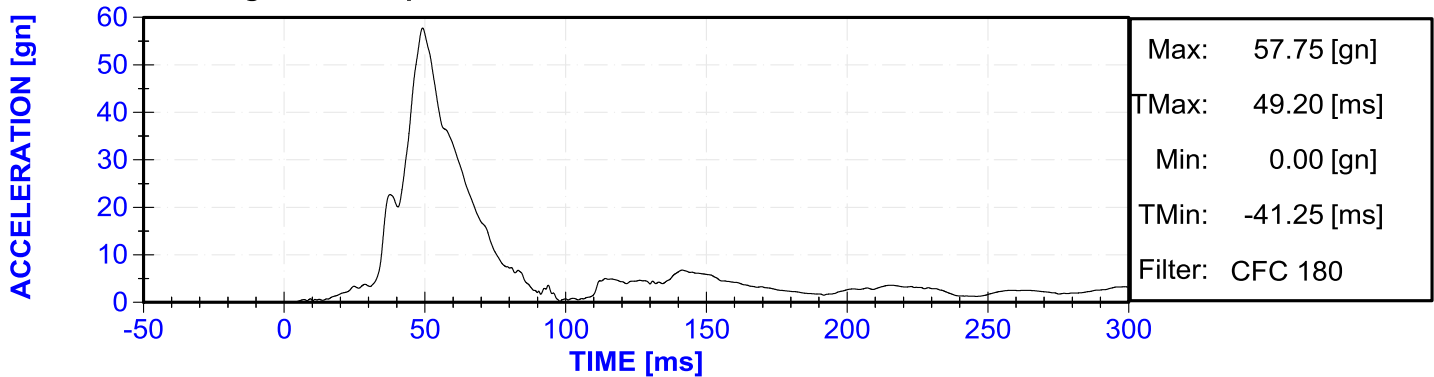

Passenger Iliac Force on Impact Side (Y) vs. Time

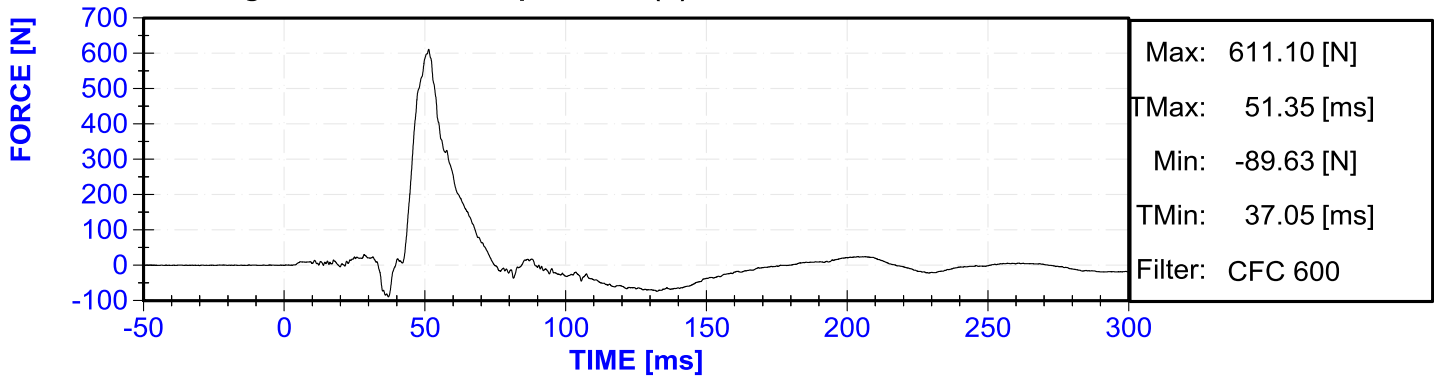

Passenger Acetabulum Force on Impact Side (Y) vs. Time

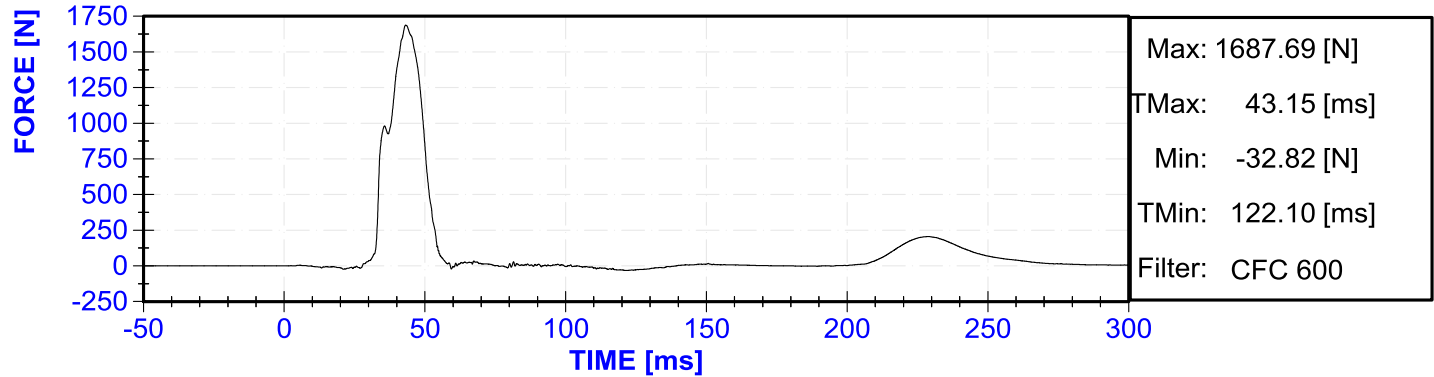

Passenger Total Pelvic Force on Impact Side (Y) vs. Time

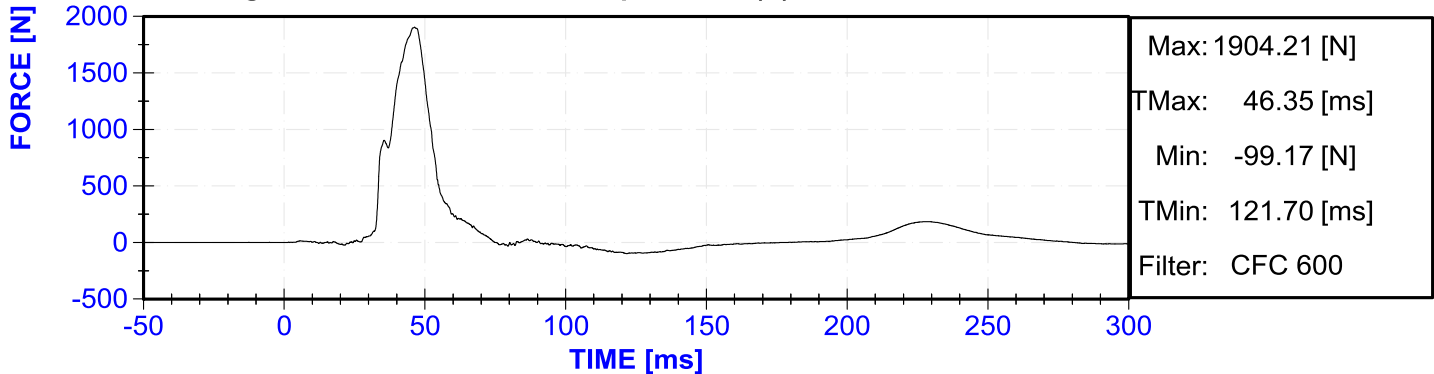

APPENDIX C

DUMMY PERFORMANCE CALIBRATION TEST DATA

CALIBRATION TEST RESULTS

PRE-TEST

EUROSID 2 (ES-2RE) MALE – DRIVER ATD

SERIAL NO: F034

(CONFIGURED FOR LEFT SIDE IMPACT)



External Measurements - EuroSID-2re

Technician: M. Goehle

Date: 10/30/2017

Dummy Serial Number: F034

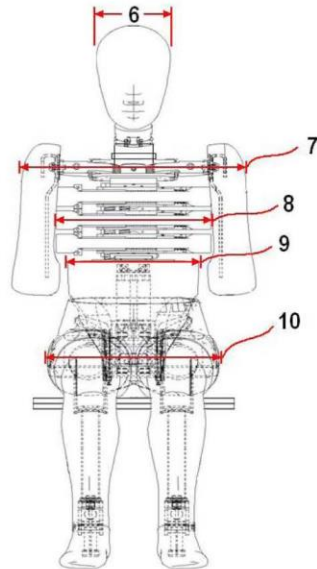

FRONT VIEW

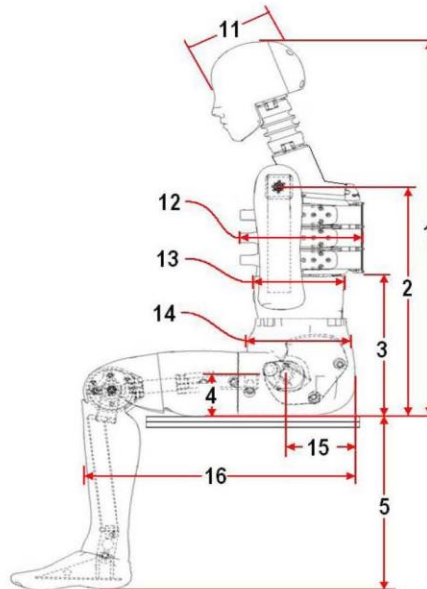

SIDE VIEW

Dim. No.	Description	Specification (mm)		Result (mm)	Pass/Fail
1	Sitting Height	900	918	913	Pass
2	Seat to Shoulder Joint	558	572	565	Pass
3	Seat to Lower Face of Thoracic Spine Box	346	356	350	Pass
4	Seat to Hip Joint (center of bolt)	97	103	100	Pass
5	Sole to Seat, Sitting	333	451	420	Pass
6	Head Width	152	158	154	Pass
7	Shoulder/Arm Width	461	479	469	Pass
8	Thorax Width	322	332	326	Pass
9	Abdomen Width	273	287	282	Pass
10	Pelvis Lap Width	359	373	367	Pass
11	Head Depth	196	206	202	Pass
12	Thorax Depth	262	272	268	Pass
13	Abdomen Depth	194	204	199	Pass
14	Pelvis Depth	235	245	241	Pass
15	Back of Buttocks to Hip Joint (center of bolt)	150	160	154	Pass
16	Back of Buttocks to Front Knee	597	615	600	Pass

ATD Manufacturer	FTSS	Test Technician	K. Brogan
ATD Serial Number	F034	Laboratory Supervisor	M. Goehle

Results

Test Parameter	Minimum Specification	Maximum Specification	Unit	Result	Pass/Fail
Temperature	20.6	22.2	°C	21.1	Pass
Humidity	10	70	%	35.1	Pass
Resultant Acceleration	125	155	g's	131.7	Pass
Oscillation	0	15	%	2.60	Pass
Fore-Aft Acceleration	-15	15	g's	5.0	Pass

Transducer Calibrations

Channel	Manufacturer	Serial Number	Calibration Date	Calibration Due Date
X Accelerometer	ENDEVCO 7264CT	AC-P58904	10/24/2017	4/24/2018
Y Accelerometer	ENDEVCO 7264CT	AC-P58911	10/24/2017	4/24/2018
Z Accelerometer	ENDEVCO 7264CT	AC-P58776	10/24/2017	4/24/2018

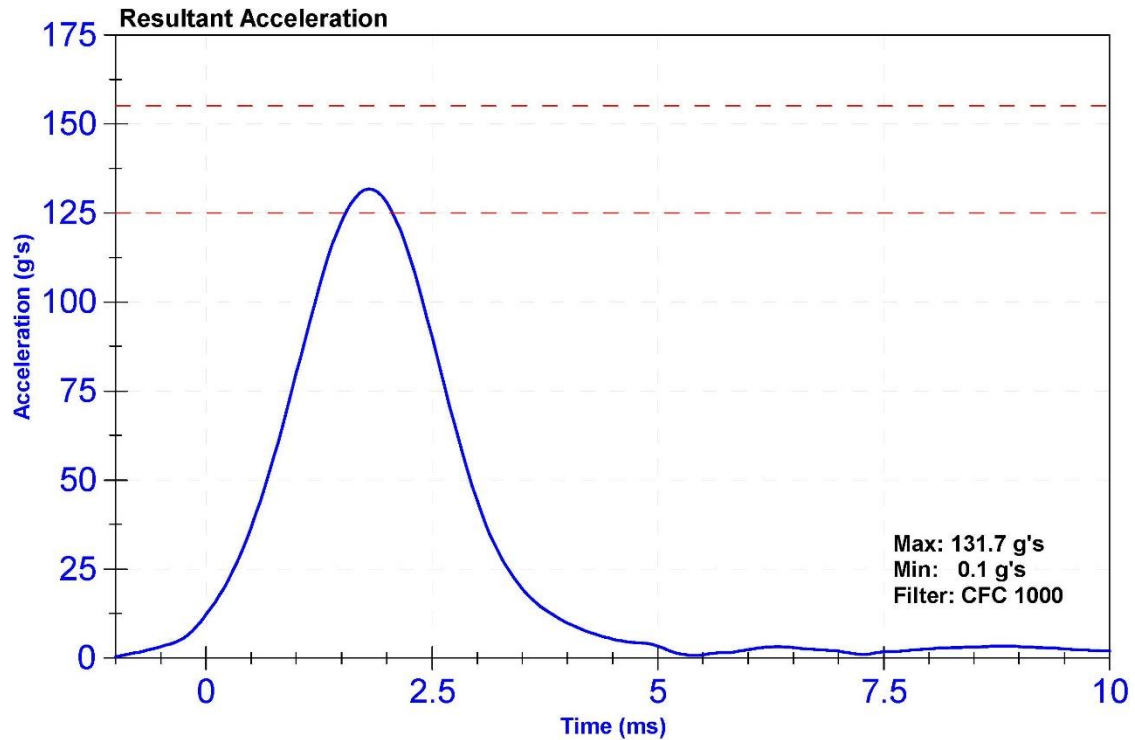

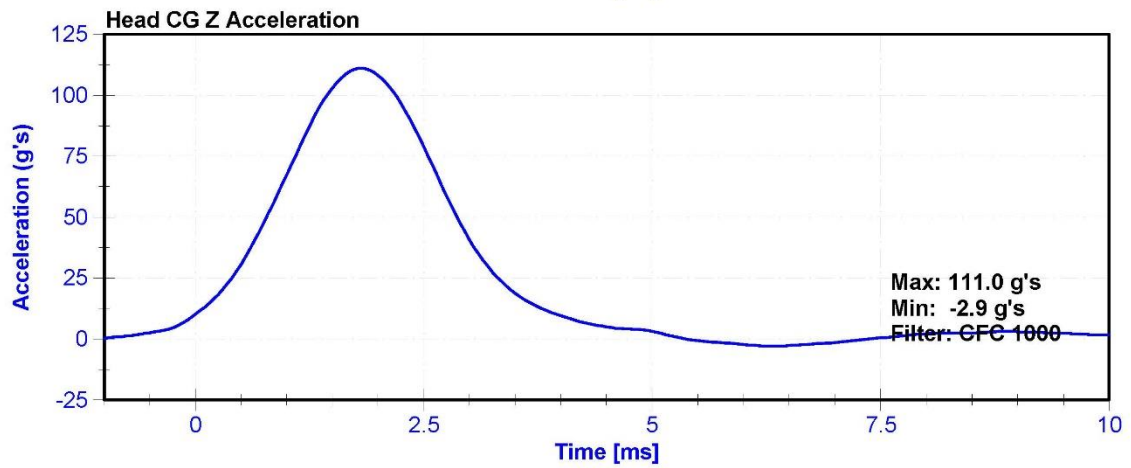
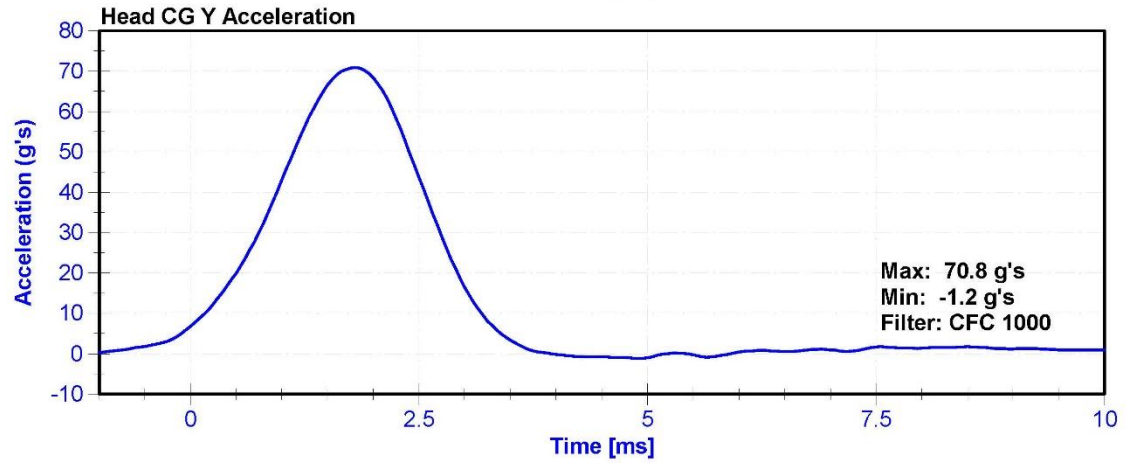
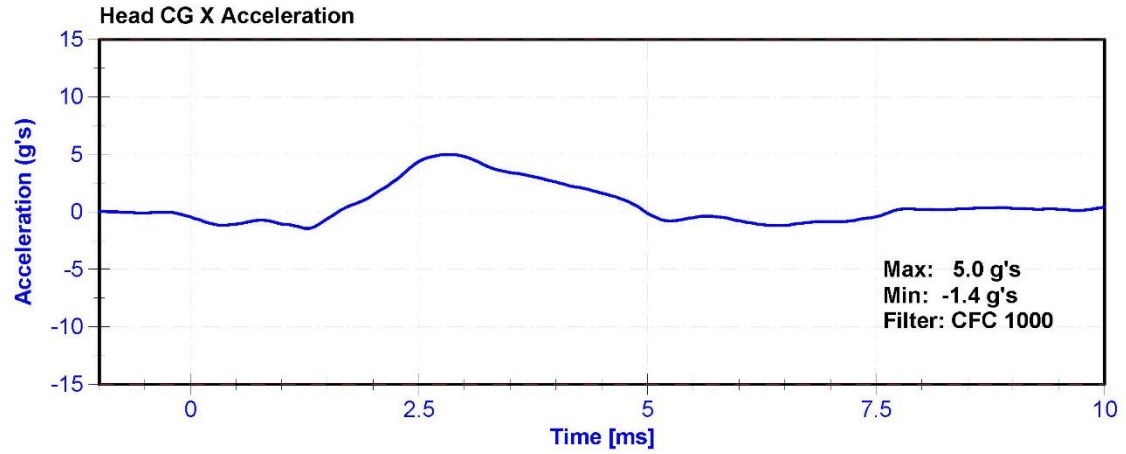

ATD Manufacturer	FTSS	Test Technician	K. Brogan
ATD Serial Number	F034	Laboratory Supervisor	M. Goehle

Results

Test Parameter	Minimum Specification	Maximum Specification	Unit	Result	Pass/Fail
Temperature	20.6	22.2	°C	20.9	Pass
Humidity	10	70	%	35.1	Pass
Velocity	3.3	3.5	m/s	3.40	Pass
Lateral Neck Rotation	49	59	deg	53.9	Pass
Time at Maximum Rotation	54	66	ms	59.1	Pass
Time of Rotation Decay from Maximum	53	88	ms	56.9	Pass

Transducer Calibrations

Channel	Manufacturer	Serial Number	Calibration Date	Calibration Due Date
Pendulum Accelerometer	ENDEVCO 7231CT	AC-AH5F3	5/11/2017	5/11/2018
Front Pendulum Potentiometer	SP22G	DS-094	10/30/2017	10/30/2018
Headform Potentiometer	SP22G	DS-095	10/30/2017	10/30/2018

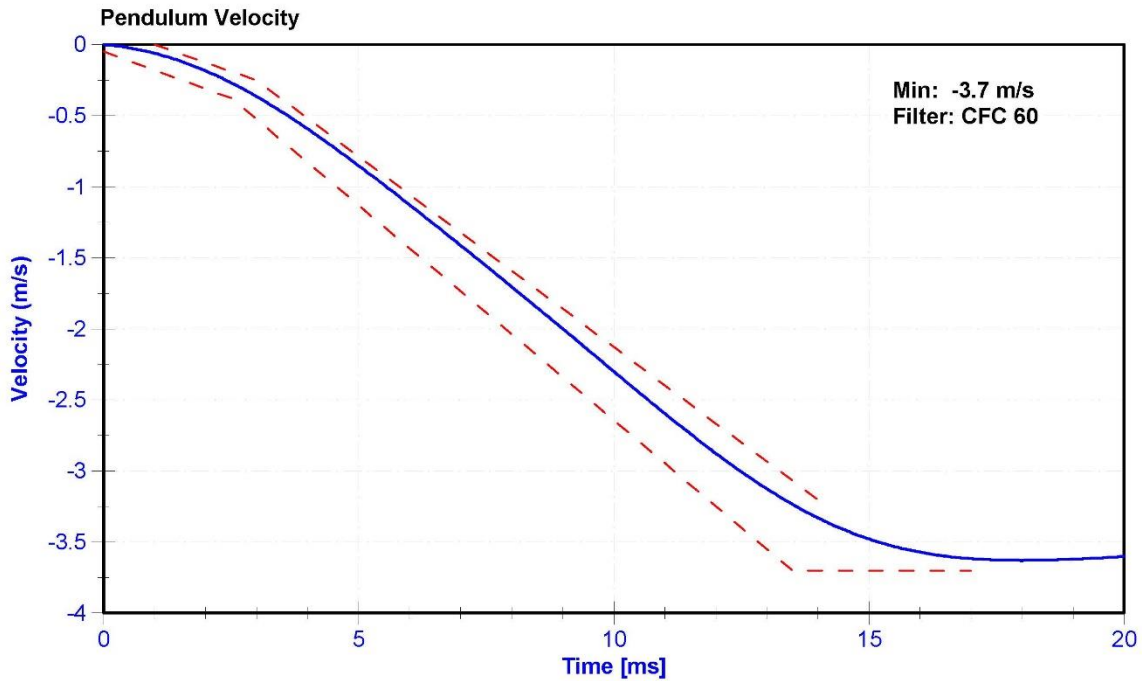

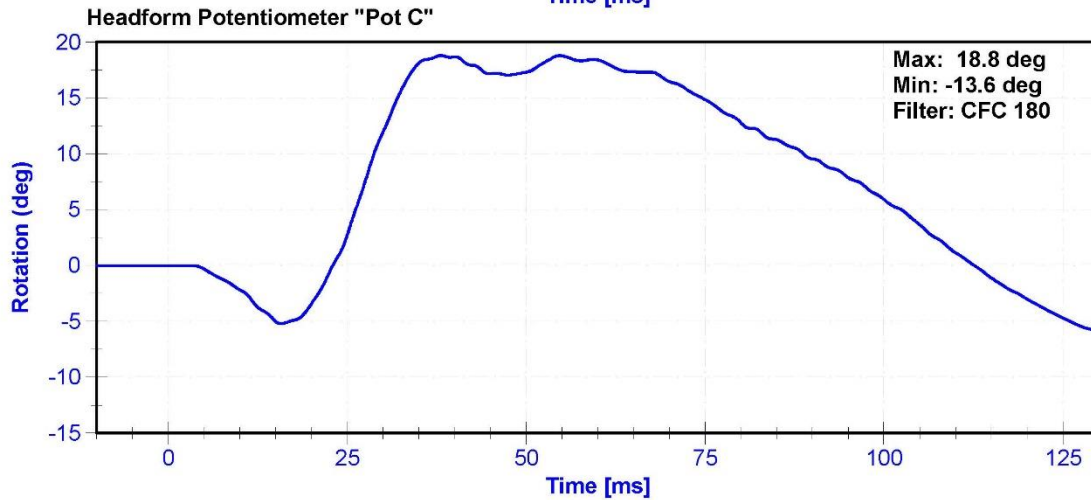
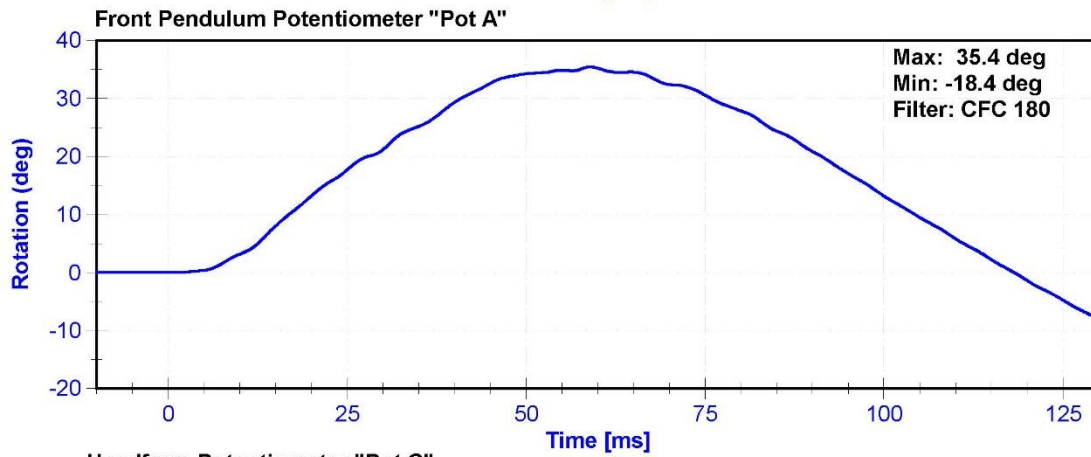
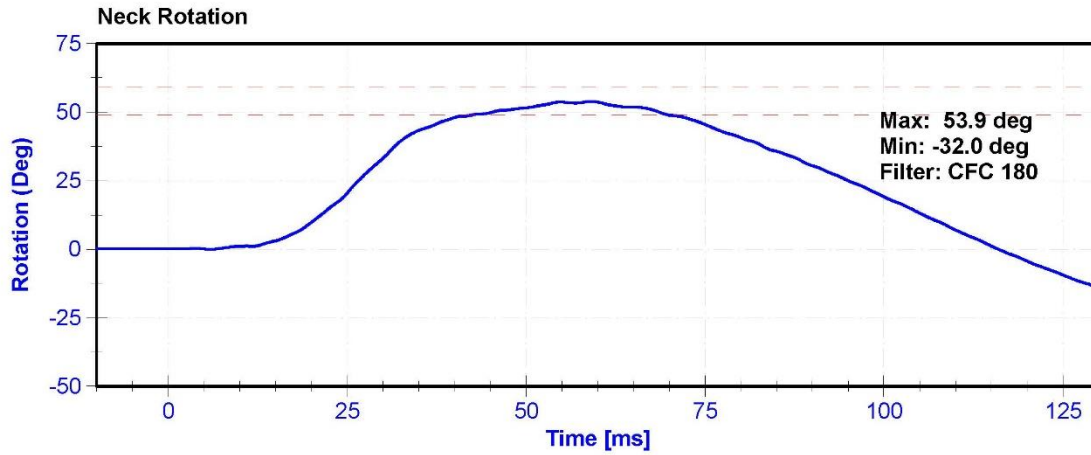

ATD Manufacturer	FTSS	Test Technician	K. Brogan
ATD Serial Number	F034	Laboratory Supervisor	M. Goehle

Results

Test Parameter	Minimum Specification	Maximum Specification	Unit	Result	Pass/Fail
Temperature	20.6	22.2	°C	21.7	Pass
Humidity	10	70	%	34.4	Pass
Velocity	4.2	4.4	m/s	4.21	Pass
Probe Acceleration	7.5	10.5	g's	9.82	Pass

Transducer Calibrations

Channel	Manufacturer	Serial Number	Calibration Date	Calibration Due Date
Probe Accelerometer	ENDEVCO 7264CT	AC-P32453	10/17/2017	4/17/2018

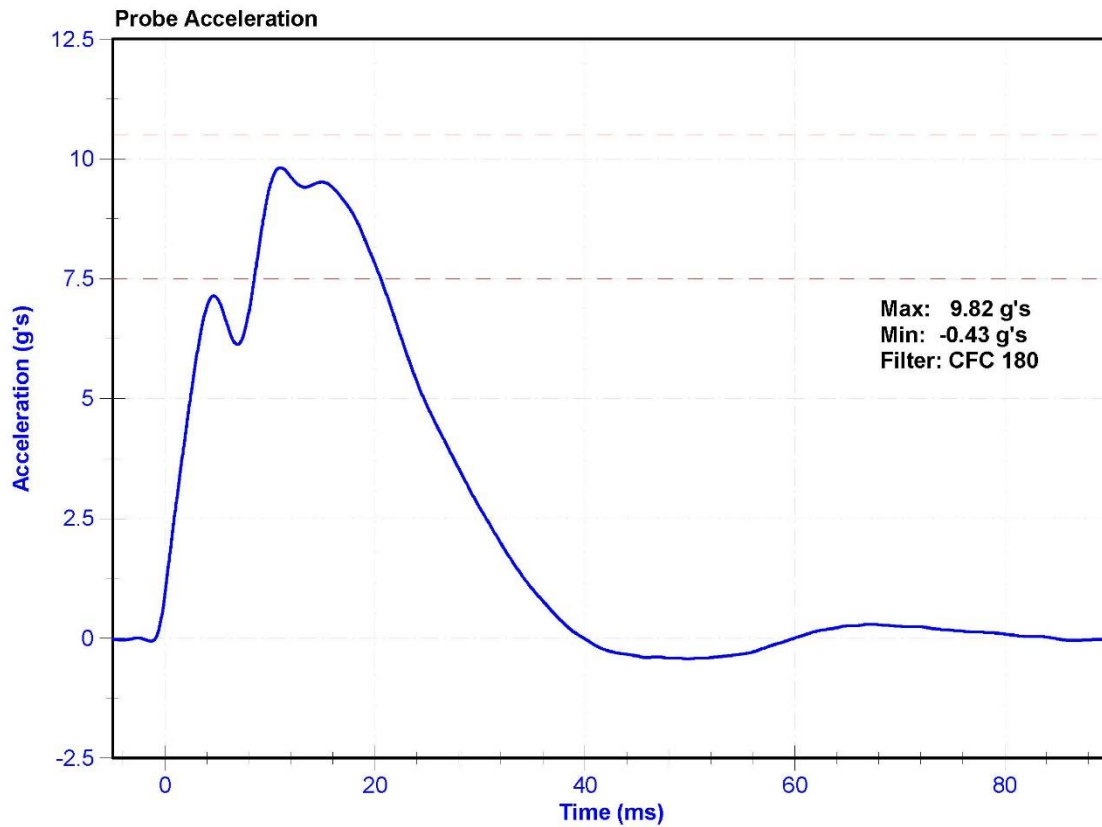

ATD Manufacturer	FTSS	Test Technician	S. Keller
ATD Serial Number	F034	Laboratory Supervisor	M. Goehle

Results

Test Parameter	Minimum Specification	Maximum Specification	Unit	Result	Pass/Fail
Temperature	20.6	22.2	°C	21.4	Pass
Humidity	10	70	%	40.5	Pass
Rib Displacement	36	40	mm	36.6	Pass

Transducer Calibrations

Channel	Manufacturer	Serial Number	Calibration Date	Calibration Due Date
Rib Potentiometer	Honeywell MLT-38000203	DS-183GFE	9/27/2017	9/27/2018

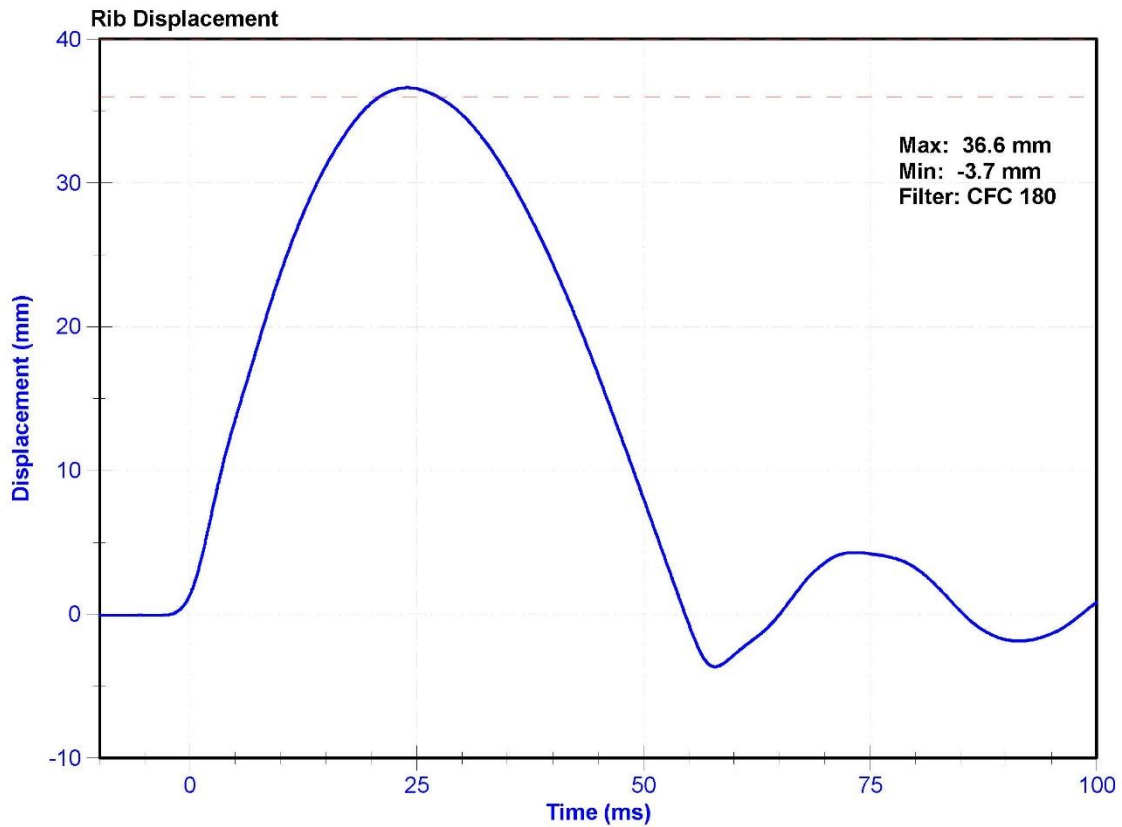

ATD Manufacturer	FTSS	Test Technician	S. Keller
ATD Serial Number	F034	Laboratory Supervisor	M. Goehle

Results

Test Parameter	Minimum Specification	Maximum Specification	Unit	Result	Pass/Fail
Temperature	20.6	22.2	°C	21.4	Pass
Humidity	10	70	%	40.5	Pass
Rib Displacement	46	51	mm	47.3	Pass

Transducer Calibrations

Channel	Manufacturer	Serial Number	Calibration Date	Calibration Due Date
Rib Potentiometer	Honeywell MLT-38000203	DS-183GFE	9/27/2017	9/27/2018

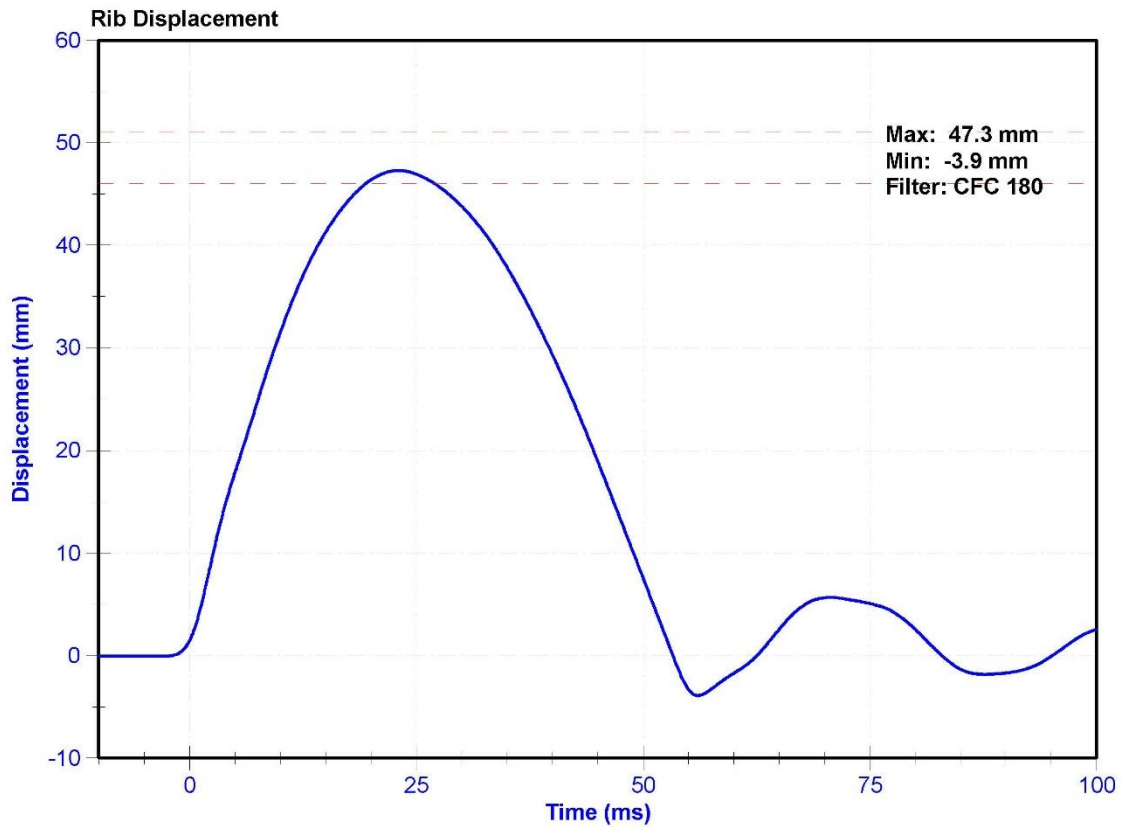

ATD Manufacturer	FTSS	Test Technician	K. Brogan
ATD Serial Number	F034	Laboratory Supervisor	M. Goehle

Results

Test Parameter	Minimum Specification	Maximum Specification	Unit	Result	Pass/Fail
Temperature	20.6	22.2	°C	22.0	Pass
Humidity	10	70	%	37.9	Pass
Rib Displacement	36	40	mm	37.5	Pass

Transducer Calibrations

Channel	Manufacturer	Serial Number	Calibration Date	Calibration Due Date
Rib Potentiometer	Honeywell MLT-38000203	DS-184GFE	9/27/2017	9/27/2018

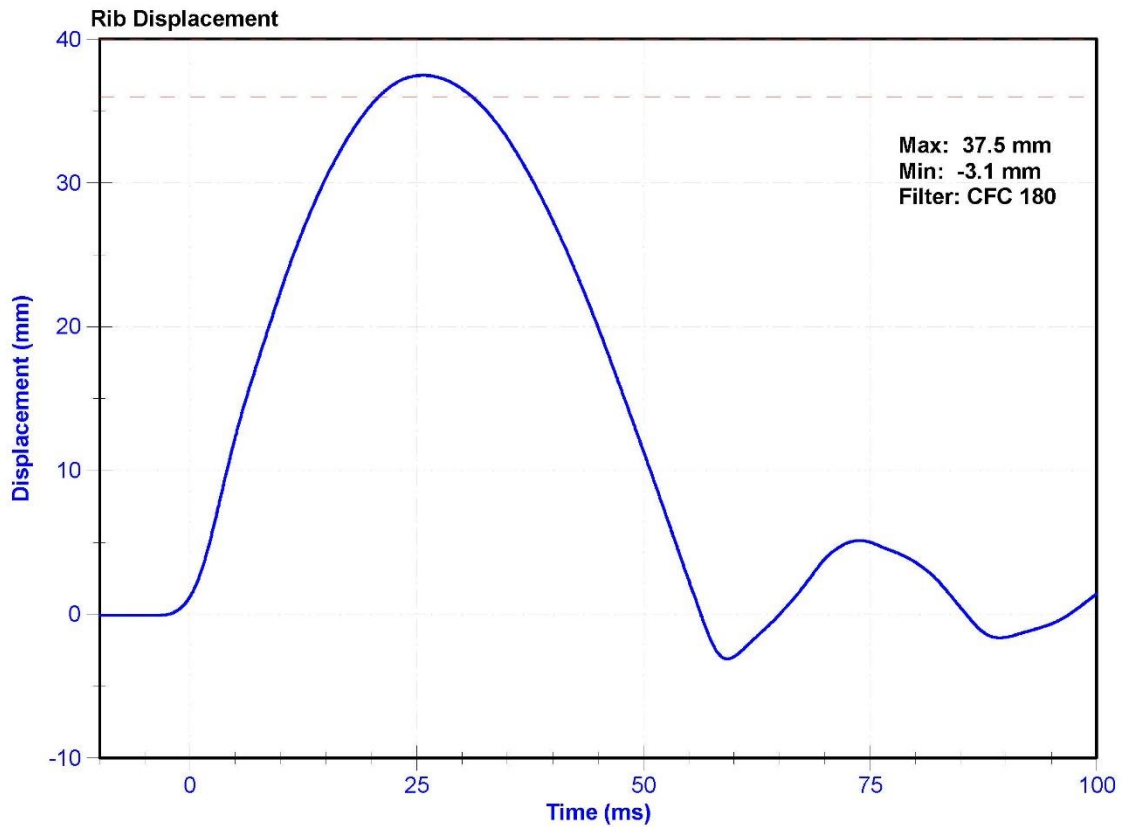

ATD Manufacturer	FTSS	Test Technician	K. Brogan
ATD Serial Number	F034	Laboratory Supervisor	M. Goehle

Results

Test Parameter	Minimum Specification	Maximum Specification	Unit	Result	Pass/Fail
Temperature	20.6	22.2	°C	22.0	Pass
Humidity	10	70	%	37.9	Pass
Rib Displacement	46	51	mm	48.1	Pass

Transducer Calibrations

Channel	Manufacturer	Serial Number	Calibration Date	Calibration Due Date
Rib Potentiometer	Honeywell MLT-38000203	DS-184GFE	9/27/2017	9/27/2018

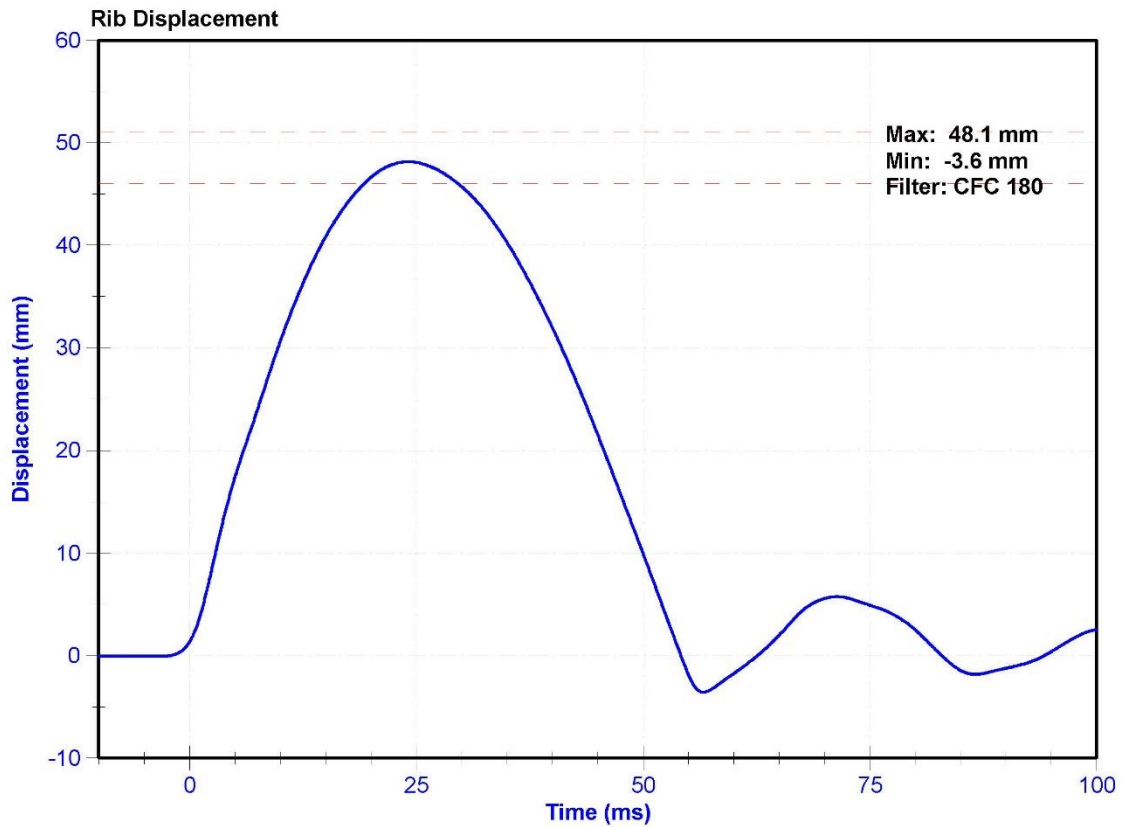

ATD Manufacturer	FTSS	Test Technician	K. Brogan
ATD Serial Number	F034	Laboratory Supervisor	M. Goehle

Results

Test Parameter	Minimum Specification	Maximum Specification	Unit	Result	Pass/Fail
Temperature	20.6	22.2	°C	21.9	Pass
Humidity	10	70	%	33.6	Pass
Rib Displacement	36	40	mm	38.3	Pass

Transducer Calibrations

Channel	Manufacturer	Serial Number	Calibration Date	Calibration Due Date
Rib Potentiometer	Honeywell MLT-38000203	DS-182GFE	9/27/2017	9/27/2018

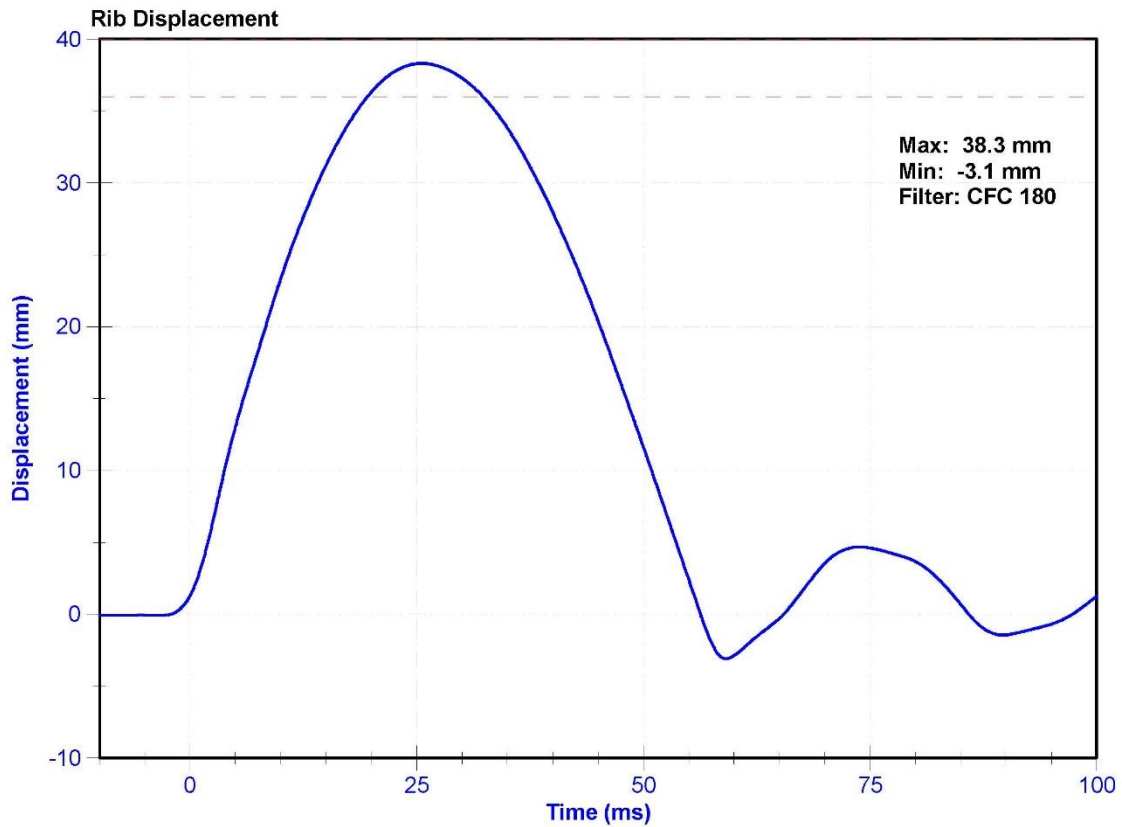

ATD Manufacturer	FTSS	Test Technician	K. Brogan
ATD Serial Number	F034	Laboratory Supervisor	M. Goehle

Results

Test Parameter	Minimum Specification	Maximum Specification	Unit	Result	Pass/Fail
Temperature	20.6	22.2	°C	21.9	Pass
Humidity	10	70	%	33.6	Pass
Rib Displacement	46	51	mm	49.1	Pass

Transducer Calibrations

Channel	Manufacturer	Serial Number	Calibration Date	Calibration Due Date
Rib Potentiometer	Honeywell MLT-38000203	DS-182GFE	9/27/2017	9/27/2018

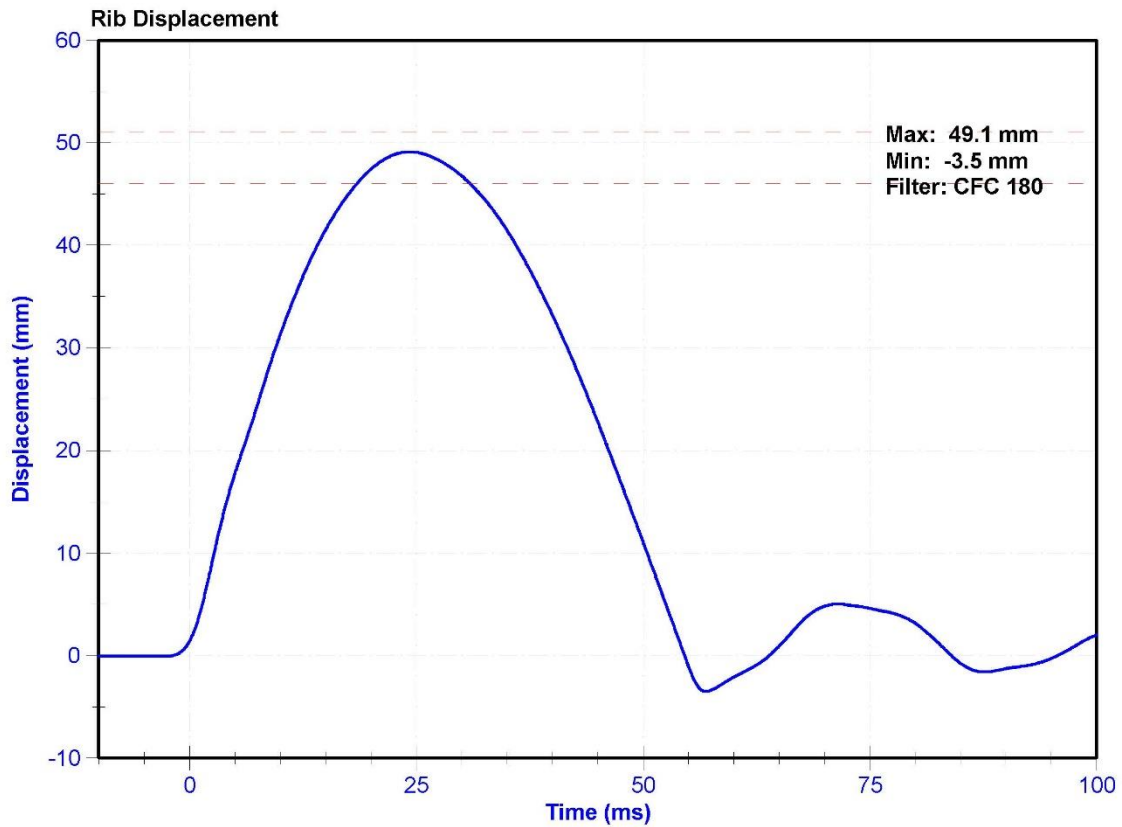

ATD Manufacturer	FTSS	Test Technician	K. Brogan
ATD Serial Number	F034	Laboratory Supervisor	M. Goehle

Results

Test Parameter	Minimum Specification	Maximum Specification	Unit	Result	Pass/Fail
Temperature	20.6	22.2	°C	21.4	Pass
Humidity	10	70	%	35.4	Pass
Velocity	5.4	5.6	m/s	5.56	Pass
Resistive Force after 6ms	5100	6200	N	5381.8	Pass
Upper Thorax Rib Deflection	34	41	mm	36.8	Pass
Mid Thorax Rib Deflection	37	45	mm	41.5	Pass
Lower Thorax Rib Deflection	37	44	mm	41.9	Pass

Transducer Calibrations

Channel	Manufacturer	Serial Number	Calibration Date	Calibration Due Date
Probe Accelerometer	ENDEVCO 7264CT	AC-P32453	10/17/2017	4/17/2018
Upper Thorax Rib Potentiometer	Honeywell MLT-38000203	DS-183GFE	9/27/2017	9/27/2018
Middle Thorax Rib Potentiometer	Honeywell MLT-38000203	DS-184GFE	9/27/2017	9/27/2018
Lower Thorax Rib Potentiometer	Honeywell MLT-38000203	DS-182GFE	9/27/2017	9/27/2018

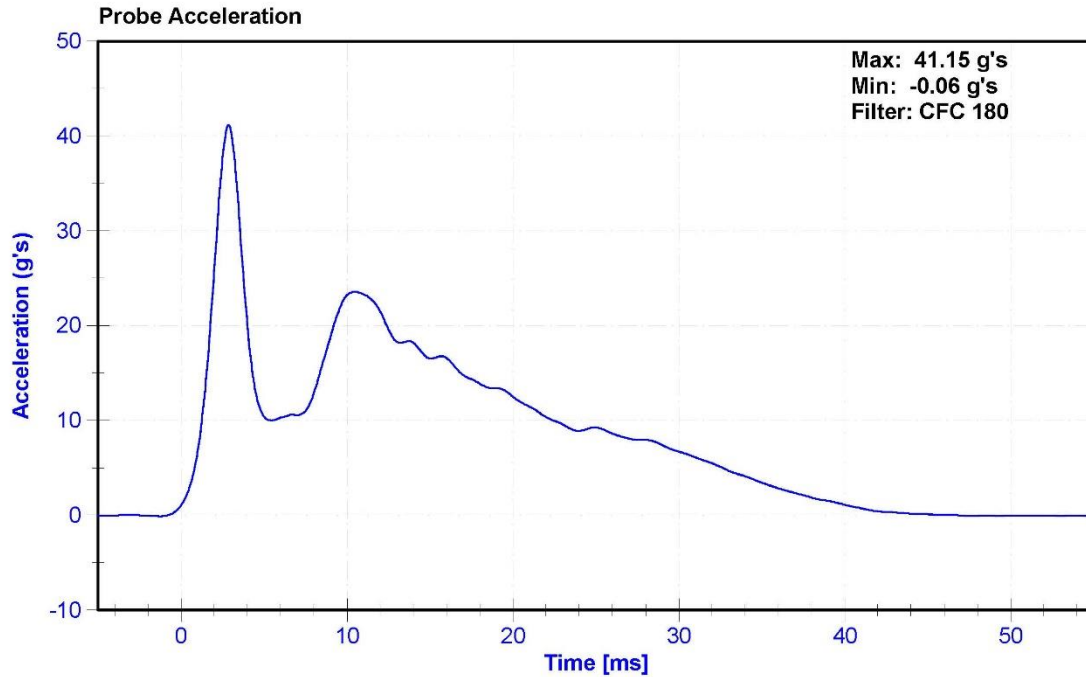

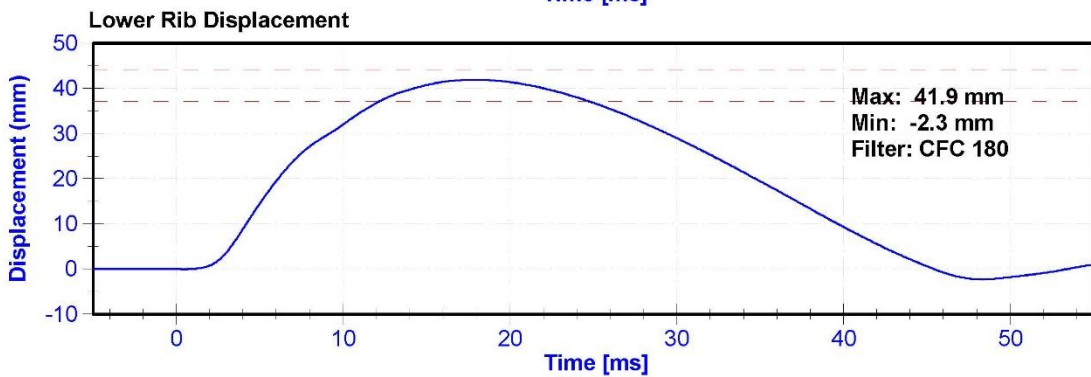
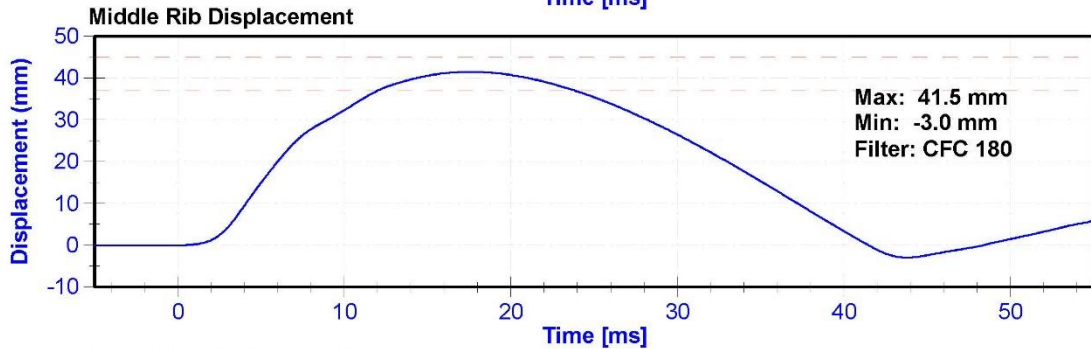
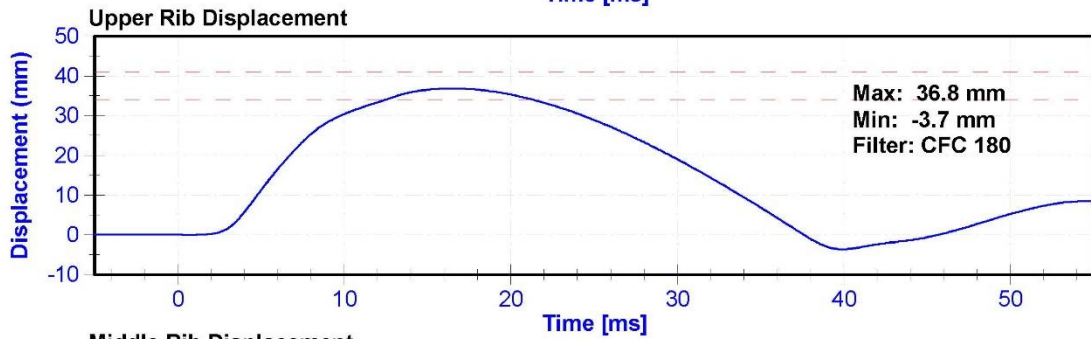
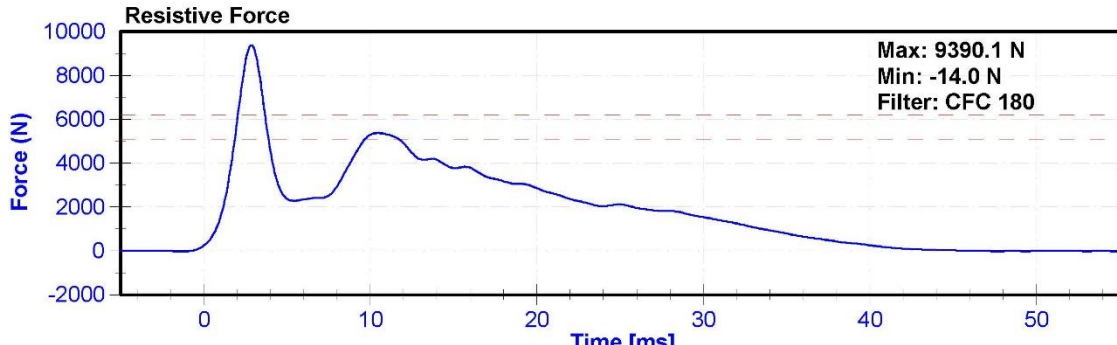

ATD Manufacturer	FTSS	Test Technician	K. Brogan
ATD Serial Number	F034	Laboratory Supervisor	M. Goehle

Results

Test Parameter	Minimum Specification	Maximum Specification	Unit	Result	Pass/Fail
Temperature	20.6	22.2	°C	21.5	Pass
Humidity	10	70	%	36.1	Pass
Velocity	3.9	4.1	m/s	4.06	Pass
Combined Abdomen Force	2200	2700	N	2426.2	Pass
Time at Peak Abdomen Force	10.0	12.3	ms	10.65	Pass
Resistive Probe Force	4000	4800	N	4319.3	Pass
Time at Peak Resistive Force	10.6	13.0	ms	11.35	Pass

Transducer Calibrations

Channel	Manufacturer	Serial Number	Calibration Date	Calibration Due Date
Pendulum Accelerometer	ENDEVCO 7264CT	AC-P32453	10/17/2017	4/17/2018
Front Abdomen Load Cell	DENTON 2631	LC-1512	6/5/2017	6/5/2018
Middle Abdomen Load Cell	DENTON 2631	LC-1526	6/5/2017	6/5/2018
Rear Abdomen Load Cell	DENTON 2631	LC-1516	6/5/2017	6/5/2018

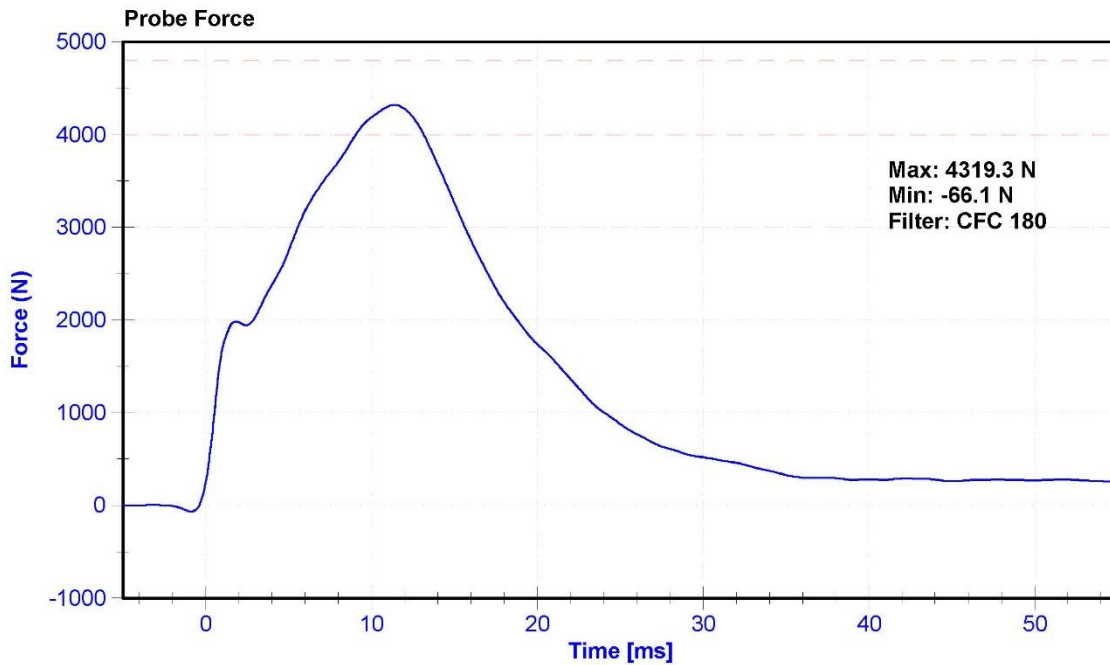

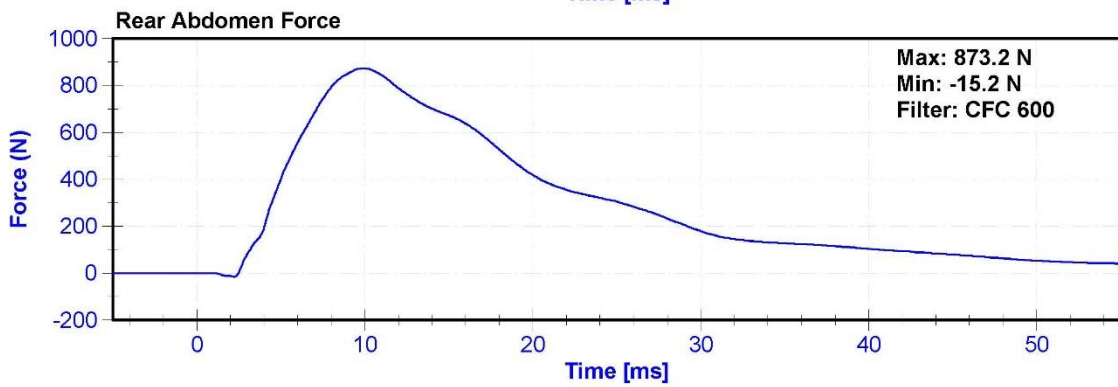
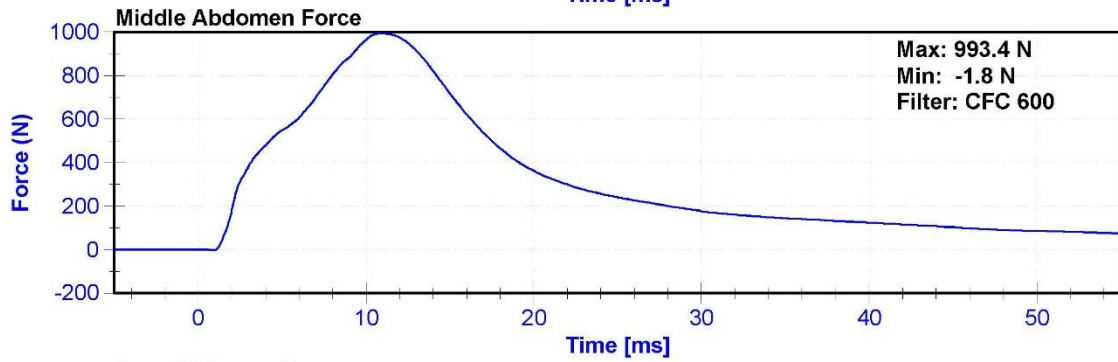
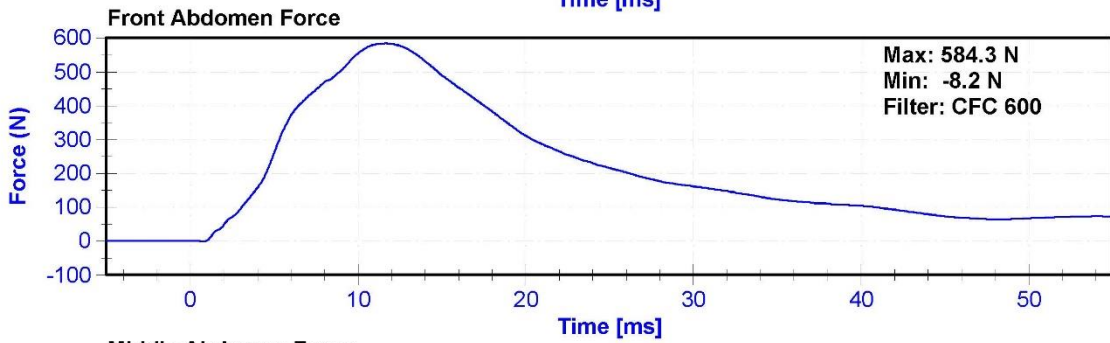
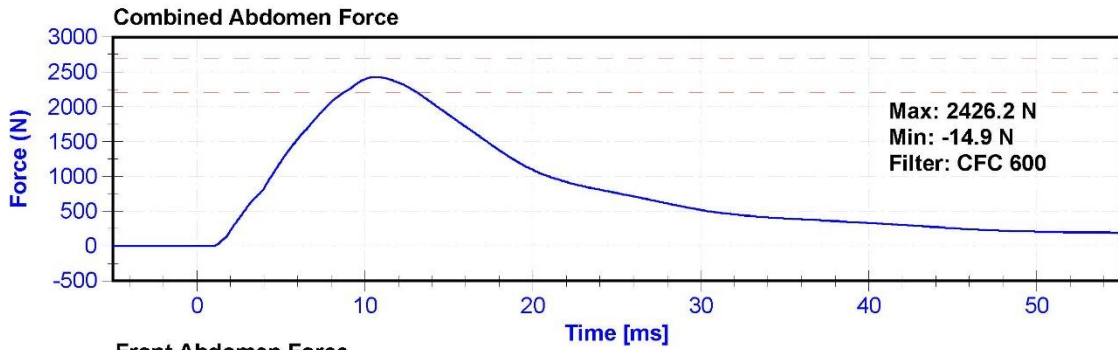

ATD Manufacturer	FTSS	Test Technician	K. Brogan
ATD Serial Number	F034	Laboratory Supervisor	M. Goehle

Results

Test Parameter	Minimum Specification	Maximum Specification	Unit	Result	Pass/Fail
Temperature	20.6	22.2	°C	21.0	Pass
Humidity	10	70	%	34.6	Pass
Velocity	5.95	6.15	m/s	6.113	Pass
Lateral Spine Rotation	45	55	deg	45.6	Pass
Time at Maximum Rotation	39	53	ms	43.4	Pass
Time of Decay to Zero Degrees	37	57	ms	37.1	Pass
Pulse within Corridor?	-	-	-		

Transducer Calibrations

Channel	Manufacturer	Serial Number	Calibration Date	Calibration Due Date
Pendulum Accelerometer	ENDEVCO 7231CT	AC-AH5F3	5/11/2017	5/11/2018
Pendulum "A" Potentiometer	SP22G	DS-094	10/30/2017	10/30/2018
Condyle "B" Potentiometer	SP22G	DS-095	10/30/2017	10/30/2018

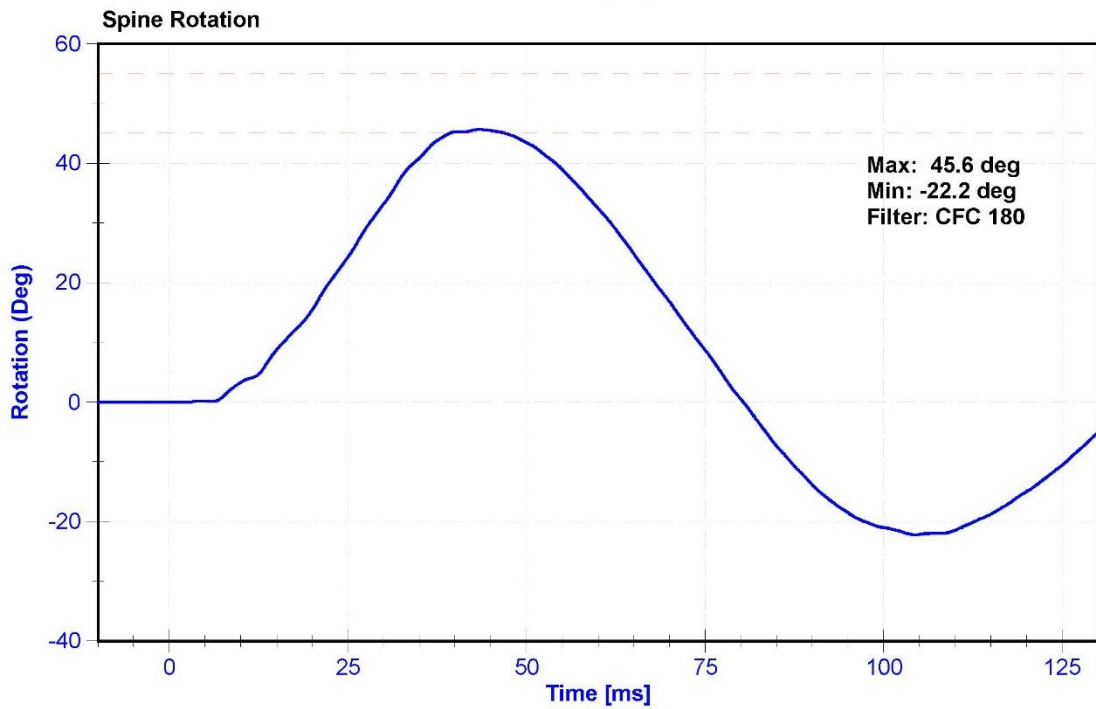
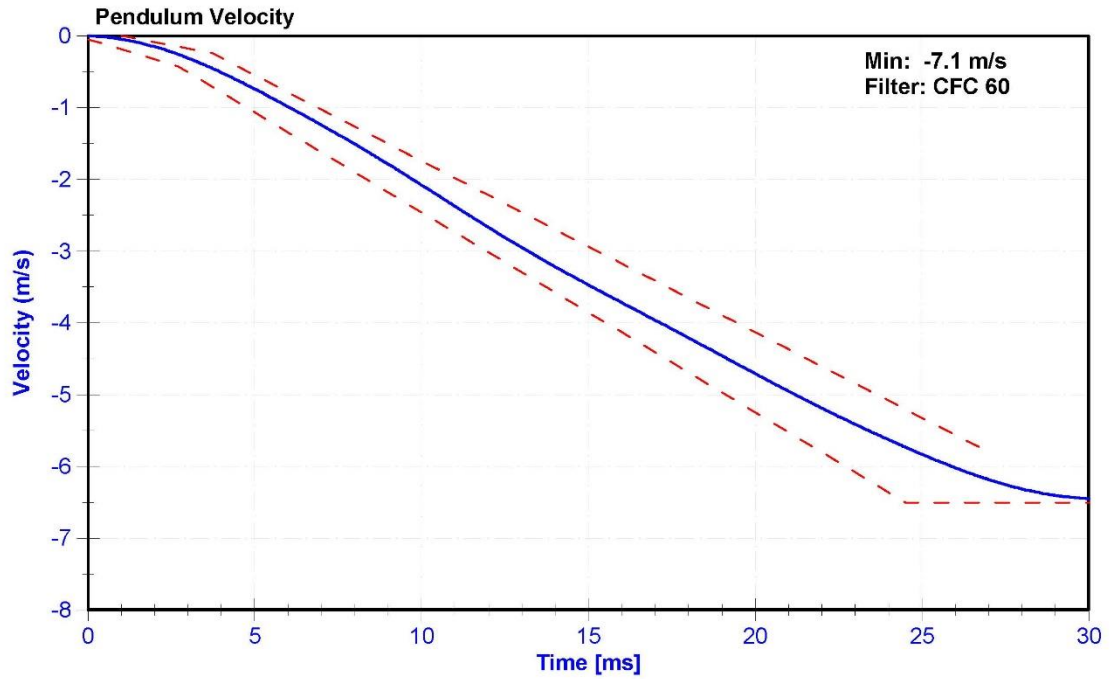

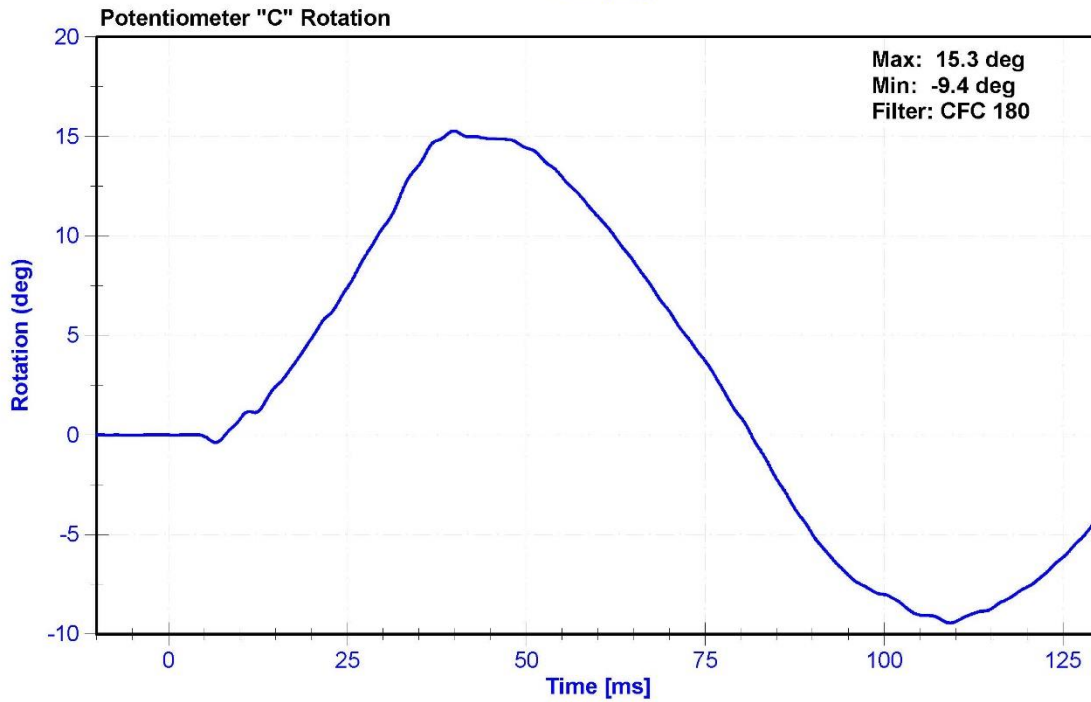
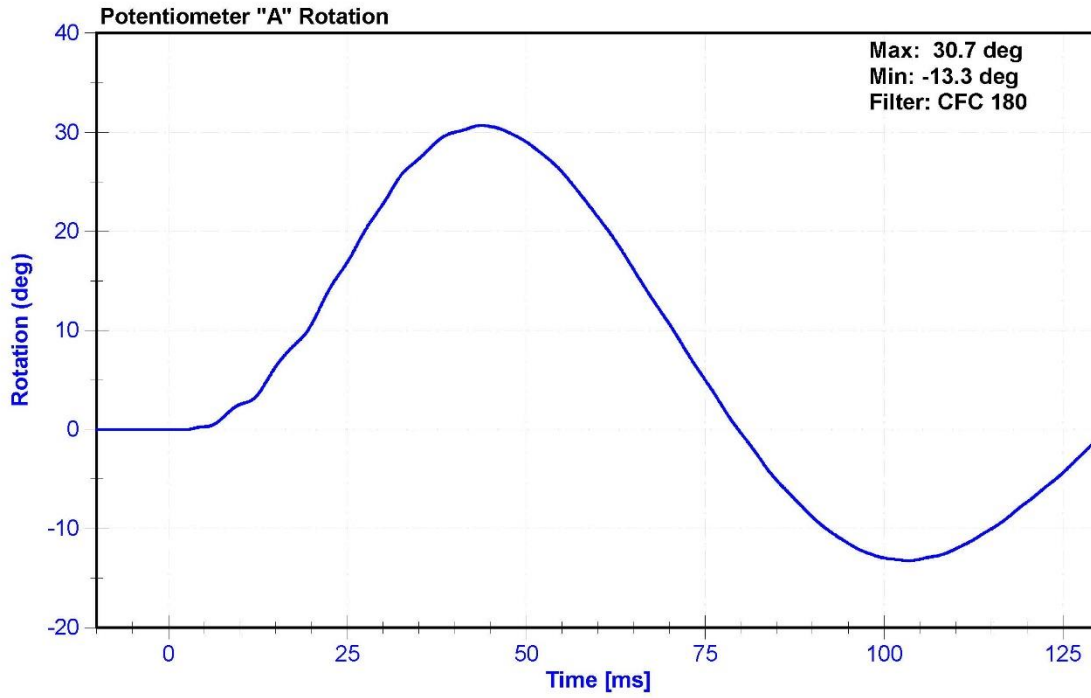

ATD Manufacturer	FTSS	Test Technician	K. Brogan
ATD Serial Number	F034	Laboratory Supervisor	M. Goehle

Results

Test Parameter	Minimum Specification	Maximum Specification	Unit	Result	Pass/Fail
Temperature	20.6	22.2	°C	21.6	Pass
Humidity	10	70	%	36.4	Pass
Velocity	4.2	4.4	m/s	4.36	Pass
Resistive Force	4700	5400	N	4778.7	Pass
Time at Peak Resistive Force	11.8	16.1	ms	13.15	Pass
Pubic Force	-1590	-1230	N	-1318.9	Pass
Time at Peak Pubic Force	12.2	17.0	ms	13.30	Pass

Transducer Calibrations

Channel	Manufacturer	Serial Number	Calibration Date	Calibration Due Date
Pendulum Accelerometer	ENDEVCO 7264CT	AC-P32453	10/17/2017	4/17/2018
Pubic Load Cell	Denton 3096JFL	LC-465Fy	6/6/2017	6/6/2018

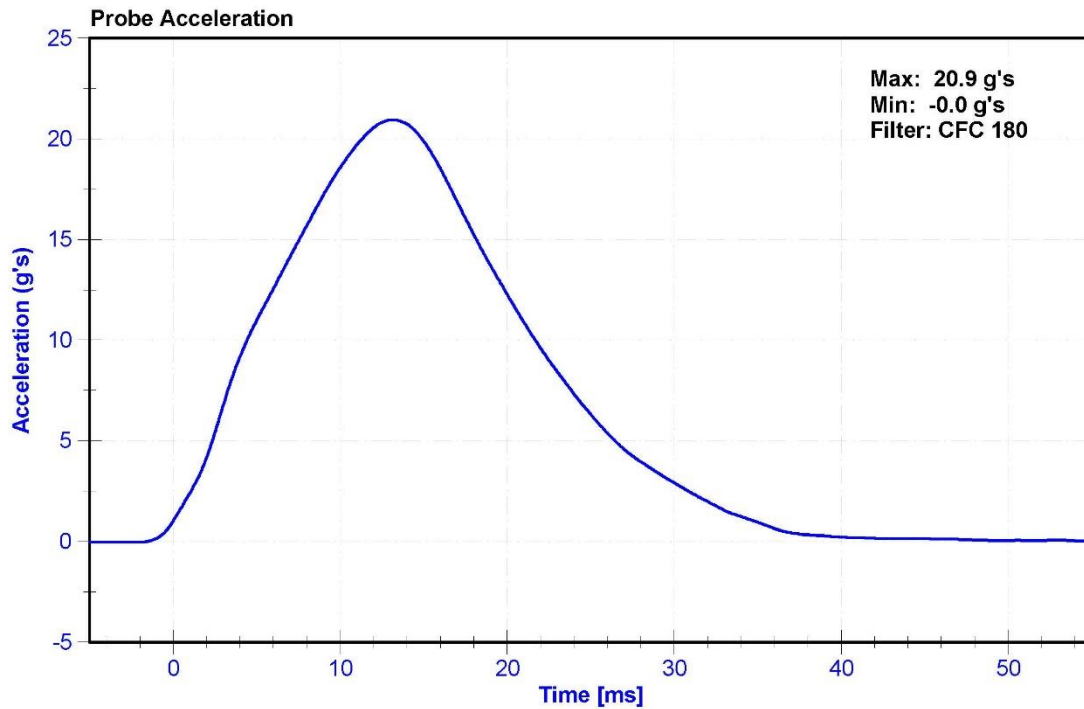

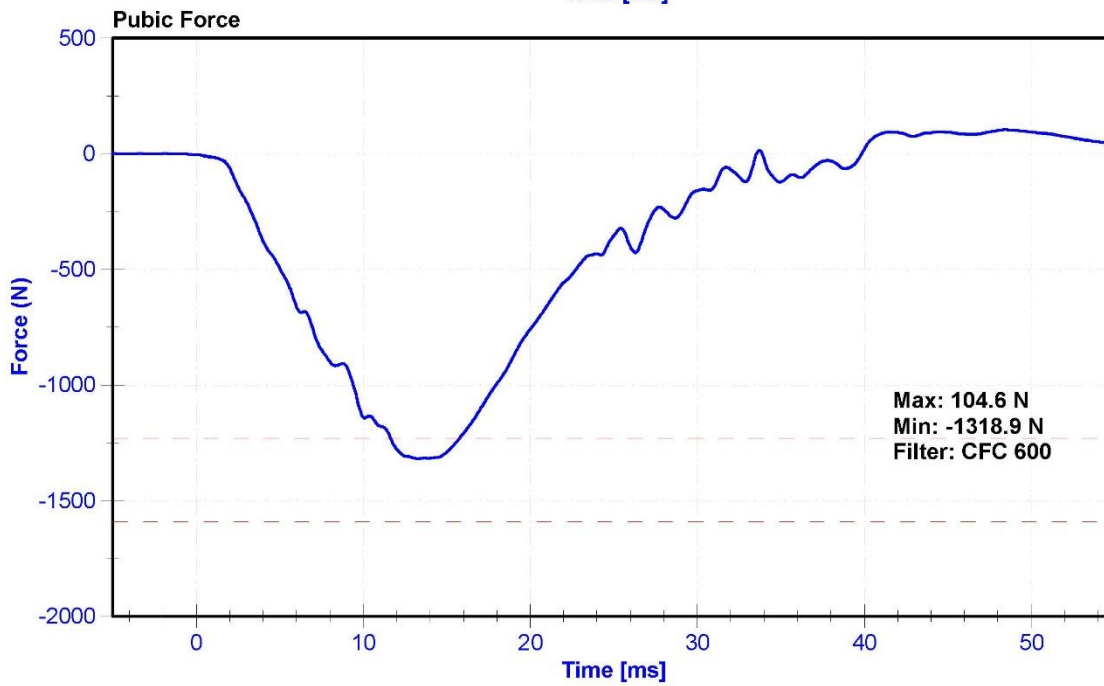
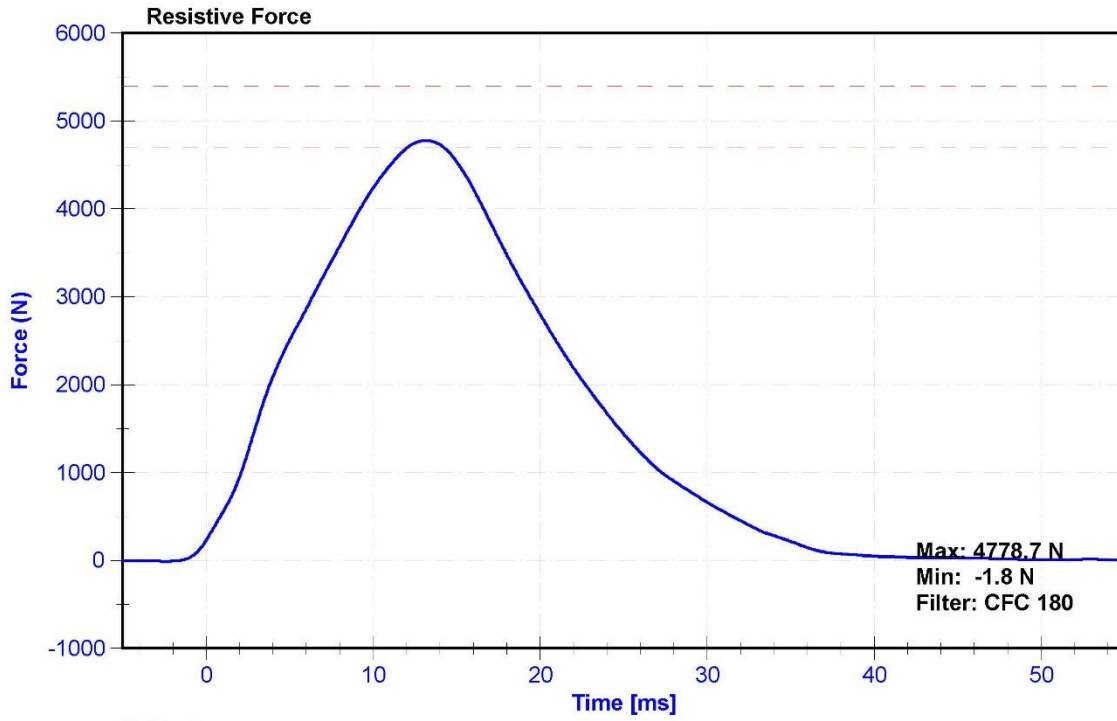

CALIBRATION TEST RESULTS

PRE-TEST

SID-IIS 5TH PERCENTILE FEMALE - PASSENGER ATD

SERIAL No: 300

(CONFIGURED FOR LEFT SIDE IMPACT)



External Measurements - SID-IIs

Technician: K. Brogan

Date: 10/31/2017

Dummy Serial Number: 300

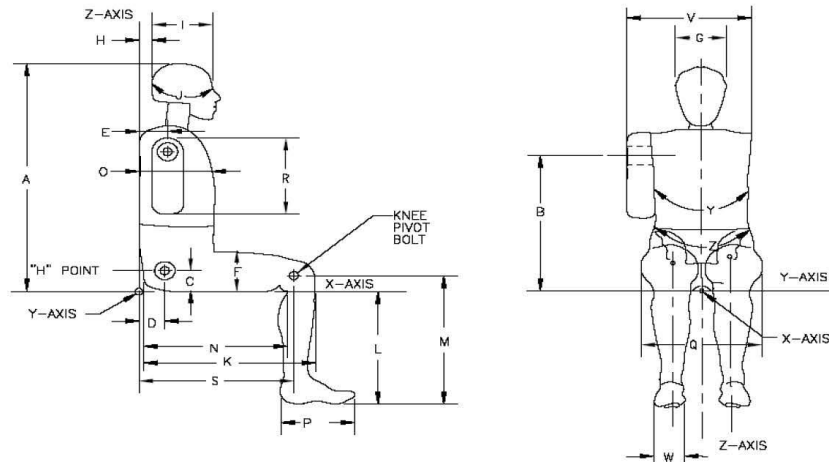

Symbol	Description	Specification (mm)		Result (mm)	Pass/Fail
A	Sitting Height	772	788	780	Pass
B	Shoulder Pivot Height	437	453	446	Pass
C	H-point Height	79	89	86	Pass
D	H-point from seatback	141	151	147	Pass
E	Shoulder Pivot from Backline	97	107	103	Pass
F	Thigh Clearance	119	135	123	Pass
G	Head Breadth	140	148	144	Pass
H	Head Back from Backline	40	46	46	Pass
I	Head Depth	178	188	182	Pass
J	Head Circumference	541	551	547	Pass
K	Buttock to Knee Length	514	540	535	Pass
L	Popliteal Height	343	369	356	Pass
M	Knee Pivot to floor height	392	409	402	Pass
N	Buttock Popliteal Length	416	442	435	Pass
O	Chest Depth w/o jacket	195	211	206	Pass
P	Foot Length	216	232	220	Pass
Q	Hip Breadth (w/pelvic plugs)	313	323	319	Pass
R	Arm Length	249	259	252	Pass
S	Knee Joint to seatback	477	493	485	Pass
V	Shoulder Width	341	357	350	Pass
W	Foot Width	78	94	85	Pass
Y	Chest Circumference w/jacket	851	881	870	Pass
Z	Waist Circumference	761	791	770	Pass

ATD Manufacturer	FTSS	Test Technician	K. Brogan
ATD Serial Number	300	Laboratory Supervisor	M. Goehle

Results

Test Parameter	Minimum Specification	Maximum Specification	Unit	Result	Pass/Fail
Temperature	20.6	22.2	°C	21.5	Pass
Humidity	10	70	%	34.6	Pass
Resultant Acceleration	115	137	g's	131.6	Pass
Oscillation	0	15	%	1.9	Pass
Fore-Aft Acceleration	-15	15	g's	-3.8	Pass

Transducer Calibrations

Channel	Manufacturer	Serial Number	Calibration Date	Calibration Due Date
X Accelerometer	ENDEVCO 7264CT	AC-P58777	9/28/2017	3/29/2018
Y Accelerometer	ENDEVCO 7264CT	AC-P59018	9/28/2017	3/29/2018
Z Accelerometer	ENDEVCO 7264	AC-P79189	9/28/2017	3/29/2018

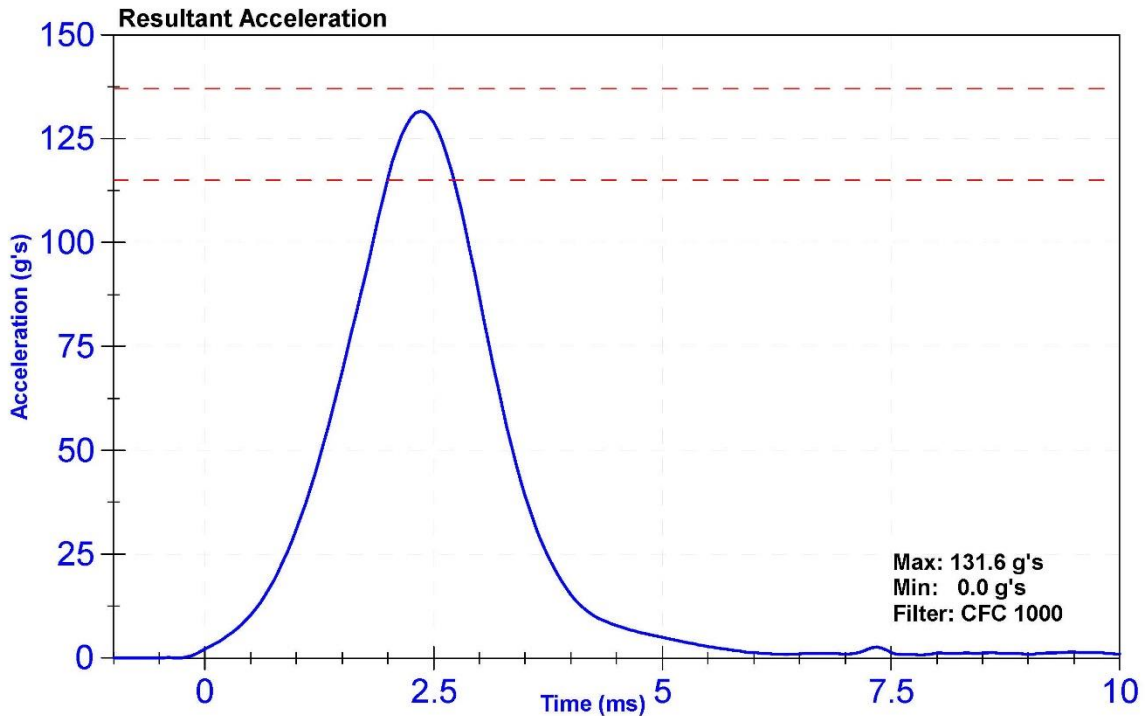

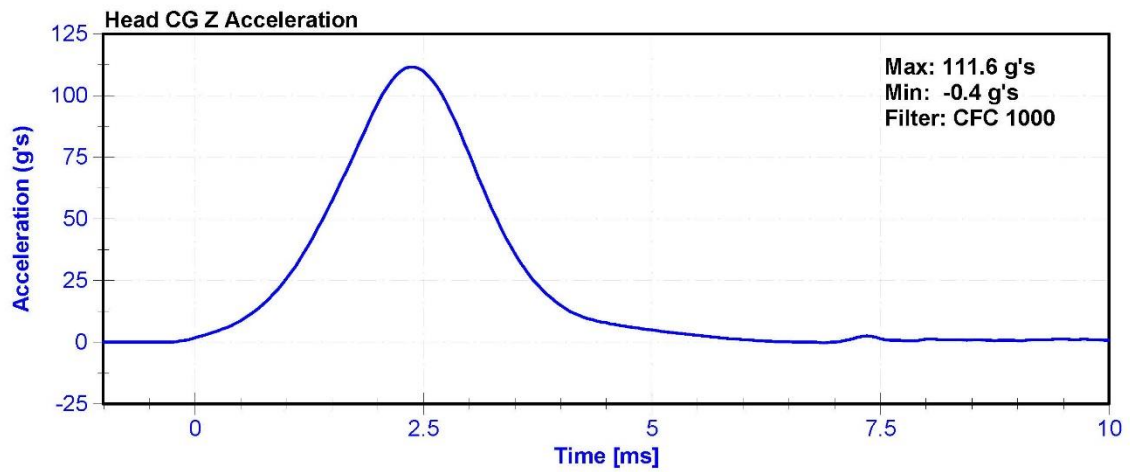
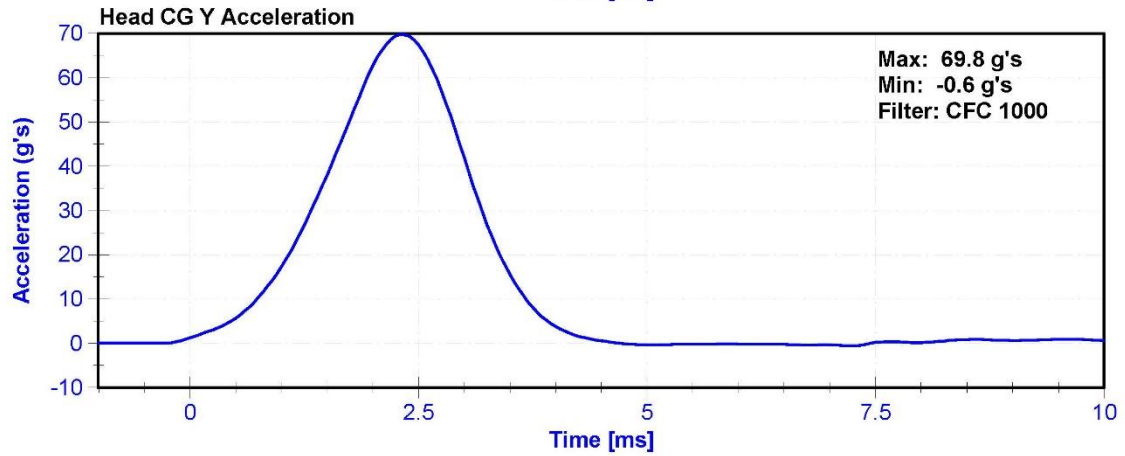
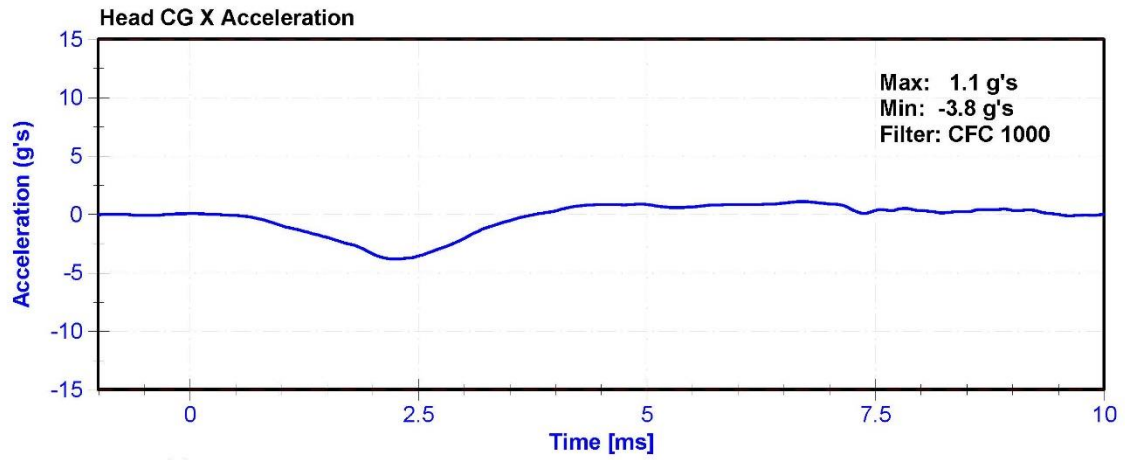

ATD Manufacturer	FTSS	Test Technician	K. Brogan
ATD Serial Number	300	Laboratory Supervisor	M.Goehle

Results

Test Parameter	Minimum Specification	Maximum Specification	Unit	Result	Pass/Fail
Temperature	20.6	22.2	°C	21.3	Pass
Humidity	10	70	%	38.8	Pass
Velocity	5.51	5.63	m/s	5.620	Pass
Pendulum Impulse at 10ms	2.2	2.8	m/s	2.46	Pass
Pendulum Impulse at 15ms	3.3	4.1	m/s	3.59	Pass
Pendulum Impulse at 20ms	4.4	5.4	m/s	4.80	Pass
Pendulum Impulse at 25ms	5.4	6.1	m/s	5.67	Pass
Pendulum Impulse from 25 to 100ms	5.5	6.2	m/s	5.90	Pass
Neck Rotation	71	81	deg	75.4	Pass
Time at Maximum Rotation	50	70	ms	61.3	Pass
Moment about the OC	36	44	Nm	39.7	Pass
Moment Decay to 0 Nm	102	126	ms	118.0	Pass

Transducer Calibrations

Channel	Manufacturer	Serial Number	Calibration Date	Calibration Due Date
Pendulum Accelerometer	ENDEVCO 7231CT	AC-AH5F3	5/11/2017	5/11/2018
Pendulum Potentiometer	Denton 78051-342	DS-184Pend	10/27/2017	10/27/2018
Condyle Potentiometer	Denton 78051-342	DS-185Pend	10/27/2017	10/27/2018
Upper Neck Load Cell	Denton 1716	LC-1872 FY	7/26/2017	7/26/2018

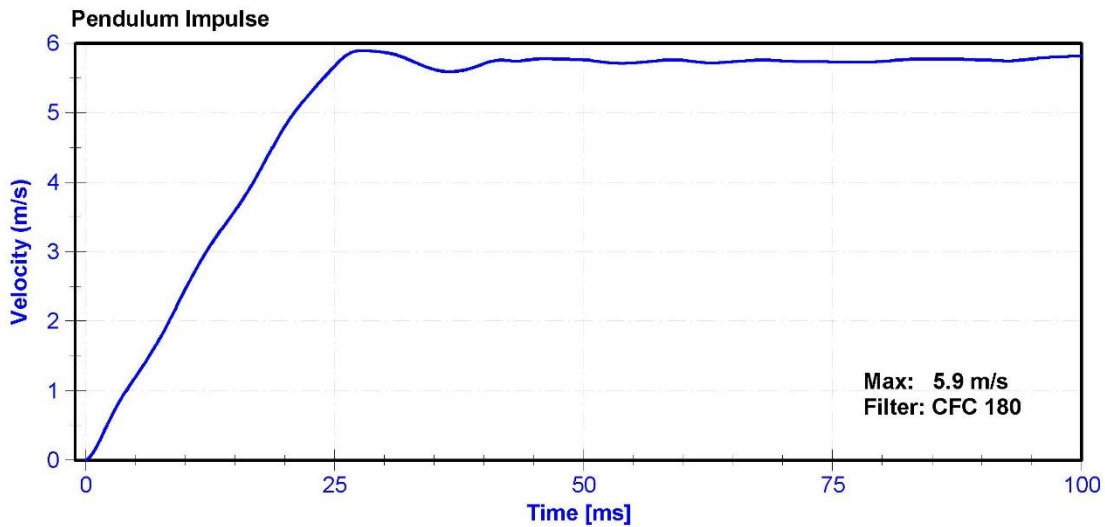

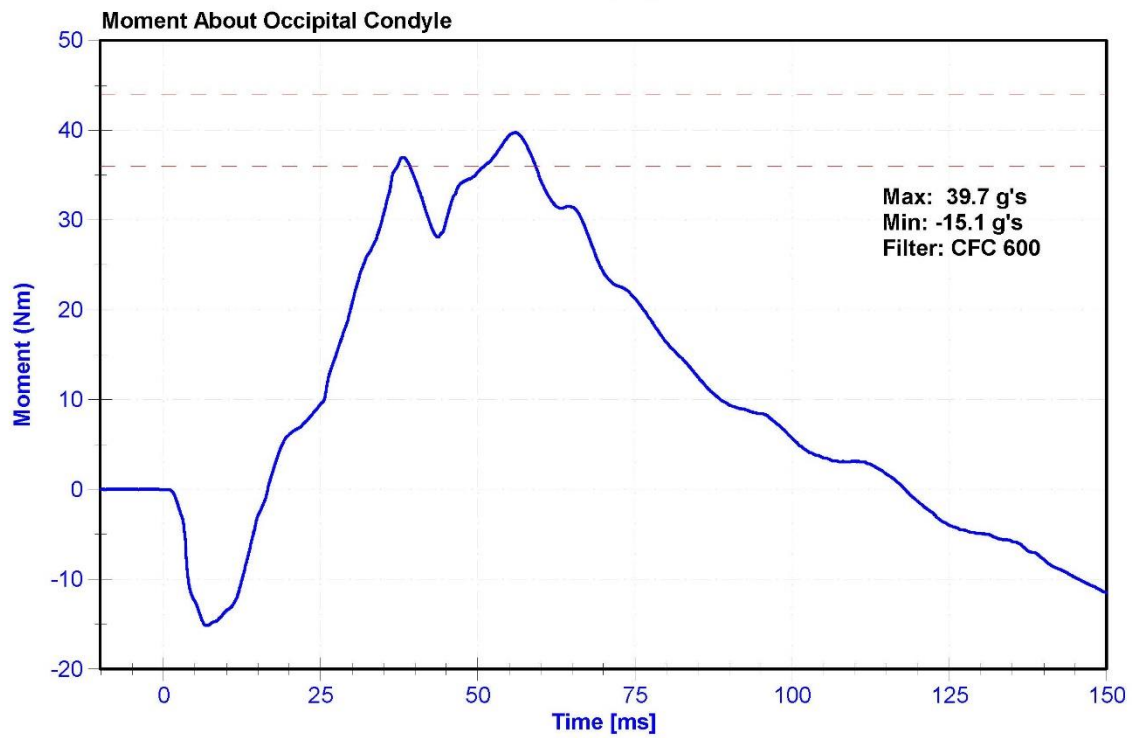
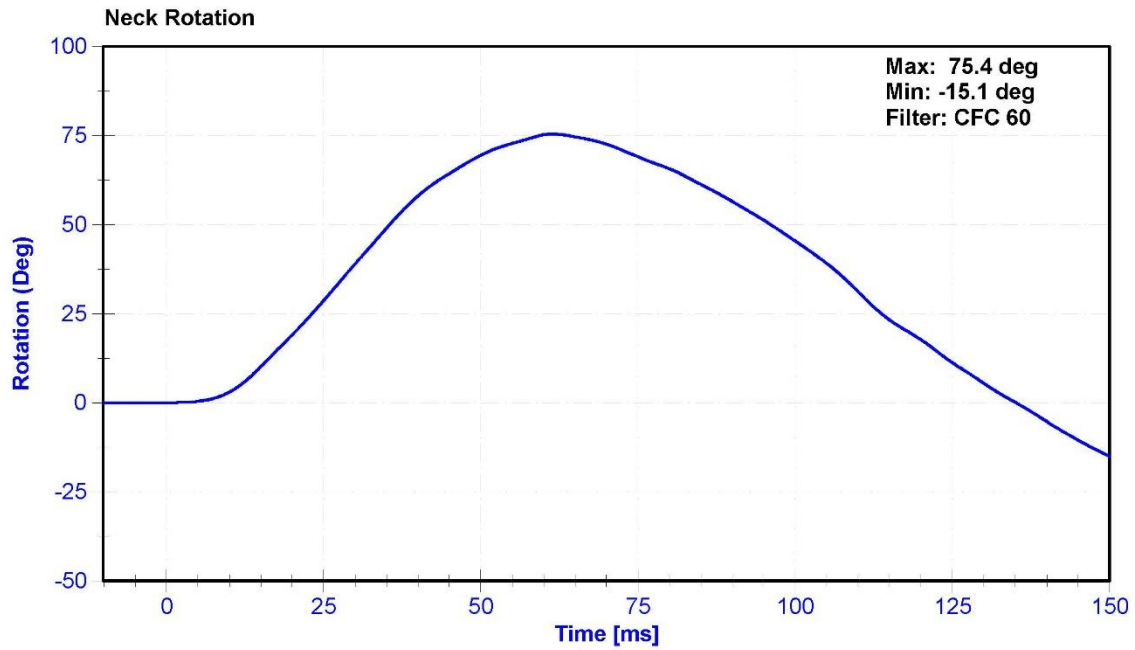

ATD Manufacturer	FTSS	Test Technician	K. Brogan
ATD Serial Number	300	Laboratory Supervisor	M. Goehle

Results

Test Parameter	Minimum Specification	Maximum Specification	Unit	Result	Pass/Fail
Temperature	20.6	22.2	°C	21.7	Pass
Humidity	10	70	%	35.1	Pass
Velocity	4.2	4.4	m/s	4.37	Pass
Probe Acceleration	13	18	g's	14.5	Pass
Shoulder Deflection	28	37	mm	30.1	Pass
Lateral Upper Spine Acceleration	17	22	g's	19.2	Pass

Transducer Calibrations

Channel	Manufacturer	Serial Number	Calibration Date	Calibration Due Date
Pendulum Accelerometer	ENDEVCO 7264CT	AC-P32453	10/17/2017	4/17/2018
Shoulder Potentiometer	Servo 08TC1-3725	DS-1063GFE	9/27/2017	9/27/2018
Upper Spine Y Accelerometer	ENDEVCO 7264	AC-P83320	9/27/2017	3/28/2018

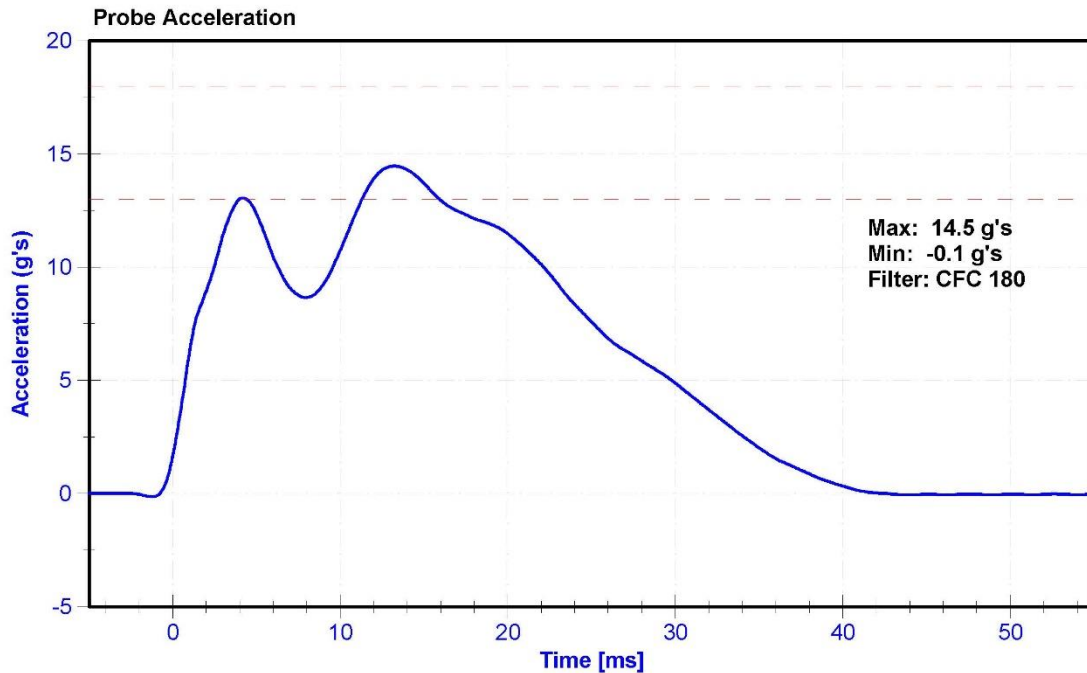

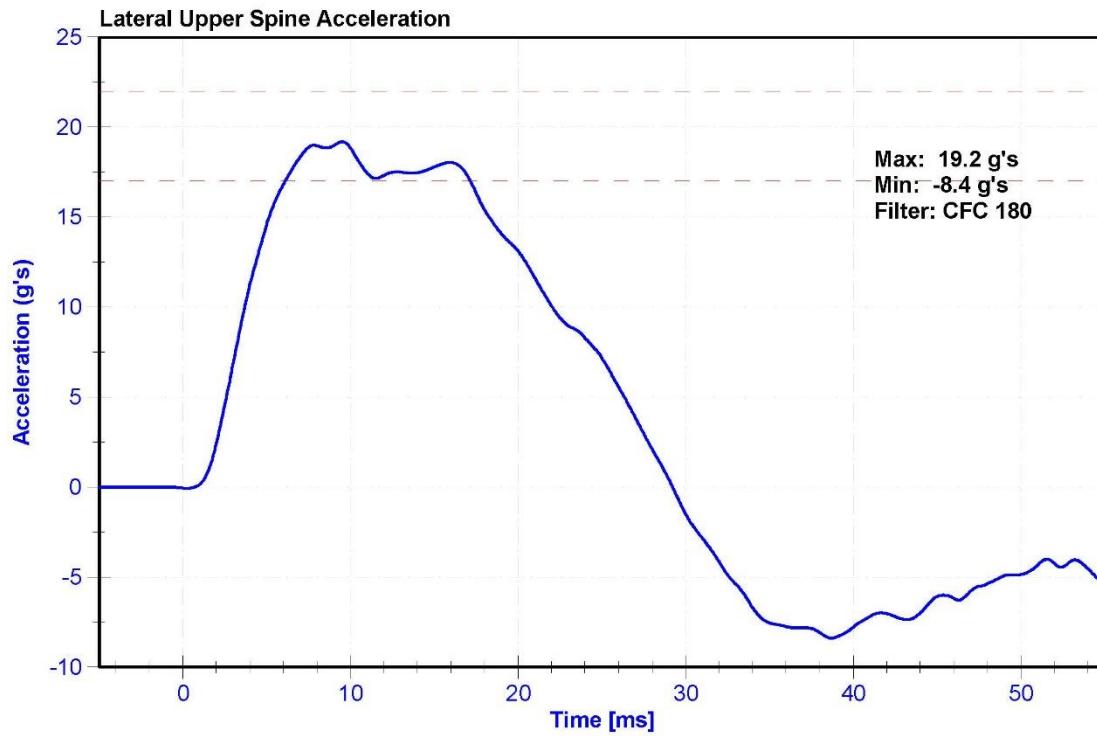
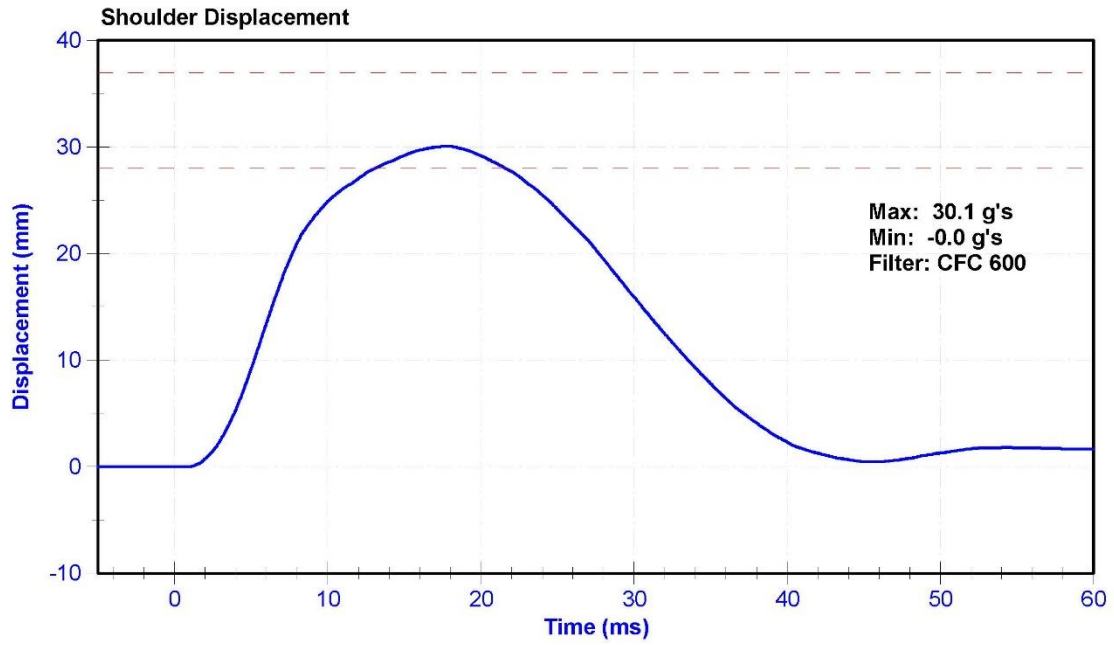

ATD Manufacturer	FTSS	Test Technician	K. Brogan
ATD Serial Number	300	Laboratory Supervisor	M. Goehle

Results

Test Parameter	Minimum Specification	Maximum Specification	Unit	Result	Pass/Fail
Temperature	20.6	22.2	°C	21.0	Pass
Humidity	10	70	%	35.9	Pass
Velocity	6.6	6.8	m/s	6.73	Pass
Probe Acceleration after 5 ms	30	36	g's	32.3	Pass
Lateral Upper Spine Acceleration	34	43	g's	37.4	Pass
Lateral Lower Spine Acceleration	29	37	g's	34.6	Pass
Shoulder Deflection	31	40	mm	34.6	Pass
Upper Thorax Rib Deflection	25	32	mm	27.9	Pass
Mid Thorax Rib Deflection	30	36	mm	32.1	Pass
Lower Thorax Rib Deflection	32	38	mm	33.4	Pass

Transducer Calibrations

Channel	Manufacturer	Serial Number	Calibration Date	Calibration Due Date
Pendulum Accelerometer	ENDEVCO 7264CT	AC-P32453	10/17/2017	4/17/2018
Upper Spine T1 Y Accelerometer	ENDEVCO 7264	AC-P83320	9/27/2017	3/28/2018
Upper Spine T12 Y Accelerometer	ENDEVCO 7264	AC-P64147	9/27/2017	3/28/2018
Shoulder Potentiometer	Servo 08TC1-3725	DS-1063GFE	9/27/2017	9/27/2018
Upper Thorax Rib Potentiometer	Servo 08CT1-3725	DS-451GFE	9/27/2017	9/27/2018
Middle Thorax Rib Potentiometer	Servo 08TC1-3725	DS-1151GFE	9/27/2017	9/27/2018
Lower Thorax Rib Potentiometer	Servo 08TC1-3725	DS-1156GFE	9/27/2017	9/27/2018

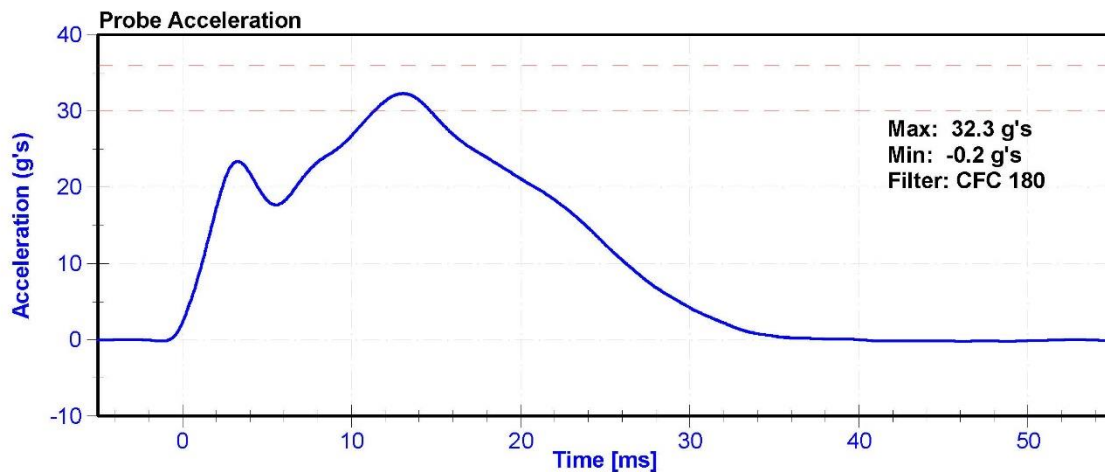

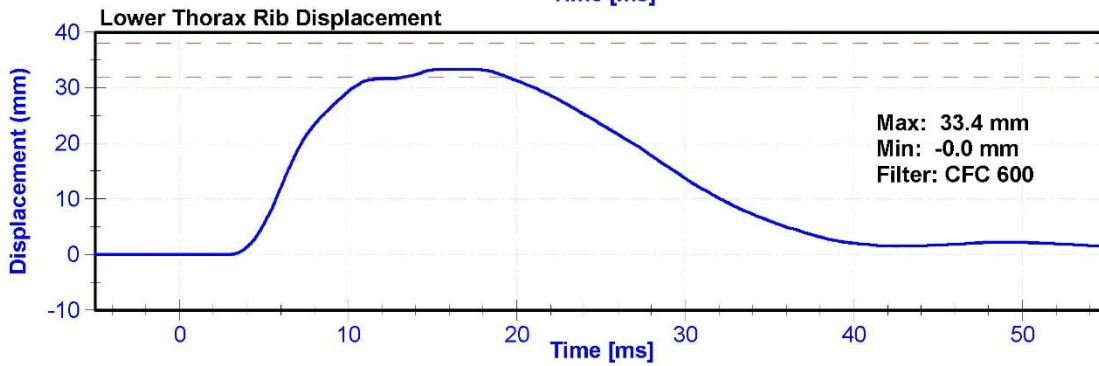
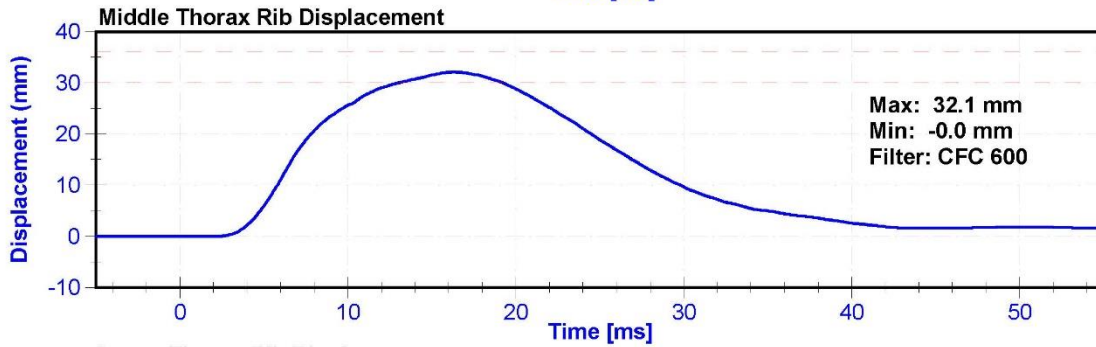
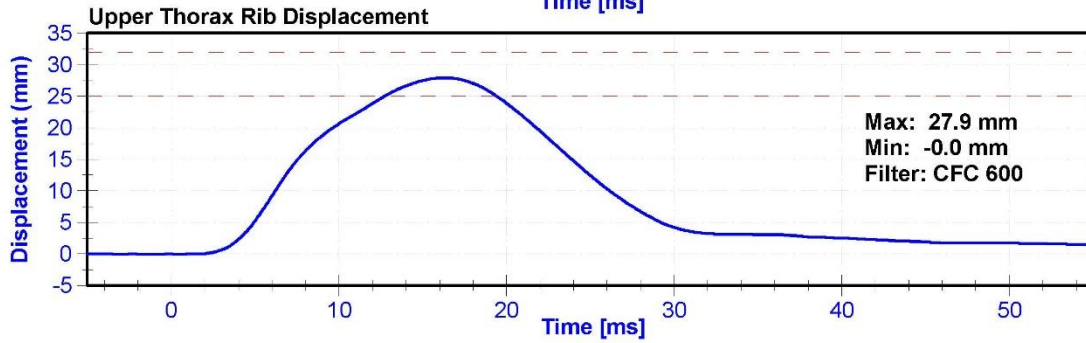
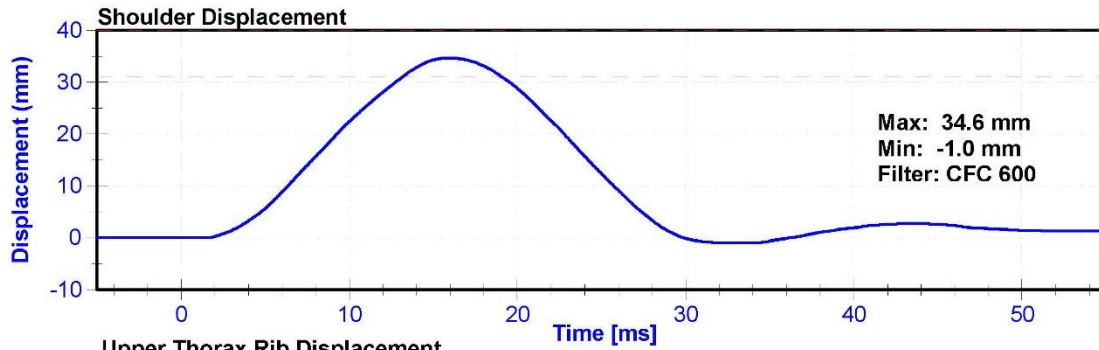

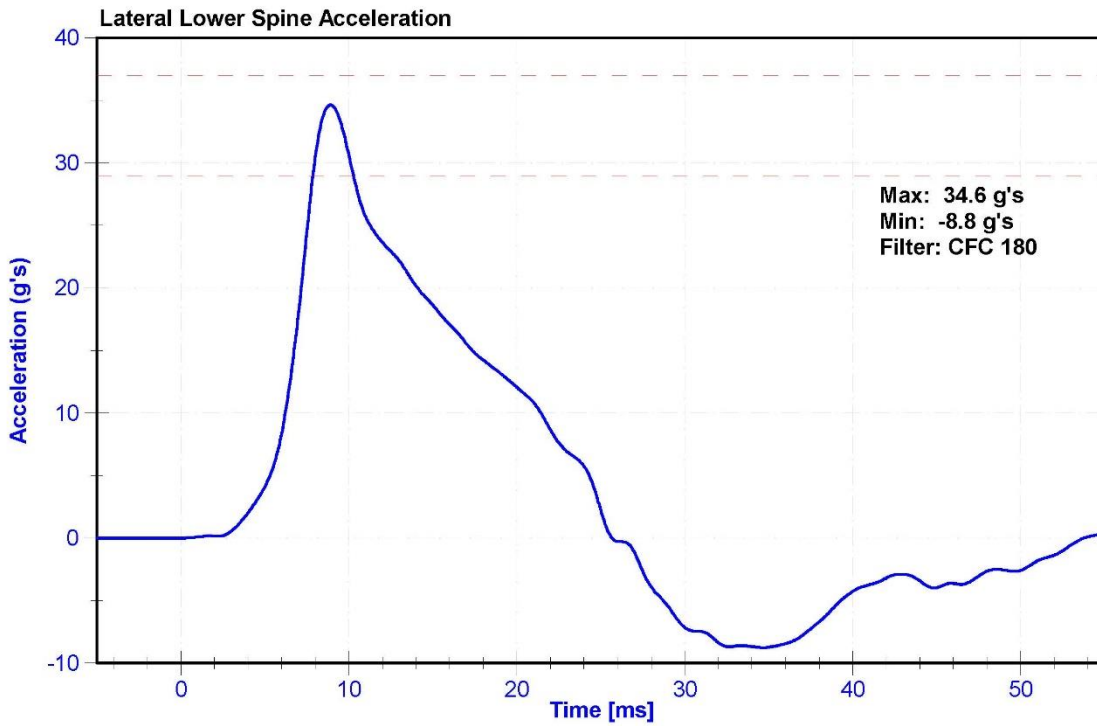
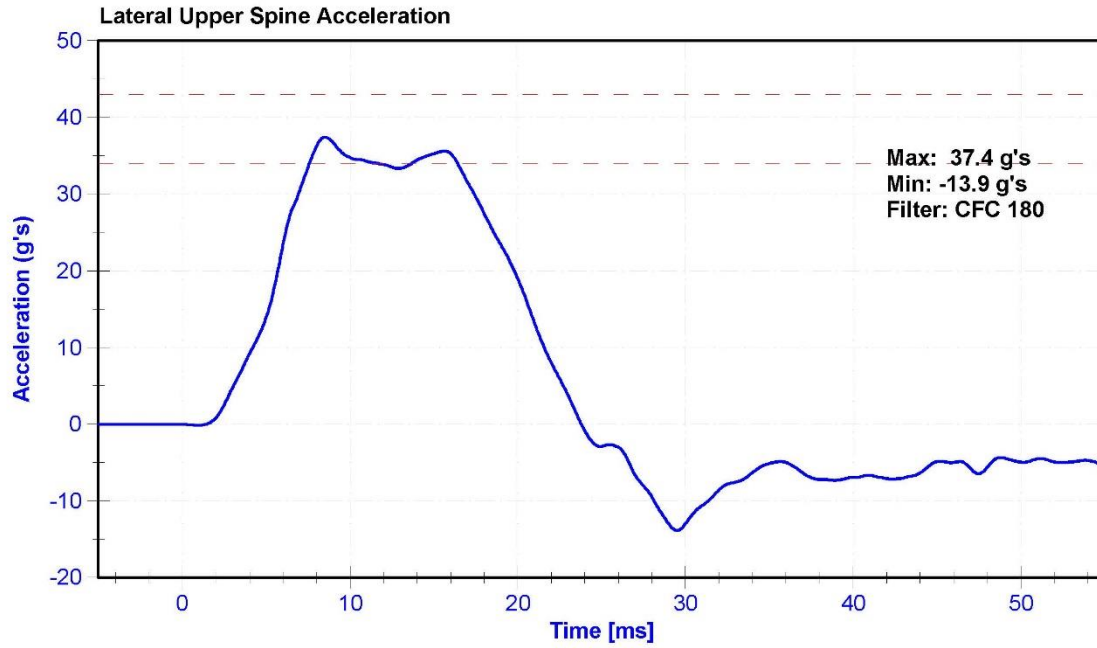

ATD Manufacturer	FTSS	Test Technician	K. Brogan
ATD Serial Number	300	Laboratory Supervisor	M. Goehle

Results

Test Parameter	Minimum Specification	Maximum Specification	Unit	Result	Pass/Fail
Temperature	20.6	22.2	°C	21.3	Pass
Humidity	10	70	%	35.7	Pass
Velocity	4.2	4.4	m/s	4.37	Pass
Probe Acceleration	14	18	g's	15.4	Pass
Lateral Upper Spine Acceleration	13	17	g's	15.6	Pass
Lateral Lower Spine Acceleration	7	11	g's	9.5	Pass
Upper Thorax Rib Deflection	32	40	mm	35.5	Pass
Middle Thorax Rib Deflection	39	45	mm	39.6	Pass
Lower Thorax Rib Deflection	35	43	mm	35.3	Pass

Transducer Calibrations

Channel	Manufacturer	Serial Number	Calibration Date	Calibration Due Date
Pendulum Accelerometer	ENDEVCO 7264CT	AC-P32453	10/17/2017	4/17/2018
Upper Spine Y Accelerometer	ENDEVCO 7264	AC-P83320	9/27/2017	3/28/2018
Lower Spine Y Accelerometer	ENDEVCO 7264	AC-P64147	9/27/2017	3/28/2018
Upper Thorax Rib Potentiometer	Servo 08CT1-3725	DS-451GFE	9/27/2017	9/27/2018
Middle Thorax Rib Potentiometer	Servo 08TC1-3725	DS-1151GFE	9/27/2017	9/27/2018
Lower Thorax Rib Potentiometer	Servo 08TC1-3725	DS-1156GFE	9/27/2017	9/27/2018

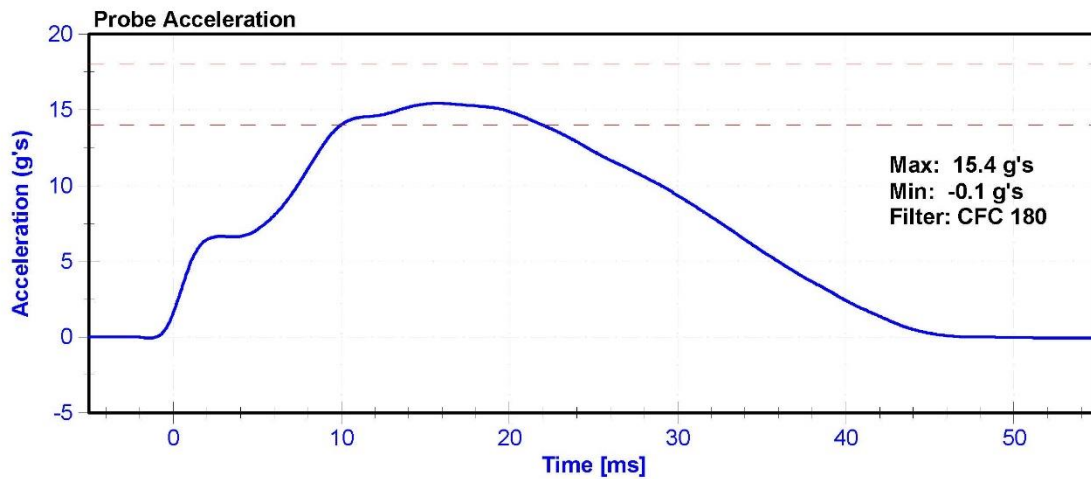

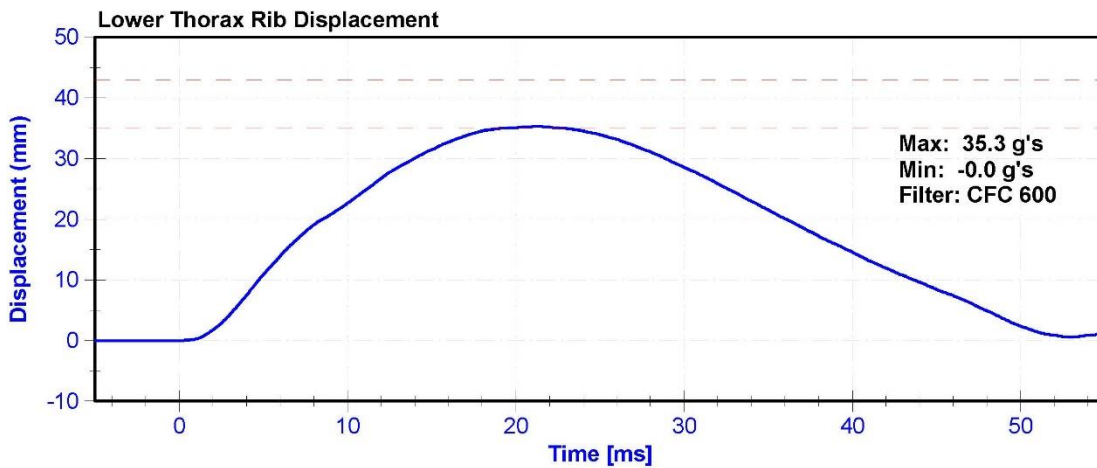
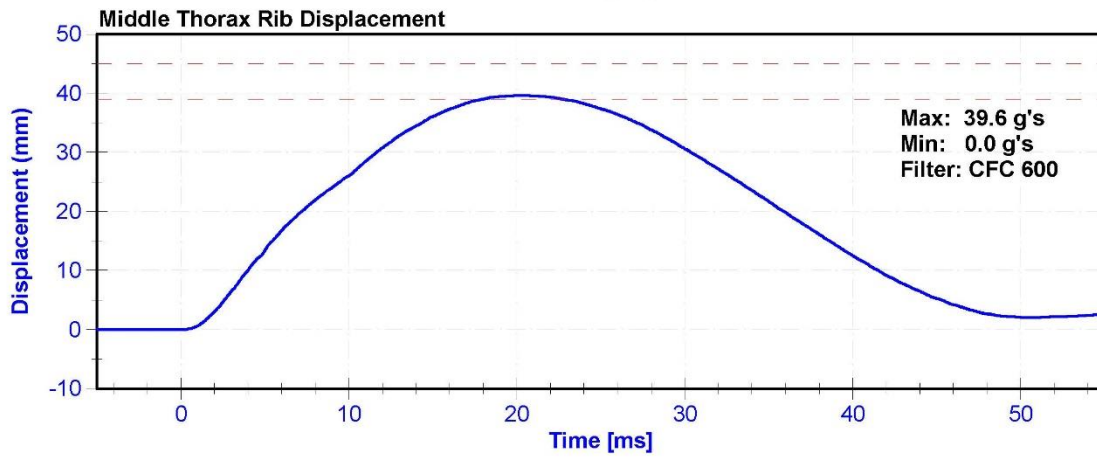
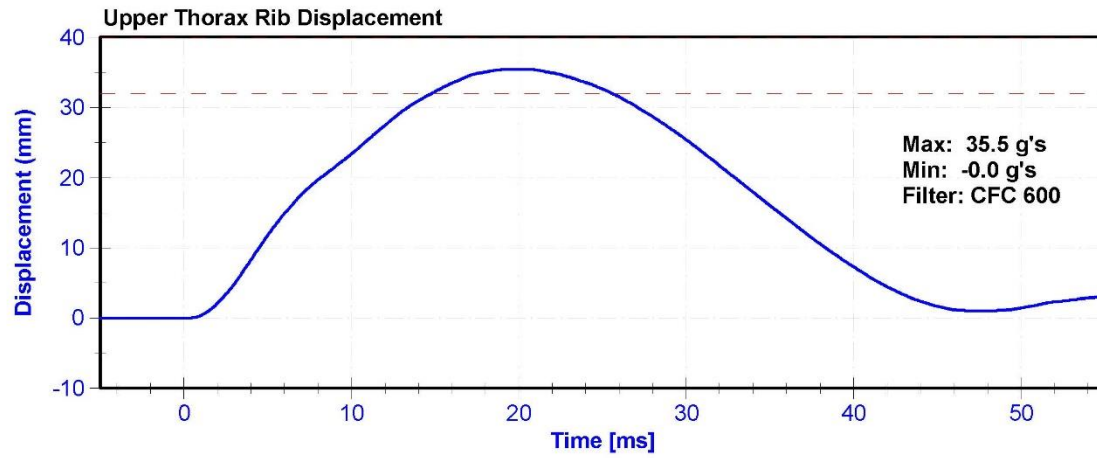

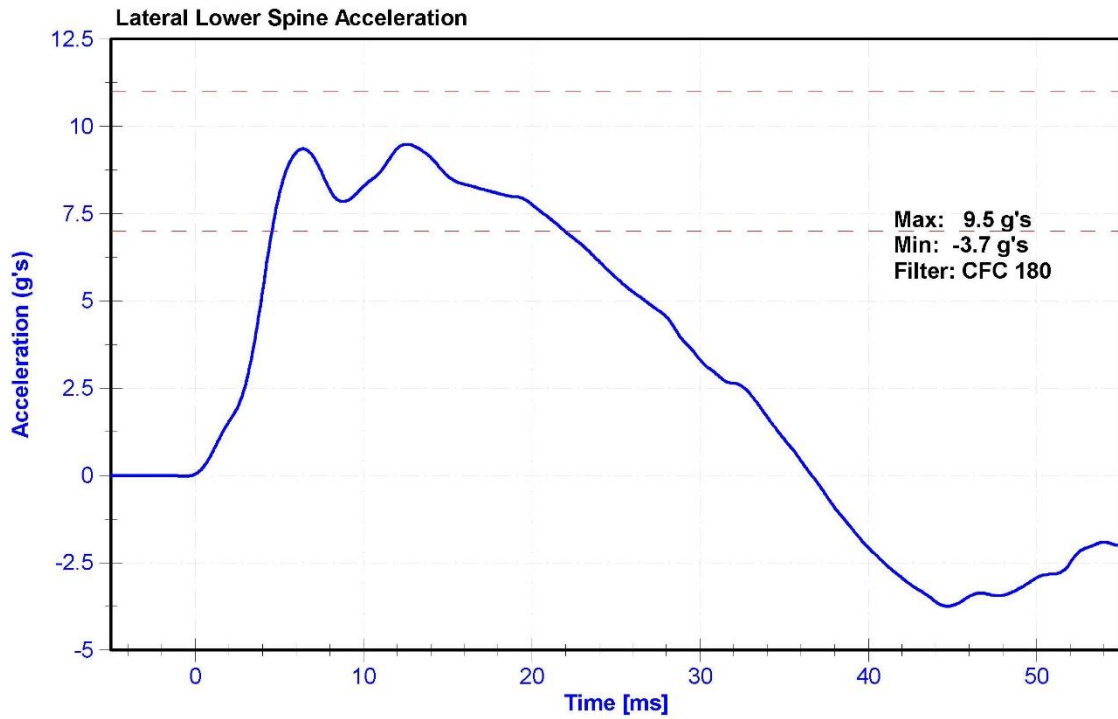
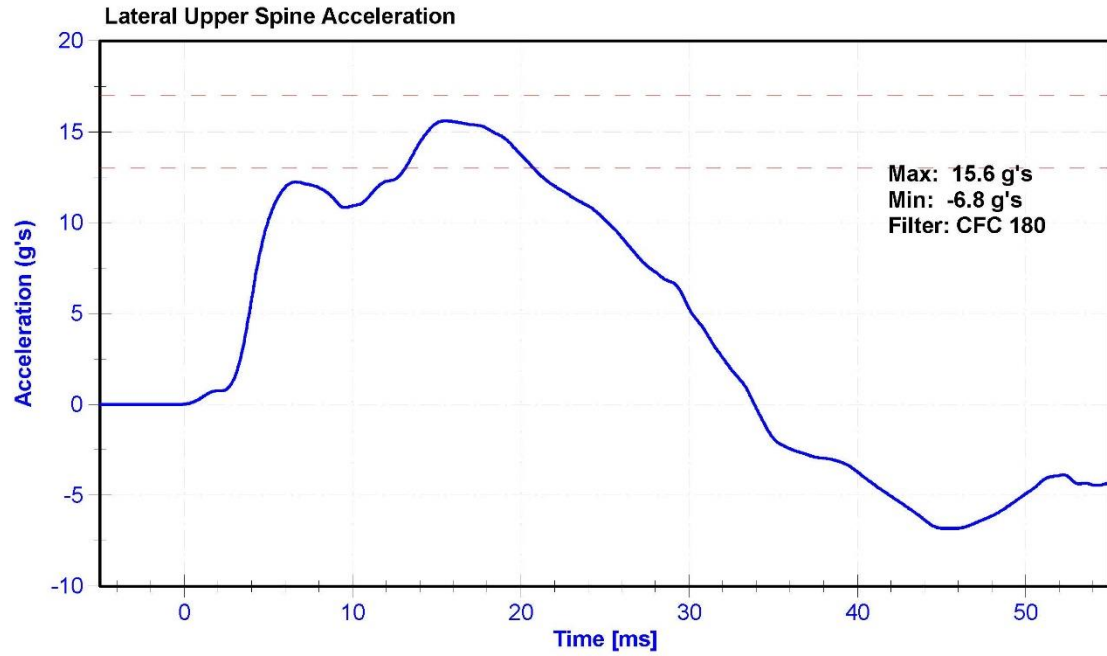

ATD Manufacturer	FTSS	Test Technician	K. Brogan
ATD Serial Number	300	Laboratory Supervisor	M. Goehle

Results

Test Parameter	Minimum Specification	Maximum Specification	Unit	Result	Pass/Fail
Temperature	20.6	22.2	°C	21.0	Pass
Humidity	10	70	%	36.1	Pass
Velocity	4.2	4.4	m/s	4.37	Pass
Probe Acceleration	12	16	g's	14.2	Pass
Lateral Lower Spine Acceleration	9	14	g's	11.2	Pass
Upper Abdomen Rib Deflection	36	47	mm	40.8	Pass
Lower Abdomen Rib Deflection	33	44	mm	36.5	Pass

Transducer Calibrations

Channel	Manufacturer	Serial Number	Calibration Date	Calibration Due Date
Probe Accelerometer	ENDEVCO 7264CT	AC-P32453	10/17/2017	4/17/2018
Lower Spine Y Accelerometer	ENDEVCO 7264	AC-P64147	9/27/2017	3/28/2018
Upper Abdomen Rib Potentiometer	Servo 08CT1-3725	DS-308GFE	9/27/2017	9/27/2018
Lower Abdomen Rib Potentiometer	Servo 08CT1-3725	DS-307GFE	9/27/2017	9/27/2018

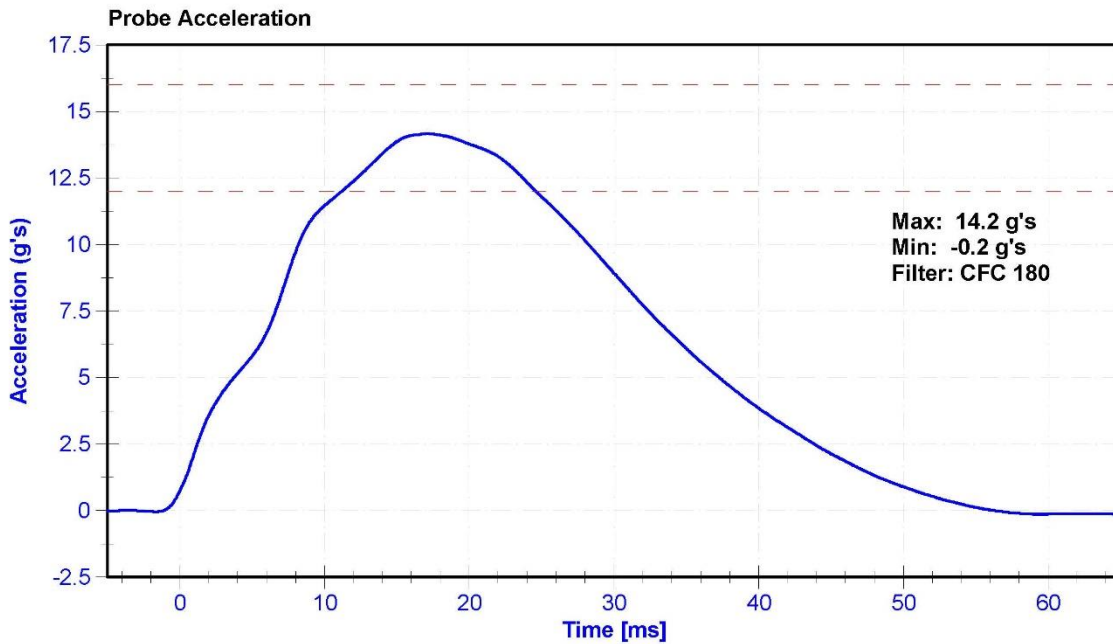

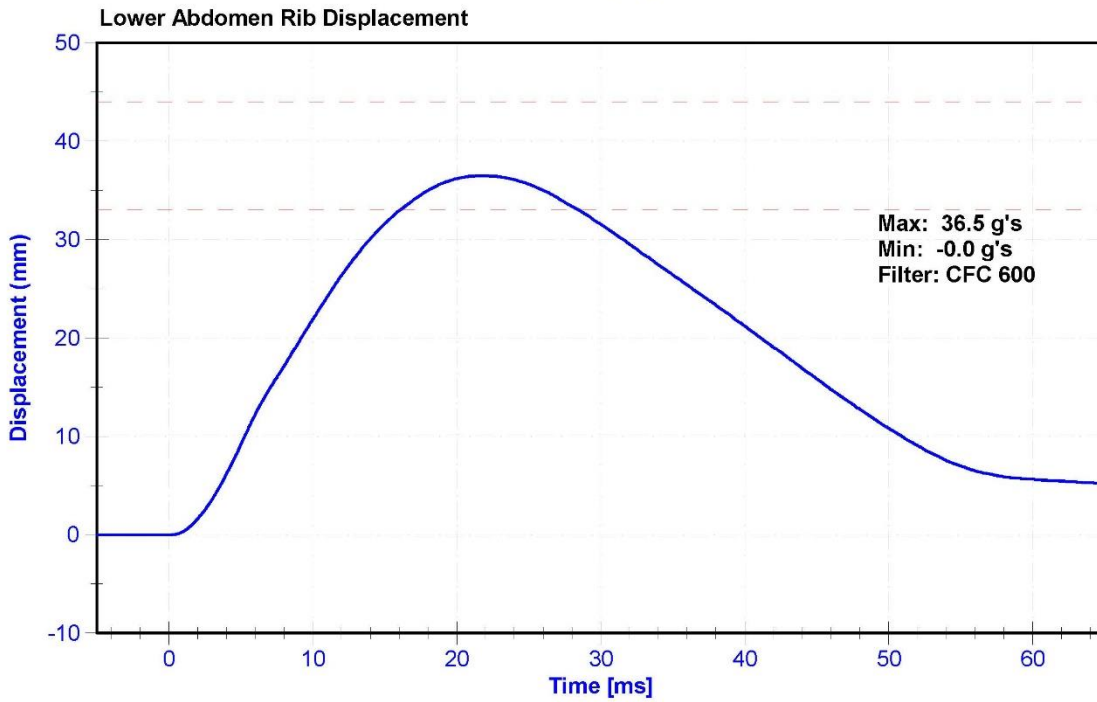
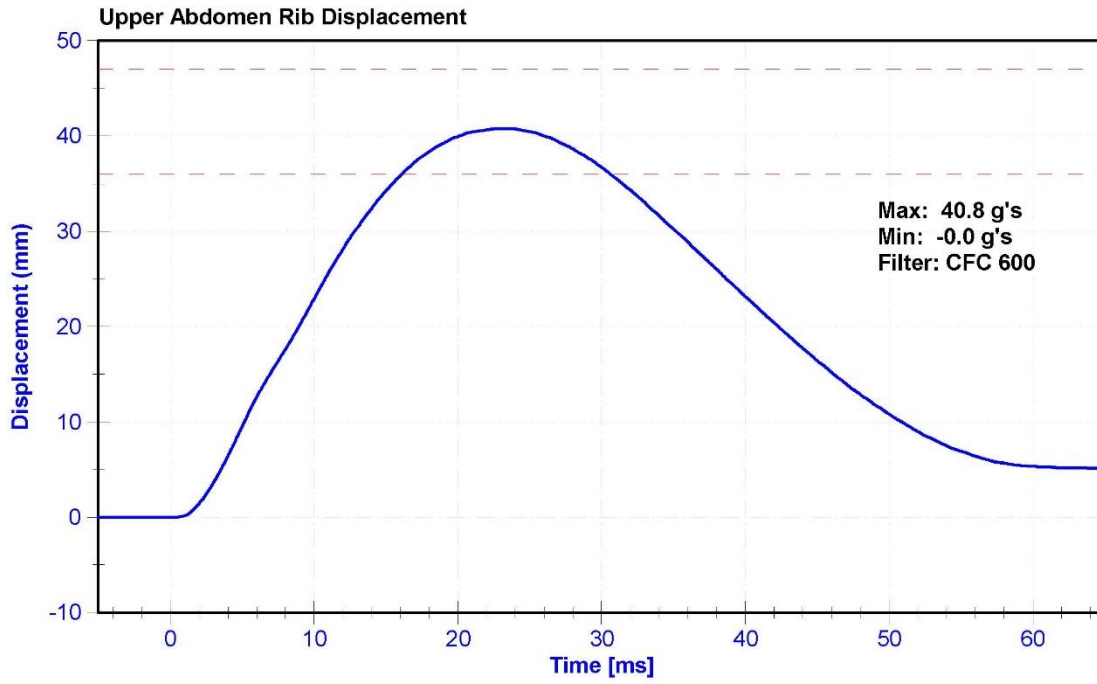

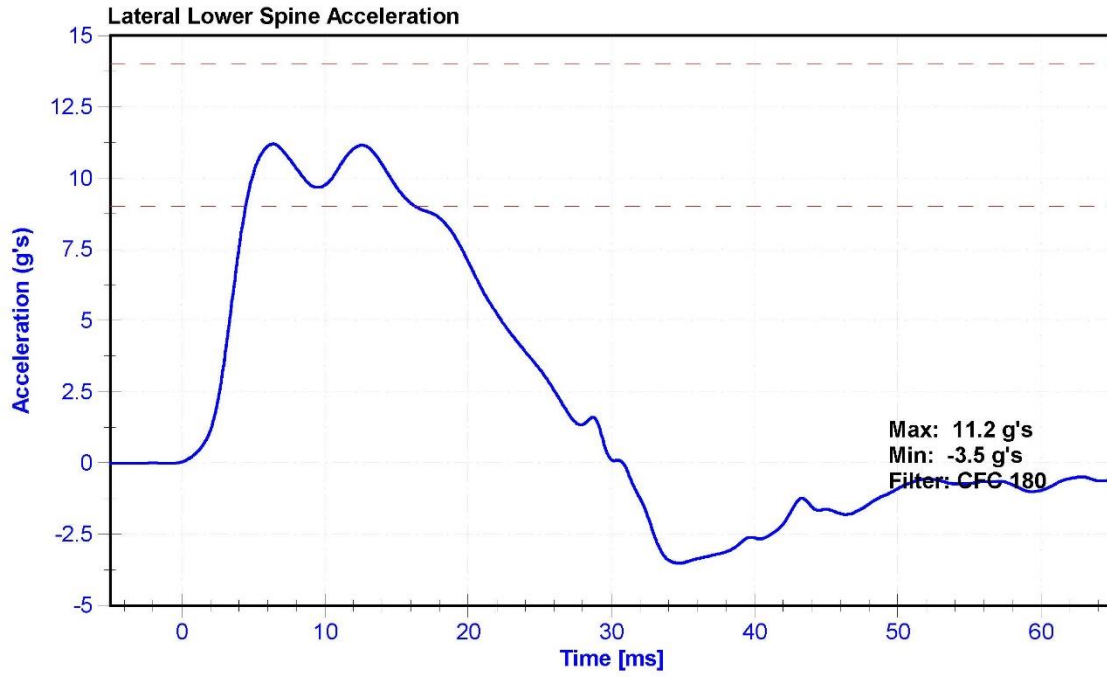

ATD Manufacturer	FTSS	Test Technician	K. Brogan
ATD Serial Number	300	Laboratory Supervisor	M. Goehle

Results

Test Parameter	Minimum Specification	Maximum Specification	Unit	Result	Pass/Fail
Temperature	20.6	22.2	°C	21.3	Pass
Humidity	10	70	%	38.8	Pass
Velocity	6.6	6.8	m/s	6.63	Pass
Probe Acceleration	38	47	g's	41.3	Pass
Lateral Pelvis Acceleration after 6ms	34	42	g's	40.6	Pass
Acetabulum Force	3600	4300	N	3756.1	Pass

Transducer Calibrations

Channel	Manufacturer	Serial Number	Calibration Date	Calibration Due Date
Pendulum Accelerometer	ENDEVCO 7264CT	AC-P32453	10/17/2017	4/17/2018
Pelvis Y Accelerometer	ENDEVCO 7264CT	AC-P79602	9/27/2017	3/28/2018
Acetabulum Load Cell	DENTON 3249J	LC-275Fy	6/20/2017	6/20/2018
Certification Plug	Humanetics	10963		N/A
Crash Test Plug	Humanetics	10837	3/15/2016	N/A

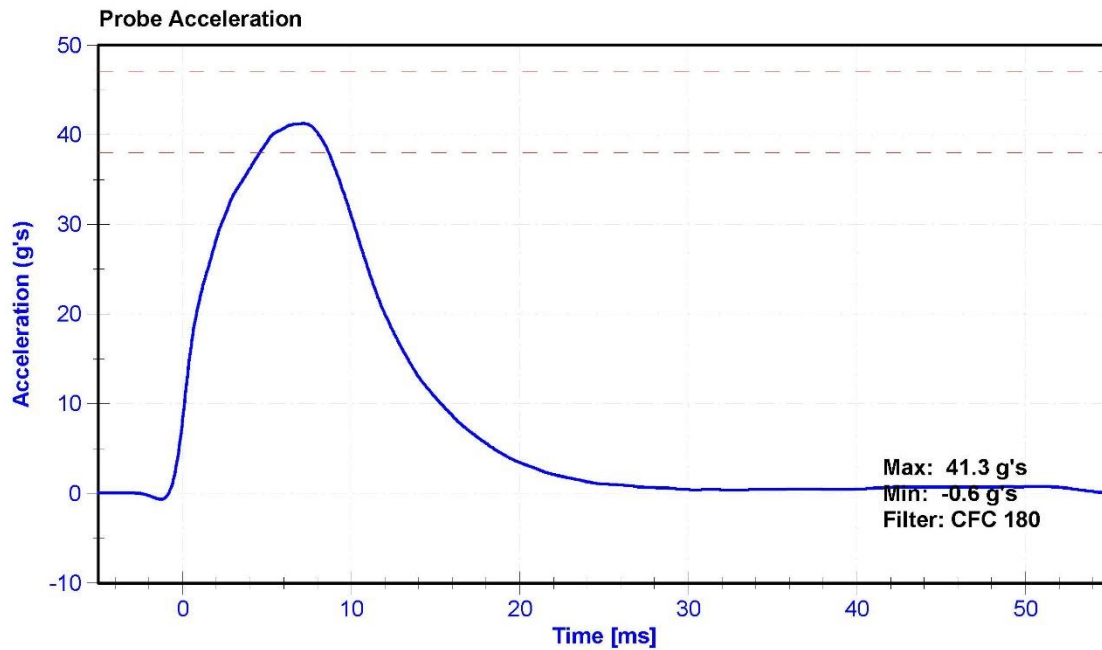

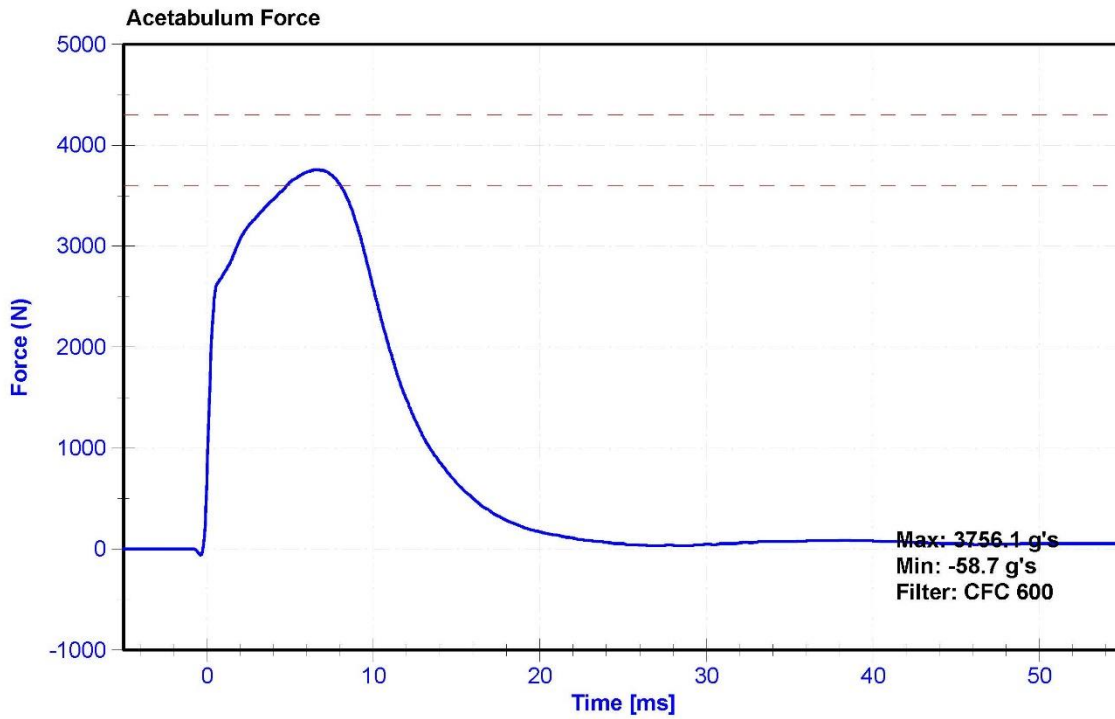
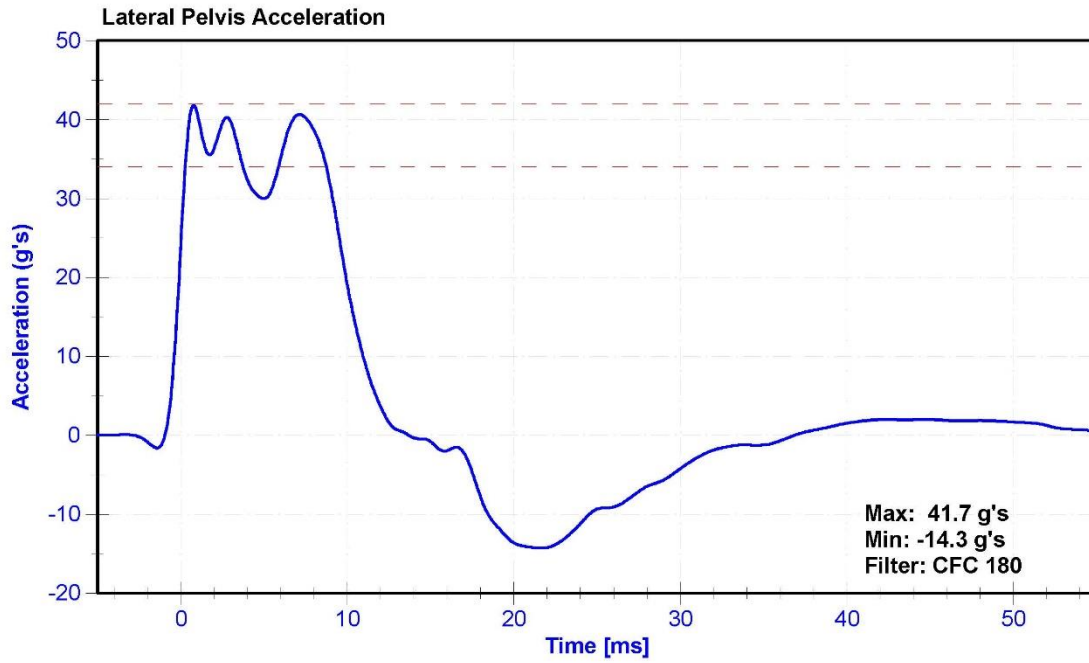



Test 4
10-30-2017

SID-Its Pelvis Plug Certification Test

Plug S/N 10983
Test Number 2026
Report Number 2020
Test Date 4/5/2016 8:52:23 AM

Test Results	
Force @ 0.5 mm (N)	382.30
Force @ 1.5 mm (N)	1,154.94
Force @ 2.5 mm (N)	1,479.74
Force @ 3.0 mm (N)	1,574.36
Spec Min.	1,361.00
Spec Max.	1,673.00

Testing Machine STM-20 596542
Load Cell S/N (TT240813) Units (LBS) 1000
Crosshead Speed (mm/min) or Rate 12.7
Extension or Position Measured by XHD_100 (XHD100)

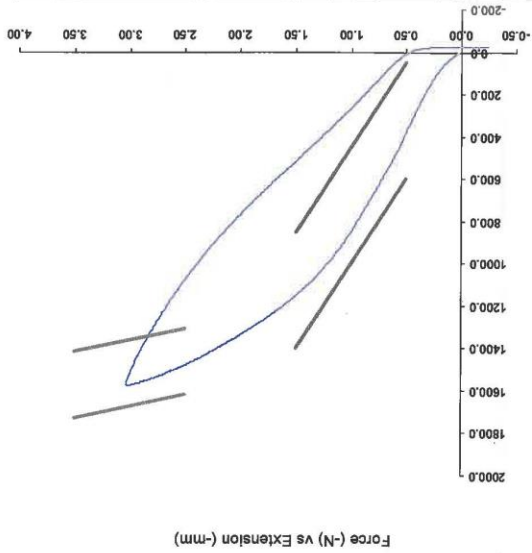

Operator DC
Part Number 180-4450

Template No 107
05-Apr-16
SACO Research

By: *DC*
Date: *4/5/16*
SACO Research 41735 Elm St, #401 Murfeta, CA 92662 Tel 910-694-2082 FAX



SID IIS 300
Crash 11/1/2017

SID-IIS Pelvis Plug Certification Test

Plug S/N 10837

Test Number 1691

Report Number 1685

Test Date 3/15/2016 8:27:11 AM

	Test Results	Spec Min	Spec Max
Force @ 0.5 mm (N)	322.43	50.00	600.00
Force @ 1.5 mm (N)	1,094.87	850.00	1,400.00
Force @ 2.5 mm (N)	1,448.50	1,306.00	1,618.00
Force @ 3.0 mm (N)	1,575.96	1,361.00	1,673.00

Testing Machine STM-20 596542
Load Cell S/N (T1240813), Units (LBS) 1000
Crosshead Speed (mm / min) or Rate 12.7
Extension or Position Measured by XHD_100 (XHD100)

Notes:

Force (-N) vs Extension (-mm)

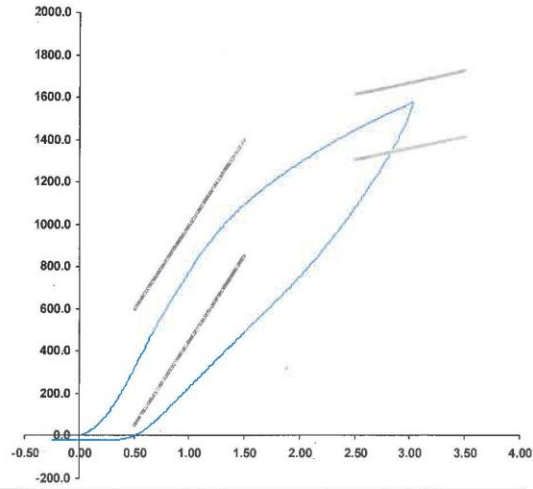

Operator DC
Part Number 180-4450

Template No 107 15-Mar-16
SACO Research

By: DC Date: 3/15/16

SACO Research 41735 Elm St, #401, Murrieta, CA 92562 Tel 310-694-2082 FAX

ATD Manufacturer	FTSS	Test Technician	K. Brogan
ATD Serial Number	300	Laboratory Supervisor	M. Goehle

Results

Test Parameter	Minimum Specification	Maximum Specification	Unit	Result	Pass/Fail
Temperature	20.6	22.2	°C	20.8	Pass
Humidity	10	70	%	38.1	Pass
Velocity	4.2	4.4	m/s	4.37	Pass
Probe Acceleration	36	45	g's	38.1	Pass
Lateral Pelvis Acceleration	28	39	g's	35.0	Pass
Iliac Force	4100	5100	N	4602.8	Pass

Transducer Calibrations

Channel	Manufacturer	Serial Number	Calibration Date	Calibration Due Date
Pendulum Accelerometer	ENDEVCO 7264CT	AC-P32453	10/17/2017	4/17/2018
Pelvis Y Accelerometer	ENDEVCO 7264CT	AC-P79602	9/27/2017	3/28/2018
Iliac Load Cell	DENTON 3228J	LC-279Fy	6/21/2017	6/21/2018

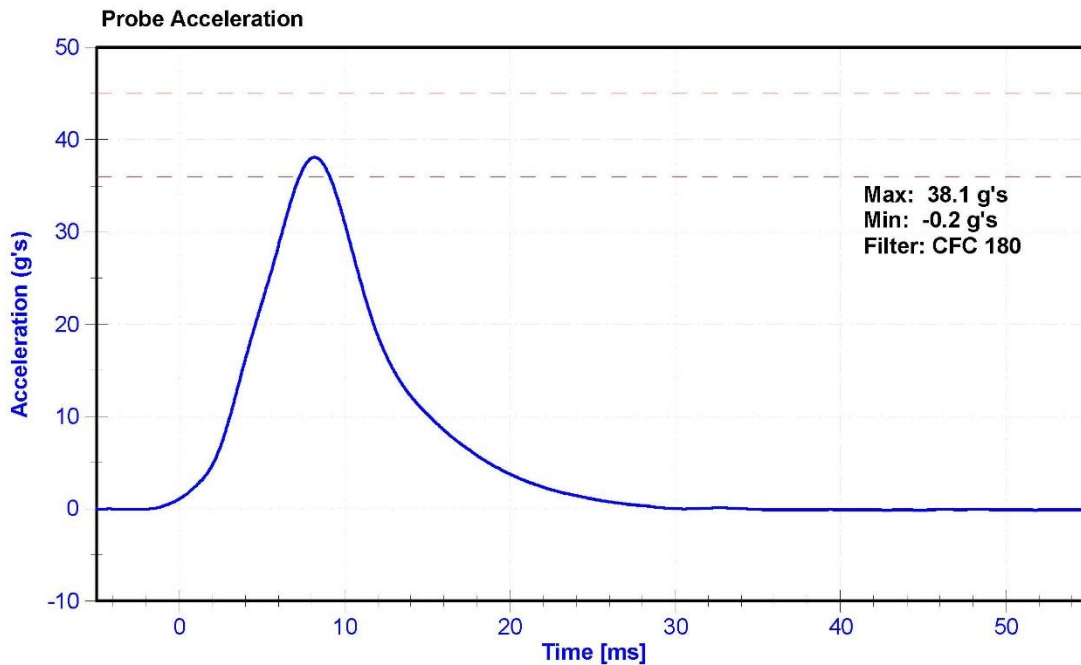

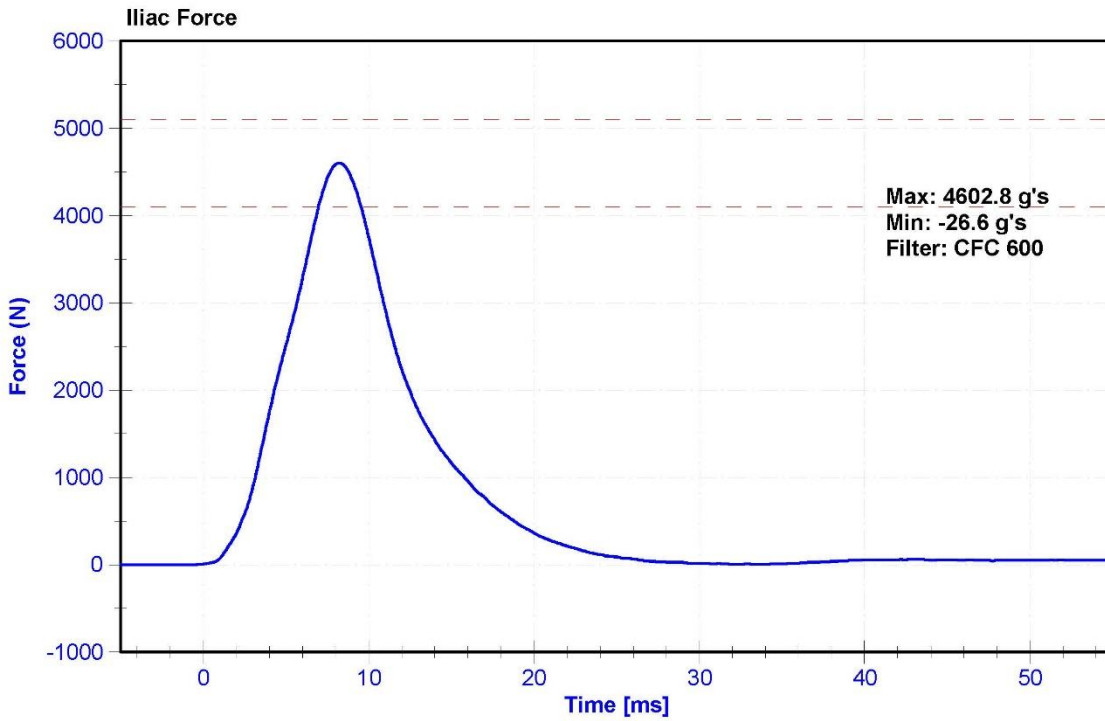
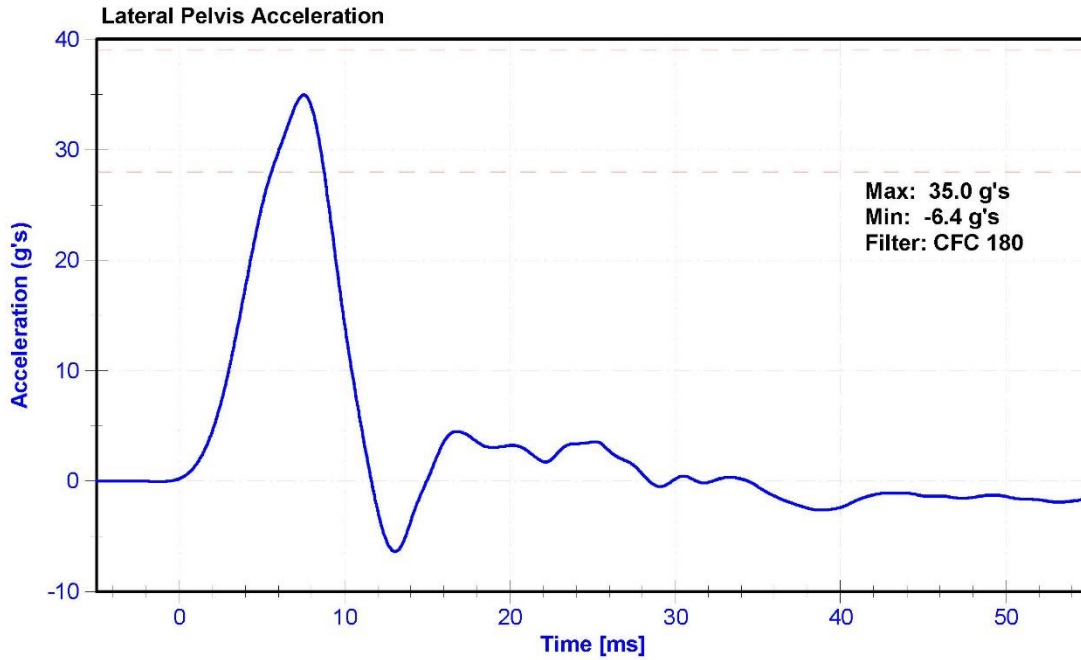

CALIBRATION TEST RESULTS

POST-TEST

EUROSID 2 (ES-2RE) MALE – DRIVER ATD

SERIAL NO: F034

(CONFIGURED FOR LEFT SIDE IMPACT)



External Measurements - EuroSID-2re

Technician: K. Brogan

Date: 11-06-20107

Dummy Serial Number: F034

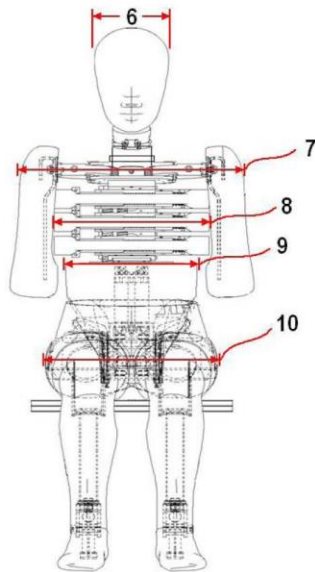

FRONT VIEW

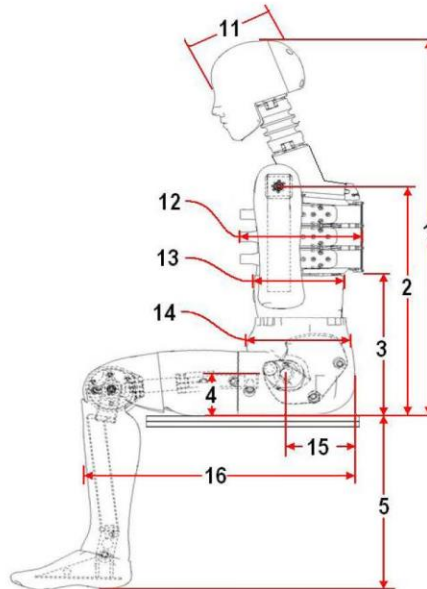

SIDE VIEW

Dim. No.	Description	Specification (mm)		Result (mm)	Pass/Fail
1	Sitting Height	900	918	913	Pass
2	Seat to Shoulder Joint	558	572	565	Pass
3	Seat to Lower Face of Thoracic Spine Box	346	356	350	Pass
4	Seat to Hip Joint (center of bolt)	97	103	100	Pass
5	Sole to Seat, Sitting	333	451	420	Pass
6	Head Width	152	158	154	Pass
7	Shoulder/Arm Width	461	479	469	Pass
8	Thorax Width	322	332	326	Pass
9	Abdomen Width	273	287	282	Pass
10	Pelvis Lap Width	359	373	367	Pass
11	Head Depth	196	206	202	Pass
12	Thorax Depth	262	272	268	Pass
13	Abdomen Depth	194	204	199	Pass
14	Pelvis Depth	235	245	241	Pass
15	Back of Buttocks to Hip Joint (center of bolt)	150	160	154	Pass
16	Back of Buttocks to Front Knee	597	615	600	Pass

ATD Manufacturer	DP6741	Test Technician	K. Brogan
ATD Serial Number	F034	Laboratory Supervisor	M. Goehle

Results

Test Parameter	Minimum Specification	Maximum Specification	Unit	Result	Pass/Fail
Temperature	20.6	22.2	°C	21.6	Pass
Humidity	10	70	%	46.1	Pass
Resultant Acceleration	125	155	g's	134.0	Pass
Oscillation	0	15	%	2.38	Pass
Fore-Aft Acceleration	-15	15	g's	5.4	Pass

Transducer Calibrations

Channel	Manufacturer	Serial Number	Calibration Date	Calibration Due Date
X Accelerometer	ENDEVCO 7264CT	AC-P58904	10/24/2017	4/24/2018
Y Accelerometer	ENDEVCO 7264CT	AC-P58911	10/24/2017	4/24/2018
Z Accelerometer	ENDEVCO 7264CT	AC-P58776	10/24/2017	4/24/2018

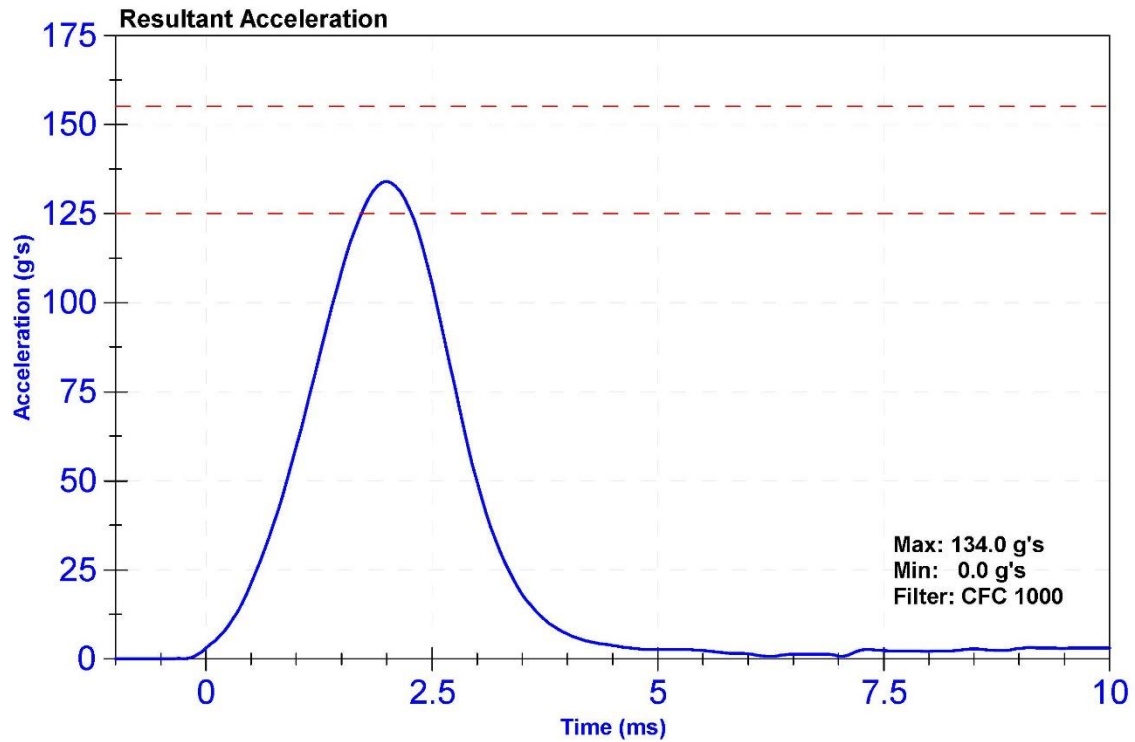

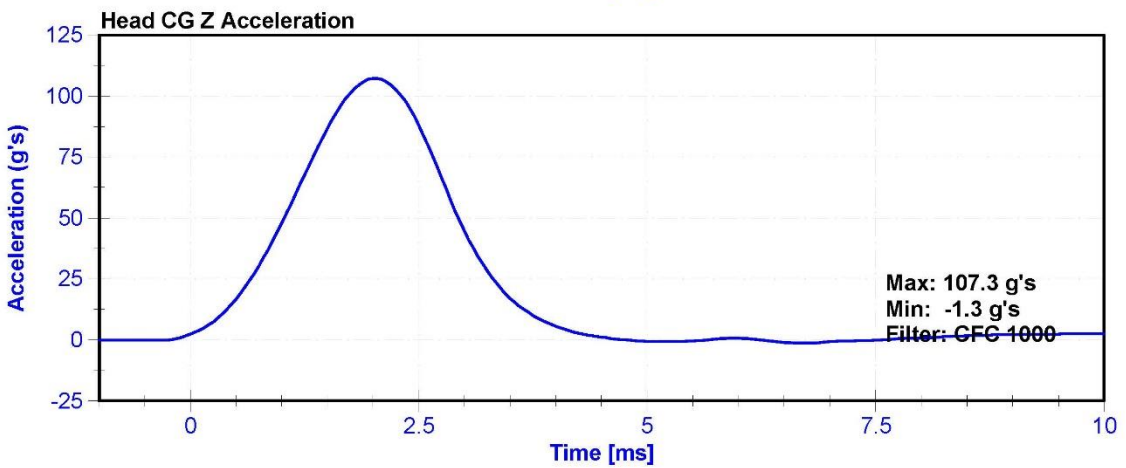
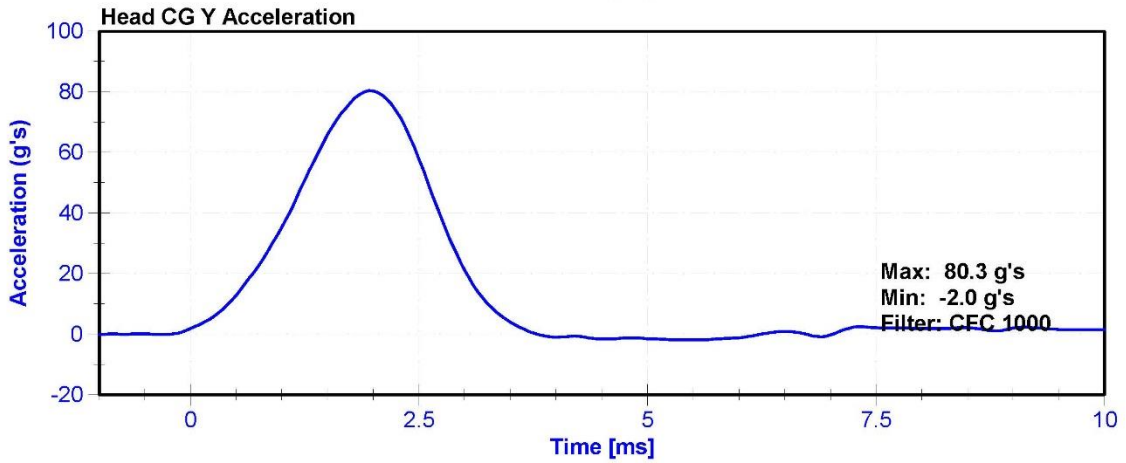
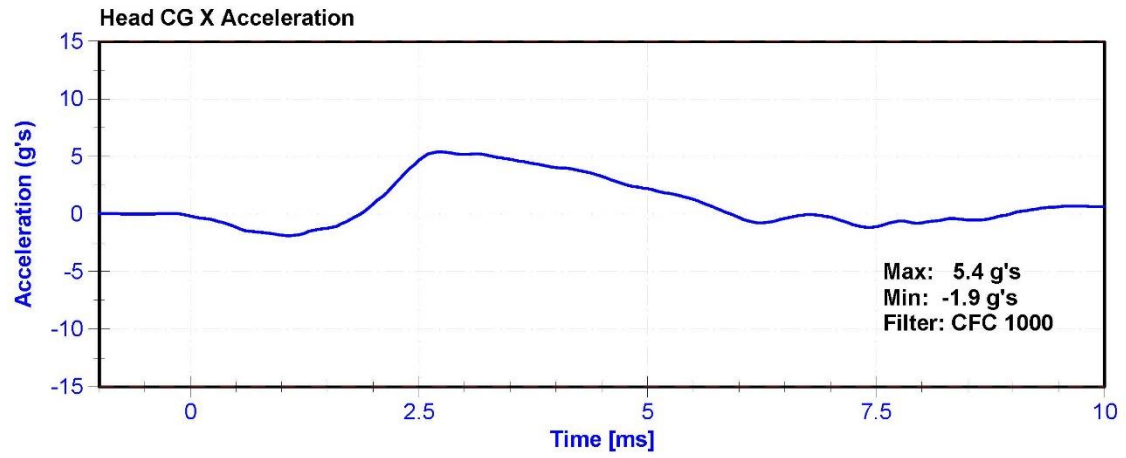

ATD Manufacturer	FTSS	Test Technician	K. Brogan
ATD Serial Number	F034	Laboratory Supervisor	M. Goehle

Results

Test Parameter	Minimum Specification	Maximum Specification	Unit	Result	Pass/Fail
Temperature	20.6	22.2	°C	21.8	Pass
Humidity	10	70	%	48.1	Pass
Velocity	3.3	3.5	m/s	3.40	Pass
Lateral Neck Rotation	49	59	deg	52.5	Pass
Time at Maximum Rotation	54	66	ms	59.0	Pass
Time of Rotation Decay from Maximum	53	88	ms	55.7	Pass

Transducer Calibrations

Channel	Manufacturer	Serial Number	Calibration Date	Calibration Due Date
Pendulum Accelerometer	ENDEVCO 7231CT	AC-AH5F3	5/11/2017	5/11/2018
Front Pendulum Potentiometer	SP22G	DS-094	10/30/2017	10/30/2018
Headform Potentiometer	SP22G	DS-095	10/30/2017	10/30/2018

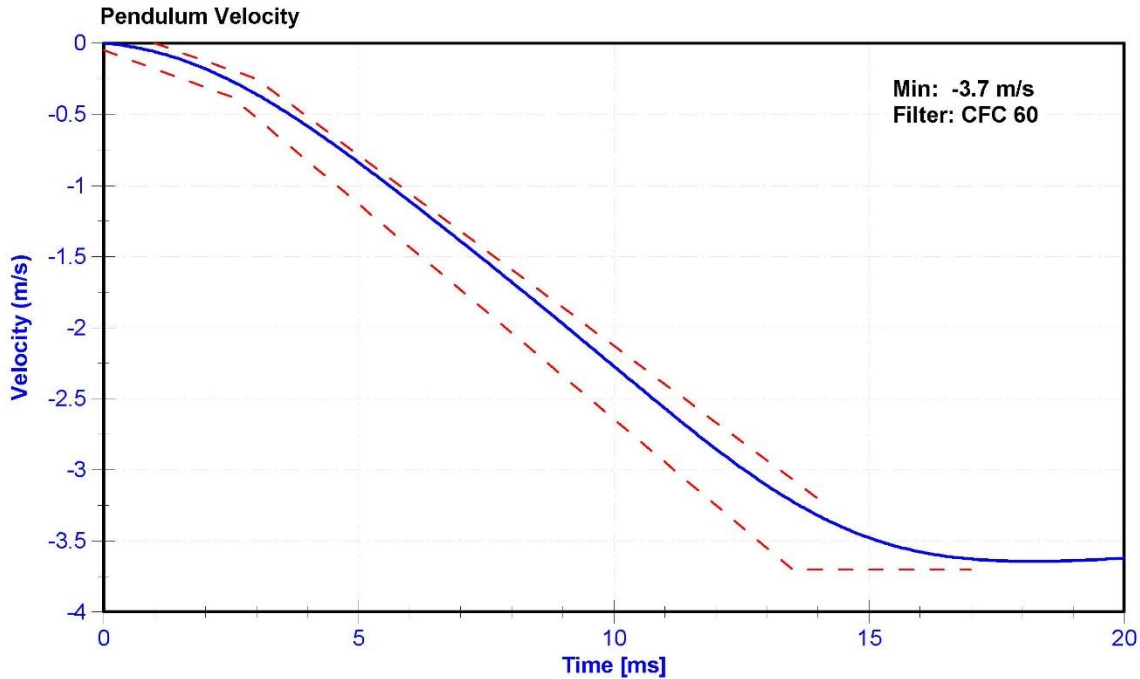

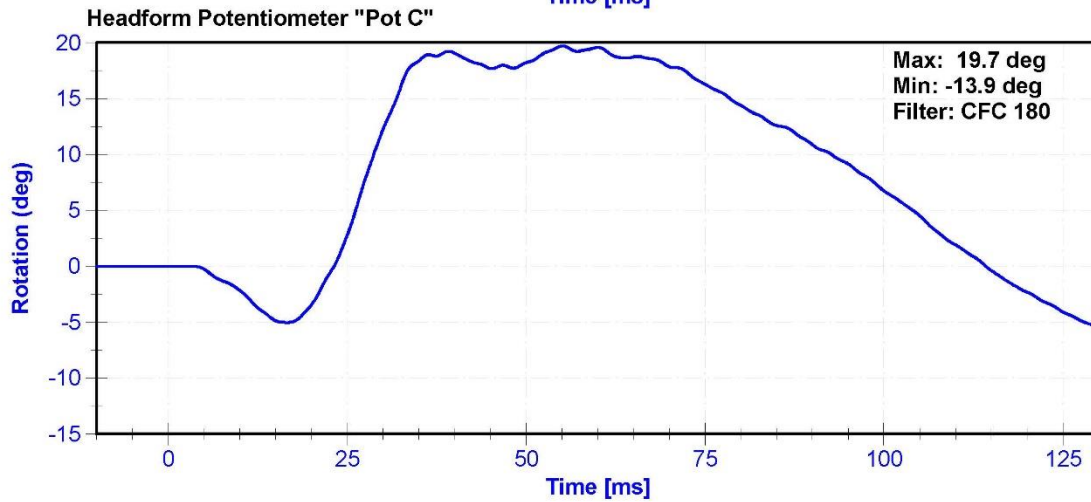
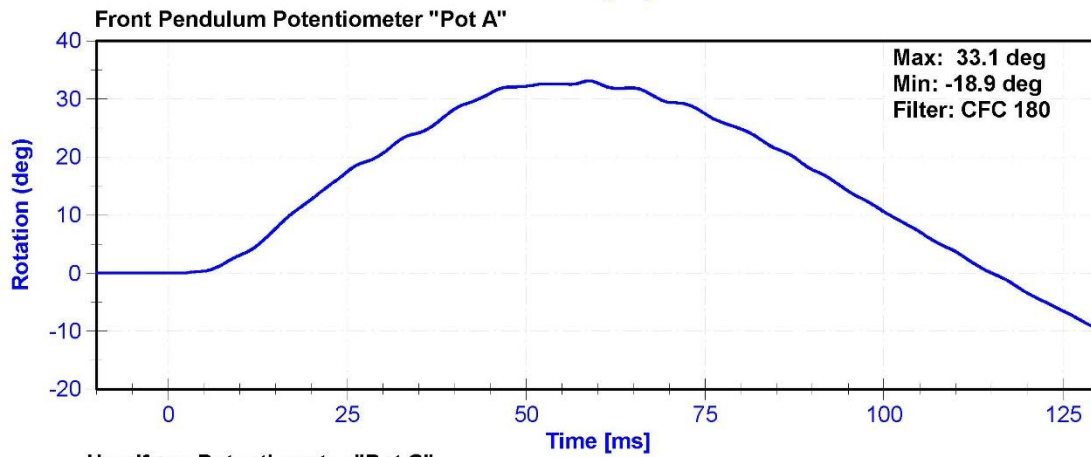
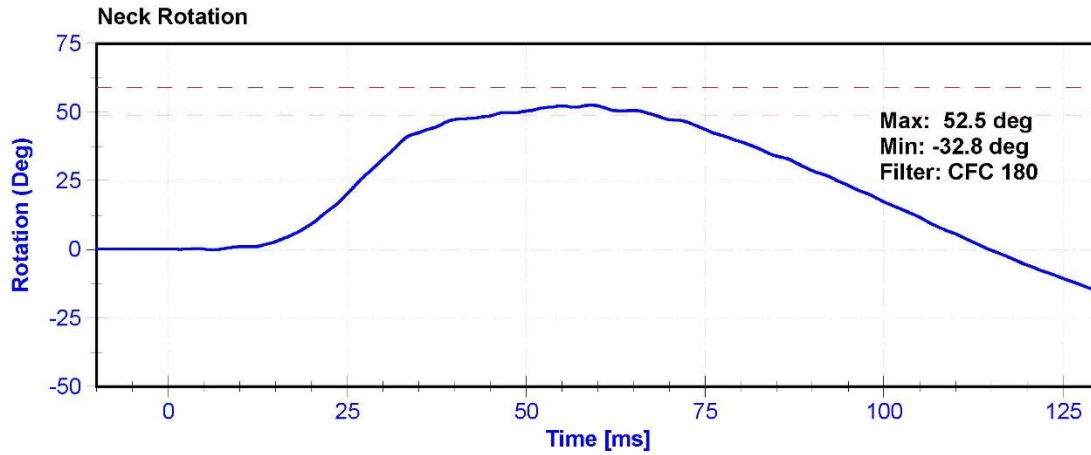

ATD Manufacturer	FTSS	Test Technician	K. Brogan
ATD Serial Number	F034	Laboratory Supervisor	M. Goehle

Results

Test Parameter	Minimum Specification	Maximum Specification	Unit	Result	Pass/Fail
Temperature	20.6	22.2	°C	21.1	Pass
Humidity	10	70	%	44.4	Pass
Velocity	4.2	4.4	m/s	4.22	Pass
Probe Acceleration	7.5	10.5	g's	9.53	Pass

Transducer Calibrations

Channel	Manufacturer	Serial Number	Calibration Date	Calibration Due Date
Probe Accelerometer	ENDEVCO 7264CT	AC-P32453	10/17/2017	4/17/2018

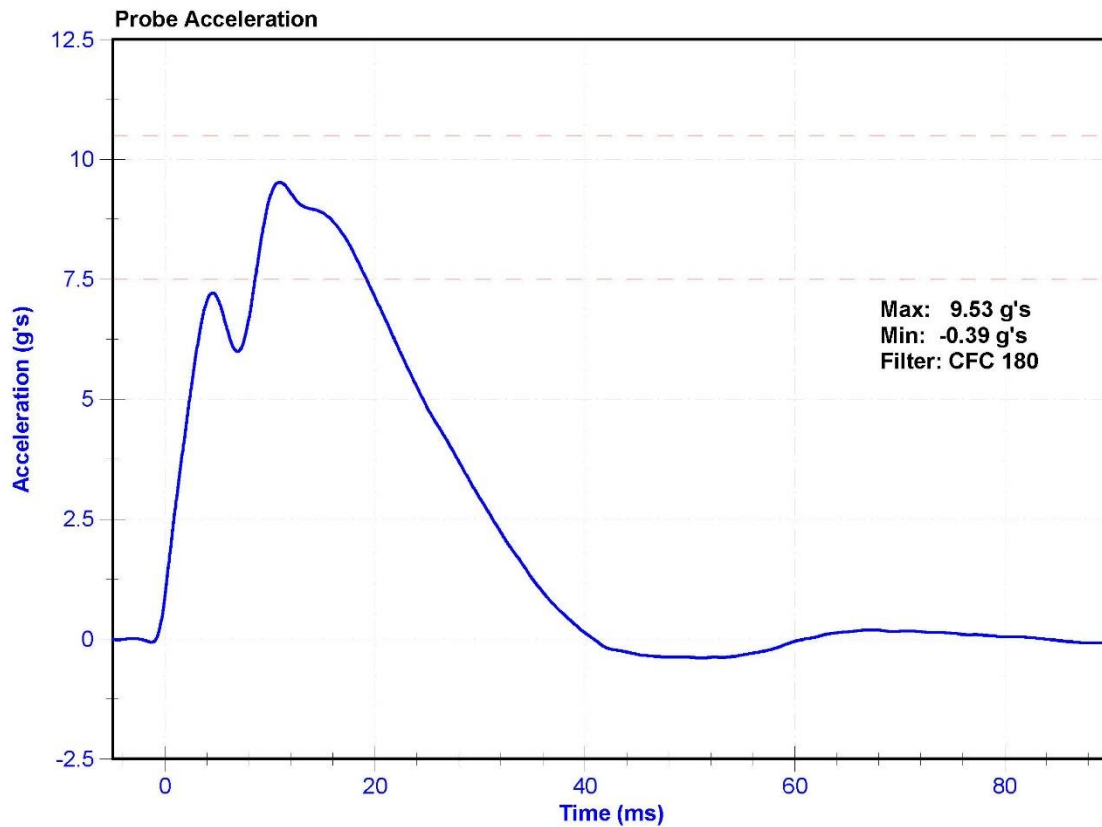

ATD Manufacturer	FTSS	Test Technician	K. Brogan
ATD Serial Number	F034	Laboratory Supervisor	M. Goehle

Results

Test Parameter	Minimum Specification	Maximum Specification	Unit	Result	Pass/Fail
Temperature	20.6	22.2	°C	21.3	Pass
Humidity	10	70	%	50.2	Pass
Rib Displacement	36	40	mm	37.2	Pass

Transducer Calibrations

Channel	Manufacturer	Serial Number	Calibration Date	Calibration Due Date
Rib Potentiometer	Honeywell MLT-38000203	DS-183GFE	9/27/2017	9/27/2018

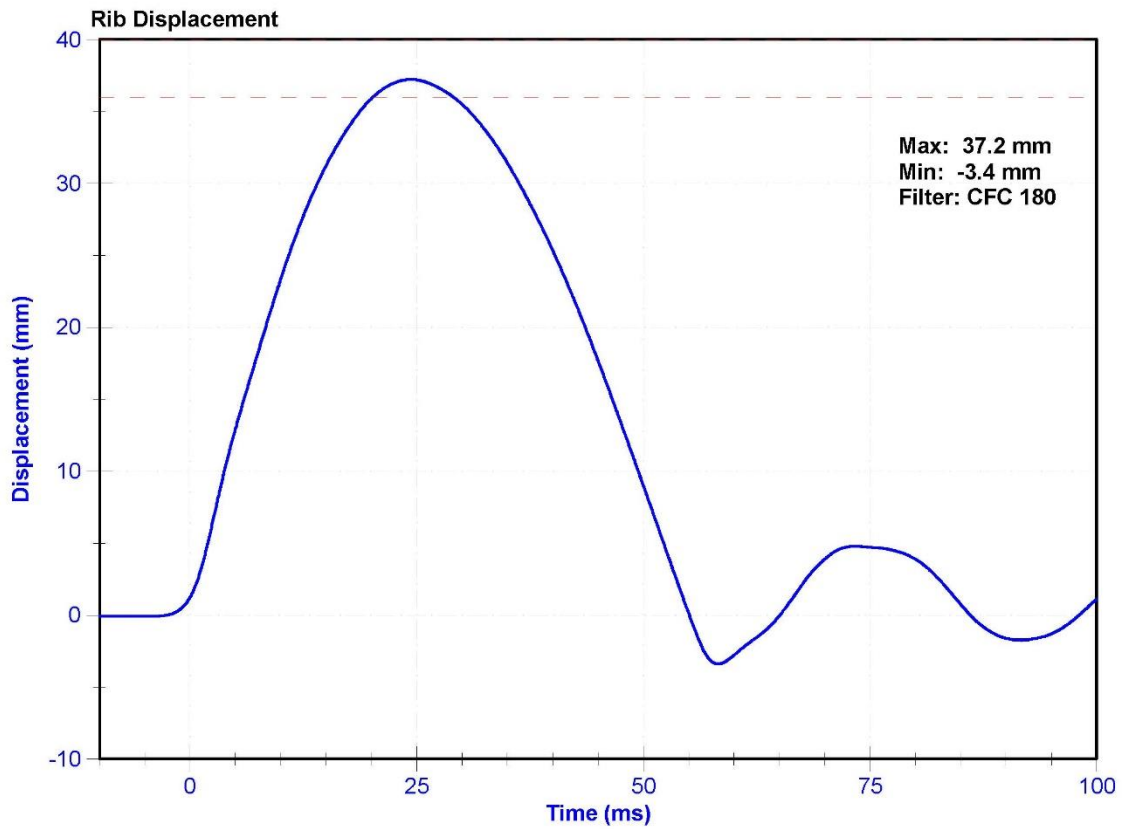

ATD Manufacturer	FTSS	Test Technician	K. Brogan
ATD Serial Number	F034	Laboratory Supervisor	M. Goehle

Results

Test Parameter	Minimum Specification	Maximum Specification	Unit	Result	Pass/Fail
Temperature	20.6	22.2	°C	21.3	Pass
Humidity	10	70	%	50.1	Pass
Rib Displacement	46	51	mm	47.5	Pass

Transducer Calibrations

Channel	Manufacturer	Serial Number	Calibration Date	Calibration Due Date
Rib Potentiometer	Honeywell MLT-38000203	DS-183GFE	9/27/2017	9/27/2018

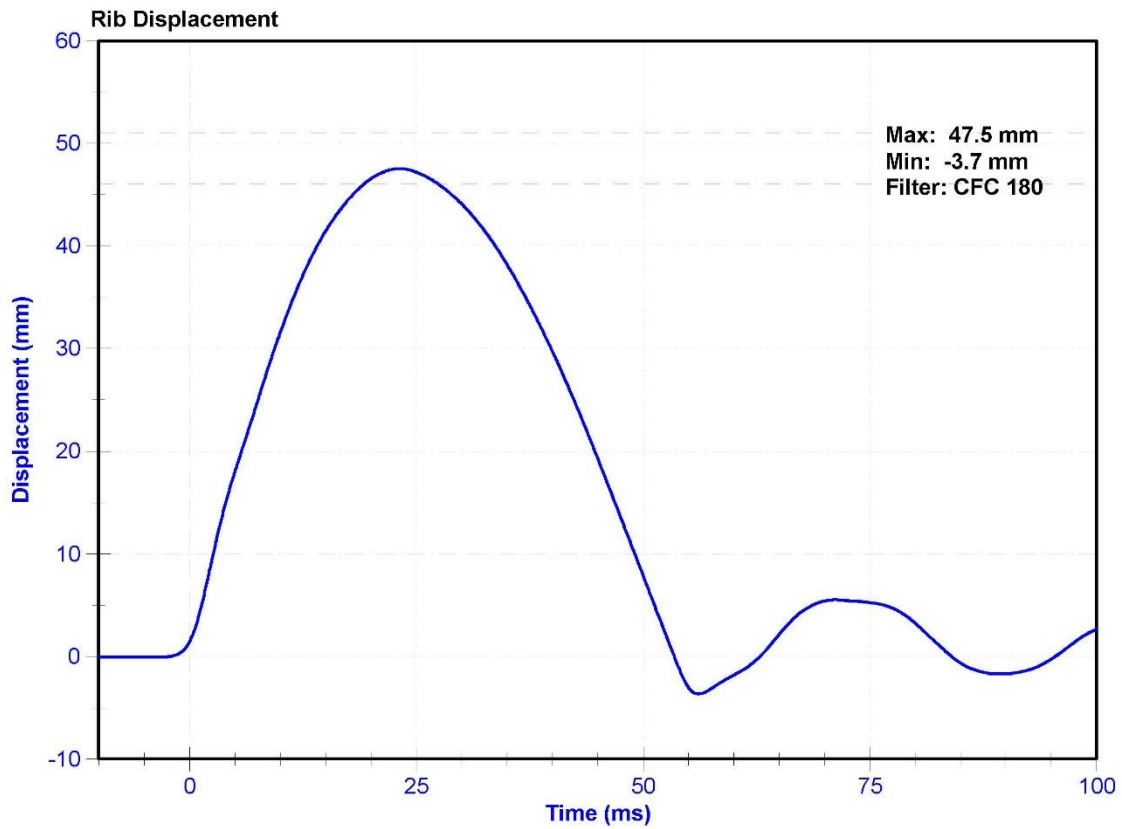

ATD Manufacturer	FTSS	Test Technician	K. Brogan
ATD Serial Number	F034	Laboratory Supervisor	M. Goehle

Results

Test Parameter	Minimum Specification	Maximum Specification	Unit	Result	Pass/Fail
Temperature	20.6	22.2	°C	21.9	Pass
Humidity	10	70	%	49.8	Pass
Rib Displacement	36	40	mm	37.4	Pass

Transducer Calibrations

Channel	Manufacturer	Serial Number	Calibration Date	Calibration Due Date
Rib Potentiometer	Honeywell MLT-38000203	DS-184GFE	9/27/2017	9/27/2018

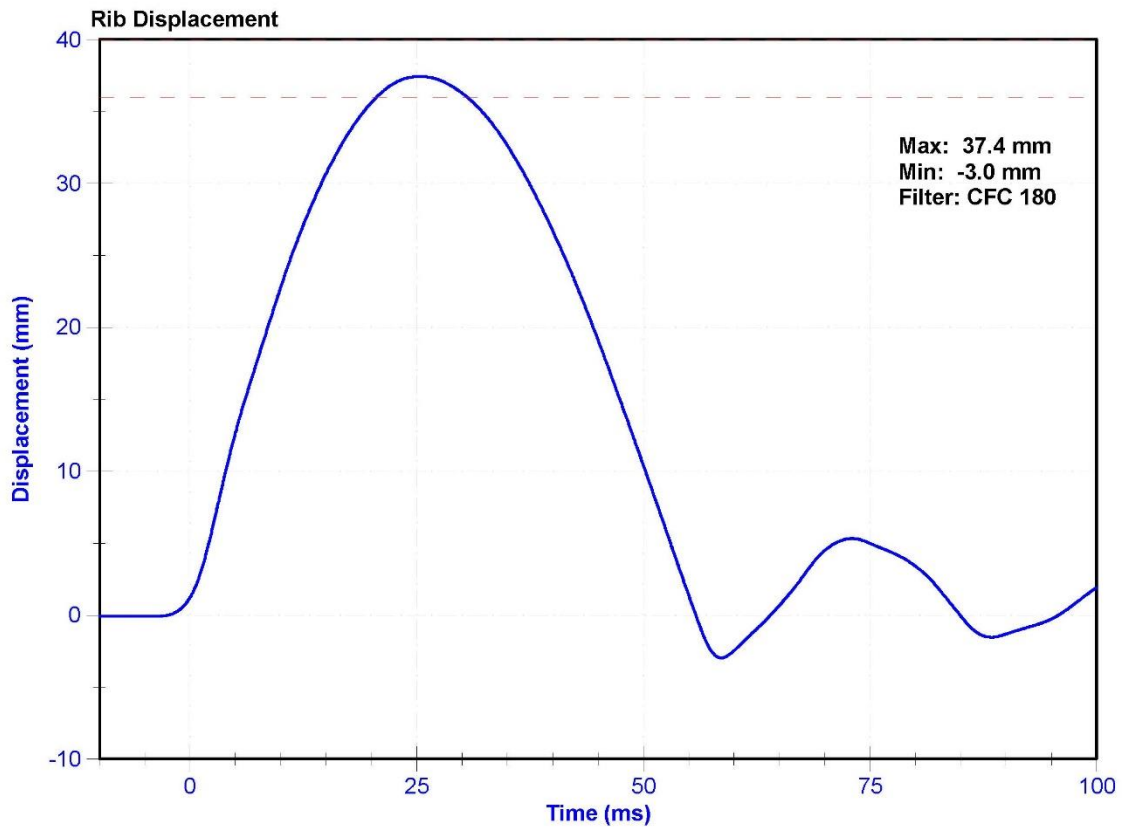

ATD Manufacturer	FTSS	Test Technician	K. Brogan
ATD Serial Number	F034	Laboratory Supervisor	M. Goehle

Results

Test Parameter	Minimum Specification	Maximum Specification	Unit	Result	Pass/Fail
Temperature	20.6	22.2	°C	21.9	Pass
Humidity	10	70	%	47.4	Pass
Rib Displacement	46	51	mm	48.4	Pass

Transducer Calibrations

Channel	Manufacturer	Serial Number	Calibration Date	Calibration Due Date
Rib Potentiometer	Honeywell MLT-38000203	DS-184GFE	9/27/2017	9/27/2018

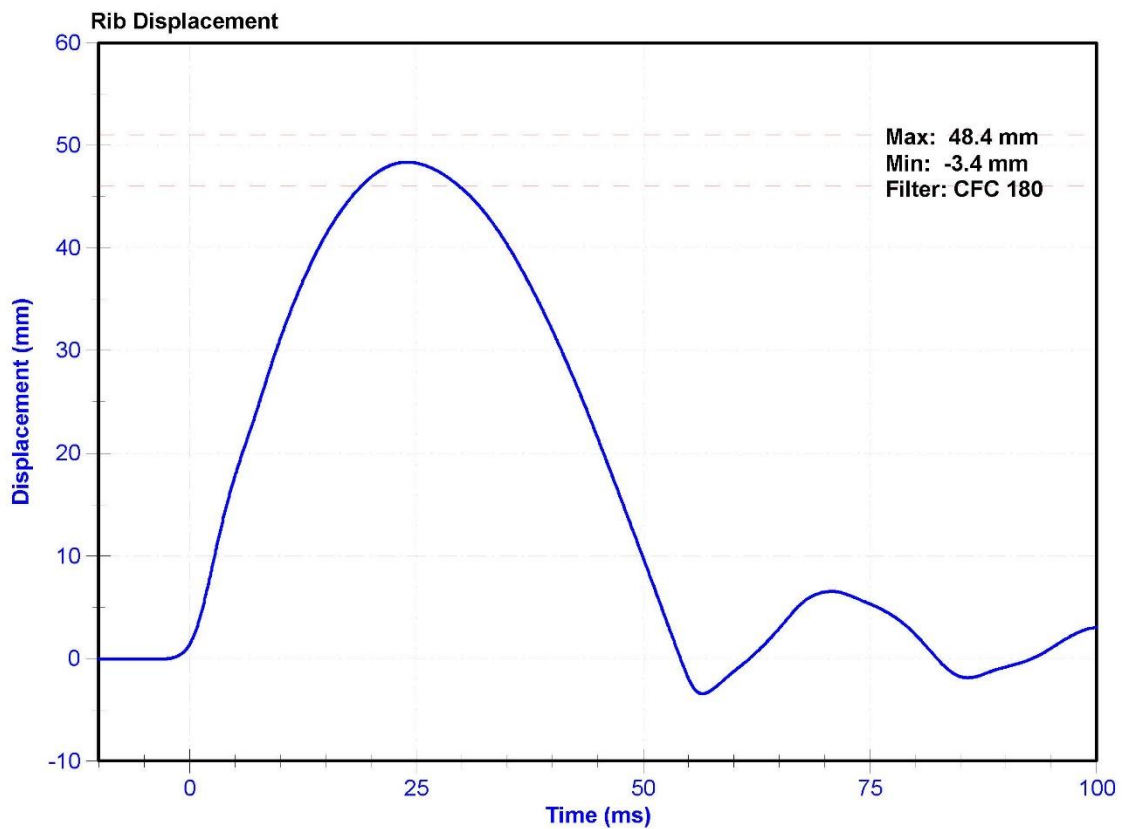

ATD Manufacturer	FTSS	Test Technician	K. Brogan
ATD Serial Number	F034	Laboratory Supervisor	M. Goehle

Results

Test Parameter	Minimum Specification	Maximum Specification	Unit	Result	Pass/Fail
Temperature	20.6	22.2	°C	21.7	Pass
Humidity	10	70	%	41.9	Pass
Rib Displacement	36	40	mm	38.6	Pass

Transducer Calibrations

Channel	Manufacturer	Serial Number	Calibration Date	Calibration Due Date
Rib Potentiometer	Honeywell MLT-38000203	DS-182GFE	9/27/2017	9/27/2018

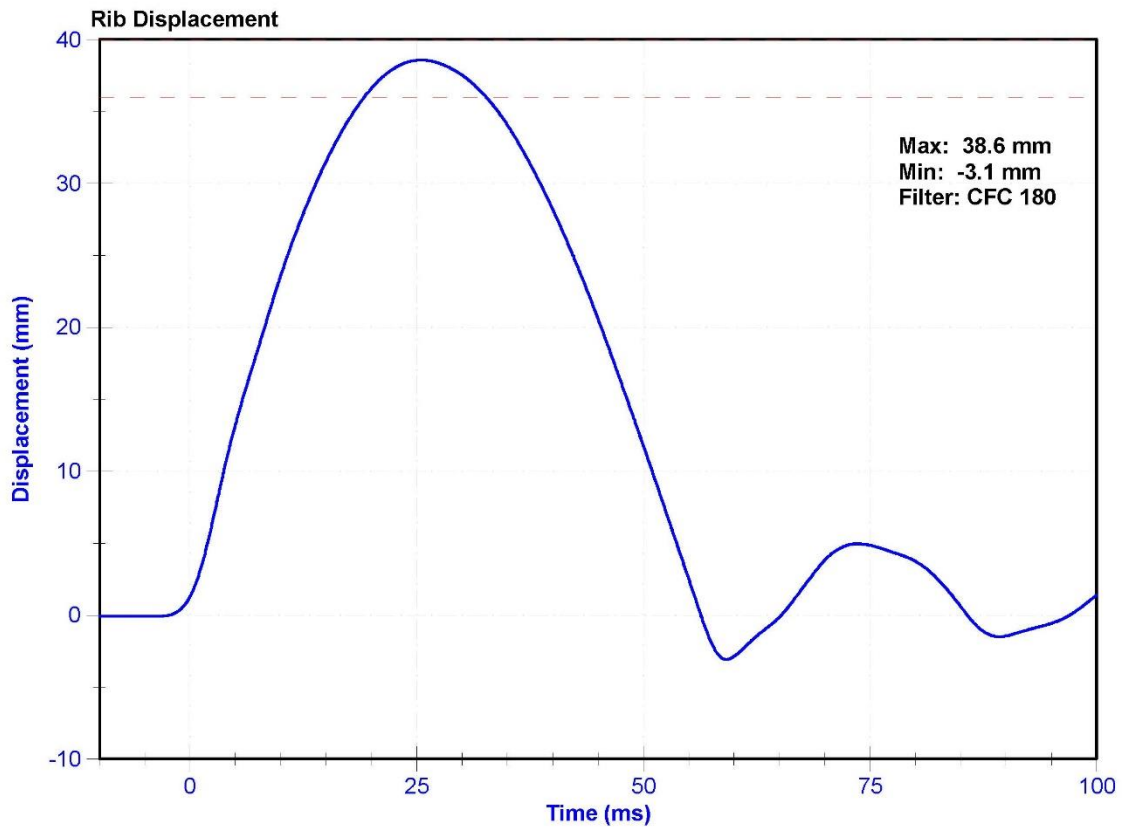

ATD Manufacturer	FTSS	Test Technician	K. Brogan
ATD Serial Number	F034	Laboratory Supervisor	M. Goehle

Results

Test Parameter	Minimum Specification	Maximum Specification	Unit	Result	Pass/Fail
Temperature	20.6	22.2	°C	21.9	Pass
Humidity	10	70	%	45.3	Pass
Rib Displacement	46	51	mm	49.2	Pass

Transducer Calibrations

Channel	Manufacturer	Serial Number	Calibration Date	Calibration Due Date
Rib Potentiometer	Honeywell MLT-38000203	DS-182GFE	9/27/2017	9/27/2018

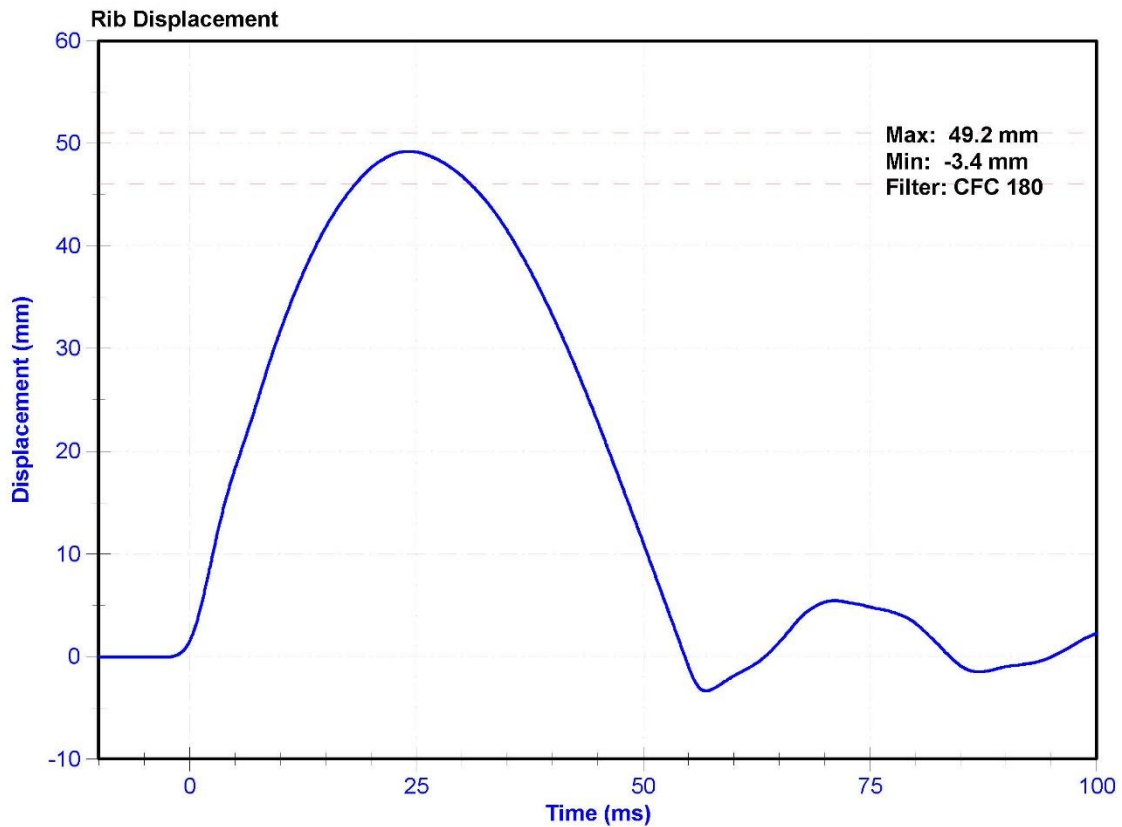

ATD Manufacturer	FTSS	Test Technician	K. Brogan
ATD Serial Number	F034	Laboratory Supervisor	M. Goehle

Results

Test Parameter	Minimum Specification	Maximum Specification	Unit	Result	Pass/Fail
Temperature	20.6	22.2	°C	21.0	Pass
Humidity	10	70	%	44.6	Pass
Velocity	5.4	5.6	m/s	5.56	Pass
Resistive Force after 6ms	5100	6200	N	5177.6	Pass
Upper Thorax Rib Deflection	34	41	mm	37.4	Pass
Mid Thorax Rib Deflection	37	45	mm	42.9	Pass
Lower Thorax Rib Deflection	37	44	mm	43.0	Pass

Transducer Calibrations

Channel	Manufacturer	Serial Number	Calibration Date	Calibration Due Date
Probe Accelerometer	ENDEVCO 7264CT	AC-P32453	10/17/2017	4/17/2018
Upper Thorax Rib Potentiometer	Honeywell MLT-38000203	DS-183GFE	9/27/2017	9/27/2018
Middle Thorax Rib Potentiometer	Honeywell MLT-38000203	DS-184GFE	9/27/2017	9/27/2018
Lower Thorax Rib Potentiometer	Honeywell MLT-38000203	DS-182GFE	9/27/2017	9/27/2018

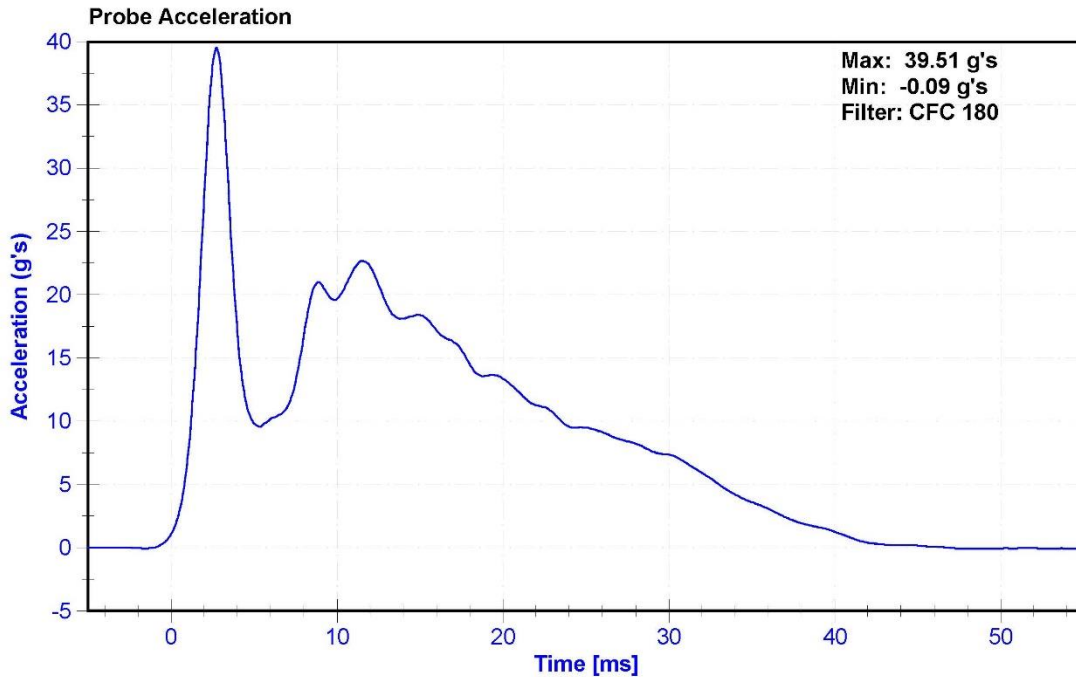

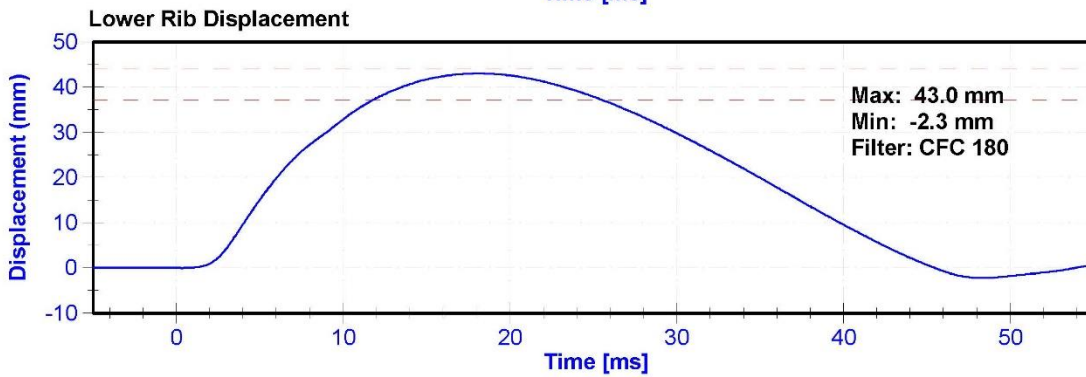
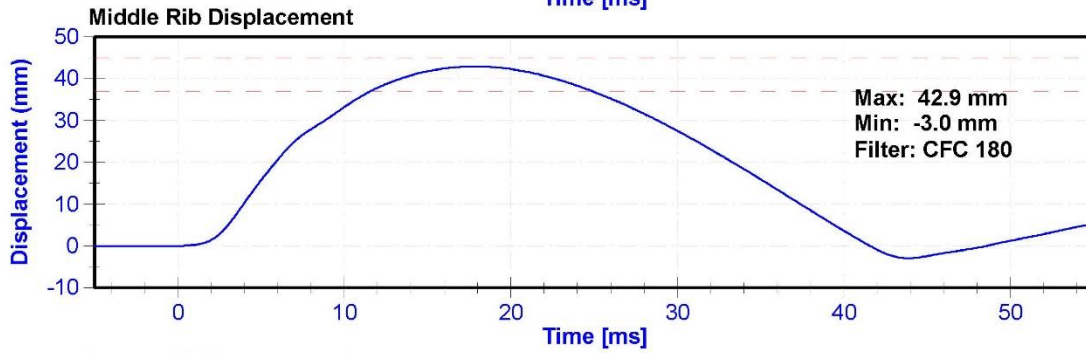
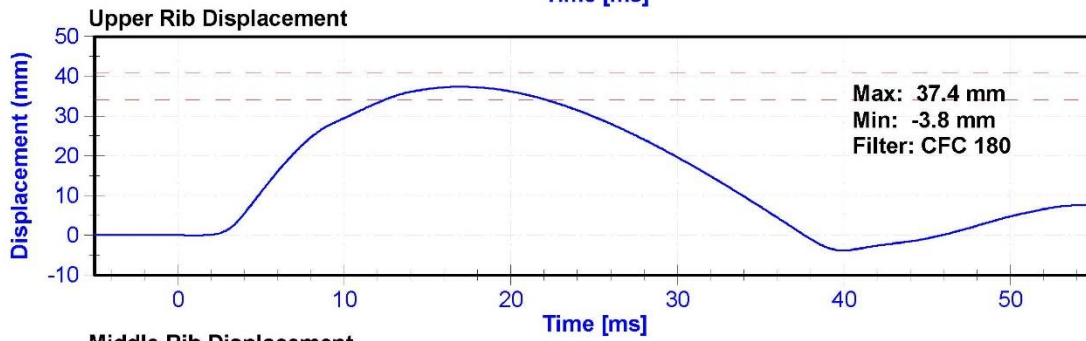
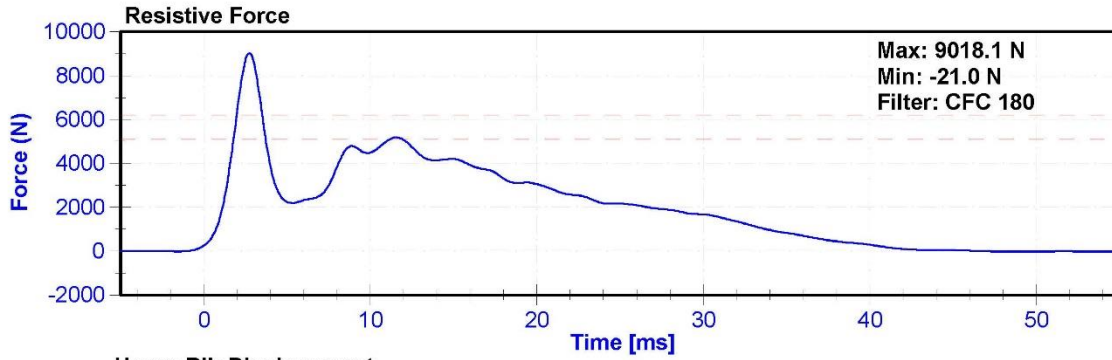

ATD Manufacturer	FTSS	Test Technician	K. Brogan
ATD Serial Number	F034	Laboratory Supervisor	M. Goehle

Results

Test Parameter	Minimum Specification	Maximum Specification	Unit	Result	Pass/Fail
Temperature	20.6	22.2	°C	21	Pass
Humidity	10	70	%	41.2	Pass
Velocity	3.9	4.1	m/s	4.07	Pass
Combined Abdomen Force	2200	2700	N	2536.4	Pass
Time at Peak Abdomen Force	10.0	12.3	ms	11.05	Pass
Resistive Probe Force	4000	4800	N	4302.7	Pass
Time at Peak Resistive Force	10.6	13.0	ms	11.30	Pass

Transducer Calibrations

Channel	Manufacturer	Serial Number	Calibration Date	Calibration Due Date
Pendulum Accelerometer	ENDEVCO 7264CT	AC-P32453	10/17/2017	4/17/2018
Front Abdomen Load Cell	DENTON 2631	LC-1512	6/5/2017	6/5/2018
Middle Abdomen Load Cell	DENTON 2631	LC-1526	6/5/2017	6/5/2018
Rear Abdomen Load Cell	DENTON 2631	LC-1516	6/5/2017	6/5/2018

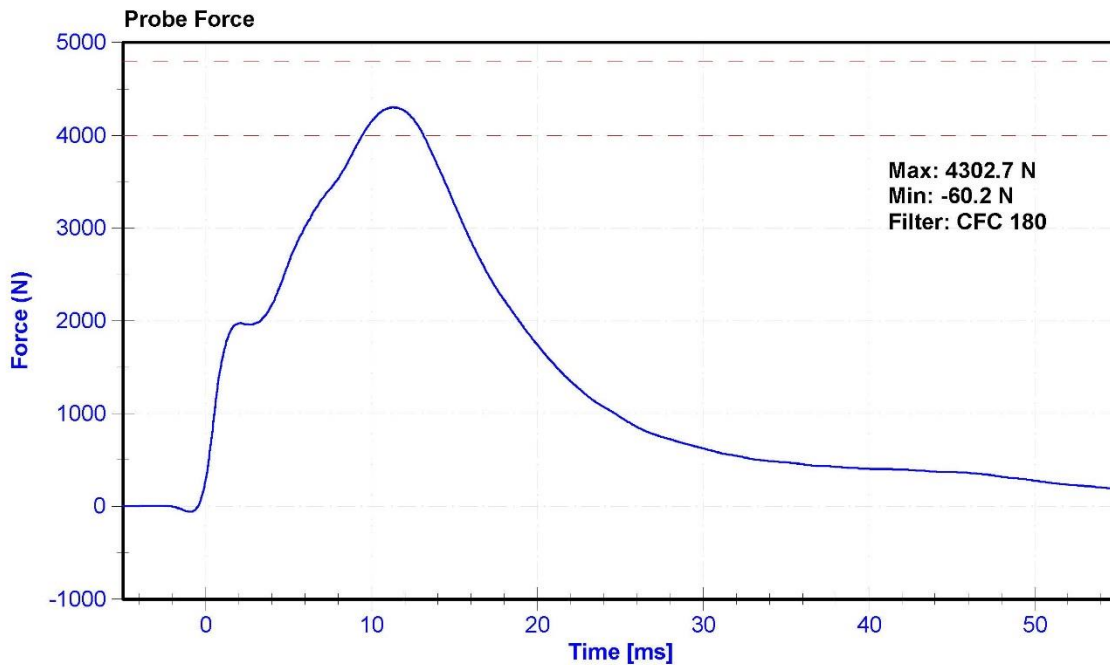

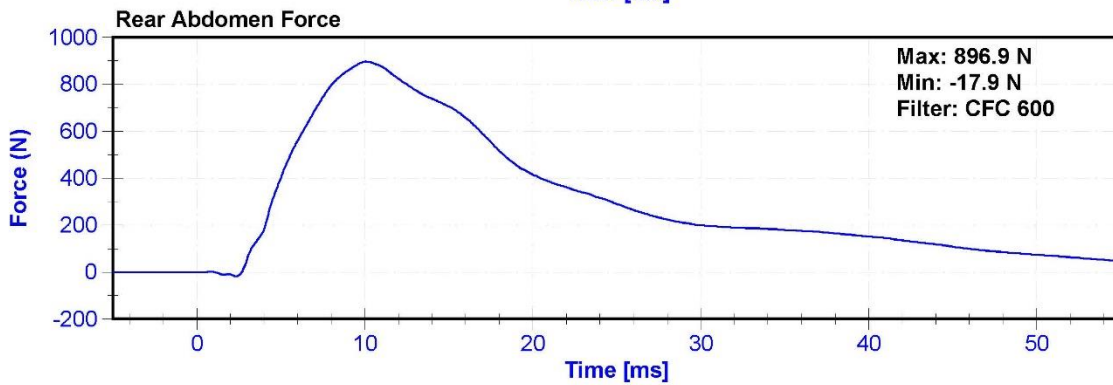
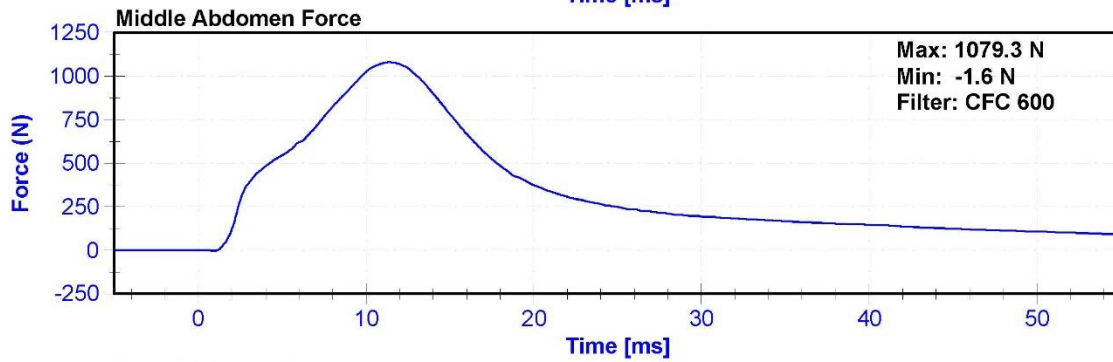
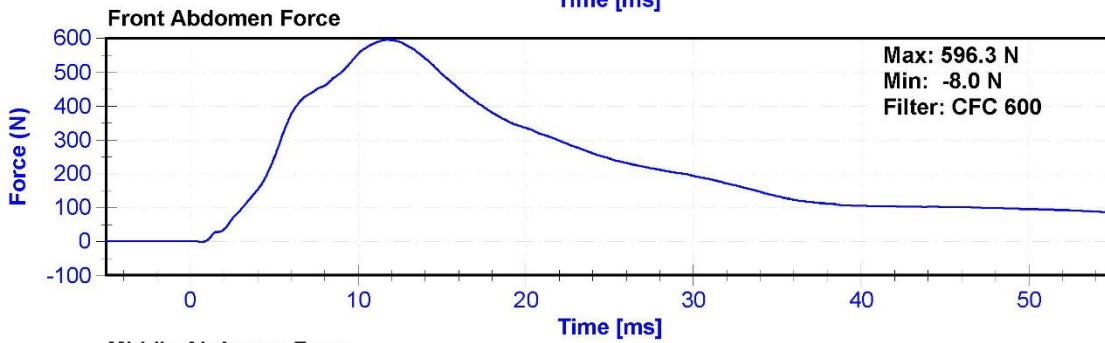
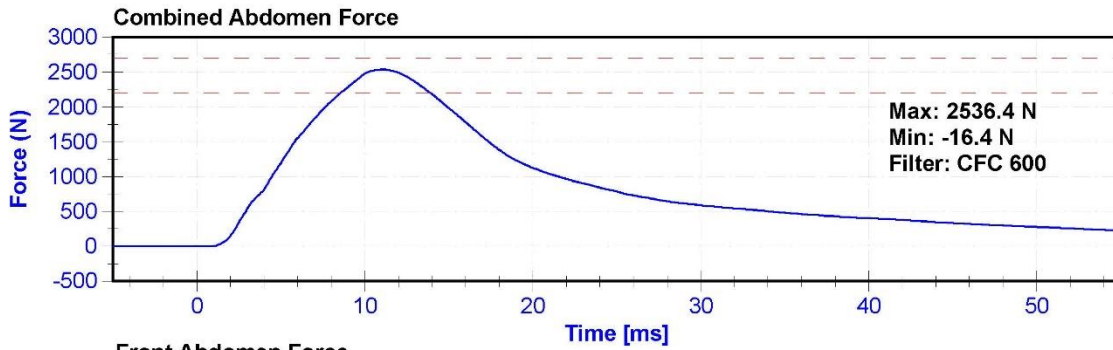

ATD Manufacturer	FTSS	Test Technician	K. Brogan
ATD Serial Number	F034	Laboratory Supervisor	M. Goehle

Results

Test Parameter	Minimum Specification	Maximum Specification	Unit	Result	Pass/Fail
Temperature	20.6	22.2	°C	21.3	Pass
Humidity	10	70	%	47.3	Pass
Velocity	5.95	6.15	m/s	6.113	Pass
Lateral Spine Rotation	45	55	deg	46.1	Pass
Time at Maximum Rotation	39	53	ms	44.5	Pass
Time of Decay to Zero Degrees	37	57	ms	37.5	Pass
Pulse within Corridor?	-	-	-		

Transducer Calibrations

Channel	Manufacturer	Serial Number	Calibration Date	Calibration Due Date
Pendulum Accelerometer	ENDEVCO 7231CT	AC-AH5F3	5/11/2017	5/11/2018
Pendulum "A" Potentiometer	SP22G	DS-094	10/30/2017	10/30/2018
Condyle "B" Potentiometer	SP22G	DS-095	10/30/2017	10/30/2018

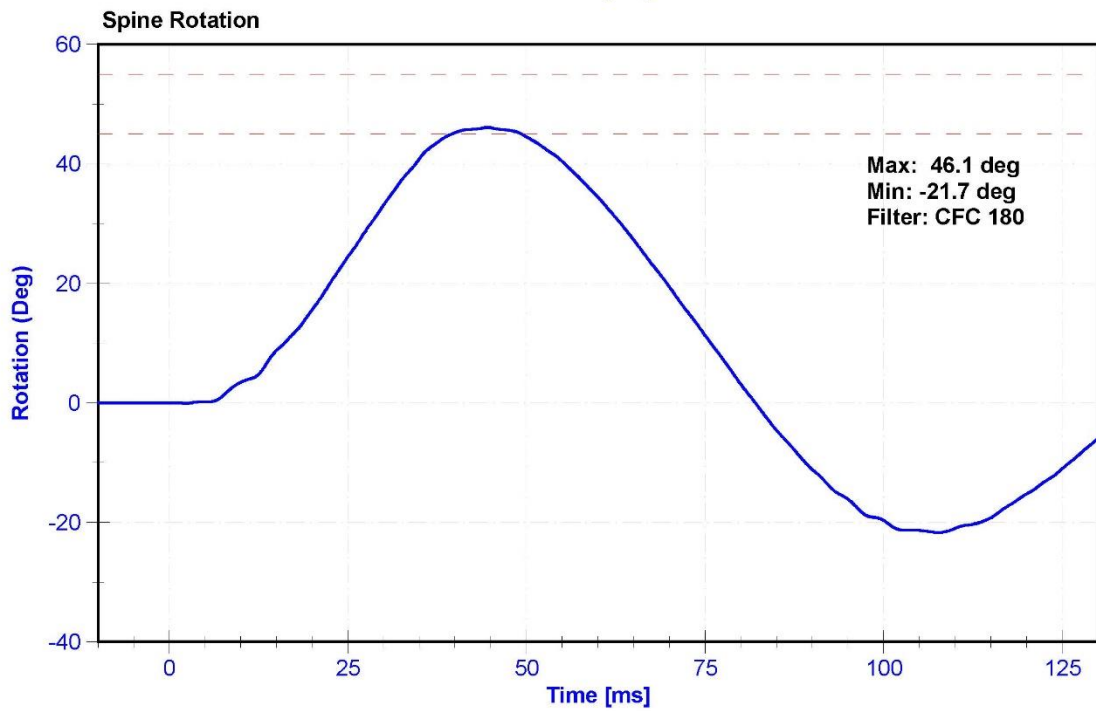
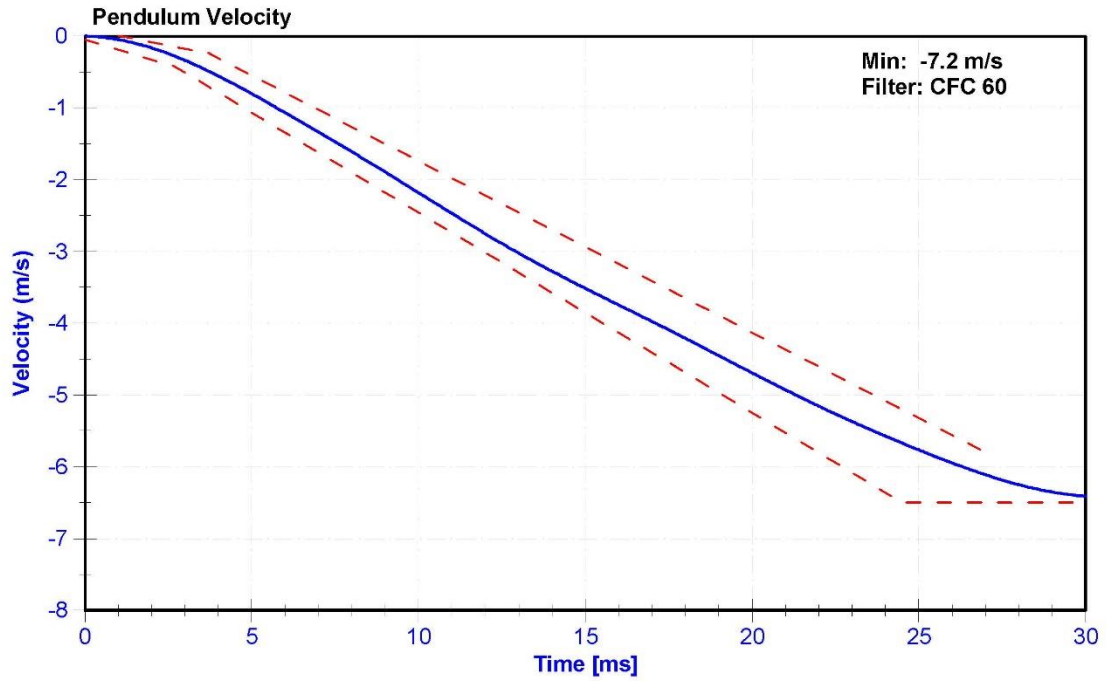

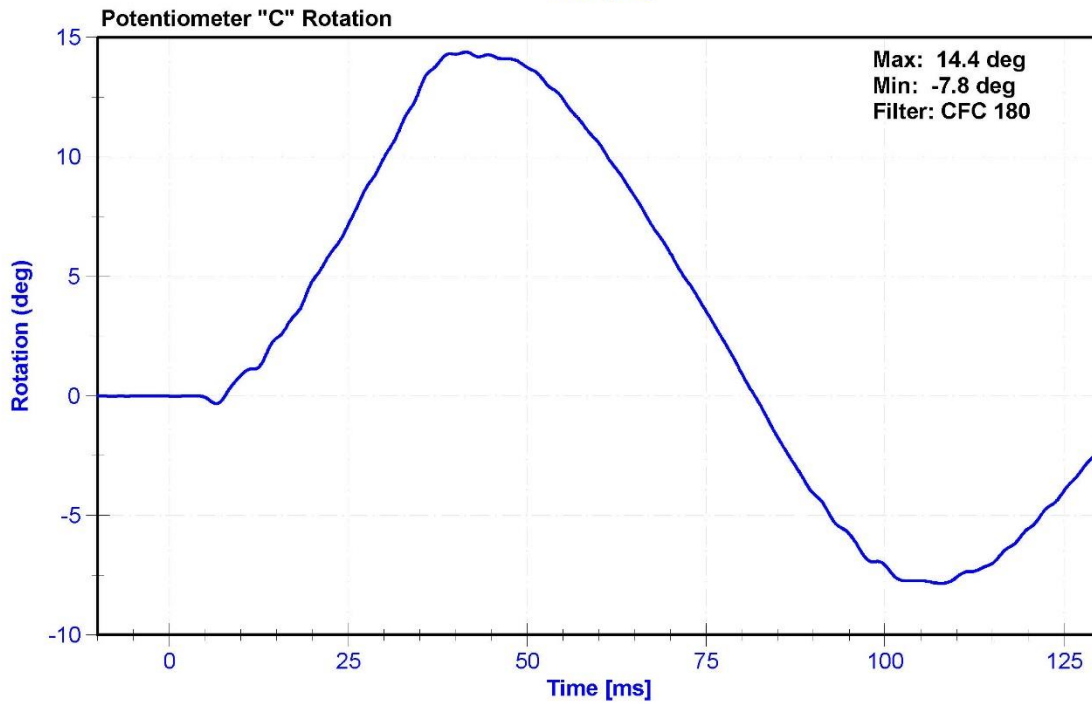
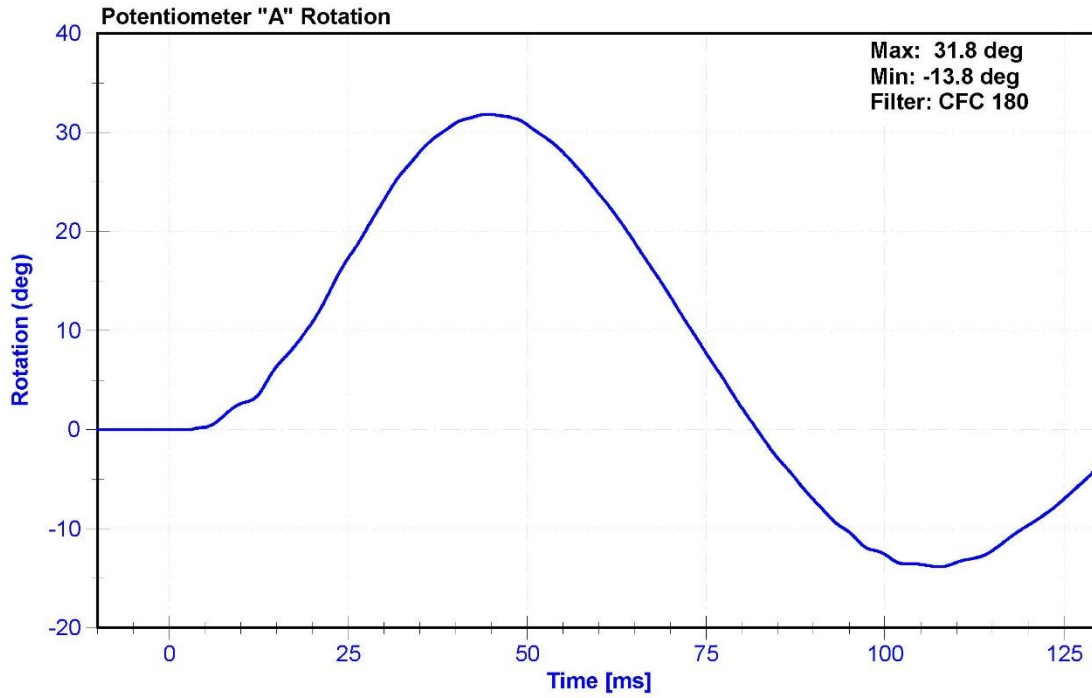

ATD Manufacturer	FTSS	Test Technician	K. Brogan
ATD Serial Number	F034	Laboratory Supervisor	M. Goehle

Results

Test Parameter	Minimum Specification	Maximum Specification	Unit	Result	Pass/Fail
Temperature	20.6	22.2	°C	21.0	Pass
Humidity	10	70	%	39.9	Pass
Velocity	4.2	4.4	m/s	4.37	Pass
Resistive Force	4700	5400	N	4703.6	Pass
Time at Peak Resistive Force	11.8	16.1	ms	12.80	Pass
Pubic Force	-1590	-1230	N	-1391.6	Pass
Time at Peak Pubic Force	12.2	17.0	ms	14.20	Pass

Transducer Calibrations

Channel	Manufacturer	Serial Number	Calibration Date	Calibration Due Date
Pendulum Accelerometer	ENDEVCO 7264CT	AC-P32453	10/17/2017	4/17/2018
Pubic Load Cell	Denton 3096JFL	LC-465Fy	6/6/2017	6/6/2018

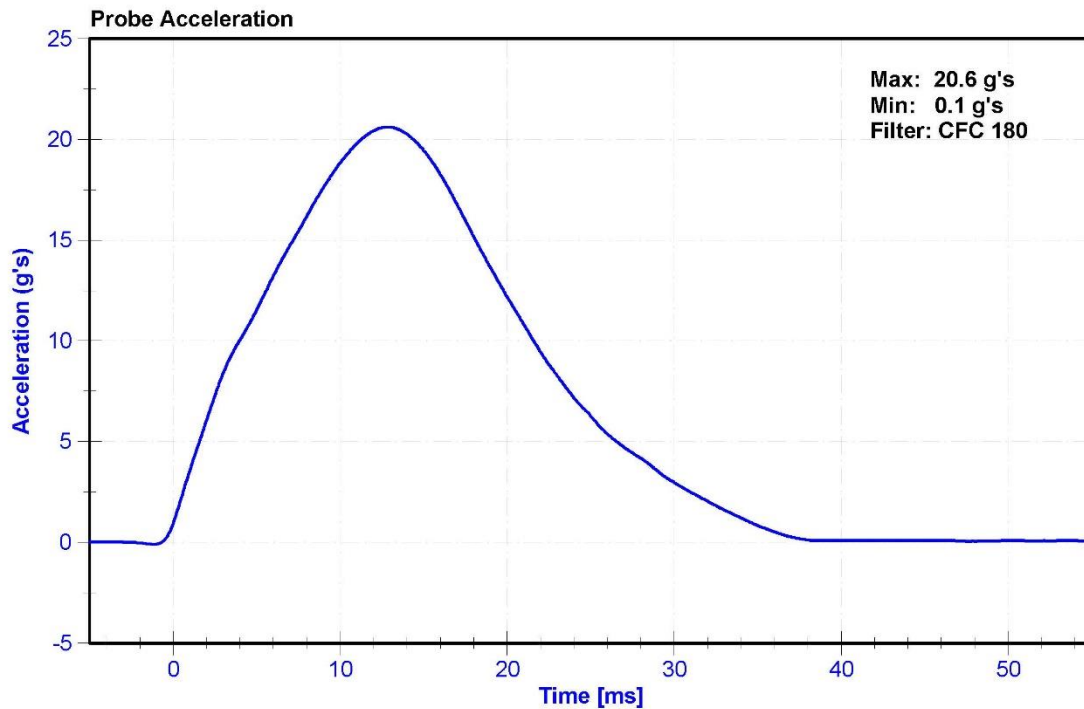

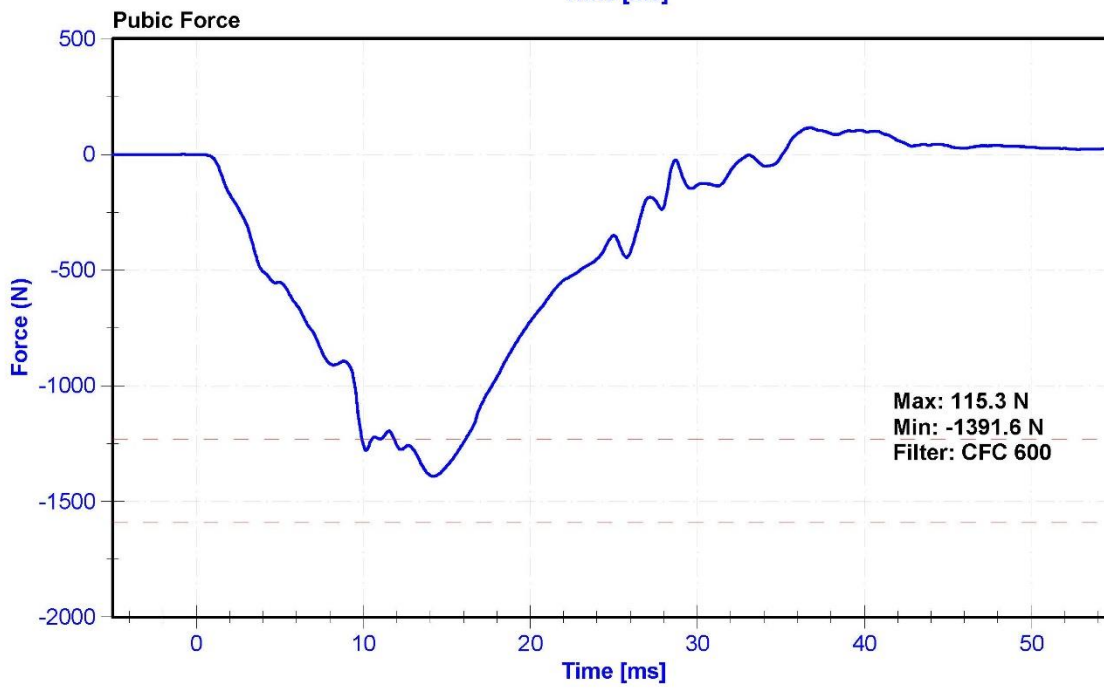
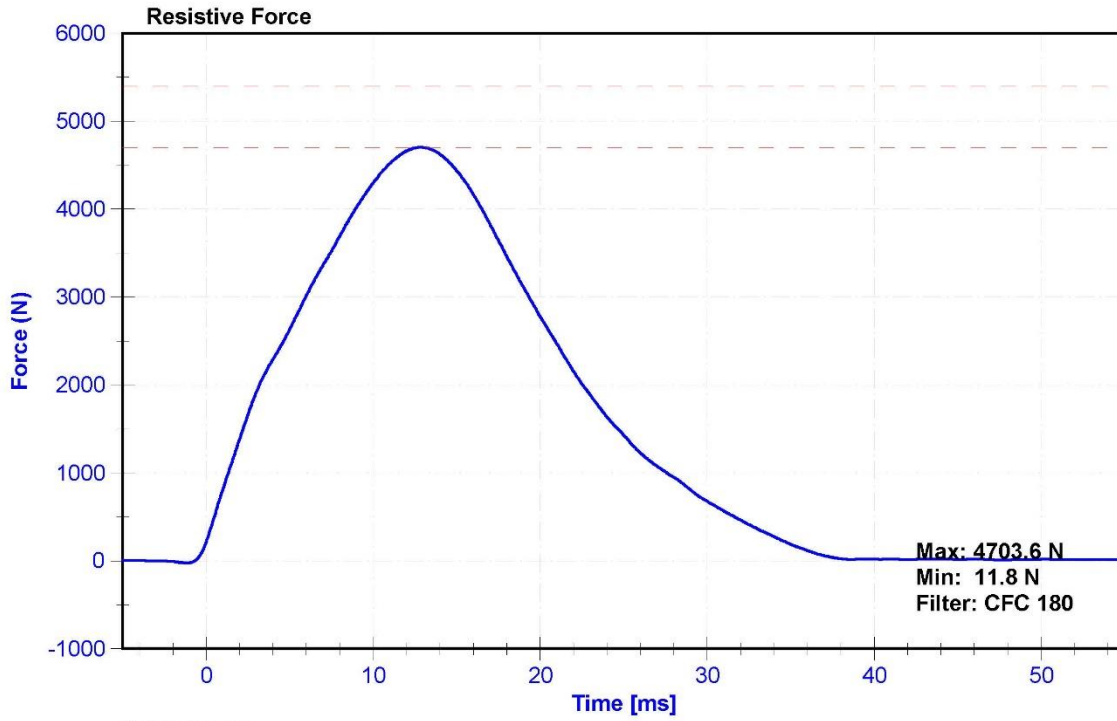

CALIBRATION TEST RESULTS

POST-TEST

SID-IIS 5TH PERCENTILE FEMALE - PASSENGER ATD

SERIAL No: 300



External Measurements - SID-IIs

Technician: Steve Keller

Date: 11/3/2017

Dummy Serial Number: 300

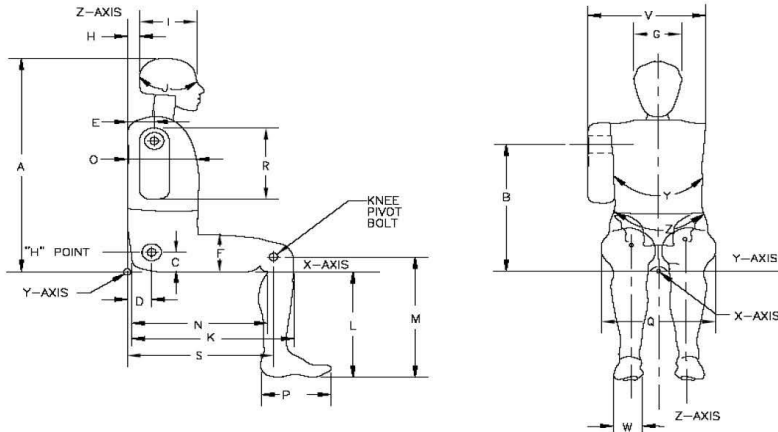

Symbol	Description	Specification (mm)		Result (mm)	Pass/Fail
A	Sitting Height	772	788	781	Pass
B	Shoulder Pivot Height	437	453	446	Pass
C	H-point Height	79	89	86	Pass
D	H-point from seatback	141	151	146	Pass
E	Shoulder Pivot from Backline	97	107	103	Pass
F	Thigh Clearance	119	135	122	Pass
G	Head Breadth	140	148	145	Pass
H	Head Back from Backline	40	46	46	Pass
I	Head Depth	178	188	182	Pass
J	Head Circumference	541	551	547	Pass
K	Buttock to Knee Length	514	540	536	Pass
L	Popliteal Height	343	369	356	Pass
M	Knee Pivot to floor height	392	409	402	Pass
N	Buttock Popliteal Length	416	442	435	Pass
O	Chest Depth w/o jacket	195	211	205	Pass
P	Foot Length	216	232	221	Pass
Q	Hip Breadth (w/pelvic plugs)	313	323	319	Pass
R	Arm Length	249	259	251	Pass
S	Knee Joint to seatback	477	493	485	Pass
V	Shoulder Width	341	357	351	Pass
W	Foot Width	78	94	85	Pass
Y	Chest Circumference w/jacket	851	881	870	Pass
Z	Waist Circumference	761	791	770	Pass

ATD Manufacturer	FTSS	Test Technician	M. Goehle
ATD Serial Number	300	Laboratory Supervisor	M. Goehle

Results

Test Parameter	Minimum Specification	Maximum Specification	Unit	Result	Pass/Fail
Temperature	20.6	22.2	°C	21	Pass
Humidity	10	70	%	33.5	Pass
Resultant Acceleration	115	137	g's	123.1	Pass
Oscillation	0	15	%	7.5	Pass
Fore-Aft Acceleration	-15	15	g's	-4.7	Pass

Transducer Calibrations

Channel	Manufacturer	Serial Number	Calibration Date	Calibration Due Date
X Accelerometer	ENDEVCO 7264CT	AC-P58777	9/28/2017	3/29/2018
Y Accelerometer	ENDEVCO 7264CT	AC-P59018	9/28/2017	3/29/2018
Z Accelerometer	ENDEVCO 7264	AC-P79189	9/28/2017	3/29/2018

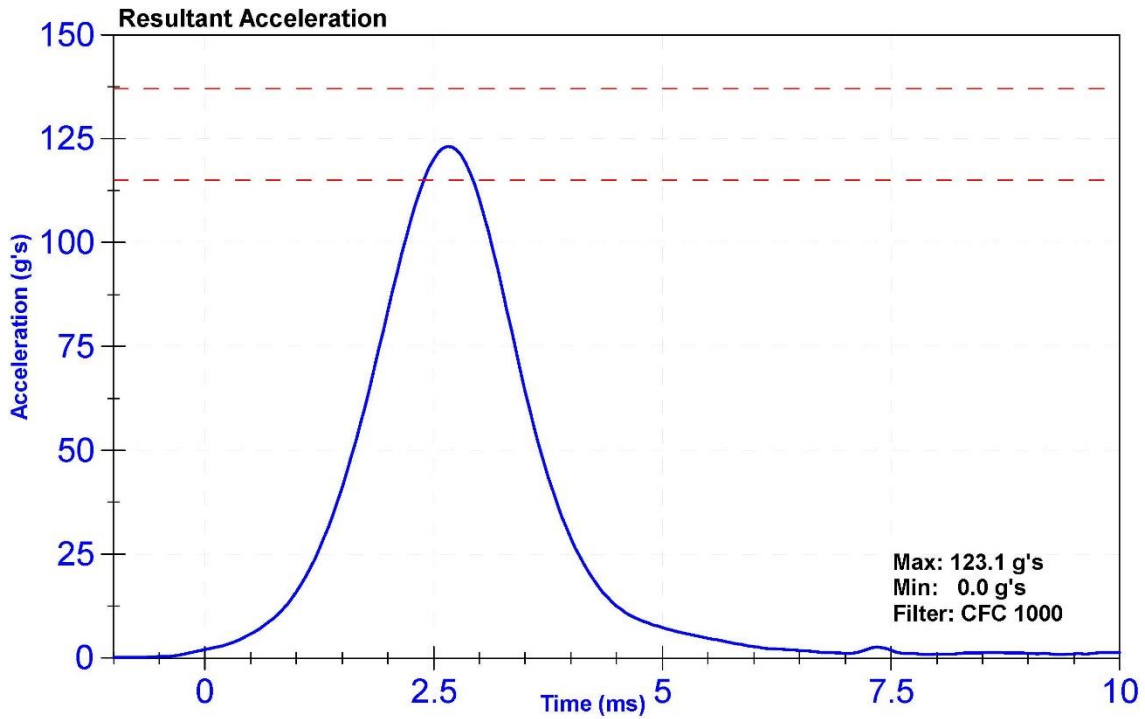

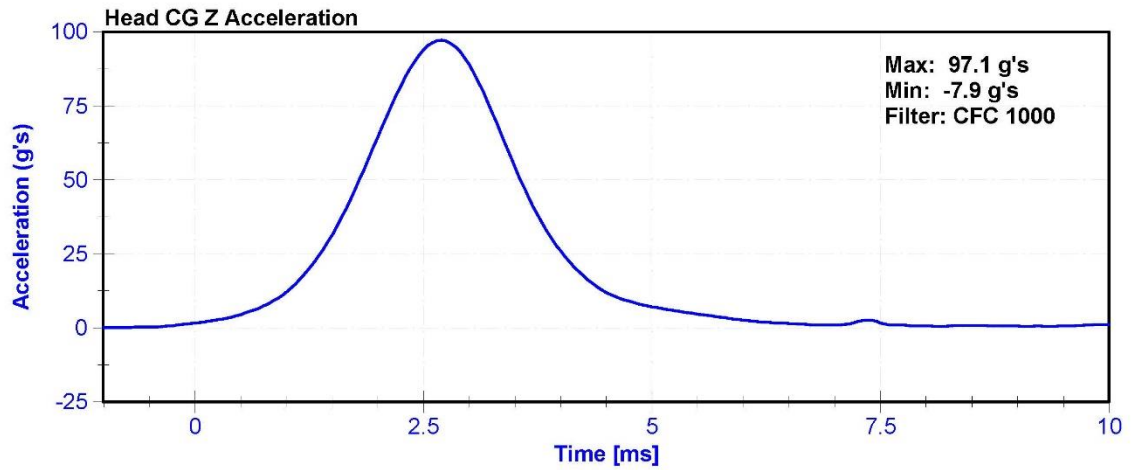
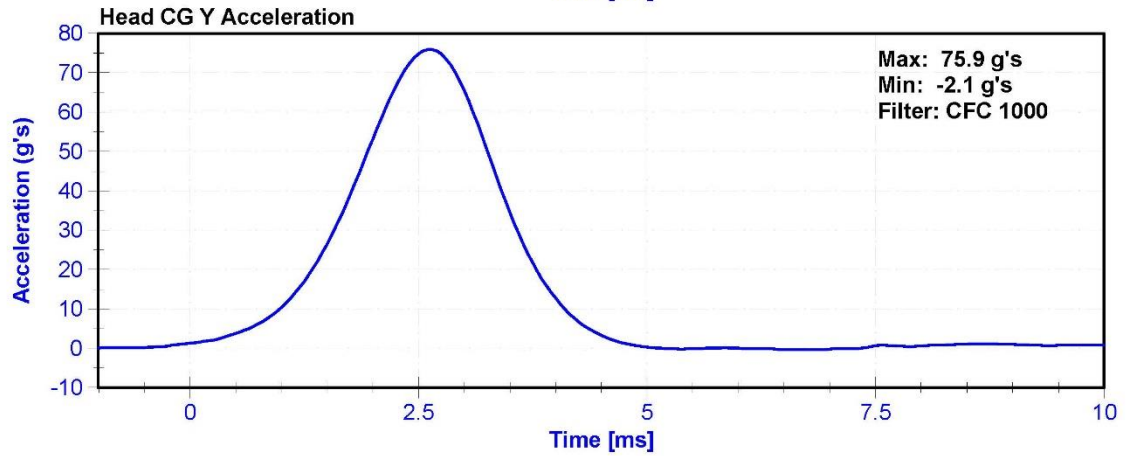
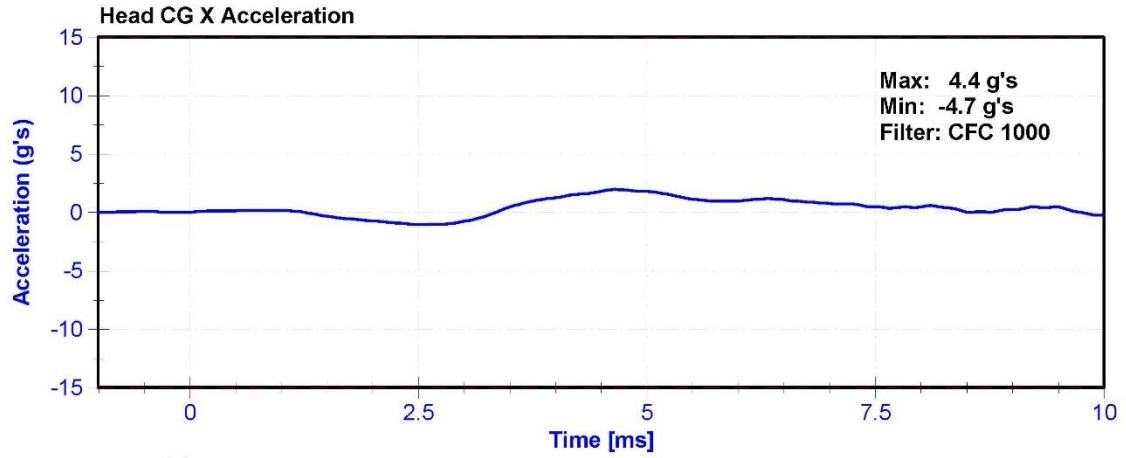

ATD Manufacturer	FTSS	Test Technician	M. Goehle
ATD Serial Number	300	Laboratory Supervisor	M. Goehle

Results

Test Parameter	Minimum Specification	Maximum Specification	Unit	Result	Pass/Fail
Temperature	20.6	22.2	°C	21	Pass
Humidity	10	70	%	34	Pass
Velocity	5.51	5.63	m/s	5.583	Pass
Pendulum Impulse at 10ms	2.2	2.8	m/s	2.57	Pass
Pendulum Impulse at 15ms	3.3	4.1	m/s	3.81	Pass
Pendulum Impulse at 20ms	4.4	5.4	m/s	5.09	Pass
Pendulum Impulse at 25ms	5.4	6.1	m/s	5.84	Pass
Pendulum Impulse from 25 to 100ms	5.5	6.2	m/s	5.87	Pass
Neck Rotation	71	81	deg	73.8	Pass
Time at Maximum Rotation	50	70	ms	58.7	Pass
Moment about the OC	36	44	Nm	40.0	Pass
Moment Decay to 0 Nm	102	126	ms	112.7	Pass

Transducer Calibrations

Channel	Manufacturer	Serial Number	Calibration Date	Calibration Due Date
Pendulum Accelerometer	ENDEVCO 7231CT	AC-AH5F3	5/11/2017	5/11/2018
Pendulum Potentiometer	Denton 78051-342	DS-184Pend	10/27/2017	10/27/2018
Condyle Potentiometer	Denton 78051-342	DS-185Pend	10/27/2017	10/27/2018
Upper Neck Load Cell	Denton 1716	LC-1872 FY	7/26/2017	7/26/2018

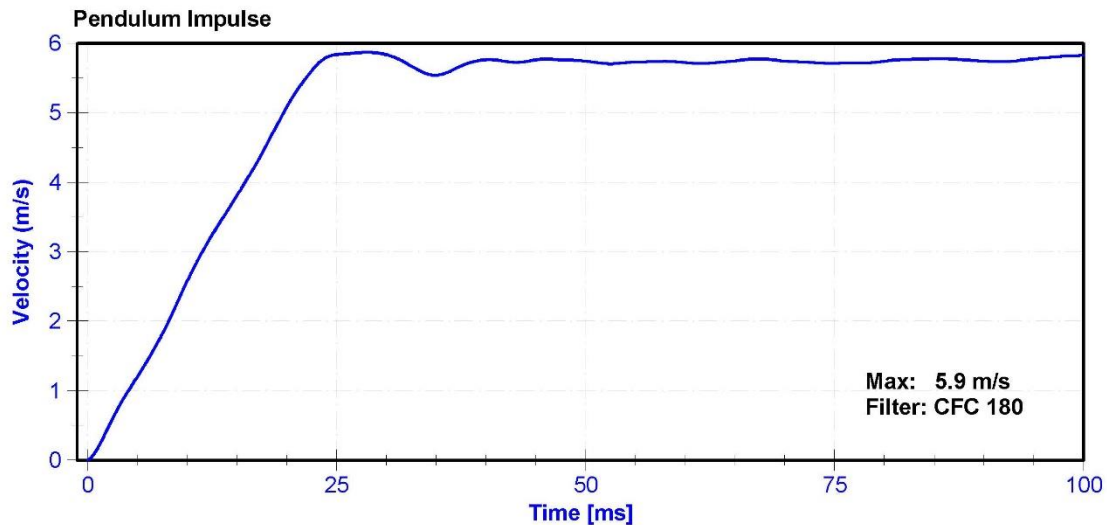

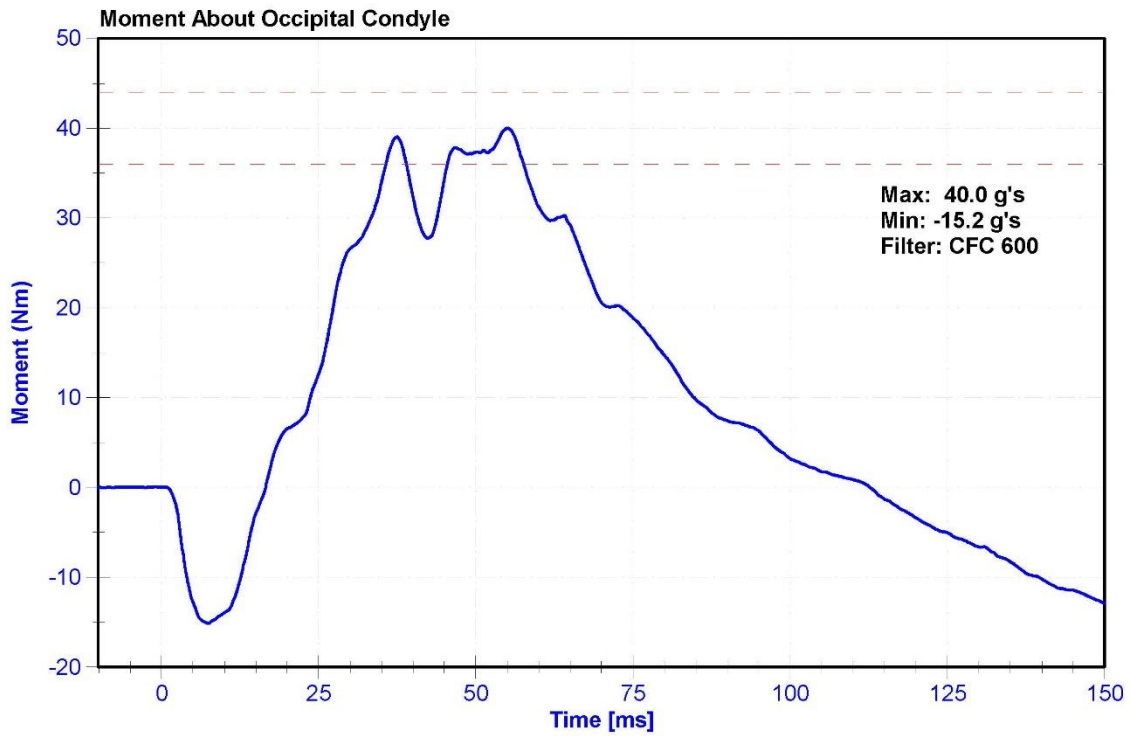
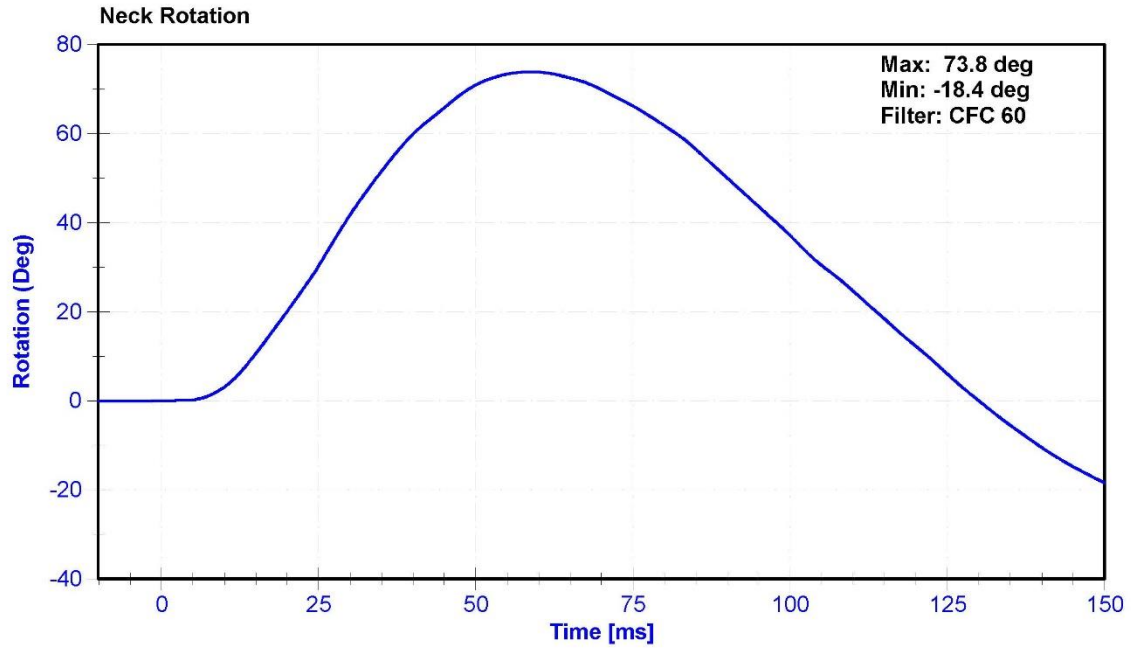

ATD Manufacturer	FTSS	Test Technician	K. Brogan
ATD Serial Number	300	Laboratory Supervisor	M. Goehle

Results

Test Parameter	Minimum Specification	Maximum Specification	Unit	Result	Pass/Fail
Temperature	20.6	22.2	°C	20.8	Pass
Humidity	10	70	%	51.2	Pass
Velocity	4.2	4.4	m/s	4.36	Pass
Probe Acceleration	13	18	g's	14.6	Pass
Shoulder Deflection	28	37	mm	31.7	Pass
Lateral Upper Spine Acceleration	17	22	g's	19.9	Pass

Transducer Calibrations

Channel	Manufacturer	Serial Number	Calibration Date	Calibration Due Date
Pendulum Accelerometer	ENDEVCO 7264CT	AC-P32453	10/17/2017	4/17/2018
Shoulder Potentiometer	Servo 08TC1-3725	DS-1063GFE	9/27/2017	9/27/2018
Upper Spine Y Accelerometer	ENDEVCO 7264	AC-P83320	9/27/2017	3/28/2018

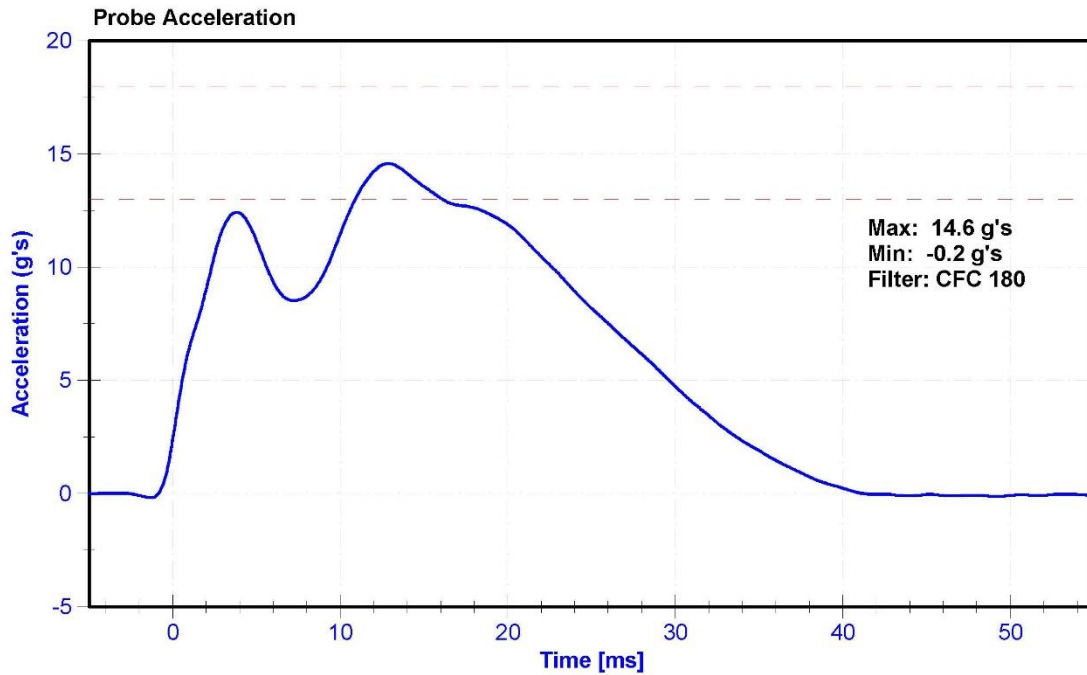

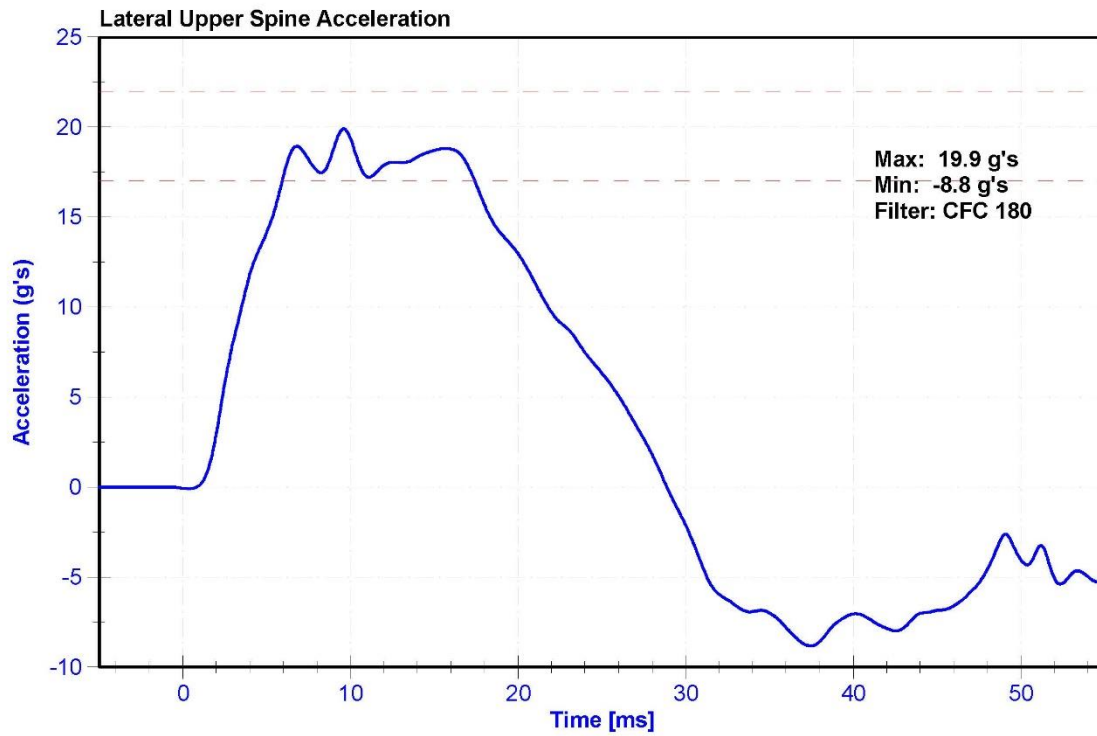
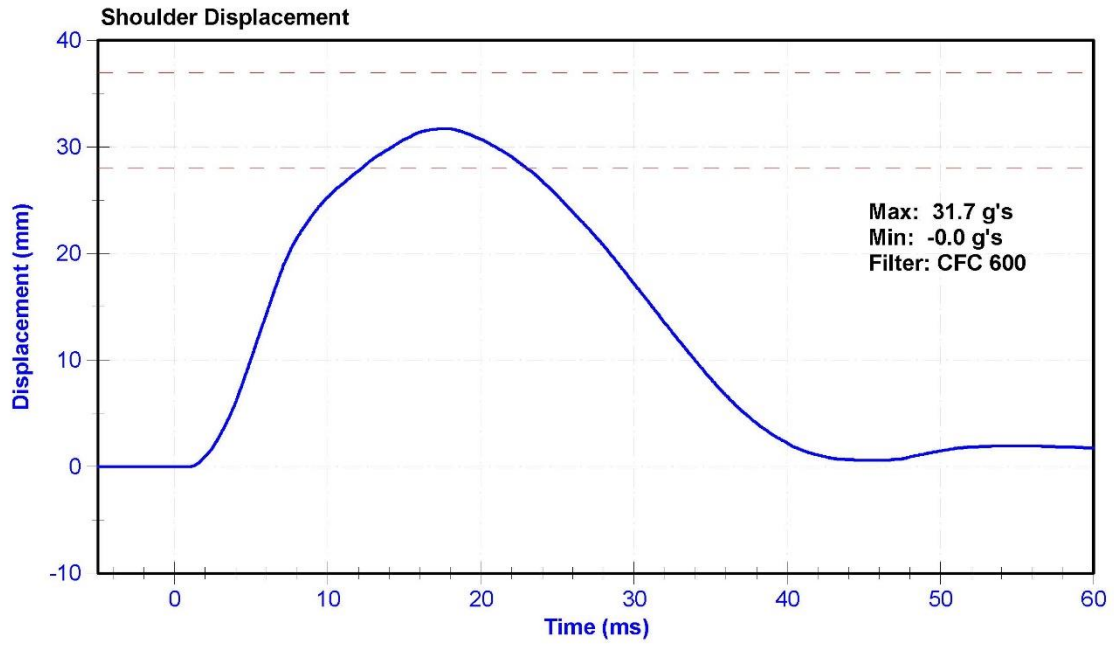

ATD Manufacturer	FTSS	Test Technician	K. Brogan
ATD Serial Number	300	Laboratory Supervisor	M. Goehle

Results

Test Parameter	Minimum Specification	Maximum Specification	Unit	Result	Pass/Fail
Temperature	20.6	22.2	°C	21.1	Pass
Humidity	10	70	%	50.5	Pass
Velocity	6.6	6.8	m/s	6.71	Pass
Probe Acceleration after 5 ms	30	36	g's	32.1	Pass
Lateral Upper Spine Acceleration	34	43	g's	37.0	Pass
Lateral Lower Spine Acceleration	29	37	g's	35.8	Pass
Shoulder Deflection	31	40	mm	37.2	Pass
Upper Thorax Rib Deflection	25	32	mm	28.4	Pass
Mid Thorax Rib Deflection	30	36	mm	31.6	Pass
Lower Thorax Rib Deflection	32	38	mm	32.3	Pass

Transducer Calibrations

Channel	Manufacturer	Serial Number	Calibration Date	Calibration Due Date
Pendulum Accelerometer	ENDEVCO 7264CT	AC-P32453	10/17/2017	4/17/2018
Upper Spine T1 Y Accelerometer	ENDEVCO 7264	AC-P83320	9/27/2017	3/28/2018
Upper Spine T12 Y Accelerometer	ENDEVCO 7264	AC-P64147	9/27/2017	3/28/2018
Shoulder Potentiometer	Servo 08TC1-3725	DS-1063GFE	9/27/2017	9/27/2018
Upper Thorax Rib Potentiometer	Servo 08CT1-3725	DS-451GFE	9/27/2017	9/27/2018
Middle Thorax Rib Potentiometer	Servo 08TC1-3725	DS-1151GFE	9/27/2017	9/27/2018
Lower Thorax Rib Potentiometer	Servo 08TC1-3725	DS-1156GFE	9/27/2017	9/27/2018

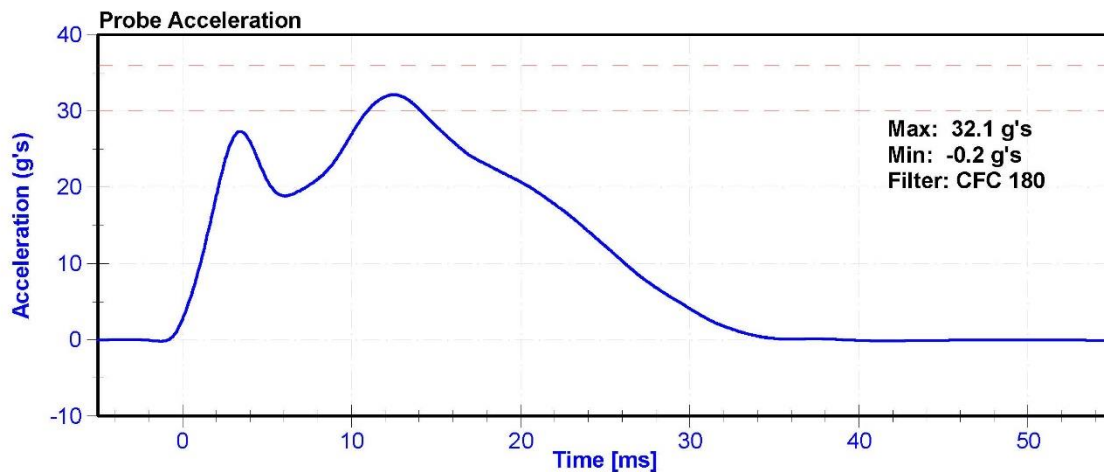

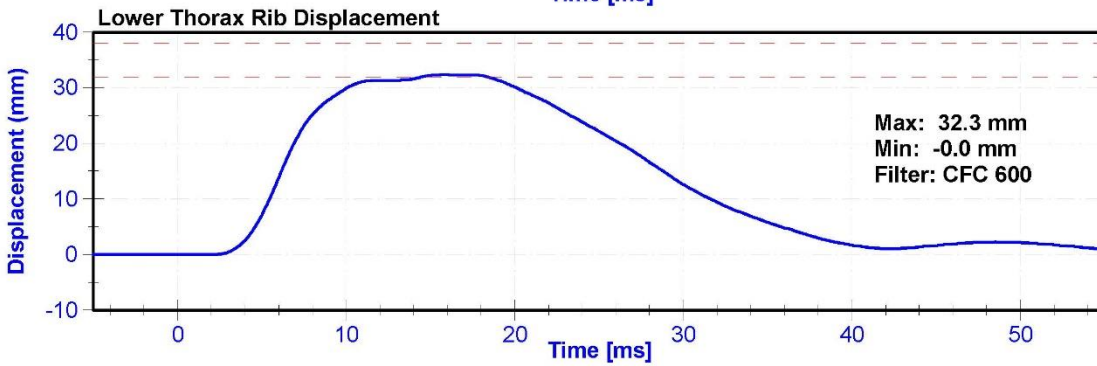
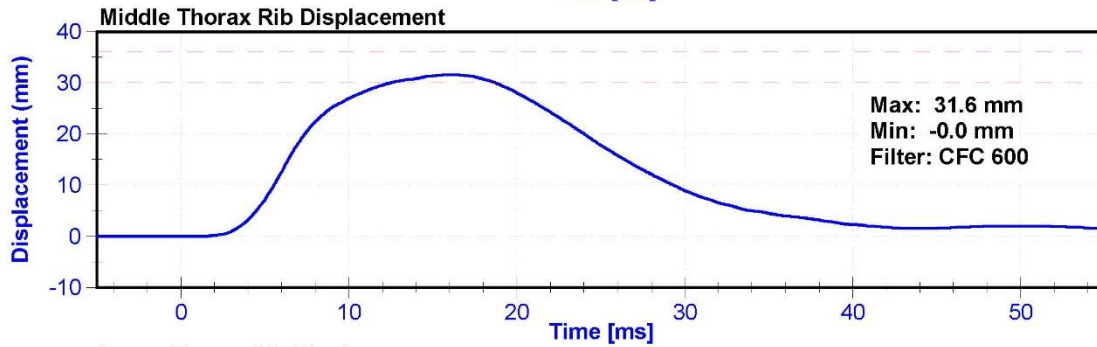
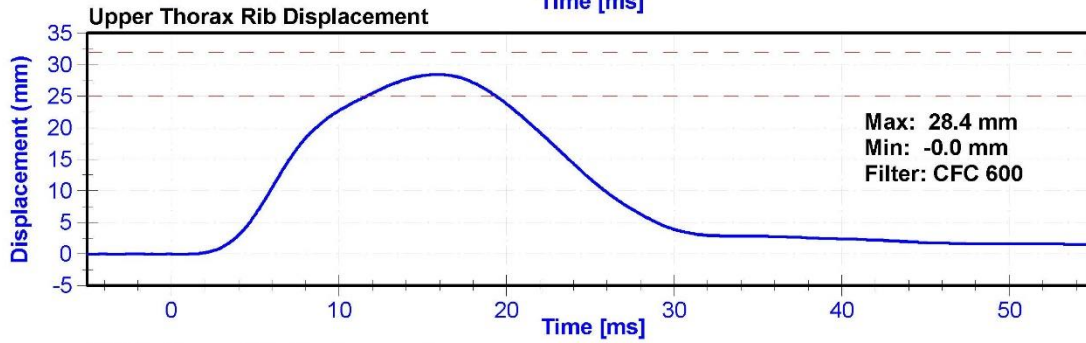
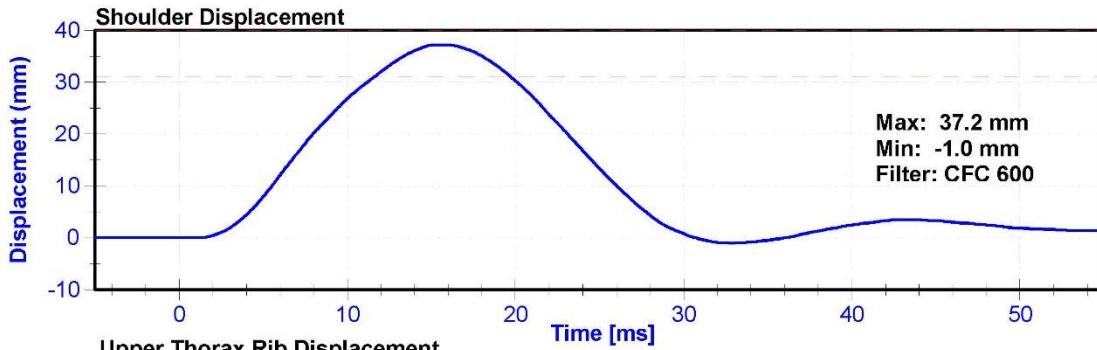

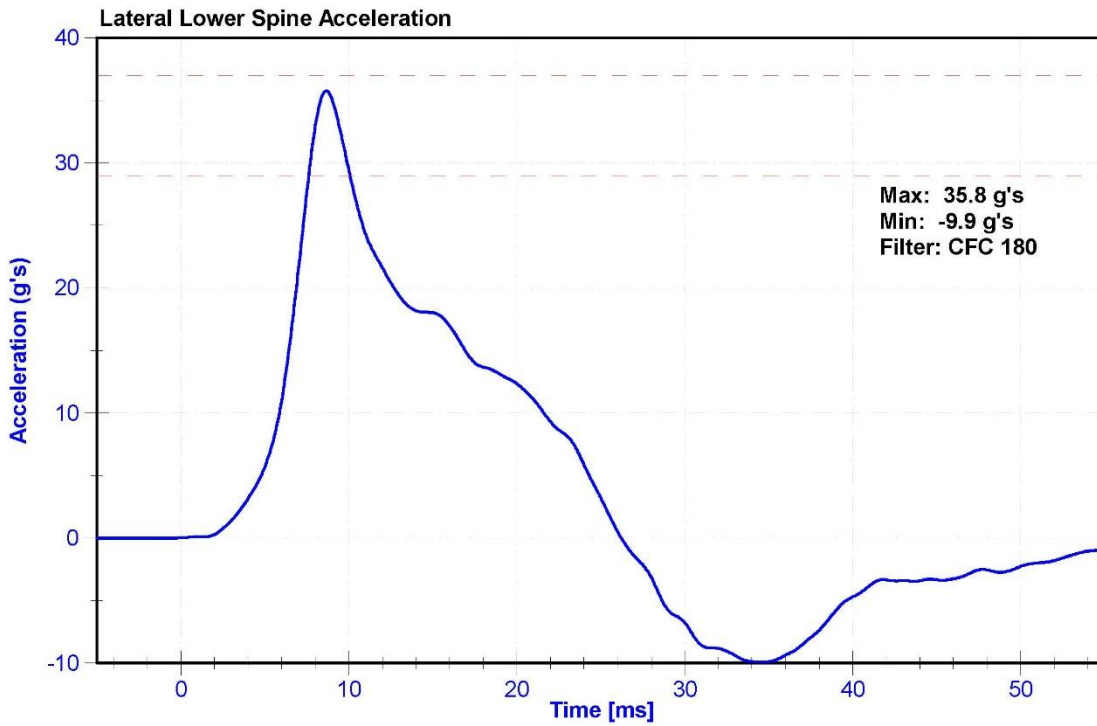
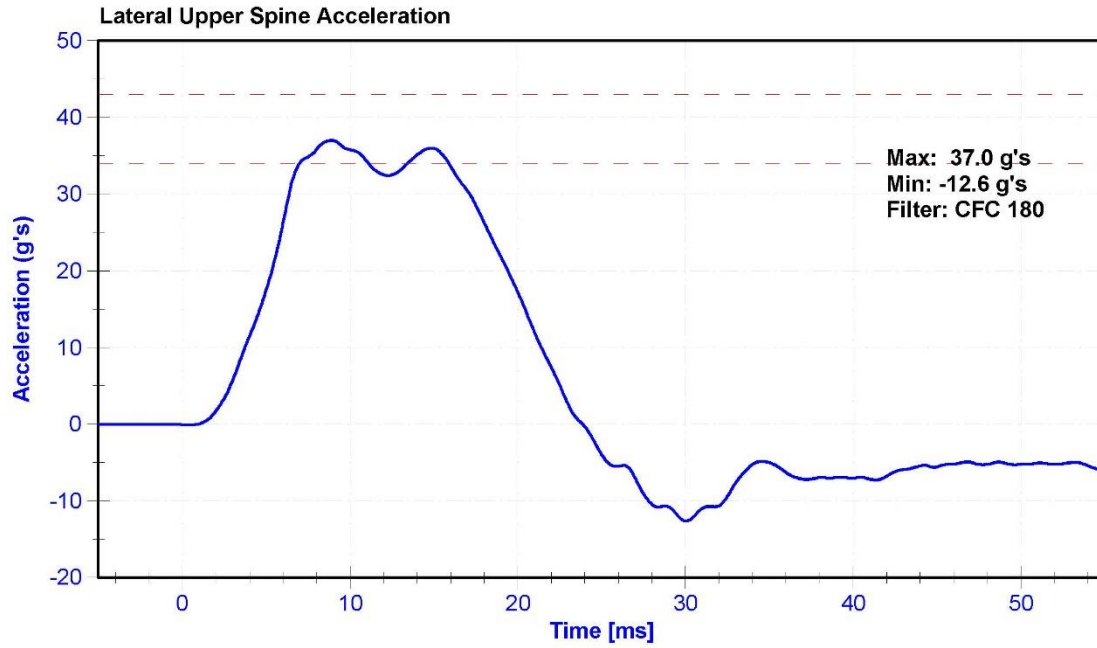

ATD Manufacturer	FTSS	Test Technician	K. Brogan
ATD Serial Number	300	Laboratory Supervisor	M. Goehle

Results

Test Parameter	Minimum Specification	Maximum Specification	Unit	Result	Pass/Fail
Temperature	20.6	22.2	°C	20.9	Pass
Humidity	10	70	%	51.1	Pass
Velocity	4.2	4.4	m/s	4.36	Pass
Probe Acceleration	14	18	g's	15.3	Pass
Lateral Upper Spine Acceleration	13	17	g's	16.1	Pass
Lateral Lower Spine Acceleration	7	11	g's	9.6	Pass
Upper Thorax Rib Deflection	32	40	mm	36.0	Pass
Middle Thorax Rib Deflection	39	45	mm	40.2	Pass
Lower Thorax Rib Deflection	35	43	mm	35.8	Pass

Transducer Calibrations

Channel	Manufacturer	Serial Number	Calibration Date	Calibration Due Date
Pendulum Accelerometer	ENDEVCO 7264CT	AC-P32453	10/17/2017	4/17/2018
Upper Spine Y Accelerometer	ENDEVCO 7264	AC-P83320	9/27/2017	3/28/2018
Lower Spine Y Accelerometer	ENDEVCO 7264	AC-P64147	9/27/2017	3/28/2018
Upper Thorax Rib Potentiometer	Servo 08CT1-3725	DS-451GFE	9/27/2017	9/27/2018
Middle Thorax Rib Potentiometer	Servo 08TC1-3725	DS-1151GFE	9/27/2017	9/27/2018
Lower Thorax Rib Potentiometer	Servo 08TC1-3725	DS-1156GFE	9/27/2017	9/27/2018

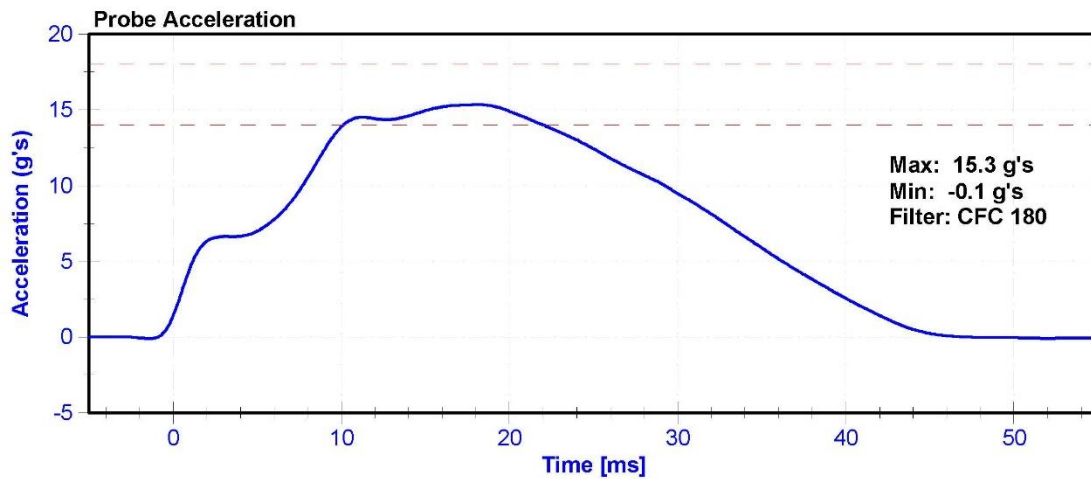

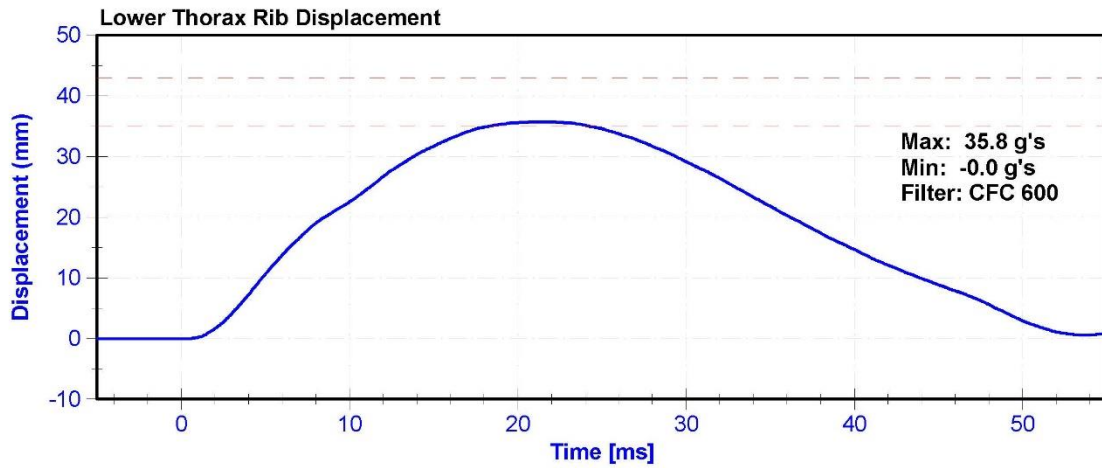
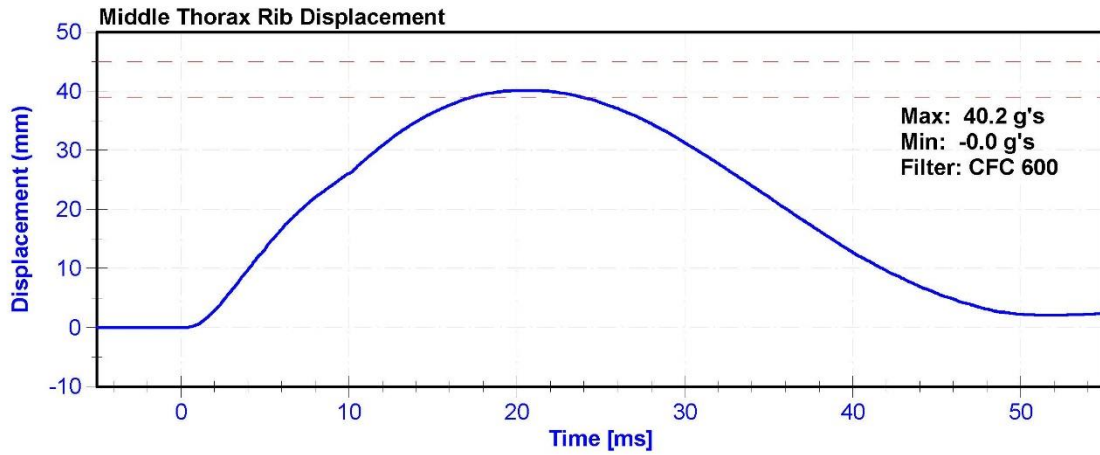
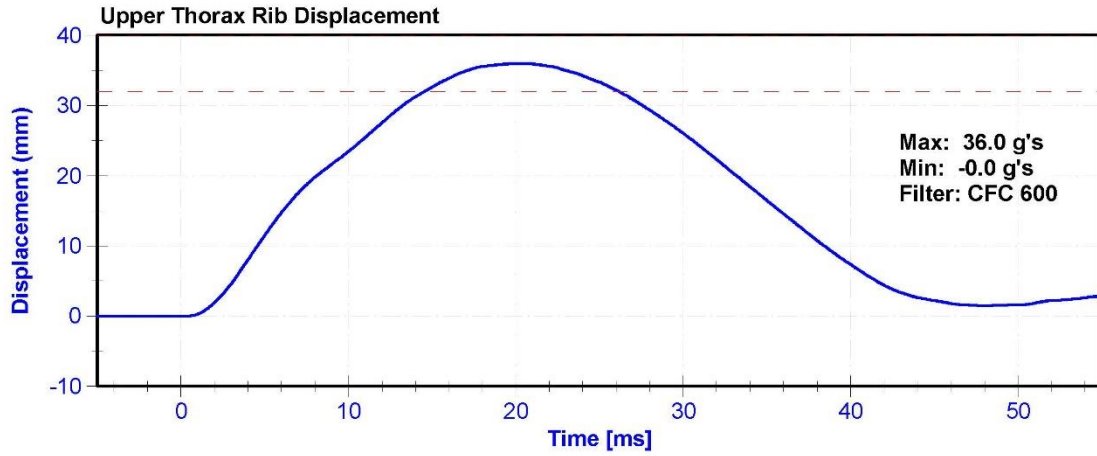

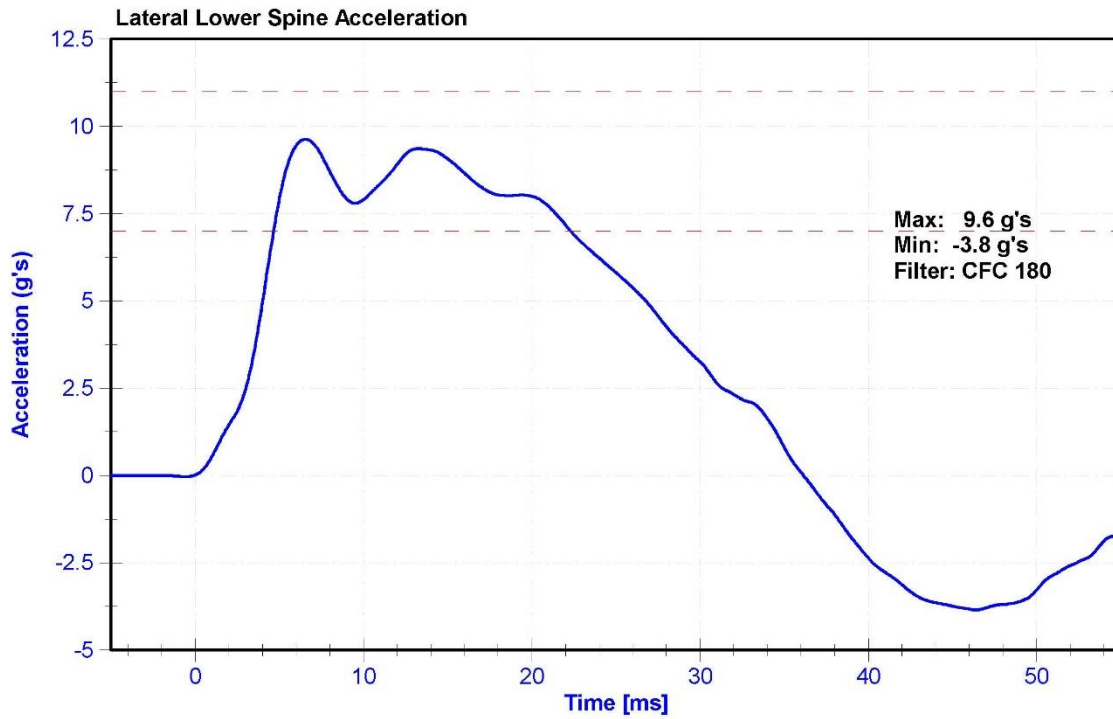
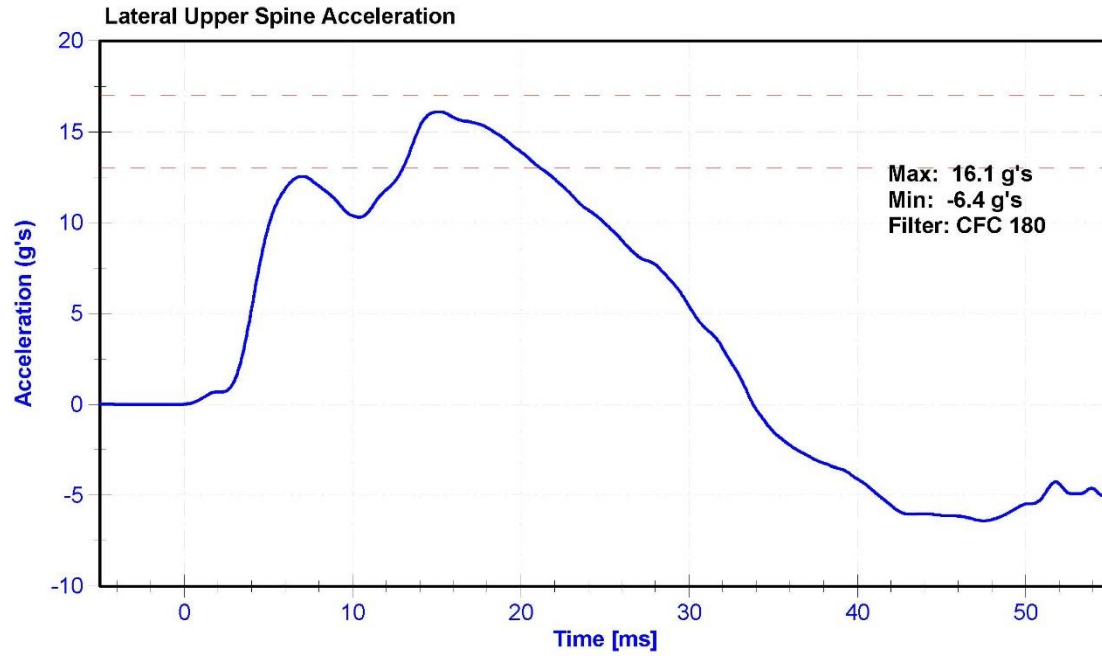

ATD Manufacturer	FTSS	Test Technician	K. Brogan
ATD Serial Number	300	Laboratory Supervisor	M. Goehle

Results

Test Parameter	Minimum Specification	Maximum Specification	Unit	Result	Pass/Fail
Temperature	20.6	22.2	°C	21.0	Pass
Humidity	10	70	%	58.1	Pass
Velocity	4.2	4.4	m/s	4.37	Pass
Probe Acceleration	12	16	g's	14.1	Pass
Lateral Lower Spine Acceleration	9	14	g's	11.3	Pass
Upper Abdomen Rib Deflection	36	47	mm	39.9	Pass
Lower Abdomen Rib Deflection	33	44	mm	36.3	Pass

Transducer Calibrations

Channel	Manufacturer	Serial Number	Calibration Date	Calibration Due Date
Probe Accelerometer	ENDEVCO 7264CT	AC-P32453	10/17/2017	4/17/2018
Lower Spine Y Accelerometer	ENDEVCO 7264	AC-P64147	9/27/2017	3/28/2018
Upper Abdomen Rib Potentiometer	Servo 08CT1-3725	DS-308GFE	9/27/2017	9/27/2018
Lower Abdomen Rib Potentiometer	Servo 08CT1-3725	DS-307GFE	9/27/2017	9/27/2018

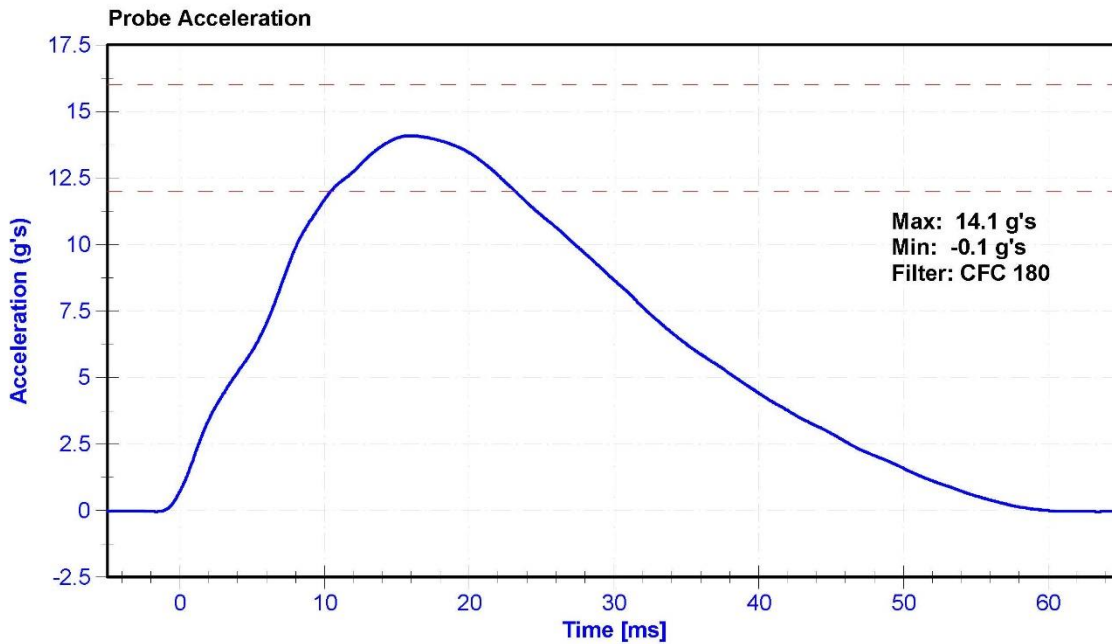

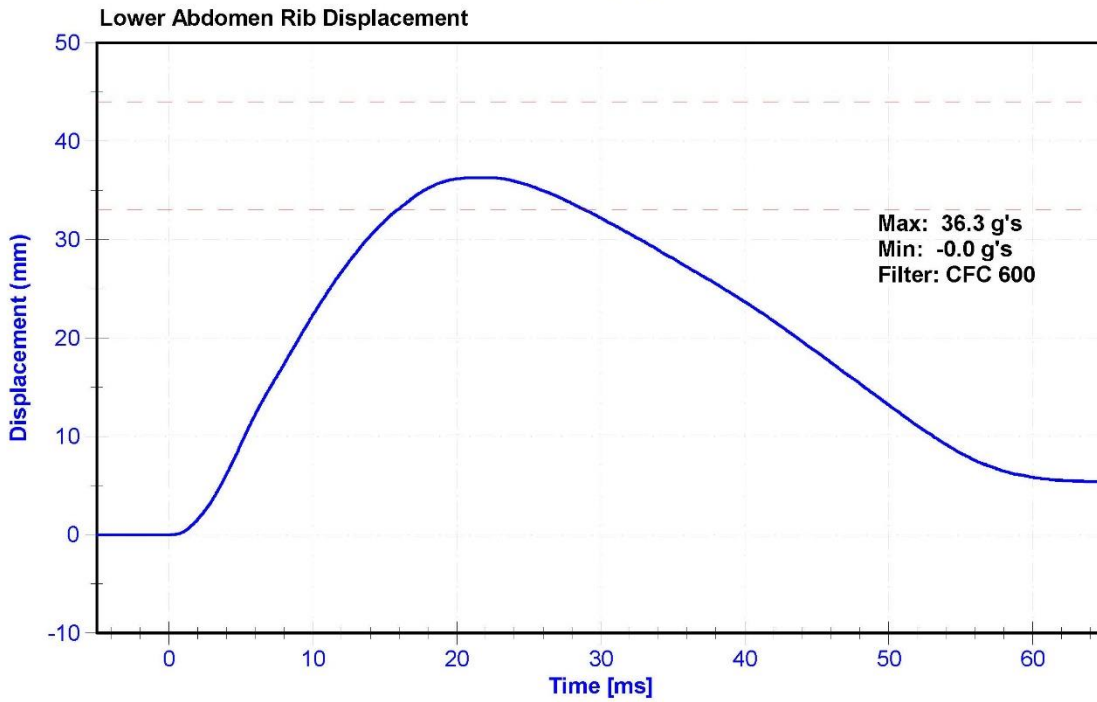
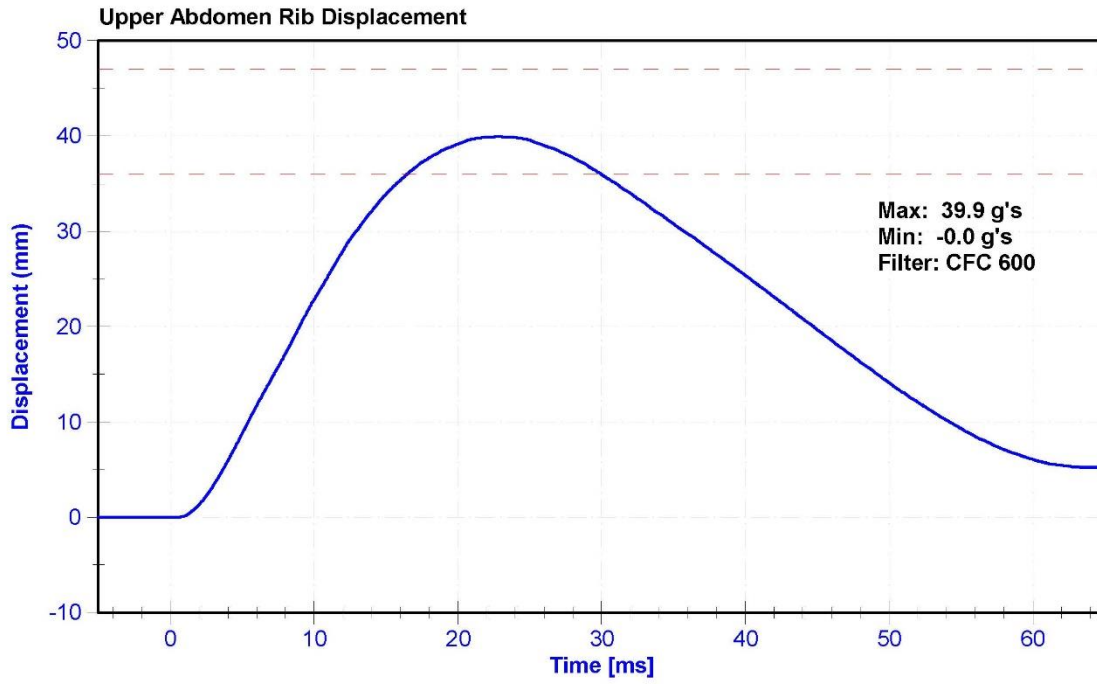

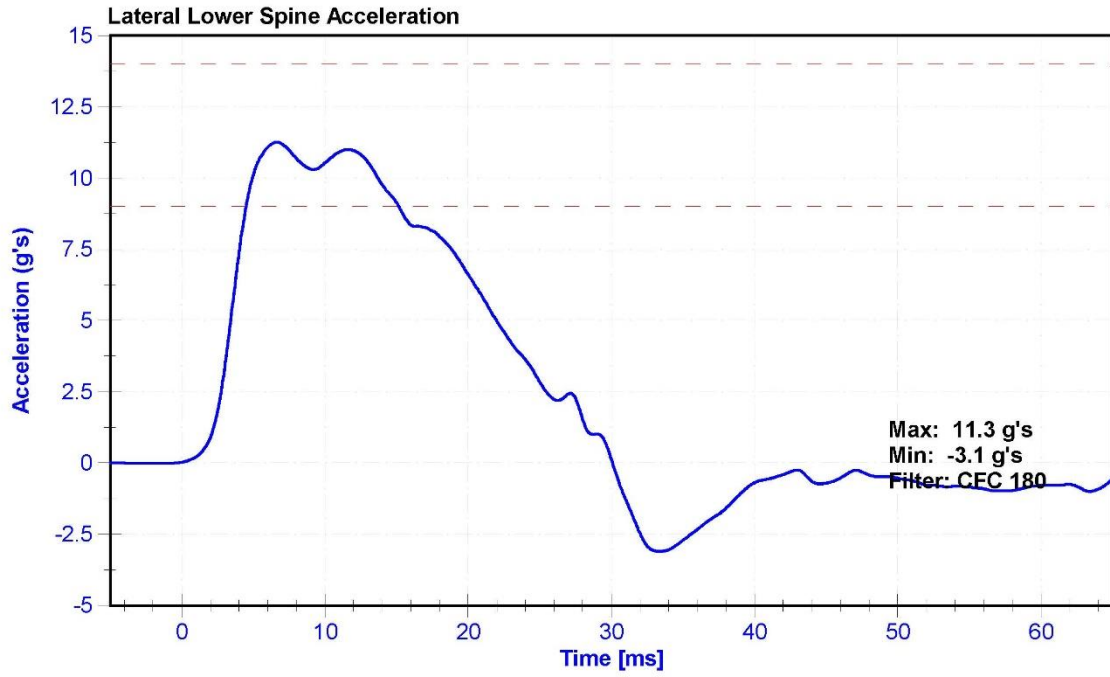

ATD Manufacturer	FTSS	Test Technician	K. Brogan
ATD Serial Number	300	Laboratory Supervisor	M. Goehle

Results

Test Parameter	Minimum Specification	Maximum Specification	Unit	Result	Pass/Fail
Temperature	20.6	22.2	°C	21.1	Pass
Humidity	10	70	%	50.1	Pass
Velocity	6.6	6.8	m/s	6.66	Pass
Probe Acceleration	38	47	g's	43.2	Pass
Lateral Pelvis Acceleration after 6ms	34	42	g's	41.4	Pass
Acetabulum Force	3600	4300	N	3907.9	Pass

Transducer Calibrations

Channel	Manufacturer	Serial Number	Calibration Date	Calibration Due Date
Pendulum Accelerometer	ENDEVCO 7264CT	AC-P32453	10/17/2017	4/17/2018
Pelvis Y Accelerometer	ENDEVCO 7264CT	AC-P79602	9/27/2017	3/28/2018
Acetabulum Load Cell	DENTON 3249J	LC-275Fy	6/20/2017	6/20/2018
Certification Plug	Humanetics	10914	03/23/2016	N/A
Crash Test Plug	Humanetics	10822	03/11/2016	N/A

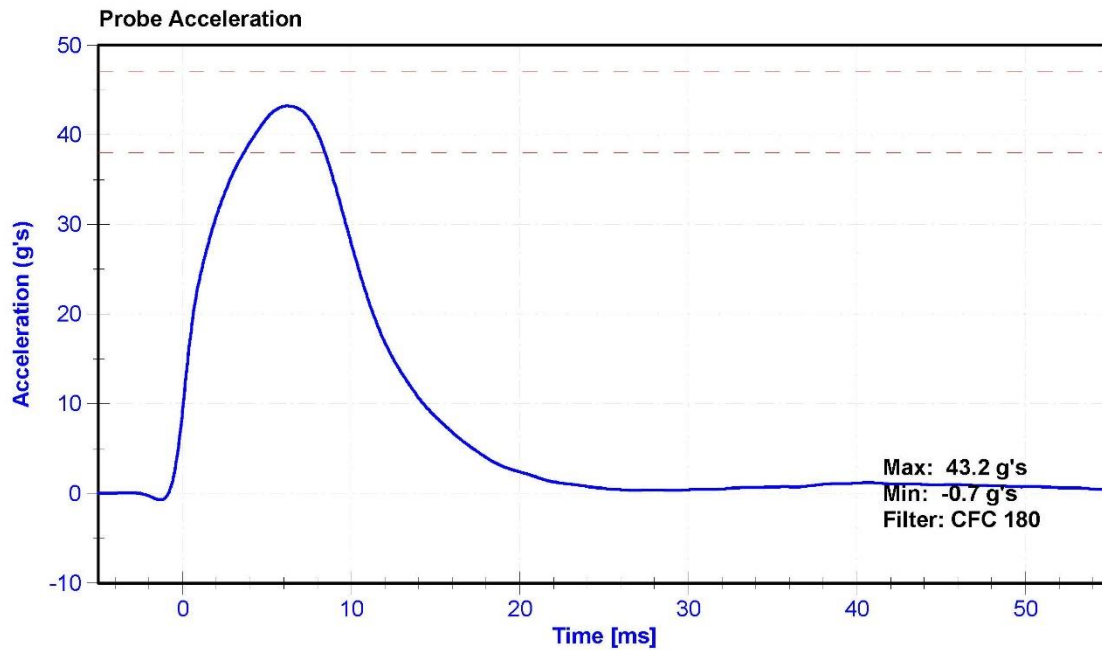

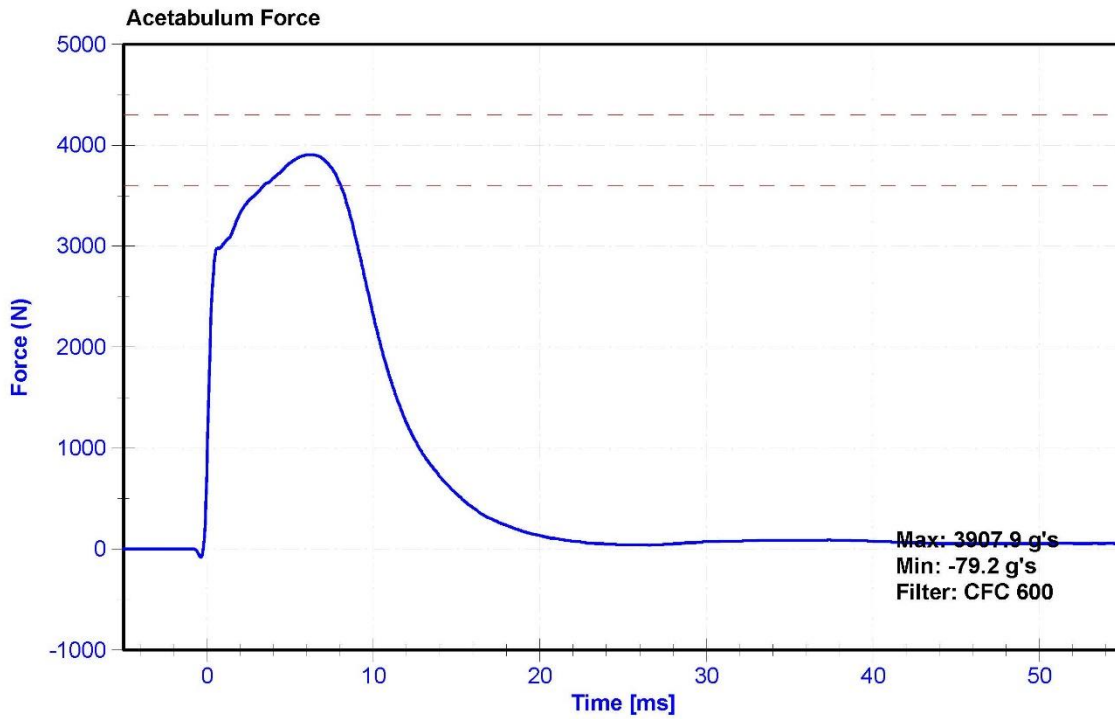
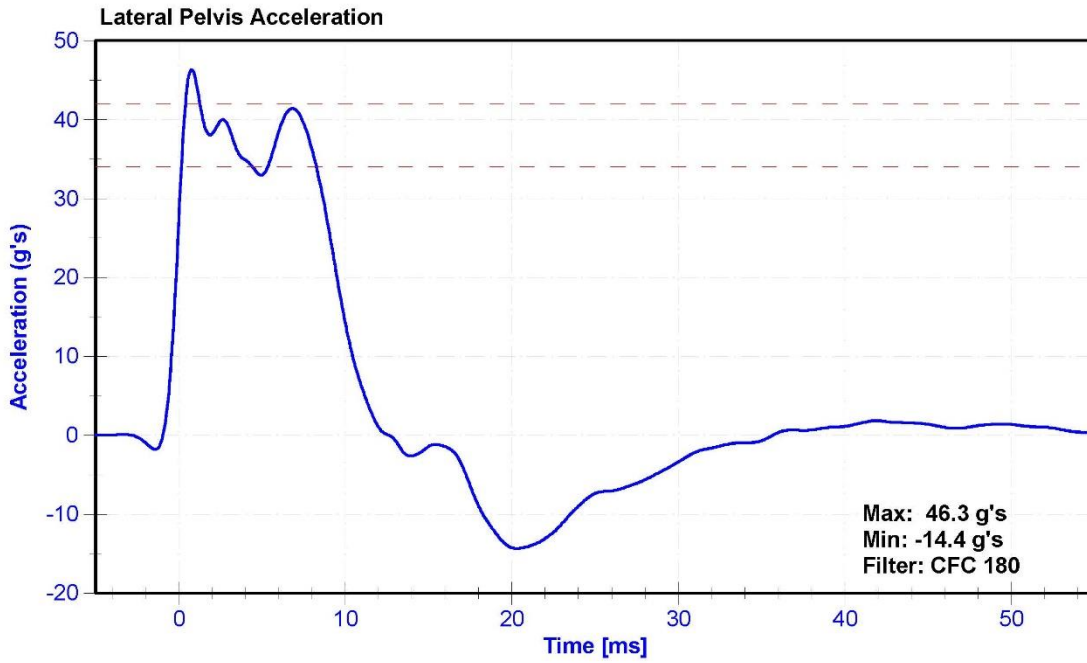



Cert-1

SID-Ils Pelvis Plug Certification Test

Plug S/N 10914
Test Number 1890
Report Number 1884
Test Date 3/23/2016 10:04:58 AM

	Test Results	Spec Min	Spec Max
Force @ 0.5 mm (N)	340.74	50.00	800.00
Force @ 1.5 mm (N)	1,098.98	850.00	1,400.00
Force @ 2.5 mm (N)	1,451.88	1,306.00	1,618.00
Force @ 3.0 mm (N)	1,585.18	1,361.00	1,673.00

Testing Machine STM-20 5965542
 Load Cell S/N (T1240813), Units (LBS) 1000
 Crosshead Speed (mm / min) or Rate 12.7
 Extension or Position Measured by XHD_100 (XHD100)

Notes:

Force (-N) vs Extension (-mm)

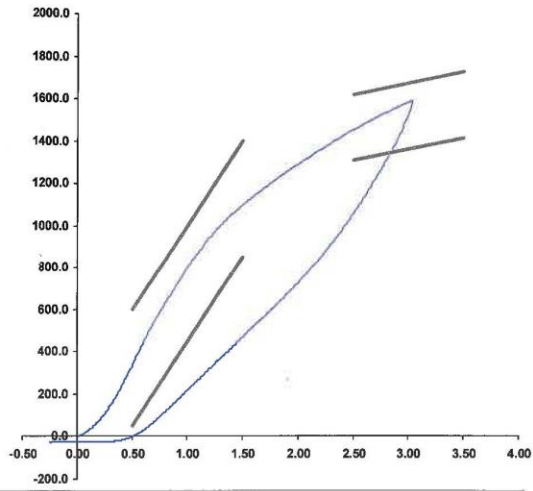

Operator DC
 Part Number 180-4450

Template No 107 23-Mar-16
 SACO Research

By: DC Date: 3/23/16

SACO Research 41735 Elm St, #401 Murrieta, CA 92562 Tel 310-694-2082 FAX



Crash

SID-Its Pelvis Plug Certification Test

Plug S/N 10822

Test Number 1639

Report Number 1633

Test Date 3/11/2016 11:25:08 AM

Test Results	Spec_Min	Spec_Max
Force @ 0.5 mm (N)	292.74	50.00 600.00
Force @ 1.5 mm (N)	1,206.00	850.00 1,400.00
Force @ 2.5 mm (N)	1,541.47	1,306.00 1,618.00
Force @ 3.0 mm (N)	1,575.73	1,361.00 1,673.00

Testing Machine STM-20 5965542
 Load Cell S/N (TI240813), Units (LBS) 1000
 Crosshead Speed (mm / min) or Rate 12.7
 Extension or Position Measured by XHD_100 (XHD100)

Notes:

Force (-N) vs Extension (-mm)

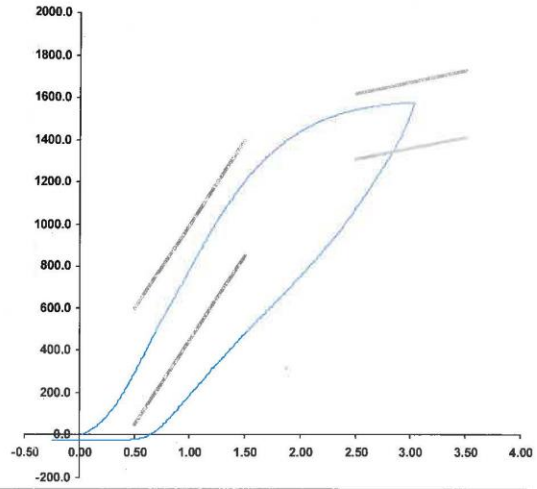

Operator DC

Part Number 180-4450

Template No 107 11-Mar-16
SACO Research

By: DC Date: 3/11/16

SACO Research 41735 Elm St, #401 Murrieta, CA 92562 Tel 310-694-2082 FAX

ATD Manufacturer	FTSS	Test Technician	K. Brogan
ATD Serial Number	300	Laboratory Supervisor	M. Goehle

Results

Test Parameter	Minimum Specification	Maximum Specification	Unit	Result	Pass/Fail
Temperature	20.6	22.2	°C	21.2	Pass
Humidity	10	70	%	48.8	Pass
Velocity	4.2	4.4	m/s	4.35	Pass
Probe Acceleration	36	45	g's	38.1	Pass
Lateral Pelvis Acceleration	28	39	g's	33.9	Pass
Iliac Force	4100	5100	N	4556.4	Pass

Transducer Calibrations

Channel	Manufacturer	Serial Number	Calibration Date	Calibration Due Date
Pendulum Accelerometer	ENDEVCO 7264CT	AC-P32453	10/17/2017	4/17/2018
Pelvis Y Accelerometer	ENDEVCO 7264CT	AC-P79602	9/27/2017	3/28/2018
Iliac Load Cell	DENTON 3228J	LC-279Fy	6/21/2017	6/21/2018

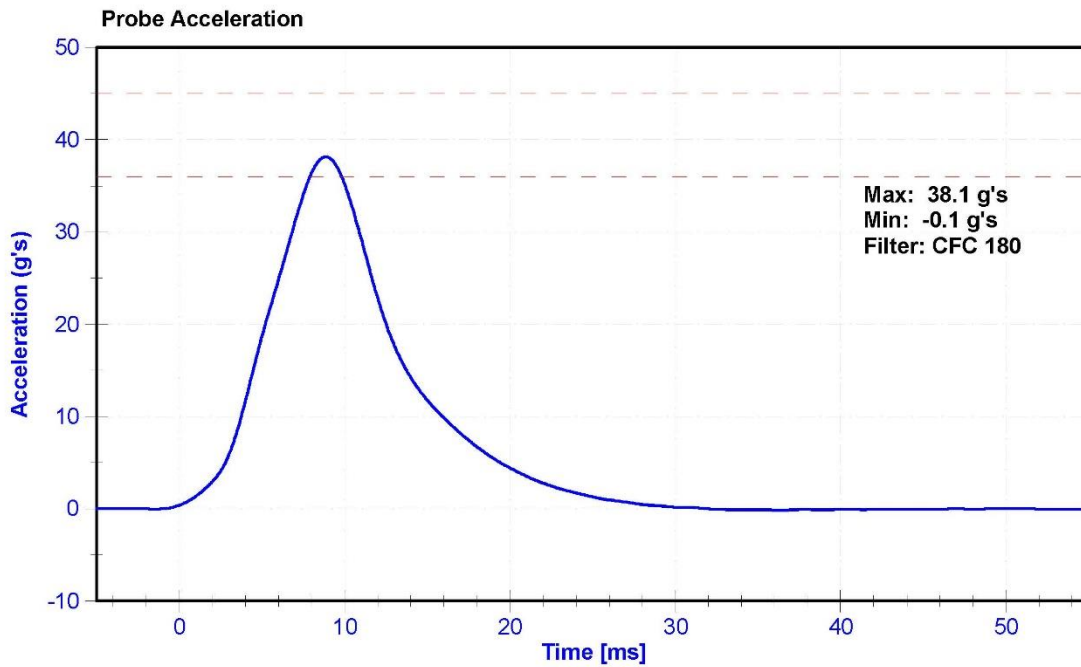

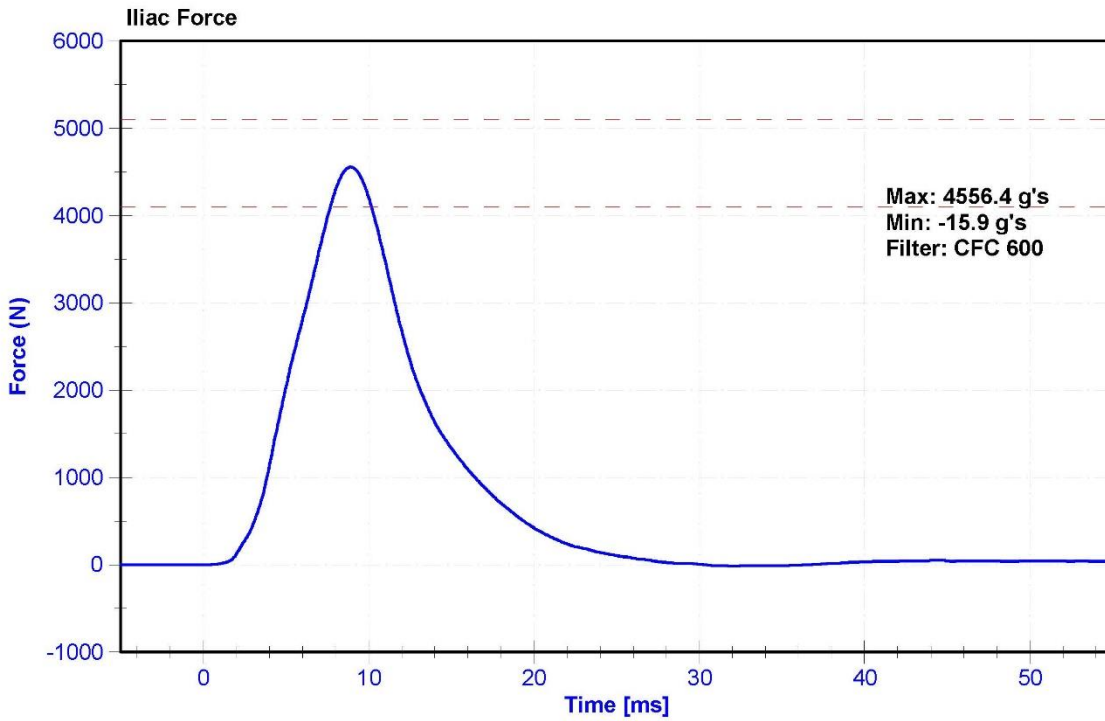
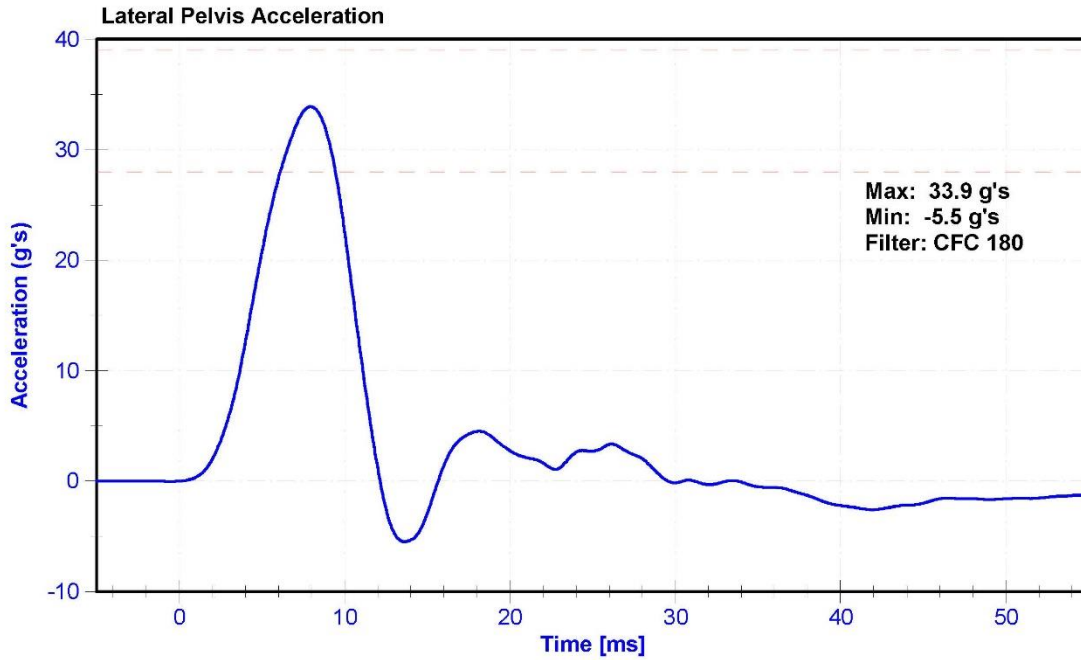

APPENDIX D

TEST EQUIPMENT AND INSTRUMENTATION CALIBRATION DATA

Table 1 – Dummy Instrumentation (ES-2re)

			ES-2re S/N: F034		
			Serial Number	Manufacturer	Calibration Date
Head Accelerometers	Primary	X	AC-P58904	ENDEVCO	10/24/2017
		Y	AC-P58911	ENDEVCO	10/24/2017
		Z	AC-P58776	ENDEVCO	10/24/2017
	Redundant	X	AC-P58887	ENDEVCO	10/24/2017
		Y	AC-P58888	ENDEVCO	10/24/2017
		Z	AC-P51734	ENDEVCO	10/24/2017
Thorax Rib Displacement Potentiometers	Upper	Y	DS-183GFE	Honeywell	9/27/2017
	Middle	Y	DS-184GFE	Honeywell	9/27/2017
	Lower	Y	DS-182GFE	Honeywell	9/27/2017
Abdomen Load Cells	Forward	Y	LC-1512	DENTON	6/5/2017
	Middle	Y	LC-1526	DENTON	6/5/2017
	Rear	Y	LC-1516	DENTON	6/5/2017
Lower Spine Accelerometers (T12)		X	AC-P52079	ENDEVCO	10/24/2017
		Y	AC-P51948	ENDEVCO	10/24/2017
		Z	AC-P51269	ENDEVCO	10/24/2017
Pubic Symphysis Load Cell		Y	LC-465Fy	Denton	6/6/2017

Table 2 – Dummy Instrumentation (SID-IIs)

			SID-IIs S/N: 300			
			Serial Number	Manufacturer	Calibration Date	
Head Accelerometers	Primary	X	AC-P58777	ENDEVCO	9/28/2017	
		Y	AC-P59018	ENDEVCO	9/28/2017	
		Z	AC-P79189	ENDEVCO	9/28/2017	
	Redundant	X	AC-P52095	ENDEVCO	9/28/2017	
		Y	AC-P58986	ENDEVCO	9/28/2017	
		Z	AC-P68057	ENDEVCO	9/28/2017	
Displacement Potentiometers	Thoracic Rib	Upper	Y	DS-451GFE	Servo	9/27/2017
		Middle	Y	DS-1151GFE	Servo	9/27/2017
		Lower	Y	DS-1156GFE	Servo	9/27/2017
	Abdominal Rib	Upper	Y	DS-308GFE	Servo	9/27/2017
		Lower	Y	DS-307GFE	Servo	9/27/2017
Lower Spine Accelerometers (T12)		X	AC-P58883	ENDEVCO 7264	9/27/2017	
		Y	AC-P64147	ENDEVCO 7264	9/27/2017	
		Z	AC-P58786	ENDEVCO 7264	9/27/2017	
Acetabulum Load Cell		Y	LC-275Fy	DENTON 3249J	6/20/2017	
Iliac Wing Load Cell		Y	LC-279Fy	DENTON 3228J	6/21/2017	
Pelvis Plug (struck side)			10822	SACO	3/11/2016	
Pelvis Plug (non-struck side)			-	-	-	

Table 3 – Vehicle Instrumentation

Vehicle Instrumentation			Serial Number	Manufacturer	Calibration Date
1	Vehicle Center of Gravity	X	AC-A206883	MSI 1201-1000	10/23/2017
	Vehicle Center of Gravity	Y	AC-A211599	MSI 1201-1000	10/23/2017
	Vehicle Center of Gravity	Z	AC-A217550	MSI 1201-1000	10/23/2017
2	Right Sill at Front Seat	X	AC-A192200	Measurement Specialties 1201-1000	10/3/2017
	Right Sill at Front Seat	Y	AC-A197033	MSI 1201-1000	10/3/2017
	Right Sill at Front Seat	Z	AC-A206921	MSI 1201-1000	10/3/2017
3	Right Sill at Rear Seat	X	AC-A196979	MSI 1201-1000	9/26/2017
	Right Sill at Rear Seat	Y	AC-A197030	MSI 1201-1000	9/26/2017
	Right Sill at Rear Seat	Z	AC-A197050	MSI 1201-1000	9/26/2017
4	Left Sill at Front Door	Y	AC-A185911	MSI 1201-1000	10/17/2017
5	Left Sill at Rear Door	Y	AC-A189596	MSI 1201-1000	10/12/2017
6	Left A-Post Lower	Y	AC-A217555	MSI 1201-1000	10/23/2017
7	Left A-Post Middle	Y	AC-A184944	MSI 1201-1000	10/23/2017
8	Left B-Post Lower	Y	AC-A192201	MSI 1201-1000	10/23/2017
9	Left B-Post Middle	Y	AC-A197016	MSI 1201-1000	10/23/2017
10	Front Seat Track	Y	AC-A217552	MSI 1201-1000	10/3/2017
11	Rear Seat Track or Structure	Y	AC-A192198	MSI 1201-1000	10/17/2017
12	Right Rear Occ. Compartment	Y	AC-A197058	MSI 1201-1000	10/12/2017
13	Engine Block	X	AC-A217577	MSI 1201-1000	9/27/2017
	Engine Block	Y	AC-A228323	MSI 1201-1000	9/27/2017
14	Rear Floorpan Above Axle	X	AC-A217546	MSI 1201-1000	10/23/2017
	Rear Floorpan Above Axle	Y	AC-A217553	MSI 1201-1000	10/23/2017
	Rear Floorpan Above Axle	Z	AC-A217564	MSI 1201-1000	10/23/2017

TABLE 4 – MDB Instrumentation

MDB Instrumentation		Serial Number	Manufacturer	Calibration Date
MDB Center of Gravity	X	AC-A197006	MSI 1201-1000	10/17/2017
MDB Center of Gravity	Y	AC-A197023	MSI 1201-1000	10/17/2017
MDB Center of Gravity	Z	AC-A197032	MSI 1201-1000	10/17/2017
Left Frame at Rear Axle Centerline	X	AC-A217559	MSI 1201-1000	10/17/2017
Left Frame at Rear Axle Centerline	Y	AC-A222646	MSI 1201-1000	10/17/2017