

**REPORT NUMBER: 301-KAR-19-006**  
**SAFETY COMPLIANCE TESTING FOR FMVSS 301R**  
**FUEL SYSTEM INTEGRITY – REAR IMPACT**  
**79.3 KM/H 70% OVERLAP REAR IMPACT**

**TOYOTA MOTOR MANUFACTURING CANADA INC.**  
**2019 NISSAN ALTIMA 4-DOOR SEDAN**

**NHTSA NUMBER: C20195207**

**PREPARED BY:**  
**APPLUS+ IDIADA KARCO ENGINEERING, LLC.**  
**9270 HOLLY ROAD**  
**ADELANTO, CA 92301**



**TEST DATE:**  
**OCTOBER 14, 2019**

**REPORT DATE:**  
**OCTOBER 25, 2019**  
**FINAL REPORT**

**U.S. DEPARTMENT OF TRANSPORTATION**  
**NATIONAL HIGHWAY TRAFFIC SAFETY ADMINISTRATION**  
**ENFORCEMENT**  
**OFFICE OF VEHICLE SAFETY COMPLIANCE**  
**ROOM 6111, NVS-220**  
**400 SEVENTH STREET, SW**  
**WASHINGTON, DC 20590**

This publication is distributed by the U.S. Department of Transportation, National Highway Traffic Safety Administration, in the interest of information exchange. The opinions, findings and conclusions expressed in this publication are those of the author(s) and not necessarily those of the Department of Transportation or the National Highway Traffic Safety Administration. The United States Government assumes no liability for its contents or use thereof. If trade or manufacturers' names or products are mentioned, it is only because they are considered essential to the object of the publication and should not be construed as an endorsement. The United States Government does not endorse products or manufacturers.

Prepared By:   
Mr. Eduard Lucas Caba, Project Engineer  
Applus+ IDIADA KARCO Engineering, LLC.

Reviewed By:   
Mr. Michael L. Dunlap, Director of Operations  
Applus+ IDIADA KARCO Engineering, LLC.

Approved By:   
Mr. Steven D. Matsusaka, Engineering Manager  
Applus+ IDIADA KARCO Engineering, LLC.

Approval Date: October 25, 2019

FINAL REPORT ACCEPTANCE BY OVSC:

\_\_\_\_\_

Date: \_\_\_\_\_

## TECHNICAL REPORT DOCUMENTATION PAGE

<b>1. Report No.</b> 301-KAR-19-006	<b>2. Government Accession No.</b>	<b>3. Recipient's Catalog No.</b>	
<b>4. Title and Subtitle</b> Final Report of FMVSS 301R Compliance Testing of a 2019 Nissan Altima 4-Door Sedan NHTSA No. C20195207		<b>5. Report Date</b> 10/25/2019	
		<b>6. Performing Organization Code</b> KAR	
<b>7. Authors</b> Mr. Eduard Lucas Caba, Project Engineer, Applus+ IDIADA KARCO Mr. Steven Matsusaka, Engineering Manager, Applus+ IDIADA KARCO		<b>8. Performing Organization Report No.</b> TR-P39292-01-NC	
		<b>9. Performing Organization Name and Address</b> Applus+ IDIADA KARCO Engineering, LLC. 9270 Holly Rd. Adelanto, CA 92301	
<b>12. Sponsoring Agency Name and Address</b> U. S. Department of Transportation National Highway Traffic Safety Administration Enforcement Office of Vehicle Safety Compliance Room 6111, NVS-220 400 Seventh Street, SW Washington, D.C. 20590		<b>10. Work Unit No.</b>	
		<b>11. Contract or Grant No.</b> DTNH22-16-D-00029	
<b>15. Supplementary Notes</b>		<b>13. Type of Report and Period Covered</b> Final Test Report, Oct. 14 - Oct. 25, 2019	
		<b>14. Sponsoring Agency Code</b> <p style="text-align: center;">NVS-220</p>	
<b>16. Abstract</b> <p>A 79.3 km/h 70% overlap rear impact test was conducted on the subject 2019 Nissan Altima 4-Door Sedan in accordance with the Office of Vehicle Safety Compliance Laboratory Test Procedure No. TP-301R-02 for the determination of FMVSS 301 compliance. The test was conducted at the Applus+ IDIADA KARCO Engineering, LLC. facility in Adelanto, California on October 14, 2019.</p> <p>The impact velocity was 79.93 km/h and the outside ambient temperature was 26.7° C. There was no Stoddard solvent leakage immediately after the test nor during any portion of the static rollover. The test vehicle appeared to comply with all requirements of FMVSS 301R.</p>			
<b>17. Key Words</b> FMVSS 301R 70% Overlap Rear Impact MDB 2019 Nissan Altima 4-Door Sedan		<b>18. Distribution Statement</b> Copies of this report are available from the following: U.S. Department of Transportation NHTSA Technical Information Services (TIS) Mail Code: NIO-120, Room E-12 -100 1200 New Jersey Avenue, SE Washington, DC 20590 Telephone No. 202-366-4946	
<b>19. Security Classification of this report</b> UNCLASSIFIED	<b>20. Security Classification of this page</b> UNCLASSIFIED	<b>21. No. of Pages</b> 37	<b>22. Price</b>

## TABLE OF CONTENTS

<u>Section</u>		<u>Page No.</u>
1	Summary of Test	1
2	Data Sheets	2

<u>Data Sheet No.</u>		<u>Page No.</u>
1	Test Vehicle Specifications	3
2	Pre-Test Data	5
3	Moving Barrier Data	9
4	Post-Test Data	10
5	Static Rollover Test Data	12

<u>Appendix</u>		<u>Page No.</u>
A	Photographs	A

## **SECTION 1**

### **SUMMARY OF TEST**

#### **SUMMARY**

The purpose of this rear impact test is to measure the performance of the subject vehicle, a 2019 Nissan Altima 4-Door Sedan, for FMVSS 301 compliance.

This 79.3 km/h 70% Overlap Rear Impact is sponsored by the National Highway Traffic Safety Administration (NHTSA) under contract number DTNH22-16-D-00029. It was conducted in accordance with the Office of Vehicle Safety Compliance Laboratory Test Procedure TP-301R-02 for FMVSS 301R "Fuel System Integrity – Rear Impact", dated January 2007.

The test was performed at Applus+ IDIADA KARCO Engineering, LLC. on October 14, 2019. Pre- and post- test photographs of the vehicle and ATD's can be found in Appendix A of this report.

Three (3) real-time cameras and three (3) high-speed cameras were used to document the rear impact event.

Two Part 572E 50<sup>th</sup> percentile male anthropomorphic test devices (ATD) were placed in the driver and right front passenger seating positions. Neither of the ATD's were instrumented for this test.

There was no Stoddard solvent leakage after the impact or during any portion of the static rollover. The test vehicle appeared to comply with all requirements of FMVSS 301R-02 "Fuel System Integrity – Rear Impact". FMVSS 301 data is summarized in Data Sheets 4 and 5.

**SECTION 2**  
**DATA SHEETS**

Test Vehicle: 2019 Nissan Altima 4-Door Sedan NHTSA No.: C20195207  
 Test Program: 79.3 km/h 70% Overlap Rear Impact Test Date: 10/14/19

**CONVERSION FACTORS**

Quantity	Typical Application	Std Units	Metric Unit	Multiply By
Mass	Vehicle Weight	lb	kg	0.4536
Linear Velocity	Impact Velocity	miles/hr	km/hr	1.609344
Length or Distance	Measurements	in	mm	25.4
Volume	Fuel Systems	gal	liter	3.785
Volume	Small Fluids	oz	mL	29.574
Pressure	Tire Pressures	lbf/in <sup>2</sup>	kPa	6.895
Temperature	General Use	°F	°C	$=(T_f - 32)/1.8$
Force	Dynamic Forces	lbf	N	4.448
Moment	Torque	lbf-ft	N•m	1.355

**DATA SHEET NO. 1**

**TEST VEHICLE SPECIFICATIONS**

Test Vehicle: 2019 Nissan Altima 4-Door Sedan NHTSA No.: C20195207  
 Test Program: 79.3 km/h 70% Overlap Rear Impact Test Date: 10/14/19

**TEST VEHICLE INFORMATION AND OPTIONS**

NHTSA Number	C20195207
Model Year	2019
Make	Nissan
Model	Altima
Body Style	4-Door Sedan
VIN	1N4BL4DV6KC123127
Body Color	Black
Odometer Reading (km / mi)	77 / 122
Engine Displacement (L)	2.5
Type / No. of Cylinders	Inline 4 Cylinder
Engine Placement	Transverse
Transmission Type	Automatic
Transmission Speeds	CVT
Overdrive	Yes
Final Drive	FWD
Roof Rack	No
Sunroof / T-Top	Yes
Running Boards	No
Tilt Steering Wheel	Yes
Power Seats	Yes
Anti-Lock Brakes (ABS)	Yes
Automatic Door Locks (ADLs)	Yes

Traction Control System	Yes
Power Steering	Yes
Power Window Auto-Reverse	Yes
Driver Frontal Airbag	Yes
Driver Curtain Airbag	Yes
Driver Head/Torso Airbag	No
Driver Torso Airbag	No
Driver Torso/Pelvis Airbag	Yes
Driver Pelvis Airbag	No
Driver Knee Airbag	Yes
Front Pass. Frontal Airbag	Yes
Front Pass. Curtain Airbag	Yes
Front Pass. Head/Torso Airbag	No
Front Pass. Torso Airbag	No
Front Pass. Torso/Pelvis Airbag	Yes
Front Pass. Pelvis Airbag	No
Front Pass. Knee Airbag	Yes
Driver Seat Belt Pretensioner	Yes
Driver Load Limiter	Yes
Front Pass. Seat Belt Pretensioner	Yes
Front Pass. Load Limiter	Yes
Other	No

Does Owner's Manual provide instructions to turn off automatic door locks? Yes

**DATA FROM CERTIFICATION LABEL**

Manufactured By	Nissan Motor Co. LTD
Date of Manufacture	10/18

GVWR (kg)	1963
GAWR Front (kg)	1097
GAWR Rear (kg)	945

**VEHICLE SEATING AND CAPACITY WEIGHT INFORMATION**

Measured Parameter	Front	Rear	Third	Total	
Type of Seats	Bucket	Bench			
Designated Seating Capacity	2	3		5	
Capacity Weight (VCW) (kg)				408.0	A
DSC x 68 (kg)				340.0	B
Cargo Weight (RCLW) (kg)				68.0	A-B

## DATA SHEET NO. 1 ... (CONTINUED)

### TEST VEHICLE SPECIFICATIONS

Test Vehicle: 2019 Nissan Altima 4-Door Sedan

NHTSA No.: C20195207

Test Program: 79.3 km/h 70% Overlap Rear Impact

Test Date: 10/14/19

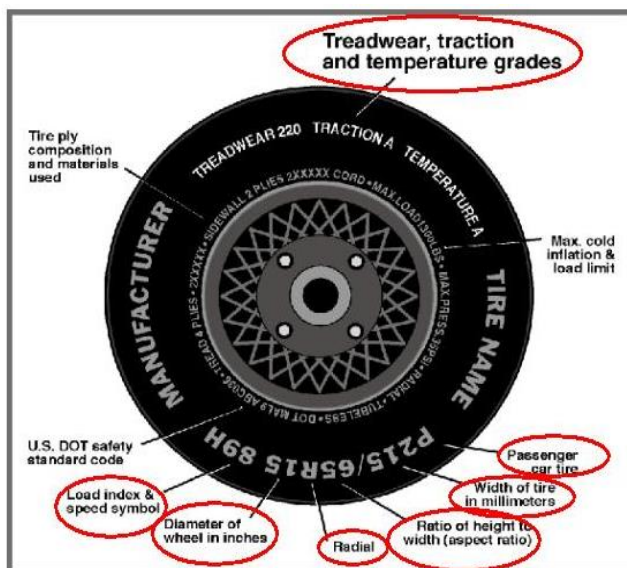

### VEHICLE TIRE INFORMATION

Measured Parameter	Front	Rear
Max Tire Pressure (kPa)	350	350
Cold Tire Pressure (kPa)	230	230
Recommended Tire Size	215/55R17	215/55R17
Tire Size on Vehicle	215/55R17	215/55R17
Tire Manufacturer	Continental	Continental
Tire Model	Pro Contact TX	Pro Contact TX
Treadwear Rating	400	400
Traction Rating	A	A
Temperature Grades	A	A
Tire Plies Sidewall	1 Polyester	1 Polyester
Tire Plies Body	1 Polyester, 2 Steel, 1 Polymide	1 Polyester, 2 Steel, 1 Polymide
Load Index/Speed Symbol	94V	94V
Tire Material	Polyester, Steel, Polymide	Polyester, Steel, Polymide
DOT Safety Code Left	VY3R WCN5 3818	VY3R WCN5 3818
DOT Safety Code Right	VY3R WCN5 3818	VY3R WCN5 3818
Type of Spare Tire	T135/70D16	
Location of Tire Placard on Vehicle	Driver Side B-Pillar	

**DATA SHEET NO. 2**

**PRE-TEST DATA**

Test Vehicle: 2019 Nissan Altima 4-Door Sedan

NHTSA No.: C20195207

Test Program: 79.3 km/h 70% Overlap Rear Impact

Test Date: 10/14/19

**TEST VEHICLE AXLE WEIGHTS**

	Units	As Delivered (UVW)			As Tested (ATW)			Fully Loaded		
		Front	Rear	Total	Front	Rear	Total	Front	Rear	Total
Left	kg	451.5	300.0	751.5	500.5	374.0	874.5	488.5	383.0	871.5
Right	kg	440.0	294.5	734.5	487.0	332.5	819.5	464.0	366.0	830.0
Ratio	%	60.0%	40.0%	100.0%	58.3%	41.7%	100.0%	56.0%	44.0%	100.0%
Total	kg	891.5	594.5	1486.0	987.5	706.5	1694.0	952.5	749.0	1701.5

**TARGET TEST WEIGHT CALCULATION**

Measured Parameter	Units	Value	
Total Delivered Weight (UVW)	kg	1489.0	A
Actual Weight of 2 P572 ATDs Used	kg	148.0	B
Rated Cargo/Luggage Wt (RCLW)	kg	68.0	C
Calculated Vehicle Target Wt (TVTW)	kg	1702.0	A+B+C

**TEST VEHICLE ATTITUDES**

Condition	Units	LF	RF	LR	RR	CG Aft of Front Axle
As Delivered	mm	705	710	720	725	1129
As Tested	mm	687	698	703	714	1177
Fully Loaded	mm	692	704	692	697	1242

**GENERAL TEST VEHICLE DATA**

Measured Parameter	Units	Value
Total Vehicle Wheel Base	mm	2822
Total Vehicle Length	mm	4885
Total Vehicle Width	mm	1850
Amount of Stoddard Solvent in Fuel Tank	L	57.16

**DATA SHEET NO. 2... (CONTINUED)**

**PRE-TEST DATA**

Test Vehicle: 2019 Nissan Altima 4-Door Sedan NHTSA No.: C20195207  
 Test Program: 79.3 km/h 70% Overlap Rear Impact Test Date: 10/14/19

**BALLAST DATA**

Description	Value
Type of Ballast	Ballast Bottles
Method of Securing Ballast	Strapped to Rear Seat
Total Weight of Ballast	53.0
Weight of Vehicle Components Removed	0.0 kg

**VEHICLE COMPONENTS REMOVED TO MEET TEST WEIGHT:**

None

**FUEL TANK CAPACITY**

Description	Liters
Fuel System Capacity Listed in Owners Manual	61.32
Usable Capacity of "Standard Tank"	61.32
91 - 94% of Usable Capacity	55.80-57.64
Actual Amount of Stoddard Solvent Used	57.16

**FUEL PUMP**

The vehicle is equipped with an electric fuel pump. The fuel pump is activated when the ignition is turned to the "ON" position. The fuel pump will run when the engine is running.

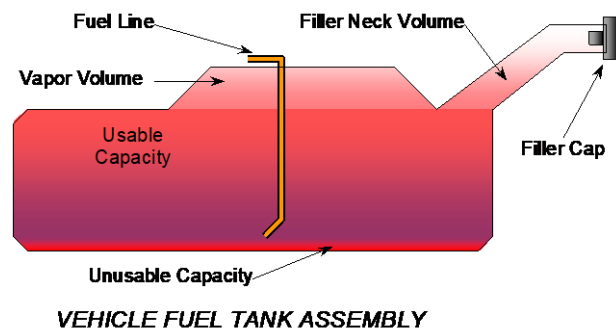

**TEST FLUID**

Description	Value
Test Fluid Type	Stoddard Solvent
Test Fluid Specific Gravity	0.758
Test Fluid Kinematic Viscosity	
Test Fluid Color	Purple

**DATA SHEET NO. 2... (CONTINUED)**

**PRE-TEST DATA**

Test Vehicle: 2019 Nissan Altima 4-Door Sedan

NHTSA No.: C20195207

Test Program: 79.3 km/h 70% Overlap Rear Impact

Test Date: 10/14/19

**NOMINAL DESIGN RIDING POSITION**

Seat back angle is measured using a digital inclinometer placed on the headrest post.

**SEAT BACK ANGLE**

Seating Position	Degrees
Driver Seat Back Angle	6.0
Passenger Seat Back Angle	6.0

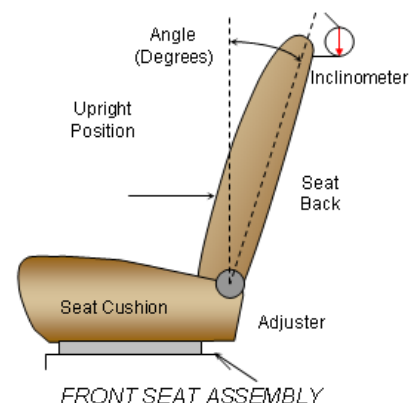

**SEAT FORE / AFT POSITIONING**

The total seat travel is measured from the forward most possible position to the rear most possible position. The driver's and passenger's seats are set to the middle of the fore-aft travel.

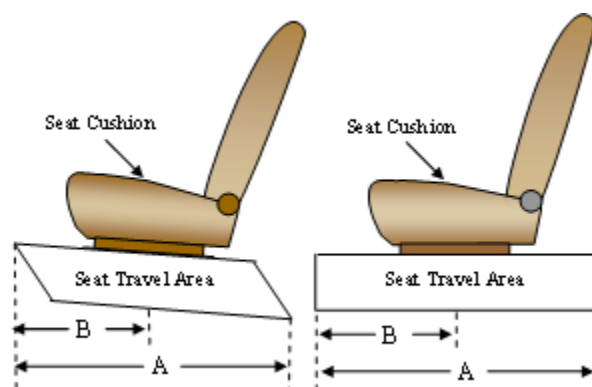

**SEAT FORE/AFT POSITIONS**

Seating Position	Total Fore-Aft Travel	Placed in Position
Driver Seat	278 mm	139 mm
Passenger Seat	240 mm	120 mm

## DATA SHEET NO. 2... (CONTINUED)

### PRE-TEST DATA

Test Vehicle: 2019 Nissan Altima 4-Door Sedan

NHTSA No.: C20195207

Test Program: 79.3 km/h 70% Overlap Rear Impact

Test Date: 10/14/19

### STEERING COLUMN ADJUSTMENT

Steering wheel and column adjustments are made so that the steering wheel hub is at the geometric center of the locus it describes when moved through its full range of motion. A digital inclinometer is used to measure a plate which is placed across the rim of the steering wheel for angular measurements. A tape measure is used to measure telescoping steering wheel travel.

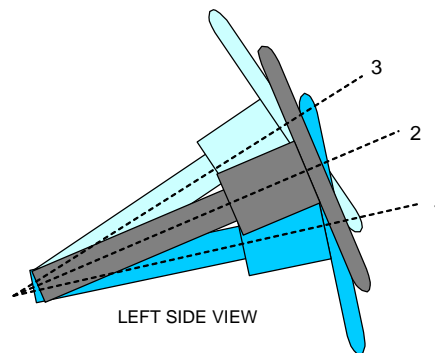

LEFT SIDE VIEW  
STEERING COLUMN ASSEMBLY

### STEERING COLUMN POSITIONING

	Degrees	Fore-Aft Position (mm)
Lowermost Position, No. 1	20.9	72
Geometric Center Position, No. 2	23.6	100
Uppermost Position, No. 3	26.2	127
Telescoping Steering Wheel Travel		55
Test Position	23.6	100

**DATA SHEET NO. 3**  
**MOVING BARRIER DATA**

Test Vehicle: 2019 Nissan Altima 4-Door Sedan NHTSA No.: C20195207  
 Test Program: 79.3 km/h 70% Overlap Rear Impact Test Date: 10/14/19

**MOVING BARRIER TEST WEIGHT**

	Units	As Tested Weights (ATW)		
		Front Axle	Rear Axle	Total
Left	kg	386.5	316.5	703.0
Right	kg	385.5	271.5	657.0
Ratio	%	56.8%	43.2%	100.0%
Total	kg	772.0	588.0	1360.0

**MOVING BARRIER TIRE INFORMATION**

Measured Parameter	Front	Rear
Recommended Tire Size	205/75R15	205/75R15
Tire Size on Vehicle	205/75R15	205/75R15
Tire Manufacturer	Pacemark	Pacemark
Tire Model	All Weather	All Weather
Treadwear	420	420
Traction	A	A
Temperature Grades	B	B
Tire Pressure - Front	220	220
Tire Pressure - Rear	220	220

**MOVING BARRIER DIMENSIONS**

Measurement Description	Length (mm)
Overall Width	1676
Overall Height	559
Honeycomb Depth	381
Overall Depth	483
Bottom Honeycomb to Bottom Bumper	51
Bumper Height	203
Ground to Top of MDB	788
Ground to Bottom of MDB	229
Ground to Bottom of Bumper	280
Ground to Top of Bumper	483

**DATA SHEET NO. 4****POST-TEST DATA**Test Vehicle: 2019 Nissan Altima 4-Door Sedan NHTSA No.: C20195207Test Program: 79.3 km/h 70% Overlap Rear Impact Test Date: 10/14/19Temperature at Time of Impact: 26.7°C Test Time: 12:03 PMVIN: 1N4BL4DV6KC123127**IMPACT VELOCITY DATA**

Measured Parameter	Units	Value
Trap No. 1 Velocity (Primary)	km/h	79.93
Trap No. 2 Velocity (Redundant)	km/h	79.91

**IMPACT POINT LOCATION DATA**

Measured Parameter	Units	Tolerance	Value
Vehicle Width	mm		1855
Vertical Impact Reference Line (Right of Vehicle Center Line)	mm		370
Actual Impact Point (Right of Vehicle Center Line)	mm		355
Horizontal Offset (+ right / - left)	mm	± 50 of Intended Impact Point	-15
Vertical Offset (- down / + up)	mm	± 40 of Intended Impact Point	-5

**TARGET VEHICLE STRUCTURAL MEASUREMENTS**

No.	Description	Pre-Test	Post-Test	Difference
1	Total Length at Centerline	4885	4350	535
2	Total Length	4885	4870	15
3	Total Width	1850	2200	350
4	Left Side Wheelbase	2822	2745	77
5	Right Side Wheelbase	2822	2823	1

**MAXIMUM STATIC CRUSH OF HONEYCOMB FACE**

Vertical Location			From Centerline		Max. Crush (mm)
Row	Description	Height (mm)	Distance (mm)	Direction	
A	Center of Bumper	785	800	Right	181
B	Top of Bumper	846	800	Right	108
C	Mid Level	919	800	Right	64
D	Top of Stack	664	400	Left	65

**DATA SHEET NO. 4... (CONTINUED)**

**POST-TEST DATA**

Test Vehicle: 2019 Nissan Altima 4-Door Sedan NHTSA No.: C20195207  
Test Program: 79.3 km/h 70% Overlap Rear Impact Test Date: 10/14/19

**DOOR OPENING AND SEAT TRACK INFORMATION**

Description	Driver	Passenger
Front Door Opening	Remained closed and latched	Remained closed and latched
Rear Door Opening	Jammed shut	Remained closed and latched
Hatch and other doors	Rear Hatch Jammed Shut	

**FMVSS 301 FUEL SYSTEM INTEGRITY POST-IMPACT DATA**

**Stoddard Solvent Spillage Measurements**

- A. From impact until vehicle motion ceases: 0 g  
(Maximum allowable = 28 g)
- B. For the 5 minute period after motion ceases: 0 g  
(Maximum allowable = 142 g)
- C. For the following 25 minutes: 0 g  
(Maximum allowable = 28 g/minute)
- D. Spillage: None  
\_\_\_\_\_  
\_\_\_\_\_  
\_\_\_\_\_  
\_\_\_\_\_

**DATA SHEET NO. 5**  
**STATIC ROLLOVER TEST DATA**

Test Vehicle: 2019 Nissan Altima 4-Door Sedan

NHTSA No.: C20195207

Test Program: 79.3 km/h 70% Overlap Rear Impact

Test Date: 10/14/19

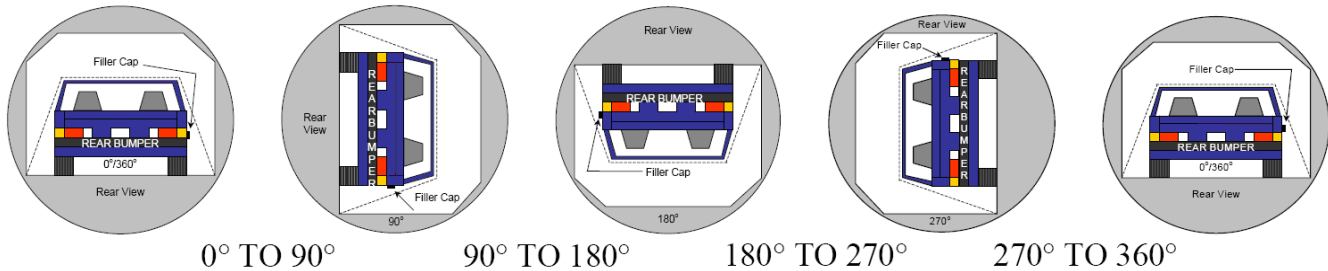

1. The specified fixture rollover rate for each 90° of rotation is 60 to 180 seconds.
2. The position hold time at each position is 300 seconds (minimum).

Details of Stoddard solvent spillage: None

**SOLVENT COLLECTION TIME TABLE IN SECONDS**

Test Phase	Rotation Time	Hold Time	Total Time
0° To 90°	81	300	381
90° To 180°	80	300	380
180° To 270°	79	300	379
270° To 360°	78	300	378

**FMVSS 301 SPILLAGE TABLE**

Test Phase	First 5 Minutes	Sixth Minute	Seventh Minute	Eighth Minute
0° To 90°	0 g			
90° To 180°	0 g			
180° To 270°	0 g			
270° To 360°	0 g			

**SOLVENT SPILLAGE LOCATION TABLE**

Test Phase	Spillage Location
0° To 90°	No Spillage
90° To 180°	No Spillage
180° To 270°	No Spillage
270° To 360°	No Spillage

**APPENDIX A  
PHOTOGRAPHS**

## TABLE OF PHOTOGRAPHS

Figure		Page
1	As Received Right Front $\frac{3}{4}$ View of Test Vehicle	A-1
2	As Received Left Rear $\frac{3}{4}$ View of Test Vehicle	A-1
3	Test Vehicle Manufacturer's Label	A-2
4	Test Vehicle Tire Information Placard	A-2
5	Pre-Test Front View of Test Vehicle	A-3
6	Post-Test Front View of Test Vehicle	A-3
7	Pre-Test Left Front $\frac{3}{4}$ View Test Vehicle	A-4
8	Post-Test Left Front $\frac{3}{4}$ View Test Vehicle	A-4
9	Pre-Test Left View of Test Vehicle	A-5
10	Post-Test Left View of Test Vehicle	A-5
11	Pre-Test Left Rear $\frac{3}{4}$ View of Test Vehicle	A-6
12	Post-Test Left Rear $\frac{3}{4}$ View of Test Vehicle	A-6
13	Pre-Test Rear View of Test Vehicle	A-7
14	Post-Test Rear View of Test Vehicle	A-7
15	Pre-Test Right Rear $\frac{3}{4}$ View of Test Vehicle	A-8
16	Post-Test Right Rear $\frac{3}{4}$ View of Test Vehicle	A-8
17	Pre-Test Right View of Test Vehicle	A-9
18	Post-Test Right View of Test Vehicle	A-9
19	Pre-Test Right Front $\frac{3}{4}$ View Test Vehicle	A-10
20	Post-Test Right Front $\frac{3}{4}$ View Test Vehicle	A-10
21	Pre-Test Close-Up View of Impact Point Target	A-11
22	Post-Test Close-Up View of Impact Point Target	A-11
23	Pre-Test View of Fuel Filler Cap	A-12
24	Post-Test View of Fuel Filler Cap	A-12
25	Pre-Test Rear Underbody View of Test Vehicle	A-13
26	Post-Test Rear Underbody View of Test Vehicle	A-13
27	Pre-Test Underbody View of Fuel Tank	A-14
28	Post-Test Underbody View of Fuel Tank	A-14
29	Pre-Test Rear Underbody View of Fuel Lines	A-15
30	Post-Test Rear Underbody View of Fuel Lines	A-15
31	Test Vehicle at 0° on FMVSS 301 Static Rollover Device	A-16
32	Test Vehicle at 90° on FMVSS 301 Static Rollover Device	A-16
33	Test Vehicle at 180° on FMVSS 301 Static Rollover Device	A-17
34	Test Vehicle at 270° on FMVSS 301 Static Rollover Device	A-17
35	Test Vehicle at 360° on FMVSS 301 Static Rollover Device	A-18





FIGURE 1. As Received Right Front  $\frac{3}{4}$  View of Test Vehicle



FIGURE 2. As Received Left Rear  $\frac{3}{4}$  View of Test Vehicle



FIGURE 3. Test Vehicle Manufacturer's Label

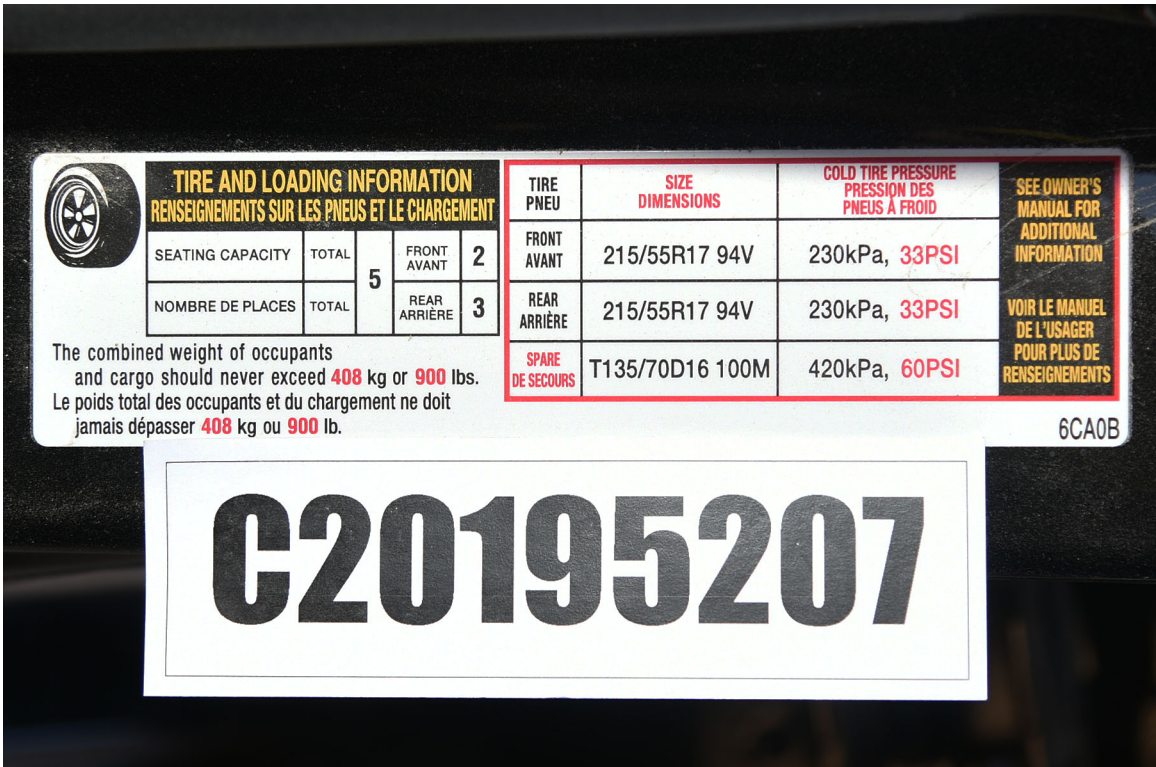

FIGURE 4. Test Vehicle Tire Information Placard



FIGURE 5. Pre-Test Front View of Test Vehicle



FIGURE 6. Post-Test Front View of Test Vehicle



FIGURE 7. Pre-Test Left Front  $\frac{3}{4}$  View of Test Vehicle



FIGURE 8. Post-Test Left Front  $\frac{3}{4}$  View of Test Vehicle



FIGURE 9. Pre-Test Left View of Test Vehicle



FIGURE 10. Post-Test Left View of Test Vehicle



FIGURE 11. Pre-Test Left Rear  $\frac{3}{4}$  View of Test Vehicle



FIGURE 12. Post-Test Left Rear  $\frac{3}{4}$  View of Test Vehicle



FIGURE 13. Pre-Test Rear View of Test Vehicle



FIGURE 14. Post-Test Rear View of Test Vehicle



FIGURE 15. Pre-Test Right Rear  $\frac{3}{4}$  View of Test Vehicle



FIGURE 16. Post-Test Right Rear  $\frac{3}{4}$  View of Test Vehicle



FIGURE 17. Pre-Test Right View of Test Vehicle



FIGURE 18. Post-Test Right View of Test Vehicle



FIGURE 19. Pre-Test Right Front  $\frac{3}{4}$  View of Test Vehicle



FIGURE 20. Post-Test Right Front  $\frac{3}{4}$  View of Test Vehicle



FIGURE 21. Pre-Test Close-Up View of Impact Point Target



FIGURE 22. Post-Test Close-Up View of Impact Point Target



FIGURE 23. Pre-Test View of Fuel Filler Cap



FIGURE 24. Post-Test View of Fuel Filler Cap

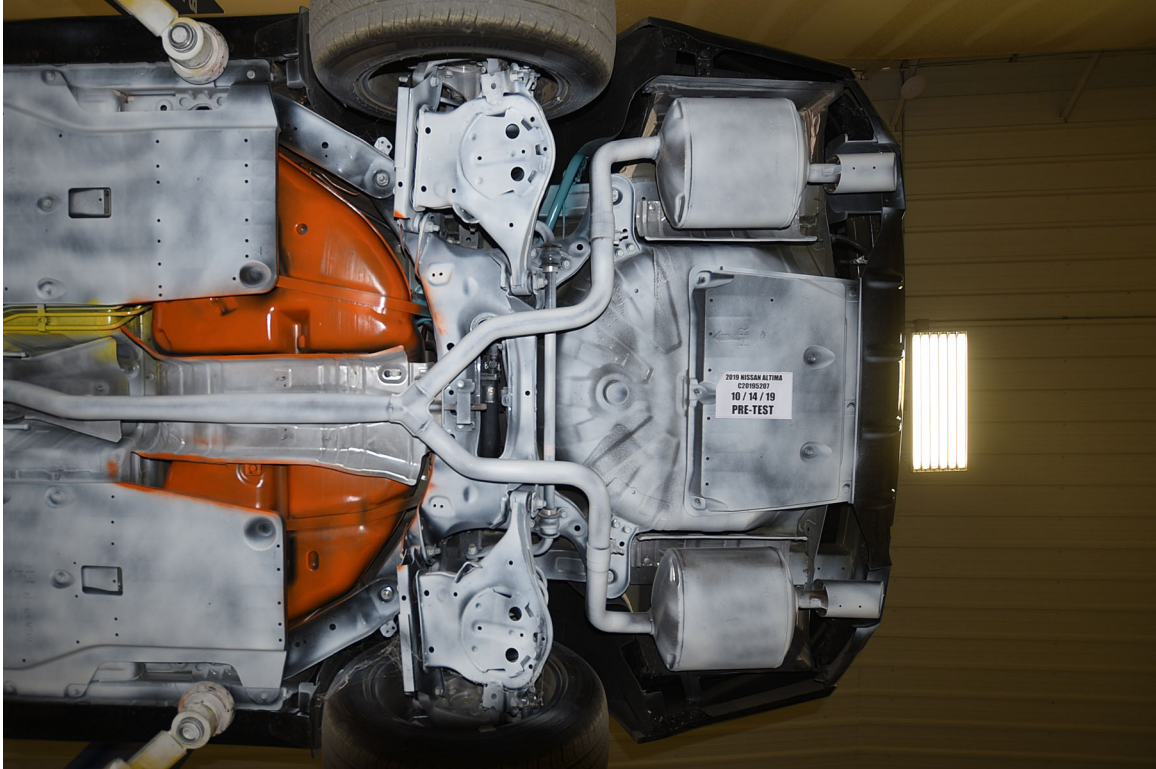

FIGURE 25. Pre-Test Rear Underbody View of Test Vehicle

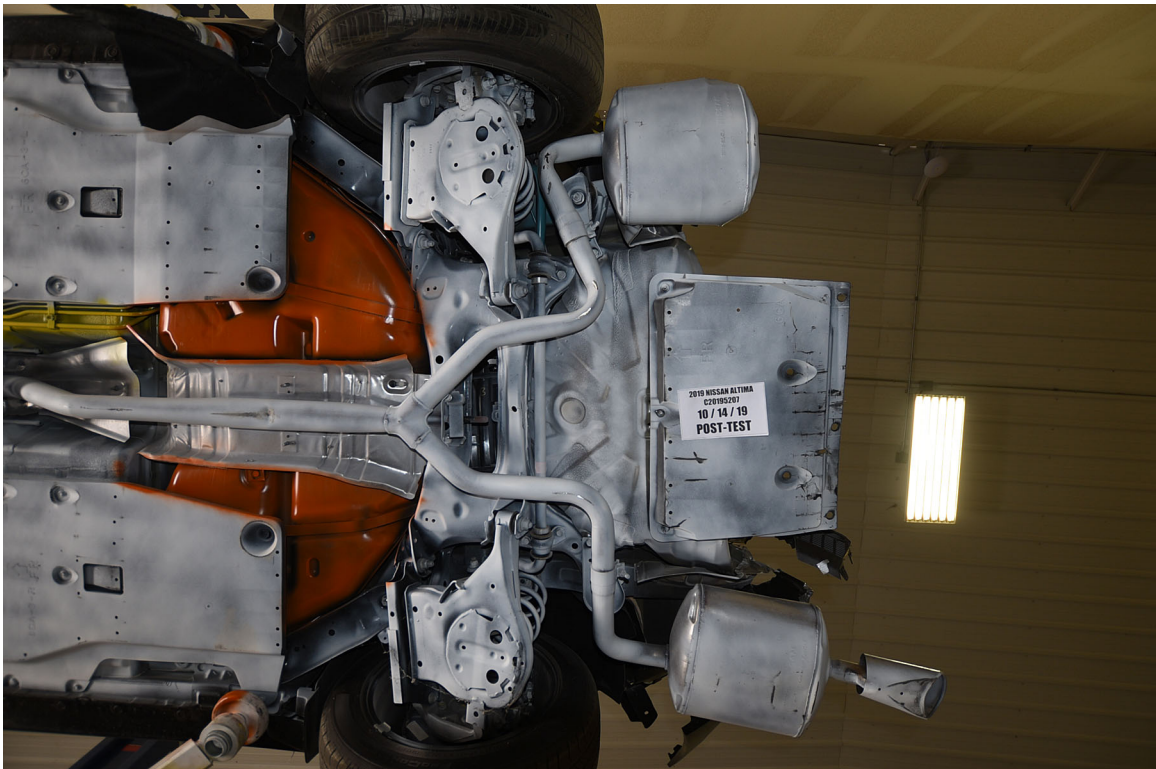

FIGURE 26. Post-Test Rear Underbody View of Test Vehicle



FIGURE 27. Pre-Test Underbody View of Fuel Tank

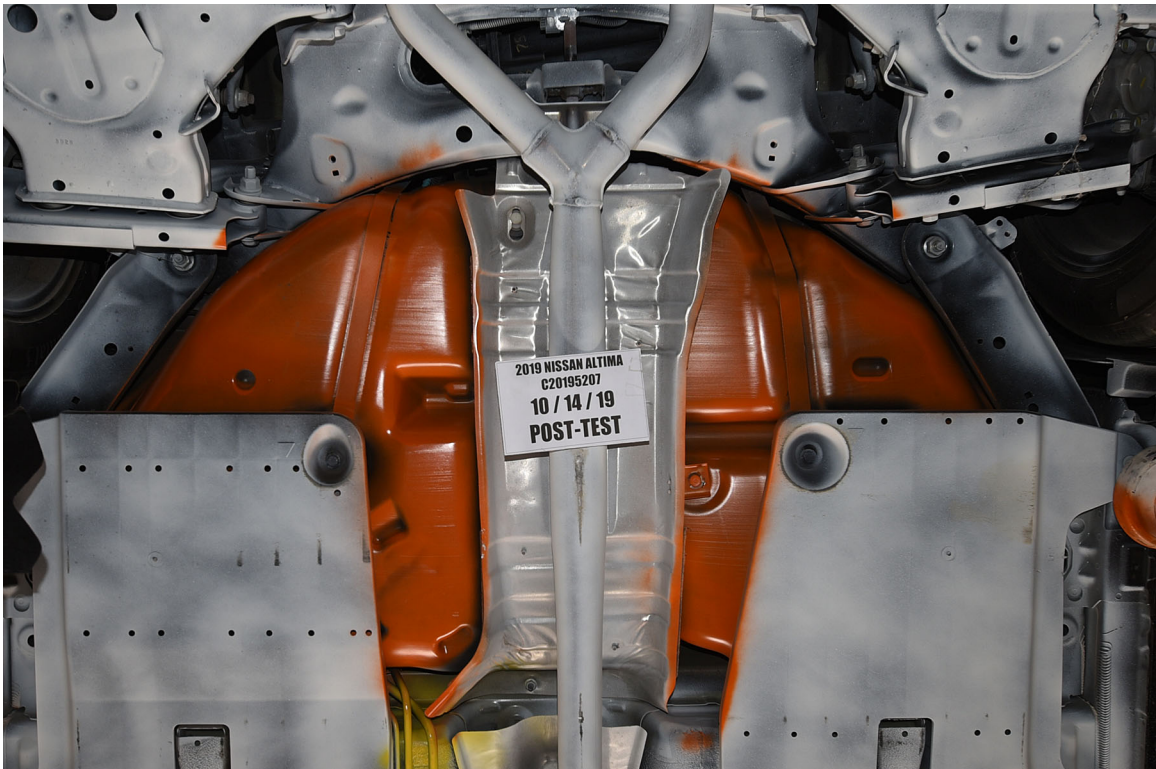

FIGURE 28. Post-Test Underbody View of Fuel Tank



FIGURE 29. Pre-Test Underbody View of Fuel Lines

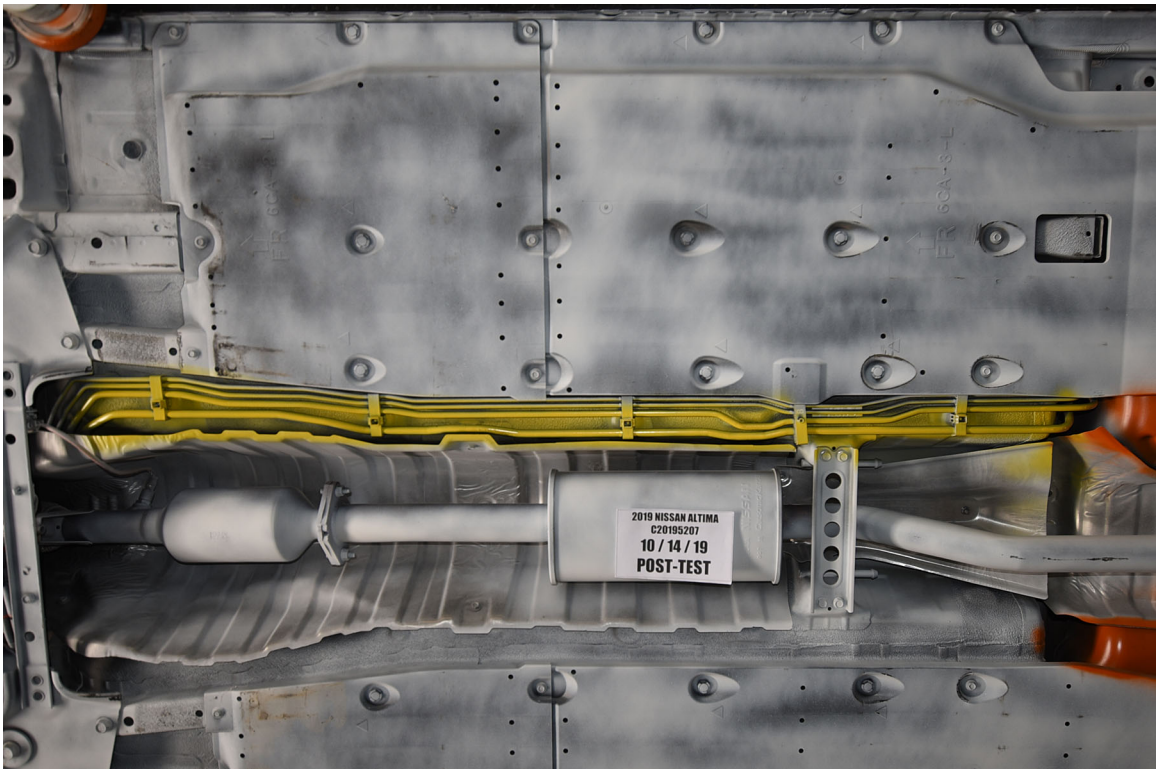

FIGURE 30. Post-Test Underbody View of Fuel Lines



FIGURE 31. Test Vehicle at 0° on FMVSS 301 Static Rollover Device



FIGURE 32. Test Vehicle at 90° on FMVSS 301 Static Rollover Device



FIGURE 33. Test Vehicle at 180° on FMVSS 301 Static Rollover Device

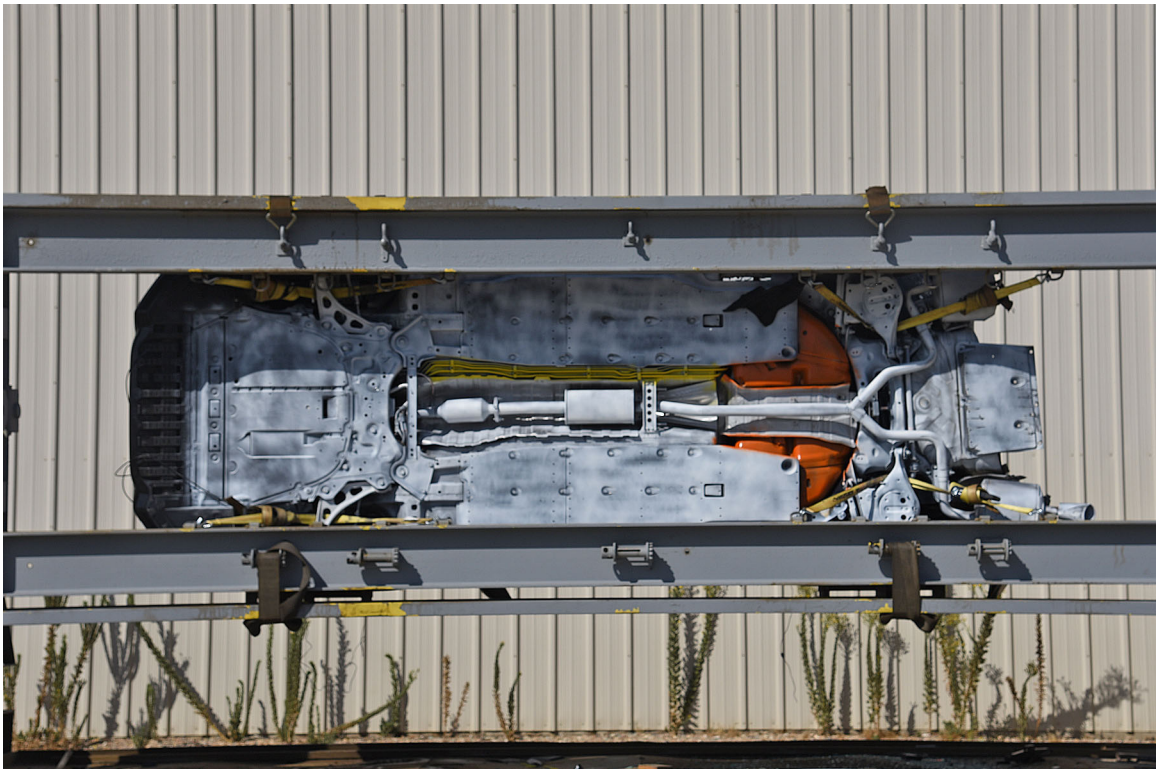

FIGURE 34. Test Vehicle at 270° on FMVSS 301 Static Rollover Device



FIGURE 35. Test Vehicle at 360° on FMVSS 301 Static Rollover Device



FIGURE 36. Impact Event