

**REPORT NUMBER: SPNCAP-MGA-2019-010**

**NEW CAR ASSESSMENT PROGRAM (NCAP)  
Side Impact Pole Test**

**FCA US LLC  
2019 Dodge Durango SXT 5-Door SUV  
NHTSA No.: M20190301**

**MGA RESEARCH CORPORATION  
5000 Warren Road  
Burlington, WI 53105**



**Test Date: November 1, 2018**

**Final Report Date: August 27, 2019**

**FINAL REPORT**

**U.S. DEPARTMENT OF TRANSPORTATION  
National Highway Traffic Safety Administration  
Office of Crashworthiness Standards  
Mail Code: NRM-110  
1200 New Jersey Ave, SE  
Room W43-410  
Washington, DC 20590**

This publication is distributed by the U.S. Department of Transportation, National Highway Traffic Safety Administration, in the interest of information exchange. The opinions, findings and conclusions expressed in this publication are those of the author(s) and not necessarily those of the Department of Transportation or the National Highway Traffic Safety Administration. The United States Government assumes no liability for its contents or use thereof.

If trade or manufacturers' names or products are mentioned, it is only because they are considered essential to the object of the publication and should not be construed as an endorsement. The United States Government does not endorse products or manufacturers.

Prepared by:   
Robert Schnorenberg, Project Engineer

Approved by:   
Ben Fischer, Project Engineer

Approval Date: August 27, 2019

FINAL REPORT ACCEPTANCE BY OCWS:

\_\_\_\_\_  
Division Chief, New Car Assessment Program  
NHTSA, Office of Crashworthiness Standards

Date: \_\_\_\_\_

\_\_\_\_\_  
COTR, New Car Assessment Program  
NHTSA, Office of Crashworthiness Standards

Date: \_\_\_\_\_

### Technical Report Documentation Page

<b>1. Report No.</b> SPNCAP-MGA-2019-010	<b>2. Government Accession No.</b>	<b>3. Recipient's Catalog No.</b>																												
<b>4. Title and Subtitle</b> Final Report of New Car Assessment Program Side Impact Pole Testing of a 2019 Dodge Durango SXT 5-Door SUV, NHTSA No.: M20190301		<b>5. Report Date</b> August 27, 2019																												
		<b>6. Performing Organization Code</b> MGA																												
<b>7. Author(s)</b> Robert Schnorenberg, Project Engineer		<b>8. Performing Organization Report No.</b> SPNCAP-MGA-2019-010																												
<b>9. Performing Organization Name and Address</b> MGA Research Corporation 5000 Warren Road Burlington, WI 53105		<b>10. Work Unit No.</b>																												
		<b>11. Contract or Grant No.</b> DTNH22-14-D-00353																												
<b>12. Sponsoring Agency Name and Address</b> United States Department of Transportation National Highway Traffic Safety Administration Office of Crashworthiness Standards (NRM-110) 1200 New Jersey Ave, SE, Room W43-410 Washington, DC 20590		<b>13. Type of Report and Period Covered:</b> Final Test Report November 1, 2018 to August 27, 2019																												
		<b>14. Sponsoring Agency Code</b> NRM-110																												
<b>15. Supplementary Notes</b>																														
<b>16. Abstract</b> A 32.20 km/h, 75° oblique impact Side NCAP Test was conducted on the subject 2019 Dodge Durango SXT 5-Door SUV in accordance with the specifications of the Office of Crashworthiness Standards Side NCAP Pole Laboratory Test Procedure for the generation of consumer information on vehicle side pole crash protection. The test was conducted at MGA Research Corporation in Burlington, Wisconsin on November 1, 2018.  The impact velocity was 32.29 km/h, and the ambient temperature at the struck (driver's) side of the target vehicle at the time of impact was 21.9°C. The test vehicle post-test maximum crush was 401 mm at level 3. The test vehicle's performance was as follows:																														
<table border="1" style="margin: auto; border-collapse: collapse;"> <thead> <tr> <th rowspan="2" style="text-align: left;">Measurement Description</th> <th colspan="3" style="text-align: center;">Driver ATD (SID-IIs)</th> </tr> <tr> <th style="text-align: center;">Units</th> <th style="text-align: center;">Threshold</th> <th style="text-align: center;">Result</th> </tr> </thead> <tbody> <tr> <td>Head Injury Criteria (HIC<sub>36</sub>)</td> <td style="text-align: center;">N/A</td> <td style="text-align: center;">1000</td> <td style="text-align: center;">194</td> </tr> <tr> <td>Resultant Lower Spine Acceleration</td> <td style="text-align: center;">Gs</td> <td style="text-align: center;">82</td> <td style="text-align: center;">43</td> </tr> <tr> <td>Total Pelvic Force (sum of acetabular and iliac forces)</td> <td style="text-align: center;">N</td> <td style="text-align: center;">5525</td> <td style="text-align: center;">3177</td> </tr> <tr> <td>Maximum Thoracic Rib Deflection</td> <td style="text-align: center;">mm</td> <td style="text-align: center;">38*</td> <td style="text-align: center;">22</td> </tr> <tr> <td>Maximum Abdomen Rib Deflection</td> <td style="text-align: center;">mm</td> <td style="text-align: center;">45*</td> <td style="text-align: center;">21</td> </tr> </tbody> </table>				Measurement Description	Driver ATD (SID-IIs)			Units	Threshold	Result	Head Injury Criteria (HIC <sub>36</sub> )	N/A	1000	194	Resultant Lower Spine Acceleration	Gs	82	43	Total Pelvic Force (sum of acetabular and iliac forces)	N	5525	3177	Maximum Thoracic Rib Deflection	mm	38*	22	Maximum Abdomen Rib Deflection	mm	45*	21
Measurement Description	Driver ATD (SID-IIs)																													
	Units	Threshold	Result																											
Head Injury Criteria (HIC <sub>36</sub> )	N/A	1000	194																											
Resultant Lower Spine Acceleration	Gs	82	43																											
Total Pelvic Force (sum of acetabular and iliac forces)	N	5525	3177																											
Maximum Thoracic Rib Deflection	mm	38*	22																											
Maximum Abdomen Rib Deflection	mm	45*	21																											
*Proposed IARV																														
The doors on the struck side of the vehicle did not separate from the body at the hinges or latches and the opposite doors did not open during the side impact event.																														
<b>17. Key Words</b> New Car Assessment Program (NCAP) Side Impact Pole Part 572V SID-IIs		<b>18. Distribution Statement</b> Copies of this report are available from: National Highway Traffic Safety Administration Technical Information Services Division, NPO-411 1200 New Jersey Ave, SE Washington, DC 20590																												
<b>19. Security Classification of Report</b> Unclassified	<b>20. Security Classification of Page</b> Unclassified	<b>21. No. of Pages</b> 138	<b>22. Price</b>																											

## TABLE OF CONTENTS

<u>Section</u>		<u>Page No.</u>
1	Test Purpose and Procedure	1
2	Summary of Test Results	2
3	Occupant and Vehicle Information	4

<u>Data Sheet No.</u>		<u>Page No.</u>
1	General Test and Vehicle Parameter Data	5
2	Seat, Seat Belt, Steering Wheel Adjustment and Fuel System Data	8
3	Dummy Longitudinal Clearance Dimensions	11
4	Dummy Lateral Clearance Dimensions	12
5	Camera and Instrumentation Data	13
6	Vehicle Accelerometer Data	14
7	Rigid Pole Load Cell Data	15
8	Post-Test Observations	16
9	Vehicle Profile Measurements	18
10	Vehicle Exterior Crush Measurements	19
11	Vehicle Damage Profile Distances	22
12	FMVSS No. 301 Static Rollover Results	23
13	Dummy/Vehicle Temperature Stabilization Data	24

### Appendix

A	Photographs	A
B	Vehicle and Dummy Response Data Plots	B
C	Dummy Configuration and Performance Verification Data	C
D	Test Equipment and Instrumentation Calibration Data	D

**SECTION 1**  
**TEST PURPOSE AND PROCEDURE**

This side impact test is part of the MY 2019 New Car Assessment Program Side Impact Test Program, sponsored by the National Highway Traffic Safety Administration (NHTSA), under Contract No. DTNH22-14-D-00353. The purpose of this test is to generate comparative side impact performance in a 2019 Dodge Durango SXT 5-Door SUV. The side impact test was conducted in accordance with the Office of Crashworthiness Standard's Side NCAP Pole Laboratory Test Procedure, dated October 2015.

## SECTION 2 SUMMARY OF TEST RESULTS

A rigid pole side impact test was conducted on a 2019 Dodge Durango SXT 5-Door SUV. The subject vehicle was towed into the rigid pole at an angle of 75° and a velocity of 32.29 km/h. The test was conducted by MGA Research Corporation in Burlington, Wisconsin on November 1, 2018. Pre-test and post-test photographs of the test vehicle and side impact dummy (SID-IIs) are included in Appendix A of this report.

One Part 572V (SID-IIs) dummy was placed in the driver designated seating position according to instructions specified in the OCWS Side NCAP Pole Laboratory Test Procedure dated October 2015. Camera locations and other pertinent camera information are included in this report.

The Part 572V (SID-IIs) dummy was instrumented accordingly:

Primary and Redundant Head CG Triaxial Accelerometers  
 Thorax Upper, Middle, and Lower Rib Displacement Potentiometers  
 Abdomen Upper Rib and Lower Rib Displacement Potentiometers  
 Lower Spine (T12) Triaxial Accelerometers  
 Iliac Load Cell  
 Acetabulum Load Cell

Appendix B contains the vehicle and dummy response data. Dummy configuration and performance verification data can be found in Appendix C of this report. Appendix D contains the test equipment and instrumentation calibration data.

Injury readings for the SID-IIs dummy were recorded as follows:

Measurement Description	Driver ATD (SID-IIs)		
	Units	Threshold	Result
Head Injury Criteria (HIC <sub>36</sub> )	N/A	1000	194
Resultant Lower Spine Acceleration	Gs	82	43
Total Pelvic Force (sum of acetabular and iliac forces)	N	5525	3177
Maximum Thoracic Rib Deflection	mm	38*	22
Maximum Abdominal Rib Deflection	mm	45*	21

\*Proposed IARV

Supplemental restraint information is given below:

Restraint Type	Struck Side Driver		Struck Side Rear Passenger	
	Mounted	Deployed	Mounted	Deployed
Frontal Airbag	Yes	Yes		
Knee Airbag	Yes	Yes		
Side Curtain Airbag	Yes	Yes	Yes	Yes
Side Torso/Pelvis Airbag	Yes	Yes	No	
Seat Belt Pretensioner	Yes	Yes	No	
Seat Belt Load Limiter	Yes		No	
Other				

The test data can be found on the NHTSA website at [www.nhtsa.gov](http://www.nhtsa.gov)

### **GENERAL COMMENTS**

Passenger Frontal Airbag deployed during event.

Left B-Post @ Sill Y recorded no valid data after 38 ms.

Left Lower B-Post Y was not installed.

Left Mid B-Post Y was not installed.

MGA does not endorse or certify products. The manufacturer's name appears solely for identification purposes.

**SECTION 3  
OCCUPANT AND VEHICLE INFORMATION**

**DATA SHEET NO. 1  
GENERAL TEST AND VEHICLE PARAMETER DATA**

Test Vehicle: 2019 Dodge Durango SXT 5-Door SUV  
Test Program: NCAP Side Pole Impact Test

NHTSA No. M20190301  
Test Date: 11/1/2018

**TEST VEHICLE INFORMATION AND OPTIONS**

NHTSA No.	M20190301	Traction Control System (TCS)	Yes
Model Year	2019	Auto-Leveling System	No
Make	Dodge	Automatic Door Locks (ADL)	Yes
Model	Durango SXT	Power Window Auto-Reverse	Yes
Body Style	5-Door SUV	Other Optional Feature	N/A
VIN	1C4RDHAG1KC550055	Driver Front Airbag	Yes
Body Color	Octane Red	Driver Curtain Airbag	Yes
Odometer Reading (km/mi)	11 km / 7 mi	Driver Head/Torso Airbag	No
Engine Displacement (L)	3.6 L	Driver Torso Airbag	No
Type/No. Cylinders	V6	Driver Torso/Pelvis Airbag	Yes
Engine Placement	Longitudinal	Driver Pelvis Airbag	No
Transmission Type	Automatic	Driver Knee Airbag	Yes
Transmission Speeds	8	Rear Pass. Curtain Airbag	Yes
Overdrive	Yes	Rear Pass. Head/Torso Airbag	No
Final Drive	RWD	Rear Pass. Torso Airbag	No
Roof Rack	No	Rear Pass. Torso/Pelvis Airbag	No
Sunroof/T-Top	No	Rear Pass. Pelvis Airbag	No
Running Boards	No	Driver Seat Belt Pretensioner	Yes
Tilt Steering Wheel	Yes	Rear Pass. Seat Belt Pretensioner	No
Power Seats	No	Driver Load Limiter	Yes
Anti-Lock Brakes (ABS)	Yes	Rear Pass. Load Limiter	No
		Other Restraint Feature	N/A

Does owner's manual provide instructions to turn off automatic door locks?	Yes
--	-----

**DATA FROM CERTIFICATION LABEL**

Manufactured By	FCA US LLC	GVWR (kg)	2949
Date of Manufacture	09/18	GAWR Front (kg)	1452
Vehicle Type	MPV	GAWR Rear (kg)	1770

**VEHICLE SEATING AND WEIGHT CAPACITY DATA**

Measured Parameter	Front	Rear	Third	Total	
Designated Seating Capacity (DSC)	2	3	2	7	
Capacity Weight (VCW) (kg)				544	(A)
DSC x 68.04 kg				476	(B)
Rated Cargo and Luggage Weight (RCLW) (kg)				68	(A-B)

**VEHICLE SEAT TYPE**

Seating Location	Type of Seat Pan				Type of Seat Back		
	Bucket	Bench	Split Bench	Contoured	Fixed	Adjustable	
						Manual	Power
Front Seat	X					X	
Rear or Second Row			X			X	
Third Row Seat			X		X		



**DATA SHEET NO. 1 (CONTINUED)**  
**GENERAL TEST AND VEHICLE PARAMETER DATA**

Test Vehicle: 2019 Dodge Durango SXT 5-Door SUV  
 Test Program: NCAP Side Pole Impact Test

NHTSA No. M20190301  
 Test Date: 11/1/2018

**TEST PRESSURES**

	Units	LF	RF	LR	RR
As Delivered	kpa	290	290	296	310
Tire Placard	kpa	250	250	250	250
Owner's Manual	kpa	250	250	250	250
As Tested	kpa	250	250	250	250

**TEST VEHICLE WEIGHTS**

	Units	As Delivered (UVW)			As Tested (ATW)			Fully Loaded		
		Front	Rear	Total	Front	Rear	Total	Front	Rear	Total
Left	kg	521.5	550.5		532.0	611.0		538.0	606.5	
Right	kg	536.0	556.5		527.0	607.0		535.5	604.0	
Ratio	%	48.9%	51.1%		46.5%	53.5%		47.0%	53.0%	
Totals	kg	1057.5	1107.0	2164.5	1059.0	1218.0	2277.0	1073.5	1210.5	2284.0

**TARGET TEST WEIGHT CALCULATION**

Measured Parameter	Units	Value	
Total Delivered Weight (UVW)	kg	2164.5	(A)
Actual Weight of 1 P572V ATD (SID-IIs) ATD Used	kg	52	(B)
Rated Cargo/Luggage Weight (RCLW)	kg	68	(C)
Calculated Vehicle Target Weight (TVTW)	kg	2284.5	(A+B+C)

Does the measured As Tested Vehicle Weight lie within the required weight range (i.e. Calculated Test Vehicle Target Weight – 4.5 kg to 9 kg)? **YES**

**TEST VEHICLE ATTITUDES AND CG**

	Units	As Delivered	As Tested	Fully Loaded	Meets Requirement***
Driver Door Sill Angle (front-to-rear)*	deg	0.4	0.6	0.7	Yes
Front Pass. Sill Angle (front-to-rear)*	deg	-0.8	-0.6	-0.6	Yes
Front Bumper Angle (left-to-right)**	deg	-0.3	-0.4	-0.4	Yes
Rear Bumper Angle (left-to-right)**	deg	0.4	0.4	0.4	Yes
Vehicle CG (Aft of Front Axle)	mm	1559	1632	1617	
Vehicle CG (Left (+) / Right (-) from Longitudinal Centerline)	mm	-8	3	2	

\*ND=Nose Down (-), NU=Nose Up (+) \*\* LD=Left Down (-), LU=Left Up (+)

\*\*\* The "As Tested" vehicle attitude measurements must be equal to or between the "As Delivered" and "Fully Loaded" vehicle attitude measurements.

**WEIGHT OF BALLAST AND VEHICLE COMPONENTS REMOVED TO MEET TVTW**

Component Description	Weight (kg)
Ballast (if any)	45
None	

Test height adjustable suspension setting, if applicable:	Not Applicable
---	----------------

**DATA SHEET NO. 2**  
**SEAT, SEAT BELT, STEERING WHEEL ADJUSTMENT AND FUEL SYSTEM DATA**

Test Vehicle: 2019 Dodge Durango SXT 5-Door SUV  
 Test Program: NCAP Side Pole Impact Test

NHTSA No. M20190301  
 Test Date: 11/1/2018

**SEAT POSITIONING**

The driver's seat, front center seat (if applicable), and right front passenger's seat should be set to the forward-most, mid-height, mid-angle position. The struck-side rear passenger's seat, rear center seat, and non-struck side rear passenger's seats should be set to the rear-most, lowest, mid-angle position.

**SCRL ANGLE RANGE**

Seat	SCRL (°)		
	Max	Min	Mid
Driver Seat	Fixed	Fixed	Fixed
Front Passenger Seat	Fixed	Fixed	Fixed
Front Center Seat			
Struck Side Rear Seat	Fixed	Fixed	Fixed
Non-Struck Side Rear Seat	Fixed	Fixed	Fixed
Rear Center Seat	Fixed	Fixed	Fixed

**SEAT HEIGHT AND ANGLE**

Seat	As Tested SCRL Angle (Mid) (°)	As Tested SCRP Height (mm)	SCRP Height Position	SCRP Height (mm)		
				Rear-most	Mid-Fore/Aft	Forward-Most
Driver Seat	Fixed	Fixed	Max	Fixed	Fixed	Fixed
			Mid	Fixed	Fixed	Fixed
			Min	Fixed	Fixed	Fixed
Front Passenger Seat	Fixed	Fixed	Max	Fixed	Fixed	Fixed
			Mid	Fixed	Fixed	Fixed
			Min	Fixed	Fixed	Fixed
Front Center Seat			Max			
			Mid			
			Min			
Struck Side Rear Seat	Fixed	Fixed	Max	Fixed	Fixed	Fixed
			Mid	Fixed	Fixed	Fixed
			Min	Fixed	Fixed	Fixed
Non-Struck Side Rear Seat	Fixed	Fixed	Max	Fixed	Fixed	Fixed
			Mid	Fixed	Fixed	Fixed
			Min	Fixed	Fixed	Fixed
Rear Center Seat	Fixed	Fixed	Max	Fixed	Fixed	Fixed
			Mid	Fixed	Fixed	Fixed
			Min	Fixed	Fixed	Fixed

**DATA SHEET NO. 2 (CONTINUED)**  
**SEAT, SEAT BELT, STEERING WHEEL ADJUSTMENT, AND FUEL SYSTEM DATA**

Test Vehicle: 2019 Dodge Durango SXT 5-Door SUV  
 Test Program: NCAP Side Pole Impact Test

NHTSA No. M20190301  
 Test Date: 11/1/2018

**SEAT FORE/AFT POSITIONS**

Seat	Total Fore/Aft Travel		Test Position from Forward-most Position	
	mm	Detents	mm	Detent
Driver Seat	280	42 (1 <sup>st</sup> as 1)	0	0 <sup>th</sup> (1 <sup>st</sup> as 0)
Front Passenger Seat	235	35 (1 <sup>st</sup> as 1)	0	0 <sup>th</sup> (1 <sup>st</sup> as 0)
Front Center Seat				
Struck Side Rear Seat	Fixed	Fixed	Fixed	Fixed
Non-Struck Side Rear Seat	Fixed	Fixed	Fixed	Fixed
Rear Center Seat	Fixed	Fixed	Fixed	Fixed

**SEAT BACK ANGLE ADJUSTMENT**

The driver's seat back is positioned such that the dummy's head is level. The front center and front passenger's seat backs are positioned in a similar manner as the driver's seat back. The struck-side rear passenger seat back is positioned in accordance with the information provided by the manufacturer on Form No. 1 for the 5<sup>th</sup> percentile female dummy in a Side NCAP MDB test. The rear center and non-struck side rear passenger's seat back is set to match the struck-side rear seat back.

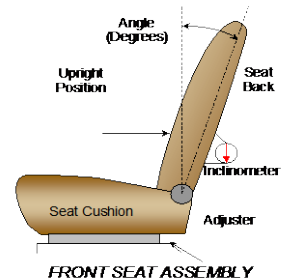

Seat	Total Seat Back Angle Range		Test Position from Vertical	
	Degrees	Detents	Degree	Detent
Driver Seat w/Seated Dummy	74.2	34 (1 <sup>st</sup> as 1)	2.5	0 <sup>th</sup> (1 <sup>st</sup> as 0)
Front Passenger Seat	64.2	30 (1 <sup>st</sup> as 1)	1.8	0 <sup>th</sup> (1 <sup>st</sup> as 0)
Front Center Seat				
Struck Side Rear Seat	10.9	7 (1 <sup>st</sup> as 1)	N/A	0 <sup>th</sup> (1 <sup>st</sup> as 0)
Non-Struck Side Rear Seat	10.9	7 (1 <sup>st</sup> as 1)	N/A	0 <sup>th</sup> (1 <sup>st</sup> as 0)
Rear Center Seat	10.9	7 (1 <sup>st</sup> as 1)	N/A	0 <sup>th</sup> (1 <sup>st</sup> as 0)

Front seat back angle measured on outboard headrest post.

**SEAT BELT ANCHORAGE ADJUSTMENT**

Seat belt anchorages are adjusted in accordance with the information provided by the manufacturer on Form No. 1.

	Total # of Positions	Placed in Position #
Driver Seat	5 detents (1 <sup>st</sup> as 1)	0 <sup>th</sup> (Uppermost as 0)

**HEAD RESTRAINT ADJUSTMENT**

Head restraints are adjusted to the lowest and most full forward in-use position.

	Total # of Positions	Placed in Position #
Driver Seat	5 detents (1 <sup>st</sup> as 1)	0 (Lowermost as 0)

**DATA SHEET NO. 2 (CONTINUED)**  
**SEAT, SEAT BELT, STEERING WHEEL ADJUSTMENT, AND FUEL SYSTEM DATA**

Test Vehicle: 2019 Dodge Durango SXT 5-Door SUV  
 Test Program: NCAP Side Pole Impact Test

NHTSA No. M20190301  
 Test Date: 11/1/2018

**STEERING COLUMN ADJUSTMENT**

Steering wheel and column adjustments are made so that the steering wheel geometric locus is described when it moves through its full range of motion.

	Degrees	Fore/Aft Position (mm)
Lowermost, Position 1	70.6	247
Geometric Center, Position 2	68.3	220
Uppermost, Position 3	66.0	192
Telescoping Steering Wheel Travel		55
Test Position	68.3	220

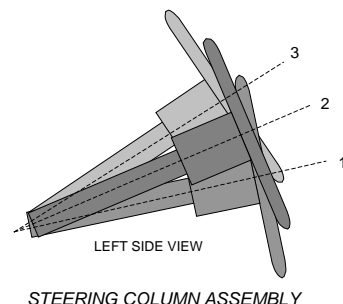

**FUEL PUMP**

Describe the fuel pump type, details about how it operates and the location of the fuel filler pipe.

The vehicle is equipped with an electronic fuel pump. The fuel pump starts pumping fuel when the key is in "ON" position. The filler neck is located on the driver's side.

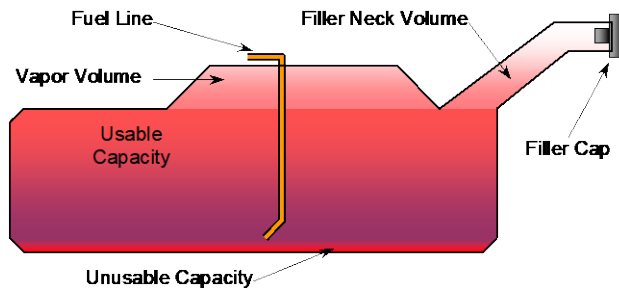

VEHICLE FUEL TANK ASSEMBLY

**FUEL TANK CAPACITY DATA**

	Liters
Usable Capacity of "Standard Tank" (see Form No. 1)	93.5
Usable Capacity of "Optional Tank" (see Form No. 1)	
Usable Capacity of Standard Tank as Specified in Owner's Manual	93.5
Usable Capacity of Optional Tank as Specified in Owner's Manual	
93% of Usable Capacity	87.0
Actual Amount of Solvent Used	87.1
1/3 of Usable Capacity	31.2

Is the actual amount of solvent used in the test equal to 93%  $\pm$  1% of the Usable Capacity stated in Form No. 1? **YES**

**DATA SHEET NO. 3  
DUMMY LONGITUDINAL CLEARANCE DIMENSIONS**

Test Vehicle: 2019 Dodge Durango SXT 5-Door SUV  
 Test Program: NCAP Side Pole Impact Test

NHTSA No. M20190301  
 Test Date: 11/1/2018

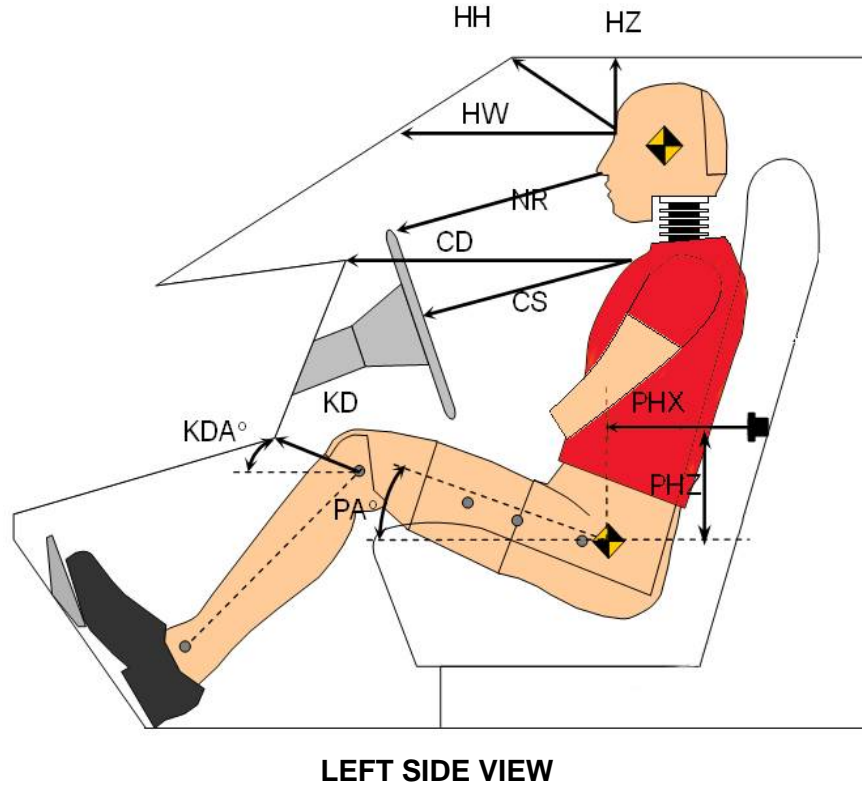

Code	Measurement Description	Driver	
		Length (mm)	Angle (°)
HH	Head to Header	262	
HW	Head to Windshield	531	
HZ	Head to Roof Liner	202	
NR	Nose to Rim	182	
CD	Chest to Dashboard	388	
CS	Chest to Steering Wheel	128	
KDL/KDAL°	Left Knee to Dash	105	35.5
KDR/KDAR°	Right Knee to Dash	107	36.0
PAX°	Pelvic Tilt Angle (X-Axis)		20.4
PAY°	Pelvic Tilt Angle (Y-Axis)		-1.0
PHX	Hip Point to Striker (X-Axis)	350	
PHZ	Hip Point to Striker (Z-Axis)	72	

**DATA SHEET NO. 4  
DUMMY LATERAL CLEARANCE DIMENSIONS**

Test Vehicle: 2019 Dodge Durango SXT 5-Door SUV  
 Test Program: NCAP Side Pole Impact Test

NHTSA No. M20190301  
 Test Date: 11/1/2018

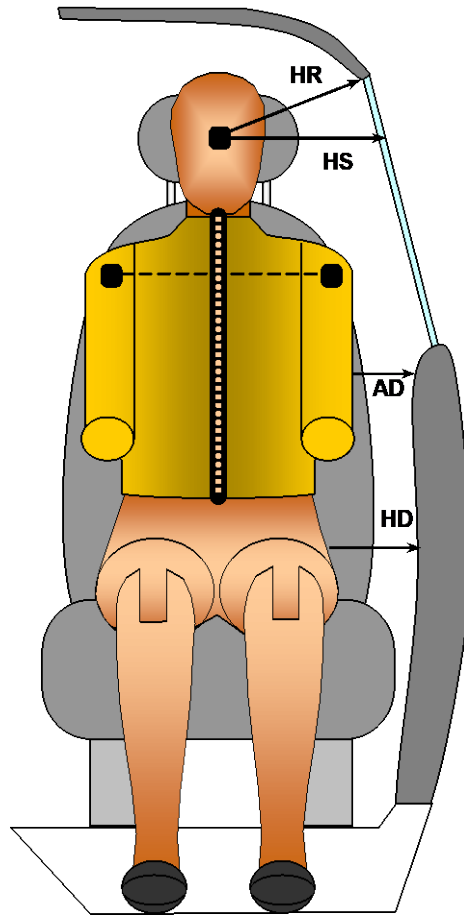

**FRONT VIEW OF DUMMY**

Code	Measurement Description	Driver
		Length (mm)
HR	Head to Side Header	258
HS	Head to Side Window	374
AD	Arm to Door	183
HD	Hip Point to Door	173

**DATA SHEET NO. 5  
CAMERA AND INSTRUMENTATION DATA**

Test Vehicle: 2019 Dodge Durango SXT 5-Door SUV  
 Test Program: NCAP Side Pole Impact Test

NHTSA No. M20190301  
 Test Date: 11/1/2018

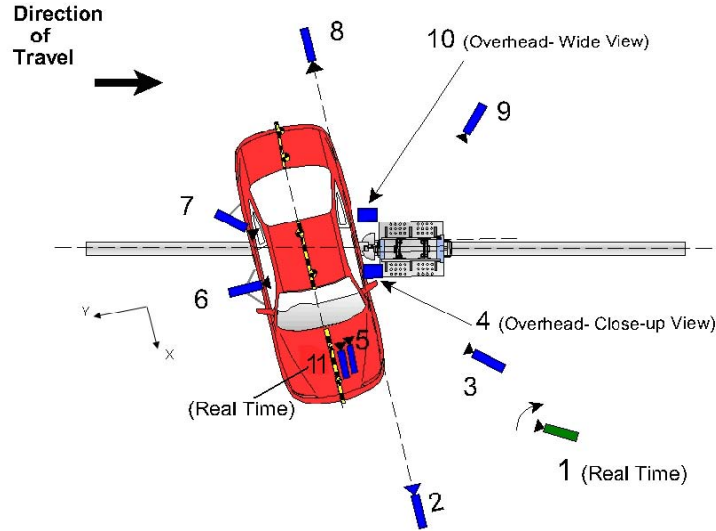

Reference: (from Point of Impact for X and Y; from Ground for Z):  
 +X = Forward of Impact, + Y = Right of Impact, +Z = Down

Camera No.	View	Coordinates (mm)			Lens (mm)	Film Speed (fps)
		X*	Y*	Z*		
1	Real-Time Pan View					30
2	Front Ground Level	7220	140	-2050	25	1000
3	Impact Side 45° Forward	5460	-1860	-2080	20	1000
4	Overhead Closeup	0	0	-6670	70	1000
5	Onboard – Driver Front				16	1000
6	Onboard – Driver Side				8	1000
7	Onboard – Driver Rear				8	1000
8	Rear Ground Level	-7350	-100	-1940	25	1000
9	Impact Side 45° Rearward	-3570	-3800	-2030	20	1000
10	Overhead Wide View	80	850	-6650	14	1000
11	Real-Time Dummy Front View					30

\*All measurements accurate to  $\pm 6$  mm

Note: Vehicle was at a 75° angle to the rigid pole.

Explain why camera(s) did not operate as intended: None

INSTRUMENTATION	Number of Channels
Driver Dummy	19
Vehicle Structure	18
Pole Load Cells	8
<b>TOTAL</b>	<b>45</b>

**DATA SHEET NO. 6  
VEHICLE ACCELEROMETER DATA**

Test Vehicle: 2019 Dodge Durango SXT 5-Door SUV  
 Test Program: NCAP Side Pole Impact Test

NHTSA No. M20190301  
 Test Date: 11/1/2018

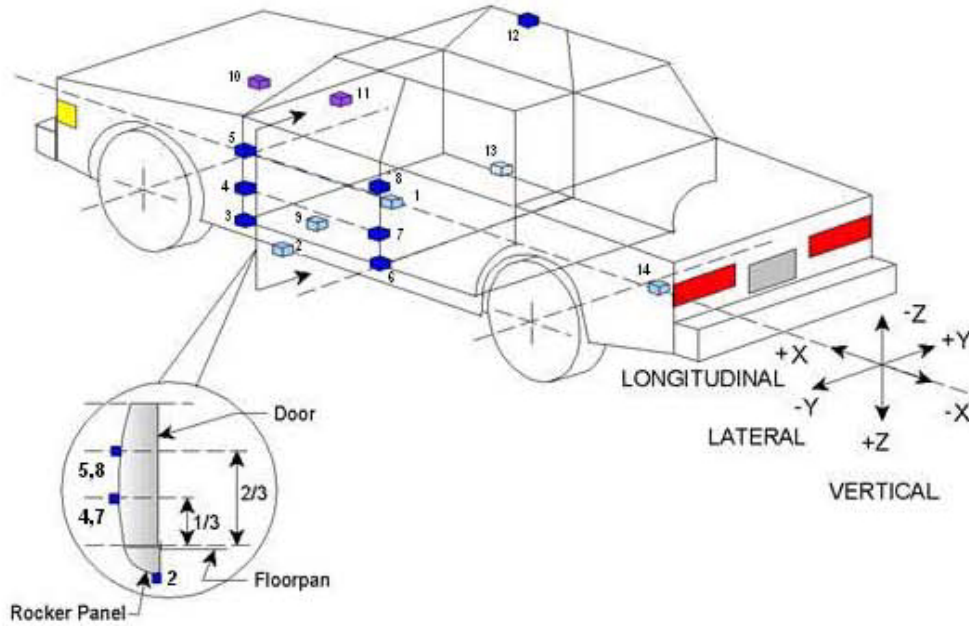

	Accelerometer Location			
	ID	Coordinates (mm)		
		X	Y	Z
1	Vehicle CG	2510	361	-315
2	Left Floor Sill	3322	-743	-303
3	A Pillar Sill	3653	-743	-294
4	A Pillar Low	3530	-786	-730
5	A Pillar Mid	3538	-875	-952
6	B Pillar Sill	2465	-743	-310
7	B Pillar Low			
8	B Pillar Mid			
9	Driver Seat Track	2545	-263	-454
10	Engine Top	4240	-13	-989
11	Firewall	3818	0	-1051
12	Right Roof	2520	584	-1718
13	Right Floor Sill	3400	743	-315
14	Rear Floorpan	700	0	-555

Reference:

- X – Test Vehicle Rear Bumper (+forward)
- Y – Test Vehicle Centerline (+ to right)
- Z – Ground Plane (+ down)

**DATA SHEET NO. 7**  
**RIGID POLE LOAD CELL DATA**

Test Vehicle: 2019 Dodge Durango SXT 5-Door SUV  
Test Program: NCAP Side Pole Impact Test

NHTSA No. M20190301  
Test Date: 11/1/2018

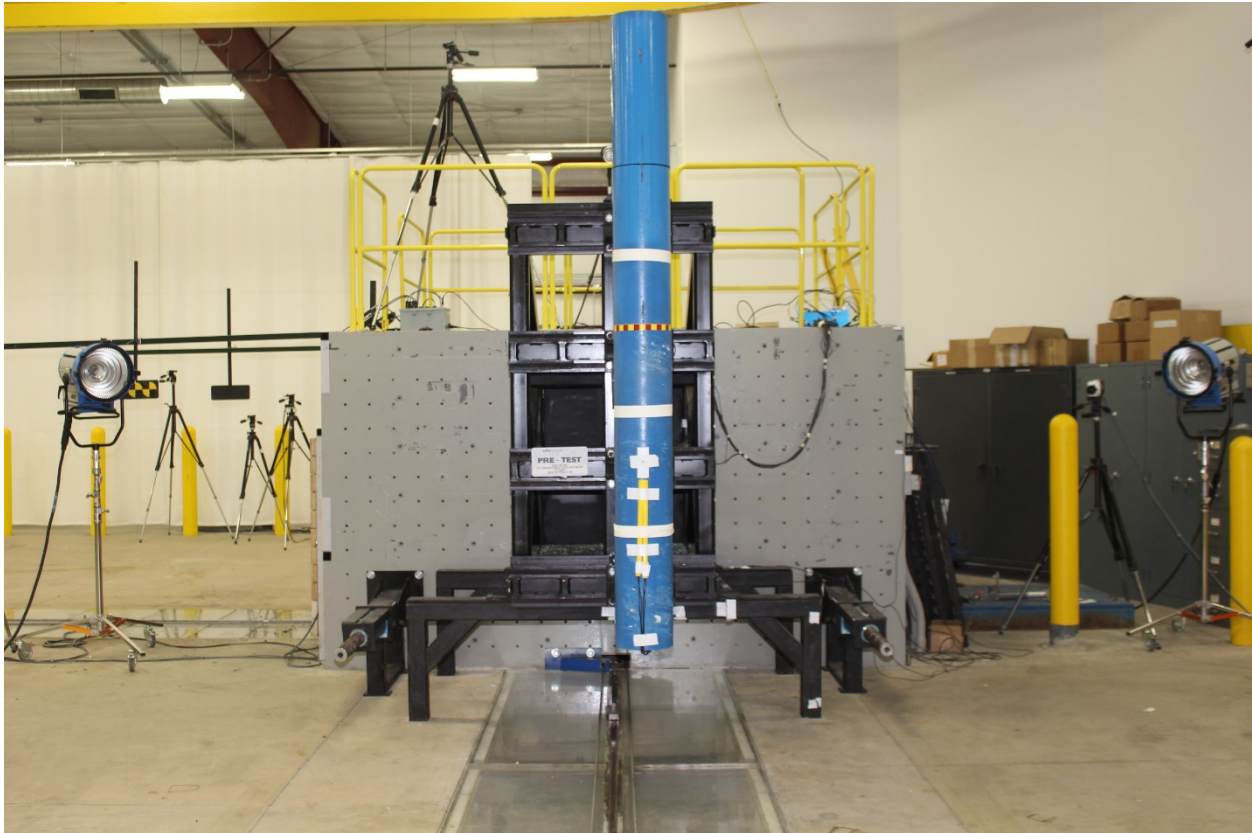

254 mm Diameter Rigid Pole

Load Cell Locations	
ID	Height From Impact Surface (mm)
1	182
2	470
3	698
4	986
5	1212
6	1641
7	1854
8	2053

**DATA SHEET NO. 8  
POST-TEST OBSERVATIONS**

Test Vehicle: 2019 Dodge Durango SXT 5-Door SUV  
 Test Program: NCAP Side Pole Impact Test

NHTSA No. M20190301  
 Test Date: 11/1/2018

**TEST DUMMY INFORMATION AND CONTACT POINTS**

Description	Driver SID-IIs Dummy
Face	Curtain Airbag
Top of Head	Curtain Airbag
Left Side of Head	Curtain Airbag
Back of Head	Curtain Airbag, Headrest
Left Shoulder	Curtain Airbag, Side Torso/Pelvis Airbag
Upper Torso	Side Torso/Pelvis Airbag
Lower Torso	Side Torso/Pelvis Airbag
Left Hip	Side Torso/Pelvis Airbag, Seat Cushion
Left Knee	Door Panel

**POST-TEST DOOR PERFORMANCE**

Description	Struck Side		Non-Struck Side		Rear Hatch/ Other Door
	Front	Rear	Front	Rear	
Remained Closed and Operational	No	No	Yes	Yes	Yes
Total Separation from Vehicle at Hinges or Latches	No	No	No	No	No
Latch or Hinge Systems Pulled Out of Their Anchorages	No	No	No	No	No
Disengaged from Latched Position	No	No	No	No	No
Latch Separated from Striker	No	No	No	No	No
Jammed Shut	Yes	Yes	No	No	No
If Door Opened at Striker, Record Width of Opening at Striker (mm)	N/A	N/A	N/A	N/A	N/A

**POST-TEST SEAT PERFORMANCE**

Description	Struck Side		Non-Struck Side	
	Front	Rear	Front	Rear
Seat Movement Along Seat Track	No	No	No	No
Seat Disengagement from Floor Pan	No	No	No	No
Seat Back Movement from Initial Position	No	No	No	No
Seat Back Collapse	No	No	No	No

**POST-TEST STRUCTURAL OBSERVATIONS**

Critical Areas of Performance	Observations and Conclusions
Pillar Performance	No Separation
Sill Separation	None
Windshield Damage	Cracked
Side Window Damage	Left Front Window Cracked
Other Notable Effects	None

**DATA SHEET NO. 8 (CONTINUED)  
POST-TEST OBSERVATIONS**

Test Vehicle: 2019 Dodge Durango SXT 5-Door SUV  
 Test Program: NCAP Side Pole Impact Test

NHTSA No. M20190301  
 Test Date: 11/1/2018

**SUPPLEMENTAL RESTRAINT SYSTEM INFORMATION**

Restraint Type	Struck Side Driver		Struck Side Rear Passenger	
	Mounted	Deployed	Mounted	Deployed
Frontal Airbag	Yes	Yes		
Knee Airbag	Yes	Yes		
Side Curtain Airbag	Yes	Yes	Yes	Yes
Side Torso/Pelvis Airbag	Yes	Yes	No	
Seat Belt Pretensioner	Yes	Yes	No	
Seat Belt Load Limiter	Yes		No	
Other				

**VEHICLE SPEED, VEHICLE ANGLE AT IMPACT, AND IMPACT POINT LOCATION DATA**

Measured Parameter	Units	Tolerance	Value
Vertical Impact Reference Line (Aft of Front Axle) (Intended Impact Point)	mm		1254
Actual Impact Point (Aft of Front Axle)	mm		1257
Horizontal Offset (+forward / -rearward)	mm	+/- 38 of Intended Impact Point	-3
Angle Between Vehicle's Longitudinal Centerline and Line of Forward Motion	deg	75 +/- 3	74.8
Trap No. 1 Velocity (Primary)	km/h	31.4 to 33.0	32.29
Trap No. 2 Velocity (Redundant)	km/h	31.4 to 33.0	32.32

**DATA SHEET NO. 9  
VEHICLE PROFILE MEASUREMENTS**

Test Vehicle: 2019 Dodge Durango SXT 5-Door SUV  
Test Program: NCAP Side Pole Impact Test

NHTSA No. M20190301  
Test Date: 11/1/2018

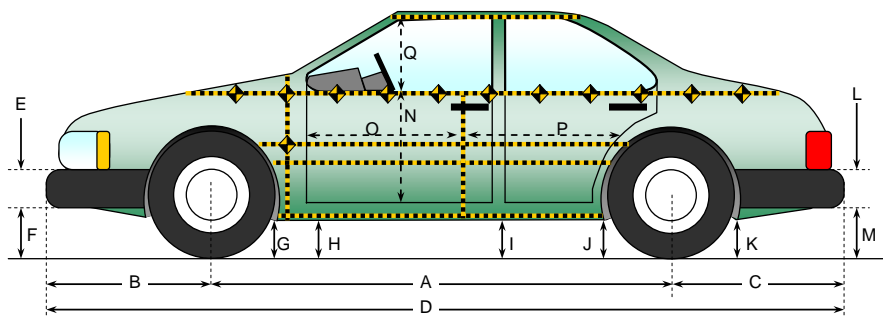

All measurements in (mm) with tolerance of  $\pm 3$  mm

**LEFT SIDE VIEW**

**VEHICLE PRE- AND POST-TEST MEASUREMENT INFORMATION**

Code	Measurement Description	Pre-Test	Post-Test	Difference
A	Wheelbase	3050	2936	114
B	Front Axle to FSOV	865	875	-10
C	Rear Axle to RSOV	1170	1171	-1
D	Total Vehicle Length at Centerline	5085	4982	103
E	Front Bumper Thickness	122	122	0
F	Front Bumper Bottom to Ground	225	248	-23
G	Sill Height at Front Wheel Well	294	286	8
H	Sill Height at Front Door Leading Edge	291	289	2
I	Sill Height at B-Pillar	288	306	-18
J1	Sill Height at Rear Wheel Well	293	300	-7
J2	Pinch Weld Height at Rear Wheel Well	234	241	-7
K	Sill Height Aft of Rear Wheel Well	263	260	3
L	Rear Bumper Thickness	70	70	0
M	Rear Bumper Bottom to Ground	380	365	15
N	Sill Height to Bottom of Front Window Sill	820	846	-26
O	Front Door Leading Edge to Impact CL	648	627	21
P	Rear Door Trailing Edge to Impact CL	1496	1571	-75
Q	Front Window Opening	421	403	18
R	Right Side Length	4213	4236	-23
S	Left Side Length	4213	4072	141
T	Vehicle Width at B-Pillars	1915	1849	66

**DATA SHEET NO. 10  
VEHICLE EXTERIOR CRUSH MEASUREMENTS**

Test Vehicle: 2019 Dodge Durango SXT 5-Door SUV  
 Test Program: NCAP Side Pole Impact Test

NHTSA No. M20190301  
 Test Date: 11/1/2018

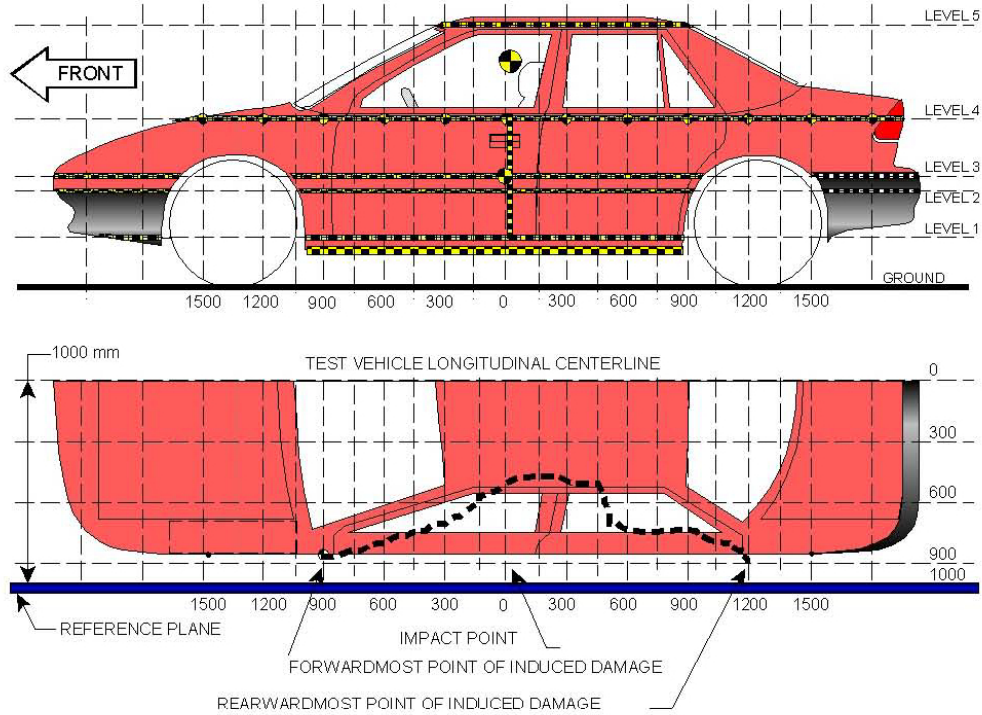

NOTE: The measurements are taken along the vertical impact reference line. Vehicle measurements forward of the vertical impact reference line are negative.

**MAXIMUM EXTERIOR CRUSH MEASUREMENTS**

Level	Measurement Description	Height Above Ground (mm)	Maximum Exterior Static Crush	Distance from Impact
1	Sill Top	416	343	0
2	Mid Door	776	399	0
3	Occupant Hip Point	801	401	0
4	Window Sill	1154	354	0
5	Window Top	1635	197	0

**DATA SHEET NO. 10 (CONTINUED)**  
**VEHICLE EXTERIOR CRUSH MEASUREMENTS**

Test Vehicle: 2019 Dodge Durango SXT 5-Door SUV  
 Test Program: NCAP Side Pole Impact Test

NHTSA No. M20190301  
 Test Date: 11/1/2018

	Pre-Test					Post-Test					Difference				
	1	2	3	4	5	1	2	3	4	5	1	2	3	4	5
-2700															
-2550															
-2400															
-2250															
-2100															
-1950															
-1800															
-1650															
-1500															
-1350															
-1200															
-1050															
-900		143	142	256			181	181	287			38	39	31	
-825															
-750		148	147	246			173	173	276			25	26	30	
-675	203	152	151	243		251	169	170	277		48	17	19	34	
-600	208	156	155	240		279	201	199	277		71	45	44	37	
-525	210	159	157	239		312	245	244	306		102	86	87	67	
-450	210	160	158	234		342	292	290	331		132	132	132	97	
-375	212	162	161	232		373	339	338	369		161	177	177	137	
-300	210	164	162	229		398	377	380	395		188	213	218	166	
-225	209	165	164	227		436	429	426	440		227	264	262	213	
-150	209	166	165	226		481	474	479	484		272	308	314	258	
-75	210	168	166	224	444	529	529	529	543	617	319	361	363	319	173
0	209	168	167	223	431	552	567	568	577	628	343	399	401	354	197
75	209	169	168	222	424	525	550	552	561	600	316	381	384	339	176
150	209	169	169	221	421	472	510	508	519	575	263	341	339	298	154
225	210	169	169	220	419	411	456	457	459	518	201	287	288	239	99
300	210	170	169	218	417	358	393	394	406	490	148	223	225	188	73
375	209	170	169	215	416	300	326	326	350	454	91	156	157	135	38
450	210	169	169	216	415	239	261	265	297	422	29	92	96	81	7
525	211	169	169	214	414	265	232	241	281	464	54	63	72	67	50
600	213	169	169	214	413	265	227	242	278	462	52	58	73	64	49
675															
750	218	168	168	212	414	248	206	206	261	448	30	38	38	49	34
825															
900	223	166	166	210	415	239	185	185	251	439	16	19	19	41	24
1050	224	162	162	207	417	223	159	159	232	427	-1	-3	-3	25	10
1200	207	157	156	202	420	196	142	140	224	425	-11	-15	-16	22	5
1350		147	147	198	423		143	138	201	434		-4	-9	3	11
1500				193	426				188	438				-5	12
1650				193	429				200	438				7	9
1800				196	433				204	442				8	9
1950				203	439				210	447				7	8
2100				212	447				220	453				8	6
2250				226	459				235	465				9	6
2400				243					249					6	
2550															
2700															

Pre-test measurements are taken when the vehicle is in the "As Tested" weight condition. Vehicle measurements forward of the vertical impact reference line are negative. The crush pile grid is established prior to the test based on an estimated impact point. The final distance from impact is determined after the final dummy positioning and the pole is aligned with the center of gravity of the dummy's head.

**DATA SHEET NO. 10 (CONTINUED)**  
**VEHICLE EXTERIOR CRUSH MEASUREMENTS**

Test Vehicle: 2019 Dodge Durango SXT 5-Door SUV  
Test Program: NCAP Side Pole Impact Test

NHTSA No. M20190301  
Test Date: 11/1/2018

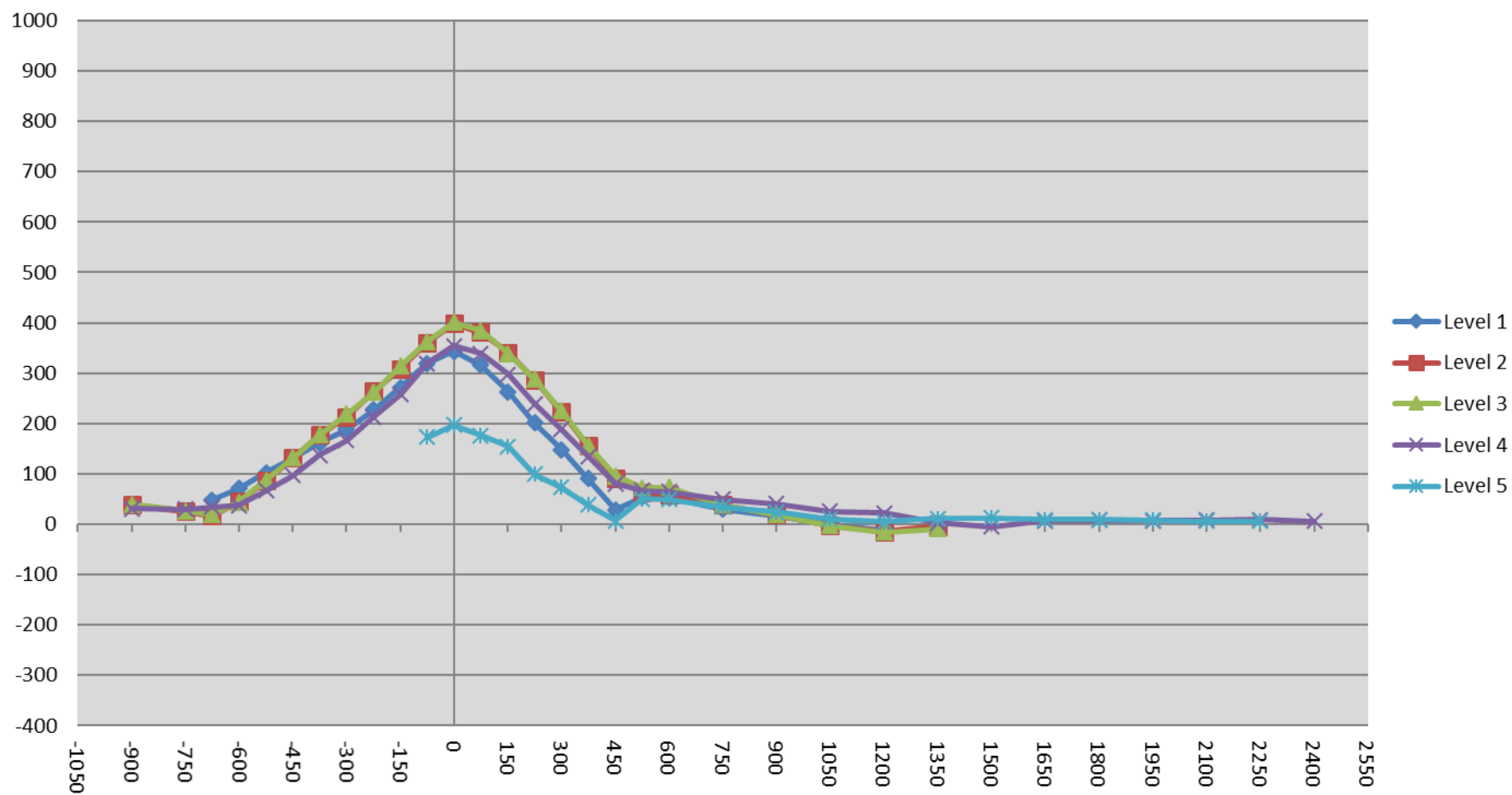

**DATA SHEET NO. 11  
VEHICLE DAMAGE PROFILE DISTANCES**

Test Vehicle: 2019 Dodge Durango SXT 5-Door SUV  
 Test Program: NCAP Side Pole Impact Test

NHTSA No. M20190301  
 Test Date: 11/1/2018

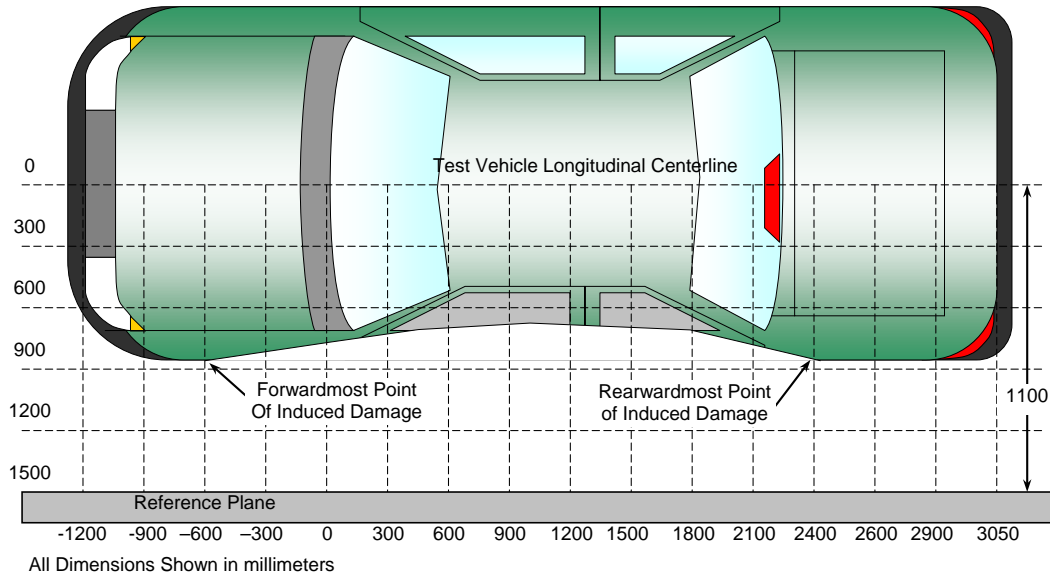

**TOP VIEW**

**DAMAGE PROFILE DISTANCES**

DPD	Distance from Impact Point (mm)	Level	Pre-Test (mm)	Post-Test (mm)	Crush (mm)
1	465	3	169	252	83
2	243	3	169	441	272
3	21	3	168	569	401
4	-201	3	164	543	379
5	-423	3	158	310	152
6	-645	3	151	177	26

**DATA SHEET NO. 12  
FMVSS NO. 301 STATIC ROLLOVER RESULTS**

Test Vehicle: 2019 Dodge Durango SXT 5-Door SUV  
Test Program: NCAP Side Pole Impact Test

NHTSA No. M20190301  
Test Date: 11/1/2018

Test Time: 2:00 p.m.

Temperature: 21.9°C

- A. From impact until vehicle motion ceases: 0 oz.  
(Maximum Allowable = 1 ounce)
- B. For the 5 minute period after motion ceases: None  
(Maximum allowable = 5 ounces)
- C. For the following 25 minutes: None  
(Maximum allowable = 1 oz./minute)
- D. Spillage Details: None

**FMVSS 301 STATIC ROLLOVER DATA**

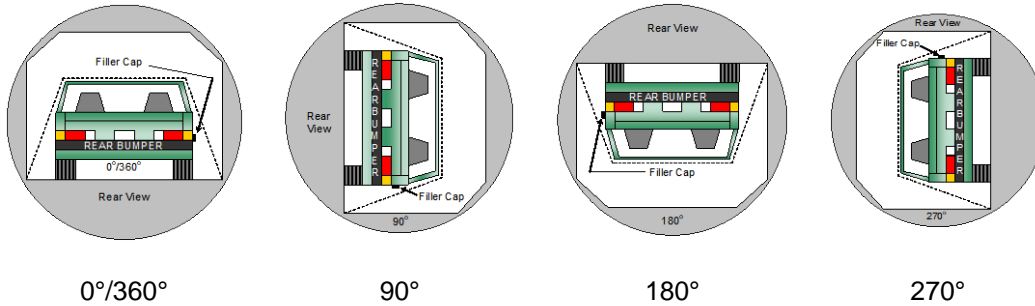

**ROLLOVER SOLVENT COLLECTION TIME TABLE IN SECONDS**

Test Phase	Rotation Time	Hold Time	Total Time
0° to 90°	110	300	410
90° to 180°	110	300	410
180° to 270°	108	300	408
270° to 360°	111	300	411

**FMVSS 301 ROLLOVER SPILLAGE TABLE (units in ounces)**

Test Phase	First 5 Minutes	Sixth Minute	Seventh Minute	Eight Minute
0° to 90°	0	0	0	0
90° to 180°	0	0	0	0
180° to 270°	0	0	0	0
270° to 360°	0	0	0	0

**ROLLOVER SOLVENT SPILLAGE LOCATION TABLE**

Test Phase	Spillage Location
0° to 90°	
90° to 180°	
180° to 270°	
270° to 360°	

**DATA SHEET NO. 13  
DUMMY/VEHICLE TEMPERATURE STABILIZATION DATA**

Test Vehicle: 2019 Dodge Durango SXT 5-Door SUV  
 Test Program: NCAP Side Pole Impact Test

NHTSA No. M20190301  
 Test Date: 11/1/2018

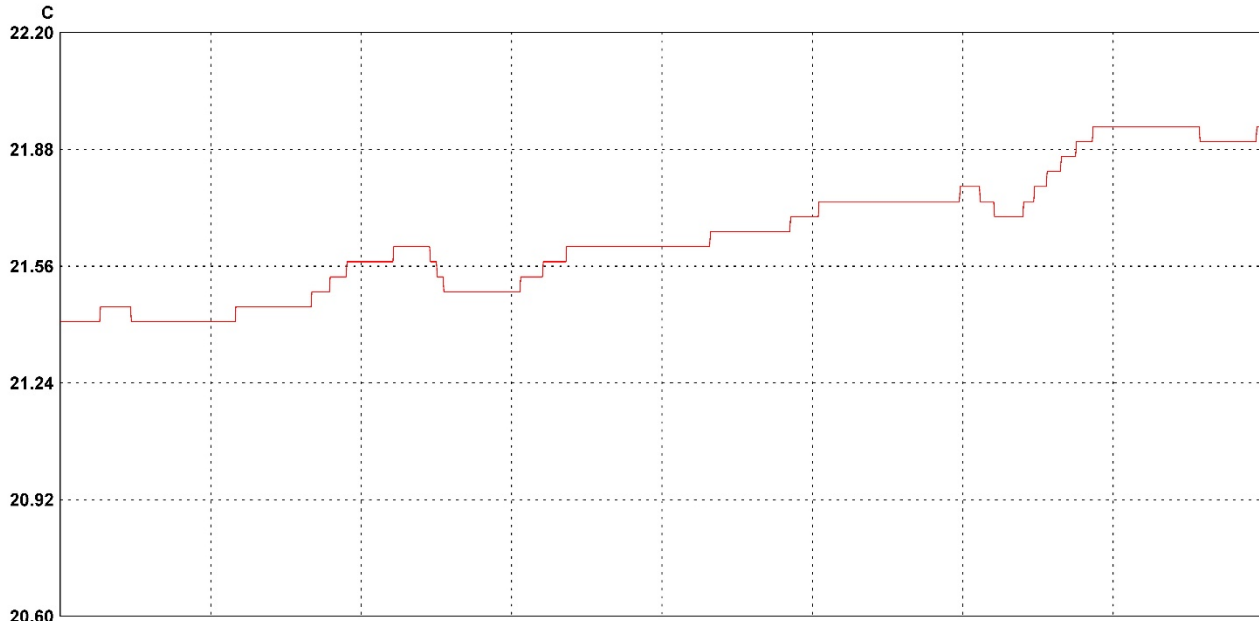

11/1/2018 11/1/2018 11/1/2018 11/1/2018 11/1/2018 11/1/2018 11/1/2018 11/1/2018 11/1/2018  
 10:00:00 AM 10:30:00 AM 11:00:00 AM 11:30:00 AM 12:00:00 PM 12:30:00 PM 1:00:00 PM 1:30:00 PM 2:00:00 PM  
 30 minutes/div 4 hours (M/d/yyyy h:mm:ss tt) Central Time Graph file (truncated): M20190301 2019 Dodge Durango SXT 5-Door SUV SPNCAP.spg

LN	Serial #	Description	CH	Value	Maximum	Average	Minimum	Units	CH description	Logger file
1	14312013	VSC_South_Hall 1		21.94	21.64	21.41	C	Temperature	M20190301 2019 Dodge Durango SXT 5-Door SUV SPNCAP	

**APPENDIX A  
PHOTOGRAPHS**

## TABLE OF PHOTOGRAPHS

		<u>Page No.</u>
Photo No. 001	As Delivered Right Front $\frac{3}{4}$ View of Test Vehicle	A-1
Photo No. 002	As Delivered Left Rear $\frac{3}{4}$ View of Test Vehicle	A-1
Photo No. 003	Pre-Test Frontal View of Test Vehicle	A-2
Photo No. 004	Post-Test Frontal View of Test Vehicle	A-2
Photo No. 005	Pre-Test Left Front $\frac{3}{4}$ View of Test Vehicle	A-3
Photo No. 006	Post-Test Left Front $\frac{3}{4}$ View of Test Vehicle	A-3
Photo No. 007	Pre-Test Left Side View of Test Vehicle	A-4
Photo No. 008	Post-Test Left Side View of Test Vehicle	A-4
Photo No. 009	Pre-Test Left Rear $\frac{3}{4}$ View of Test Vehicle	A-5
Photo No. 010	Post-Test Left Rear $\frac{3}{4}$ View of Test Vehicle	A-5
Photo No. 011	Pre-Test Rear View of Test Vehicle	A-6
Photo No. 012	Post-Test Rear View of Test Vehicle	A-6
Photo No. 013	Pre-Test Right Side View of Test Vehicle	A-7
Photo No. 014	Post-Test Right Side View of Test Vehicle	A-7
Photo No. 015	Pre-Test Overhead View of Test Area	A-8
Photo No. 016	Post-Test Overhead View of Test Area	A-8
Photo No. 017	Pre-Test Left Side View of Pole Positioned Against Side of Vehicle	A-9
Photo No. 018	Pre-Test Right Side View of Pole Positioned Against Side of Vehicle	A-9
Photo No. 019	Pre-Test Close-Up View of Impact Point Target	A-10
Photo No. 020	Post-Test Close-Up View of Impact Point Target Showing Impact Location	A-10
Photo No. 021	Pre-Test Front Close-Up View of Dummy Head and Chest	A-11
Photo No. 022	Post-Test Front Close-Up View of Dummy	A-11
Photo No. 023	Pre-Test Left Side View of Dummy Showing Belt and Chalking	A-12
Photo No. 024	Pre-Test Left Side View of Dummy Shoulder and Door Top View	A-12
Photo No. 025	Post-Test Left Side View of Dummy Shoulder and Door Top View	A-13

		<u>Page No.</u>
Photo No. 026	Pre-Test Front View of Seat Back Prior to Dummy Positioning	A-13
Photo No. 027	Pre-Test Front Close-Up View of Dummy Head and Shoulders in Relation to Head Restraint	A-14
Photo No. 028	Pre-Test Front View of Seat Pan Prior to Dummy Positioning	A-14
Photo No. 029	Pre-Test Overhead View of Dummy Thighs on Seat Pan	A-15
Photo No. 030	Pre-Test Left Side View of Dummy's Neck Showing Position of Adjustable Neck Bracket	A-15
Photo No. 031	Pre-Test Left Side View of Dummy's Head Showing Dummy's Head is Level	A-16
Photo No. 032	Pre-Test Placement of Dummy's Feet	A-16
Photo No. 033	Pre-Test View of Belt Anchorage for Dummy	A-17
Photo No. 034	Pre-Test Left Side View of Steering Wheel	A-17
Photo No. 035	Pre-Test View of Disengaged Parking Brake	A-18
Photo No. 036	Pre-Test View of Parking Brake	A-18
Photo No. 037	Pre-Test Close-Up Left Side View of Driver Seat Track	A-19
Photo No. 038	Pre-Test Close-Up Left Side View of Driver Seat Back	A-19
Photo No. 039	Pre-Test Close-Up View of Driver Seat Back or Head Restraint	A-20
Photo No. 040	Pre-Test Dummy and Door Clearance View	A-20
Photo No. 041	Post-Test Dummy and Door Clearance View	A-21
Photo No. 042	Pre-Test Right Side View of Dummy and Front Seat of Occupant Compartment	A-21
Photo No. 043	Post-Test Right Side View of Dummy and Front Seat of Occupant Compartment	A-22
Photo No. 044	Pre-Test Inner Door Panel View	A-22
Photo No. 045	Post-Test Inner Door Panel View Showing Dummy Contact Location	A-23
Photo No. 046	Post-Test Dummy Close-Up Head Contact with Vehicle Interior View	A-23
Photo No. 047	Post-Test Dummy Close-Up Head Contact with Side Air Bag View	A-24
Photo No. 048	Post-Test Dummy Close-Up Torso Contact with Vehicle Interior View	A-24
Photo No. 049	Post-Test Dummy Close-Up Torso Contact with Side Air Bag View	A-25

		<u>Page No.</u>
Photo No. 050	Post-Test Dummy Close-Up Pelvis Contact with Vehicle Interior View	A-25
Photo No. 051	Post-Test Dummy Close-Up Pelvis Contact with Side Air Bag View	A-26
Photo No. 052	Post-Test Dummy Close-Up Knee Contact with Vehicle Interior View	A-26
Photo No. 053	Pre-Test View of Fuel Filler Cap or Fuel Filler Neck	A-27
Photo No. 054	Post-Test View of Fuel Filler Cap or Fuel Filler Neck	A-27
Photo No. 055	Close-Up View of Vehicle's Certification Label	A-28
Photo No. 056	Close-Up View of Vehicle's Tire Information Placard or Label	A-28
Photo No. 057	Pre-Test Pole Barrier Front View	A-29
Photo No. 058	Post-Test Pole Barrier Front View	A-29
Photo No. 059	Pre-Test Pole Barrier Side View	A-30
Photo No. 060	Post-Test Pole Barrier Side View	A-30
Photo No. 061	Pre-Test Ballast View	A-31
Photo No. 062	Post-Test Primary and Redundant Speed Trap Read-Out	A-31
Photo No. 063	FMVSS No. 301 Static Rollover 0 Degrees	A-32
Photo No. 064	FMVSS No. 301 Static Rollover 90 Degrees	A-32
Photo No. 065	FMVSS No. 301 Static Rollover 180 Degrees	A-33
Photo No. 066	FMVSS No. 301 Static Rollover 270 Degrees	A-33
Photo No. 067	FMVSS No. 301 Static Rollover 360 Degrees	A-34
Photo No. 068	Impact Event	A-34
Photo No. 069	Monroney Label	A-35
Photo No. 070	Head Restraint Use and Adjustment Information from Vehicle Owner's Manual	A-35
Photo No. 071	Post-Test View of Shattered Vehicle Inner Door Panel	A-36



Photo No. 001 - As Delivered Right Front Three-Quarter View of Test Vehicle



Photo No. 002 - As Delivered Left Rear Three-Quarter View of Test Vehicle

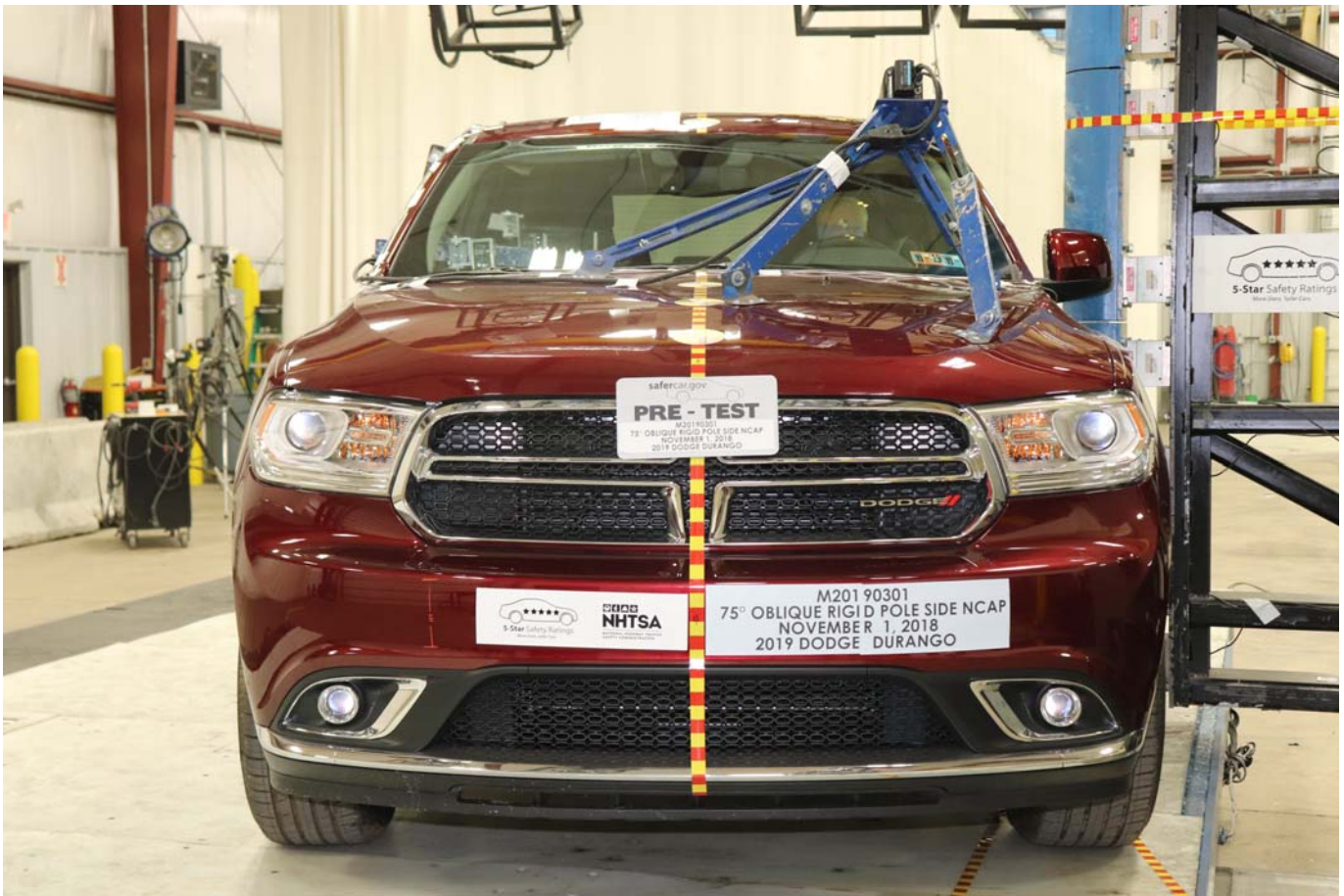

Photo No. 003 - Pre-Test Frontal View of Test Vehicle

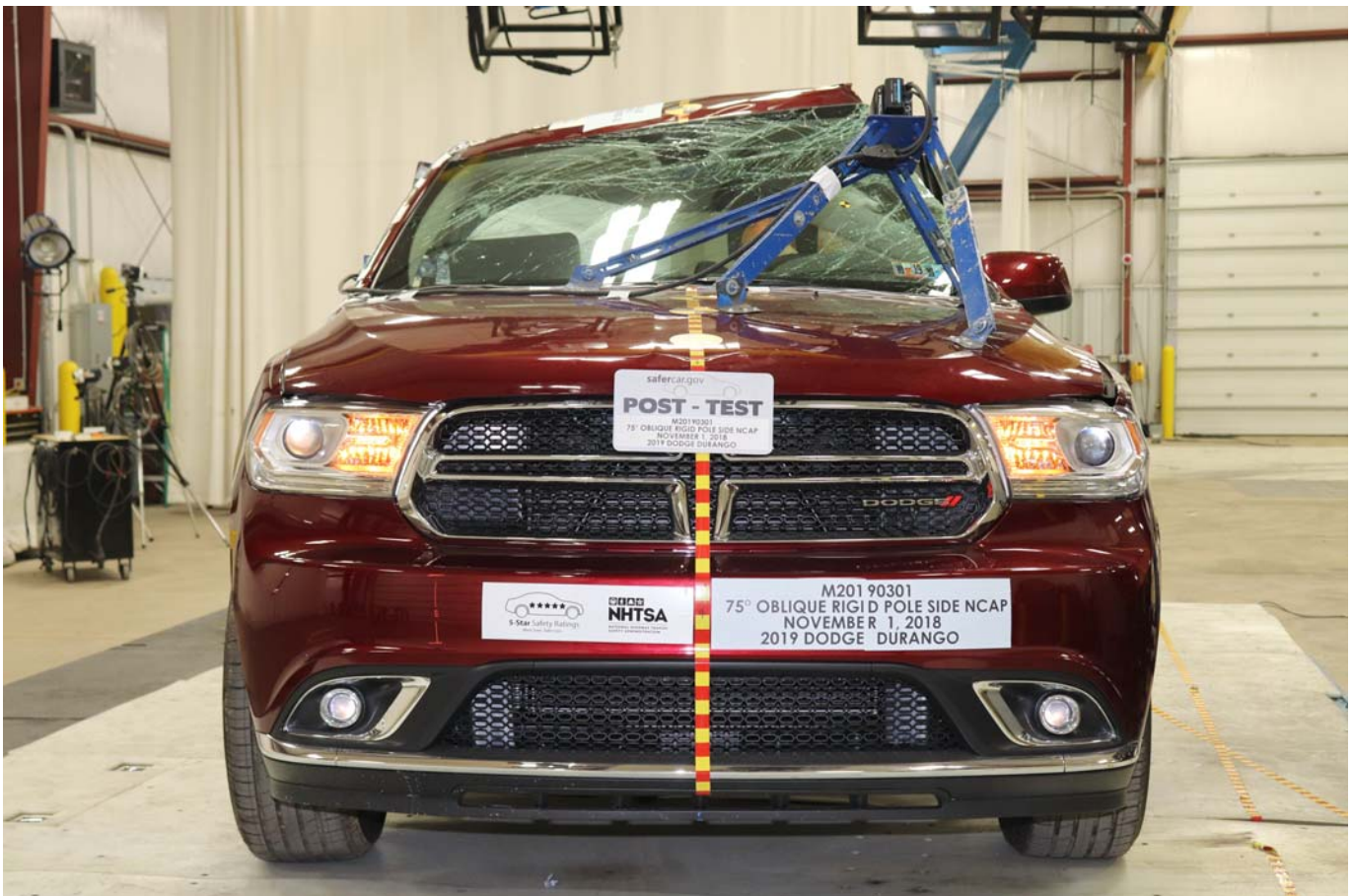

Photo No. 004 - Post-Test Frontal View of Test Vehicle



Photo No. 005 - Pre-Test Left Front Three-Quarter View of Test Vehicle

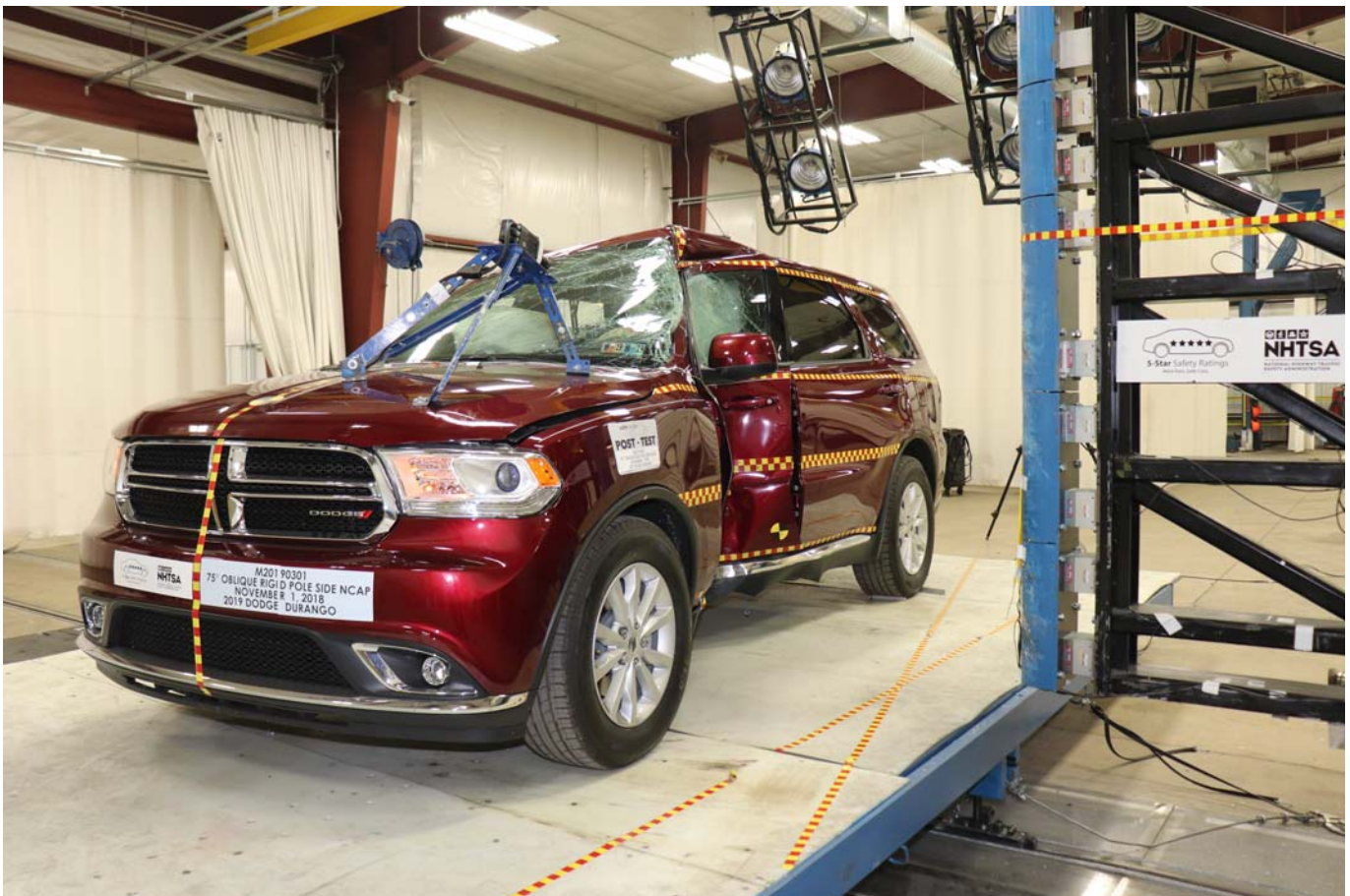

Photo No. 006 - Post-Test Left Front Three-Quarter View of Test Vehicle



Photo No. 007 - Pre-Test Left Side View of Test Vehicle



Photo No. 008 - Post-Test Left Side View of Test Vehicle



Photo No. 009 - Pre-Test Left Rear Three-Quarter View of Test Vehicle

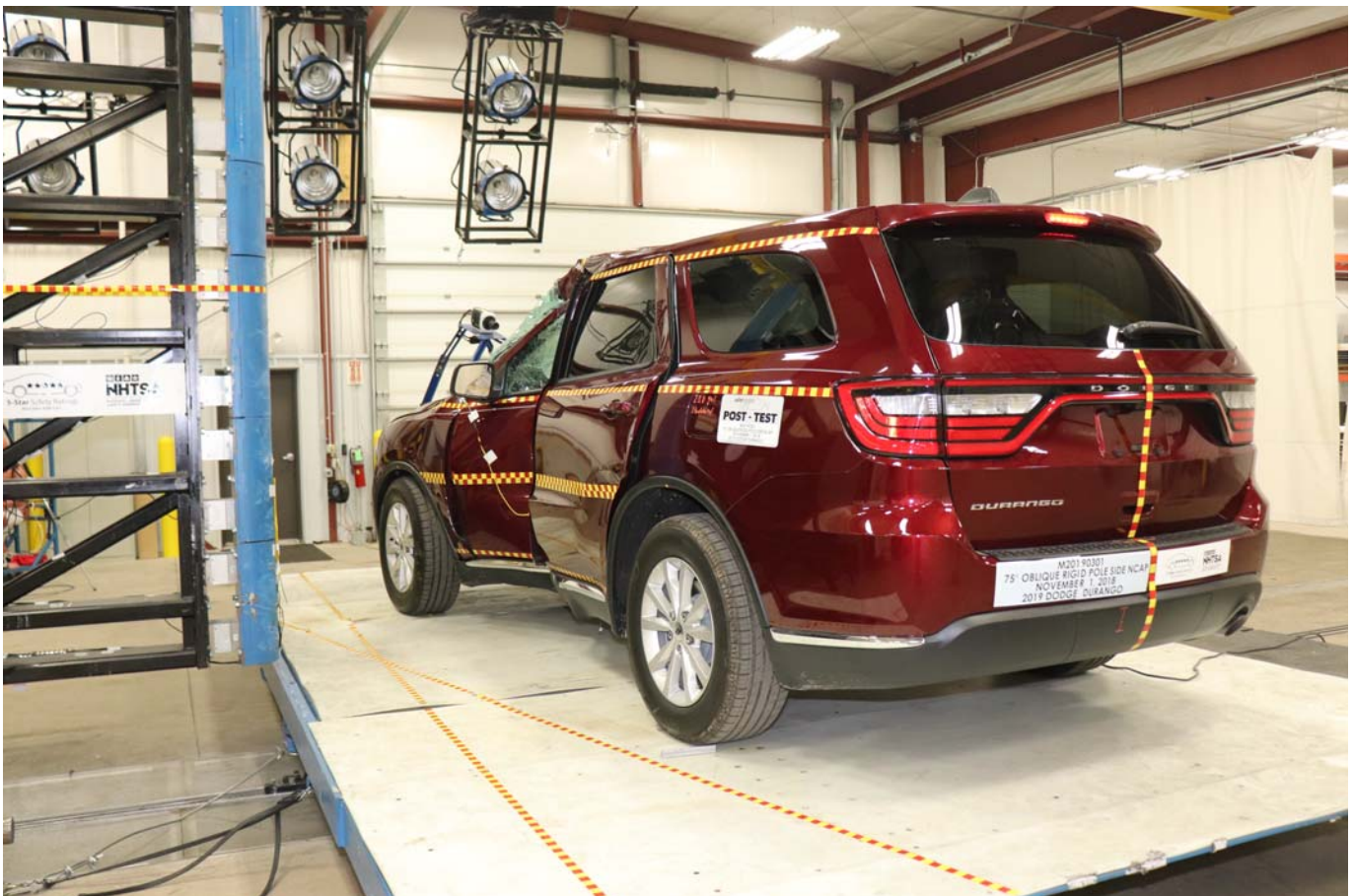

Photo No. 010 - Post-Test Left Rear Three-Quarter View of Test Vehicle



Photo No. 011 - Pre-Test Rear View of Test Vehicle



Photo No. 012 - Post-Test Rear View of Test Vehicle



Photo No. 013 - Pre-Test Right Side View of Test Vehicle



Photo No. 014 - Post-Test Right Side View of Test Vehicle

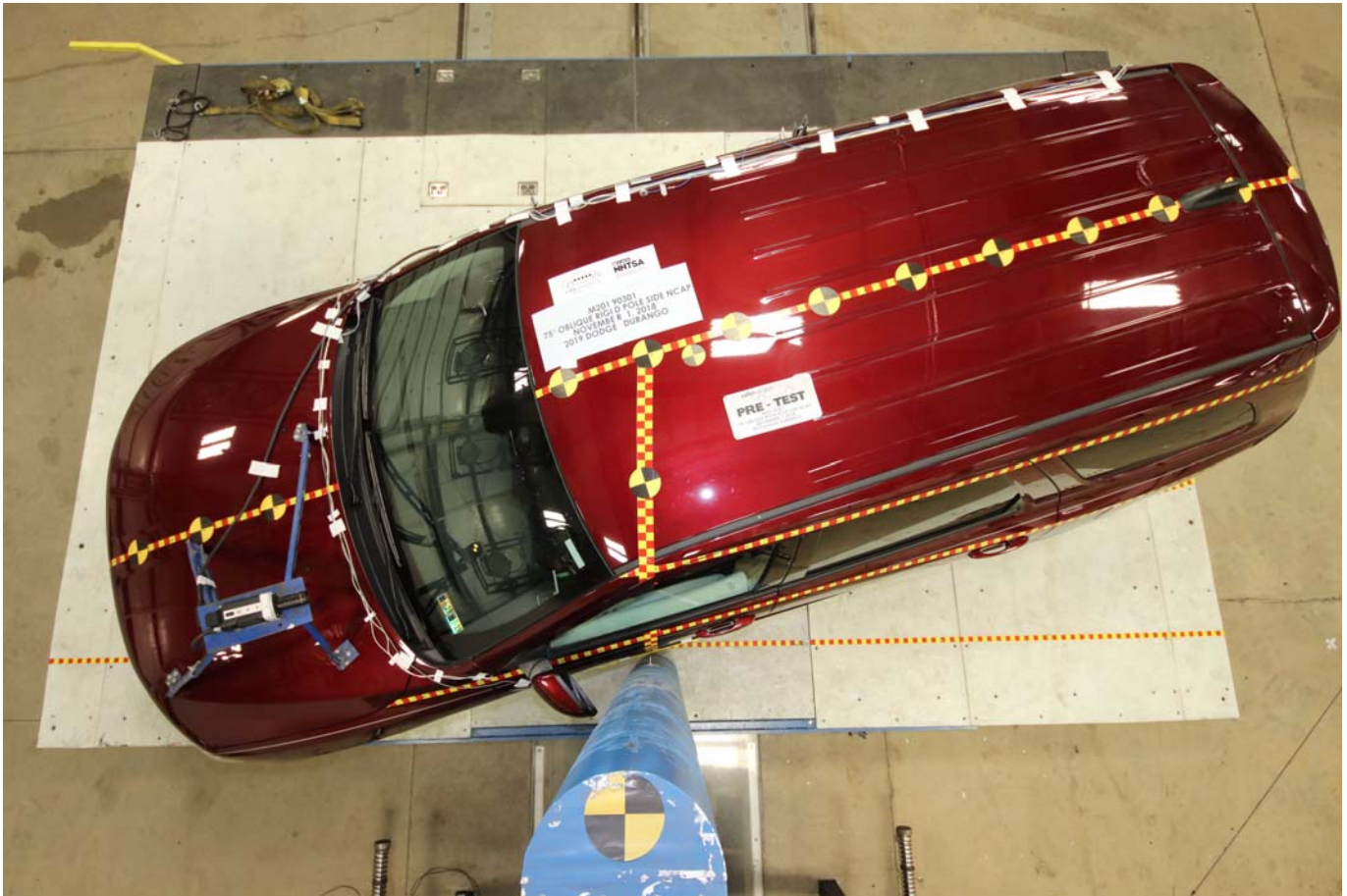

Photo No. 015 - Pre-Test Overhead View of Test Area



Photo No. 016 - Post-Test Overhead View of Test Area



Photo No. 017 - Pre-Test Left Side View of Pole Positioned Against Side of Vehicle



Photo No. 018 - Pre-Test Right Side View of Pole Positioned Against Side of Vehicle



Photo No. 019 - Pre-Test Close-Up View of Impact Point Target



Photo No. 020 - Post-Test Close-Up View of Impact Point Target Showing Impact Location

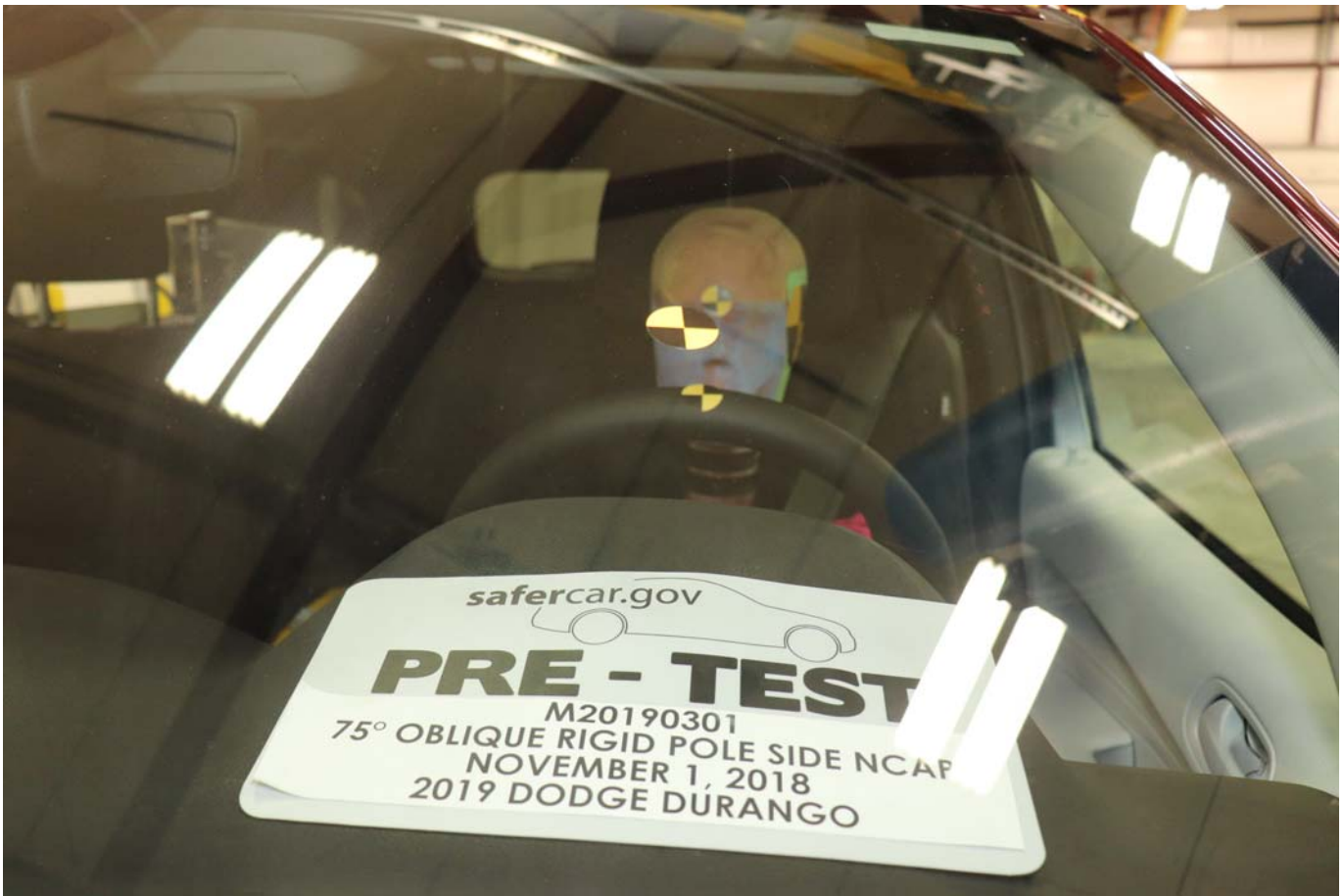

Photo No. 021 - Pre-Test Front Close-Up View of Dummy Head and Chest



Photo No. 022 - Post-Test Front Close-Up View of Dummy



Photo No. 023 - Pre-Test Left Side View of Dummy Showing Belt and Chalking



Photo No. 024 - Pre-Test Left Side View of Dummy Shoulder and Door Top View



Photo No. 025 - Post-Test Left Side View of Dummy Shoulder and Door Top View



Photo No. 026 - Pre-Test Front View of Seat Back Prior to Dummy Positioning



Photo No. 027 - Pre-Test Front Close-Up View of Dummy Head and Shoulders in Relation to Head Restraint



Photo No. 028 - Pre-Test Front View of Seat Pan Prior to Dummy Positioning



Photo No. 029 - Pre-Test Overhead View of Dummy Thighs on Seat Pan



Photo No. 030 - Pre-Test Left Side View of Dummy Neck Showing Position of Adjustable Neck Bracket



Photo No. 031 - Pre-Test Left Side View of Dummy Head Showing Dummy Head is Level



Photo No. 032 - Pre-Test Placement of Dummy Feet



Photo No. 033 - Pre-Test View of Belt Anchorage for Dummy



Photo No. 034 - Pre-Test Left Side View of Steering Wheel



Photo No. 035 - Pre-Test View of Disengaged Parking Brake



Photo No. 036 - Pre-Test View of Parking Brake

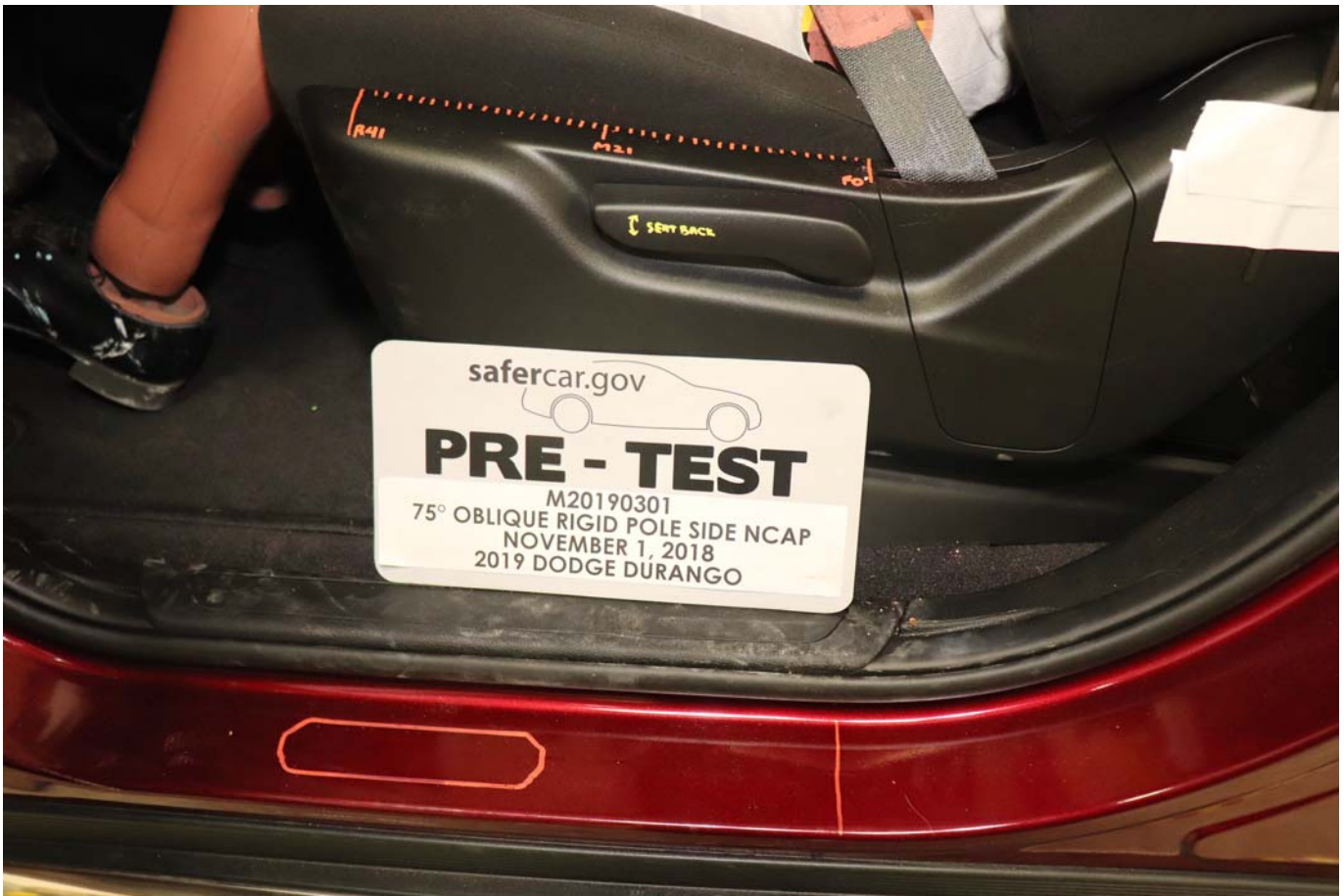

Photo No. 037 - Pre-Test Close-Up Left Side View of Driver Seat Track

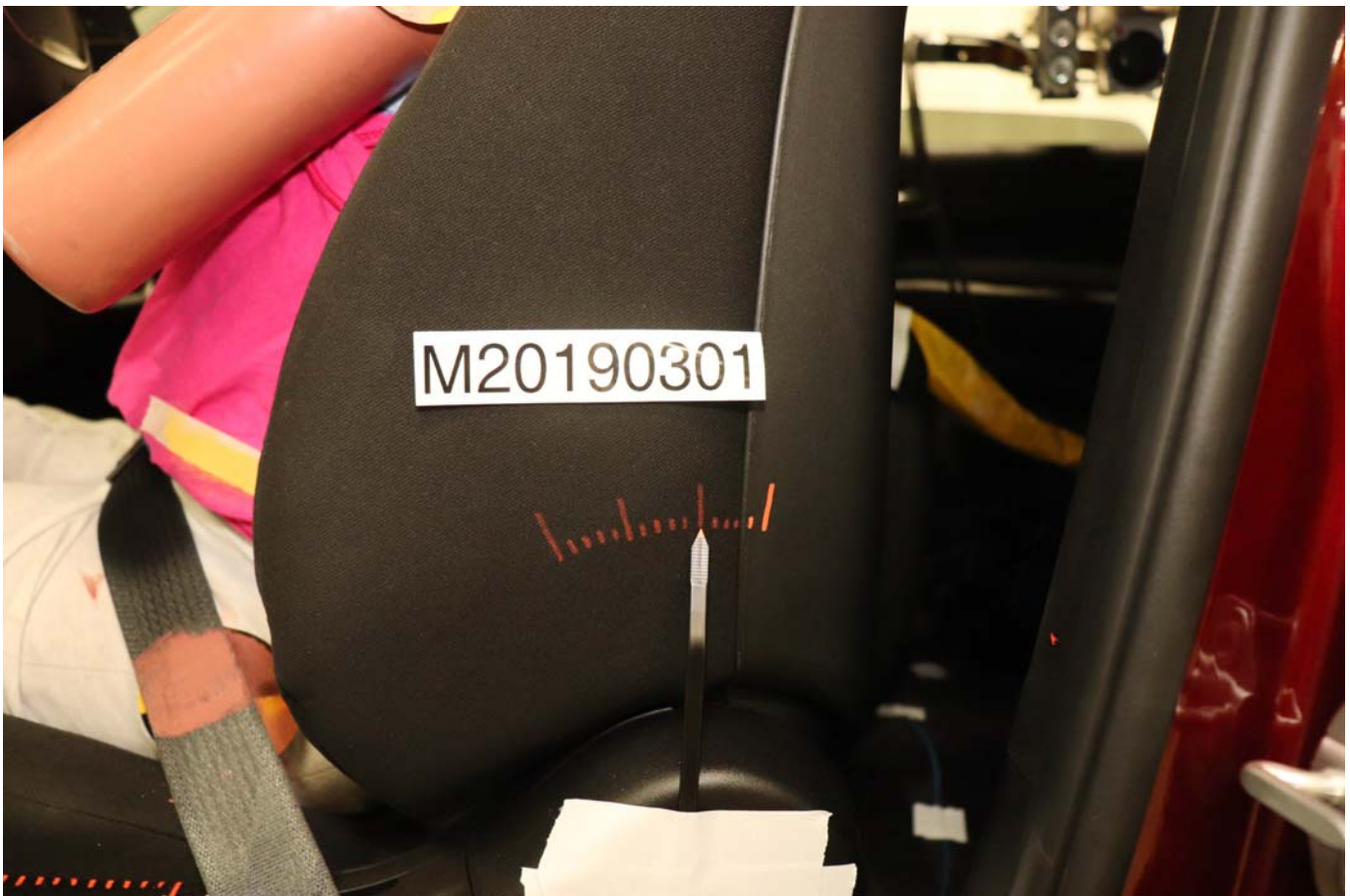

Photo No. 038 - Pre-Test Close-Up Left Side View of Driver Seat Back



Photo No. 039 - Pre-Test Close-Up View of Driver Seat Back or Head Restraint



Photo No. 040 - Pre-Test Dummy and Door Clearance View

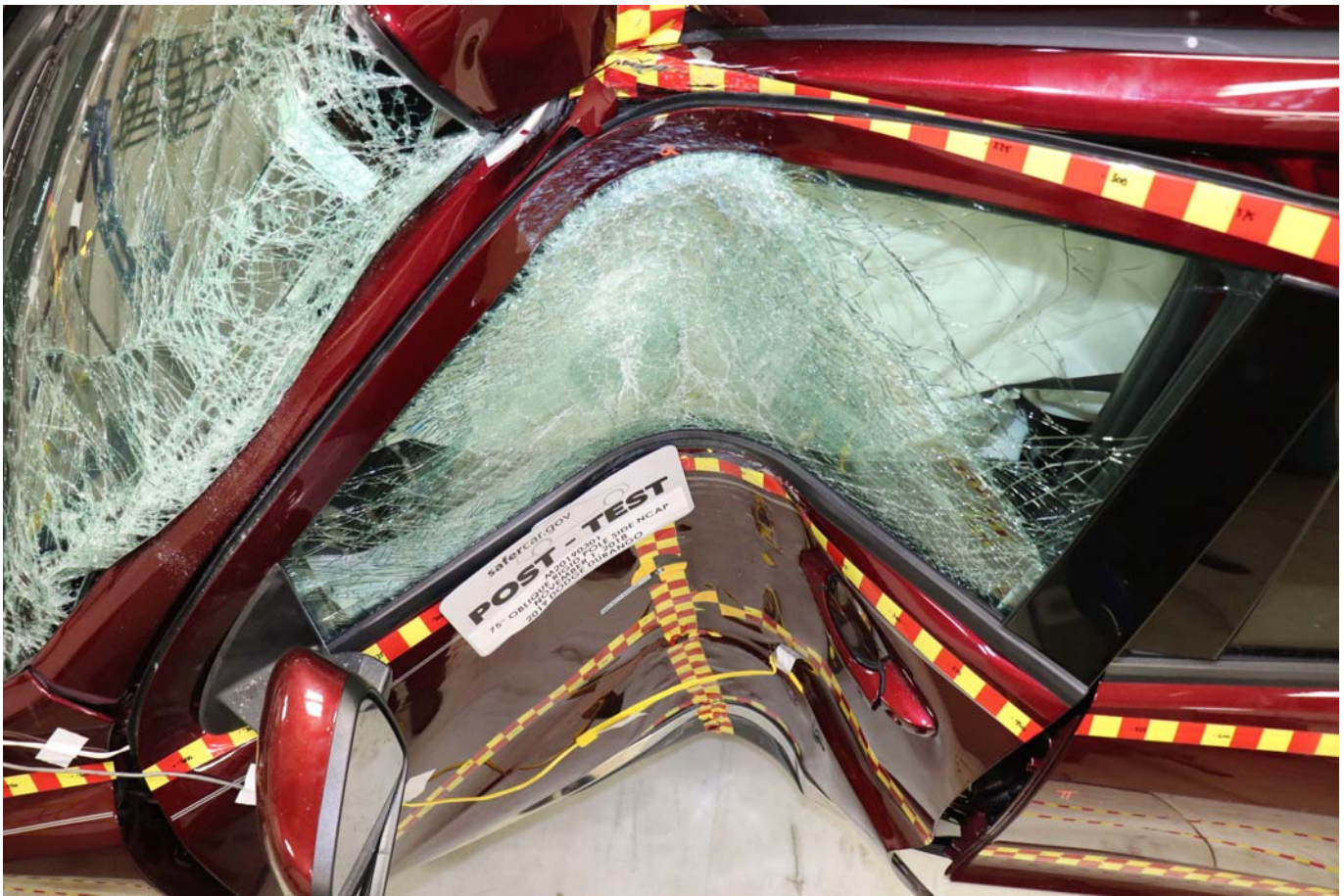

Photo No. 041 - Post-Test Dummy and Door Clearance View



Photo No. 042 - Pre-Test Right Side View of Dummy and Front Seat of Occupant Compartment



Photo No. 043 - Post-Test Right Side View of Dummy and Front Seat of Occupant Compartment



Photo No. 044 - Pre-Test Inner Door Panel View



Photo No. 045 - Post-Test Inner Door Panel View Showing Dummy Contact Location

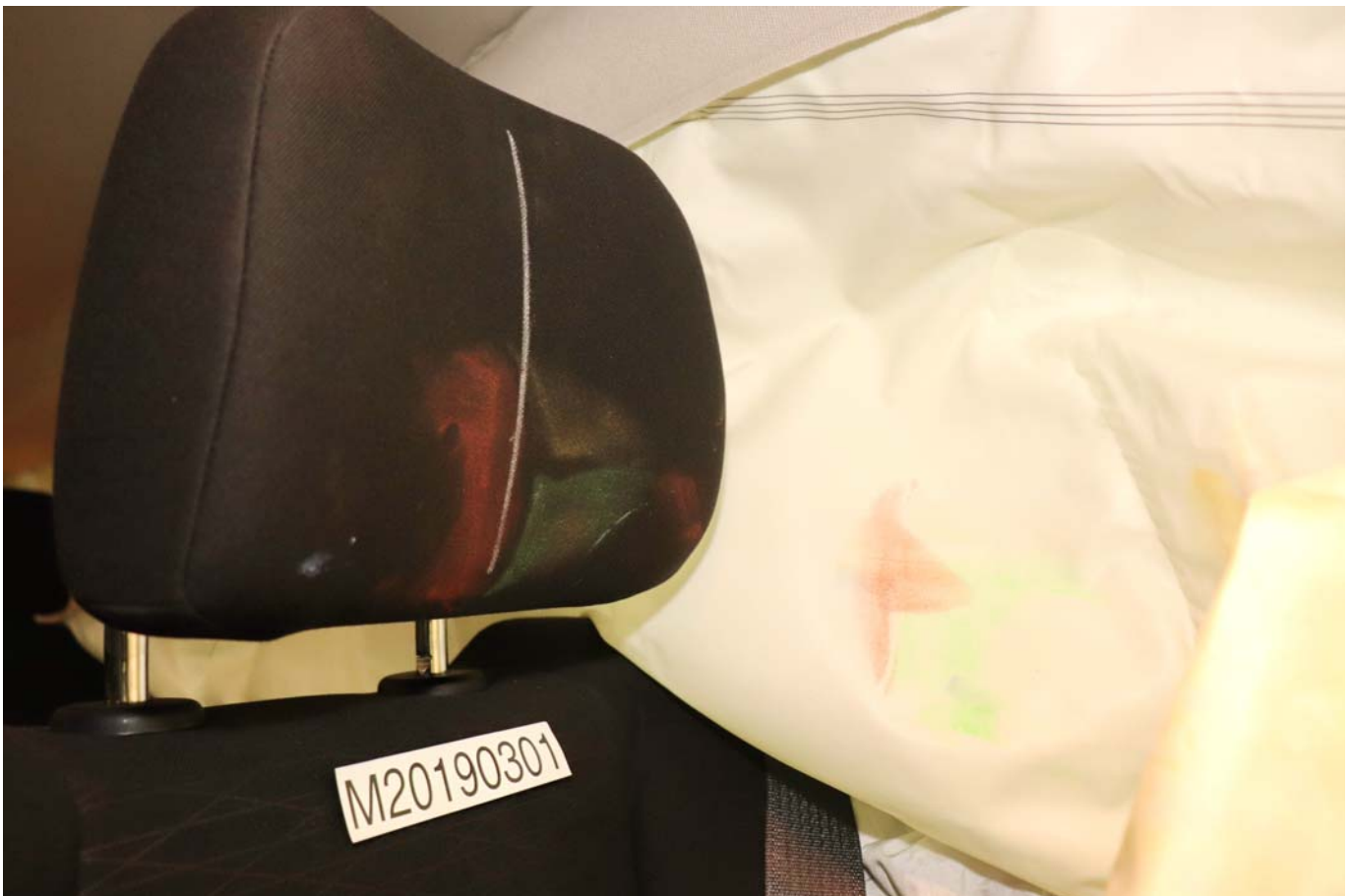

Photo No. 046 - Post-Test Dummy Close-Up Head Contact with Vehicle Interior View



Photo No. 047 - Post-Test Dummy Close-Up Head Contact with Side Air Bag View



Photo No. 048 - Post-Test Dummy Close-Up Torso Contact with Vehicle Interior View

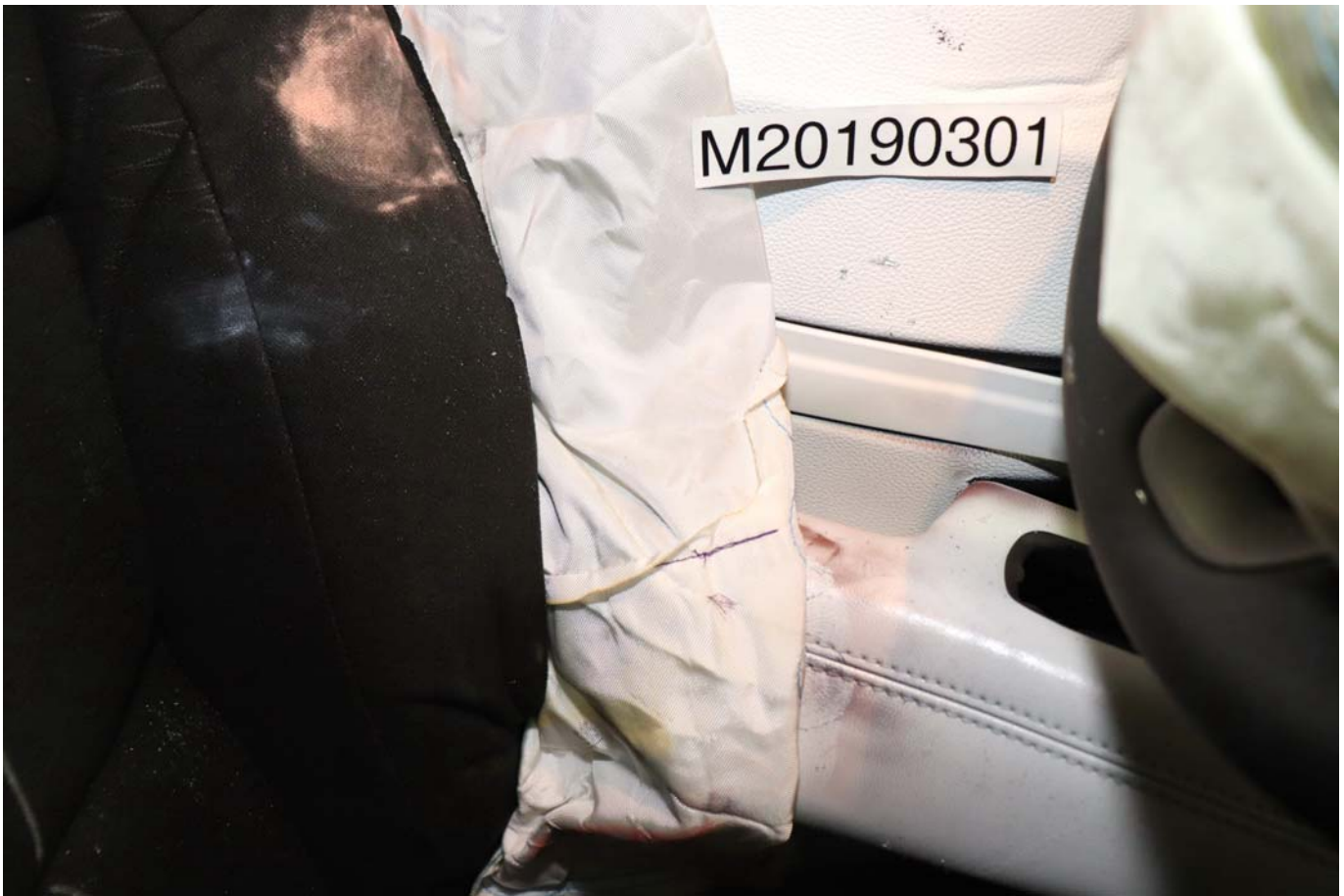

Photo No. 049 - Post-Test Dummy Close-Up Torso Contact with Side Air Bag View



Photo No. 050 - Post-Test Dummy Close-Up Pelvis Contact with Vehicle Interior View



Photo No. 051 - Post-Test Dummy Close-Up Pelvis Contact with Side Air Bag View

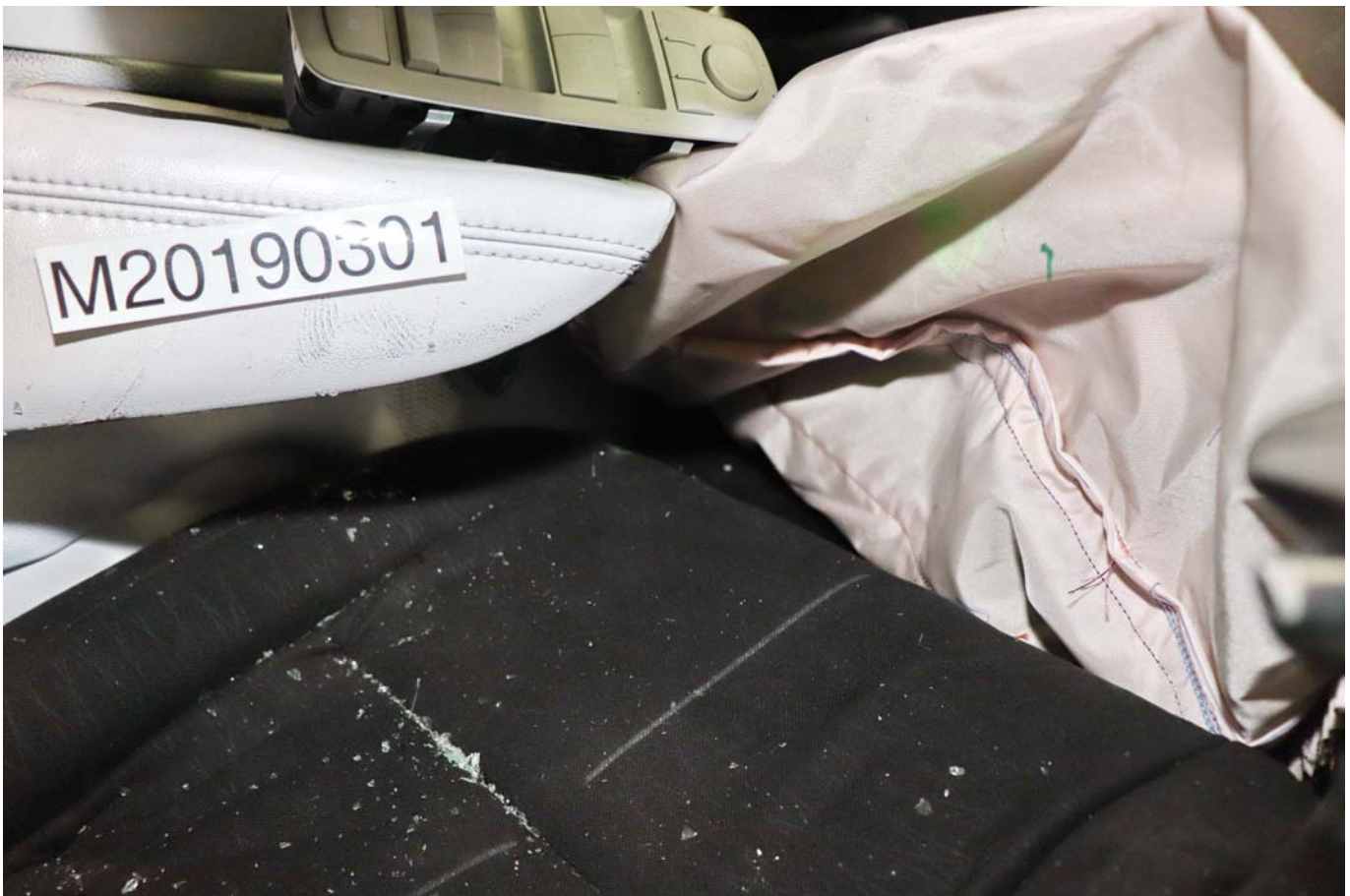

Photo No. 052 - Post-Test Dummy Close-Up Knee Contact with Vehicle Interior View



Photo No. 053 - Pre-Test View of Fuel Filler Cap or Fuel Filler Neck



Photo No. 054 - Post-Test View of Fuel Filler Cap or Fuel Filler Neck



Photo No. 055 - Close-Up View of Vehicle Certification Label

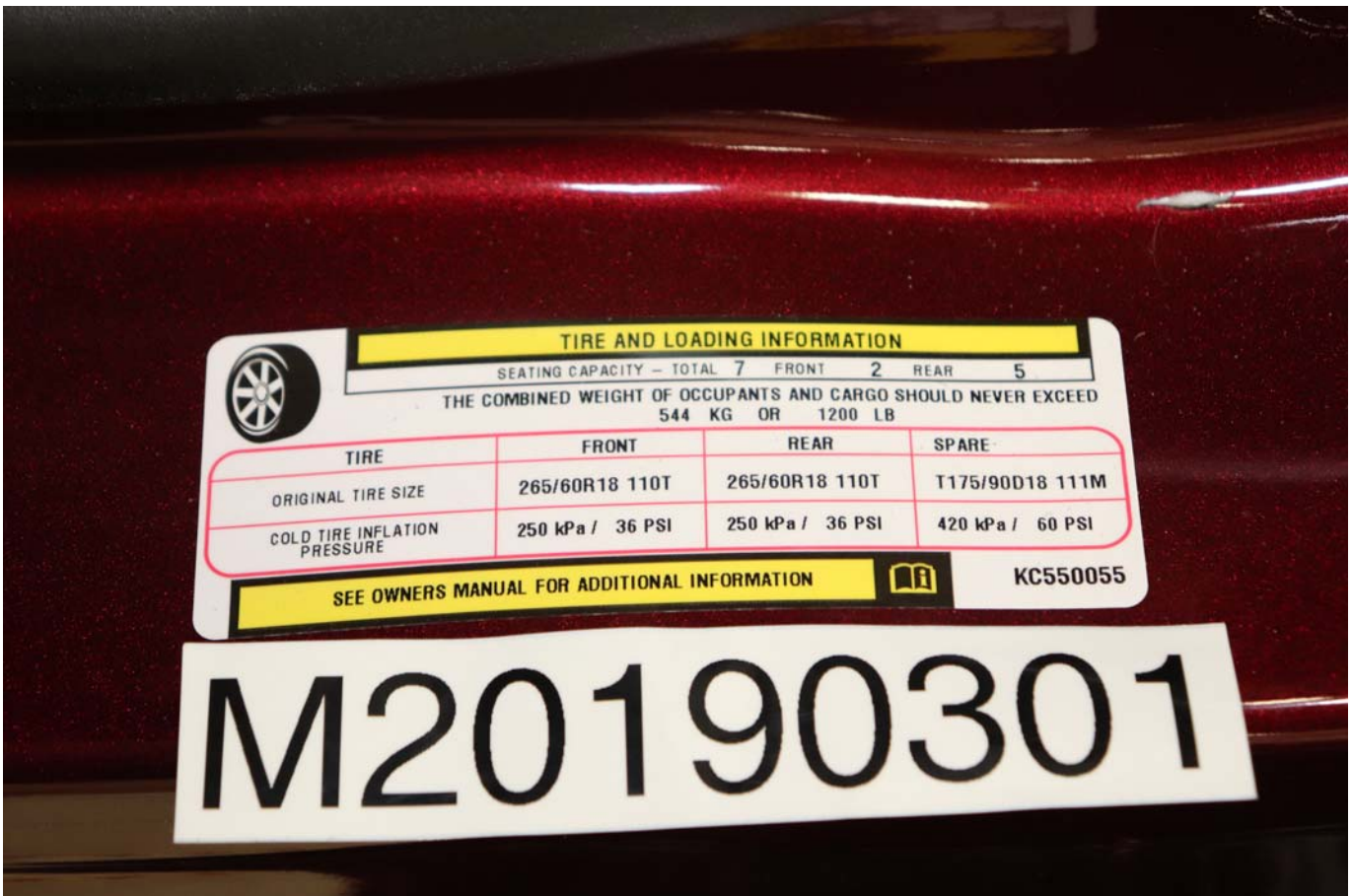

Photo No. 056 - Close-Up View of Vehicle Tire Information Placard or Label

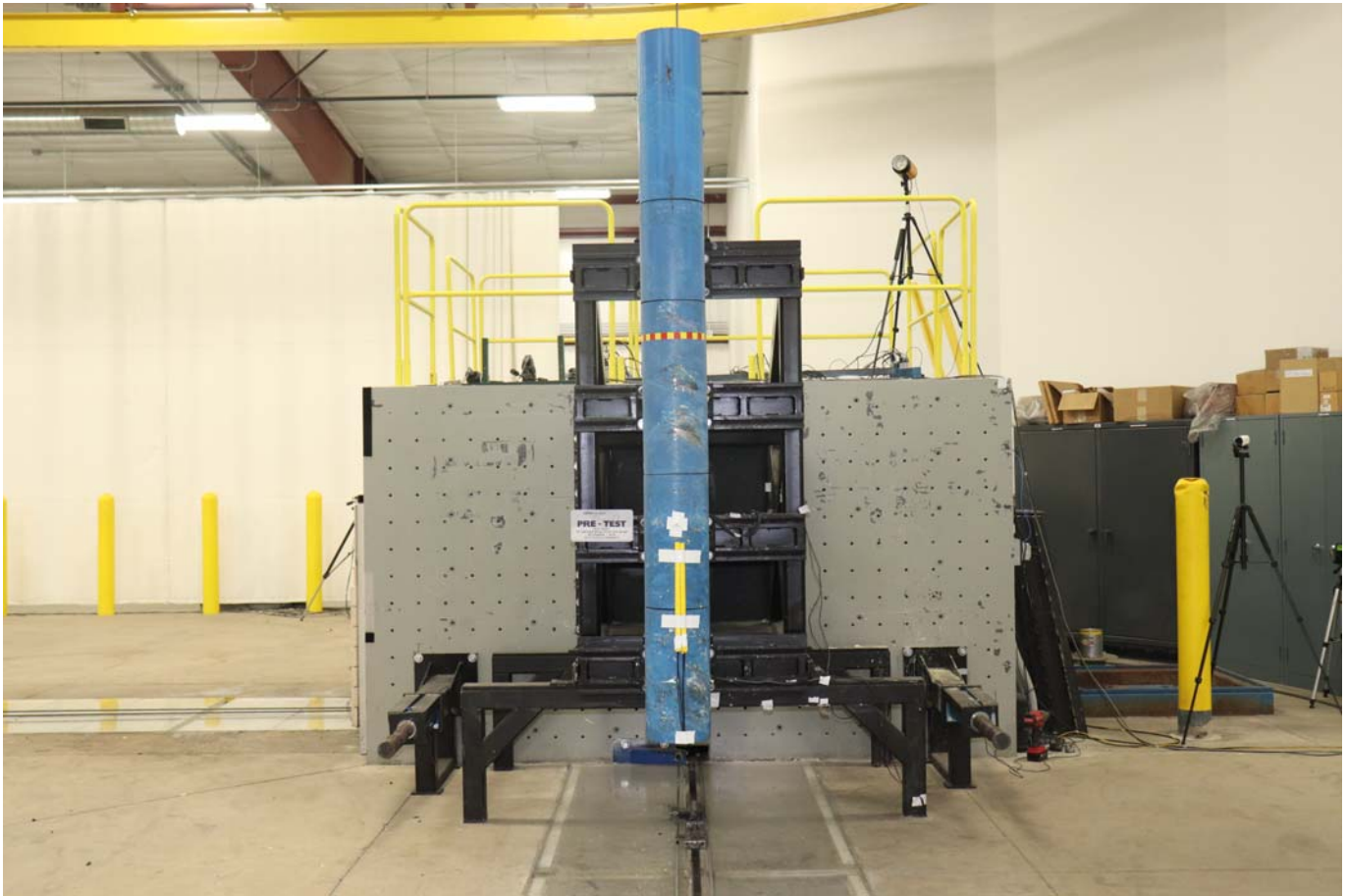

Photo No. 057 - Pre-Test Pole Barrier Front View

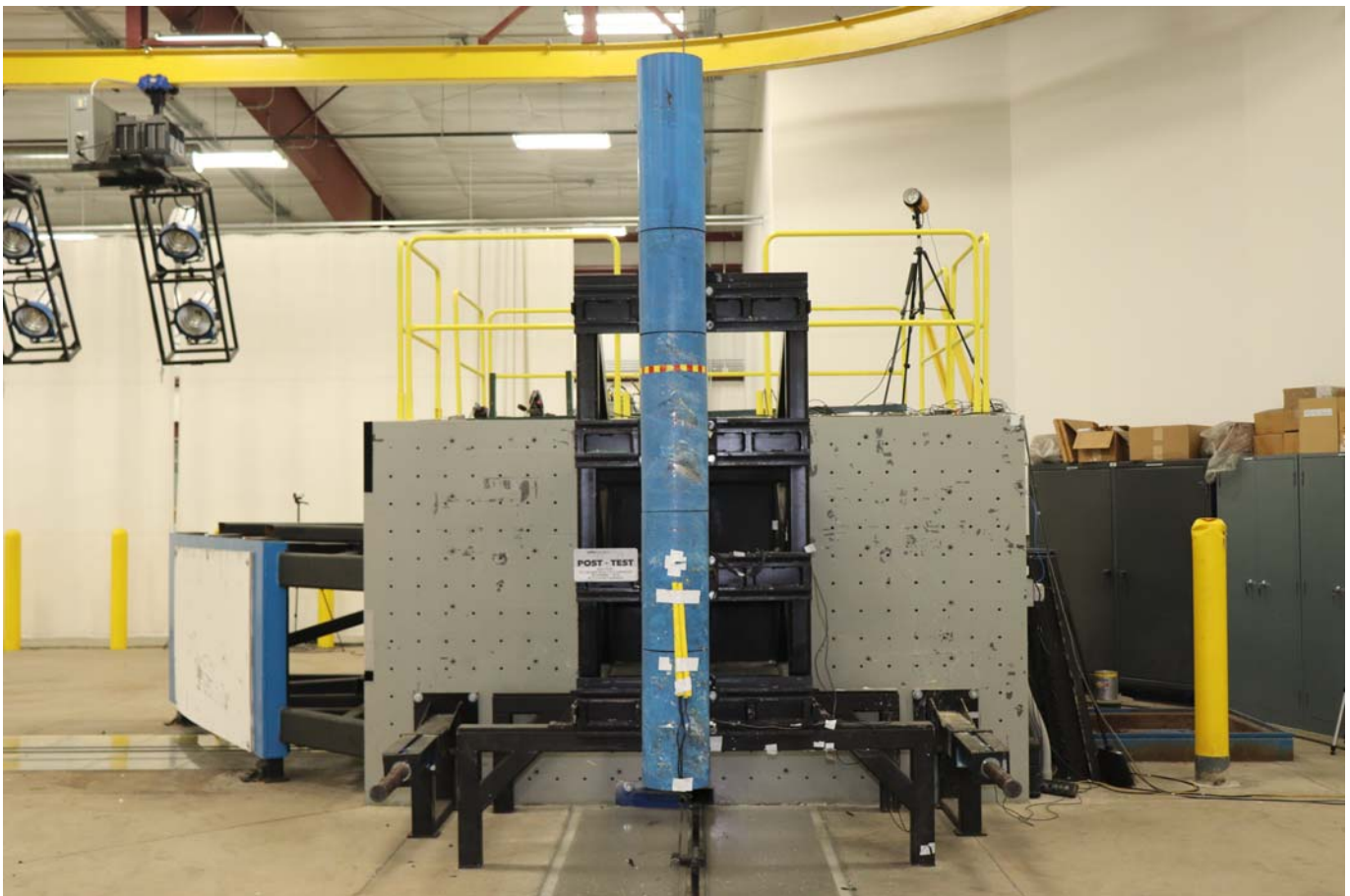

Photo No. 058 - Post-Test Pole Barrier Front View



Photo No. 059 - Pre-Test Pole Barrier Side View



Photo No. 060 - Post-Test Pole Barrier Side View

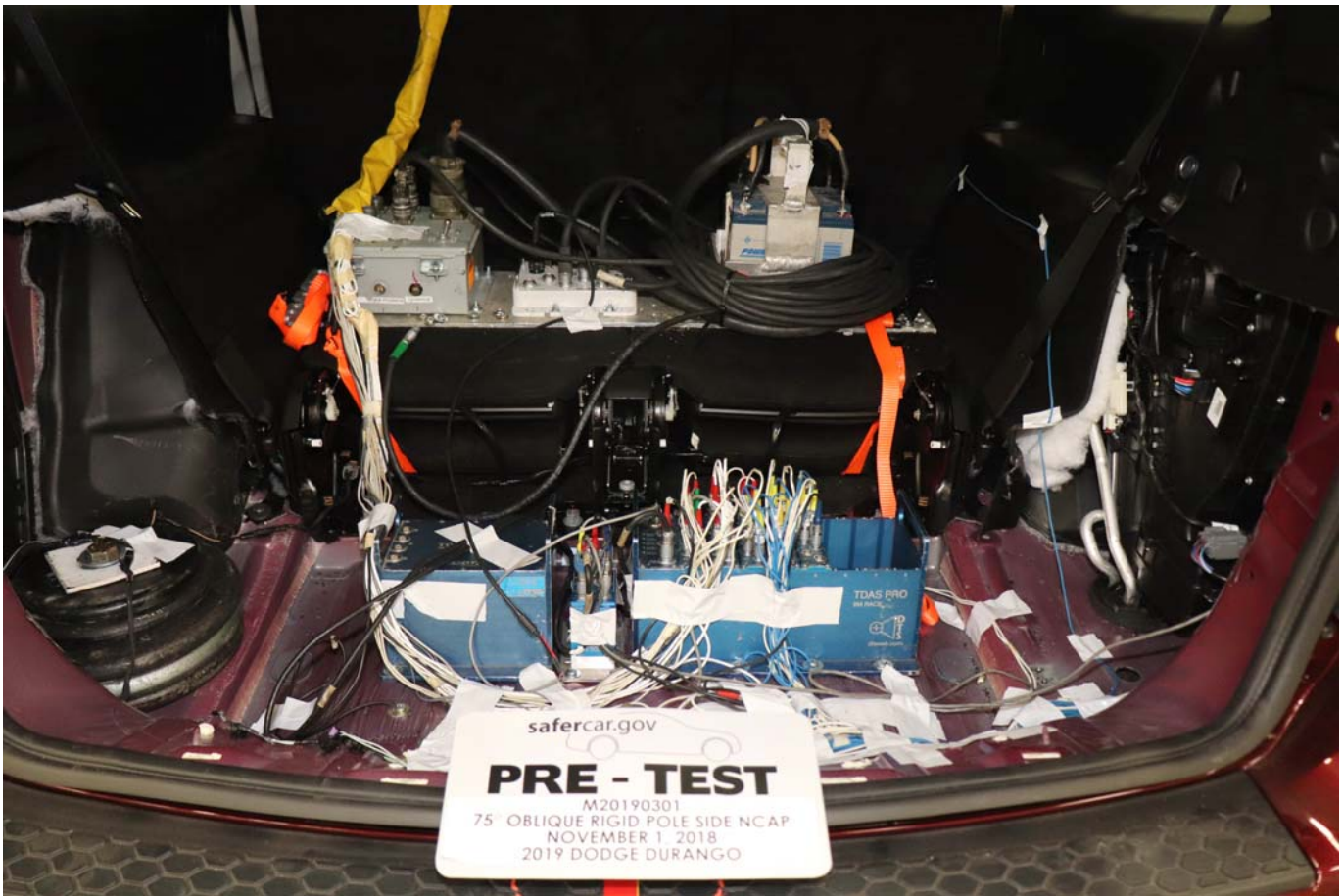

Photo No. 061 - Pre-Test Ballast View



Photo No. 062 - Post-Test Primary and Redundant Speed Trap Read-Out

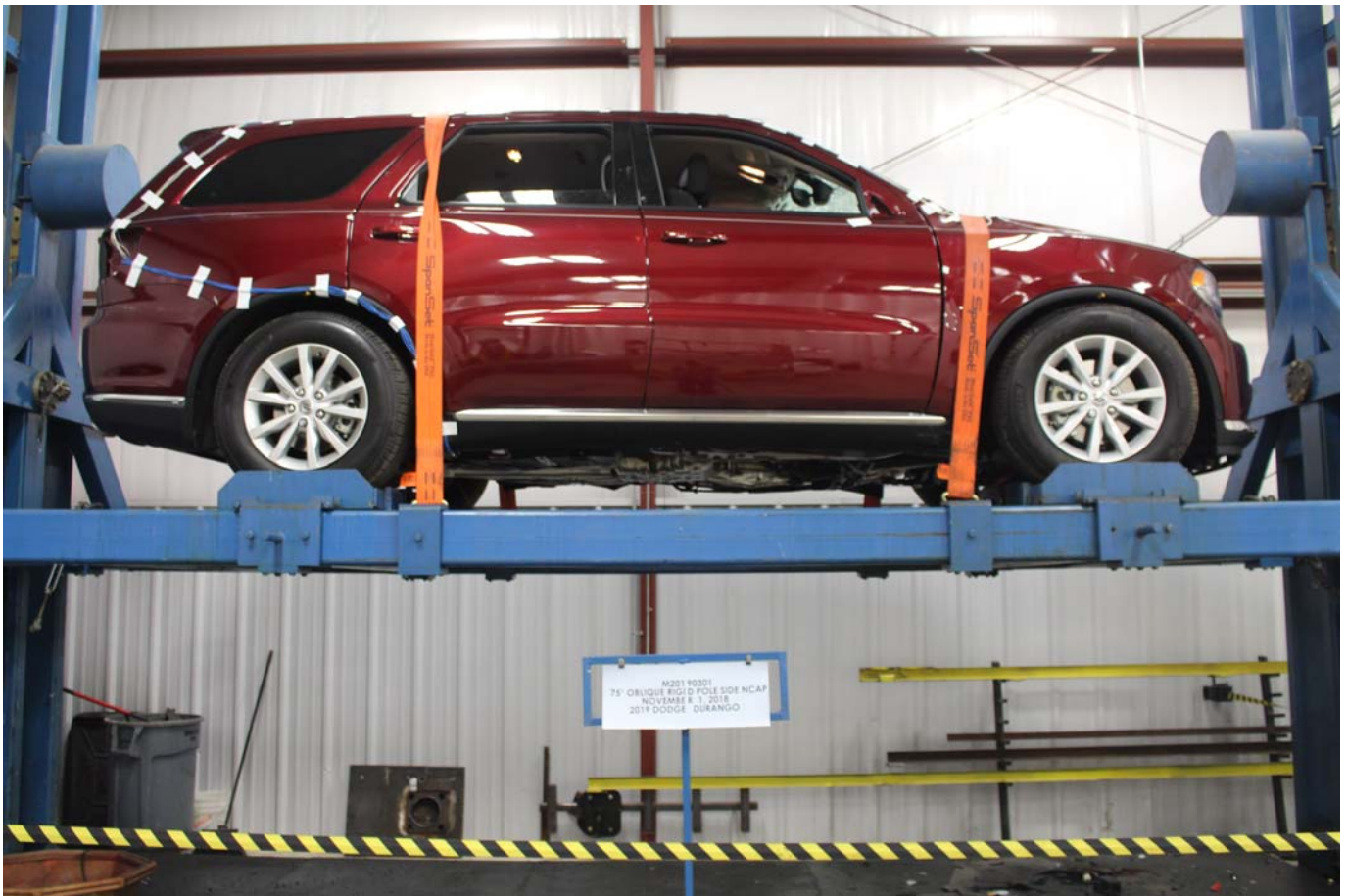

Photo No. 063 - FMVSS Photo No. 301 Static Rollover 0 Degrees

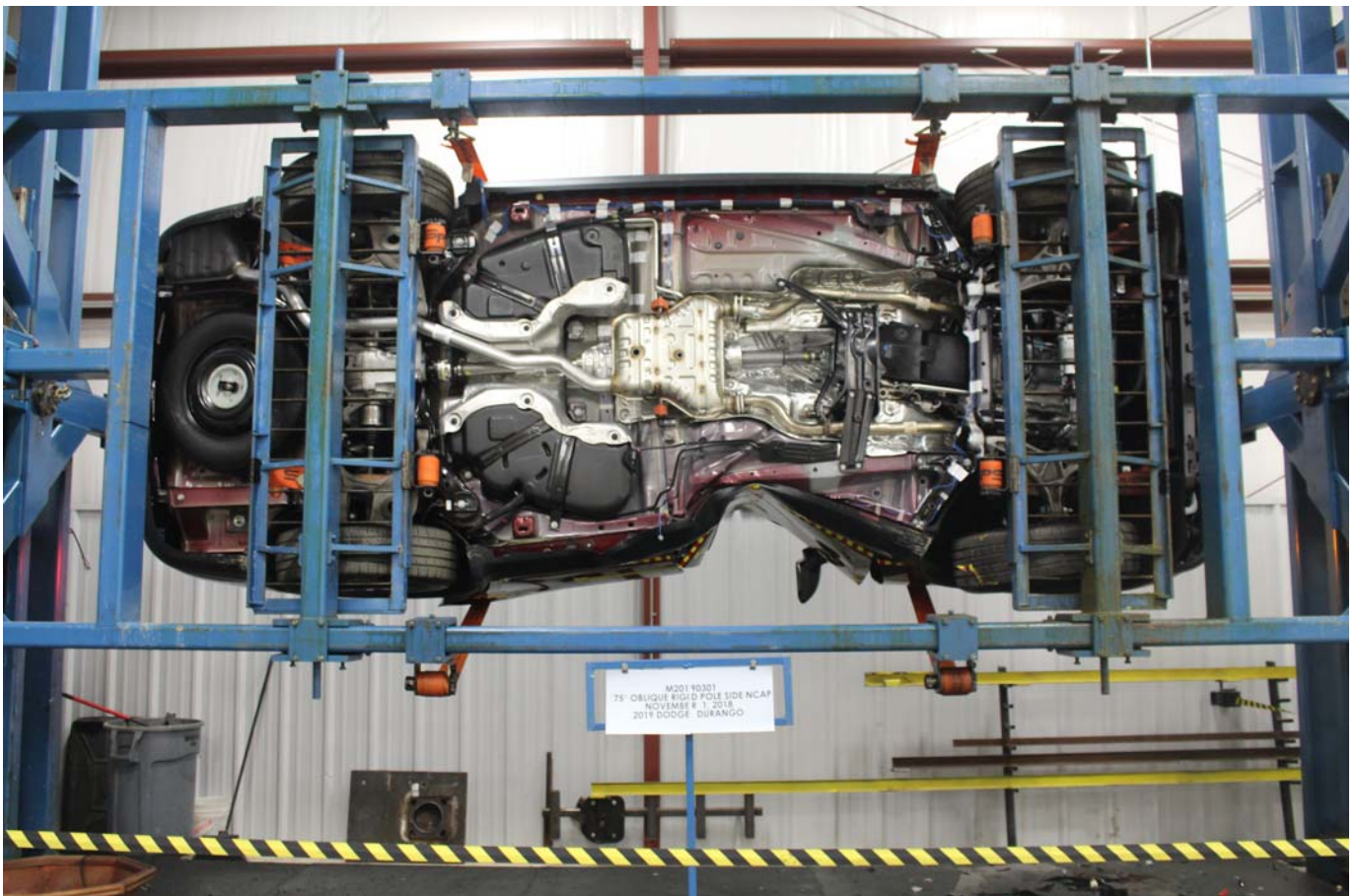

Photo No. 064 - FMVSS Photo No. 301 Static Rollover 90 Degrees



Photo No. 065 - FMVSS Photo No. 301 Static Rollover 180 Degrees



Photo No. 066 - FMVSS Photo No. 301 Static Rollover 270 Degrees

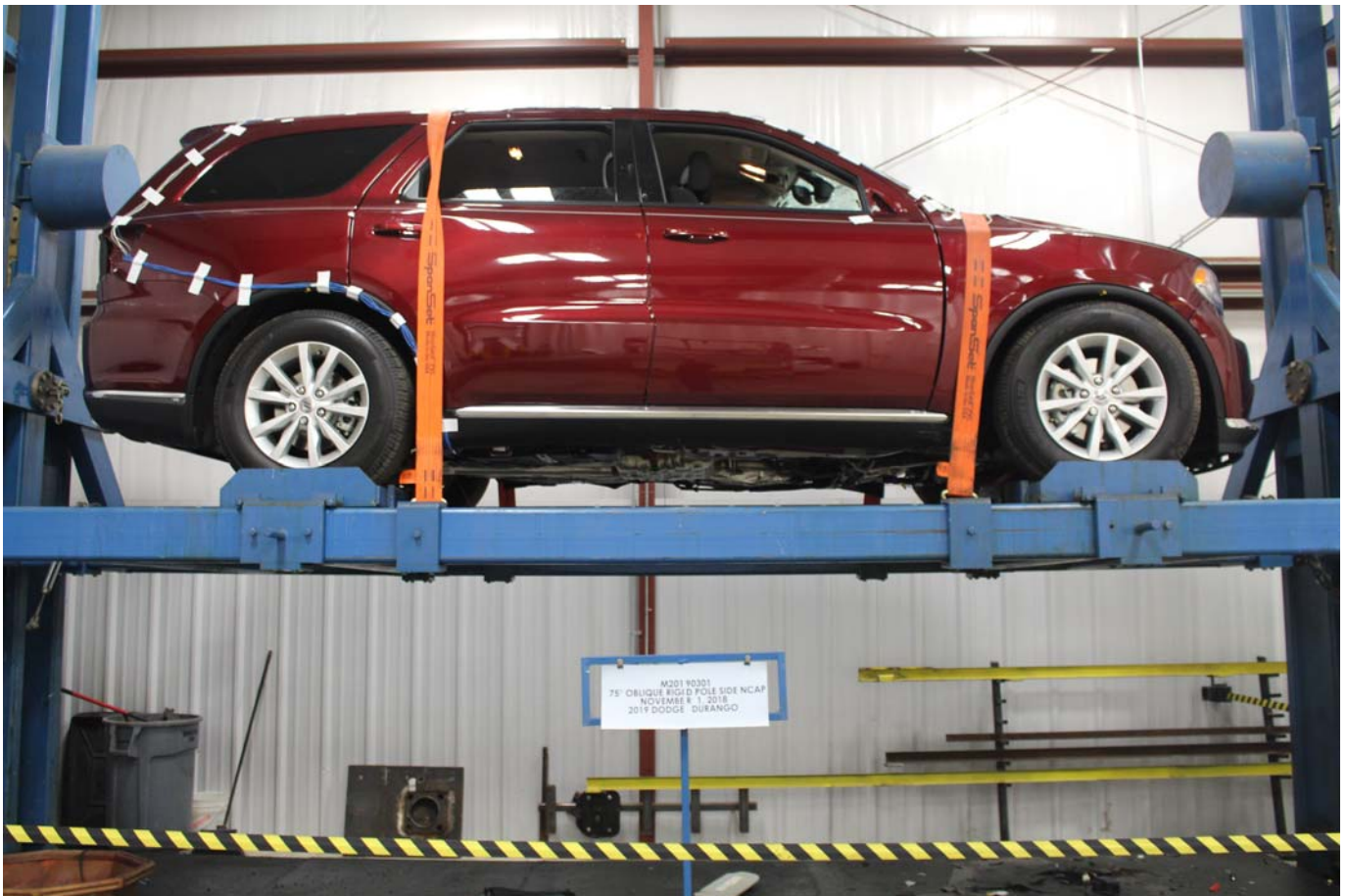

Photo No. 067 - FMVSS Photo No. 301 Static Rollover 360 Degrees

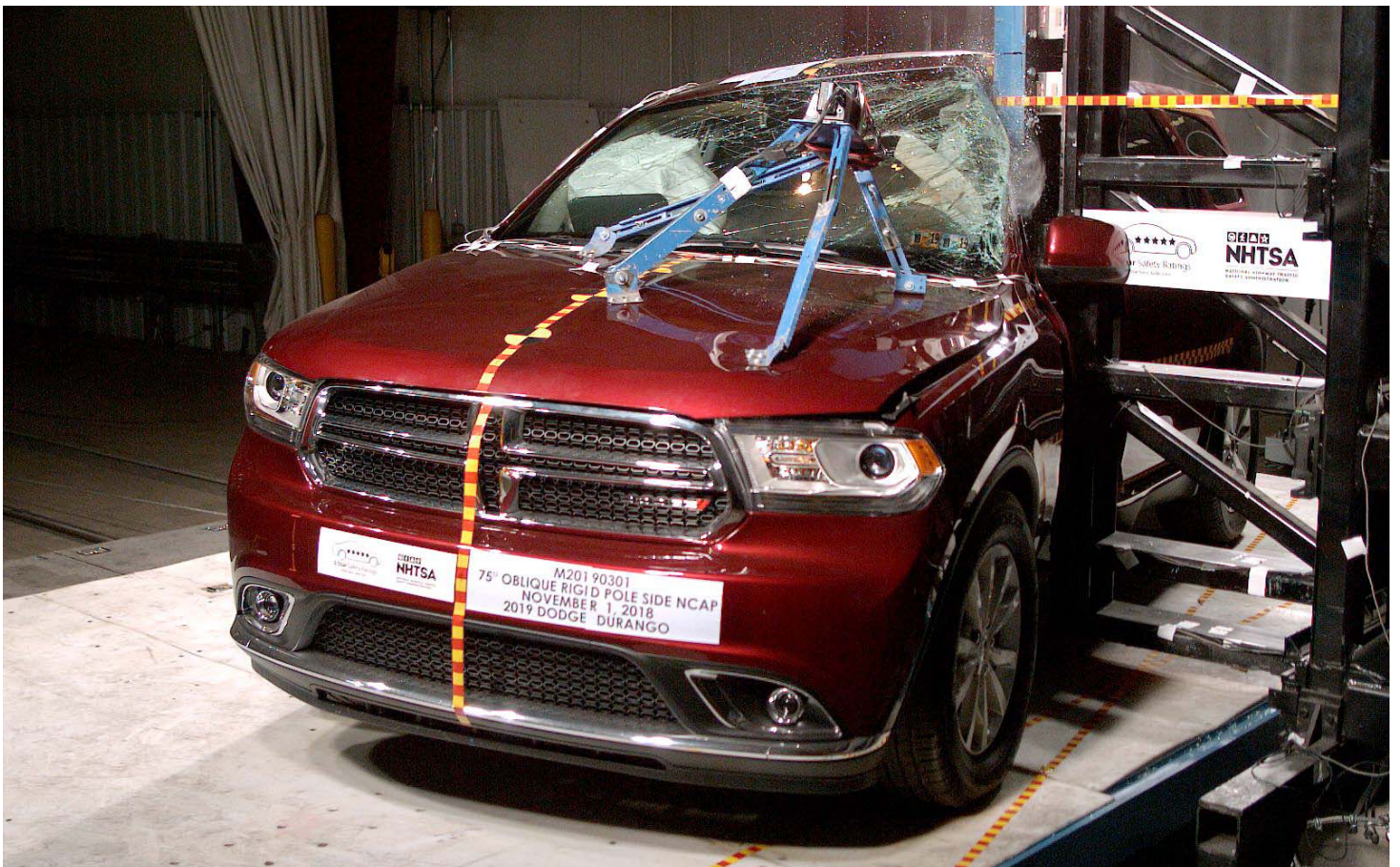

Photo No. 068 - Impact Event

THIS VEHICLE IS MANUFACTURED TO MEET SPECIFIC UNITED STATES REQUIREMENTS. THIS VEHICLE IS NOT MANUFACTURED FOR SALE OR REGISTRATION OUTSIDE OF THE UNITED STATES.

**MANUFACTURER'S SUGGESTED RETAIL PRICE OF THIS MODEL INCLUDING DEALER PREPARATION**

**Base Price: \$29,995**

**DODGE DURANGO SXT RWD**  
 Exterior Color: Octane Red Exterior Paint  
 Interior Color: Black Interior Color  
 Interior: Cloth-Trimmed Bucket Seats  
 Engine: 3.6-Liter V6 24-Valve VVT Engine with ESS  
 Transmission: 8-Speed Automatic 850RE Transmission

**STANDARD EQUIPMENT (UNLESS REPLACED BY OPTIONAL EQUIPMENT)**  
 FUNCTIONAL/SAFETY FEATURES

Advanced Multistage Front Airbags  
 Supplemental Side-Curtain Airbags in All Rows  
 Supplemental Front Seat-Mounted Side Airbags  
 Rear Load Leveling Suspension  
 Sport Mode  
 Sentry Key® Theft Deterrent System  
 ParkView® Rear Back Up Camera  
 Auto-Dimming Rear View Mirror  
 Selectable Steering Modes  
 Active Head Restraints  
 Enhanced Accident Response System  
 Electronic Stability Control  
 Hill Start Assist  
 Rain Brake Support  
 24.6-Gallon Fuel Tank  
 Remote Keyless Entry  
 Keyless Go™  
 650-Amp Maintenance Free AGM Battery

**INTERIOR FEATURES**

Uconnect® 4 with 7-Inch Display  
 Integrated Center Stack Radio  
 Apple CarPlay®  
 Google Android Auto™  
 Integrated Voice Command with Bluetooth®  
 Media Hub (2 USB, Aux)  
 6-Speakers  
 Perforated Leather-Wrapped Steering Wheel  
 Steering Wheel Mounted Audio Controls  
 Power Front Windows w/ 1-Touch Up and Down Feature  
 Air Conditioning with 3-Zone Automatic Temp Control  
 Speed Control  
 Power Door Locks  
 Rear Window Defroster

Tilt / Telescope Steering Column  
 Tire Pressure Monitoring Display  
 Luxury Front and Rear Floor Mats  
 12-Volt Auxiliary Power Outlet  
 Overhead Console  
 Full-Length Floor Console  
 Illuminated Cup Holders  
 Front and Rear Interior LED Lamps

**EXTERIOR FEATURES**

18.0-Inch x 8.0-Inch Painted Aluminum Wheels  
 P265/60R18 BSW All-Season LRR Tires  
 Power-Heated Mirrors with Manual Fold-Away  
 Automatic Headlamps  
 Halogen Headlamps  
 Deep Tint Sunscreen Glass  
 Rear Window Wiper / Washer

**OPTIONAL EQUIPMENT (May Replace Standard Equipment)**

**Customer Preferred Package 28A**  
 3rd-Row Seating Group \$995  
 Third-Row Seat  
 Third-Row Remote Headrest Fold Down  
 Second-Row 60 / 40 Fold and Tumble Seat  
 7 Passenger Seating  
 SiriusXM® Sat Radio w/ 1-Yr Sub Call 800-643-2112 \$195

**DESTINATION CHARGE \$1,395**

**TOTAL PRICE: \* \$32,580**

**WARRANTY COVERAGE**  
 5-year or 60,000-mile Powertrain Limited Warranty.  
 3-year or 36,000-mile Basic Limited Warranty.  
 Ask Dealer for a copy of the limited warranties or see your owner's manual for details.

**5 YEAR / 60,000 MILE  
 POWERTRAIN WARRANTY**

Assembly Point/Port of Entry: DETROIT, MICHIGAN, U.S.A.

VIN: 1C4RDHAG1KC550055

LA VIN: 3651

SHIP TO: 06903 33 BARBERA'S AUTO AND 7910 ROOSEVELT BLVD. PHILADELPHIA PA 19152-3005  
 06907 25 06907 25 06907 25 BARBERA'S AUTO AND 7910 ROOSEVELT BLVD. PHILADELPHIA PA 19152-3005  
THIS LABEL IS ADDED TO THIS VEHICLE TO COMPLY WITH FEDERAL LAW. THE LABEL CANNOT BE REMOVED OR ALTERED PRIOR TO DELIVERY TO THE ULTIMATE PURCHASER.  
 STATE AND/OR LOCAL TAXES IF ANY, LICENSE AND TITLE FEES AND DEALER SUPPLIED AND INSTALLED OPTIONS AND ACCESSORIES ARE NOT INCLUDED IN THIS PRICE. DISCOUNT, IF ANY, IS BASED ON PRICE OF OPTIONS IF PURCHASED SEPARATELY.



**EPA DOT Fuel Economy and Environment** Gasoline Vehicle

**Fuel Economy** These estimates reflect new EPA methods beginning with 2017 models. Standard SUV 2WD range from 11 to 93 MPG. The best vehicle rates 136 MPG.

**21 MPG** combined city/hwy  
**19** city  
**26** highway  
**4.8** gallons per 100 miles

**You spend \$2,000** more in fuel costs over 5 years compared to the average new vehicle.

**Annual fuel cost \$1,800**

**Fuel Economy & Greenhouse Gas Rating (tailpipe only)** 4  
**Smog Rating (tailpipe only)** 5

**Actual results will vary for many reasons, including driving conditions and how you drive and maintain your vehicle. The average new vehicle gets 27 MPG and cost \$7,000 to fuel over 5 years. Cost estimates are based on 15,000 miles per year at \$2.55 per gallon. MPG is miles per gasoline gallon equivalent. Vehicle emissions are a significant cause of climate change and smog.**

**fuel economy.gov**  
 Calculate personalized estimates and compare vehicles

Smartphone QR Code™

**GOVERNMENT 5-STAR SAFETY RATINGS**

**Overall Vehicle Score Not Rated**  
 Based on the combined ratings of frontal, side, and rollover. Should ONLY be compared to other vehicles of similar size and weight.

<b>Frontal Crash</b>	<b>Driver Passenger</b>	<b>Not Rated</b>
Based on the risk of injury in a frontal impact. Should ONLY be compared to other vehicles of similar size and weight.		
<b>Side Crash</b>	<b>Front seat Rear seat</b>	<b>Not Rated</b>
Based on the risk of injury in a side impact.		
<b>Rollover</b>		<b>★★★★</b>
Based on the risk of rollover in a single-vehicle crash.		

**Star ratings range from 1 to 5 stars (★★★★) with 5 being the highest. Source: National Highway Traffic Safety Administration (NHTSA) www.safercar.gov or 1-888-327-4236**

**PARTS CONTENT INFORMATION**  
 FOR VEHICLES IN THIS CARLINE: U.S./CANADIAN PARTS CONTENT: 60%  
**MAJOR SOURCES OF FOREIGN PARTS CONTENT:**  
 MEXICO: 26%  
 NOTE: PARTS CONTENT DOES NOT INCLUDE FINAL ASSEMBLY, DISTRIBUTION, OR OTHER NON-PARTS COSTS.  
**FOR THIS VEHICLE:**  
 FINAL ASSEMBLY POINT: DETROIT, MICHIGAN, U.S.A.  
 COUNTRY OF ORIGIN: ENGINE: MEXICO  
 TRANSMISSION: UNITED STATES

**VEHICLE PROTECTION**  
 A PRODUCT OF FCA US LLC  
 Ask for Mopar Vehicle Protection for your vehicle. We Built It. We Back It.

Photo No. 069 - Monroney Label

**HEAD RESTRAINTS**

Head restraints are designed to reduce the risk of injury by restricting head movement in the event of a rear impact. Head restraints should be adjusted so that the top of the head restraint is located above the top of your ear.

**WARNING!**

- All occupants, including the driver, should not operate a vehicle or sit in a vehicle's seat until the head restraints are placed in their proper positions in order to minimize the risk of neck injury in the event of a crash.
- Head restraints should never be adjusted while the vehicle is in motion. Driving a vehicle with the head restraints improperly adjusted or removed could cause serious injury or death in the event of a collision.

**Supplemental Active Head Restraints — Front Seats**

Active Head Restraints (AHR) are passive, deployable components, and vehicles with this equipment cannot be readily identified by any markings, only through visual inspection of the head restraint. The AHR will be split in two halves, with the front half being soft foam and trim, while the back half is decorative plastic.

When AHRs deploy during a rear impact, the front half of the head restraint extends forward to reduce the gap between the back of the occupant's head and the AHR. This system is design to reduce the risk of injury to the driver or front passenger in certain types of rear impacts. Refer to "Occupant Restraint Systems" in "Safety" for further information.

To raise the head restraint, pull upward on the head restraint. To lower the head restraint, push the adjustment button, located at the base of the head restraint, and push downward on the head restraint.

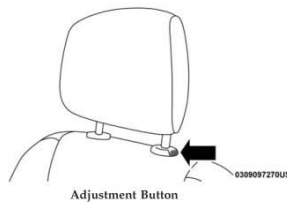

For comfort the Active Head Restraints can be tilted forward and rearward. To tilt the head restraint closer to the back of your head, pull forward on the bottom of the head restraint. Push rearward on the bottom of the head restraint to move the head restraint away from your head.



**NOTE:**

- The head restraints should only be removed by qualified technicians, for service purposes only. If either of the head restraints require removal, see an authorized dealer.
- In the event of deployment of an Active Head Restraint, refer to "Occupant Restraint Systems/Resetting Active Head Restraints (AHR)" in "Safety" for further information.

**WARNING!**

- All occupants, including the driver, should not operate a vehicle or sit in a vehicle's seat until the head restraints are placed in their proper positions in order to minimize the risk of neck injury in the event of a collision.
- Do not place items over the top of the Active Head Restraint, such as coats, seat covers or portable DVD players. These items may interfere with the operation of the Active Head Restraint in the event of a collision and could result in serious injury or death.
- Active Head Restraints may be deployed if they are struck by an object such as a hand, foot or loose cargo. To avoid accidental deployment of the Active Head Restraint ensure that all cargo is secured, as loose cargo could contact the Active Head Restraint during sudden stops. Failure to follow this warning could cause personal injury if the Active Head Restraint is deployed.

**Head Restraints — Rear Seats**

The head restraints on the outboard seats are not adjustable. They automatically fold forward when the rear seat is folded to a load floor position, but do not return to their normal position when the rear seat is raised. After returning either seat to its upright position, raise the head restraint until it locks in place. The outboard head restraints are not removable.

The center head restraint has limited adjustment. Lift upward on the head restraint to raise it or push downward on the head restraint to lower it.



**WARNING!**

Sitting in a seat with the head restraint in its lowered position could result in serious injury or death in a collision. Always make sure the outboard head restraints are in their upright positions when the seat is to be occupied.

**NOTE:** For proper routing of a Child Seat Tether, refer to "Occupant Restraint Systems" in "Safety" for further information.

**Head Restraint Removal — Rear Seats**

The center head restraint can be adjusted when occupied, or removed for Child Seat Tethering. To remove the head restraint, raise it as far as it can go by pulling upward. Then, push the release button at the base of the post while pulling the head restraint upward. To reinstall the head restraint, put the head restraint posts into the holes and push downward. Then, adjust the head restraint to the appropriate height.

Photo No. 070 - Head Restraint Use and Adjustment Information from Vehicle Owners Manual



Photo No. 071 - Post-Test View of Shattered Vehicle Inner Door Panel

**APPENDIX B**  
**DUMMY RESPONSE DATA PLOTS**

**TABLE OF DATA PLOTS**  
**Driver Dummy Instrumentation Plots**

		<u>Page No.</u>
Figure No. 1.	Driver Head CG Acceleration (X) vs. Time	B-1
Figure No. 2.	Driver Head CG Acceleration (Y) vs. Time	B-1
Figure No. 3.	Driver Head CG Acceleration (Z) vs. Time	B-1
Figure No. 4.	Driver Head CG Resultant Acceleration (X) vs. Time	B-1
Figure No. 5.	Driver Lower Spine T12 Acceleration (X) vs. Time	B-2
Figure No. 6.	Driver Lower Spine T12 Acceleration (Y) vs. Time	B-2
Figure No. 7.	Driver Lower Spine T12 Acceleration (Z) vs. Time	B-2
Figure No. 8.	Driver Lower Spine T12 Resultant Acceleration vs. Time	B-2
Figure No. 9.	Driver Iliac Wing Force on Impact Side (Y) vs. Time	B-3
Figure No. 10.	Driver Acetabulum Force on Impact Side (Y) vs. Time	B-3
Figure No. 11.	Driver Total Pelvis Force on Impact Side (Y) vs. Time	B-3

**The following additional data for this test can be obtained from the Research and Development section of the NHTSA website. The website can be found at [www.NHTSA.gov](http://www.NHTSA.gov)**

**Additional Driver Dummy Instrumentation Data**

Driver Head CG Redundant Acceleration (X) vs. Time

Driver Head CG Redundant Acceleration (Y) vs. Time

Driver Head CG Redundant Acceleration (Z) vs. Time

Driver Head Angular Velocity X (Deg/Sec) vs. Time

Driver Head Angular Velocity Y (Deg/Sec) vs. Time

Driver Head Angular Velocity Z (Deg/Sec) vs. Time

Driver Upper Thorax Rib Deflection (Y)

Driver Middle Thorax Rib Deflection (Y)

Driver Lower Thorax Rib Deflection (Y)

Driver Upper Abdomen Rib Deflection (Y)

Driver Lower Abdomen Rib Deflection (Y)

### **Vehicle Instrumentation Data**

Vehicle Center of Gravity Acceleration (X)

Vehicle Center of Gravity Acceleration (Y)

Vehicle Center of Gravity Acceleration (Z)

Left Floor Sill Acceleration (Y)

Left A-Pillar Sill Acceleration (Y)

Left Lower A-Pillar Acceleration (Y)

Left Mid A-Pillar Acceleration (Y)

Left B-Pillar Sill Acceleration (Y)

Left Lower B-Pillar Acceleration (Y)

Left Mid B-Pillar Acceleration (Y)

Driver Seat Track at Dummy Hip Point Acceleration (Y)

Engine Top Acceleration (X)

Engine Top Acceleration (Y)

Firewall Center Acceleration (Y)

Right Roof at Vertical Impact Reference Line Acceleration (Y)

Right Sill at Vertical Impact Reference Line Acceleration (Y)

Rear Floorpan Behind Rear Axle at Centerline Acceleration (X)

Rear Floorpan Behind Rear Axle at Centerline Acceleration (Y)

### **Pole Instrumentation Data**

Load Cell Pole Barrier #1 Force (Y)

Load Cell Pole Barrier #2 Force (Y)

Load Cell Pole Barrier #3 Force (Y)

Load Cell Pole Barrier #4 Force (Y)

Load Cell Pole Barrier #5 Force (Y)

Load Cell Pole Barrier #6 Force (Y)

Load Cell Pole Barrier #7 Force (Y)

Load Cell Pole Barrier #8 Force (Y)

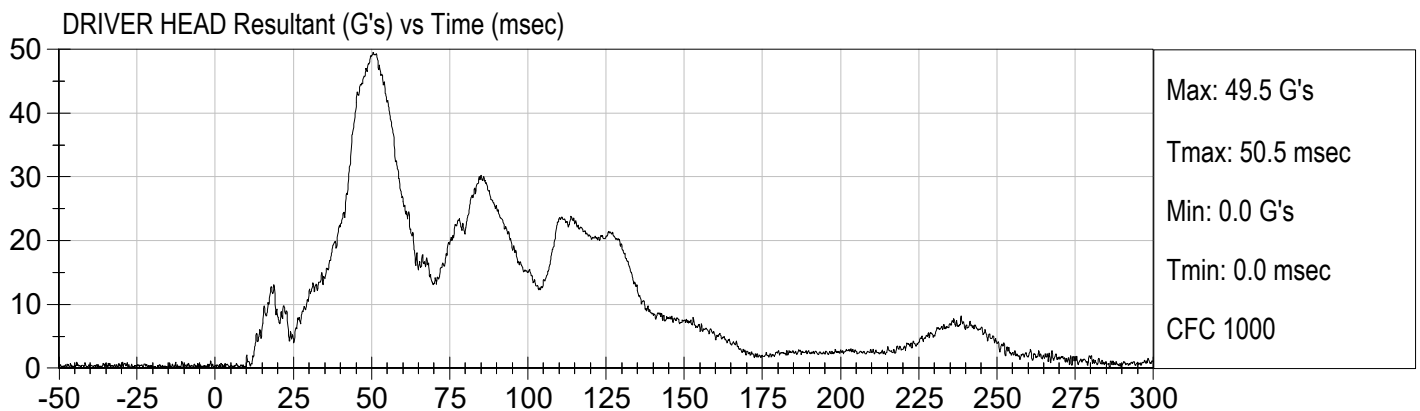
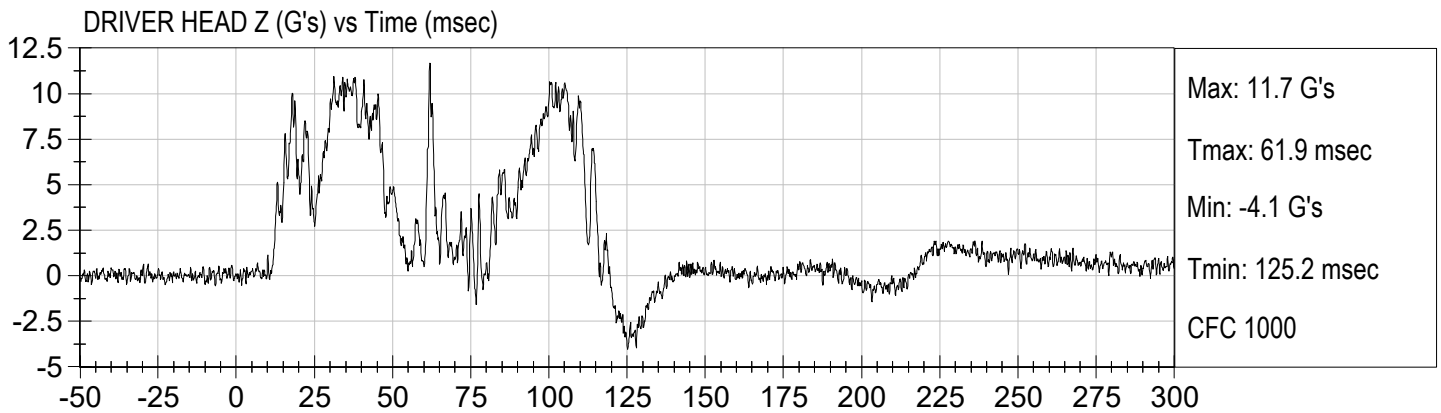
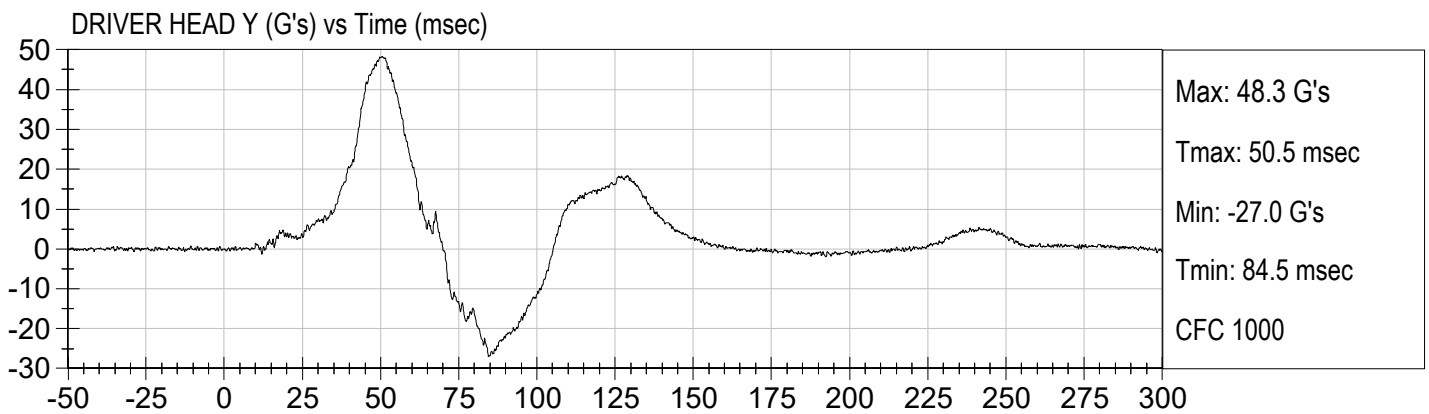
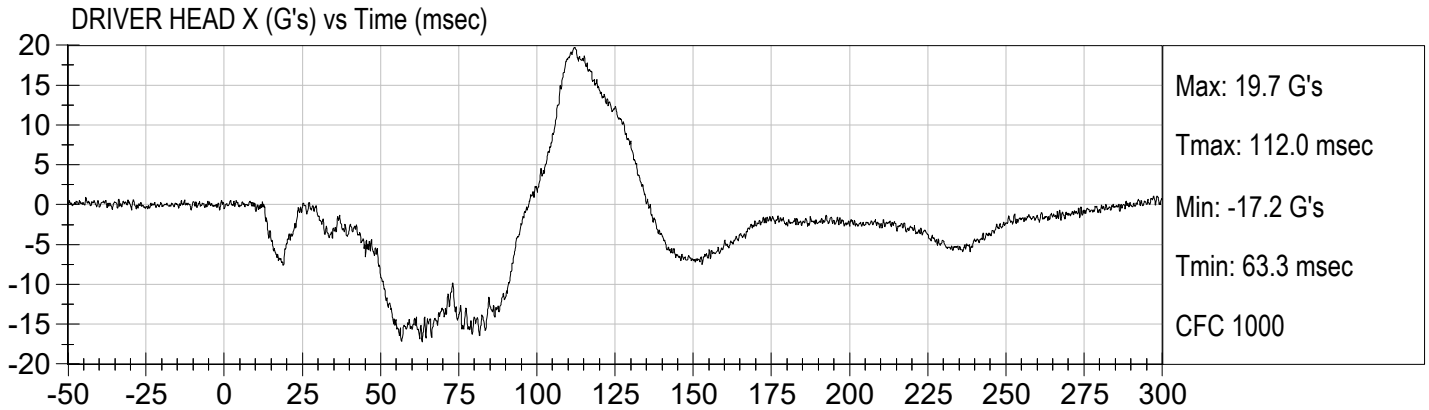

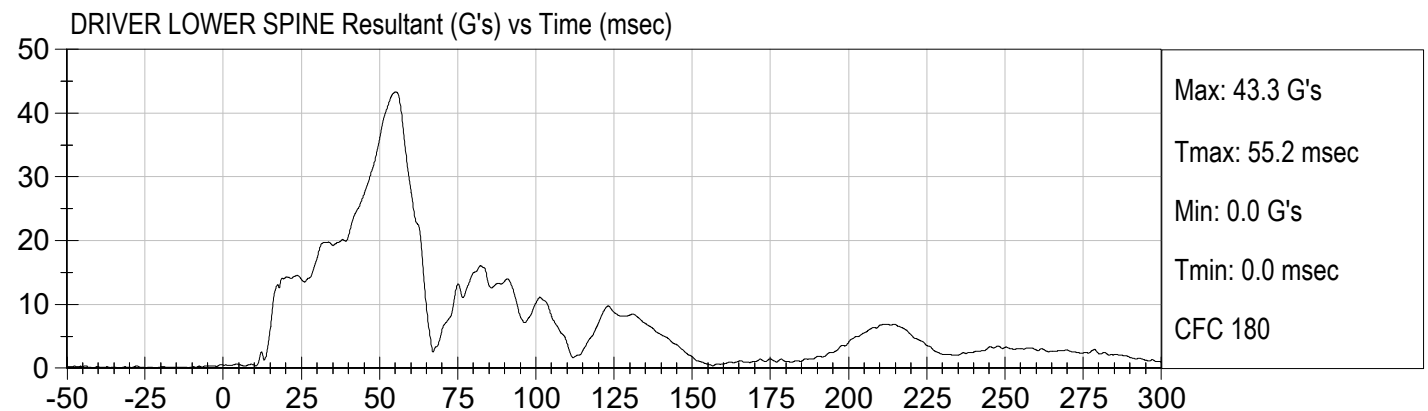
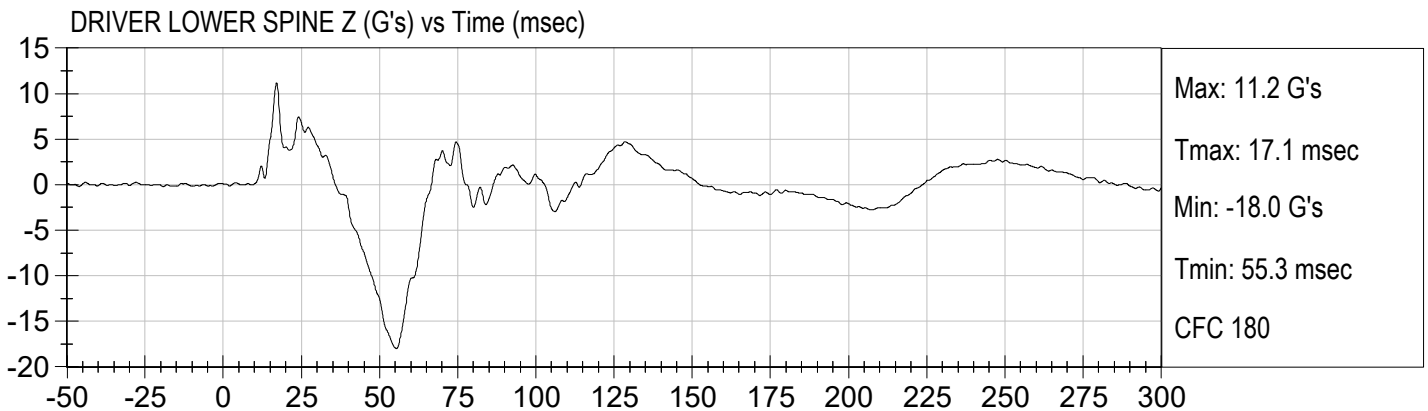
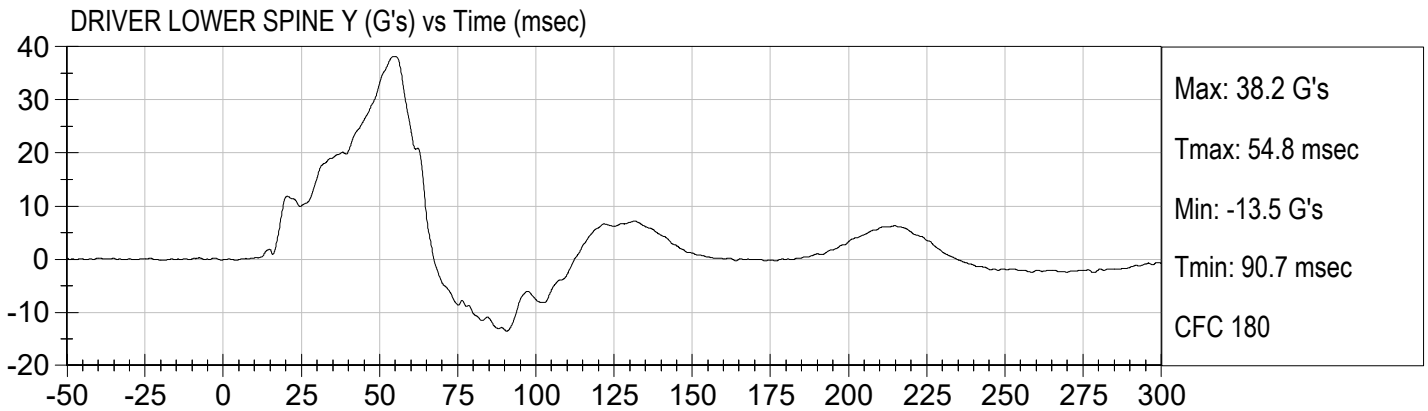
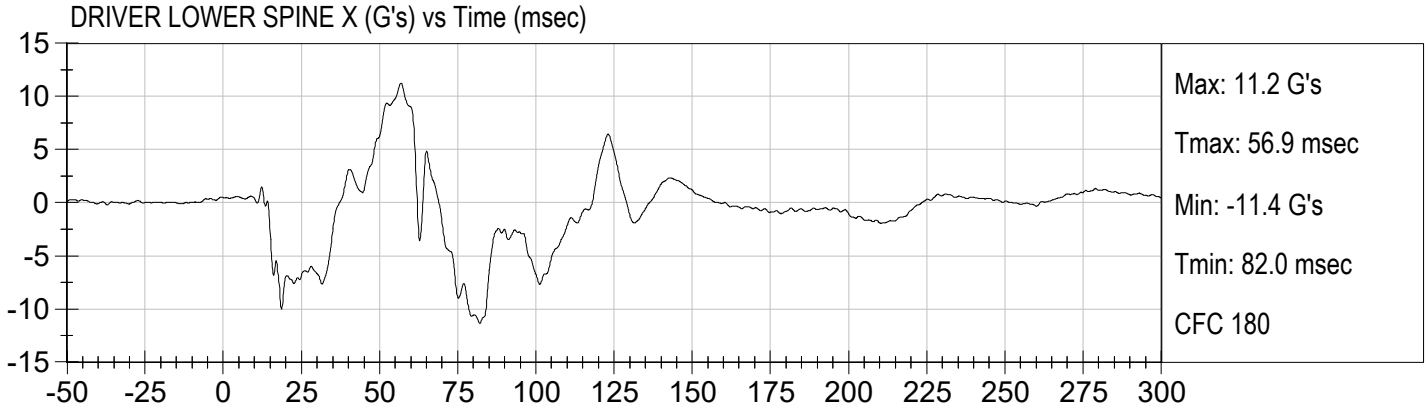

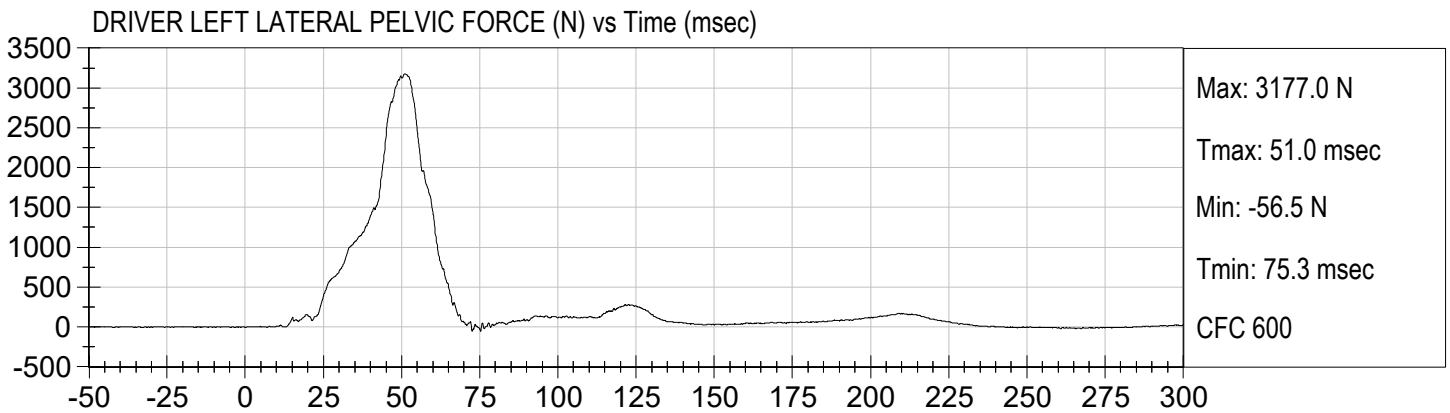
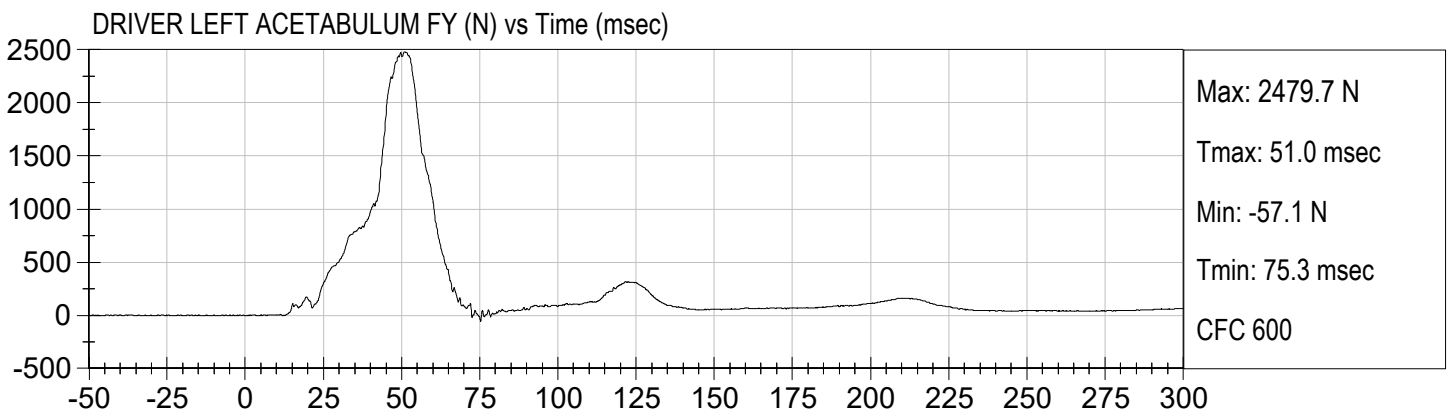
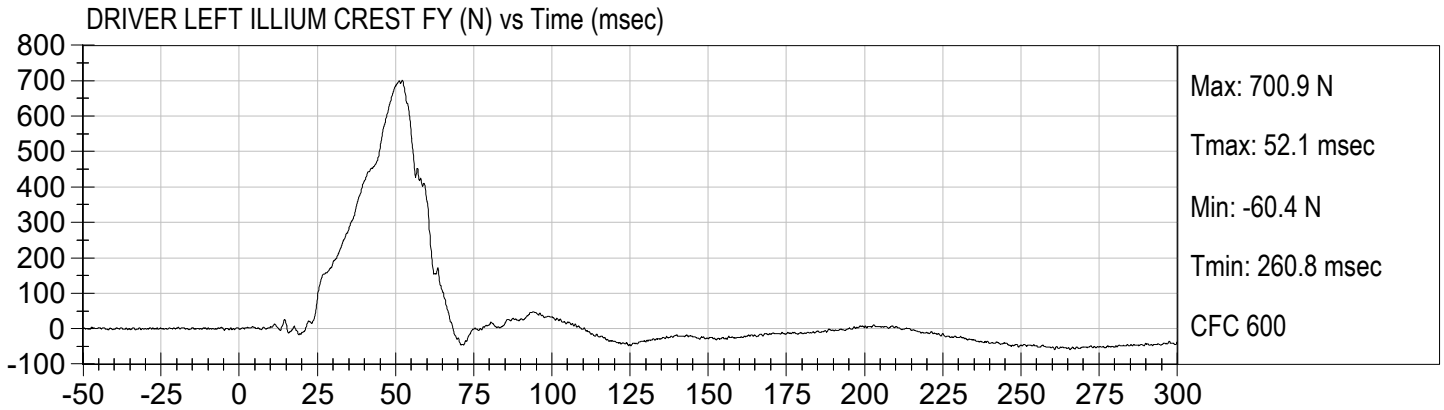

**APPENDIX C**  
**DUMMY CONFIGURATION AND PERFORMANCE VERIFICATION DATA**

**CALIBRATION TEST RESULTS**

**PRE-TEST**

**SID-IIS 5<sup>TH</sup> PERCENTILE FEMALE - DRIVER ATD**

**SID-IIsD External Measurements**  
**SN: 296**

<b>No.</b>	<b>Name</b>	<b>Spec. (mm)</b>	<b>Result</b>	<b>Pass/Fail</b>
<b>A</b>	Sitting Height	772 - 788	784	Pass
<b>B</b>	Shoulder Pivot Height	437 - 453	442	Pass
<b>C</b>	H-point Height	79 - 89	83	Pass
<b>D</b>	H-point from Seatback	141 - 151	145	Pass
<b>E</b>	Shoulder Pivot from Backline	97 - 107	99	Pass
<b>F</b>	Thigh Clearance	119 - 135	121	Pass
<b>G</b>	Head Breadth	140 - 148	142	Pass
<b>H</b>	Head Back from Backline	40 - 46	45	Pass
<b>I</b>	Head Depth	178 - 188	180	Pass
<b>J</b>	Head Circumference	541 - 551	548	Pass
<b>K</b>	Buttock to Knee Length	514 - 540	535	Pass
<b>L</b>	Popliteal Height	343 - 369	358	Pass
<b>M</b>	Knee Pivot to Floor Height	392 - 409	404	Pass
<b>N</b>	Buttock Popliteal Length	416 - 442	435	Pass
<b>O</b>	Chest Depth w/o Jacket	195 - 211	206	Pass
<b>P</b>	Foot Length	216 - 232	219	Pass
<b>Q</b>	Hip Breadth (w/ pelvic plugs)	313 - 323	316	Pass
<b>R</b>	Arm Length	249 - 259	250	Pass
<b>S</b>	Knee Joint to Seatback	477 - 493	481	Pass
<b>V</b>	Shoulder Width	341 - 357	346	Pass
<b>W</b>	Foot Width	78 - 94	85	Pass
<b>Y</b>	Chest Circumference w/ jacket	851 - 881	870	Pass
<b>Z</b>	Waist Circumference	761 - 791	772	Pass

**MGA RESEARCH CORPORATION  
HEAD DROP TEST  
SID-IIs BUILD LEVEL D DUMMY**

ATD Serial No: 296

Test ID: D183001

Tested Parameter	Units	Specification	Result	Pass/Fail
Laboratory Temperature	deg C	20.6 to 22.2	22	Pass
Laboratory Relative Humidity	%	10 to 70	50	Pass
Peak Resultant Acceleration	G's	115 to 137	130	Pass
Peak Longitudinal Acceleration	G's	+/- 15	3.1	Pass
Unimodal	N/A	Yes	Yes	Pass
Oscillations	N/A	<15%	Yes	Pass
Overall Test Results				Pass

*Danielle Redinlaugh*  
Laboratory Technician

10/04/2018  
Test Date

*Ben Fink*  
Approved By

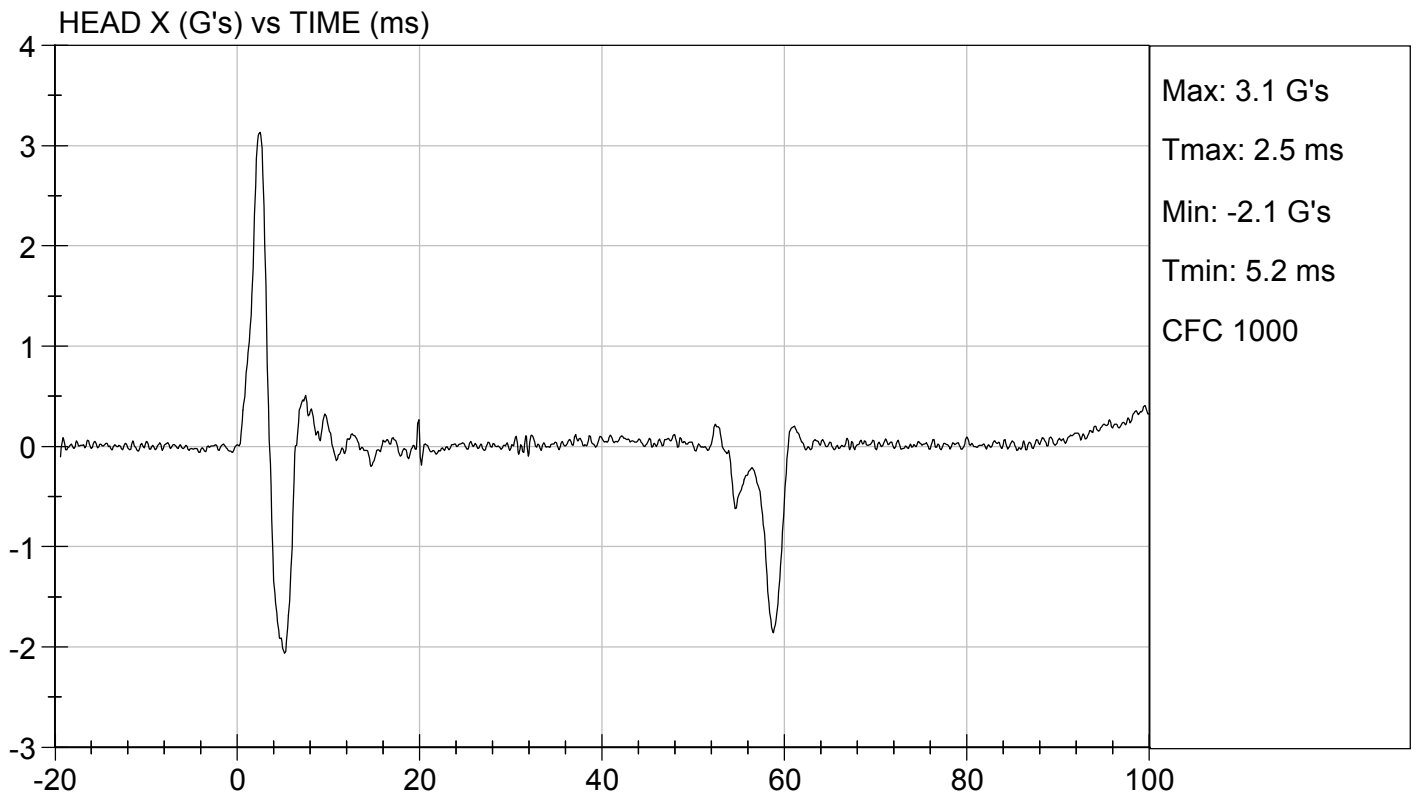
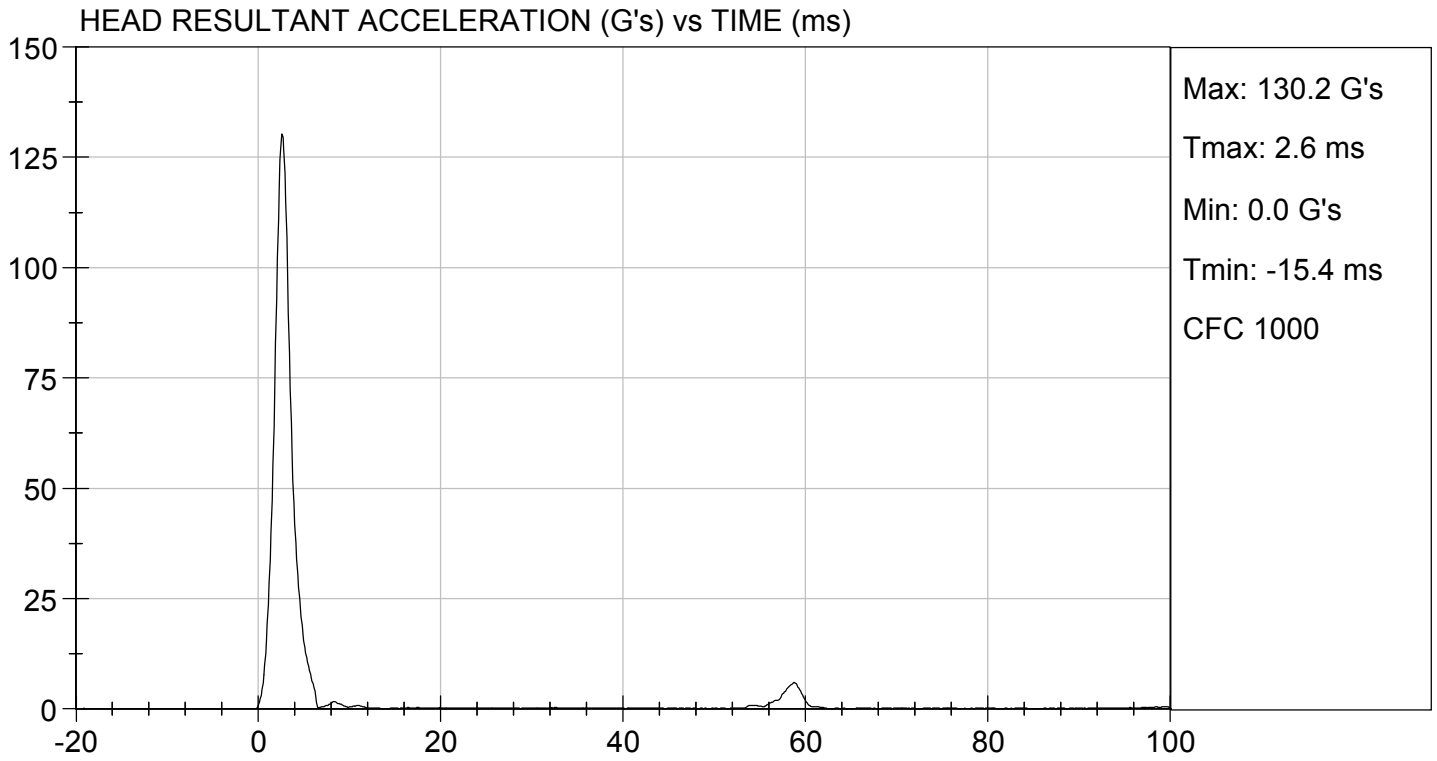

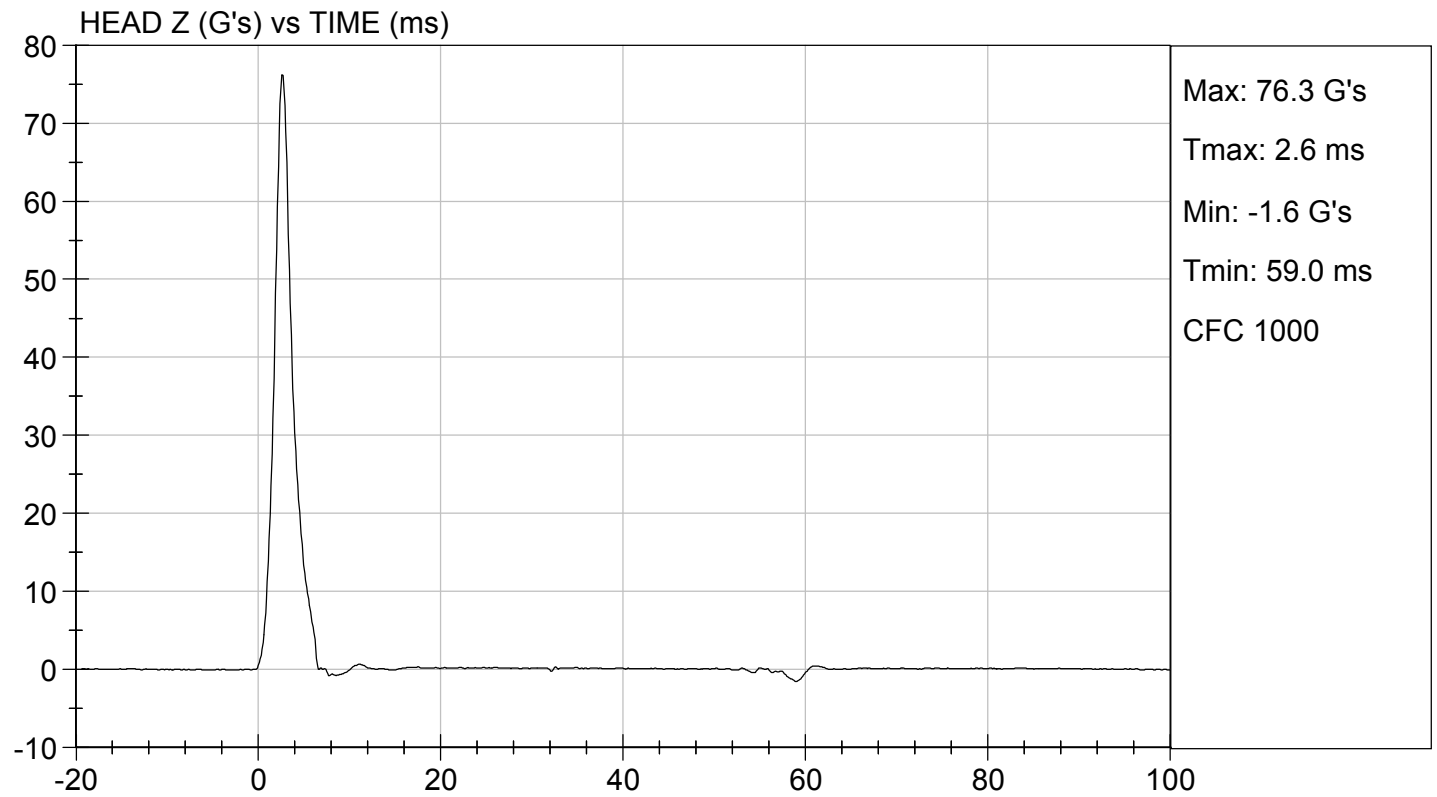
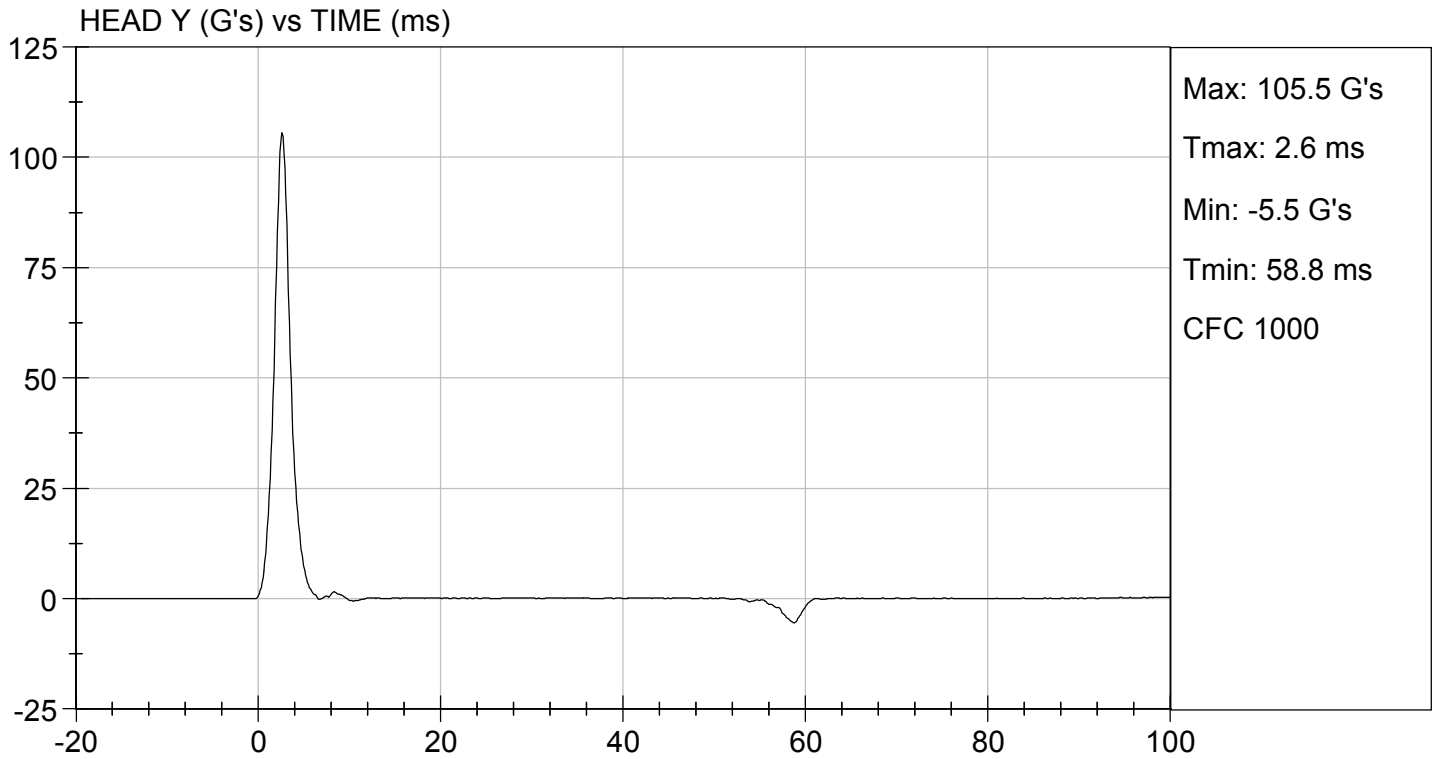

**MGA RESEARCH CORPORATION  
LATERAL NECK PENDULUM TEST  
SID-IIs BUILD LEVEL D DUMMY**

ATD Serial No: 296

Test I.D: D183002

Tested Parameter	Units	Specification	Result	Pass/Fail	
Temperature	deg C	20.6 to 22.2	20.9	Pass	
Humidity	%	10 to 70	48	Pass	
Impact Velocity	m/s	5.51 to 5.63	5.58	Pass	
Pendulum Velocity	10 ms	m/s	2.20 to 2.80	2.60	Pass
	15 ms	m/s	3.30 to 4.10	3.84	Pass
	20 ms	m/s	4.40 to 5.40	5.33	Pass
	25 ms	m/s	5.40 to 6.10	5.70	Pass
	25-100 ms	m/s	5.50 to 6.20	5.73	Pass
Maximum D-Plane Rotation	deg	71 to 81	72	Pass	
Time of Maximum D-Plane Rotation	ms	50 to 70	62	Pass	
Maximum Occipital Condyle Moment	Nm	-44 to -36	-42	Pass	
Time of Moment Decay to 0 Nm	ms	102 to 126	110	Pass	
<b>Overall Test Results</b>				<b>Pass</b>	

*Danielle Redinlaugh*  
Laboratory Technician

10/04/2018  
Test Date

*B. F.*  
Approved By



PENDULUM VELOCITY (m/s) vs TIME (ms)

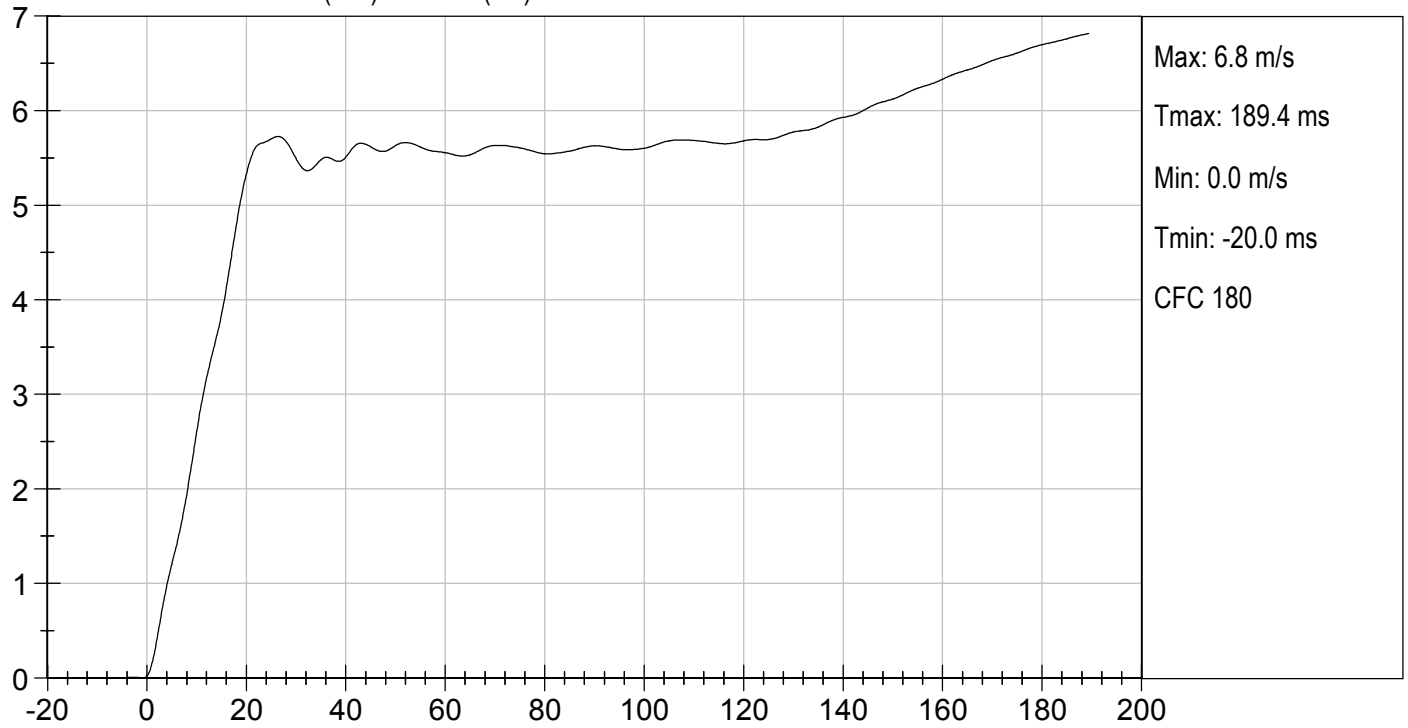

FLEXION ANGLE (DEG) vs TIME (ms)

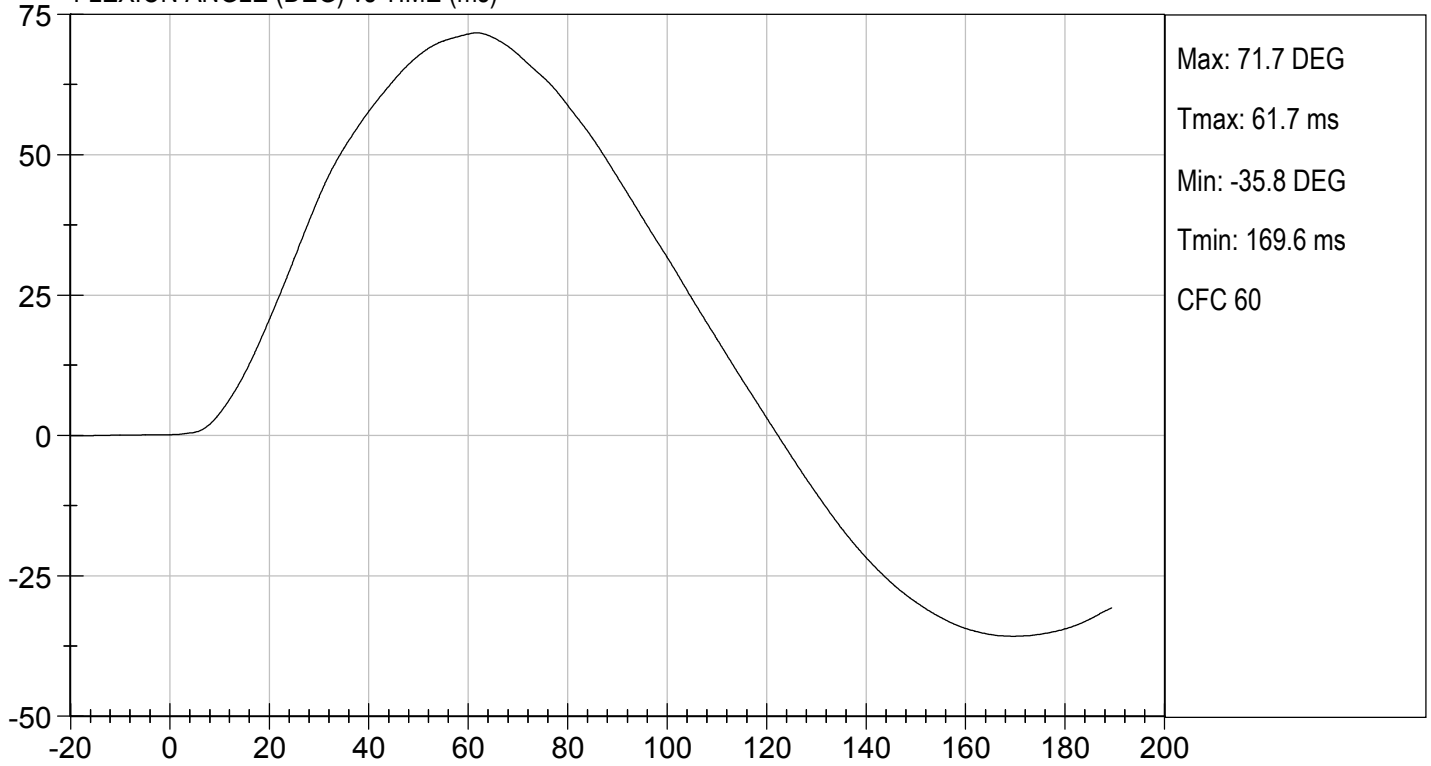

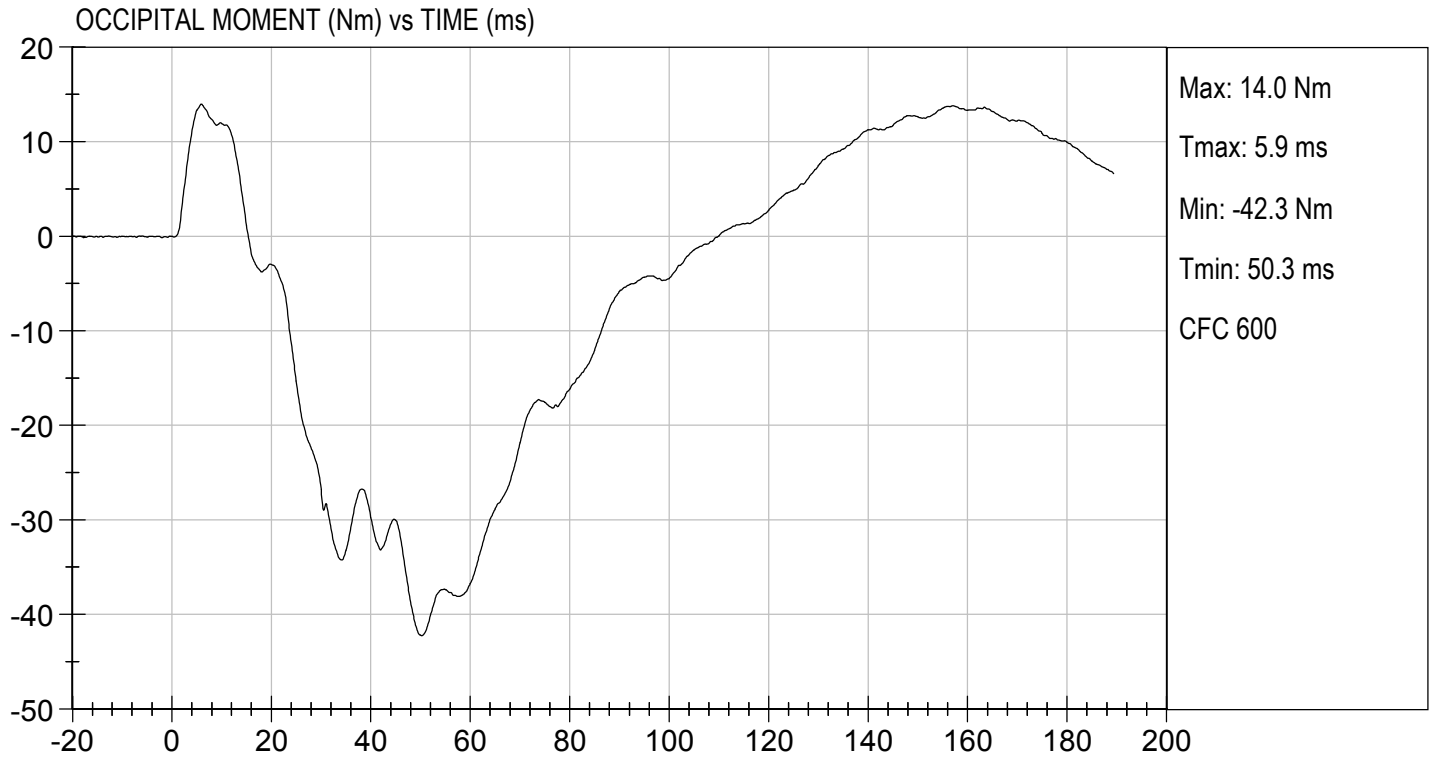

**MGA RESEARCH CORPORATION  
SHOULDER IMPACT TEST  
SID-IIs BUILD LEVEL D DUMMY**

ATD Serial No: 296

Test ID: D183003

Tested Parameter	Units	Specification	Result	Pass/Fail
Laboratory Temperature	deg C	20.6 to 22.2	21.3	Pass
Laboratory Relative Humidity	%	10 to 70	39	Pass
Impact Velocity	m/s	4.20 to 4.40	4.27	Pass
Maximum Probe Acceleration	G's	13 to 18	15	Pass
Shoulder Displacement	mm	28 to 37	29	Pass
Upper Spine (T1) Y Acceleration	G's	17 to 22	20	Pass
Overall Test Results				Pass

Jacob D Taylor  
Laboratory Technician

10/04/2018  
Test Date

B. F. H.  
Approved By

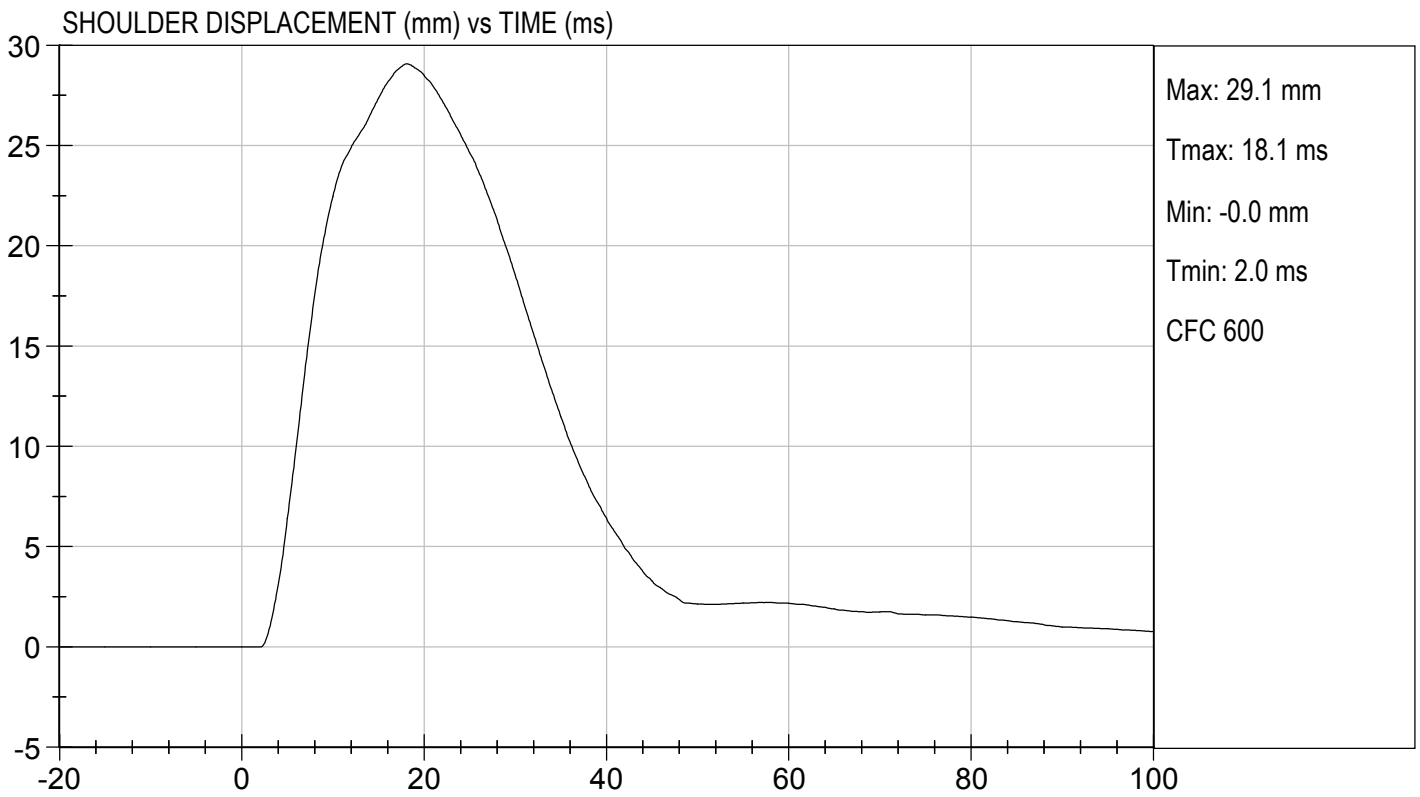
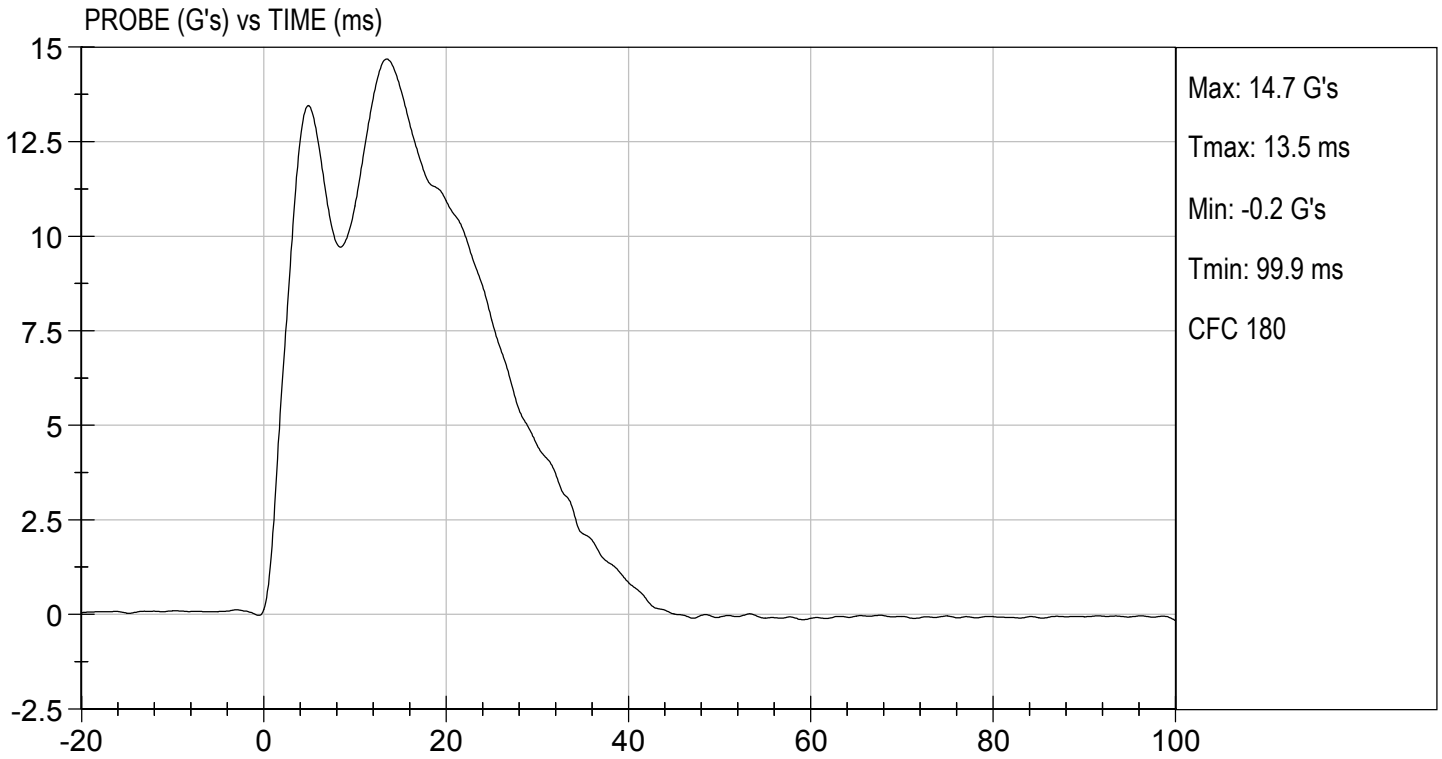

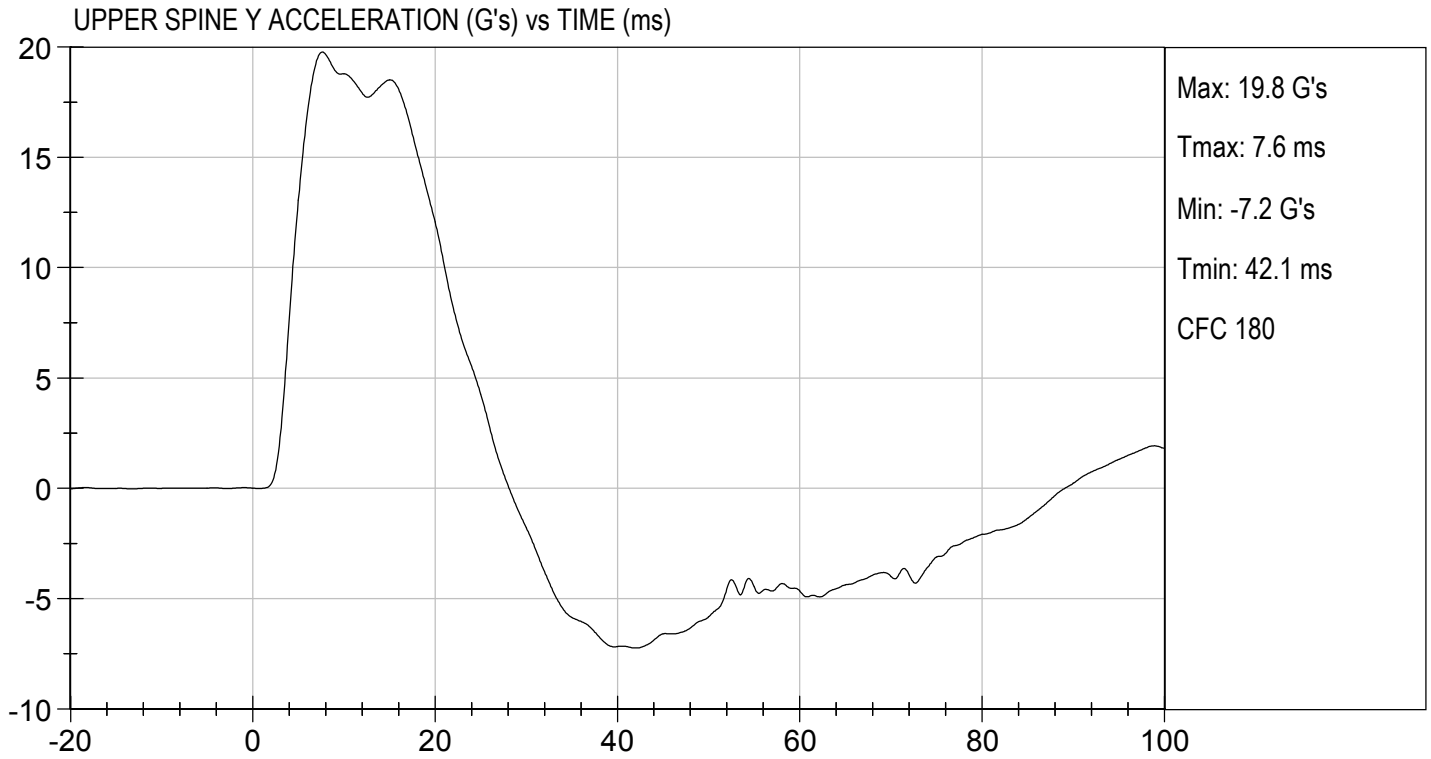

**MGA RESEARCH CORPORATION**  
**THORAX (WITH ARM) IMPACT TEST**  
**SID-IIs BUILD LEVEL D DUMMY**

ATD Serial No: 296

Test I.D: D183004

Tested Parameter	Units	Specification	Result	Pass/Fail
Temperature	deg C	20.6 to 22.2	21.3	Pass
Humidity	%	10 to 70	39	Pass
Impact Velocity	m/s	6.60 to 6.80	6.60	Pass
Maximum Probe Acceleration	G's	30 to 36	32	Pass
Shoulder Displacement	mm	31 to 40	36	Pass
Upper Rib Displacement	mm	25 to 32	27	Pass
Middle Rib Displacement	mm	30 to 36	30	Pass
Lower Rib Displacement	mm	32 to 38	32	Pass
Upper Spine (T1) Y Acceleration	G's	34 to 43	39	Pass
Lower Spine (T12) Y Acceleration	G's	29 to 37	35	Pass
Overall Test Results				Pass

Jacob D Taylor  
Laboratory Technician

10/04/2018  
Test Date

B. F. H.  
Approved By

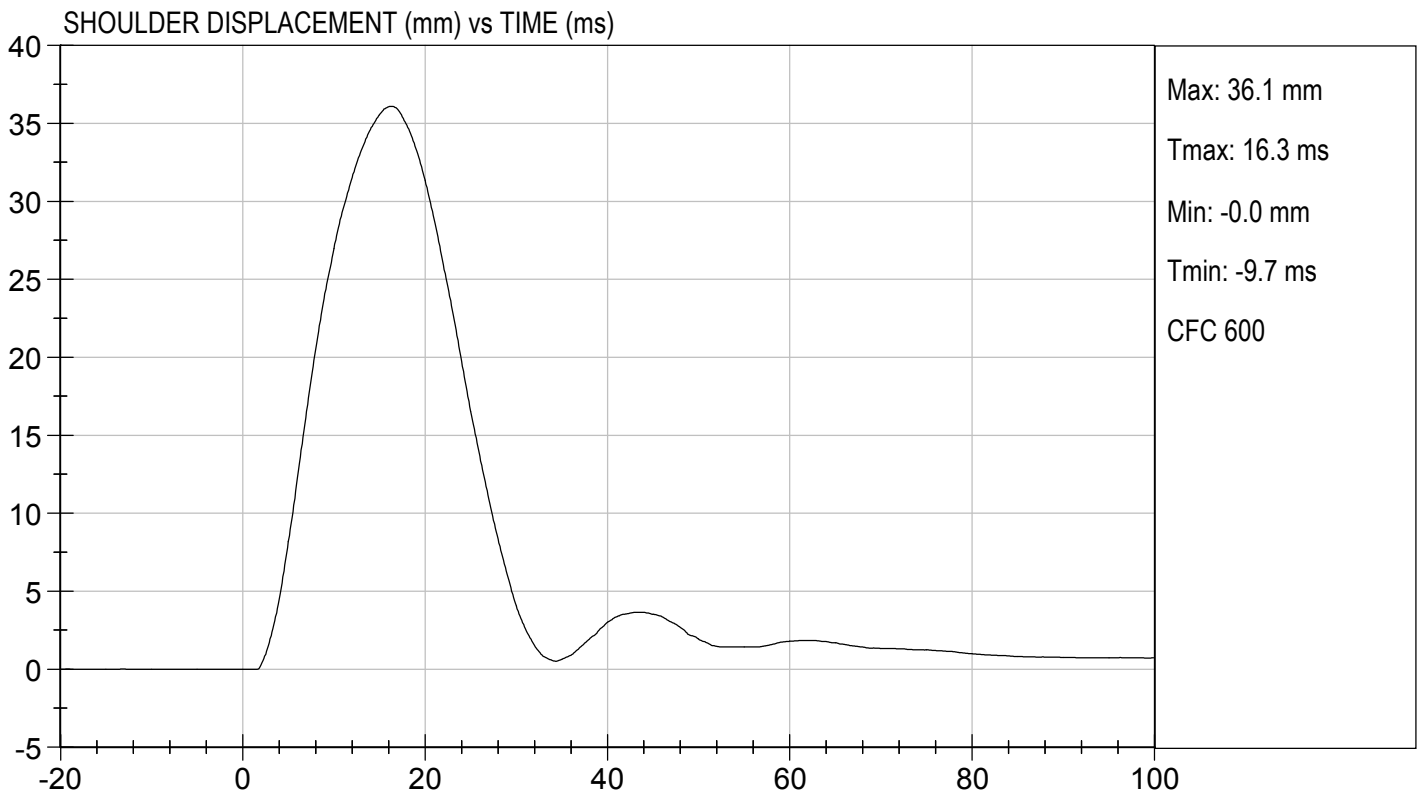
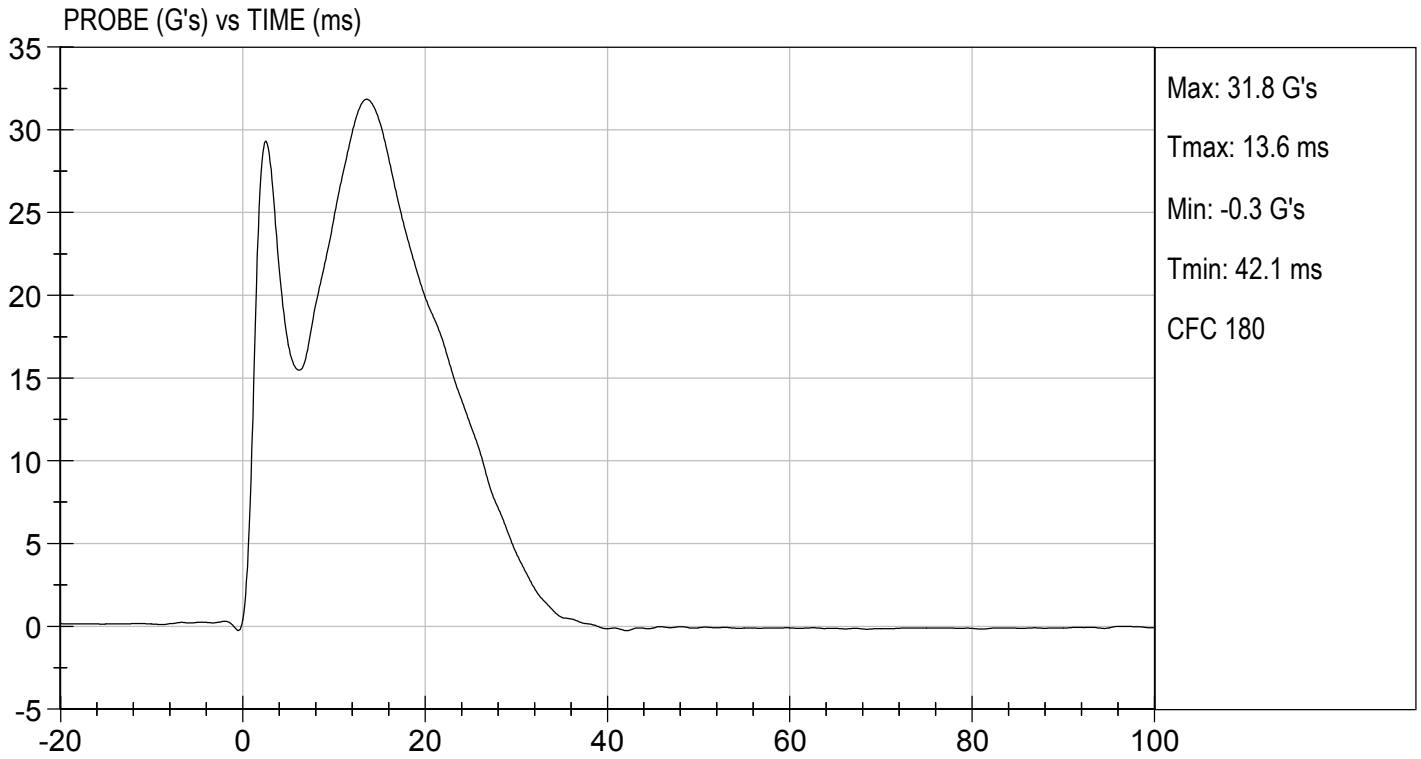

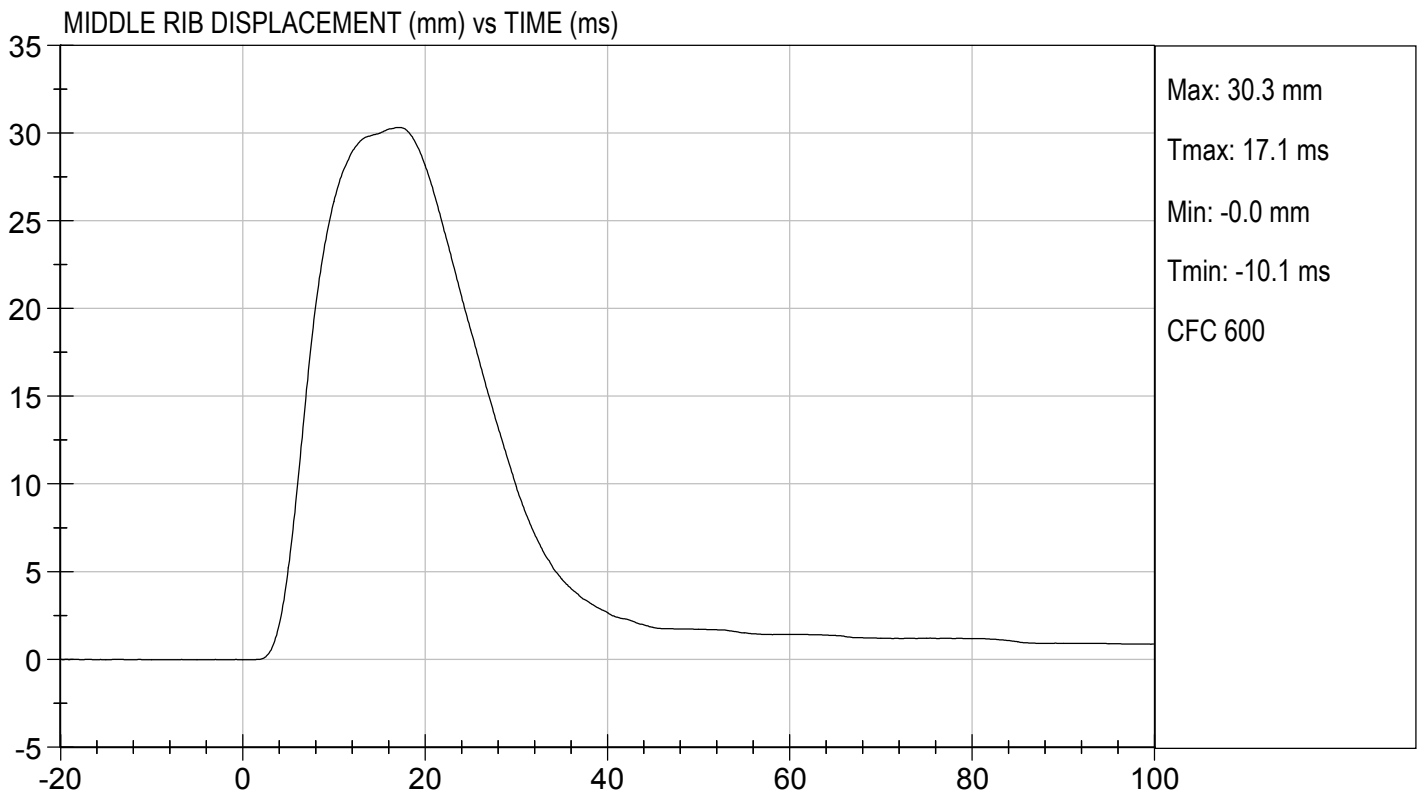
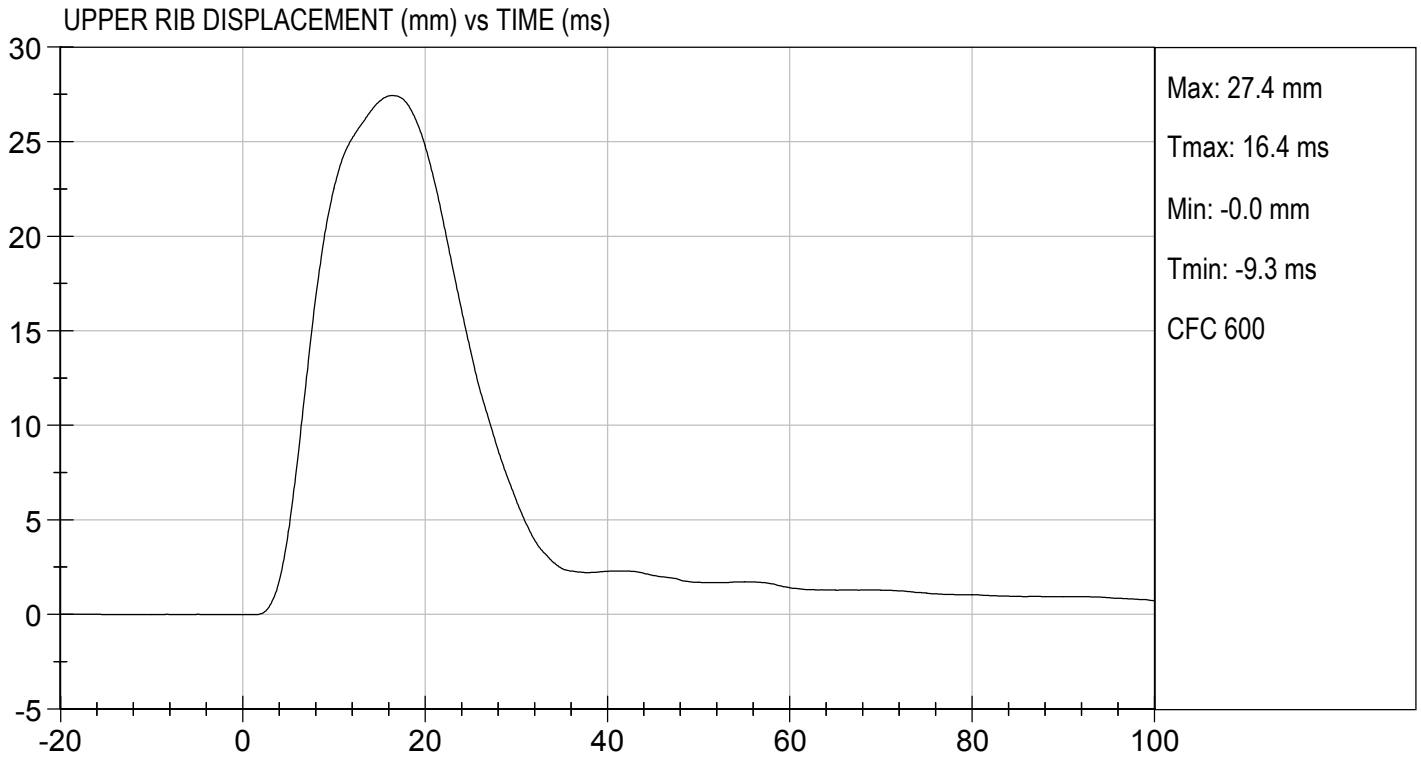

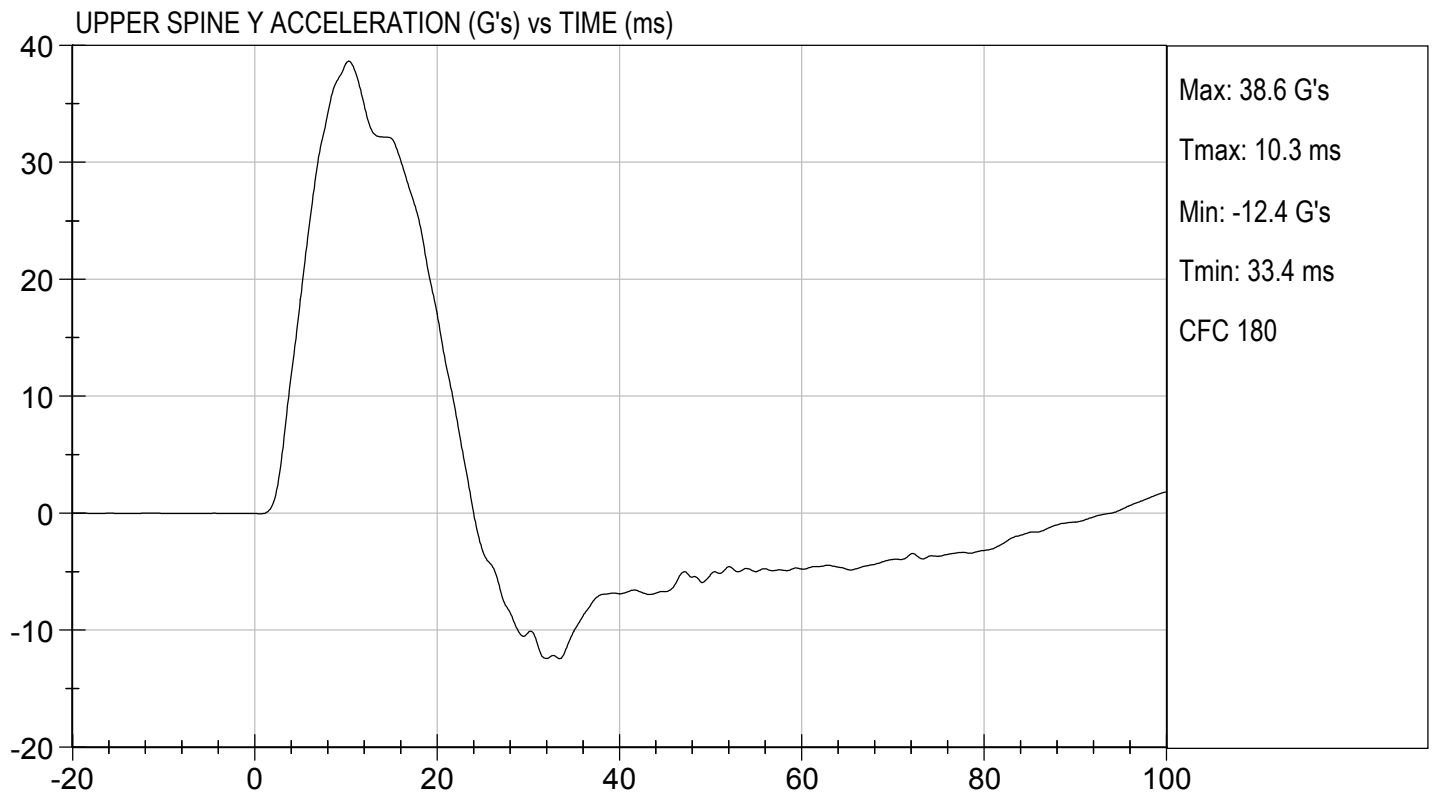
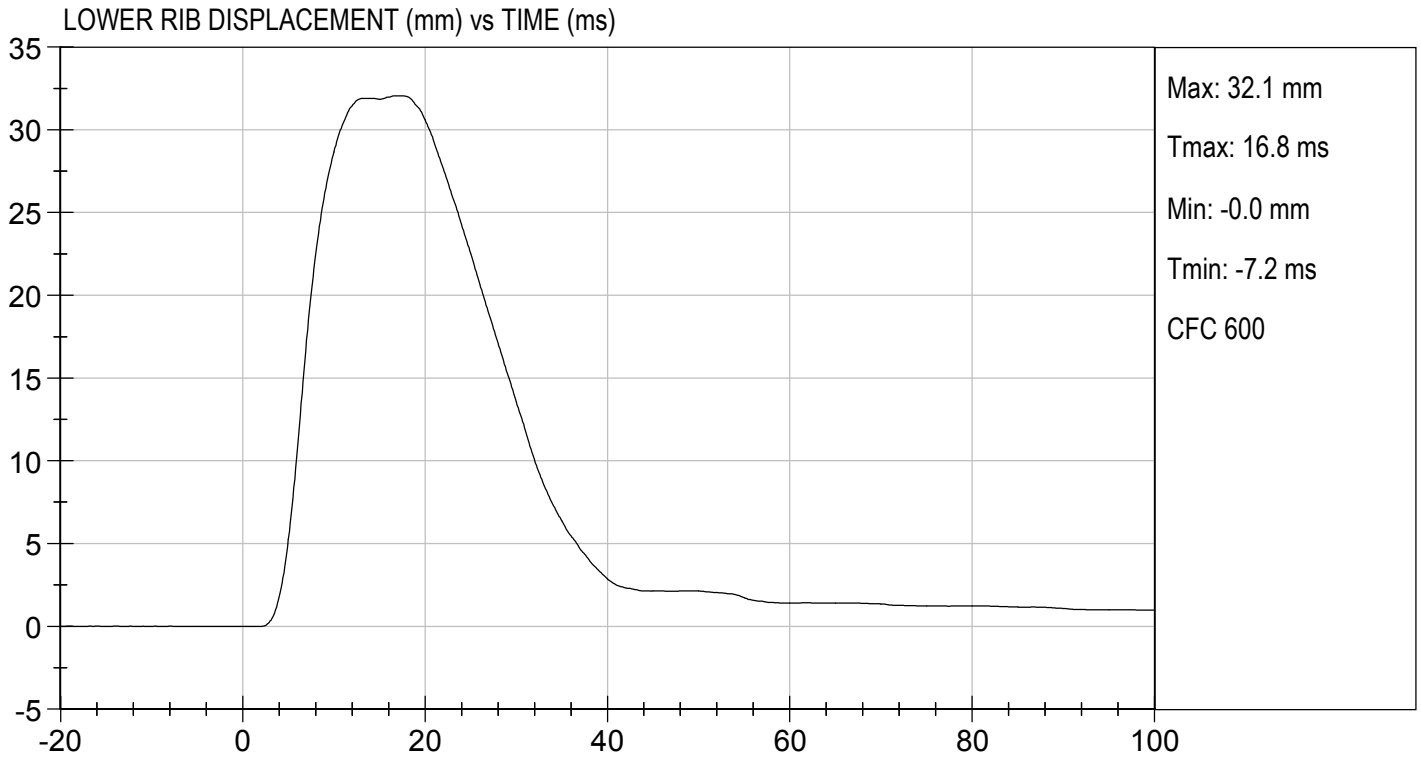

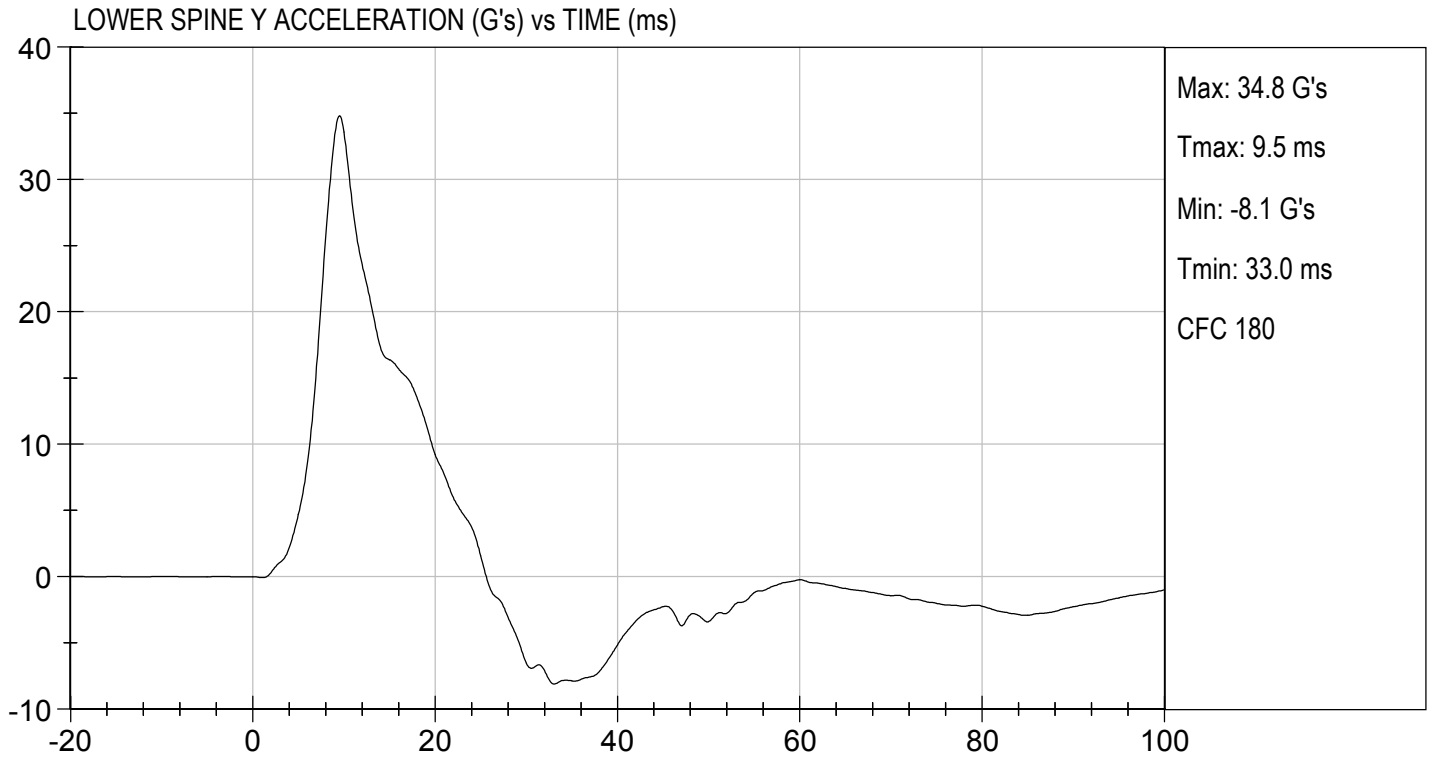

**MGA RESEARCH CORPORATION**  
**THORAX (WITHOUT ARM) IMPACT TEST**  
**SID-IIs BUILD LEVEL D DUMMY**

ATD Serial No: 306

Test I.D: D183005

Tested Parameter	Units	Specification	Result	Pass/Fail
Temperature	deg C	20.6 to 22.2	21.8	Pass
Humidity	%	10 to 70	41	Pass
Impact Velocity	m/s	4.20 to 4.40	4.21	Pass
Maximum Probe Acceleration	G's	14 to 18	15	Pass
Upper Rib Displacement	mm	32 to 40	39	Pass
Middle Rib Displacement	mm	39 to 45	43	Pass
Lower Rib Displacement	mm	35 to 43	40	Pass
Upper Spine (T1) Y Acceleration	G's	13 to 17	14	Pass
Lower Spine (T12) Y Acceleration	G's	7 to 11	8	Pass
Overall Test Results				Pass

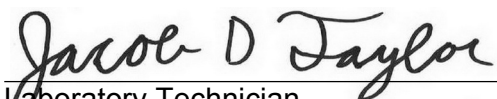
  
 Laboratory Technician

10/05/2018  
 Test Date

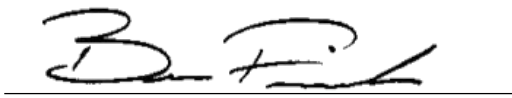
  
 Approved By

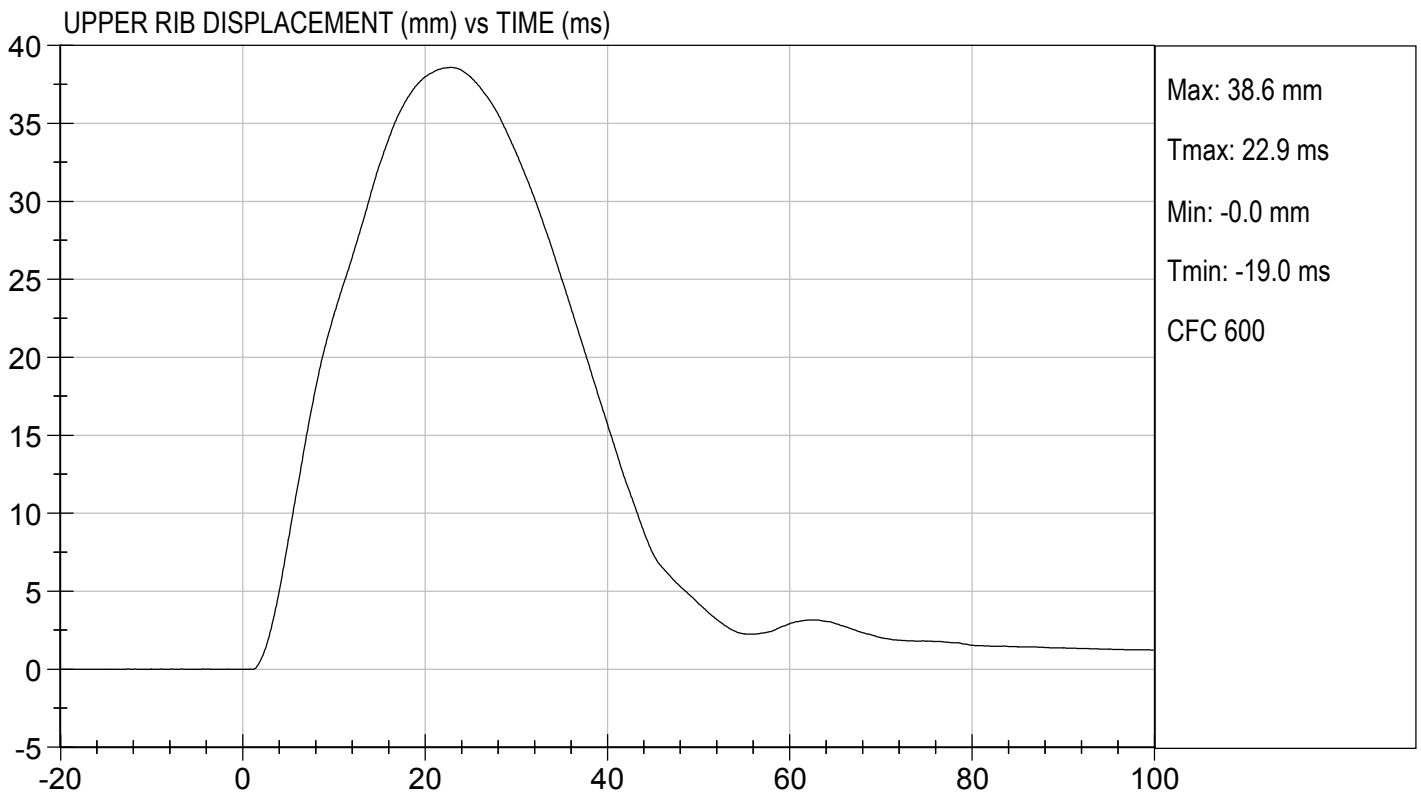
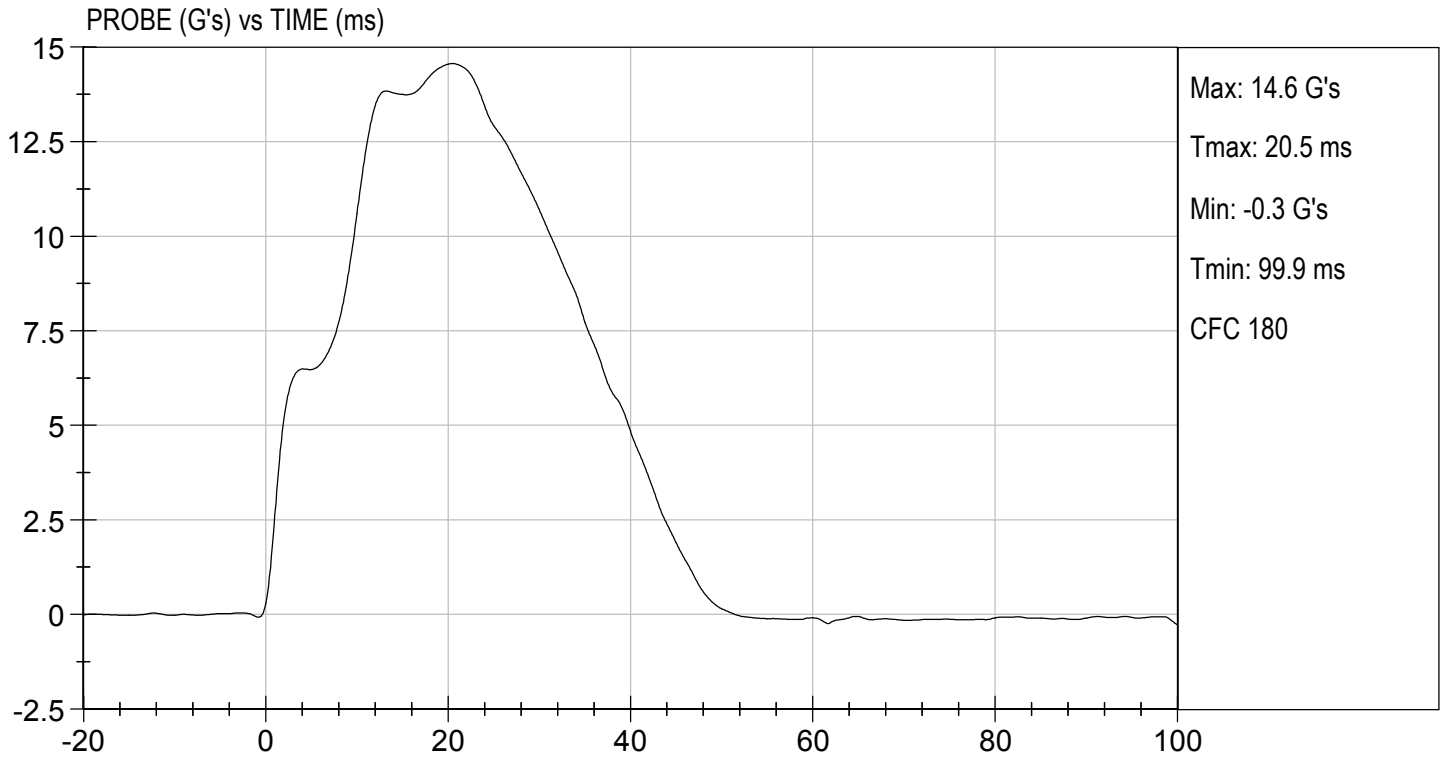

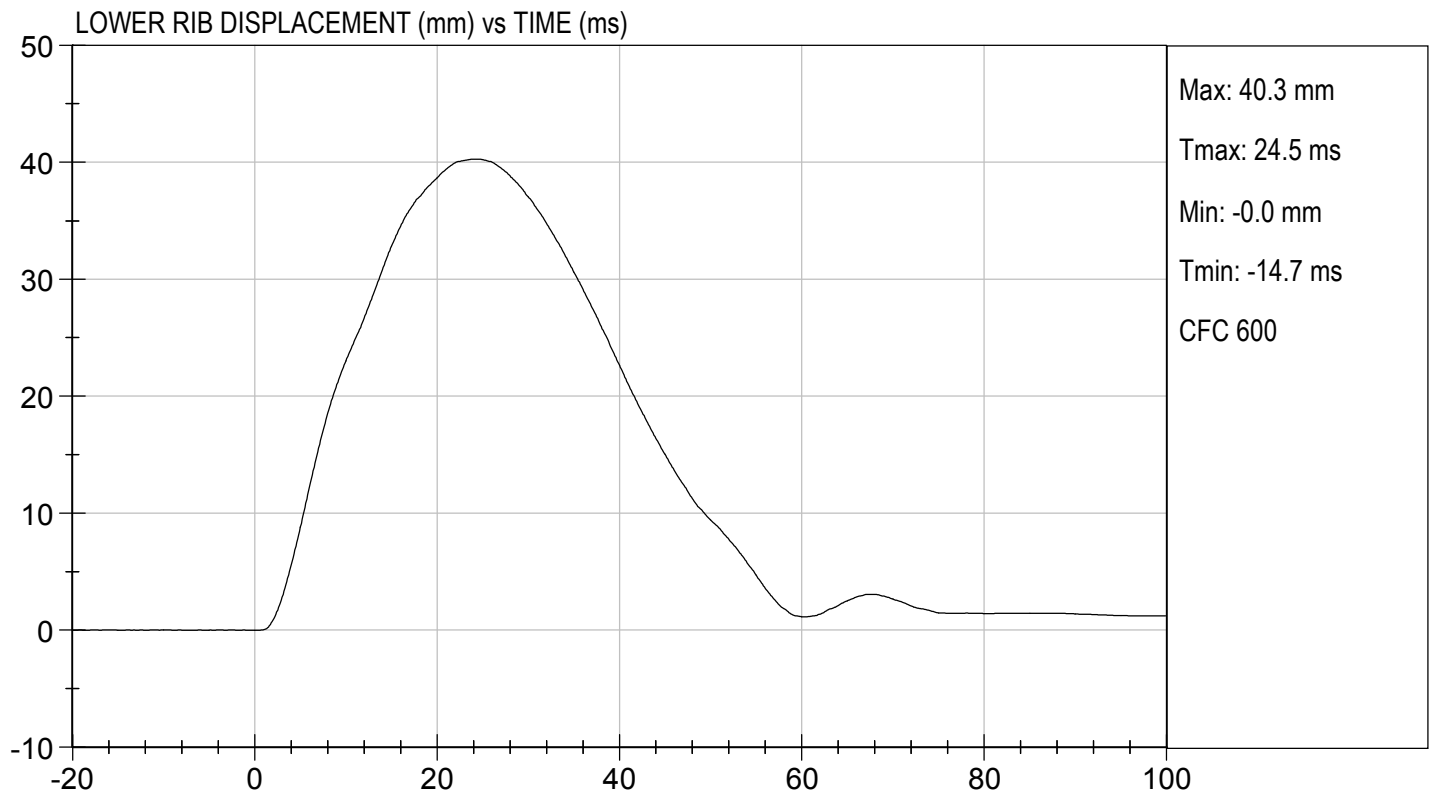
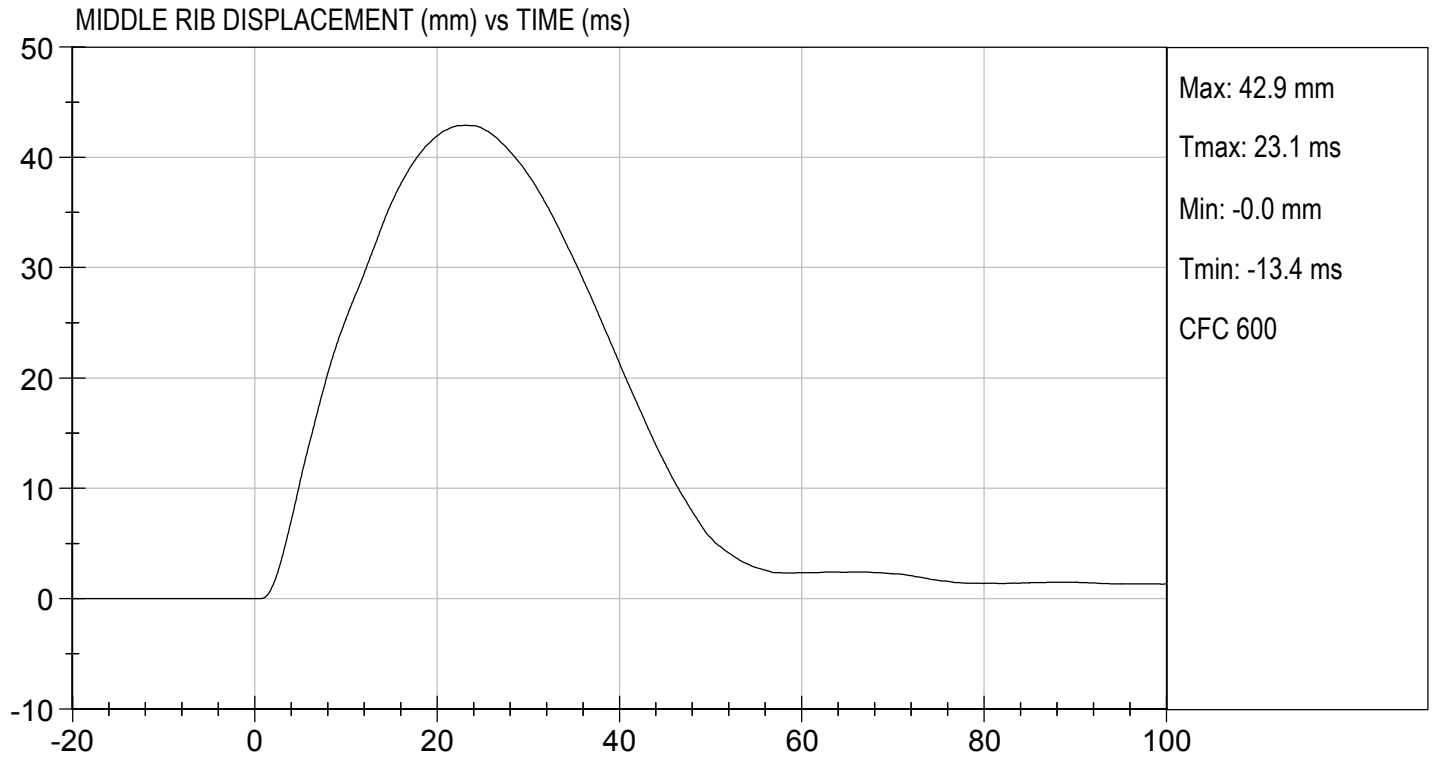

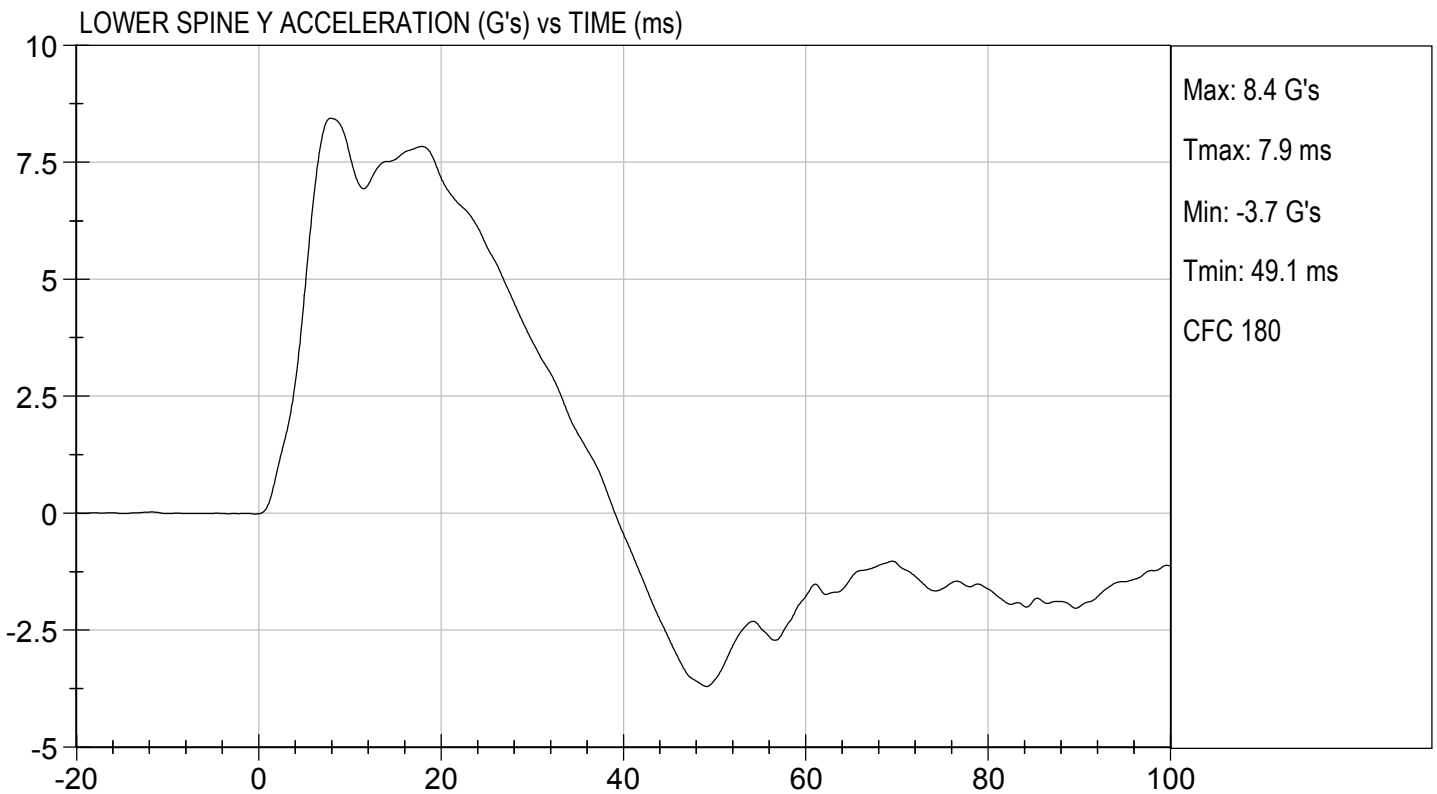
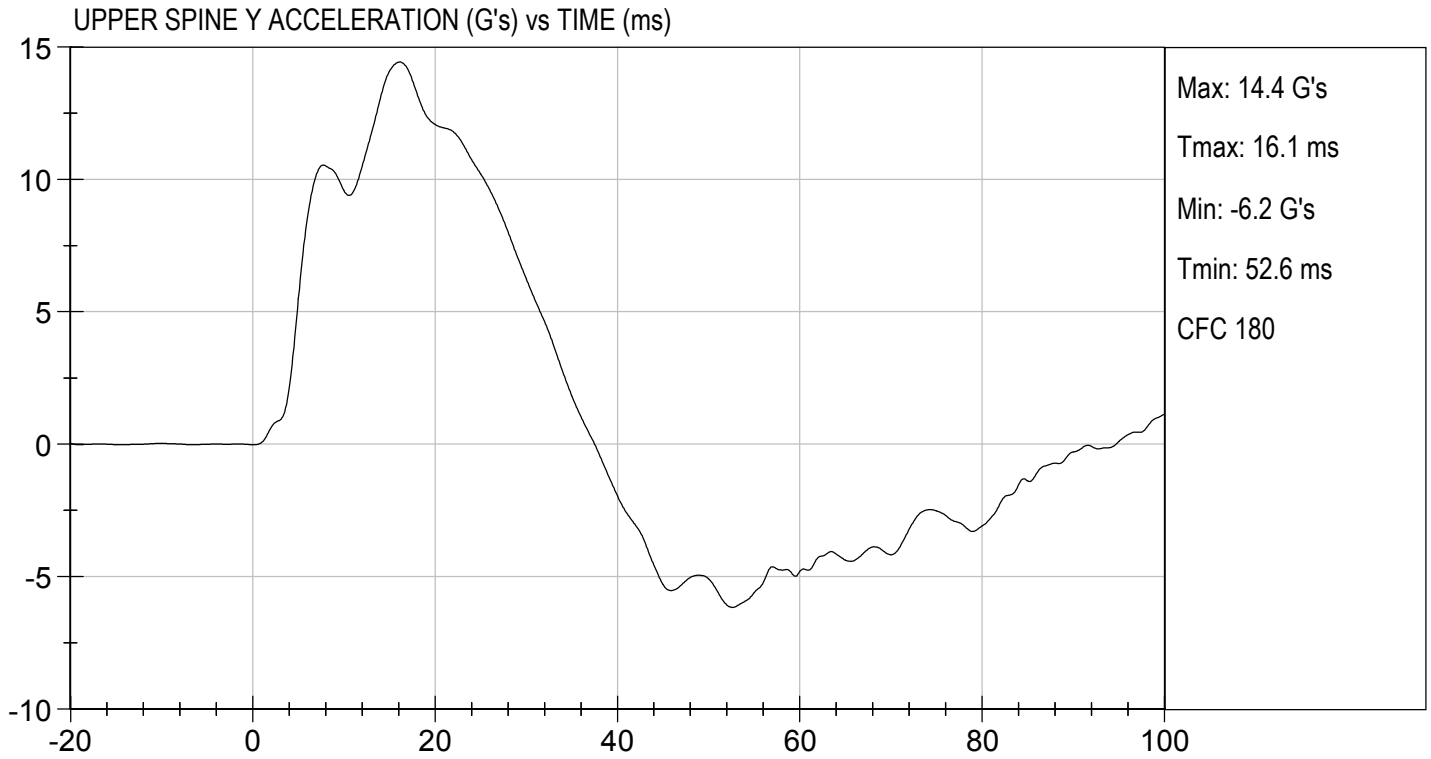

**MGA RESEARCH CORPORATION**  
**ABDOMINAL IMPACT TEST**  
**SID-IIs BUILD LEVEL D DUMMY**

ATD Serial No: 306

Test I.D: D183006

Tested Parameter	Units	Specification	Result	Pass/Fail
Temperature	deg C	20.6 to 22.2	21.8	Pass
Humidity	%	10 to 70	41	Pass
Impact Velocity	m/s	4.20 to 4.40	4.21	Pass
Maximum Probe Acceleration	G's	12 to 16	13	Pass
Upper Abdomen Rib Displacement	mm	36 to 47	43	Pass
Lower Abdomen Rib Displacement	mm	33 to 44	38	Pass
Lower Spine (T12) Y Acceleration	G's	9 to 14	11	Pass
Overall Test Results				Pass

Jacob D Taylor  
 Laboratory Technician

10/05/2018  
 Test Date

B. F. [Signature]  
 Approved By

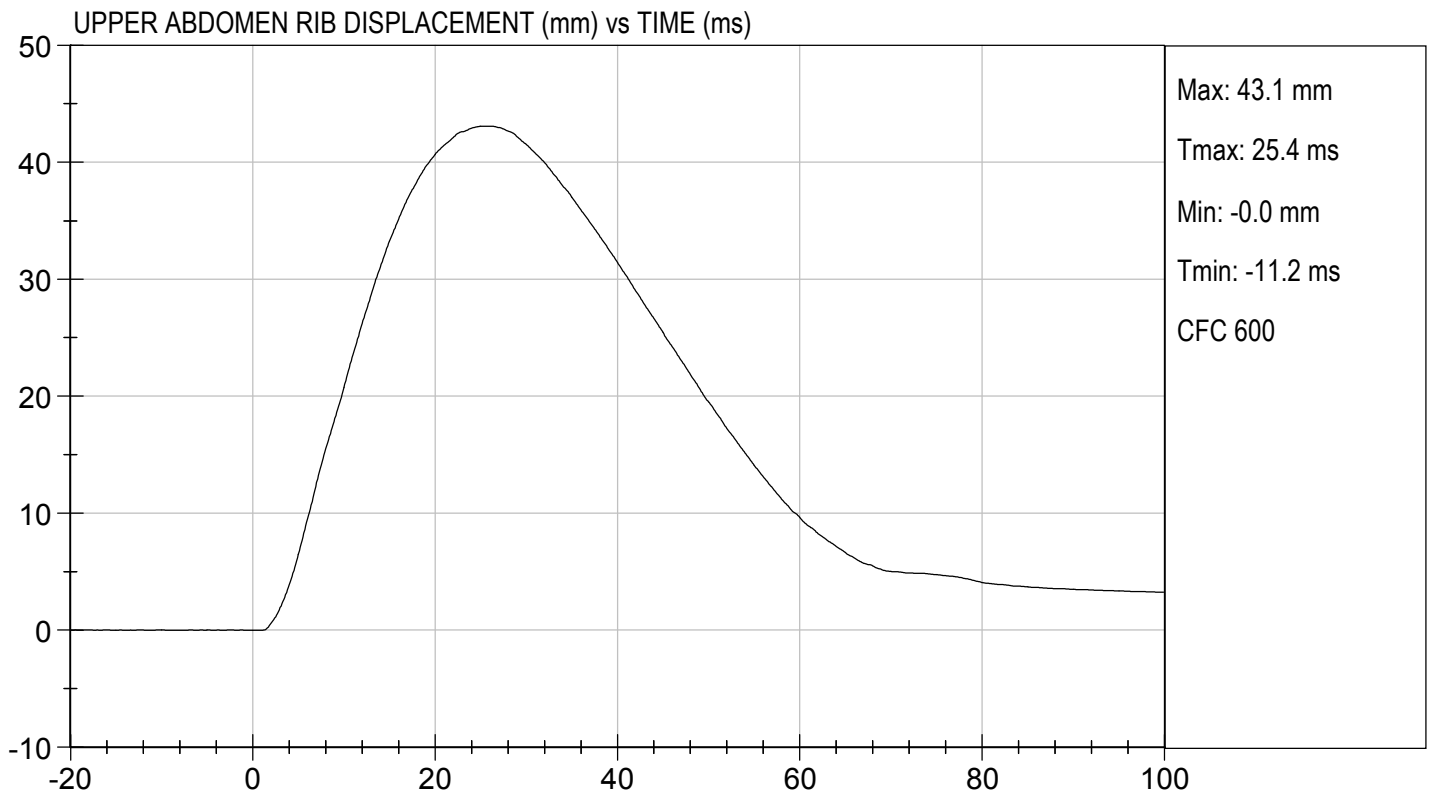
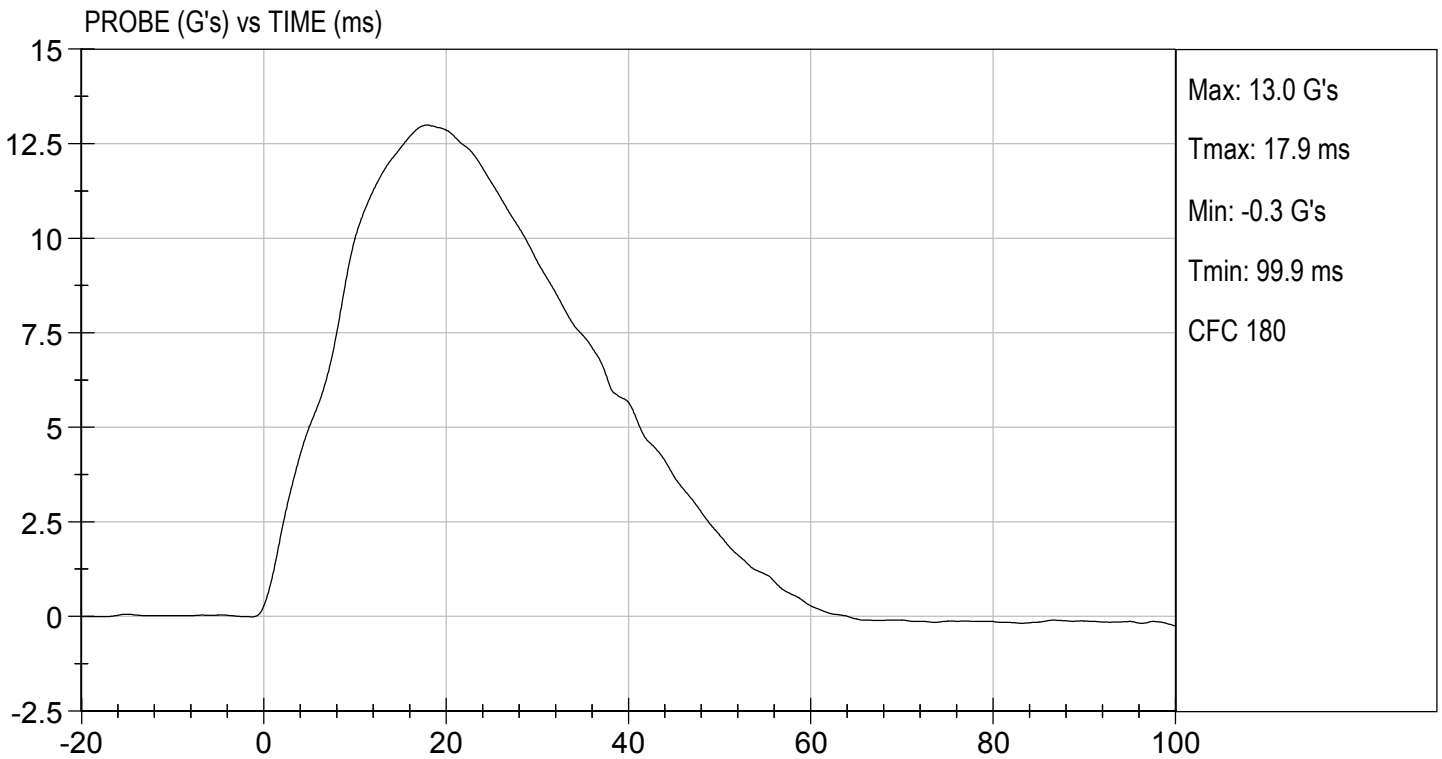

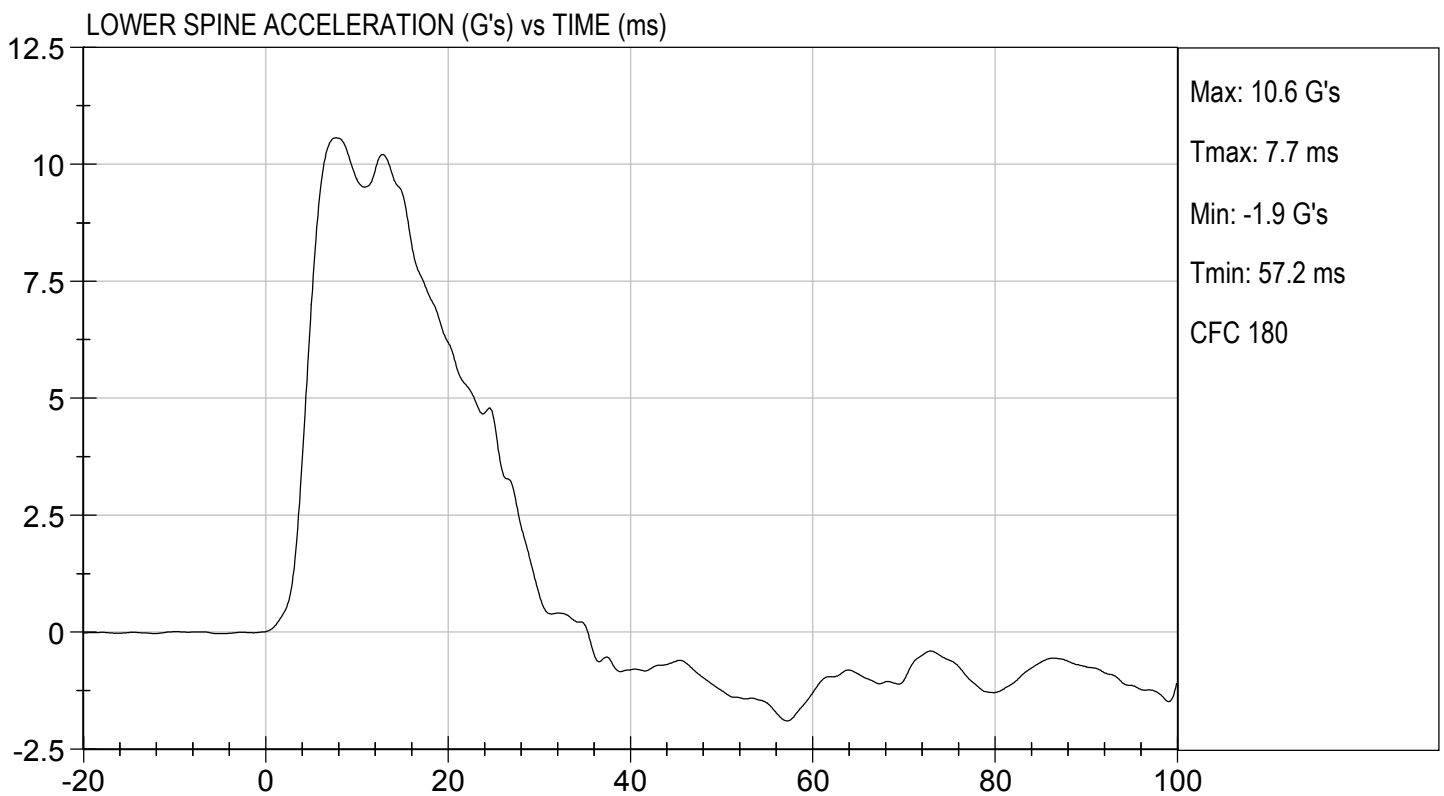
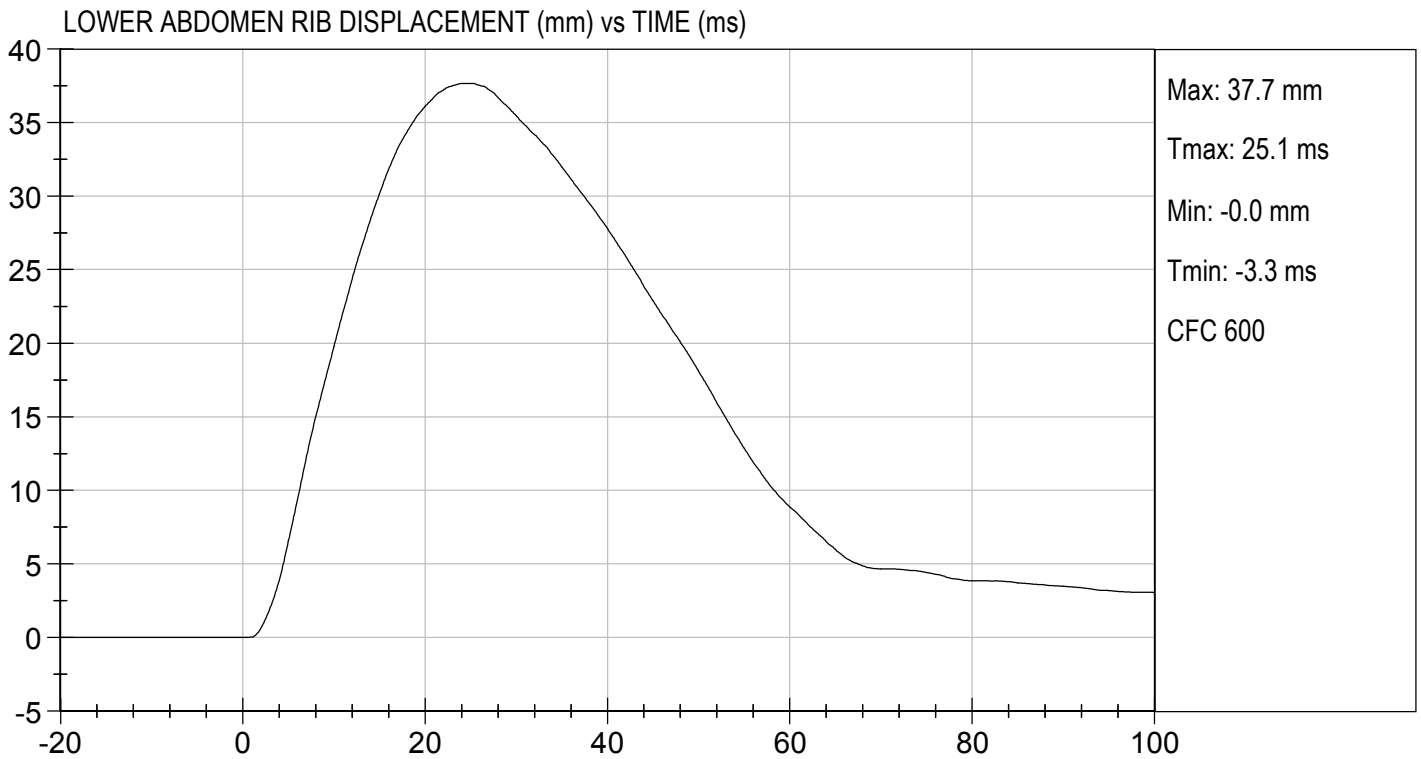

**MGA RESEARCH CORPORATION**  
**PELVIS IMPACT TEST**  
**SID-IIs BUILD LEVEL D DUMMY**

ATD Serial No: 296

Test I.D: D183007

Tested Parameter	Units	Specification	Result	Pass/Fail
Temperature	deg C	20.6 to 22.2	21.8	Pass
Humidity	%	10 to 70	41	Pass
Impact Velocity	m/s	6.60 to 6.80	6.60	Pass
Maximum Probe Acceleration	G's	38 to 47	42	Pass
Pelvis Y Acceleration After 6 ms	G's	34 to 42	40	Pass
Peak Acetabulum Force	N	3600 to 4300	4,055	Pass
Overall Test Results				Pass

Jacob D Taylor  
 Laboratory Technician

10/05/2018  
 Test Date

B. F. H.  
 Approved By

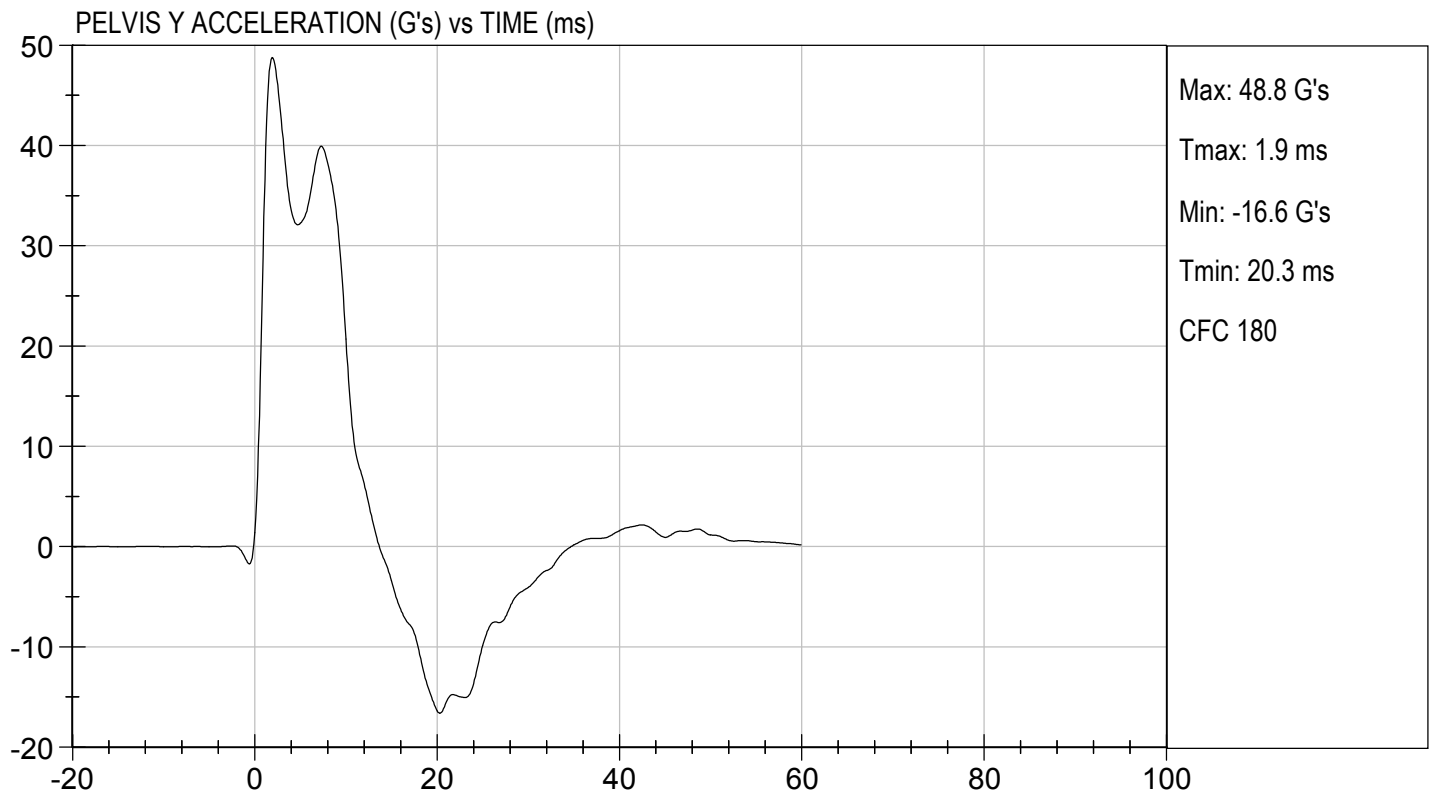
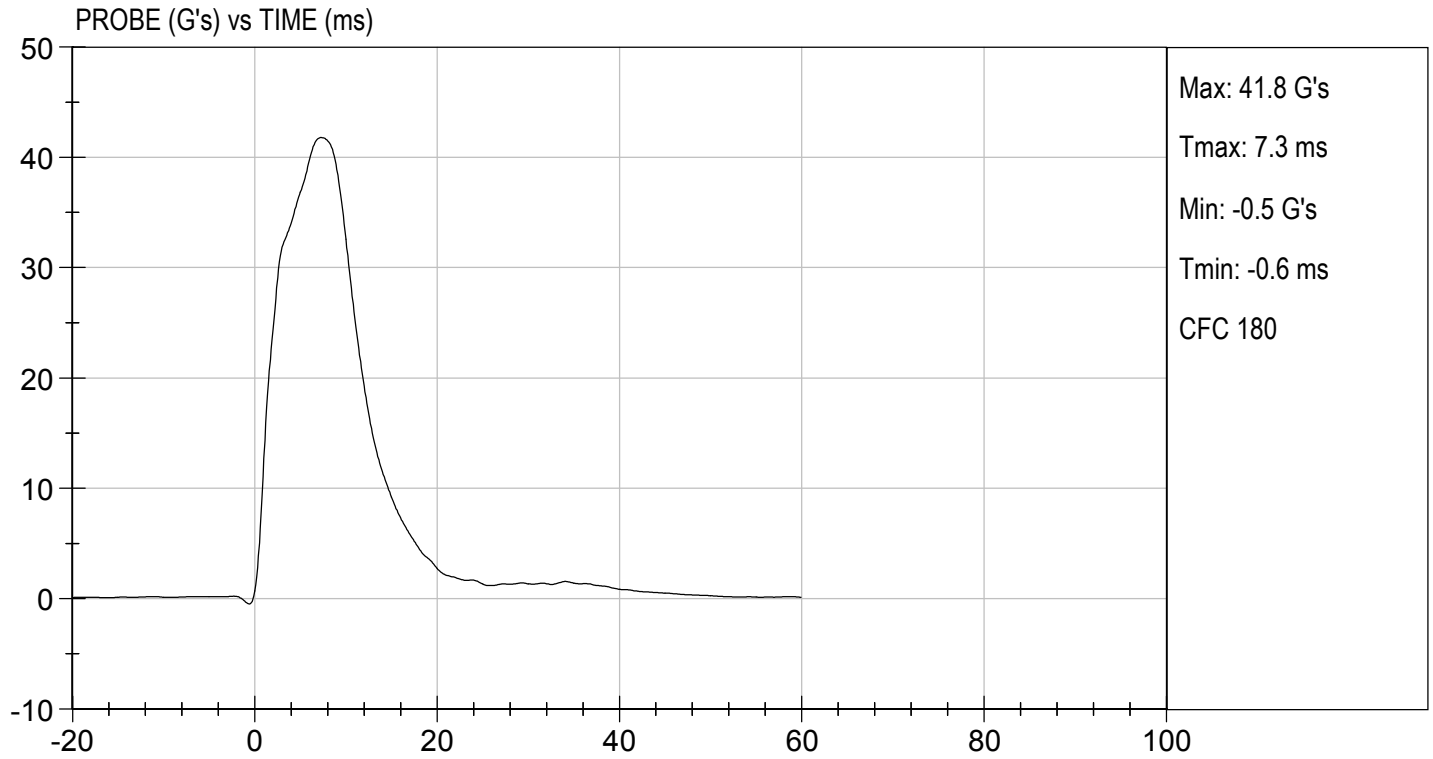

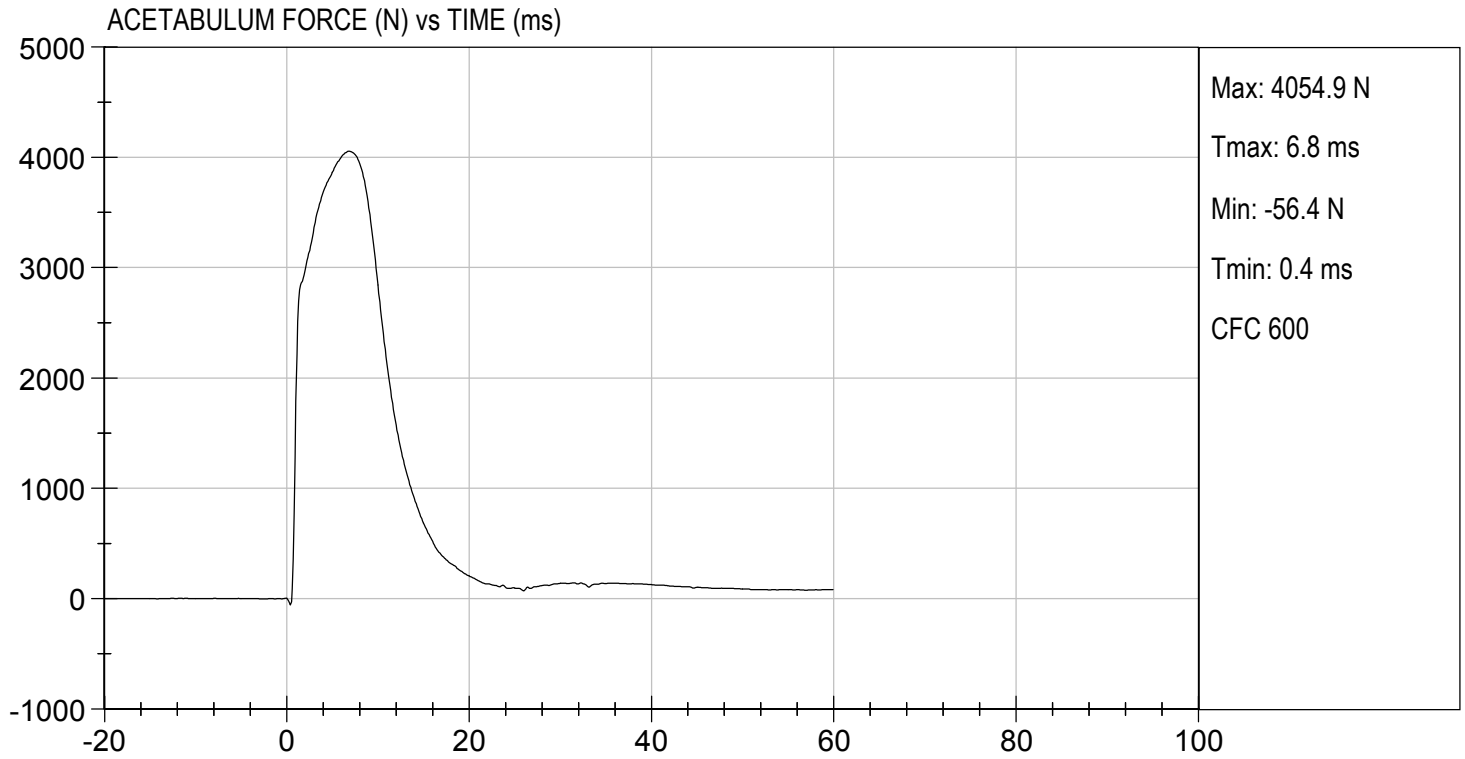

**MGA RESEARCH CORPORATION**  
**ILIAC IMPACT TEST**  
**SID-IIs BUILD LEVEL D DUMMY**

ATD Serial No: 296

Test I.D: D183008

Tested Parameter	Units	Specification	Result	Pass/Fail
Temperature	deg C	20.6 to 22.2	21.8	Pass
Humidity	%	10 to 70	41	Pass
Impact Velocity	m/s	4.20 to 4.40	4.38	Pass
Maximum Probe Acceleration	G's	36 to 45	36	Pass
Pelvis Y Acceleration	G's	28 to 39	28	Pass
Peak Pelvis Iliac Force	N	4100 to 5100	4,155	Pass
Overall Test Results				Pass

Jacob D Taylor  
 Laboratory Technician

10/05/2018  
 Test Date

B. F. H.  
 Approved By

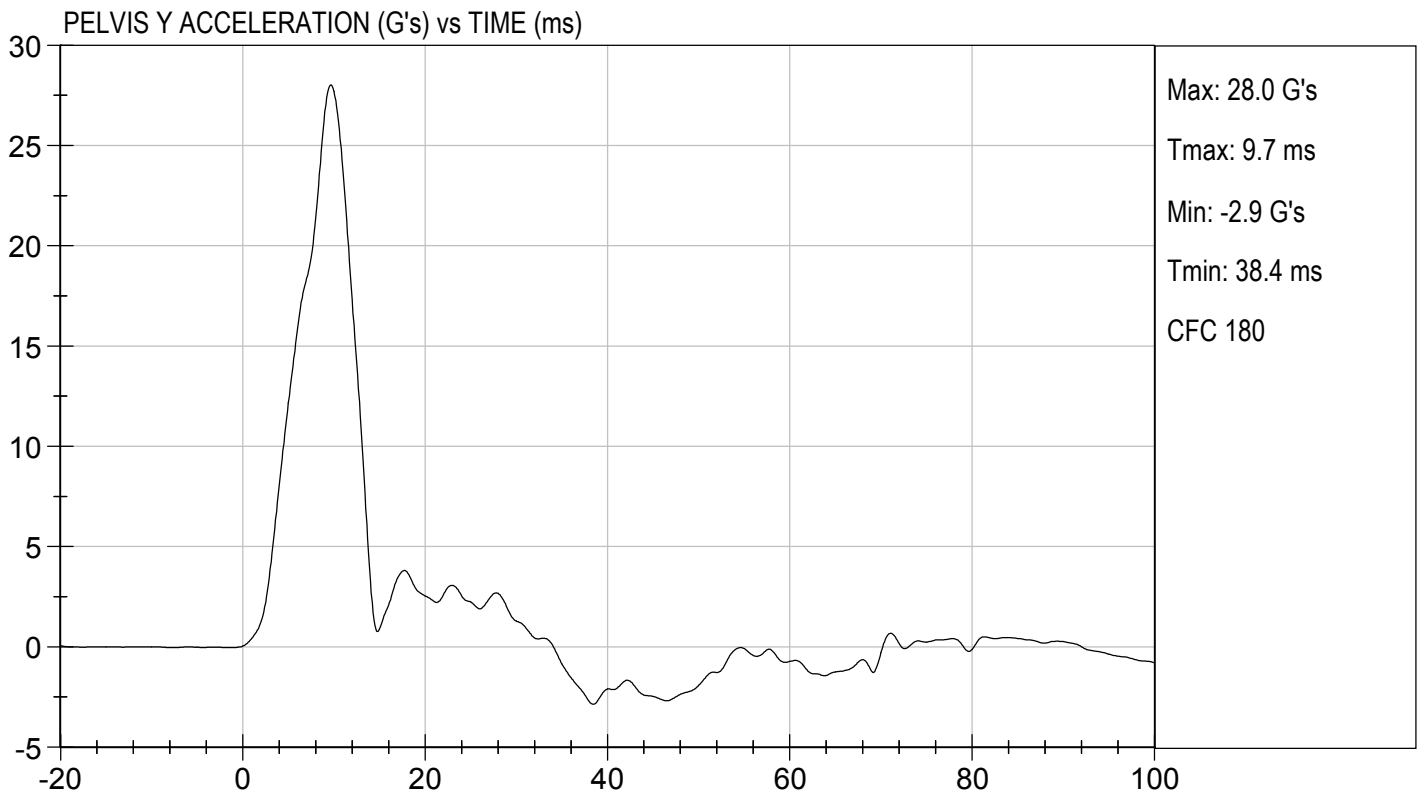
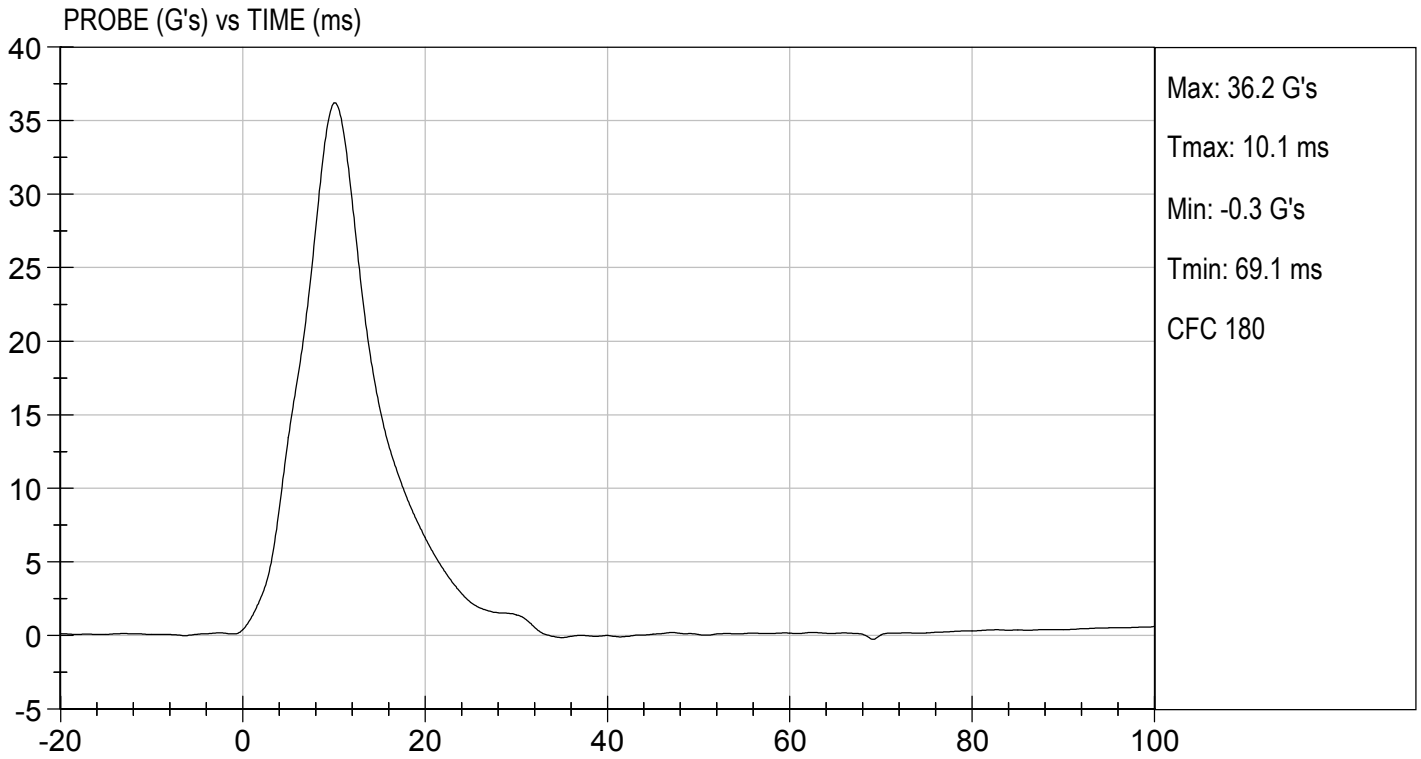



TEST DESC: ILLIAC  
VELOCITY: 14.37 ft/s, 4.38 m/s

TEST DATE: 10/05/2018  
TEST #: D183008

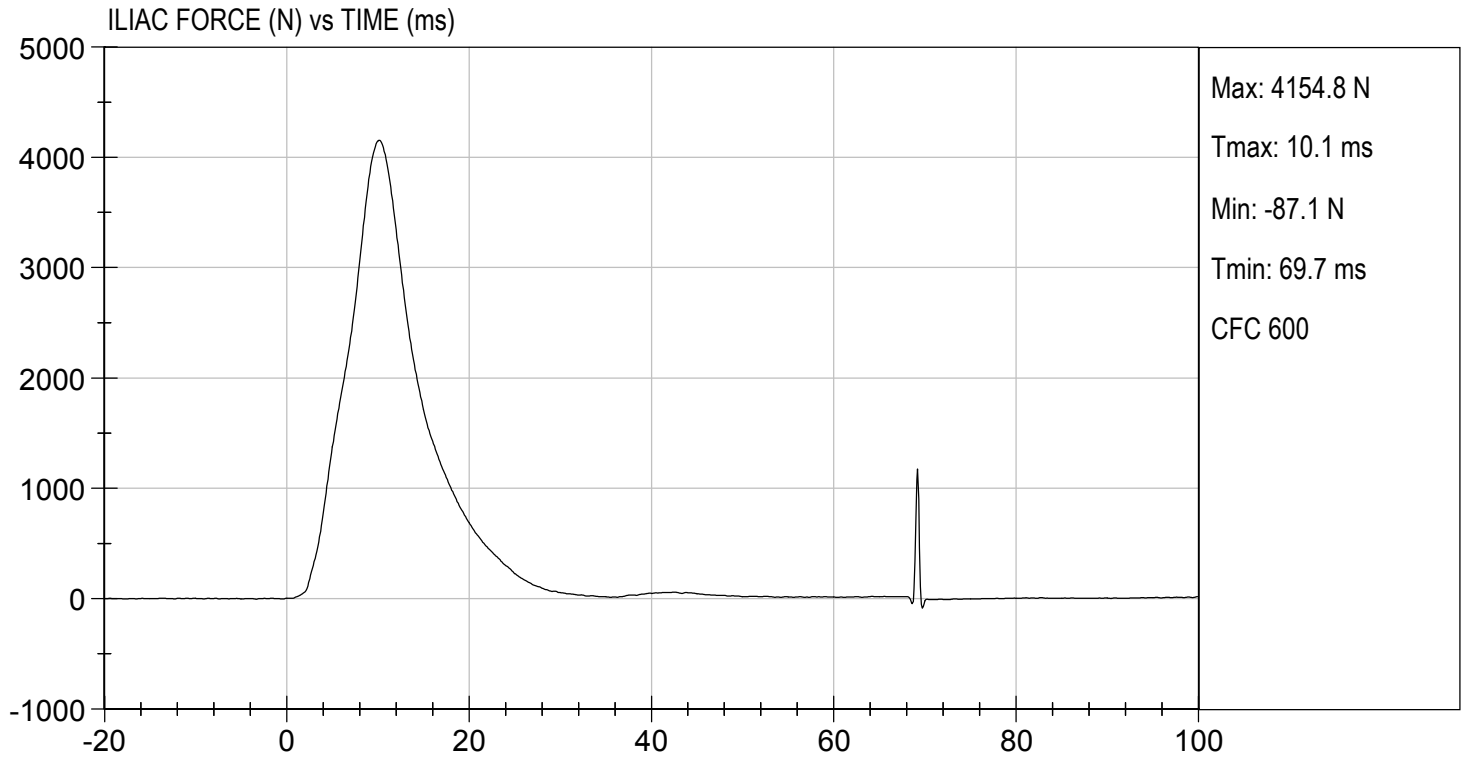

**CALIBRATION TEST RESULTS**

**POST-TEST**

**SID-IIS 5<sup>TH</sup> PERCENTILE FEMALE - DRIVER ATD**

**SID-IIsD External Measurements**  
**SN: 296**

<b>No.</b>	<b>Name</b>	<b>Spec. (mm)</b>	<b>Result</b>	<b>Pass/Fail</b>
<b>A</b>	Sitting Height	772 - 788	784	Pass
<b>B</b>	Shoulder Pivot Height	437 - 453	442	Pass
<b>C</b>	H-point Height	79 - 89	83	Pass
<b>D</b>	H-point from Seatback	141 - 151	145	Pass
<b>E</b>	Shoulder Pivot from Backline	97 - 107	99	Pass
<b>F</b>	Thigh Clearance	119 - 135	121	Pass
<b>G</b>	Head Breadth	140 - 148	142	Pass
<b>H</b>	Head Back from Backline	40 - 46	45	Pass
<b>I</b>	Head Depth	178 - 188	180	Pass
<b>J</b>	Head Circumference	541 - 551	548	Pass
<b>K</b>	Buttock to Knee Length	514 - 540	535	Pass
<b>L</b>	Popliteal Height	343 - 369	358	Pass
<b>M</b>	Knee Pivot to Floor Height	392 - 409	404	Pass
<b>N</b>	Buttock Popliteal Length	416 - 442	435	Pass
<b>O</b>	Chest Depth w/o Jacket	195 - 211	206	Pass
<b>P</b>	Foot Length	216 - 232	219	Pass
<b>Q</b>	Hip Breadth (w/ pelvic plugs)	313 - 323	316	Pass
<b>R</b>	Arm Length	249 - 259	250	Pass
<b>S</b>	Knee Joint to Seatback	477 - 493	481	Pass
<b>V</b>	Shoulder Width	341 - 357	346	Pass
<b>W</b>	Foot Width	78 - 94	85	Pass
<b>Y</b>	Chest Circumference w/ jacket	851 - 881	870	Pass
<b>Z</b>	Waist Circumference	761 - 791	772	Pass

**MGA RESEARCH CORPORATION**  
**HEAD DROP TEST**  
**SID-IIs BUILD LEVEL D DUMMY**

ATD Serial No: 296

Test ID: D183321

Tested Parameter	Units	Specification	Result	Pass/Fail
Laboratory Temperature	deg C	20.6 to 22.2	21.2	Pass
Laboratory Relative Humidity	%	10 to 70	32	Pass
Peak Resultant Acceleration	G's	115 to 137	133	Pass
Peak Longitudinal Acceleration	G's	+/- 15	7.5	Pass
Unimodal	N/A	Yes	Yes	Pass
Oscillations	N/A	<15%	Yes	Pass
Overall Test Results				Pass

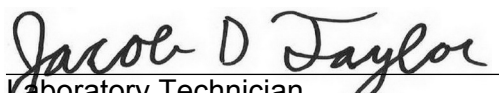
  
 Laboratory Technician

11/02/2018

Test Date

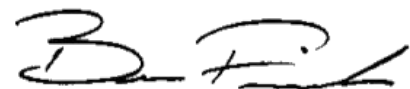
  
 Approved By

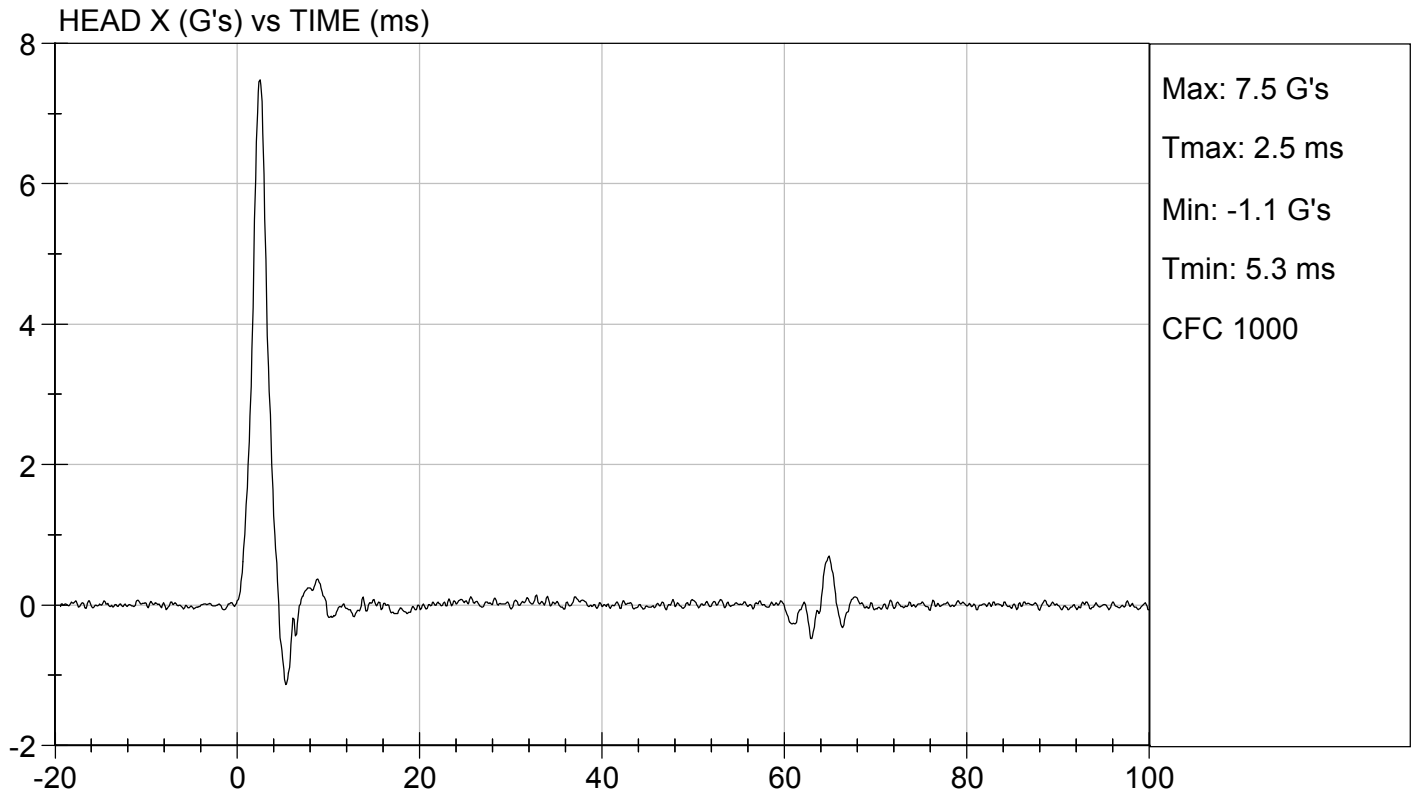
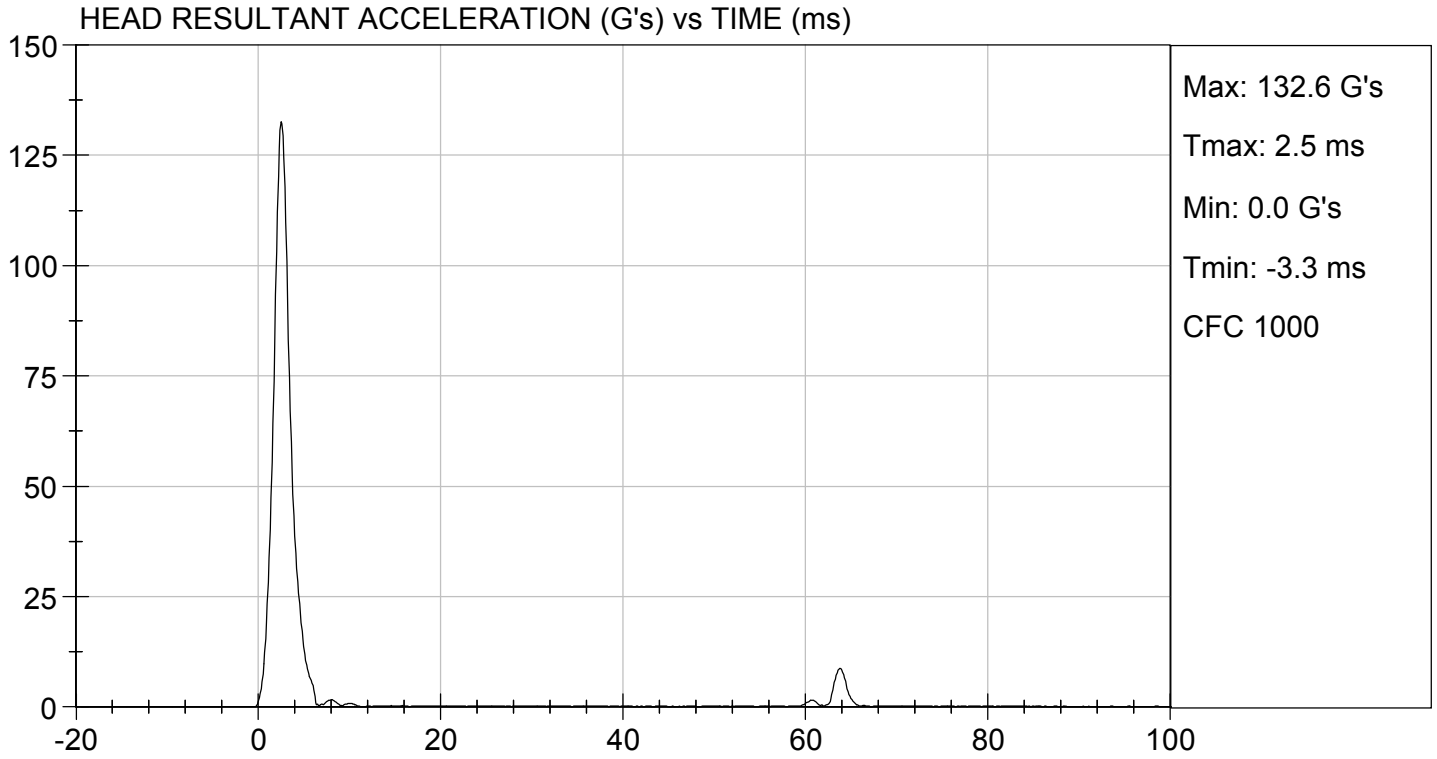

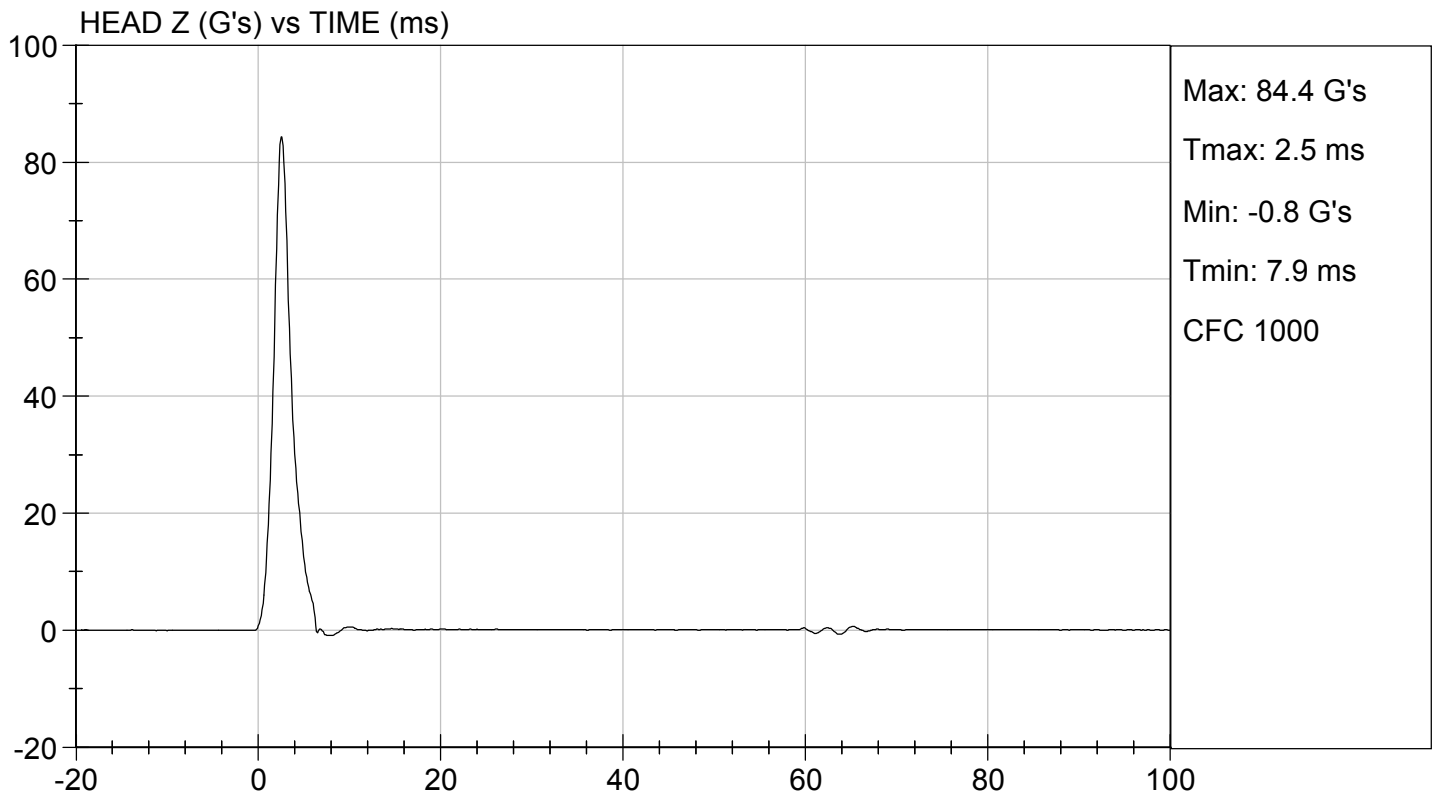
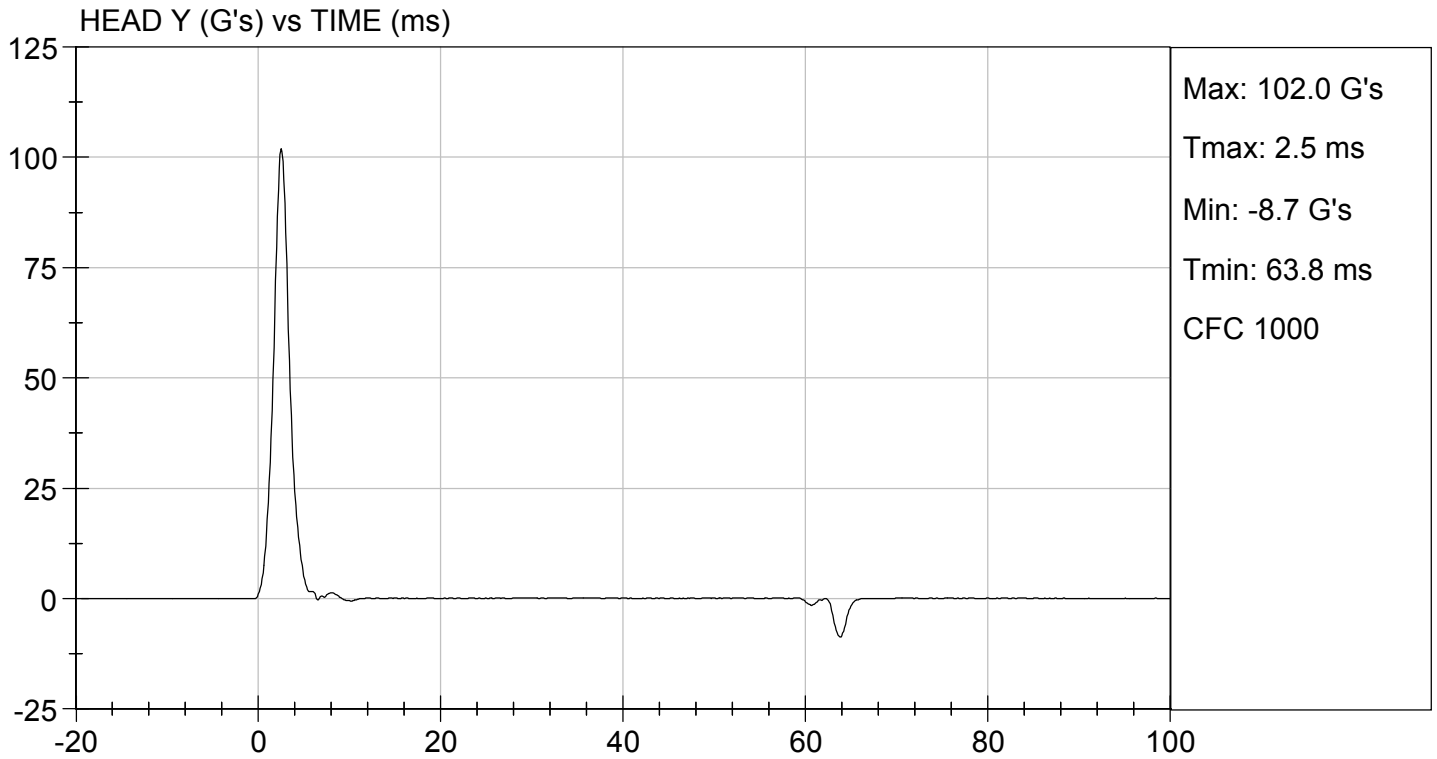

**MGA RESEARCH CORPORATION  
LATERAL NECK PENDULUM TEST  
SID-IIs BUILD LEVEL D DUMMY**

ATD Serial No: 296

Test I.D.: D183322

Tested Parameter	Units	Specification	Result	Pass/Fail	
Temperature	deg C	20.6 to 22.2	21.2	Pass	
Humidity	%	10 to 70	32	Pass	
Impact Velocity	m/s	5.51 to 5.63	5.58	Pass	
Pendulum Velocity	10 ms	m/s	2.20 to 2.80	2.64	Pass
	15 ms	m/s	3.30 to 4.10	3.91	Pass
	20 ms	m/s	4.40 to 5.40	5.38	Pass
	25 ms	m/s	5.40 to 6.10	5.72	Pass
	25-100 ms	m/s	5.50 to 6.20	5.74	Pass
Maximum D-Plane Rotation	deg	71 to 81	72	Pass	
Time of Maximum D-Plane Rotation	ms	50 to 70	60	Pass	
Maximum Occipital Condyle Moment	Nm	-44 to -36	-43	Pass	
Time of Moment Decay to 0 Nm	ms	102 to 126	104	Pass	
<b>Overall Test Results</b>				<b>Pass</b>	

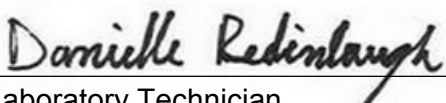
  
Laboratory Technician

11/02/2018

Test Date

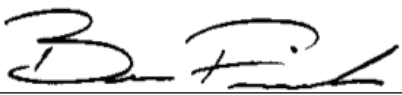
  
Approved By

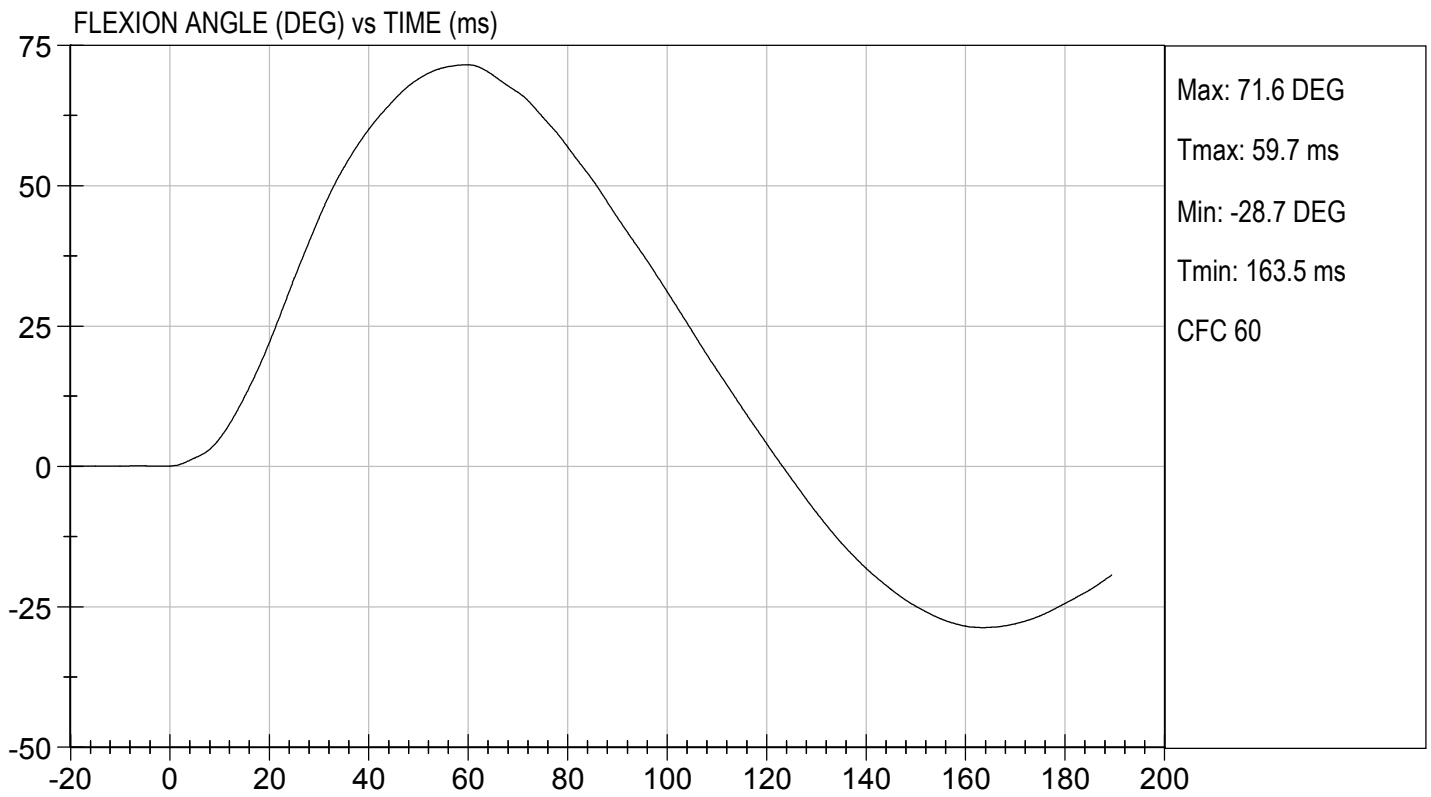
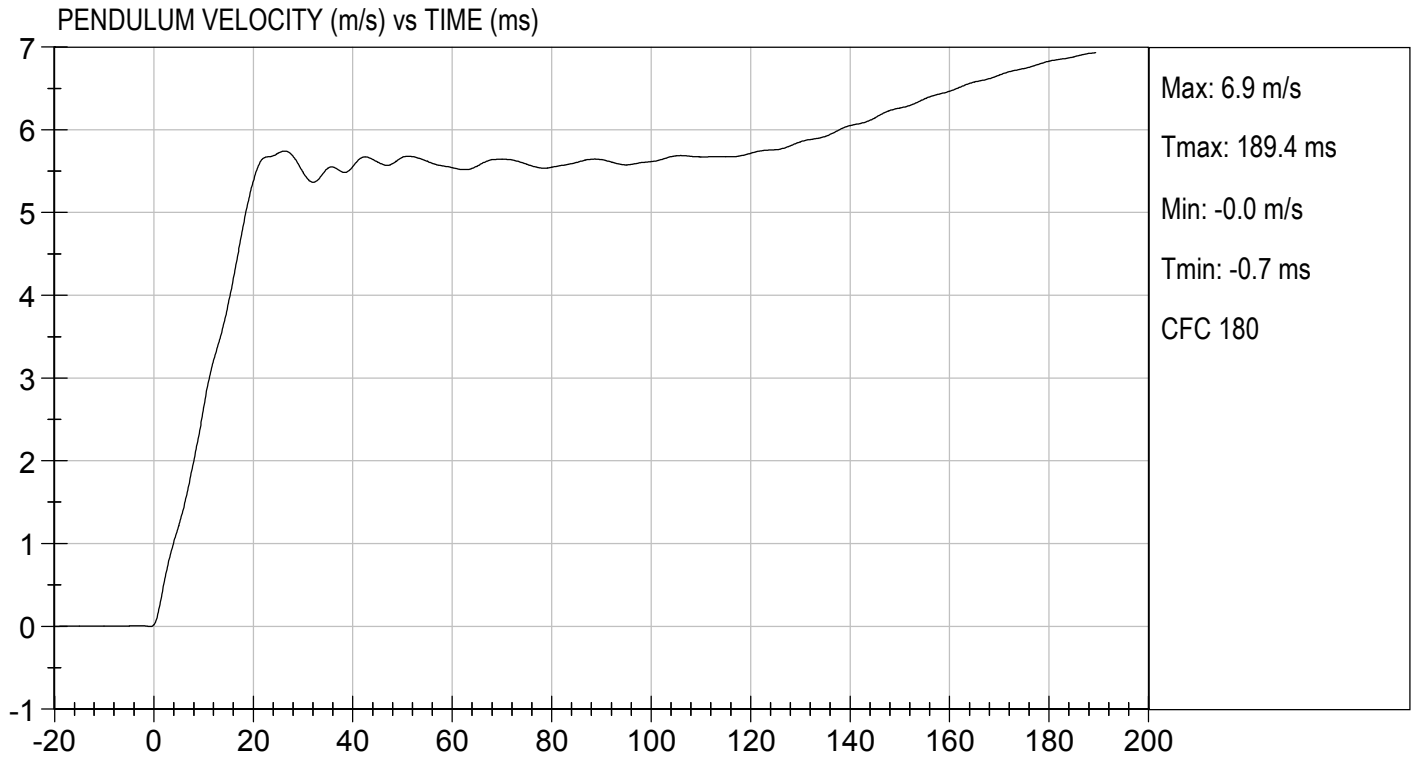

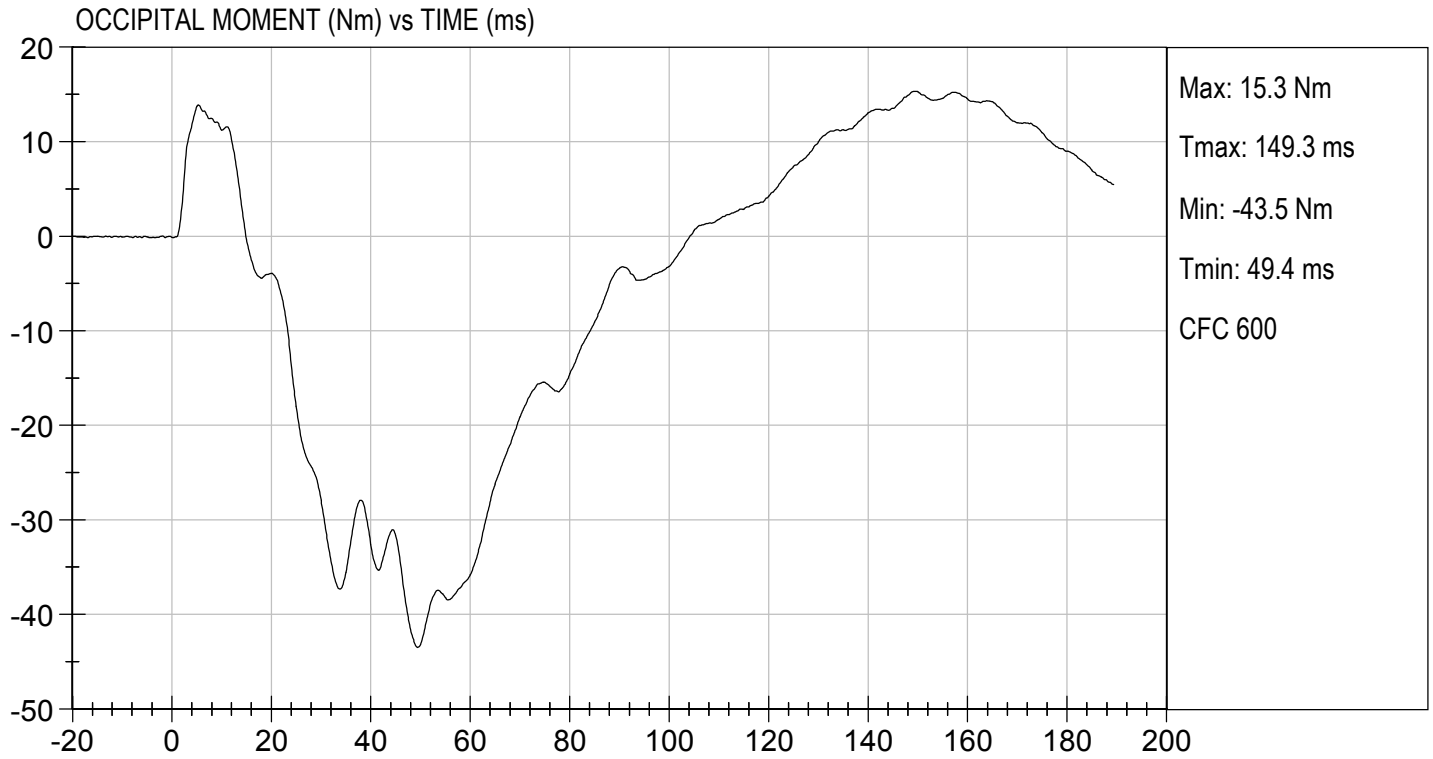

**MGA RESEARCH CORPORATION**  
**SHOULDER IMPACT TEST**  
**SID-IIs BUILD LEVEL D DUMMY**

ATD Serial No: 296

Test ID: D183323

Tested Parameter	Units	Specification	Result	Pass/Fail
Laboratory Temperature	deg C	20.6 to 22.2	21	Pass
Laboratory Relative Humidity	%	10 to 70	40	Pass
Impact Velocity	m/s	4.20 to 4.40	4.38	Pass
Maximum Probe Acceleration	G's	13 to 18	15	Pass
Shoulder Displacement	mm	28 to 37	29	Pass
Upper Spine (T1) Y Acceleration	G's	17 to 22	21	Pass
Overall Test Results				Pass

*Jacob D Taylor*  
 Laboratory Technician

11/06/2018

Test Date

*B. F. H.*

Approved By

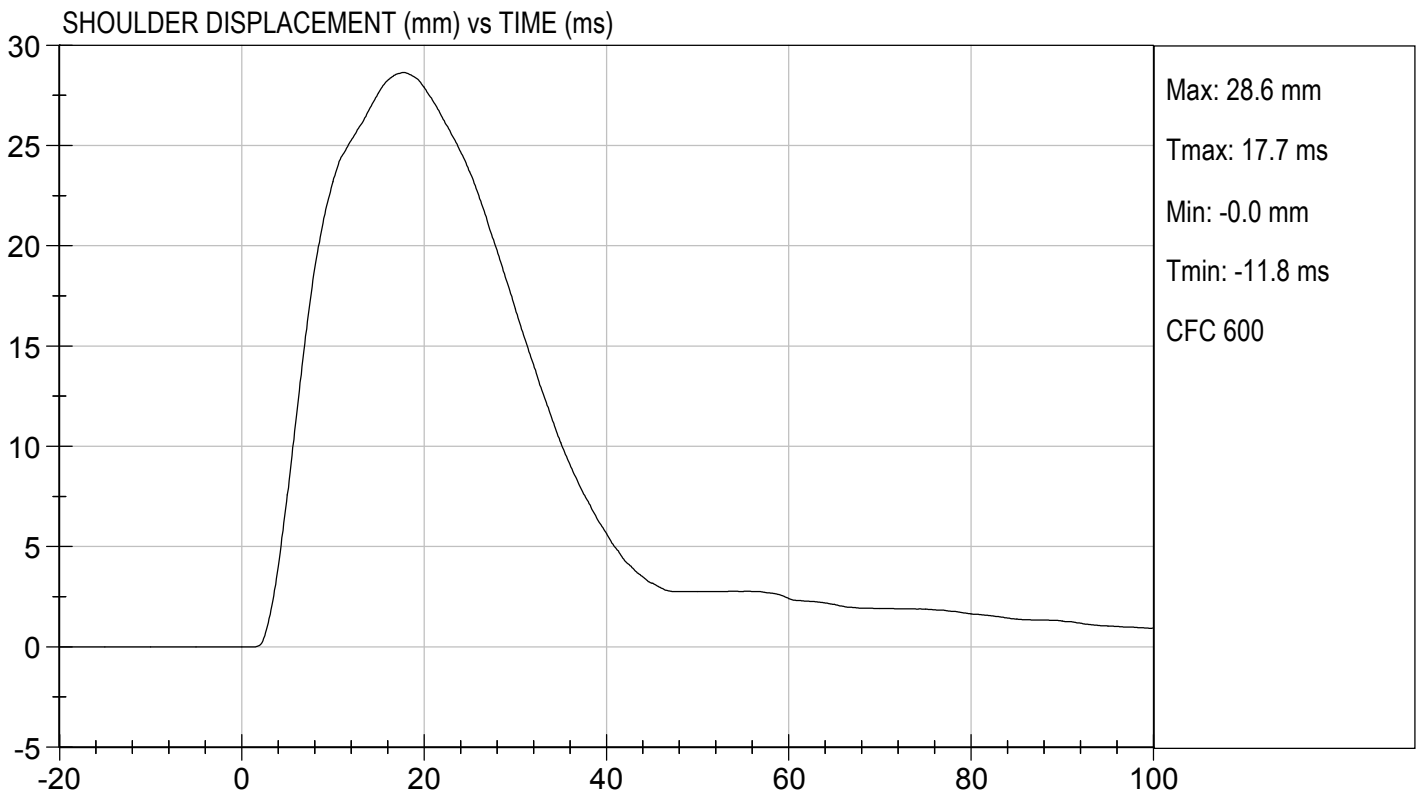
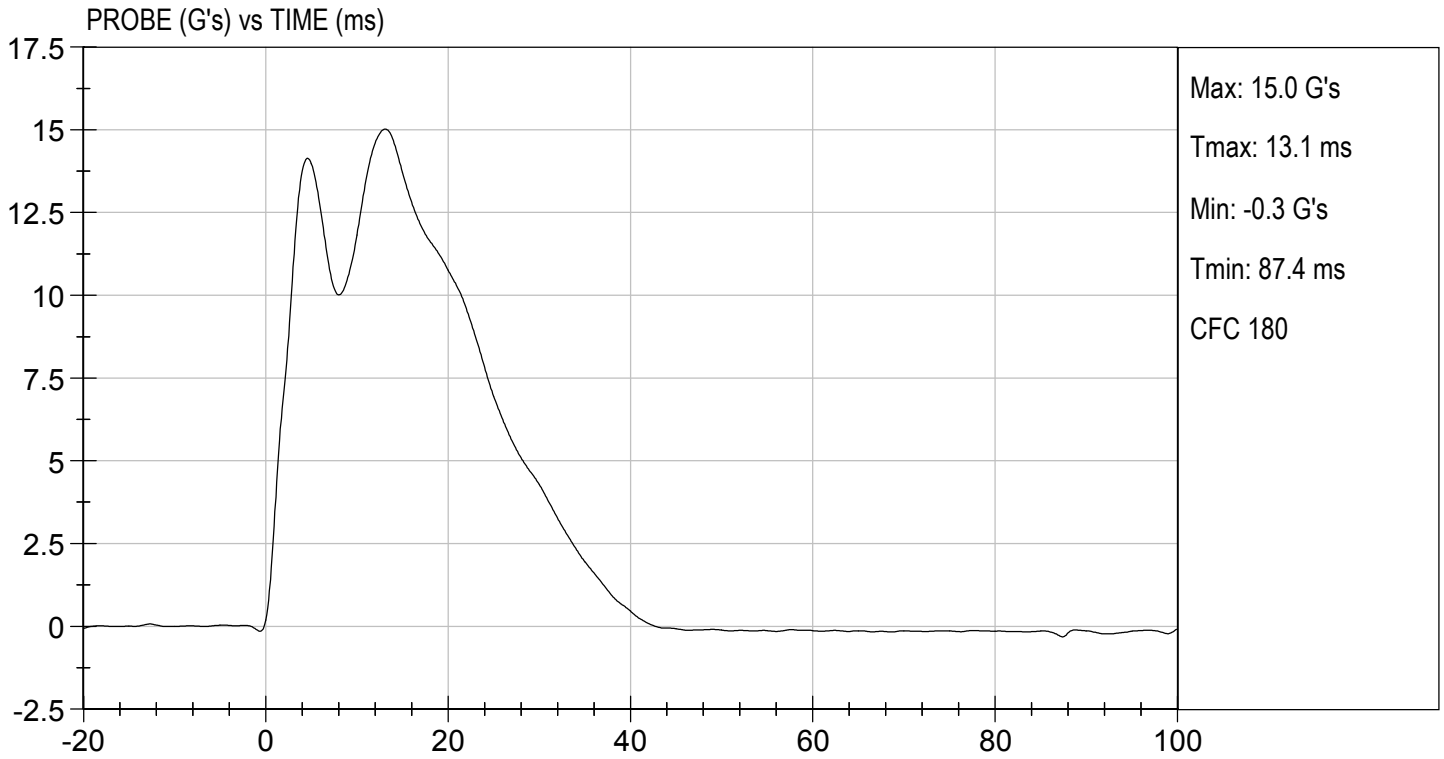

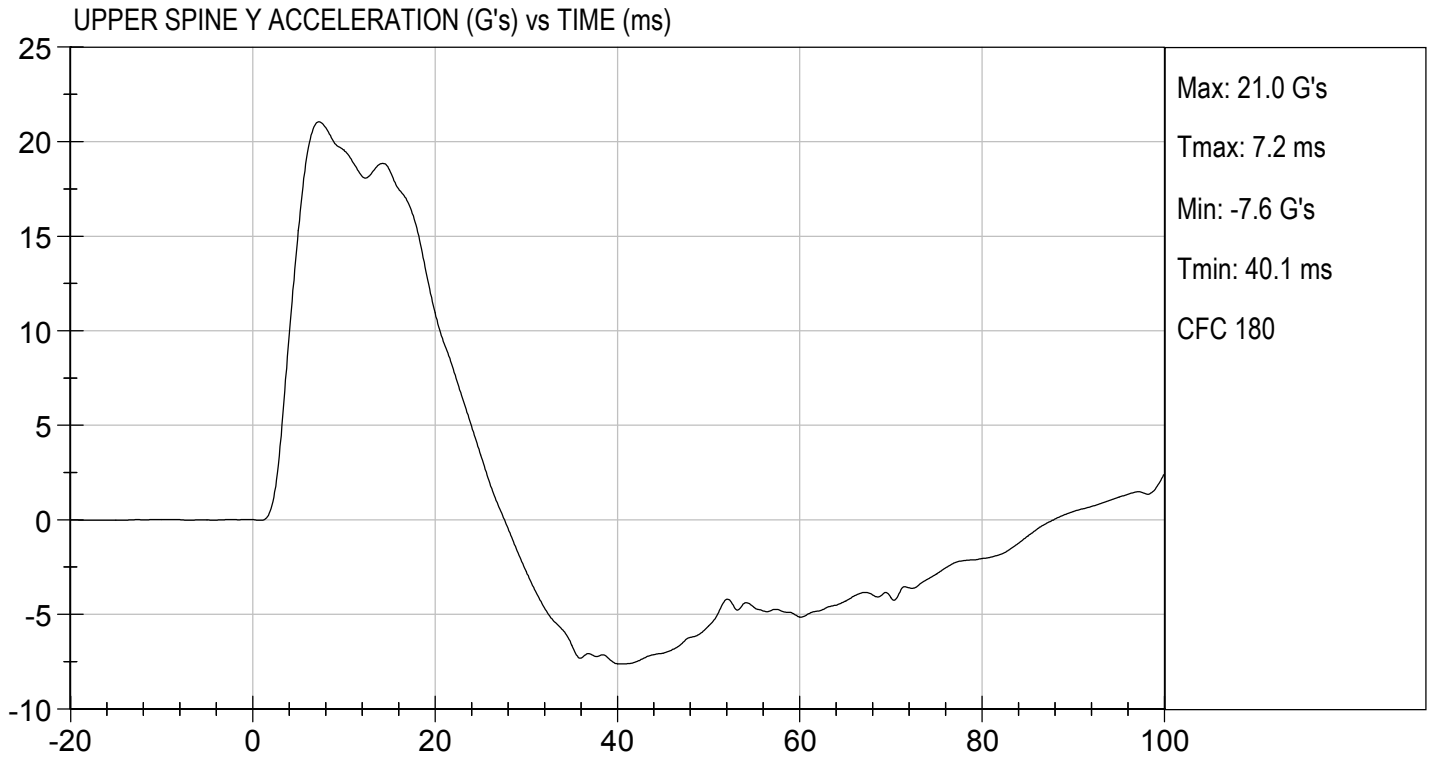

**MGA RESEARCH CORPORATION  
THORAX (WITH ARM) IMPACT TEST  
SID-IIs BUILD LEVEL D DUMMY**

ATD Serial No: 296

Test I.D: D183324

Tested Parameter	Units	Specification	Result	Pass/Fail
Temperature	deg C	20.6 to 22.2	21	Pass
Humidity	%	10 to 70	40	Pass
Impact Velocity	m/s	6.60 to 6.80	6.77	Pass
Maximum Probe Acceleration	G's	30 to 36	33	Pass
Shoulder Displacement	mm	31 to 40	32	Pass
Upper Rib Displacement	mm	25 to 32	26	Pass
Middle Rib Displacement	mm	30 to 36	31	Pass
Lower Rib Displacement	mm	32 to 38	33	Pass
Upper Spine (T1) Y Acceleration	G's	34 to 43	41	Pass
Lower Spine (T12) Y Acceleration	G's	29 to 37	33	Pass
Overall Test Results				Pass

  
Laboratory Technician

11/06/2018

Test Date

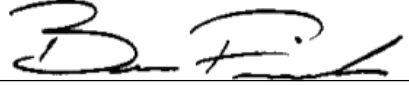
  
Approved By

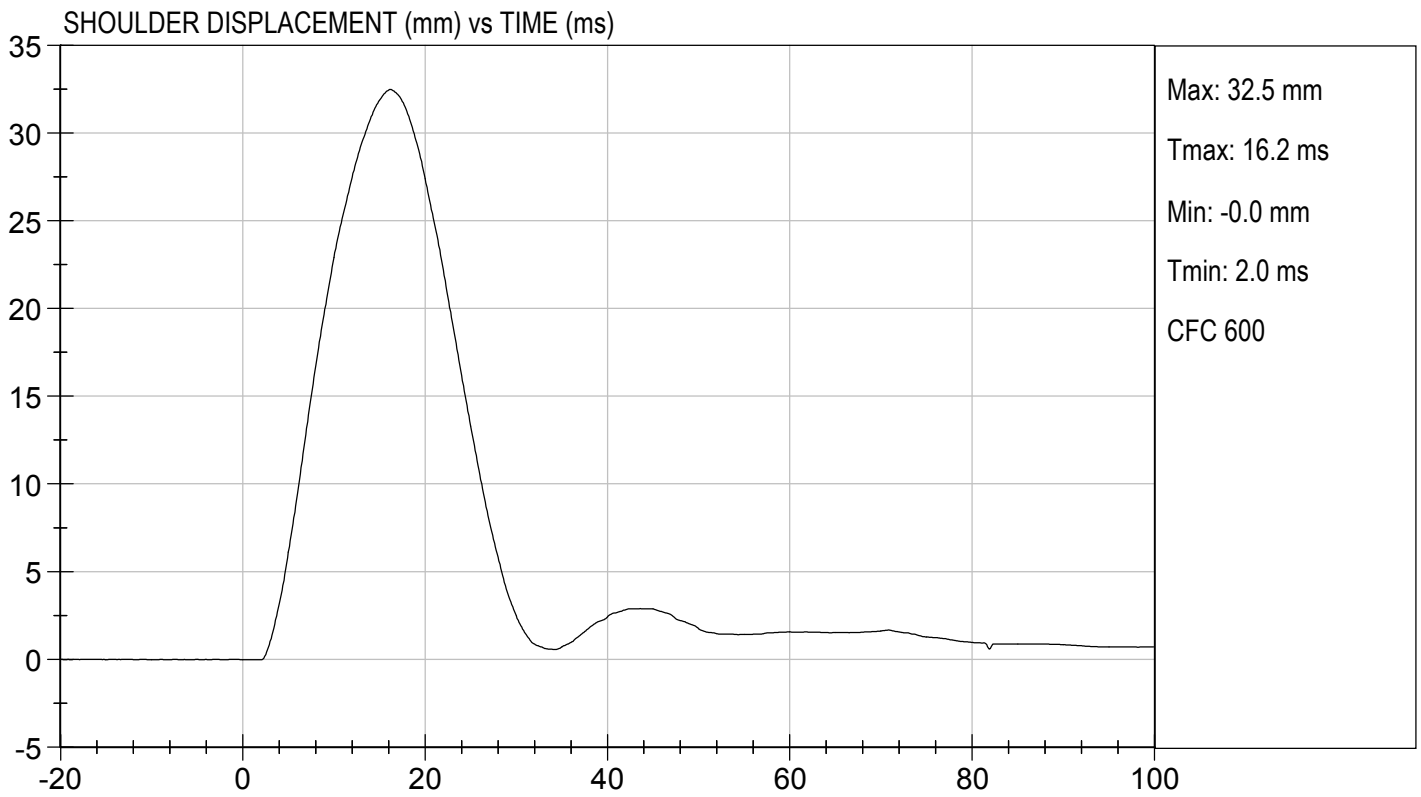
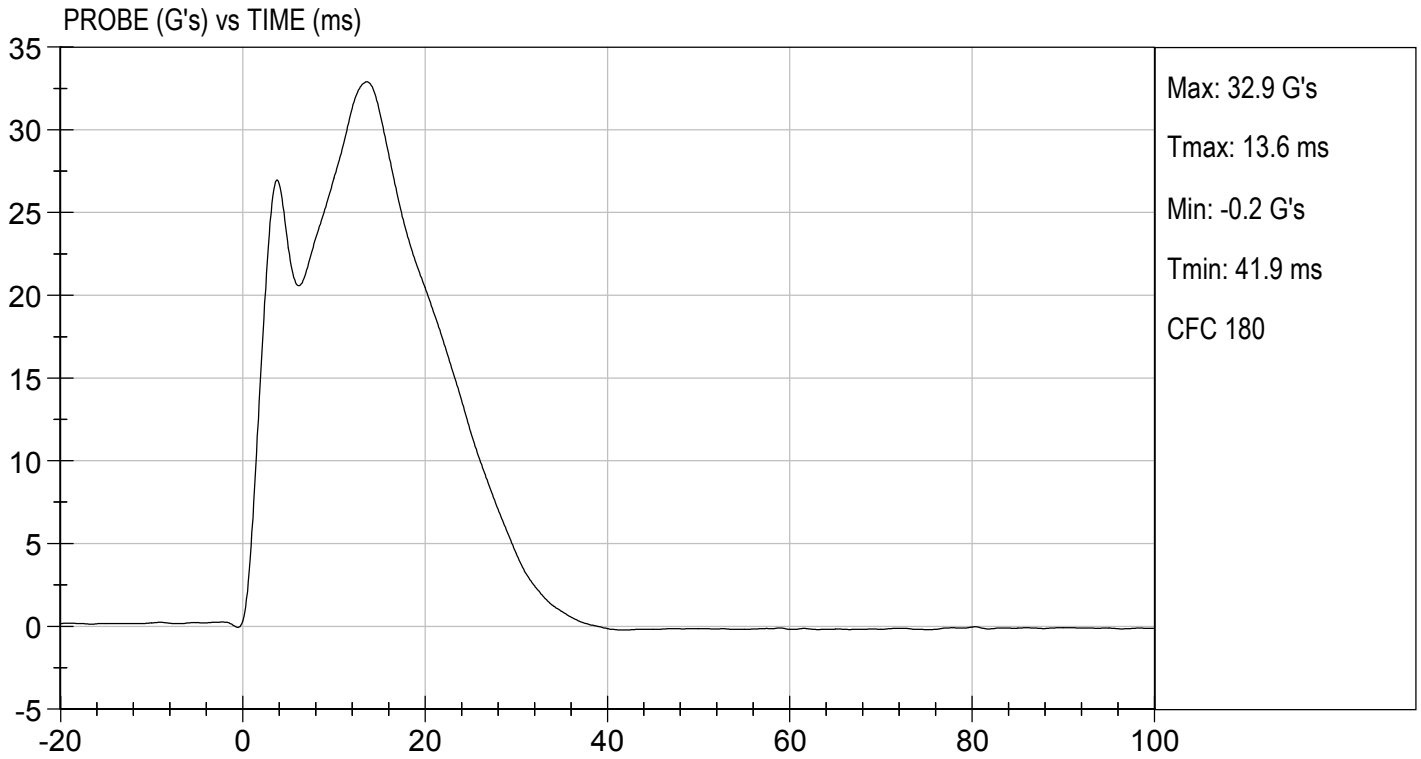

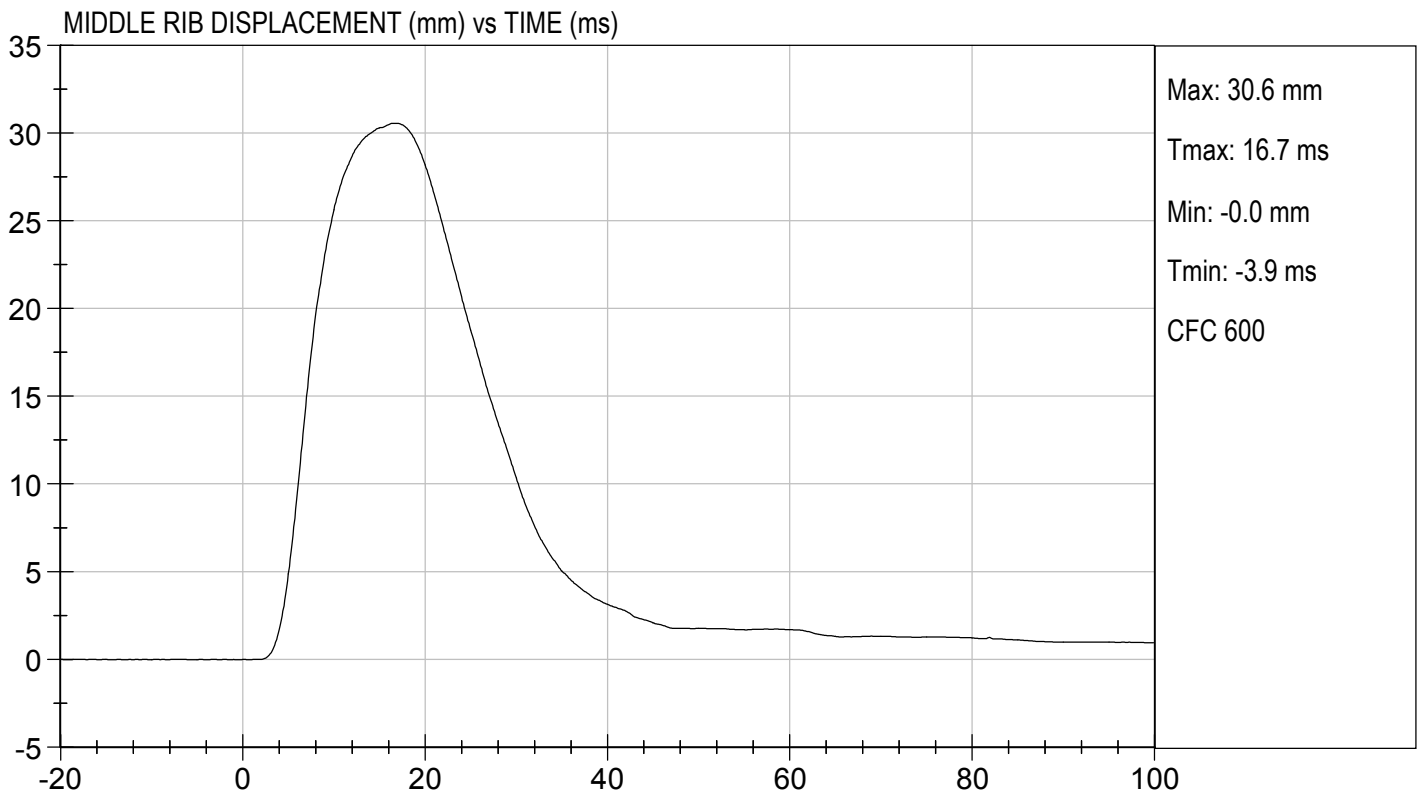
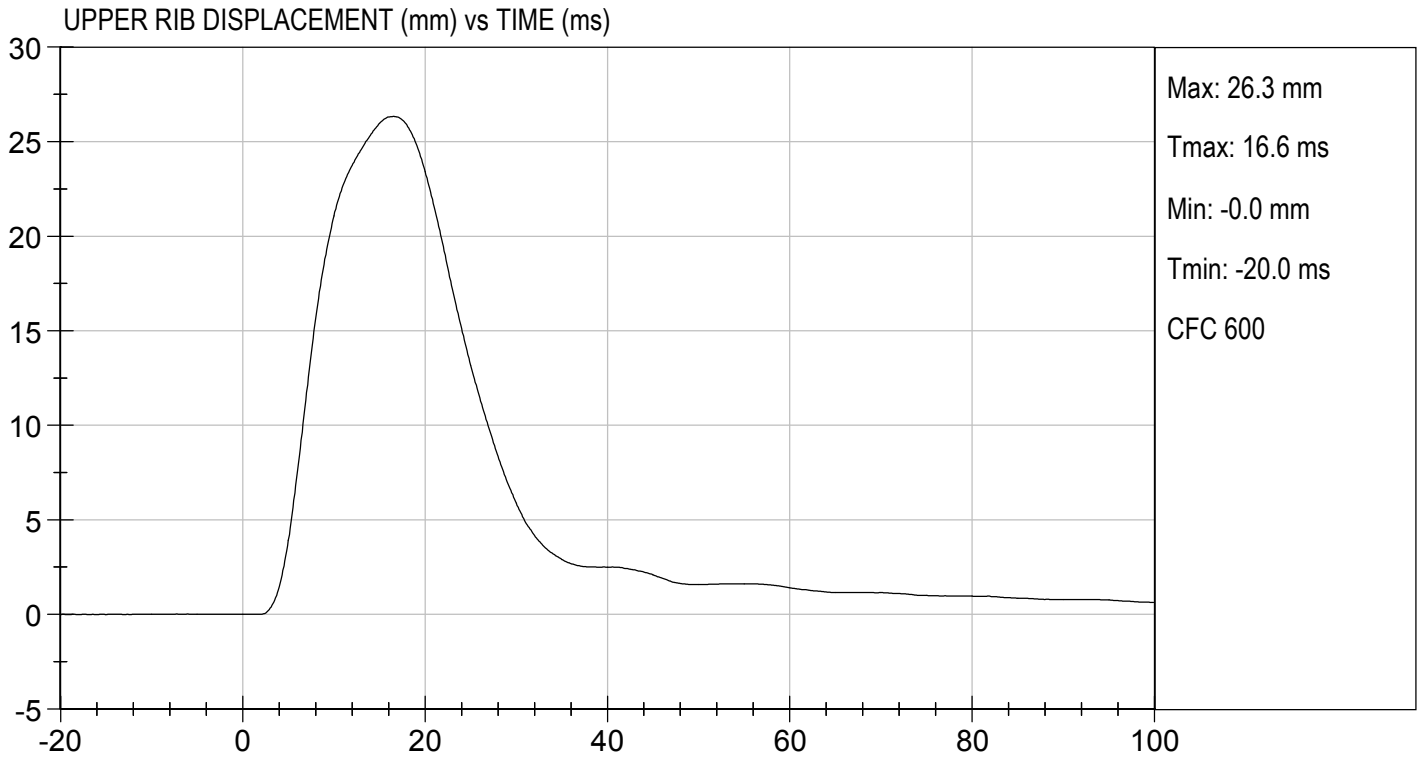

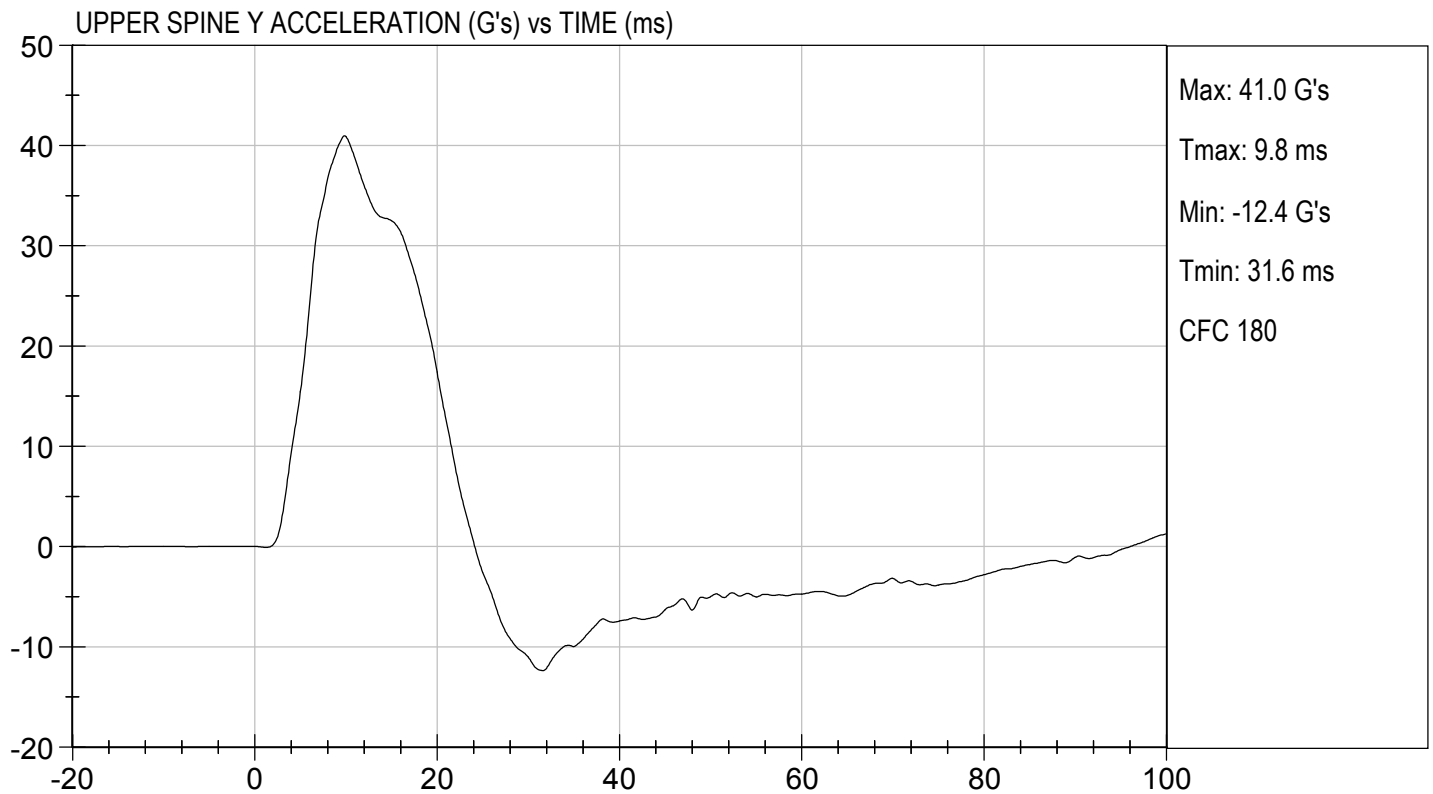
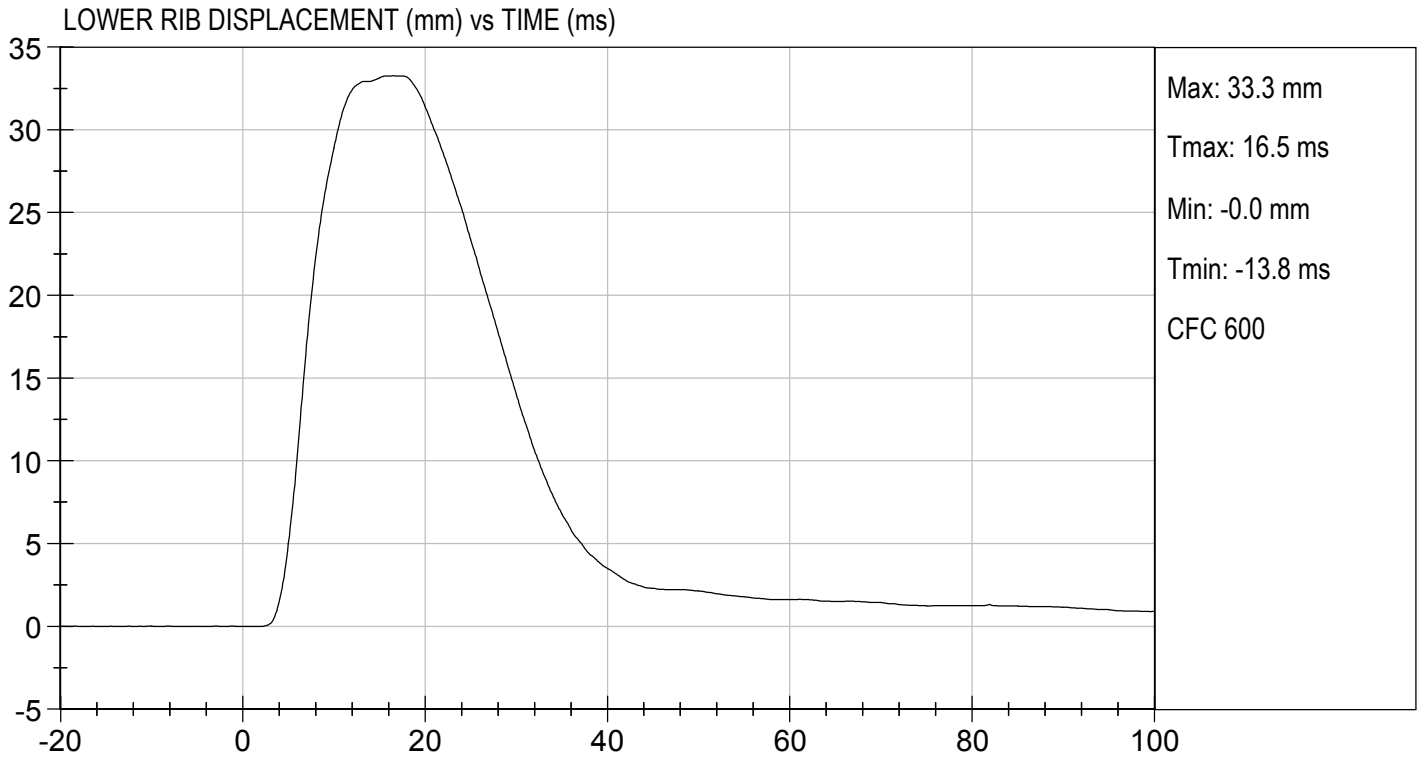

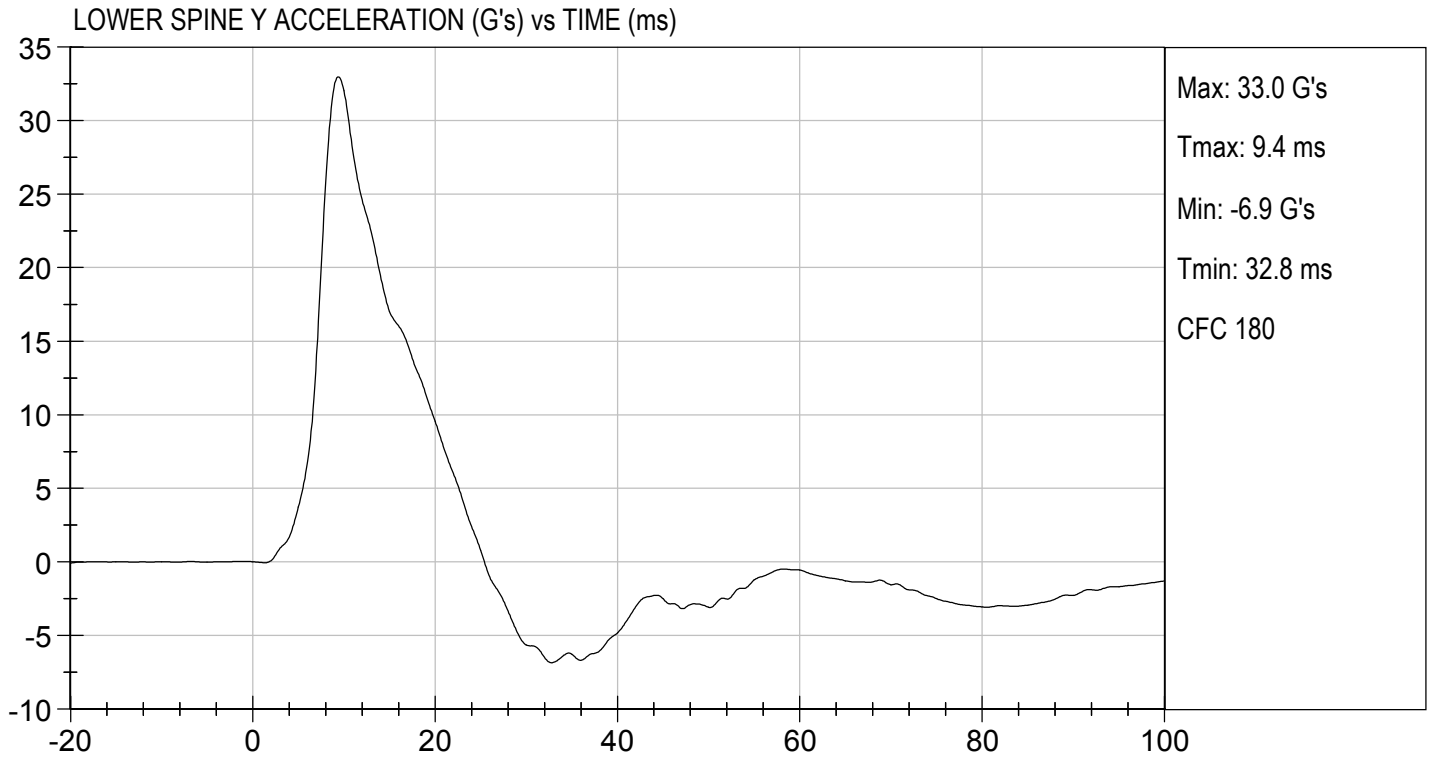

**MGA RESEARCH CORPORATION**  
**THORAX (WITHOUT ARM) IMPACT TEST**  
**SID-IIs BUILD LEVEL D DUMMY**

ATD Serial No: 296

Test I.D: D183325

Tested Parameter	Units	Specification	Result	Pass/Fail
Temperature	deg C	20.6 to 22.2	21	Pass
Humidity	%	10 to 70	40	Pass
Impact Velocity	m/s	4.20 to 4.40	4.34	Pass
Maximum Probe Acceleration	G's	14 to 18	15	Pass
Upper Rib Displacement	mm	32 to 40	37	Pass
Middle Rib Displacement	mm	39 to 45	43	Pass
Lower Rib Displacement	mm	35 to 43	43	Pass
Upper Spine (T1) Y Acceleration	G's	13 to 17	15	Pass
Lower Spine (T12) Y Acceleration	G's	7 to 11	9	Pass
Overall Test Results				Pass

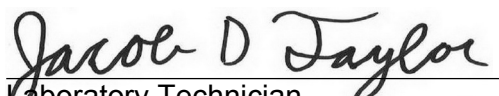
  
 Laboratory Technician

11/06/2018

Test Date

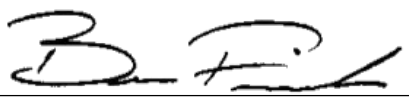
  
 Approved By

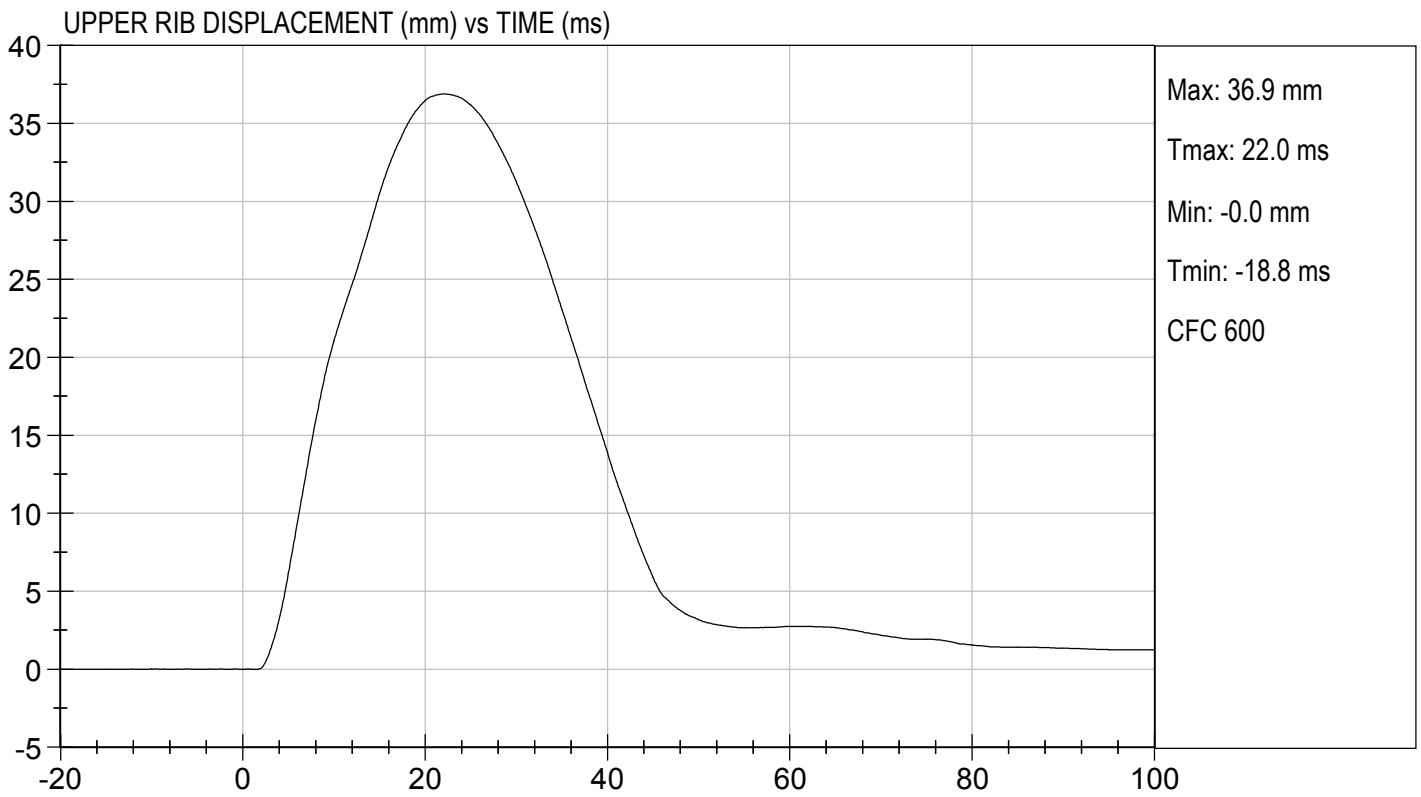
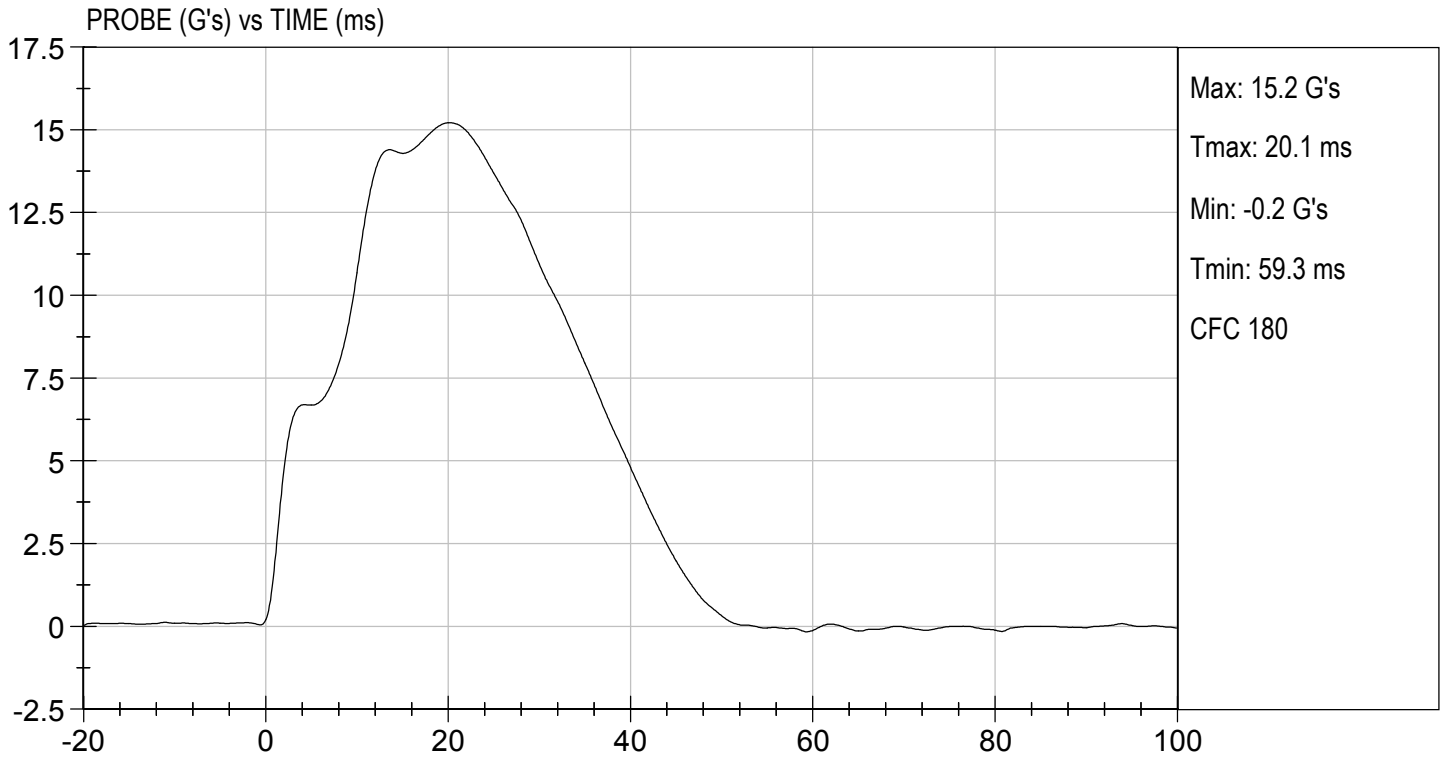

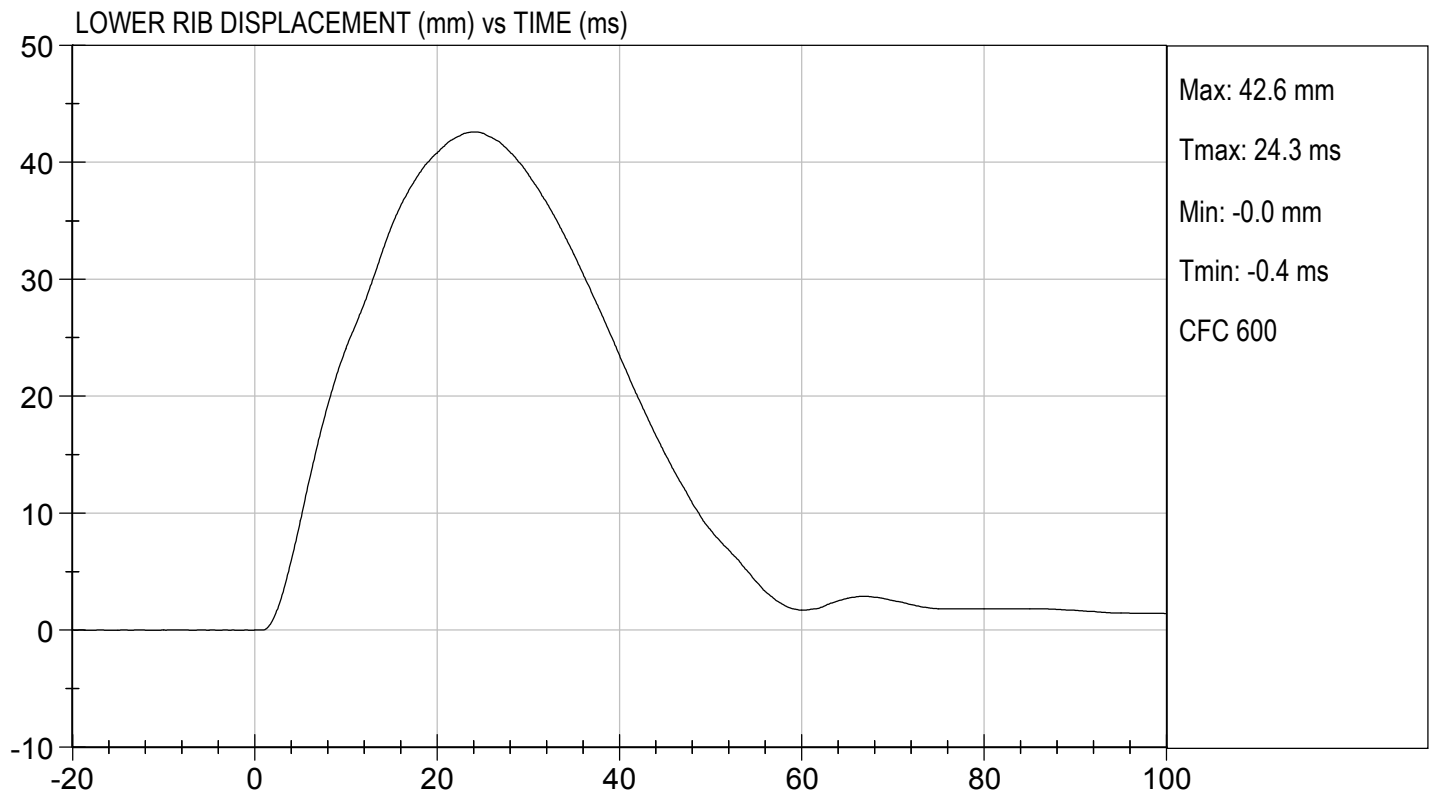
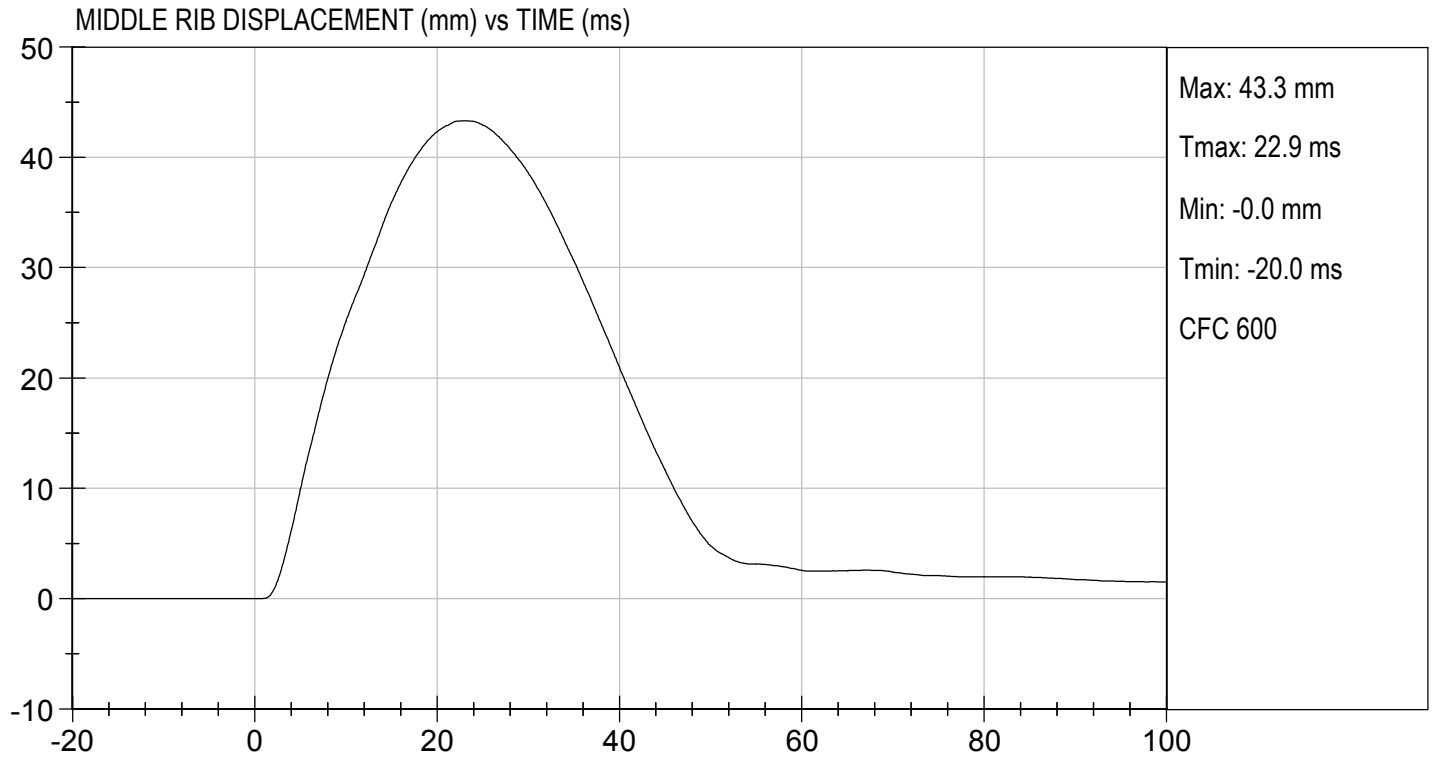

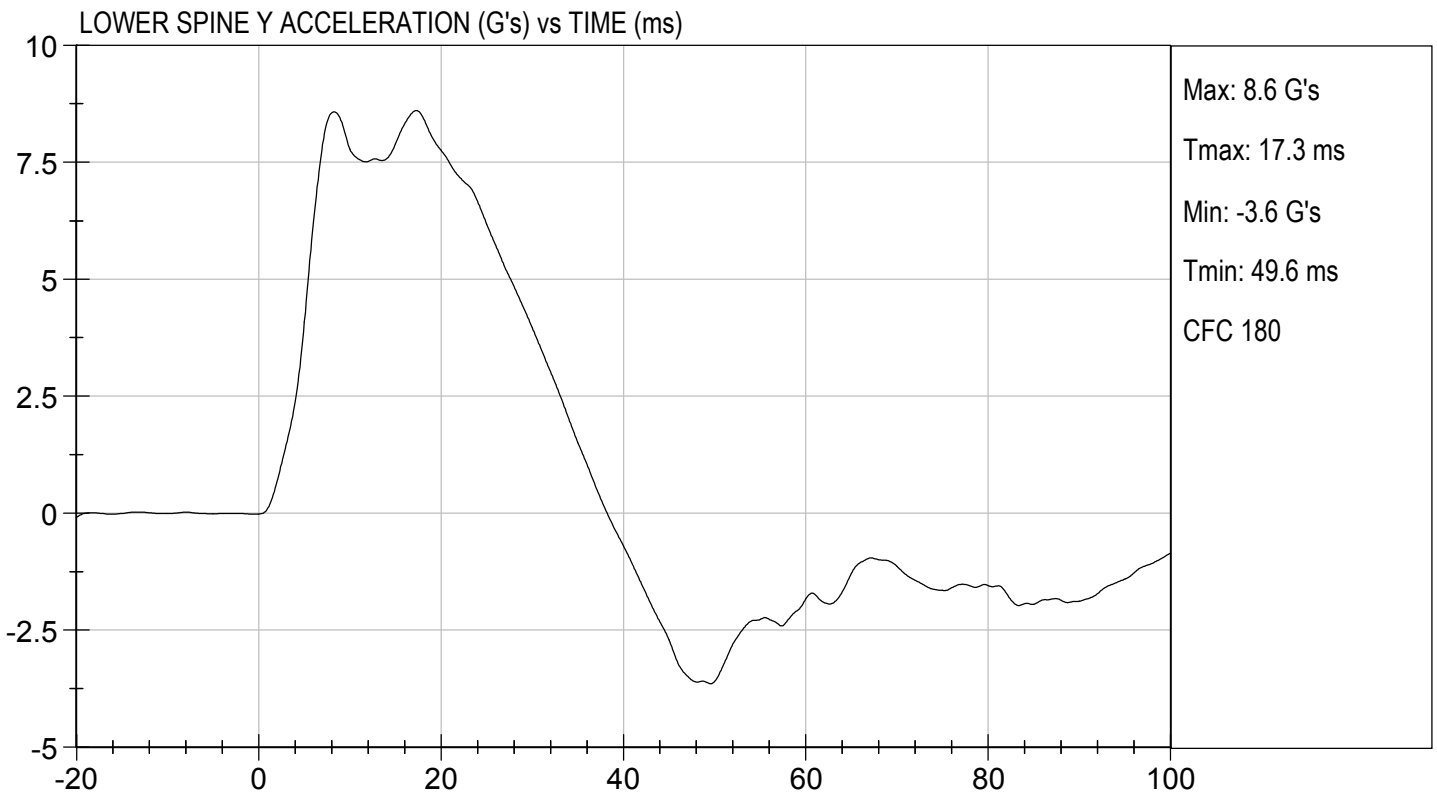
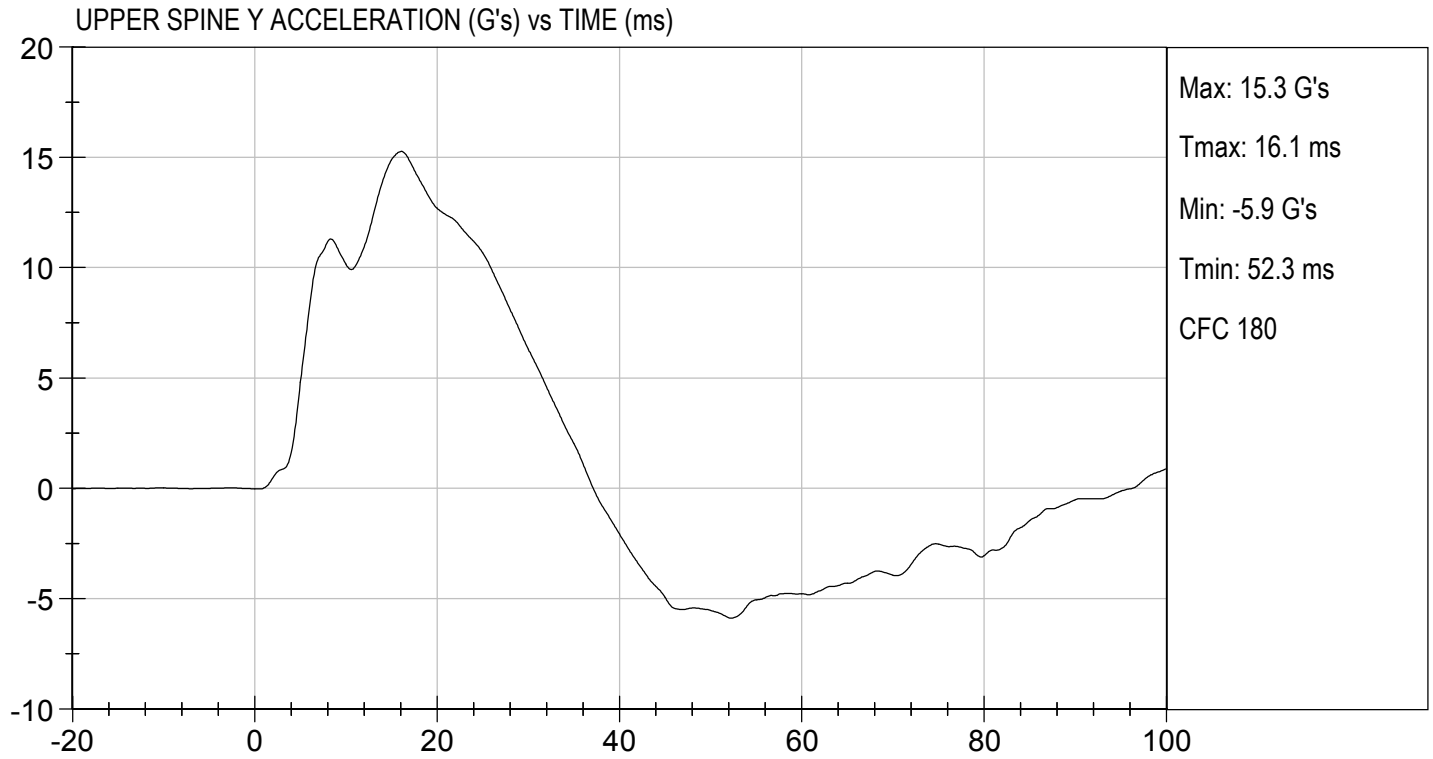

**MGA RESEARCH CORPORATION**  
**ABDOMINAL IMPACT TEST**  
**SID-IIs BUILD LEVEL D DUMMY**

ATD Serial No: 296

Test I.D: D183326

Tested Parameter	Units	Specification	Result	Pass/Fail
Temperature	deg C	20.6 to 22.2	21	Pass
Humidity	%	10 to 70	40	Pass
Impact Velocity	m/s	4.20 to 4.40	4.30	Pass
Maximum Probe Acceleration	G's	12 to 16	14	Pass
Upper Abdomen Rib Displacement	mm	36 to 47	44	Pass
Lower Abdomen Rib Displacement	mm	33 to 44	38	Pass
Lower Spine (T12) Y Acceleration	G's	9 to 14	11	Pass
Overall Test Results				Pass

Jacob D Taylor  
 Laboratory Technician

11/06/2018

Test Date

B. Fink  
 Approved By

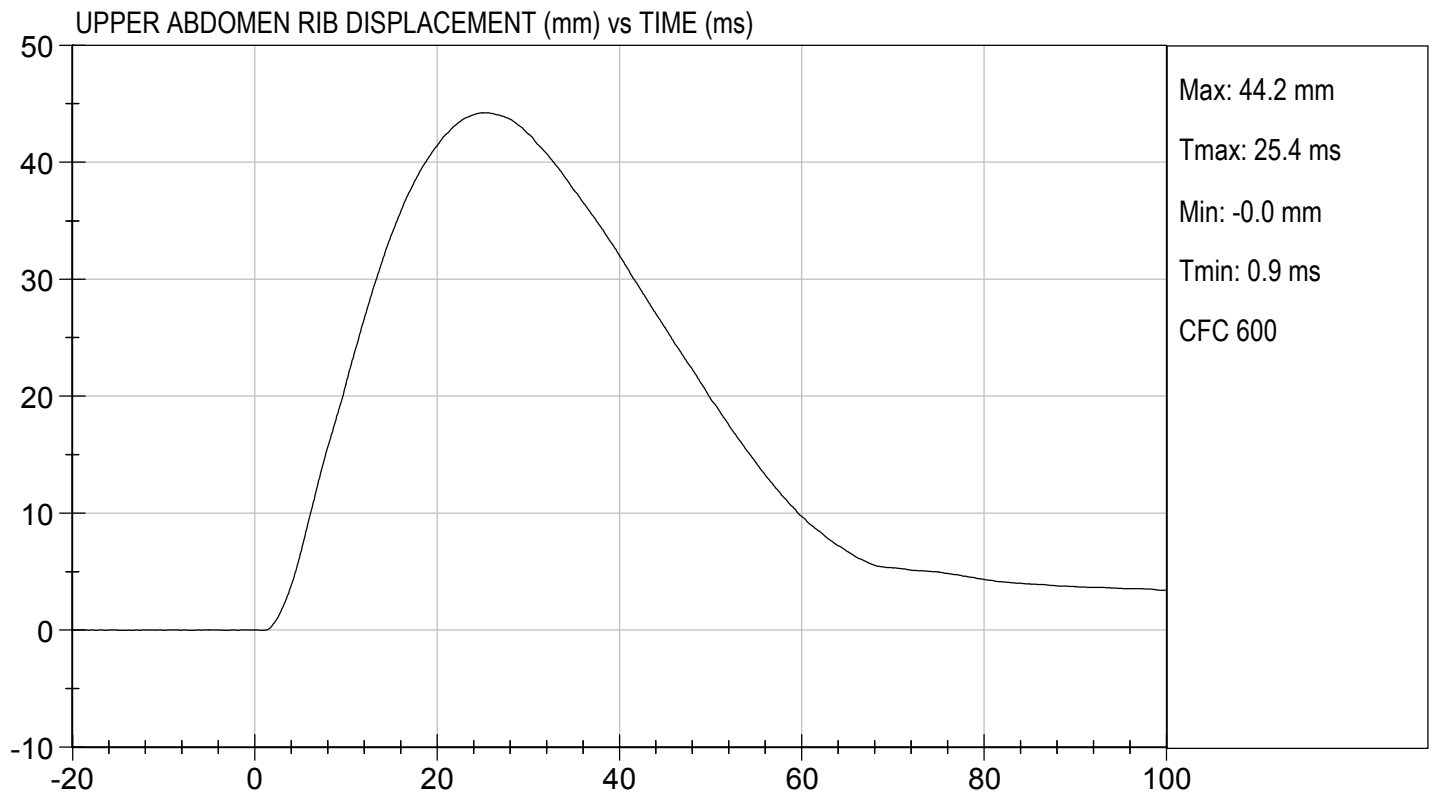
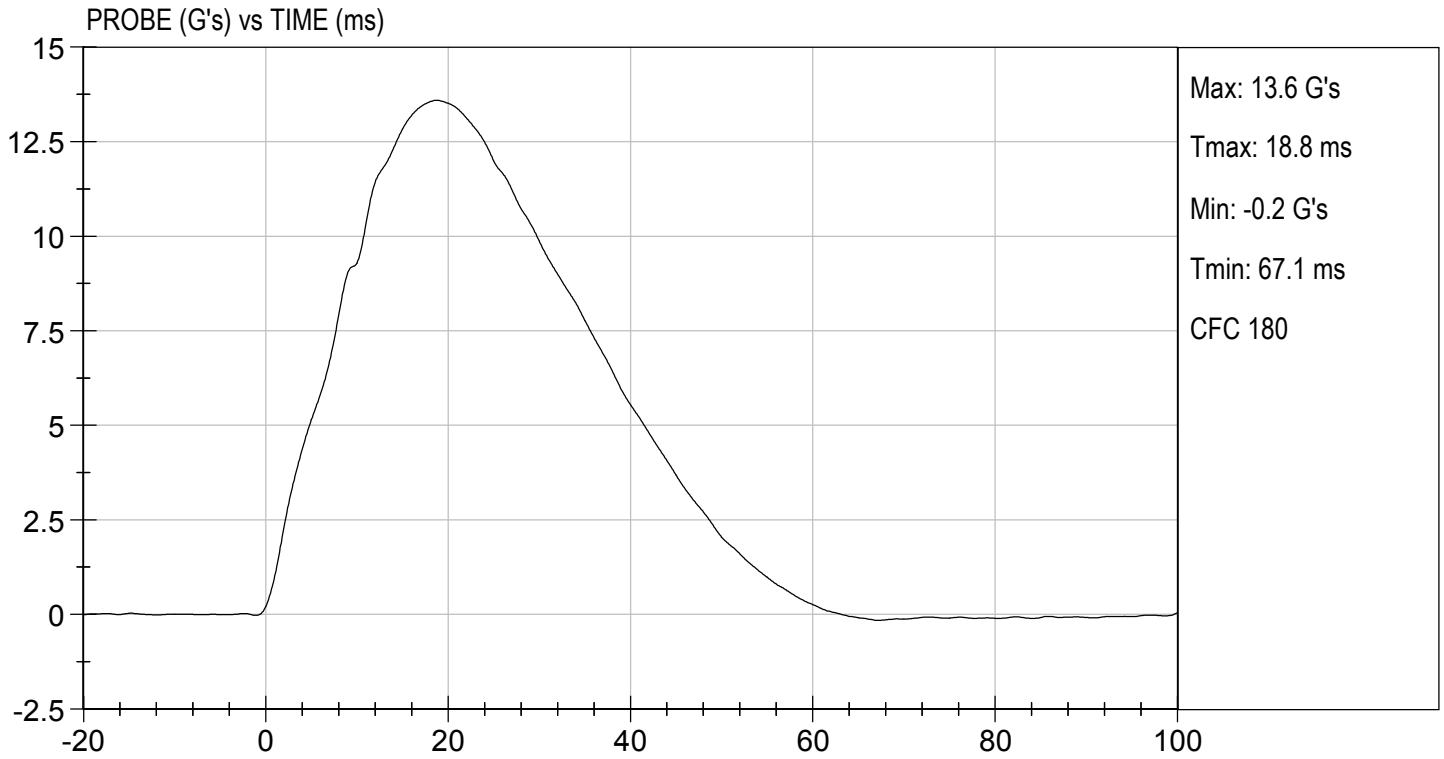

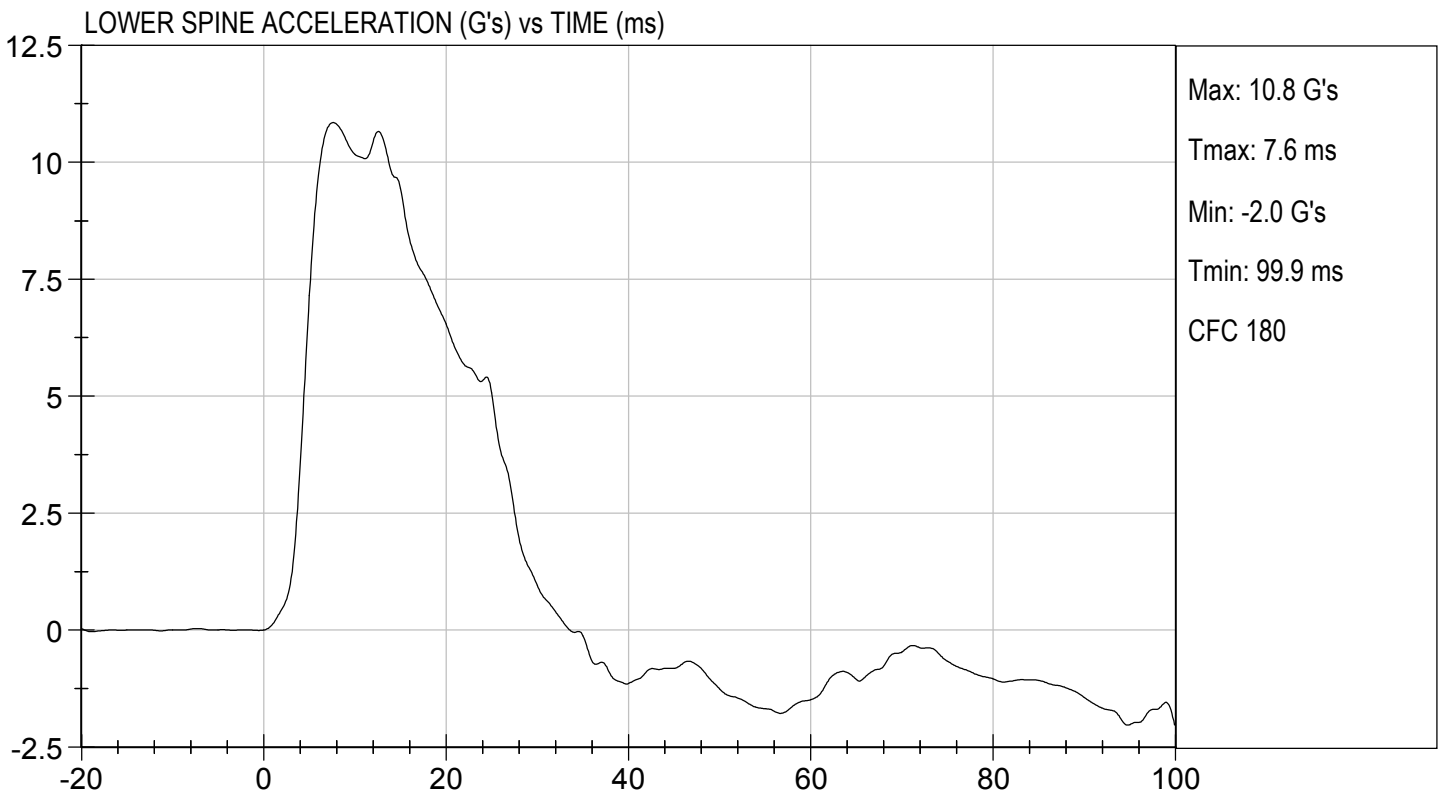
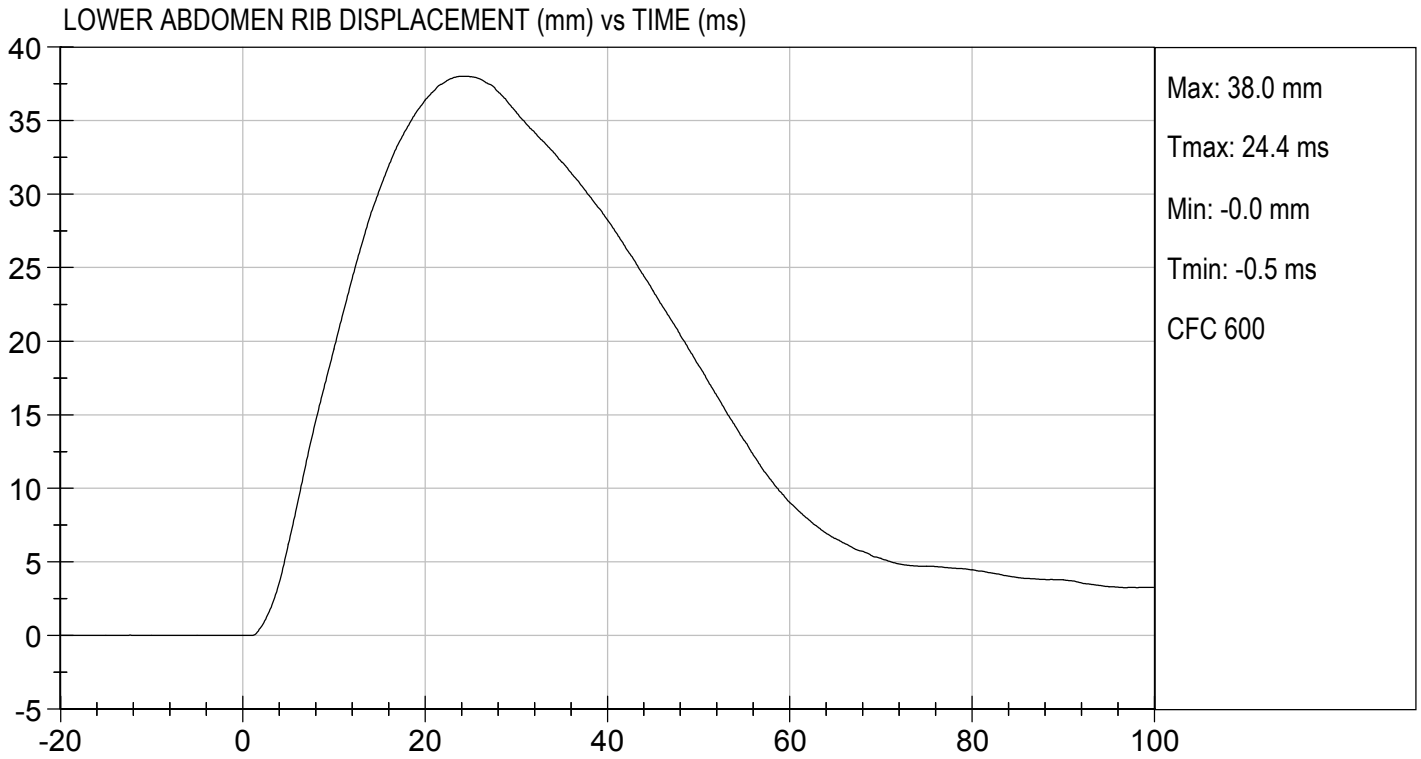

**MGA RESEARCH CORPORATION**  
**PELVIS IMPACT TEST**  
**SID-IIs BUILD LEVEL D DUMMY**

ATD Serial No: 296

Test I.D: D183327

Tested Parameter	Units	Specification	Result	Pass/Fail
Temperature	deg C	20.6 to 22.2	21	Pass
Humidity	%	10 to 70	40	Pass
Impact Velocity	m/s	6.60 to 6.80	6.60	Pass
Maximum Probe Acceleration	G's	38 to 47	45	Pass
Pelvis Y Acceleration After 6 ms	G's	34 to 42	41	Pass
Peak Acetabulum Force	N	3600 to 4300	4,204	Pass
Overall Test Results				Pass

Jacob D Taylor  
 Laboratory Technician

11/06/2018

Test Date

B. F. H.  
 Approved By

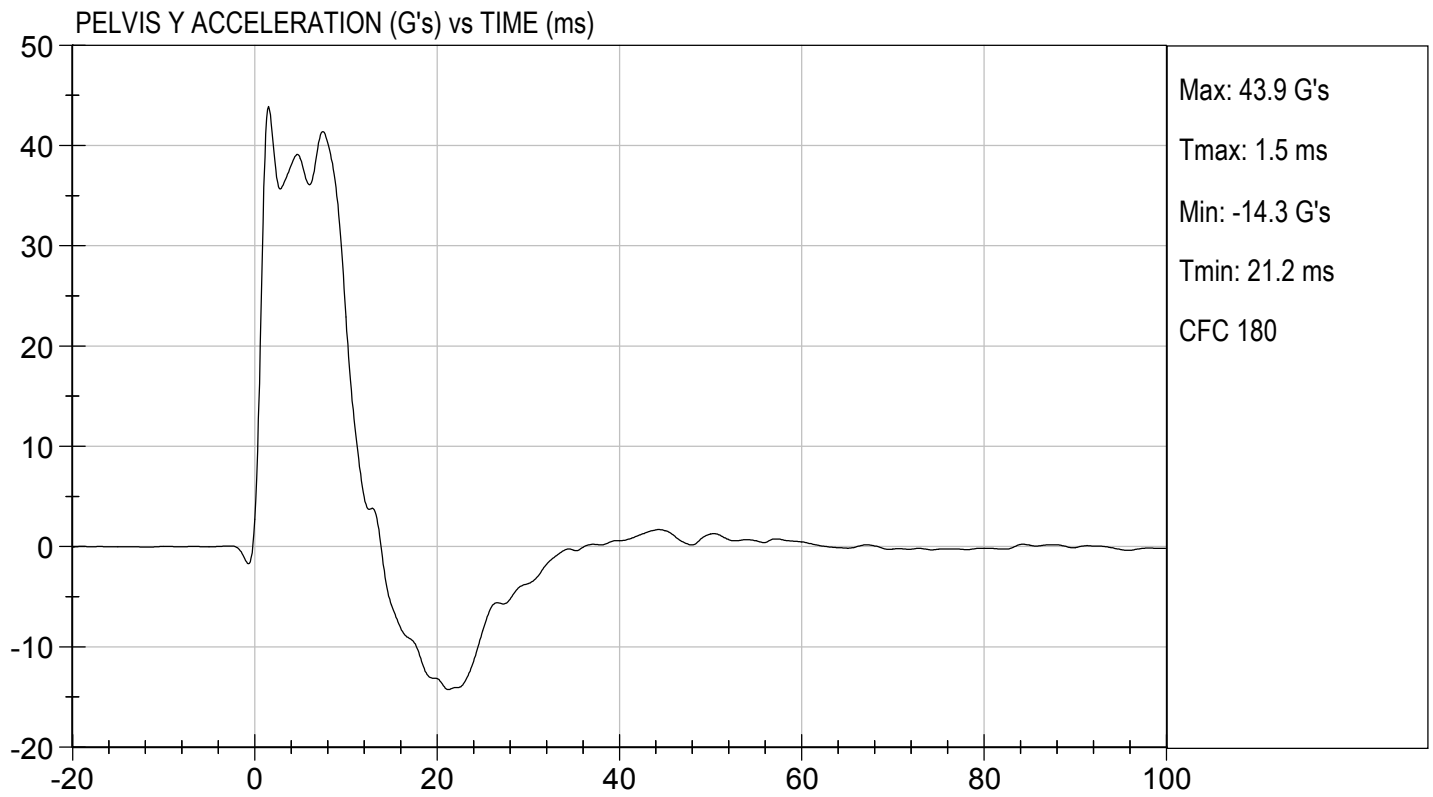
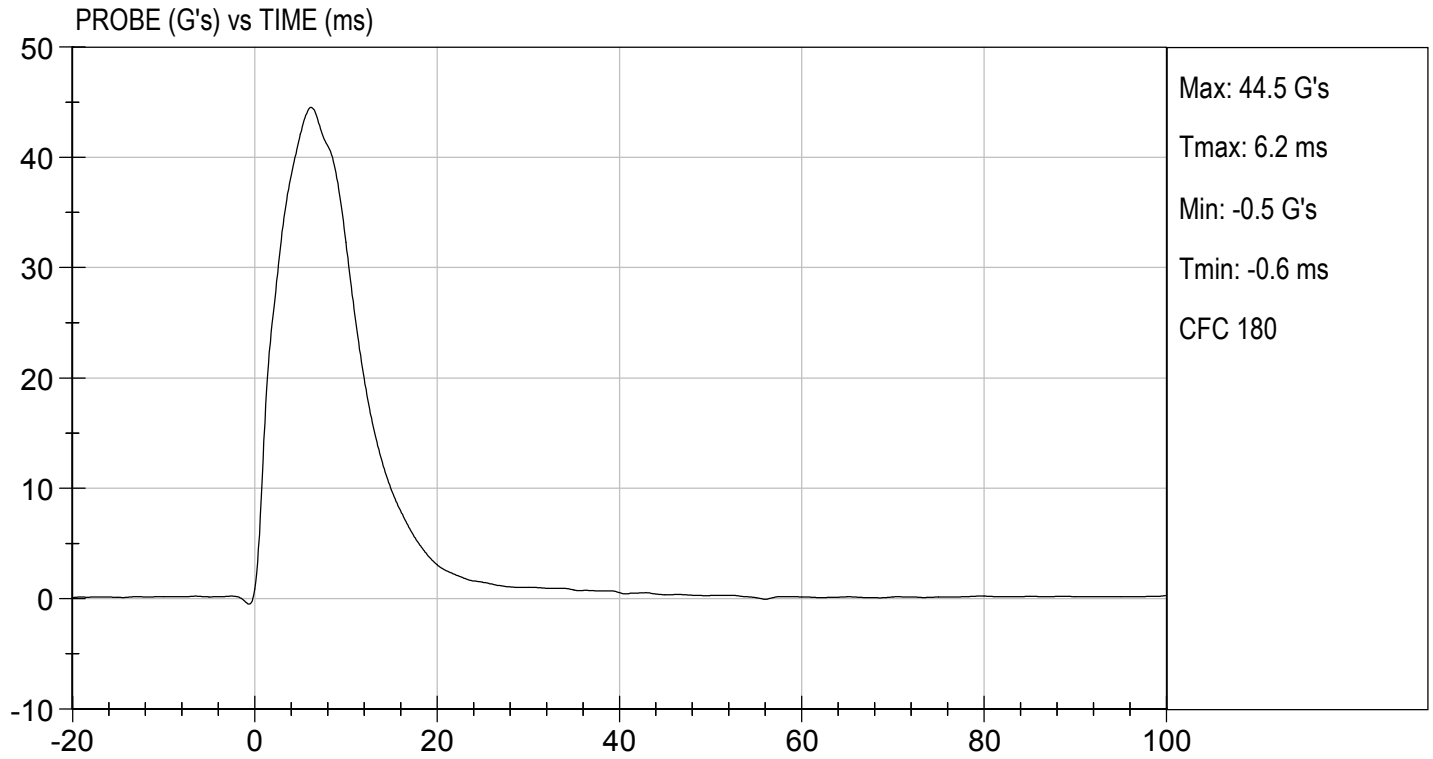

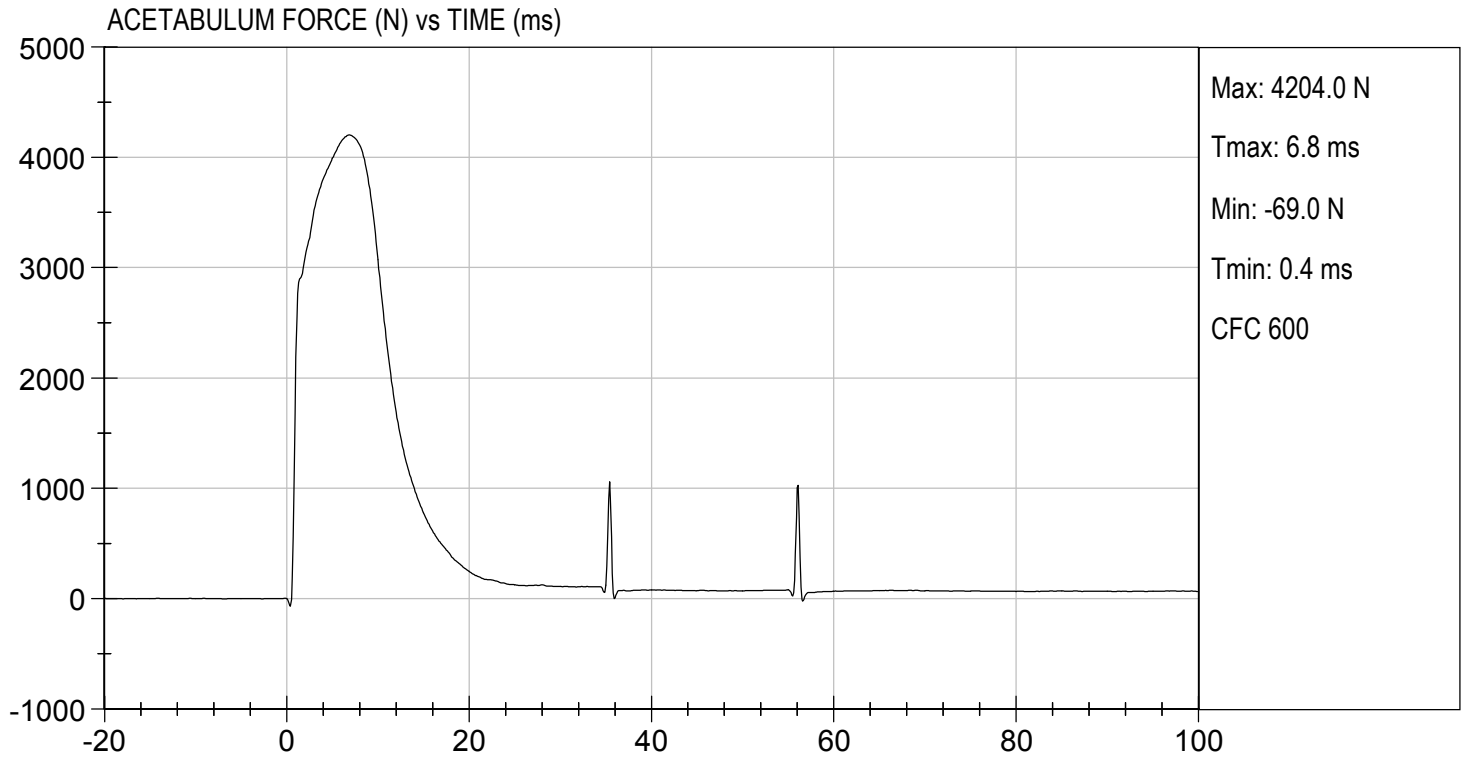

**MGA RESEARCH CORPORATION**  
**ILIAC IMPACT TEST**  
**SID-IIs BUILD LEVEL D DUMMY**

ATD Serial No: 296

Test I.D: D183328

Tested Parameter	Units	Specification	Result	Pass/Fail
Temperature	deg C	20.6 to 22.2	21	Pass
Humidity	%	10 to 70	40	Pass
Impact Velocity	m/s	4.20 to 4.40	4.39	Pass
Maximum Probe Acceleration	G's	36 to 45	37	Pass
Pelvis Y Acceleration	G's	28 to 39	28	Pass
Peak Pelvis Iliac Force	N	4100 to 5100	4,270	Pass
Overall Test Results				Pass

*Danielle Redinlaugh*  
 Laboratory Technician

11/06/2018  
 Test Date

*B. F. K.*  
 Approved By

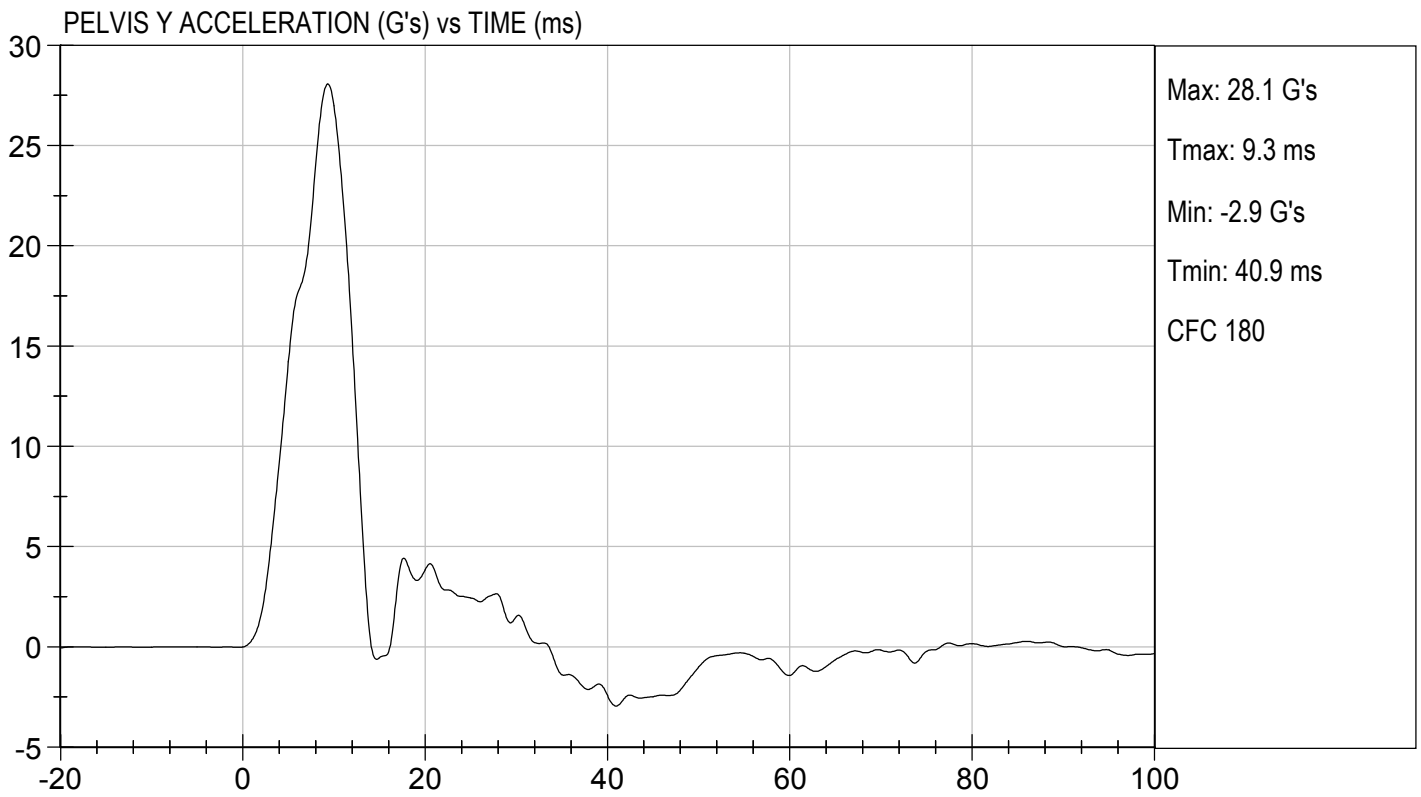
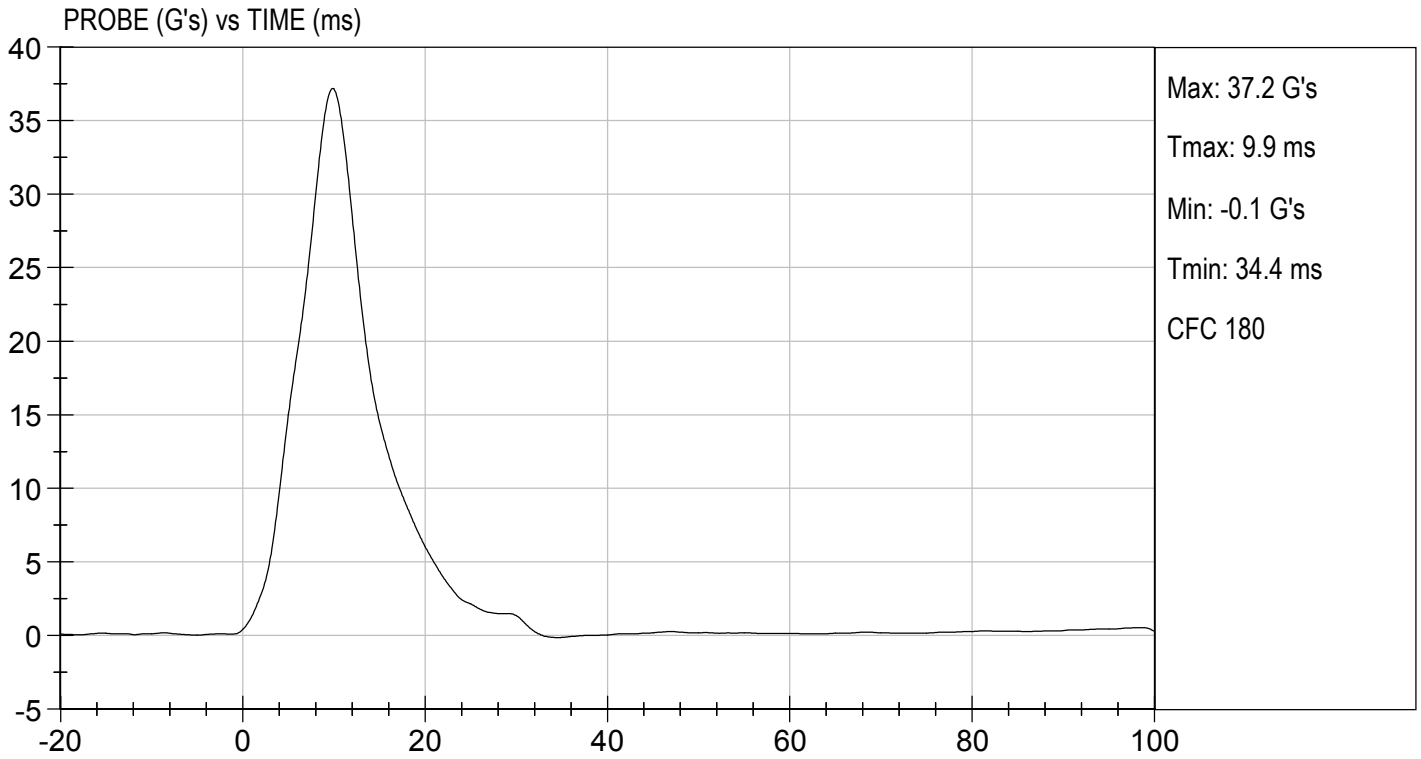



TEST DESC: ILLIAC  
VELOCITY: 14.40 ft/s, 4.39 m/s

TEST DATE: 11/06/2018  
TEST #: D183328

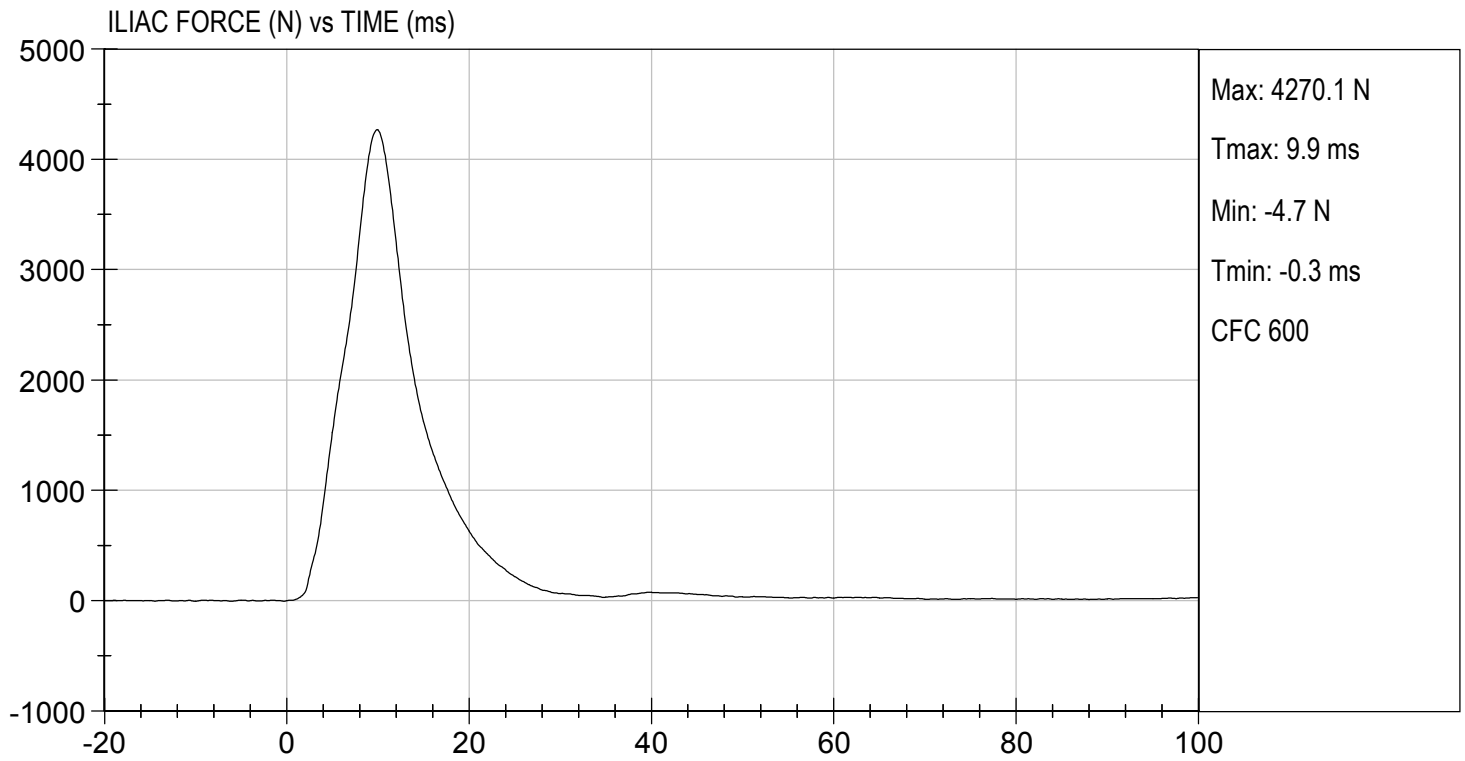



**SID-IIs Pelvis Plug Certification Test**

Plug S/N 12056

Test Number 6410

Report Number 6425

Test Date 2/26/2018 12:59:08 PM

	<u>Test Results</u>	<u>Spec Min</u>	<u>Spec Max</u>
Force @ 0.5 mm (N)	268.83	50.00	600.00
Force @ 1.5 mm (N)	1,209.40	850.00	1,400.00
Force @ 2.5 mm (N)	1,511.59	1,306.00	1,618.00
Force @ 3.0 mm (N)	1,568.14	1,361.00	1,673.00

Testing Machine STM-20 5965542  
 Load Cell S/N (FI360947), Units (LBS) 1000  
 Crosshead Speed ( mm / min ) or Rate 12.7  
 Extension or Position Measured by XHD\_100 ( XHD100 )

Notes:

Force (-N) vs Extension (-mm)

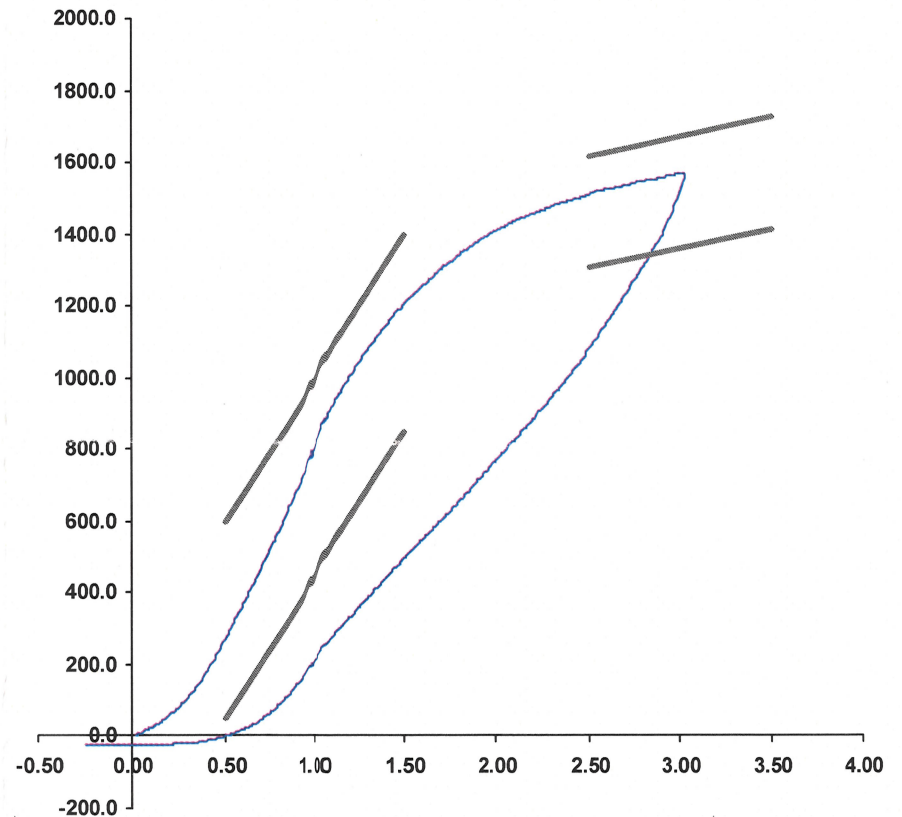

Operator \_\_\_\_\_  
 Part Number 180-4450

Template No 107 26-Feb-18  
 SACO Research

By : DC Date : 2/26/18



**SID-IIs Pelvis Plug Certification Test**

Plug S/N 12243

Test Number 6629

Report Number 6644

Test Date 3/14/2018 1:10:29 PM

	<u>Test Results</u>	<u>Spec Min</u>	<u>Spec Max</u>
Force @ 0.5 mm (N)	302.23	50.00	600.00
Force @ 1.5 mm (N)	1,167.27	850.00	1,400.00
Force @ 2.5 mm (N)	1,437.29	1,306.00	1,618.00
Force @ 3.0 mm (N)	1,489.99	1,361.00	1,673.00

Testing Machine STM-20 5965542  
 Load Cell S/N (FI360947), Units (LBS) 1000  
 Crosshead Speed ( mm / min ) or Rate 12.7  
 Extension or Position Measured by XHD\_100 ( XHD100 )

Notes:

Force (-N) vs Extension (-mm)

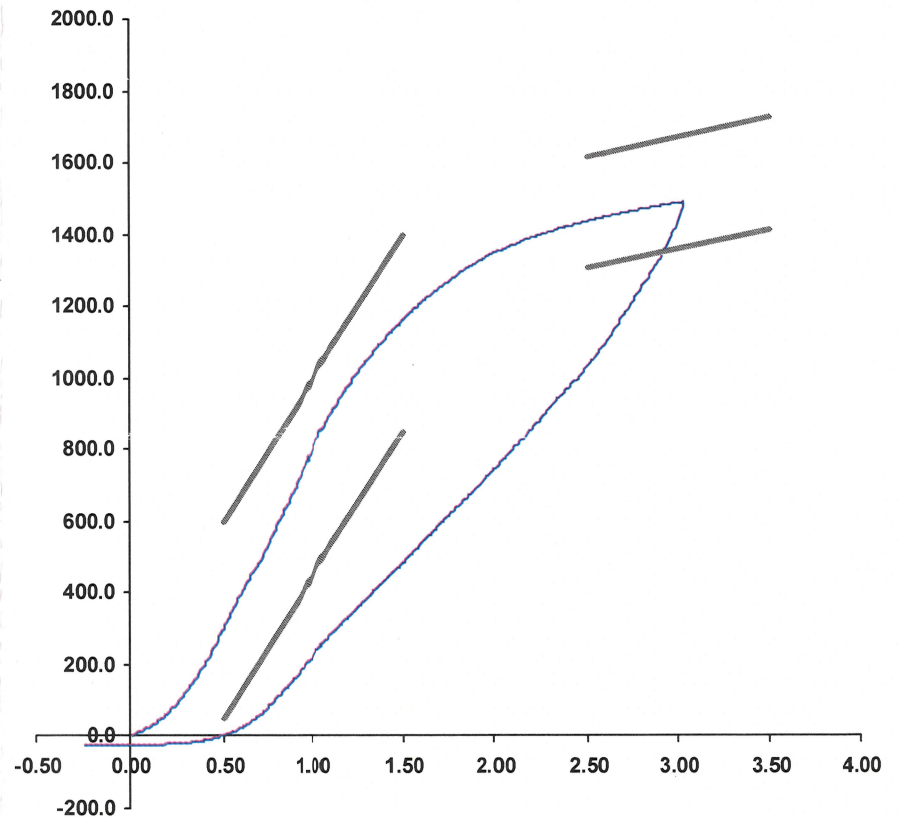

Operator \_\_\_\_\_

Part Number 180-4450

Template No 107 14-Mar-18  
 SACO Research

By : DC Date : 3/14/18

**APPENDIX D**  
**TEST EQUIPMENT AND INSTRUMENTATION CALIBRATION DATA**

**Table 1 – Dummy Instrumentation**

			SID-IIs S/N 296			
			Serial Number	Manufacturer	Calibration Date	
Head CG Accelerometers			X	P85003	Endevco	07/17/18
			Y	P94783	Endevco	07/17/18
			Z	P94786	Endevco	07/17/18
			Xr	P94938	Endevco	07/17/18
			Yr	P96854	Endevco	07/17/18
			Zr	P97386	Endevco	07/17/18
Head Angular Rate Sensors			X	ARS7413	DTS	07/15/14
			Y	ARS7421	DTS	07/15/14
			Z	ARS7423	DTS	07/15/14
Displacement Potentiometers	Thoracic Rib	Upper	Y	G012	FTSS	07/31/18
		Middle	Y	G1163	FTSS	07/31/18
		Lower	Y	G1158	FTSS	07/31/18
	Abdominal Rib	Upper	Y	G1146	FTSS	07/31/18
		Lower	Y	G1126	FTSS	07/31/18
Lower Spine Accelerometers (T12)			X	P79418	Endevco	07/17/18
			Y	P79439	Endevco	07/17/18
			Z	P79614	Endevco	07/17/18
Acetabulum Load Cell			Y	ACG111	FTSS	04/04/18
Iliac Wing Load Cell			Y	IWG226	FTSS	04/04/18
Pelvis Plug (struck side)				12056	SACO	02/26/18
Pelvis Plug (non-struck side)				12243	SACO	03/14/18

**Table 2 – Vehicle Instrumentation**

		Serial Number	Manufacturer	Calibration Date
Vehicle Center of Gravity	X	PCB1356	PCB	08/20/18
Vehicle Center of Gravity	Y	PCB1354	PCB	08/20/18
Vehicle Center of Gravity	Z	PCB1370	PCB	08/17/18
Left Floor Sill	Y	PCB1368	PCB	08/20/18
A-Pillar Sill	Y	PCB1053	PCB	10/01/18
A-Pillar Low	Y	T16822	Edevco	08/16/18
A-Pillar Mid	Y	T10504	Edevco	08/06/18
B-Pillar Sill	Y	PCB1373	PCB	08/06/18
B-Pillar Low	Y			
B-Pillar Mid	Y			
Driver Seat	Y	PCB1027	PCB	10/01/18
Engine Top	X	P95356	PCB	10/01/18
Engine Top	Y	P95084	PCB	10/01/18
Firewall	Y	PCB1069	PCB	09/24/18
Right Roof	Y	PCB1040	PCB	09/24/18
Right Floor Sill	Y	PCB1020	PCB	09/25/18
Rear Floorpan	X	T16846	Edevco	08/15/18
Rear Floorpan	Y	T16863	Edevco	08/16/18

**Table 3 – Pole Instrumentation**

	Serial Number	Manufacturer	Calibration Date
Load Cell 1	DG6277	FTSS	07/30/18
Load Cell 2	DG6278	FTSS	07/30/18
Load Cell 3	DG6279	FTSS	07/30/18
Load Cell 4	DG6280	FTSS	07/30/18
Load Cell 5	DG6281	FTSS	07/30/18
Load Cell 6	DG6283	FTSS	07/30/18
Load Cell 7	DG6284	FTSS	07/30/18
Load Cell 8	DG6582	FTSS	07/30/18