

REPORT NUMBER: NCAP-KAR-18-020

**NEW CAR ASSESSMENT PROGRAM (NCAP)
FRONTAL BARRIER IMPACT TEST**

TESLA INC.

2018 TESLA MODEL 3 LONG RANGE RWD 4-DOOR SEDAN

NHTSA NUMBER: O20185000

PREPARED BY:

APPLUS IDIADA KARCO ENGINEERING, LLC.

9270 HOLLY ROAD

ADELANTO, CA 92301



SEPTEMBER 4, 2018

FINAL REPORT

**U.S. DEPARTMENT OF TRANSPORTATION
NATIONAL HIGHWAY TRAFFIC SAFETY ADMINISTRATION
OFFICE OF CRASHWORTHINESS STANDARDS
1200 NEW JERSEY AVE, SE
ROOM W43-410
WASHINGTON, DC 20590**

This publication is distributed by the U.S. Department of Transportation, National Highway Traffic Safety Administration, in the interest of information exchange. The opinions, findings and conclusions expressed in this publication are those of the author(s) and not necessarily those of the Department of Transportation or the National Highway Traffic Safety Administration. The United States Government assumes no liability for its contents or use thereof. If trade or manufacturers' names or products are mentioned, it is only because they are considered essential to the object of the publication and should not be construed as an endorsement. The United States Government does not endorse products or manufacturers.

Prepared By: Amjad A. Jadallah

Mr. Amjad A. Jadallah, Project Engineer
Applus IDIADA KARCO Engineering, LLC.

Reviewed By: MSD

Mr. Michael L. Dunlap, Director of Operations
Applus IDIADA KARCO Engineering, LLC.

Approved By: SDM

Mr. Steven D. Matsusaka, Engineering Manager
Applus IDIADA KARCO Engineering, LLC.

Approval Date: September 4, 2018

FINAL REPORT ACCEPTANCE BY OCWS:

Division Chief, New Car Assessment Program
NHTSA, Office of Crashworthiness Standards

Date: _____

COTR, New Car Assessment Program
NHTSA, Office of Crashworthiness Standards

Date: _____

TECHNICAL REPORT DOCUMENTATION PAGE

1. Report No. NCAP-KAR-18-020	2. Government Accession No.	3. Recipient's Catalog No.																																																					
4. Title and Subtitle Final Report of New Car Assessment Program Testing of a 2018 Tesla Model 3 Long Range RWD 4-Door Sedan NHTSA No. O20185000		5. Report Date September 4, 2018																																																					
		6. Performing Organization Code KAR																																																					
7. Authors Mr. Amjad A. Jadallah, Project Engineer, Applus IDIADA KARCO Mr. Steven D. Matsusaka, Engineering Manager, Applus IDIADA KARCO		8. Performing Organization Report No. TR-P38233-01-NC																																																					
		10. Work Unit No.																																																					
9. Performing Organization Name and Address Applus IDIADA KARCO Engineering, LLC. 9270 Holly Rd. Adelanto, CA 92301		11. Contract or Grant No. DTNH22-12-D-00259																																																					
		13. Type of Report and Period Covered Final Test Report, August 20 - September 4, 2018																																																					
12. Sponsoring Agency Name and Address U. S. Department of Transportation National Highway Traffic Safety Administration Office of Crashworthiness Standards 1200 New Jersey Ave., SE, Room W43-410 Washington, D.C. 20590		14. Sponsoring Agency Code NRM-110																																																					
		15. Supplementary Notes																																																					
16. Abstract <p>A 56.3 km/h NCAP Frontal Impact Test was conducted on a 2018 Tesla Model 3 Long Range RWD 4-door sedan in accordance with the specifications of the Office of Crashworthiness Standards Frontal NCAP Laboratory Test Procedure. This test was conducted to obtain data indicant of FMVSS 208, 212, 219 (partial), 301, and footwell intrusion performance. The test was conducted at the Applus IDIADA KARCO Engineering, LLC. facility in Adelanto, California on August 20, 2018.</p> <p>The impact velocity of the vehicle was 56.41 km/h and the ambient temperature at the barrier face at the time of impact was 31.7°C. The target vehicle's post-test maximum crush was 437 mm at DPD4 to the right of the vehicle's centerline. The test vehicle's performance is as follows:</p> <table border="1" style="width: 100%; border-collapse: collapse; text-align: center;"> <thead> <tr> <th rowspan="2">Measurement Description</th> <th rowspan="2">Units</th> <th colspan="2">Driver ATD</th> <th colspan="2">Passenger ATD</th> </tr> <tr> <th>Threshold</th> <th>Result</th> <th>Threshold</th> <th>Result</th> </tr> </thead> <tbody> <tr> <td>Head Injury Criteria (HIC₁₅)</td> <td>N/A</td> <td>700</td> <td>80.6</td> <td>700</td> <td>234.7</td> </tr> <tr> <td>Maximum Chest Compression</td> <td>mm</td> <td>63</td> <td>-18</td> <td>52</td> <td>-13</td> </tr> <tr> <td>Nij</td> <td>N/A</td> <td>1</td> <td>0.22</td> <td>1</td> <td>0.33</td> </tr> <tr> <td>Neck Tension</td> <td>N</td> <td>4170</td> <td>1021.8</td> <td>2620</td> <td>845.9</td> </tr> <tr> <td>Neck Compression</td> <td>N</td> <td>4000</td> <td>-184.7</td> <td>2520</td> <td>-449.6</td> </tr> <tr> <td>Left Femur Force</td> <td>N</td> <td>10000</td> <td>-1480.5</td> <td>6800</td> <td>-161.4</td> </tr> <tr> <td>Right Femur Force</td> <td>N</td> <td>10000</td> <td>-2023.3</td> <td>6800</td> <td>-126.1</td> </tr> </tbody> </table>				Measurement Description	Units	Driver ATD		Passenger ATD		Threshold	Result	Threshold	Result	Head Injury Criteria (HIC ₁₅)	N/A	700	80.6	700	234.7	Maximum Chest Compression	mm	63	-18	52	-13	Nij	N/A	1	0.22	1	0.33	Neck Tension	N	4170	1021.8	2620	845.9	Neck Compression	N	4000	-184.7	2520	-449.6	Left Femur Force	N	10000	-1480.5	6800	-161.4	Right Femur Force	N	10000	-2023.3	6800	-126.1
Measurement Description	Units	Driver ATD				Passenger ATD																																																	
		Threshold	Result	Threshold	Result																																																		
Head Injury Criteria (HIC ₁₅)	N/A	700	80.6	700	234.7																																																		
Maximum Chest Compression	mm	63	-18	52	-13																																																		
Nij	N/A	1	0.22	1	0.33																																																		
Neck Tension	N	4170	1021.8	2620	845.9																																																		
Neck Compression	N	4000	-184.7	2520	-449.6																																																		
Left Femur Force	N	10000	-1480.5	6800	-161.4																																																		
Right Femur Force	N	10000	-2023.3	6800	-126.1																																																		
17. Key Words 35 mph Frontal Barrier Impact Test New Car Assessment Program (NCAP)		18. Distribution Statement Copies of this report are available from: National Highway Traffic Safety Administration Technical Information Services Division, NPO-411 1200 New Jersey Ave., SE Washington, DC 20590 e-mail: tis@nhtsa.dot.gov FAX: 202-493-2833																																																					
19. Security Classification of this report UNCLASSIFIED	20. Security Classification of this page UNCLASSIFIED	21. No. of Pages 133	22. Price																																																				

TABLE OF CONTENTS

<u>Section</u>		<u>Page No.</u>
1	Purpose and Summary of Test	1
2	Occupant and Vehicle Information / Data Sheets	3
<u>Data Sheet No.</u>		<u>Page No.</u>
1	General Test and Vehicle Parameter Data	4
2	Seat Adjustment, Fuel System, and Steering Wheel Data	8
3	Dummy Longitudinal Clearance Dimensions	10
4	Dummy Lateral Clearance Dimensions	11
5	Seat Belt Positioning Data	12
6	High-Speed Camera Locations and Data	13
7	Vehicle Accelerometer Locations	15
8	Photographic Reference Target Locations	16
9	Load Cell Locations on Fixed Barrier	17
10	Test Vehicle Camera and Instrumentation Summary	18
11	Post-Test Observations	19
12	Vehicle Profile Measurements	20
13	Accident Investigation Division Data	22
14	Vehicle Intrusion Measurements	23
15	Summary of FMVSS 212, 219 (Partial), and 301 Data	25
16	FMVSS 301 Static Rollover Results	27
17	Dummy / Vehicle Temperature Stabilization Chart	28
<u>Appendix</u>		<u>Page No.</u>
A	Photographs	A
B	Dummy Response Data Traces	B
C	ATD Calibration and Performance Verification Data	C

SECTION 1

PURPOSE AND SUMMARY OF TEST

PURPOSE

This 56.3 km/h frontal barrier impact test is part of the Vehicle Barrier Impact Testing Program, sponsored by the National Highway Traffic Safety Administration (NHTSA) under contract number DTNH22-12-D-00259. The purpose of this test was to obtain vehicle crashworthiness and occupant restraint system performance data for consumer information purposes.

The 56.3 km/h frontal barrier impact test was conducted in accordance with the Office of Crashworthiness Standards Frontal NCAP Laboratory Test Procedure, dated October 2015.

SUMMARY

A load cell barrier consisting of 176 load cells was impacted by a 2018 Tesla Model 3 Long Range RWD 4-door sedan at a velocity of 56.41 km/h. The test was performed at Applus IDIADA KARCO Engineering, LLC. on August 20, 2018. Pre- and post-test photographs of the vehicle and dummies can be found in Appendix A of this report.

Three (3) real-time cameras and sixteen (16) high-speed cameras were used to document the frontal barrier impact event. Camera locations and other pertinent camera information can be found in Data Sheet 6 of this report.

One Part 572E 50th percentile male anthropomorphic test device (ATD) was placed in the driver seating position and one Part 572O 5th percentile female ATD was placed in the right-front passenger seating position according to dummy placement instructions specified in the Frontal NCAP Laboratory Test Procedure.

Both ATDs were fully instrumented with head, chest and pelvis tri-axial accelerometers, chest displacement potentiometers, upper neck force transducers, right / left femur load cells, and lower leg instrumentation. The driver (position 1) ATD (Serial No. 360) and the right-front passenger (position 2) ATD (Serial No. 141) were calibrated prior to this test. Certification details, along with instrumentation calibration data, are found in Appendix C of this report.

The 104 channels of dummy and vehicle response data were recorded on an on-board data acquisition system. Appendix B contains the dummy response data traces.

There was 100% windshield retention and no intrusion into the protected zone of the windshield during the event.

The maximum static crush was 437 mm at DPD4 to the right of the vehicle's centerline. Both the driver and passenger side doors remained closed during the impact event and were operable after the impact.

The driver's visible contact points were as follows: The driver ATD's head contacted the frontal airbag and headrest. The upper torso contacted the frontal airbag. Both the left and right knees contacted the knee airbag. Both the left and right thighs contacted the steering wheel.

The passenger's visible contact points were as follows: The passenger ATD's head contacted the frontal airbag, headrest, and seatback. The upper torso contacted the frontal airbag.

The occupant data is summarized below:

ATD Position	HIC ₁₅	T ¹ (ms)	T ² (ms)	Chest Disp. (mm)	Nij	Neck Tension (N)	Neck Comp. (N)	Left Femur (N)	Right Femur (N)
Driver (50th)	80.6	59.4	74.4	-18	0.22	1021.8	-184.7	-1480.5	-2023.3
Passenger (5th)	234.7	63.2	78.2	-13	0.33	845.9	-449.6	-161.4	-126.1

The NHTSA number in the placards used in Appendix A of this report are listed incorrectly with the first character as the numeral zero "0" instead of the letter "O".

SECTION 2

OCCUPANT AND VEHICLE INFORMATION / DATA SHEETS

Test Vehicle: 2018 Tesla Model 3 Long Range RWD 4-Door Sedan NHTSA No.: O20185000

Test Program: 56.3 km/h Frontal Impact NCAP Test Test Date: 08/20/18

CONVERSION FACTORS

Quantity	Typical Application	Std Units	Metric Unit	Multiply By
Mass	Vehicle Weight	lb	kg	0.4536
Linear Velocity	Impact Velocity	miles/hr	km/hr	1.609344
Length or Distance	Measurements	in	mm	25.4
Volume	Fuel Systems	gal	liter	3.785
Volume	Small Fluids	oz	mL	29.574
Pressure	Tire Pressures	lbf/in ²	kPa	6.895
Temperature	General Use	°F	°C	$=(T_f - 32)/1.8$
Force	Dynamic Forces	lbf	N	4.448
Moment	Torque	lbf-ft	N•m	1.355

DATA SHEET NO. 1

GENERAL TEST AND VEHICLE PARAMETER DATA

Test Vehicle: 2018 Tesla Model 3 Long Range RWD 4-Door Sedan NHTSA No.: O20185000

Test Program: 56.3 km/h Frontal Impact NCAP Test Test Date: 08/20/18

TEST VEHICLE INFORMATION AND OPTIONS

NHTSA Number	O20185000
Model Year	2018
Make	Tesla
Model	Model 3
Body Style	4-Door Sedan
VIN	5YJ3E1EA5JF061210
Body Color	Black
Odometer Reading (km / mi)	6 / 4
Engine Displacement (L)	N/A
Type / No. of Cylinders	Electric
Engine Placement	N/A
Transmission Type	Automatic
Transmission Speeds	1
Overdrive	No
Final Drive	RWD
Roof Rack	No
Sunroof / T-Top	Yes
Running Boards	No
Tilt Steering Wheel	Yes
Power Seats	Yes
Anti-Lock Brakes (ABS)	Yes
Automatic Door Locks (ADLs)	Yes

Traction Control System	Yes
Power Steering	Yes
Power Window Auto-Reverse	Yes
Driver Frontal Airbag	Yes
Driver Curtain Airbag	Yes
Driver Head/Torso Airbag	No
Driver Torso Airbag	No
Driver Torso/Pelvis Airbag	Yes
Driver Pelvis Airbag	No
Driver Knee Airbag	Yes
Front Pass. Frontal Airbag	Yes
Front Pass. Curtain Airbag	Yes
Front Pass. Head/Torso Airbag	No
Front Pass. Torso Airbag	No
Front Pass. Torso/Pelvis Airbag	Yes
Front Pass. Pelvis Airbag	No
Front Pass. Knee Airbag	Yes
Driver Seat Belt Pretensioner	Yes
Driver Load Limiter	Yes
Front Pass. Seat Belt Pretensioner	Yes
Front Pass. Load Limiter	Yes
Other Safety Restraint	No

Does Owner's Manual provide instructions to turn off automatic door locks? No

DATA FROM CERTIFICATION LABEL

Manufactured By	Tesla, INC.
Date of Manufacture	Jul-18

GVWR (kg)	2180
GAWR Front (kg)	1110
GAWR Rear (kg)	1257

VEHICLE SEATING AND CAPACITY WEIGHT INFORMATION

Measured Parameter	Front	Rear	Third	Total	
Type of Seats	Bucket	Bench			
Designated Seating Capacity	2	3		5	
Capacity Weight (VCW) (kg)				405.0	A
DSC x 68.04 (kg)				340.2	B
Cargo Weight (RCLW) (kg)*				64.8	A-B

DATA SHEET NO. 1 ... (CONTINUED)

GENERAL TEST AND VEHICLE PARAMETER DATA

Test Vehicle: 2018 Tesla Model 3 Long Range RWD 4-Door Sedan NHTSA No.: O20185000
 Test Program: 56.3 km/h Frontal Impact NCAP Test Test Date: 08/20/18



VEHICLE TIRE INFORMATION

Measured Parameter	Front	Rear
Max. Tire Pressure (kPa)	350	350
Cold Pressure (kPa)	290	290
Recommended Tire Size	P235/40R19	P235/40R19
Tire Size on Vehicle	P235/40R19	P235/40R19
Tire Manufacturer	Continental	Continental
Tire Model	Pro Contact RX	Pro Contact RX
Treadwear	400	400
Traction	A	A
Temperature Grades	A	A
Tire Plies Sidewall	2 Rayon	2 Rayon
Tire Plies Body	1 Rayon, 2 Steel, 1 Polyamide	1 Rayon, 2 Steel, 1 Polyamide
Load Index / Speed Symbol	96W	96W
Tire Material	Rayon, Steel, Polyamide	Rayon, Steel, Polyamide
DOT Safety Code Left	AF18 WD4H 0118	AF18 WD4H 0118
DOT Safety Code Right	AF18 WD4H 0118	AF18 WD4H 0118

DATA SHEET NO. 1 ... (CONTINUED)

GENERAL TEST AND VEHICLE PARAMETER DATA

Test Vehicle: 2018 Tesla Model 3 Long Range RWD 4-Door Sedan NHTSA No.: O20185000
 Test Program: 56.3 km/h Frontal Impact NCAP Test Test Date: 08/20/18

TEST VEHICLE WEIGHTS

	Units	As Delivered Weights (UVW)			As Tested Weights (ATW)		
		Front Axle	Rear Axle	Total	Front Axle	Rear Axle	Total
Left	kg	413.0	469.0		443.0	547.0	
Right	kg	429.0	451.0		464.5	505.0	
Ratio	%	47.8%	52.2%	100.0%	46.3%	53.7%	100.0%
Total	kg	842.0	920.0	1762.0	907.5	1052.0	1959.5

TARGET TEST WEIGHT CALCULATION

Measured Parameter	Units	Value	
Total Delivered Weight (UVW)	kg	1762.0	A
Weight of 1 P572E ATD & 1 P572O ATD	kg	141.0	B
Rated Cargo/Luggage Weight (RCLW)	kg	64.8	C
Calculated Vehicle Target Weight (TVTW)	kg	1967.8	A+B+C

TEST VEHICLE ATTITUDES

Condition	Units	LF	RF	LR	RR	CG Aft of Front Axle
As Delivered	mm	749	759	749	746	1502
As Tested	mm	716	719	710	714	1545
Post-Test	mm	767	749	714	714	

GENERAL TEST VEHICLE DATA

Measurement Description	Units	Value
Total Vehicle Wheelbase	mm	2877
Total Vehicle Length at Left Side	mm	4027
Total Vehicle Length at Centerline	mm	4662
Total Vehicle Length at Right Side	mm	4027
Weight of Ballast in Cargo Area	kg	89.5
Weight of Vehicle Components Removed	kg	47.0
Amount of Stoddard Solvent in Fuel Tank	L	N/A

VEHICLE COMPONENTS REMOVED TO MEET TEST WEIGHT:

Rear Seat Assembly (26.0 kg), Rear Trim (14.0 kg), Underbody Cover (7.0 kg)

DATA SHEET NO. 1 ... (CONTINUED)

GENERAL TEST AND VEHICLE PARAMETER DATA

Test Vehicle: 2018 Tesla Model 3 Long Range RWD 4-Door Sedan NHTSA No.: O20185000

Test Program: 56.3 km/h Frontal Impact NCAP Test Test Date: 08/20/18

TARGET VEHICLE STRUCTURAL MEASUREMENTS

No.	Description	Pre-Test
1	Total Length	4662
2	Total Width	1840
3	Bumper Top Height	587
4	Bumper Bottom Height	357
5	Longitudinal Member Top Height	560
6	Distance Between Longitudinal Members	790
7	Longitudinal Member Width	110
8	Engine Top Height	N/A
9	Engine Bottom Height	N/A
10	Engine and Gearbox Width	N/A
11	Front Bumper to Engine Distance	N/A
12	Front Shock Absorber Fixing Height	805
13	Bonnet Leading Edge Height	665
14	Front Shock Absorber Fixing Width	978
15	Front Bumper to Front Axle Distance	825
16	Front Axle to A-Pillar Distance	550
17	A-Pillar to B-Pillar Distance	987
18	B-Pillar to Rear Axle Distance	1195
19	B-Pillar to C-Pillar Distance	843
20	Roof Sill Bottom Height	1280
21	Roof Sill Top Height	1390
22	Floor Sill Bottom Height	330
23	Floor Sill Top Height	400

All measurements in millimeters.

DATA SHEET NO. 2

SEAT ADJUSTMENT, FUEL SYSTEM, AND STEERING WHEEL DATA

Test Vehicle: 2018 Tesla Model 3 Long Range RWD 4-Door Sedan NHTSA No.: O20185000

Test Program: 56.3 km/h Frontal Impact NCAP Test Test Date: 08/20/18

NOMINAL DESIGN RIDING POSITION

The procedure for the driver is as follows: the seat back is set to the manufacturer’s designated angle. The procedure for the passenger is as follows: the seat back is set to position the transverse instrumentation platform of the dummy’s head at $0^\circ \pm 0.5^\circ$. Seat back angle is measured along the seatback.

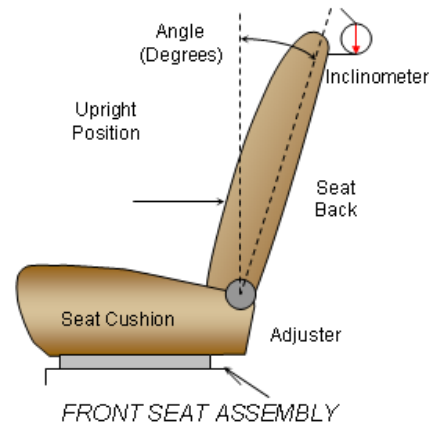

SEAT BACK ANGLE

Seating Position	Degrees
Driver Seat Back Angle	19.9
Passenger Seat Back Angle	17.3

SEAT FORE / AFT POSITIONING

The total seat travel is measured from the forward most possible position to the rear most possible position. The driver’s seat is set to the middle of the fore-aft travel. The passenger’s seat is set to the forward most position where the ATD will not contact any interior panels.

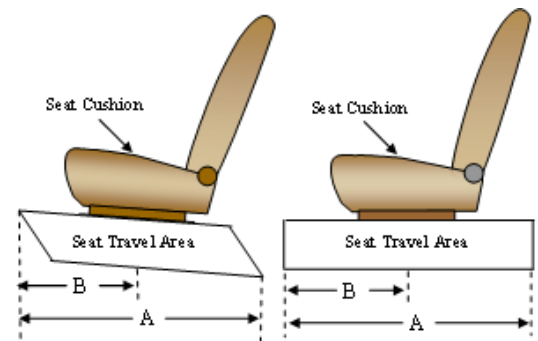

SEAT FORE/AFT POSITIONS

Seating Position	Total Fore-Aft Travel	Placed in Position
Driver Seat	322 mm	161 mm
Passenger Seat	260 mm	0 mm

SEAT BELT UPPER ANCHORAGE

The seat belt upper anchorage is positioned to the manufacturer’s design position for a 50th percentile adult male ATD for the driver, and a 5th percentile adult female ATD for the passenger. Position “H” is the uppermost position, followed by position “M”. Position “L” is the lowermost position.

SEAT BELT UPPER ANCHORAGES

Seating Position	Total No. of Positions	Placed in Position
Driver Seat	3	H
Passenger Seat	3	H

DATA SHEET NO. 2 ... (CONTINUED)

SEAT ADJUSTMENT, FUEL SYSTEM, AND STEERING WHEEL DATA

Test Vehicle: 2018 Tesla Model 3 Long Range RWD 4-Door Sedan NHTSA No.: O20185000

Test Program: 56.3 km/h Frontal Impact NCAP Test Test Date: 08/20/18

FUEL TANK CAPACITY

Description	Liters
Usable Capacity of "Standard Tank"	N/A
Usable Capacity of "Optional Tank"	N/A
92 - 94% of Usable Capacity	N/A
Actual Amount of Stoddard Solvent Used	N/A
1/3 of Usable Capacity	N/A

FUEL PUMP

The vehicle is electric and is not equipped with a fuel system.

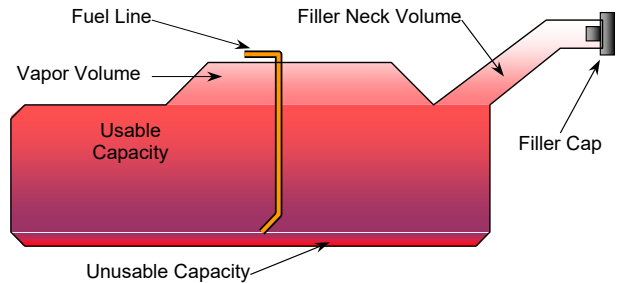

VEHICLE FUEL TANK ASSEMBLY

STEERING COLUMN ADJUSTMENT

Steering wheel and column adjustments are made so that the steering wheel hub is at the geometric center of the locus it describes when moved through its full range of motion. A digital inclinometer is used to measure a plate which is placed across the rim of the steering wheel for angular measurements.

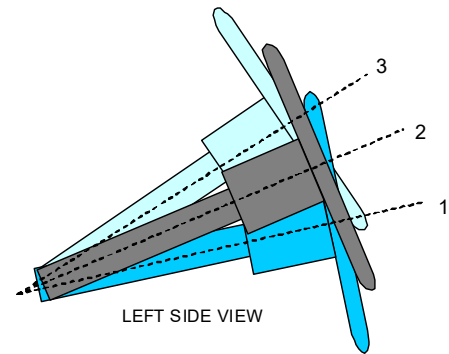

STEERING COLUMN ASSEMBLY

STEERING COLUMN POSITIONING

	Degrees	Fore-Aft Position (mm)
Lowermost Position, No. 1	21.3	293
Geometric Center Position, No. 2	18.9	322
Uppermost Position, No. 3	21.3	350
Telescoping Steering Wheel Travel		57
Test Position	18.9	322

DATA SHEET NO. 3

DUMMY LONGITUDINAL CLEARANCE DIMENSIONS

Test Vehicle: 2018 Tesla Model 3 Long Range RWD 4-Door Sedan NHTSA No.: O20185000

Test Program: 56.3 km/h Frontal Impact NCAP Test Test Date: 08/20/18

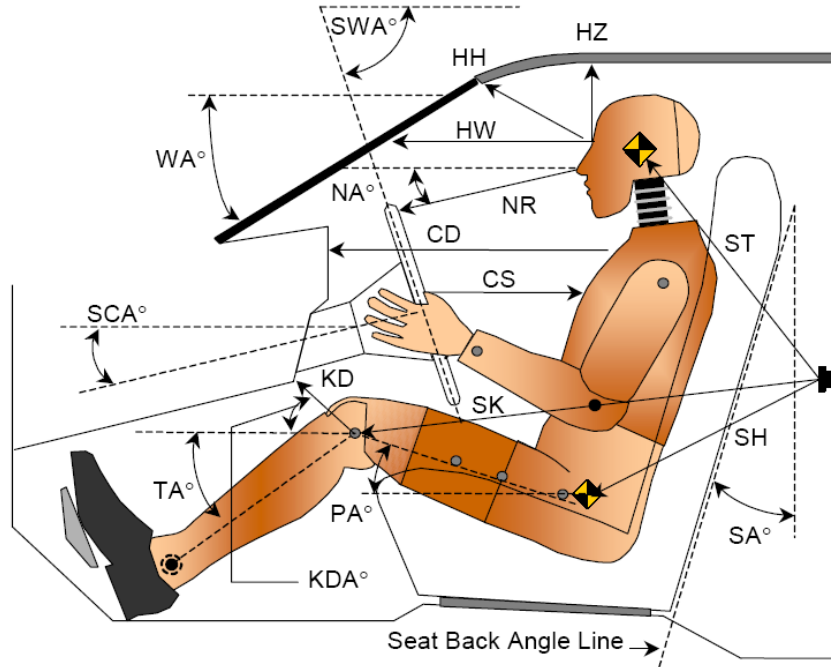

LEFT SIDE VIEW

Code	Measurement Description	Driver		Passenger	
		Length (mm)	Angle (°)	Length (mm)	Angle (°)
WA°	Windshield Angle		21.9		
SWA°	Steering Wheel Angle		71.1		
SCA°	Steering Column Angle		18.9		
SA°	Seat Back Angle (On Headrest Post)		19.9		17.3
HZ	Head to Roof	245	90.0	227	90.0
HH	Head to Header	327	27.5	281	49.5
HW	Head to Windshield	674	0.0	623	0.0
NR	Nose to Rim	357	8.7	486	27.7
CD	Chest to Dash	568	4.5	444	1.1
CS	Chest to Steering Hub	297	1.3		
RA	Rim to Abdomen	198	0.0		
KDL	Left Knee to Dash	221	29.1	163	31.6
KDR	Right Knee to Dash	212	24.8	175	36.5
PA°	Pelvic Angle		24.6		20.7
TA°	Tibia Angle		40.4		46.4
SK	Striker to Knee	535	2.8	636	0.5
ST	Striker to Head	497	82.5	486	69.1
SH	Striker to H-Point	234	40.6	332	19.5

DATA SHEET NO. 4

DUMMY LATERAL CLEARANCE DIMENSIONS

Test Vehicle: 2018 Tesla Model 3 Long Range RWD 4-Door Sedan NHTSA No.: O20185000

Test Program: 56.3 km/h Frontal Impact NCAP Test Test Date: 08/20/18

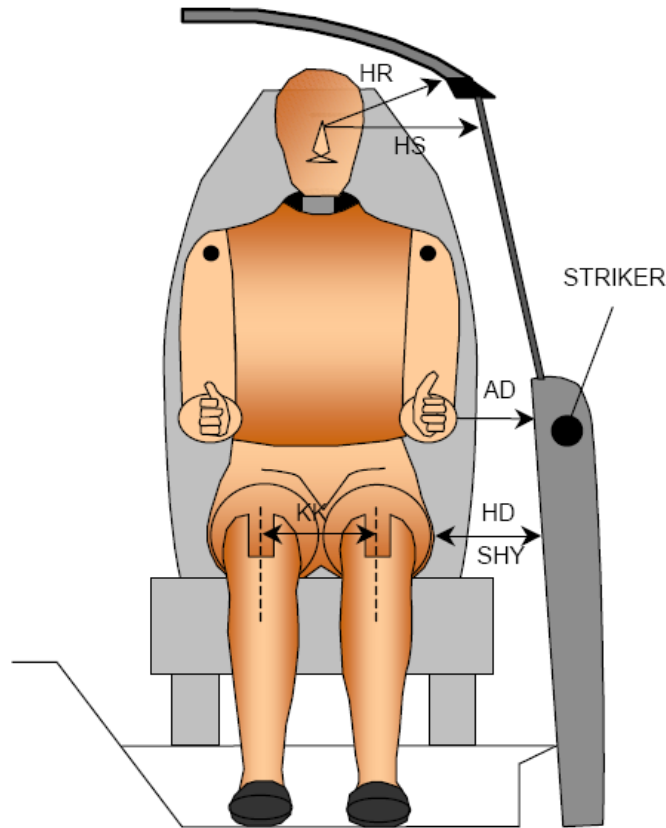

Code	Description	Driver (mm)	Passenger (mm)
AD	Arm to Door	78	82
HD	H-Point to Door	149	171
HR	Head to Side Header	250	339
HS	Head to Side Window	355	395
KK	Knee to Knee	330	160
SHY	Striker to H-Point (Y-Direction)	241	286
AA	Ankle to Ankle	325	208

DATA SHEET NO. 5

SEAT BELT POSITIONING DATA

Test Vehicle: 2018 Tesla Model 3 Long Range RWD 4-Door Sedan NHTSA No.: O20185000

Test Program: 56.3 km/h Frontal Impact NCAP Test Test Date: 08/20/18

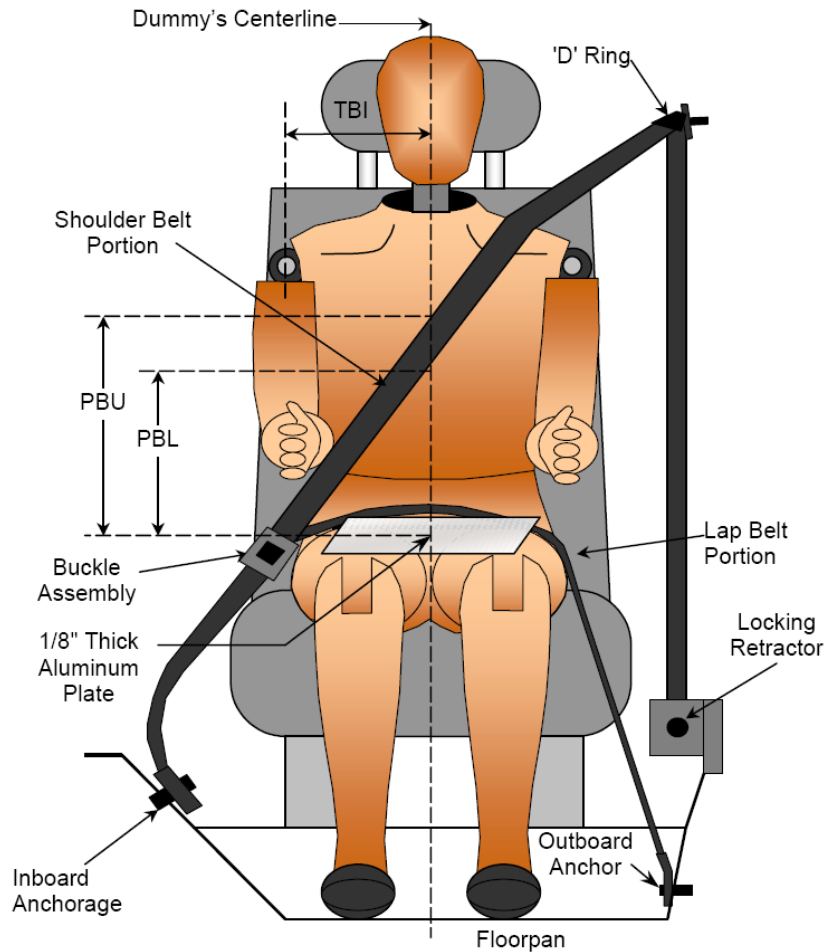

FRONT VIEW OF DUMMY

SEAT BELT POSITIONING MEASUREMENTS

Code	Measurement Description	Units	Driver	Passenger
PBU	Top Surface of Aluminum Plate to Belt Upper Edge	mm	270	280
PBL	Top Surface of Aluminum Plate to Belt Lower Edge	mm	200	190

BELT LENGTH DATA

Measurement Description	Units	Driver	Passenger
Shoulder Belt Length as Measured on ATD	mm	908	942
Lap Belt Length as Measured on ATD	mm	568	499
Remainder of Belt on Reel	mm	1078	1105
Total Belt Length for Continuous Webbing Systems	mm	2554	2546

DATA SHEET NO. 6

HIGH-SPEED CAMERA LOCATIONS AND DATA

Test Vehicle: 2018 Tesla Model 3 Long Range RWD 4-Door Sedan NHTSA No.: O20185000

Test Program: 56.3 km/h Frontal Impact NCAP Test Test Date: 08/20/18

CAMERA POSITIONS FOR FRONTAL IMPACTS

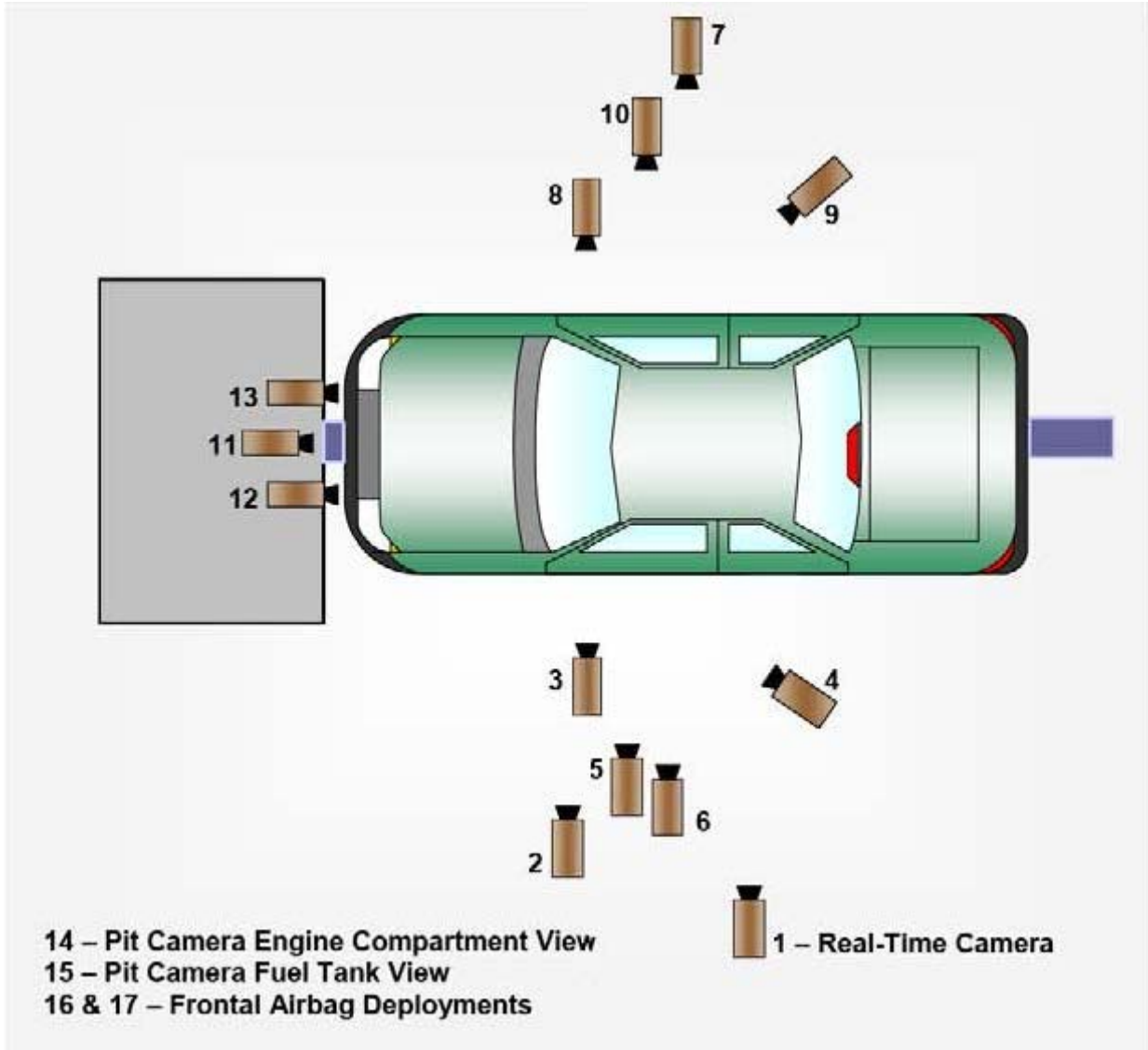

DATA SHEET NO. 6 ... (CONTINUED)

HIGH-SPEED CAMERA LOCATIONS AND DATA

Test Vehicle: 2018 Tesla Model 3 Long Range RWD 4-Door Sedan NHTSA No.: O20185000

Test Program: 56.3 km/h Frontal Impact NCAP Test Test Date: 08/20/18

CAMERA LOCATIONS

No.	Description	Location (mm)			Lens (mm)	Speed (fps)
		X	Y	Z		
1	Real-Time Left Overall	-11412	-8150	-1484		30
2	Driver Close-Up	-2590	-7950	-1371	50	1000
3	Left Front Half	-1701	-6197	-1701	35	1000
4	Left Angle	-6696	-10308	-3211	105	1000
5	Steering Column - Top	-1966	-10412	-3688	35	1000
6	Steering Column - Bottom	-1972	-10412	-3379	35	1000
7	Right Overall	-2336	7569	-1012	20	1000
8	Passenger Close-Up	-1733	7581	-1408	50	1000
9	Right Front Half	-1600	8214	-1811	35	1000
10	Right Angle	-6217	9516	-4830	85	1000
11	Windshield	-354	0	-5749	28	1000
12	Driver Windshield	297	-366	-2460	24	1000
13	Passenger Windshield	297	366	-2460	24	1000
14	Pit Front	-756	0	1495	20	1000
15	Pit Rear	-3398	0	1495	20	1000
16	Onboard Driver Airbag (Optional)	-950	300	-1100	8	1000
17	Onboard Passenger Airbag (Optional)	-950	-300	-1100	8	1000
18	Real-Time Left View of Impact					
19	Real-Time Right View of Impact					

Coordinates: +X = forward impact plane
 +Y = right of monorail center
 +Z = into ground

DATA SHEET NO. 7

VEHICLE ACCELEROMETER LOCATIONS

Test Vehicle: 2018 Tesla Model 3 Long Range RWD 4-Door Sedan NHTSA No.: O20185000

Test Program: 56.3 km/h Frontal Impact NCAP Test Test Date: 08/20/18

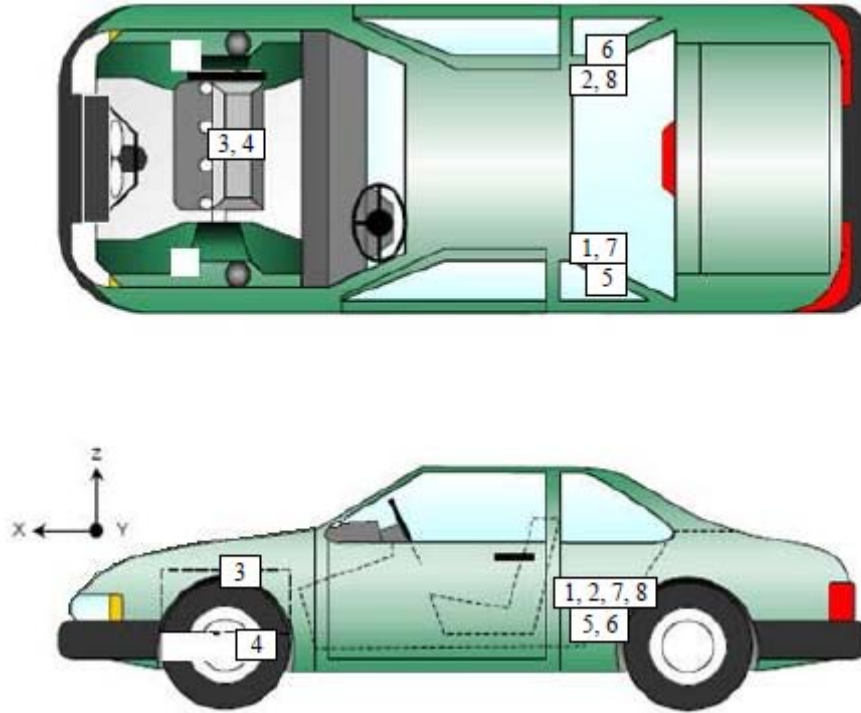

VEHICLE ACCELEROMETER PRE-TEST LOCATIONS

No.	Description	Location		
		X	Y	Z
1	Left Rear Accelerometer X-Direction	1800	-740	-380
2	Right Rear Accelerometer X-Direction	1800	740	-380
3	Engine Top X	3825	30	-700
4	Engine Bottom X	3620	-5	-650
5	Left Rear Accelerometer Z-Direction	1800	-740	-380
6	Right Rear Accelerometer Z-Direction	1800	740	-380
7	Left Rear Accelerometer X-Direction Redundant	1800	-740	-380
8	Right Rear Accelerometer X-Direction Redundant	1800	740	-380

Reference Points: X – Rear Surface of Vehicle (+ forward)
 Y – Vehicle Centerline (+ to right)
 Z – Ground Plane (+ down)

DATA SHEET NO. 8

PHOTOGRAPHIC REFERENCE TARGET LOCATIONS

Test Vehicle: 2018 Tesla Model 3 Long Range RWD 4-Door Sedan NHTSA No.: O20185000

Test Program: 56.3 km/h Frontal Impact NCAP Test Test Date: 08/20/18

Item	Value
A	N/A
B	920
C	2240
D	610
E	1800
F	305
G	1825
H	720
I	1290
J	986
K	986
L	1400
M	720
N	1400
O	986
P	986
Q	1290

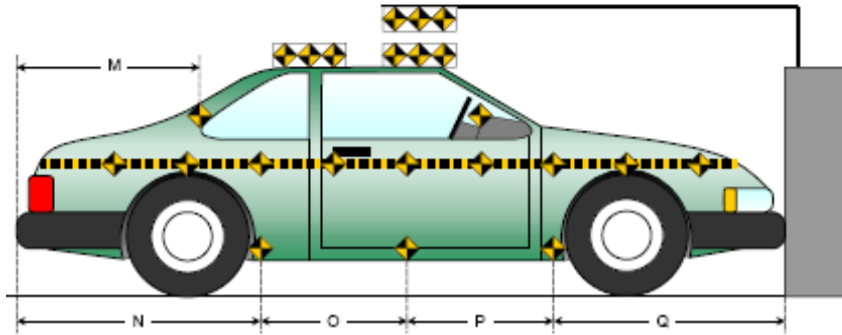
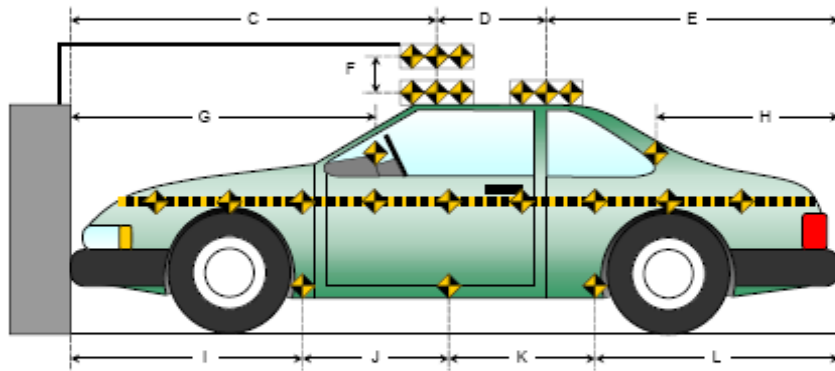
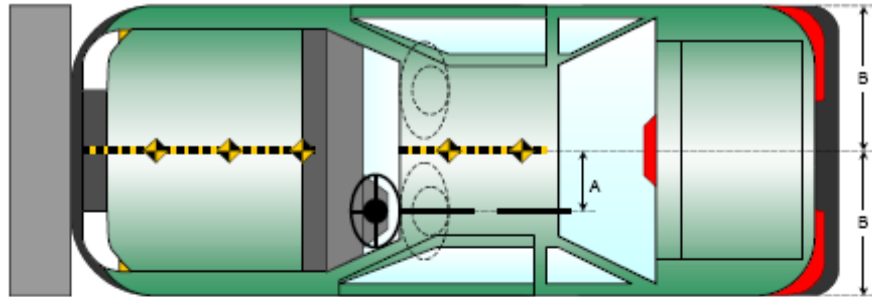

All measurements in millimeters.

DATA SHEET NO. 9

LOAD CELL LOCATIONS ON FIXED BARRIER

Test Vehicle: 2018 Tesla Model 3 Long Range RWD 4-Door Sedan NHTSA No.: O20185000

Test Program: 56.3 km/h Frontal Impact NCAP Test Test Date: 08/20/18

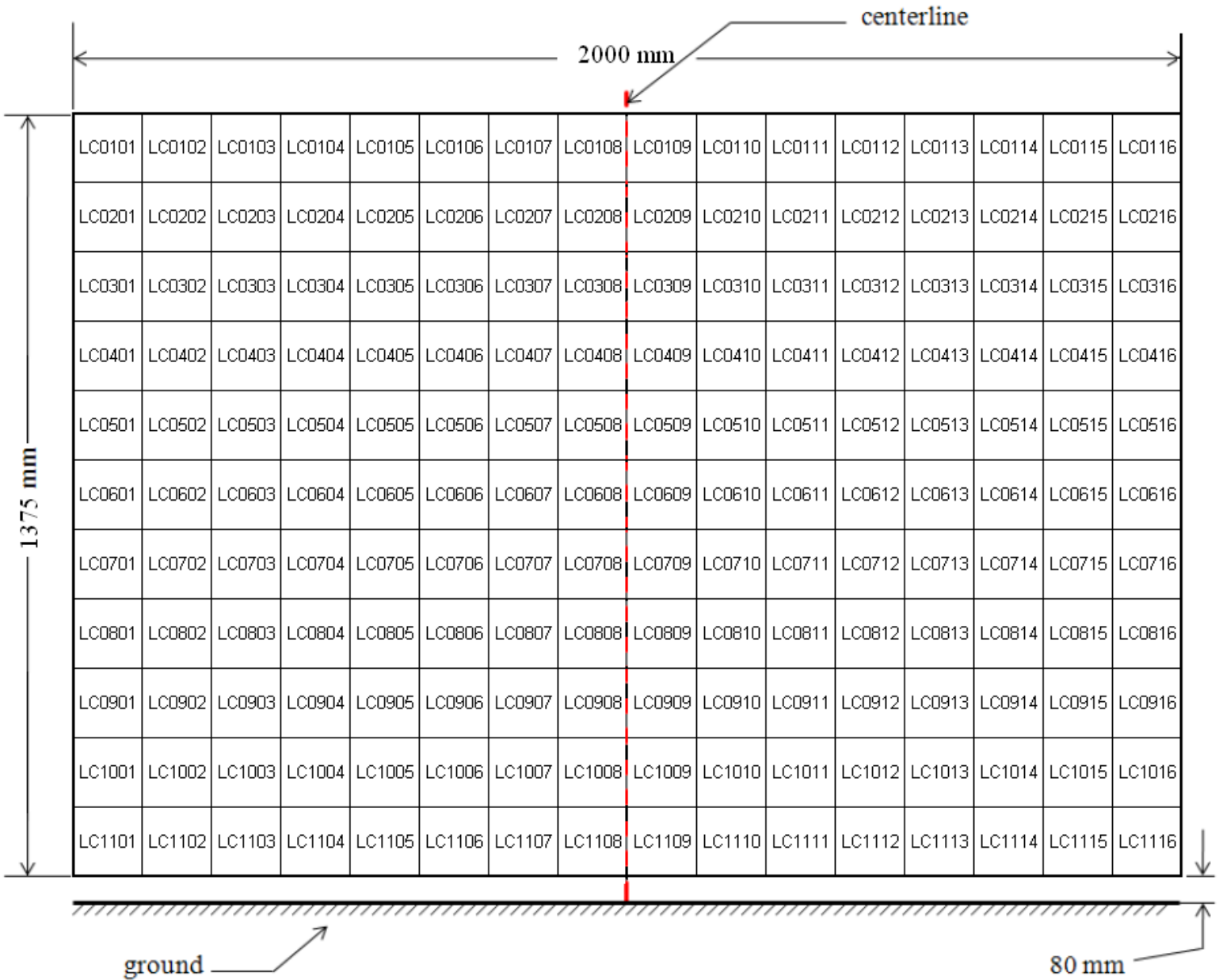

DATA SHEET NO. 10

TEST VEHICLE CAMERA AND INSTRUMENTATION SUMMARY

Test Vehicle: 2018 Tesla Model 3 Long Range RWD 4-Door Sedan NHTSA No.: O20185000

Test Program: 56.3 km/h Frontal Impact NCAP Test Test Date: 08/20/18

INSTRUMENTATION

Driver Dummy Accelerometers	47
Passenger Dummy Accelerometers	47
Vehicle Structure Accelerometers	8
Seat Belt Load Cells	2
Load Cell Barrier	528
Total	632

CAMERA COVERAGE

High-Speed Vehicle On Board	2
High-Speed Off Board	14
Real Time	3
Total	19

DATA SHEET NO. 11
POST-TEST OBSERVATIONS

Test Vehicle: 2018 Tesla Model 3 Long Range RWD 4-Door Sedan NHTSA No.: O20185000
 Test Program: 56.3 km/h Frontal Impact NCAP Test Test Date: 08/20/18

TEST DUMMY INFORMATION AND CONTACT

Description	Driver	Passenger
Dummy Type/Serial No.	P572E 50th Percentile Male ATD / 360	P572O 5th Percentile Female ATD / 141
Head Contact	Frontal Airbag, Headrest	Frontal Airbag, Headrest, Seatback
Upper Torso Contact	Frontal Airbag	Frontal Airbag
Lower Torso Contact	None	None
Left Knee Contact	Knee Airbag, Steering Wheel Rim ¹	None
Right Knee Contact	Knee Airbag, Steering Wheel Rim ¹	None

DOOR OPENING AND SEAT TRACK INFORMATION

Description	Driver	Passenger
Locked / Unlocked Doors	Unlocked	Unlocked
Front Door Opening	Remained closed and latched, operational	Remained closed and latched, operational
Rear Door Opening	Remained closed and latched, operational	Remained closed and latched, operational
Seat Track Shift (mm)	5	14
Seat Back Failure	None	None
Glazing Damage	None	None

POST-TEST STRUCTURAL OBSERVATIONS

Critical Areas of Performance	Observations and Conclusions
Windshield Damage	None
Window Damage	None
Other Notable Effects	None

VEHICLE REBOUND FROM BARRIER

Measured Parameter	Units	Value
Left Side	mm	1105
Center	mm	1045
Right Side	mm	1140
Average	mm	1097

SUPPLEMENTAL RESTRAINT SYSTEM INFORMATION

Restraint Type	Driver		Passenger	
	Installed	Operated	Installed	Operated
Front Airbag	Yes	Yes	Yes	Yes
Side Airbag 1 (Curtain)	Yes	No	Yes	No
Side Airbag 2 (Torso/Pelvis)	Yes	No	Yes	No
Knee Airbag	Yes	Yes	Yes	No*
Seat Belt Pretensioner	Yes	Yes	Yes	Yes
Seat Belt Load Limiter	Yes	Yes	Yes	Yes

*Passenger knee airbag is not designed to deploy for 5th percentile female.

¹The Driver's left and right thighs contacted the steering wheel rim.

DATA SHEET NO. 12

VEHICLE PROFILE MEASUREMENTS

Test Vehicle: 2018 Tesla Model 3 Long Range RWD 4-Door Sedan NHTSA No.: O20185000

Test Program: 56.3 km/h Frontal Impact NCAP Test Test Date: 08/20/18

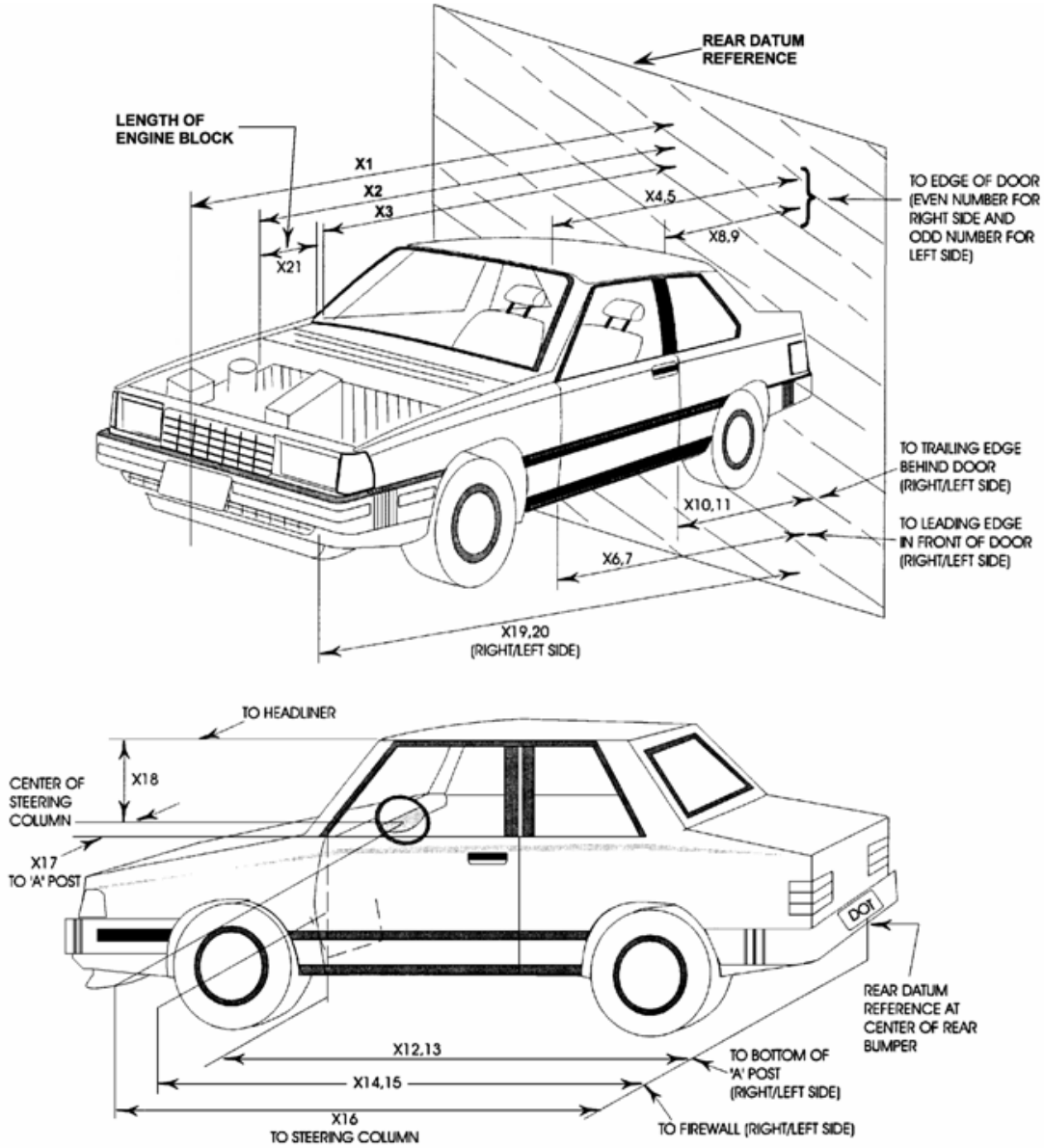

DATA SHEET NO. 12 ... (CONTINUED)

VEHICLE PROFILE MEASUREMENTS

Test Vehicle: 2018 Tesla Model 3 Long Range RWD 4-Door Sedan NHTSA No.: O20185000

Test Program: 56.3 km/h Frontal Impact NCAP Test Test Date: 08/20/18

No.	Description	Pre-Test	Post-Test	Difference
1	Total Length of Vehicle at Centerline	4662	4307	-355
2	Rear Surface of Vehicle to Front of Engine	N/A	N/A	N/A
3	RSOV to Firewall	3547	3557	10
4	RSOV to Upper Leading Edge of Right Door	3282	3282	0
5	RSOV to Upper Leading Edge of Left Door	3277	3297	20
6	RSOV to Lower Leading Edge of Right Door	3270	3257	-13
7	RSOV to Lower Leading Edge of Left Door	3265	3265	0
8	RSOV to Upper Trailing Edge of Right Door	2112	2117	5
9	RSOV to Upper Trailing Edge of Left Door	2110	2115	5
10	RSOV to Lower Trailing Edge of Right Door	2159	2145	-14
11	RSOV to Lower Trailing Edge of Left Door	2162	2155	-7
12	RSOV to Bottom of A-Pillar, Right Side	3184	3171	-13
13	RSOV to Bottom of A-Pillar, Left Side	3186	3176	-10
14	RSOV to Firewall, Right Side	3407	3422	15
15	RSOV to Firewall, Left Side	3407	3422	15
16	RSOV to Steering Column	2690	2805	115
17	Center of Steering Column to A-Pillar	420	423	3
18	Center of Steering Column to Headliner	400	430	30
19	RSOV to Right Side of Front Bumper	4027	3955	-72
20	RSOV to Left Side of Front Bumper	4027	3880	-147
21	Length of Engine Block	N/A	N/A	N/A
RD	RSOV to Right Side of Dash Panel	2985	3000	15
CD	RSOV to Center of Dash Panel	2870	2966	96
LD	RSOV to Left Side of Dash Panel	2985	2980	-5

All measurements in millimeters.

DATA SHEET NO. 13

ACCIDENT INVESTIGATION DIVISION DATA

Test Vehicle: 2018 Tesla Model 3 Long Range RWD 4-Door Sedan NHTSA No.: O20185000

Test Program: 56.3 km/h Frontal Impact NCAP Test Test Date: 08/20/18

VEHICLE INFORMATION

VIN: 5YJ3E1EA5JF061210
 Vehicle Size Category: Passenger Car

Wheelbase (mm): 2877
 Test Weight (kg): 1959.5

ACCELEROMETER DATA

Accelerometer Locations: Left Rear Crossmember
 Cal. Procedure/Interval: Vibration Test / 6 months
 Integration Algorithm: NHTSA Standard
 Impact Velocity (km/h): 56.41
 Velocity Change (km/h): 64.7
 Time of Separation (msec): 81.8

Linearity: Good

CRUSH PROFILE

Collision Deformation Classification: 12FDEW2
 Midpoint of Damage: Vehicle Centerline
 Damage Region Length (mm): 1376
 Impact Mode: Full Frontal

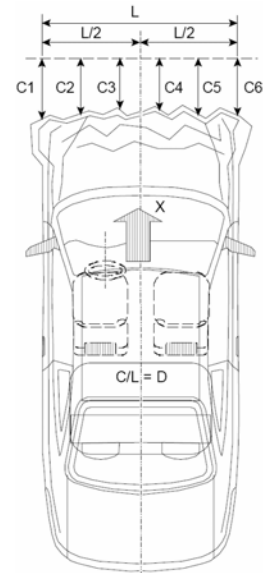

No.	Measurement Description	Units	Pre-Test	Post-Test	Difference
C1	Crush Zone 1 at Left Side	mm	210	490	280
C2	Crush Zone 2 at Left Side	mm	75	470	395
C3	Crush Zone 3 at Left Side	mm	8	440	432
C4	Crush Zone 4 at Right Side	mm	8	445	437
C5	Crush Zone 5 at Right Side	mm	75	440	365
C6	Crush Zone 6 at Right Side	mm	210	485	275
L	C1 to C6	mm	1376		

DATA SHEET NO. 14

VEHICLE INTRUSION MEASUREMENTS

Test Vehicle: 2018 Tesla Model 3 Long Range RWD 4-Door Sedan NHTSA No.: O20185000

Test Program: 56.3 km/h Frontal Impact NCAP Test Test Date: 08/20/18

DOOR OPENING WIDTH

Item	Description	Units	Pre-Test	Post-Test	Difference
A	Left Side Upper	mm	987	991	-4
B	Left Side Lower	mm	964	989	-25
D	Right Side Upper	mm	989	990	-1
E	Right Side Lower	mm	967	968	-1

WHEELBASE MEASUREMENTS

Item	Description	Units	Pre-Test	Post-Test	Difference
C	Left Side Wheelbase	mm	2877	2790	87
F	Right Side Wheelbase	mm	2877	2760	117

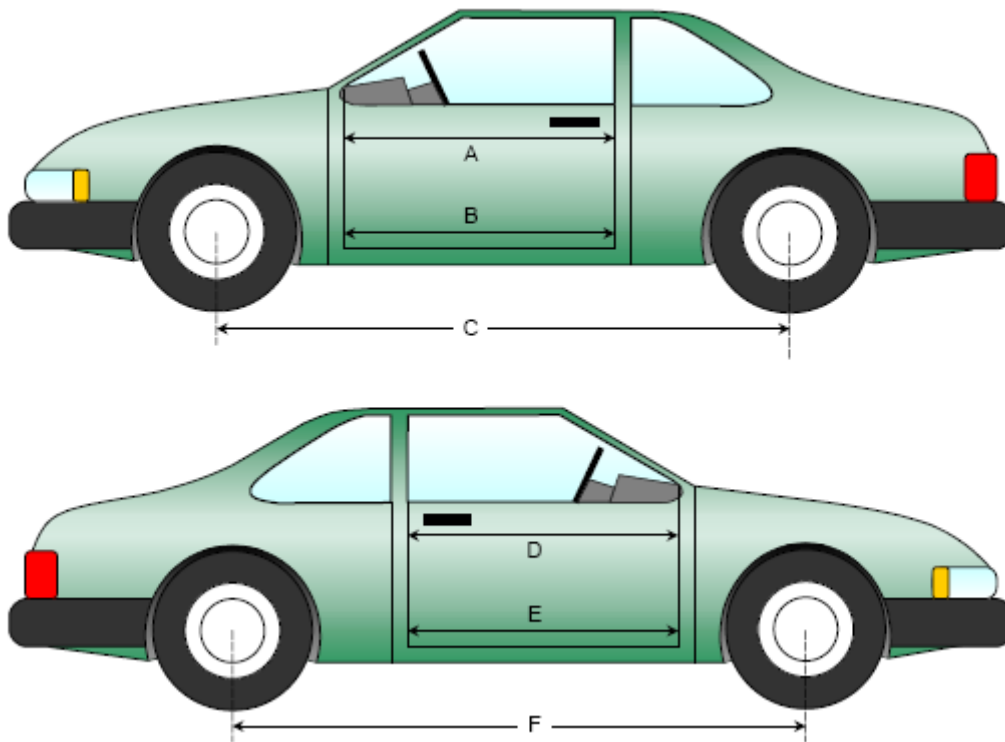

DATA SHEET NO. 14 ... (CONTINUED)
VEHICLE INTRUSION MEASUREMENTS

Test Vehicle: 2018 Tesla Model 3 Long Range RWD 4-Door Sedan NHTSA No.: O20185000
 Test Program: 56.3 km/h Frontal Impact NCAP Test Test Date: 08/20/18

DRIVER COMPARTMENT INTRUSION

Item	Description	Units	Pre-Test	Post-Test	Difference
AB	Door Opening (Inside Window Jam)	mm	916	918	-2
CX	Left Knee Bolster to X	mm	360	330	30
DX	Right Knee Bolster to X	mm	360	330	30
EX	Brake Pedal to X	mm	575	550	25
FX	Foot Rest to X	mm	625	600	25
GX	Center of Steering Wheel Hub to X	mm	70	65	5

X = Front of Seat Track (Stationary)

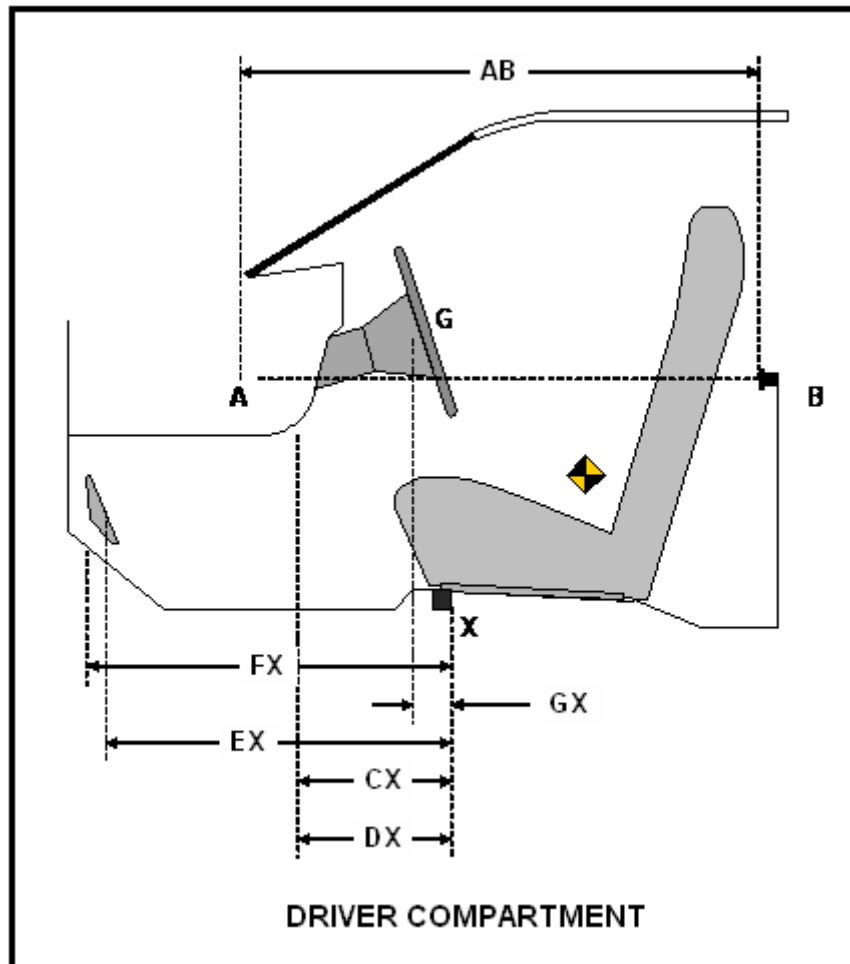

DATA SHEET NO. 15

SUMMARY OF FMVSS 212, 219 (PARTIAL), AND 301 DATA

Test Vehicle: 2018 Tesla Model 3 Long Range RWD 4-Door Sedan NHTSA No.: O20185000

Test Program: 56.3 km/h Frontal Impact NCAP Test Test Date: 08/20/18

Windshield Mounting Details: Windshield glass is secured to the vehicle frame with rubber molding and rubber cement.

The standard requires that the post-test retention measurement be a minimum of 75% of the pre-test total periphery measurement for vehicles not equipped with occupant passive restraints and 50% for each side of the windshield for vehicles which are equipped with occupant passive restraints.

Temperature of windshield molding during test: 20.9° C

WINDSHIELD PERIPHERY MEASUREMENTS

Measurement	Pre-Test (mm)	Post-Test (mm)	% Retention
Left Side	2552	2552	100.0%
Right Side	2552	2552	100.0%
Total	5104	5104	100.0%

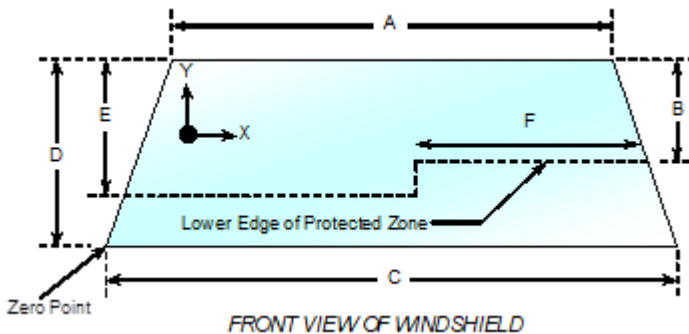

FRONT VIEW OF WINDSHIELD

Item	Units	Value
A	mm	1276
B	mm	705
C	mm	1468
D	mm	1180
E	mm	705
F	mm	560

AREAS OF PROTECTED ZONE FAILURES

A. Provide Coordinates of the area that the protected zone was penetrated more than 0.25 inches by a vehicle component other than one that is normally in contact with the windshield.

X	Y

B. Provide coordinates of the area beneath the protected zone that the inner surface of the windshield was penetrated by a vehicle component.

X	Y

DATA SHEET NO. 15 ... (CONTINUED)

SUMMARY OF FMVSS 212, 219 (PARTIAL), AND 301 DATA

Test Vehicle: 2018 Tesla Model 3 Long Range RWD 4-Door Sedan NHTSA No.: O20185000

Test Program: 56.3 km/h Frontal Impact NCAP Test Test Date: 08/20/18

FMVSS 301 FUEL SYSTEM INTEGRITY POST IMPACT DATA

Temperature at Time of Impact: 31.7° C Test Time: 6:45 PM

Stoddard Solvent Spillage Measurements

- A. From impact until vehicle motion ceases: 0 oz.
(Maximum allowable = 1 oz.)
- B. For the 5 minute period after motion ceases: 0 oz.
(Maximum allowable = 5 oz.)
- C. For the following 25 minutes: 0 oz.
(Maximum allowable = 1 oz./minute)
- D. Spillage: The vehicle is electric and did not contain Stoddard solvent.

DATA SHEET NO. 16

FMVSS 301 STATIC ROLLOVER RESULTS

Test Vehicle: 2018 Tesla Model 3 Long Range RWD 4-Door Sedan NHTSA No.: O20185000

Test Program: 56.3 km/h Frontal Impact NCAP Test Test Date: 08/20/18

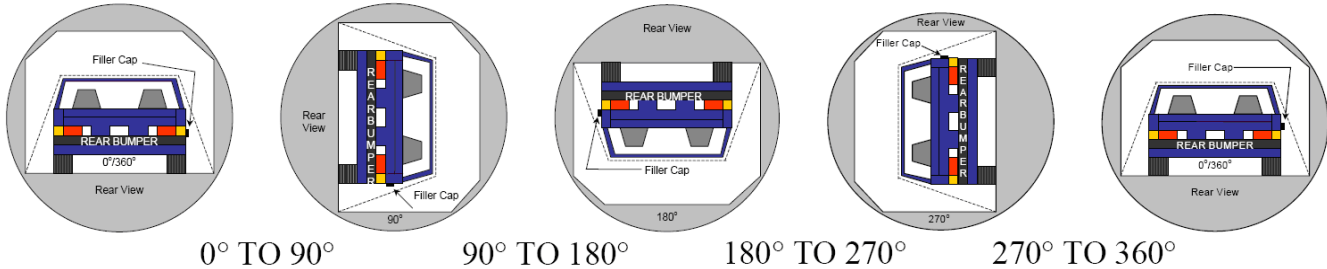

1. The specified fixture rollover rate for each 90° of rotation is 60 to 180 seconds.
2. The position hold time at each position is 300 seconds (minimum).
3. Details of Stoddard solvent spillage: The vehicle is electric and did not contain Stoddard Solvent.

SOLVENT COLLECTION TIME TABLE IN SECONDS

Test Phase	Rotation Time	Hold Time	Total Time
0° To 90°			
90° To 180°			
180° To 270°			
270° To 360°			

FMVSS 301 SPILLAGE TABLE

Test Phase	First 5 Minutes	Sixth Minute	Seventh Minute	Eighth Minute
0° To 90°	0			
90° To 180°	0			
180° To 270°	0			
270° To 360°	0			

SOLVENT SPILLAGE LOCATION TABLE

Test Phase	Spillage Location
0° To 90°	
90° To 180°	
180° To 270°	
270° To 360°	

DATA SHEET NO. 17

DUMMY / VEHICLE TEMPERATURE STABILIZATION CHART

Test Vehicle: 2018 Tesla Model 3 Long Range RWD 4-Door Sedan NHTSA No.: O20185000

Test Program: 56.3 km/h Frontal Impact NCAP Test Test Date: 08/20/18

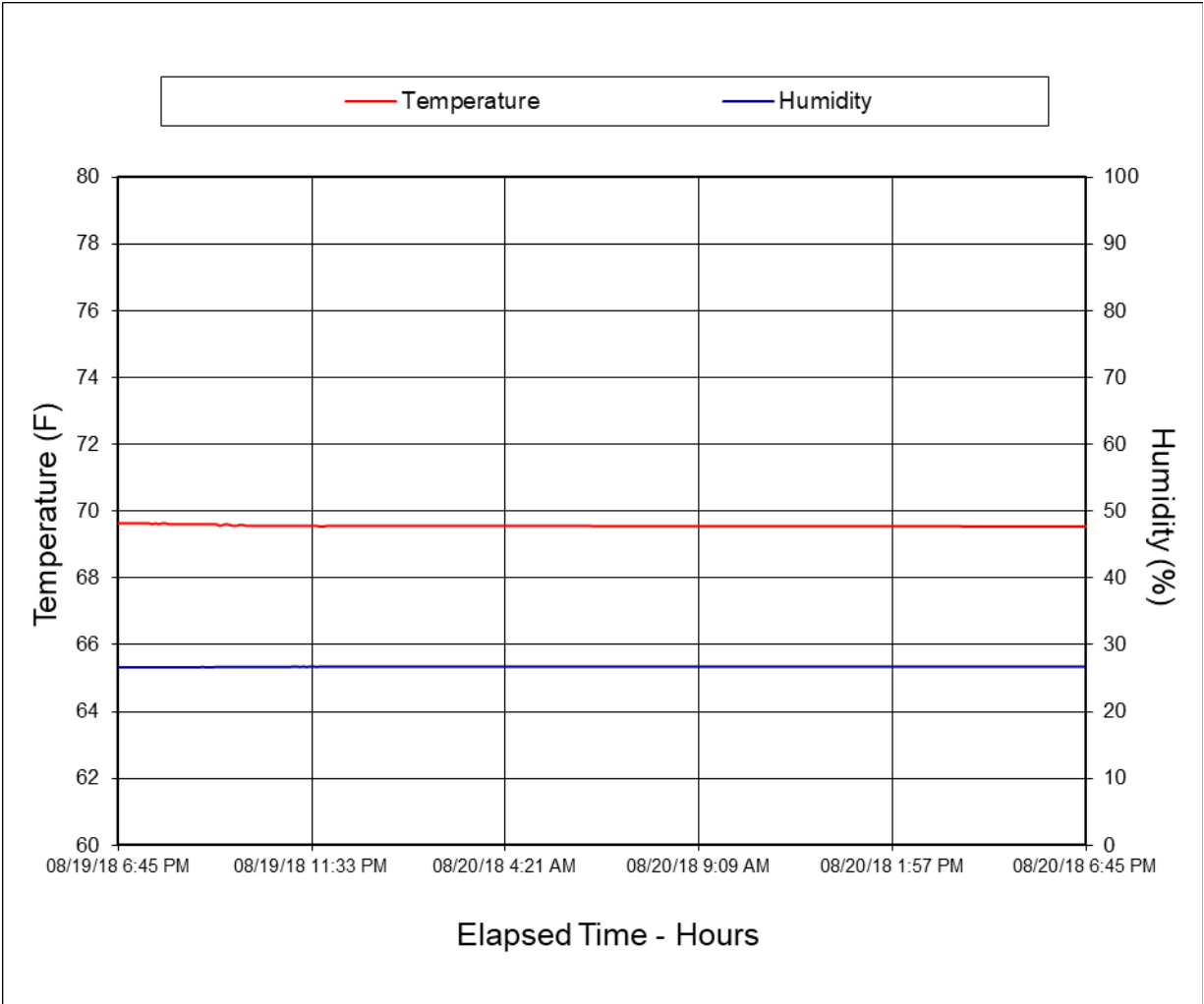

**APPENDIX A
PHOTOGRAPHS**

TABLE OF PHOTOGRAPHS

Figure		Page
1	Load Cell Location	A-1
2	Pre-Test Load Cell Wall	A-1
3	Post-Test Load Cell Wall	A-2
4	Manufacturer's Label	A-2
5	Tire Placard	A-3
6	2018 Tesla Model 3 Long Range RWD Frontal as Delivered	A-3
7	Left Rear $\frac{3}{4}$ View, as Received	A-4
8	Pre-Test Front View of Test Vehicle	A-4
9	Post-Test Front View of Test Vehicle	A-5
10	Pre-Test Left View of Test Vehicle	A-5
11	Post-Test Left View of Test Vehicle	A-6
12	Pre-Test Right View of Test Vehicle	A-6
13	Post-Test Right View of Test Vehicle	A-7
14	Pre-Test Right Front $\frac{3}{4}$ View	A-7
15	Post-Test Right Front $\frac{3}{4}$ View	A-8
16	Pre-Test Left Rear $\frac{3}{4}$ View	A-8
17	Post-Test Left Rear $\frac{3}{4}$ View	A-9
18	Pre-Test Windshield View	A-9
19	Post-Test Windshield View	A-10
20	Pre-Test Front Storage Compartment View	A-10
21	Post-Test Front Storage Compartment View	A-11
22	Pre-Test Fuel Filler Cap – Charge Port View	A-11
23	Post-Test Fuel Filler Cap – Charge Port View	A-12
24	Pre-Test Front Underbody View	A-12
25	Post-Test Front Underbody View	A-13
26	Pre-Test Rear Underbody View	A-13
27	Post-Test Rear Underbody View	A-14
28	Pre-Test Dummy Cable Routing	A-14
29	Post-Test Dummy Cable Routing	A-15
30	Pre-Test Driver Dummy Front View	A-15
31	Post-Test Driver Dummy Front View	A-16
32	Pre-Test Driver Dummy Window View	A-16
33	Post-Test Driver Dummy Window View	A-17
34	Pre-Test Driver Dummy and Vehicle Interior View	A-17
35	Post-Test Driver Dummy and Vehicle Interior View	A-18
36	Pre-Test Driver's Seat Fore-Aft Markings	A-18

TABLE OF PHOTOGRAPHS ... (CONTINUED)

Figure		Page
37	Post-Test Driver's Seat Fore-Aft Markings	A-19
38	Pre-Test View of Belt Anchorage for Driver Dummy	A-19
39	Post-Test View of Belt Anchorage for Driver Dummy	A-20
40	Pre-Test Driver Dummy Feet	A-20
41	Post-Test Driver Dummy Feet	A-21
42	Pre-Test Driver's Side Knee Bolster	A-21
43	Post-Test Driver's Side Knee Bolster	A-22
44	Pre-Test Driver's Side Floorpan	A-22
45	Post-Test Driver's Side Floorpan	A-23
46	Post-Test Driver Dummy Face	A-23
47	Post-Test Driver Dummy Contact with Airbag	A-24
48	Post-Test Driver Dummy Contact with Headrest	A-24
48a	Post-Test Driver Dummy Contact with Knee Airbag	A-25
49	Pre-Test View of the Steering Wheel	A-25
50	Post-Test View of the Steering Wheel	A-26
51	Pre-Test Passenger Dummy Front View	A-26
52	Post-Test Passenger Dummy Front View	A-27
53	Pre-Test Passenger Dummy Window View	A-27
54	Post-Test Passenger Dummy Window View	A-28
55	Pre-Test Passenger Dummy and Vehicle Interior View	A-28
56	Post-Test Passenger Dummy and Vehicle Interior View	A-29
57	Pre-Test Passenger's Seat Fore-Aft Markings	A-29
58	Post-Test Passenger's Seat Fore-Aft Markings	A-30
59	Pre-Test View of Belt Anchorage for Passenger Dummy	A-30
60	Post-Test View of Belt Anchorage for Passenger Dummy	A-31
61	Pre-Test Passenger Dummy Feet	A-31
62	Post-Test Passenger Dummy Feet	A-32
63	Pre-Test Passenger's Side Knee Bolster	A-32
64	Post-Test Passenger's Side Knee Bolster	A-33
65	Pre-Test Passenger's Side Floorpan	A-33
66	Post-Test Passenger's Side Floorpan	A-34
67	Post-Test Passenger Dummy Face	A-34
68	Post-Test Passenger Dummy Contact with Airbag	A-35
69	Post-Test Passenger Dummy Contact with Headrest	A-35
70	Photograph of Ballast Installed in Vehicle	A-36
71	Post-Test Stoddard Solvent Spillage Location View	A-36

TABLE OF PHOTOGRAPHS ... (CONTINUED)

<u>Figure</u>		<u>Page</u>
72	Post-Test Speed Trap Read-Out	A-37
73	Vehicle at 0° on Static Rollover Device	A-37
74	Vehicle at 90° on Static Rollover Device	A-38
75	Vehicle at 180° on Static Rollover Device	A-38
76	Vehicle at 270° on Static Rollover Device	A-39
77	Vehicle at 360° on Static Rollover Device	A-39
78	2018 Tesla Model 3 Long Range RWD Frontal Impact Event	A-40
79	Monroney Label Photograph	A-40

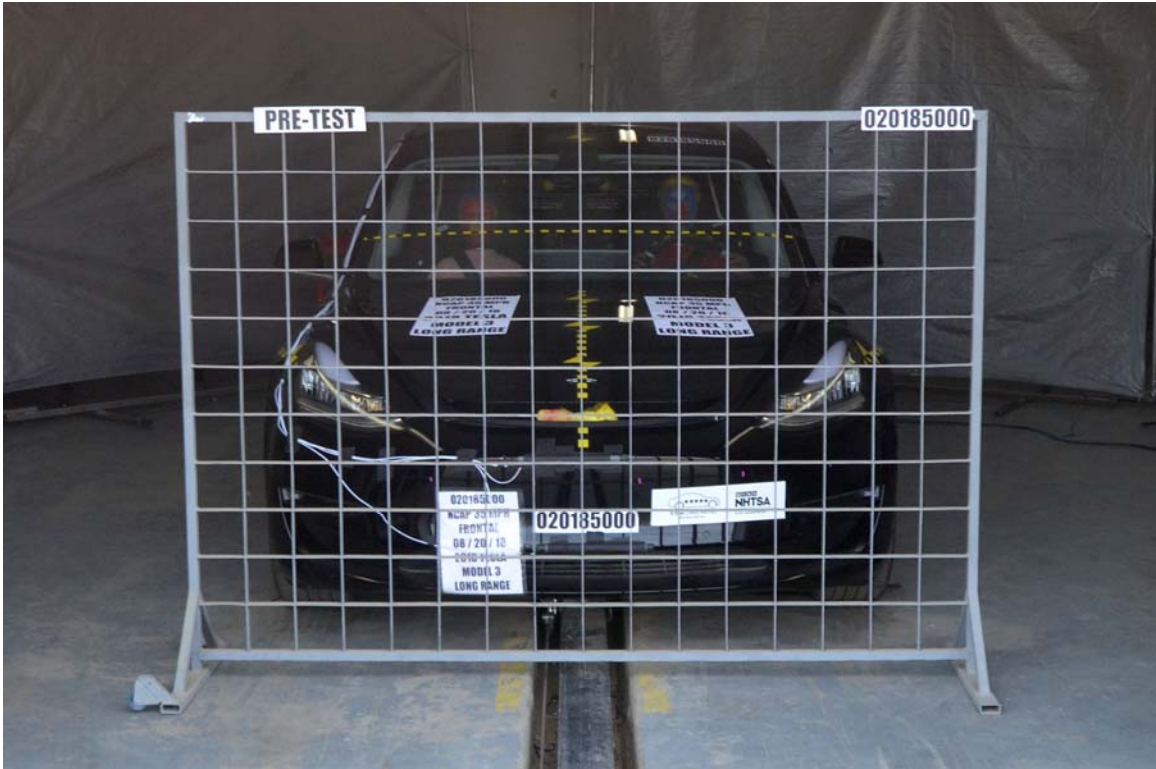

FIGURE 1. Load Cell Location

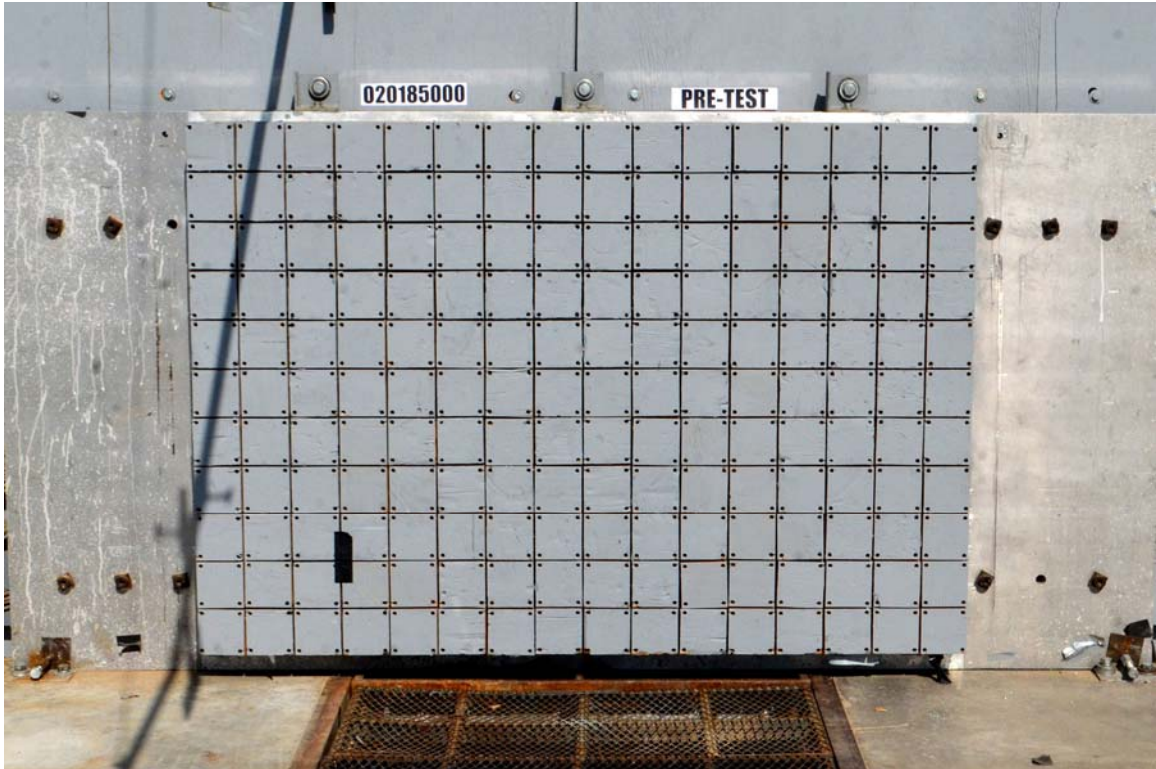

FIGURE 2. Pre-Test Load Cell Wall

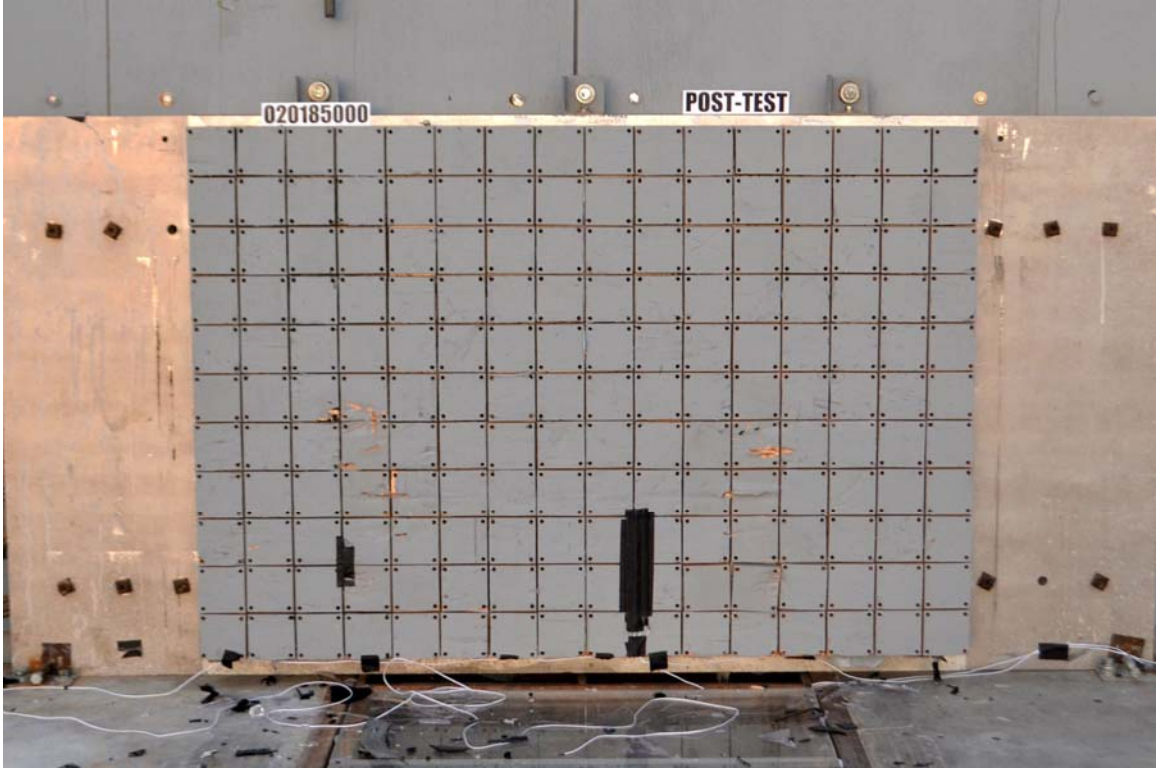

FIGURE 3. Post-Test Load Cell Wall



FIGURE 4. Manufacturer's Label

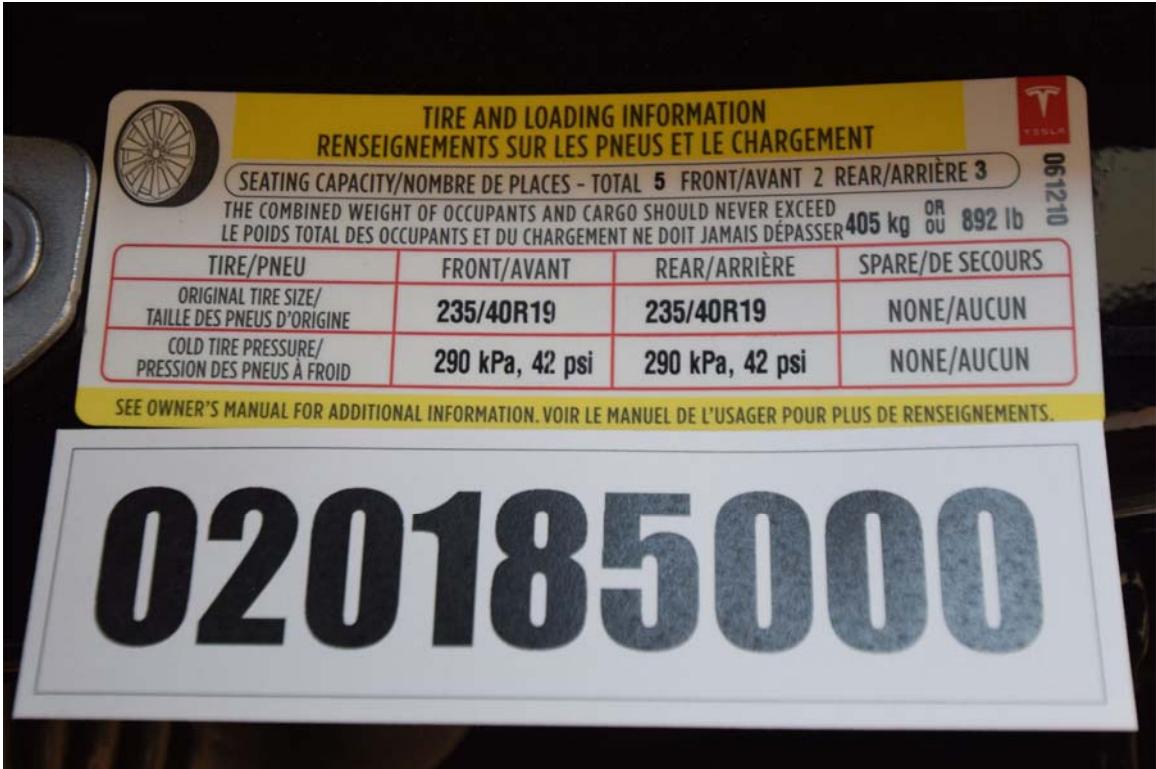

FIGURE 5. Tire Placard



FIGURE 6. 2018 Tesla Model 3 Long Range RWD Frontal as Delivered



FIGURE 7. Left Rear $\frac{3}{4}$ View, as Received



FIGURE 8. Pre-Test Front View of Test Vehicle



FIGURE 9. Post-Test Front View of Test Vehicle



FIGURE 10. Pre-Test Left View of Test Vehicle



FIGURE 11. Post-Test Left View of Test Vehicle



FIGURE 12. Pre-Test Right View of Test Vehicle



FIGURE 13. Post-Test Right View of Test Vehicle



FIGURE 14. Pre-Test Right Front 3/4 View



FIGURE 15. Post-Test Right Front $\frac{3}{4}$ View



FIGURE 16. Pre-Test Left Rear $\frac{3}{4}$ View



FIGURE 17. Post-Test Left Rear $\frac{3}{4}$ View



FIGURE 18. Pre-Test Windshield View



FIGURE 19. Post-Test Windshield View



FIGURE 20. Pre-Test Front Storage Compartment View

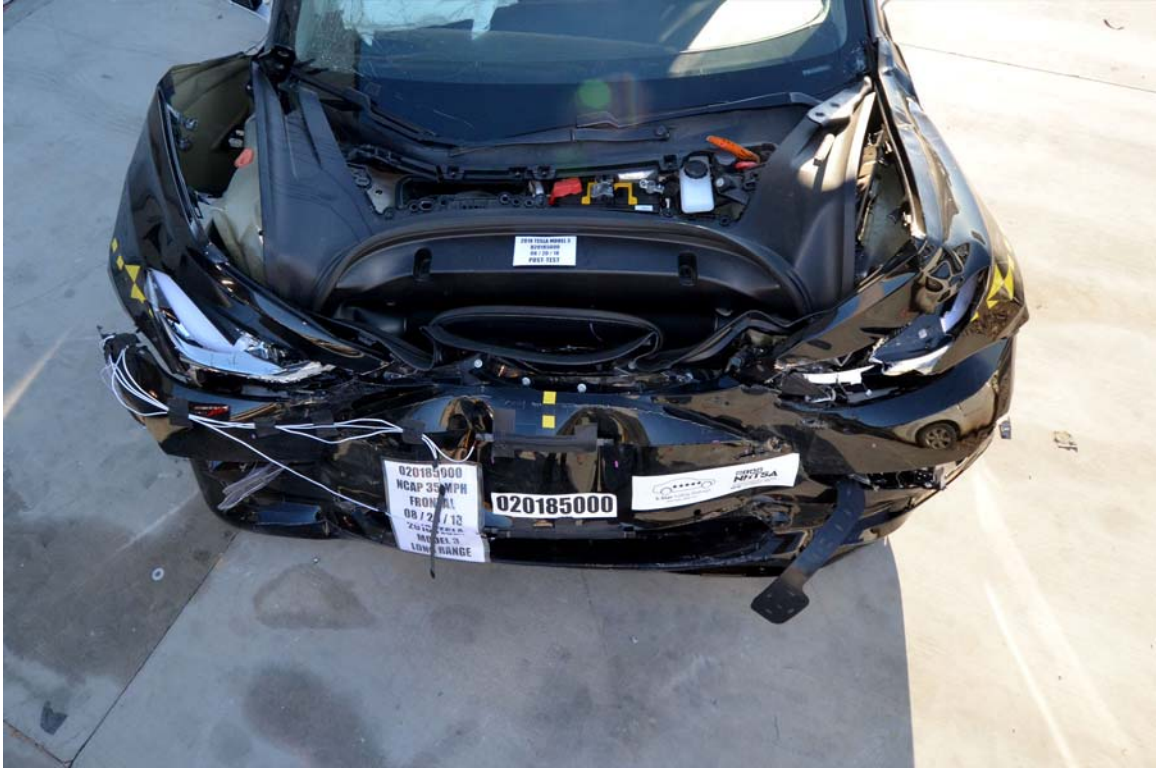

FIGURE 21. Post-Test Front Storage Compartment View



FIGURE 22. Pre-Test Fuel Filler Cap – Charge Port View



FIGURE 23. Post-Test Fuel Filler Cap – Charge Port View

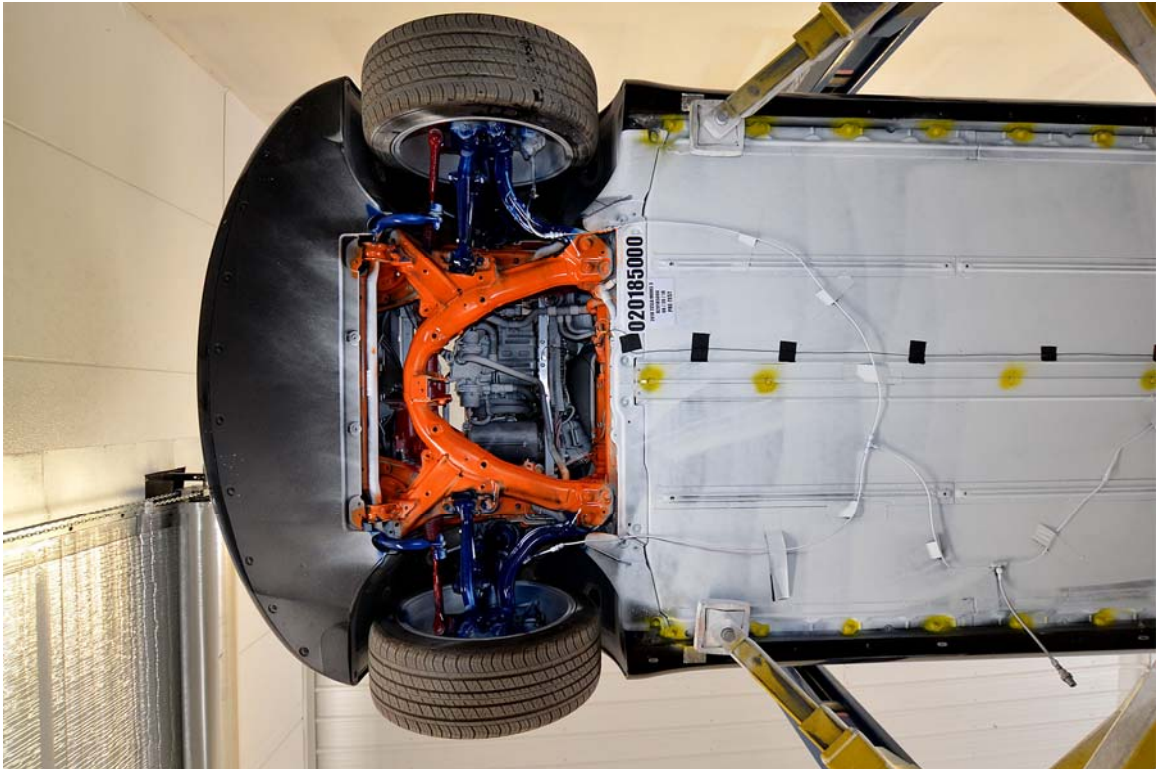

FIGURE 24. Pre-Test Front Underbody View

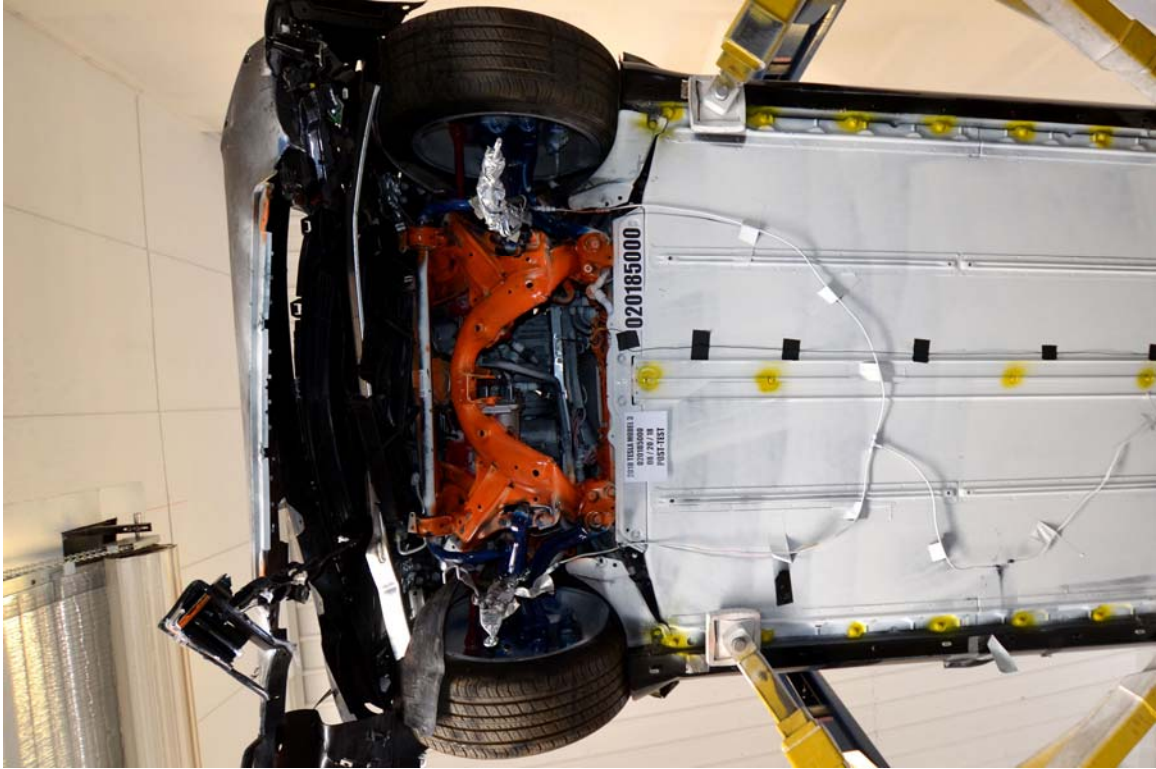

FIGURE 25. Post-Test Front Underbody View

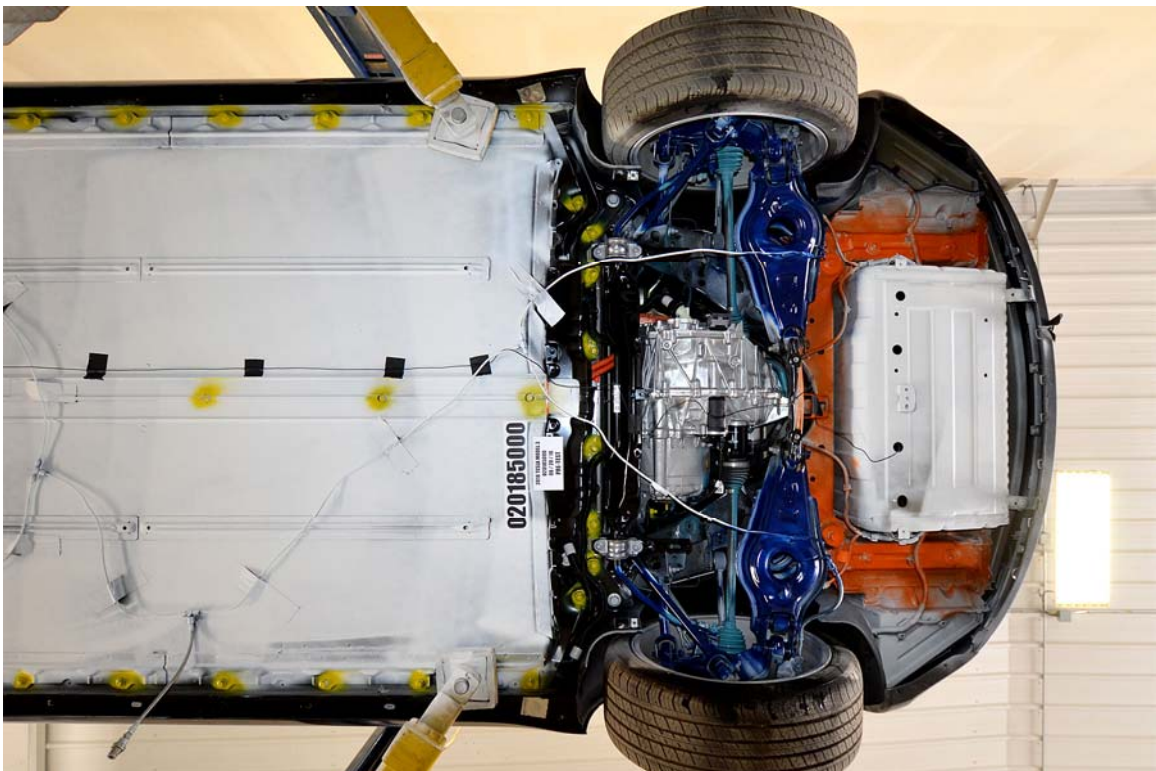

FIGURE 26. Pre-Test Rear Underbody View

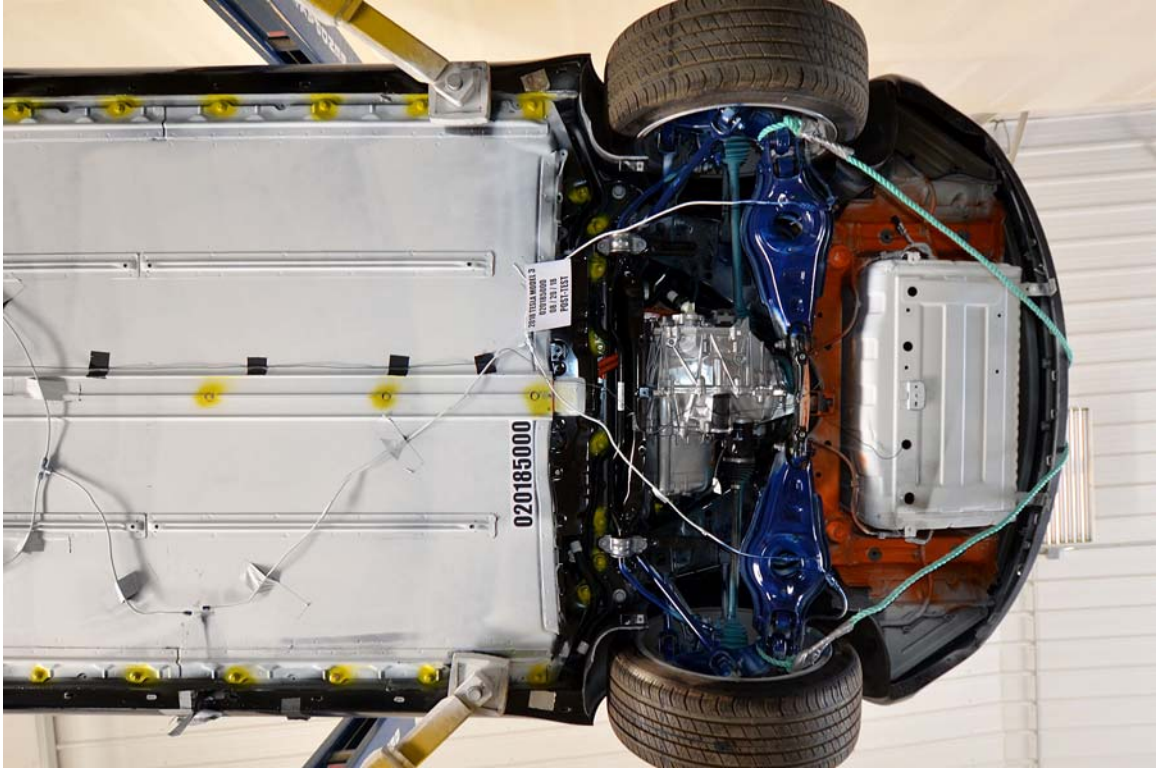

FIGURE 27. Post-Test Rear Underbody View



FIGURE 28. Pre-Test Dummy Cable Routing



FIGURE 29. Post-Test Dummy Cable Routing



FIGURE 30. Pre-Test Driver Dummy Front View



FIGURE 31. Post-Test Driver Dummy Front View



FIGURE 32. Pre-Test Driver Dummy Window View



FIGURE 33. Post-Test Driver Dummy Window View



FIGURE 34. Pre-Test Driver Dummy and Vehicle Interior View



FIGURE 35. Post-Test Driver Dummy and Vehicle Interior View



FIGURE 36. Pre-Test Driver's Seat Fore-Aft Markings



FIGURE 37. Post-Test Driver's Seat Fore-Aft Markings



FIGURE 38. Pre-Test View of Belt Anchorage for Driver Dummy



FIGURE 39. Post-Test View of Belt Anchorage for Driver Dummy



FIGURE 40. Pre-Test Driver Dummy Feet



FIGURE 41. Post-Test Driver Dummy Feet



FIGURE 42. Pre-Test Driver's Side Knee Bolster

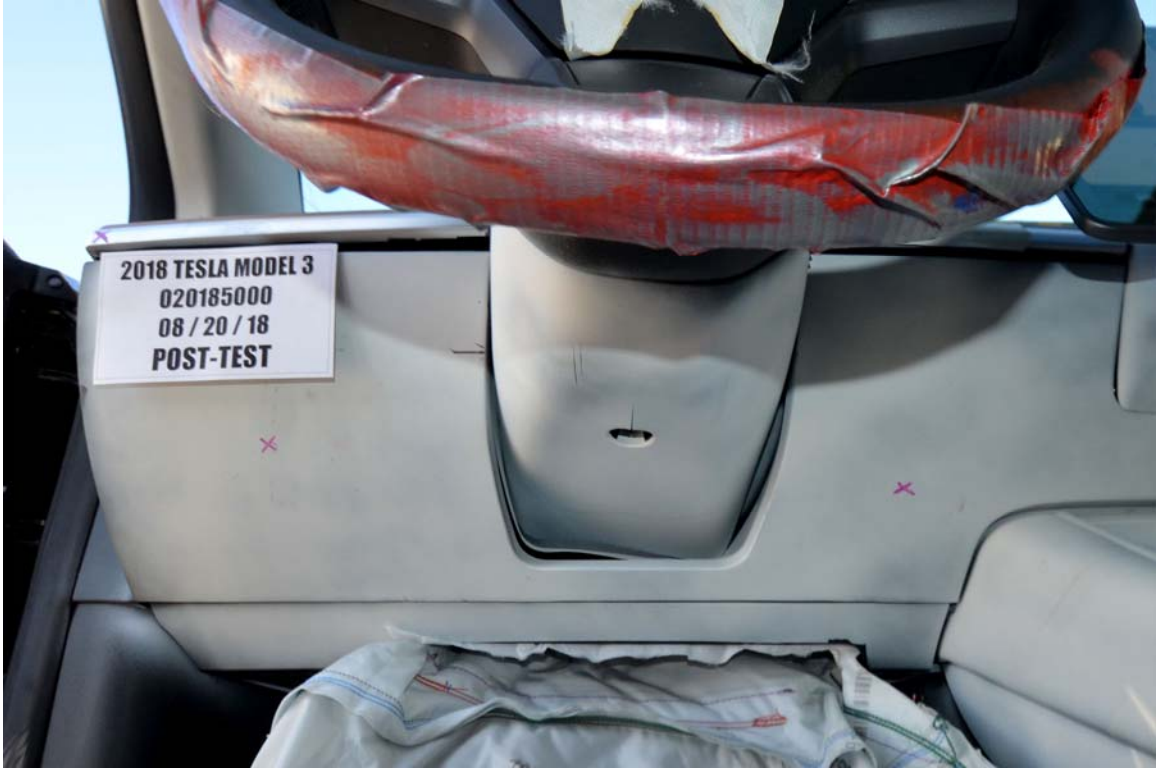

FIGURE 43. Post-Test Driver's Side Knee Bolster



FIGURE 44. Pre-Test Driver's Side Floorpan



FIGURE 45. Post-Test Driver's Side Floorpan



FIGURE 46. Post-Test Driver Dummy Face



FIGURE 47. Post-Test Driver Dummy Contact with Airbag



FIGURE 48. Post-Test Driver Dummy Contact with Headrest



FIGURE 48a. Post-Test Driver Dummy Contact with Knee Airbag



FIGURE 49. Pre-Test View of the Steering Wheel



FIGURE 50. Post-Test View of the Steering Wheel



FIGURE 51. Pre-Test Passenger Dummy Front View



FIGURE 52. Post-Test Passenger Dummy Front View



FIGURE 53. Pre-Test Passenger Dummy Window View



FIGURE 54. Post-Test Passenger Dummy Window View



FIGURE 55. Pre-Test Passenger Dummy and Vehicle Interior View



FIGURE 56. Post-Test Passenger Dummy and Vehicle Interior View



FIGURE 57. Pre-Test Passenger's Seat Fore-Aft Markings



FIGURE 58. Post-Test Passenger's Seat Fore-Aft Markings



FIGURE 59. Pre-Test View of Belt Anchorage for Passenger Dummy



FIGURE 60. Post-Test View of Belt Anchorage for Passenger Dummy



FIGURE 61. Pre-Test Passenger Dummy Feet



FIGURE 62. Post-Test Passenger Dummy Feet



FIGURE 63. Pre-Test Passenger's Side Knee Bolster



FIGURE 64. Post-Test Passenger's Side Knee Bolster



FIGURE 65. Pre-Test Passenger's Side Floorpan



FIGURE 66. Post-Test Passenger's Side Floorpan



FIGURE 67. Post-Test Passenger Dummy Face



FIGURE 68. Post-Test Passenger Dummy Contact with Airbag



FIGURE 69. Post-Test Passenger Dummy Contact with Headrest

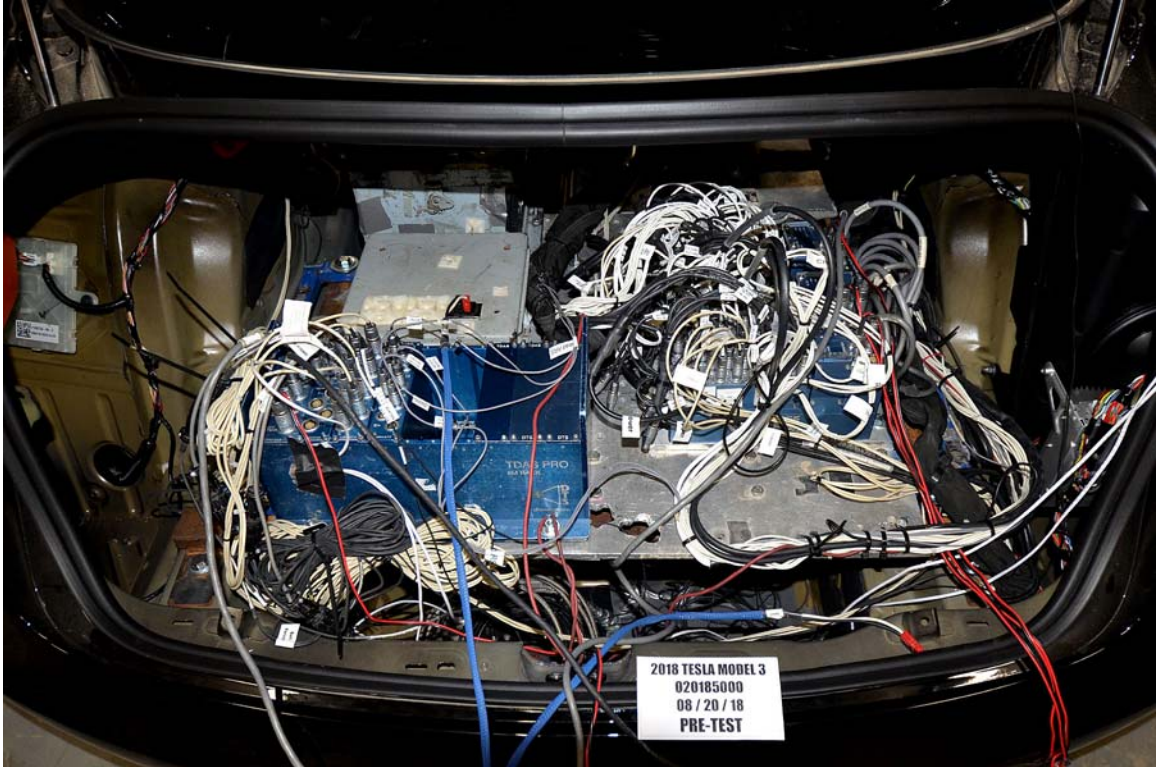

FIGURE 70. Photograph of Ballast Installed in Vehicle

Photograph Not Applicable

**No Stoddard
Solvent Spillage**

FIGURE 71. Post-Test Stoddard Solvent Spillage Location View



FIGURE 72. Post-Test Speed Trap Read-Out



FIGURE 73. Vehicle at 0° on Static Rollover Device



FIGURE 74. Vehicle at 90° on Static Rollover Device



FIGURE 75. Vehicle at 180° on Static Rollover Device



FIGURE 76. Vehicle at 270° on Static Rollover Device

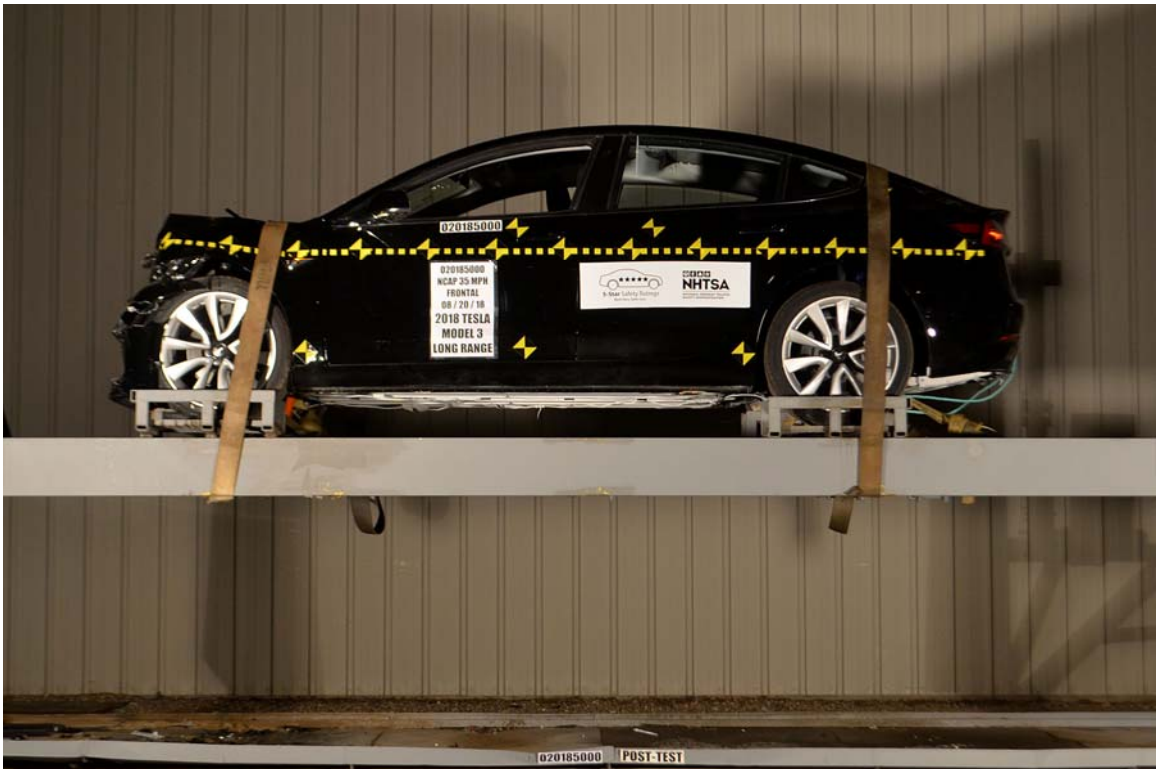

FIGURE 77. Vehicle at 360° on Static Rollover Device



FIGURE 78. 2018 Tesla Model 3 Long Range RWD Frontal Impact Event

TESLA Model 3 Long Range

Vehicle Identification Number: 5YJ3E1EASJF061210
 Date Of Manufacture: 07/2018
 Transportation Method: Truck
 Delivered to: TESLA MOTORS, INC. Fremont, California, USA

STANDARD FEATURES		AS CONFIGURED	
<p>TECHNICAL</p> <ul style="list-style-type: none"> Three phase, six pole, internal permanent magnet motor Drive inverter with regenerative braking system Microprocessor controlled, lithium-ion battery Onboard charger and mobile connector 120 volt, 240 volt and J1772 charging adapters <p>SAFETY</p> <ul style="list-style-type: none"> Seven cameras, forward radar and twelve ultrasonic sensors Six front row and two side curtain airbags Three point safety belts with belt-reminders for driver and four passengers Two LATCH (Lower Anchors and Tethers for Children) attachments in second row Electronic stability and traction control Four wheel antilock disc brakes with electronic parking brake Child safety locks and manual cargo door release mechanisms Anti-Theft Alarm System 	<p>INTERIOR</p> <ul style="list-style-type: none"> 15 inch capacitive touchscreen Onboard maps and navigation WiFi and Mobile network connectivity FM and Internet streaming radio Hands free talking with Bluetooth Voice activated controls High definition backup camera One touch power windows Dual zone climate control 12 volt power outlet and two USB ports for media and power <p>EXTERIOR</p> <ul style="list-style-type: none"> Full LED lighting 	<p>Model 3</p> <ul style="list-style-type: none"> Long Range Rear Wheel Drive INCLUDED \$49,900 Premium Interior INCLUDED Solid Black Paint INCLUDED 19" Wheels \$1,500 Premium Black INCLUDED 	<p>Destination and Regulatory Doc Fee \$1,000</p> <p>Total vehicle price \$51,500</p>

GOVERNMENT 5-STAR SAFETY RATINGS

This vehicle has not been rated by the government for overall vehicle score, frontal crash, side crash, or rollover risk.

Source: National Highway Traffic Safety Administration (NHTSA)
www.safercar.gov or 1-888-327-4236

PARTS CONTENT INFORMATION

FOR THIS VEHICLE:
 US/CANADIAN PARTS CONTENT: 50%
 MAJOR SOURCES OF FOREIGN PARTS CONTENT MEXICO: 25%

Note: Parts content does not include final assembly, distribution of other non-parts content.

FOR THIS VEHICLE:
 FINAL ASSEMBLY POINT: FREMONT, CA
 COUNTRY OF ORIGIN: USA
 MOTOR ASSEMBLY: USA
 GEARBOX/TRANSMISSION: USA

ADDITIONAL ASSEMBLY INFORMATION

FOR THIS VEHICLE:
 BATTERY FINAL ASSEMBLY POINT: FREMONT, CA, USA
 ON-BOARD CHARGER FINAL ASSEMBLY POINT: FREMONT, CA, USA

EPA DOT Fuel Economy and Environment Electric Vehicle

These estimates reflect new EPA methods beginning with 2017 models. Midsize cars range from 14 to 198 MPGe. The best vehicle rates 136 MPGe.

130 MPGe (combined city/hwy)

136 city 123 highway 26 kWh per 100 miles

Driving Range: **310 miles**

Charge Time: 10 hours (240V)

Annual fuel cost \$500

Save \$4,250 in fuel costs over 5 years compared to the average new vehicle.

Fuel Economy & Greenhouse Gas Rating (Best)

This vehicle emits 0 grams CO₂ per mile. The best emits 0 grams per mile (tailpipe only). Producing and distributing fuel also create emissions; learn more at fuel-economy.gov.

Actual results vary for many reasons, including driving conditions and how you drive and maintain your vehicle. The average new vehicle gets 27 MPG and costs \$6,715 to fuel over 5 years. Cost estimates are based on 15,000 miles per year at 0.12 per kWh for MPGe is miles per gasoline gallon equivalent. Vehicle emissions are a significant cause of climate change and smog.

fuel-economy.gov

Calculate personalized estimates and compare vehicles.

FIGURE 79. 2018 Monroney Label Photograph

APPENDIX B
DUMMY RESPONSE DATA TRACES

TABLE OF DATA PLOTS

<u>Plot</u>		<u>Page</u>
1	Driver Head Acceleration X Primary	B-1
2	Driver Head Acceleration Y Primary	B-1
3	Driver Head Acceleration Z Primary	B-1
4	Driver Head Resultant Acceleration Primary	B-1
5	Driver Chest X Deflection	B-2
6	Driver Chest Acceleration X Primary	B-3
7	Driver Chest Acceleration Y Primary	B-3
8	Driver Chest Acceleration Z Primary	B-3
9	Driver Chest Resultant Acceleration Primary	B-3
10	Driver Upper Neck Force X	B-4
11	Driver Upper Neck Force Z	B-4
12	Driver Upper Neck Moment Y	B-4
13	Driver Nij	B-4
14	Driver Left Femur Force Z	B-5
15	Driver Right Femur Force Z	B-5
16	Passenger Head Acceleration X Primary	B-6
17	Passenger Head Acceleration Y Primary	B-6
18	Passenger Head Acceleration Z Primary	B-6
19	Passenger Head Resultant Acceleration Primary	B-6
20	Passenger Chest X Deflection	B-7
21	Passenger Chest Acceleration X Primary	B-8
22	Passenger Chest Acceleration Y Primary	B-8
23	Passenger Chest Acceleration Z Primary	B-8
24	Passenger Chest Resultant Acceleration Primary	B-8
25	Passenger Upper Neck Force X	B-9
26	Passenger Upper Neck Force Z	B-9
27	Passenger Upper Neck Moment Y	B-9
28	Passenger Nij	B-9
29	Passenger Left Femur Force Z	B-10
30	Passenger Right Femur Force Z	B-10

The following additional dummy and vehicle response data can be found in the R&D section of the NHTSA website at www.nhtsa.dot.gov

Driver Head X Acceleration Redundant
Driver Head Y Acceleration Redundant
Driver Head Z Acceleration Redundant
Driver Upper Neck Force Y
Driver Upper Neck Moment X
Driver Upper Neck Moment Z
Driver Chest X Acceleration Redundant
Driver Chest Y Acceleration Redundant
Driver Chest Z Acceleration Redundant
Driver Pelvis X
Driver Pelvis Y
Driver Pelvis Z
Driver Left Femur Force Z Redundant
Driver Right Femur Force Z Redundant
Driver Left Upper Tibia Moment X
Driver Left Upper Tibia Moment Y
Driver Left Upper Tibia Force Z
Driver Left Lower Tibia Moment X
Driver Left Lower Tibia Moment Y
Driver Left Lower Tibia Force Z
Driver Right Upper Tibia Moment X
Driver Right Upper Tibia Moment Y
Driver Right Upper Tibia Force Z
Driver Right Lower Tibia Moment X
Driver Right Lower Tibia Moment Y
Driver Right Lower Tibia Force Z
Driver Left Foot Fore Z
Driver Left Foot Aft X
Driver Left Foot Aft Z
Driver Right Foot Fore Z
Driver Right Foot Aft X
Driver Right Foot Aft Z
Driver Shoulder Belt Force
Driver Lap Belt Force
Passenger Head X Acceleration Redundant
Passenger Head Y Acceleration Redundant
Passenger Head Z Acceleration Redundant
Passenger Upper Neck Force X
Passenger Upper Neck Force Z
Passenger Upper Neck Moment Y
Passenger Chest X Acceleration Redundant
Passenger Chest Y Acceleration Redundant
Passenger Chest Z Acceleration Redundant

Passenger Pelvis X
Passenger Pelvis Y
Passenger Pelvis Z
Passenger Left Femur Force Redundant
Passenger Right Femur Force Redundant
Passenger Left Upper Tibia Moment X
Passenger Left Upper Tibia Moment Y
Passenger Left Upper Tibia Force Z
Passenger Left Lower Tibia Moment X
Passenger Left Lower Tibia Moment Y
Passenger Left Lower Tibia Force Z
Passenger Right Upper Tibia Moment X
Passenger Right Upper Tibia Moment Y
Passenger Right Upper Tibia Force Z
Passenger Right Lower Tibia Moment X
Passenger Right Lower Tibia Moment Y
Passenger Right Lower Tibia Force Z
Passenger Left Foot Fore Z
Passenger Left Foot Aft X
Passenger Left Foot Aft Z
Passenger Right Foot Fore Z
Passenger Right Foot Aft X
Passenger Right Foot Aft Z
Passenger Shoulder Belt Force
Passenger Lap Belt Force
Left Rear Seat Crossmember X
Left Rear Seat Crossmember Z
Right Rear Seat Crossmember X
Right Rear Seat Crossmember Z
Left Rear Seat Crossmember X Redundant
Right Rear Seat Crossmember X Redundant
Vehicle Engine Top X
Vehicle Engine Bottom X
Load Cell Barrier Forces and Moments

Test Vehicle: 2018 Tesla Model 3 Long Range RWD 4-Door Sedan
 Test Program: 56.3 km/h Frontal Impact NCAP Test

NHTSA No.: O20185000
 Test Date: 8/20/2018

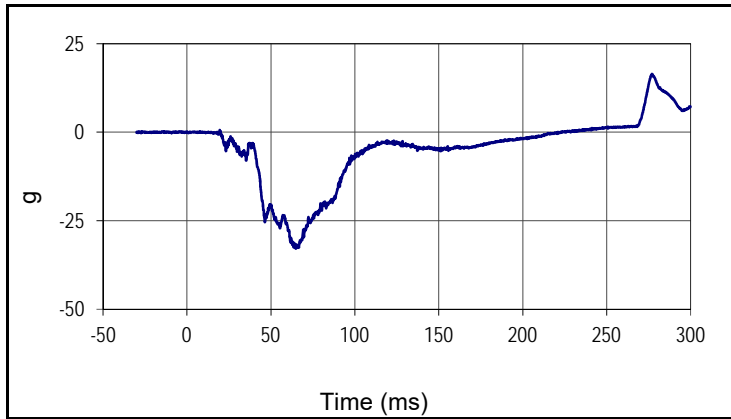

Curve Description			
Driver Head Acceleration X Primary			
Plot No.		SAE Class	Units
001		1000	g
Max	Time	Min	Time
16.5	276.9	-32.9	64.8

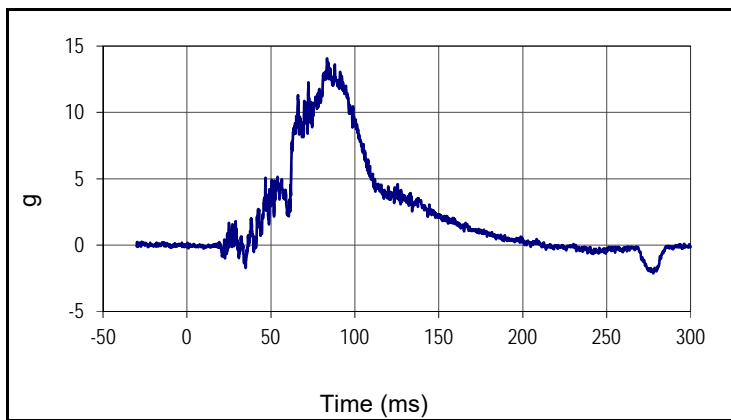

Curve Description			
Driver Head Acceleration Y Primary			
Plot No.		SAE Class	Units
002		1000	g
Max	Time	Min	Time
14.1	83.4	-2.1	277.7

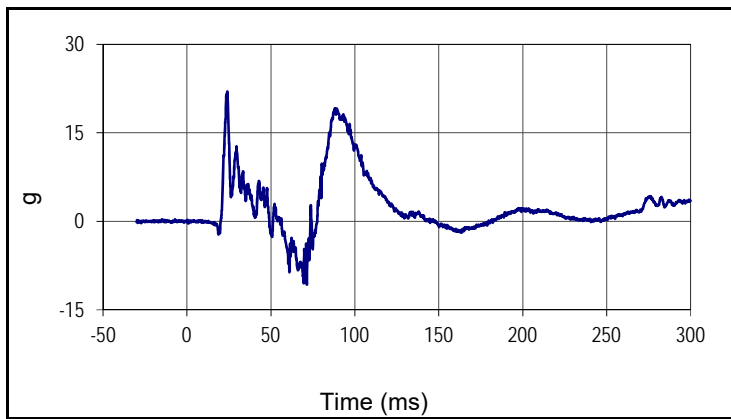

Curve Description			
Driver Head Acceleration Z Primary			
Plot No.		SAE Class	Units
003		1000	g
Max	Time	Min	Time
22.0	24.0	-10.7	71.4

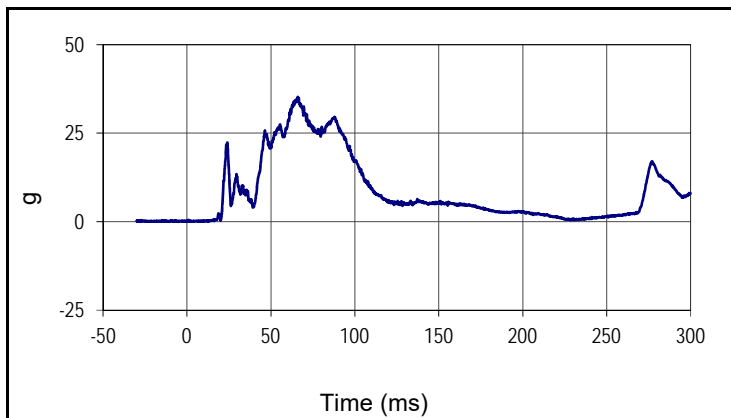

Curve Description			
Driver Head Resultant Acceleration Primary			
Plot No.		SAE Class	Units
004		1000	g
Max	Time	Min	Time
35.3	66.0	0.0	9.6

Test Vehicle: 2018 Tesla Model 3 Long Range RWD 4-Door Sedan

NHTSA No.: O20185000

Test Program: 56.3 km/h Frontal Impact NCAP Test

Test Date: 8/20/2018

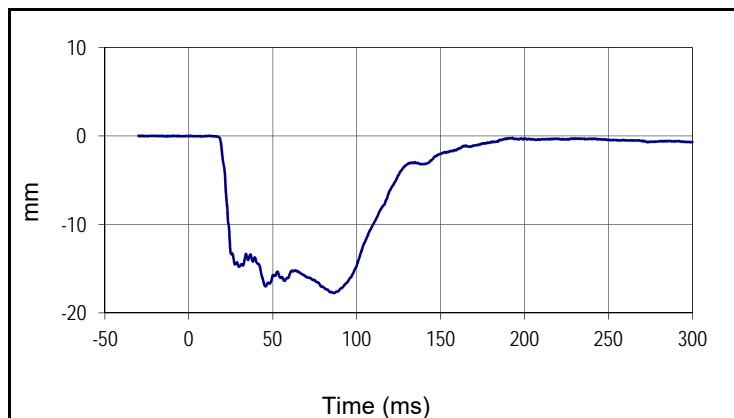

Curve Description			
Driver Chest Deflection			
Plot No.		SAE Class	Units
005		600	mm
Max	Time	Min	Time
0.0	0.8	-17.7	86.5

Test Vehicle: 2018 Tesla Model 3 Long Range RWD 4-Door Sedan
 Test Program: 56.3 km/h Frontal Impact NCAP Test

NHTSA No.: O20185000
 Test Date: 8/20/2018

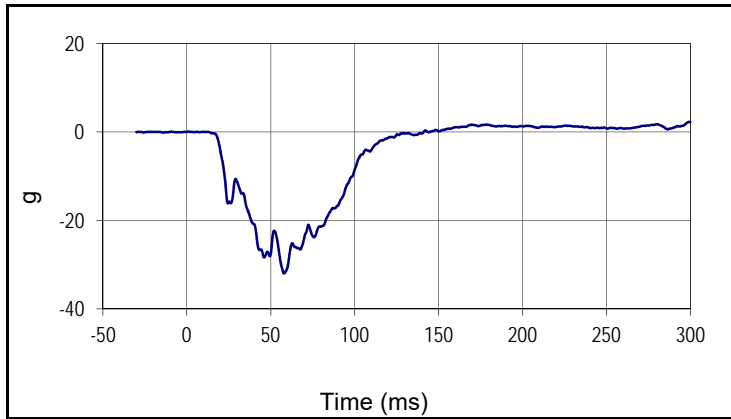

Curve Description			
Driver Chest Acceleration X Primary			
Plot No.		SAE Class	Units
006		180	g
Max	Time	Min	Time
2.3	299.4	-32.0	57.9

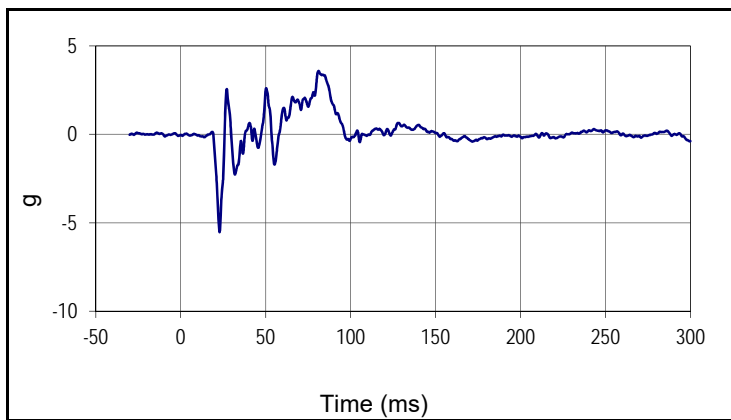

Curve Description			
Driver Chest Acceleration Y Primary			
Plot No.		SAE Class	Units
007		180	g
Max	Time	Min	Time
3.6	81.1	-5.5	22.9

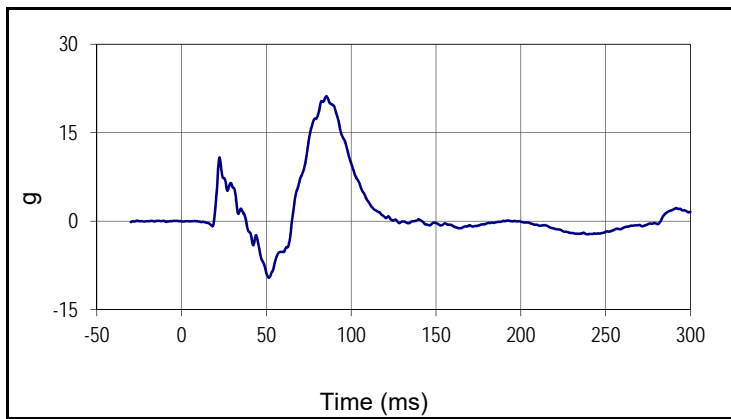

Curve Description			
Driver Chest Acceleration Z Primary			
Plot No.		SAE Class	Units
008		180	g
Max	Time	Min	Time
21.2	85.3	-9.6	51.4

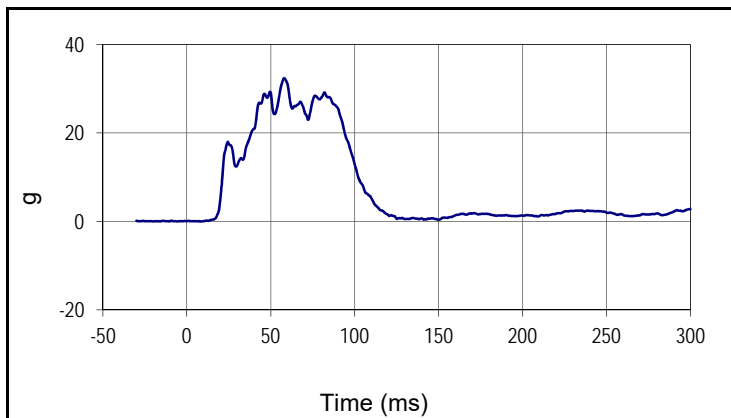

Curve Description			
Driver Chest Resultant Acceleration Primary			
Plot No.		SAE Class	Units
009		180	g
Max	Time	Min	Time
32.4	57.9	0.0	8.4

Test Vehicle: 2018 Tesla Model 3 Long Range RWD 4-Door Sedan
 Test Program: 56.3 km/h Frontal Impact NCAP Test

NHTSA No.: O20185000
 Test Date: 8/20/2018

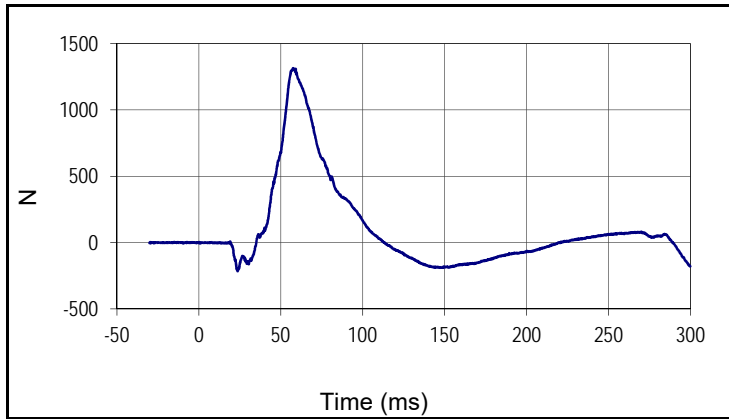

Curve Description			
Driver Upper Neck Force X			
Plot No.		SAE Class	Units
010		1000	N
Max	Time	Min	Time
1313.6	57.5	-215.4	23.7

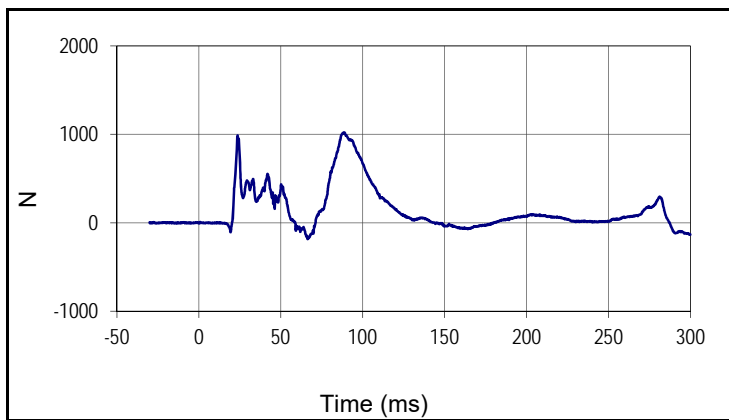

Curve Description			
Driver Upper Neck Force Z			
Plot No.		SAE Class	Units
011		1000	N
Max	Time	Min	Time
1021.8	88.7	-184.7	66.4

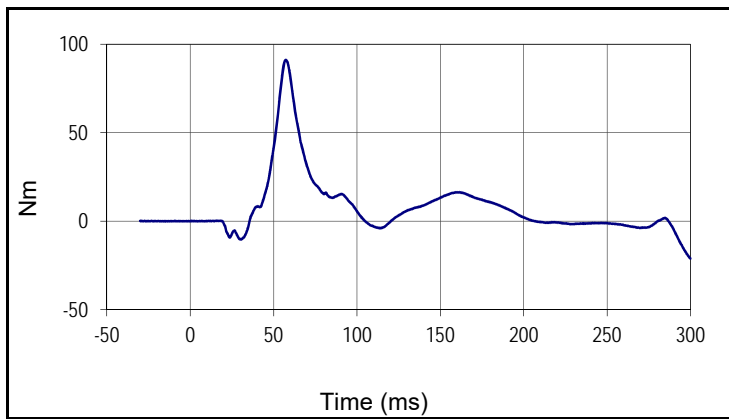

Curve Description			
Driver Upper Neck Moment Y			
Plot No.		SAE Class	Units
012		600	Nm
Max	Time	Min	Time
91.1	57.3	-21.1	299.9

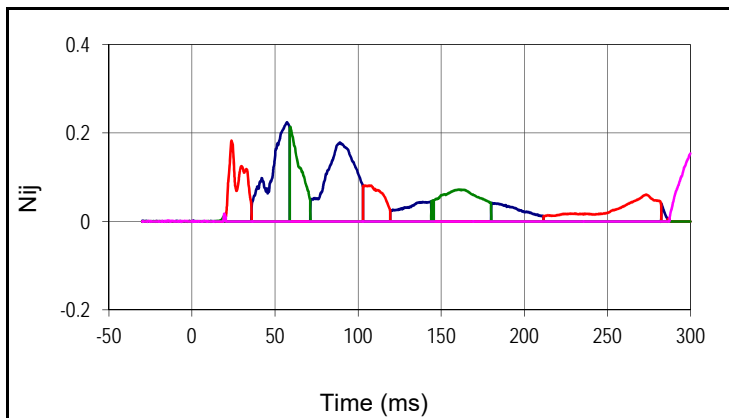

Curve Description		
Driver Nij		
Units	Max	Time
Ntf	0.22	57.2
Units	Max	Time
Nte	0.18	23.8
Units	Max	Time
Ncf	0.21	59.3
Units	Max	Time
Nce	0.15	299.9

Test Vehicle: 2018 Tesla Model 3 Long Range RWD 4-Door Sedan
 Test Program: 56.3 km/h Frontal Impact NCAP Test

NHTSA No.: O20185000
 Test Date: 8/20/2018

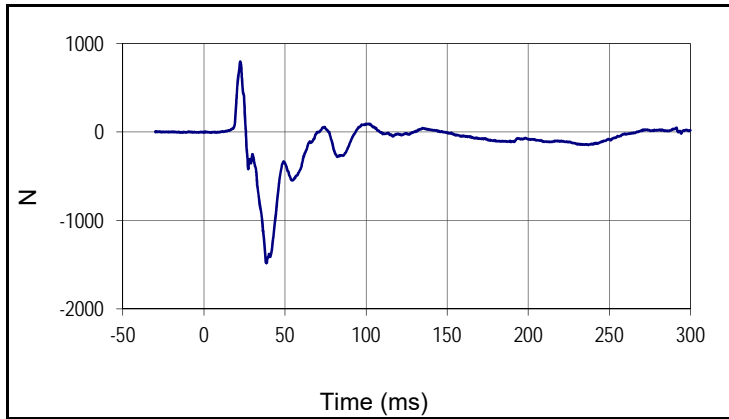

Curve Description			
Driver Left Femur Force Z			
Plot No.		SAE Class	Units
014		600	N
Max	Time	Min	Time
796.4	22.4	-1480.5	38.7

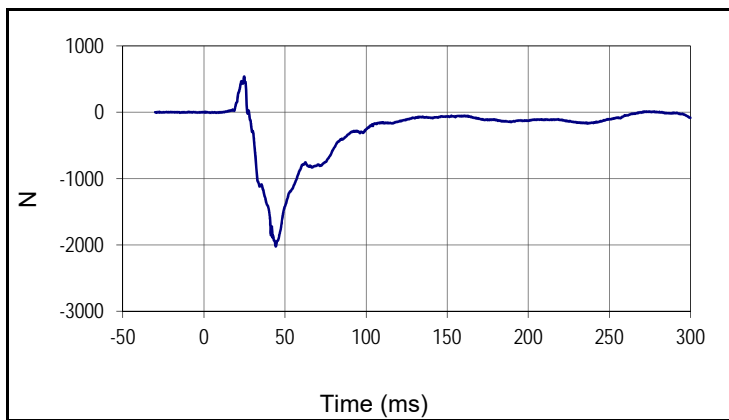

Curve Description			
Driver Right Femur Force Z			
Plot No.		SAE Class	Units
015		600	N
Max	Time	Min	Time
540.2	24.8	-2023.3	44.3

Test Vehicle: 2018 Tesla Model 3 Long Range RWD 4-Door Sedan
 Test Program: 56.3 km/h Frontal Impact NCAP Test

NHTSA No.: O20185000
 Test Date: 8/20/2018

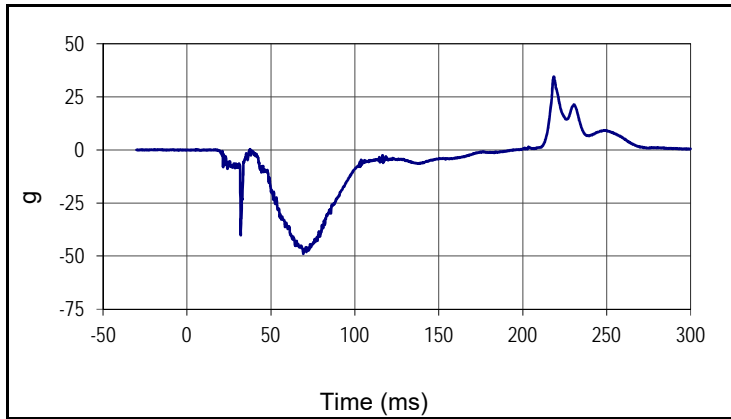

Curve Description			
Passenger Head Acceleration X Primary			
Plot No.		SAE Class	Units
016		1000	g
Max	Time	Min	Time
34.5	218.5	-48.9	69.3

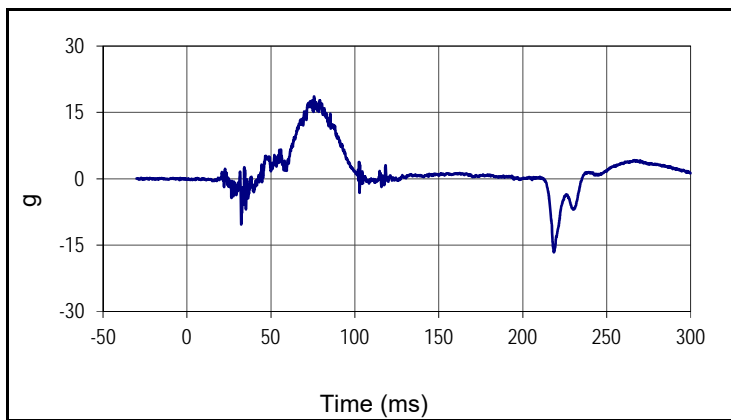

Curve Description			
Passenger Head Acceleration Y Primary			
Plot No.		SAE Class	Units
017		1000	g
Max	Time	Min	Time
18.6	75.7	-16.6	218.5

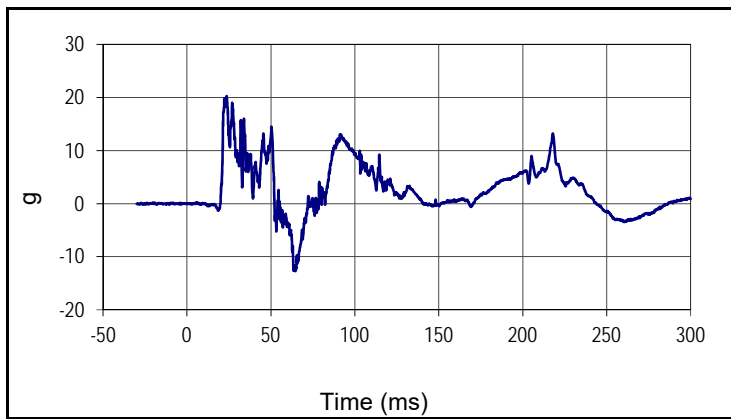

Curve Description			
Passenger Head Acceleration Z Primary			
Plot No.		SAE Class	Units
018		1000	g
Max	Time	Min	Time
20.2	23.6	-12.7	64.6

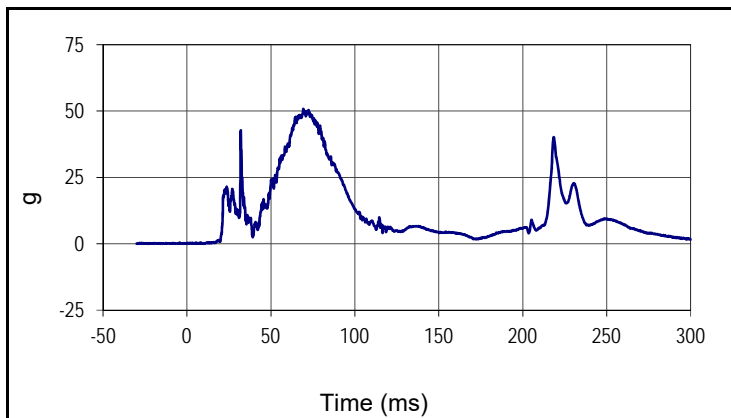

Curve Description			
Passenger Head Resultant Acceleration Primary			
Plot No.		SAE Class	Units
019		1000	g
Max	Time	Min	Time
50.8	69.3	0.0	0.9

Test Vehicle: 2018 Tesla Model 3 Long Range RWD 4-Door Sedan

NHTSA No.: O20185000

Test Program: 56.3 km/h Frontal Impact NCAP Test

Test Date: 8/20/2018

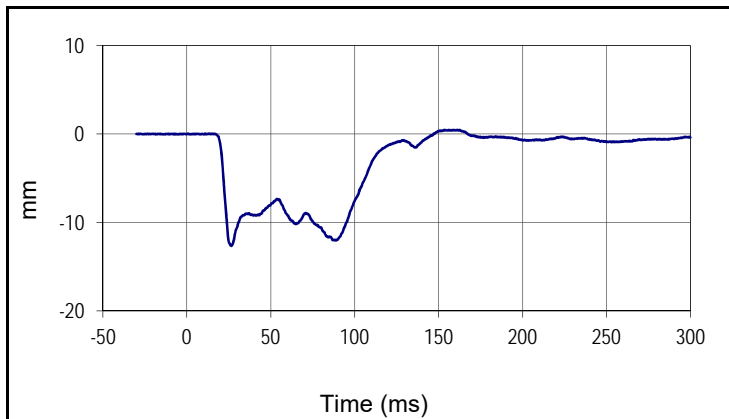

Curve Description			
Passenger Chest Deflection			
Plot No.		SAE Class	Units
020		600	mm
Max	Time	Min	Time
0.5	159.3	-12.6	26.6

Test Vehicle: 2018 Tesla Model 3 Long Range RWD 4-Door Sedan
 Test Program: 56.3 km/h Frontal Impact NCAP Test

NHTSA No.: O20185000
 Test Date: 8/20/2018

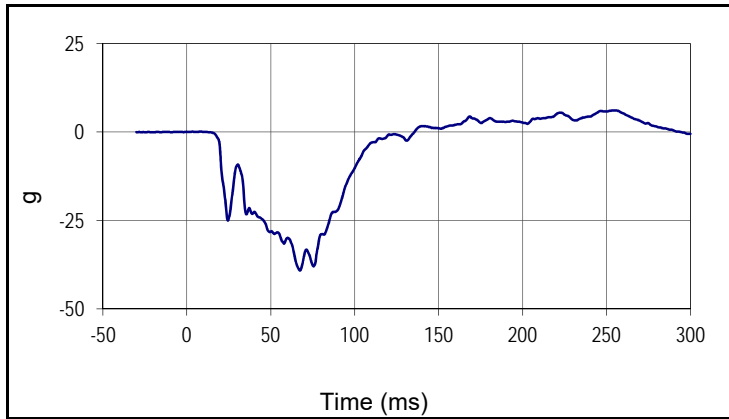

Curve Description			
Passenger Chest Acceleration X Primary			
Plot No.		SAE Class	Units
021		180	g
Max	Time	Min	Time
6.1	253.8	-39.1	67.4

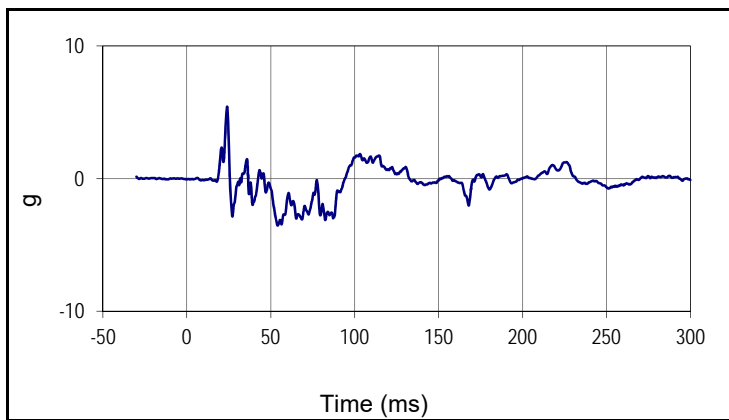

Curve Description			
Passenger Chest Acceleration Y Primary			
Plot No.		SAE Class	Units
022		180	g
Max	Time	Min	Time
5.4	24.0	-3.5	54.1

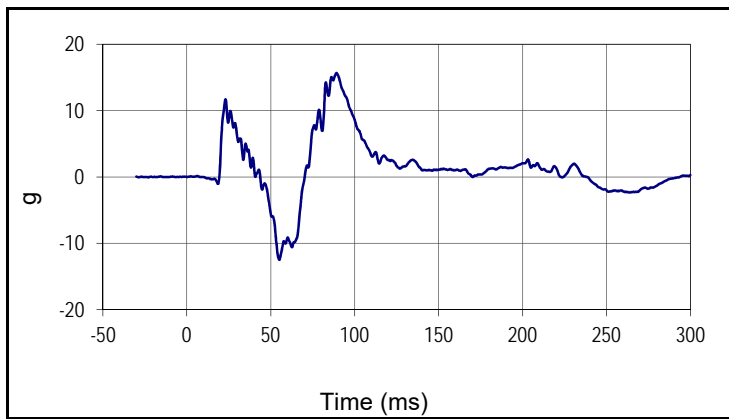

Curve Description			
Passenger Chest Acceleration Z Primary			
Plot No.		SAE Class	Units
023		180	g
Max	Time	Min	Time
15.7	89.2	-12.5	55.1

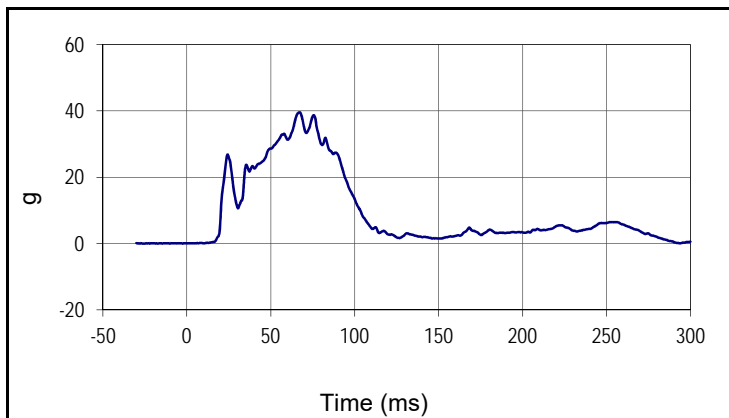

Curve Description			
Passenger Chest Resultant Acceleration Primary			
Plot No.		SAE Class	Units
024		180	g
Max	Time	Min	Time
39.6	67.2	0.1	4.8

Test Vehicle: 2018 Tesla Model 3 Long Range RWD 4-Door Sedan
 Test Program: 56.3 km/h Frontal Impact NCAP Test

NHTSA No.: O20185000
 Test Date: 8/20/2018

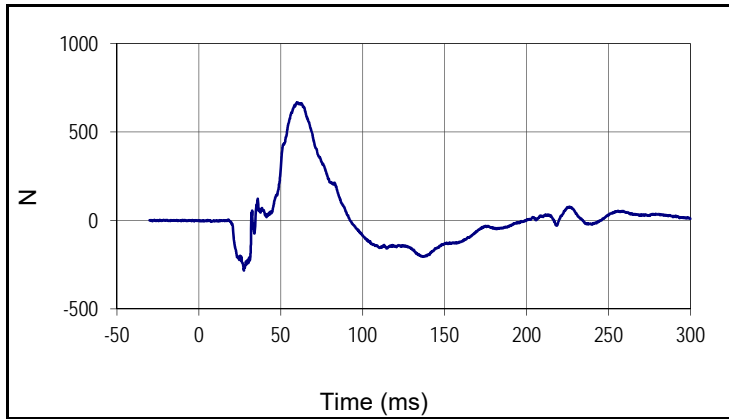

Curve Description			
Passenger Upper Neck Force X			
Plot No.		SAE Class	Units
025		1000	N
Max	Time	Min	Time
667.9	60.0	-282.6	27.5

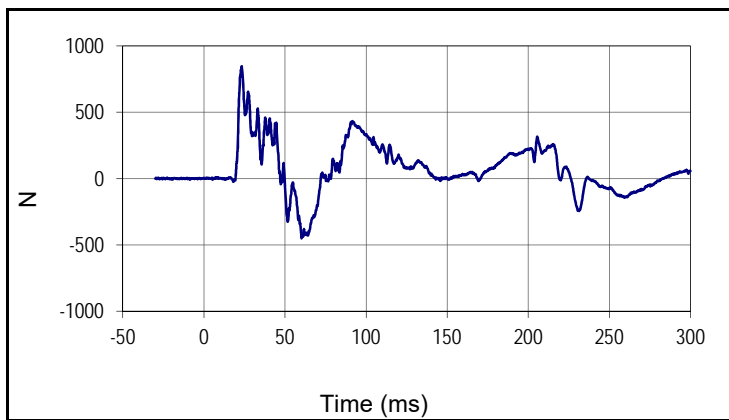

Curve Description			
Passenger Upper Neck Force Z			
Plot No.		SAE Class	Units
026		1000	N
Max	Time	Min	Time
845.9	23.3	-449.6	60.2

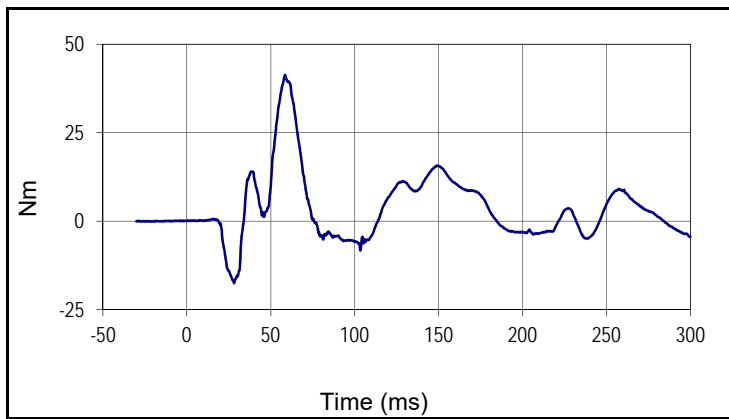

Curve Description			
Passenger Upper Neck Moment Y			
Plot No.		SAE Class	Units
027		600	Nm
Max	Time	Min	Time
41.3	58.5	-17.5	28.1

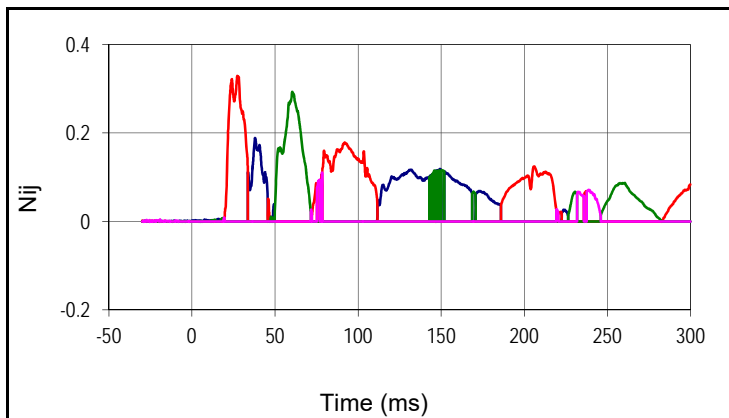

Curve Description		
Passenger Nij		
Units	Max	Time
Ntf	0.19	38.0
Nte	0.33	27.3
Ncf	0.29	60.4
Nce	0.11	78.3

Test Vehicle: 2018 Tesla Model 3 Long Range RWD 4-Door Sedan
 Test Program: 56.3 km/h Frontal Impact NCAP Test

NHTSA No.: O20185000
 Test Date: 8/20/2018

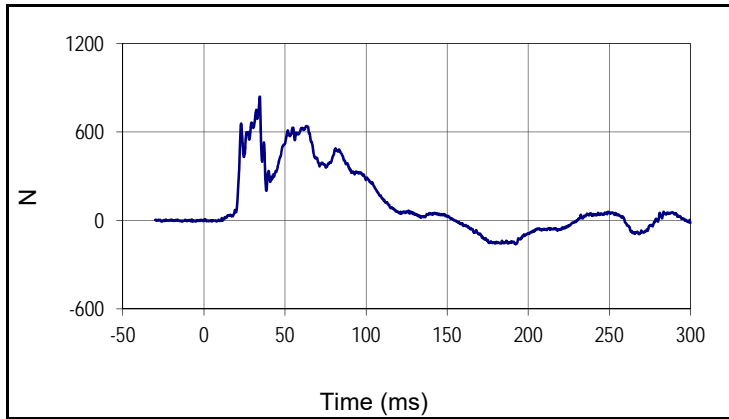

Curve Description			
Passenger Left Femur Force Z			
Plot No.		SAE Class	Units
029		600	N
Max	Time	Min	Time
839.6	34.4	-161.4	192.2

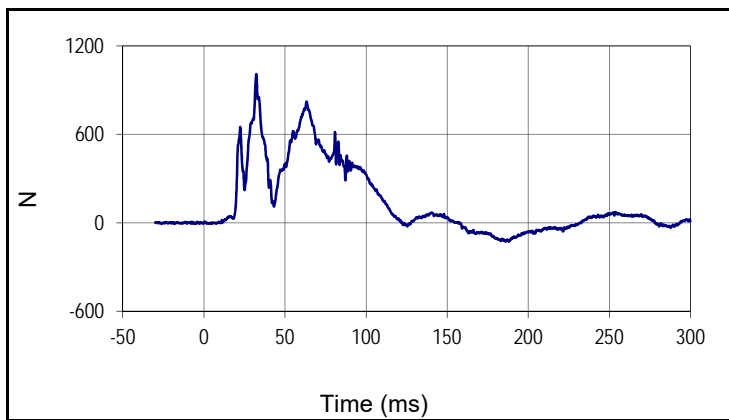

Curve Description			
Passenger Right Femur Force Z			
Plot No.		SAE Class	Units
030		600	N
Max	Time	Min	Time
1008.2	32.3	-126.1	186.2

APPENDIX C
ATD CALIBRATION AND PERFORMANCE VERIFICATION DATA

APPENDIX C
PRE-TEST ATD CONFIGURATION AND PERFORMANCE VERIFICATION DATA





ATD Serial No.: 360

Test Date: 2018-07-17

Dummy Item	Inspect for	Comments	Damage	OK
Entire ATD	Perform general cleaning			✓
Outer Skin	Gashes, rips, cracks			✓
Head	Ballast secure			✓
	General appearance			✓
Neck bracket	Upper neck firmly attached to lower bracket			✓
Neck	Broken or cracked rubber			✓
	Looseness at the condyle joint			✓
Nodding block	Cracked or out of position			✓
Lumbar Spine	Broken or cracked rubber			✓
Ribs	Broken or bent ribs			✓
	Broken or bent rib supports			✓
	Damping material separated or cracked			✓
	Rubber bumpers in place			✓
Chest Displ. Assembly	Bent shaft			✓
	Slider arm riding in track			✓
Sensors	Check cables for cuts, tears			✓
	Check for damaged insulation			✓
Accelerometer Mounting	Head mounting secure			✓
	Chest mounting secure			✓
Knees	Skin condition			✓
	Insert (do not remove)			✓
	Casting			✓
Limbs	Normal movement and adjustment			✓
Knee Sliders	Wires intact			✓
	Rubber returned to "resting" position			✓
Pelvis	Broken			✓
Other	Describe below as needed			✓

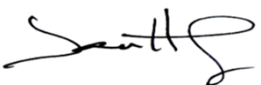
Describe any repairs or replacement of parts or other findings:

Technician: 
 J. Hernandez

Approved By: 
 P. Puzzuto





**Hybrid III 50th Percentile Male
 External Measurements**

ATD Serial No.: 360

Test Date: 2018-07-17

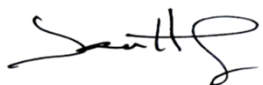
Tested Parameter	Units	Spec. Low	Spec. High	Result	Pass/Fail
Laboratory Temperature	°C	20.6	22.2	21.4	Pass
Laboratory Relative Humidity	%	10	70	26	Pass
A - Total sitting height	mm	879	889	887	Pass
B - Shoulder pivot height	mm	505	521	517	Pass
C - 'H' point height	mm	84	89	87	Pass
D - 'H' point location from backline	mm	135	140	139	Pass
E - Shoulder pivot from backline	mm	84	94	91	Pass
F - Thigh clearance	mm	140	155	151	Pass
G - Back of elbow to wrist pivot	mm	290	305	297	Pass
H - Head back to backline	mm	41	46	46	Pass
I - Shoulder to elbow length	mm	330	345	343	Pass
J - Elbow rest height	mm	190	211	204	Pass
K - Buttock to knee length	mm	579	604	589	Pass
L - Popliteal length	mm	429	455	440	Pass
M - Knee pivot height	mm	485	500	495	Pass
N - Buttock popliteal length	mm	452	477	464	Pass
O - Chest depth without jacket	mm	213	229	220	Pass
P - Foot length	mm	251	267	258	Pass
V - Shoulder breadth	mm	422	437	431	Pass
W - Foot breadth	mm	91	107	103	Pass
Y - Chest circum. (w/chest jacket)	mm	970	1001	980	Pass
Z - Waist circum.	mm	836	866	851	Pass
AA - Location for chest circum.	mm	429	434	432	Pass
BB - Location for waist circum.	mm	226	231	228	Pass
Overall Test Results					Pass

Technician: 
 J. Hernandez

Approved By: 
 P. Puzzuto



ATD Serial No.: 360

Test Date: 2018-07-16

Tested Parameter	Units	Spec. Low	Spec. High	Result	Pass/Fail
Laboratory Temperature	°C	18.9	25.6	21.4	Pass
Laboratory Humidity	%	10	70	31	Pass
Peak Resultant Acceleration	g	225.0	275.0	259.0	Pass
Peak Lateral Acceleration	g	-15.0	15.0	-7.6	Pass
Oscillations After Main Pulse	%	0.0	10.0	1.8	Pass
Is Acceleration Unimodal?	Yes/No	Yes		Yes	Pass
Overall Test Results					Pass

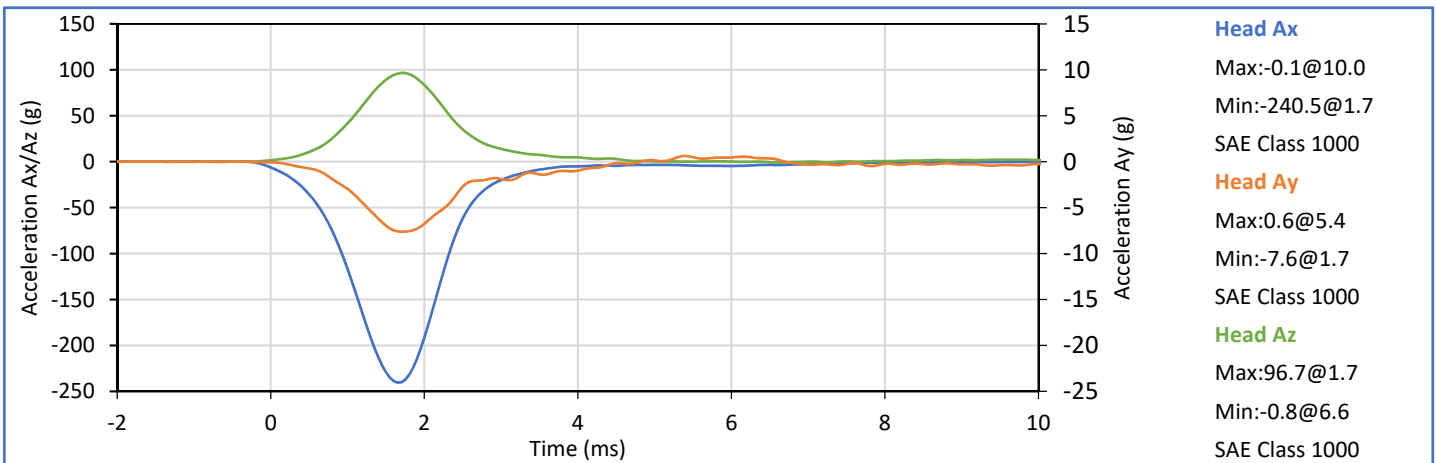
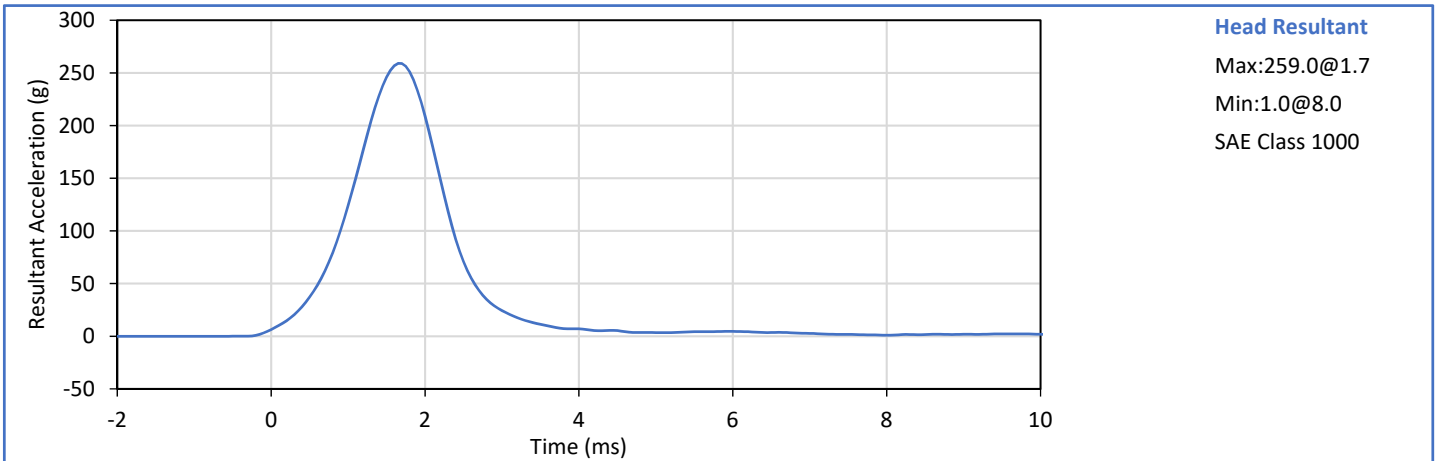

Technician:
 J. Hernandez

Approved By:
 P. Puzzuto



ATD Serial No.: 360

Test Date: 2018-07-17

Tested Parameter	Units	Spec. Low	Spec. High	Result	Pass/Fail
Laboratory Temperature	°C	20.6	22.2	21.2	Pass
Laboratory Humidity	%	10	70	30	Pass
Pendulum Velocity	m/s	6.89	7.13	6.91	Pass
Pendulum Deceleration at 10 ms	g	22.5	27.5	24.4	Pass
Pendulum Deceleration at 20 ms	g	17.6	22.6	20.8	Pass
Pendulum Deceleration at 30 ms	g	12.5	18.5	17.3	Pass
Peak Pendulum Decel. after 30 ms	g	0.0	29.0	17.3	Pass
Deceleration Decay to Cross 5 g	ms	34.0	42.0	38.6	Pass
"D" Plane Rotation peak	deg	64.0	78.0	73.2	Pass
	ms	57.0	64.0	59.3	Pass
"D" Plane Rotation Decay To Zero	ms	113.0	128.0	114.0	Pass
Moment About Occipital Condyle	Nm	88.1	108.5	90.7	Pass
	ms	47.0	58.0	50.4	Pass
Moment Decay, Peak to Zero	deg	97.0	107.0	102.2	Pass
Overall Test Results					Pass

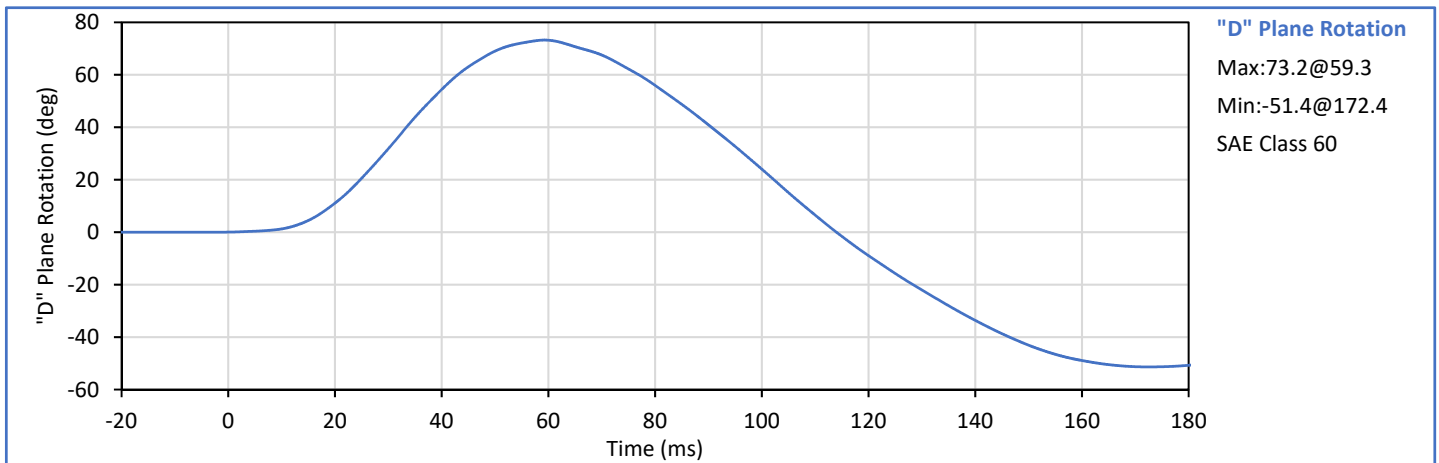
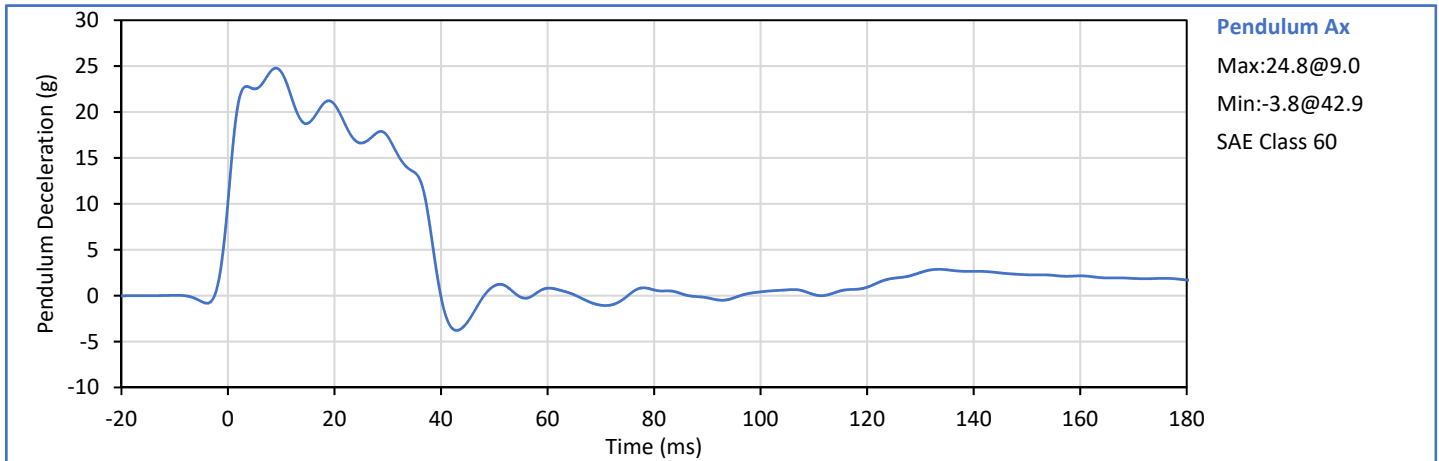

Technician: *J. Hernandez*
 J. Hernandez

Approved By: *P. Puzzuto*
 P. Puzzuto



ATD Serial No.: 360

Test Date: 2018-07-17

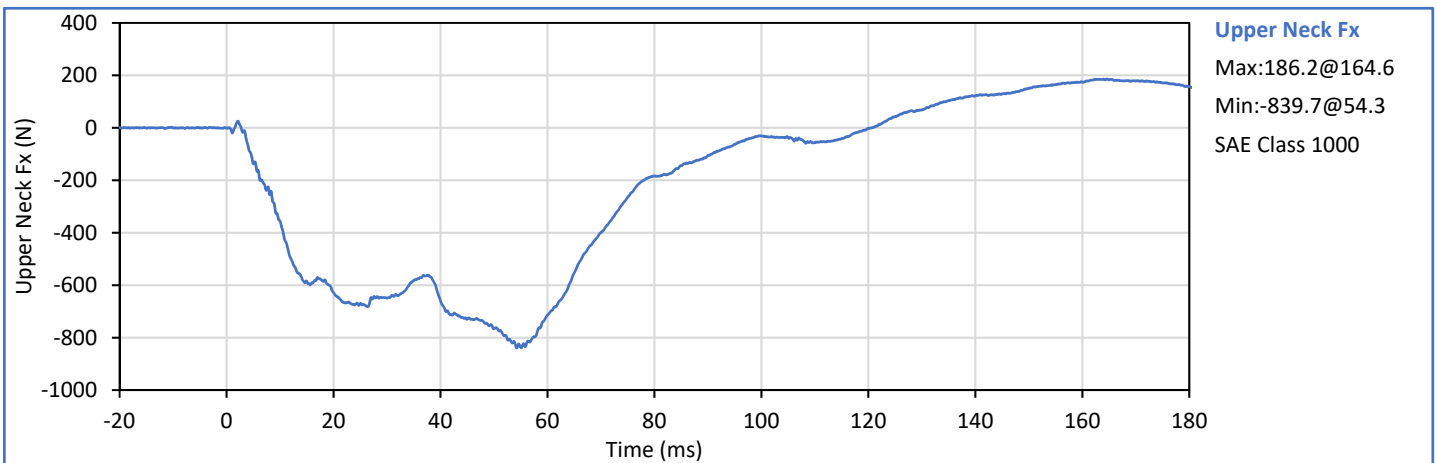
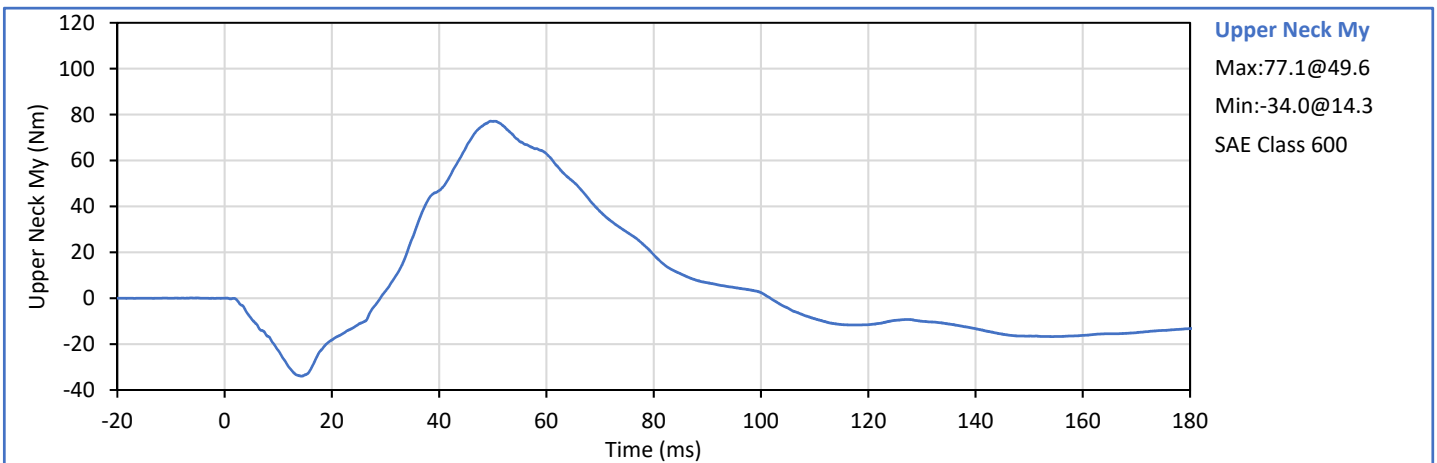
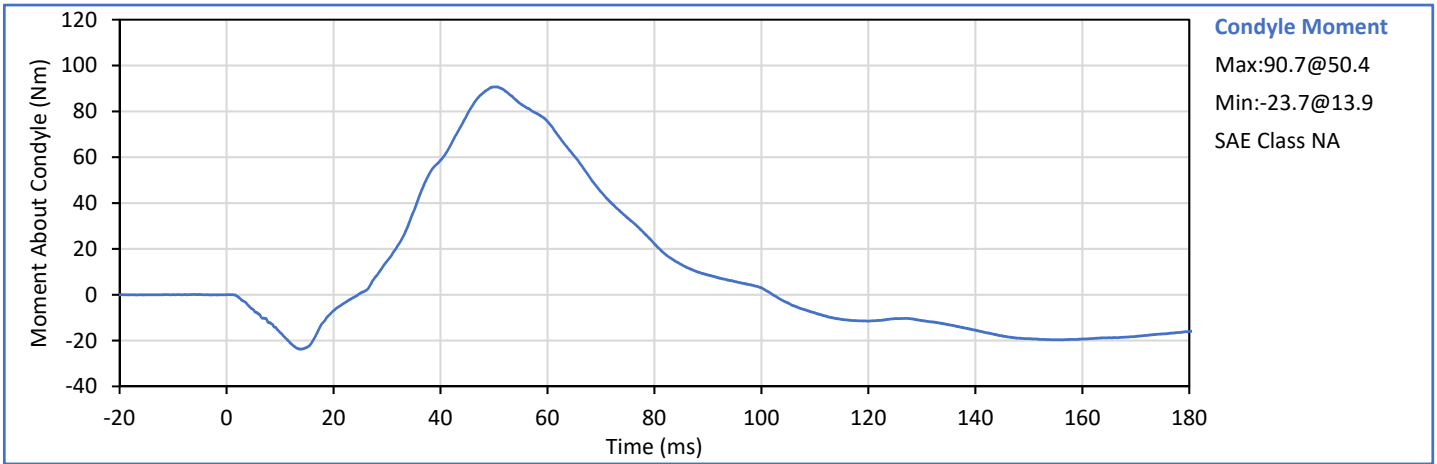





ATD Serial No.: 360

Test Date: 2018-07-17

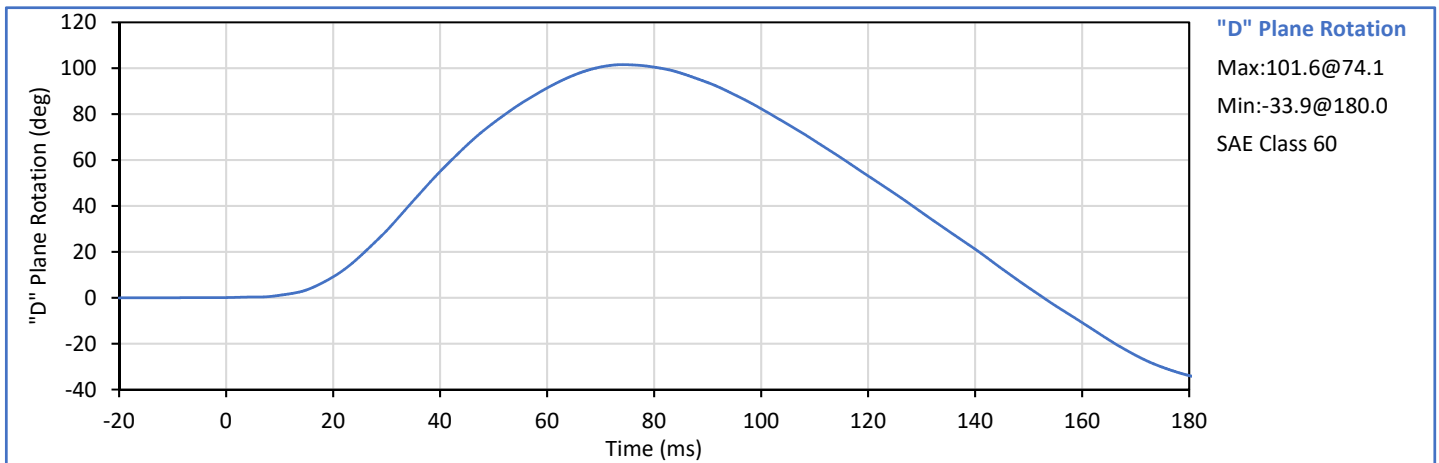
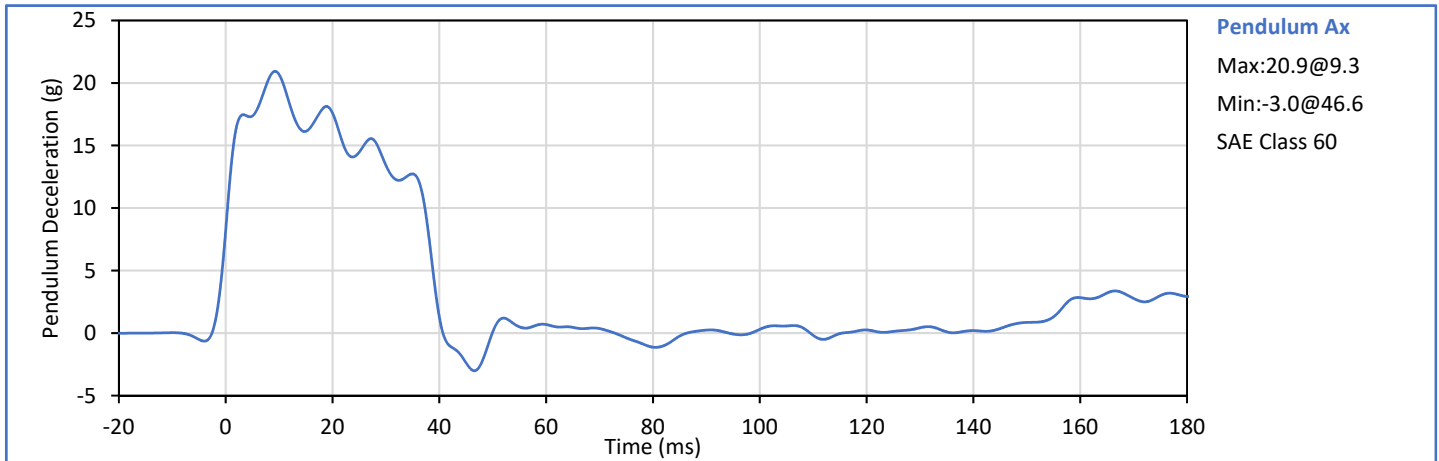
Tested Parameter	Units	Spec. Low	Spec. High	Result	Pass/Fail
Laboratory Temperature	°C	20.6	22.2	21.2	Pass
Laboratory Humidity	%	10	70	30	Pass
Pendulum Velocity	m/s	5.94	6.19	6.05	Pass
Pendulum Deceleration at 10 ms	g	17.2	21.2	20.7	Pass
Pendulum Deceleration at 20 ms	g	14.0	19.0	17.6	Pass
Pendulum Deceleration at 30 ms	g	11.0	16.0	13.4	Pass
Peak Pendulum Decel. after 30 ms	g	0.0	22.0	13.4	Pass
Deceleration Decay to Cross 5 g	ms	38.0	46.0	38.8	Pass
"D" Plane Rotation peak	deg	81.0	106.0	101.6	Pass
	ms	72.0	82.0	74.1	Pass
"D" Plane Rotation Decay To Zero	ms	147.0	174.0	152.8	Pass
Moment About Occipital Condyle	Nm	-79.9	-52.9	-71.4	Pass
	ms	65.0	79.0	70.1	Pass
Moment Decay, Peak to Zero	deg	120.0	148.0	140.7	Pass
Overall Test Results					Pass

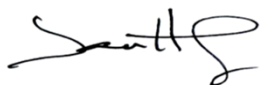

Technician: 
 J. Hernandez

Approved By: 
 P. Puzzuto



ATD Serial No.: 360

Test Date: 2018-07-17

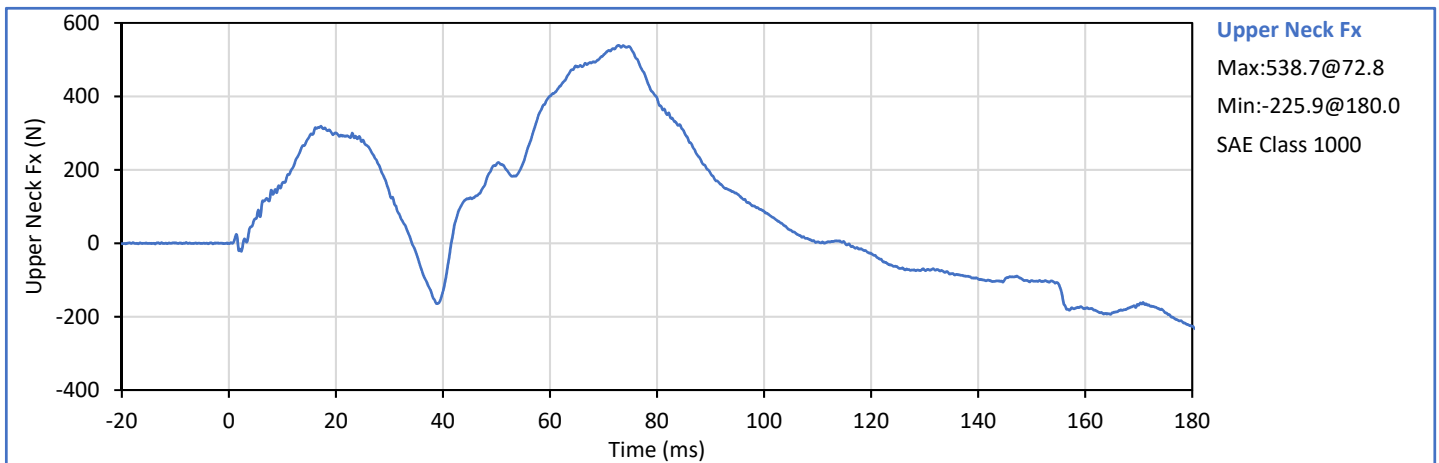
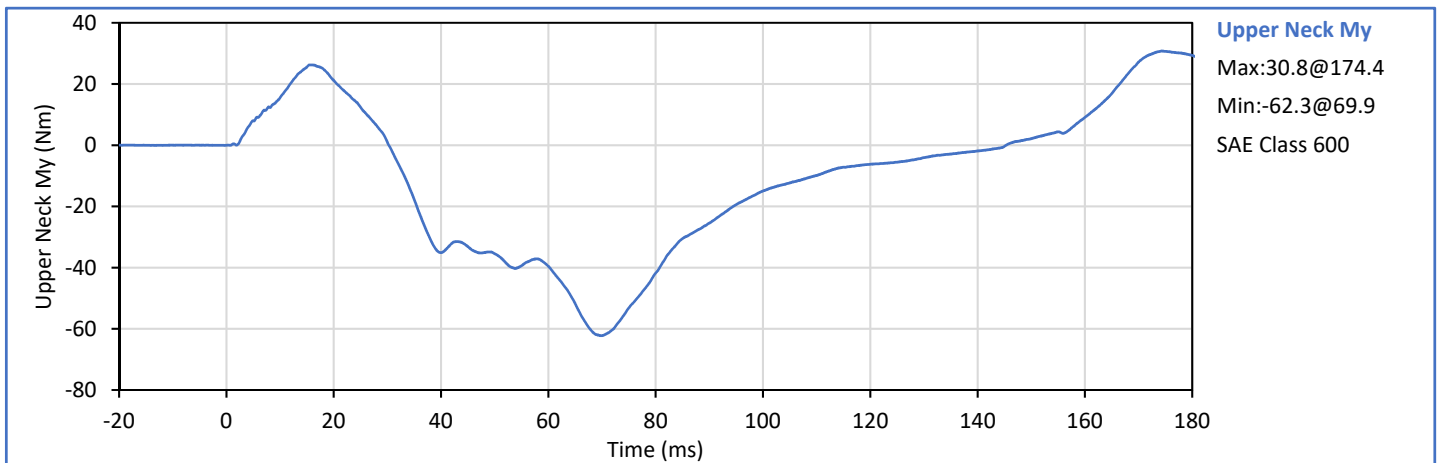
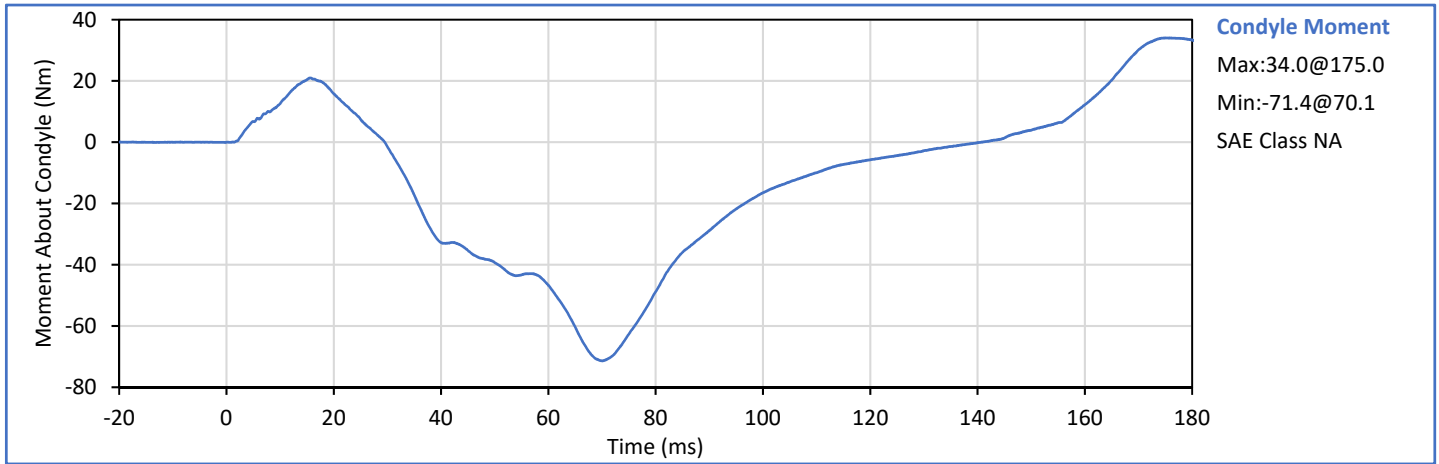



ATD Serial No.: 360

Test Date: 2018-07-16

Tested Parameter	Units	Spec. Low	Spec. High	Result	Pass/Fail
Laboratory Temperature	°C	20.6	22.2	21.4	Pass
Laboratory Humidity	%	10	70	28	Pass
Probe Velocity	m/s	6.58	6.82	6.65	Pass
Peak Chest Deflection	cm	6.35	7.26	6.43	Pass
Peak Probe Force	kN	5.159	5.893	5.653	Pass
Internal Hysterisis	%	69.0	85.0	75.8	Pass
Overall Test Results					Pass

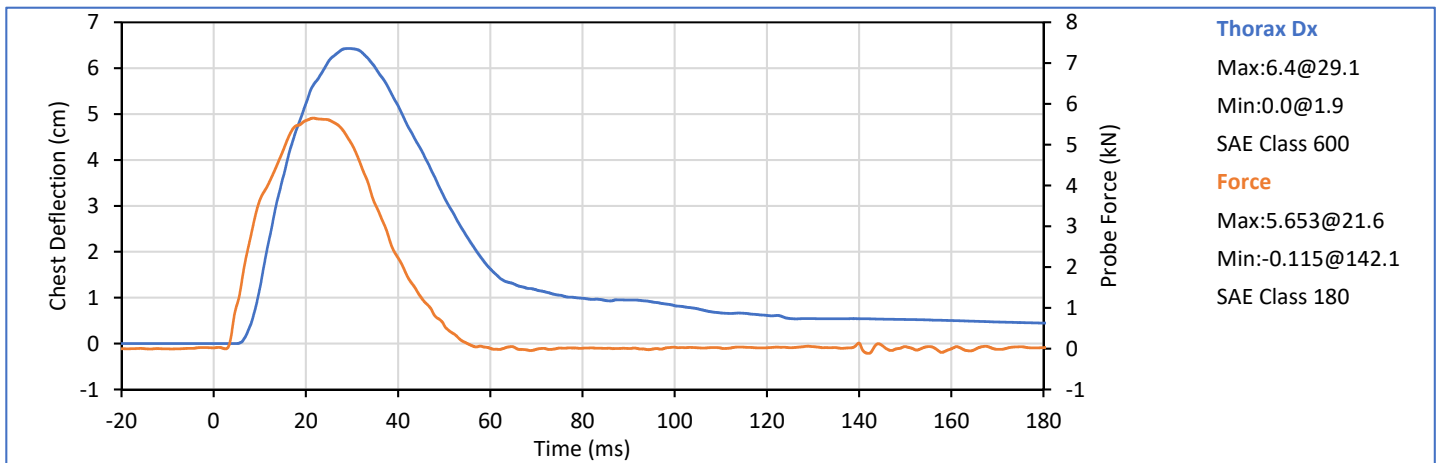
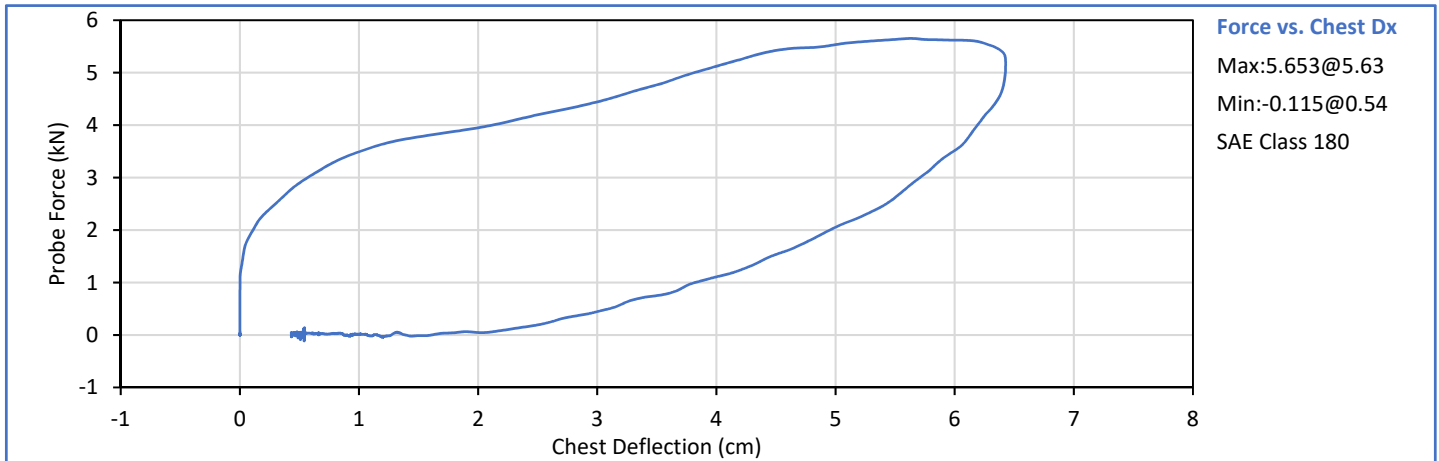

Technician: J. Hernandez

Approved By: P. Puzzuto



ATD Serial No.: 360

Test Date: 2018-07-17

	Tested Parameter	Units	Spec. Low	Spec. High	Result	Pass/Fail
	Laboratory Temperature	°C	18.9	25.6	21.4	Pass
	Laboratory Humidity	%	10	70	29	Pass
Left Hip	Left Hip Rotation Rate	deg/s	5.0	10.0	6.3	Pass
	Left Femur Torque at 30°	Nm	0.0	95.0	68.1	Pass
	Left Hip Rotation at 203 Nm	deg	40.0	50.0	44.6	Pass
Right Hip	Right Hip Rotation Rate	deg/s	5.0	10.0	6.8	Pass
	Right Femur Torque at 30°	Nm	0.0	95.0	58.9	Pass
	Right Hip Rotation at 203 Nm	deg	40.0	50.0	47.6	Pass
Overall Test Results						Pass

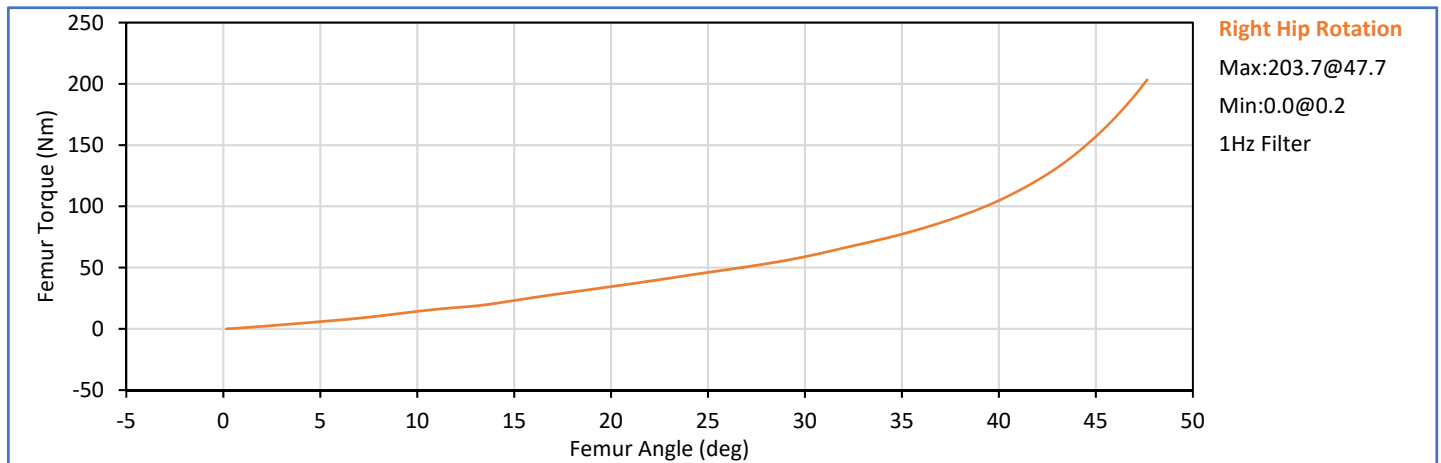
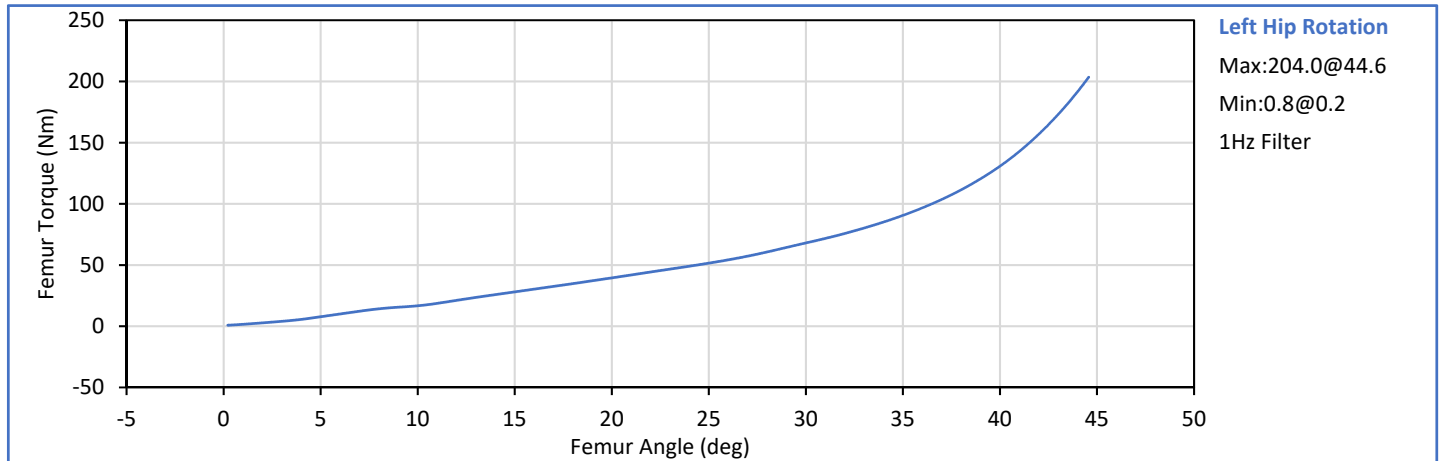

Technician:
 J. Hernandez

Approved By:
 P. Puzzuto



**Hybrid III 50th Percentile Male
 Knee Impact (Left/Right)**

ATD Serial No.: 360

Test Date: 2018-07-16

Tested Parameter	Units	Spec. Low	Spec. High	Result	Pass/Fail
Laboratory Temperature	°C	18.9	25.6	21.3	Pass
Laboratory Humidity	%	10	70	21	Pass
Left Knee Probe Velocity	m/s	2.070	2.130	2.071	Pass
Left Knee Peak Resistive Force	N	4715	5782	4957	Pass
Right Knee Probe Velocity	m/s	2.070	2.130	2.070	Pass
Right Knee Peak Resistive Force	N	4715	5782	4822	Pass
Overall Test Results					Pass

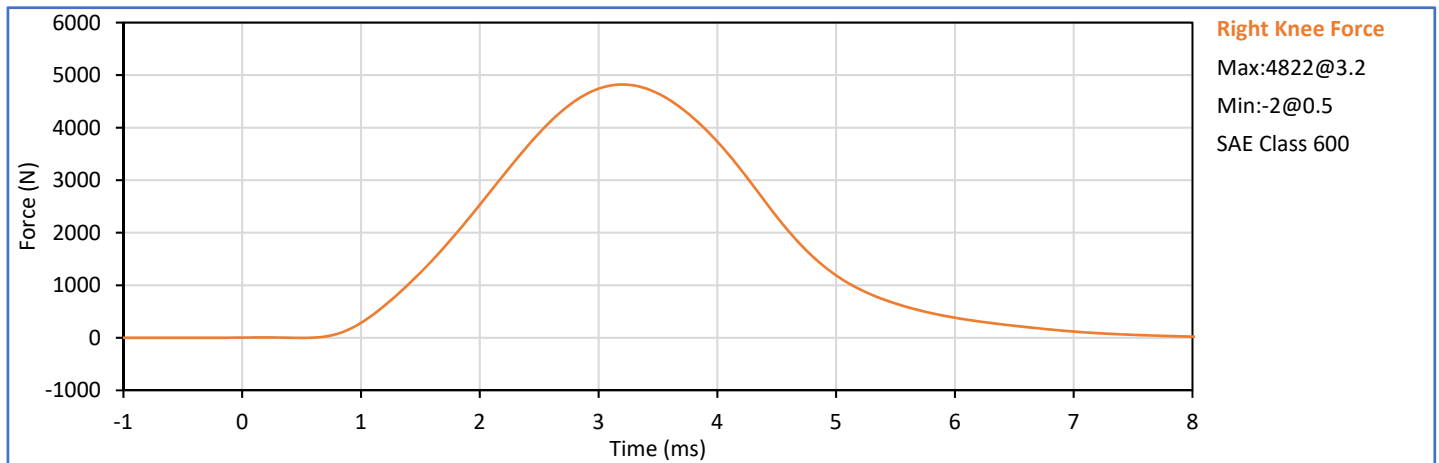
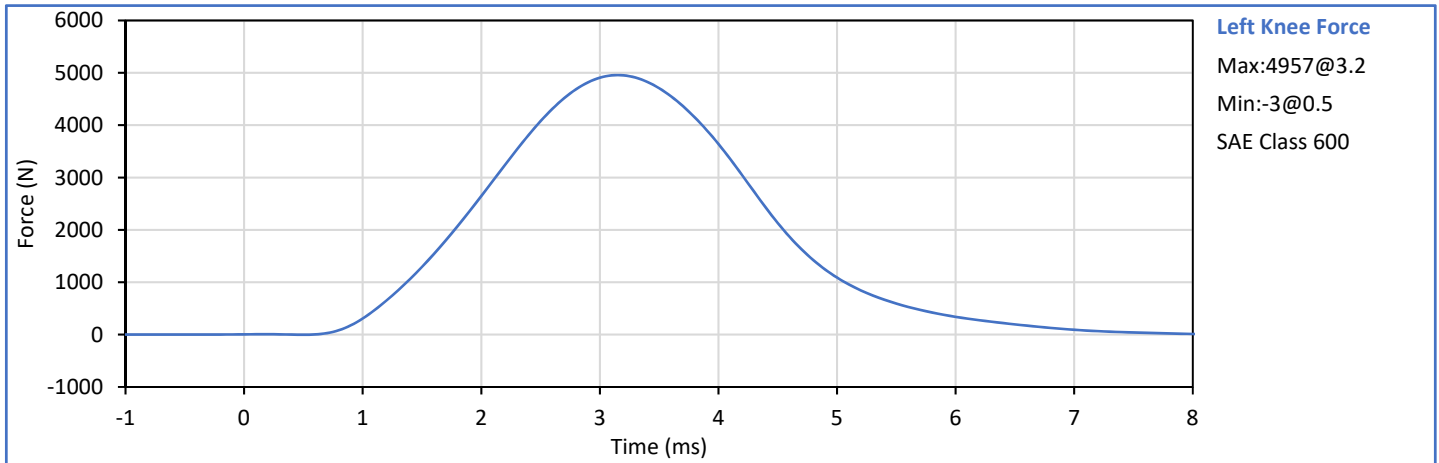

Technician:
 T. Lowman

Approved By:
 P. Puzzuto



**Hybrid III 5th Percentile Female
 Damage Checklist**

ATD Serial No.: 141

Test Date: 2018-07-12

Dummy Item	Inspect for	Comments	Damage	Okay
Entire ATD	Perform general cleaning			✓
Outer Skin	Gashes, rips, cracks			✓
Head	Ballast secure			✓
	General appearance			✓
Neck bracket	Upper neck firmly attached to lower bracket			✓
Neck	Broken or cracked rubber			✓
	Looseness at the condyle joint			✓
Nodding block	Cracked or out of position			✓
Lumbar Spine	Broken or cracked rubber			✓
Ribs	Broken or bent ribs			✓
	Broken or bent rib supports			✓
	Damping material separated or cracked			✓
	Rubber bumpers in place			✓
Chest Displ. Assembly	Bent shaft			✓
	Slider arm riding in track			✓
Sensors	Check cables for cuts, tears			✓
	Check for damaged insulation			✓
Accelerometer Mounting	Head mounting secure			✓
	Chest mounting secure			✓
Knees	Skin condition			✓
	Insert (do not remove)			✓
	Casting			✓
Limbs	Normal movement and adjustment			✓
Knee Sliders	Wires intact			✓
	Rubber returned to "resting" position			✓
Pelvis	Broken			✓
Other	Describe below as needed			✓

Describe any repairs or replacement of parts or other findings:

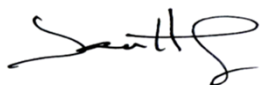
Technician: 
 J. Hernandez

Approved By: 
 P. Puzzuto



ATD Serial No.: 141

Test Date: 2018-07-12

Tested Parameter	Units	Spec. Low	Spec. High	Result	Pass/Fail
Laboratory Temperature	°C	20.6	22.2	21.1	Pass
Laboratory Relative Humidity	%	10	70	22	Pass
A - Total sitting height	mm	775	800	788	Pass
B - Shoulder pivot height	mm	432	457	453	Pass
C - 'H' point height	mm	81	86	86	Pass
D - 'H' point location from backline	mm	145	150	148	Pass
E - Shoulder pivot from backline	mm	69	84	78	Pass
F - Thigh clearance	mm	119	135	128	Pass
G - Back of elbow to wrist pivot	mm	244	259	254	Pass
H - Head back to backline	mm	41	46	43	Pass
I - Shoulder to elbow length	mm	277	297	287	Pass
J - Elbow rest height	mm	183	203	197	Pass
K - Buttock to knee length	mm	521	546	531	Pass
L - Popliteal length	mm	356	376	367	Pass
M - Knee pivot height	mm	394	419	407	Pass
N - Buttock popliteal length	mm	414	439	428	Pass
O - Chest depth without jacket	mm	175	191	183	Pass
P - Foot length	mm	219	234	231	Pass
R - Buttock to Knee Pivot Length	mm	457	483	473	Pass
S - Head Breadth	mm	137	147	144	Pass
T - Head Depth	mm	178	188	184	Pass
U - Hip Breadth	mm	300	315	308	Pass
V - Shoulder breadth	mm	351	366	360	Pass
W - Foot breadth	mm	79	94	88	Pass
X - Head circum.	mm	528	549	535	Pass
Y - Chest circum. (w/chest jacket)	mm	851	881	868	Pass
Z - Waist circum.	mm	760	790	776	Pass
AA - Location for chest circum.	mm	333	358	339	Pass
BB - Location for waist circum.	mm	160	170	168	Pass
Overall Test Results					Pass

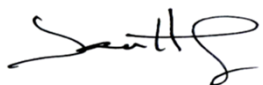
Technician: 
 J. Hernandez

Approved By: 
 P. Puzzuto



ATD Serial No.: 141

Test Date: 2018-07-12

Tested Parameter	Units	Spec. Low	Spec. High	Result	Pass/Fail
Laboratory Temperature	°C	18.9	25.6	21.4	Pass
Laboratory Humidity	%	10	70	28	Pass
Peak Resultant Acceleration	g	250.0	300.0	276.0	Pass
Peak Lateral Acceleration	g	-15.0	15.0	4.8	Pass
Oscillations After Main Pulse	%	0.0	10.0	1.4	Pass
Is Acceleration Unimodal?	Yes/No	Yes		Yes	Pass
Overall Test Results					Pass

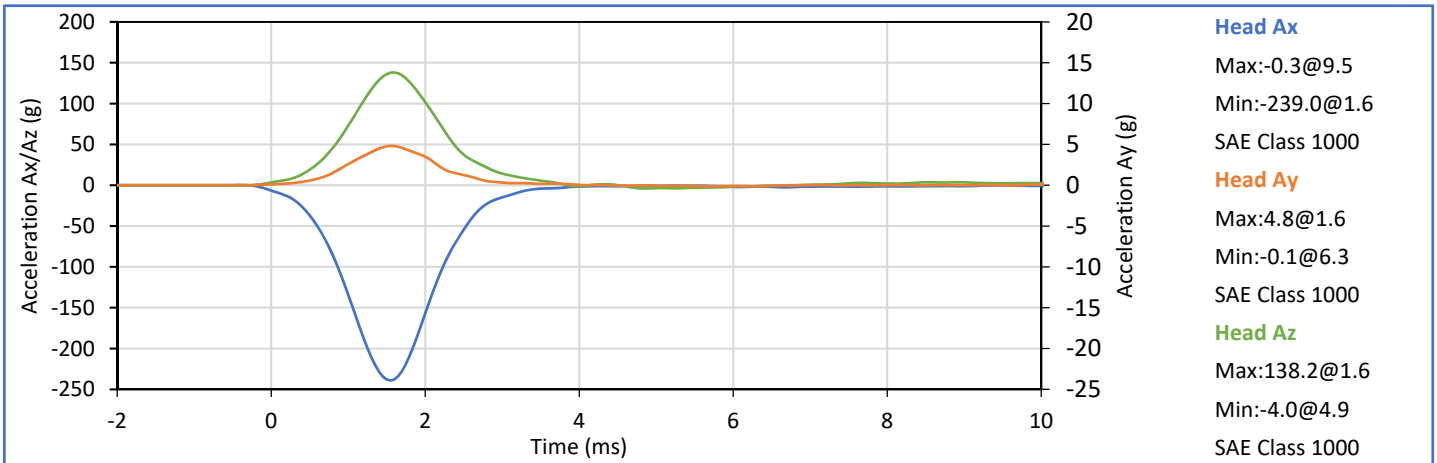
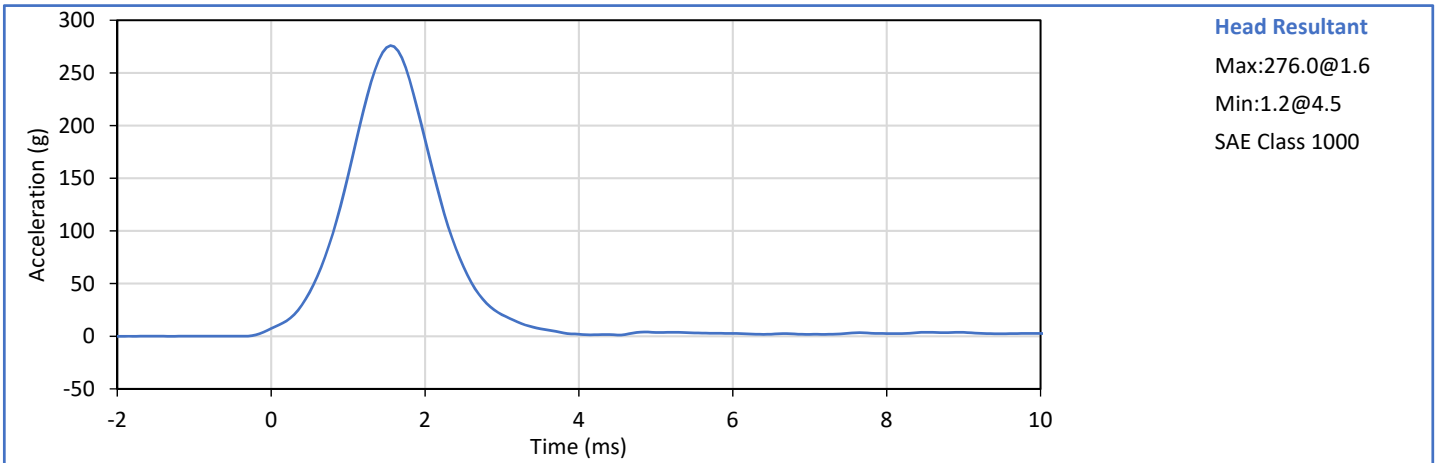

Technician:
 T. Lowman

Approved By:
 P. Puzzuto



ATD Serial No.: 141

Test Date: 2018-07-13

Tested Parameter	Units	Spec. Low	Spec. High	Result	Pass/Fail
Laboratory Temperature	°C	20.6	22.2	20.8	Pass
Laboratory Humidity	%	10	70	30	Pass
Pendulum Velocity	m/s	6.89	7.13	7.06	Pass
Pendulum Velocity at 10 ms	m/s	2.10	2.50	2.31	Pass
Pendulum Velocity at 20 ms	m/s	4.00	5.00	4.66	Pass
Pendulum Velocity at 30 ms	m/s	5.80	7.00	6.60	Pass
Peak "D" Plane Rotation	deg	77.0	91.0	80.4	Pass
Peak Moment in Rotation	Nm	69.0	83.0	76.9	Pass
Positive Moment Decay to 10 Nm	ms	80.0	100.0	85.2	Pass
Overall Test Results					Pass

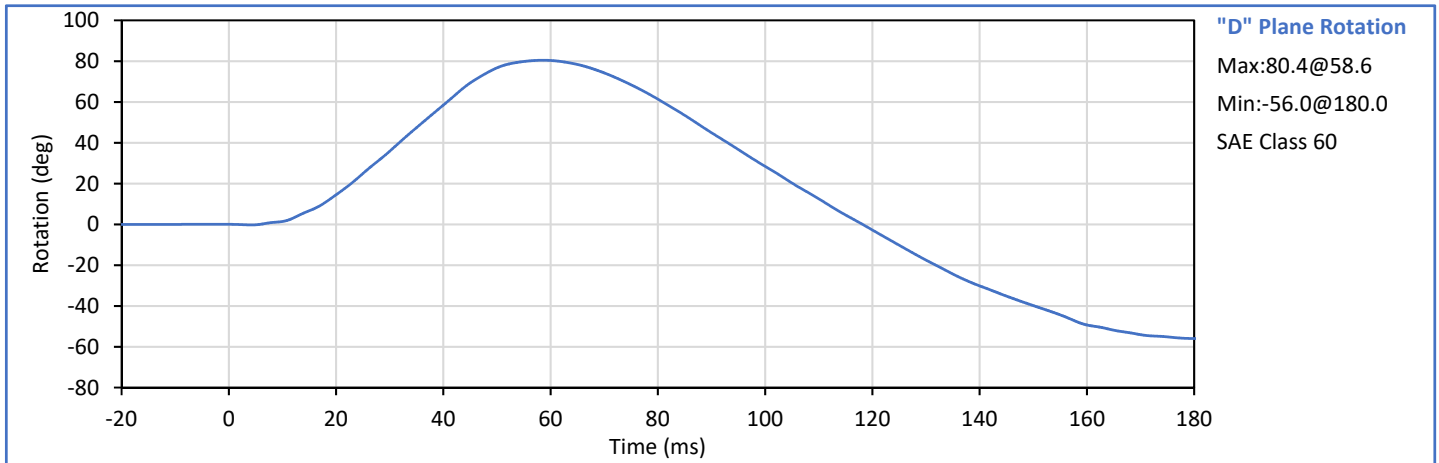
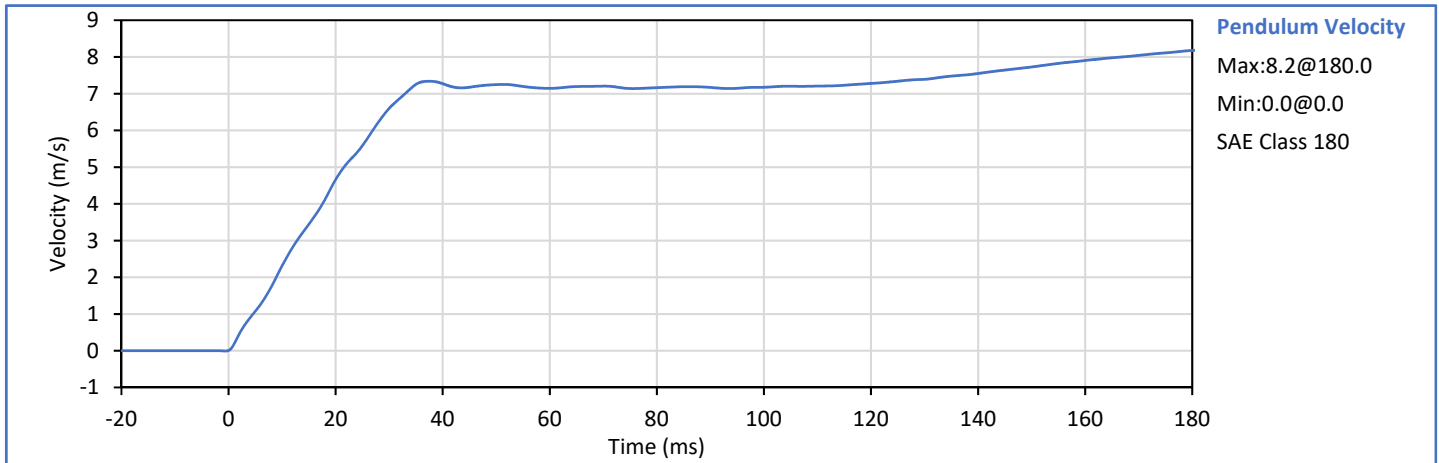

Technician:
 J. Hernandez

Approved By:
 P. Puzzuto



ATD Serial No.: 141

Test Date: 2018-07-13

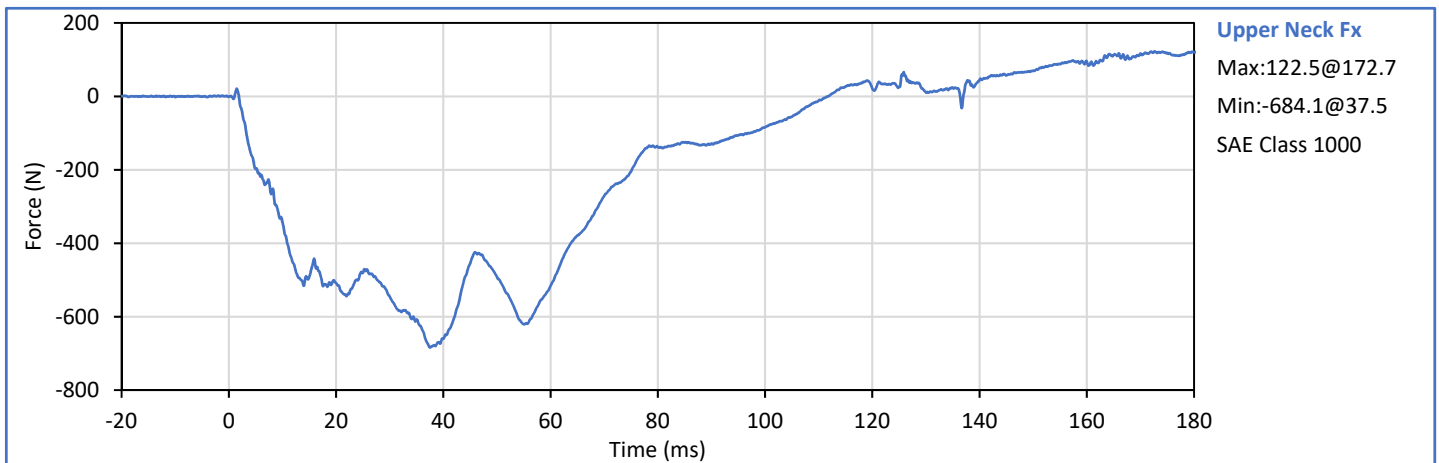
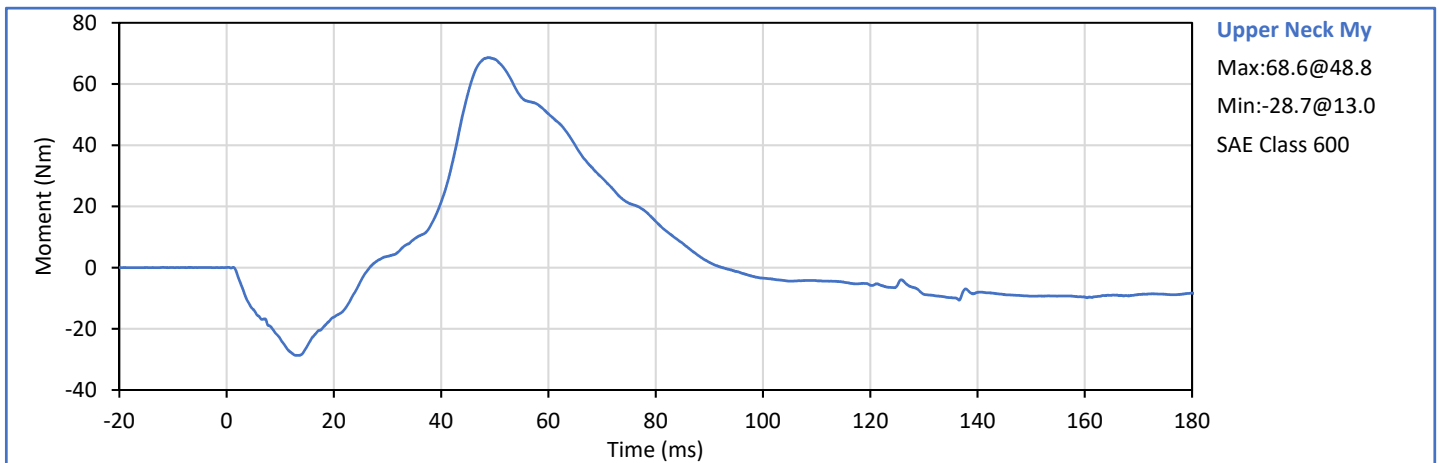
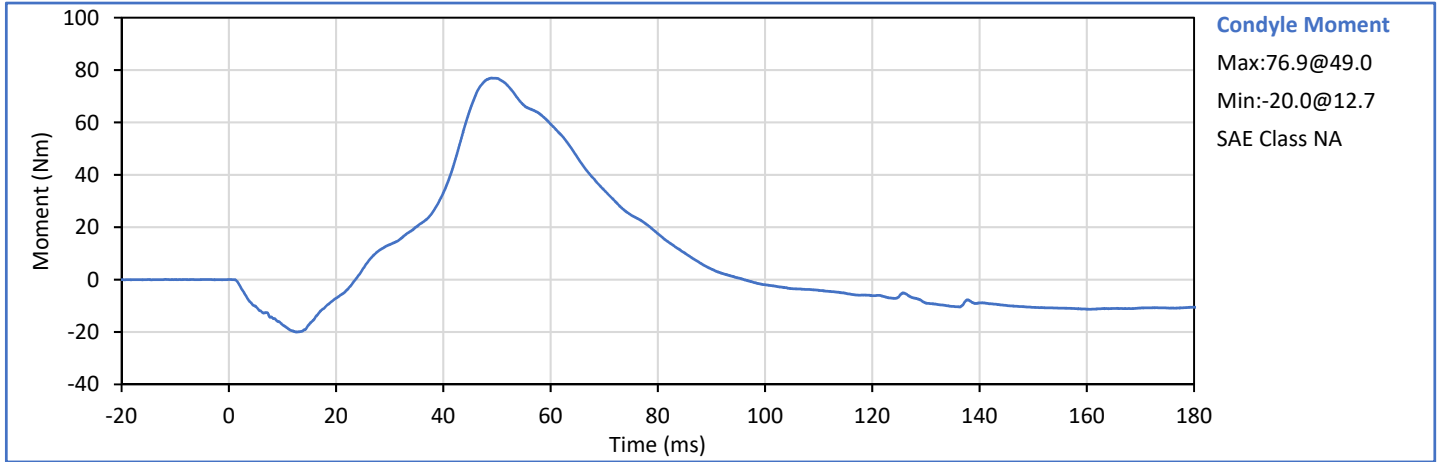





ATD Serial No.: 141

Test Date: 2018-07-13

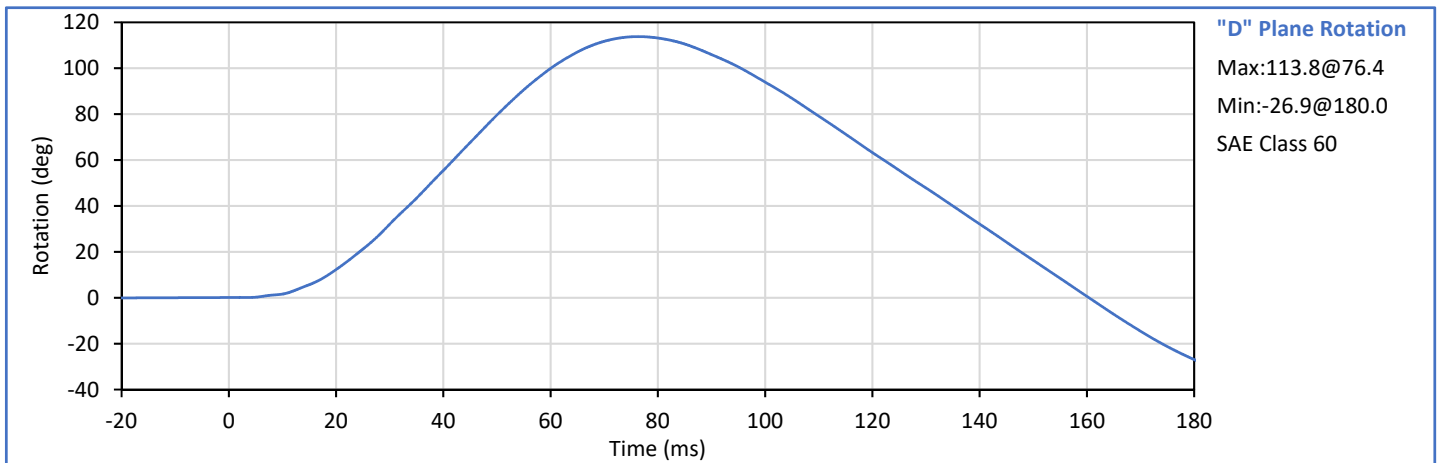
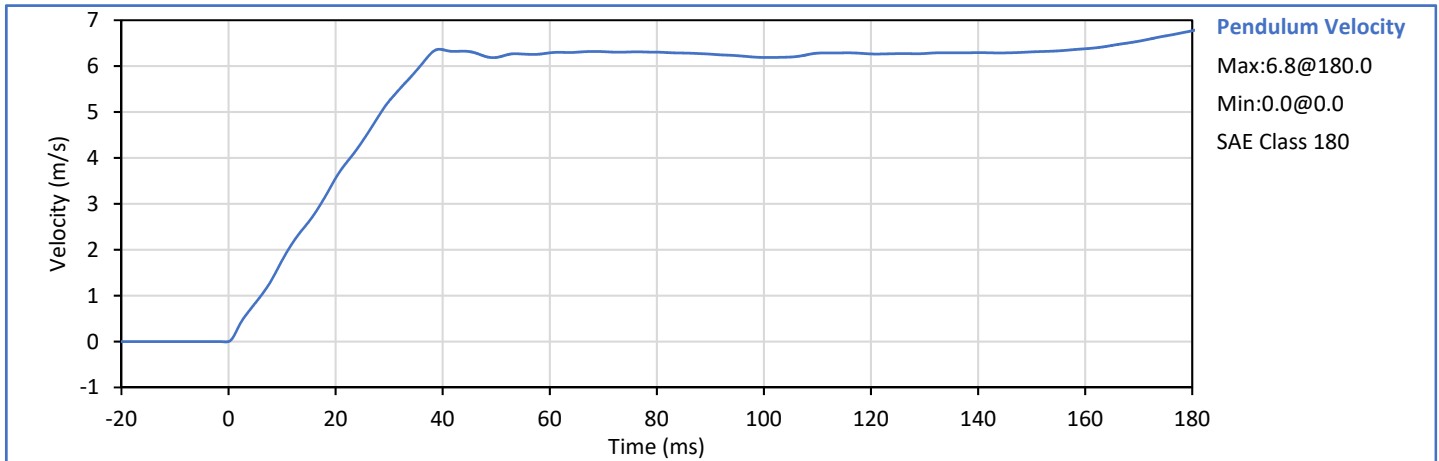
Tested Parameter	Units	Spec. Low	Spec. High	Result	Pass/Fail
Laboratory Temperature	°C	20.6	22.2	20.8	Pass
Laboratory Humidity	%	10	70	30	Pass
Pendulum Velocity	m/s	5.95	6.19	6.12	Pass
Pendulum Velocity at 10 ms	m/s	1.50	1.90	1.77	Pass
Pendulum Velocity at 20 ms	m/s	3.10	3.90	3.56	Pass
Pendulum Velocity at 30 ms	m/s	4.60	5.60	5.24	Pass
Peak "D" Plane Rotation	deg	99.0	114.0	113.8	Pass
Peak Moment in Rotation	Nm	-65.0	-53.0	-57.5	Pass
Negative Moment Decay to -10 Nm	ms	94.0	114.0	105.0	Pass
Overall Test Results					Pass

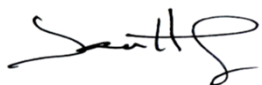

Technician: 
 J. Hernandez

Approved By: 
 P. Puzzuto



ATD Serial No.: 141

Test Date: 2018-07-13

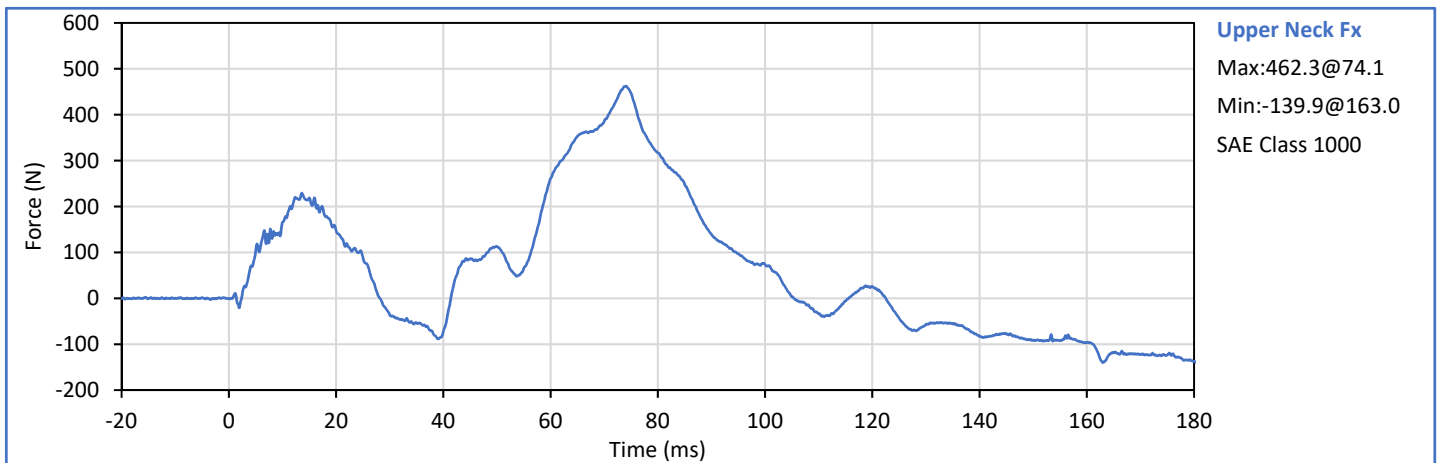
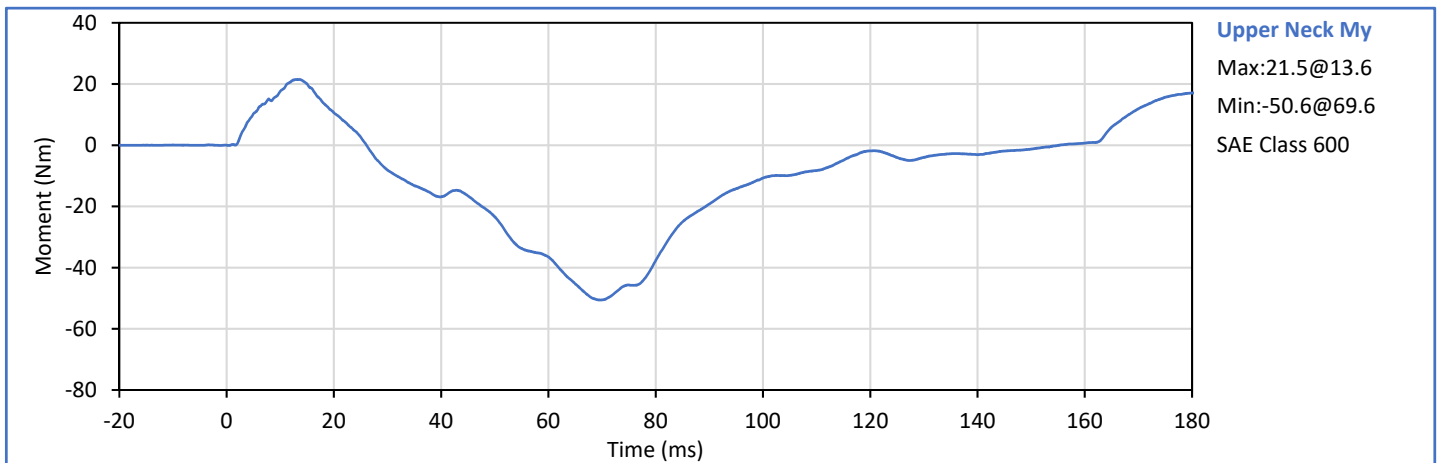
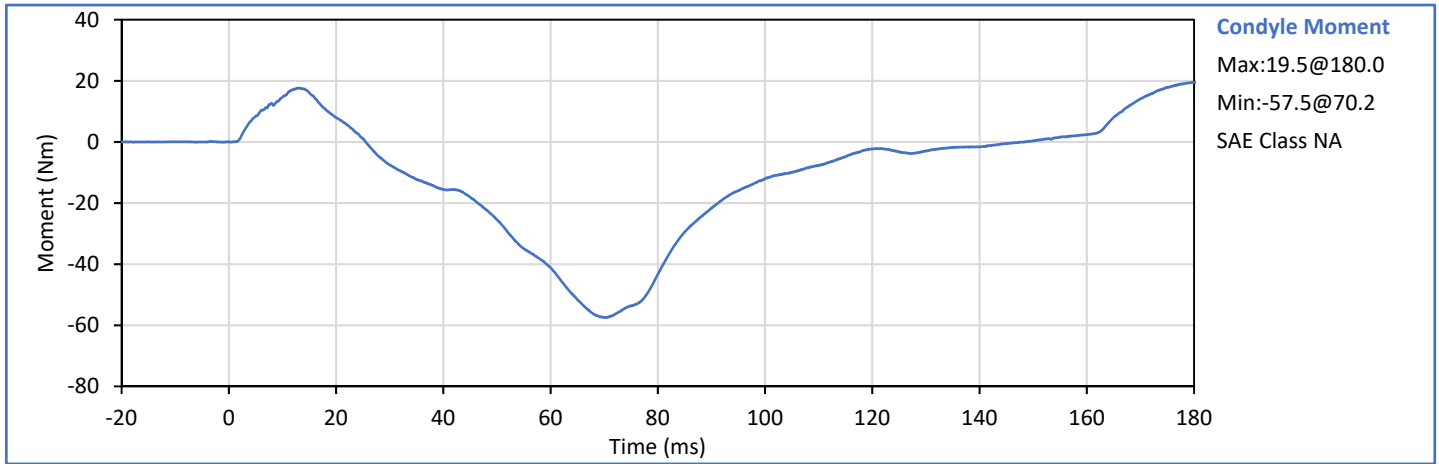



ATD Serial No.: 141

Test Date: 2018-07-13

Tested Parameter	Units	Spec. Low	Spec. High	Result	Pass/Fail
Laboratory Temperature	°C	20.6	22.2	21.2	Pass
Laboratory Humidity	%	10	70	29	Pass
Probe Velocity	m/s	6.59	6.83	6.62	Pass
Peak Chest Deflection	mm	50.0	58.0	56.4	Pass
Peak Probe Force, 50 and 58 mm	kN	3.900	4.400	4.130	Pass
Peak Probe Force, 18 and 50 mm	kN	0.000	4.600	4.097	Pass
Internal Hysterisis	%	69.0	85.0	77.3	Pass
Overall Test Results					Pass

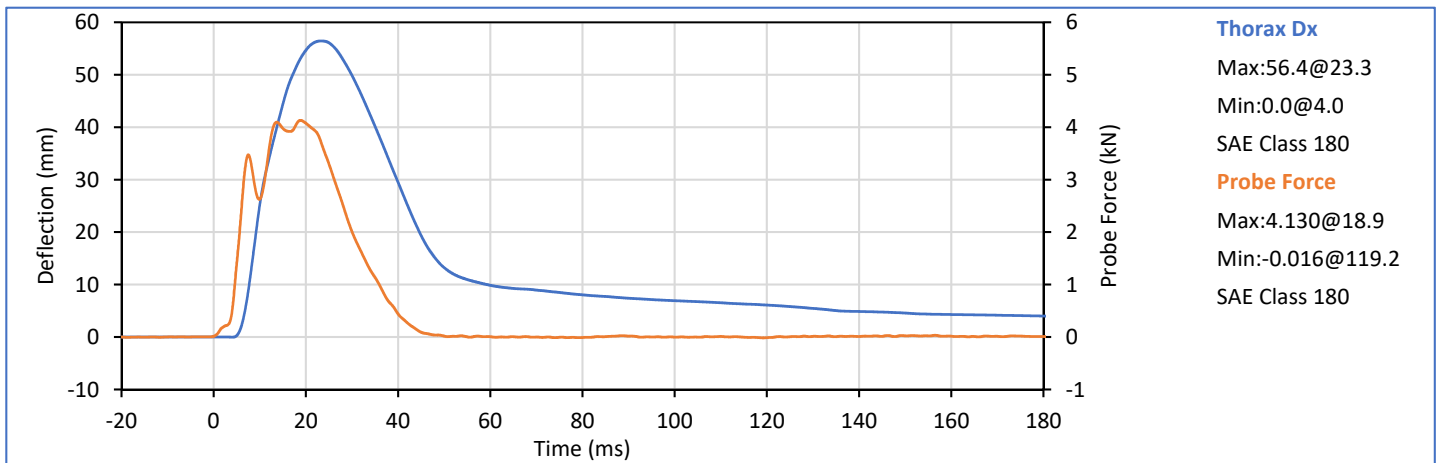
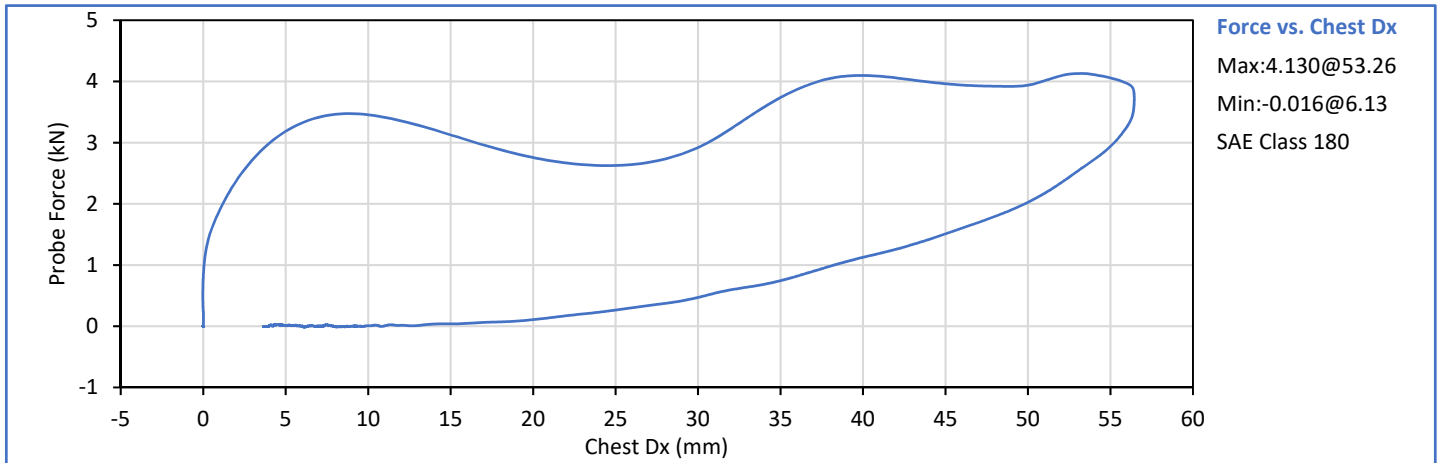

Technician: J. Hernandez

Approved By: P. Puzzuto



**Hybrid III 5th Percentile Female
 Torso Flexion Test**

ATD Serial No.: 141

Test Date: 2018-07-12

Tested Parameter	Units	Spec. Low	Spec. High	Result	Pass/Fail
Laboratory Temperature	°C	18.9	25.6	21.0	Pass
Laboratory Humidity	%	10	70	38	Pass
Orientation Angle	deg	0.0	20.0	13.2	Pass
Test Initial Angle	deg	11.0	19.0	14.8	Pass
Peak Force at 45° (+/-0.5°)	N	320.0	390.0	351.8	Pass
Torso Flexion Rate	deg/s	0.50	1.50	1.19	Pass
Final Reference Plane Angle	deg	-8.0	8.0	4.3	Pass
Overall Test Results					Pass

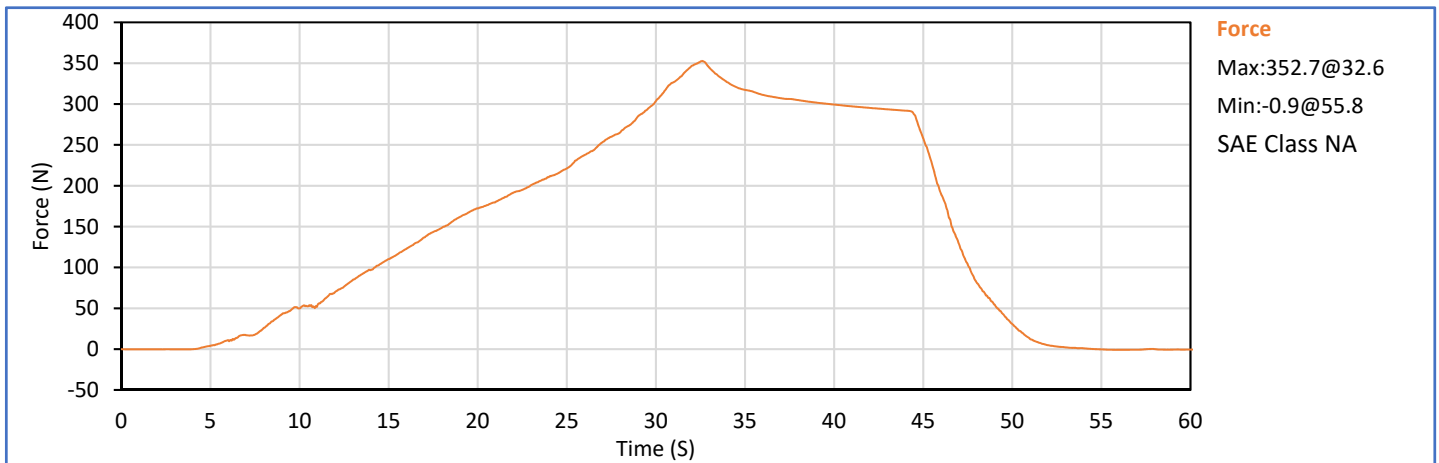
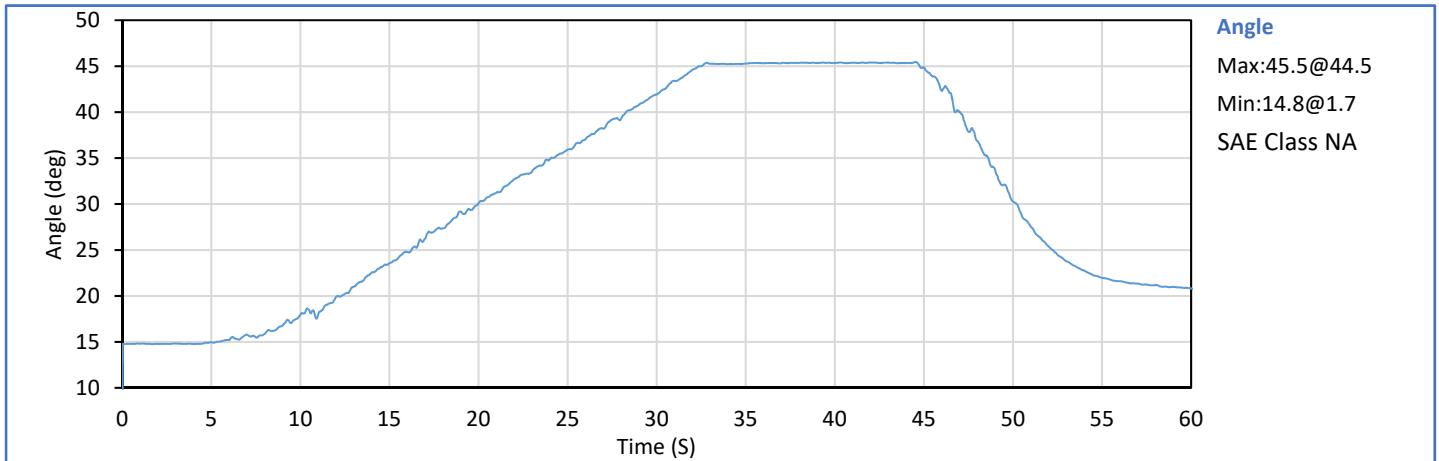

Technician:
 J. Hernandez

Approved By:
 P. Puzzuto



ATD Serial No.: 141

Test Date: 2018-07-12

	Tested Parameter	Units	Spec. Low	Spec. High	Result	Pass/Fail
	Laboratory Temperature	°C	18.9	25.6	21.1	Pass
	Laboratory Humidity	%	10	70	22	Pass
Left	Probe Velocity	m/s	2.070	2.130	2.080	Pass
Knee	Peak Resistive Force	N	3450	4060	3918	Pass
Right	Probe Velocity	m/s	2.070	2.130	2.079	Pass
Knee	Peak Resistive Force	N	3450	4060	3948	Pass
Overall Test Results						Pass

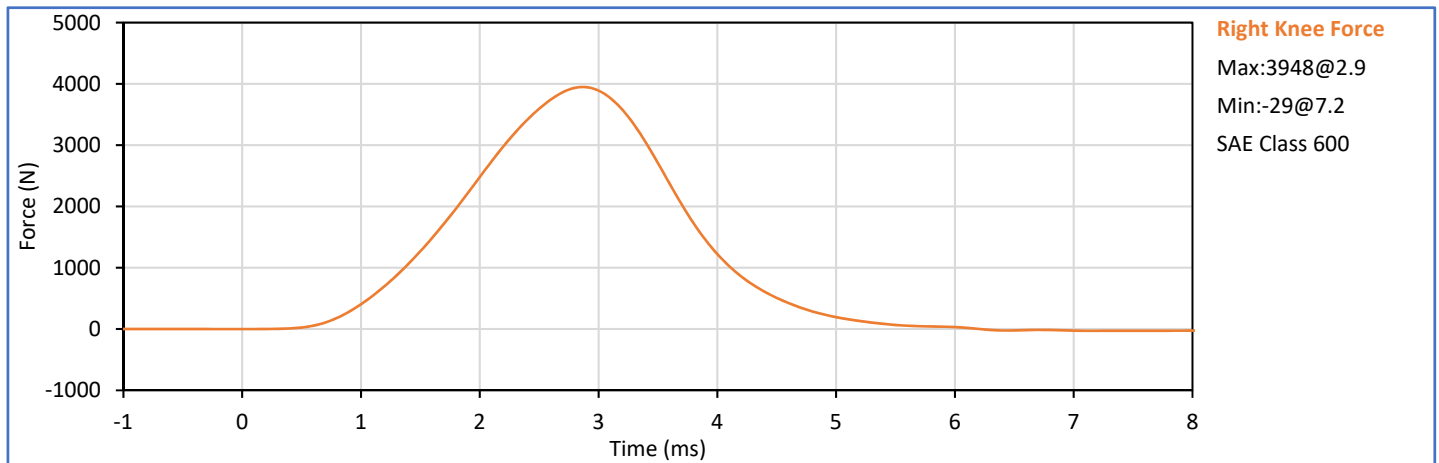
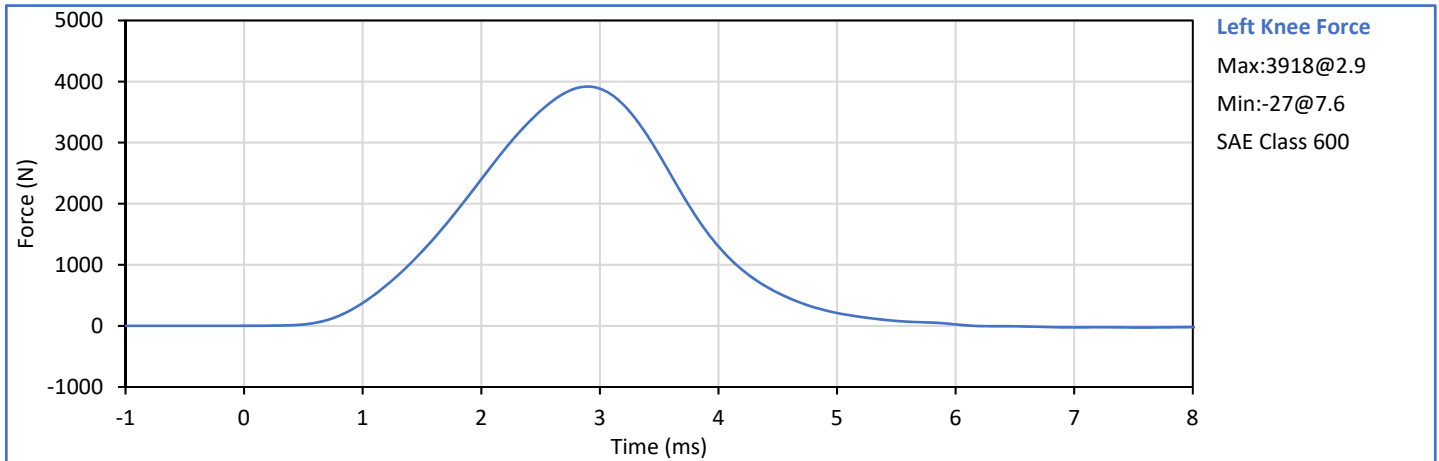

Technician: Nicholas Garcia
 N. Garcia

Approved By: P. Puzzuto
 P. Puzzuto

APPENDIX C
POST-TEST ATD CONFIGURATION AND PERFORMANCE VERIFICATION DATA





ATD Serial No.: 360

Test Date: 2018-08-22

Dummy Item	Inspect for	Comments	Damage	OK
Entire ATD	Perform general cleaning			✓
Outer Skin	Gashes, rips, cracks			✓
Head	Ballast secure			✓
	General appearance			✓
Neck bracket	Upper neck firmly attached to lower bracket			✓
Neck	Broken or cracked rubber			✓
	Looseness at the condyle joint			✓
Nodding block	Cracked or out of position			✓
Lumbar Spine	Broken or cracked rubber			✓
Ribs	Broken or bent ribs			✓
	Broken or bent rib supports			✓
	Damping material separated or cracked			✓
	Rubber bumpers in place			✓
Chest Displ. Assembly	Bent shaft			✓
	Slider arm riding in track			✓
Sensors	Check cables for cuts, tears			✓
	Check for damaged insulation			✓
Accelerometer Mounting	Head mounting secure			✓
	Chest mounting secure			✓
Knees	Skin condition			✓
	Insert (do not remove)			✓
	Casting			✓
Limbs	Normal movement and adjustment			✓
Knee Sliders	Wires intact			✓
	Rubber returned to "resting" position			✓
Pelvis	Broken			✓
Other	Describe below as needed			✓

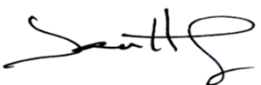
Describe any repairs or replacement of parts or other findings:

Technician: 
 J. Hernandez

Approved By: 
 P. Puzzuto





**Hybrid III 50th Percentile Male
 External Measurements**

ATD Serial No.: 360

Test Date: 2018-08-22

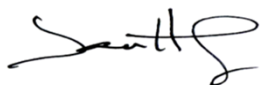
Tested Parameter	Units	Spec. Low	Spec. High	Result	Pass/Fail
Laboratory Temperature	°C	20.6	22.2	21.4	Pass
Laboratory Relative Humidity	%	10	70	26	Pass
A - Total sitting height	mm	879	889	886	Pass
B - Shoulder pivot height	mm	505	521	517	Pass
C - 'H' point height	mm	84	89	86	Pass
D - 'H' point location from backline	mm	135	140	138	Pass
E - Shoulder pivot from backline	mm	84	94	88	Pass
F - Thigh clearance	mm	140	155	153	Pass
G - Back of elbow to wrist pivot	mm	290	305	301	Pass
H - Head back to backline	mm	41	46	45	Pass
I - Shoulder to elbow length	mm	330	345	342	Pass
J - Elbow rest height	mm	190	211	204	Pass
K - Buttock to knee length	mm	579	604	585	Pass
L - Popliteal length	mm	429	455	443	Pass
M - Knee pivot height	mm	485	500	496	Pass
N - Buttock popliteal length	mm	452	477	460	Pass
O - Chest depth without jacket	mm	213	229	223	Pass
P - Foot length	mm	251	267	255	Pass
V - Shoulder breadth	mm	422	437	428	Pass
W - Foot breadth	mm	91	107	98	Pass
Y - Chest circum. (w/chest jacket)	mm	970	1001	984	Pass
Z - Waist circum.	mm	836	866	846	Pass
AA - Location for chest circum.	mm	429	434	432	Pass
BB - Location for waist circum.	mm	226	231	227	Pass
Overall Test Results					Pass

Technician: 
 J. Hernandez

Approved By: 
 P. Puzzuto



ATD Serial No.: 360

Test Date: 2018-08-22

Tested Parameter	Units	Spec. Low	Spec. High	Result	Pass/Fail
Laboratory Temperature	°C	18.9	25.6	21.2	Pass
Laboratory Humidity	%	10	70	44	Pass
Peak Resultant Acceleration	g	225.0	275.0	255.5	Pass
Peak Lateral Acceleration	g	-15.0	15.0	-10.2	Pass
Oscillations After Main Pulse	%	0.0	10.0	2.4	Pass
Is Acceleration Unimodal?	Yes/No	Yes		Yes	Pass
Overall Test Results					Pass

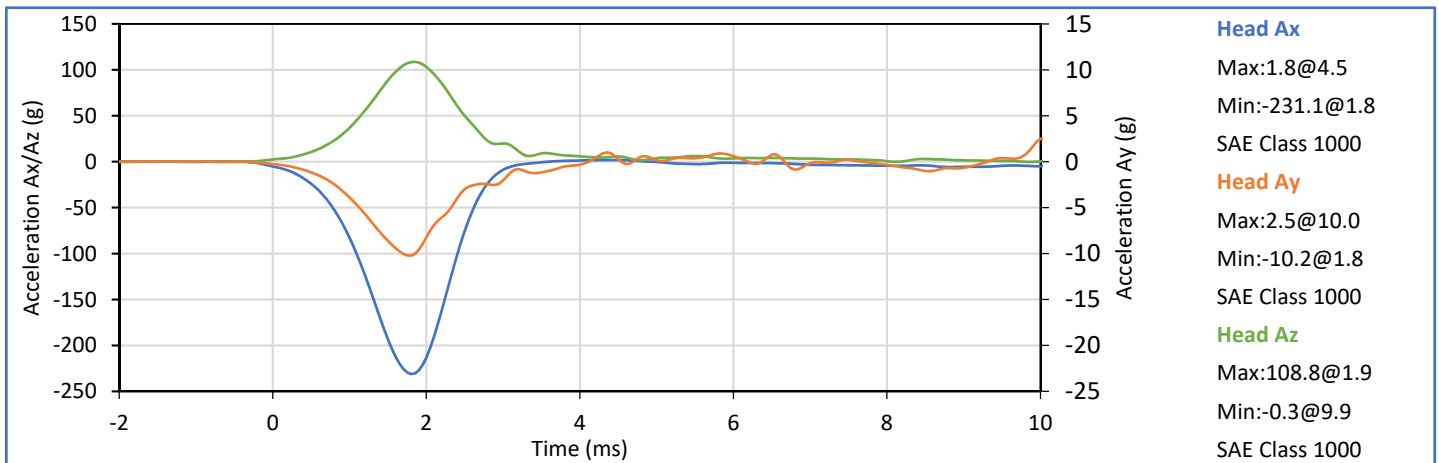
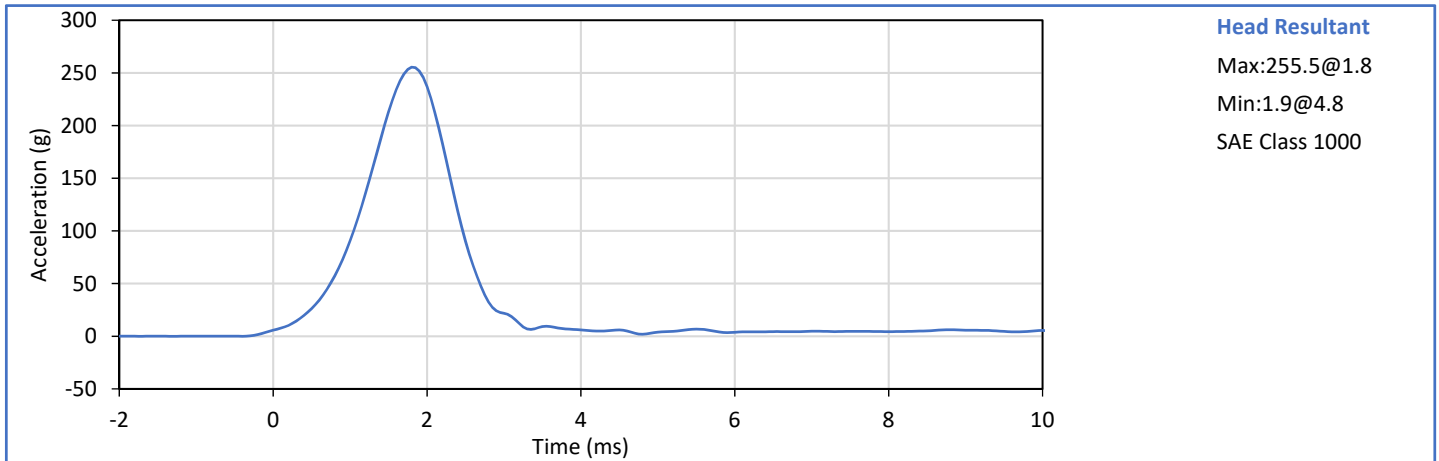

Technician:
 T. Lowman

Approved By:
 P. Puzzuto



ATD Serial No.: 360

Test Date: 2018-08-22

Tested Parameter	Units	Spec. Low	Spec. High	Result	Pass/Fail
Laboratory Temperature	°C	20.6	22.2	21.2	Pass
Laboratory Humidity	%	10	70	44	Pass
Pendulum Velocity	m/s	6.89	7.13	6.89	Pass
Pendulum Deceleration at 10 ms	g	22.5	27.5	24.5	Pass
Pendulum Deceleration at 20 ms	g	17.6	22.6	19.0	Pass
Pendulum Deceleration at 30 ms	g	12.5	18.5	14.2	Pass
Peak Pendulum Decel. after 30 ms	g	0.0	29.0	14.2	Pass
Deceleration Decay to Cross 5 g	ms	34.0	42.0	41.7	Pass
"D" Plane Rotation peak	deg	64.0	78.0	71.6	Pass
	ms	57.0	64.0	61.3	Pass
"D" Plane Rotation Decay To Zero	ms	113.0	128.0	119.8	Pass
Moment About Occipital Condyle	Nm	88.1	108.5	95.5	Pass
	ms	47.0	58.0	55.6	Pass
Moment Decay, Peak to Zero	deg	97.0	107.0	99.4	Pass
Overall Test Results					Pass

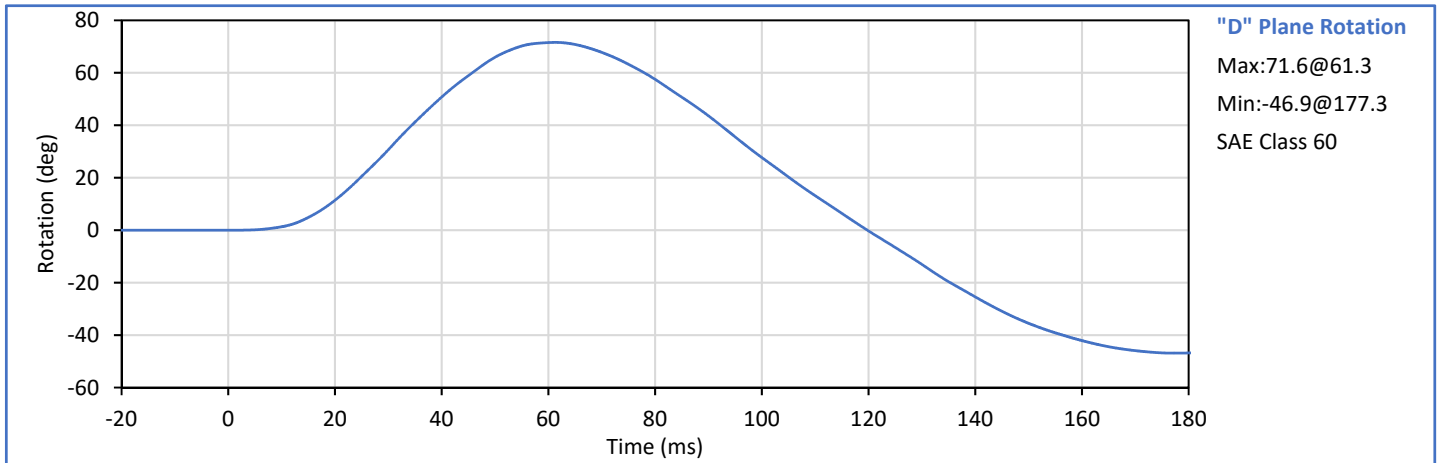
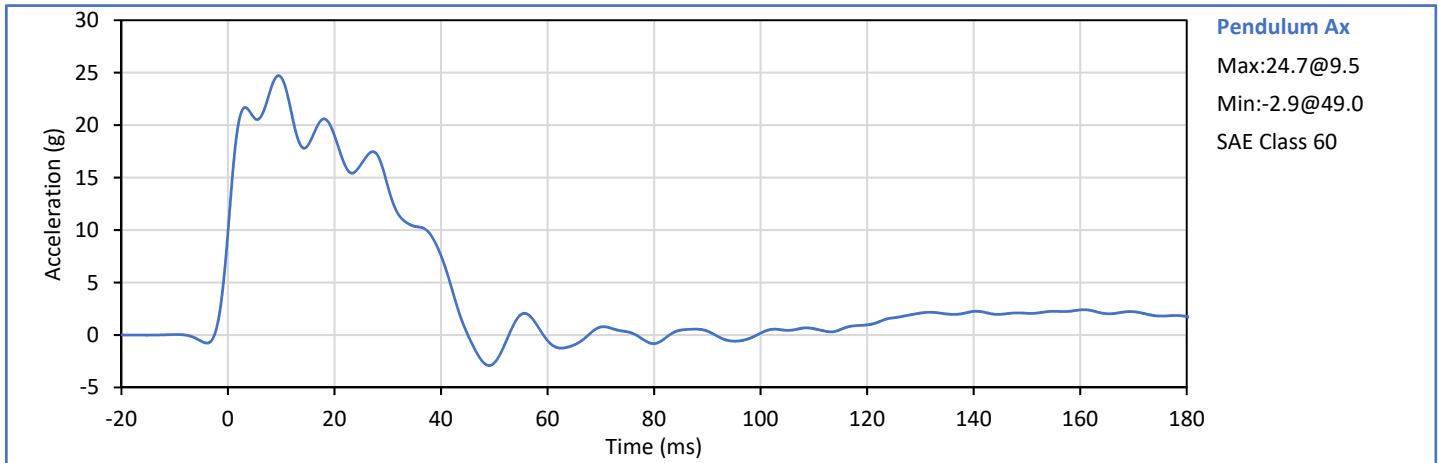

Technician: *J. Hernandez*
 J. Hernandez

Approved By: *P. Puzzuto*
 P. Puzzuto



ATD Serial No.: 360

Test Date: 2018-08-22

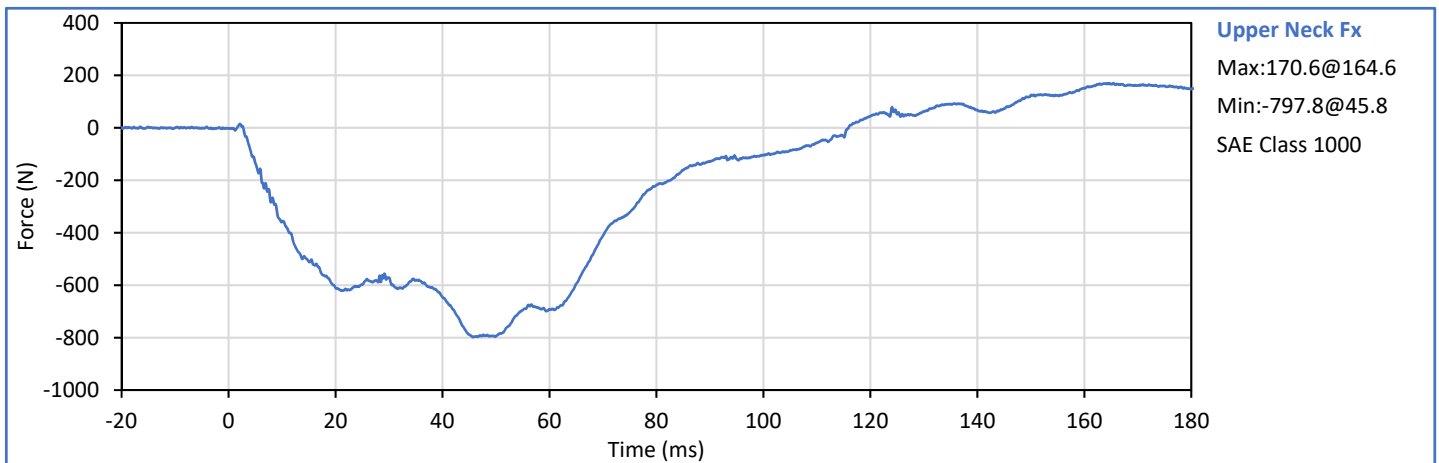
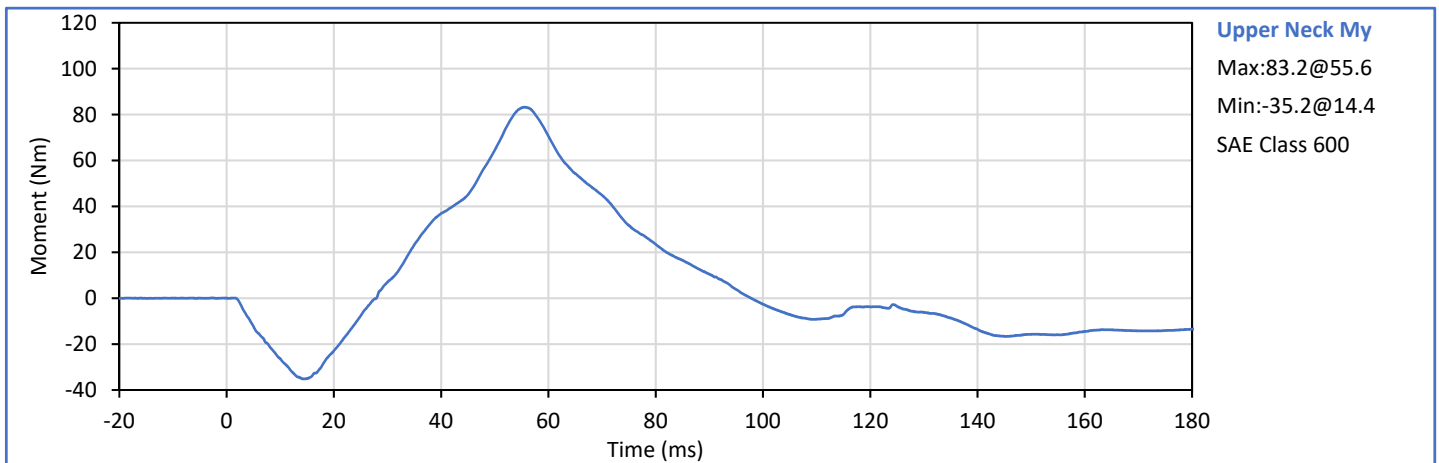
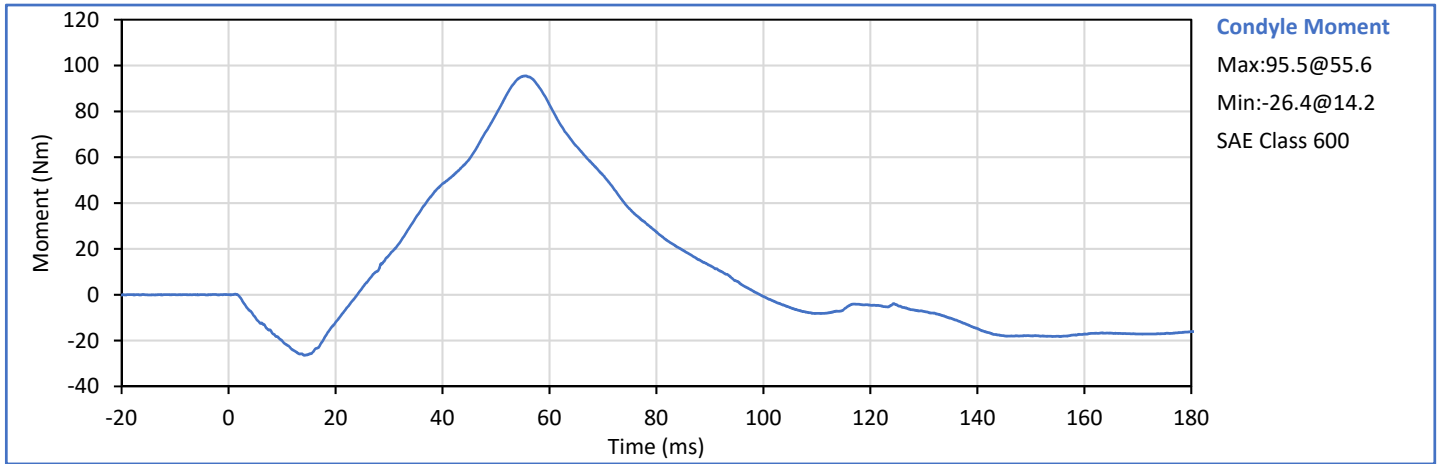



ATD Serial No.: 360

Test Date: 2018-08-22

Tested Parameter	Units	Spec. Low	Spec. High	Result	Pass/Fail
Laboratory Temperature	°C	20.6	22.2	21.2	Pass
Laboratory Humidity	%	10	70	44	Pass
Pendulum Velocity	m/s	5.94	6.19	6.05	Pass
Pendulum Deceleration at 10 ms	g	17.2	21.2	20.4	Pass
Pendulum Deceleration at 20 ms	g	14.0	19.0	17.8	Pass
Pendulum Deceleration at 30 ms	g	11.0	16.0	13.4	Pass
Peak Pendulum Decel. after 30 ms	g	0.0	22.0	13.4	Pass
Deceleration Decay to Cross 5 g	ms	38.0	46.0	40.2	Pass
"D" Plane Rotation peak	deg	81.0	106.0	96.7	Pass
	ms	72.0	82.0	76.5	Pass
"D" Plane Rotation Decay To Zero	ms	147.0	174.0	156.0	Pass
Moment About Occipital Condyle	Nm	-79.9	-52.9	-72.4	Pass
	ms	65.0	79.0	70.0	Pass
Moment Decay, Peak to Zero	deg	120.0	148.0	141.4	Pass
Overall Test Results					Pass

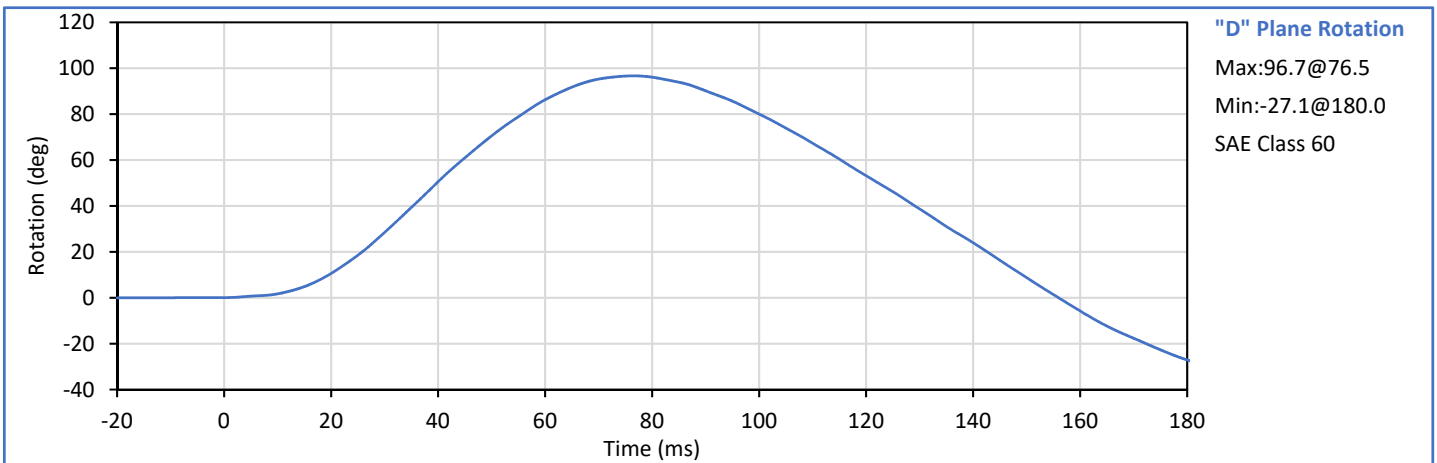
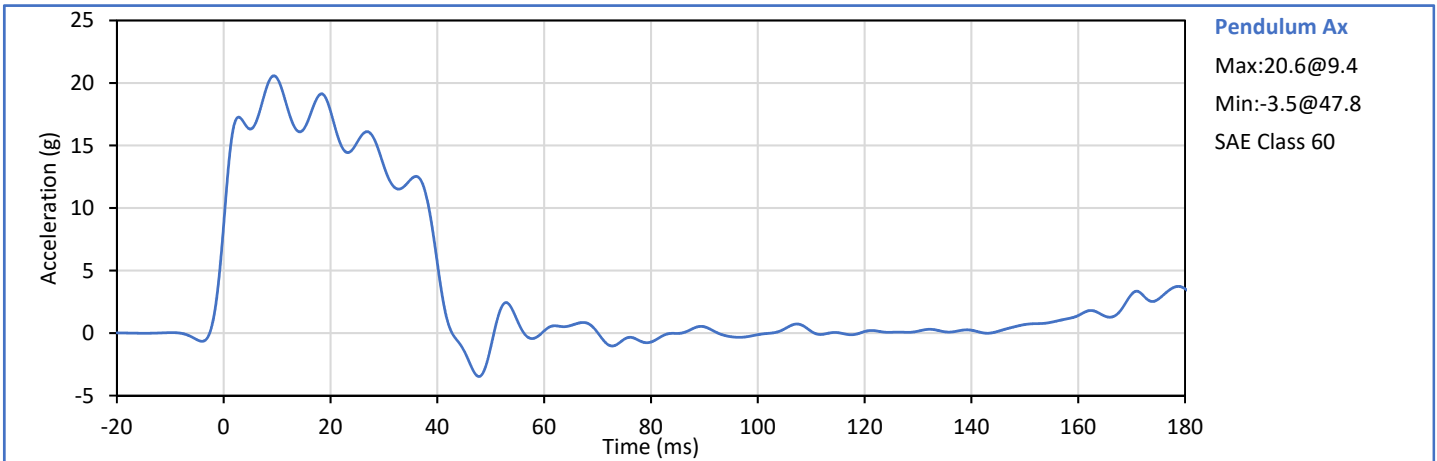

Technician: *J. Hernandez*
 J. Hernandez

Approved By: *P. Puzzuto*
 P. Puzzuto



ATD Serial No.: 360

Test Date: 2018-08-22

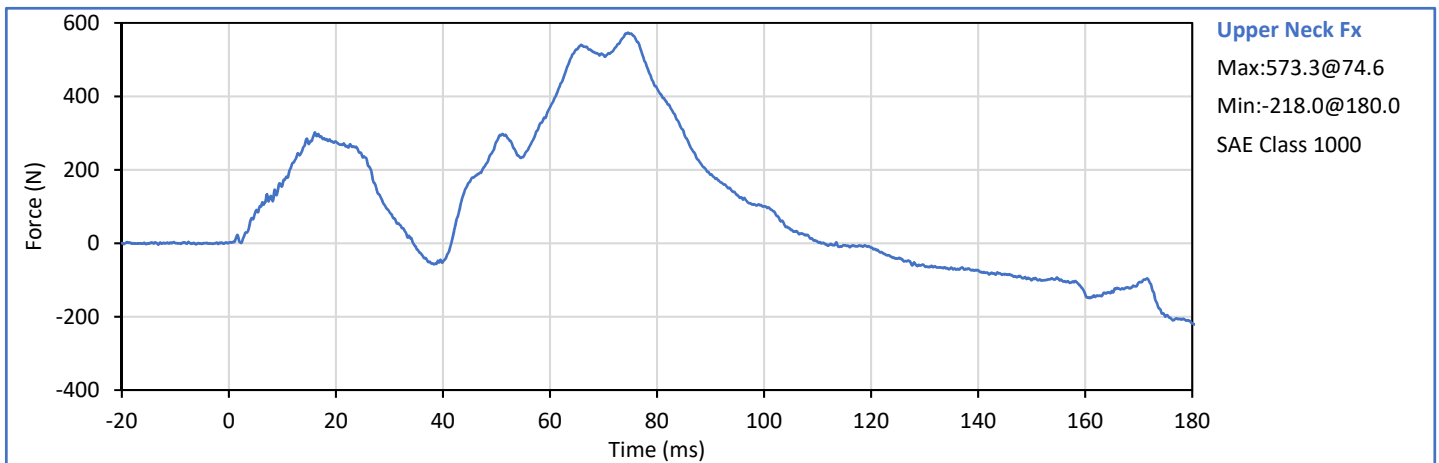
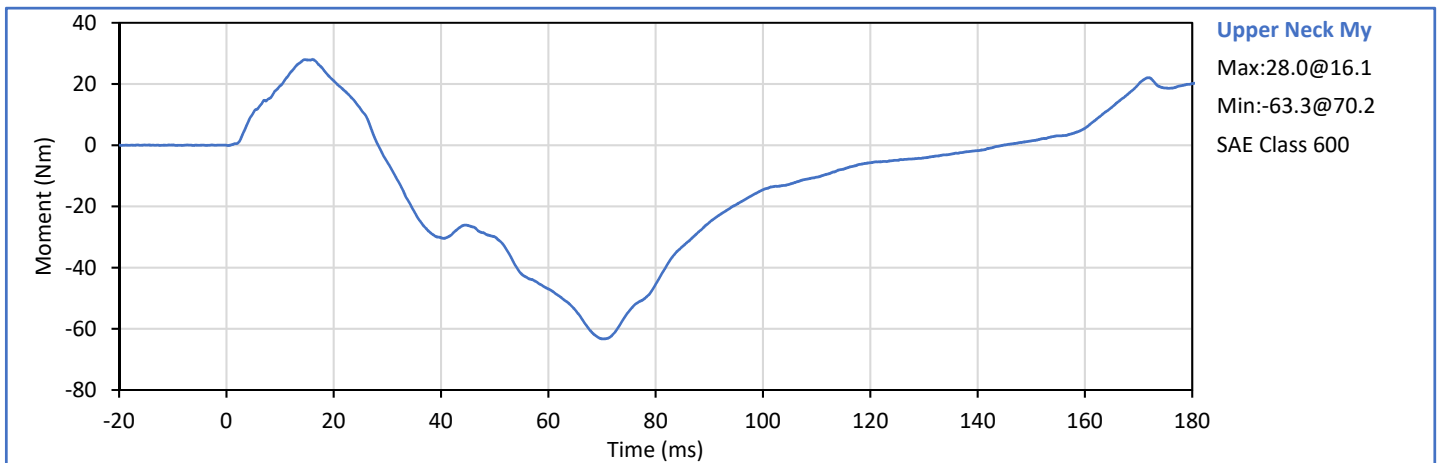
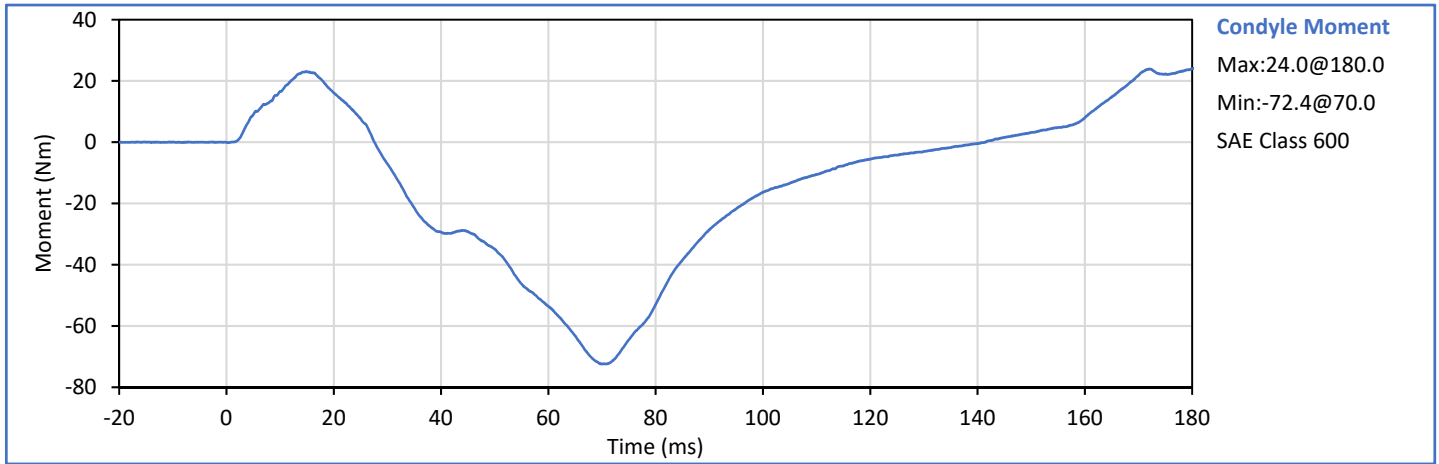



ATD Serial No.: 360

Test Date: 2018-08-22

Tested Parameter	Units	Spec. Low	Spec. High	Result	Pass/Fail
Laboratory Temperature	°C	20.6	22.2	21.1	Pass
Laboratory Humidity	%	10	70	44	Pass
Probe Velocity	m/s	6.58	6.82	6.65	Pass
Peak Chest Deflection	cm	6.35	7.26	6.73	Pass
Peak Probe Force	kN	5.159	5.893	5.355	Pass
Internal Hysterisis	%	69.0	85.0	70.0	Pass
Overall Test Results					Pass

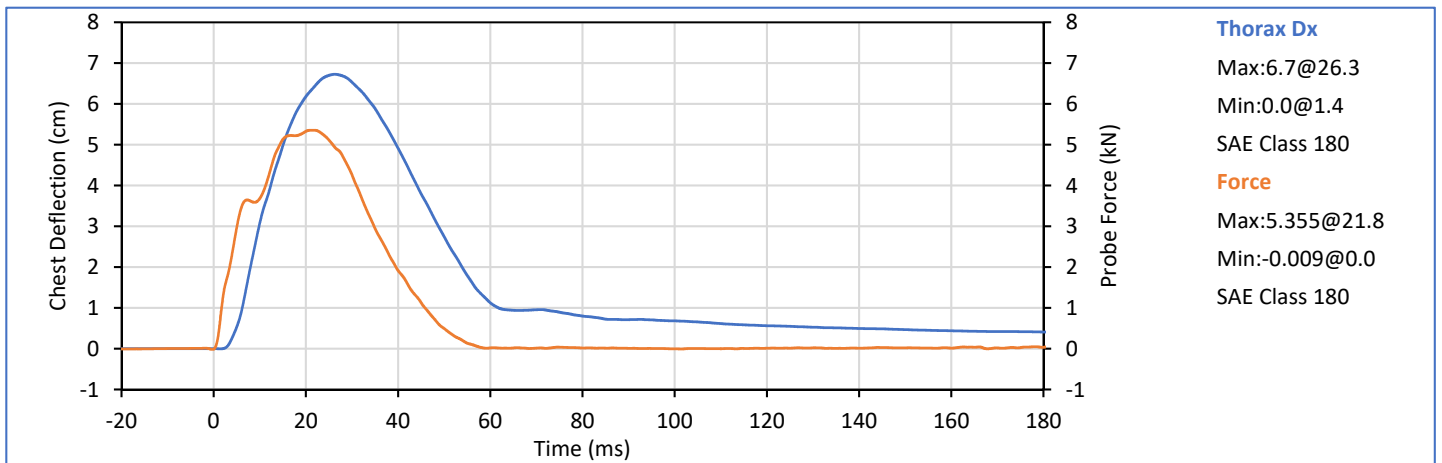
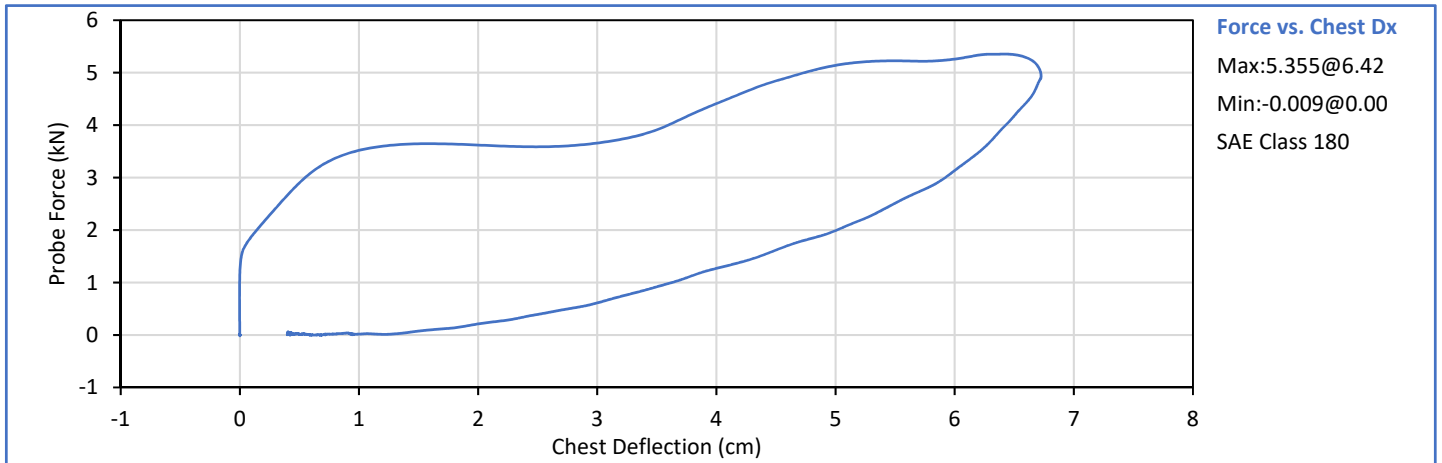

Technician:
 J. Hernandez

Approved By:
 P. Puzzuto



ATD Serial No.: 360

Test Date: 2018-08-22

	Tested Parameter	Units	Spec. Low	Spec. High	Result	Pass/Fail
	Laboratory Temperature	°C	18.9	25.6	21.1	Pass
	Laboratory Humidity	%	10	70	40	Pass
Left Hip	Left Hip Rotation Rate	deg/s	5.0	10.0	5.8	Pass
	Left Femur Torque at 30°	Nm	0.0	95.0	87.1	Pass
	Left Hip Rotation at 203 Nm	deg	40.0	50.0	47.9	Pass
Right Hip	Right Hip Rotation Rate	deg/s	5.0	10.0	5.7	Pass
	Right Femur Torque at 30°	Nm	0.0	95.0	80.0	Pass
	Right Hip Rotation at 203 Nm	deg	40.0	50.0	47.9	Pass
Overall Test Results						Pass

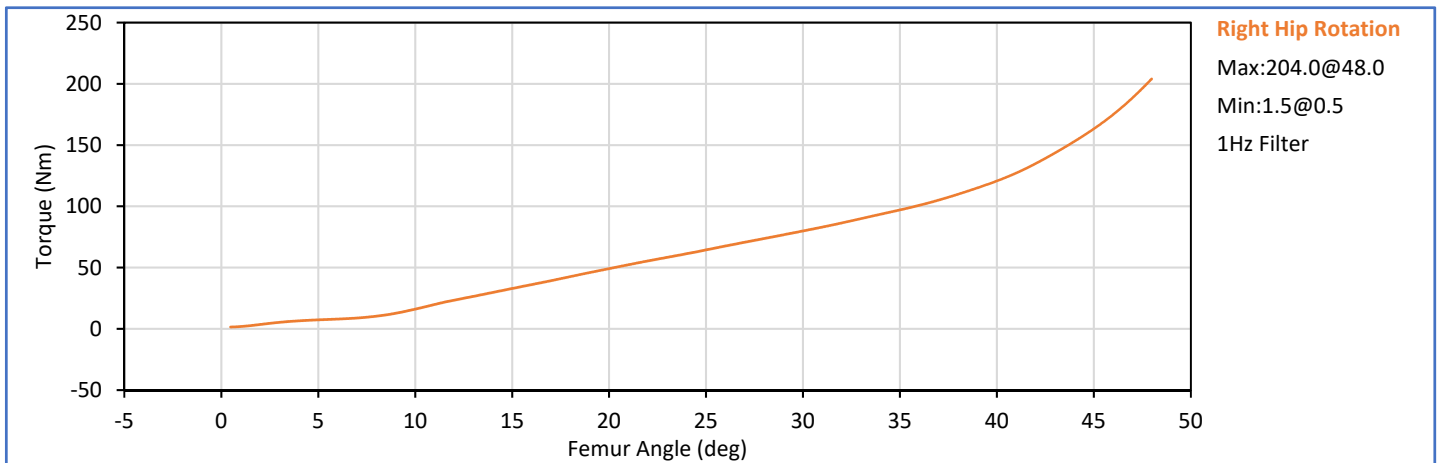
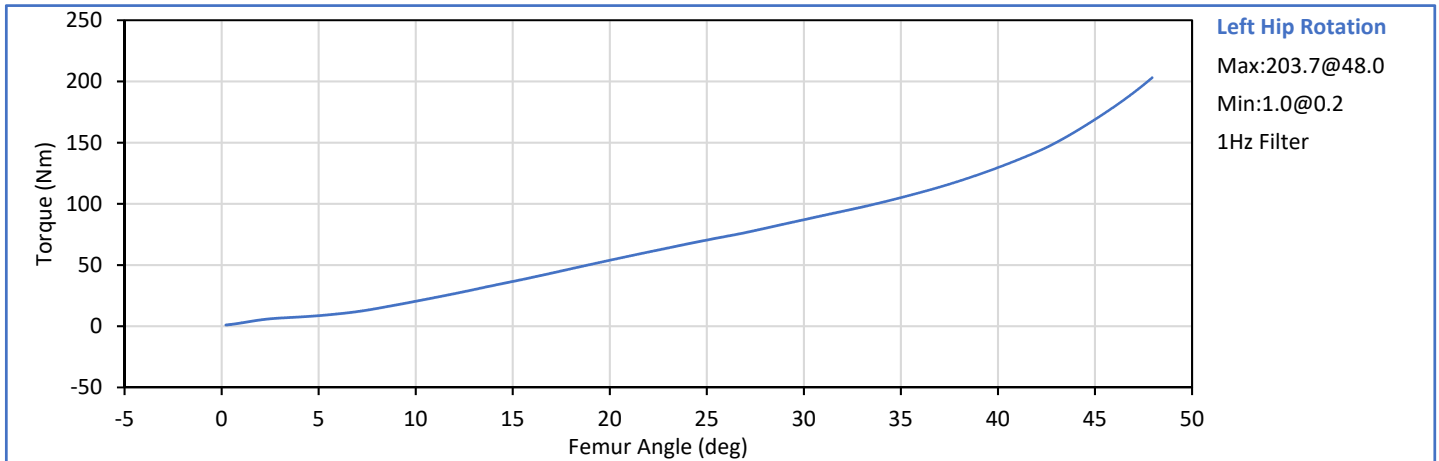

Technician:
 J. Hernandez

Approved By:
 P. Puzzuto



ATD Serial No.: 360

Test Date: 2018-08-22

	Tested Parameter	Units	Spec. Low	Spec. High	Result	Pass/Fail
	Laboratory Temperature	°C	18.9	25.6	21.2	Pass
	Laboratory Humidity	%	10	70	44	Pass
Left	Probe Velocity	m/s	2.070	2.130	2.101	Pass
Knee	Peak Resistive Force	N	4715	5782	5154	Pass
Right	Probe Velocity	m/s	2.070	2.130	2.103	Pass
Knee	Peak Resistive Force	N	4715	5782	5213	Pass
Overall Test Results						Pass

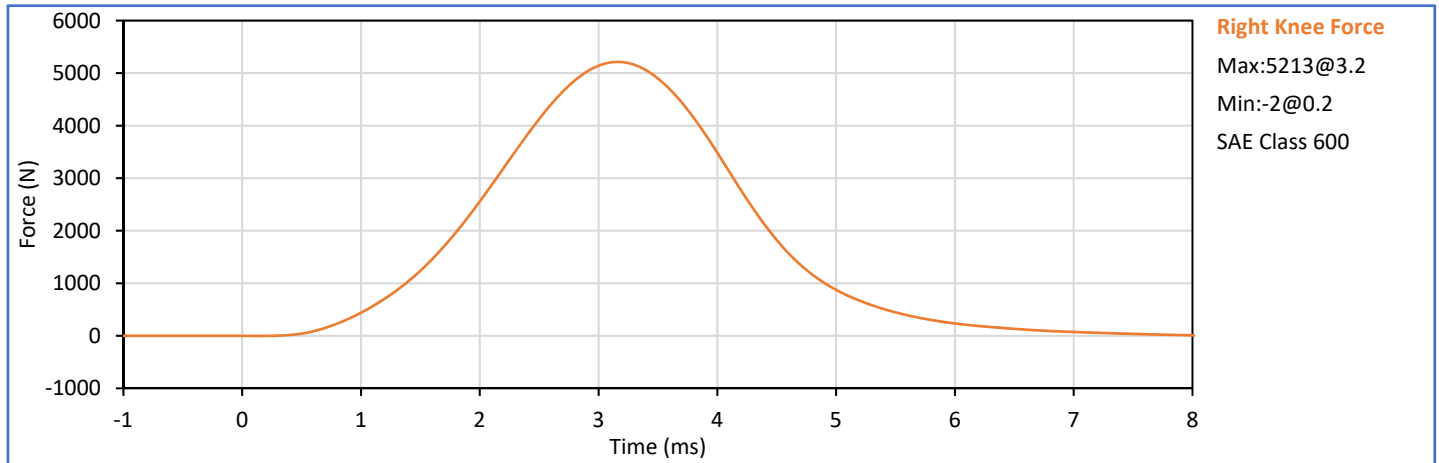
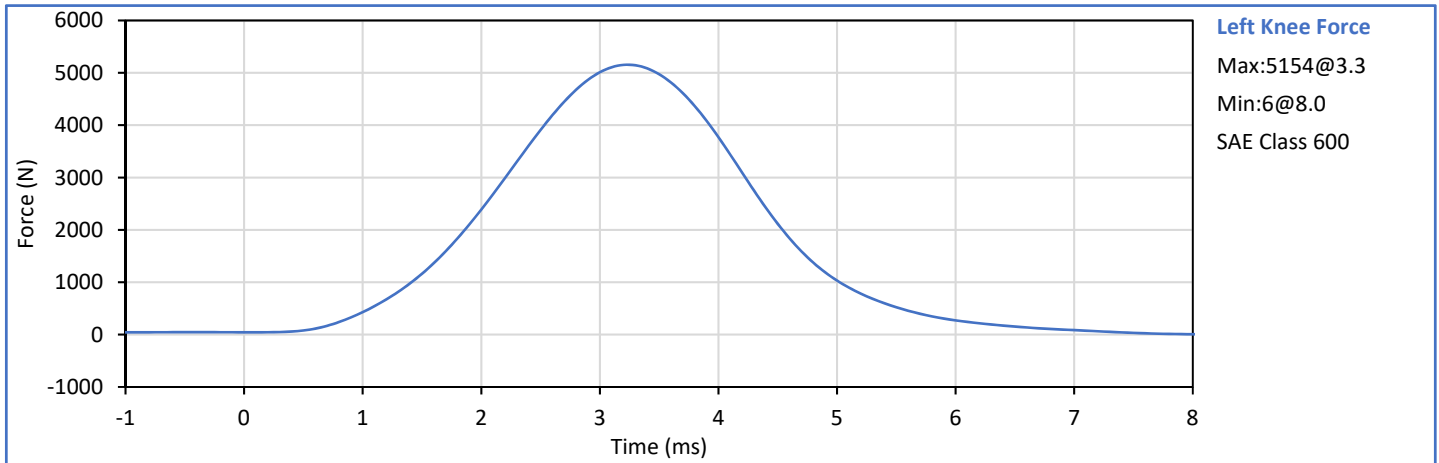

Technician:
 T. Lowman

Approved By:
 P. Puzzuto



**Hybrid III 5th Percentile Female
 Damage Checklist**

ATD Serial No.: 141

Test Date: 2018-08-22

Dummy Item	Inspect for	Comments	Damage	Okay
Entire ATD	Perform general cleaning			✓
Outer Skin	Gashes, rips, cracks			✓
Head	Ballast secure			✓
	General appearance			✓
Neck bracket	Upper neck firmly attached to lower bracket			✓
Neck	Broken or cracked rubber			✓
	Looseness at the condyle joint			✓
Nodding block	Cracked or out of position			✓
Lumbar Spine	Broken or cracked rubber			✓
Ribs	Broken or bent ribs			✓
	Broken or bent rib supports			✓
	Damping material separated or cracked			✓
	Rubber bumpers in place			✓
Chest Displ. Assembly	Bent shaft			✓
	Slider arm riding in track			✓
Sensors	Check cables for cuts, tears			✓
	Check for damaged insulation			✓
Accelerometer Mounting	Head mounting secure			✓
	Chest mounting secure			✓
Knees	Skin condition			✓
	Insert (do not remove)			✓
	Casting			✓
Limbs	Normal movement and adjustment			✓
Knee Sliders	Wires intact			✓
	Rubber returned to "resting" position			✓
Pelvis	Broken			✓
Other	Describe below as needed			✓

Describe any repairs or replacement of parts or other findings:

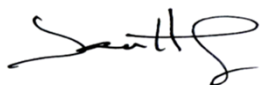
Technician: 
 J. Hernandez

Approved By: 
 P. Puzzuto





**Hybrid III 5th Percentile Female
 External Measurements**

ATD Serial No.: 141

Test Date: 2018-08-22

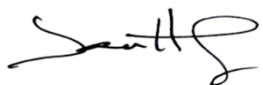
Tested Parameter	Units	Spec. Low	Spec. High	Result	Pass/Fail
Laboratory Temperature	°C	20.6	22.2	21.1	Pass
Laboratory Relative Humidity	%	10	70	40	Pass
A - Total sitting height	mm	775	800	790	Pass
B - Shoulder pivot height	mm	432	457	452	Pass
C - 'H' point height	mm	81	86	84	Pass
D - 'H' point location from backline	mm	145	150	147	Pass
E - Shoulder pivot from backline	mm	69	84	81	Pass
F - Thigh clearance	mm	119	135	126	Pass
G - Back of elbow to wrist pivot	mm	244	259	251	Pass
H - Head back to backline	mm	41	46	42	Pass
I - Shoulder to elbow length	mm	277	297	284	Pass
J - Elbow rest height	mm	183	203	194	Pass
K - Buttock to knee length	mm	521	546	536	Pass
L - Popliteal length	mm	356	376	370	Pass
M - Knee pivot height	mm	394	419	407	Pass
N - Buttock popliteal length	mm	414	439	430	Pass
O - Chest depth without jacket	mm	175	191	181	Pass
P - Foot length	mm	219	234	228	Pass
R - Buttock to Knee Pivot Length	mm	457	483	468	Pass
S - Head Breadth	mm	137	147	142	Pass
T - Head Depth	mm	178	188	182	Pass
U - Hip Breadth	mm	300	315	307	Pass
V - Shoulder breadth	mm	351	366	363	Pass
W - Foot breadth	mm	79	94	91	Pass
X - Head circum.	mm	528	549	533	Pass
Y - Chest circum. (w/chest jacket)	mm	851	881	870	Pass
Z - Waist circum.	mm	760	790	774	Pass
AA - Location for chest circum.	mm	333	358	337	Pass
BB - Location for waist circum.	mm	160	170	169	Pass
Overall Test Results					Pass

Technician: 
 J. Hernandez

Approved By: 
 P. Puzzuto



ATD Serial No.: 141

Test Date: 2018-08-22

Tested Parameter	Units	Spec. Low	Spec. High	Result	Pass/Fail
Laboratory Temperature	°C	18.9	25.6	21.1	Pass
Laboratory Humidity	%	10	70	40	Pass
Peak Resultant Acceleration	g	250.0	300.0	280.8	Pass
Peak Lateral Acceleration	g	-15.0	15.0	-4.2	Pass
Oscillations After Main Pulse	%	0.0	10.0	0.7	Pass
Is Acceleration Unimodal?	Yes/No	Yes		Yes	Pass
Overall Test Results					Pass

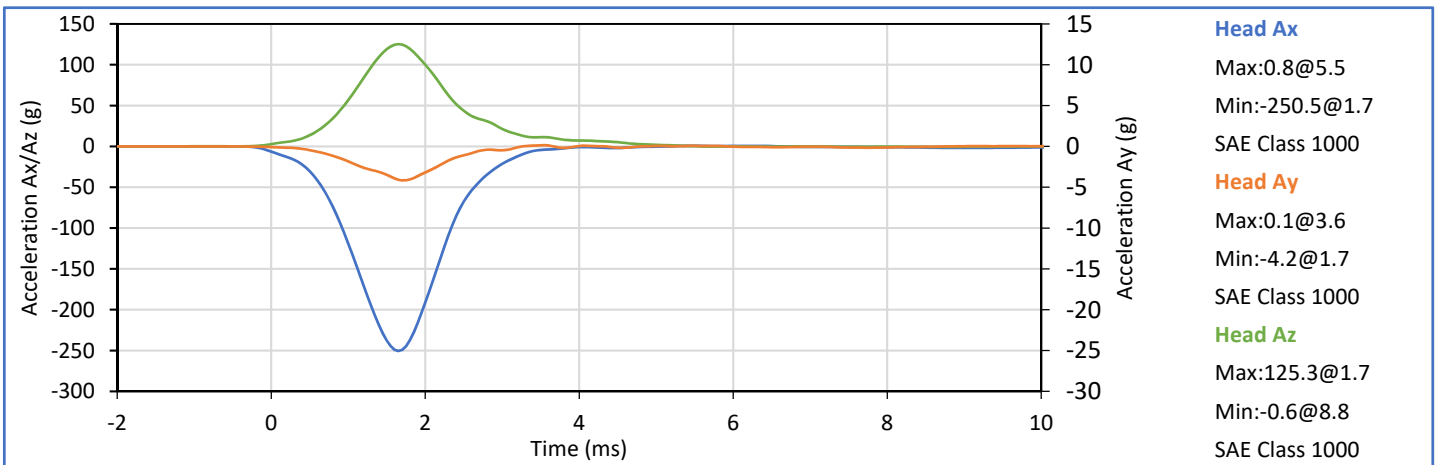
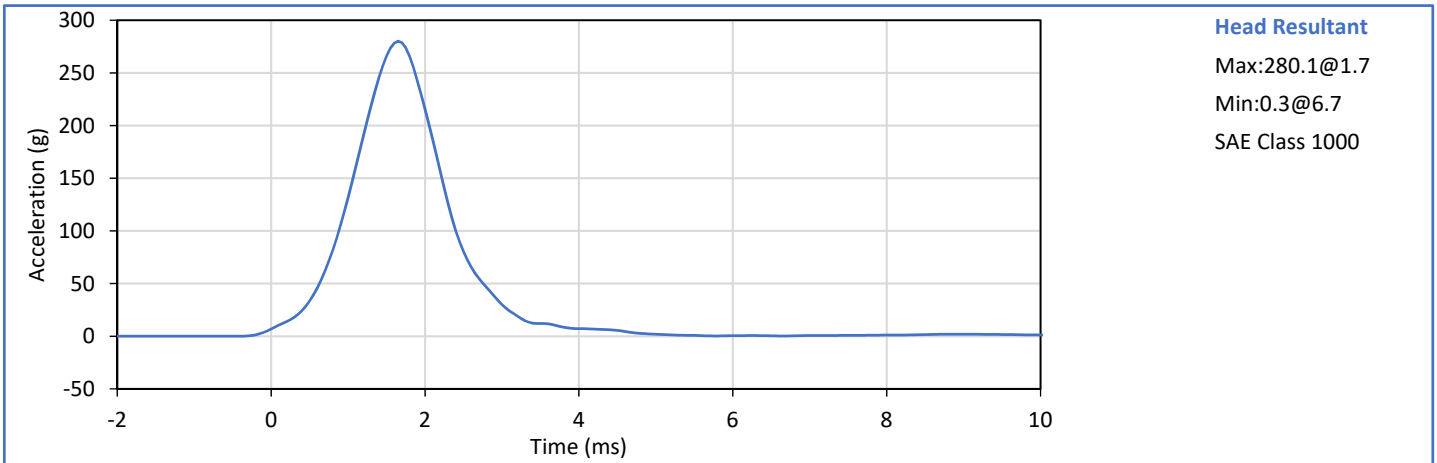

Technician: *J. Hernandez*
 J. Hernandez

Approved By: *P. Puzzuto*
 P. Puzzuto





ATD Serial No.: 141

Test Date: 2018-08-22

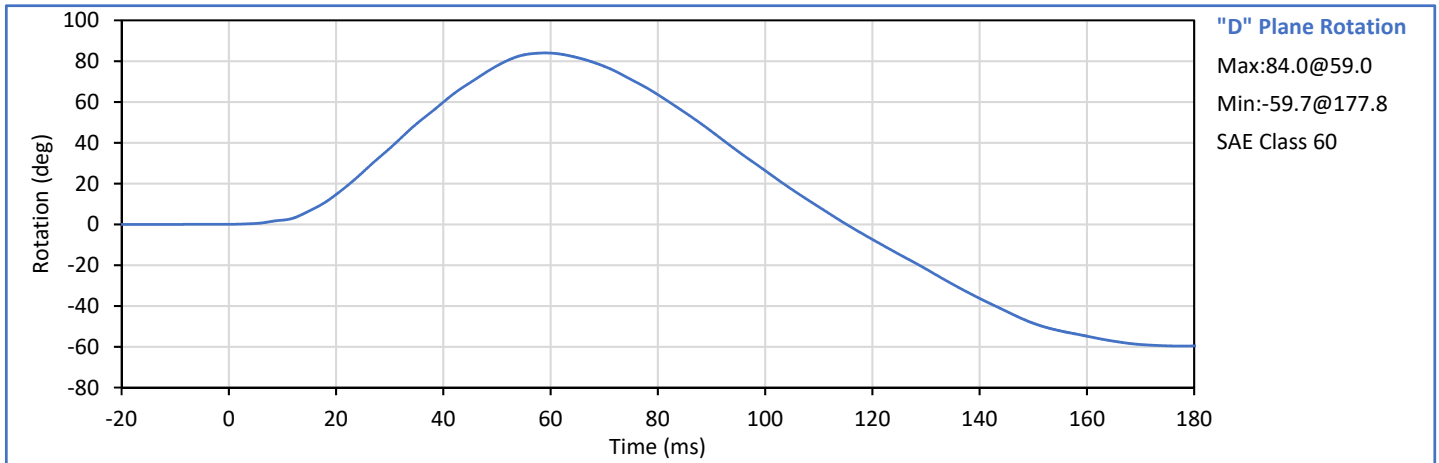
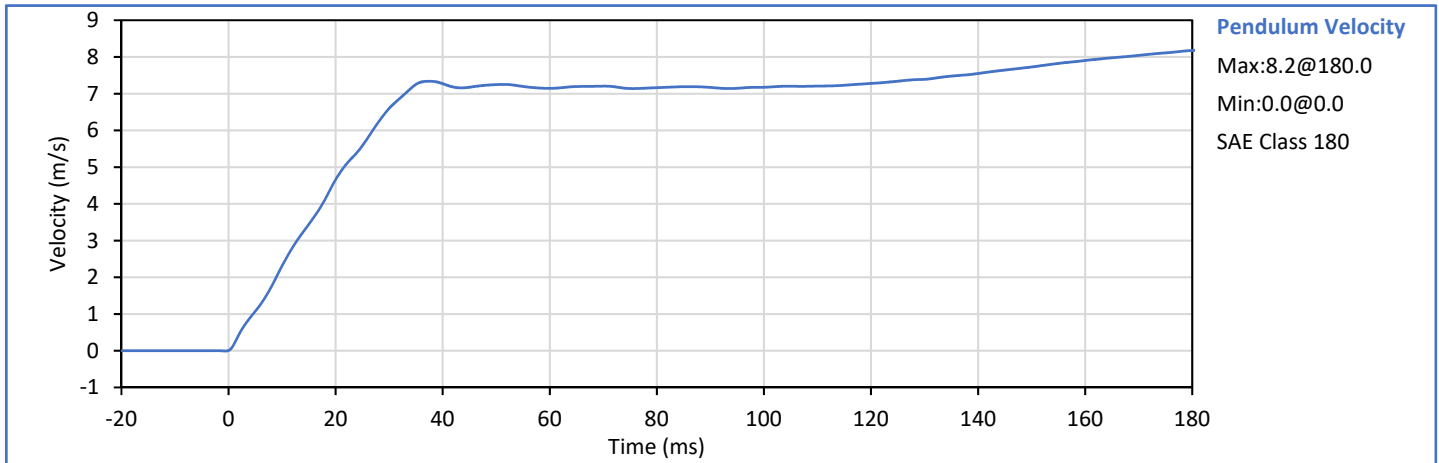
Tested Parameter	Units	Spec. Low	Spec. High	Result	Pass/Fail
Laboratory Temperature	°C	20.6	22.2	21.2	Pass
Laboratory Humidity	%	10	70	44	Pass
Pendulum Velocity	m/s	6.89	7.13	7.01	Pass
Pendulum Velocity at 10 ms	m/s	2.10	2.50	2.31	Pass
Pendulum Velocity at 20 ms	m/s	4.00	5.00	4.66	Pass
Pendulum Velocity at 30 ms	m/s	5.80	7.00	6.60	Pass
Peak "D" Plane Rotation	deg	77.0	91.0	84.0	Pass
Peak Moment in Rotation	Nm	69.0	83.0	80.6	Pass
Positive Moment Decay to 10 Nm	ms	80.0	100.0	86.8	Pass
Overall Test Results					Pass

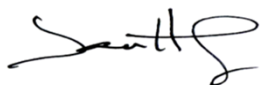

Technician: 
 J. Hernandez

Approved By: 
 P. Puzzuto



ATD Serial No.: 141

Test Date: 2018-08-22

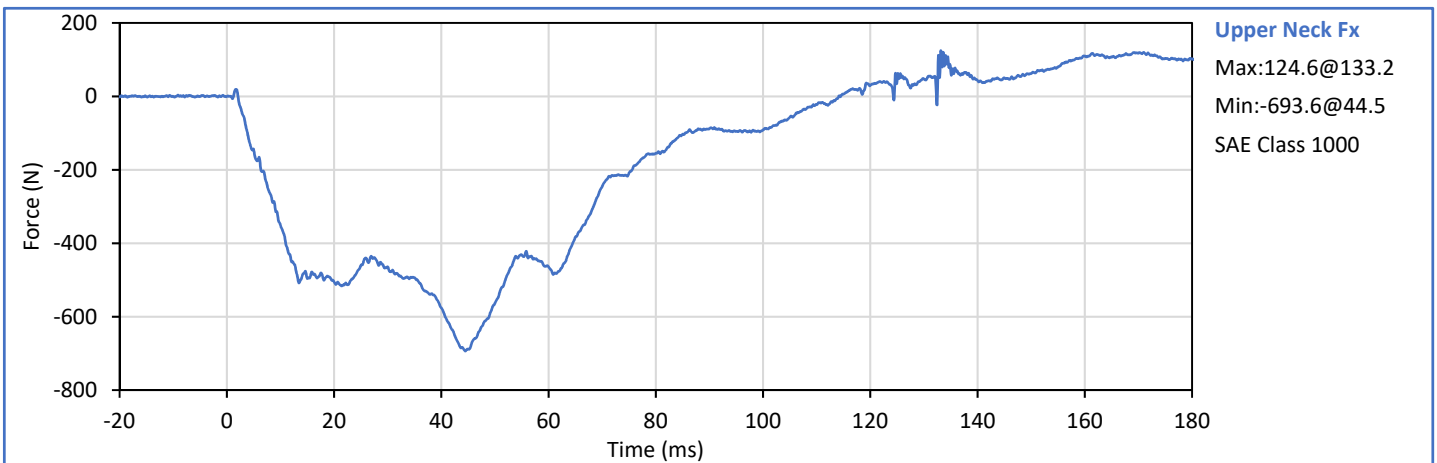
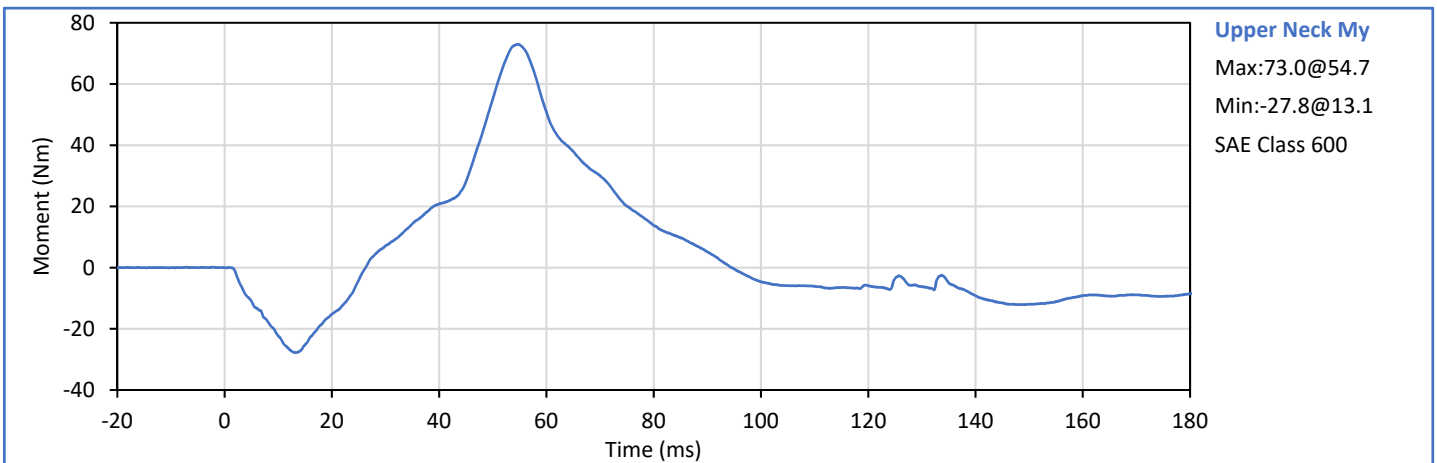
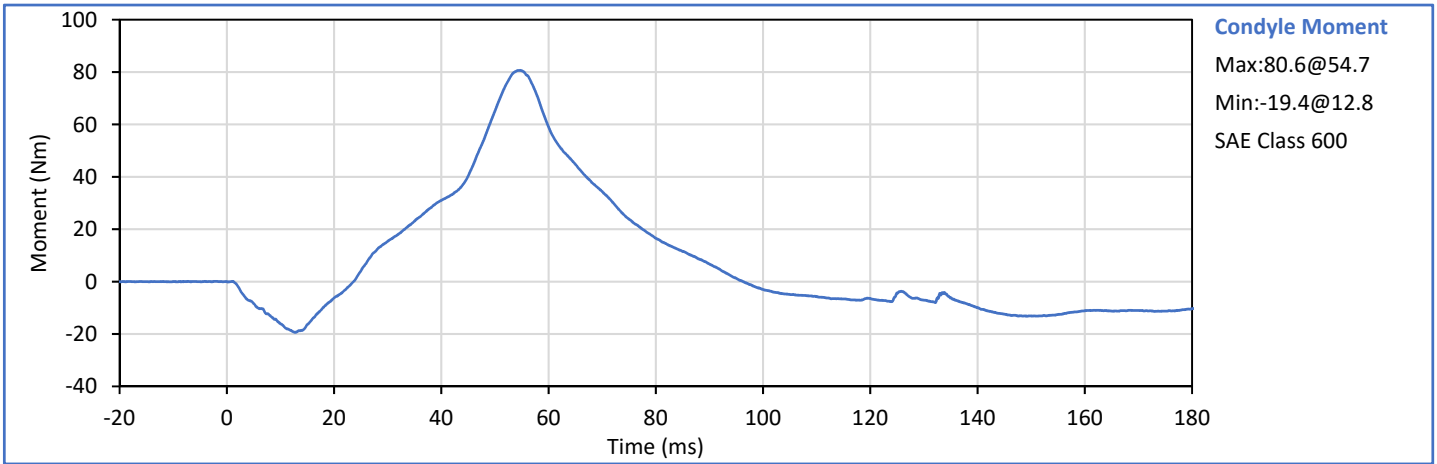



ATD Serial No.: 141

Test Date: 2018-08-22

Tested Parameter	Units	Spec. Low	Spec. High	Result	Pass/Fail
Laboratory Temperature	°C	20.6	22.2	21.4	Pass
Laboratory Humidity	%	10	70	44	Pass
Pendulum Velocity	m/s	5.95	6.19	6.14	Pass
Pendulum Velocity at 10 ms	m/s	1.50	1.90	1.77	Pass
Pendulum Velocity at 20 ms	m/s	3.10	3.90	3.59	Pass
Pendulum Velocity at 30 ms	m/s	4.60	5.60	5.21	Pass
Peak "D" Plane Rotation	deg	99.0	114.0	106.5	Pass
Peak Moment in Rotation	Nm	-65.0	-53.0	-58.4	Pass
Negative Moment Decay to -10 Nm	ms	94.0	114.0	100.2	Pass
Overall Test Results					Pass

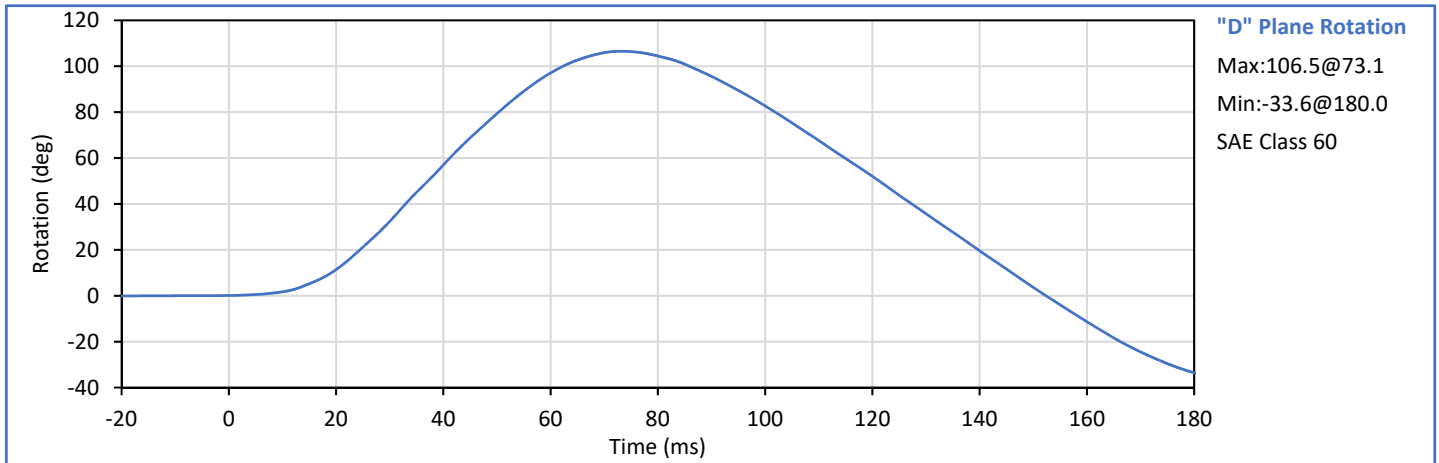
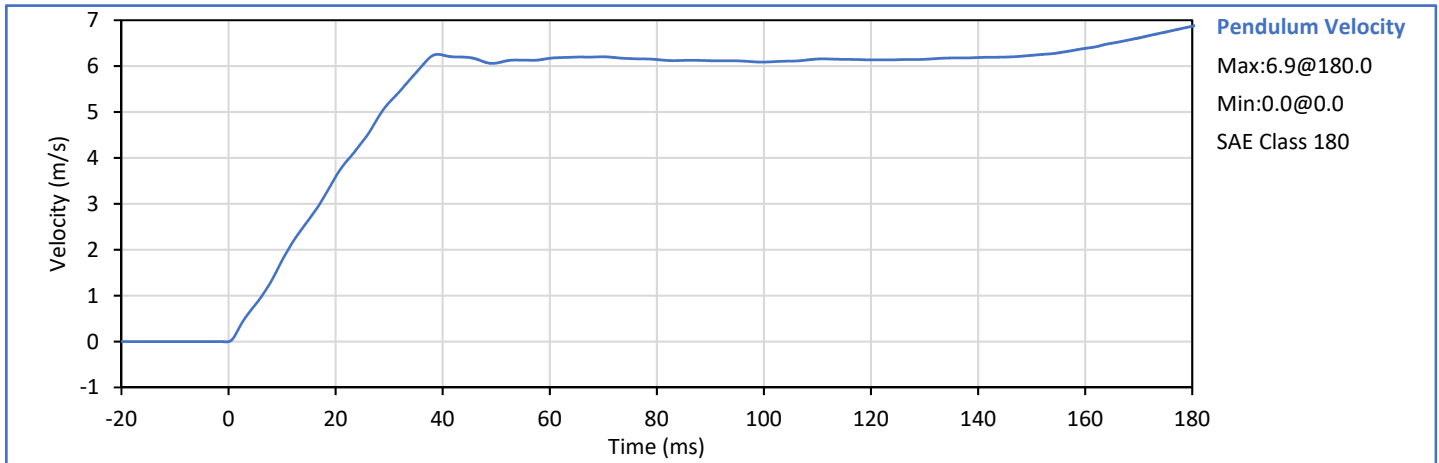

Technician:
 J. Hernandez

Approved By:
 P. Puzzuto



ATD Serial No.: 141

Test Date: 2018-08-22

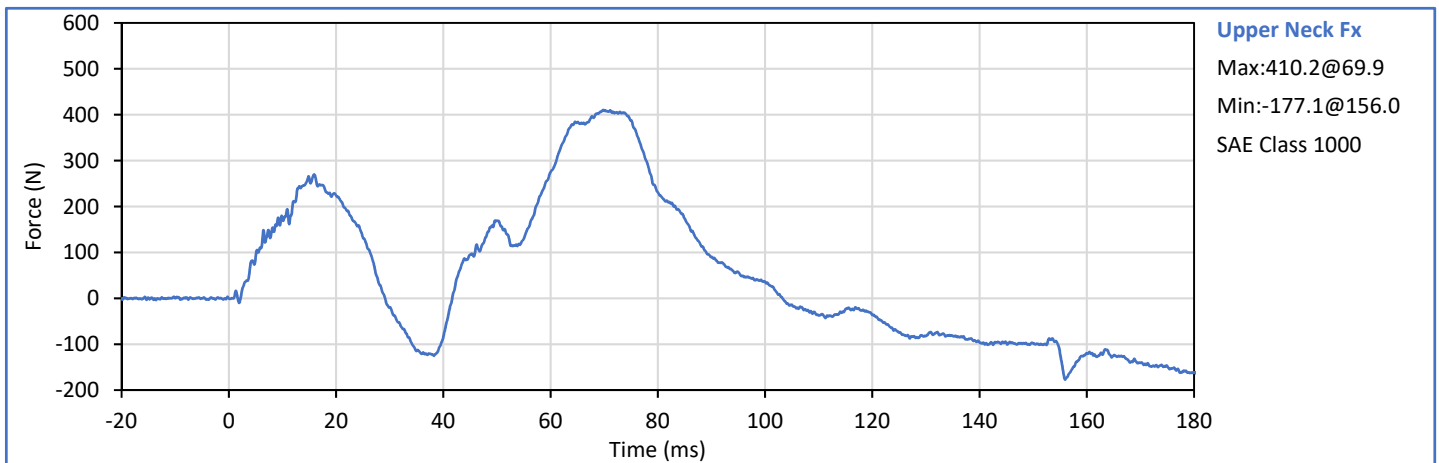
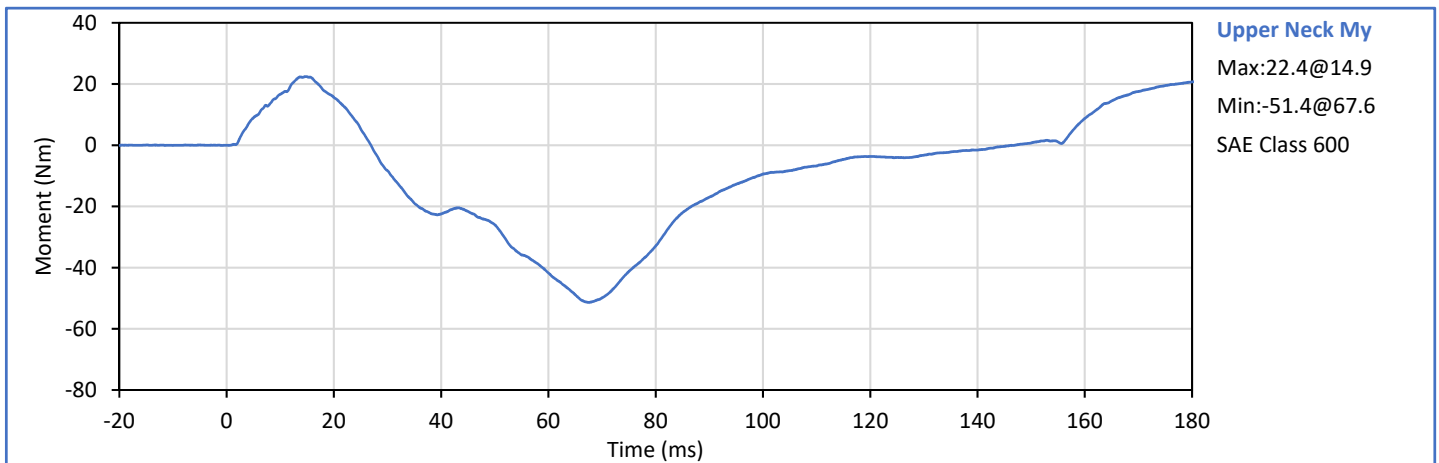
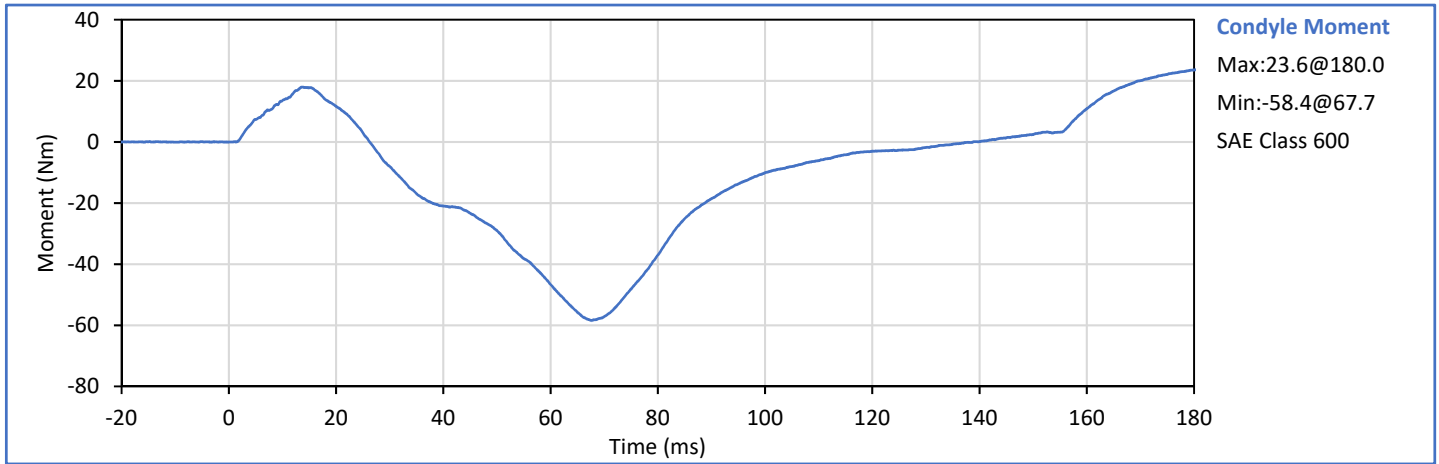



ATD Serial No.: 141

Test Date: 2018-08-22

Tested Parameter	Units	Spec. Low	Spec. High	Result	Pass/Fail
Laboratory Temperature	°C	20.6	22.2	21.1	Pass
Laboratory Humidity	%	10	70	42	Pass
Probe Velocity	m/s	6.59	6.83	6.66	Pass
Peak Chest Deflection	mm	50.0	58.0	52.8	Pass
Peak Probe Force, 50 and 58 mm	kN	3.900	4.400	4.192	Pass
Peak Probe Force, 18 and 50 mm	kN	0.000	4.600	4.192	Pass
Internal Hysterisis	%	69.0	85.0	74.6	Pass
Overall Test Results					Pass

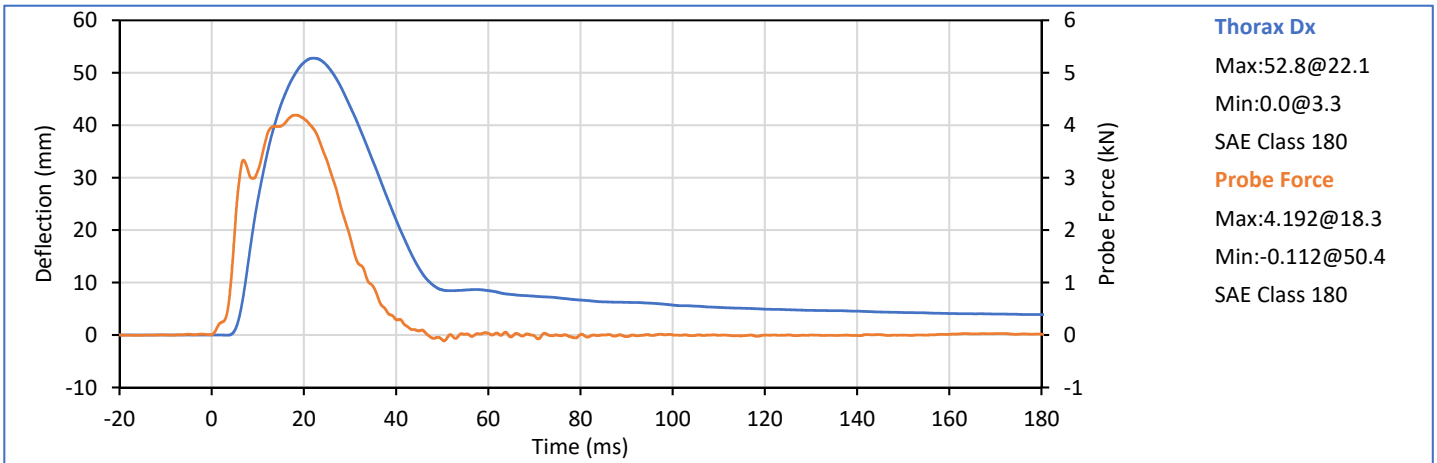
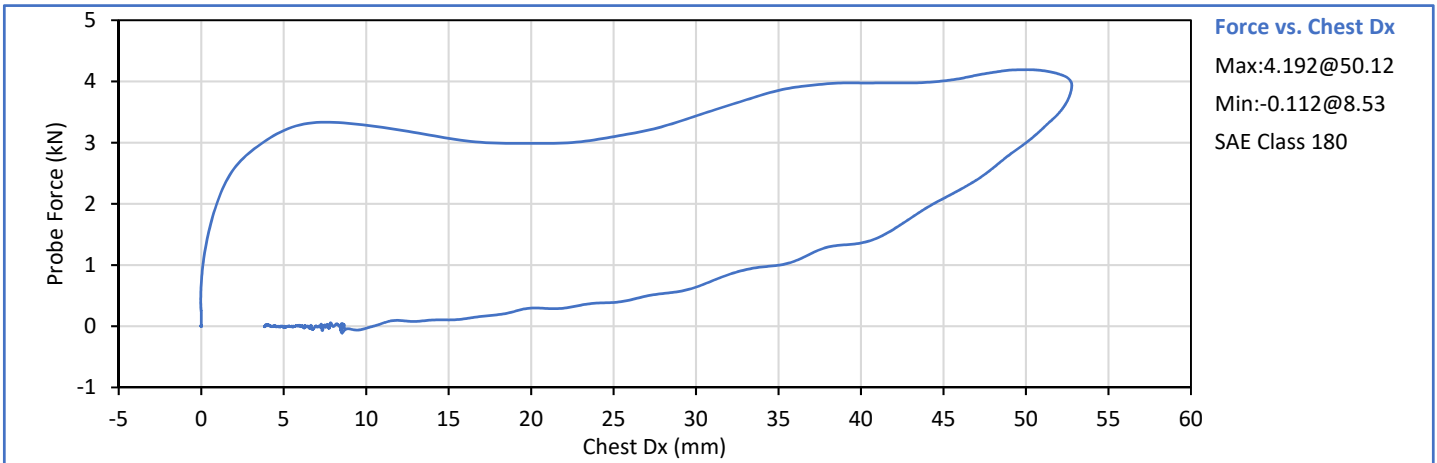

Technician:
 J. Hernandez

Approved By:
 P. Puzzuto



**Hybrid III 5th Percentile Female
 Torso Flexion Test**

ATD Serial No.: 141

Test Date: 2018-08-22

Tested Parameter	Units	Spec. Low	Spec. High	Result	Pass/Fail
Laboratory Temperature	°C	18.9	25.6	21.2	Pass
Laboratory Humidity	%	10	70	44	Pass
Orientation Angle	deg	0.0	20.0	9.5	Pass
Test Initial Angle	deg	11.0	19.0	13.1	Pass
Peak Force at 45° (+/-0.5°)	N	320.0	390.0	352.3	Pass
Torso Flexion Rate	deg/s	0.50	1.50	1.29	Pass
Final Reference Plane Angle	deg	-8.0	8.0	6.5	Pass
Overall Test Results					Pass

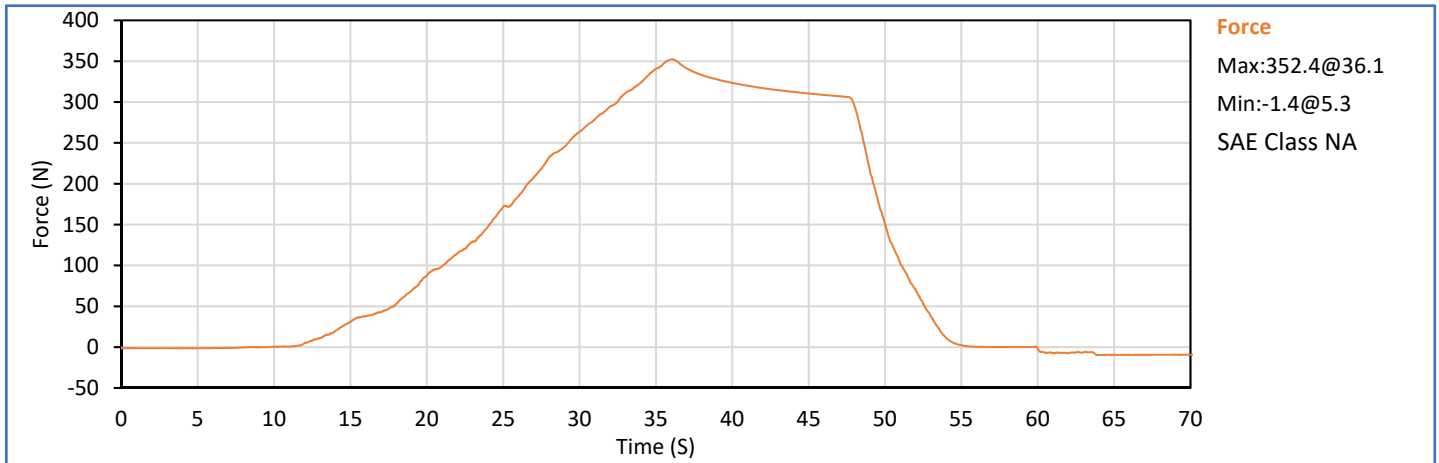
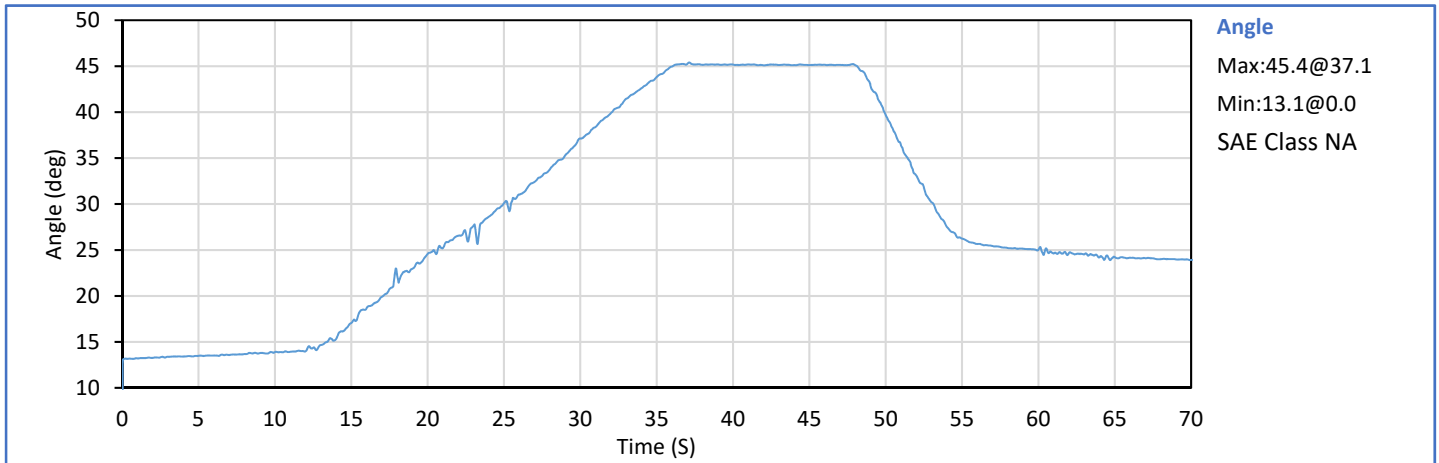

Technician:
 J. Hernandez

Approved By:
 P. Puzzuto



ATD Serial No.: 141

Test Date: 2018-08-22

	Tested Parameter	Units	Spec. Low	Spec. High	Result	Pass/Fail
	Laboratory Temperature	°C	18.9	25.6	21.2	Pass
	Laboratory Humidity	%	10	70	44	Pass
Left	Probe Velocity	m/s	2.070	2.130	2.119	Pass
Knee	Peak Resistive Force	N	3450	4060	3950	Pass
Right	Probe Velocity	m/s	2.070	2.130	2.114	Pass
Knee	Peak Resistive Force	N	3450	4060	3756	Pass
Overall Test Results						Pass

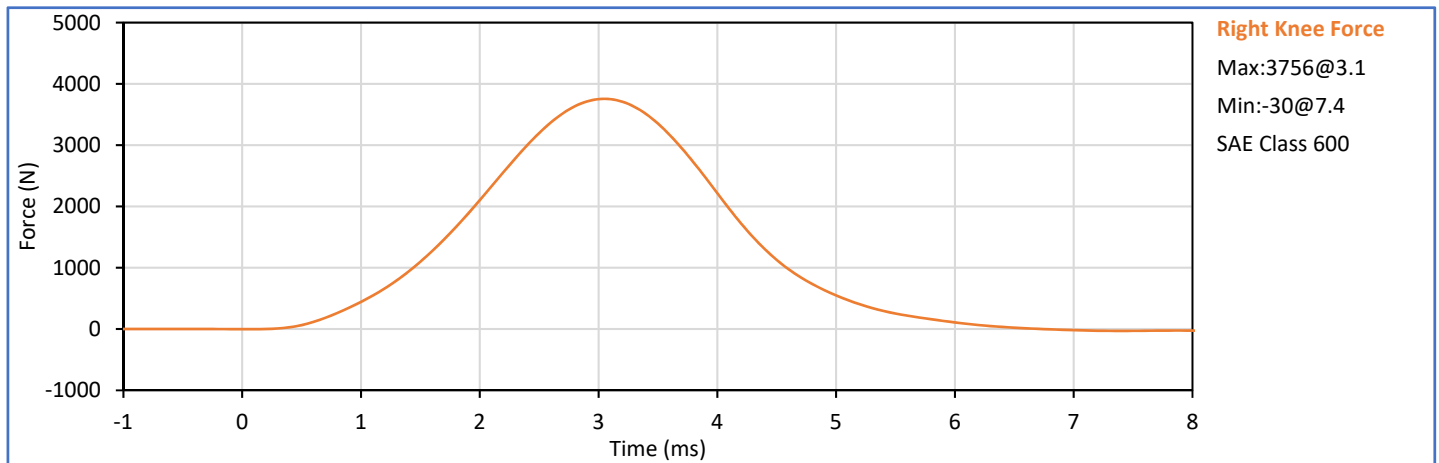
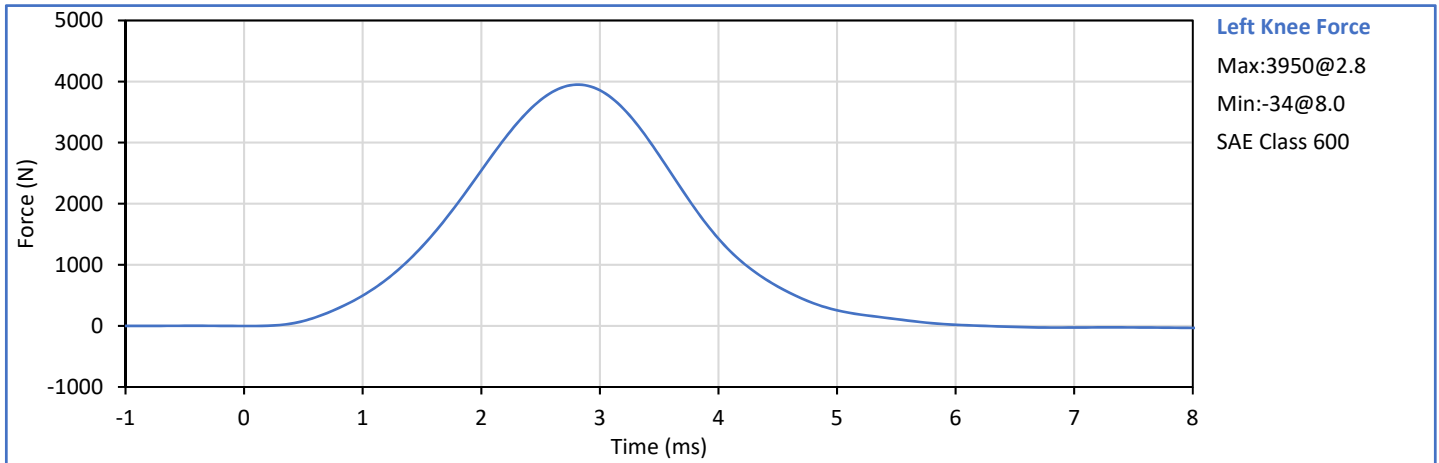

Technician:
 J. Hernandez

Approved By:
 P. Puzzuto