

REPORT NUMBER: NCAP-KAR-18-001

**NEW CAR ASSESSMENT PROGRAM (NCAP)
FRONTAL BARRIER IMPACT TEST**

**SUBARU CORP.
2018 SUBARU LEGACY 2.5I/JAB 4-DOOR SEDAN**

NHTSA NUMBER: M20185504

**PREPARED BY:
KARCO ENGINEERING, LLC.
9270 HOLLY ROAD
ADELANTO, CA 92301**



OCTOBER 31, 2017

FINAL REPORT

**U.S. DEPARTMENT OF TRANSPORTATION
NATIONAL HIGHWAY TRAFFIC SAFETY ADMINISTRATION
OFFICE OF CRASHWORTHINESS STANDARDS
1200 NEW JERSEY AVE, SE
ROOM W43-410
WASHINGTON, DC 20590**

This publication is distributed by the U.S. Department of Transportation, National Highway Traffic Safety Administration, in the interest of information exchange. The opinions, findings and conclusions expressed in this publication are those of the author(s) and not necessarily those of the Department of Transportation or the National Highway Traffic Safety Administration. The United States Government assumes no liability for its contents or use thereof. If trade or manufacturers' names or products are mentioned, it is only because they are considered essential to the object of the publication and should not be construed as an endorsement. The United States Government does not endorse products or manufacturers.

Prepared By: Amjad A. Jadallah
Mr. Amjad A. Jadallah, Project Engineer
KARCO Engineering, LLC.

Reviewed By: MLD
Mr. Michael L. Dunlap, Director of Operations
KARCO Engineering, LLC.

Approved By: SDM
Mr. Steven D. Matsusaka, Engineering Dept. Supervisor
KARCO Engineering, LLC.

Approval Date: October 31, 2017

FINAL REPORT ACCEPTANCE BY OCWS:

Division Chief, New Car Assessment Program
NHTSA, Office of Crashworthiness Standards

Date: _____

COTR, New Car Assessment Program
NHTSA, Office of Crashworthiness Standards

Date: _____

TECHNICAL REPORT DOCUMENTATION PAGE

1. Report No. NCAP-KAR-18-001	2. Government Accession No.	3. Recipient's Catalog No.																																																					
4. Title and Subtitle Final Report of New Car Assessment Program Testing of a 2018 Subaru Legacy 2.5i/JAB 4-Door Sedan NHTSA No. M20185504		5. Report Date October 31, 2017																																																					
		6. Performing Organization Code KAR																																																					
7. Authors Mr. Amjad A. Jadallah, Project Engineer, KARCO Mr. Frank Richardson, Program Manager, KARCO		8. Performing Organization Report No. TR-P37327-01-NC																																																					
9. Performing Organization Name and Address KARCO Engineering, LLC. 9270 Holly Rd. Adelanto, CA 92301		10. Work Unit No.																																																					
		11. Contract or Grant No. DTNH22-12-D-00259																																																					
12. Sponsoring Agency Name and Address U. S. Department of Transportation National Highway Traffic Safety Administration Office of Crashworthiness Standards 1200 New Jersey Ave., SE, Room W43-410 Washington, D.C. 20590		13. Type of Report and Period Covered Final Test Report, October 18 - 31, 2017																																																					
		14. Sponsoring Agency Code NRM-110																																																					
15. Supplementary Notes																																																							
16. Abstract <p>A 56.3 km/h NCAP Frontal Impact Test was conducted on a 2018 Subaru Legacy 2.5i/JAB 4-door sedan in accordance with the specifications of the Office of Crashworthiness Standards Frontal NCAP Laboratory Test Procedure. This test was conducted to obtain data indicant of FMVSS 208, 212, 219 (partial), 301, and footwell intrusion performance. The test was conducted at the KARCO Engineering, LLC. facility in Adelanto, California on October 18, 2017.</p> <p>The impact velocity of the vehicle was 56.29 km/h and the ambient temperature at the barrier face at the time of impact was 30.6°C. The target vehicle's post-test maximum crush was 385 mm at the vehicle's centerline. The test vehicle's performance is as follows:</p> <table border="1" style="width: 100%; border-collapse: collapse; margin-top: 10px;"> <thead> <tr> <th rowspan="2">Measurement Description</th> <th rowspan="2">Units</th> <th colspan="2">Driver ATD</th> <th colspan="2">Passenger ATD</th> </tr> <tr> <th>Threshold</th> <th>Result</th> <th>Threshold</th> <th>Result</th> </tr> </thead> <tbody> <tr> <td>Head Injury Criteria (HIC₁₅)</td> <td>N/A</td> <td>700</td> <td>94.7</td> <td>700</td> <td>167.9</td> </tr> <tr> <td>Maximum Chest Compression</td> <td>mm</td> <td>63</td> <td>-25</td> <td>52</td> <td>-15</td> </tr> <tr> <td>Nij</td> <td>N/A</td> <td>1</td> <td>0.25</td> <td>1</td> <td>0.32</td> </tr> <tr> <td>Neck Tension</td> <td>N</td> <td>4170</td> <td>1333.0</td> <td>2620</td> <td>936.3</td> </tr> <tr> <td>Neck Compression</td> <td>N</td> <td>4000</td> <td>-288.2</td> <td>2520</td> <td>-172.4</td> </tr> <tr> <td>Left Femur Force</td> <td>N</td> <td>10000</td> <td>-143.2</td> <td>6800</td> <td>-442.4</td> </tr> <tr> <td>Right Femur Force</td> <td>N</td> <td>10000</td> <td>-715.5</td> <td>6800</td> <td>-1036.8</td> </tr> </tbody> </table>				Measurement Description	Units	Driver ATD		Passenger ATD		Threshold	Result	Threshold	Result	Head Injury Criteria (HIC ₁₅)	N/A	700	94.7	700	167.9	Maximum Chest Compression	mm	63	-25	52	-15	Nij	N/A	1	0.25	1	0.32	Neck Tension	N	4170	1333.0	2620	936.3	Neck Compression	N	4000	-288.2	2520	-172.4	Left Femur Force	N	10000	-143.2	6800	-442.4	Right Femur Force	N	10000	-715.5	6800	-1036.8
Measurement Description	Units	Driver ATD				Passenger ATD																																																	
		Threshold	Result	Threshold	Result																																																		
Head Injury Criteria (HIC ₁₅)	N/A	700	94.7	700	167.9																																																		
Maximum Chest Compression	mm	63	-25	52	-15																																																		
Nij	N/A	1	0.25	1	0.32																																																		
Neck Tension	N	4170	1333.0	2620	936.3																																																		
Neck Compression	N	4000	-288.2	2520	-172.4																																																		
Left Femur Force	N	10000	-143.2	6800	-442.4																																																		
Right Femur Force	N	10000	-715.5	6800	-1036.8																																																		
17. Key Words 35 mph Frontal Barrier Impact Test New Car Assessment Program (NCAP)		18. Distribution Statement Copies of this report are available from: National Highway Traffic Safety Administration Technical Information Services Division, NPO-411 1200 New Jersey Ave., SE Washington, DC 20590 e-mail: tis@nhtsa.dot.gov FAX: 202-493-2833																																																					
19. Security Classification of this report UNCLASSIFIED	20. Security Classification of this page UNCLASSIFIED	21. No. of Pages 134	22. Price																																																				

TABLE OF CONTENTS

<u>Section</u>		<u>Page No.</u>
1	Purpose and Summary of Test	1
2	Occupant and Vehicle Information / Data Sheets	3
<u>Data Sheet No.</u>		<u>Page No.</u>
1	General Test and Vehicle Parameter Data	4
2	Seat Adjustment, Fuel System, and Steering Wheel Data	8
3	Dummy Longitudinal Clearance Dimensions	10
4	Dummy Lateral Clearance Dimensions	11
5	Seat Belt Positioning Data	12
6	High-Speed Camera Locations and Data	13
7	Vehicle Accelerometer Locations	15
8	Photographic Reference Target Locations	16
9	Load Cell Locations on Fixed Barrier	17
10	Test Vehicle Camera and Instrumentation Summary	18
11	Post-Test Observations	19
12	Vehicle Profile Measurements	20
13	Accident Investigation Division Data	22
14	Vehicle Intrusion Measurements	23
15	Summary of FMVSS 212, 219 (Partial), and 301 Data	25
16	FMVSS 301 Static Rollover Results	27
17	Dummy / Vehicle Temperature Stabilization Chart	28
<u>Appendix</u>		<u>Page No.</u>
A	Photographs	A
B	Dummy Response Data Traces	B
C	ATD Calibration and Performance Verification Data	C

SECTION 1

PURPOSE AND SUMMARY OF TEST

PURPOSE

This 56.3 km/h frontal barrier impact test is part of the Vehicle Barrier Impact Testing Program, sponsored by the National Highway Traffic Safety Administration (NHTSA) under contract number DTNH22-12-D-00259. The purpose of this test was to obtain vehicle crashworthiness and occupant restraint system performance data for consumer information purposes.

The 56.3 km/h frontal barrier impact test was conducted in accordance with the Office of Crashworthiness Standards Frontal NCAP Laboratory Test Procedure, dated October 2015.

SUMMARY

A load cell barrier consisting of 176 load cells was impacted by a 2018 Subaru Legacy 2.5i/JAB 4-door sedan at a velocity of 56.29 km/h. The test was performed at KARCO Engineering, LLC. on October 18, 2017. Pre- and post-test photographs of the vehicle and dummies can be found in Appendix A of this report.

Three (3) real-time cameras and sixteen (16) high-speed cameras were used to document the frontal barrier impact event. Camera locations and other pertinent camera information can be found in Data Sheet 6 of this report.

One Part 572E 50th percentile male anthropomorphic test device (ATD) was placed in the driver seating position and one Part 572O 5th percentile female ATD was placed in the right-front passenger seating position according to dummy placement instructions specified in the Frontal NCAP Laboratory Test Procedure.

Both ATDs were fully instrumented with head, chest and pelvis tri-axial accelerometers, chest displacement potentiometers, upper neck force transducers, right / left femur load cells, and lower leg instrumentation. The driver (position 1) ATD (Serial No. 360) and the right-front passenger (position 2) ATD (Serial No. 630) were calibrated prior to this test. Certification details, along with instrumentation calibration data, are found in Appendix C of this report.

The 106 channels of dummy and vehicle response data were recorded on an on-board data acquisition system. Appendix B contains the dummy response data traces.

There was 100% windshield retention and no intrusion into the protected zone of the windshield during the event.

The maximum static crush was 385 mm at the vehicle's centerline. Both the driver and passenger side doors remained closed during the impact event and were operable after the impact.

The driver's visible contact points were as follows: The driver ATD's head contacted the frontal airbag, headrest, and the handle on the headliner. The upper torso contacted the frontal airbag. Both the left and right thighs contacted the steering wheel rim. Both the left and right knees contacted the knee bolster.

The passenger's visible contact points were as follows: The passenger ATD's head contacted the frontal airbag, headrest, and sun visor. The upper torso contacted the frontal airbag. Both the left and right knees contacted the knee bolster.

The occupant data is summarized below:

ATD Position	HIC ₁₅	T ¹ (ms)	T ² (ms)	Chest Disp. (mm)	Nij	Neck Tension (N)	Neck Comp. (N)	Left Femur (N)	Right Femur (N)
Driver (50th)	94.7	71.0	86.0	-25	0.25	1333.0	-288.2	-143.2	-715.5
Passenger (5th)	167.9	68.1	83.1	-15	0.32	936.3	-172.4	-442.4	-1036.8

SECTION 2

OCCUPANT AND VEHICLE INFORMATION / DATA SHEETS

Test Vehicle: 2018 Subaru Legacy 2.5i/JAB 4-Door Sedan NHTSA No.: M20185504
Test Program: 56.3 km/h Frontal Impact NCAP Test Test Date: 10/18/17

CONVERSION FACTORS

Quantity	Typical Application	Std Units	Metric Unit	Multiply By
Mass	Vehicle Weight	lb	kg	0.4536
Linear Velocity	Impact Velocity	miles/hr	km/hr	1.609344
Length or Distance	Measurements	in	mm	25.4
Volume	Fuel Systems	gal	liter	3.785
Volume	Small Fluids	oz	mL	29.574
Pressure	Tire Pressures	lbf/in ²	kPa	6.895
Temperature	General Use	°F	°C	$=(T_f - 32)/1.8$
Force	Dynamic Forces	lbf	N	4.448
Moment	Torque	lbf-ft	N•m	1.355

DATA SHEET NO. 1

GENERAL TEST AND VEHICLE PARAMETER DATA

Test Vehicle: 2018 Subaru Legacy 2.5i/JAB 4-Door Sedan NHTSA No.: M20185504
 Test Program: 56.3 km/h Frontal Impact NCAP Test Test Date: 10/18/17

TEST VEHICLE INFORMATION AND OPTIONS

NHTSA Number	M20185504
Model Year	2018
Make	Subaru
Model	Legacy 2.5i/JAB
Body Style	4-Door Sedan
VIN	4S3BNAB64J3007745
Body Color	Magnetite Gray Metallic
Odometer Reading (km / mi)	23 / 14
Engine Displacement (L)	2.5
Type / No. of Cylinders	Inline 4
Engine Placement	Transverse
Transmission Type	Automatic
Transmission Speeds	CVT
Overdrive	Yes
Final Drive	AWD
Roof Rack	No
Sunroof / T-Top	No
Running Boards	No
Tilt Steering Wheel	Yes
Power Seats	No
Anti-Lock Brakes (ABS)	Yes
Automatic Door Locks (ADLs)	Yes

Traction Control System	Yes
Power Steering	Yes
Power Window Auto-Reverse	Yes
Driver Frontal Airbag	Yes
Driver Curtain Airbag	Yes
Driver Head/Torso Airbag	No
Driver Torso Airbag	No
Driver Torso/Pelvis Airbag	Yes
Driver Pelvis Airbag	No
Driver Knee Airbag	No
Front Pass. Frontal Airbag	Yes
Front Pass. Curtain Airbag	Yes
Front Pass. Head/Torso Airbag	No
Front Pass. Torso Airbag	No
Front Pass. Torso/Pelvis Airbag	Yes
Front Pass. Pelvis Airbag	No
Front Pass. Knee Airbag	No
Driver Seat Belt Pretensioner	Yes
Driver Load Limiter	Yes
Front Pass. Seat Belt Pretensioner	Yes
Front Pass. Load Limiter	Yes
Other Safety Restraint	Seat Pan Airbag

Does Owner's Manual provide instructions to turn off automatic door locks? Yes

DATA FROM CERTIFICATION LABEL

Manufactured By	Subaru Corporation
Date of Manufacture	Aug-17

GVWR (kg)	2050
GAWR Front (kg)	1150
GAWR Rear (kg)	1200

VEHICLE SEATING AND CAPACITY WEIGHT INFORMATION

Measured Parameter	Front	Rear	Third	Total
Type of Seats	Bucket	Bench		
Designated Seating Capacity	2	3		5
Capacity Weight (VCW) (kg)				385.0
DSC x 68.04 (kg)				340.2
Cargo Weight (RCLW) (kg)				34.8

DATA SHEET NO. 1 ... (CONTINUED)

GENERAL TEST AND VEHICLE PARAMETER DATA

Test Vehicle: 2018 Subaru Legacy 2.5i/JAB 4-Door Sedan NHTSA No.: M20185504
 Test Program: 56.3 km/h Frontal Impact NCAP Test Test Date: 10/18/17



VEHICLE TIRE INFORMATION

Measured Parameter	Front	Rear
Max. Tire Pressure (kPa)	350	350
Cold Pressure (kPa)	230	220
Recommended Tire Size	P225/55/R17	P225/55/R17
Tire Size on Vehicle	P225/55/R17	P225/55/R17
Tire Manufacturer	GoodYear	GoodYear
Tire Model	Assurance	Assurance
Treadwear	580	580
Traction	A	A
Temperature Grades	A	A
Tire Plies Sidewall	2 Polyester	2 Polyester
Tire Plies Body	2 Polyamide, 2 Steel, 1 Polyamide	2 Polyamide, 2 Steel, 1 Polyamide
Load Index / Speed Symbol	97V	97V
Tire Material	Polyester, Polyamide, Steel	Polyester, Polyamide, Steel
DOT Safety Code Left	M600 ML1R 1517	M600 ML1R 1517
DOT Safety Code Right	M600 ML1R 1517	M600 ML1R 1517

DATA SHEET NO. 1 ... (CONTINUED)

GENERAL TEST AND VEHICLE PARAMETER DATA

Test Vehicle: 2018 Subaru Legacy 2.5i/JAB 4-Door Sedan NHTSA No.: M20185504
 Test Program: 56.3 km/h Frontal Impact NCAP Test Test Date: 10/18/17

TEST VEHICLE WEIGHTS

	Units	As Delivered Weights (UVW)			As Tested Weights (ATW)		
		Front Axle	Rear Axle	Total	Front Axle	Rear Axle	Total
Left	kg	467.5	339.0		494.5	402.0	
Right	kg	457.0	312.5		483.5	375.5	
Ratio	%	58.7%	41.3%	100.0%	55.7%	44.3%	100.0%
Total	kg	924.5	651.5	1576.0	978.0	777.5	1755.5

TARGET TEST WEIGHT CALCULATION

Measured Parameter	Units	Value	
Total Delivered Weight (UVW)	kg	1576.0	A
Weight of 1 P572E ATD & 1 P572O ATD	kg	141.0	B
Rated Cargo/Luggage Weight (RCLW)	kg	44.8	C
Calculated Vehicle Target Weight (TVTW)	kg	1761.8	A+B+C

TEST VEHICLE ATTITUDES

Condition	Units	LF	RF	LR	RR	CG Aft of Front Axle
As Delivered	mm	750	755	745	750	1139
As Tested	mm	736	739	712	716	1220
Post-Test	mm	771	773	699	694	

GENERAL TEST VEHICLE DATA

Measurement Description	Units	Value
Total Vehicle Wheel Base	mm	2755
Total Vehicle Length at Left Side	mm	4100
Total Vehicle Length at Centerline	mm	4810
Total Vehicle Length at Right Side	mm	4100
Weight of Ballast in Cargo Area	kg	83.4
Weight of Vehicle Components Removed	kg	7.0
Amount of Stoddard Solvent in Fuel Tank	L	65.14

VEHICLE COMPONENTS REMOVED TO MEET TEST WEIGHT:

Tail Lights and Cargo Trim

DATA SHEET NO. 1 ... (CONTINUED)

GENERAL TEST AND VEHICLE PARAMETER DATA

Test Vehicle: 2018 Subaru Legacy 2.5i/JAB 4-Door Sedan NHTSA No.: M20185504
Test Program: 56.3 km/h Frontal Impact NCAP Test Test Date: 10/18/17

TARGET VEHICLE STRUCTURAL MEASUREMENTS

No.	Description	Pre-Test
1	Total Length	4810
2	Total Width	1842
3	Bumper Top Height	645
4	Bumper Bottom Height	530
5	Longitudinal Member Top Height	520
6	Distance Between Longitudinal Members	910
7	Longitudinal Member Width	55
8	Engine Top Height	860
9	Engine Bottom Height	224
10	Engine and Gearbox Width	775
11	Front Bumper to Engine Distance	495
12	Front Shock Absorber Fixing Height	900
13	Bonnet Leading Edge Height	842
14	Front Shock Absorber Fixing Width	1170
15	Front Bumper to Front Axle Distance	1010
16	Front Axle to A-Pillar Distance	515
17	A-Pillar to B-Pillar Distance	1054
18	B-Pillar to Rear Axle Distance	1150
19	B-Pillar to C-Pillar Distance	931
20	Roof Sill Bottom Height	1300
21	Roof Sill Top Height	1480
22	Floor Sill Bottom Height	192
23	Floor Sill Top Height	325

All measurements in millimeters.

DATA SHEET NO. 2

SEAT ADJUSTMENT, FUEL SYSTEM, AND STEERING WHEEL DATA

Test Vehicle: 2018 Subaru Legacy 2.5i/JAB 4-Door Sedan

NHTSA No.: M20185504

Test Program: 56.3 km/h Frontal Impact NCAP Test

Test Date: 10/18/17

NOMINAL DESIGN RIDING POSITION

The procedure for the driver is as follows: the seat back is set to the manufacturer's designated angle. The procedure for the passenger is as follows: the seat back is set to position the transverse instrumentation platform of the dummy's head at $0^\circ \pm 0.5^\circ$. Seat back angle is measured at the headrest post.

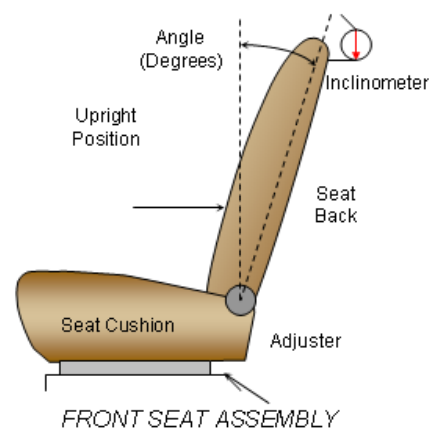

SEAT BACK ANGLE

Seating Position	Degrees
Driver Seat Back Angle	1.7
Passenger Seat Back Angle	1.7

SEAT FORE / AFT POSITIONING

The total seat travel is measured from the forward most possible position to the rear most possible position. The driver's seat is set to the middle of the fore-aft travel. The passenger's seat is set to the forward most position where the ATD will not contact any interior panels.

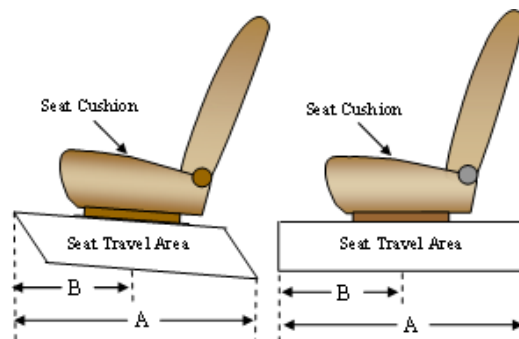

SEAT FORE/AFT POSITIONS

Seating Position	Total Fore-Aft Travel	Placed in Position
Driver Seat	290 mm	145 mm
Passenger Seat	250 mm	0 mm

SEAT BELT UPPER ANCHORAGE

The seat belt upper anchorage is positioned to the manufacturer's design position for a 50th percentile adult male ATD for the driver, and a 5th percentile adult female ATD for the passenger. Position "H" is the uppermost position, followed by position "M2," and position M1. Position "L" is the lowermost position.

SEAT BELT UPPER ANCHORAGES

Seating Position	Total No. of Positions	Placed in Position
Driver Seat	4	M2
Passenger Seat	4	M2

DATA SHEET NO. 2 ... (CONTINUED)

SEAT ADJUSTMENT, FUEL SYSTEM, AND STEERING WHEEL DATA

Test Vehicle: 2018 Subaru Legacy 2.5i/JAB 4-Door Sedan NHTSA No.: M20185504
 Test Program: 56.3 km/h Frontal Impact NCAP Test Test Date: 10/18/17

FUEL TANK CAPACITY

Description	Liters
Usable Capacity of "Standard Tank"	70.02
Usable Capacity of "Optional Tank"	N/A
92 - 94% of Usable Capacity	64.42 to 65.82
Actual Amount of Stoddard Solvent Used	65.14
1/3 of Usable Capacity	23.34

FUEL PUMP

The vehicle is equipped with an electric fuel pump. The fuel pump operates when the starter or engine is activated. The pump operates a few seconds after ignition switch is turned ON. After that the pump operates only while the engine is running.

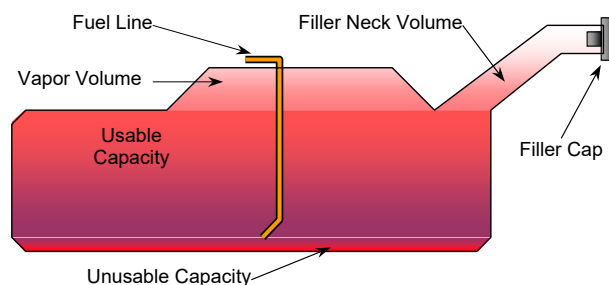

VEHICLE FUEL TANK ASSEMBLY

STEERING COLUMN ADJUSTMENT

Steering wheel and column adjustments are made so that the steering wheel hub is at the geometric center of the locus it describes when moved through its full range of motion. A digital inclinometer is used to measure a plate which is placed across the rim of the steering wheel for angular measurements.

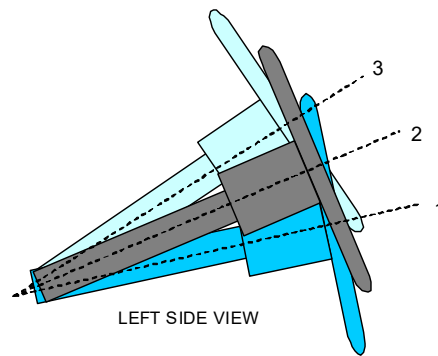

STEERING COLUMN ASSEMBLY

STEERING COLUMN POSITIONING

	Degrees	Fore-Aft Position (mm)
Lowermost Position, No. 1	21.5	110
Geometric Center Position, No. 2	23.0	130
Uppermost Position, No. 3	24.5	150
Telescoping Steering Wheel Travel		40
Test Position	23.0	130

DATA SHEET NO. 3

DUMMY LONGITUDINAL CLEARANCE DIMENSIONS

Test Vehicle: 2018 Subaru Legacy 2.5i/JAB 4-Door Sedan

NHTSA No.: M20185504

Test Program: 56.3 km/h Frontal Impact NCAP Test

Test Date: 10/18/17

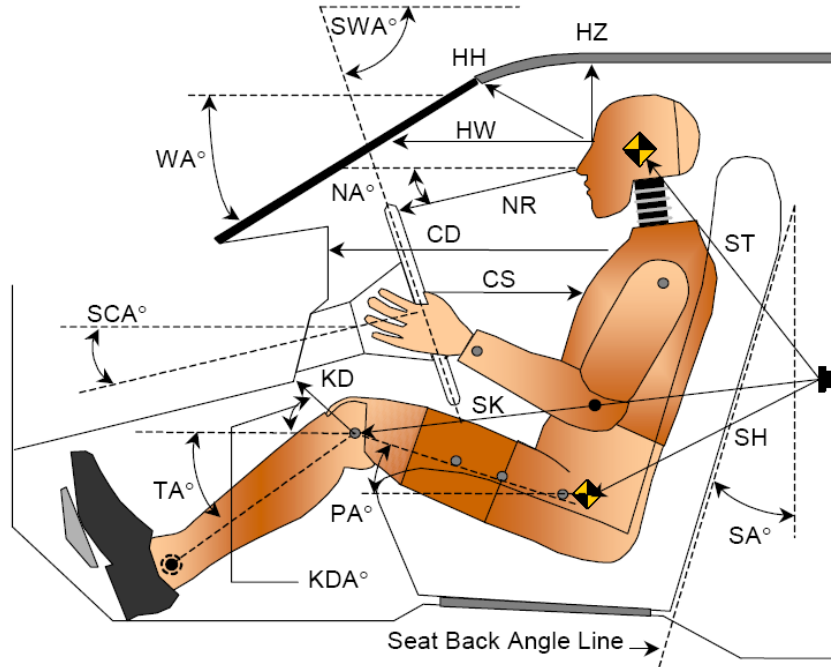

LEFT SIDE VIEW

Code	Measurement Description	Driver		Passenger	
		Length (mm)	Angle (°)	Length (mm)	Angle (°)
WA°	Windshield Angle		27.0		
SWA°	Steering Wheel Angle		67.0		
SCA°	Steering Column Angle		23.0		
SA°	Seat Back Angle (On Headrest Post)		1.7		1.7
HZ	Head to Roof	197	90.0	216	90.0
HH	Head to Header	344	31.1	331	45.5
HW	Head to Windshield	648	0.0	653	0.0
NR	Nose to Rim	362	10.5	513	24.9
CD	Chest to Dash	509	13.1	440	12.8
CS	Chest to Steering Hub	280	0.0		
RA	Rim to Abdomen	183	0.0		
KDL	Left Knee to Dash	194	29.0	107	38.7
KDR	Right Knee to Dash	183	35.5	122	44.5
PA°	Pelvic Angle		24.4		20.8
TA°	Tibia Angle		39.6		48.1
SK	Striker to Knee	603	9.4	716	11.2
ST	Striker to Head	447	72.9	420	61.1
SH	Striker to H-Point	318	46.2	414	29.3

DATA SHEET NO. 4

DUMMY LATERAL CLEARANCE DIMENSIONS

Test Vehicle: 2018 Subaru Legacy 2.5i/JAB 4-Door Sedan NHTSA No.: M20185504
 Test Program: 56.3 km/h Frontal Impact NCAP Test Test Date: 10/18/17

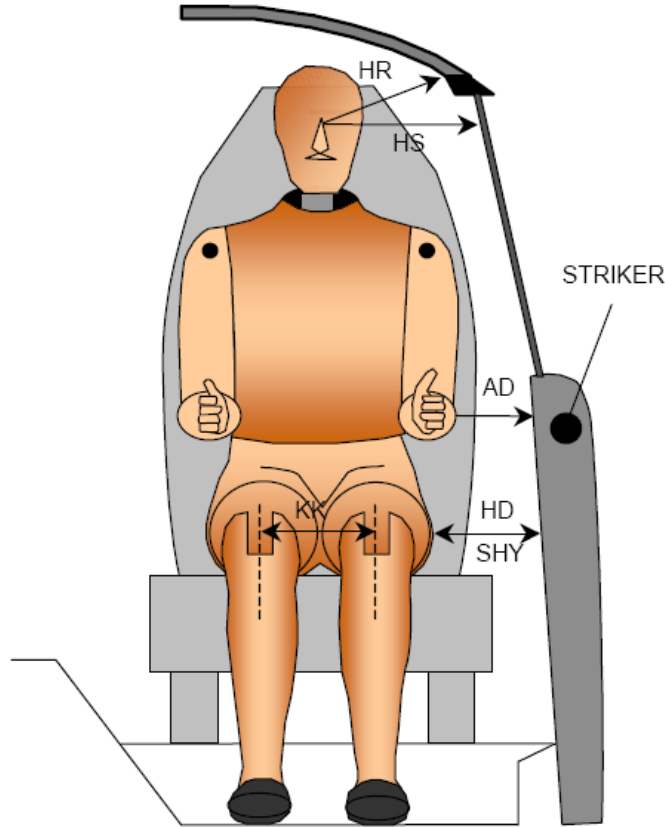

Code	Description	Driver (mm)	Passenger (mm)
AD	Arm to Door	127	101
HD	H-Point to Door	125	204
HR	Head to Side Header	253	260
HS	Head to Side Window	325	363
KK	Knee to Knee	330	215
SHY	Striker to H-Point (Y-Direction)	141	166
AA	Ankle to Ankle	310	175

DATA SHEET NO. 5
SEAT BELT POSITIONING DATA

Test Vehicle: 2018 Subaru Legacy 2.5i/JAB 4-Door Sedan

NHTSA No.: M20185504

Test Program: 56.3 km/h Frontal Impact NCAP Test

Test Date: 10/18/17

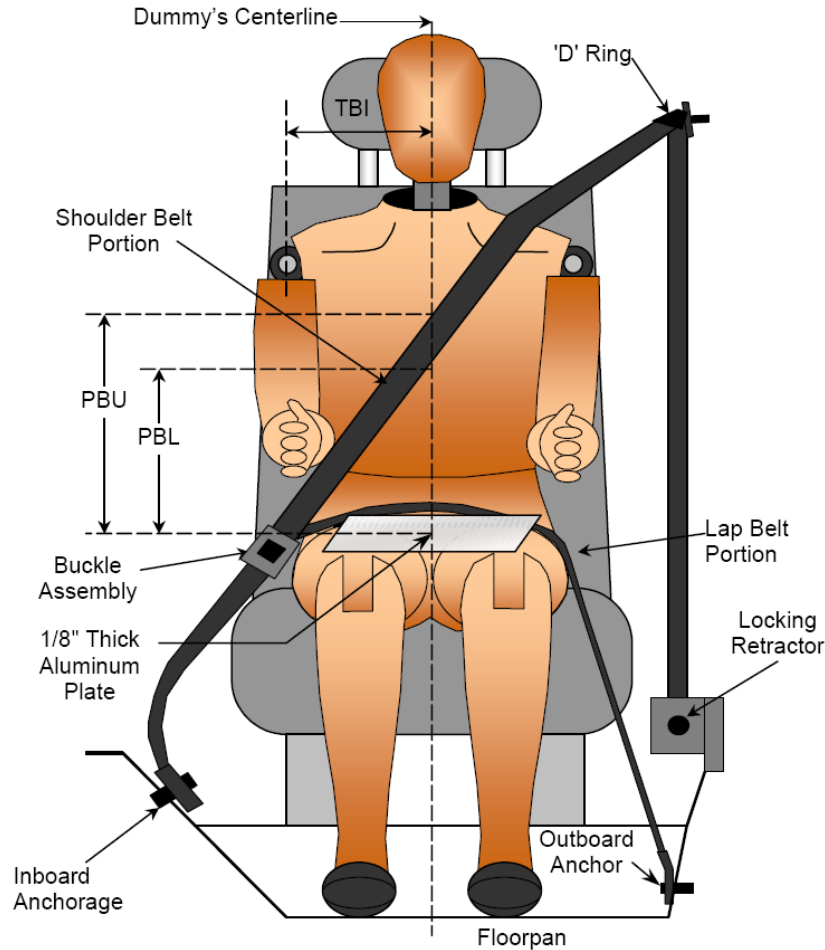

FRONT VIEW OF DUMMY

SEAT BELT POSITIONING MEASUREMENTS

Code	Measurement Description	Units	Driver	Passenger
PBU	Top Surface of Aluminum Plate to Belt Upper Edge	mm	380	315
PBL	Top Surface of Aluminum Plate to Belt Lower Edge	mm	310	225

BELT LENGTH DATA

Measurement Description	Units	Driver	Passenger
Shoulder Belt Length as Measured on ATD	mm	847	945
Lap Belt Length as Measured on ATD	mm	740	790
Remainder of Belt on Reel	mm	950	766
Total Belt Length for Continuous Webbing Systems	mm	2537	2501

DATA SHEET NO. 6

HIGH-SPEED CAMERA LOCATIONS AND DATA

Test Vehicle: 2018 Subaru Legacy 2.5i/JAB 4-Door Sedan NHTSA No.: M20185504

Test Program: 56.3 km/h Frontal Impact NCAP Test Test Date: 10/18/17

CAMERA POSITIONS FOR FRONTAL IMPACTS

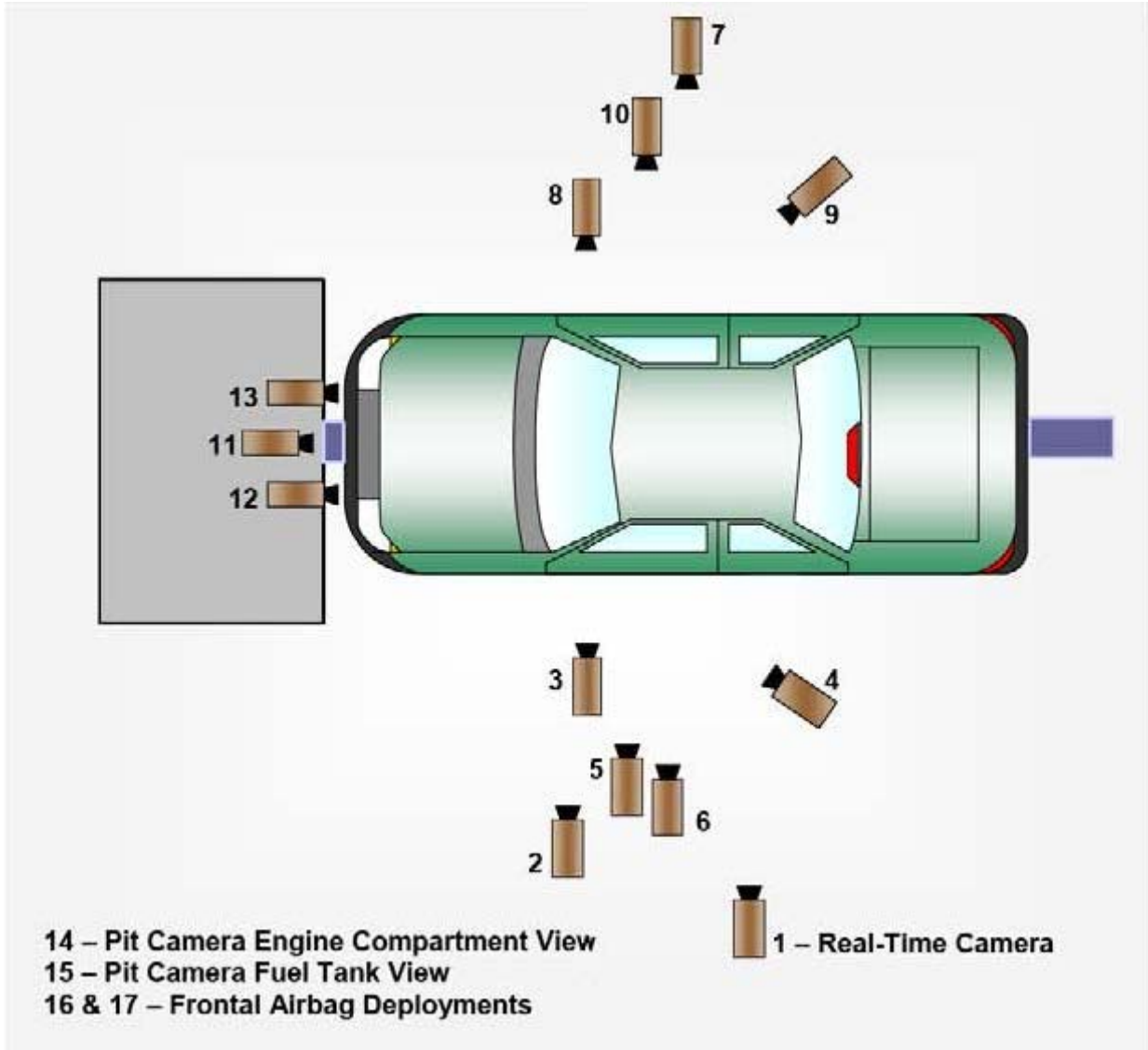

DATA SHEET NO. 6 ... (CONTINUED)

HIGH-SPEED CAMERA LOCATIONS AND DATA

Test Vehicle: 2018 Subaru Legacy 2.5i/JAB 4-Door Sedan NHTSA No.: M20185504
 Test Program: 56.3 km/h Frontal Impact NCAP Test Test Date: 10/18/17

CAMERA LOCATIONS

No.	Description	Location (mm)			Lens (mm)	Speed (fps)
		X	Y	Z		
1	Real-Time Left Overall	-11412	-8150	-1484		30
2	Driver Close-Up	-2590	-7950	-1371	50	1000
3	Left Front Half	-1701	-6197	-1701	35	1000
4	Left Angle	-6696	-10308	-3211	105	1000
5	Steering Column - Top	-1966	-10412	-3688	35	1000
6	Steering Column - Bottom	-1972	-10412	-3379	35	1000
7	Right Overall	-2336	7569	-1012	24	1000
8	Passenger Close-Up	-1733	7581	-1408	50	1000
9	Right Front Half	-1600	8214	-1811	35	1000
10	Right Angle	-6217	9516	-4830	85	1000
11	Windshield	-354	0	-5749	24	1000
12	Driver Windshield	297	-366	-2460	20	1000
13	Passenger Windshield	297	366	-2460	20	1000
14	Pit Front	-756	0	1495	20	1000
15	Pit Rear	-3398	0	1495	14	1000
16	Onboard Driver Airbag (Optional)	-1440	280	-1300	8	1000
17	Onboard Passenger Airbag (Optional)	-1440	-280	-1300	8	1000
18	Real-Time Left View of Impact					
19	Real-Time Right View of Impact					

Coordinates: +X = forward impact plane
 +Y = right of monorail center
 +Z = into ground

DATA SHEET NO. 7

VEHICLE ACCELEROMETER LOCATIONS

Test Vehicle: 2018 Subaru Legacy 2.5i/JAB 4-Door Sedan NHTSA No.: M20185504
 Test Program: 56.3 km/h Frontal Impact NCAP Test Test Date: 10/18/17

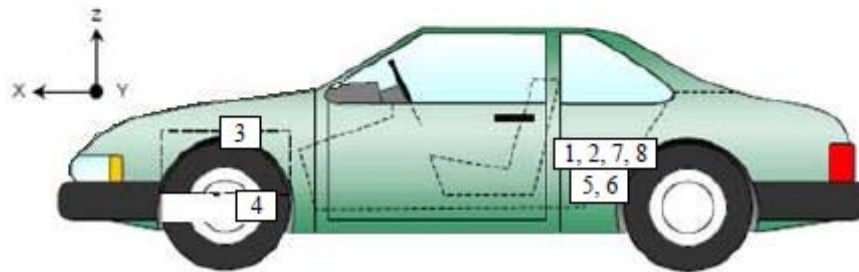
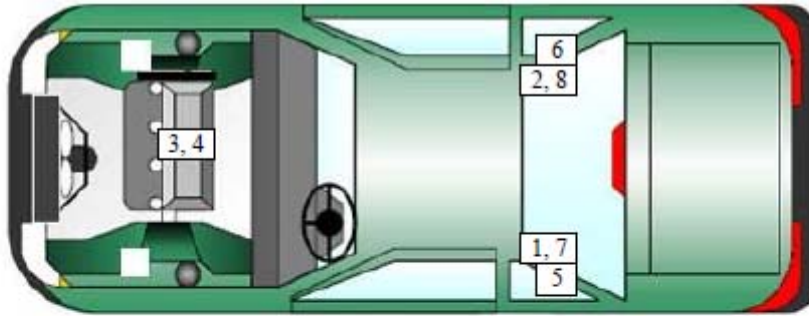

VEHICLE ACCELEROMETER PRE-TEST LOCATIONS

No.	Description	Location		
		X	Y	Z
1	Left Rear Accelerometer X-Direction	1812	-718	-348
2	Right Rear Accelerometer X-Direction	1812	718	-348
3	Engine Top X	3831	-27	-852
4	Engine Bottom X	3397	-118	-154
5	Left Rear Accelerometer Z-Direction	N/A	N/A	N/A
6	Right Rear Accelerometer Z-Direction	N/A	N/A	N/A
7	Left Rear Accelerometer X-Direction Redundant	1812	-718	-348
8	Right Rear Accelerometer X-Direction Redundant	1812	718	-348

Reference Points: X – Rear Surface of Vehicle (+ forward)
 Y – Vehicle Centerline (+ to right)
 Z – Ground Plane (+ down)

DATA SHEET NO. 8

PHOTOGRAPHIC REFERENCE TARGET LOCATIONS

Test Vehicle: 2018 Subaru Legacy 2.5i/JAB 4-Door Sedan NHTSA No.: M20185504

Test Program: 56.3 km/h Frontal Impact NCAP Test Test Date: 10/18/17

Item	Value
A	410
B	921
C	2305
D	610
E	1915
F	305
G	2030
H	910
I	1525
J	880
K	880
L	1517
M	908
N	1516
O	880
P	880
Q	1525

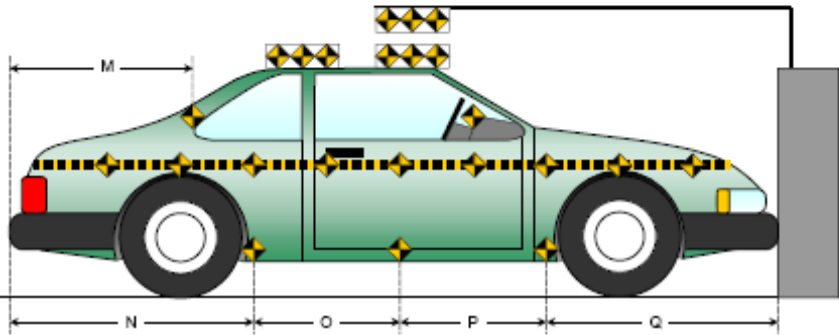
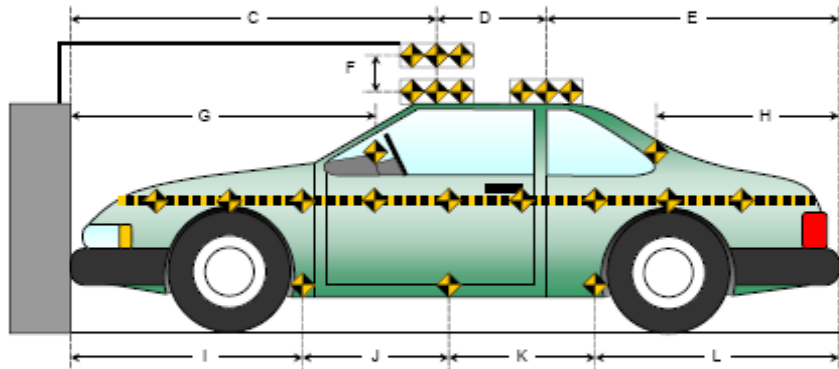
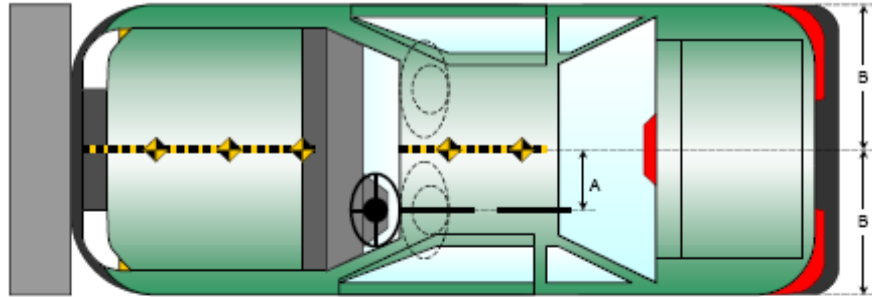

All measurements in millimeters.

DATA SHEET NO. 9

LOAD CELL LOCATIONS ON FIXED BARRIER

Test Vehicle: 2018 Subaru Legacy 2.5i/JAB 4-Door Sedan NHTSA No.: M20185504

Test Program: 56.3 km/h Frontal Impact NCAP Test Test Date: 10/18/17

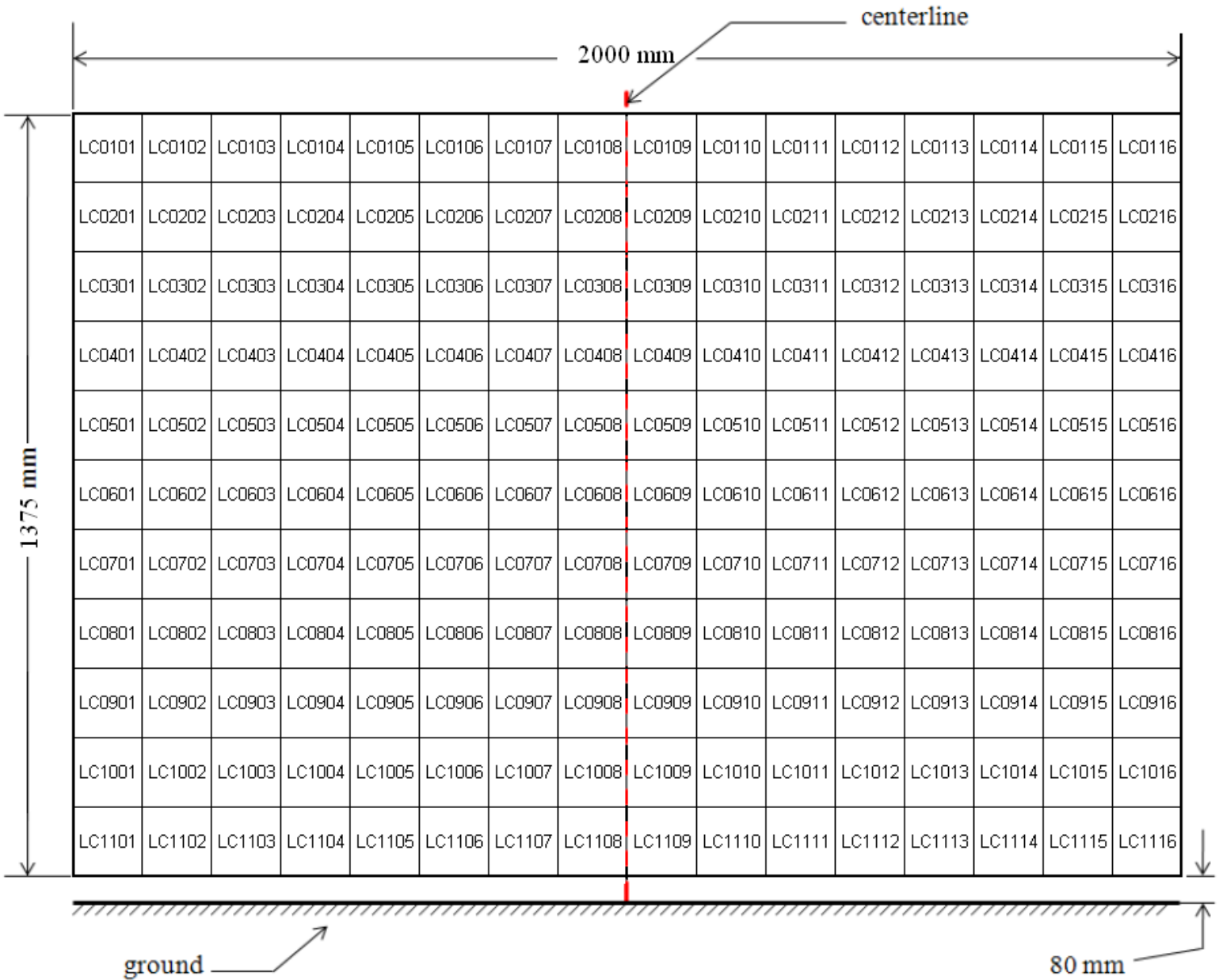

DATA SHEET NO. 10

TEST VEHICLE CAMERA AND INSTRUMENTATION SUMMARY

Test Vehicle: 2018 Subaru Legacy 2.5i/JAB 4-Door Sedan NHTSA No.: M20185504
Test Program: 56.3 km/h Frontal Impact NCAP Test Test Date: 10/18/17

INSTRUMENTATION

Driver Dummy Accelerometers	47
Passenger Dummy Accelerometers	47
Vehicle Structure Accelerometers	8
Seat Belt Load Cells	4
Load Cell Barrier	528
Total	634

CAMERA COVERAGE

High-Speed Vehicle On Board	2
High-Speed Off Board	14
Real Time	3
Total	19

DATA SHEET NO. 11
POST-TEST OBSERVATIONS

Test Vehicle: 2018 Subaru Legacy 2.5i/JAB 4-Door Sedan NHTSA No.: M20185504
 Test Program: 56.3 km/h Frontal Impact NCAP Test Test Date: 10/18/17

TEST DUMMY INFORMATION AND CONTACT

Description	Driver	Passenger
Dummy Type/Serial No.	P572E 50th Percentile Male ATD / 360	P572O 5th Percentile Female ATD / 630
Head Contact	Frontal Airbag, Headrest, Headliner Handle	Frontal Airbag, Headrest, Sun Visor
Upper Torso Contact	Frontal Airbag	Frontal Airbag
Lower Torso Contact	None	None
Left Knee Contact	Knee Bolster, Steering Column	Knee Bolster
Right Knee Contact	Knee Bolster, Steering Column	Knee Bolster

DOOR OPENING AND SEAT TRACK INFORMATION

Description	Driver	Passenger
Locked / Unlocked Doors	Unlocked	Unlocked
Front Door Opening	Remained closed and latched, operational	Remained closed and latched, operational
Rear Door Opening	Remained closed and latched, operational	Remained closed and latched, operational
Seat Track Shift (mm)	12	0
Seat Back Failure	None	None
Glazing Damage	Yes	Yes

POST TEST STRUCTURAL OBSERVATIONS

Critical Areas of Performance	Observations and Conclusions
Windshield Damage	Yes
Window Damage	None
Other Notable Effects	None

VEHICLE REBOUND FROM BARRIER

Measured Parameter	Units	Value
Left Side	mm	655
Center	mm	693
Right Side	mm	721
Average	mm	690

SUPPLEMENTAL RESTRAINT SYSTEM INFORMATION

Restraint Type	Driver		Passenger	
	Installed	Operated	Installed	Operated
Front Airbag	Yes	Yes	Yes	Yes
Side Airbag 1 (Curtain)	Yes	No	Yes	No
Side Airbag 2 (Torso/Pelvis)	Yes	No	Yes	No
Knee Airbag	No		No	
Seat Pan Airbag	Yes	Yes	Yes	Yes
Seat Belt Pretensioner	Yes	Yes	Yes	Yes
Seat Belt Load Limiter	Yes	Yes	Yes	Yes

DATA SHEET NO. 12
VEHICLE PROFILE MEASUREMENTS

Test Vehicle: 2018 Subaru Legacy 2.5i/JAB 4-Door Sedan NHTSA No.: M20185504
 Test Program: 56.3 km/h Frontal Impact NCAP Test Test Date: 10/18/17

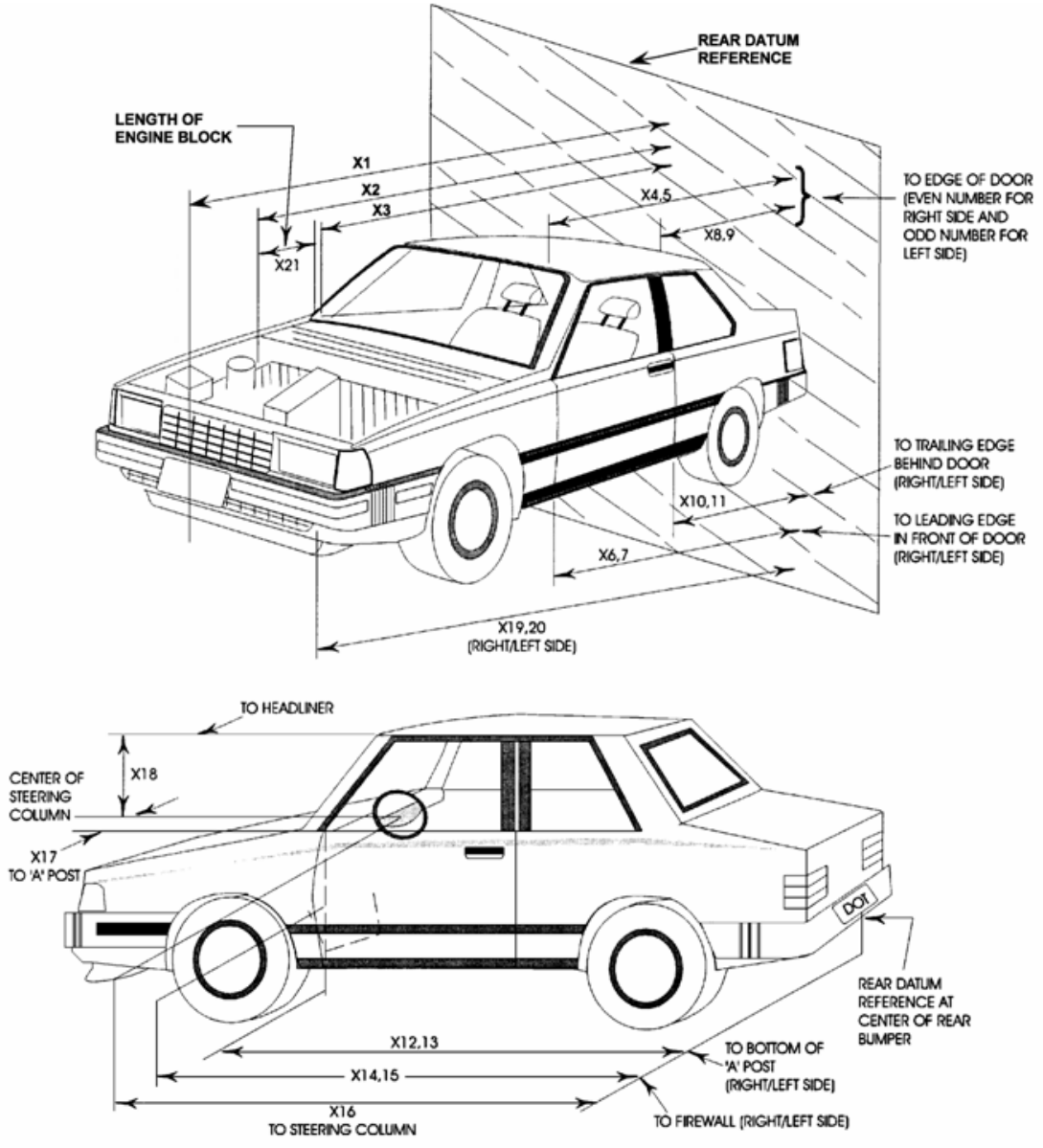

DATA SHEET NO. 12 ... (CONTINUED)

VEHICLE PROFILE MEASUREMENTS

Test Vehicle: 2018 Subaru Legacy 2.5i/JAB 4-Door Sedan NHTSA No.: M20185504
 Test Program: 56.3 km/h Frontal Impact NCAP Test Test Date: 10/18/17

No.	Description	Pre-Test	Post-Test	Difference
1	Total Length of Vehicle at Centerline	4810	4425	-385
2	Rear Surface of Vehicle to Front of Engine	3800	4120	320
3	RSOV to Firewall	3650	3611	-39
4	RSOV to Upper Leading Edge of Right Door	3332	3325	-7
5	RSOV to Upper Leading Edge of Left Door	3333	3350	17
6	RSOV to Lower Leading Edge of Right Door	3278	3273	-5
7	RSOV to Lower Leading Edge of Left Door	3280	3280	0
8	RSOV to Upper Trailing Edge of Right Door	2198	2184	-14
9	RSOV to Upper Trailing Edge of Left Door	2200	2200	0
10	RSOV to Lower Trailing Edge of Right Door	2220	2216	-4
11	RSOV to Lower Trailing Edge of Left Door	2220	2215	-5
12	RSOV to Bottom of A-Pillar, Right Side	3310	3311	1
13	RSOV to Bottom of A-Pillar, Left Side	3310	3309	-1
14	RSOV to Firewall, Right Side	3610	3610	0
15	RSOV to Firewall, Left Side	3590	3584	-6
16	RSOV to Steering Column	2760	2904	144
17	Center of Steering Column to A-Pillar	410	400	-10
18	Center of Steering Column to Headliner	490	470	-20
19	RSOV to Right Side of Front Bumper	4100	3983	-117
20	RSOV to Left Side of Front Bumper	4100	3832	-268
21	Length of Engine Block	640	640	0
RD	RSOV to Right Side of Dash Panel	3030	3042	12
CD	RSOV to Center of Dash Panel	2960	3003	43
LD	RSOV to Left Side of Dash Panel	3030	3000	-30

All measurements in millimeters.

DATA SHEET NO. 13

ACCIDENT INVESTIGATION DIVISION DATA

Test Vehicle: 2018 Subaru Legacy 2.5i/JAB 4-Door Sedan NHTSA No.: M20185504
 Test Program: 56.3 km/h Frontal Impact NCAP Test Test Date: 10/18/17

VEHICLE INFORMATION

VIN: 4S3BNAB64J3007745 Wheelbase (mm): 2755
 Vehicle Size Category: Passenger Car Test Weight (kg): 1755.5

ACCELEROMETER DATA

Accelerometer Locations: Left Rear Crossmember
 Cal. Procedure/Interval: Vibration Test / 6 months
 Integration Algorithm: NHTSA Standard
 Impact Velocity (km/h): 56.29
 Velocity Change (km/h): 63.3
 Time of Separation (msec): 69.4

Linearity: Good

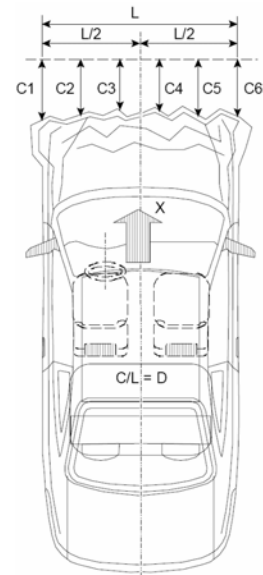

CRUSH PROFILE

Collision Deformation Classification: 12FDEW2
 Midpoint of Damage: Vehicle Centerline
 Damage Region Length (mm): 1616
 Impact Mode: Full Frontal

No.	Measurement Description	Units	Pre-Test	Post-Test	Difference
C1	Crush Zone 1 at Left Side	mm	310	581	271
C2	Crush Zone 2 at Left Side	mm	72	425	353
C3	Crush Zone 3 at Left Side	mm	20	391	371
C4	Crush Zone 4 at Right Side	mm	20	386	366
C5	Crush Zone 5 at Right Side	mm	72	394	322
C6	Crush Zone 6 at Right Side	mm	310	516	206
L	C1 to C6	mm	1616		

DATA SHEET NO. 14

VEHICLE INTRUSION MEASUREMENTS

Test Vehicle: 2018 Subaru Legacy 2.5i/JAB 4-Door Sedan NHTSA No.: M20185504

Test Program: 56.3 km/h Frontal Impact NCAP Test Test Date: 10/18/17

DOOR OPENING WIDTH

Item	Description	Units	Pre-Test	Post-Test	Difference
A	Left Side Upper	mm	1054	1050	4
B	Left Side Lower	mm	961	956	5
D	Right Side Upper	mm	1048	1040	8
E	Right Side Lower	mm	959	946	13

WHEELBASE MEASUREMENTS

Item	Description	Units	Pre-Test	Post-Test	Difference
C	Left Side Wheelbase	mm	2755	2735	20
F	Right Side Wheelbase	mm	2755	2775	-20

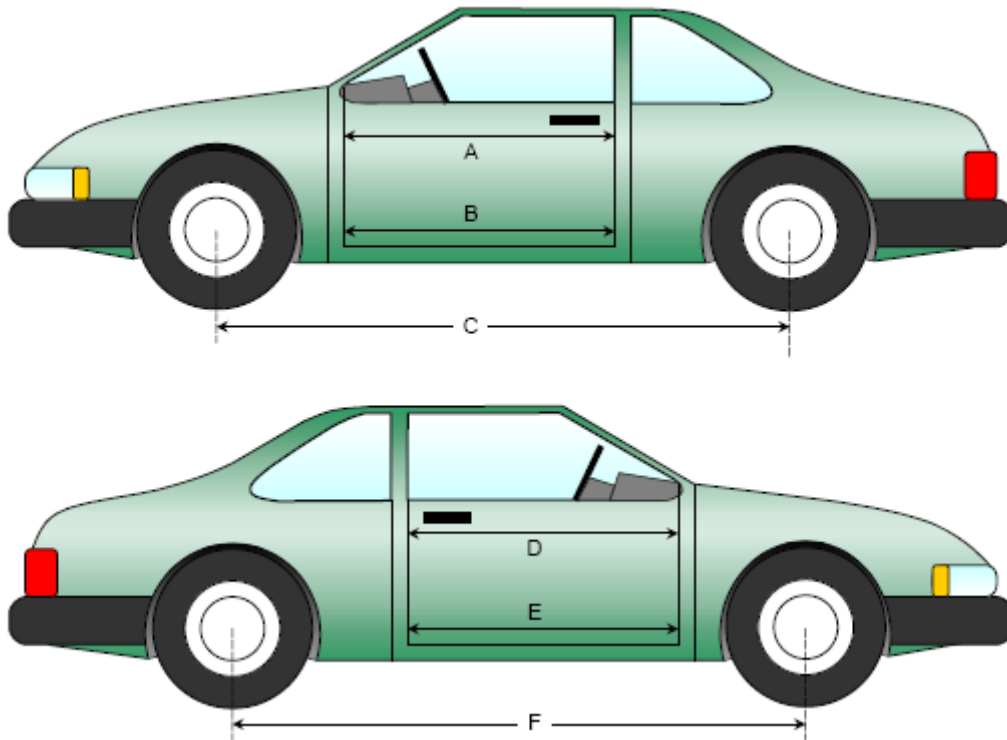

DATA SHEET NO. 14 ... (CONTINUED)
VEHICLE INTRUSION MEASUREMENTS

Test Vehicle: 2018 Subaru Legacy 2.5i/JAB 4-Door Sedan NHTSA No.: M20185504
 Test Program: 56.3 km/h Frontal Impact NCAP Test Test Date: 10/18/17

DRIVER COMPARTMENT INTRUSION

Item	Description	Units	Pre-Test	Post-Test	Difference
AB	Door Opening (Inside Window Jam)	mm	971	970	1
CX	Left Knee Bolster to X	mm	300	300	0
DX	Right Knee Bolster to X	mm	315	323	-8
EX	Brake Pedal to X	mm	580	495	85
FX	Foot Rest to X	mm	560	557	3
GX	Center of Steering Wheel Hub to X	mm	70	55	15

X = Front of Seat Track (Stationary)

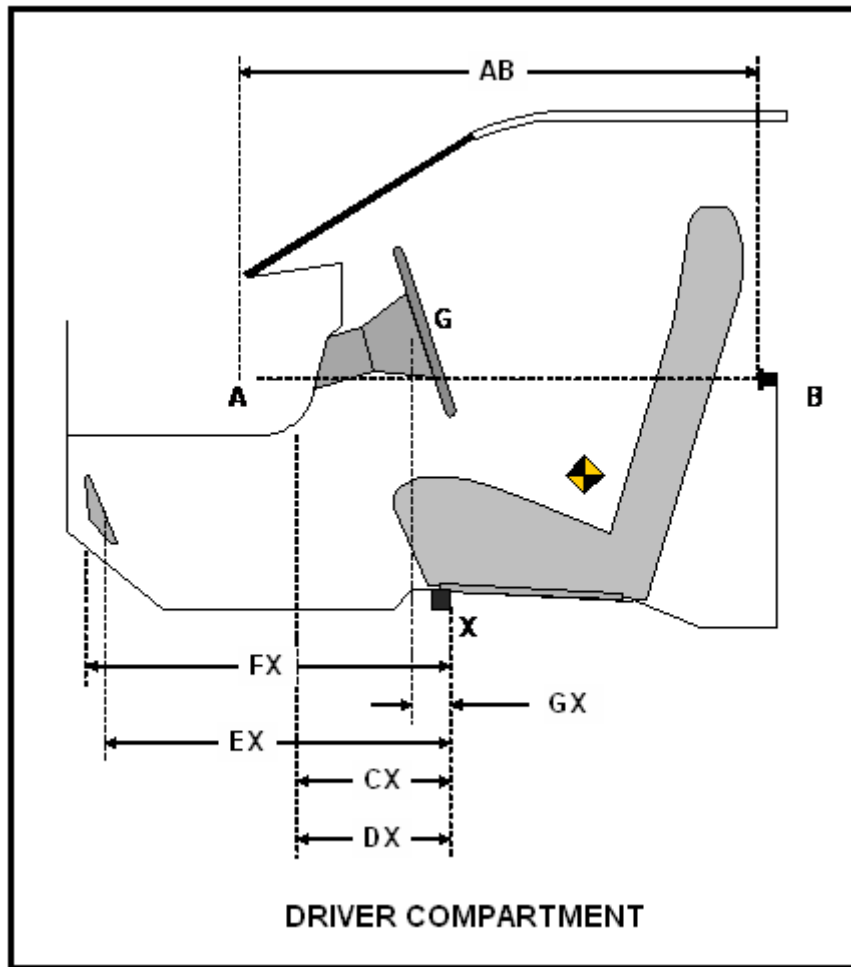

DATA SHEET NO. 15

SUMMARY OF FMVSS 212, 219 (PARTIAL), AND 301 DATA

Test Vehicle: 2018 Subaru Legacy 2.5i/JAB 4-Door Sedan NHTSA No.: M20185504

Test Program: 56.3 km/h Frontal Impact NCAP Test Test Date: 10/18/17

Windshield Mounting Details: Windshield glass is secured to the vehicle frame with plastic molding and rubber cement.

The standard requires that the post-test retention measurement be a minimum of 75% of the pre-test total periphery measurement for vehicles not equipped with occupant passive restraints and 50% for each side of the windshield for vehicles which are equipped with occupant passive restraints.

Temperature of windshield molding during test: 21.1° C

WINDSHIELD PERIPHERY MEASUREMENTS

Measurement	Pre-Test (mm)	Post-Test (mm)	% Retention
Left Side	2238	2238	100.0%
Right Side	2238	2238	100.0%
Total	4476	4476	100.0%

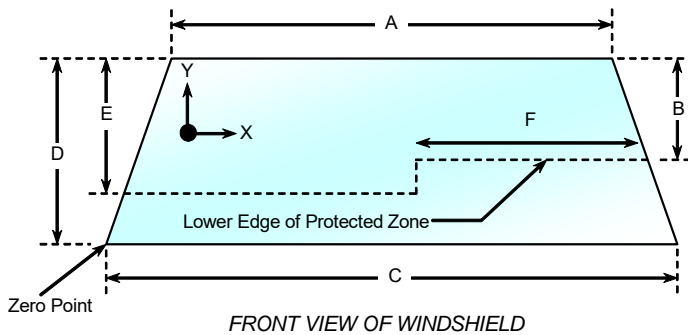

Item	Units	Value
A	mm	1197
B	mm	397
C	mm	1459
D	mm	910
E	mm	544
F	mm	556

AREAS OF PROTECTED ZONE FAILURES

A. Provide Coordinates of the area that the protected zone was penetrated more than 0.25 inches by a vehicle component other than one that is normally in contact with the windshield.

X	Y

B. Provide coordinates of the area beneath the protected zone that the inner surface of the windshield was penetrated by a vehicle component.

X	Y

DATA SHEET NO. 15 ... (CONTINUED)

SUMMARY OF FMVSS 212, 219 (PARTIAL), AND 301 DATA

Test Vehicle: 2018 Subaru Legacy 2.5i/JAB 4-Door Sedan NHTSA No.: M20185504
Test Program: 56.3 km/h Frontal Impact NCAP Test Test Date: 10/18/17

FMVSS 301 FUEL SYSTEM INTEGRITY POST IMPACT DATA

Temperature at Time of Impact: 30.6° C Test Time: 3:57 PM

Stoddard Solvent Spillage Measurements

- A. From impact until vehicle motion ceases: 0 oz.
(Maximum allowable = 1 oz.)
- B. For the 5 minute period after motion ceases: 0 oz.
(Maximum allowable = 5 oz.)
- C. For the following 25 minutes: 0 oz.
(Maximum allowable = 1 oz./minute)
- D. Spillage: There was no Stoddard solvent spillage.

DATA SHEET NO. 16

FMVSS 301 STATIC ROLLOVER RESULTS

Test Vehicle: 2018 Subaru Legacy 2.5i/JAB 4-Door Sedan NHTSA No.: M20185504
 Test Program: 56.3 km/h Frontal Impact NCAP Test Test Date: 10/18/17

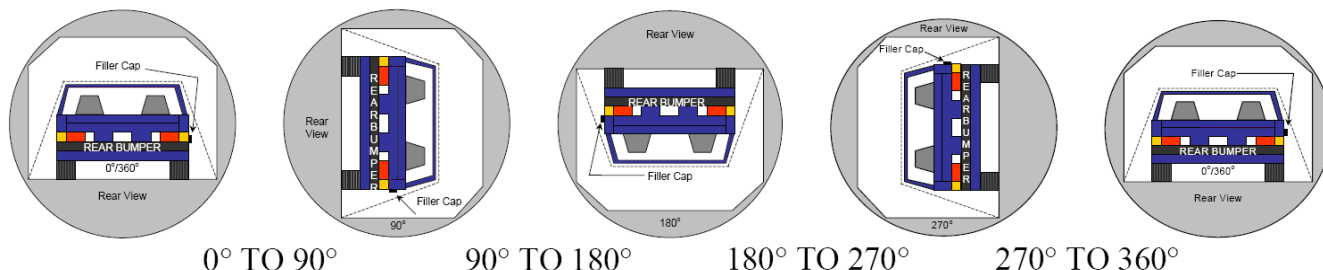

1. The specified fixture rollover rate for each 90° of rotation is 60 to 180 seconds.
2. The position hold time at each position is 300 seconds (minimum).
3. Details of Stoddard solvent spillage: There was no Stoddard solvent spillage.

SOLVENT COLLECTION TIME TABLE IN SECONDS

Test Phase	Rotation Time	Hold Time	Total Time
0° To 90°	76	300	376
90° To 180°	82	300	382
180° To 270°	81	300	381
270° To 360°	79	300	379

FMVSS 301 SPILLAGE TABLE

Test Phase	First 5 Minutes	Sixth Minute	Seventh Minute	Eighth Minute
0° To 90°	0			
90° To 180°	0			
180° To 270°	0			
270° To 360°	0			

SOLVENT SPILLAGE LOCATION TABLE

Test Phase	Spillage Location
0° To 90°	
90° To 180°	
180° To 270°	
270° To 360°	

DATA SHEET NO. 17

DUMMY / VEHICLE TEMPERATURE STABILIZATION CHART

Test Vehicle: 2018 Subaru Legacy 2.5i/JAB 4-Door Sedan NHTSA No.: M20185504

Test Program: 56.3 km/h Frontal Impact NCAP Test Test Date: 10/18/17

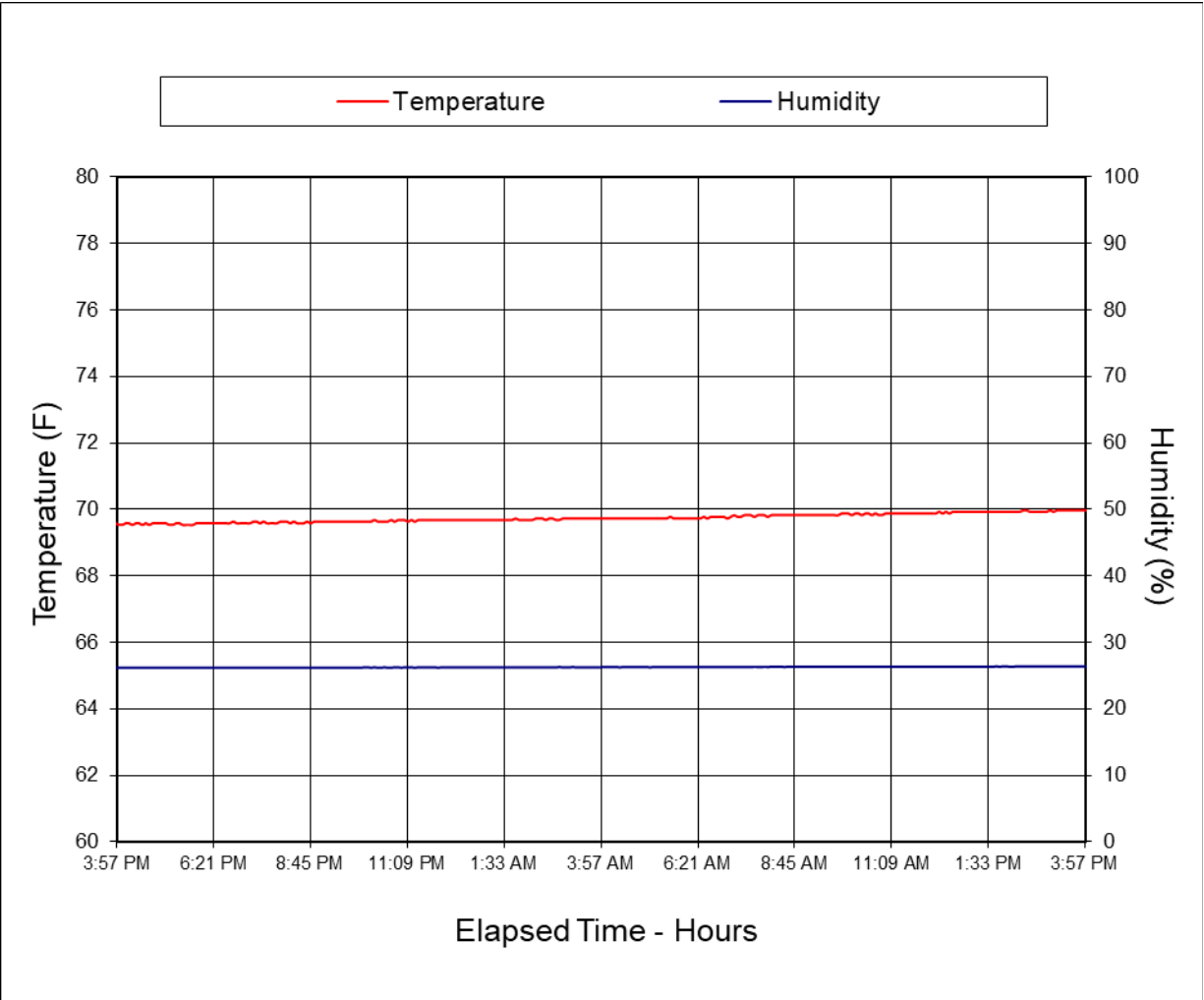

**APPENDIX A
PHOTOGRAPHS**

TABLE OF PHOTOGRAPHS

Figure		Page
1	Load Cell Location	A-1
2	Pre-Test Load Cell Wall	A-1
3	Post-Test Load Cell Wall	A-2
4	Manufacturer's Label	A-2
5	Tire Placard	A-3
6	2018 Subaru Legacy 2.5i/JAB Frontal as Delivered	A-3
7	Left Rear $\frac{3}{4}$ View, as Received	A-4
8	Pre-Test Front View of Test Vehicle	A-4
9	Post-Test Front View of Test Vehicle	A-5
10	Pre-Test Left View of Test Vehicle	A-5
11	Post-Test Left View of Test Vehicle	A-6
12	Pre-Test Right View of Test Vehicle	A-6
13	Post-Test Right View of Test Vehicle	A-7
14	Pre-Test Right Front $\frac{3}{4}$ View	A-7
15	Post-Test Right Front $\frac{3}{4}$ View	A-8
16	Pre-Test Left Rear $\frac{3}{4}$ View	A-8
17	Post-Test Left Rear $\frac{3}{4}$ View	A-9
18	Pre-Test Windshield View	A-9
19	Post-Test Windshield View	A-10
20	Pre-Test Engine Compartment View	A-10
21	Post-Test Engine Compartment View	A-11
22	Pre-Test Fuel Filler Cap View	A-11
23	Post-Test Fuel Filler Cap View	A-12
24	Pre-Test Front Underbody View	A-12
25	Post-Test Front Underbody View	A-13
26	Pre-Test Rear Underbody View	A-13
27	Post-Test Rear Underbody View	A-14
28	Pre-Test Dummy Cable Routing	A-14
29	Post-Test Dummy Cable Routing	A-15
30	Pre-Test Driver Dummy Front View	A-15
31	Post-Test Driver Dummy Front View	A-16
32	Pre-Test Driver Dummy Window View	A-16
33	Post-Test Driver Dummy Window View	A-17
34	Pre-Test Driver Dummy and Vehicle Interior View	A-17
35	Post-Test Driver Dummy and Vehicle Interior View	A-18
36	Pre-Test Driver's Seat Fore-Aft Markings	A-18

TABLE OF PHOTOGRAPHS ... (CONTINUED)

Figure		Page
37	Post-Test Driver's Seat Fore-Aft Markings	A-19
38	Pre-Test View of Belt Anchorage for Driver Dummy	A-19
39	Post-Test View of Belt Anchorage for Driver Dummy	A-20
40	Pre-Test Driver Dummy Feet	A-20
41	Post-Test Driver Dummy Feet	A-21
42	Pre-Test Driver's Side Knee Bolster	A-21
43	Post-Test Driver's Side Knee Bolster	A-22
44	Pre-Test Driver's Side Floorpan	A-22
45	Post-Test Driver's Side Floorpan	A-23
46	Post-Test Driver Dummy Face	A-23
47	Post-Test Driver Dummy Contact with Airbag	A-24
48	Post-Test Driver Dummy Contact with Headrest	A-24
48a	Post-Test Driver Dummy Contact with Steering Column	A-25
48b	Post-Test Driver Dummy Contact with Knee Bolster	A-25
49	Pre-Test View of the Steering Wheel	A-26
50	Post-Test View of the Steering Wheel	A-26
51	Pre-Test Passenger Dummy Front View	A-27
52	Post-Test Passenger Dummy Front View	A-27
53	Pre-Test Passenger Dummy Window View	A-28
54	Post-Test Passenger Dummy Window View	A-28
55	Pre-Test Passenger Dummy and Vehicle Interior View	A-29
56	Post-Test Passenger Dummy and Vehicle Interior View	A-29
57	Pre-Test Passenger's Seat Fore-Aft Markings	A-30
58	Post-Test Passenger's Seat Fore-Aft Markings	A-30
59	Pre-Test View of Belt Anchorage for Passenger Dummy	A-31
60	Post-Test View of Belt Anchorage for Passenger Dummy	A-31
61	Pre-Test Passenger Dummy Feet	A-32
62	Post-Test Passenger Dummy Feet	A-32
63	Pre-Test Passenger's Side Knee Bolster	A-33
64	Post-Test Passenger's Side Knee Bolster	A-33
65	Pre-Test Passenger's Side Floorpan	A-34
66	Post-Test Passenger's Side Floorpan	A-34
67	Post-Test Passenger Dummy Face	A-35
68	Post-Test Passenger Dummy Contact with Airbag	A-35
69	Post-Test Passenger Dummy Contact with Sun Visor	A-36

TABLE OF PHOTOGRAPHS ... (CONTINUED)

<u>Figure</u>		<u>Page</u>
69a	Post-Test Passenger Dummy Contact with Headrest	A-36
69b	Post-Test Passenger Dummy Contact with Knee Bolster	A-37
70	Photograph of Ballast Installed in Vehicle	A-37
71	Post-Test Stoddard Solvent Spillage Location View	A-38
72	Post-Test Speed Trap Read-Out	A-38
73	Vehicle at 0° on Static Rollover Device	A-39
74	Vehicle at 90° on Static Rollover Device	A-39
75	Vehicle at 180° on Static Rollover Device	A-40
76	Vehicle at 270° on Static Rollover Device	A-40
77	Vehicle at 360° on Static Rollover Device	A-41
78	2017 Subaru Legacy 2.5i/JAB Frontal Impact Event	A-41
79	Monroney Label Photograph	A-42

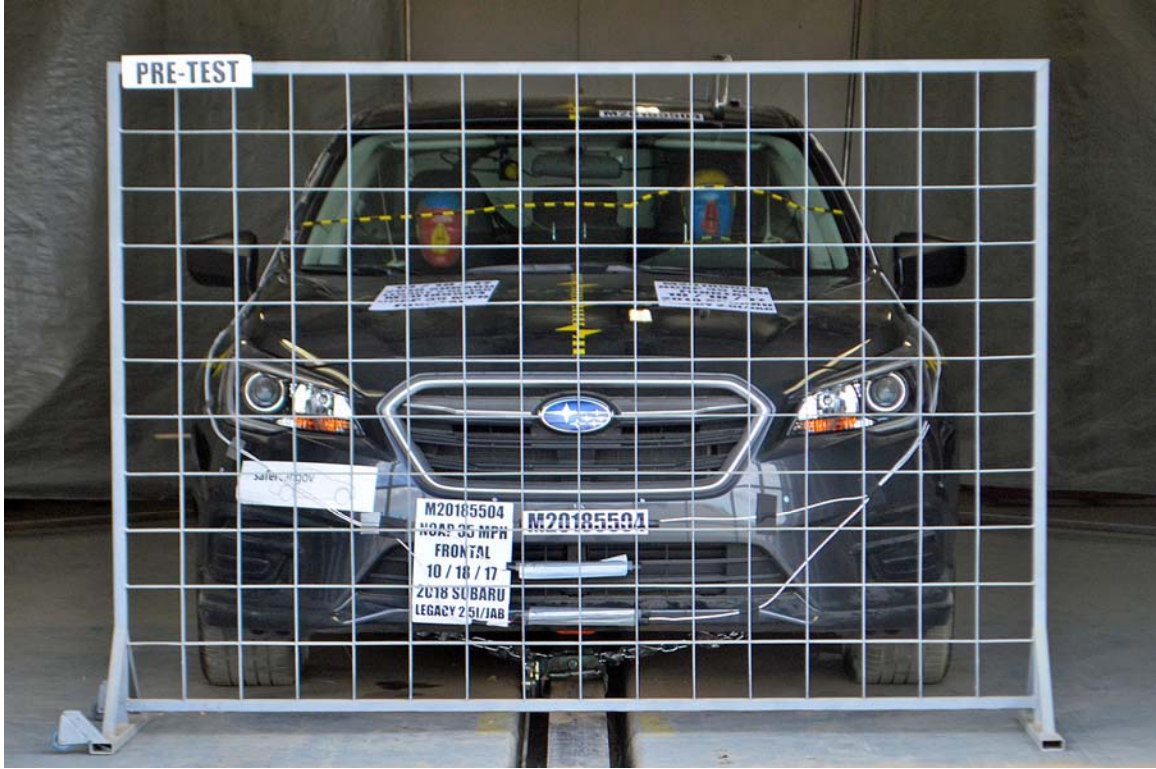

FIGURE 1. Load Cell Location



FIGURE 2. Pre-Test Load Cell Wall

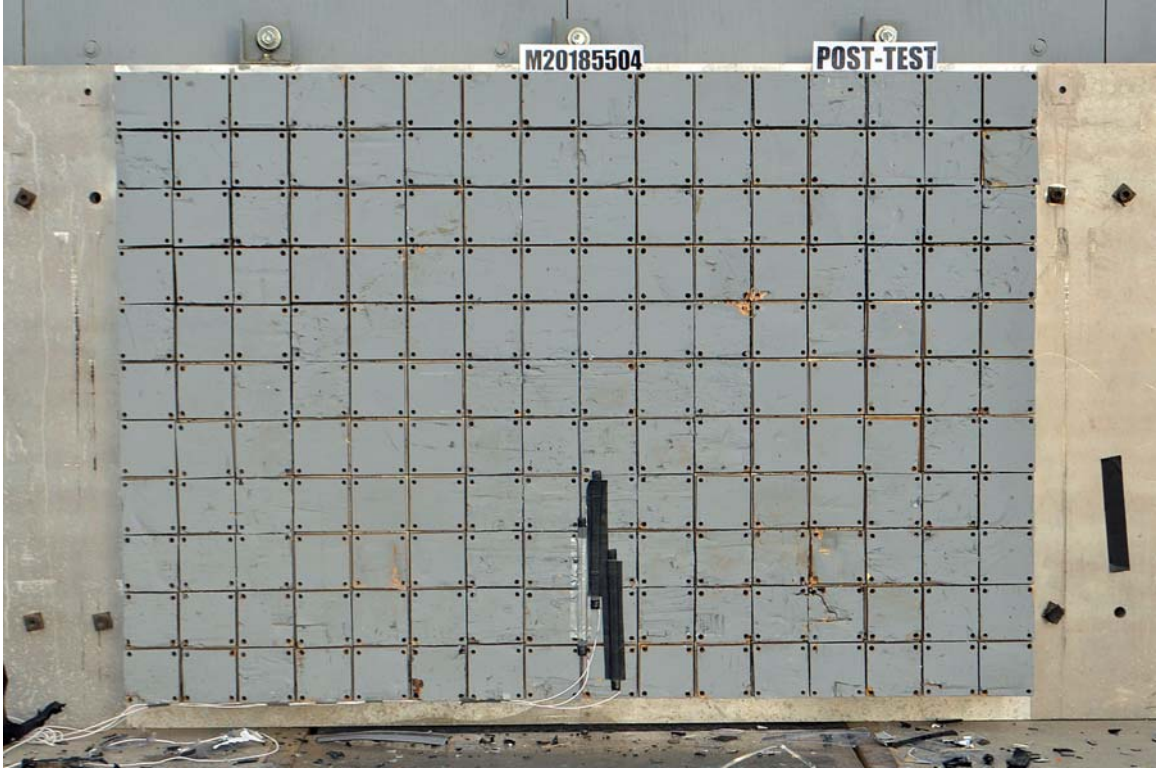

FIGURE 3. Post-Test Load Cell Wall



FIGURE 4. Manufacturer's Label

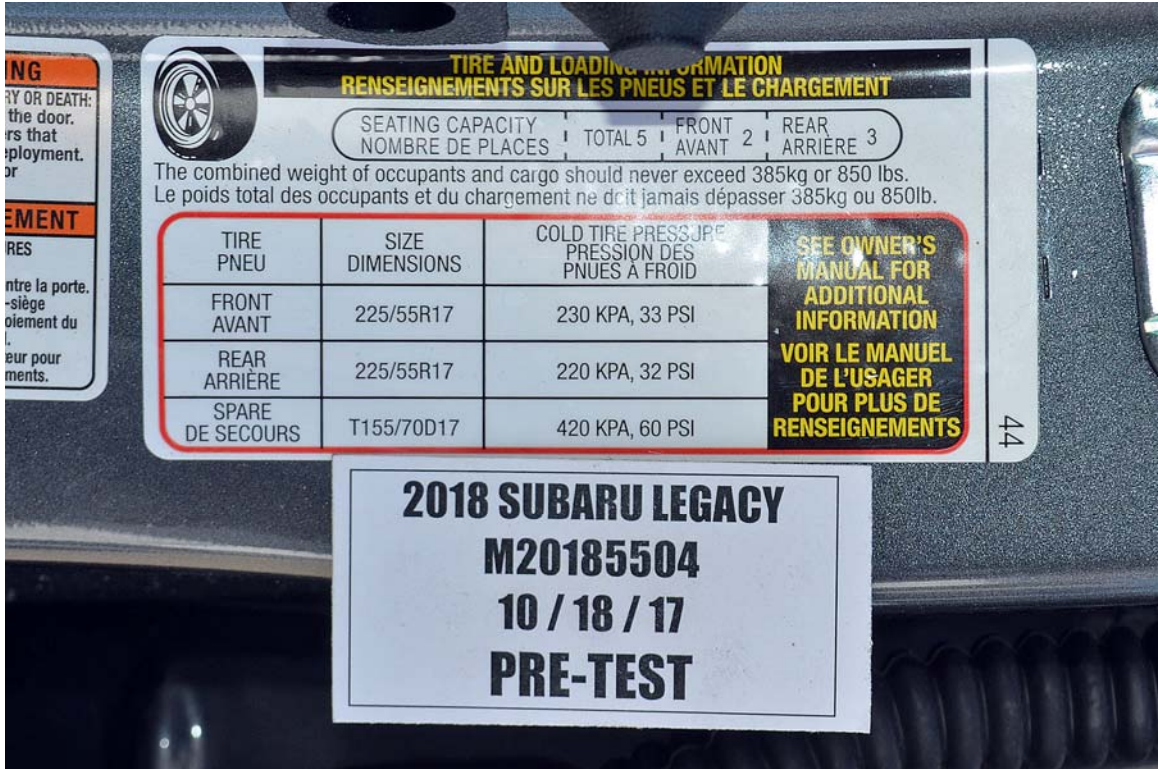

FIGURE 5. Tire Placard



FIGURE 6. 2018 Subaru Legacy 2.5i/JAB Frontal as Delivered



FIGURE 7. Left Rear $\frac{3}{4}$ View, as Received



FIGURE 8. Pre-Test Front View of Test Vehicle



FIGURE 9. Post-Test Front View of Test Vehicle



FIGURE 10. Pre-Test Left View of Test Vehicle



FIGURE 11. Post-Test Left View of Test Vehicle



FIGURE 12. Pre-Test Right View of Test Vehicle



FIGURE 13. Post-Test Right View of Test Vehicle



FIGURE 14. Pre-Test Right Front 3/4 View



FIGURE 15. Post-Test Right Front $\frac{3}{4}$ View



FIGURE 16. Pre-Test Left Rear $\frac{3}{4}$ View



FIGURE 17. Post-Test Left Rear $\frac{3}{4}$ View



FIGURE 18. Pre-Test Windshield View



FIGURE 19. Post-Test Windshield View



FIGURE 20. Pre-Test Engine Compartment View



FIGURE 21. Post-Test Engine Compartment View



FIGURE 22. Pre-Test Fuel Filler Cap View



FIGURE 23. Post-Test Fuel Filler Cap View

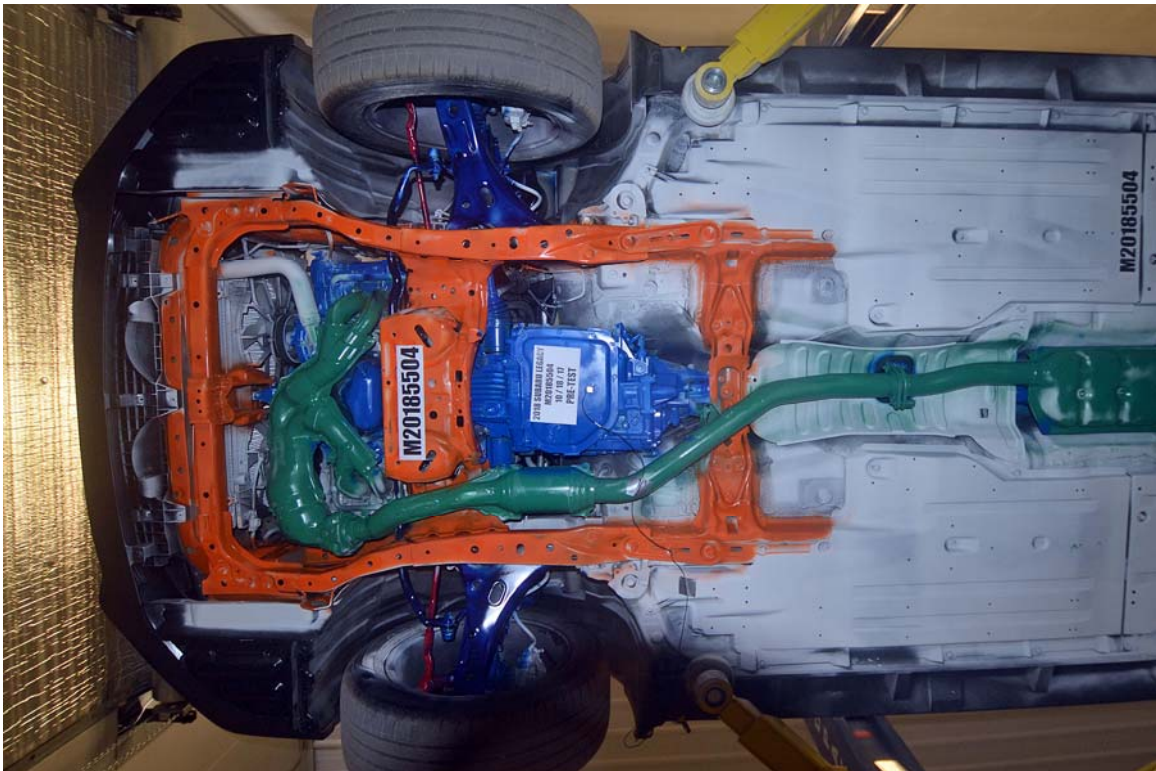

FIGURE 24. Pre-Test Front Underbody View



FIGURE 25. Post-Test Front Underbody View

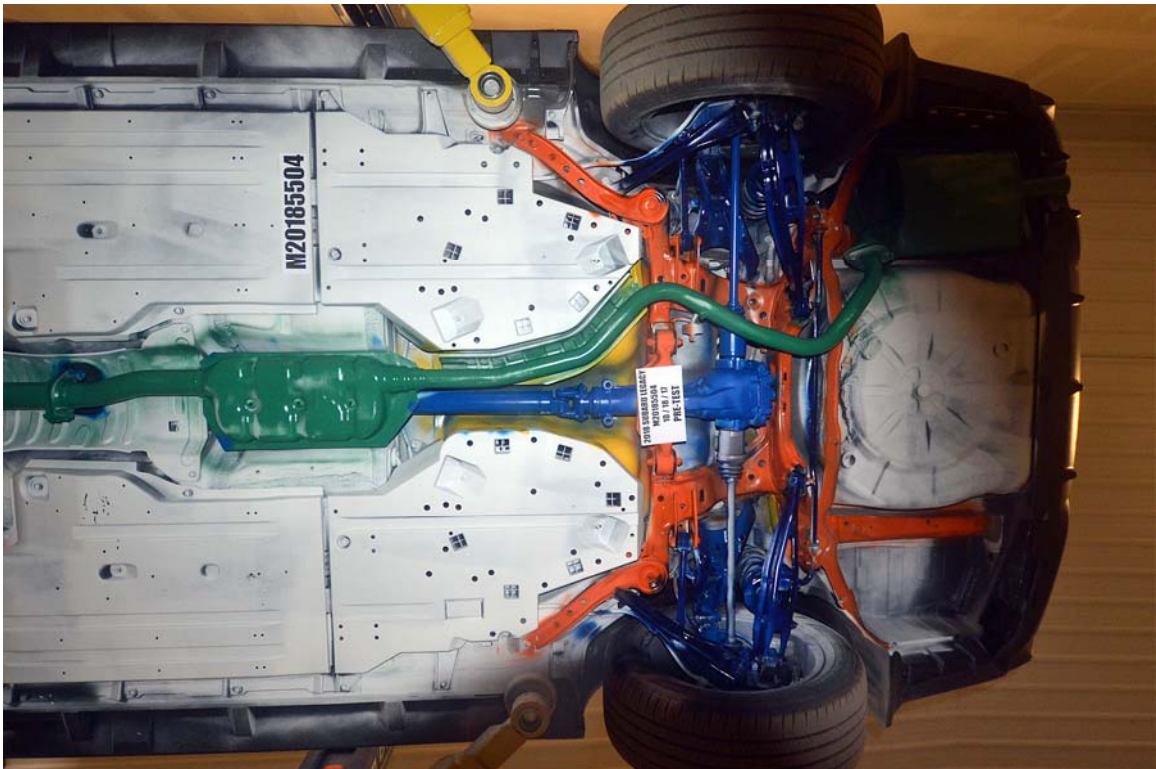

FIGURE 26. Pre-Test Rear Underbody View

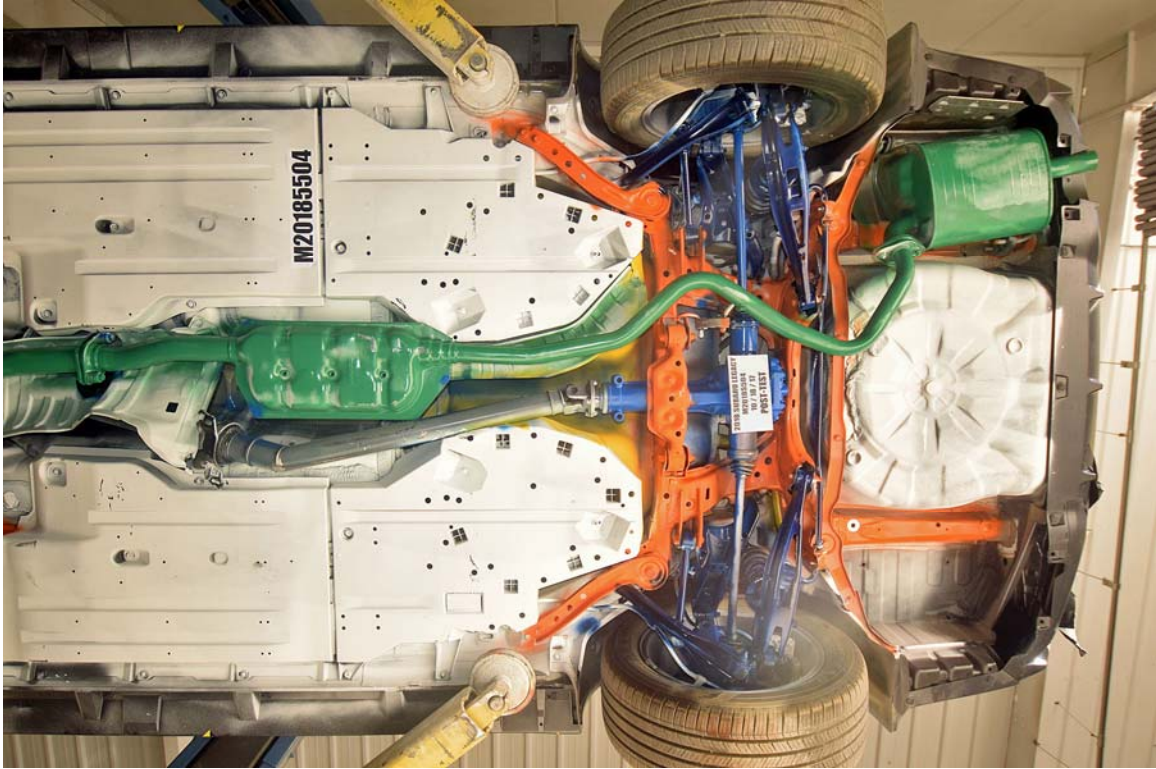

FIGURE 27. Post-Test Rear Underbody View



FIGURE 28. Pre-Test Dummy Cable Routing



FIGURE 29. Post-Test Dummy Cable Routing



FIGURE 30. Pre-Test Driver Dummy Front View



FIGURE 31. Post-Test Driver Dummy Front View



FIGURE 32. Pre-Test Driver Dummy Window View



FIGURE 33. Post-Test Driver Dummy Window View



FIGURE 34. Pre-Test Driver Dummy and Vehicle Interior View



FIGURE 35. Post-Test Driver Dummy and Vehicle Interior View



FIGURE 36. Pre-Test Driver's Seat Fore-Aft Markings



FIGURE 37. Post-Test Driver's Seat Fore-Aft Markings



FIGURE 38. Pre-Test View of Belt Anchorage for Driver Dummy



FIGURE 39. Post-Test View of Belt Anchorage for Driver Dummy



FIGURE 40. Pre-Test Driver Dummy Feet



FIGURE 41. Post-Test Driver Dummy Feet



FIGURE 42. Pre-Test Driver's Side Knee Bolster



FIGURE 43. Post-Test Driver's Side Knee Bolster



FIGURE 44. Pre-Test Driver's Side Floorpan



FIGURE 45. Post-Test Driver's Side Floorpan



FIGURE 46. Post-Test Driver Dummy Face



FIGURE 47. Post-Test Driver Dummy Contact with Airbag



FIGURE 48. Post-Test Driver Dummy Contact with Headrest



FIGURE 48a. Post-Test Driver Dummy Contact with Steering Column



FIGURE 48b. Post-Test Driver Dummy Contact with Knee Bolster



FIGURE 49. Pre-Test View of the Steering Wheel



FIGURE 50. Post-Test View of the Steering Wheel



FIGURE 51. Pre-Test Passenger Dummy Front View



FIGURE 52. Post-Test Passenger Dummy Front View



FIGURE 53. Pre-Test Passenger Dummy Window View



FIGURE 54. Post-Test Passenger Dummy Window View



FIGURE 55. Pre-Test Passenger Dummy and Vehicle Interior View



FIGURE 56. Post-Test Passenger Dummy and Vehicle Interior View



FIGURE 57. Pre-Test Passenger's Seat Fore-Aft Markings



FIGURE 58. Post-Test Passenger's Seat Fore-Aft Markings



FIGURE 59. Pre-Test View of Belt Anchorage for Passenger Dummy



FIGURE 60. Post-Test View of Belt Anchorage for Passenger Dummy



FIGURE 61. Pre-Test Passenger Dummy Feet



FIGURE 62. Post-Test Passenger Dummy Feet



FIGURE 63. Pre-Test Passenger's Side Knee Bolster



FIGURE 64. Post-Test Passenger's Side Knee Bolster



FIGURE 65. Pre-Test Passenger's Side Floorpan



FIGURE 66. Post-Test Passenger's Side Floorpan



FIGURE 67. Post-Test Passenger Dummy Face



FIGURE 68. Post-Test Passenger Dummy Contact with Airbag



FIGURE 69. Post-Test Passenger Dummy Contact with Sun Visor



FIGURE 69a. Post-Test Passenger Dummy Contact with Headrest



FIGURE 69b. Post-Test Passenger Dummy Contact with Knee Bolster



FIGURE 70. Photograph of Ballast Installed in Vehicle

Photograph Not Applicable

No Stoddard Solvent Spillage

FIGURE 71. Post-Test Stoddard Solvent Spillage Location View



FIGURE 72. Post-Test Speed Trap Read-Out



FIGURE 73. Vehicle at 0° on Static Rollover Device



FIGURE 74. Vehicle at 90° on Static Rollover Device



FIGURE 75. Vehicle at 180° on Static Rollover Device

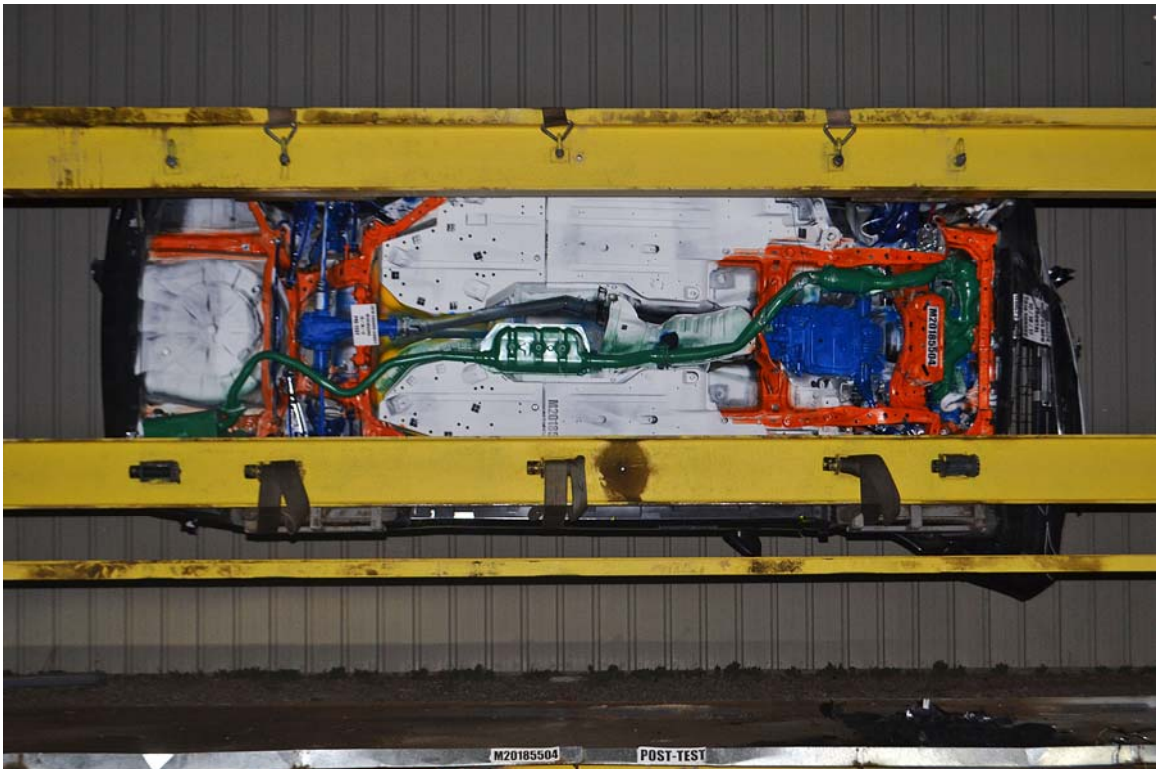

FIGURE 76. Vehicle at 270° on Static Rollover Device



FIGURE 77. Vehicle at 360° on Static Rollover Device



FIGURE 78. 2018 Subaru Legacy 2.5i/JAB Frontal Impact Event

LEGACY

VIN: 4S3BNAB64J3007745
 Model/Code: 2018 SUBARU LEGACY 2.0I J48
 Port/Assembly: LAFAYETTE, IN
 Deliver by/Carrier: TRUCK, 402

SHIP TO: 401289
 KENOSHA SUBARU
 7900 120TH AVE
 KENOSHA, WI 53142

SOLD TO: 401289
 KENOSHA SUBARU
 7900 120TH AVE
 KENOSHA, WI 53142

GOVERNMENT 5-STAR SAFETY RATINGS

Overall Vehicle Score Not Rated
Based on the combined ratings of frontal, side and rollover. Should ONLY be compared to other vehicles of similar size and weight.

Crash	Driver Passenger	Not Rated
Frontal	Not Rated	Not Rated
Side	★★★★★	★★★★★
Rollover	★★★★★	★★★★★

Star ratings range from 1 to 5 stars (★★★★★) with 5 being the highest.
Source: National Highway Traffic Safety Administration (NHTSA) www.safercar.gov or 1-888-327-4236

Protect Your Investment

Subaru Added Security®
The Only Standard Service Agreement Backed By Subaru

- Protection designed to fit your driving needs, up to 7 years/100,000 miles of coverage
- Maintenance plans also available
- We use Genuine Subaru replacement parts - on the best
- We use technicians trained by Subaru - those who know your vehicle best
- Towing, rental and trip interruption benefits available
- Transferable to the next owner
- Ask your sales representative for more details

Accept nothing less than Added Security®

STANDARD EQUIPMENT

SAFETY
 Symmetrical All-Wheel Drive (AWD)
 Vehicle Dynamics Control (VDC)
 Anti-Lock Brakes (ABS)
 4-Wheel Disc Brakes with Brake Assist
 Rear Vision Camera
 Subaru Advanced Frontal Airbag System
 First Seat Cushion Airbags
 Side Curtain Airbags with Rollover Sensor and Seat Side Airbags
 3-Point Seatbelts with Front Pretensioners
 LATCH System for Child Safety Seats
 Anti-Theft Alarm & Immobilizer System
 Brake Override System
 Daytime Running Lights
 Electronic Brake-Force Distribution
 Whiplash Protection Front Seats

PERFORMANCE AND EXTERIOR
 2.5L DOHC 4 Cylinder Boxer Engine
 Lineartronic CVT with 6-Speed Manual Mode
 Active Torque Vectoring
 Front McPherson Strut Suspension
 Rear Double-Wishbone Suspension
 Auto Lights with Welcoming Lighting
 Electric Power-Assisted Steering
 Folding Exterior Mirrors

COMFORT, CONVENIENCE & INTERIOR
 6.5" Multimedia System with Hi-Resolution Touch Screen
 Bluetooth Hands-Free Phone Connectivity
 Apple CarPlay® & Android Auto, Aha, Pandora
 Car-Fi Music Restoration Technology
 USB Port with iPod & iPhone Connectivity
 Air Conditioning with Air Filtration System
 Retained Accessory Power for Audio System & Power Windows
 Auto-Up/Down Front Driver's Window
 Remote Keyless Entry, Power Locks & Mirrors
 60/40 Split Fold-Down Rear Seatback
 Tilt/Telescopic Steering Wheel with Cruise Control
 Variable Intermittent Windshield Wipers
 Height Adjustable Driver's Seat
 Carpeted Floor Mats & Cargo Area Mat
 Automatic Power Door Locks (Speed Activated)

LIMITED WARRANTY/ROADSIDE ASSISTANCE
 3 years / 36,000 Miles Basic
 5 years / 60,000 Miles Powertrain
 5 yrs/Unlimited Mileage Rust Perforation
 3 yrs / 36,000 24/7 Roadside Assistance
 See Owner Info Kit/Warranty For Details

OPTIONAL EQUIPMENT AND OTHER ITEMS

Manufacturer's Suggested Retail Price	\$22,195.00
Exterior Color: Magnetite Gray Metallic	
Full Tank of Gas	INCLD
Option Package: 02	
ALLOY WHEEL PKG SUGGESTED VALUE	\$715.00
17-Inch Alloy Wheels w/ Machine Finish	
ALLOY WHEEL PACKAGE DISCOUNT	-\$365.00
ALLOY WHEEL PACKAGE PRICE	\$350.00
Splash Guards	\$164.00
Rear Bumper Applique	\$102.00
All Weather Floor Mats	\$101.00
Cargo Tray	\$95.00
Rear Cargo Net	\$72.00

EPA DOT Fuel Economy and Environment

Fuel Economy MIDSIZE cars range from 13 to 136 MPG. The best vehicle rates 136 MPG.

29 MPG	25	34
combined city/hwy	city	highway
3.4		
gallons per 100 miles		

You save \$500 in fuel costs over 5 years compared to the average new vehicle.

Annual fuel cost \$1,250

Fuel Economy & Greenhouse Gas Rating (EPA only) Smog Rating (EPA only)

This vehicle emits 311 grams CO₂ per mile. The best emits 0 grams per mile (tailpipe only). Producing and distributing fuel also creates emissions. Learn more at fuelconomy.gov.

Actual results will vary for many reasons, including driving conditions and how you drive and maintain your vehicle. The average new vehicle gets 27 MPG and costs \$6,750 to fuel over 5 years. Cost estimates are based on 15,000 miles per year at \$2.40 per gallon. MPG is miles per gallon equivalent. Vehicle emissions are a significant cause of climate change and smog.

fuelconomy.gov
Calculate personalized estimates and compare vehicles

PARTS CONTENT INFORMATION

FOR VEHICLES IN THIS COUNTRY:	FOR THIS VEHICLE:
U.S./CANADIAN PARTS CONTENT: 45%	FINAL ASSEMBLY POINT: Lafayette, IN
MAJOR SOURCES OF FOREIGN PARTS CONTENT: JAPAN: 40%	COUNTRY OF ORIGIN: ENGINE: JAPAN
	TRANSMISSION: JAPAN

Note: Parts content does not include final assembly, distribution, or other non-parts costs.

Destination and Delivery \$860.00
Total Suggested Retail Price \$23,939.00

This price does not include any government or Federal taxes. MSRP does not include dealer fees from the dealership to the ultimate purchaser.

FIGURE 79. Monroney Label Photograph

APPENDIX B
DUMMY RESPONSE DATA TRACES

TABLE OF DATA PLOTS

<u>Plot</u>		<u>Page</u>
1	Driver Head Acceleration X Primary	B-1
2	Driver Head Acceleration Y Primary	B-1
3	Driver Head Acceleration Z Primary	B-1
4	Driver Head Resultant Acceleration Primary	B-1
5	Driver Chest X Deflection	B-2
6	Driver Chest Acceleration X Primary	B-3
7	Driver Chest Acceleration Y Primary	B-3
8	Driver Chest Acceleration Z Primary	B-3
9	Driver Chest Resultant Acceleration Primary	B-3
10	Driver Upper Neck Force X	B-4
11	Driver Upper Neck Force Z	B-4
12	Driver Upper Neck Moment Y	B-4
13	Driver Nij	B-4
14	Driver Left Femur Force Z	B-5
15	Driver Right Femur Force Z	B-5
16	Passenger Head Acceleration X Primary	B-6
17	Passenger Head Acceleration Y Primary	B-6
18	Passenger Head Acceleration Z Primary	B-6
19	Passenger Head Resultant Acceleration Primary	B-6
20	Passenger Chest X Deflection	B-7
21	Passenger Chest Acceleration X Primary	B-8
22	Passenger Chest Acceleration Y Primary	B-8
23	Passenger Chest Acceleration Z Primary	B-8
24	Passenger Chest Resultant Acceleration Primary	B-8
25	Passenger Upper Neck Force X	B-9
26	Passenger Upper Neck Force Z	B-9
27	Passenger Upper Neck Moment Y	B-9
28	Passenger Nij	B-9
29	Passenger Left Femur Force Z	B-10
30	Passenger Right Femur Force Z	B-10

The following additional dummy and vehicle response data can be found in the R&D section of the NHTSA website at www.nhtsa.dot.gov

Driver Head X Acceleration Redundant
Driver Head Y Acceleration Redundant
Driver Head Z Acceleration Redundant
Driver Upper Neck Force Y
Driver Upper Neck Moment X
Driver Upper Neck Moment Z
Driver Chest X Acceleration Redundant
Driver Chest Y Acceleration Redundant
Driver Chest Z Acceleration Redundant
Driver Pelvis X
Driver Pelvis Y
Driver Pelvis Z
Driver Left Femur Force Z Redundant
Driver Right Femur Force Z Redundant
Driver Left Upper Tibia Moment X
Driver Left Upper Tibia Moment Y
Driver Left Upper Tibia Force Z
Driver Left Lower Tibia Moment X
Driver Left Lower Tibia Moment Y
Driver Left Lower Tibia Force Z
Driver Right Upper Tibia Moment X
Driver Right Upper Tibia Moment Y
Driver Right Upper Tibia Force Z
Driver Right Lower Tibia Moment X
Driver Right Lower Tibia Moment Y
Driver Right Lower Tibia Force Z
Driver Left Foot Fore Z
Driver Left Foot Aft X
Driver Left Foot Aft Z
Driver Right Foot Fore Z
Driver Right Foot Aft X
Driver Right Foot Aft Z
Driver Shoulder Belt Force
Driver Lap Belt Force
Passenger Head X Acceleration Redundant
Passenger Head Y Acceleration Redundant
Passenger Head Z Acceleration Redundant
Passenger Upper Neck Force X
Passenger Upper Neck Force Z
Passenger Upper Neck Moment Y
Passenger Chest X Acceleration Redundant
Passenger Chest Y Acceleration Redundant
Passenger Chest Z Acceleration Redundant

Passenger Pelvis X
Passenger Pelvis Y
Passenger Pelvis Z
Passenger Left Femur Force Redundant
Passenger Right Femur Force Redundant
Passenger Left Upper Tibia Moment X
Passenger Left Upper Tibia Moment Y
Passenger Left Upper Tibia Force Z
Passenger Left Lower Tibia Moment X
Passenger Left Lower Tibia Moment Y
Passenger Left Lower Tibia Force Z
Passenger Right Upper Tibia Moment X
Passenger Right Upper Tibia Moment Y
Passenger Right Upper Tibia Force Z
Passenger Right Lower Tibia Moment X
Passenger Right Lower Tibia Moment Y
Passenger Right Lower Tibia Force Z
Passenger Left Foot Fore Z
Passenger Left Foot Aft X
Passenger Left Foot Aft Z
Passenger Right Foot Fore Z
Passenger Right Foot Aft X
Passenger Right Foot Aft Z
Passenger Shoulder Belt Force
Passenger Lap Belt Force
Left Rear Seat Crossmember X
Left Rear Seat Crossmember Z
Right Rear Seat Crossmember X
Right Rear Seat Crossmember Z
Left Rear Seat Crossmember X Redundant
Right Rear Seat Crossmember X Redundant
Vehicle Engine Top X
Vehicle Engine Bottom X
Load Cell Barrier Forces and Moments

Test Vehicle: 2018 Subaru Legacy 2.5I /JAB 4-Door Sedan
 Test Program: 56 km/h Frontal Impact NCAP Test

NHTSA No.: M20185504
 Test Date: 10/18/17

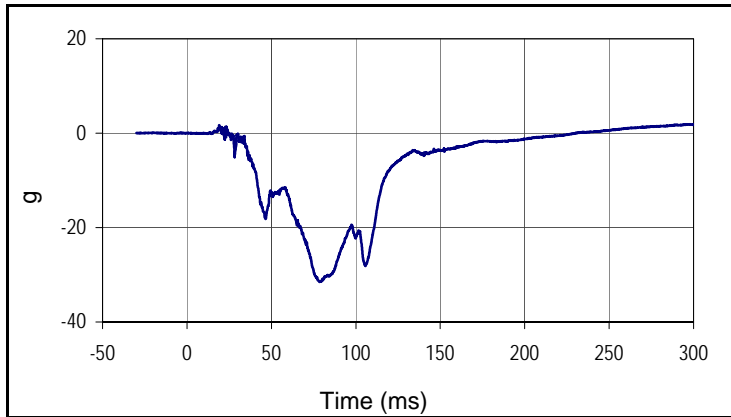

Curve Description			
Driver Head Acceleration X Primary			
Plot No.		SAE Class	Units
001		1000	g
Max	Time	Min	Time
1.9	295.0	-31.5	78.5

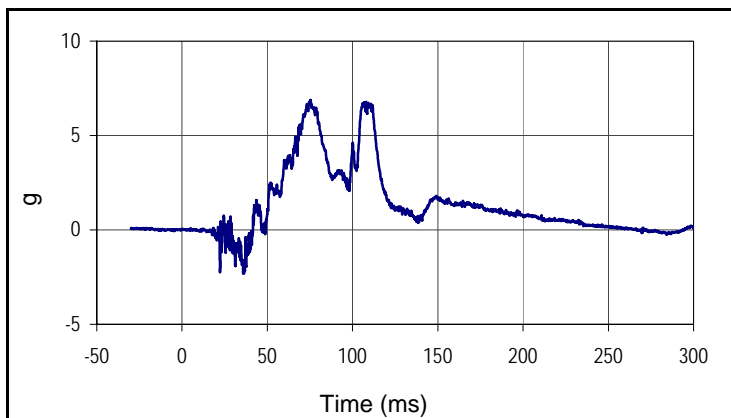

Curve Description			
Driver Head Acceleration Y Primary			
Plot No.		SAE Class	Units
002		1000	g
Max	Time	Min	Time
6.9	75.4	-2.3	35.9

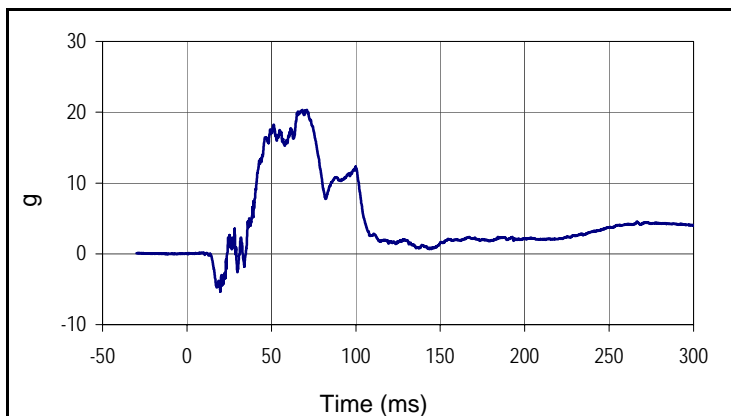

Curve Description			
Driver Head Acceleration Z Primary			
Plot No.		SAE Class	Units
003		1000	g
Max	Time	Min	Time
20.3	70.9	-5.3	19.8

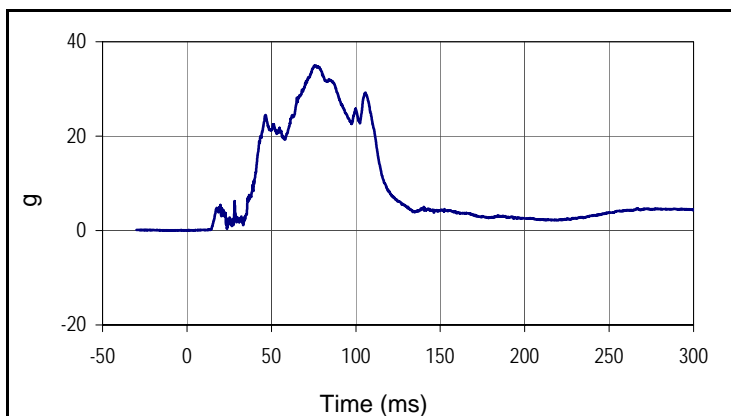

Curve Description			
Driver Head Resultant Acceleration Primary			
Plot No.		SAE Class	Units
004		1000	g
Max	Time	Min	Time
35.0	76.1	0.0	3.6

Test Vehicle: 2018 Subaru Legacy 2.5I /JAB 4-Door Sedan

NHTSA No.: M20185504

Test Program: 56 km/h Frontal Impact NCAP Test

Test Date: 10/18/17

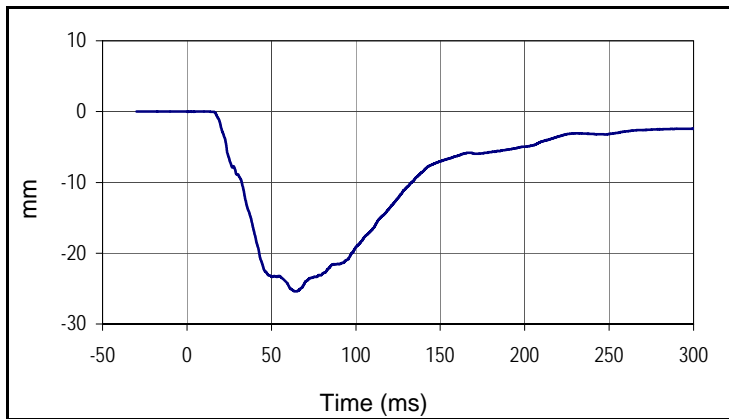

Curve Description			
Driver Chest Deflection			
Plot No.		SAE Class	Units
005		600	mm
Max	Time	Min	Time
0.0	12.8	-25.4	64.0

Test Vehicle: 2018 Subaru Legacy 2.5I /JAB 4-Door Sedan
 Test Program: 56 km/h Frontal Impact NCAP Test

NHTSA No.: M20185504
 Test Date: 10/18/17

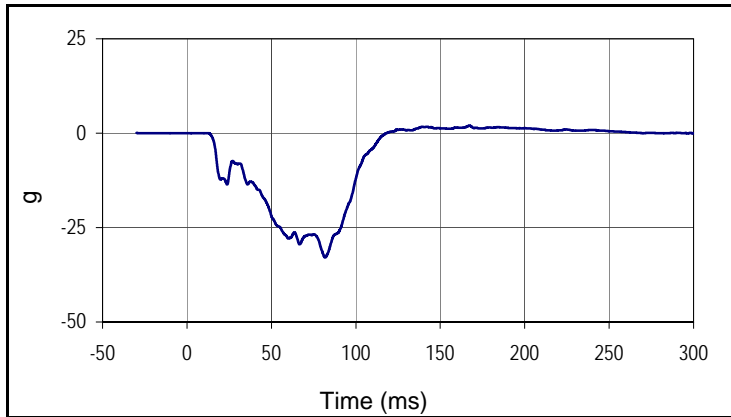

Curve Description			
Driver Chest Acceleration X Primary			
Plot No.		SAE Class	Units
006		180	g
Max	Time	Min	Time
2.0	167.4	-32.9	81.8

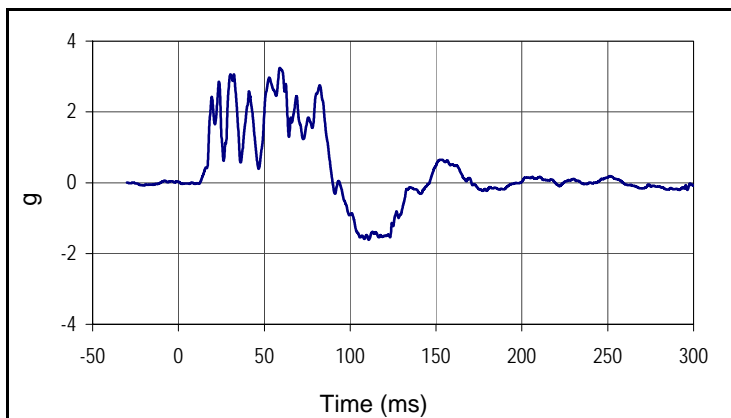

Curve Description			
Driver Chest Acceleration Y Primary			
Plot No.		SAE Class	Units
007		180	g
Max	Time	Min	Time
3.2	59.1	-1.6	110.9

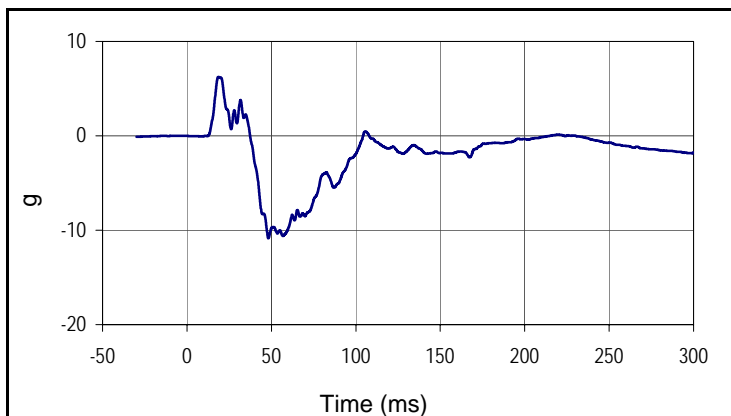

Curve Description			
Driver Chest Acceleration Z Primary			
Plot No.		SAE Class	Units
008		180	g
Max	Time	Min	Time
6.2	18.7	-10.9	48.2

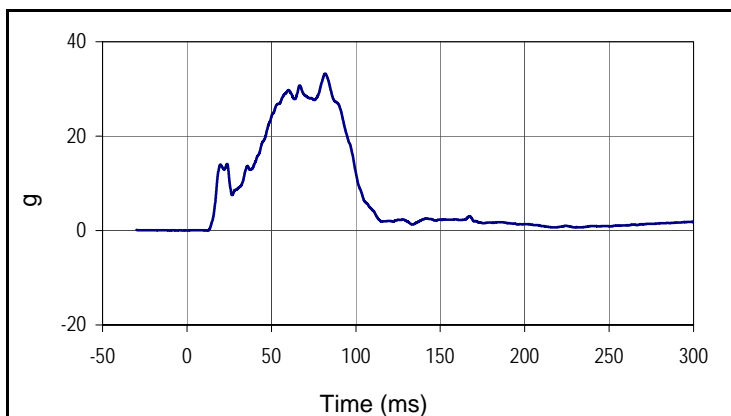

Curve Description			
Driver Chest Resultant Acceleration Primary			
Plot No.		SAE Class	Units
009		180	g
Max	Time	Min	Time
33.2	81.8	0.0	12.6

Test Vehicle: 2018 Subaru Legacy 2.5I /JAB 4-Door Sedan
 Test Program: 56 km/h Frontal Impact NCAP Test

NHTSA No.: M20185504
 Test Date: 10/18/17

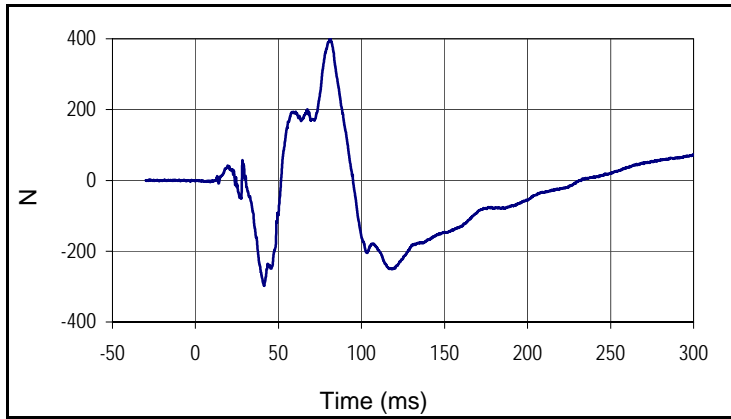

Curve Description			
Driver Upper Neck Force X			
Plot No.		SAE Class	Units
010		1000	N
Max	Time	Min	Time
399.6	81.2	-297.9	41.3

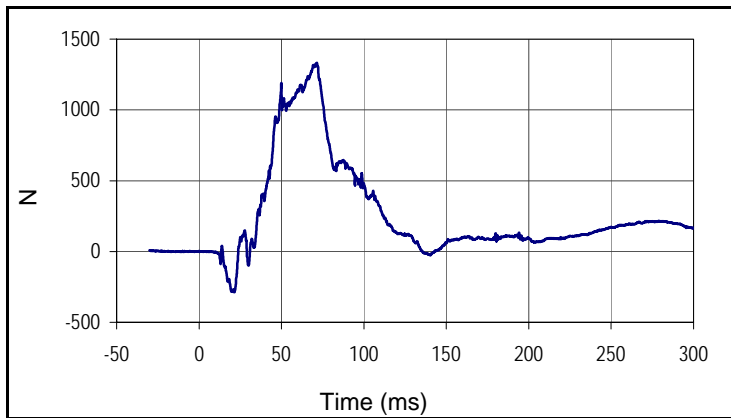

Curve Description			
Driver Upper Neck Force Z			
Plot No.		SAE Class	Units
011		1000	N
Max	Time	Min	Time
1333.0	71.5	-288.2	21.5

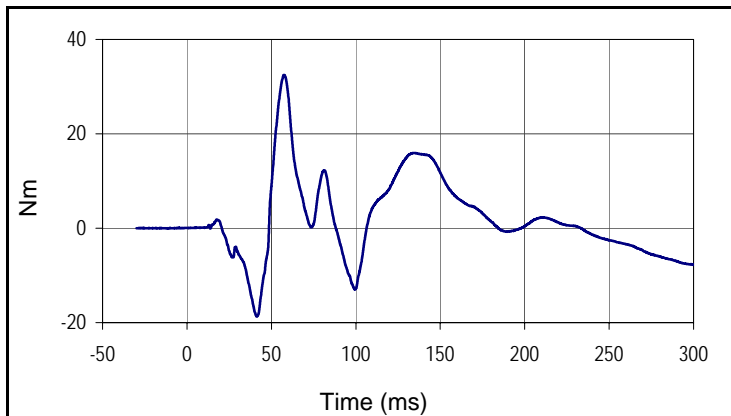

Curve Description			
Driver Upper Neck Moment Y			
Plot No.		SAE Class	Units
012		600	Nm
Max	Time	Min	Time
32.5	57.5	-18.7	41.3

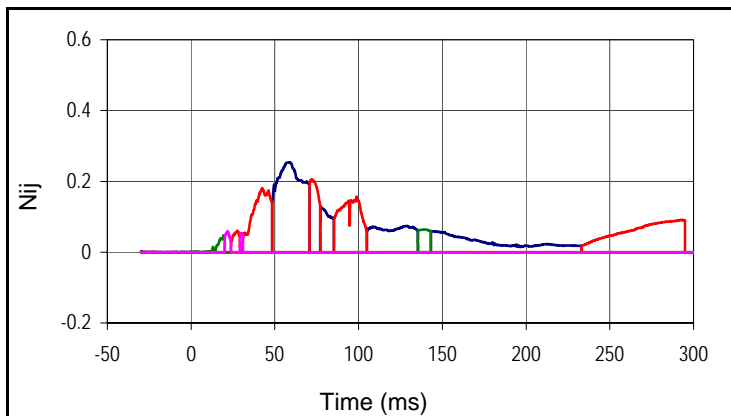

Curve Description		
Driver Nij		
Units	Max	Time
Ntf	0.25	58.9
Units	Max	Time
Nte	0.21	72.2
Units	Max	Time
Ncf	0.06	140.2
Units	Max	Time
Nce	0.06	21.8

Test Vehicle: 2018 Subaru Legacy 2.5I /JAB 4-Door Sedan
 Test Program: 56 km/h Frontal Impact NCAP Test

NHTSA No.: M20185504
 Test Date: 10/18/17

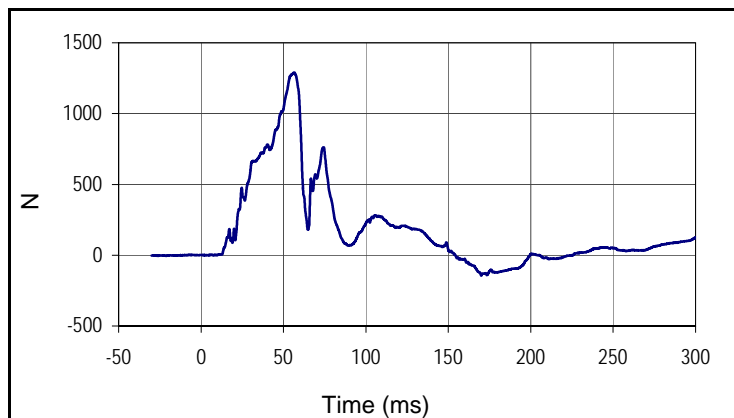

Curve Description			
Driver Left Femur Force Z			
Plot No.		SAE Class	Units
014		600	N
Max	Time	Min	Time
1290.8	56.6	-143.2	170.0

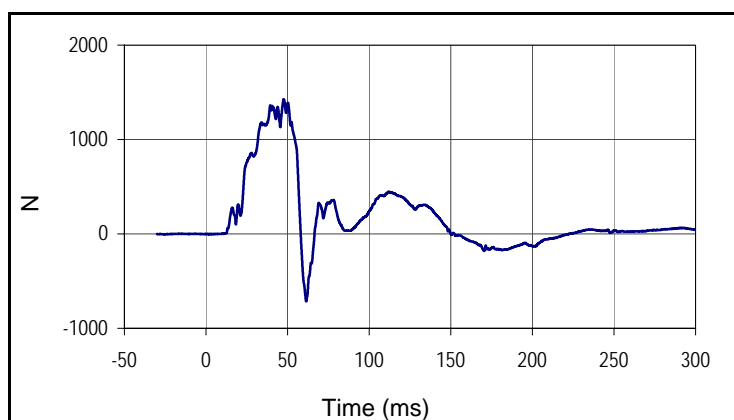

Curve Description			
Driver Right Femur Force Z			
Plot No.		SAE Class	Units
015		600	N
Max	Time	Min	Time
1426.4	47.7	-715.5	61.4

Test Vehicle: 2018 Subaru Legacy 2.5I /JAB 4-Door Sedan
 Test Program: 56 km/h Frontal Impact NCAP Test

NHTSA No.: M20185504
 Test Date: 10/18/17

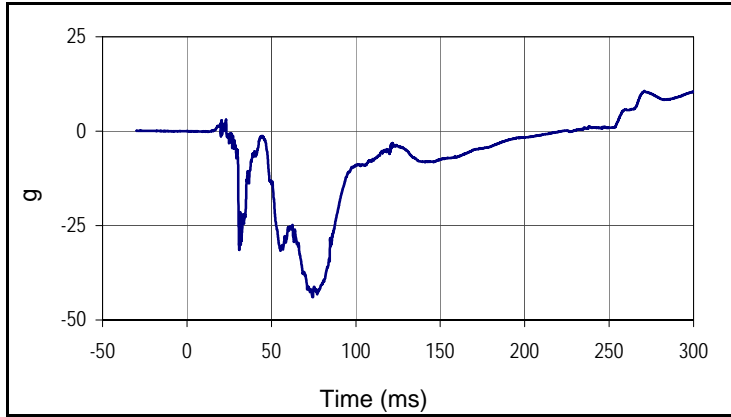

Curve Description			
Passenger Head Acceleration X Primary			
Plot No.		SAE Class	Units
016		1000	g
Max	Time	Min	Time
10.6	270.9	-44.0	74.5

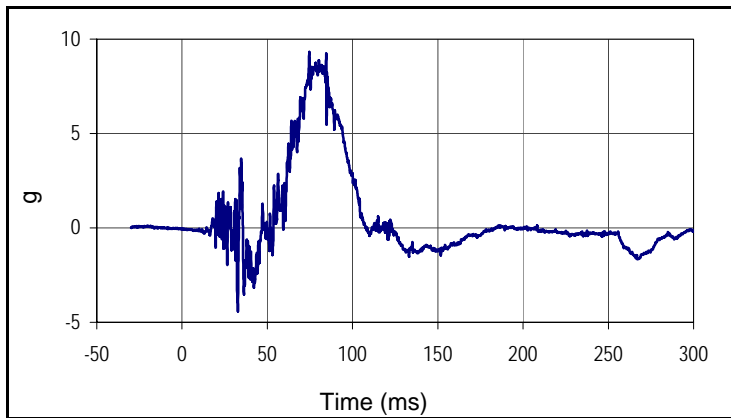

Curve Description			
Passenger Head Acceleration Y Primary			
Plot No.		SAE Class	Units
017		1000	g
Max	Time	Min	Time
9.3	74.7	-4.4	32.7

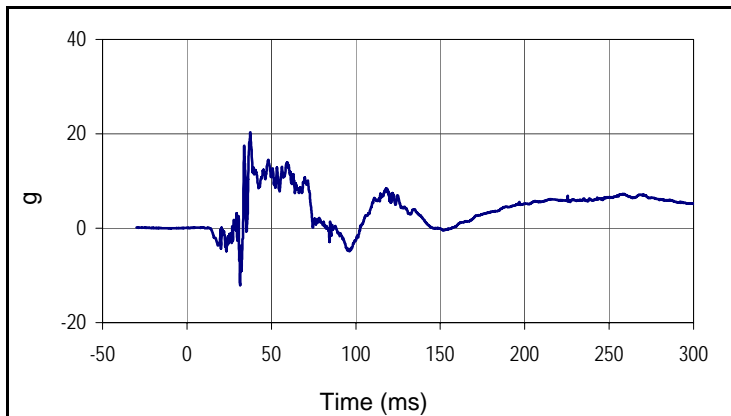

Curve Description			
Passenger Head Acceleration Z Primary			
Plot No.		SAE Class	Units
018		1000	g
Max	Time	Min	Time
20.4	37.5	-12.1	31.4

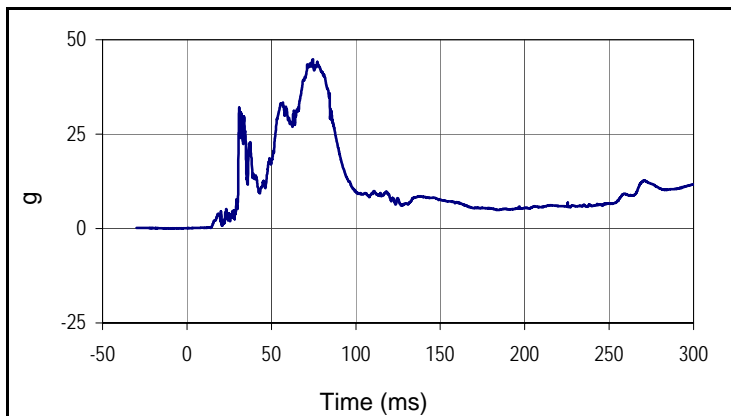

Curve Description			
Passenger Head Resultant Acceleration Primary			
Plot No.		SAE Class	Units
019		1000	g
Max	Time	Min	Time
44.8	74.5	0.0	0.8

Test Vehicle: 2018 Subaru Legacy 2.5I /JAB 4-Door Sedan

NHTSA No.: M20185504

Test Program: 56 km/h Frontal Impact NCAP Test

Test Date: 10/18/17

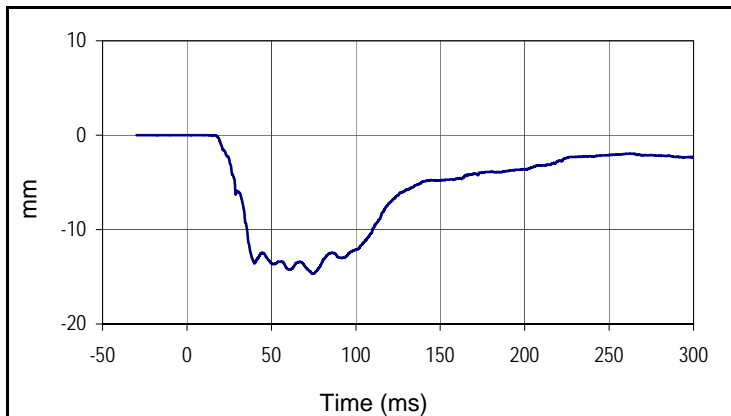

Curve Description			
Passenger Chest Deflection			
Plot No.		SAE Class	Units
020		600	mm
Max	Time	Min	Time
0.0	16.3	-14.7	74.2

Test Vehicle: 2018 Subaru Legacy 2.5I /JAB 4-Door Sedan
 Test Program: 56 km/h Frontal Impact NCAP Test

NHTSA No.: M20185504
 Test Date: 10/18/17

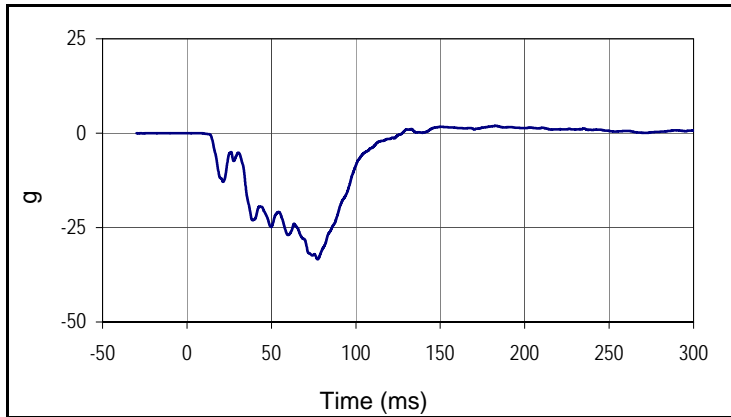

Curve Description			
Passenger Chest Acceleration X Primary			
Plot No.		SAE Class	Units
021		180	g
Max	Time	Min	Time
1.9	182.9	-33.4	77.4

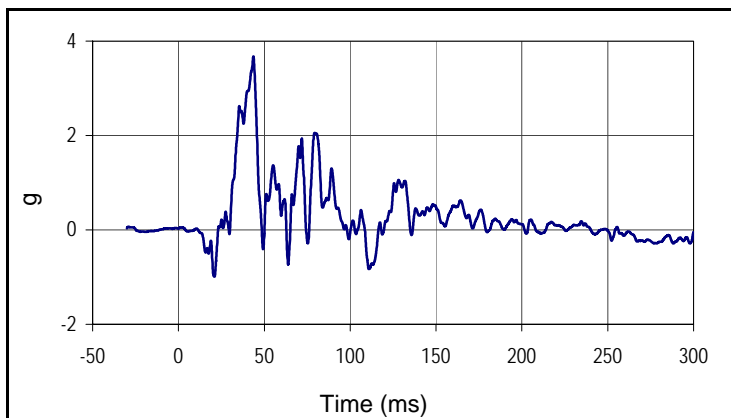

Curve Description			
Passenger Chest Acceleration Y Primary			
Plot No.		SAE Class	Units
022		180	g
Max	Time	Min	Time
3.7	43.6	-1.0	21.0

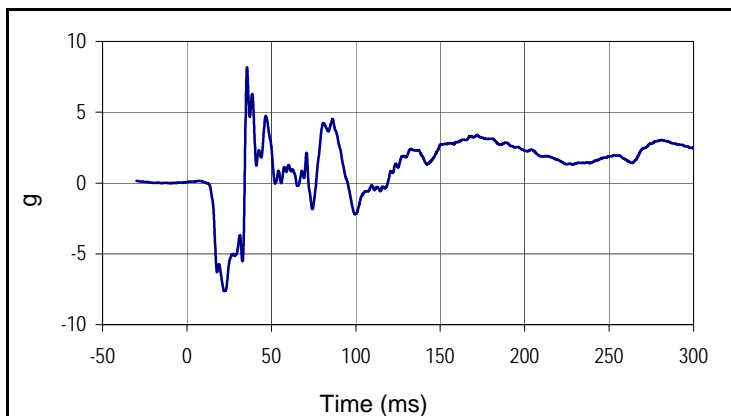

Curve Description			
Passenger Chest Acceleration Z Primary			
Plot No.		SAE Class	Units
023		180	g
Max	Time	Min	Time
8.2	35.6	-7.6	22.2

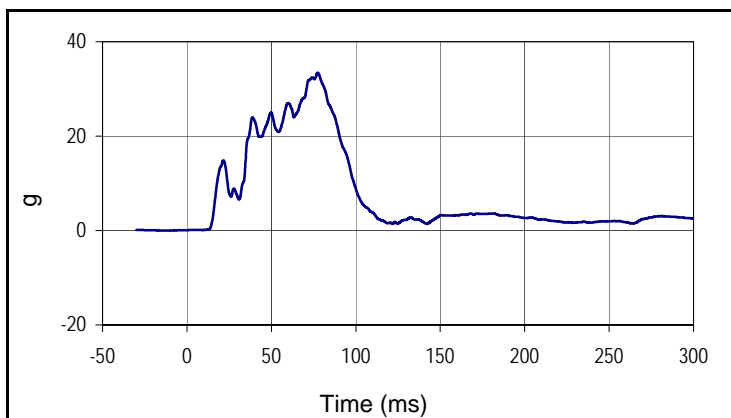

Curve Description			
Passenger Chest Resultant Acceleration Primary			
Plot No.		SAE Class	Units
024		180	g
Max	Time	Min	Time
33.4	77.5	0.1	0.0

Test Vehicle: 2018 Subaru Legacy 2.5I /JAB 4-Door Sedan
 Test Program: 56 km/h Frontal Impact NCAP Test

NHTSA No.: M20185504
 Test Date: 10/18/17

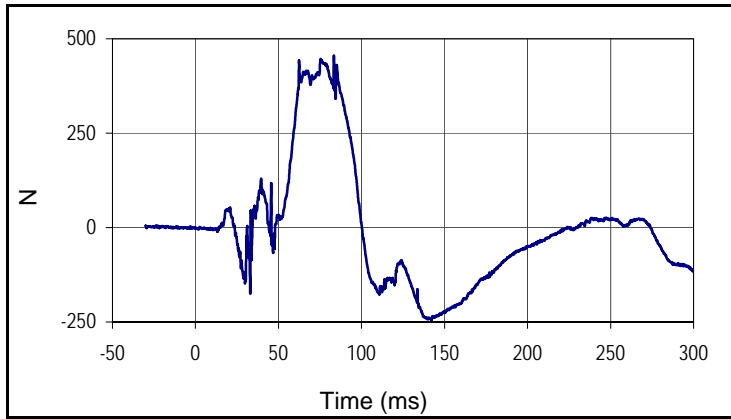

Curve Description			
Passenger Upper Neck Force X			
Plot No.		SAE Class	Units
025		1000	N
Max	Time	Min	Time
454.0	83.4	-244.8	142.2

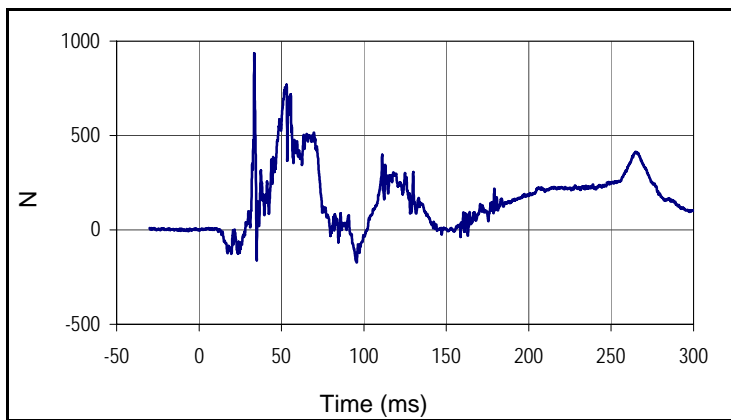

Curve Description			
Passenger Upper Neck Force Z			
Plot No.		SAE Class	Units
026		1000	N
Max	Time	Min	Time
936.3	33.5	-172.4	95.6

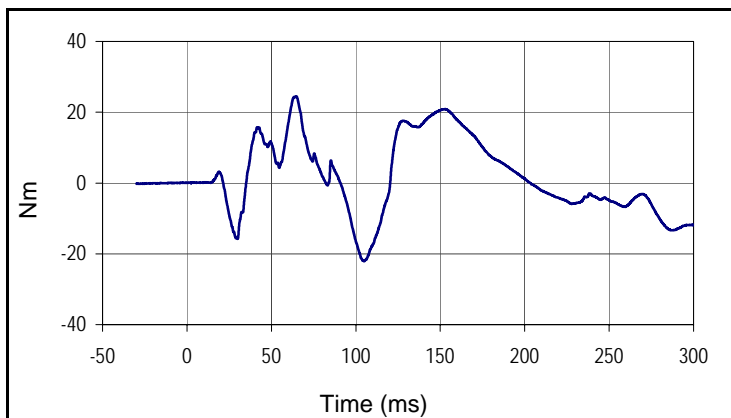

Curve Description			
Passenger Upper Neck Moment Y			
Plot No.		SAE Class	Units
027		600	Nm
Max	Time	Min	Time
24.5	64.9	-22.1	104.9

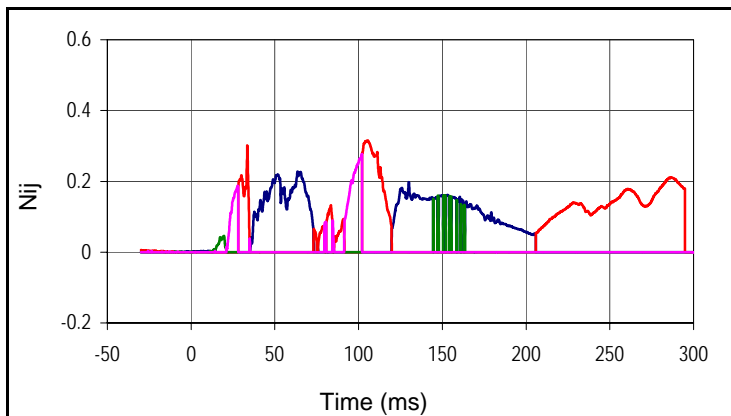

Curve Description			
Passenger Nij			
Units	Max	Time	
Ntf	0.23	63.6	
Units	Max	Time	
Nte	0.31	105.4	
Units	Max	Time	
Ncf	0.16	151.3	
Units	Max	Time	
Nce	0.28	102.0	

Test Vehicle: 2018 Subaru Legacy 2.5I /JAB 4-Door Sedan
 Test Program: 56 km/h Frontal Impact NCAP Test

NHTSA No.: M20185504
 Test Date: 10/18/17

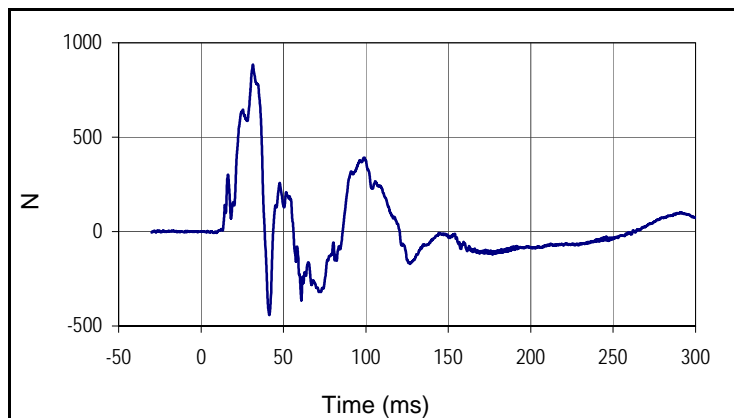

Curve Description			
Passenger Left Femur Force Z			
Plot No.		SAE Class	Units
029		600	N
Max	Time	Min	Time
884.8	31.5	-442.4	41.5

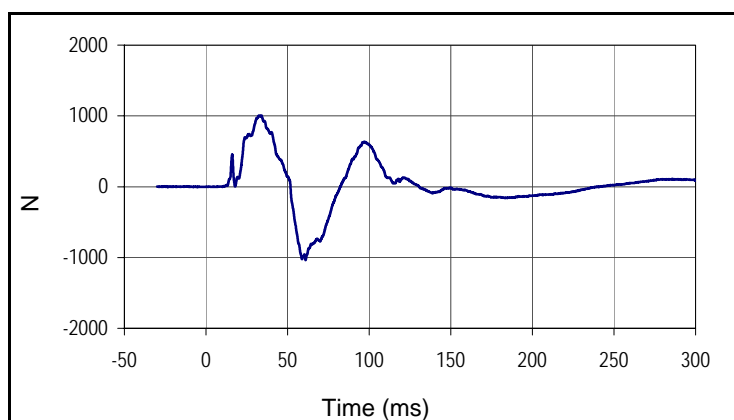

Curve Description			
Passenger Right Femur Force Z			
Plot No.		SAE Class	Units
030		600	N
Max	Time	Min	Time
1005.5	34.0	-1036.8	61.0

APPENDIX C
ATD CALIBRATION AND PERFORMANCE VERIFICATION DATA



ATD Serial No.: 360

Test Date: 2017-10-13

Dummy Item	Inspect for	Comments	Damage	Okay
Entire ATD	Perform general cleaning			✓
Outer Skin	Gashes, rips, cracks			✓
Head	Ballast secure			✓
	General appearance			✓
Neck bracket	Upper neck firmly attached to lower bracket			✓
Neck	Broken or cracked rubber			✓
	Looseness at the condyle joint			✓
Nodding block	Cracked or out of position			✓
Lumbar Spine	Broken or cracked rubber			✓
Ribs	Broken or bent ribs			✓
	Broken or bent rib supports			✓
	Damping material separated or cracked			✓
	Rubber bumpers in place			✓
Chest Displ. Assembly	Bent shaft			✓
	Slider arm riding in track			✓
Sensors	Check cables for cuts, tears			✓
	Check for damaged insulation			✓
Accelerometer Mounting	Head mounting secure			✓
	Chest mounting secure			✓
Knees	Skin condition			✓
	Insert (do not remove)			✓
	Casting			✓
Limbs	Normal movement and adjustment			✓
Knee Sliders	Wires intact			✓
	Rubber returned to "resting" position			✓
Pelvis	Broken			✓
Other	Describe below as needed			✓

Describe any repairs or replacement of parts or other findings:

Technician: 

Approved By: 



ATD Serial No.: 360

Test Date: 2017-10-13

Tested Parameter	Units	Spec. Low	Spec. High	Result	Pass/Fail
Laboratory Temperature	°C	20.6	22.2	21.1	Pass
Laboratory Relative Humidity	%	10	70	29	Pass
A - Total sitting height	mm	879.0	889.0	886	Pass
B - Shoulder pivot height	mm	505.0	521.0	510	Pass
C - 'H' point height	mm	84.0	89.0	86	Pass
D - 'H' point location from backline	mm	135.0	140.0	139	Pass
E - Shoulder pivot from backline	mm	84.0	94.0	91	Pass
F - Thigh clearance	mm	140.0	155.0	147	Pass
G - Back of elbow to wrist pivot	mm	290.0	305.0	298	Pass
H - Head back to backline	mm	41.0	46.0	44	Pass
I - Shoulder to elbow length	mm	330.0	345.0	337	Pass
J - Elbow rest height	mm	190.0	211.0	205	Pass
K - Buttock to knee length	mm	579.0	604.0	587	Pass
L - Popliteal length	mm	429.0	455.0	437	Pass
M - Knee pivot height	mm	485.0	500.0	495	Pass
N - Buttock popliteal length	mm	452.0	477.0	473	Pass
O - Chest depth without jacket	mm	213.0	229.0	227	Pass
P - Foot length	mm	251.0	267.0	263	Pass
V - Shoulder breadth	mm	422.0	437.0	436	Pass
W - Foot breadth	mm	91.0	107.0	99	Pass
Y - Chest circum. (w/chest jacket)	mm	970.0	1001.0	982	Pass
Z - Waist circum.	mm	836.0	866.0	865	Pass
AA - Location for chest circum.	mm	429.0	434.0	431	Pass
BB - Location for waist circum.	mm	226.0	231.0	231	Pass
Overall Test Results					Pass

Technician: 

Approved By: 



ATD Serial No.: 360

Test Date: 2017-10-02

Tested Parameter	Units	Spec. Low	Spec. High	Result	Pass/Fail
Laboratory Temperature	°C	18.9	25.6	21.7	Pass
Laboratory Humidity	%	10	70	23	Pass
Peak Resultant Acceleration	g	225.0	275.0	231.4	Pass
Peak Lateral Acceleration	g	-15.0	15.0	-6.0	Pass
Oscillations After Main Pulse	%	0.0	10.0	3.1	Pass
Is Acceleration Unimodal?	Yes/No	Yes		Yes	Pass
Overall Test Results					Pass

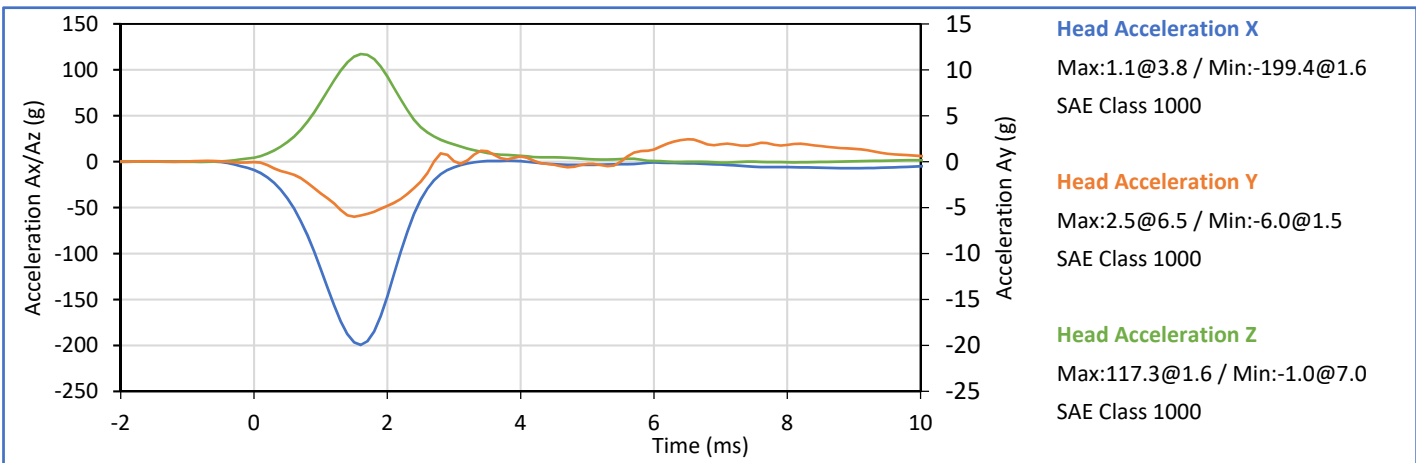
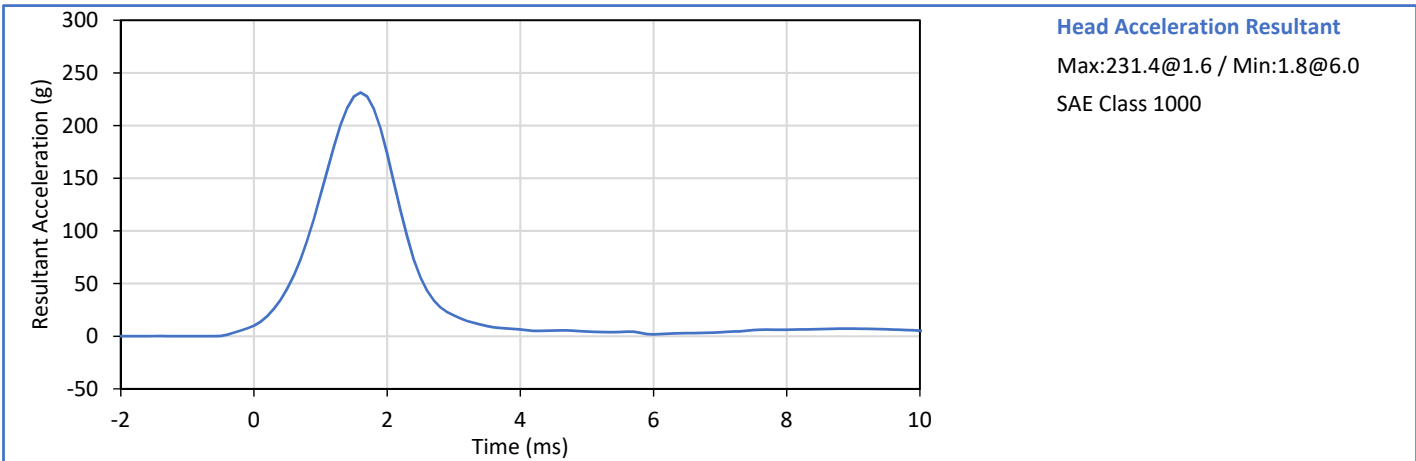

Technician: *Smith*

Approved By: *Wep*



ATD Serial No.: 360

Test Date: 2017-10-02

Tested Parameter	Units	Spec. Low	Spec. High	Result	Pass/Fail
Laboratory Temperature	°C	20.6	22.2	21.1	Pass
Laboratory Humidity	%	10	70	22	Pass
Pendulum Velocity	m/s	6.89	7.13	7.04	Pass
Pendulum Deceleration at 10 ms	g	22.5	27.5	24.8	Pass
Pendulum Deceleration at 20 ms	g	17.6	22.6	21.7	Pass
Pendulum Deceleration at 30 ms	g	12.5	18.5	16.7	Pass
Peak Pendulum Decel. after 30 ms	g	0.0	29.0	16.7	Pass
Deceleration Decay to Cross 5 g	ms	34.0	42.0	37.3	Pass
"D" Plane Rotation peak	deg	64.0	78.0	72.0	Pass
	ms	57.0	64.0	57.4	Pass
"D" Plane Rotation Decay To Zero	ms	113.0	128.0	113.9	Pass
Moment About Occipital Condyle	Nm	88.1	108.5	94.3	Pass
	ms	47.0	58.0	49.8	Pass
Moment Decay, Peak to Zero	deg	97.0	107.0	98.4	Pass
Overall Test Results					Pass

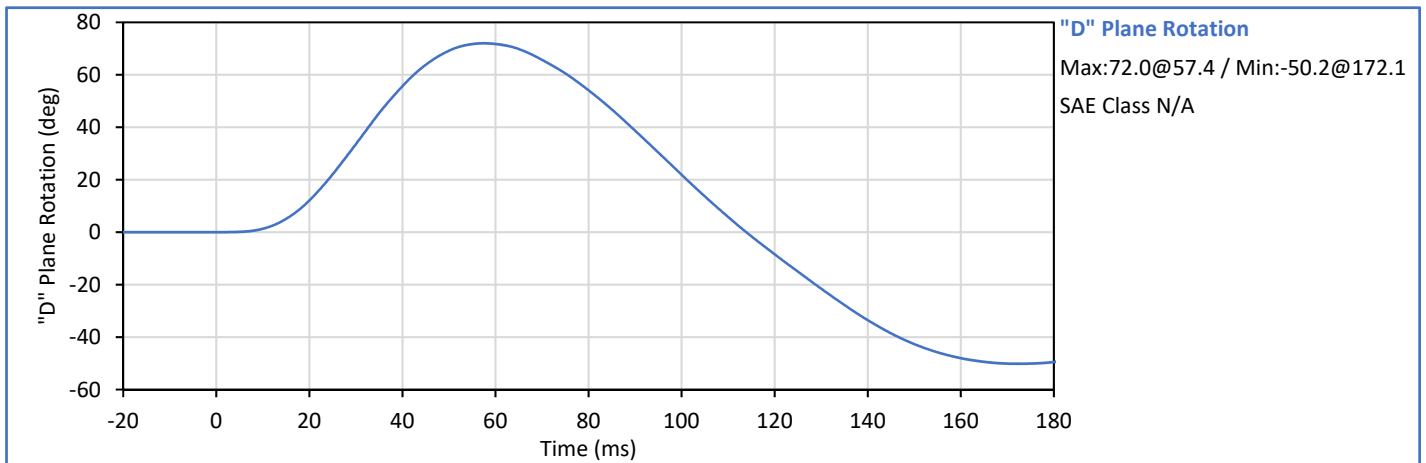
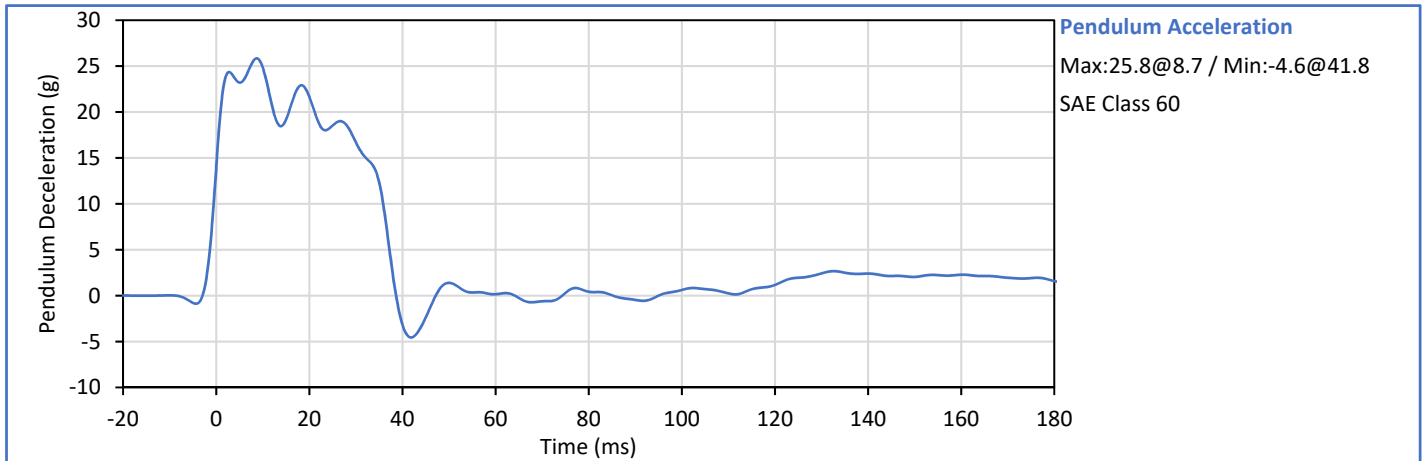

Technician: *Smith*

Approved By: *Wep*



ATD Serial No.: 360

Test Date: 2017-10-02

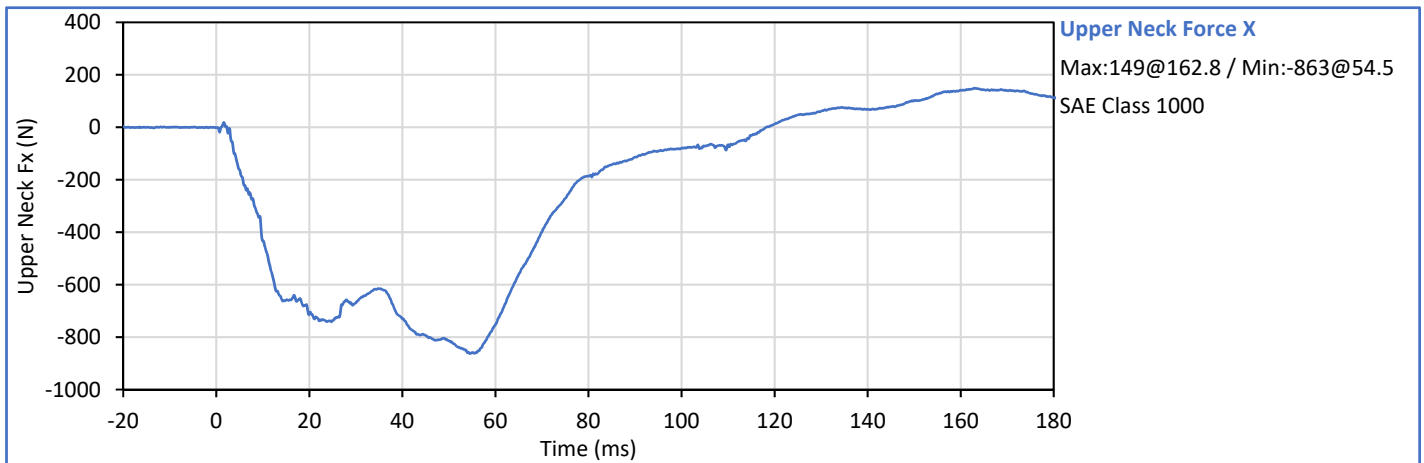
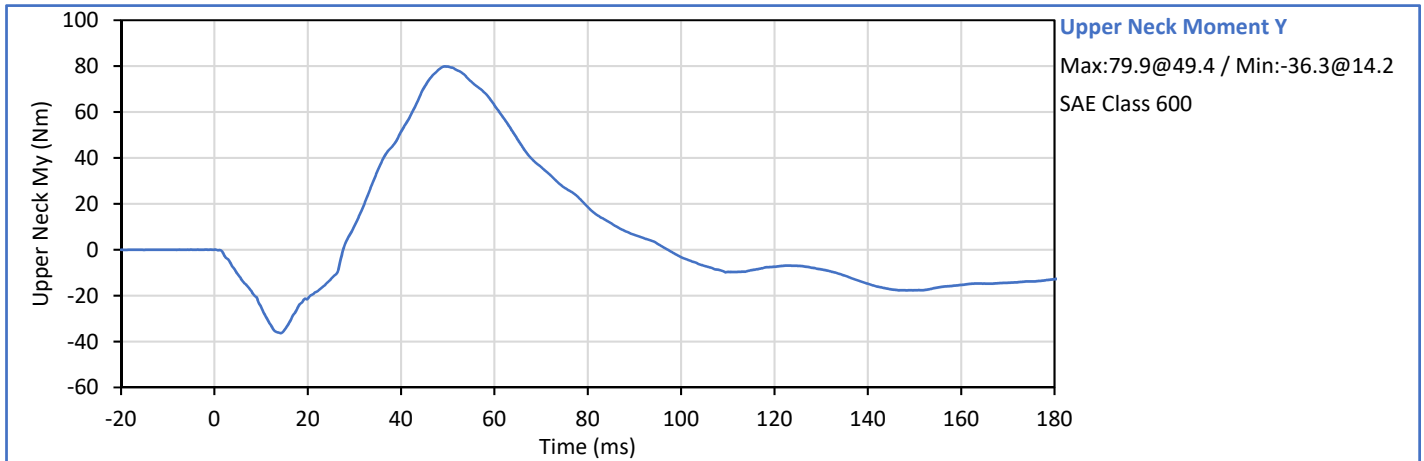
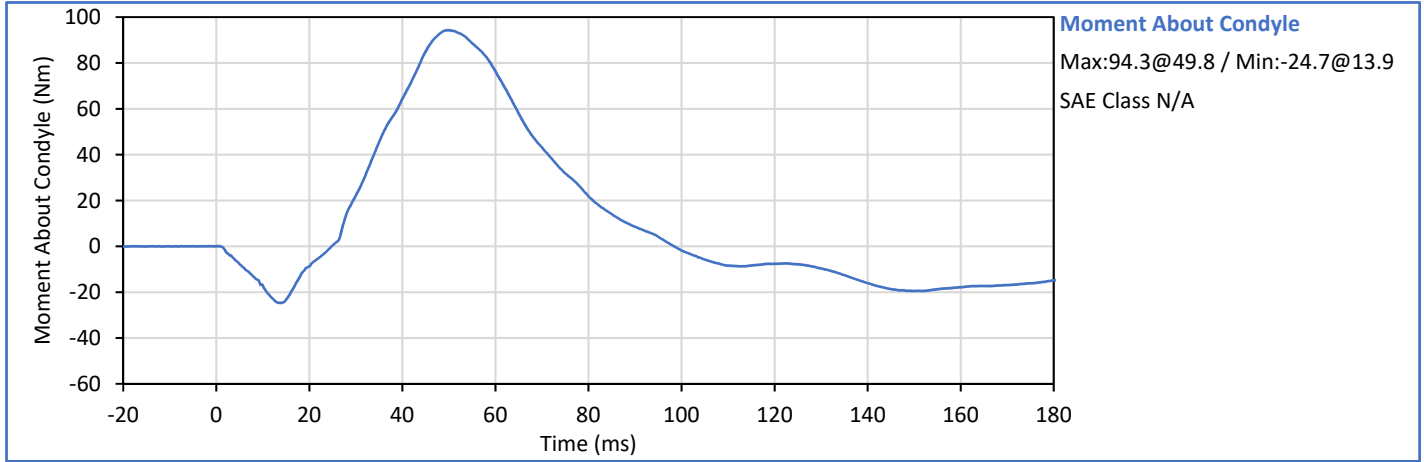



ATD Serial No.: 360

Test Date: 2017-10-03

Tested Parameter	Units	Spec. Low	Spec. High	Result	Pass/Fail
Laboratory Temperature	°C	20.6	22.2	20.9	Pass
Laboratory Humidity	%	10	70	29	Pass
Pendulum Velocity	m/s	5.94	6.19	6.04	Pass
Pendulum Deceleration at 10 ms	g	17.2	21.2	19.4	Pass
Pendulum Deceleration at 20 ms	g	14.0	19.0	18.8	Pass
Pendulum Deceleration at 30 ms	g	11.0	16.0	14.5	Pass
Peak Pendulum Decel. after 30 ms	g	0.0	22.0	14.5	Pass
Deceleration Decay to Cross 5 g	ms	38.0	46.0	38.2	Pass
"D" Plane Rotation peak	deg	81.0	106.0	105.7	Pass
	ms	72.0	82.0	79.9	Pass
"D" Plane Rotation Decay To Zero	ms	147.0	174.0	161.7	Pass
Moment About Occipital Condyle	Nm	-79.9	-52.9	-72.5	Pass
	ms	65.0	79.0	67.1	Pass
Moment Decay, Peak to Zero	deg	120.0	148.0	134.6	Pass
Overall Test Results					Pass

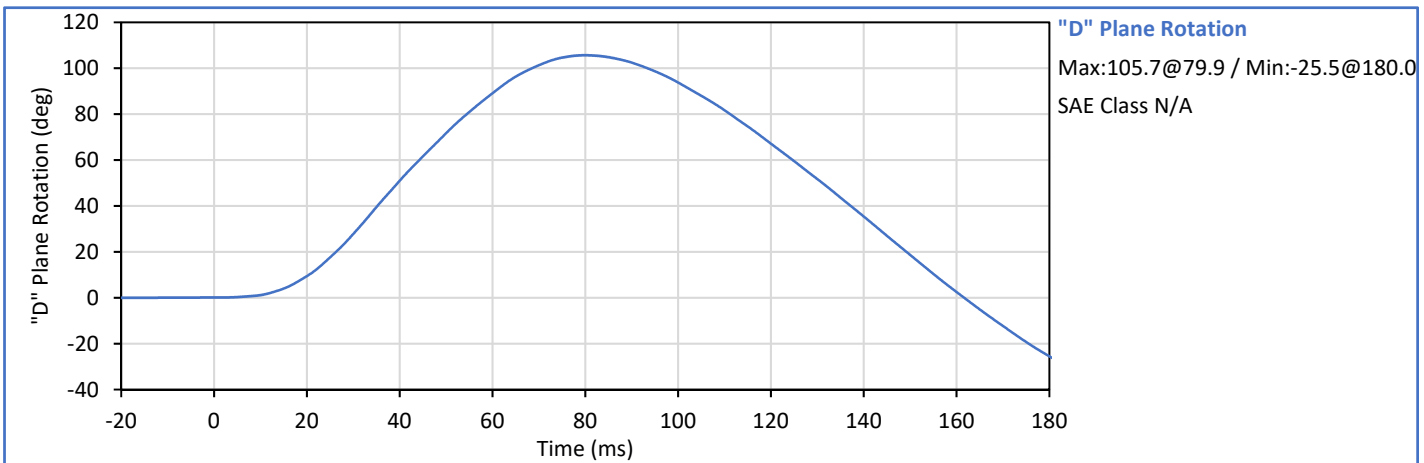
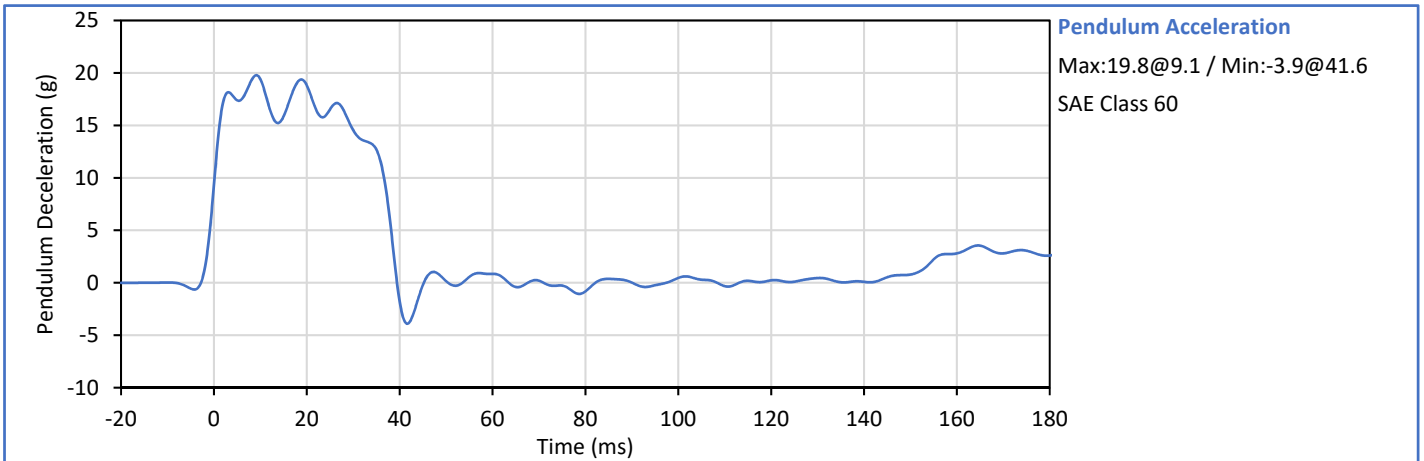

Technician: *Smith*

Approved By: *Wep*



ATD Serial No.: 360

Test Date: 2017-10-03

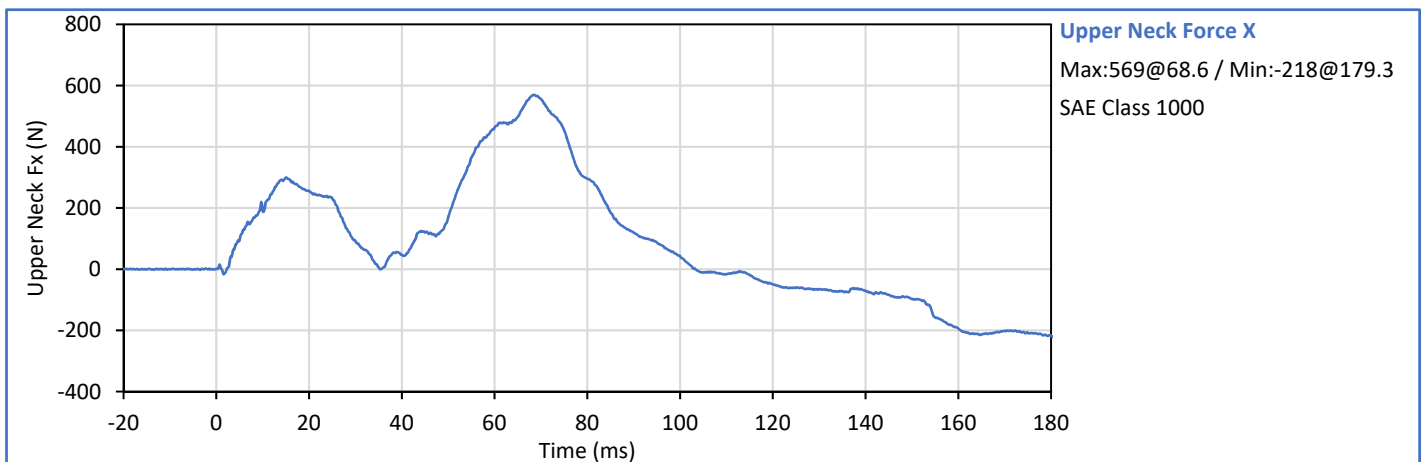
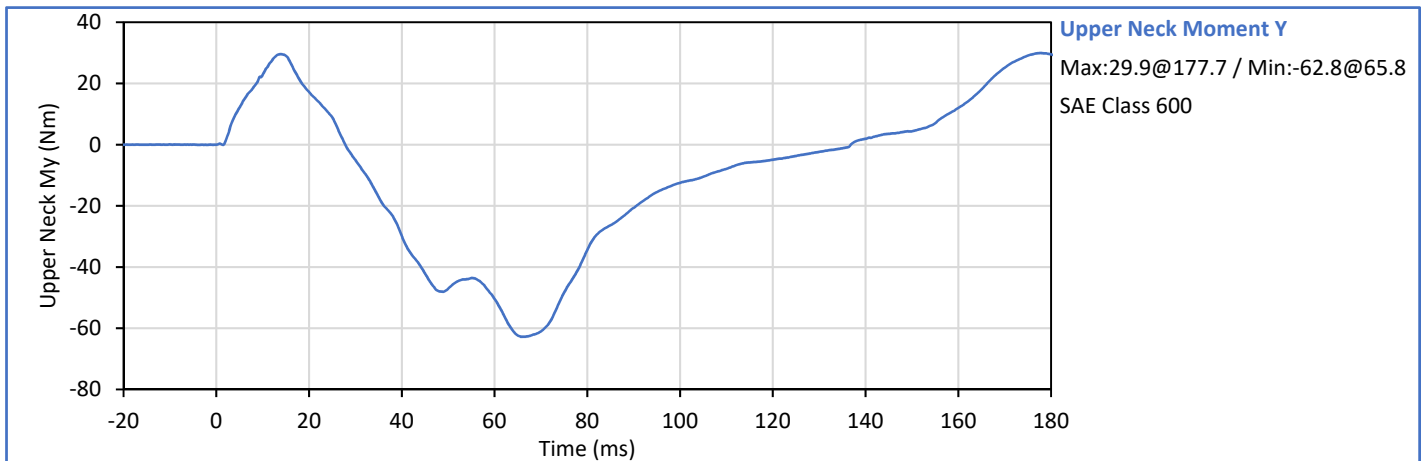
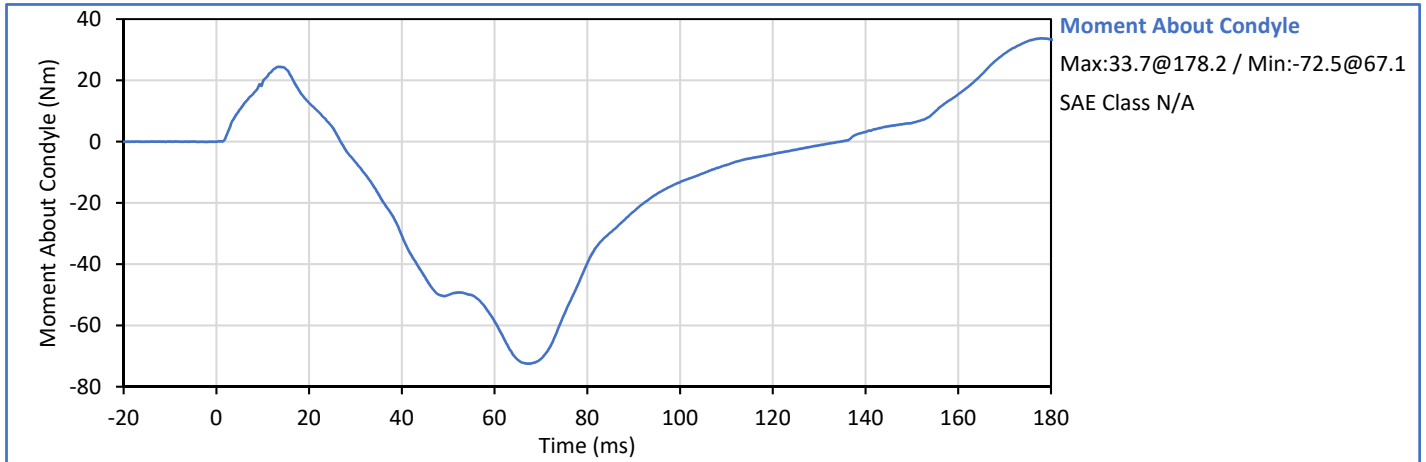



ATD Serial No.: 360

Test Date: 2017-10-13

Tested Parameter	Units	Spec. Low	Spec. High	Result	Pass/Fail
Laboratory Temperature	°C	20.6	22.2	20.9	Pass
Laboratory Humidity	%	10	70	29	Pass
Probe Velocity	m/s	6.58	6.82	6.77	Pass
Peak Chest Deflection	cm	6.35	7.26	6.38	Pass
Peak Probe Force	kN	5.159	5.893	5.669	Pass
Internal Hysteresis	%	69.0	85.0	72.6	Pass
Overall Test Results					Pass

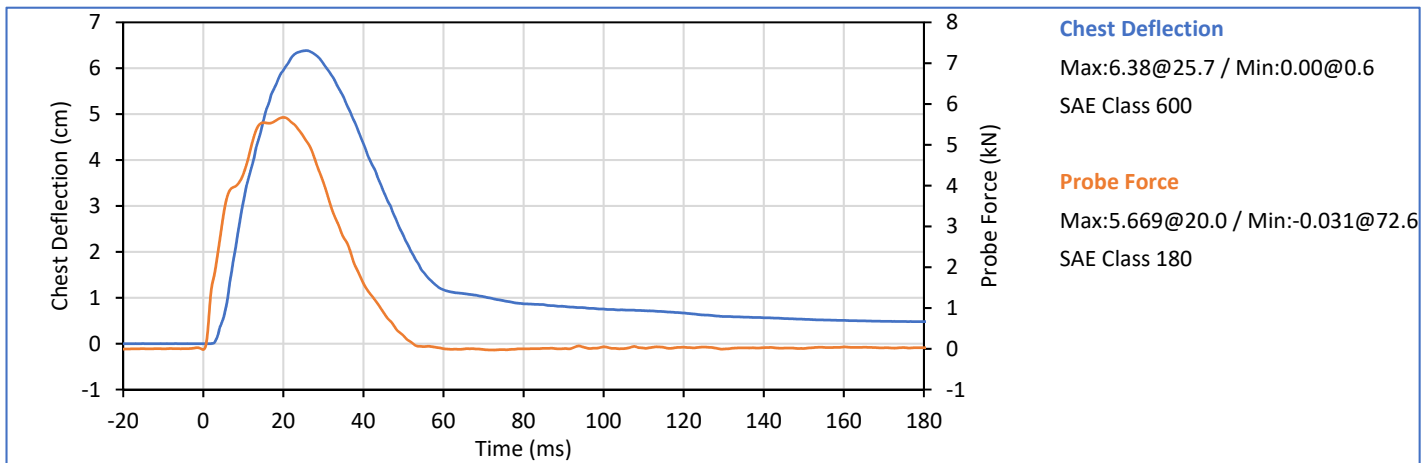
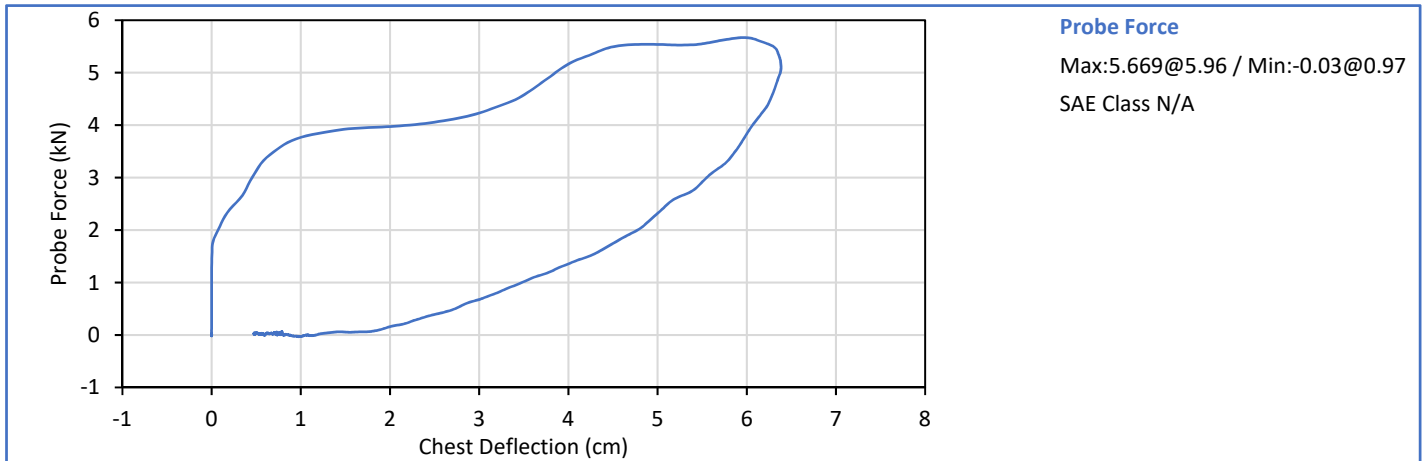

Technician: *Smith*

Approved By: *Wep*



ATD Serial No.: 360

Test Date: 2017-10-11

Tested Parameter		Units	Spec. Low	Spec. High	Result	Pass/Fail
Laboratory Temperature		°C	18.9	25.6	21.1	Pass
Laboratory Humidity		%	10	70	16	Pass
Left Knee	Probe Velocity	m/s	2.070	2.130	2.106	Pass
	Peak Resistive Force	N	4715	5782	5089	Pass
Right Knee	Probe Velocity	m/s	2.070	2.130	2.110	Pass
	Peak Resistive Force	N	4715	5782	5363	Pass
Overall Test Results					Pass	Pass

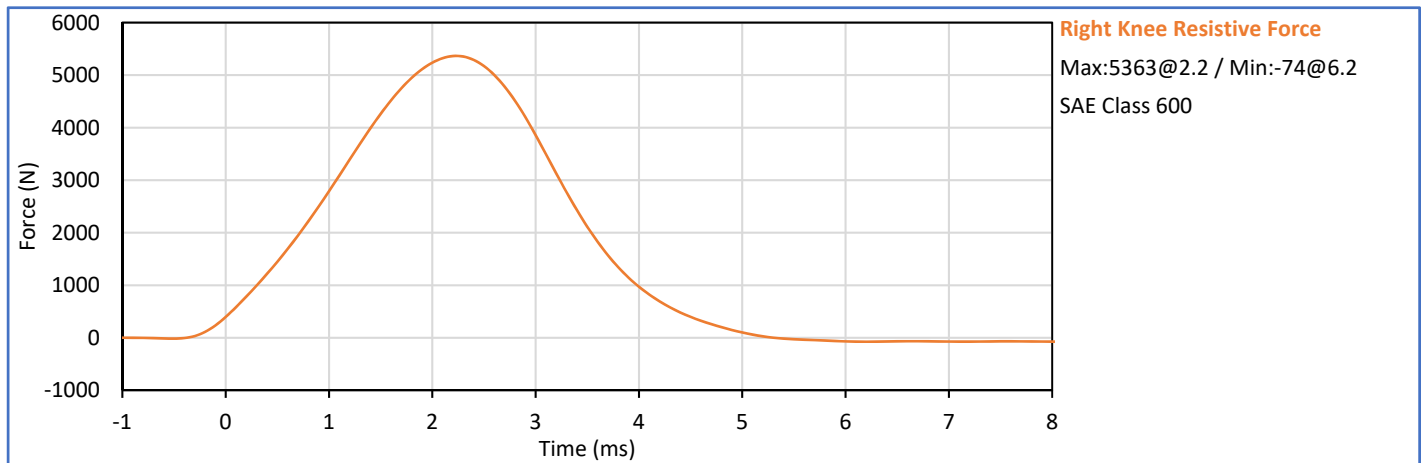
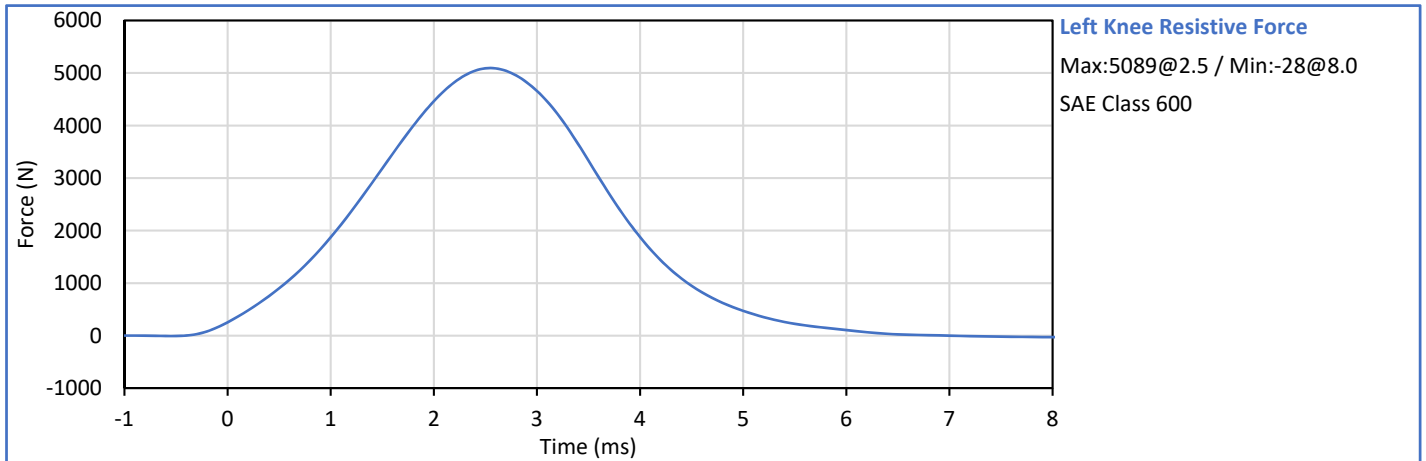

Technician: *Smith*

Approved By: *Wep*



ATD Serial No.: 360

Test Date: 2017-10-10

Tested Parameter	Units	Spec. Low	Spec. High	Result	Pass/Fail	
Laboratory Temperature	°C	18.9	25.6	21.7	Pass	
Laboratory Humidity	%	10	70	26	Pass	
Left Hip	Left Hip Rotation Rate	deg/s	5.0	10.0	9.5	Pass
	Left Femur Torque at 30°	Nm	0.0	95.0	83.5	Pass
	Left Hip Rotation at 203 Nm	deg	40.0	50.0	44.1	Pass
Right Hip	Right Hip Rotation Rate	deg/s	5.0	10.0	9.1	Pass
	Right Femur Torque at 30°	Nm	0.0	95.0	92.8	Pass
	Right Hip Rotation at 203 Nm	deg	40.0	50.0	43.3	Pass
Overall Test Results					Pass	

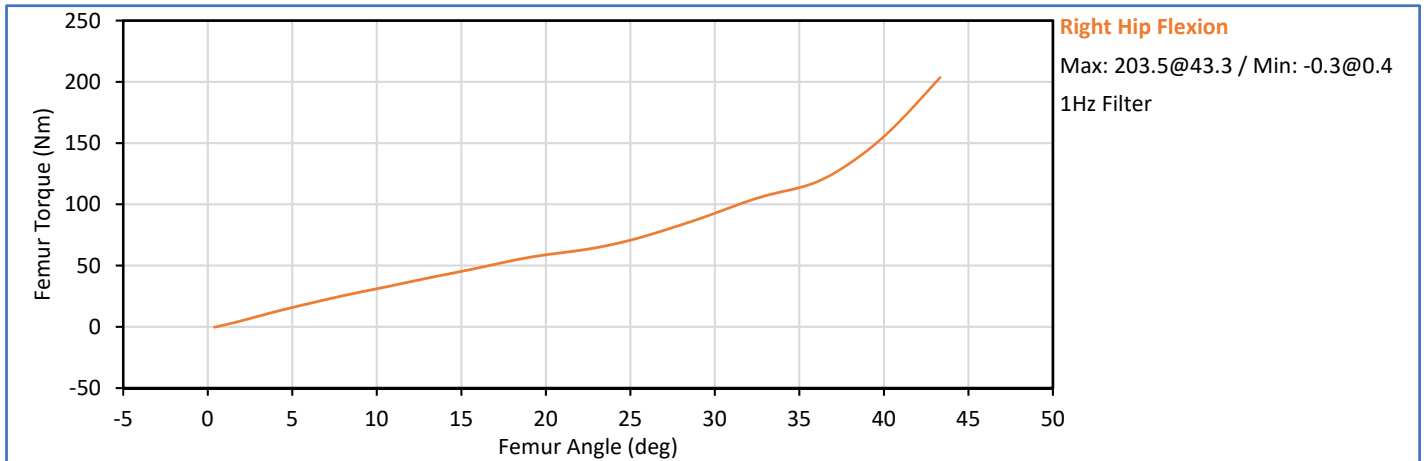
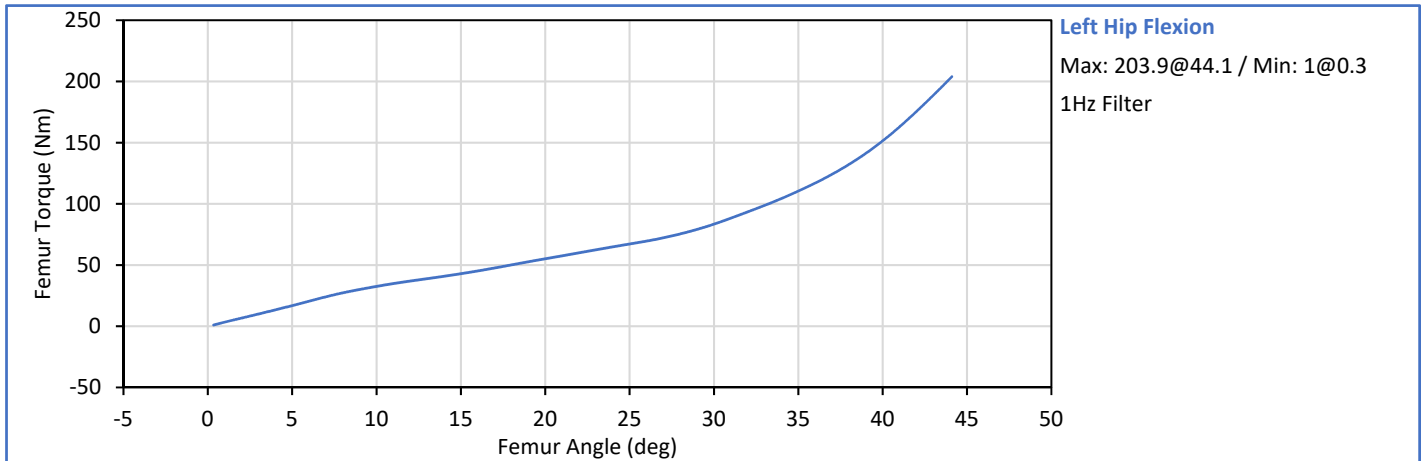

Technician: *Smith*

Approved By: *Wep*



ATD Serial No.: 630

Test Date: 2017-10-17

Dummy Item	Inspect for	Comments	Damage	Okay
Entire ATD	Perform general cleaning			✓
Outer Skin	Gashes, rips, cracks			✓
Head	Ballast secure			✓
	General appearance			✓
Neck bracket	Upper neck firmly attached to lower bracket			✓
Neck	Broken or cracked rubber			✓
	Looseness at the condyle joint			✓
Nodding block	Cracked or out of position			✓
Lumbar Spine	Broken or cracked rubber			✓
Ribs	Broken or bent ribs			✓
	Broken or bent rib supports			✓
	Damping material separated or cracked			✓
	Rubber bumpers in place			✓
Chest Displ. Assembly	Bent shaft			✓
	Slider arm riding in track			✓
Sensors	Check cables for cuts, tears			✓
	Check for damaged insulation			✓
Accelerometer Mounting	Head mounting secure			✓
	Chest mounting secure			✓
Knees	Skin condition			✓
	Insert (do not remove)			✓
	Casting			✓
Limbs	Normal movement and adjustment			✓
Knee Sliders	Wires intact			✓
	Rubber returned to "resting" position			✓
Pelvis	Broken			✓
Other	Describe below as needed			✓

Describe any repairs or replacement of parts or other findings:

Technician: 

Approved by: 



ATD Serial No.: 630

Test Date: 2017-10-17

Tested Parameter	Units	Spec. Low	Spec. High	Result	Pass/Fail
Laboratory Temperature	°C	20.6	22.2	21.2	Pass
Laboratory Relative Humidity	%	10	70	45	Pass
A - Total sitting height	mm	775	800	786	Pass
B - Shoulder pivot height	mm	432	457	450	Pass
C - 'H' point height	mm	81	86	85	Pass
D - 'H' point location from backline	mm	145	150	146	Pass
E - Shoulder pivot from backline	mm	69	84	77	Pass
F - Thigh clearance	mm	119	135	126	Pass
G - Back of elbow to wrist pivot	mm	244	259	250	Pass
H - Head back to backline	mm	41	46	44	Pass
I - Shoulder to elbow length	mm	277	297	285	Pass
J - Elbow rest height	mm	183	203	198	Pass
K - Buttock to knee length	mm	521	546	531	Pass
L - Popliteal length	mm	356	376	371	Pass
M - Knee pivot height	mm	394	419	402	Pass
N - Buttock popliteal length	mm	414	439	420	Pass
O - Chest depth without jacket	mm	175	191	186	Pass
P - Foot length	mm	219	234	221	Pass
R - Buttock to Knee Pivot Length	mm	457	483	473	Pass
S - Head Breadth	mm	137	147	144	Pass
T - Head Depth	mm	178	188	180	Pass
U - Hip Breadth	mm	300	315	302	Pass
V - Shoulder breadth	mm	351	366	359	Pass
W - Foot breadth	mm	79	94	90	Pass
X - Head circum.	mm	528	549	541	Pass
Y - Chest circum. (w/chest jacket)	mm	851	881	864	Pass
Z - Waist circum.	mm	760	790	766	Pass
AA - Location for chest circum.	mm	300	310	300	Pass
BB - Location for waist circum.	mm	160	170	164	Pass
Overall Test Results					Pass

Technician: 

Approved by: 



ATD Serial No.: 630

Test Date: 2017-10-16

Tested Parameter	Units	Spec. Low	Spec. High	Result	Pass/Fail
Laboratory Temperature	°C	18.9	25.6	21.2	Pass
Laboratory Humidity	%	10	70	37	Pass
Peak Resultant Acceleration	g	250.0	300.0	261.7	Pass
Peak Lateral Acceleration	g	-15.0	15.0	4.7	Pass
Oscillations After Main Pulse	%	0.0	10.0	3.1	Pass
Is Acceleration Unimodal?	Yes/No	Yes		Yes	Pass
Overall Test Results					Pass

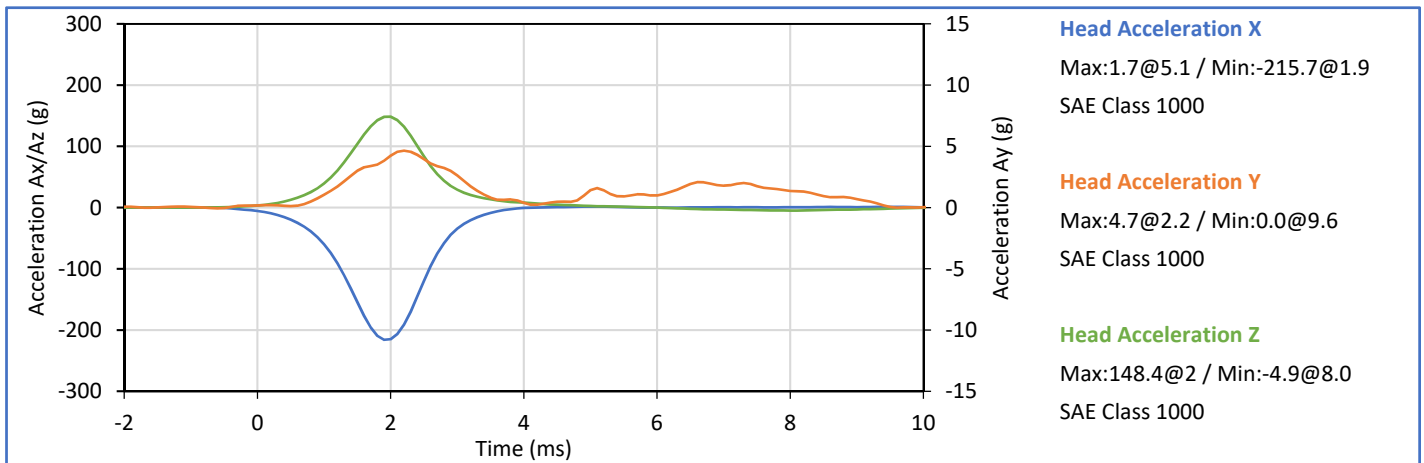
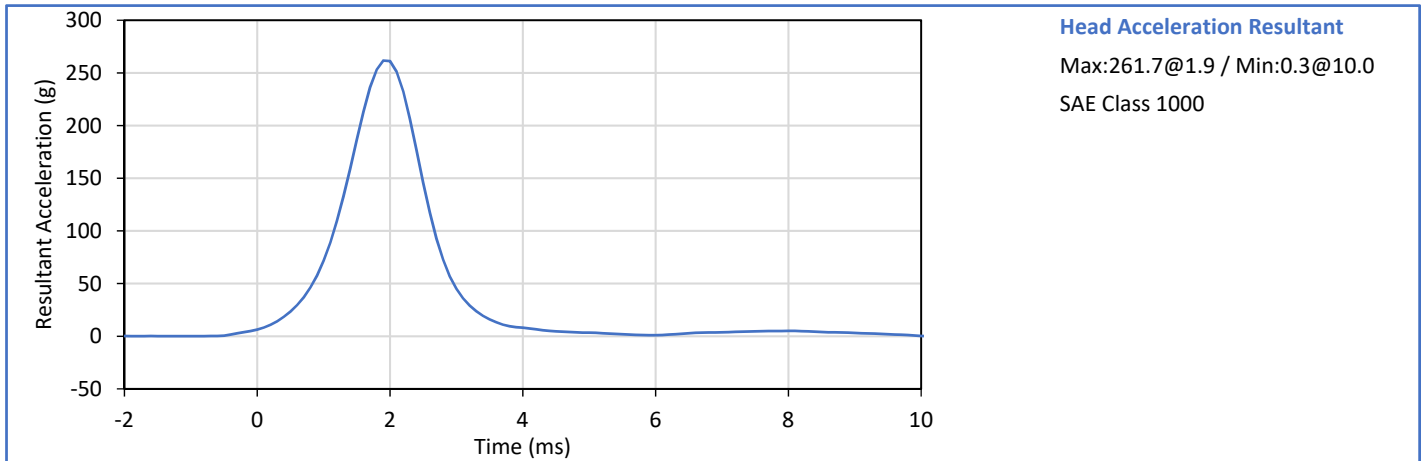

Technician: *Smith*

Approved by: *Wep*



ATD Serial No.: 630

Test Date: 2017-10-16

Tested Parameter	Units	Spec. Low	Spec. High	Result	Pass/Fail
Laboratory Temperature	°C	20.6	22.2	21.2	Pass
Laboratory Humidity	%	10	70	36	Pass
Pendulum Velocity	m/s	6.89	7.13	7.05	Pass
Pendulum Velocity at 10 ms	m/s	2.10	2.50	2.36	Pass
Pendulum Velocity at 20 ms	m/s	4.00	5.00	4.54	Pass
Pendulum Velocity at 30 ms	m/s	5.80	7.00	6.40	Pass
Peak "D" Plane Rotation	deg	77.0	91.0	88.4	Pass
Peak Moment in Rotation	Nm	69.0	83.0	76.7	Pass
Positive Moment Decay to 10 Nm	ms	80.0	100.0	84.1	Pass
Overall Test Results					Pass

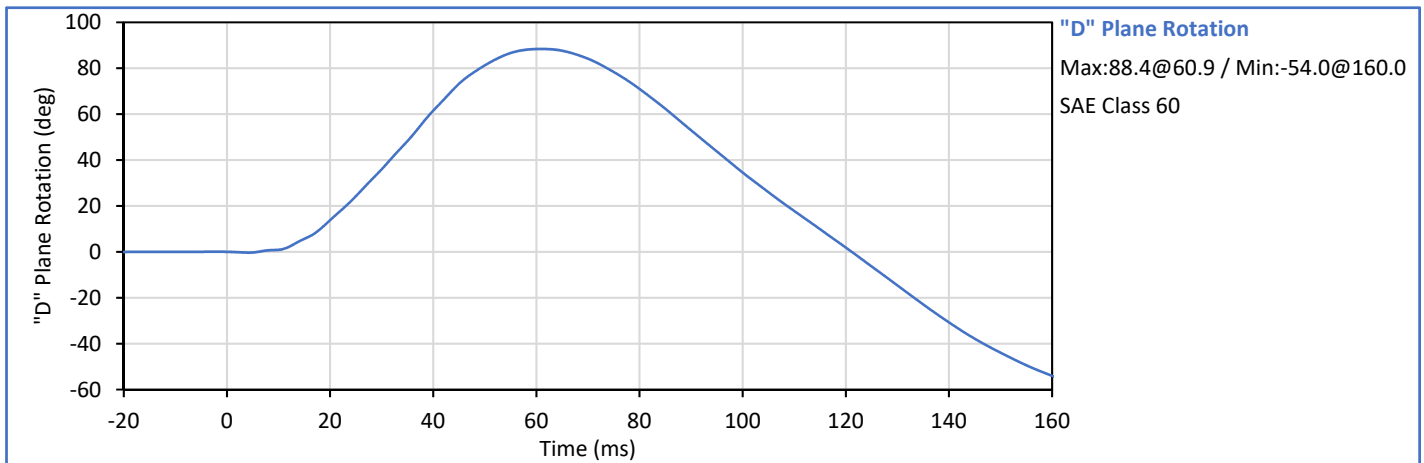
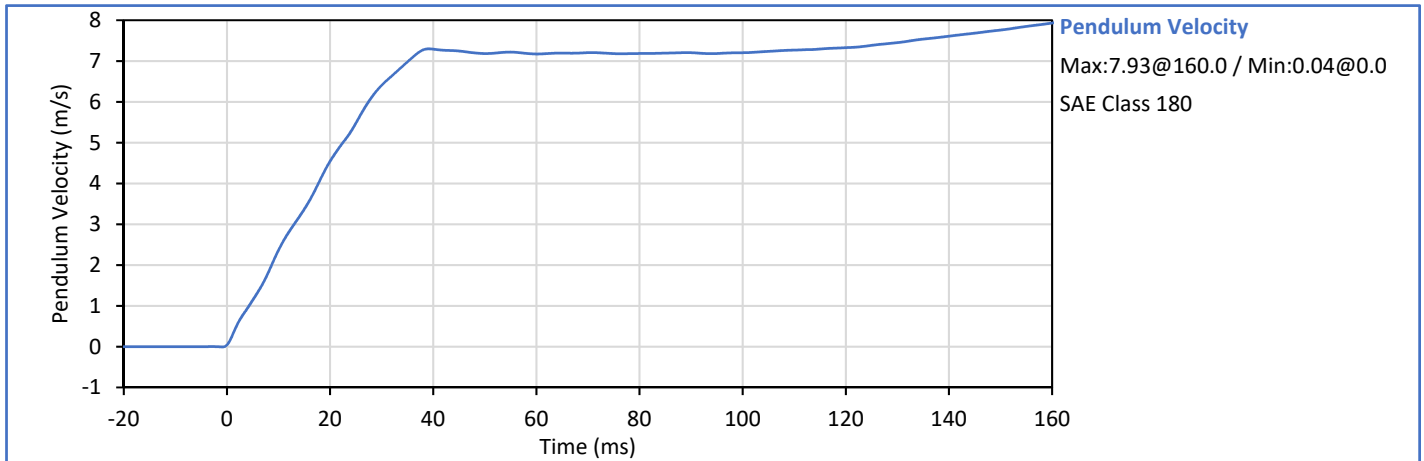

Technician: *Scotty*

Approved by: *Wep*



ATD Serial No.: 630

Test Date: 2017-10-16

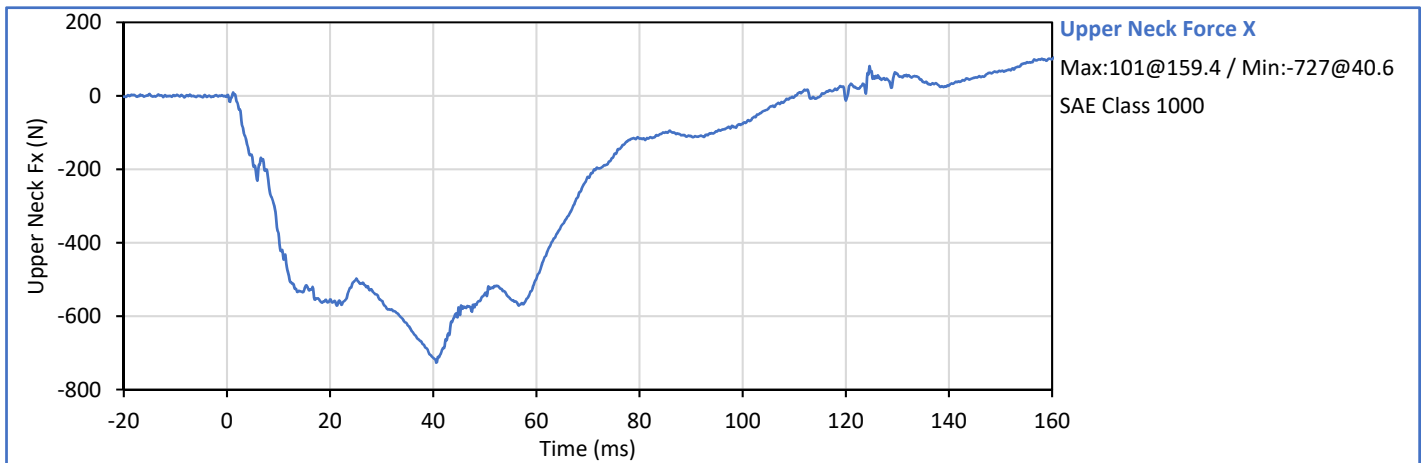
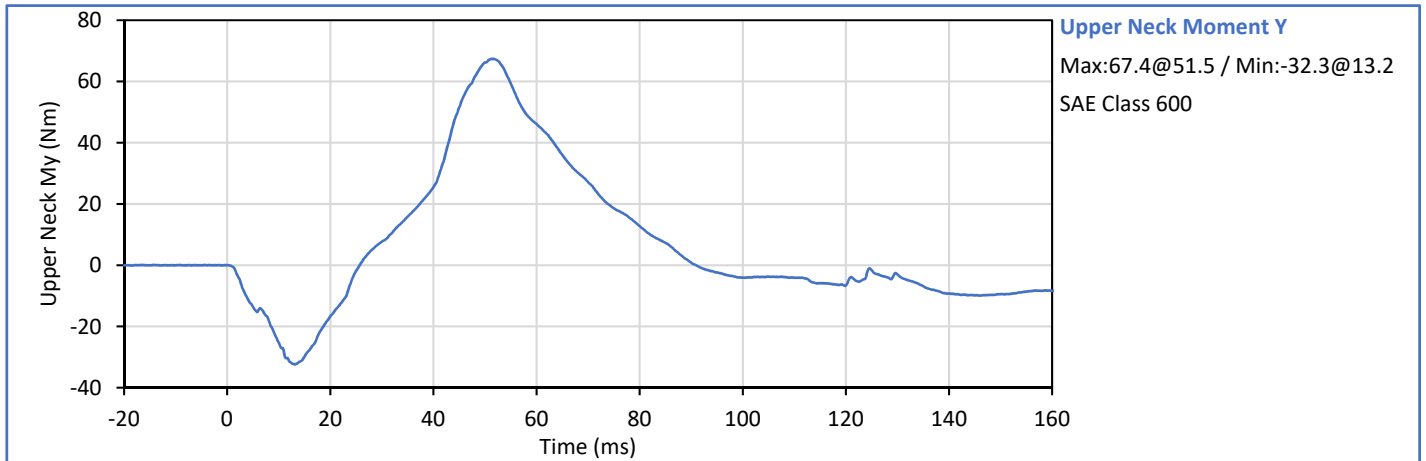
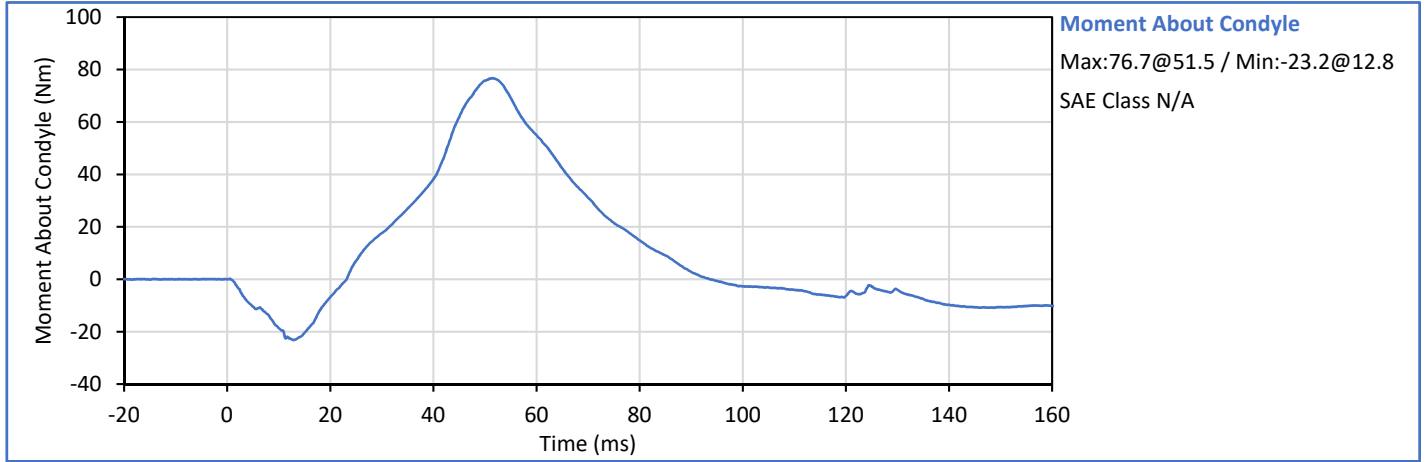



**Hybrid III 5th Percentile Female
 Neck Extension Test**

ATD Serial No.: 630

Test Date: 2017-10-16

Tested Parameter	Units	Spec. Low	Spec. High	Result	Pass/Fail
Laboratory Temperature	°C	20.6	22.2	21.9	Pass
Laboratory Humidity	%	10	70	20	Pass
Pendulum Velocity	m/s	5.95	6.19	6.07	Pass
Pendulum Velocity at 10 ms	m/s	1.50	1.90	1.74	Pass
Pendulum Velocity at 20 ms	m/s	3.10	3.90	3.44	Pass
Pendulum Velocity at 30 ms	m/s	4.60	5.60	4.81	Pass
Peak "D" Plane Rotation	deg	99.0	114.0	106.1	Pass
Peak Moment in Rotation	Nm	-65.0	-53.0	-58.4	Pass
Negative Moment Decay to -10 Nm	ms	94.0	114.0	100.0	Pass
Overall Test Results					Pass

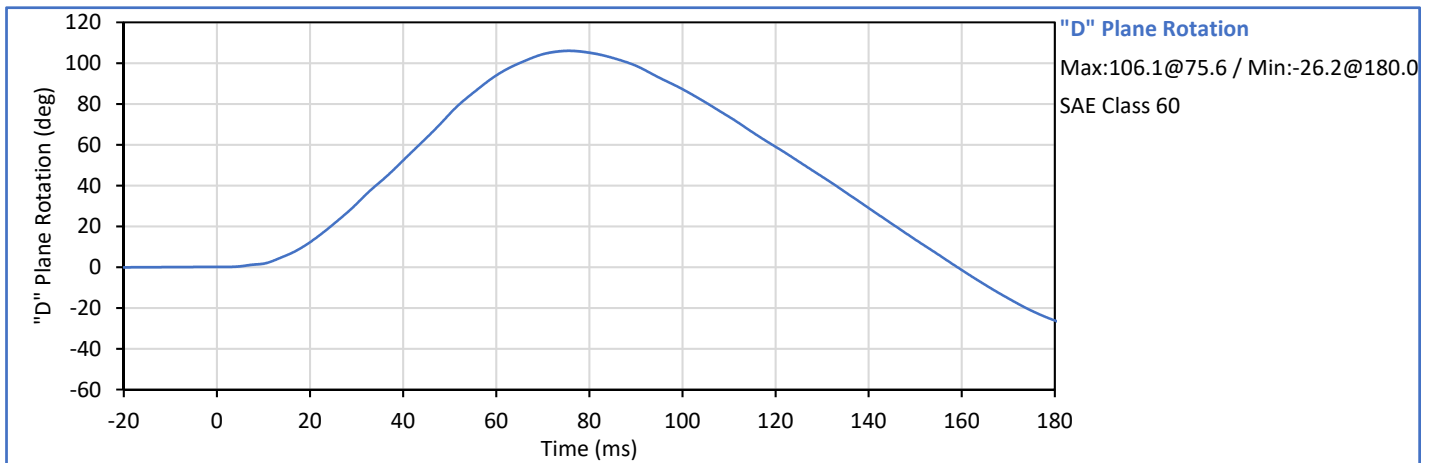
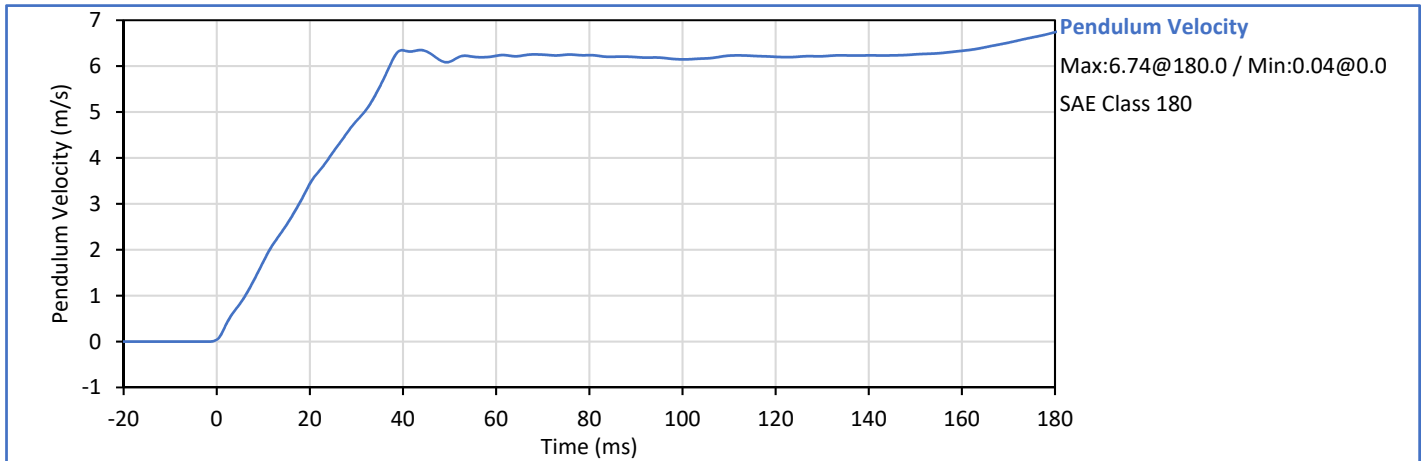

Technician:

Approved by:



ATD Serial No.: 630

Test Date: 2017-10-16

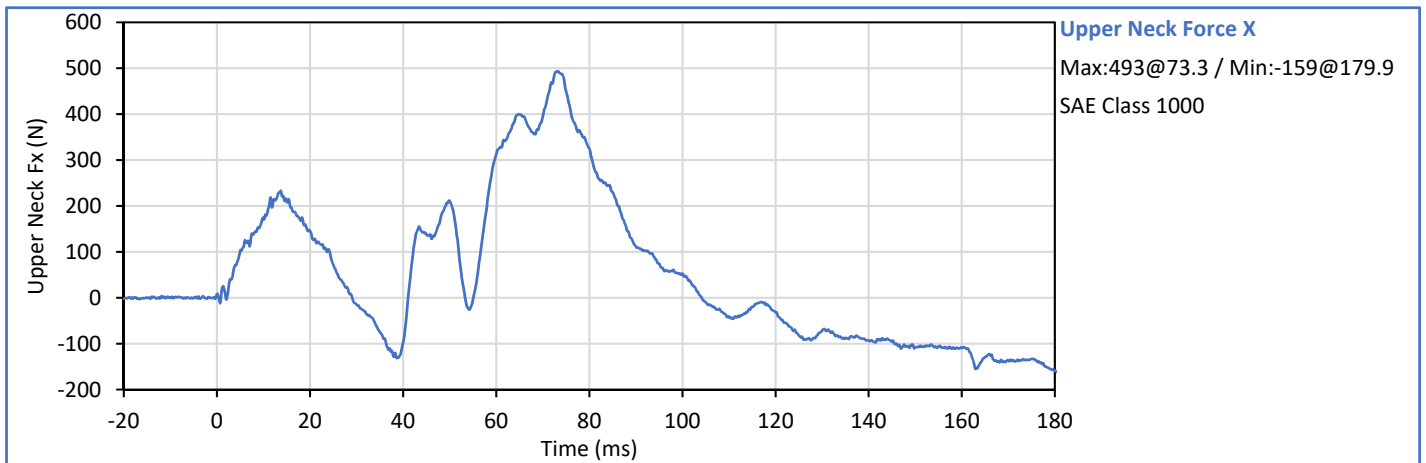
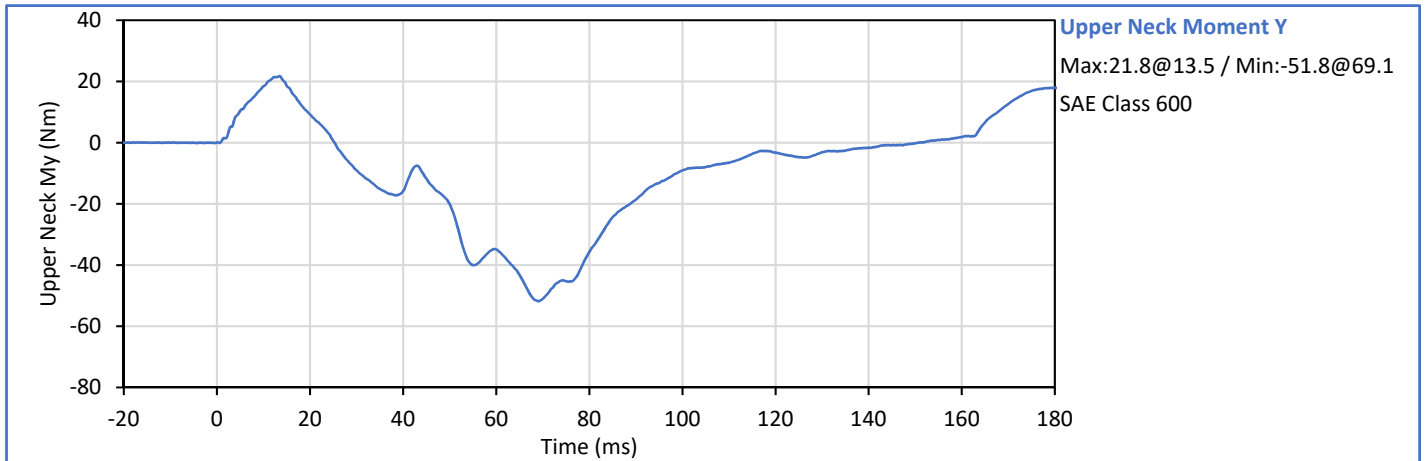
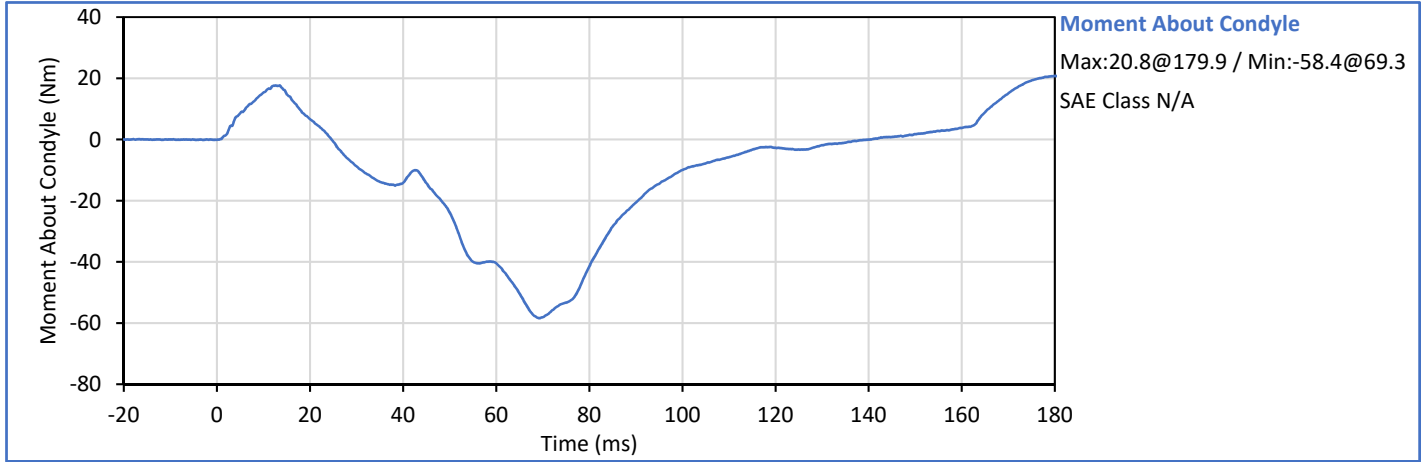



ATD Serial No.: 630

Test Date: 2017-10-17

Tested Parameter	Units	Spec. Low	Spec. High	Result	Pass/Fail
Laboratory Temperature	°C	20.6	22.2	21.9	Pass
Laboratory Humidity	%	10	70	21	Pass
Probe Velocity	m/s	6.59	6.83	6.77	Pass
Peak Chest Deflection	mm	50.0	58.0	57.6	Pass
Peak Probe Force, 50 and 58 mm	kN	3.900	4.400	4.175	Pass
Peak Probe Force, 18 and 50 mm	kN	0.000	4.600	3.866	Pass
Internal Hysterisis	%	69.0	85.0	69.9	Pass
Overall Test Results					Pass

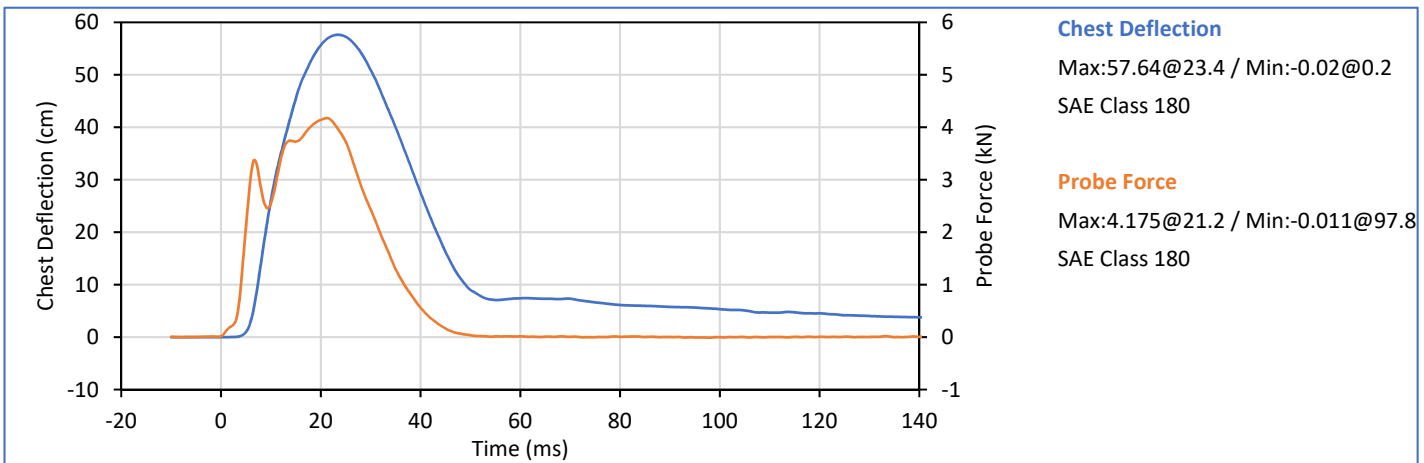
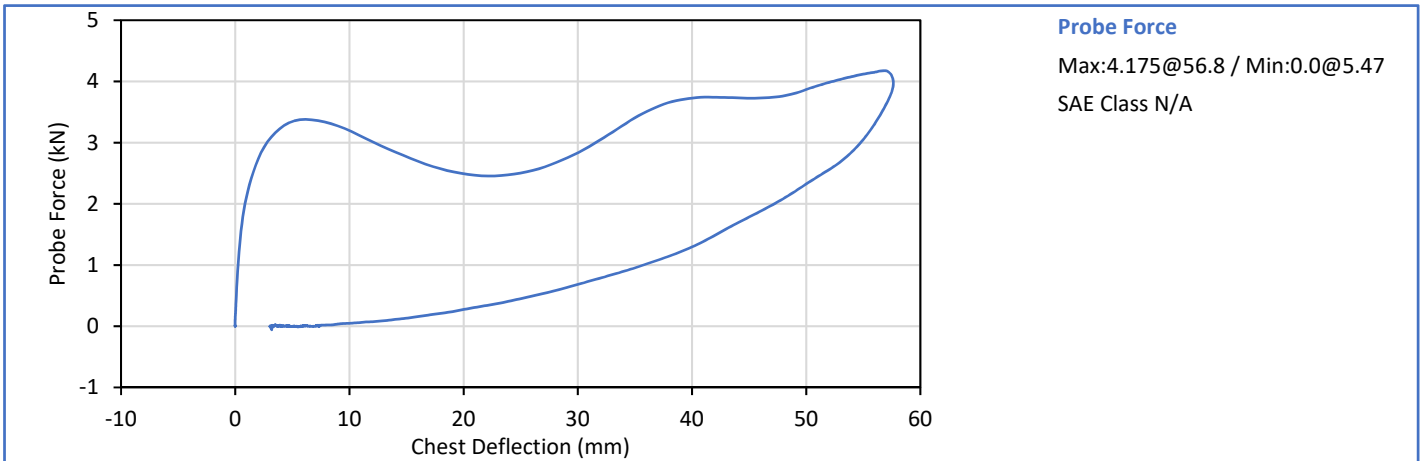

Technician: *Scotty*

Approved by: *Wep*



ATD Serial No.: 630

Test Date: 2017-09-26

	Tested Parameter	Units	Spec. Low	Spec. High	Result	Pass/Fail
	Laboratory Temperature	°C	18.9	25.6	22.0	Pass
	Laboratory Humidity	%	10	70	22	Pass
Left Knee	Probe Velocity	m/s	2.070	2.130	2.107	Pass
	Peak Resistive Force	N	3450	4060	3871	Pass
Right Knee	Probe Velocity	m/s	2.070	2.130	2.109	Pass
	Peak Resistive Force	N	3450	4060	3949	Pass
					Overall Test Results	Pass

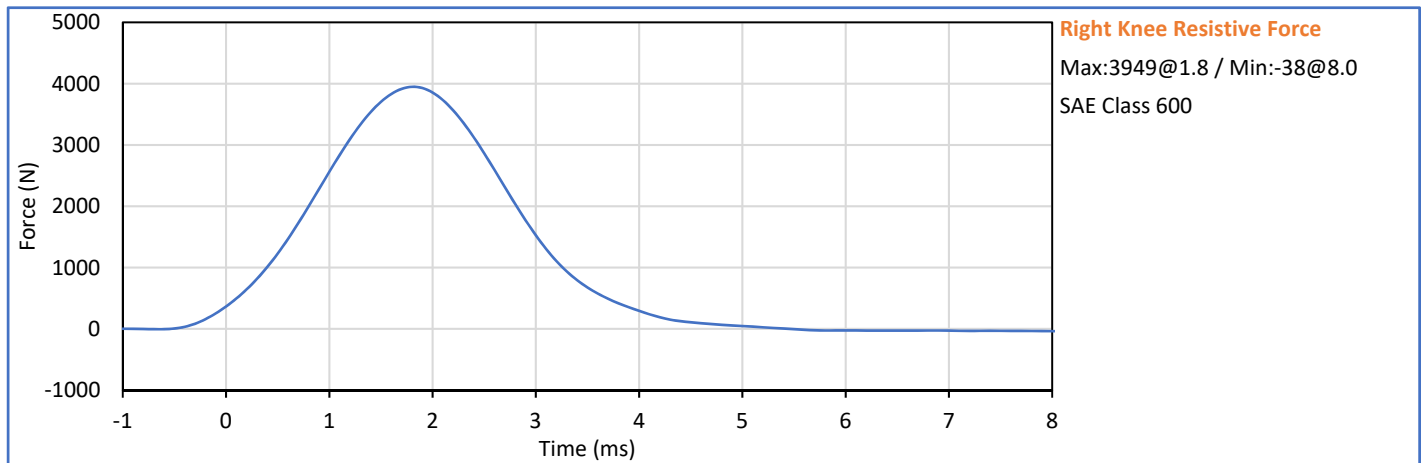
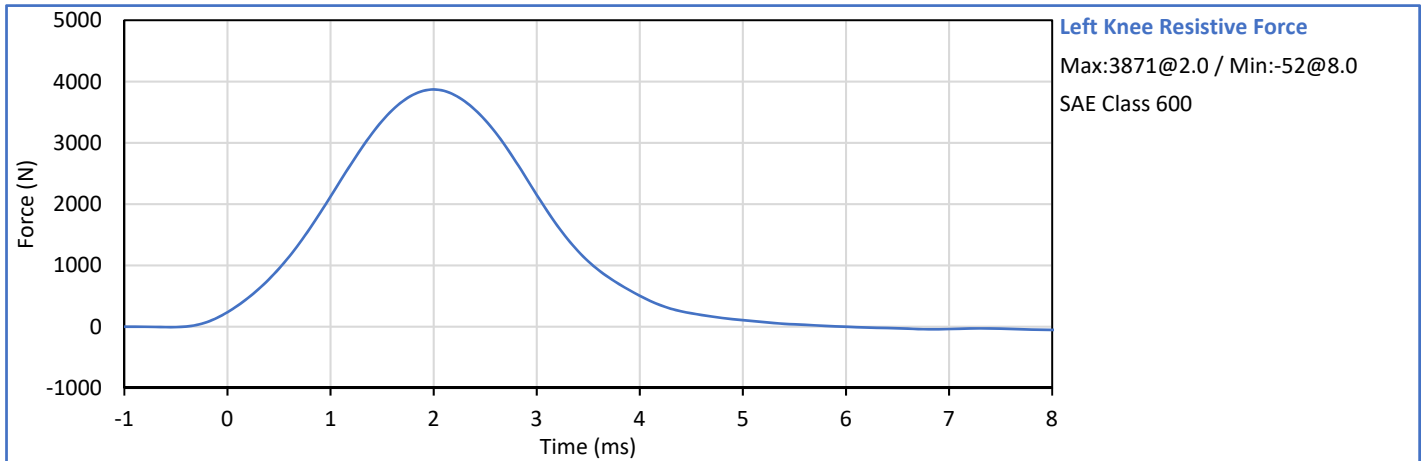

Technician:

Approved by:



Hybrid III 5th Percentile Female Torso Flexion Test

ATD Serial No.: 630

Test Date: 2017-09-27

Tested Parameter	Units	Spec. Low	Spec. High	Result	Pass/Fail
Laboratory Temperature	°C	20.6	22.2	21.8	Pass
Laboratory Humidity	%	10	70	27	Pass
Orientation Angle	deg	0.0	20.0	12.2	Pass
Test Initial Angle	deg	11.0	19.0	16.2	Pass
Peak Force at 45° (+/-0.5°)	N	320.0	390.0	385.1	Pass
Torso Flexion Rate	deg/s	0.50	1.50	1.07	Pass
Final Reference Plane Angle	deg	-8.0	8.0	5.1	Pass
Overall Test Results					Pass

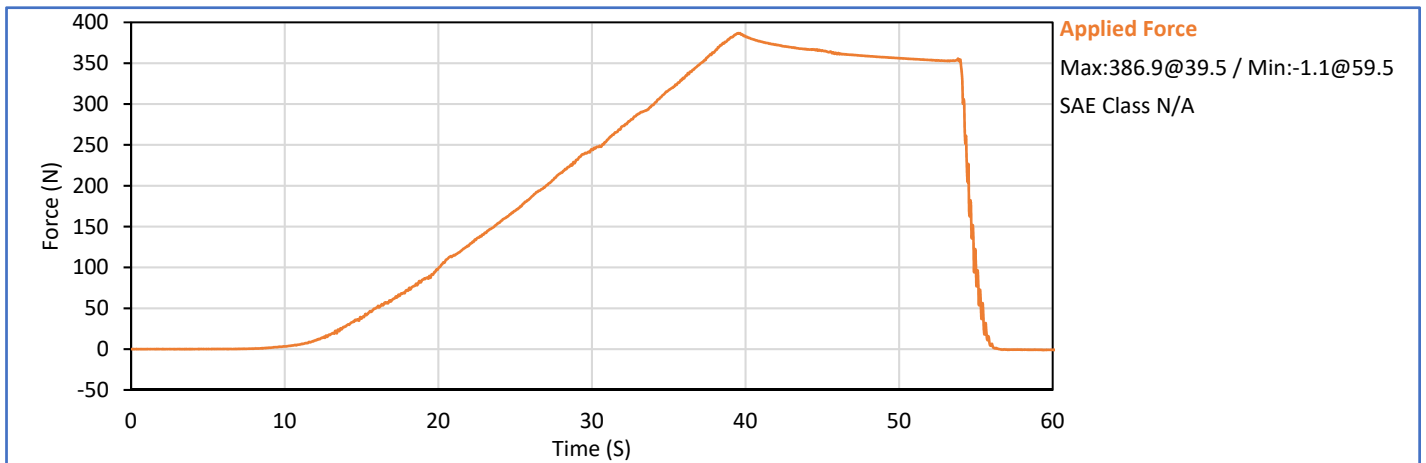
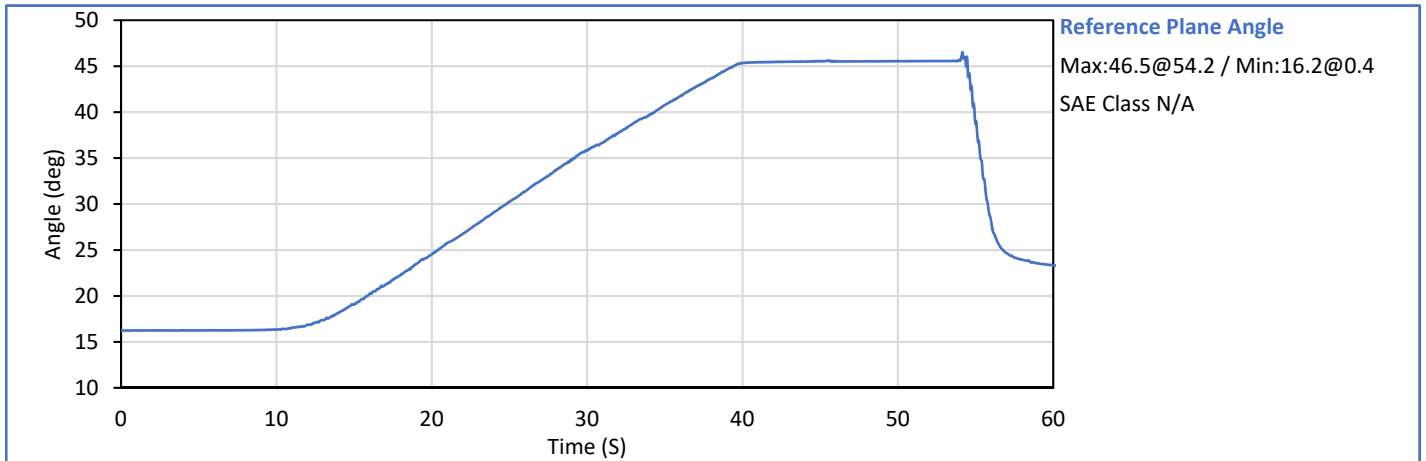

Technician: *Smith*

Approved by: *Wep*

APPENDIX C
POST-TEST ATD CONFIGURATION AND PERFORMANCE VERIFICATION DATA



ATD Serial No.: 360

Test Date: 2017-10-23

Dummy Item	Inspect for	Comments	Damage	Okay
Entire ATD	Perform general cleaning			✓
Outer Skin	Gashes, rips, cracks			✓
Head	Ballast secure			✓
	General appearance			✓
Neck bracket	Upper neck firmly attached to lower bracket			✓
Neck	Broken or cracked rubber			✓
	Looseness at the condyle joint			✓
Nodding block	Cracked or out of position			✓
Lumbar Spine	Broken or cracked rubber			✓
Ribs	Broken or bent ribs			✓
	Broken or bent rib supports			✓
	Damping material separated or cracked			✓
	Rubber bumpers in place			✓
Chest Displ. Assembly	Bent shaft			✓
	Slider arm riding in track			✓
Sensors	Check cables for cuts, tears			✓
	Check for damaged insulation			✓
Accelerometer Mounting	Head mounting secure			✓
	Chest mounting secure			✓
Knees	Skin condition			✓
	Insert (do not remove)			✓
	Casting			✓
Limbs	Normal movement and adjustment			✓
Knee Sliders	Wires intact			✓
	Rubber returned to "resting" position			✓
Pelvis	Broken			✓
Other	Describe below as needed			✓

Describe any repairs or replacement of parts or other findings:

Technician: 

Approved By: 



ATD Serial No.: 360

Test Date: 2017-10-23

Tested Parameter	Units	Spec. Low	Spec. High	Result	Pass/Fail
Laboratory Temperature	°C	20.6	22.2	21.1	Pass
Laboratory Relative Humidity	%	10	70	29	Pass
A - Total sitting height	mm	879.0	889.0	886	Pass
B - Shoulder pivot height	mm	505.0	521.0	510	Pass
C - 'H' point height	mm	84.0	89.0	86	Pass
D - 'H' point location from backline	mm	135.0	140.0	139	Pass
E - Shoulder pivot from backline	mm	84.0	94.0	91	Pass
F - Thigh clearance	mm	140.0	155.0	147	Pass
G - Back of elbow to wrist pivot	mm	290.0	305.0	298	Pass
H - Head back to backline	mm	41.0	46.0	44	Pass
I - Shoulder to elbow length	mm	330.0	345.0	337	Pass
J - Elbow rest height	mm	190.0	211.0	205	Pass
K - Buttock to knee length	mm	579.0	604.0	587	Pass
L - Popliteal length	mm	429.0	455.0	437	Pass
M - Knee pivot height	mm	485.0	500.0	495	Pass
N - Buttock popliteal length	mm	452.0	477.0	473	Pass
O - Chest depth without jacket	mm	213.0	229.0	227	Pass
P - Foot length	mm	251.0	267.0	263	Pass
V - Shoulder breadth	mm	422.0	437.0	436	Pass
W - Foot breadth	mm	91.0	107.0	99	Pass
Y - Chest circum. (w/chest jacket)	mm	970.0	1001.0	982	Pass
Z - Waist circum.	mm	836.0	866.0	865	Pass
AA - Location for chest circum.	mm	429.0	434.0	431	Pass
BB - Location for waist circum.	mm	226.0	231.0	231	Pass
Overall Test Results					Pass

Technician: 

Approved By: 



ATD Serial No.: 360

Test Date: 2017-10-19

Tested Parameter	Units	Spec. Low	Spec. High	Result	Pass/Fail
Laboratory Temperature	°C	18.9	25.6	21.7	Pass
Laboratory Humidity	%	10	70	23	Pass
Peak Resultant Acceleration	g	225.0	275.0	242.9	Pass
Peak Lateral Acceleration	g	-15.0	15.0	1.3	Pass
Oscillations After Main Pulse	%	0.0	10.0	3.1	Pass
Is Acceleration Unimodal?	Yes/No	Yes		Yes	Pass
Overall Test Results					Pass

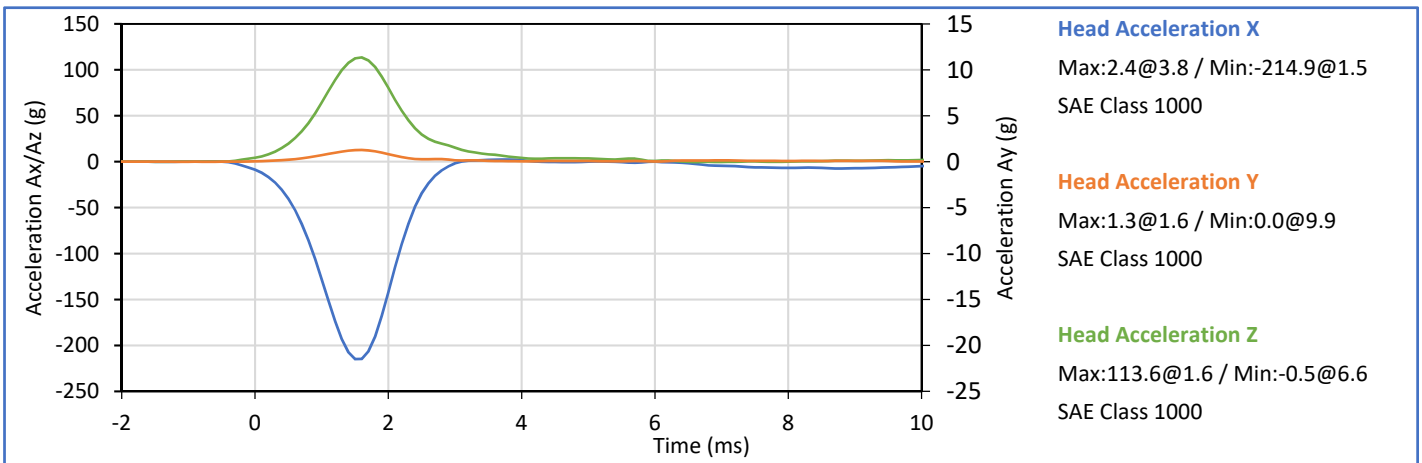
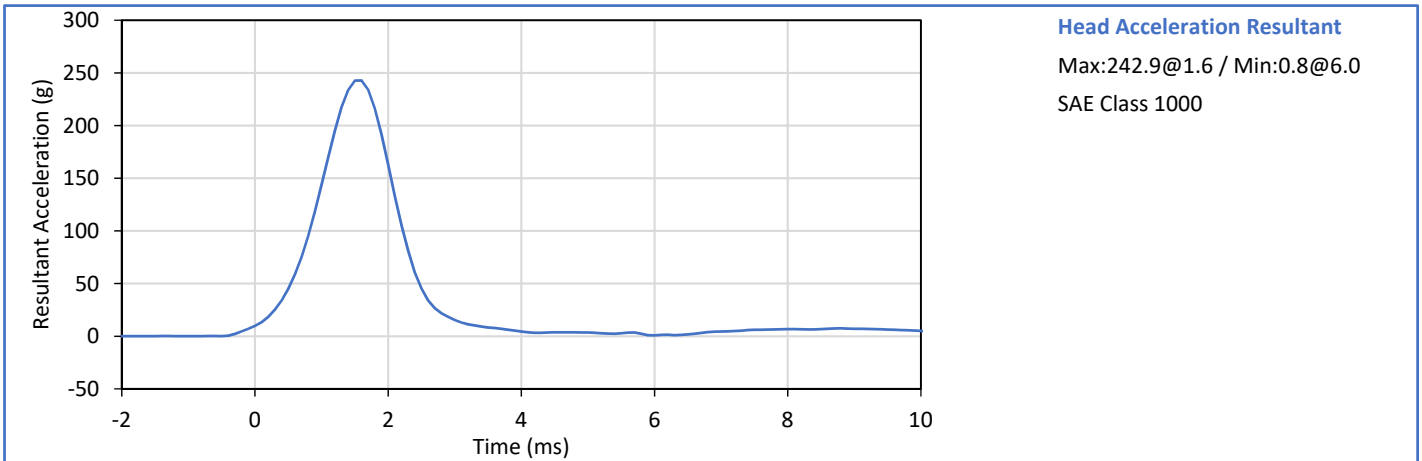

Technician: *Smith*

Approved By: *Wep*



ATD Serial No.: 360

Test Date: 2017-10-20

Tested Parameter	Units	Spec. Low	Spec. High	Result	Pass/Fail
Laboratory Temperature	°C	20.6	22.2	21.1	Pass
Laboratory Humidity	%	10	70	22	Pass
Pendulum Velocity	m/s	6.89	7.13	7.06	Pass
Pendulum Deceleration at 10 ms	g	22.5	27.5	25.6	Pass
Pendulum Deceleration at 20 ms	g	17.6	22.6	20.8	Pass
Pendulum Deceleration at 30 ms	g	12.5	18.5	15.4	Pass
Peak Pendulum Decel. after 30 ms	g	0.0	29.0	15.4	Pass
Deceleration Decay to Cross 5 g	ms	34.0	42.0	37.9	Pass
"D" Plane Rotation peak	deg	64.0	78.0	71.4	Pass
	ms	57.0	64.0	57.7	Pass
"D" Plane Rotation Decay To Zero	ms	113.0	128.0	113.3	Pass
Moment About Occipital Condyle	Nm	88.1	108.5	89.3	Pass
	ms	47.0	58.0	50.7	Pass
Moment Decay, Peak to Zero	deg	97.0	107.0	97.7	Pass
Overall Test Results					Pass

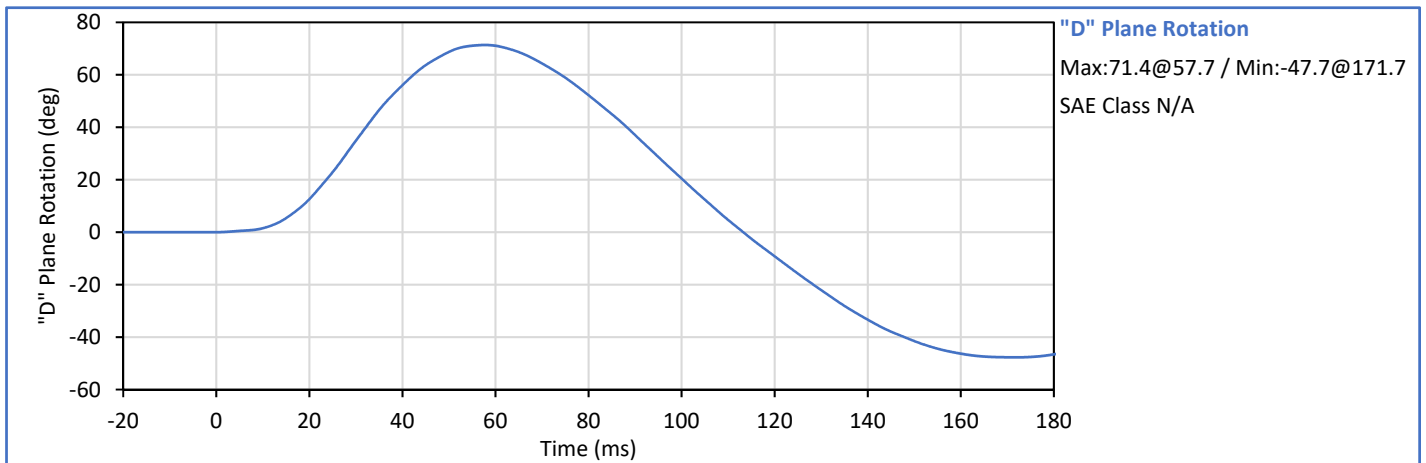
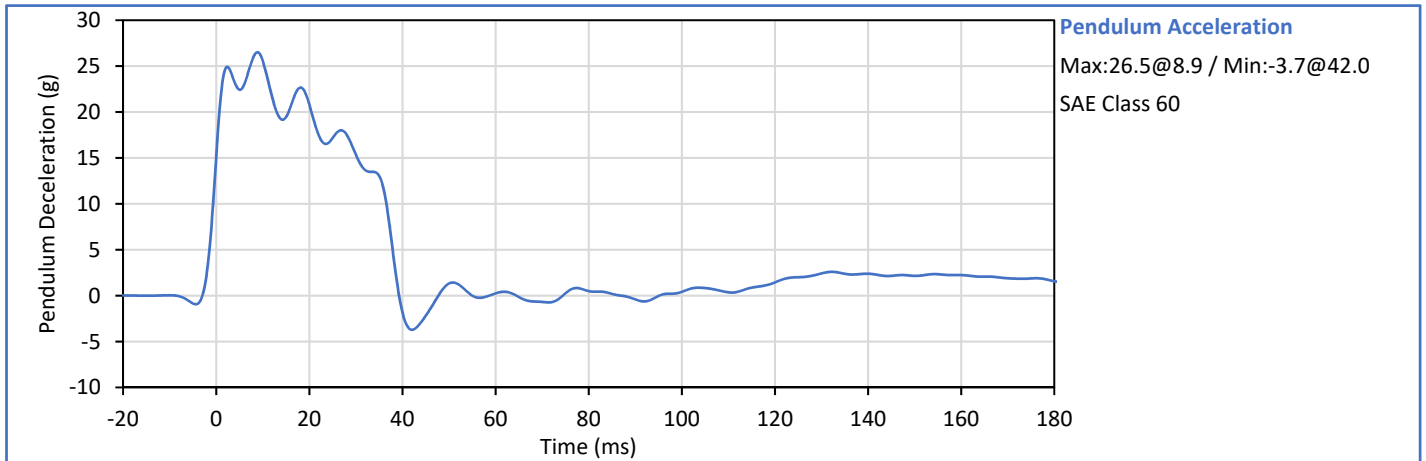

Technician: *Smith*

Approved By: *Wep*



ATD Serial No.: 360

Test Date: 2017-10-20

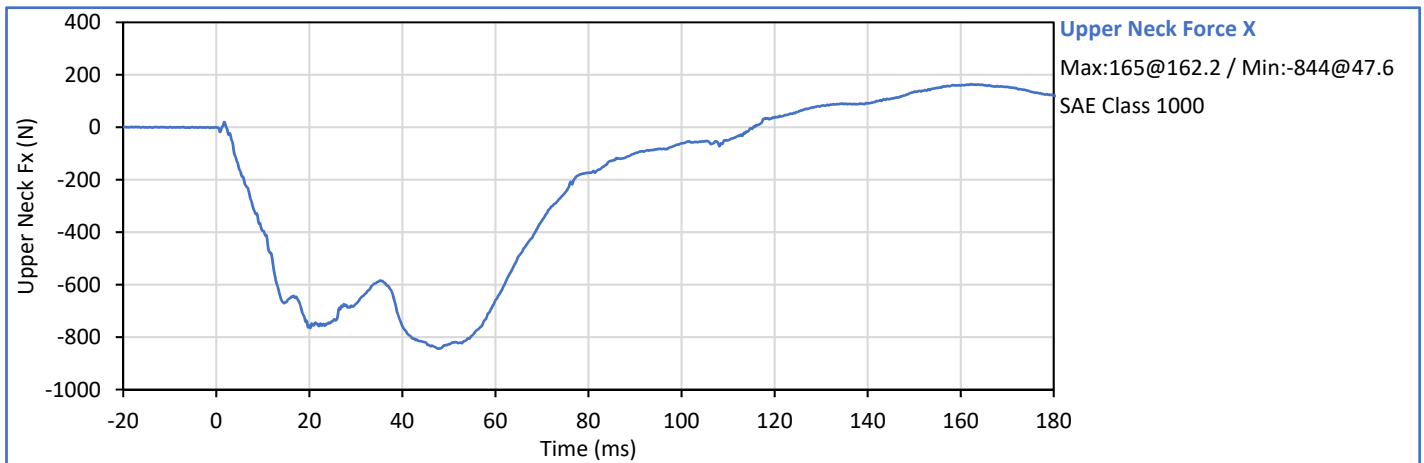
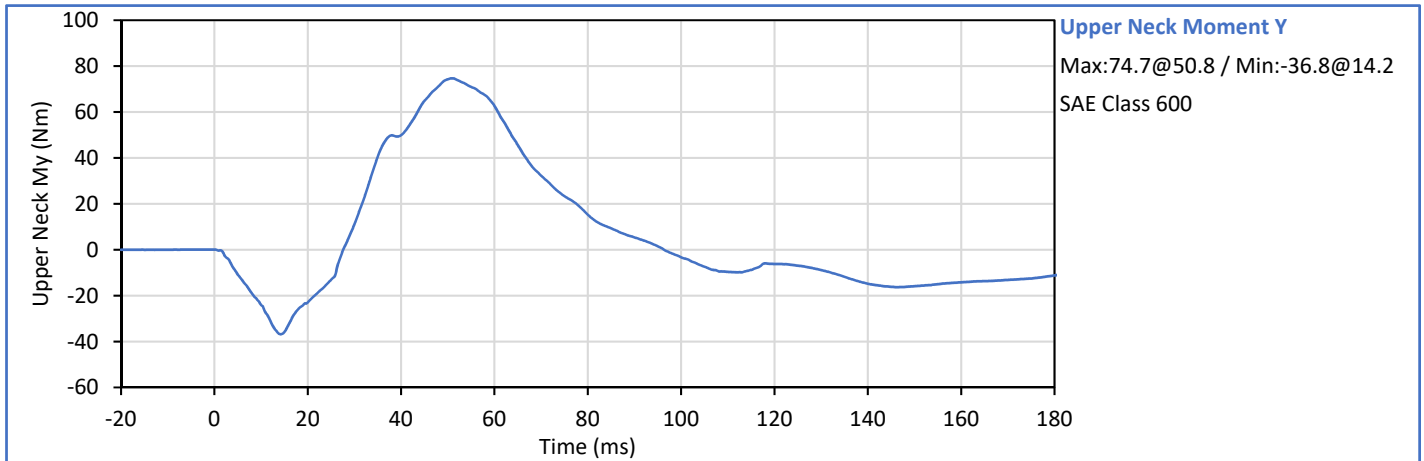
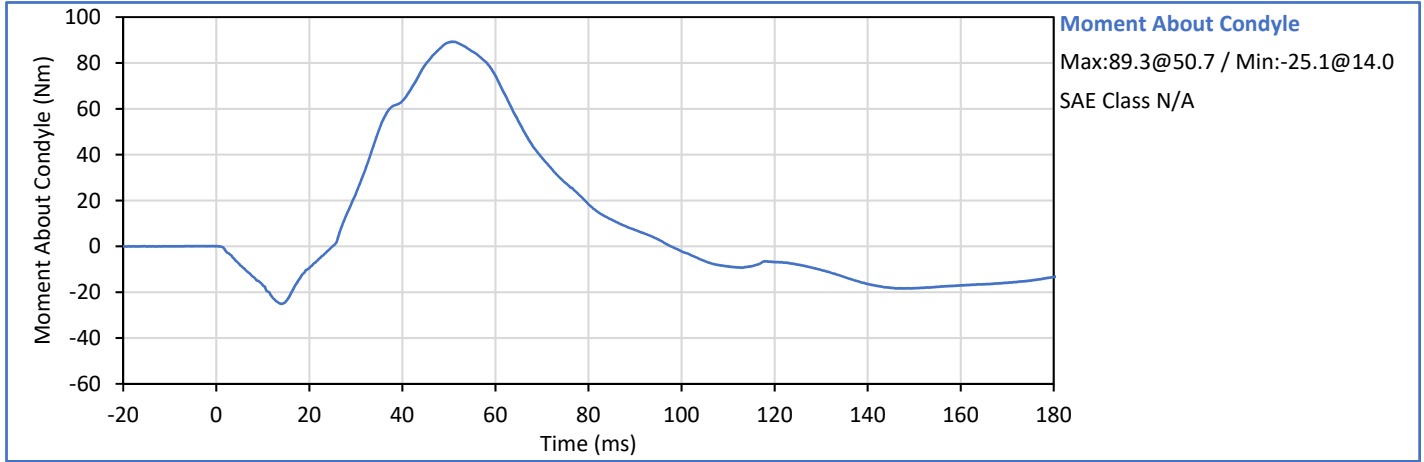



ATD Serial No.: 360

Test Date: 2017-10-20

Tested Parameter	Units	Spec. Low	Spec. High	Result	Pass/Fail
Laboratory Temperature	°C	20.6	22.2	21.6	Pass
Laboratory Humidity	%	10	70	35	Pass
Pendulum Velocity	m/s	5.94	6.19	6.08	Pass
Pendulum Deceleration at 10 ms	g	17.2	21.2	20.4	Pass
Pendulum Deceleration at 20 ms	g	14.0	19.0	18.1	Pass
Pendulum Deceleration at 30 ms	g	11.0	16.0	14.3	Pass
Peak Pendulum Decel. after 30 ms	g	0.0	22.0	14.3	Pass
Deceleration Decay to Cross 5 g	ms	38.0	46.0	38.2	Pass
"D" Plane Rotation peak	deg	81.0	106.0	101.0	Pass
	ms	72.0	82.0	72.4	Pass
"D" Plane Rotation Decay To Zero	ms	147.0	174.0	151.9	Pass
Moment About Occipital Condyle	Nm	-79.9	-52.9	-73.3	Pass
	ms	65.0	79.0	66.4	Pass
Moment Decay, Peak to Zero	deg	120.0	148.0	131.3	Pass
Overall Test Results					Pass

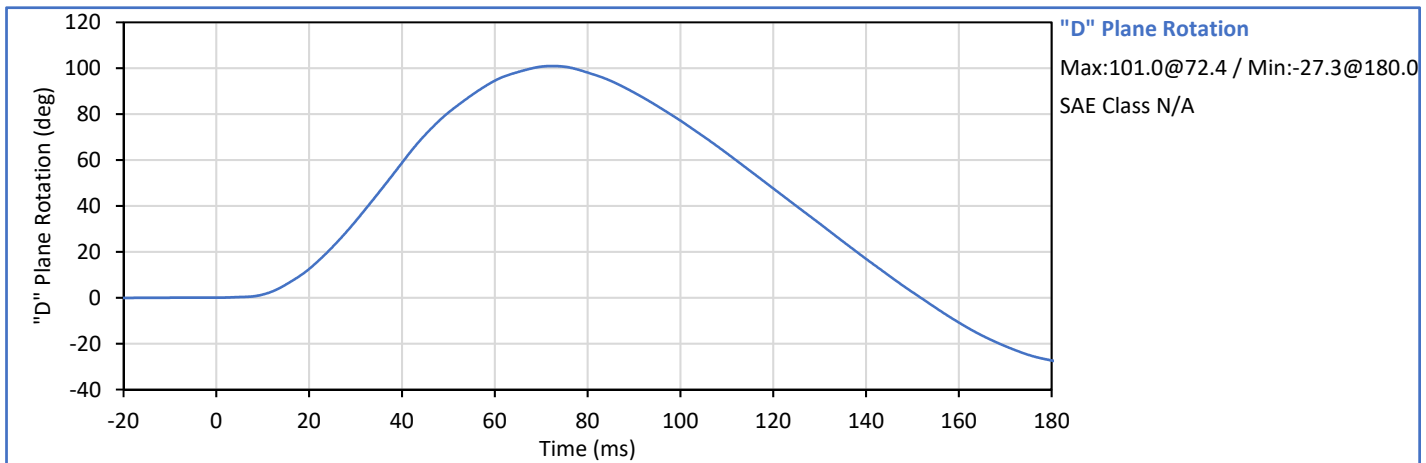
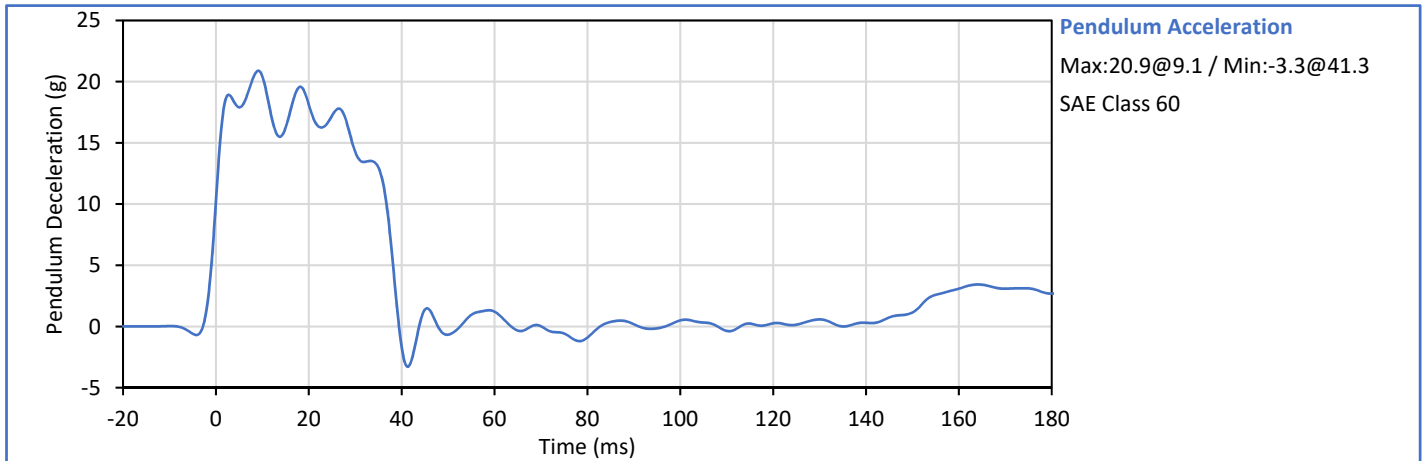

Technician: *Smith*

Approved By: *Wep*



ATD Serial No.: 360

Test Date: 2017-10-20

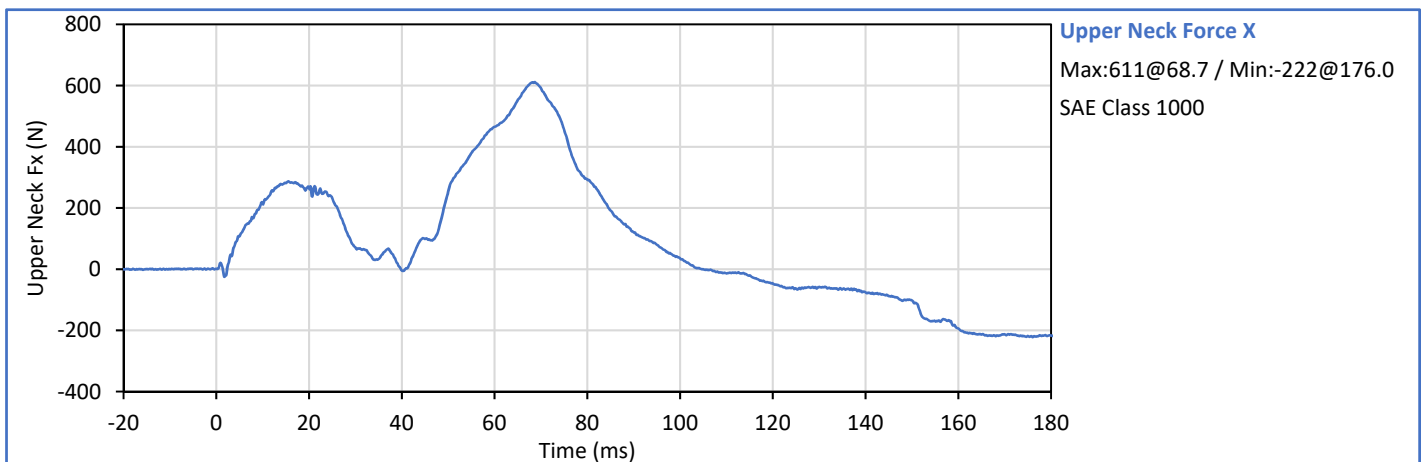
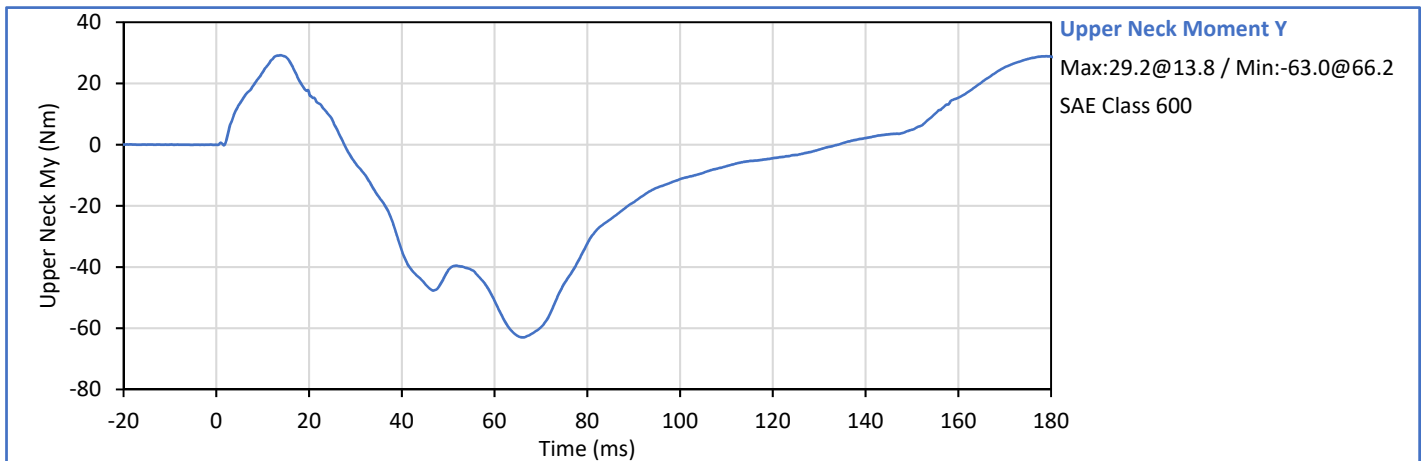
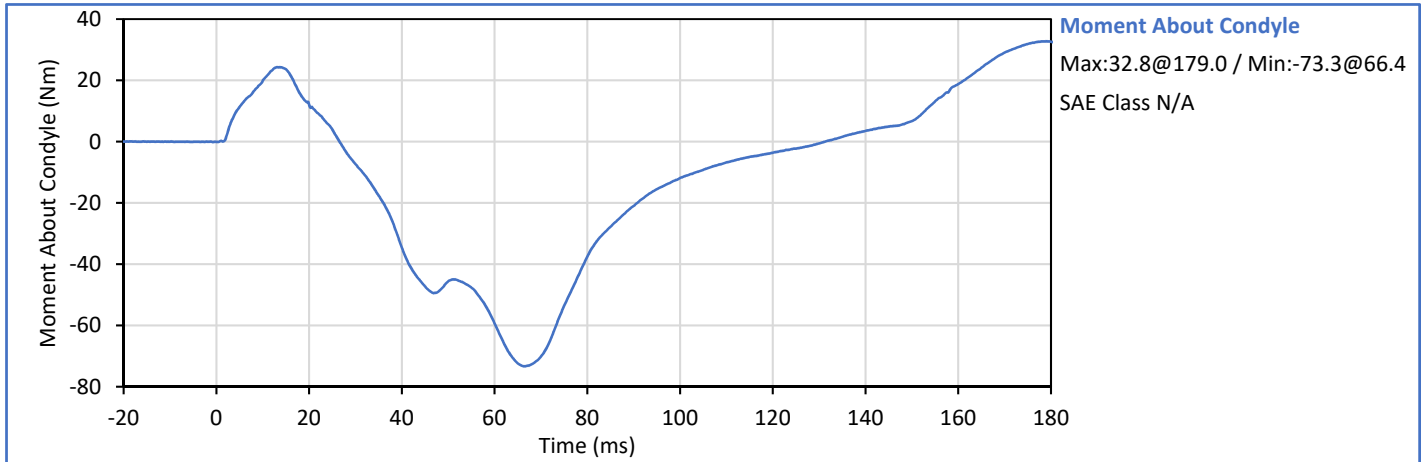



ATD Serial No.: 360

Test Date: 2017-10-19

Tested Parameter	Units	Spec. Low	Spec. High	Result	Pass/Fail
Laboratory Temperature	°C	20.6	22.2	21.8	Pass
Laboratory Humidity	%	10	70	26	Pass
Probe Velocity	m/s	6.58	6.82	6.75	Pass
Peak Chest Deflection	cm	6.35	7.26	6.77	Pass
Peak Probe Force	kN	5.159	5.893	5.723	Pass
Internal Hysteresis	%	69.0	85.0	71.3	Pass
Overall Test Results					Pass

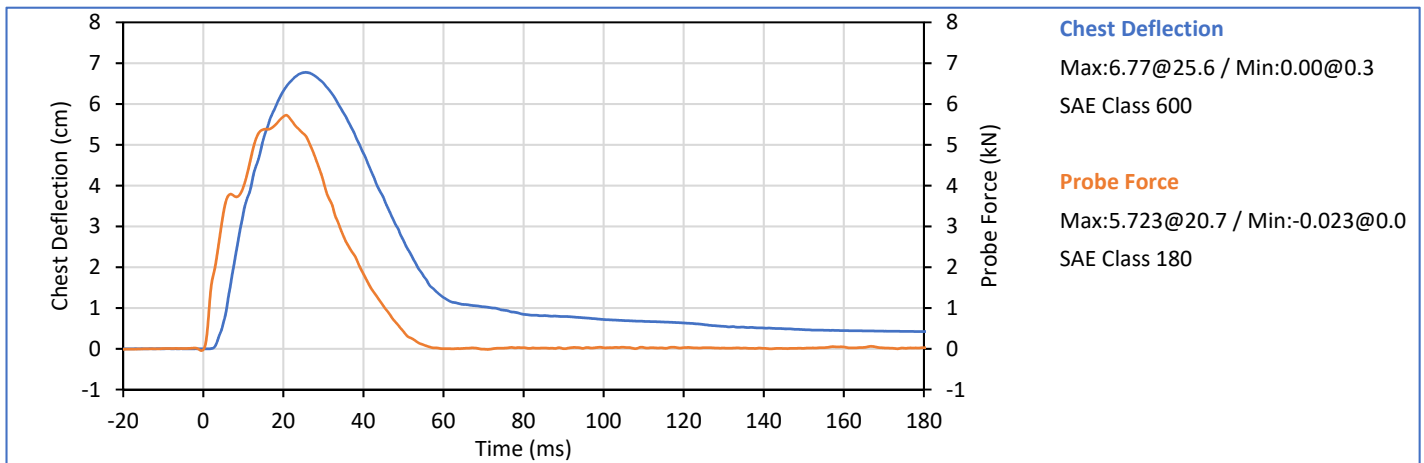
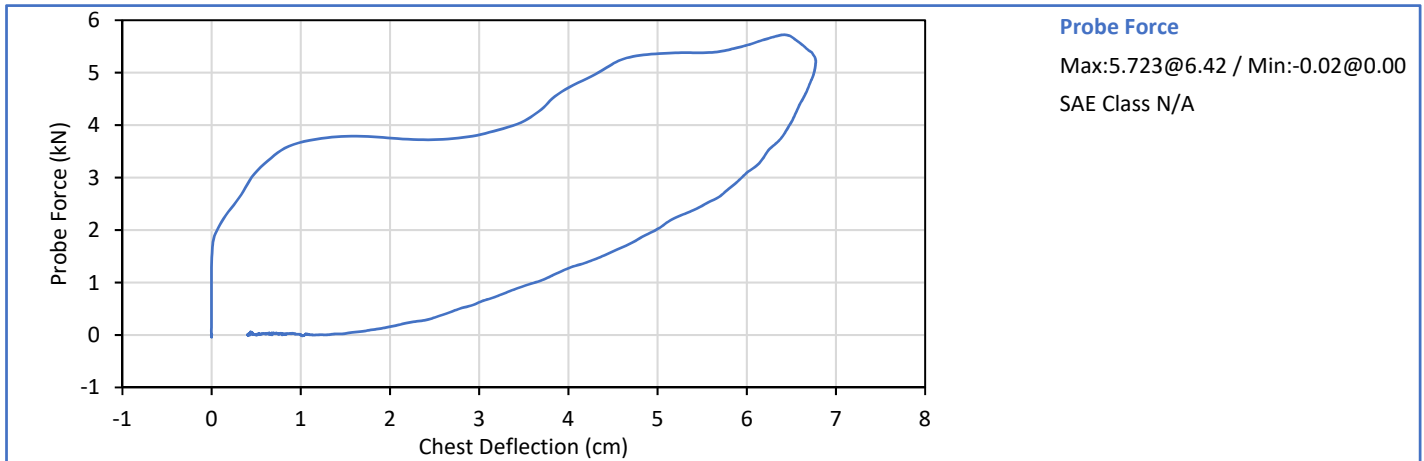

Technician: *Smith*

Approved By: *Wep*



ATD Serial No.: 360

Test Date: 2017-10-19

	Tested Parameter	Units	Spec. Low	Spec. High	Result	Pass/Fail
	Laboratory Temperature	°C	18.9	25.6	21.3	Pass
	Laboratory Humidity	%	10	70	23	Pass
Left Knee	Probe Velocity	m/s	2.070	2.130	2.083	Pass
	Peak Resistive Force	N	4715	5782	5174	Pass
Right Knee	Probe Velocity	m/s	2.070	2.130	2.111	Pass
	Peak Resistive Force	N	4715	5782	5717	Pass
					Overall Test Results	Pass

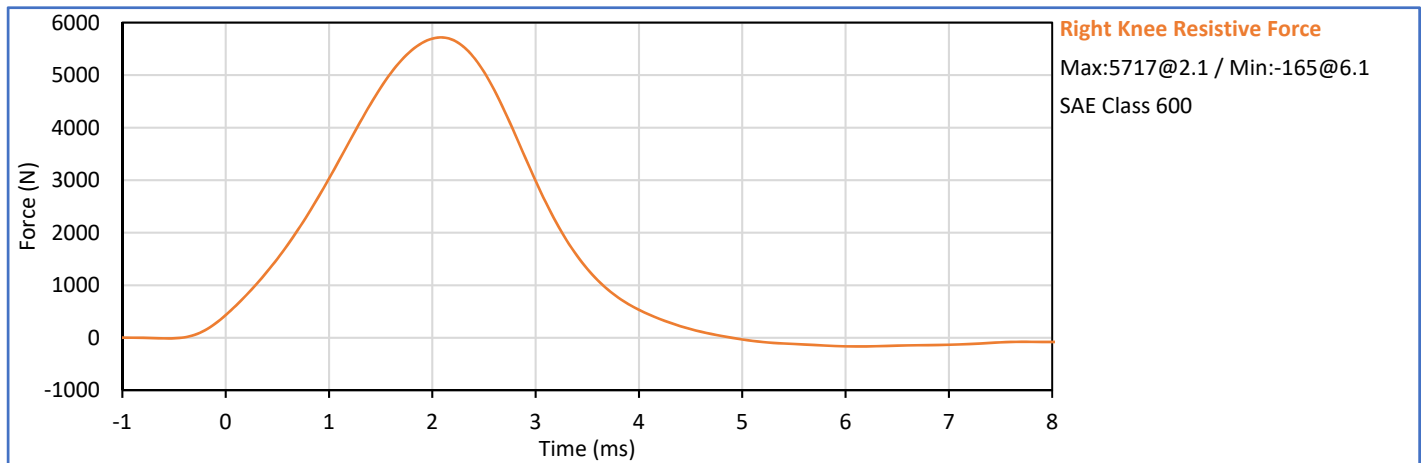
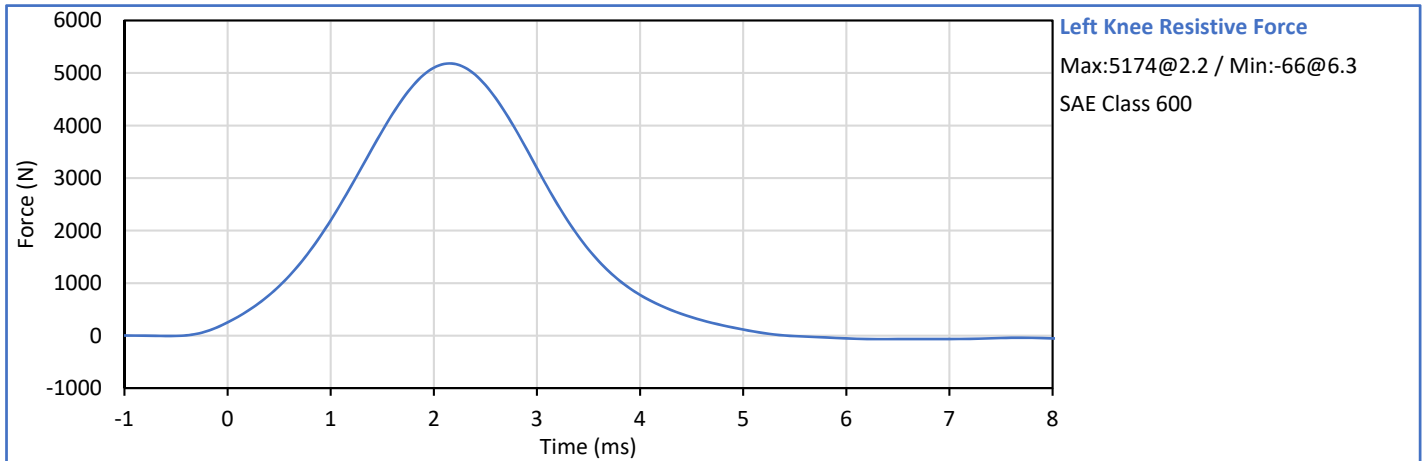

Technician:

Approved By:



ATD Serial No.: 360

Test Date: 2017-10-23

Tested Parameter	Units	Spec. Low	Spec. High	Result	Pass/Fail	
Laboratory Temperature	°C	18.9	25.6	21.7	Pass	
Laboratory Humidity	%	10	70	26	Pass	
Left Hip	Left Hip Rotation Rate	deg/s	5.0	10.0	8.4	Pass
	Left Femur Torque at 30°	Nm	0.0	95.0	91.0	Pass
	Left Hip Rotation at 203 Nm	deg	40.0	50.0	44.1	Pass
Right Hip	Right Hip Rotation Rate	deg/s	5.0	10.0	8.0	Pass
	Right Femur Torque at 30°	Nm	0.0	95.0	90.4	Pass
	Right Hip Rotation at 203 Nm	deg	40.0	50.0	44.1	Pass
Overall Test Results					Pass	

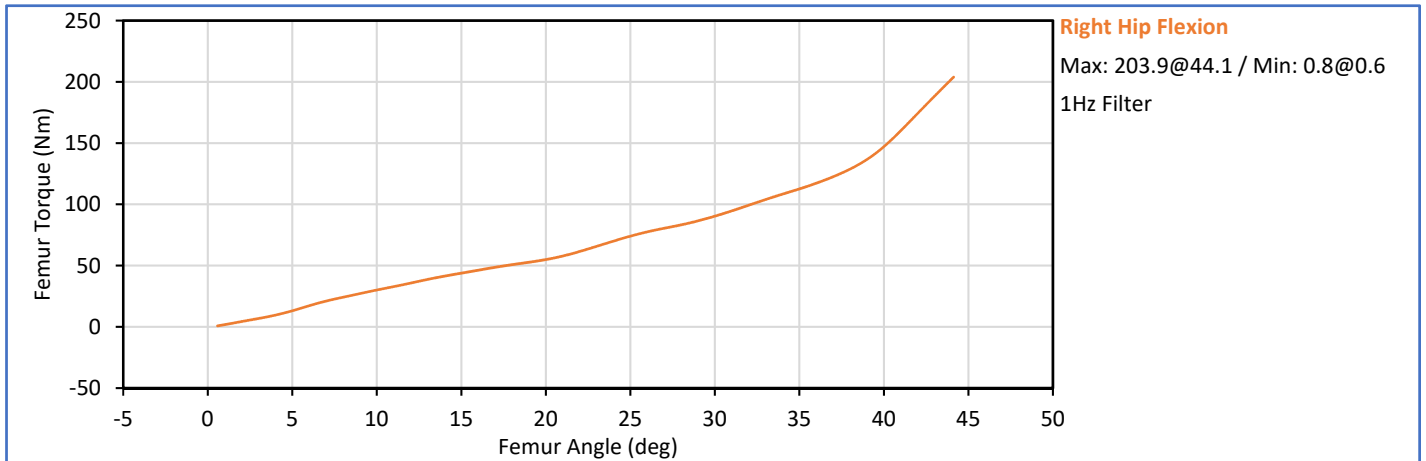
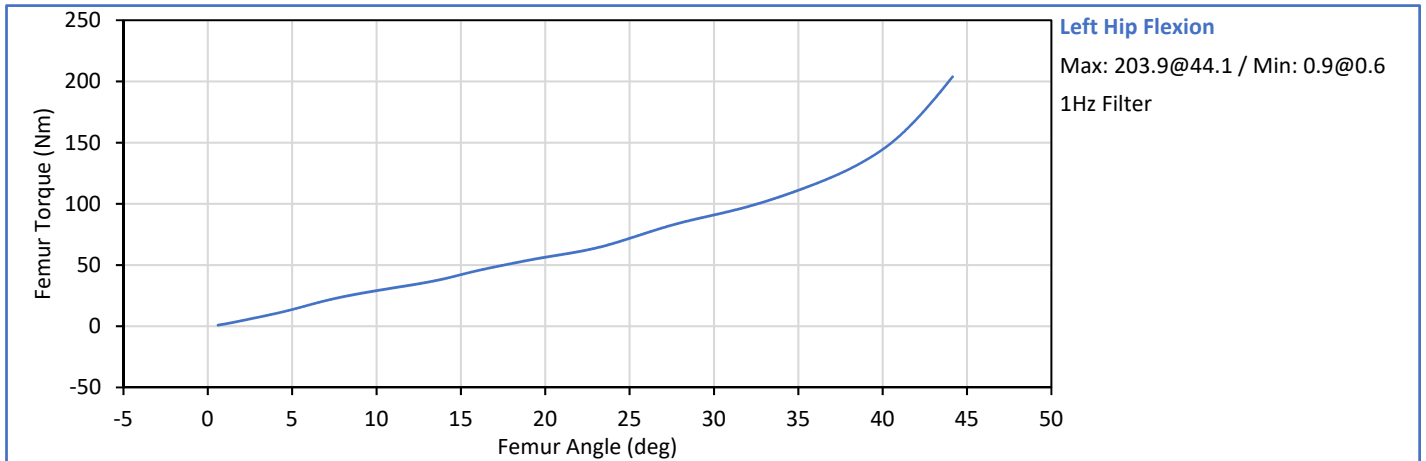

Technician: *Smith*

Approved By: *Wep*



ATD Serial No.: 630

Test Date: 2017-10-23

Dummy Item	Inspect for	Comments	Damage	Okay
Entire ATD	Perform general cleaning			✓
Outer Skin	Gashes, rips, cracks			✓
Head	Ballast secure			✓
	General appearance			✓
Neck bracket	Upper neck firmly attached to lower bracket			✓
Neck	Broken or cracked rubber			✓
	Looseness at the condyle joint			✓
Nodding block	Cracked or out of position			✓
Lumbar Spine	Broken or cracked rubber			✓
Ribs	Broken or bent ribs			✓
	Broken or bent rib supports			✓
	Damping material separated or cracked			✓
	Rubber bumpers in place			✓
Chest Displ. Assembly	Bent shaft			✓
	Slider arm riding in track			✓
Sensors	Check cables for cuts, tears			✓
	Check for damaged insulation			✓
Accelerometer Mounting	Head mounting secure			✓
	Chest mounting secure			✓
Knees	Skin condition			✓
	Insert (do not remove)			✓
	Casting			✓
Limbs	Normal movement and adjustment			✓
Knee Sliders	Wires intact			✓
	Rubber returned to "resting" position			✓
Pelvis	Broken			✓
Other	Describe below as needed			✓

Describe any repairs or replacement of parts or other findings:

Technician: 

Approved By: 



ATD Serial No.: 630

Test Date: 2017-10-23

Tested Parameter	Units	Spec. Low	Spec. High	Result	Pass/Fail
Laboratory Temperature	°C	20.6	22.2	21.2	Pass
Laboratory Relative Humidity	%	10	70	45	Pass
A - Total sitting height	mm	775	800	786	Pass
B - Shoulder pivot height	mm	432	457	450	Pass
C - 'H' point height	mm	81	86	85	Pass
D - 'H' point location from backline	mm	145	150	146	Pass
E - Shoulder pivot from backline	mm	69	84	77	Pass
F - Thigh clearance	mm	119	135	126	Pass
G - Back of elbow to wrist pivot	mm	244	259	250	Pass
H - Head back to backline	mm	41	46	44	Pass
I - Shoulder to elbow length	mm	277	297	285	Pass
J - Elbow rest height	mm	183	203	198	Pass
K - Buttock to knee length	mm	521	546	531	Pass
L - Popliteal length	mm	356	376	371	Pass
M - Knee pivot height	mm	394	419	402	Pass
N - Buttock popliteal length	mm	414	439	420	Pass
O - Chest depth without jacket	mm	175	191	186	Pass
P - Foot length	mm	219	234	221	Pass
R - Buttock to Knee Pivot Length	mm	457	483	473	Pass
S - Head Breadth	mm	137	147	144	Pass
T - Head Depth	mm	178	188	180	Pass
U - Hip Breadth	mm	300	315	302	Pass
V - Shoulder breadth	mm	351	366	359	Pass
W - Foot breadth	mm	79	94	90	Pass
X - Head circum.	mm	528	549	541	Pass
Y - Chest circum. (w/chest jacket)	mm	851	881	864	Pass
Z - Waist circum.	mm	760	790	766	Pass
AA - Location for chest circum.	mm	300	310	300	Pass
BB - Location for waist circum.	mm	160	170	164	Pass
Overall Test Results					Pass

Technician: 

Approved By: 



ATD Serial No.: 630

Test Date: 2017-10-19

Tested Parameter	Units	Spec. Low	Spec. High	Result	Pass/Fail
Laboratory Temperature	°C	18.9	25.6	21.9	Pass
Laboratory Humidity	%	10	70	24	Pass
Peak Resultant Acceleration	g	250.0	300.0	276.4	Pass
Peak Lateral Acceleration	g	-15.0	15.0	-8.3	Pass
Oscillations After Main Pulse	%	0.0	10.0	2.6	Pass
Is Acceleration Unimodal?	Yes/No	Yes		Yes	Pass
Overall Test Results					Pass

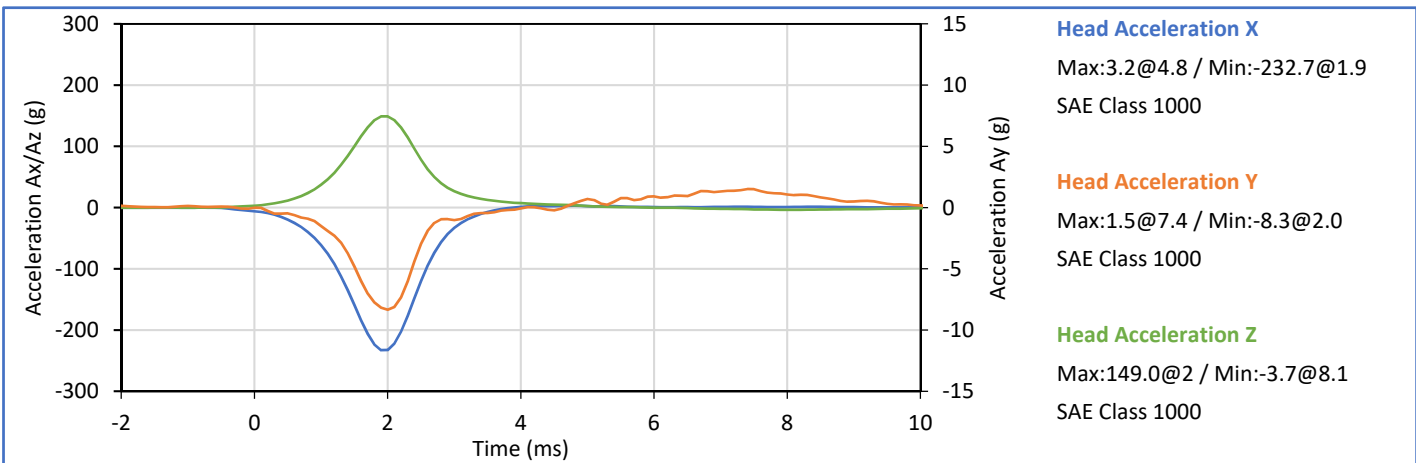
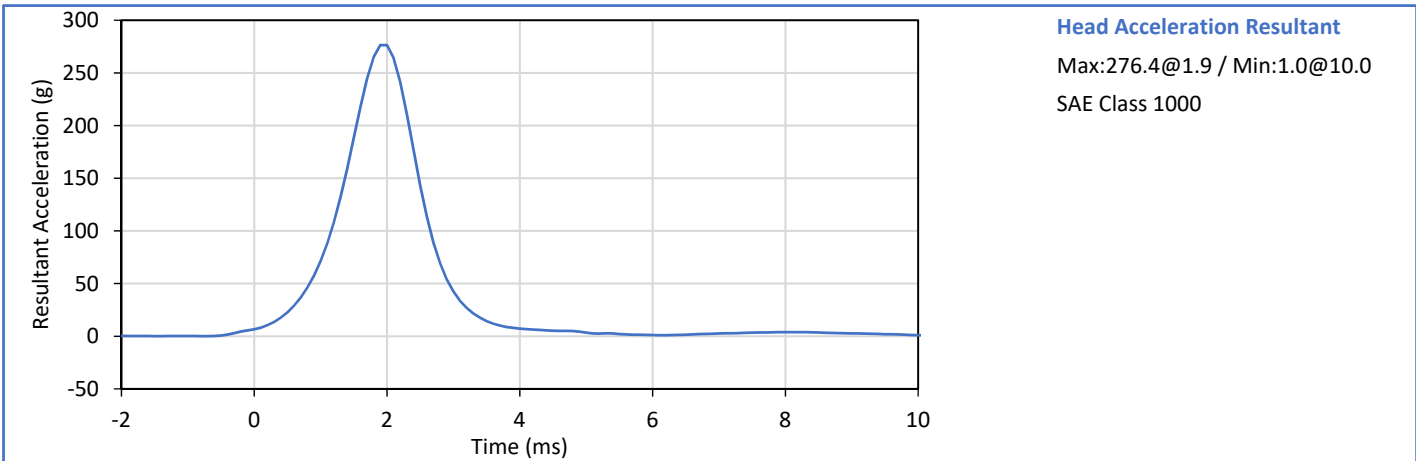

Technician: *Smith*

Approved By: *Wep*



ATD Serial No.: 630

Test Date: 2017-10-20

Tested Parameter	Units	Spec. Low	Spec. High	Result	Pass/Fail
Laboratory Temperature	°C	20.6	22.2	21.8	Pass
Laboratory Humidity	%	10	70	34	Pass
Pendulum Velocity	m/s	6.89	7.13	7.00	Pass
Pendulum Velocity at 10 ms	m/s	2.10	2.50	2.40	Pass
Pendulum Velocity at 20 ms	m/s	4.00	5.00	4.57	Pass
Pendulum Velocity at 30 ms	m/s	5.80	7.00	6.35	Pass
Peak "D" Plane Rotation	deg	77.0	91.0	79.2	Pass
Peak Moment in Rotation	Nm	69.0	83.0	79.6	Pass
Positive Moment Decay to 10 Nm	ms	80.0	100.0	86.4	Pass
Overall Test Results					Pass

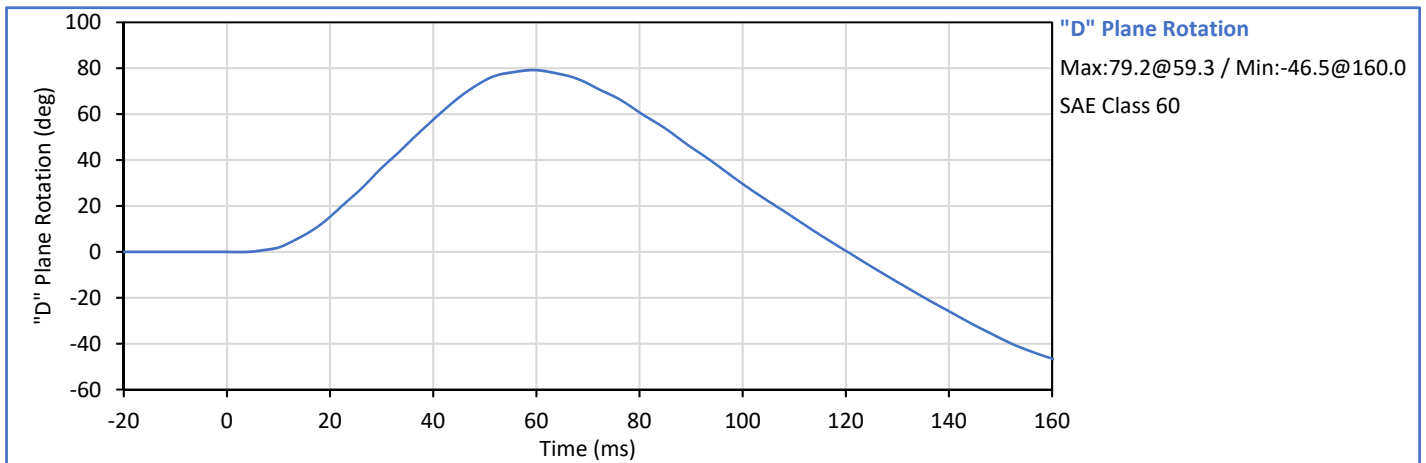
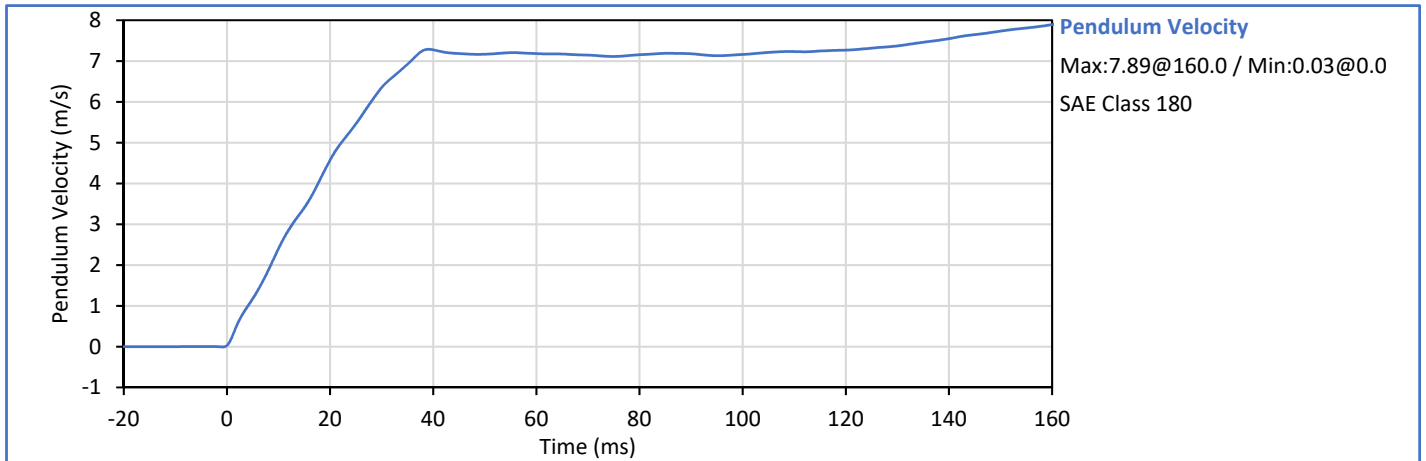

Technician: *Scott J*

Approved By: *Wep*



ATD Serial No.: 630

Test Date: 2017-10-20

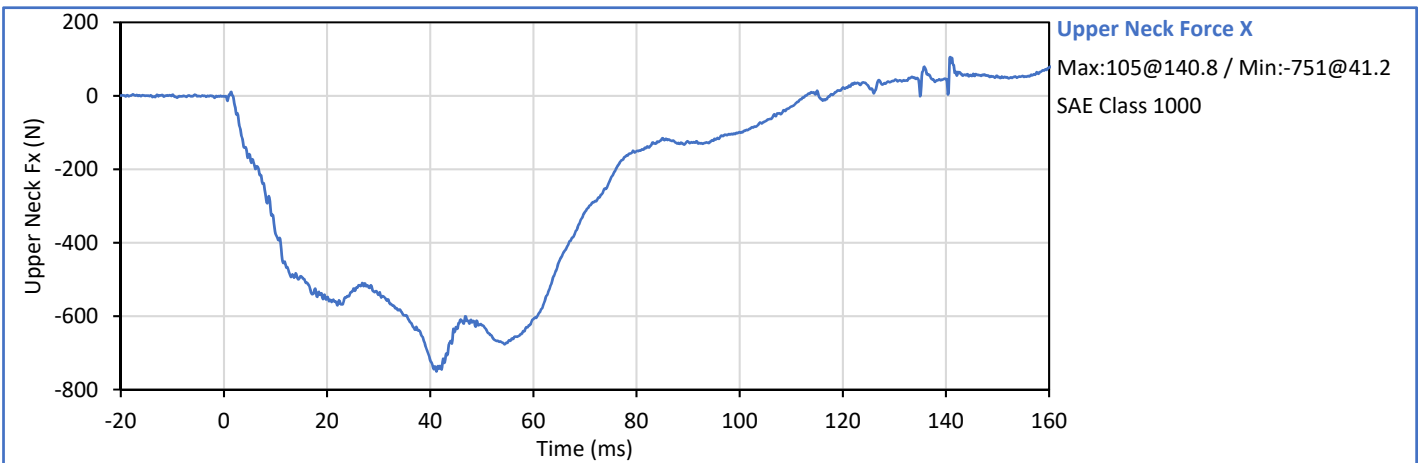
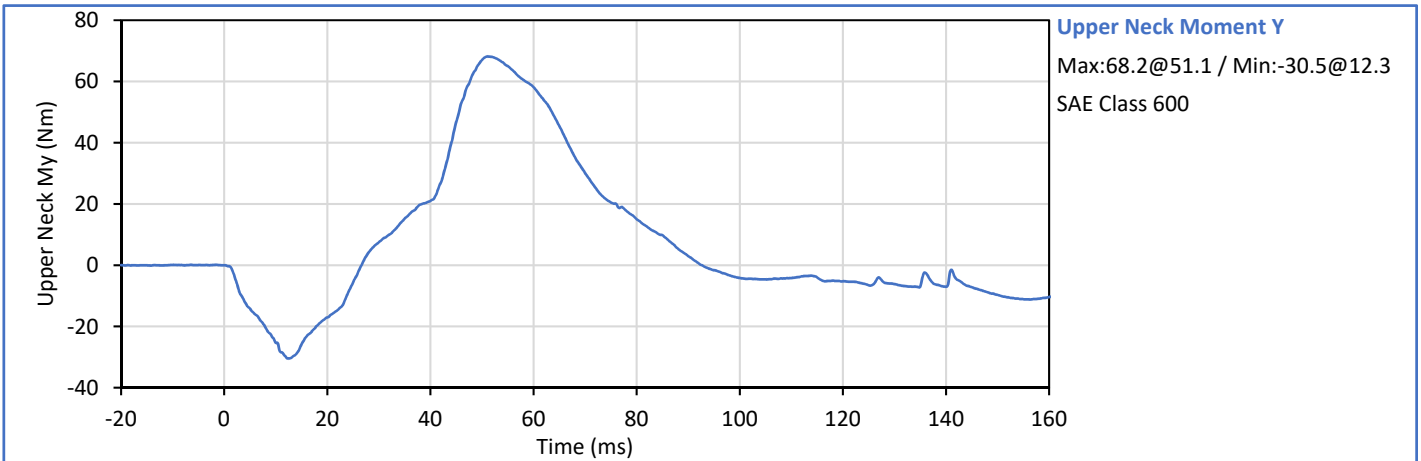
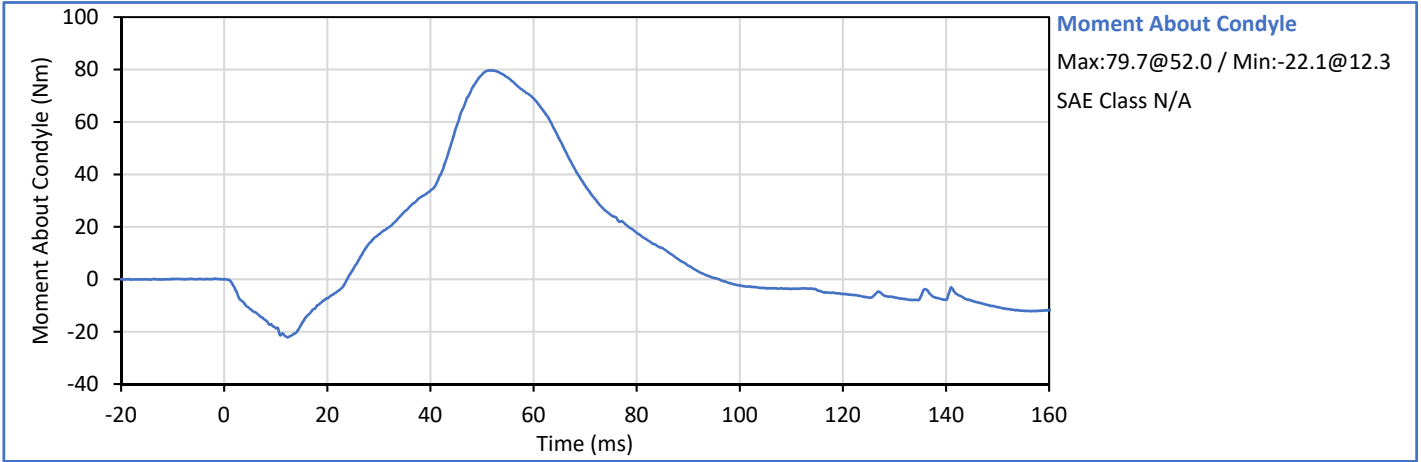



ATD Serial No.: 630

Test Date: 2017-10-20

Tested Parameter	Units	Spec. Low	Spec. High	Result	Pass/Fail
Laboratory Temperature	°C	20.6	22.2	21.6	Pass
Laboratory Humidity	%	10	70	35	Pass
Pendulum Velocity	m/s	5.95	6.19	6.07	Pass
Pendulum Velocity at 10 ms	m/s	1.50	1.90	1.79	Pass
Pendulum Velocity at 20 ms	m/s	3.10	3.90	3.57	Pass
Pendulum Velocity at 30 ms	m/s	4.60	5.60	5.17	Pass
Peak "D" Plane Rotation	deg	99.0	114.0	109.5	Pass
Peak Moment in Rotation	Nm	-65.0	-53.0	-63.1	Pass
Negative Moment Decay to -10 Nm	ms	94.0	114.0	102.4	Pass
Overall Test Results					Pass

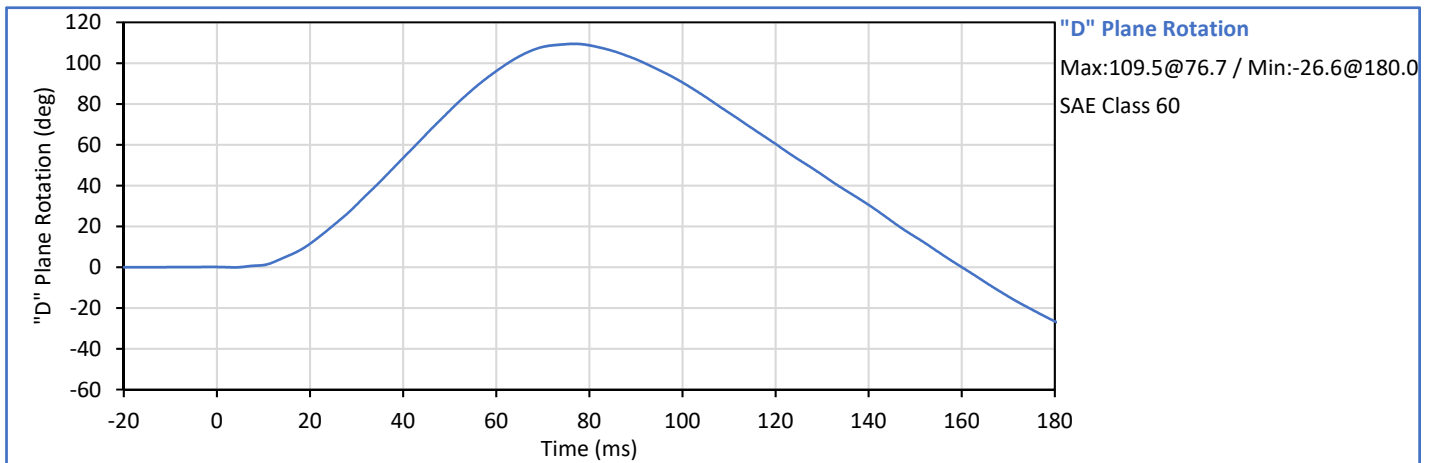
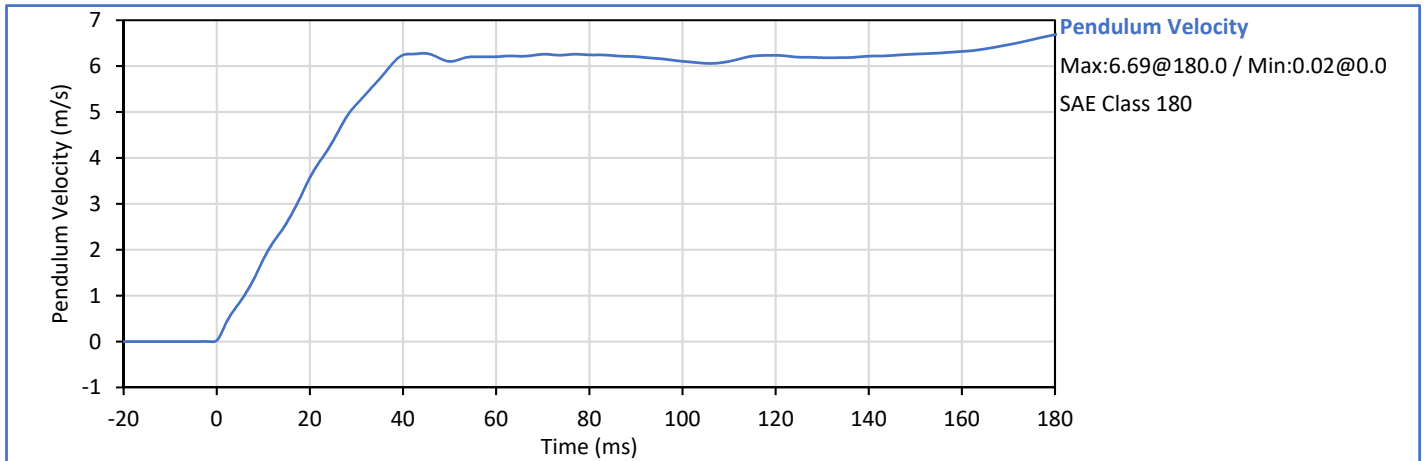

Technician:

Approved By:



ATD Serial No.: 630

Test Date: 2017-10-20

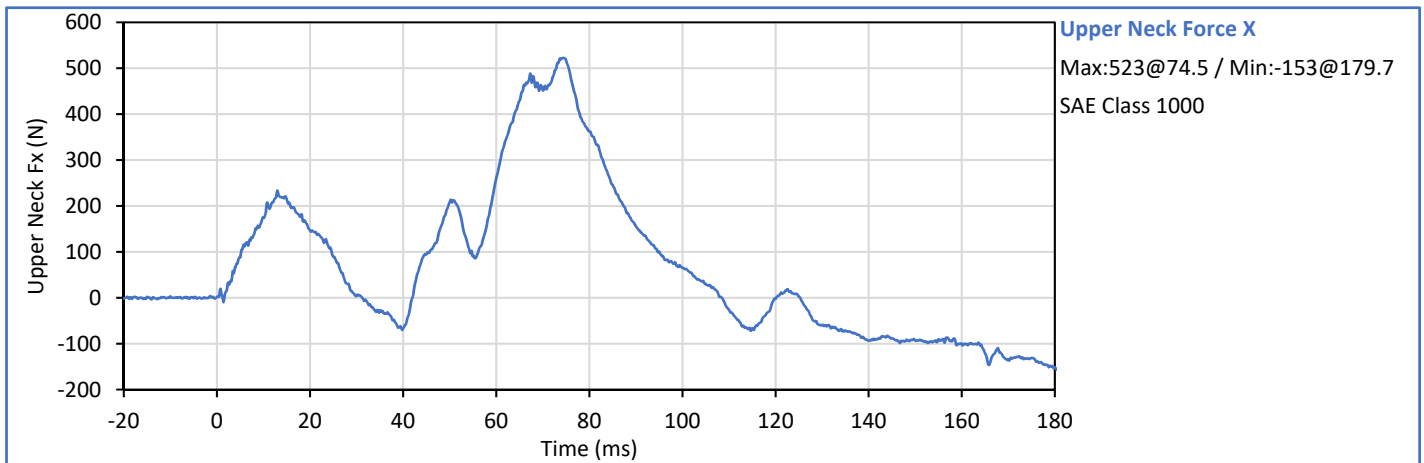
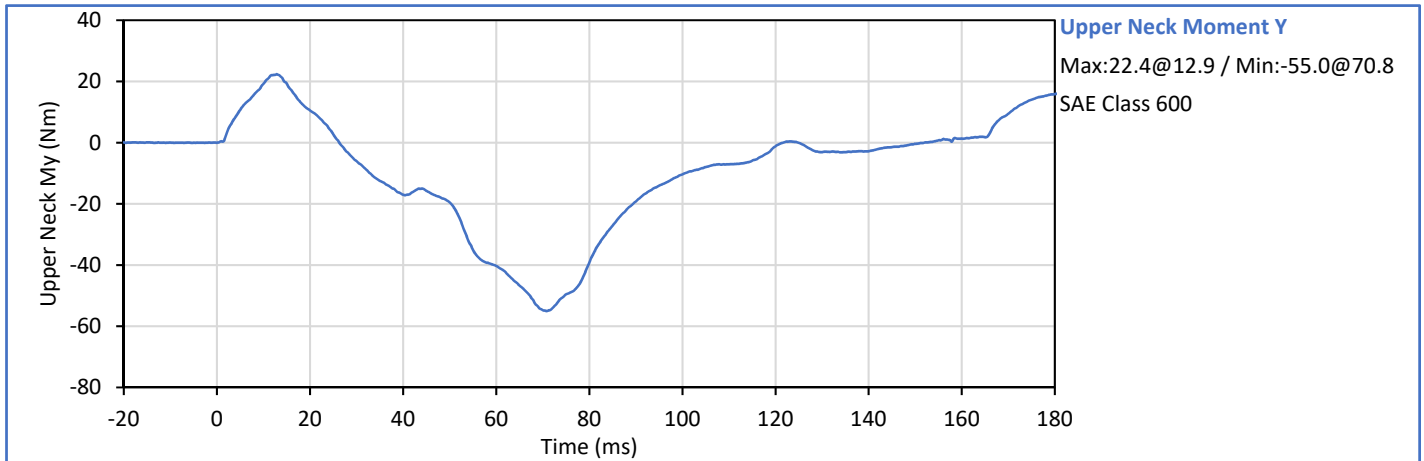
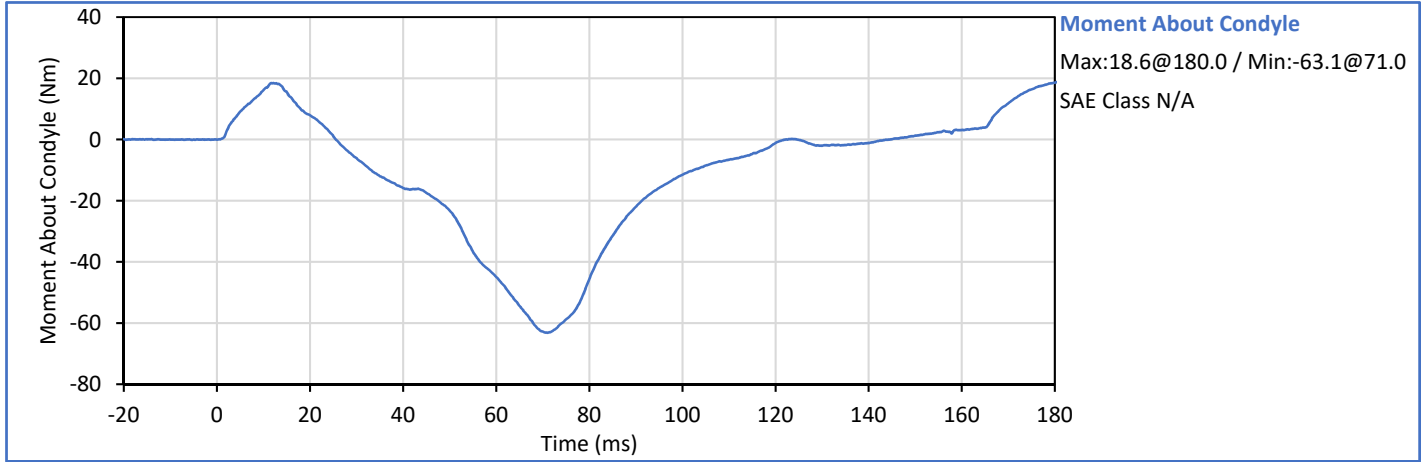



ATD Serial No.: 630

Test Date: 2017-10-19

Tested Parameter	Units	Spec. Low	Spec. High	Result	Pass/Fail
Laboratory Temperature	°C	20.6	22.2	20.7	Pass
Laboratory Humidity	%	10	70	19	Pass
Probe Velocity	m/s	6.59	6.83	6.78	Pass
Peak Chest Deflection	mm	50.0	58.0	56.6	Pass
Peak Probe Force, 50 and 58 mm	kN	3.900	4.400	4.054	Pass
Peak Probe Force, 18 and 50 mm	kN	0.000	4.600	3.857	Pass
Internal Hysterisis	%	69.0	85.0	70.7	Pass
Overall Test Results					Pass

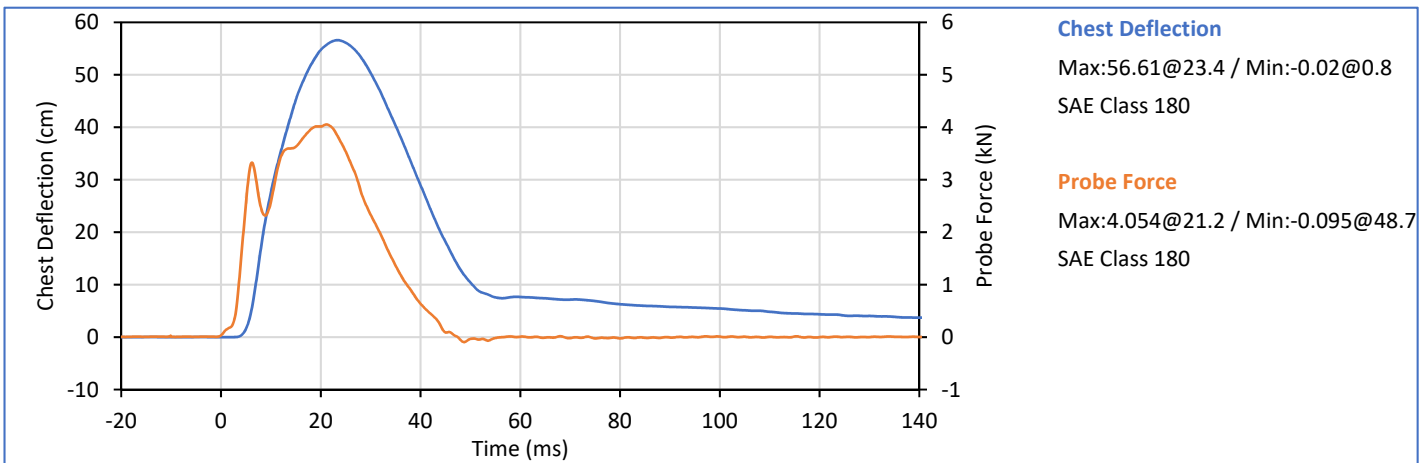
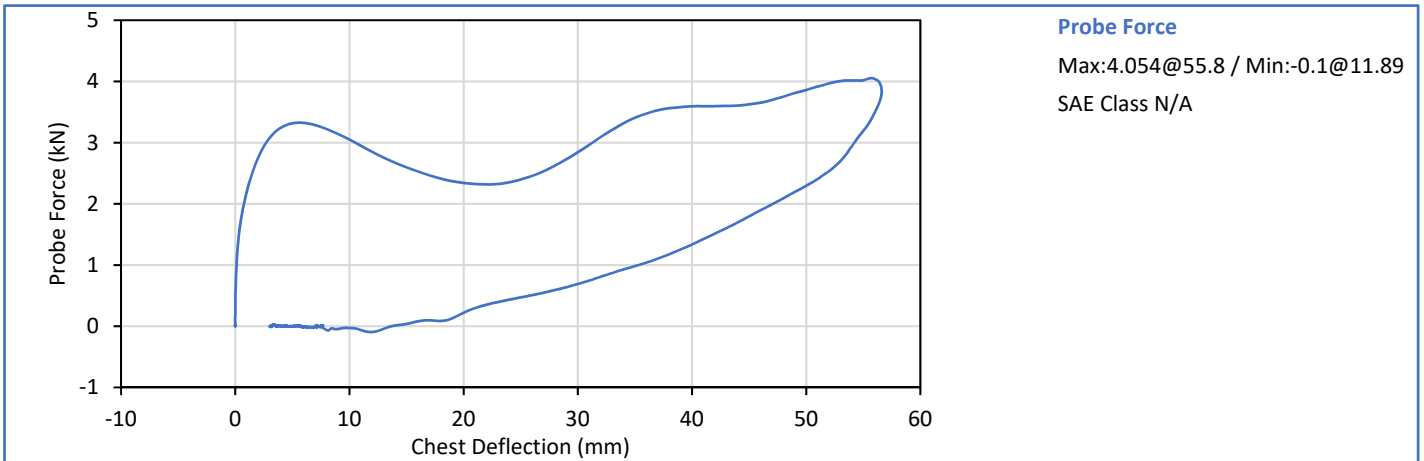

Technician: *Scotty*

Approved By: *Wep*



ATD Serial No.: 630

Test Date: 2017-10-19

	Tested Parameter	Units	Spec. Low	Spec. High	Result	Pass/Fail
	Laboratory Temperature	°C	18.9	25.6	22.0	Pass
	Laboratory Humidity	%	10	70	22	Pass
Left Knee	Probe Velocity	m/s	2.070	2.130	2.110	Pass
	Peak Resistive Force	N	3450	4060	3859	Pass
Right Knee	Probe Velocity	m/s	2.070	2.130	2.106	Pass
	Peak Resistive Force	N	3450	4060	3877	Pass
					Overall Test Results	Pass

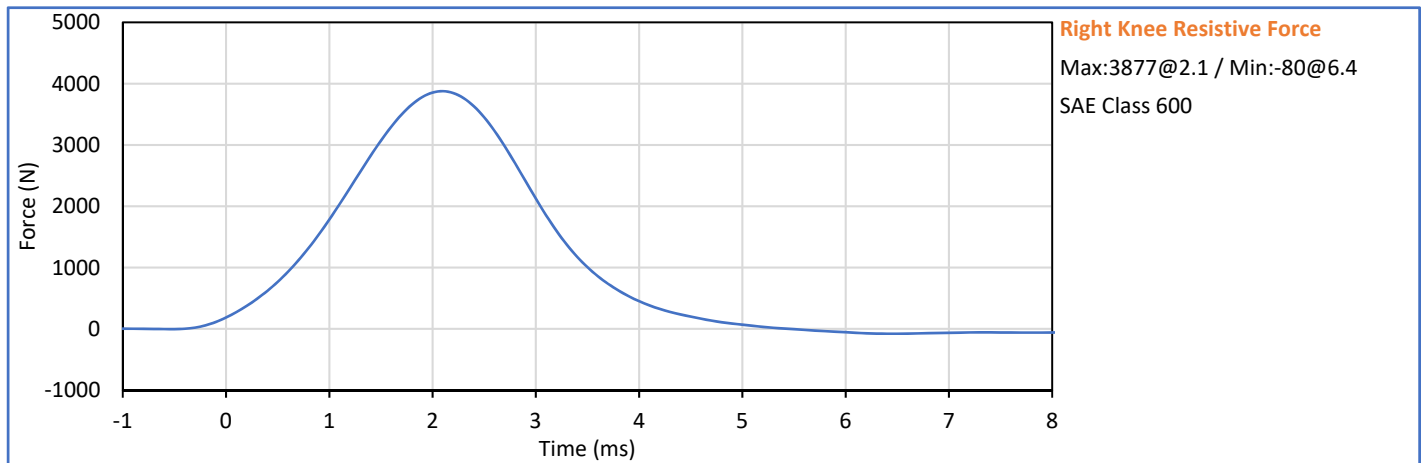
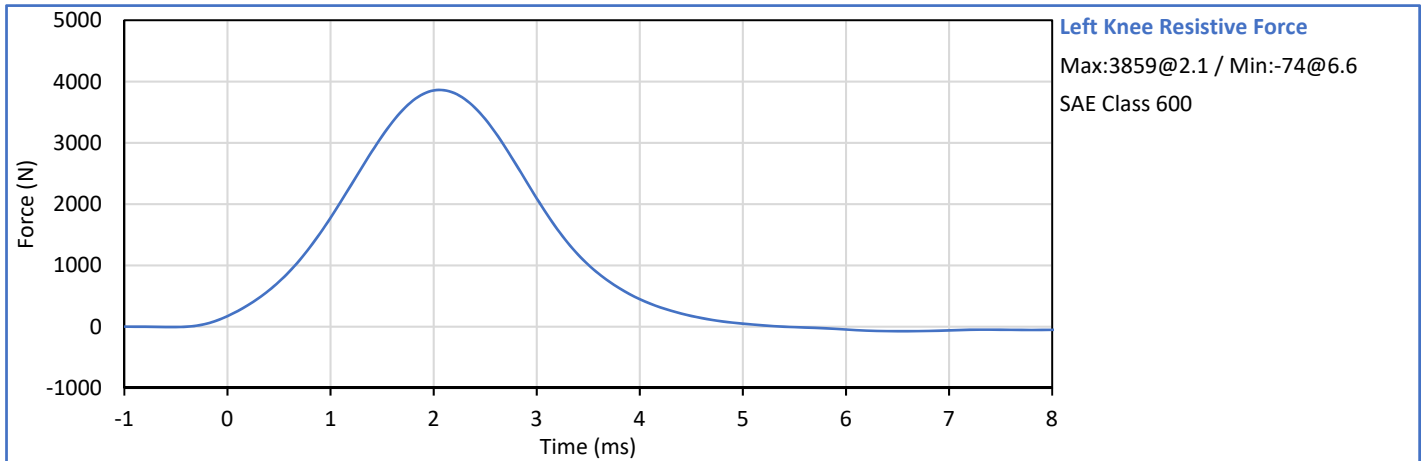

Technician:

Approved By:



ATD Serial No.: 630

Test Date: 2017-10-23

Tested Parameter	Units	Spec. Low	Spec. High	Result	Pass/Fail
Laboratory Temperature	°C	20.6	22.2	21.2	Pass
Laboratory Humidity	%	10	70	31	Pass
Orientation Angle	deg	0.0	20.0	12.2	Pass
Test Initial Angle	deg	11.0	19.0	15.0	Pass
Peak Force at 45° (+/-0.5°)	N	320.0	390.0	383.3	Pass
Torso Flexion Rate	deg/s	0.50	1.50	1.22	Pass
Final Reference Plane Angle	deg	-8.0	8.0	7.6	Pass
Overall Test Results					Pass

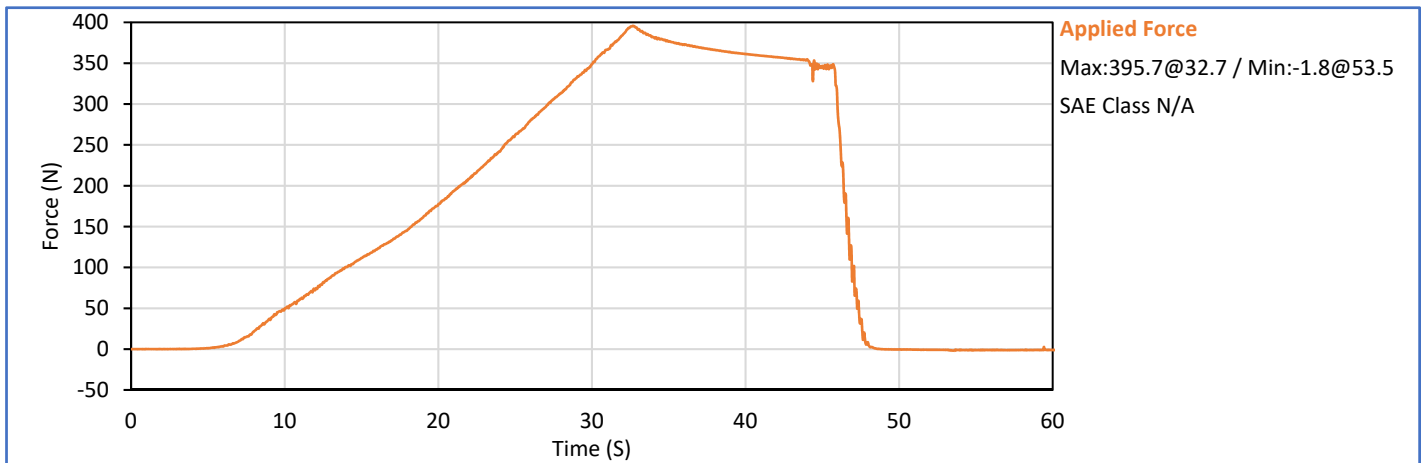
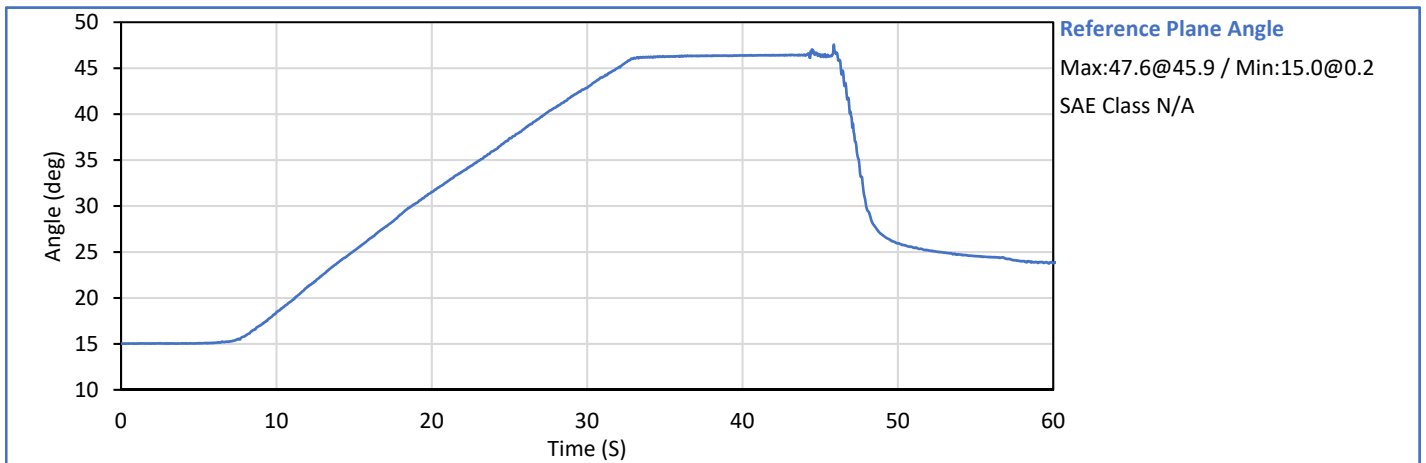

Technician: *Smith*

Approved By: *Wep*