

REPORT NUMBER: TR-P34135-01-NC
SAFETY COMPLIANCE TESTING FOR FMVSS 301R
FUEL SYSTEM INTEGRITY – REAR IMPACT
79.3 KM/H 70% OVERLAP REAR IMPACT

HONDA OF AMERICA MFG., INC.
2014 HONDA ACCORD 4-DOOR SEDAN

NHTSA NUMBER: C20145302

PREPARED BY:
KARCO ENGINEERING, LLC.
9270 HOLLY ROAD
ADELANTO, CA 92301



TEST DATE:
SEPTEMBER 3, 2014

REPORT DATE:
SEPTEMBER 17, 2014
FINAL REPORT

U.S. DEPARTMENT OF TRANSPORTATION
NATIONAL HIGHWAY TRAFFIC SAFETY ADMINISTRATION
ENFORCEMENT
OFFICE OF VEHICLE SAFETY COMPLIANCE
ROOM 6111, NVS-220
400 SEVENTH STREET, SW
WASHINGTON, DC 20590

TECHNICAL REPORT DOCUMENTATION PAGE

1. Report No. TR-P34135-01-NC	2. Government Accession No.	3. Recipient's Catalog No.	
4. Title and Subtitle Final Report of FMVSS 301R 70% Overlap Rear Impact Testing of a 2014 Honda Accord 4-Door Sedan NHTSA No. C20145302		5. Report Date September 17, 2014	
		6. Performing Organization Code KAR	
7. Authors Mr. Balbino A. Beltran, Project Engineer, KARCO Mr. Frank Richardson, Program Manager, KARCO		8. Performing Organization Report No. TR-P34135-01-NC	
9. Performing Organization Name and Address KARCO Engineering, LLC. 9270 Holly Rd. Adelanto, CA 92301		10. Work Unit No.	
		11. Contract or Grant No. DTNH22-11-D-00245	
12. Sponsoring Agency Name and Address U. S. Department of Transportation National Highway Traffic Safety Administration Enforcement Office of Vehicle Safety Compliance Room 6111, NVS-220 400 Seventh Street, SW Washington, D.C. 20590		13. Type of Report and Period Covered Final Test Report, Sept. 3 - 17, 2014	
		14. Sponsoring Agency Code	
15. Supplementary Notes			
16. Abstract A 79.3 km/h 70% overlap rear impact test was conducted on the subject 2014 Honda Accord 4-door sedan in accordance with the specifications of the Office of Vehicle Safety Compliance Laboratory Test Procedure for FMVSS 301R. The test was conducted at the KARCO Engineering, LLC. facility in Adelanto, California on September 3, 2014. The impact velocity was 78.79 km/h and the outside ambient temperature was 36.7 deg. C. There was no Stoddard solvent leakage immediately after the impact or during any portion of the static rollover			
17. Key Words FMVSS 301R Overlap Rear Impact MDB 2014 Honda Accord		18. Distribution Statement	
19. Security Classification of this report UNCLASSIFIED	20. Security Classification of this page UNCLASSIFIED	21. No. of Pages 38	22. Price

TABLE OF CONTENTS

<u>Section</u>		<u>Page No.</u>
1	Summary of Test	1
2	Data Sheets	2

<u>Data Sheet No.</u>		<u>Page No.</u>
1	Test Vehicle Specifications	3
2	Pre-Test Data	5
3	Moving Barrier Data	9
4	Post-Test Data	10
5	Static Rollover Test Data	12

<u>Appendix</u>		<u>Page No.</u>
A	Photographs	A

SECTION 1 SUMMARY OF TEST

SUMMARY

The purpose of this rear impact test series is to measure the performance of the subject vehicle, a 2014 Honda Accord 4-door sedan, for FMVSS 301R '*Fuel System Integrity – Rear Impact*'.

This 79.3 km/h 70% Overlap Rear Impact is sponsored by the National Highway Traffic Safety Administration (NHTSA) under contract number DTNH22-11-D-00245. It was conducted in accordance with the Office of Vehicle Safety Compliance Laboratory Test Procedure TP-301R-02 for FMVSS 301R '*Fuel System Integrity – Rear Impact*', dated January, 2007.

The test was performed at KARCO Engineering, LLC. on September 3, 2014. Pre- and post-test photographs of the vehicle and ATD's can be found in Appendix A of this report.

Two (2) real-time cameras and three (3) high-speed cameras were used to document the rear impact event.

Two Part 572E 50th percentile male anthropomorphic test devices (ATD) were placed in the driver and right front passenger seating positions. Both ATD's were not instrumented for this test.

There was no Stoddard solvent leakage after the impact or during any portion of the static rollover. FMVSS 301 data is summarized in Data Sheets 6 and 7.

SECTION 2
DATA SHEETS

Test Vehicle: 2014 Honda Accord 4-Door Sedan NHTSA No.: C20145302
 Test Program: 79.3 km/h 70% Overlap Rear Impact Test Date: 09/03/14

CONVERSION FACTORS

Quantity	Typical Application	Std Units	Metric Unit	Multiply By
Mass	Vehicle Weight	lb	kg	0.4536
Linear Velocity	Impact Velocity	miles/hr	km/hr	1.609344
Length or Distance	Measurements	in	mm	25.4
Volume	Fuel Systems	gal	liter	3.785
Volume	Small Fluids	oz	mL	29.574
Pressure	Tire Pressures	lbf/in ²	kPa	6.895
Temperature	General Use	°F	°C	=(Tf -32)/1.8
Force	Dynamic Forces	lbf	N	4.448
Moment	Torque	lbf-ft	N•m	1.355

DATA SHEET NO. 1

TEST VEHICLE SPECIFICATIONS

Test Vehicle: 2014 Honda Accord 4-Door Sedan NHTSA No.: C20145302
 Test Program: 79.3 km/h 70% Overlap Rear Impact Test Date: 09/03/14

TEST VEHICLE INFORMATION AND OPTIONS

NHTSA Number	C20145302
Model Year	2014
Make	Honda
Model	Accord
Body Style	4-Door Sedan
VIN	1HGCR2F33EA155936
Body Color	Silver
Odometer Reading (km / mi)	1,069 / 0664
Engine Displacement (L)	2.4
Type / No. of Cylinders	4 Cylinders
Engine Placement	Transverse
Transmission Type	CVT
Transmission Speeds	3
Overdrive	Yes
Final Drive	Front
Roof Rack	No
Sunroof / T-Top	No
Running Boards	No
Tilt Steering Wheel	Yes
Power Seats	No
Anti-Lock Brakes (ABS)	Yes
Automatic Door Locks (ADLs)	Yes

Traction Control System	Yes
Power Steering	Yes
Power Window Auto-Reverse	Yes
Driver Frontal Airbag	Yes
Driver Curtain Airbag	Yes
Driver Head/Torso Airbag	No
Driver Torso Airbag	No
Driver Torso/Pelvis Airbag	Yes
Driver Pelvis Airbag	No
Driver Knee Airbag	No
Front Pass. Frontal Airbag	Yes
Front Pass. Curtain Airbag	Yes
Front Pass. Head/Torso Airbag	No
Front Pass. Torso Airbag	No
Front Pass. Torso/Pelvis Airbag	Yes
Front Pass. Pelvis Airbag	No
Front Pass. Knee Airbag	No
Driver Seat Belt Pretensioner	Yes
Driver Load Limiter	Yes
Front Pass. Seat Belt Pretensioner	Yes
Front Pass. Load Limiter	Yes
Other	Yes

Does Owner's Manual provide instructions to turn off automatic door locks?

DATA FROM CERTIFICATION LABEL

Manufactured By	Honda of America Mfg., Inc.
Date of Manufacture	Feb-14

GVWR (kg)	1905
GAWR Front (kg)	1020
GAWR Rear (kg)	910

VEHICLE SEATING AND CAPACITY WEIGHT INFORMATION

Measured Parameter	Front	Rear	Third	Total	
Type of Seats	Bucket	Bench			
Designated Seating Capacity	2	3		5	
Capacity Weight (VCW) (kg)				385.0	A
DSC x 68 (kg)				340.0	B
Cargo Weight (RCLW) (kg)				45.0	A-B

DATA SHEET NO. 1 ... (CONTINUED)

TEST VEHICLE SPECIFICATIONS

Test Vehicle: 2014 Honda Accord 4-Door Sedan

NHTSA No.: C20145302

Test Program: 79.3 km/h 70% Overlap Rear Impact

Test Date: 09/03/14

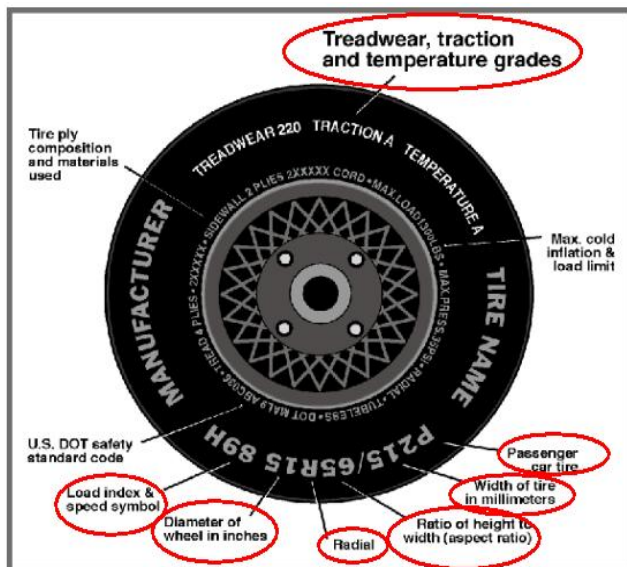

VEHICLE TIRE INFORMATION

Measured Parameter	Front	Rear
Max Tire Pressure (kPa)	300	300
Cold Tire Pressure (kPa)	230	230
Max Load Tire Pressure (kPa)		
Recommended Tire Size	P205/65R16	P205/65R16
Tire Size on Vehicle	P205/65R16	P205/65R16
Tire Manufacturer	Firestone	Firestone
Tire Model	Affinity	Affinity
Load Range	690	690
Treadwear Rating	500	500
Traction Rating	A	A
Temperature Grades	A	A
Tire Plies Sidewall	2 Polyester	2 Polyester
Tire Plies Body	2 Polyester, 2 Steel, 1 Nylon	2 Polyester, 2 Steel, 1 Nylon
Load Index/Speed Symbol	95H	95H
Tire Material	Polyester, Steel, Nylon	Polyester, Steel, Nylon
DOT Safety Code Left	W23P A1A 2014	W23P A1A 2014
DOT Safety Code Right	W23P A1A 2014	W23P A1A 2014
Type of Spare Tire	Compact Size Spare Tire T125/80D16	
Location of Tire Placard on Vehicle	Driver Side 'B' Pillar Panel	

DATA SHEET NO. 2

PRE-TEST DATA

Test Vehicle: 2014 Honda Accord 4-Door Sedan

NHTSA No.: C20145302

Test Program: 79.3 km/h 70% Overlap Rear Impact

Test Date: 09/03/14

TEST VEHICLE AXLE WEIGHTS

	Units	As Delivered (UVW)			As Tested (ATW)			Fully Loaded		
		Front	Rear	Total	Front	Rear	Total	Front	Rear	Total
Left	kg	459.0	296.0		506.0	347.5		493.0	360.5	
Right	kg	436.5	283.0		476.5	329.0		467.0	343.5	
Ratio	%	60.7%	39.3%	100.0%	59.2%	40.8%	100.0%	57.7%	42.3%	100.0%
Total	kg	895.5	579.0	1474.5	982.5	676.5	1659.0	960.0	704.0	1664.0

TARGET TEST WEIGHT CALCULATION

Measured Parameter	Units	Value	
Total Delivered Weight (UVW)	kg	1474.5	A
Actual Weight of 2 P572 ATDs Used	kg	148.0	B
Rated Cargo/Luggage Wt (RCLW)	kg	45.0	C
Calculated Vehicle Target Wt (TVTW)	kg	1667.5	A+B+C

TEST VEHICLE ATTITUDES

Condition	Units	LF	RF	LR	RR	CG Aft of Front Axle
As Delivered	mm	459	437	296	283	1112
As Tested	mm	689	691	693	699	1155
Fully Loaded	mm	696	698	688	696	1199
Post-Test	mm	681	698	700	758	

GENERAL TEST VEHICLE DATA

Measured Parameter	Units	Value
Total Vehicle Wheel Base	mm	2782
Total Vehicle Length	mm	4844
Total Vehicle Width	mm	1831
Amount of Stoddard Solvent in Fuel Tank	L	60.5

DATA SHEET NO. 2... (CONTINUED)

PRE-TEST DATA

Test Vehicle: 2014 Honda Accord 4-Door Sedan NHTSA No.: C20145302
 Test Program: 79.3 km/h 70% Overlap Rear Impact Test Date: 09/03/14

BALLAST DATA

Description	Value
Type of Ballast	Ballast Dummies
Method of Securing Ballast	Seat Belt
Weight of Ballast in Cargo Area	0 kg
Weight of Vehicle Components Removed	0 kg

VEHICLE COMPONENTS REMOVED TO MEET TEST WEIGHT:

No vehicle components were removed

FUEL TANK CAPACITY

Description	Liters
Fuel System Capacity Listed in Owners Manual	65.10
Usable Capacity of "Standard Tank"	65.10
91 - 94% of Usable Capacity	59.24 - 61.19
Actual Amount of Stoddard Solvent Used	60.54

FUEL PUMP

The vehicle is equipped with an electric fuel pump. The fuel pump is activated on the ignition key is set to the 'ON' position. The pump is filled for two seconds after which pressure is maintained.

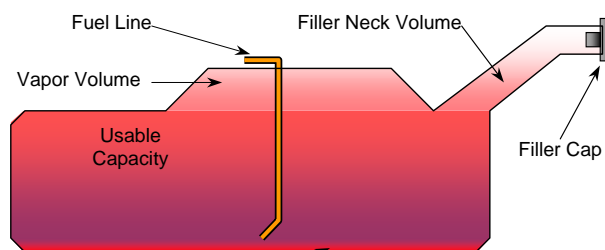

VEHICLE FUEL TANK ASSEMBLY

TEST FLUID

Description	Value
Test Fluid Type	Stoddard Solvent
Test Fluid Specific Gravity	0.76
Test Fluid Kinematic Viscosity	
Test Fluid Color	Purple

DATA SHEET NO. 2... (CONTINUED)

PRE-TEST DATA

Test Vehicle: 2014 Honda Accord 4-Door Sedan
 Test Program: 79.3 km/h 70% Overlap Rear Impact

NHTSA No.: C20145302
 Test Date: 09/03/14

NOMINAL DESIGN RIDING POSITION

Seat back angle is measured at the headrest post using a digital inclinometer.

SEAT BACK ANGLE

Seating Position	Degrees
Driver Seat Back Angle	3.8
Passenger Seat Back Angle	3.8

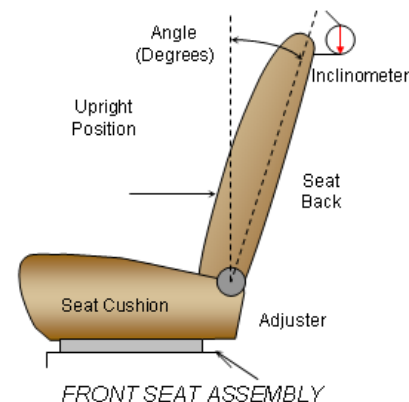

SEAT FORE / AFT POSITIONING

The total seat travel is measured from the forward most possible position to the rear most possible position. The driver's seat is set to the middle of the fore-aft travel. The passenger's seat is set to the middle of the fore-aft travel.

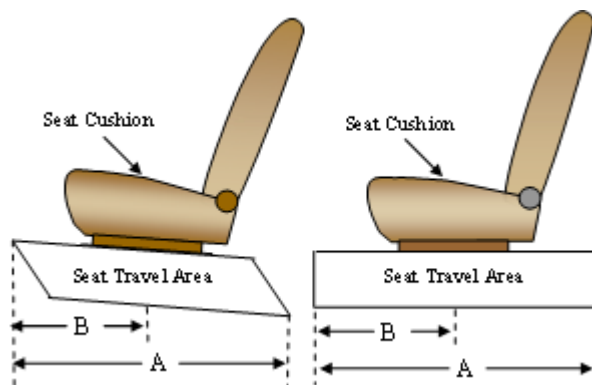

SEAT FORE/AFT POSITIONS

Seating Position	Total Fore-Aft Travel	Placed in Position
Driver Seat	282 mm	149 mm
Passenger Seat	242 mm	121 mm

DATA SHEET NO. 2... (CONTINUED)

PRE-TEST DATA

Test Vehicle: 2014 Honda Accord 4-Door Sedan

NHTSA No.: C20145302

Test Program: 79.3 km/h 70% Overlap Rear Impact

Test Date: 09/03/14

STEERING COLUMN ADJUSTMENT

Steering wheel and column adjustments are made so that the steering wheel hub is at the geometric center of the locus it describes when moved through its full range of motion. A digital inclinometer is used to measure a plate which is placed across the rim of the steering wheel for angular measurements. A tape measure is used to measure telescoping steering wheel travel.

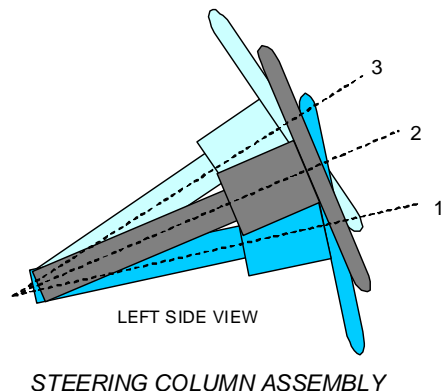

STEERING COLUMN POSITIONING

	Degrees	Fore-Aft Position (mm)
Lowermost Position, No. 1	17.6	152
Geometric Center Position, No. 2	21.0	132
Uppermost Position, No. 3	24.3	112
Telescoping Steering Wheel Travel	6.7	40
Test Position	21.0	132

DATA SHEET NO. 3
MOVING BARRIER DATA

Test Vehicle: 2014 Honda Accord 4-Door Sedan NHTSA No.: C20145302
 Test Program: 79.3 km/h 70% Overlap Rear Impact Test Date: 09/03/14

MOVING BARRIER TEST WEIGHT

	Units	As Delivered Weights (UVW)		
		Front Axle	Rear Axle	Total
Left	kg	402.0	298.0	700.0
Right	kg	377.0	292.0	669.0
Ratio	%	56.9%	43.1%	100.0%
Total	kg	779.0	590.0	1369.0

MOVING BARRIER TIRE INFORMATION

Measured Parameter	Front	Rear
Recommended Tire Size	205/75R15	205/75R15
Tire Size on Vehicle	205/75R15	205/75R15
Tire Manufacturer	Pacemark	Pacemark
Tire Model	All Weather	All Weather
Treadwear	420	420
Traction	A	A
Temperature Grades	B	B
Tire Pressure - Front	220	220
Tire Pressure - Rear	220	220

MOVING BARRIER DIMENSIONS

Measurement Description	Length (mm)
Overall Width	1676
Overall Height	559
Honeycomb Depth	382
Overall Depth	484
Bottom Honeycomb to Bottom Bumper	50
Bumper Height	203
Ground to Top of MDB	788
Ground to Bottom of MDB	229
Ground to Bottom of Bumper	279
Ground to Top of Bumper	483

DATA SHEET NO. 4**POST-TEST DATA**Test Vehicle: 2014 Honda Accord 4-Door Sedan NHTSA No.: C20145302Test Program: 79.3 km/h 70% Overlap Rear Impact Test Date: 09/03/14Temperature at Time of Impact: 36.7°C Test Time: 11:47 AMVIN: 1HGCR2F33EA155936**IMPACT VELOCITY DATA**

Measured Parameter	Units	Value
Trap No. 1 Velocity (Primary)	km/h	78.79
Trap No. 2 Velocity (Redundant)	km/h	

IMPACT POINT LOCATION DATA

Measured Parameter	Units	Tolerance	Value
Vehicle Width	mm		1831
Vertical Impact Reference Line (Right of Vehicle Center Line)	mm		366
Actual Impact Point (Right of Vehicle Center Line)	mm		383
Horizontal Offset (+ right / - left)	mm	± 50 of Intended Impact Point	17
Vertical Offset (+ down / - up)	mm	± 40 of Intended Impact Point	10

TARGET VEHICLE PRE- AND POST- TEST STRUCTURAL MEASUREMENTS

No.	Description	Pre-Test	Post-Test	Difference
1	Total Length at Centerline	4844	4500	344
2	Total Length	4844	4860	16
3	Total Width	1831	2620	789
4	Left Side Wheelbase	2782	2677	105
5	Right Side Wheelbase	2782	2777	5

MAXIMUM STATIC CRUSH OF HONEYCOMB FACE

Vertical Location			From Centerline		Max. Crush (mm)
Row	Description	Height (mm)	Distance (mm)	Direction	
A	Center of Bumper	432	800	Right	194
B	Top of Bumper	533	800	Right	231
C	Mid Level	686	800	Right	279
D	Top of Stack	813	800	Right	57

² – Redundant Speed Trap failed

DATA SHEET NO. 4... (CONTINUED)

POST-TEST DATA

Test Vehicle: 2014 Honda Accord 4-Door Sedan NHTSA No.: C20145302
Test Program: 79.3 km/h 70% Overlap Rear Impact Test Date: 09/03/14

DOOR OPENING AND SEAT TRACK INFORMATION

Description	Driver	Passenger
Front Door Opening	Remained Closed and Latched	Remained closed and latched
Rear Door Opening	Remained Closed and Latched	Remained closed and latched
Hatch and other doors	Jammed Shut	

FMVSS 301 FUEL SYSTEM INTEGRITY POST-IMPACT DATA

Stoddard Solvent Spillage Measurements

- A. From impact until vehicle motion ceases: 0 g
(Maximum allowable = 28 g)
- B. For the 5 minute period after motion ceases: 0 g
(Maximum allowable = 28 g)
- C. For the following 25 minutes: 0 g
(Maximum allowable = 28 g/minute)
- D. Spillage: No Stoddard Solvent leakage

DATA SHEET NO. 5
STATIC ROLLOVER TEST DATA

Test Vehicle: 2014 Honda Accord 4-Door Sedan

NHTSA No.: C20145302

Test Program: 79.3 km/h 70% Overlap Rear Impact

Test Date: 09/03/14

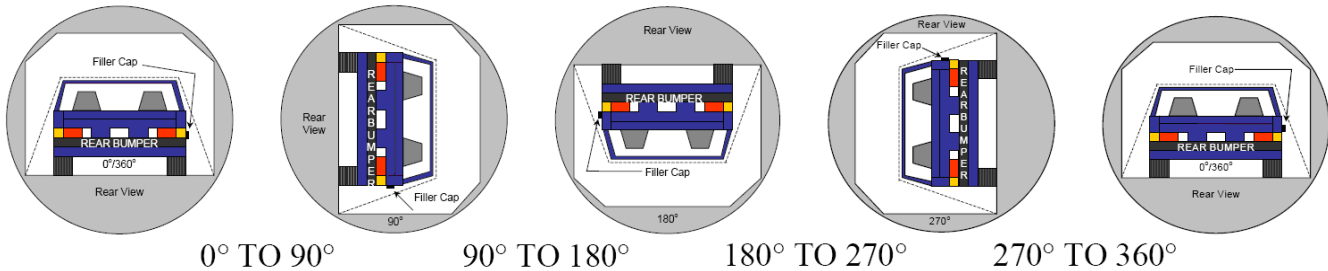

1. The specified fixture rollover rate for each 90° of rotation is 60 to 180 seconds.

2. The position hold time at each position is 300 seconds (minimum).

Details of Stoddard solvent spillage: No Stoddard solvent spillage

SOLVENT COLLECTION TIME TABLE IN SECONDS

Test Phase	Rotation Time	Hold Time	Total Time
0° To 90°	80	300	380
90° To 180°	78	300	378
180° To 270°	78	300	378
270° To 360°	79	300	379

FMVSS 301 SPILLAGE TABLE

Test Phase	First 5 Minutes	Sixth Minute	Seventh Minute	Eighth Minute
0° To 90°	0 g			
90° To 180°	0 g			
180° To 270°	0 g			
270° To 360°	0 g			

SOLVENT SPILLAGE LOCATION TABLE

Test Phase	Spillage Location
0° To 90°	No Spillage
90° To 180°	No Spillage
180° To 270°	No Spillage
270° To 360°	No Spillage

**APPENDIX A
PHOTOGRAPHS**

TABLE OF PHOTOGRAPHS

Figure		Page
1	As Received Right Front $\frac{3}{4}$ View of Test Vehicle	A-1
2	As Received Left Rear $\frac{3}{4}$ View of Test Vehicle	A-1
3	Test Vehicle Manufacturer's Label	A-2
4	Test Vehicle Tire Information Placard	A-2
5	Pre-Test Front View of Test Vehicle	A-3
6	Post-Test Front View of Test Vehicle	A-3
7	Pre-Test Left Front $\frac{3}{4}$ View Test Vehicle	A-4
8	Post-Test Left Front $\frac{3}{4}$ View Test Vehicle	A-4
9	Pre-Test Left Side View of Test Vehicle	A-5
10	Post-Test Left Side View of Test Vehicle	A-5
11	Pre-Test Left Rear $\frac{3}{4}$ View of Test Vehicle	A-6
12	Post-Test Left Rear $\frac{3}{4}$ View of Test Vehicle	A-6
13	Pre-Test Rear View of Test Vehicle	A-7
14	Post-Test Rear View of Test Vehicle	A-7
15	Pre-Test Right Rear $\frac{3}{4}$ View of Test Vehicle	A-8
16	Post-Test Right Rear $\frac{3}{4}$ View of Test Vehicle	A-8
17	Pre-Test Right Side View of Test Vehicle	A-9
18	Post-Test Right Side View of Test Vehicle	A-9
19	Pre-Test Right Front $\frac{3}{4}$ View Test Vehicle	A-10
20	Post-Test Right Front $\frac{3}{4}$ View Test Vehicle	A-10
21	Pre-Test Close-Up View of Impact Point Target	A-11
22	Post-Test Close-Up View of Impact Point Target	A-11
23	Pre-Test View of Fuel Filler Cap	A-12
24	Post-Test View of Fuel Filler Cap	A-12
25	Pre-Test Rear Underbody View of Test Vehicle	A-13
26	Post-Test Rear Underbody View of Test Vehicle	A-13
27	Pre-Test Underbody View of Fuel Tank	A-14
28	Post-Test Underbody View of Fuel Tank	A-14
29	Pre-Test Underbody View of Fuel Filler Neck	A-15
30	Post-Test Underbody View of Fuel Filler Neck	A-15
31	Pre-Test Underbody View of Fuel Lines	A-16
32	Post-Test Underbody View of Fuel Lines	A-16
33	Test Vehicle at 0° on FMVSS 301 Static Rollover Device	A-17
34	Test Vehicle at 90° on FMVSS 301 Static Rollover Device	A-17

TABLE OF PHOTOGRAPHS

<u>Figure</u>		<u>Page</u>
35	Test Vehicle at 180° on FMVSS 301 Static Rollover Device	A-18
36	Test Vehicle at 270° on FMVSS 301 Static Rollover Device	A-18
37	Test Vehicle at 360° on FMVSS 301 Static Rollover Device	A-19
38	Impact Event	A-19



FIGURE 1. As Received Right Front $\frac{3}{4}$ View of Test Vehicle



FIGURE 2. As Received Left Rear $\frac{3}{4}$ View of Test Vehicle

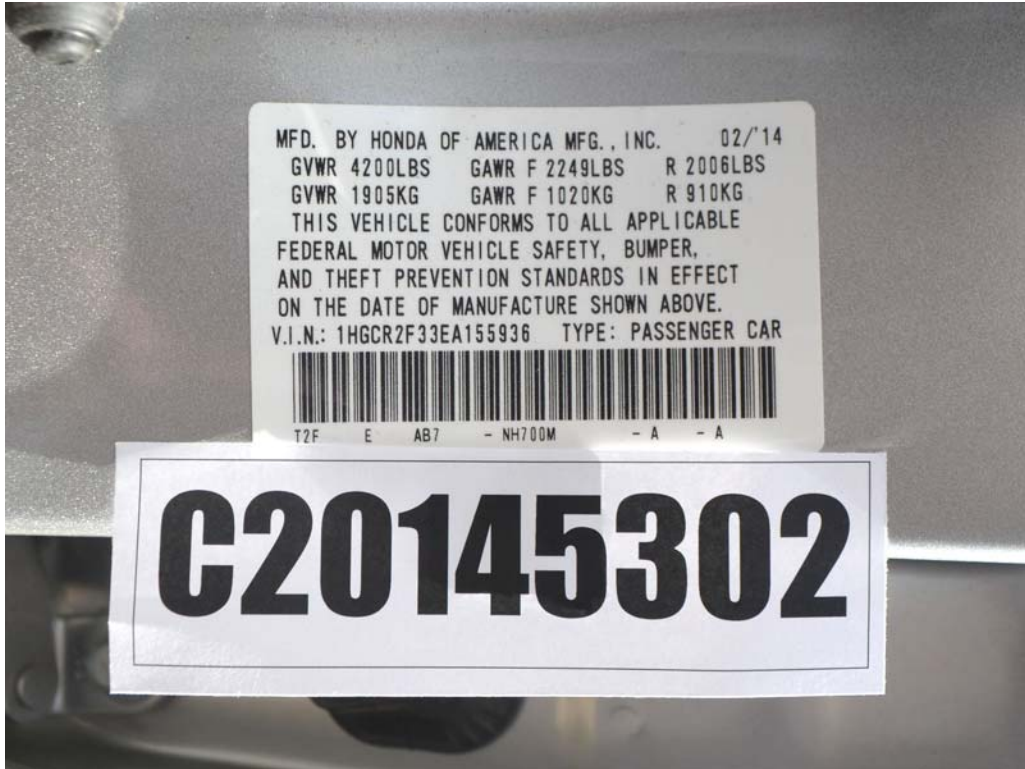

FIGURE 3. Test Vehicle Manufacturer's Label



FIGURE 4. Test Vehicle Tire Information Placard



FIGURE 5. Pre-Test Front View of Test Vehicle



FIGURE 6. Post-Test Front View of Test Vehicle



FIGURE 7. Pre-Test Left Front $\frac{3}{4}$ View of Test Vehicle



FIGURE 8. Post-Test Left Front $\frac{3}{4}$ View of Test Vehicle



FIGURE 9. Pre-Test Left Side View of Test Vehicle



FIGURE 10. Post-Test Left Side View of Test Vehicle



FIGURE 11. Pre-Test Left Rear $\frac{3}{4}$ View of Test Vehicle



FIGURE 12. Post-Test Left Rear $\frac{3}{4}$ View of Test Vehicle



FIGURE 13. Pre-Test Rear View of Test Vehicle



FIGURE 14. Post-Test Rear View of Test Vehicle



FIGURE 15. Pre-Test Right Rear $\frac{3}{4}$ View of Test Vehicle



FIGURE 16. Post-Test Right Rear $\frac{3}{4}$ View of Test Vehicle



FIGURE 17. Pre-Test Right Side View of Test Vehicle



FIGURE 18. Post-Test Right Side View of Test Vehicle



FIGURE 21. Pre-Test Close-Up View of Impact Point Target



FIGURE 22. Post-Test Close-Up View of Impact Point Target



FIGURE 23. Pre-Test View of Fuel Filler Cap



FIGURE 24. Post-Test View of Fuel Filler Cap

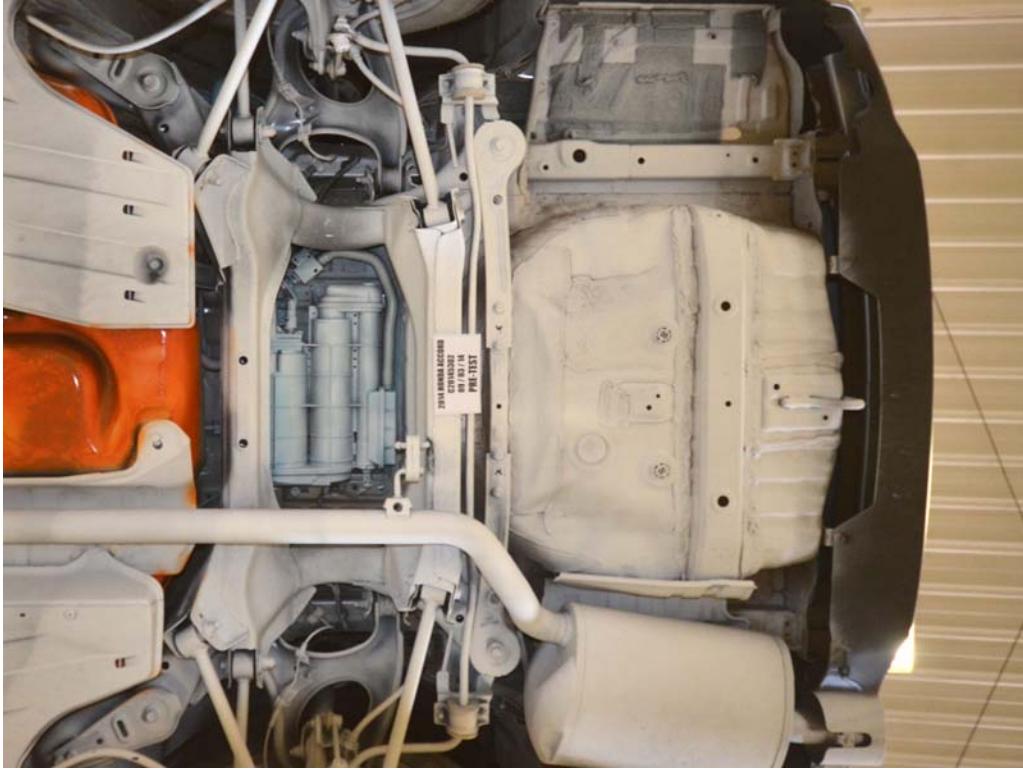

FIGURE 25. Pre-Test Rear Underbody View of Test Vehicle



FIGURE 26. Post-Test Rear Underbody View of Test Vehicle



FIGURE 27. Pre-Test Underbody View of Fuel Tank



FIGURE 28. Post-Test Underbody View of Fuel Tank



FIGURE 29. Pre-Test Underbody View of Fuel Filler Neck



FIGURE 30. Post-Test Underbody View of Fuel Filler Neck



FIGURE 31. Pre-Test Underbody View of Fuel Lines

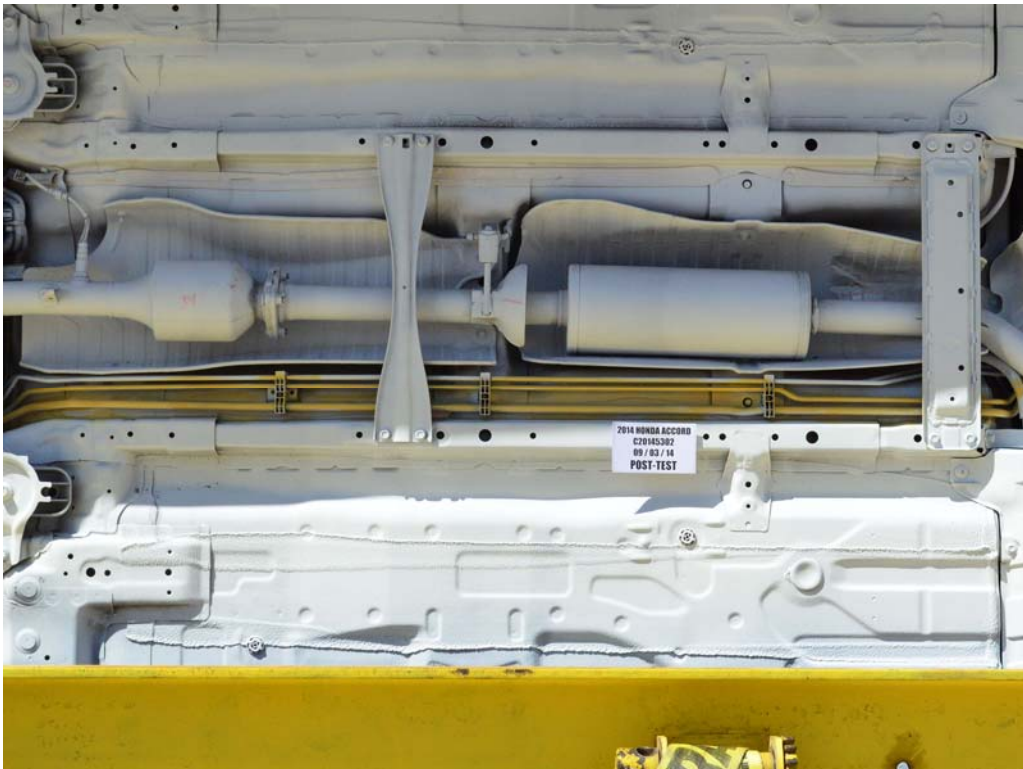

FIGURE 32. Post-Test Underbody View of Fuel Lines



FIGURE 33. Test Vehicle at 0° on FMVSS 301 Static Rollover Device

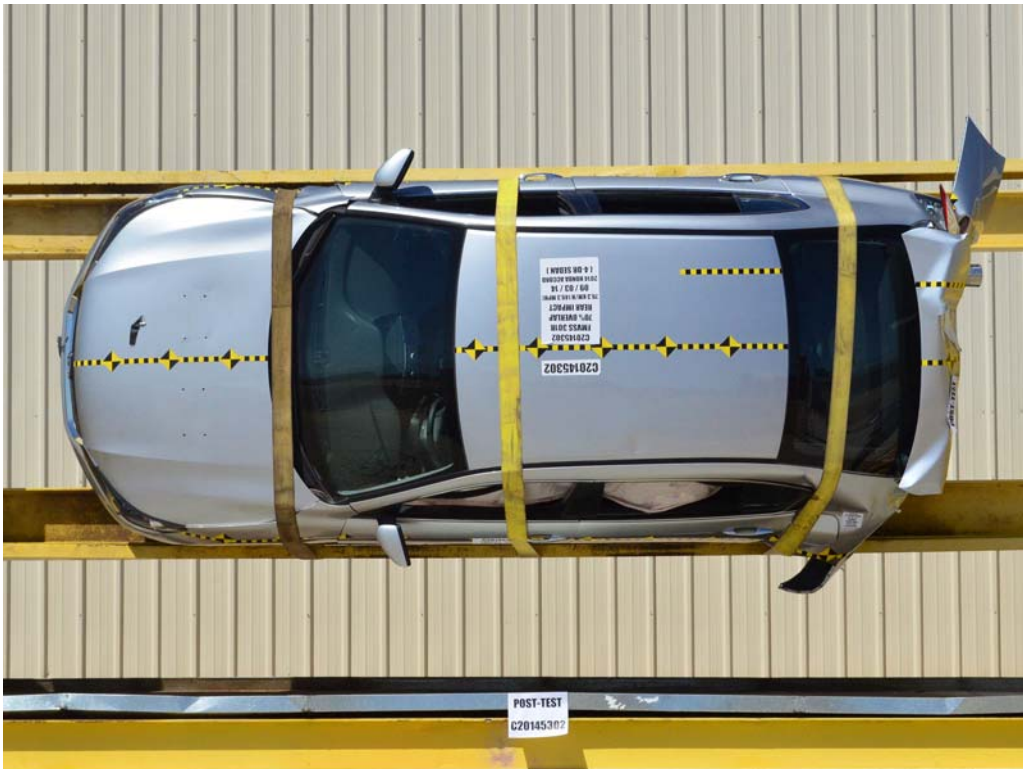

FIGURE 34. Test Vehicle at 90° on FMVSS 301 Static Rollover Device



FIGURE 35. Test Vehicle at 180° on FMVSS 301 Static Rollover Device

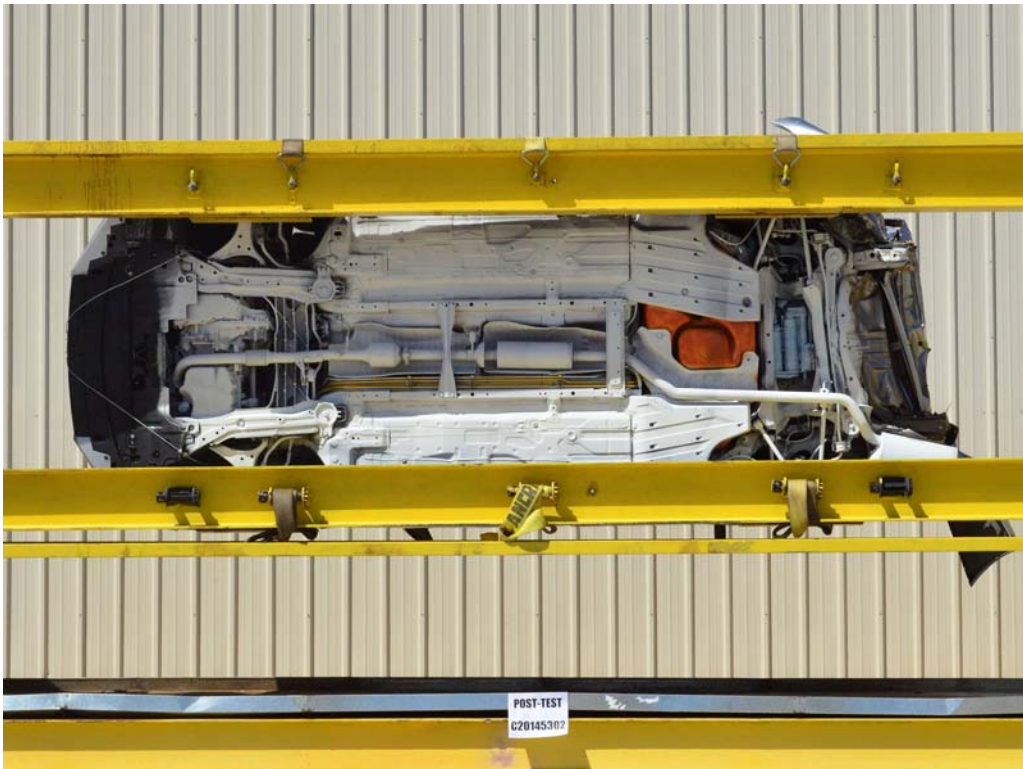

FIGURE 36. Test Vehicle at 270° on FMVSS 301 Static Rollover Device



FIGURE 37. Test Vehicle at 360° on FMVSS 301 Static Rollover Device



FIGURE 38. Impact Event