

REPORT NUMBER: R&D-KAR-16-009

**OBLIQUE MOVING BARRIER INTO ANGLED STATIONARY VEHICLE CRASH TESTING IN
SUPPORT OF NHTSA'S FRONTAL OBLIQUE PROGRAM**

**OBLIQUE MOVING DEFORMABLE BARRIER INTO LEFT FRONT OF A MOVING
CONTOURED BARRIER**

60 KM/H, 15 DEGREE ANGLE, 35% OVERLAP

TEST DATE: 05/27/2016

**PREPARED BY:
KARCO ENGINEERING, LLC.
9270 HOLLY ROAD
ADELANTO, CA 92301**





FINAL REPORT SUBMITTED

July 18, 2016

**PREPARED FOR
U.S. DEPARTMENT OF TRANSPORTATION
NATIONAL HIGHWAY TRAFFIC SAFETY ADMINISTRATION
VEHICLE SAFETY RESEARCH
1200 NEW JERSEY AVE, SE
ROOM W46-446
WASHINGTON, DC 20590**

This publication is distributed by the U.S. Department of Transportation, National Highway Traffic Safety Administration, in the interest of information exchange. The opinions, findings and conclusions expressed in this publication are those of the author(s) and not necessarily those of the Department of Transportation or the National Highway Traffic Safety Administration. The United States Government assumes no liability for its contents or use thereof. If trade or manufacturers' names or products are mentioned, it is only because they are considered essential to the object of the publication and should not be construed as an endorsement. The United States Government does not endorse products or manufacturers.

Prepared by:  _____ Date: July 18, 2016
[Mr. Robert S. Ramos, Project Engineer]
KARCO Engineering, LLC.

Approved by:  _____ Date: July 18, 2016
[Mr. Frank D. Richardson, Program Manager]
KARCO Engineering, LLC.

FINAL REPORT ACCEPTANCE BY VEHICLE SAFETY RESEARCH, OFFICE OF STRUCTURAL AND RESTRAINTS RESEARCH DIVISION:

Approved by: _____ Date: _____
[Name, Title]

TECHNICAL REPORT DOCUMENTATION PAGE

Test Vehicle: OMDB (Half Face) to MCB NHTSA No. N/A
 Test Program: NHTSA R&D Left Oblique Offset 15deg/35% Test Date: 05/27/16

Report No. R&D-KAR-16-009	Government Accession No.	Recipient's Catalog No.	
Title and Subtitle Report for Frontal Oblique Offset Program Testing of a OMDB to MCB		Report Date July 18, 2016	
		Performing Organization Code KAR	
Author(s) Mr. Robert S. Ramos, Project Engineer, KARCO Mr. Frank Richardson, Program Manager, KARCO		Performing Organization Report No. TR-P36072-06-NC	
		Work Unit No.	
Performing Organization Name and Address KARCO Engineering, LLC. 9270 Holly Rd. Adelanto, CA 92301		Contract or Grant No. DTNH22-14-D-00360	
		Type of Report and Period Covered Final Test Report, May 27 – July 18, 2016	
Sponsoring Agency Name and Address DOT / National Highway Traffic Safety Administration Office of Vehicle Safety Research 1200 New Jersey Ave., SE, Room W46-446 Washington, D.C. 20590		Sponsoring Agency Code NSR210	
Supplementary Notes			
Abstract A test was conducted in accordance with Contract DTNH22-14-D-00360, Task Order #0002. The Test consisted of an Oblique Moving Deformable Barrier (OMDB) traveling at a target speed of 60 km/h into a stationary FMVSS 301 Moving Contoured Barrier (MCB). The struck vehicle was positioned 15 degrees clockwise relative to the moving barrier which impacted 35% of the left side of the vehicle. The test was conducted to obtain performance of the half-barrier face in an oblique test. The test was conducted at KARCO Engineering, LLC. facility in Adelanto, California on May 26, 2016. The OMDB impact velocity was 59.79 km/h and the ambient temperature at the test vehicle at the time of impact was 30.0°C. The OMDB maximum static crush was 231.0 mm.			
Key Words Oblique Offset Contoured OMDB MCB		Distribution Statement. Copies of this report are available from:	
		National Highway Traffic Safety Administration Technical Reference Division 1200 New Jersey Ave., SE. Washington, D.C. 20590	
Security Classif. (of this report) UNCLASSIFIED	Security Classif. (of this Page) UNCLASSIFIED	No. of Pages 42	Price

Form DOT F1700.7 (8-72)

TABLE OF CONTENTS

<u>Section</u>		<u>Page</u>
1	Test Purpose	1
2	Summary of Test Results	2
3	Vehicle Information / Data Sheets	4
<u>Data Sheet</u>		<u>Page</u>
1	High Speed Camera Locations and Data	5
2	MCB Accelerometer Locations	7
3	MCB Photographic Reference Target Locations	8
4	OMDB Instrumentation Data	9
5	OMDB Photographic Reference Target Locations	10
6	Test Vehicle Summary of Results	11
7	OMDB Crush Measurements	12
<u>Appendix</u>		<u>Page</u>
A	Photographs	A
B	Data Plots	B

SECTION 1
TEST PURPOSE

This 60.0 km/h (37.3 mph) Oblique Moving Deformable Barrier (OMDB) into a Moving Contoured Barrier (MCB) test is part of Frontal Oblique Offset Program sponsored by the National Highway Traffic Safety Administration (NHTSA) under Contract No. DTNH22-14-D-00360, Task Order #0002. The purpose of this test was to evaluate half-barrier face utilization.

This test was conducted in accordance with the instructions set forth by NHTSA for a 15°, 35% offset moving barrier to vehicle impact, outlined in Task Order (TO) #0002. Data was obtained to the requirements of TO #0002.

SECTION 2

SUMMARY OF TEST RESULTS

A Moving Contoured Barrier (MCB) was impacted on the left front corner by an Oblique Moving Deformable Barrier. The MCB was stationary and positioned at a target angle of 15° and a target offset of 35% to the line of forward motion of the OMDB. The OMDB was towed down the test track in a full forward direction, without any crabbing, and the targeted impact velocity of 60.0 km/h (37.3 mph) into the MCB.

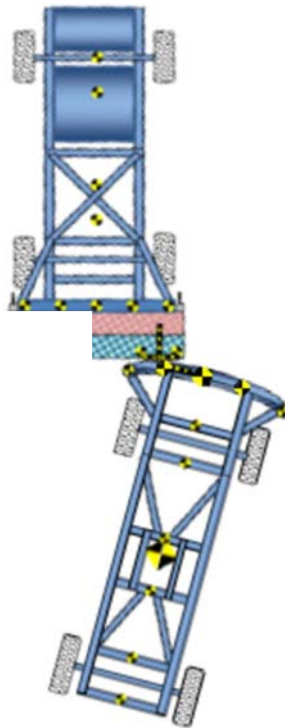

The MCB mass was 1,898.5 kg (4185.4 lbs), and the OMDB mass was 2,496.5 kg (5,503.8 lbs). A half face honeycomb barrier was mounted on the left side of the OMDB. The test was conducted by KARCO Engineering, LLC. on May 27, 2016.

The OMDB impacted the MCB at a speed of 59.79 km/h. After impact the OMDB turned 111.1° coming to rest 6.44 m forward and 1.12 m left of its initial position. As a result of the impact, three M10x1.5 x 90 mm SHCS bolts on the left rear axle mount sheared causing the wheel assembly to rotate about the axle adapter. After the impact the MCB turned 74.7° and traveled 13.55 m rearward and 7.74 m left of its initial position.

The test was documented by three (3) real time and seven (7) high-speed video cameras. Pre- and post-test photographs of the MCB, the OMDB and the test setup were taken using a digital still camera. Photographic documentation of the test is presented in Appendix A of this report.

Twenty four (24) channels of data from the OMDB and MCB were collected using a Diversified Technical Systems, Inc. data acquisition system. Appendix B contains MCB and OMDB response data plots.

PRIMARY IMPACT DATA

Measured Parameter	Units	Value
OMDB Velocity at Impact	km/h	59.79
OMDB Test Weight	kg	2496.5
OMDB Maximum Static Crush	mm	231.0
MCB Test Weight	kg	1898.5
Actual MCB Angle	°	14.9
Vertical Offset from Target Point (+ down / - up)*	mm	9
Lateral Offset from Target Point (+ left / - right)*	mm	-1
Number of Data Channels		24
Number of Real-Time Cameras		3
Number of High-Speed Cameras		7

*Offsets are in relation to the vehicle coordinate system.

SECTION 3

VEHICLE INFORMATION/DATA SHEETS

Test Vehicle: OMDB (Half Face) to MCB NHTSA No. N/A

Test Program: NHTSA R&D Left Oblique Offset 15deg/35% Test Date: 05/27/16

CONVERSION FACTORS

Quantity	Typical Application	Std Units	Metric Unit	Multiply By
Mass	Vehicle Weight	lb	kg	0.4536
Linear Velocity	Impact Velocity	miles/hr	km/hr	1.609344
Length or Distance	Measurements	in	mm	25.4
Volume	Fuel Systems	gal	liter	3.785
Volume	Small Fluids	oz	mL	29.574
Pressure	Tire Pressures	lbf/in ²	kPa	6.895
Temperature	General Use	°F	°C	$=(T_f - 32)/1.8$
Force	Dynamic Forces	lbf	N	4.448
Moment	Torque	lbf-ft	N•m	1.355

DATA SHEET NO. 1

HIGH SPEED CAMERA LOCATIONS AND DATA

Test Vehicle: OMDB (Half Face) to MCB

NHTSA No. N/A

Test Program: NHTSA R&D Left Oblique Offset 15deg/35%

Test Date: 05/27/16

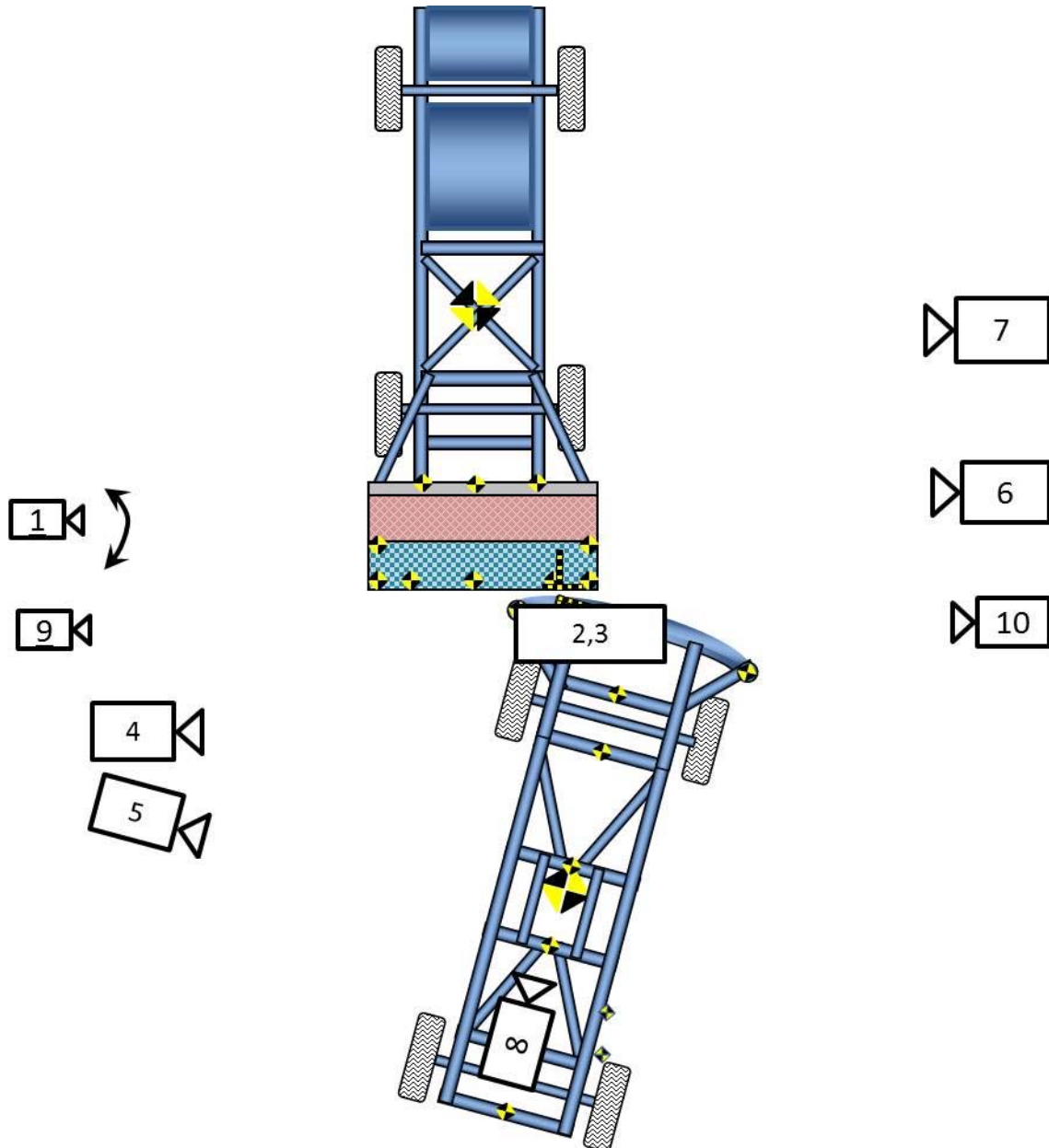

DATA SHEET NO. 1 ... (CONTINUED)

HIGH SPEED CAMERA LOCATIONS AND DATA

Test Vehicle: OMDB (Half Face) to MCB NHTSA No. N/A

Test Program: NHTSA R&D Left Oblique Offset 15deg/35% Test Date: 05/27/16

CAMERA LOCATIONS

No.	Camera View	Location (mm)			Lens (mm)	Speed (fps)
		X	Y	Z		
1	Real-Time Left Side Panning View	N/A	N/A	N/A	N/A	29.97
2	Overall Top View	3736	-291	12697	20	1000
3	Zoomed Top View	N/A	N/A	N/A	50	1000
4	Overall Left Side	5054	11698	131	35	1000
5	MCB Left Side	940	16037	970	50	1000
6	Overall Right Side	2328	-8534	625	50	1000
7	OMDB Right Side	907	-14046	401	85	1000
8	Onboard MCB	N/A	N/A	N/A	12	1000
9	Real-Time Left Side View	N/A	N/A	N/A	N/A	29.97
10	Real-Time Right Side View	N/A	N/A	N/A	N/A	29.97

Reference point: center most rearward point of the OMDB when in contact with the MCB:

+X = from back of OMDB to front of OMDB

+Y = right of monorail center

+Z = up from ground

DATA SHEET NO. 2

MCB ACCELEROMETER LOCATIONS

Test Vehicle: OMDB (Half Face) to MCB NHTSA No. N/A
 Test Program: NHTSA R&D Left Oblique Offset 15deg/35% Test Date: 05/27/16

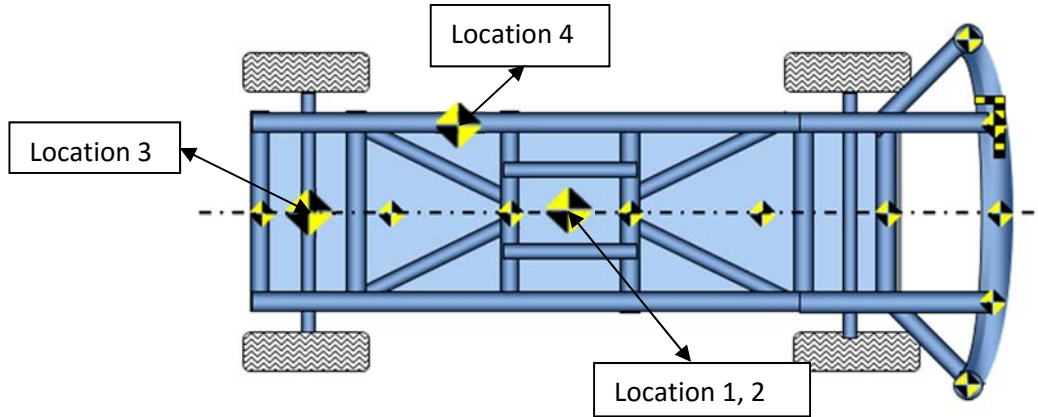

MCB ACCELEROMETER PRE-TEST LOCATIONS

No.	Accelerometer Location	Axes	Units	Location (mm)		
				X	Y	Z
1	Vehicle CG Accelerometers	X, Y, Z	g's	1965	0	324
2	Vehicle CG ARS	X, Y, Z	deg/s	1965	0	324
3	Rear C/L Axle	X, Y, Z	g's	267	0	419
4	Left Rear Frame	X, Y, Z	g's	1437	-498	522

Reference point: center most rearward point of the MCB:

- +X = from back of MCB to front of MCB
- +Y = from left side of MCB to right side of MCB
- +Z = up from ground

DATA SHEET NO. 3

MCB PHOTOGRAPHIC REFERENCE TARGET LOCATIONS

Test Vehicle: OMDB (Half Face) to MCB NHTSA No. N/A

Test Program: NHTSA R&D Left Oblique Offset 15deg/35% Test Date: 05/27/16

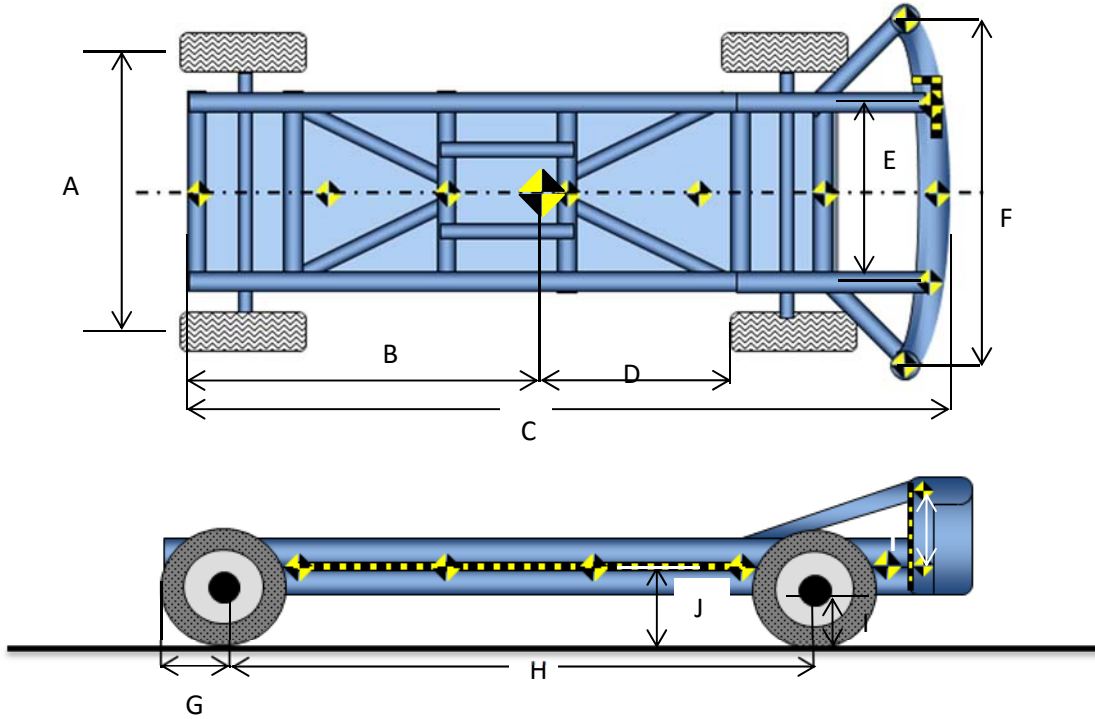

Item	Value	Item	Value
A	1495	F	1965
B	1970	G	312
C	4135	H	3048
D	1072	I	207
E	1040	J	355

All units in millimeters

	Units	Front Axle	Rear Axle	Total
Left	kg	522.5	427.0	949.5
Right	kg	525.0	424.0	949.0
Ratio	kg	55.1%	44.8%	100%
Total	kg	1047.5	851.0	1898.5
CG Aft of Front Axle	mm			1366

DATA SHEET NO. 4

OMDB INSTRUMENTATION DATA

Test Vehicle: OMDB (Half Face) to MCB NHTSA No. N/A

Test Program: NHTSA R&D Left Oblique Offset 15deg/35% Test Date: 05/27/16

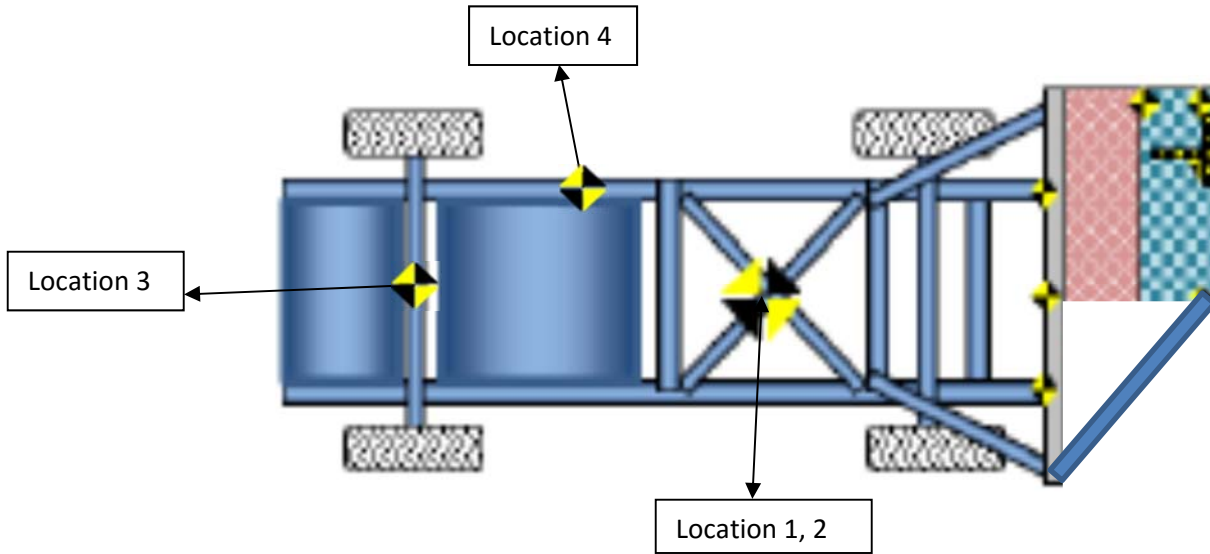

OMDB ACCELEROMETER PRE-TEST LOCATIONS

No.	Accelerometer Location	Axes	Units	Location (mm)		
				X	Y	Z
1	Vehicle CG Accelerometers	X, Y, Z	g's	1675	0	6
2	Vehicle CG ARS	X, Y, Z	deg/s	1675	0	6
3	Rear C/L Axle	X, Y, Z	g's	-4	0	-11
4	Left Rear Frame	X, Y, Z	g's	1187	-622	-97

Reference point: Center point, right above the rear axle of the OMDB:

- +X = from back of OMDB to front of OMDB
- +Y = from left side of OMDB to right side of OMDB
- +Z = up from ground

DATA SHEET NO. 5

OMDB PHOTOGRAPHIC REFERENCE TARGET LOCATIONS

Test Vehicle: OMDB (Half Face) to MCB NHTSA No. N/A

Test Program: NHTSA R&D Left Oblique Offset 15deg/35% Test Date: 05/27/16

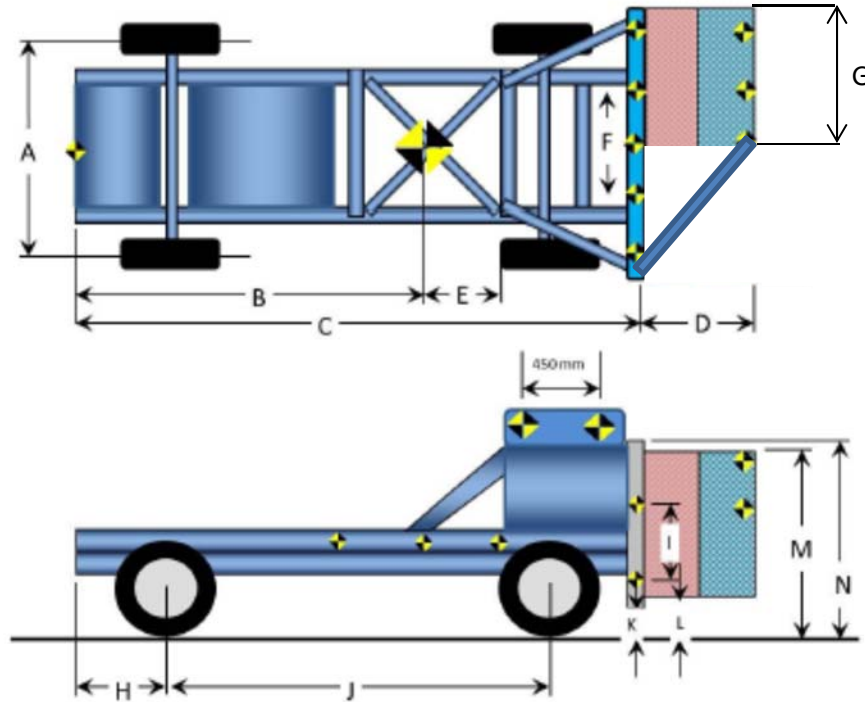

Note: All targets on the OMDB honeycomb are 450mm apart unless otherwise noted.

Item	Value	Item	Value
A	1914	H	796
B	2397	I	450
C	3988	J	2590
D	602	K	87
E	986	L	79
F	1202	M	1087
G	1200	N	1187

All units in millimeters

	Units	Front Axle	Rear Axle	Total
Left	kg	763.0	451.0	1214.0
Right	kg	770.0	512.5	1282.5
Ratio	kg	61.4%	38.6%	100.0%
Total	kg	1533.0	963.5	2496.5
CG Aft of Front Axle	mm			999.6

DATA SHEET NO. 6

TEST VEHICLE SUMMARY OF RESULTS

Test Vehicle: OMDB (Half Face) to MCB NHTSA No. N/A
Test Program: NHTSA R&D Left Oblique Offset 15deg/35% Test Date: 05/27/16

INSTRUMENTATION

Instrumentation	Number of Channels Collected
MCB Vehicle Accelerometers	12
OMDB Vehicle Accelerometers	12
Total	24

CAMERA COVERAGE

Type of Camera	Number Used in this Test
High-Speed Vehicle Onboard	1
High-Speed Off-Board	6
Real-Time Panning	3
Total	10

DATA SHEET NO. 7
OMDB CRUSH MEASUREMENTS

Test Vehicle: OMDB (Half Face) to MCB NHTSA No. N/A

Test Program: NHTSA R&D Left Oblique Offset 15deg/35% Test Date: 05/27/16

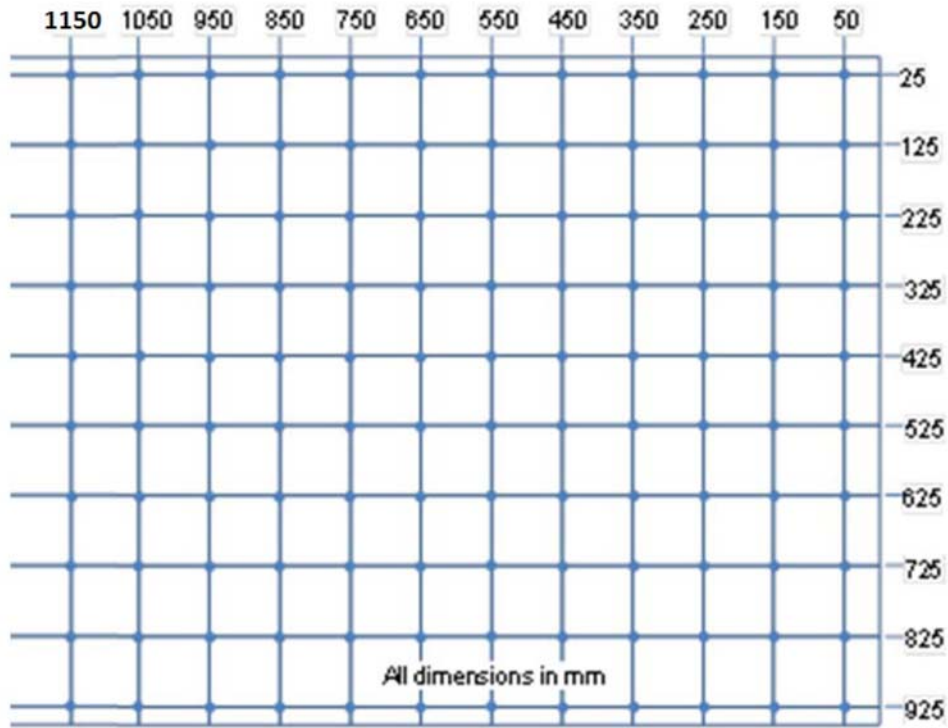

DATA SHEET NO. 7 ... (CONTINUED)

OMDB CRUSH MEASUREMENTS

Test Vehicle: OMDB (Half Face) to MCB

NHTSA No. N/A

Test Program: NHTSA R&D Left Oblique Offset 15deg/35%

Test Date: 05/27/16

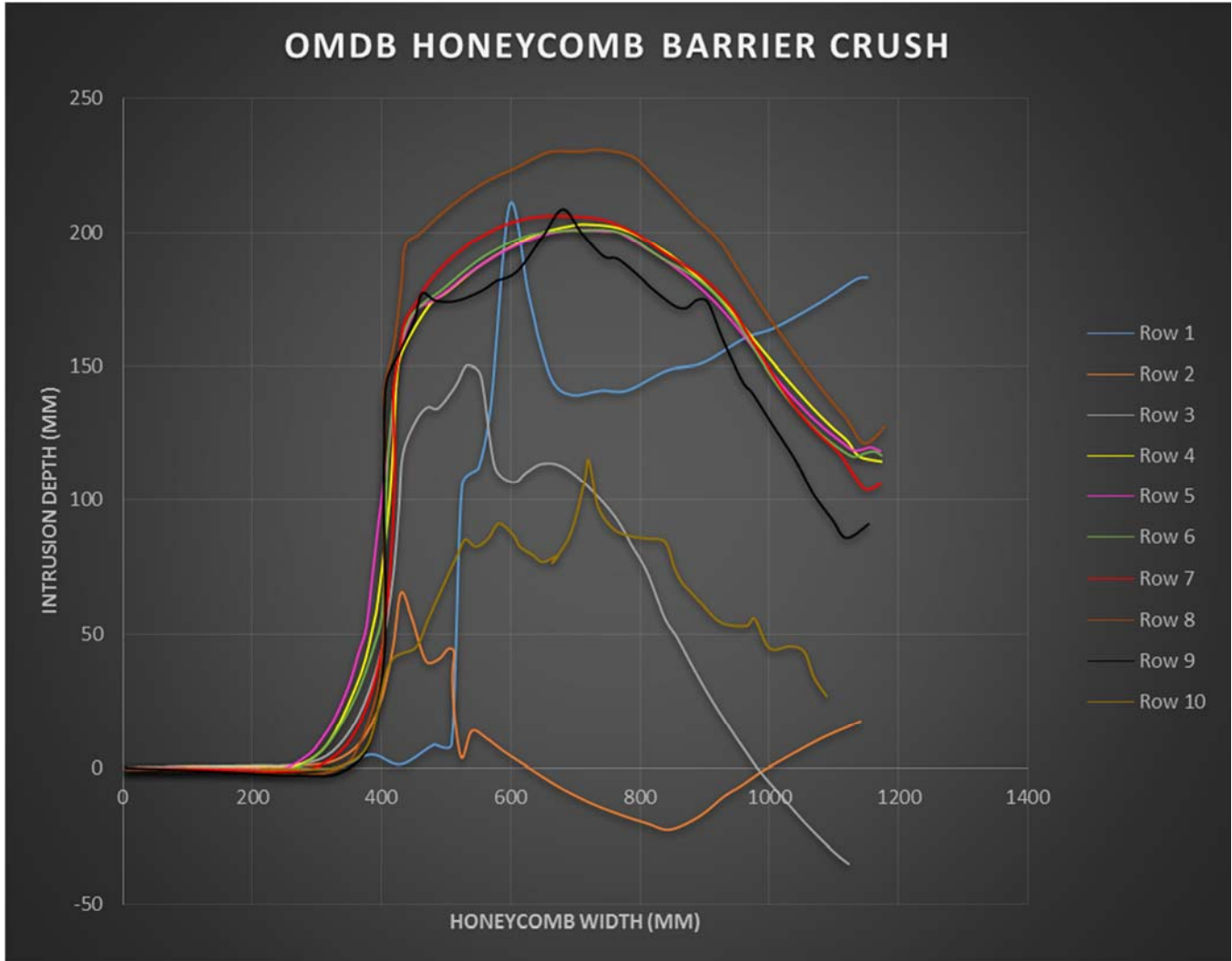

**APPENDIX A
PHOTOGRAPHS**

TABLE OF PHOTOGRAPHS

Figure		Page
1	Pre-Test Right View of OMDB and MCB	A-1
2	Pre-Test Left View of OMDB and MCB	A-1
3	Pre-Test Top View of OMDB and MCB	A-2
4	Post-Test Top View of OMDB and MCB	A-2
5	Pre-Test Close-Up View of Impact Point	A-3
6	Post-Test Close-Up View of Impact Point	A-3
7	Pre-Test Right View of MCB	A-4
8	Post-Test Right View of MCB	A-4
9	Pre-Test Right Front 3/4 View of MCB	A-5
10	Post-Test Right Front 3/4 View of MCB	A-5
11	Pre-Test Front View of MCB	A-6
12	Post-Test Front View of MCB	A-6
13	Pre-Test Left Front 3/4 View of MCB	A-7
14	Post-Test Left Front 3/4 View of MCB	A-7
15	Pre-Test Left View of MCB	A-8
16	Post-Test Left View of MCB	A-8
17	Pre-Test Left View of OMDB Impactor Face	A-9
18	Post-Test Left View of OMDB Impactor Face	A-9
19	Pre-Test Right View of OMDB Impactor Face	A-10
20	Post-Test Right View of OMDB Impactor Face	A-10
21	Pre-Test Top View of OMDB Impactor Face	A-11
22	Post-Test Top View of OMDB Impactor Face	A-11
23	Pre-Test Front View of OMDB Impactor Face	A-12
24	Post-Test Front View of OMDB Impactor Face	A-12
25	Pre-Test Right View of OMDB	A-13
26	Post-Test Right View of OMDB	A-13
27	Pre-Test Left View of OMDB	A-14
28	Post-Test Left View of OMDB	A-14
29	Pre-Test OMDB and Vehicle Alignment	A-15
30	Impact Event	A-15



FIGURE 1. Pre-Test Right View of OMDB and MCB



FIGURE 2. Pre-Test Left View of OMDB and MCB

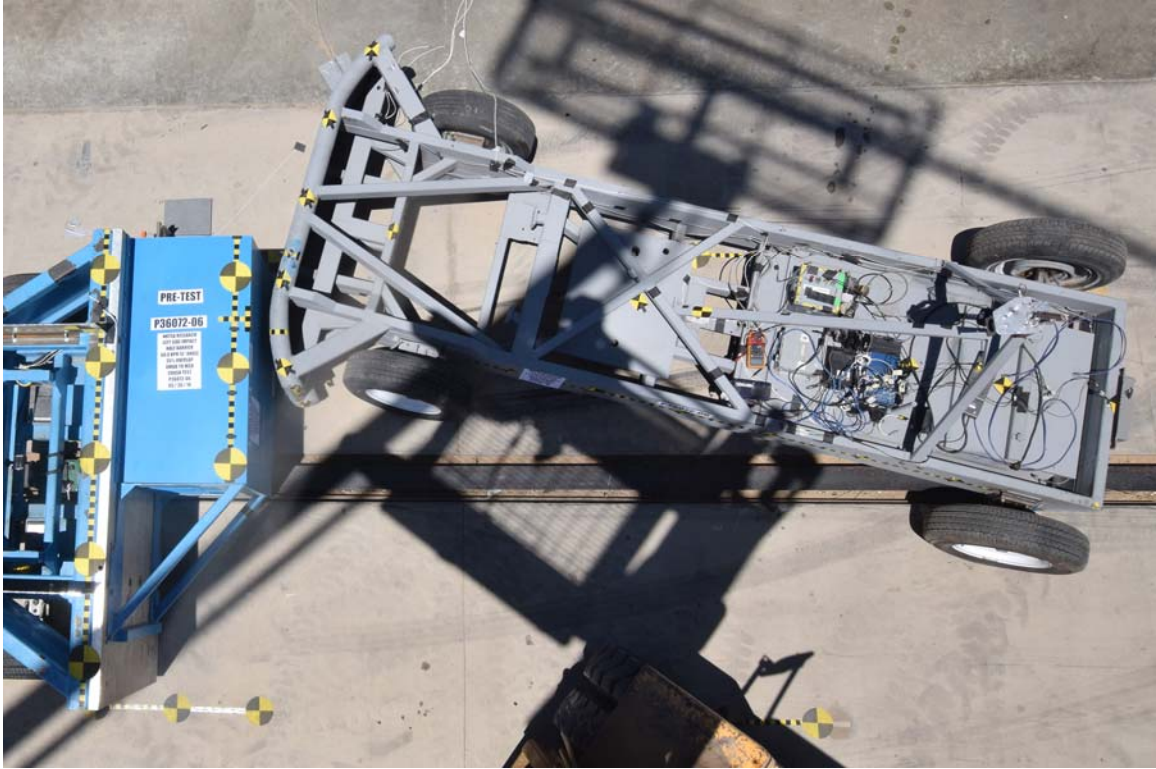

FIGURE 3. Pre-Test Top View of OMDB and MCB



FIGURE 4. Post-Test Top View of OMDB and MCB



FIGURE 5. Pre-Test Close-up View Of Impact Point



FIGURE 6. Post-Test Close-up View Of Impact Point



FIGURE 7. Pre-Test Right View of MCB



FIGURE 8. Post-Test Right View of MCB



FIGURE 9. Pre-Test Right Front $\frac{3}{4}$ View of MCB



FIGURE 10. Post-Test Right Front $\frac{3}{4}$ View of MCB



FIGURE 11. Pre-Test Front View of MCB



FIGURE 12. Post-Test Front View of MCB



FIGURE 13. Pre-Test Left Front $\frac{3}{4}$ View of MCB

Photograph Not Available

FIGURE 14. Post-Test Left Front $\frac{3}{4}$ View of MCB



FIGURE 15. Pre-Test Left View of MCB



FIGURE 16. Post-Test Left View of MCB



FIGURE 17. Pre-Test Left View of OMDB Impactor Face



FIGURE 18. Post-Test Left View of OMDB Impactor Face



FIGURE 19. Pre-Test Right View of OMDB Impactor Face



FIGURE 20. Post-Test Right View of OMDB Impactor Face



FIGURE 21. Pre-Test Top View of OMDB Impactor Face



FIGURE 22. Post-Test Top View of OMDB Impactor Face



FIGURE 23. Pre-Test Front View of OMDB Impactor Face



FIGURE 24. Post-Test Front View of OMDB Impactor Face



FIGURE 25. Pre-Test Right View of OMDB



FIGURE 26. Post-Test Right View of OMDB



FIGURE 27. Pre-Test Left View of OMDB



FIGURE 28. Post-Test Left View of OMDB



FIGURE 29. Pre-Test OMDB and MCB Alignment



FIGURE 30. Impact Event

**APPENDIX B
DATA PLOTS**

TABLE OF DATA PLOTS

<u>Figure</u>		<u>Page</u>
1	V2 MCB CG X Acceleration	B-1
2	V2 MCB CG Y Acceleration	B-1
3	V2 MCB CG Z Acceleration	B-1
4	V2 MCB CG Angular Rate X	B-1
5	V2 MCB CG Angular Rate Y	B-2
6	V2 MCB CG Angular Rate Z	B-2
7	V2 MCB Rear C/L X Acceleration	B-2
8	V2 MCB Rear C/L Y Acceleration	B-2
9	V2 MCB Rear C/L Z Acceleration	B-3
10	V2 MCB Left Rear Frame X Acceleration	B-3
11	V2 MCB Left Rear Frame Y Acceleration	B-3
12	V2 MCB Left Rear Frame Z Acceleration	B-3
13	V1 OMDB CG X Acceleration	B-4
14	V1 OMDB CG Y Acceleration	B-4
15	V1 OMDB CG Z Acceleration	B-4
16	V1 OMDB CG Angular Rate X	B-4
17	V1 OMDB CG Angular Rate Y	B-5
18	V1 OMDB CG Angular Rate Z	B-5
19	V1 OMDB Rear C/L X Acceleration	B-5
20	V1 OMDB Rear C/L Y Acceleration	B-5
21	V1 OMDB Rear C/L Z Acceleration	B-6
22	V1 OMDB Left Rear Frame X Acceleration	B-6
23	V1 OMDB Left Rear Frame Y Acceleration	B-6
24	V1 OMDB Left Rear Frame Z Acceleration	B-6

Test Vehicle: OMDB (Half Face) to MCB
 Test Program: NHTSA R&D Left Oblique Offset 15deg/35%

NHTSA No.: N/A
 Test Date: 5/27/16

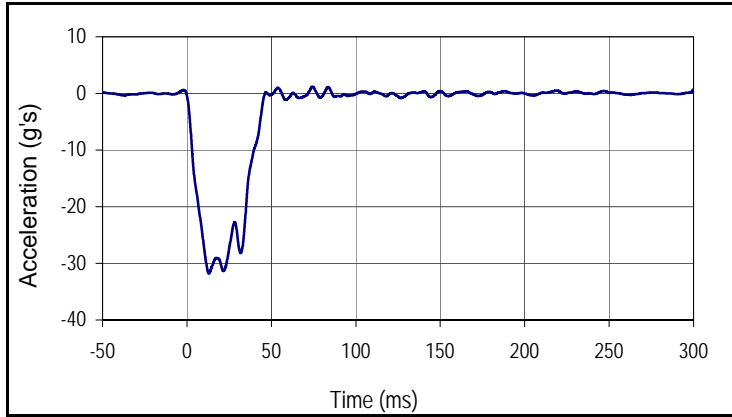

Curve Description			
V2 MCB CG X Acceleration			
Plot No.		SAE Class	Units
001		60	g's
Max	Time	Min	Time
1.2	74.4	-31.8	13.0

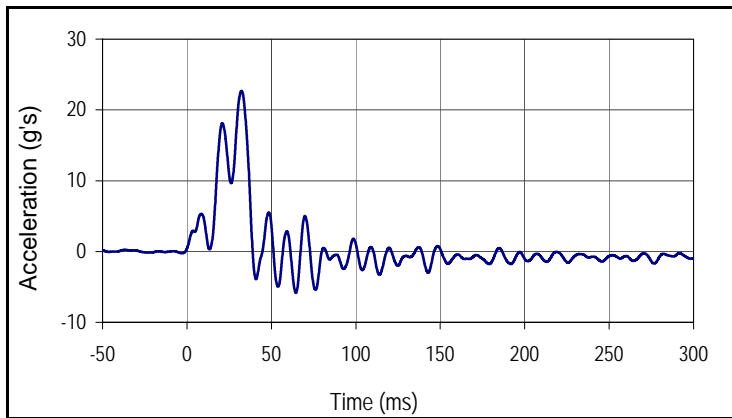

Curve Description			
V2 MCB CG Y Acceleration			
Plot No.		SAE Class	Units
002		60	g's
Max	Time	Min	Time
22.7	32.3	-5.9	64.5

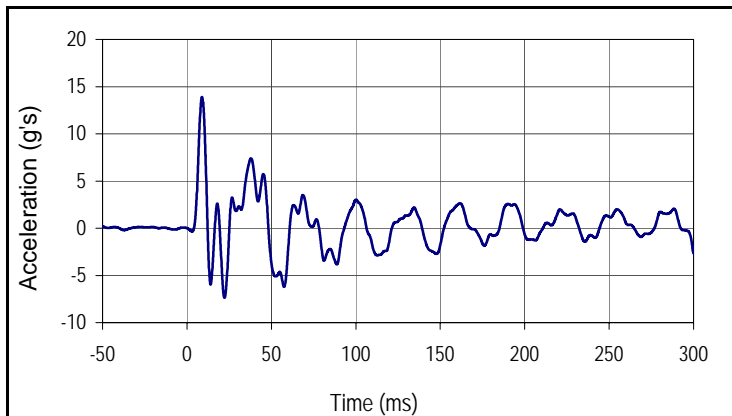

Curve Description			
V2 MCB CG Z Acceleration			
Plot No.		SAE Class	Units
003		60	g's
Max	Time	Min	Time
13.9	8.9	-7.4	22.2

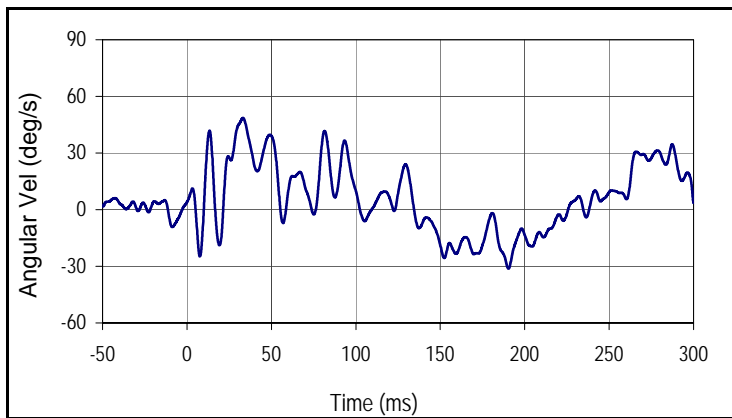

Curve Description			
V2 MCB CG Angular Rate X			
Plot No.		SAE Class	Units
004		60	deg/s
Max	Time	Min	Time
48.6	33.2	-31.2	190.4

Test Vehicle: OMDB (Half Face) to MCB
 Test Program: NHTSA R&D Left Oblique Offset 15deg/35%

NHTSA No.: N/A
 Test Date: 5/27/16

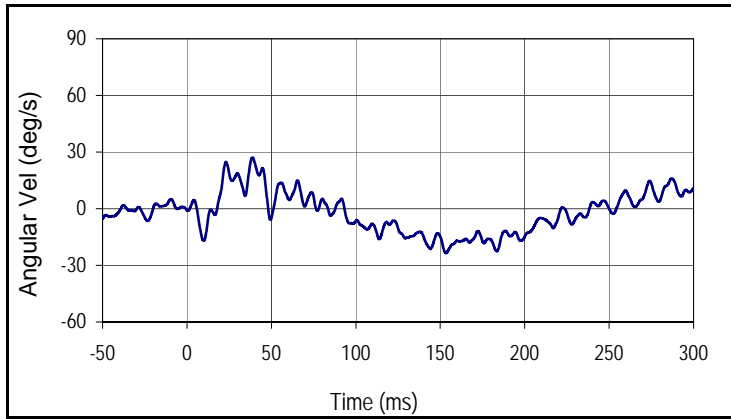

Curve Description			
V2 MCB CG Angular Rate Y			
Plot No.		SAE Class	Units
005		60	deg/s
Max	Time	Min	Time
27.2	38.8	-23.5	153.3

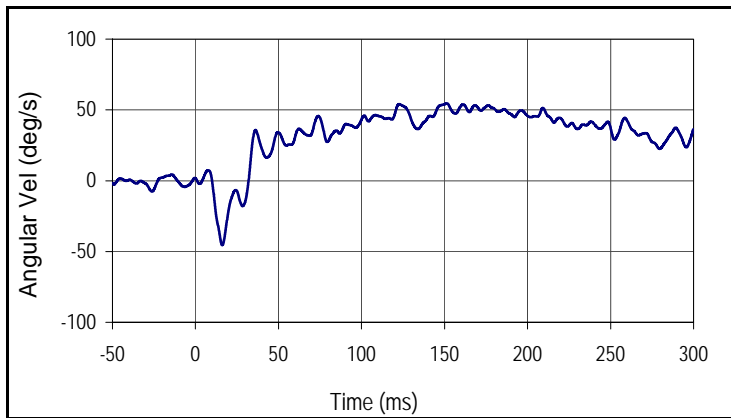

Curve Description			
V2 MCB CG Angular Rate Z			
Plot No.		SAE Class	Units
006		60	deg/s
Max	Time	Min	Time
54.7	151.4	-45.4	16.1

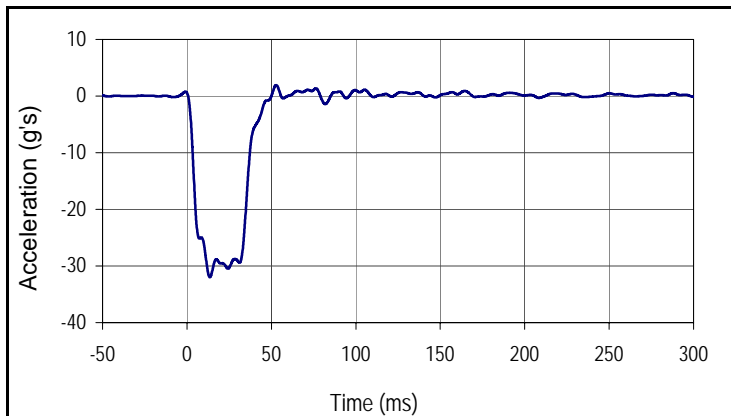

Curve Description			
V2 MCB Rear C/L X Acceleration			
Plot No.		SAE Class	Units
007		60	g's
Max	Time	Min	Time
1.9	52.8	-32.0	13.6

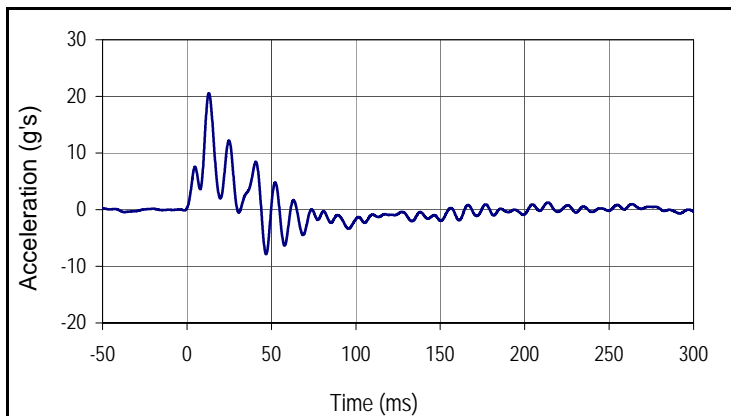

Curve Description			
V2 MCB Rear C/L Y Acceleration			
Plot No.		SAE Class	Units
008		60	g's
Max	Time	Min	Time
20.6	13.0	-7.9	46.9

Test Vehicle: OMDB (Half Face) to MCB
 Test Program: NHTSA R&D Left Oblique Offset 15deg/35%

NHTSA No.: N/A
 Test Date: 5/27/16

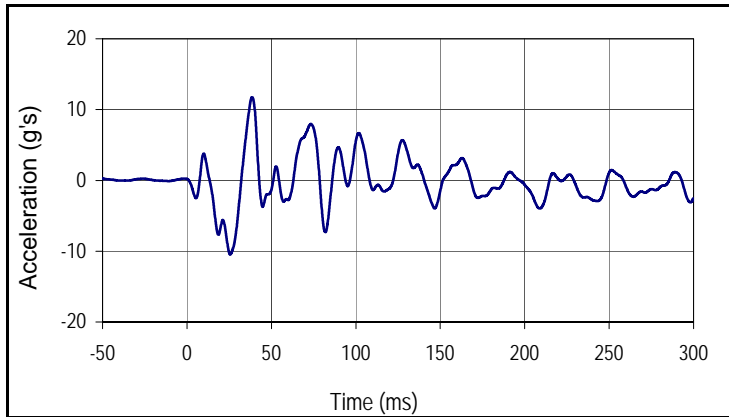

Curve Description			
V2 MCB Rear C/L Z Acceleration			
Plot No.		SAE Class	Units
009		60	g's
Max	Time	Min	Time
11.7	38.6	-10.4	25.6

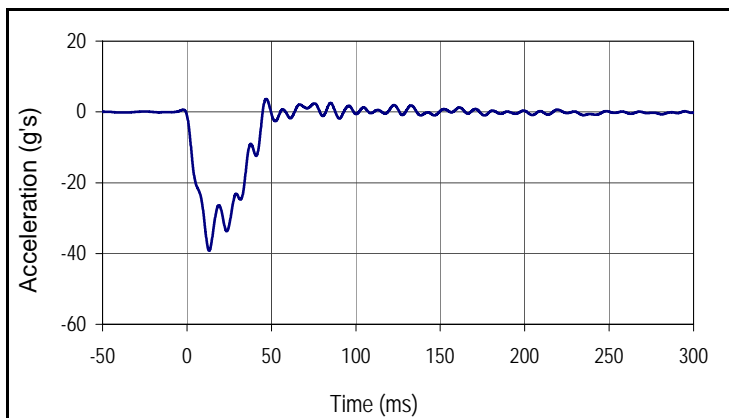

Curve Description			
V1 MCB Left Frame X Acceleration			
Plot No.		SAE Class	Units
010		60	g's
Max	Time	Min	Time
3.7	46.9	-39.2	13.2

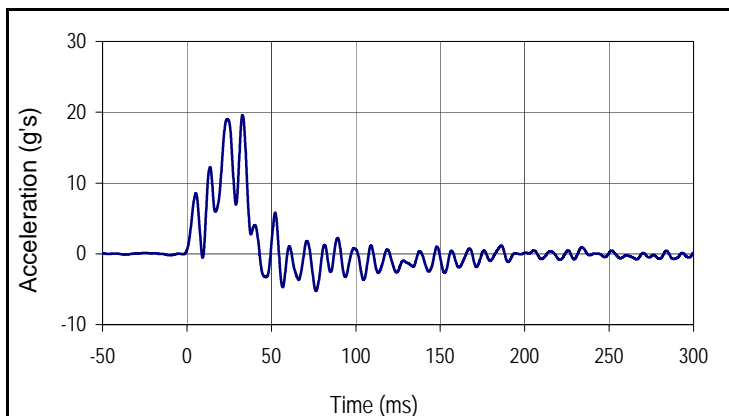

Curve Description			
V1 MCB Left Frame Y Acceleration			
Plot No.		SAE Class	Units
011		60	g's
Max	Time	Min	Time
19.6	32.9	-5.2	76.4

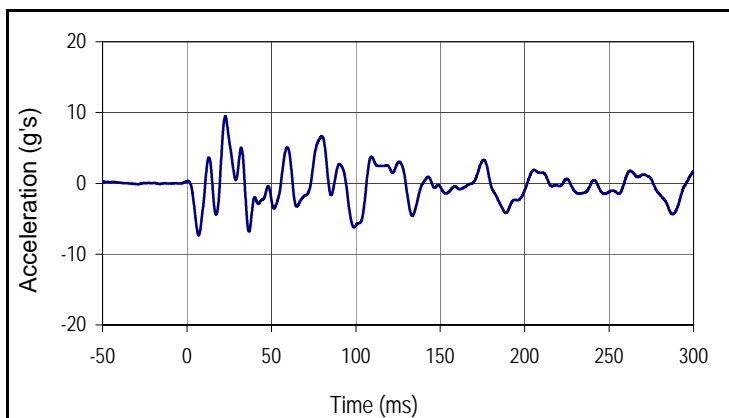

Curve Description			
V1 MCB Left Frame Z Acceleration			
Plot No.		SAE Class	Units
012		60	g's
Max	Time	Min	Time
9.5	22.7	-7.4	6.9

Test Vehicle: OMDB (Half Face) to MCB
 Test Program: NHTSA R&D Left Oblique Offset 15deg/35%

NHTSA No.: N/A
 Test Date: 5/27/16

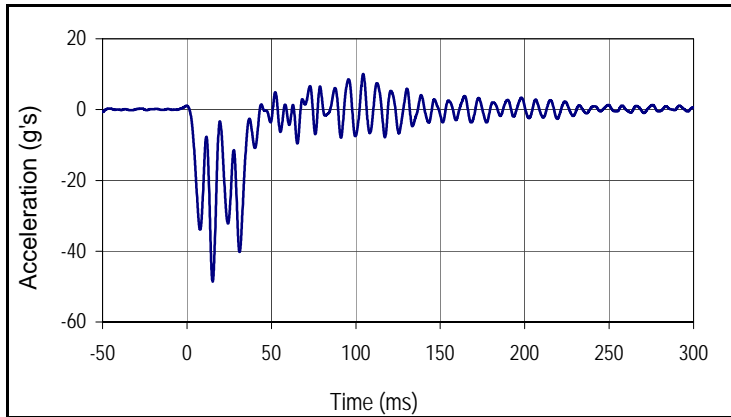

Curve Description			
V1 OMDB CG X Acceleration			
Plot No.		SAE Class	Units
013		60	g's
Max	Time	Min	Time
10.1	104.4	-48.6	15.2

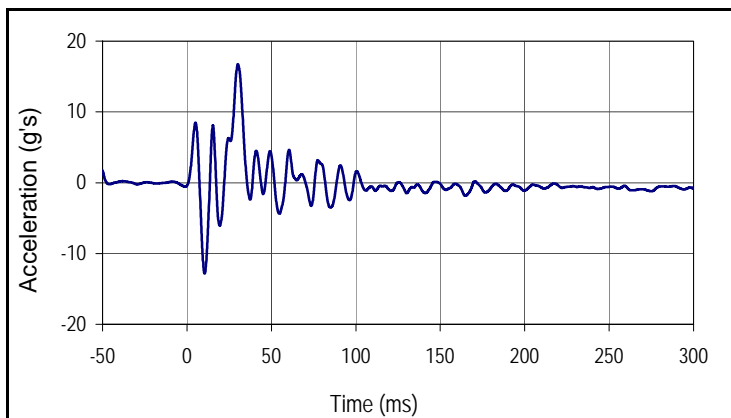

Curve Description			
V1 OMDB CG Y Acceleration			
Plot No.		SAE Class	Units
014		60	g's
Max	Time	Min	Time
16.7	30.2	-12.8	10.5

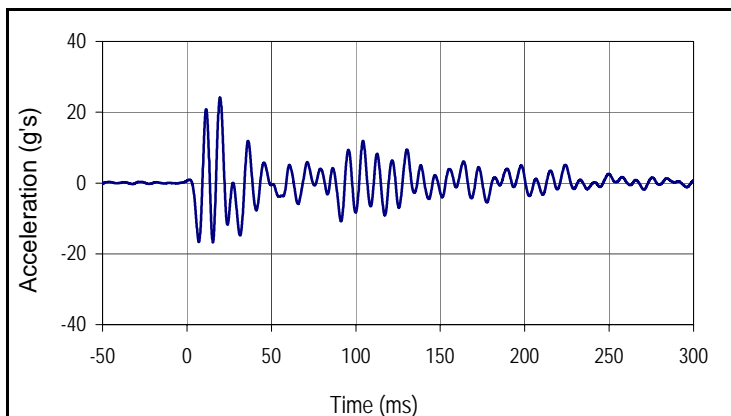

Curve Description			
V1 OMDB CG Z Acceleration			
Plot No.		SAE Class	Units
015		60	g's
Max	Time	Min	Time
24.1	19.6	-16.8	15.4

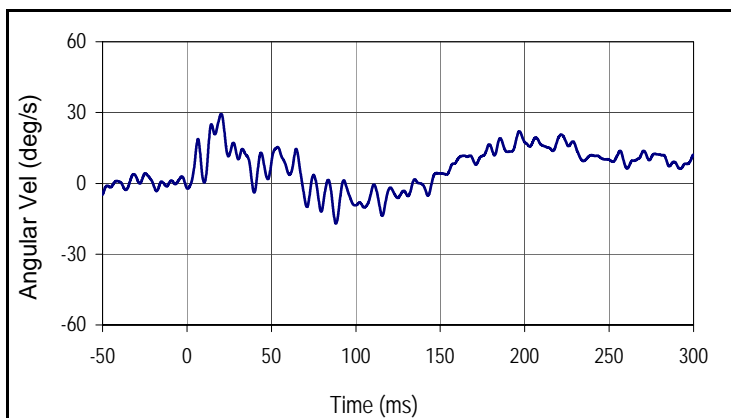

Curve Description			
V1 OMDB Angular Rate X			
Plot No.		SAE Class	Units
016		60	deg/s
Max	Time	Min	Time
29.4	20.3	-17.0	88.2

Test Vehicle: OMDB (Half Face) to MCB
 Test Program: NHTSA R&D Left Oblique Offset 15deg/35%

NHTSA No.: N/A
 Test Date: 5/27/16

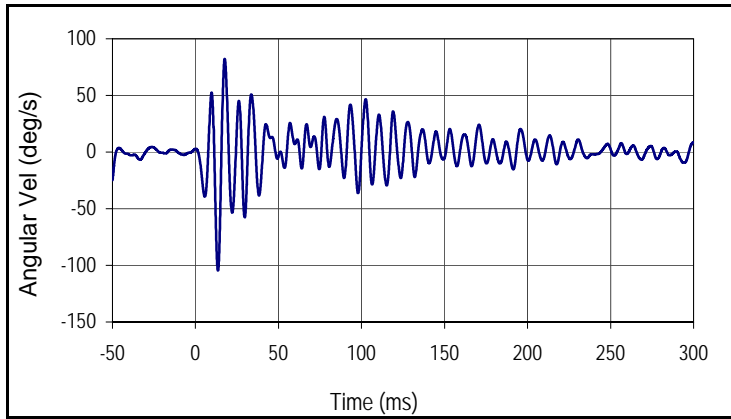

Curve Description			
V1 OMDB Angular Rate Y			
Plot No.		SAE Class	Units
017		60	deg/s
Max	Time	Min	Time
82.2	17.6	-104.5	13.6

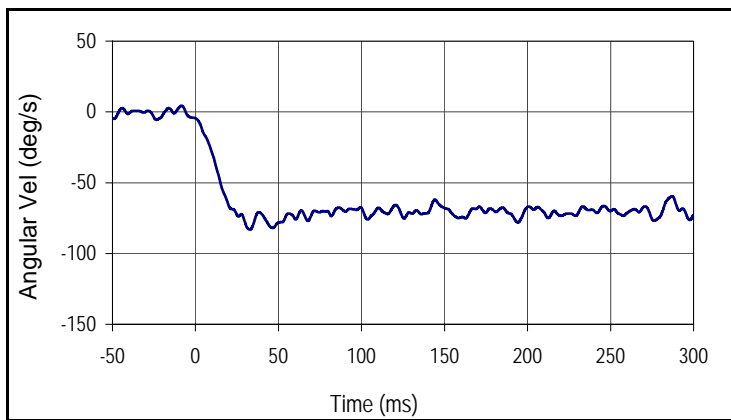

Curve Description			
V1 OMDB Angular Rate Z			
Plot No.		SAE Class	Units
018		60	deg/s
Max	Time	Min	Time
4.3	-8.3	-83.1	32.6

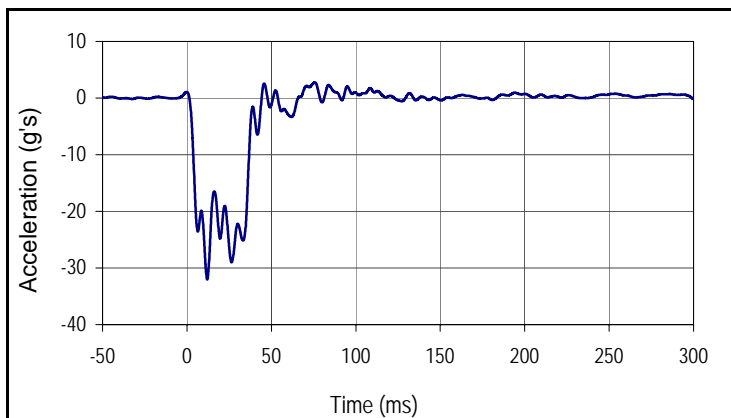

Curve Description			
V1 OMDB Rear C/L X Acceleration			
Plot No.		SAE Class	Units
019		60	g's
Max	Time	Min	Time
2.8	75.7	-32.0	12.0

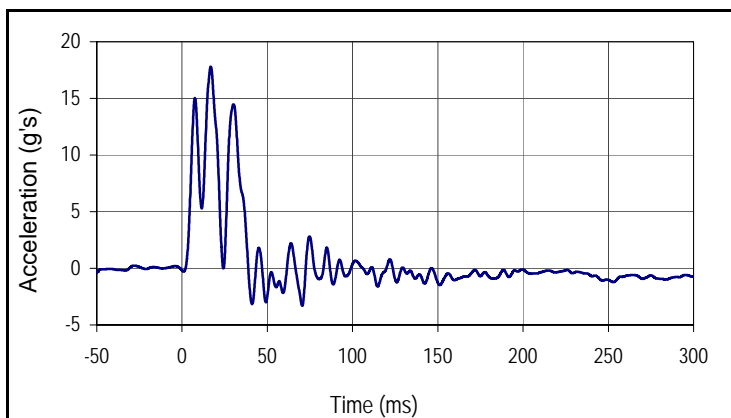

Curve Description			
V1 OMDB Rear C/L Y Acceleration			
Plot No.		SAE Class	Units
020		60	g's
Max	Time	Min	Time
17.8	16.8	-3.3	70.5

Test Vehicle: OMDB (Half Face) to MCB
 Test Program: NHTSA R&D Left Oblique Offset 15deg/35%

NHTSA No.: N/A
 Test Date: 5/27/16

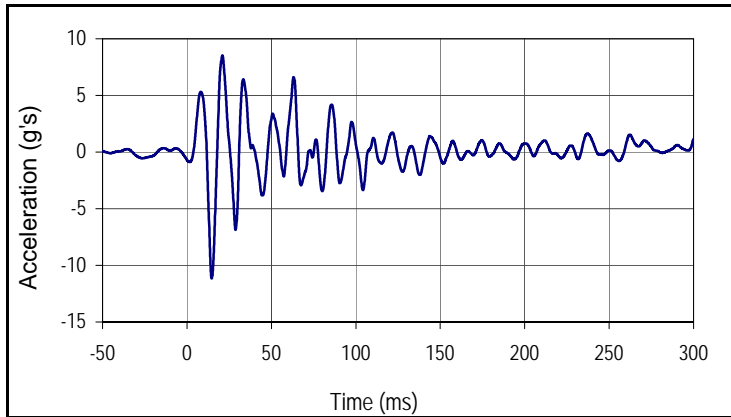

Curve Description			
V1 OMDB Rear C/L Z Acceleration			
Plot No.		SAE Class	Units
021		60	g's
Max	Time	Min	Time
8.5	21.0	-11.2	14.7

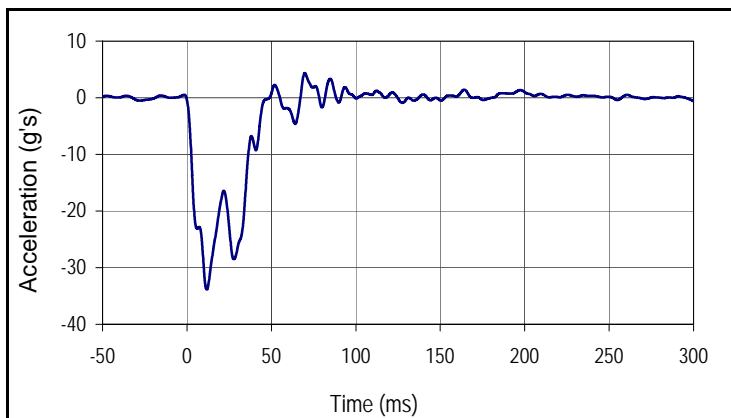

Curve Description			
V1 OMDB Left Frame X Acceleration			
Plot No.		SAE Class	Units
022		60	g's
Max	Time	Min	Time
4.3	69.8	-33.9	11.7

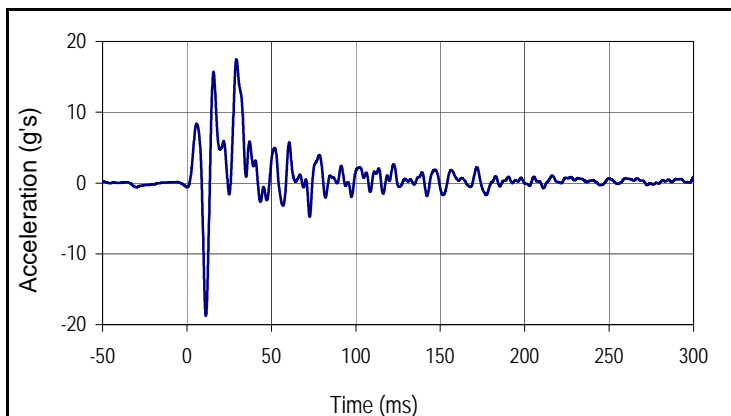

Curve Description			
V1 OMDB Left Frame Y Acceleration			
Plot No.		SAE Class	Units
023		60	g's
Max	Time	Min	Time
17.5	29.3	-18.8	11.2

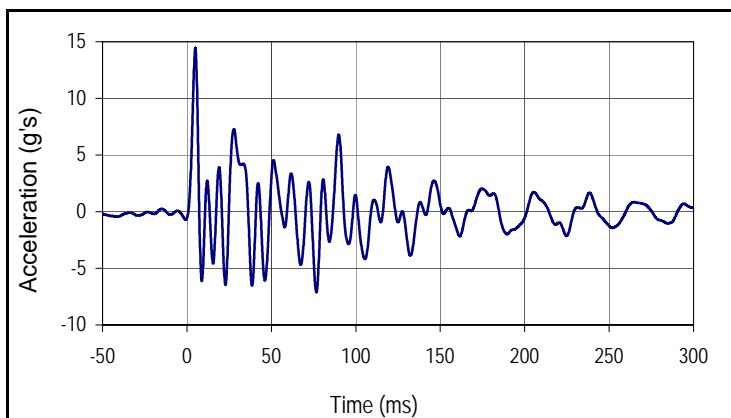

Curve Description			
V1 OMDB Left Frame Z Acceleration			
Plot No.		SAE Class	Units
024		60	g's
Max	Time	Min	Time
14.5	5.0	-7.1	76.6