

REPORT NUMBER: R&D-CAL-15-018

**MOVING BARRIER TO VEHICLE CRASH TEST IN SUPPORT OF NHTSA'S
FRONTAL OBLIQUE OFFSET PROGRAM
OBLIQUE MOVING DEFORMABLE BARRIER INTO LEFT FRONT OF A**

2016 Honda Fit

90.1KPH, 15 DEGREE ANGLE, 35% OVERLAP

TEST DATE: 2/11/2016

NHTSA No: M20165307

**CALSPAN CORPORATION
TRANSPORTATION TEST OPERATIONS
P.O. BOX 400
BUFFALO, NEW YORK 14225**

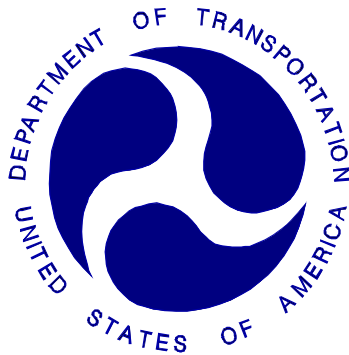

FINAL REPORT SUBMITTED:

April 8, 2016

PREPARED FOR:

**U. S. DEPARTMENT OF TRANSPORTATION
National Highway Traffic Safety Administration
Vehicle safety Research
1200 New Jersey Ave, SE
Room W46-446
Washington, DC 20590**

This publication is distributed by the U.S. Department of Transportation, National Highway Traffic Safety Administration, in the interest of information exchange. The opinions, findings and conclusions expressed in this publication are those of the author(s) and not necessarily those of the Department of Transportation or the National Highway Traffic Safety Administration. The United States Government assumes no liability for its contents or use thereof. If trade or manufacturers' names or products are mentioned it is only because they are considered essential to the object of the publication and should not be construed as an endorsement. The United States Government does not endorse products or manufacturers.

Prepared by: Vanessa Hansen
Vanessa Hansen, Test Engineer

Date: April 8, 2016

Approved by: Edward Dutton
Edward J. Dutton, Operations Manager
Transportation Test Operations

Date: April 8, 2016

FINAL REPORT ACCEPTANCE BY VEHICLE SAFETY RESEARCH, OFFICE OF STRUCTURAL AND RESTRAINTS RESEARCH DIVISION:

Date: _____

TOM, Vehicle Crash Testing
NHTSA, Office of Structures and Restraints Research
Date: _____

TECHNICAL REPORT STANDARD TITLE PAGE

1. Report No. R&D-CAL-15-018	2. Government Accession No.	3. Recipient's Catalog No.																																					
4. Title and Subtitle Report for Frontal Oblique Offset Program Testing of a 2016 Honda Fit hatchback NHTSA No.: M20165307		5. Report Date 4/8/2016																																					
		6. Performing Organization Code CAL																																					
7. Author(s) Vanessa Hansen, Test Engineer Ed Dutton, Operations Manager		8. Performing Organization Report No. CAL-DOT-2015-018																																					
9. Performing Organization Name and Address Calspan Corporation 4455 Genesee Street Buffalo, New York 14225		10. Work Unit No.																																					
		11. Contract or Grant No. DTNH22-14-D-00359																																					
12. Sponsoring Agency Name and Address U.S. Department of Transportation National Highway Traffic Safety Administration Office of Vehicle Safety Research 1200 New Jersey Ave SE, Room W46-446 Washington, DC 20590		13. Type of Report and Period Covered Final Report, 4/8/2016																																					
		14. Sponsoring Agency Code NVS-321																																					
15. Supplementary Notes																																							
16. Abstract A test was conducted in accordance with Contract DTNH22-14-D-00359, Task Order #001. The Test consisted of a Oblique Moving Deformable Barrier (OMDB) traveling at a target speed of 90.12 kph into a stationary 2016 Honda Fit hatchback. The struck vehicle was positioned 15 degrees relative to the moving barrier and impacted 35% of the left side of the vehicle. The test was conducted to obtain data indicant of FMVSS 208, 212, 219 (partial), 301, and foot well intrusion performance. The test was conducted at the Calspan Corporation's Transportation Test Operation's facility in Buffalo, New York on February 11, 2016. The OMDB impact velocity was 90.05 kph and the ambient temperature at the test vehicle at the time of impact was 21°C. The target vehicle post-test maximum crush was 593 mm. The test vehicle's performance was as follows:																																							
<table border="1"> <thead> <tr> <th>Measurement Description</th> <th>Units</th> <th>Driver THOR</th> <th>Pass. THOR</th> </tr> </thead> <tbody> <tr> <td>Head Injury Criteria (HIC₁₅)</td> <td>N/A</td> <td>295.64</td> <td>1277.28</td> </tr> <tr> <td>Brain Injury Criteria (BrIC)</td> <td>N/A</td> <td>1.15</td> <td>1.78</td> </tr> <tr> <td>Peak Neck Tension</td> <td>N</td> <td>2082.37</td> <td>2510.86</td> </tr> <tr> <td>Peak Resultant Chest Deflection</td> <td>mm</td> <td>51.33</td> <td>52.67</td> </tr> <tr> <td>Peak Abdomen Deflection</td> <td>mm</td> <td>-65.19</td> <td>-69.93</td> </tr> <tr> <td>Peak Resultant Acetabulum force</td> <td>N</td> <td>4673.30</td> <td>3559.50</td> </tr> <tr> <td>Peak Femur Force</td> <td>N</td> <td>-9184.08</td> <td>-3915.78</td> </tr> <tr> <td>Right Tibia Index</td> <td>N/A</td> <td>1.14</td> <td>0.86</td> </tr> </tbody> </table>				Measurement Description	Units	Driver THOR	Pass. THOR	Head Injury Criteria (HIC ₁₅)	N/A	295.64	1277.28	Brain Injury Criteria (BrIC)	N/A	1.15	1.78	Peak Neck Tension	N	2082.37	2510.86	Peak Resultant Chest Deflection	mm	51.33	52.67	Peak Abdomen Deflection	mm	-65.19	-69.93	Peak Resultant Acetabulum force	N	4673.30	3559.50	Peak Femur Force	N	-9184.08	-3915.78	Right Tibia Index	N/A	1.14	0.86
Measurement Description	Units	Driver THOR	Pass. THOR																																				
Head Injury Criteria (HIC ₁₅)	N/A	295.64	1277.28																																				
Brain Injury Criteria (BrIC)	N/A	1.15	1.78																																				
Peak Neck Tension	N	2082.37	2510.86																																				
Peak Resultant Chest Deflection	mm	51.33	52.67																																				
Peak Abdomen Deflection	mm	-65.19	-69.93																																				
Peak Resultant Acetabulum force	N	4673.30	3559.50																																				
Peak Femur Force	N	-9184.08	-3915.78																																				
Right Tibia Index	N/A	1.14	0.86																																				
17. Key Words THOR Oblique Offset		18. Distribution Statement Copies of this report are available from: National Highway Traffic Safety Administration Technical Reference Division 1200 New Jersey Ave, SE Washington, DC 20590																																					
19. Security Classif. (of this report) UNCLASSIFIED	20. Security Classif. (of this page) UNCLASSIFIED	21. No. of Pages	22. Price																																				

DISCLAIMER

The contents of this report relate only to the specific product evaluated under the specific test conditions, as defined within this report. The findings and conclusions are those of the author(s) and not necessarily those of Calspan Corporation. For the purposes of this report, Calspan Corporation provided test services only and was not involved with the consulting, design or manufacture of any product. Calspan Corporation does not endorse products or manufacturers. Further, Calspan Corporation (to include: any of its affiliates, parent companies or subsidiaries) assumes no liability associated with the contents of this report or the use of this report.

Prepared by: Vanessa Hansen
Vanessa Hansen, Project Engineer

Date: April 8, 2016

Approved by: Edward Dutton
Edward J. Dutton, Test Engineer Director
Transportation Test Operations

Date: April 8, 2016

TABLE OF CONTENTS

Test Vehicle: 2016 Honda Fit hatchback
 Test Program: R&D 90.1kph, 15° / 35% Left Oblique Offset

NHTSA No.: M20165307
 Test Date: 2/11/2016

Section	Page No.
1 Purpose of Test	1-1
2 Summary of Test	2-1
Crash Vehicle Summary	2-3
Preliminary Injury Summary: Driver	2-5
Preliminary Injury Summary: Front Right Passenger	2-6
3 Data Sheets	3-1

Data Sheet No.	Page No.
1 General Test and Vehicle Parameter Data	3-2
2 Seat Adjustment, Fuel System, and Steering Wheel	3-6
3 Dummy Longitudinal Clearance Dimensions	3-8
4 Dummy Lateral Clearance Dimensions	3-10
5 Seat Belt Positioning Data	3-11
6 High-Speed Camera Locations and Data	3-12
7 Vehicle Instrumentation Data	3-15
8 Photographic Reference Target Locations	3-18
9 Test Vehicle Summary of Results	3-25
10 Post-Test Observations	3-26
11 Vehicle Profile Measurements	3-27
12 Accident Investigation Division Data	3-29
13 Vehicle Intrusion Measurements	3-30
14 OMDB Crush Measurements	3-47
15 Summary of FMVSS 212, 219 (Partial), and 301 Data	3-48
Windshield Periphery Measurements	3-48
Areas of Protected Zone Failures	3-48
Fuel System Integrity Post Impact Data	3-49
16 FMVSS 301 Static Rollover Results	3-50
17 Dummy / Vehicle Temperature Stabilization	3-51

Appendix	Page No.
A Photographs	A-1
B Vehicle & Dummy Response Data Traces	B-1
C Part 572 E/O Dummy Calibration and Performance Verification Data Sheets	C-1
D CMM Measurement Procedures	D-1

**SECTION 1
PURPOSE OF TEST**

Test Vehicle: 2016 Honda Fit hatchback
Test Program: R&D 90.1kph, 15° / 35% Left Oblique Offset

NHTSA No.: M20165307
Test Date: 2/11/2016

This 90.12 kph (56 mph) Moving Barrier into a test vehicle is part of the Frontal Offset Test outlined in Contract No. DTNH22-14-D-00359, Task Order 0001. The purpose of this test is to obtain vehicle crashworthiness and occupant restraint system performance data for consumer information purposes.

This test was conducted in accordance with the instructions set forth for a 15° angle, 35% offset moving barrier to vehicle impact, outlined in Contract No. DTNH22-14-D-00359, Task Order 0001. Data was obtained indicant of Federal Motor Vehicle Safety Standard FMVSS 208-Occupant Crash Protection, FMVSS 212 – Windshield Mounting, FMVSS 219 (partial) – Windshield Zone Intrusion, and FMVSS 301 – Fuel System Integrity, in addition to the requirements of Contract No. DTNH22-14-D-00359, Task Order 0001.

SECTION 2 SUMMARY OF TEST

Test Vehicle: 2016 Honda Fit hatchback
Test Program: R&D 90.1kph, 15° / 35% Left Oblique Offset

NHTSA No.: M20165307
Test Date: 2/11/2016

A 2016 Honda Fit hatchback was impacted on the left front corner by an Oblique Moving Deformable Barrier (OMDB). This test vehicle was stationary and positioned at a target angle of 15° and at a target offset of 35% to the forward line of motion of the OMDB. The OMDB was towed down the test track in a full forward direction, without any crabbing, and at the targeted impact velocity of 90.12 kph (56.0 mph) into the test vehicle. The test vehicle's mass was 1,403 kg (3,093.1 lbs), and the OMDB's mass was 2519 kg (5,552 lbs). The test was conducted by Calspan Corporation on February 11, 2016.

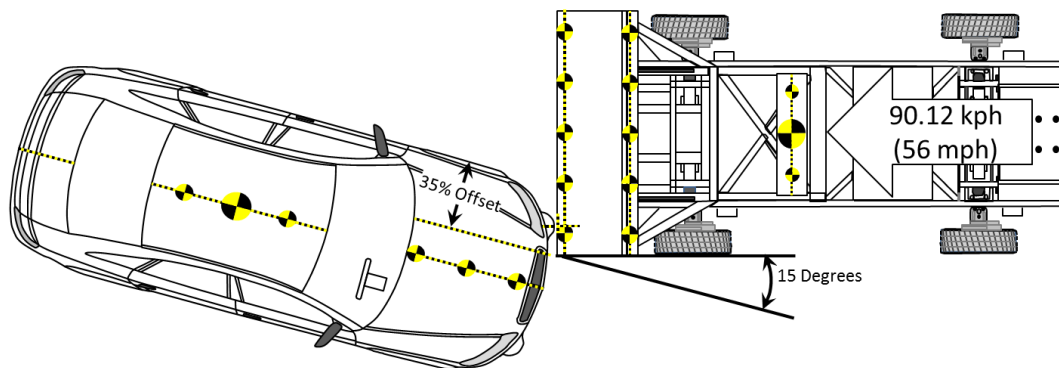

The test was documented by two (2) real time and fifteen (15) high-speed video cameras. Camera locations and other pertinent data are located in Data Sheet No. 6 of this report. Pre and post – test photographs of the test vehicle, OMDB, and test setup were taken using a digital still camera. Photographic documentation of the test is presented in Appendix A of this report.

One 50% adult male THOR-NT anthropomorphic test device (ATD) (Serial No. DL9207) was seated in the left, front (P1 -Driver's) seating position and one 50% adult male THOR-NT adult male ATD (Serial No. DO9798) was seated in the right front passenger seating position (P2). The driver and passenger were positioned according to instructions specified in the THOR seating procedures.

The driver was restrained with a 3 – point seat belt, frontal, curtain, and torso airbag. The passenger was restrained with a 3 – point seat belt, frontal, curtain, and torso airbag.

SECTION 2 (CONTINUED)
SUMMARY OF TEST

Test Vehicle: 2016 Honda Fit hatchback
Test Program: R&D 90.1kph, 15° / 35% Left Oblique Offset

NHTSA No.: M20165307
Test Date: 2/11/2016

Two hundred and fifty eight (258) channels of data from the two ATD's, test vehicle and OMDB were collected using Kayser – Threde data acquisition systems. Appendix B contains dummy data plots, as well as vehicle and OMDB response data plots.

There was 94.3% total windshield retention, with 88.7% and 100% retention on the left and right sides, respectively. There appeared to be no intrusion into the protected zone of the windshield during any portion of the impact event. The maximum static crush of the vehicle was 495 mm at C2 to the left of the vehicle's centerline. The maximum crush of the structural bumper beam was 593 mm at B1, to the left of the vehicle's centerline. Full vehicle measurements are presented in Section 3 of this report.

All four vehicle doors remained closed and latched during the test. All doors remained operational after the impact event.

Structure observations include the following:

- Windshield had cracks throughout with minor separation along the driver side. And an 800mm tear along the passenger side
- The A-Pillar, B-Pillar and C-Pillars Buckled during impact
- Driver's Side Sill Buckled
- Hood bent inwards and exposed part of the engine compartment

The driver ATD's visible contact points were:

- Head contacted the frontal and curtain airbags
- Torso contacted the frontal and torso airbag, shoulder/arm contacted the door
- Left Knee contacted the knee bolster
- Right Knee contacted the knee bolster

The right front passenger ATD's visible contact points were:

- Head contacted the frontal airbag and center instrument panel
- Torso contacted the frontal airbag
- Shoulder contacted the center instrument panel
- Knees contacted the glove box

**SECTION 2 (CONTINUED)
CRASH VEHICLE SUMMARY**

Test Vehicle: 2016 Honda Fit hatchback
 Test Program: R&D 90.1kph, 15° / 35% Left Oblique Offset

NHTSA No.: M20165307
 Test Date: 2/11/2016

Primary Impact Data

Measured Parameter	Units	Value
OMDB Velocity at Impact	kph	90.05
OMDB Test Weight	kg	2519
OMDB Maximum Static Crush	mm	231
Vehicle Test Weight	kg	1403
Actual Vehicle Angle	degrees	15
Vehicle Maximum Static Crush	mm	495
Vertical Offset from Target Point (+ down / - up)*	mm	-14
Lateral Offset from Target Point (+ left / - right)*	mm	-1
Number of Data Channels		258
Number of Real-Time Cameras		2
Number of High-Speed Cameras		15

*Offsets are in relation to the vehicle coordinate system.

Dummy Contacts

	Driver	Picture Ref.	Passenger	Picture Ref.
Dummy Type	THOR, S/N: DL9207		THOR, S/N: DO9798	
Head Contact	Front & Curtain Airbag	A49-A51	Front Airbag & Center Instrument Panel	A70-A72
Upper Torso Contact	Front Airbag	N/A	Front Airbag	N/A
Lower Torso Contact	None	N/A	None	N/A
Side Torso Contact	Torso Airbag & Driver Door	N/A	Shoulder contact Center Instrument Panel	N/A
Left Knee Contact	Knee Bolster	A28	Glove Box	A52
Right Knee Contact	Knee Bolster	A28	Glove Box	A52

Data Anomalies

CHANNEL DESCRIPTION	EXPLANATION
Driver Abdomen Left X Displacement, Questionable spikes throughout	The front clip from the IRTRACC disconnected.
Driver Lower Tibia Left Z Force, Questionable data after 34.4ms	Wire pulled out of Amphenol pin
Driver Femur Right X Moment, Questionable data 52ms to 139ms	Signal wire opens and closes when pinching cable at channel breakout. Recommend replacing the femur load cell.
Front Passenger Foot Right X Acceleration, Questionable data after 102ms	Cable pulled out of Amphenol Adapter
Vehicle CG X Angular Rate, Questionable data throughout,	Unable to reproduce issue
Passenger Shoulder Force, Questionable spikes 73ms to 77.4ms	Cable pulled tight at the load cell

PRELIMINARY INJURY SUMMARY: Driver

Test Vehicle: M20165307 - 2016 Honda Fit NHTSA No.: M20165307
 Test Program: NHTSA R&D Left Oblique Offset 15deg/35% Test Date: 2/11/2016

Driver: THOR Serial No. DL9207 Injury Summary

Location	Description	Unit	Source	Max	Min
Head	HIC 15ms		Compute	295.64	
	Brain Injury Criteria (BRIC)		Compute	1.15	
	Head Rotational Velocity X	Deg/s	60	453.57	-1177.79
	Head Rotational Velocity Y	Deg/s	60	284.81	-1538.38
	Head Rotational Velocity Z	Deg/s	60	2442.87	-1246.69
Neck	Upper Neck Z-axis Force	N	1000	2082.37	-809.56
	Upper Neck Y-axis Moment	Nm	Thortest	53.67	-21.52
Chest	Upper Left Resultant Chest Deflection	mm	Thortest	32.90	
	Upper Right Resultant Chest Deflection	mm	Thortest	51.33	
	Lower Left Resultant Chest Deflection	mm	Thortest	12.59	
	Lower Right Resultant Chest Deflection	mm	Thortest	35.52	
Abdomen	Lower Left X-axis Deflection	mm	Thortest	149.62 ⁽¹⁾	-58.20 ⁽¹⁾
	Lower Right X-axis Deflection	mm	Thortest	0.07	-65.19
Acetabulum	Left Acetabulum Resultant Force	N	Compute	4673.30	0.09
	Right Acetabulum Resultant Force	N	Compute	2126.76	0.04
Femur	Left Femur Force, FZ	N	600	281.29	-9184.08
	Right Femur Force, FZ	N	600	1943.23	-4463.31
Tibia	Left Upper Tibia, FZ	N	600	136.55	-1204.72
	Left Upper Tibia Index		Compute	0.52	
	Right Upper Tibia, FZ	N	600	517.59	-1943.22
	Right Upper Tibia Index		Compute	0.68	
	Left Lower Tibia, FZ	N	600	155.03 ⁽²⁾	-1729.17 ⁽²⁾
	Left Lower Tibia Index		Compute	0.34 ⁽²⁾	
	Right Lower Tibia, FZ	N	600	550.90	-4313.32
	Right Lower Tibia Index		Compute	1.14	
Ankle	Left Ankle Rotation, RX	Deg	180	6.29	-22.94
	Left Ankle Rotation, RY	Deg	180	31.81	3.06
	Left Ankle Dorsiflexion Moment, MY	Nm	Compute	67.48	-28.06
	Left Ankle In/Eversion Moment, MX	Nm	Compute	9.98	-51.47
	Right Ankle Rotation, RX	Deg	180	16.22	-35.22
	Right Ankle Rotation, RY	Deg	180	34.25	-7.29
	Right Ankle Dorsiflexion Moment, MY	Nm	Compute	148.35	-18.92
	Right Ankle In/Eversion Moment, MX	Nm	Compute	27.22	-209.70

Anomalies: (1) Questionable spikes throughout
 (2) Questionable data after 34.4ms

PRELIMINARY INJURY SUMMARY: Right Front Passenger

Test Vehicle: M20165307 - 2016 Honda Fit NHTSA No.: M20165307
 Test Program: NHTSA R&D Left Oblique Offset 15deg/35% Test Date: 2/11/2016

Right Front Passenger: THOR Serial No. DO9798 Injury Summary

Location	Description	Unit	Source	Max	Min
Head	HIC 15ms		Compute	1277.28	
	Brain Injury Criteria (Bric)		Compute	1.78	
	Head Rotational Velocity X	Deg/s	60	716.43	-3036.29
	Head Rotational Velocity Y	Deg/s	60	982.68	-2112.14
	Head Rotational Velocity Z	Deg/s	60	3557.89	-1243.75
Neck	Upper Neck Z-axis Force	N	1000	2510.86	-684.76
	Upper Neck Y-axis Moment	Nm	Thortest	36.74	-30.97
Chest	Upper Left Resultant Chest Deflection	mm	Thortest	52.12	
	Upper Right Resultant Chest Deflection	mm	Thortest	22.87	
	Lower Left Resultant Chest Deflection	mm	Thortest	52.67	
	Lower Right Resultant Chest Deflection	mm	Thortest	12.94	
Abdomen	Lower Left X-axis Deflection	mm	Thortest	0.07	-69.93
	Lower Right X-axis Deflection	mm	Thortest	0.08 ⁽³⁾	-76.05 ⁽³⁾
Acetabulum	Left Acetabulum Resultant Force	N	Compute	2437.13	0.10
	Right Acetabulum Resultant Force	N	Compute	3559.50	0.09
Femur	Left Femur Force, FZ	N	600	903.60	-2477.70
	Right Femur Force, FZ	N	600	776.46	-3915.78
Tibia	Left Upper Tibia, FZ	N	600	200.67	-1666.38
	Left Upper Tibia Index		Compute	0.44	
	Right Upper Tibia, FZ	N	600	153.98	-1754.03
	Right Upper Tibia Index		Compute	0.78	
	Left Lower Tibia, FZ	N	600	239.49	-2231.22
	Left Lower Tibia Index		Compute	0.57	
	Right Lower Tibia, FZ	N	600	188.17	-3069.09
	Right Lower Tibia Index		Compute	0.86	
Ankle	Left Ankle Rotation, RX	Deg	180	17.00	-29.15
	Left Ankle Rotation, RY	Deg	180	10.43	-28.04
	Left Ankle Dorsiflexion Moment, MY	Nm	Compute	12.08	-49.05
	Left Ankle In/Eversion Moment, MX	Nm	Compute	37.21	-76.18
	Right Ankle Rotation, RX	Deg	180	22.55	-39.60
	Right Ankle Rotation, RY	Deg	180	22.68	-31.24
	Right Ankle Dorsiflexion Moment, MY	Nm	Compute	11.85	-44.24
	Right Ankle In/Eversion Moment, MX	Nm	Compute	80.15	-166.27

Anomalies: (3) Questionable spike 122ms

**SECTION 3
DATA SHEETS**

Test Vehicle: 2016 Honda Fit hatchback
Test Program: R&D 90.1kph, 15° / 35% Left Oblique Offset

NHTSA No.: M20165307
Test Date: 2/11/2016

<u>Data Sheet No.</u>		<u>Page No.</u>
1	General Test and Vehicle Parameter Data	3-2
2	Seat Adjustment, Fuel System, and Steering Wheel	3-6
3	Dummy Longitudinal Clearance Dimensions	3-8
4	Dummy Lateral Clearance Dimensions	3-10
5	Seat Belt Positioning Data	3-11
6	High-Speed Camera Locations and Data	3-12
7	Vehicle Instrumentation Data	3-15
8	Photographic Reference Target Locations	3-18
9	Test Vehicle Summary of Results	3-25
10	Post-Test Observations	3-26
11	Vehicle Profile Measurements	3-27
12	Accident Investigation Division Data	3-29
13	Vehicle Intrusion Measurements	3-30
14	OMDB Crush Measurements	3-47
15	Summary of FMVSS 212, 219 (Partial), and 301 Data	3-48
	Windshield Periphery Measurements	3-48
	Areas of Protected Zone Failures	3-48
	Fuel System Integrity Post Impact Data	3-49
16	FMVSS 301 Static Rollover Results	3-50
17	Dummy / Vehicle Temperature Stabilization	3-51

**DATA SHEET NO. 1
GENERAL TEST AND VEHICLE PARAMETER DATA**

Test Vehicle: 2016 Honda Fit hatchback
 Test Program: R&D 90.1kph, 15° / 35% Left Oblique Offset

NHTSA No.: M20165307
 Test Date: 2/11/2016

VEHICLE INFORMATION

NHTSA No.	M20165307
Model Year	2016
Make	Honda
Model	Fit
Body Style	4 Dr Hatchback
VIN	JHMGK5H5XGX004174
Body Color	Silver
Odometer Reading (km/mi)	46.7 km / 29 mi
Engine Displacement. (L)	1.5
Type/No. Cylinders	I4
Engine Placement	Transverse
Transmission Type	Automatic
Transmission Speeds	CVT
Overdrive	Yes
Final Drive	FWD
Roof Rack	No
Sunroof/T-Top	No
Running Boards	No
Tilt Steering Wheel	Yes
Power Seats	No
Anti-Lock Brakes (ABS)	Yes
All-Wheel Drive (AWD)	No
Traction Control System (TCS)	Yes

VEHICLE OPTIONS

Auto-Leveling System	No
Automatic Door Locks (ADL)	Yes
Power Window Auto-Reverse	No
Other Optional Feature	-
Driver Front Airbag	Yes
Driver Curtain Airbag	Yes
Driver Head/Torso Airbag	No
Driver Torso Airbag	No
Driver Torso/Pelvis Airbag	Yes
Driver Pelvis Airbag	No
Driver Knee Airbag	No
Pass. Front Airbag	Yes
Pass. Curtain Airbag	Yes
Pass. Head/Torso Airbag	No
Pass. Torso Airbag	No
Pass. Torso/Pelvis Airbag	Yes
Pass. Pelvis Airbag	No
Pass. Knee Airbag	No
Driver Seat Belt Pretensioner	Yes
Pass. Seat Belt Pretensioner	Yes
Driver Load Limiter	Yes
Pass. Load Limiter	Yes
Other Safety Restraint	-

Does owner's manual provide instructions to turn off automatic door locks?

Yes

DATA FROM CERTIFICATION LABEL

Manufactured By	Honda Motor Co, LTD
Date of Manufacture	10/15

GWR (kg)	1539
GAWR Front (kg)	832
GAWR Rear (kg)	716

VEHICLE SEATING AND WEIGHT CAPACITY

Measured Parameter	Front	Rear	Third	Total
Type of Seats	Bucket	Bench	-	
Number of Occupants	2	3	-	5
Capacity Wt. (VCW) (kg)				385
Cargo Wt. (RCLW) (kg)				44.8

DATA SHEET NO. 1 (CONTINUED)
GENERAL TEST AND VEHICLE PARAMETER DATA

Test Vehicle: 2016 Honda Fit hatchback
 Test Program: R&D 90.1kph, 15° / 35% Left Oblique Offset

NHTSA No.: M20165307
 Test Date: 2/11/2016

Collect items circled in red, tire manufacturer, and tire name.

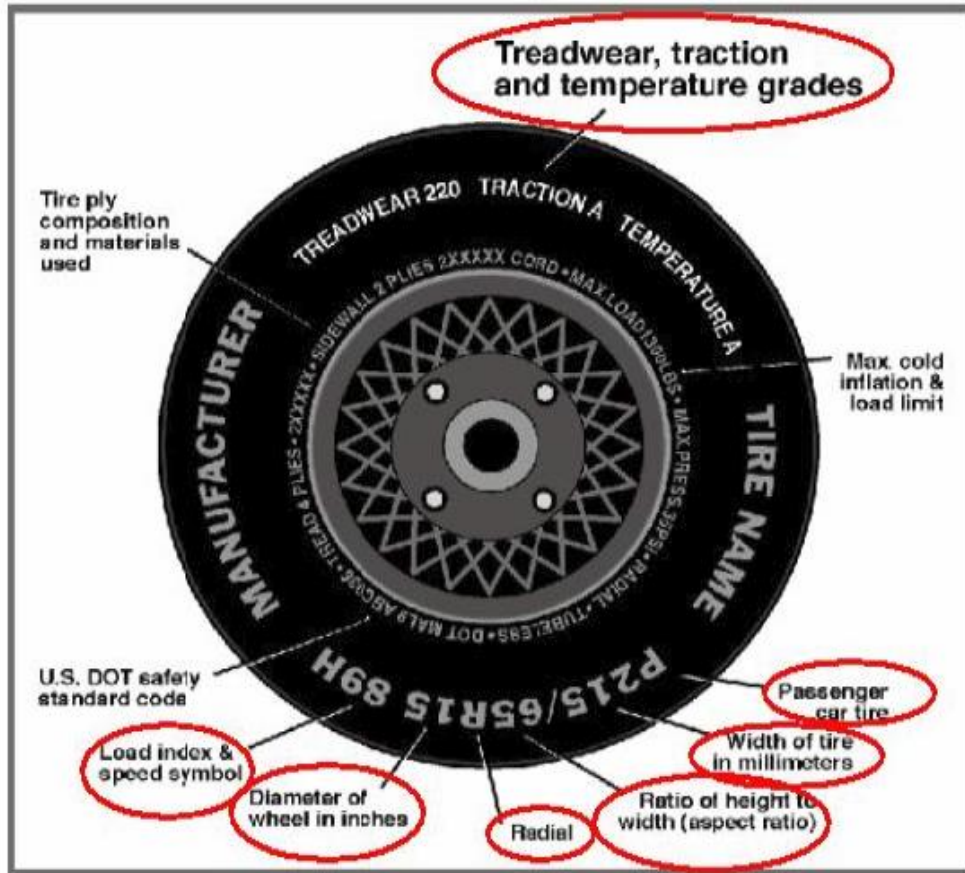

Measured Parameter	Front	Rear
Maximum Tire Pressure (kPa)	300	300
Cold Pressure (kPa)	230	230
Recommended Tire Size	P185/60R15	P185/60R15
Tire Size on Vehicle	P185/60R15	P185/60R15
Tire Manufacturer	Firestone	Firestone
Tire Model	FR740	FR740
Treadwear	400	400
Traction	A	A
Temperature Grades	A	A
Tire Plies Sidewall	1 Polyester	1 Polyester
Tire Plies Body	1 Polyester, 2 Steel, 1 Nylon	1 Polyester, 2 Steel, 1 Nylon
Load Index/Speed Symbol	84T	84T
Tire Material	Rubber	Rubber
DOT Safety Code Right	K1401 ELCA	K1401 ELCA
DOT Safety Code Left	K1401 ELCA	K1401 ELCA

DATA SHEET NO. 1 (CONTINUED)
GENERAL TEST AND VEHICLE PARAMETER DATA

Test Vehicle: 2016 Honda Fit hatchback
 Test Program: R&D 90.1kph, 15° / 35% Left Oblique Offset

NHTSA No.: M20165307
 Test Date: 2/11/2016

TEST VEHICLE WEIGHTS

	Units	As Delivered (UVW) (Axle)			As Tested (ATW) (Axle)		
		Front	Rear	Total	Front	Rear	Total
Left	kg	370	213		407	311	
Right	kg	353	217		407	278	
Ratio	%	63	37		58	42	
Totals	kg	723	430	1153	814	589	1403

TARGET TEST WEIGHT CALCULATION

Measured Parameter	Units	Value
Total Delivered Weight (UVW)	kg	1153
Weight of 2 THOR ATDs	kg	190
Rated Cargo/Luggage Weight (RCLW)	kg	44.8
Calculated Vehicle Target Weight (TVTW)	kg	1387.8

TEST VEHICLE ATTITUDES AND CG

	Units	LF	RF	LR	RR	CG (aft of front axle)
As Delivered	mm	649	651	658	662	944
As Tested	mm	632	636	620	624	1063
Post Test	mm	670	611	604	661	

GENERAL TEST VEHICLE DATA

Measurement Description	Units	Value
Total Vehicle Wheel Base	mm	2532
Total Vehicle Length at Left Side	mm	3991
Total Vehicle Length at Centerline	mm	4065
Total Vehicle Length at Right Side	mm	3991
Weight of Ballast in Cargo Area	kg	0
Weight of Vehicle Components Removed	kg	80
Amount of Stoddard Solvent in Fuel Tank	L	13.4

LIST OF COMPONENTS REMOVED TO MEET TEST WEIGHT:

Trunk Carpeting, Spare Tire, Jack, Tail Lights, Rear Seats, Rear Mirrors, Door Skins,
Door Internals

DATA SHEET NO.1 (CONTINUED)
GENERAL TEST AND VEHICLE PARAMETER DATA

Test Vehicle: 2016 Honda Fit hatchback
 Test Program: R&D 90.1kph, 15° / 35% Left Oblique Offset

NHTSA No.: M20165307
 Test Date: 2/11/2016

TARGET VEHICLE STRUCTURAL MEASUREMENT

	Elements	Units	Pre-Test
1	Total Length	mm	4065
2	Total Width	mm	1698
3*	Bumper Top Height	mm	542
4*	Bumper Bottom Height	mm	438
5*	Longitudinal Member Top Height	mm	544
6	Distance Between Longitudinal Members	mm	1016
7	Longitudinal Member Width	mm	52
8*	Engine Top Height	mm	822
9*	Engine Bottom Height	mm	172
10	Engine and Gearbox Width	mm	527
11	Front Bumper-Engine Distance	mm	534
12*	Front Shock Absorber Fixing Height	mm	899
13*	Bonnet Leading Edge Height	mm	776
14	Front Shock Absorber Fixing Width	mm	1116
15	Front Bumper – Front Axle Distance	mm	810
16	Front Axle – A Pillar Distance	mm	190
17	A-Pillar – B-Pillar Distance	mm	1325
18	B-Pillar – Rear Axle Distance	mm	1016
19	B-Pillar – C-Pillar Distance	mm	916
20*	Roof Sill Bottom Height	mm	1417
21*	Roof Sill Top Height	mm	1447
22*	Floor Sill Bottom Height	mm	295
23*	Floor Sill Top Height	mm	382

*Note: Height measurements are in reference to the ground.

DATA SHEET NO. 2
SEAT ADJUSTMENT, FUEL SYSTEM, AND STEERING WHEEL

Test Vehicle: 2016 Honda Fit hatchback
 Test Program: R&D 90.1kph, 15° / 35% Left Oblique Offset

NHTSA No.: M20165307
 Test Date: 2/11/2016

NORMAL DESIGN RIDING POSITION

For adjustable driver and passenger seat backs. Please describe how to position the inclinometer to measure the seat back angle. Include description of the location of the adjustment latch detent, if applicable.

Driver seat: The driver seat back was positioned according to the Nominal Design Riding position listed in FORM 1 and following the THOR seating procedure

Passenger Seat: The passenger seat back was positioned according to the Nominal Design Riding position listed in FORM 1 and following the THOR seating procedure.

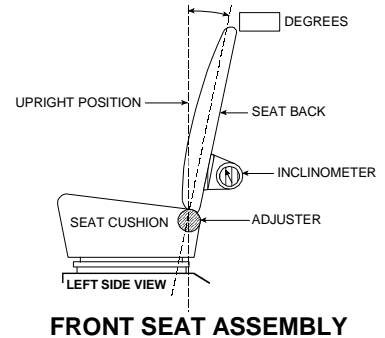

	UNIT	FORM 1 POSITION	AFTER ATD POSITIONING
Driver Seat Back Angle	deg	1.0	1.4
Passenger Seat Back Angle	deg	1.0	1.3

SEAT FORE/AFT POSITIONS

Describe the method used of determining seat fore/aft positions.

The driver's seat was positioned at its mid cushion angle and set 2 detents rearward of mid travel following THOR seating procedure.

The passenger's seat was set 4 detents rear of mid travel following THOR seating procedure.

	Total Fore/Aft Travel	Placed in Position #
Driver Seat	234 mm / 35 Detents (0-34)	131 mm / 19 th Detent
Passenger Seat	234 mm / 35 Detents (0-34)	145 mm / 21 st Detent

SEAT BELT UPPER ANCHORAGES

Describe the method of positioning seat belt upper anchorages. Belt anchorages were moved along the full range of motion, and marked on the B-Pillar to their respective possible positions. Photographic evidence can be found in Appendix A of this report. Zero is defined as the upper-most position.

	Total # of Positions	Placed in Position #
Driver Seat	4	0
Passenger Seat	4	0

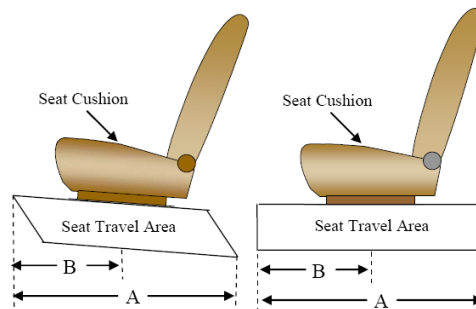

DATA SHEET NO. 2 (CONTINUED)
SEAT ADJUSTMENT, FUEL SYSTEM, AND STEERING WHEEL DATA

Test Vehicle: 2016 Honda Fit hatchback
 Test Program: R&D 90.1kph, 15° / 35% Left Oblique Offset

NHTSA No.: M20165307
 Test Date: 2/11/2016

FUEL TANK CAPACITY

	Liters
Usable Capacity of "Standard Tank"	40.1
Usable Capacity of "Optional Tank"	
93% of Usable Capacity	37.3
Actual Amount of Solvent Used	13.4
1/3 of Usable Capacity	13.4

FUEL PUMP

Describe the fuel system - what type of fuel pump, details about how it operates, etc.

Fuel evacuated according to the specifications provided by the manufacturer in Form 1. Electric fuel pump operates when the ignition is in the 'on' position and the engine is running. The fuel filler neck is located above the left rear wheel.

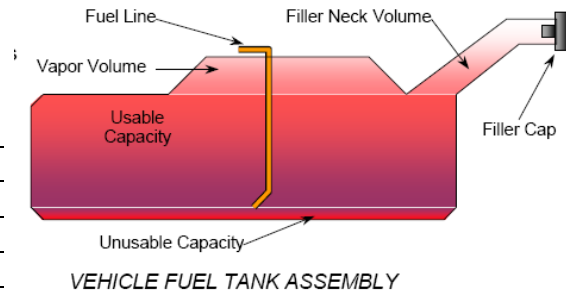

STEERING COLUMN ADJUSTMENT

Steering wheel and column adjustments are made so that the steering wheel hub is at the geometric center of the locus it describes when moved through its full range of motion. Describe how this measurement was taken.

The steering wheel was adjusted to the midpoint of tilt angle range and the midpoint of the telescoping travel

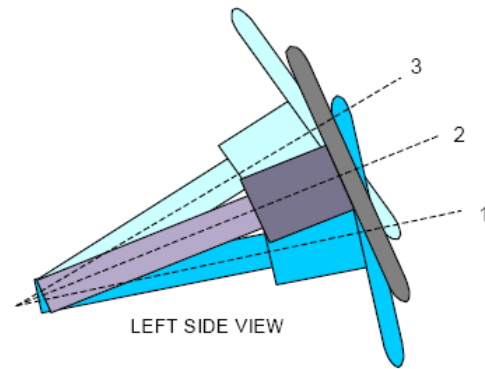

STEERING COLUMN ASSEMBLY

STEERING COLUMN POSITIONS

	Tilt (degrees)	Fore/Aft Position (mm)
Lowermost position No. 1	24.8	
Geometric center position No. 2	27.2	
Uppermost position No. 3	29.5	
Telescoping Steering Wheel Travel		40
Test Position	27.2	20

DATA SHEET NO. 3
DUMMY LONGITUDINAL CLEARANCE DIMENSIONS

Test Vehicle: 2016 Honda Fit hatchback
Test Program: R&D 90.1kph, 15° / 35% Left Oblique Offset

NHTSA No.: M20165307
Test Date: 2/11/2016

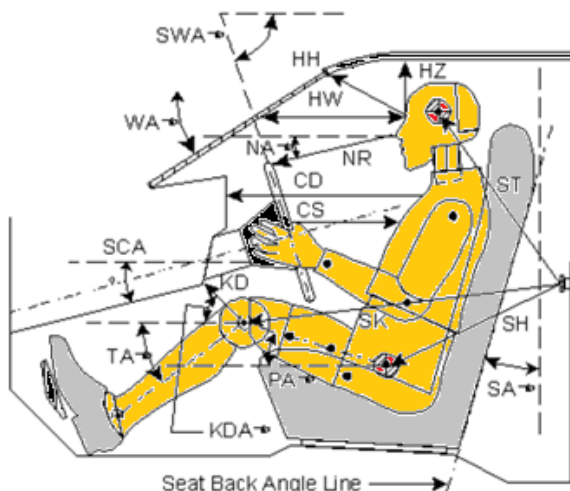

Code	Measurement Description	Driver (Serial#THOR DL9207)		Passenger (Serial#THOR DO9798)	
		Length (mm)	Angle(°)	Length (mm)	Angle (°)
WA°	Windshield Angle		27.0		
SWA°	Steering Wheel Angle		27.9		
SCA°	Steering Column Angle		62.8		
SA°	Seat Back Angle (on headrest post)		1.4		1.3
SA°	Seat Back Angle		22.8		23.9
HZ	Head to Roof (Z)	198	90	205	90
HH	Head to Header	410	17.7	438	17.3
HW	Head to Windshield	765	0	777	0
NR	Nose to Rim	521	19.5	708	31.7
CD	Chest to Dash	606		562	
CS	Chest to Steering Hub	380	3.4		
RA	Rim to Abdomen	169	0		
KDL	Left Knee to Dash	83	28.2	80	31.7
KDR	Right Knee to Dash	58	42.3	89	25.6
PA°	Pelvic Angle		33.6		34.3
TA°	Tibia Angle		55.2		52.2
SK	Striker to Knee	639	6.2	623	6.5
ST	Striker to Head	587	89.6	581	89.1
SH	Striker to H-Point	252	14.4	232	16.6
HAX°	Head Angle (X)		0.3		-0.5
HAY°	Head Angle (Y)		-2.7		-3.4
TAX°	T6 Angle (X)		0.4		-1.1
TAY°	T6 Angle (Y)		25.1		24.0
TAX°	T1 (X)		0.4		-1.1
TAY°	T1 (Y)		4.8		4.9
TAX°	T12 (X)		0.7		-1.3
TAY°	T12 (Y)		36.9		33.7
PAX°	Pelvic (X)		0		-0.2
PAY°	Pelvic (Y)		33.6		34.3

DATA SHEET NO.3 (CONTINUED) DUMMY CMM MEASUREMENTS

Test Vehicle: 2016 Honda Fit hatchback
 Test Program: R&D 90.1kph, 15° / 35% Left Oblique Offset

NHTSA No.: M20165307
 Test Date: 2/11/2016

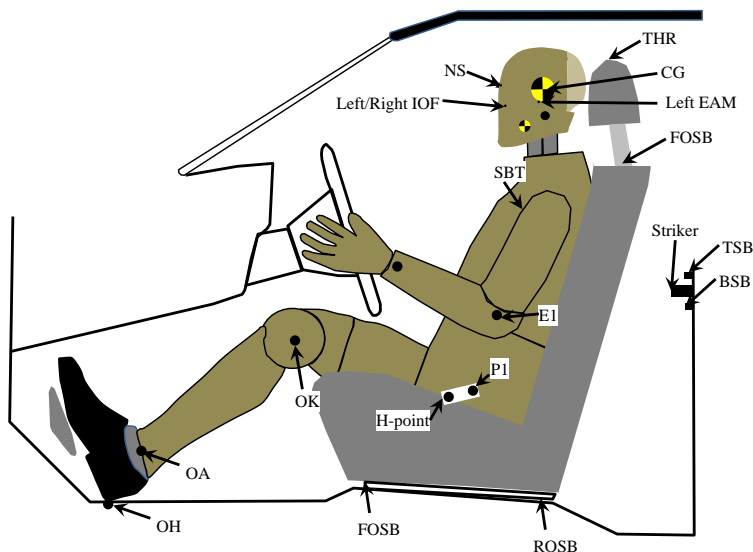

Description	Units	Driver			Passenger		
		X	Y	Z	X	Y	Z
Head CG	mm	1844	-414	-730	1829	421	-723
Nasion	mm	1940	-337	-735	1919	339	-727
Tip of Nose	mm	1939	-339	-697	1918	339	-689
Tip of Chin	mm	1933	-341	-601	1910	340	-593
Left EAM	mm	1850	-409	-701	1829	267	-696
Right EAM	mm	1854	-264	-700	1834	417	-694
Left IOF	mm	1935	-370	-698	1914	306	-690
Right IOF	mm	1936	-306	-697	1916	370	-689
Outboard Elbow	mm	2076	-581	-286	1978	619	-216
H-Point	mm	2084	-677	-81	2060	670	-76
H-Point Tool	mm	2009	-600	-113	1984	594	-104
Outboard Knee Bolt	mm	2475	-564	-212	2457	513	-212
Inboard Knee Bolt	mm	2490	-251	-208	2454	308	-207
Outboard Ankle Bolt	mm	2726	-578	124	2713	515	120
Outer Heel Point	mm	2740	-559	256	2702	467	262
Inboard Heel Point	mm	2745	-205	261	2695	272	264
Striker Top Bolt	mm	1802	-741	-158	1801	740	-158
Striker Bottom Bolt	mm	1804	-744	-122	1803	742	-122
Center Tip of Striker	mm	1840	-743	-143	1838	741	-142
Front Outboard Seat Anchor Bolt	mm	2361	-567	153	2362	561	154
Rear Outboard Seat Anchor Bolt	mm	1818	-564	236	1818	558	238
Outboard Head Restraint Post	mm	1669	-420	-549	1651	417	-536
Top of Head Restraint	mm	1693	-341	-839	1689	340	-822
Center of Steering Wheel	mm	2577	-440	-318			

Reference point:

- +X – From the rear of the vehicle to the front of the vehicle
- +Y – From the left side of the vehicle to the right side of the vehicle
- +Z – From the top of the vehicle to the bottom of the vehicle

**DATA SHEET NO. 4
DUMMY LATERAL CLEARANCE DIMENSIONS**

Test Vehicle: 2016 Honda Fit hatchback
 Test Program: R&D 90.1kph, 15° / 35% Left Oblique Offset

NHTSA No.: M20165307
 Test Date: 2/11/2016

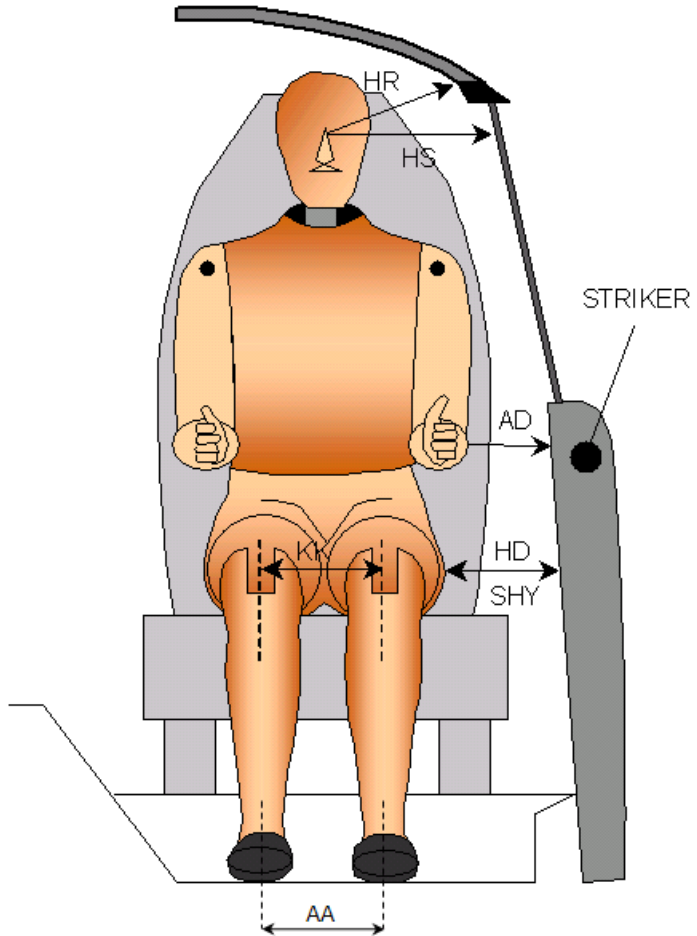

Code	Description	Units	Driver	Passenger
AD	Arm to Door	mm	128	30
HD	H-Point to Door	mm	134	133
HR	Head to Side Header	mm	208	211
HS	Head to Side Window	mm	345	345
KK	Knee to Knee	mm	360	245
SHY	Striker to H-Point (Y Direction)	mm	210	210
AA	Ankle to Ankle	mm	330	187

**DATA SHEET NO. 5
SEAT BELT POSITIONING DATA**

Test Vehicle: 2016 Honda Fit hatchback
 Test Program: R&D 90.1kph, 15° / 35% Left Oblique Offset

NHTSA No.: M20165307
 Test Date: 2/11/2016

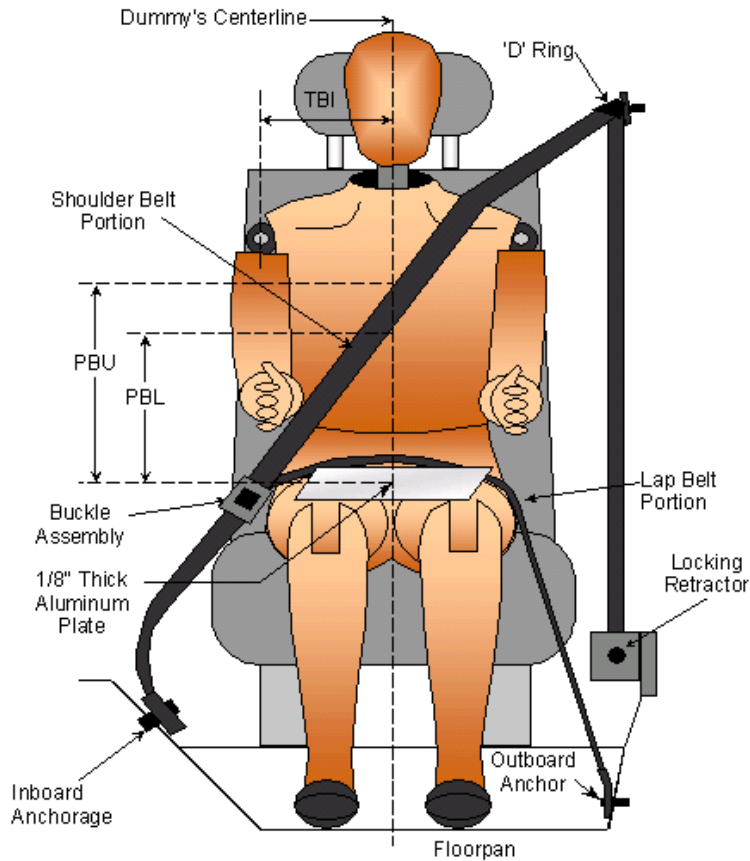

SEAT BELT POSITIONING MEASUREMENTS

Measurement Description	Units	Driver	Passenger
PBU — Top surface of reference to belt upper edge	mm	365	345
PBL — Top surface of reference to belt lower edge	mm	290	260

BELT LENGTH DATA

Measurement Description	Units	Driver	Passenger
Shoulder belt length as measured on ATD	mm	830	840
Lap Belt Length as measured on ATD	mm	745	575
Remainder of belt on reel	mm	825	985
Total belt length for continuous webbing systems	mm	2400	2400

**DATA SHEET NO. 6
HIGH-SPEED CAMERA LOCATIONS AND DATA**

Test Vehicle: 2016 Honda Fit hatchback
 Test Program: R&D 90.1kph, 15° / 35% Left Oblique Offset

NHTSA No.: M20165307
 Test Date: 2/11/2016

HORIZONTAL LOCATION

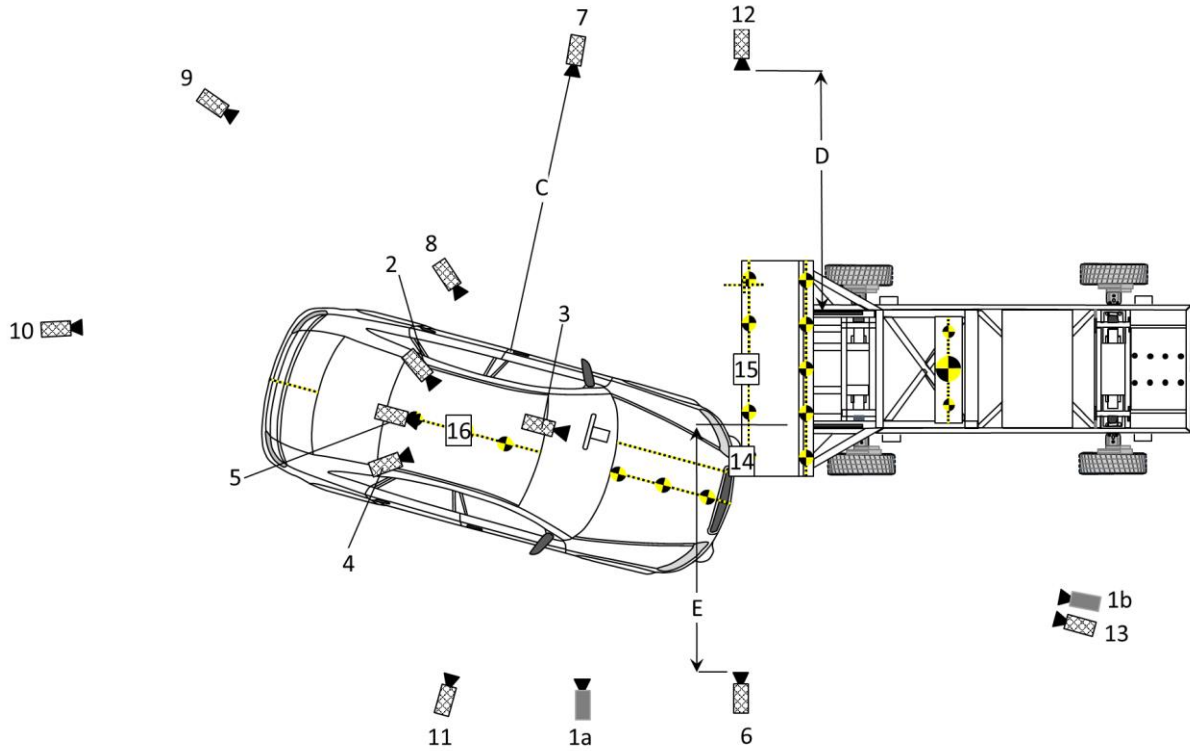

VERTICAL LOCATION

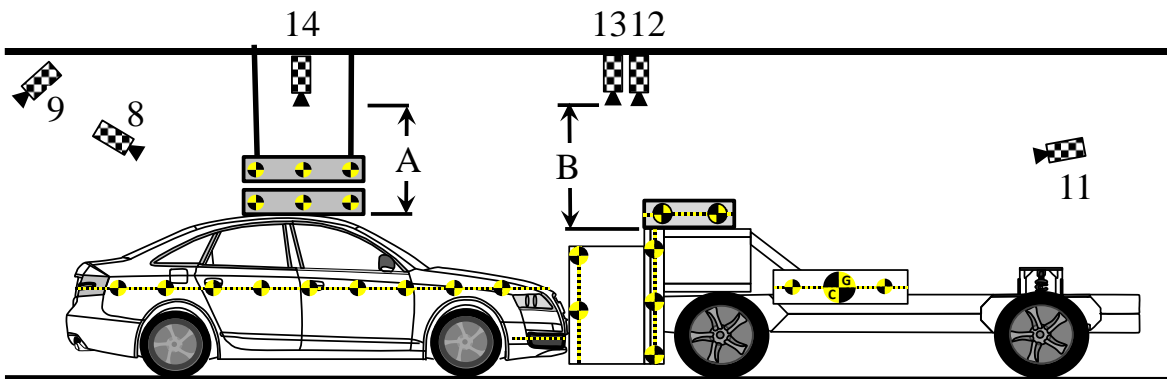

A	mm	3862
B	mm	4139
C	mm	8153
D	mm	7276
E	mm	7240

DATA SHEET NO. 6 (CONTINUED)
HIGH-SPEED CAMERA LOCATIONS AND DATA

Test Vehicle: 2016 Honda Fit hatchback
 Test Program: R&D 90.1kph, 15° / 35% Left Oblique Offset

NHTSA No.: M20165307
 Test Date: 2/11/2016

CAMERA LOCATIONS

No.	Camera View	Location (mm)			Lens (mm)	Speed (fps)
		X	Y	Z		
1	Real-Time Left Side	--	--	--	Zoom	60
2	Onboard Passenger Movement	7313	-515	1280	8	1000
3	Onboard Driver Lower Leg	6367	-214	415	6.5	1000
4	Onboard Driver Movement	7401	-842	1280	8	1000
5	Onboard Centerline	7518	-657	1263	8	1000
6	Right Side OMDB View	5080	8378	1208	20	1000
7	Left Side of Test Vehicle	5968	8005	1188	24	1000
8	Target Vehicle Left Side Perpendicular (High)	8265	2223	3709	24	1000
9	Oblique Rear View of Vehicle	13676	6795	2745	28	1000
10	Rear View of Vehicle and OMDB	28750	0	3421	10	1000
11	Right Side Target Vehicle and OMDB	10982	-10245	2610	24	1000
12	Left of Vehicle and OMDB	5090	-8342	1182	24	1000
13	Front of Vehicle and OMDB	560	-3668	1133	28	1000
14	Overhead Impact Point View	4937	-1166	4563	28	1000
15	Overhead OMDB View	7369	0	5327	15	1000
16	Overhead Vehicle View	4678	0	5327	15	1000

Reference Point:

- +X – From back of OMDB to front of OMDB
- +Y – Right of monorail center
- +Z – Up from ground

**DATA SHEET NO. 7
VEHICLE INSTRUMENTATION DATA**

Test Vehicle: 2016 Honda Fit hatchback
 Test Program: R&D 90.1kph, 15° / 35% Left Oblique Offset

NHTSA No.: M20165307
 Test Date: 2/11/2016

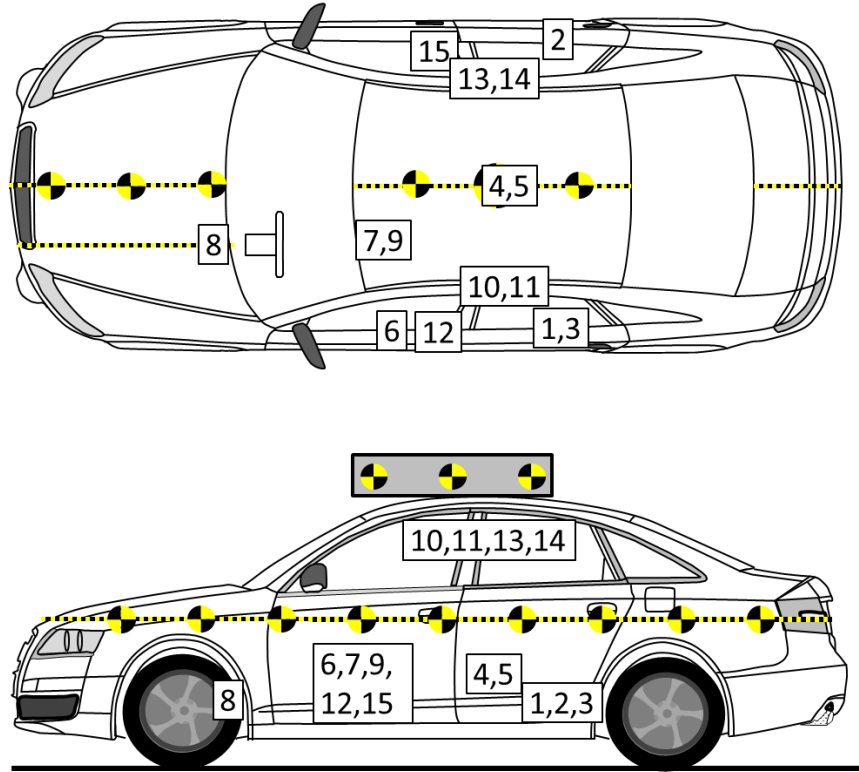

VEHICLE ACCELEROMETER PRE-TEST LOCATIONS RELATIVE TO VCS

No.	Accelerometer Location	Axes	Units	Measurements (mm)		
				X	Y	Z
1	Left Rear Sill	X,Y	mm	1412	-689	195
2	Right Rear Sill	X,Y	mm	1439	687	188
3	Left Rear Sill Redundant	X,Y	mm	1426	-689	195
4	Vehicle CG	X,Y,Z	mm	1521	-1	203
		X	mm	1532	-1	204
		Y	mm	1520	10	204
5	Vehicle CG Angular Displacement	Z	mm	1521	-1	203
		X,Y,Z	mm	2117	-585	145
6	Left Side Seat Track	X,Y,Z	mm	2117	-585	145
8	Left Side Toe Pan	X,Y,Z	mm	2975	-332	114
7	Left Side String Pot	N/A	mm	2976	-351	137

Reference point:

- +X – From the rear of the vehicle to the front of the vehicle
- +Y – From the left side of the vehicle to the right side of the vehicle
- +Z – From the top of the vehicle to the bottom of the vehicle

DATA SHEET NO. 7 (Continued)
VEHICLE INSTRUMENTATION DATA

Test Vehicle: 2016 Honda Fit hatchback
 Test Program: R&D 90.1kph, 15° / 35% Left Oblique Offset

NHTSA No.: M20165307
 Test Date: 2/11/2016

ANGULAR RATE SENSOR MOUNTING PLATE & THOR HEAT POINT DEFINITIONS

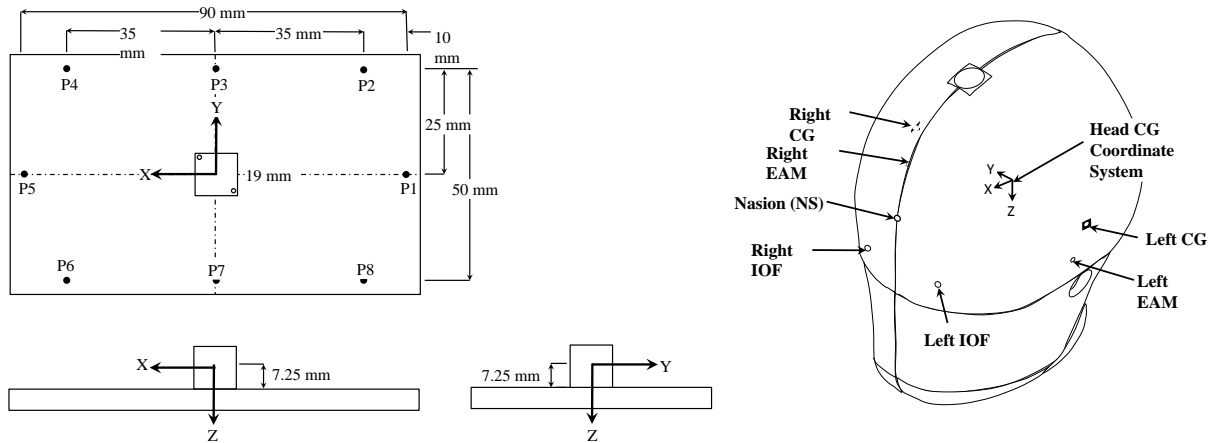

ARS MOUNTING PLATE - VEHICLE COORDINATE SYSTEM					
No.	Description	Units	Measurements (mm)		
			X	Y	Z
P1	Plate Point 1	mm	1476	-1	217
P2	Plate Point 2	mm	1485	24	217
P3	Plate Point 3	mm	1520	24	218
P4	Plate Point 4	mm	1556	24	218
P5	Plate Point 5	mm	1566	0	217
P6	Plate Point 6	mm	1556	-26	217
P7	Plate Point 7	mm	1521	-26	217
P8	Plate Point 8	mm	1486	-26	217

HEAD POINTS IN RELATION TO HEAD CG COORDINATE SYSTEM					
Description	Units	X	Y	Z	
CG	mm	0	0	0	
Left CG	mm	0	-77	0	
Right CG	mm	0	77	0	
Left EAM	mm	7	-72	27	
Right EAM	mm	7	72	27	
Left IOF	mm	89	-32	28	
Right IOF	mm	89	32	28	
Nasion	mm	92	0	-10	

DATA SHEET NO. 7 (Continued)
VEHICLE INSTRUMENTATION DATA

Test Vehicle: 2016 Honda Fit hatchback
 Test Program: R&D 90.1kph, 15° / 35% Left Oblique Offset

NHTSA No.: M20165307
 Test Date: 2/11/2016

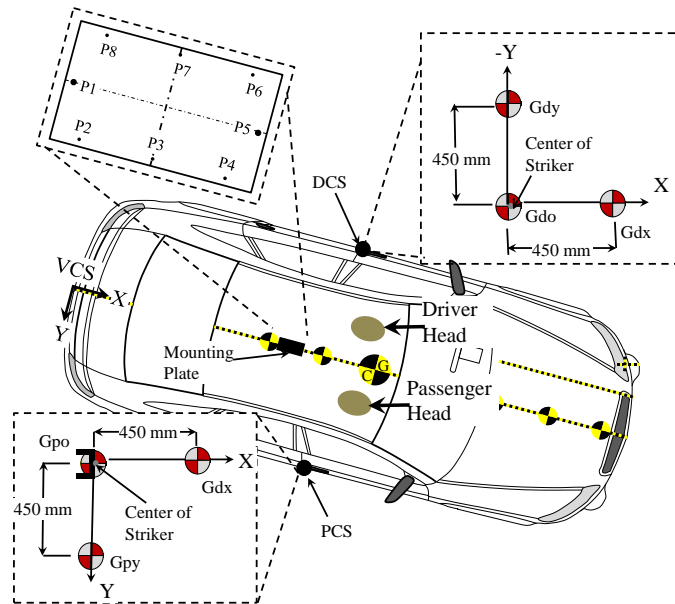

ARS MOUNTING PLATE & ATD'S HEAD POINTS RELATIVE TO GLOBAL COORDINATE SYSTEMS

DESCRIPTION	DRIVER DCS			PASS. PCS		
	X	Y	Z	X	Y	Z
G _o	0	0	0	0	0	0
G _x	450	0	0	451	0	0
G _y	0	-451	-1	-2	451	0
P1	-515	629	-277	-128	-801	-279
P2	-513	656	-277	-125	-774	-278
P3	-479	666	-277	-91	-765	-278
P4	-445	675	-277	-57	-756	-278
P5	-429	654	-277	-41	-777	-279
P6	-432	627	-278	-44	-804	-279
P7	-465	617	-278	-78	-813	-279
P8	-499	608	-278	-111	-823	-279
Left CG	-51	328	-1225			
Right CG				104	-301	-1219
Left EAM	-47	335	-1196			
Right EAM				110	-304	-1190
Left IOF	24	394	-1192	216	-391	-1186
Right IOF	9	456	-1191	201	-328	-1185
Nasion	21	427	-1230	212	-358	-1223

**DATA SHEET NO. 7 (CONTINUED)
VEHICLE INSTRUMENTATION DATA**

Test Vehicle: 2016 Honda Fit hatchback
Test Program: R&D 90.1kph, 15° / 35% Left Oblique Offset

NHTSA No.: M20165307
Test Date: 2/11/2016

No.	Description	Axes	Units	Positive Direction		Negative Direction	
				Max	Time (ms)	Max	Time (ms)
1	Left Rear Sill	X	g	2.47	82.60	-55.37	34.80
		Y	g	29.46	40.00	-5.11	19.65
2	Right Rear Sill	X	g	1.78	108.90	-51.65	40.85
		Y	g	27.83	43.30	-3.58	18.35
3	Impact Side Rear Sill Redundant	X	g	2.52	82.60	-54.02	34.80
		Y	g	29.23	40.00	-5.18	19.70
4	Vehicle CG Acceleration	X	g	2.52	18.20	-47.70	44.80
		Y	g	25.13	42.70	-3.95	17.65
		Z	g	13.88	48.25	-18.62	20.65
5	Impact Side Seat Track	X	g	4.70	140.00	-51.90	35.70
		Y	g	25.92	50.35	-4.48	62.25
		Z	g	27.19	43.90	-17.18	38.25
6	Impact Side Seat Crossmember	X	g	8.86	138.95	-59.16	46.25
		Z	g	27.54	44.65	-29.16	69.30
7	Impact Side Toe Pan	X	g	31.83	14.90	-184.29	35.85
		Y	g	82.50	36.55	-35.02	42.00
		Z	g	61.07	38.75	-34.18	26.50
8	Angular Rate Sensors	X	Deg/s	6359.60	108.60	-19062.25	17.65
		Y	Deg/s	104.99	27.40	-131.58	39.70
		Z	Deg/s	221.56	37.60	-82.39	43.75
9	Driver Shoulder Displacement		mm	32.73	24.85	-228.72	83.70
10	Driver Shoulder Belt		N	4093.17	46.30	-8.60	14.60
11	Driver Lap Belt		N	5049.99	57.55	-24.09	13.25
12	Passenger Shoulder Displacement		mm	69.21	31.05	-124.09	93.65
13	Passenger Shoulder Belt		N	8789.11	76.40	-8.41	14.85
14	Passenger Lap Belt		N	8408.94	69.00	-0.29	-37.30
15	Impact Side Floor String Pot		mm	0.04	0.85	-137.11	74.15

Note: See Appendix B for all vehicle data plots.

TIME TO FIRE RESTRAINT TIMING

No.	Description	Axes	Units	Time to Fire (ms)
1	Driver Air Bag Squib 1	*	A	17.05
2	Driver Air Bag Squib 2	*	A	37.05
3	Driver Curtain Airbag	*	A	32.10
4	Driver Torso Airbag	*	A	34.60
5	Driver Knee Airbag	*	A	N/A
6	Driver Pretensioner	*	A	15.05
7	Passenger Air Bag Squib 1	*	A	15.05
8	Passenger Air Bag Squib 2	*	A	55.05
9	Passenger Curtain Airbag	*	A	Did not fire
10	Passenger Torso Airbag	*	A	Did not fire
11	Passenger Knee Airbag	*	A	N/A
12	Passenger Pretensioner	*	A	15.10

* The measurement indicates the time the voltage changed

DATA SHEET NO. 8
PHOTOGRAPHIC REFERENCE TARGET LOCATIONS

Test Vehicle: 2016 Honda Fit hatchback
 Test Program: R&D 90.1kph, 15° / 35% Left Oblique Offset

NHTSA No.: M20165307
 Test Date: 2/11/2016

VEHICLE TARGETS

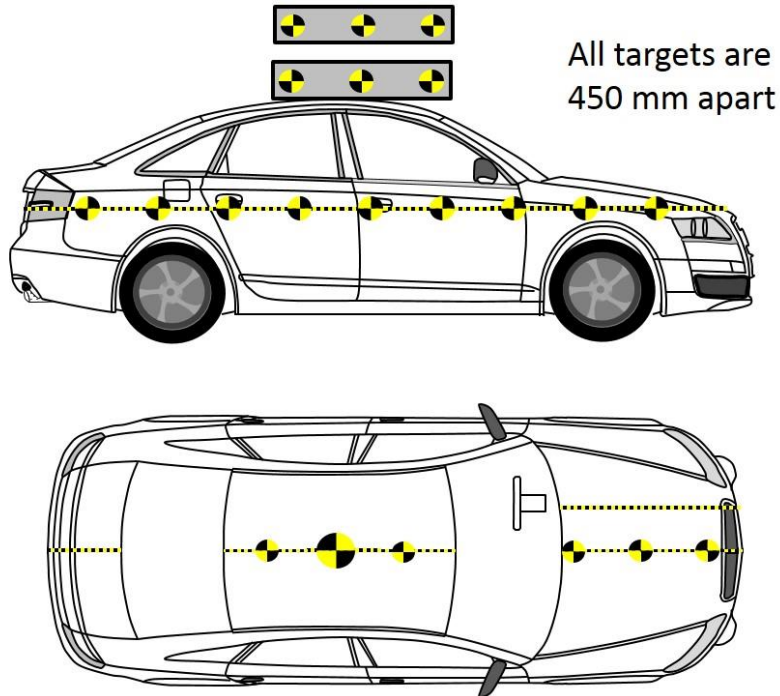

ATD HEAD TARGETS

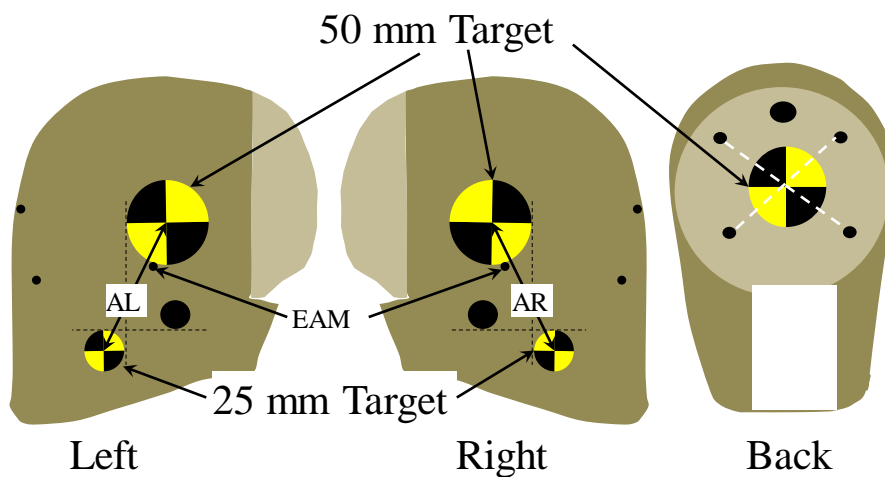

Target	Measurement
AL	91 mm
AR	91 mm

DATA SHEET NO. 8 (CONTINUED)
PHOTOGRAPHIC REFERENCE TARGET LOCATIONS

Test Vehicle: 2016 Honda Fit hatchback
 Test Program: R&D 90.1kph, 15° / 35% Left Oblique Offset

NHTSA No.: M20165307
 Test Date: 2/11/2016

OVERHEAD TARGET BARS

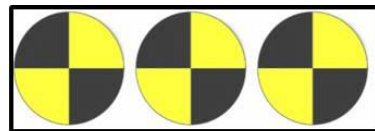
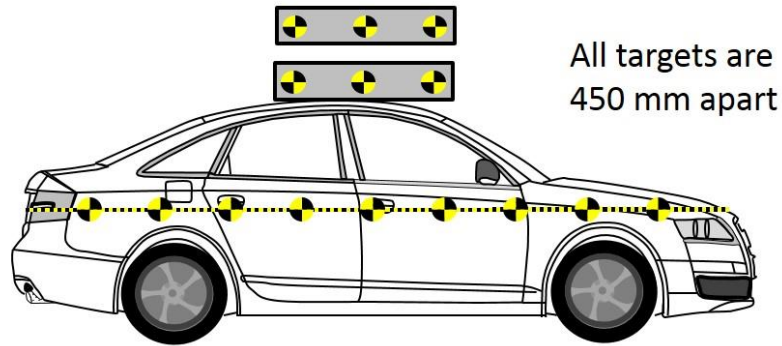

1 2 3

Vertical Target
 Plane 1
 (Driver's Side)

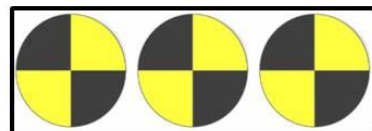

4 5 6

Vertical Target
 Plane 2
 (Passenger Side)

Target	Units	X	Y	Z
1	mm	2130	-389	-1338
2	mm	1678	-386	-1342
3	mm	1225	-380	-1345
4	mm	2136	354	-1356
5	mm	1685	349	-1358
6	mm	1228	353	-1355

Reference point:

- +X – From the rear of the vehicle to the front of the vehicle
- +Y – From the left side of the vehicle to the right side of the vehicle
- +Z – From the top of the vehicle to the bottom of the vehicle

DATA SHEET NO. 8 (CONTINUED)
PHOTOGRAPHIC REFERENCE TARGET LOCATIONS

Test Vehicle: 2016 Honda Fit hatchback
Test Program: R&D 90.1kph, 15° / 35% Left Oblique Offset

NHTSA No.: M20165307
Test Date: 2/11/2016

GROUND TARGETS LOCATED IN REFERENCE TO OMDB

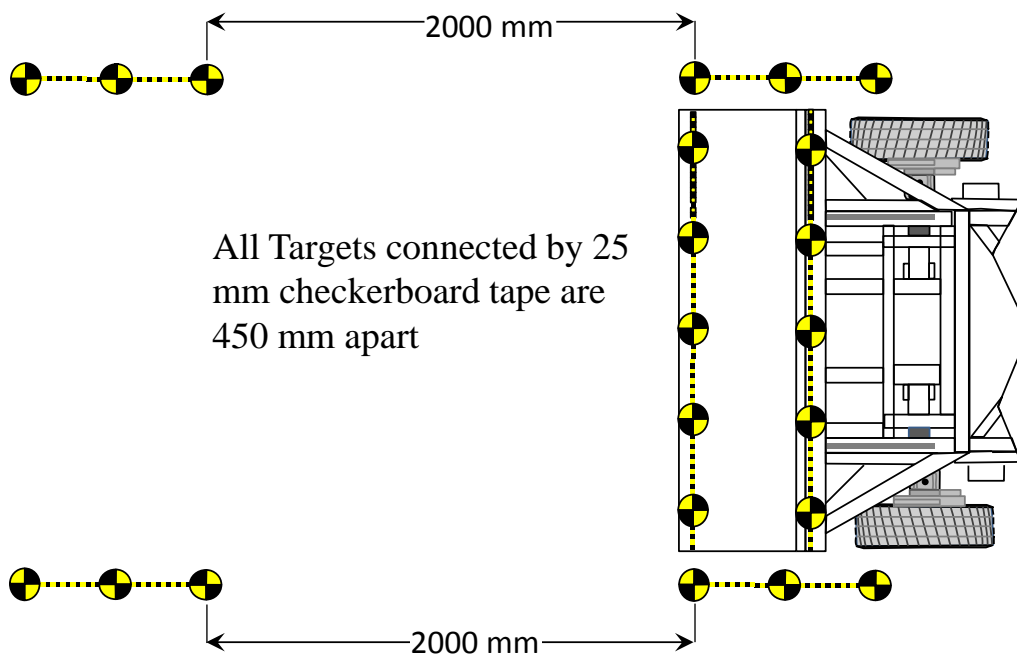

DATA SHEET NO. 8 (CONTINUED)
OMDB PHOTOGRAPHIC REFERENCE TARGET LOCATIONS

Test Vehicle: 2016 Honda Fit hatchback
 Test Program: R&D 90.1kph, 15° / 35% Left Oblique Offset

NHTSA No.: M20165307
 Test Date: 2/11/2016

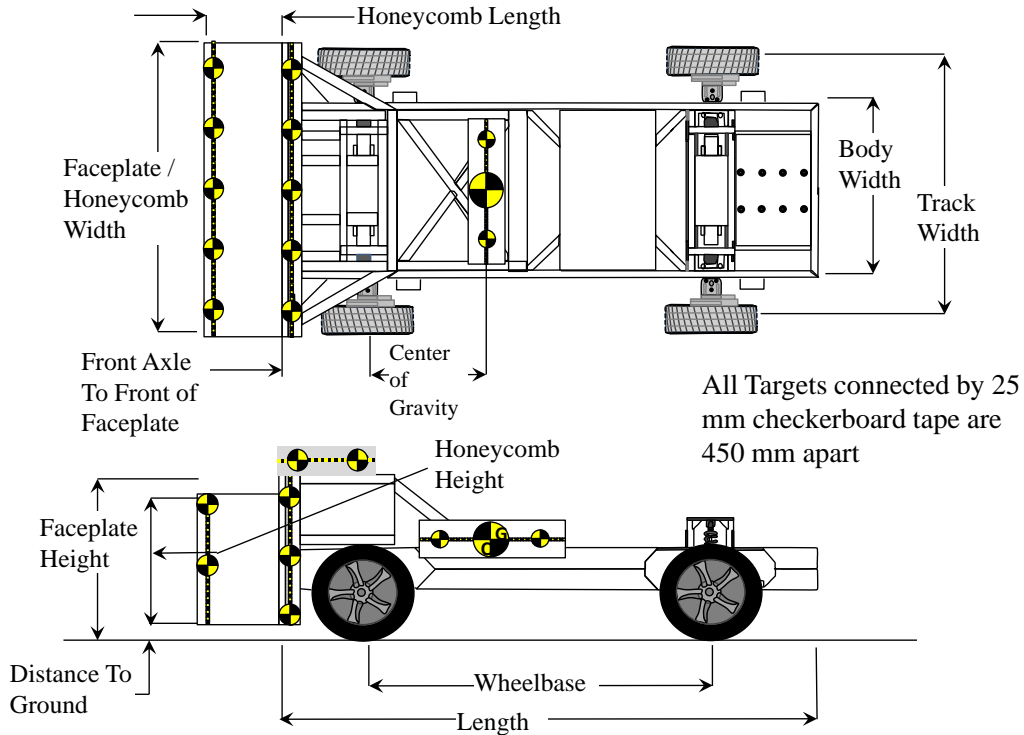

Item	Units	Value	Item	Units	Value
Honeycomb Width	mm	2205	Faceplate Height	mm	1183
Honeycomb Length	mm	605	Faceplate to Ground	mm	83
Honeycomb Height	mm	947	Wheelbase	mm	2589
Left Front Axle to Front Faceplate	mm	600	Cart Length	mm	3993
Right Front Axle to Front Faceplate	mm	601	Body Width	mm	1301
Front Axle to CG	mm	926	Track Width	mm	1884

	Units	Front Axle	Rear Axle	Total
Left	kg	826	434	1260
Right	kg	792	467	1259
Ratio	%	64%	36%	
Total	kg	1618	901	2519
CG Aft of Front Axle	mm			926

Note: All targets on the OMDB honeycomb are 450mm apart

DATA SHEET NO. 9
TEST VEHICLE SUMMARY OF RESULTS

Test Vehicle: 2016 Honda Fit hatchback
 Test Program: R&D 90.1kph, 15° / 35% Left Oblique Offset

NHTSA No.: M20165307
 Test Date: 2/11/2016

INSTRUMENTATION

Instrumentation	Number of Channels Collected
Driver Dummy Accelerometers	105
Passenger Dummy Accelerometers	105
Vehicle Structure Accelerometers	27
SRS Inductive Pickups	12
OMDB Cart Accelerometers	9
Total	258

CAMERA COVERAGE

Type of Camera	Number Used in this Test
High-Speed Vehicle Onboard	4
High-Speed Off-board	11
Real-Time Panning	2
Total	17

**DATA SHEET NO. 10
POST TEST OBSERVATIONS**

Test Vehicle: 2016 Honda Fit hatchback
 Test Program: R&D 90.1kph, 15° / 35% Left Oblique Offset

NHTSA No.: M20165307
 Test Date: 2/11/2016

TEST DUMMY INFORMATION AND CONTACT LOCATIONS

Description	Driver	Right Front Passenger
Dummy Type/Serial No.	THOR DL9207	THOR DO9798
Lower Leg Type	LX	LX
Lower Leg Serial No.	LX0045/ LX0046	LX655/LX654
Head Contact	Front & Curtain Airbag	Front Airbag & Center Instrument Panel
Upper Torso Contact	Front & Torso Airbag, Shoulder Contacted Door	Front Airbag, Shoulder contacted Center Instrument Panel
Lower Torso Contact	None	None
Left Knee Contact	Knee Bolster	Glove Box
Right Knee Contact	Knee Bolster	Glove Box

DOOR OPENING AND SEAT TRACK INFORMATION

Description	Driver	Right Front Passenger
Locked/Unlocked Doors	Unlocked	Unlocked
Front Door Opening	Non Functional After Opening	Closed & Operational
Rear Door Opening	Closed & Operational	Closed & Operational
Seat Track Shift (mm)	0	0
Seat Back Failure	No	No
Glazing Damage	None	None

POST TEST STRUCTURAL OBSERVATIONS

Critical Areas of Performance	Observations and Conclusions	Photo Taken (Y/N)
Pillar Performance	A-Pillar, B-Pillar & C-Pillar Buckled	Y
Windshield Damage	800 mm rear on passenger side center, 400 mm tear on the driver side center	Y
Window Damage	Front Side triangle windows shattered	Y
Other Notable Effects	Driver's side sill buckled	--

SUPPLEMENTAL RESTRAINT SYSTEM INFORMATION

Restraint Type	Driver (Occupant 1)		Right Front Passenger (Occupant 2)	
	Installed	Deployed	Installed	Deployed
Front Airbag	Yes	Yes	Yes	Yes
Curtain Airbag	Yes	Yes	Yes	Yes
Torso Airbag	Yes	Yes	Yes	No
Knee Airbag	No	N/A	No	N/A
Seat Belt Pretensioner	Yes	Yes	Yes	Yes
Seat Belt Load Limiter	Yes	Yes	Yes	Yes
Other				

**DATA SHEET NO. 11 (CONTINUED)
VEHICLE PROFILE MEASUREMENTS**

Test Vehicle: 2016 Honda Fit hatchback
 Test Program: R&D 90.1kph, 15° / 35% Left Oblique Offset

NHTSA No.: M20165307
 Test Date: 2/11/2016

No.	Measurement Description	Units	Pre-Test	Post-Test	Difference
1	Total Length of Vehicle at Centerline	mm	4065	3816	248
2	Rear Surface of Vehicle (RSOV) to Front of Engine	mm	3530	3456	74
3	RSOV to Firewall	mm	3309	3216	93
4	RSOV to Upper Leading Edge of Right Door	mm	2793	2791	2
5	RSOV to Upper Leading Edge of Left Door	mm	2795	2732	63
6	RSOV to Lower Leading Edge of Right Door	mm	2785	2783	2
7	RSOV to Lower Leading Edge of Left Door	mm	2784	2781	3
8	RSOV to Upper Trailing Edge of Right Door	mm	1744	1742	2
9	RSOV to Upper Trailing Edge of Left Door	mm	1745	1727	18
10	RSOV to Lower Trailing Edge of Right Door	mm	1763	1765	-2
11	RSOV to Lower Trailing Edge of Left Door	mm	1767	1772	-5
12	RSOV to Bottom of "A" Post of Right Side	mm	2990	2988	2
13	RSOV to Bottom of "A" Post of Left Side	mm	2990	2996	-5
14	RSOV to Firewall, Right Side	mm	3304	3307	-2
15	RSOV to Firewall, Left Side	mm	3307	3044	264
16	RSOV to Steering Column	mm	2380	2349	31
17	Center of Steering Column to "A" Post	mm	287	257	30
18	Center of Steering Column to Headliner	mm	433	404	29
19	RSOV to Right Side of Front Bumper	mm	4028	4090	-62
20	RSOV to Left Side of Front Bumper	mm	4027	3536	491
21	Length of Engine Block	mm	243	289	-47
RD	RSOV to Right Side of Dash Panel	mm	2529	2523	6
CD	RSOV to Center of Dash Panel	mm	2600	2551	50
LD	RSOV to Left Side of Dash Panel	mm	2555	2502	53

UR* = Unrecoverable Data Point

DATA SHEET NO. 12
ACCIDENT INVESTIGATION DIVISION DATA

Test Vehicle: 2016 Honda Fit hatchback
Test Program: R&D 90.1kph, 15° / 35% Left Oblique Offset

NHTSA No.: M20165307
Test Date: 2/11/2016

VEHICLE INFORMATION

VIN: JHMGK5H5XGX004174 Wheelbase (mm): 2,532
Vehicle Size Category: Passenger Test Weight (kg): 1403

ACCELEROMETER DATA

Accelerometer Locations: As Described in Data Sheet No. 7
Cal. Procedure/Interval: Calspan Procedure / 6 month
Integration Algorithm: Trapezoidal
Linearity: > 99%
Impact Velocity (kph): 90.05
Velocity Change (kph): 90.05

CRUSH PROFILE

Collision Deformation Classification: 12FLEE6
Midpoint of Damage: C2
Damage Region Length (mm): 1341
Impact Mode: Frontal 15° Angle, 35% Left Offset

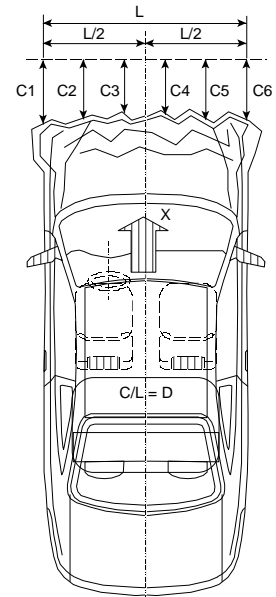

Crush Measurements: Bumper Cover

No.	Measurement Description	Units	Pre-Test	Post-Test	Difference
C1	Crush zone 1 at left side	mm	3896	3418	478
C2	Crush zone 2 at left side	mm	4028	3533	495
C3	Crush zone 3 at left side	mm	4051	3722	329
C4	Crush zone 4 at right side	mm	4051	3890	161
C5	Crush zone 5 at right side	mm	4027	4029	-2
C6	Crush zone 6 at right side	mm	3893	4039	-146
L	C1 to C6	mm	1341	1212	129

Crush Measurements: Bumper Cover Removed

No.	Measurement Description	Units	Pre-Test	Post-Test	Difference
B1	Bumper Beam 1 at left side	mm	3918	3324	-594
B2	Bumper Beam 2 at left side	mm	4005	3413	-592
B3	Bumper Beam 3 at left side	mm	4023	3504	-519
B4	Bumper Beam 4 at left side	mm	4035	3614	-421
B5	Bumper Beam 5 at right side	mm	4039	3707	-332
B6	Bumper Beam 6 at right side	mm	4035	3787	-248
B7	Bumper Beam 7 at right side	mm	4023	3860	-163
B8	Bumper Beam 8 at right side	mm	4006	3930	-76
B9	Bumper Beam 9 at right side	mm	3919	3945	26
L	B1 to B9	mm	1113	928	-185

**DATA SHEET NO. 13
VEHICLE INTRUSION MEASUREMENTS**

Test Vehicle: 2016 Honda Fit hatchback
 Test Program: R&D 90.1kph, 15° / 35% Left Oblique Offset

NHTSA No.: M20165307
 Test Date: 2/11/2016

DOOR OPENING WIDTH

Item	Description	Units	Pre-Test	Post-Test	Difference
A	Left Side Upper	mm	784	703	-81
B	Left Side Lower	mm	780	742	-38
D	Right Side Upper	mm	784	782	-2
E	Right Side Lower	mm </td <td>781</td> <td>780</td> <td>-1</td>	781	780	-1

WHEELBASE MEASUREMENTS

Item	Description	Units	Pre-Test	Post-Test	Difference
C	Left Side Wheelbase	mm	2532	2329	-203
F	Right Side Wheelbase	mm	2532	2655	123

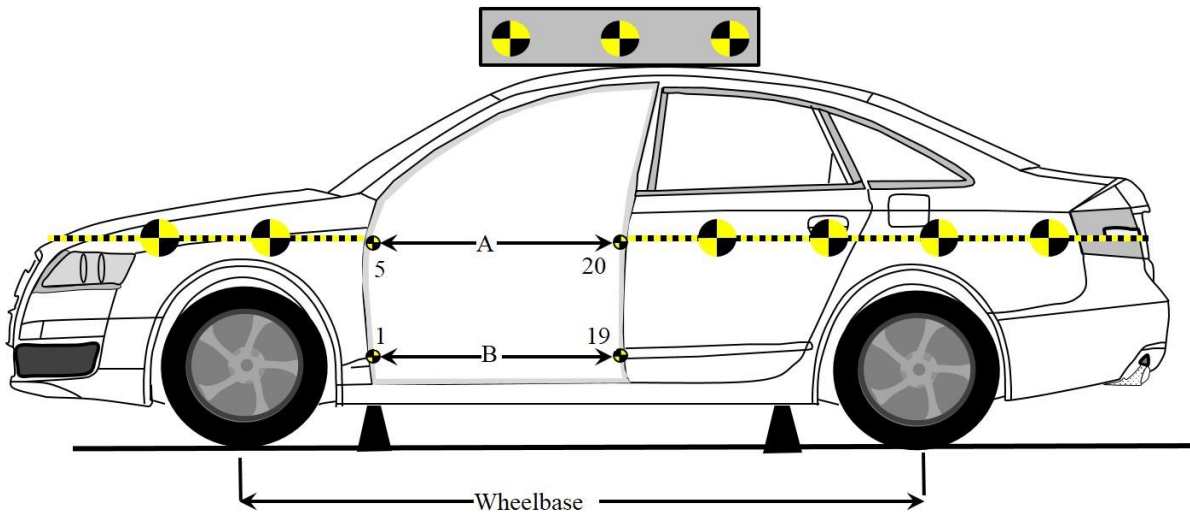

**DATA SHEET NO.13 (CONTINUED)
VEHICLE INTRUSION MEASUREMENTS**

Test Vehicle: 2016 Honda Fit hatchback
 Test Program: R&D 90.1kph, 15° / 35% Left Oblique Offset

NHTSA No.: M20165307
 Test Date: 2/11/2016

DRIVER COMPARTMENT INTRUSION

Item	Description	Units	Pre-Test	Post-Test	Difference
AB	Door Opening (Inside Window Jam)	mm	757	705	-52
CX	Left Knee Bolster to X	mm	196	185	-11
DX	Right Knee Bolster to X	mm	182	116	-66
EX	Brake Pedal to X	mm	470	345	-125
FX	Foot Rest to X	mm	549	479	-70
GX	Center of Steering Column Wheel Hub to X	mm	8	-33	-41

X = Front of Seat Track (Stationary)

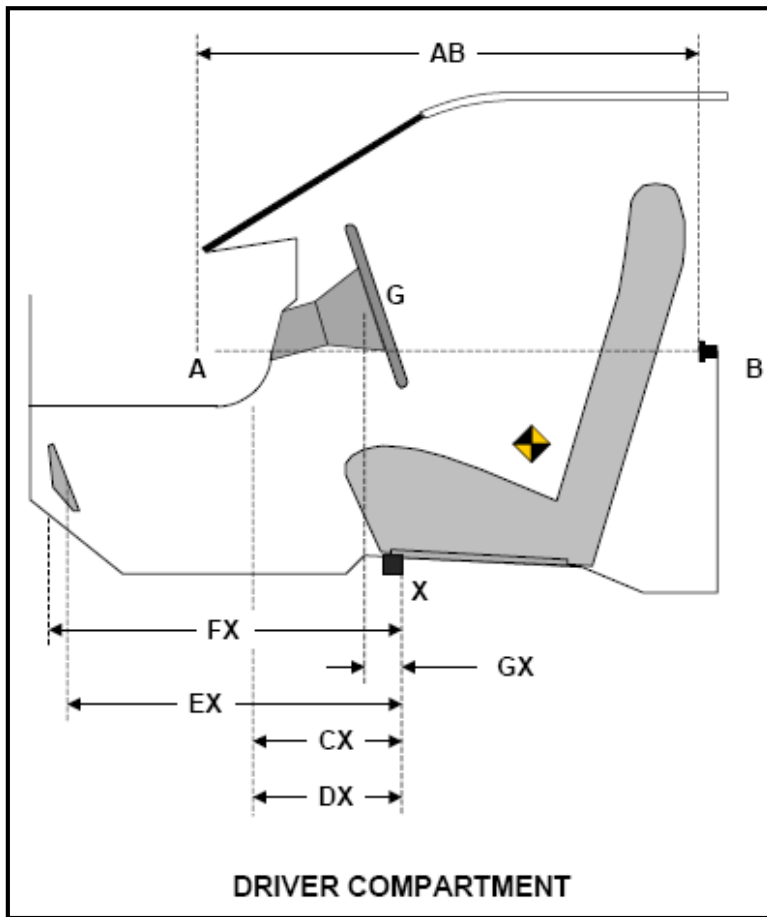

**DATA SHEET NO.13 (CONTINUED)
VEHICLE INTRUSION MEASUREMENTS**

Test Vehicle: 2016 Honda Fit hatchback
 Test Program: R&D 90.1kph, 15° / 35% Left Oblique Offset

NHTSA No.: M20165307
 Test Date: 2/11/2016

DRIVER SIDE DOOR SILL INTRUSIONS

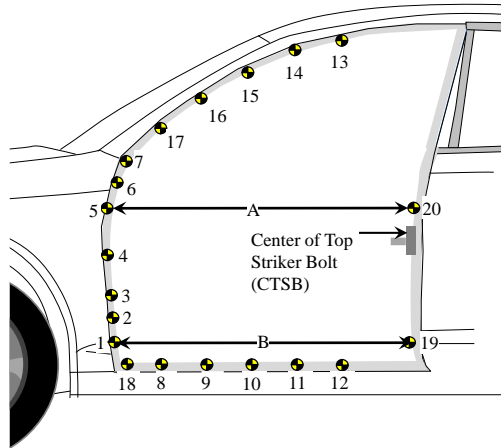

- +X – From the rear of the vehicle to the front of the vehicle
- +Y – From the left side of the vehicle to the right side of the vehicle
- +Z – From the top of the vehicle to the bottom of the vehicle

Point	Pre-Test			Post-Test			Difference		
	X	Y	Z	X	Y	Z	X	Y	Z
1	2733	-712	83	2703	-709	41	-30	3	-42
2	2733	-711	8	2693	-707	-31	-40	4	-39
3	2724	-709	-67	2674	-708	-104	-50	1	-37
4	2683	-710	-217	2620	-720	-249	-63	-10	-32
5	2618	-709	-367	2541	-729	-395	-77	-20	-28
6	2600	-702	-442	2517	-721	-471	-83	-19	-29
7	2583	-688	-517	2535	-684	-578	-48	4	-61
17	2556	-653	-632	2569	-649	-674	13	4	-42
16	2495	-617	-727	2501	-623	-767	6	-6	-40
15	2377	-602	-768	2381	-606	-803	4	-4	-35
14	2256	-589	-802	2259	-589	-832	3	0	-30
13	2133	-579	-830	2135	-578	-854	2	1	-24
20	1833	-692	-368	1838	-688	-381	5	4	-13
19	1954	-711	83	1961	-705	68	7	6	-15
12	1984	-713	116	1992	-706	102	8	7	-14
11	2133	-713	154	2143	-707	140	10	6	-14
10	2283	-714	154	2293	-707	140	10	7	-14
9	2433	-714	154	2443	-704	137	10	10	-17
8	2583	-714	154	2591	-698	136	8	16	-18
18	2658	-713	151	2641	-716	125	-17	-3	-26

**DATA SHEET NO.13 (CONTINUED)
VEHICLE INTRUSION MEASUREMENTS**

Test Vehicle: 2016 Honda Fit hatchback
 Test Program: R&D 90.1kph, 15° / 35% Left Oblique Offset

NHTSA No.: M20165307
 Test Date: 2/11/2016

PASSENGER SIDE DOOR SILL INTRUSIONS

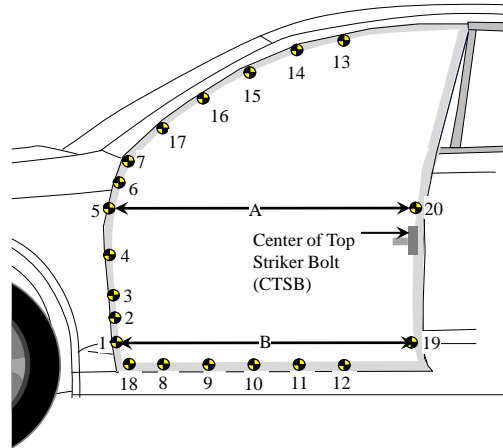

- +X – From the rear of the vehicle to the front of the vehicle
- +Y – From the left side of the vehicle to the right side of the vehicle
- +Z – From the top of the vehicle to the bottom of the vehicle

Point	Pre-Test			Post-Test			Difference		
	X	Y	Z	X	Y	Z	X	Y	Z
1	2733	708	83	2732	733	80	-1	25	-3
2	2730	705	8	2731	731	5	1	26	-3
3	2721	703	-68	2721	726	-72	0	23	-4
4	2679	705	-217	2677	726	-221	-2	21	-4
5	2615	706	-368	2613	721	-371	-2	15	-3
6	2598	697	-442	2595	711	-444	-3	14	-2
7	2580	683	-517	2578	695	-520	-2	12	-3
17	2555	647	-632	2553	658	-634	-2	11	-2
16	2493	612	-726	2491	619	-726	-2	7	0
15	2375	598	-765	2374	601	-765	-1	3	0
14	2255	585	-799	2254	587	-799	-1	2	0
13	2133	575	-826	2133	574	-826	0	-1	0
20	1832	688	-367	1831	695	-369	-1	7	-2
19	1952	706	83	1952	718	81	0	12	-2
12	1983	708	118	1983	721	116	0	13	-2
11	2133	709	157	2134	725	154	1	16	-3
10	2283	709	158	2283	728	155	0	19	-3
9	2433	708	157	2433	730	154	0	22	-3
8	2583	706	156	2583	732	153	0	26	-3
18	2657	708	154	2657	735	151	0	27	-3

**DATA SHEET NO.13 (CONTINUED)
VEHICLE INTRUSION MEASUREMENTS**

Test Vehicle: 2016 Honda Fit hatchback
 Test Program: R&D 90.1kph, 15° / 35% Left Oblique Offset

NHTSA No.: M20165307
 Test Date: 2/11/2016

**VEHICLE EXTERIOR CRUSH PROFILE
SECTION A-A**

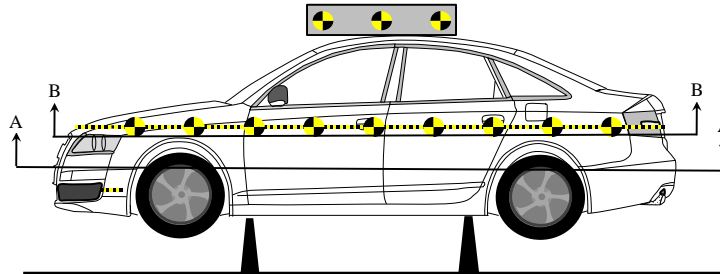

Reference point:

- +X – From the rear of the vehicle to the front of the vehicle
- +Y – From the left side of the vehicle to the right side of the vehicle
- +Z – From the top of the vehicle to the bottom of the vehicle

Point	Pre-Test			Point	Post-Test		
	X	Y	Z		X	Y	Z
1	1766	-831	48	1	1,760	-822	48
2	2050	-832	48	2	1,916	-833	48
3	2395	-834	48	3	2,170	-844	49
4	2719	-840	49	4	2,295	-854	48
5	2913	-845	49	5	2,457	-863	48
6	3571	-836	48	6	2,653	-868	48
7	3710	-808	49	7	2,804	-843	49
8	3829	-752	49	8	2,866	-911	49
9	3984	-560	49	9	2,960	-847	48
10	4036	-339	49	10	3,198	-655	49
11	4054	-136	48	11	3,206	-564	48
12	4056	-5	48	12	3,344	-401	49
13	4055	89	49	13	3,433	-299	48
14	4038	326	49	14	3,451	-194	49
15	3989	551	48	15	3,542	-94	48
16	3749	793	48	16	3,627	6	49
17	3571	833	49	17	3,722	130	47
18	2915	844	49	18	3,811	261	49
19	2756	840	49	19	3,929	478	48
20	2369	833	48	20	3,745	773	49
21	2029	830	49	21	3,680	815	48
22	1766	829	49	22	3,540	810	48
				23	3,221	905	48
				24	2,926	862	48
				25	2,860	871	48

DATA SHEET NO.13 (CONTINUED)
VEHICLE INTRUSION MEASUREMENTS

Test Vehicle: 2016 Honda Fit hatchback
Test Program: R&D 90.1kph, 15° / 35% Left Oblique Offset

NHTSA No.: M20165307
Test Date: 2/11/2016

VEHICLE EXTERIOR CRUSH PROFILE
SECTION A-A (Continued)

Point	Post-Test		
	X	Y	Z
26	2,789	867	49
27	2,479	852	48
28	2,242	847	48
29	2,036	842	48
30	1,862	838	48
31	1,765	836	48

**DATA SHEET NO.13 (CONTINUED)
VEHICLE INTRUSION MEASUREMENTS**

Test Vehicle: 2016 Honda Fit hatchback
 Test Program: R&D 90.1kph, 15° / 35% Left Oblique Offset

NHTSA No.: M20165307
 Test Date: 2/11/2016

**VEHICLE EXTERIOR CRUSH PROFILE
SECTION B-B**

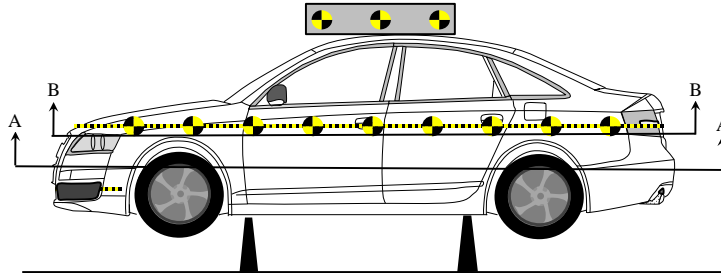

Reference point:

- +X – From the rear of the vehicle to the front of the vehicle
- +Y – From the left side of the vehicle to the right side of the vehicle
- +Z – From the top of the vehicle to the bottom of the vehicle

Point	Pre-Test			Point	Post-Test		
	X	Y	Z		X	Y	Z
1	1780	-848	-180	1	1769	-846	-180
2	2039	-845	-179	2	1899	-866	-180
3	2362	-838	-180	3	2139	-870	-179
4	2734	-841	-179	4	2320	-870	-179
5	3050	-847	-180	5	2459	-883	-180
6	3224	-847	-179	6	2622	-890	-179
7	3437	-840	-179	7	2725	-871	-179
8	3649	-786	-179	8	2798	-844	-179
9	3713	-735	-180	9	2800	-938	-179
10	3785	-618	-179	10	2845	-928	-180
11	3877	-430	-180	11	2862	-892	-180
12	3937	-262	-180	12	2994	-774	-180
13	3959	-79	-179	13	3077	-660	-180
14	3970	-20	-179	14	3122	-460	-179
15	3974	32	-179	15	3271	-336	-179
16	3950	116	-179	16	3345	-196	-180
17	3920	336	-179	17	3387	-151	-179
18	3766	647	-180	18	3574	21	-179
19	3451	837	-180	19	3718	210	-179
20	3279	846	-180	20	3783	313	-179
21	2944	845	-180	21	3799	464	-179
22	2658	836	-179	22	3630	793	-179
23	2374	838	-179	23	3517	853	-180
24	2114	844	-179	24	3389	866	-179
25	1778	848	-179	25	3212	869	-179

DATA SHEET NO.13 (CONTINUED)
VEHICLE INTRUSION MEASUREMENTS

Test Vehicle: 2016 Honda Fit hatchback
Test Program: R&D 90.1kph, 15° / 35% Left Oblique Offset

NHTSA No.: M20165307
Test Date: 2/11/2016

VEHICLE EXTERIOR CRUSH PROFILE
SECTION B-B (Continued)

Point	Post-Test		
	X	Y	Z
26	2991	867	-179
27	2849	863	-179
28	2822	865	-179
29	2661	855	-180
30	2468	852	-179
31	2224	853	-179
32	2008	854	-180
33	1777	852	-179

DATA SHEET NO.13 (CONTINUED)
VEHICLE INTRUSION MEASUREMENTS

Test Vehicle: 2016 Honda Fit hatchback
Test Program: R&D 90.1kph, 15° / 35% Left Oblique Offset

NHTSA No.: M20165307
Test Date: 2/11/2016

VEHICLE EXTERIOR CRUSH PROFILE
SECTION A-A

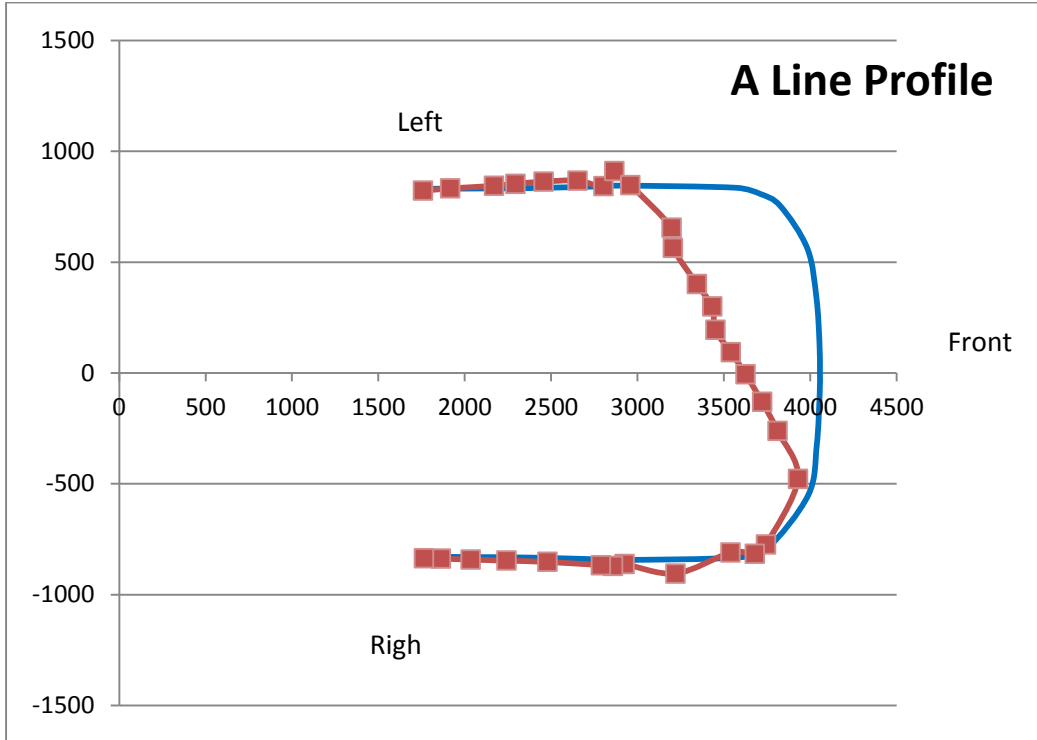

SECTION B-B

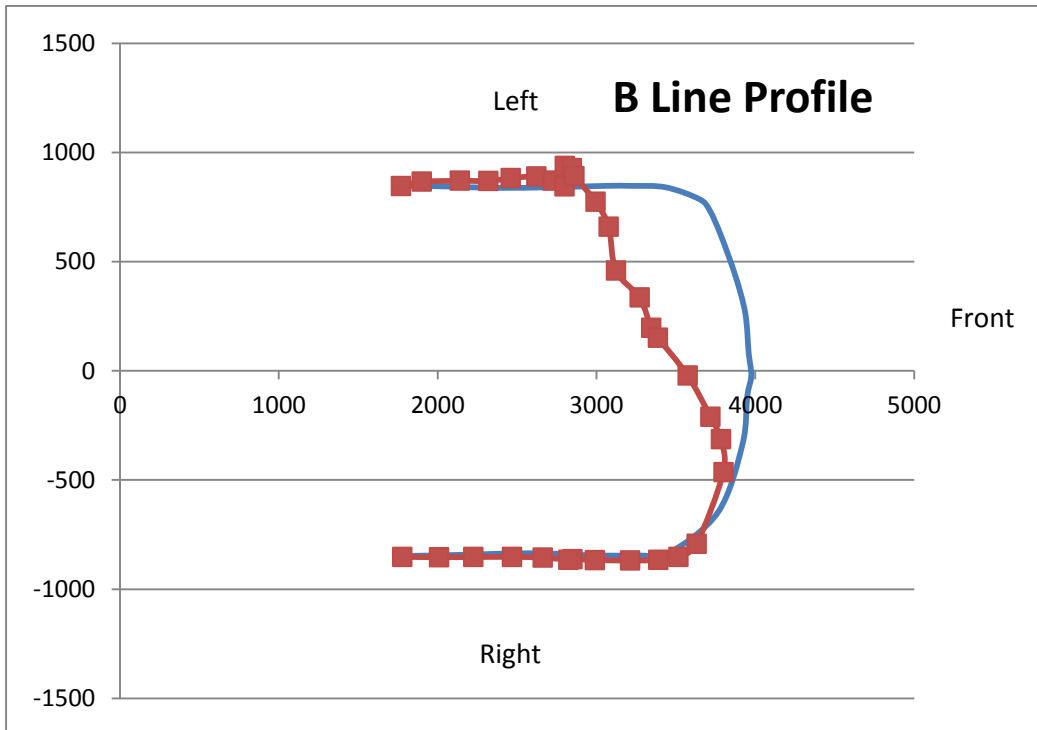

**DATA SHEET NO.13 (CONTINUED)
VEHICLE INTRUSION MEASUREMENTS**

Test Vehicle: 2016 Honda Fit hatchback
 Test Program: R&D 90.1kph, 15° / 35% Left Oblique Offset

NHTSA No.: M20165307
 Test Date: 2/11/2016

STRUCTURAL BUMPER BEAM POINTS

	Point	Pre-Test (mm)			Post-Test (mm)			Difference (mm)		
		X	Y	Z	X	Y	Z	X	Y	Z
Structural Bumper Beam	B1	3918	-558	48	3324	-402	-47	-594	156	-95
	B2	4005	-418	49	3413	-283	-41	-592	135	-90
	B3	4023	-279	48	3504	-179	-38	-519	100	-86
	B4	4035	-141	48	3614	-92	-40	-421	49	-88
	B5	4039	0	49	3707	13	-37	-332	13	-86
	B6	4035	138	49	3787	124	-32	-248	-14	-81
	B7	4023	277	49	3860	242	-26	-163	-35	-75
	B8	4006	416	49	3930	364	-19	-76	-52	-68
	B9	3919	555	47	3945	526	-2	26	-29	-49

Reference point:

- +X – From the rear of the vehicle to the front of the vehicle
- +Y – From the left side of the vehicle to the right side of the vehicle
- +Z – From the top of the vehicle to the bottom of the vehicle

**DATA SHEET NO.13 (CONTINUED)
VEHICLE INTRUSION MEASUREMENTS**

Test Vehicle: 2016 Honda Fit hatchback
 Test Program: R&D 90.1kph, 15° / 35% Left Oblique Offset

NHTSA No.: M20165307
 Test Date: 2/11/2016

DRIVER FLOOR PAN MEASUREMENTS

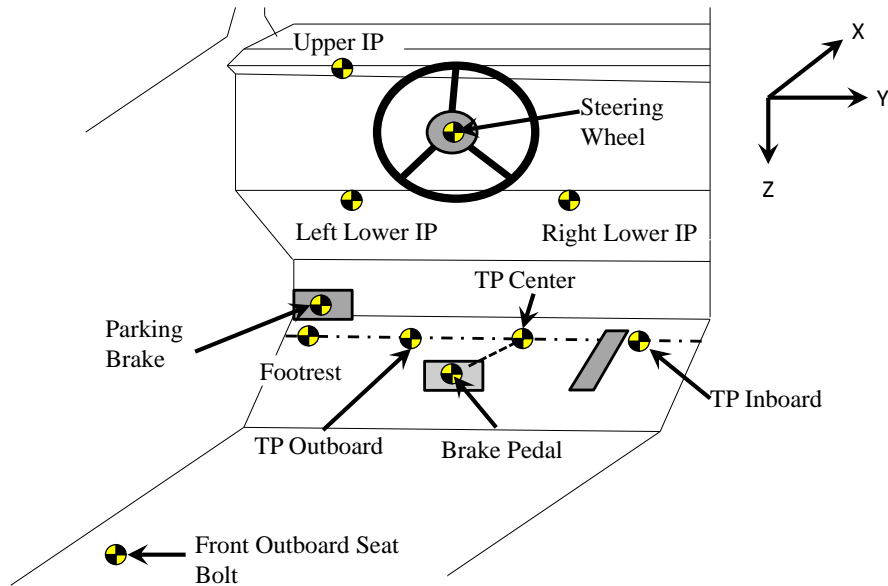

Intrusion Location	Pre-Test (mm)			Post-Test (mm)			Difference (mm)		
	X	Y	Z	X	Y	Z	X	Y	Z
TP Inboard	3019	-179	84	2889	-119	65	-130	60	-19
TP Center	3026	-330	83	2886	-267	30	-140	63	-53
TP Outboard	3001	-480	84	2877	-415	24	-124	65	-60
TP Footrest	2910	-579	84	2851	-544	42	-59	35	-42
Brake Pedal	2831	-329	83	2717	-338	48	-114	-9	-35
Left Lower IP	2558	-484	-239	2556	-494	-293	-2	-10	-54
Right Lower IP	2543	-183	-239	2488	-176	-304	-55	7	-65
Upper IP	2542	-584	-305	2480	-593	-363	-62	-9	-58
Steering Wheel	2370	-334	-426	2339	-354	-478	-31	-20	-52
Front Outboard Bolt	2361	-567	153	2372	-553	143	11	14	-10
Emergency Brake									

Reference point:

- +X – From the rear of the vehicle to the front of the vehicle
- +Y – From the left side of the vehicle to the right side of the vehicle
- +Z – From the top of the vehicle to the bottom of the vehicle

**DATA SHEET NO.13 (CONTINUED)
VEHICLE INTRUSION MEASUREMENTS**

Test Vehicle: 2016 Honda Fit hatchback
 Test Program: R&D 90.1kph, 15° / 35% Left Oblique Offset

NHTSA No.: M20165307
 Test Date: 2/11/2016

PASSENGER FLOOR PAN MEASUREMENTS

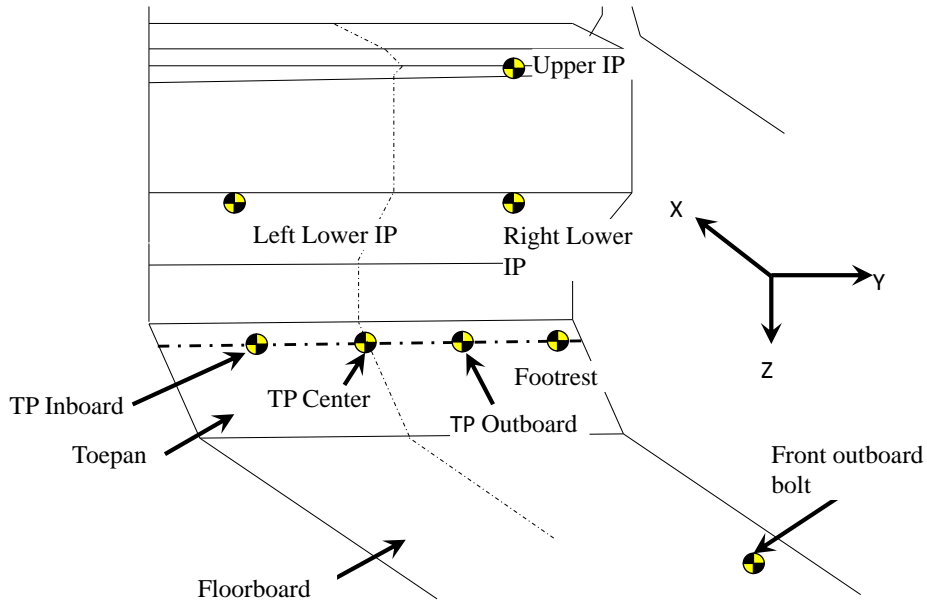

Intrusion Location	Pre-Test (mm)			Post-Test (mm)			Difference (mm)		
	X	Y	Z	X	Y	Z	X	Y	Z
TP Inboard	3002	189	83	2979	222	75	-23	33	-8
TP Center	3025	338	83	3024	366	76	-1	28	-7
TP Outboard	2990	490	82	2988	516	74	-2	26	-8
TP Footrest	2897	589	84	2895	618	76	-2	29	-8
Left Lower IP	2556	189	-190	2603	178	-211	47	-11	-21
Right Lower IP	2588	490	-190	2604	481	-181	16	-9	9
Upper IP	2528	590	-371	2517	604	-370	-11	14	1
Front Outboard Bolt	2362	561	154	2365	575	155	3	14	1

Reference point:

- +X – From the rear of the vehicle to the front of the vehicle
- +Y – From the left side of the vehicle to the right side of the vehicle
- +Z – From the top of the vehicle to the bottom of the vehicle

DATA SHEET NO.14
OMDB CRUSH MEASUREMENTS

Test Vehicle: 2016 Honda Fit hatchback
Test Program: R&D 90.1kph, 15° / 35% Left Oblique Offset

NHTSA No.: M20165307
Test Date: 2/11/2016

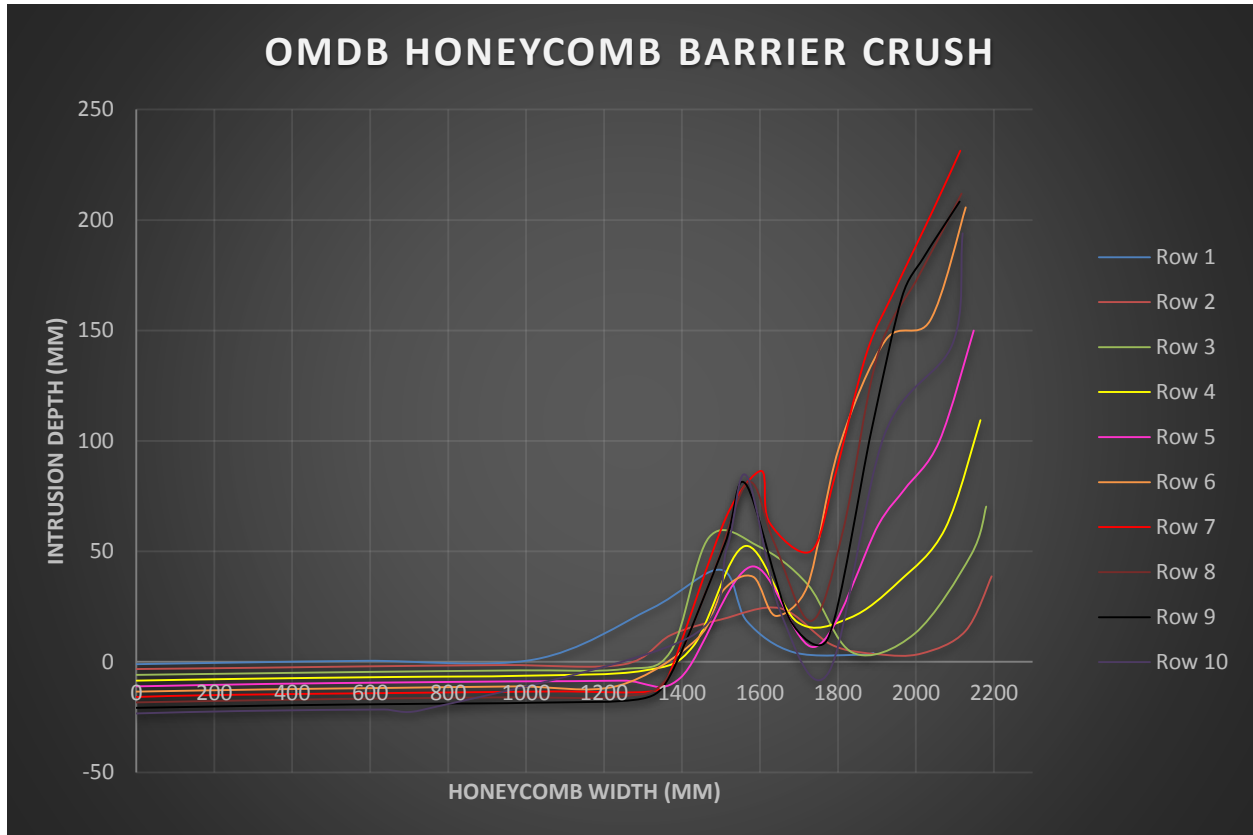

**DATA SHEET NO. 15
SUMMARY OF FMVSS 212, 219 (PARTIAL), AND 301 DATA**

Test Vehicle: 2016 Honda Fit hatchback
 Test Program: R&D 90.1kph, 15° / 35% Left Oblique Offset

NHTSA No.: M20165307
 Test Date: 2/11/2016

Please provide windshield mounting details. A 0.8 mm trim surrounds the top and side of windshield while a plastic shroud is on the bottom.

The standard requires that the post-test retention measurement be a minimum of 75% of the pre-test total periphery measurement for vehicles not equipped with occupant passive restraints and 50% for each side of the windshield for vehicles which are equipped with occupant passive restraints.

Temperature of windshield molding during test: 21°C

WINDSHIELD PERIPHERY MEASUREMENTS

Measurement	Pre-Test (mm)	Post-Test (mm)	% Retention
Left Side	2157	1952	90.5
Right Side	2168	2168	100
Total	4325	4120	95.3

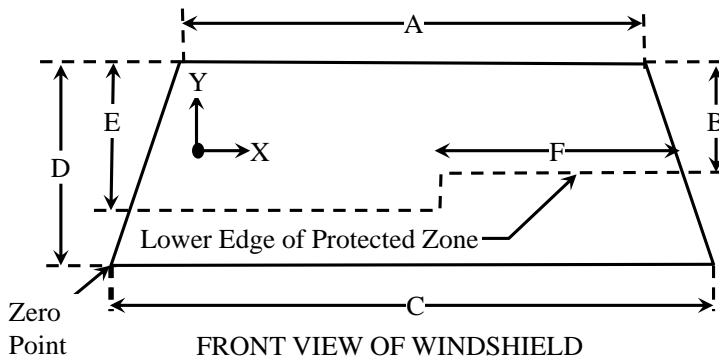

Item	Units	Value
A	mm	1076
B	mm	503
C	mm	1348
D	mm	956
E	mm	601
F	mm	432

AREAS OF PROTECTED ZONE FAILURES

A. Provide coordinates of the area that the protected zone was penetrated more than .25 inches by a vehicle component other than one that is normally in contact with the windshield.

- No penetration

X	Y

B. Provide coordinates of the area beneath the protected zone that the inner surface of the windshield was penetrated by a vehicle component.

- No Penetration

X	Y

DATA SHEET NO. 15 (CONTINUED)
SUMMARY OF FMVSS 212, 219 (PARTIAL), AND 301 DATA

Test Vehicle: 2016 Honda Fit hatchback
Test Program: R&D 90.1kph, 15° / 35% Left Oblique Offset

NHTSA No.: M20165307
Test Date: 2/11/2016

FMVSS 301 FUEL SYSTEM INTEGRITY POST IMPACT DATA

Ambient Temperature at Test Vehicle Time of Impact: 21.1° C

Test Time: 2:15 PM

Stoddard Solvent Spillage Measurements

A.	From impact until vehicle motion ceases: (Maximum allowable = 1 oz.)	<u>0</u>	oz
B.	For the 5-minute period after motion ceases: (Maximum allowable = 5 oz.)	<u>0</u>	oz
C.	For the following 25 minutes: (Maximum allowable = 1 oz./minute)	<u>0</u>	oz
D.	Spillage	<u>0</u>	oz

**DATA SHEET NO. 16
FMVSS 301 STATIC ROLLOVER RESULTS N/A**

Test Vehicle: 2016 Honda Fit hatchback
 Test Program: R&D 90.1kph, 15° / 35% Left Oblique Offset

NHTSA No.: M20165307
 Test Date: 2/11/2016

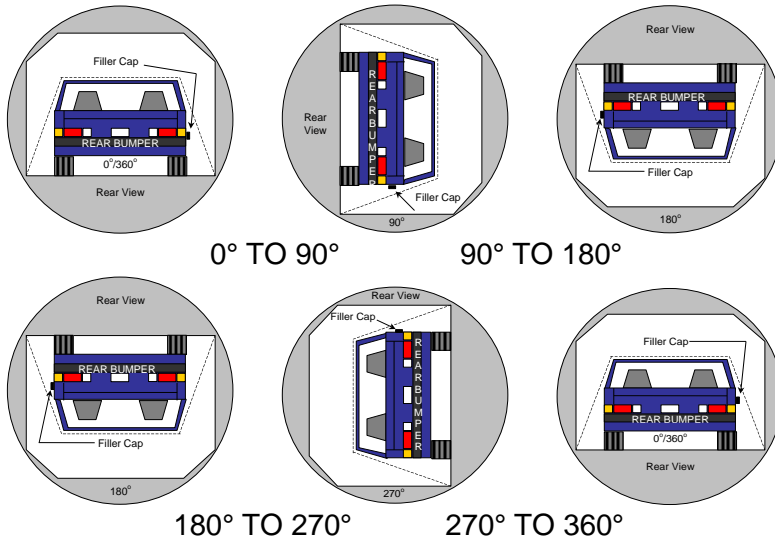

1. The specified fixture rollover rate for each 90° of rotation is 60 to 180 seconds.
2. The position hold time at each position is 300 seconds (minimum).
3. Details of Stoddard Solvent spillage: None

SOLVENT COLLECTION TIME TABLE IN SECONDS

Test Phase	Rotation Time	Hold Time	Total Time
0° to 90°	74	300	374
90° to 180°	66	300	366
180° to 270°	61	300	361
270° to 360°	69	300	369

FMVSS 301 SPILLAGE TABLE

Test Phase	First 5 Minutes	Sixth Minute	Seventh Minute	Eighth Minute
0° to 90°	0	0	0	
90° to 180°	0	0	0	
180° to 270°	0	0	0	
270° to 360°	0	0	0	

SOLVENT SPILLAGE LOCATION TABLE

Test Phase	Spillage Location
0° to 90°	None
90° to 180°	None
180° to 270°	None
270° to 360°	None

DATA SHEET NO. 17
DUMMY/VEHICLE TEMPERATURE STABILIZATION

Test Vehicle: 2016 Honda Fit hatchback
Test Program: R&D 90.1kph, 15° / 35% Left Oblique Offset

NHTSA No.: M20165307
Test Date: 2/11/2016

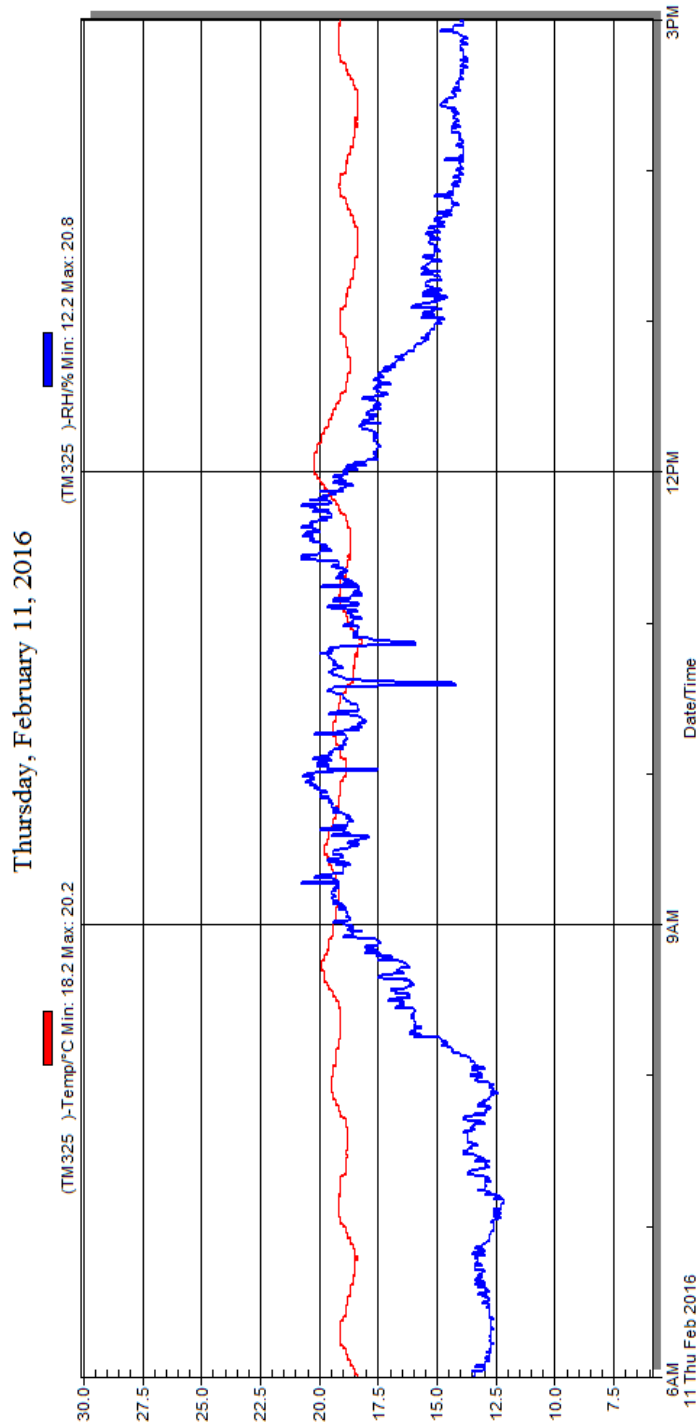

Temperature Stabilization Chart/Data

APPENDIX A
PHOTOGRAPHS

TABLE OF PHOTOGRAPHS		
No.	Description	Page
1	As Delivered Right Front 3-4 View of Test Vehicle	A-9
2	As Delivered Left Rear 3-4 View of Test Vehicle	A-9
3	Test Vehicle Certification Label	A-10
4	Test Vehicle Tire Placard	A-10
5	Pre-Test Front View of Test Vehicle	A-11
6	Post-Test Front View of Test Vehicle	A-11
7	Pre-Test Left Front 3-4 View of Test Vehicle	A-12
8	Post-Test Left Front 3-4 View of Test Vehicle	A-12
9	Pre-Test Left Side View of Test Vehicle	A-13
10	Post-Test Left Side View of Test Vehicle	A-13
11	Pre-Test Left Rear 3-4 View of Test Vehicle	A-14
12	Post-Test Left Rear 3-4 View of Test Vehicle	A-14
13	Pre-Test Rear View of Test Vehicle	A-15
14	Post-Test Rear View of Test Vehicle	A-15
15	Pre-Test Right Rear 3-4 View of Test Vehicle	A-16
16	Post-Test Right Rear 3-4 View of Test Vehicle	A-16
17	Pre-Test Right Side View of Test Vehicle	A-17
18	Post-Test Right Side View of Test Vehicle	A-17
19	Pre-Test Right Front 3-4 View of Test Vehicle	A-18
20	Post-Test Right Front 3-4 View of Test Vehicle	A-18
21	Monroney Label Photograph	A-19
22	Pre-Test Overhead View of OMDB against target vehicle at ideal Impact Point	A-19
23	Pre-Test Left Side View of OMDB against target vehicle at ideal Impact Point	A-20
24	Pre-Test Right Side View of OMDB against target vehicle at ideal Impact Point	A-20
25	Pre-Test Close-up View of Impact Point	A-21
26	Post-Test Close-up View of Impact Point	A-21
27	Post-Test Vehicle Overhead View	A-22
28	Pre-Test Close-up View of Driver Door Latch	A-23
29	Post-Test Close-up View of Driver Door Latch	A-23
30	Pre-Test Close-up View of Passenger Door Latch	A-24

TABLE OF PHOTOGRAPHS (Continued)		
No.	Description	Page
31	Post-Test Close-up View of Passenger Door Latch	A-24
32	Pre-Test Windshield View	A-25
33	Post-Test Windshield View	A-25
34	Pre-Test View of Driver Inner Door Panel	A-26
35	Post-Test View of Driver Inner Door Panel	A-26
36	Pre-Test View of Passenger Inner Door Panel	A-27
37	Post-Test View of Passenger Inner Door Panel	A-27
38	Pre-Test Overall View of Driver Knee Bolsters	A-28
39	Post-Test Overall View of Driver Knee Bolsters	A-28
40	Pre-Test Left Side View of Driver Knee Bolsters	A-29
41	Post-Test Left Side View of Driver Knee Bolsters	A-29
42	Pre-Test Right Side View of Driver Knee Bolsters	A-30
43	Post-Test Right Side View of Driver Knee Bolsters	A-30
44	Pre-Test View of Driver Floor pan at Left sill level, w/carpet	A-31
45	Post-Test View of Driver Floor pan at Left sill level, w/carpet	A-31
46	Pre-Test View of Driver Floor pan at Mid seat level, w/carpet	A-32
47	Post-Test view of Driver Floor pan at Mid seat level, w/carpet	A-32
48	Pre-Test View of Driver Floor pan at Right sill level, w/carpet	A-33
49	Post-Test View of Driver Floor pan at Right sill level, w/carpet	A-33
50	Pre-Test Driver Front Windshield View	A-34
51	Post-Test Driver Front Windshield View	A-34
52	Pre-Test Left Side View of Driver and Interior	A-35
53	Post-Test Left Side View of Driver and Interior	A-35
54	Pre-Test Left Side Driver Window View	A-36
55	Post-Test Left Side Driver Window View	A-36
56	Pre-Test Right Side View of Driver and Interior	A-37
57	Post-Test Right Side View of Driver and Interior	A-37
58	Pre-Test View of Driver Door Clearance	A-38
59	Post-Test View of Driver Door Clearance	A-38

TABLE OF PHOTOGRAPHS (Continued)		
No.	Description	Page
60	Pre-Test View of Parking Brake	A-39
61	Pre-Test Driver Seat Fore Aft Markings	A-40
62	Post-Test Driver Seat Fore Aft Markings	A-40
63	Pre-Test Driver Seat Back Markings	A-41
64	Pre-Test Overhead View of Driver Thighs on Seat	A-41
65	Pre-Test Driver Adjustable D-ring	A-42
66	Post-Test Driver Adjustable D-ring	A-42
67	Pre-Test Driver Feet	A-43
68	Post-Test Driver Feet	A-43
69	Pre-Test View of Driver Right Knee and Bolster	A-44
70	Post-Test View of Driver Right Knee and Bolster	A-44
71	Pre-Test View of Driver Left Knee and Bolster	A-45
72	Post-Test View of Driver Left Knee and Bolster	A-45
73	Pre-Test View of Driver Abdomen	A-46
74	Post-Test View of Driver Abdomen	A-46
75	Pre-Test Left Side View of Steering Wheel set position	A-47
76	Post-Test Left Side View of Steering Wheel set position	A-47
77	Post-Test View of Driver Head Contact with Airbag – Front	A-48
78	Post-Test View of Driver Head Contact with Airbag – Curtain	A-48
79	Post-Test View of Driver Head Contact with Vehicle Interior – A	A-49
80	Post-Test View of Driver Head Contact with Vehicle Interior – B	A-49
81	Post-Test View of Driver Head Contact with Vehicle Interior – C	A-50
82	Pre-Test Overall View of Passenger Knee Bolsters	A-51
83	Post-Test Overall View of Passenger Knee Bolsters	A-51
84	Pre-Test Left Side View of Passenger Knee Bolsters	A-52
85	Post-Test Left Side View of Passenger Knee Bolsters	A-52
86	Pre-Test Right Side View of Passenger Knee Bolsters	A-53
87	Post-Test Right Side View of Passenger Knee Bolsters	A-53
88	Pre-Test View of Passenger Floor pan at Right sill level, w/carpet	A-54
89	Post-Test View of Passenger Floor pan at Right sill level, w/carpet	A-54

TABLE OF PHOTOGRAPHS (Continued)		
No.	Description	Page
90	Pre-Test View of Passenger Floor pan at Mid seat level, w/carpet	A-55
91	Post-Test view of Passenger Floor pan at Mid seat level, w/carpet	A-55
92	Pre-Test View of Passenger Floor pan at Left View, w/carpet	A-56
93	Post-Test View of Passenger Floor pan at Left View, w/carpet	A-56
94	Pre-Test Passenger Front Close-up View, Windshield	A-57
95	Post-Test Passenger Front Close-up View, Windshield	A-57
96	Pre-Test Left Side Passenger and Interior View	A-58
97	Post-Test Left Side Passenger and Interior View	A-58
98	Pre-Test Right Side Passenger Window View	A-59
99	Post-Test Right Side Passenger Window View	A-59
100	Pre-Test Right Side Passenger and Interior View	A-60
101	Post-Test Right Side Passenger and Interior View	A-60
102	Pre-Test View of Passenger Door Clearance	A-61
103	Post-Test View of Passenger Door Clearance	A-61
104	Pre-Test Passenger Seat Fore-Aft Markings	A-62
105	Post-Test Passenger Seat Fore-Aft Markings	A-62
106	Pre-Test Passenger Seat Back Markings	A-63
107	Pre-Test Overhead View of Passenger Thighs on seat	A-63
108	Pre-Test Passenger Adjustable D-ring	A-64
109	Post-Test Passenger Adjustable D-ring	A-64
110	Pre-Test View of Passenger Feet	A-65
111	Post-Test View of Passenger Feet	A-65
112	Pre-Test View of Passenger Right Knee and Bolster	A-66
113	Post-Test View of Passenger Right Knee and Bolster	A-66
114	Pre-Test View of Passenger Left Knee and Bolster	A-67
115	Post-Test View of Passenger Left Knee and Bolster	A-67
116	Pre-Test View of Passenger Abdomen	A-68
117	Post-Test View of Passenger Abdomen	A-68
118	Post-Test View of Passenger Head contact with Airbag – Front	A-69
119	Post-Test View of Passenger Head contact with Airbag – Curtain	A-69

TABLE OF PHOTOGRAPHS (Continued)		
No.	Description	Page
120	Post-Test View of Passenger Head contact with Interior	A-70
121	Post-Test View of Passenger Body contact with Interior	A-70
122	Post-Test View of Passenger Head contact with Interior	A-71
123	Post-Test Passenger Contact With Glovebox	A-71
124	Pre-Test Ballast Locations	A-72
125	Post-Test Speed Trap Readout	A-72
126	Pre-Test View of Fuel Filler Cap	A-73
127	Post-Test View of Fuel Filler Cap	A-73
128	Pre-Test Engine Compartment View	A-74
129	Post-Test Engine Compartment View	A-74
130	Pre-Test Right Side Engine Compartment View	A-75
131	Post-Test Right Side Engine Compartment View	A-75
132	Pre-Test Left Side Engine Compartment View	A-76
133	Post-Test Left Side Engine Compartment View	A-76
134	Pre-Test View of Front Underbody (perpendicular to vehicle)	A-77
135	Post-Test View of Front Underbody (perpendicular to vehicle)	A-77
136	Pre-Test View of Mid Underbody (perpendicular to vehicle)	A-78
137	Post-Test View of Mid Underbody (perpendicular to vehicle)	A-78
138	Pre-Test View of Rear Underbody (perpendicular to vehicle)	A-79
139	Post-Test View of Rear Underbody (perpendicular to vehicle)	A-79
140	Pre-Test View of Steering rack and or sway bar	A-80
141	Post-Test View of Steering rack and or sway bar	A-80
142	Pre-Test Bumper to Rail Attachments and Crush Initiators	A-81
143	Post-Test Bumper to Rail Attachments and Crush Initiators	A-81
144	Post-Test View of Front Sub-Frame Deformation	A-82
145	Pre-Test Frame Rail with tire removed	A-83
146	Post-Test Frame Rail with tire removed	A-83
147	Pre-Test View of Front Driver Wheel Well with tire removed	A-84
148	Post-Test ¼ View of Front Driver Wheel Well w/ tire removed	A-84
149	Post-Test Side View of Front Driver Wheel Well w/ tire removed	A-85

TABLE OF PHOTOGRAPHS (Continued)		
No.	Description	Page
150	Post-Test Right Side 3/4 Rear View of the Front Driver Wheel Well w/ tire removed	A-85
151	Post-Test Looking Down at the Front Driver Shotgun	A-86
152	Post-Test Right Side ¾ View of Front Driver Shotgun	A-86
153	Post-Test Front Driver Close up View of Suspension w/ tire removed	A-87
154	Post-Test ¾ View of Front Passenger Wheel Well w/ tire removed	A-87
155	Post-Test Side View of Front Passenger Wheel Well w/ tire removed	A-88
156	Post-Test Right Side 3/4 Rear View of the Front Passenger Wheel Well w/ tire removed	A-88
157	Post-Test Looking Down at the Front Passenger Shotgun	A-89
158	Post-Test Right Side ¾ View of Front Passenger Shotgun	A-89
159	Post-Test Front Passenger Close up View of Suspension w/ tire removed	A-90
160	Post-Test View of Door Sill with door open-Struck Side	A-90
161	Post-Test View of Deformation of A pillar-Struck Side	A-91
162	Post-Test View of Deformation of B pillar-Struck Side	A-91
163	Post-Test View of Deformation of C pillar-Struck Side	A-92
164	Post-Test View of Wheel and/or Tire Deformation-Struck Side	A-92
165	Post-Test View of Deformation of Rocker or Post-Struck Side	A-93
166	Post-Test View of Windshield Separation	A-93
167	Pre-Test Left Side View of OMDB	A-94
168	Post-Test Left Side View of OMDB	A-94
169	Pre-Test Right Side View of OMDB	A-95
170	Post-Test Right Side View of OMDB	A-95
171	Pre-Test Top View of OMDB	A-96
172	Post-Test Top View of OMDB	A-96
173	Pre-Test Front View of OMDB	A-97
174	Post-Test Front View of OMDB	A-97
175	Pre-Test Left Front ¾ View of OMDB	A-98
176	Post-Test Left Front ¾ View of OMDB	A-98
177	Pre-Test Right Front ¾ View of OMDB	A-99
178	Post-Test Right Front ¾ View of OMDB	A-99
179	Pre-Test Right Side View of OMDB	A-100

TABLE OF PHOTOGRAPHS (Continued)		
No.	Description	Page
180	Post-Test Right Side View of OMDB	A-100
181	Pre-Test Left Side View of OMDB	A-101
182	Post-Test Left Side View of OMDB	A-101
183	Pre-Test OMDB & Vehicle, Right Side	A-102
184	Post-Test OMDB & Vehicle, Right Side	A-102
185	Pre-Test OMDB & Vehicle, Left Side	A-103
186	Post-Test OMDB & Vehicle, Left Side	A-103
187	Pre-Test OMDB & Vehicle, Top View	A-104
188	Post-Test OMDB & Vehicle, Top View	A-104
189	Pre-Test OMDB & Vehicle, Rear View	A-105
190	Post-Test OMDB & Vehicle, Rear View	A-105
191	Pre-Test OMDB & Vehicle, Front View	A-106
192	Post-Test OMDB & Vehicle, Front View	A-106
193	Pre-Test OMDB & Vehicle Alignment View	A-107
194	Vehicle at 0 Degrees on Static Rollover Device	A-107
195	Vehicle at 90 Degrees on Static Rollover Device	A-108
196	Vehicle at 180 Degrees on Static Rollover Device	A-108
197	Vehicle at 270 Degrees on Static Rollover Device	A-109
198	Vehicle at 360 Degrees on Static Rollover Device	A-109
199	Impact Photo	A-110
200	Pre-Test Vehicle Bumper Left Side View	A-111
201	Post-Test Vehicle Bumper Left Side View	A-111
202	Pre-Test Vehicle Bumper Left Front View	A-112
203	Post-Test Vehicle Bumper Left Front View	A-112
204	Pre-Test Vehicle Bumper Front View	A-113
205	Post-Test Vehicle Bumper Front View	A-113
206	Pre-Test Vehicle Bumper Right Side View	A-114
207	Post-Test Vehicle Bumper Right Side View	A-114
208	Pre-Test Vehicle Bumper Right Front View	A-115
209	Post-Test Vehicle Bumper Right Front View	A-115



No. 001 As Delivered Right Front 3-4 View of Test Vehicle



No. 002 As Delivered Left Rear 3-4 View of Test Vehicle



No. 003 Test Vehicle Certification Label

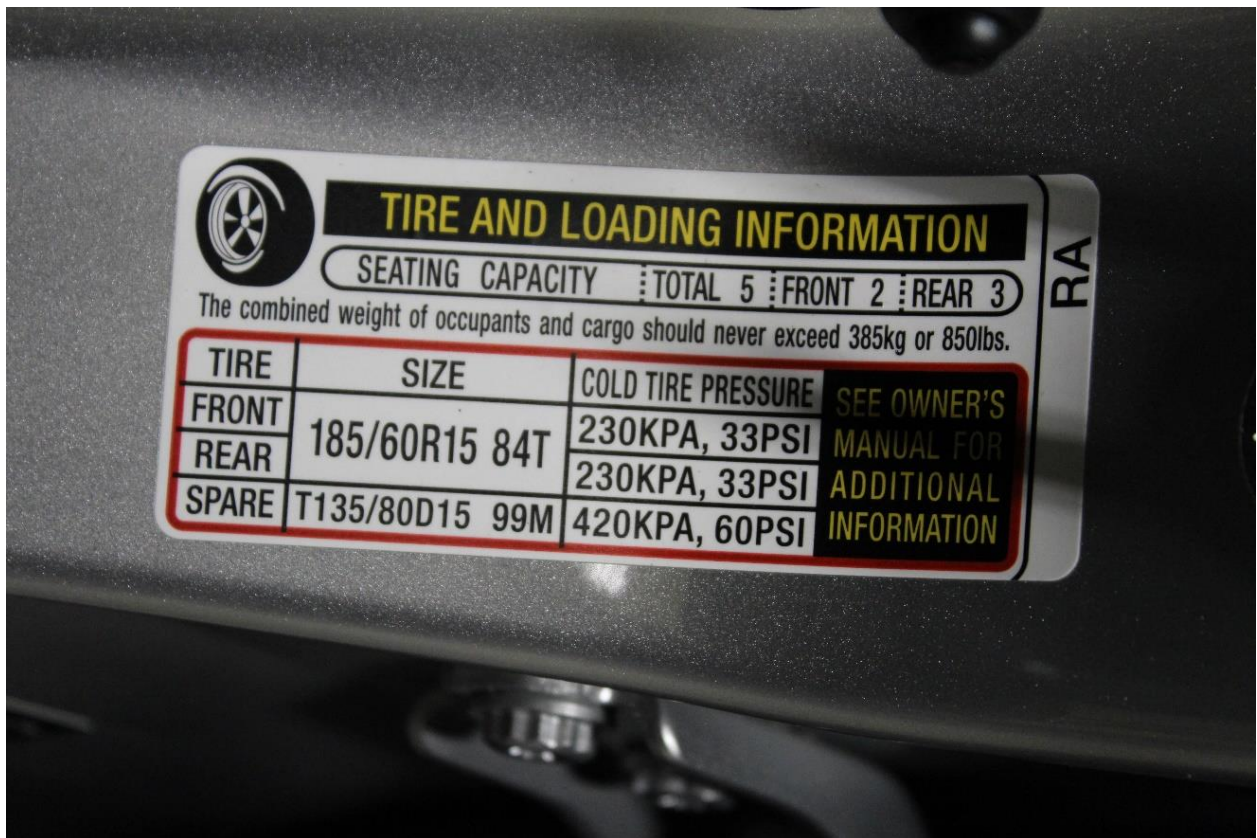

No. 004 Test Vehicle Tire Placard



No. 005 Pre-Test Front View of Test Vehicle



No. 006 Post-Test Front View of Test Vehicle



No. 007 Pre-Test Left Front 3-4 View of Test Vehicle



No. 008 Post-Test Left Front 3-4 View of Test Vehicle



No. 009 Pre-Test Left Side View of Test Vehicle



No. 010 Post-Test Left Side View of Test Vehicle



No. 011 Pre-Test Left Rear 3-4 View of Test Vehicle



No. 012 Post-Test Left Rear 3-4 View of Test Vehicle



No. 013 Pre-Test Rear View of Test Vehicle



No. 014 Post-Test Rear View of Test Vehicle



No. 015 Pre-Test Right Rear 3-4 View of Test Vehicle



No. 016 Post-Test Right Rear 3-4 View of Test Vehicle



No. 017 Pre-Test Right Side View of Test Vehicle



No. 018 Post-Test Right Side View of Test Vehicle



No. 019 Pre-Test Right Front 3-4 View of Test Vehicle



No. 020 Post-Test Right Front 3-4 View of Test Vehicle

HONDA

2016 FIT 5DR LX
EXT: ALABASTER SILVER M ENGINE NUMBER: L15B11104178
INT: BLACK

Manufacturer's Suggested Retail Price
\$16,590.00

Full Tank of Fuel **No Charge**

-Honda Roadside Assistance-
3-YR/36K Mile Warranty Term

STANDARD EQUIPMENT AT NO EXTRA COST

- **TECHNICAL FEATURES**
- 130hp 1.8-Liter DOHC 16-Valve i-VTEC 4-Cylinder Direct Injection Engine w/ Earth Dreams Technology
- Continuously Variable Transmission (CVT) with Sport Mode
- Drive-by-Wire Throttle System
- Electric Power-Assisted Rack-and-Pinion Steering
- Front MacPherson Strut Suspension
- Rear Torsion Beam Suspension
- Immobilizer Theft-Deterrent System
- ECO Assist System
- **SAFETY FEATURES**
- Driver's and Front Passenger's Dual-Stage Airbags (SRS)
- Driver's and Front Passenger's Side Airbags
- Side Curtain Airbags with Rollover Sensor
- Anti-Lock Braking System (ABS)
- Brake Assist
- Electronic Brake Distribution (EBD)
- Vehicle Stability Assist (VSA)
- Tire Pressure Monitoring System
- ACE Body Structure
- Daytime Running Lights (DRL)
- LATCH System for Child Seats

28 miles
10/15
H45410

Interior Features

- AM/FM/CD/MP3 Audio System with 4 Speakers
- 5-Inch Color LCD Screen with Rearview Camera
- Bluetooth Audio
- Bluetooth HandsFreeLink
- USB Audio Interface
- Steering Wheel-Mounted Controls
- MP3/Auxiliary Input Jack
- Air Conditioning with Air Filtration System
- Center Storage Console w/ Armrest
- Driver's Seat Height Adjustment
- 60/40 Split 2nd-Row Magic Seat
- Power Windows and Programmable Auto Door Locks
- Driver's Auto Up/Down Window
- Tilt & Telescopic Steering Column
- Cargo Area Light
- Vainor Vanity Mirrors
- Cruise Control
- 12-Volt Power Outlets

Exterior Features

- 15" x 5.5" Steel Wheels with Full Wheel Covers
- P185/80 R15 All-Season Tires
- Intermittent Windshield Wipers
- Rear Window Defogger
- Rear Wiper with Washer
- Auto On/Off Headlights
- Expanded View Driver's Mirror
- Body-Colored Power Door Mirrors
- LED Brake Lights
- Rear Roofline Spoiler
- Remote Entry with Security System

Destination and Handling **820.00**

TOTAL VEHICLE PRICE
(Includes Pre-Delivery Service)
\$17,410.00

License and title fees, state and local taxes and dealer options and accessories are not included in the manufacturer's suggested retail price.

MPG
36 city **33** highway **41** combined
2.8 gallons per 100 miles

Fuel Economy and Environment

You Save \$2,750
in fuel costs over 5 years compared to the average new vehicle.

Annual fuel Cost \$1,250

Fuel Economy & Greenhouse Gas Rating (Large only) **Smog Rating** (Large only)

1 Best **8** **10** Best **1** Best **5** Best **10** Best

This vehicle emits 241 grams CO₂ per mile. The best emits 0 grams per mile (battery only). Producing and using less fuel also creates less smog. Learn more at fuel-economy.gov.

fuel-economy.gov
Calculate personalized estimates and compare vehicles.

PARTS CONTENT INFORMATION

FOR VEHICLES IN THIS CARLINE U.S./Canadian Parts Content: **15%**

Major Sources of Foreign Parts Content:
JAPAN 55%
MEXICO 15%

NOTE: Parts content does not include final assembly, distribution or other non-parts costs.

Two or more assembly plants produce the vehicles in this carline. The vehicles assembled at the plant where this vehicle was assembled have a U.S./Canadian parts content of 15%.

GOVERNMENT 5-STAR SAFETY RATING

Overall Vehicle Score ★★★★★

Based on the combined ratings of frontal, side and rollover. Should ONLY be compared to other vehicles of similar size and weight.

Frontal Crash Driver ★★★★★ Passenger ★★★★★

Based on the risk of injury in a frontal impact. Should ONLY be compared to other vehicles of similar size and weight.

Side Crash Front seat ★★★★★ Rear seat ★★★★★

Based on the risk of injury in a side impact.

Rollover ★★★★★

Based on the risk of rollover in a single vehicle crash.

Star Ratings range from 1 to 5 stars (★★★★★) with 5 being the highest. Source: National Highway Traffic Safety Administration (NHTSA) www.safercar.gov or 1-888-327-4236

This vehicle is equipped with a front bumper of a type that has been tested at an impact speed of 6 miles per hour, and a rear bumper of a type that has been tested at an impact speed of 5 miles per hour, resulting in no damage to the vehicle's body and safety systems and minimal damage to the bumper and attachment hardware. "Minimal damage to the bumper" means minor cosmetic damage that can be repaired with the use of common repair materials and without replacing any parts. The stronger the bumper, the less likely the vehicle will require repair after a low-speed collision. This vehicle exceeds the current federal bumper standard of 2.5 miles per hour.

FOR THIS VEHICLE

Final Assembly Point:
YORII-MACHI, SAITAMA JAPAN

Country of Origin: Engine: **JAPAN**

Transmission: **JAPAN**

MULLER HONDA
550 SKOKIE VALLEY ROAD
HIGHLAND PARK, IL 60035

PORT OF ENTRY: PORTLAND
DELIVERY POINT: SCHAUMBURG
BI/PF: 814-73882
ROWS/PAF: TRANS METHOD: N50 ELWOOD

ORIG. DLR: 206855
REF. NO: 40653
HN CODE: HN-4342
EMISSION: 50 STATE
CONTROL NO: 331363
DEALER: 206855

VIN: JHM GK5H5XG004174

No. 021 Monroney Label Photograph

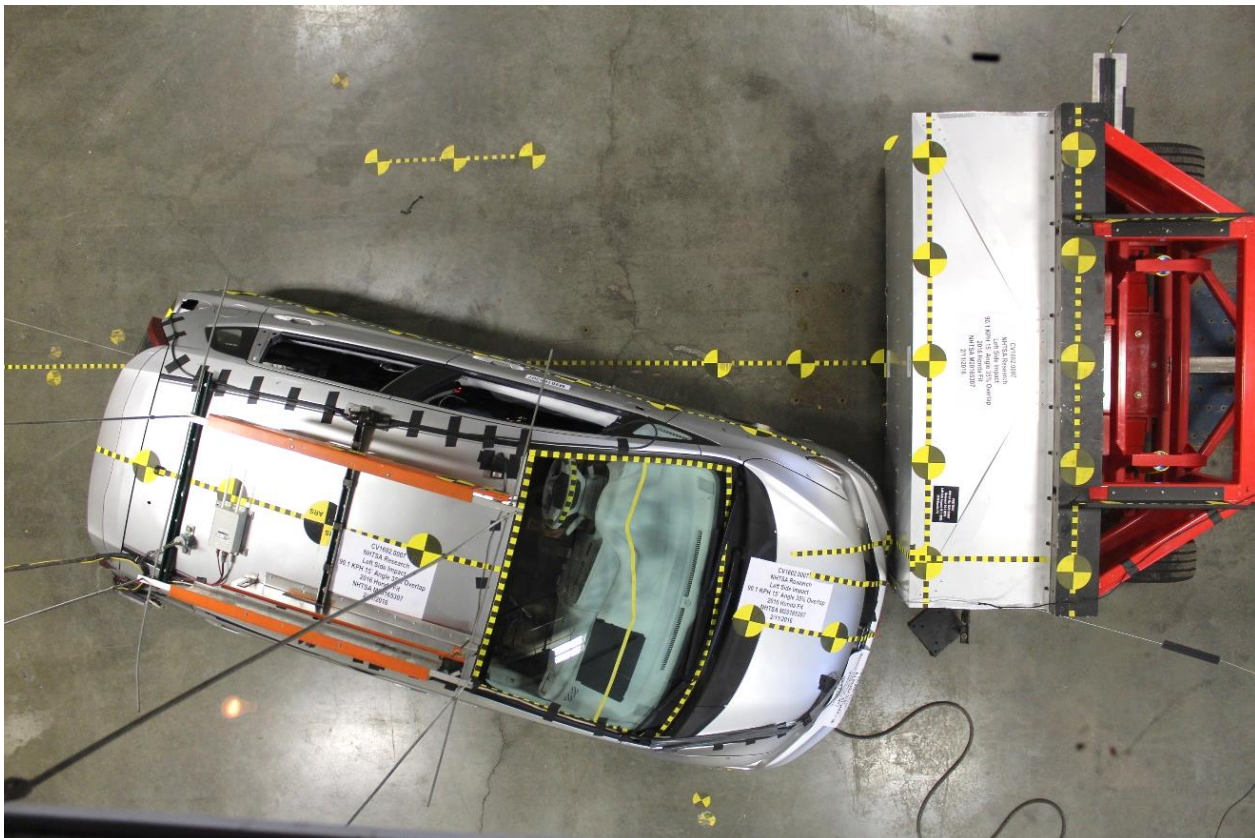

No. 022 Pre-Test Overhead View of OMDB against target vehicle at ideal Impact Point



No. 023 Pre-Test Left Side View of OMDB against target vehicle at ideal Impact Point



No. 024 Pre-Test Right Side View of OMDB against target vehicle at ideal Impact Point

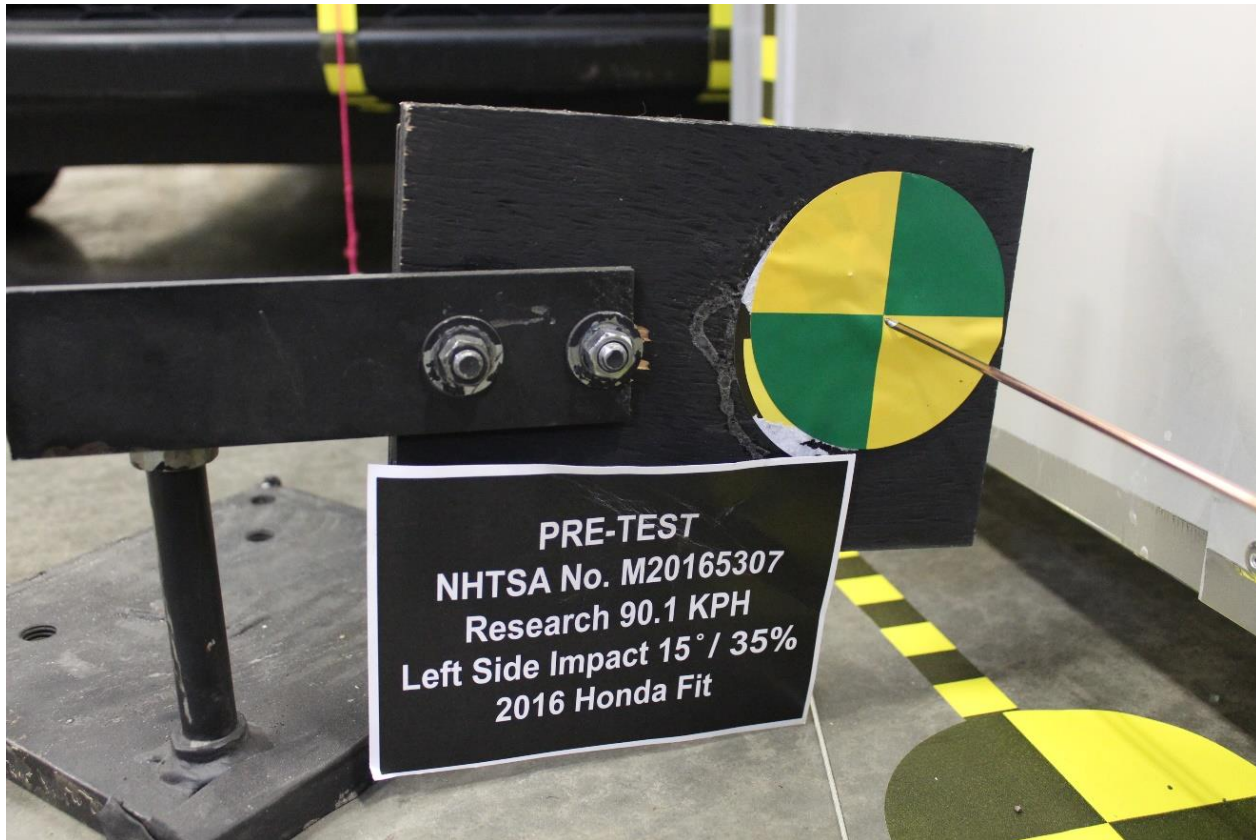

No. 025 Pre-Test Close-up View of Impact Point

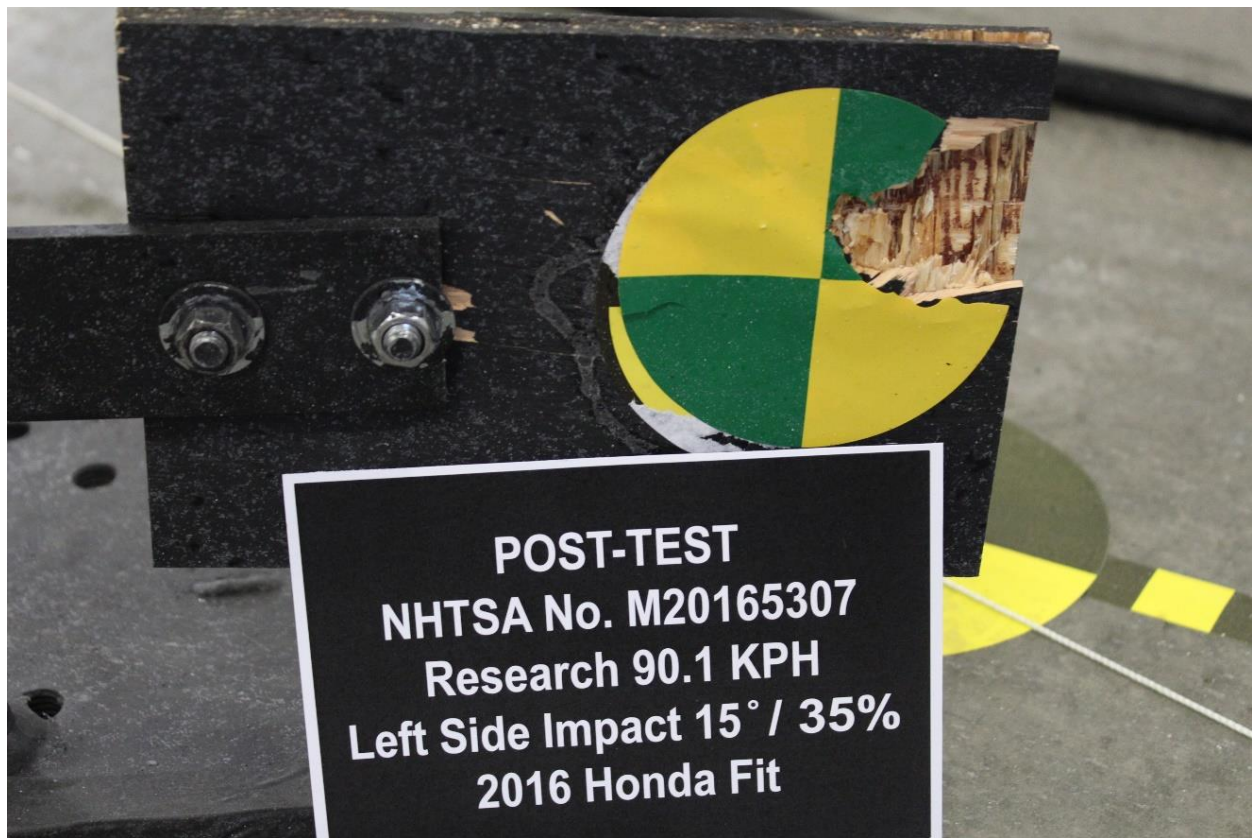

No. 026 Post-Test Close-up View of Impact Point

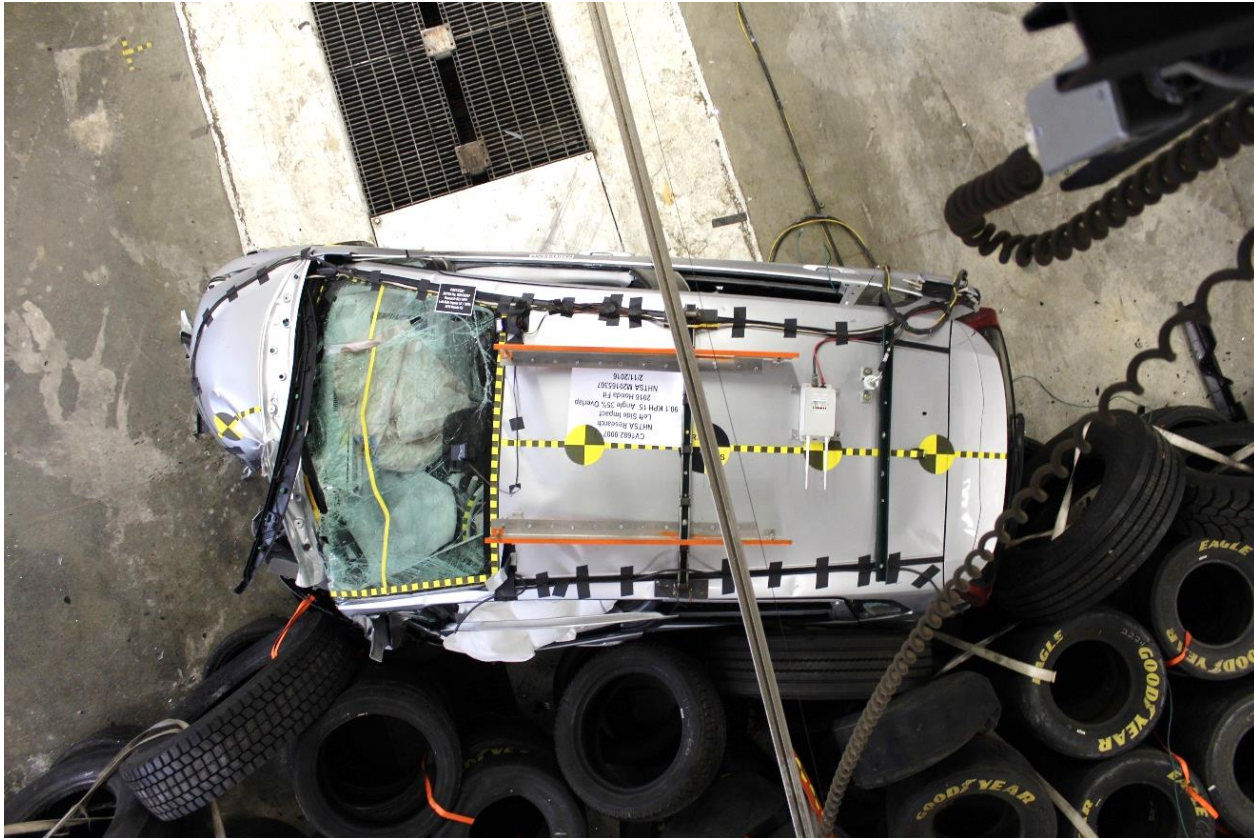

No. 027 Post-Test Vehicle Overhead View



No. 028 Pre-Test Close-up View of Driver Door Latch

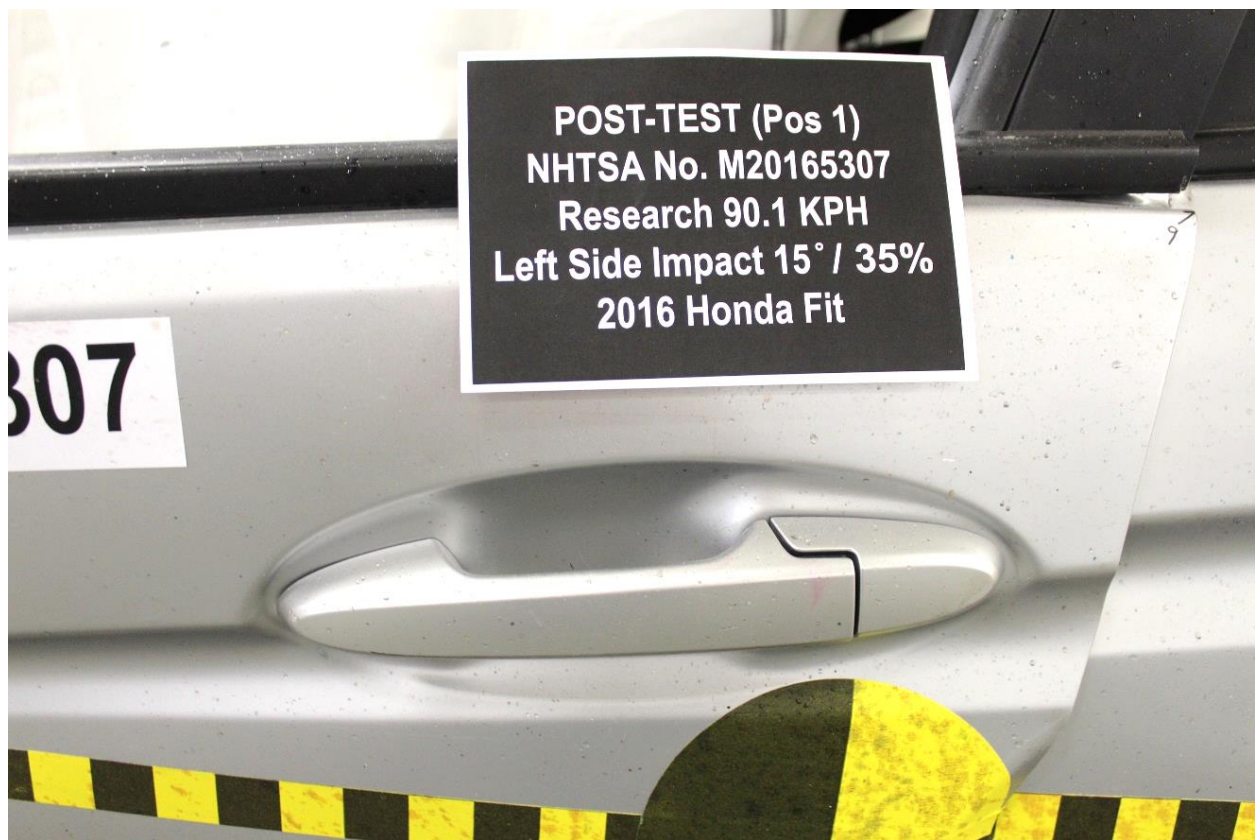

No. 029 Post-Test Close-up View of Driver Door Latch

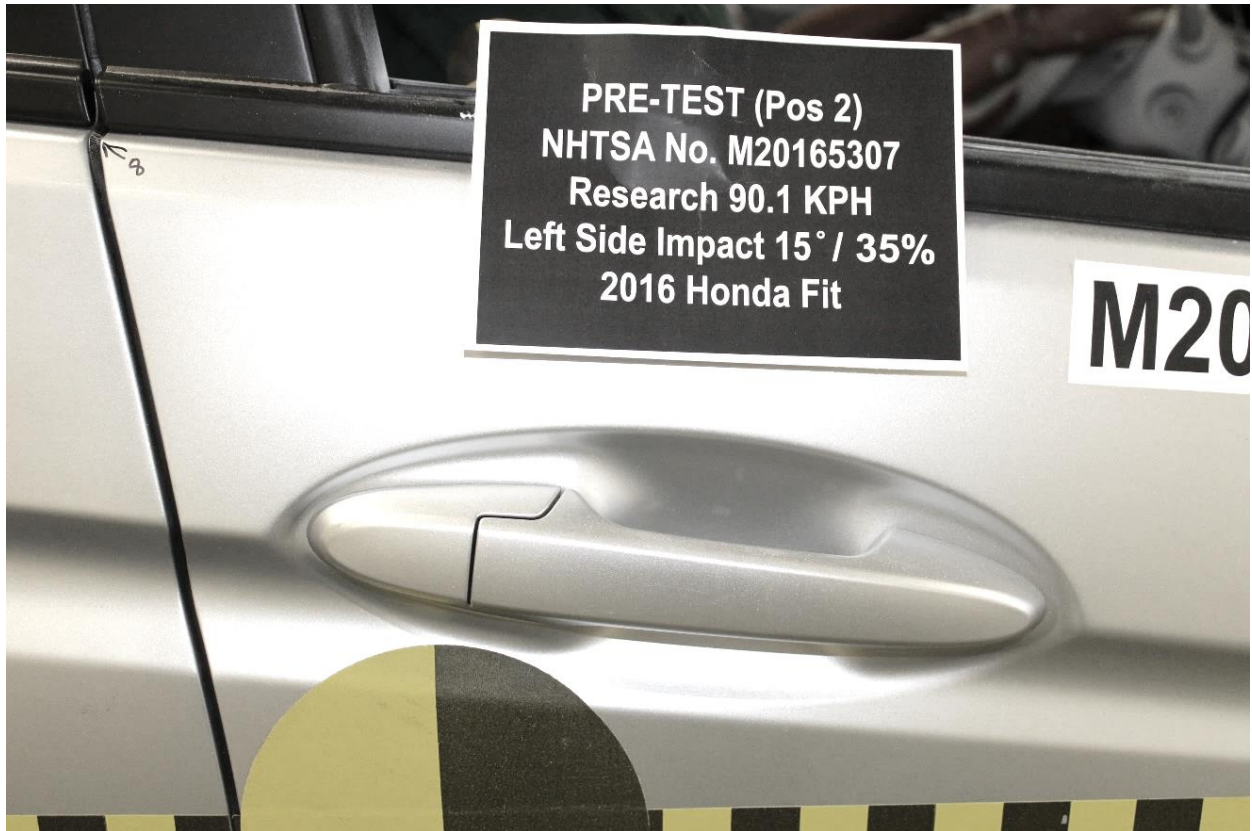

No. 030 Pre-Test Close-up View of Passenger Door Latch



No. 031 Post-Test Close-up View of Passenger Door Latch



No. 032 Pre-Test Windshield View



No. 033 Post-Test Windshield View



No. 034 Pre-Test View of Driver Inner Door Panel



No. 035 Post-Test View of Driver Inner Door Panel



No. 036 Pre-Test View of Passenger Inner Door Panel



No. 037 Post-Test View of Passenger Inner Door Panel

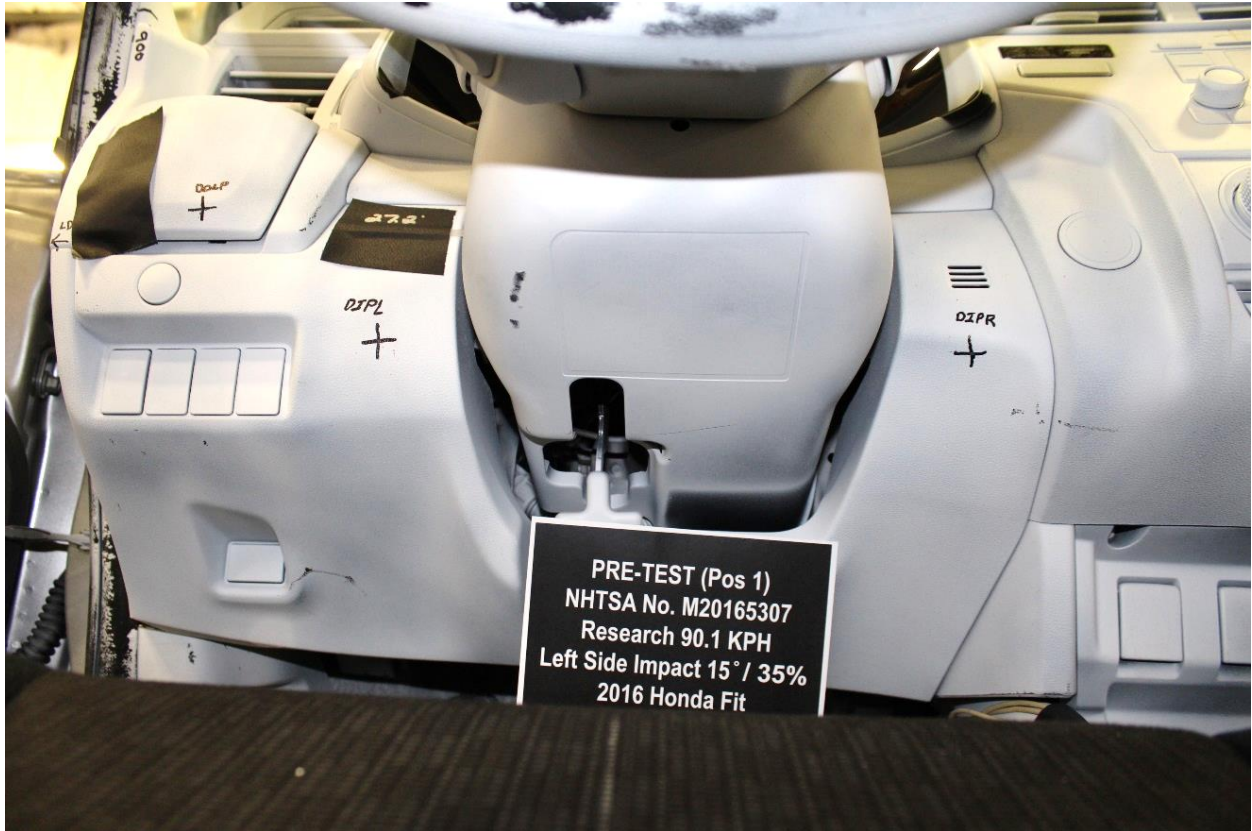

No. 038 Pre-Test Overall View of Driver Knee Bolsters

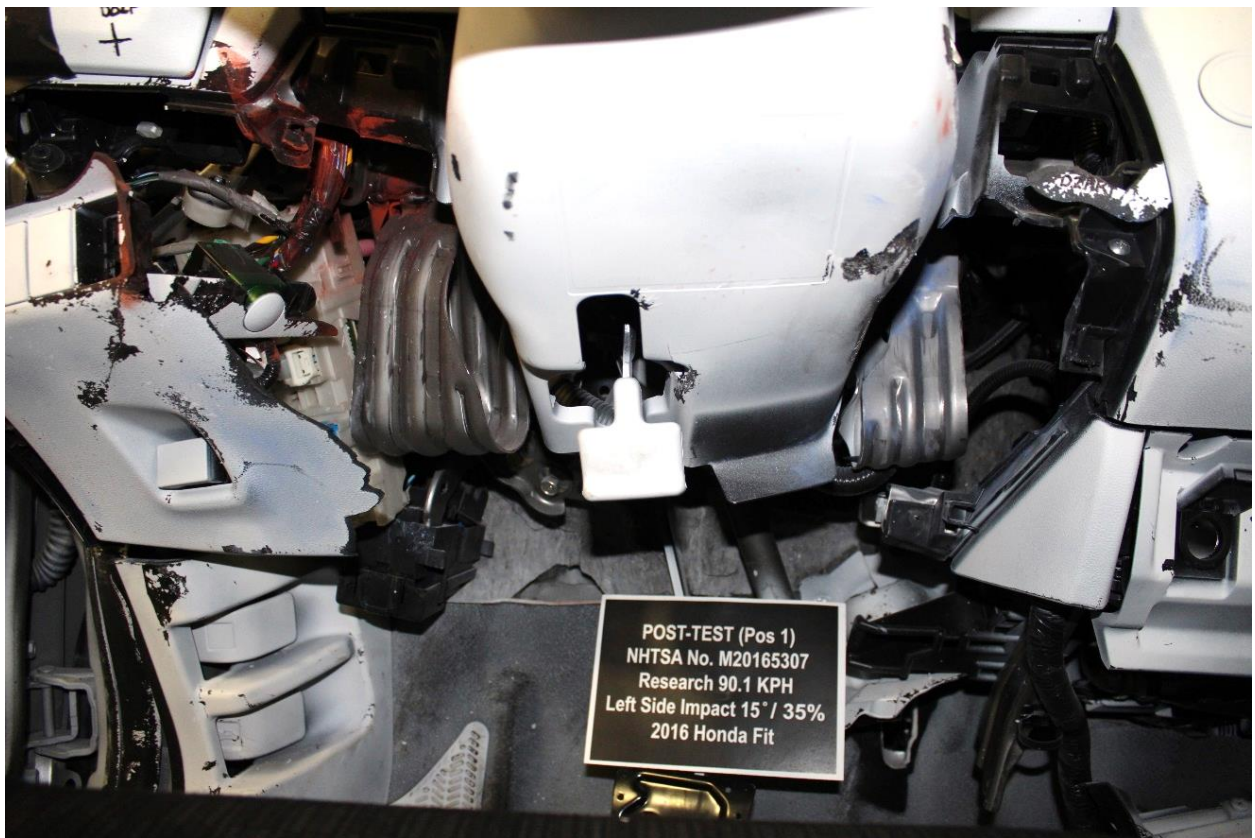

No. 039 Post-Test Overall View of Driver Knee Bolsters

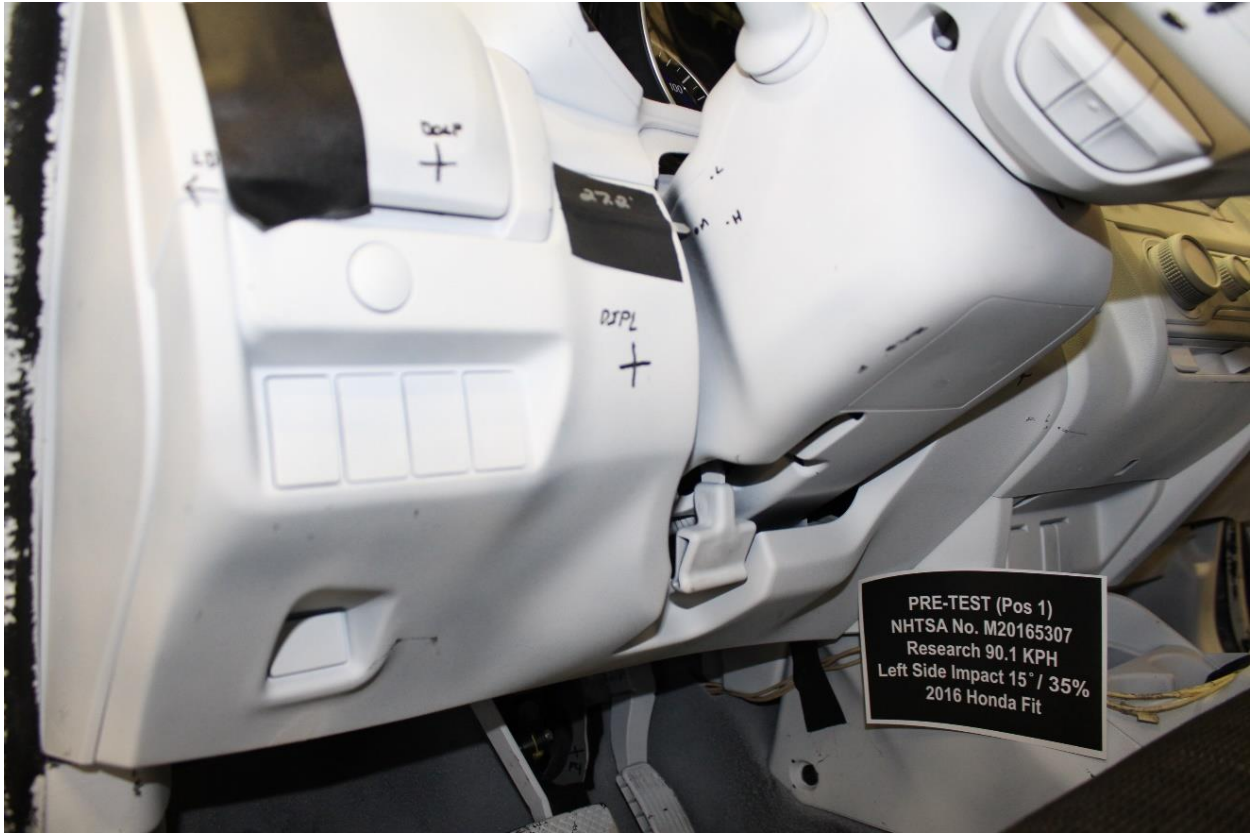

No. 040 Pre-Test Left Side View of Driver Knee Bolsters



No. 041 Post-Test Left Side View of Driver Knee Bolsters

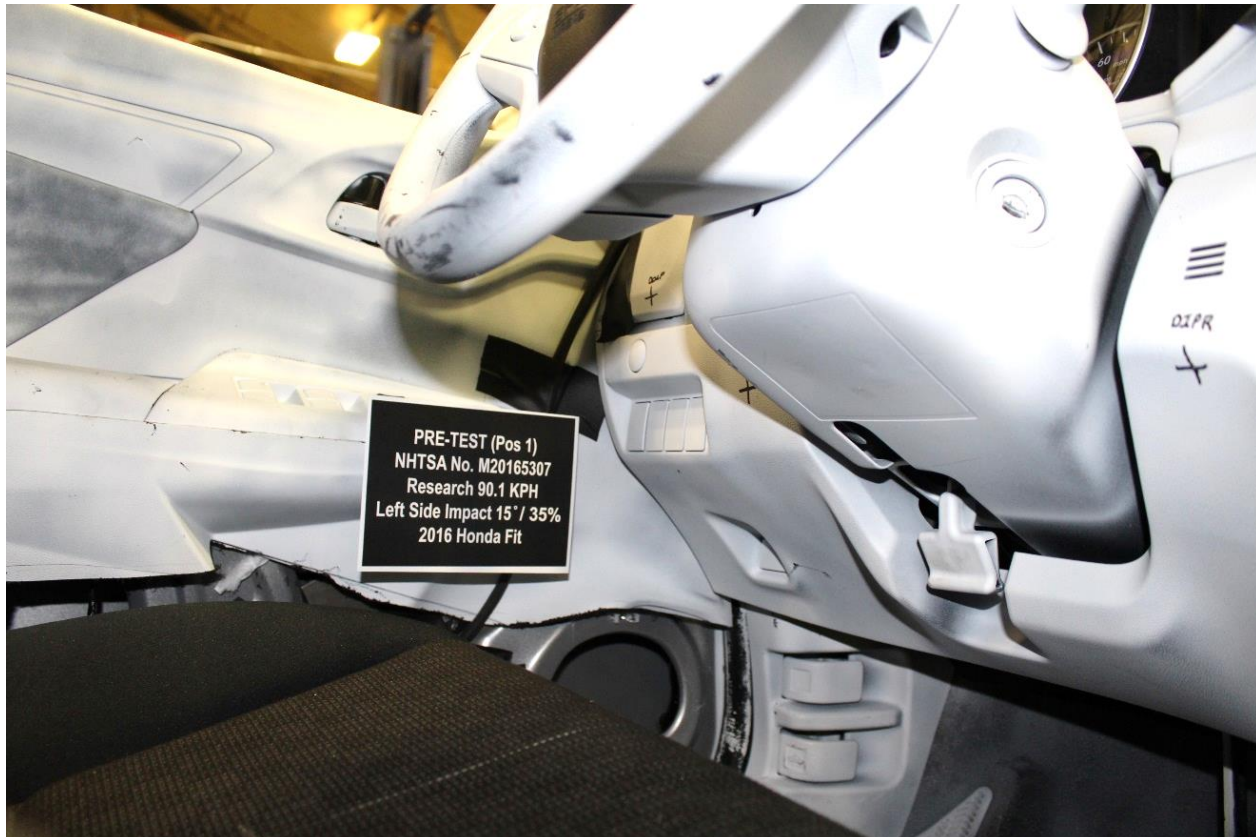

No. 042 Pre-Test Right Side View of Driver Knee Bolsters

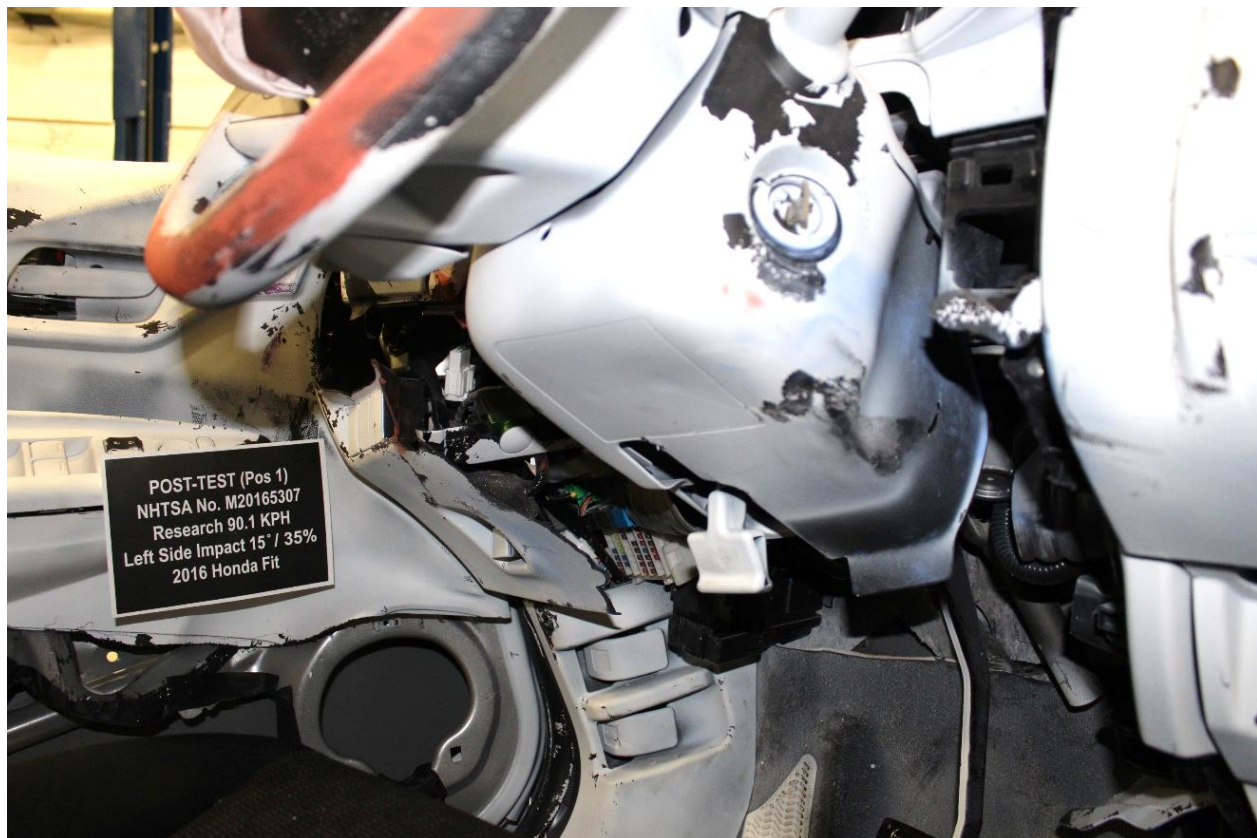

No. 043 Post-Test Right Side View of Driver Knee Bolsters

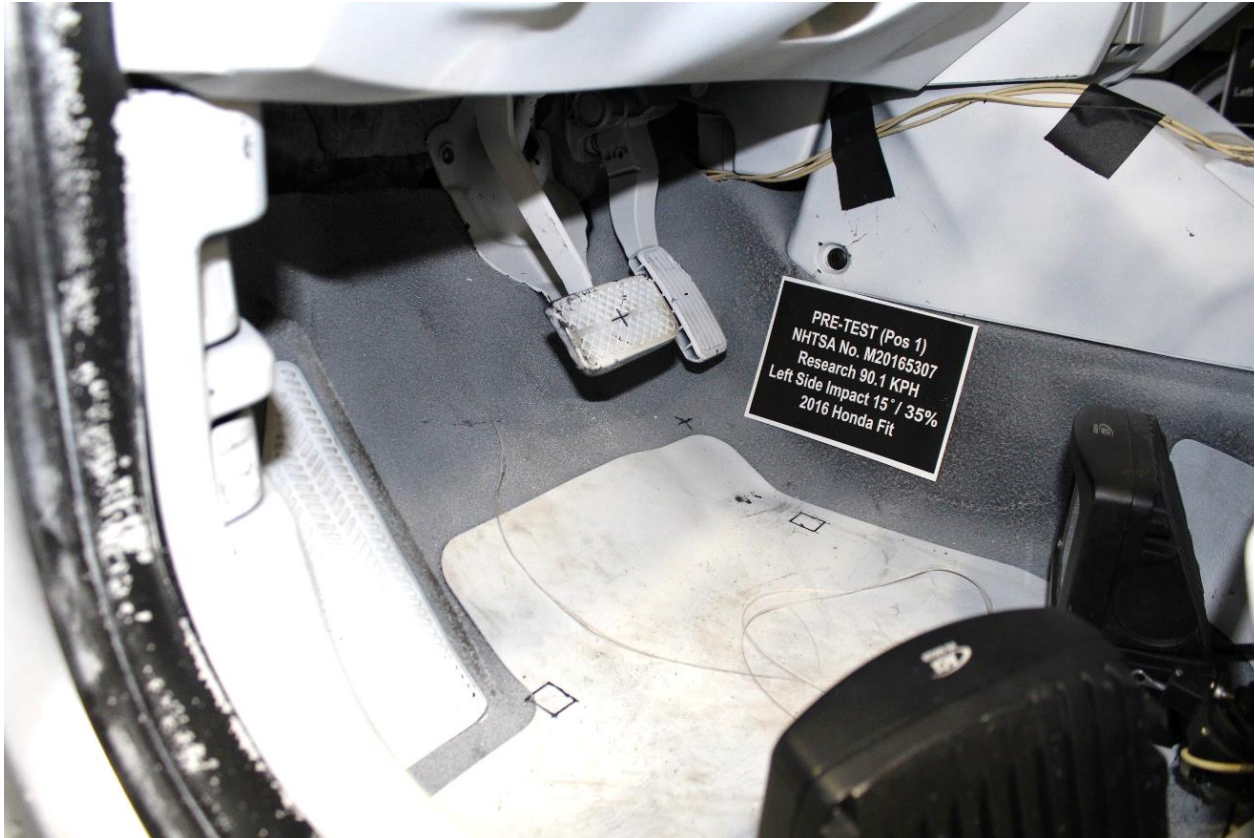

No. 044 Pre-Test View of Driver Floor pan at Left sill level, w/carpet

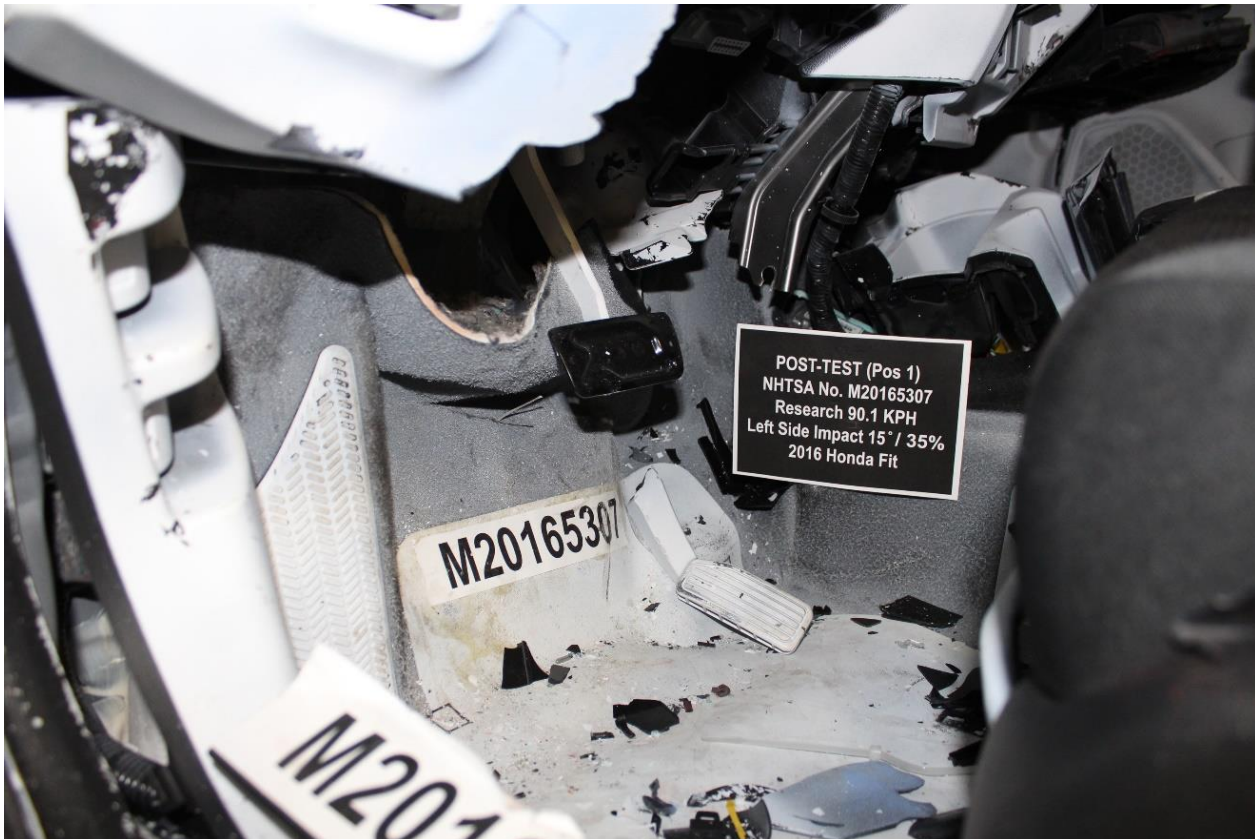

No. 045 Post-Test View of Driver Floor pan at Left sill level, w/carpet

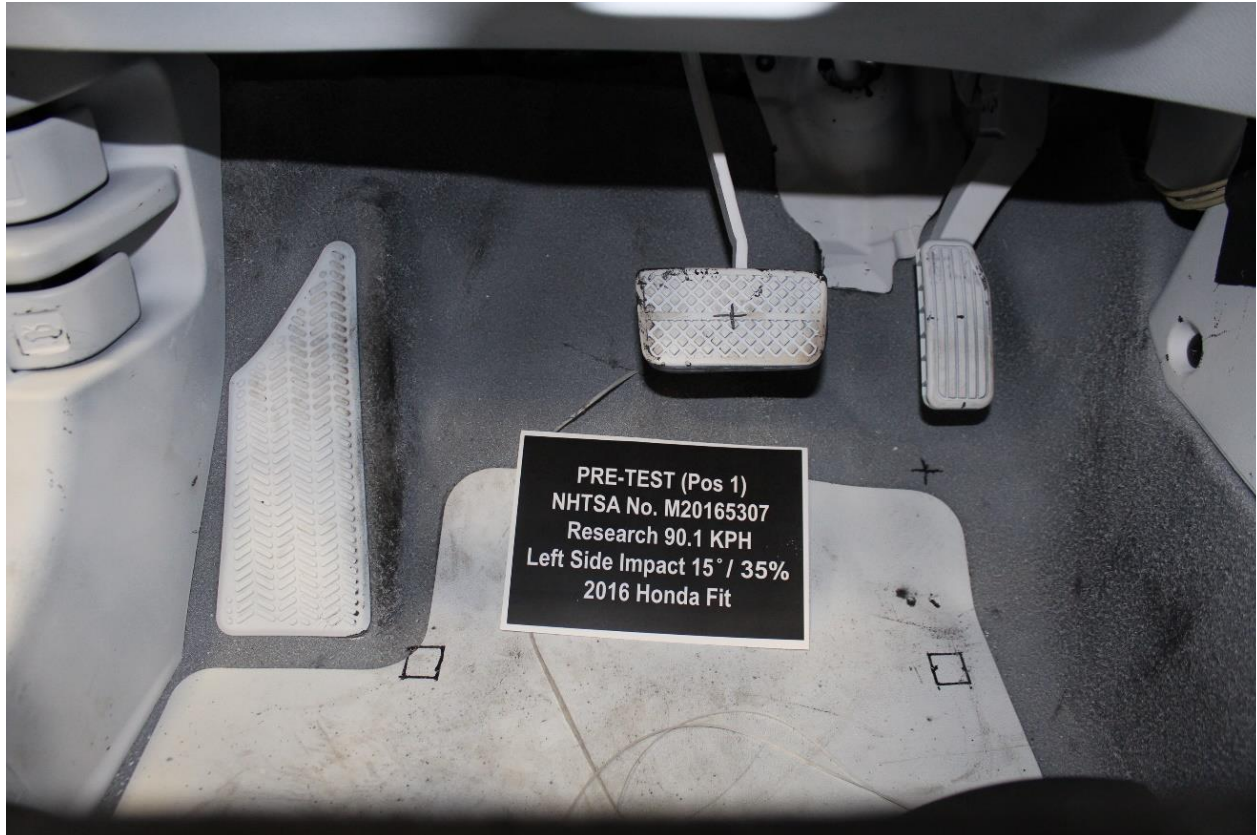

No. 046 Pre-Test View of Driver Floor pan at Mid seat level, w/carpet



No. 047 Post-Test view of Driver Floor pan at Mid seat level, w/carpet



No. 048 Pre-Test View of Driver Floor pan at Right Side



No. 049 Post-Test View of Driver Floor pan at Right Side



No. 050 Pre-Test Driver Front Windshield View



No. 051 Post-Test Driver Front Windshield View



No. 052 Pre-Test Left Side View of Driver and Interior



No. 053 Post-Test Left Side View of Driver and Interior



No. 054 Pre-Test Left Side Driver Window View



No. 055 Post-Test Left Side Driver Window View



No. 056 Pre-Test Right Side View of Driver and Interior



No. 057 Post-Test Right Side View of Driver and Interior



No. 058 Pre-Test View of Driver Door Clearance



No. 059 Post-Test View of Driver Door Clearance



No. 060 Pre-Test View of Parking Brake

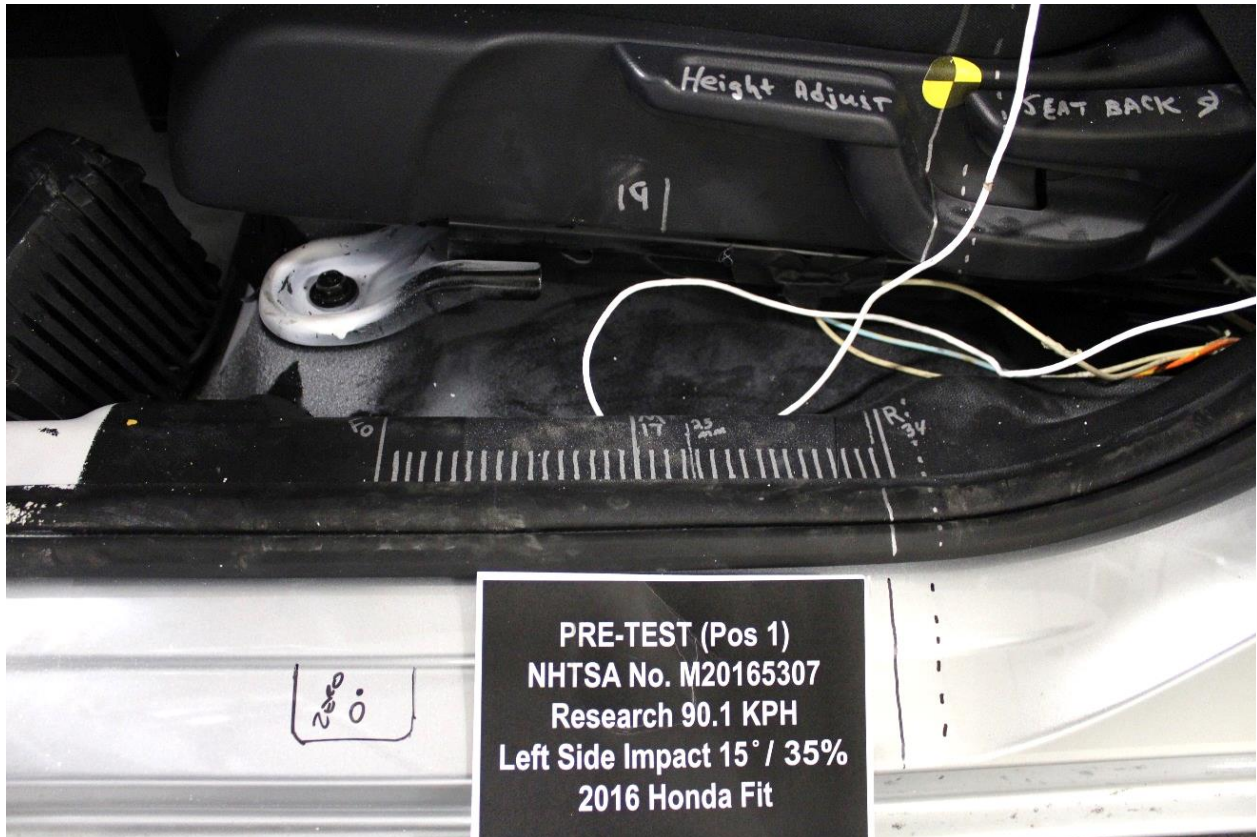

No. 061 Pre-Test Driver Seat Fore Aft Markings

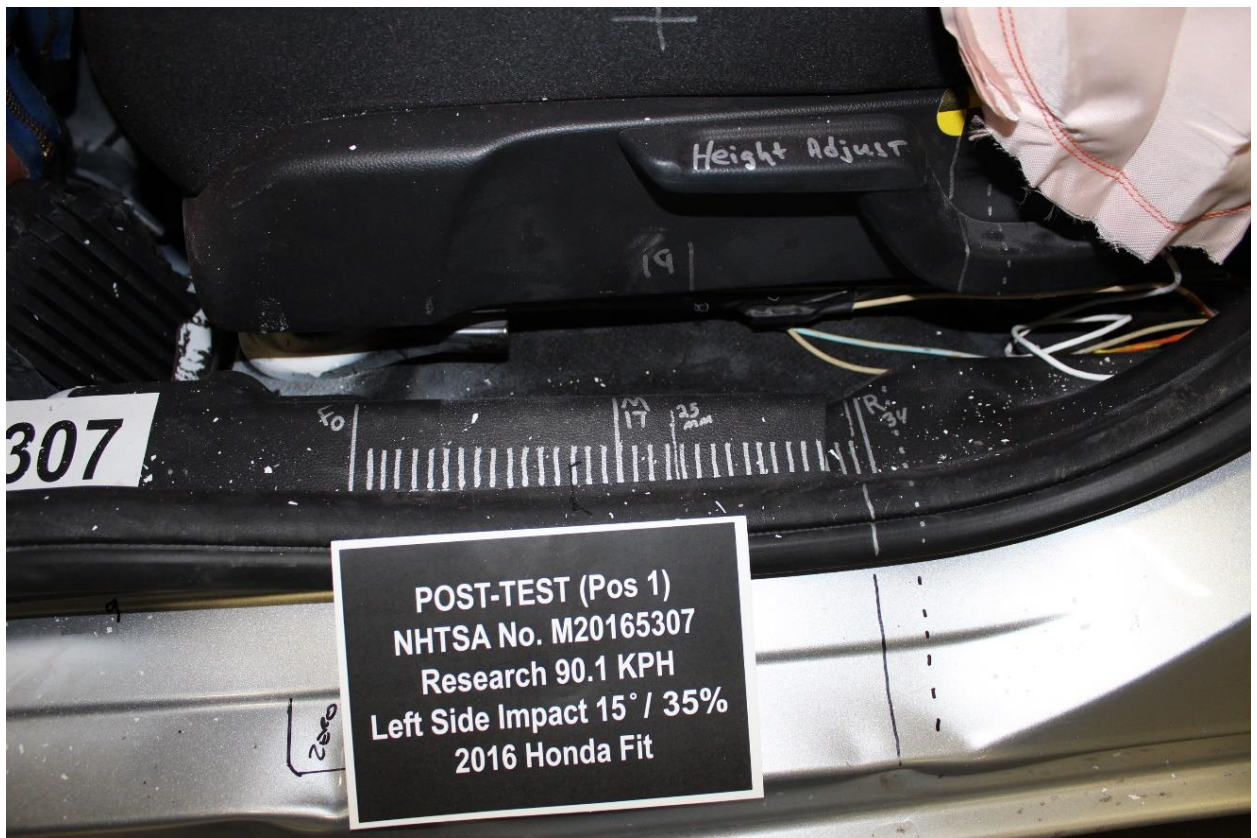

No. 062 Post-Test Driver Seat Fore Aft Markings



No. 063 Pre-Test Driver Seat Back Markings



No. 064 Pre-Test Overhead View of Driver Thighs on Seat



No. 065 Pre-Test Driver Adjustable D-Ring



No. 066 Post-Test Driver Adjustable D-Ring

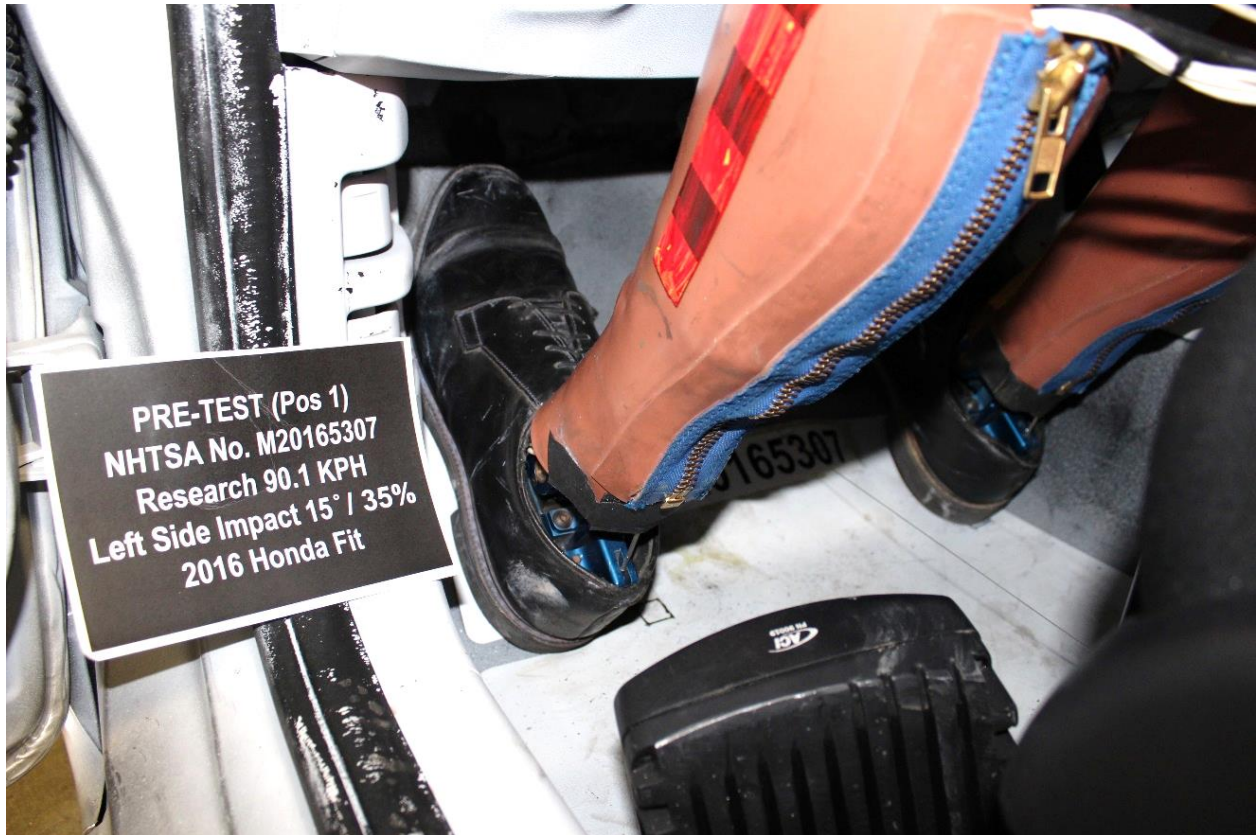

No. 067 Pre-Test Driver Feet

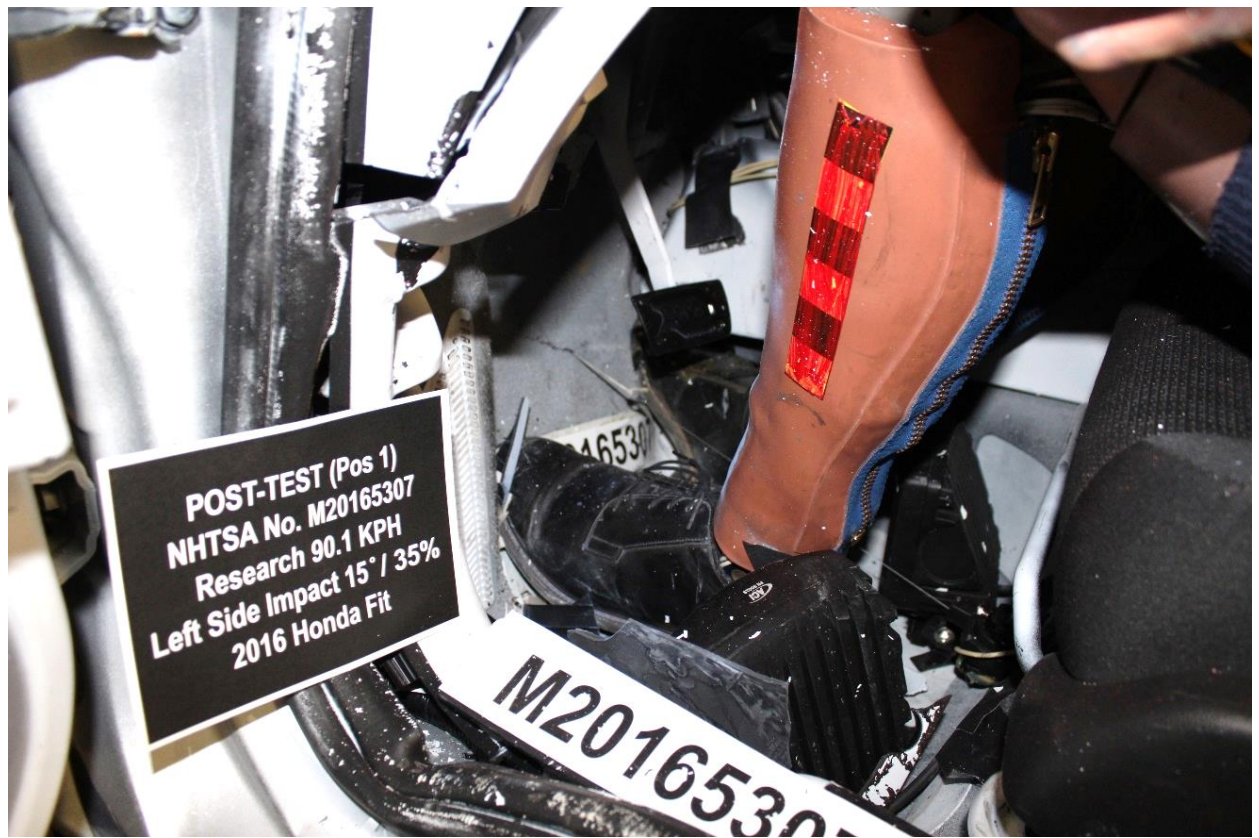

No. 068 Post-Test Driver Feet



No. 069 Pre-Test View of Driver Right Knee and Bolster



No. 070 Post-Test View of Driver Right Knee and Bolster

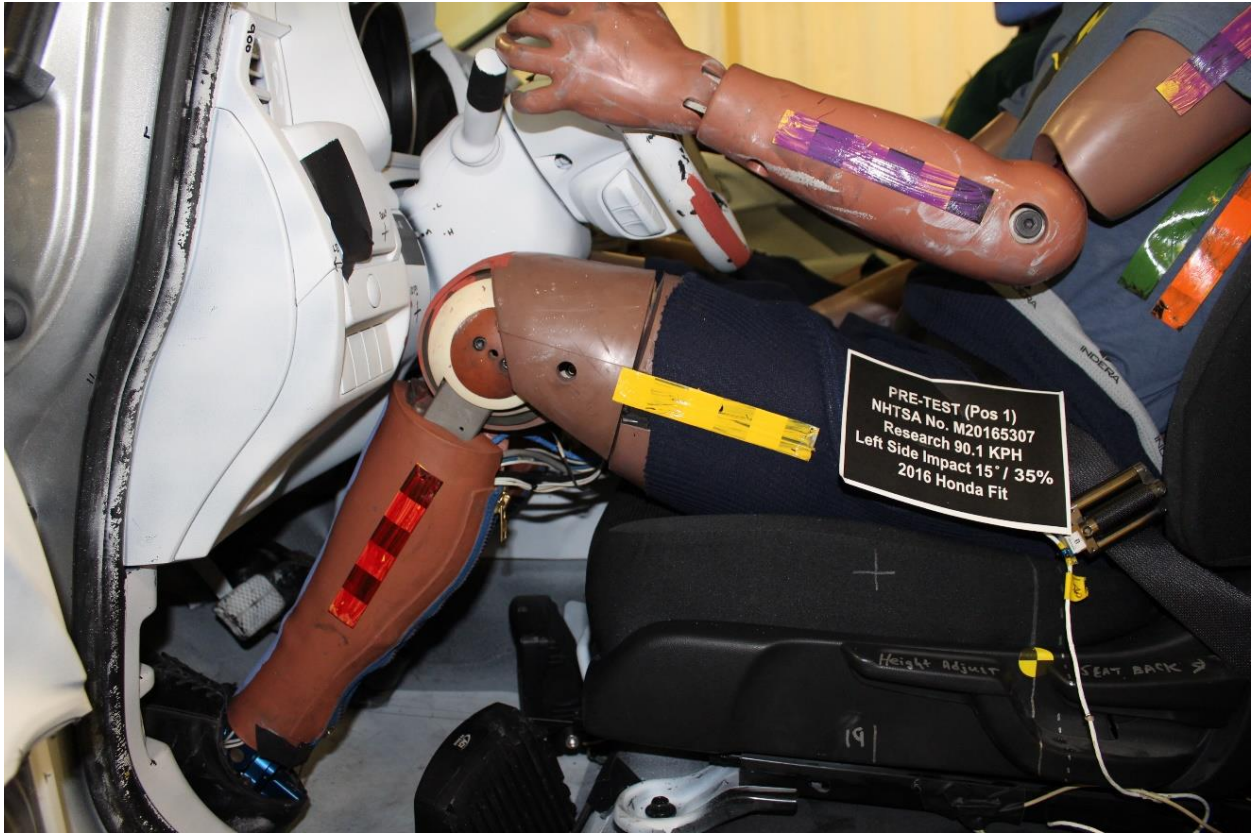

No. 071 Pre-Test View of Driver Left Knee and Bolster

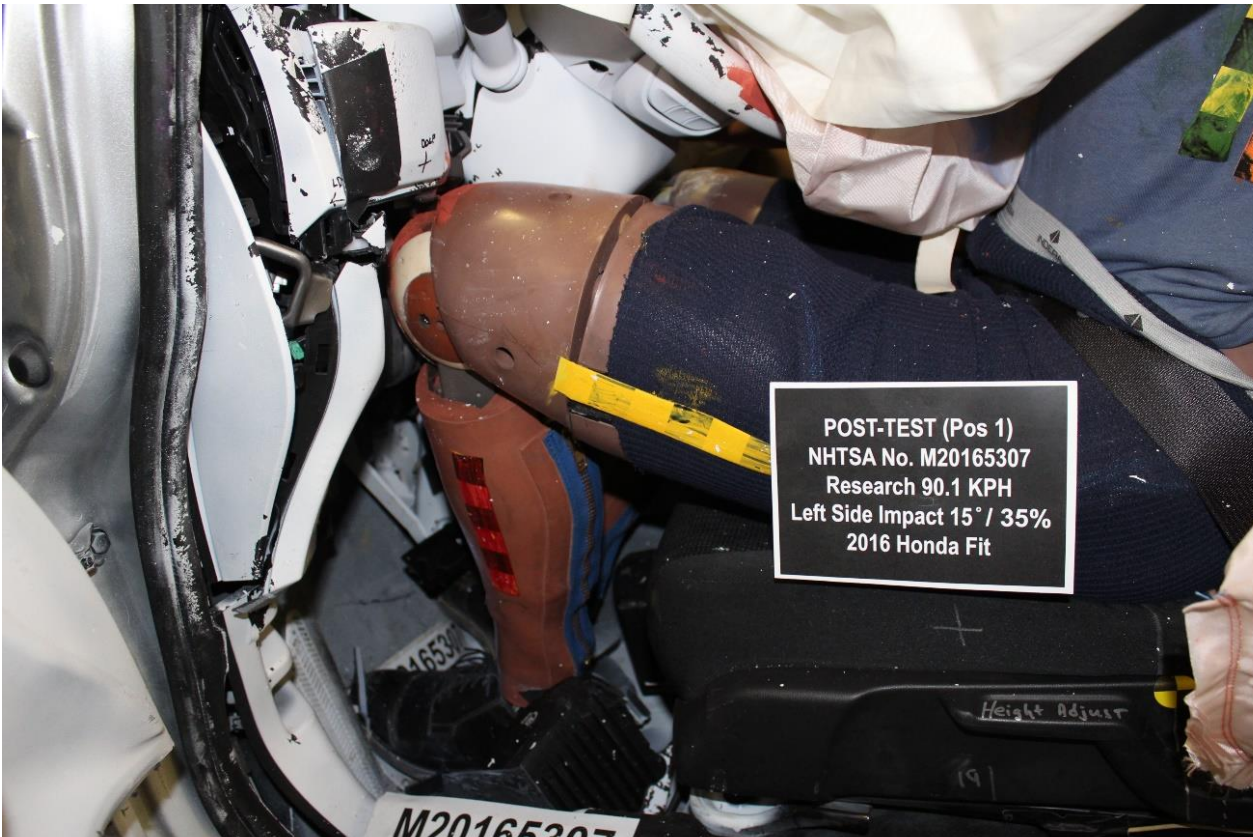

No. 072 Post-Test View of Driver Left Knee and Bolster

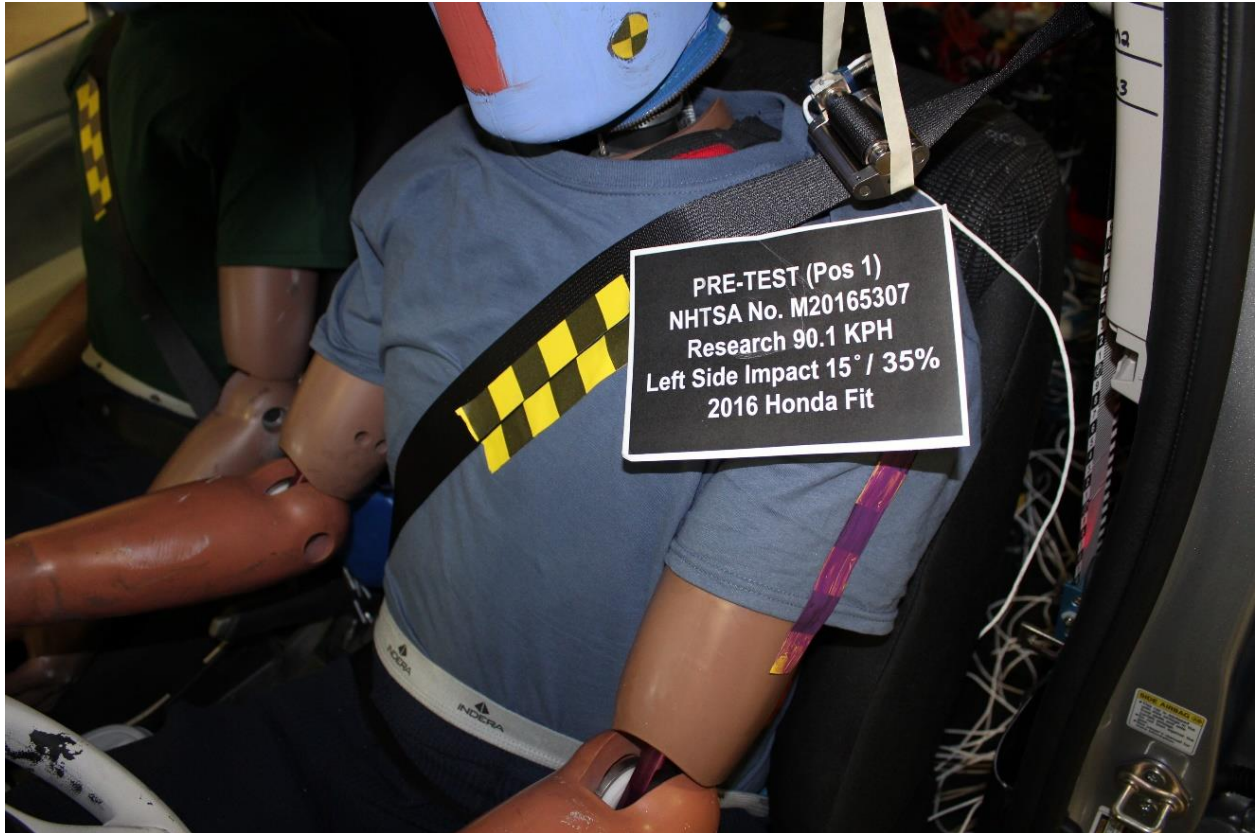

No. 073 Pre-Test View of Driver Abdomen



No. 074 Post-Test View of Driver Abdomen



No. 075 Pre-Test Left Side View of Steering Wheel set position



No. 076 Post-Test Left Side View of Steering Wheel set position



No. 077 Post-Test View of Driver Head Contact with Front Airbag



No. 078 Post-Test View of Driver Head Contact with Curtain Airbag



No. 079 Post-Test View of Driver Head Contact with Vehicle Interior – A

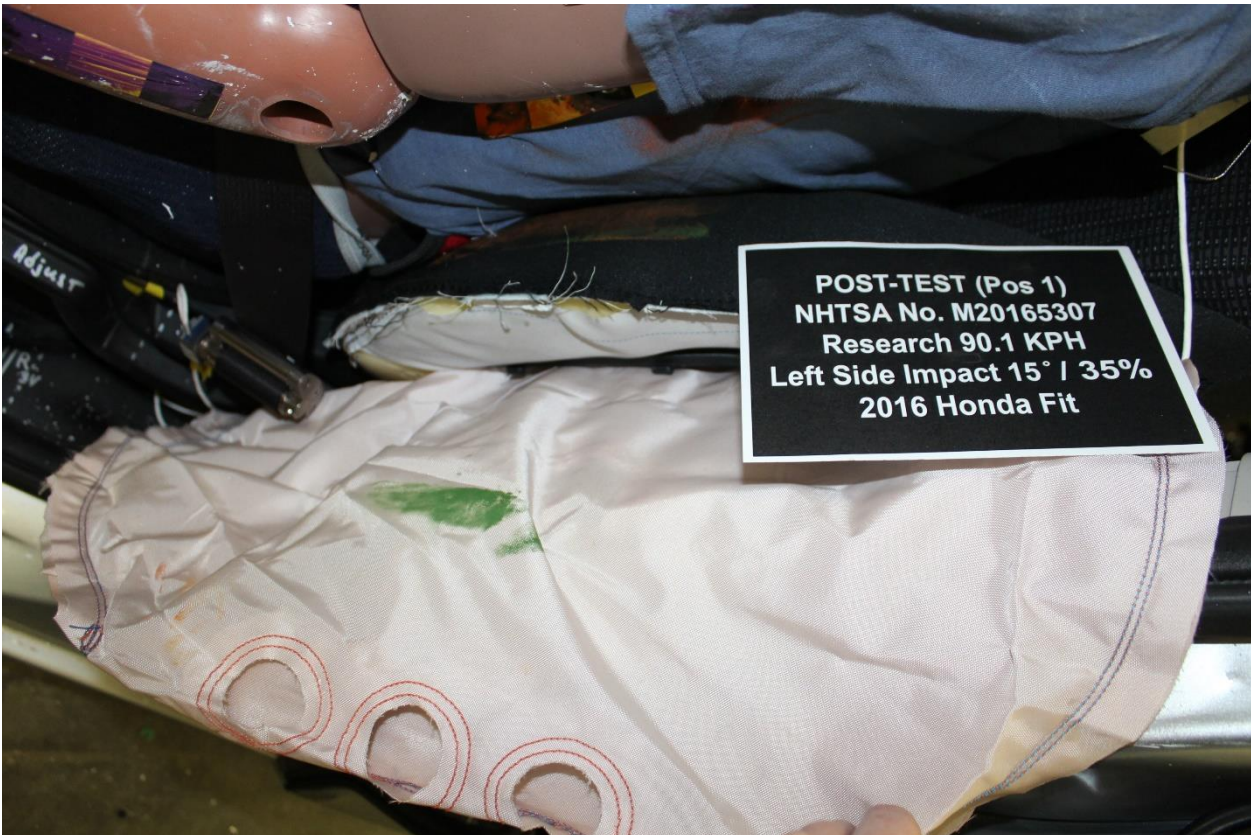

No. 080: Post-Test View of Driver Body Contact with Vehicle Interior - B

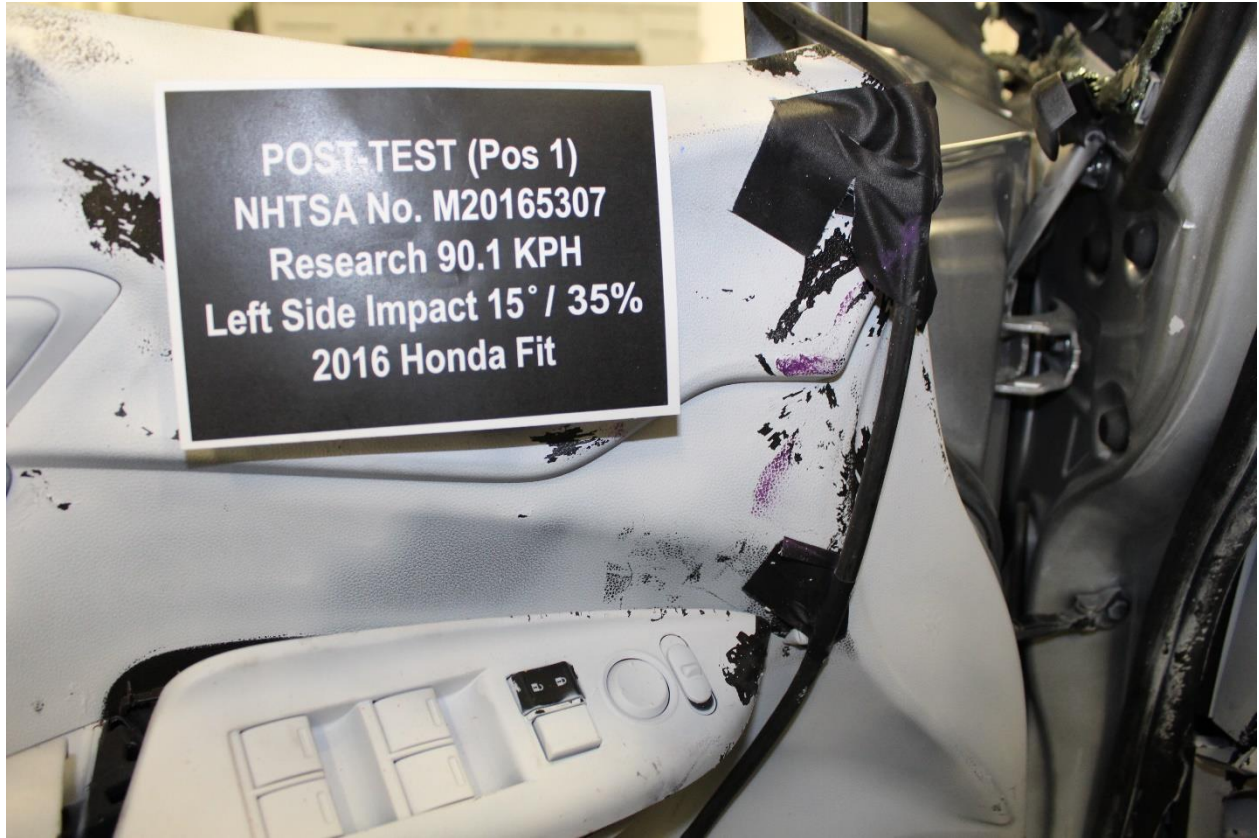

No. 081: Post-Test View of Driver Body Contact with Vehicle Interior - C

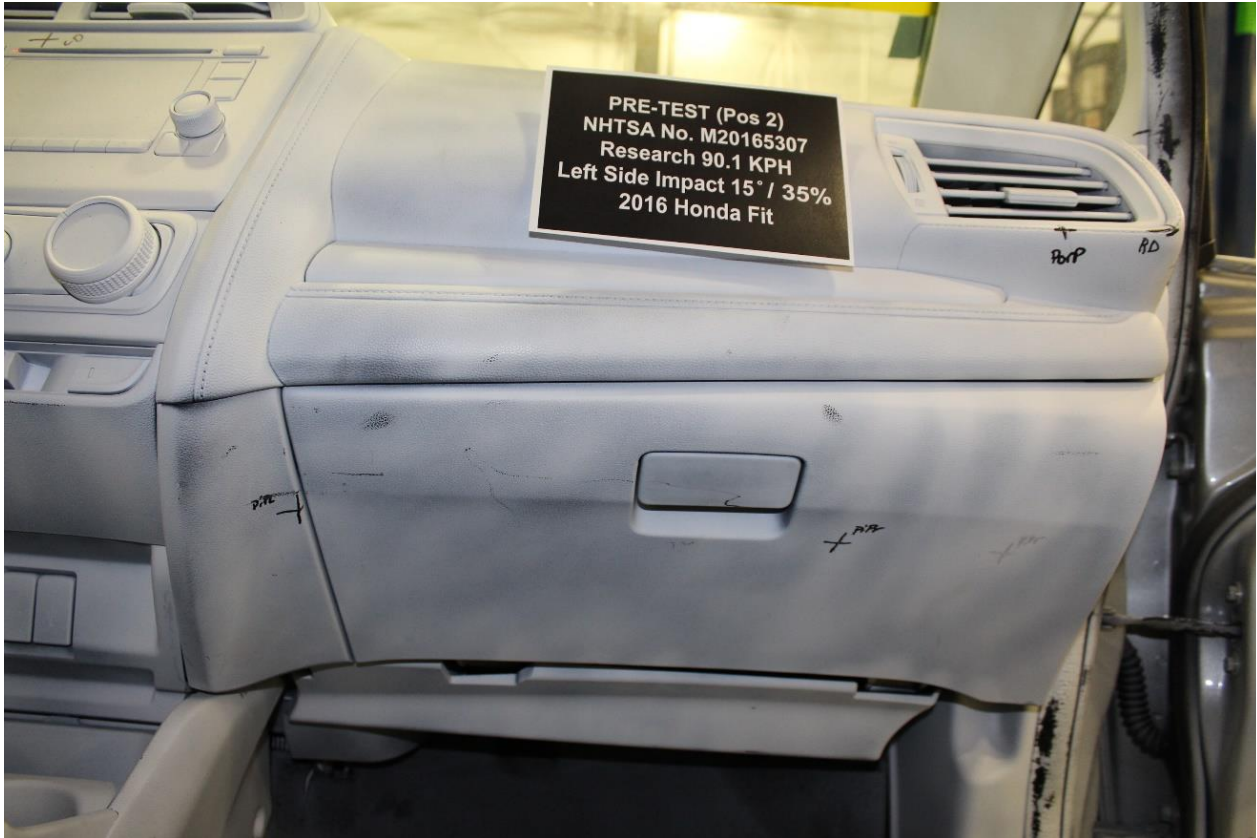

No. 082: Pre-Test Overall View of Passenger Knee Bolsters



No. 083: Post-Test Overall View of Passenger Knee Bolsters



No. 084: Pre-Test Left Side View of Passenger Knee Bolsters



No. 085: Post-Test Left Side View of Passenger Knee Bolsters



No. 086: Pre-Test Right Side View of Passenger Knee Bolsters



No. 087: Post-Test Right Side View of Passenger Knee Bolsters



No. 088: Pre-Test View of Passenger Floor pan at Right sill level, w/carpet



No. 089: Post-Test View of Passenger Floor pan at Right sill level, w/carpet

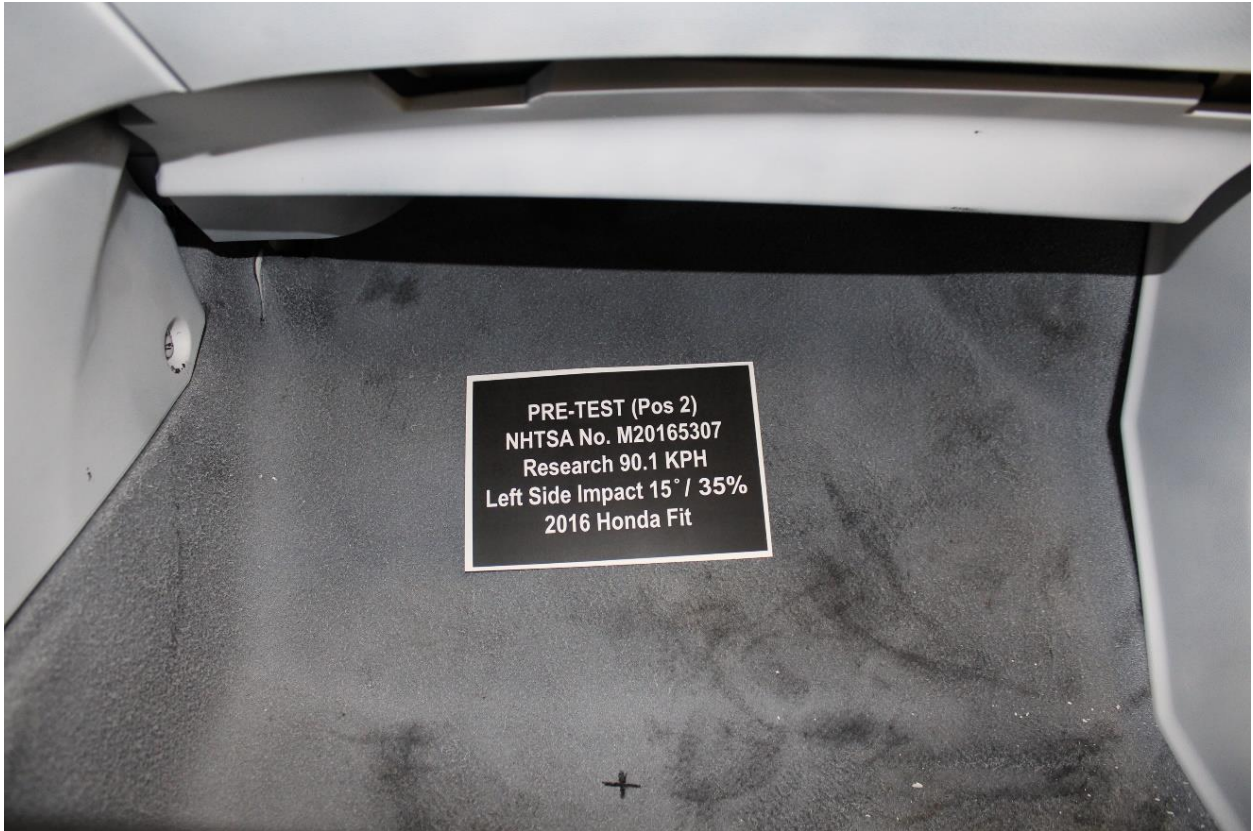

No. 090: Pre-Test View of Passenger Floor pan at Mid seat level, w/carpet



No. 091: Post-Test view of Passenger Floor pan at Mid seat level, w/carpet



No. 092: Pre-Test View of Passenger Floor pan at Left view



No. 093: Post-Test View of Passenger Floor pan at Left View



No. 094: Pre-Test Passenger Front Close-up View, Windshield



No. 095: Post-Test Passenger Front Close-up View, Windshield



No. 096: Pre-Test Left Side Passenger and Interior View



No. 097: Post-Test Left Side Passenger and Interior View



No. 98: Pre-Test Right Side Passenger Window View



No. 99: Post-Test Right Side Passenger Window View



No. 100: Pre-Test Right Side Passenger and Interior View



No. 101: Post-Test Right Side Passenger and Interior View



No. 102: Pre-Test View of Passenger Door Clearance



No. 103: Post-Test View of Passenger Door Clearance



No. 104: Pre-Test Passenger Seat Fore-Aft Markings

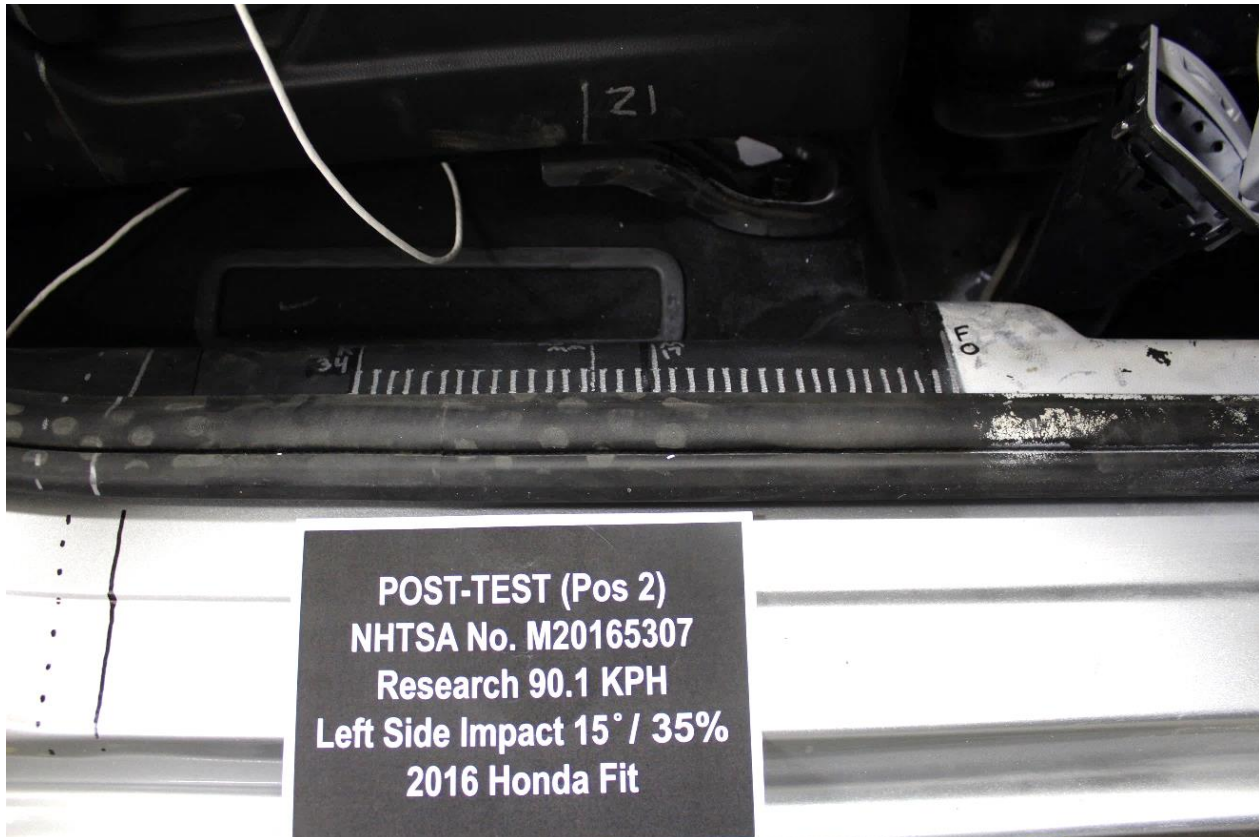

No. 105: Post-Test Passenger Seat Fore-Aft Markings

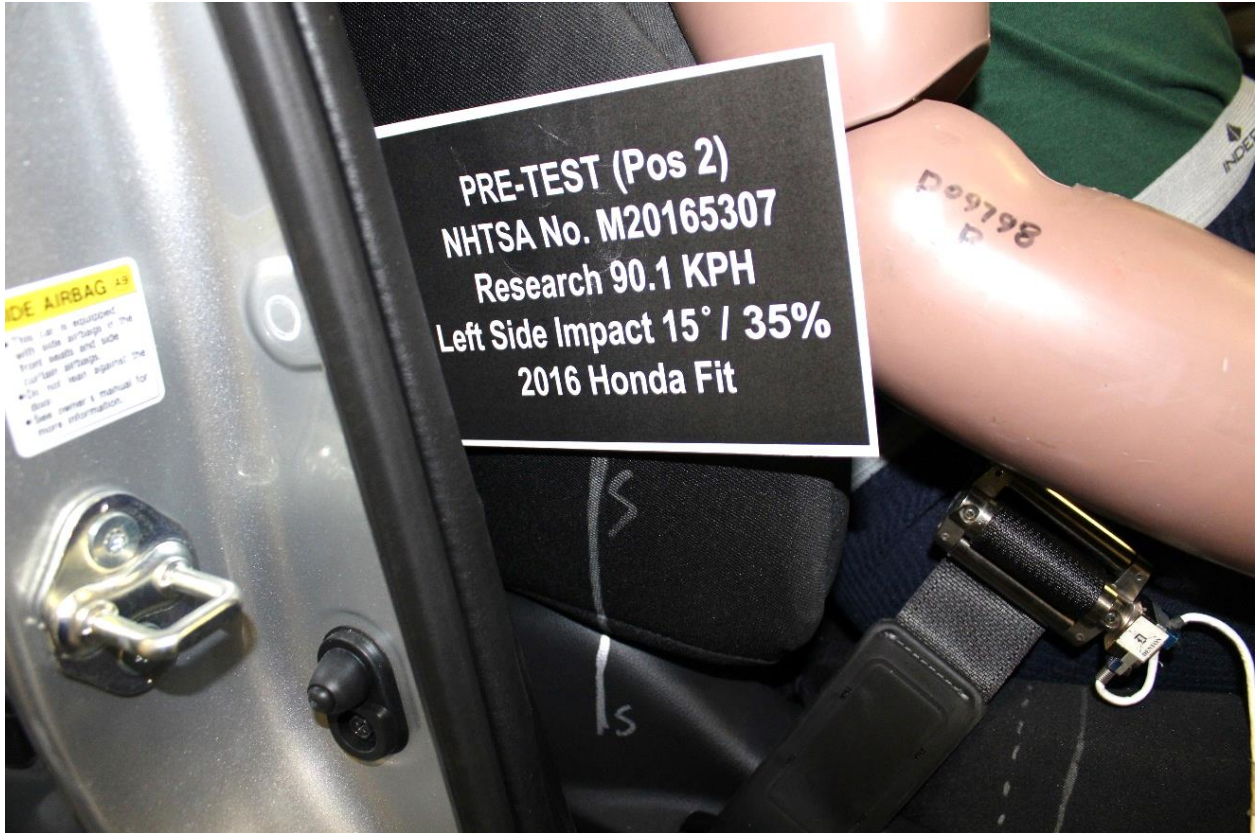

No. 106: Pre-Test Passenger Seat Back Markings



No. 107: Pre-Test Overhead View of Passenger Thighs on seat

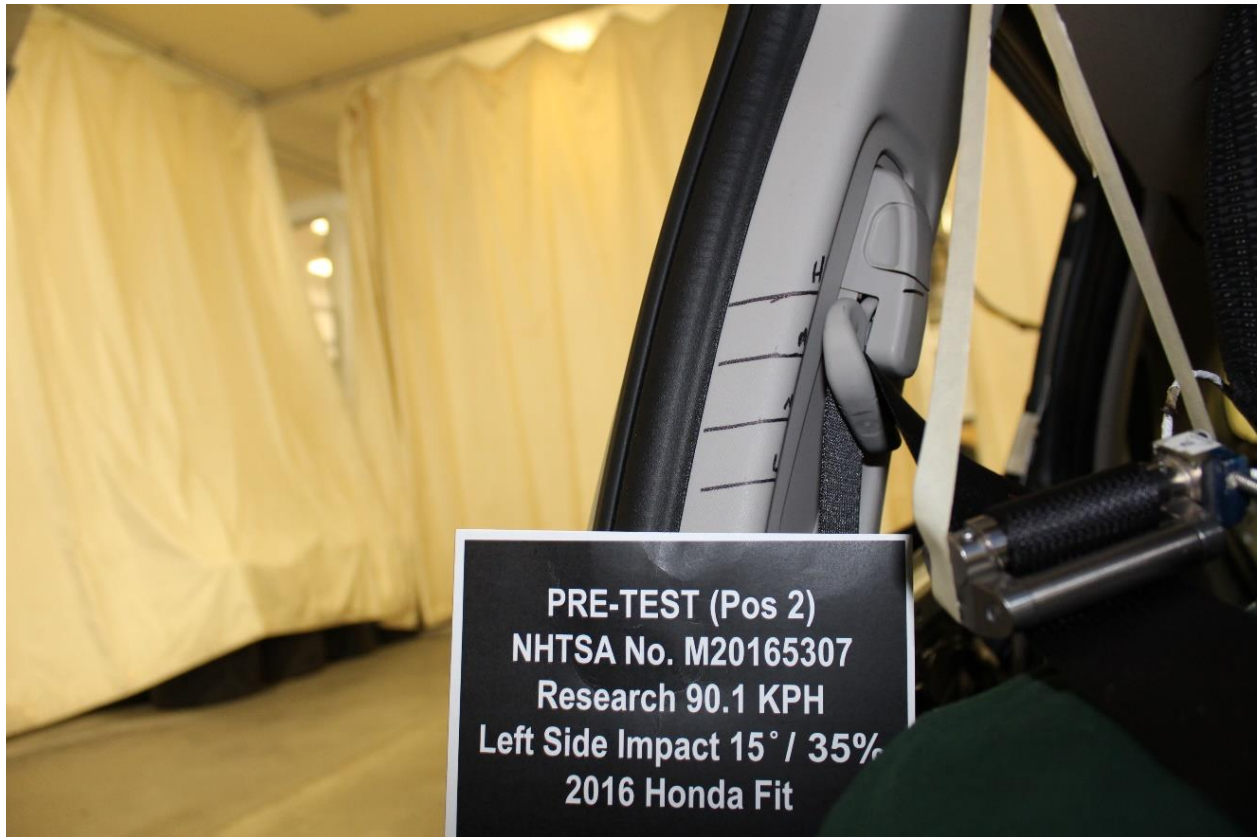

PRE-TEST (Pos 2)
NHTSA No. M20165307
Research 90.1 KPH
Left Side Impact 15° / 35%
2016 Honda Fit

No. 108: Pre-Test Passenger Adjustable D-ring



POST-TEST (Pos 2)
NHTSA No. M20165307
Research 90.1 KPH
Left Side Impact 15° / 35%
2016 Honda Fit

No. 109: Post-Test Passenger Adjustable D-ring



No. 110: Pre-Test View of Passenger Feet



No. 111: Post-Test View of Passenger Feet



No. 112: Pre-Test View of Passenger Right Knee and Bolster

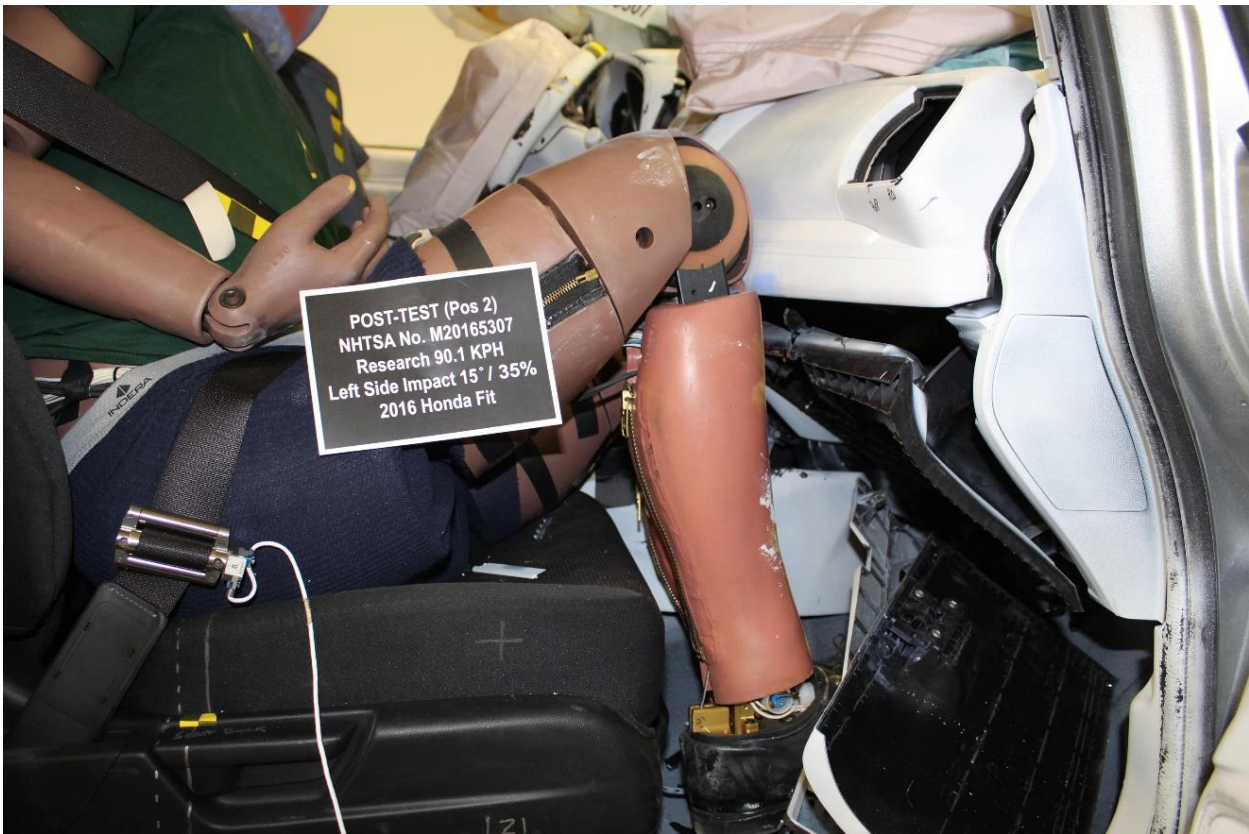

No. 113: Post-Test View of Passenger Right Knee and Bolster

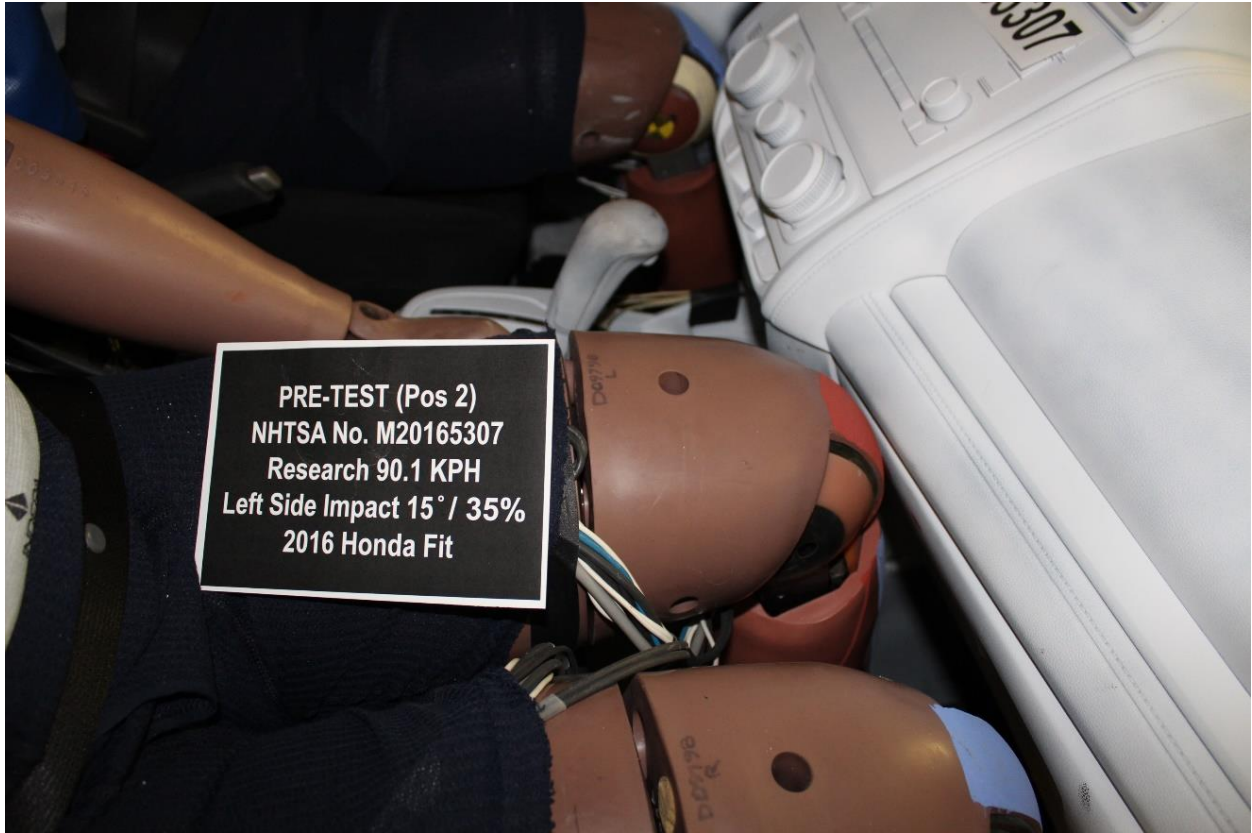

No. 114: Pre-Test View of Passenger Left Knee and Bolster

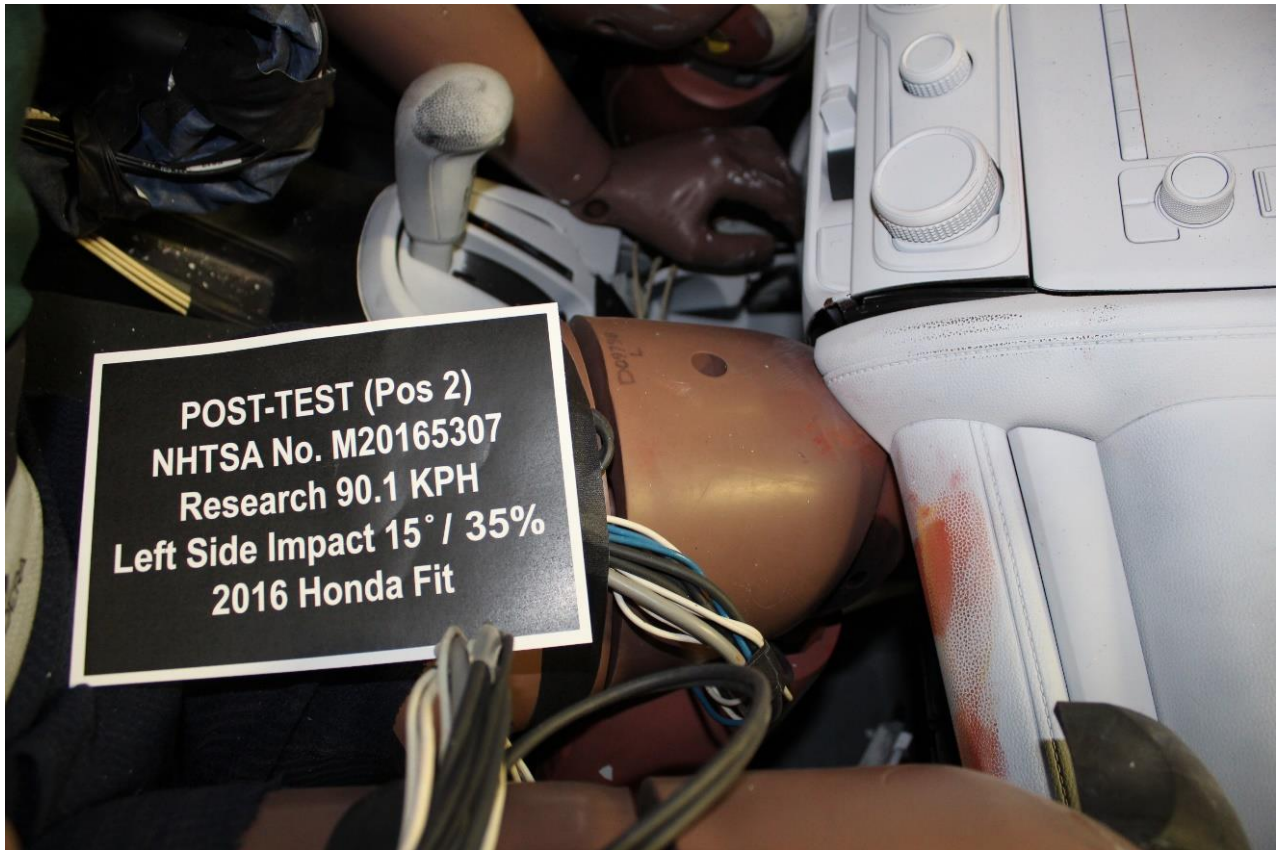

No. 115: Post-Test View of Passenger Left Knee and Bolster



No. 116: Pre-Test View of Passenger Abdomen



No. 117: Post-Test View of Passenger Abdomen



No. 118: Post-Test View of Passenger Head contact with Airbag – Front



**No. 119: Post-Test View of Passenger Head contact with Airbag - Curtain
Note: Curtain Airbag did not fire during Impact Event**

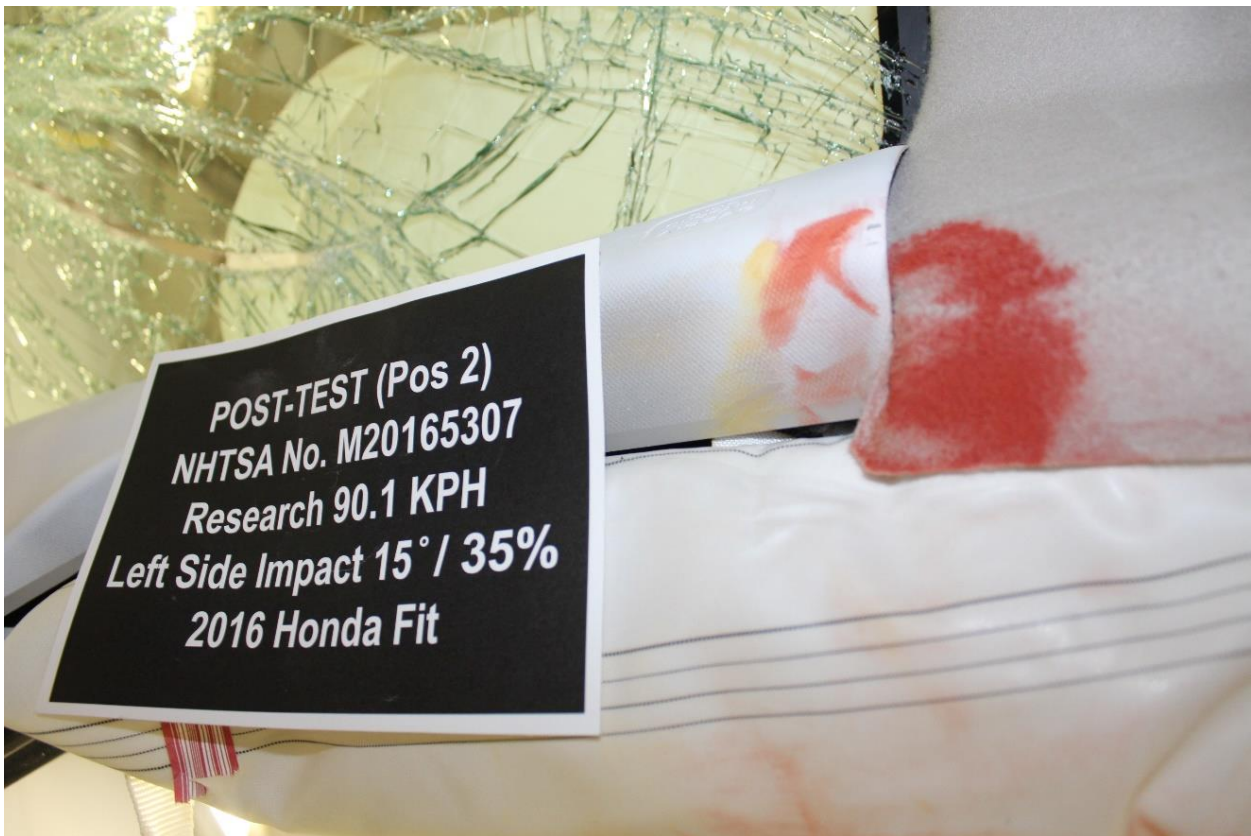

No. 120: Post-Test View of Passenger Head contact with Interior

Photo Not Applicable

No. 121: Post-Test View of Passenger Body contact with Interior

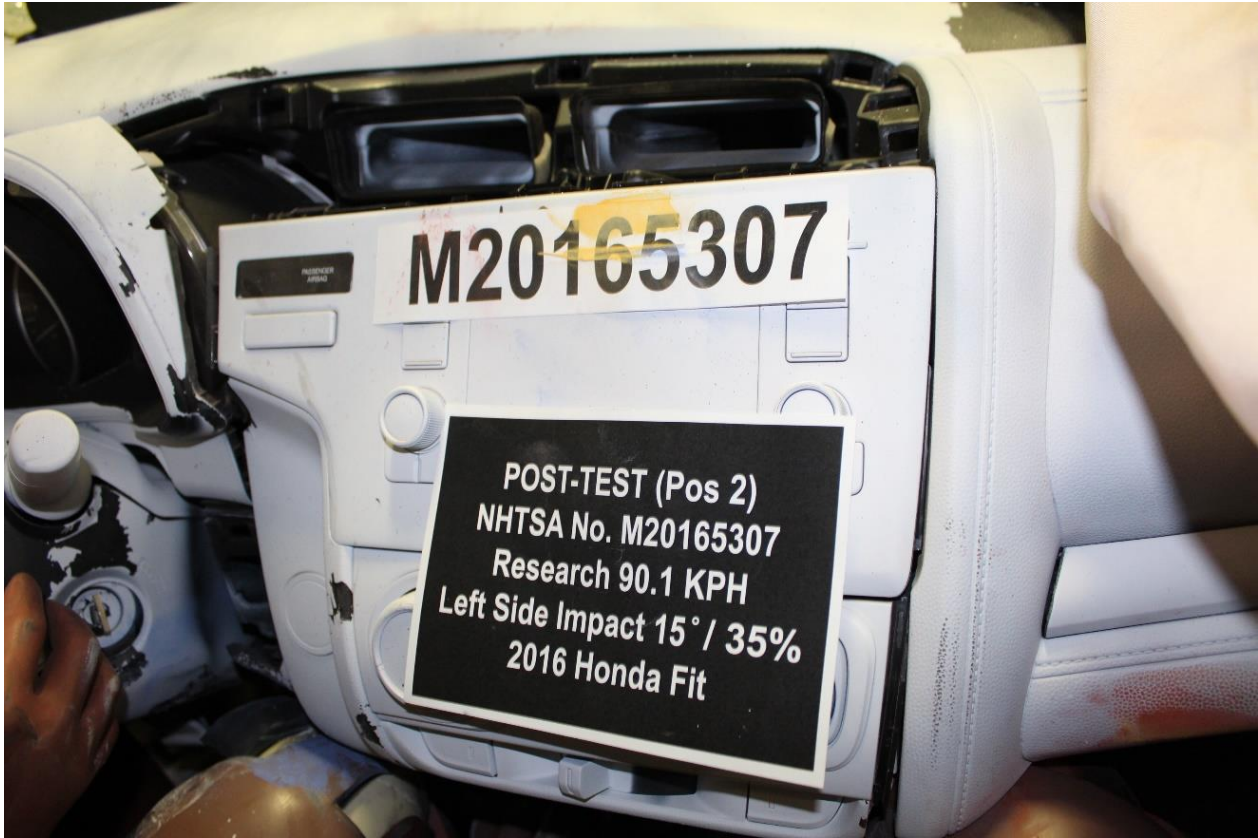

No. 122: Post-Test View of Passenger Head contact with Interior



No. 123: Post-Test Passenger Contact With Glovebox



No. 124: Pre-Test Ballast Locations



No. 125: Post-Test Speed Trap Readout

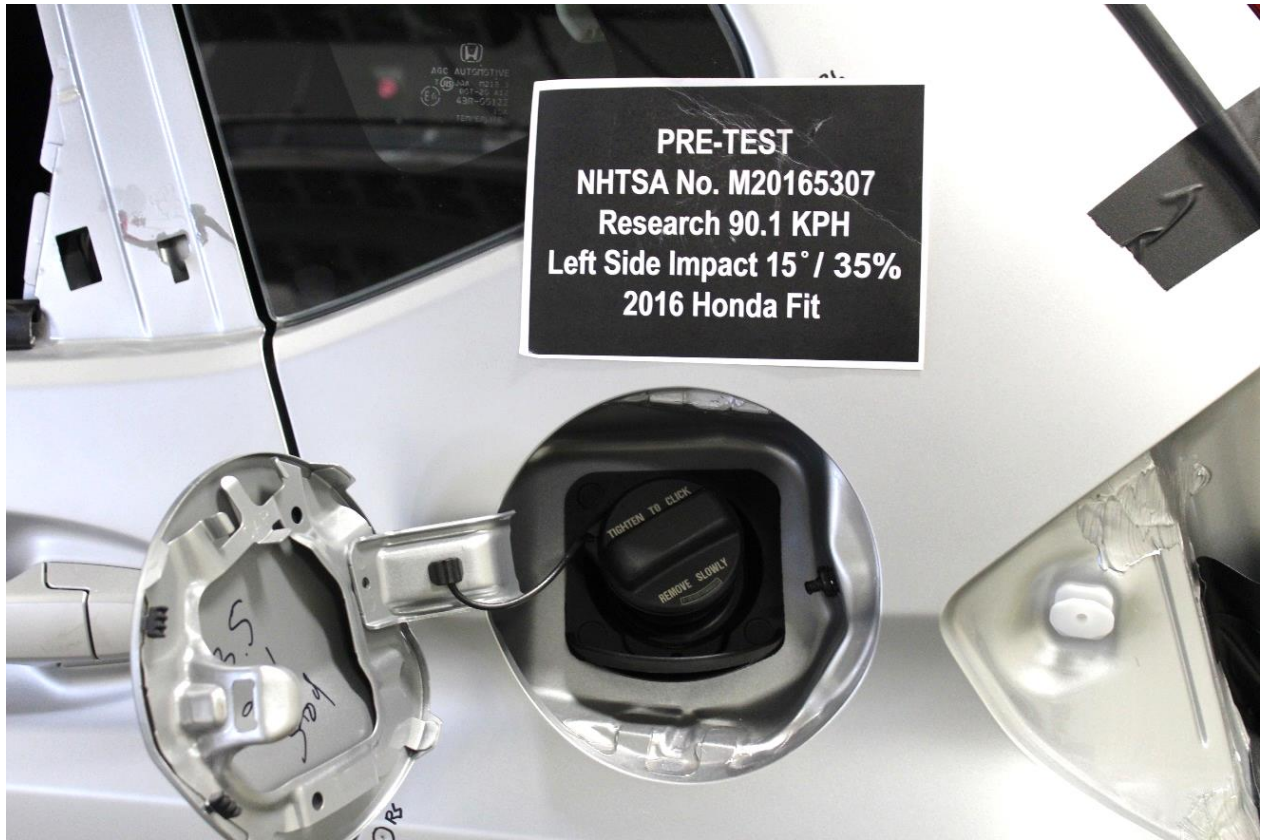

No. 126: Pre-Test View of Fuel Filler Cap

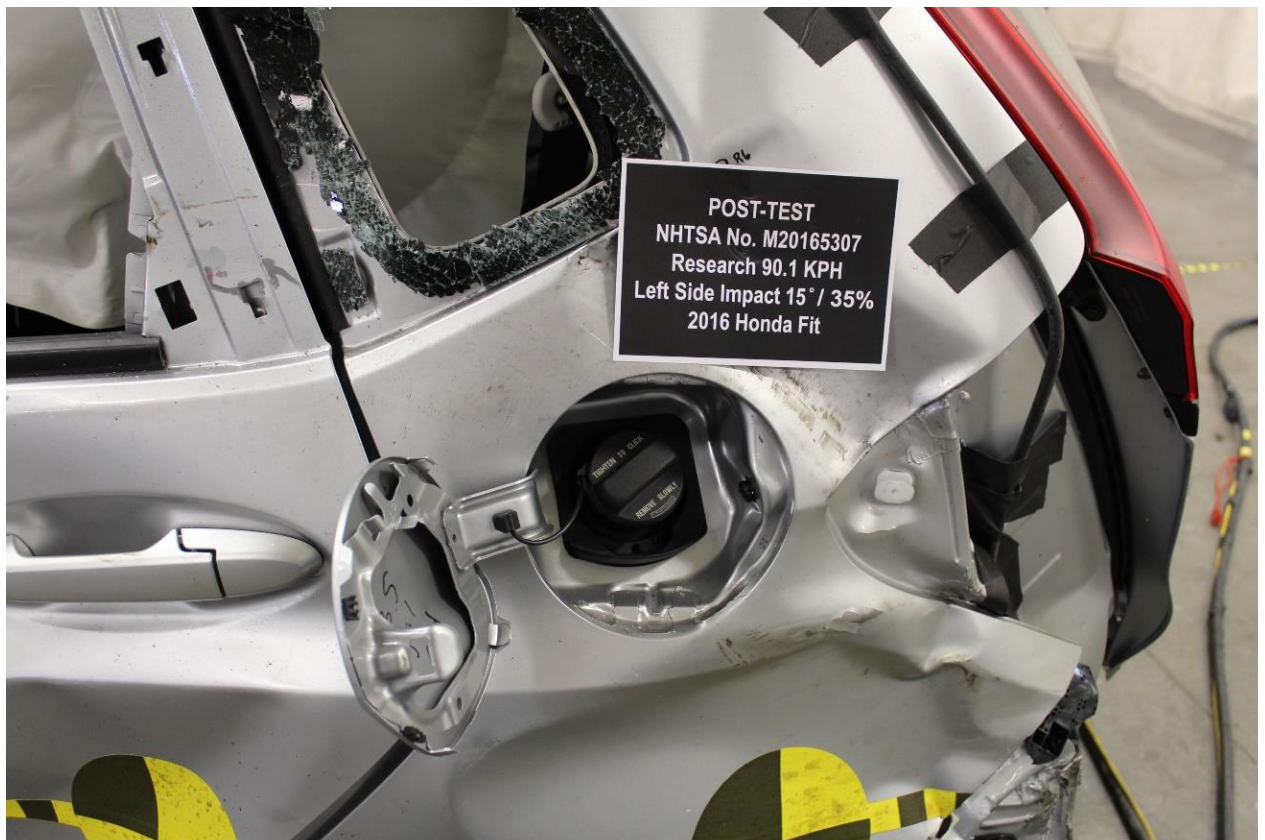

No. 127: Post-Test View of Fuel Filler Cap



No. 128: Pre-Test Engine Compartment View

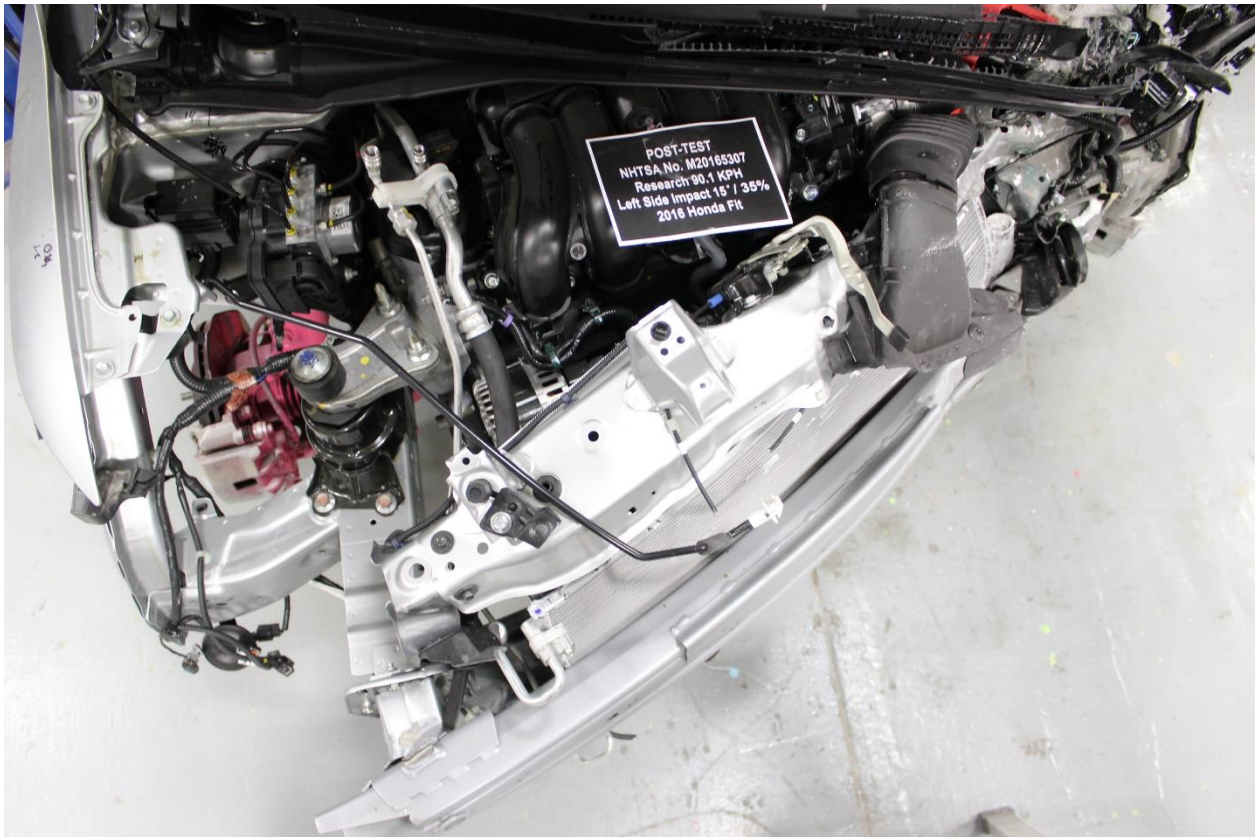

No. 129: Post-Test Engine Compartment View

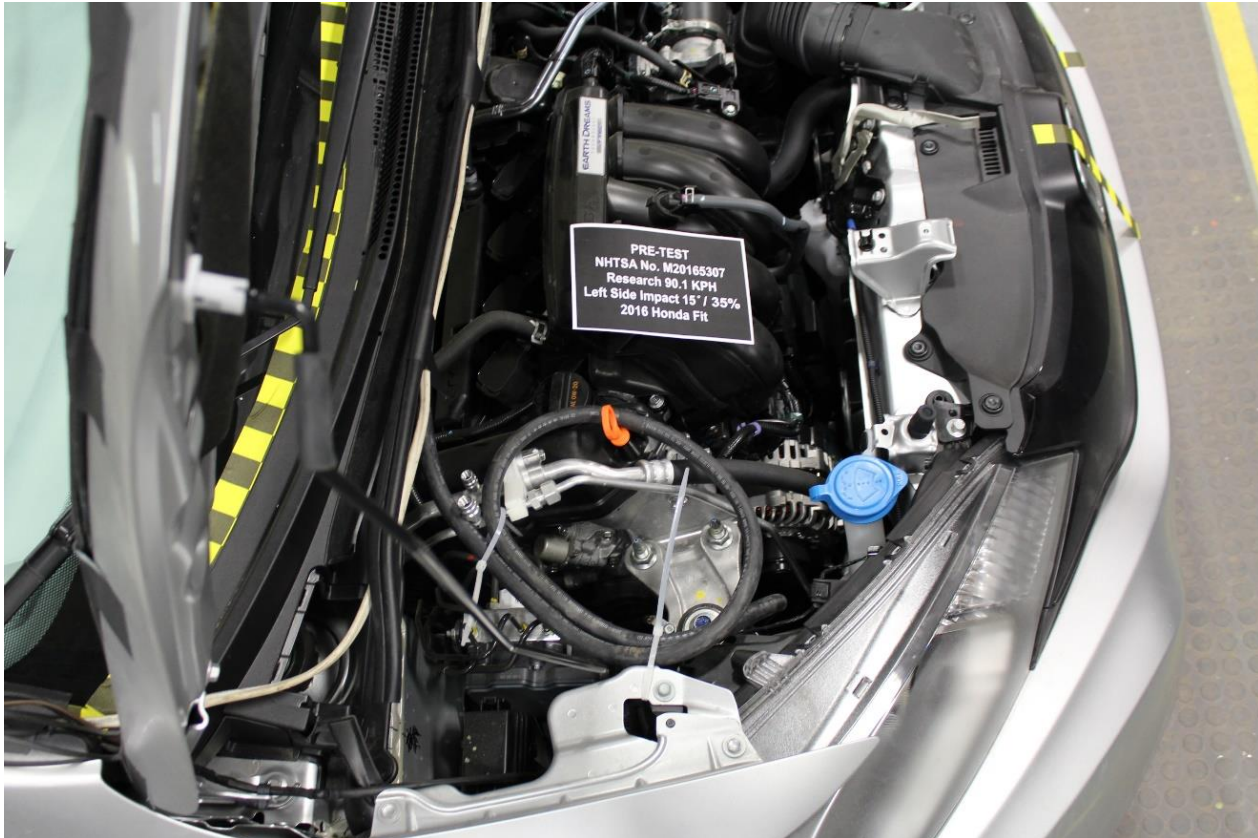

No. 130: Pre-Test Right Side Engine Compartment View

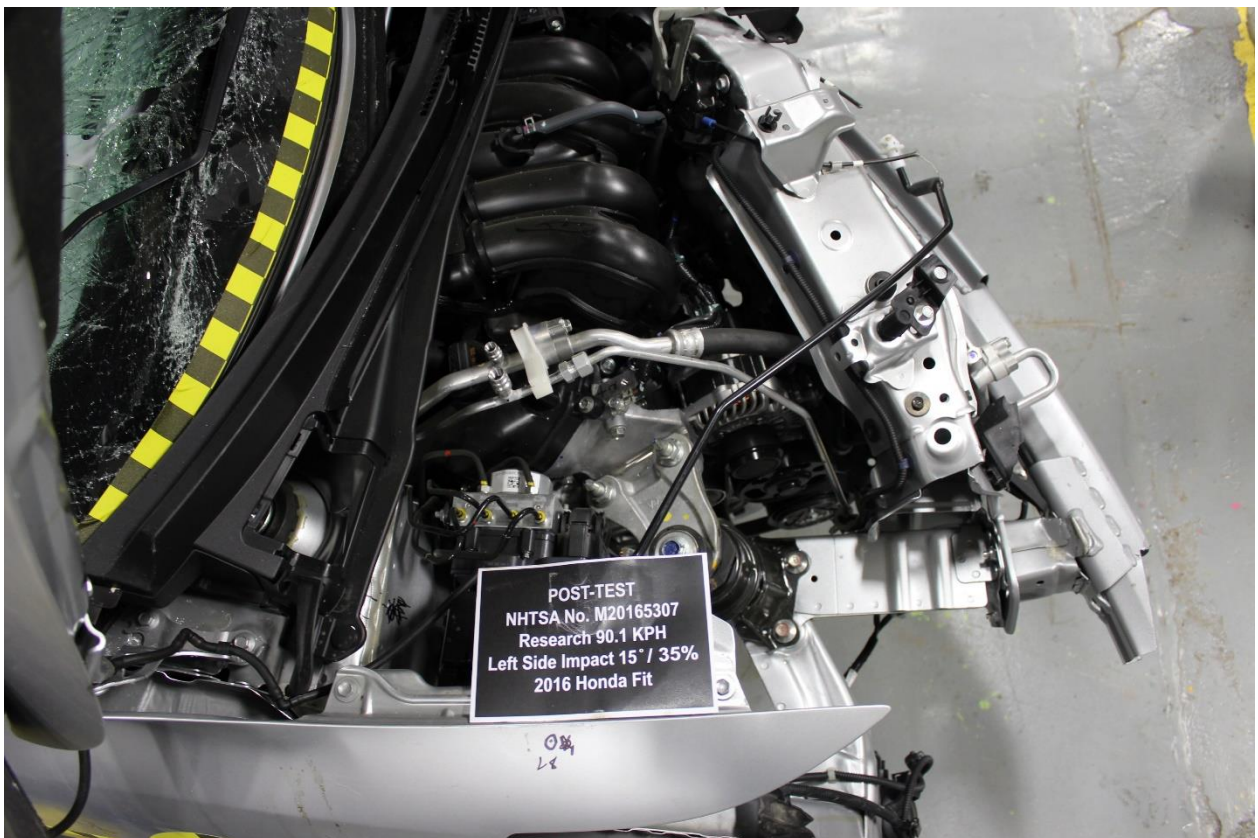

No. 131: Post-Test Right Side Engine Compartment View

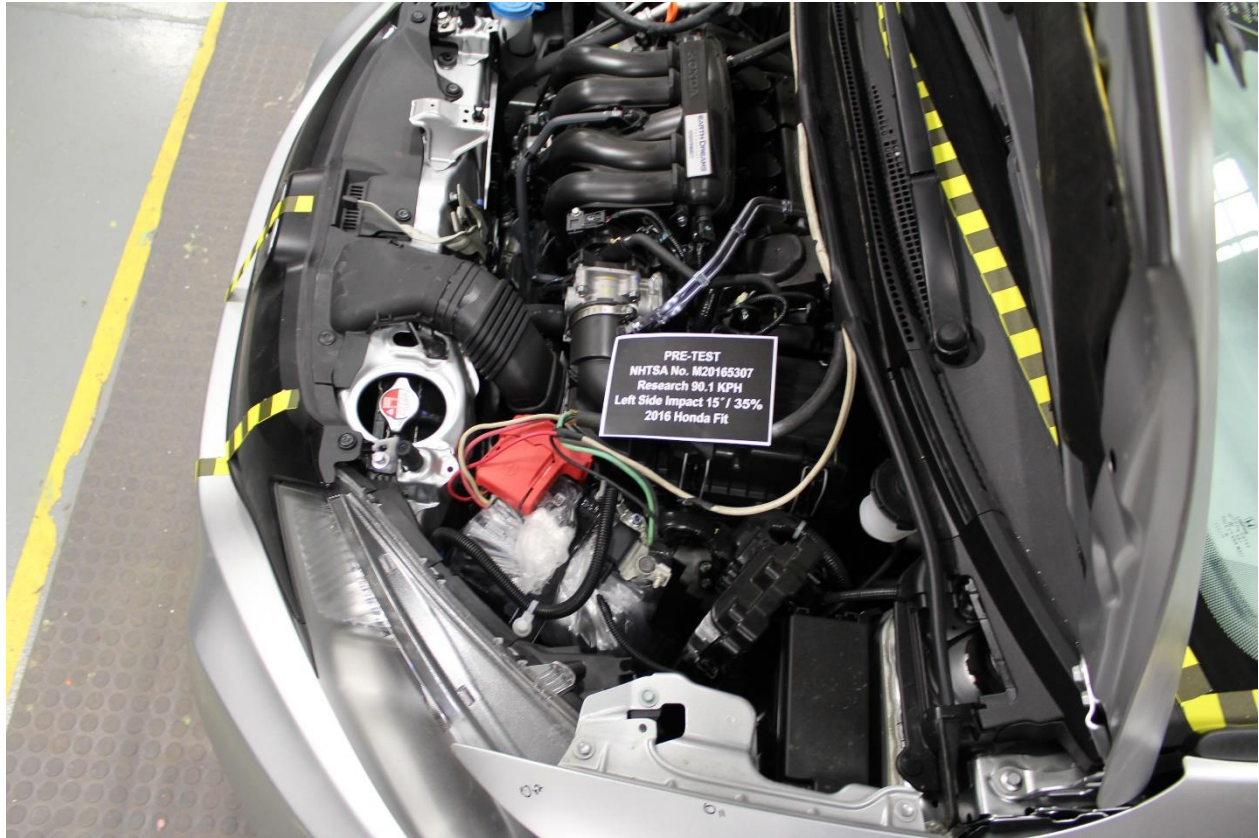

No. 132: Pre-Test Left Side Engine Compartment View

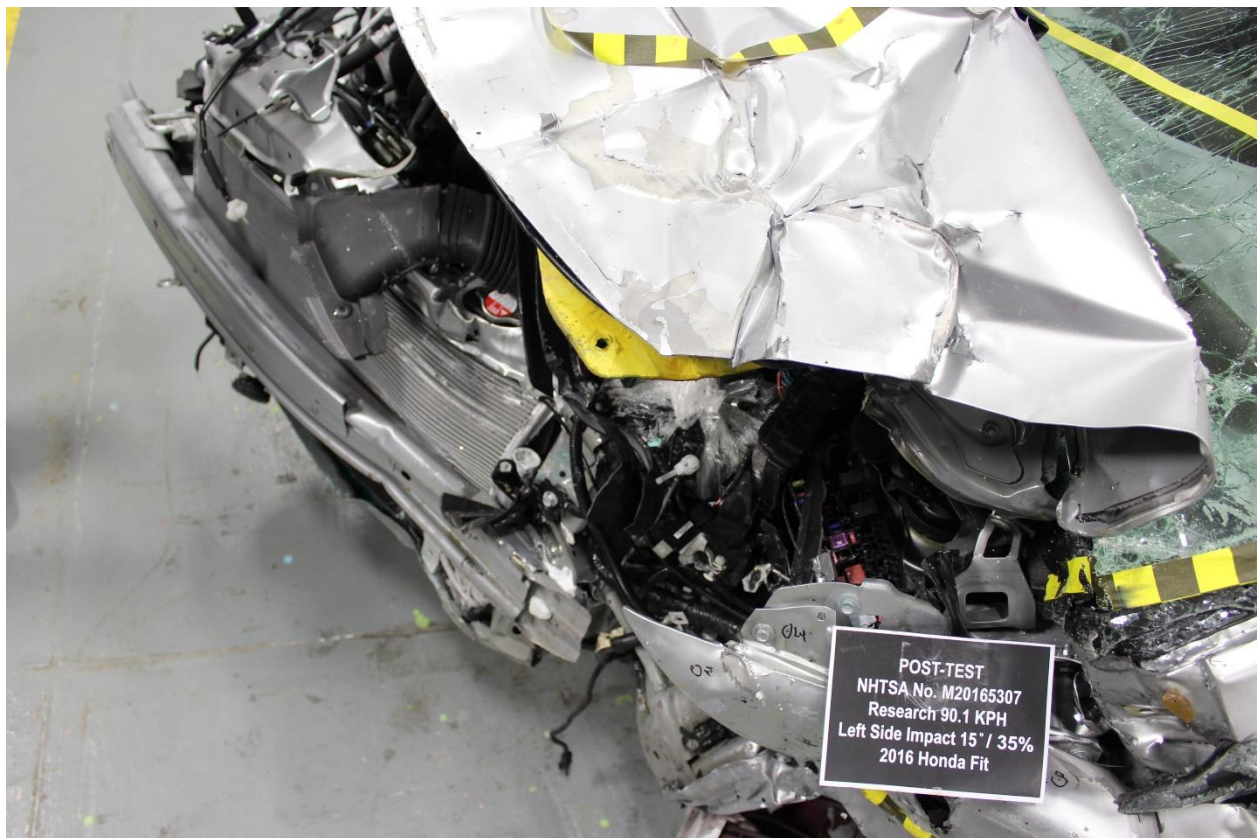

No. 133: Post-Test Left Side Engine Compartment View

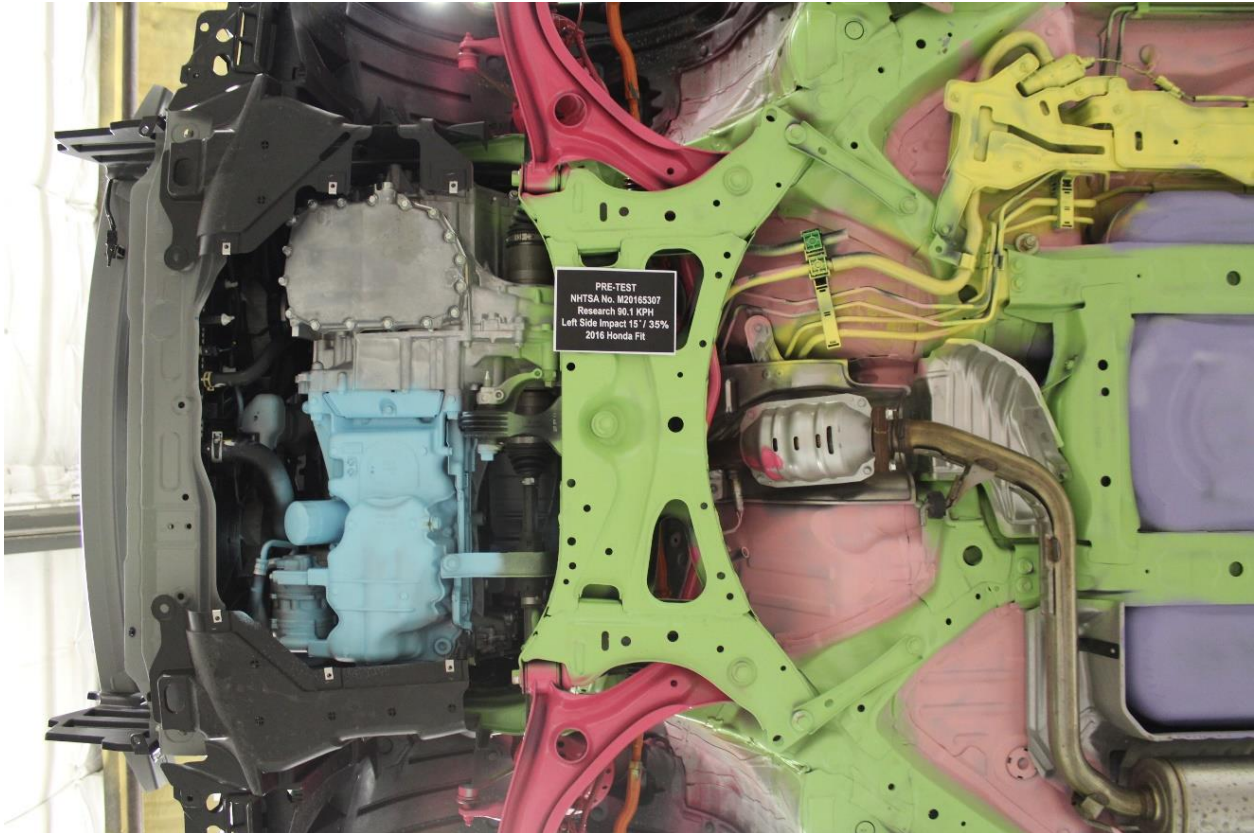

No. 134: Pre-Test View of Front Underbody (perpendicular to vehicle)

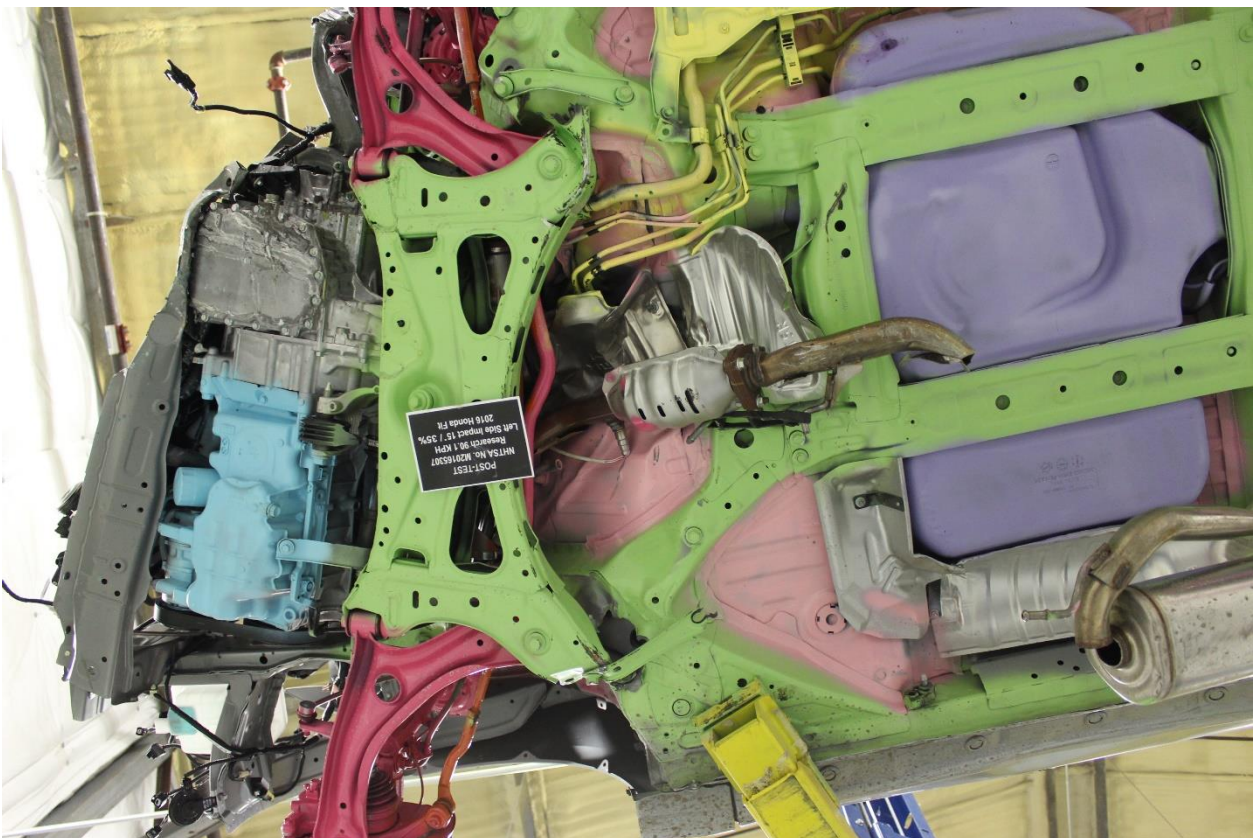

No. 135: Post-Test View of Front Underbody (perpendicular to vehicle)

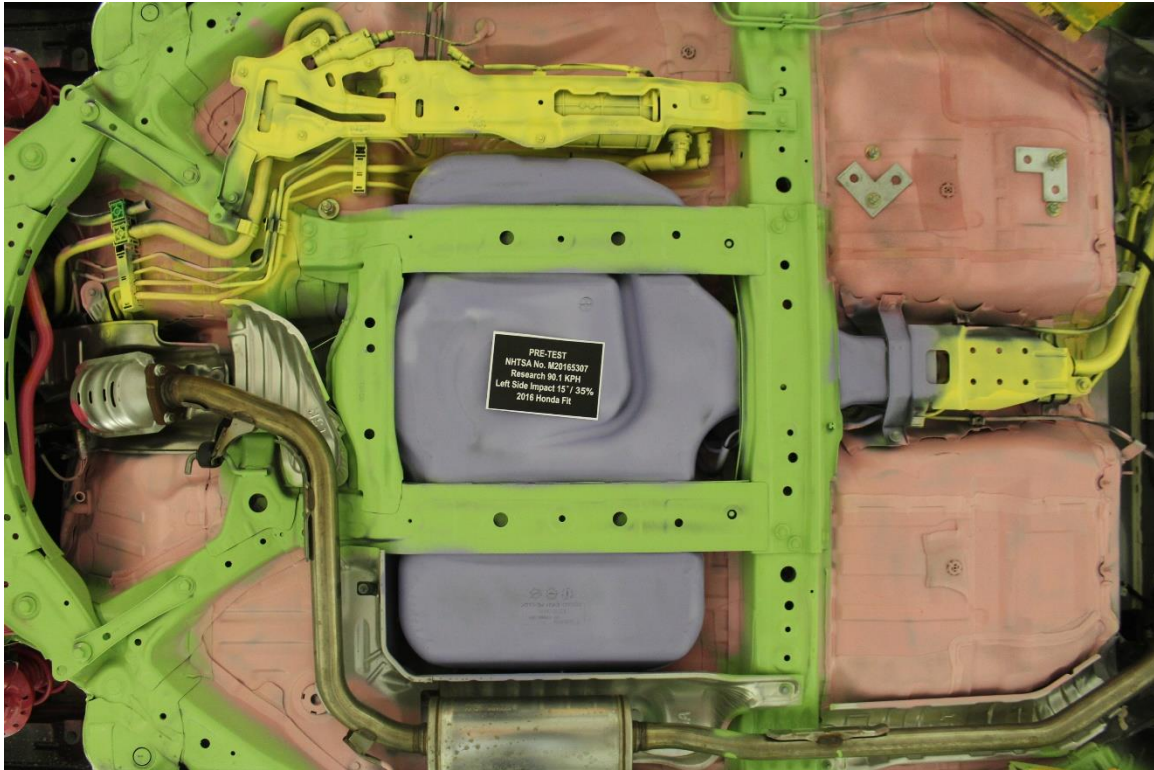

No. 136: Pre-Test View of Mid Underbody (perpendicular to vehicle)

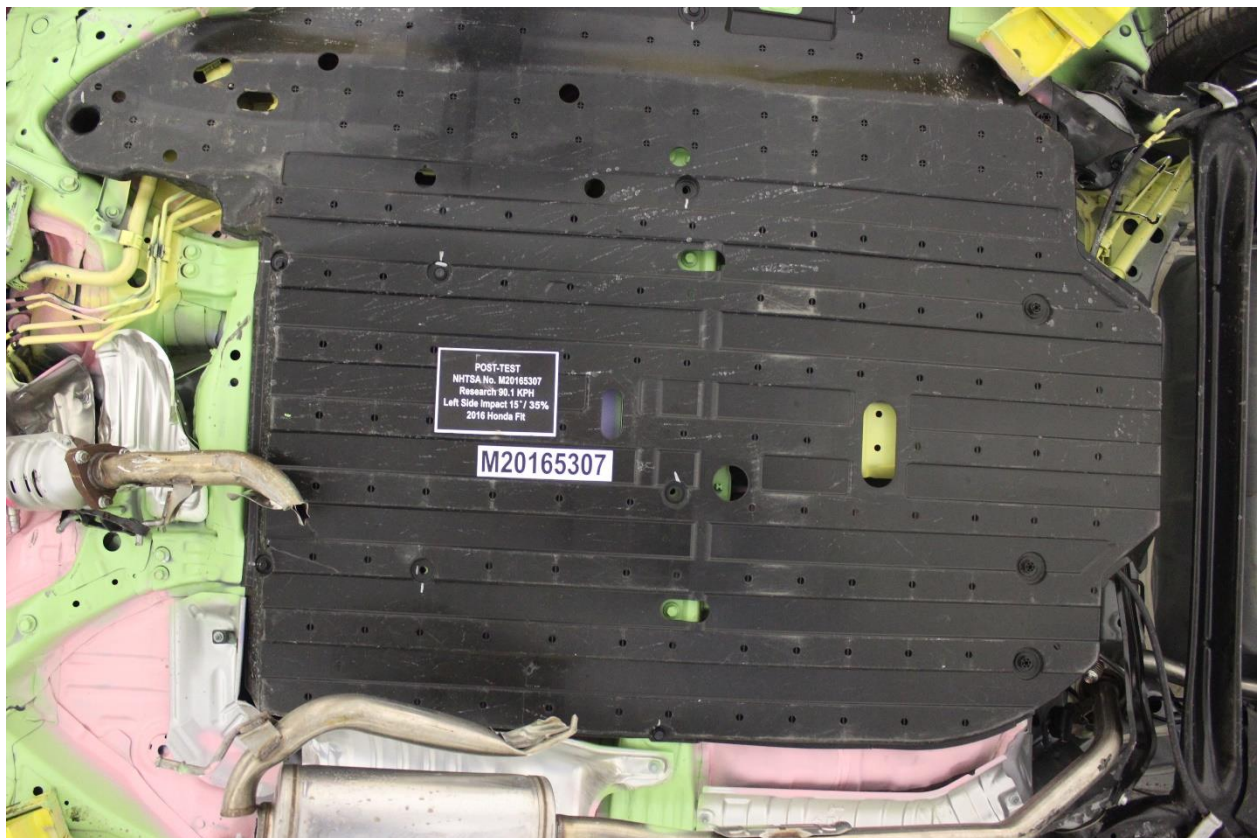

No. 137: Post-Test View of Mid Underbody (perpendicular to vehicle)

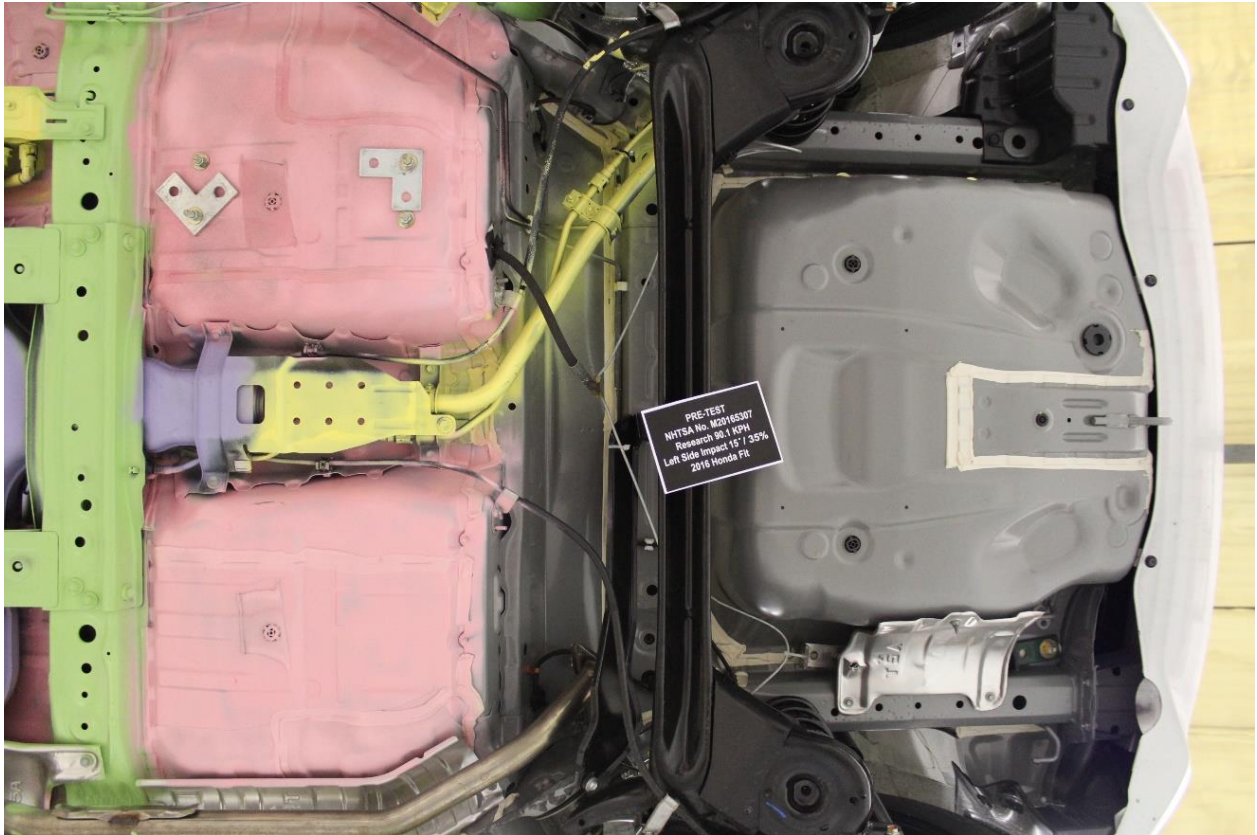

No. 138: Pre-Test View of Rear Underbody (perpendicular to vehicle)

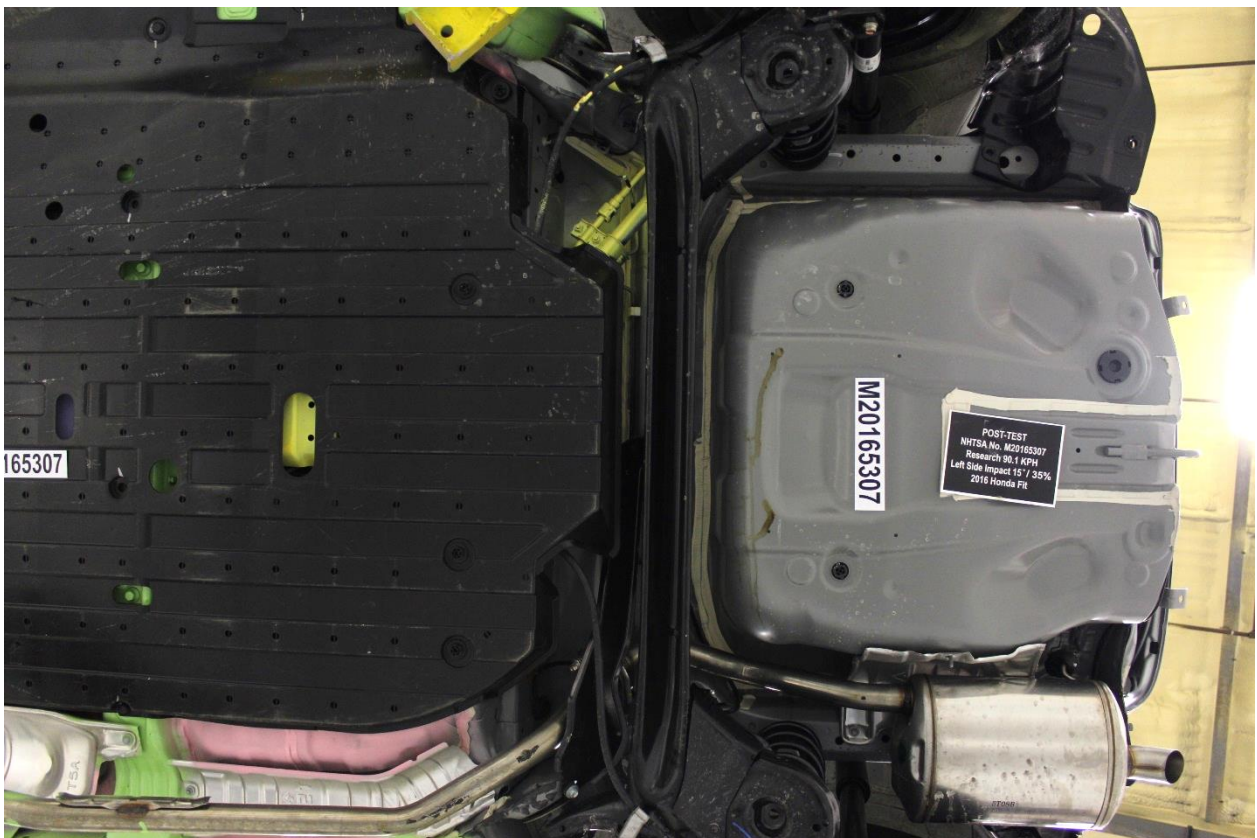

No. 139: Post-Test View of Rear Underbody (perpendicular to vehicle)

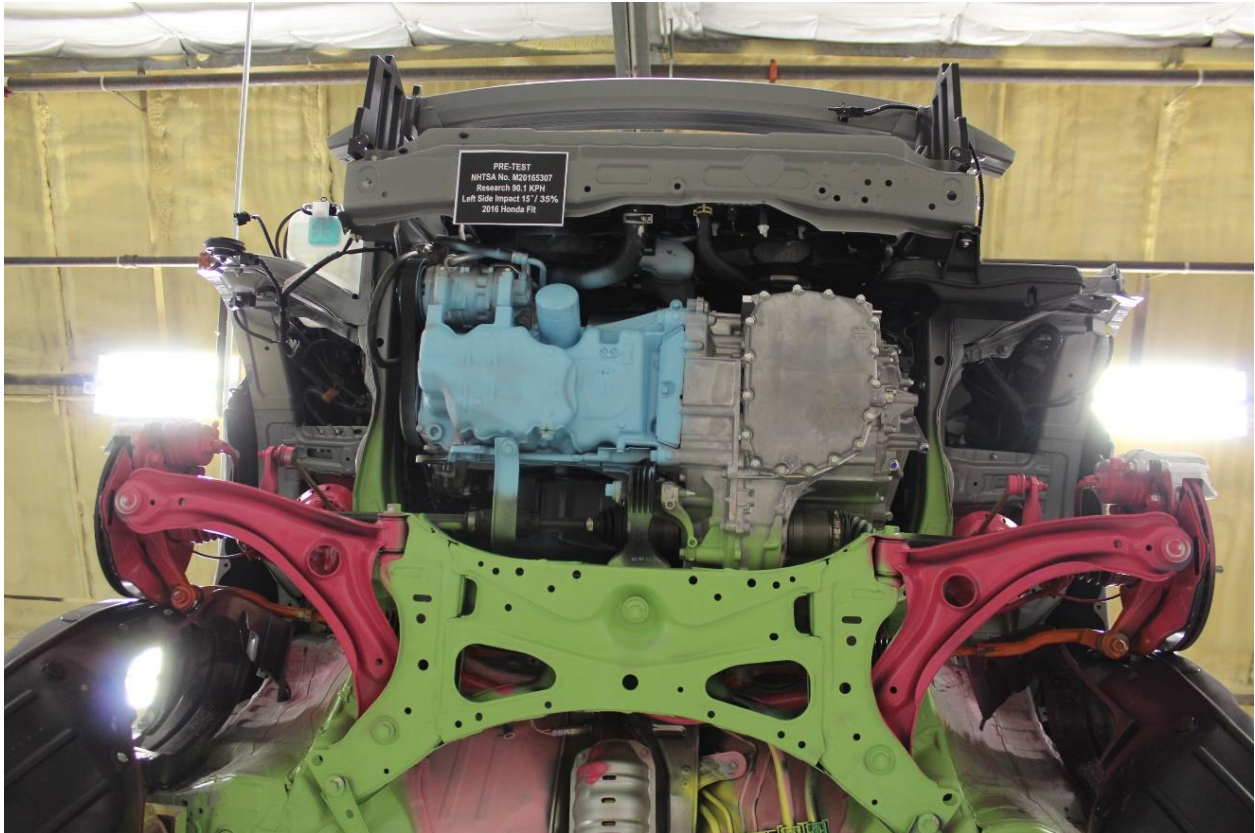

No. 140: Pre-Test View of Steering rack and or sway bar



No. 141: Post-Test View of Steering rack and or sway bar

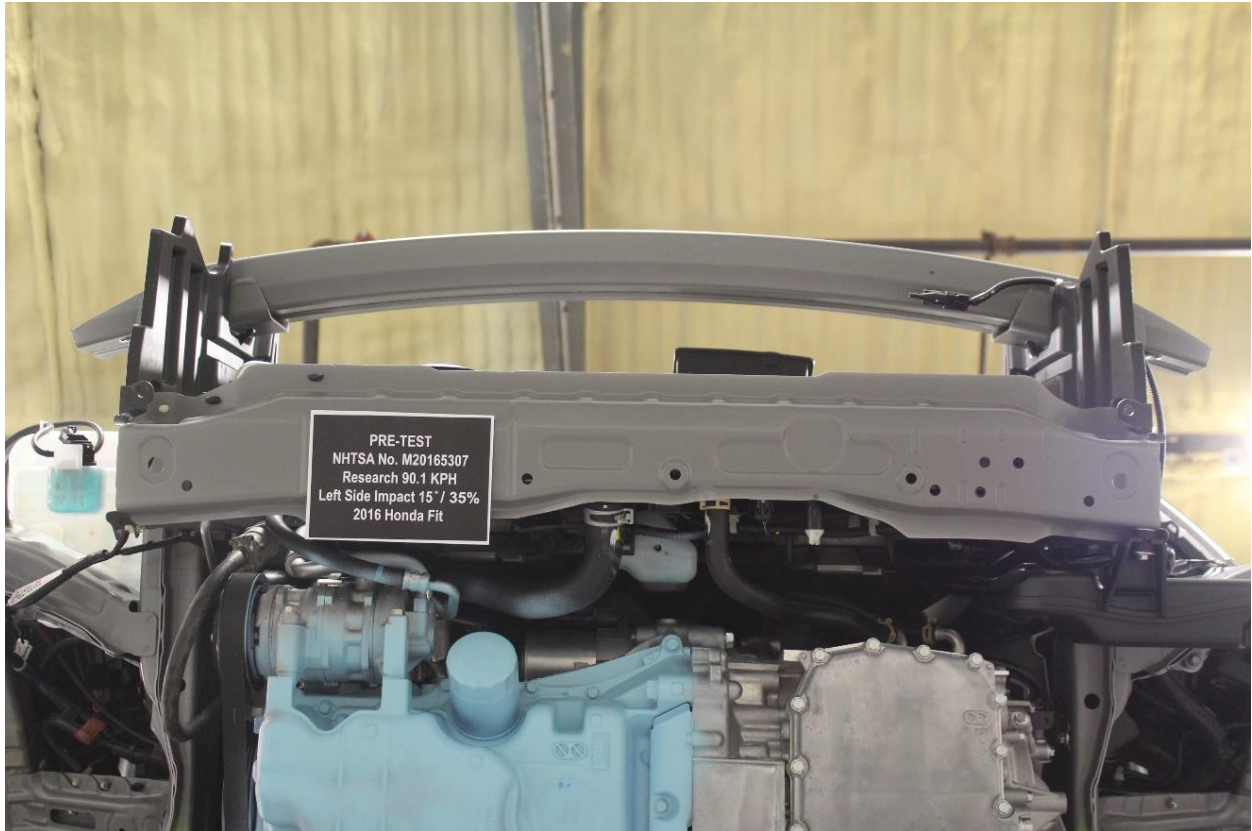

No. 142: Pre-Test Bumper to Rail Attachments and Crush Initiators

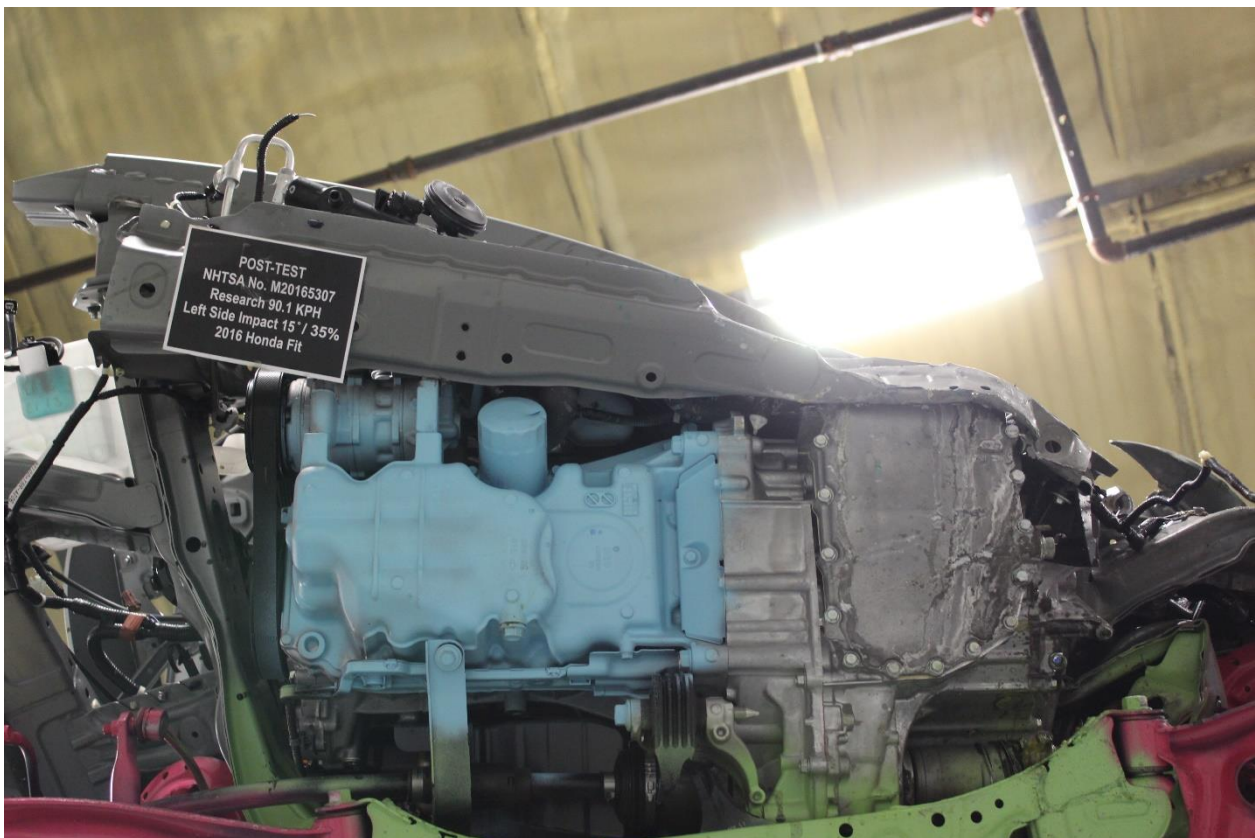

No. 143: Post-Test Bumper to Rail Attachments and Crush Initiators

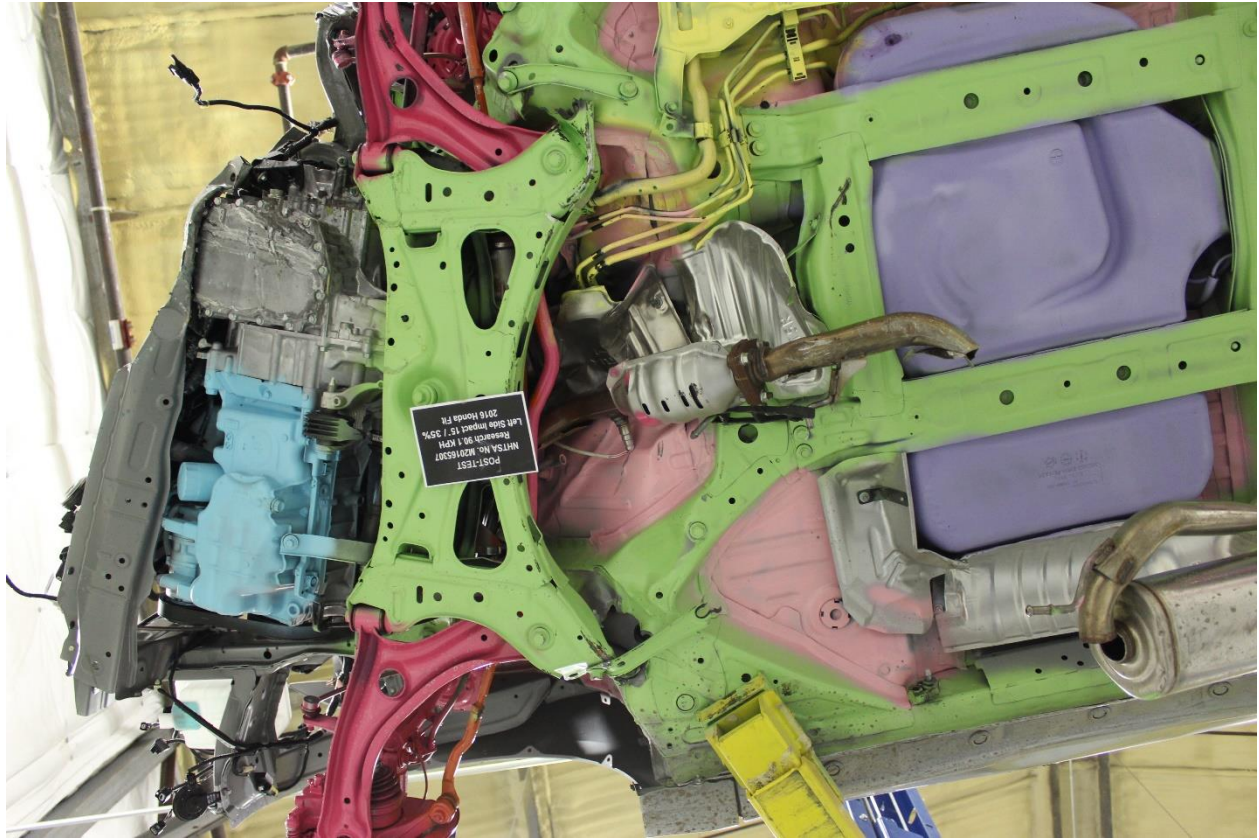

No. 144: Post-Test View of Front Sub-Frame Deformation

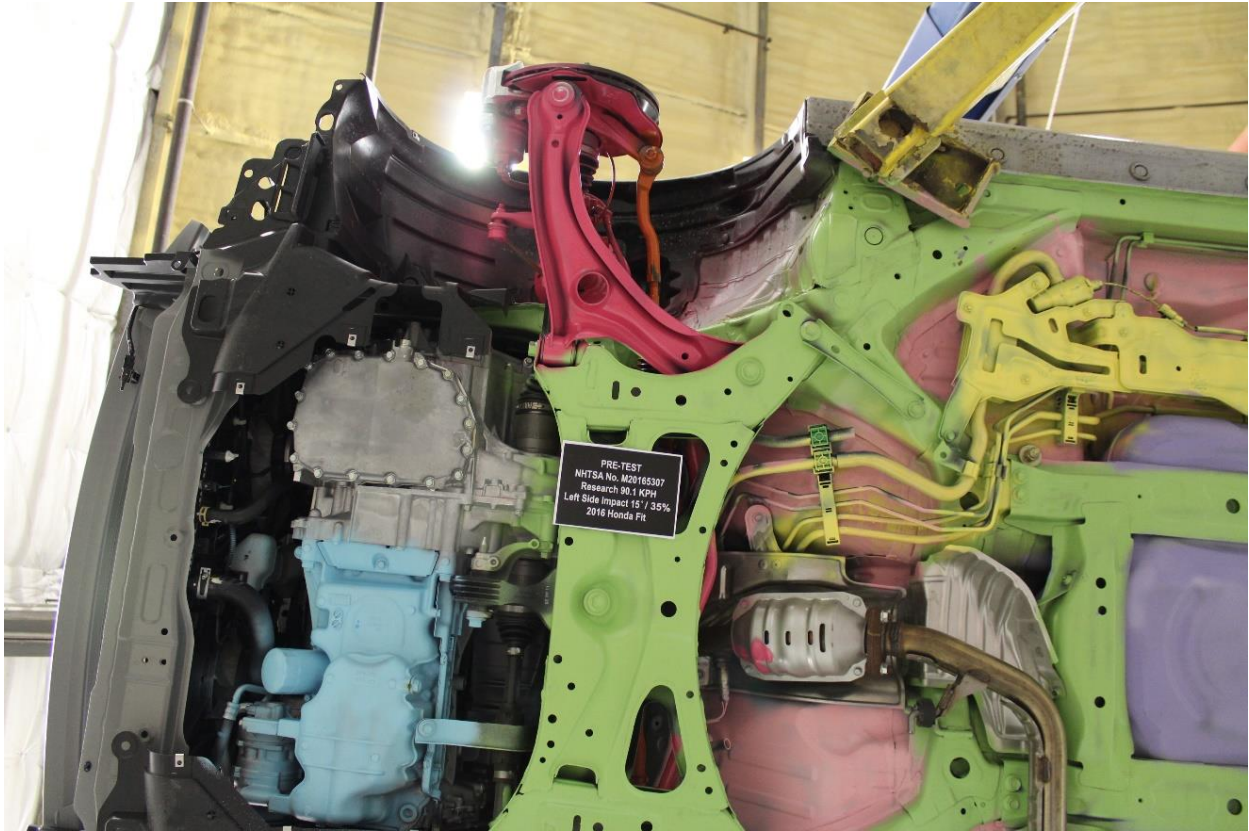

No. 145: Pre-Test Frame Rail with tire removed

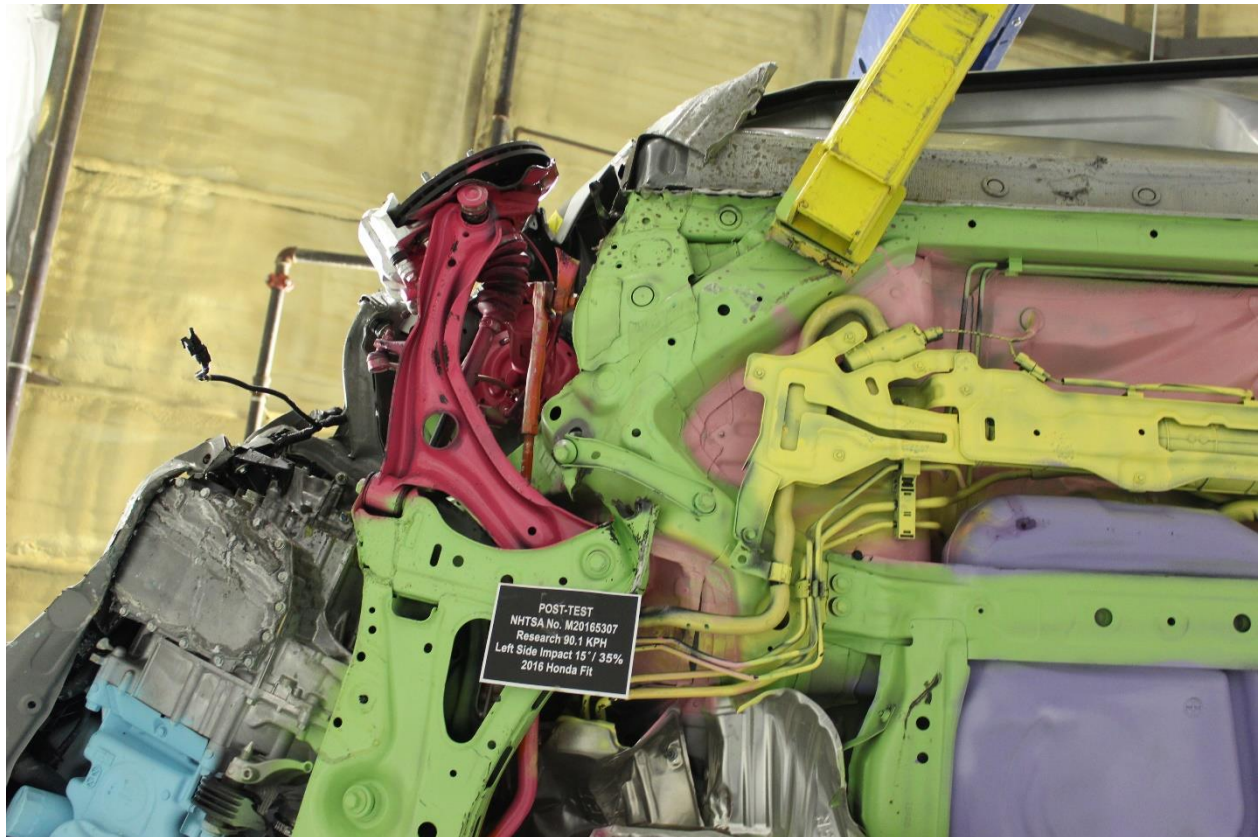

No. 146: Post-Test Frame Rail with tire removed



No. 147: Pre-Test View of Front Driver Wheel Well w/ Tire Removed



No. 148: Post-Test ¾ View of Front Driver Wheel Well w/ Tire Removed



No. 149: Post-Test Side View of Front Driver Wheel Well w/ Tire Removed



No. 150: Post-Test Right Side 3/4 Rear View of the Front Driver Wheel Well w/ Tire Removed



No. 151: Post-Test Looking Down at the Front Driver Shotgun

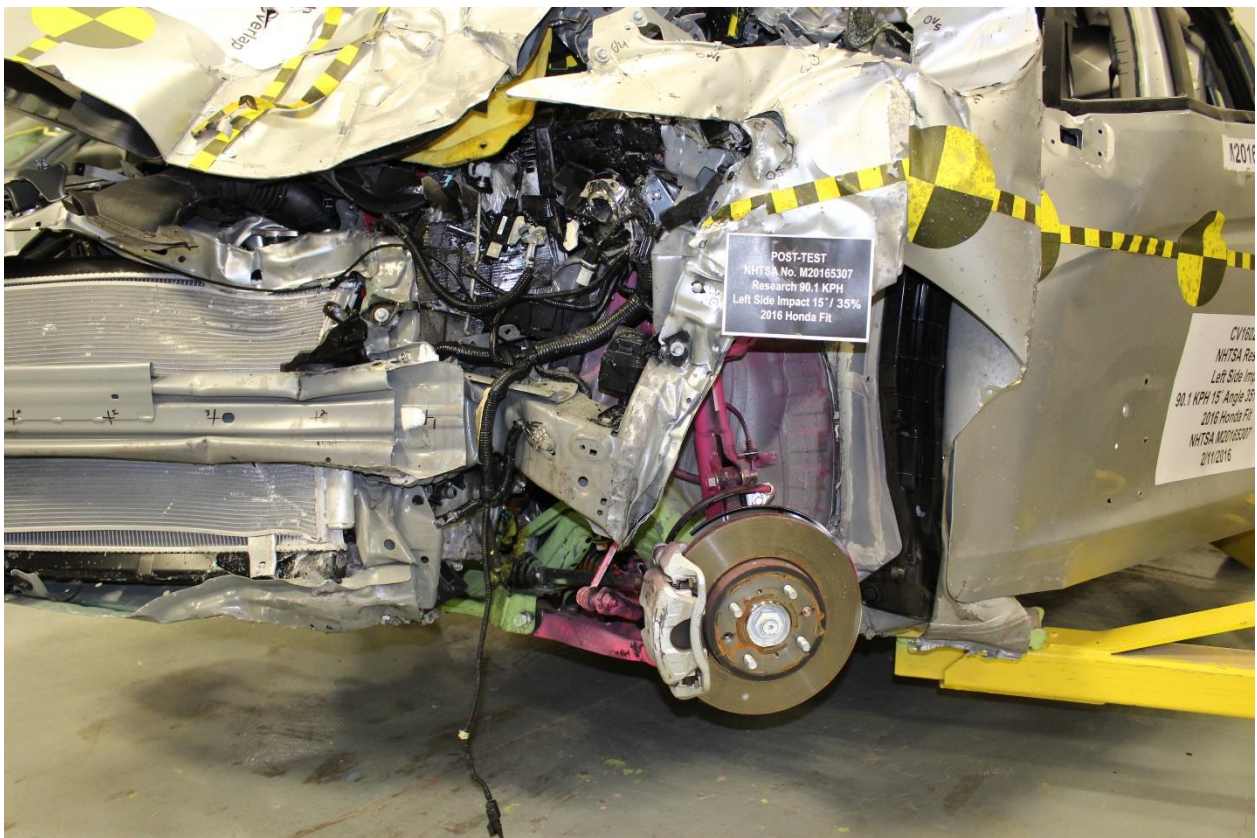

No. 152: Post-Test Right Side 3/4 View of Front Driver Shotgun

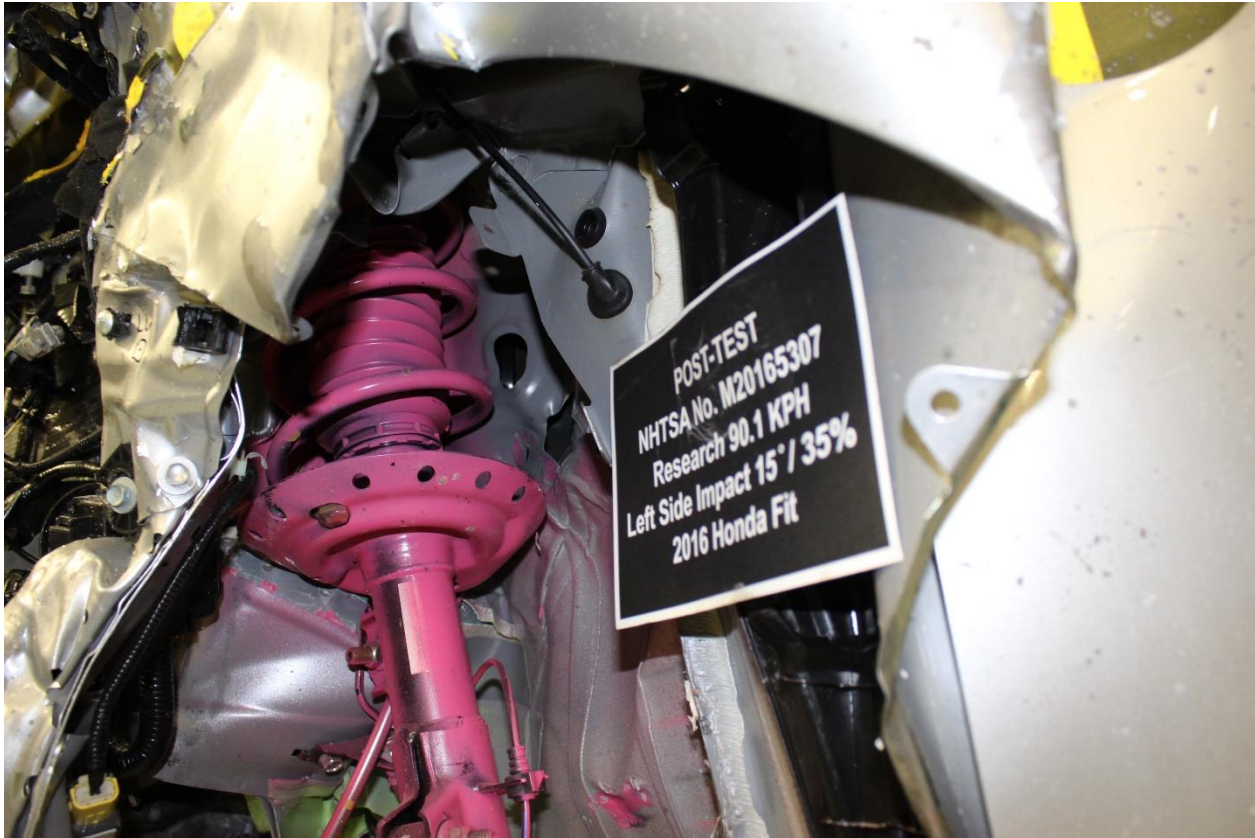

No. 153: Post-Test Front Driver Close up View of Suspension w/ Tire Removed

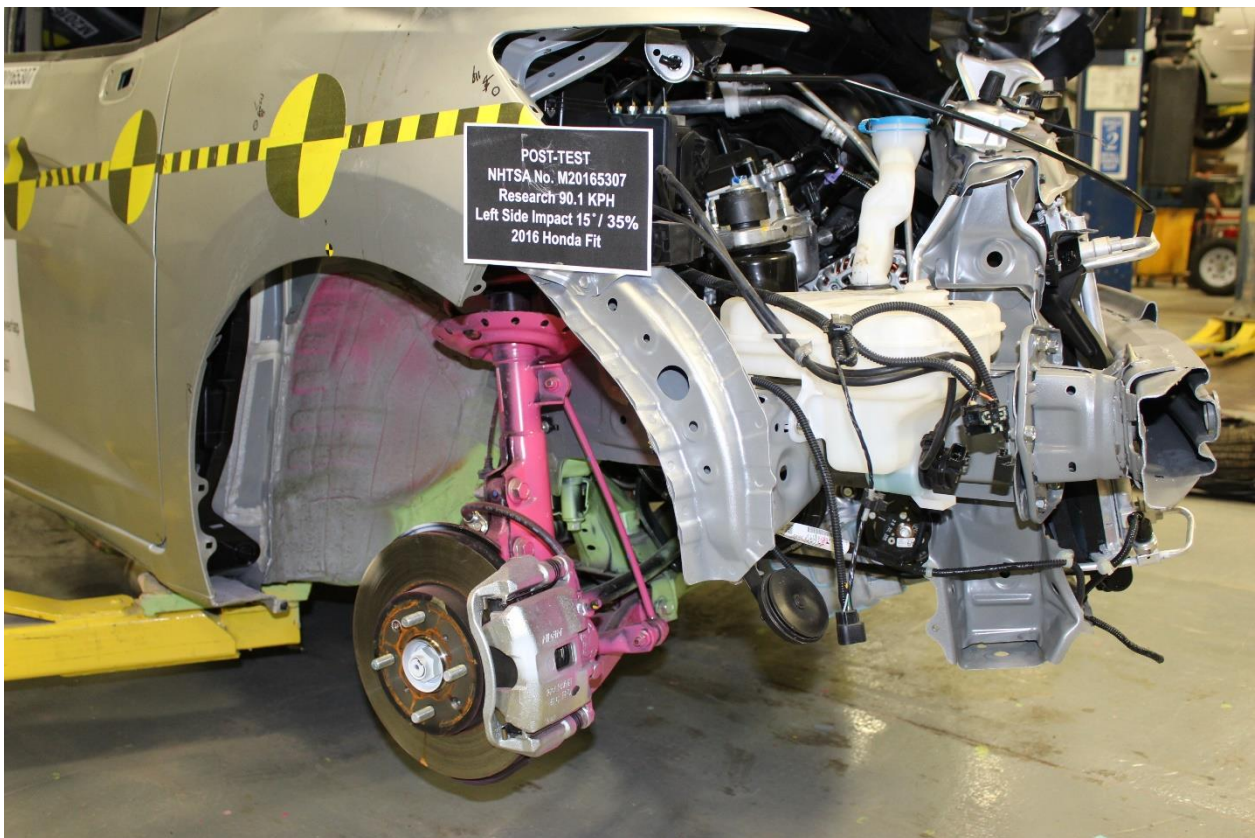

No. 154: Post-Test ¾ View of Front Passenger Wheel Well w/ Tire Removed

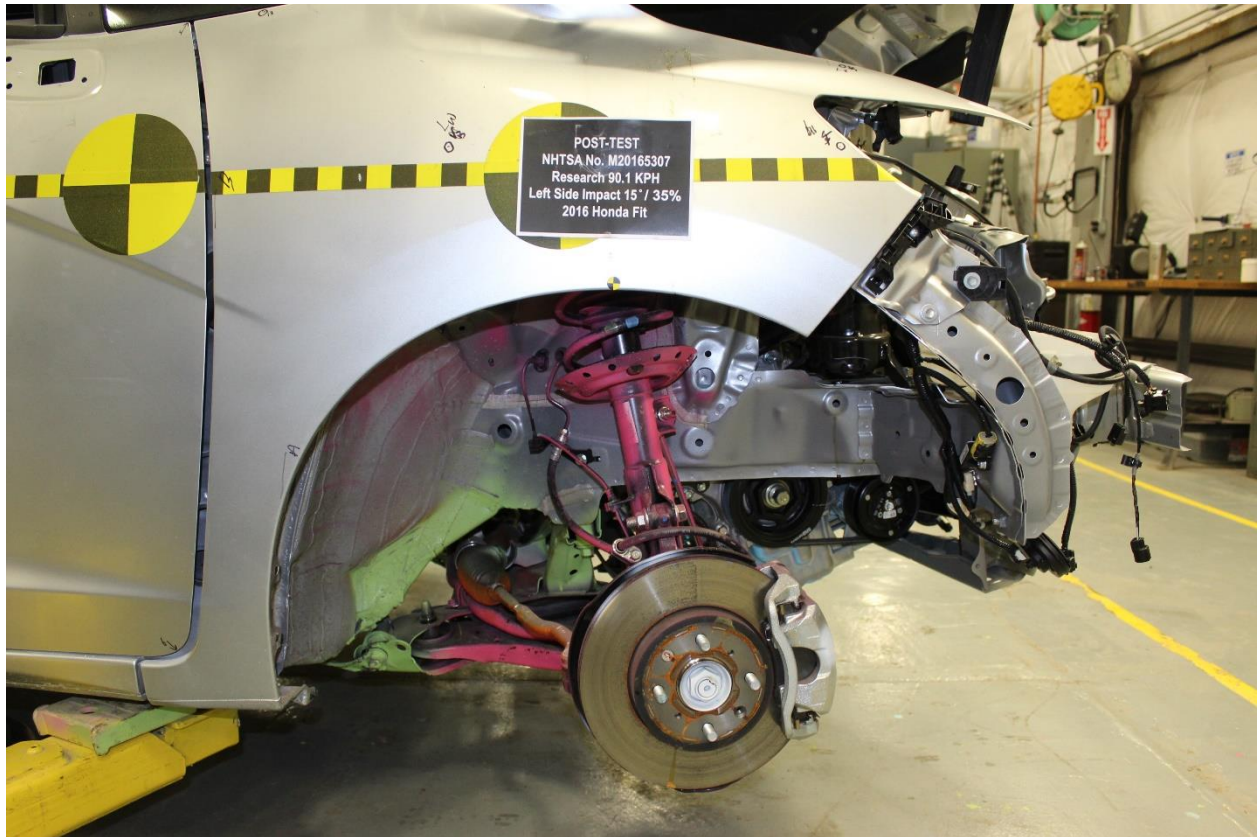

No. 155: Post-Test Side View of Front Passenger Wheel Well w/ Tire Removed



No. 156: Post-Test Right Side 3/4 Rear View of the Front Passenger Wheel Well w/ Tire Removed



No. 157: Post-Test Looking Down at the Front Passenger Shotgun

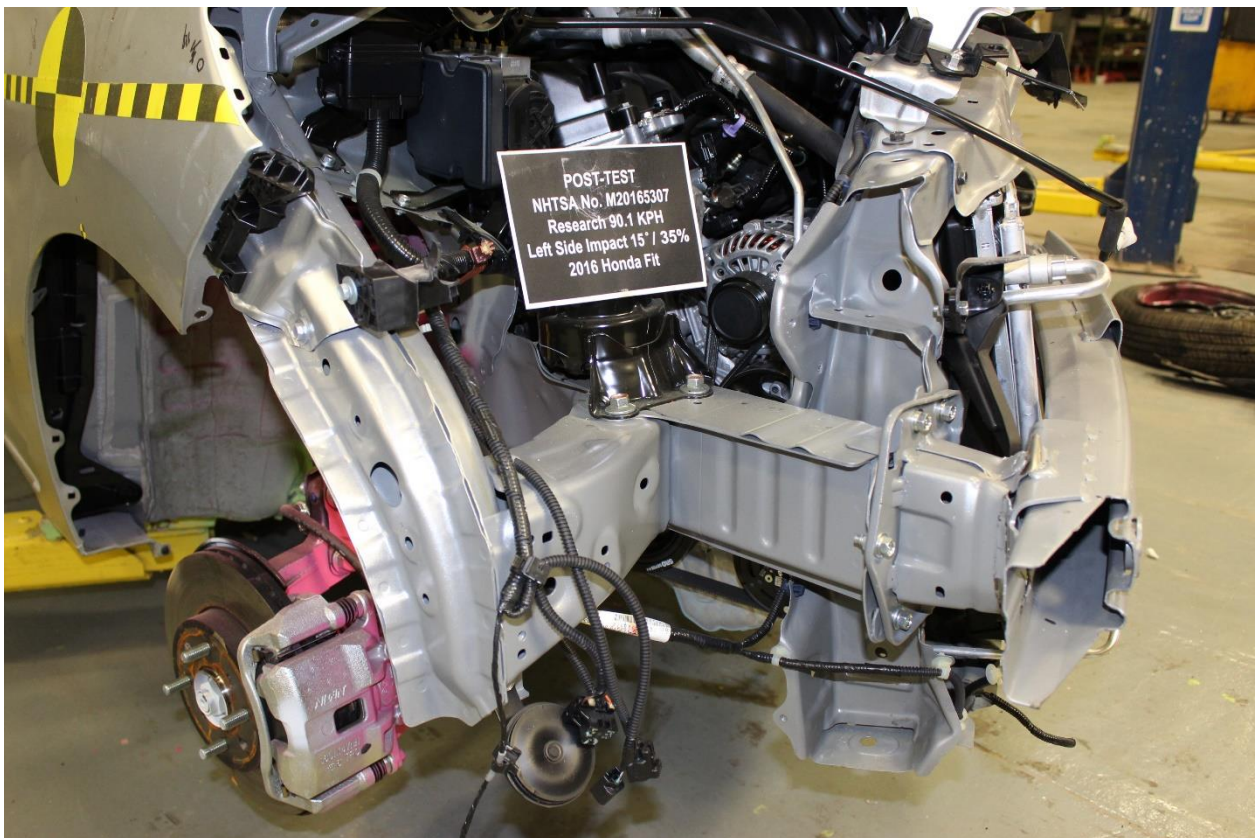

No. 158: Post-Test Right Side $\frac{3}{4}$ View of Front Passenger Shotgun

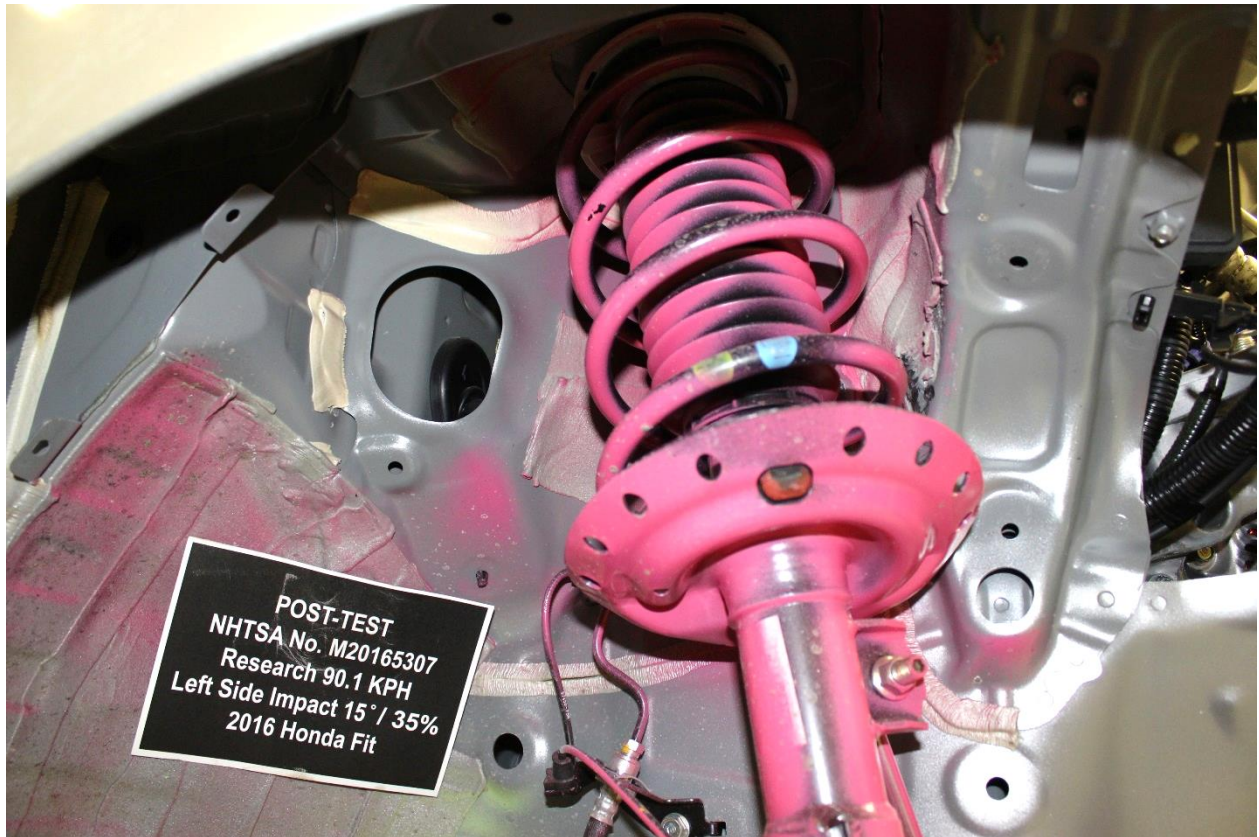

No. 159: Post-Test Front Passenger Close up View of Suspension w/ Tire Removed



No. 160: Post-Test View of Door Sill with Door Open- Struck Side



No. 161: Post-Test View of Deformation of A pillar-Struck Side



No. 162: Post-Test View of Deformation of B pillar-Struck Side



No. 163: Post-Test View of Deformation of C pillar-Struck Side



No. 164: Post-Test View of Wheel and/or Tire Deformation-Struck Side



No. 165: Post-Test View of Deformation of Rocker or Post-Struck Side



No. 166: Post-Test View of Windshield Separation



No. 167: Pre-Test Left Side View of OMDB



No. 168: Post-Test Left Side View of OMDB



No. 169: Pre-Test Right Side View of OMDB



No. 170: Post-Test Right Side View of OMDB



No. 171: Pre-Test Top View of OMDB



No. 172: Post-Test Top View of OMDB



No. 173: Pre-Test Front View of OMDB



No. 174: Post-Test Front View of OMDB



No. 175: Pre-Test Left Front $\frac{3}{4}$ View of O MDB



No. 176: Post-Test Left Front $\frac{3}{4}$ View of O MDB



No. 177: Pre-Test Right Front $\frac{3}{4}$ View of O MDB



No. 178: Post-Test Right Front $\frac{3}{4}$ View of O MDB



No. 179: Pre-Test Right Side View of OMDB



No. 180: Post-Test Right Side View of OMDB



No. 181: Pre-Test Left Side View of OMDB



No. 182: Post-Test Left Side View of OMDB



No. 183: Pre-Test OMDB & Vehicle, Right Side



No. 184: Post-Test OMDB & Vehicle, Right Side



No. 185: Pre-Test OMDB & Vehicle, Left Side



No. 186: Post-Test OMDB & Vehicle, Left Side

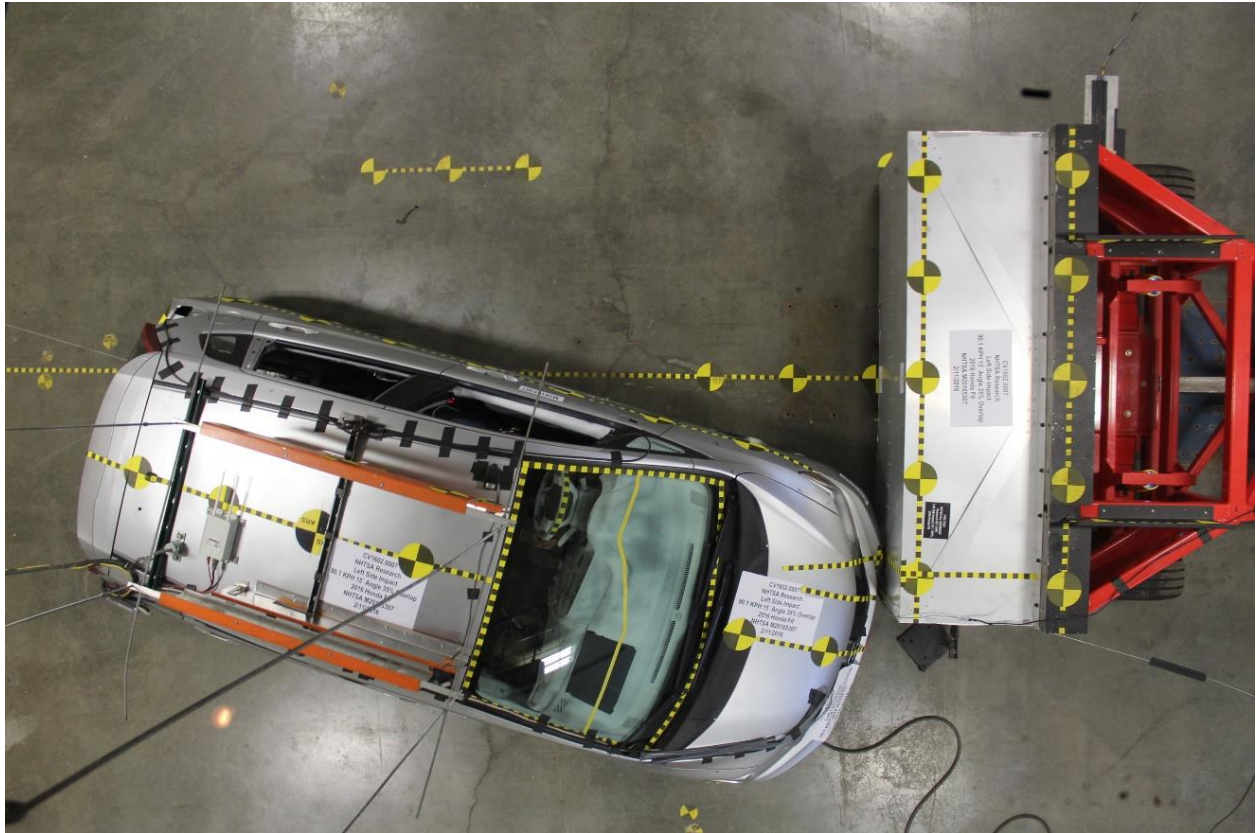

No. 187: Pre-Test OMDB & Vehicle, Top View

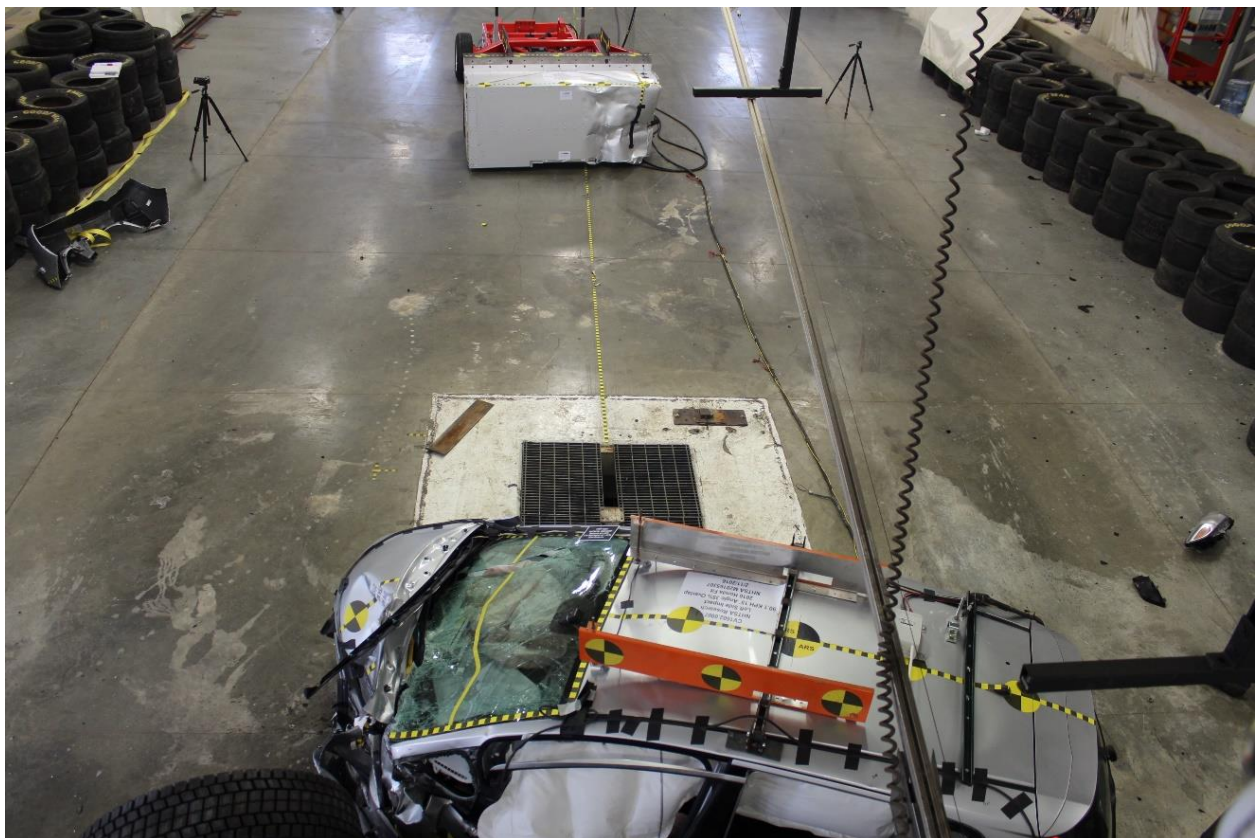

No. 188: Post-Test OMDB & Vehicle, Top View



No. 189: Pre-Test OMDB & Vehicle, Rear View



No. 190: Post-Test OMDB & Vehicle, Rear View



No. 191: Pre-Test OMDB & Vehicle, Front View

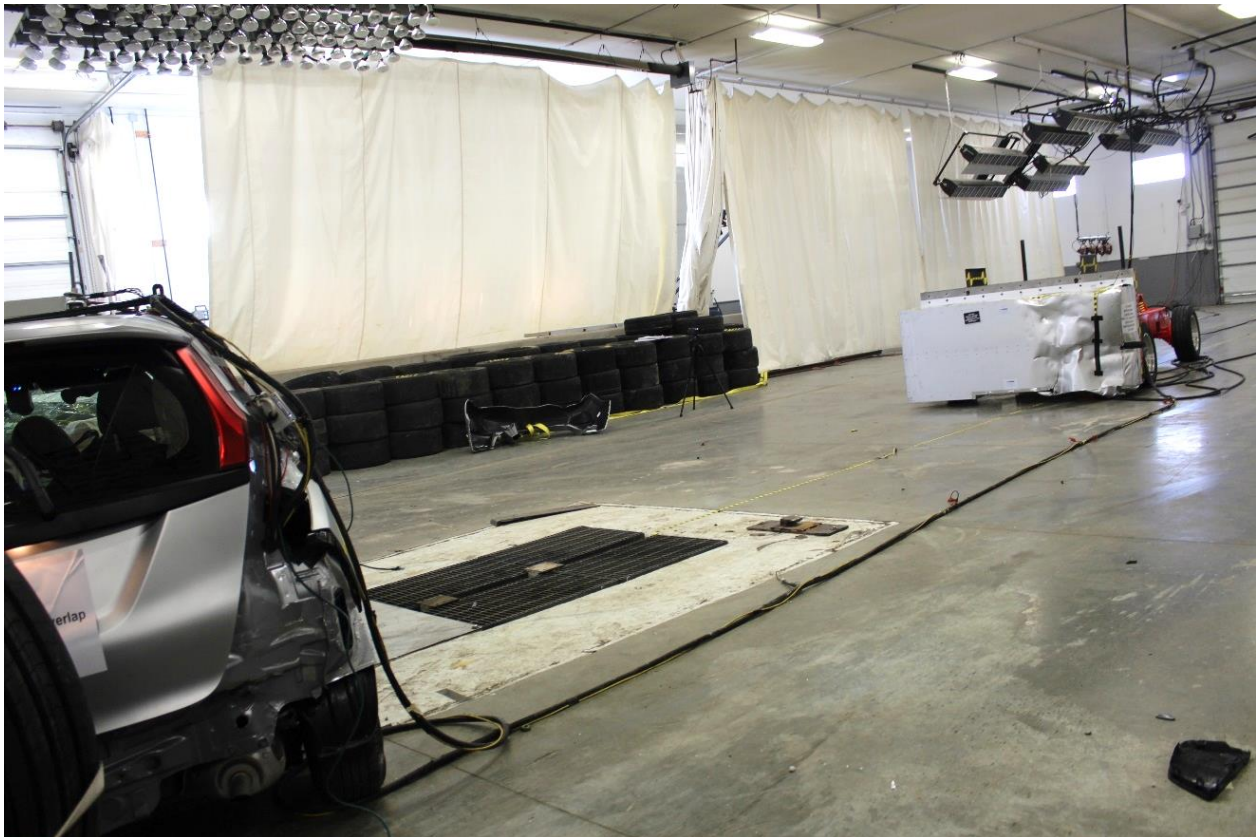

No. 192: Post-Test OMDB & Vehicle, Front View



No. 193: Pre-Test OMDB & Vehicle Alignment



No. 194: Vehicle at 0 Degrees on Static Rollover Device



No. 195: Vehicle at 90 Degrees on Static Rollover Device



No. 196: Vehicle at 180 Degrees on Static Rollover Device



No. 197: Vehicle at 270 Degrees on Static Rollover Device



No. 198: Vehicle at 360 Degrees on Static Rollover Device



No. 199: Impact Photo



No. 200: Pre-Test Vehicle Bumper Left Side View



No. 201 Post-Test Vehicle Bumper Left View



No. 202 Pre-Test Vehicle Bumper Left Front View

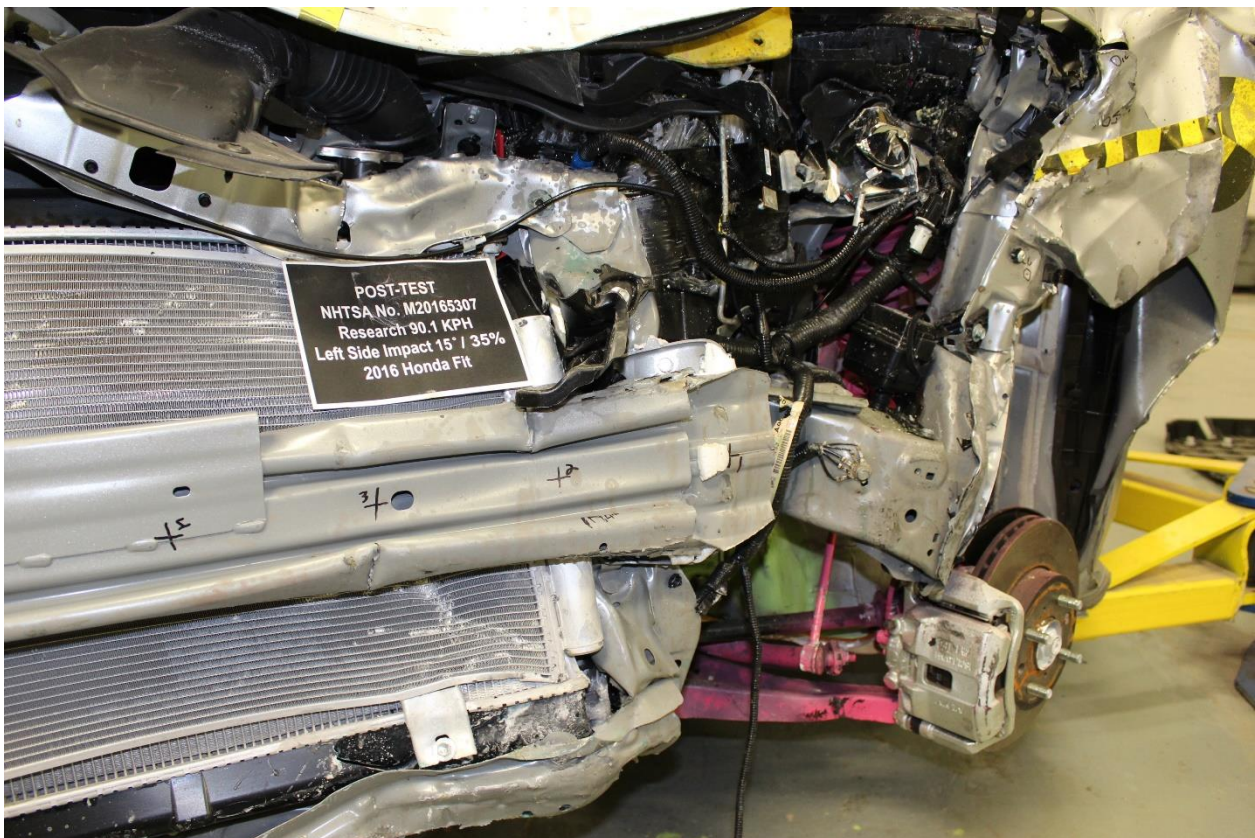

No. 203 Post-Test Vehicle Bumper Left Front View



No. 204 Pre-Test Vehicle Bumper Front View

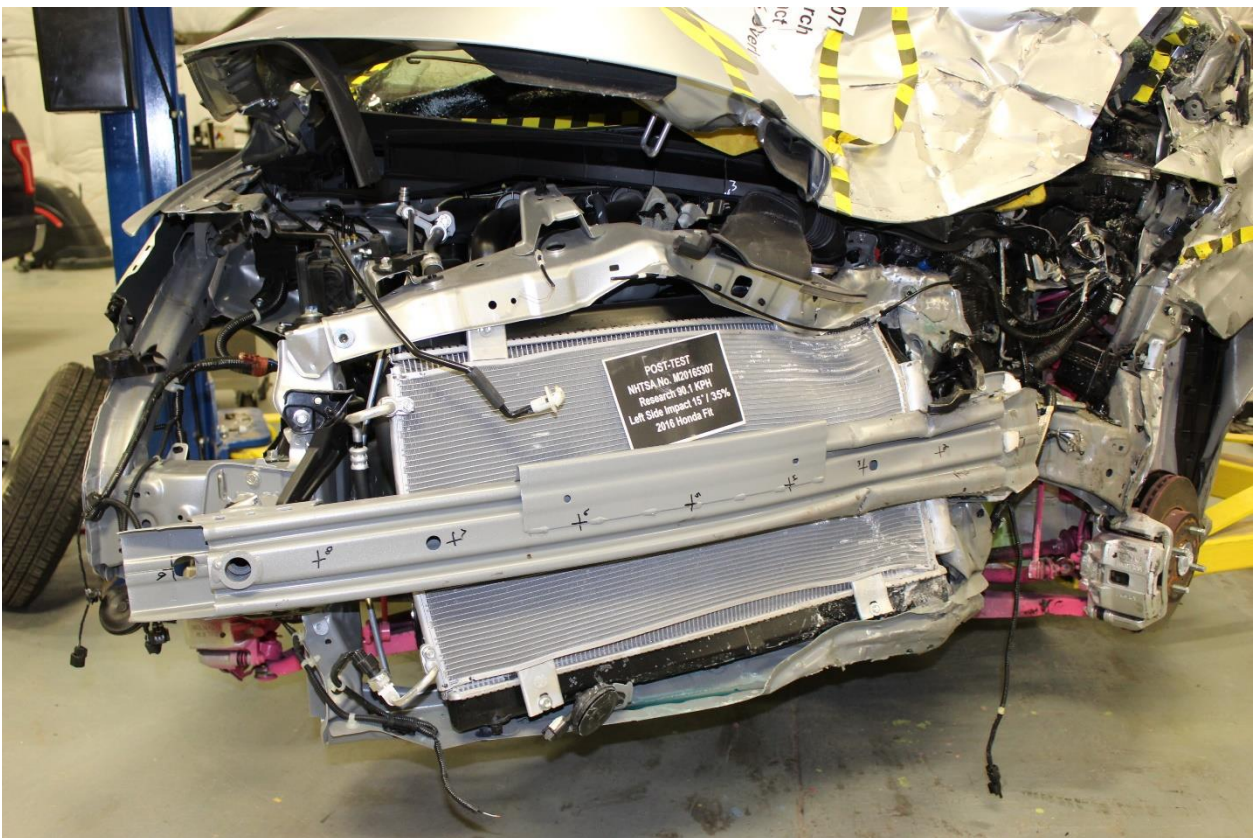

No. 205 Post-Test Vehicle Bumper Front View



No. 206 Pre-Test Vehicle Bumper Right Side View

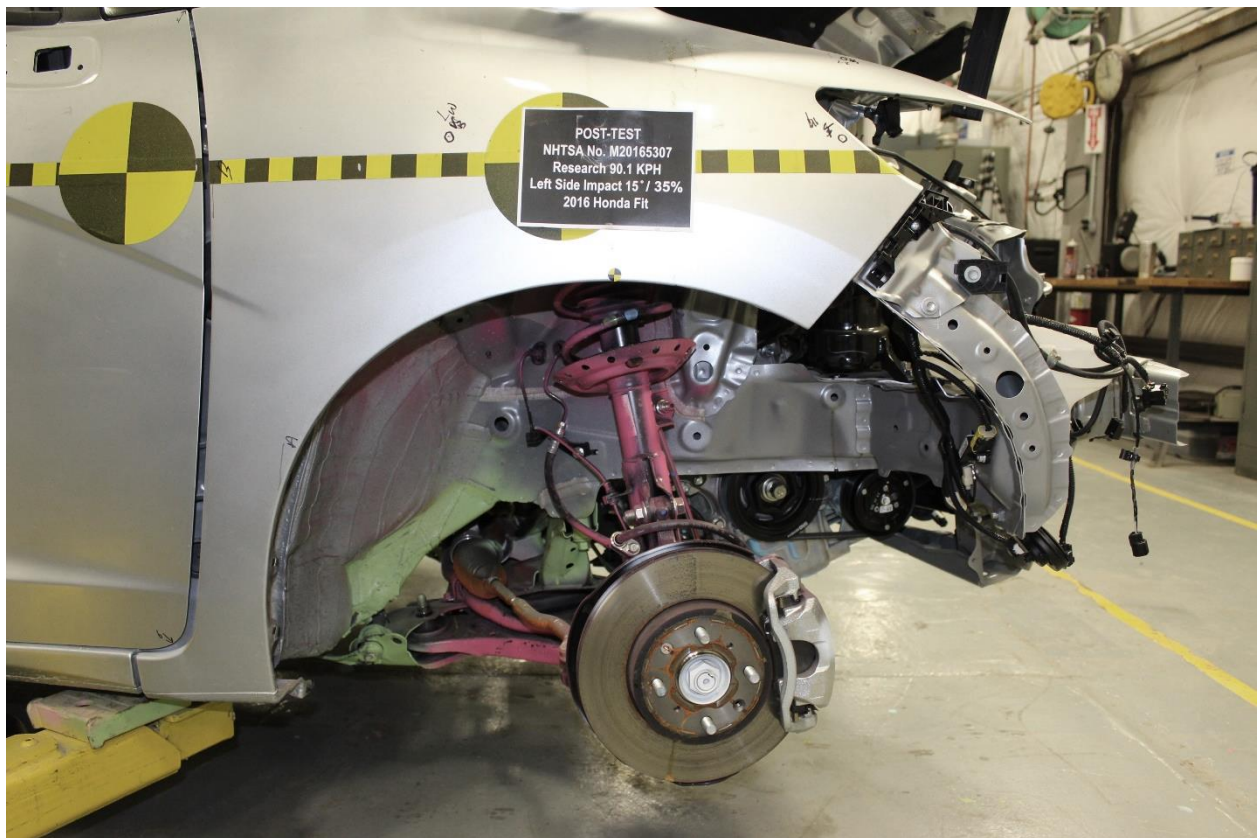

No. 207 Post-Test Vehicle Bumper Right View

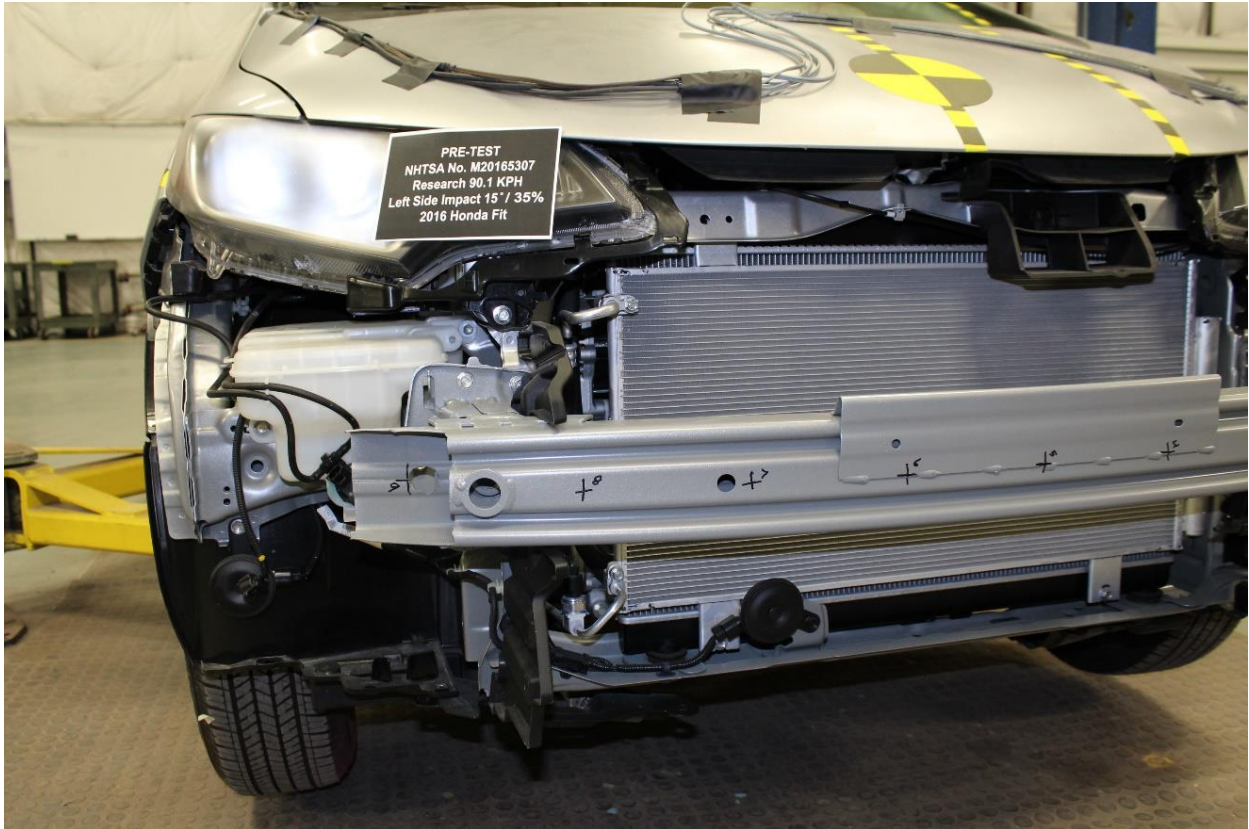

No. 208 Pre-Test Vehicle Bumper Right Front View

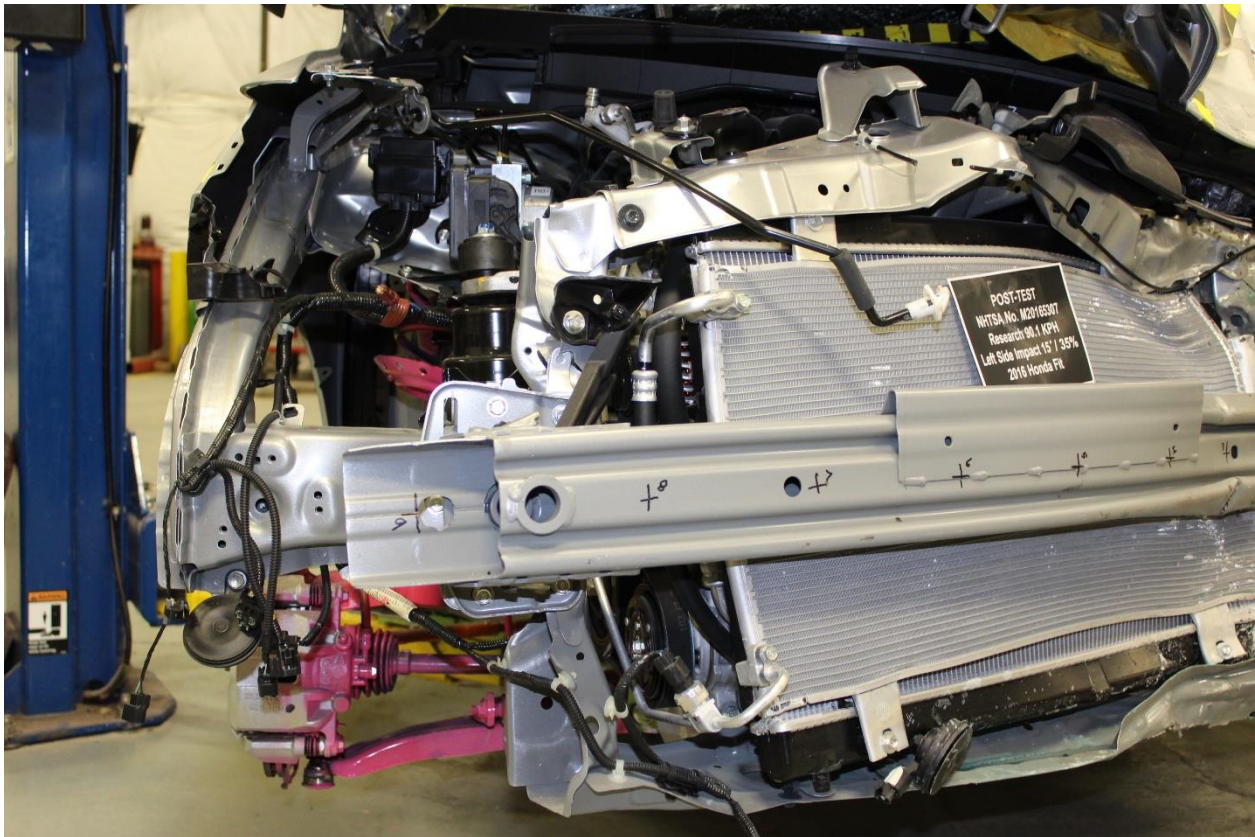

No. 209 Post-Test Vehicle Bumper Right Front View

APPENDIX B
VEHICLE & DUMMY RESPONSE DATA TRACES

Table of Data Plots

No.	Description	Page
Plot 1	V2P1 Head CG X Acceleration	B-9
Plot 2	V2P1 Head CG Y Acceleration	B-9
Plot 3	V2P1 Head CG Z Acceleration	B-9
Plot 4	V2P1 Head CG Angular Velocity About X	B-9
Plot 5	V2P1 Head CG Angular Velocity About Y	B-10
Plot 6	V2P1 Head CG Angular Velocity About Z	B-10
Plot 7	V2P1 Upper Neck X Force	B-10
Plot 8	V2P1 Upper Neck Y Force	B-10
Plot 9	V2P1 Upper Neck Z Force	B-11
Plot 10	V2P1 Upper Neck X Moment	B-11
Plot 11	V2P1 Upper Neck Y Moment	B-11
Plot 12	V2P1 Upper Neck Z Moment	B-11
Plot 13	V2P1 Lower Neck X Force	B-12
Plot 14	V2P1 Lower Neck Y Force	B-12
Plot 15	V2P1 Lower Neck Z Force	B-12
Plot 16	V2P1 Lower Neck X Moment	B-12
Plot 17	V2P1 Lower Neck Y Moment	B-13
Plot 18	V2P1 Lower Neck Z Moment	B-13
Plot 19	V2P1 Front Neck Spring Tower Load Cell	B-13
Plot 20	V2P1 Rear Neck Spring Tower Load Cell	B-13
Plot 21	V2P1 Occipital Condyle Rotation Potentiometer	B-14
Plot 22	V2P1 Upper Left DGIR X Displacement	B-14
Plot 23	V2P1 Upper Left DGIR Y Rotation	B-14
Plot 24	V2P1 Upper Left DGIR Z Rotation	B-14
Plot 25	V2P1 Upper Right DGIR X Displacement	B-15
Plot 26	V2P1 Upper Right DGIR Y Rotation	B-15
Plot 27	V2P1 Upper Right DGIR Z Rotation	B-15
Plot 28	V2P1 Lower Left DGIR X Displacement	B-15
Plot 29	V2P1 Lower Left DGIR Y Rotation	B-16
Plot 30	V2P1 Lower Left DGIR Z Rotation	B-16
Plot 31	V2P1 Lower Right DGIR X Displacement	B-16
Plot 32	V2P1 Lower Right DGIR Y Rotation	B-16
Plot 33	V2P1 Lower Right DGIR Z Rotation	B-17
Plot 34	V2P1 Spine Force X	B-17
Plot 35	V2P1 Spine Force Y	B-17
Plot 36	V2P1 Spine Force Z	B-17
Plot 37	V2P1 Spine Moment X	B-18
Plot 38	V2P1 Spine Moment Y	B-18
Plot 39	V2P1 T6 X Acceleration	B-18
Plot 40	V2P1 T6 Y Acceleration	B-18
Plot 41	V2P1 T6 Z Acceleration	B-19
Plot 42	V2P1 T1 X Acceleration	B-19
Plot 43	V2P1 T1 Y Acceleration	B-19
Plot 44	V2P1 T1 Z Acceleration	B-19
Plot 45	V2P1 Abdomen Left DGIR X Displacement	B-20
Plot 46	V2P1 Abdomen Left DGIR Y Rotation	B-20
Plot 47	V2P1 Abdomen Left DGIR Z Rotation	B-20
Plot 48	V2P1 Abdomen Right DGIR X Displacement	B-20
Plot 49	V2P1 Abdomen Right DGIR Y Rotation	B-21
Plot 50	V2P1 Abdomen Right DGIR Z Rotation	B-21
Plot 51	V2P1 Pelvis Acetabulum Left X Force	B-21
Plot 52	V2P1 Pelvis Acetabulum Left Y Force	B-21
Plot 53	V2P1 Pelvis Acetabulum Left Z Force	B-22
Plot 54	V2P1 Pelvis Acetabulum Right X Force	B-22
Plot 55	V2P1 Pelvis Acetabulum Right Y Force	B-22
Plot 56	V2P1 Pelvis Acetabulum Right Z Force	B-22
Plot 57	V2P1 Pelvis X Acceleration	B-23

Plot 58	V2P1 Pelvis Y Acceleration	B-23
Plot 59	V2P1 Pelvis Z Acceleration	B-23
Plot 60	V2P1 ASIS Left X Force	B-23
Plot 61	V2P1 Left ASIS Y Moment	B-24
Plot 62	V2P1 ASIS Right X Force	B-24
Plot 63	V2P1 Right ASIS Y Moment	B-24
Plot 64	V2P1 Femur Left X Force	B-24
Plot 65	V2P1 Femur Left Y Force	B-25
Plot 66	V2P1 Femur Left Z Force	B-25
Plot 67	V2P1 Femur Left X Moment	B-25
Plot 68	V2P1 Femur Left Y Moment	B-25
Plot 69	V2P1 Femur Right X Force	B-26
Plot 70	V2P1 Femur Right Y Force	B-26
Plot 71	V2P1 Femur Right Z Force	B-26
Plot 72	V2P1 Femur Right X Moment	B-26
Plot 73	V2P1 Femur Right Y Moment	B-27
Plot 74	V2P1 Knee Left X Displacement	B-27
Plot 75	V2P1 Knee Right X Displacement	B-27
Plot 76	V2P1 Upper Tibia Left Z Force	B-27
Plot 77	V2P1 Upper Tibia Left X Moment	B-28
Plot 78	V2P1 Upper Tibia Left Y Moment	B-28
Plot 79	V2P1 Upper Tibia Right Z Force	B-28
Plot 80	V2P1 Upper Tibia Right X Moment	B-28
Plot 81	V2P1 Upper Tibia Right Y Moment	B-29
Plot 82	V2P1 Lower Tibia Left X Force	B-29
Plot 83	V2P1 Lower Tibia Left Y Force	B-29
Plot 84	V2P1 Lower Tibia Left Z Force	B-29
Plot 85	V2P1 Lower Tibia Left X Moment	B-30
Plot 86	V2P1 Lower Tibia Left Y Moment	B-30
Plot 87	V2P1 Lower Tibia Right X Force	B-30
Plot 88	V2P1 Lower Tibia Right Y Force	B-30
Plot 89	V2P1 Lower Tibia Right Z Force	B-31
Plot 90	V2P1 Lower Tibia Right X Moment	B-31
Plot 91	V2P1 Lower Tibia Right Y Moment	B-31
Plot 92	V2P1 Left Mid Tibia X Acceleration	B-31
Plot 93	V2P1 Left Mid Tibia Y Acceleration	B-32
Plot 94	V2P1 Right Mid Tibia X Acceleration	B-32
Plot 95	V2P1 Right Mid Tibia Y Acceleration	B-32
Plot 96	V2P1 Foot Left X Acceleration	B-32
Plot 97	V2P1 Foot Left Z Acceleration	B-33
Plot 98	V2P1 Foot Right X Acceleration	B-33
Plot 99	V2P1 Foot Right Z Acceleration	B-33
Plot 100	V2P1 Ankle Left X Rotation	B-33
Plot 101	V2P1 Ankle Left Y Rotation	B-34
Plot 102	V2P1 Ankle Left Z Rotation	B-34
Plot 103	V2P1 Ankle Right X Rotation	B-34
Plot 104	V2P1 Ankle Right Y Rotation	B-34
Plot 105	V2P1 Ankle Right Z Rotation	B-35
Plot 106	V2 Driver Lap Belt Force	B-35
Plot 107	V2 Driver Shoulder Belt Upper Force	B-35
Plot 108	V2 Driver Shoulder Belt Displacement	B-35
Plot 109	V2P2 Head CG X Acceleration	B-36
Plot 110	V2P2 Head CG Y Acceleration	B-36
Plot 111	V2P2 Head CG Z Acceleration	B-36
Plot 112	V2P2 Head CG Angular Velocity About X	B-36
Plot 113	V2P2 Head CG Angular Velocity About Y	B-37
Plot 114	V2P2 Head CG Angular Velocity About Z	B-37
Plot 115	V2P2 Upper Neck X Force	B-37
Plot 116	V2P2 Upper Neck Y Force	B-37

Plot 117	V2P2 Upper Neck Z Force	B-38
Plot 118	V2P2 Upper Neck X Moment	B-38
Plot 119	V2P2 Upper Neck Y Moment	B-38
Plot 120	V2P2 Upper Neck Z Moment	B-38
Plot 121	V2P2 Lower Neck X Force	B-39
Plot 122	V2P2 Lower Neck Y Force	B-39
Plot 123	V2P2 Lower Neck Z Force	B-39
Plot 124	V2P2 Lower Neck X Moment	B-39
Plot 125	V2P2 Lower Neck Y Moment	B-40
Plot 126	V2P2 Lower Neck Z Moment	B-40
Plot 127	V2P2 Front Neck Spring Tower Load Cell	B-40
Plot 128	V2P2 Rear Neck Spring Tower Load Cell	B-40
Plot 129	V2P2 Occipital Condyle Rotation Potentiometer	B-41
Plot 130	V2P2 Upper Left DGIR X Displacement	B-41
Plot 131	V2P2 Upper Left DGIR Y Rotation	B-41
Plot 132	V2P2 Upper Left DGIR Z Rotation	B-41
Plot 133	V2P2 Upper Right DGIR X Displacement	B-42
Plot 134	V2P2 Upper Right DGIR Y Rotation	B-42
Plot 135	V2P2 Upper Right DGIR Z Rotation	B-42
Plot 136	V2P2 Lower Left DGIR X Displacement	B-42
Plot 137	V2P2 Lower Left DGIR Y Rotation	B-43
Plot 138	V2P2 Lower Left DGIR Z Rotation	B-43
Plot 139	V2P2 Lower Right DGIR X Displacement	B-43
Plot 140	V2P2 Lower Right DGIR Y Rotation	B-43
Plot 141	V2P2 Lower Right DGIR Z Rotation	B-44
Plot 142	V2P2 Spine Force X	B-44
Plot 143	V2P2 Spine Force Y	B-44
Plot 144	V2P2 Spine Force Z	B-44
Plot 145	V2P2 Spine Moment X	B-45
Plot 146	V2P2 Spine Moment Y	B-45
Plot 147	V2P2 T6 X Acceleration	B-45
Plot 148	V2P2 T6 Y Acceleration	B-45
Plot 149	V2P2 T6 Z Acceleration	B-46
Plot 150	V2P2 T1 X Acceleration	B-46
Plot 151	V2P2 T1 Y Acceleration	B-46
Plot 152	V2P2 T1 Z Acceleration	B-46
Plot 153	V2P2 Abdomen Left DGIR X Displacement	B-47
Plot 154	V2P2 Abdomen Left DGIR Y Rotation	B-47
Plot 155	V2P2 Abdomen Left DGIR Z Rotation	B-47
Plot 156	V2P2 Abdomen Right DGIR X Displacement	B-47
Plot 157	V2P2 Abdomen Right DGIR Y Rotation	B-48
Plot 158	V2P2 Abdomen Right DGIR Z Rotation	B-48
Plot 159	V2P2 Pelvis Acetabulum Left X Force	B-48
Plot 160	V2P2 Pelvis Acetabulum Left Y Force	B-48
Plot 161	V2P2 Pelvis Acetabulum Left Z Force	B-49
Plot 162	V2P2 Pelvis Acetabulum Right X Force	B-49
Plot 163	V2P2 Pelvis Acetabulum Right Y Force	B-49
Plot 164	V2P2 Pelvis Acetabulum Right Z Force	B-49
Plot 165	V2P2 Pelvis X Acceleration	B-50
Plot 166	V2P2 Pelvis Y Acceleration	B-50
Plot 167	V2P2 Pelvis Z Acceleration	B-50
Plot 168	V2P2 ASIS Left X Force	B-50
Plot 169	V2P2 Left ASIS Y Moment	B-51
Plot 170	V2P2 ASIS Right X Force	B-51
Plot 171	V2P2 Right ASIS Y Moment	B-51
Plot 172	V2P2 Femur Left X Force	B-51
Plot 173	V2P2 Femur Left Y Force	B-52
Plot 174	V2P2 Femur Left Z Force	B-52
Plot 175	V2P2 Femur Left X Moment	B-52

Plot 176	V2P2 Femur Left Y Moment	B-52
Plot 177	V2P2 Femur Right X Force	B-53
Plot 178	V2P2 Femur Right Y Force	B-53
Plot 179	V2P2 Femur Right Z Force	B-53
Plot 180	V2P2 Femur Right X Moment	B-53
Plot 181	V2P2 Femur Right Y Moment	B-54
Plot 182	V2P2 Knee Left X Displacement	B-54
Plot 183	V2P2 Knee Right X Displacement	B-54
Plot 184	V2P2 Upper Tibia Left Z Force	B-54
Plot 185	V2P2 Upper Tibia Left X Moment	B-55
Plot 186	V2P2 Upper Tibia Left Y Moment	B-55
Plot 187	V2P2 Upper Tibia Right Z Force	B-55
Plot 188	V2P2 Upper Tibia Right X Moment	B-55
Plot 189	V2P2 Upper Tibia Right Y Moment	B-56
Plot 190	V2P2 Lower Tibia Left X Force	B-56
Plot 191	V2P2 Lower Tibia Left Y Force	B-56
Plot 192	V2P2 Lower Tibia Left Z Force	B-56
Plot 193	V2P2 Lower Tibia Left X Moment	B-57
Plot 194	V2P2 Lower Tibia Left Y Moment	B-57
Plot 195	V2P2 Lower Tibia Right X Force	B-57
Plot 196	V2P2 Lower Tibia Right Y Force	B-57
Plot 197	V2P2 Lower Tibia Right Z Force	B-58
Plot 198	V2P2 Lower Tibia Right X Moment	B-58
Plot 199	V2P2 Lower Tibia Right Y Moment	B-58
Plot 200	V2P2 Left Mid Tibia X Acceleration	B-58
Plot 201	V2P2 Left Mid Tibia Y Acceleration	B-59
Plot 202	V2P2 Right Mid Tibia X Acceleration	B-59
Plot 203	V2P2 Right Mid Tibia Y Acceleration	B-59
Plot 204	V2P2 Foot Left X Acceleration	B-59
Plot 205	V2P2 Foot Left Z Acceleration	B-60
Plot 206	V2P2 Foot Right X Acceleration	B-60
Plot 207	V2P2 Foot Right Z Acceleration	B-60
Plot 208	V2P2 Ankle Left X Rotation	B-60
Plot 209	V2P2 Ankle Left Y Rotation	B-61
Plot 210	V2P2 Ankle Left Z Rotation	B-61
Plot 211	V2P2 Ankle Right X Rotation	B-61
Plot 212	V2P2 Ankle Right Y Rotation	B-61
Plot 213	V2P2 Ankle Right Z Rotation	B-62
Plot 214	V2 Passenger Lap Belt Force	B-62
Plot 215	V2 Passenger Shoulder Belt Upper Force	B-62
Plot 216	V2 Passenger Shoulder Belt Displacement	B-62
Plot 217	V2 Left Rear Sill X Acceleration	B-63
Plot 218	V2 Left Rear Sill Y Acceleration	B-63
Plot 219	V2 Left Rear Sill Redundant X Acceleration	B-63
Plot 220	V2 Left Rear Sill Redundant Y Acceleration	B-63
Plot 221	V2 Right Rear Sill X Acceleration	B-64
Plot 222	V2 Right Rear Sill Y Acceleration	B-64
Plot 223	V2 Vehicle CG X Acceleration	B-64
Plot 224	V2 Vehicle CG Y Acceleration	B-64
Plot 225	V2 Vehicle CG Z Acceleration	B-65
Plot 226	Vehicle CG X Angular Rate	B-65
Plot 227	Vehicle CG Y Angular Rate	B-65
Plot 228	Vehicle CG Z Angular Rate	B-65
Plot 229	V2 Driver Seat Track X Acceleration	B-66
Plot 230	V2 Driver Seat Track Y Acceleration	B-66
Plot 231	V2 Driver Seat Track Z Acceleration	B-66
Plot 232	V2 Driver Seat Thigh Bar X Acceleration	B-66
Plot 233	V2 Driver Seat Thigh Bar Z Acceleration	B-67
Plot 234	V2 Driver Floor Pan X Acceleration	B-67

Plot 235	V2 Driver Floor Pan Y Acceleration	B-67
Plot 236	V2 Driver Floor Pan Z Acceleration	B-67
Plot 237	V2 Driver Floor Pan X Deflection	B-68
Plot 238	Driver Front Airbag Stage 1 Monitor	B-68
Plot 239	Driver Front Airbag Stage 2 Monitor	B-68
Plot 240	Driver Curtain Airbag Monitor	B-68
Plot 241	Driver Seat Torso Airbag Monitor	B-69
Plot 242	Driver Retractor Pretensioner Monitor	B-69
Plot 243	Driver Anchor Pretensioner Monitor	B-69
Plot 244	Passenger Front Airbag Stage 1 Monitor	B-69
Plot 245	Passenger Front Airbag Stage 2 Monitor	B-70
Plot 246	Passenger Curtain Airbag Monitor	B-70
Plot 247	Passenger Seat Torso Airbag Monitor	B-70
Plot 248	Passenger Retractor Pretensioner Monitor	B-70
Plot 249	V1 OMDB CG X Acceleration	B-71
Plot 250	V1 OMDB CG Y Acceleration	B-71
Plot 251	V1 OMDB CG Z Acceleration	B-71
Plot 252	V1 OMDB CG Angular Rate X	B-71
Plot 253	V1 OMDB CG Angular Rate Y	B-72
Plot 254	V1 OMDB CG Angular Rate Z	B-72
Plot 255	V1 OMDB Rear C/L X Acceleration	B-72
Plot 256	V1 OMDB Rear C/L Y Acceleration	B-72
Plot 257	V1 OMDB Rear C/L Z Acceleration	B-73
Plot 258	V2P1 Fx on head acting through the O.C. joint only	B-73
Plot 259	V2P1 Fz on head acting through the O.C. joint only	B-73
Plot 260	V2P1 My on head acting through the O.C. joint only	B-73
Plot 261	V2P1 Fx on head acting through the total neck section	B-74
Plot 262	V2P1 Fy on head acting through the total neck section	B-74
Plot 263	V2P1 Fz on head acting through the total neck section	B-74
Plot 264	V2P1 Mx on head acting through the total neck section	B-74
Plot 265	V2P1 My on head acting through the total neck section	B-75
Plot 266	V2P1 Mz on head acting through the total neck section	B-75
Plot 267	V2P1 Chest Left Upper Dx	B-75
Plot 268	V2P1 Chest Left Upper Dy	B-75
Plot 269	V2P1 Chest Left Upper Dz	B-76
Plot 270	V2P1 Chest Left Upper Resultant	B-76
Plot 271	V2P1 Chest Right Upper Dx	B-76
Plot 272	V2P1 Chest Right Upper Dy	B-76
Plot 273	V2P1 Chest Right Upper Dz	B-77
Plot 274	V2P1 Chest Right Upper Resultant	B-77
Plot 275	V2P1 Chest Left Lower Dx	B-77
Plot 276	V2P1 Chest Left Lower Dy	B-77
Plot 277	V2P1 Chest Left Lower Dz	B-78
Plot 278	V2P1 Chest Left Lower Resultant	B-78
Plot 279	V2P1 Chest Right Lower Dx	B-78
Plot 280	V2P1 Chest Right Lower Dy	B-78
Plot 281	V2P1 Chest Right Lower Dz	B-79
Plot 282	V2P1 Chest Right Lower Resultant	B-79
Plot 283	V2P1 Abdomen Left Lower Dx	B-79
Plot 284	V2P1 Abdomen Left Lower Dy	B-79
Plot 285	V2P1 Abdomen Left Lower Dz	B-80
Plot 286	V2P1 Abdomen Left Lower Resultant	B-80
Plot 287	V2P1 Abdomen Right Lower Dx	B-80
Plot 288	V2P1 Abdomen Right Lower Dy	B-80
Plot 289	V2P1 Abdomen Right Lower Dz	B-81
Plot 290	V2P1 Abdomen Right Lower Resultant	B-81
Plot 291	V2P2 Fx on head acting through the O.C. joint only	B-81
Plot 292	V2P2 Fz on head acting through the O.C. joint only	B-81
Plot 293	V2P2 My on head acting through the O.C. joint only	B-82

Plot 294	V2P2 Fx on head acting through the total neck section	B-82
Plot 295	V2P2 Fy on head acting through the total neck section	B-82
Plot 296	V2P2 Fz on head acting through the total neck section	B-82
Plot 297	V2P2 Mx on head acting through the total neck section	B-83
Plot 298	V2P2 My on head acting through the total neck section	B-83
Plot 299	V2P2 Mz on head acting through the total neck section	B-83
Plot 300	V2P2 Chest Left Upper Dx	B-83
Plot 301	V2P2 Chest Left Upper Dy	B-84
Plot 302	V2P2 Chest Left Upper Dz	B-84
Plot 303	V2P2 Chest Left Upper Resultant	B-84
Plot 304	V2P2 Chest Right Upper Dx	B-84
Plot 305	V2P2 Chest Right Upper Dy	B-85
Plot 306	V2P2 Chest Right Upper Dz	B-85
Plot 307	V2P2 Chest Right Upper Resultant	B-85
Plot 308	V2P2 Chest Left Lower Dx	B-85
Plot 309	V2P2 Chest Left Lower Dy	B-86
Plot 310	V2P2 Chest Left Lower Dz	B-86
Plot 311	V2P2 Chest Left Lower Resultant	B-86
Plot 312	V2P2 Chest Right Lower Dx	B-86
Plot 313	V2P2 Chest Right Lower Dy	B-87
Plot 314	V2P2 Chest Right Lower Dz	B-87
Plot 315	V2P2 Chest Right Lower Resultant	B-87
Plot 316	V2P2 Abdomen Left Lower Dx	B-87
Plot 317	V2P2 Abdomen Left Lower Dy	B-88
Plot 318	V2P2 Abdomen Left Lower Dz	B-88
Plot 319	V2P2 Abdomen Left Lower Resultant	B-88
Plot 320	V2P2 Abdomen Right Lower Dx	B-88
Plot 321	V2P2 Abdomen Right Lower Dy	B-89
Plot 322	V2P2 Abdomen Right Lower Dz	B-89
Plot 323	V2P2 Abdomen Right Lower Resultant	B-89

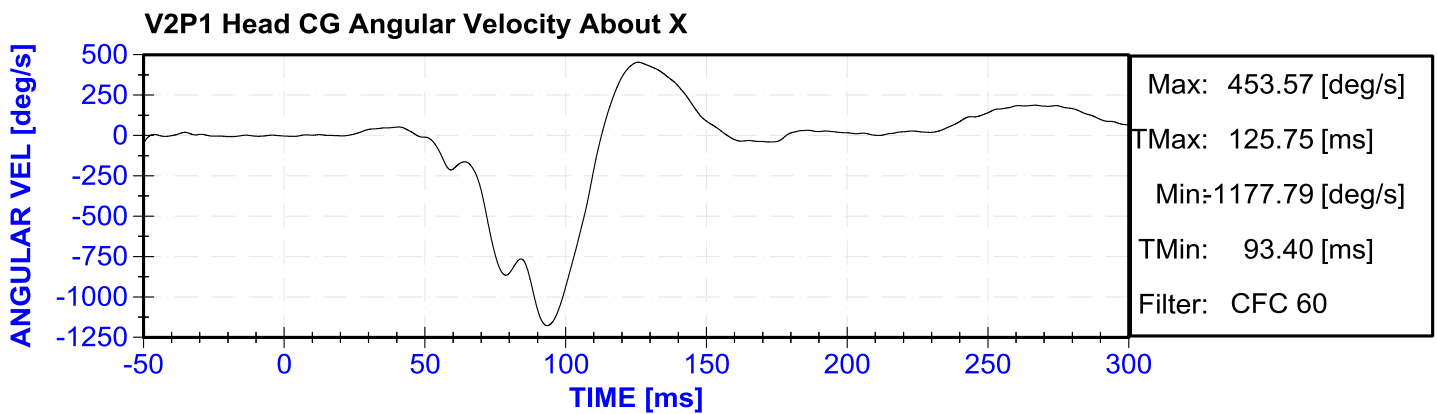
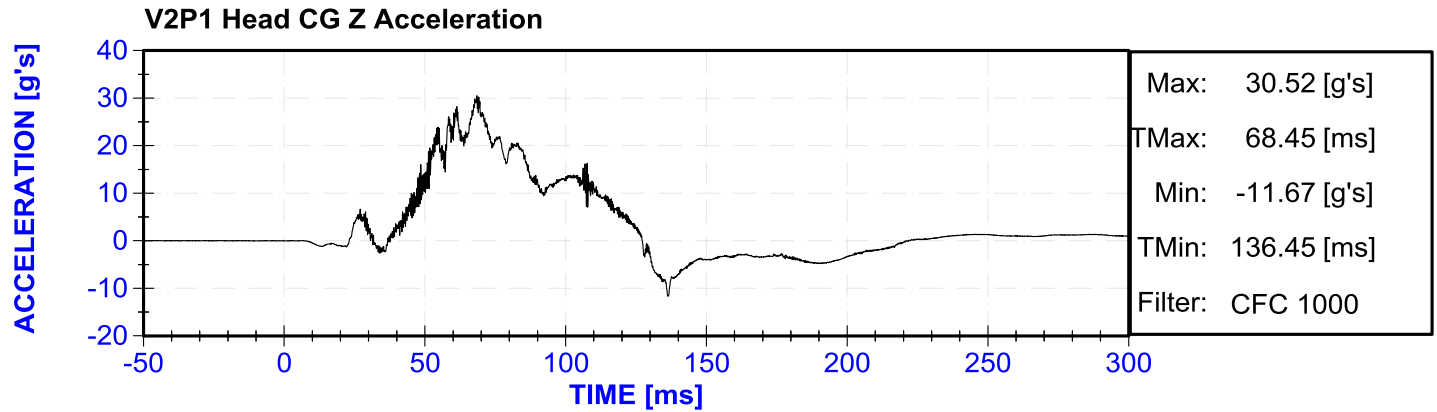
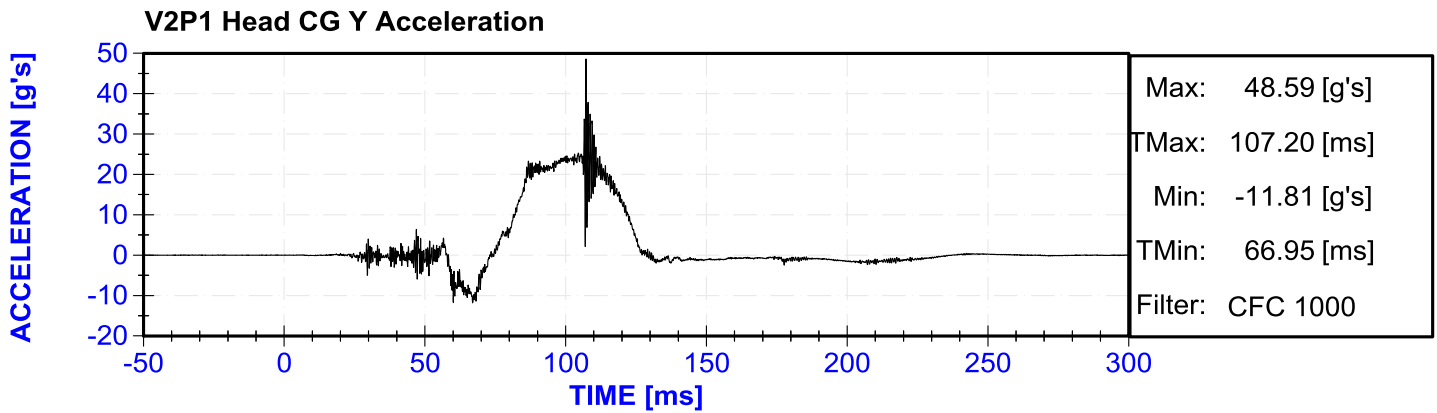
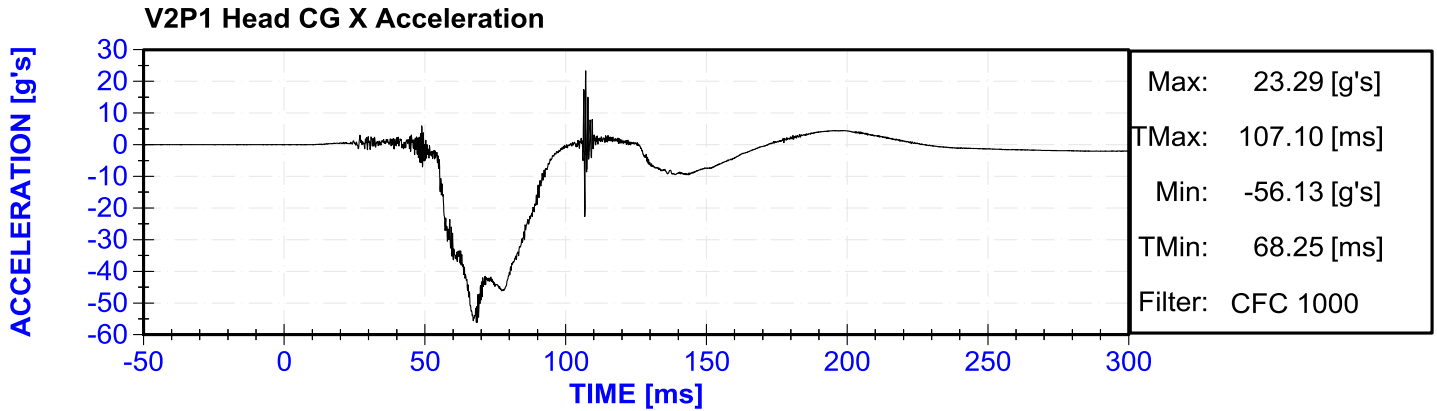

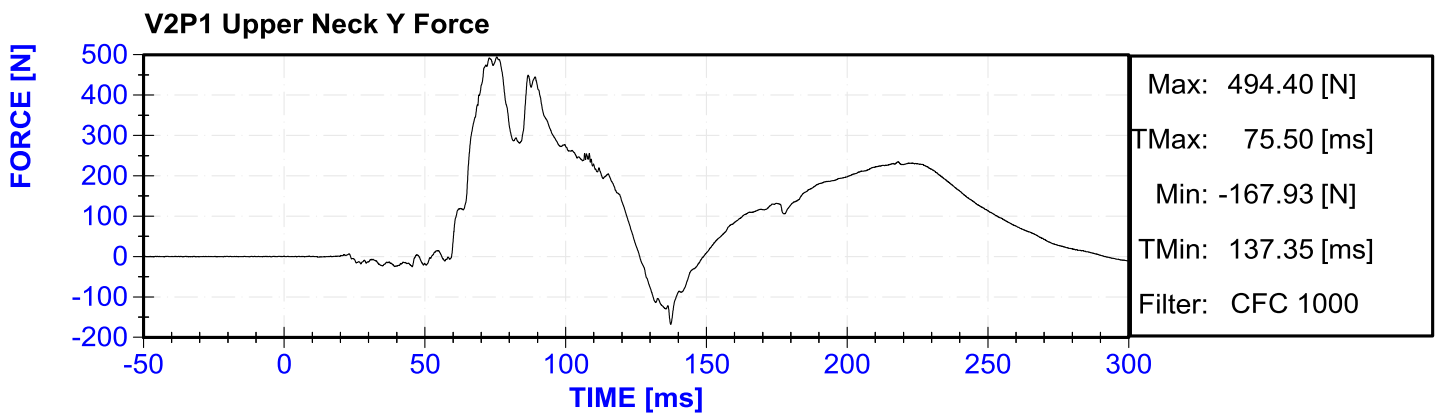
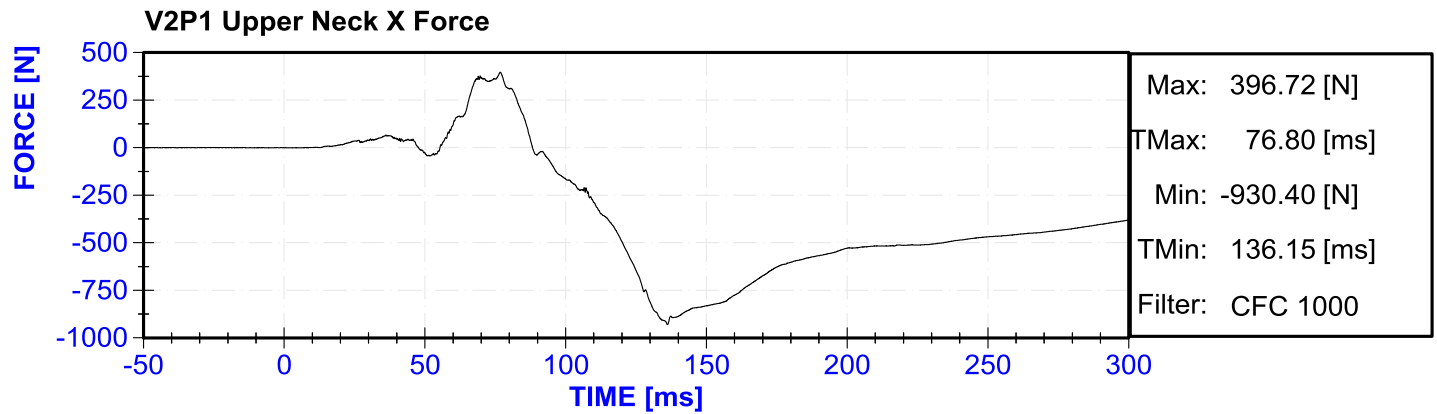
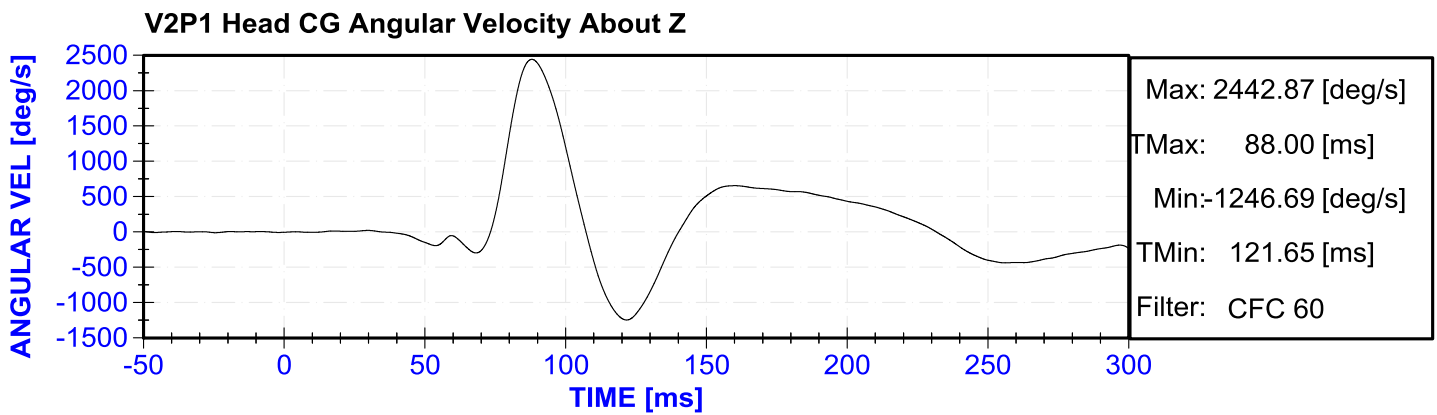
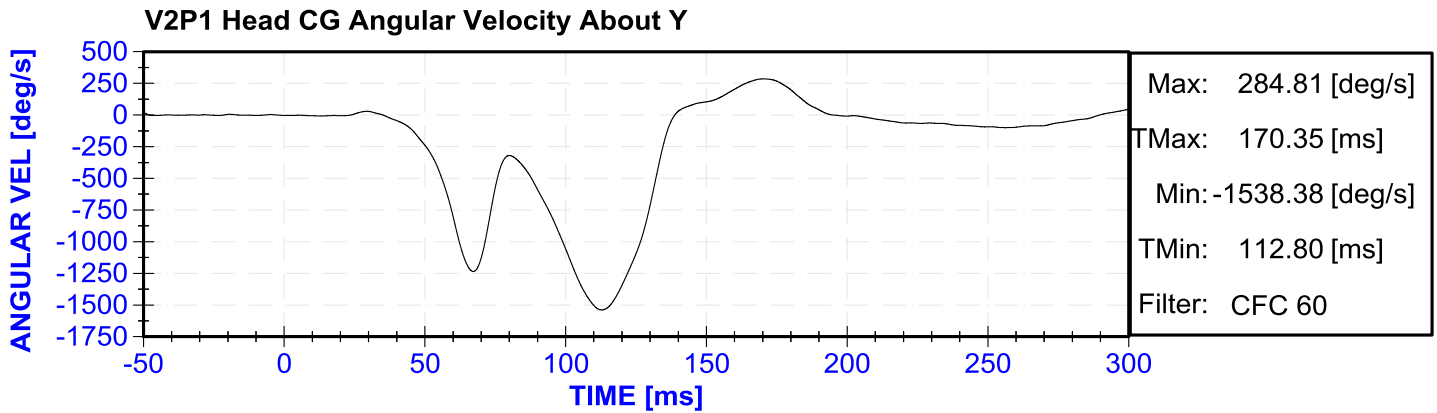

V2P1 Upper Neck Z Force

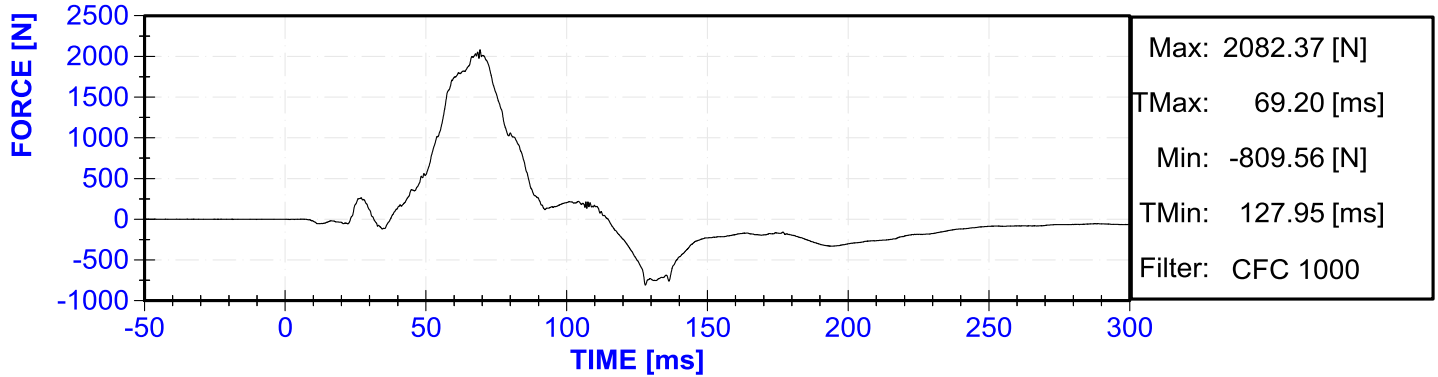

V2P1 Upper Neck X Moment

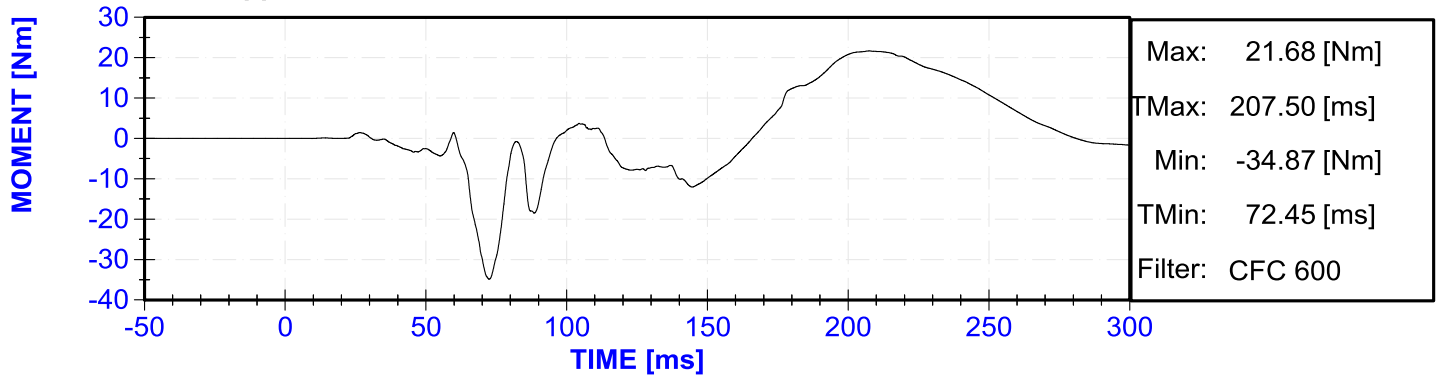

V2P1 Upper Neck Y Moment

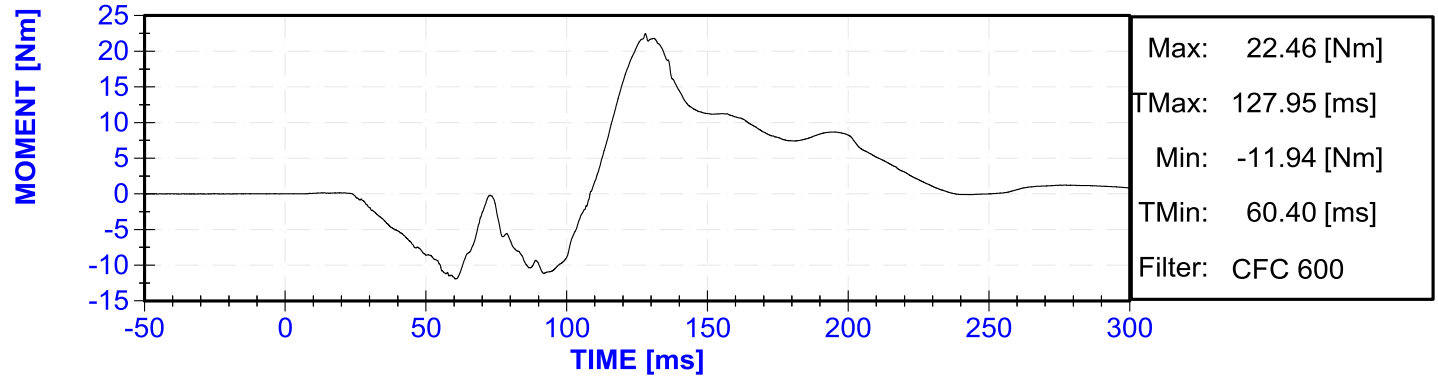

V2P1 Upper Neck Z Moment

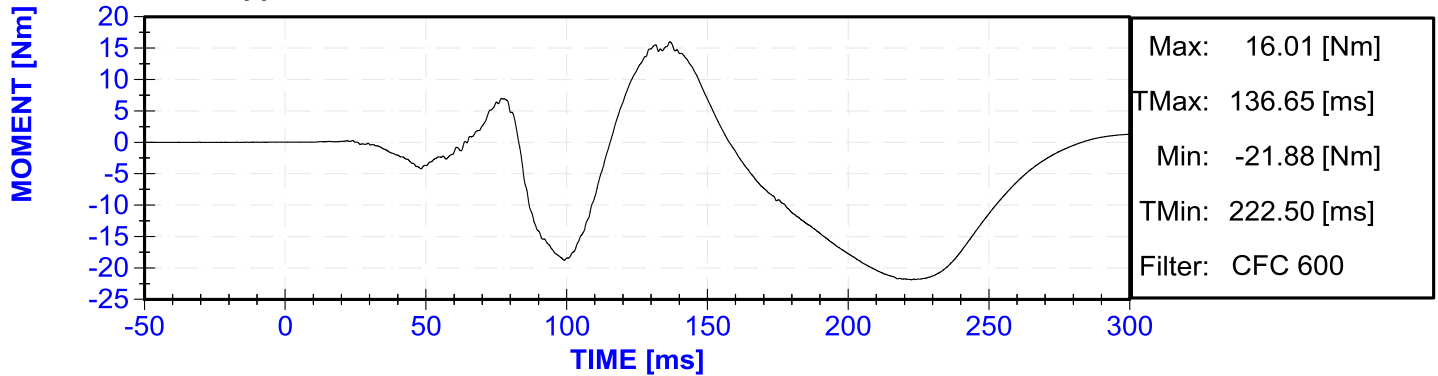

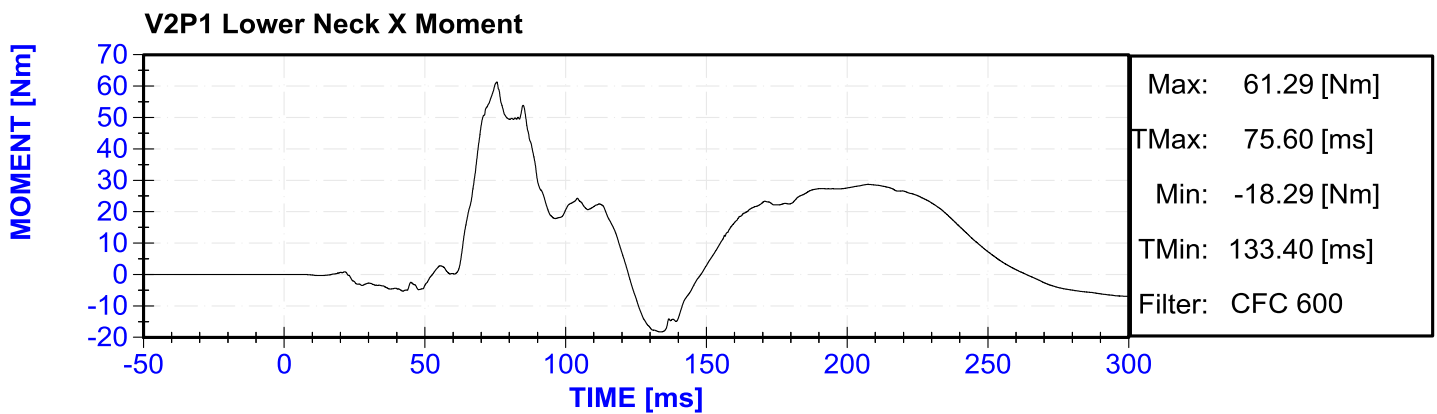
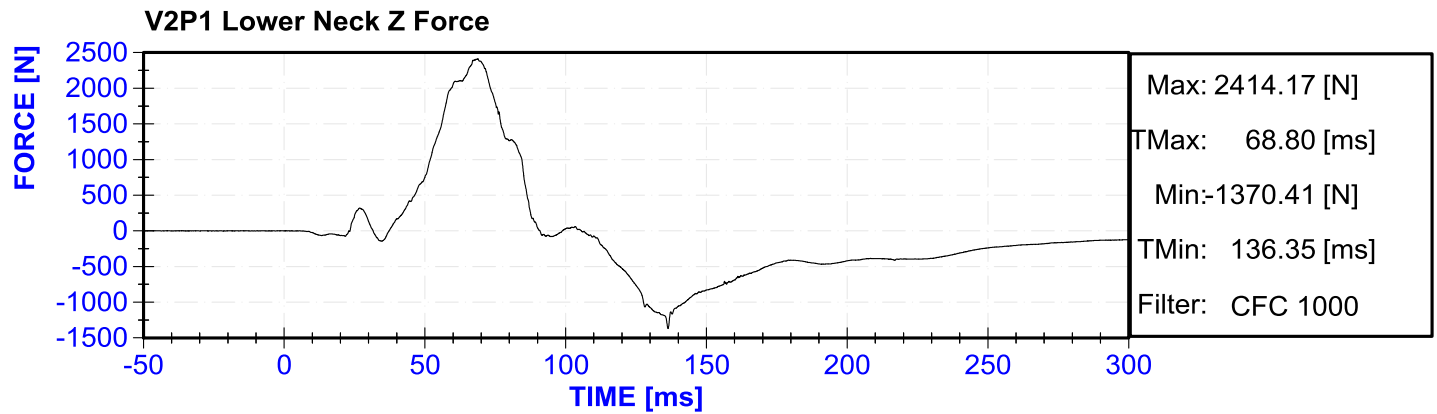
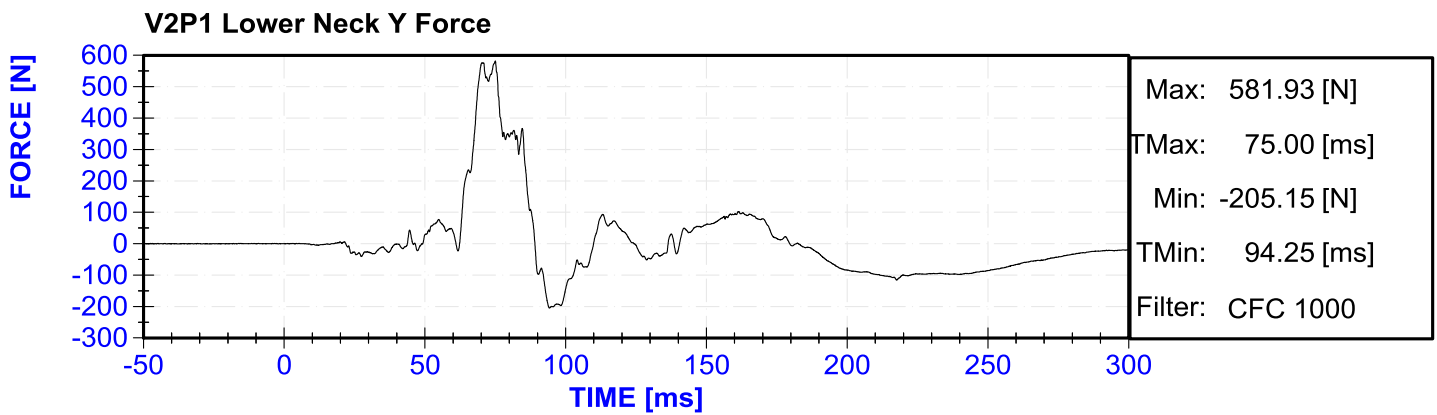
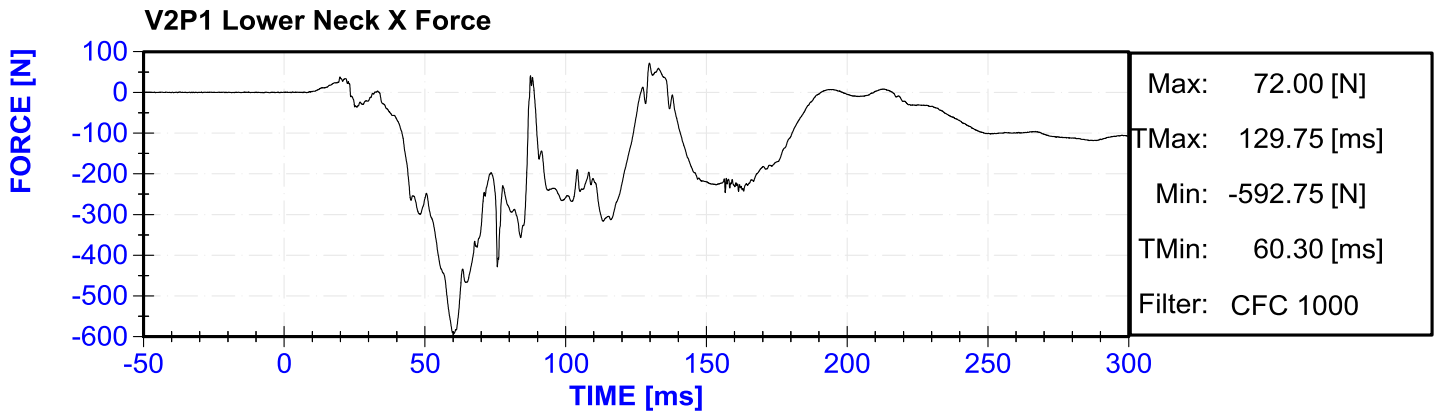

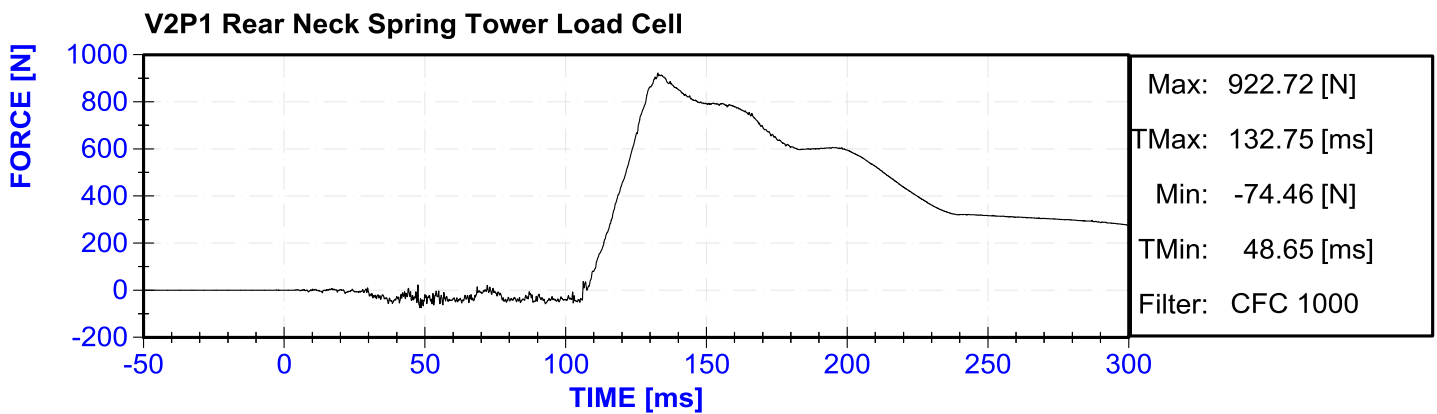
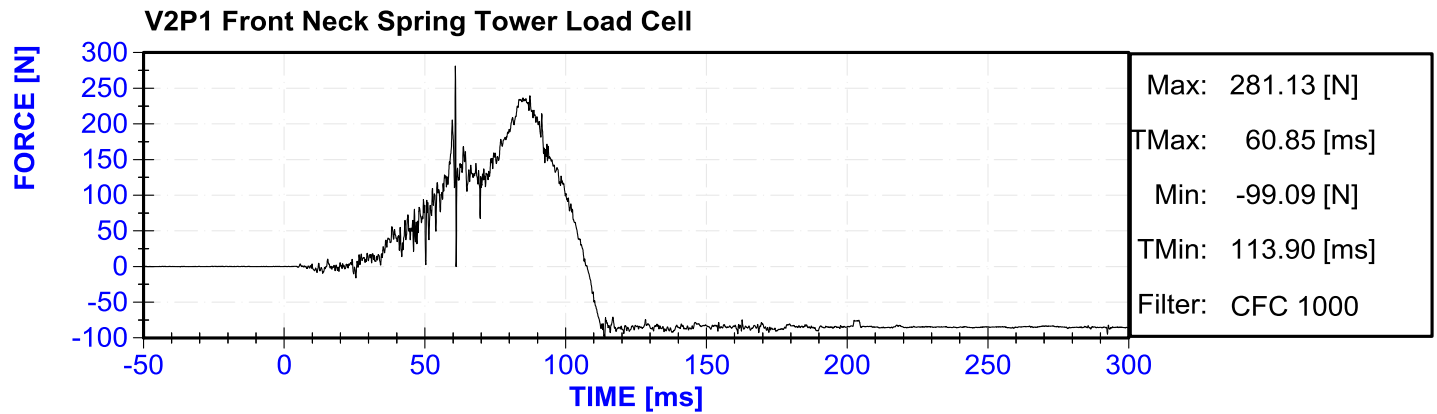
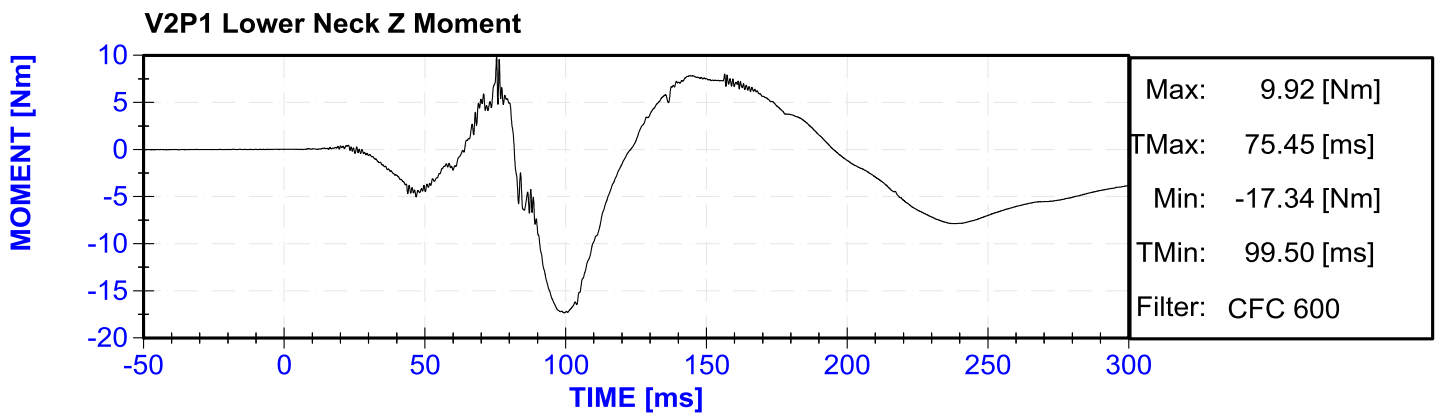
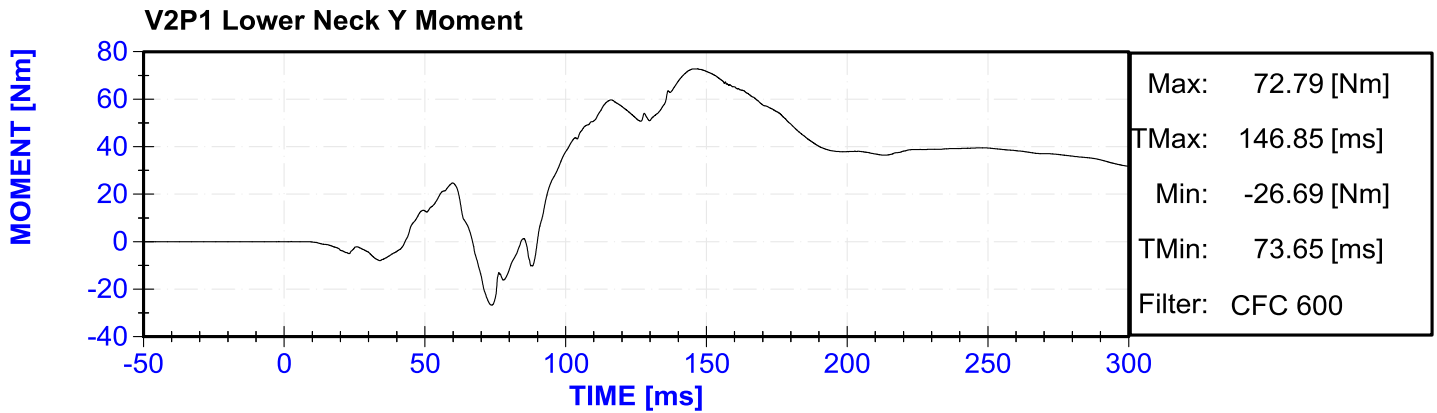

V2P1 Occipital Condyle Rotation Potentiometer

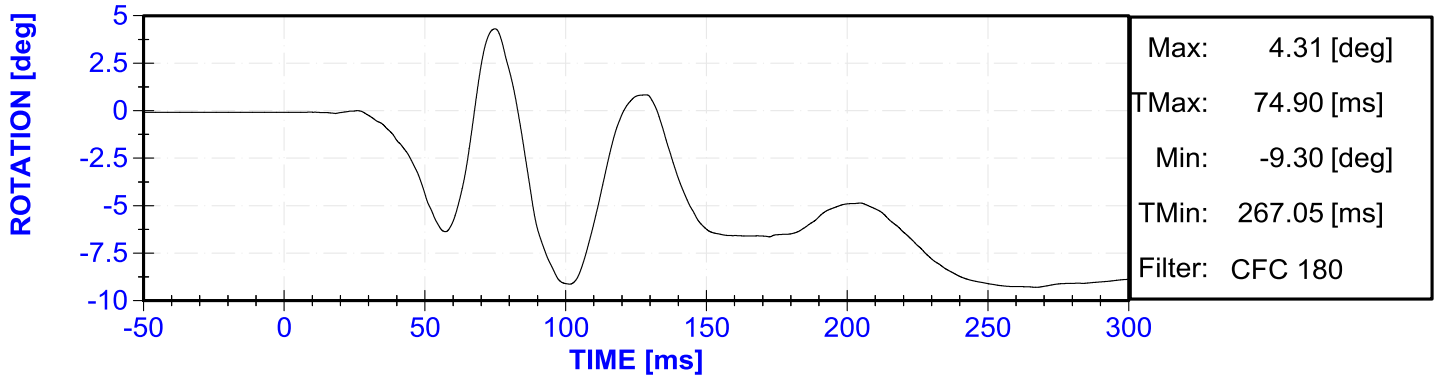

V2P1 Upper Left DGIR X Displacement

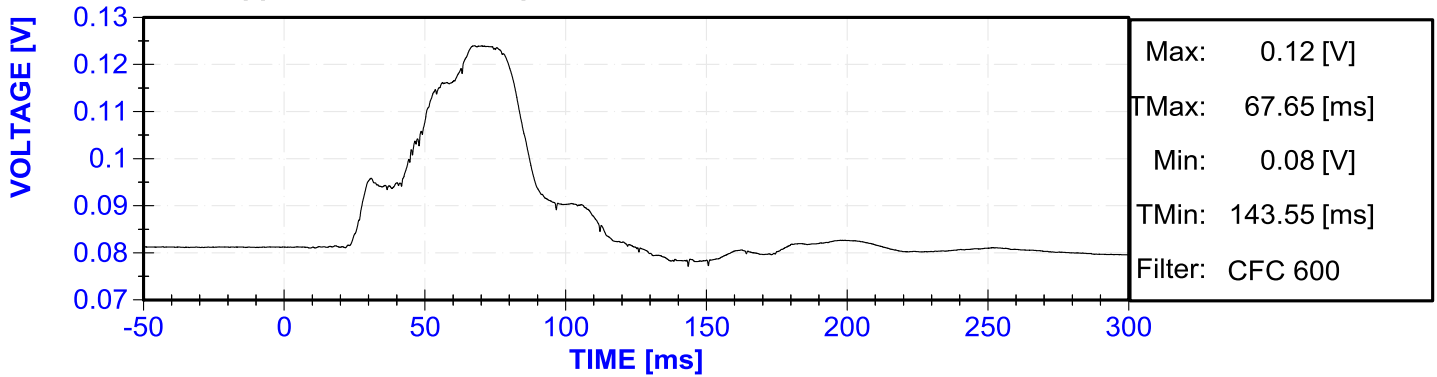

V2P1 Upper Left DGIR Y Rotation

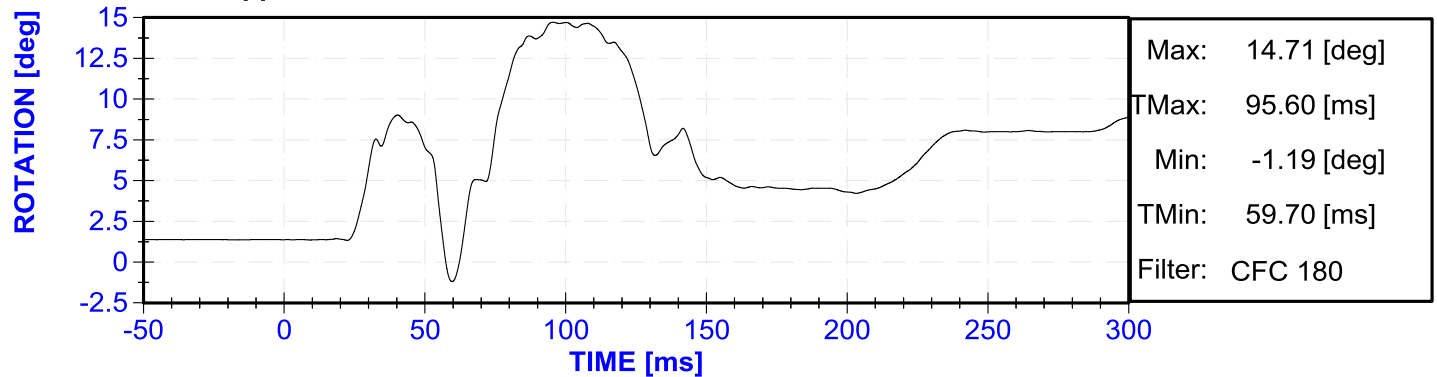

V2P1 Upper Left DGIR Z Rotation

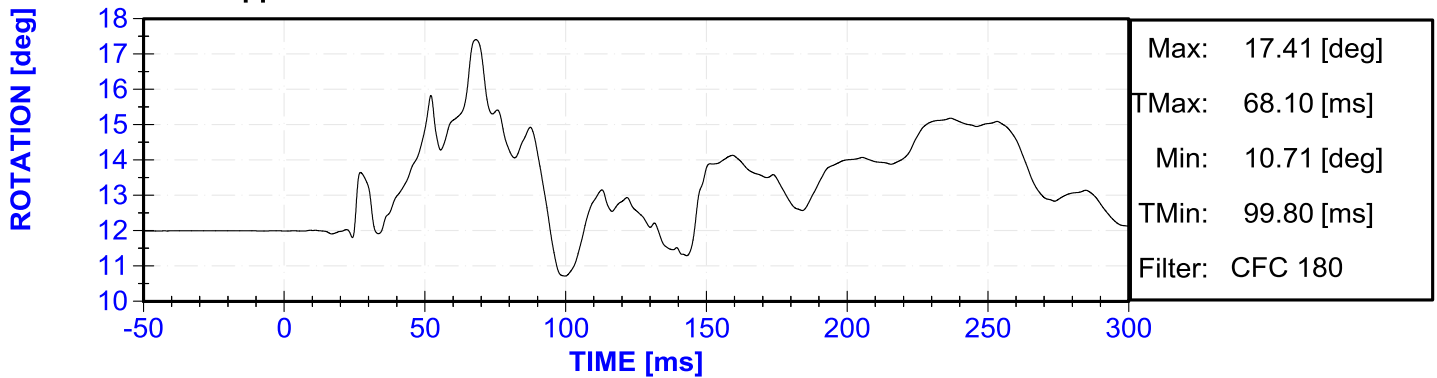

V2P1 Upper Right DGIR X Displacement

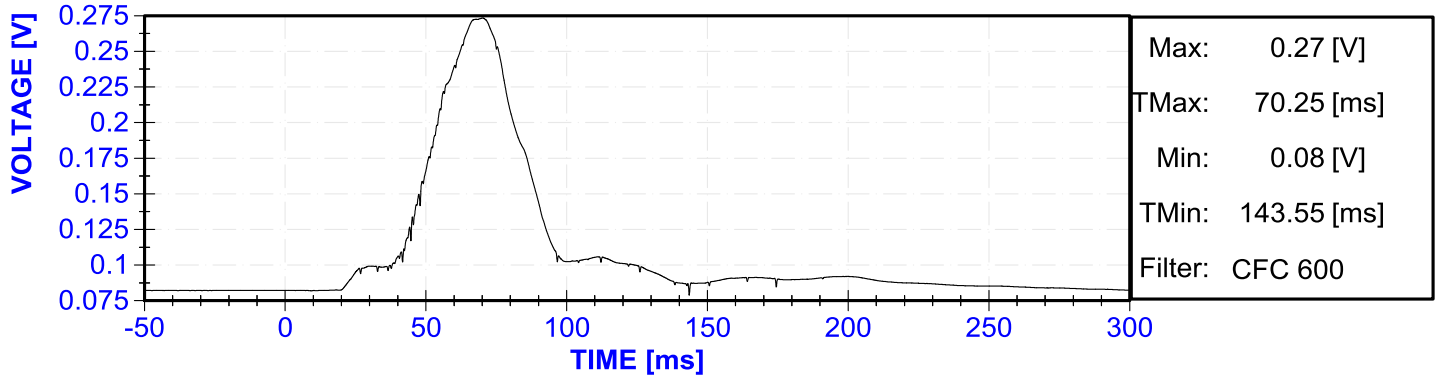

V2P1 Upper Right DGIR Y Rotation

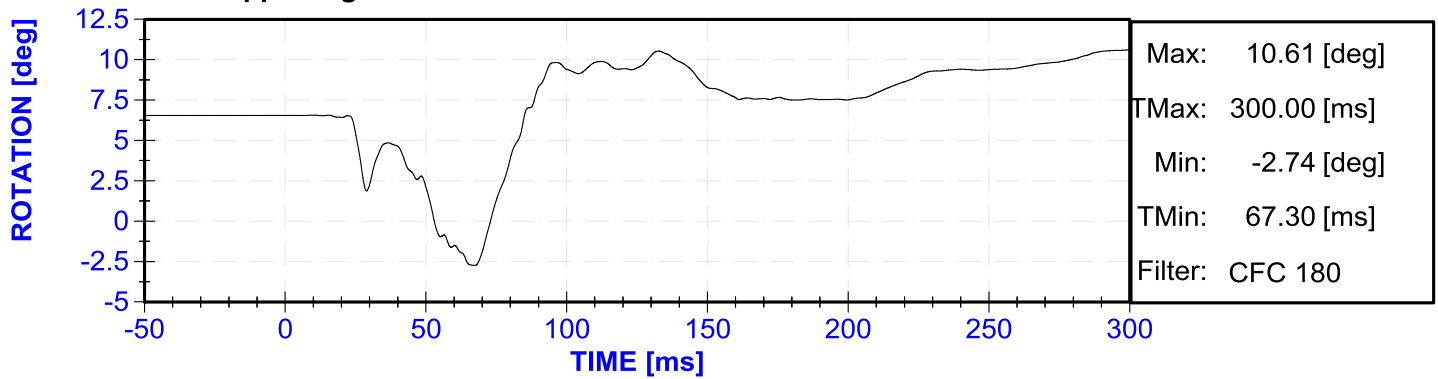

V2P1 Upper Right DGIR Z Rotation

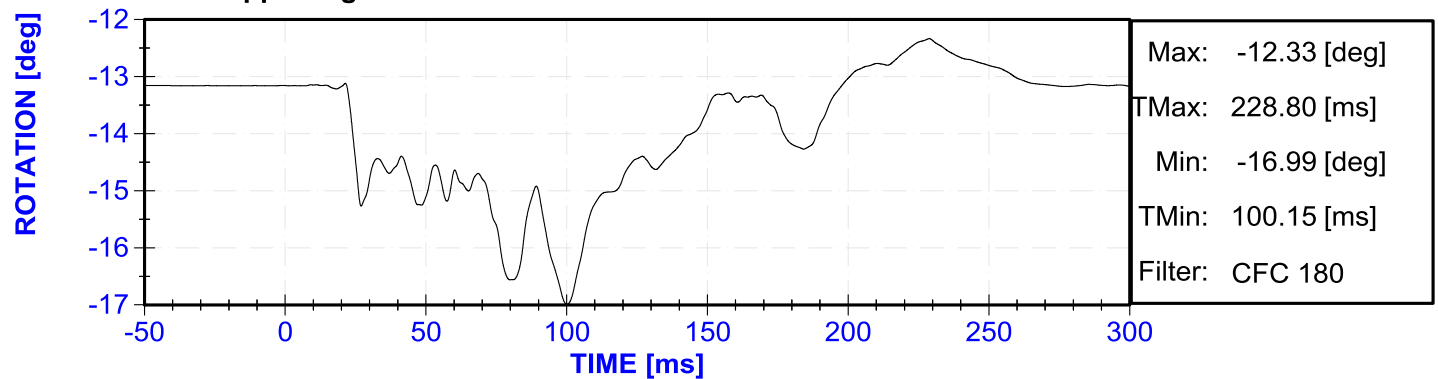

V2P1 Lower Left DGIR X Displacement

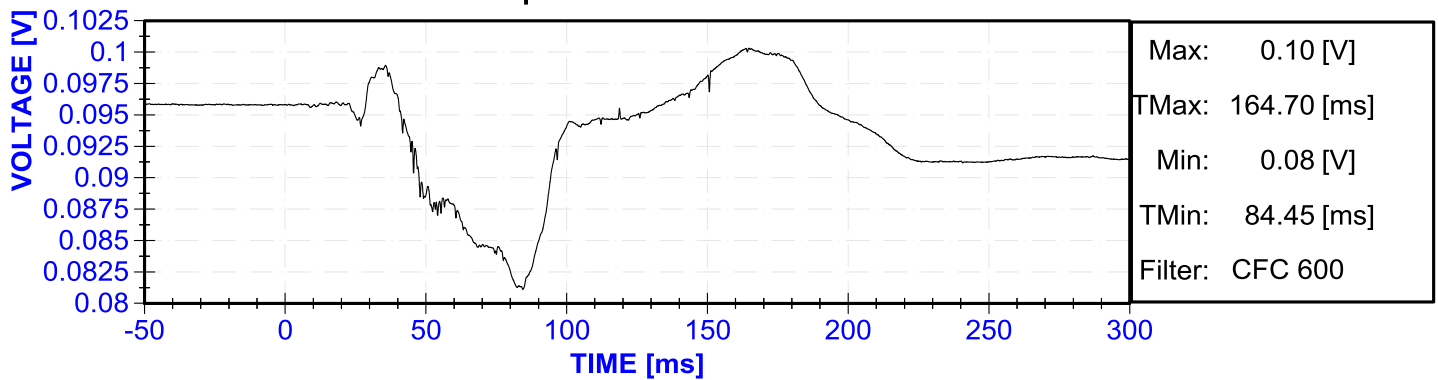

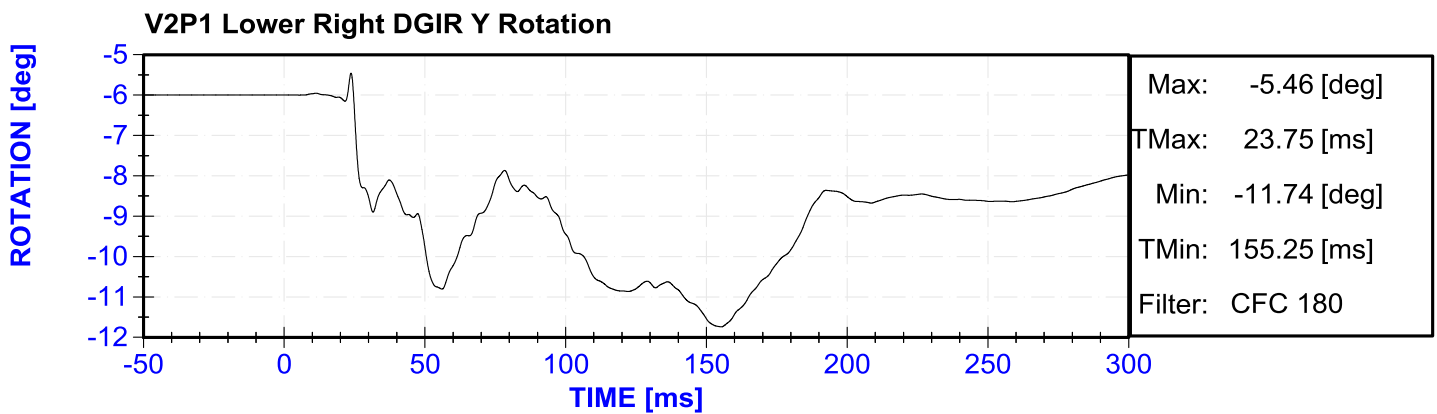
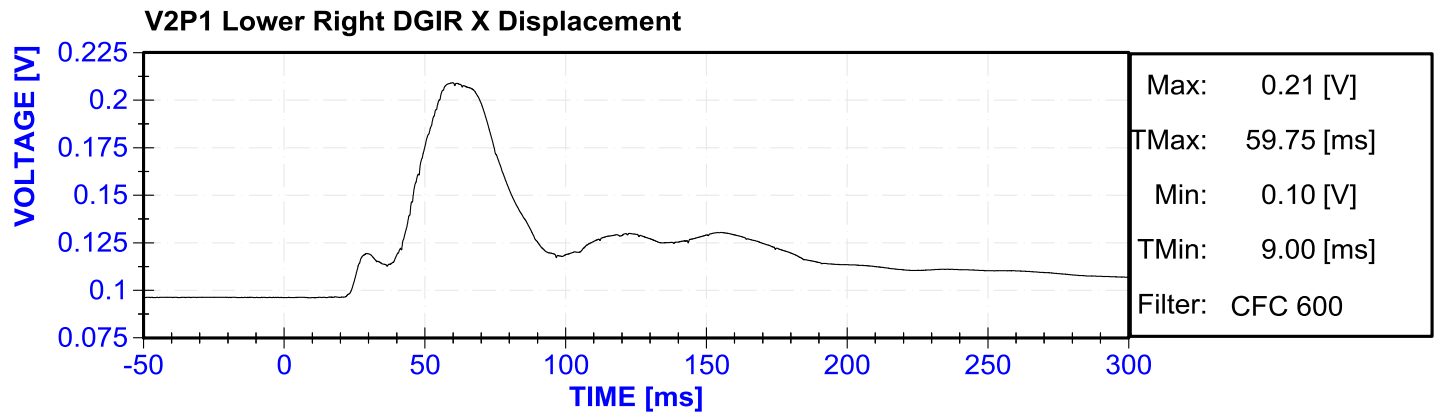
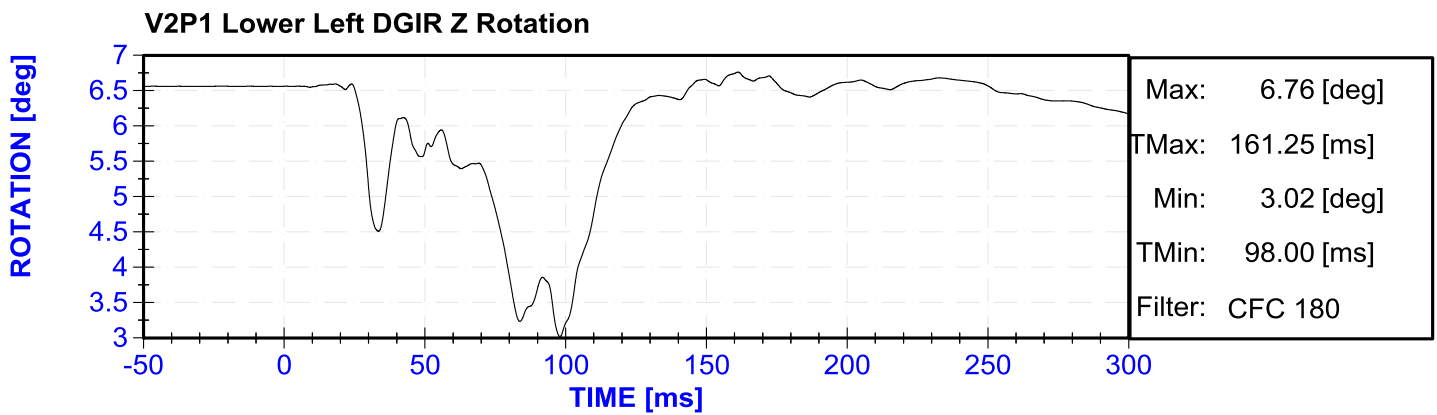
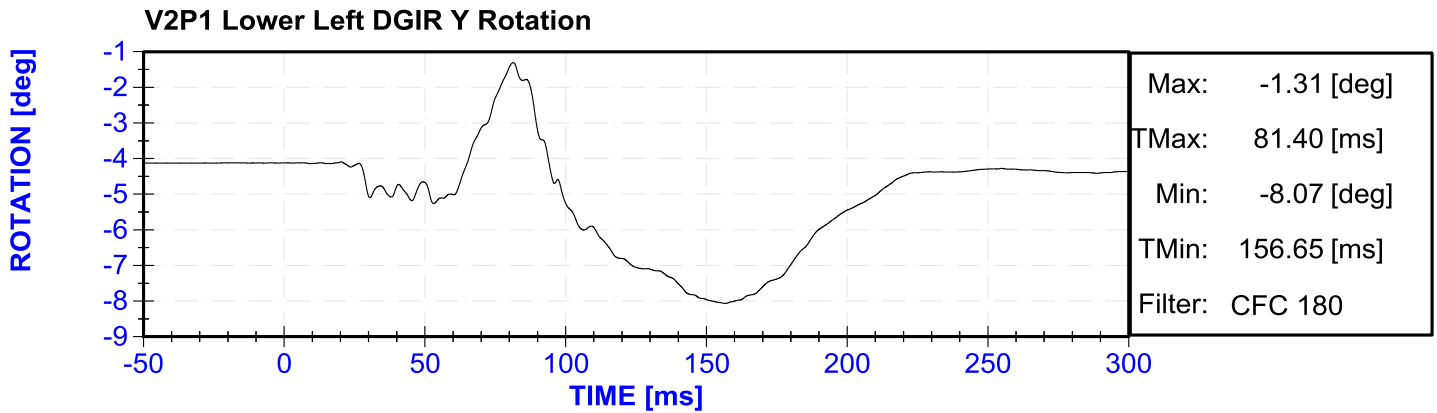

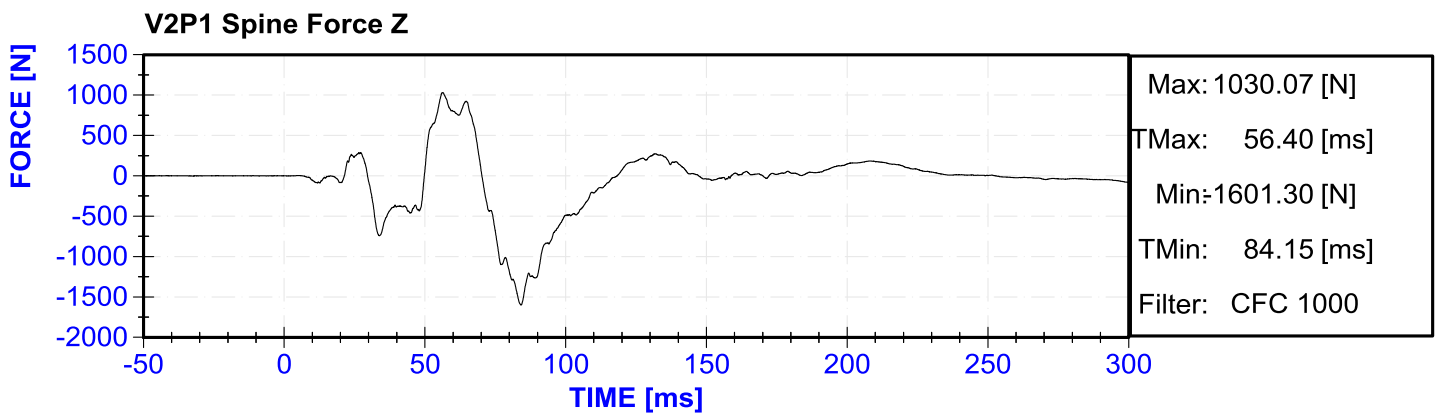
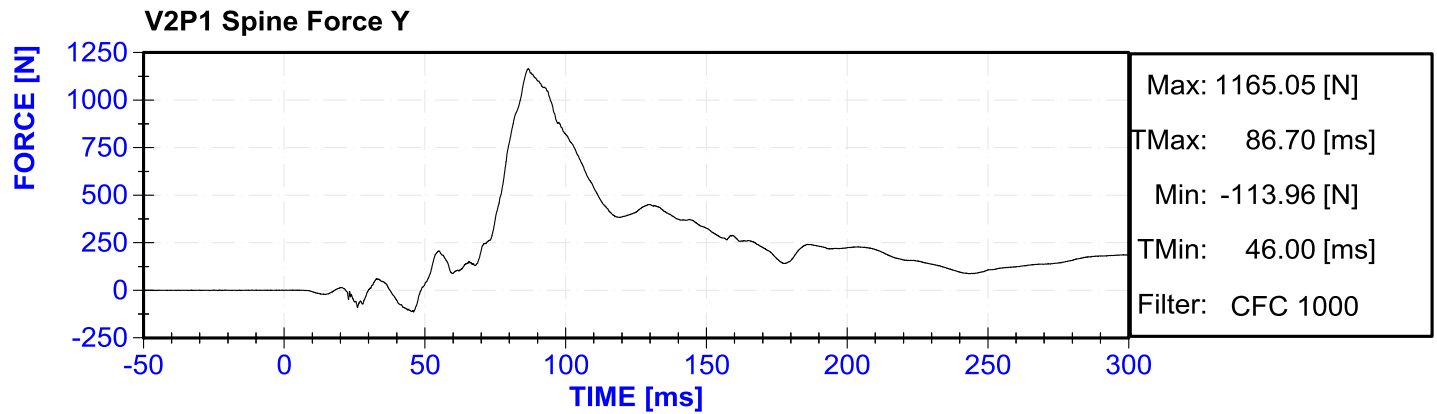
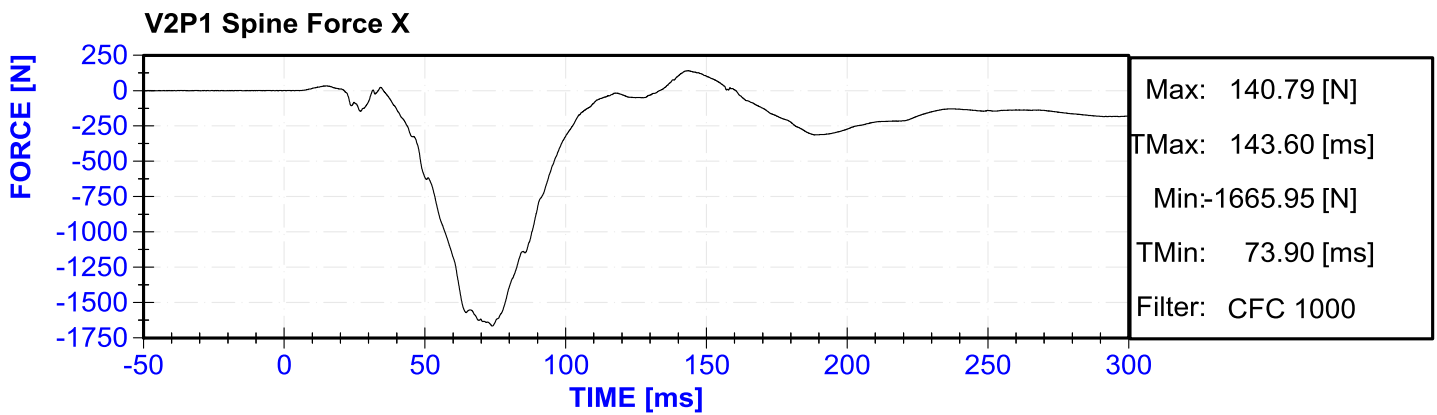
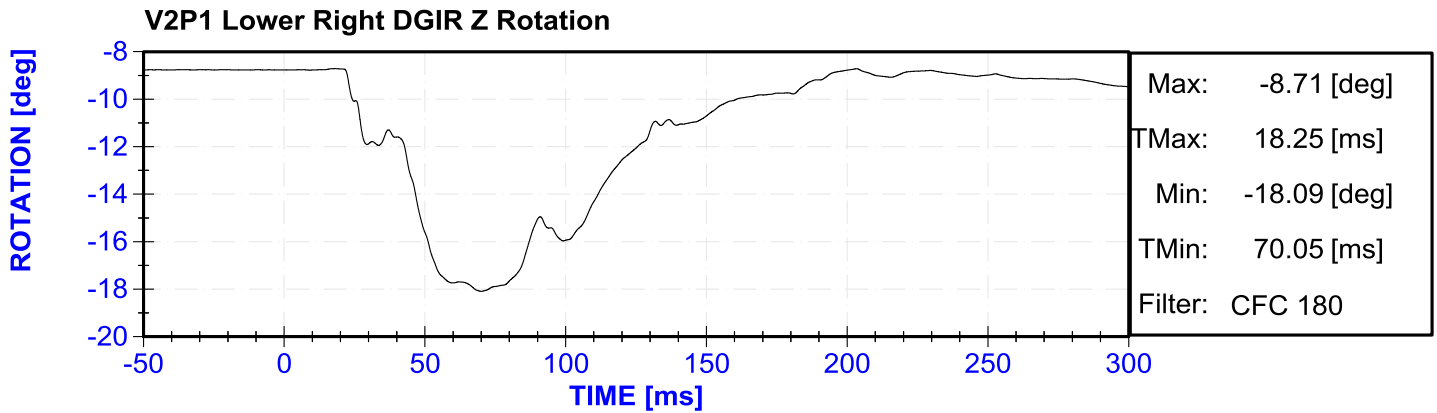

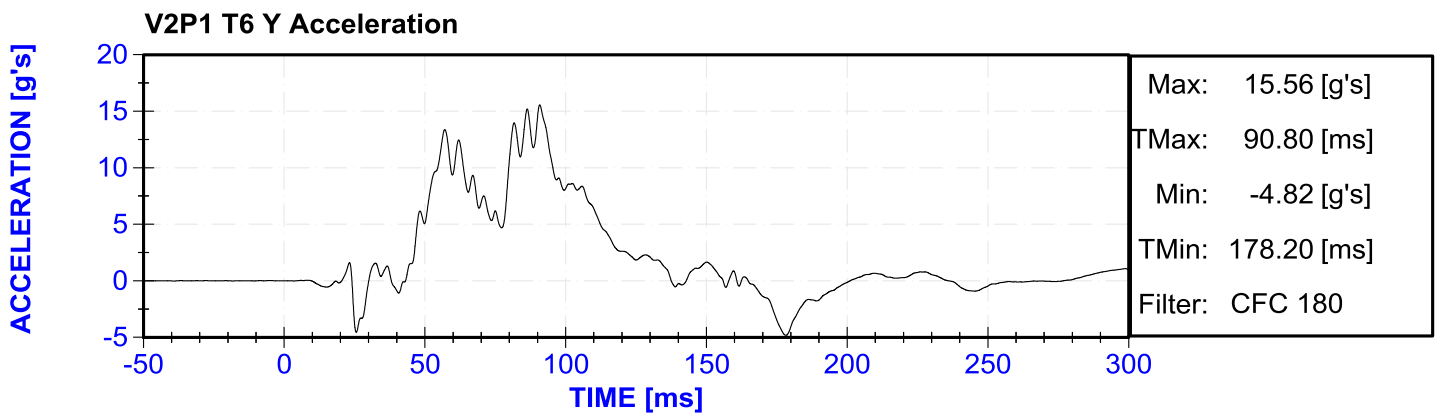
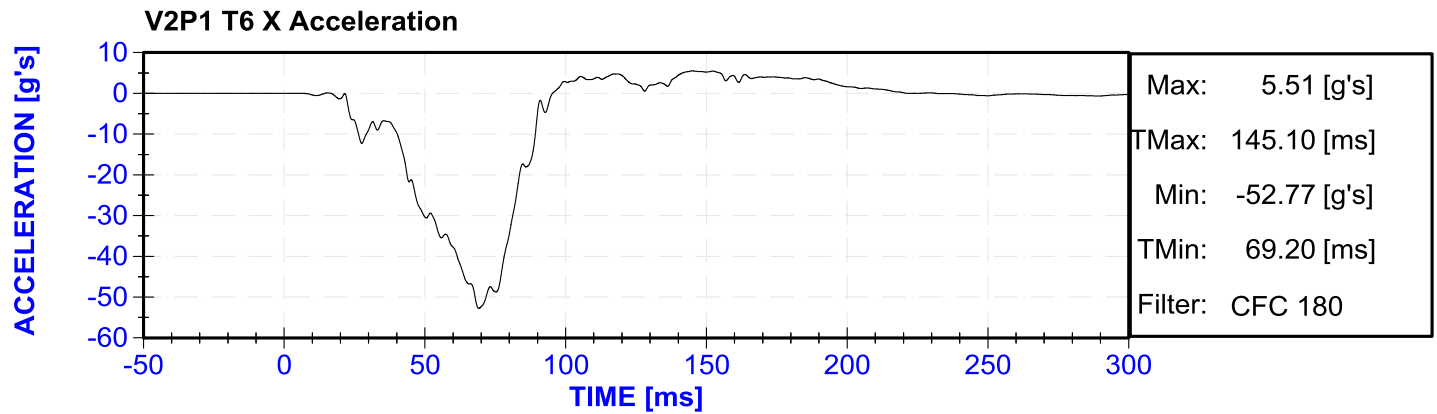
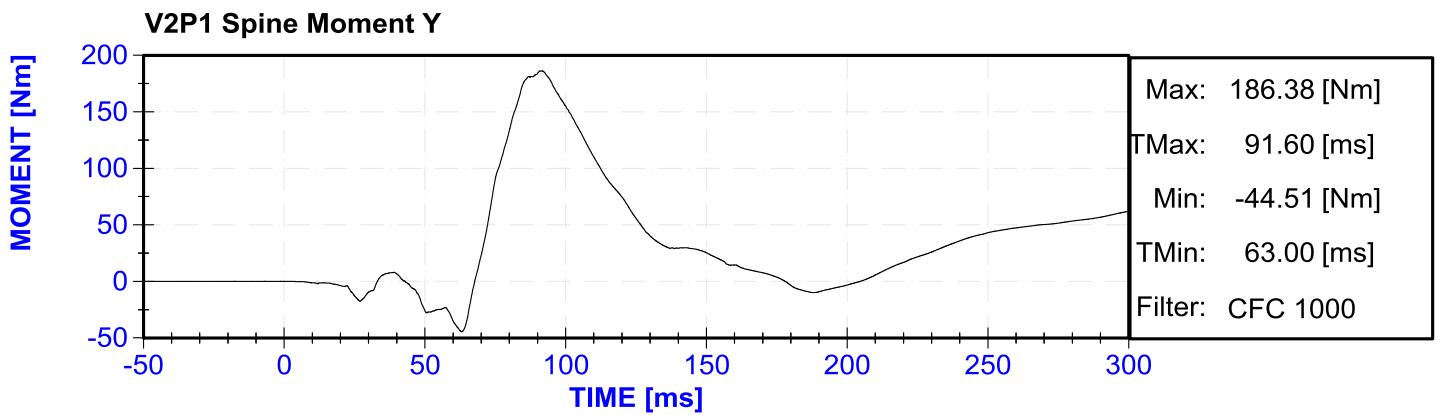
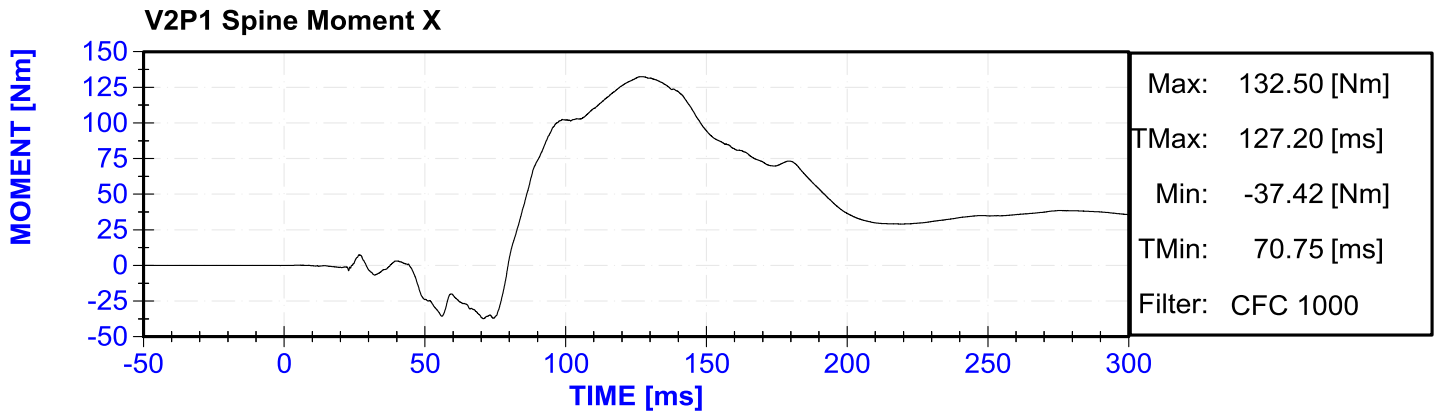

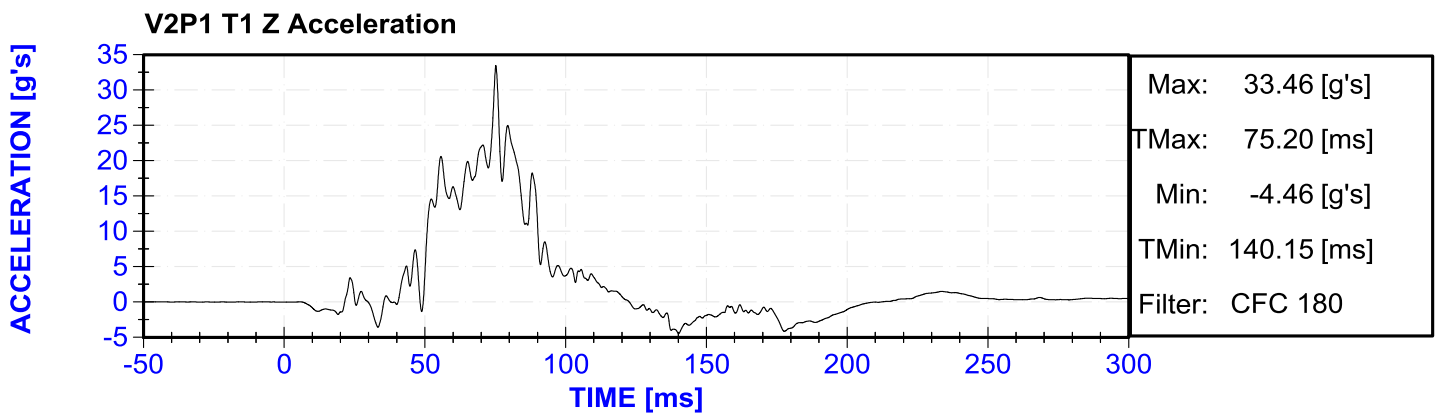
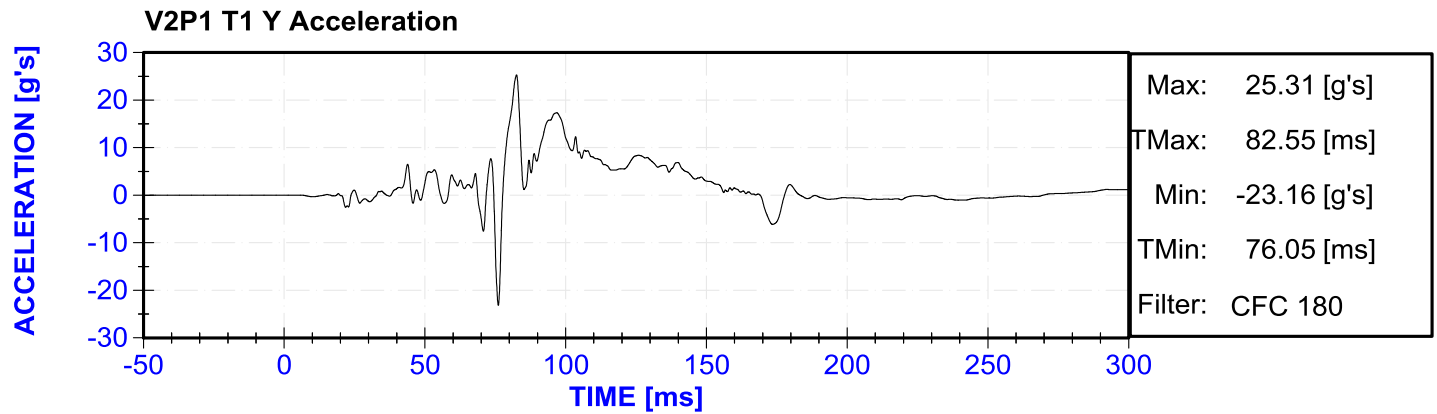
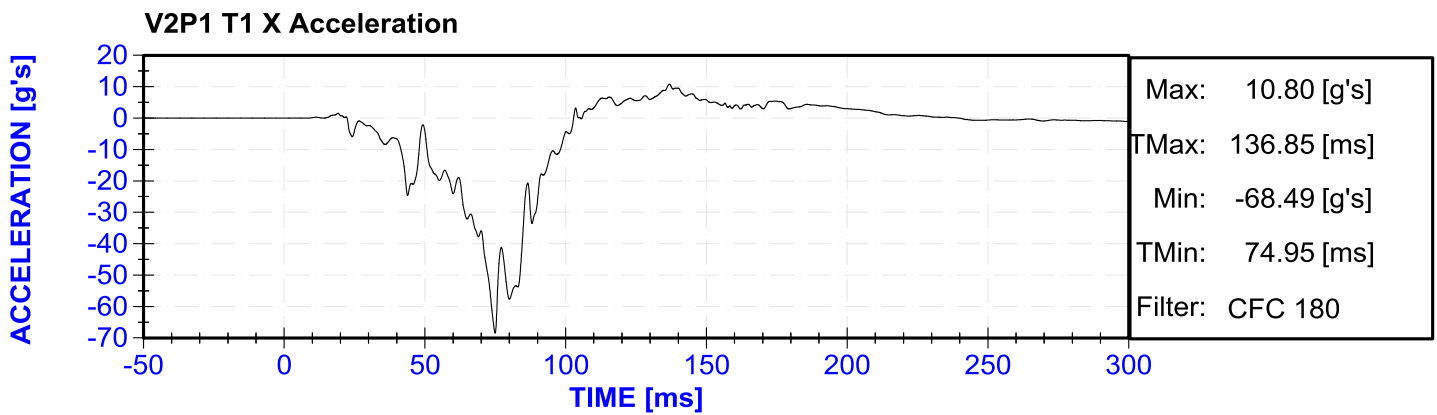
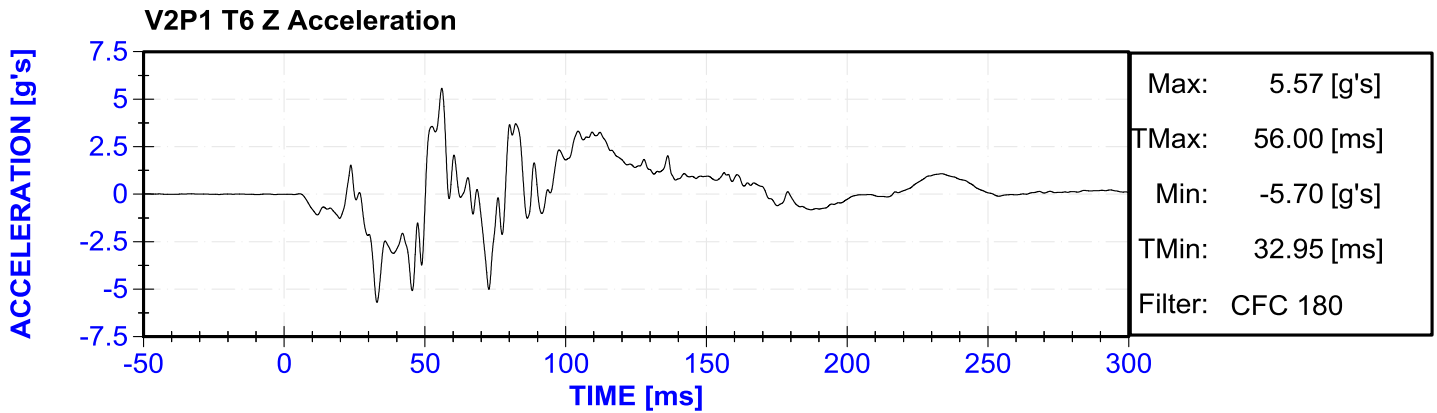

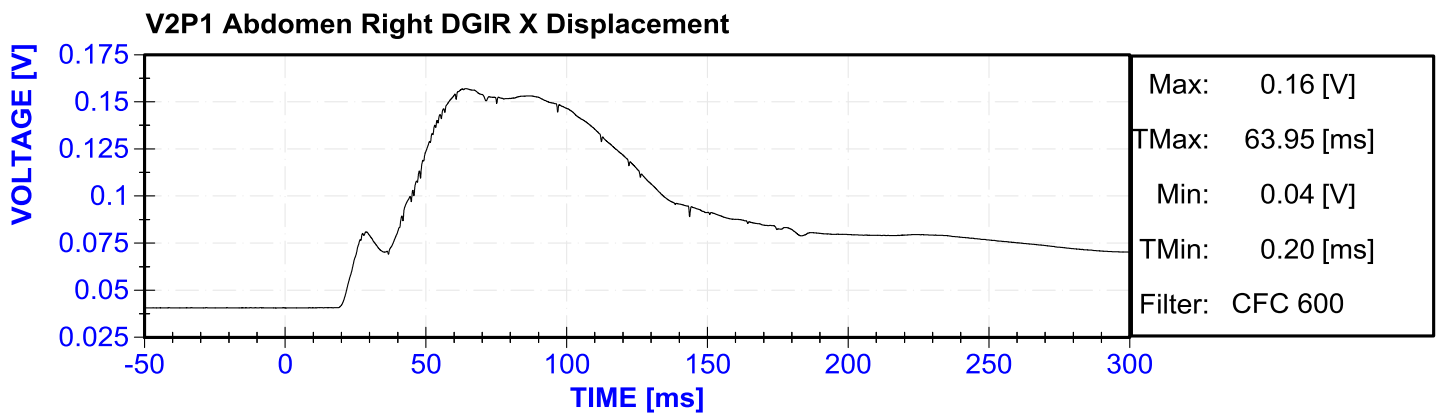
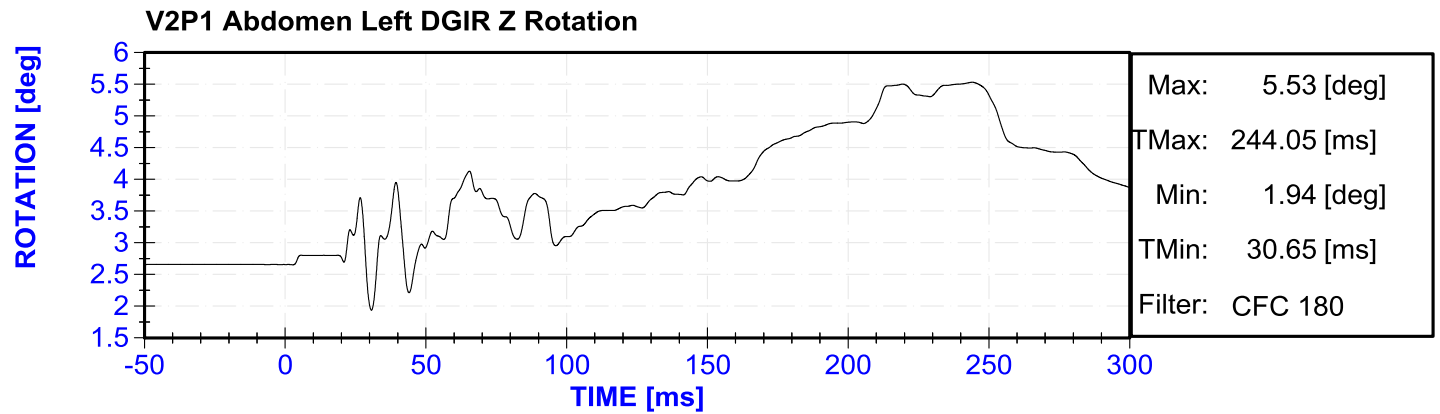
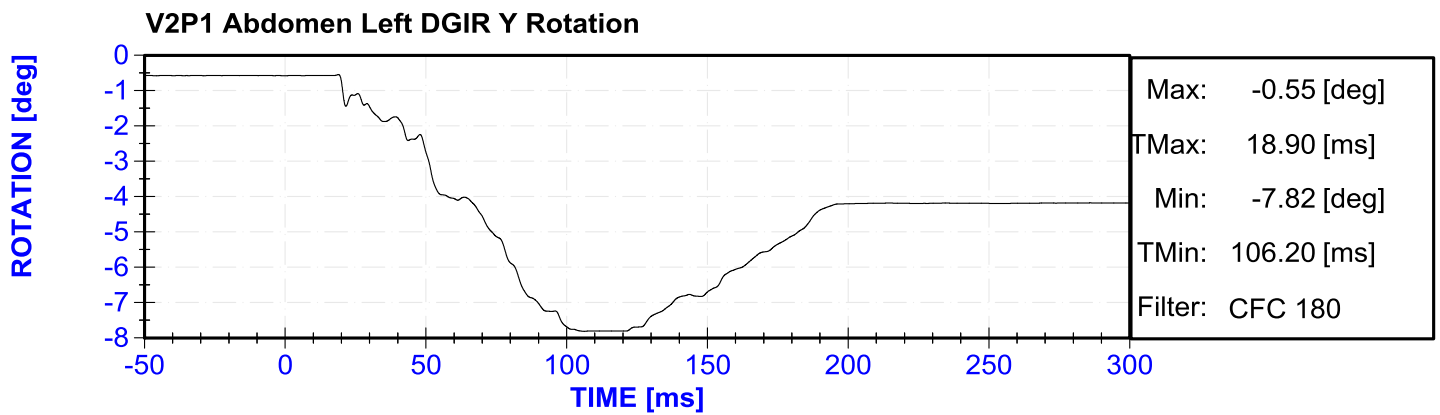
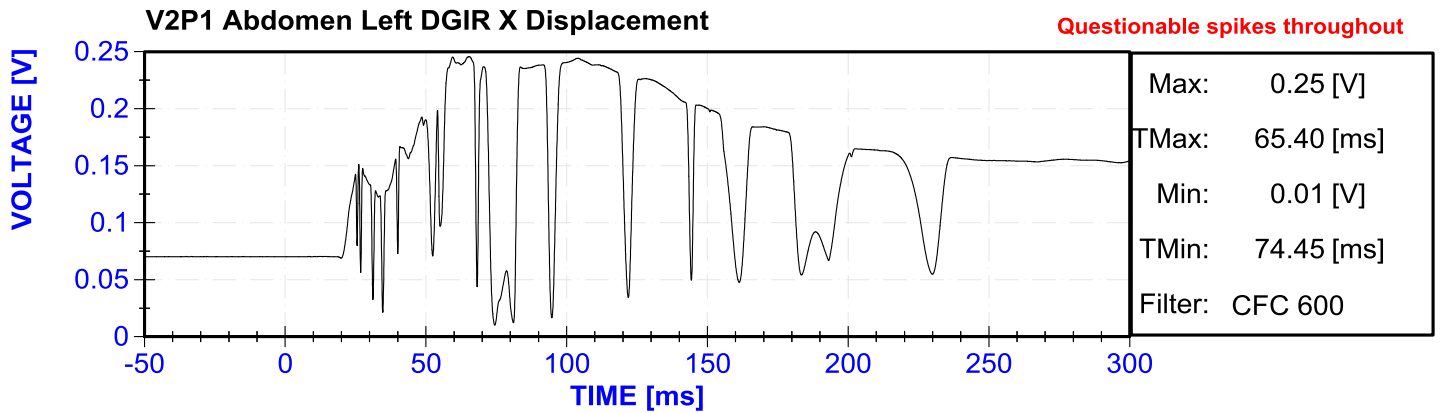

V2P1 Abdomen Right DGIR Y Rotation

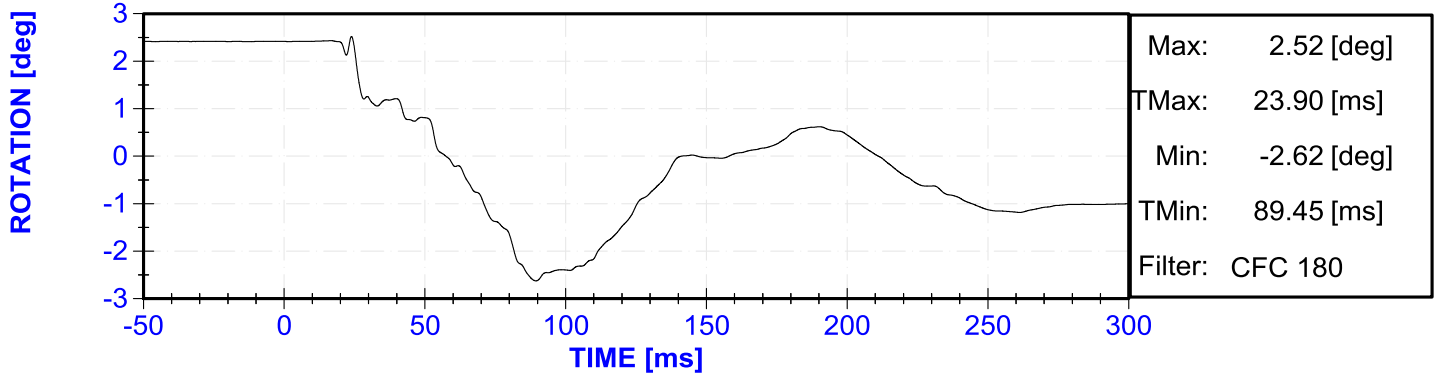

V2P1 Abdomen Right DGIR Z Rotation

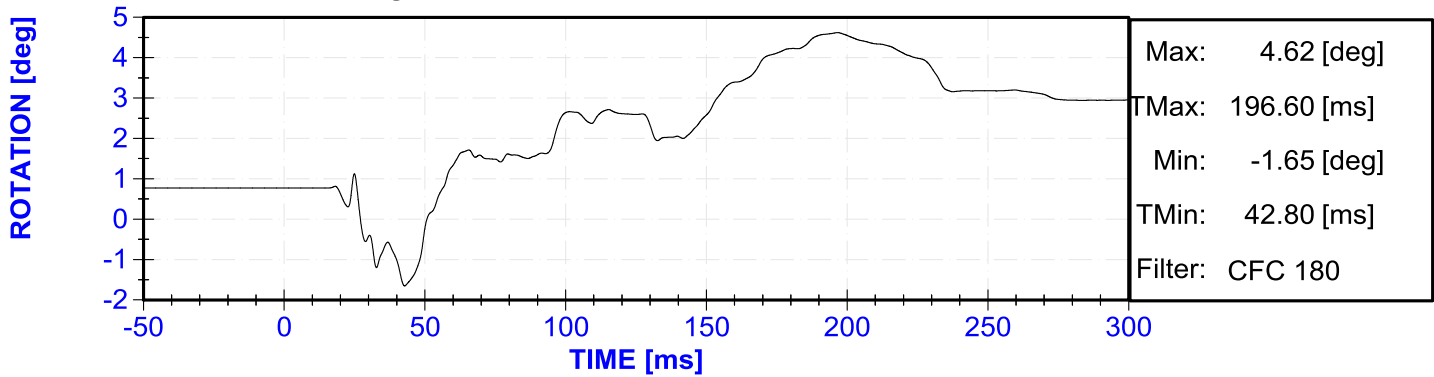

V2P1 Pelvis Acetabulum Left X Force

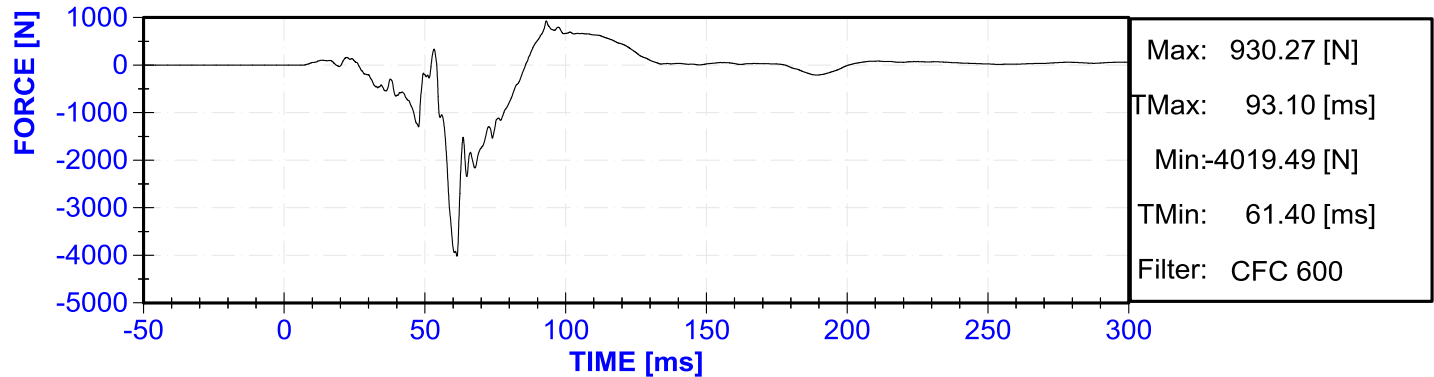

V2P1 Pelvis Acetabulum Left Y Force

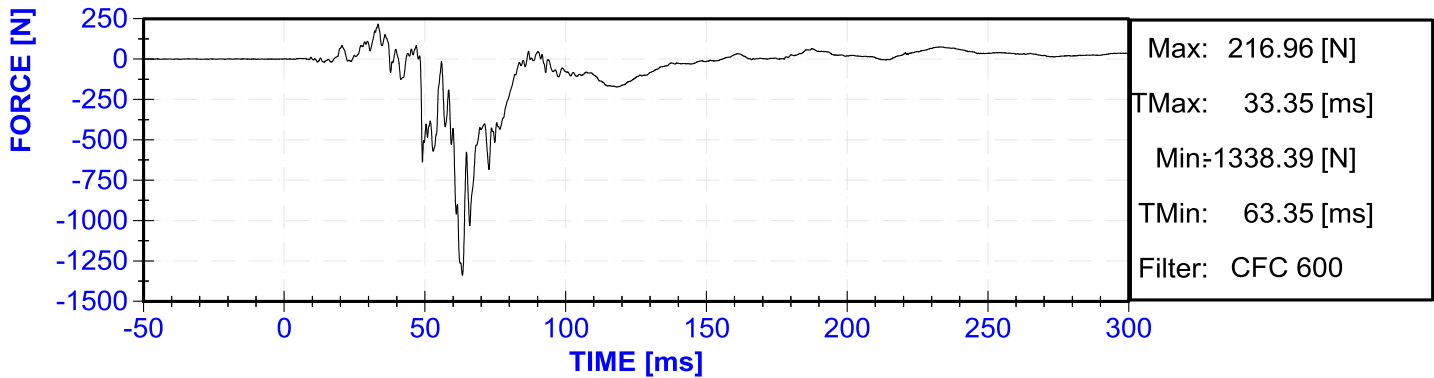

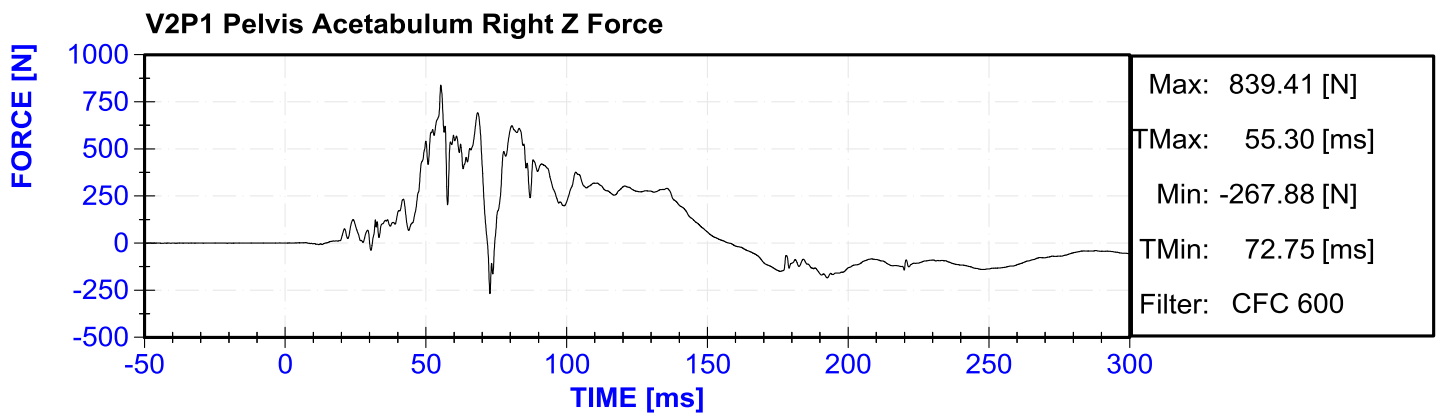
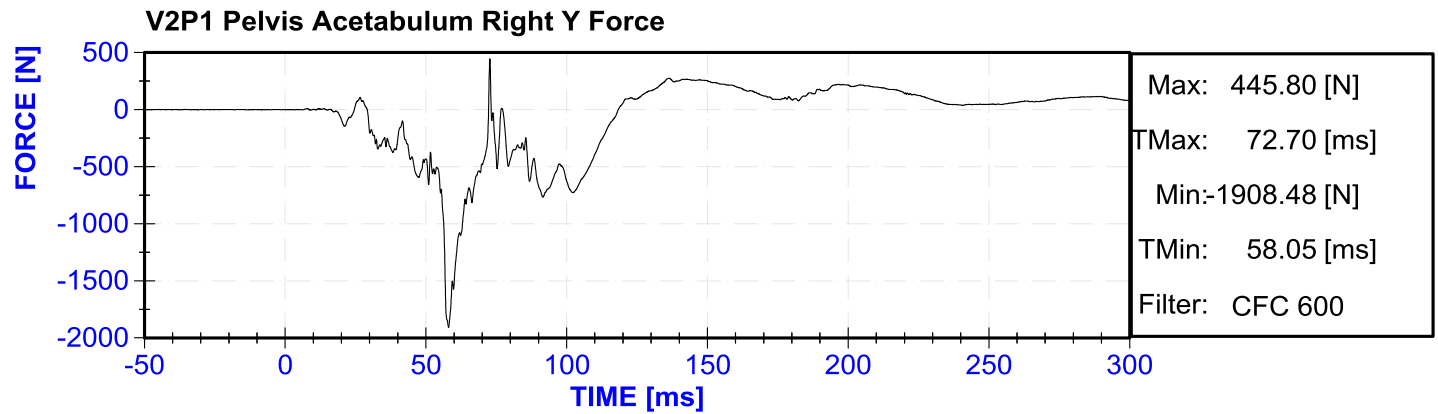
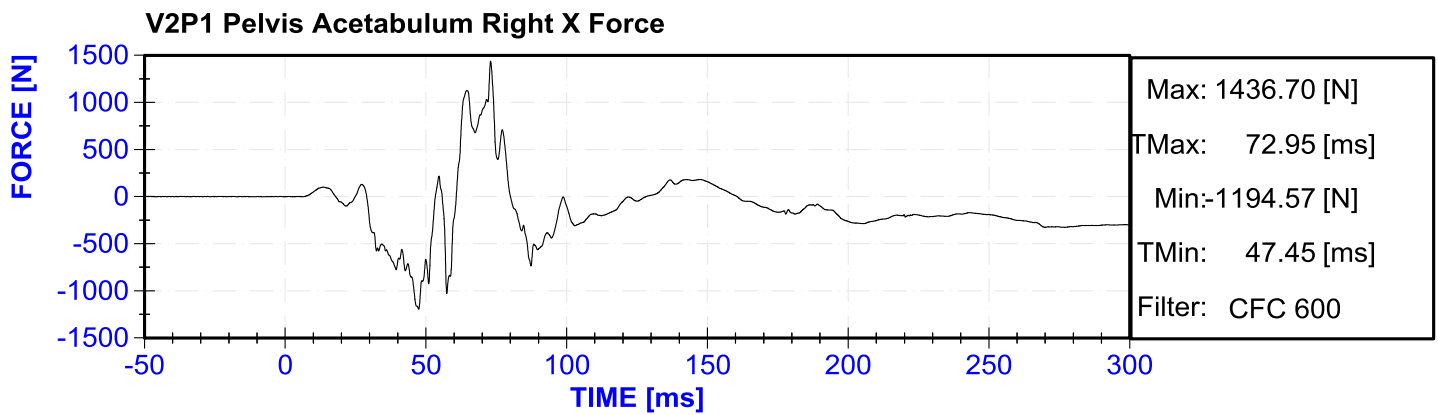
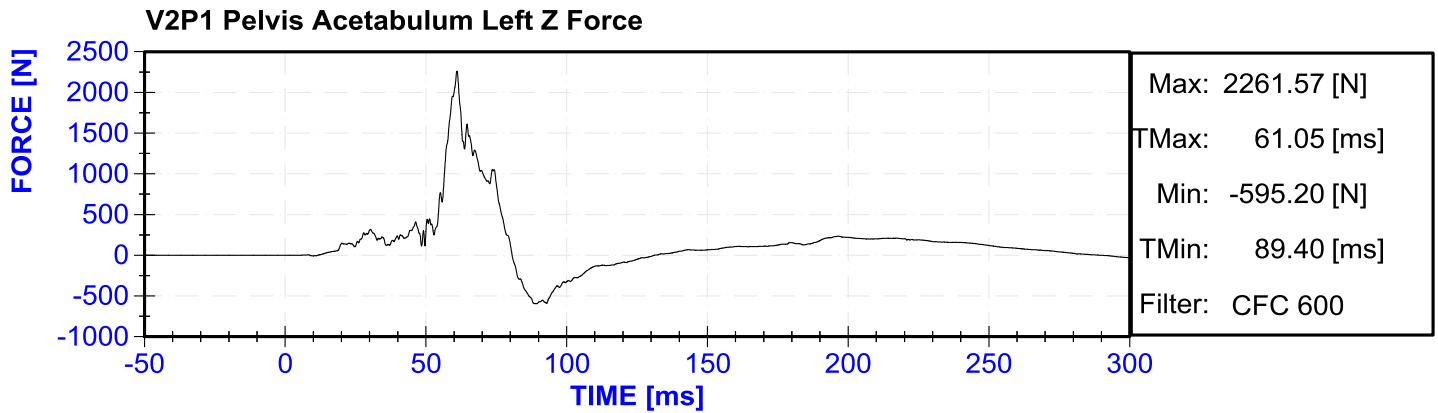

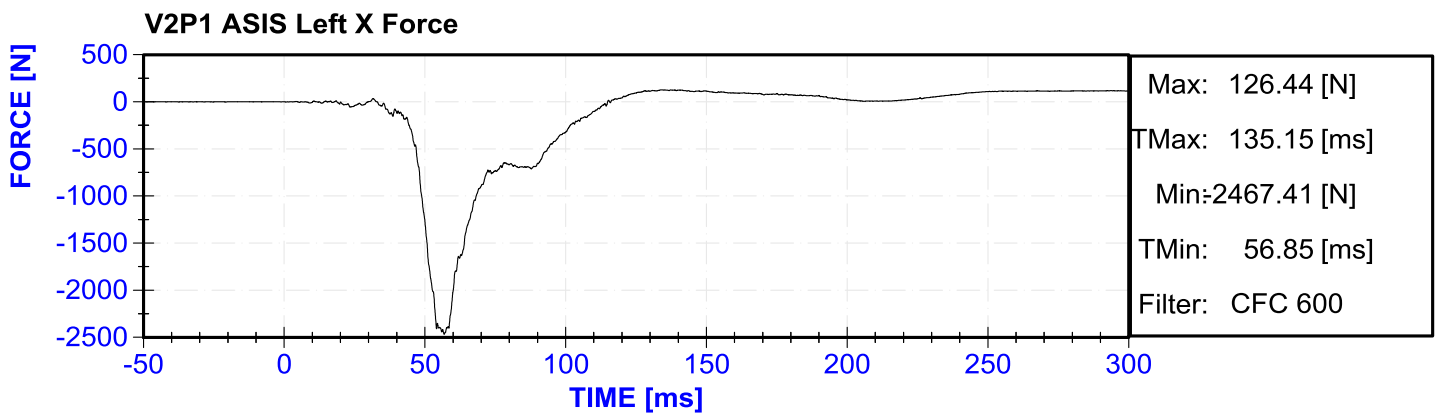
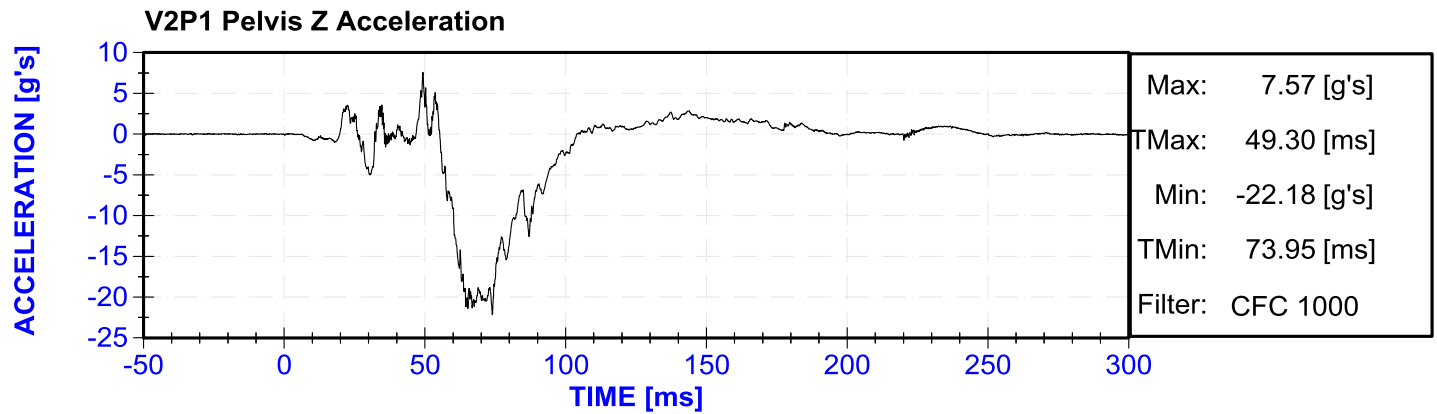
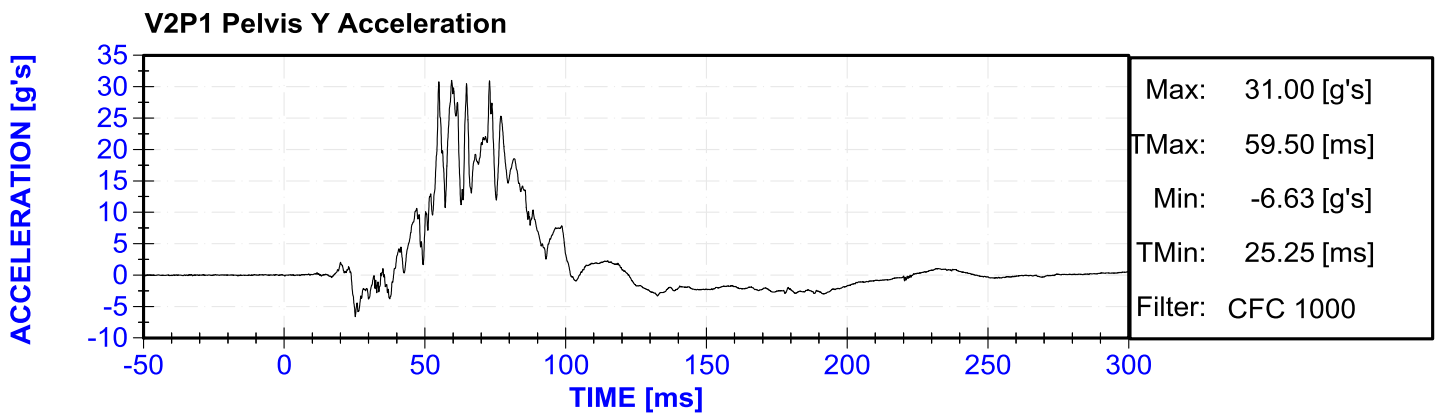
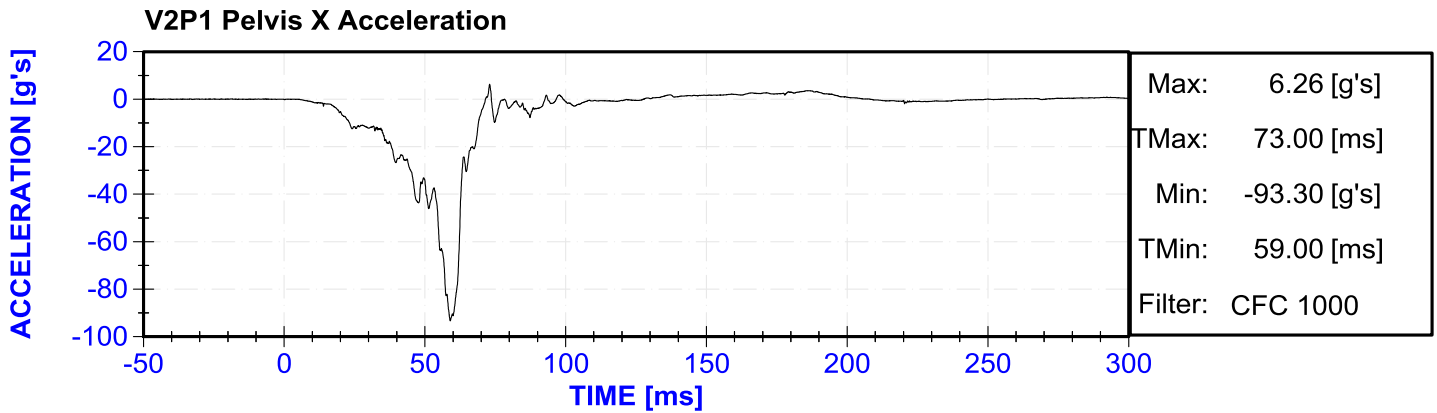

V2P1 Left ASIS Y Moment

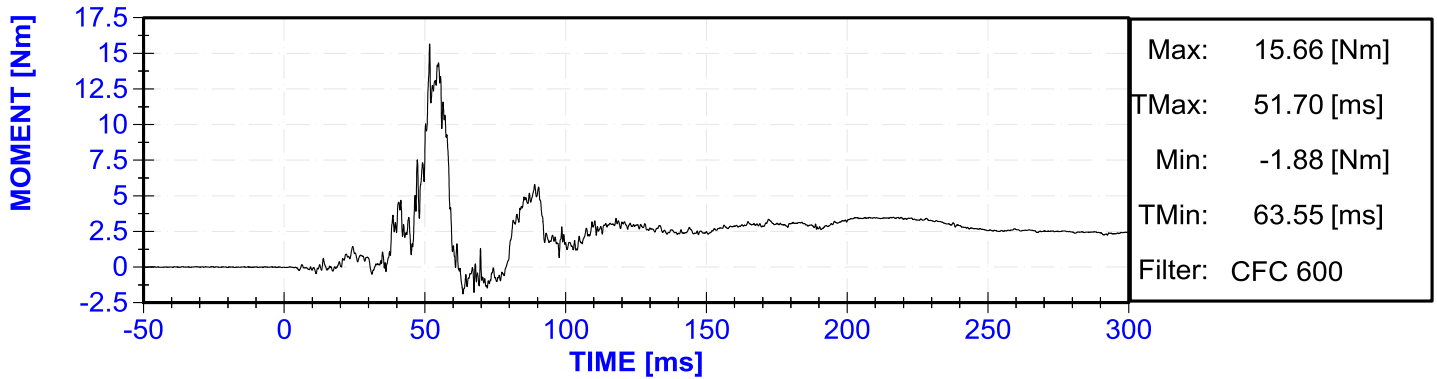

V2P1 ASIS Right X Force

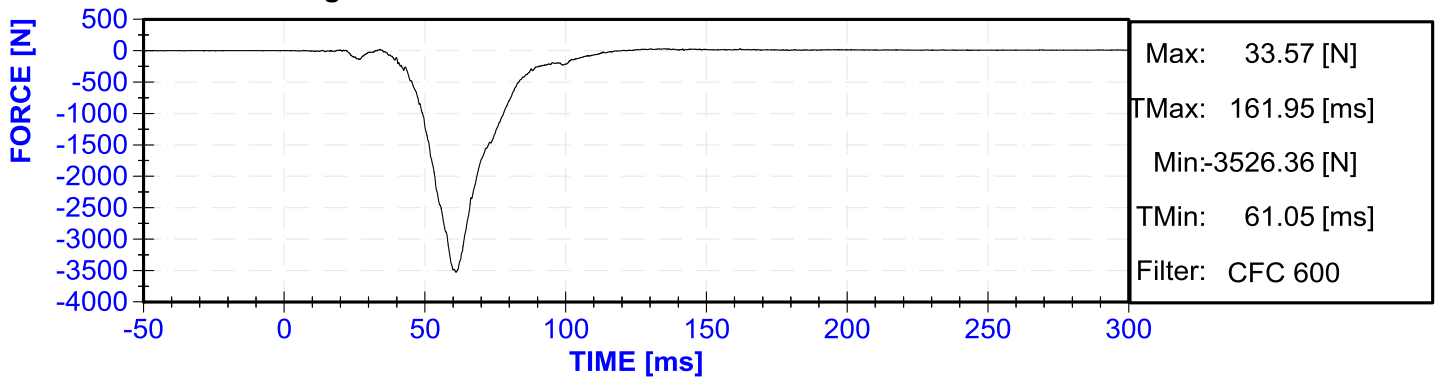

V2P1 Right ASIS Y Moment

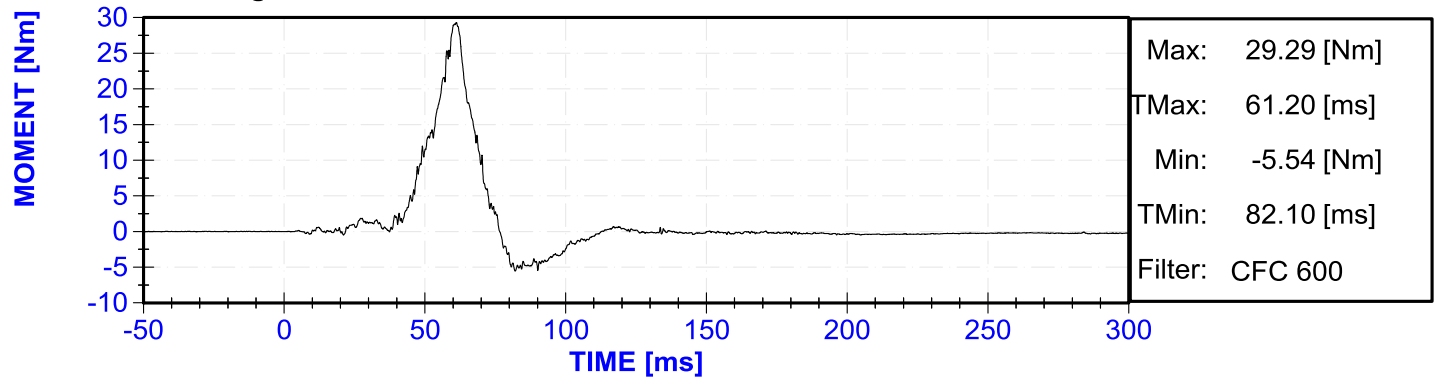

V2P1 Femur Left X Force

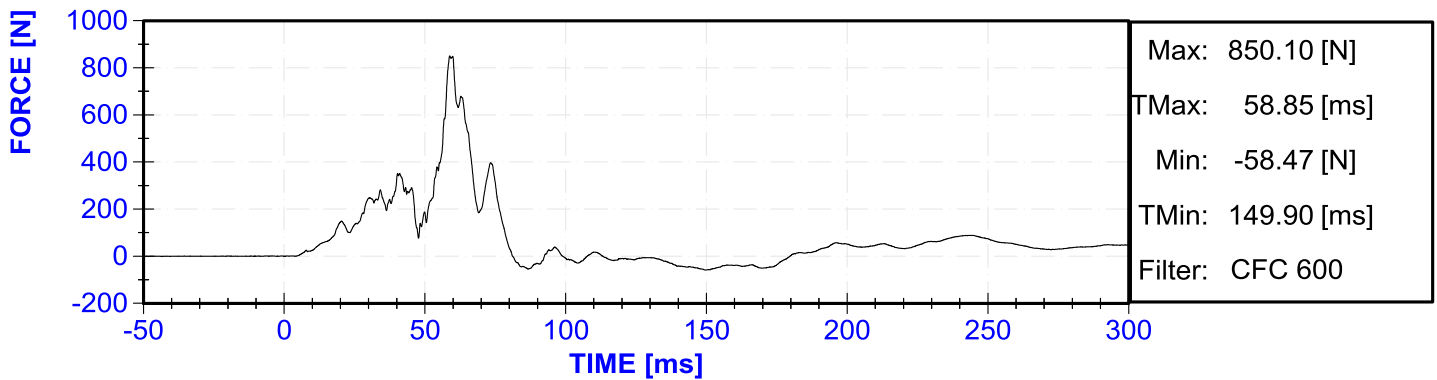

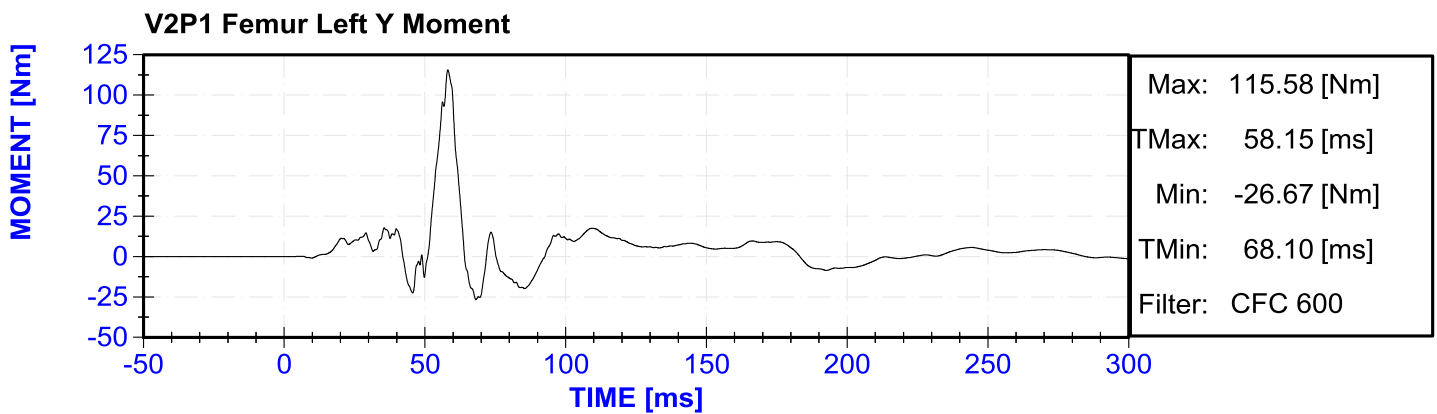
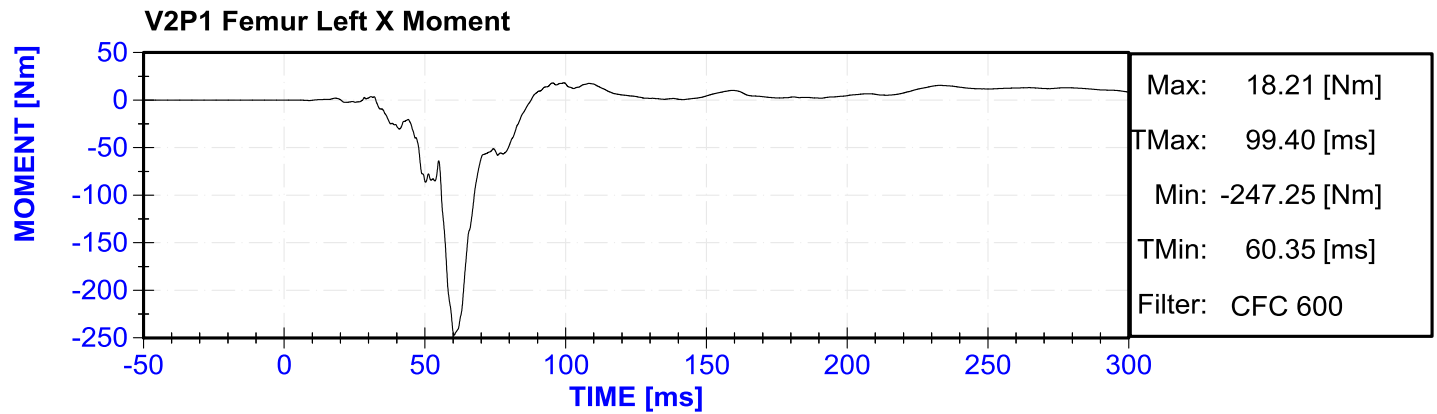
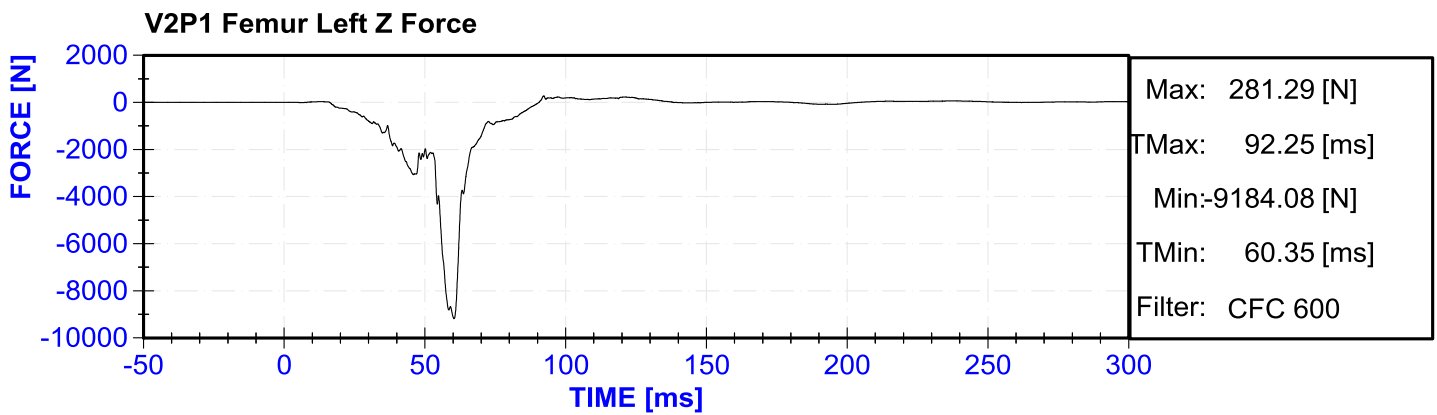
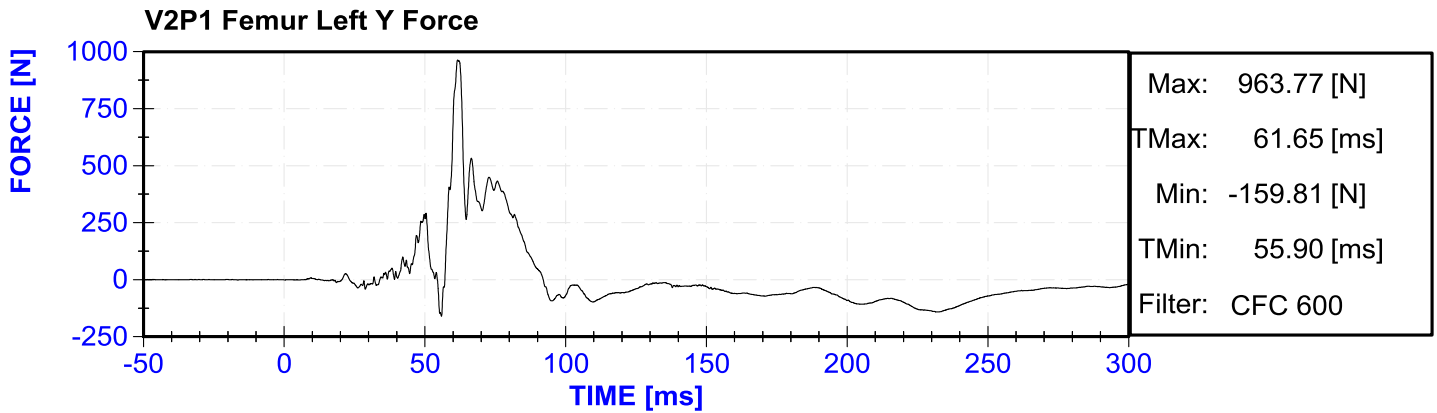

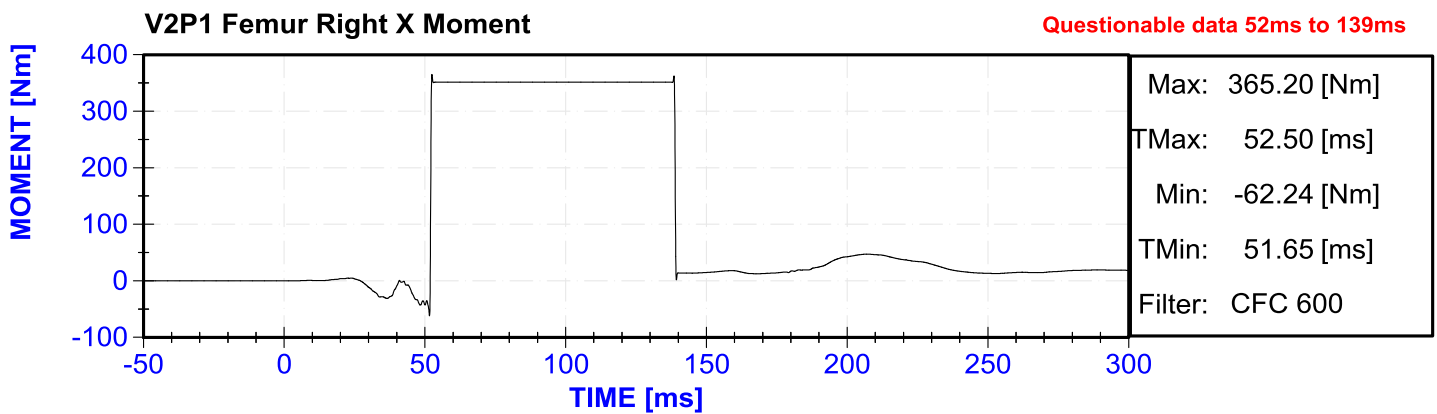
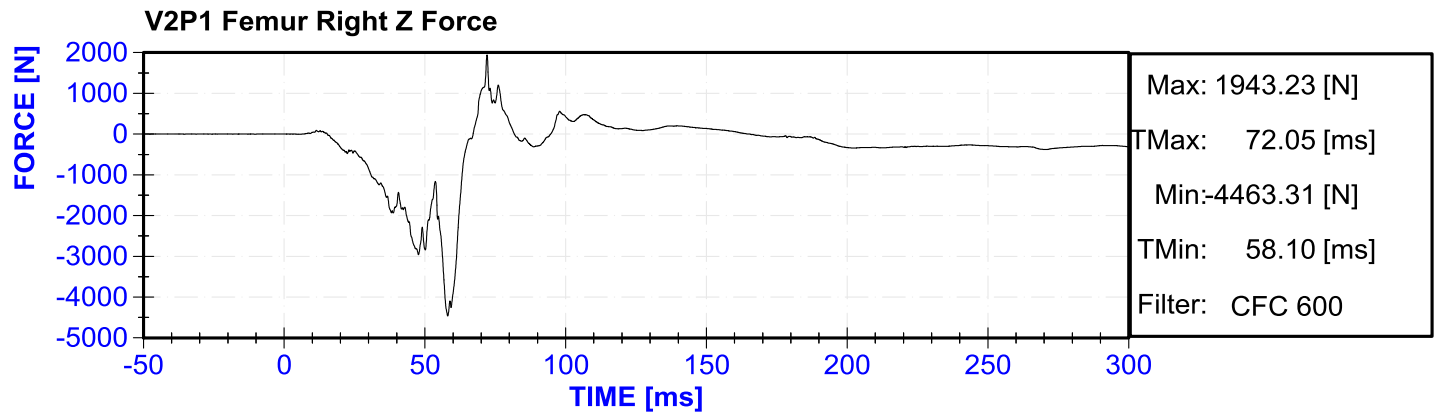
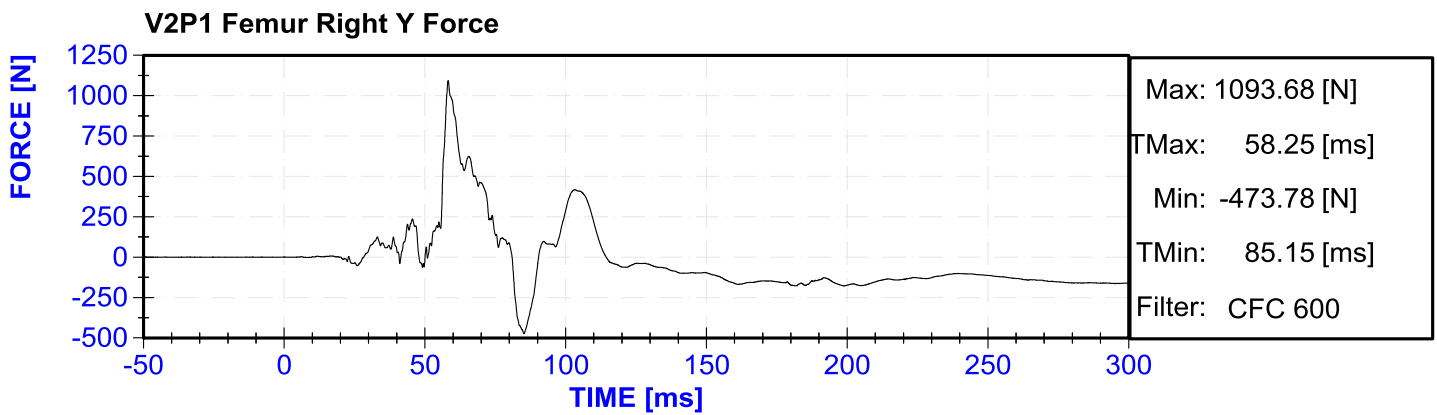
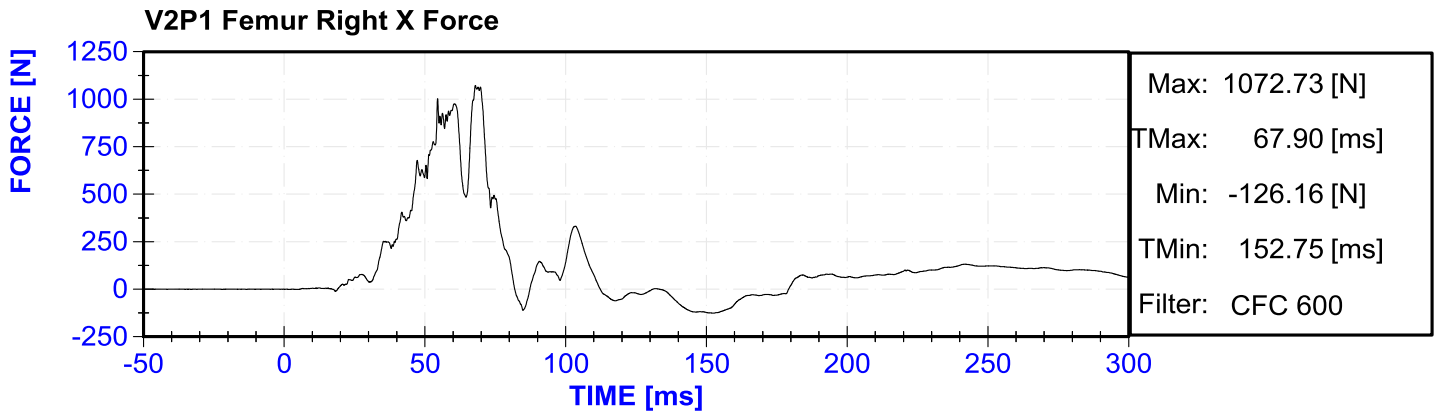

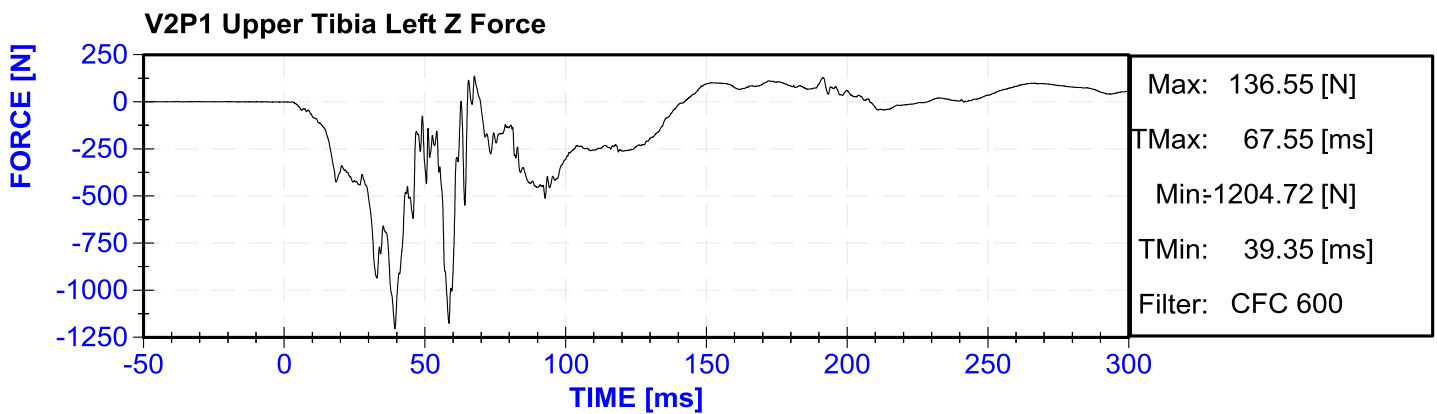
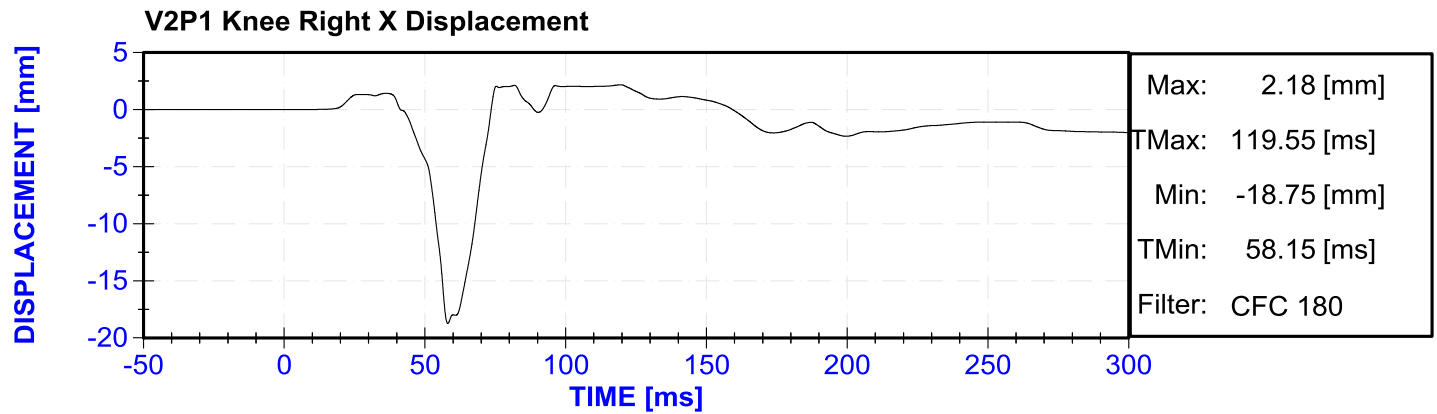
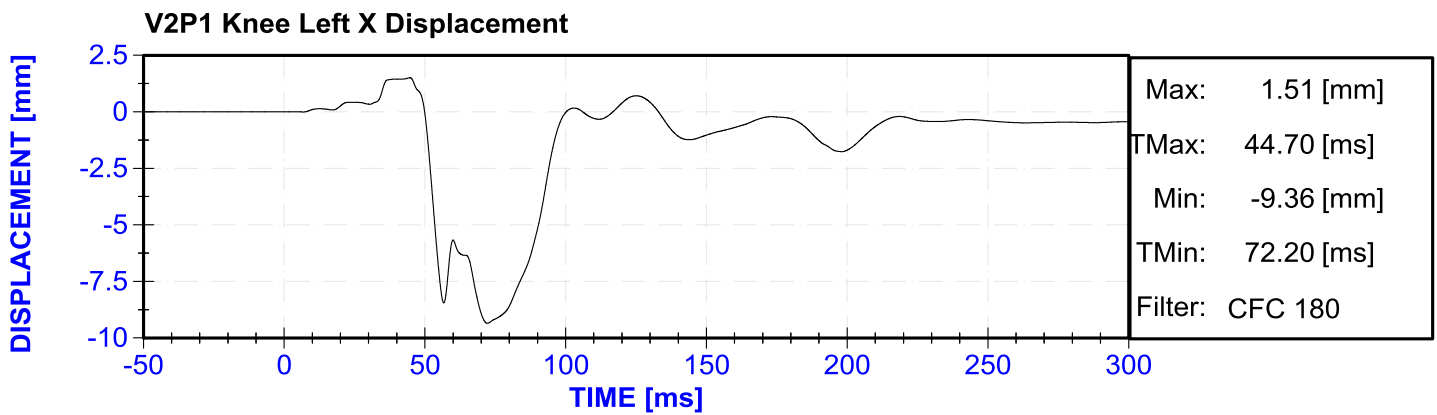
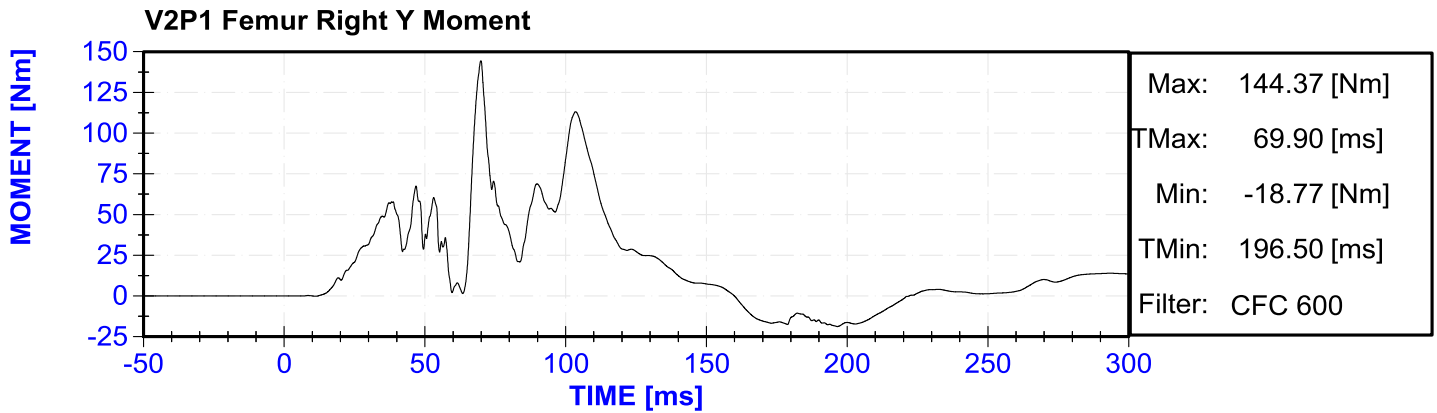

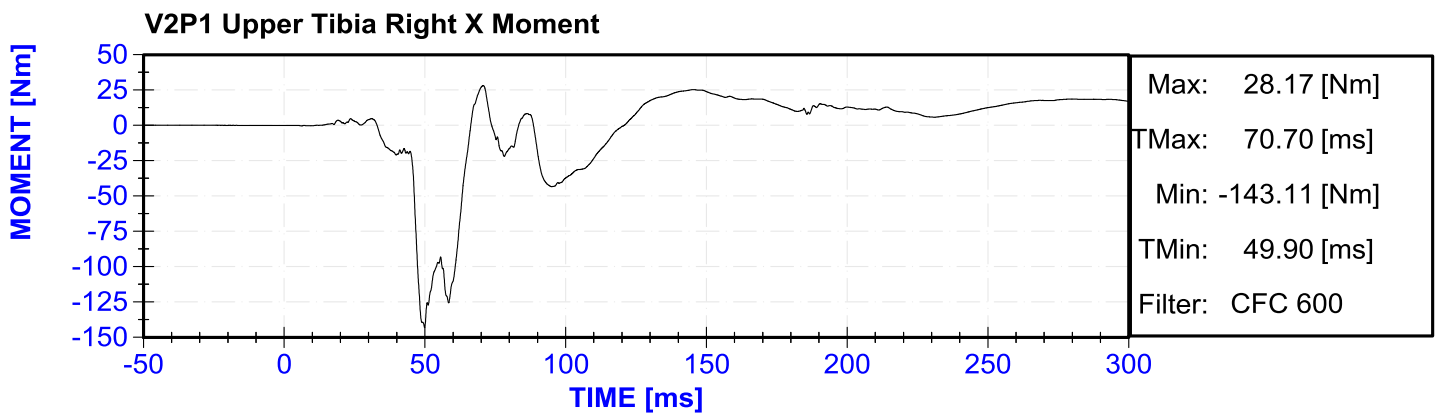
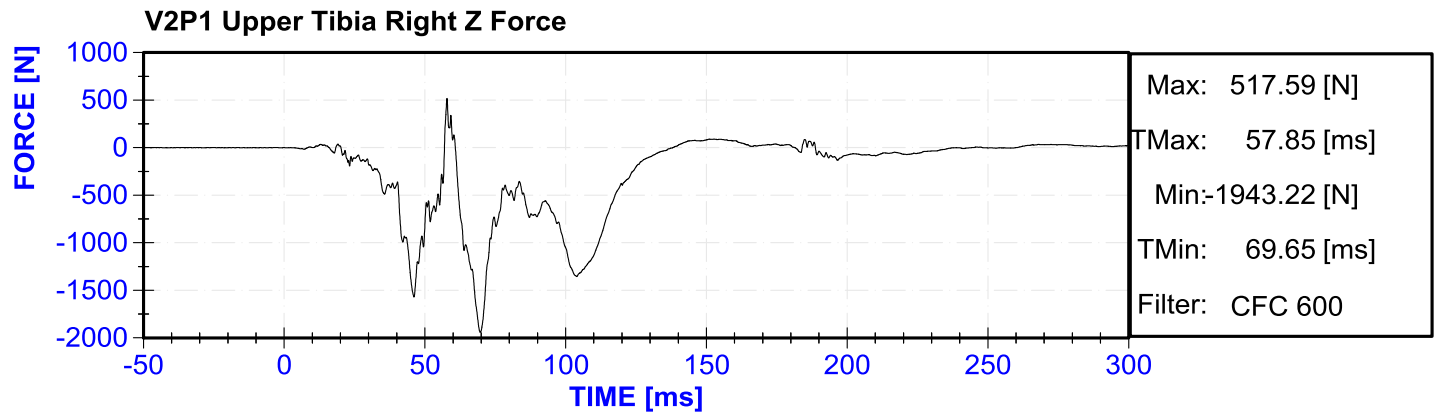
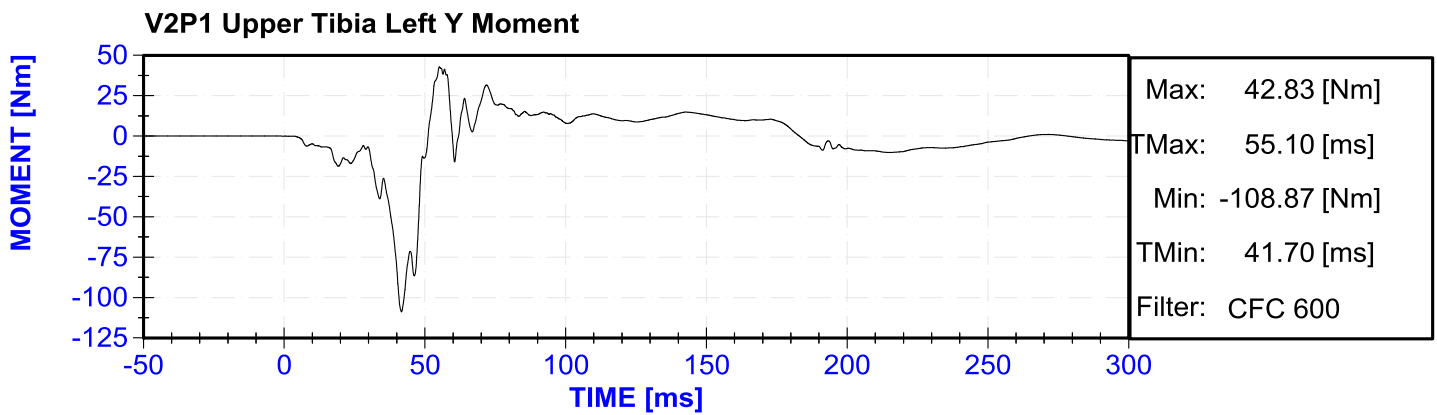
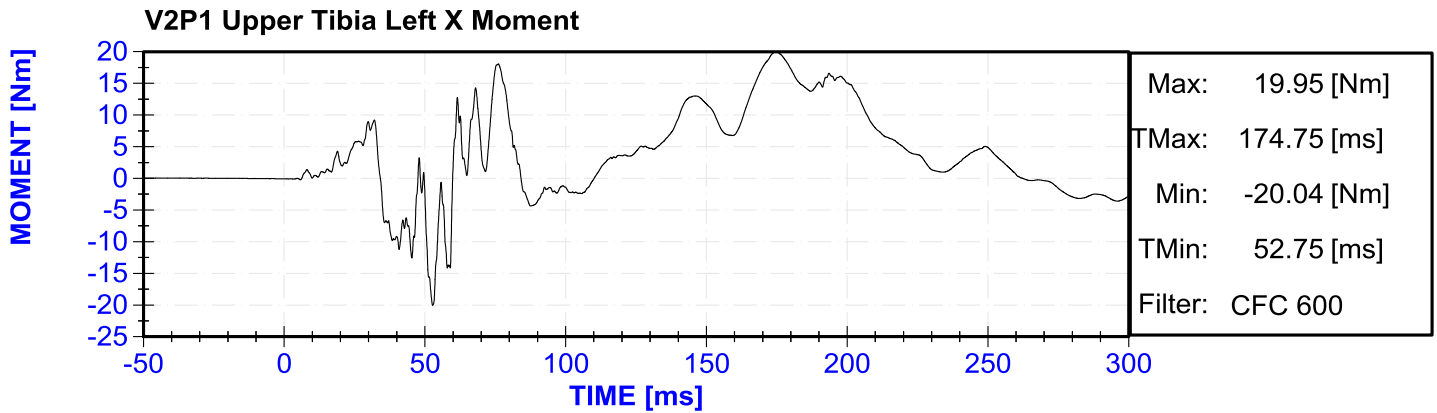

V2P1 Upper Tibia Right Y Moment

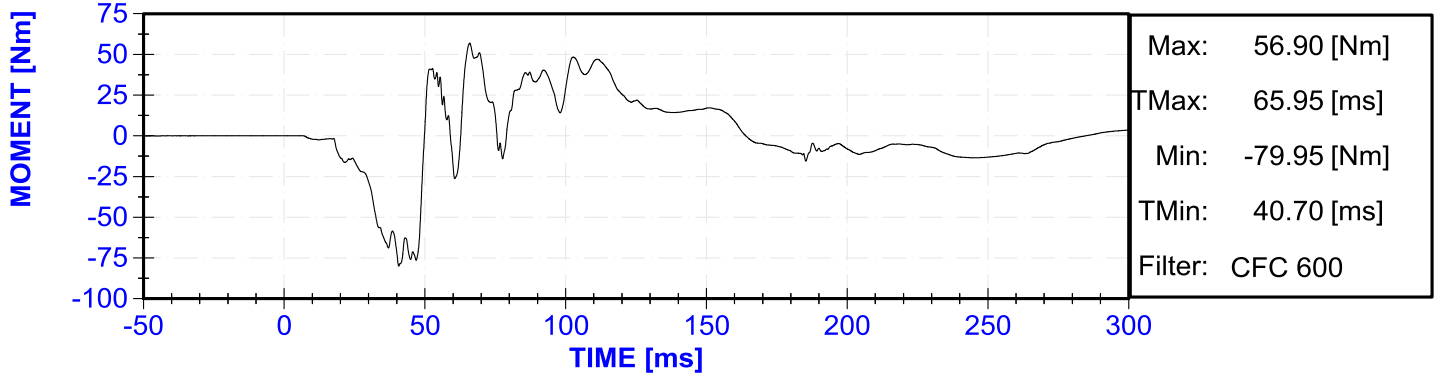

V2P1 Lower Tibia Left X Force

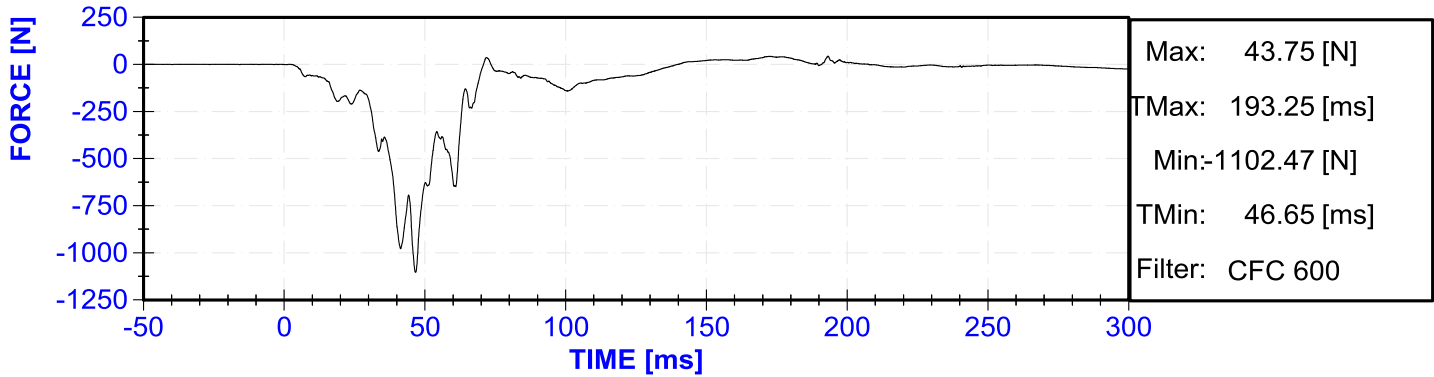

V2P1 Lower Tibia Left Y Force

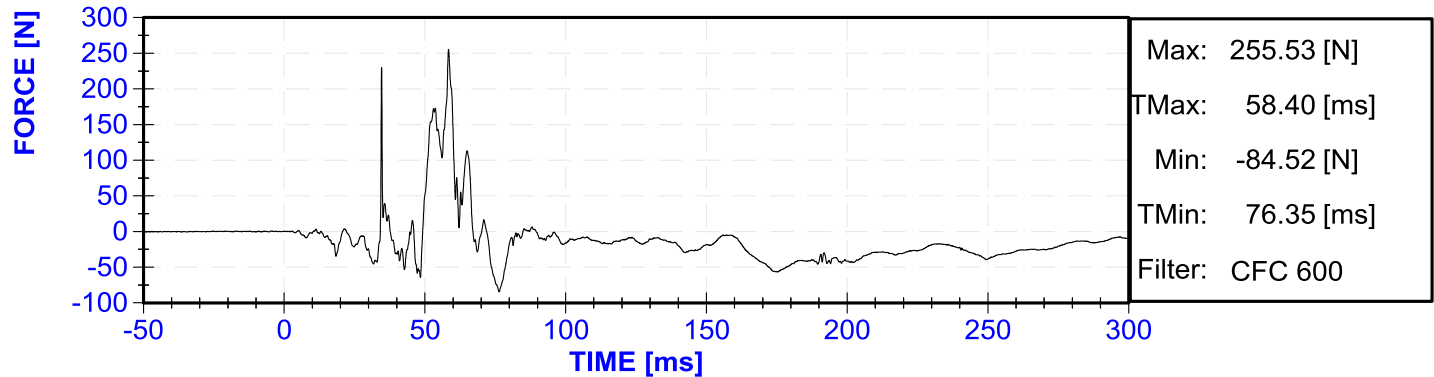

V2P1 Lower Tibia Left Z Force

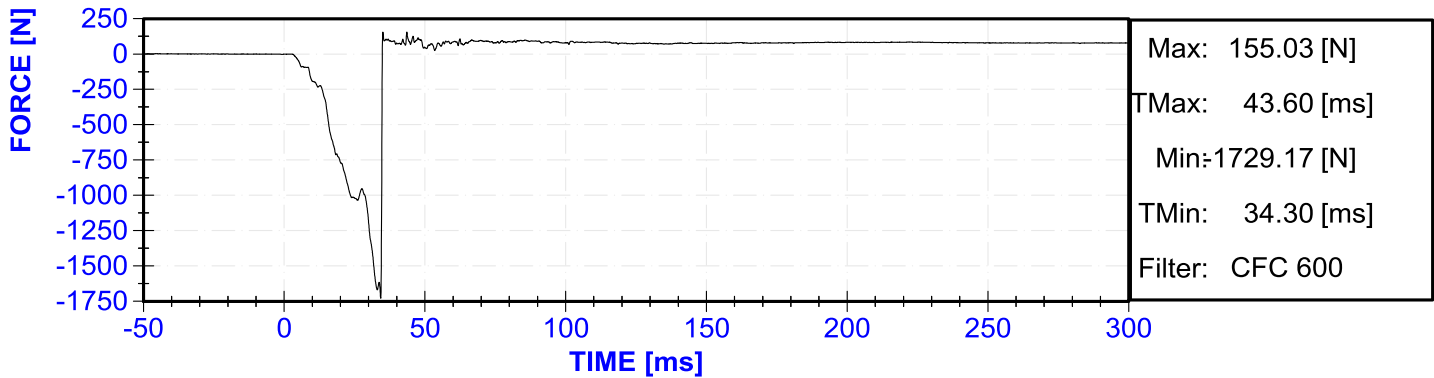

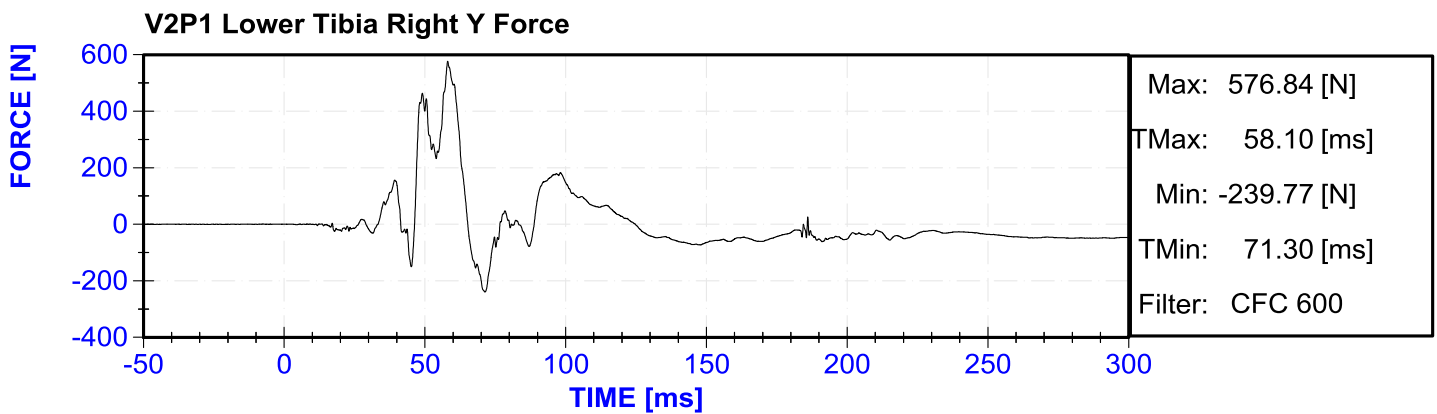
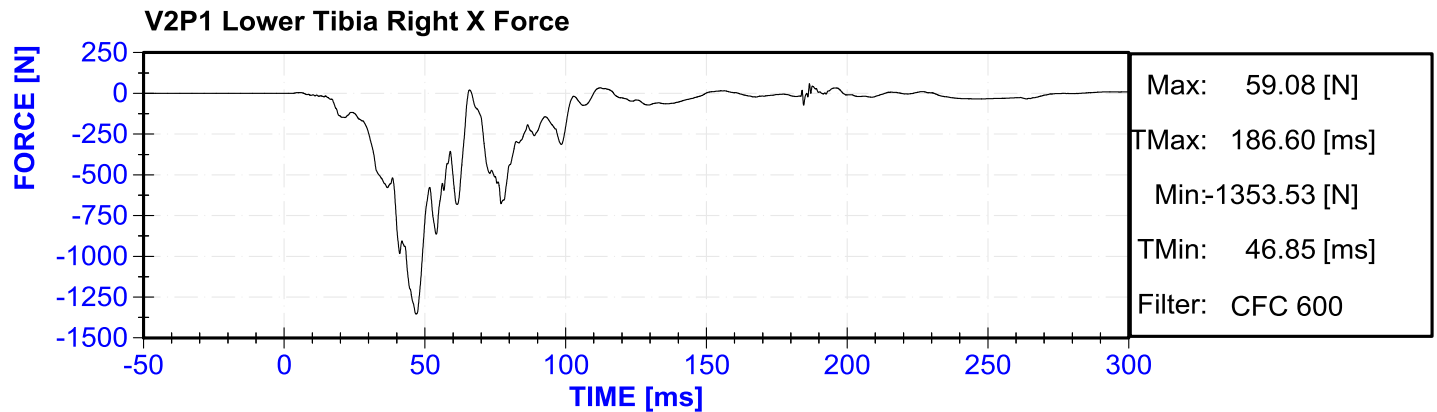
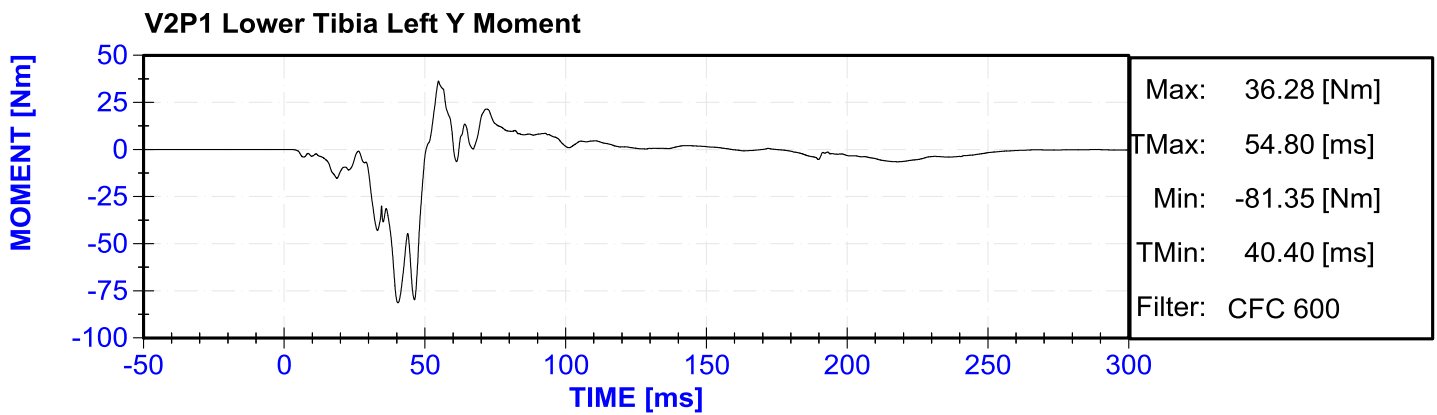
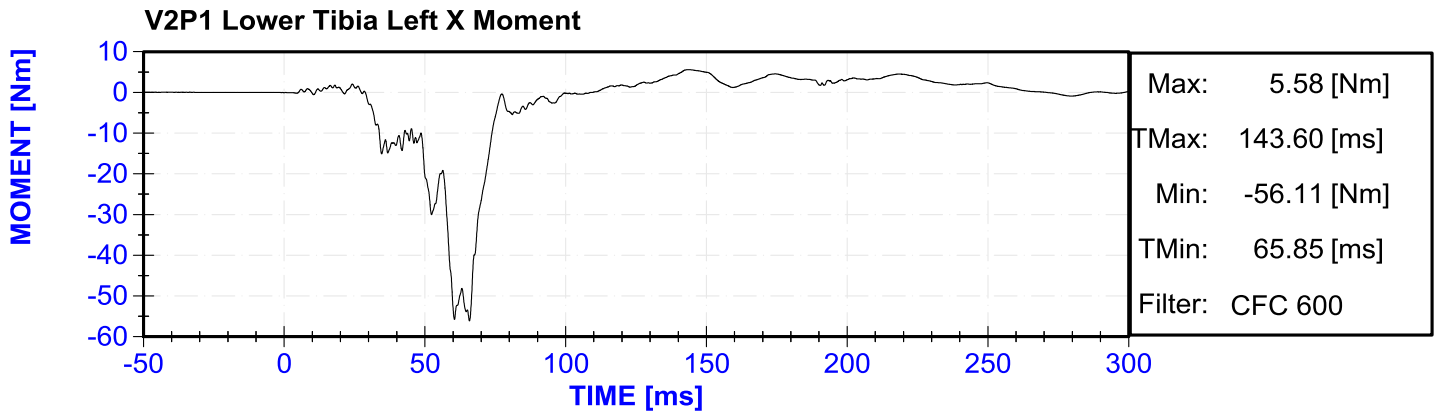

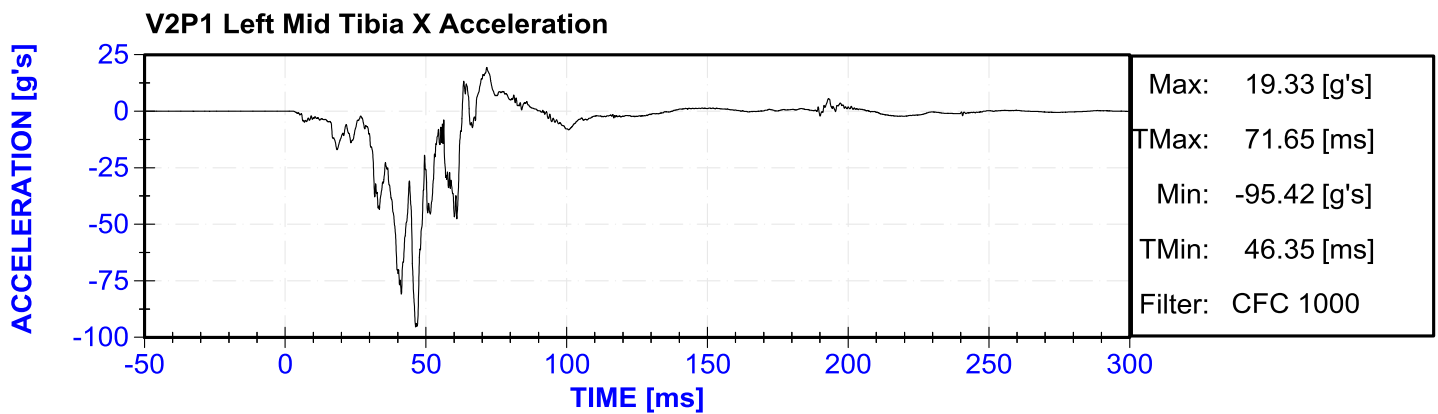
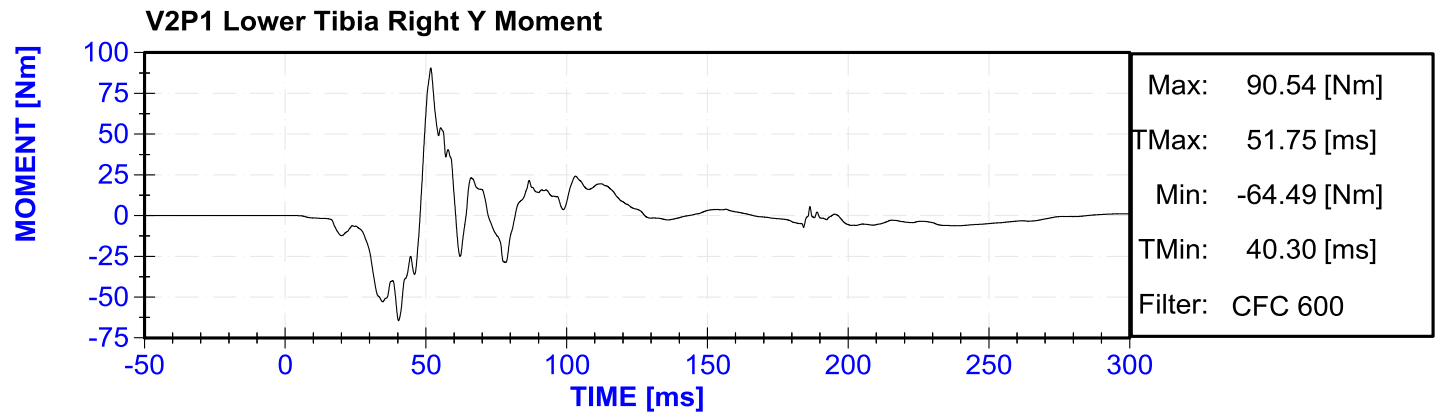
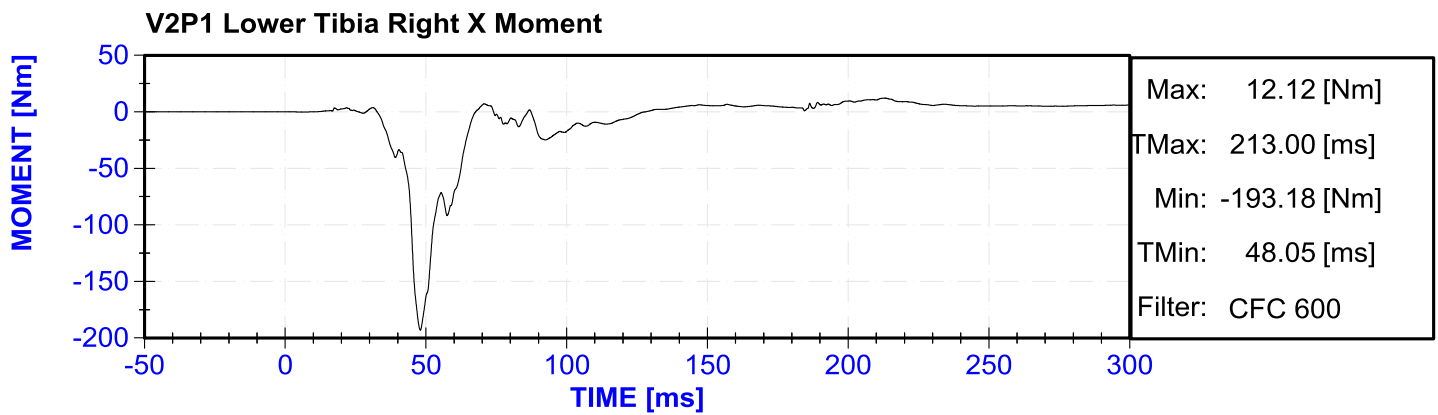
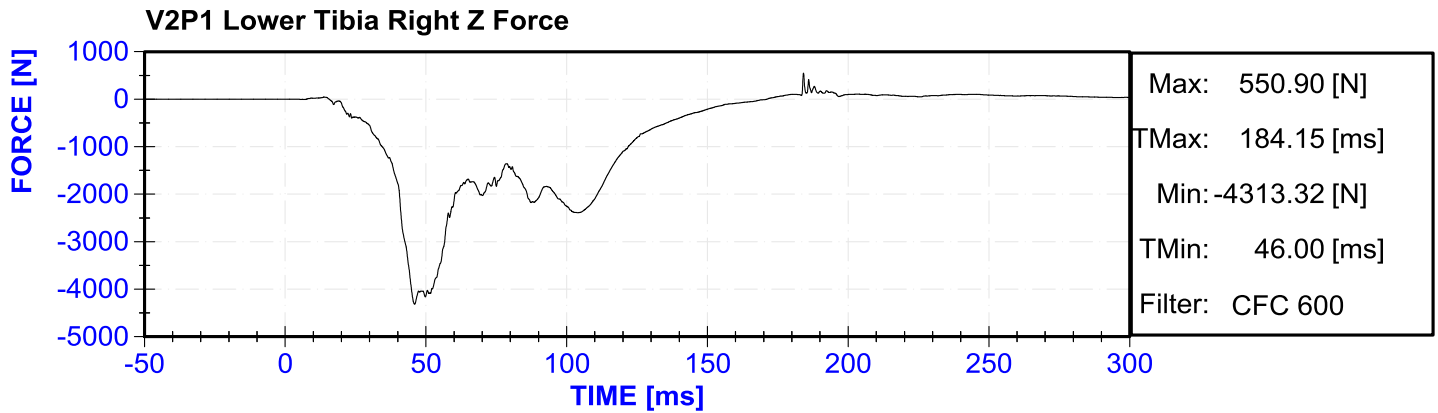

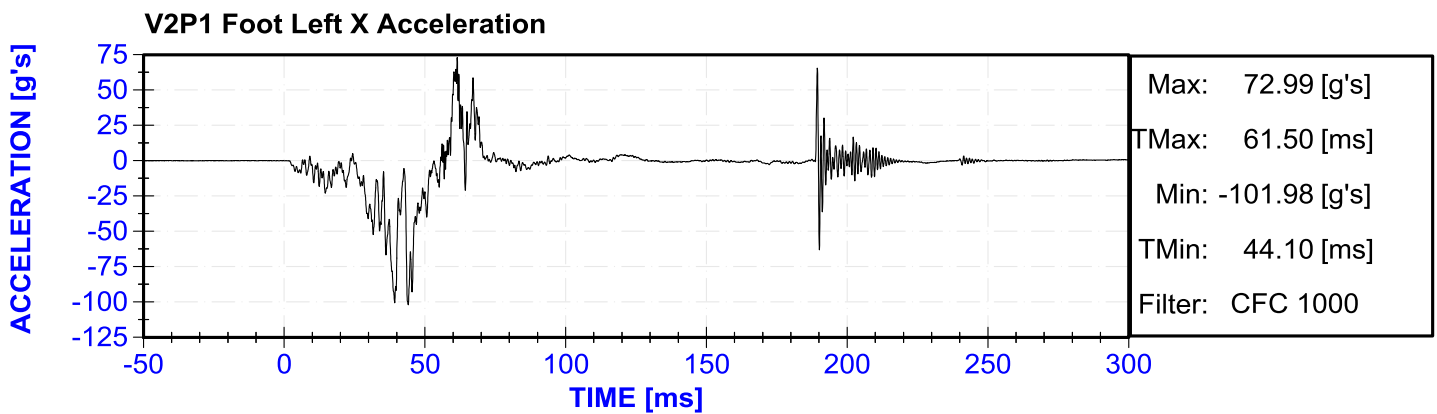
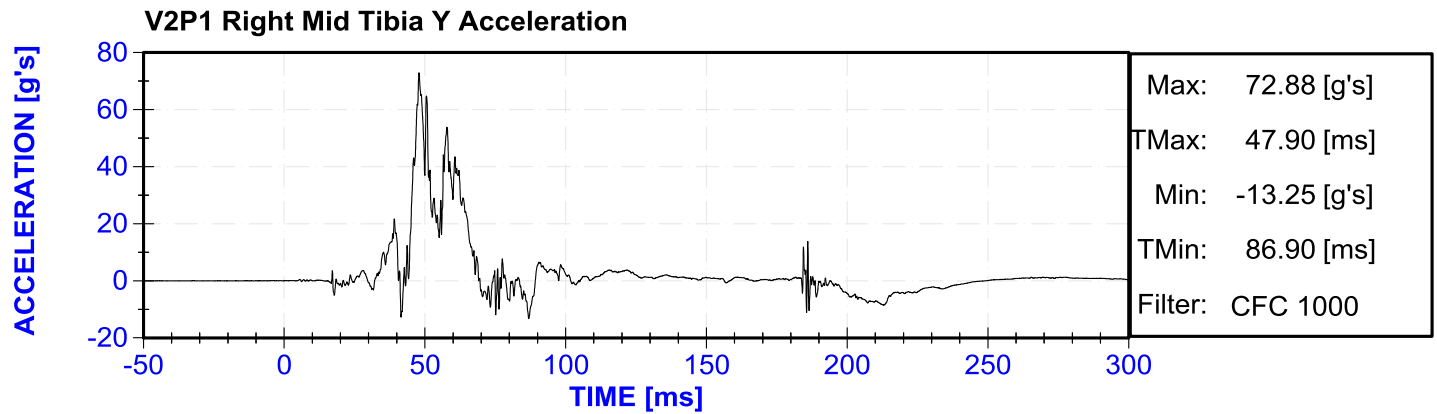
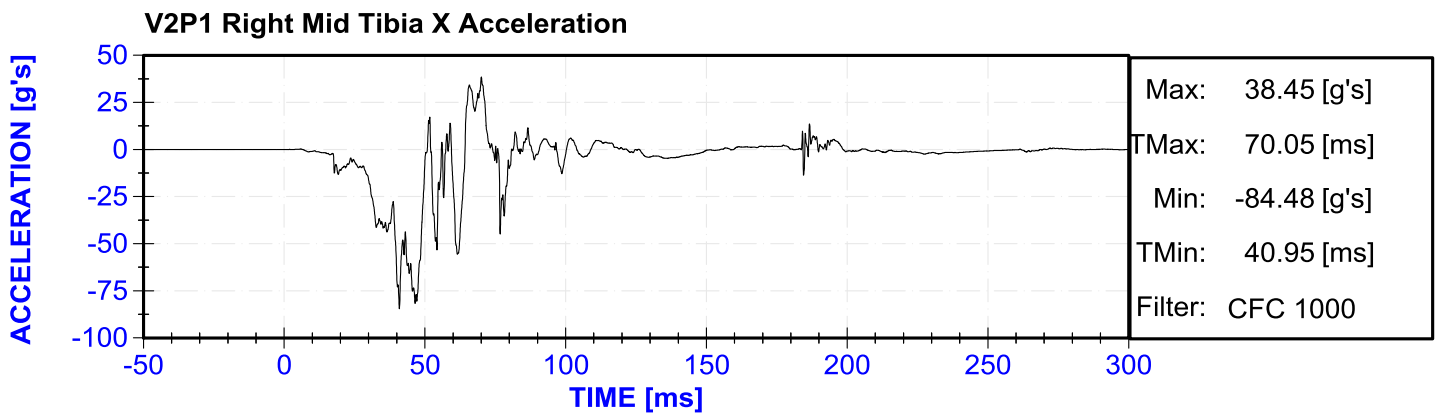
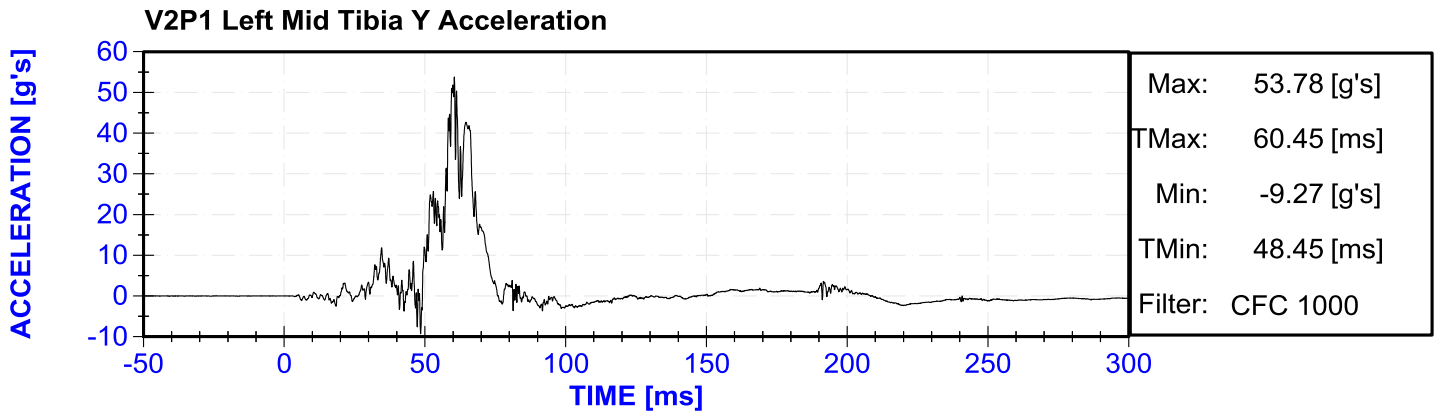

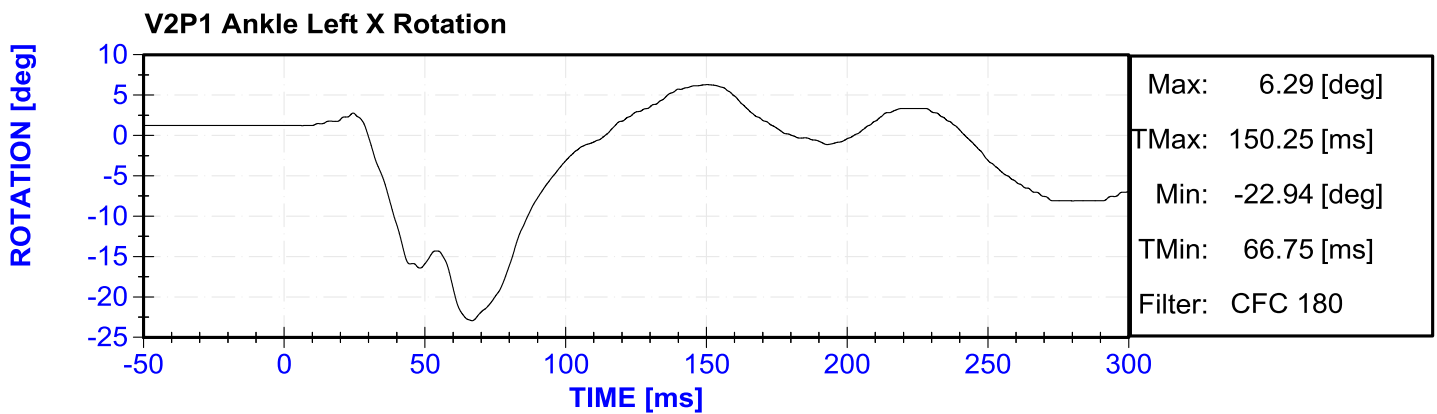
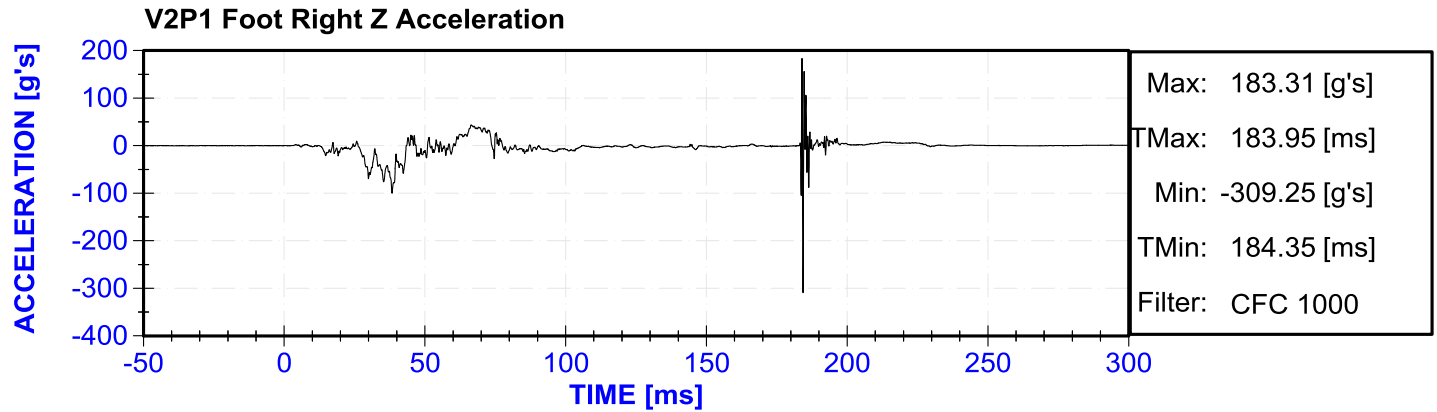
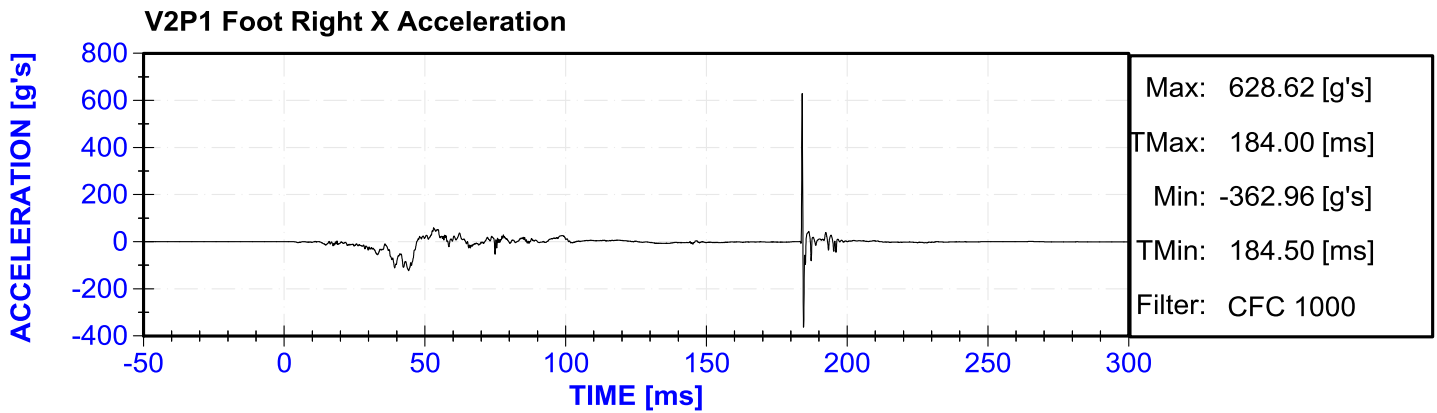
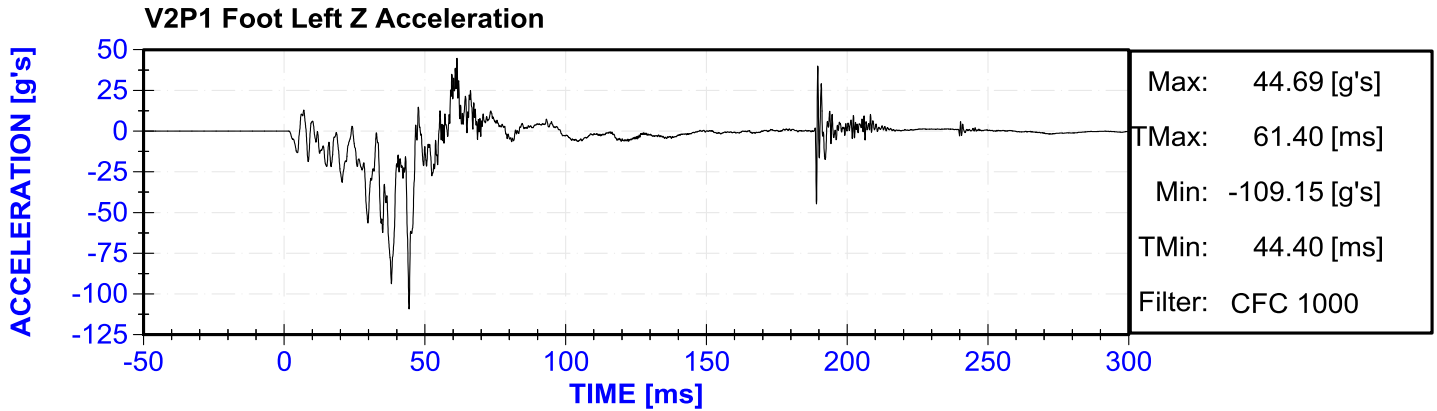

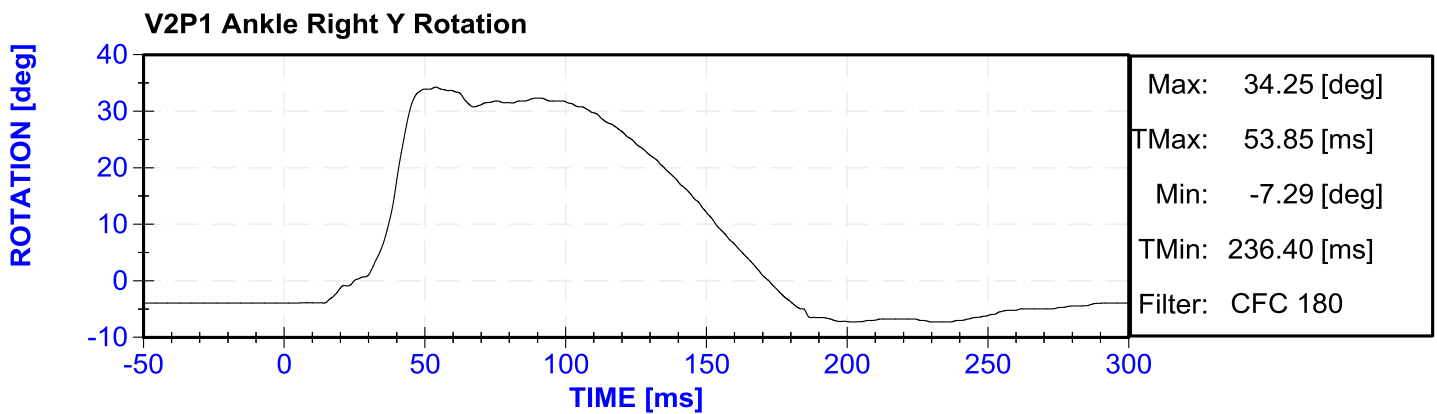
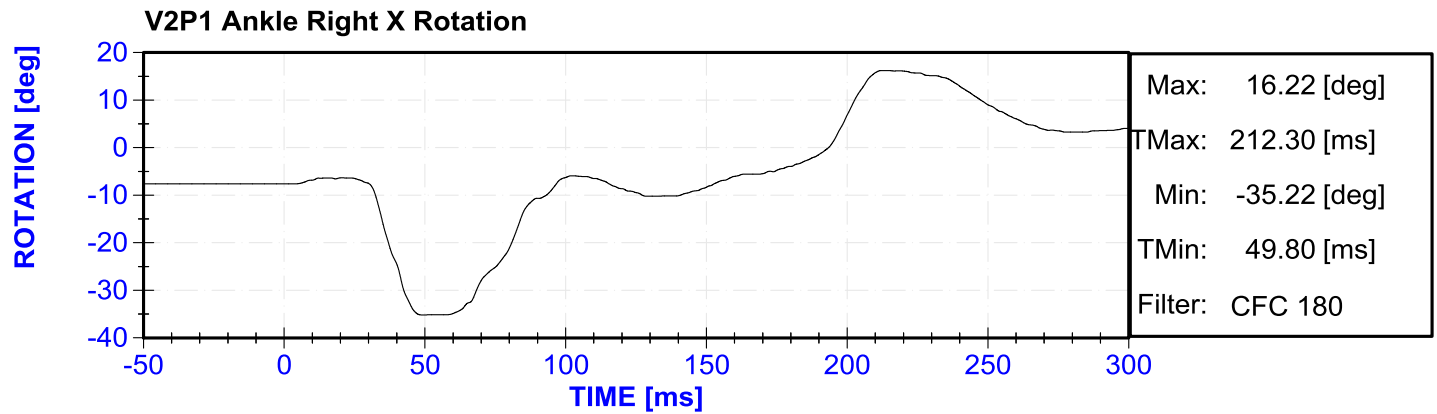
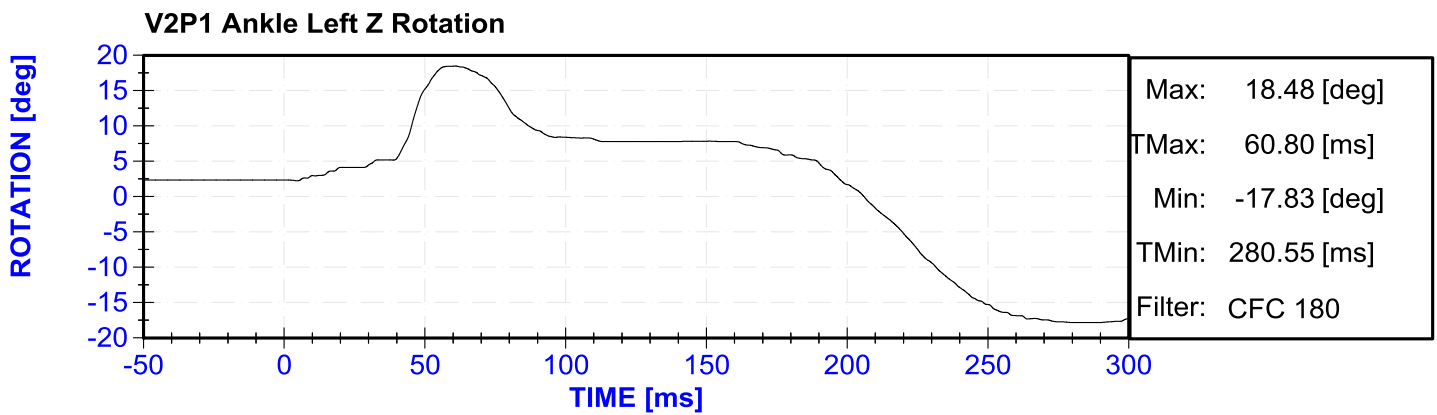
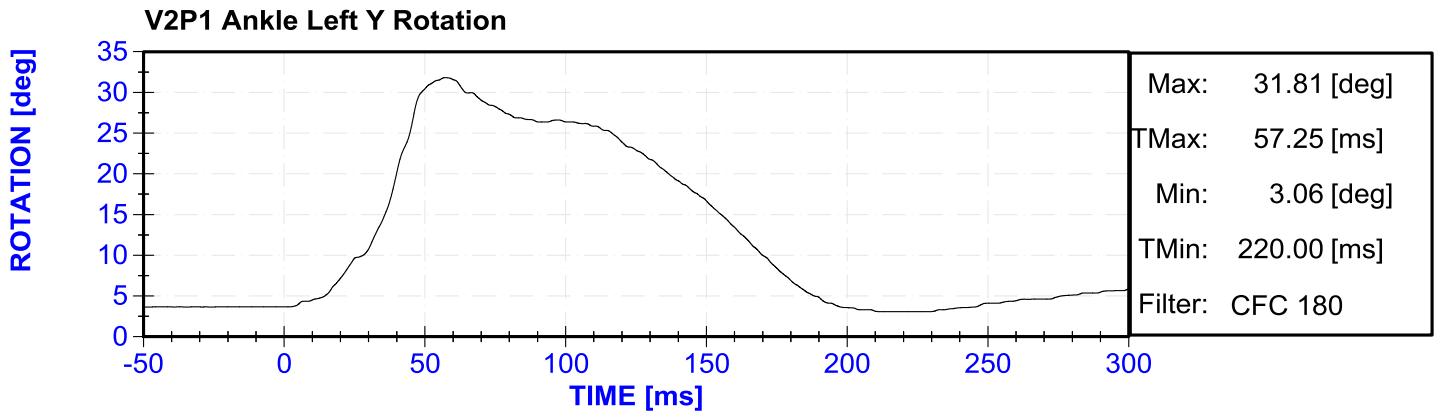

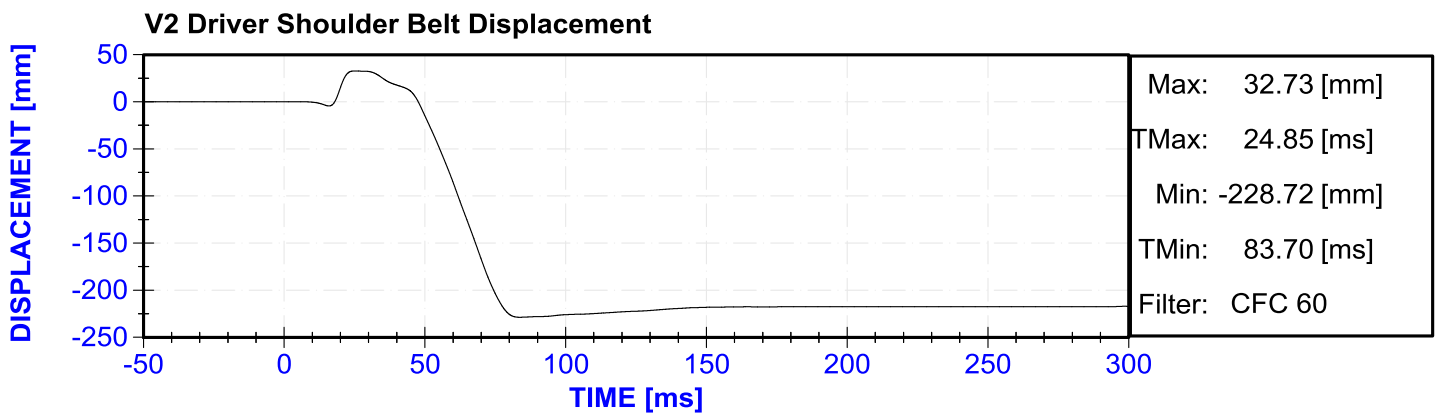
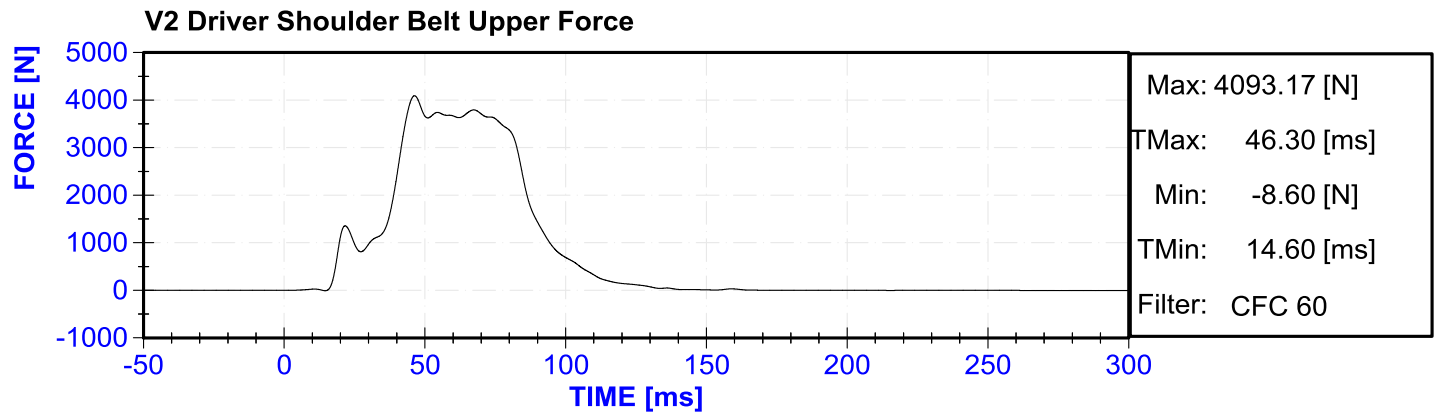
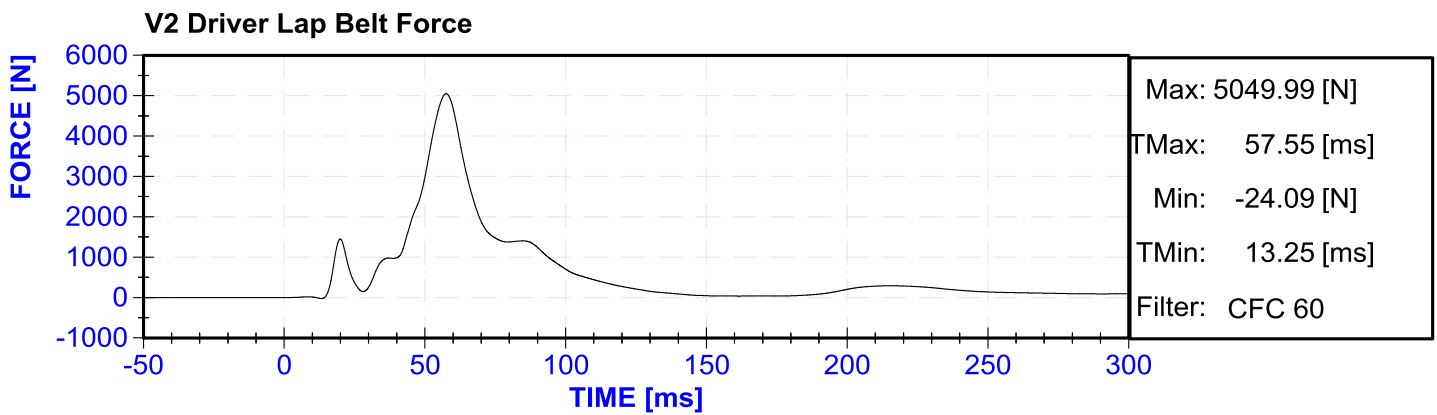
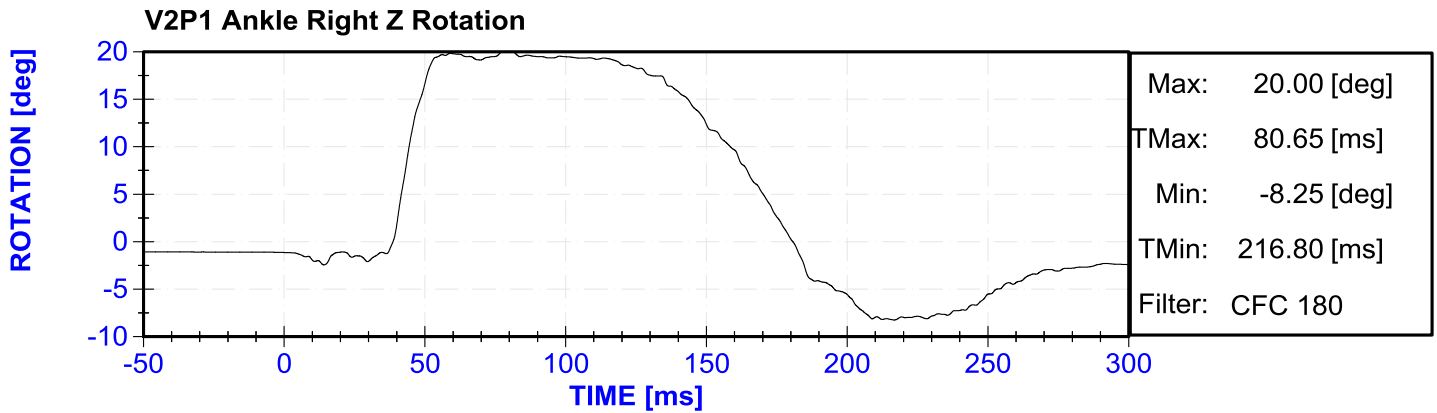

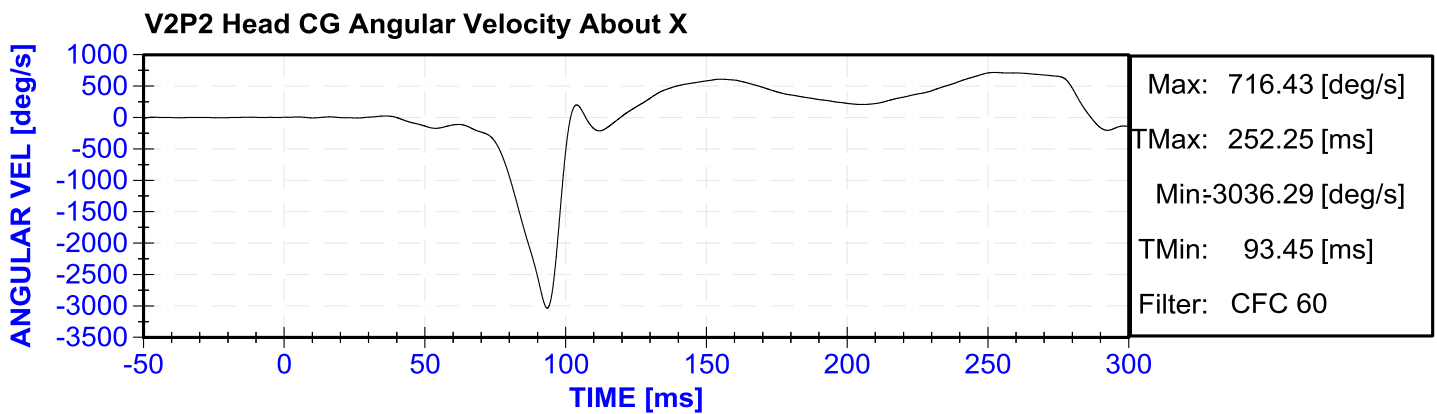
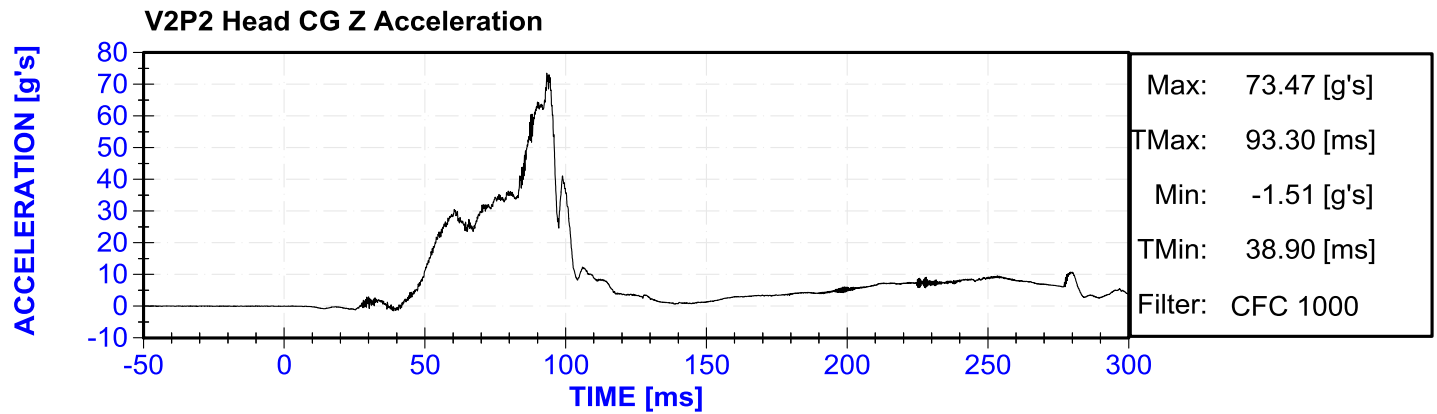
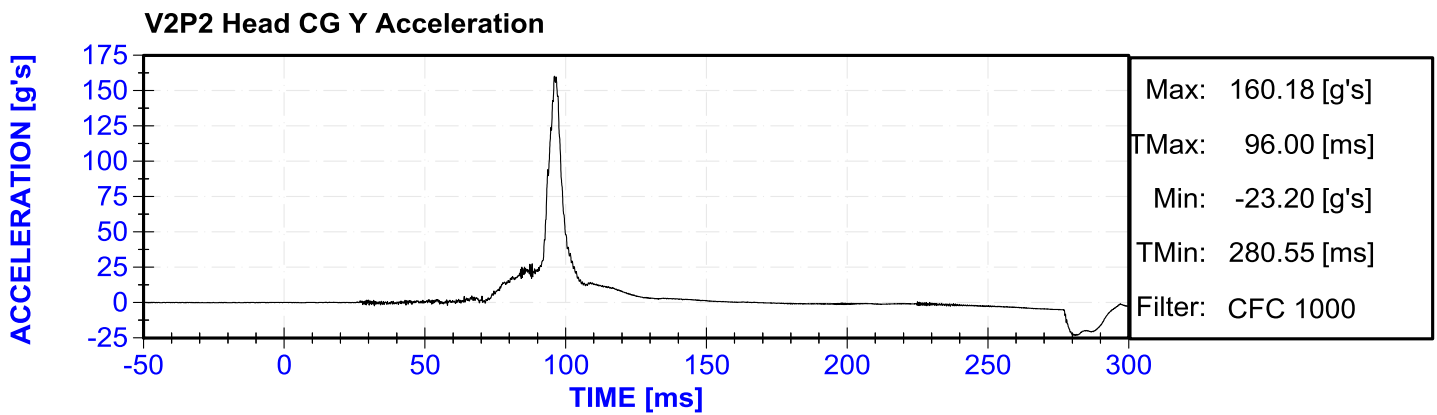
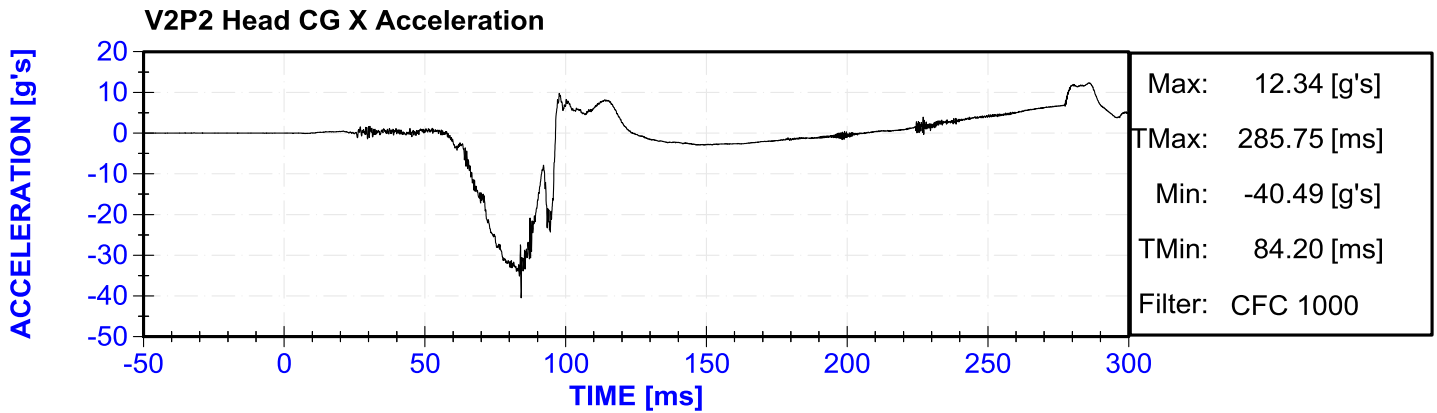

V2P2 Head CG Angular Velocity About Y

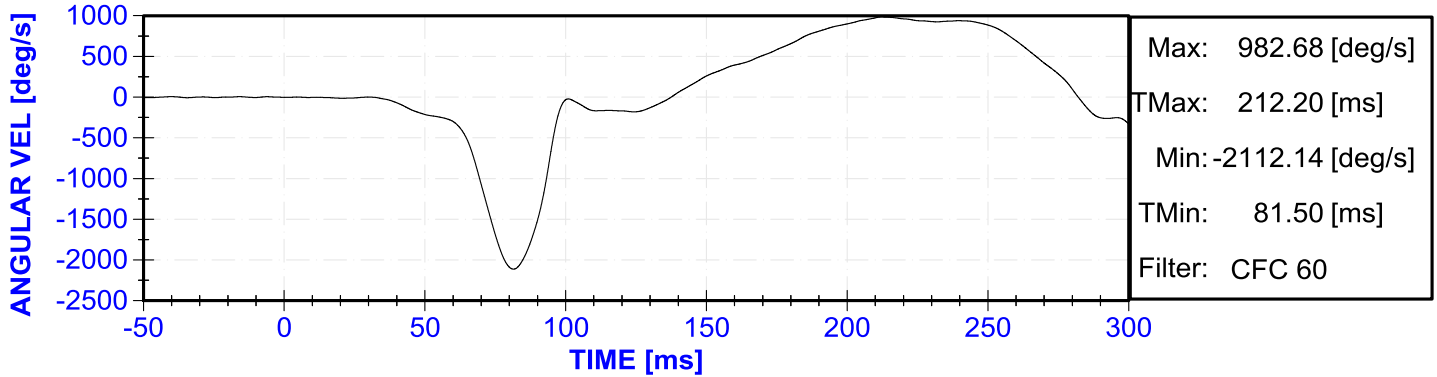

V2P2 Head CG Angular Velocity About Z

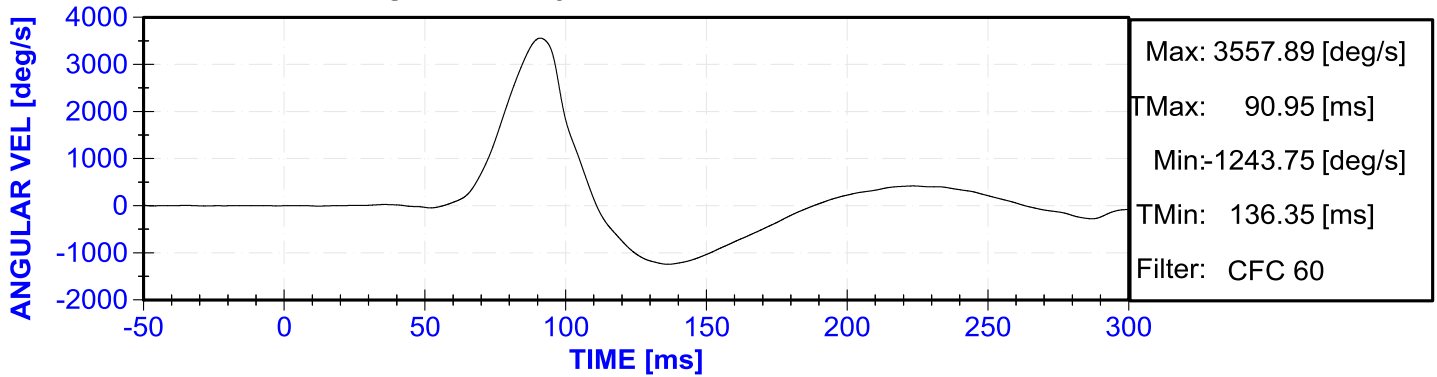

V2P2 Upper Neck X Force

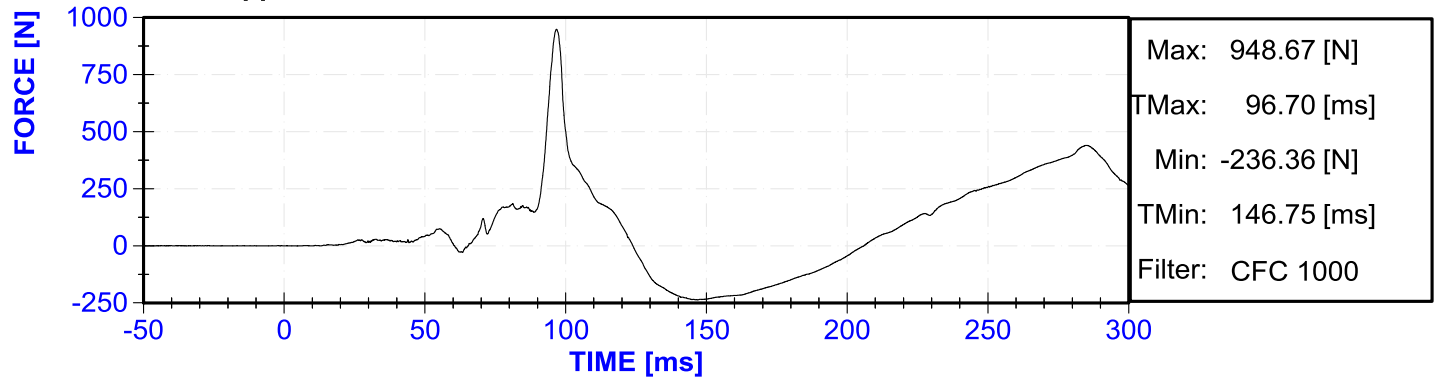

V2P2 Upper Neck Y Force

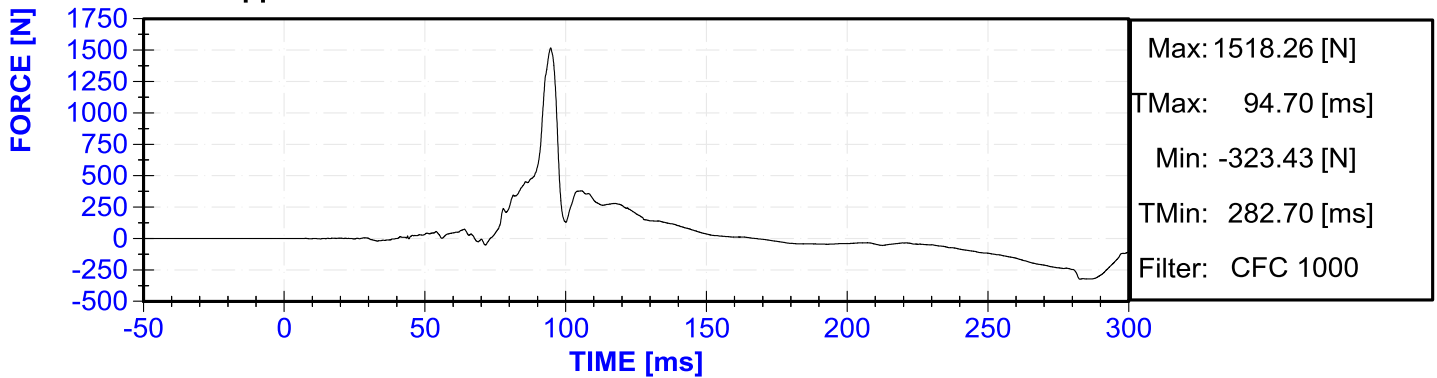

V2P2 Upper Neck Z Force

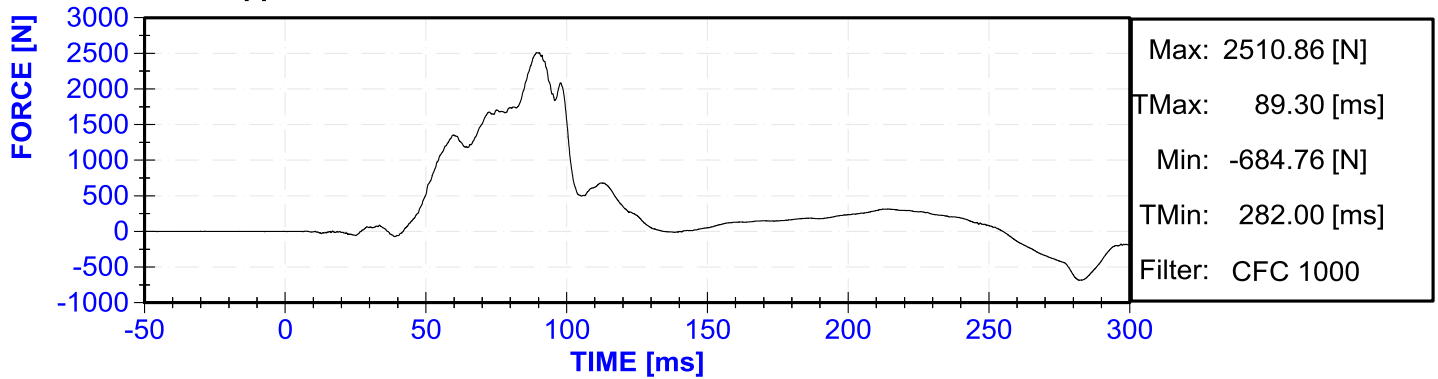

V2P2 Upper Neck X Moment

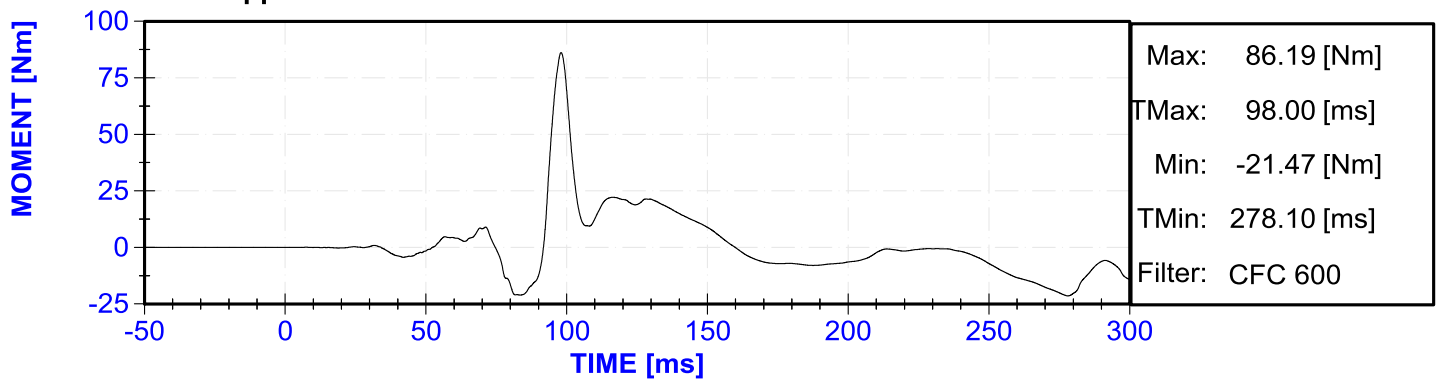

V2P2 Upper Neck Y Moment

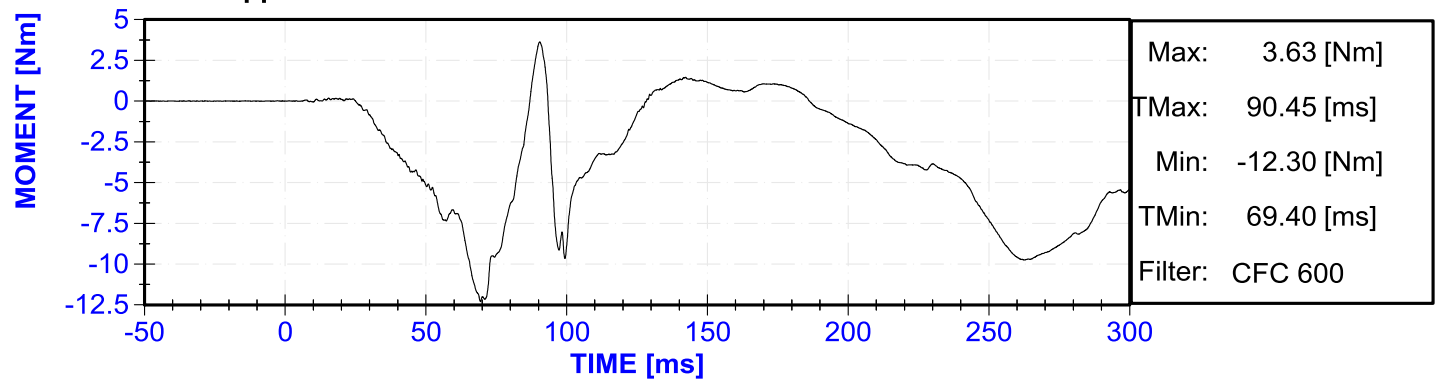

V2P2 Upper Neck Z Moment

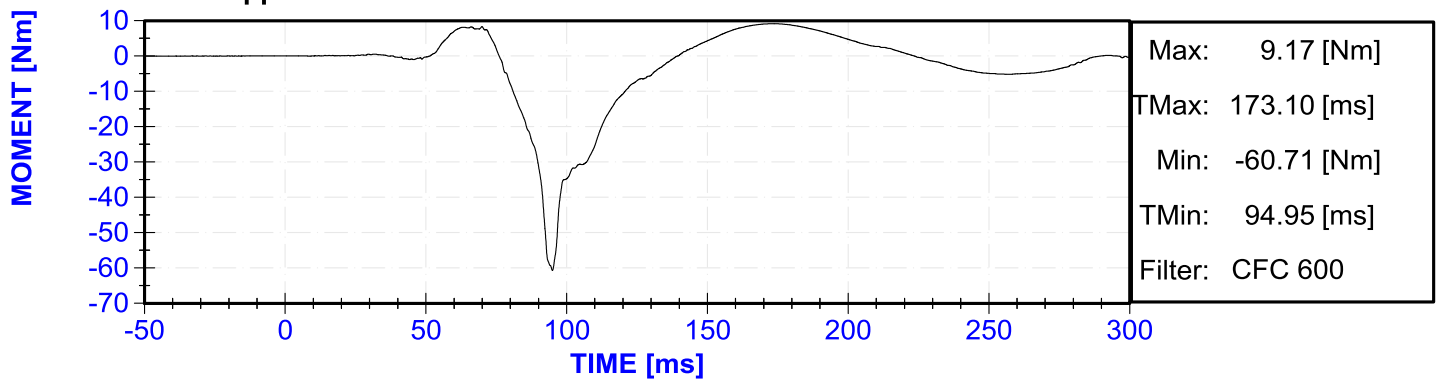

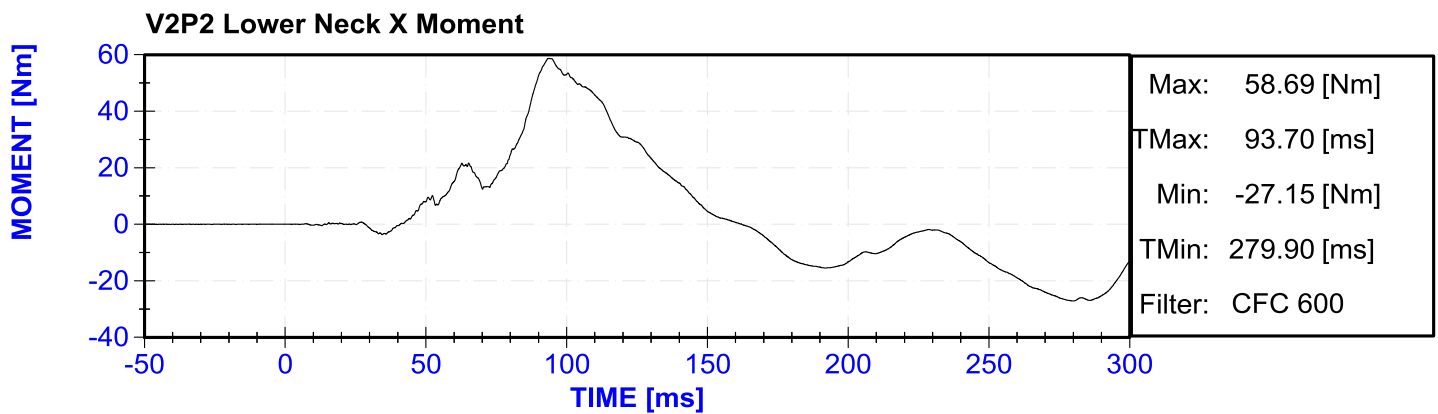
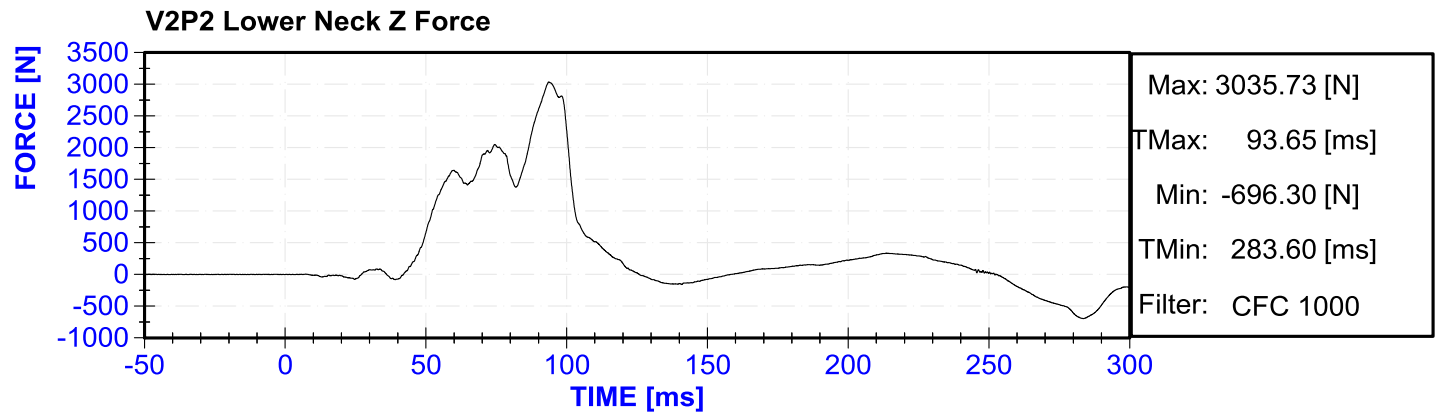
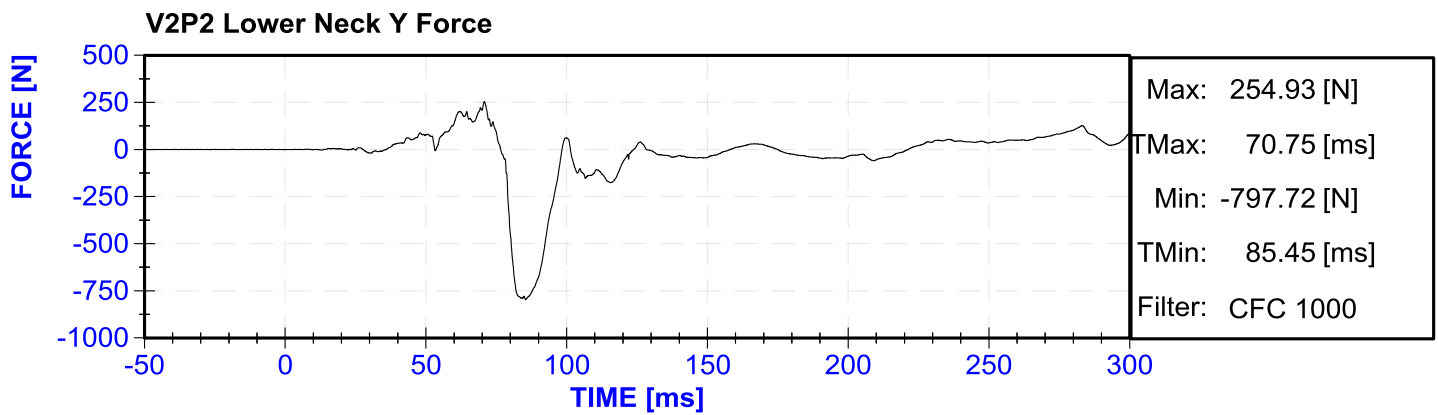
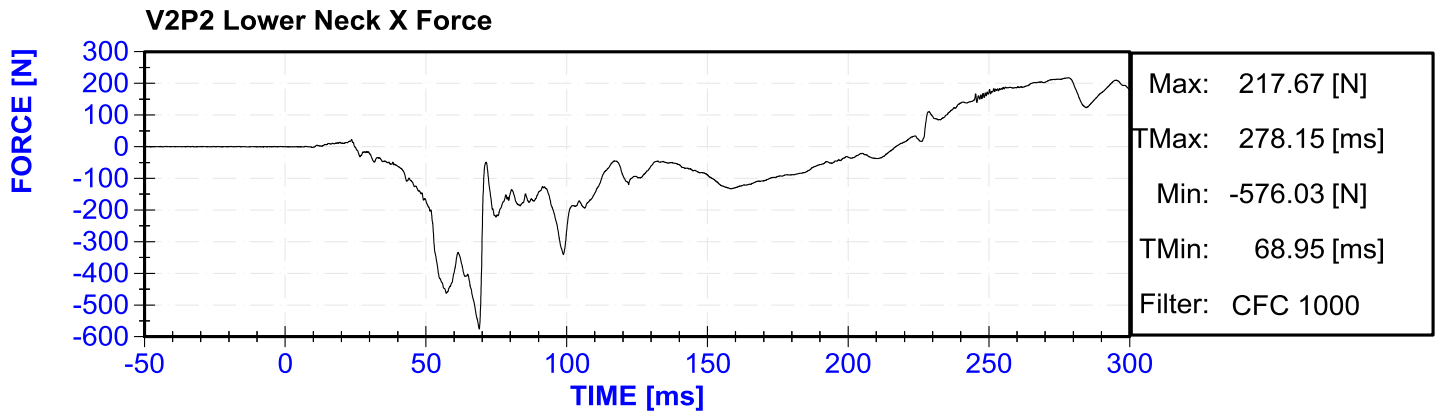

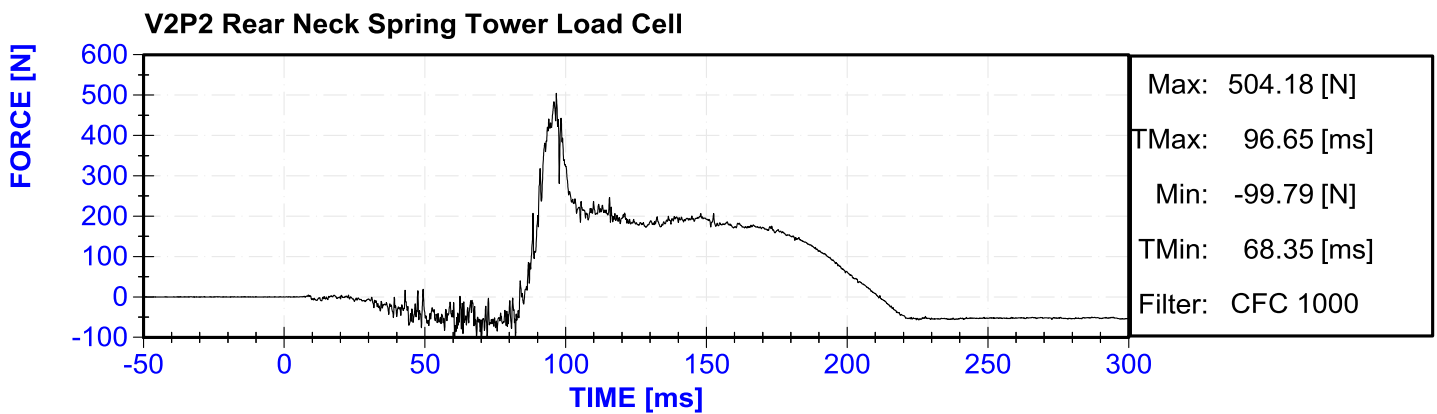
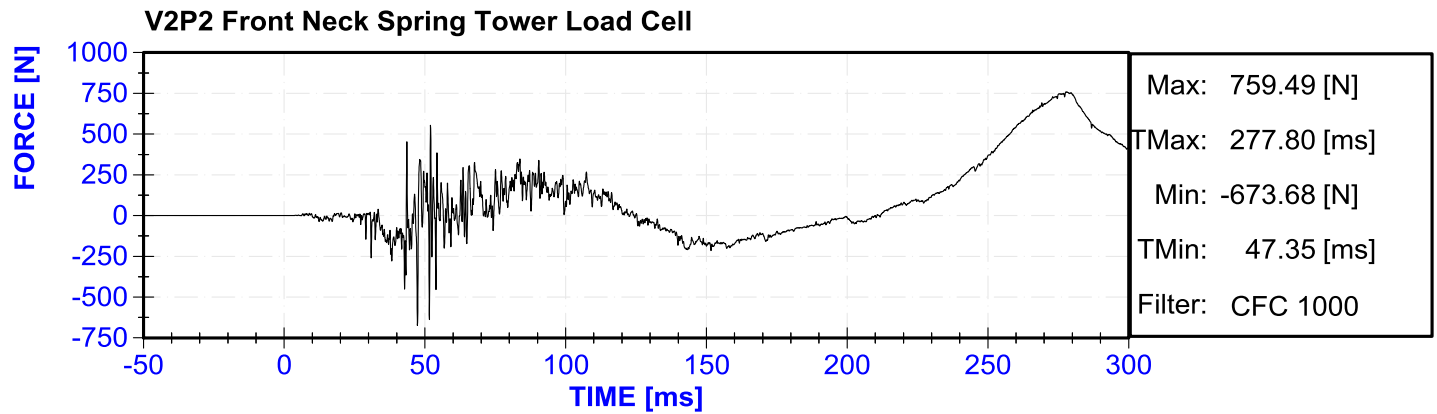
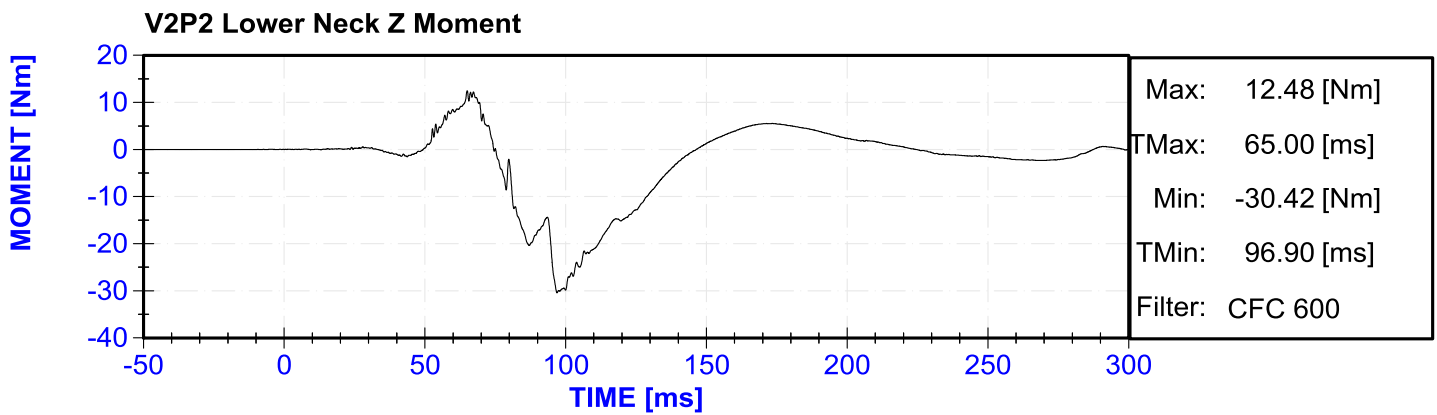
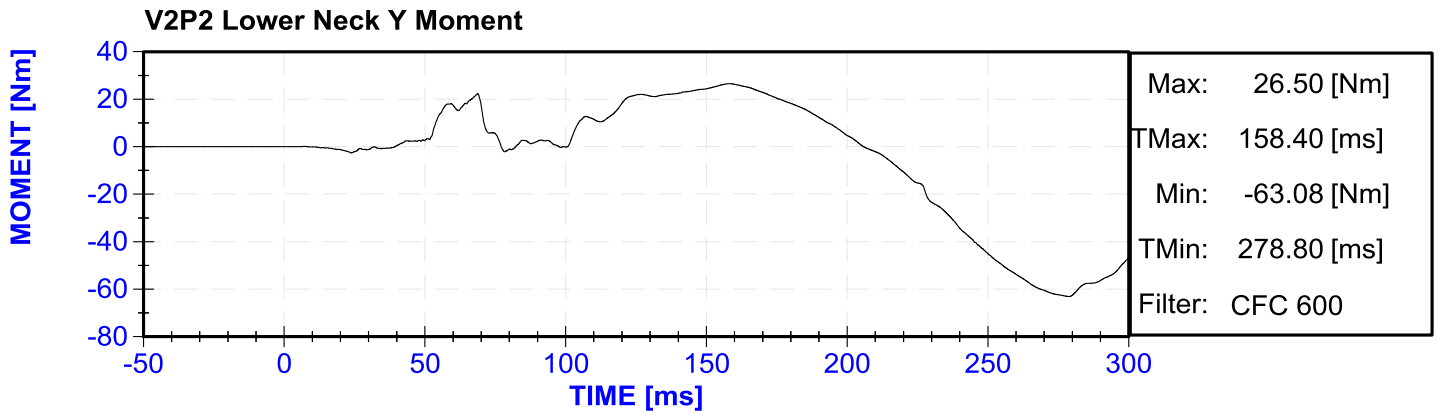

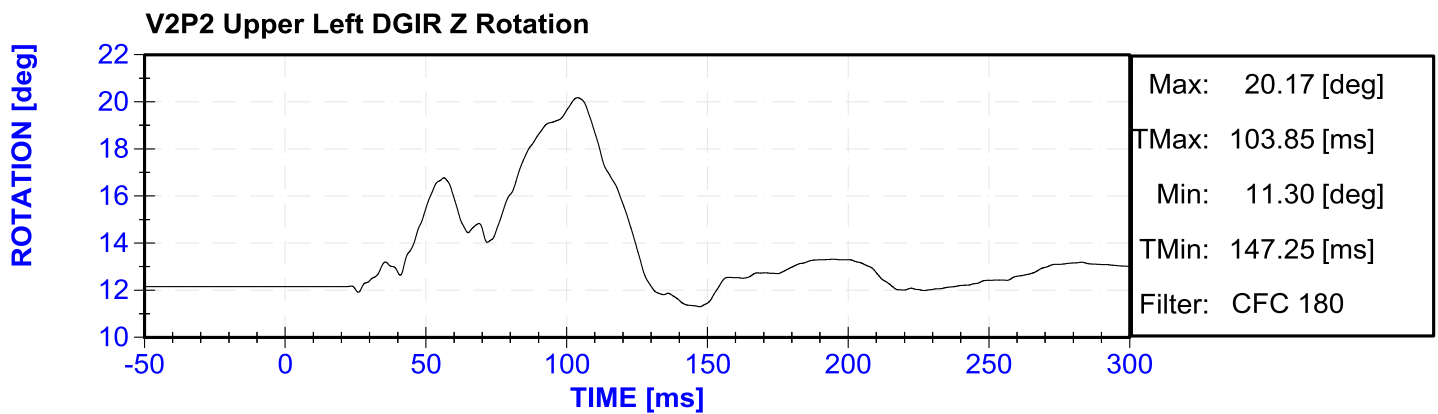
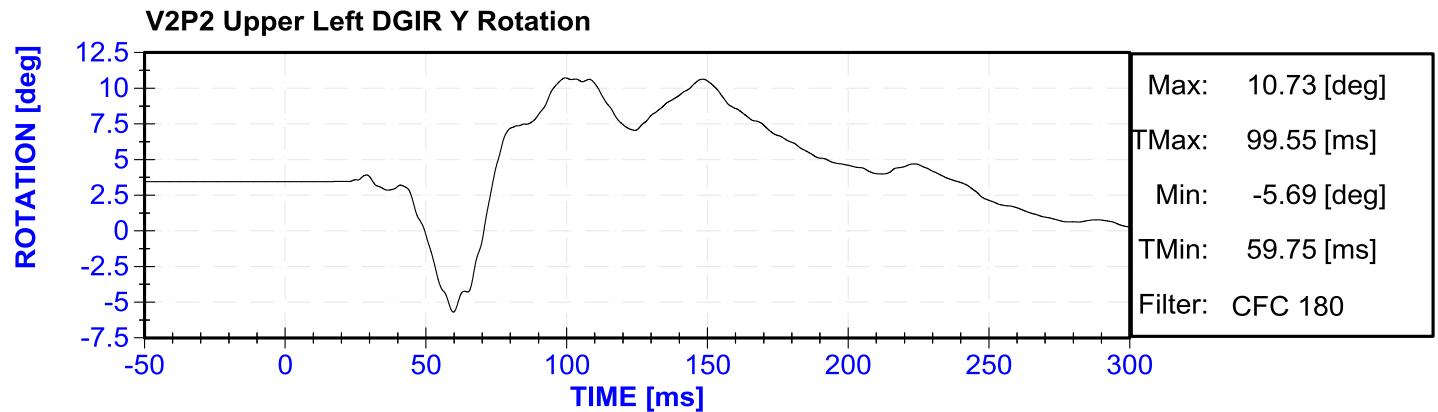
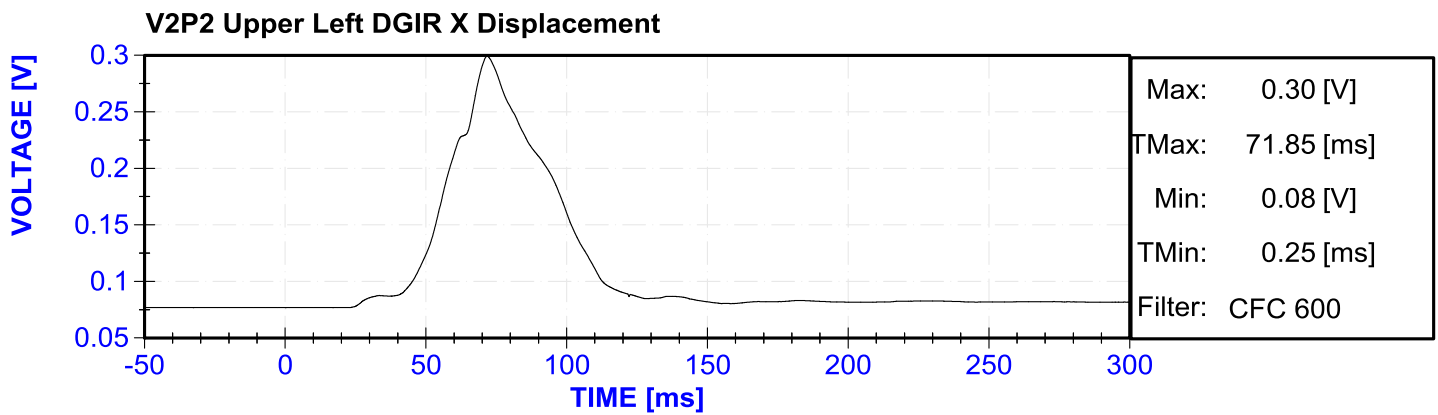
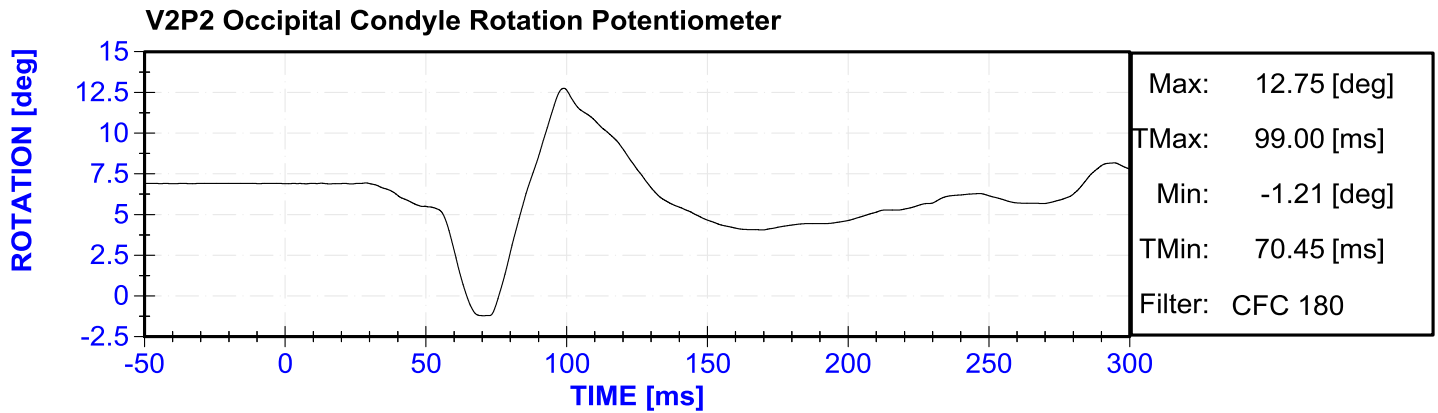

V2P2 Upper Right DGIR X Displacement

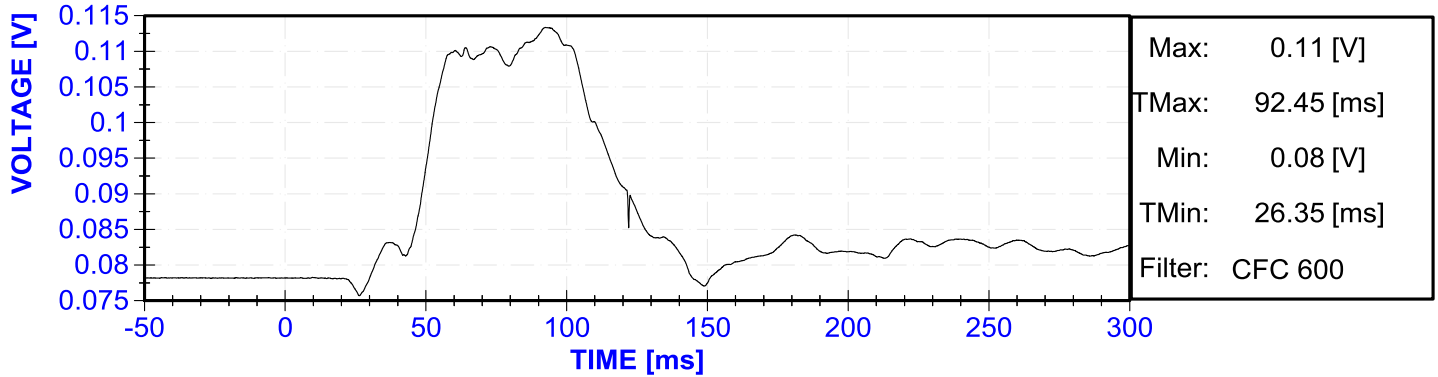

V2P2 Upper Right DGIR Y Rotation

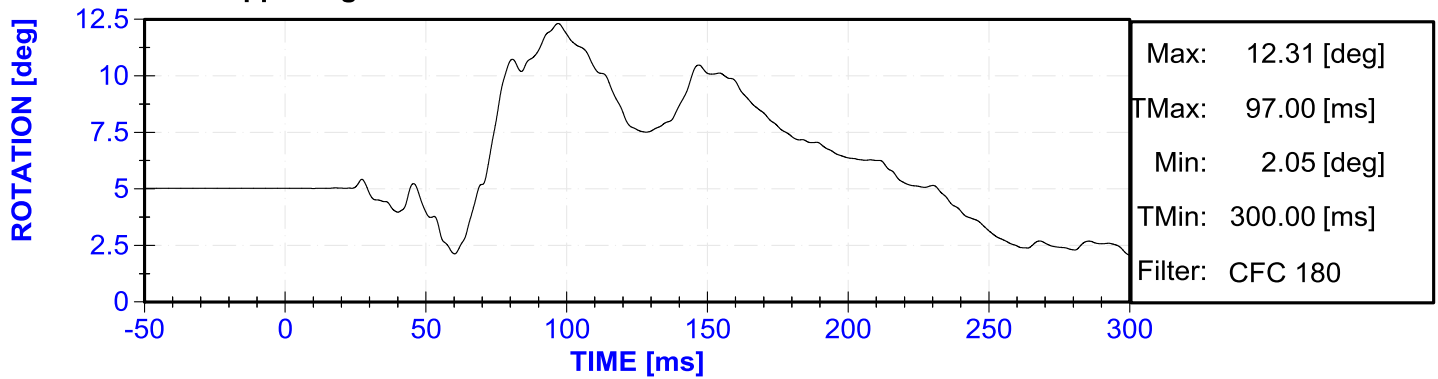

V2P2 Upper Right DGIR Z Rotation

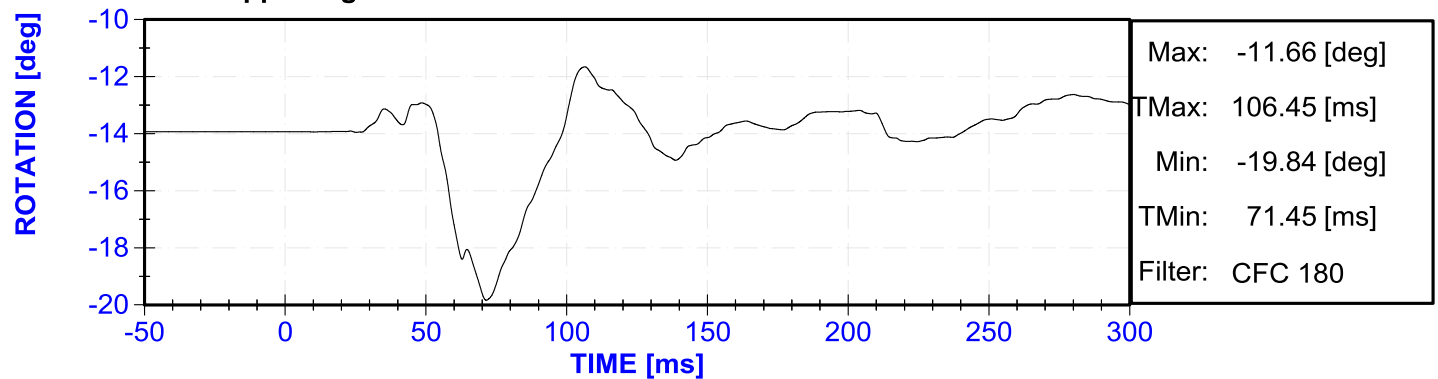

V2P2 Lower Left DGIR X Displacement

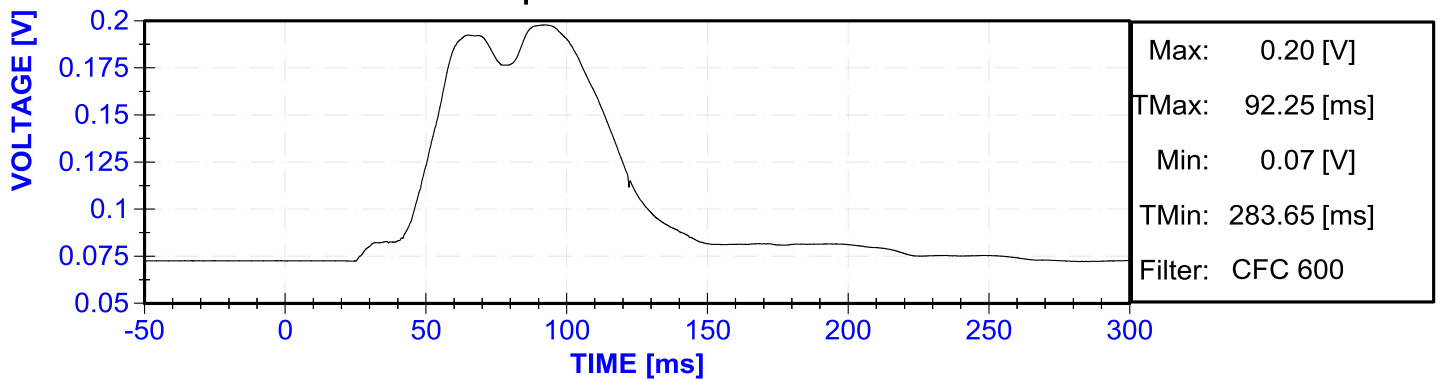

V2P2 Lower Left DGIR Y Rotation

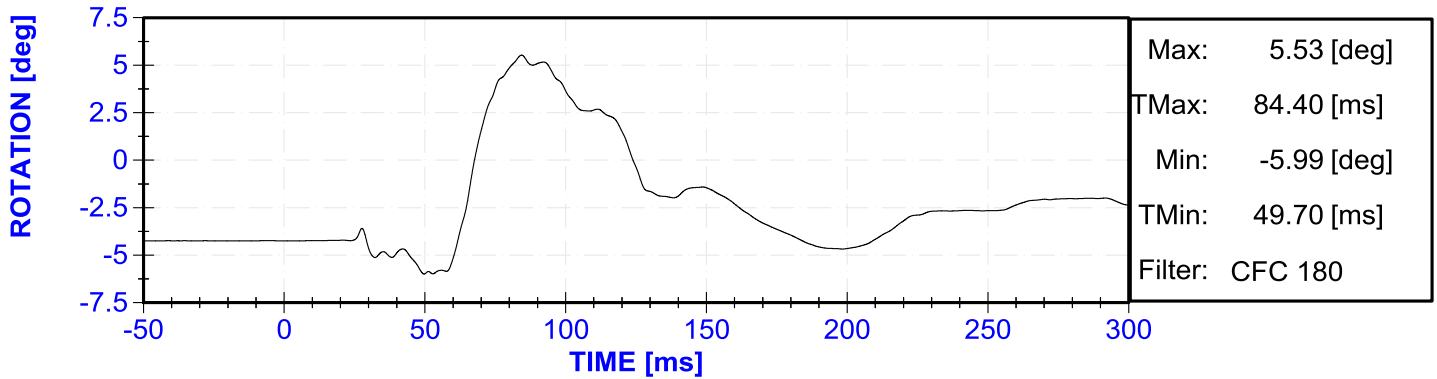

V2P2 Lower Left DGIR Z Rotation

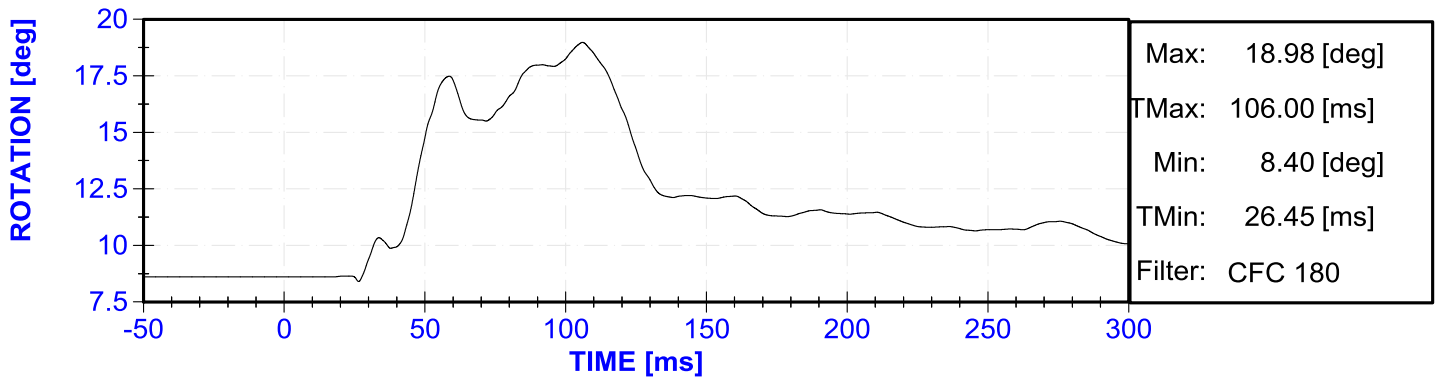

V2P2 Lower Right DGIR X Displacement

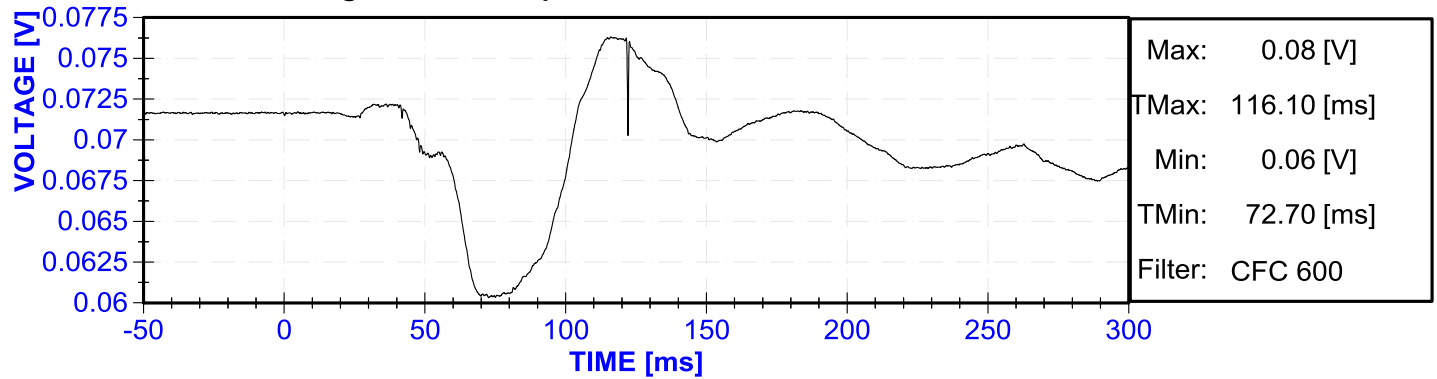

V2P2 Lower Right DGIR Y Rotation

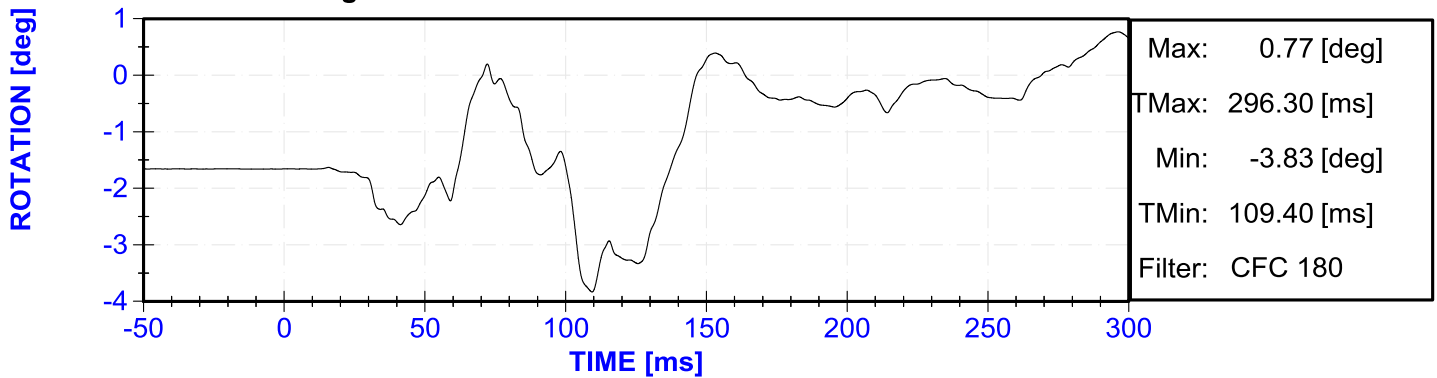

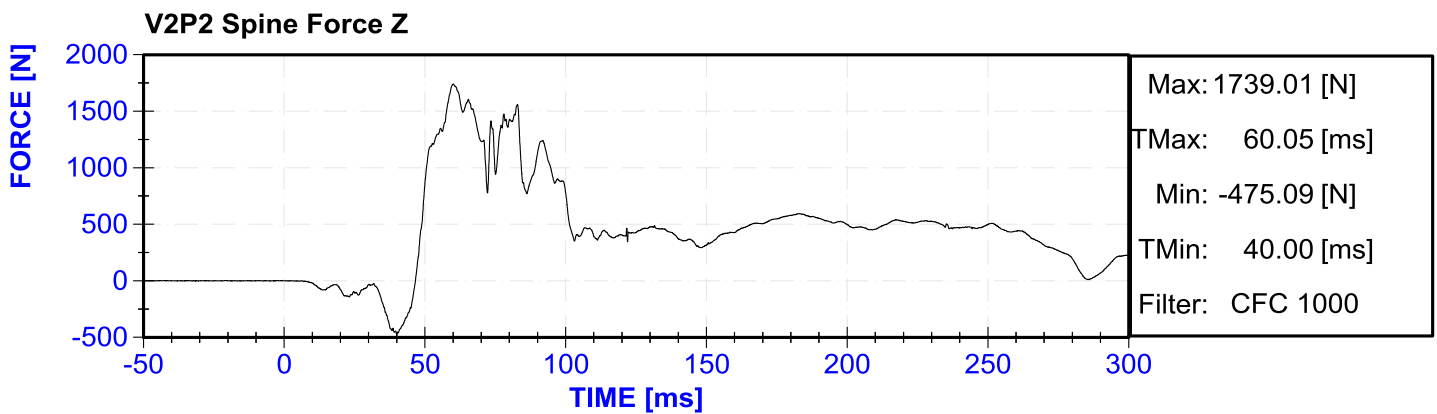
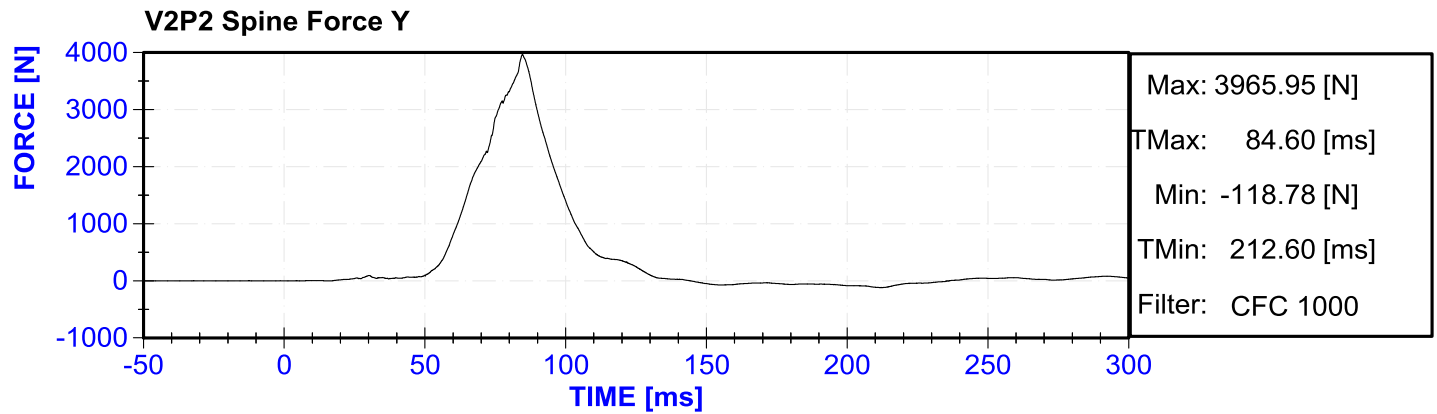
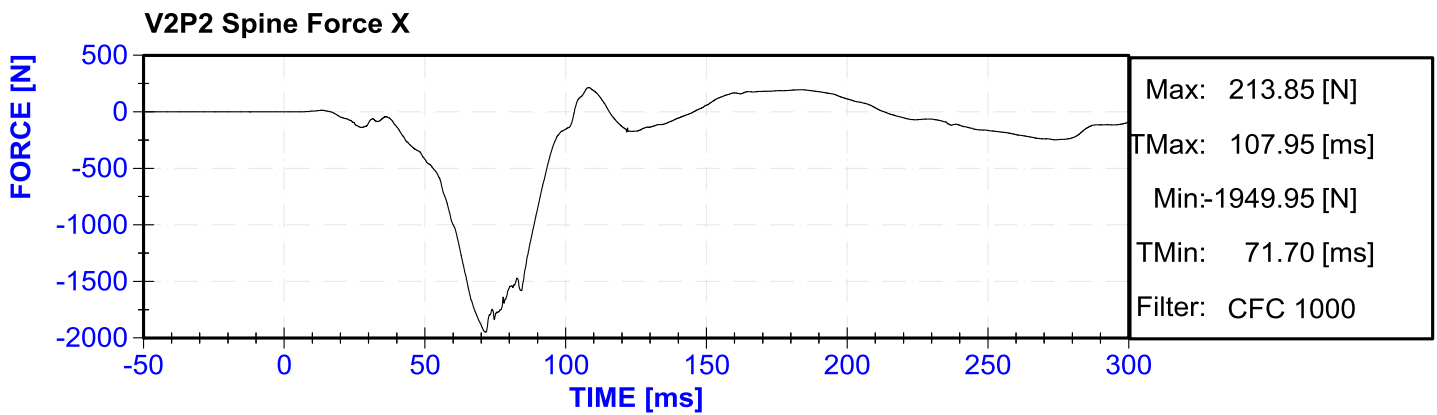
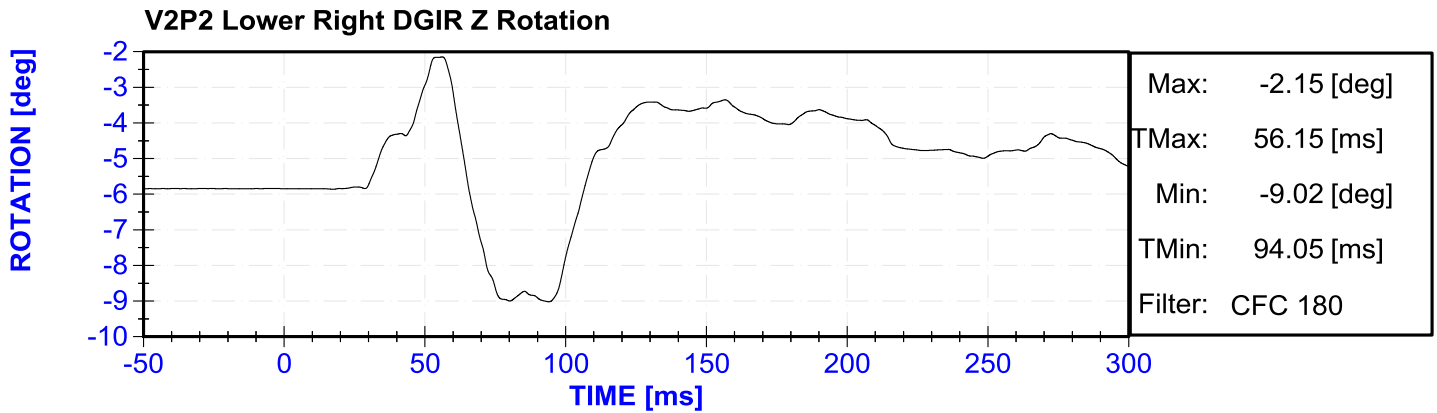

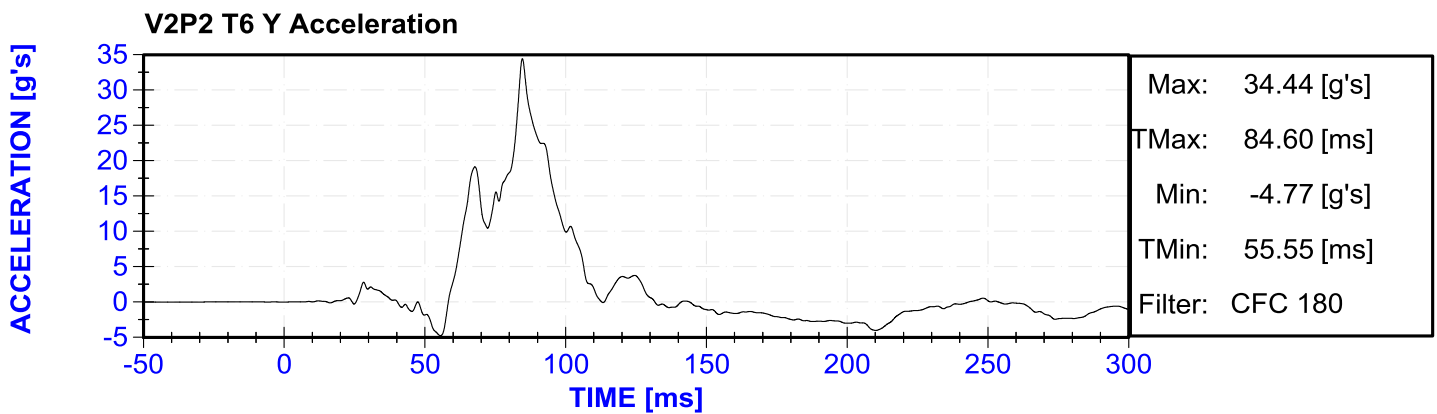
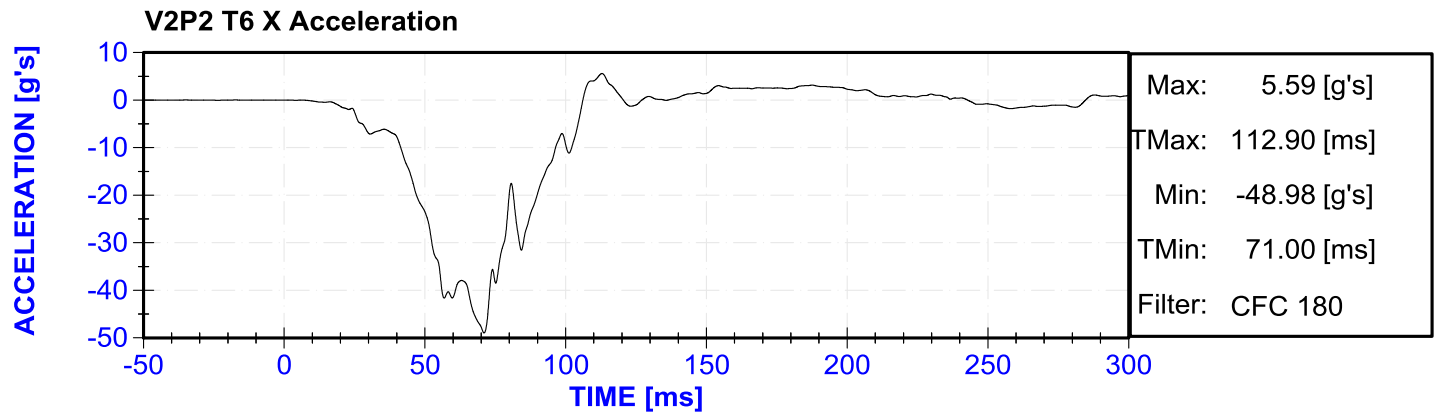
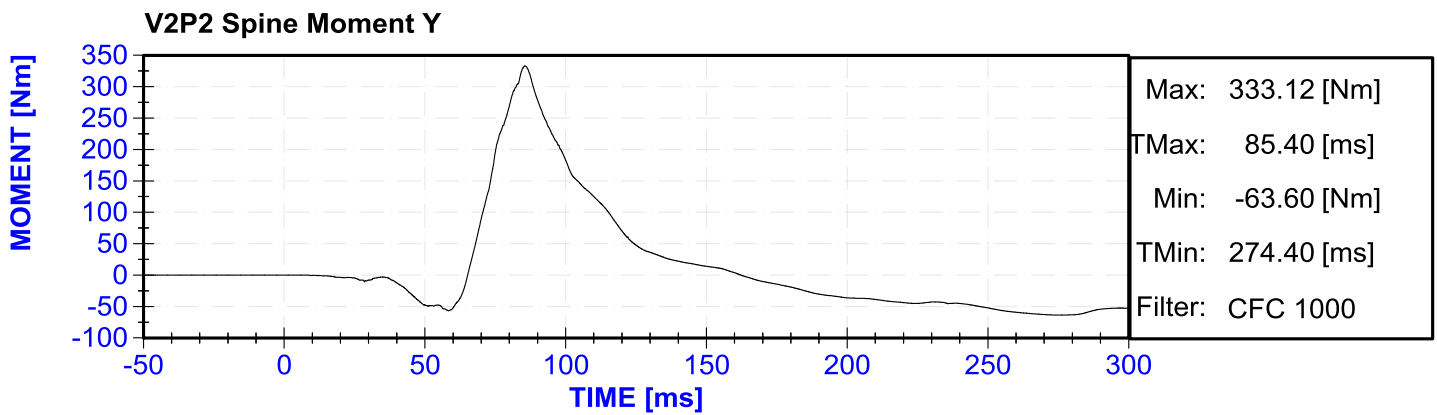
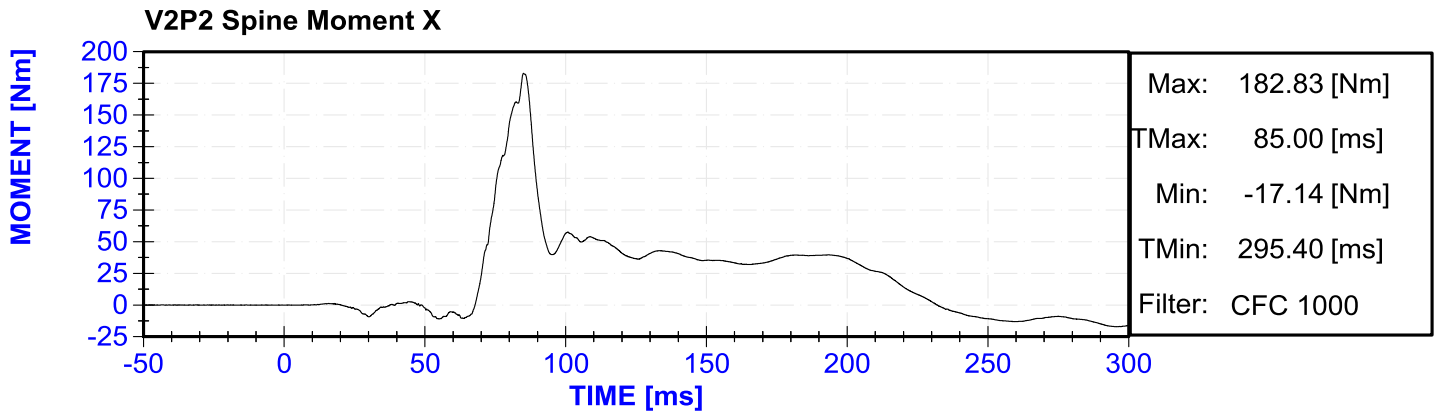

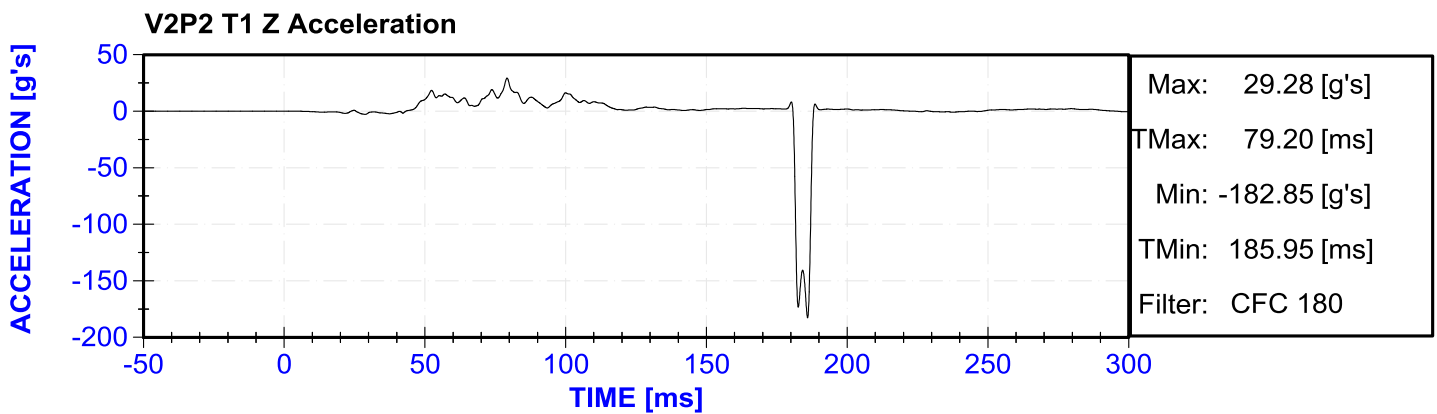
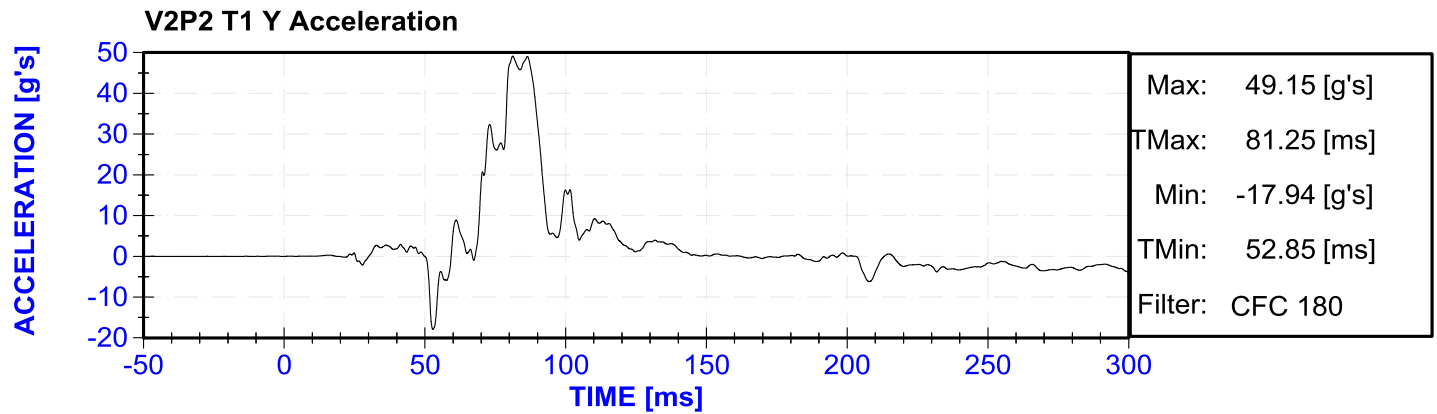
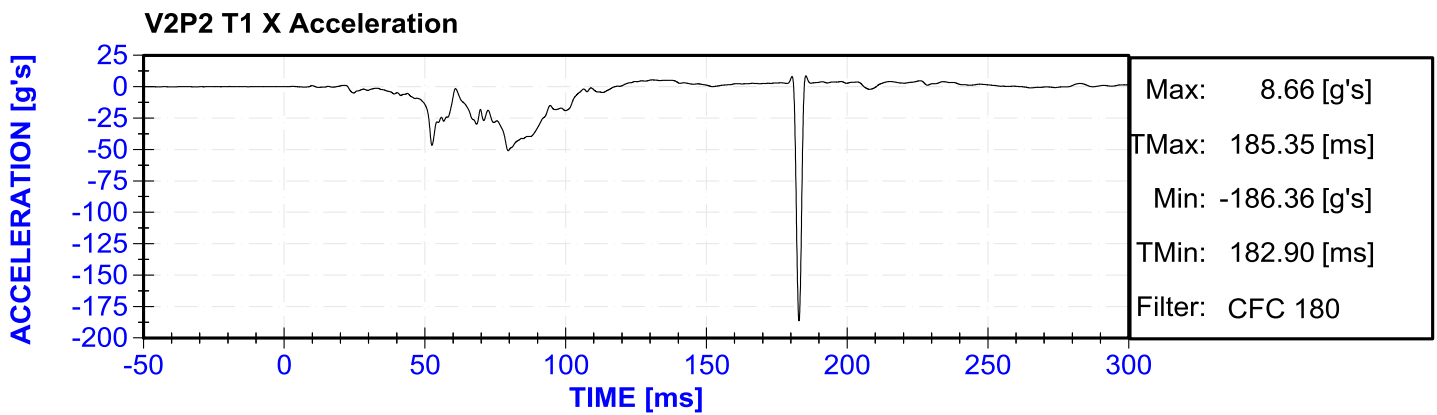
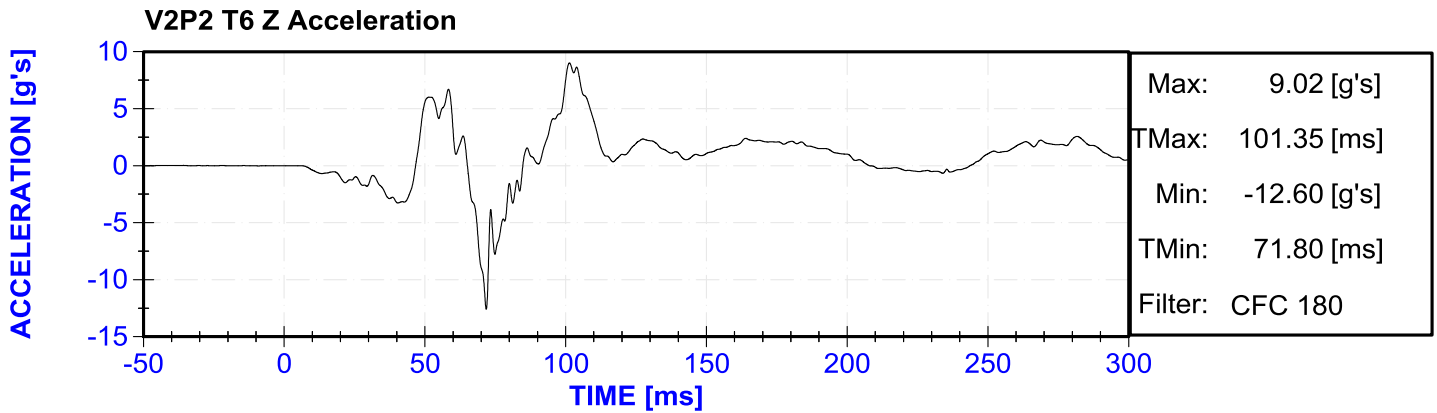

V2P2 Abdomen Left DGIR X Displacement

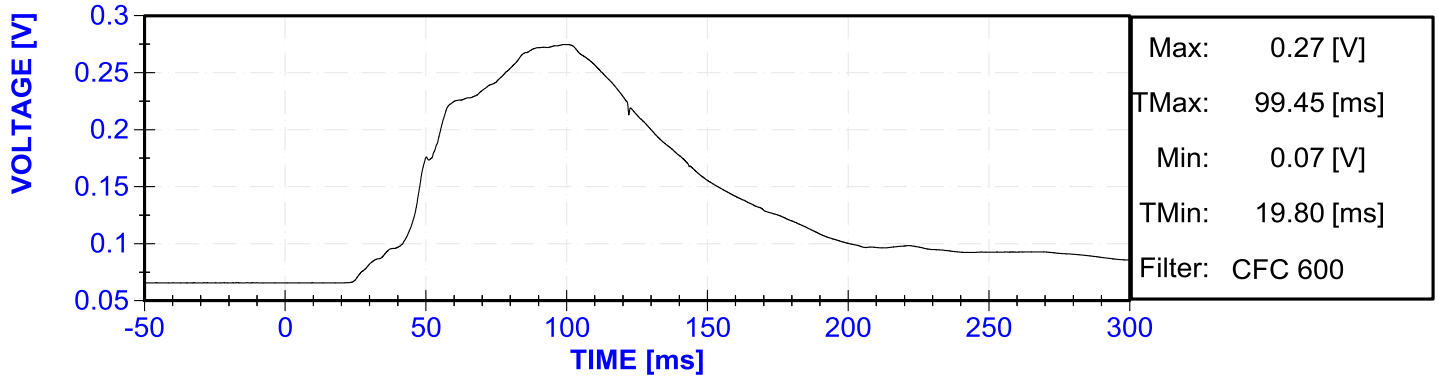

V2P2 Abdomen Left DGIR Y Rotation

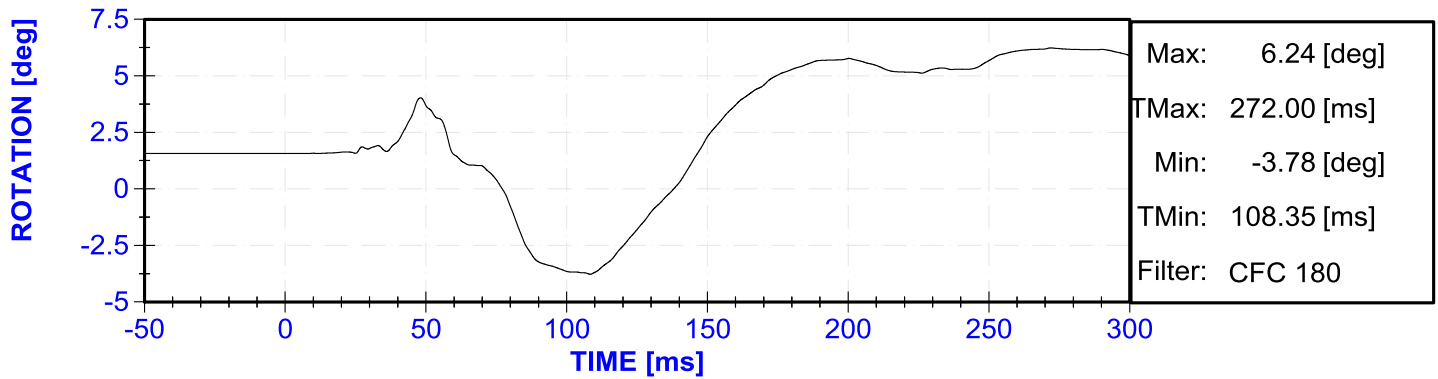

V2P2 Abdomen Left DGIR Z Rotation

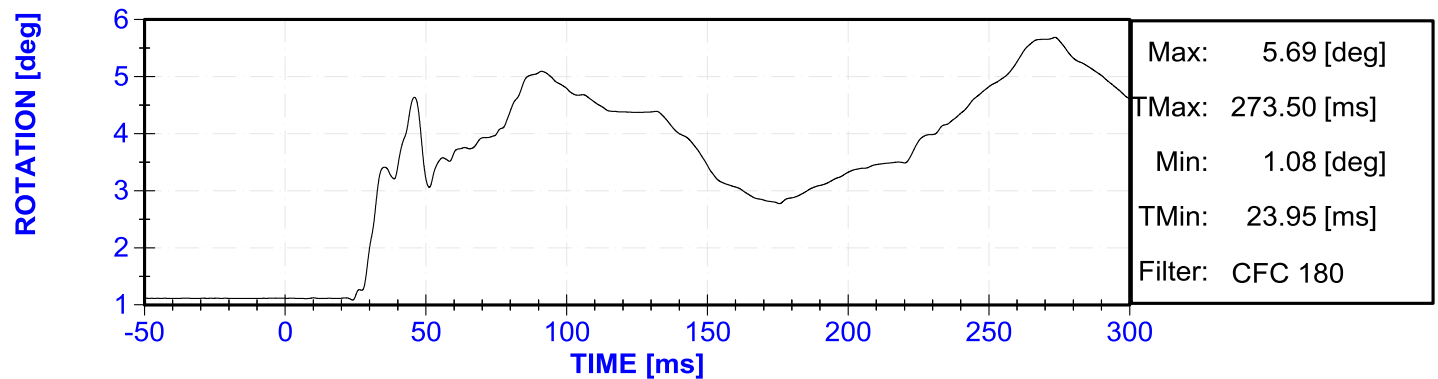

V2P2 Abdomen Right DGIR X Displacement

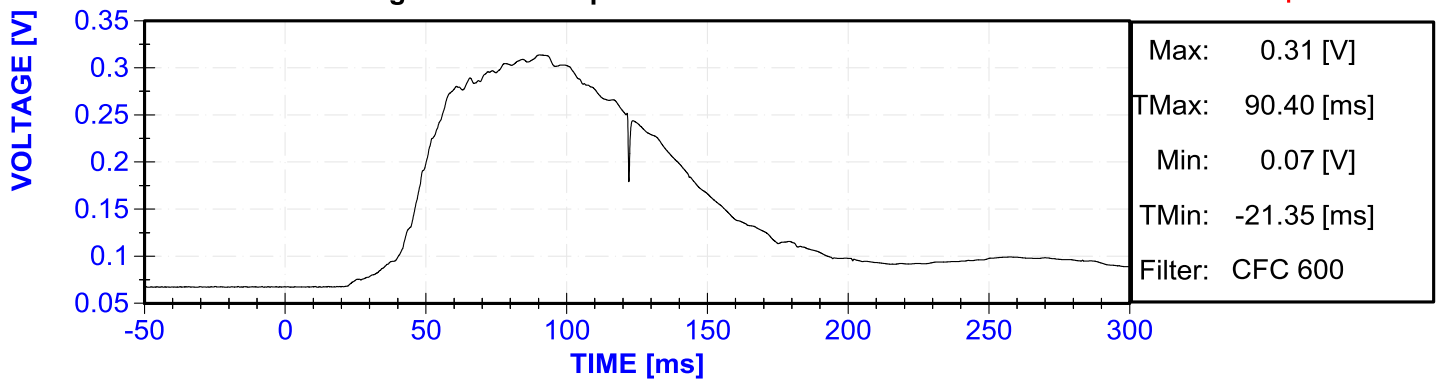

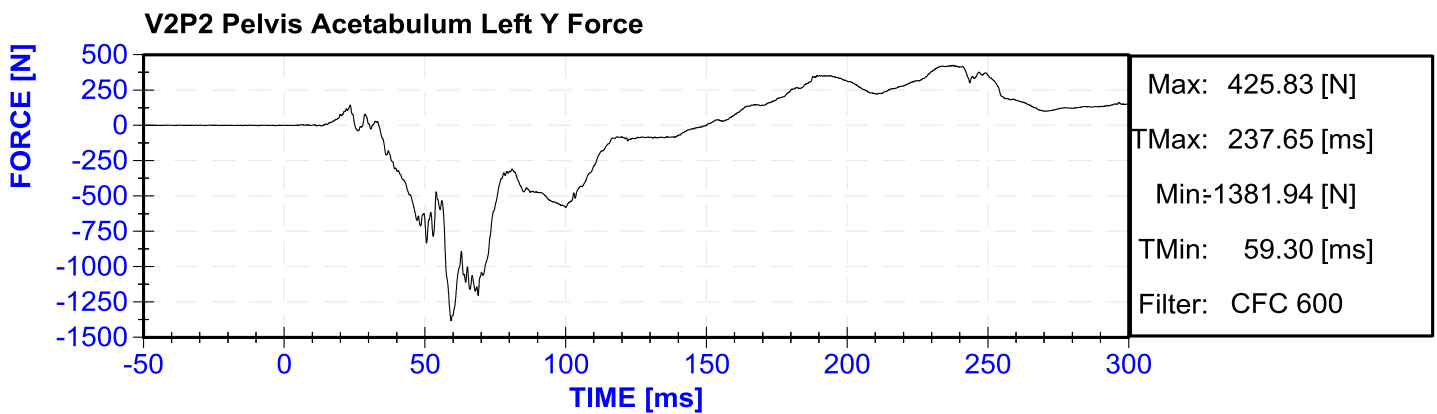
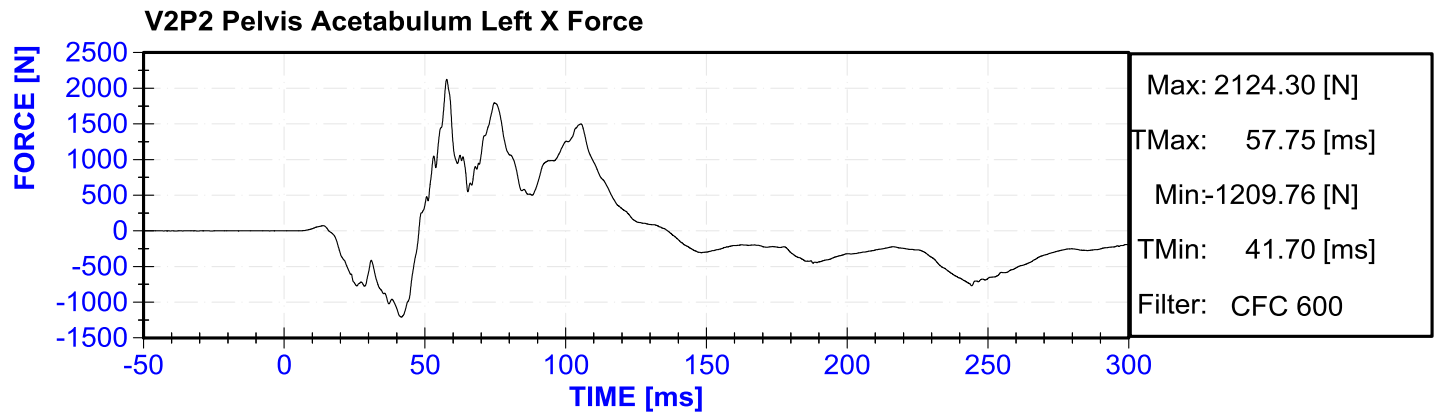
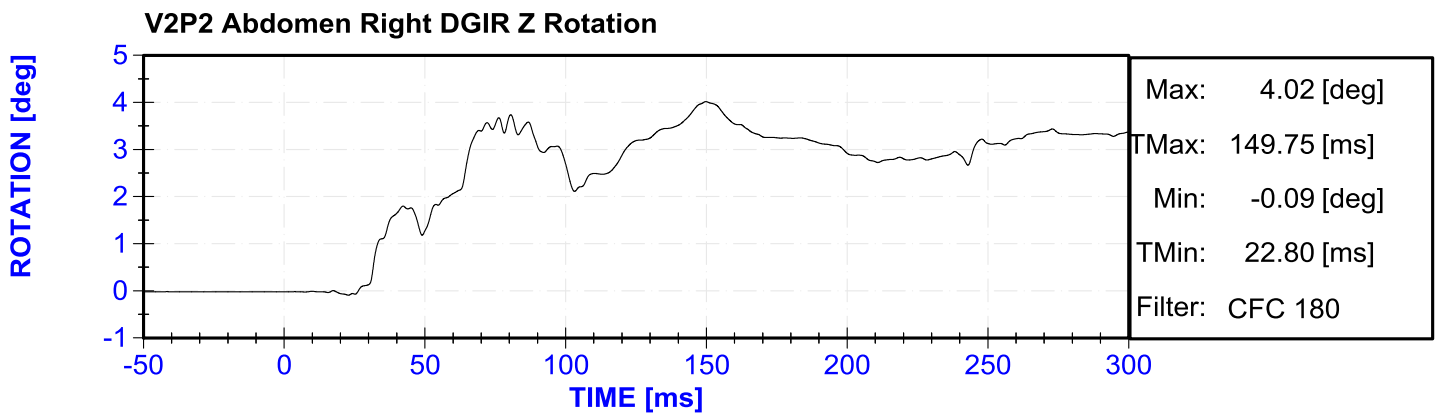
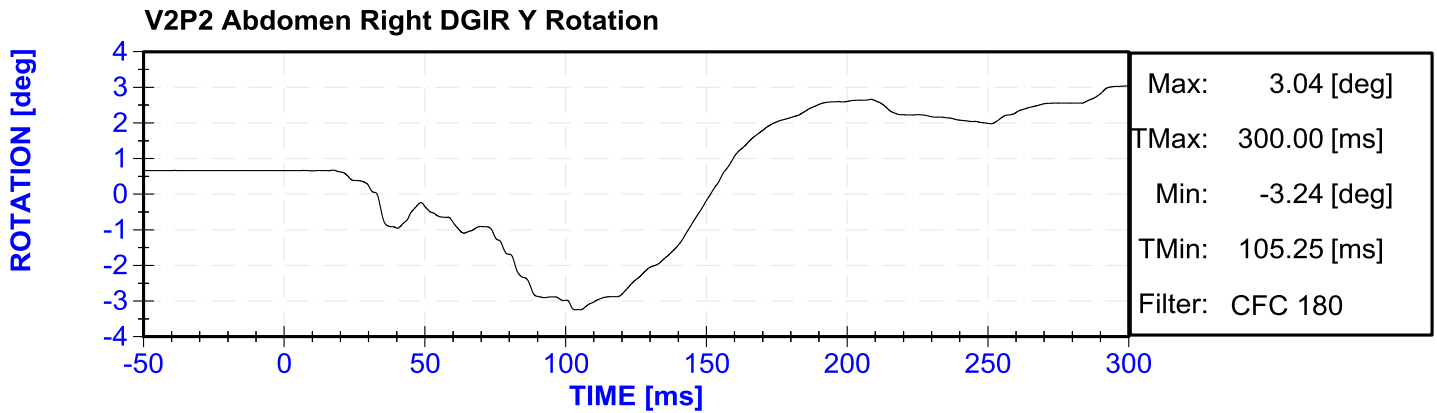

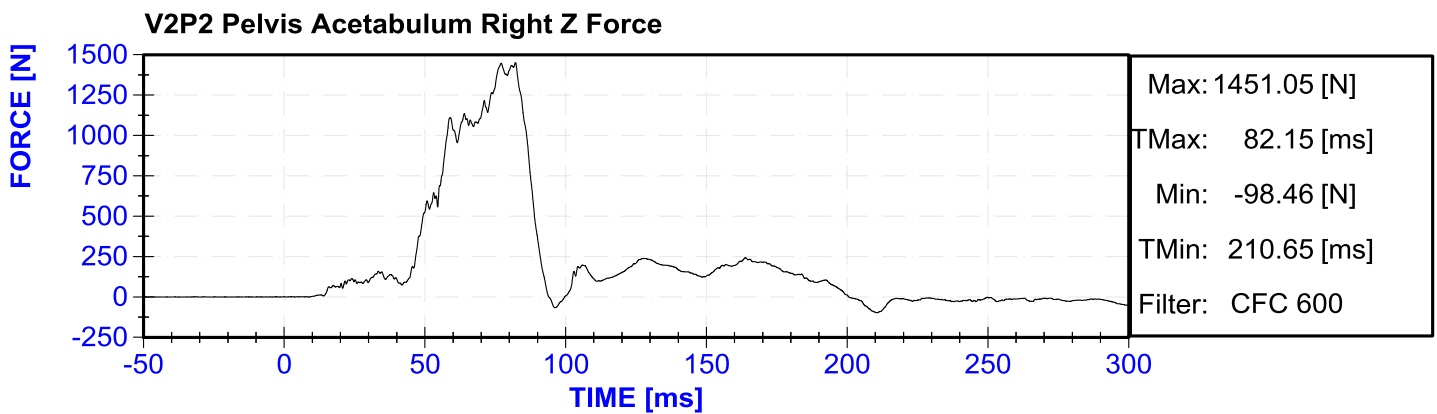
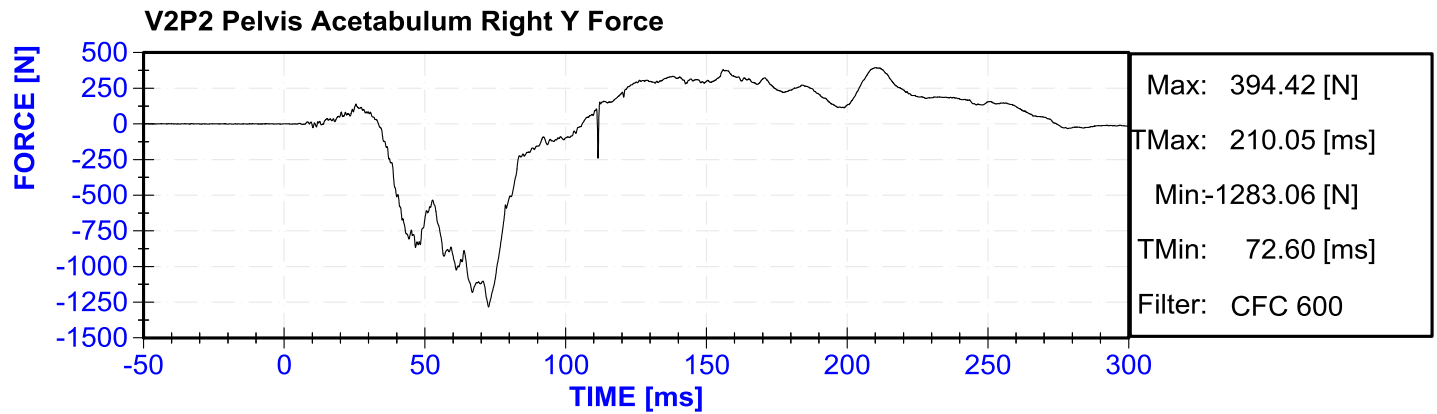
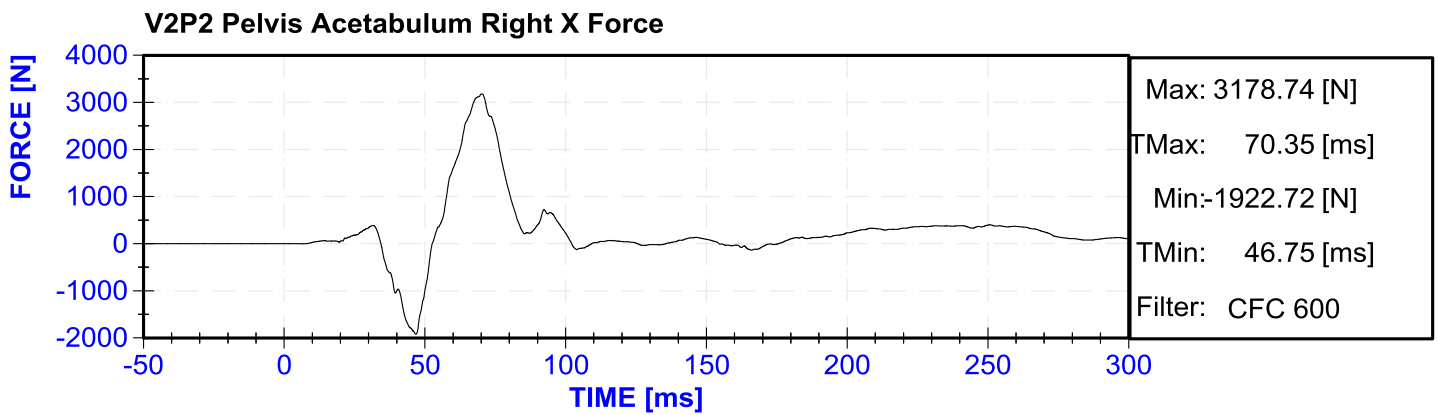
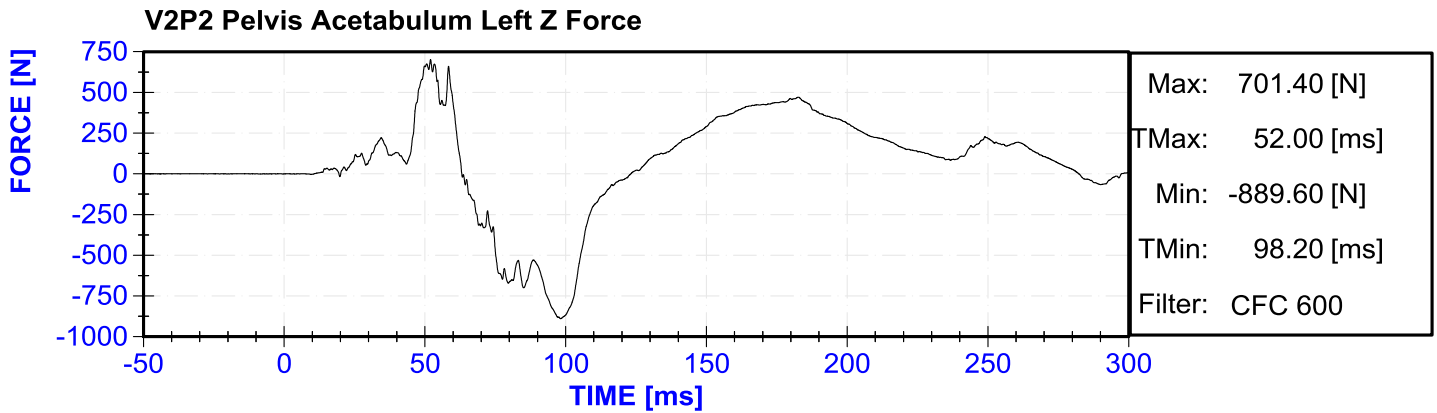

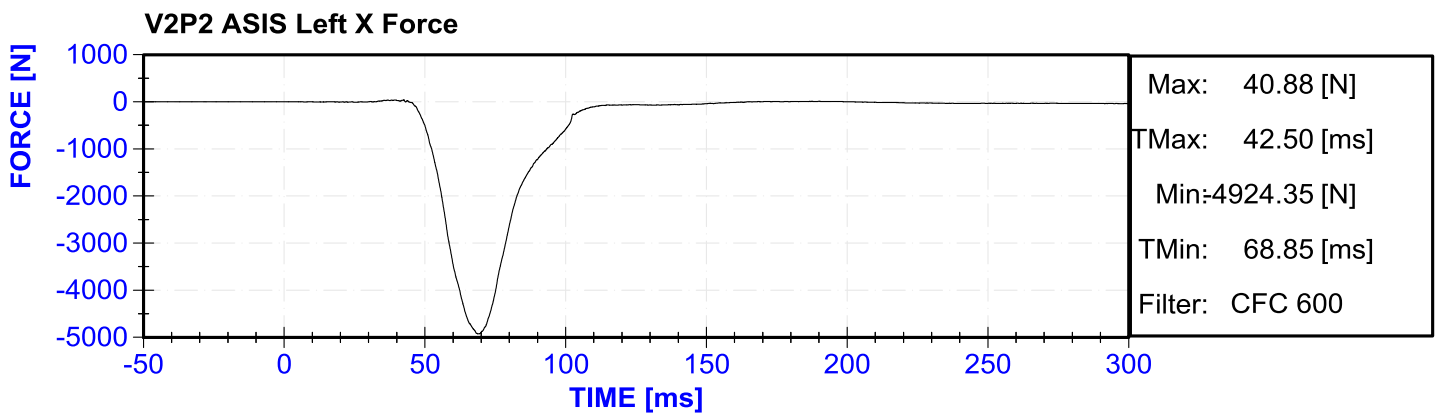
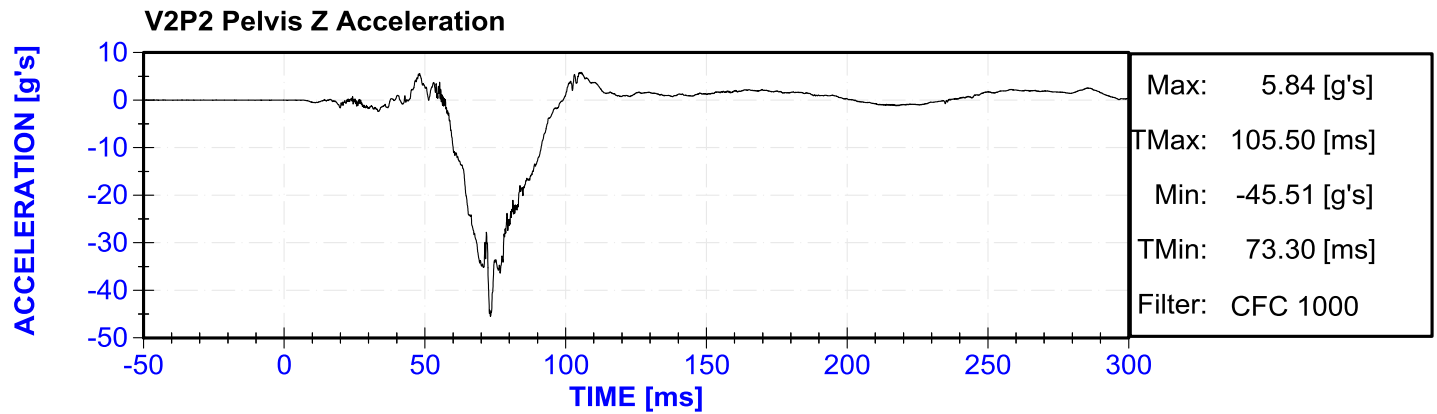
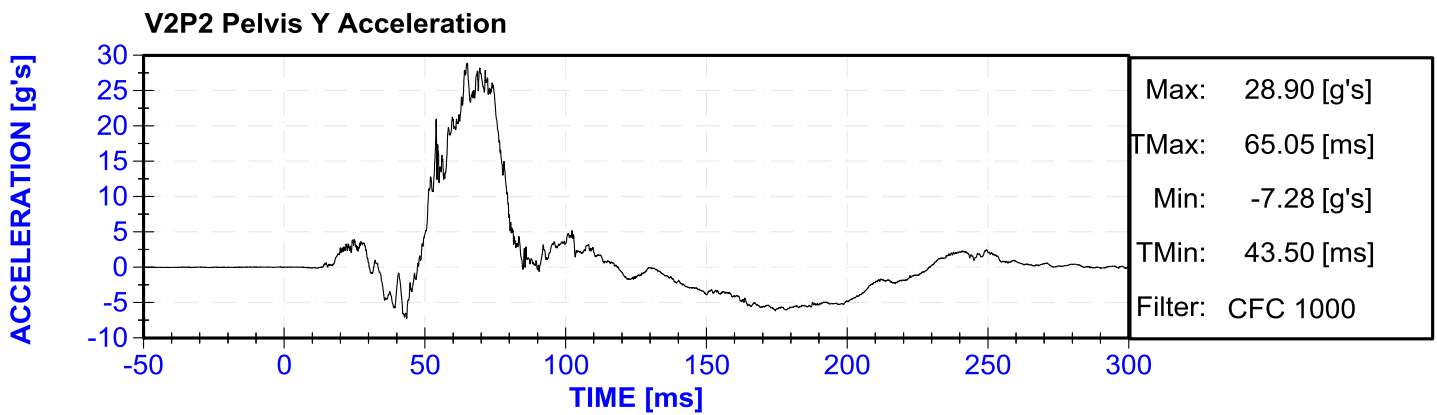
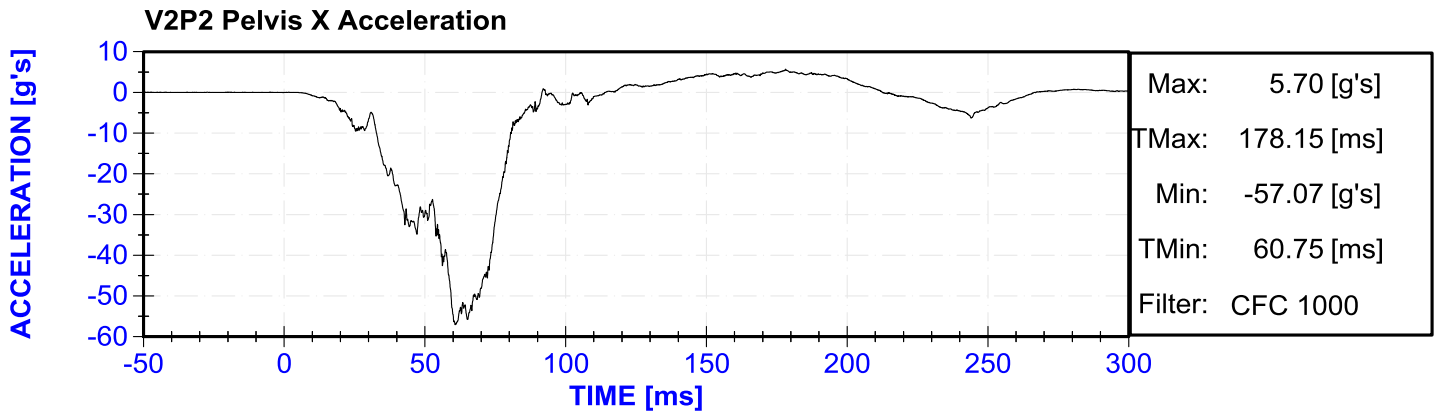

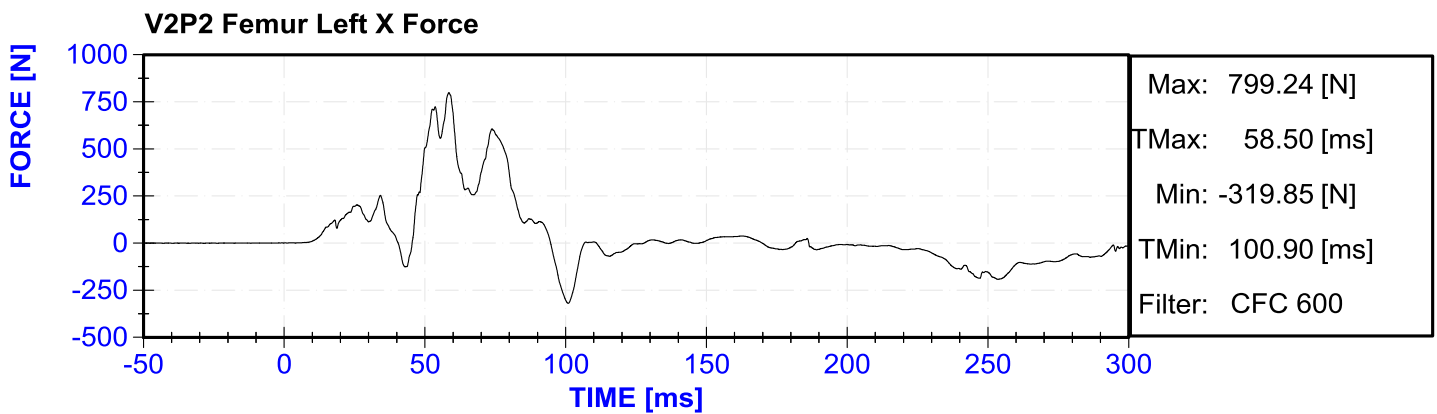
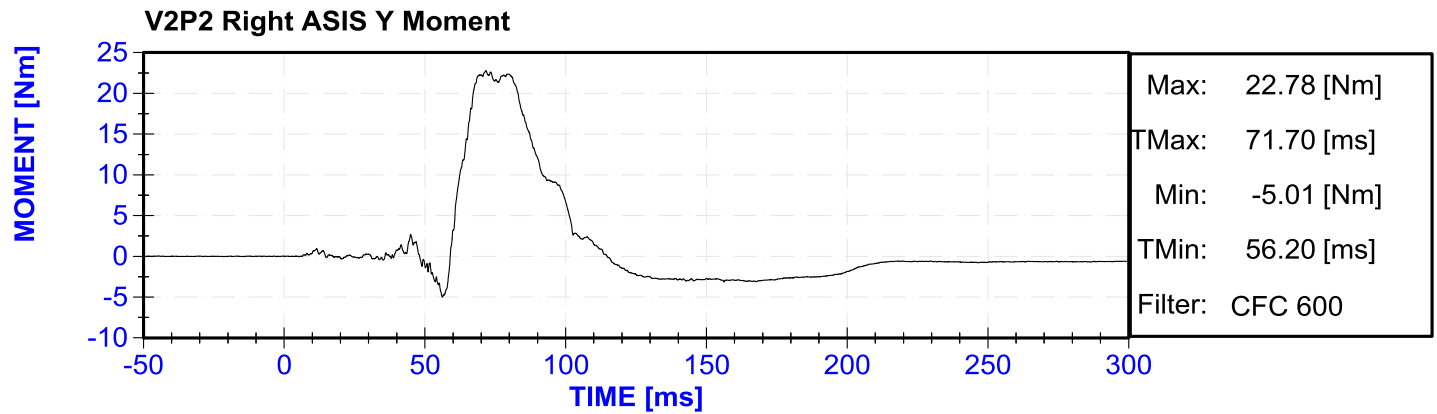
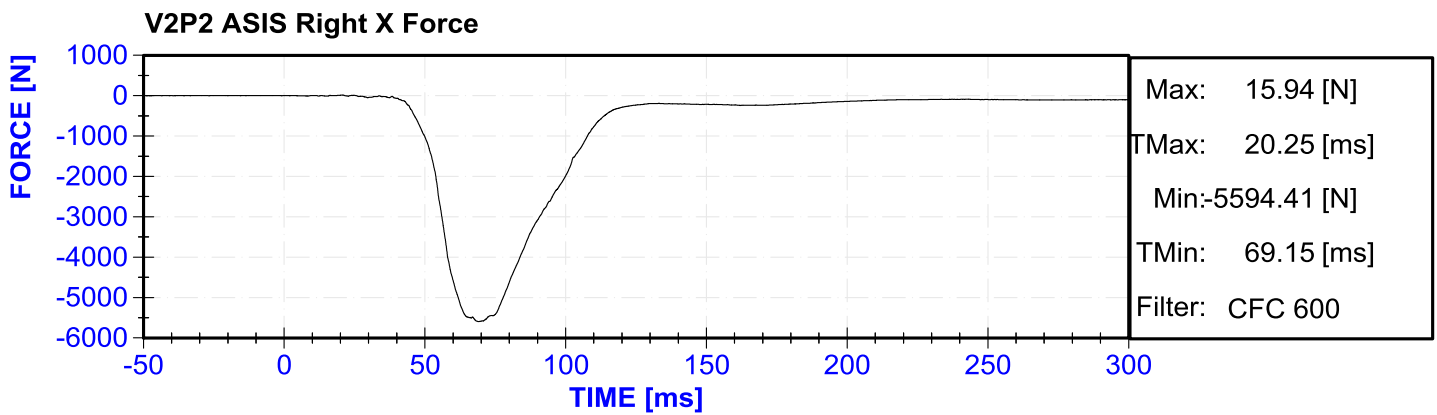
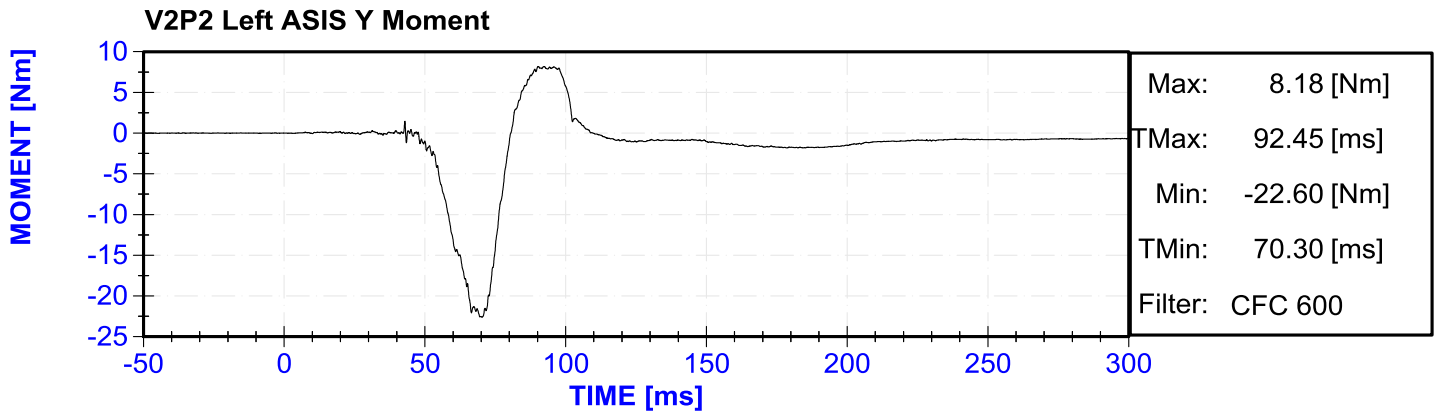

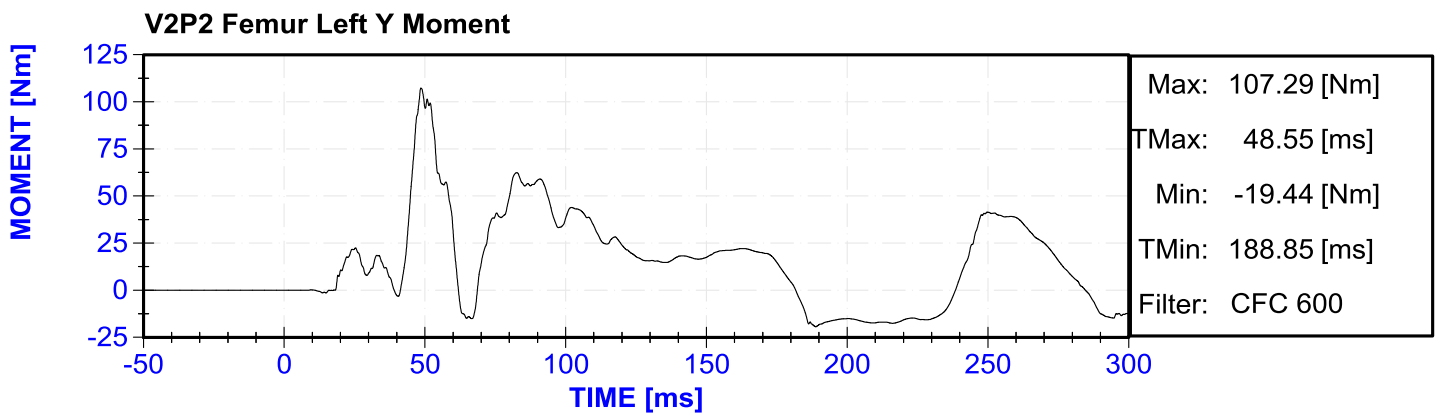
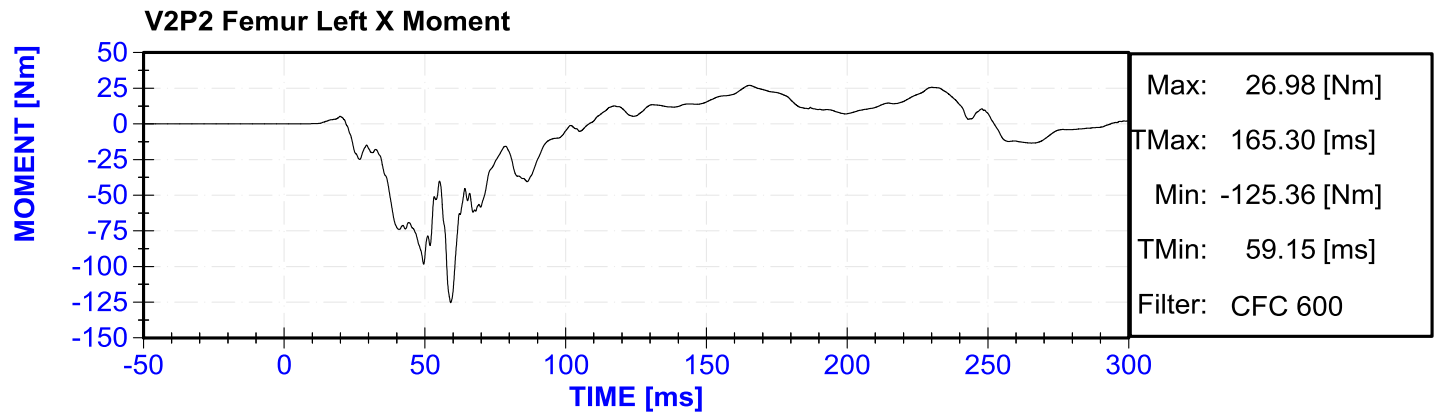
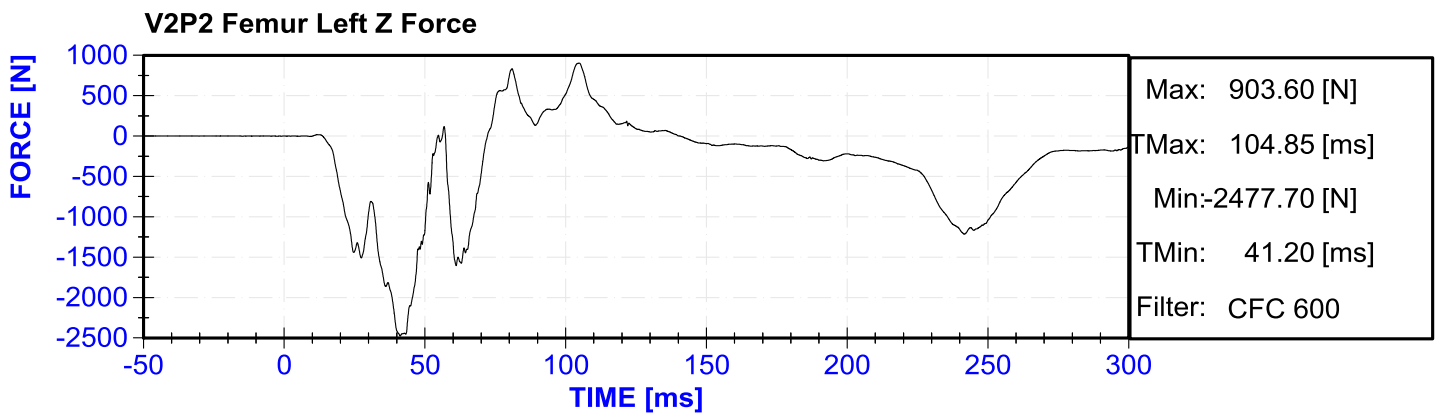
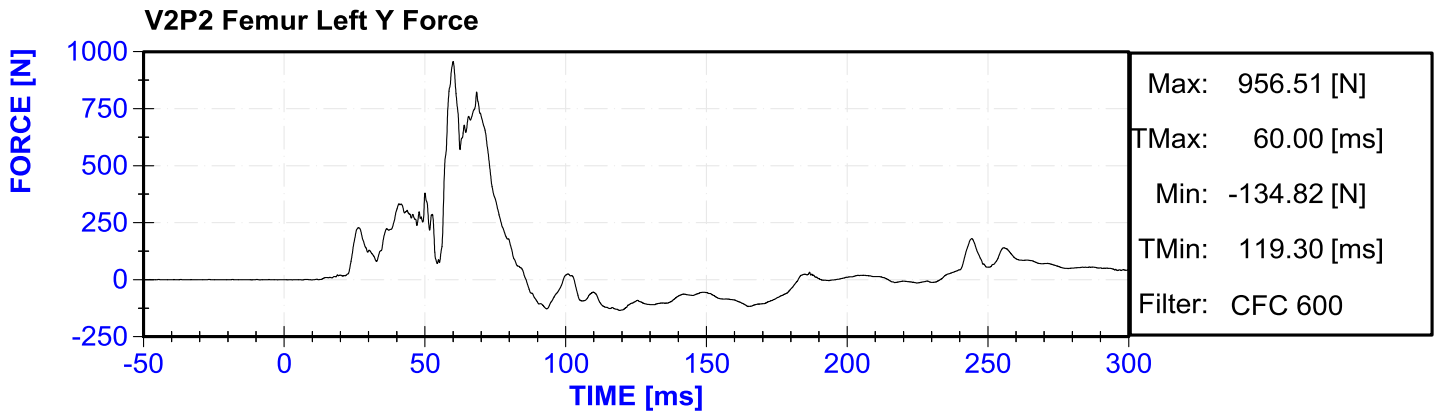

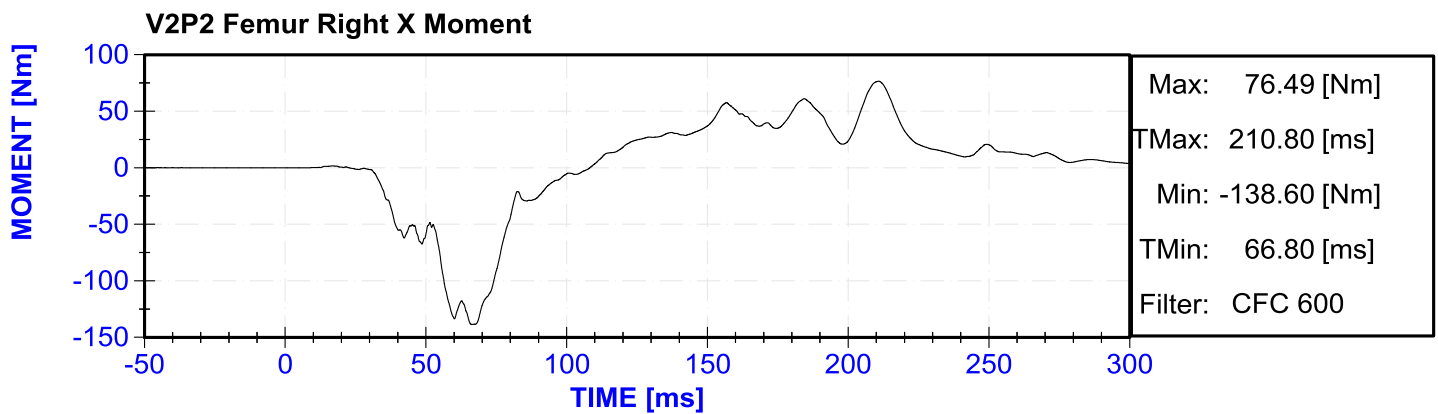
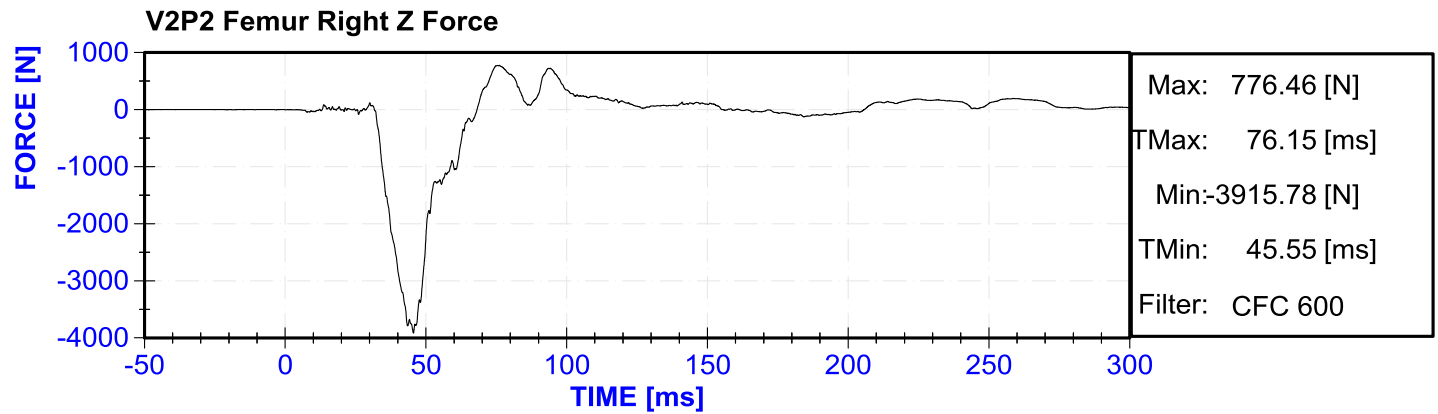
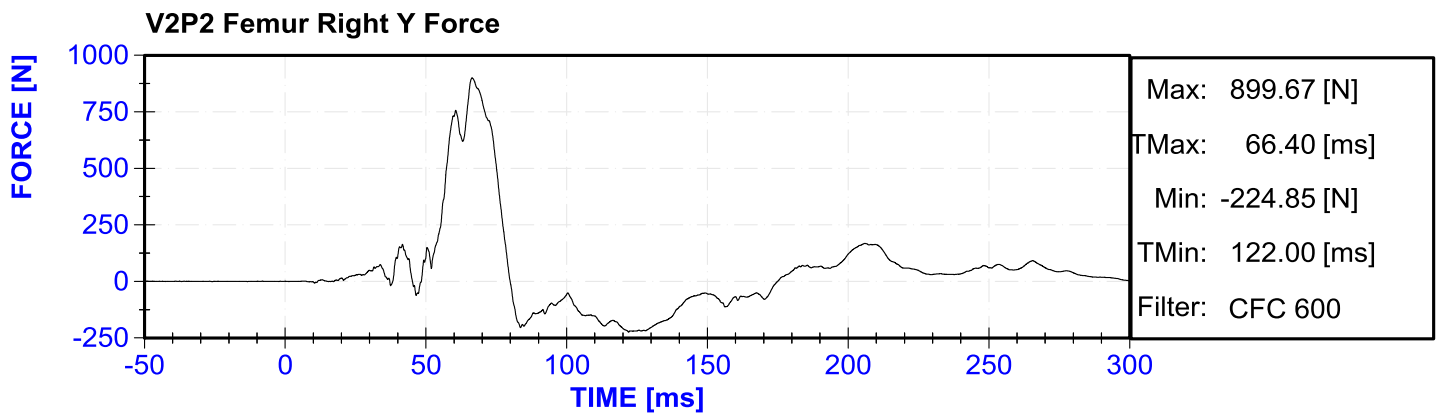
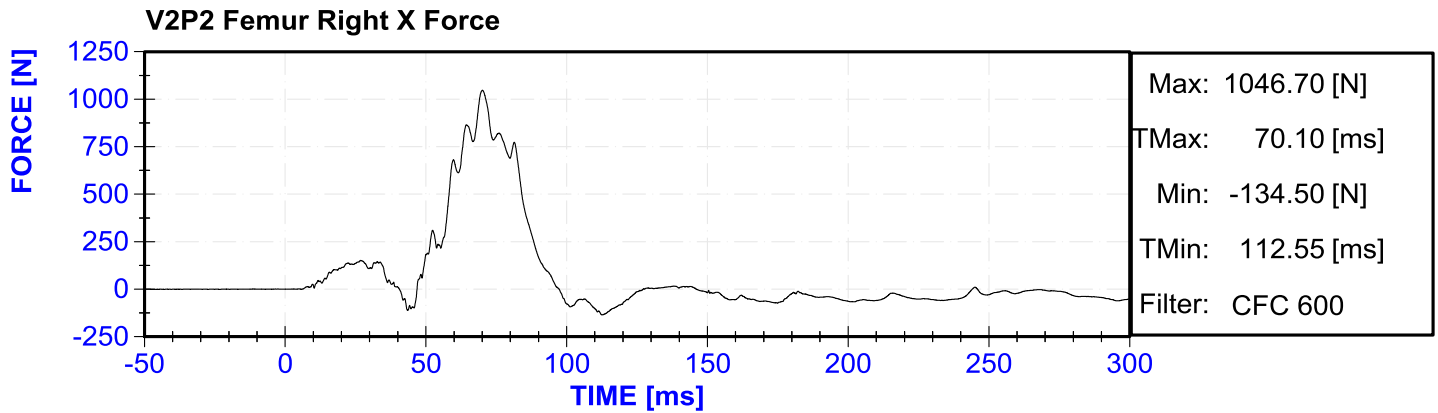

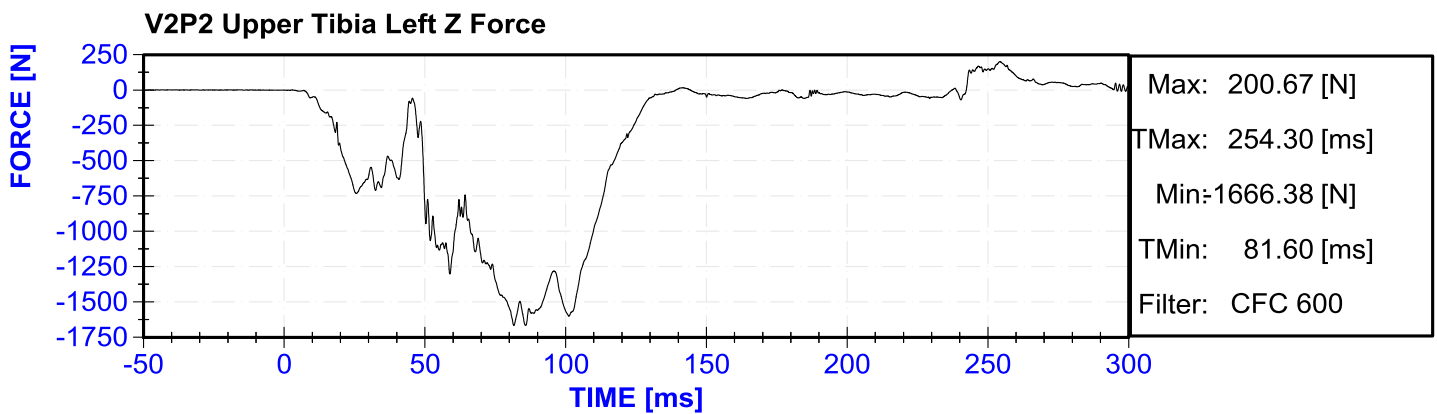
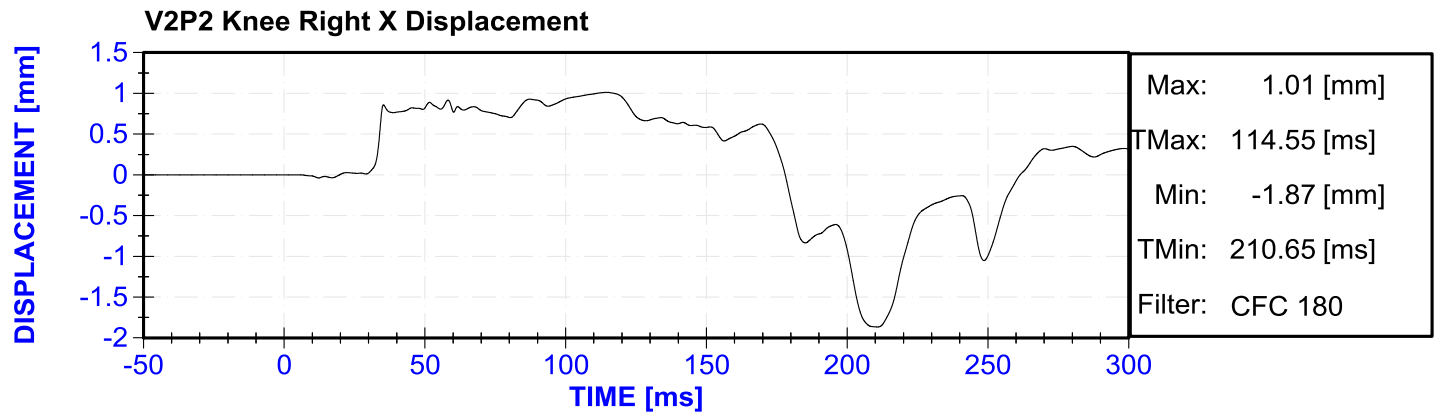
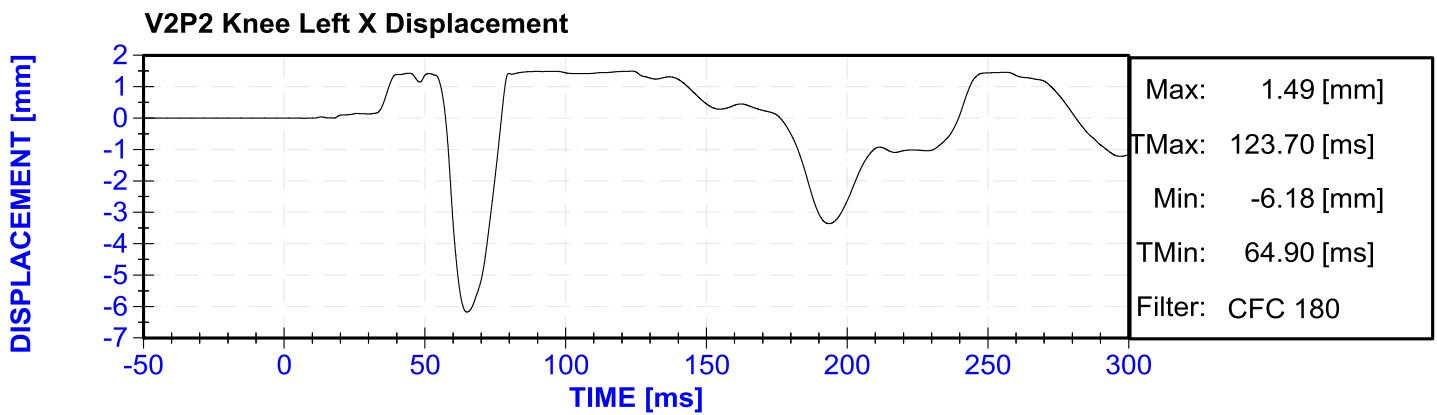
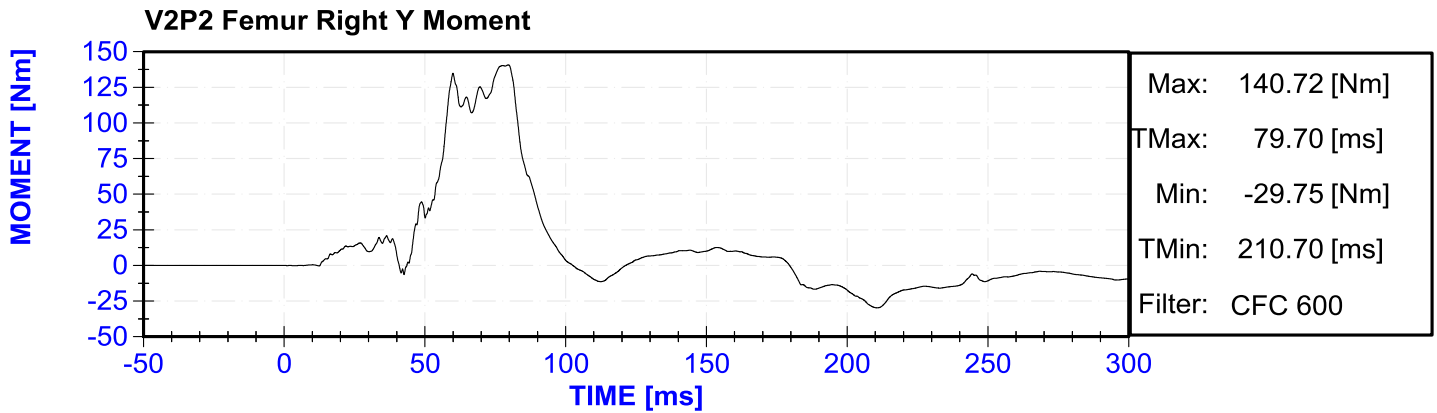

V2P2 Upper Tibia Left X Moment

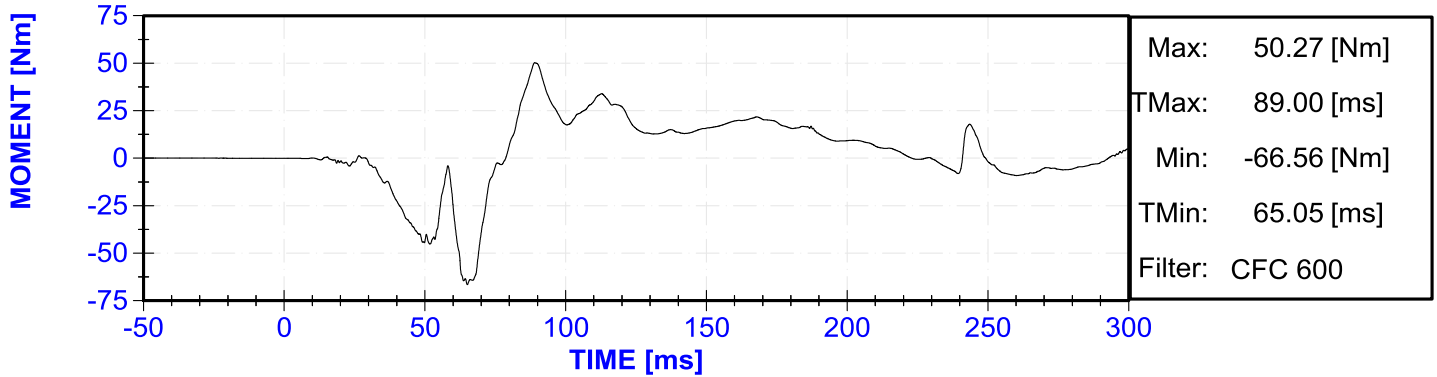

V2P2 Upper Tibia Left Y Moment

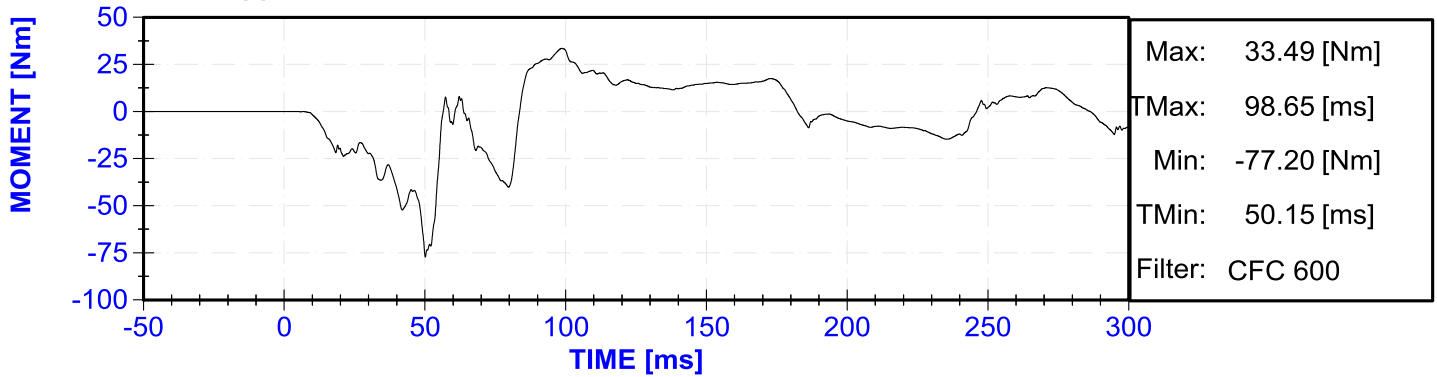

V2P2 Upper Tibia Right Z Force

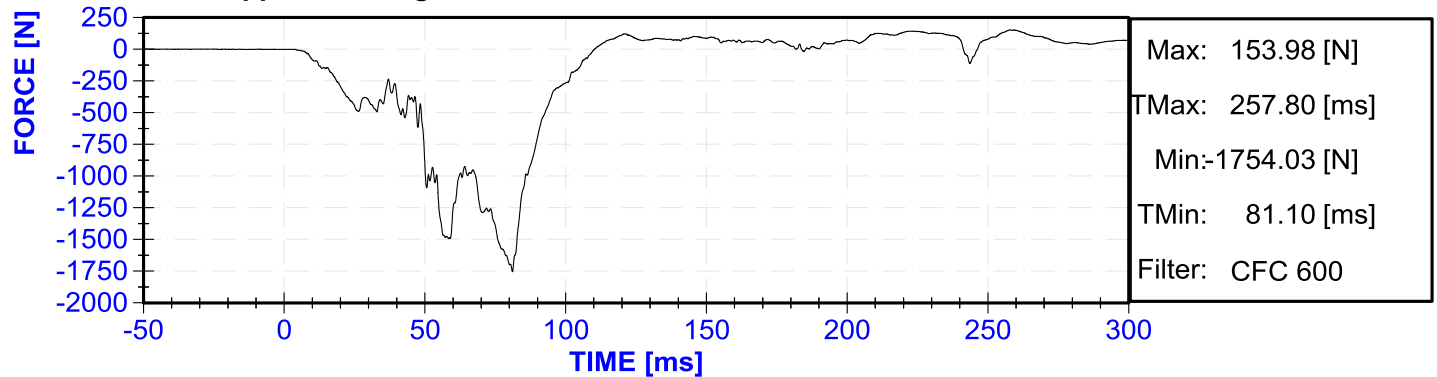

V2P2 Upper Tibia Right X Moment

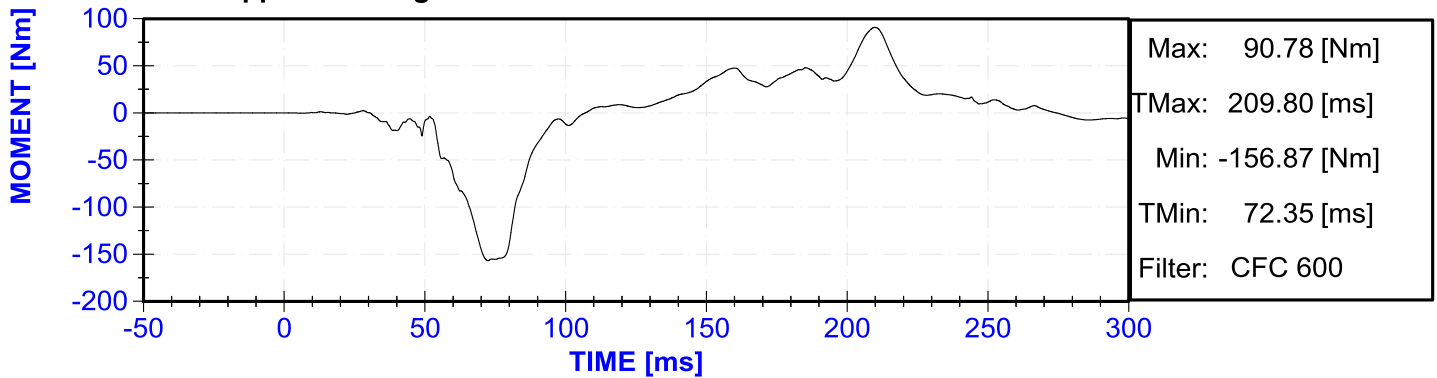

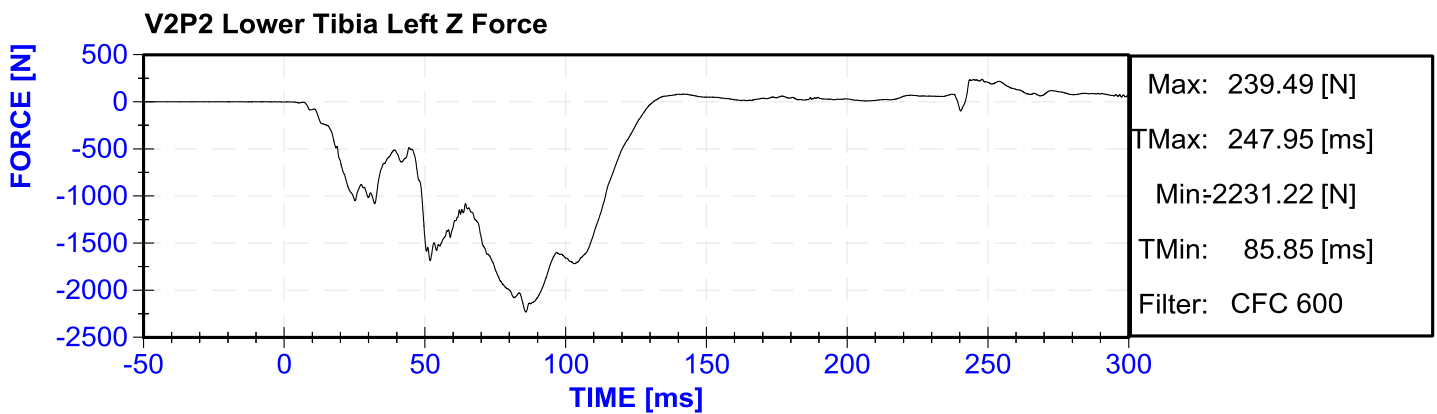
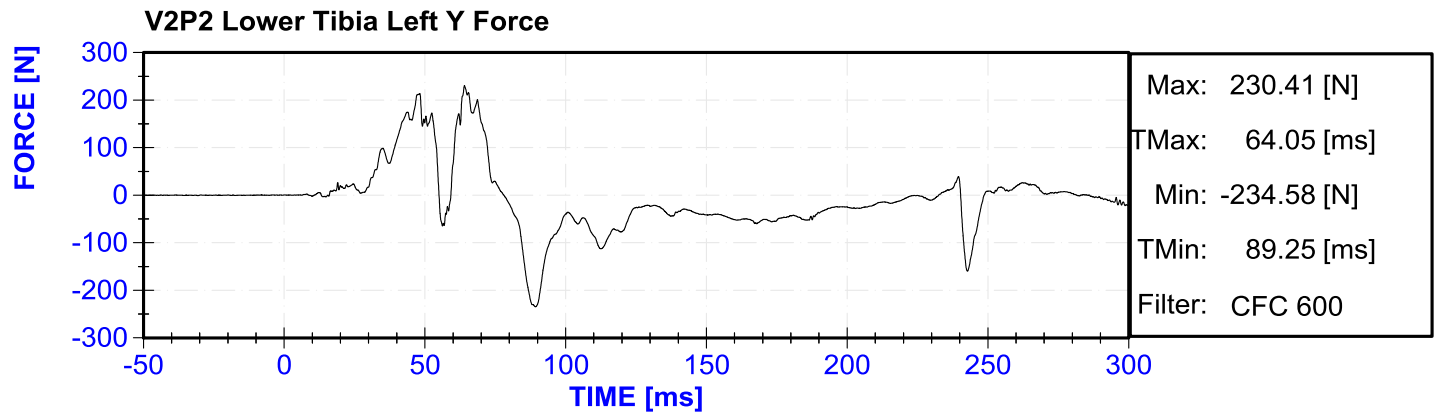
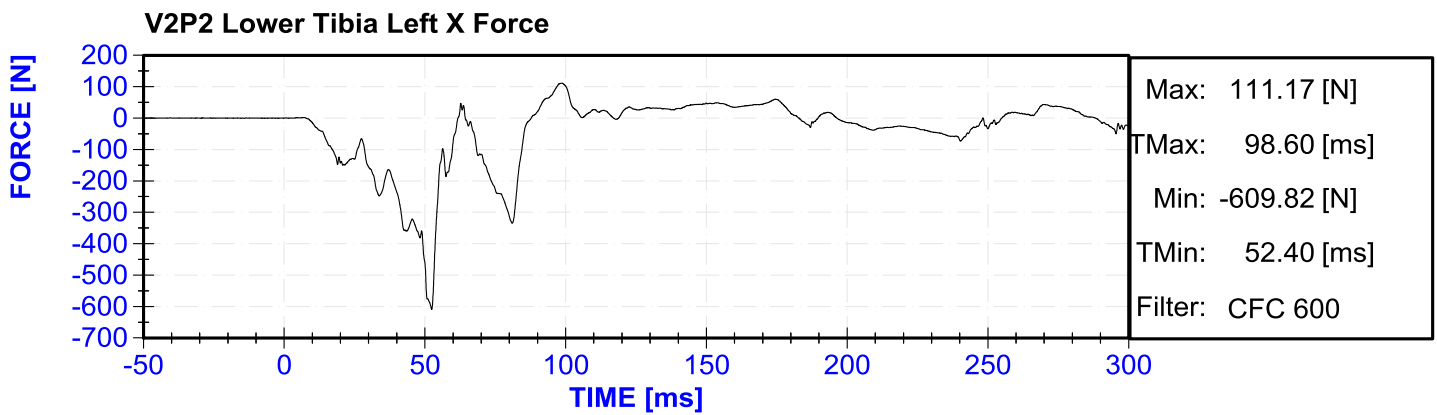
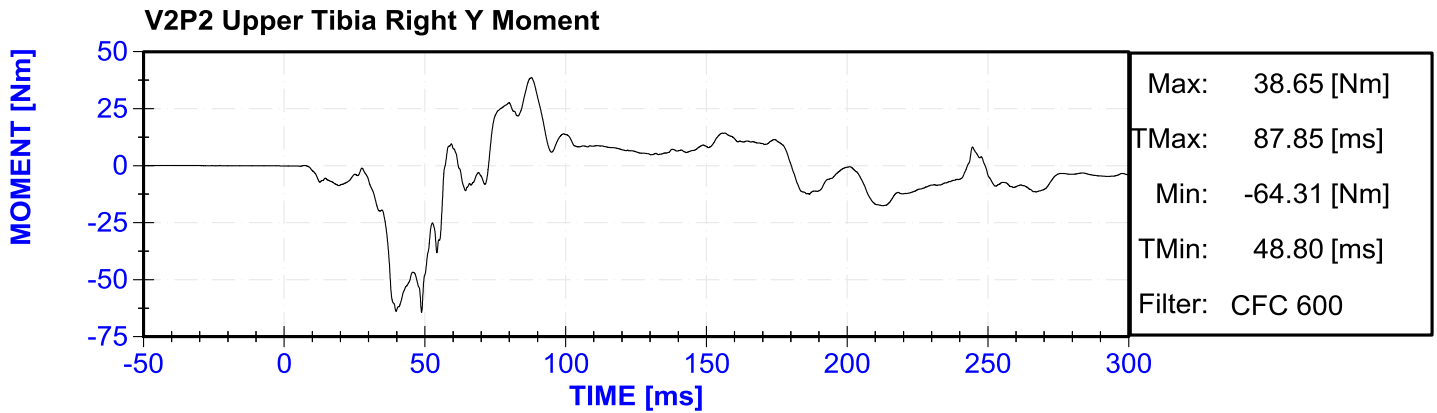

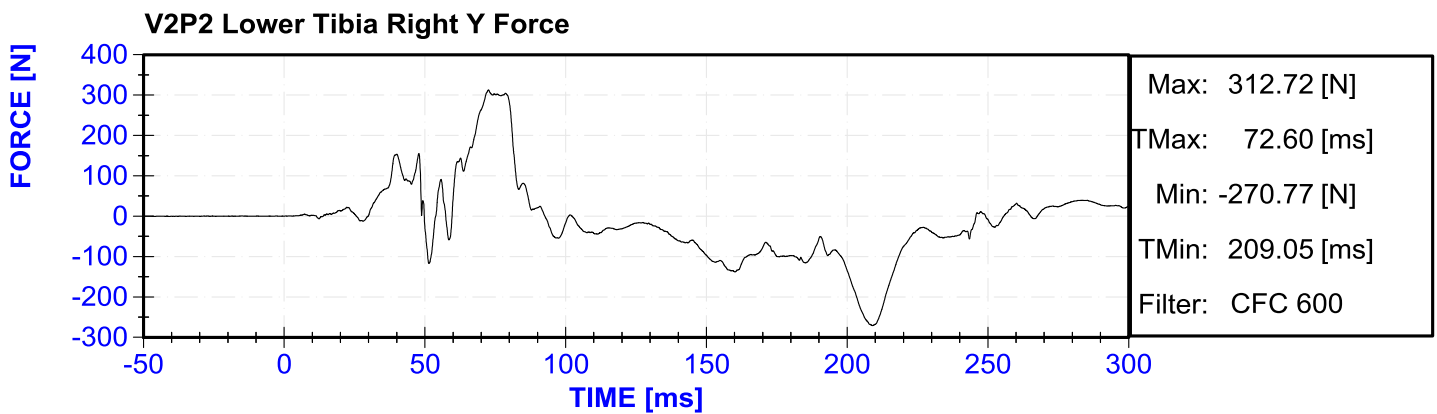
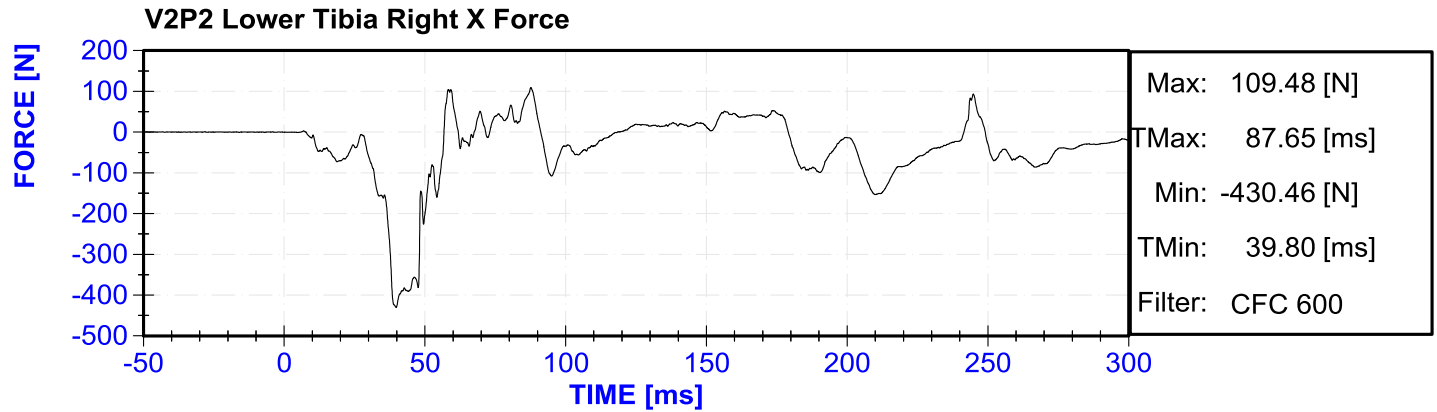
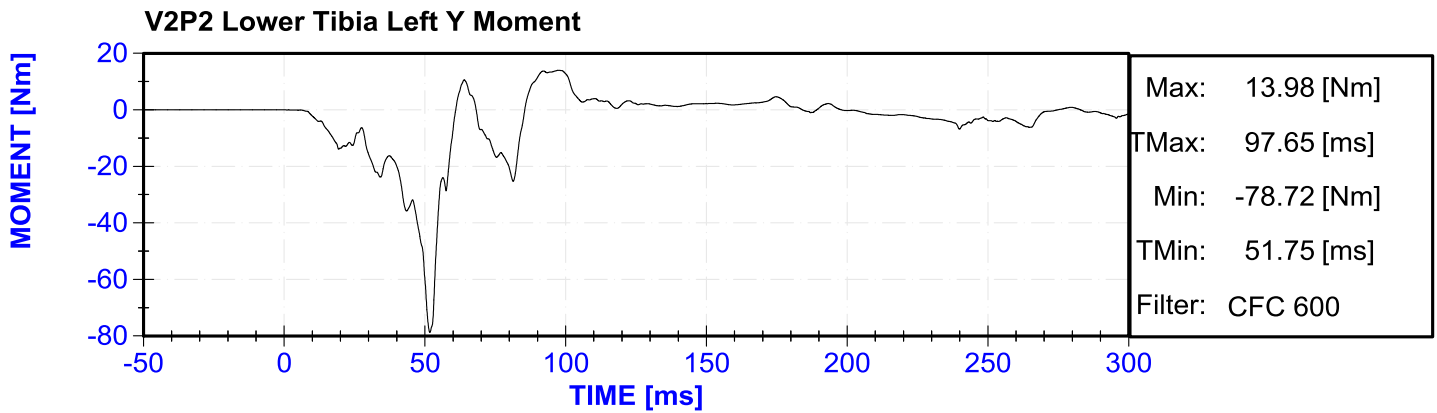
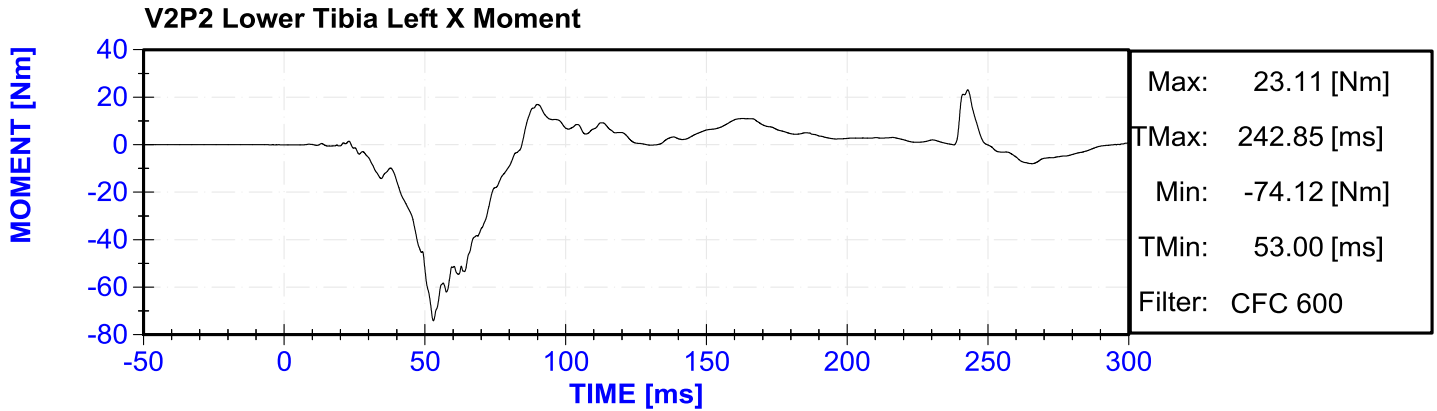

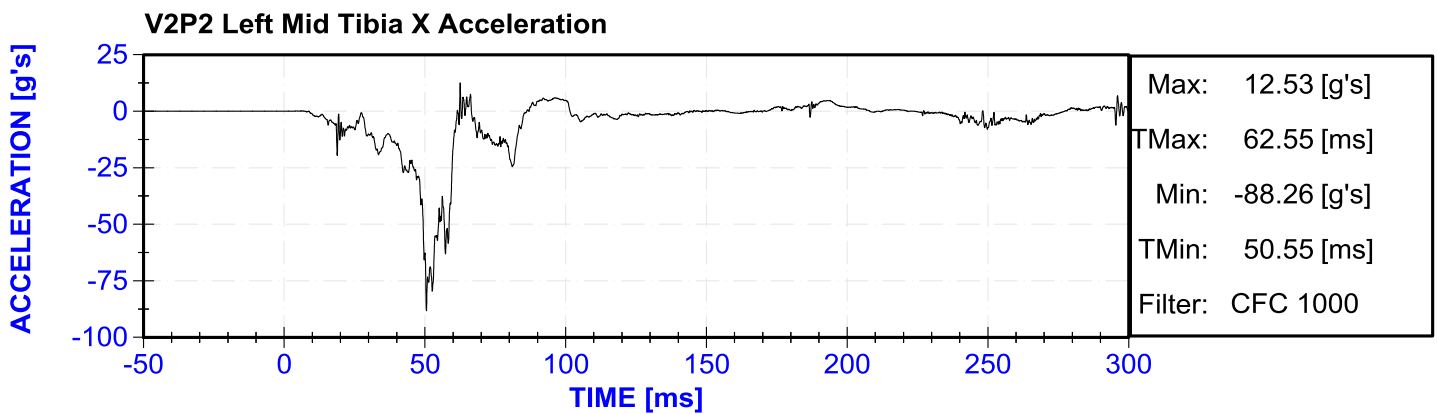
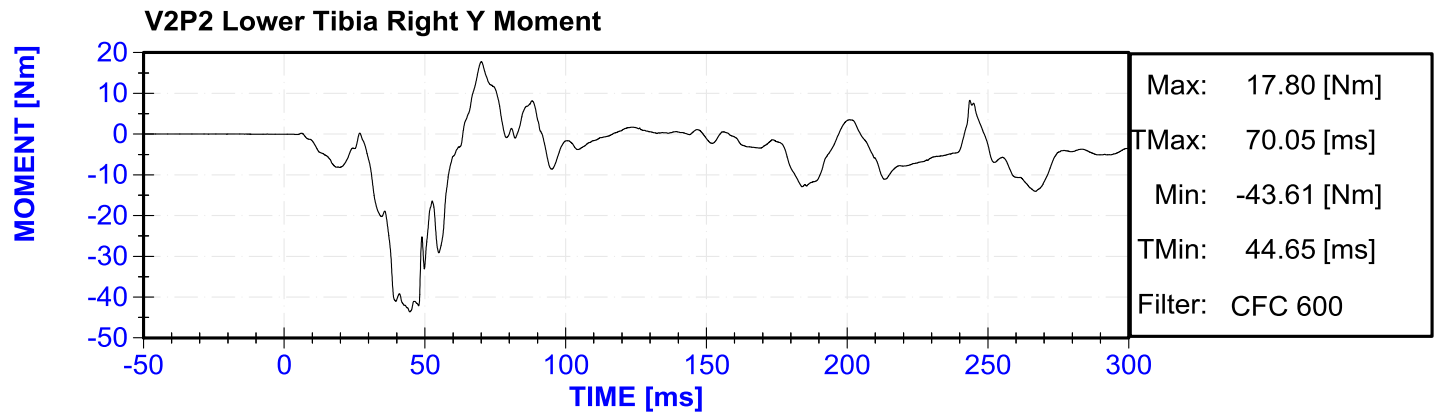
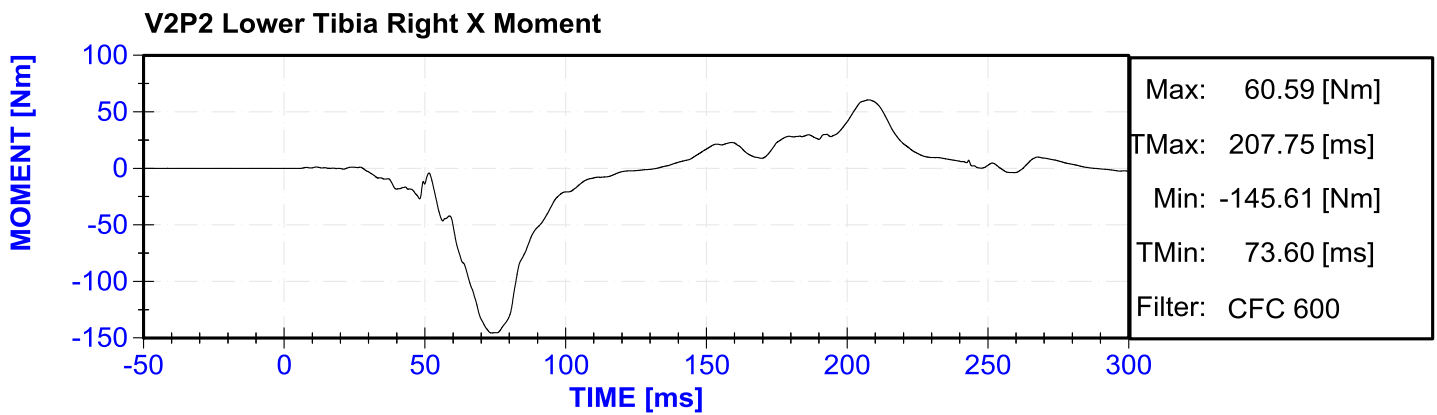
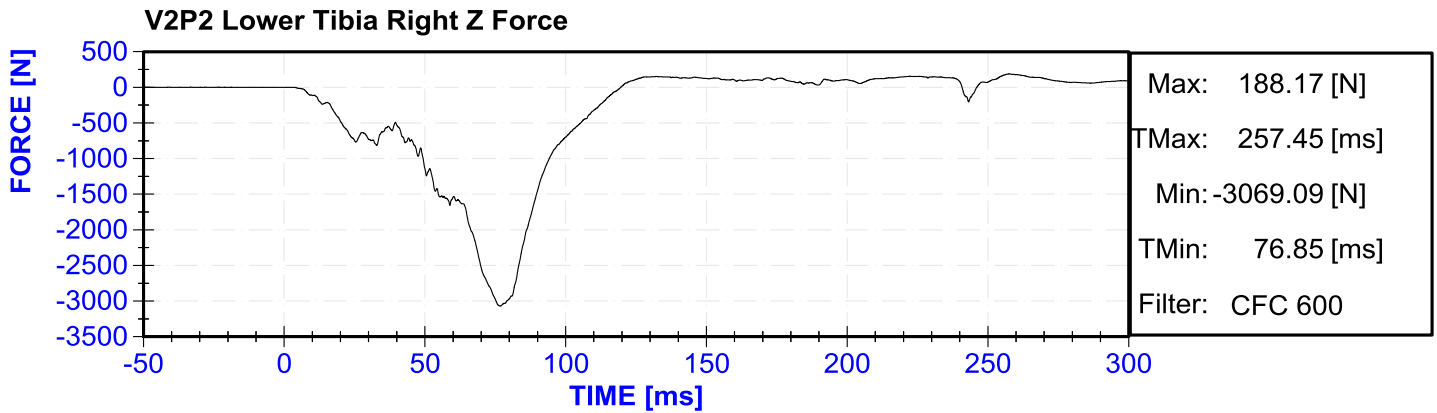

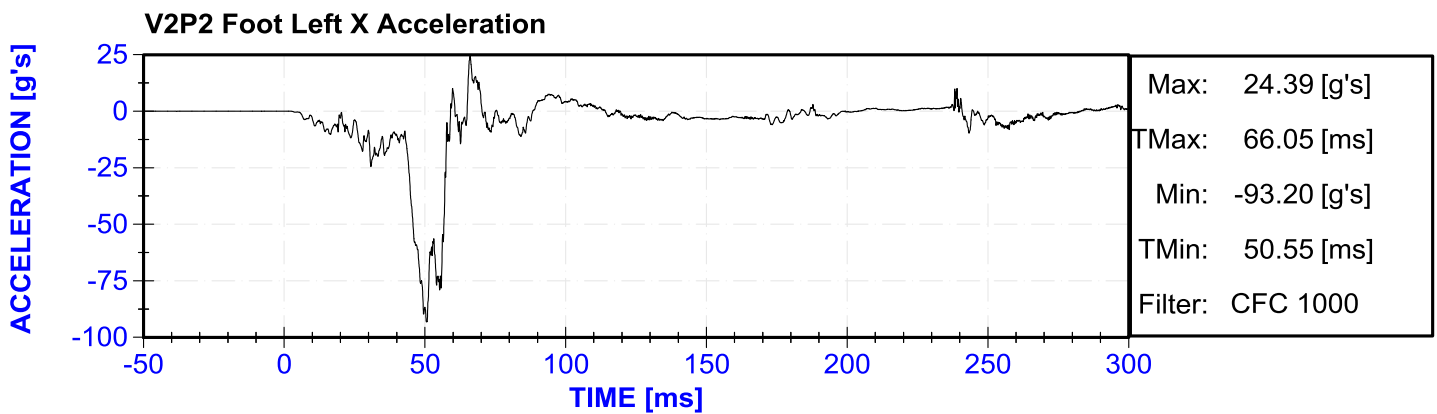
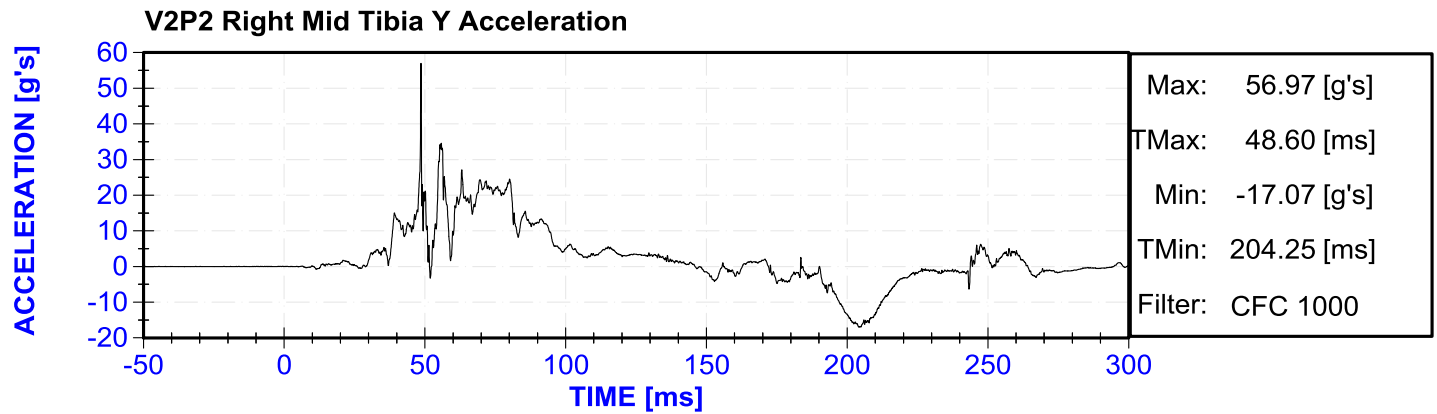
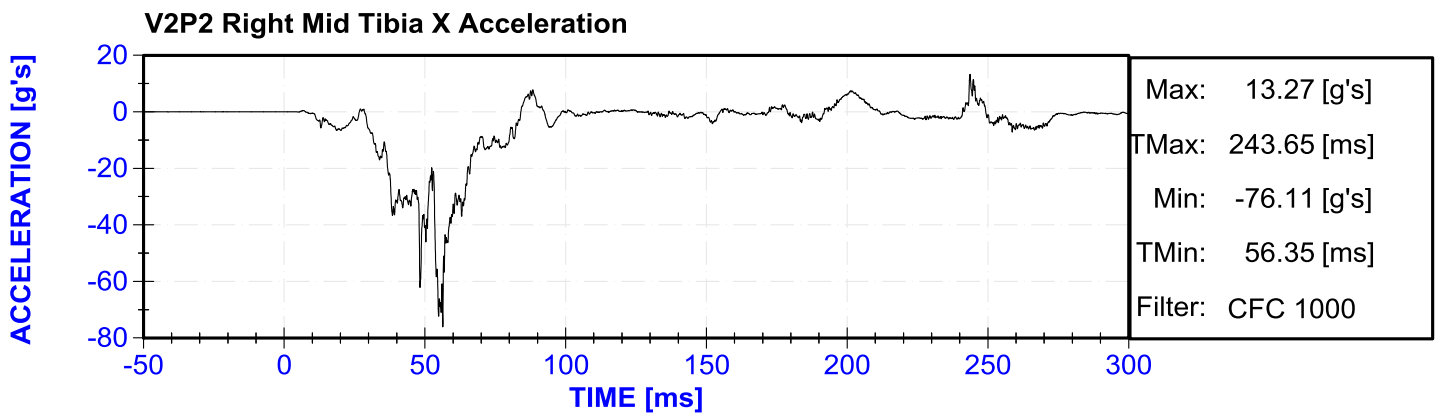
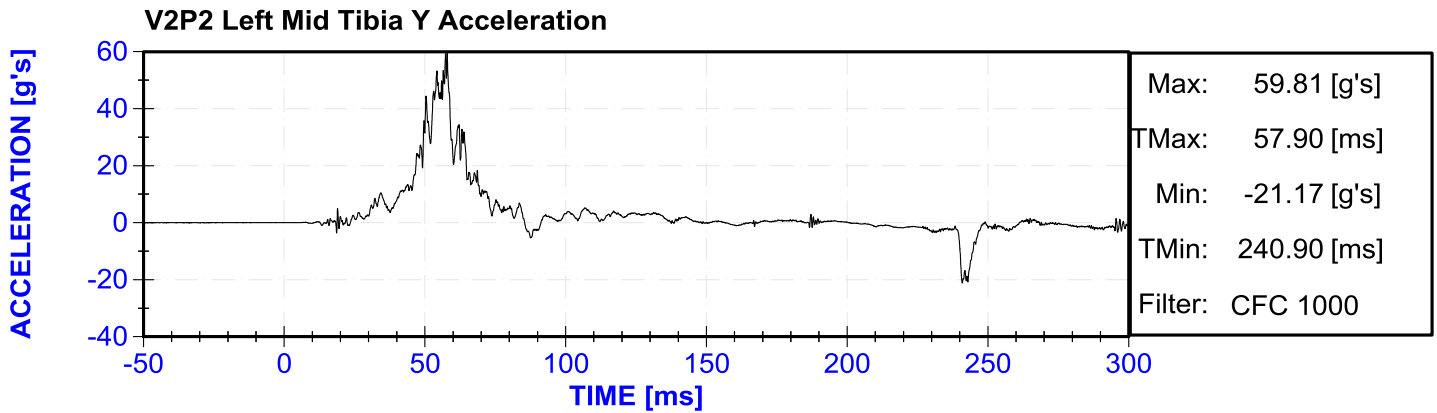

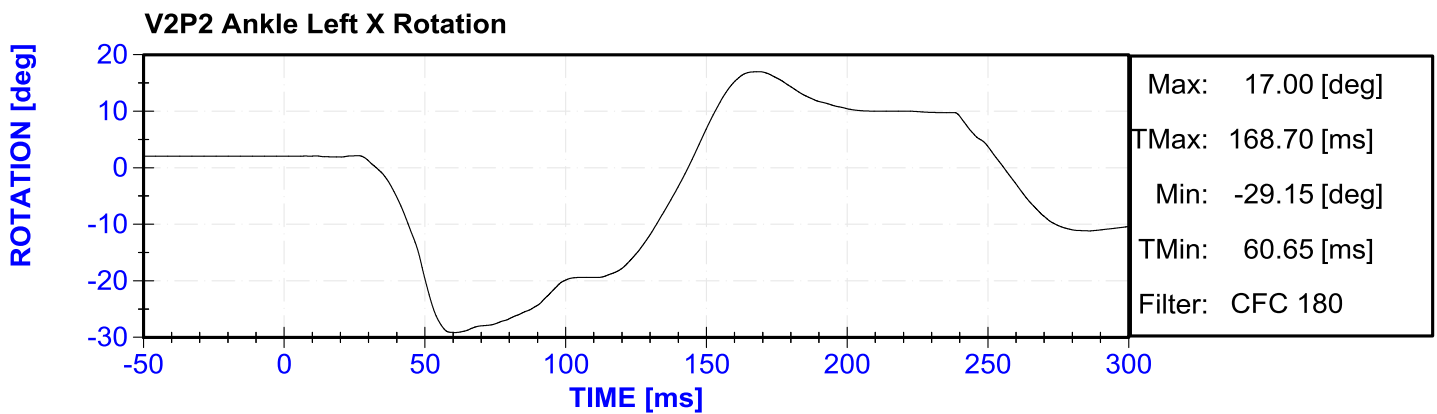
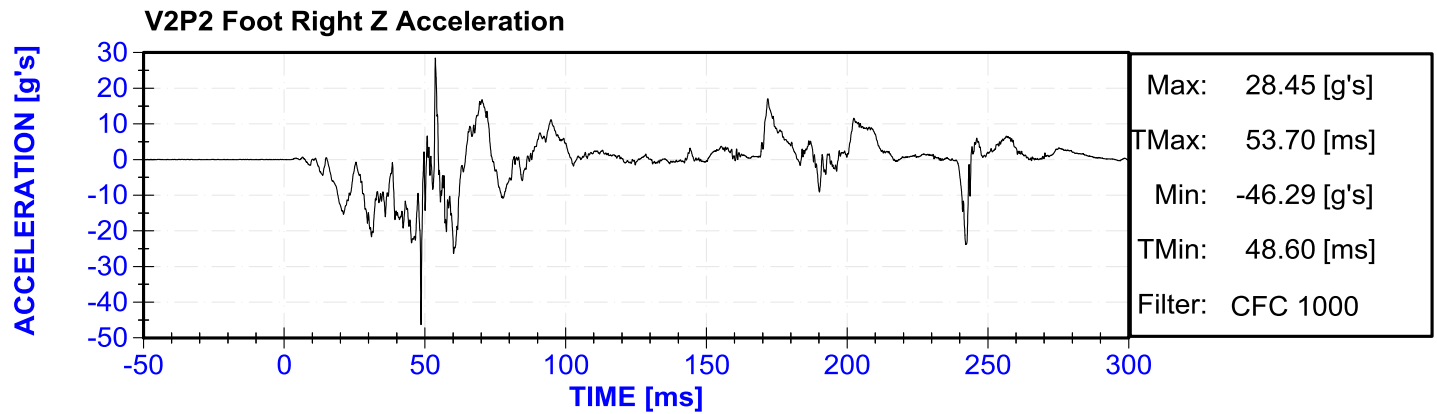
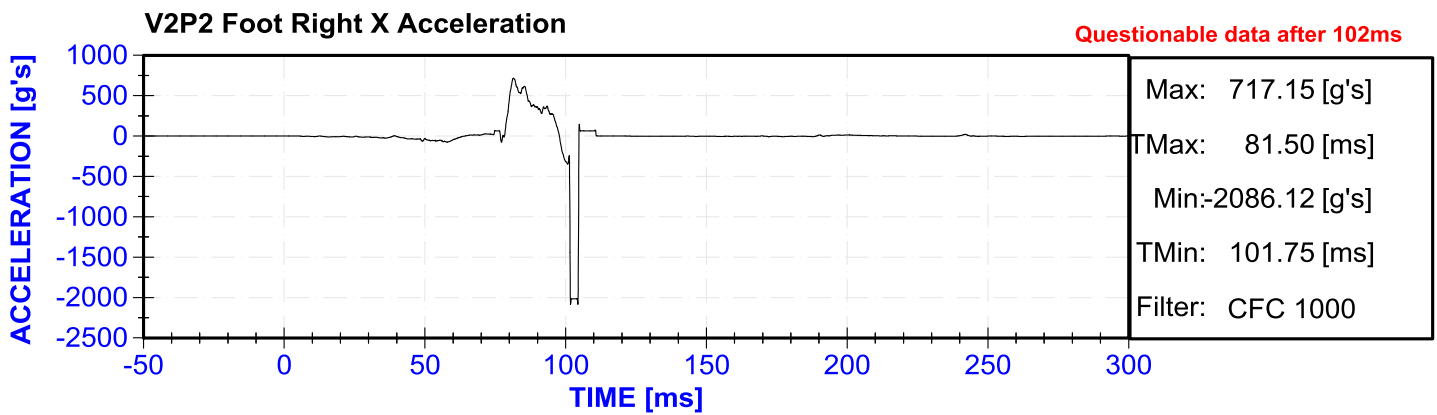
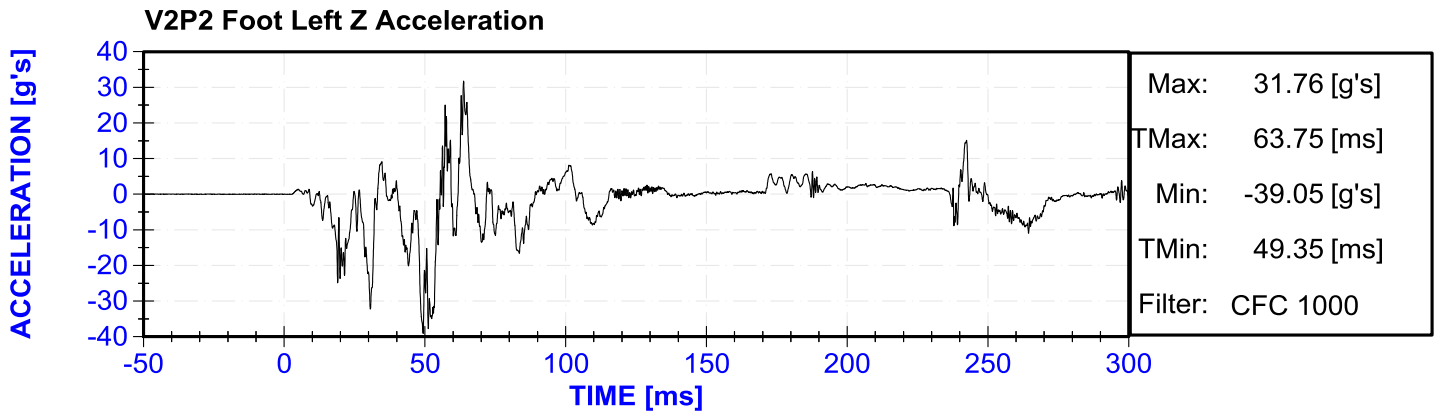

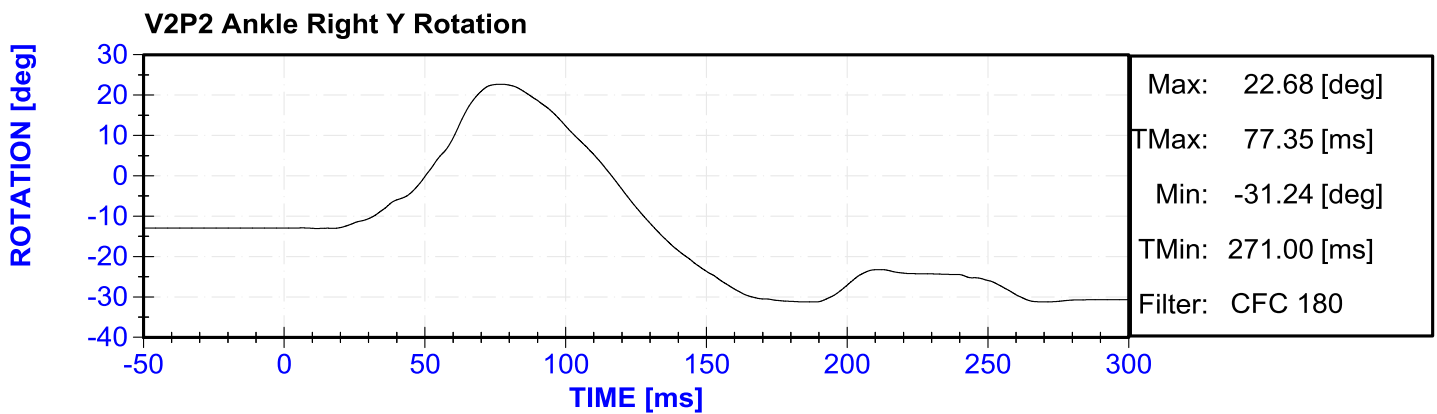
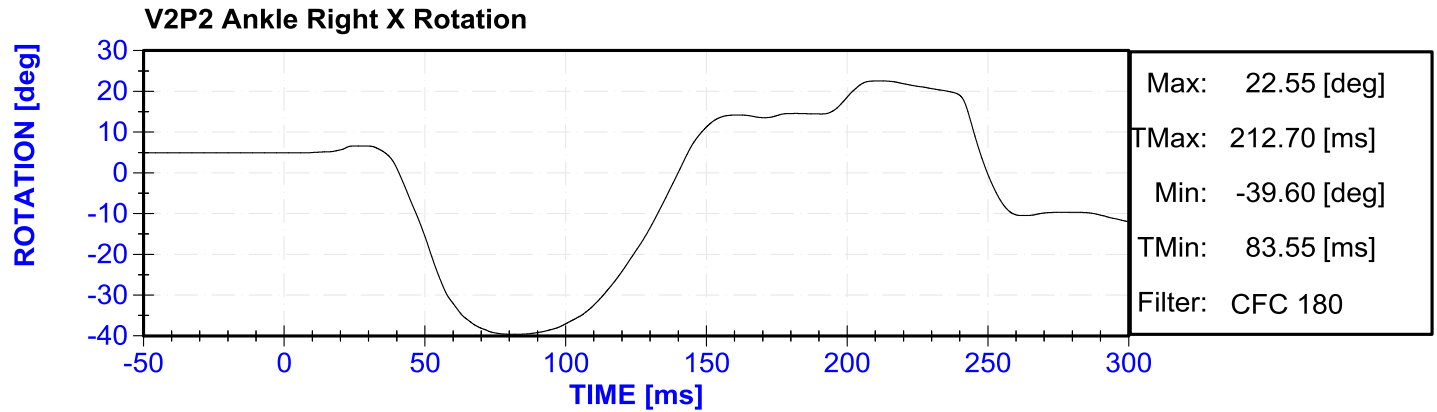
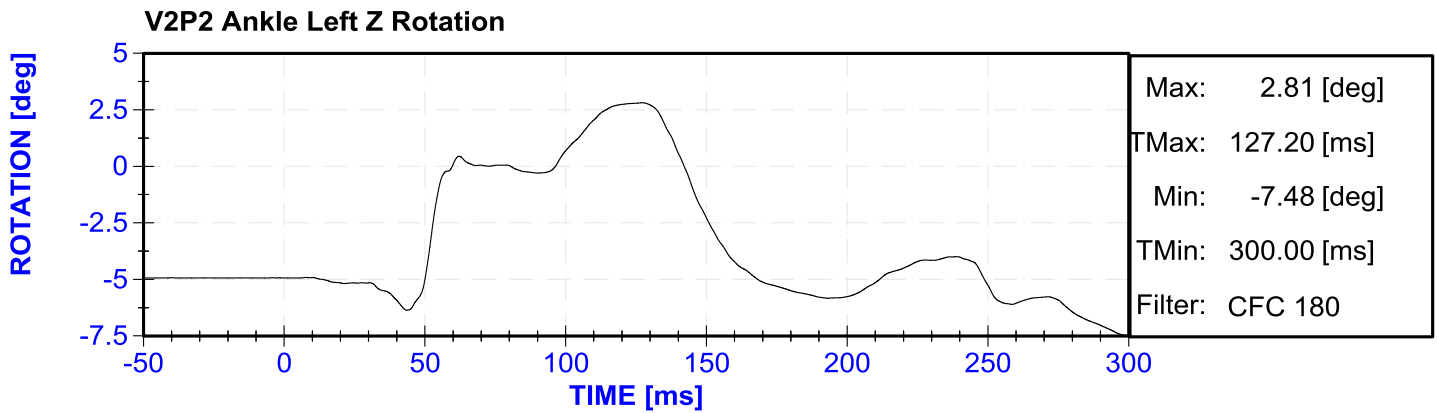
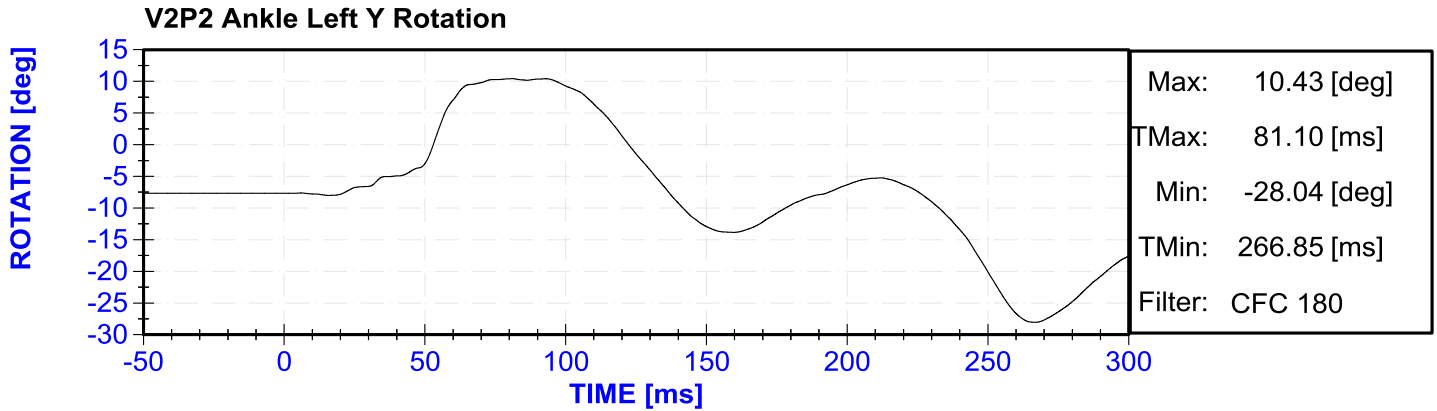

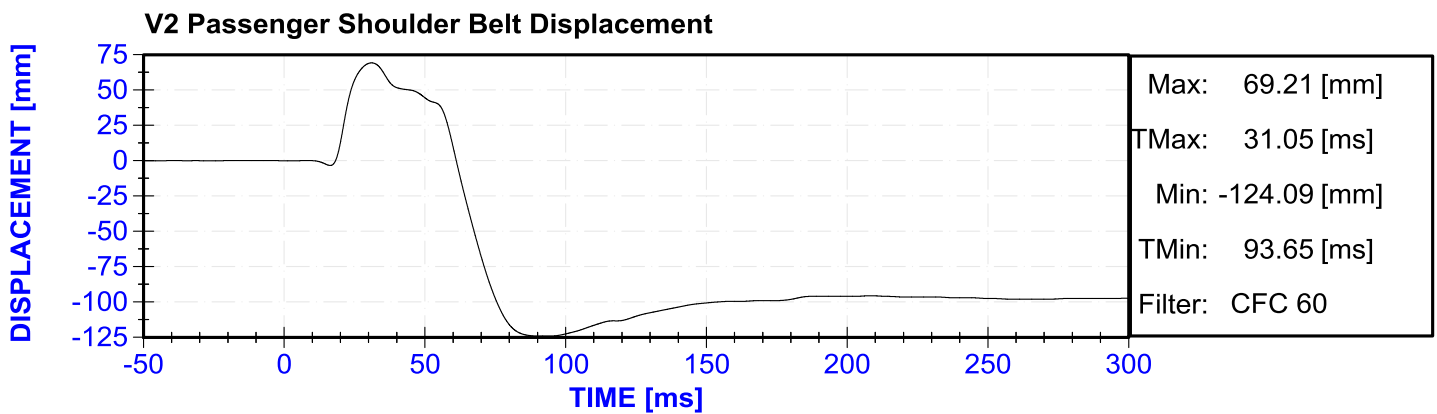
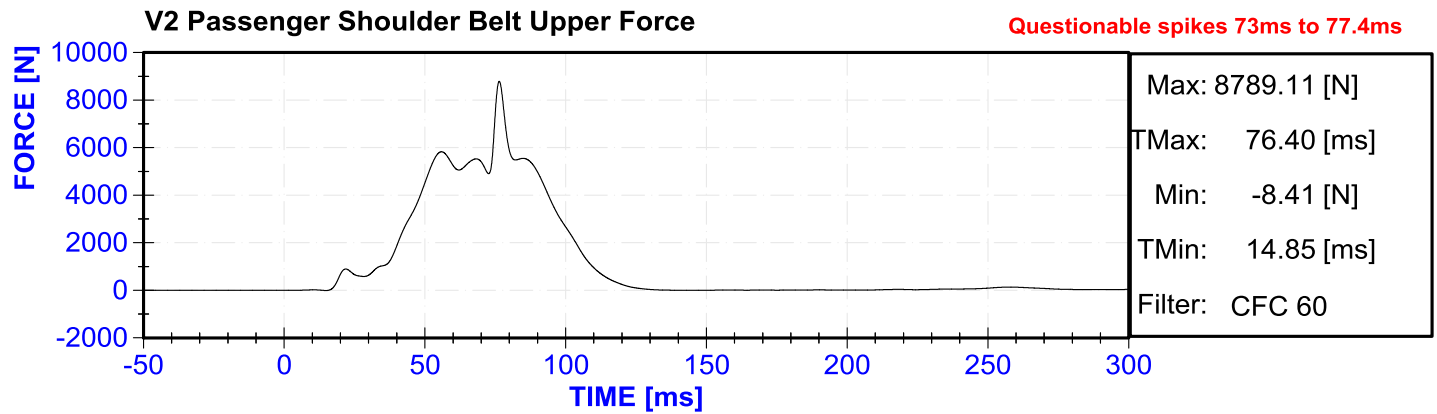
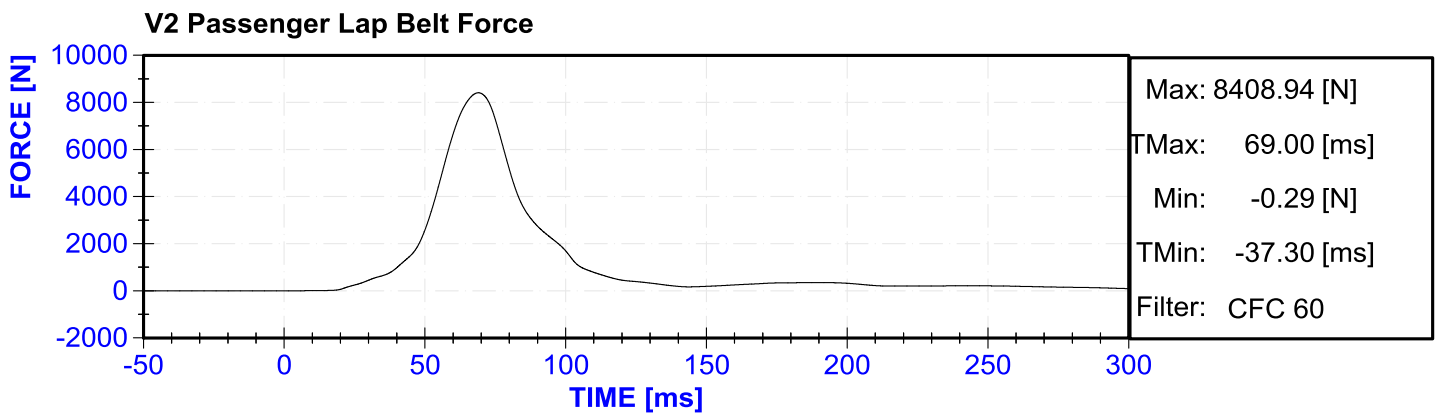
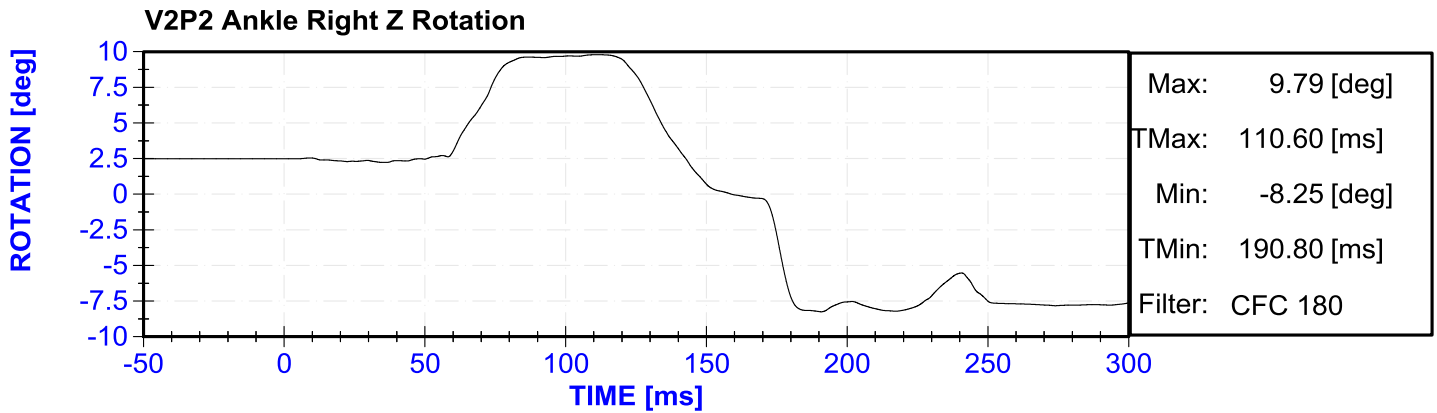

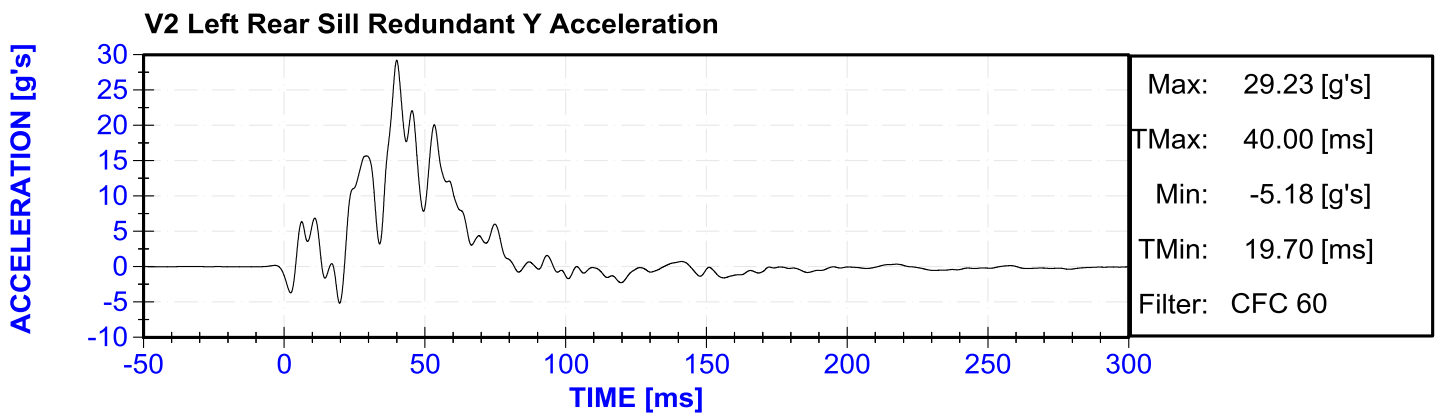
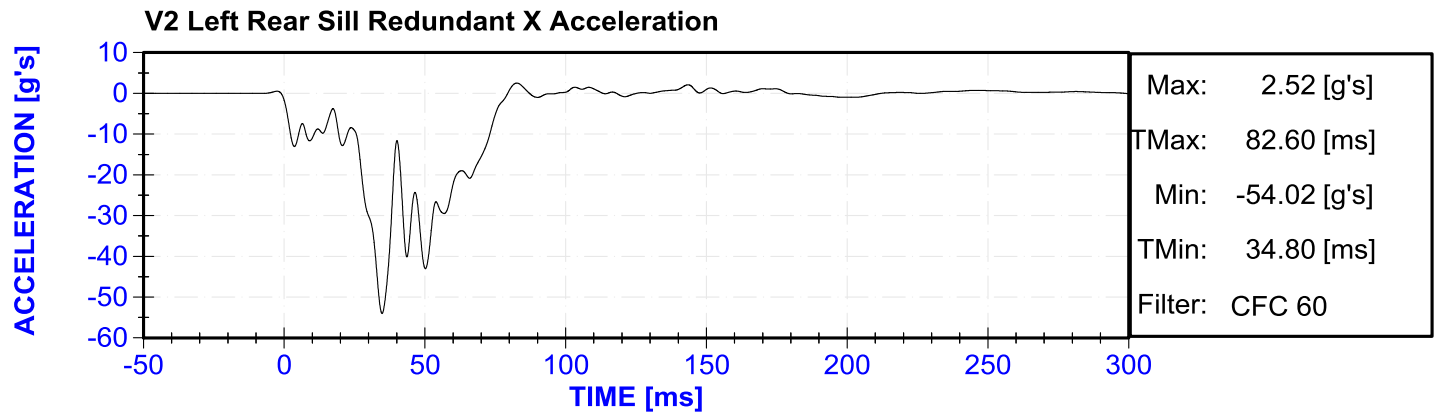
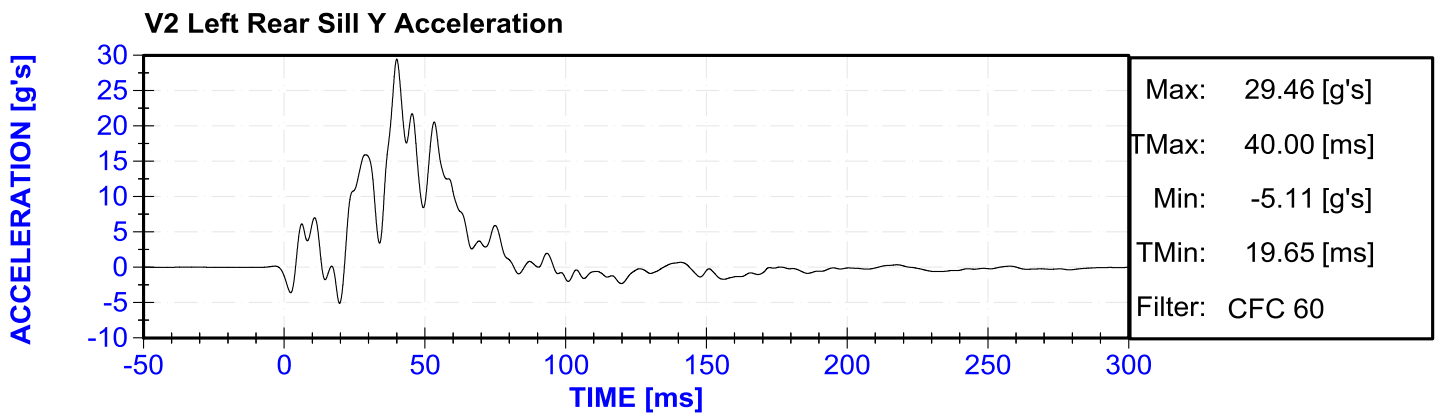
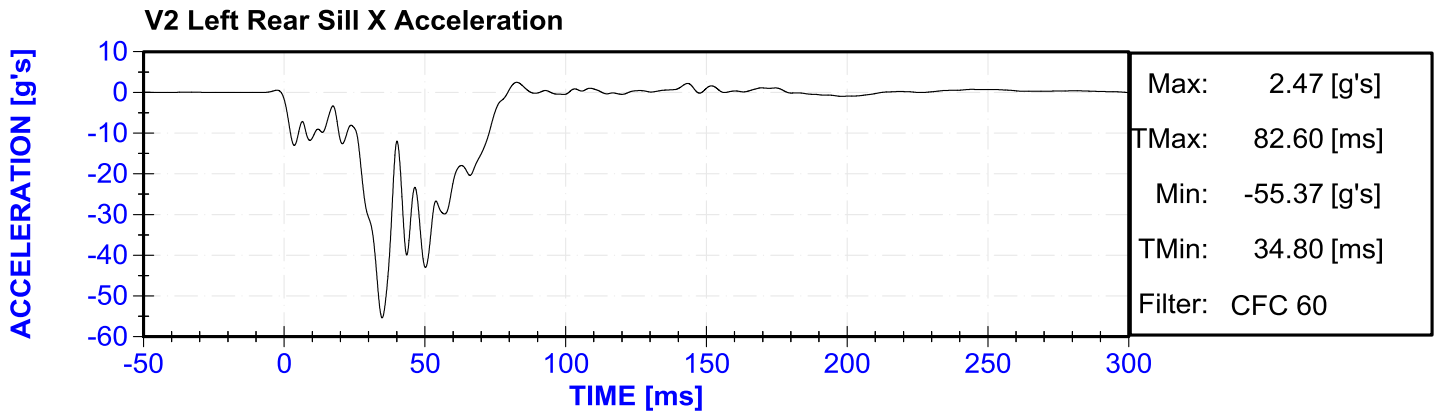

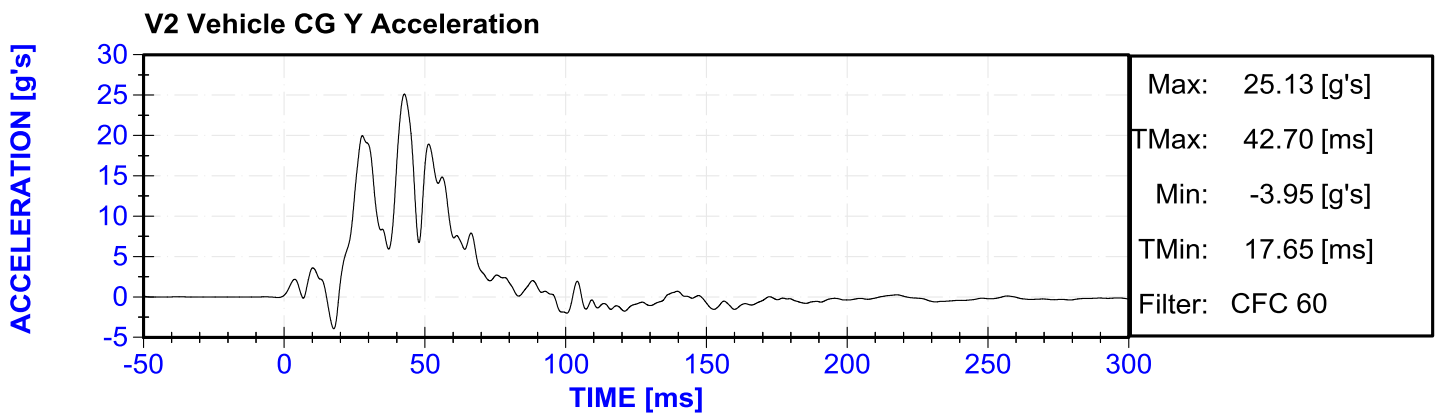
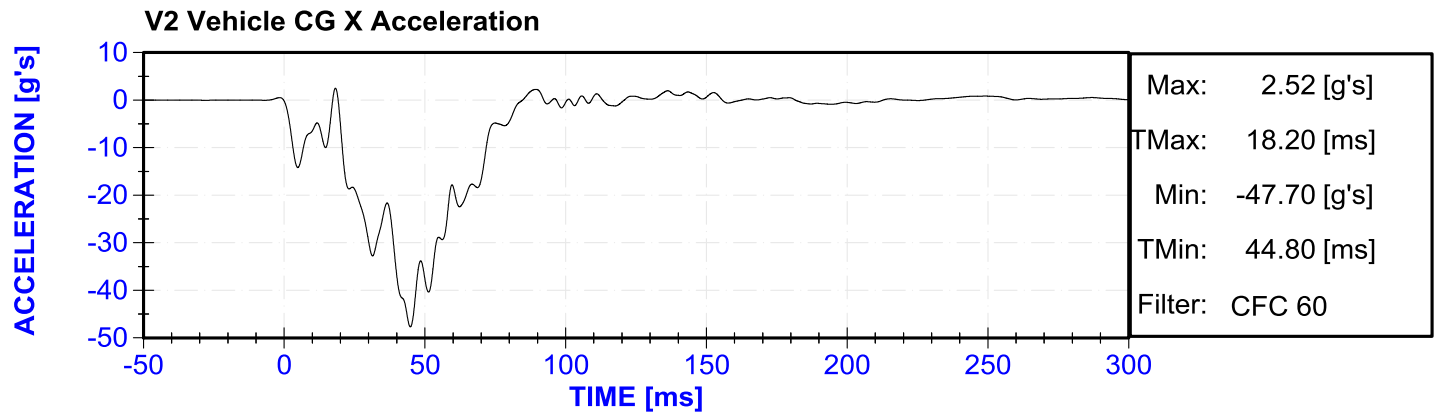
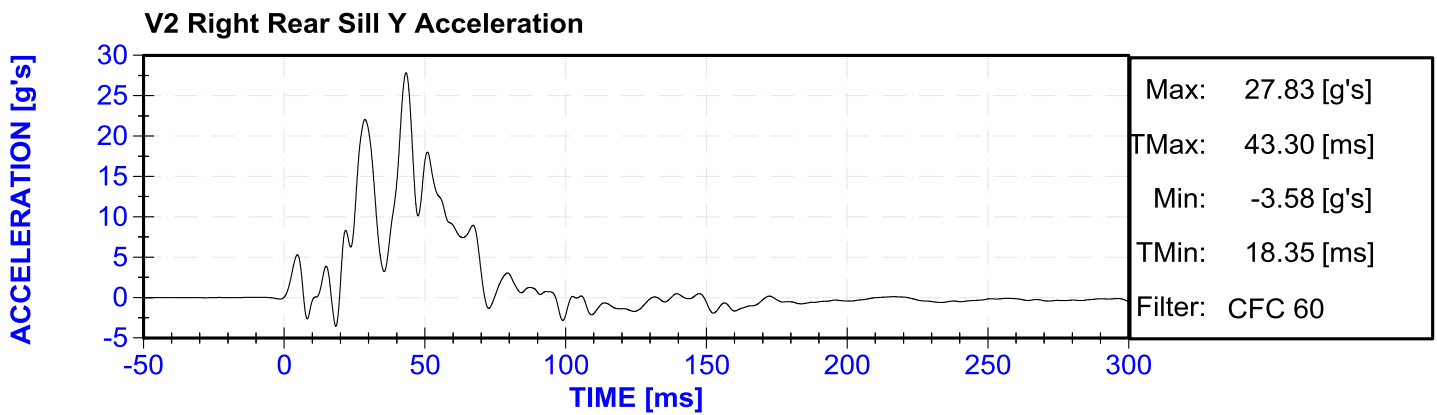
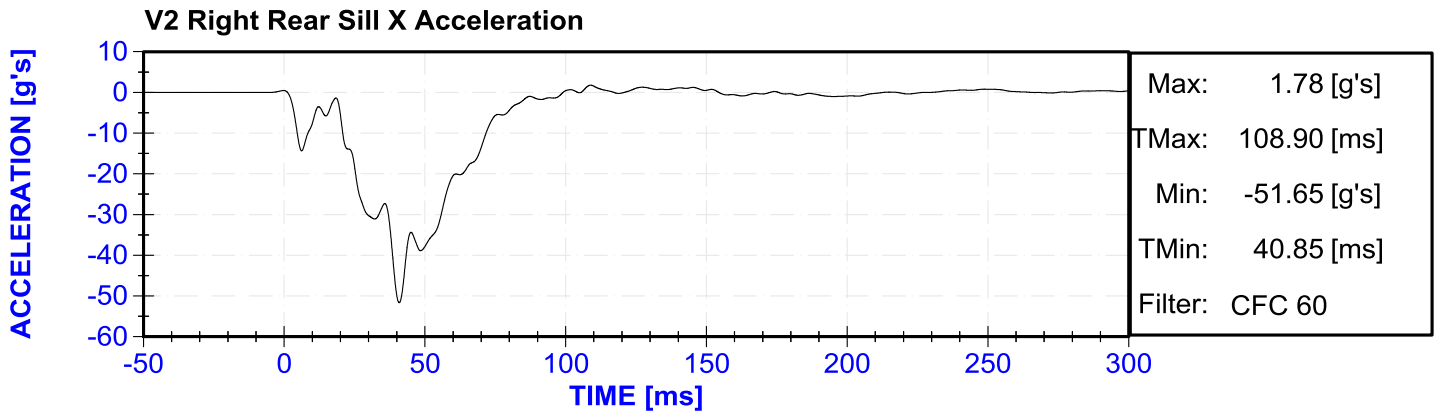

V2 Vehicle CG Z Acceleration

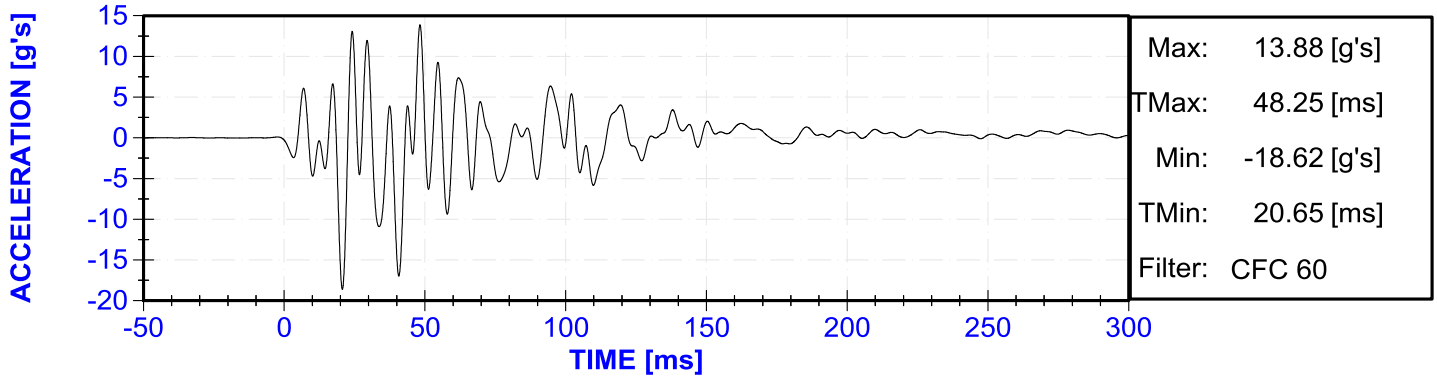

Vehicle CG X Angular Rate

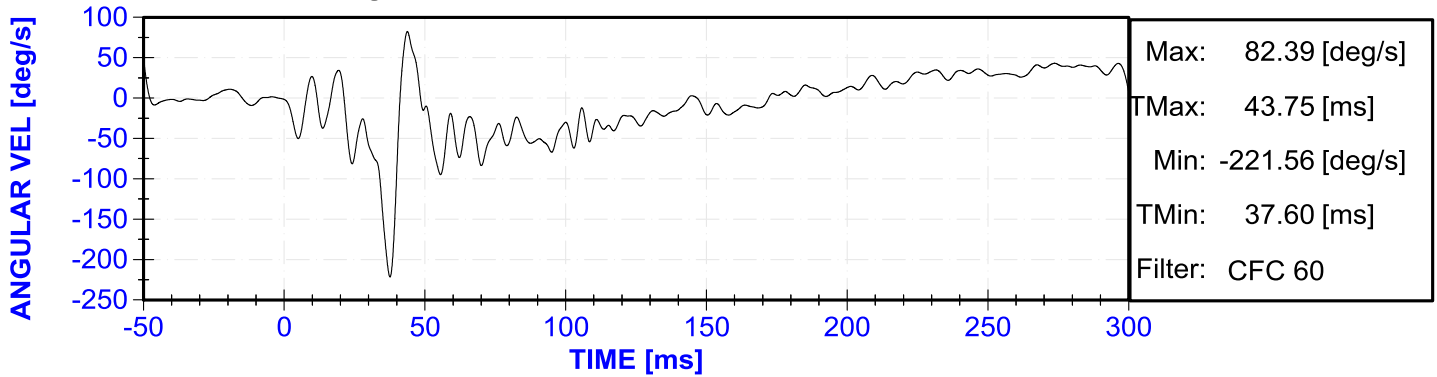

Vehicle CG Y Angular Rate

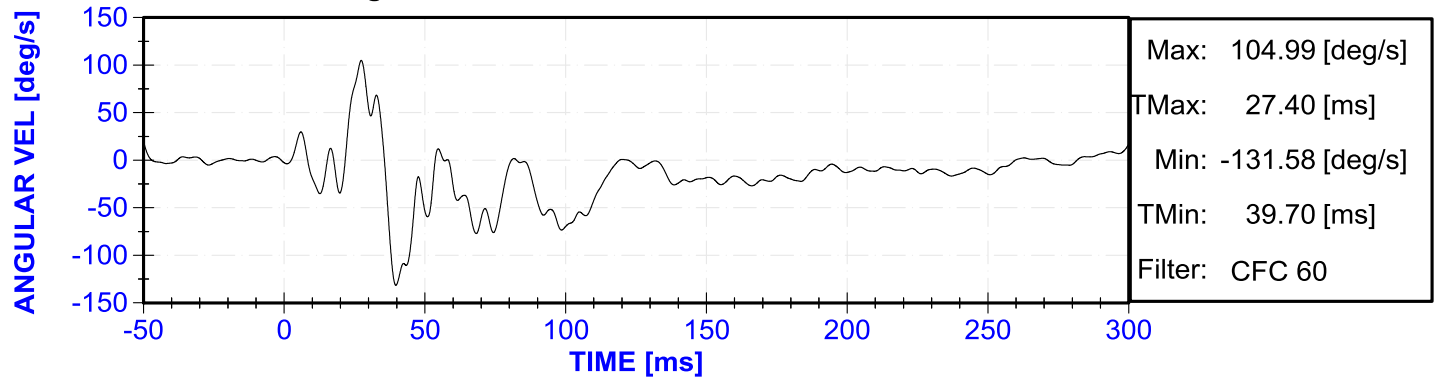

Vehicle CG Z Angular Rate

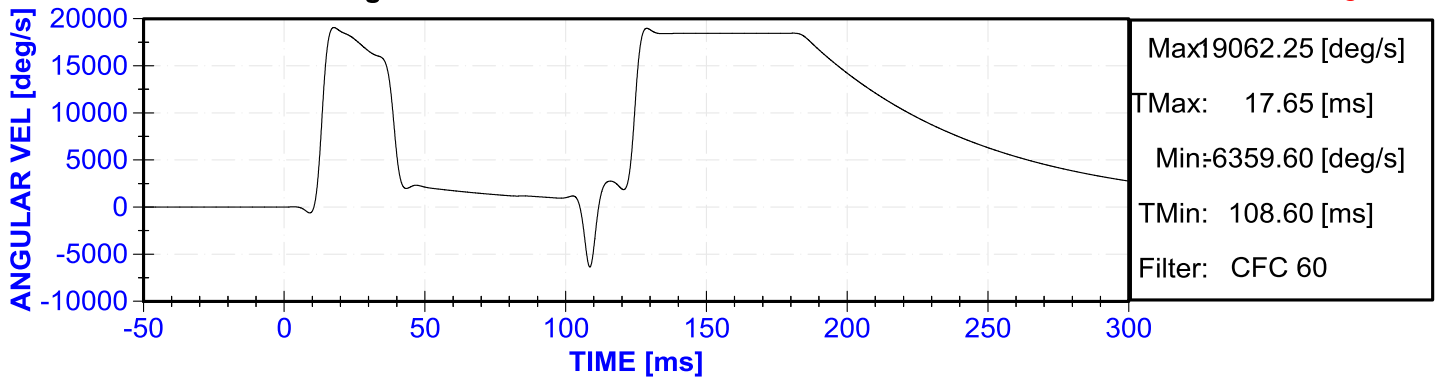

V2 Driver Seat Track X Acceleration

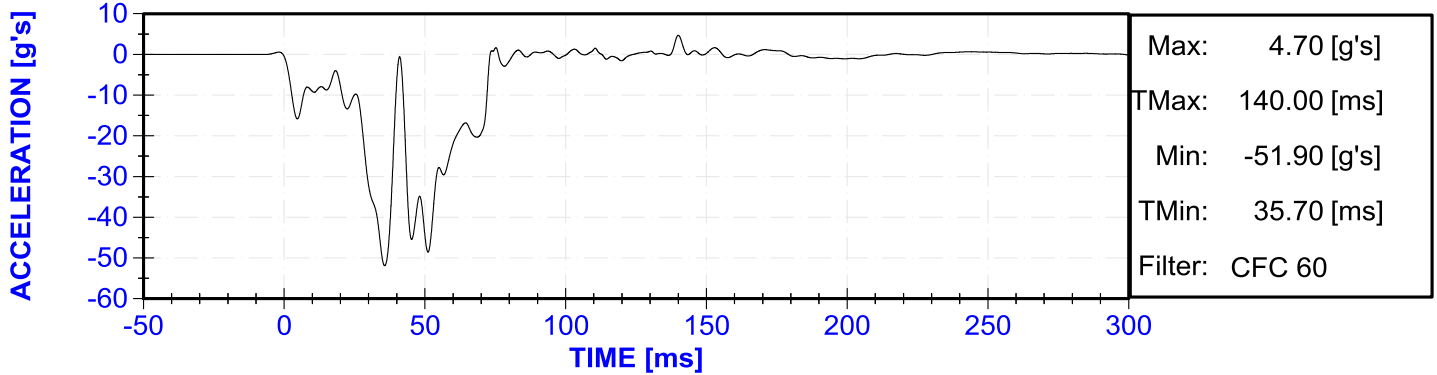

V2 Driver Seat Track Y Acceleration

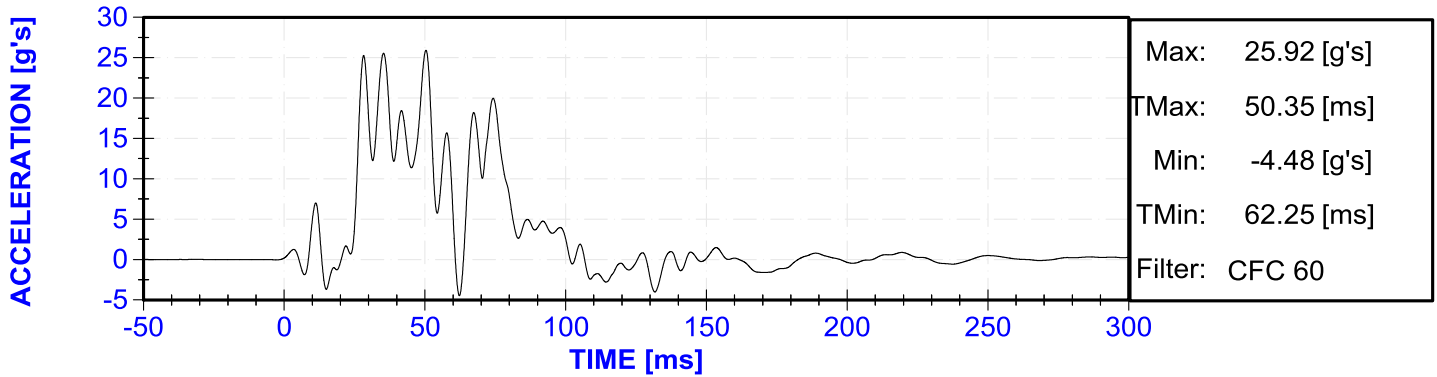

V2 Driver Seat Track Z Acceleration

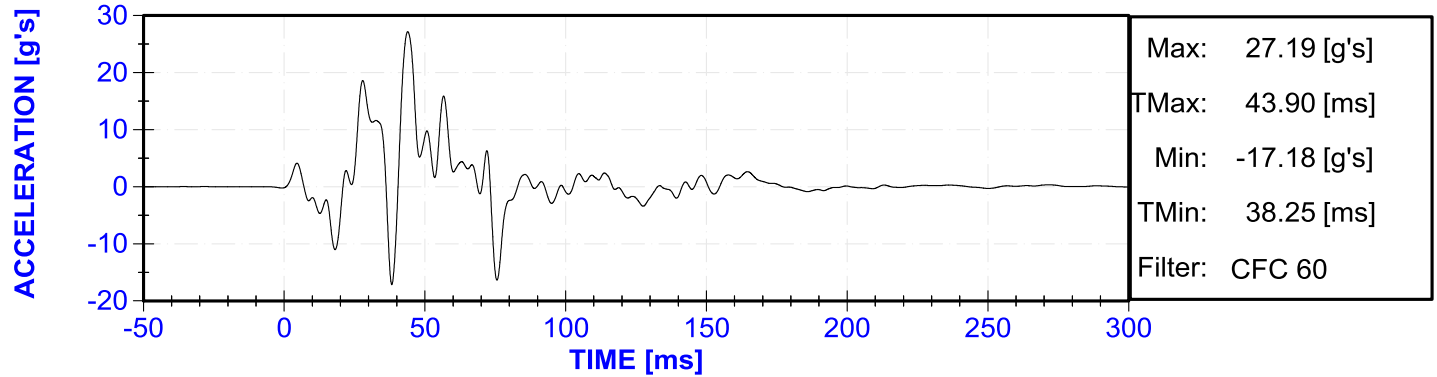

V2 Driver Seat Thigh Bar X Acceleration

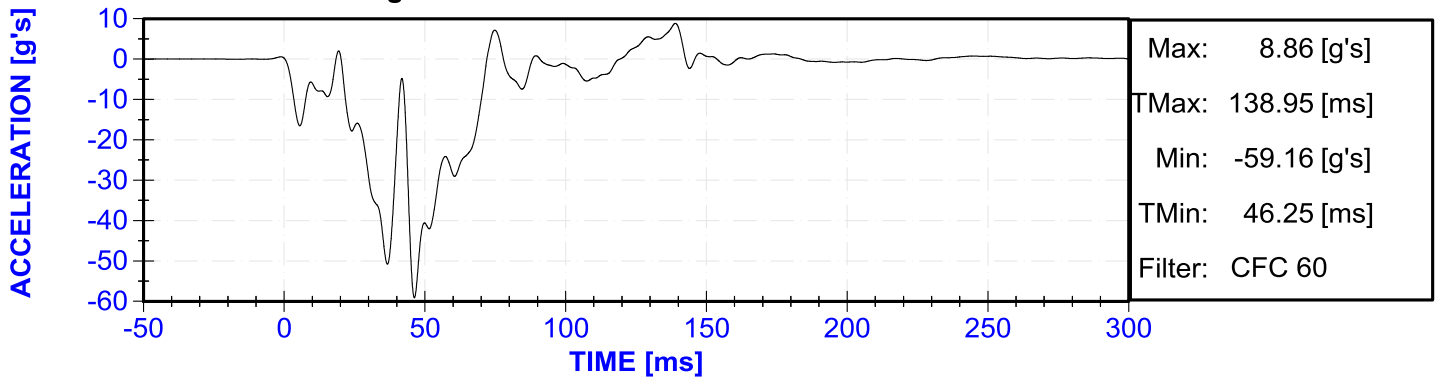

V2 Driver Seat Thigh Bar Z Acceleration

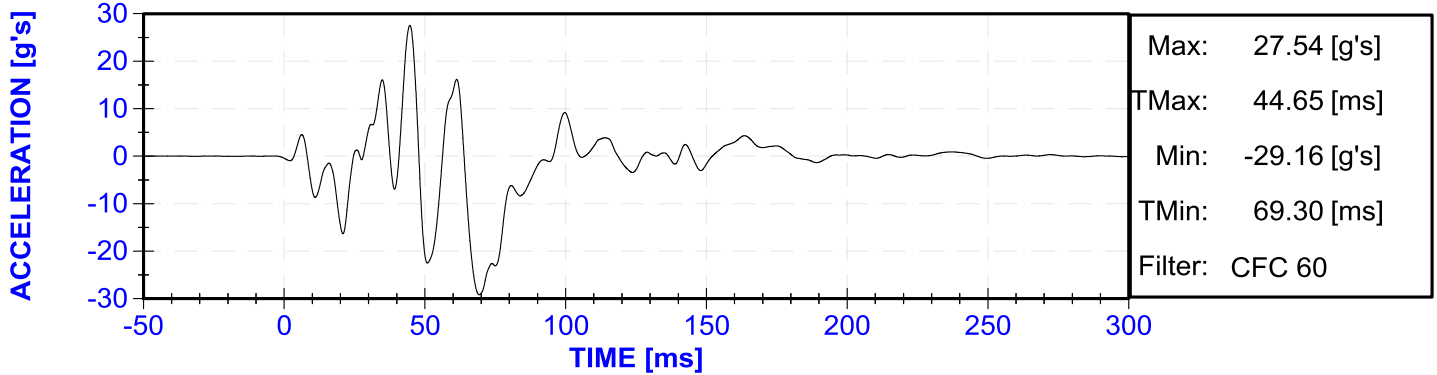

V2 Driver Floor Pan X Acceleration

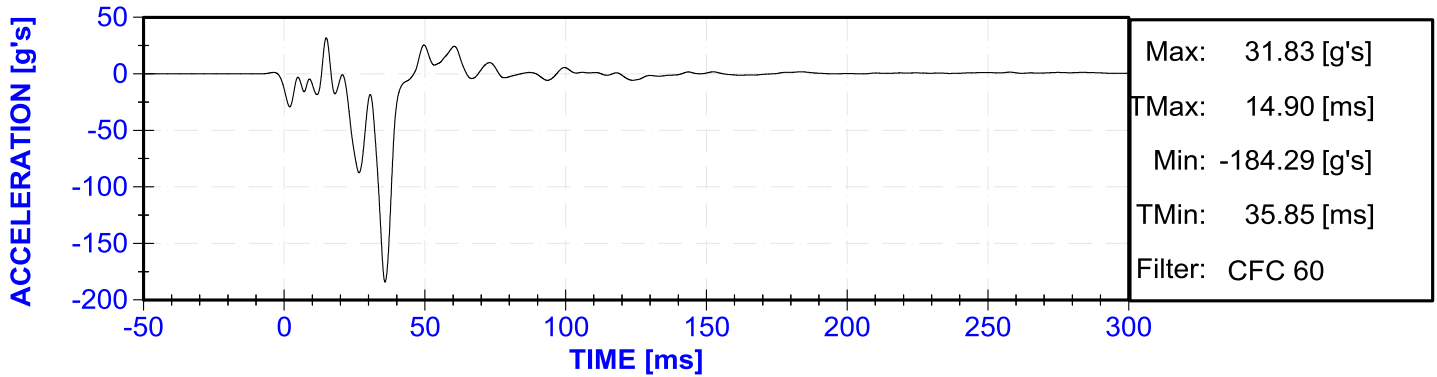

V2 Driver Floor Pan Y Acceleration

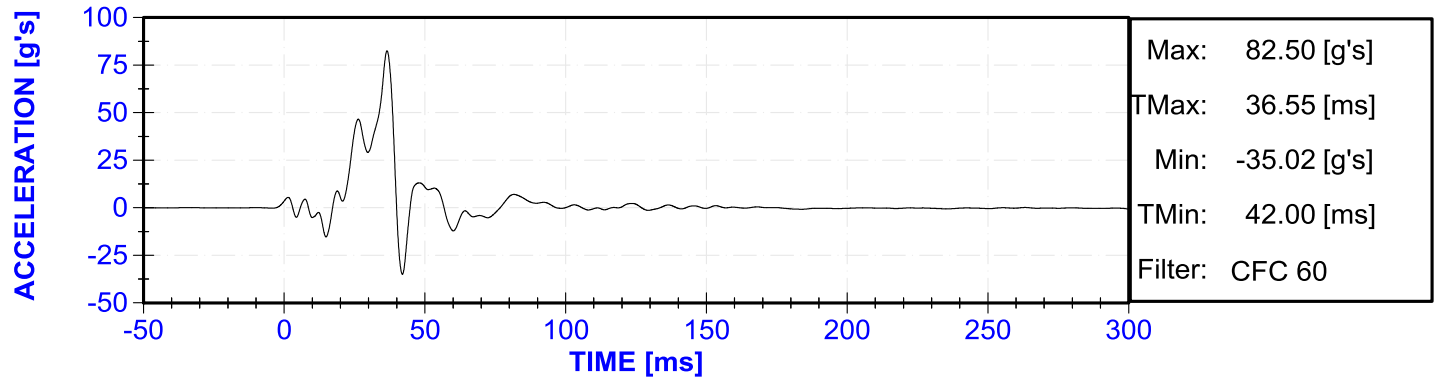

V2 Driver Floor Pan Z Acceleration

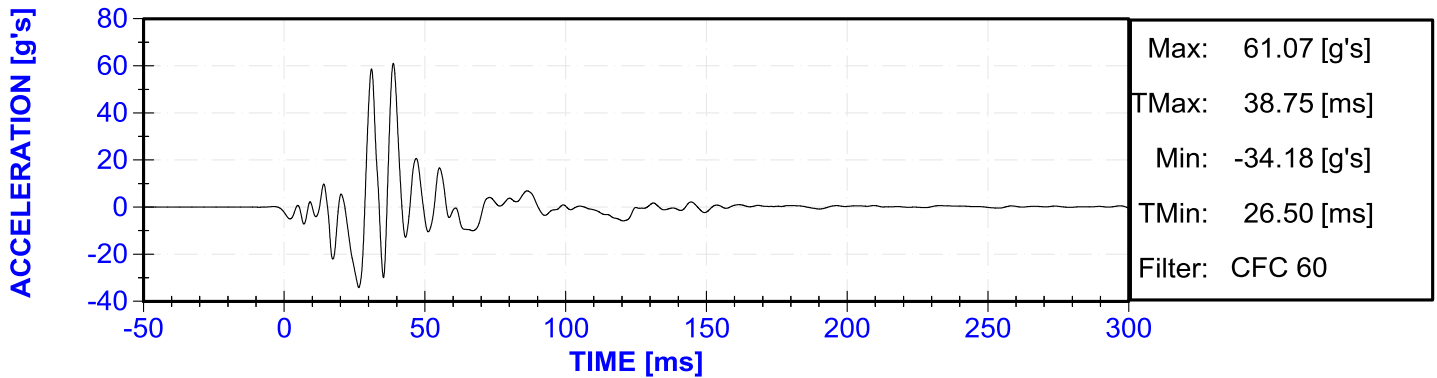

V2 Driver Floor Pan X Deflection

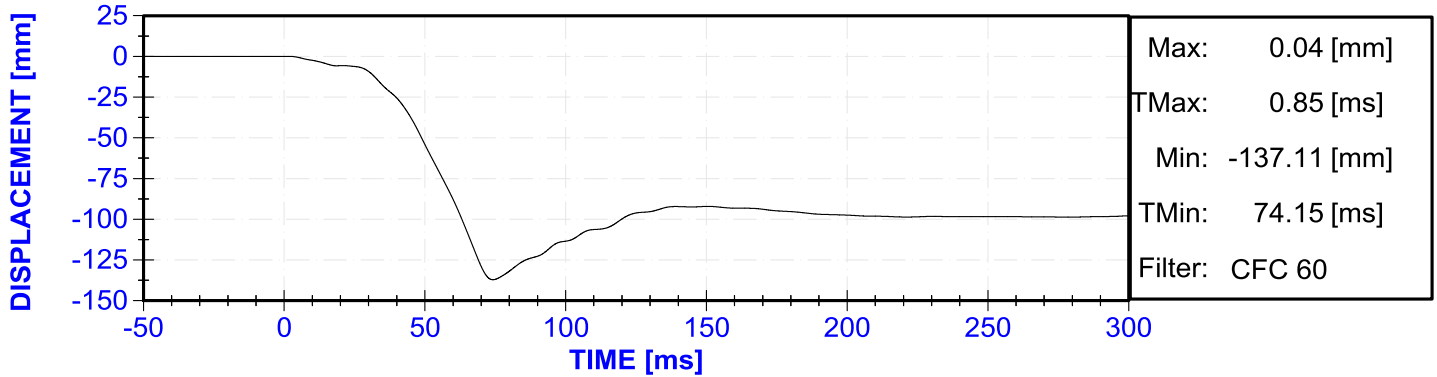

Driver Front Airbag Stage 1 Monitor

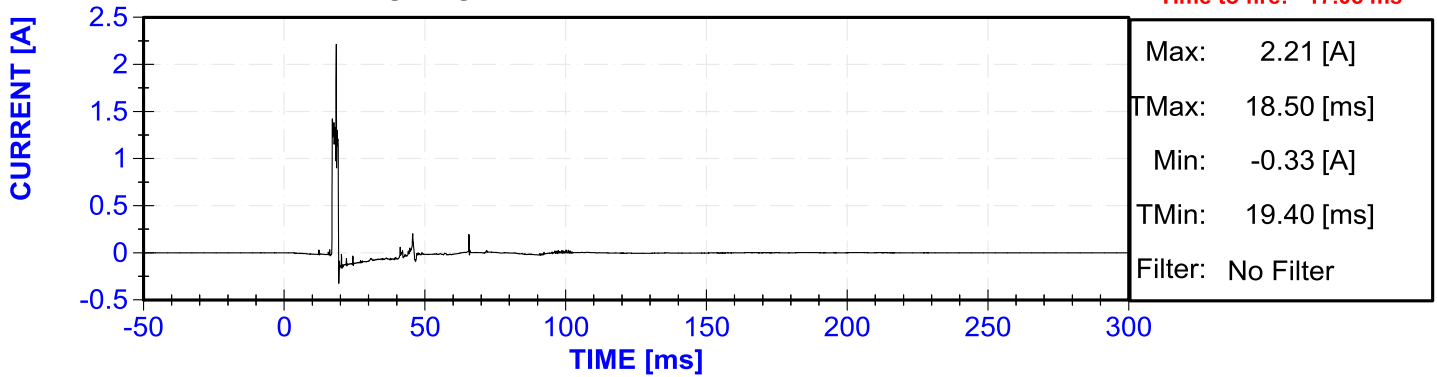

Driver Front Airbag Stage 2 Monitor

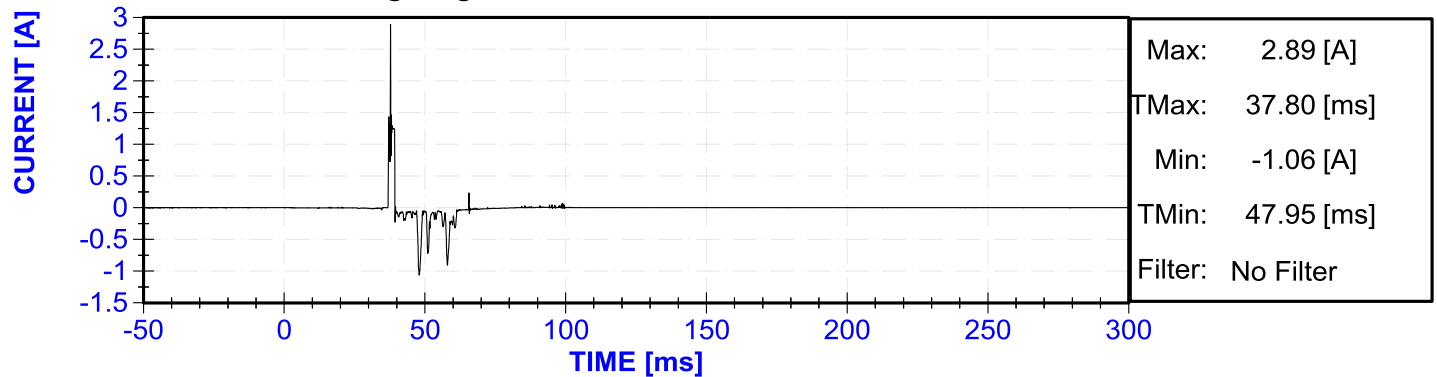

Driver Curtain Airbag Monitor

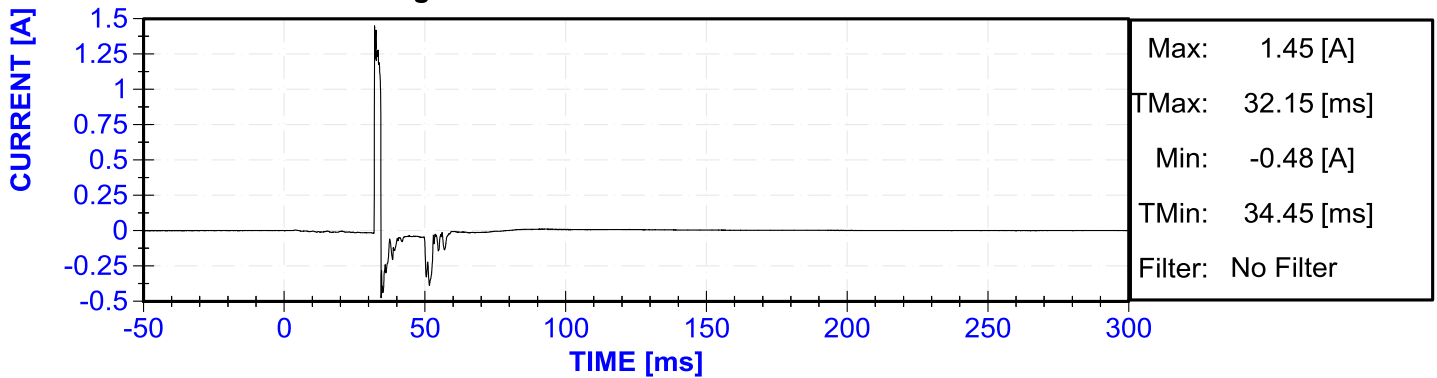

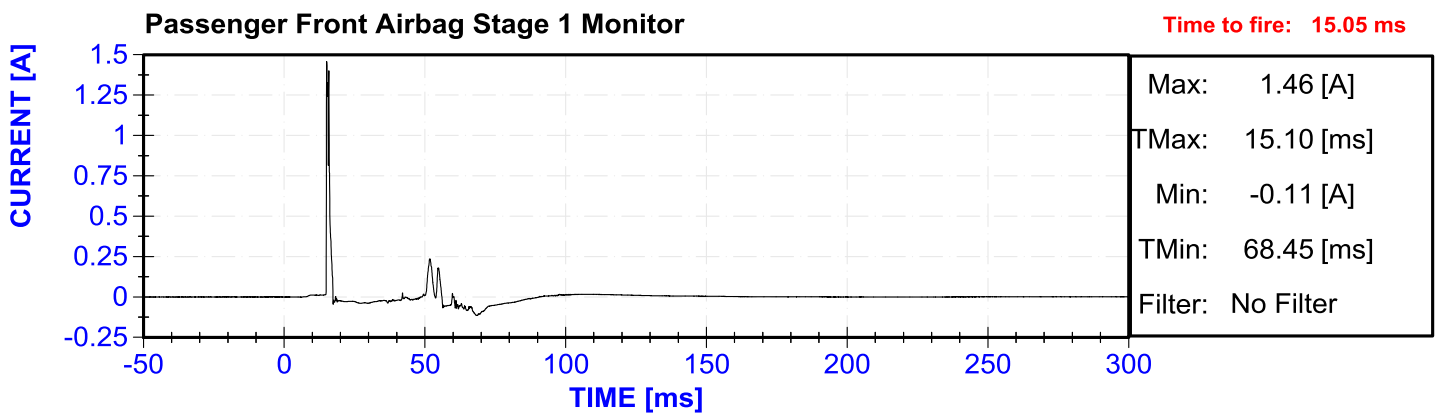
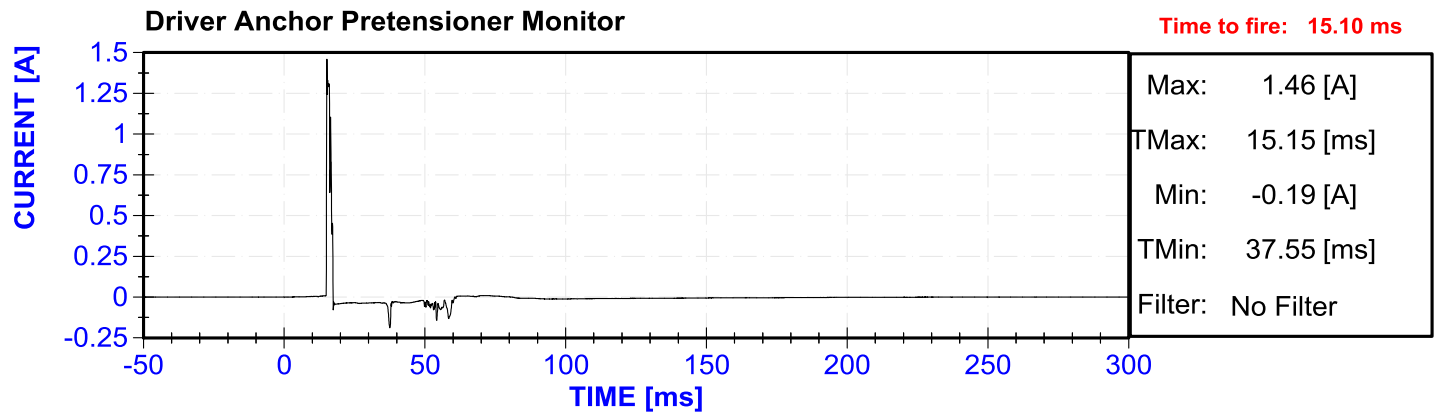
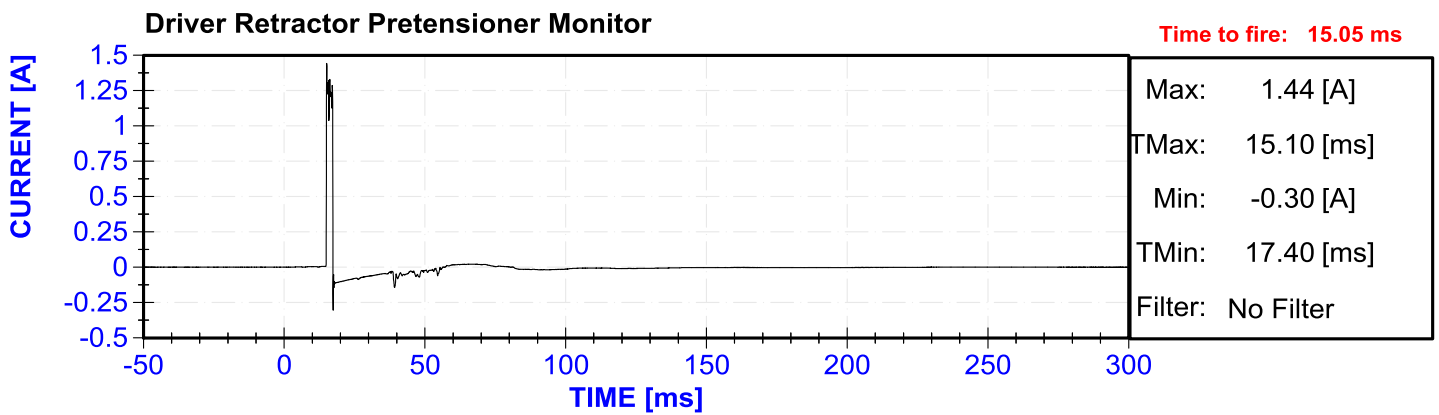
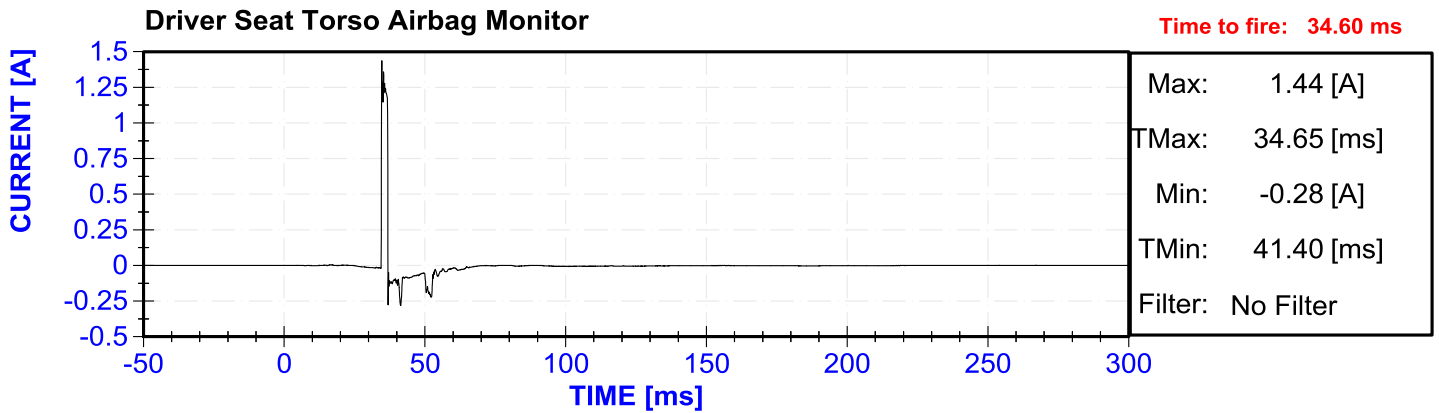

Passenger Front Airbag Stage 2 Monitor

Time to fire: 55.05 ms

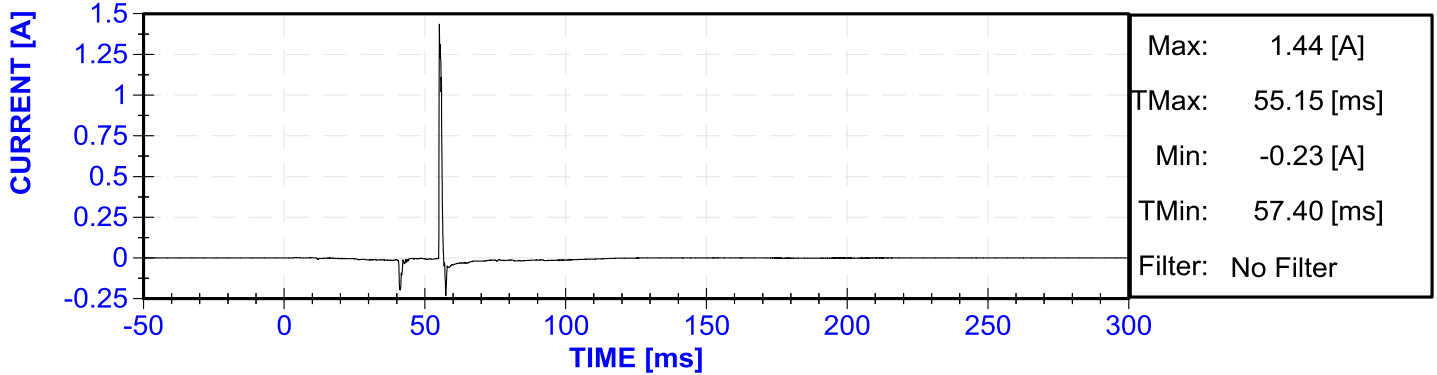

Passenger Curtain Airbag Monitor

Did not fire

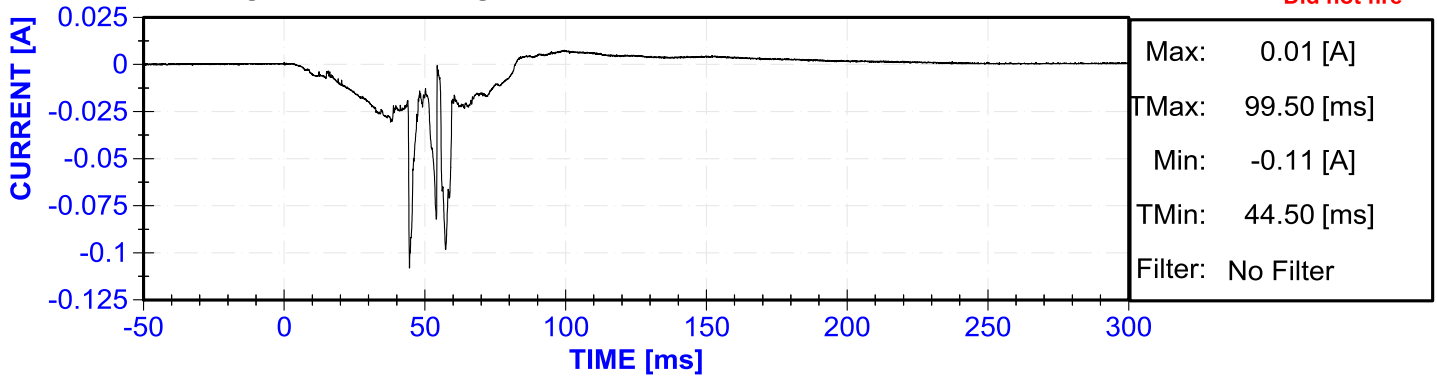

Passenger Seat Torso Airbag Monitor

Did not fire

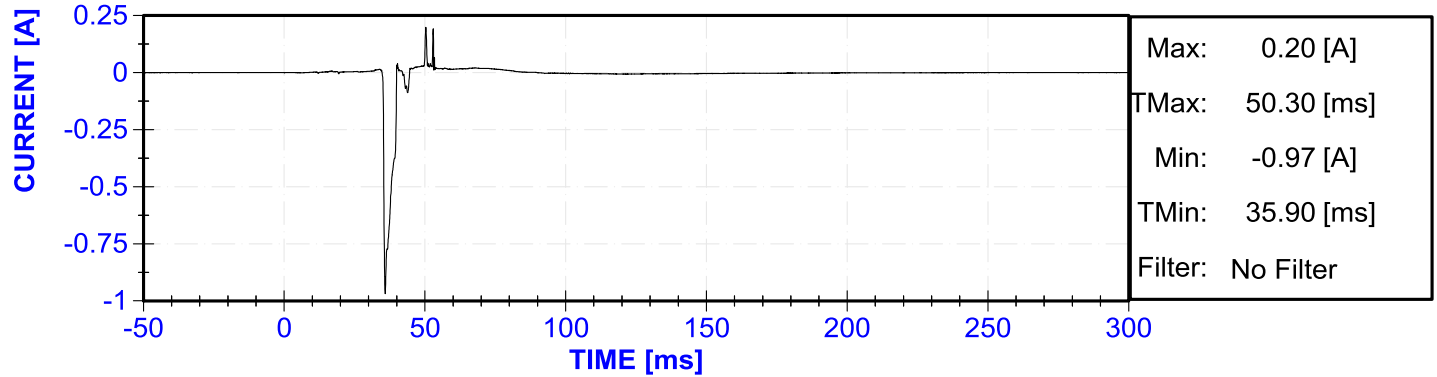

Passenger Retractor Pretensioner Monitor

Time to fire: 15.10 ms

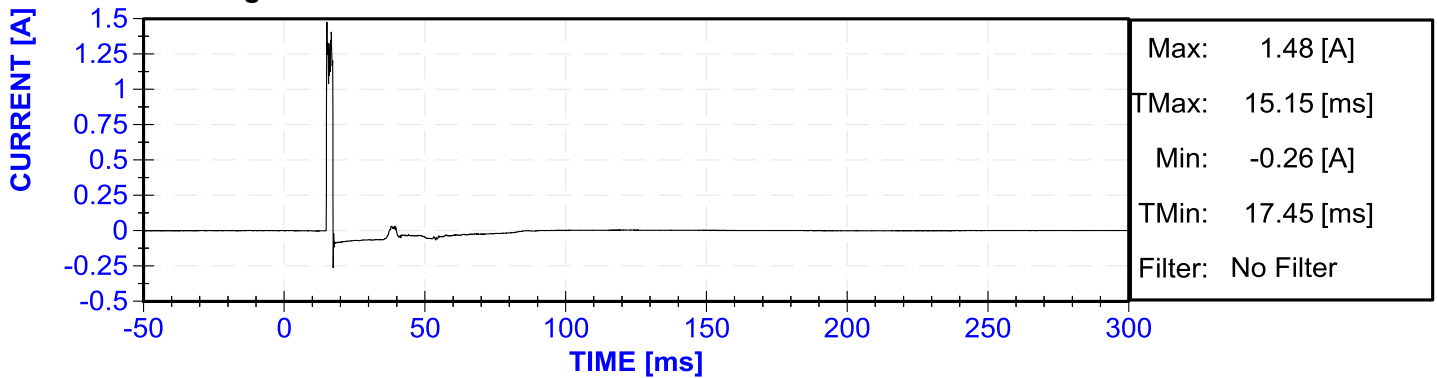

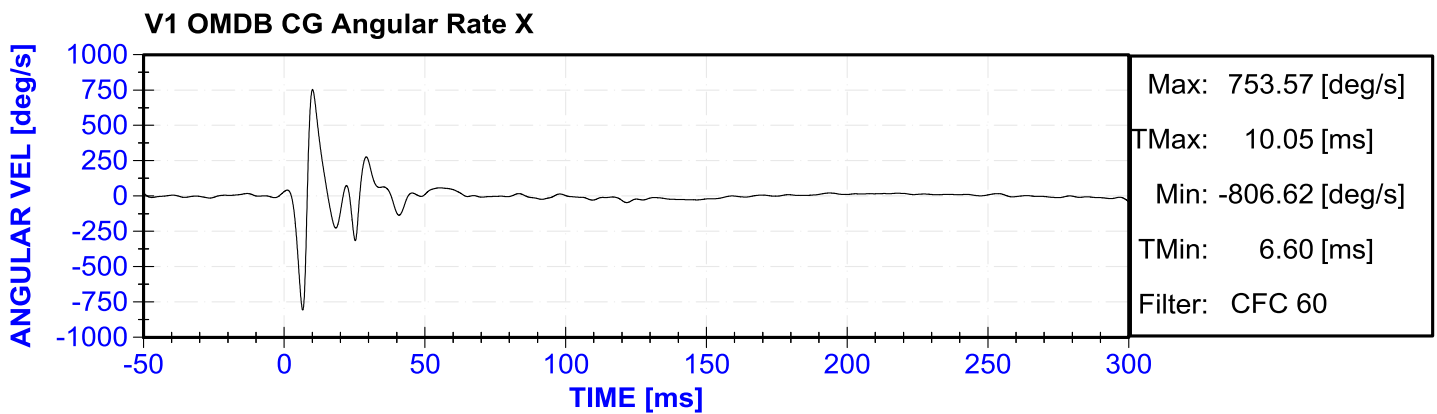
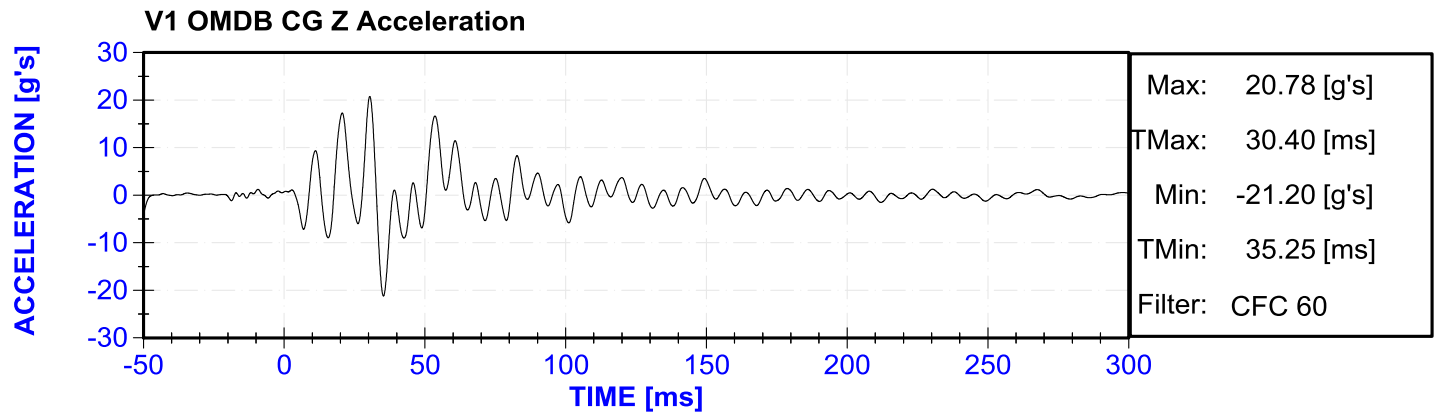
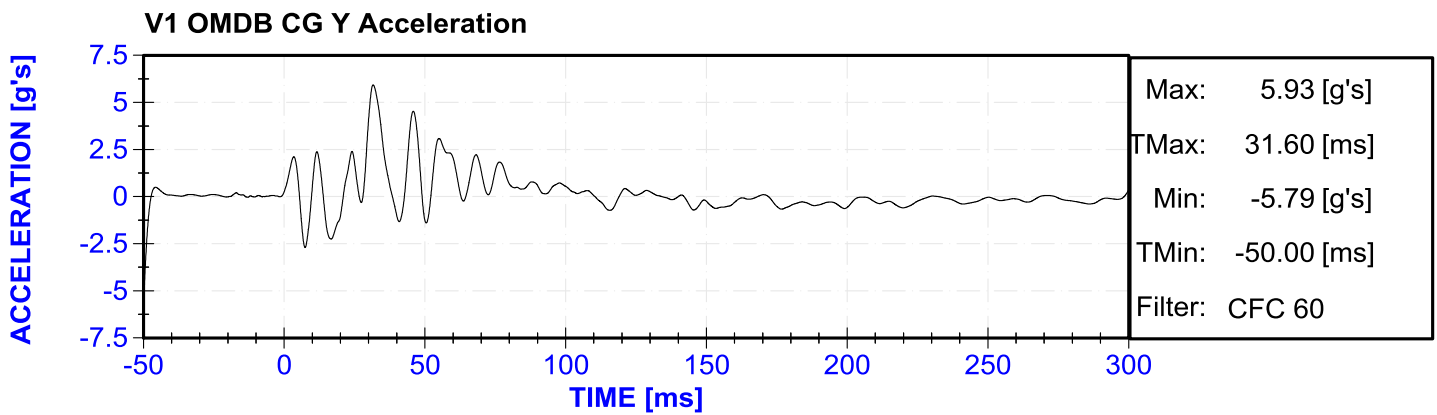
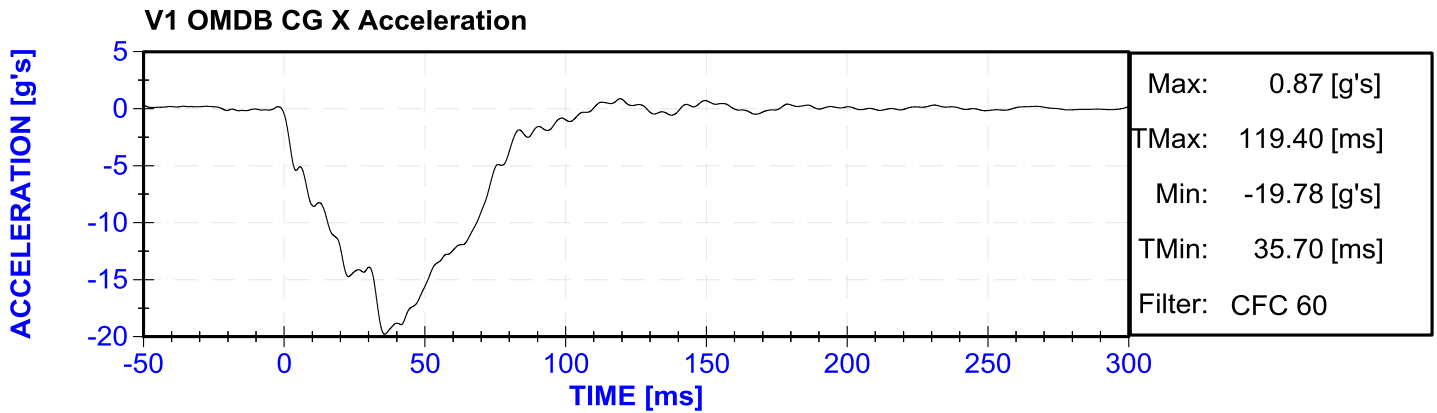

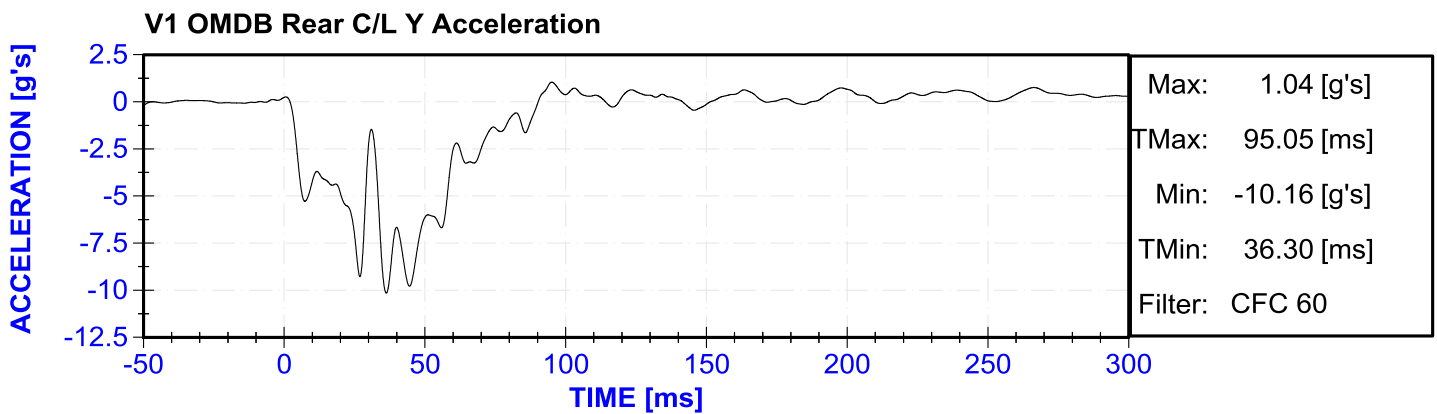
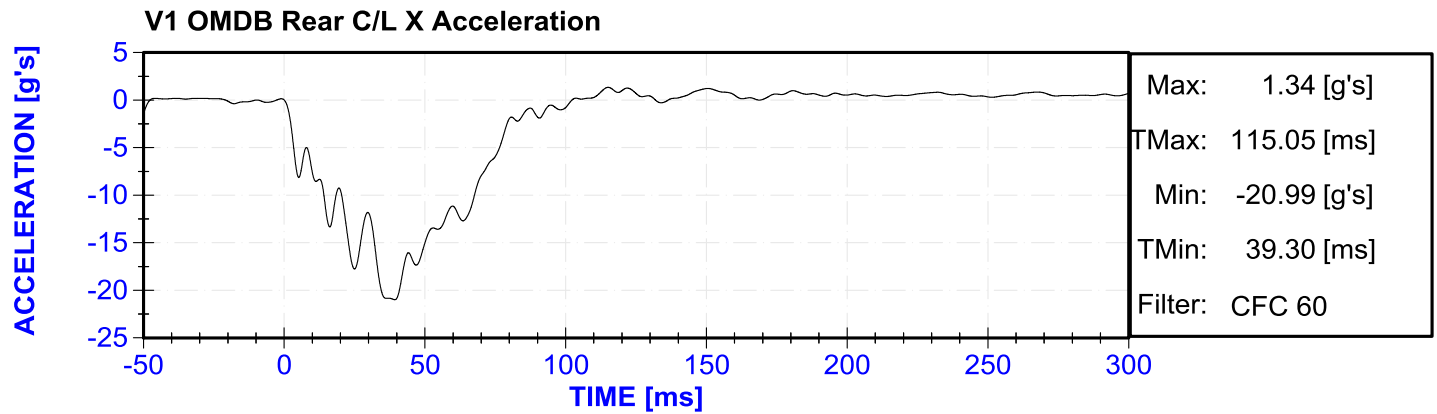
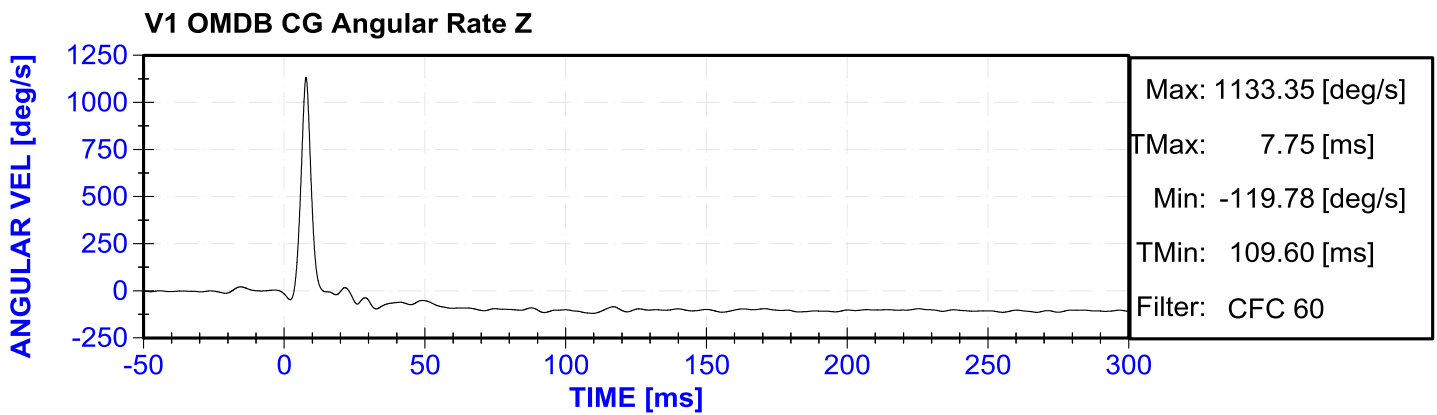
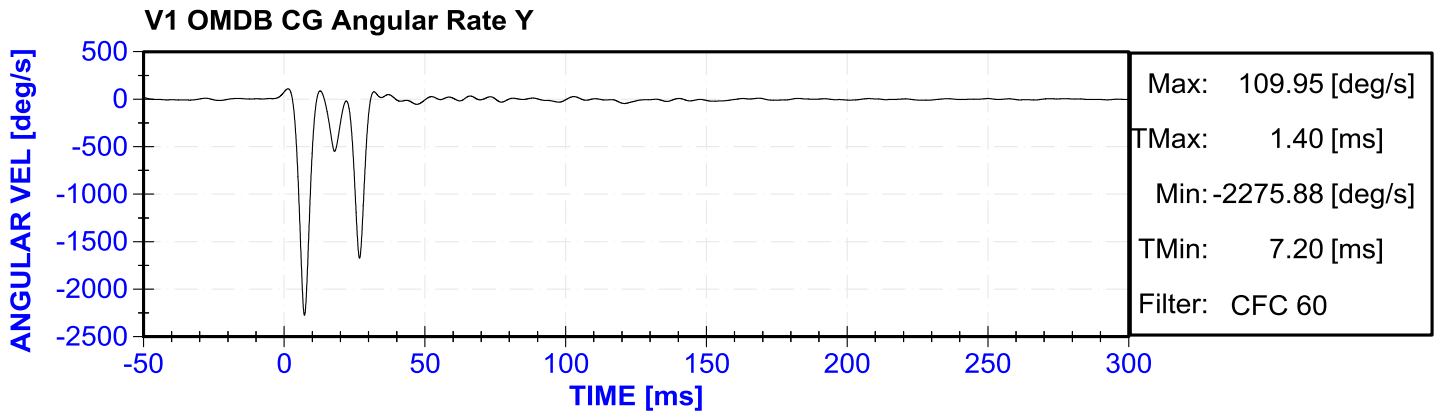

V1 OMDB Rear C/L Z Acceleration

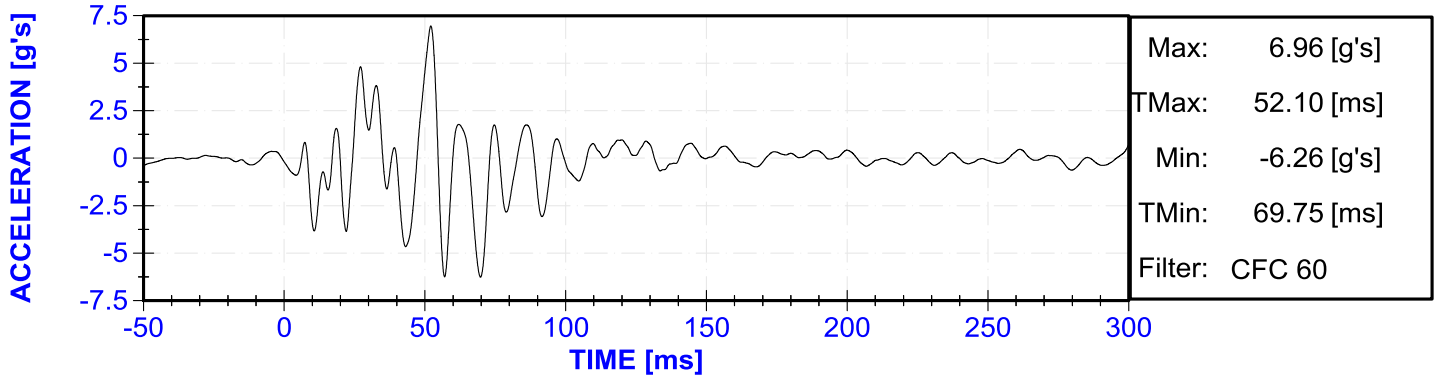

V2P1 Fx on head acting through the O.C. joint only

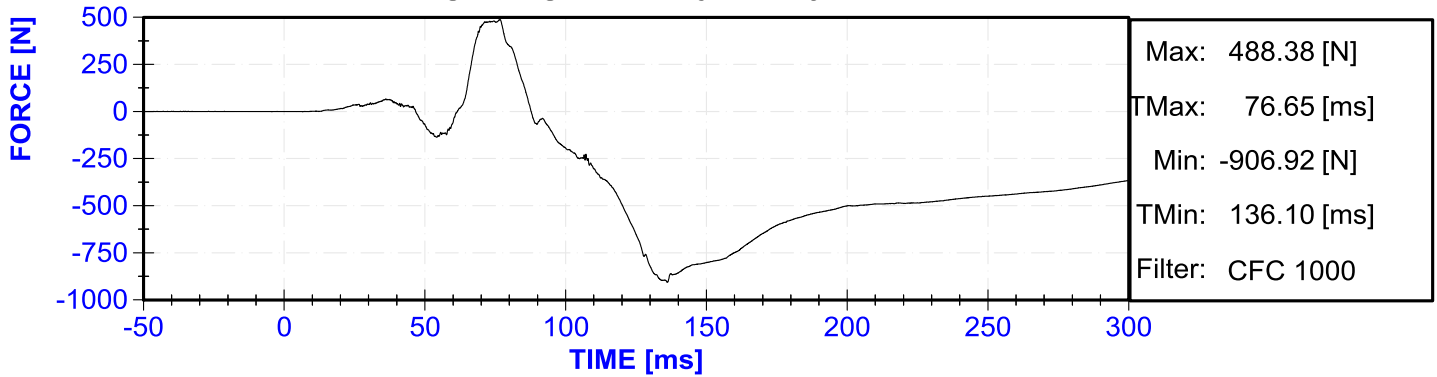

V2P1 Fz on head acting through the O.C. joint only

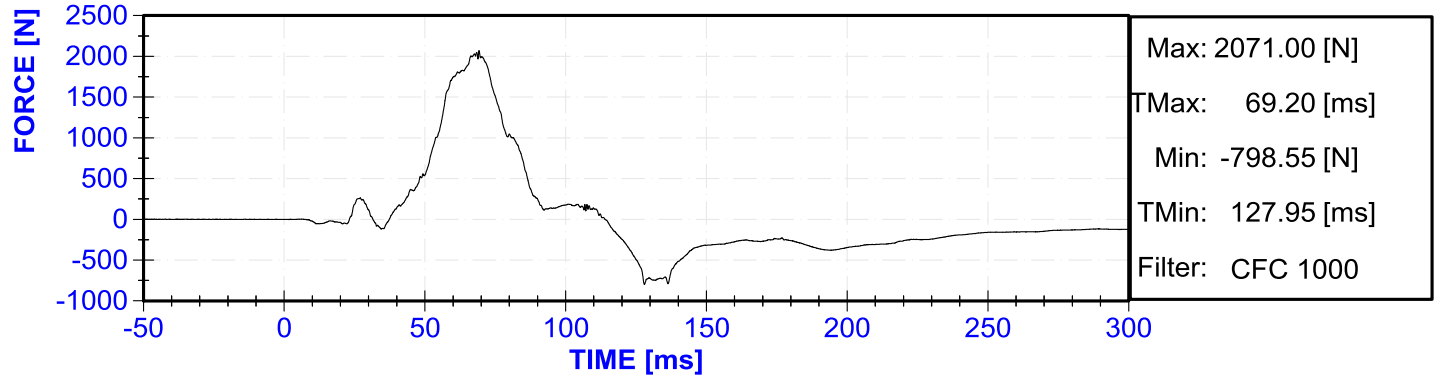

V2P1 My on head acting through the O.C. joint only

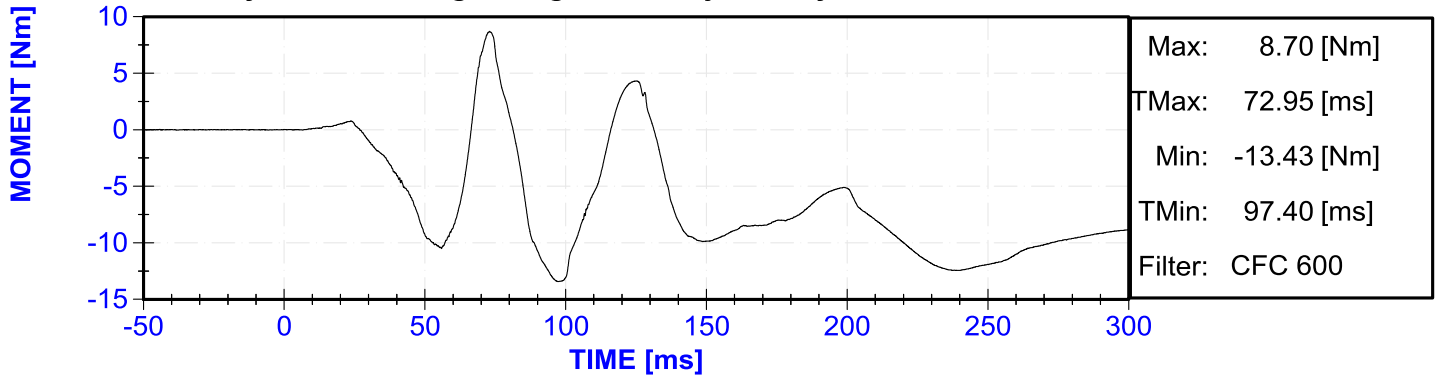

V2P1 Fx on head acting through the total neck section

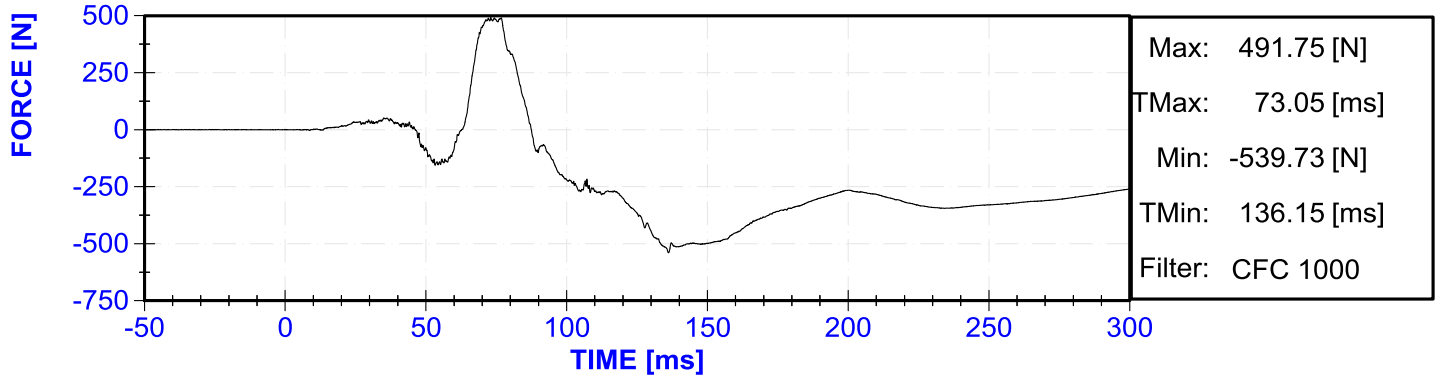

V2P1 Fy on head acting through the total neck section

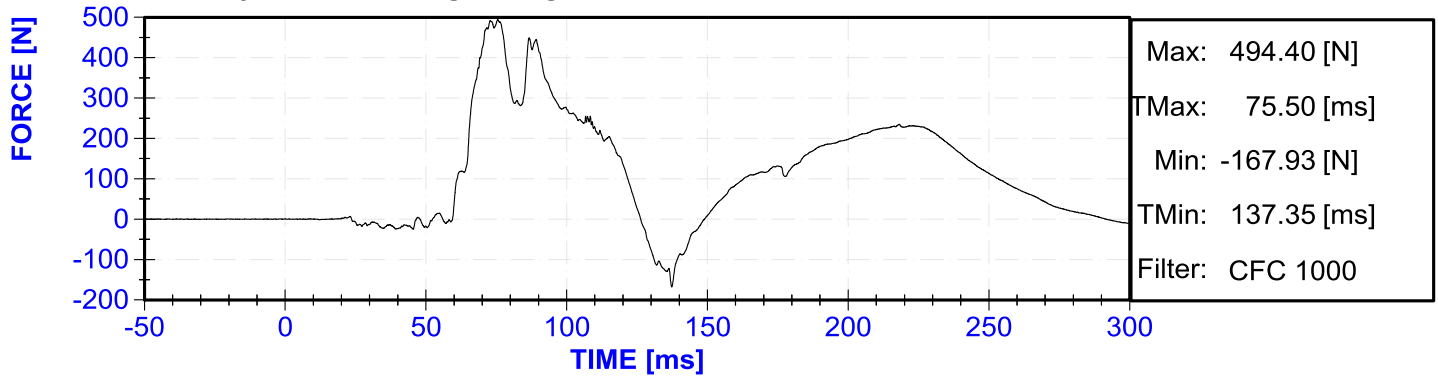

V2P1 Fz on head acting through the total neck section

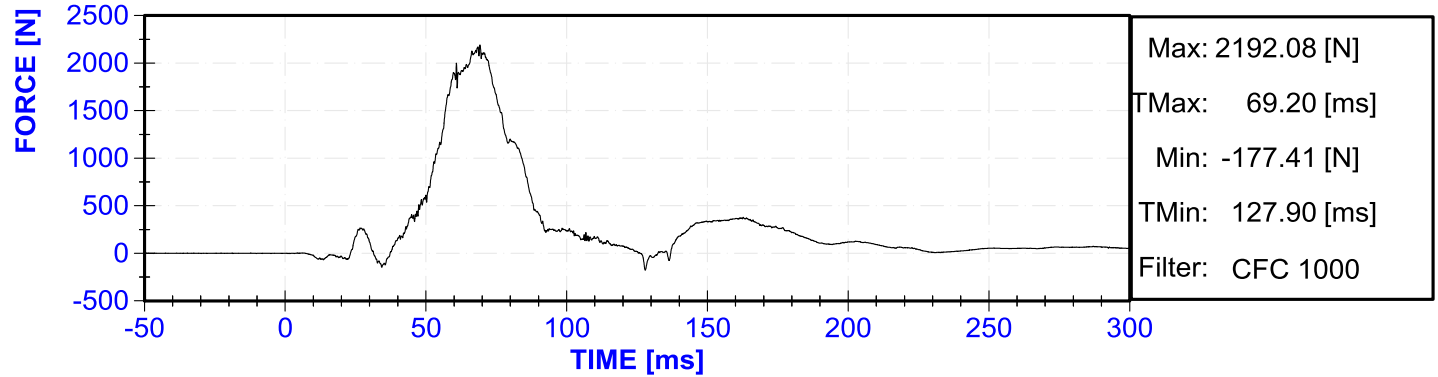

V2P1 Mx on head acting through the total neck section

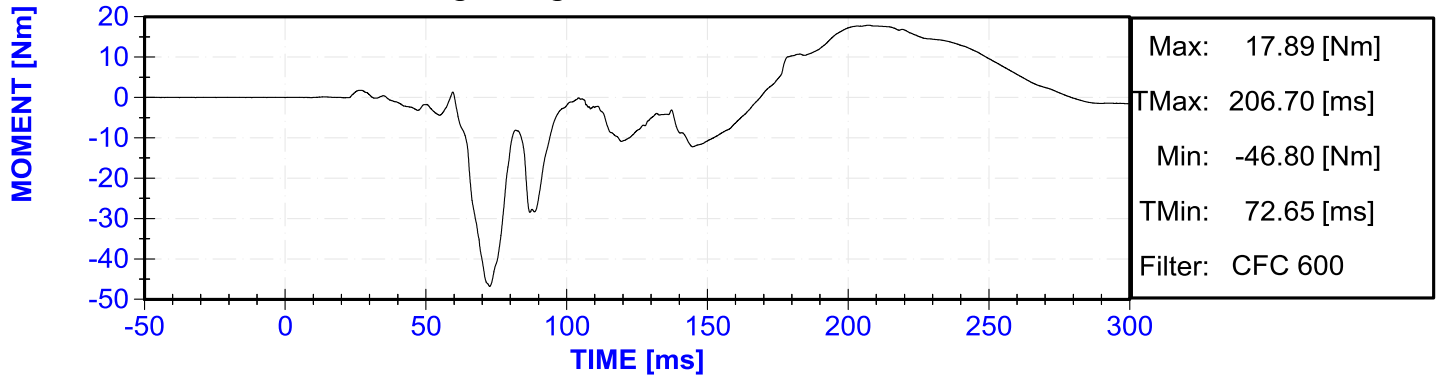

V2P1 My on head acting through the total neck section

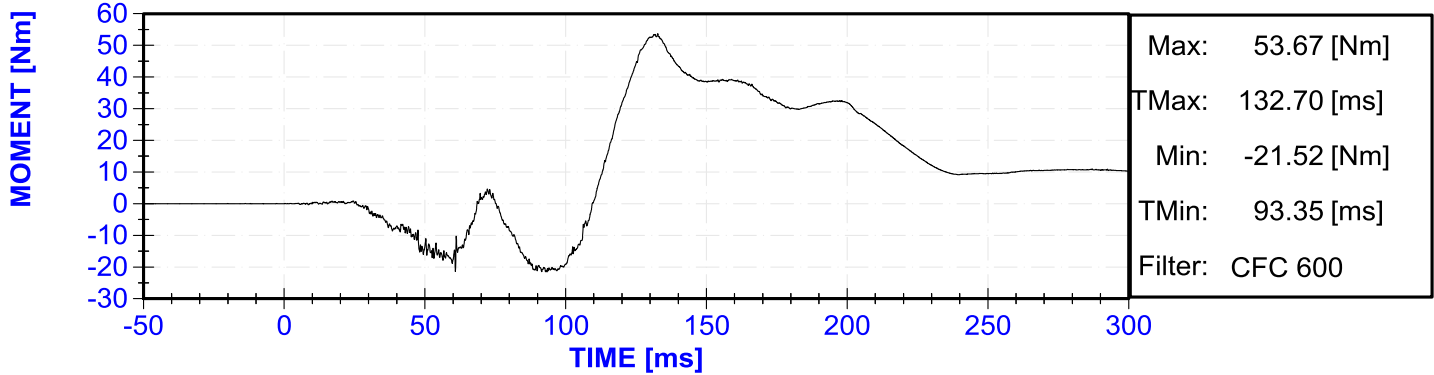

V2P1 Mz on head acting through the total neck section

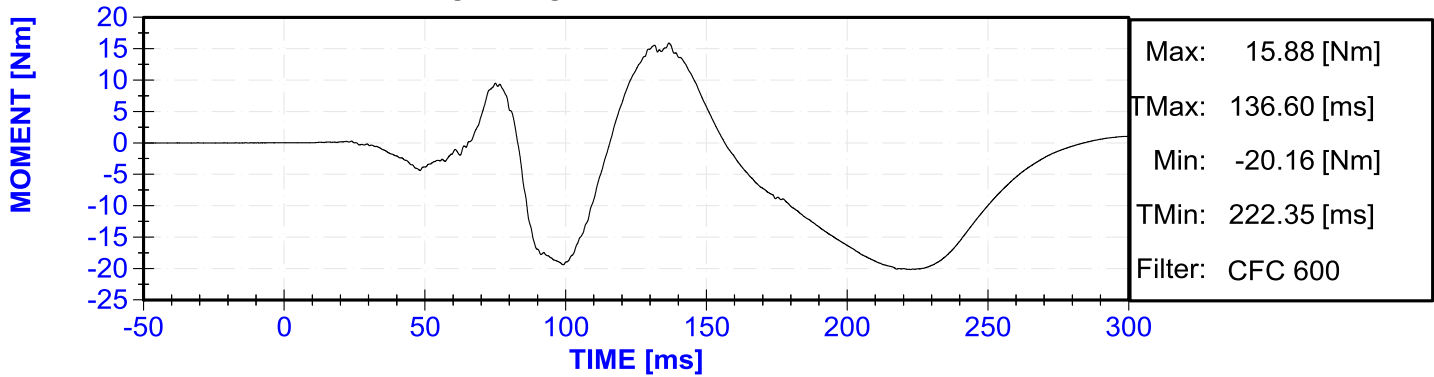

V2P1 Chest Left Upper Dx

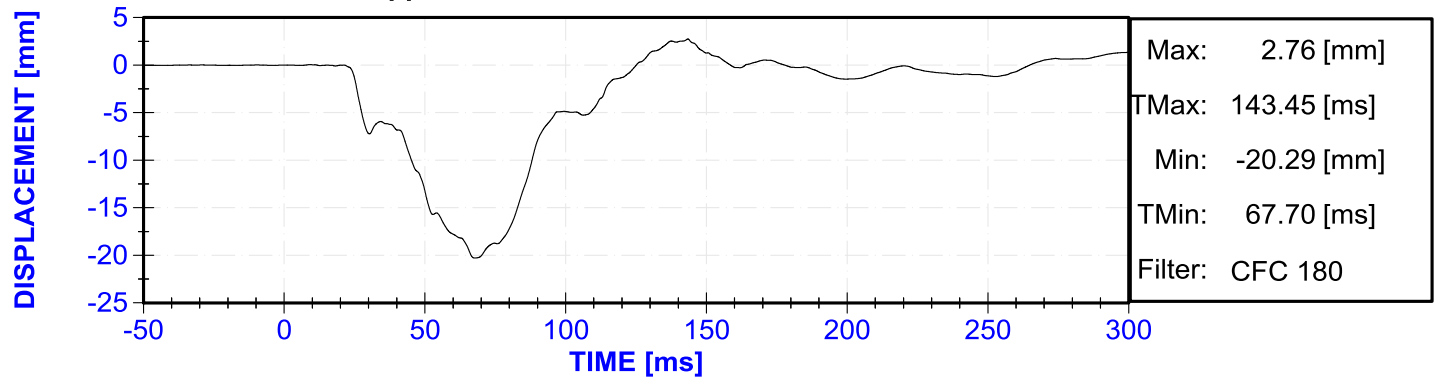

V2P1 Chest Left Upper Dy

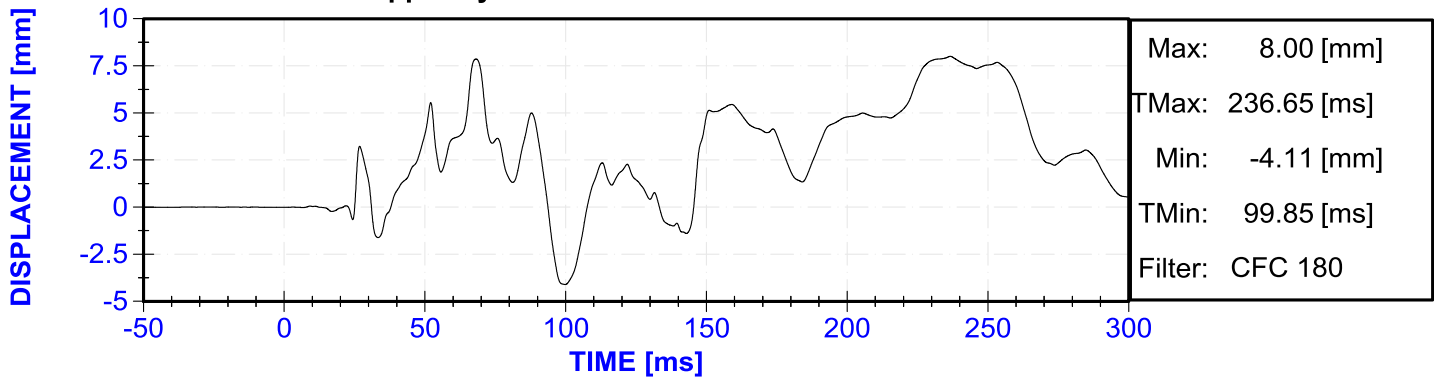

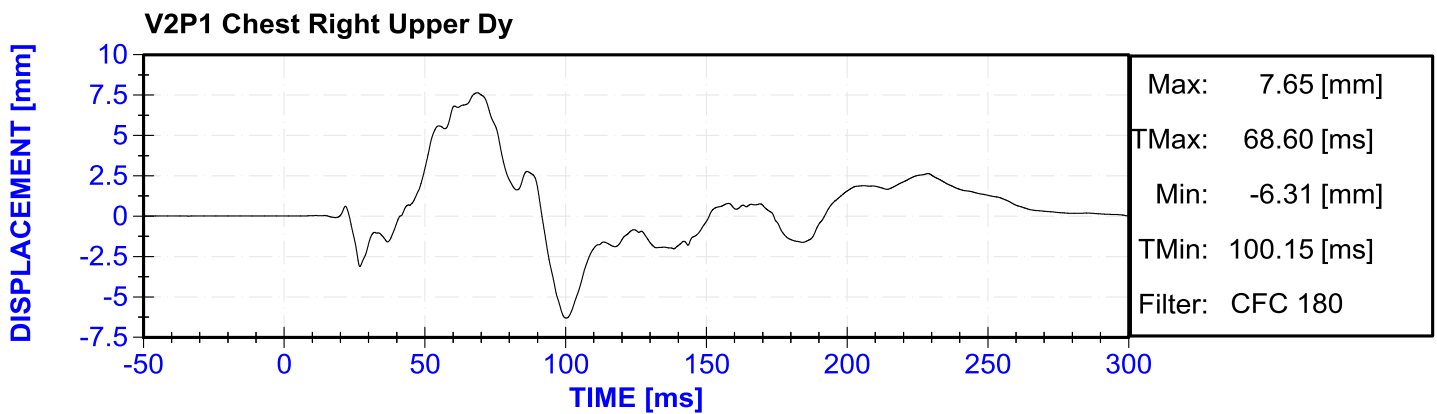
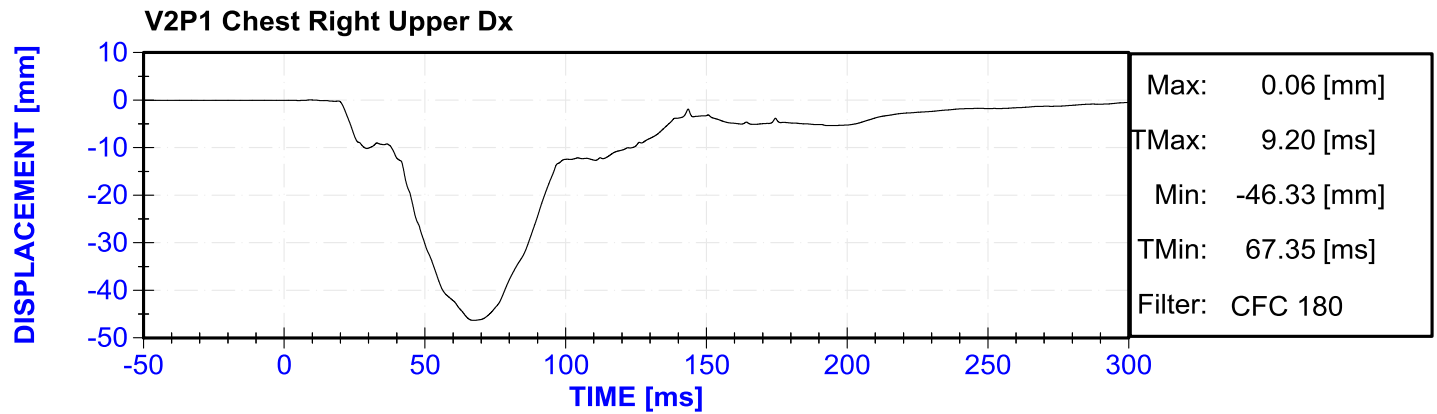
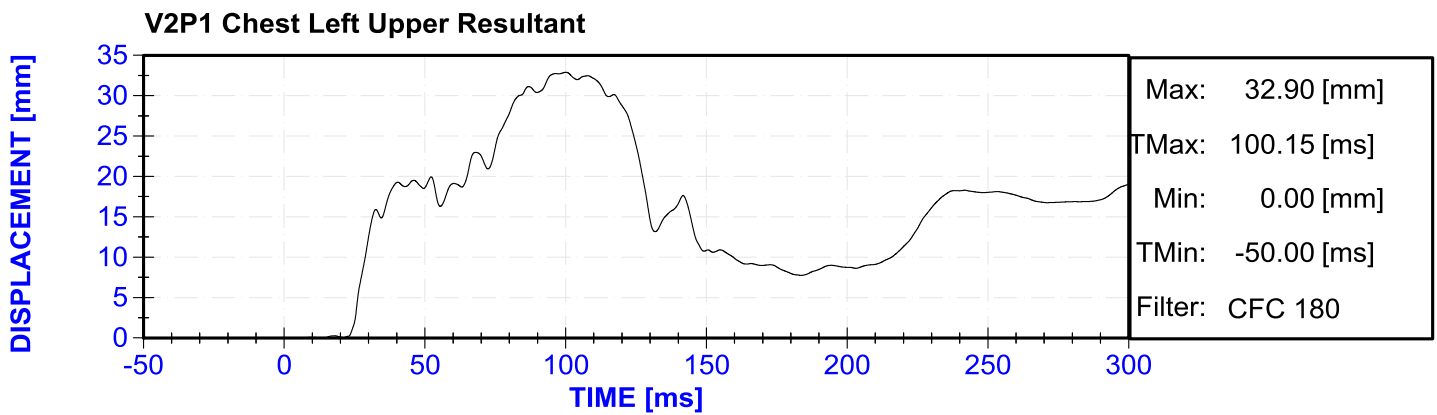
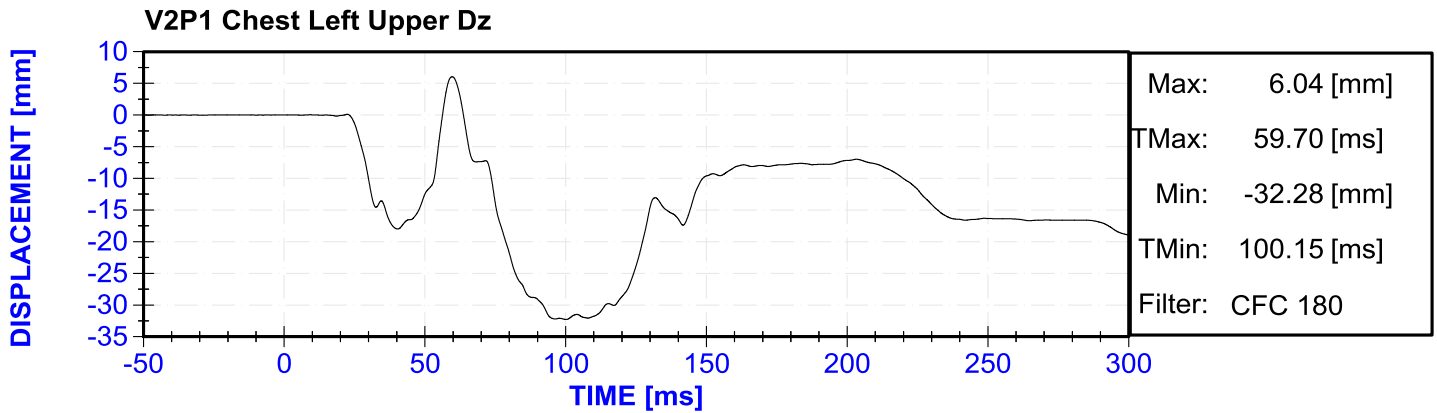

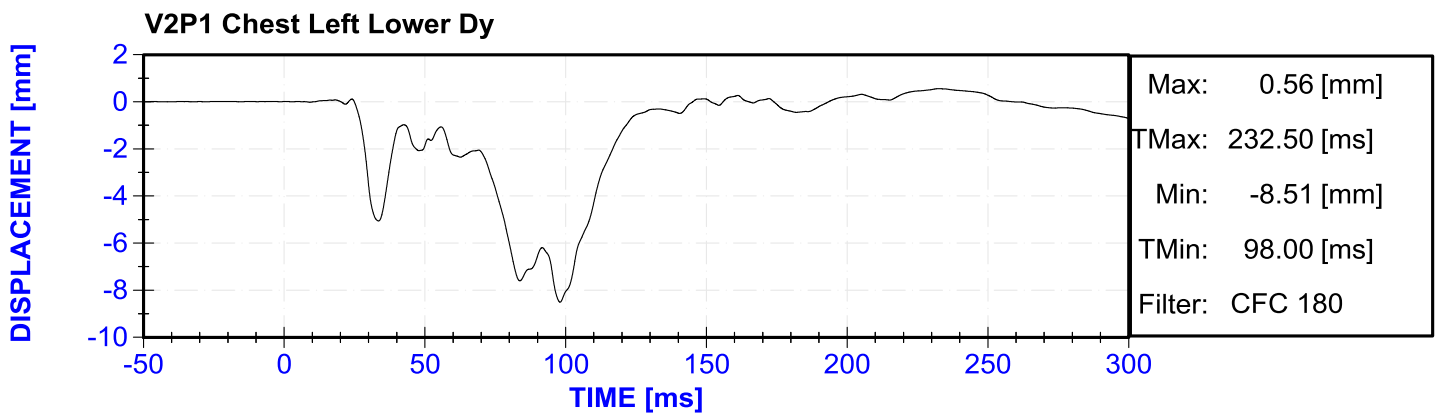
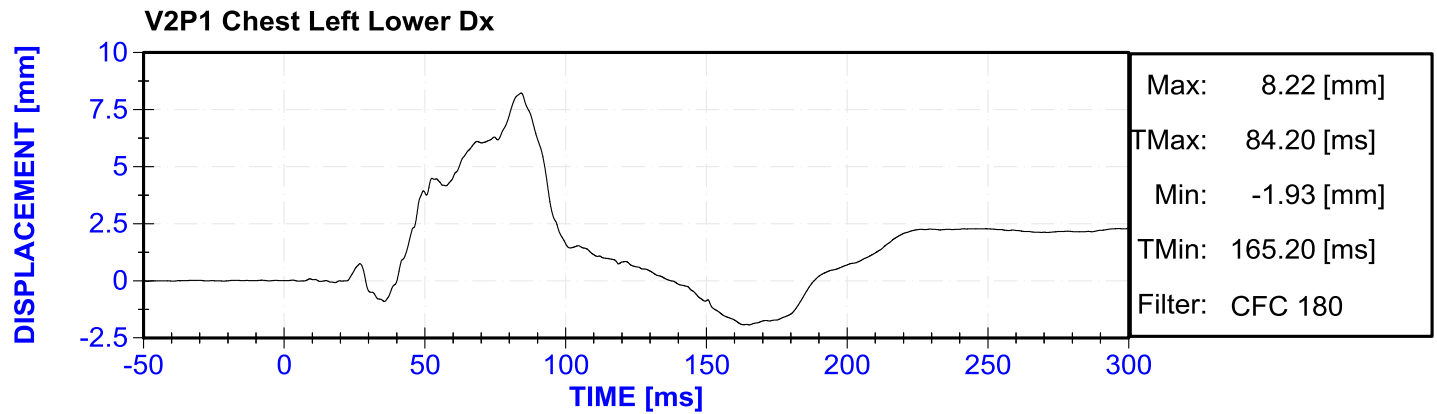
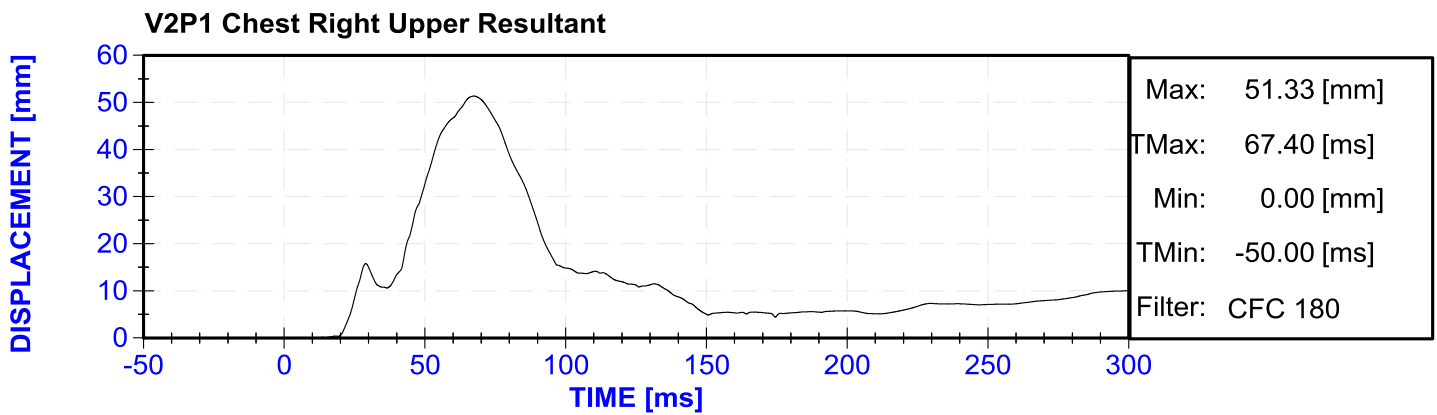
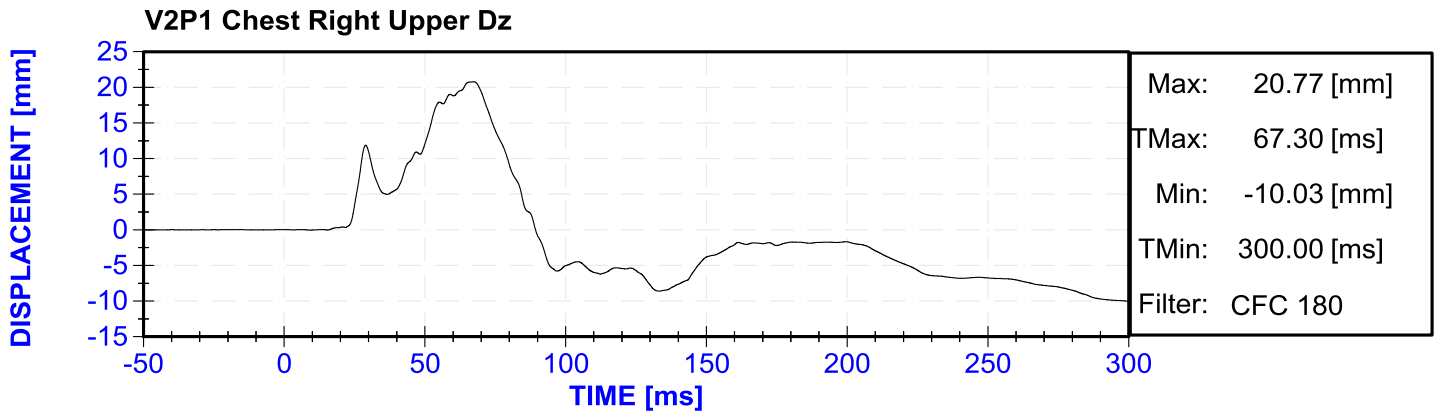

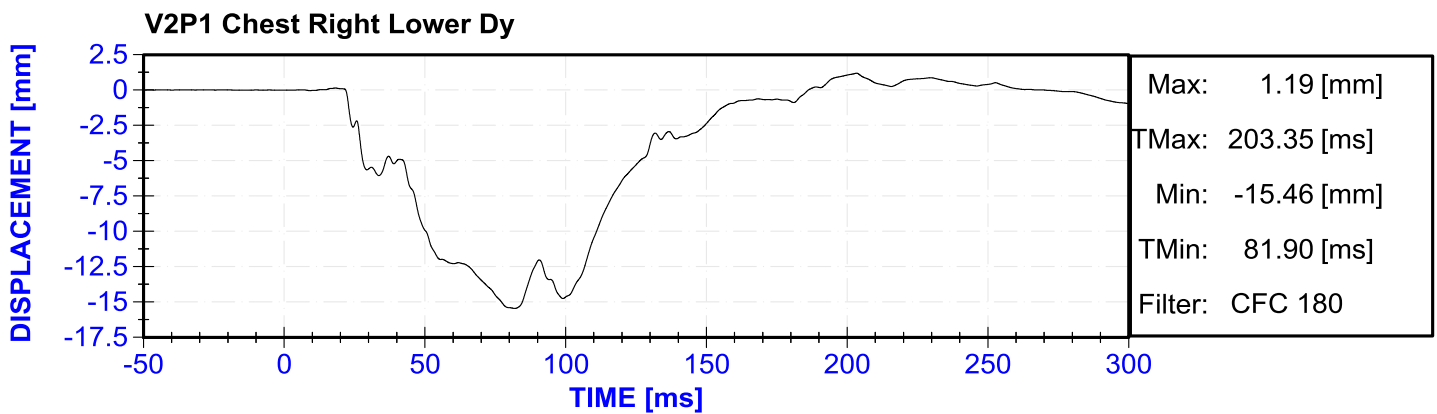
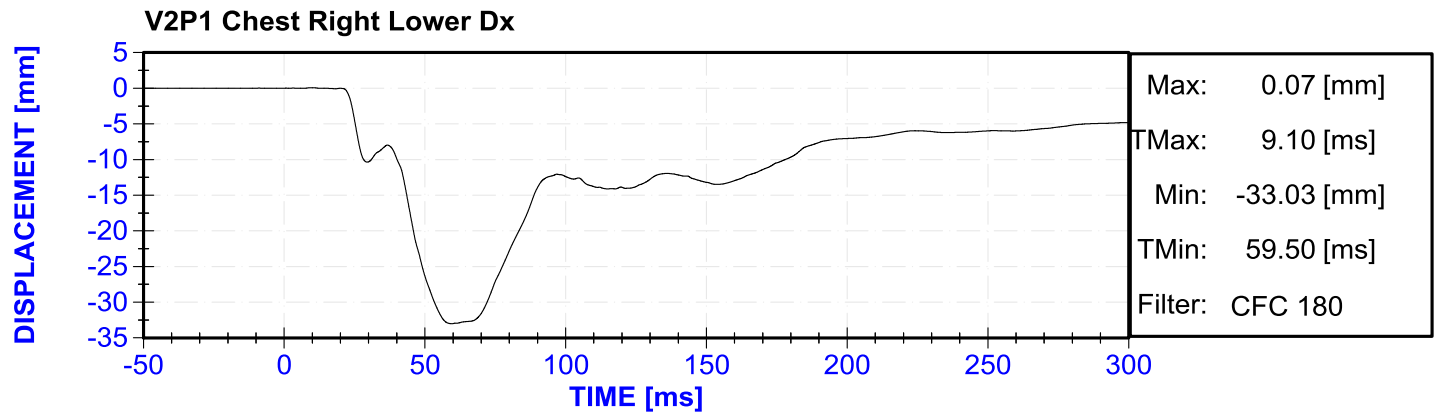
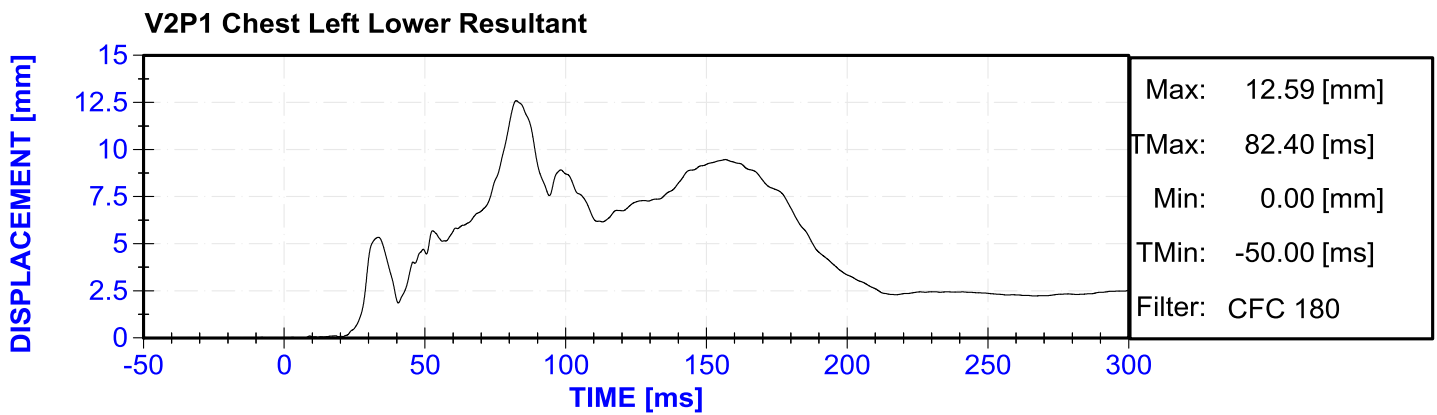
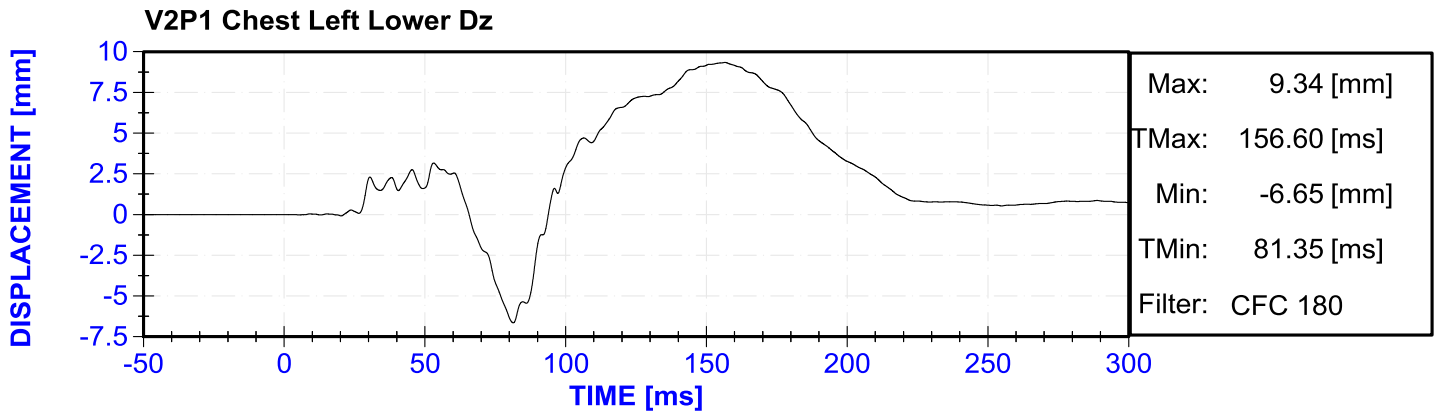

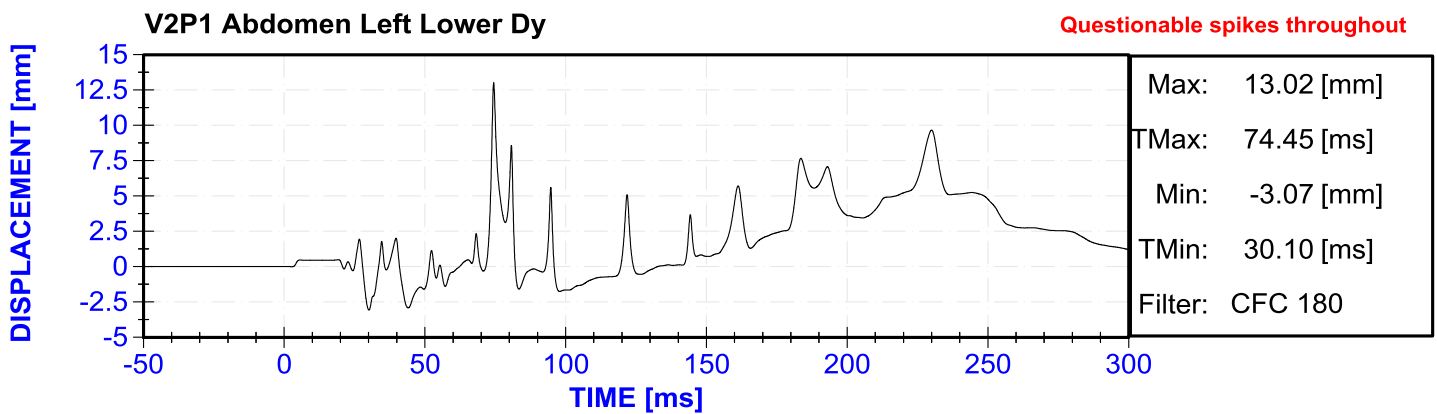
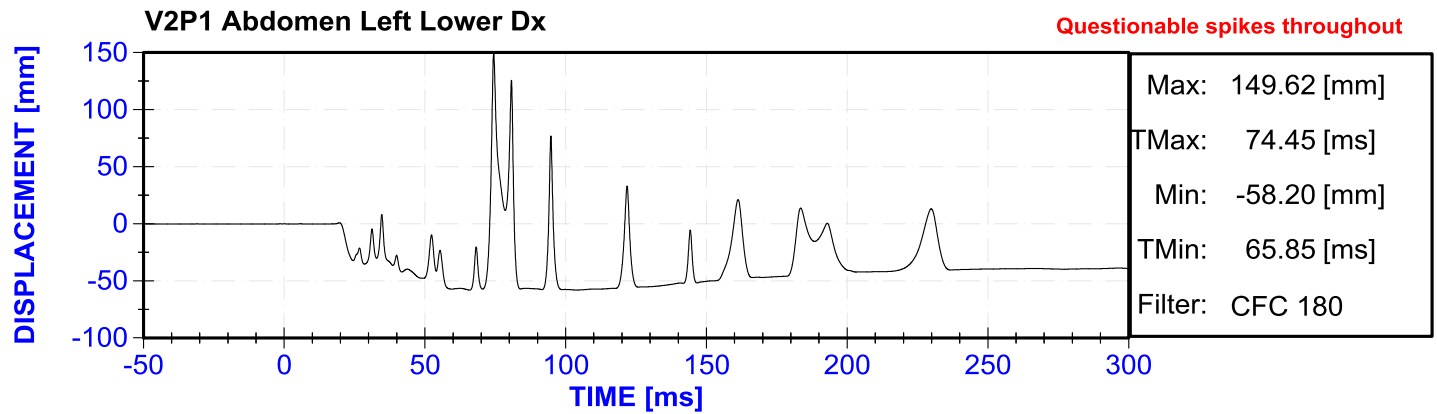
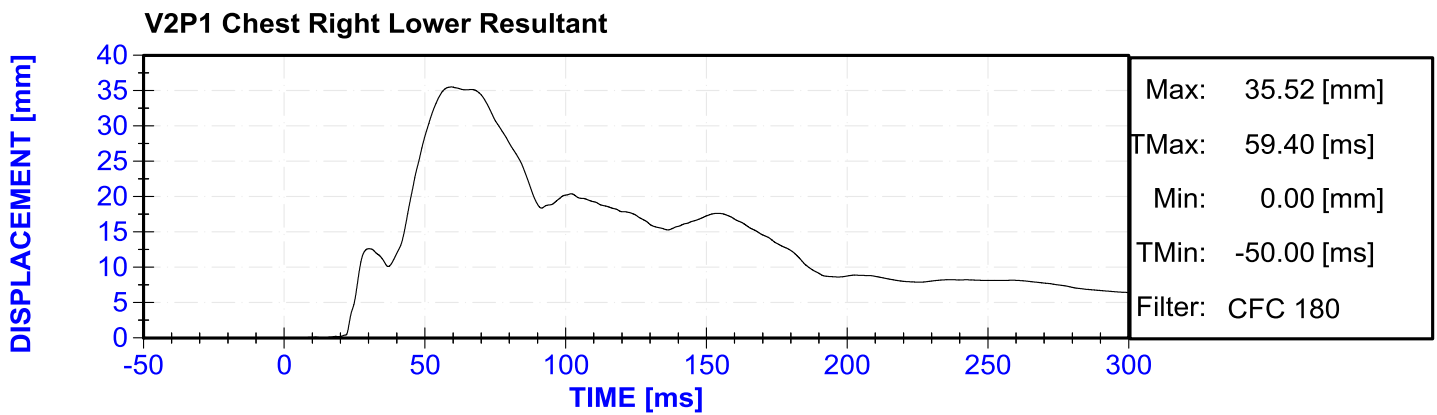
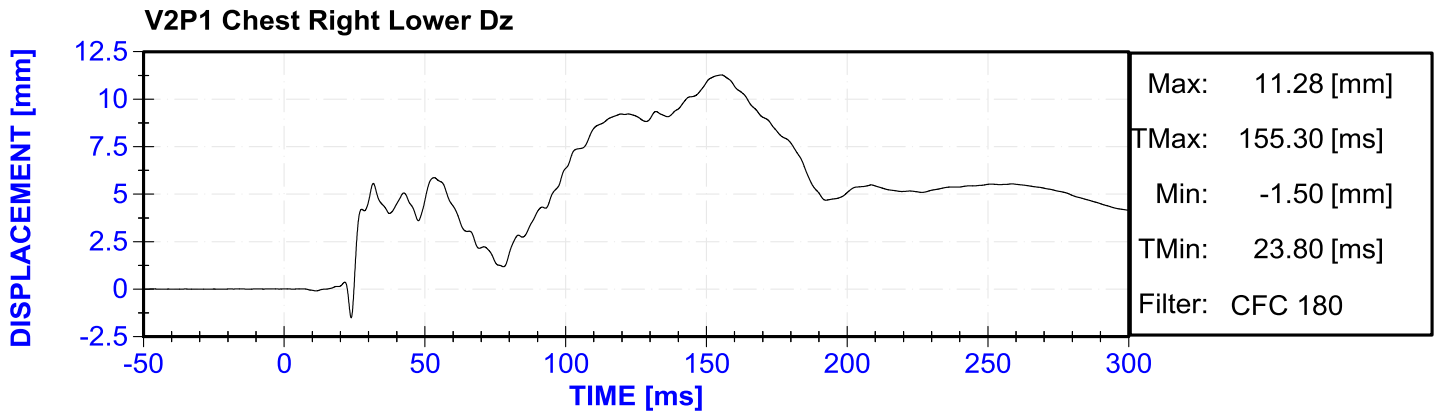

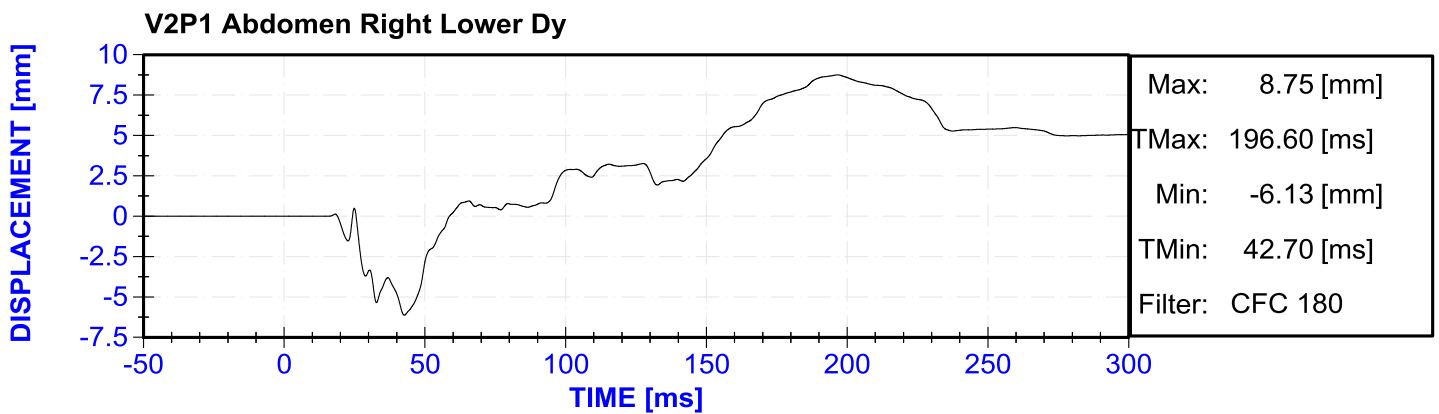
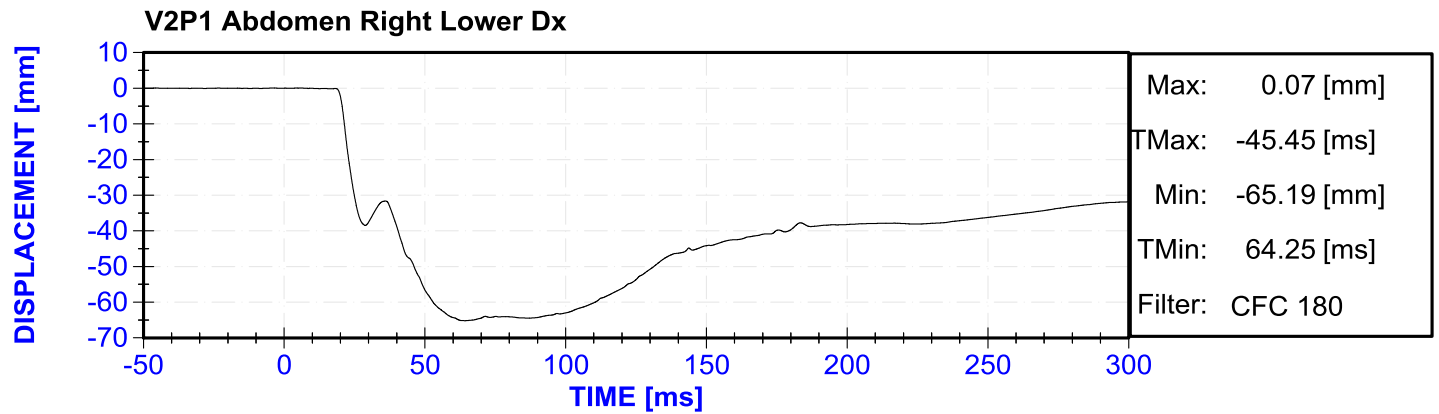
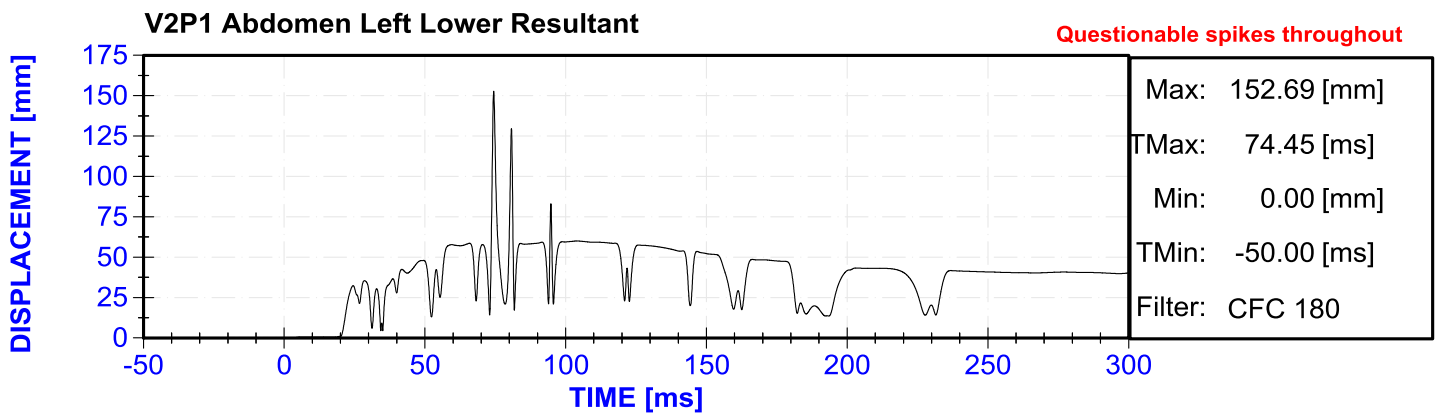
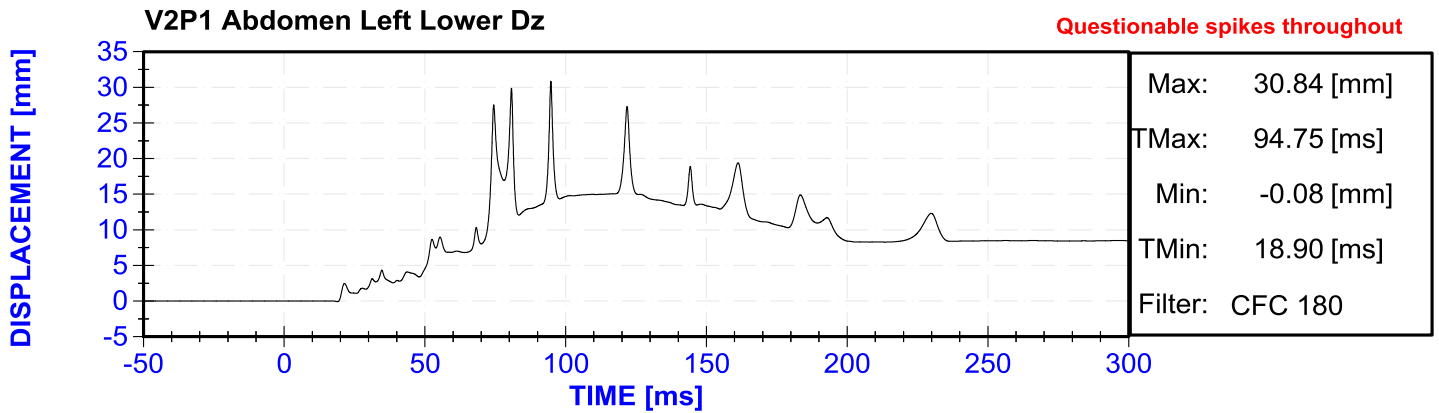

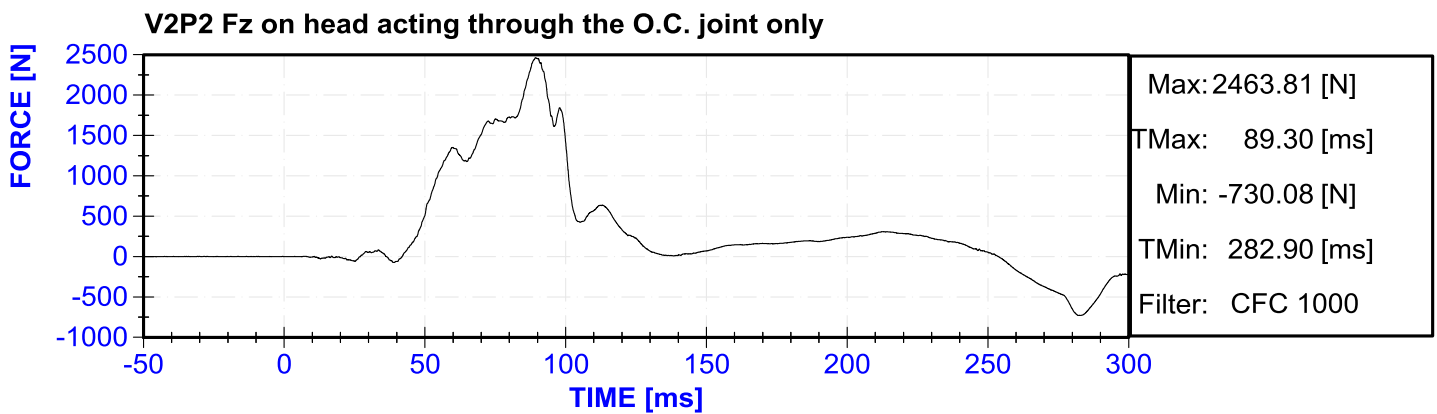
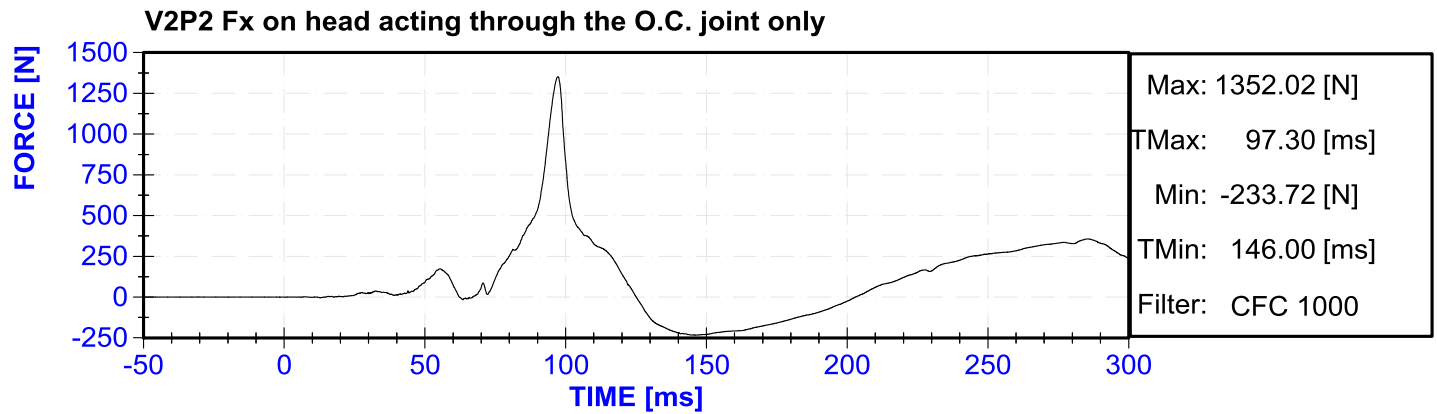
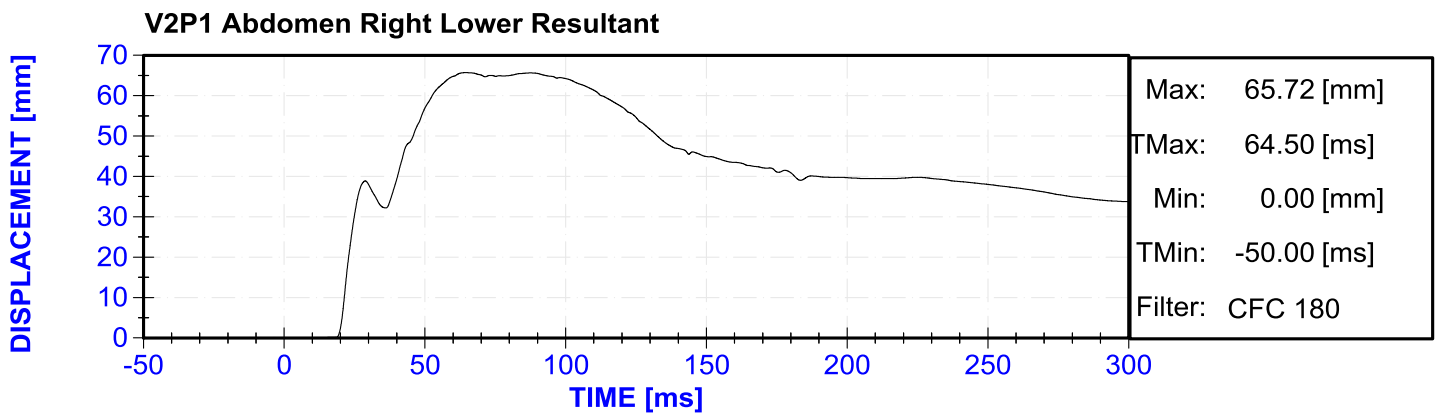
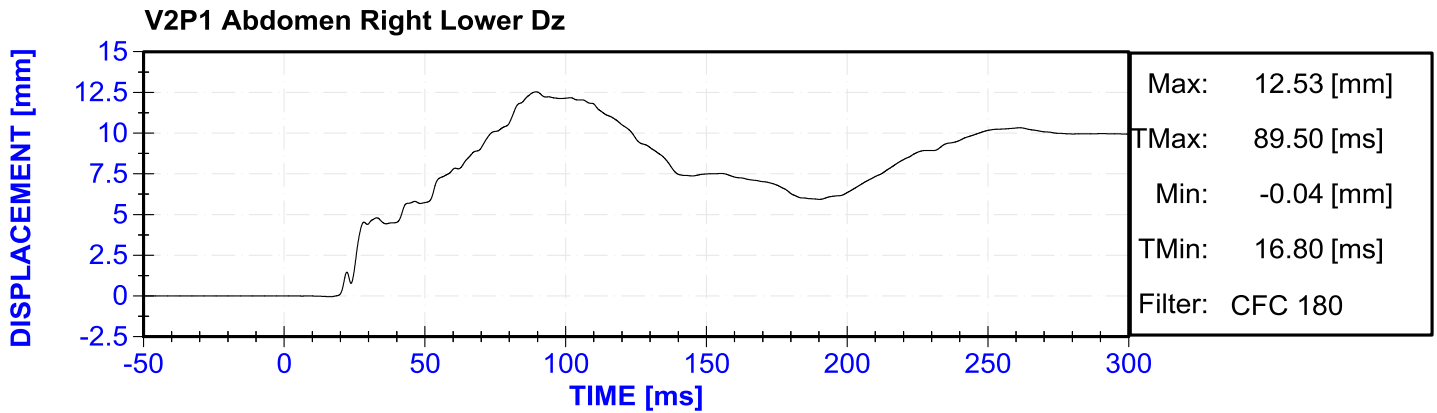

V2P2 My on head acting through the O.C. joint only

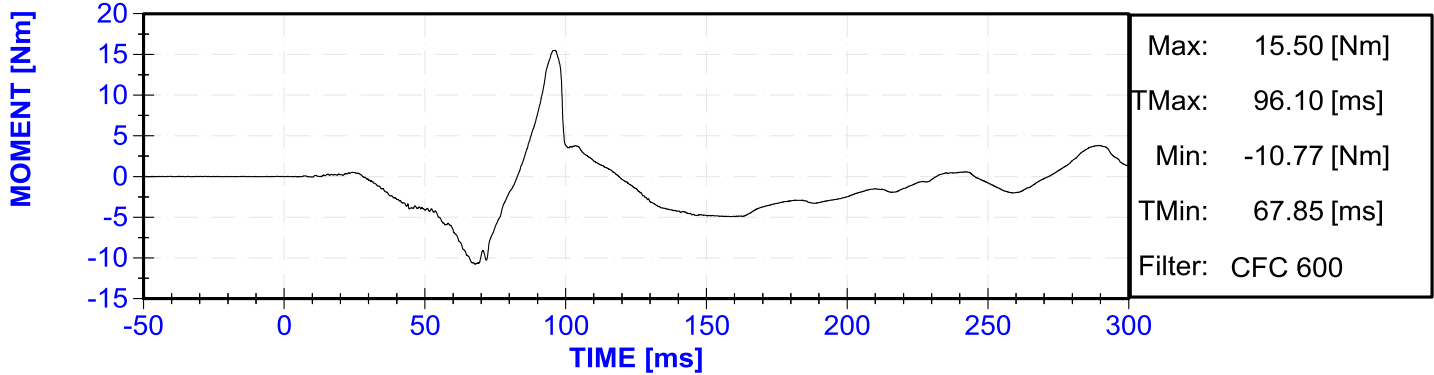

V2P2 Fx on head acting through the total neck section

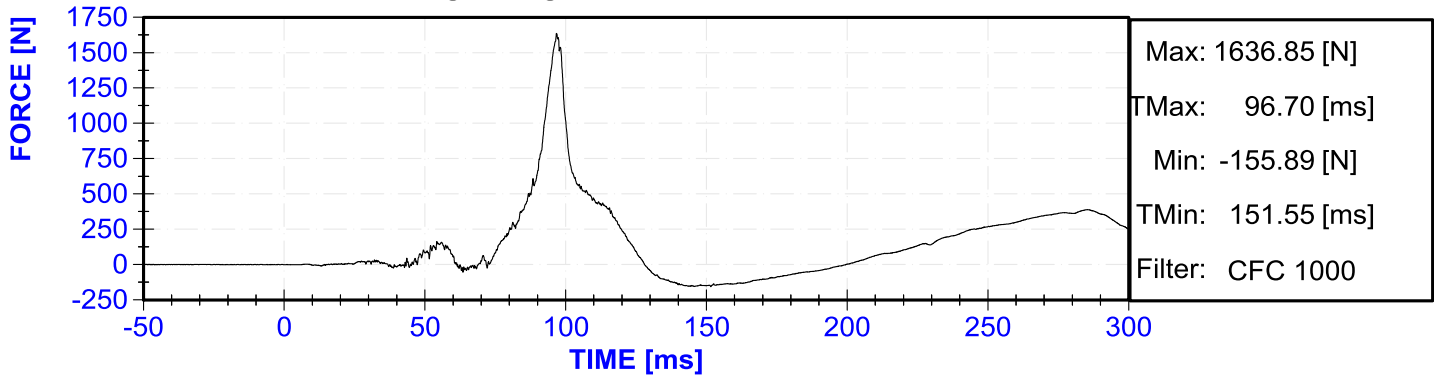

V2P2 Fy on head acting through the total neck section

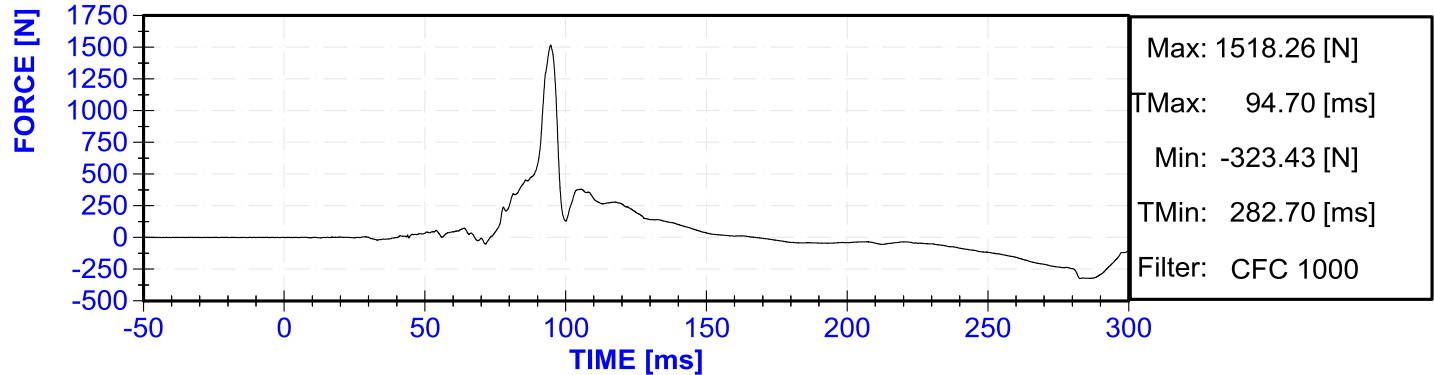

V2P2 Fz on head acting through the total neck section

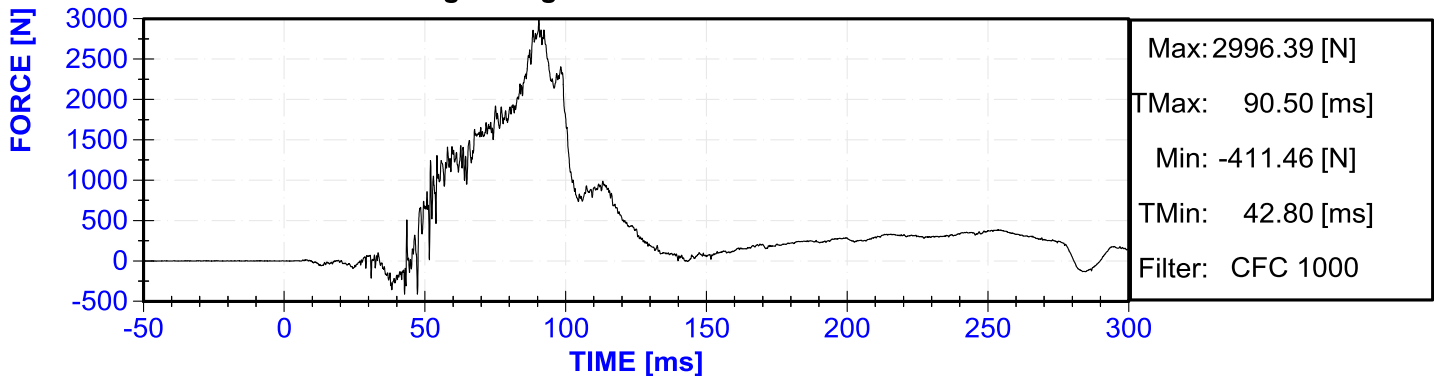

V2P2 Mx on head acting through the total neck section

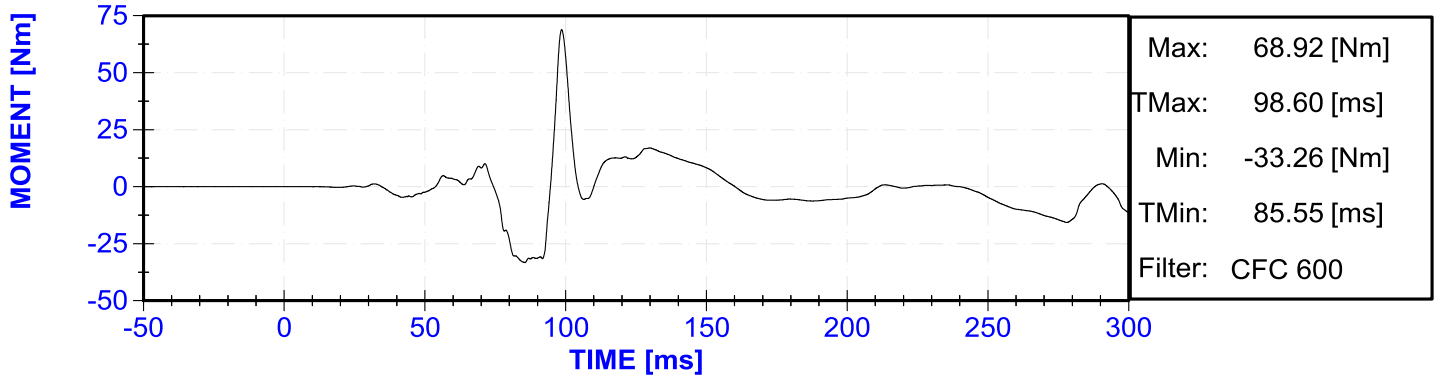

V2P2 My on head acting through the total neck section

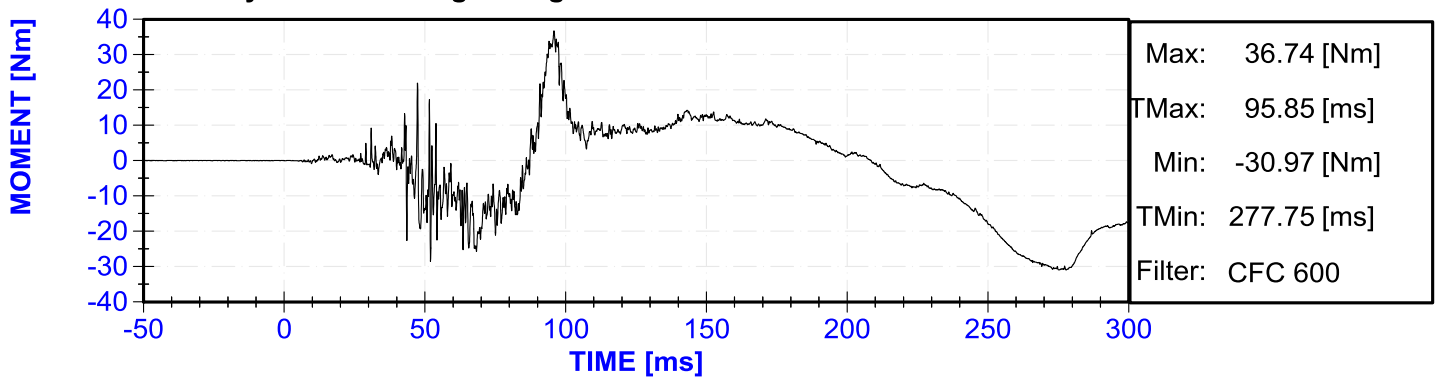

V2P2 Mz on head acting through the total neck section

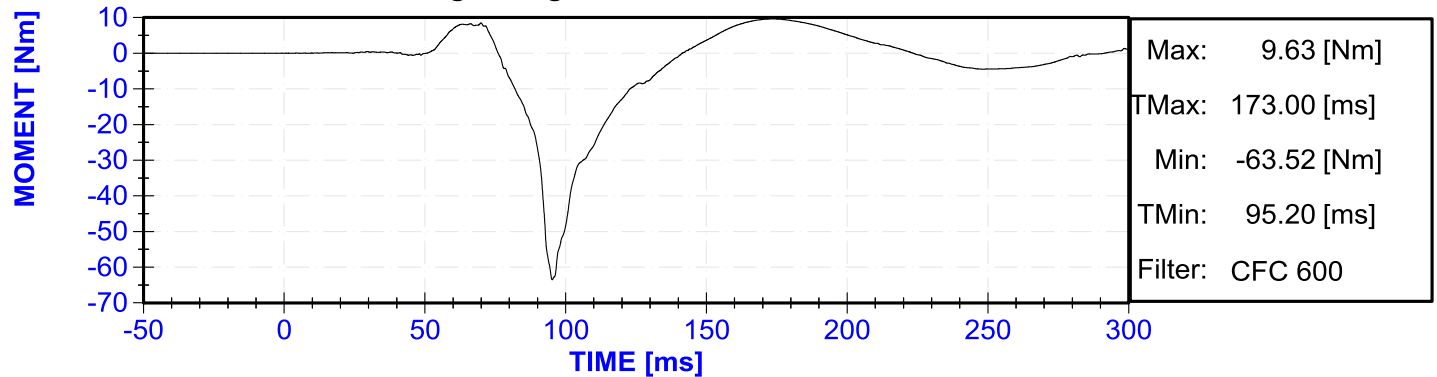

V2P2 Chest Left Upper Dx

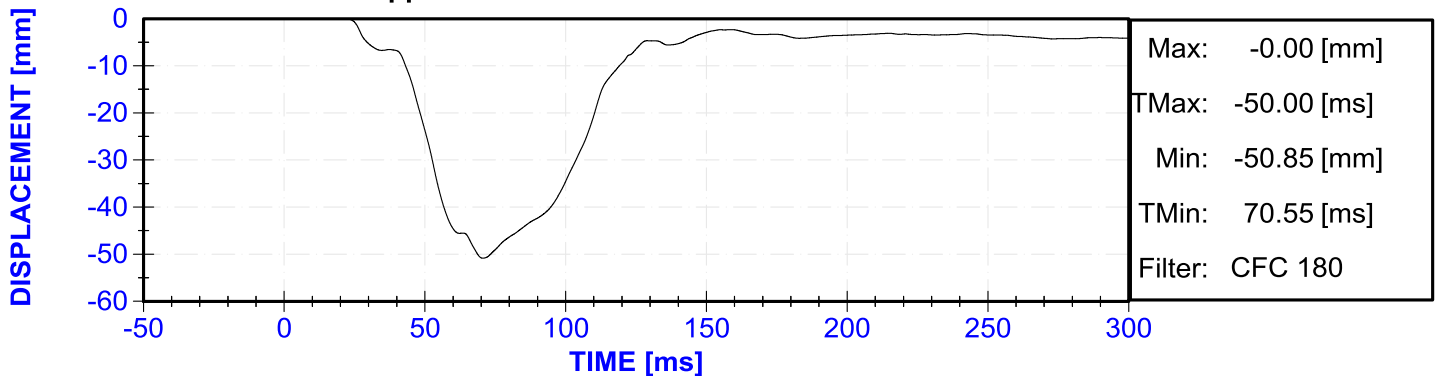

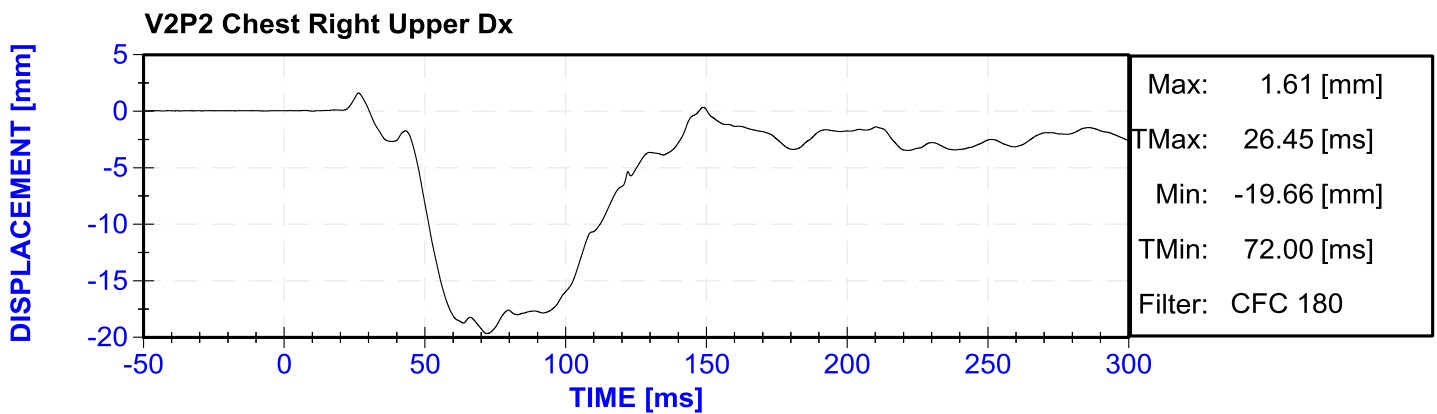
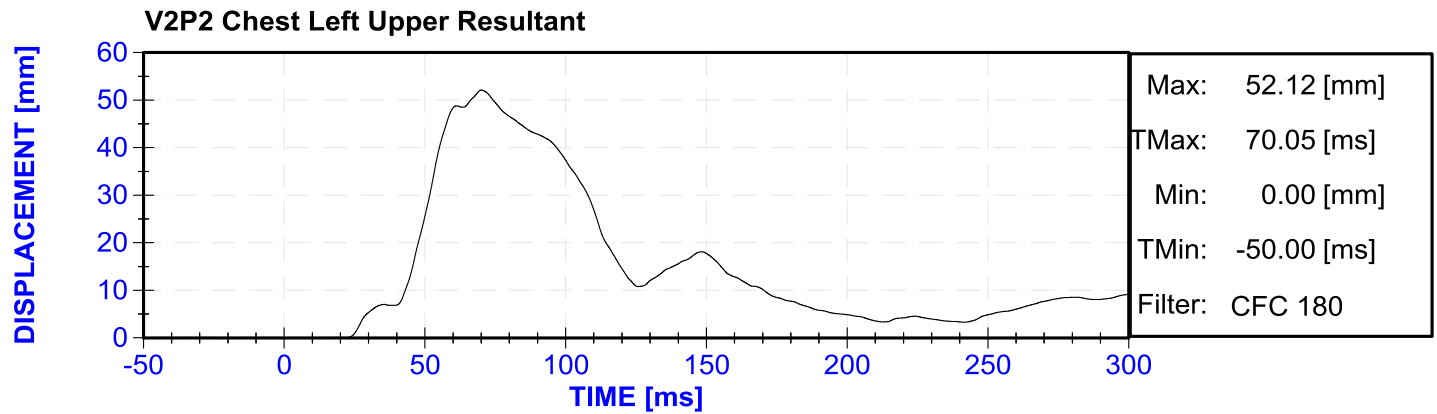
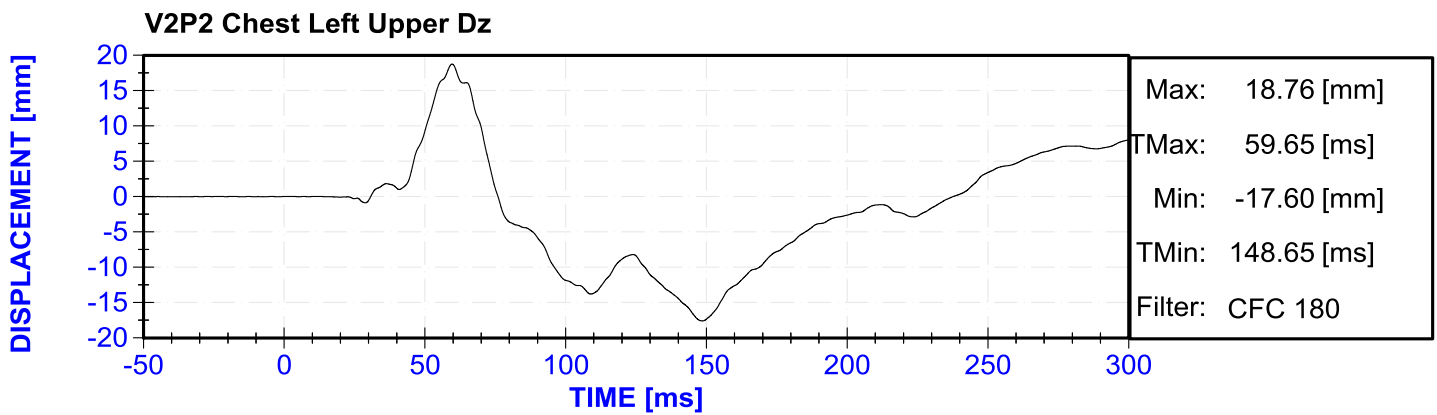
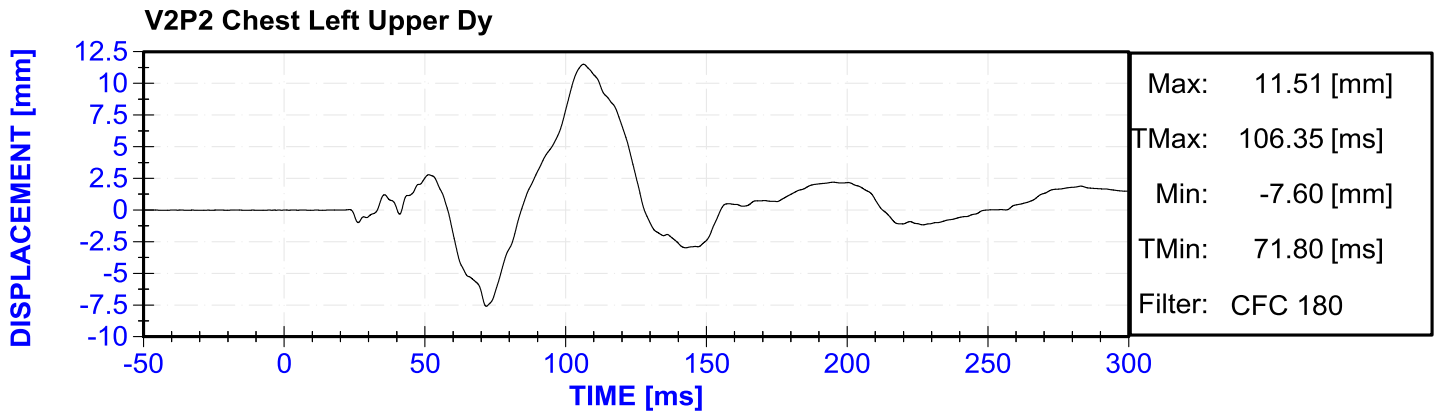

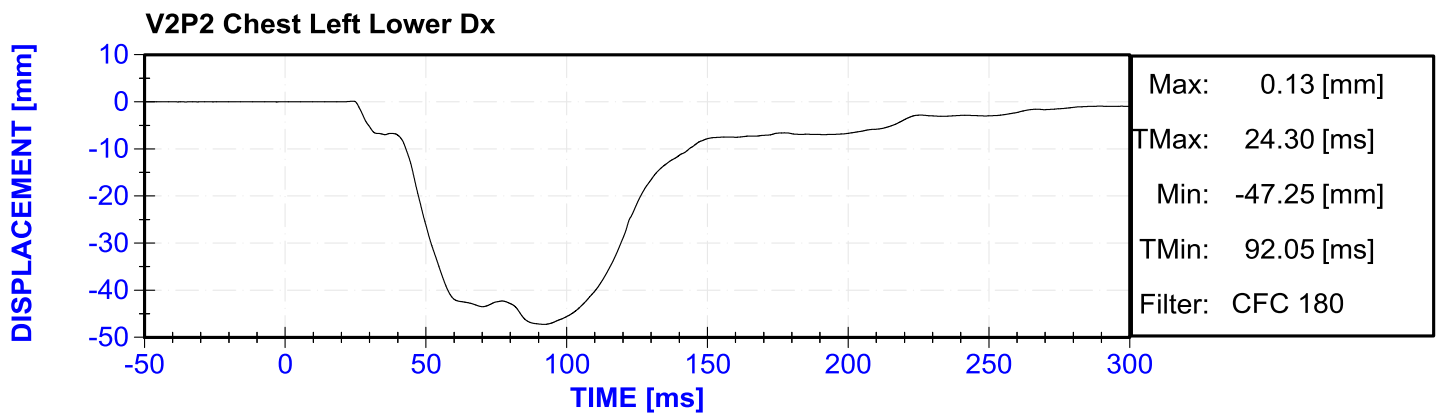
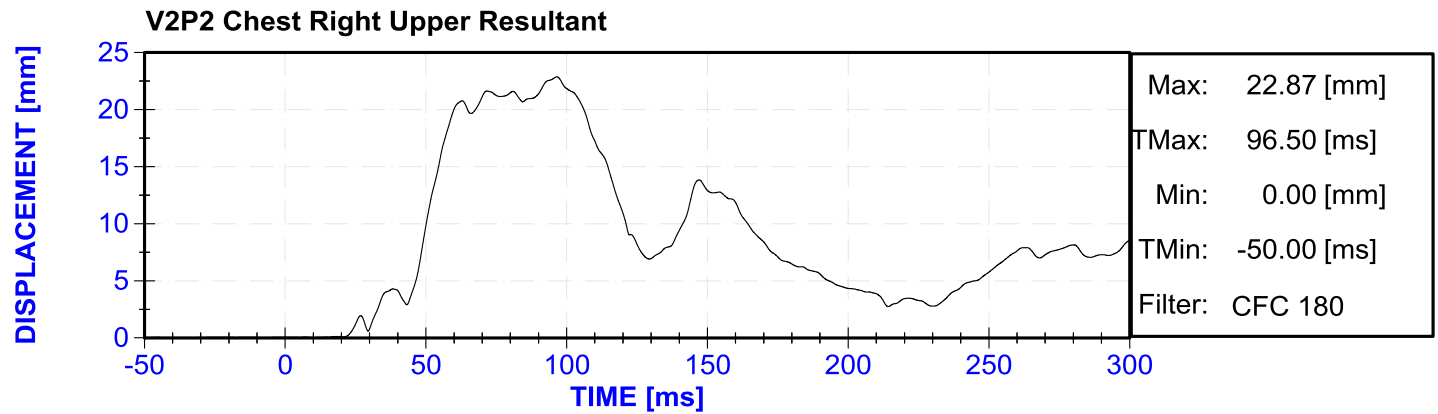
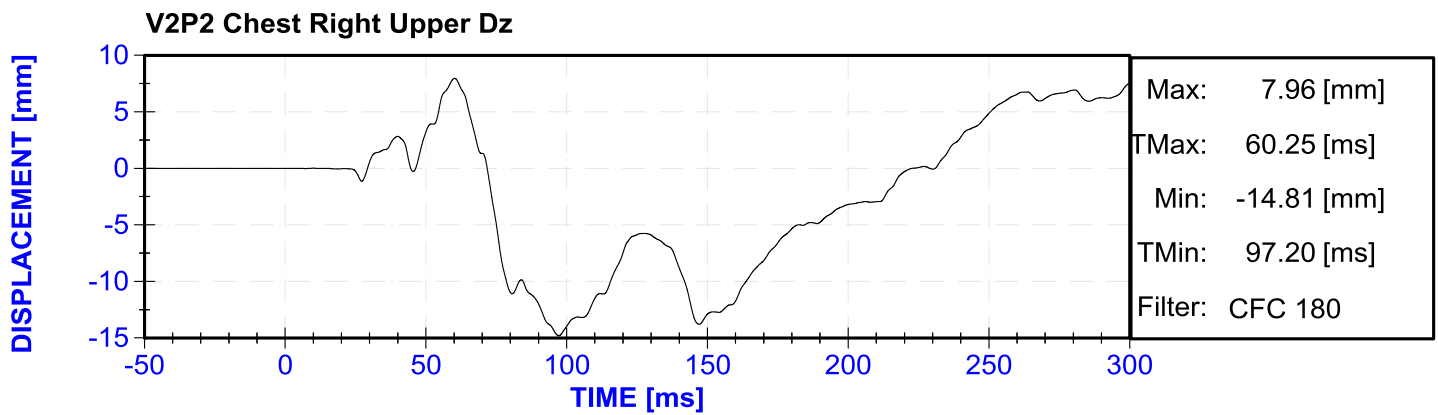
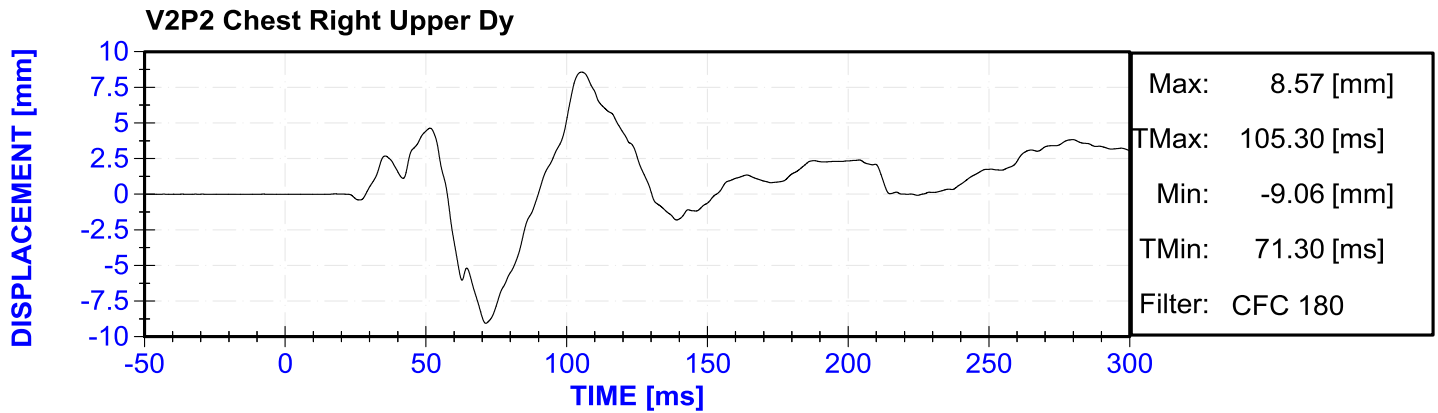

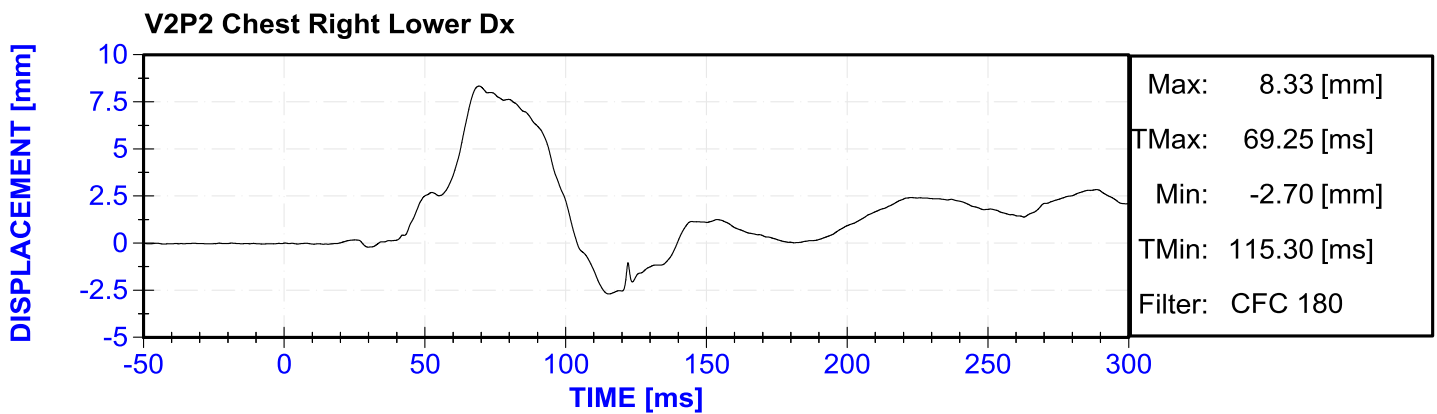
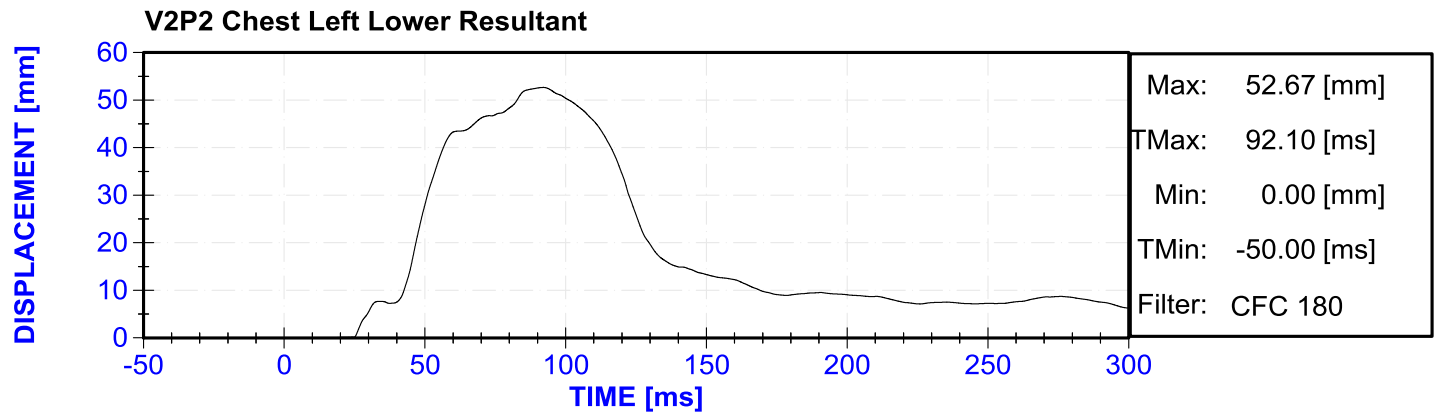
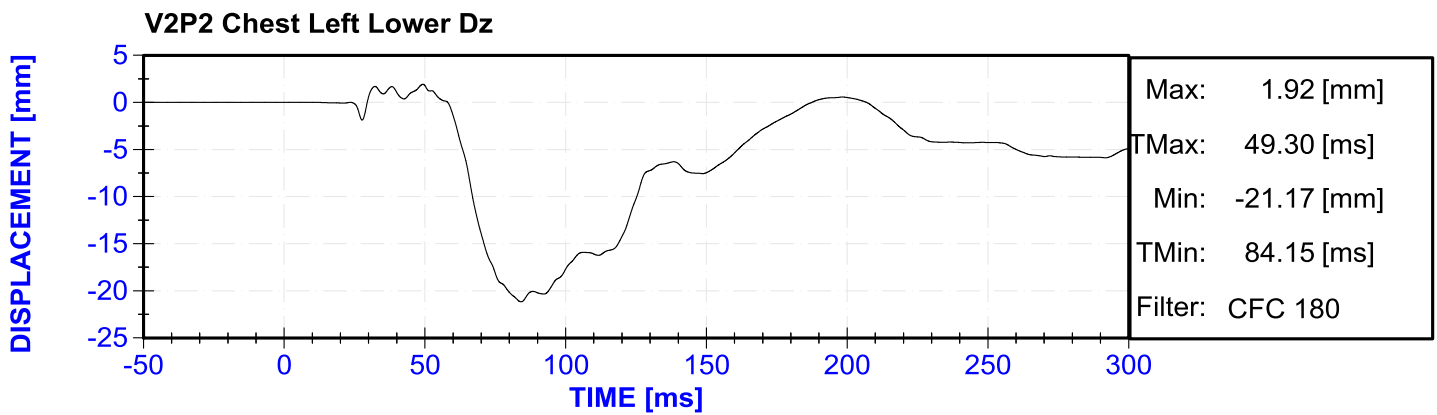
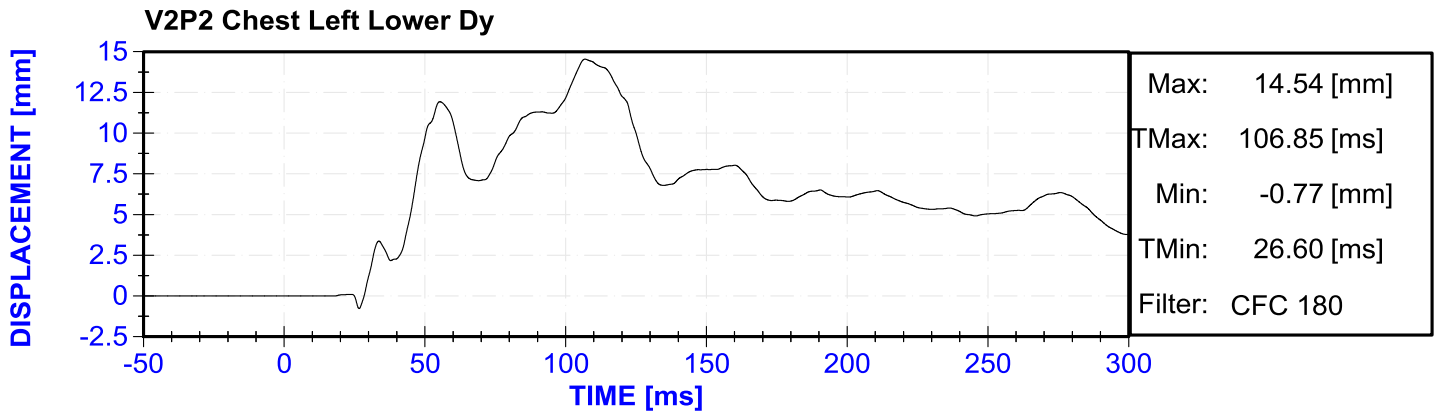

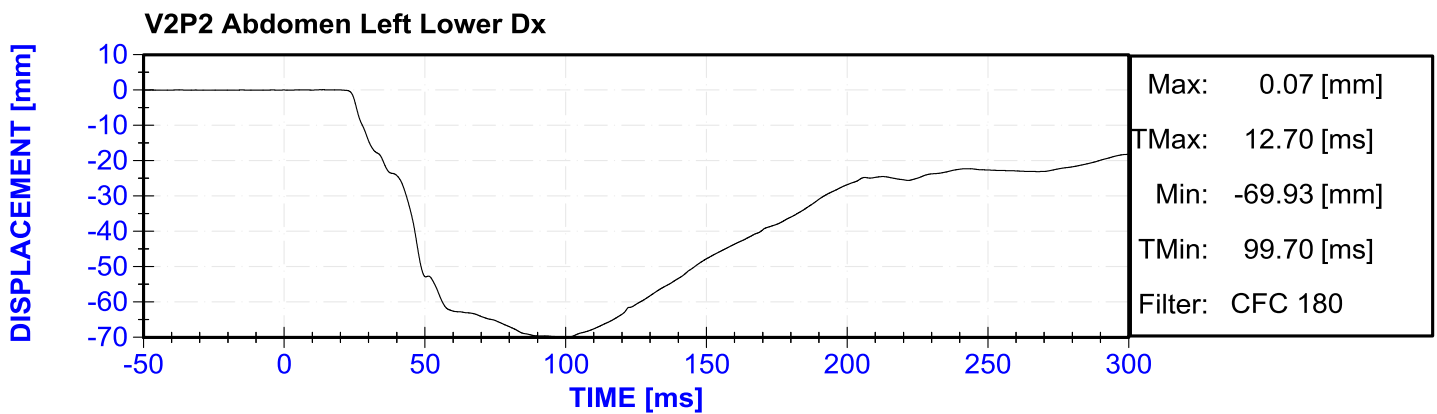
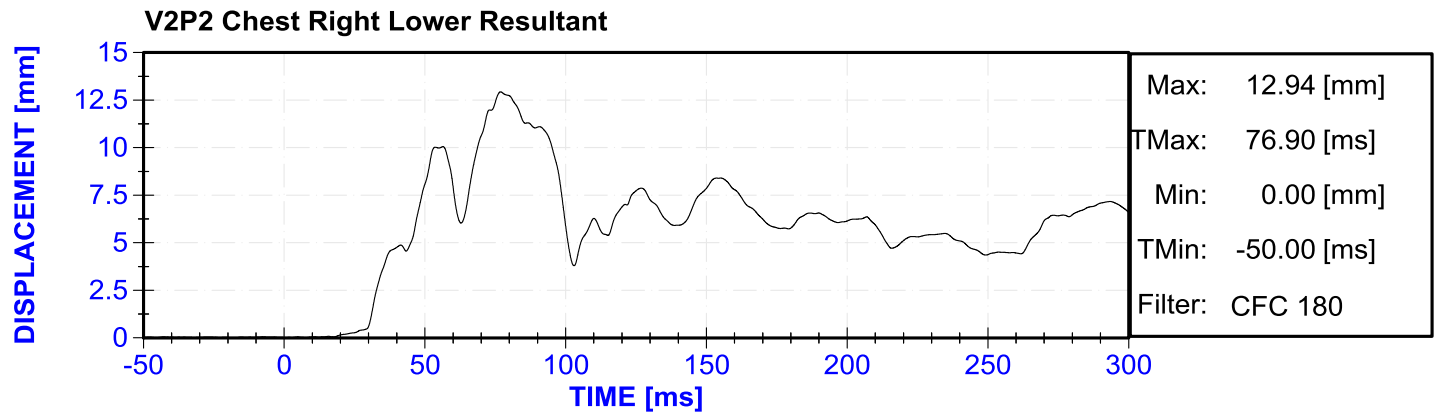
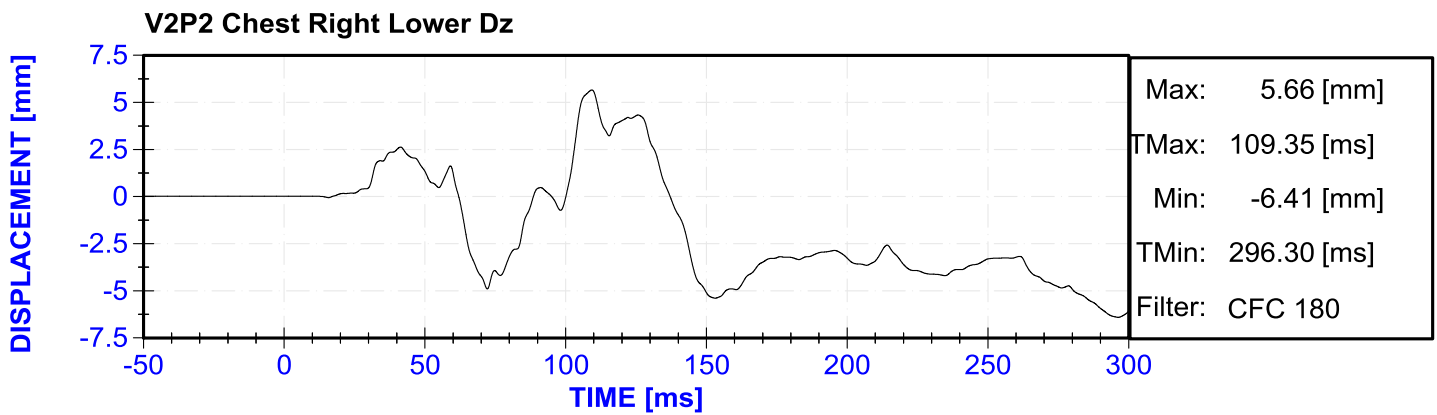
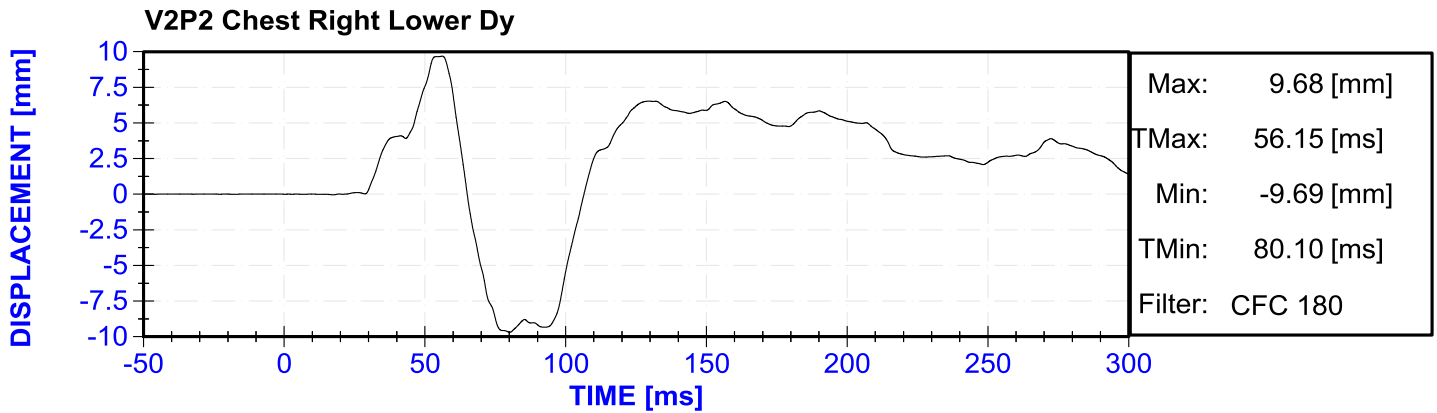

V2P2 Abdomen Left Lower Dy

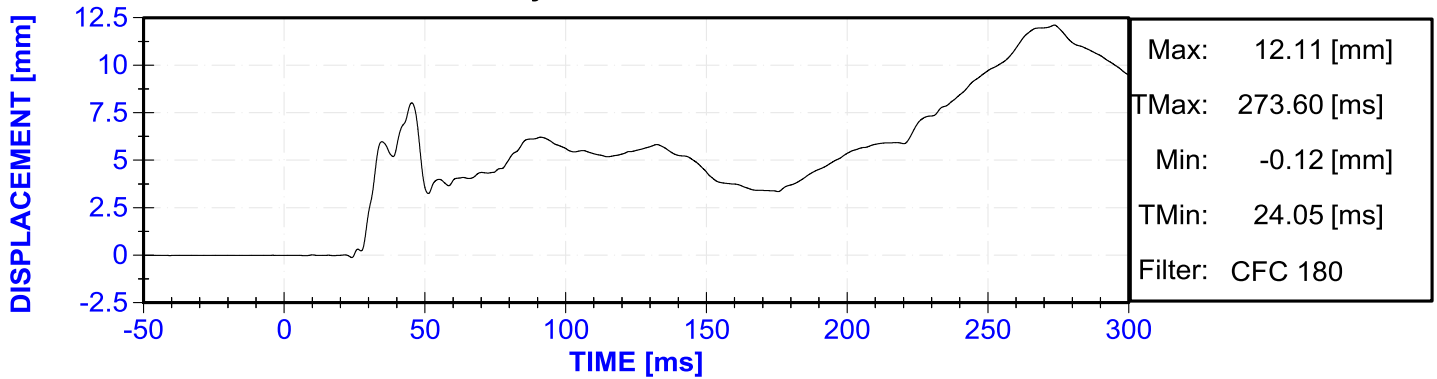

V2P2 Abdomen Left Lower Dz

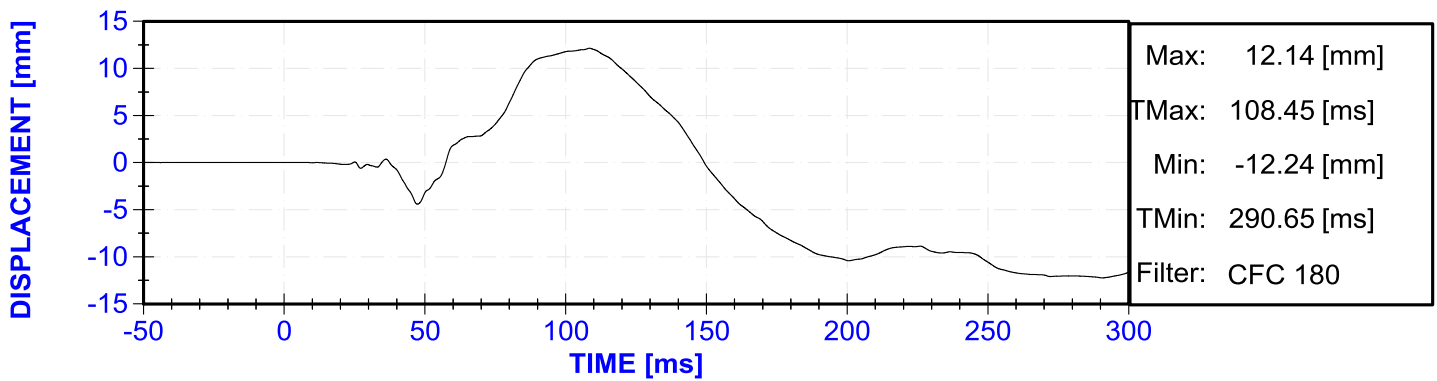

V2P2 Abdomen Left Lower Resultant

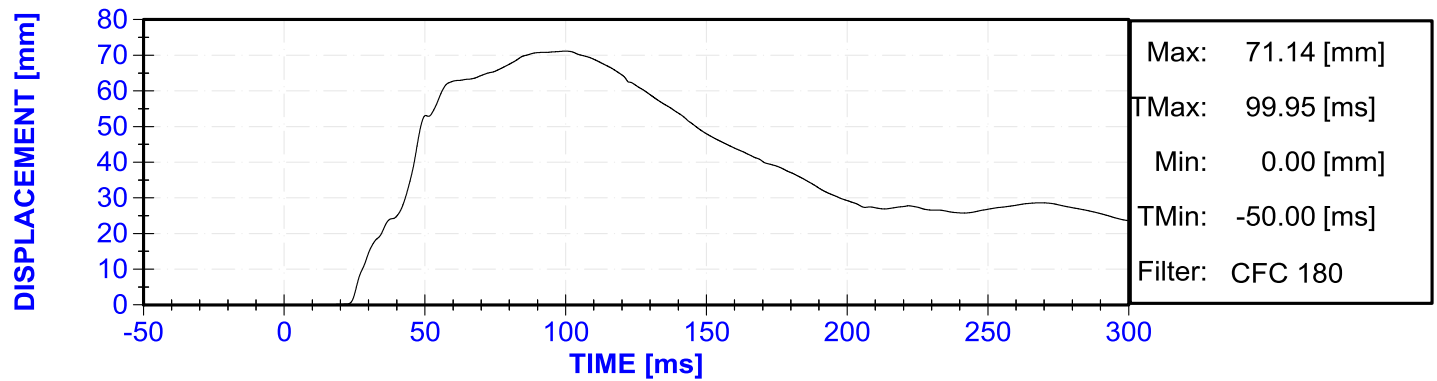

V2P2 Abdomen Right Lower Dx

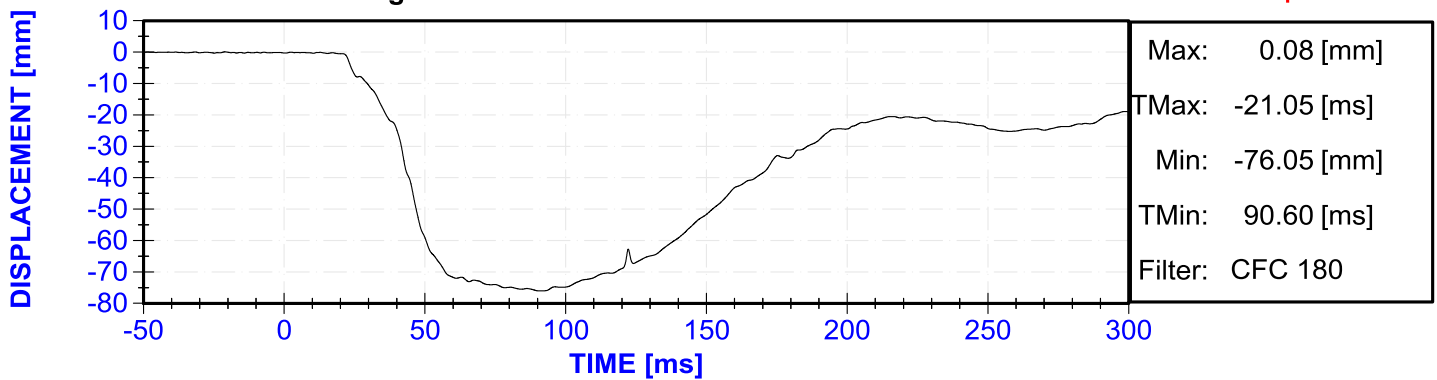

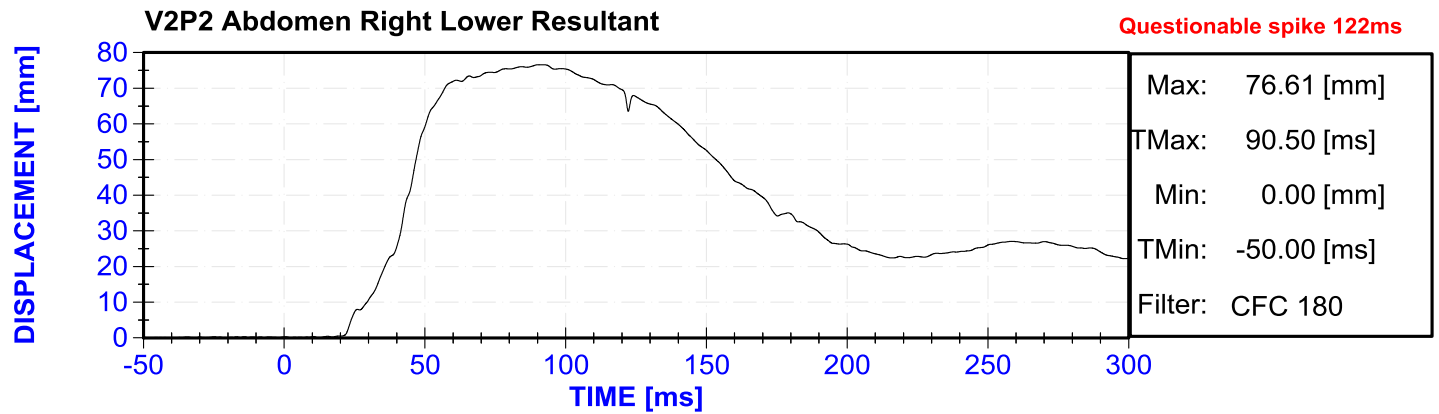
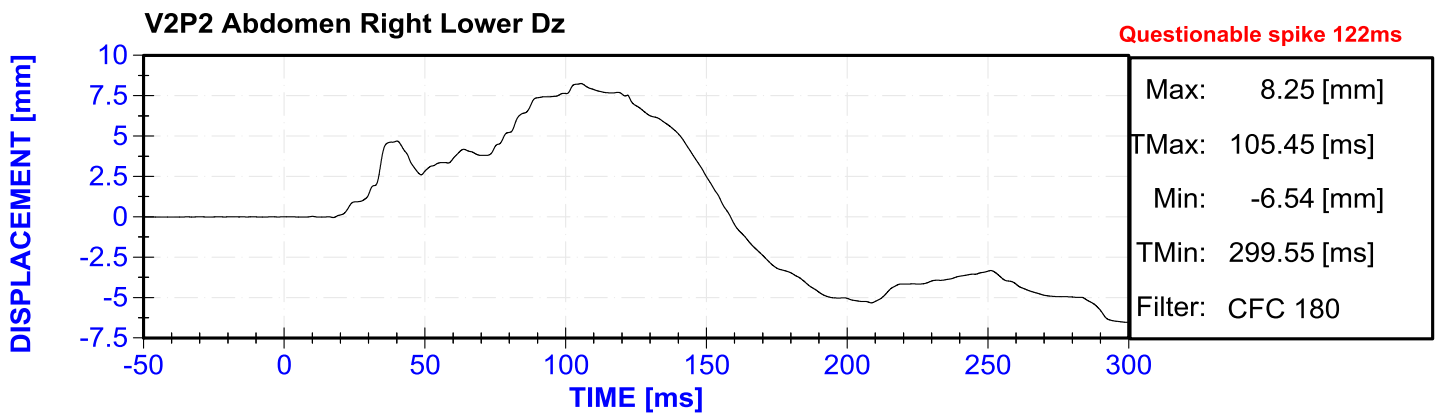
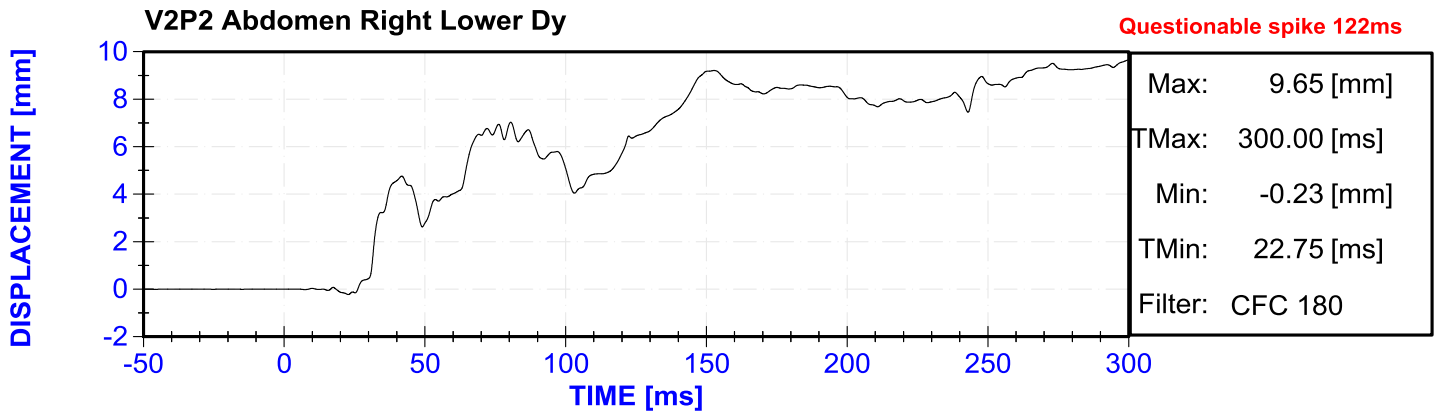

APPENDIX C

DUMMY CALIBRATION AND PERFORMANCE VERIFICATION DATA SHEETS

Table C-1: Dummy Information

TYPE	SERIAL NUMBER
THOR-M 50 TH Male	DO9798
THOR-M 50 TH Male	DL9207

Table C- 2: THOR Dummy Initial Set-Up Information

THOR – M S/N: DO9798					
Sensor	Manufacturer	Serial Number	Range	Sensitivity	Sensitivity Units
Head CG X Acceleration	Endevco 7264	AC-P52001	2003	0.019659999	mV/V/g
Head CG Y Acceleration	Endevco 7264	AC-P51697	2029	0.022130000	mV/V/g
Head CG Z Acceleration	Endevco 7264	AC-P75155	2039	0.017939999	mV/V/g
Head CG Angular Velocity About X	DTS ARS 18k	ARS-6733	18098	0.094299998	mV/deg/s
Head CG Angular Velocity About Y	DTS ARS 18k	ARS-4071	18334	0.093089999	mV/deg/s
Head CG Angular Velocity About Z	DTS ARS 18k	ARS-4719	18343	0.093039998	mV/deg/s
Front Neck Spring Tower Load Cell	Humanetics 6005JFL	LC-93	4480	0.000524200	mV/V/N
Rear Neck Spring Tower Load Cell	Humanetics 6005JFL	LC-132	4480	0.000484300	mV/V/N
Occipital Condyle Rotation Potentiometer	Sfernice 9945	DS-DK5913	120	3.045160091	mV/V/deg
Upper Neck X Force	Humanetics 10380J14	LC-DS9758 Fx	8900	0.000232900	mV/V/N
Upper Neck Y Force	Humanetics 10380J14	LC-DS9758 Fy	8925	0.000230400	mV/V/N
Upper Neck Z Force	Humanetics 10380J14	LC-DS9758 Fz	13345	0.000087000	mV/V/N
Upper Neck X Moment	Humanetics 10380J14	LC-DS9758 Mx	283	0.005890300	mV/V/Nm
Upper Neck Y Moment	Humanetics 10380J14	LC-DS9758 My	283	0.005963400	mV/V/Nm
Upper Neck Z Moment	Humanetics 10380J14	LC-DS9758 Mz	283	0.009479200	mV/V/Nm
Lower Neck X Force	Humanetics 10381J14	LC-DK3607 Fx	13445	0.000168500	mV/V/N
Lower Neck Y Force	Humanetics 10381J14	LC-DK3607 Fy	13429	0.000168700	mV/V/N
Lower Neck Z Force	Humanetics 10381J14	LC-DK3607 Fz	13385	0.000068800	mV/V/N
Lower Neck X Moment	Humanetics 10381J14	LC-DK3607 Mx	452	0.004012500	mV/V/Nm
Lower Neck Y Moment	Humanetics 10381J14	LC-DK3607 My	452	0.004072100	mV/V/Nm
Lower Neck Z Moment	Humanetics 10381J14	LC-DK3607 Mz	227	0.006723800	mV/V/Nm
Thorax Upper Left X Displacement	Humanetics IF-364-C-R3	DS-DQ2255	2	1000.000000000	mV/V
Thorax Upper Left Y Rotation	Sfernice 9945	DS-DM4779	94	3.039699979	mV/V/deg
Thorax Upper Left Z Rotation	Sfernice 9945	DS-DM4778	93	3.046999918	mV/V/deg
Thorax Upper Right X Displacement	Humanetics IF-364-C-R3	DS-DQ2254	2	1000.000000000	mV/V
Thorax Upper Right Y Rotation	Sfernice 9945	DS-DM4774	94	3.041200107	mV/V/deg
Thorax Upper Right Z Rotation	Sfernice 9945	DS-DM4775	93	3.062600037	mV/V/deg
Thorax Lower Left X Displacement	Humanetics IF-364-C-R3	DS-DK3866	2	1000.000000000	mV/V
Thorax Lower Left Y Rotation	Sfernice 9945	DS-DJ5455	93	3.046999918	mV/V/deg
Thorax Lower Left Z Rotation	Sfernice 9945	DS-DJ5454	93	3.051300067	mV/V/deg
Thorax Lower Right X Displacement	Humanetics IF-364-C-R3	DS-DK3865	2	1000.000000000	mV/V

Thorax Lower Right Y Rotation	Sfernice 9945	DS-DJ5453	93	3.059299896	mV/V/deg
Thorax Lower Right Z Rotation	Sfernice 9945	DS-DJ5452	93	3.050599946	mV/V/deg
Abdomen Left X Displacement	Humanetics 9910	DS-183	2	1000.000000000	mV/V
Abdomen Left Y Rotation	Sfernice 9945	DS-DJ5443	94	3.029499901	mV/V/deg
Abdomen Left Z Rotation	Sfernice 9945	DS-DJ5444	90	2.990900073	mV/V/deg
Abdomen Right X Displacement	Humanetics 9910	DS-DI4779	2	1000.000000000	mV/V
Abdomen Right Y Rotation	Sfernice 9945	DS-DJ5445	93	3.059600014	mV/V/deg
Abdomen Right Z Rotation	Sfernice 9945	DS-DJ5446	93	3.072099993	mV/V/deg
T1 X Acceleration	Endevco 7264	AC-P63843	2012	0.023560000	mV/V/g
T1 Y Acceleration	Endevco 7264	AC-P52008	2017	0.018940000	mV/V/g
T1 Z Acceleration	Endevco 7264	AC-P51636	2032	0.021719999	mV/V/g
T4 X Acceleration	Endevco 7264	AC-P75156	2009	0.018200000	mV/V/g
T4 Y Acceleration	Endevco 7264	AC-P84363	2019	0.019810001	mV/V/g
T4 Z Acceleration	Endevco 7264	AC-P51715	2012	0.017920000	mV/V/g
Pelvis X Acceleration	Endevco 7264	AC-P58747	2004	0.018510000	mV/V/g
Pelvis Y Acceleration	Endevco 7264	AC-P52004	2031	0.021010001	mV/V/g
Pelvis Z Acceleration	Endevco 7264	AC-P71875	2029	0.020680000	mV/V/g
Spine Force X	Humanetics 10415J14	LC-DQ5600 Fx	13376	0.000146100	mV/V/N
Spine Force Y	Humanetics 10415J14	LC-DQ5600 Fy	13412	0.000145700	mV/V/N
Spine Force Z	Humanetics 10415J14	LC-DQ5600 Fz	17795	0.000060700	mV/V/N
Spine Moment X	Humanetics 10415J14	LC-DQ5600 Mx	680	0.002202000	mV/V/Nm
Spine Moment Y	Humanetics 10415J14	LC-DQ5600 My	906	0.001909600	mV/V/Nm
Acetabular Left X Force	Humanetics 10530J14	LC-DM1945 Fx	22315	0.000119500	mV/V/N
Acetabular Left Y Force	Humanetics 10530J14	LC-DM1945 Fy	13348	0.000060500	mV/V/N
Acetabular Left Z Force	Humanetics 10530J14	LC-DM1945 Fz	13358	0.000163800	mV/V/N
Acetabular Right X Force	Humanetics 10670J14	LC-DL9552 Fx	22309	0.000118300	mV/V/N
Acetabular Right Y Force	Humanetics 10670J14	LC-DL9552 Fy	13375	0.000060000	mV/V/N
Acetabular Right Z Force	Humanetics 10670J14	LC-DL9552 Fz	13378	0.000160800	mV/V/N
Iliac Left X Force	Humanetics 9490JFL	LC-77 Fx	13022	0.000068500	mV/V/N
Iliac Left Y Moment	Humanetics 9490JFL	LC-77 My	326	0.003816600	mV/V/Nm
Iliac Right X Force	Humanetics 9490JFL	LC-DJ5524 Fx	13027	0.000071200	mV/V/N
Iliac Right Y Moment	Humanetics 9490JFL	LC-DJ5524 My	326	0.003790700	mV/V/Nm
Femur Left X Force	Humanetics W50-71010	LC-DK0842 Fx	15118	0.000143500	mV/V/N
Femur Left Y Force	Humanetics W50-71010	LC-DK0842 Fy	15118	0.000143500	mV/V/N
Femur Left Z Force	Humanetics W50-71010	LC-DK0842 Fz	15005	0.000072600	mV/V/N
Femur Left X Moment	Humanetics W50-71010	LC-DK0842 Mx	351	0.006399600	mV/V/Nm
Femur Left Y Moment	Humanetics W50-71010	LC-DK0842 My	352	0.006497300	mV/V/Nm
Knee Left X Displacement	Space Age 150-0121V	DS-13073811	26	23.231299594	mV/V/mm
Tibia Upper Left Z Force	Denton 10390J14	LC-DQ5598 Fz	11100	0.000095300	mV/V/N
Tibia Upper Left X Moment	Denton 10390J14	LC-DQ5598 Mx	399	0.007466800	mV/V/Nm
Tibia Upper Left Y Moment	Denton 10390J14	LC-DQ5598 My	398	0.007471200	mV/V/Nm
Tibia Lower Left X Force	Denton 9329J	LC-DQ9685 Fx	11204	0.000173100	mV/V/N
Tibia Lower Left Y Force	Denton 9329J	LC-DQ9685 Fy	11128	0.000170400	mV/V/N
Tibia Lower Left Z Force	Denton 9329J	LC-DQ9685 Fz	11134	0.000096200	mV/V/N
Tibia Lower Left X Moment	Denton 9329J	LC-DQ9685 Mx	400	0.007535600	mV/V/Nm

Tibia Lower Left Y Moment	Denton 9329J	LC-DQ9685 My	397	0.007595100	mV/V/Nm
Tibia Left X Acceleration	Endevco 7264C	AC-P81386	2003	0.017750001	mV/V/g
Tibia Left Y Acceleration	Endevco 7264C	AC-P52069	2066	0.019060000	mV/V/g
Foot Left X Acceleration	Endevco 7264C	AC-P64131	2050	0.019210000	mV/V/g
Foot Left Z Acceleration	Endevco 7264C	AC-P51725	2175	0.021399999	mV/V/g
Ankle Left X Rotation	SFERNICE ECO50ESC10	DS-ANKL004	127	3.058000002	mV/V/deg
Ankle Left Y Rotation	SFERNICE ECO50ESC10	DS-ANKL005	126	3.040000098	mV/V/deg
Ankle Left Z Rotation	SFERNICE ECO50ESC10	DS-ANKL006	120	3.036200069	mV/V/deg
Femur Right X Force	Humanetics W50-71010	LC-DK3608 Fx	15055	0.000144100	mV/V/N
Femur Right Y Force	Humanetics W50-71010	LC-DK3608 Fy	15055	0.000144100	mV/V/N
Femur Right Z Force	Humanetics W50-71010	LC-DK3608 Fz	15007	0.000072900	mV/V/N
Femur Right X Moment	Humanetics W50-71010	LC-DK3608 Mx	351	0.006456800	mV/V/Nm
Femur Right Y Moment	Humanetics W50-71010	LC-DK3608 My	353	0.006419100	mV/V/Nm
Knee Right X Displacement	Space Age 150-0121V	DS-13073814	26	23.322600871	mV/V/mm
Tibia Upper Right Z Force	Denton 10390J14	LC-DQ5734 Fz	11135	0.000095400	mV/V/N
Tibia Upper Tibia Right X Moment	Denton 10390J14	LC-DQ5734 Mx	399	0.007462700	mV/V/Nm
Tibia Upper Tibia Right Y Moment	Denton 10390J14	LC-DQ5734 My	397	0.007502400	mV/V/Nm
Tibia Lower Right X Force	Denton 9329J	LC-DQ9684 Fx	11193	0.000177300	mV/V/N
Tibia Lower Right Y Force	Denton 9329J	LC-DQ9684 Fy	11173	0.000174900	mV/V/N
Tibia Lower Right Z Force	Denton 9329J	LC-DQ9684 Fz	11161	0.000097600	mV/V/N
Tibia Lower Right X Moment	Denton 9329J	LC-DQ9684 Mx	396	0.007698000	mV/V/Nm
Tibia Lower Right Y Moment	Denton 9329J	LC-DQ9684 My	398	0.007654700	mV/V/Nm
Tibia Right X Acceleration	Endevco 7264C	AC-P79626	2026	0.021059999	mV/V/g
Tibia Right Y Acceleration	Endevco 7264C	AC-P74953	2020	0.017849999	mV/V/g
Foot Right X Acceleration	Endevco 7264C	AC-P49441	2015	0.017890001	mV/V/g
Foot Right Z Acceleration	Endevco 7264C	AC-P80272	2015	0.019550000	mV/V/g
Ankle Right X Rotation	SFERNICE ECO50ESC10	DS-ANKL001	127	3.040099982	mV/V/deg
Ankle Right Y Rotation	SFERNICE ECO50ESC10	DS-ANKL002	124	3.036200069	mV/V/deg
Ankle Right Z Rotation	SFERNICE ECO50ESC10	DS-ANKL003	120	3.044900019	mV/V/deg

Table C- 3: Initial Set-Up Information

THOR-M S/N: DL9207					
Sensor	Manufacturer	Serial Number	Range	Sensitivity	Sensitivity Units
Head CG X Acceleration	Endevco 7264	AC-P82183	2010	0.017689999	mV/V/G's
Head CG Y Acceleration	Endevco 7264	AC-P81384	2020	0.017599999	mV/V/G's
Head CG Z Acceleration	Endevco 7264	AC-P81797	2005	0.019350000	mV/V/G's
Head CG Angular Velocity About X	DTS ARS-18K	ARS-4740	18666	0.091430004	mV/Deg/s
Head CG Angular Velocity About Y	DTS ARS-18K	ARS-4737	19119	0.095640004	mV/Deg/s
Head CG Angular Velocity About Z	DTS ARS-18K	ARS-4073	18203	0.093759998	mV/Deg/s
Front Neck Spring Tower Load Cell	Humanetics 10386JI4	LC-DO9740	4457	0.000512814	mV/V/N
Rear Neck Spring Tower Load Cell	Humanetics 10386JI4	LC-DO9741	4458	0.000508183	mV/V/N
Occipital Condyle Rotation Potentiometer	Humanetics 9945	DS-DK5911	121	3.020999953	mV/V/Deg
Upper Neck X Force	Humanetics 10380JI4	LC-DP3956 Fx	8922	0.000224158	mV/V/N

Upper Neck Y Force	Humanetics 10380JI4	LC-DP3956 Fy	8921	0.000227755	mV/V/N
Upper Neck Z Force	Humanetics 10380JI4	LC-DP3956 Fz	13346	0.000085255	mV/V/N
Upper Neck X Moment	Humanetics 10380JI4	LC-DP3956 Mx	284	0.005819469	mV/V/Nm
Upper Neck Y Moment	Humanetics 10380JI4	LC-DP3956 My	283	0.005983009	mV/V/Nm
Upper Neck Z Moment	Humanetics 10380JI4	LC-DP3956 Mz	283	0.009425133	mV/V/Nm
Lower Neck X Force	Humanetics 10381JI4	LC-DP4780 Fx	13398	0.000173709	mV/V/N
Lower Neck Y Force	Humanetics 10381JI4	LC-DP4780 Fy	13460	0.000174489	mV/V/N
Lower Neck Z Force	Humanetics 10381JI4	LC-DP4780 Fz	13385	0.000070575	mV/V/N
Lower Neck X Moment	Humanetics 10381JI4	LC-DP4780 Mx	455	0.004108210	mV/V/Nm
Lower Neck Y Moment	Humanetics 10381JI4	LC-DP4780 My	454	0.004147000	mV/V/Nm
Lower Neck Z Moment	Humanetics 10381JI4	LC-DP4780 Mz	226	0.006740000	mV/V/Nm
Thorax Upper Left X Displacement	Humanetics IF-364-C-R3	DS-DS6355	3	1000.000000000	mV/V
Thorax Upper Left Y Rotation	Humanetics 9945	DS-DI2382	123	2.978800097	mV/V/deg
Thorax Upper Left Z Rotation	Humanetics 9945	DS-DI2383	122	3.007299965	mV/V/deg
Thorax Upper Right X Displacement	Humanetics IF-364-C-R3	DS-DJ2613	3	1000.000000000	mV/V
Thorax Upper Right Y Rotation	Humanetics 9945	DS-DI7753	120	3.035899950	mV/V/deg
Thorax Upper Right Z Rotation	Humanetics 9945	DS-DI7752	129	3.052399959	mV/V/deg
Thorax Lower Left X Displacement	Humanetics IF-364-C-R3	DS-DS6353	3	1000.000000000	mV/V
Thorax Lower Left Y Rotation	Humanetics 9945	DS-DM4781	122	3.001400037	mV/V/deg
Thorax Lower Left Z Rotation	Humanetics 9945	DS-DS4092	128	3.072499996	mV/V/deg
Thorax Lower Right X Displacement	Humanetics IF-364-C-R3	DS-DS6354	3	1000.000000000	mV/V
Thorax Lower Right Y Rotation	Humanetics 9945	DS-DM4776	122	3.004899947	mV/V/deg
Thorax Lower Right Z Rotation	Humanetics 9945	DS-DM4777	122	2.994700102	mV/V/deg
Abdomen Left X Displacement	Humanetics 9910	DS-DQ2303	3	1000.000000000	mV/V
Abdomen Left Y Rotation	Humanetics 9945	DS-DS8363	121	3.024100093	mV/V/deg
Abdomen Left Z Rotation	Humanetics 9945	DS-DS8361	120	3.047399921	mV/V/deg
Abdomen Right X Displacement	Humanetics 9910	DS-DM2641	3	1000.000000000	mV/V
Abdomen Right Y Rotation	Humanetics 9945	DS-DS4094	121	3.012300003	mV/V/deg
Abdomen Right Z Rotation	Humanetics 9945	DS-DS4121	121	3.021799959	mV/V/deg
T1 X Acceleration	Endevco 7264	AC-P79630	2011	0.020870000	mV/V/G's
T1 Y Acceleration	Endevco 7264	AC-P78880	2018	0.019820000	mV/V/G's
T1 Z Acceleration	Endevco 7264	AC-P82758	2023	0.018610001	mV/V/G's
T4 X Acceleration	Endevco 7264	AC-P49229	2002	0.018010000	mV/V/G's
T4 Y Acceleration	Endevco 7264	AC-P49215	2014	0.016950000	mV/V/G's
T4 Z Acceleration	Endevco 7264	AC-P52122	2002	0.017050001	mV/V/G's
Pelvis X Acceleration	Endevco 7264	AC-P83434	2027	0.017540000	mV/V/G's
Pelvis Y Acceleration	Endevco 7264	AC-P82752	2026	0.018310000	mV/V/G's
Pelvis Z Acceleration	Endevco 7264	AC-P80296	2029	0.019409999	mV/V/G's
Spine Force Y	Humanetics 10415JI4	LC-DP2984 Fy	13386	0.000147107	mV/V/N
Spine Force X	Humanetics 10415JI4	LC-DP2984 Fx	13352	0.000146365	mV/V/N
Spine Force Z	Humanetics 10415JI4	LC-DP2984 Fz	17795	0.000060193	mV/V/N
Spine Moment X	Humanetics 10415JI4	LC-DP2984 Mx	682	0.002146039	mV/V/Nm
Spine Moment Y	Humanetics 10415JI4	LC-DP2984 My	910	0.001914371	mV/V/Nm
Acetabular Left X Force	Humanetics 10670JI4	LC-DP3835 Fx	22270	0.000118506	mV/V/N
Acetabular Left Y Force	Humanetics 10670JI4	LC-DP3835 Fy	13356	0.000059342	mV/V/N

Acetabular Left Z Force	Humanetics 10670JI4	LC-DP3835 Fz	13348	0.000161173	mV/V/N
Acetabular Right X Force	Humanetics 10530JI4	LC-DP4639 Fx	22456	0.000121280	mV/V/N
Acetabular Right Y Force	Humanetics 10530JI4	LC-DP4639 Fy	13377	0.000059432	mV/V/N
Acetabular Right Z Force	Humanetics 10530JI4	LC-DP4639 Fz	13421	0.000165871	mV/V/N
Iliac Left X Force	Humanetics 10387JI4	LC-DP5092 Fx	13022	0.000067323	mV/V/N
Iliac Left Y Moment	Humanetics 10387JI4	LC-DP5092 My	326	0.003688923	mV/V/Nm
Iliac Right X Force	Humanetics 10387JI4	LC-DP5091 Fx	13041	0.000065215	mV/V/N
Iliac Right Y Moment	Humanetics 10387JI4	LC-DP5091 My	325	0.003697538	mV/V/Nm
Femur Left X Force	Denton W50-7101051	LC-DM4975 Fx	15097	0.000143700	mV/V/N
Femur Left Y Force	Denton W50-7101051	LC-DM4975 Fy	15108	0.000143600	mV/V/N
Femur Left Z Force	Denton W50-7101051	LC-DM4975 Fz	15048	0.000072700	mV/V/N
Femur Left X Moment	Denton W50-7101051	LC-DM4975 Mx	353	0.006601400	mV/V/Nm
Femur Left Y Moment	Denton W50-7101051	LC-DM4975 My	350	0.006642000	mV/V/Nm
Knee Left X Displacement	Space Age 150-0121V	DS-C2102639B	20	24.094099179	mV/V/mm
Upper Tibia Left Z Force	Denton 4353J	LC-97 Fz	11131	0.000093300	mV/V/N
Upper Tibia Left X Moment	Denton 4353J	LC-97 Mx	397	0.007333200	mV/V/Nm
Upper Tibia Left Y Moment	Denton 4353J	LC-97 My	395	0.007398000	mV/V/Nm
Lower Tibia Left X Force	Denton 4929J	LC-121 Fx	11118	0.000175100	mV/V/N
Lower Tibia Left Y Force	Denton 4929J	LC-121 Fy	11120	0.000171800	mV/V/N
Lower Tibia Left Z Force	Denton 4929J	LC-121 Fz	11111	0.000095800	mV/V/N
Lower Tibia Left X Moment	Denton 4929J	LC-121 Mx	396	0.007396500	mV/V/Nm
Lower Tibia Left Y Moment	Denton 4929J	LC-121 My	395	0.007447200	mV/V/Nm
Left Tibia X Acceleration	Endevco 7264C	AC-P77996	2028	0.018029999	mV/V/G's
Left Tibia Y Acceleration	Endevco 7264C	AC-P64094	2029	0.022140001	mV/V/G's
Foot Left X Acceleration	Endevco 7264C	AC-P80271	2032	0.021000000	mV/V/G's
Foot Left Z Acceleration	Endevco 7264C	AC-P51684	2017	0.019530000	mV/V/G's
Ankle Left X Rotation	Contelec PD210-4B	DS-0525	145	3.187899943	mV/V/deg
Ankle Left Y Rotation	Contelec PD210-4B	DS-0524	148	3.190600080	mV/V/deg
Ankle Left Z Rotation	Contelec PD210-4B	DS-0523	157	3.178599989	mV/V/deg
Femur Right X Force	Denton W50-7101051	LC-DM4976 Fx	15086	0.000142600	mV/V/N
Femur Right Y Force	Denton W50-7101051	LC-DM4976 Fy	15054	0.000142900	mV/V/N
Femur Right Z Force	Denton W50-7101051	LC-DM4976 Fz	15024	0.000072200	mV/V/N
Femur Right X Moment	Denton W50-7101051	LC-DM4976 Mx	351	0.006505700	mV/V/Nm
Femur Right Y Moment	Denton W50-7101051	LC-DM4976 My	352	0.006488900	mV/V/Nm
Knee Right X Displacement	Space Age 150-0121VL	DS-021033	20	23.250799626	mV/V/mm
Upper Tibia Right Z Force	Denton 4353J	LC-75 Fz	11158	0.000095200	mV/V/N
Upper Tibia Right X Moment	Denton 4353J	LC-75 Mx	397	0.007490000	mV/V/Nm
Upper Tibia Right Y Moment	Denton 4353J	LC-75 My	398	0.007475800	mV/V/Nm
Lower Tibia Right X Force	Denton 4929J	LC-166 Fx	11129	0.000175600	mV/V/N
Lower Tibia Right Y Force	Denton 4929J	LC-166 Fy	11153	0.000171300	mV/V/N
Lower Tibia Right Z Force	Denton 4929J	LC-166 Fz	11138	0.000099500	mV/V/N
Lower Tibia Right X Moment	Denton 4929J	LC-166 Mx	396	0.007424800	mV/V/Nm
Lower Tibia Right Y Moment	Denton 4929J	LC-166 My	399	0.007372600	mV/V/Nm
Right Tibia X Acceleration	Endevco 7264C	AC-P82744	2002	0.018270001	mV/V/G's
Right Tibia Y Acceleration	Endevco 7264C	AC-P82322	2004	0.017259999	mV/V/G's

Foot Right X Acceleration	Endevco 7264C	AC-P74976	2021	0.017840001	mV/V/G's
Foot Right Z Acceleration	Endevco 7264C	AC-P83339	2010	0.019900001	mV/V/G's
Ankle Right X Rotation	Contelec PD210-4B	DS-0528	144	3.202199936	mV/V/deg
Ankle Right Y Rotation	Contelec PD210-4B	DS-0526	146	3.155299928	mV/V/deg
Ankle Right Z Rotation	Contelec PD210-4B	DS-0527-1	157	3.160600085	mV/V/deg

Table 4 – THOR IR-TRACC Polarity

In order to reduce the risk of damage to instrumentation, it is recommended that the 3D IR-TRACC units are not disconnected from the rib cage to conduct the polarity test. An alternate procedure for checking the IR-TRACC polarity is described below.

1. Using the data acquisition system control software, open a live view of each channel. If possible, view the DX, RY, and RZ components of a given quadrant simultaneously.
2. Record the initial reading of each channel
3. Perform the following motions on each of the four rib attachment locations and two abdomen attachment locations (specified by the hexagonal bolt attaching the blue ribs).
 - a. DX: Push inward (front-to-back). The IR-TRACC tube voltage should increase.
 - b. RY: Push downward (head-to-pelvis). The Y-axis potentiometer reading should decrease.
 - c. RZ: Push rightward (left-to-right). The Z-axis potentiometer should increase.
4. Record the final reading of each channel
5. If the “Measured” value (increase or decrease) does not match the “Expected” value, the polarity of the channel must be inverted.

THOR 50th Male DL9207

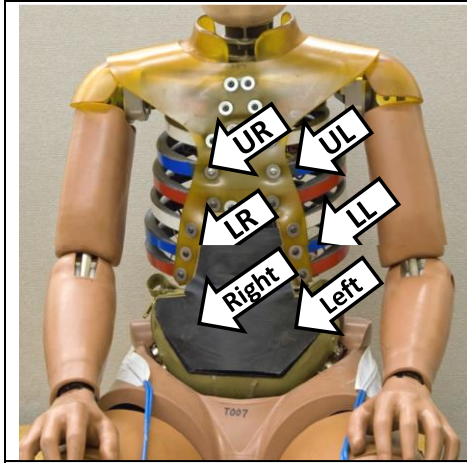

Figure 1. Manipulation to determine thoracic and abdominal IR-TRACC polarity.

Channel	Motion
DX	Push inward
RY	Push upward
RZ	Push rightward

Upper Right Thorax				Upper Left Thorax			
Channel	Initial Value	Expected Polarity	Recorded Polarity	Channel	Initial Value	Expected Polarity	Recorded Polarity
DX (V)	0.11203	+	+	DX (V)	0.10139	+	+
RY (Deg)	10.5792	+	+	RY (Deg)	11.7954	+	+
RZ (Deg)	-12.961	+	+	RZ (Deg)	13.0209	+	+
Lower Right Thorax				Lower Left Thorax			
Channel	Initial Value	Expected Polarity	Recorded Polarity	Channel	Initial Value	Expected Polarity	Recorded Polarity
DX (V)	0.09578	+	+	DX (V)	0.08445	+	+
RY (Deg)	-3.4367	+	+	RY (Deg)	-2.3055	+	+
RZ (Deg)	-5.1227	+	+	RZ (Deg)	5.23523	+	+
Abdomen Right				Abdomen Left			
Channel	Initial Value	Expected Polarity	Recorded Polarity	Channel	Initial Value	Expected Polarity	Recorded Polarity
DX (V)	0.06672	+	+	DX (V)	0.06328	+	+
RY (Deg)	2.86058	+	+	RY (Deg)	1.87899	+	+
RZ (Deg)	-0.8069	+	+	RZ (Deg)	1.53933	+	+

THOR 50th Male DO9798

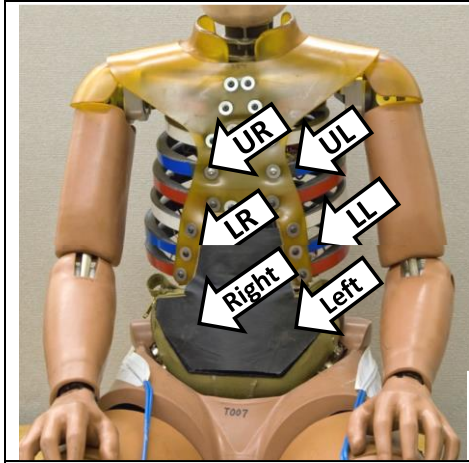

Figure 2. Manipulation to determine thoracic and abdominal IR-TRACC polarity.

Channel	Motion
DX	Push inward
RY	Push upward
RZ	Push rightward



Upper Right Thorax				Upper Left Thorax			
Channel	Initial Value	Expected Polarity	Recorded Polarity	Channel	Initial Value	Expected Polarity	Recorded Polarity
DX (V)	0.08380	+	+	DX (V)	0.85751	+	+
RY (Deg)	10.0137	+	+	RY (Deg)	4.55342	+	+
RZ (Deg)	-11.962	+	+	RZ (Deg)	11.7694	+	+
Lower Right Thorax				Lower Left Thorax			
Channel	Initial Value	Expected Polarity	Recorded Polarity	Channel	Initial Value	Expected Polarity	Recorded Polarity
DX (V)	0.08025	+	+	DX (V)	0.08125	+	+
RY (Deg)	-6.1346	+	+	RY (Deg)	-4.0026	+	+
RZ (Deg)	-2.2819	+	+	RZ (Deg)	7.84761	+	+
Abdomen Right				Abdomen Left			
Channel	Initial Value	Expected Polarity	Recorded Polarity	Channel	Initial Value	Expected Polarity	Recorded Polarity
DX (V)	0.07470	+	+	DX (V)	0.07571	+	+
RY (Deg)	3.52947	+	+	RY (Deg)	3.10074	+	+
RZ (Deg)	1.27844	+	+	RZ (Deg)	5.10226	+	+



Test Data/Sensor Repair Notes



THOR Inspection Checklist

Date: 1/28/2016	
NHTSA Representative: Tim Keon	
Inspection Reporter: Matt Goehle	
Inspection type (check one): <input checked="" type="checkbox"/> Pre-Test <input type="checkbox"/> Post-Test	
Dummy S/N: DL9207	Legs S/N: LX0045/LX0046
Dummy Description: THOR-M 50th Male	
Date of last Certification: 12/23/2015	
Tests conducted since last inspection: M20155112 - 2015 Toyota Sienna	Since last certification: M20165306 - 2016 Honda Fit M20160113 – 2016 Chevrolet Malibu M20160118 - Chevrolet Tahoe <i>LX Leg Certification 1-20-2016</i> M20165212 - 2016 Nissan Rogue M20155112 - 2015 Toyota Sienna
<u>Known errors in data channels (no data, clipping, unexpected drops):</u> 11ANKLRI00THANZP,Ankle Right Z Rotation, Questionable data 131ms to 136ms	
<u>Physical evidence of damage:</u> None New	
<u>Anecdotal evidence of damage:</u> None	
<u>Equipment delivered to Borrower:</u> THOR DL9207 ATD 26 Accelerometers 3 Angular Rate Sensors 2 Skull Spring LC 1 Condyle Pot 1 Upper Neck LC 6 IRTracs 12 Rotational Pots 1 Spine LC 2 Acetabulum LC 2 ASIS LC 2 Femur LC	<i>Continued</i> 2 LX Leg Assemblies 2 Upper Tibia LC 2 Lower Tibia LC 6 Ank1e Potentiometers 2 Knee Sliders 1 Neck Skin 1 Neck Foam 1 Tiltview Interface Cable 4 Tilt Sensors 1 H-Point Tool 1 Tool Box 1 Laptop

Note: New Damage is Noted in Red

HEAD	
Y / N	Rear head cap mounts securely to head
Y / N	Head skin fits securely over skull
Y / N	Head skin shows no sign of tears or damage
Y / N	Interior components of skull cavity (ballast, accelerometer mount, accelerometers) securely attached
Y / N	Head securely mounted to OC joint
OTHER	
NECK	
Y / N	Neck cables slide freely through holes in neck plates
Y / N	Neck cables show no sign of fraying, broken strands, or kinking
Y / N	No evidence of de-bonding between neck pucks and plates
Y / N	No evidence of de-bonding or permanent compression in neck soft stop assemblies Front of the neck is missing the soft stop
	
Y / N	Neck securely attached to upper neck load cell
Y / N	Neck securely attached to lower neck load cell
Y / N	Neck pitch change joint mechanism mating teeth are engaged
OTHER	
SHOULDER	
Y / N	Urethane shoulder pads show no evidence of contact
Y / N	Clavicles securely attached to sternum and shoulder
Y / N	No evidence of de-bonding, tearing, or permanent compression of posterior soft stops Damage to both the left and right shoulder soft stops. The left shoulder is missing one.
	Left:  Right: 
OTHER	
SPINE	
Y / N	No evidence of de-bonding between thoracic spine flex joint and metal plates
Y / N	No evidence of de-bonding between lumbar spine flex joint and metal plates
Y / N	Lumbar spine pitch change joint mechanism mating teeth are engaged
OTHER	
THORAX	
Y / N	No evidence of contact at top, bottom, or interior faces of rib damping material
Y / N	No evidence of de-bonding between rib damping material and ribs
Y / N	IRTRACCs securely attached to anterior ribs
Y / N	IRTRACCs securely attached to double gimbals, spine
Y / N	Urethane bib is securely attached to ribs with no sign of tearing or washer penetration
Y / N	Ribs securely attached to posterior spine
Y / N	Rib stiffeners show no evidence of bending (no gaps between ribs and stiffeners)
OTHER	

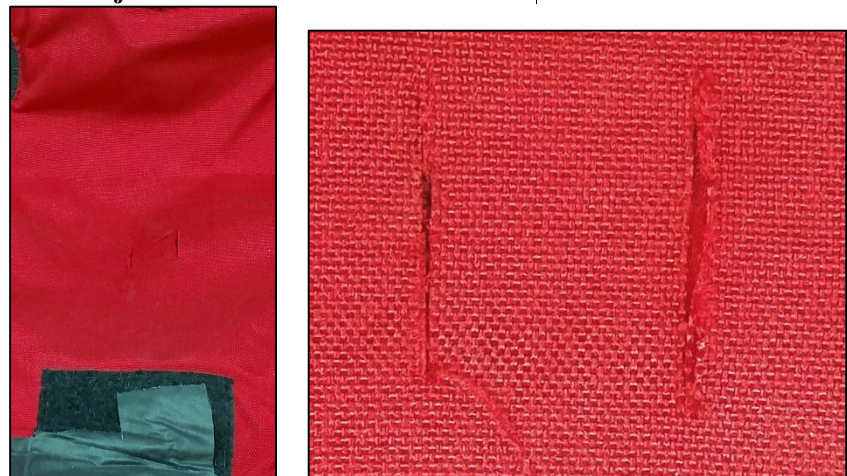

ABDOMEN	
Y / N	No evidence of tearing, cuts, or broken stitches in upper abdomen bag and zipper
Y / N	Upper abdomen insert securely attached to spine
Y / N	Upper abdomen insert shows no evidence of permanent set
Y / N	No evidence of tearing, cuts, or broken stitches in lower abdomen bag and zipper Multiple tears and broken stitches in lower abdomen bag. The upper and lower abdomen bags appear to be from THOR SN007
	
Y / N	Lower abdomen insert securely attached to spine
Y / N	Lower abdomen insert shows no evidence of permanent set
OTHER	
PELVIS	
Y / N	Pelvis flesh fits securely over pelvis bones
Y / N	H-point tool fits securely into hole on both sides of pelvis
OTHER	
FEMUR	
Y / N	Acetabular load cells firmly attached
Y / N	Femur load cells firmly attached
Y / N	No evidence of deformation of knee slider bump stop
Y / N	No cuts, tears, or scuffing of knee flesh Right knee flesh torn
	

OTHER	<p>Left femur flesh is separating from zipper. We placed gaffer's tape across zipper to prevent further damage.</p> 
LOWER EXTREMITY (LX)	
Y / N	Rotational potentiometers in ankle securely attached
Y / N	Achilles tendon provides resistance to dorsiflexion
Y / N	No evidence of de-bonding, tearing, or permanent compression of ankle soft stops
Y / N	<p>No cuts, tears, or scuffing of leg flesh Left lower leg flesh is torn near zipper. We placed gaffer's tape around the flesh to prevent further damage.</p> 
OTHER	
JACKET	
Y / N	Rib stiffeners show no sign of permanent deformation
Y / N	<p>No evidence of tears or holes in jacket fabric, Velcro, or zippers The chest jacket has two tears near the middle:</p> 
OTHER	





THOR Inspection Checklist



Date: 2/12/2016	
NHTSA Representative: James Saunders	
Inspection Reporter: Matt Goehle	
Inspection type (check one): <input type="checkbox"/> Pre-Test <input checked="" type="checkbox"/> Post-Test	
Dummy S/N: DL9207	Legs S/N: LX0045/LX0046
Dummy Description: THOR-M 50th Male	
Date of last Certification: 2/1/2016	
Tests conducted since last inspection: M20165307-2016 Honda Fit	Since last certification: M20165307-2016 Honda Fit
<u>Known errors in data channels (no data, clipping, unexpected drops):</u> 11ABDOLE00THVO0P,Abdomen Left X Displacement, Questionable spikes throughout 11TIBILELOTHFOZP,Lower Tibia Left Z Force, Questionable data after 34.4ms 11FEMRRI00THMOXP,Femur Right X Moment, Questionable data 52ms to 139ms	
<u>Physical evidence of damage:</u> Right Leg Cut	
<u>Anecdotal evidence of damage:</u> None	
<u>Equipment delivered to Borrower:</u> THOR DL9207 ATD 26 Accelerometers 3 Angular Rate Sensors 2 Skull Spring LC 1 Condyle Pot 1 Upper Neck LC 6 IRTraccs 12 Rotational Pots 1 Spine LC 2 Acetabulum LC 2 ASIS LC 2 Femur LC	<i>Continued</i> 2 LX Leg Assemblies 2 Upper Tibia LC 2 Lower Tibia LC 6 Ankle Potentiometers 2 Knee Sliders 1 Neck Skin 1 Neck Foam 1 Tiltview Interface Cable 4 Tilt Sensors 1 H-Point Tool 1 Tool Box 1 Laptop

Note: New Damage is Noted in Red

HEAD	
Y / N	Rear head cap mounts securely to head
Y / N	Head skin fits securely over skull
Y / N	Head skin shows no sign of tears or damage
Y / N	Interior components of skull cavity (ballast, accelerometer mount, accelerometers) securely attached
Y / N	Head securely mounted to OC joint
OTHER	
NECK	
Y / N	Neck cables slide freely through holes in neck plates
Y / N	Neck cables show no sign of fraying, broken strands, or kinking
Y / N	No evidence of de-bonding between neck pucks and plates
Y / N	No evidence of de-bonding or permanent compression in neck soft stop assemblies Front of the neck is missing the soft stop
	
Y / N	Neck securely attached to upper neck load cell
Y / N	Neck securely attached to lower neck load cell
Y / N	Neck pitch change joint mechanism mating teeth are engaged
OTHER	
SHOULDER	
Y / N	Urethane shoulder pads show no evidence of contact
Y / N	Clavicles securely attached to sternum and shoulder
Y / N	No evidence of de-bonding, tearing, or permanent compression of posterior soft stops Damage to both the left and right shoulder soft stops. The left shoulder is missing one.
	Left:  Right: 
OTHER	
SPINE	
Y / N	No evidence of de-bonding between thoracic spine flex joint and metal plates
Y / N	No evidence of de-bonding between lumbar spine flex joint and metal plates
Y / N	Lumbar spine pitch change joint mechanism mating teeth are engaged
OTHER	
THORAX	
Y / N	No evidence of contact at top, bottom, or interior faces of rib damping material
Y / N	No evidence of de-bonding between rib damping material and ribs
Y / N	IRTRACCs securely attached to anterior ribs
Y / N	IRTRACCs securely attached to double gimbals, spine
Y / N	Urethane bib is securely attached to ribs with no sign of tearing or washer penetration
Y / N	Ribs securely attached to posterior spine
Y / N	Rib stiffeners show no evidence of bending (no gaps between ribs and stiffeners)
OTHER	

ABDOMEN	
Y / N	No evidence of tearing, cuts, or broken stitches in upper abdomen bag and zipper
Y / N	Upper abdomen insert securely attached to spine
Y / N	Upper abdomen insert shows no evidence of permanent set
Y / N	No evidence of tearing, cuts, or broken stitches in lower abdomen bag and zipper Multiple tears and broken stitches in lower abdomen bag. The upper and lower abdomen bags appear to be from THOR SN007
Y / N	Lower abdomen insert securely attached to spine
Y / N	Lower abdomen insert shows no evidence of permanent set
OTHER	
PELVIS	
Y / N	Pelvis flesh fits securely over pelvis bones
Y / N	H-point tool fits securely into hole on both sides of pelvis
OTHER	

FEMUR	
Y / N	Acetabular load cells firmly attached
Y / N	Femur load cells firmly attached
Y / N	No evidence of deformation of knee slider bump stop
Y / N	No cuts, tears, or scuffing of knee flesh Right knee flesh torn 
OTHER	Left femur flesh is separating from zipper. We placed gaffer's tape across zipper to prevent further damage. 
LOWER EXTREMITY (LX)	
Y / N	Rotational potentiometers in ankle securely attached
Y / N	Achilles tendon provides resistance to dorsiflexion
Y / N	No evidence of de-bonding, tearing, or permanent compression of ankle soft stops
Y / N	No cuts, tears, or scuffing of leg flesh Right lower leg flesh has large cut.  Left lower leg flesh is torn near zipper. We placed gaffer's tape around the flesh to prevent further damage. 
OTHER	

JACKET	
Y / N	Rib stiffeners show no sign of permanent deformation
Y / N	<p>No evidence of tears or holes in jacket fabric, Velcro, or zippers</p> <p>The chest jacket has two tears near the middle:</p> <div style="display: flex; justify-content: space-around;">   </div>
OTHER	

THOR Inspection Checklist

Date: 11/18/2015	
NHTSA Representative: James Saunders	
Inspection Reporter: Mary Geesey	
Inspection type (check one): <input checked="" type="checkbox"/> Pre-Test <input type="checkbox"/> Post-Test	
Dummy S/N: DO9798	Legs S/N: LX655/LX654
Dummy Description: THOR-M 50th Male	
Date of last Certification: 11/4/2015	
Tests conducted since last inspection: R20165410 - 2016 Mazda CX-5	Since last certification: R20165408 - 2016 Mazda CX-5 R20165409 - 2016 Mazda CX-5 R20165410 - 2016 Mazda CX-5
<u>Known errors in data channels (no data, clipping, unexpected drops):</u> <ul style="list-style-type: none"> - 13CHSTRIUPTHVO0P, Thorax Upper Right X Displacement, Questionable spikes - 13ABDORI00THVO0P, Abdomen Right X Displacement, Questionable spikes 	
<u>Physical evidence of damage:</u> None New	
<u>Anecdotal evidence of damage:</u> None	
<u>Equipment delivered to Borrower:</u> THOR DO9798 ATD 26 Accelerometers 3 Angular Rate Sensors 2 Skull Spring LC 1 Condyle Pot 1 Upper Neck LC 6 IRTracs 12 Rotational Pots 1 Spine LC 2 Acetabulum LC 2 ASIS LC 2 Femur LC	<i>Continued</i> 2 LX Leg Assemblies 2 Upper Tibia LC 2 Lower Tibia LC 6 Ankle Potentiometers 2 Knee Sliders 1 Neck Skin 1 Neck Foam 1 Tiltview Interface Cable with 3 channel hub 4 Tilt Sensors 1 H-Point Tool 1 Tool Box 1 Laptop

Note: New Damage is Noted in Red

HEAD	
Y / N	Rear head cap mounts securely to head
Y / N	Head skin fits securely over skull
Y / N	Head skin shows no sign of tears or damage
Y / N	Interior components of skull cavity (ballast, accelerometer mount, accelerometers) securely attached
Y / N	Head securely mounted to OC joint
OTHER	
NECK	
Y / N	Neck cables slide freely through holes in neck plates
Y / N	Neck cables show no sign of fraying, broken strands, or kinking
Y / N	No evidence of de-bonding between neck pucks and plates
Y / N	No evidence of de-bonding or permanent compression in neck soft stop assemblies
Y / N	Neck securely attached to upper neck load cell
Y / N	Neck securely attached to lower neck load cell
Y / N	Neck pitch change joint mechanism mating teeth are engaged
OTHER	
SHOULDER	
Y / N	Urethane shoulder pads show no evidence of contact
Y / N	Clavicles securely attached to sternum and shoulder
Y / N	No evidence of de-bonding, tearing, or permanent compression of posterior soft stops
OTHER	
SPINE	
Y / N	No evidence of de-bonding between thoracic spine flex joint and metal plates
Y / N	No evidence of de-bonding between lumbar spine flex joint and metal plates
Y / N	Lumbar spine pitch change joint mechanism mating teeth are engaged
OTHER	
THORAX	
Y / N	No evidence of contact at top, bottom, or interior faces of rib damping material
Y / N	No evidence of de-bonding between rib damping material and ribs
Y / N	IRTRACCs securely attached to anterior ribs
Y / N	IRTRACCs securely attached to double gimbals, spine
Y / N	Urethane bib is securely attached to ribs with no sign of tearing or washer penetration
Y / N	Ribs securely attached to posterior spine
Y / N	Rib stiffeners show no evidence of bending (no gaps between ribs and stiffeners)
OTHER	
ABDOMEN	
Y / N	No evidence of tearing, cuts, or broken stitches in upper abdomen bag and zipper
Y / N	Upper abdomen insert securely attached to spine
Y / N	Upper abdomen insert shows no evidence of permanent set
Y / N	No evidence of tearing, cuts, or broken stitches in lower abdomen bag and zipper Tear in center of bag.
	
Y / N	Lower abdomen insert securely attached to spine
Y / N	Lower abdomen insert shows no evidence of permanent set
OTHER	

PELVIS	
Y / N	Pelvis flesh fits securely over pelvis bones
Y / N	H-point tool fits securely into hole on both sides of pelvis
OTHER	
FEMUR	
Y / N	Acetabular load cells firmly attached
Y / N	Femur load cells firmly attached
Y / N	No evidence of deformation of knee slider bump stop
Y / N	No cuts, tears, or scuffing of knee flesh
OTHER	
LOWER EXTREMITY (LX)	
Y / N	Rotational potentiometers in ankle securely attached
Y / N	Achilles tendon provides resistance to dorsiflexion
Y / N	No evidence of de-bonding, tearing, or permanent compression of ankle soft stops
Y / N	No cuts, tears, or scuffing of leg flesh
OTHER	
JACKET	
Y / N	Rib stiffeners show no sign of permanent deformation
Y / N	No evidence of tears or holes in jacket fabric, Velcro, or zippers
OTHER	

THOR Inspection Checklist

Date: 2/14/2016	
NHTSA Representative: James Saunders	
Inspection Reporter: Matt Goehle	
Inspection type (check one): <input type="checkbox"/> Pre-Test <input checked="" type="checkbox"/> Post-Test	
Dummy S/N: DO9798	Legs S/N: LX655/LX654
Dummy Description: THOR-M 50th Male	
Date of last Certification: 1/4/2016	
Tests conducted since last inspection: M20160114 - 2016 Chevrolet Malibu	Since last certification: M20165307 - 2016 Honda Fit
<u>Known errors in data channels (no data, clipping, unexpected drops):</u> 13ABDORI00THVO0P, Abdomen Right X Displacement, Questionable spike 122ms 13FOOTRI00THACXP, Foot Right X Acceleration, Questionable data after 102ms	
<u>Physical evidence of damage:</u> Cut in Face	
<u>Anecdotal evidence of damage:</u> None	
<u>Equipment delivered to Borrower:</u> THOR DO9798 ATD 26 Accelerometers 3 Angular Rate Sensors 2 Skull Spring LC 1 Condyle Pot 1 Upper Neck LC 6 IRTraccs 12 Rotational Pots 1 Spine LC 2 Acetabulum LC 2 ASIS LC 2 Femur LC	<i>Continued</i> 2 LX Leg Assemblies 2 Upper Tibia LC 2 Lower Tibia LC 6 Ankle Potentiometers 2 Knee Sliders 1 Neck Skin 1 Neck Foam 1 Tiltview Interface Cable with 3 channel hub 4 Tilt Sensors 1 H-Point Tool 1 Tool Box 1 Laptop

Note: New Damage is Noted in Red

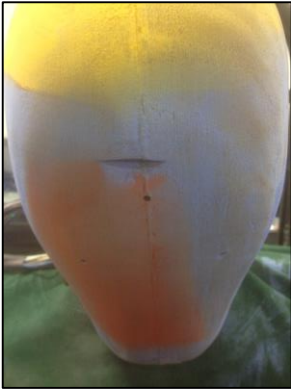
HEAD	
Y / N	Rear head cap mounts securely to head
Y / N	Head skin fits securely over skull
Y / N	Head skin shows no sign of tears or damage Small cut in center of face above Nasion
	
Y / N	Interior components of skull cavity (ballast, accelerometer mount, accelerometers) securely attached
Y / N	Head securely mounted to OC joint
OTHER	
NECK	
Y / N	Neck cables slide freely through holes in neck plates
Y / N	Neck cables show no sign of fraying, broken strands, or kinking
Y / N	No evidence of de-bonding between neck pucks and plates
Y / N	No evidence of de-bonding or permanent compression in neck soft stop assemblies
Y / N	Neck securely attached to upper neck load cell
Y / N	Neck securely attached to lower neck load cell
Y / N	Neck pitch change joint mechanism mating teeth are engaged
OTHER	
SHOULDER	
Y / N	Urethane shoulder pads show no evidence of contact
Y / N	Clavicles securely attached to sternum and shoulder
Y / N	No evidence of de-bonding, tearing, or permanent compression of posterior soft stops
OTHER	
SPINE	
Y / N	No evidence of de-bonding between thoracic spine flex joint and metal plates
Y / N	No evidence of de-bonding between lumbar spine flex joint and metal plates
Y / N	Lumbar spine pitch change joint mechanism mating teeth are engaged
OTHER	
THORAX	
Y / N	No evidence of contact at top, bottom, or interior faces of rib damping material
Y / N	No evidence of de-bonding between rib damping material and ribs
Y / N	IRTRACCs securely attached to anterior ribs
Y / N	IRTRACCs securely attached to double gimbals, spine
Y / N	Urethane bib is securely attached to ribs with no sign of tearing or washer penetration
Y / N	Ribs securely attached to posterior spine
Y / N	Rib stiffeners show no evidence of bending (no gaps between ribs and stiffeners)
OTHER	
ABDOMEN	
Y / N	No evidence of tearing, cuts, or broken stitches in upper abdomen bag and zipper
Y / N	Upper abdomen insert securely attached to spine
Y / N	Upper abdomen insert shows no evidence of permanent set
Y / N	No evidence of tearing, cuts, or broken stitches in lower abdomen bag and zipper Tear in center of bag.

		
Y / N	Lower abdomen insert securely attached to spine	
Y / N	Lower abdomen insert shows no evidence of permanent set	
OTHER		
PELVIS		
Y / N	Pelvis flesh fits securely over pelvis bones	
Y / N	H-point tool fits securely into hole on both sides of pelvis	
OTHER		
FEMUR		
Y / N	Acetabular load cells firmly attached	
Y / N	Femur load cells firmly attached	
Y / N	No evidence of deformation of knee slider bump stop	
Y / N	No cuts, tears, or scuffing of knee flesh	
OTHER		
LOWER EXTREMITY (LX)		
Y / N	Rotational potentiometers in ankle securely attached	
Y / N	Achilles tendon provides resistance to dorsiflexion	
Y / N	No evidence of de-bonding, tearing, or permanent compression of ankle soft stops	
Y / N	No cuts, tears, or scuffing of leg flesh	
OTHER		
JACKET		
Y / N	Rib stiffeners show no sign of permanent deformation	
Y / N	No evidence of tears or holes in jacket fabric, Velcro, or zippers	
OTHER		

DUMMY CALIBRATIONS

50% ADULT MALE THOR DL9207 DUMMY CALIBRATIONS



Certification Report
THOR-M 50th Male Neck Flexion Frontal - NHTSA Oct 2015 Draft

2015-12-29 12:01:57

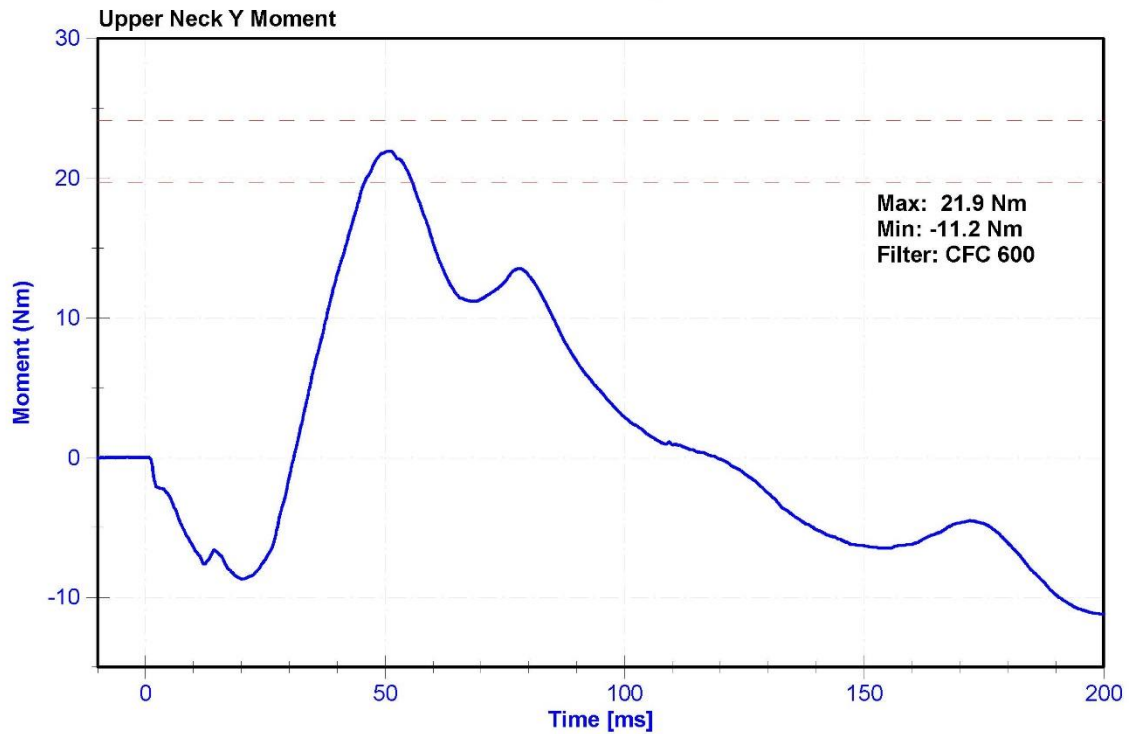
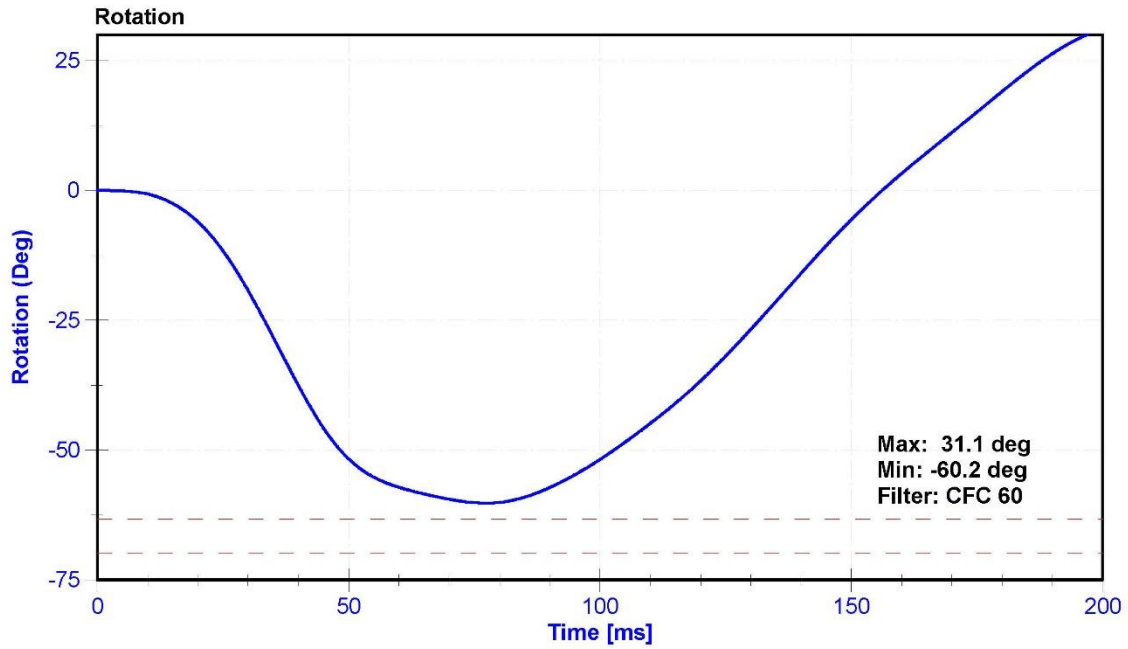

Upper Neck Force

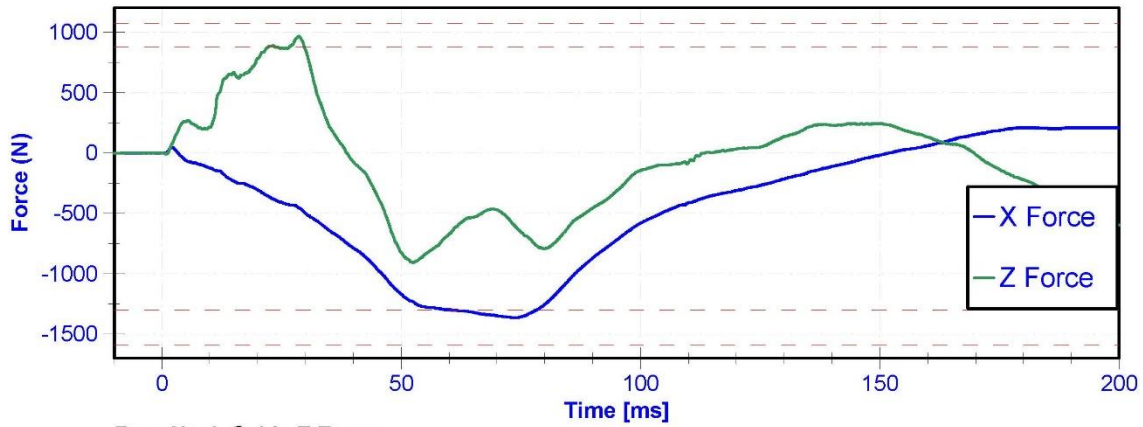

Rear Neck Cable Z Force

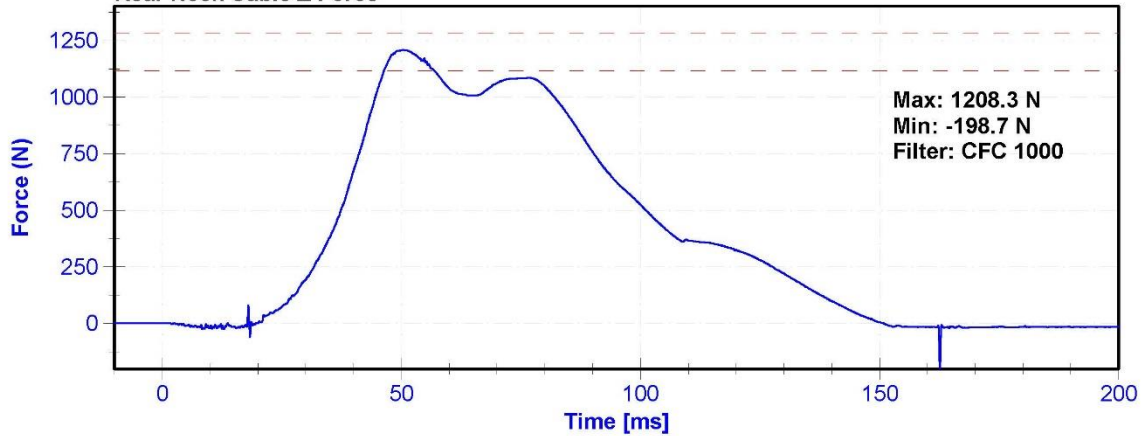

Angular Rate Sensors

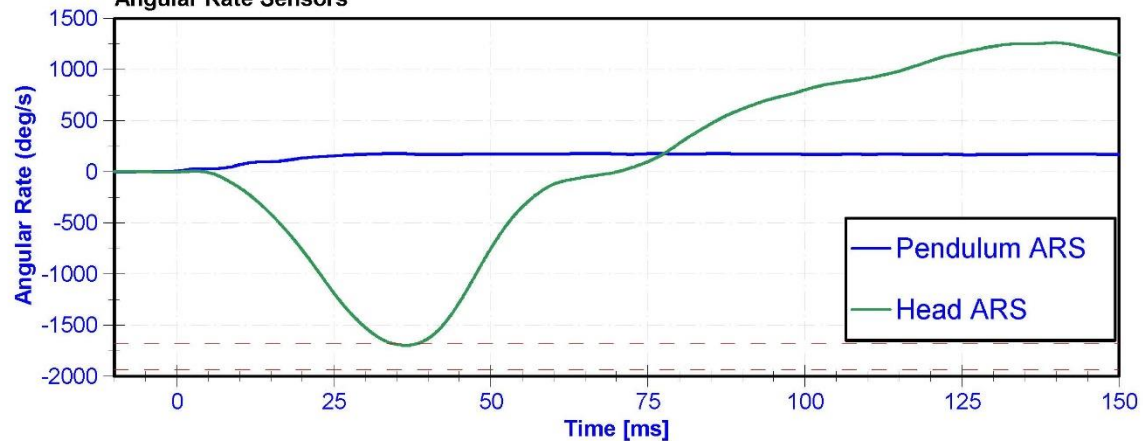

ATD Manufacturer	Humanetics	Test Technician	M. Goehle
ATD Serial Number	DL9207	Laboratory Supervisor	M. Goehle

Results

Test Parameter	Minimum Specification	Maximum Specification	Unit	Result	Pass/Fail
Temperature	20.6	22.2	°C	21.3	Pass
Humidity	10	70	%	36.0	Pass
Velocity	4.95	5.05	m/s	4.985	Pass
Pendulum Impulse at 10ms	1.76	1.91	m/s	1.840	Pass
Pendulum Impulse at 20ms	3.50	3.75	m/s	3.727	Pass
Pendulum Impulse at 30ms	4.88	5.20	m/s	5.134	Pass
Peak Upper Neck Y Moment	-21.3	-17.5	Nm	-22.12	Fail
Peak Upper Neck X Force	967	1182	N	1078.0	Pass
Peak Upper Neck Z Force	-2893	-2603	N	-2701.5	Pass
Peak Front Neck Cable Force	2482	2809	N	2546.2	Pass
Peak Head Y Angular Rate	1907	2043	deg/s	2056.4	Fail
Peak Head Y Rotation	57.6	64.2	deg	45.50	Fail
Rotational Decay Time to Zero	79.3	82.5	ms	56.30	Fail

Transducer Calibrations

Channel	Manufacturer	Serial Number	Calibration Date	Calibration Due Date
Pendulum Accelerometer	ENDEVCO 7231CT	AC-AH5F3	5/7/2015	5/6/2016
Upper Neck Load Cell	Humanetics 10380JI4	LC-DP3956 Fx	3/5/2015	3/4/2016
Fr Neck Cable Load	Humanetics 10386JI4	LC-DO9740	3/6/2015	3/5/2016
Pendulum ARS	DTS ARS PRO-18K	ARS-9122	9/30/2015	9/29/2016
Head ARS Y-Axis	DTS ARS-18K	ARS-4737	3/30/2015	3/29/2016

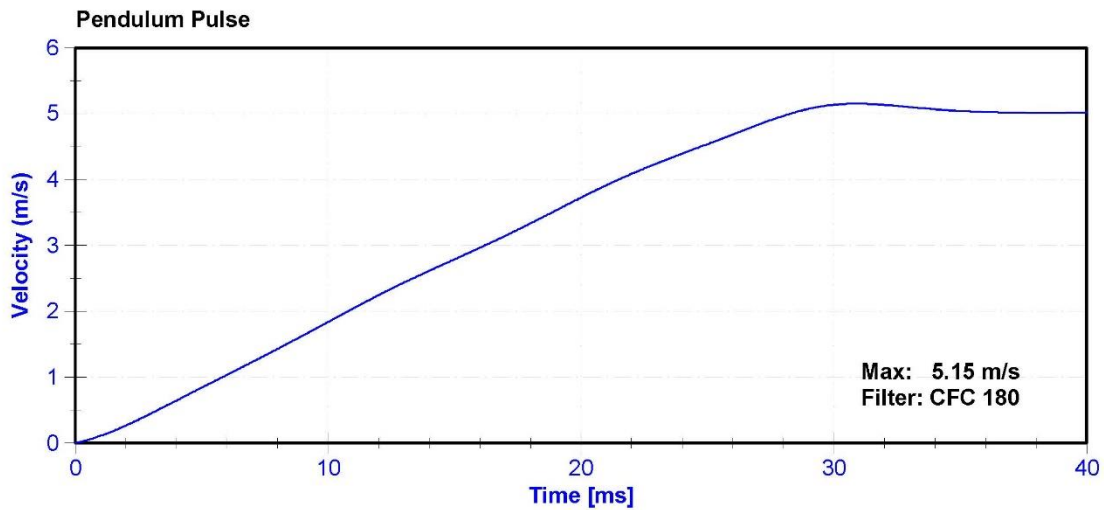

Headform Rotation

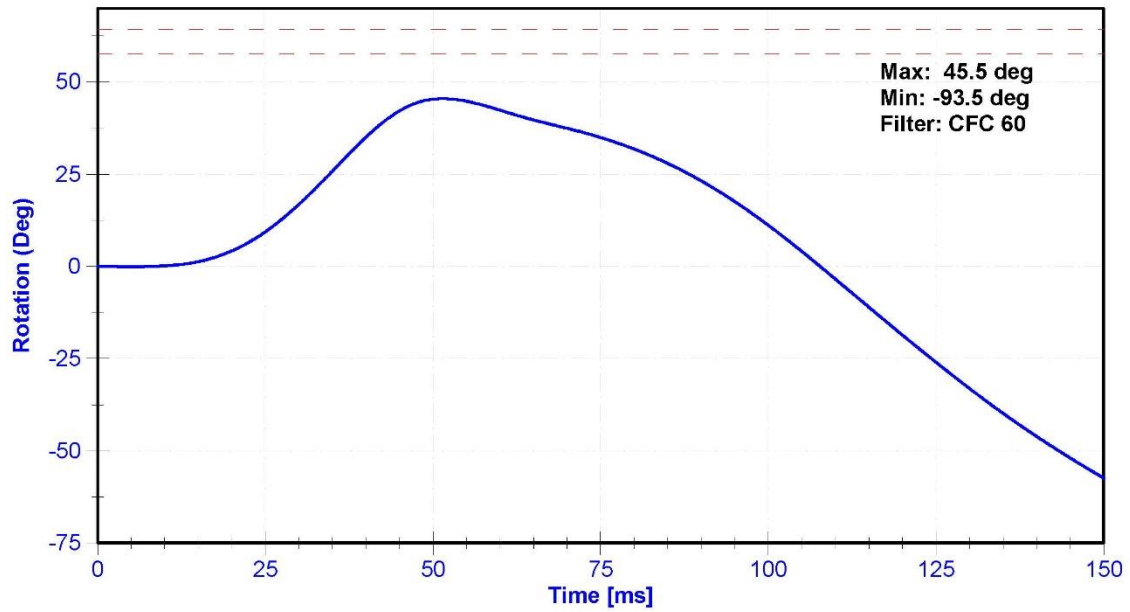

Upper Neck Y Moment

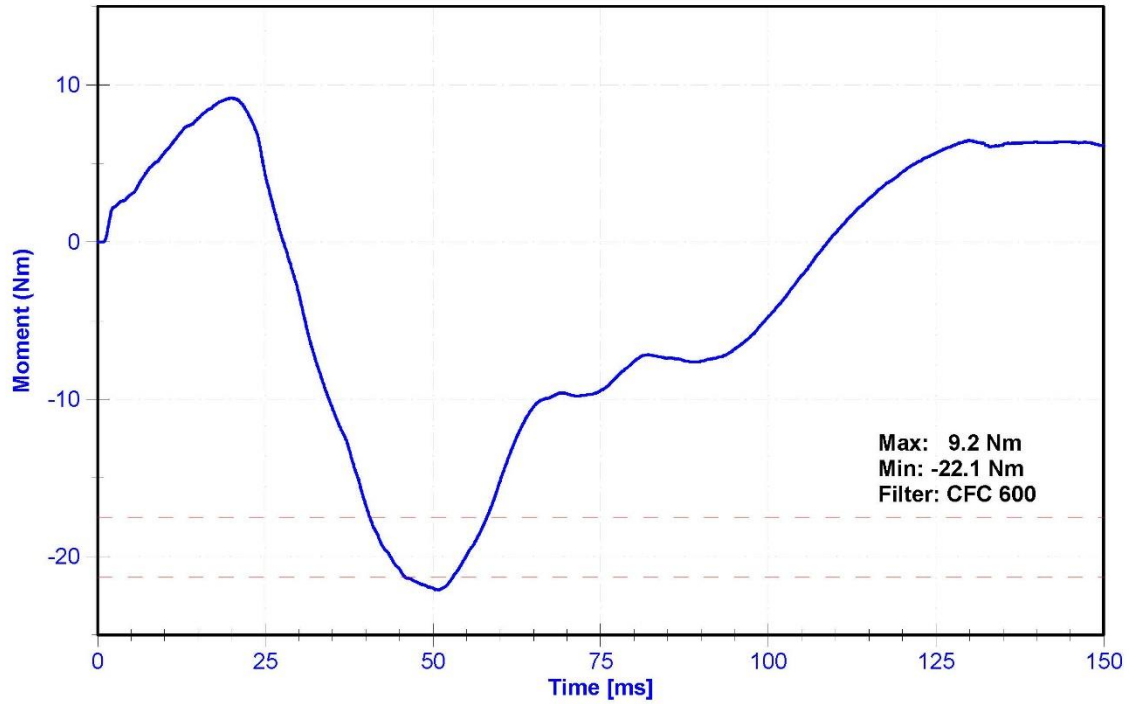

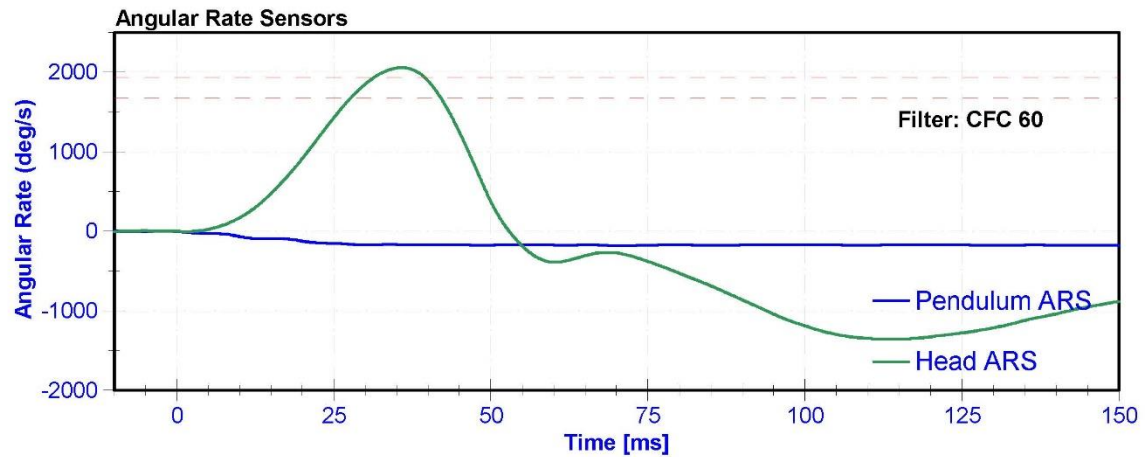
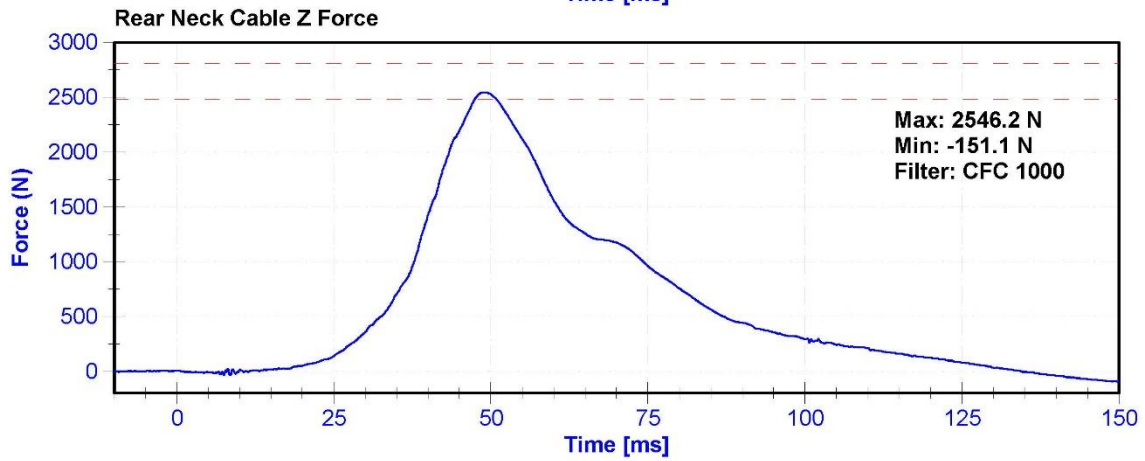
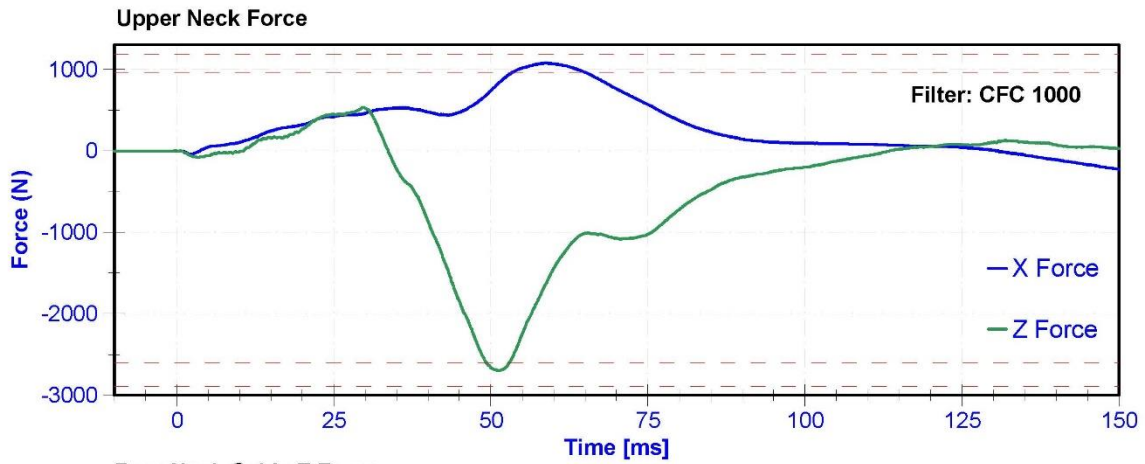

ATD Manufacturer	Humanetics	Test Technician	M. Goehle
ATD Serial Number	DL9207	Laboratory Supervisor	M. Goehle

Results

Test Parameter	Minimum Specification	Maximum Specification	Unit	Result	Pass/Fail
Temperature	20.6	22.2	°C	21.3	Pass
Humidity	10	70	%	35.5	Pass
Velocity	3.35	3.45	m/s	3.418	Pass
Pendulum Impulse at 4ms	0.89	1.08	m/s	0.977	Pass
Pendulum Impulse at 8ms	2.04	2.36	m/s	2.150	Pass
Pendulum Impulse at 12ms	3.21	3.46	m/s	3.273	Pass
Peak Upper Neck X Moment after 40ms	37.4	45.7	Nm	42.80	Pass
Peak Head X Angular Rate	-1462	-1375	deg/s	-1440.0	Pass
Peak Head X Rotation	-55.3	-45.4	deg	-46.41	Pass
Rotational Decay Time to Zero	83.7	90.9	ms	82.95	Fail

Transducer Calibrations

Channel	Manufacturer	Serial Number	Calibration Date	Calibration Due Date
Pendulum Accelerometer	ENDEVCO 7231CT	AC-AH5F3	5/7/2015	5/6/2016
Upper Neck Load Cell	Humanetics 10380J14	LC-DP3956 Mx	3/5/2015	3/4/2016
Pendulum ARS	DTS ARS PRO-18K	ARS-9122	9/30/2015	9/29/2016
Head X ARS	DTS ARS-18K	ARS-4740	3/30/2015	3/29/2016

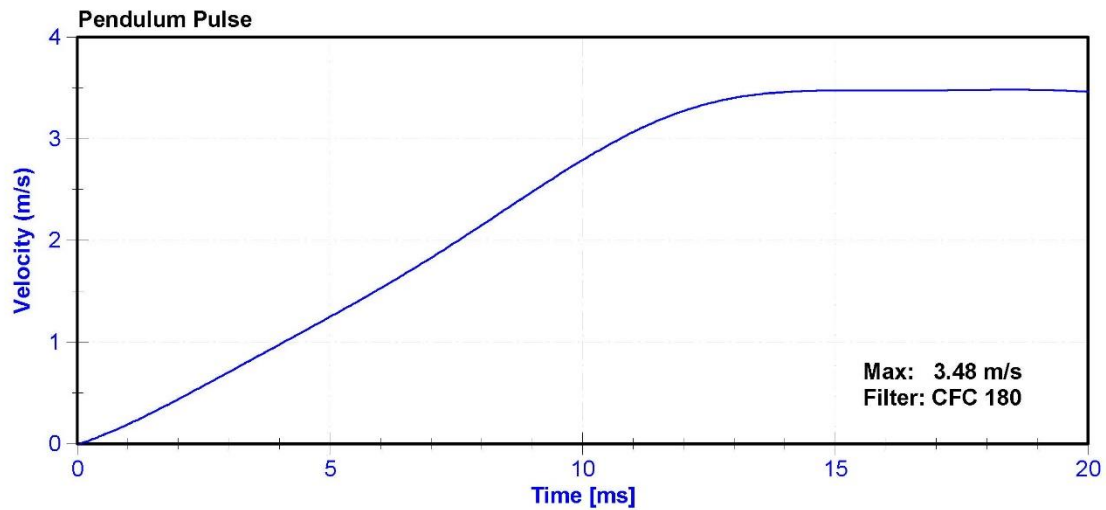

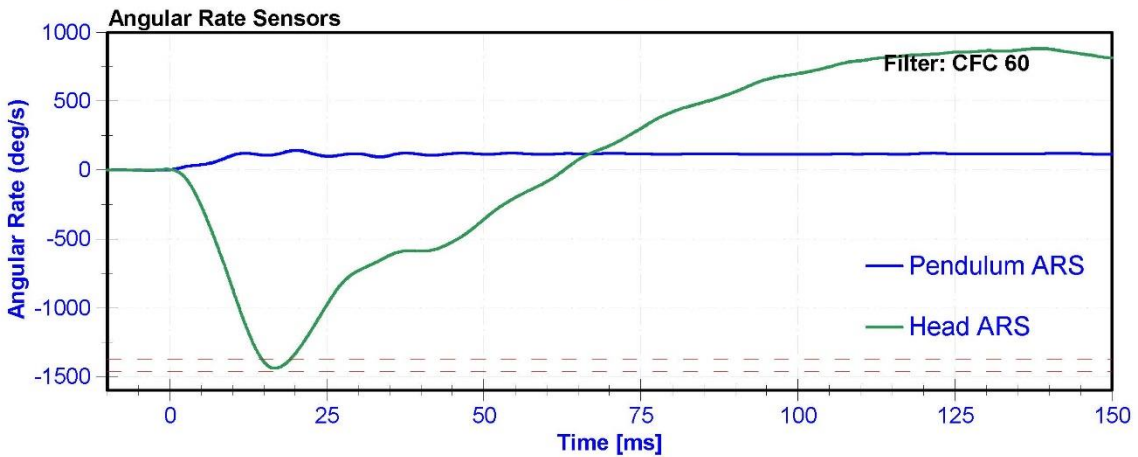
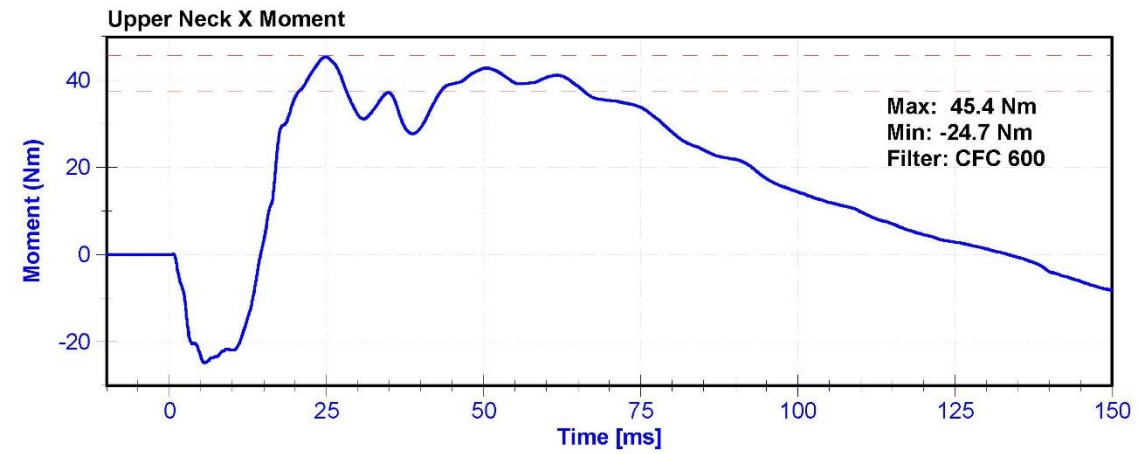
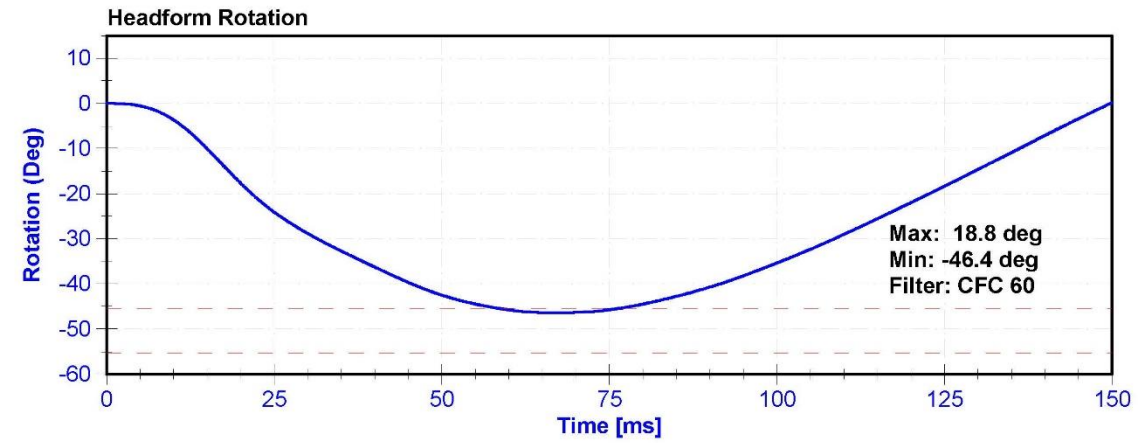

ATD Manufacturer	Humanetics	Test Technician	M. Goehle
ATD Serial Number	DL9207	Laboratory Supervisor	M. Goehle

Results

Test Parameter	Minimum Specification	Maximum Specification	Unit	Result	Pass/Fail
Temperature	20.6	22.2	°C	21.3	Pass
Humidity	10	70	%	34.3	Pass
Velocity	3.35	3.45	m/s	3.42	Pass
Pendulum Impulse at 4ms	0.89	1.08	m/s	0.977	Pass
Pendulum Impulse at 8ms	2.04	2.36	m/s	2.107	Pass
Pendulum Impulse at 12ms	3.21	3.46	m/s	3.246	Pass
Peak Upper Neck X Moment after 40ms	-45.7	-37.4	Nm	-42.03	Pass
Peak Head X Angular Rate	1375	1462	deg/s	1430.3	Pass
Peak Head X Rotation	45.4	55.3	deg	47.06	Pass
Rotation Decay Time to Zero	83.7	90.9	ms	83.85	Pass

Transducer Calibrations

Channel	Manufacturer	Serial Number	Calibration Date	Calibration Due Date
Pendulum Accelerometer	ENDEVCO 7231CT	AC-AH5F3	5/7/2015	5/6/2016
Upper Neck Load Cell	Humanetics 10380J14	LC-DP3956 Mx	3/5/2015	3/4/2016
Pendulum ARS	DTS ARS PRO-18K	ARS-9122	9/30/2015	9/29/2016
Head X ARS	DTS ARS-18K	ARS-4740	3/30/2015	3/29/2016

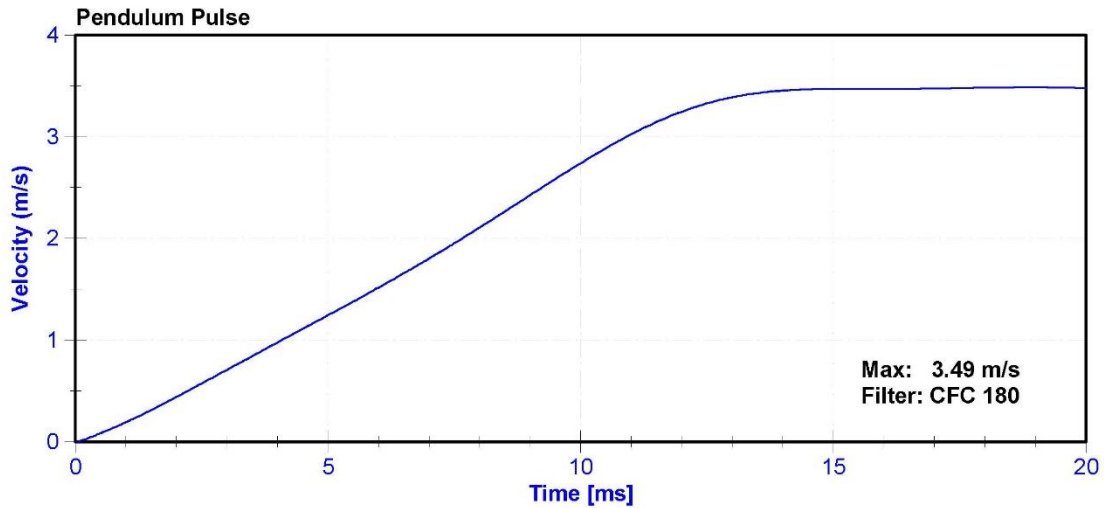

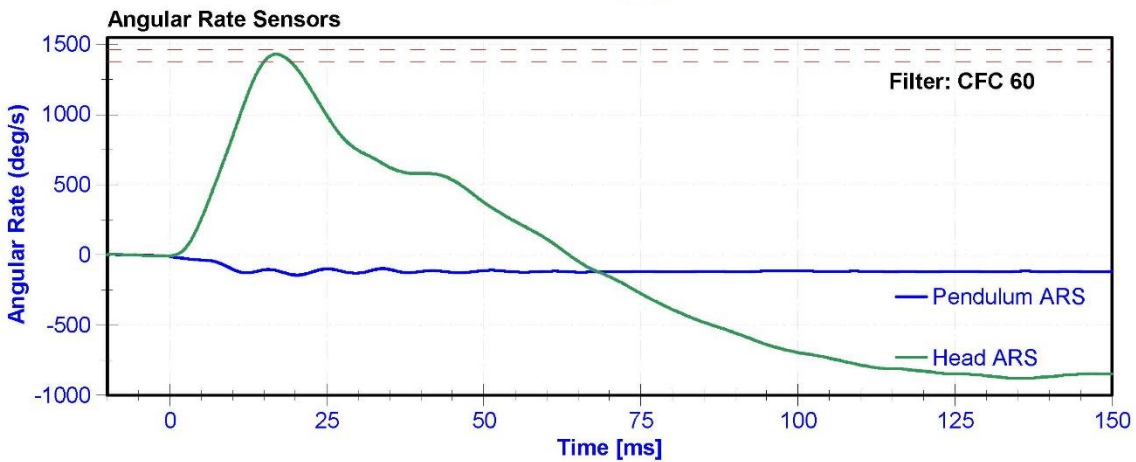
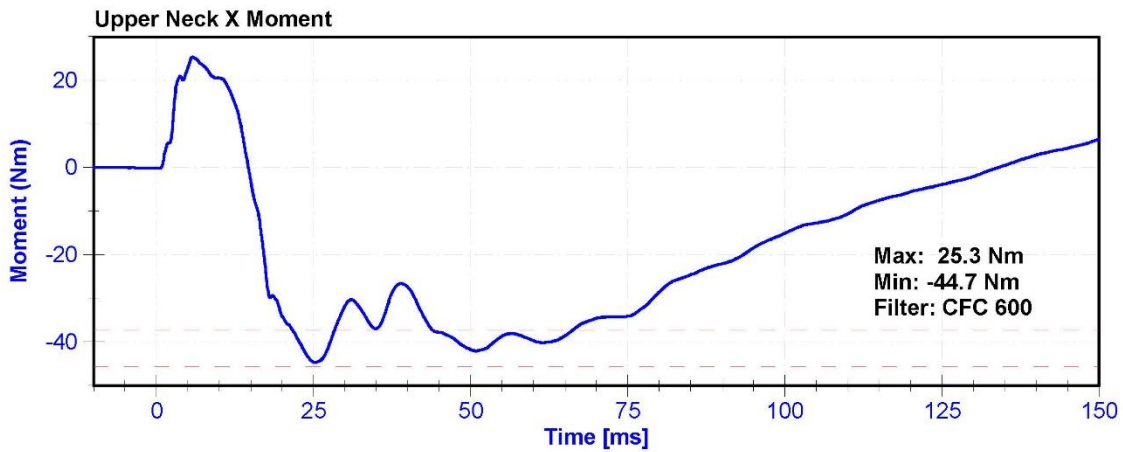
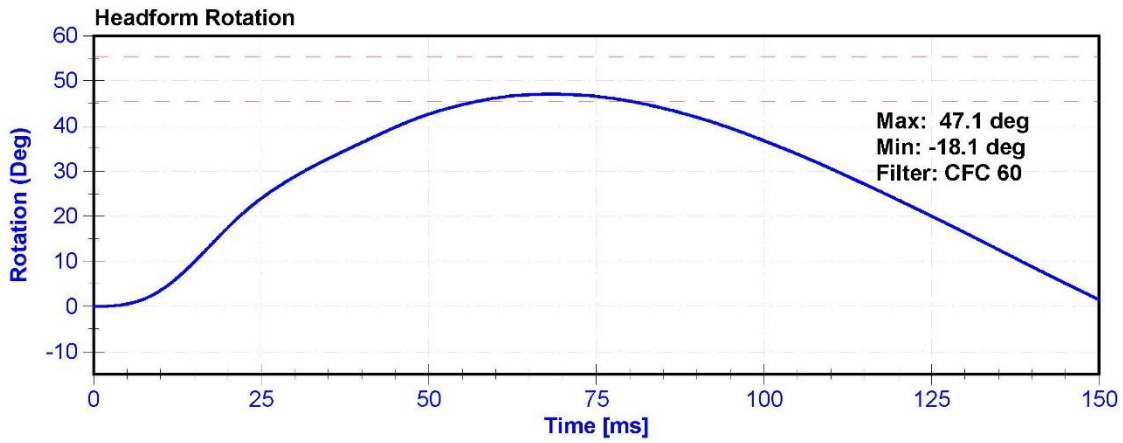

ATD Manufacturer	Humanetics	Test Technician	M. Goehle
ATD Serial Number	DL9207	Laboratory Supervisor	M. Goehle

Results

Test Parameter	Minimum Specification	Maximum Specification	Unit	Result	Pass/Fail
Temperature	20.6	22.2	°C	21.1	Pass
Humidity	10	70	%	29.7	Pass
Velocity	4.95	5.05	m/s	5.04	Pass
Pendulum Impulse at 10ms	1.72	1.98	m/s	1.829	Pass
Pendulum Impulse at 15ms	2.67	2.97	m/s	2.816	Pass
Pendulum Impulse at 20ms	3.59	3.98	m/s	3.817	Pass
Pendulum Impulse at 25ms	4.43	4.92	m/s	4.769	Pass
Peak Upper Neck Z Moment	32.6	38.3	Nm	38.98	Fail
Peak Neck Axial Rotation	55.6	66.6	deg	48.54	Fail
Rotation Decay Time to Zero	58.0	61.6	ms	61.35	Pass
Peak Upper Neck Angular Velocity	1559	1709	deg/s	1576.78	Pass

Transducer Calibrations

Channel	Manufacturer	Serial Number	Calibration Date	Calibration Due Date
Pendulum Accelerometer	ENDEVCO 7231CT	AC-AH5F3	5/7/2015	5/6/2016
Neck Fixture Potentiometer	Servo 14CB1-3615	DS-0001	10/21/2015	10/20/2016
Upper Neck Load Cell	Humanetics 10380JI4	LC-DP3956 Mz	3/5/2015	3/4/2016
Upper Neck ARS	DTS ARS PRO-18K	ARS-9097	9/30/2015	9/29/2016

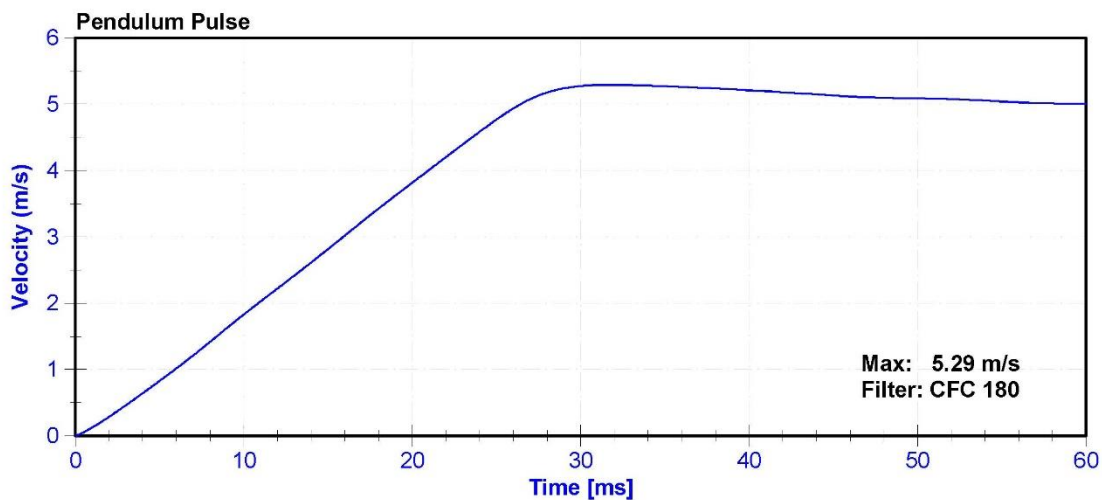

ATD Manufacturer	Humanetics	Test Technician	M. Goehle
ATD Serial Number	DL9207	Laboratory Supervisor	M. Goehle

Results

Test Parameter	Minimum Specification	Maximum Specification	Unit	Result	Pass/Fail
Temperature	20.6	22.2	°C	21.3	Pass
Humidity	10	70	%	17.7	Pass
Impact Velocity	1.95	2.05	m/s	2.020	Pass
Probe Force	5498	5660	N	5901.4	Fail
Resultant Acceleration	112.2	118.7	g's	122.37	Fail

Transducer Calibrations

Channel	Manufacturer	Serial Number	Calibration Date	Calibration Due Date
Head X Accel	Endevco 7264	AC-P82183	4/3/2015	4/2/2016
Head Y Accel	Endevco 7264	AC-P81384	4/3/2015	4/2/2016
Head Z Accel	Endevco 7264	AC-P81797	4/3/2015	4/2/2016
Probe Accel	ENDEVCO 7231CT	AC-C15018	7/15/2015	7/14/2016

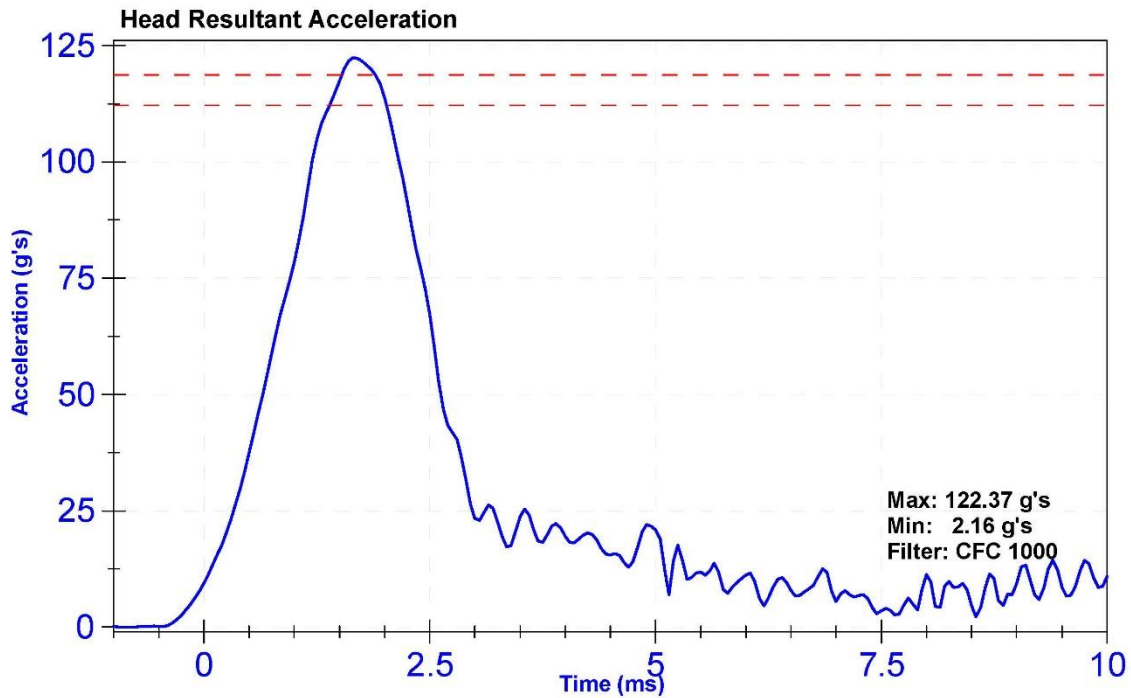

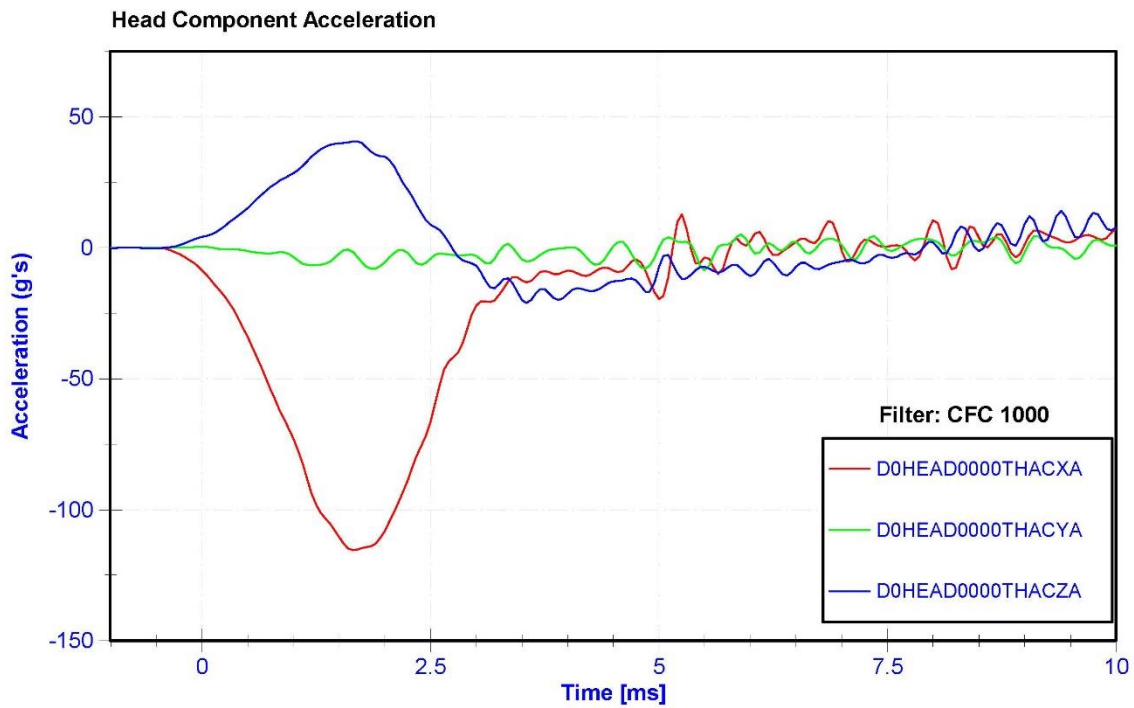
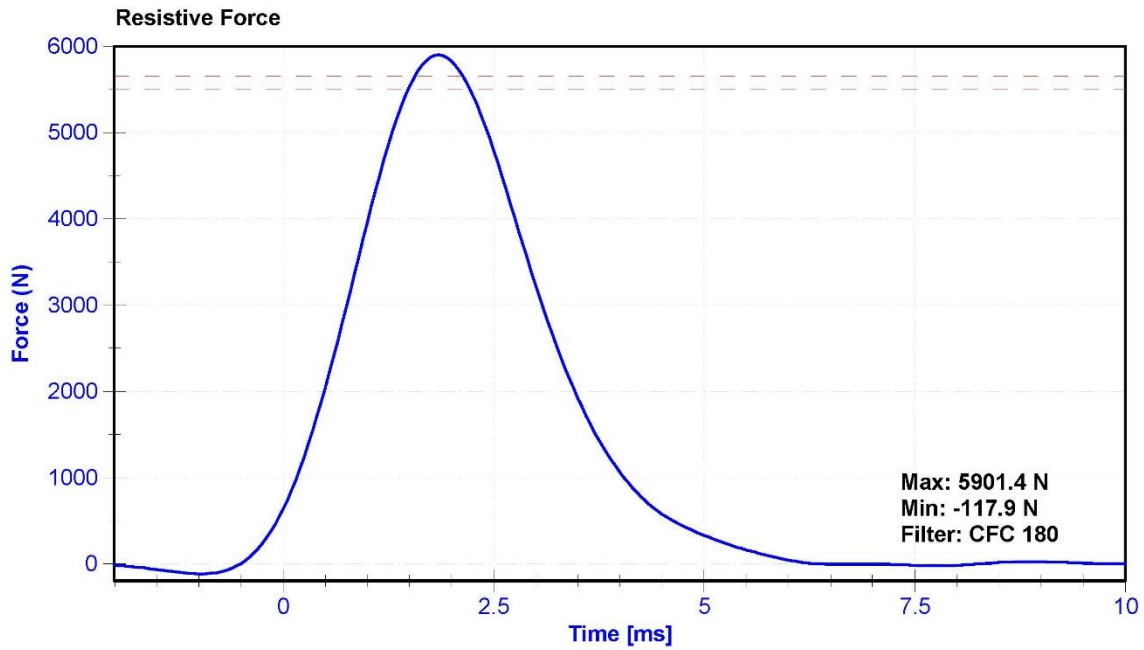

ATD Manufacturer	Humanetics	Test Technician	M. Goehle
ATD Serial Number	DL9207	Laboratory Supervisor	M. Goehle

Results

Test Parameter	Minimum Specification	Maximum Specification	Unit	Result	Pass/Fail
Temperature	20.6	22.2	°C	21.2	Pass
Humidity	10	70	%	20.7	Pass
Impact Velocity	6.68	6.78	m/s	6.699	Pass
Probe Force	9067	11082	N	8577.7	Fail
Resultant Acceleration	209	255	g's	173.5	Fail

Transducer Calibrations

Channel	Manufacturer	Serial Number	Calibration Date	Calibration Due Date
Head X Accel	Endevco 7264	AC-P82183	4/3/2015	4/2/2016
Head Y Accel	Endevco 7264	AC-P81384	4/3/2015	4/2/2016
Head Z Accel	Endevco 7264	AC-P81797	4/3/2015	4/2/2016
Probe Accel	ENDEVCO 7231CT	AC-C15018	7/15/2015	7/14/2016

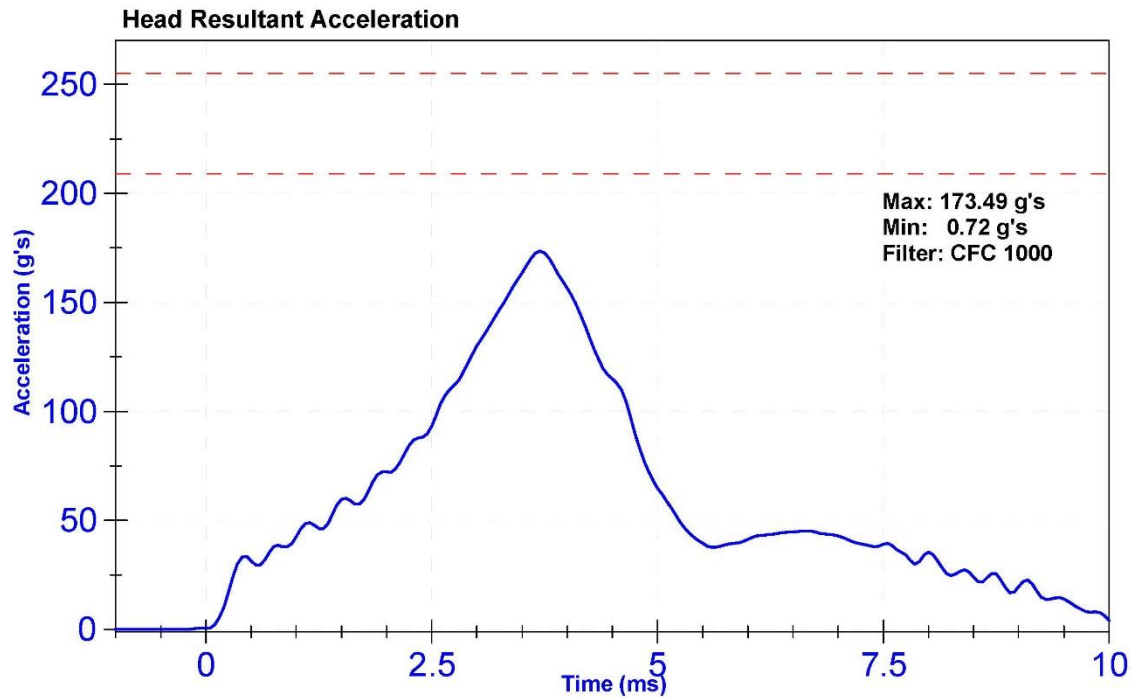

Resistive Force

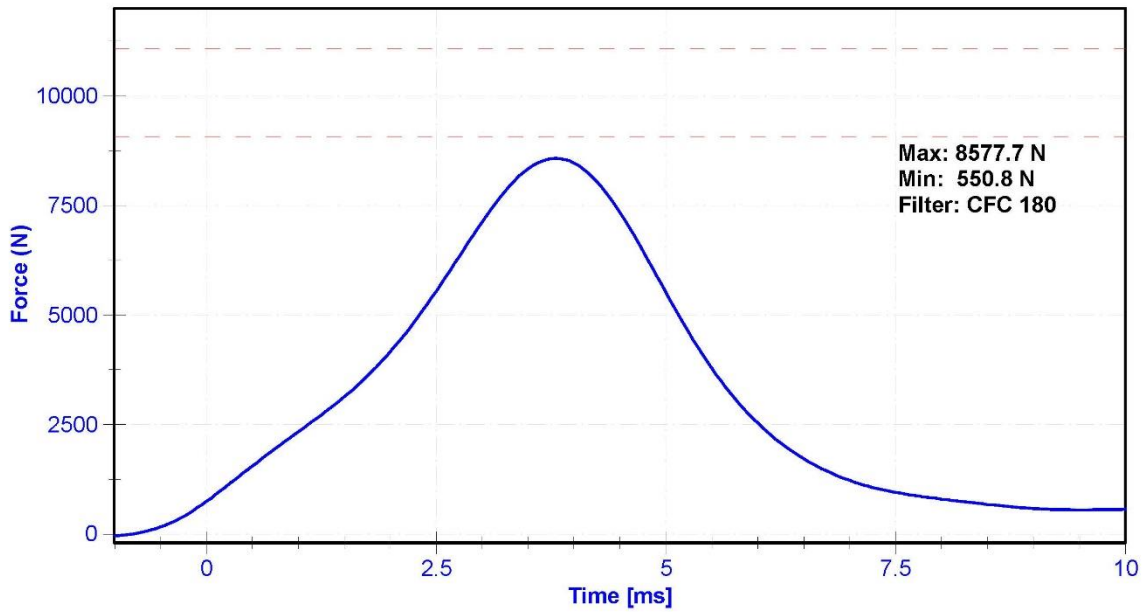

Head Component Acceleration

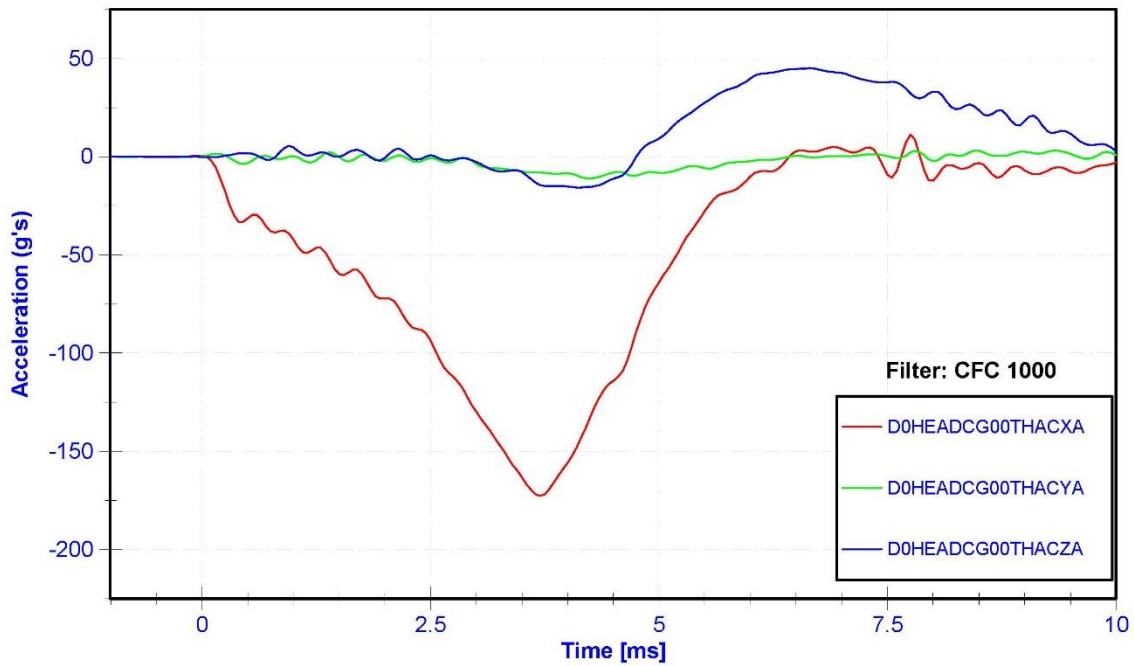

ATD Manufacturer	Humanetics	Test Technician	M. Goehle
ATD Serial Number	DL9207	Laboratory Supervisor	M. Goehle

Results

Test Parameter	Minimum Specification	Maximum Specification	Unit	Result	Pass/Fail
Temperature	20.6	22.2	°C	21.0	Pass
Humidity	10	70	%	33.0	Pass
Velocity	4.95	5.05	m/s	4.985	Pass
Pendulum Impulse at 8ms	1.49	1.85	m/s	1.515	Pass
Pendulum Impulse at 16ms	3.08	3.86	m/s	3.134	Pass
Pendulum Impulse at 24ms	4.48	5.26	m/s	4.536	Pass
Peak Upper Neck Y Moment	19.7	24.1	Nm	21.94	Pass
Peak Upper Neck X Force	-1592	-1302	N	-1364.0	Pass
Maximum Upper Neck Z Force	877	1072	N	965.4	Pass
First Peak Rear Neck Cable Force	1115	1282	N	1208.3	Pass
Peak Head Y Angular Rate	-1935	-1675	deg/s	-1696.4	Pass
Peak Head Y Rotation	-69.9	-63.3	deg	-60.20	Fail
Rotation Decay Time to Zero	83.0	86.2	ms	78.70	Fail

Transducer Calibrations

Channel	Manufacturer	Serial Number	Calibration Date	Calibration Due Date
Pendulum Accelerometer	ENDEVCO 7231CT	AC-AH5F3	5/7/2015	5/6/2016
Upper Neck Load Cell	Humanetics 10380J14	LC-DP3956 Fx	3/5/2015	3/4/2016
Rear Neck Cable Load Cell	Humanetics 10386J14	LC-DO9741	3/6/2015	3/5/2016
Pendulum ARS	DTS ARS PRO-18K	ARS-9122	9/30/2015	9/29/2016
Head Y ARS	DTS ARS-18K	ARS-4737	3/30/2015	3/29/2016

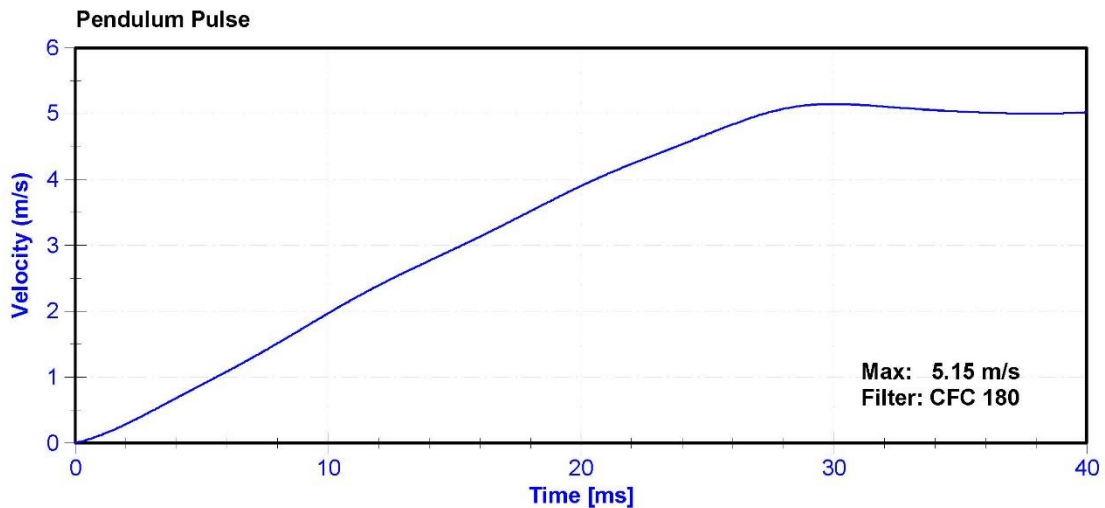

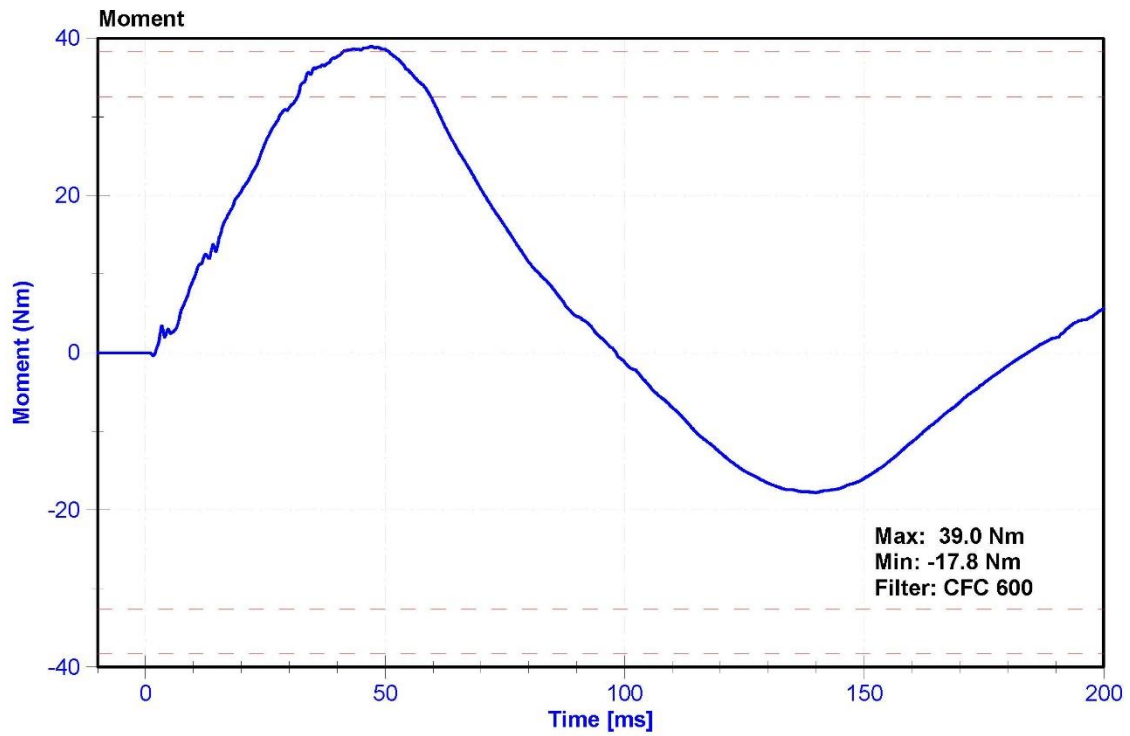
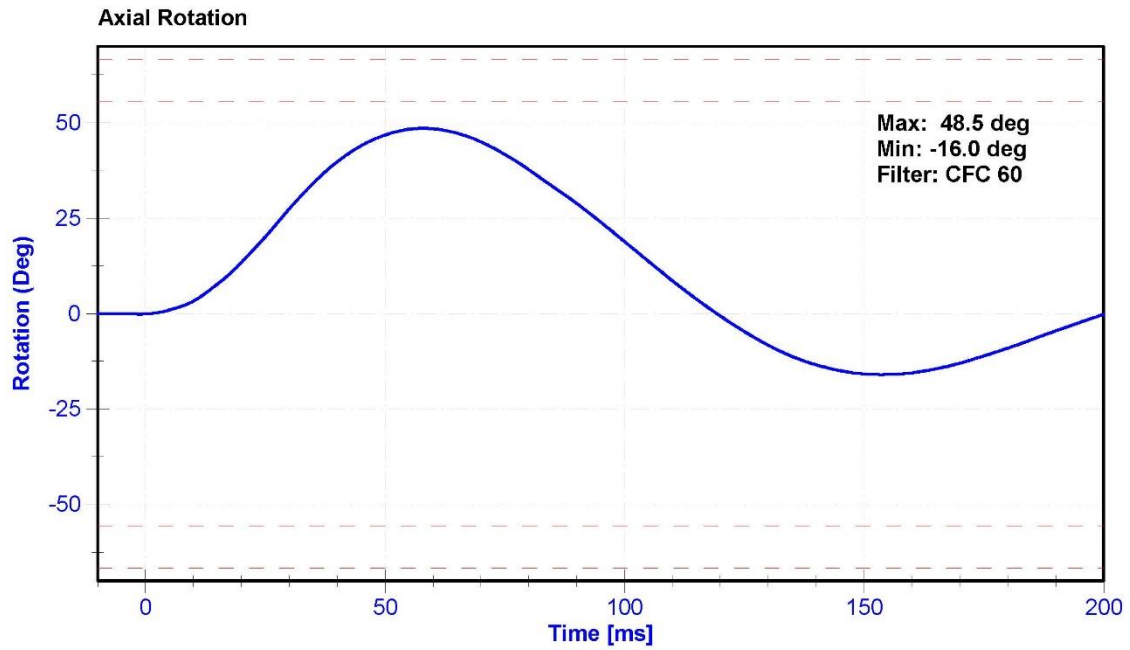

ATD Manufacturer	Humanetics	Test Technician	M. Goehle
ATD Serial Number	DL9207	Laboratory Supervisor	M. Goehle

Results

Test Parameter	Minimum Specification	Maximum Specification	Unit	Result	Pass/Fail
Temperature	20.6	22.2	°C	21.0	Pass
Humidity	10	70	%	31.8	Pass
Velocity	4.95	5.05	m/s	5.045	Pass
Pendulum Impulse at 10ms	1.72	1.98	m/s	1.746	Pass
Pendulum Impulse at 15ms	2.67	2.97	m/s	2.693	Pass
Pendulum Impulse at 20ms	3.59	3.98	m/s	3.674	Pass
Pendulum Impulse at 25ms	4.43	4.92	m/s	4.615	Pass
Peak Upper Neck Z Moment	32.6	38.3	Nm	38.26	Pass
Peak Neck Axial Rotation	55.6	66.6	deg	47.76	Fail
Rotation Decay Time to Zero	58.0	61.6	ms	47.00	Fail
Peak Upper Neck Angular Velocity	1559	1709	deg/s	1566.1	Pass

Transducer Calibrations

Channel	Manufacturer	Serial Number	Calibration Date	Calibration Due Date
Pendulum Accelerometer	ENDEVCO 7231CT	AC-AH5F3	5/7/2015	5/6/2016
Neck Fixture Potentiometer	Servo 14CB1-3615	DS-0001	10/21/2015	10/20/2016
Upper Neck Load Cell	Humanetics 10380JI4	LC-DP3956 Mz	3/5/2015	3/4/2016
Upper Neck ARS	DTS ARS PRO-18K	ARS-9097	9/30/2015	9/29/2016

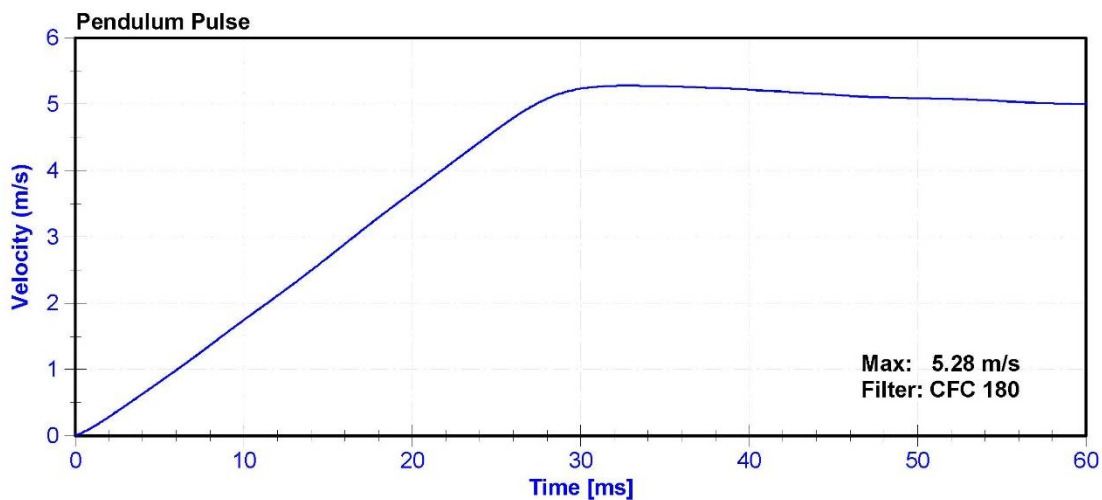

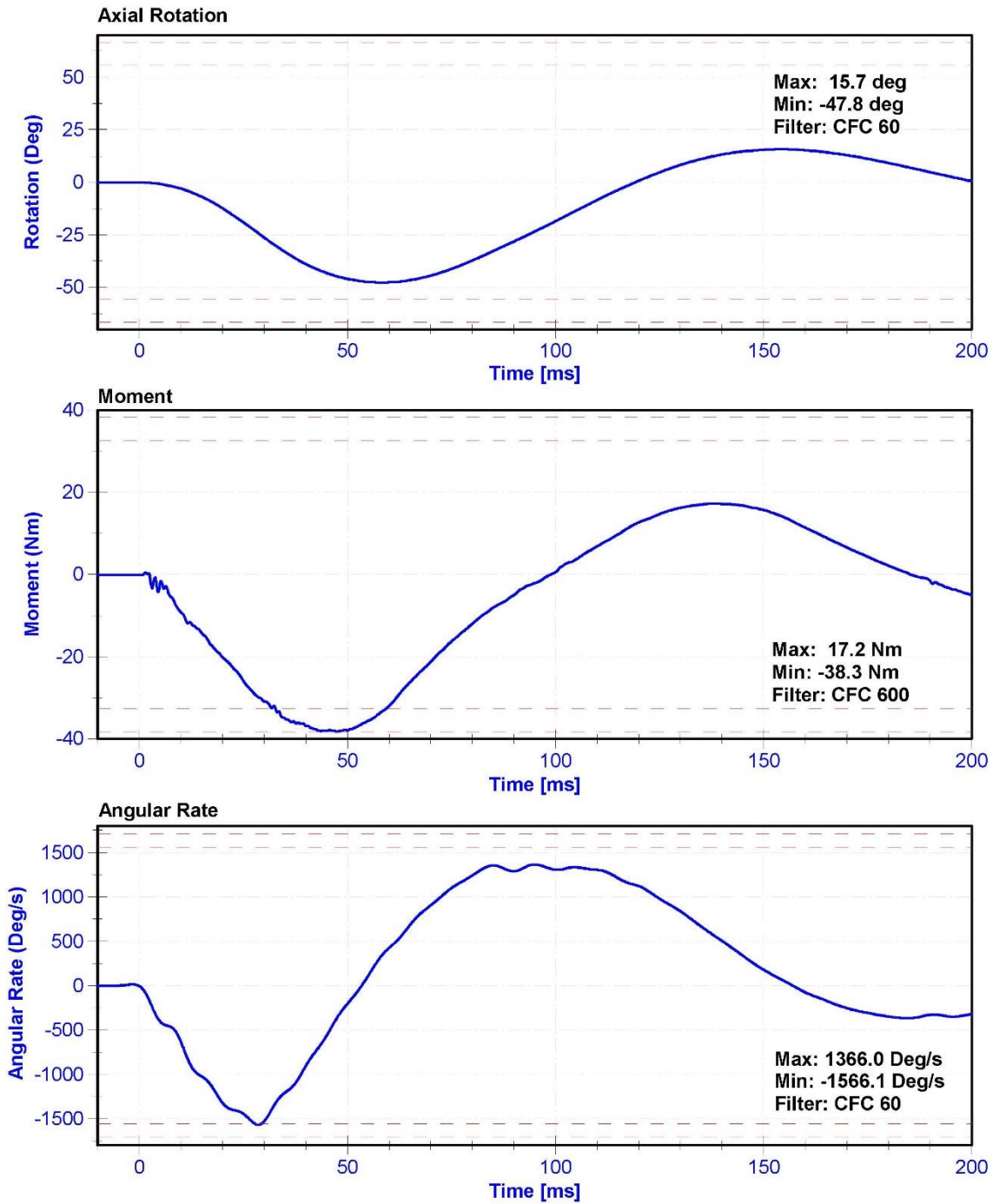

ATD Manufacturer	Humanetics	Test Technician	M. Goehle
ATD Serial Number	DL9207	Laboratory Supervisor	M. Goehle

Results

Test Parameter	Minimum Specification	Maximum Specification	Unit	Result	Pass/Fail
Temperature	18.9	25.6	°C	20.8	Pass
Humidity	10	70	%	30.8	Pass
Impact Velocity	4.25	4.35	m/s	4.323	Pass
Probe Force	2474	2850	N	2822.3	Pass
Upper Left X Rib Deflection	-47.6	-41.0	mm	-43.87	Pass
Upper Right X Rib Deflection	-47.6	-41.0	mm	-43.90	Pass
Left/Right X Rib Deviation	-7.00	7.00	mm	0.033	Pass
Upper Left Z Rib Deflection	27.3	31.7	mm	31.86	Fail
Upper Right Z Rib Deflection	27.3	31.7	mm	31.90	Fail
Left/Right Z Rib Deviation	-7.00	7.00	mm	-0.031	Pass

Transducer Calibrations

Channel	Manufacturer	Serial Number	Calibration Date	Calibration Due Date
Probe Accelerometer	ENDEVCO 7231CT	AC-C14972	8/13/2015	2/11/2016
Upper Left IRTRACC	Humanetics IF-364-C-R3	DS-DS6355	11/10/2015	11/9/2016
Upper Left Y Potentiometer	Humanetics 9945	DS-DI2382	4/8/2015	4/7/2016
Upper Left Z Potentiometer	Humanetics 9945	DS-DI2383	4/8/2015	4/7/2016
Upper Right IRTRACC	Humanetics IF-364-C-R3	DS-DJ2613	4/8/2015	4/7/2016
Upper Right Y Potentiometer	Humanetics 9945	DS-DI7753	4/9/2015	4/8/2016
Upper Right Z Potentiometer	Humanetics 9945	DS-DI7752	4/9/2015	4/8/2016

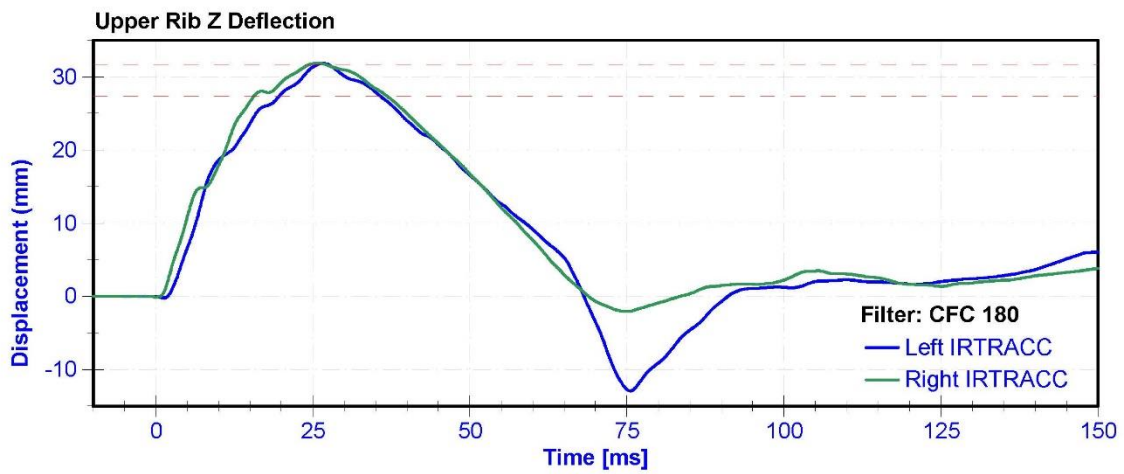
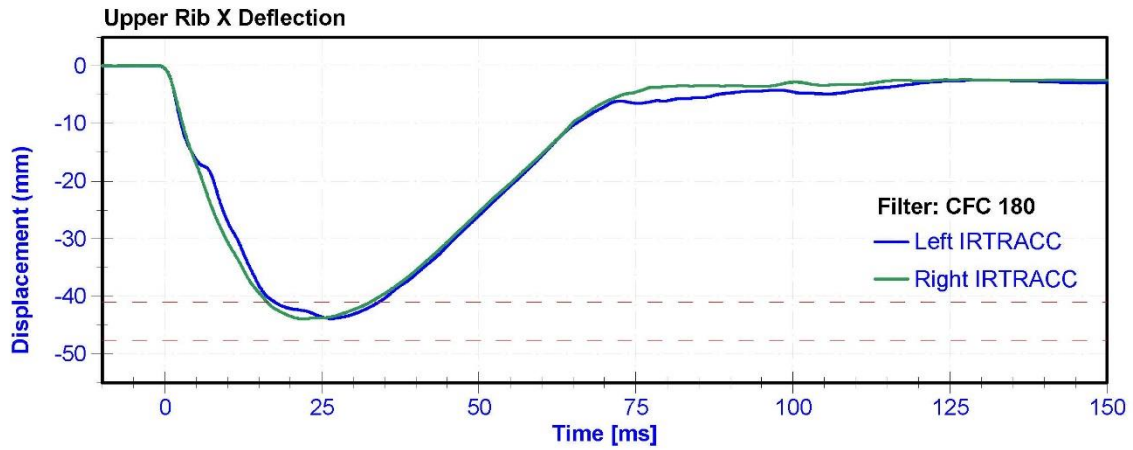
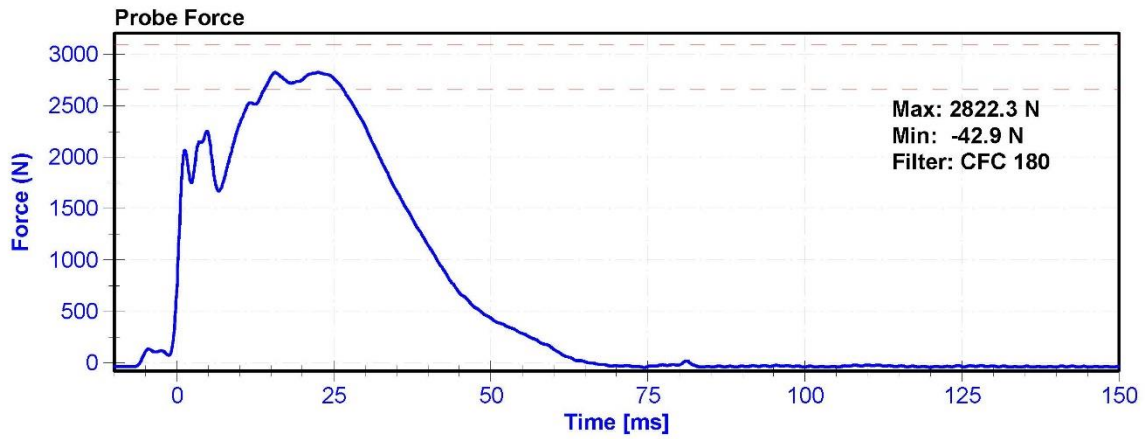

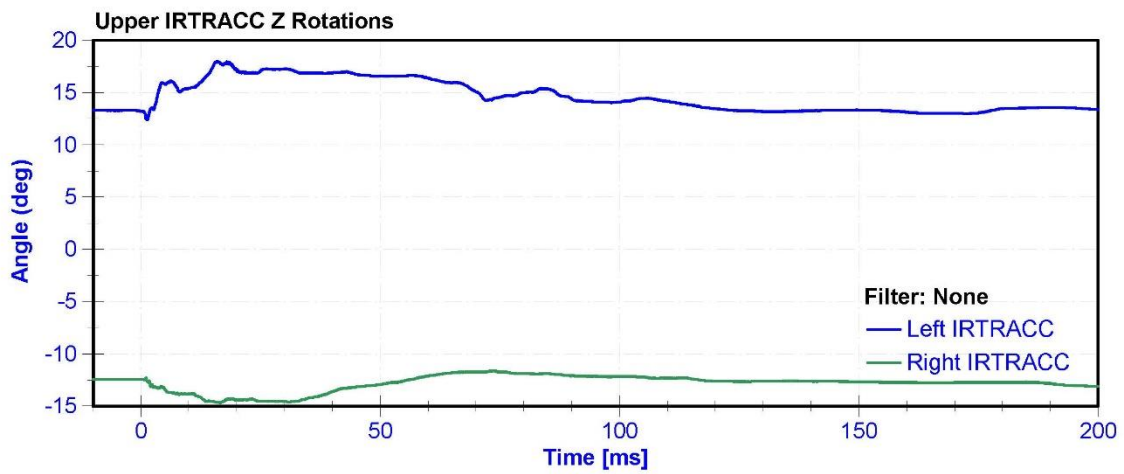
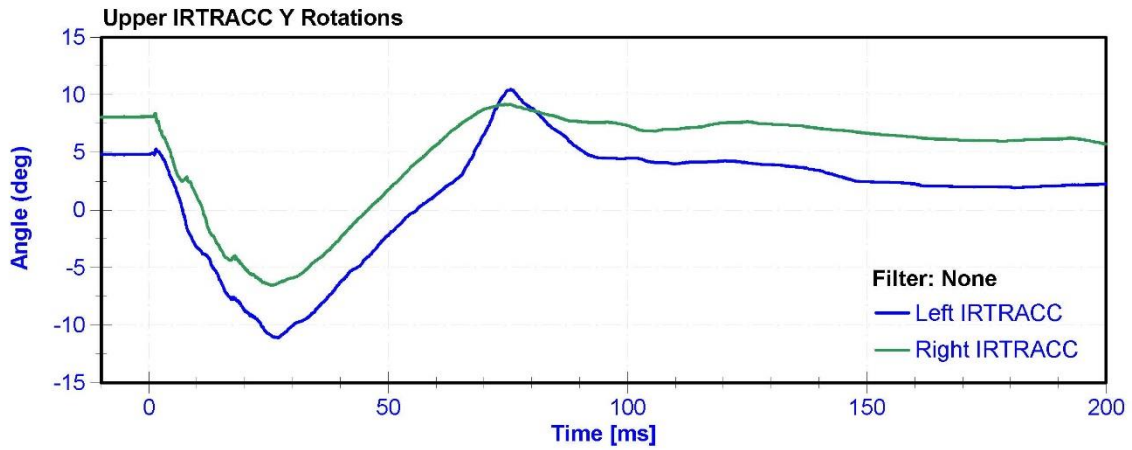
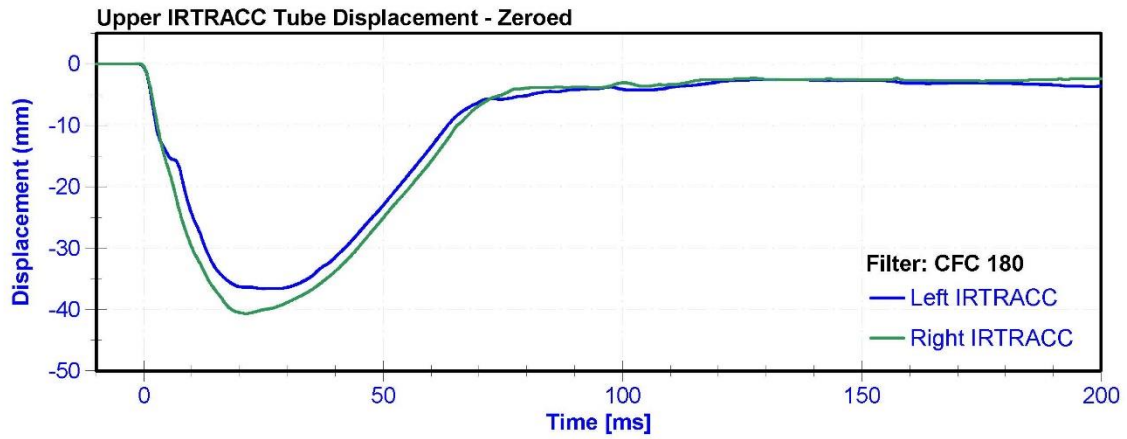

ATD Manufacturer	Humanetics	Test Technician	M. Goehle
ATD Serial Number	DL9207	Laboratory Supervisor	M. Goehle

Results

Test Parameter	Minimum Specification	Maximum Specification	Unit	Result	Pass/Fail
Temperature	20.6	22.2	°C	20.8	Pass
Humidity	10	70	%	17.4	Pass
Impact Velocity	4.25	4.35	m/s	4.311	Pass
Peak Left X Rib Deflection	-54.5	-46.2	mm	-46.28	Pass
Probe Force during Peak Deflection	3083	3571	N	3511.1	Pass

Transducer Calibrations

Channel	Manufacturer	Serial Number	Calibration Date	Calibration Due Date
Probe Accel	ENDEVCO 7231CT	AC-C14972	8/13/2015	2/11/2016
Lower Left IRTRACC	Humanetics IF-364-C-R3	DS-DS6353	11/10/2015	11/9/2016
Lower Left Y Potentiometer	Humanetics 9945	DS-DM4781	4/7/2015	4/6/2016
Lower Left Z Potentiometer	Humanetics 9945	DS-DS4092	4/7/2015	4/6/2016

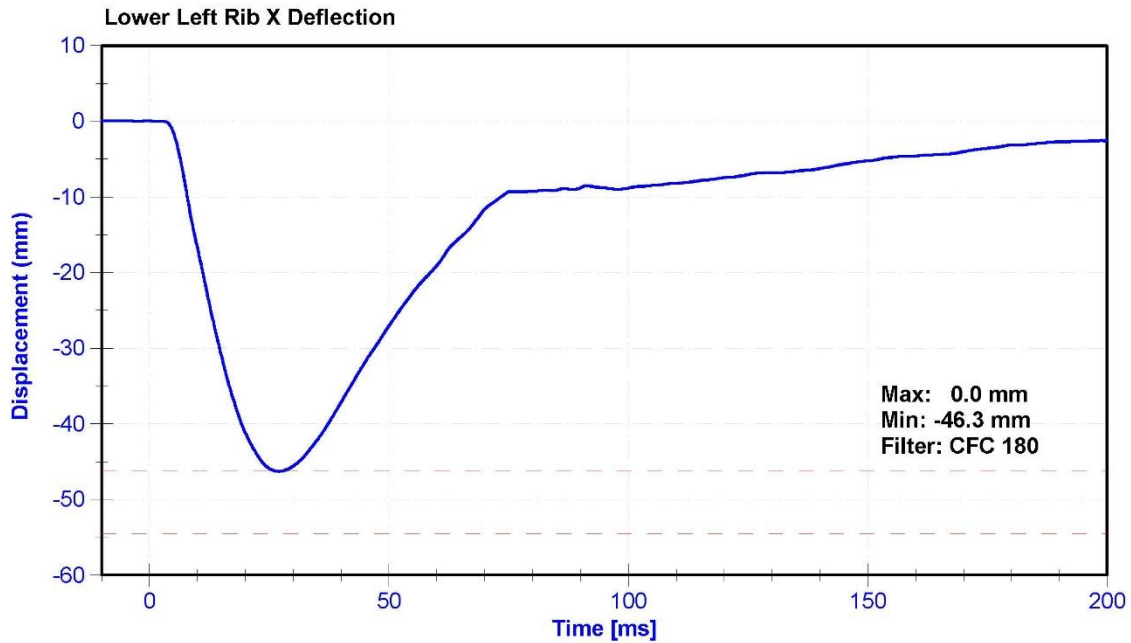

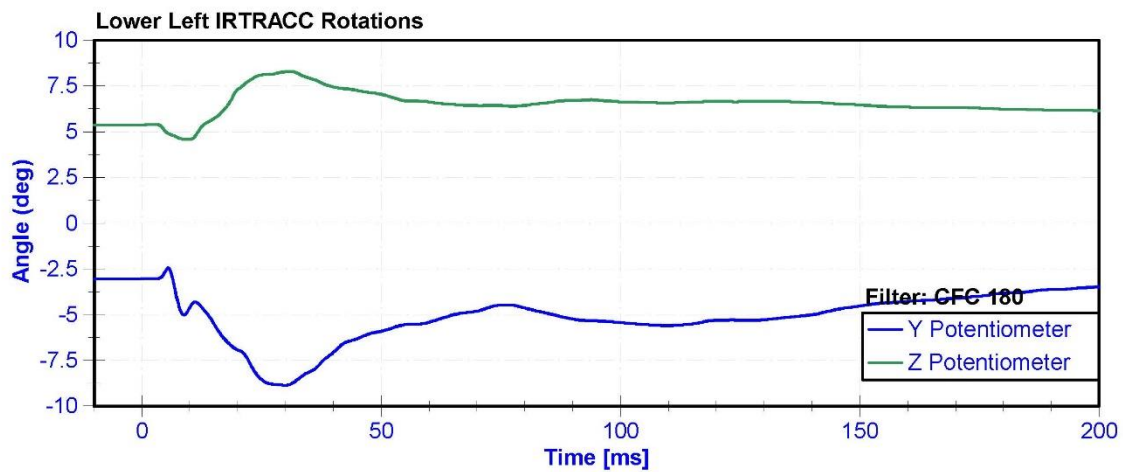
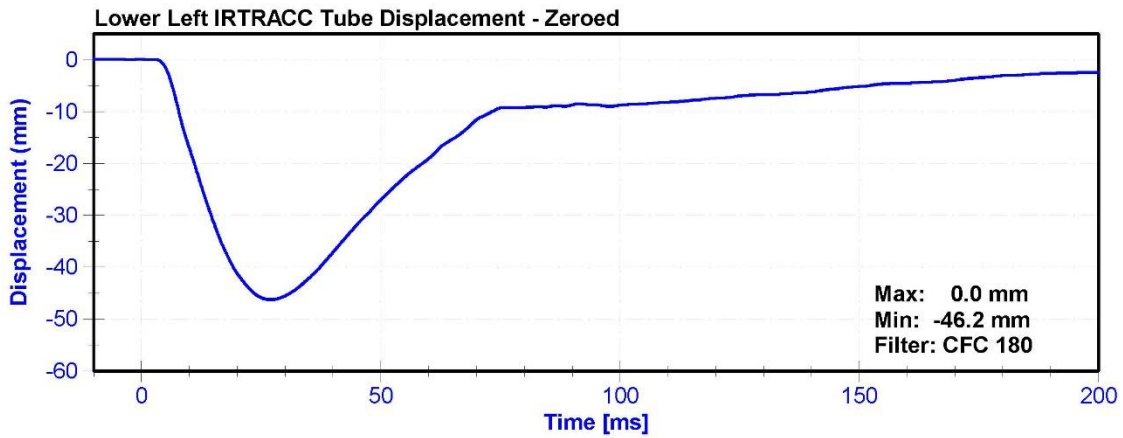
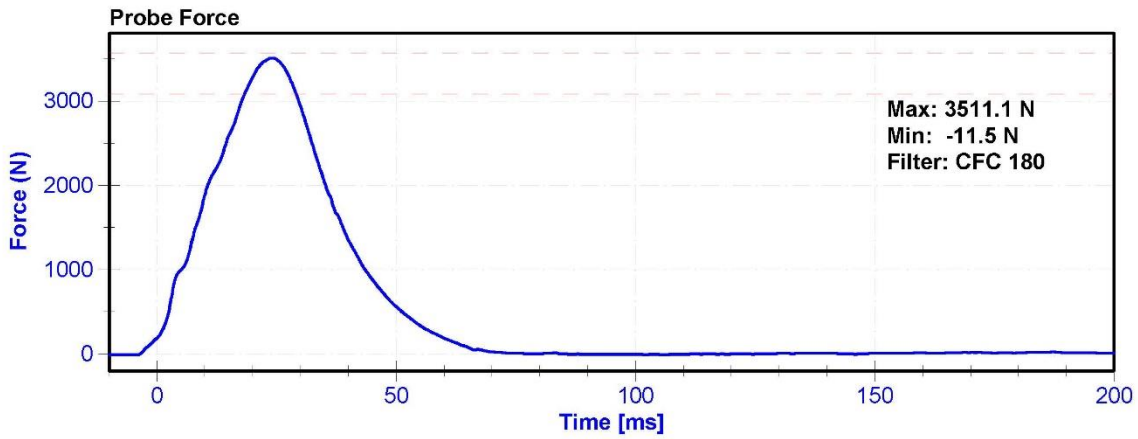

ATD Manufacturer	Humanetics	Test Technician	M. Goehle
ATD Serial Number	DL9207	Laboratory Supervisor	M. Goehle

Results

Test Parameter	Minimum Specification	Maximum Specification	Unit	Result	Pass/Fail
Temperature	20.6	22.2	°C	20.7	Pass
Humidity	10	70	%	16.9	Pass
Impact Velocity	4.25	4.35	m/s	4.281	Pass
Peak Right X Rib Deflection	-54.5	-46.2	mm	-47.15	Pass
Probe Force during Peak Deflection	3083	3571	N	3802.1	Fail

Transducer Calibrations

Channel	Manufacturer	Serial Number	Calibration Date	Calibration Due Date
Probe Accel	ENDEVCO 7231CT	AC-C14972	8/13/2015	2/11/2016
Lower Right IRTRACC	Humanetics IF-364-C-R3	DS-DS6354	11/10/2015	11/9/2016
Lower Right Y Potentiometer	Humanetics 9945	DS-DM4776	4/7/2015	4/6/2016
Lower Right Z Potentiometer	Humanetics 9945	DS-DM4777	4/7/2015	4/6/2016

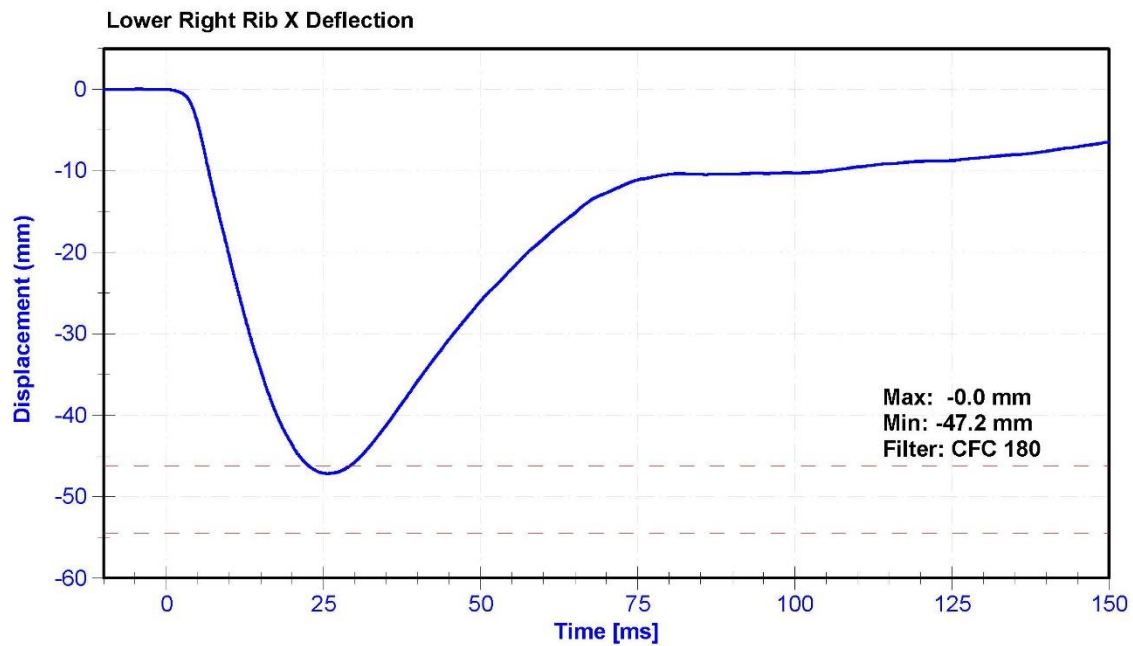

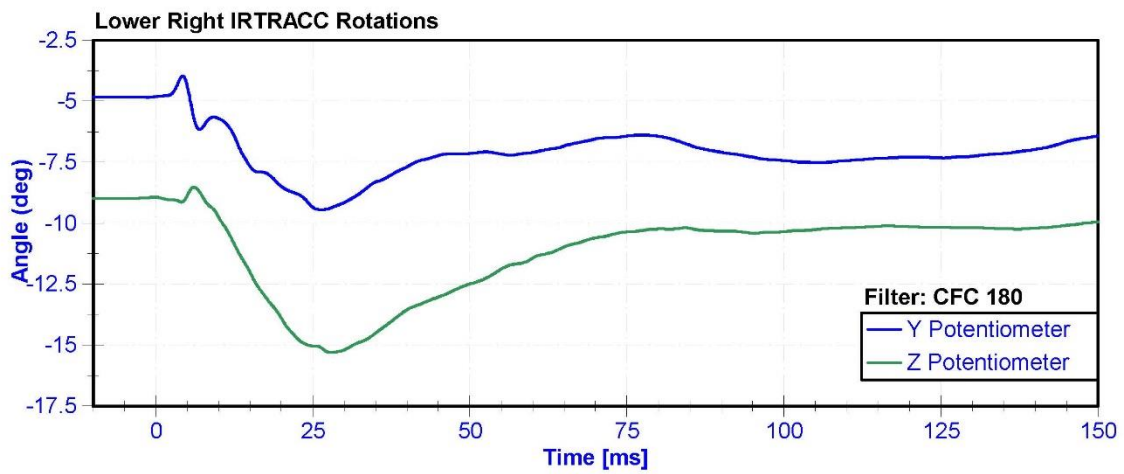
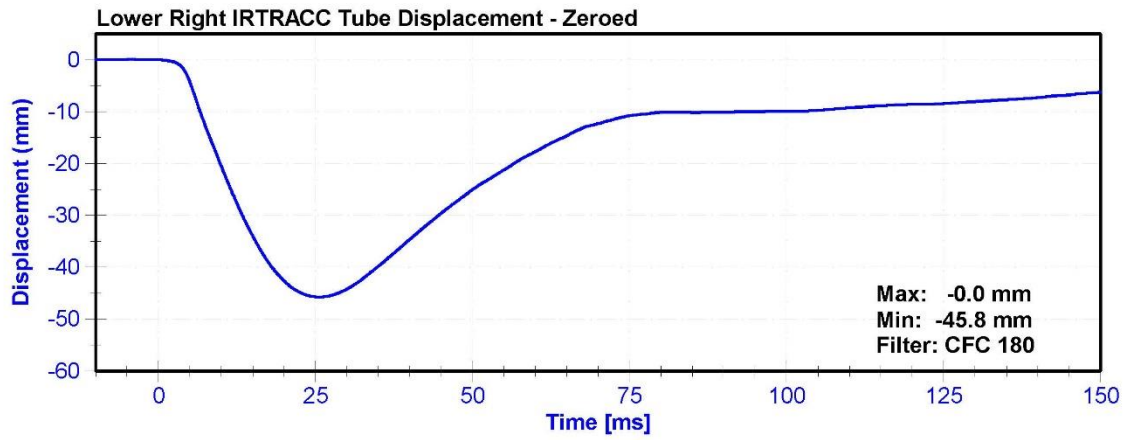
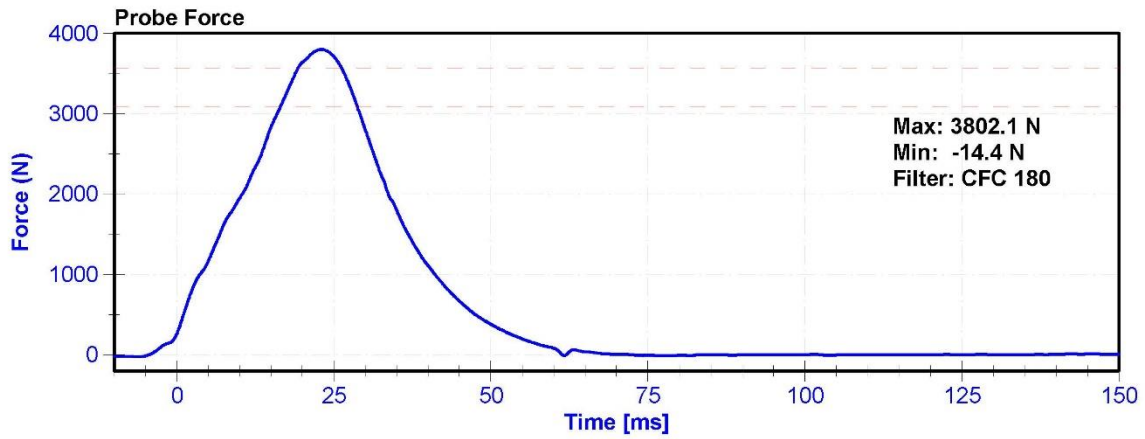

ATD Manufacturer	Humanetics	Test Technician	M. Goehle
ATD Serial Number	DL9207	Laboratory Supervisor	M. Goehle

Results

Test Parameter	Minimum Specification	Maximum Specification	Unit	Result	Pass/Fail
Temperature	20.6	22.2	°C	20.9	Pass
Humidity	10	70	%	17.9	Pass
Impact Velocity	3.25	3.35	m/s	3.315	Pass
Probe Force	2523	3083	N	2949.7	Pass
Left Abdomen X Deflection	-101.6	-91.2	mm	-75.86	Fail
Right Abdomen X Deflection	-101.6	-91.2	mm	-77.68	Fail
Left/Right X Deviation	-7.00	7.00	mm	1.824	Pass

Transducer Calibrations

Channel	Manufacturer	Serial Number	Calibration Date	Calibration Due Date
Probe Accel	ENDEVCO 7231CT	AC-C14972	8/13/2015	2/11/2016
Abdomen Left IRTRACC	Humanetics 9910	DS-DQ2303	4/13/2015	4/12/2016
Abdomen Left Y Potentiometer	Humanetics 9945	DS-DS8363	12/16/2015	12/15/2016
Abdomen Left Z Potentiometer	Humanetics 9945	DS-DS8361	12/16/2015	12/15/2016

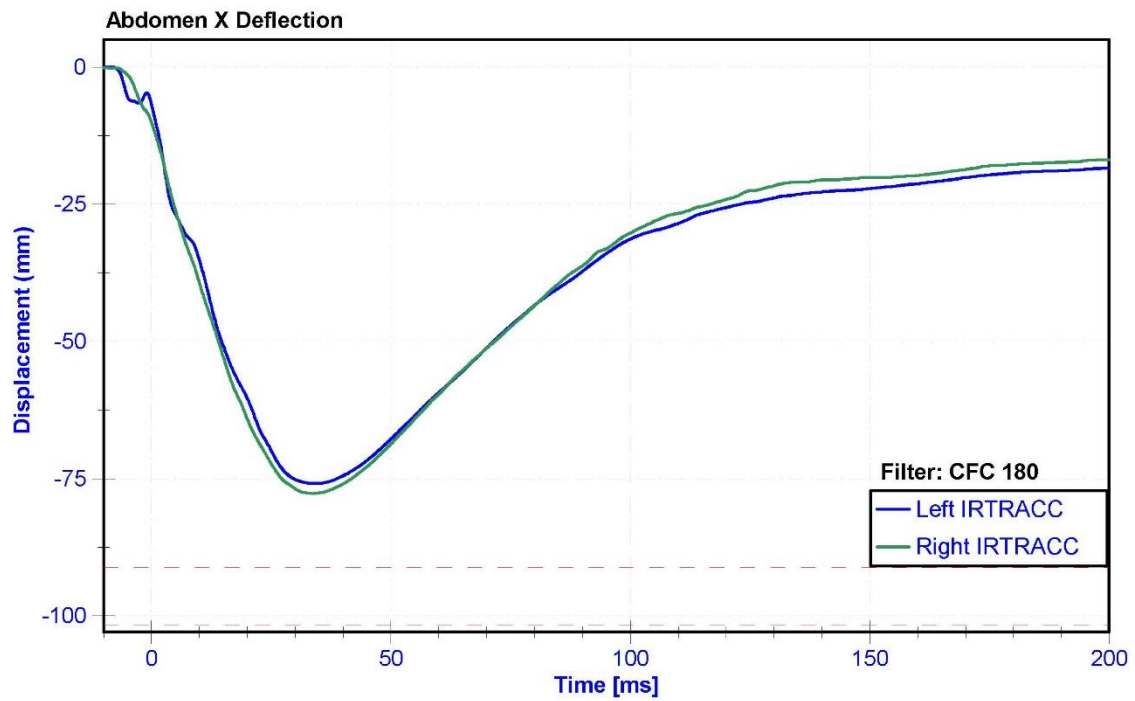
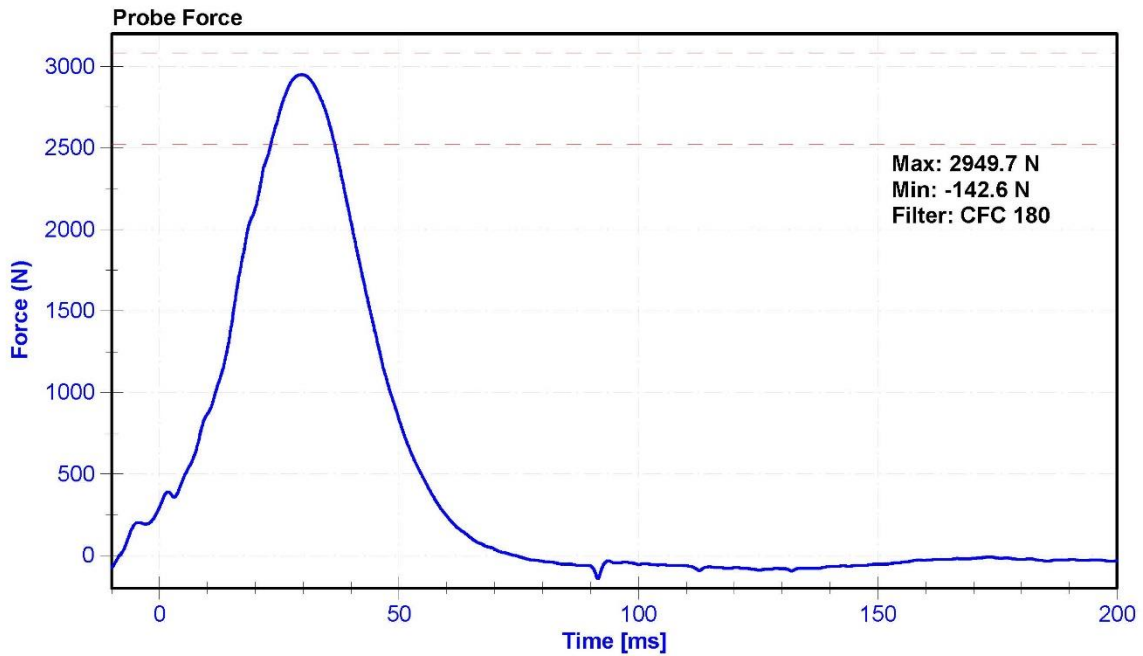

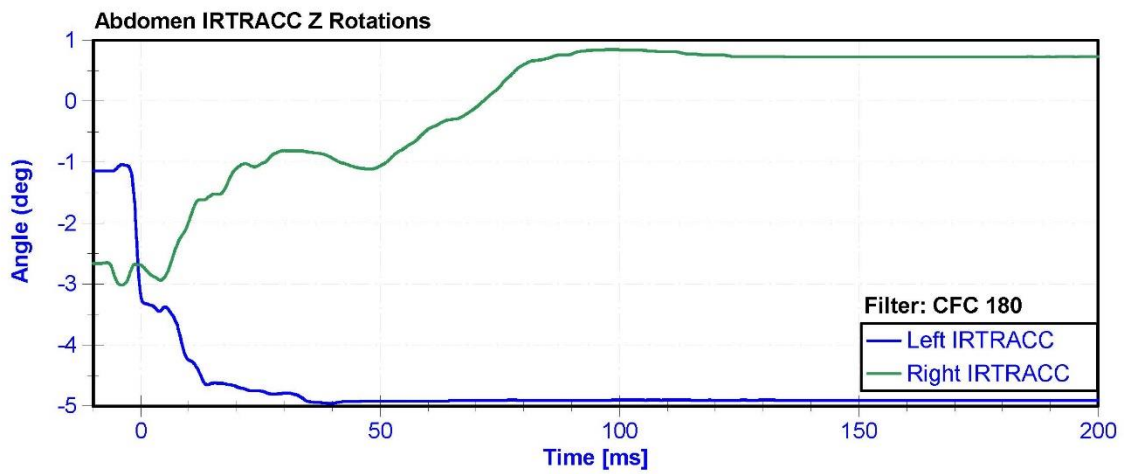
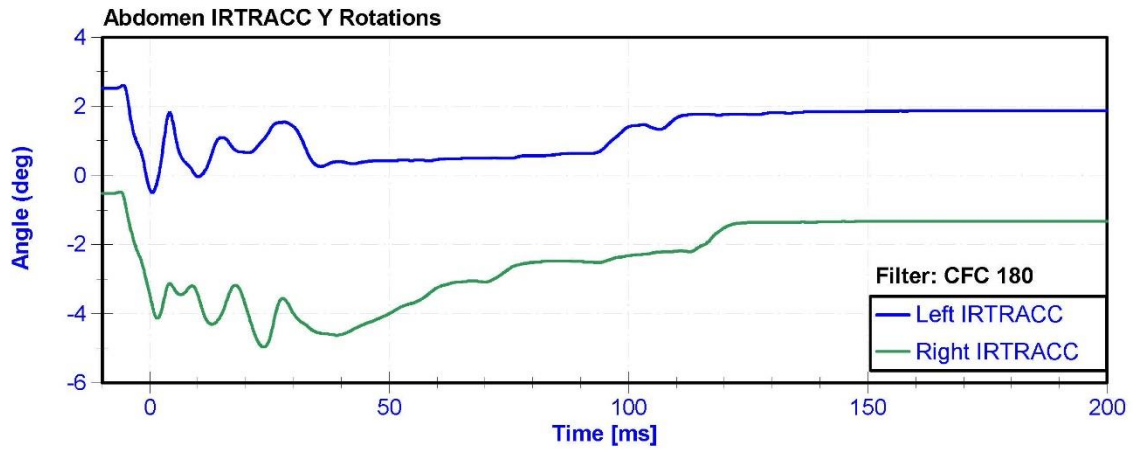
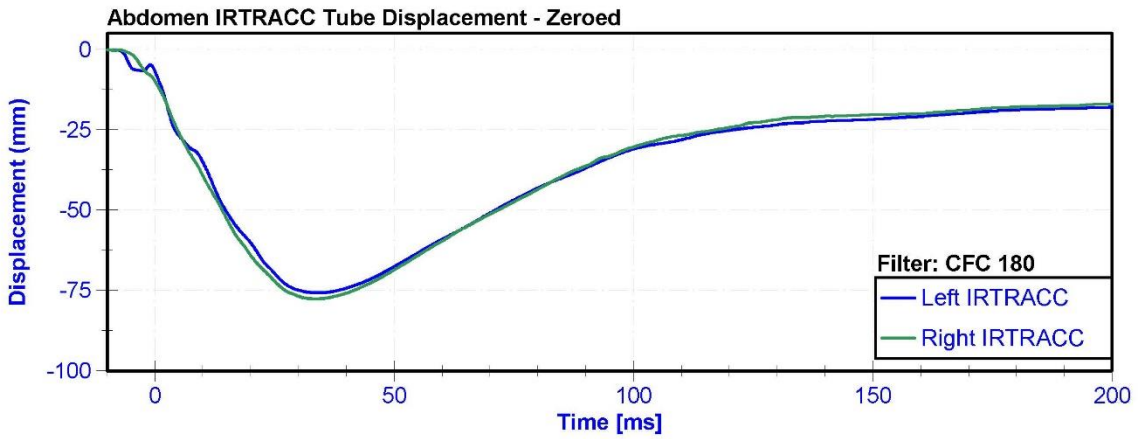

ATD Manufacturer	Humanetics	Test Technician	M. Goehle
ATD Serial Number	DL9207	Laboratory Supervisor	M. Goehle

Results

Test Parameter	Minimum Specification	Maximum Specification	Unit	Result	Pass/Fail
Temperature	20.6	22.2	°C	21.2	Pass
Humidity	10	70	%	15.3	Pass
Impact Velocity	2.55	2.65	m/s	2.592	Pass
Probe Force	4318	4989	N	4706.0	Pass
Peak Femur Z Force	-3241	-2652	N	-3042.13	Pass
Peak Resultant Acetabulum Force	1462	1787	N	1796.09	Fail

Transducer Calibrations

Channel	Manufacturer	Serial Number	Calibration Date	Calibration Due Date
Probe Accel	ENDEVCO 7231CT	AC-C14972	8/13/2015	2/11/2016
Left Femur Load Cell	Denton W50-7101051	LC-DM4975 Fz	2/20/2015	2/20/2016
Left Acetabulum Load Cell	Humanetics 10530JI4	LC-DP4639 Fx	3/6/2015	3/5/2016

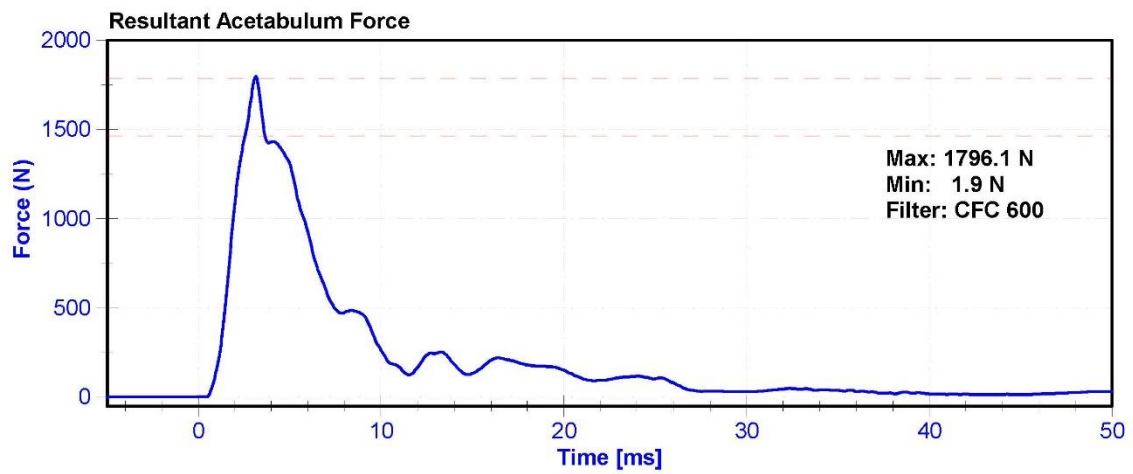
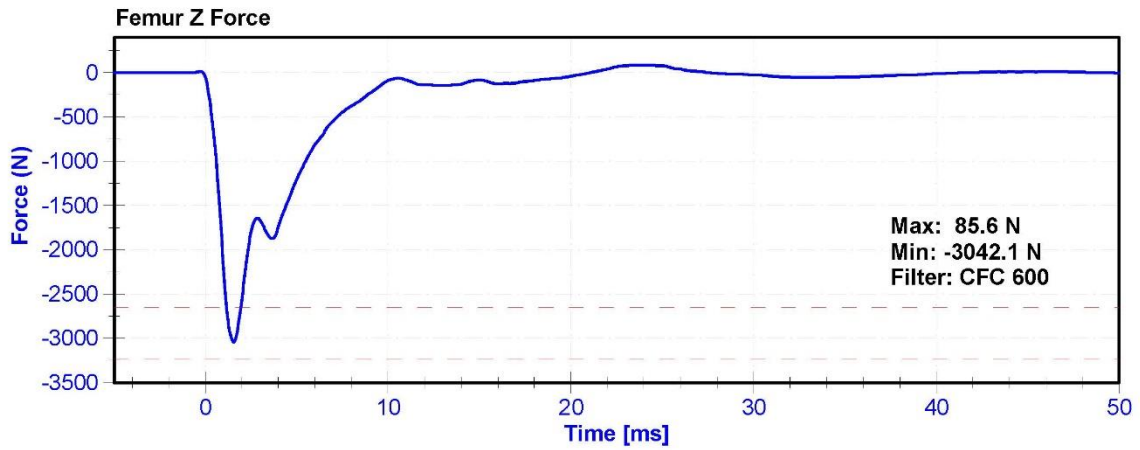
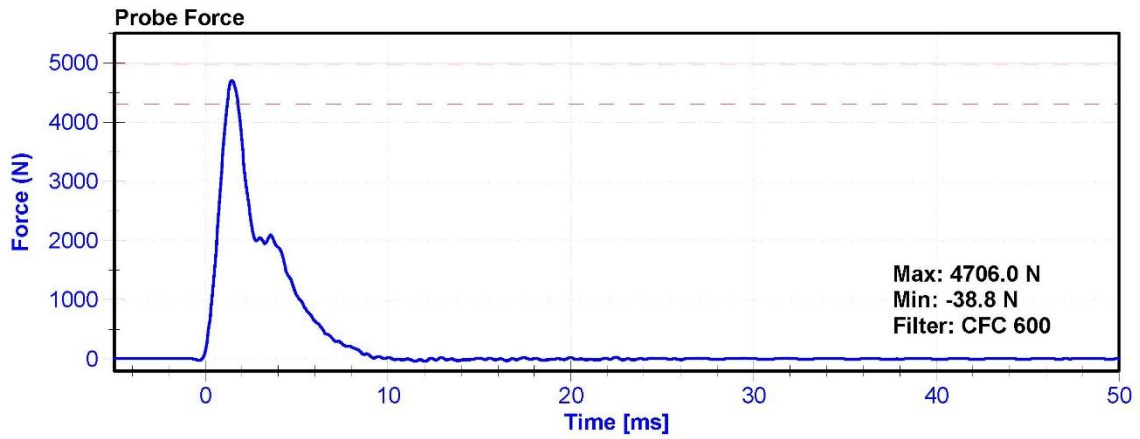

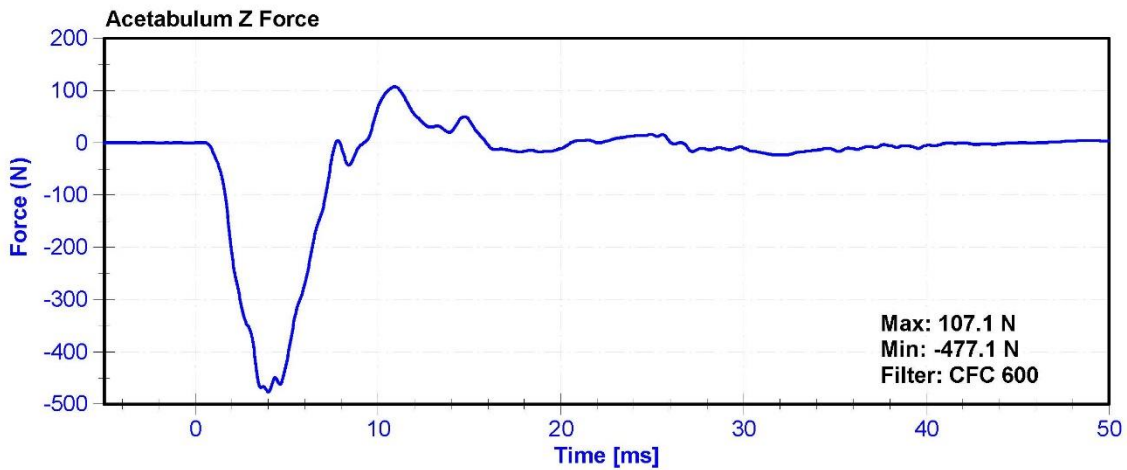
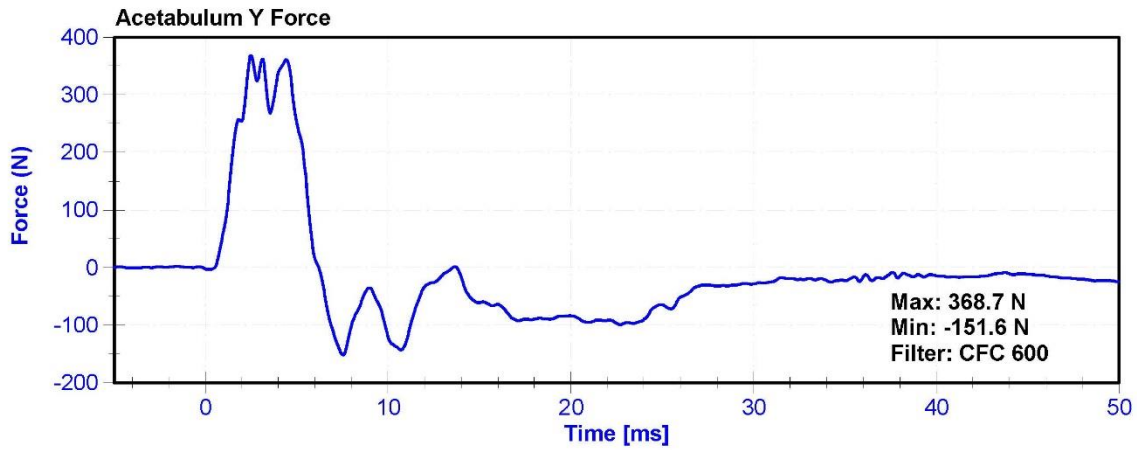
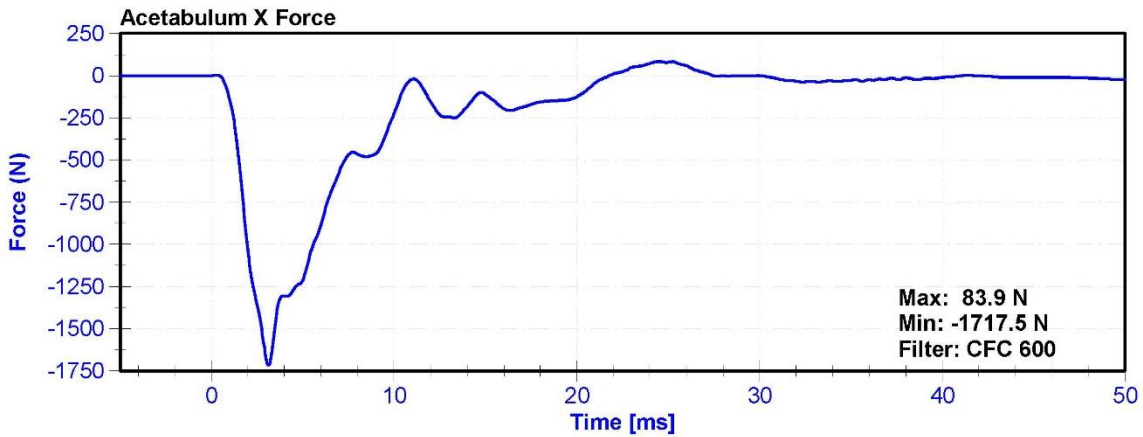

ATD Manufacturer	Humanetics	Test Technician	M. Goehle
ATD Serial Number	DL9207	Laboratory Supervisor	M. Goehle

Results

Test Parameter	Minimum Specification	Maximum Specification	Unit	Result	Pass/Fail
Temperature	20.6	22.2	°C	21.1	Pass
Humidity	10	70	%	15.6	Pass
Impact Velocity	2.55	2.65	m/s	2.579	Pass
Probe Force	4318	4989	N	4599.4	Pass
Peak Femur Z Force	-3241	-2652	N	-2936.62	Pass
Peak Resultant Acetabulum Force	1462	1787	N	1795.97	Fail

Transducer Calibrations

Channel	Manufacturer	Serial Number	Calibration Date	Calibration Due Date
Probe Accel	ENDEVCO 7231CT	AC-C14972	8/13/2015	2/11/2016
Right Femur Load Cell	Denton W50-7101051	LC-DM4976 Fz	2/23/2015	2/23/2016
Right Acetabulum Load Cell	Humanetics 10670JI4	LC-DP3835 Fx	3/7/2015	3/6/2016

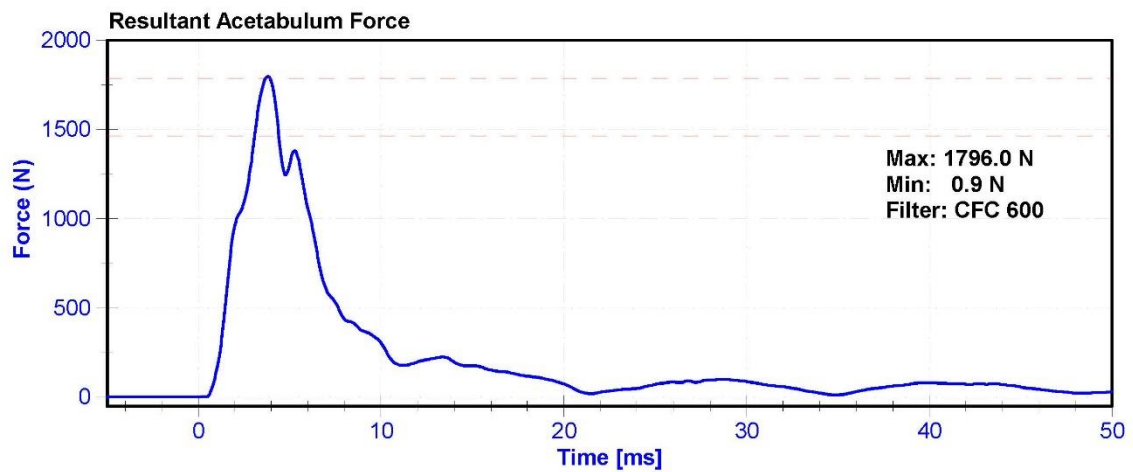
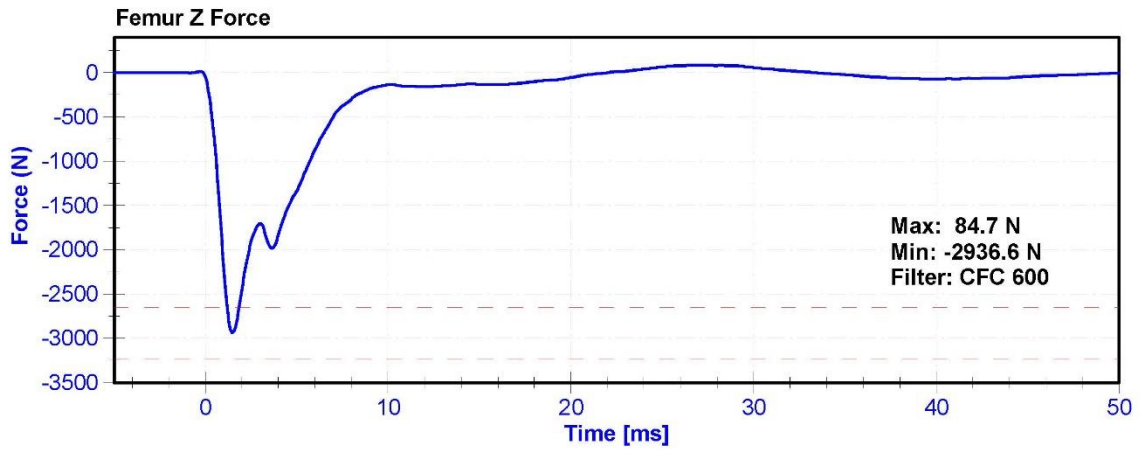
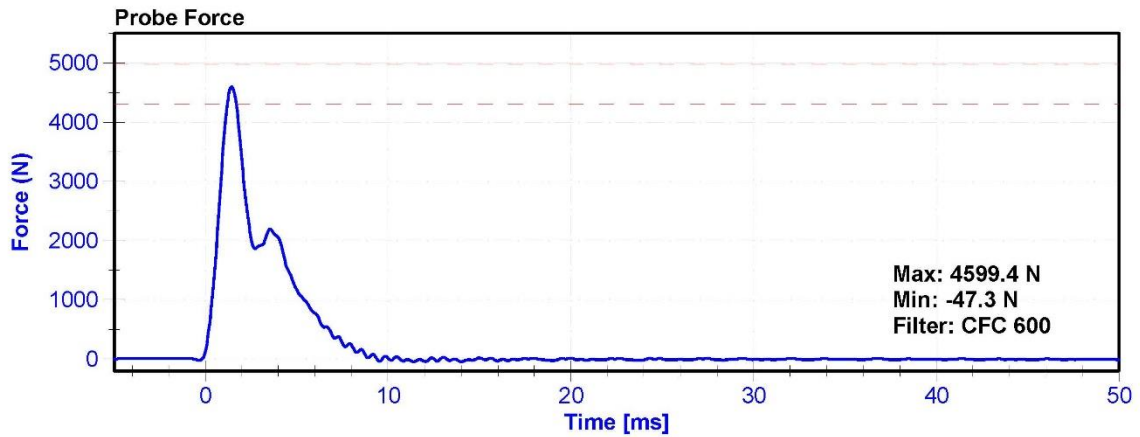

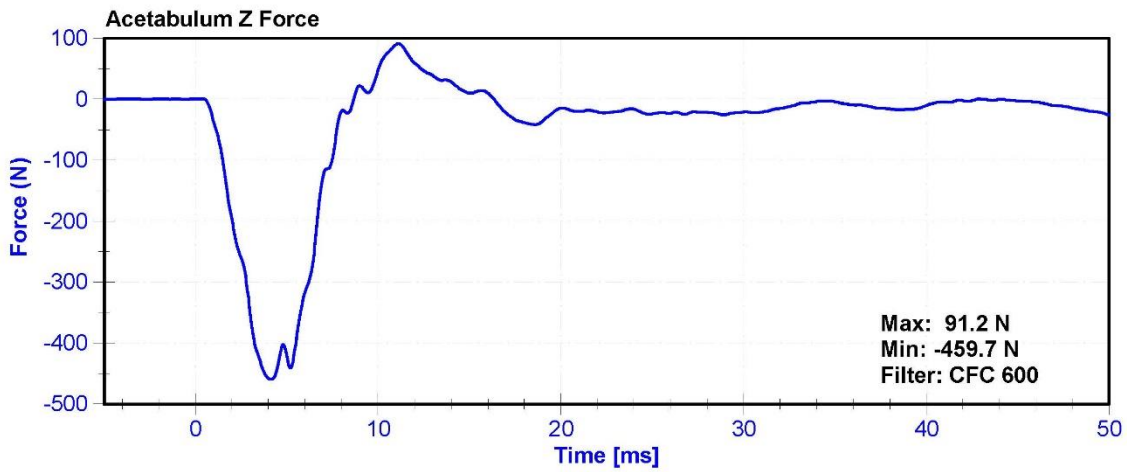
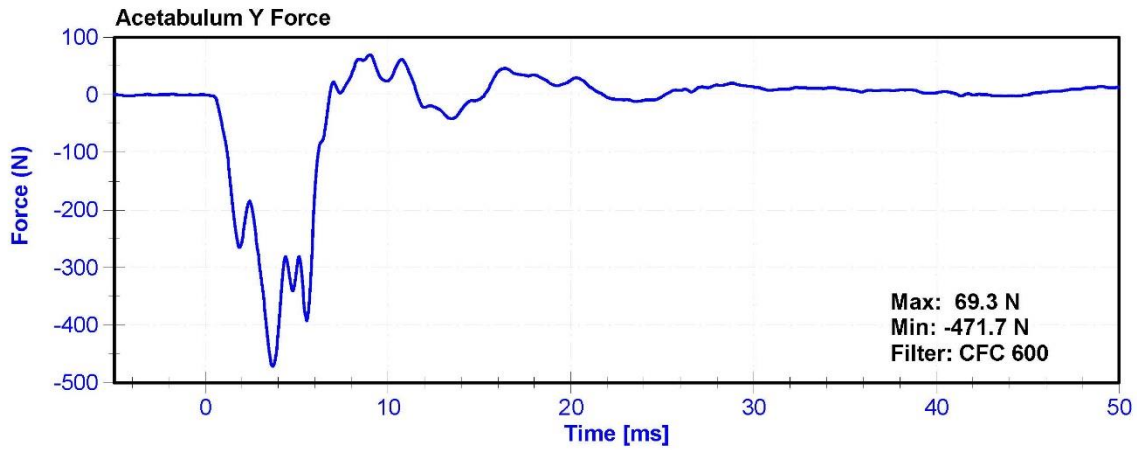
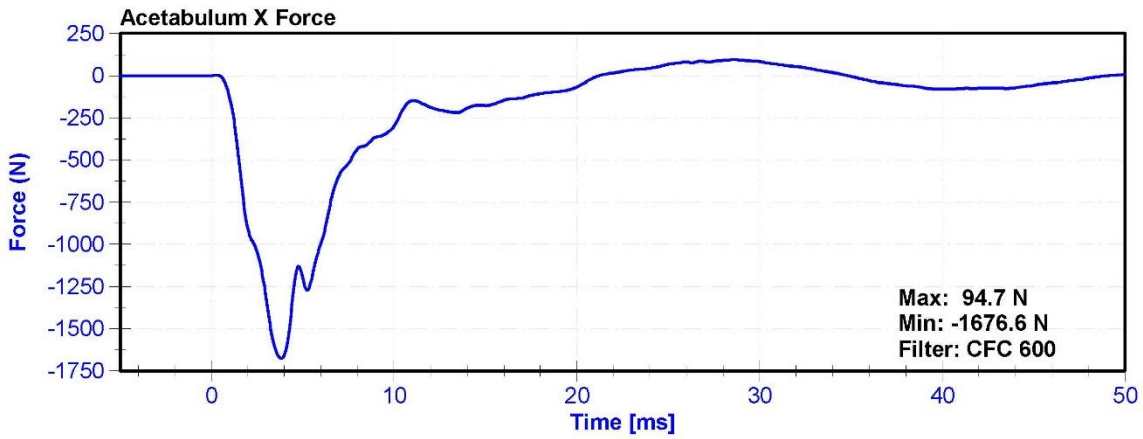

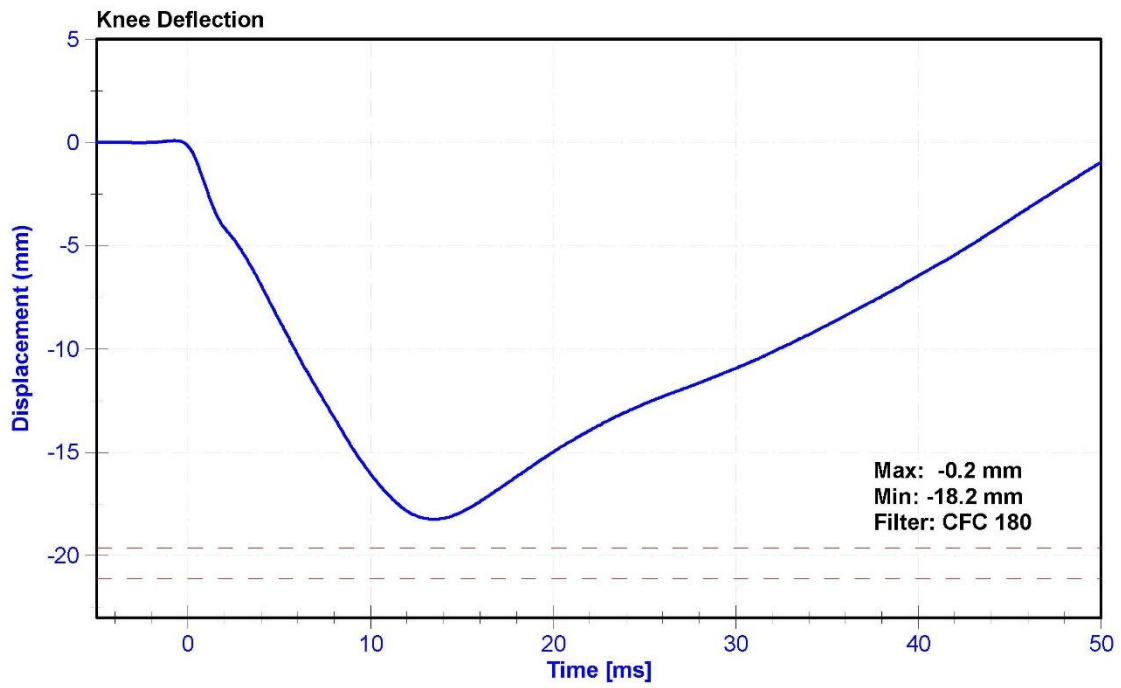
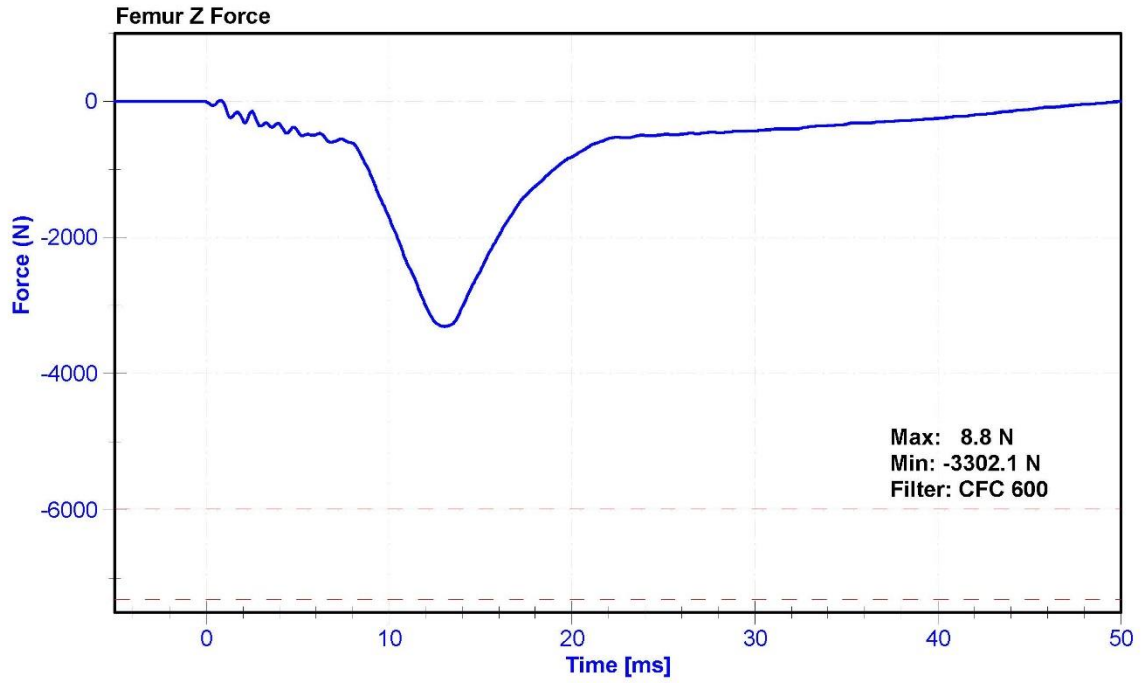

ATD Manufacturer	Humanetics	Test Technician	M. Goehle
ATD Serial Number	DL9207	Laboratory Supervisor	M. Goehle

Results

Test Parameter	Minimum Specification	Maximum Specification	Unit	Result	Pass/Fail
Temperature	20.6	22.2	°C	21.2	Pass
Humidity	10	70	%	16.4	Pass
Impact Velocity	2.15	2.25	m/s	2.190	Pass
Peak Femur Z Force	-7317	-5987	N	-3251.5	Fail
Knee Deflection at Peak Force	-21.12	-19.62	mm	-18.82	Fail

Transducer Calibrations

Channel	Manufacturer	Serial Number	Calibration Date	Calibration Due Date
Probe Accel	ENDEVCO 7231CT	AC-C14972	8/13/2015	2/11/2016
Femur Load Cell	Denton W50-7101051	LC-DM4976 Fz	2/23/2015	2/23/2016
Knee Potentiometer	Space Age 150-0121VL	DS-021033	3/18/2015	3/17/2016

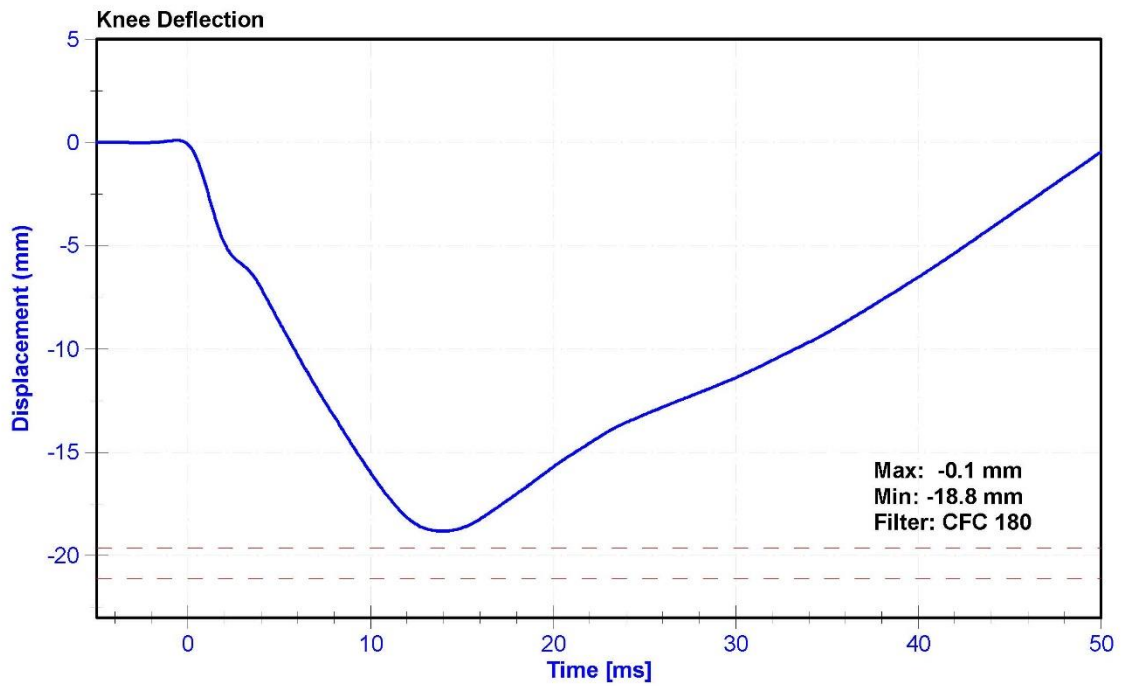
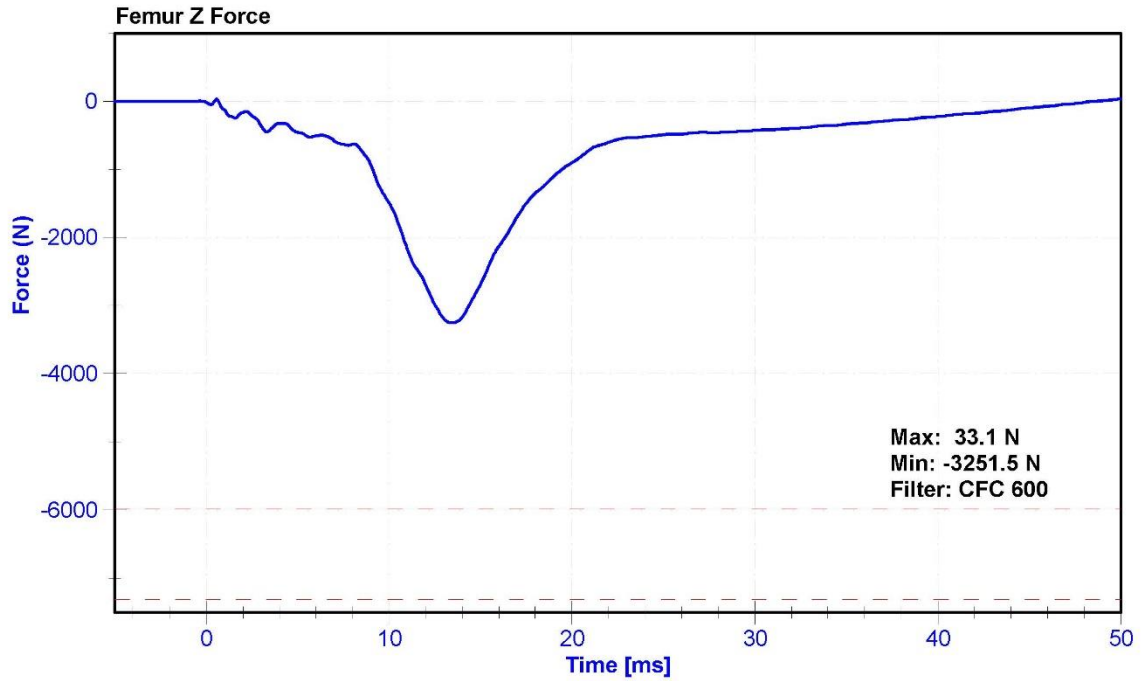

ATD Manufacturer	Humanetics	Test Technician	M.Hartung
ATD Serial Number	DL9207	Laboratory Supervisor	M. Goehle

Results

Test Parameter	Minimum Specification	Maximum Specification	Unit	Result	Pass/Fail
Temperature	20.6	22.2	°C	21.2	Pass
Humidity	10	70	%	44.9	Pass
Velocity	4.9	5.1	m/s	4.948	Pass
Lower Tibia Compressive Force	-3613	-2956	N	-3564.2	Pass
Peak Moment about Y-Axis	77.1	94.2	Nm	79.35	Pass
Peak Rotation about Y-Axis	32.7	39.9	deg	33.08	Pass

Transducer Calibrations

Channel	Manufacturer	Serial Number	Calibration Date	Calibration Due Date
Pendulum Accelerometer	ENDEVCO 7231CT	AC-C15018	7/15/2015	7/14/2016
Lower Tibia Load Cell	Denton 4929J	LC-121 Fz	2/10/2015	2/10/2016
Ankle Y Potentiometer	Contelec PD210-4B	DS-0524	2/18/2015	2/18/2016

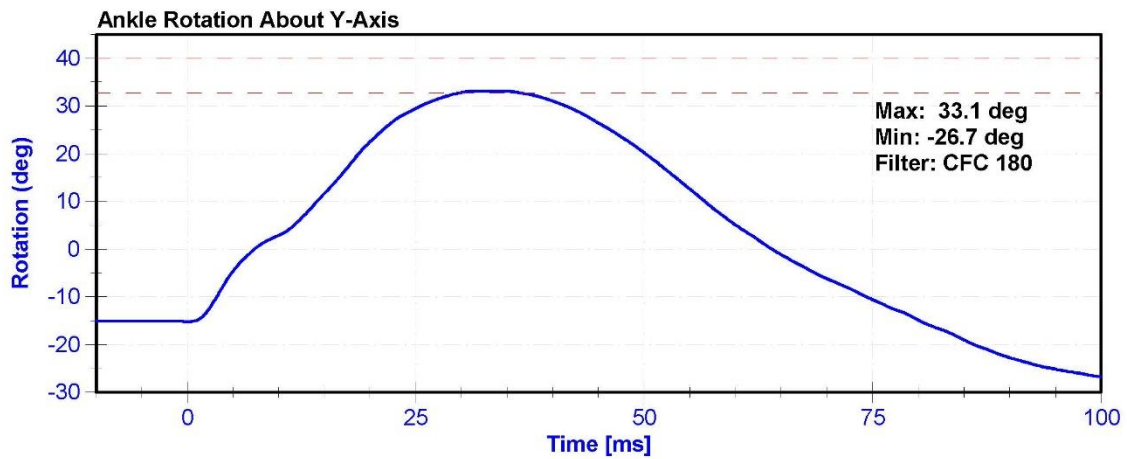
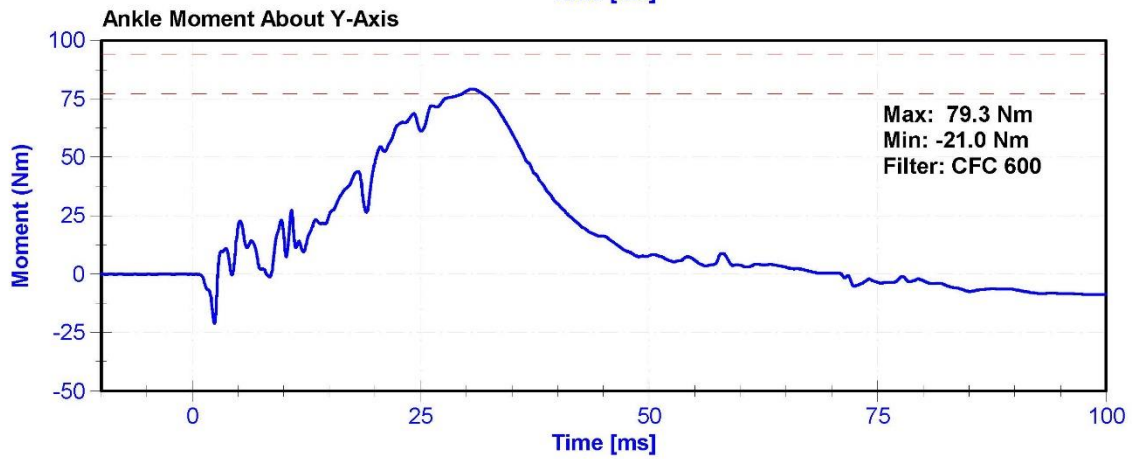
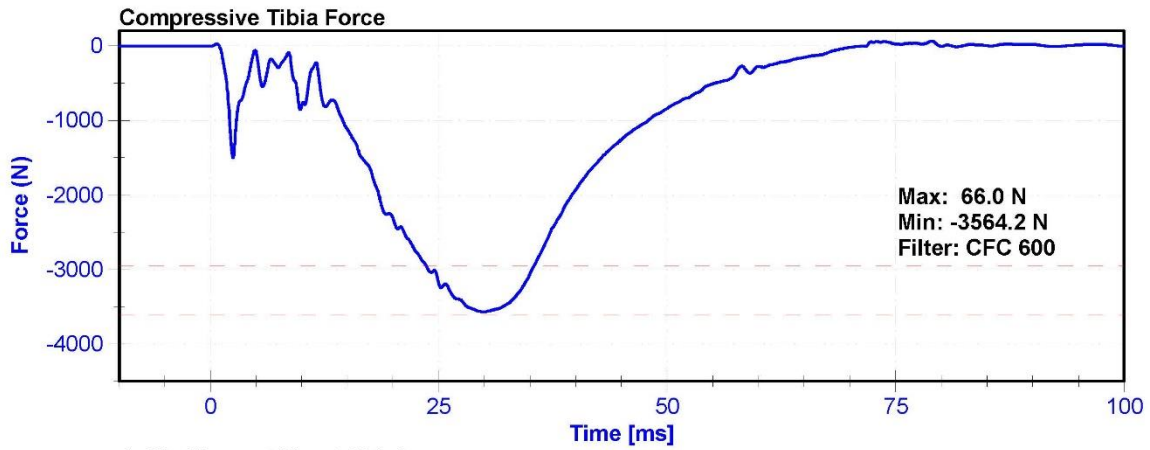

ATD Manufacturer	Humanetics	Test Technician	M.Hartung
ATD Serial Number	DL9207	Laboratory Supervisor	M. Goehle

Results

Test Parameter	Minimum Specification	Maximum Specification	Unit	Result	Pass/Fail
Temperature	20.6	22.2	°C	21.1	Pass
Humidity	10	70	%	45.7	Pass
Velocity	1.9	2.1	m/s	2.016	Pass
Lower Tibia Compressive Force	-675	-552	N	-593.4	Pass
Peak Moment about X-Axis	36.3	44.4	Nm	43.27	Pass
Peak Rotation about X-Axis	30.3	37.0	deg	32.78	Pass

Transducer Calibrations

Channel	Manufacturer	Serial Number	Calibration Date	Calibration Due Date
Pendulum Accelerometer	ENDEVCO 7231CT	AC-C15018	7/15/2015	7/14/2016
Lower Tibia Load Cell	Denton 4929J	LC-121 Fz	2/10/2015	2/10/2016
Ankle Y Potentiometer	Contelec PD210-4B	DS-0525	2/18/2015	2/18/2016

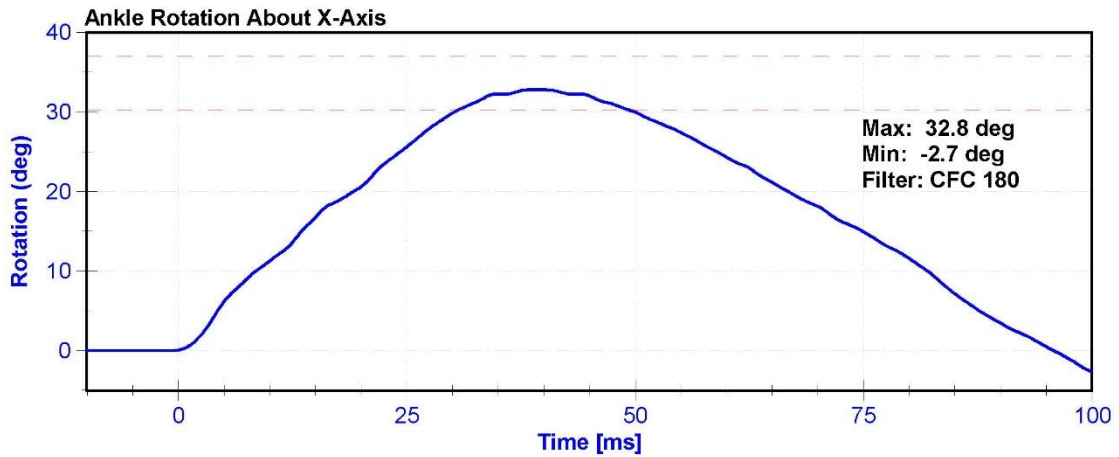
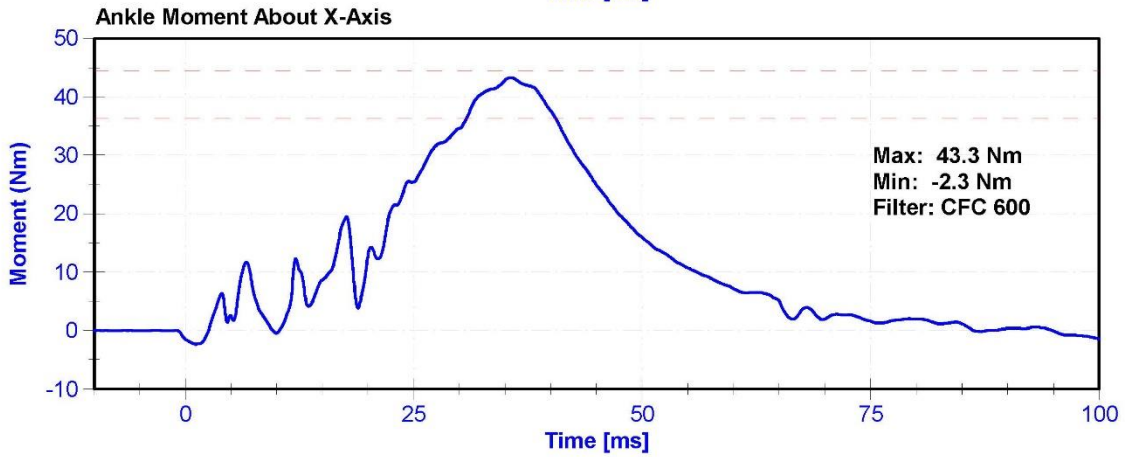
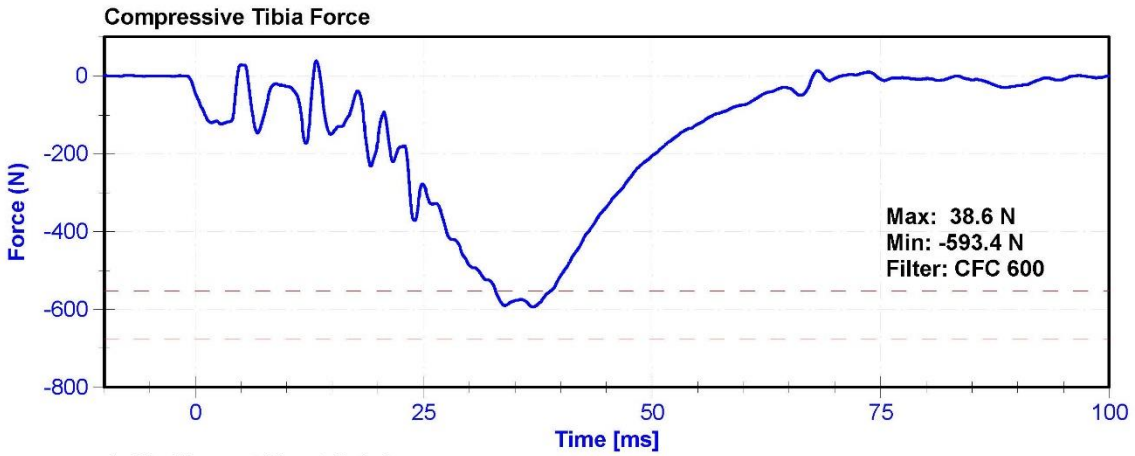

ATD Manufacturer	Humanetics	Test Technician	M.Hartung
ATD Serial Number	DL9207	Laboratory Supervisor	M. Goehle

Results

Test Parameter	Minimum Specification	Maximum Specification	Unit	Result	Pass/Fail
Temperature	20.6	22.2	°C	21	Pass
Humidity	10	70	%	43.2	Pass
Velocity	3.9	4.1	m/s	4.053	Pass
Lower Tibia Compressive Force	-3346	-2738	N	-3894.1	Fail

Transducer Calibrations

Channel	Manufacturer	Serial Number	Calibration Date	Calibration Due Date
Pendulum Accelerometer	ENDEVCO 7231CT	AC-C15018	7/15/2015	7/14/2016
Lower Tibia Load Cell	Denton 4929J	LC-121 Fz	2/10/2015	2/10/2016

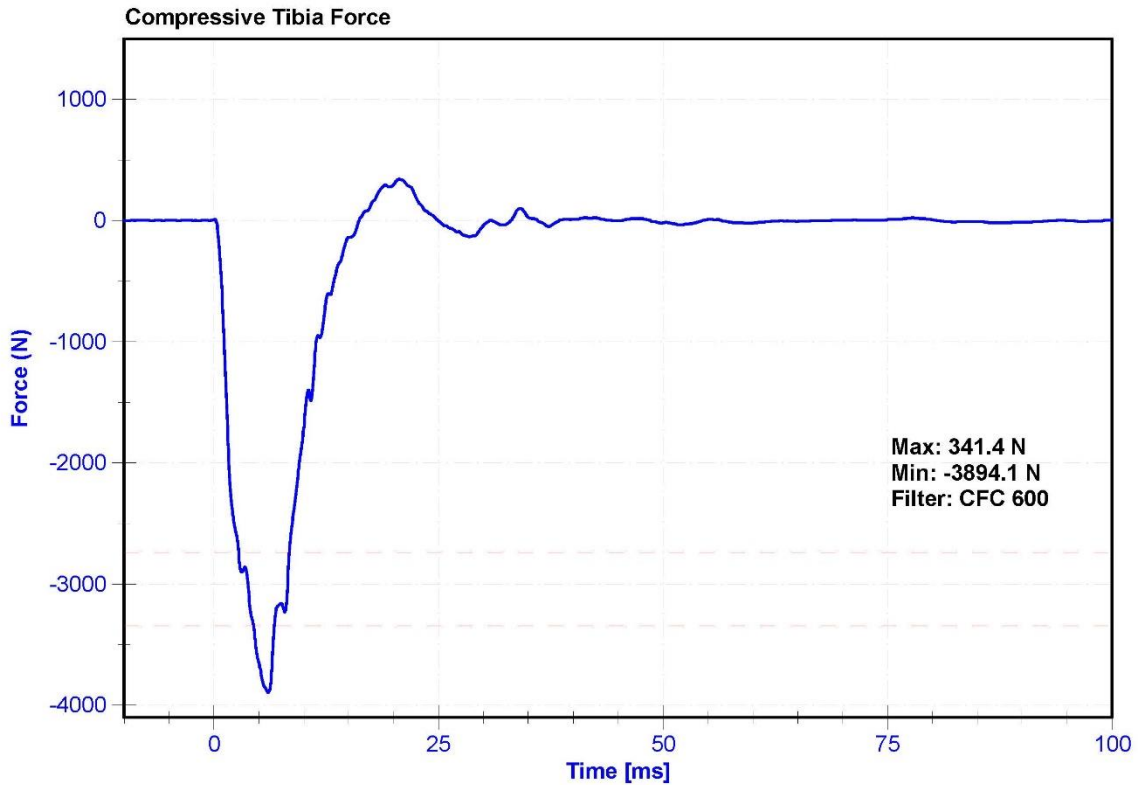

ATD Manufacturer	Humanetics	Test Technician	M.Hartung
ATD Serial Number	DL9207	Laboratory Supervisor	M. Goehle

Results

Test Parameter	Minimum Specification	Maximum Specification	Unit	Result	Pass/Fail
Temperature	20.6	22.2	°C	21.1	Pass
Humidity	10	70	%	45.5	Pass
Velocity	1.9	2.1	m/s	2.016	Pass
Lower Tibia Compressive Force	-675	-552	N	-640.1	Pass
Peak Moment about X-Axis	-44.4	-36.3	Nm	-49.36	Fail
Peak Rotation about X-Axis	-37.0	-30.3	deg	-32.11	Pass

Transducer Calibrations

Channel	Manufacturer	Serial Number	Calibration Date	Calibration Due Date
Pendulum Accelerometer	ENDEVCO 7231CT	AC-C15018	7/15/2015	7/14/2016
Lower Tibia Load Cell	Denton 4929J	LC-121 Fz	2/10/2015	2/10/2016
Ankle Y Potentiometer	Contelec PD210-4B	DS-0525	2/18/2015	2/18/2016

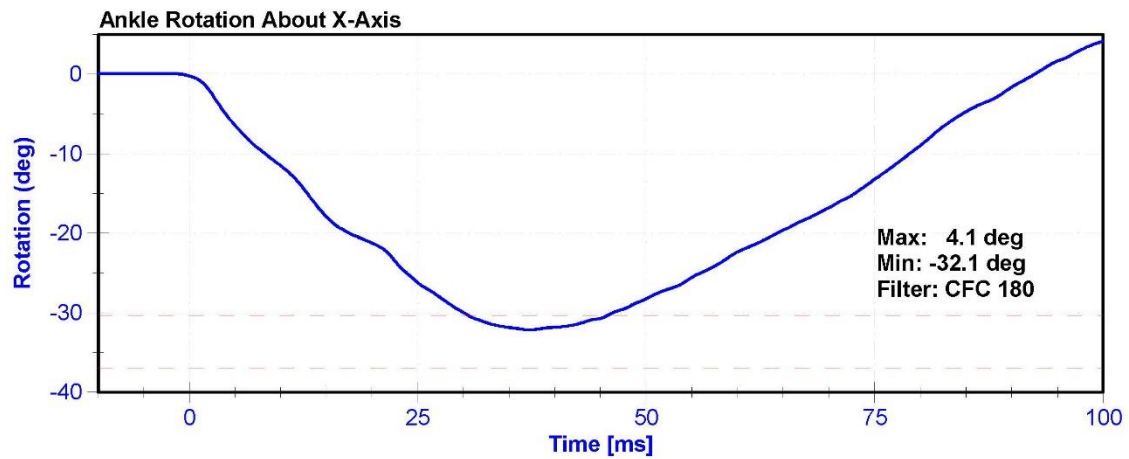
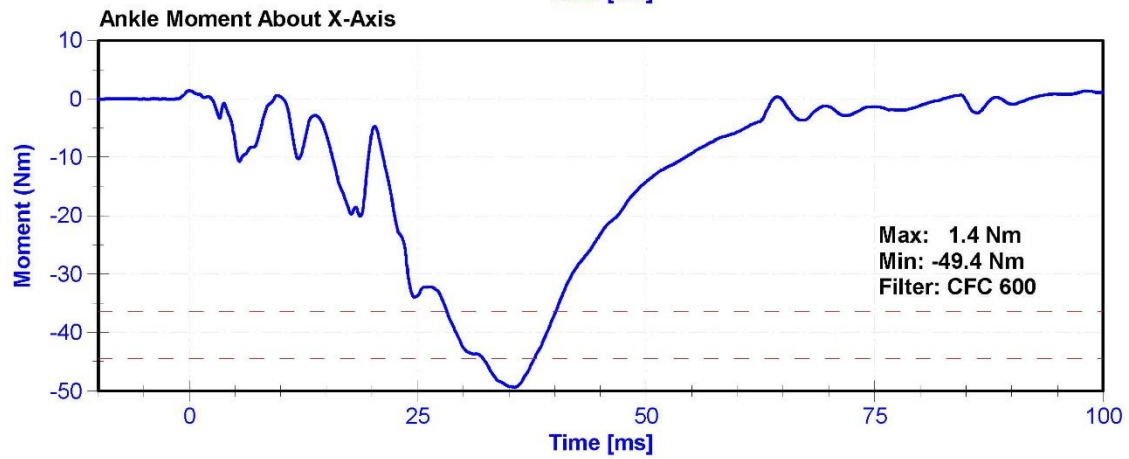
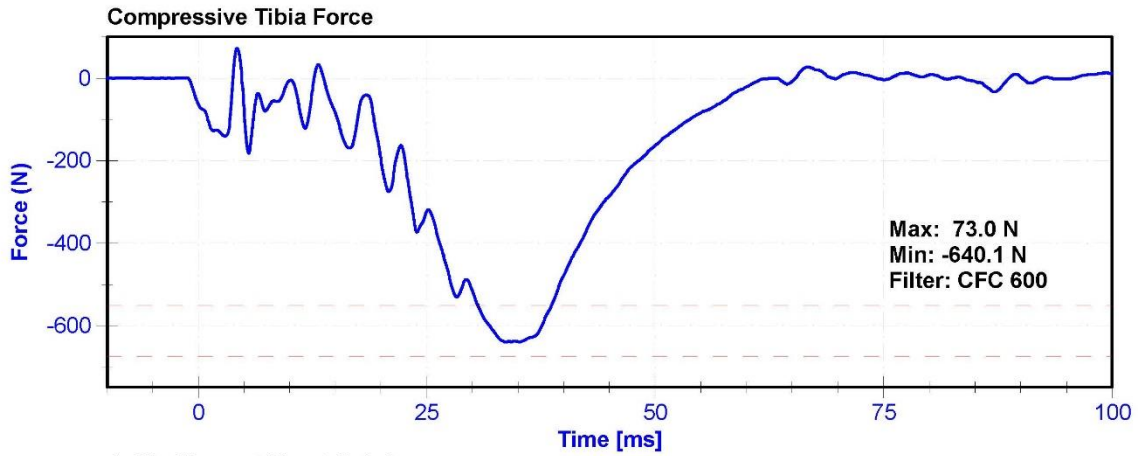

ATD Manufacturer	Humanetics	Test Technician	M.Hartung
ATD Serial Number	DL9207	Laboratory Supervisor	M. Goehle

Results

Test Parameter	Minimum Specification	Maximum Specification	Unit	Result	Pass/Fail
Temperature	20.6	22.2	°C	21.3	Pass
Humidity	10	70	%	48.7	Pass
Velocity	4.9	5.1	m/s	4.916	Pass
Lower Tibia Compressive Force	-3613	-2956	N	-3447.5	Pass
Peak Moment about Y-Axis	77.1	94.2	Nm	80.21	Pass
Peak Rotation about Y-Axis	32.7	39.9	deg	32.14	Fail

Transducer Calibrations

Channel	Manufacturer	Serial Number	Calibration Date	Calibration Due Date
Pendulum Accelerometer	ENDEVCO 7231CT	AC-C15018	7/15/2015	7/14/2016
Lower Tibia Load Cell	Denton 4929J	LC-166 Fz	2/9/2015	2/9/2016
Ankle Y Potentiometer	Contelec PD210-4B	DS-0526	2/19/2015	2/19/2016

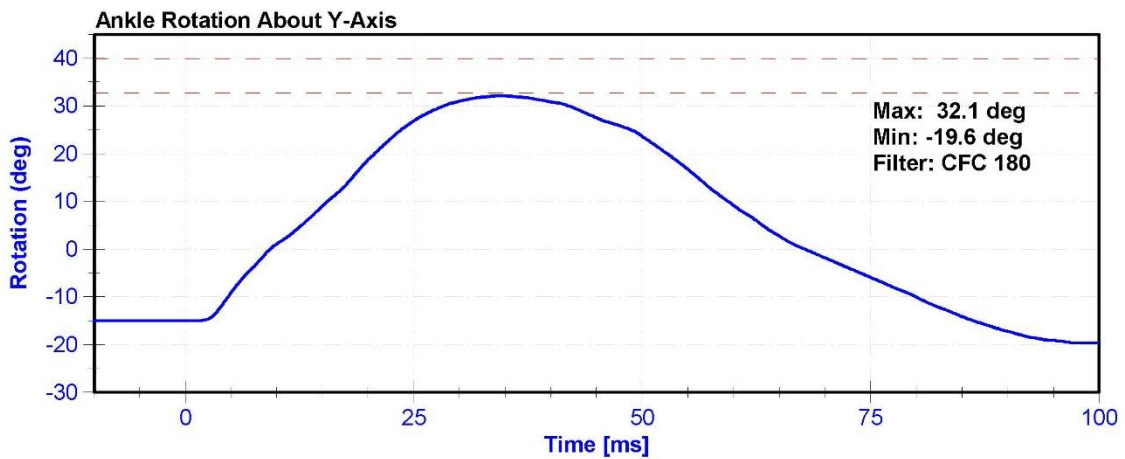
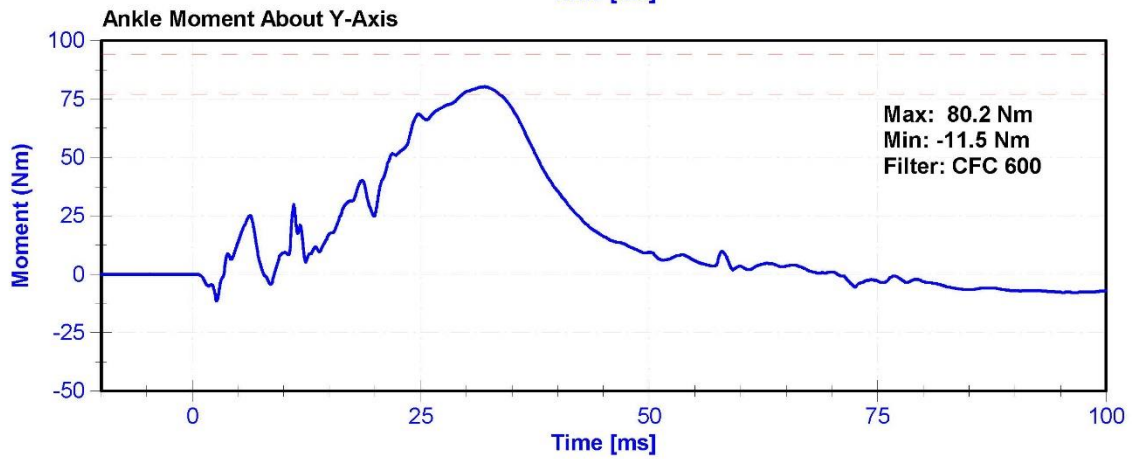
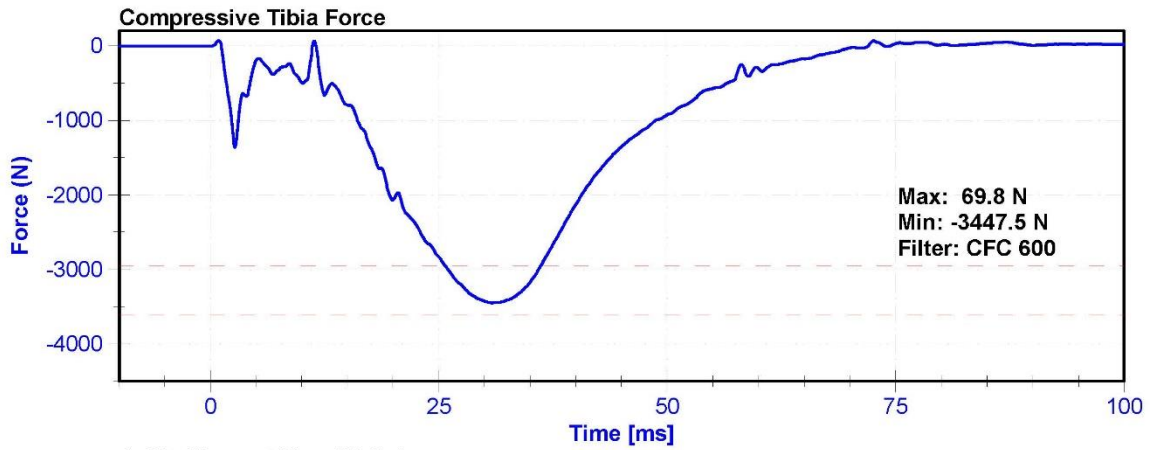

ATD Manufacturer	Humanetics	Test Technician	M.Hartung
ATD Serial Number	DL9207	Laboratory Supervisor	M. Goehle

Results

Test Parameter	Minimum Specification	Maximum Specification	Unit	Result	Pass/Fail
Temperature	20.6	22.2	°C	21.3	Pass
Humidity	10	70	%	51.6	Pass
Velocity	1.9	2.1	m/s	1.944	Pass
Lower Tibia Compressive Force	-675	-552	N	-596.3	Pass
Peak Moment about X-Axis	-44.4	-36.3	Nm	-47.18	Fail
Peak Rotation about X-Axis	-37.0	-30.3	deg	-33.66	Pass

Transducer Calibrations

Channel	Manufacturer	Serial Number	Calibration Date	Calibration Due Date
Pendulum Accelerometer	ENDEVCO 7231CT	AC-C15018	7/15/2015	7/14/2016
Lower Tibia Load Cell	Denton 4929J	LC-166 Fz	2/9/2015	2/9/2016
Ankle Y Potentiometer	Contelec PD210-4B	DS-0528	2/19/2015	2/19/2016

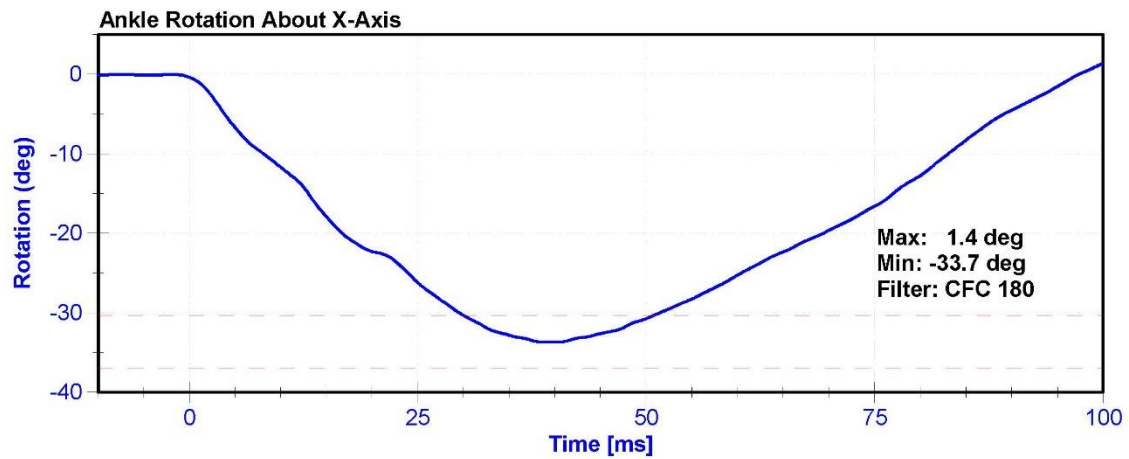
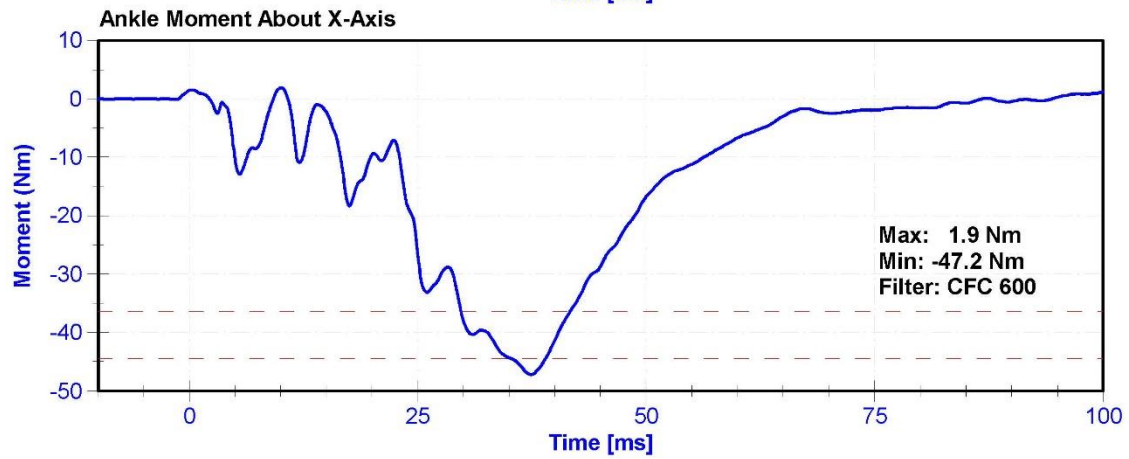
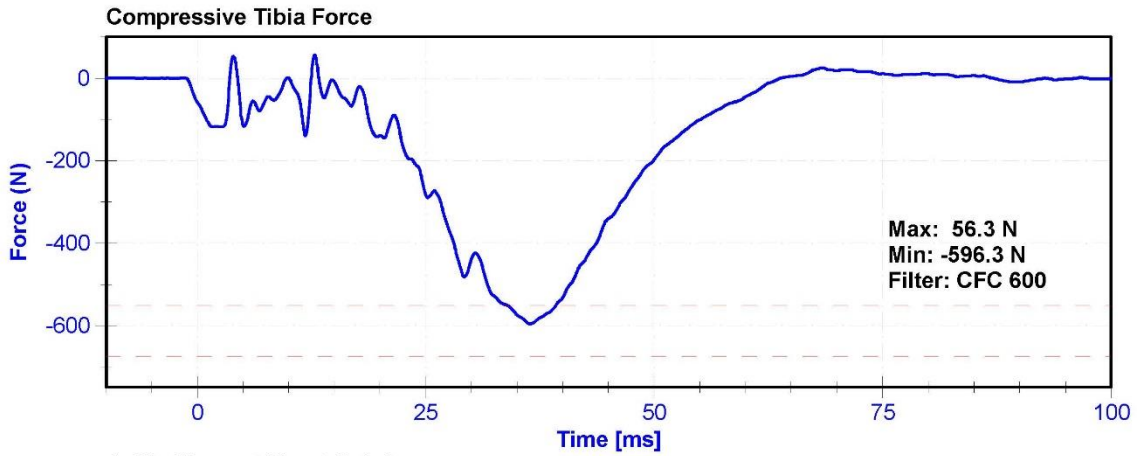

ATD Manufacturer	Humanetics	Test Technician	M.Hartung
ATD Serial Number	DL9207	Laboratory Supervisor	M. Goehle

Results

Test Parameter	Minimum Specification	Maximum Specification	Unit	Result	Pass/Fail
Temperature	20.6	22.2	°C	21.3	Pass
Humidity	10	70	%	48.3	Pass
Velocity	3.9	4.1	m/s	4.032	Pass
Lower Tibia Compressive Force	-3346	-2738	N	-3946.8	Fail

Transducer Calibrations

Channel	Manufacturer	Serial Number	Calibration Date	Calibration Due Date
Pendulum Accelerometer	ENDEVCO 7231CT	AC-C15018	7/15/2015	7/14/2016
Lower Tibia Load Cell	Denton 4929J	LC-166 Fz	2/9/2015	2/9/2016

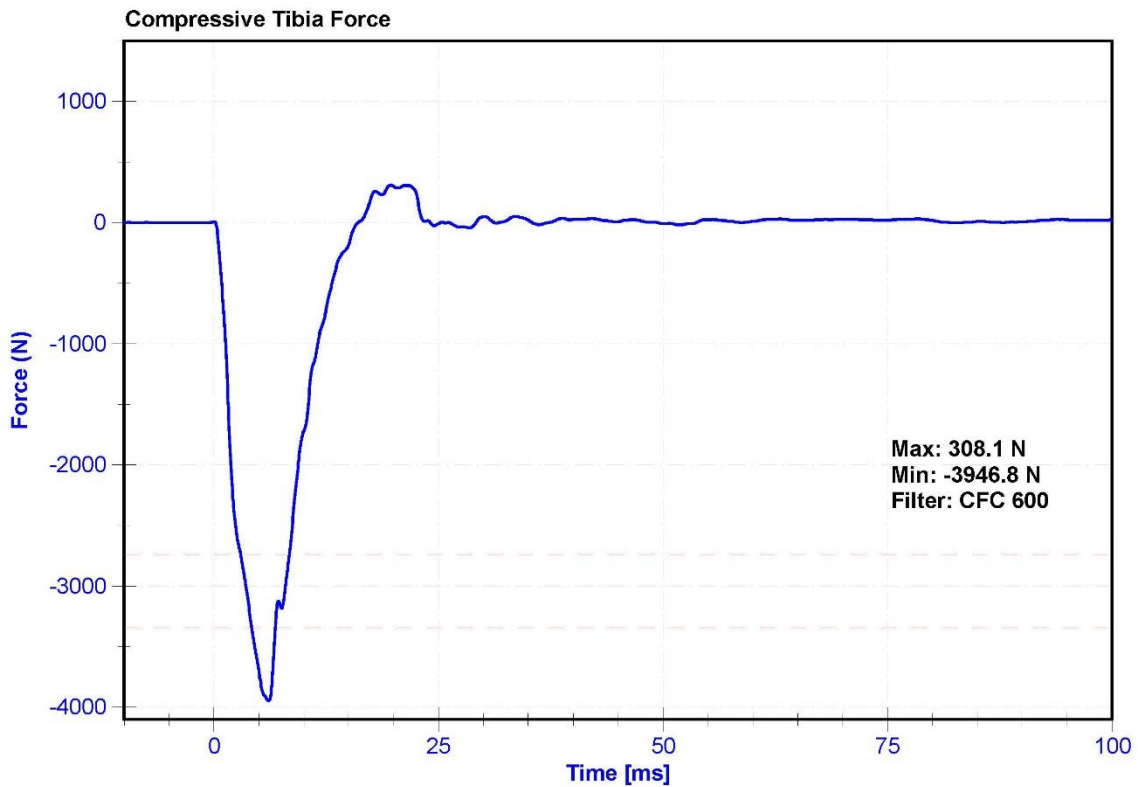

ATD Manufacturer	Humanetics	Test Technician	M.Hartung
ATD Serial Number	DL9207	Laboratory Supervisor	M. Goehle

Results

Test Parameter	Minimum Specification	Maximum Specification	Unit	Result	Pass/Fail
Temperature	20.6	22.2	°C	21.3	Pass
Humidity	10	70	%	51.0	Pass
Velocity	1.9	2.1	m/s	1.949	Pass
Lower Tibia Compressive Force	-675	-552	N	-639.3	Pass
Peak Moment about X-Axis	36.3	44.4	Nm	47.58	Fail
Peak Rotation about X-Axis	30.3	37.0	deg	31.61	Pass

Transducer Calibrations

Channel	Manufacturer	Serial Number	Calibration Date	Calibration Due Date
Pendulum Accelerometer	ENDEVCO 7231CT	AC-C15018	7/15/2015	7/14/2016
Lower Tibia Load Cell	Denton 4929J	LC-166 Fz	2/9/2015	2/9/2016
Ankle Y Potentiometer	Contelec PD210-4B	DS-0528	2/19/2015	2/19/2016

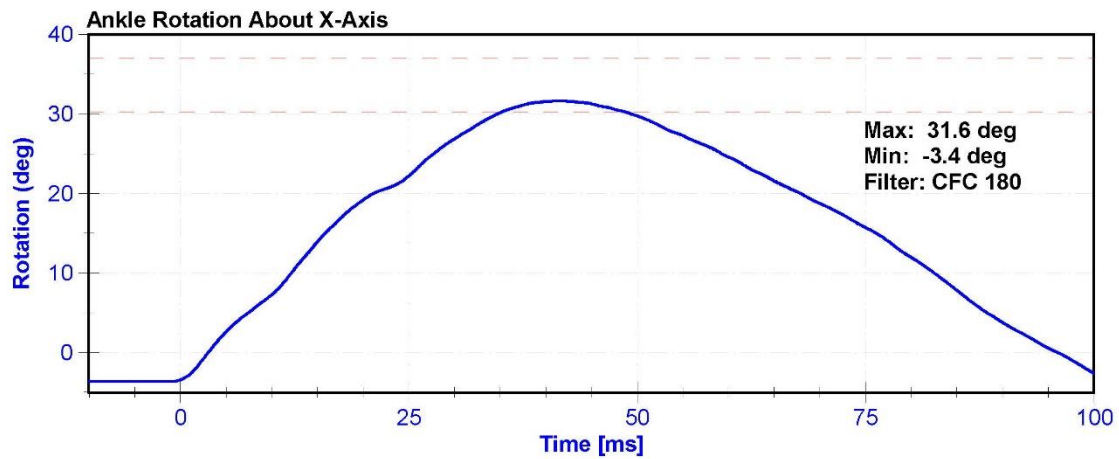
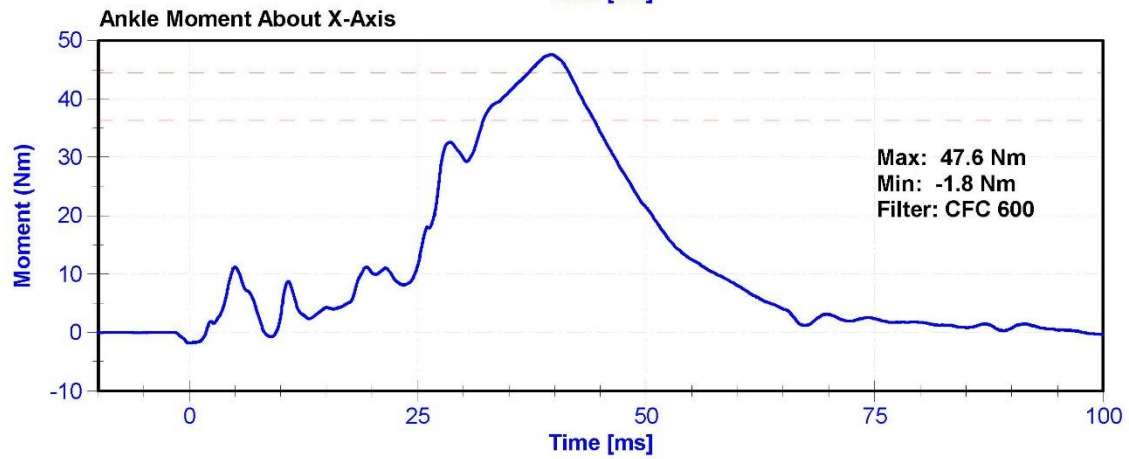
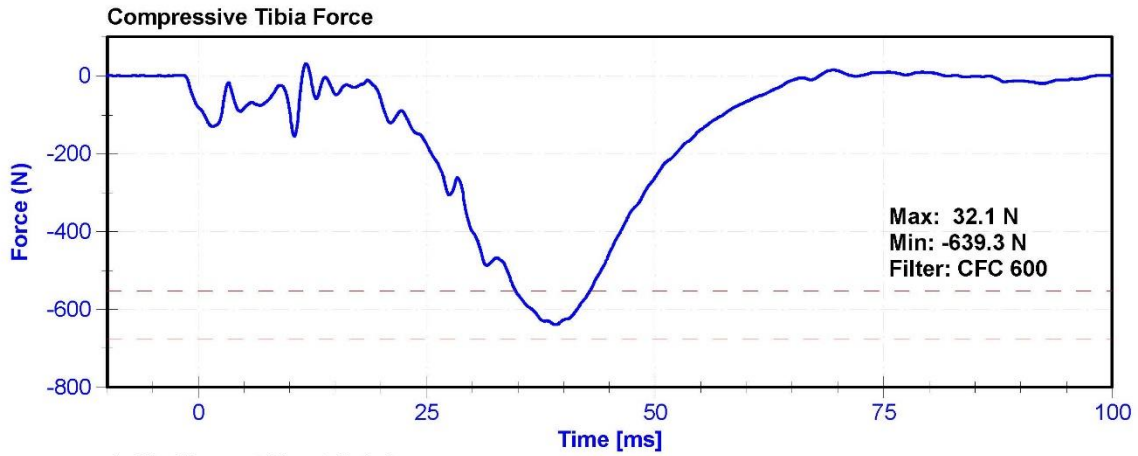

ATD Manufacturer	Humanetics	Test Technician	M. Goehle
ATD Serial Number	DL9207	Laboratory Supervisor	M. Goehle

Results

Test Parameter	Minimum Specification	Maximum Specification	Unit	Result	Pass/Fail
Temperature	20.6	22.2	°C	21.5	Pass
Humidity	10	70	%	16.4	Pass
Impact Velocity	2.15	2.25	m/s	2.223	Pass
Peak Femur Z Force	-7317	-5987	N	-3302.1	Fail
Knee Deflection at Peak Force	-21.12	-19.62	mm	-18.24	Fail

Transducer Calibrations

Channel	Manufacturer	Serial Number	Calibration Date	Calibration Due Date
Probe Accel	ENDEVCO 7231CT	AC-C14972	8/13/2015	2/11/2016
Femur Load Cell	Denton W50-7101051	LC-DM4975 Fz	2/20/2015	2/20/2016
Knee Potentiometer	Space Age 150-0121V	DS-C2102639B	2/17/2015	2/17/2016

50% ADULT MALE THOR DO9798 DUMMY CALIBRATIONS

