

**REPORT NUMBER: R&D-CAL-15-002**

**MOVING BARRIER TO VEHICLE CRASH TEST IN SUPPORT OF NHTSA'S  
FRONTAL OBLIQUE OFFSET PROGRAM  
OBLIQUE MOVING DEFORMABLE BARRIER INTO RIGHT FRONT OF A**

**2015 Ford F-150**

**90.1KPH, 15 DEGREE ANGLE, 35% OVERLAP**

**TEST DATE: 09/16/2015**

**NHTSA No: R20150227**

**CALSPAN CORPORATION  
TRANSPORTATION TEST OPERATIONS  
P.O. BOX 400  
BUFFALO, NEW YORK 14225**

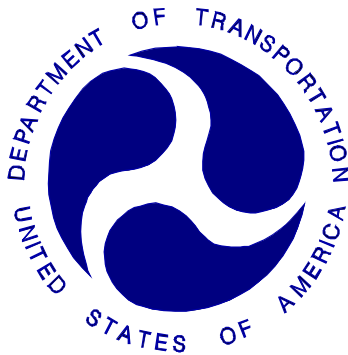

**FINAL REPORT SUBMITTED:**

**May 19, 2016**

**PREPARED FOR:**

**U. S. DEPARTMENT OF TRANSPORTATION  
National Highway Traffic Safety Administration  
Vehicle safety Research  
1200 New Jersey Ave, SE  
Room W46-446  
Washington, DC 20590**

This publication is distributed by the U.S. Department of Transportation, National Highway Traffic Safety Administration, in the interest of information exchange. The opinions, findings and conclusions expressed in this publication are those of the author(s) and not necessarily those of the Department of Transportation or the National Highway Traffic Safety Administration. The United States Government assumes no liability for its contents or use thereof. If trade or manufacturers' names or products are mentioned it is only because they are considered essential to the object of the publication and should not be construed as an endorsement. The United States Government does not endorse products or manufacturers.

Prepared by: Vanessa Hansen  
Vanessa Hansen, Test Engineer

Date: May 19, 2016

Approved by: Edward J. Dutton  
Edward J. Dutton, Operations Manager  
Transportation Test Operations

Date: May 19, 2016

FINAL REPORT ACCEPTANCE BY VEHICLE SAFETY RESEARCH, OFFICE OF STRUCTURAL AND RESTRAINTS RESEARCH DIVISION:

\_\_\_\_\_  
Date: \_\_\_\_\_

\_\_\_\_\_  
TOM, Vehicle Crash Testing  
NHTSA, Office of Structures and Restraints Research  
Date: \_\_\_\_\_

**TECHNICAL REPORT STANDARD TITLE PAGE**

<b>1. Report No.</b> R&D-CAL-15-002	<b>2. Government Accession No.</b>	<b>3. Recipient's Catalog No.</b>																																					
<b>4. Title and Subtitle</b> Report for Frontal Oblique Offset Program Testing of a 2015 Ford F-150 Pickup truck NHTSA No.: R20150227		<b>5. Report Date</b> 5/19/2016																																					
		<b>6. Performing Organization Code</b> CAL																																					
<b>7. Author(s)</b> Vanessa Hansen, Test Engineer Ed Dutton, Operations Manager		<b>8. Performing Organization Report No.</b> CAL-DOT-2015-002																																					
<b>9. Performing Organization Name and Address</b> Calspan Corporation 4455 Genesee Street Buffalo, New York 14225		<b>10. Work Unit No.</b>																																					
		<b>11. Contract or Grant No.</b> DTNH22-14-D-00359																																					
<b>12. Sponsoring Agency Name and Address</b> U.S. Department of Transportation National Highway Traffic Safety Administration Office of Vehicle Safety Research 1200 New Jersey Ave SE, Room W46-446 Washington, DC 20590		<b>13. Type of Report and Period Covered</b> Final Report, 5/19/2016																																					
		<b>14. Sponsoring Agency Code</b> NVS-321																																					
<b>15. Supplementary Notes</b>																																							
<b>16. Abstract</b> A test was conducted in accordance with Contract DTNH22-14-D-00359. The Test consisted of a Oblique Moving Deformable Barrier (OMDB) traveling at a target speed of 90.12 kph into a stationary 2015 Ford F-150 Pickup truck. The struck vehicle was positioned 15 degrees relative to the moving barrier and impacted 35% of the right side of the vehicle. The test was conducted to obtain data indicant of FMVSS 208, 212, 219 (partial), 301, and foot well intrusion performance. The test was conducted at the Calspan Corporation's Transportation Test Operation's facility in Buffalo, New York on September 16, 2015. The OMDB impact velocity was 90.22 kph and the ambient temperature at the test vehicle at the time of impact was 21°C. The target vehicle post-test maximum crush was 684 mm. The test vehicle's performance was as follows:																																							
<table border="1"> <thead> <tr> <th>Measurement Description</th> <th>Units</th> <th>Driver THOR</th> <th>Pass. THOR</th> </tr> </thead> <tbody> <tr> <td>Head Injury Criteria (HIC<sub>15</sub>)</td> <td>N/A</td> <td>191.09</td> <td>140.82</td> </tr> <tr> <td>Brain Injury Criteria (BrIC)</td> <td>N/A</td> <td>1.74</td> <td>1.08</td> </tr> <tr> <td>Peak Neck Tension</td> <td>mm</td> <td>1378.77</td> <td>937.46</td> </tr> <tr> <td>Peak Resultant Chest Deflection</td> <td>N/A</td> <td>40.13</td> <td>37.26</td> </tr> <tr> <td>Peak Abdomen Deflection</td> <td>N</td> <td>-54.40</td> <td>-60.80</td> </tr> <tr> <td>Peak Resultant Acetabulum force</td> <td>N</td> <td>1516.53</td> <td>2164.77</td> </tr> <tr> <td>Peak Femur Force</td> <td>N</td> <td>-2963.07</td> <td>-4153.25</td> </tr> <tr> <td>Right Tibia Index</td> <td>N/A</td> <td>0.90</td> <td>0.31</td> </tr> </tbody> </table>				Measurement Description	Units	Driver THOR	Pass. THOR	Head Injury Criteria (HIC <sub>15</sub> )	N/A	191.09	140.82	Brain Injury Criteria (BrIC)	N/A	1.74	1.08	Peak Neck Tension	mm	1378.77	937.46	Peak Resultant Chest Deflection	N/A	40.13	37.26	Peak Abdomen Deflection	N	-54.40	-60.80	Peak Resultant Acetabulum force	N	1516.53	2164.77	Peak Femur Force	N	-2963.07	-4153.25	Right Tibia Index	N/A	0.90	0.31
Measurement Description	Units	Driver THOR	Pass. THOR																																				
Head Injury Criteria (HIC <sub>15</sub> )	N/A	191.09	140.82																																				
Brain Injury Criteria (BrIC)	N/A	1.74	1.08																																				
Peak Neck Tension	mm	1378.77	937.46																																				
Peak Resultant Chest Deflection	N/A	40.13	37.26																																				
Peak Abdomen Deflection	N	-54.40	-60.80																																				
Peak Resultant Acetabulum force	N	1516.53	2164.77																																				
Peak Femur Force	N	-2963.07	-4153.25																																				
Right Tibia Index	N/A	0.90	0.31																																				
<b>17. Key Words</b> THOR Oblique Offset		<b>18. Distribution Statement</b> Copies of this report are available from: National Highway Traffic Safety Administration Technical Reference Division 1200 New Jersey Ave, SE Washington, DC 20590																																					
<b>19. Security Classif. (of this report)</b> UNCLASSIFIED	<b>20. Security Classif. (of this page)</b> UNCLASSIFIED	<b>21. No. of Pages</b>	<b>22. Price</b>																																				

## DISCLAIMER

*The contents of this report relate only to the specific product evaluated under the specific test conditions, as defined within this report. The findings and conclusions are those of the author(s) and not necessarily those of Calspan Corporation. For the purposes of this report, Calspan Corporation provided test services only and was not involved with the consulting, design or manufacture of any product. Calspan Corporation does not endorse products or manufacturers. Further, Calspan Corporation (to include: any of its affiliates, parent companies or subsidiaries) assumes no liability associated with the contents of this report or the use of this report.*

Prepared by: Vanessa Hansen  
Vanessa Hansen, Project Engineer

Date: May 19, 2016

Approved by: Edward J. Dutton  
Edward J. Dutton, Test Engineer Director  
Transportation Test Operations

Date: May 19, 2016

## TABLE OF CONTENTS

Test Vehicle: 2015 Ford F-150 Pickup truck  
 Test Program: R&D 90.1kph, 15° / 35% Right Oblique Offset

NHTSA No.: R20150227  
 Test Date: 9/16/2015

Section	Page No.
1 Purpose of Test	1-1
2 Summary of Test	2-1
Crash Vehicle Summary	2-3
Preliminary Injury Summary: Driver	2-5
Preliminary Injury Summary: Front Right Passenger	2-6
3 Data Sheets	3-1

Data Sheet No.	Page No.
1 General Test and Vehicle Parameter Data	3-2
2 Seat Adjustment, Fuel System, and Steering Wheel	3-6
3 Dummy Longitudinal Clearance Dimensions	3-8
4 Dummy Lateral Clearance Dimensions	3-10
5 Seat Belt Positioning Data	3-11
6 High-Speed Camera Locations and Data	3-12
7 Vehicle Instrumentation Data	3-15
8 Photographic Reference Target Locations	3-18
9 Test Vehicle Summary of Results	3-25
10 Post-Test Observations	3-26
11 Vehicle Profile Measurements	3-27
12 Accident Investigation Division Data	3-29
13 Vehicle Intrusion Measurements	3-30
14 OMDB Crush Measurements	3-47
15 Summary of FMVSS 212, 219 (Partial), and 301 Data	3-48
Windshield Periphery Measurements	3-48
Areas of Protected Zone Failures	3-48
Fuel System Integrity Post Impact Data	3-49
16 FMVSS 301 Static Rollover Results	3-50
17 Dummy / Vehicle Temperature Stabilization	3-51

Appendix	Page No.
A Photographs	A-1
B Vehicle & Dummy Response Data Traces	B-1
C Part 572 E/O Dummy Calibration and Performance Verification Data Sheets	C-1

**SECTION 1  
PURPOSE OF TEST**

Test Vehicle: 2015 Ford F-150 Pickup truck  
Test Program: R&D 90.1kph, 15° / 35% Right Oblique Offset

NHTSA No.: R20150227  
Test Date: 9/16/2015

This 90.12 kph (56 mph) Moving Barrier into a test vehicle is part of the Frontal Offset Test outlined in Contract No. DTNH22-14-D-00359, Task Order 0001. The purpose of this test is to obtain vehicle crashworthiness and occupant restraint system performance data for consumer information purposes.

This test was conducted in accordance with the instructions set forth for a 15° angle, 35% offset moving barrier to vehicle impact, outlined in Contract No. DTNH22-14-D-00359, Task Order 0001. Data was obtained indicant of Federal Motor Vehicle Safety Standard FMVSS 208-Occupant Crash Protection, FMVSS 212 – Windshield Mounting, FMVSS 219 (partial) – Windshield Zone Intrusion, and FMVSS 301 – Fuel System Integrity, in addition to the requirements of Contract No. DTNH22-14-D-00359, Task Order 0001.

## SECTION 2 SUMMARY OF TEST

Test Vehicle: 2015 Ford F-150 Pickup truck  
Test Program: R&D 90.1kph, 15° / 35% Right Oblique Offset

NHTSA No.: R20150227  
Test Date: 9/16/2015

A 2015 Ford F-150 Pickup truck was impacted on the right front corner by an Oblique Moving Deformable Barrier (OMDB). This test vehicle was stationary and positioned at a target angle of 15° and at a target offset of 35% to the forward line of motion of the OMDB. The OMDB was towed down the test track in a full forward direction, without any crabbing, and at the targeted impact velocity of 90.12 kph (56.0 mph) into the test vehicle. The test vehicle's mass was 2,461kg (5,424 lbs), and the OMDB's mass was 2519 kg (5,552 lbs). The test was conducted by Calspan Corporation on September 16, 2015.

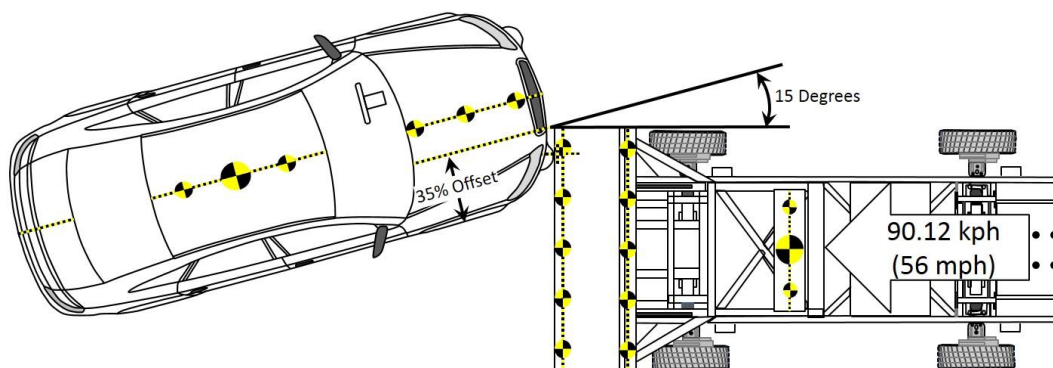

The test was documented by two (2) real time and fifteen (15) high-speed video cameras. Camera locations and other pertinent data are located in Data Sheet No. 6 of this report. Pre and post – test photographs of the test vehicle, OMDB, and test setup were taken using a digital still camera. Photographic documentation of the test is presented in Appendix A of this report.

One 50% adult male THOR-NT anthropomorphic test device (ATD) (Serial No. 015) was seated in the left, front (P1 -Driver's) seating position and one 50% adult male THOR-NT adult male ATD (Serial No. 016) was seated in the right front passenger seating position (P2). The driver and passenger were positioned according to instructions specified in the THOR seating procedures.

The driver was restrained with a 3 – point seat belt and frontal airbag. The passenger was restrained with a 3 – point seat belt, a frontal, curtain, and torso airbags. The driver's curtain and torso airbags were disabled.

**SECTION 2 (CONTINUED)**  
**SUMMARY OF TEST**

Test Vehicle: 2015 Ford F-150 Pickup truck  
Test Program: R&D 90.1kph, 15° / 35% Right Oblique Offset

NHTSA No.: R20150227  
Test Date: 9/16/2015

Two hundred and fifty eight (258) channels of data from the two ATD's, test vehicle and OMDB were collected using Kayser – Threde data acquisition systems. Appendix B contains dummy data plots, as well as vehicle and OMDB response data plots.

There was 84.1% total windshield retention, with 100% and 68.3% retention on the left and right sides, respectively. There appeared to be no intrusion into the protected zone of the windshield during any portion of the impact event. The maximum static crush of the vehicle was 684 mm at C6 to the right of the vehicle's centerline. The maximum crush of the structural bumper beam was 678 mm at B8, to the right of the vehicle's centerline. Full vehicle measurements are presented in Section 3 of this report.

All four vehicle doors remained closed and latched during the test. All doors remained operational after the impact event.

Structure observations include the following:

- Windshield had cracks throughout with minor separation along the passenger side.
- All pillars remained in good condition
- Hood bent inwards and exposed part of the engine compartment
- All windows remained in good condition

The driver ATD's visible contact points were:

- Head contacted the frontal airbag, right hand, and headrest
- Torso contacted the frontal airbag
- Left Knee contacted the knee bolster
- Right Knee contacted the knee airbag

The right front passenger ATD's visible contact points were:

- Head contacted the frontal and curtain airbag
- Torso contacted the frontal airbag, and right shoulder/arm and side torso contacted the passenger door
- Knees contacted the glove box

**SECTION 2 (CONTINUED)  
CRASH VEHICLE SUMMARY**

Test Vehicle: 2015 Ford F-150 Pickup truck  
 Test Program: R&D 90.1kph, 15° / 35% Right Oblique Offset

NHTSA No.: R20150227  
 Test Date: 9/16/2015

**Primary Impact Data**

Measured Parameter	Units	Value
OMDB Velocity at Impact	kph	90.22
OMDB Test Weight	kg	2519
OMDB Maximum Static Crush	mm	416
Vehicle Test Weight	kg	2461
Actual Vehicle Angle	degrees	15
Vehicle Maximum Static Crush	mm	684
Vertical Offset from Target Point (+ down / - up)*	mm	-1
Lateral Offset from Target Point (+ left / - right)*	mm	+15
Number of Data Channels		258
Number of Real-Time Cameras		2
Number of High-Speed Cameras		15

\*Offsets are in relation to the vehicle coordinate system.

**Dummy Contacts**

	Driver	Picture Ref.	Passenger	Picture Ref.
Dummy Type	THOR, S/N: 015		THOR, S/N: 016	
Head Contact	Frontal Airbag, Right Hand and Headrest	A49-A51	Frontal & Curtain Airbag	A70-A72
Upper Torso Contact	Frontal Airbag	N/A	None	N/A
Lower Torso Contact	None	N/A	None	N/A
Side Torso Contact	Center Console	N/A	Left Shoulder contacts Curtain Airbag & Door	N/A
Left Knee Contact	Knee Bolster	A28	Glove Box	A52
Right Knee Contact	Knee Bolster	A28	Glove Box	A52

### Data Anomalies

CHANNEL DESCRIPTION	EXPLANATION
Driver Tibia Lower Left X Force, Questionable spikes at 58ms, 90.8ms and 201ms	Channel was grounded but the electrical resistance is quite high and intermittent between the load cell body and the tibia ground, indicating poor ground
Driver Tibia Lower Left Y Force, Questionable Spikes at 57.6, 91.2 and 201 ms	Channel was grounded but the electrical resistance is quite high and intermittent between the load cell body and the tibia ground, indicating poor ground
Driver Tibia Lower Left Z Force, Questionable spikes throughout	Channel was grounded but the electrical resistance is quite high and intermittent between the load cell body and the tibia ground, indicating poor ground
Passenger Spine Moment X, Questionable Data 54.7ms to 70ms	During a live view, spikes occurred while shaking the cable ~halfway up the umbilical. The cable was built with a stiff shrink tube around the channel-breakout section. At the end of the stiff shrink tube, flexing the wires caused the spikes.
Passenger Abdomen Right DGIR X Displacement, Questionable spikes throughout	Retaining clip was jarred lose inside the IRTRACC during impact.

**PRELIMINARY INJURY SUMMARY: Driver**

Test Vehicle: R20150227-2015 Ford F-150 NHTSA No.: R20150227  
 Test Program: NHTSA R&D Right Oblique Offset 15deg/35% Test Date: 9/16/2015

**Driver: THOR Serial No. 015 Injury Summary**

Location	Description	Unit	Source	Max	Min
<b>Head</b>	HIC 15ms		Compute	191.09	
	Brain Injury Criteria (BrIC)		Compute	1.74	
	Head Rotational Velocity X	Deg/s	60	602.22	-697.35
	Head Rotational Velocity Y	Deg/s	60	1770.99	-1987.14
	Head Rotational Velocity Z	Deg/s	60	1291.40	-3963.97
<b>Neck</b>	Upper Neck Z-axis Force	N	1000	1378.77	-507.95
	Upper Neck Y-axis Moment	Nm	Thortest	53.24	-41.99
<b>Chest</b>	Upper Left Resultant Chest Deflection	mm	Thortest	40.13	
	Upper Right Resultant Chest Deflection	mm	Thortest	37.56	
	Lower Left Resultant Chest Deflection	mm	Thortest	17.49	
	Lower Right Resultant Chest Deflection	mm	Thortest	31.73	
<b>Abdomen</b>	Lower Left X-axis Deflection	mm	Thortest	0.25	-54.40
	Lower Right X-axis Deflection	mm	Thortest	0.20	-52.95
<b>Acetabulum</b>	Left Acetabulum Resultant Force	N	Compute	1311.77	0.05
	Right Acetabulum Resultant Force	N	Compute	1516.53	0.05
<b>Femur</b>	Left Femur Force, FZ	N	600	329.86	-2963.07
	Right Femur Force, FZ	N	600	605.23	-1911.47
<b>Tibia</b>	Left Upper Tibia, FZ	N	600	186.05	-842.68
	Left Upper Tibia Index		Compute	0.39	
	Right Upper Tibia, FZ	N	600	239.44	-1530.97
	Right Upper Tibia Index		Compute	0.80	
	Left Lower Tibia, FZ	N	600	85.52 <sup>(1)</sup>	-1508.54 <sup>(1)</sup>
	Left Lower Tibia Index		Compute	0.23 <sup>(1)</sup>	
	Right Lower Tibia, FZ	N	600	212.70	-2727.73
	Right Lower Tibia Index		Compute	0.90	
<b>Ankle</b>	Left Ankle Rotation, RX	Deg	180	25.62	-19.19
	Left Ankle Rotation, RY	Deg	180	-4.30	-24.26
	Left Ankle Dorsiflexion Moment, MY	Nm	Compute	20.30 <sup>(2)</sup>	-26.56 <sup>(2)</sup>
	Left Ankle In/Eversion Moment, MX	Nm	Compute	46.10 <sup>(3)</sup>	-80.66 <sup>(3)</sup>
	Right Ankle Rotation, RX	Deg	180	27.39	-18.39
	Right Ankle Rotation, RY	Deg	180	24.06	-20.23
	Right Ankle Dorsiflexion Moment, MY	Nm	Compute	45.59	-38.00
	Right Ankle In/Eversion Moment, MX	Nm	Compute	196.28	-29.48

**Anomalies:**

- (1) Questionable spikes throughout
- (2) Tibia Lower Left X Force - Questionable spikes at 58ms, 90.8ms and 201ms
- (3) Tibia Lower Left Y Force - Questionable spikes at 57.6ms , 91.2ms and 201ms

**PRELIMINARY INJURY SUMMARY: Right Front Passenger**

Test Vehicle: R20150227-2015 Ford F-150 NHTSA No.: R20150227  
 Test Program: NHTSA R&D Right Oblique Offset 15deg/35% Test Date: 9/16/2015

**Right Front Passenger: THOR Serial No. 016 Injury Summary**

Location	Description	Unit	Source	Max	Min
<b>Head</b>	HIC 15ms		Compute	140.82	
	Brain Injury Criteria (Bric)		Compute	1.08	
	Head Rotational Velocity X	Deg/s	60	1907.53	-759.43
	Head Rotational Velocity Y	Deg/s	60	585.89	-1269.72
	Head Rotational Velocity Z	Deg/s	60	1354.11	-2136.51
<b>Neck</b>	Upper Neck Z-axis Force	N	1000	937.46	-211.15
	Upper Neck Y-axis Moment	Nm	Thortest	24.05	-23.97
<b>Chest</b>	Upper Left Resultant Chest Deflection	mm	Thortest	37.26	
	Upper Right Resultant Chest Deflection	mm	Thortest	35.60	
	Lower Left Resultant Chest Deflection	mm	Thortest	30.04	
	Lower Right Resultant Chest Deflection	mm	Thortest	23.95	
<b>Abdomen</b>	Lower Left X-axis Deflection	mm	Thortest	-0.00	-60.80
	Lower Right X-axis Deflection	mm	Thortest	544.10 <sup>(4)</sup>	-57.89 <sup>(4)</sup>
<b>Acetabulum</b>	Left Acetabulum Resultant Force	N	Compute	1006.18	0.06
	Right Acetabulum Resultant Force	N	Compute	2164.77	0.07
<b>Femur</b>	Left Femur Force, FZ	N	600	521.93	-2480.08
	Right Femur Force, FZ	N	600	426.56	-4153.25
<b>Tibia</b>	Left Upper Tibia, FZ	N	600	158.87	-713.40
	Left Upper Tibia Index		Compute	0.31	
	Right Upper Tibia, FZ	N	600	377.05	-1177.81
	Right Upper Tibia Index		Compute	0.35	
	Left Lower Tibia, FZ	N	600	49.94	-1212.14
	Left Lower Tibia Index		Compute	0.35	
	Right Lower Tibia, FZ	N	600	22.28	-1230.40
	Right Lower Tibia Index		Compute	0.31	
<b>Ankle</b>	Left Ankle Rotation, RX	Deg	180	34.70	-9.26
	Left Ankle Rotation, RY	Deg	180	0.67	-27.19
	Left Ankle Dorsiflexion Moment, MY	Nm	Compute	16.59	-36.24
	Left Ankle In/Eversion Moment, MX	Nm	Compute	43.12	-10.53
	Right Ankle Rotation, RX	Deg	180	9.42	-34.22
	Right Ankle Rotation, RY	Deg	180	4.76	-28.43
	Right Ankle Dorsiflexion Moment, MY	Nm	Compute	18.24	-64.57
	Right Ankle In/Eversion Moment, MX	Nm	Compute	33.41	-34.54

**Anomalies:**

(4) Questionable spikes 21.6 to 53.3ms and 84.6ms to 87ms

**SECTION 3  
DATA SHEETS**

Test Vehicle: 2015 Ford F-150 Pickup truck  
Test Program: R&D 90.1kph, 15° / 35% Right Oblique Offset

NHTSA No.: R20150227  
Test Date: 9/16/2015

<u>Data Sheet No.</u>		<u>Page No.</u>
1	General Test and Vehicle Parameter Data	3-2
2	Seat Adjustment, Fuel System, and Steering Wheel	3-6
3	Dummy Longitudinal Clearance Dimensions	3-8
4	Dummy Lateral Clearance Dimensions	3-10
5	Seat Belt Positioning Data	3-11
6	High-Speed Camera Locations and Data	3-12
7	Vehicle Instrumentation Data	3-15
8	Photographic Reference Target Locations	3-18
9	Test Vehicle Summary of Results	3-25
10	Post-Test Observations	3-26
11	Vehicle Profile Measurements	3-27
12	Accident Investigation Division Data	3-29
13	Vehicle Intrusion Measurements	3-30
14	OMDB Crush Measurements	3-47
15	Summary of FMVSS 212, 219 (Partial), and 301 Data	3-48
	Windshield Periphery Measurements	3-48
	Areas of Protected Zone Failures	3-48
	Fuel System Integrity Post Impact Data	3-49
16	FMVSS 301 Static Rollover Results	3-50
17	Dummy / Vehicle Temperature Stabilization	3-51

**DATA SHEET NO. 1  
GENERAL TEST AND VEHICLE PARAMETER DATA**

Test Vehicle: 2015 Ford F-150 Pickup truck  
 Test Program: R&D 90.1kph, 15° / 35% Right Oblique Offset

NHTSA No.: R20150227  
 Test Date: 9/16/2015

**VEHICLE INFORMATION**

NHTSA No.	R20150227
Model Year	2015
Make	Ford
Model	F-150
Body Style	Pickup/Crew Cab
VIN	1FTEW1CG6FKD64892
Body Color	Red
Odometer Reading (km/mi)	11.2 km / 7 mi
Engine Displacement. (L)	3.5
Type/No. Cylinders	V6
Engine Placement	Inline
Transmission Type	Automatic
Transmission Speeds	6-Speed
Overdrive	Yes
Final Drive	Rear Wheel Drive
Roof Rack	No
Sunroof/T-Top	No
Running Boards	Yes
Tilt Steering Wheel	Yes
Power Seats	No
Anti-Lock Brakes (ABS)	Yes
All-Wheel Drive (AWD)	No
Traction Control System (TCS)	Yes

**VEHICLE OPTIONS**

Auto-Leveling System	No
Automatic Door Locks (ADL)	Yes
Power Window Auto-Reverse	No
Other Optional Feature	-
Driver Front Airbag	Yes
Driver Curtain Airbag	Yes
Driver Head/Torso Airbag	No
Driver Torso Airbag	No
Driver Torso/Pelvis Airbag	Yes
Driver Pelvis Airbag	No
Driver Knee Airbag	No
Pass. Front Airbag	Yes
Pass. Curtain Airbag	Yes
Pass. Head/Torso Airbag	No
Pass. Torso Airbag	No
Pass. Torso/Pelvis Airbag	Yes
Pass. Pelvis Airbag	No
Pass. Knee Airbag	No
Driver Seat Belt Pretensioner	Yes
Pass. Seat Belt Pretensioner	Yes
Driver Load Limiter	Yes
Pass. Load Limiter	Yes
Other Safety Restraint	-

Does owner's manual provide instructions to turn off automatic door locks?

**Yes**

**DATA FROM CERTIFICATION LABEL**

Manufactured By	Ford Motor Co.
Date of Manufacture	06/15

GWR (kg)	3084
GAWR Front (kg)	1429
GAWR Rear (kg)	1724

**VEHICLE SEATING AND WEIGHT CAPACITY**

Measured Parameter	Front	Rear	Third	Total
Type of Seats	Bucket	Split Bench	--	
Number of Occupants	3	3	--	6
Capacity Wt. (VCW) (kg)				920
Cargo Wt. (RCLW) (kg)				511.76

**DATA SHEET NO. 1 (CONTINUED)**  
**GENERAL TEST AND VEHICLE PARAMETER DATA**

Test Vehicle: 2015 Ford F-150 Pickup truck  
 Test Program: R&D 90.1kph, 15° / 35% Right Oblique Offset

NHTSA No.: R20150227  
 Test Date: 9/16/2015

Collect items circled in red, tire manufacturer, and tire name.

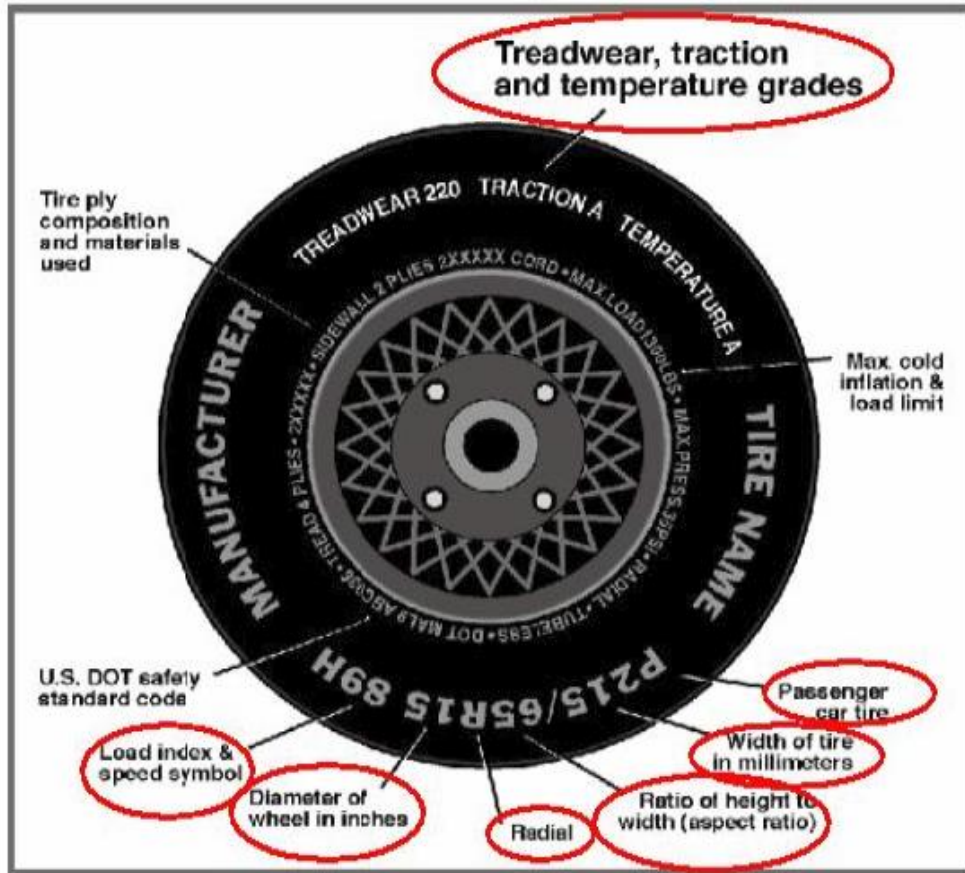

Measured Parameter	Front	Rear
Maximum Tire Pressure (kPa)	300	300
Cold Pressure (kPa)	250	250
Recommended Tire Size	P245/70R17	P245/70R17
Tire Size on Vehicle	P245/70R17	P245/70R17
Tire Manufacturer	Michelin	Michelin
Tire Model	LTX MIS <sup>2</sup>	LTX MIS <sup>2</sup>
Treadwear	720	720
Traction	A	A
Temperature Grades	A	A
Tire Plies Sidewall	2 Polyester	2 Polyester
Tire Plies Body	2 Polyester, 1 Polyamide, 2 Steel	2 Polyester, 1 Polyamide, 2 Steel
Load Index/Speed Symbol	110T	110T
Tire Material	Rubber	Rubber
DOT Safety Code Right	M3X600AX1715	M3X600AX1815
DOT Safety Code Left	M3X600AX1715	M3X600AX1815

**DATA SHEET NO. 1 (CONTINUED)**  
**GENERAL TEST AND VEHICLE PARAMETER DATA**

Test Vehicle: 2015 Ford F-150 Pickup truck  
 Test Program: R&D 90.1kph, 15° / 35% Right Oblique Offset

NHTSA No.: R20150227  
 Test Date: 9/16/2015

**TEST VEHICLE WEIGHTS**

	Units	As Delivered (UVW) (Axle)			As Tested (ATW) (Axle)		
		Front	Rear	Total	Front	Rear	Total
Left	kg	617	456		676	558	
Right	kg	621	447		683	544	
Ratio	%	58	42		55.2	44.8	
Totals	kg	1238	903	2141	1359	1102	2461

**TARGET TEST WEIGHT CALCULATION**

Measured Parameter	Units	Value
Total Delivered Weight (UVW)	kg	2141
Weight of 2 THOR ATDs	kg	190
Rated Cargo/Luggage Weight (RCLW)	kg	136
Calculated Vehicle Target Weight (TVTW)	kg	2467

**TEST VEHICLE ATTITUDES AND CG**

	Units	LF	RF	LR	RR	CG (aft of front axle)
As Delivered	mm	912	909	989	986	1555
As Tested	mm	898	894	956	959	1651
Post Test	mm	943	938	1033	888	

**GENERAL TEST VEHICLE DATA**

Measurement Description	Units	Value
Total Vehicle Wheel Base	mm	3688
Total Vehicle Length at Left Side	mm	5833
Total Vehicle Length at Centerline	mm	5879
Total Vehicle Length at Right Side	mm	5830
Weight of Ballast in Cargo Area	kg	18.1
Weight of Vehicle Components Removed	kg	52
Amount of Stoddard Solvent in Fuel Tank	L	84.5

**LIST OF COMPONENTS REMOVED TO MEET TEST WEIGHT:**

Trunk Carpeting, rear seats, jack.

---



---



---



---



---



---



---

**DATA SHEET NO.1 (CONTINUED)**  
**GENERAL TEST AND VEHICLE PARAMETER DATA**

Test Vehicle: 2015 Ford F-150 Pickup truck  
 Test Program: R&D 90.1kph, 15° / 35% Right Oblique Offset

NHTSA No.: R20150227  
 Test Date: 9/16/2015

**TARGET VEHICLE STRUCTURAL MEASUREMENT**

	Elements		Pre-Test
1	Total Length	mm	5879
2	Total Width	mm	2024
3*	Bumper Top Height	mm	715
4*	Bumper Bottom Height	mm	471
5*	Longitudinal Member Top Height	mm	675
6	Distance Between Longitudinal Members	mm	954
7	Longitudinal Member Width	mm	98
8*	Engine Top Height	mm	1154
9*	Engine Bottom Height	mm	357
10	Engine and Gearbox Width	mm	564
11	Front Bumper-Engine Distance	mm	830
12*	Front Shock Absorber Fixing Height	mm	898
13*	Bonnet Leading Edge Height	mm	1193
14	Front Shock Absorber Fixing Width	mm	977
15	Front Bumper – Front Axle Distance	mm	954
16	Front Axle – A Pillar Distance	mm	645
17	A-Pillar – B-Pillar Distance	mm	1221
18	B-Pillar – Rear Axle Distance	mm	1823
19	B-Pillar – C-Pillar Distance	mm	1034
20*	Roof Sill Bottom Height	mm	1818
21*	Roof Sill Top Height	mm	1854
22*	Floor Sill Bottom Height	mm	596
23*	Floor Sill Top Height	mm	607

\*Note: Height measurements are in reference to the ground.

**DATA SHEET NO. 2**  
**SEAT ADJUSTMENT, FUEL SYSTEM, AND STEERING WHEEL**

Test Vehicle: 2015 Ford F-150 Pickup truck  
 Test Program: R&D 90.1kph, 15° / 35% Right Oblique Offset

NHTSA No.: R20150227  
 Test Date: 9/16/2015

**NORMAL DESIGN RIDING POSITION**

*For adjustable driver and passenger seat backs. Please describe how to position the inclinometer to measure the seat back angle. Include description of the location of the adjustment latch detent, if applicable.*

**Driver seat:** The driver seat back was positioned according to the Nominal Design Riding position listed in FORM 1

**Passenger Seat:** The passenger seat back was positioned according to the Nominal Design Riding position listed in FORM 1

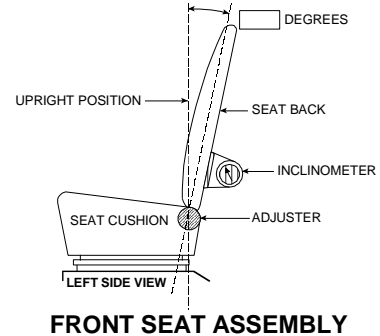

	UNIT	FORM 1 POSITION	AFTER ATD POSITIONING
Driver Seat Back Angle	deg	3.0	3.5
Passenger Seat Back Angle	deg	3.0	3.7

**SEAT FORE/AFT POSITIONS**

*Describe the method used of determining seat fore/aft positions.*

The driver's seat was positioned at its mid height position and at the mid-point of fore/aft travel. The passenger's seat was positioned at the mid-point of fore/aft travel.

	Total Fore/Aft Travel	Placed in Position #
Driver Seat	254 mm / 37 detents	130 mm / 19 <sup>th</sup> detent
Passenger Seat	255 mm / 37 detents	129 mm / 19 <sup>th</sup> detent

**SEAT BELT UPPER ANCHORAGES**

*Describe the method of positioning seat belt upper anchorages.* Belt anchorages were moved along the full range of motion, and marked on the B-Pillar to their respective possible positions. Photographic evidence can be found in Appendix A of this report. Zero is defined as the upper-most position.

	Total # of Positions	Placed in Position #
Driver Seat	4 (0 – 3)	1
Passenger Seat	4 (0 – 3)	1

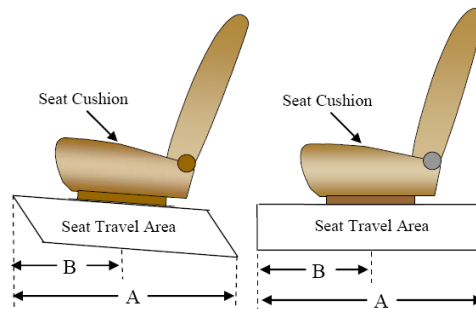

**DATA SHEET NO. 2 (CONTINUED)**  
**SEAT ADJUSTMENT, FUEL SYSTEM, AND STEERING WHEEL DATA**

Test Vehicle: 2015 Ford F-150 Pickup truck  
 Test Program: R&D 90.1kph, 15° / 35% Right Oblique Offset

NHTSA No.: R20150227  
 Test Date: 9/16/2015

**FUEL TANK CAPACITY**

	<b>Liters</b>
Usable Capacity of "Standard Tank"	90.84
Usable Capacity of "Optional Tank"	
93% of Usable Capacity	84.5
Actual Amount of Solvent Used	84.5
1/3 of Usable Capacity	30.2

**FUEL PUMP**

*Describe the fuel system - what type of fuel pump, details about how it operates, etc.*

Fuel evacuated according to the specifications provided by the manufacturer in Form 1. Electric fuel pump operates when the ignition is in the 'on' position and the engine is running. The fuel filler neck is located above the right rear wheel.

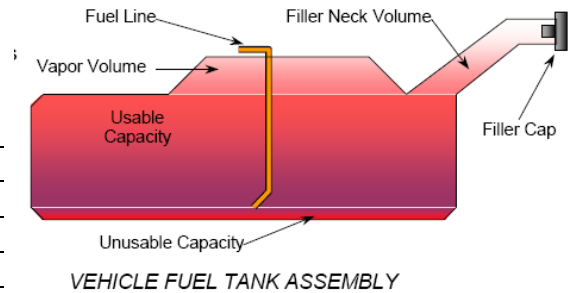

**STEERING COLUMN ADJUSTMENT**

*Steering wheel and column adjustments are made so that the steering wheel hub is at the geometric center of the locus it describes when moved through its full range of motion. Describe how this measurement was taken.*

The steering wheel was adjusted to the midpoint of tilt angle range and the midpoint of the telescoping travel

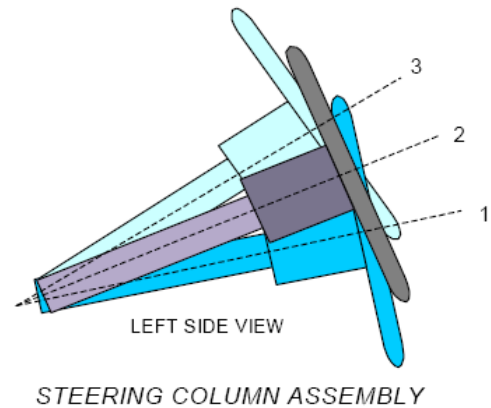

**STEERING COLUMN POSITIONS**

	<b>Tilt (degrees)</b>	<b>Fore/Aft Position (mm)</b>
Lowermost position No. 1	18.5	
Geometric center position No. 2	20.45	
Uppermost position No. 3	22.4	
Telescoping Steering Wheel Travel		40
Test Position	20.45	20

**DATA SHEET NO. 3**  
**DUMMY LONGITUDINAL CLEARANCE DIMENSIONS**

Test Vehicle: 2015 Ford F-150 Pickup truck  
 Test Program: R&D 90.1kph, 15° / 35% Right Oblique Offset

NHTSA No.: R20150227  
 Test Date: 9/16/2015

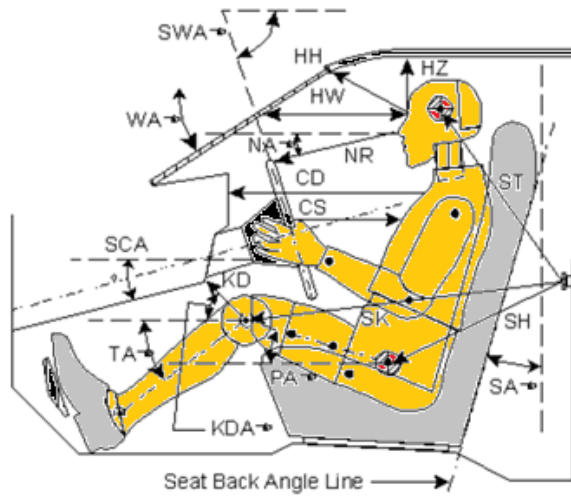

Code	Measurement Description	Driver (Serial # THOR 015)		Passenger (Serial # THOR 016)	
		Length (mm)	Angle(°)	Length (mm)	Angle (°)
WA <sup>0</sup>	Windshield Angle		32.8		
SWA <sup>0</sup>	Steering Wheel Angle		21.0		
SCA <sup>0</sup>	Steering Column Angle		69.0		
SA <sup>0</sup>	Seat Back Angle (on headrest post)		3.5		3.7
SA <sup>0</sup>	Seat Back Angle		19.4		18.5
HZ	Head to Roof (Z)	242	90	231	90
HH	Head to Header	539	16.8	529	16.6
HW	Head to Windshield	802	0	812	0
NR	Nose to Rim	515	14.6	743	25.4
CD	Chest to Dash	651		615	
CS	Chest to Steering Hub	402	1.8		
RA	Rim to Abdomen	198	0		
KDL	Left Knee to Dash	125	20	103	27.7
KDR	Right Knee to Dash	112	12	112	27.2
PA <sup>0</sup>	Pelvic Angle		32.9		31.8
TA <sup>0</sup>	Tibia Angle		47.7		53
SK	Striker to Knee	732	4.2	745	4.2
ST	Striker to Head	621	-80.5	628	-80.2
SH	Striker to H-Point	328	6.5	329	5.2
HAX <sup>0</sup>	Head Angle (X)		-0.4		0.3
HAY <sup>0</sup>	Head Angle (Y)		-2.8		-2.5
TAX <sup>0</sup>	T6 Angle (X)		-2.3		-0.2
TAY <sup>0</sup>	T6 Angle (Y)		22.7		20.1
TAX <sup>0</sup>	T1 (X)		-2.4		0.2
TAY <sup>0</sup>	T1 (Y)		0.7		-1.0
TAX <sup>0</sup>	T12 (X)		-0.7		-1.7
TAY <sup>0</sup>	T12 (Y)		30.4		29.2

### DATA SHEET NO.3 (CONTINUED) DUMMY CMM MEASUREMENTS

Test Vehicle: 2015 Ford F-150 Pickup truck  
 Test Program: R&D 90.1kph, 15° / 35% Right Oblique Offset

NHTSA No.: R20150227  
 Test Date: 9/16/2015

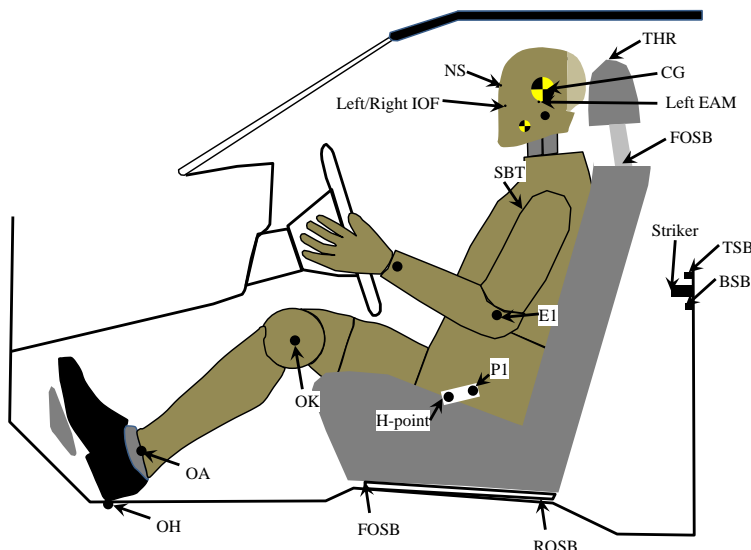

Description	Units	Driver			Passenger		
		X	Y	Z	X	Y	Z
Head CG	mm	3,241	-533	-1,081	3,247	528	-1,089
Nasion	mm	3,336	-456	-1,086	3,345	457	-1,096
Tip of Nose	mm	3,338	-457	-1,049	3,347	457	-1,057
Tip of Chin	mm	3,328	-457	-948	3,337	457	-956
Left EAM	mm	3,247	-529	-1,053	3,265	378	-1,059
Right EAM	mm	3,249	-386	-1,048	3,254	524	-1,060
Left IOF	mm	3,332	-490	-1,050	3,345	425	-1,058
Right IOF	mm	3,334	-426	-1,047	3,340	490	-1,057
Outboard Elbow	mm	3,487	-689	-655	3,413	739	-563
H-Point	mm	3,465	-652	-431	3,469	654	-439
H-Point Tool	mm	3,391	-701	-456	3,391	703	-461
Outboard Knee Bolt	mm	3,869	-664	-521	3,884	618	-524
Inboard Knee Bolt	mm	3,877	-361	-518	3,881	389	-540
Outboard Ankle Bolt	mm	4,146	-700	-207	4,135	621	-195
Outer Heel Point	mm	4,135	-678	-67	4,072	591	-68
Inboard Heel Point	mm	4,166	-325	-74	4,067	364	-69
Striker Top Bolt	mm	3,105	-897	-484	3,108	895	-486
Striker Bottom Bolt	mm	3,107	-898	-448	3,109	897	-450
Center Tip of Striker	mm	3,139	-897	-468	3,141	894	-469
Front Outboard Seat Anchor Bolt	mm	3,694	-630	-114	3,698	636	-115
Rear Outboard Seat Anchor Bolt	mm	3,202	-668	-113	3,209	671	-113
Outboard Head Restraint Post	mm	3,062	-541	-941	3,073	549	-943
Top of Head Restraint	mm	3,078	-458	-1,173	3,087	457	-1,178
Center of Steering Wheel	mm	3,773	-463	-795			

Reference point:

- +X – From the rear of the vehicle to the front of the vehicle
- +Y – From the left side of the vehicle to the right side of the vehicle
- +Z – From the top of the vehicle to the bottom of the vehicle

**DATA SHEET NO. 4**  
**DUMMY LATERAL CLEARANCE DIMENSIONS**

Test Vehicle: 2015 Ford F-150 Pickup truck  
 Test Program: R&D 90.1kph, 15° / 35% Right Oblique Offset

NHTSA No.: R20150227  
 Test Date: 9/16/2015

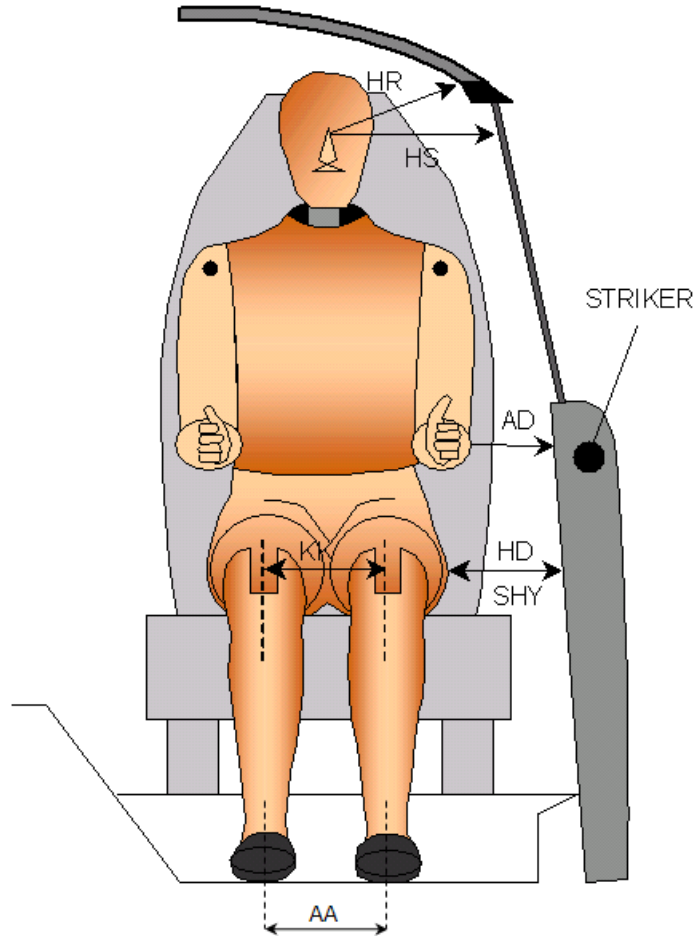

Code	Description	Units	Driver	Passenger
AD	Arm to Door	mm	145	35
HD	H-Point to Door	mm	142	143
HR	Head to Side Header	mm	223	213
HS	Head to Side Window	mm	358	351
KK	Knee to Knee	mm	338	254
SHY	Striker to H-Point (Y Direction)	mm	245	245
AA	Ankle to Ankle	mm	345	228

**DATA SHEET NO. 5  
SEAT BELT POSITIONING DATA**

Test Vehicle: 2015 Ford F-150 Pickup truck  
 Test Program: R&D 90.1kph, 15° / 35% Right Oblique Offset

NHTSA No.: R20150227  
 Test Date: 9/16/2015

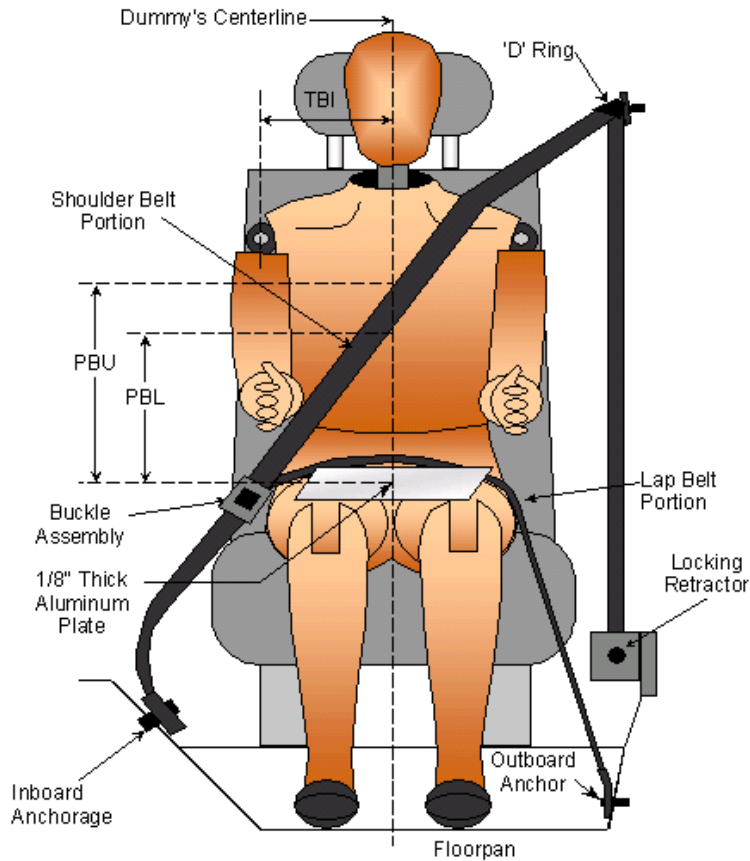

**SEAT BELT POSITIONING MEASUREMENTS**

Measurement Description	Units	Driver	Passenger
<b>PBU</b> — Top surface of reference to belt upper edge	mm	385	375
<b>PBL</b> — Top surface of reference to belt lower edge	mm	305	305

**BELT LENGTH DATA**

Measurement Description	Units	Driver	Passenger
Shoulder belt length as measured on ATD	mm	845	855
Lap Belt Length as measured on ATD	mm	770	790
Remainder of belt on reel	mm	885	855
Total belt length for continuous webbing systems	mm	2500	2500

**DATA SHEET NO. 6**  
**HIGH-SPEED CAMERA LOCATIONS AND DATA**

Test Vehicle: 2015 Ford F-150 Pickup truck  
 Test Program: R&D 90.1kph, 15° / 35% Right Oblique Offset

NHTSA No.: R20150227  
 Test Date: 9/16/2015

**HORIZONTAL LOCATION**

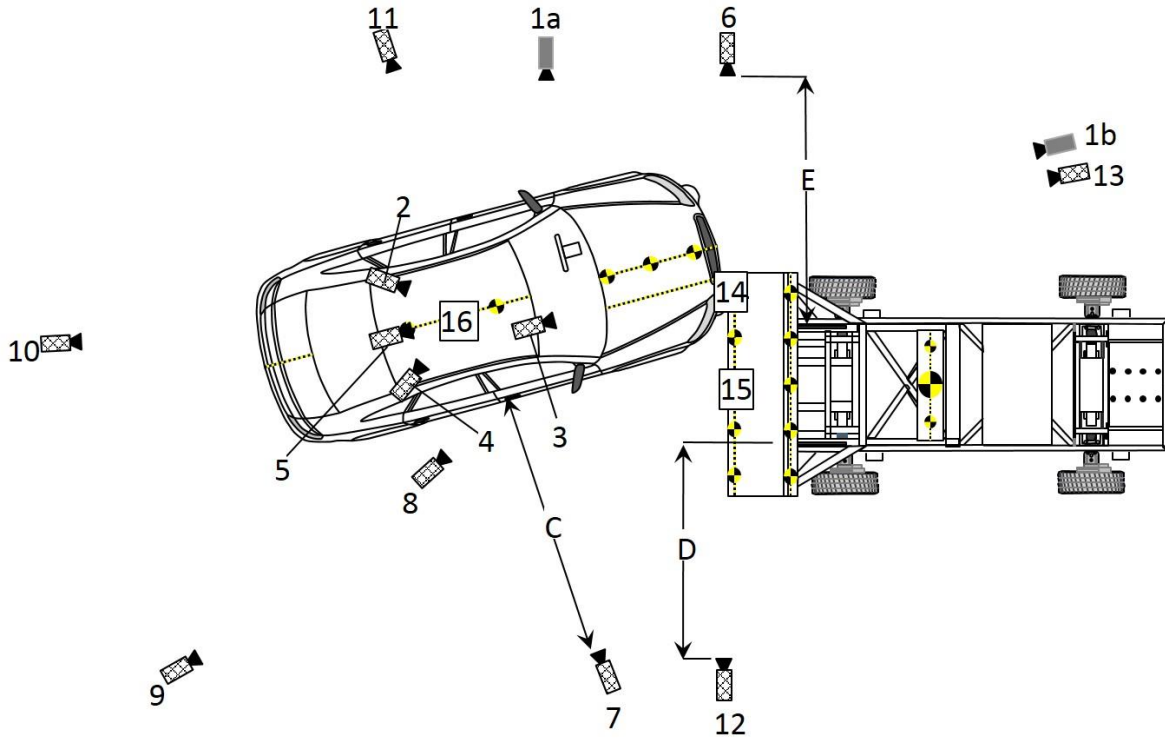

**VERTICAL LOCATION**

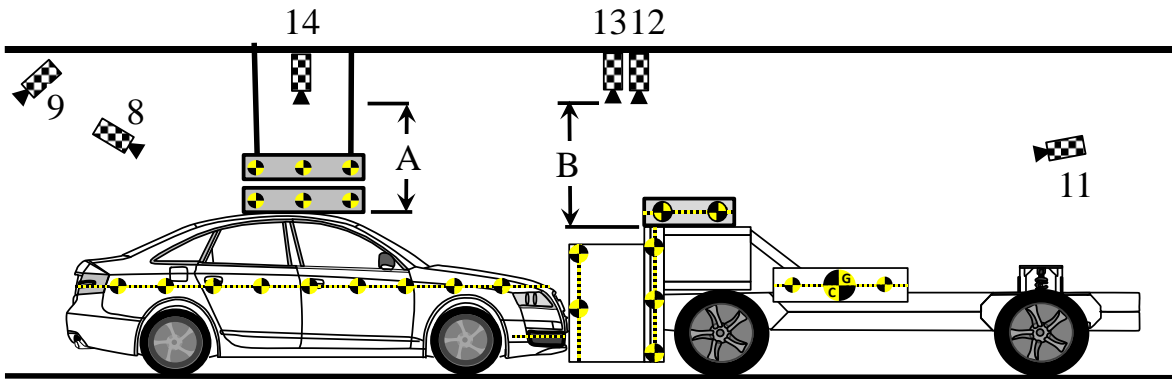

A	mm	3526
B	mm	4142
C	mm	7720
D	mm	8162
E	mm	8164

**DATA SHEET NO. 6 (CONTINUED)**  
**HIGH-SPEED CAMERA LOCATIONS AND DATA**

Test Vehicle: 2015 Ford F-150 Pickup truck  
 Test Program: R&D 90.1kph, 15° / 35% Right Oblique Offset

NHTSA No.: R20150227  
 Test Date: 9/16/2015

**CAMERA LOCATIONS**

No.	Camera View	Location (mm)			Lens (mm)	Speed (fps)
		X	Y	Z		
1	Real-Time Left Side	--	--	--	Zoom	60
2	Onboard Passenger Movement	7884	-275	1608	12.5	1000
3	Onboard Passenger Lower Leg	6766	-352	586	6.5	1000
4	Onboard Driver Movement	7809	-902	1608	12.5	1000
5	Onboard Centerline	8110	559	1703	8	1000
6	Passenger Interaction	4920	9211	1068	20	1000
7	Driver Interaction	5818	-7905	1456	28	1000
8	Target Vehicle Left Side Perpendicular (High)	8308	2288	3595	28	1000
9	Target Vehicle Driver Motion	12938	-6939	2520	24-70	1000
10	Rear View of Vehicle and OMDB	28750	0	3421	14	1000
11	Right Side Target Vehicle and OMDB	11155	9121	2714	24-70	1000
12	Front of Vehicle and OMDB	4907	-9247	1072	24	1000
13	Overhead Close-Up Impact Point	1096	3516	1260	28	1000
14	Overhead Impact Point View	4865	-1115	4733	28	1000
15	Overhead Vehicle View	7369	0	5327	15	1000
16	Overhead OMDB View	4678	0	5327	15	1000

Reference Point:

- +X – From back of OMDB to front of OMDB
- +Y – Right of monorail center
- +Z – Up from ground

**DATA SHEET NO. 7  
VEHICLE INSTRUMENTATION DATA**

Test Vehicle: 2015 Ford F-150 Pickup truck  
 Test Program: R&D 90.1kph, 15° / 35% Right Oblique Offset

NHTSA No.: R20150227  
 Test Date: 9/16/2015

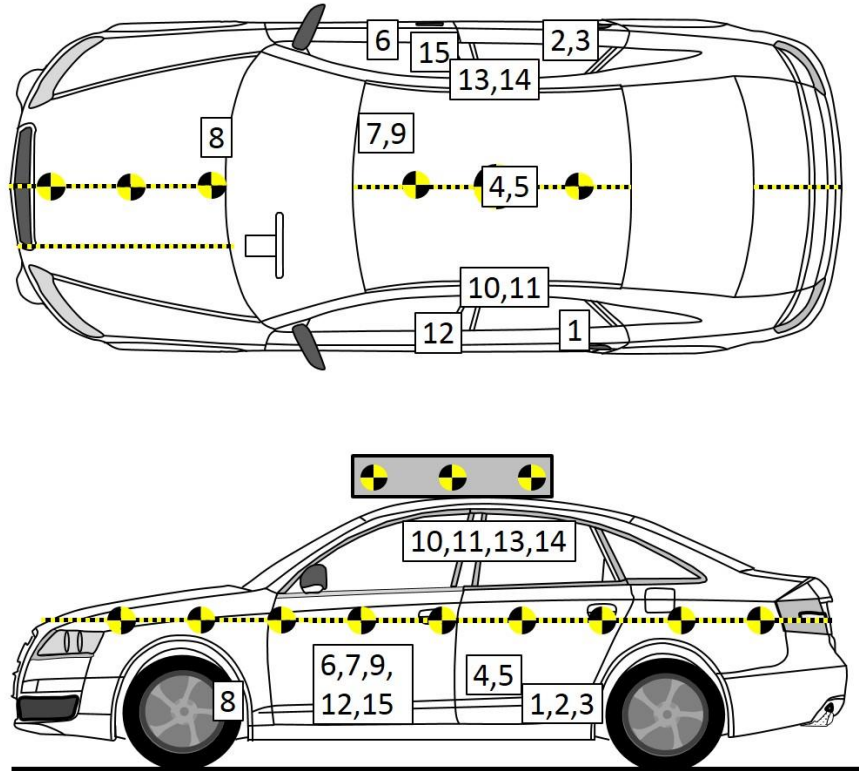

**VEHICLE ACCELEROMETER PRE-TEST LOCATIONS RELATIVE TO VCS**

No.	Accelerometer Location	Axes	Units	Measurements (mm)		
				X	Y	Z
1	Left Rear Sill	X,Y	mm	2495	-796	-17
2	Right Rear Sill	X,Y	mm	2493	807	-16
3	Right Rear Sill Redundant	X,Y	mm	2479	808	-14
4	Vehicle CG	X,Y,Z	mm	3019	-1	-138
5	Vehicle CG Angular Displacement	X	mm	3030	-1	-133
		Y	mm	3018	10	-131
		Z	mm	3019	-1	-138
6	Right Side Seat Track	X,Y,Z	mm	3484	660	-165
8	Right Side Toe Pan	X,Y,Z	mm	4468	552	-271
7	Right Side String Pot	N/A	mm	4427	458	-199

Reference point:

- +X – From the rear of the vehicle to the front of the vehicle
- +Y – From the left side of the vehicle to the right side of the vehicle
- +Z – From the top of the vehicle to the bottom of the vehicle

**DATA SHEET NO. 7 (Continued)**  
**VEHICLE INSTRUMENTATION DATA**

Test Vehicle: 2015 Ford F-150 Pickup truck  
 Test Program: R&D 90.1kph, 15° / 35% Right Oblique Offset

NHTSA No.: R20150227  
 Test Date: 9/16/2015

**ANGULAR RATE SENSOR MOUNTING PLATE & THOR HEAT POINT DEFINITIONS**

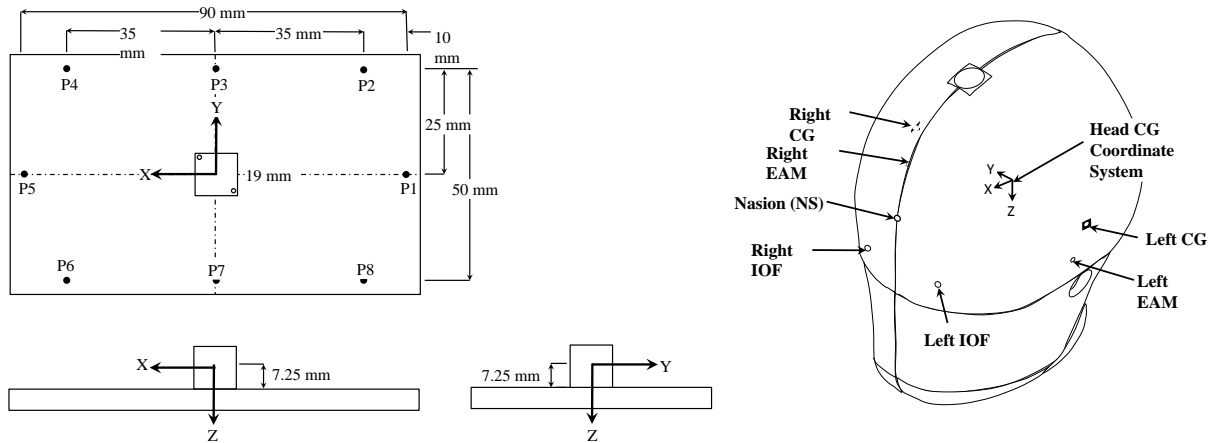

ARS MOUNTING PLATE - VEHICLE COORDINATE SYSTEM					
No.	Description	Units	Measurements (mm)		
			X	Y	Z
P1	Plate Point 1	mm	2974	-1	-124
P2	Plate Point 2	mm	2984	24	-123
P3	Plate Point 3	mm	3019	24	-123
P4	Plate Point 4	mm	3054	24	-123
P5	Plate Point 5	mm	3064	-1	-123
P6	Plate Point 6	mm	3054	-26	-123
P7	Plate Point 7	mm	3019	-26	-124
P8	Plate Point 8	mm	2984	-26	-124

HEAD POINTS IN RELATION TO HEAD CG COORDINATE SYSTEM					
Description	Units	X	Y	Z	
CG	mm	0	0	0	
Left CG	mm	0	-77	0	
Right CG	mm	0	77	0	
Left EAM	mm	7	-72	27	
Right EAM	mm	7	72	27	
Left IOF	mm	89	-32	28	
Right IOF	mm	89	32	28	
Nasion	mm	92	0	-10	

**DATA SHEET NO. 7 (Continued)**  
**VEHICLE INSTRUMENTATION DATA**

Test Vehicle: 2015 Ford F-150 Pickup truck  
 Test Program: R&D 90.1kph, 15° / 35% Right Oblique Offset

NHTSA No.: R20150227  
 Test Date: 9/16/2015

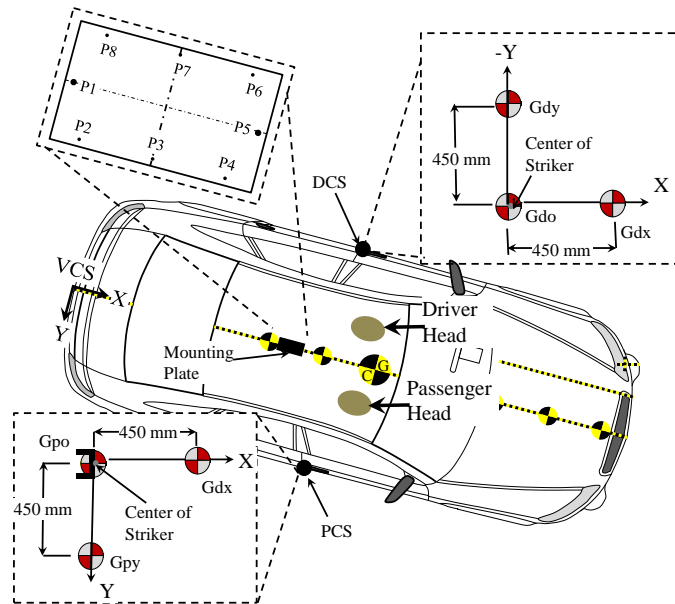

**ARS MOUNTING PLATE & ATD'S HEAD POINTS RELATIVE TO GLOBAL COORDINATE SYSTEMS**

DESCRIPTION	DRIVER DCS			PASS. PCS		
	X	Y	Z	X	Y	Z
G <sub>o</sub>	0	0	0	0	0	0
G <sub>x</sub>	453	0	-7	450	0	-8
G <sub>y</sub>	1	-450	0	-2	449	-3
P1	93	898	-614	-382	-841	-609
P2	109	919	-613	-367	-820	-609
P3	143	910	-613	-333	-828	-609
P4	177	901	-613	-299	-837	-609
P5	180	874	-613	-296	-864	-609
P6	163	853	-613	-311	-885	-609
P7	130	862	-614	-345	-877	-609
P8	96	871	-614	-379	-868	-609
Left CG	209	314	-1571			
Right CG				16	-398	-1574
Left EAM	215	316	-1543			
Right EAM				21	-405	-1546
Left IOF	308	331	-1540	84	-524	-1543
Right IOF	326	393	-1538	96	-460	-1543
Nasion	321	363	-1576	93	-492	-1581

**DATA SHEET NO. 7 (CONTINUED)  
VEHICLE INSTRUMENTATION DATA**

Test Vehicle: 2015 Ford F-150 Pickup truck  
Test Program: R&D 90.1kph, 15° / 35% Right Oblique Offset

NHTSA No.: R20150227  
Test Date: 9/16/2015

No.	Description	Axes	Units	Positive Direction		Negative Direction	
				Max	Time (ms)	Max	Time (ms)
1	Left Rear Sill	X	g	3.43	121.25	-41.66	48.15
		Y	g	9.79	79.00	-23.29	46.65
2	Right Rear Sill	X	g	3.34	117.10	-51.16	46.65
		Y	g	7.83	55.25	-20.91	49.10
3	Impact Side Rear Sill Redundant	X	g	4.09	81.60	-50.23	46.65
		Y	g	7.90	55.30	-22.08	47.60
4	Vehicle CG Acceleration	X	g	3.17	79.60	-44.81	47.05
		Y	g	2.79	78.90	-19.53	47.00
		Z	g	11.17	28.35	-16.16	79.45
5	Impact Side Seat Track	X	g	3.52	80.30	-51.07	46.95
		Y	g	5.37	97.25	-19.46	49.75
		Z	g	17.67	34.25	-11.42	58.90
6	Impact Side Seat Crossmember	X	g	7.20	79.75	-46.28	47.55
		Z	g	17.94	33.95	-22.77	83.15
7	Impact Side Toe Pan	X	g	32.34	63.80	-65.96	56.15
		Y	g	15.40	48.95	-40.43	63.95
		Z	g	27.31	63.30	-27.05	58.30
8	Angular Rate Sensors	X	Deg/s	93.02	51.85	-24.16	27.25
		Y	Deg/s	219.63	30.45	-303.92	81.55
		Z	Deg/s	23.48	23.65	-93.28	118.20
9	Driver Shoulder Displacement		mm	73.95	25.95	-142.53	93.40
10	Driver Shoulder Belt		N	4684.79	55.80	-36.32	14.30
11	Driver Lap Belt		N	4867.37	70.65	-52.06	16.65
12	Passenger Shoulder Displacement		mm	78.24	24.25	-169.64	108.75
13	Passenger Shoulder Belt		N	2986.43	73.65	-31.35	14.20
14	Passenger Lap Belt		N	3224.80	52.70	-39.79	16.30
15	Impact Side Floor String Pot		mm	11.10	300.00	-17.20	68.60

Note: See Appendix B for all vehicle data plots.

**TIME TO FIRE RESTRAINT TIMING**

No.	Description	Axes	Units	Time to Fire (ms)
1	Driver Air Bag Squib 1	*	A	33.55
2	Driver Air Bag Squib 2	*	A	53.55
3	Driver Curtain Airbag	*	A	Did not fire
4	Driver Torso Airbag	*	A	Did not fire
5	Driver Knee Airbag	*	A	N/A
6	Driver Pretensioner	*	A	15.10
7	Passenger Air Bag Squib 1	*	A	33.55
8	Passenger Air Bag Squib 2	*	A	43.55
9	Passenger Curtain Airbag	*	A	84.55
10	Passenger Torso Airbag	*	A	84.55
11	Passenger Knee Airbag	*	A	N/A
12	Passenger Pretensioner	*	A	15.10

\* The measurement indicates the time the voltage changed

**DATA SHEET NO. 8**  
**PHOTOGRAPHIC REFERENCE TARGET LOCATIONS**

Test Vehicle: 2015 Ford F-150 Pickup truck  
 Test Program: R&D 90.1kph, 15° / 35% Right Oblique Offset

NHTSA No.: R20150227  
 Test Date: 9/16/2015

**VEHICLE TARGETS**

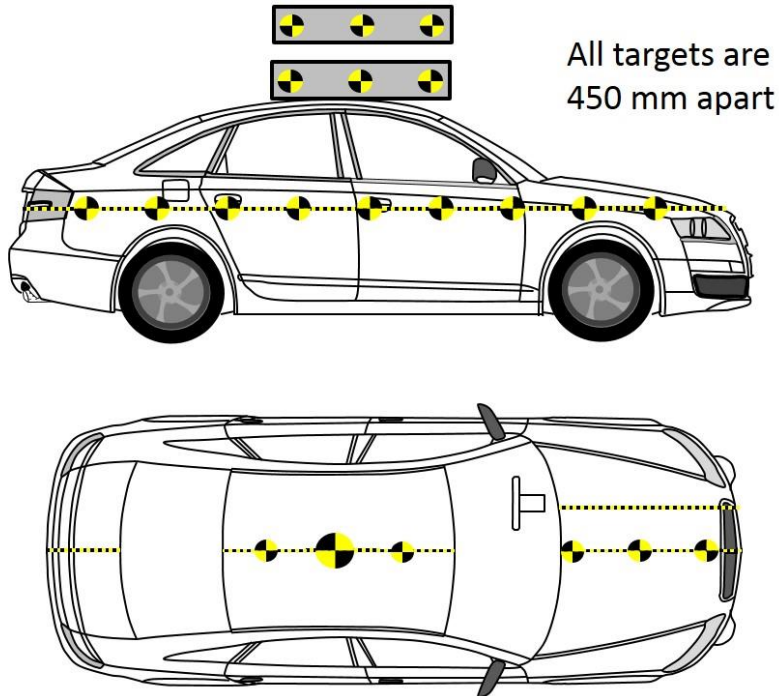

**ATD HEAD TARGETS**

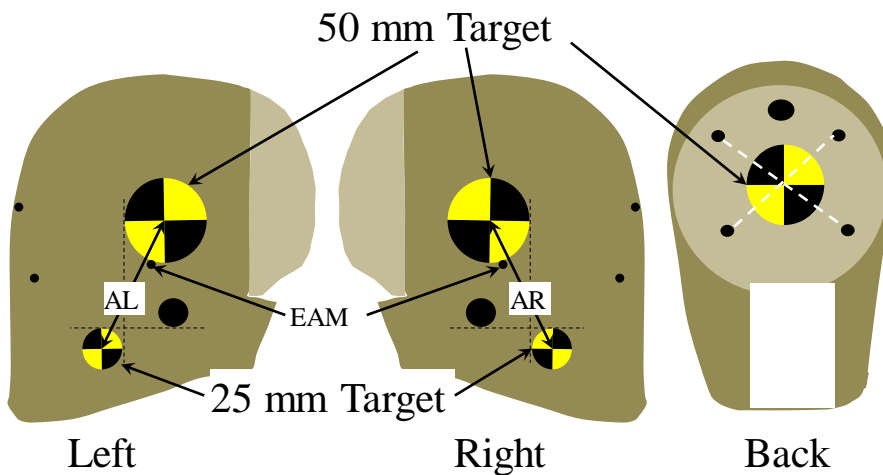

Target	Measurement
AL	85
AR	85

**DATA SHEET NO. 8 (CONTINUED)**  
**PHOTOGRAPHIC REFERENCE TARGET LOCATIONS**

Test Vehicle: 2015 Ford F-150 Pickup truck  
 Test Program: R&D 90.1kph, 15° / 35% Right Oblique Offset

NHTSA No.: R20150227  
 Test Date: 9/16/2015

**OVERHEAD TARGET BARS**

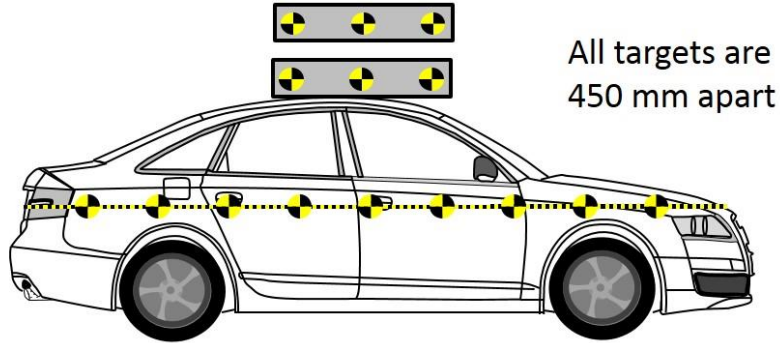

1      2      3

Vertical Target  
 Plane 1  
 (Driver's Side)

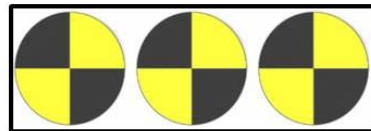

4      5      6

Vertical Target  
 Plane 2  
 (Passenger Side)

Target	Units	X	Y	Z
1	mm	3924	-493	-1707
2	mm	3471	-483	-1702
3	mm	3021	-474	-1702
4	mm	3946	451	-1739
5	mm	3497	453	-1740
6	mm	3040	457	-1733

Reference point:

- +X – From the rear of the vehicle to the front of the vehicle
- +Y – From the left side of the vehicle to the right side of the vehicle
- +Z – From the top of the vehicle to the bottom of the vehicle

**DATA SHEET NO. 8 (CONTINUED)**  
**PHOTOGRAPHIC REFERENCE TARGET LOCATIONS**

Test Vehicle: 2015 Ford F-150 Pickup truck  
Test Program: R&D 90.1kph, 15° / 35% Right Oblique Offset

NHTSA No.: R20150227  
Test Date: 9/16/2015

**GROUND TARGETS LOCATED IN REFERENCE TO OMDB**

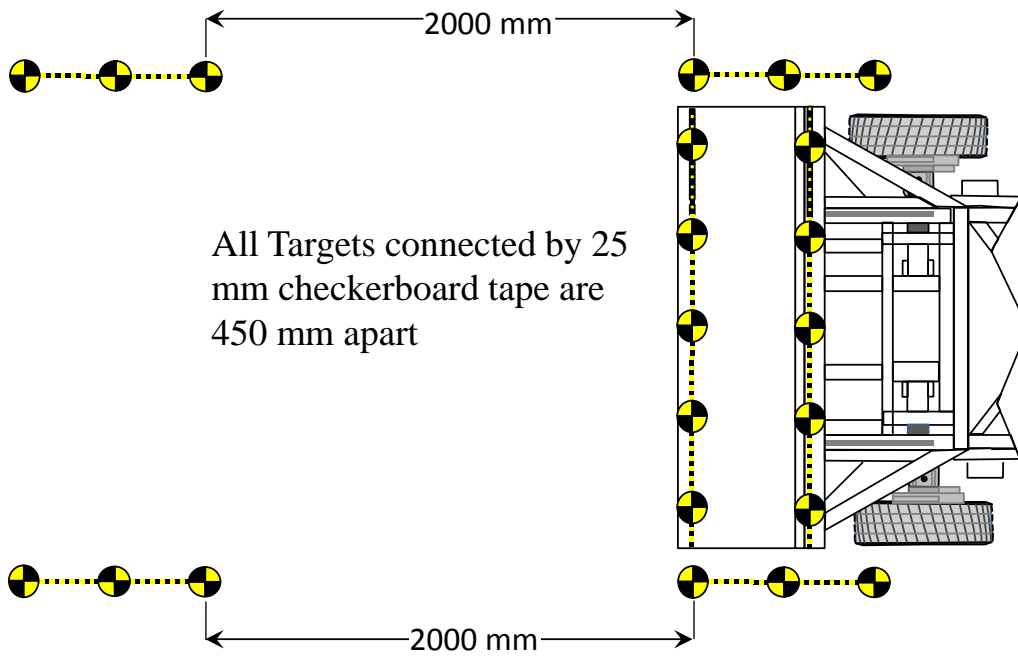

**DATA SHEET NO. 8 (CONTINUED)**  
**OMDB PHOTOGRAPHIC REFERENCE TARGET LOCATIONS**

Test Vehicle: 2015 Ford F-150 Pickup truck  
 Test Program: R&D 90.1kph, 15° / 35% Right Oblique Offset

NHTSA No.: R20150227  
 Test Date: 9/16/2015

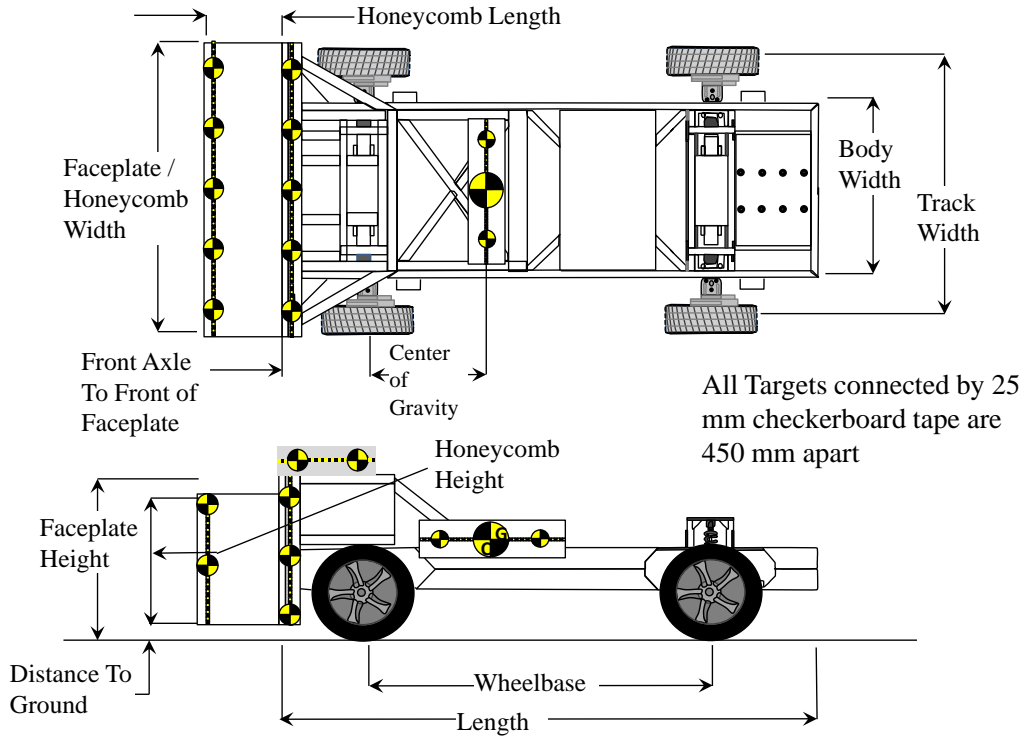

Item	Units	Value	Item	Units	Value
Honeycomb Width	mm	2205	Faceplate Height	mm	1183
Honeycomb Length	mm	605	Faceplate to Ground	mm	84
Honeycomb Height	mm	947	Wheelbase	mm	2589
Left Front Axle to Front Faceplate	mm	600	Cart Length	mm	3993
Right Front Axle to Front Faceplate	mm	601	Body Width	mm	1301
Front Axle to CG	mm	926	Track Width	mm	1884

	Units	Front Axle	Rear Axle	Total
Left	kg	826	434	1260
Right	kg	792	467	1259
Ratio	%	64%	36%	
Total	kg	1618	901	2519
CG Aft of Front Axle	mm			926

Note: All targets on the OMDB honeycomb are 450mm apart

**DATA SHEET NO. 9  
TEST VEHICLE SUMMARY OF RESULTS**

Test Vehicle: 2015 Ford F-150 Pickup truck  
 Test Program: R&D 90.1kph, 15° / 35% Right Oblique Offset

NHTSA No.: R20150227  
 Test Date: 9/16/2015

**INSTRUMENTATION**

Instrumentation	Number of Channels Collected
Driver Dummy Accelerometers	105
Passenger Dummy Accelerometers	105
Vehicle Structure Accelerometers	27
SRS Inductive Pickups	12
OMDB Cart Accelerometers	9
<b>Total</b>	<b>258</b>

**CAMERA COVERAGE**

Type of Camera	Number Used in this Test
High-Speed Vehicle Onboard	4
High-Speed Off-board	11
Real-Time Panning	2
<b>Total</b>	<b>17</b>

**DATA SHEET NO. 10  
POST TEST OBSERVATIONS**

Test Vehicle: 2015 Ford F-150 Pickup truck  
 Test Program: R&D 90.1kph, 15° / 35% Right Oblique Offset

NHTSA No.: R20150227  
 Test Date: 9/16/2015

**TEST DUMMY INFORMATION AND CONTACT LOCATIONS**

Description	Driver	Right Front Passenger
Dummy Type/Serial No.	THOR015	THOR016
Lower Leg Type	LX	LX
Lower Leg Serial No.	LX0038/LX0039	LX0018/ LX0019
Head Contact	Front Airbag, Right Hand & Headrest	Front and Curtain Airbag, & Headrest
Upper Torso Contact	Front Airbag	None
Lower Torso Contact	None	Shoulder contact curtain airbag & door
Left Knee Contact	Knee Bolster	Glove Box
Right Knee Contact	Knee Bolster	Glove Box

**DOOR OPENING AND SEAT TRACK INFORMATION**

Description	Driver	Right Front Passenger
Locked/Unlocked Doors	Unlocked	Unlocked
Front Door Opening	Closed & Operational	Closed & Operational
Rear Door Opening	Closed & Operational	Closed & Operational
Seat Track Shift (mm)	0	35
Seat Back Failure	No	No
Glazing Damage	None	None

**POST TEST STRUCTURAL OBSERVATIONS**

Critical Areas of Performance	Observations and Conclusions	Photo Taken (Y/N)
Pillar Performance	Remained in good condition	Y
Windshield Damage	Cracks throughout	Y
Window Damage	None	Y
Other Notable Effects	None	--

**SUPPLEMENTAL RESTRAINT SYSTEM INFORMATION**

Restraint Type	Driver (Occupant 1)		Right Front Passenger (Occupant 2)	
	Installed	Deployed	Installed	Deployed
Front Airbag	Yes	Yes	Yes	Yes
Curtain Airbag	Yes	Disabled	Yes	Yes
Torso Airbag	Yes	Disabled	Yes	Yes
Knee Airbag	No	N/A	No	N/A
Seat Belt Pretensioner	Yes	Yes	Yes	Yes
Seat Belt Load Limiter	Yes	Yes	Yes	Yes
Other				

**DATA SHEET NO. 11 (CONTINUED)  
VEHICLE PROFILE MEASUREMENTS**

Test Vehicle: 2015 Ford F-150 Pickup truck  
 Test Program: R&D 90.1kph, 15° / 35% Right Oblique Offset

NHTSA No.: R20150227  
 Test Date: 9/16/2015

No.	Measurement Description	Units	Pre-Test	Post-Test	Difference
1	Total Length of Vehicle at Centerline	mm	5879	5556	322
2	Rear Surface of Vehicle (RSOV) to Front of Engine	mm	5048	4822	226
3	RSOV to Firewall	mm	4734	4662	72
4	RSOV to Upper Leading Edge of Right Door	mm	4288	4293	-6
5	RSOV to Upper Leading Edge of Left Door	mm	4287	4298	-12
6	RSOV to Lower Leading Edge of Right Door	mm	4253	4258	-5
7	RSOV to Lower Leading Edge of Left Door	mm	4252	4251	1
8	RSOV to Upper Trailing Edge of Right Door	mm	3055	3061	-6
9	RSOV to Upper Trailing Edge of Left Door	mm	3057	3072	-16
10	RSOV to Lower Trailing Edge of Right Door	mm	3053	3058	-5
11	RSOV to Lower Trailing Edge of Left Door	mm	3052	3055	-2
12	RSOV to Bottom of "A" Post of Right Side	mm	4379	4383	-4
13	RSOV to Bottom of "A" Post of Left Side	mm	4376	4385	-9
14	RSOV to Firewall, Right Side	mm	4713	4594	119
15	RSOV to Firewall, Left Side	mm	4714	4715	-1
16	RSOV to Steering Column	mm	3784	3820	-36
17	Center of Steering Column to "A" Post	mm	293	318	-25
18	Center of Steering Column to Headliner	mm	440	453	-12
19	RSOV to Right Side of Front Bumper	mm	5829	5279	549
20	RSOV to Left Side of Front Bumper	mm	5834	5796	38
21	Length of Engine Block	mm	477	385	92
RD	RSOV to Right Side of Dash Panel	mm	3970	3954	16
CD	RSOV to Center of Dash Panel	mm	3996	3982	14
LD	RSOV to Left Side of Dash Panel	mm	3970	3975	-5

UR\* = Unrecoverable Data Point

**DATA SHEET NO. 12**  
**ACCIDENT INVESTIGATION DIVISION DATA**

Test Vehicle: 2015 Ford F-150 Pickup truck  
Test Program: R&D 90.1kph, 15° / 35% Right Oblique Offset

NHTSA No.: R20150227  
Test Date: 9/16/2015

**VEHICLE INFORMATION**

VIN: 1FTEW1CG6FKD64892 Wheelbase (mm): 3688  
Vehicle Size Category: Truck Test Weight (kg): 2,461

**ACCELEROMETER DATA**

Accelerometer Locations: As Described in Data Sheet No. 7  
Cal. Procedure/Interval: Calspan Procedure / 6 month  
Integration Algorithm: Trapezoidal  
Linearity: > 99%  
Impact Velocity (kph): 90.22  
Velocity Change (kph): 90.22

**CRUSH PROFILE**

Collision Deformation Classification: 12FZEW3  
Midpoint of Damage: C5  
Damage Region Length (mm): 1516  
Impact Mode: Frontal 15° Angle, 35% Right Offset

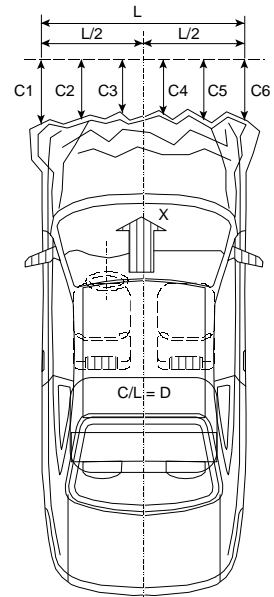

**Crush Measurements: Bumper Cover**

No.	Measurement Description	Units	Pre-Test	Post-Test	Difference
C1	Crush zone 1 at left side	mm	5663	5784	-121
C2	Crush zone 2 at left side	mm	5814	5776	38
C3	Crush zone 3 at left side	mm	5862	5635	227
C4	Crush zone 4 at right side	mm	5861	5426	435
C5	Crush zone 5 at right side	mm	5814	5197	617
C6	Crush zone 6 at right side	mm	5660	4976	684
L	C1 to C6	mm	1516	1235	281

**Crush Measurements: Bumper Cover Removed**

No.	Measurement Description	Units	Pre-Test	Post-Test	Difference
B1	Bumper Beam 1 at left side	mm	5542	5756	214
B2	Bumper Beam 2 at left side	mm	5690	5788	98
B3	Bumper Beam 3 at left side	mm	5806	5783	-23
B4	Bumper Beam 4 at left side	mm	5849	5682	-167
B5	Bumper Beam 5 at right side	mm	5860	5542	-318
B6	Bumper Beam 6 at right side	mm	5845	5349	-496
B7	Bumper Beam 7 at right side	mm	5798	5182	-616
B8	Bumper Beam 8 at right side	mm	5675	4997	-678
B9	Bumper Beam 9 at right side	mm	5524	4877	-647
L	B1 to B9	mm	1837	1599	238

**DATA SHEET NO. 13**  
**VEHICLE INTRUSION MEASUREMENTS**

Test Vehicle: 2015 Ford F-150 Pickup truck  
 Test Program: R&D 90.1kph, 15° / 35% Right Oblique Offset

NHTSA No.: R20150227  
 Test Date: 9/16/2015

**DOOR OPENING WIDTH**

Item	Description	Units	Pre-Test	Post-Test	Difference
A	Left Side Upper	mm	1014	1012	-2
B	Left Side Lower	mm	958	958	0
D	Right Side Upper	mm	1008	1007	-1
E	Right Side Lower	mm	957	954	-3

**WHEELBASE MEASUREMENTS**

Item	Description	Units	Pre-Test	Post-Test	Difference
C	Left Side Wheelbase	mm	3688	3665	-23
F	Right Side Wheelbase	mm	3688	3405	-283

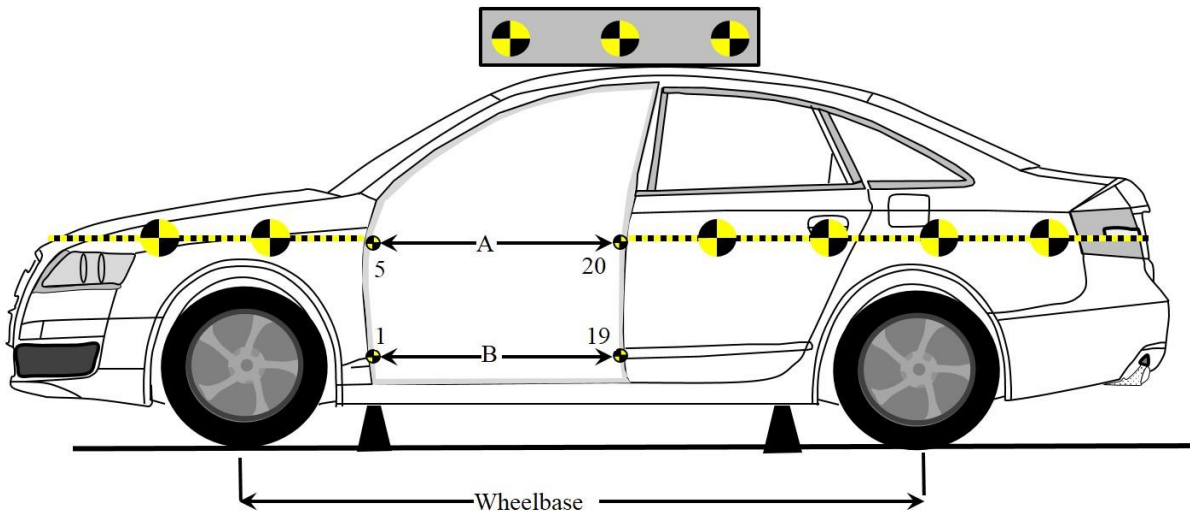

**DATA SHEET NO.13 (CONTINUED)  
VEHICLE INTRUSION MEASUREMENTS**

Test Vehicle: 2015 Ford F-150 Pickup truck  
 Test Program: R&D 90.1kph, 15° / 35% Right Oblique Offset

NHTSA No.: R20150227  
 Test Date: 9/16/2015

**DRIVER COMPARTMENT INTRUSION**

Item	Description	Units	Pre-Test	Post-Test	Difference
AB	Door Opening (Inside Window Jam)	mm	844	840	-4
CX	Left Knee Bolster to X	mm	293	294	1
DX	Right Knee Bolster to X	mm	273	288	15
EX	Brake Pedal to X	mm	554	530	-24
FX	Foot Rest to X	mm	742	737	-5
GX	Center of Steering Column Wheel Hub to X	mm	80	109	29

*X = Front of Seat Track (Stationary)*

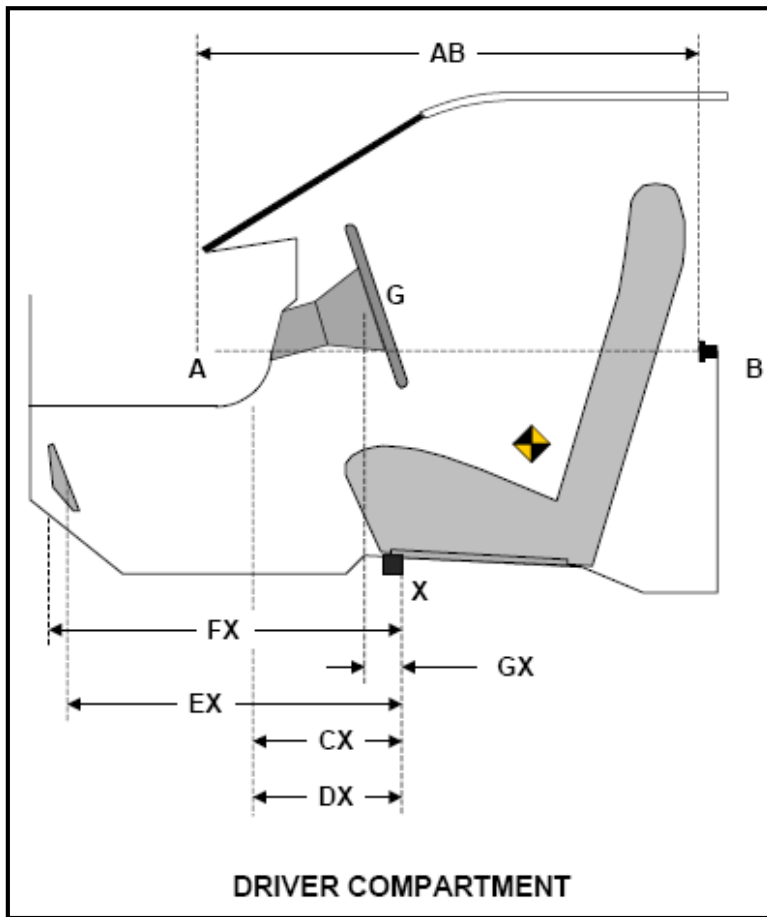

**DATA SHEET NO.13 (CONTINUED)  
VEHICLE INTRUSION MEASUREMENTS**

Test Vehicle: 2015 Ford F-150 Pickup truck  
 Test Program: R&D 90.1kph, 15° / 35% Right Oblique Offset

NHTSA No.: R20150227  
 Test Date: 9/16/2015

**DRIVER SIDE DOOR SILL INTRUSIONS**

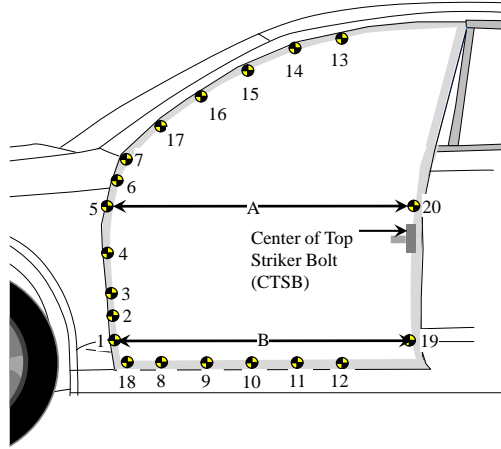

- +X – From the rear of the vehicle to the front of the vehicle
- +Y – From the left side of the vehicle to the right side of the vehicle
- +Z – From the top of the vehicle to the bottom of the vehicle

Point	Pre-Test			Post-Test			Difference		
	X	Y	Z	X	Y	Z	X	Y	Z
1	4154	-862	-247	4153	-869	-248	-1	-7	-1
2	4155	-861	-323	4154	-866	-325	-1	-5	-2
3	4157	-856	-392	4156	-861	-394	-1	-5	-2
4	4159	-853	-548	4158	-852	-548	-1	1	0
5	4162	-849	-698	4161	-845	-697	-1	4	1
6	4159	-846	-772	4158	-841	-772	-1	5	0
7	4139	-840	-847	4138	-835	-846	-1	5	1
17	4022	-807	-969	4021	-802	-968	-1	5	1
16	3904	-782	-1048	3903	-776	-1047	-1	6	1
15	3788	-756	-1120	3788	-750	-1119	0	6	1
14	3671	-730	-1182	3670	-724	-1181	-1	6	1
13	3553	-718	-1214	3552	-712	-1212	-1	6	2
20	3150	-847	-698	3149	-845	-698	-1	2	0
19	3196	-865	-248	3196	-866	-247	0	-1	1
12	3402	-866	-59	3402	-872	-57	0	-6	2
11	3554	-867	-53	3553	-875	-48	-1	-8	5
10	3699	-864	-50	3697	-876	-50	-2	-12	0
9	3854	-866	-51	3852	-876	-49	-2	-10	2
8	4003	-866	-50	4001	-878	-49	-2	-12	1
18	4122	-867	-112	4121	-878	-112	-1	-11	0

**DATA SHEET NO.13 (CONTINUED)  
VEHICLE INTRUSION MEASUREMENTS**

Test Vehicle: 2015 Ford F-150 Pickup truck  
 Test Program: R&D 90.1kph, 15° / 35% Right Oblique Offset

NHTSA No.: R20150227  
 Test Date: 9/16/2015

**PASSENGER SIDE DOOR SILL INTRUSIONS**

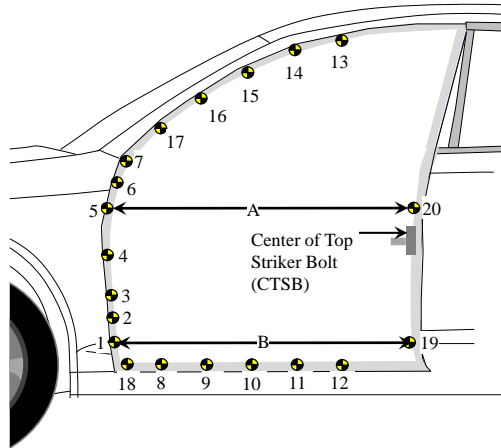

- +X – From the rear of the vehicle to the front of the vehicle
- +Y – From the left side of the vehicle to the right side of the vehicle
- +Z – From the top of the vehicle to the bottom of the vehicle

Point	Pre-Test			Post-Test			Difference		
	X	Y	Z	X	Y	Z	X	Y	Z
1	4154	860	-249	4142	855	-298	-12	-5	-49
2	4156	857	-327	4142	854	-374	-14	-3	-47
3	4156	852	-400	4140	852	-450	-16	0	-50
4	4158	847	-548	4138	848	-595	-20	1	-47
5	4161	843	-695	4138	844	-744	-23	1	-49
6	4159	839	-772	4134	842	-820	-25	3	-48
7	4138	832	-848	4111	836	-896	-27	4	-48
17	4019	801	-975	3991	808	-1018	-28	7	-43
16	3902	775	-1049	3873	783	-1091	-29	8	-42
15	3787	750	-1122	3755	756	-1160	-32	6	-38
14	3669	720	-1185	3636	730	-1219	-33	10	-34
13	3553	711	-1215	3519	716	-1247	-34	5	-32
20	3152	843	-699	3131	840	-717	-21	-3	-18
19	3199	864	-252	3188	855	-272	-11	-9	-20
12	3405	864	-61	3398	857	-86	-7	-7	-25
11	3553	865	-53	3548	859	-83	-5	-6	-30
10	3705	866	-55	3699	857	-87	-6	-9	-32
9	3854	865	-54	3848	857	-91	-6	-8	-37
8	4004	865	-55	3998	858	-95	-6	-7	-40
18	4124	865	-119	4115	858	-163	-9	-7	-44

**DATA SHEET NO.13 (CONTINUED)  
VEHICLE INTRUSION MEASUREMENTS**

Test Vehicle: 2015 Ford F-150 Pickup truck  
 Test Program: R&D 90.1kph, 15° / 35% Right Oblique Offset

NHTSA No.: R20150227  
 Test Date: 9/16/2015

**VEHICLE EXTERIOR CRUSH PROFILE  
SECTION A-A**

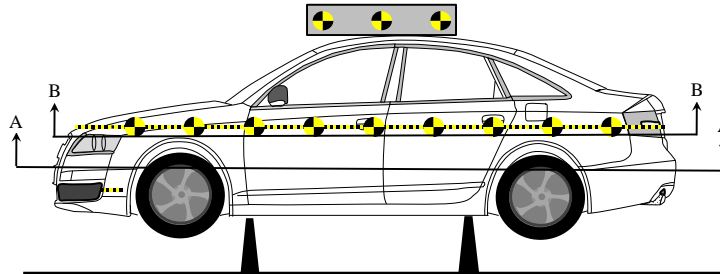

Reference point:

- +X – From the rear of the vehicle to the front of the vehicle
- +Y – From the left side of the vehicle to the right side of the vehicle
- +Z – From the top of the vehicle to the bottom of the vehicle

Point	Pre-Test			Point	Post-Test		
	X	Y	Z		X	Y	Z
1	3045	-989	-43	1	3047	-1056	-44
2	3196	-994	-43	2	3254	-1042	-44
3	3474	-992	-43	3	3564	-1020	-43
4	3756	-990	-43	4	3912	-993	-43
5	4081	-987	-43	5	4142	-975	-43
6	4259	-983	-44	6	4253	-966	-43
7	4422	-992	-43	7	4413	-966	-43
8	5396	-969	-43	8	5405	-902	-44
9	5457	-961	-43	9	5615	-1025	-44
10	5574	-879	-44	10	5723	-950	-43
11	5730	-650	-43	11	5750	-763	-44
12	5774	-580	-43	12	5786	-569	-43
13	5822	-493	-43	13	5791	-440	-43
14	5851	-363	-44	14	5790	-434	-44
15	5864	-267	-44	15	5762	-372	-44
16	5841	-80	-43	16	5720	-271	-44
17	5841	87	-44	17	5579	-28	-44
18	5865	273	-43	18	5439	152	-43
19	5845	423	-43	19	5343	260	-44
20	5793	548	-43	20	5182	489	-44
21	5727	656	-43	21	5138	519	-43
22	5580	873	-43	22	4867	494	-43
23	5495	949	-43	23	4868	615	-44
24	5413	969	-44	24	4876	724	-43
25	4412	991	-44	25	4830	818	-43

**DATA SHEET NO.13 (CONTINUED)  
VEHICLE INTRUSION MEASUREMENTS**

Test Vehicle: 2015 Ford F-150 Pickup truck  
 Test Program: R&D 90.1kph, 15° / 35% Right Oblique Offset

NHTSA No.: R20150227  
 Test Date: 9/16/2015

**VEHICLE EXTERIOR CRUSH PROFILE  
SECTION A-A (Continued)**

Point	Pre-Test			Point	Post-Test		
	X	Y	Z		X	Y	Z
26	4238	984	-43	26	4589	832	-44
27	4166	985	-43	27	4534	803	-43
28	3877	988	-44	28	4454	828	-43
29	3656	991	-44	29	4452	904	-44
30	3261	994	-43	30	4412	974	-43
31	3058	995	-44	31	4349	988	-44
32	3045	994	-43	32	4261	979	-43
				33	4149	986	-44
				34	3938	988	-44
				35	3764	989	-44
				36	3495	991	-43
				37	3265	991	-44
				38	3050	992	-44

**DATA SHEET NO.13 (CONTINUED)  
VEHICLE INTRUSION MEASUREMENTS**

Test Vehicle: 2015 Ford F-150 Pickup truck  
 Test Program: R&D 90.1kph, 15° / 35% Right Oblique Offset

NHTSA No.: R20150227  
 Test Date: 9/16/2015

**VEHICLE EXTERIOR CRUSH PROFILE  
SECTION B-B**

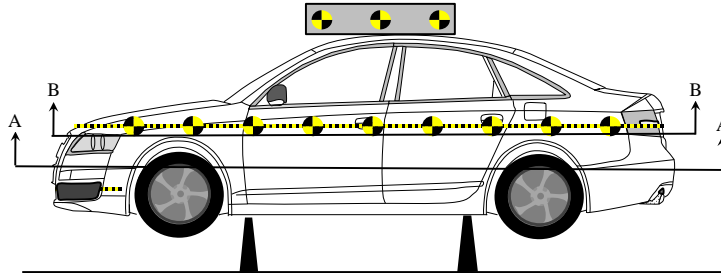

Reference point:

- +X – From the rear of the vehicle to the front of the vehicle
- +Y – From the left side of the vehicle to the right side of the vehicle
- +Z – From the top of the vehicle to the bottom of the vehicle

Point	Pre-Test			Point	Post-Test		
	X	Y	Z		X	Y	Z
1	3054	-1004	-632	1	3070	-1110	-631
2	3230	-1002	-632	2	3165	-1099	-632
3	3419	-1001	-632	3	3366	-1085	-631
4	3677	-998	-632	4	3676	-1059	-632
5	3886	-994	-632	5	3972	-1032	-632
6	4162	-987	-632	6	4234	-1006	-632
7	4608	-974	-632	7	4477	-996	-632
8	4694	-970	-632	8	4762	-971	-632
9	4941	-955	-631	9	4938	-957	-631
10	5300	-911	-631	10	5155	-932	-631
11	5521	-777	-631	11	5352	-900	-631
12	5617	-651	-632	12	5449	-853	-631
13	5743	-315	-631	13	5513	-698	-632
14	5756	-149	-632	14	5639	-553	-631
15	5760	-31	-631	15	5645	-414	-631
16	5760	57	-632	16	5617	-123	-631
17	5754	190	-631	17	5186	-1	-632
18	5736	374	-631	18	5048	126	-632
19	5683	561	-632	19	4990	326	-631
20	5535	759	-631	20	4809	439	-631
21	5450	852	-632	21	4724	628	-632
22	5302	909	-631	22	4779	771	-631
23	5107	936	-631	23	4699	901	-632
24	4940	952	-631	24	4629	985	-631
25	4697	968	-632	25	4356	998	-631

**DATA SHEET NO.13 (CONTINUED)**  
**VEHICLE INTRUSION MEASUREMENTS**

Test Vehicle: 2015 Ford F-150 Pickup truck  
 Test Program: R&D 90.1kph, 15° / 35% Right Oblique Offset

NHTSA No.: R20150227  
 Test Date: 9/16/2015

**VEHICLE EXTERIOR CRUSH PROFILE**  
**SECTION B-B (Continued)**

Point	Pre-Test			Point	Post-Test		
	X	Y	Z		X	Y	Z
26	4609	972	-631	26	4305	1077	-631
27	4336	980	-632	27	3062	1003	-632
28	4178	984	-631	28	4386	1050	-631
29	3988	988	-632	29	4296	970	-632
30	3728	993	-631	30	4279	988	-631
31	3402	999	-631	31	4108	990	-632
32	3284	996	-631	32	3829	995	-632
33	3119	1000	-631	33	3591	998	-632
34	3069	1002	-631	34	3317	999	-631
35	3054	1000	-631	35	3064	1003	-631

**DATA SHEET NO.13 (CONTINUED)**  
**VEHICLE INTRUSION MEASUREMENTS**

Test Vehicle: 2015 Ford F-150 Pickup truck  
Test Program: R&D 90.1kph, 15° / 35% Right Oblique Offset

NHTSA No.: R20150227  
Test Date: 9/16/2015

**VEHICLE EXTERIOR CRUSH PROFILE**  
**SECTION A-A**

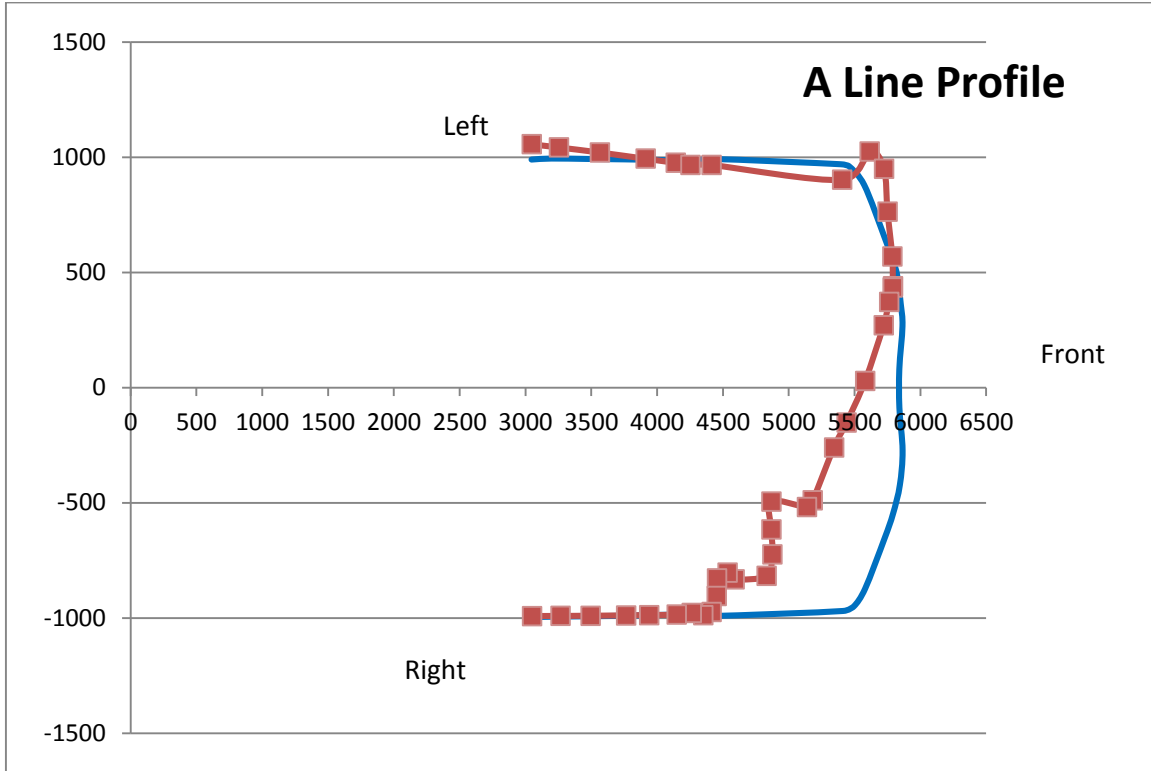

**SECTION B-B**

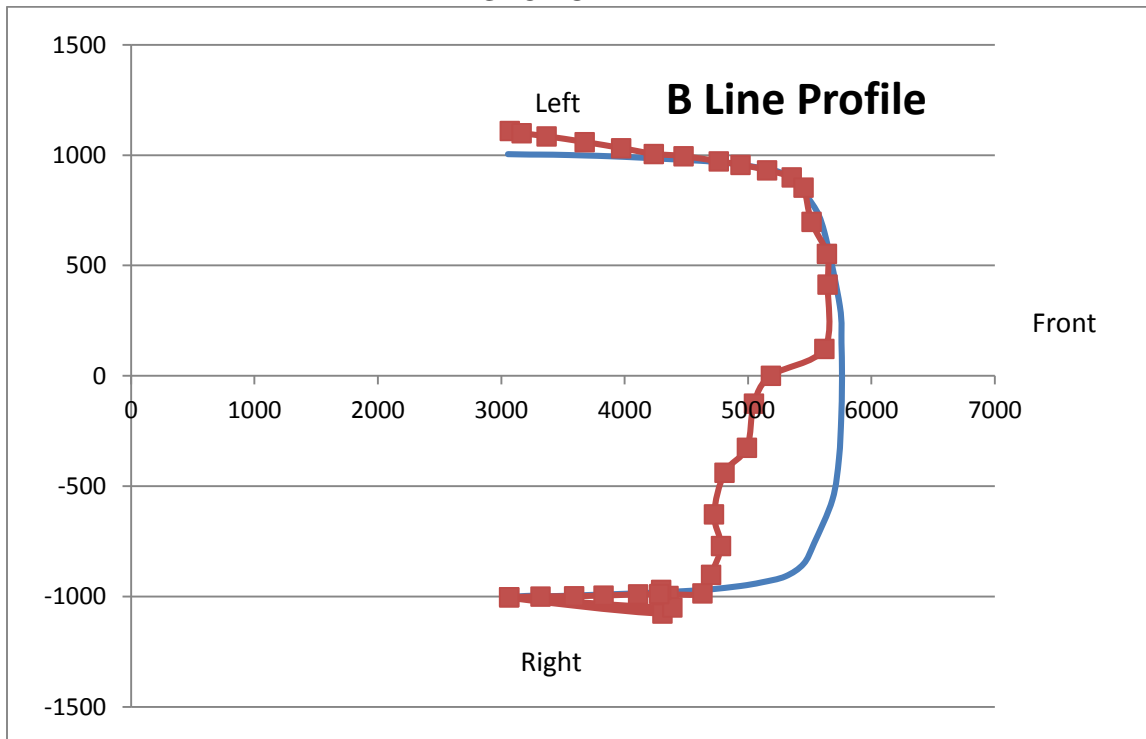

**DATA SHEET NO.13 (CONTINUED)  
VEHICLE INTRUSION MEASUREMENTS**

Test Vehicle: 2015 Ford F-150 Pickup truck  
 Test Program: R&D 90.1kph, 15° / 35% Right Oblique Offset

NHTSA No.: R20150227  
 Test Date: 9/16/2015

**STRUCTURAL BUMPER BEAM POINTS**

	Point	Pre-Test (mm)			Post-Test (mm)			Difference (mm)		
		X	Y	Z	X	Y	Z	X	Y	Z
Structural Bumper Beam	B1	5542	-897	-143	5756	-886	-41	214	11	102
	B2	5690	-691	-142	5788	-643	-99	98	48	43
	B3	5806	-471	-138	5783	-406	-160	-23	65	-22
	B4	5849	-226	-132	5682	-182	-208	-167	44	-76
	B5	5860	26	-124	5542	19	-252	-318	-7	-128
	B6	5845	277	-119	5349	186	-258	-496	-91	-139
	B7	5798	518	-112	5182	352	-257	-616	-166	-145
	B8	5675	739	-101	4997	497	-249	-678	-242	-148
	B9	5524	940	-92	4877	713	-254	-647	-227	-162

Reference point:

- +X – From the rear of the vehicle to the front of the vehicle
- +Y – From the left side of the vehicle to the right side of the vehicle
- +Z – From the top of the vehicle to the bottom of the vehicle

**DATA SHEET NO.13 (CONTINUED)  
VEHICLE INTRUSION MEASUREMENTS**

Test Vehicle: 2015 Ford F-150 Pickup truck  
 Test Program: R&D 90.1kph, 15° / 35% Right Oblique Offset

NHTSA No.: R20150227  
 Test Date: 9/16/2015

**DRIVER FLOOR PAN MEASUREMENTS**

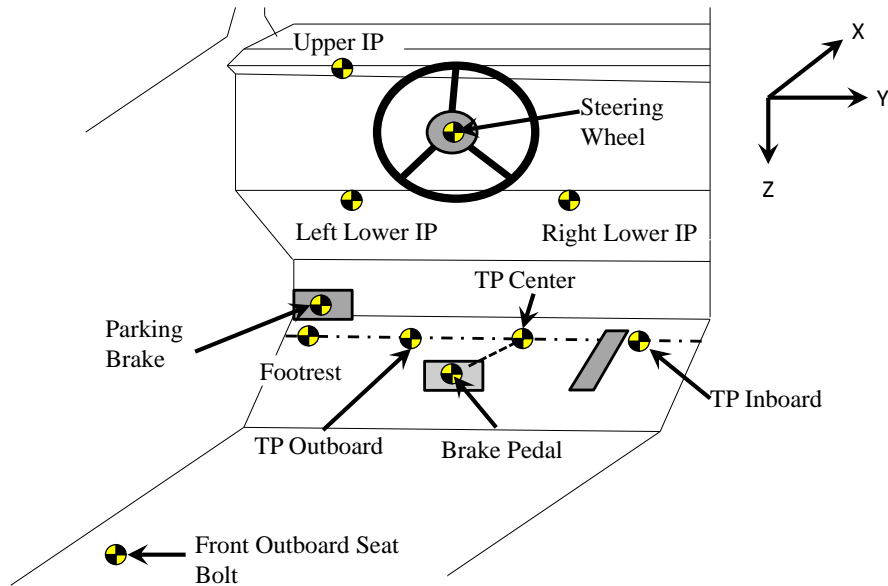

Intrusion Location	Pre-Test (mm)			Post-Test (mm)			Difference (mm)		
	X	Y	Z	X	Y	Z	X	Y	Z
TP Inboard	4450	-331	-246	4364	-364	-257	86	33	11
TP Center	4518	-482	-247	4451	-505	-255	67	23	8
TP Outboard	4501	-631	-244	4495	-636	-240	6	5	-4
TP Footrest	4436	-731	-246	4435	-739	-243	1	8	-3
Brake Pedal	4248	-482	-247	4227	-483	-255	21	1	9
Left Lower IP	3987	-614	-577	3992	-607	-580	-5	-7	3
Right Lower IP	3967	-314	-577	3985	-307	-587	-18	-7	11
Upper IP	3,959	-764	-686	3,961	-757	-687	-2	-6	1
Steering Wheel	3773	-463	-795	3806	-444	-783	33	19	12
Front Outboard Bolt	3694	-630	-114	3697	-638	-107	-4	7	-6
Emergency Brake	4,151	-724	-320	4,153	-730	-317	-2	6	-3

Reference point:

- +X – From the rear of the vehicle to the front of the vehicle
- +Y – From the left side of the vehicle to the right side of the vehicle
- +Z – From the top of the vehicle to the bottom of the vehicle

**DATA SHEET NO.13 (CONTINUED)  
VEHICLE INTRUSION MEASUREMENTS**

Test Vehicle: 2015 Ford F-150 Pickup truck  
 Test Program: R&D 90.1kph, 15° / 35% Right Oblique Offset

NHTSA No.: R20150227  
 Test Date: 9/16/2015

**PASSENGER FLOOR PAN MEASUREMENTS**

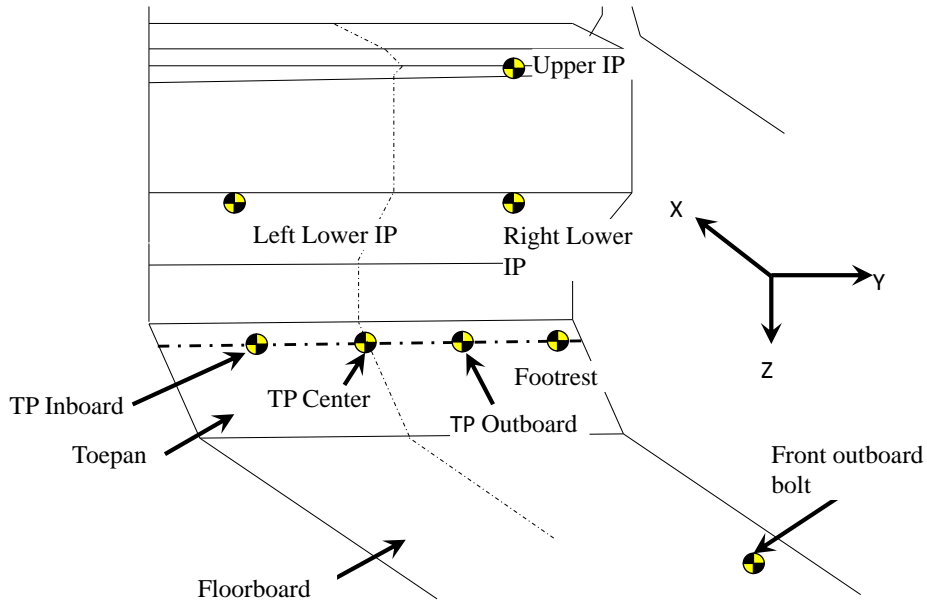

Intrusion Location	Pre-Test (mm)			Post-Test (mm)			Difference (mm)		
	X	Y	Z	X	Y	Z	X	Y	Z
TP Inboard	4398	308	-248	4390	288	-294	9	19	46
TP Center	4434	458	-248	UR	UR	UR	UR	UR	UR
TP Outboard	4441	609	-248	4395	602	-313	46	7	65
TP Footrest	4429	708	-246	4387	702	-300	42	6	54
Left Lower IP	4020	309	-520	4004	312	-562	16	-2	42
Right Lower IP	4013	608	-521	3997	606	-565	16	3	44
Upper IP	3960	708	-684	3943	706	-725	17	2	40
Front Outboard Bolt	3698	636	-115	3689	618	-139	9	18	24

Reference point:

- +X – From the rear of the vehicle to the front of the vehicle
- +Y – From the left side of the vehicle to the right side of the vehicle
- +Z – From the top of the vehicle to the bottom of the vehicle

**DATA SHEET NO.14**  
**OMDB CRUSH MEASUREMENTS**

Test Vehicle: 2015 Ford F-150 Pickup truck  
Test Program: R&D 90.1kph, 15° / 35% Right Oblique Offset

NHTSA No.: R20150227  
Test Date: 9/16/2015

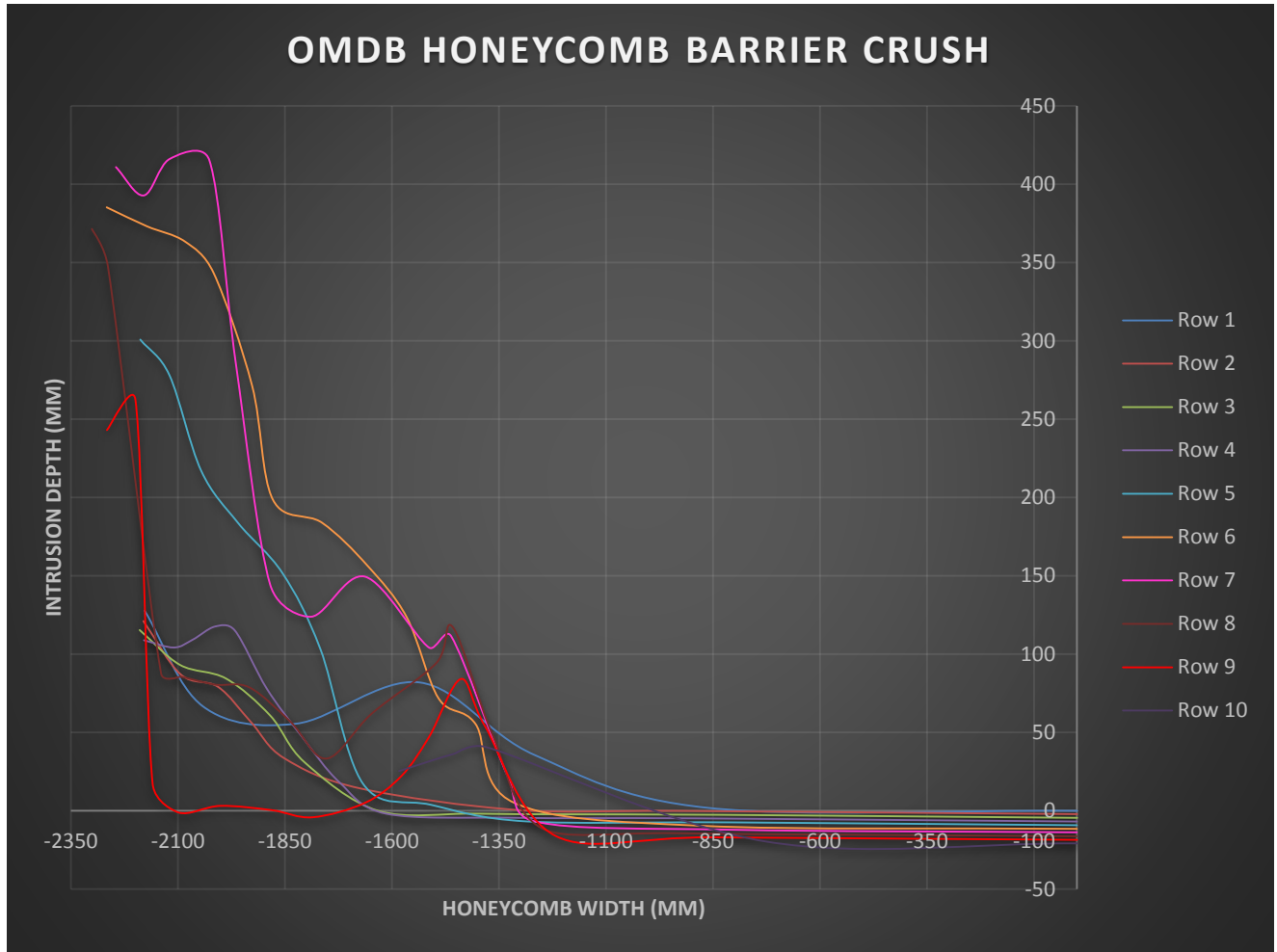

**DATA SHEET NO. 15**  
**SUMMARY OF FMVSS 212, 219 (PARTIAL), AND 301 DATA**

Test Vehicle: 2015 Ford F-150 Pickup truck  
 Test Program: R&D 90.1kph, 15° / 35% Right Oblique Offset

NHTSA No.: R20150227  
 Test Date: 9/16/2015

*Please provide windshield mounting details. A 0.8 mm trim surrounds the top and side of windshield while a plastic shroud is on the bottom.*

The standard requires that the post-test retention measurement be a minimum of 75% of the pre-test total periphery measurement for vehicles not equipped with occupant passive restraints and 50% for each side of the windshield for vehicles which are equipped with occupant passive restraints.

Temperature of windshield molding during test: 21°C

**WINDSHIELD PERIPHERY MEASUREMENTS**

Measurement	Pre-Test (mm)	Post-Test (mm)	% Retention
Left Side	2392.5	2392.5	68.3%
Right Side	2392.5	2392.5	100%
Total	4785	4785	84.1%

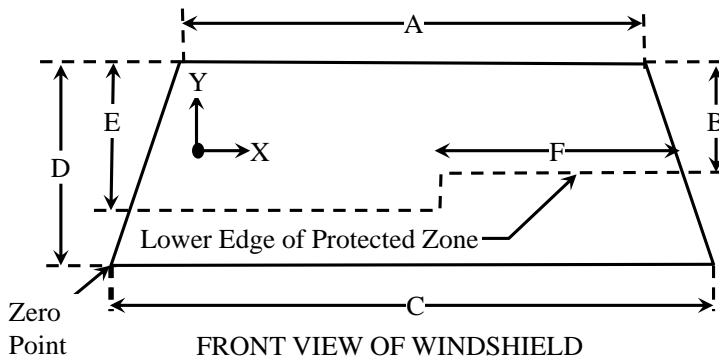

Item	Units	Value
A	mm	1475
B	mm	505
C	mm	1760
D	mm	775
E	mm	522
F	mm	555

**AREAS OF PROTECTED ZONE FAILURES**

A. Provide coordinates of the area that the protected zone was penetrated more than .25 inches by a vehicle component other than one that is normally in contact with the windshield.

- No penetration

X	Y

B. Provide coordinates of the area beneath the protected zone that the inner surface of the windshield was penetrated by a vehicle component.

- No Penetration

X	Y

**DATA SHEET NO. 15 (CONTINUED)**  
**SUMMARY OF FMVSS 212, 219 (PARTIAL), AND 301 DATA**

Test Vehicle: 2015 Ford F-150 Pickup truck  
Test Program: R&D 90.1kph, 15° / 35% Right Oblique Offset

NHTSA No.: R20150227  
Test Date: 9/16/2015

**FMVSS 301 FUEL SYSTEM INTEGRITY POST IMPACT DATA**

Ambient Temperature at Test Vehicle Time of Impact: 20° C

Test Time: 10:52 AM

Stoddard Solvent Spillage Measurements

A.	From impact until vehicle motion ceases: (Maximum allowable = 1 oz.)	<u>0</u>	oz
B.	For the 5-minute period after motion ceases: (Maximum allowable = 5 oz.)	<u>0</u>	oz
C.	For the following 25 minutes: (Maximum allowable = 1 oz./minute)	<u>0</u>	oz
D.	Spillage	<u>0</u>	oz

**DATA SHEET NO. 16**  
**FMVSS 301 STATIC ROLLOVER RESULTS**

Test Vehicle: 2015 Ford F-150 Pickup truck  
Test Program: R&D 90.1kph, 15° / 35% Right Oblique Offset

NHTSA No.: R20150227  
Test Date: 9/16/2015

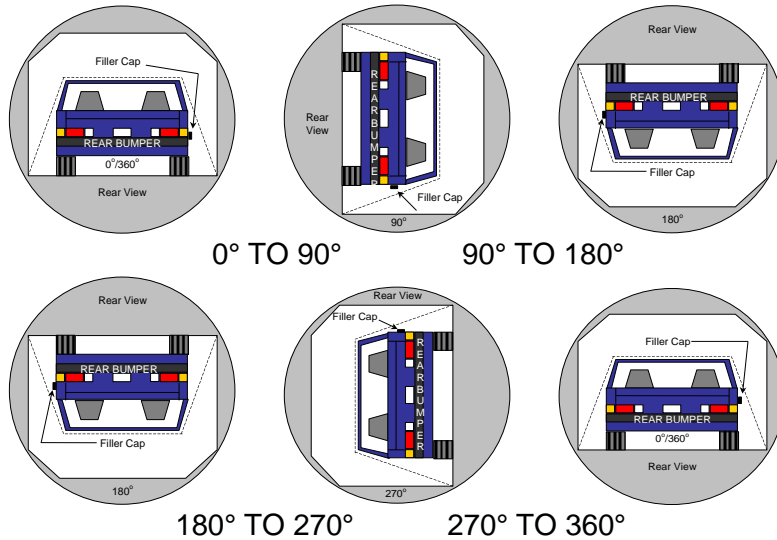

1. The specified fixture rollover rate for each 90° of rotation is 60 to 180 seconds.
2. The position hold time at each position is 300 seconds (minimum).
3. Details of Stoddard Solvent spillage: None

**SOLVENT COLLECTION TIME TABLE IN SECONDS**

Test Phase	Rotation Time	Hold Time	Total Time
0° to 90°	67	300	367
390° to 180°	68	300	368
180° to 270°	67	300	367
270° to 360°	67	300	367

**FMVSS 301 SPILLAGE TABLE**

Test Phase	First 5 Minutes	Sixth Minute	Seventh Minute	Eighth Minute
0° to 90°	0	0	0	
90° to 180°	0	0	0	
180° to 270°	0	0	0	
270° to 360°	0	0	0	

**SOLVENT SPILLAGE LOCATION TABLE**

Test Phase	Spillage Location
0° to 90°	None
90° to 180°	None
180° to 270°	None
270° to 360°	None

**DATA SHEET NO. 17  
DUMMY/VEHICLE TEMPERATURE STABILIZATION**

Test Vehicle: 2015 Ford F-150 Pickup truck  
 Test Program: R&D 90.1kph, 15° / 35% Right Oblique Offset

NHTSA No.: R20150227  
 Test Date: 9/16/2015

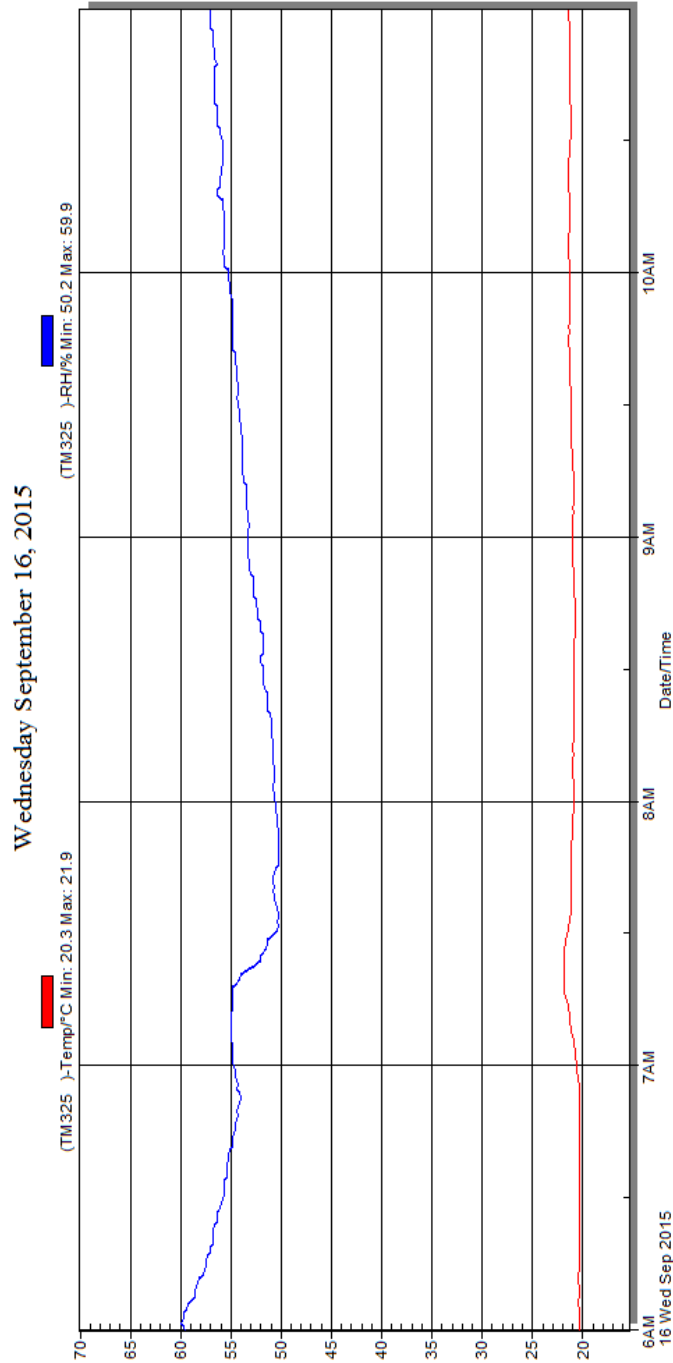

**Temperature Stabilization Chart/Data**

**APPENDIX A**  
**PHOTOGRAPHS**

TABLE OF PHOTOGRAPHS		
No.	Description	Page
1	As Delivered Right Front 3-4 View of Test Vehicle	A-9
2	As Delivered Left Rear 3-4 View of Test Vehicle	A-9
3	Test Vehicle Certification Label	A-10
4	Test Vehicle Tire Placard	A-10
5	Pre-Test Front View of Test Vehicle	A-11
6	Post-Test Front View of Test Vehicle	A-11
7	Pre-Test Left Front 3-4 View of Test Vehicle	A-12
8	Post-Test Left Front 3-4 View of Test Vehicle	A-12
9	Pre-Test Left Side View of Test Vehicle	A-13
10	Post-Test Left Side View of Test Vehicle	A-13
11	Pre-Test Left Rear 3-4 View of Test Vehicle	A-14
12	Post-Test Left Rear 3-4 View of Test Vehicle	A-14
13	Pre-Test Rear View of Test Vehicle	A-15
14	Post-Test Rear View of Test Vehicle	A-15
15	Pre-Test Right Rear 3-4 View of Test Vehicle	A-16
16	Post-Test Right Rear 3-4 View of Test Vehicle	A-16
17	Pre-Test Right Side View of Test Vehicle	A-17
18	Post-Test Right Side View of Test Vehicle	A-17
19	Pre-Test Right Front 3-4 View of Test Vehicle	A-18
20	Post-Test Right Front 3-4 View of Test Vehicle	A-18
21	Monroney Label Photograph	A-19
22	Pre-Test Overhead View of OMDB against target vehicle at ideal Impact Point	A-19
23	Pre-Test Left Side View of OMDB against target vehicle at ideal Impact Point	A-20
24	Pre-Test Right Side View of OMDB against target vehicle at ideal Impact Point	A-20
25	Pre-Test Close-up View of Impact Point	A-21
26	Post-Test Close-up View of Impact Point	A-21
27	Post-Test Vehicle Overhead View	A-22
28	Pre-Test Close-up View of Driver Door Latch	A-23
29	Post-Test Close-up View of Driver Door Latch	A-23
30	Pre-Test Close-up View of Passenger Door Latch	A-24

<b>TABLE OF PHOTOGRAPHS (Continued)</b>		
No.	Description	Page
31	Post-Test Close-up View of Passenger Door Latch	A-24
32	Pre-Test Windshield View	A-25
33	Post-Test Windshield View	A-25
34	Pre-Test View of Driver Inner Door Panel	A-26
35	Post-Test View of Driver Inner Door Panel	A-26
36	Pre-Test View of Passenger Inner Door Panel	A-27
37	Post-Test View of Passenger Inner Door Panel	A-27
38	Pre-Test Overall View of Driver Knee Bolsters	A-28
39	Post-Test Overall View of Driver Knee Bolsters	A-28
40	Pre-Test Left Side View of Driver Knee Bolsters	A-29
41	Post-Test Left Side View of Driver Knee Bolsters	A-29
42	Pre-Test Right Side View of Driver Knee Bolsters	A-30
43	Post-Test Right Side View of Driver Knee Bolsters	A-30
44	Pre-Test View of Driver Floor pan at Left sill level, w/carpet	A-31
45	Post-Test View of Driver Floor pan at Left sill level, w/carpet	A-31
46	Pre-Test View of Driver Floor pan at Mid seat level, w/carpet	A-32
47	Post-Test view of Driver Floor pan at Mid seat level, w/carpet	A-32
48	Pre-Test View of Driver Floor pan at Right sill level, w/carpet	A-33
49	Post-Test View of Driver Floor pan at Right sill level, w/carpet	A-33
50	Pre-Test Driver Front Windshield View	A-34
51	Post-Test Driver Front Windshield View	A-34
52	Pre-Test Left Side View of Driver and Interior	A-35
53	Post-Test Left Side View of Driver and Interior	A-35
54	Pre-Test Left Side Driver Window View	A-36
55	Post-Test Left Side Driver Window View	A-36
56	Pre-Test Right Side View of Driver and Interior	A-37
57	Post-Test Right Side View of Driver and Interior	A-37
58	Pre-Test View of Driver Door Clearance	A-38
59	Post-Test View of Driver Door Clearance	A-38

TABLE OF PHOTOGRAPHS (Continued)		
No.	Description	Page
60	Pre-Test View of Parking Brake	A-39
61	Pre-Test Driver Seat Fore Aft Markings	A-40
62	Post-Test Driver Seat Fore Aft Markings	A-40
63	Pre-Test Driver Seat Back Markings	A-41
64	Pre-Test Overhead View of Driver Thighs on Seat	A-41
65	Pre-Test Driver Adjustable D-ring	A-42
66	Post-Test Driver Adjustable D-ring	A-42
67	Pre-Test Driver Feet	A-43
68	Post-Test Driver Feet	A-43
69	Pre-Test View of Driver Right Knee and Bolster	A-44
70	Post-Test View of Driver Right Knee and Bolster	A-44
71	Pre-Test View of Driver Left Knee and Bolster	A-45
72	Post-Test View of Driver Left Knee and Bolster	A-45
73	Pre-Test View of Driver Abdomen	A-46
74	Post-Test View of Driver Abdomen	A-46
75	Pre-Test Left Side View of Steering Wheel set position	A-47
76	Post-Test Left Side View of Steering Wheel set position	A-47
77	Post-Test View of Driver Head Contact with Airbag – Front	A-48
78	Post-Test View of Driver Head Contact with Airbag – Curtain	A-48
79	Post-Test View of Driver Head Contact with Vehicle Interior – A	A-49
80	Post-Test View of Driver Head Contact with Vehicle Interior – B	A-49
81	Post-Test View of Driver Head Contact with Vehicle Interior – C	A-50
82	Pre-Test Overall View of Passenger Knee Bolsters	A-51
83	Post-Test Overall View of Passenger Knee Bolsters	A-51
84	Pre-Test Left Side View of Passenger Knee Bolsters	A-52
85	Post-Test Left Side View of Passenger Knee Bolsters	A-52
86	Pre-Test Right Side View of Passenger Knee Bolsters	A-53
87	Post-Test Right Side View of Passenger Knee Bolsters	A-53
88	Pre-Test View of Passenger Floor pan at Right sill level, w/carpet	A-54
89	Post-Test View of Passenger Floor pan at Right sill level, w/carpet	A-54

TABLE OF PHOTOGRAPHS (Continued)		
No.	Description	Page
90	Pre-Test View of Passenger Floor pan at Mid seat level, w/carpet	A-55
91	Post-Test view of Passenger Floor pan at Mid seat level, w/carpet	A-55
92	Pre-Test View of Passenger Floor pan at Left View, w/carpet	A-56
93	Post-Test View of Passenger Floor pan at Left View, w/carpet	A-56
94	Pre-Test Passenger Front Close-up View, Windshield	A-57
95	Post-Test Passenger Front Close-up View, Windshield	A-57
96	Pre-Test Left Side Passenger and Interior View	A-58
97	Post-Test Left Side Passenger and Interior View	A-58
98	Pre-Test Right Side Passenger Window View	A-59
99	Post-Test Right Side Passenger Window View	A-59
100	Pre-Test Right Side Passenger and Interior View	A-60
101	Post-Test Right Side Passenger and Interior View	A-60
102	Pre-Test View of Passenger Door Clearance	A-61
103	Post-Test View of Passenger Door Clearance	A-61
104	Pre-Test Passenger Seat Fore-Aft Markings	A-62
105	Post-Test Passenger Seat Fore-Aft Markings	A-62
106	Pre-Test Passenger Seat Back Markings	A-63
107	Pre-Test Overhead View of Passenger Thighs on seat	A-63
108	Pre-Test Passenger Adjustable D-ring	A-64
109	Post-Test Passenger Adjustable D-ring	A-64
110	Pre-Test View of Passenger Feet	A-65
111	Post-Test View of Passenger Feet	A-65
112	Pre-Test View of Passenger Right Knee and Bolster	A-66
113	Post-Test View of Passenger Right Knee and Bolster	A-66
114	Pre-Test View of Passenger Left Knee and Bolster	A-67
115	Post-Test View of Passenger Left Knee and Bolster	A-67
116	Pre-Test View of Passenger Abdomen	A-68
117	Post-Test View of Passenger Abdomen	A-68
118	Post-Test View of Passenger Head contact with Airbag – Front	A-69
119	Post-Test View of Passenger Head contact with Airbag – Curtain	A-69

TABLE OF PHOTOGRAPHS (Continued)		
No.	Description	Page
120	Post-Test View of Passenger Head contact with Interior	A-70
121	Post-Test View of Passenger Body contact with Interior	A-70
122	Post-Test View of Passenger Head contact with Interior	A-71
123	Post-Test Passenger Contact With Glovebox	A-71
124	Pre-Test Ballast Locations	A-72
125	Post-Test Speed Trap Readout	A-72
126	Pre-Test View of Fuel Filler Cap	A-73
127	Post-Test View of Fuel Filler Cap	A-73
128	Pre-Test Engine Compartment View	A-74
129	Post-Test Engine Compartment View	A-74
130	Pre-Test Right Side Engine Compartment View	A-75
131	Post-Test Right Side Engine Compartment View	A-75
132	Pre-Test Left Side Engine Compartment View	A-76
133	Post-Test Left Side Engine Compartment View	A-76
134	Pre-Test View of Front Underbody (perpendicular to vehicle)	A-77
135	Post-Test View of Front Underbody (perpendicular to vehicle)	A-77
136	Pre-Test View of Mid Underbody (perpendicular to vehicle)	A-78
137	Post-Test View of Mid Underbody (perpendicular to vehicle)	A-78
138	Pre-Test View of Rear Underbody (perpendicular to vehicle)	A-79
139	Post-Test View of Rear Underbody (perpendicular to vehicle)	A-79
140	Pre-Test View of Steering rack and or sway bar	A-80
141	Post-Test View of Steering rack and or sway bar	A-80
142	Pre-Test Bumper to Rail Attachments and Crush Initiators	A-81
143	Post-Test Bumper to Rail Attachments and Crush Initiators	A-81
144	Post-Test View of Front Sub-Frame Deformation	A-82
145	Pre-Test Frame Rail with tire removed	A-83
146	Post-Test Frame Rail with tire removed	A-83
147	Pre-Test View of Front Driver Wheel Well with tire removed	A-84
148	Post-Test ¼ View of Front Driver Wheel Well w/ tire removed	A-84
149	Post-Test Side View of Front Driver Wheel Well w/ tire removed	A-85

TABLE OF PHOTOGRAPHS (Continued)		
No.	Description	Page
150	Post-Test Right Side 3/4 Rear View of the Front Driver Wheel Well w/ tire removed	A-85
151	Post-Test Looking Down at the Front Driver Shotgun	A-86
152	Post-Test Right Side ¾ View of Front Driver Shotgun	A-86
153	Post-Test Front Driver Close up View of Suspension w/ tire removed	A-87
154	Post-Test ¾ View of Front Passenger Wheel Well w/ tire removed	A-87
155	Post-Test Side View of Front Passenger Wheel Well w/ tire removed	A-88
156	Post-Test Right Side 3/4 Rear View of the Front Passenger Wheel Well w/ tire removed	A-88
157	Post-Test Looking Down at the Front Passenger Shotgun	A-89
158	Post-Test Right Side ¾ View of Front Passenger Shotgun	A-89
159	Post-Test Front Passenger Close up View of Suspension w/ tire removed	A-90
160	Post-Test View of Door Sill with door open-Struck Side	A-90
161	Post-Test View of Deformation of A pillar-Struck Side	A-91
162	Post-Test View of Deformation of B pillar-Struck Side	A-91
163	Post-Test View of Deformation of C pillar-Struck Side	A-92
164	Post-Test View of Wheel and/or Tire Deformation-Struck Side	A-92
165	Post-Test View of Deformation of Rocker or Post-Struck Side	A-93
166	Post-Test View of Windshield Separation	A-93
167	Pre-Test Left Side View of OMDB	A-94
168	Post-Test Left Side View of OMDB	A-94
169	Pre-Test Right Side View of OMDB	A-95
170	Post-Test Right Side View of OMDB	A-95
171	Pre-Test Top View of OMDB	A-96
172	Post-Test Top View of OMDB	A-96
173	Pre-Test Front View of OMDB	A-97
174	Post-Test Front View of OMDB	A-97
175	Pre-Test Left Front ¾ View of OMDB	A-98
176	Post-Test Left Front ¾ View of OMDB	A-98
177	Pre-Test Right Front ¾ View of OMDB	A-99
178	Post-Test Right Front ¾ View of OMDB	A-99
179	Pre-Test Right Side View of OMDB	A-100

TABLE OF PHOTOGRAPHS (Continued)		
No.	Description	Page
180	Post-Test Right Side View of OMDB	A-100
181	Pre-Test Left Side View of OMDB	A-101
182	Post-Test Left Side View of OMDB	A-101
183	Pre-Test OMDB & Vehicle, Right Side	A-102
184	Post-Test OMDB & Vehicle, Right Side	A-102
185	Pre-Test OMDB & Vehicle, Left Side	A-103
186	Post-Test OMDB & Vehicle, Left Side	A-103
187	Pre-Test OMDB & Vehicle, Top View	A-104
188	Post-Test OMDB & Vehicle, Top View	A-104
189	Pre-Test OMDB & Vehicle, Rear View	A-105
190	Post-Test OMDB & Vehicle, Rear View	A-105
191	Pre-Test OMDB & Vehicle, Front View	A-106
192	Post-Test OMDB & Vehicle, Front View	A-106
193	Pre-Test OMDB & Vehicle Alignment View	A-107
194	Vehicle at 0 Degrees on Static Rollover Device	A-107
195	Vehicle at 90 Degrees on Static Rollover Device	A-108
196	Vehicle at 180 Degrees on Static Rollover Device	A-108
197	Vehicle at 270 Degrees on Static Rollover Device	A-109
198	Vehicle at 360 Degrees on Static Rollover Device	A-109
199	Impact Photo	A-110
200	Pre-Test Vehicle Bumper Left Side View	A-111
201	Post-Test Vehicle Bumper Left Side View	A-111
202	Pre-Test Vehicle Bumper Left Front View	A-112
203	Post-Test Vehicle Bumper Left Front View	A-112
204	Pre-Test Vehicle Bumper Front View	A-113
205	Post-Test Vehicle Bumper Front View	A-113
206	Pre-Test Vehicle Bumper Right Side View	A-114
207	Post-Test Vehicle Bumper Right Side View	A-114
208	Pre-Test Vehicle Bumper Right Front View	A-115
209	Post-Test Vehicle Bumper Right Front View	A-115



**No. 001 As Delivered Right Front 3-4 View of Test Vehicle**



**No. 002 As Delivered Left Rear 3-4 View of Test Vehicle**

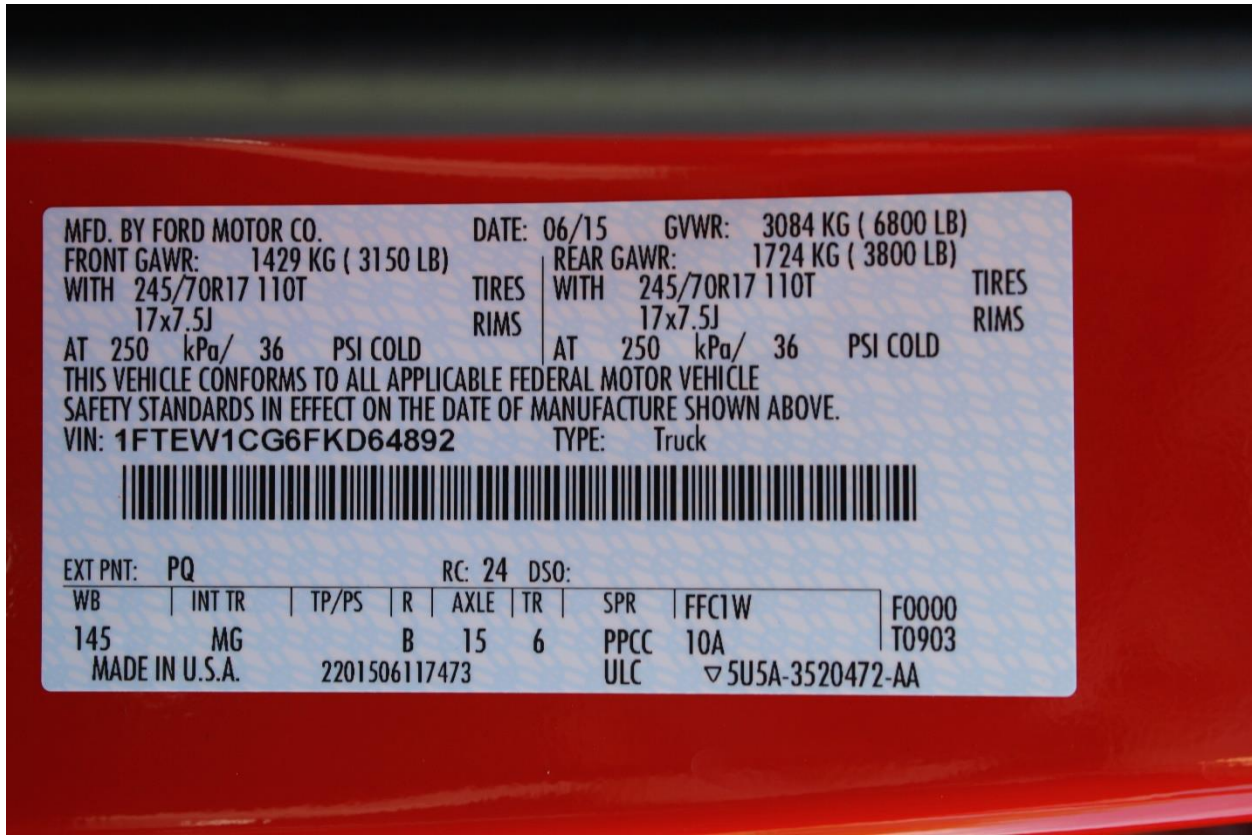

No. 003 Test Vehicle Certification Label



No. 004 Test Vehicle Tire Placard

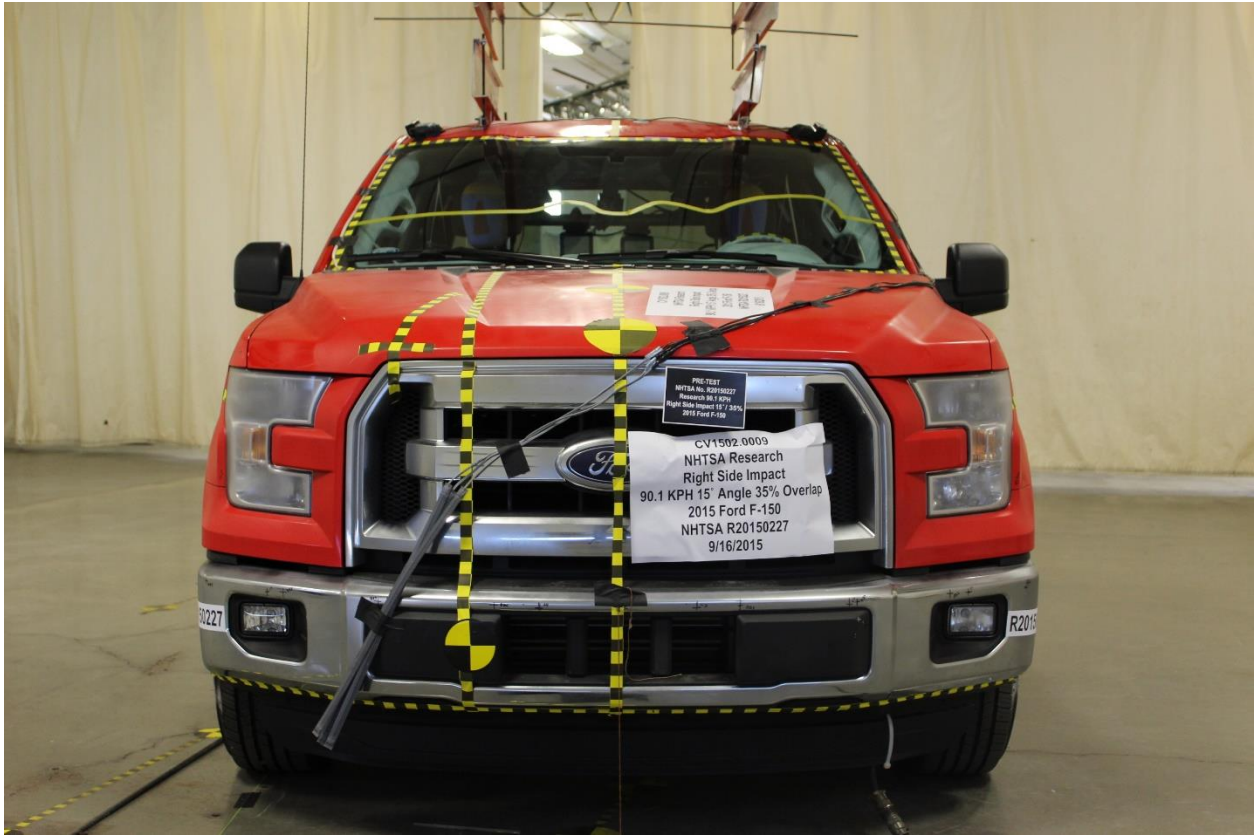

**No. 005 Pre-Test Front View of Test Vehicle**



**No. 006 Post-Test Front View of Test Vehicle**



**No. 007 Pre-Test Left Front 3-4 View of Test Vehicle**



**No. 008 Post-Test Left Front 3-4 View of Test Vehicle**



**No. 009 Pre-Test Left Side View of Test Vehicle**



**No. 010 Post-Test Left Side View of Test Vehicle**



**No. 011 Pre-Test Left Rear 3-4 View of Test Vehicle**



**No. 012 Post-Test Left Rear 3-4 View of Test Vehicle**



**No. 013 Pre-Test Rear View of Test Vehicle**



**No. 014 Post-Test Rear View of Test Vehicle**



**No. 015 Pre-Test Right Rear 3-4 View of Test Vehicle**



**No. 016 Post-Test Right Rear 3-4 View of Test Vehicle**



**No. 017 Pre-Test Right Side View of Test Vehicle**



**No. 018 Post-Test Right Side View of Test Vehicle**



**No. 019 Pre-Test Right Front 3-4 View of Test Vehicle**



**No. 020 Post-Test Right Front 3-4 View of Test Vehicle**

 <b>VEHICLE DESCRIPTION</b> <b>F-150</b> 2015 F-150 4X2 SUPERCREW 148" WHEELBASE 3.5L V6 ECOBOOST ENGINE ELEC 6-SPEED AUTO W/TWO MOD ford.com		<b>FK D64892</b> <b>EXTERIOR</b> RACE RED <b>INTERIOR</b> MEDIUM GRAY CLOTH 40/20/40		<b>EPA DOT Fuel Economy and Environment</b> <b>Gasoline Vehicle</b> <b>Fuel Economy</b> <b>20</b> MPG combined city/hwy <b>17</b> city <b>24</b> highway 5.0 gallons per 100 miles Standard Pickup Trucks range from 15 to 23 MPG. The best vehicle rates 119 MPG. <b>You spend \$2,000</b> more in fuel costs over 5 years compared to the average new vehicle.	
<b>STANDARD EQUIPMENT INCLUDED AT NO EXTRA CHARGE</b> <b>EXTERIOR</b> • BOLLINK • DOOR HANDLES - BLACK • EASY FUEL CAPLESS FILLER • FOG LAMPS • FULLY BOXED STEEL FRAME • HALOGEN HEADLAMPS • LOCKING REMOVABLE TAILGATE • PICKUP BOX TIE-DOWN HOOKS • REAR PRIVACY GLASS • SPARE TIRE & WHEEL LOCK <b>INTERIOR</b> • TOUCH UP/DOWN DRYPASS WIN • 2.3" PRODUCTIVITY SCREEN • 4.3" CENTER STACK MULTIMEDIA FUNCTION DISPLAY • A/C W/MANUAL CLIMATE CONTROL, SINGLE ZONE • AUXILIARY AUDIO INPUT JACK • COLOR COORDINATED CARPET AND FLOOR MATS • CRUISE CONTROL • DAY/NIGHT REARVIEW MIRROR • TILT/TELESCOPE STR COLUMN <b>FUNCTIONAL</b> • 4 WHEEL DISC BRAKES W/ABS • 17V AUXILIARY POWER POINT • AUTO LAMP-AUTO ON/OFF HDLMP • FADE-TO-OFF INTERIOR LIGHT • FAIL-SAFE COOLING SYSTEM • HILL START ASSIST • OUTBOARD MOUNTED REAR SHOCKS • POWER LOCKS AND WINDOWS • POWER, MAN FOLD MIRRORS • POWER TAILGATE LOCK • PWR RACK AND PINION STEER • SYNC • TRAILER SWAY CONTROL • WIPER ACTIVATED HEADLAMPS <b>SAFETY/SECURITY</b> • ADVANCE TRAC WITH RSC • AIRBAGS - FRONT SEAT MOUNTED SIDE IMPACT • AIRBAGS - SAFETY CANOPY SIDE CURTAIN • CTN HIGH MOUNT STOP LAMP • MIKEY • PERIMETER ALARM • SECURICODE KEYLESS KEYPAD • SOS POST CRASH ALERT SYS • TIRE PRESSURE MONITOR SYS <b>WARRANTY</b> • 3YR/50,000 BUMPER / BUMPER • 5YR/100,000 POWERTRAIN • 5YR/100,000 ROADSIDE ASSIST		<b>Annual fuel cost \$2,600</b> <b>Fuel Economy &amp; Greenhouse Gas Rating</b> (safer only) Smog Rating (safer only) <b>1</b> <b>5</b> <b>10</b> <b>1</b> <b>6</b> <b>10</b> Best Best This vehicle emits 451 grams CO <sub>2</sub> per mile. The best emits 0 grams per mile (tailpipe only). Producing and transporting fuel also create emissions. Learn more at fueleconomy.gov. Actual results will vary for many reasons, including driving conditions and how you drive and maintain your vehicle. The average new vehicle gets 24 MPG and costs \$11,000 to fuel over 5 years. Cost estimates are based on 18,000 miles per year at \$3.50 per gallon. MPGe is miles per gasoline gallon equivalent. Vehicle emissions are a significant cause of climate change and smog. <b>fueleconomy.gov</b> Calculate personalized estimates and compare vehicles.			
<b>INCLUDED ON THIS VEHICLE (MSRP)</b> <b>EQUIPMENT GROUP 300A</b> 95L7 SERIES <b>OPTIONAL EQUIPMENT/OTHER</b> SELECT SHIFT TRANSMISSION 17" SILVER PAINTED ALUMINUM 3.5L V6 ECOBOOST ENGINE 245/70R 17 89W ALL-SEASON 3.15 RATIO REGULAR AXLE 6000W GVWR PACKAGE FRONT LICENSE PLATE BRACKET BLACK PLATFORM RUNNING BOARDS 29 GALLON FUEL TANK 1,995.00 NO CHARGE NO CHARGE 250.00		<b>PRICE INFORMATION (MSRP)</b> BASE PRICE \$36,320.00 TOTAL OPTIONS/OTHER 2,245.00 <b>TOTAL VEHICLE &amp; OPTIONS/OTHER DESTINATION &amp; DELIVERY 38,565.00</b> <b>1,195.00</b>		<b>GOVERNMENT 5-STAR SAFETY RATINGS</b> <b>Overall Vehicle Score ★★★★★</b> Based on the combined ratings of frontal, side and rollover. Should ONLY be compared to other vehicles of similar size and weight. <b>Frontal Crash</b> Driver ★★★★★ Passenger ★★★★★ Based on the risk of injury in a frontal impact. Should ONLY be compared to other vehicles of similar size and weight. <b>Side Crash</b> Front seat ★★★★★ Rear seat ★★★★★ Based on the risk of injury in a side impact. <b>Rollover</b> ★★★★★ Based on the risk of rollover in a single-vehicle crash. Star ratings range from 1 to 5 stars (★★★★★), with 5 being the highest. Source: National Highway Traffic Safety Administration (NHTSA). www.safercar.gov or 1-888-327-4256	
<b>SELL TO</b> Don Reid Ford Inc 1875 S Orlando Ave Maitland FL 32751 24A 214 <b>RAMP ONE</b> CW29 <b>DEALER NO.</b> 24A 214 <b>TOTAL MSRP \$39,760.00</b> This label is affixed pursuant to the Federal Automobile Information Disclosure Act. Gasoline, License, and Title Fees, State and Local taxes are not included. Dealer installed options or accessories are not included unless listed above.		<b>SHIP TO</b> 24 (FORD TRUCKS/24) <b>RAMP TWO</b> FINAL ASSEMBLY PLANT KANSAS CITY <b>ITEM #:</b> 24-0432 O/T 2 <b>METHOD OF TRANSIT:</b> CONVOY <b>FF032 N RB 2X 535 001021 06 03 15</b>		<b>38 YEARS FORD F-SERIES AMERICA'S BEST SELLING TRUCK</b> Scan this code to experience this vehicle or test #FFKD64892 to #8028 or Visit ford.com/windowsticker Standard messaging & data plan rates may apply.	
<b>SHIP THROUGH</b> CONVOY		<b>Extended Service Plan</b> Ford ESP is the only extended service plan honored at every Ford dealership in the U.S. and Canada. See your dealer for additional details or visit www.FordOwner.com for more information.		<b>Choose the vehicle you want.</b> Whether you decide to lease or finance, you'll find the choices that are right for you. See your Ford Dealer for details or visit www.FordCredit.com.	

No. 021 Monroney Label Photograph



No. 022 Pre-Test Overhead View of OMDB against target vehicle at ideal Impact Point



No. 023 Pre-Test Left Side View of OMDB against target vehicle at ideal Impact Point



No. 024 Pre-Test Right Side View of OMDB against target vehicle at ideal Impact Point

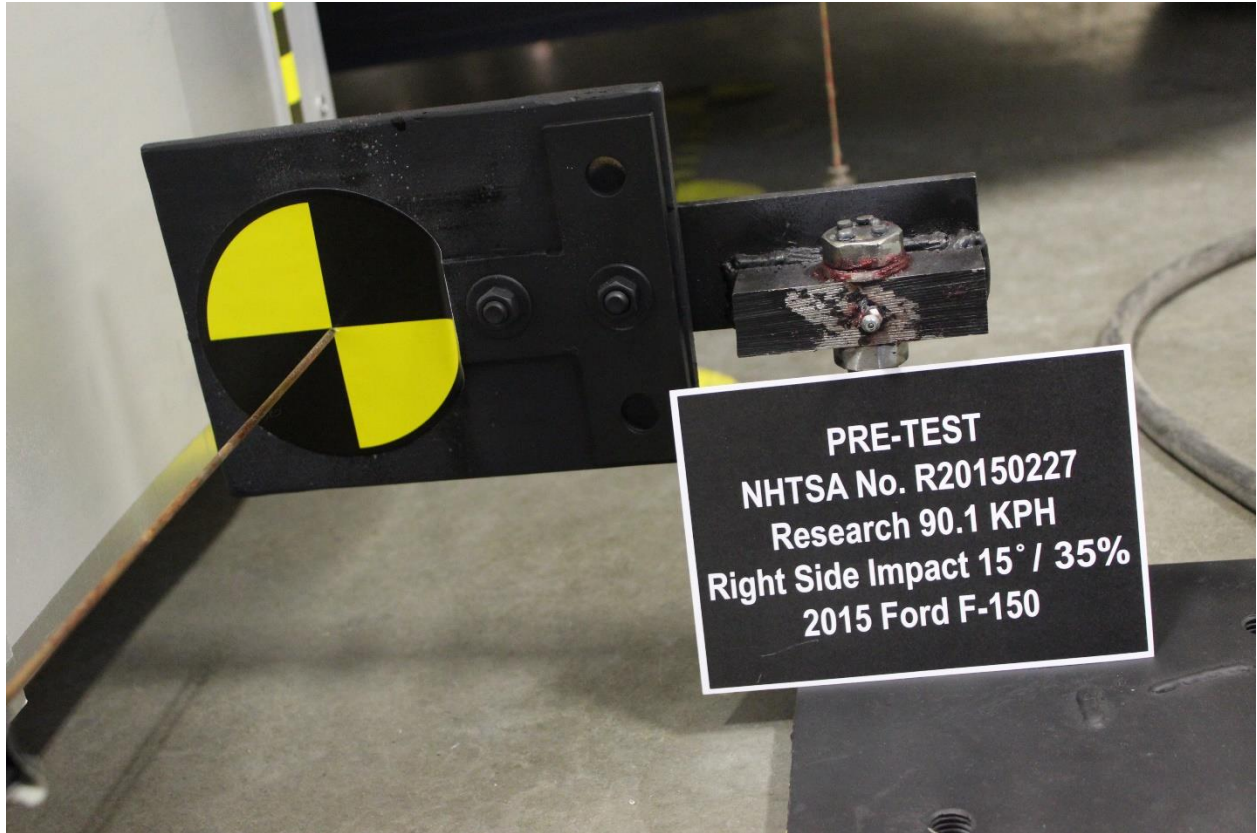

**No. 025 Pre-Test Close-up View of Impact Point**

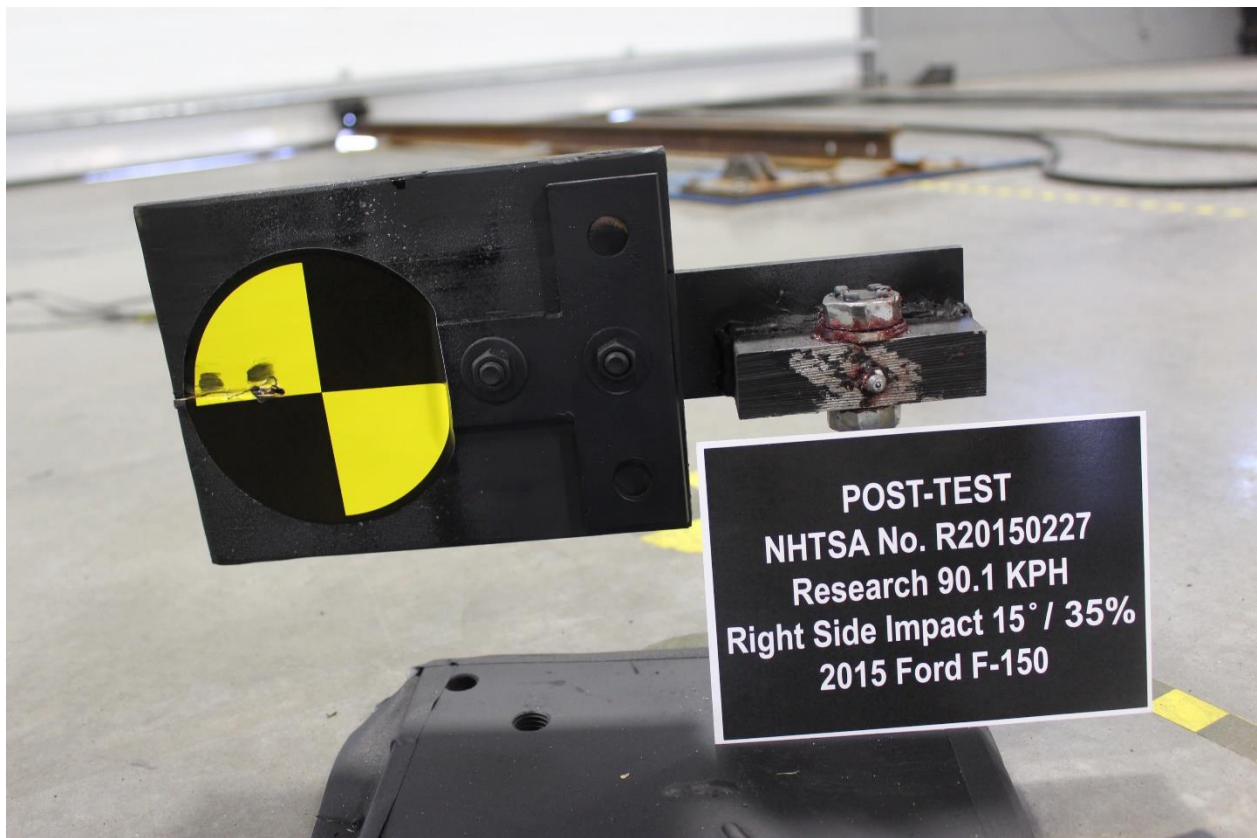

**No. 026 Post-Test Close-up View of Impact Point**

# Photo Not Available

No. 027 Post-Test Vehicle Overhead View



**No. 028 Pre-Test Close-up View of Driver Door Latch**



**No. 029 Post-Test Close-up View of Driver Door Latch**

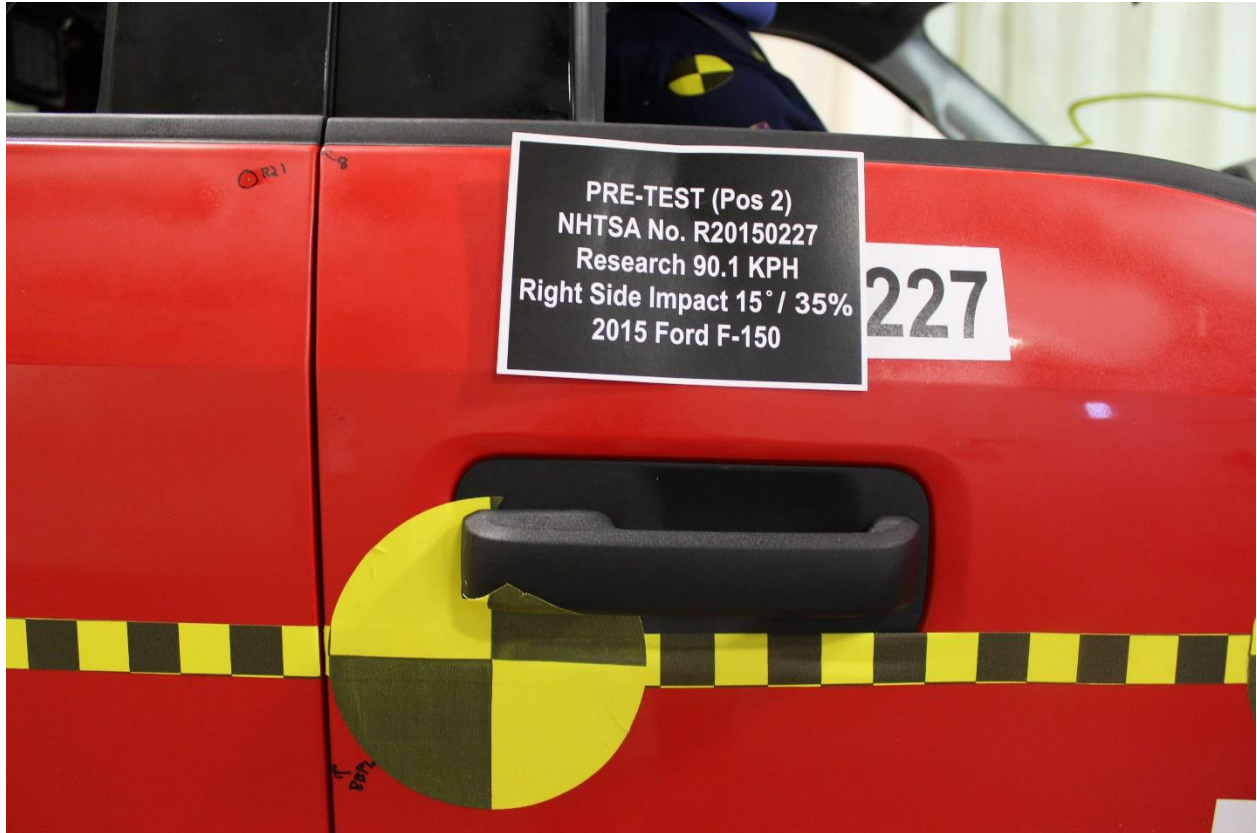

**No. 030 Pre-Test Close-up View of Passenger Door Latch**



**No. 031 Post-Test Close-up View of Passenger Door Latch**



No. 032 Pre-Test Windshield View



No. 033 Post-Test Windshield View



**No. 034 Pre-Test View of Driver Inner Door Panel**



**No. 035 Post-Test View of Driver Inner Door Panel**



**No. 036 Pre-Test View of Passenger Inner Door Panel**



**No. 037 Post-Test View of Passenger Inner Door Panel**



**No. 038 Pre-Test Overall View of Driver Knee Bolsters**



**No. 039 Post-Test Overall View of Driver Knee Bolsters**



**No. 040 Pre-Test Left Side View of Driver Knee Bolsters**

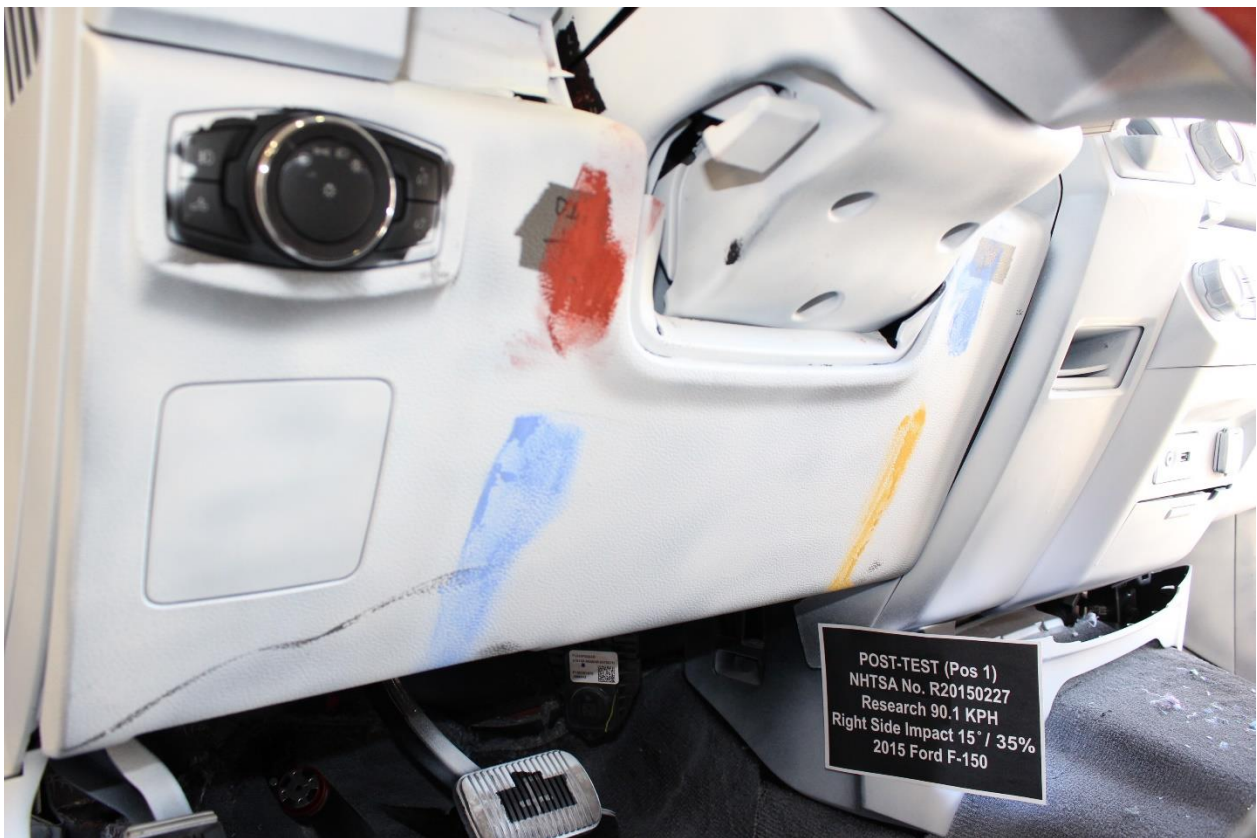

**No. 041 Post-Test Left Side View of Driver Knee Bolsters**



**No. 042 Pre-Test Right Side View of Driver Knee Bolsters**



**No. 043 Post-Test Right Side View of Driver Knee Bolsters**



**No. 044 Pre-Test View of Driver Floor pan at Left sill level, w/carpet**



**No. 045 Post-Test View of Driver Floor pan at Left sill level, w/carpet**

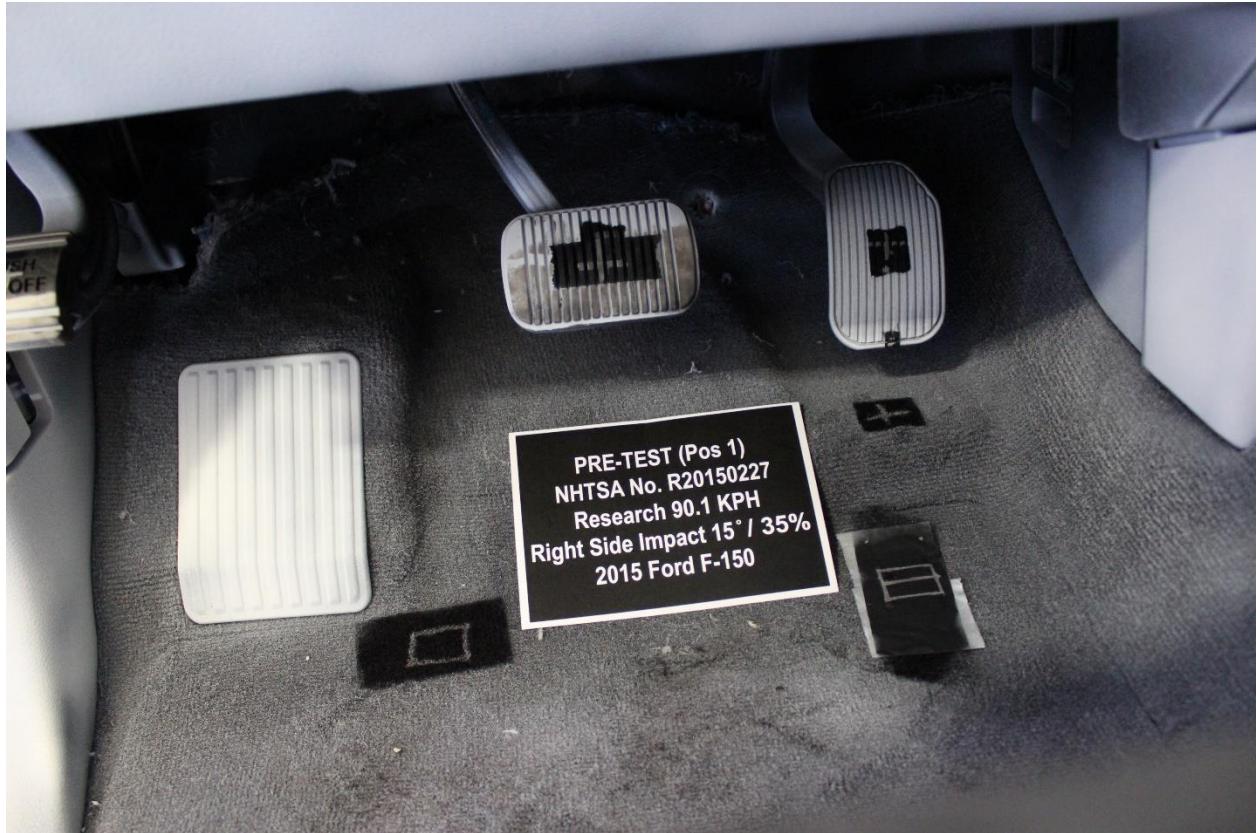

**No. 046 Pre-Test View of Driver Floor pan at Mid seat level, w/carpet**



**No. 047 Post-Test view of Driver Floor pan at Mid seat level, w/carpet**



**No. 048 Pre-Test View of Driver Floor pan at Right Side**



**No. 049 Post-Test View of Driver Floor pan at Right Side**



**No. 050 Pre-Test Driver Front Windshield View**



**No. 051 Post-Test Driver Front Windshield View**



**No. 052 Pre-Test Left Side View of Driver and Interior**



**No. 053 Post-Test Left Side View of Driver and Interior**



**No. 054 Pre-Test Left Side Driver Window View**



**No. 055 Post-Test Left Side Driver Window View**



PRE-TEST (Pos 1)  
NHTSA No. R20150227  
Research 90.1 KPH  
Right Side Impact 15' / 35%  
2015 Ford F-150

**No. 056 Pre-Test Right Side View of Driver and Interior**



POST-TEST (Pos 1)  
NHTSA No. R20150227  
Research 90.1 KPH  
Right Side Impact 15' / 35%  
2015 Ford F-150

**No. 057 Post-Test Right Side View of Driver and Interior**



**No. 058 Pre-Test View of Driver Door Clearance**



**No. 059 Post-Test View of Driver Door Clearance**



**No. 060 Pre-Test View of Parking Brake**

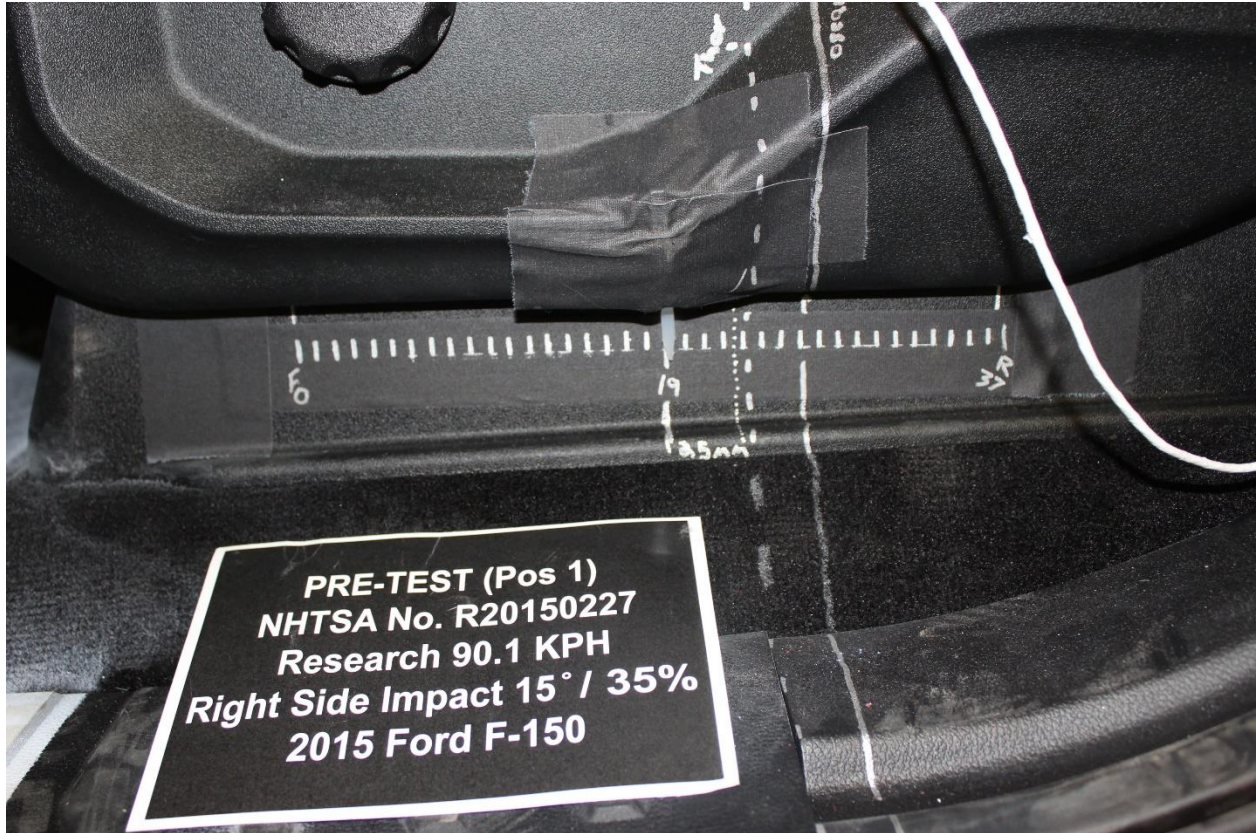

No. 061 Pre-Test Driver Seat Fore Aft Markings

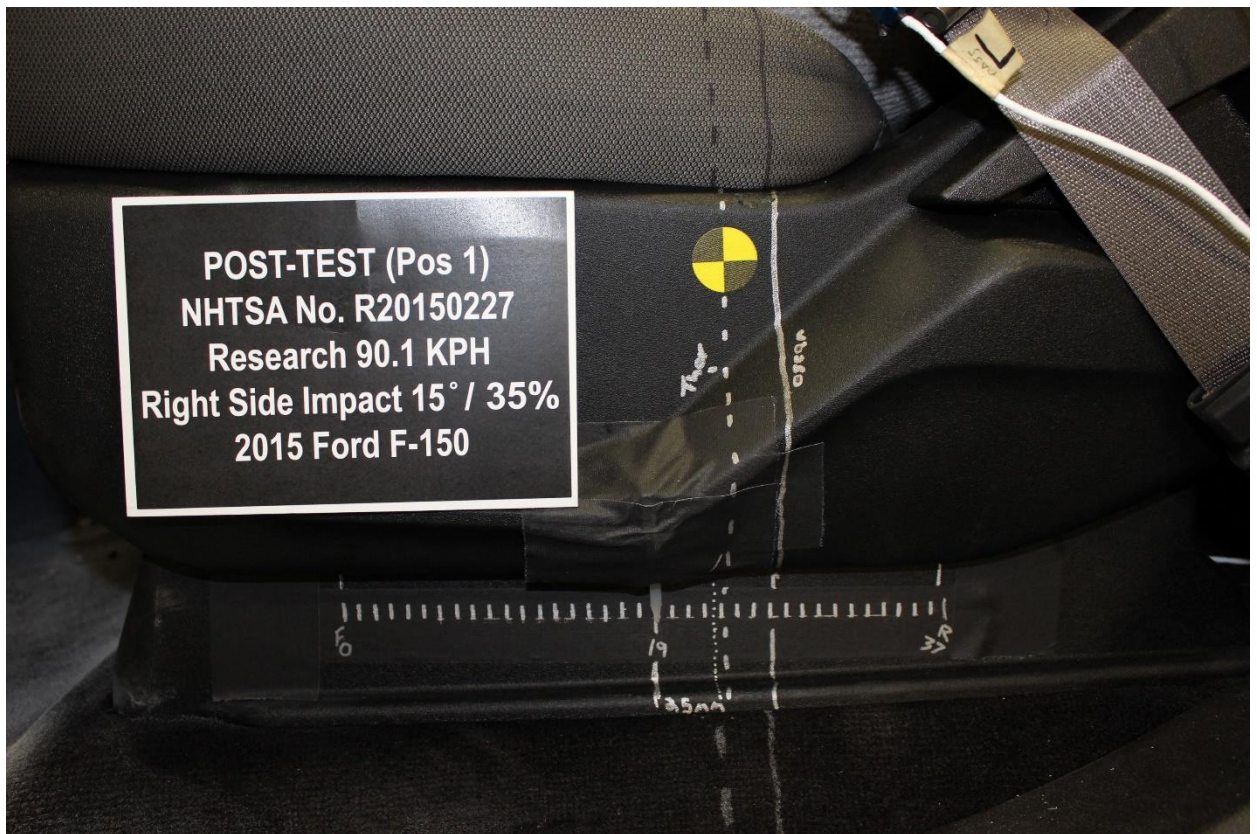

No. 062 Post-Test Driver Seat Fore Aft Markings

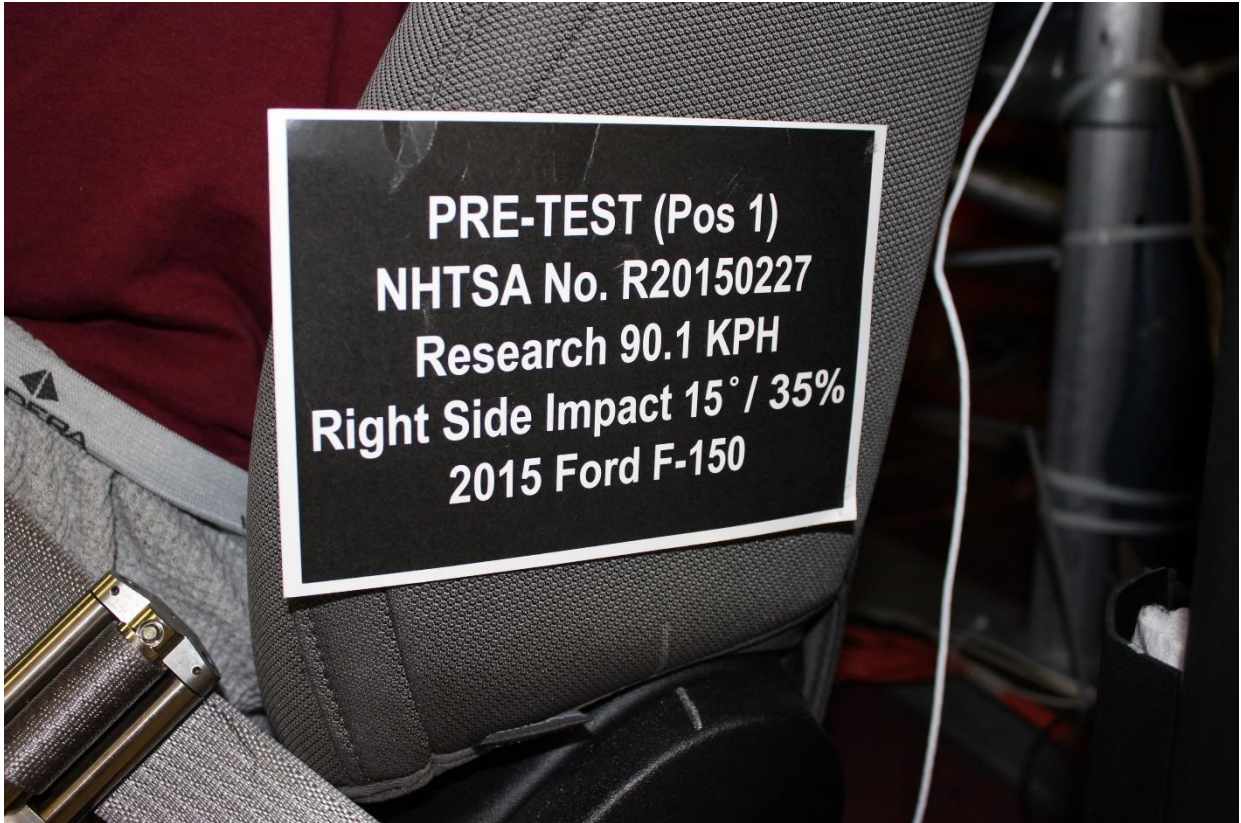

No. 063 Pre-Test Driver Seat Back Markings



No. 064 Pre-Test Overhead View of Driver Thighs on Seat

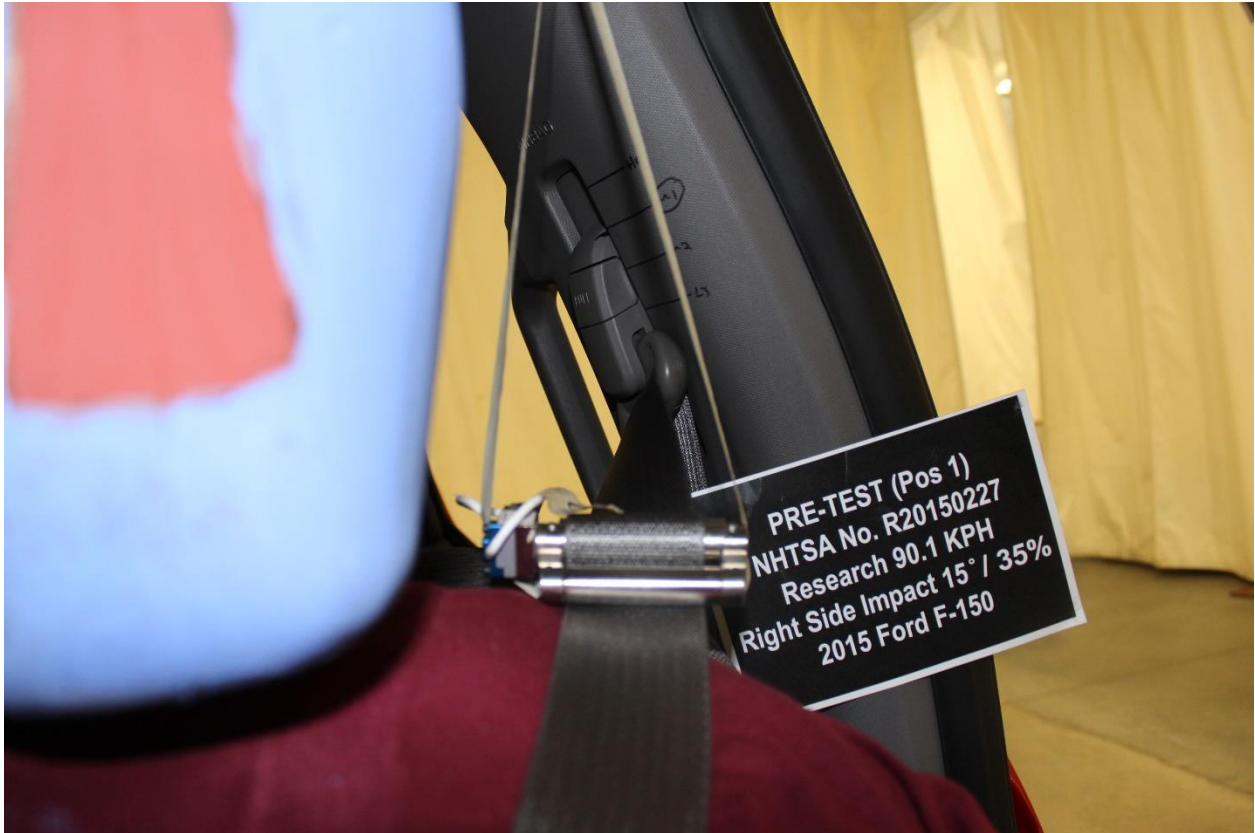

**No. 065 Pre-Test Driver Adjustable D-Ring**

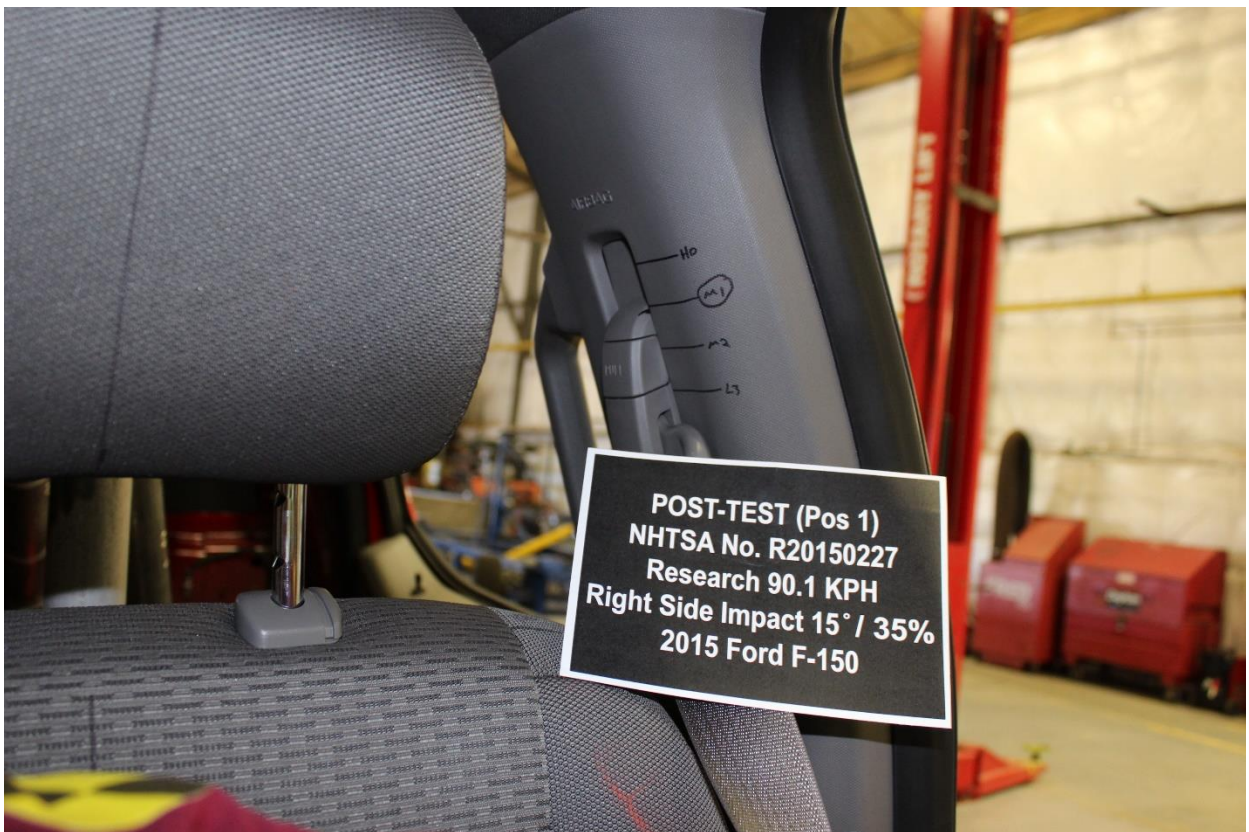

**No. 066 Post-Test Driver Adjustable D-Ring**



**No. 067 Pre-Test Driver Feet**



**No. 068 Post-Test Driver Feet**



**No. 069 Pre-Test View of Driver Right Knee and Bolster**

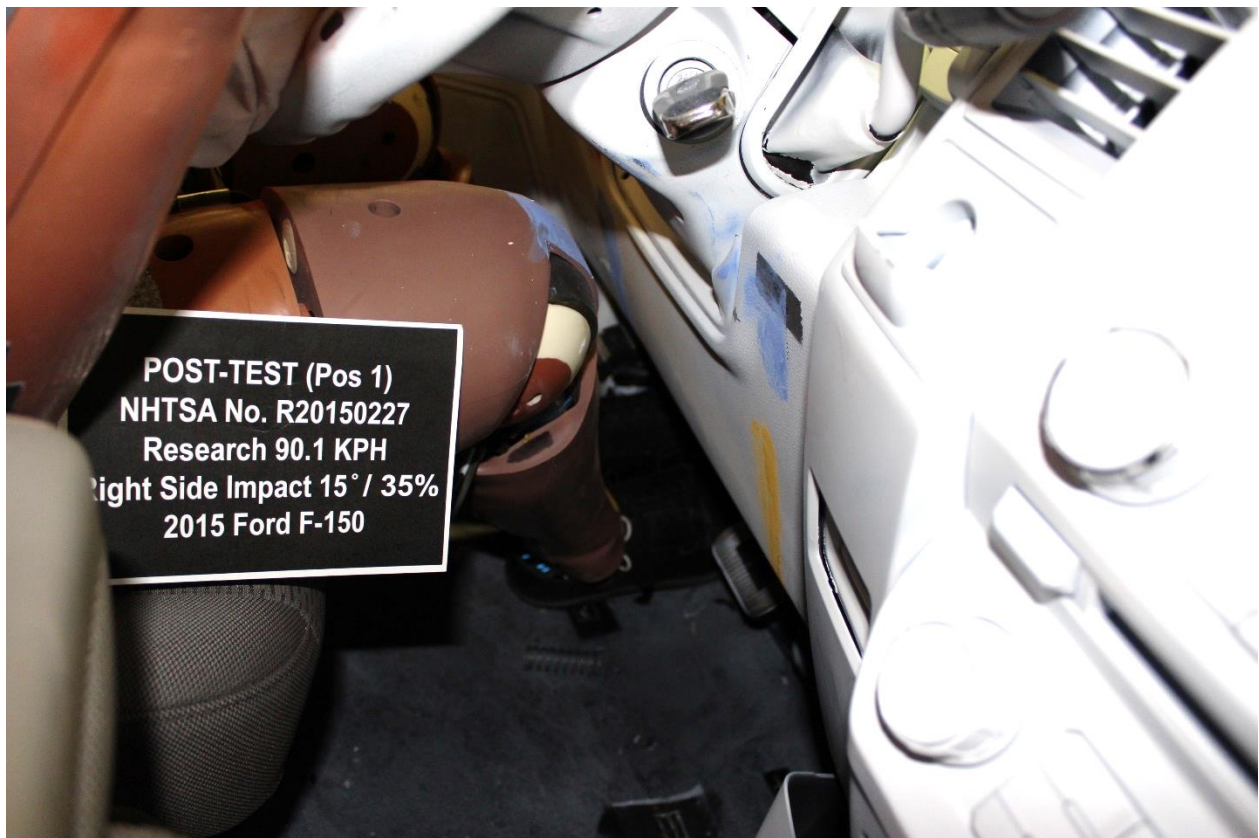

**No. 070 Post-Test View of Driver Right Knee and Bolster**

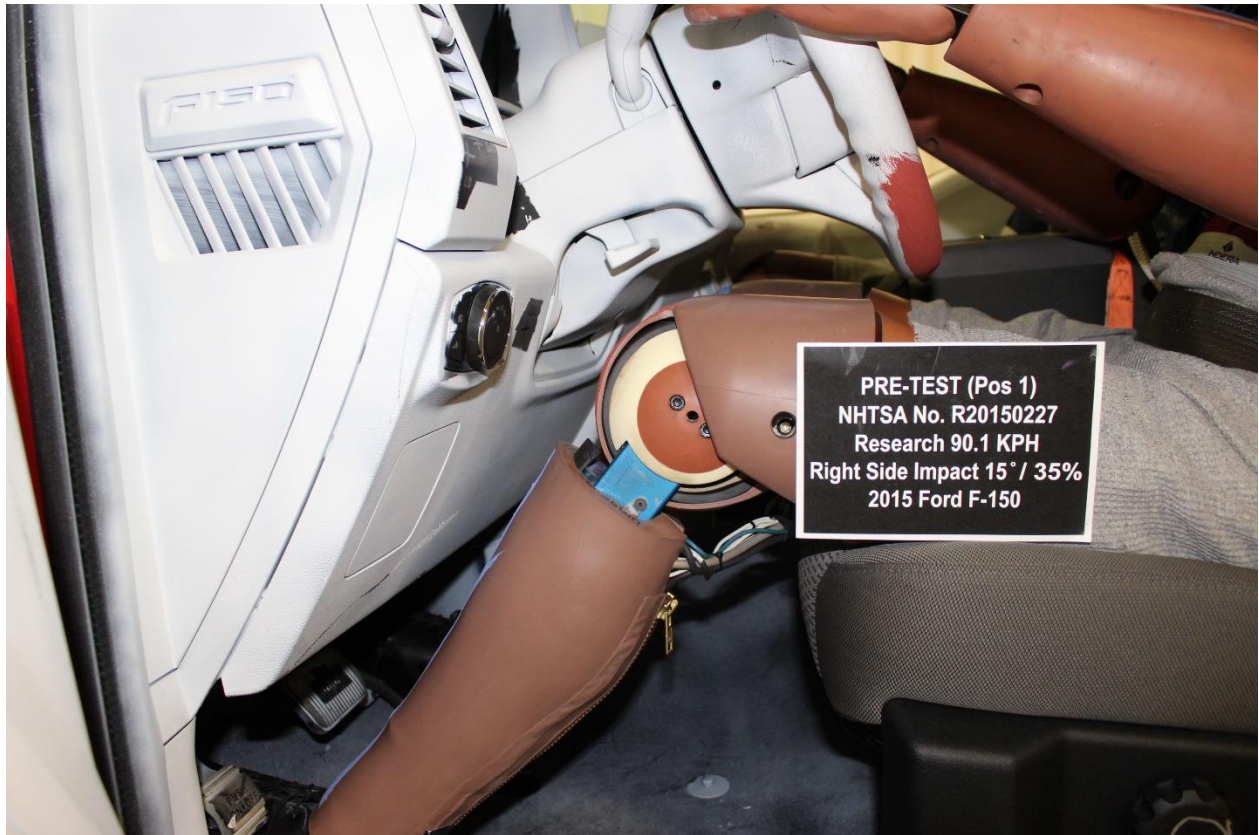

**No. 071 Pre-Test View of Driver Left Knee and Bolster**

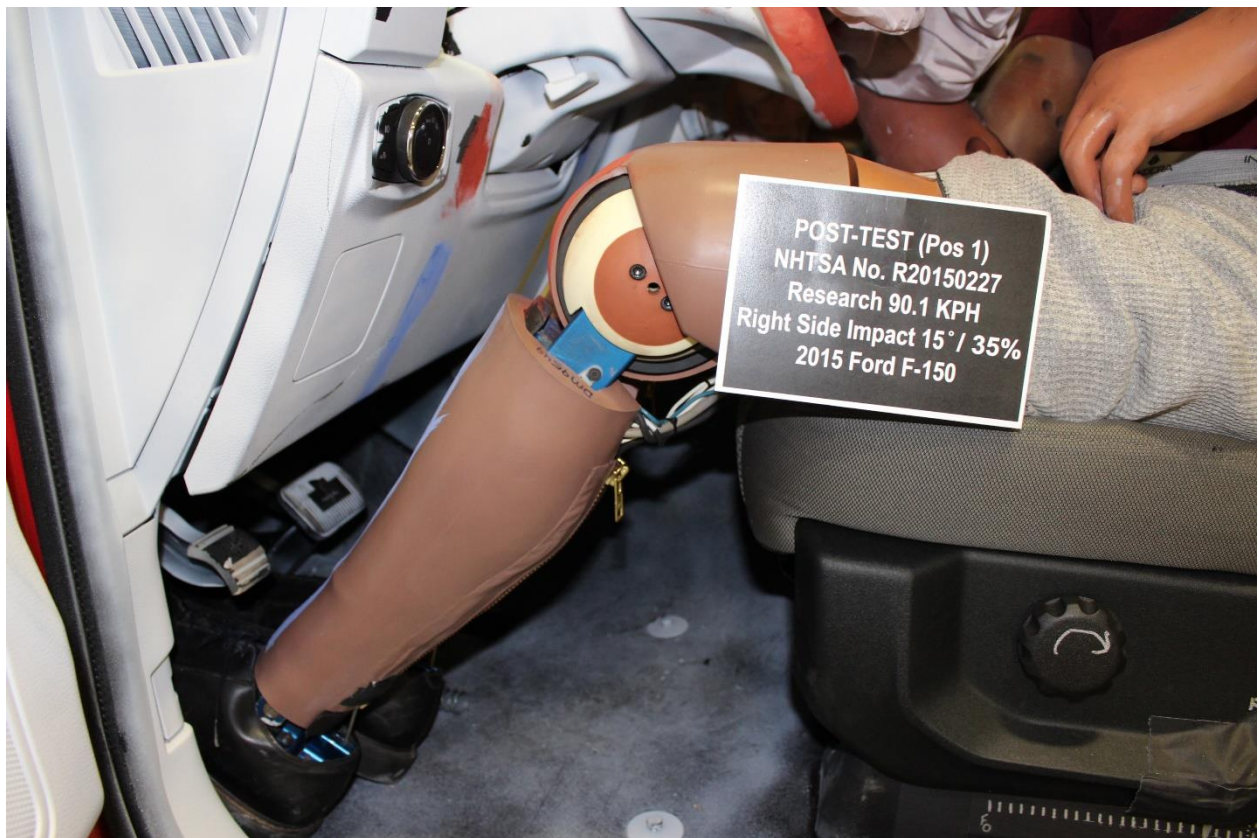

**No. 072 Post-Test View of Driver Left Knee and Bolster**



**No. 073 Pre-Test View of Driver Abdomen**



**No. 074 Post-Test View of Driver Abdomen**

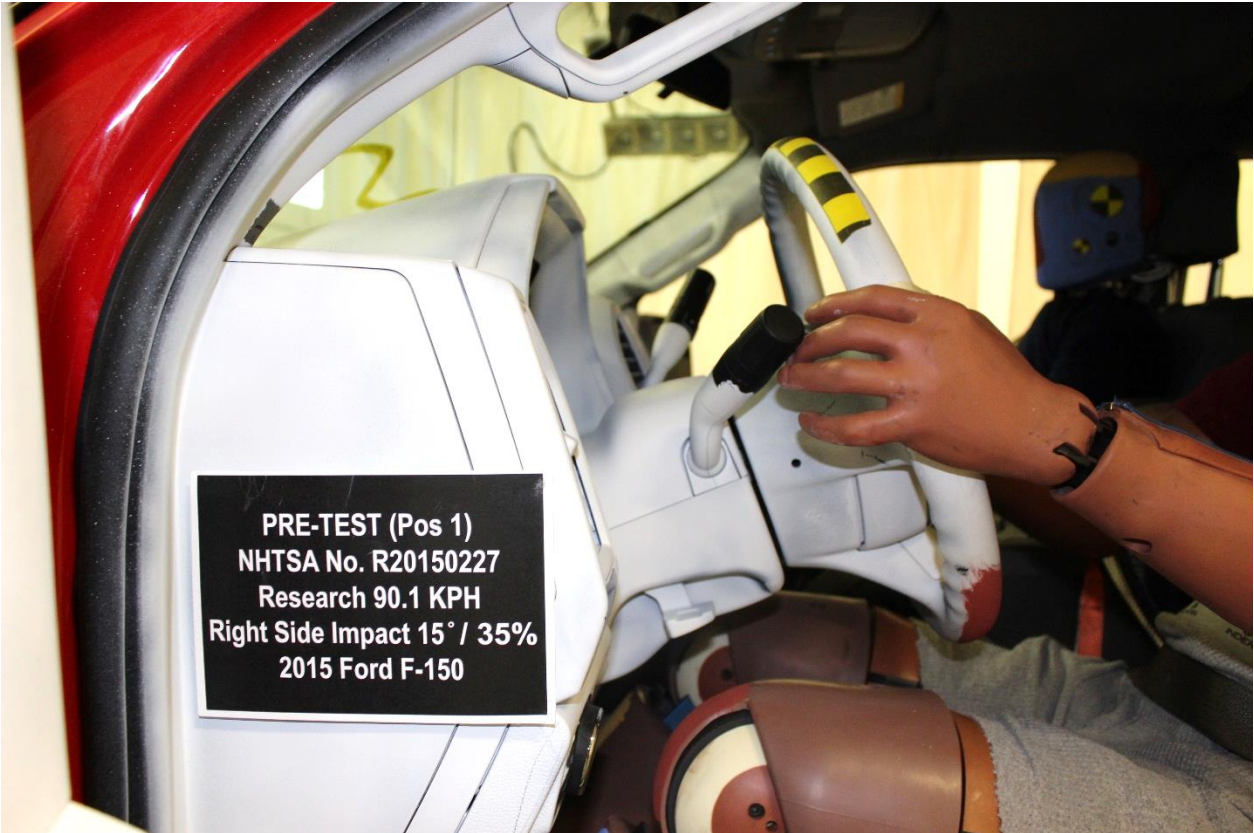

**No. 075 Pre-Test Left Side View of Steering Wheel set position**



**No. 076 Post-Test Left Side View of Steering Wheel set position**

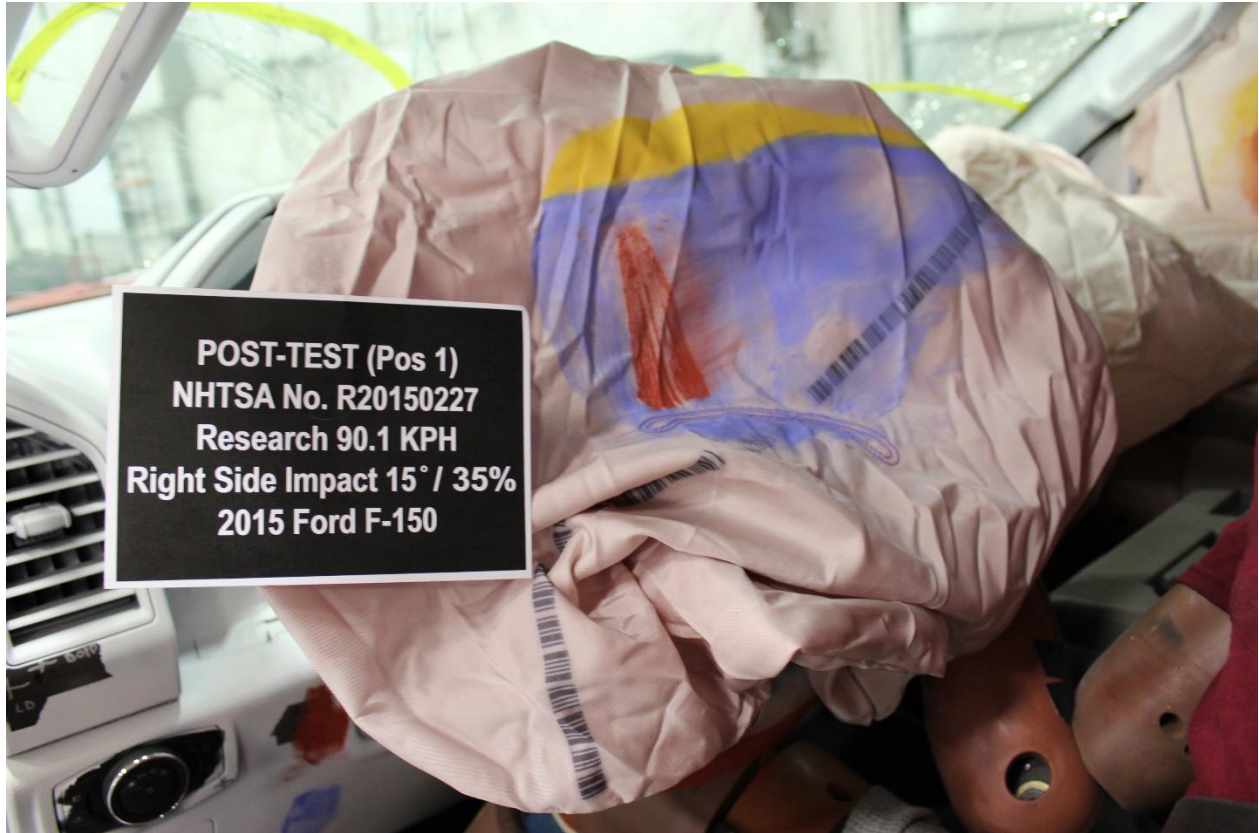

**No. 077 Post-Test View of Driver Head Contact with Front Airbag**

# Photo Not Applicable

**No. 078 Post-Test View of Driver Head Contact with Curtain Airbag**

**Photo Not Applicable**

**No. 079 Post-Test View of Driver Head Contact with Vehicle Interior – A**

**Photo Not Applicable**

**No. 080: Post-Test View of Driver Body Contact with Vehicle Interior - B**

# **Photo Not Applicable**

**No. 081: Post-Test View of Driver Body Contact with Vehicle Interior - C**



**No. 082: Pre-Test Overall View of Passenger Knee Bolsters**



**No. 083: Post-Test Overall View of Passenger Knee Bolsters**



**No. 084: Pre-Test Left Side View of Passenger Knee Bolsters**



**No. 085: Post-Test Left Side View of Passenger Knee Bolsters**



**No. 086: Pre-Test Right Side View of Passenger Knee Bolsters**



**No. 087: Post-Test Right Side View of Passenger Knee Bolsters**



**No. 088: Pre-Test View of Passenger Floor pan at Right sill level, w/carpet**



**No. 089: Post-Test View of Passenger Floor pan at Right sill level, w/carpet**



**No. 090: Pre-Test View of Passenger Floor pan at Mid seat level, w/carpet**



**No. 091: Post-Test view of Passenger Floor pan at Mid seat level, w/carpet**



**No. 092: Pre-Test View of Passenger Floor pan at Left view**



**No. 093: Post-Test View of Passenger Floor pan at Left View**



**No. 094: Pre-Test Passenger Front Close-up View, Windshield**



**No. 095: Post-Test Passenger Front Close-up View, Windshield**



**No. 096: Pre-Test Left Side Passenger and Interior View**



**No. 097: Post-Test Left Side Passenger and Interior View**



**No. 98: Pre-Test Right Side Passenger Window View**



**No. 99: Post-Test Right Side Passenger Window View**



**No. 100: Pre-Test Right Side Passenger and Interior View**



**No. 101: Post-Test Right Side Passenger and Interior View**



No. 102: Pre-Test View of Passenger Door Clearance



No. 103: Post-Test View of Passenger Door Clearance

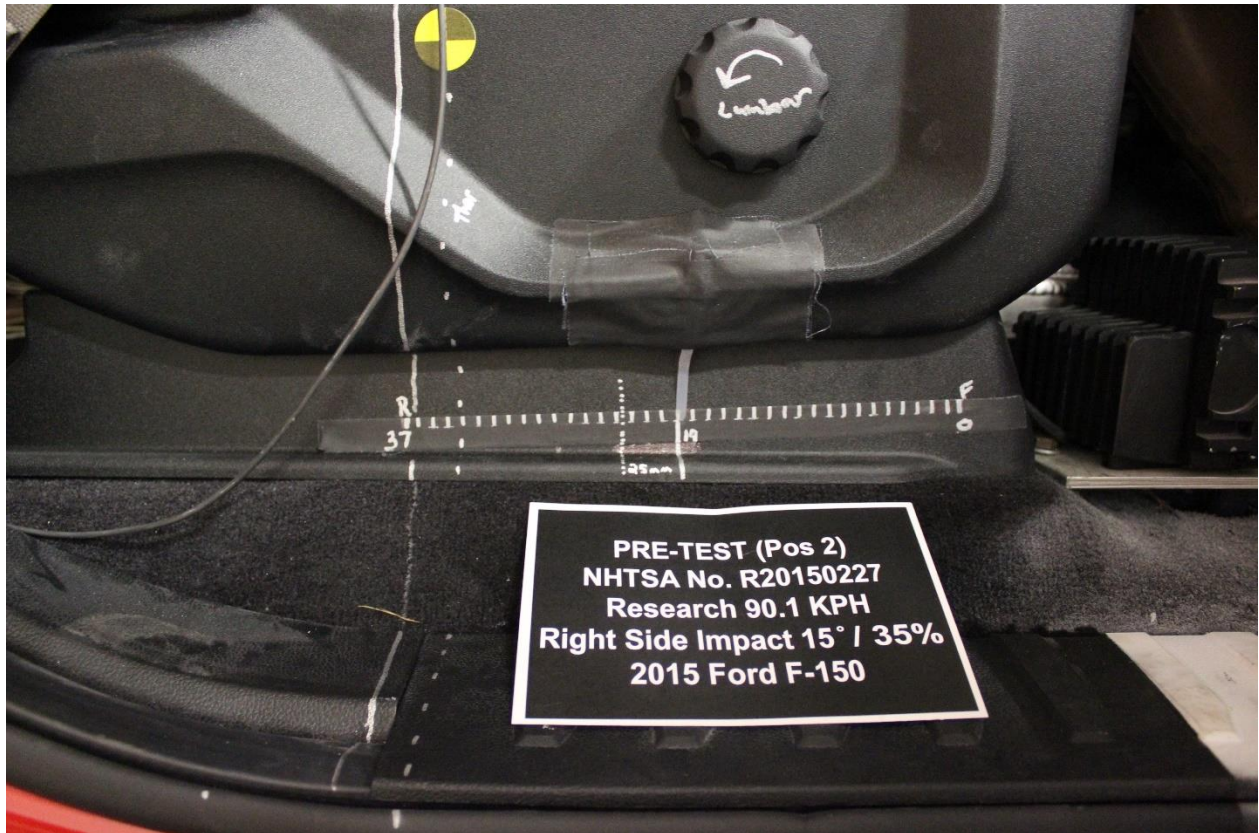

**No. 104: Pre-Test Passenger Seat Fore-Aft Markings**



**No. 105: Post-Test Passenger Seat Fore-Aft Markings (plastic moved not seat)**



**No. 106: Pre-Test Passenger Seat Back Markings**

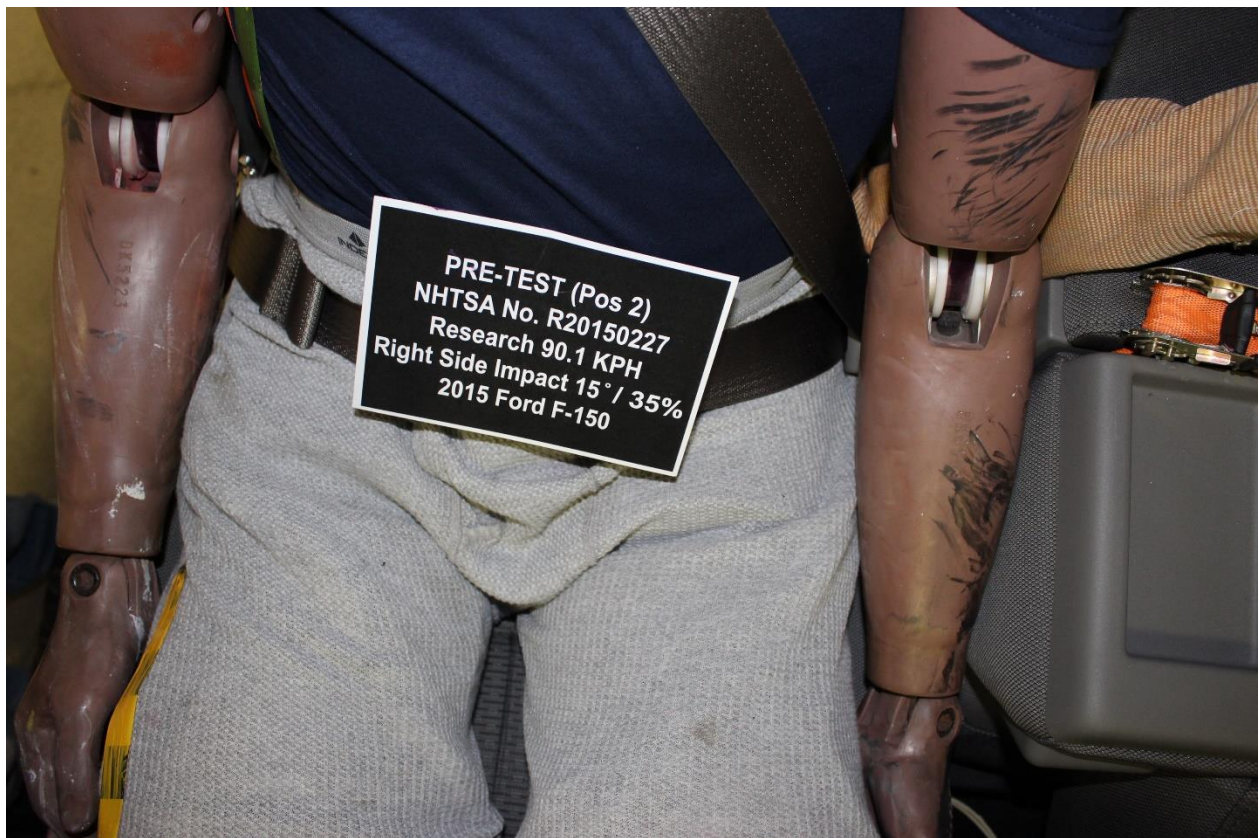

**No. 107: Pre-Test Overhead View of Passenger Thighs on seat**

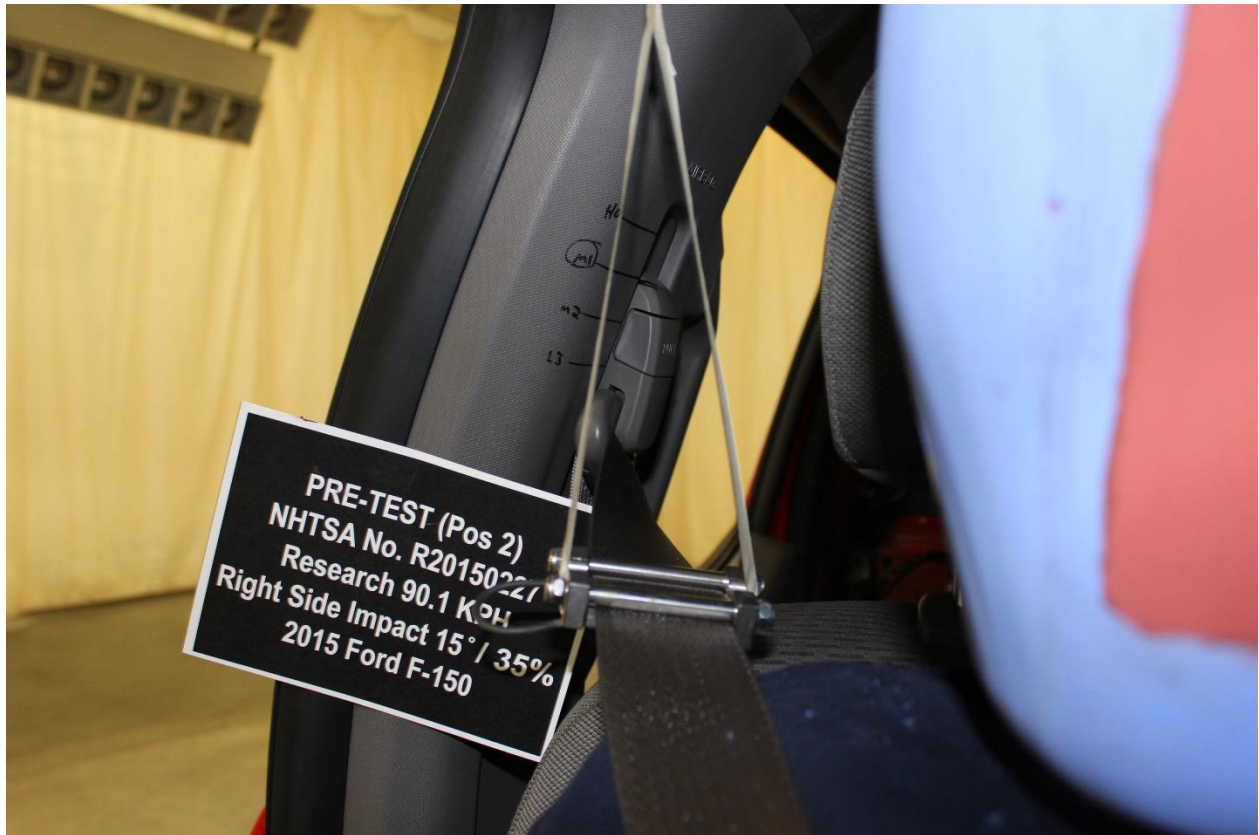

**No. 108: Pre-Test Passenger Adjustable D-ring**



**No. 109: Post-Test Passenger Adjustable D-ring**

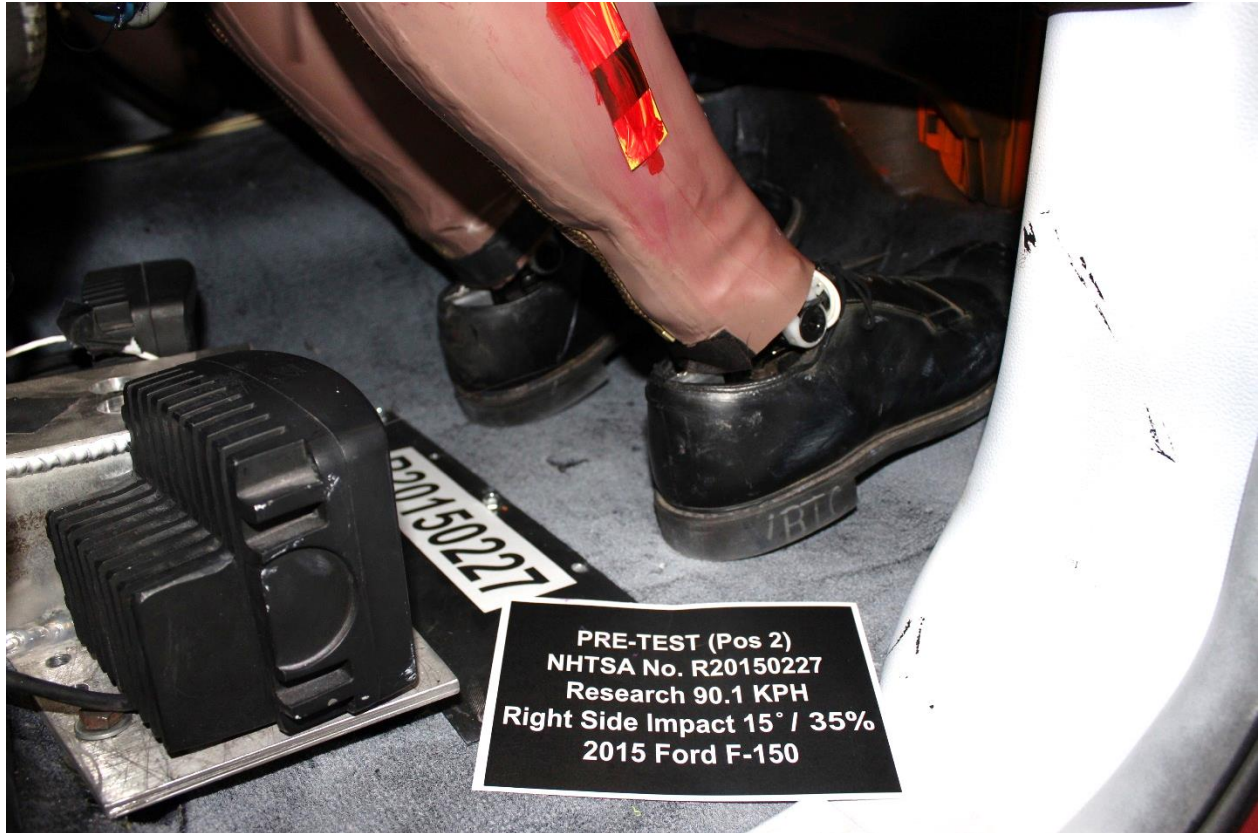

No. 110: Pre-Test View of Passenger Feet



No. 111: Post-Test View of Passenger Feet



**No. 112: Pre-Test View of Passenger Right Knee and Bolster**

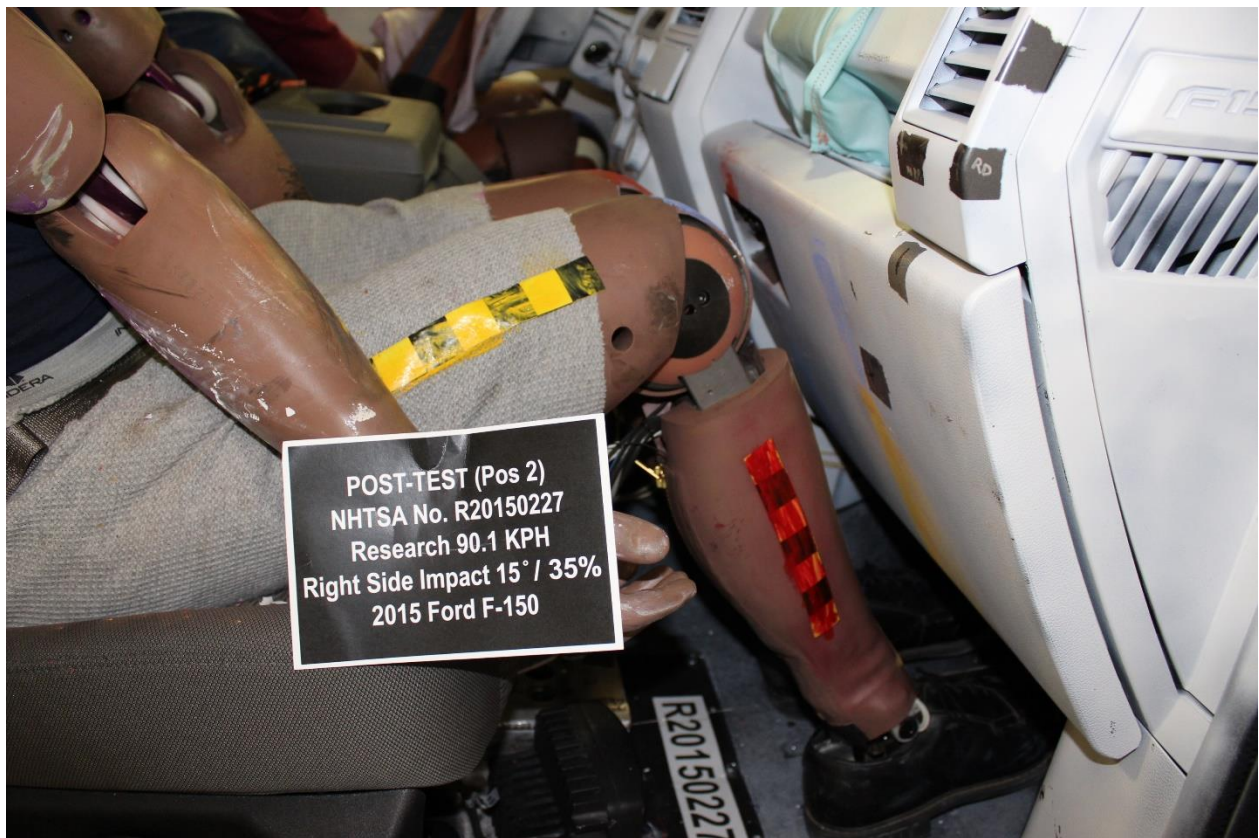

**No. 113: Post-Test View of Passenger Right Knee and Bolster**

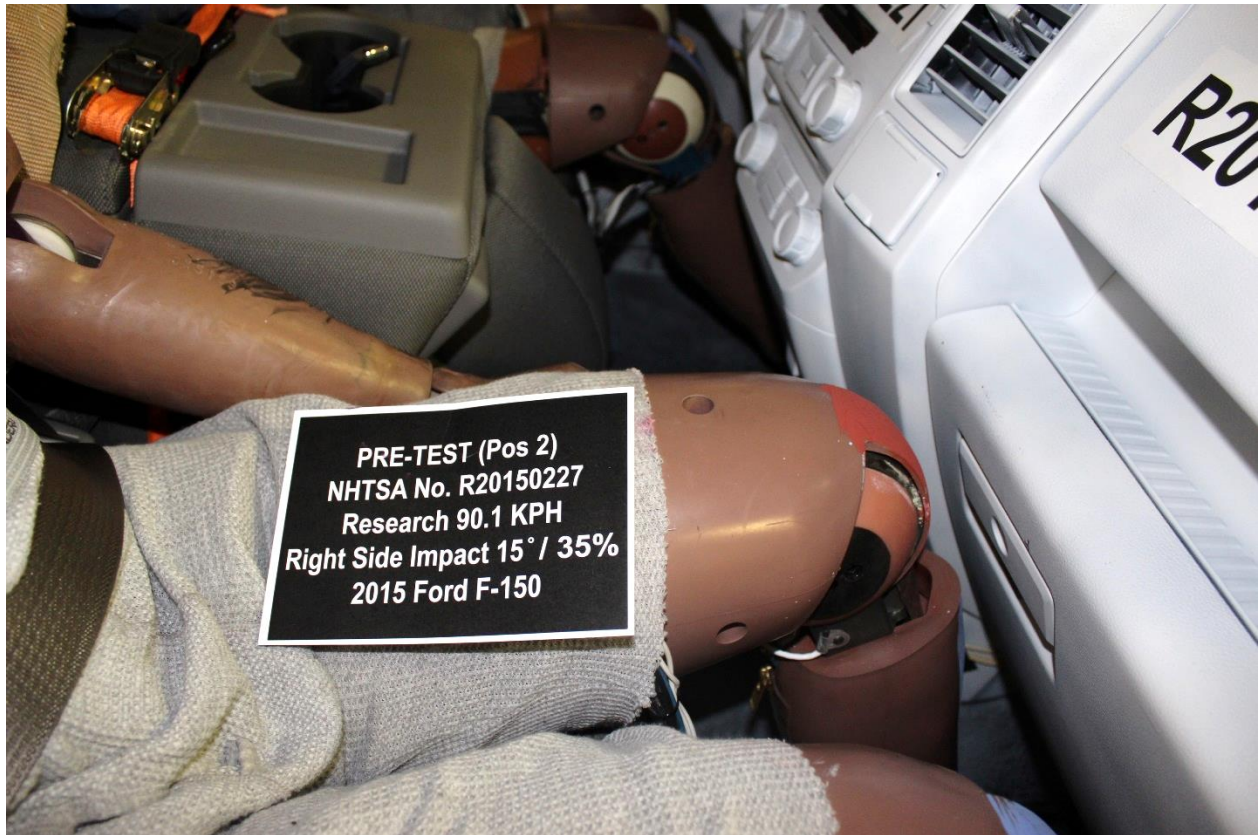

**No. 114: Pre-Test View of Passenger Left Knee and Bolster**



**No. 115: Post-Test View of Passenger Left Knee and Bolster**



**No. 116: Pre-Test View of Passenger Abdomen**



**No. 117: Post-Test View of Passenger Abdomen**



**No. 118: Post-Test View of Passenger Head contact with Airbag – Front**



**No. 119: Post-Test View of Passenger Head contact with Airbag - Curtain**

# Photo Not Applicable

**No. 120: Post-Test View of Passenger Head contact with Interior**

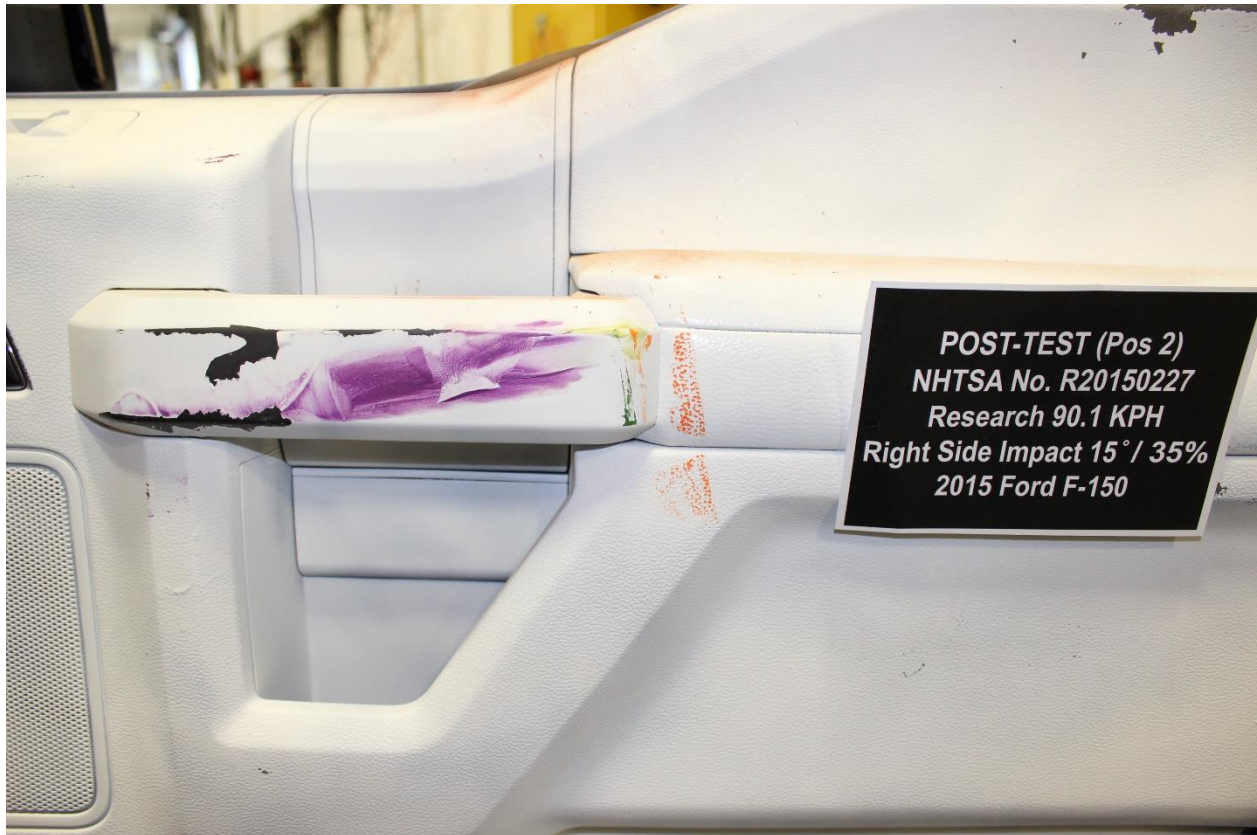

**No. 121: Post-Test View of Passenger Body contact with Interior**

# Photo Not Applicable

**No. 122: Post-Test View of Passenger Head contact with Interior**



**No. 123: Post-Test Passenger Contact With Glovebox**

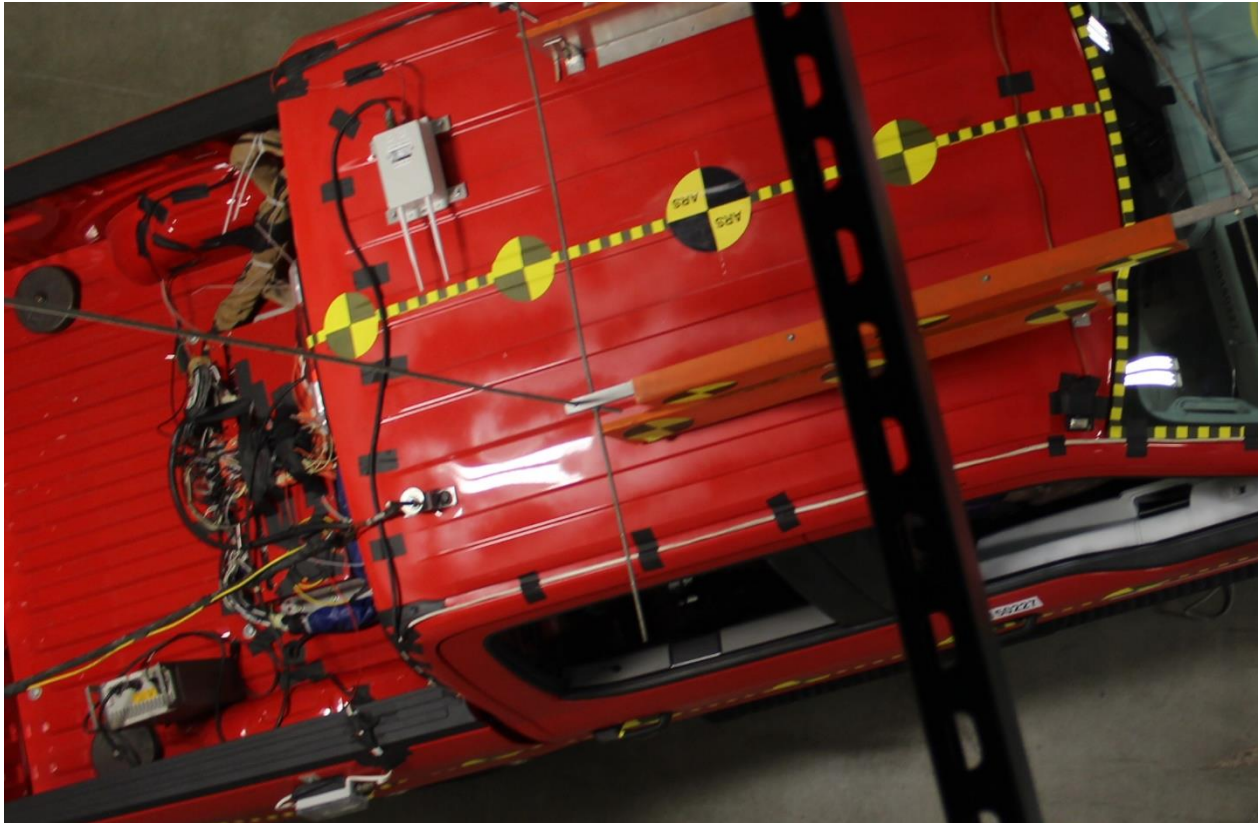

**No. 124: Pre-Test Ballast Locations**

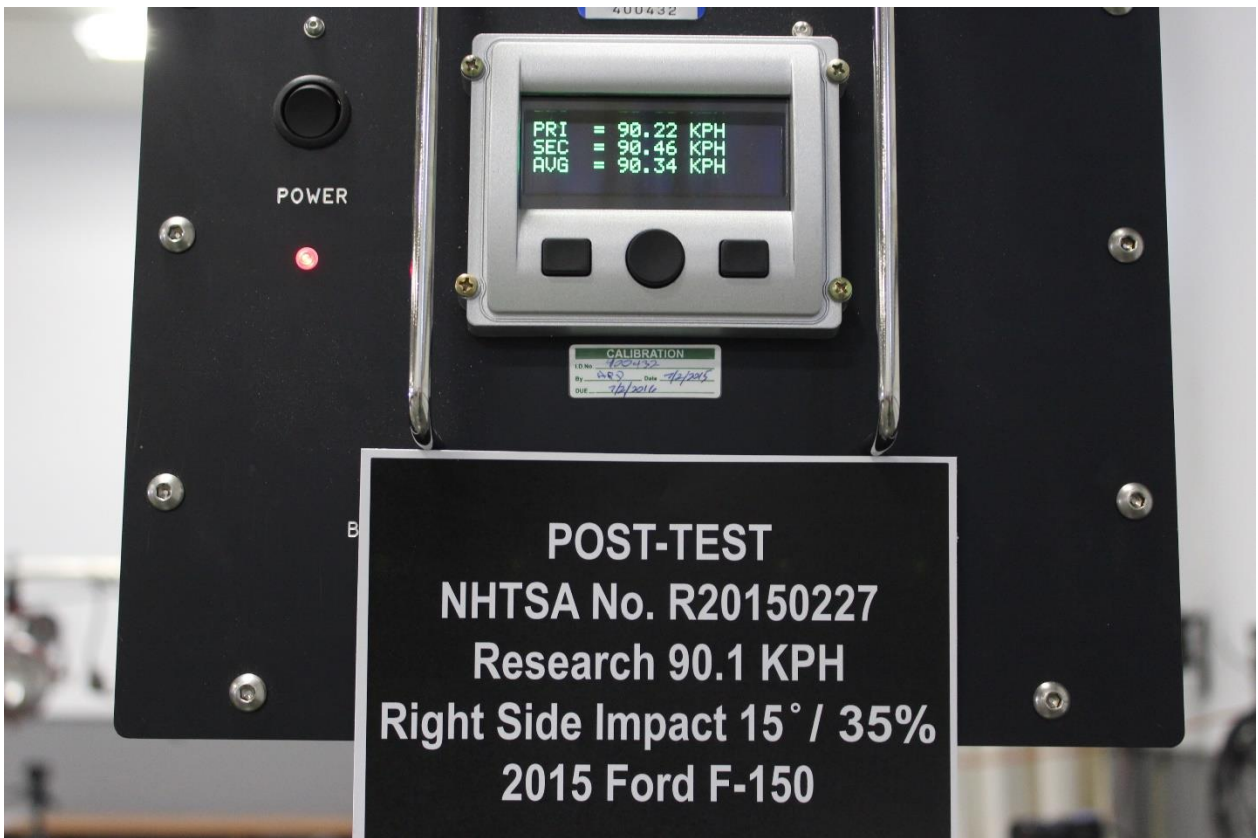

**No. 125: Post-Test Speed Trap Readout**



No. 126: Pre-Test View of Fuel Filler Cap



No. 127: Post-Test View of Fuel Filler Cap

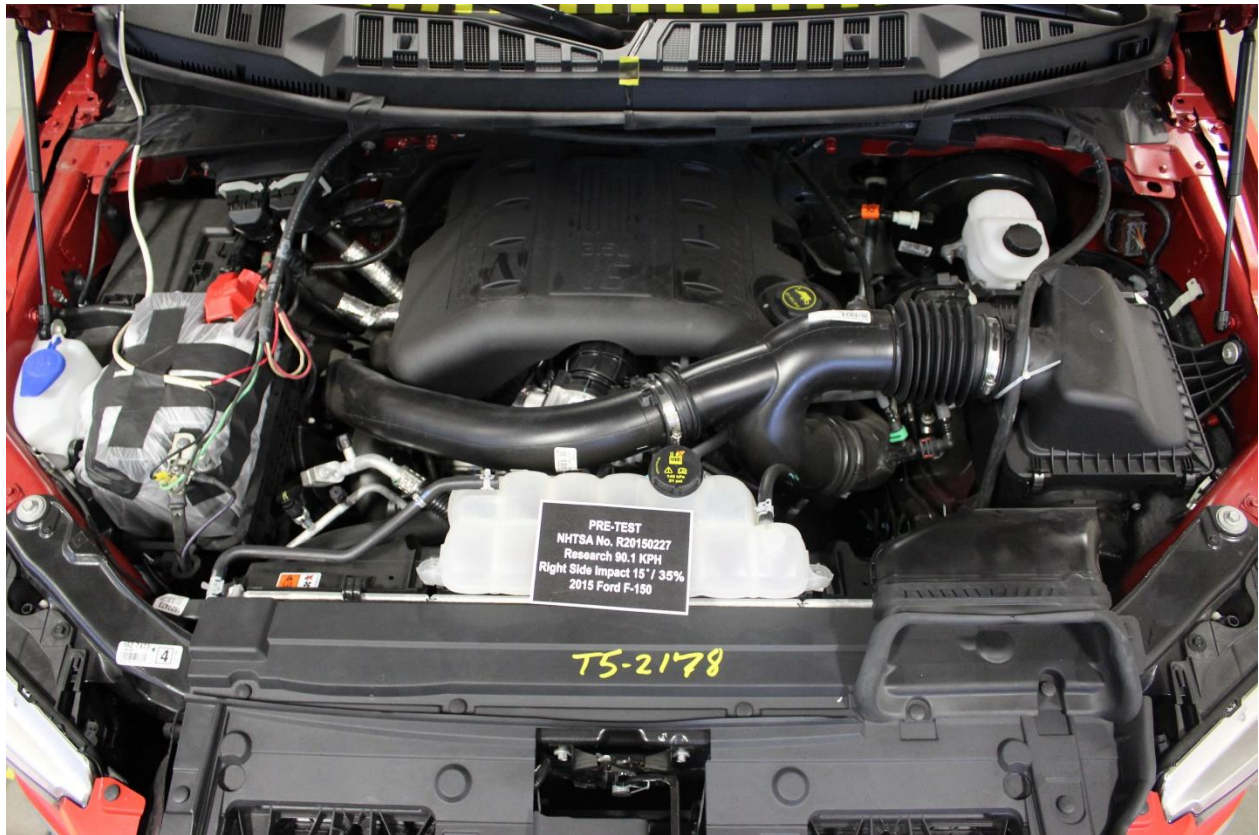

No. 128: Pre-Test Engine Compartment View

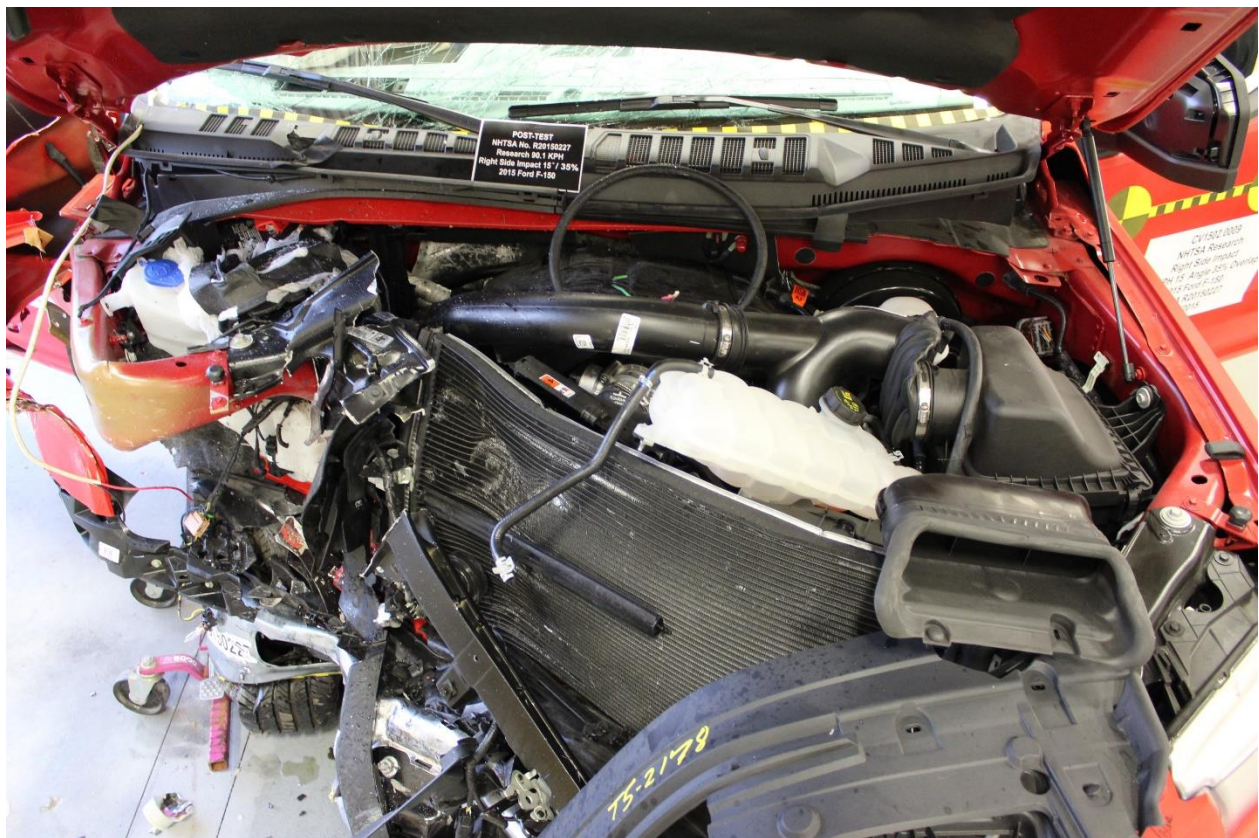

No. 129: Post-Test Engine Compartment View

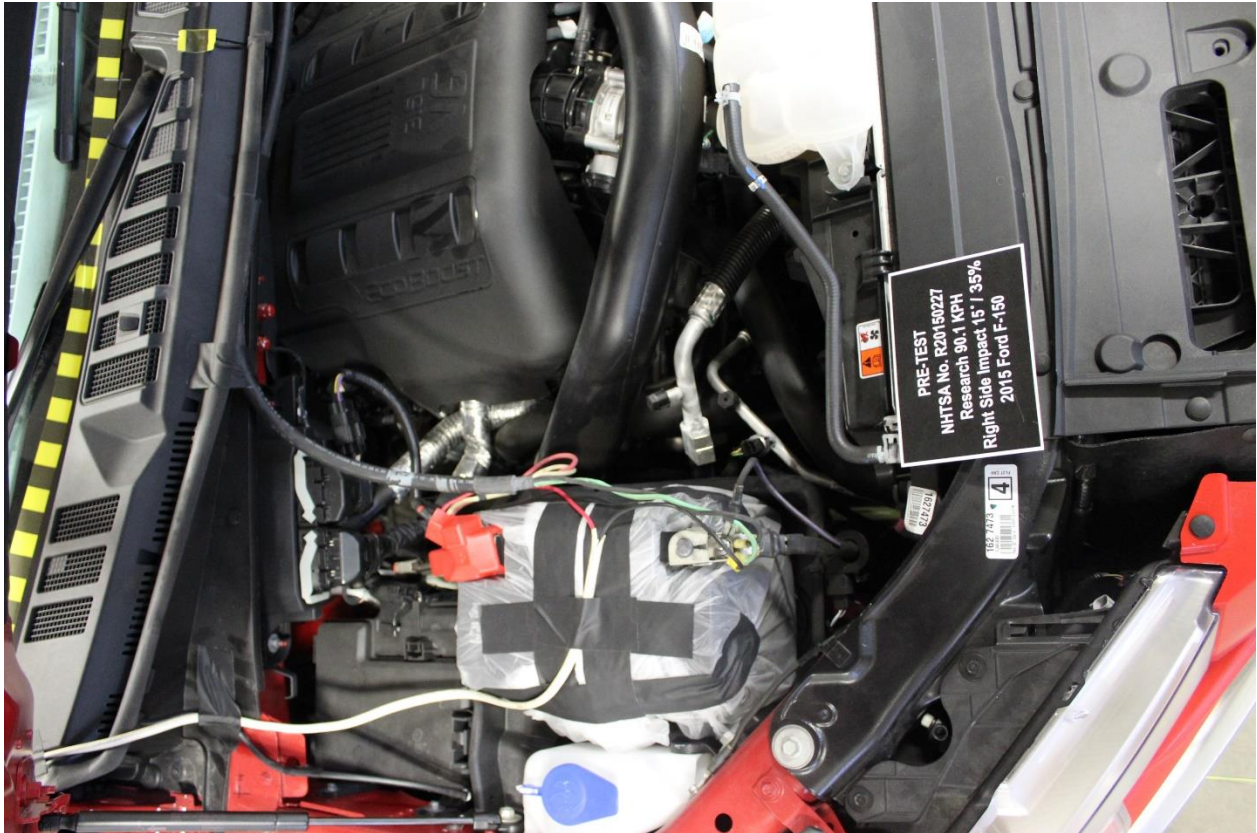

**No. 130: Pre-Test Right Side Engine Compartment View**

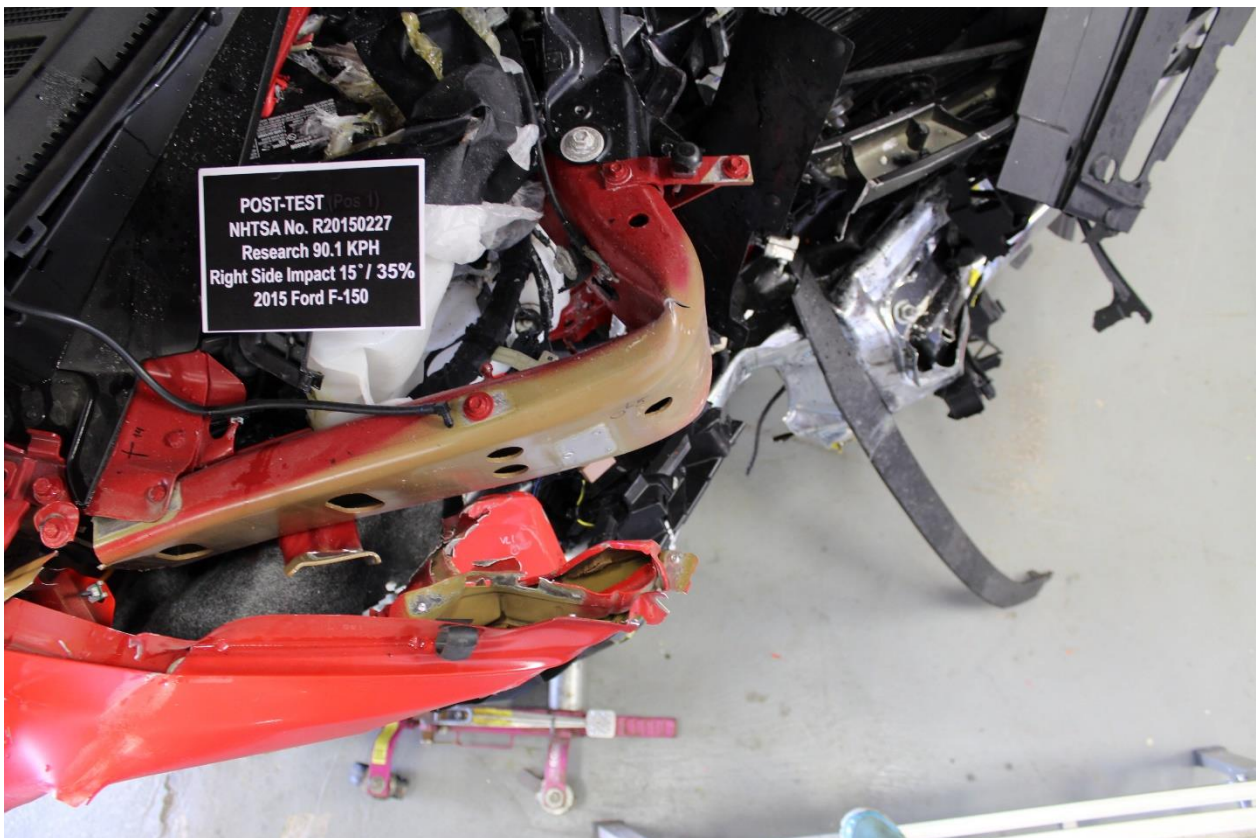

**No. 131: Post-Test Right Side Engine Compartment View**

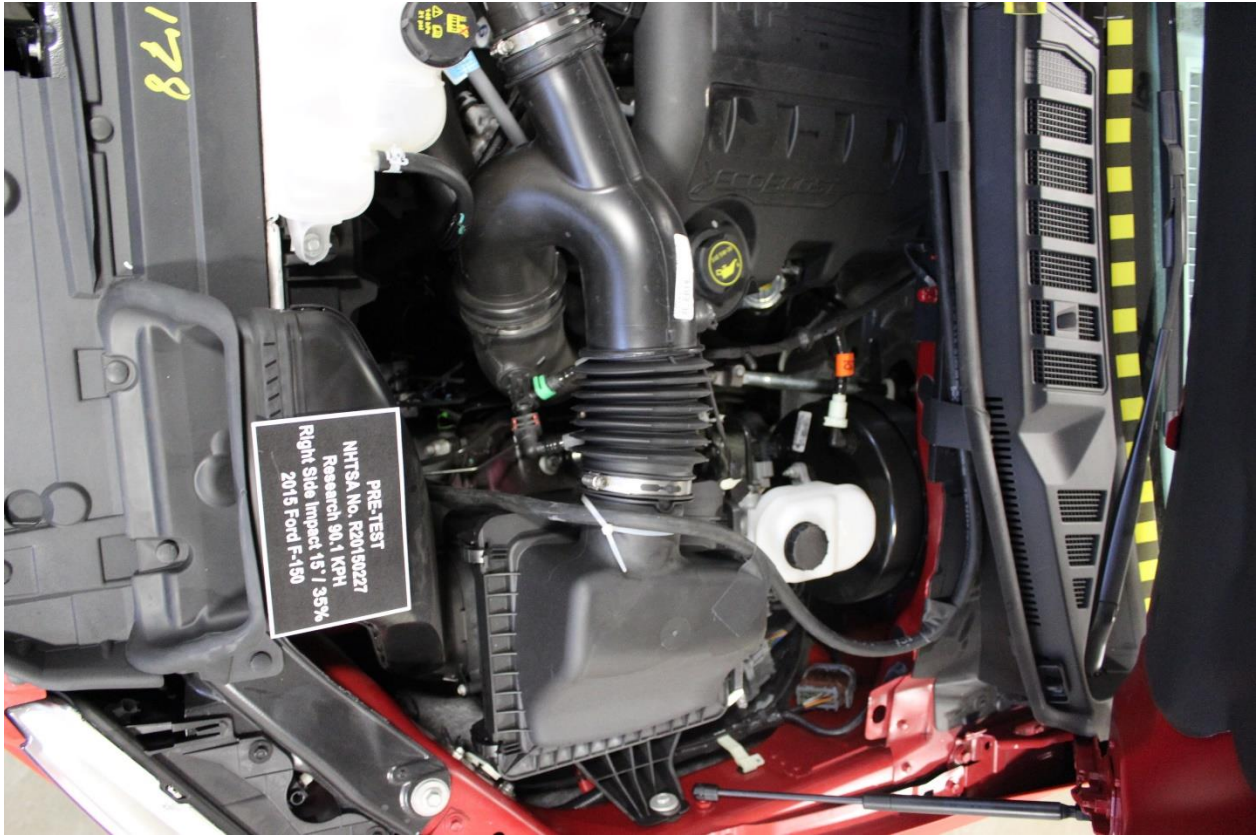

**No. 132: Pre-Test Left Side Engine Compartment View**



**No. 133: Post-Test Left Side Engine Compartment View**

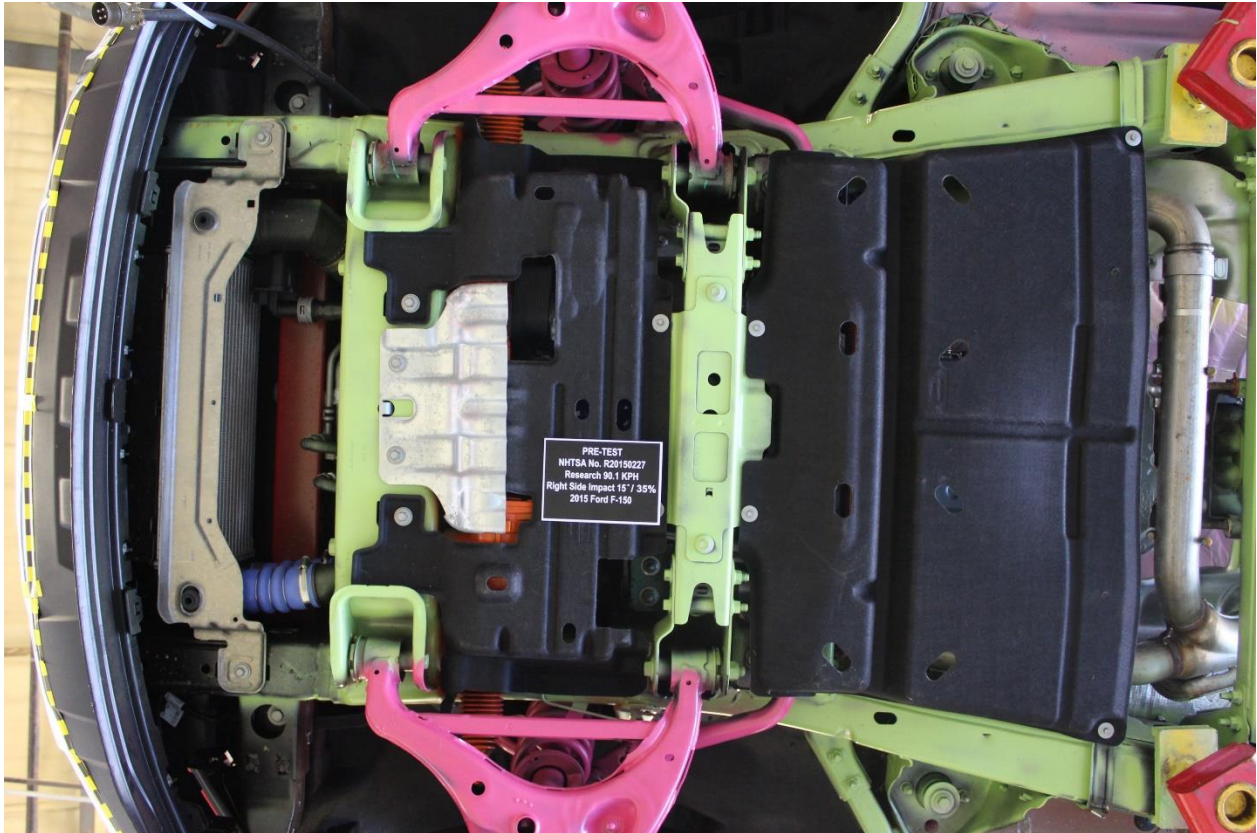

**No. 134: Pre-Test View of Front Underbody (perpendicular to vehicle)**



**No. 135: Post-Test View of Front Underbody (perpendicular to vehicle)**

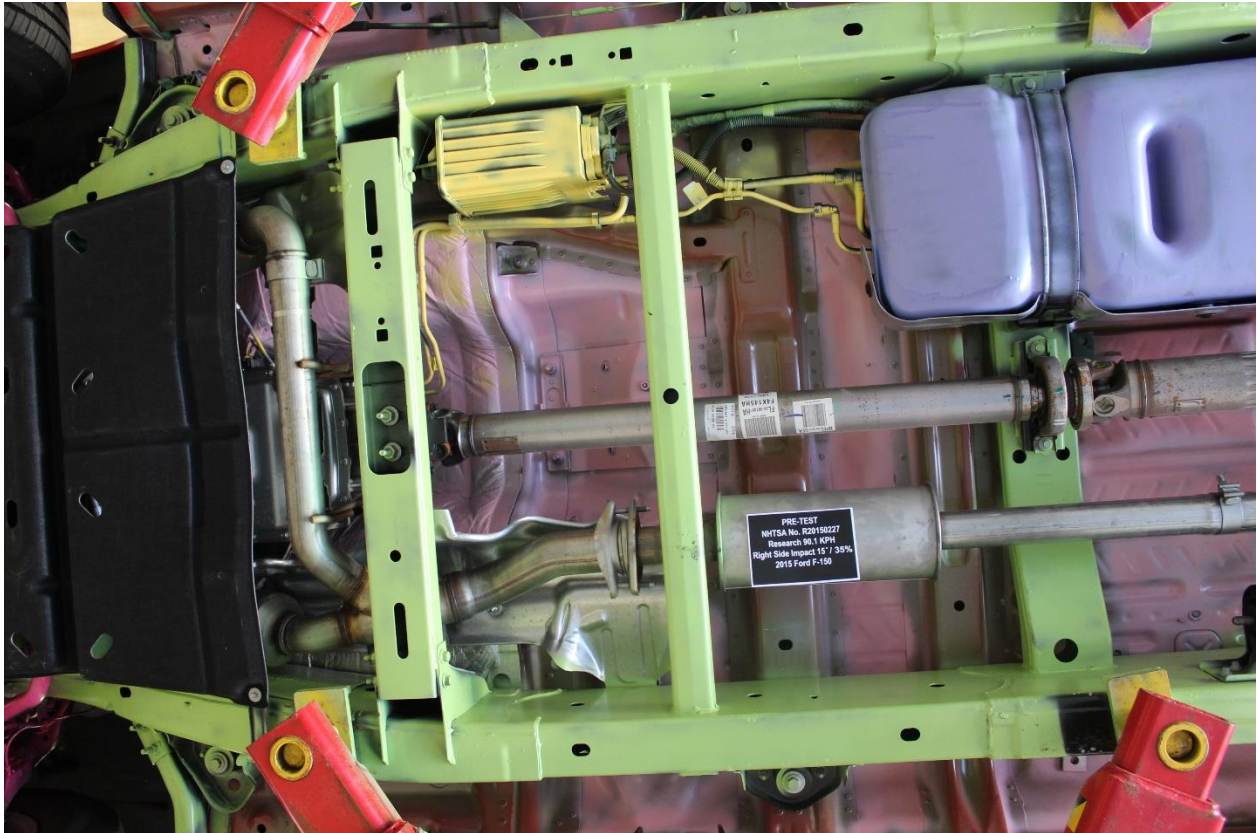

No. 136: Pre-Test View of Mid Underbody (perpendicular to vehicle)

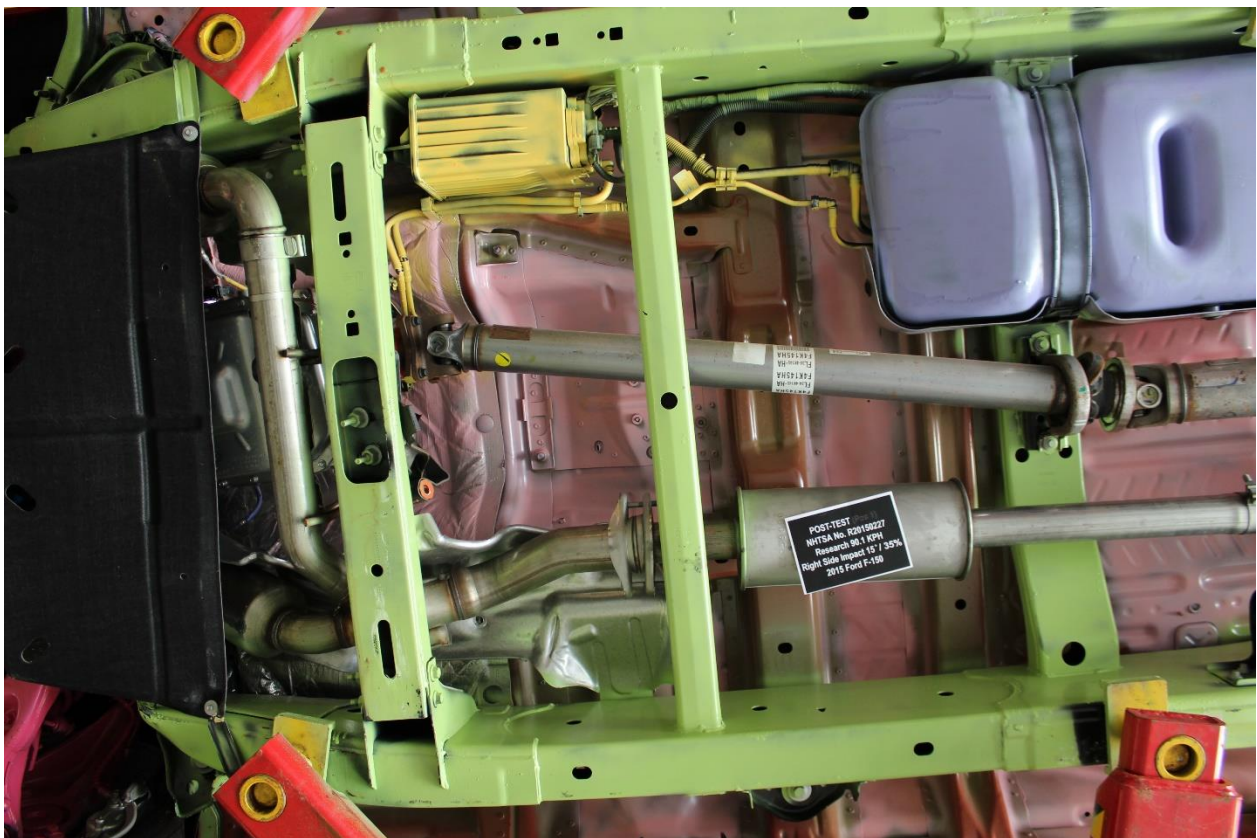

No. 137: Post-Test View of Mid Underbody (perpendicular to vehicle)

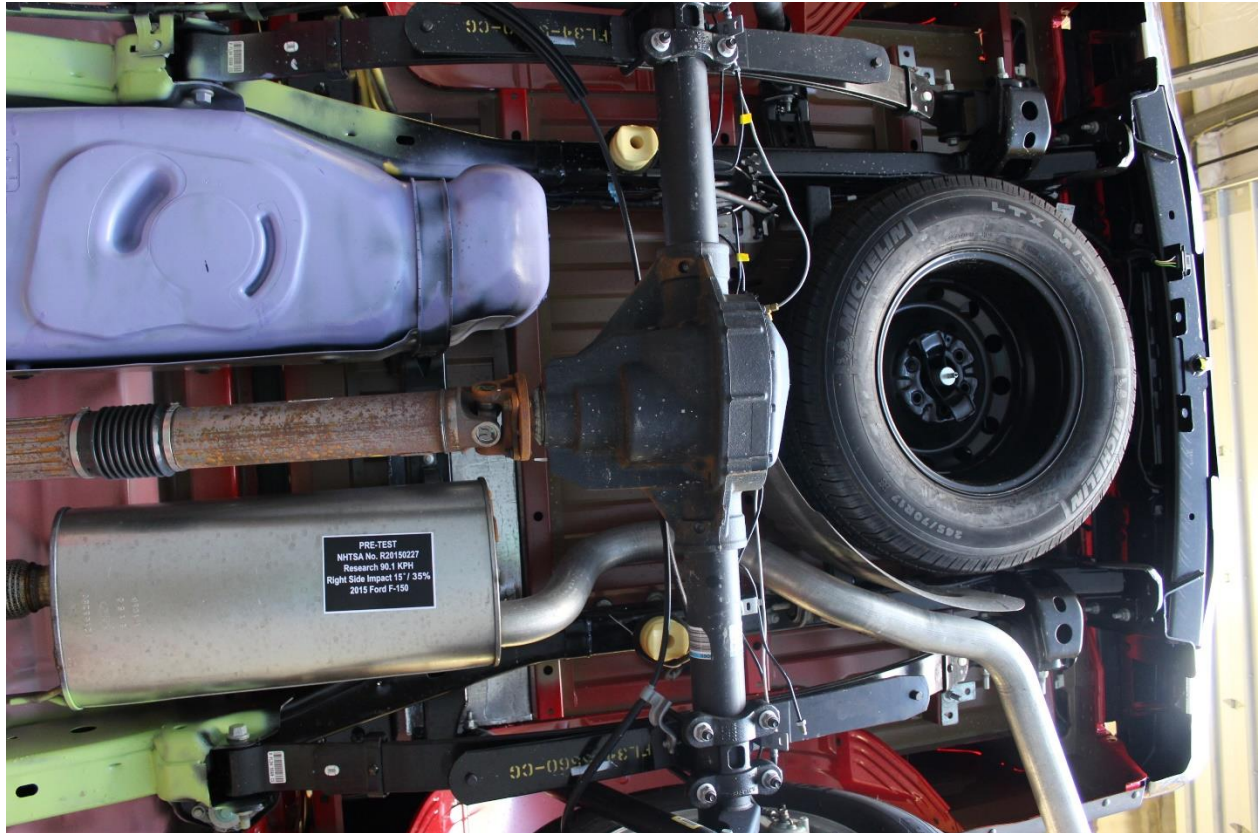

**No. 138: Pre-Test View of Rear Underbody (perpendicular to vehicle)**

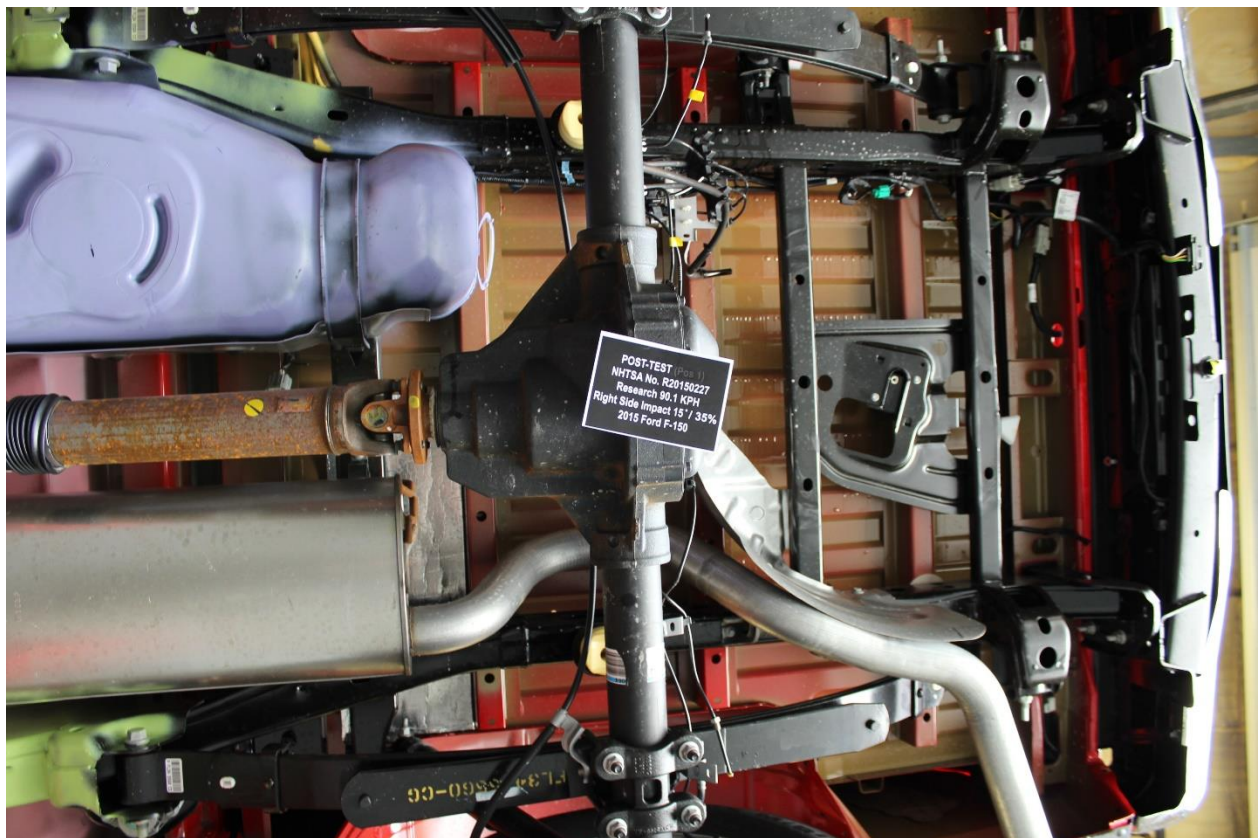

**No. 139: Post-Test View of Rear Underbody (perpendicular to vehicle)**

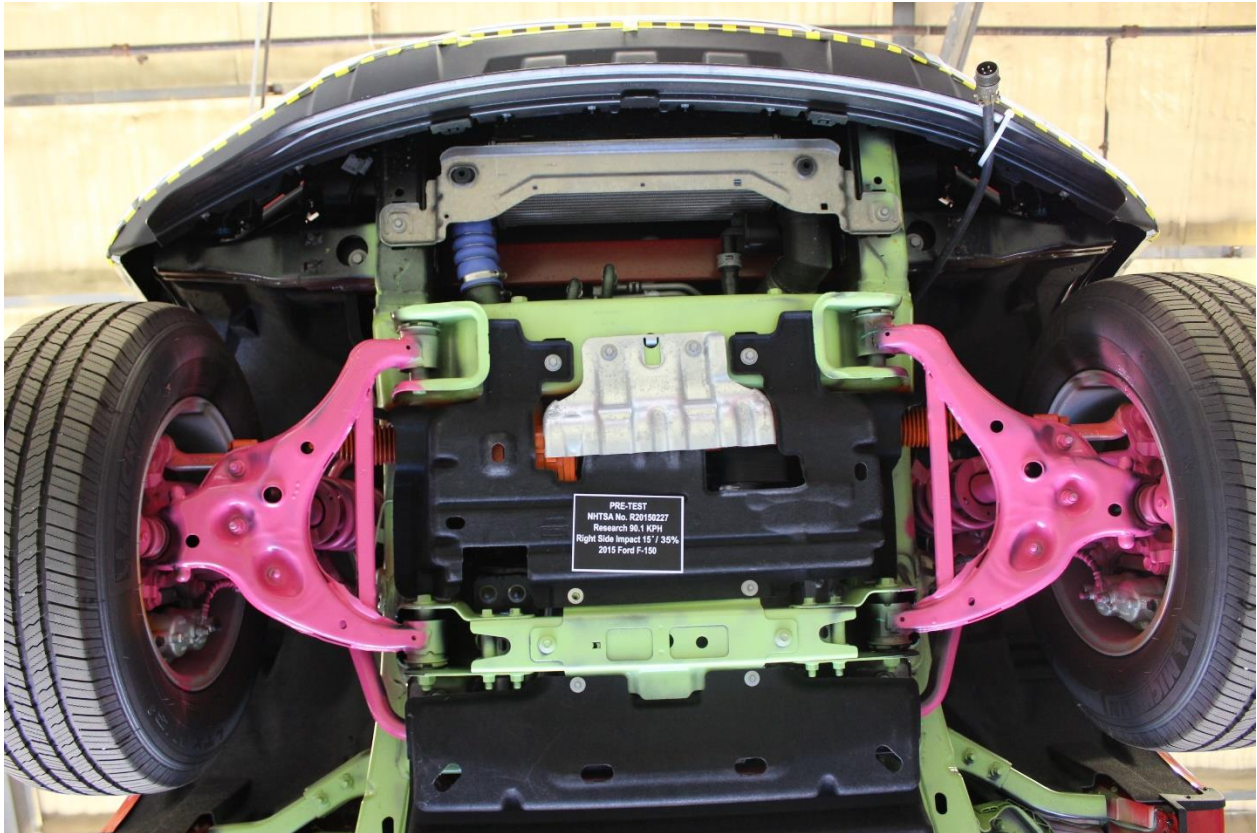

**No. 140: Pre-Test View of Steering rack and or sway bar**

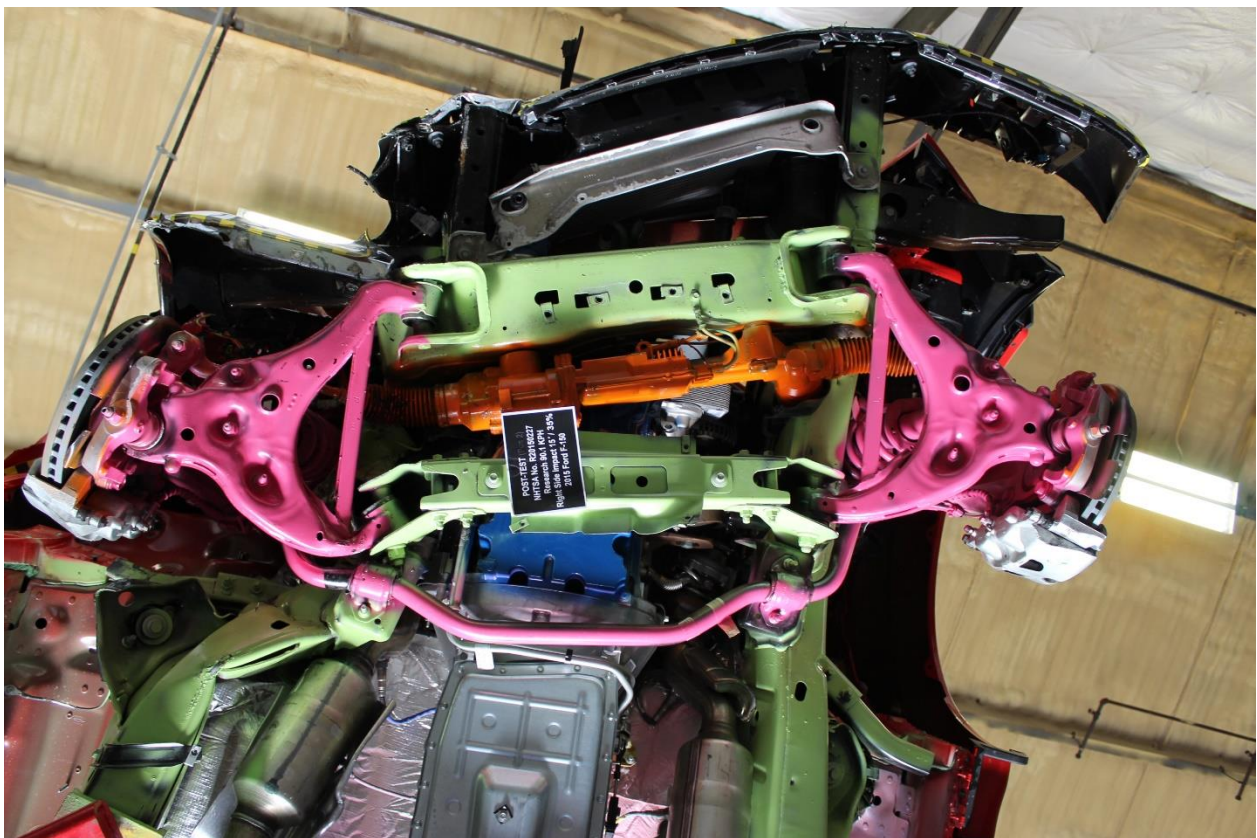

**No. 141: Post-Test View of Steering rack and or sway bar**

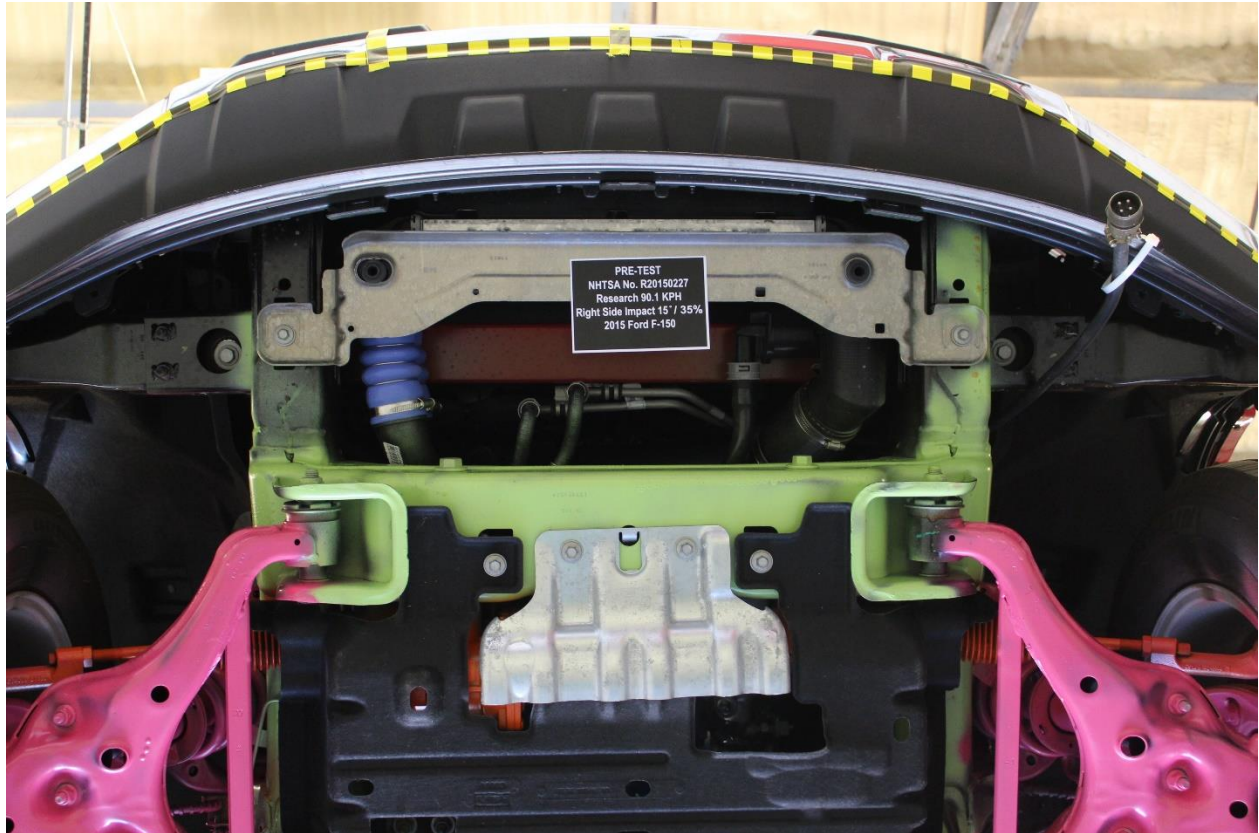

**No. 142: Pre-Test Bumper to Rail Attachments and Crush Initiators**



**No. 143: Post-Test Bumper to Rail Attachments and Crush Initiators**

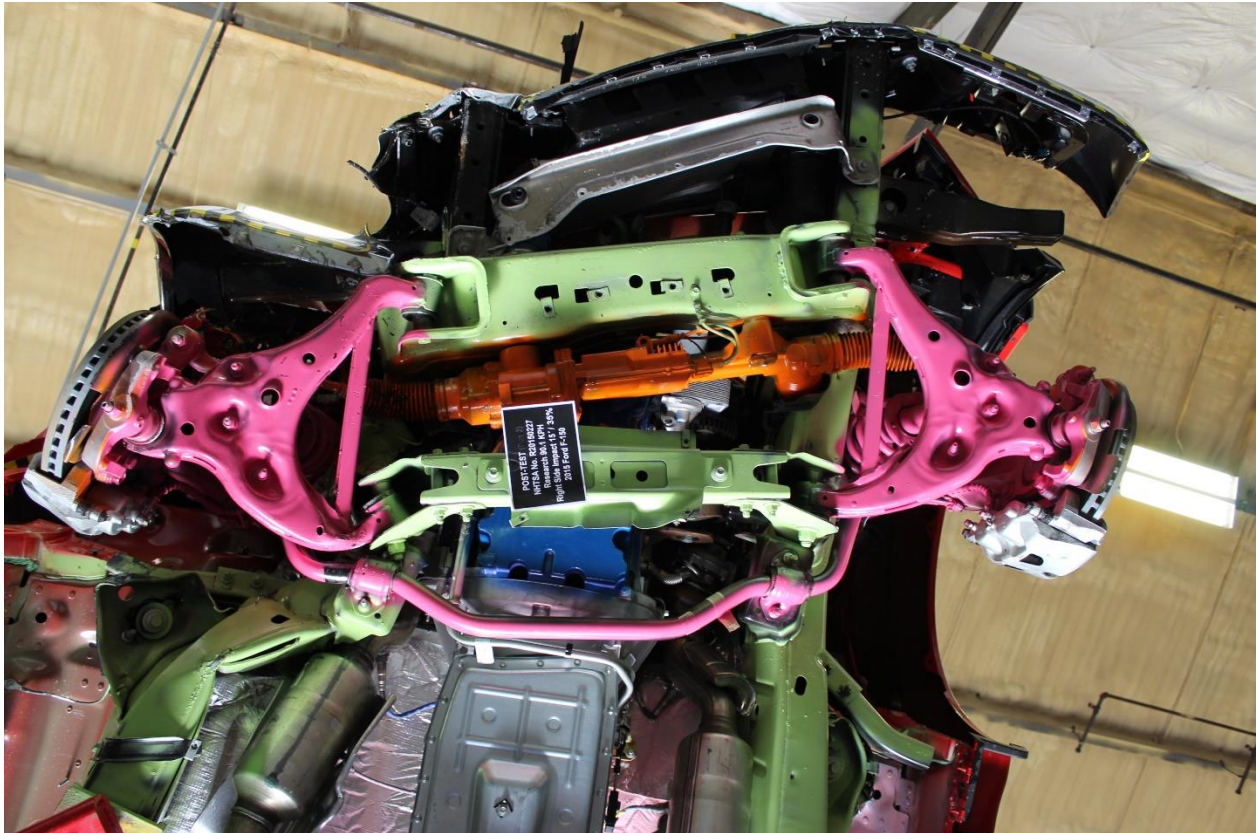

**No. 144: Post-Test View of Front Sub-Frame Deformation**



**No. 145: Pre-Test Frame Rail with tire removed**



**No. 146: Post-Test Frame Rail with tire removed**



**No. 147: Pre-Test View of Front Driver Wheel Well w/ Tire Removed**



**No. 148: Post-Test ¾ View of Front Driver Wheel Well w/ Tire Removed**



**No. 149: Post-Test Side View of Front Driver Wheel Well w/ Tire Removed**



**No. 150: Post-Test Right Side 3/4 Rear View of the Front Driver Wheel Well w/ Tire Removed**



**No. 151: Post-Test Looking Down at the Front Driver Shotgun**



**No. 152: Post-Test Right Side  $\frac{3}{4}$  View of Front Driver Shotgun**

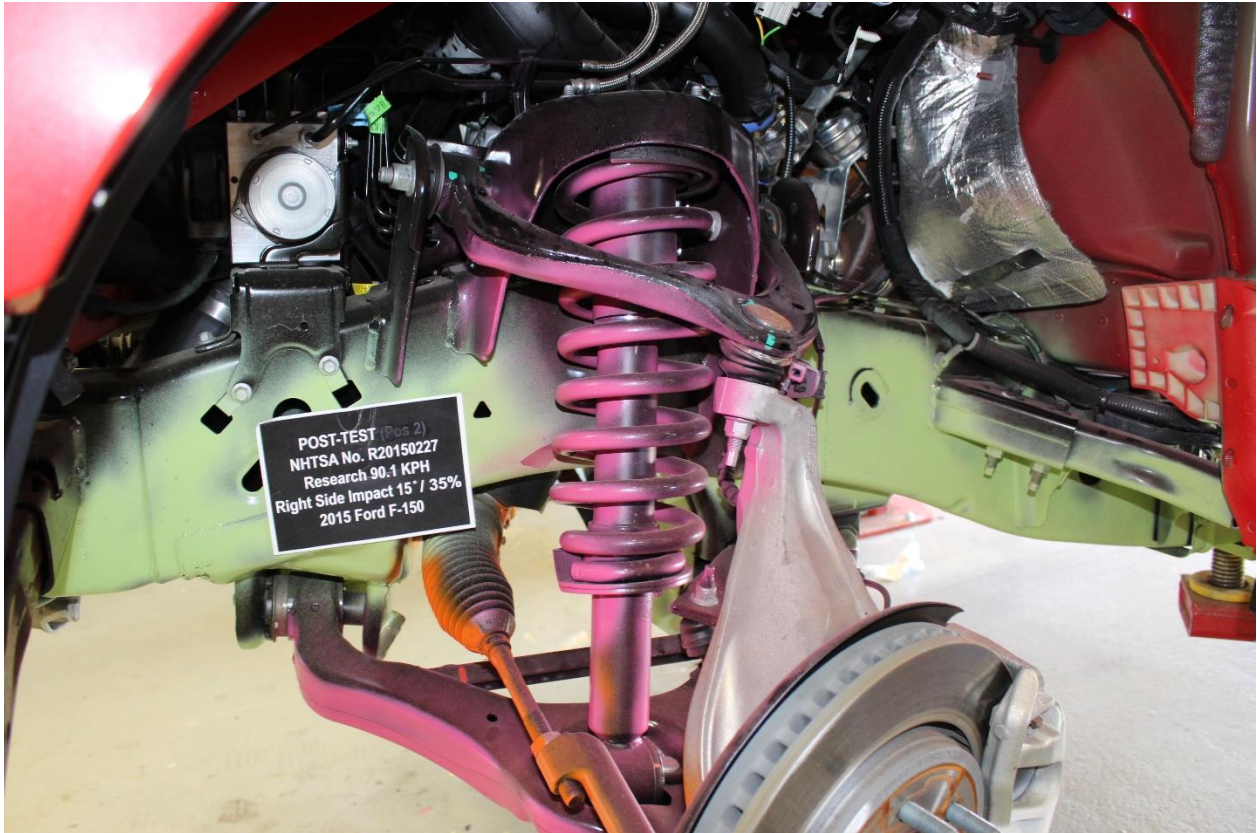

**No. 153: Post-Test Front Driver Close up View of Suspension w/ Tire Removed**



**No. 154: Post-Test ¾ View of Front Passenger Wheel Well w/ Tire Removed**



**No. 155: Post-Test Side View of Front Passenger Wheel Well w/ Tire Removed**



**No. 156: Post-Test Right Side 3/4 Rear View of the Front Passenger Wheel Well w/ Tire Removed**

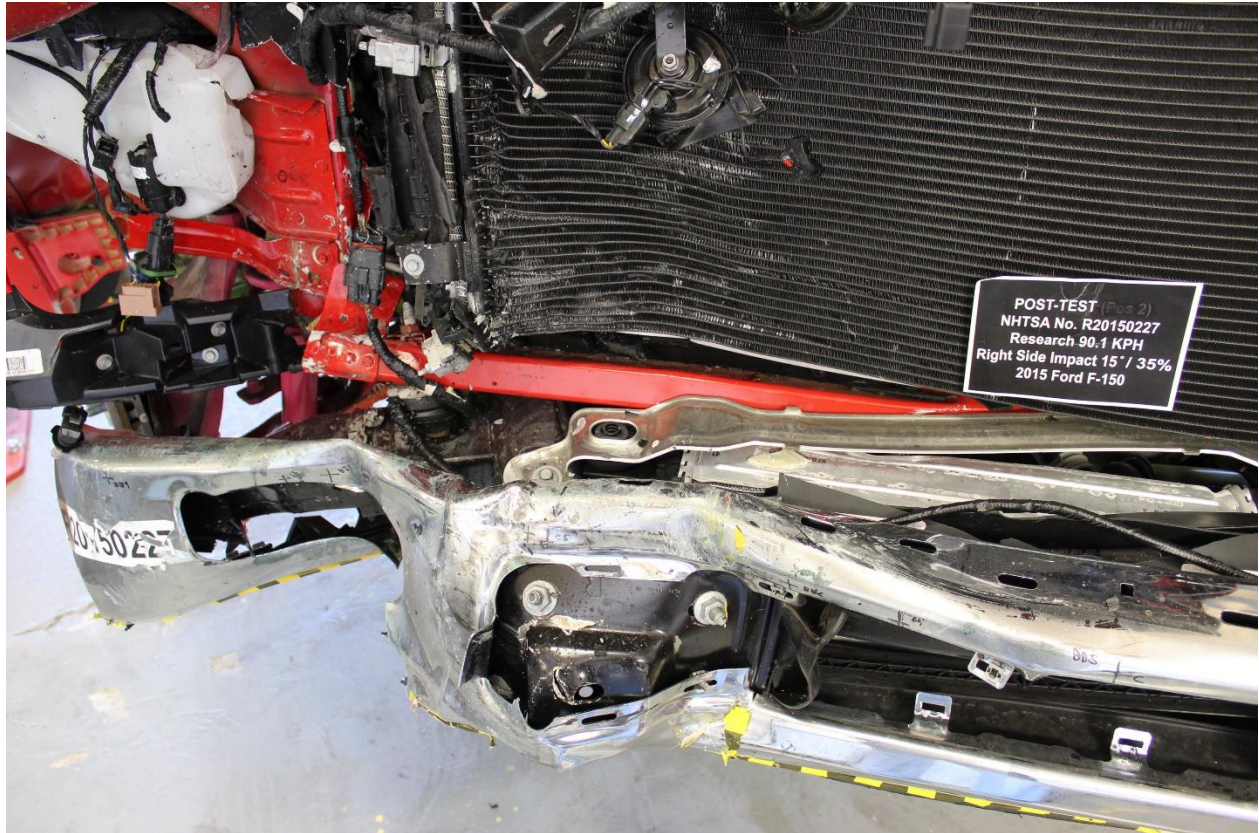

**No. 157: Post-Test Looking Down at the Front Passenger Shotgun**

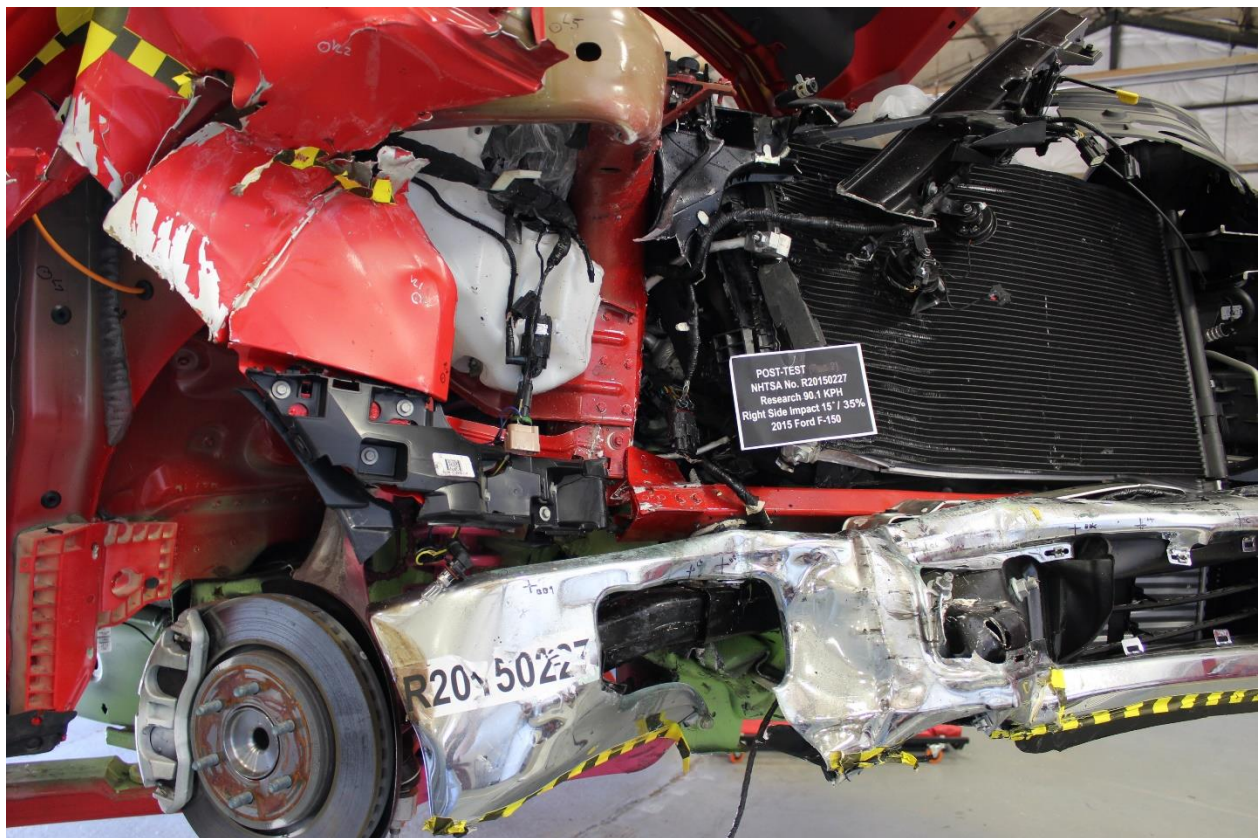

**No. 158: Post-Test Right Side ¾ View of Front Passenger Shotgun**

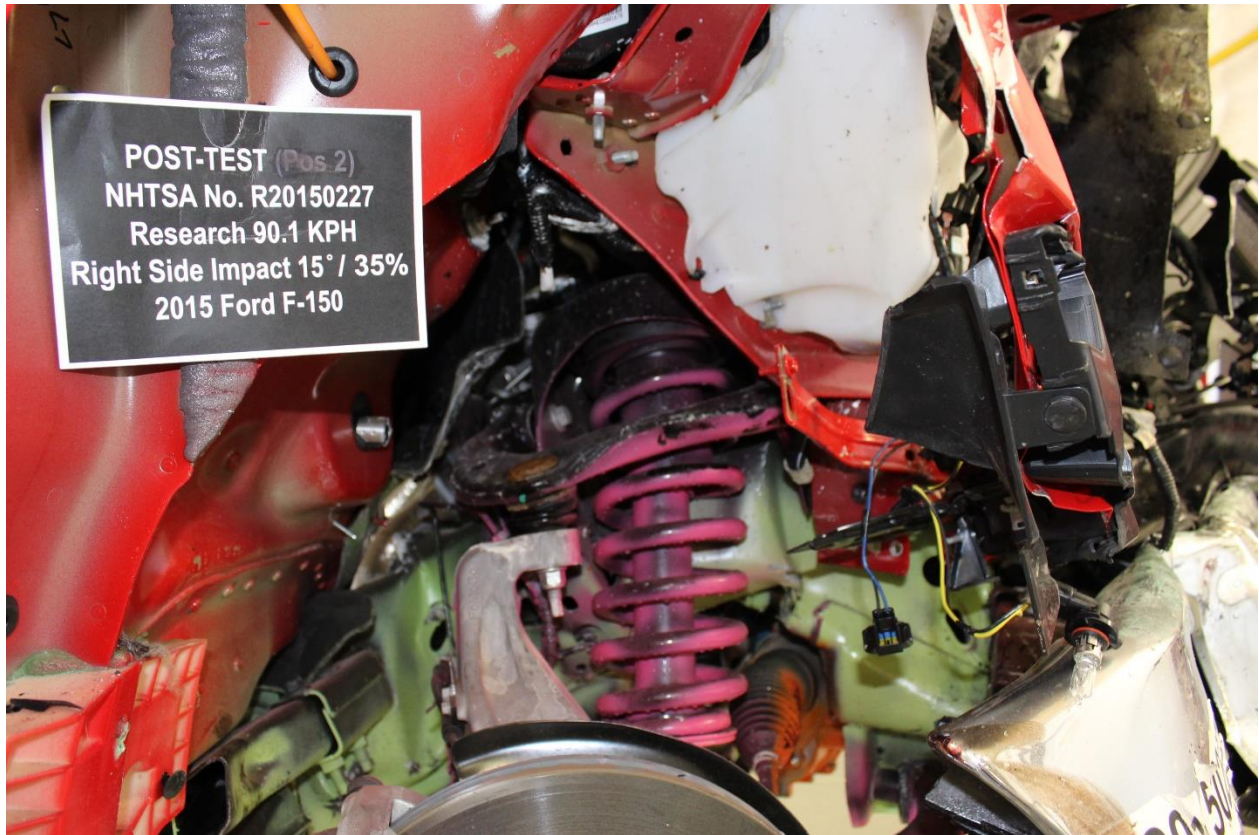

**No. 159: Post-Test Front Passenger Close up View of Suspension w/ Tire Removed**



**No. 160: Post-Test View of Door Sill with Door Open- Struck Side**



**No. 161: Post-Test View of Deformation of A pillar-Struck Side**



**No. 162: Post-Test View of Deformation of B pillar-Struck Side**



**No. 163: Post-Test View of Deformation of C pillar-Struck Side**



**No. 164: Post-Test View of Wheel and/or Tire Deformation-Struck Side**

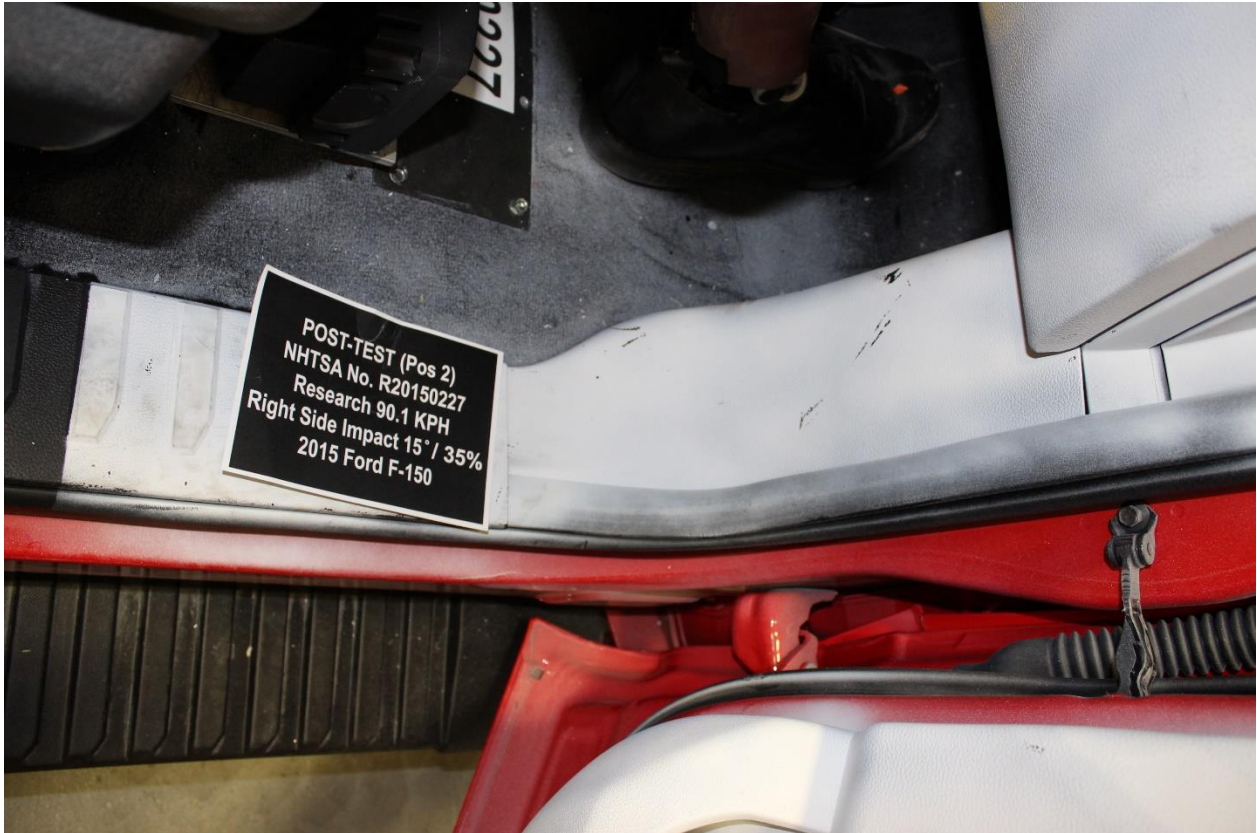

**No. 165: Post-Test View of Deformation of Rocker or Post-Struck Side**



**No. 166: Post-Test View of Windshield Separation**



**No. 167: Pre-Test Left Side View of OMDB**



**No. 168: Post-Test Left Side View of OMDB**



No. 169: Pre-Test Right Side View of OMDB



No. 170: Post-Test Right Side View of OMDB

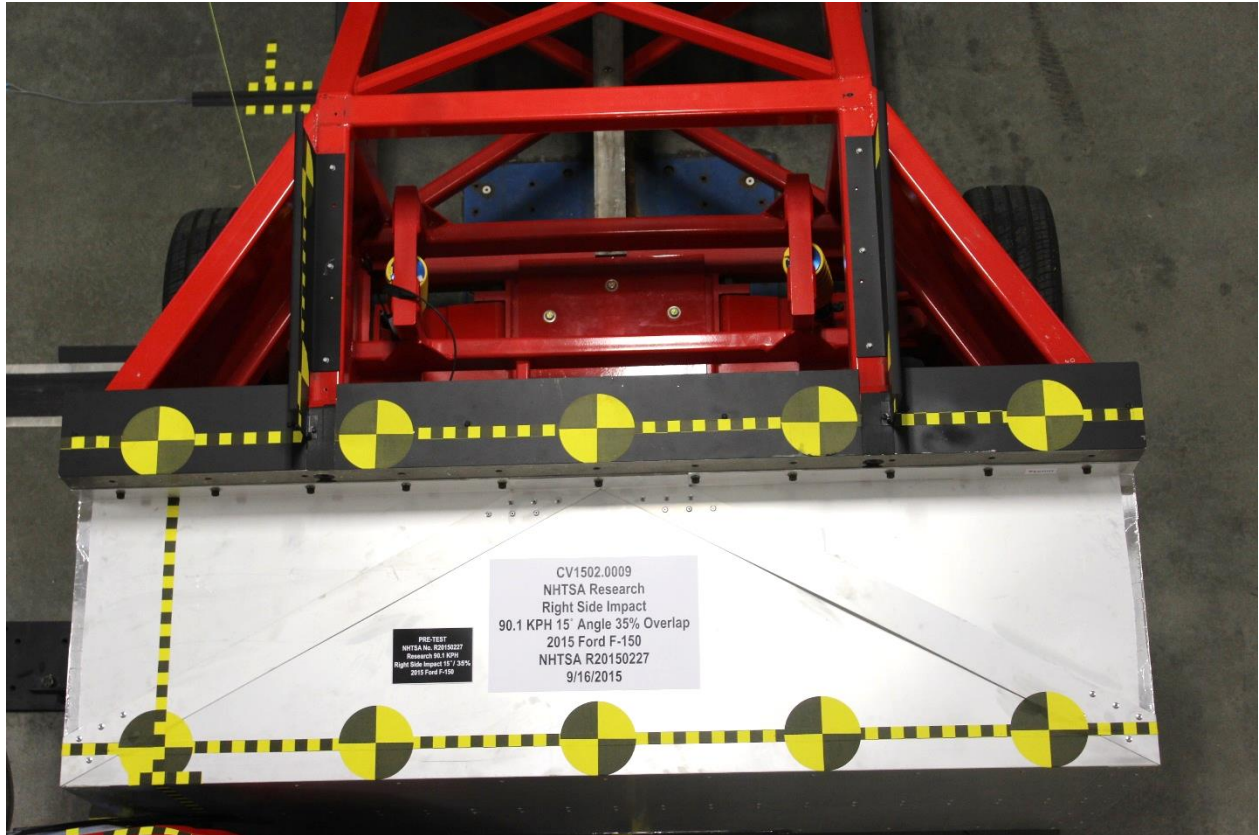

**No. 171: Pre-Test Top View of OMDB**



**No. 172: Post-Test Top View of OMDB**



**No. 173: Pre-Test Front View of OMDB**



**No. 174: Post-Test Front View of OMDB**



**No. 175: Pre-Test Left Front  $\frac{3}{4}$  View of OMDB**



**No. 176: Post-Test Left Front  $\frac{3}{4}$  View of OMDB**



**No. 177: Pre-Test Right Front  $\frac{3}{4}$  View of OMDB**



**No. 178: Post-Test Right Front  $\frac{3}{4}$  View of OMDB**



No. 179: Pre-Test Right Side View of OMDB



No. 180: Post-Test Right Side View of OMDB



**No. 181: Pre-Test Left Side View of OMDB**



**No. 182: Post-Test Left Side View of OMDB**



**No. 183: Pre-Test OMDB & Vehicle, Right Side**



**No. 184: Post-Test OMDB & Vehicle, Right Side**



**No. 185: Pre-Test OMDB & Vehicle, Left Side**



**No. 186: Post-Test OMDB & Vehicle, Left Side**

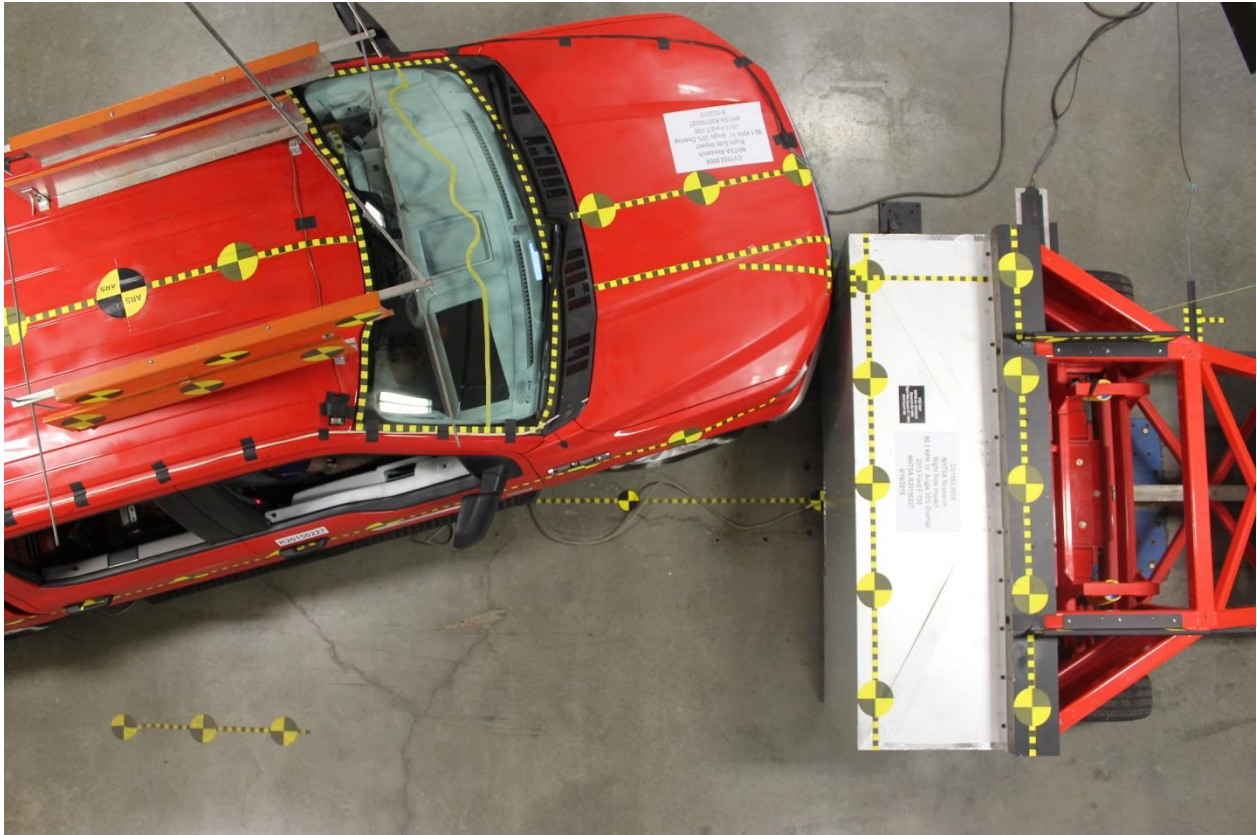

**No. 187: Pre-Test OMDB & Vehicle, Top View**

**Photo Not Available**

**No. 188: Post-Test OMDB & Vehicle, Top View**



No. 189: Pre-Test OMDB & Vehicle, Rear View



No. 190: Post-Test OMDB & Vehicle, Rear View



**No. 191: Pre-Test OMDB & Vehicle, Front View**



**No. 192: Post-Test OMDB & Vehicle, Front View**



**No. 193: Pre-Test OMDB & Vehicle Alignment**



**No. 194: Vehicle at 0 Degrees on Static Rollover Device**



**No. 195: Vehicle at 90 Degrees on Static Rollover Device**



**No. 196: Vehicle at 180 Degrees on Static Rollover Device**



**No. 197: Vehicle at 270 Degrees on Static Rollover Device**



**No. 198: Vehicle at 360 Degrees on Static Rollover Device**



**No. 199: Impact Photo**



No. 200: Pre-Test Vehicle Bumper Left Side View



No. 201 Post-Test Vehicle Bumper Left View



**No. 202 Pre-Test Vehicle Bumper Left Front View**

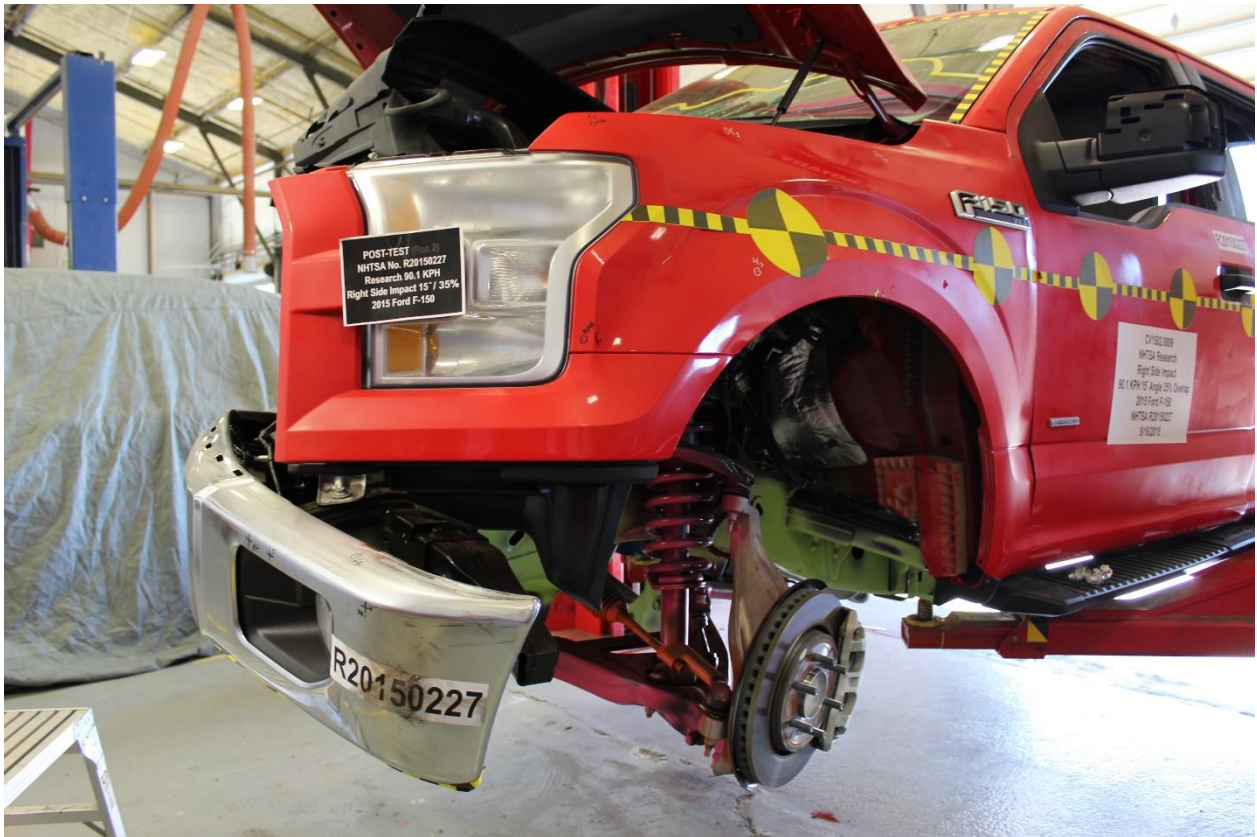

**No. 203 Post-Test Vehicle Bumper Left Front View**



**No. 204 Pre-Test Vehicle Bumper Front View**

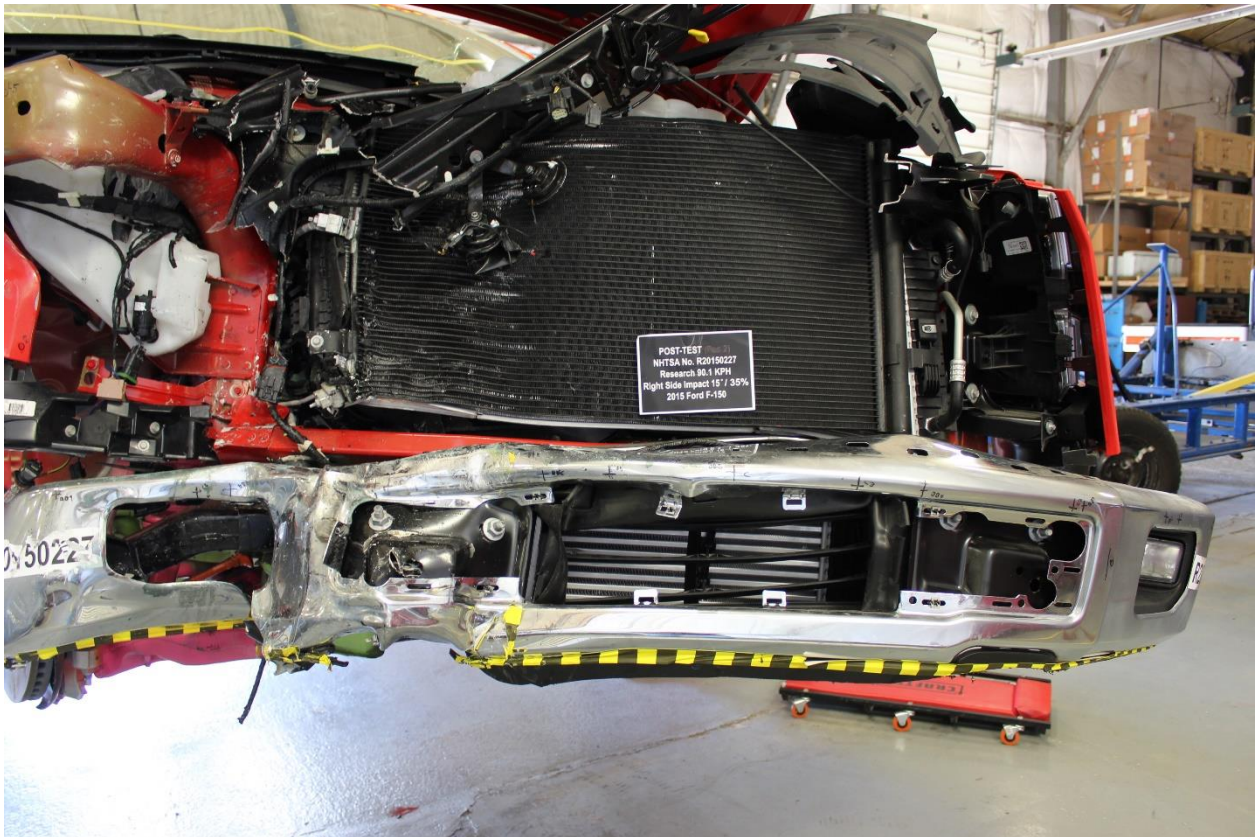

**No. 205 Post-Test Vehicle Bumper Front View**



**No. 206 Pre-Test Vehicle Bumper Right Side View**



**No. 207 Post-Test Vehicle Bumper Right View**



**No. 208 Pre-Test Vehicle Bumper Right Front View**

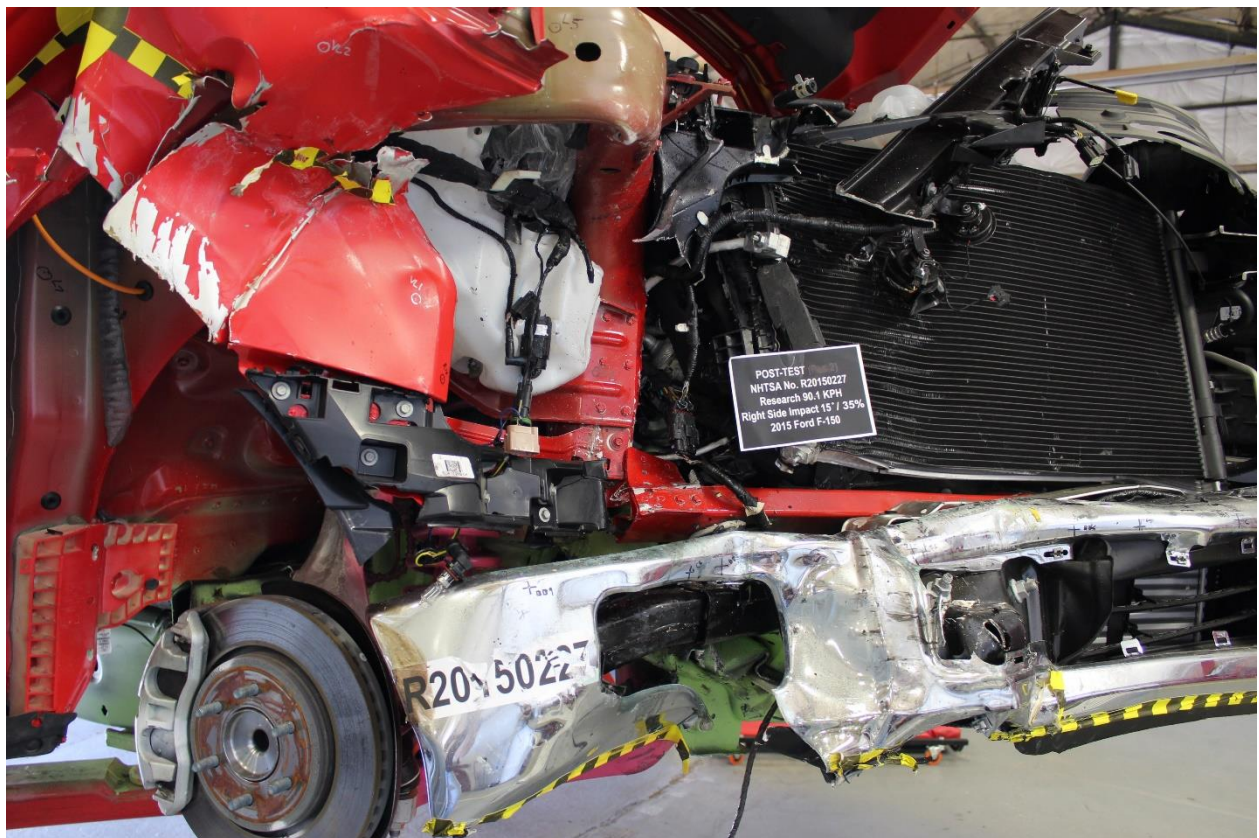

**No. 209 Post-Test Vehicle Bumper Right Front View**

**APPENDIX B**  
**VEHICLE & DUMMY RESPONSE DATA TRACES**

**Table of Data Plots**

No.	Description	Page
Plot 1	V2P1 Head CG X Acceleration	B-9
Plot 2	V2P1 Head CG Y Acceleration	B-9
Plot 3	V2P1 Head CG Z Acceleration	B-9
Plot 4	V2P1 Head CG Angular Velocity About X	B-9
Plot 5	V2P1 Head CG Angular Velocity About Y	B-10
Plot 6	V2P1 Head CG Angular Velocity About Z	B-10
Plot 7	V2P1 Upper Neck X Force	B-10
Plot 8	V2P1 Upper Neck Y Force	B-10
Plot 9	V2P1 Upper Neck Z Force	B-11
Plot 10	V2P1 Upper Neck X Moment	B-11
Plot 11	V2P1 Upper Neck Y Moment	B-11
Plot 12	V2P1 Upper Neck Z Moment	B-11
Plot 13	V2P1 Lower Neck X Force	B-12
Plot 14	V2P1 Lower Neck Y Force	B-12
Plot 15	V2P1 Lower Neck Z Force	B-12
Plot 16	V2P1 Lower Neck X Moment	B-12
Plot 17	V2P1 Lower Neck Y Moment	B-13
Plot 18	V2P1 Lower Neck Z Moment	B-13
Plot 19	V2P1 Front Neck Spring Tower Load Cell	B-13
Plot 20	V2P1 Rear Neck Spring Tower Load Cell	B-13
Plot 21	V2P1 Occipital Condyle Rotation Potentiometer	B-14
Plot 22	V2P1 Upper Left DGIR X Displacement	B-14
Plot 23	V2P1 Upper Left DGIR Y Rotation	B-14
Plot 24	V2P1 Upper Left DGIR Z Rotation	B-14
Plot 25	V2P1 Upper Right DGIR X Displacement	B-15
Plot 26	V2P1 Upper Right DGIR Y Rotation	B-15
Plot 27	V2P1 Upper Right DGIR Z Rotation	B-15
Plot 28	V2P1 Lower Left DGIR X Displacement	B-15
Plot 29	V2P1 Lower Left DGIR Y Rotation	B-16
Plot 30	V2P1 Lower Left DGIR Z Rotation	B-16
Plot 31	V2P1 Lower Right DGIR X Displacement	B-16
Plot 32	V2P1 Lower Right DGIR Y Rotation	B-16
Plot 33	V2P1 Lower Right DGIR Z Rotation	B-17
Plot 34	V2P1 Spine Force X	B-17
Plot 35	V2P1 Spine Force Y	B-17
Plot 36	V2P1 Spine Force Z	B-17
Plot 37	V2P1 Spine Moment X	B-18
Plot 38	V2P1 Spine Moment Y	B-18
Plot 39	V2P1 T6 X Acceleration	B-18
Plot 40	V2P1 T6 Y Acceleration	B-18
Plot 41	V2P1 T6 Z Acceleration	B-19
Plot 42	V2P1 T1 X Acceleration	B-19
Plot 43	V2P1 T1 Y Acceleration	B-19
Plot 44	V2P1 T1 Z Acceleration	B-19
Plot 45	V2P1 Abdomen Left DGIR X Displacement	B-20
Plot 46	V2P1 Abdomen Left DGIR Y Rotation	B-20
Plot 47	V2P1 Abdomen Left DGIR Z Rotation	B-20
Plot 48	V2P1 Abdomen Right DGIR X Displacement	B-20
Plot 49	V2P1 Abdomen Right DGIR Y Rotation	B-21
Plot 50	V2P1 Abdomen Right DGIR Z Rotation	B-21
Plot 51	V2P1 Pelvis Acetabulum Left X Force	B-21
Plot 52	V2P1 Pelvis Acetabulum Left Y Force	B-21
Plot 53	V2P1 Pelvis Acetabulum Left Z Force	B-22
Plot 54	V2P1 Pelvis Acetabulum Right X Force	B-22
Plot 55	V2P1 Pelvis Acetabulum Right Y Force	B-22

Plot 56	V2P1 Pelvis Acetabulum Right Z Force	B-22
Plot 57	V2P1 Pelvis X Acceleration	B-23
Plot 58	V2P1 Pelvis Y Acceleration	B-23
Plot 59	V2P1 Pelvis Z Acceleration	B-23
Plot 60	V2P1 ASIS Left X Force	B-23
Plot 61	V2P1 Left ASIS Y Moment	B-24
Plot 62	V2P1 ASIS Right X Force	B-24
Plot 63	V2P1 Right ASIS Y Moment	B-24
Plot 64	V2P1 Femur Left X Force	B-24
Plot 65	V2P1 Femur Left Y Force	B-25
Plot 66	V2P1 Femur Left Z Force	B-25
Plot 67	V2P1 Femur Left X Moment	B-25
Plot 68	V2P1 Femur Left Y Moment	B-25
Plot 69	V2P1 Femur Right X Force	B-26
Plot 70	V2P1 Femur Right Y Force	B-26
Plot 71	V2P1 Femur Right Z Force	B-26
Plot 72	V2P1 Femur Right X Moment	B-26
Plot 73	V2P1 Femur Right Y Moment	B-27
Plot 74	V2P1 Knee Left X Displacement	B-27
Plot 75	V2P1 Knee Right X Displacement	B-27
Plot 76	V2P1 Upper Tibia Left Z Force	B-27
Plot 77	V2P1 Upper Tibia Left X Moment	B-28
Plot 78	V2P1 Upper Tibia Left Y Moment	B-28
Plot 79	V2P1 Upper Tibia Right Z Force	B-28
Plot 80	V2P1 Upper Tibia Right X Moment	B-28
Plot 81	V2P1 Upper Tibia Right Y Moment	B-29
Plot 82	V2P1 Lower Tibia Left X Force	B-29
Plot 83	V2P1 Lower Tibia Left Y Force	B-29
Plot 84	V2P1 Lower Tibia Left Z Force	B-29
Plot 85	V2P1 Lower Tibia Left X Moment	B-30
Plot 86	V2P1 Lower Tibia Left Y Moment	B-30
Plot 87	V2P1 Lower Tibia Right X Force	B-30
Plot 88	V2P1 Lower Tibia Right Y Force	B-30
Plot 89	V2P1 Lower Tibia Right Z Force	B-31
Plot 90	V2P1 Lower Tibia Right X Moment	B-31
Plot 91	V2P1 Lower Tibia Right Y Moment	B-31
Plot 92	V2P1 Left Mid Tibia X Acceleration	B-31
Plot 93	V2P1 Left Mid Tibia Y Acceleration	B-32
Plot 94	V2P1 Right Mid Tibia X Acceleration	B-32
Plot 95	V2P1 Right Mid Tibia Y Acceleration	B-32
Plot 96	V2P1 Foot Left X Acceleration	B-32
Plot 97	V2P1 Foot Left Z Acceleration	B-33
Plot 98	V2P1 Foot Right X Acceleration	B-33
Plot 99	V2P1 Foot Right Z Acceleration	B-33
Plot 100	V2P1 Ankle Left X Rotation	B-33
Plot 101	V2P1 Ankle Left Y Rotation	B-34
Plot 102	V2P1 Ankle Left Z Rotation	B-34
Plot 103	V2P1 Ankle Right X Rotation	B-34
Plot 104	V2P1 Ankle Right Y Rotation	B-34
Plot 105	V2P1 Ankle Right Z Rotation	B-35
Plot 106	V2 Driver Lap Belt Force	B-35
Plot 107	V2 Driver Shoulder Belt Upper Force	B-35
Plot 108	V2 Driver Shoulder Belt Displacement	B-35
Plot 109	V2P2 Head CG X Acceleration	B-36
Plot 110	V2P2 Head CG Y Acceleration	B-36
Plot 111	V2P2 Head CG Z Acceleration	B-36
Plot 112	V2P2 Head CG Angular Velocity About X	B-36
Plot 113	V2P2 Head CG Angular Velocity About Y	B-37
Plot 114	V2P2 Head CG Angular Velocity About Z	B-37

Plot 115	V2P2 Upper Neck X Force	B-37
Plot 116	V2P2 Upper Neck Y Force	B-37
Plot 117	V2P2 Upper Neck Z Force	B-38
Plot 118	V2P2 Upper Neck X Moment	B-38
Plot 119	V2P2 Upper Neck Y Moment	B-38
Plot 120	V2P2 Upper Neck Z Moment	B-38
Plot 121	V2P2 Lower Neck X Force	B-39
Plot 122	V2P2 Lower Neck Y Force	B-39
Plot 123	V2P2 Lower Neck Z Force	B-39
Plot 124	V2P2 Lower Neck X Moment	B-39
Plot 125	V2P2 Lower Neck Y Moment	B-40
Plot 126	V2P2 Lower Neck Z Moment	B-40
Plot 127	V2P2 Front Neck Spring Tower Load Cell	B-40
Plot 128	V2P2 Rear Neck Spring Tower Load Cell	B-40
Plot 129	V2P2 Occipital Condyle Rotation Potentiometer	B-41
Plot 130	V2P2 Upper Left DGIR X Displacement	B-41
Plot 131	V2P2 Upper Left DGIR Y Rotation	B-41
Plot 132	V2P2 Upper Left DGIR Z Rotation	B-41
Plot 133	V2P2 Upper Right DGIR X Displacement	B-42
Plot 134	V2P2 Upper Right DGIR Y Rotation	B-42
Plot 135	V2P2 Upper Right DGIR Z Rotation	B-42
Plot 136	V2P2 Lower Left DGIR X Displacement	B-42
Plot 137	V2P2 Lower Left DGIR Y Rotation	B-43
Plot 138	V2P2 Lower Left DGIR Z Rotation	B-43
Plot 139	V2P2 Lower Right DGIR X Displacement	B-43
Plot 140	V2P2 Lower Right DGIR Y Rotation	B-43
Plot 141	V2P2 Lower Right DGIR Z Rotation	B-44
Plot 142	V2P2 Spine Force X	B-44
Plot 143	V2P2 Spine Force Y	B-44
Plot 144	V2P2 Spine Force Z	B-44
Plot 145	V2P2 Spine Moment X	B-45
Plot 146	V2P2 Spine Moment Y	B-45
Plot 147	V2P2 T6 X Acceleration	B-45
Plot 148	V2P2 T6 Y Acceleration	B-45
Plot 149	V2P2 T6 Z Acceleration	B-46
Plot 150	V2P2 T1 X Acceleration	B-46
Plot 151	V2P2 T1 Y Acceleration	B-46
Plot 152	V2P2 T1 Z Acceleration	B-46
Plot 153	V2P2 Abdomen Left DGIR X Displacement	B-47
Plot 154	V2P2 Abdomen Left DGIR Y Rotation	B-47
Plot 155	V2P2 Abdomen Left DGIR Z Rotation	B-47
Plot 156	V2P2 Abdomen Right DGIR X Displacement	B-47
Plot 157	V2P2 Abdomen Right DGIR Y Rotation	B-48
Plot 158	V2P2 Abdomen Right DGIR Z Rotation	B-48
Plot 159	V2P2 Pelvis Acetabulum Left X Force	B-48
Plot 160	V2P2 Pelvis Acetabulum Left Y Force	B-48
Plot 161	V2P2 Pelvis Acetabulum Left Z Force	B-49
Plot 162	V2P2 Pelvis Acetabulum Right X Force	B-49
Plot 163	V2P2 Pelvis Acetabulum Right Y Force	B-49
Plot 164	V2P2 Pelvis Acetabulum Right Z Force	B-49
Plot 165	V2P2 Pelvis X Acceleration	B-50
Plot 166	V2P2 Pelvis Y Acceleration	B-50
Plot 167	V2P2 Pelvis Z Acceleration	B-50
Plot 168	V2P2 ASIS Left X Force	B-50
Plot 169	V2P2 Left ASIS Y Moment	B-51
Plot 170	V2P2 ASIS Right X Force	B-51
Plot 171	V2P2 Right ASIS Y Moment	B-51
Plot 172	V2P2 Femur Left X Force	B-51
Plot 173	V2P2 Femur Left Y Force	B-52

Plot 174	V2P2 Femur Left Z Force	B-52
Plot 175	V2P2 Femur Left X Moment	B-52
Plot 176	V2P2 Femur Left Y Moment	B-52
Plot 177	V2P2 Femur Right X Force	B-53
Plot 178	V2P2 Femur Right Y Force	B-53
Plot 179	V2P2 Femur Right Z Force	B-53
Plot 180	V2P2 Femur Right X Moment	B-53
Plot 181	V2P2 Femur Right Y Moment	B-54
Plot 182	V2P2 Knee Left X Displacement	B-54
Plot 183	V2P2 Knee Right X Displacement	B-54
Plot 184	V2P2 Upper Tibia Left Z Force	B-54
Plot 185	V2P2 Upper Tibia Left X Moment	B-55
Plot 186	V2P2 Upper Tibia Left Y Moment	B-55
Plot 187	V2P2 Upper Tibia Right Z Force	B-55
Plot 188	V2P2 Upper Tibia Right X Moment	B-55
Plot 189	V2P2 Upper Tibia Right Y Moment	B-56
Plot 190	V2P2 Lower Tibia Left X Force	B-56
Plot 191	V2P2 Lower Tibia Left Y Force	B-56
Plot 192	V2P2 Lower Tibia Left Z Force	B-56
Plot 193	V2P2 Lower Tibia Left X Moment	B-57
Plot 194	V2P2 Lower Tibia Left Y Moment	B-57
Plot 195	V2P2 Lower Tibia Right X Force	B-57
Plot 196	V2P2 Lower Tibia Right Y Force	B-57
Plot 197	V2P2 Lower Tibia Right Z Force	B-58
Plot 198	V2P2 Lower Tibia Right X Moment	B-58
Plot 199	V2P2 Lower Tibia Right Y Moment	B-58
Plot 200	V2P2 Left Mid Tibia X Acceleration	B-58
Plot 201	V2P2 Left Mid Tibia Y Acceleration	B-59
Plot 202	V2P2 Right Mid Tibia X Acceleration	B-59
Plot 203	V2P2 Right Mid Tibia Y Acceleration	B-59
Plot 204	V2P2 Foot Left X Acceleration	B-59
Plot 205	V2P2 Foot Left Z Acceleration	B-60
Plot 206	V2P2 Foot Right X Acceleration	B-60
Plot 207	V2P2 Foot Right Z Acceleration	B-60
Plot 208	V2P2 Ankle Left X Rotation	B-60
Plot 209	V2P2 Ankle Left Y Rotation	B-61
Plot 210	V2P2 Ankle Left Z Rotation	B-61
Plot 211	V2P2 Ankle Right X Rotation	B-61
Plot 212	V2P2 Ankle Right Y Rotation	B-61
Plot 213	V2P2 Ankle Right Z Rotation	B-62
Plot 214	V2 Passenger Lap Belt Force	B-62
Plot 215	V2 Passenger Shoulder Belt Upper Force	B-62
Plot 216	V2 Passenger Shoulder Belt Displacement	B-62
Plot 217	V2 Left Rear Sill X Acceleration	B-63
Plot 218	V2 Left Rear Sill Y Acceleration	B-63
Plot 219	V2 Right Rear Sill X Acceleration	B-63
Plot 220	V2 Right Rear Sill Y Acceleration	B-63
Plot 221	V2 Right Rear Sill Redundant X Acceleration	B-64
Plot 222	V2 Right Rear Sill Redundant Y Acceleration	B-64
Plot 223	V2 Vehicle CG X Acceleration	B-64
Plot 224	V2 Vehicle CG Y Acceleration	B-64
Plot 225	V2 Vehicle CG Z Acceleration	B-65
Plot 226	V2 Vehicle CG Angular Rate X	B-65
Plot 227	V2 Vehicle CG Angular Rate Y	B-65
Plot 228	V2 Vehicle CG Angular Rate Z	B-65
Plot 229	V2 Passenger Seat Track X Acceleration	B-66
Plot 230	V2 Passenger Seat Track Y Acceleration	B-66
Plot 231	V2 Passenger Seat Track Z Acceleration	B-66
Plot 232	V2 Passenger Seat Thigh Bar X Acceleration	B-66

Plot 233	V2 Passenger Seat Thigh Bar Z Acceleration	B-67
Plot 234	V2 Passenger Floor Pan X Acceleration	B-67
Plot 235	V2 Passenger Floor Pan Y Acceleration	B-67
Plot 236	V2 Passenger Floor Pan Z Acceleration	B-67
Plot 237	V2 Passenger Floor Pan X Deflection	B-68
Plot 238	Driver Front Airbag Stage 1 Monitor	B-68
Plot 239	Driver Front Airbag Stage 2 Monitor	B-68
Plot 240	Driver Curtain Airbag Monitor	B-68
Plot 241	Driver Seat Torso Airbag Monitor	B-69
Plot 242	Driver Retractor Pretensioner Monitor	B-69
Plot 243	Driver Anchor Pretensioner Monitor	B-69
Plot 244	Passenger Front Airbag Stage 1 Monitor	B-69
Plot 245	Passenger Front Airbag Stage 2 Monitor	B-70
Plot 246	Passenger Front Airbag Stage 3 Monitor	B-70
Plot 247	Passenger Curtain Airbag Monitor	B-70
Plot 248	Passenger Seat Torso Airbag Monitor	B-70
Plot 249	Passenger Retractor Pretensioner Monitor	B-71
Plot 250	Passenger Anchor Pretensioner Monitor	B-71
Plot 251	V1 OMDB CG X Acceleration	B-71
Plot 252	V1 OMDB CG Y Acceleration	B-71
Plot 253	V1 OMDB CG Z Acceleration	B-72
Plot 254	V1 OMDB CG Angular Rate X	B-72
Plot 255	V1 OMDB CG Angular Rate Y	B-72
Plot 256	V1 OMDB CG Angular Rate Z	B-72
Plot 257	V1 OMDB Rear C/L X Acceleration	B-73
Plot 258	V1 OMDB Rear C/L Y Acceleration	B-73
Plot 259	V1 OMDB Rear C/L Z Acceleration	B-73
Plot 260	V2P1 Fx on head acting through the O.C. joint only	B-73
Plot 261	V2P1 Fz on head acting through the O.C. joint only	B-74
Plot 262	V2P1 My on head acting through the O.C. joint only	B-74
Plot 263	V2P1 Fx on head acting through the total neck section	B-74
Plot 264	V2P1 Fy on head acting through the total neck section	B-74
Plot 265	V2P1 Fz on head acting through the total neck section	B-75
Plot 266	V2P1 Mx on head acting through the total neck section	B-75
Plot 267	V2P1 My on head acting through the total neck section	B-75
Plot 268	V2P1 Mz on head acting through the total neck section	B-75
Plot 269	V2P1 Chest Left Upper Dx	B-76
Plot 270	V2P1 Chest Left Upper Dy	B-76
Plot 271	V2P1 Chest Left Upper Dz	B-76
Plot 272	V2P1 Chest Left Upper Resultant	B-76
Plot 273	V2P1 Chest Right Upper Dx	B-77
Plot 274	V2P1 Chest Right Upper Dy	B-77
Plot 275	V2P1 Chest Right Upper Dz	B-77
Plot 276	V2P1 Chest Right Upper Resultant	B-77
Plot 277	V2P1 Chest Left Lower Dx	B-78
Plot 278	V2P1 Chest Left Lower Dy	B-78
Plot 279	V2P1 Chest Left Lower Dz	B-78
Plot 280	V2P1 Chest Left Lower Resultant	B-78
Plot 281	V2P1 Chest Right Lower Dx	B-79
Plot 282	V2P1 Chest Right Lower Dy	B-79
Plot 283	V2P1 Chest Right Lower Dz	B-79
Plot 284	V2P1 Chest Right Lower Resultant	B-79
Plot 285	V2P1 Abdomen Left Lower Dx	B-80
Plot 286	V2P1 Abdomen Left Lower Dy	B-80
Plot 287	V2P1 Abdomen Left Lower Dz	B-80
Plot 288	V2P1 Abdomen Left Lower Resultant	B-80
Plot 289	V2P1 Abdomen Right Lower Dx	B-81
Plot 290	V2P1 Abdomen Right Lower Dy	B-81
Plot 291	V2P1 Abdomen Right Lower Dz	B-81

Plot 292	V2P1 Abdomen Right Lower Resultant	B-81
Plot 293	V2P2 Fx on head acting through the O.C. joint only	B-82
Plot 294	V2P2 Fz on head acting through the O.C. joint only	B-82
Plot 295	V2P2 My on head acting through the O.C. joint only	B-82
Plot 296	V2P2 Fx on head acting through the total neck section	B-82
Plot 297	V2P2 Fy on head acting through the total neck section	B-83
Plot 298	V2P2 Fz on head acting through the total neck section	B-83
Plot 299	V2P2 Mx on head acting through the total neck section	B-83
Plot 300	V2P2 My on head acting through the total neck section	B-83
Plot 301	V2P2 Mz on head acting through the total neck section	B-84
Plot 302	V2P2 Chest Left Upper Dx	B-84
Plot 303	V2P2 Chest Left Upper Dy	B-84
Plot 304	V2P2 Chest Left Upper Dz	B-84
Plot 305	V2P2 Chest Left Upper Resultant	B-85
Plot 306	V2P2 Chest Right Upper Dx	B-85
Plot 307	V2P2 Chest Right Upper Dy	B-85
Plot 308	V2P2 Chest Right Upper Dz	B-85
Plot 309	V2P2 Chest Right Upper Resultant	B-86
Plot 310	V2P2 Chest Left Lower Dx	B-86
Plot 311	V2P2 Chest Left Lower Dy	B-86
Plot 312	V2P2 Chest Left Lower Dz	B-86
Plot 313	V2P2 Chest Left Lower Resultant	B-87
Plot 314	V2P2 Chest Right Lower Dx	B-87
Plot 315	V2P2 Chest Right Lower Dy	B-87
Plot 316	V2P2 Chest Right Lower Dz	B-87
Plot 317	V2P2 Chest Right Lower Resultant	B-88
Plot 318	V2P2 Abdomen Left Lower Dx	B-88
Plot 319	V2P2 Abdomen Left Lower Dy	B-88
Plot 320	V2P2 Abdomen Left Lower Dz	B-88
Plot 321	V2P2 Abdomen Left Lower Resultant	B-89
Plot 322	V2P2 Abdomen Right Lower Dx	B-89
Plot 323	V2P2 Abdomen Right Lower Dy	B-89
Plot 324	V2P2 Abdomen Right Lower Dz	B-89
Plot 325	V2P2 Abdomen Right Lower Resultant	B-90

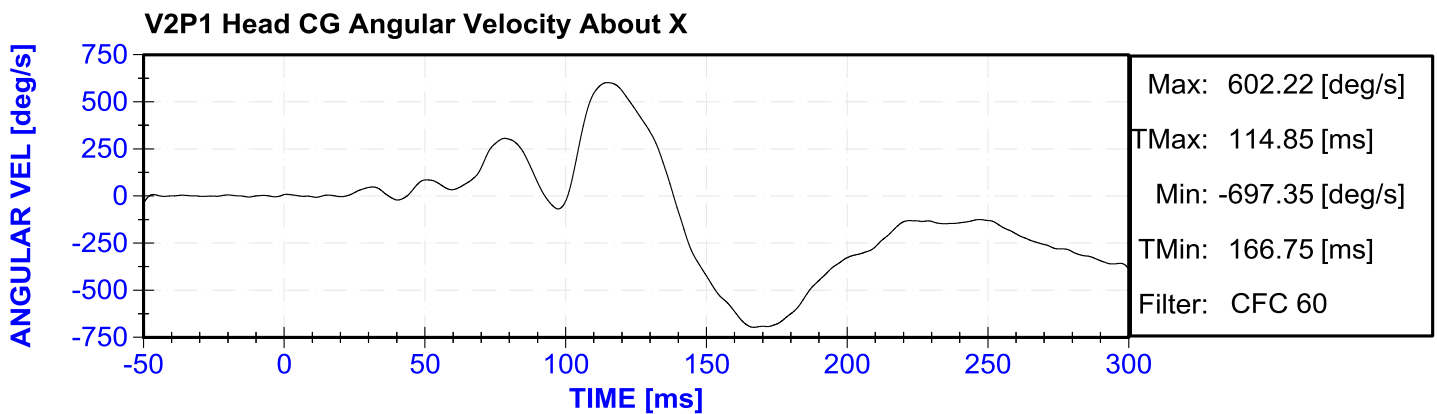
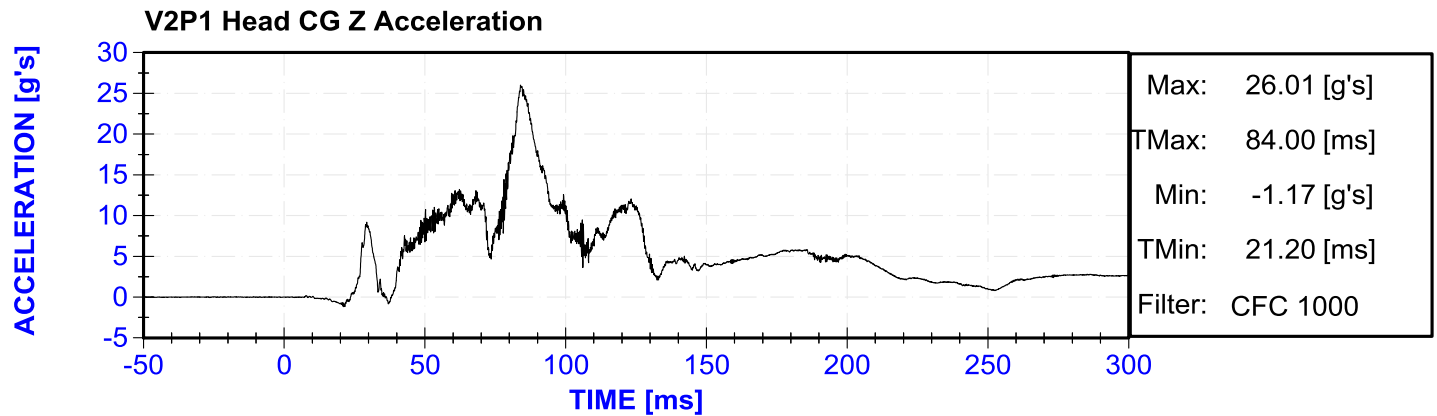
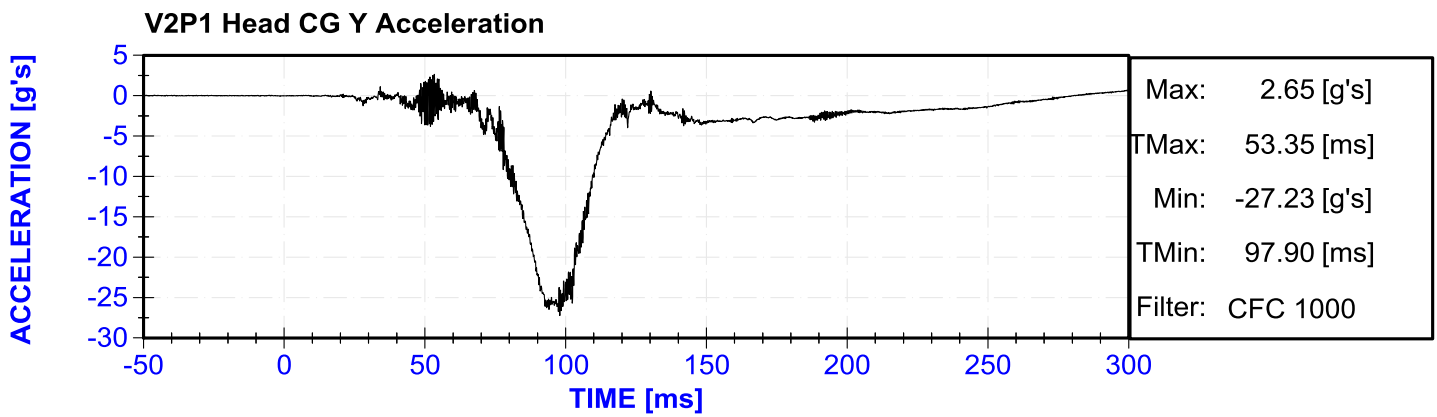
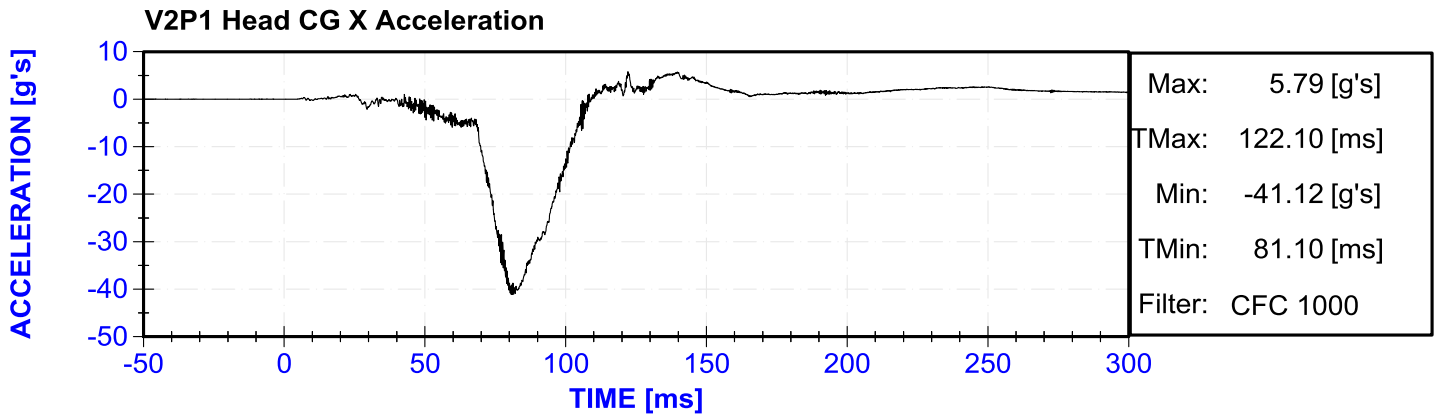

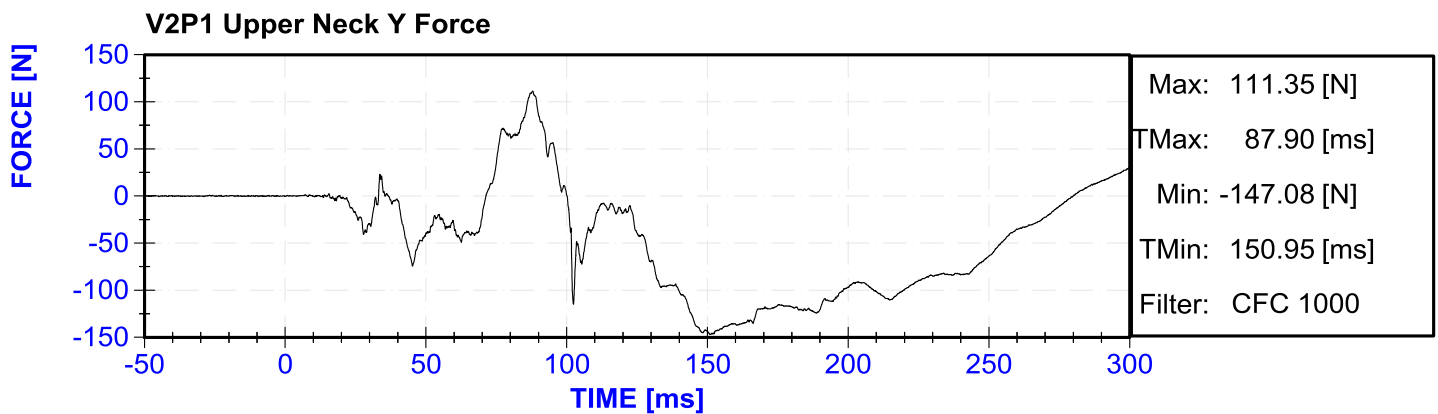
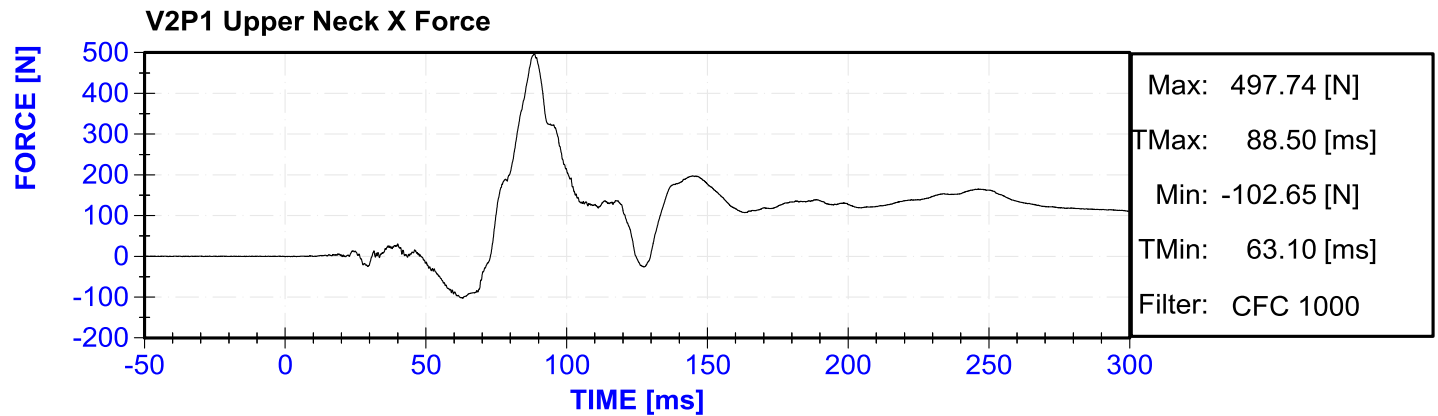
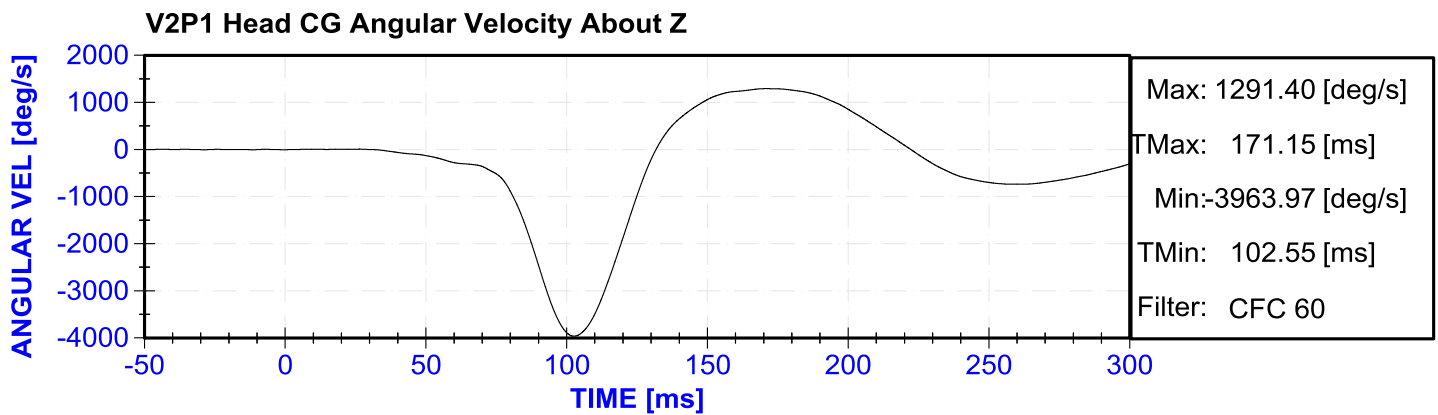
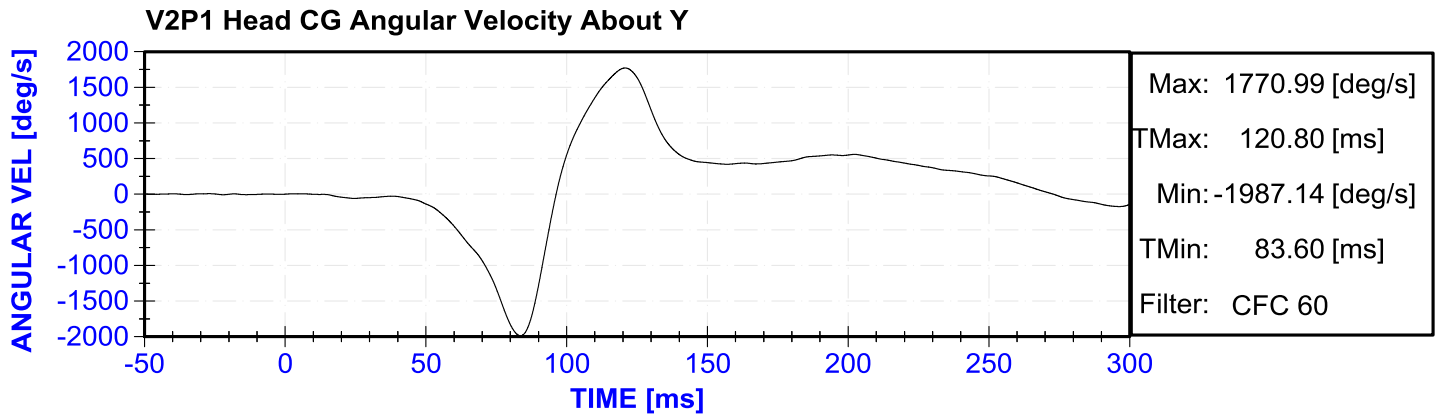

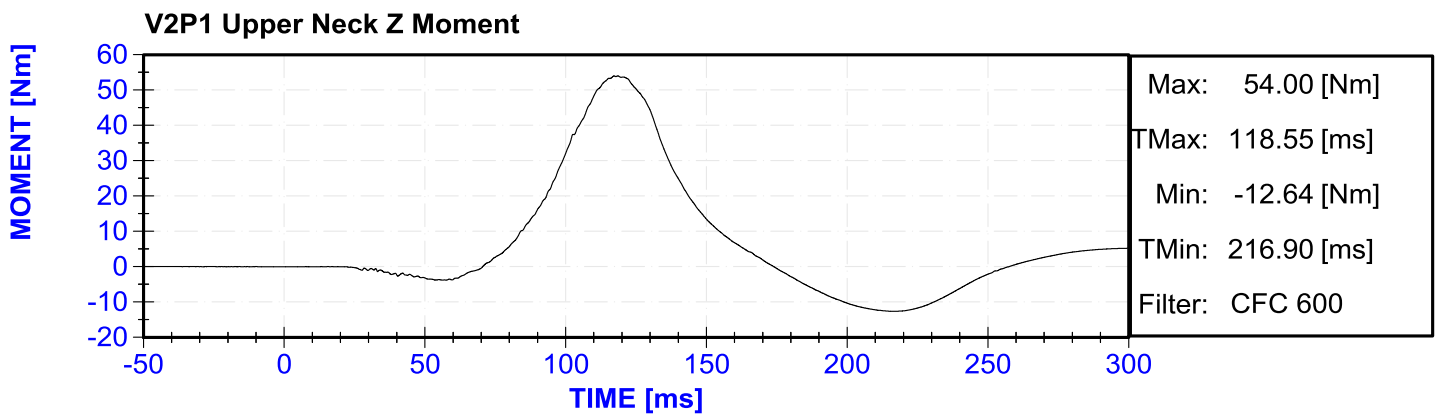
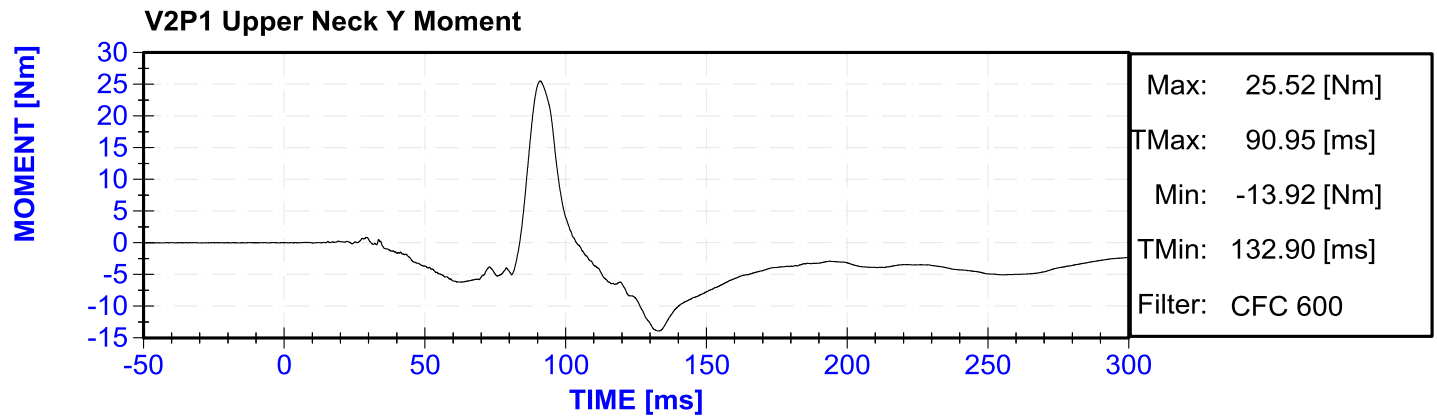
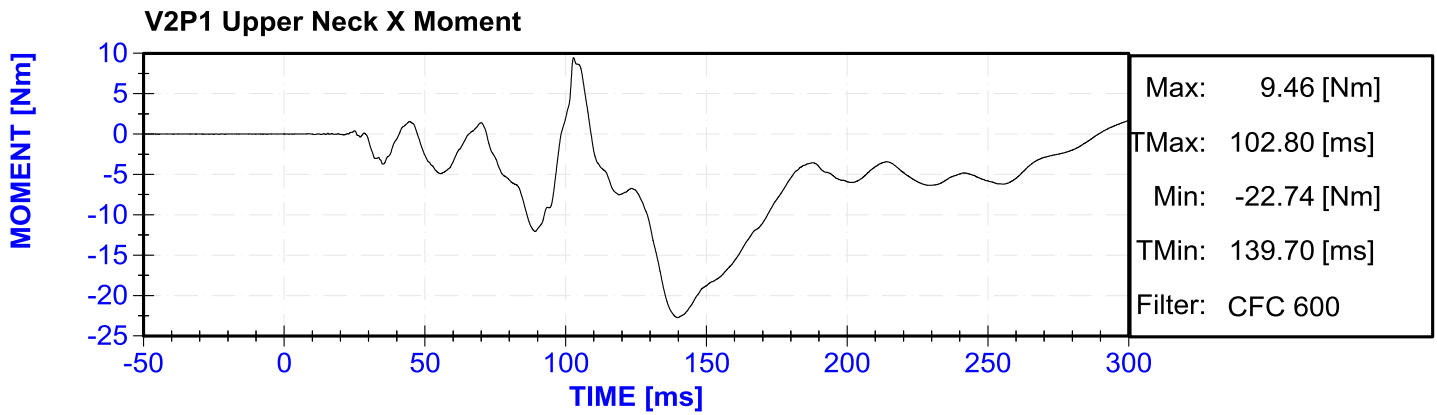
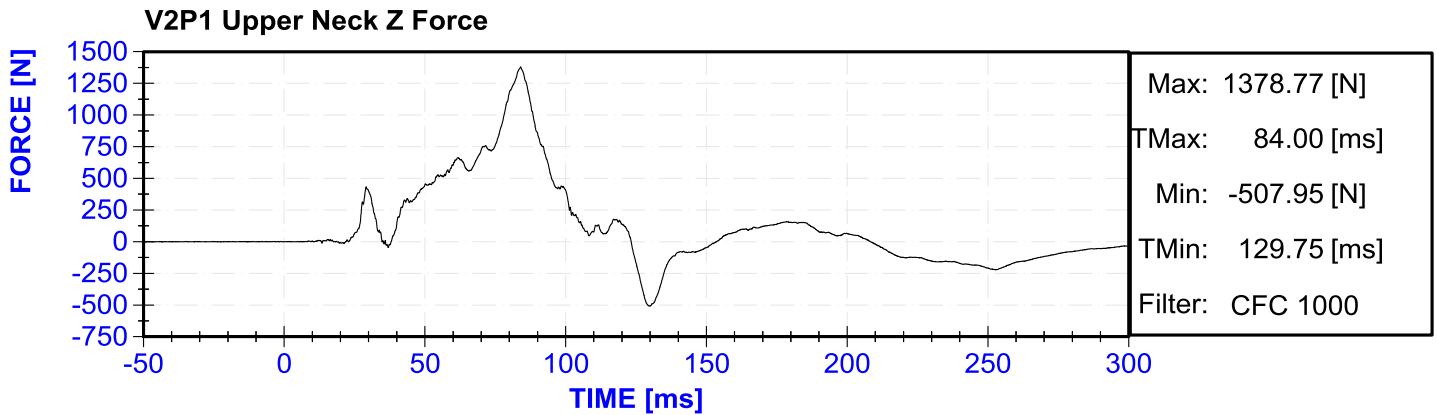

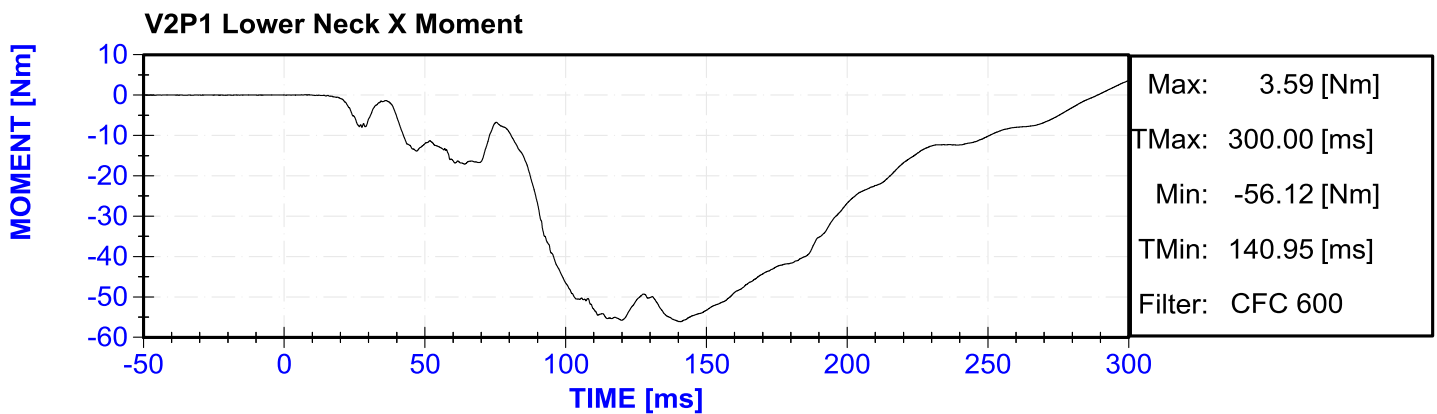
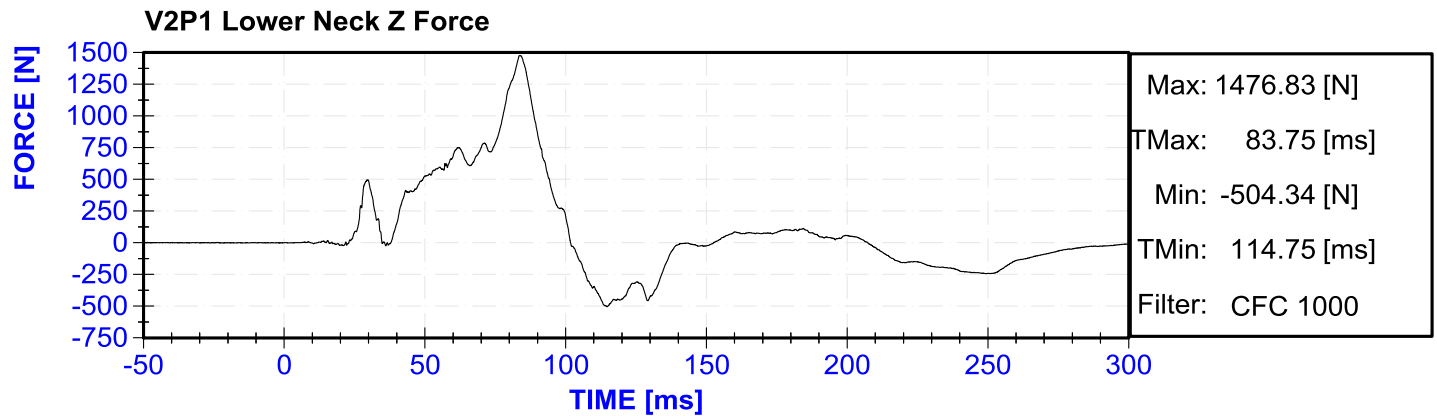
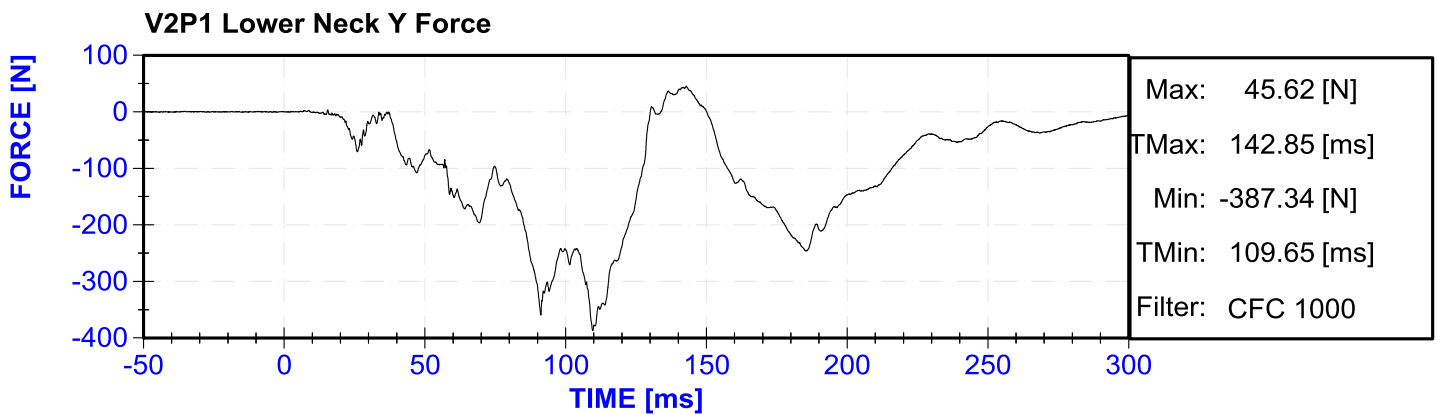
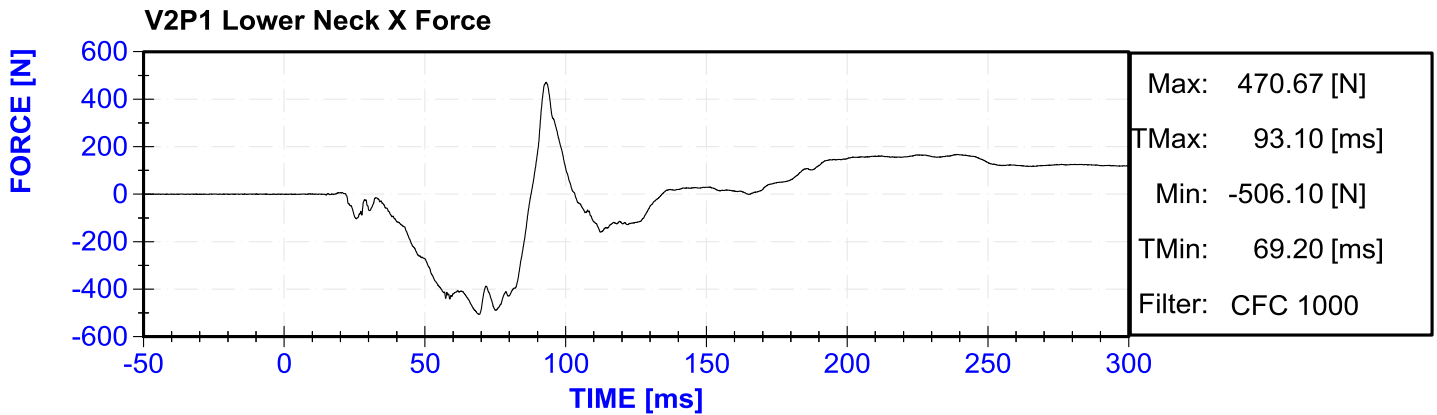

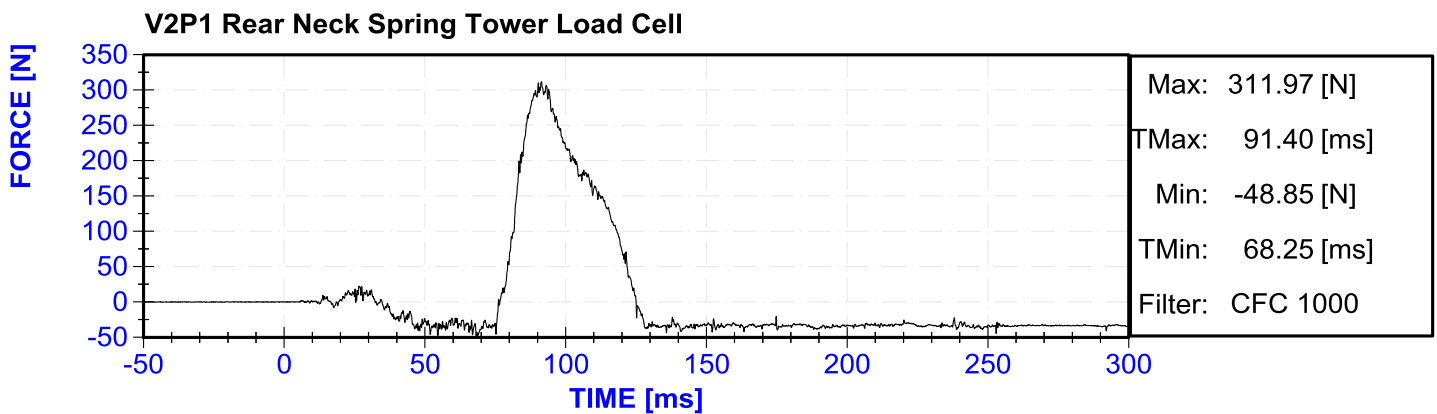
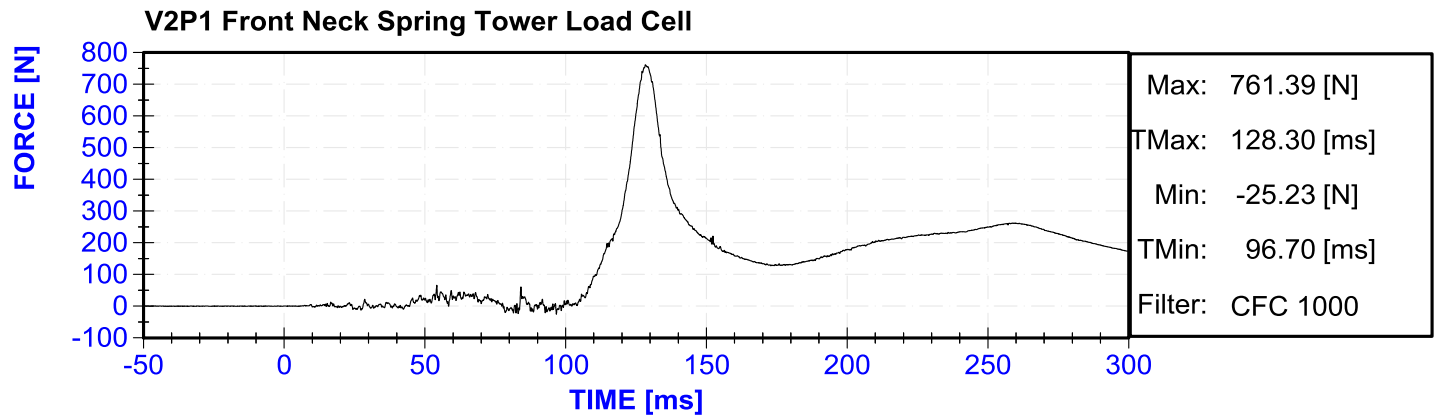
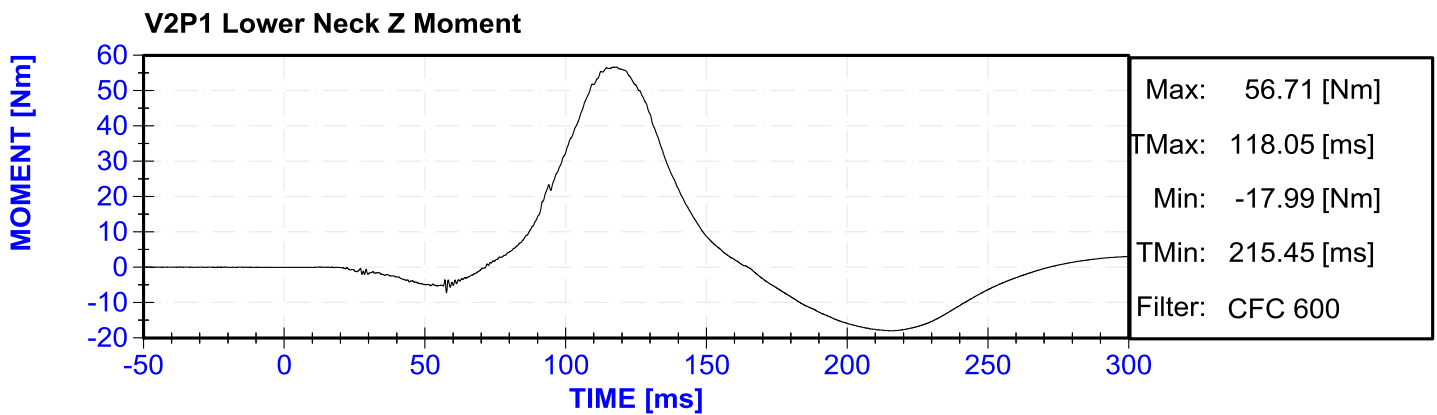
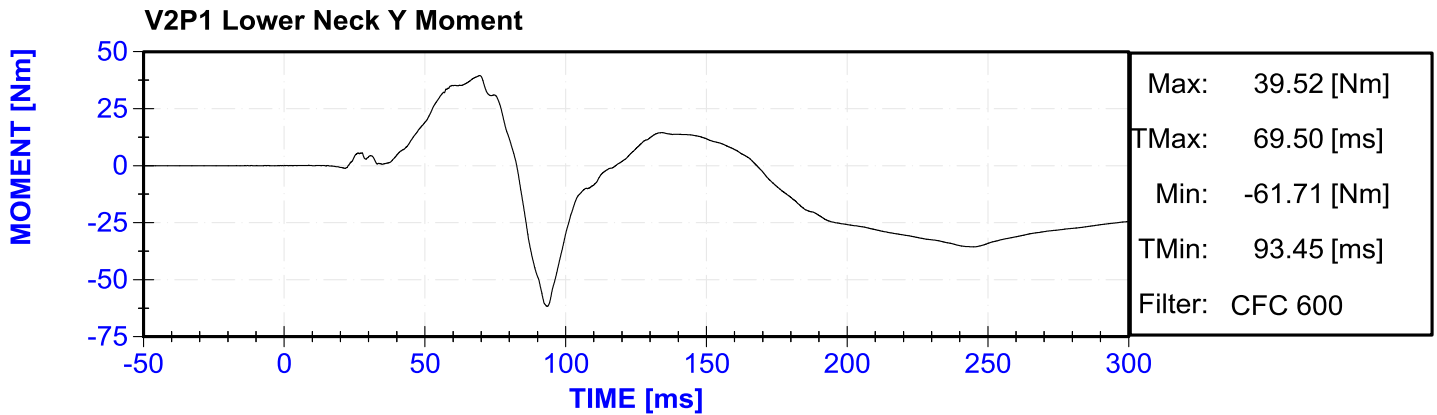

V2P1 Occipital Condyle Rotation Potentiometer

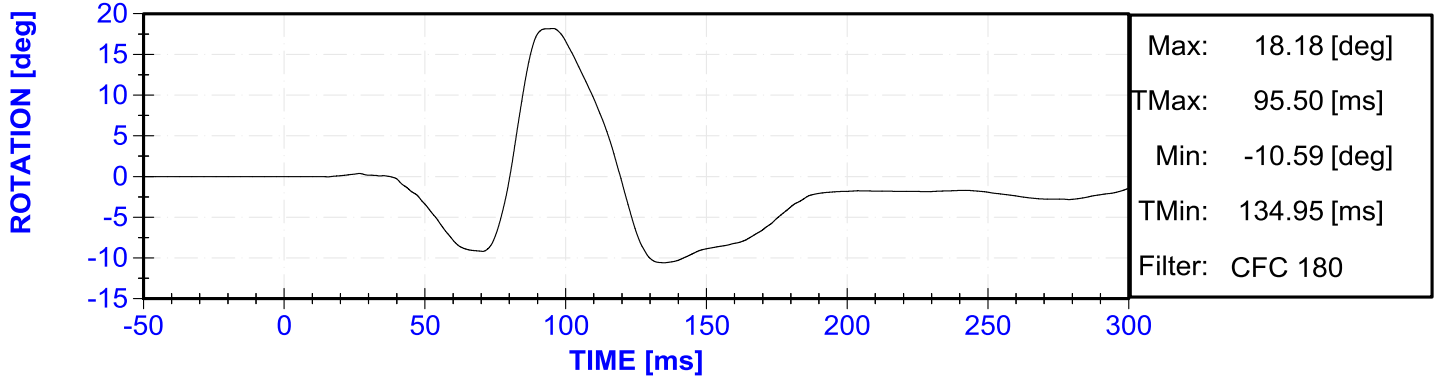

V2P1 Upper Left DGIR X Displacement

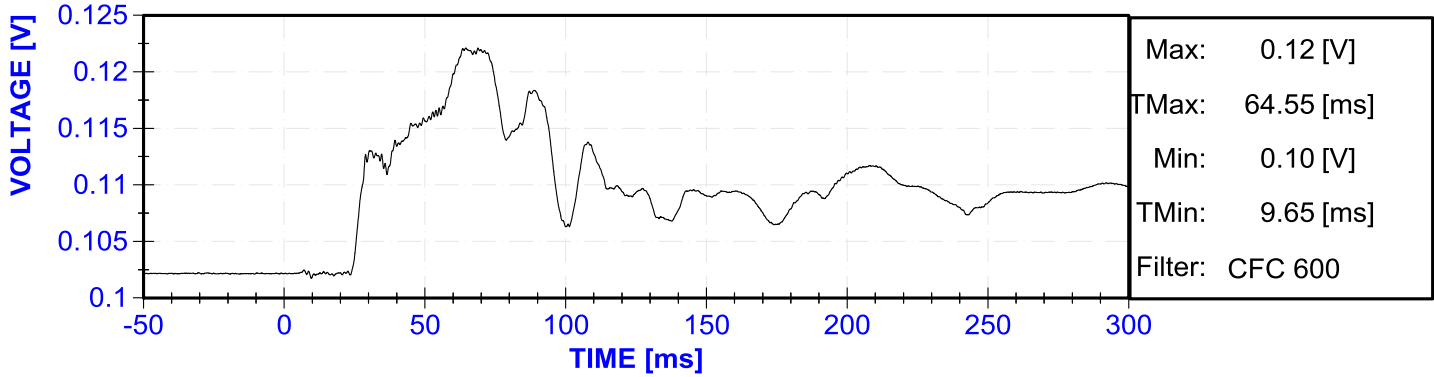

V2P1 Upper Left DGIR Y Rotation

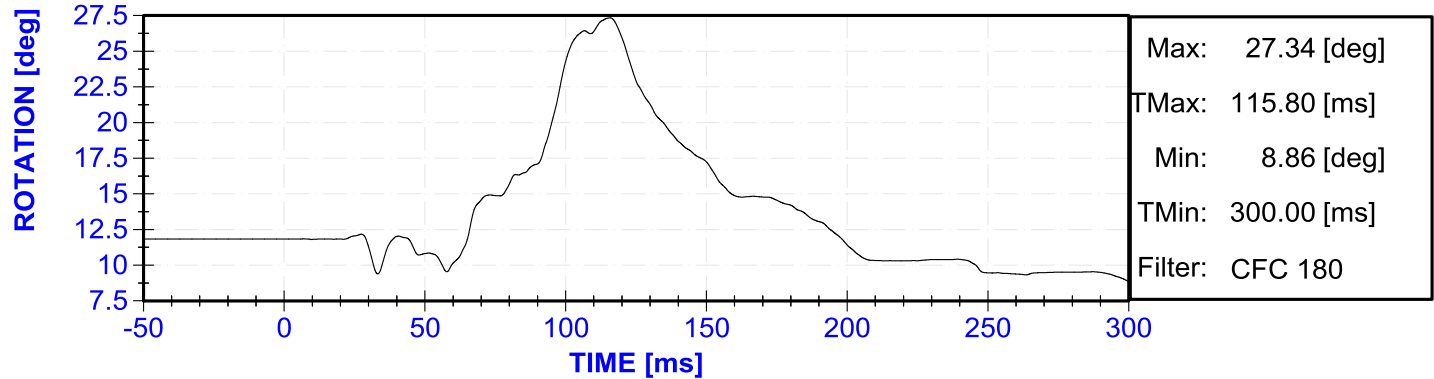

V2P1 Upper Left DGIR Z Rotation

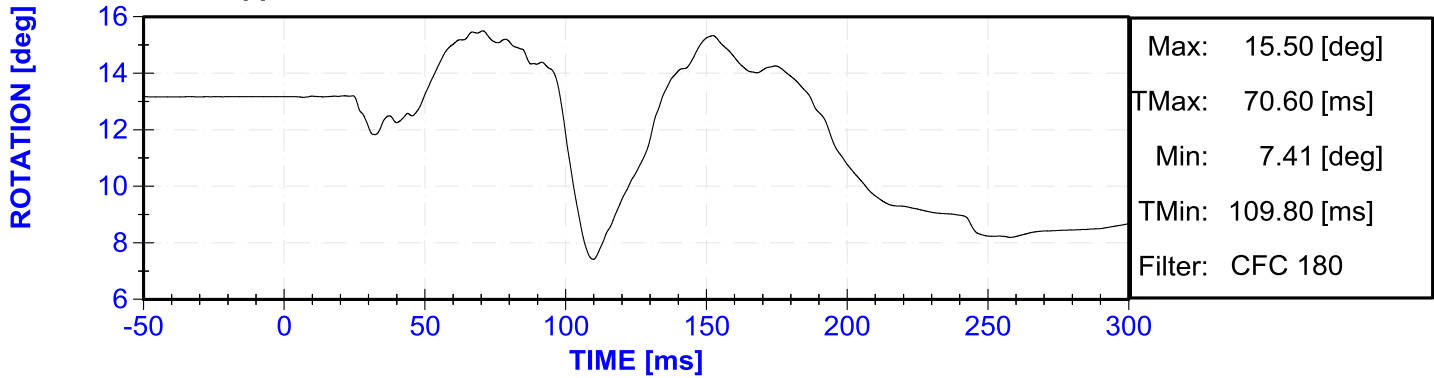

V2P1 Upper Right DGIR X Displacement

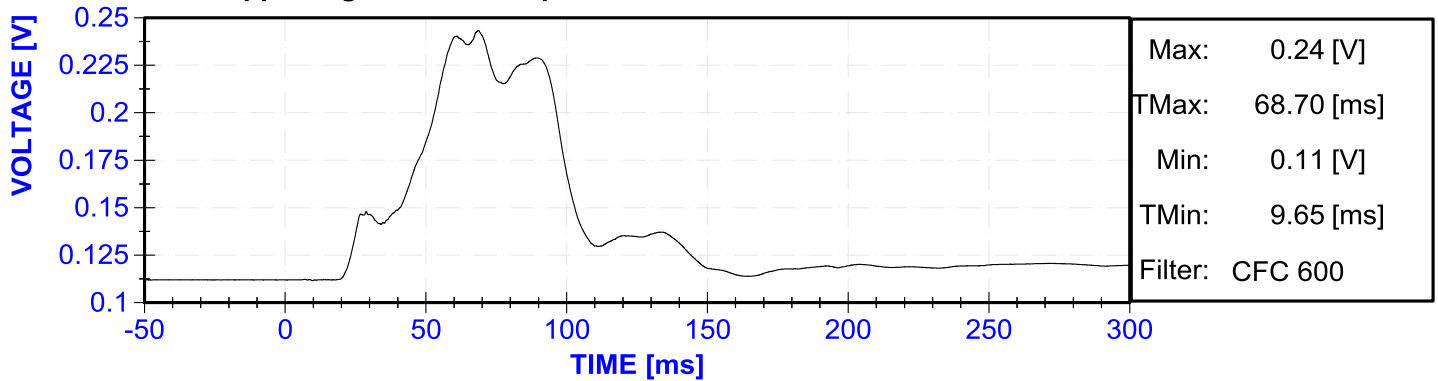

V2P1 Upper Right DGIR Y Rotation

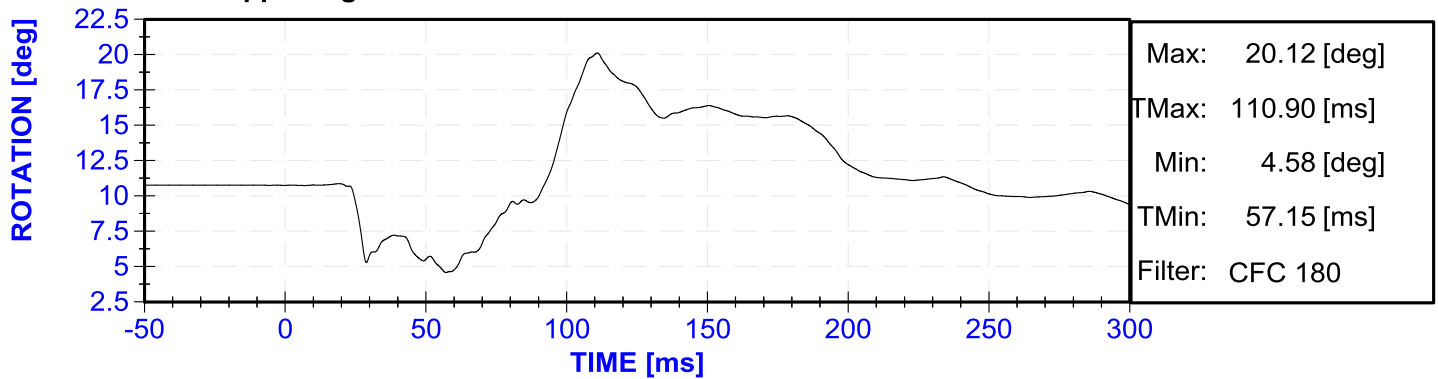

V2P1 Upper Right DGIR Z Rotation

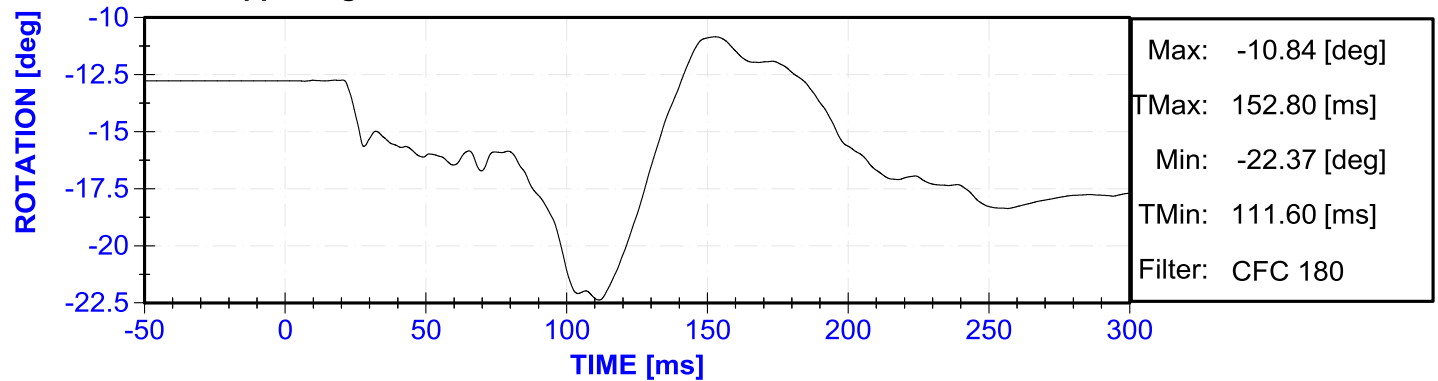

V2P1 Lower Left DGIR X Displacement

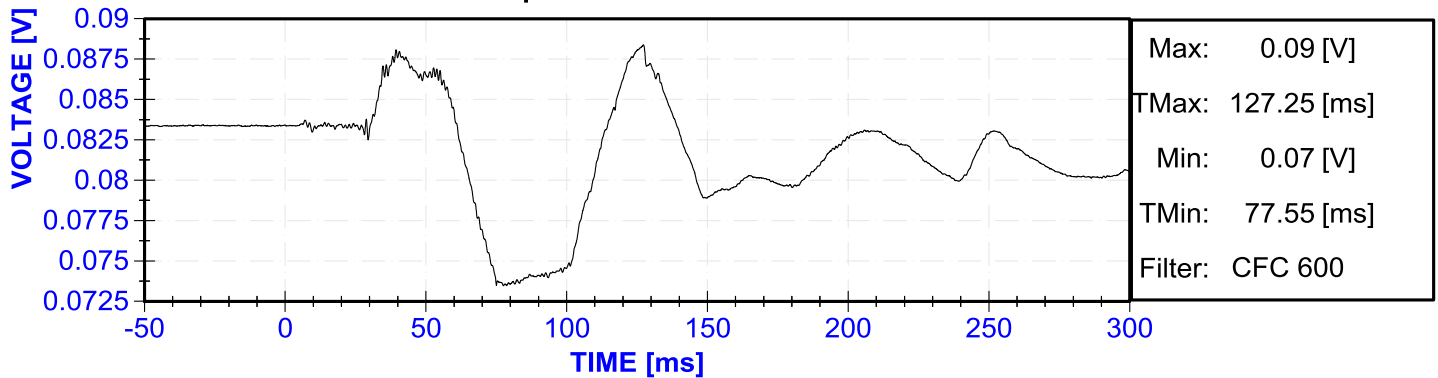

V2P1 Lower Left DGIR Y Rotation

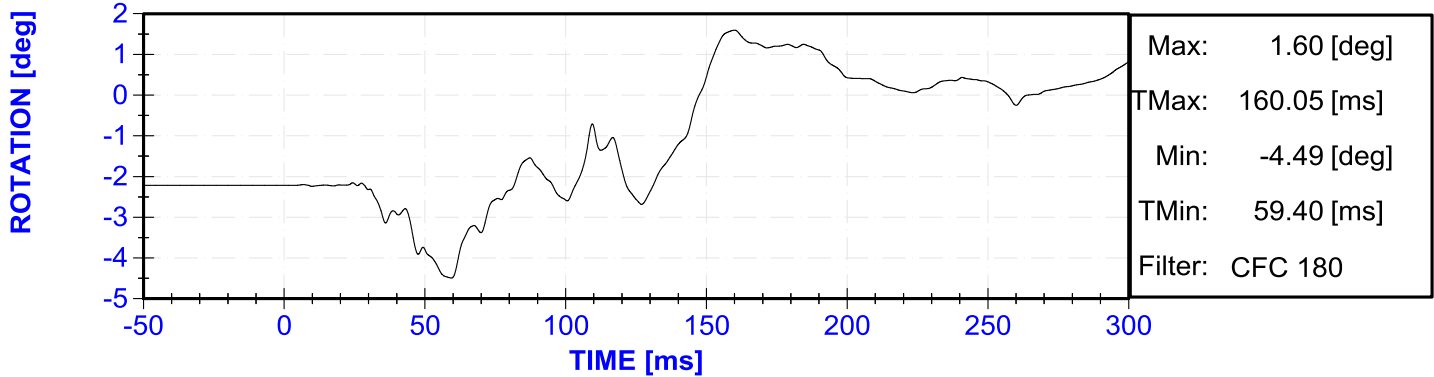

V2P1 Lower Left DGIR Z Rotation

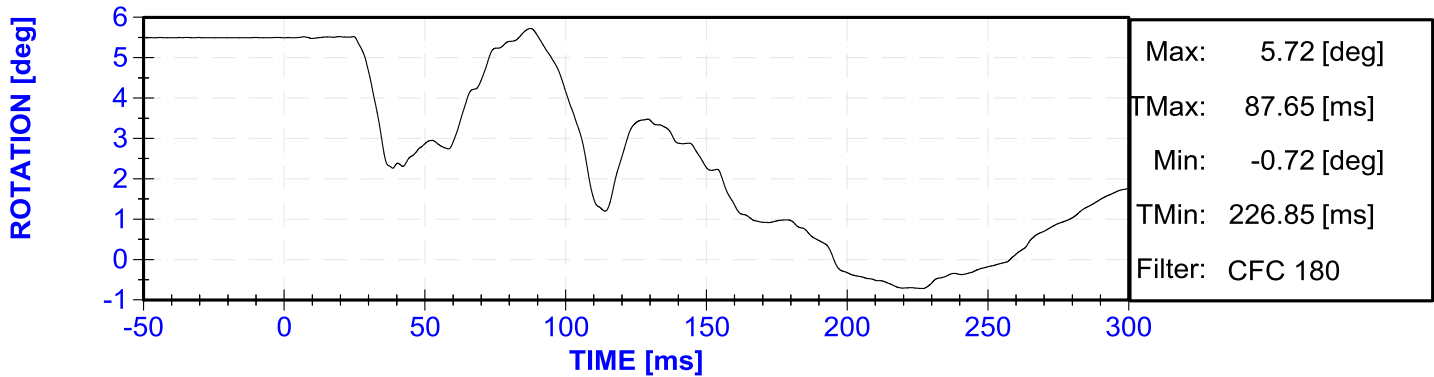

V2P1 Lower Right DGIR X Displacement

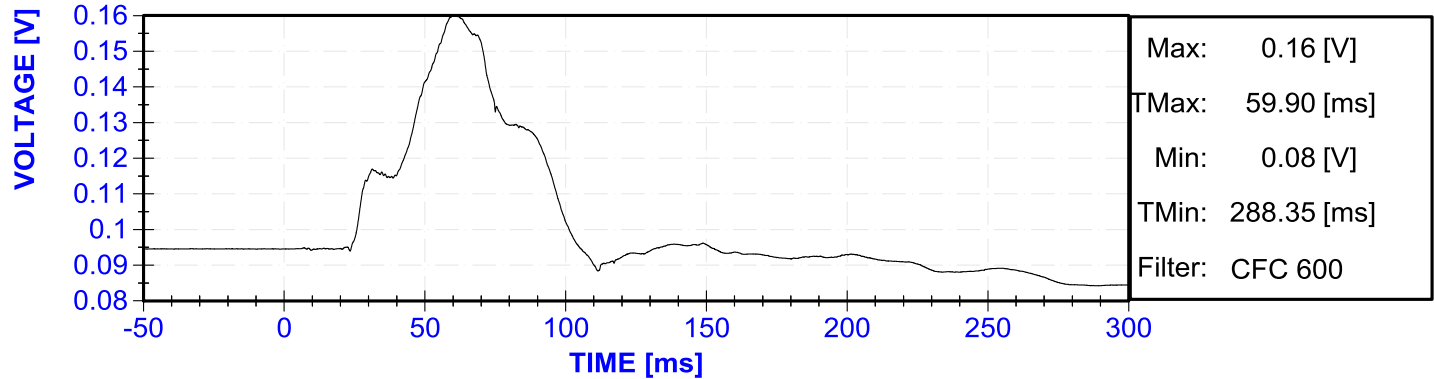

V2P1 Lower Right DGIR Y Rotation

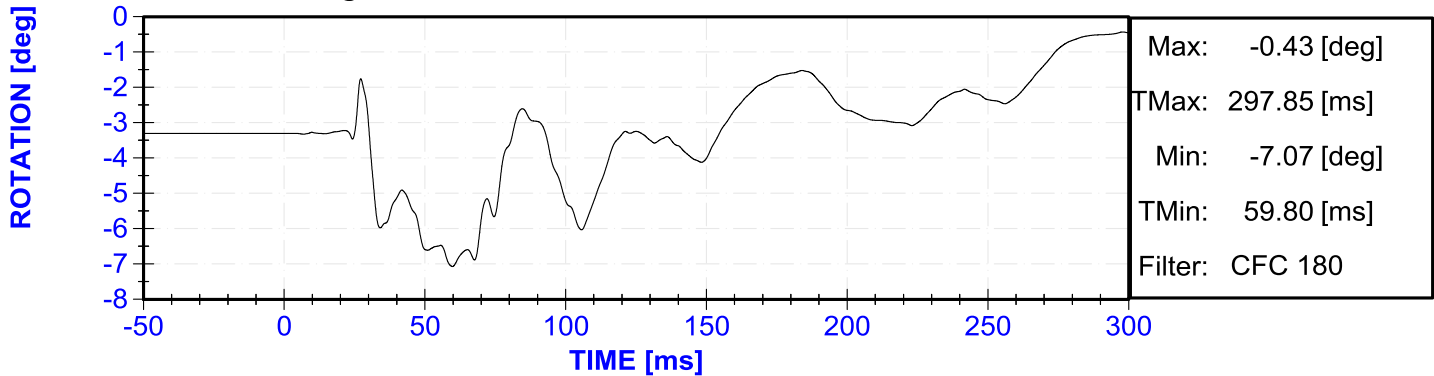

V2P1 Lower Right DGIR Z Rotation

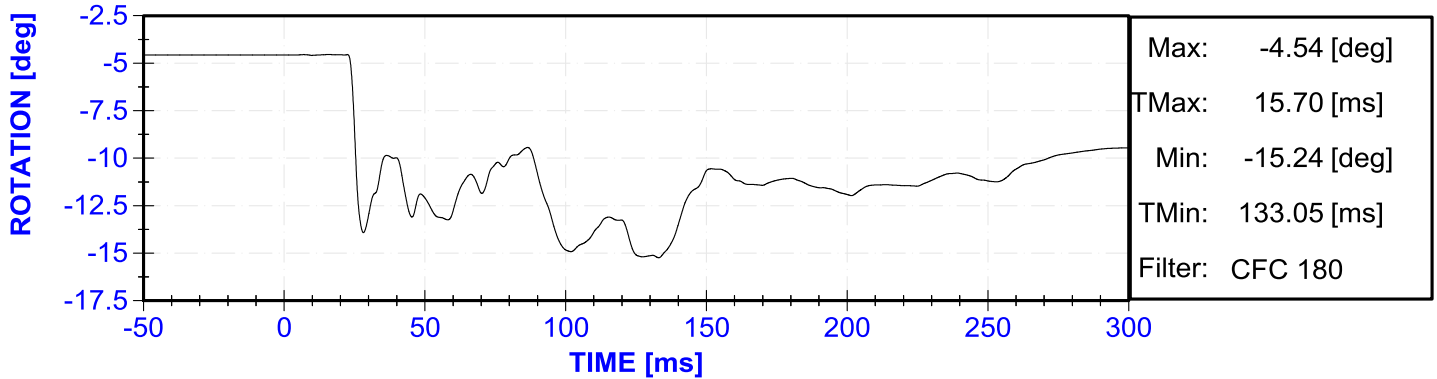

V2P1 Spine Force X

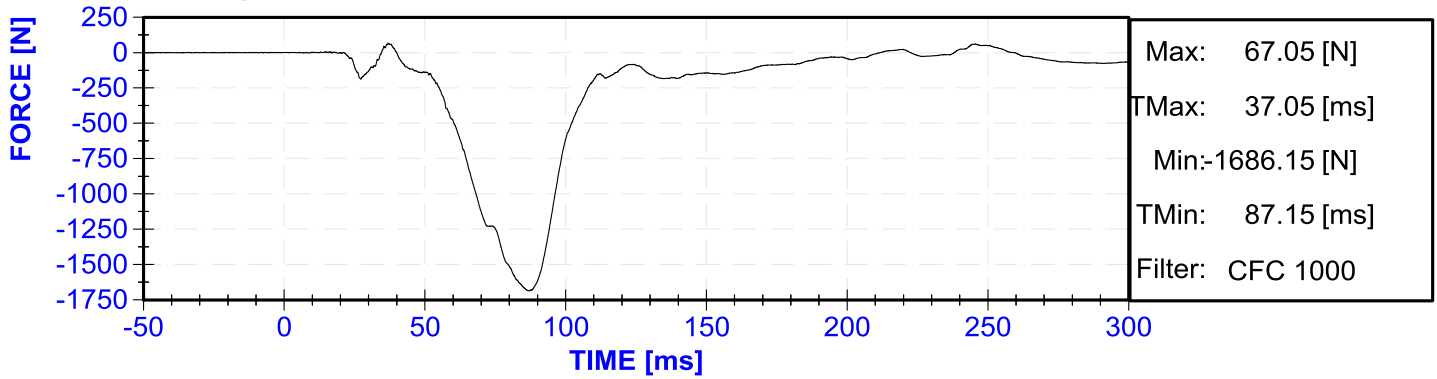

V2P1 Spine Force Y

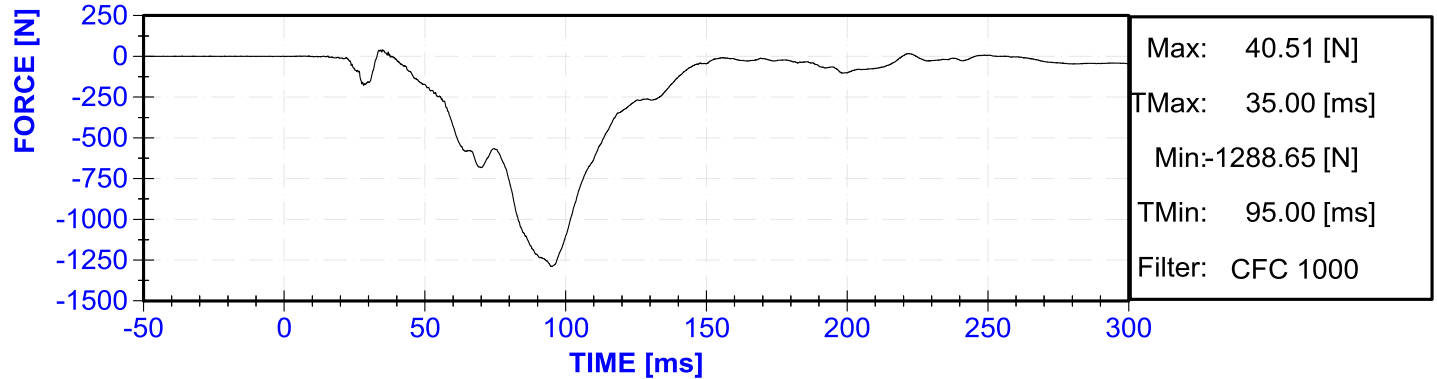

V2P1 Spine Force Z

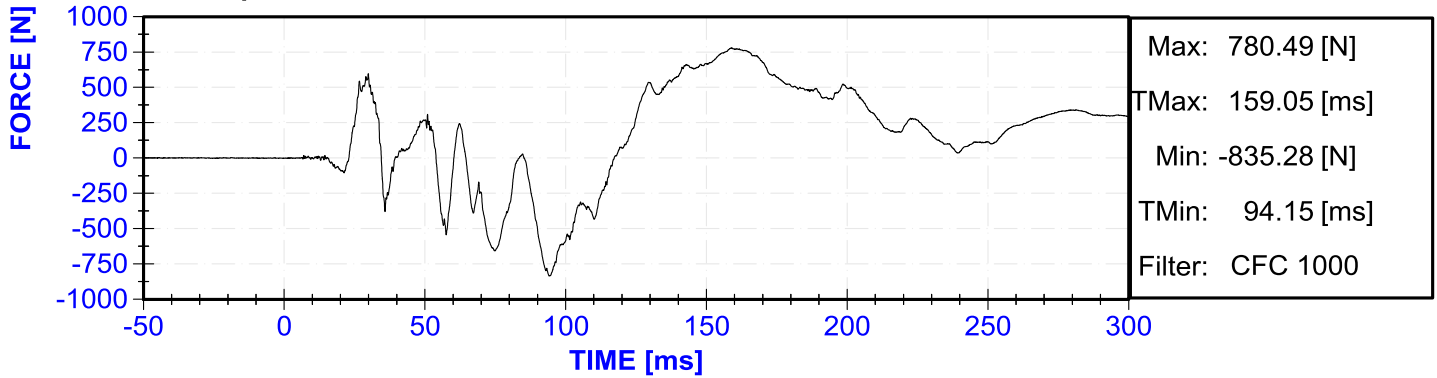

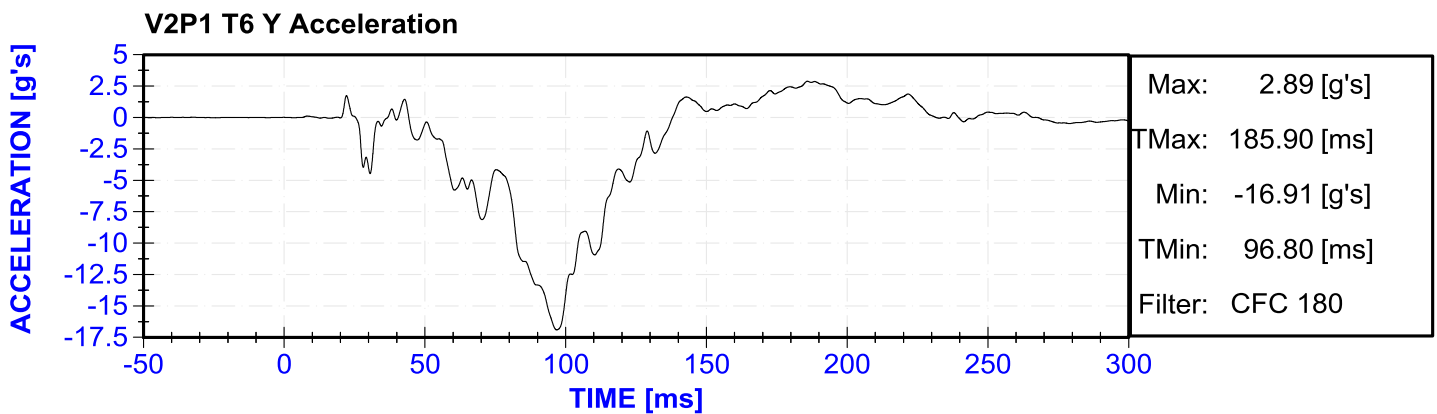
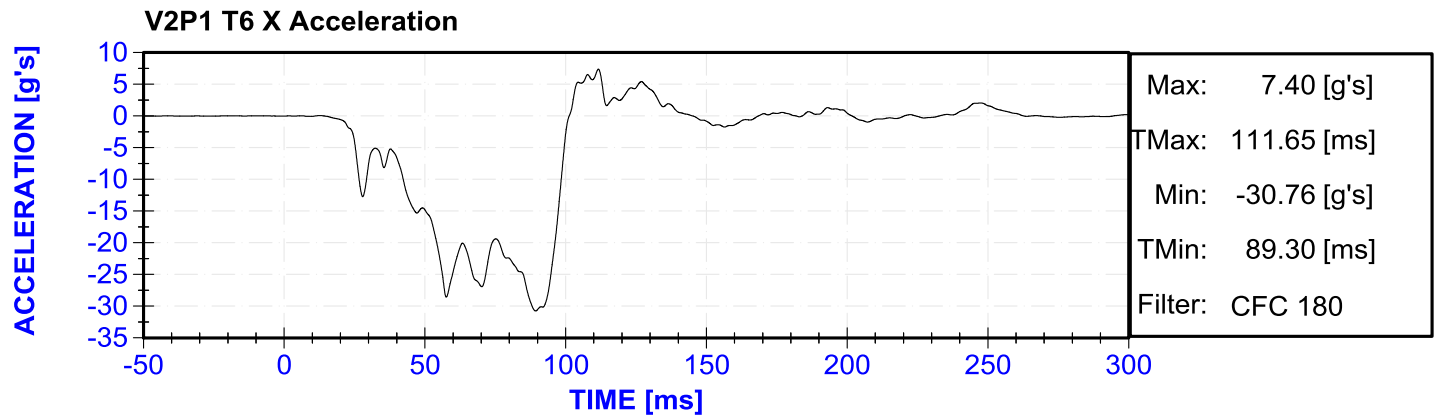
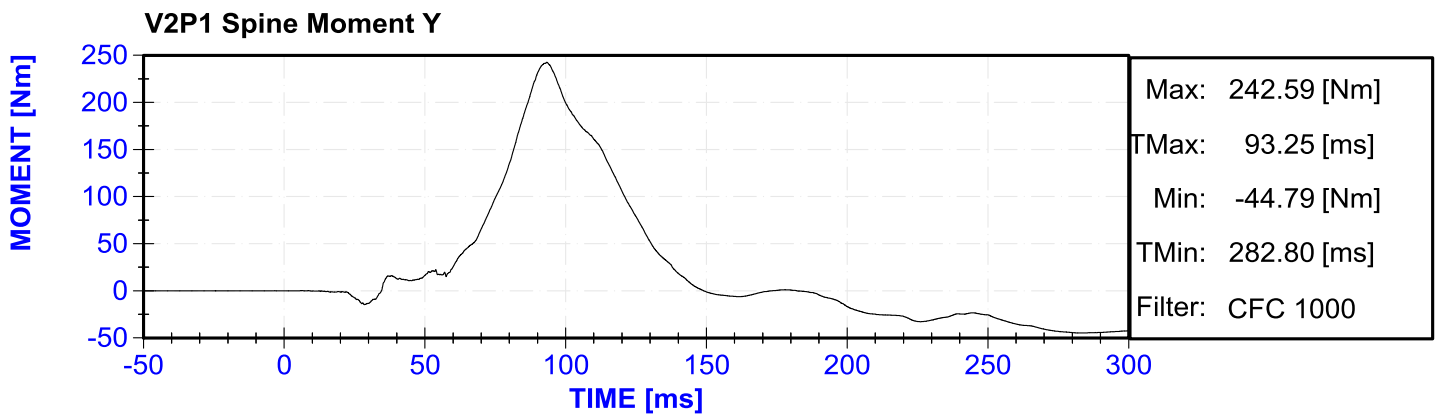
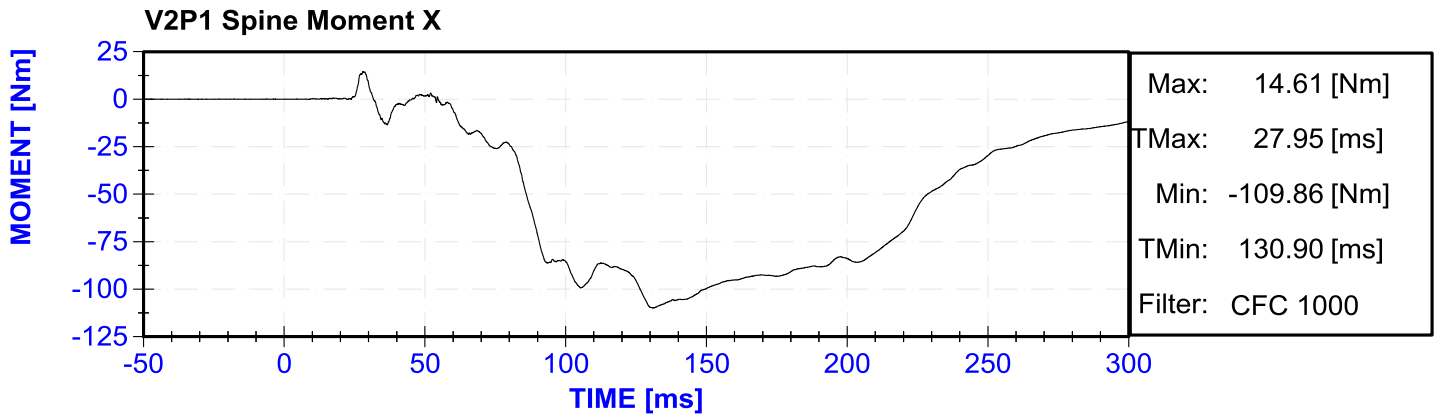

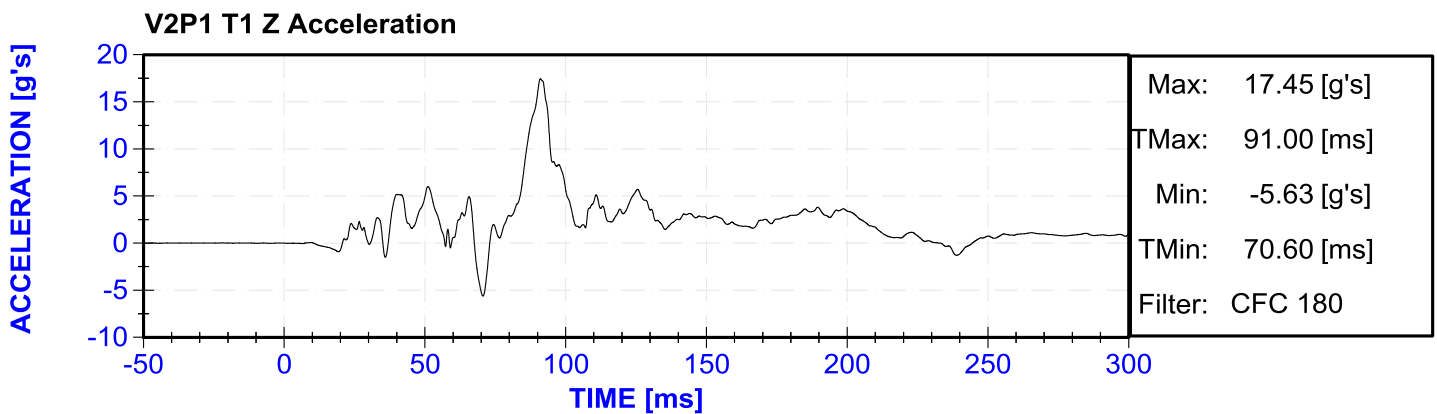
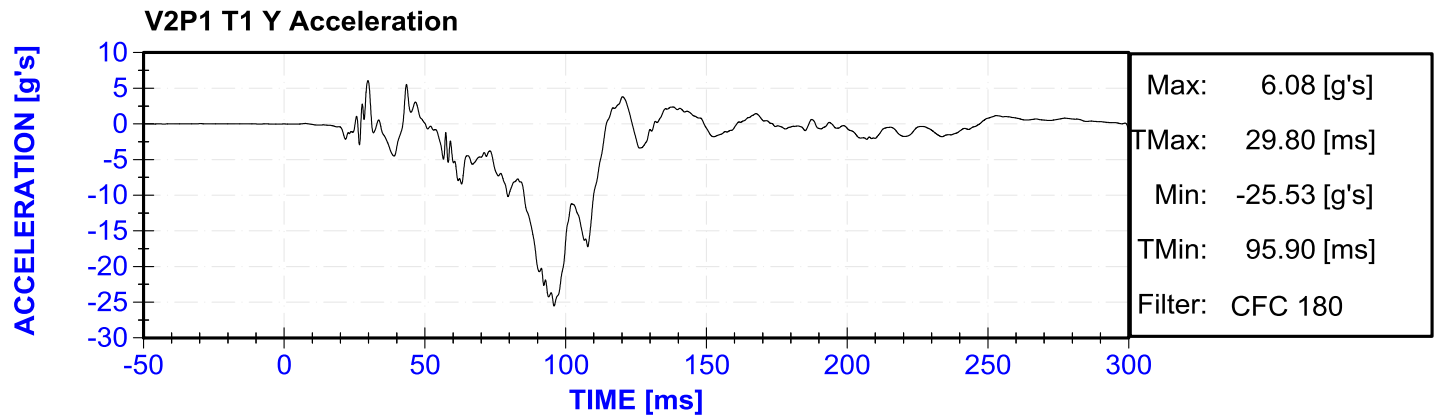
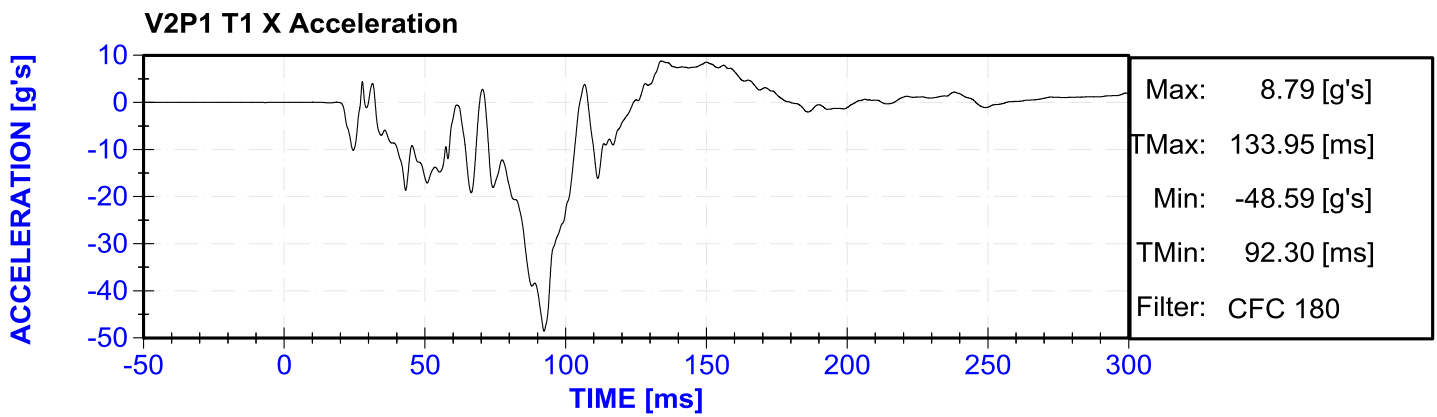
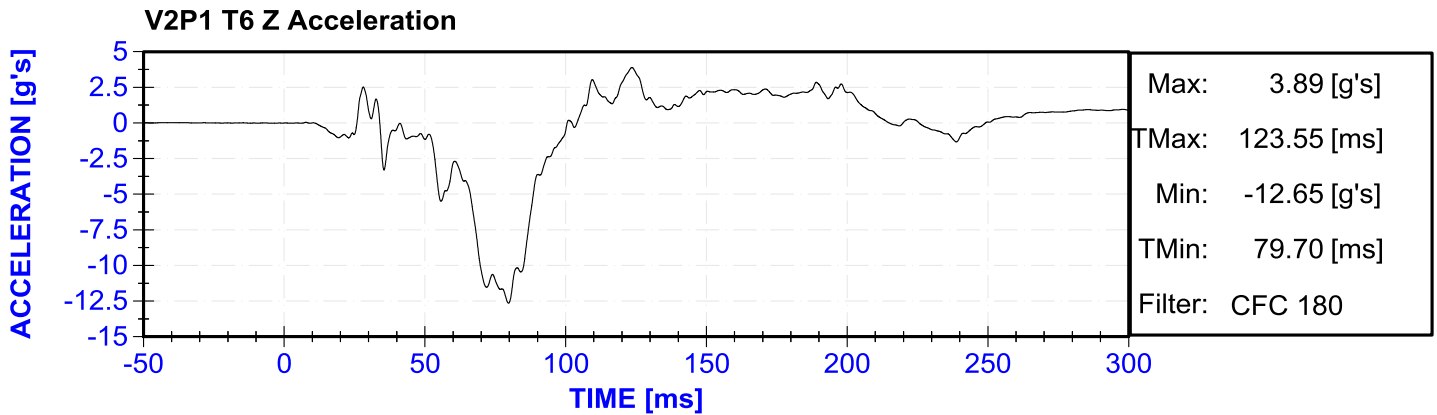

V2P1 Abdomen Left DGIR X Displacement

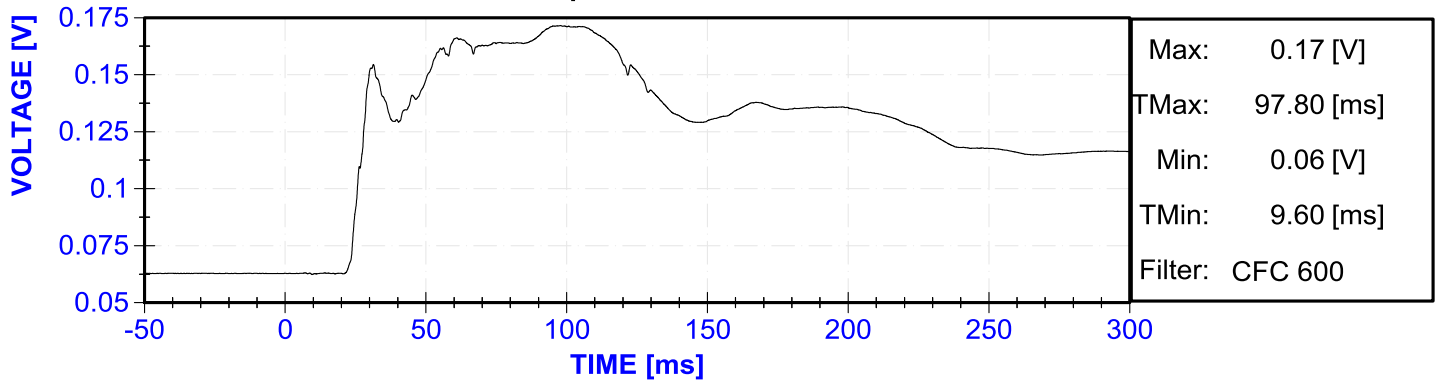

V2P1 Abdomen Left DGIR Y Rotation

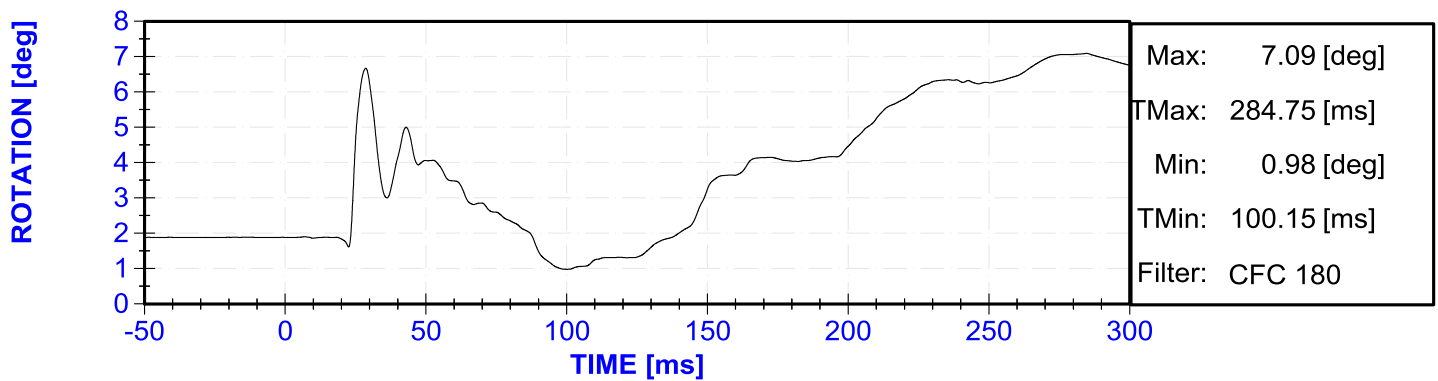

V2P1 Abdomen Left DGIR Z Rotation

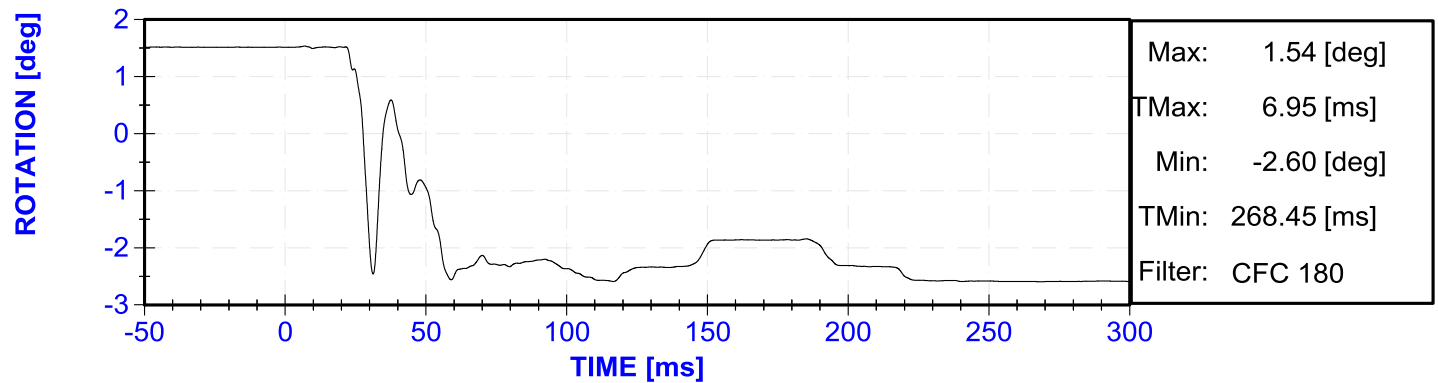

V2P1 Abdomen Right DGIR X Displacement

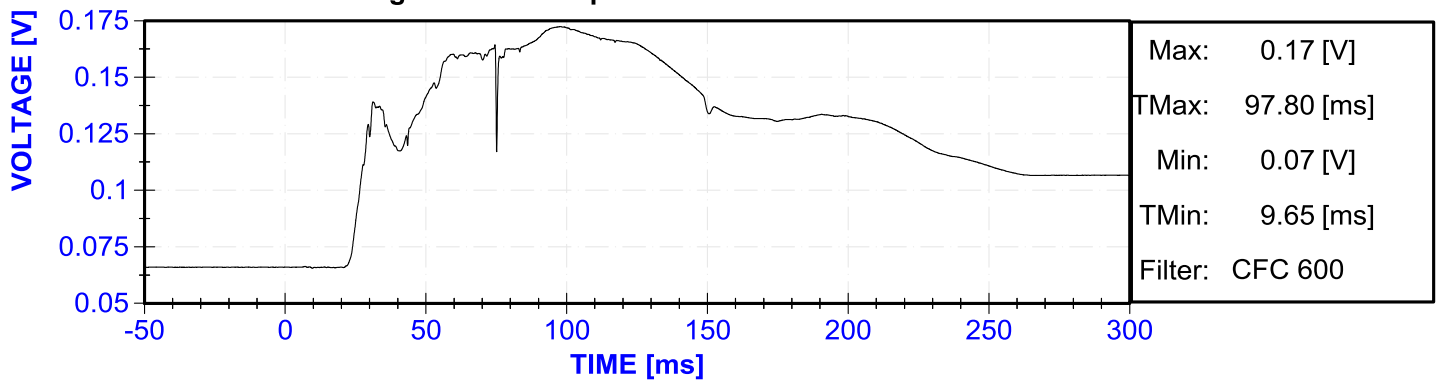

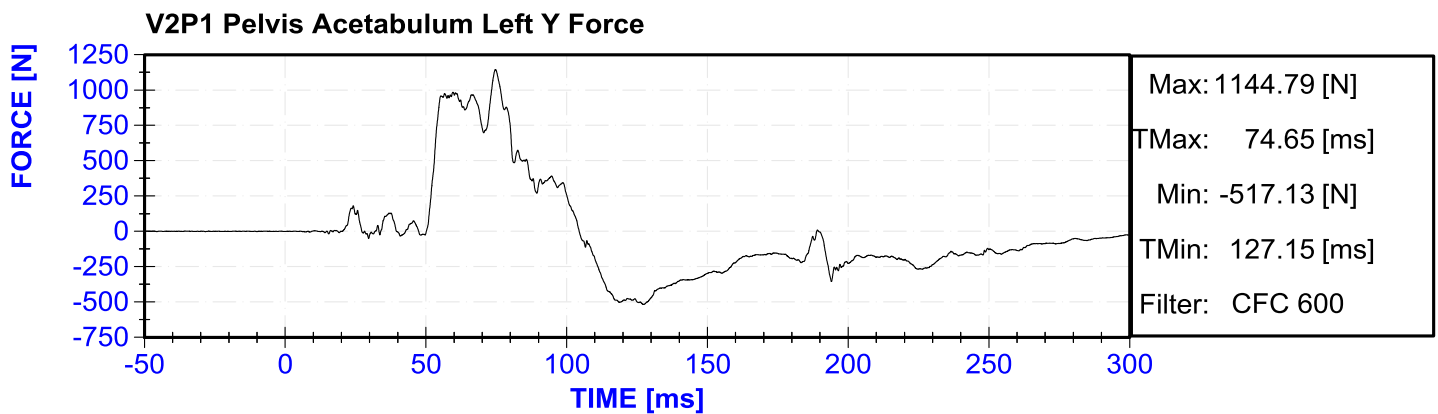
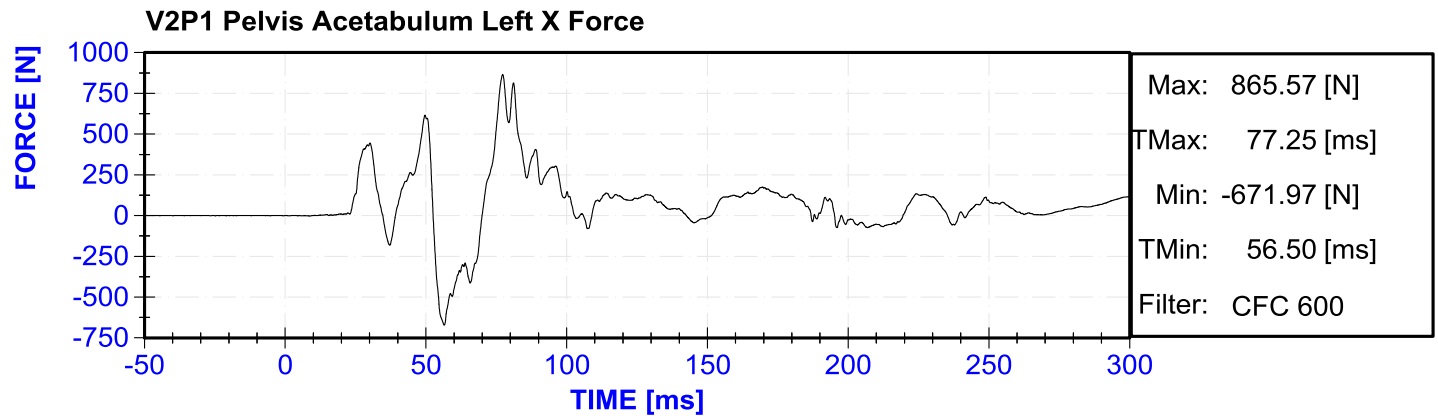
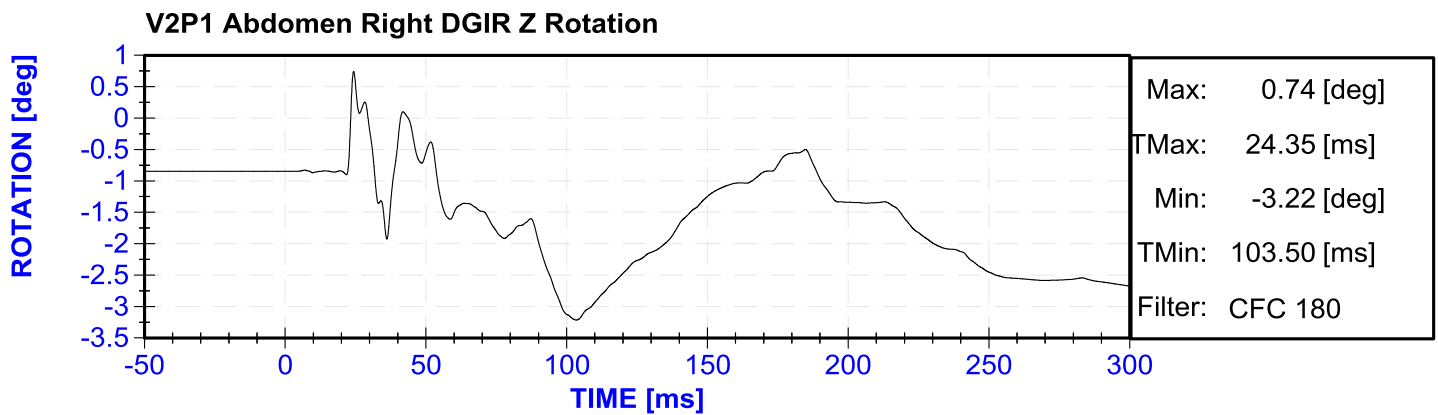
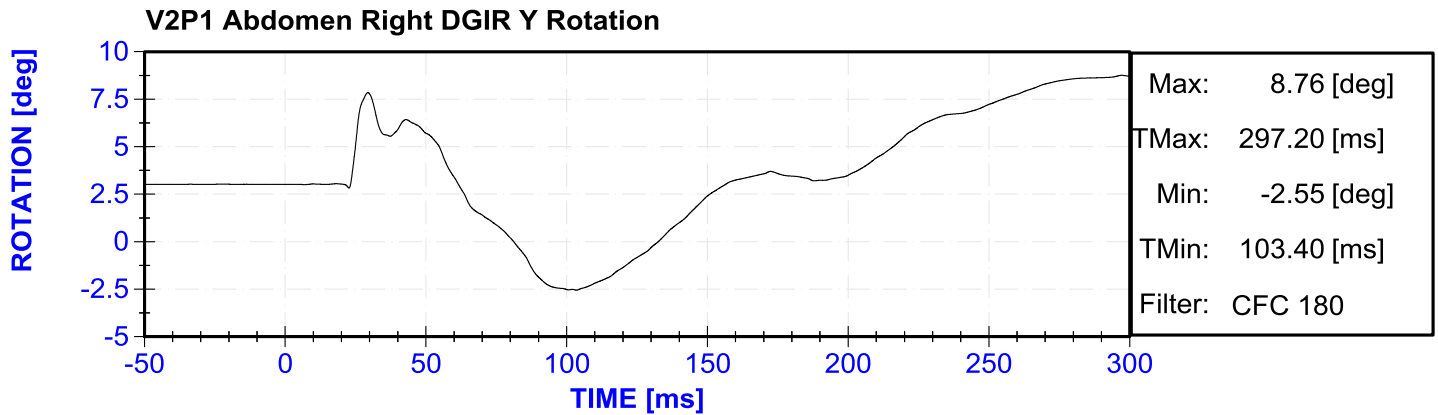

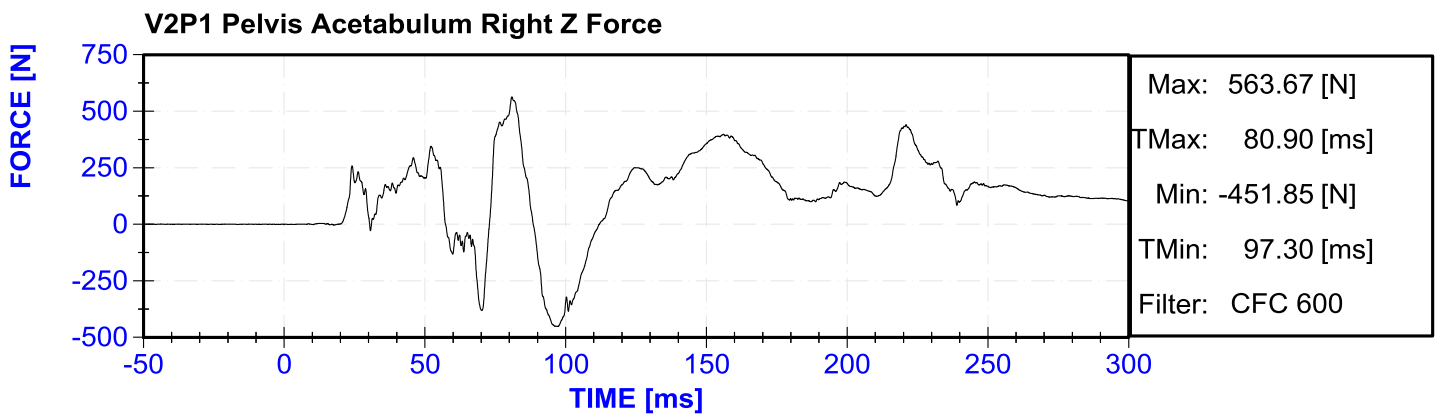
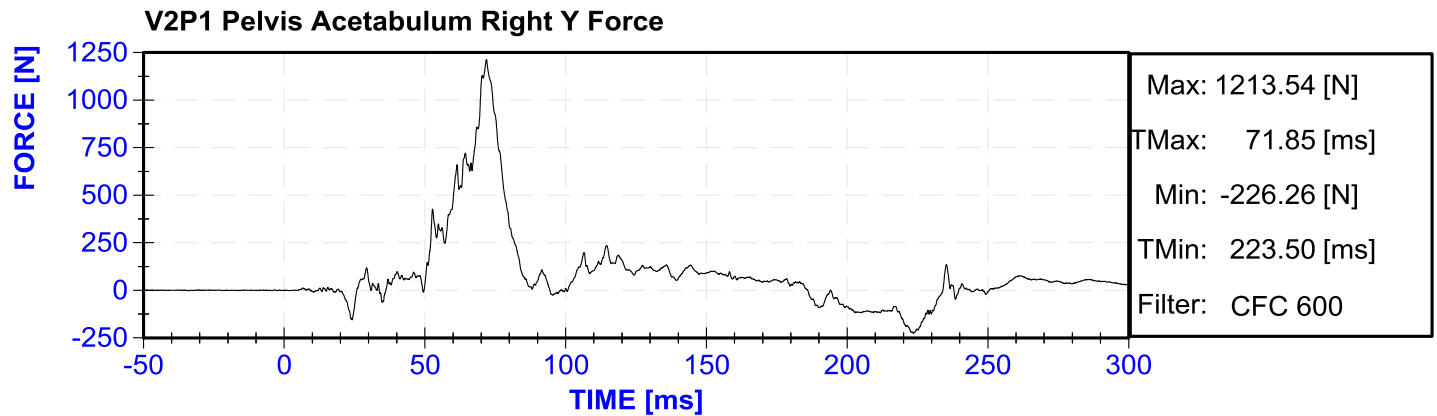
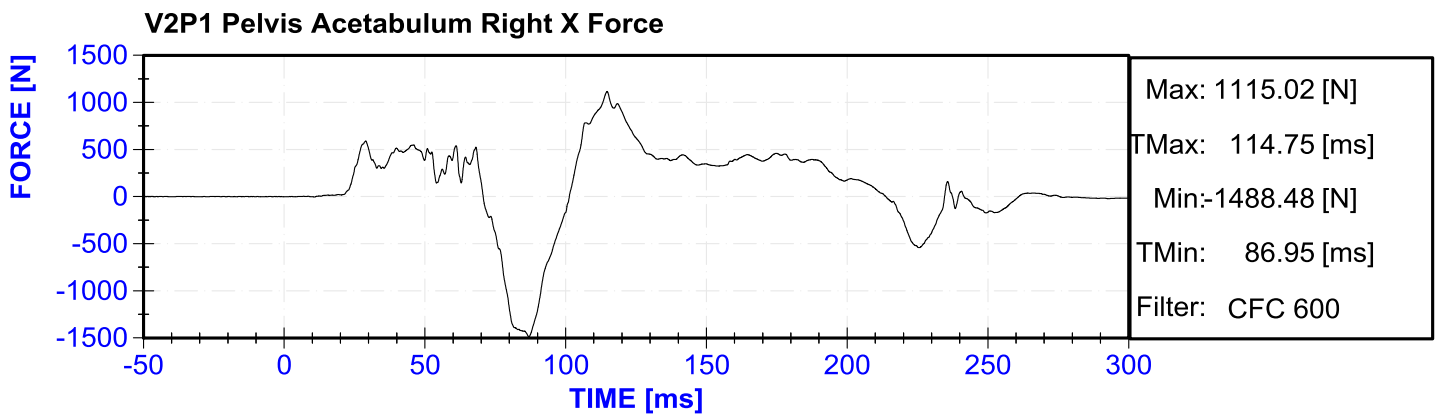
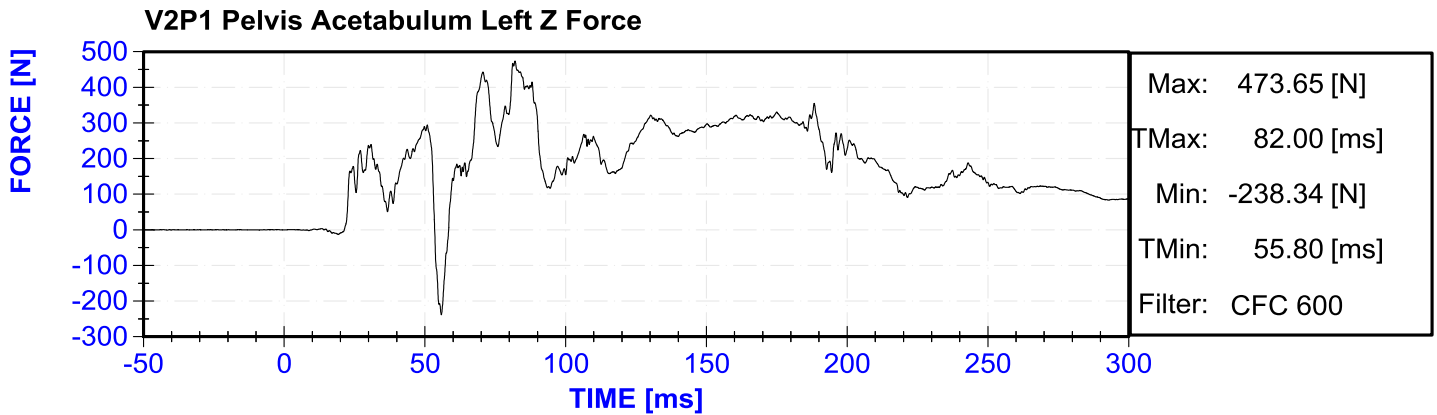

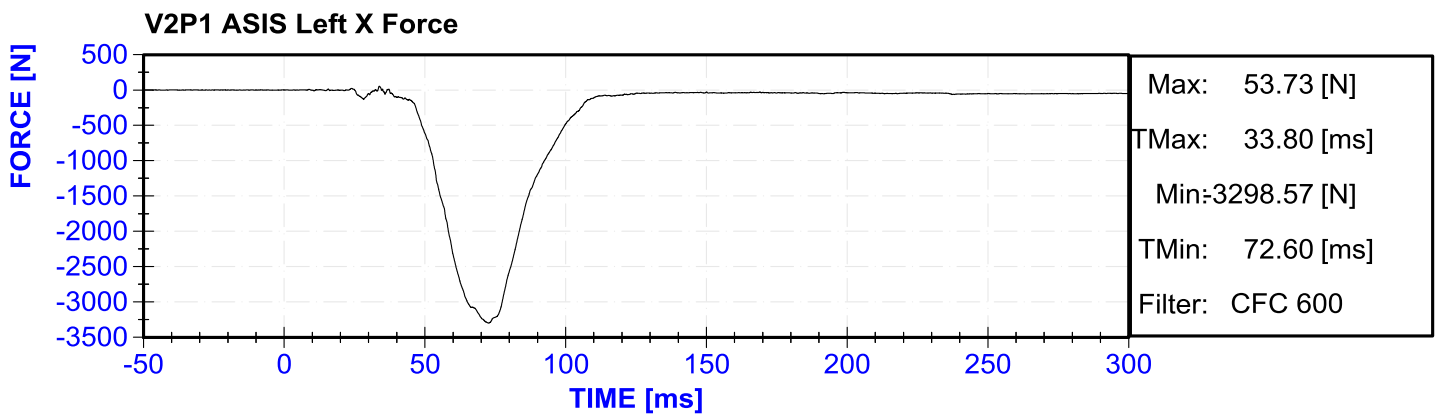
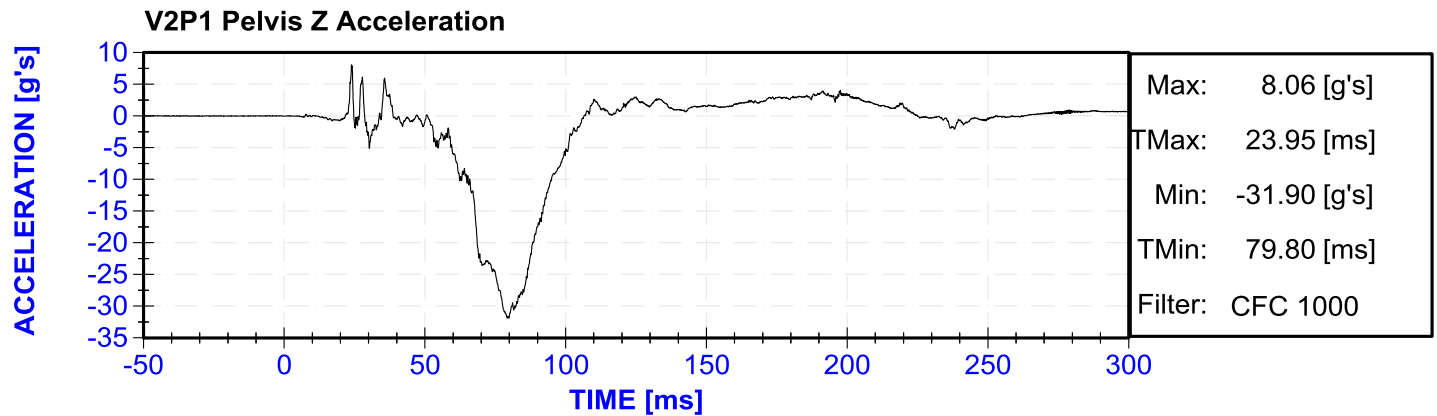
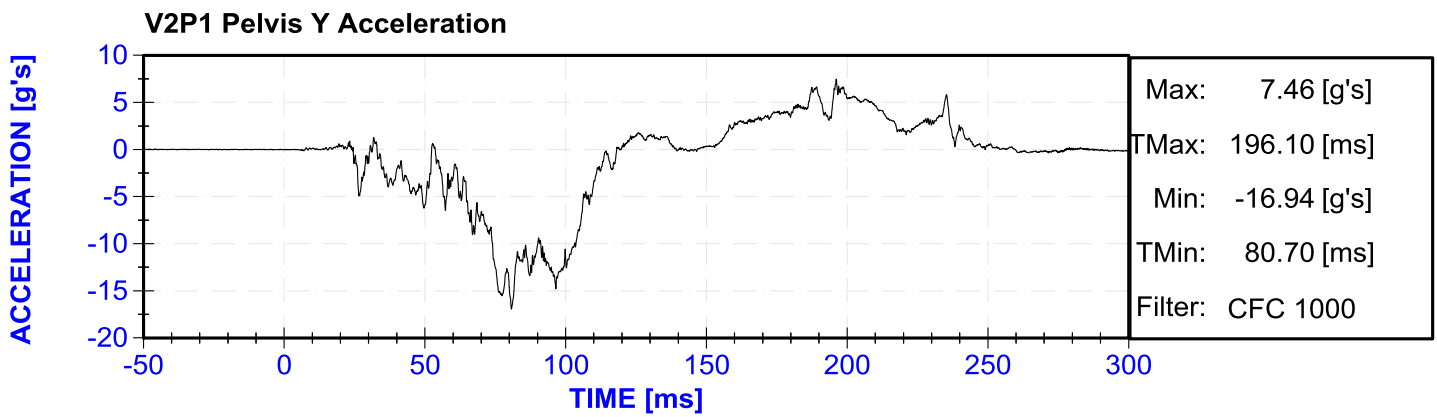
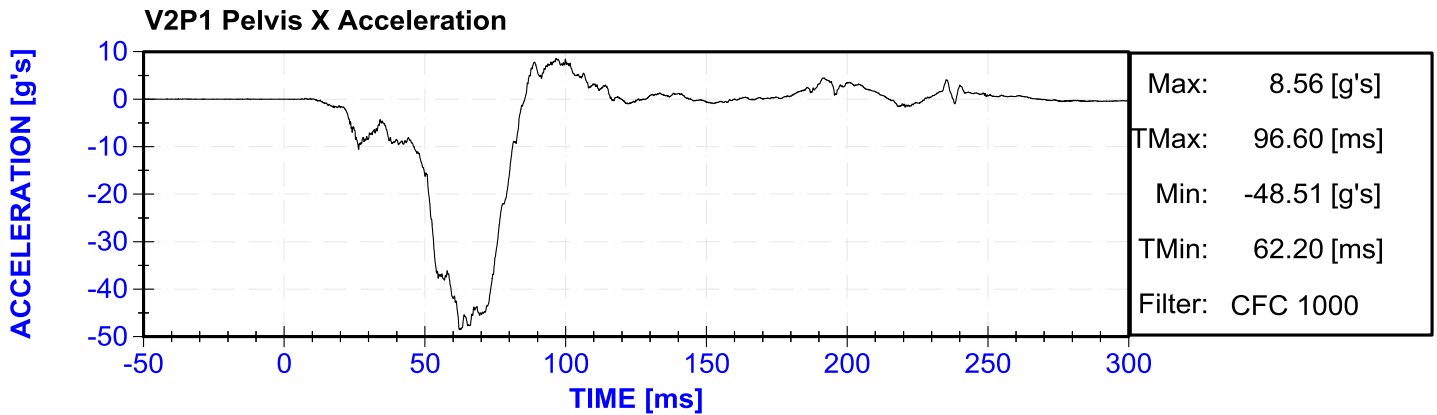

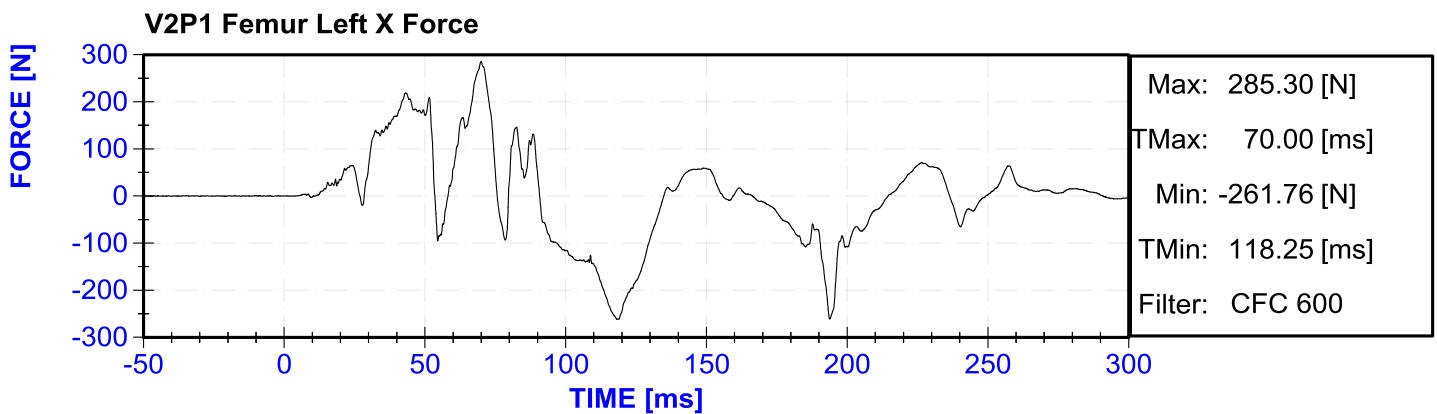
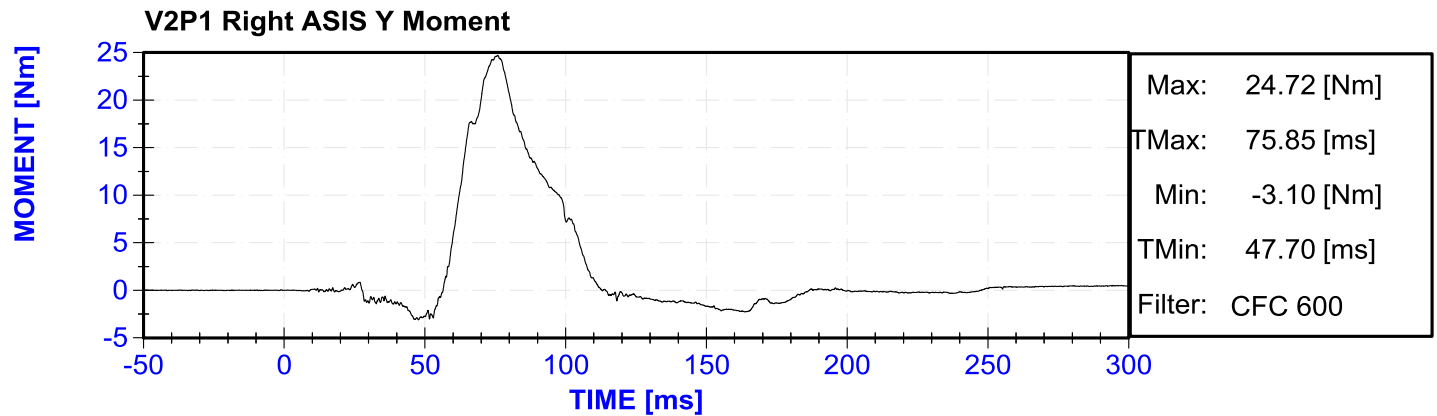
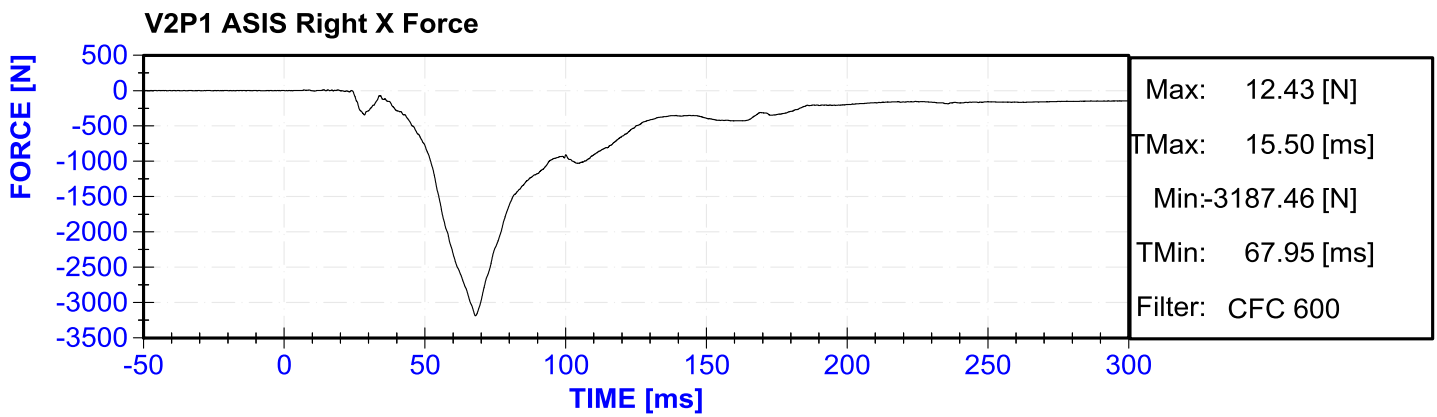
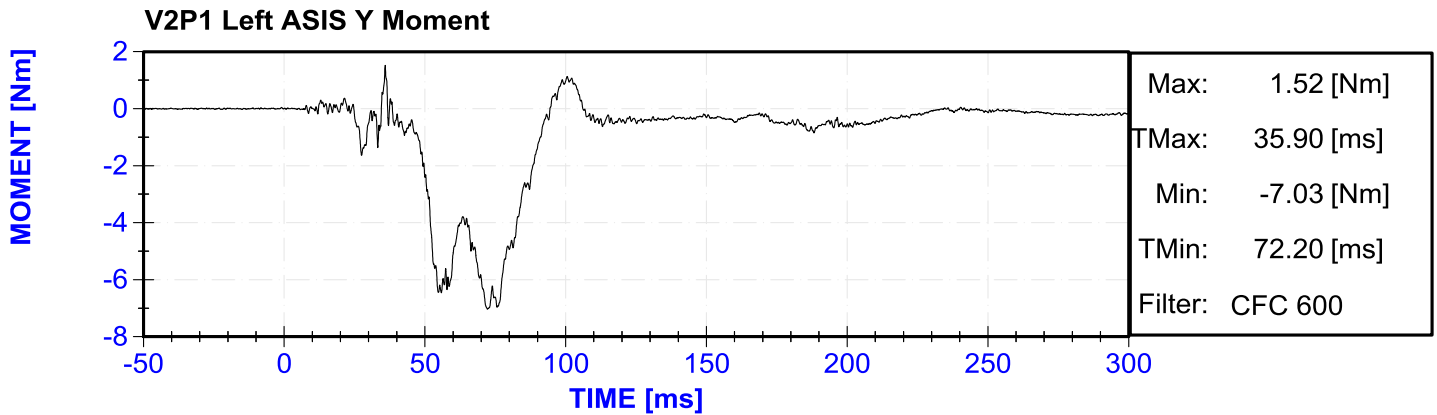

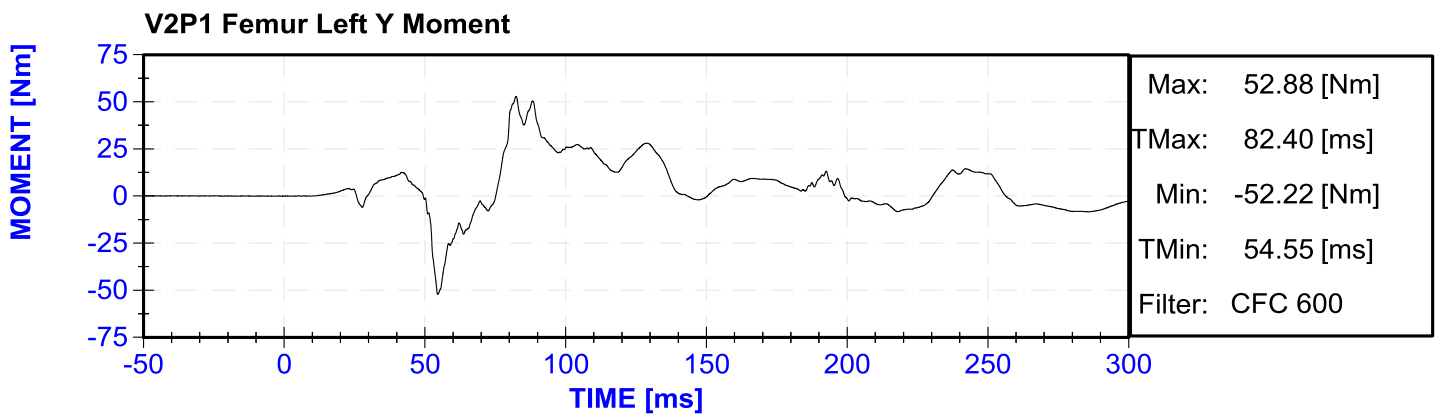
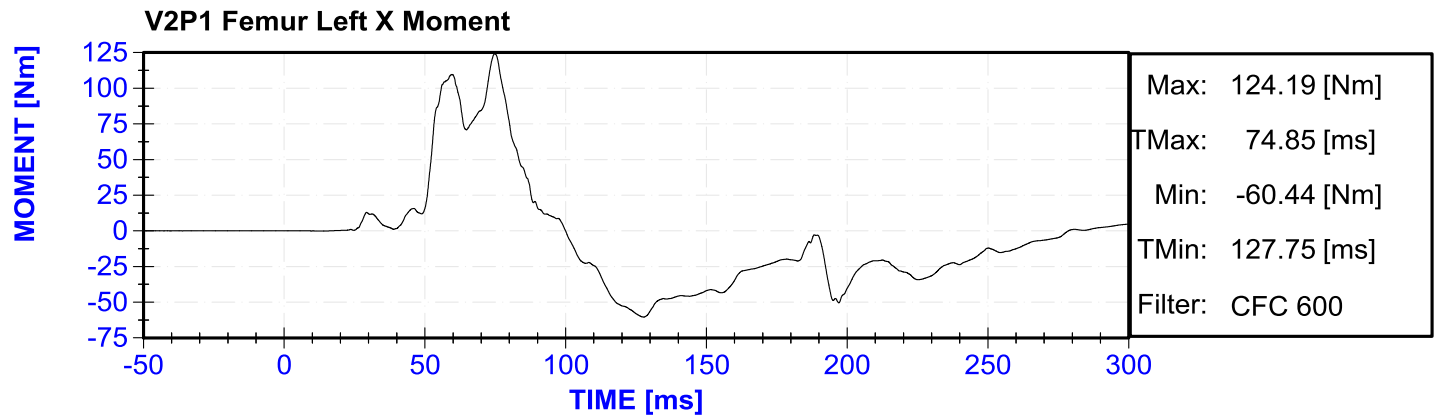
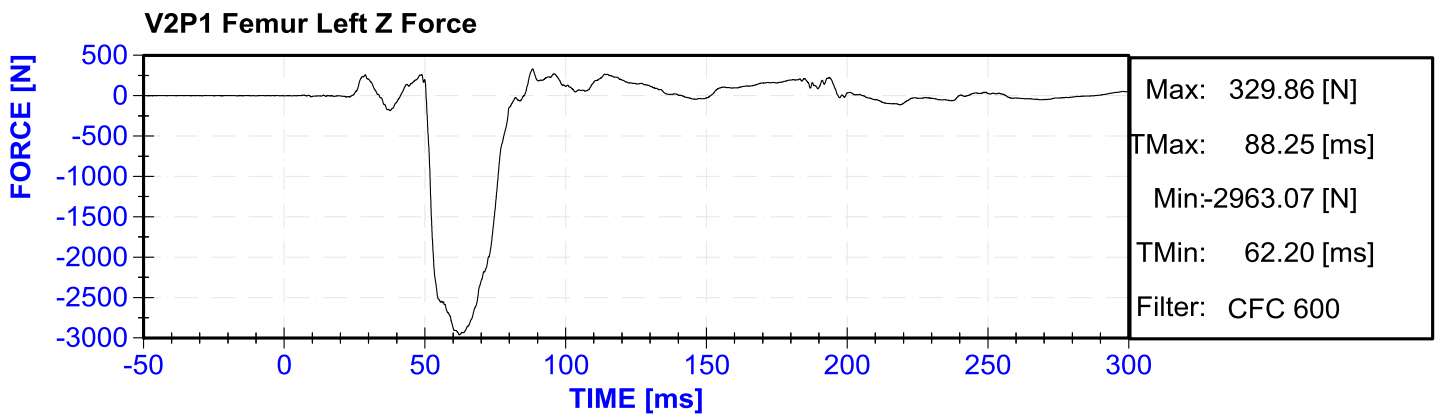
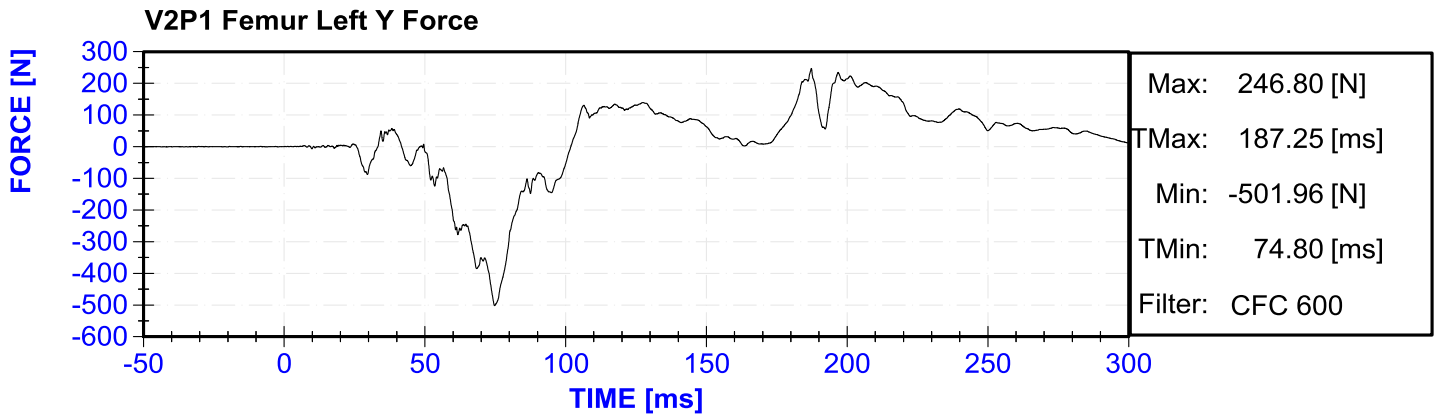

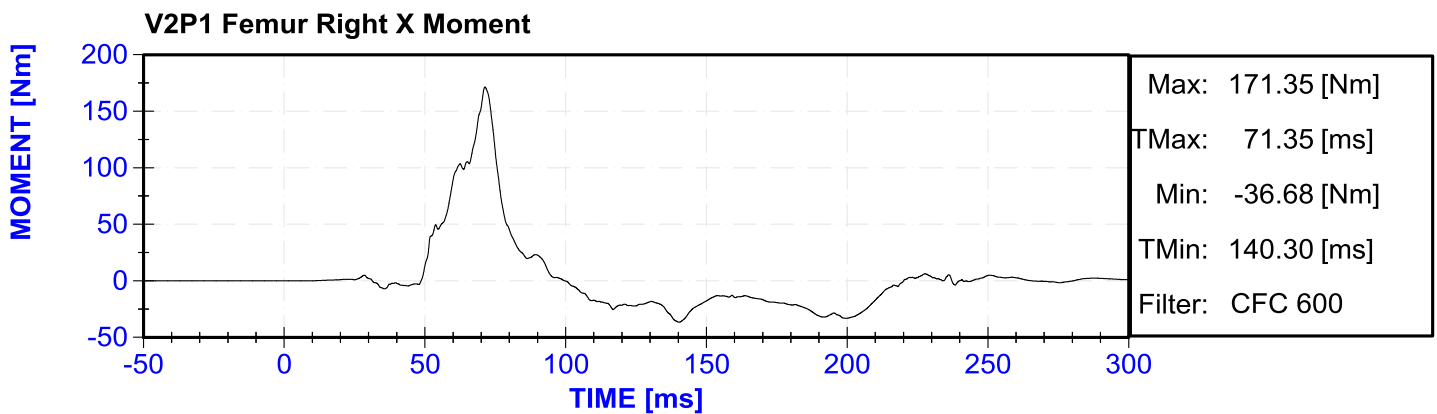
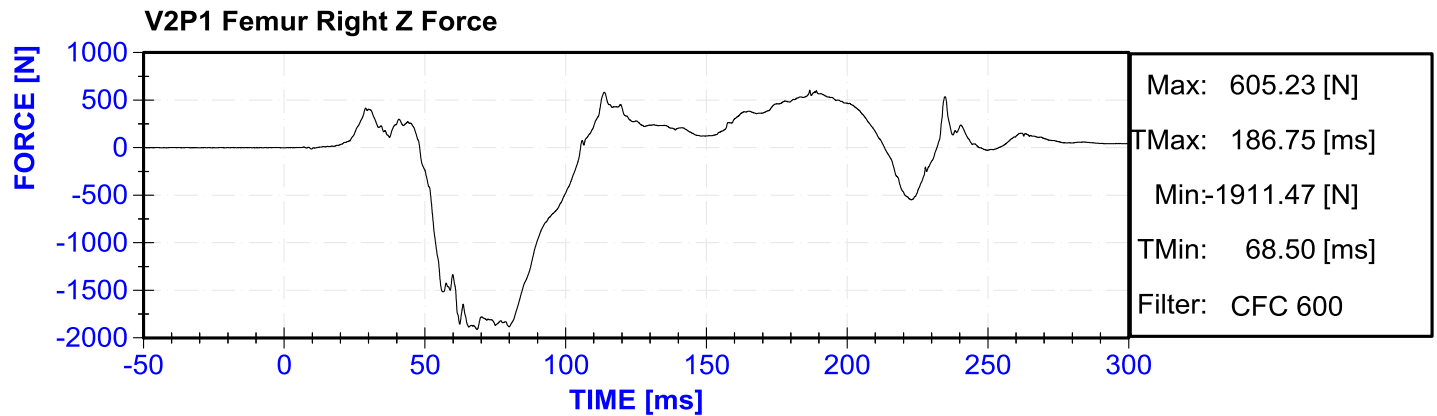
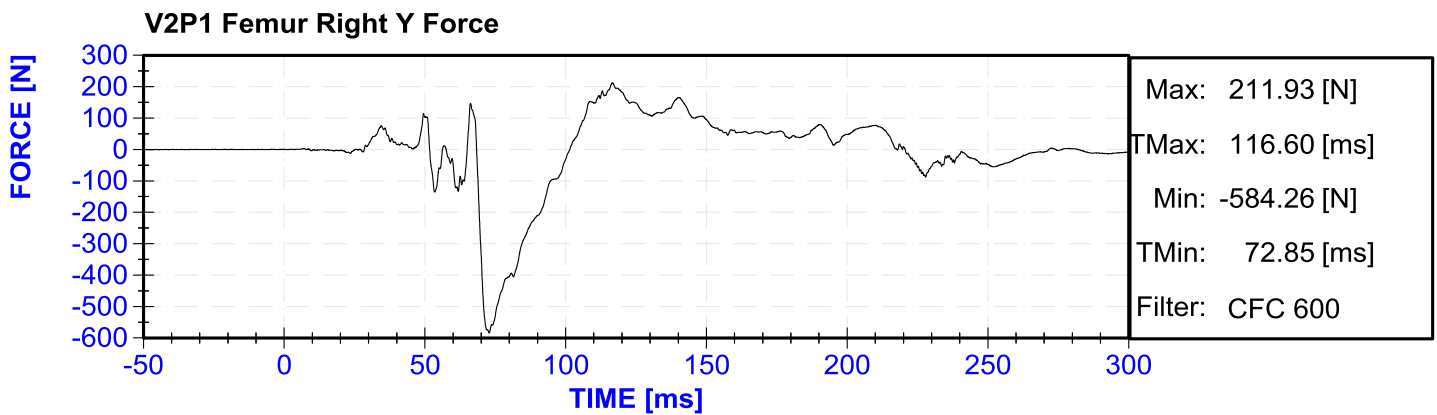
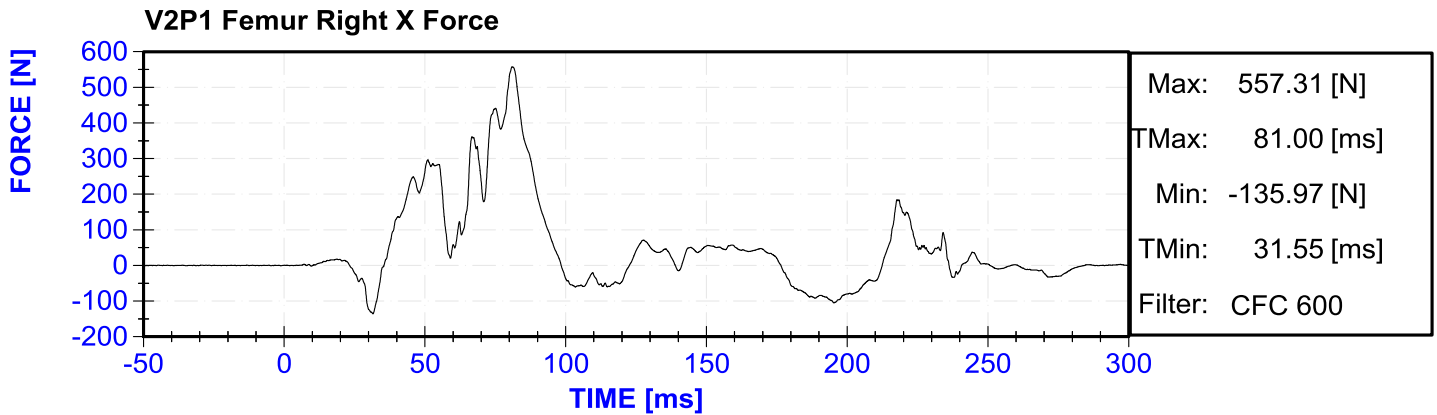

V2P1 Femur Right Y Moment

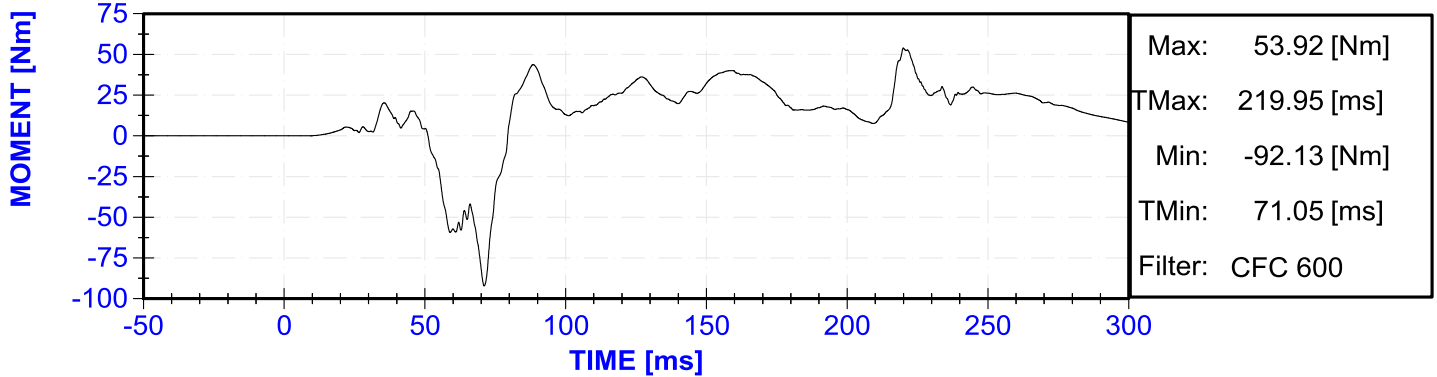

V2P1 Knee Left X Displacement

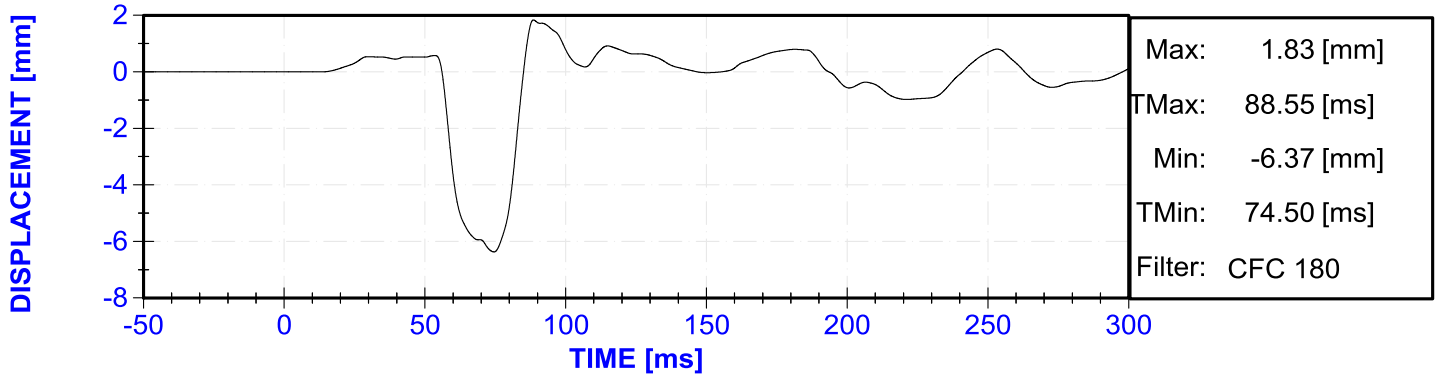

V2P1 Knee Right X Displacement

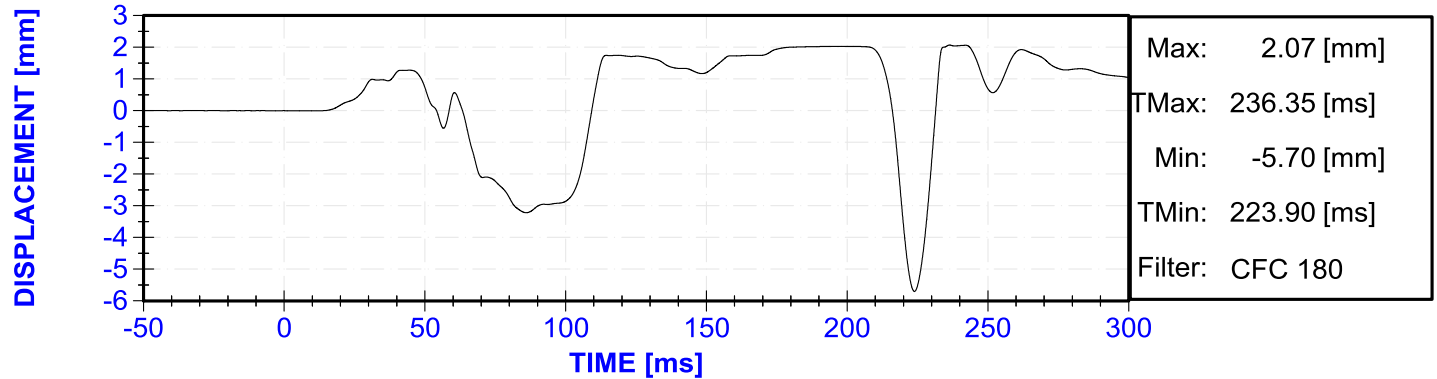

V2P1 Upper Tibia Left Z Force

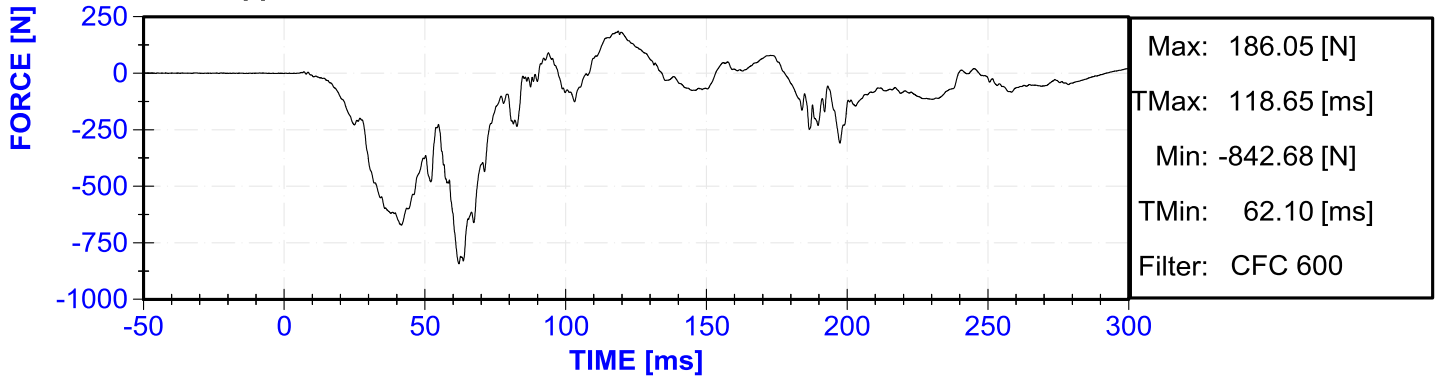

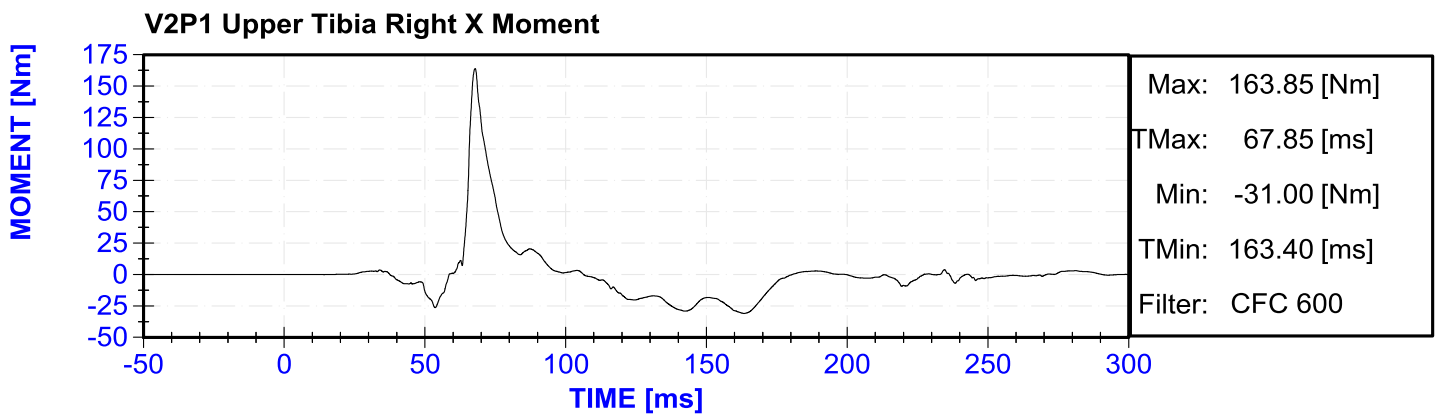
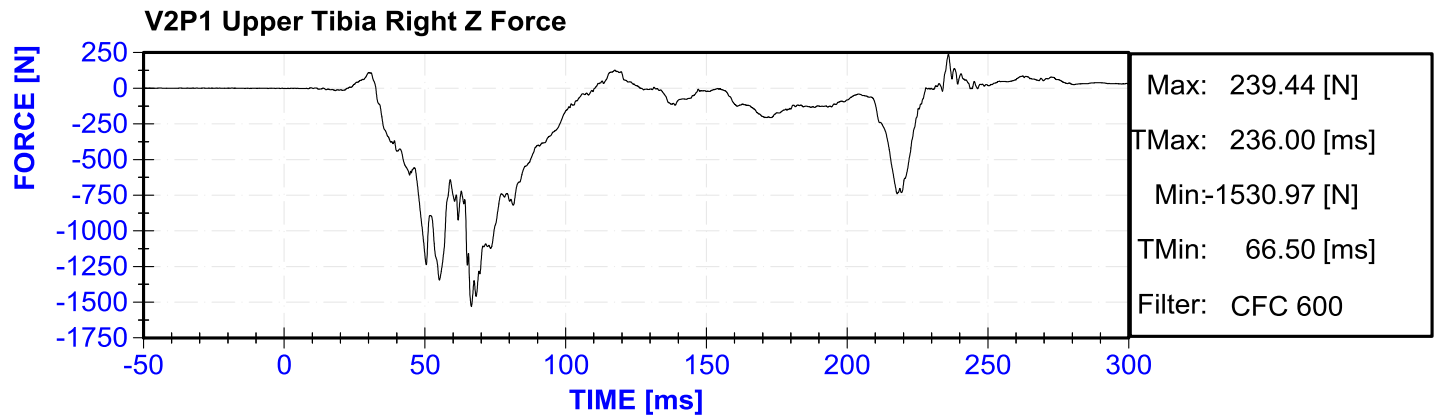
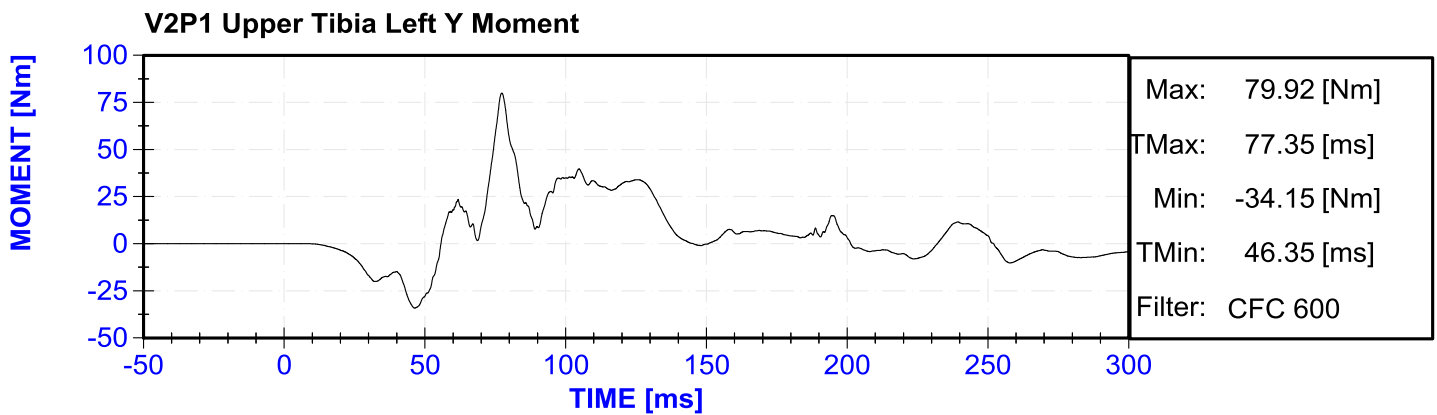
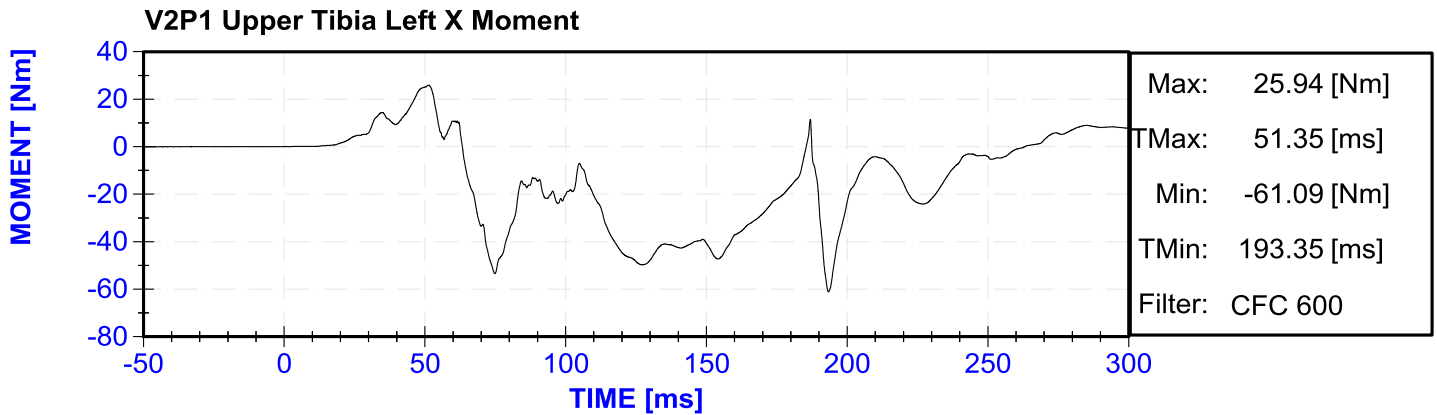

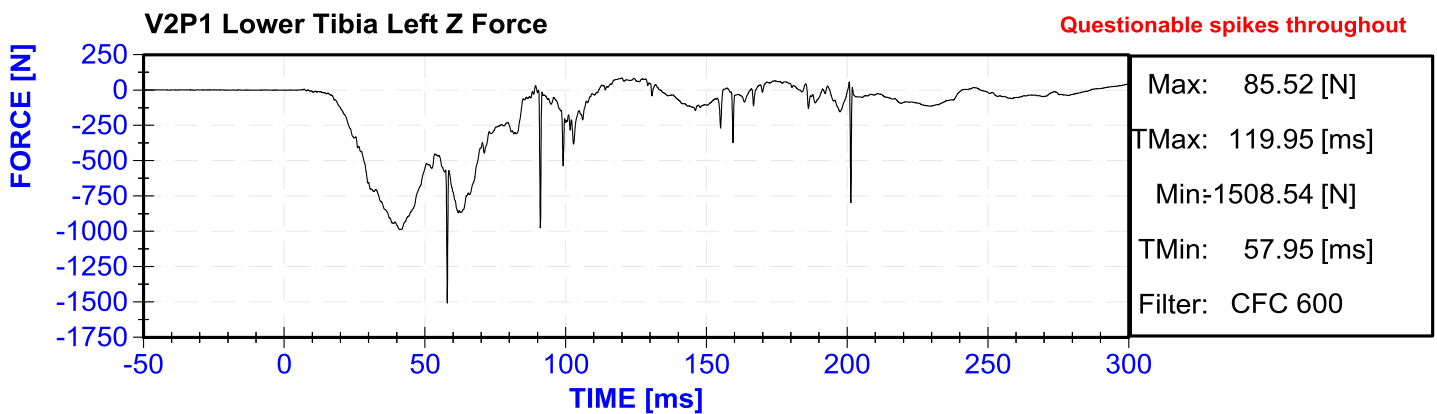
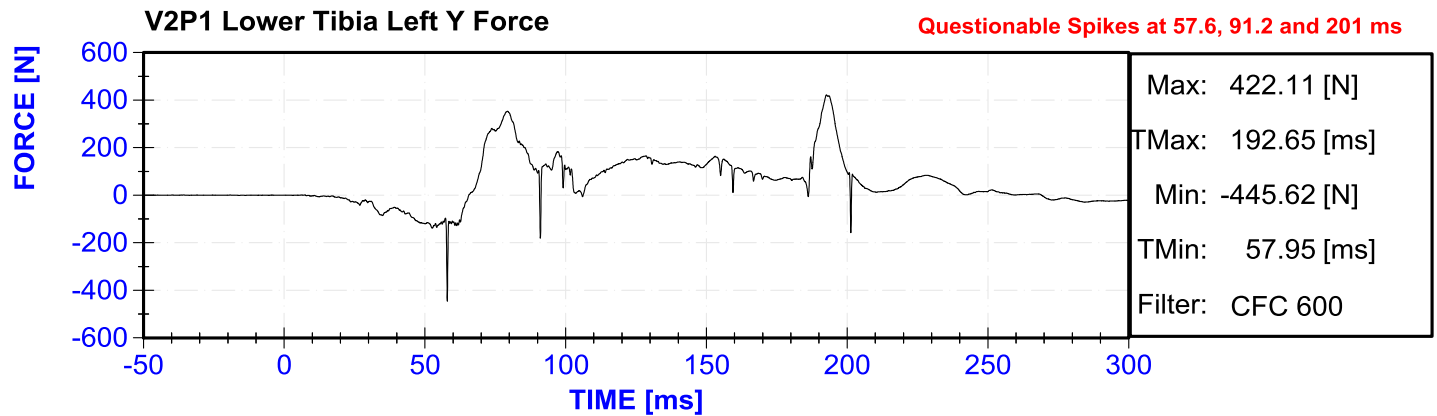
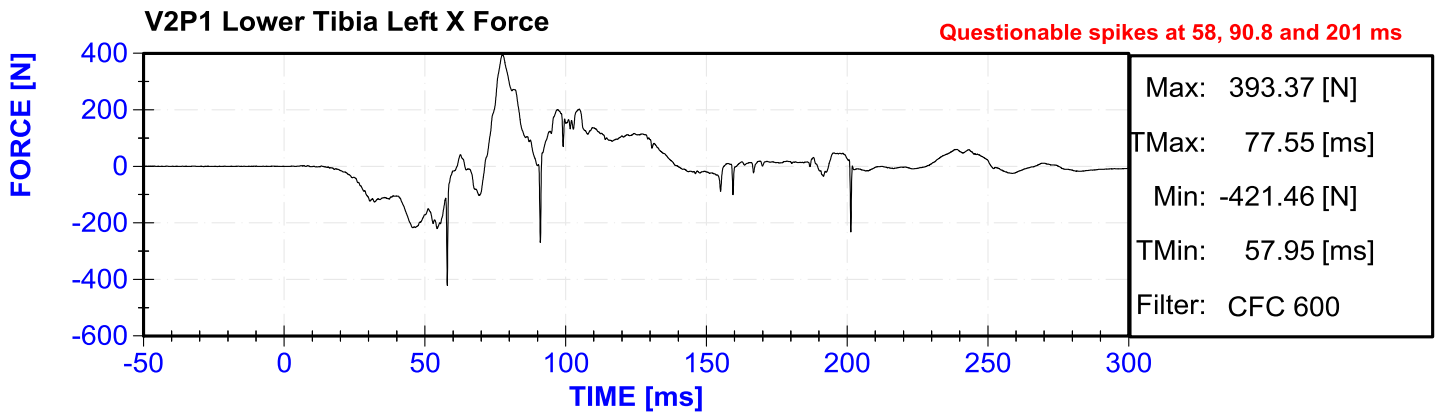
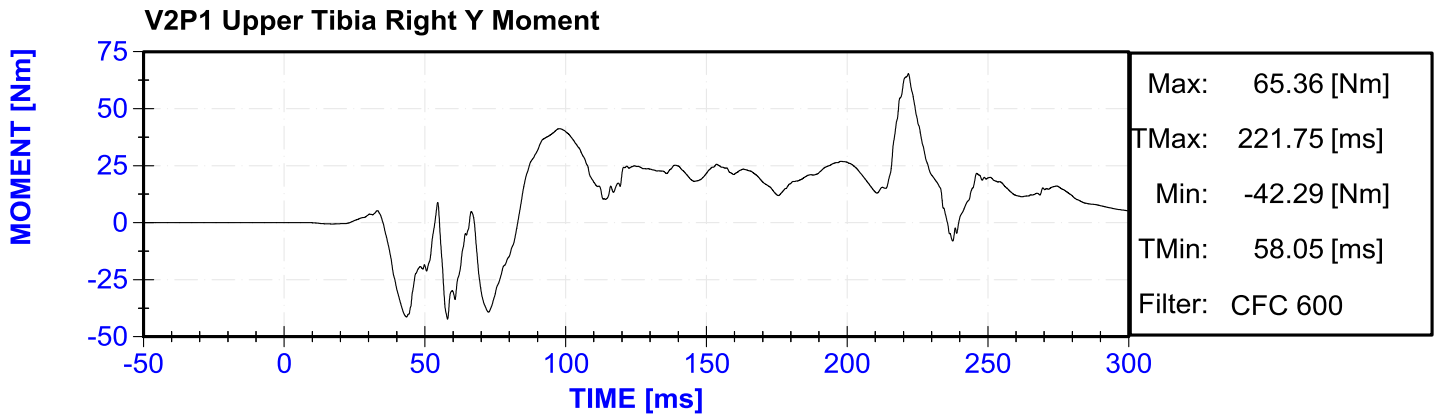

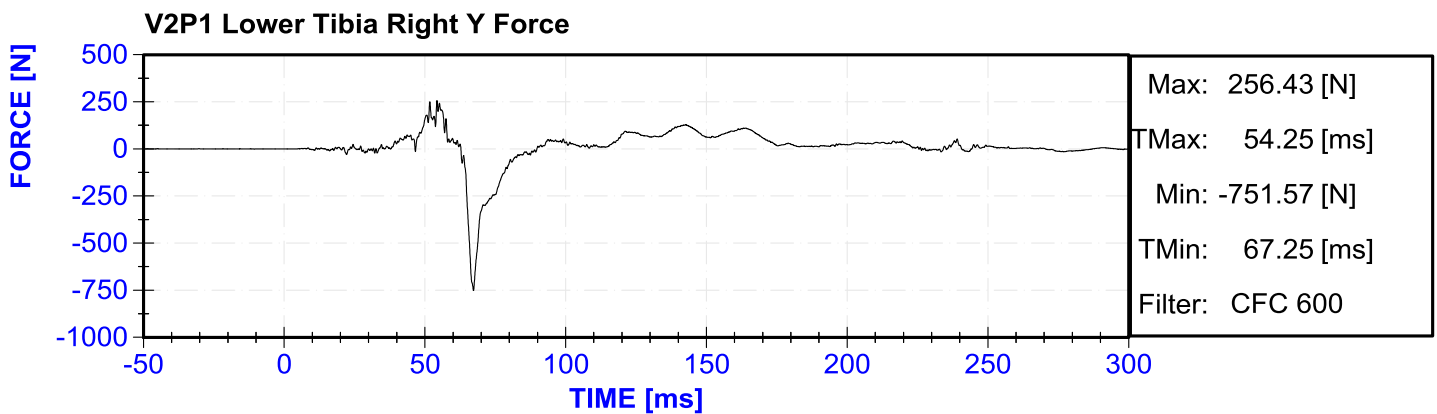
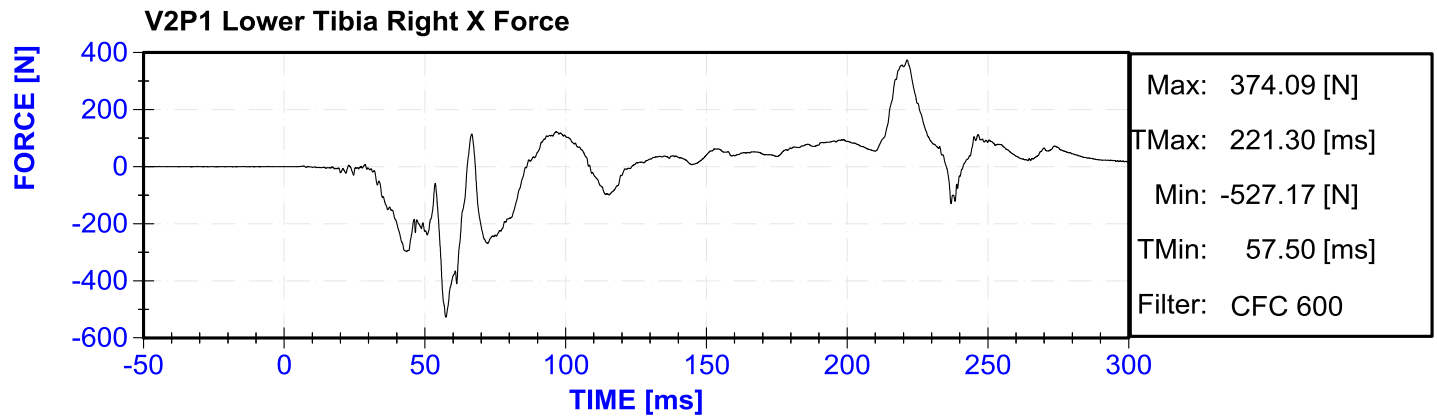
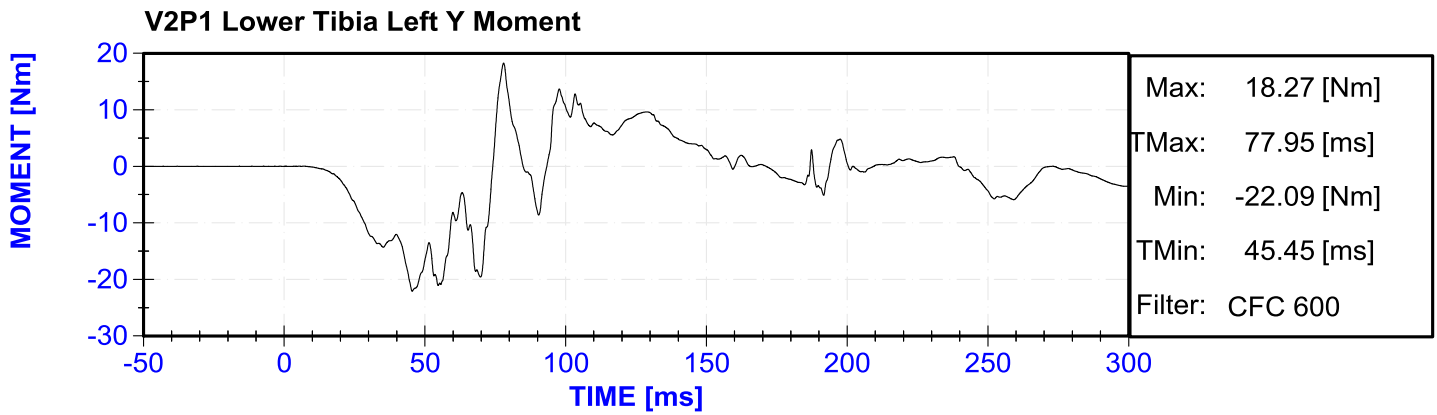
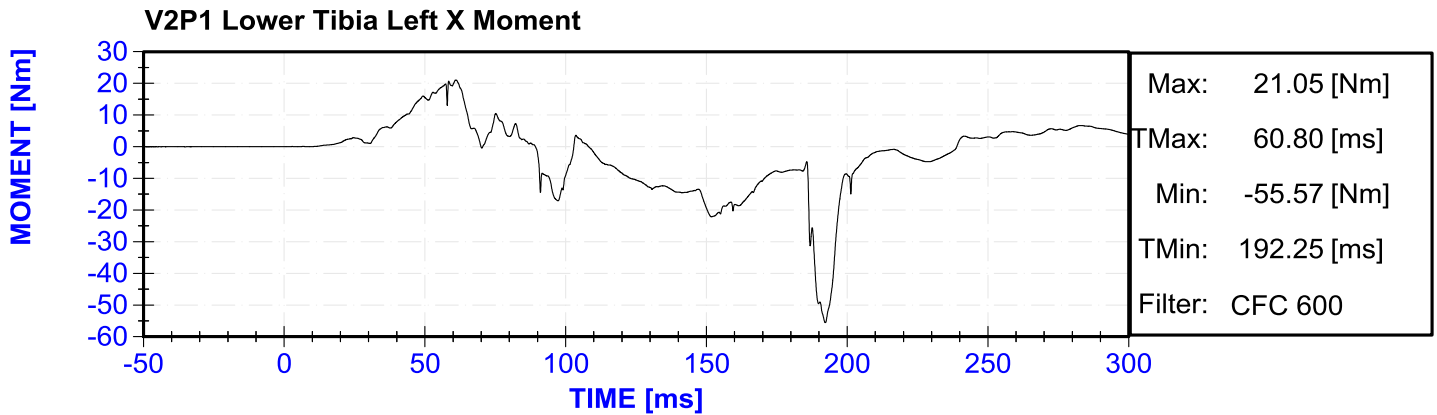

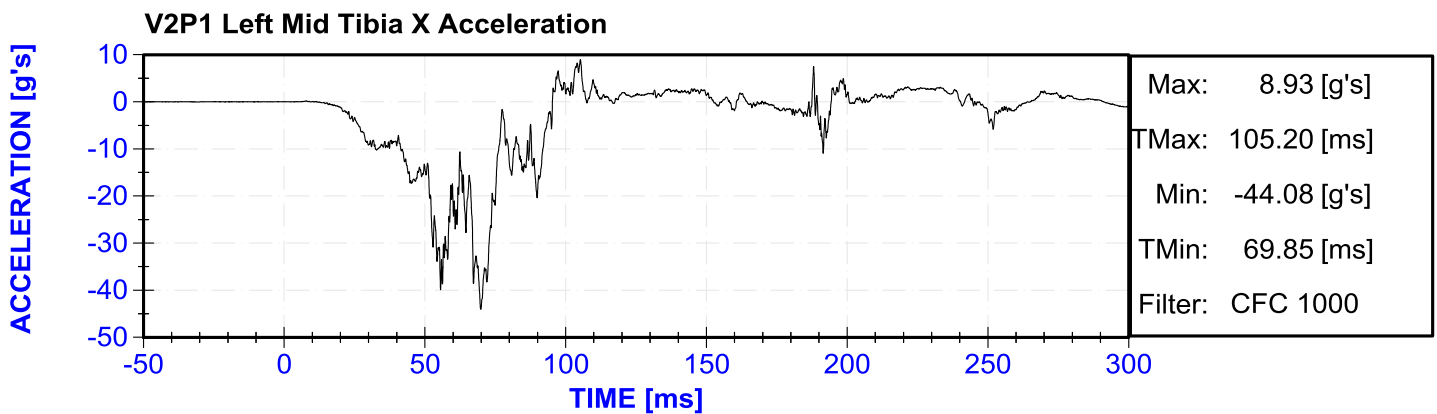
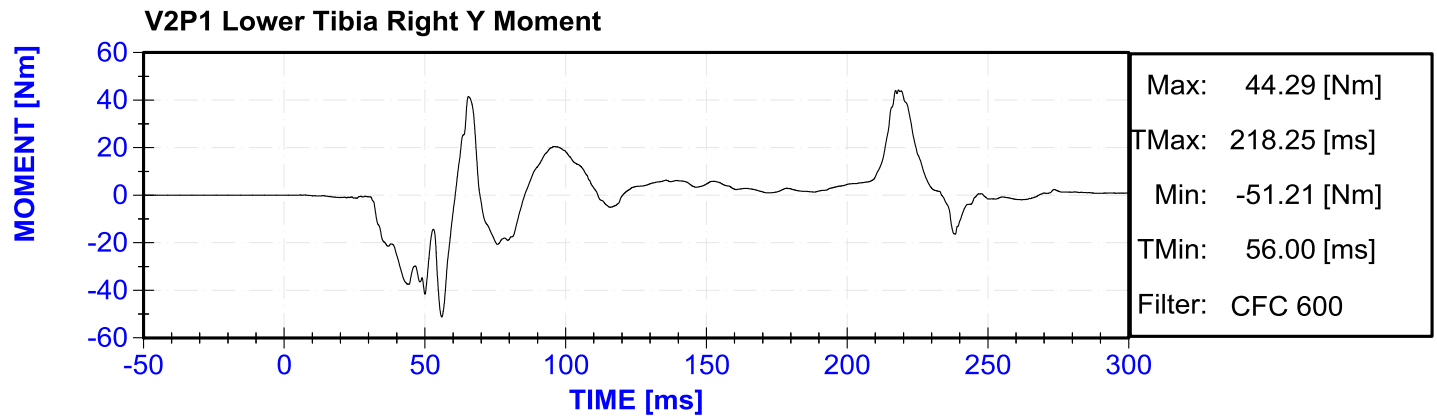
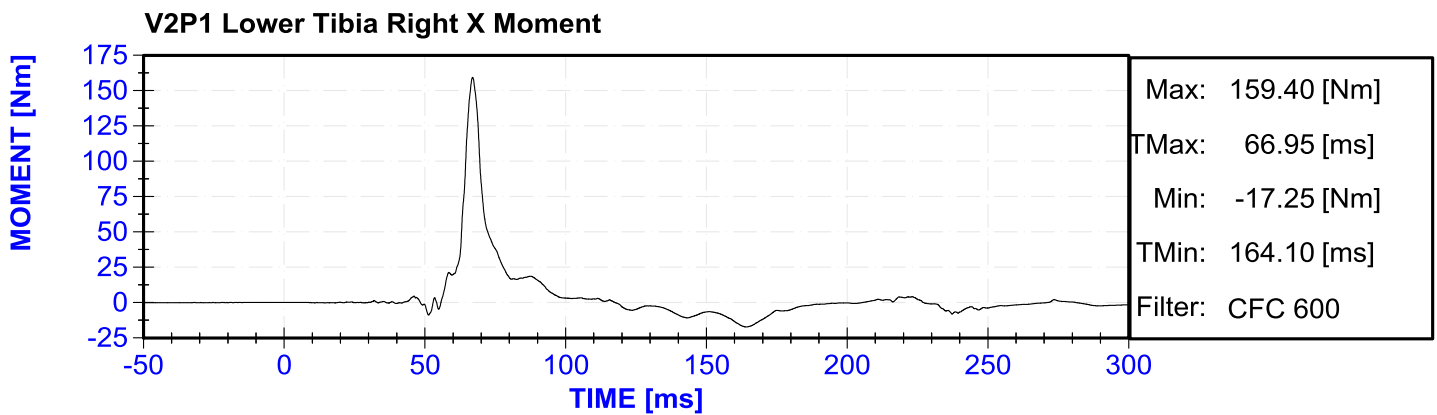
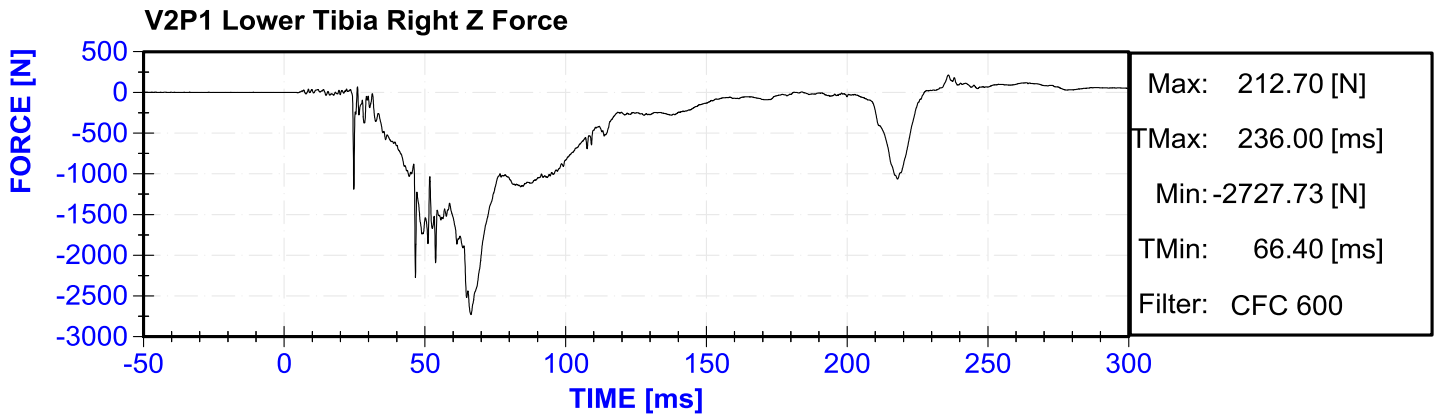

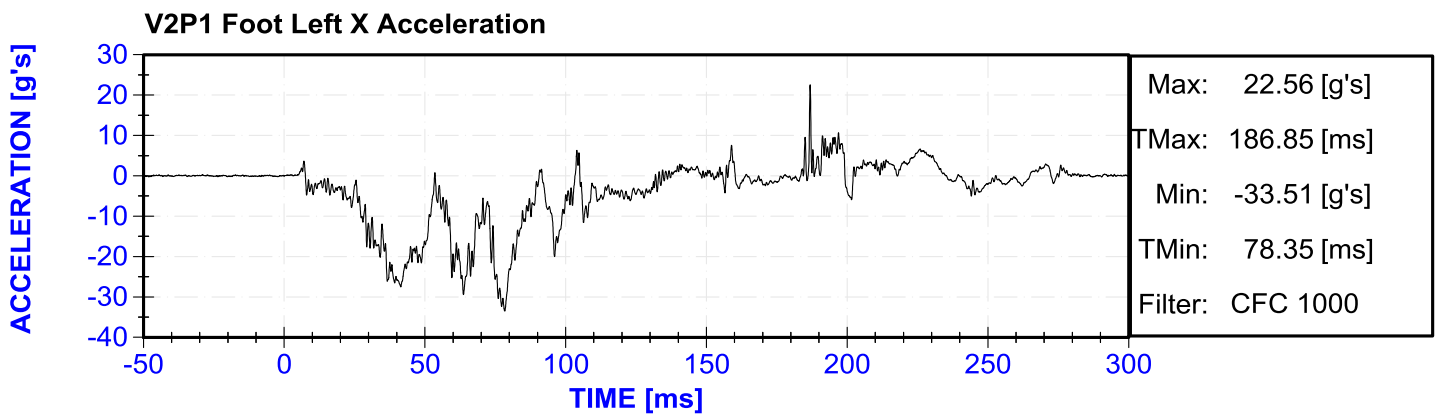
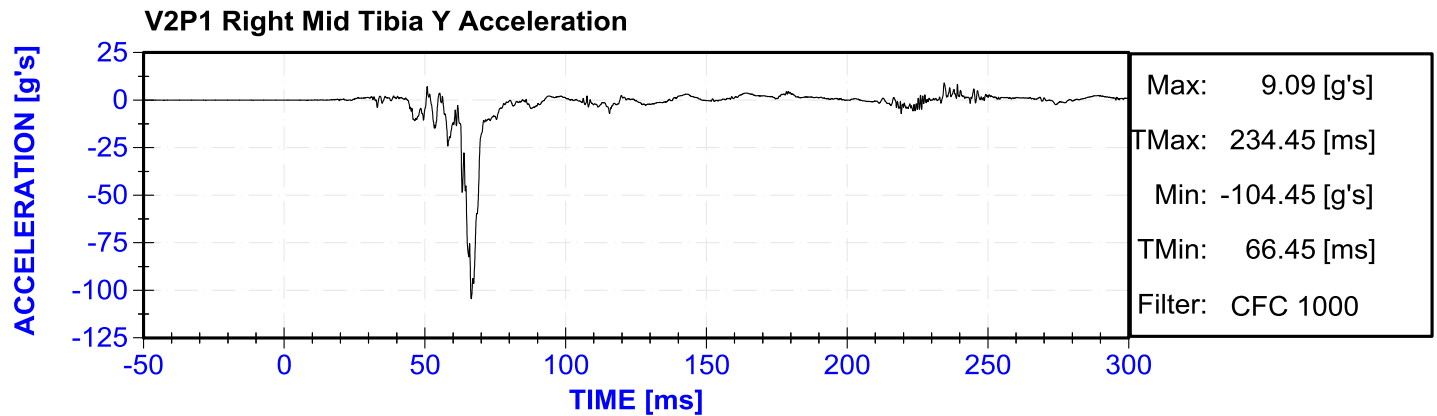
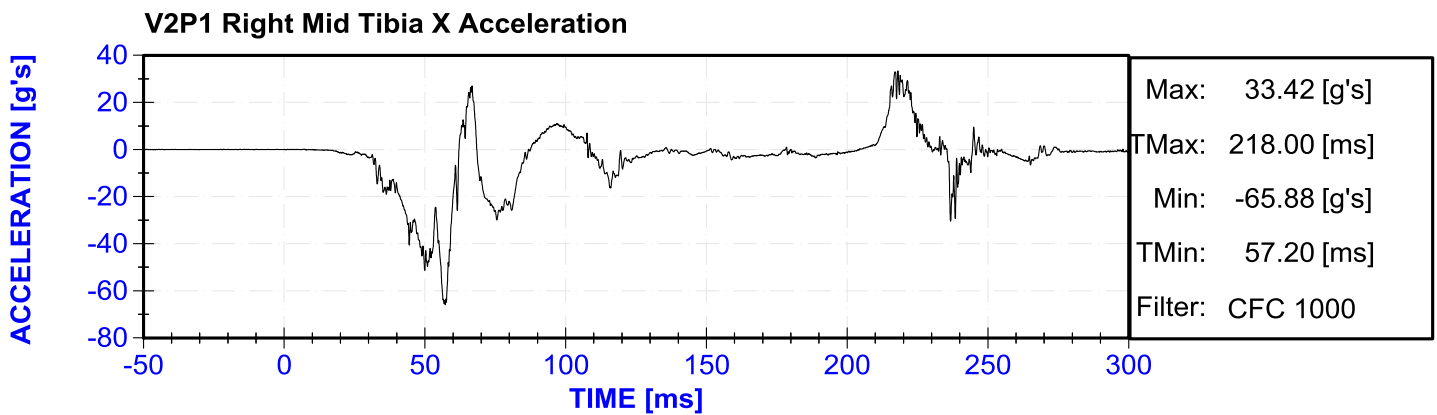
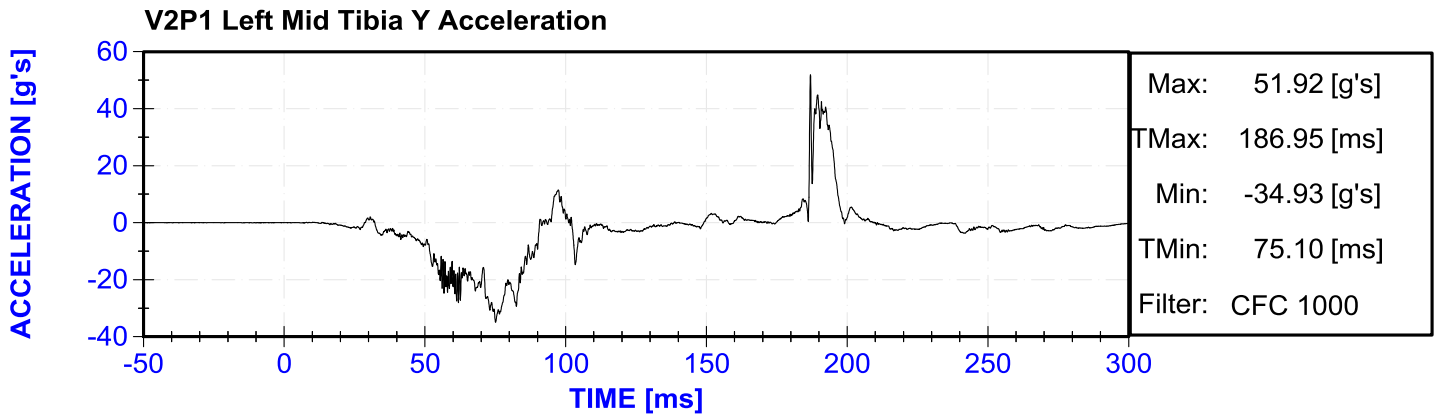

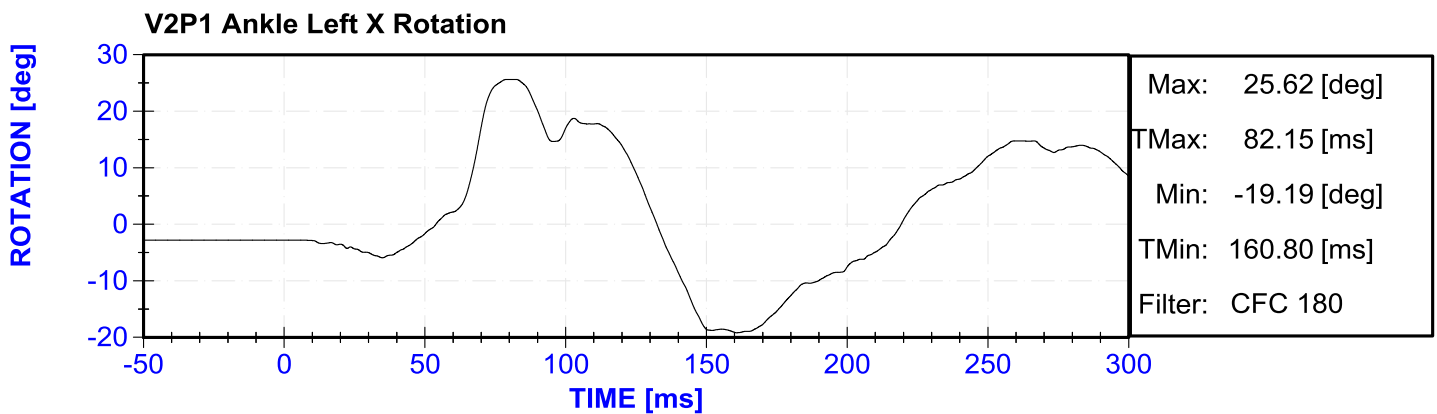
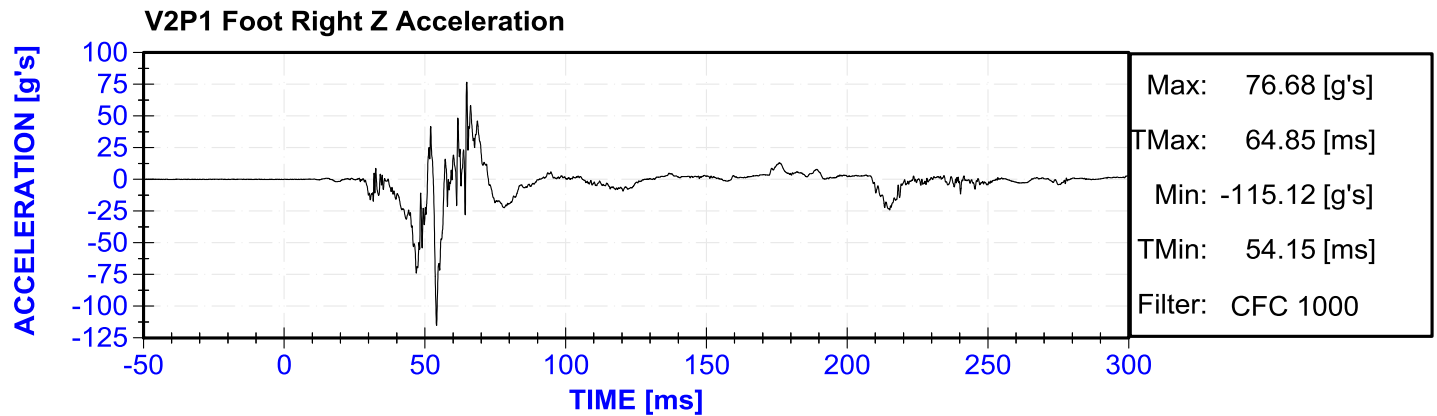
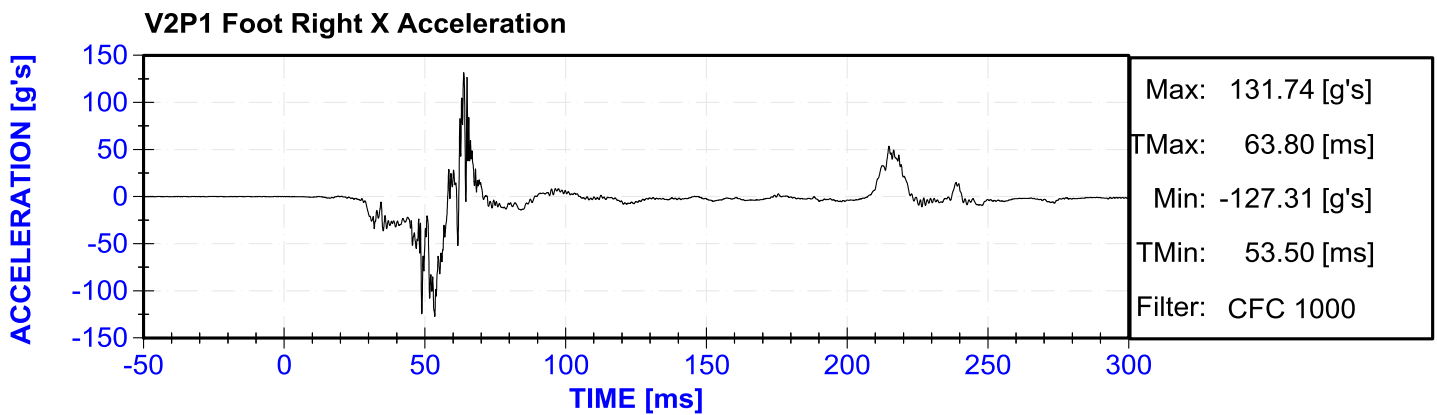
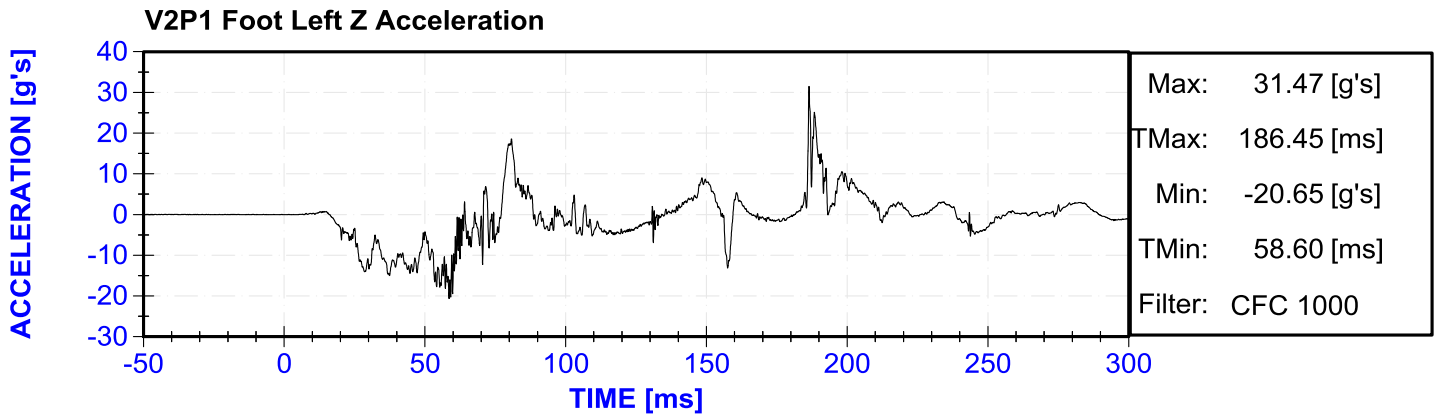

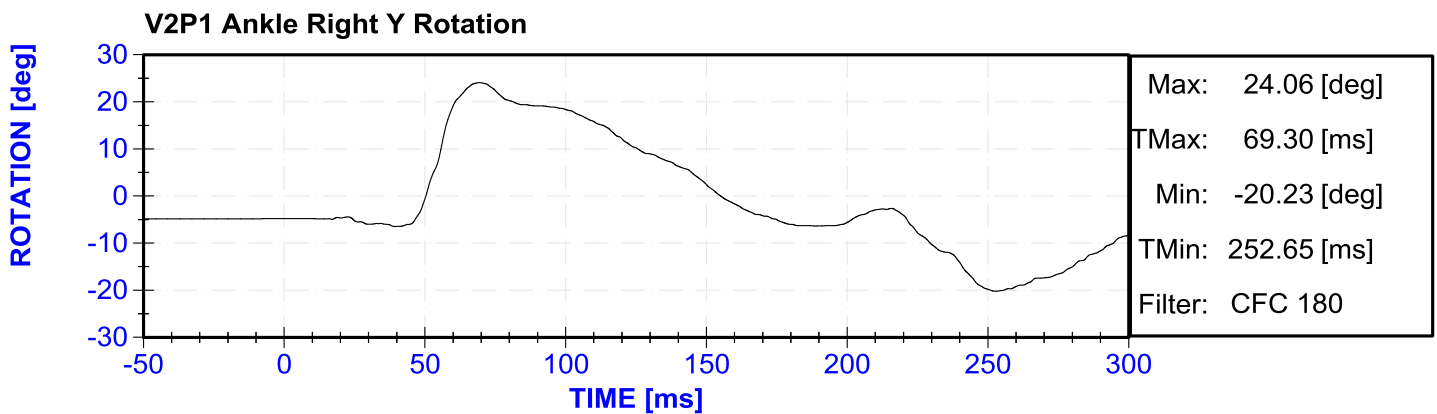
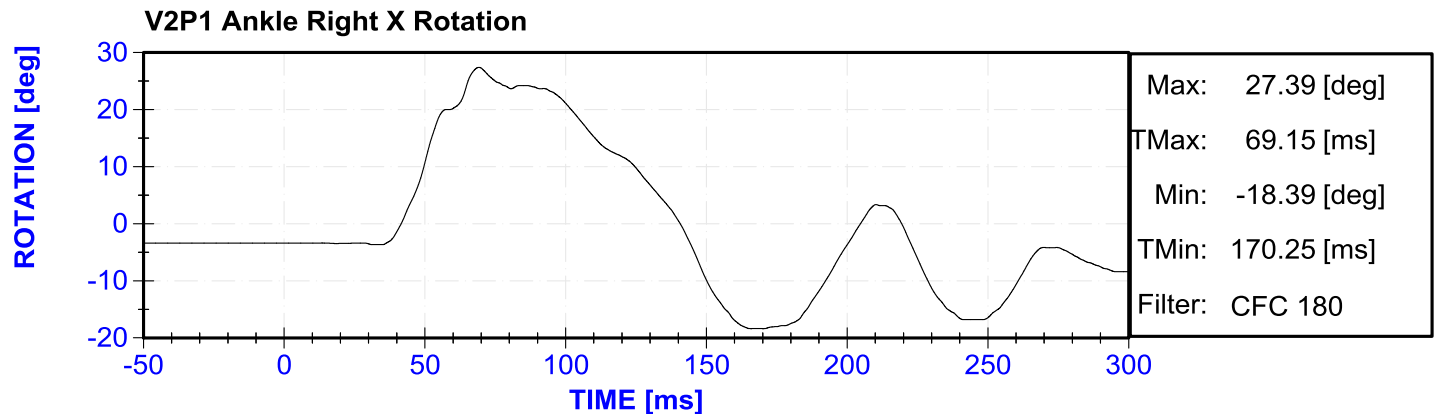
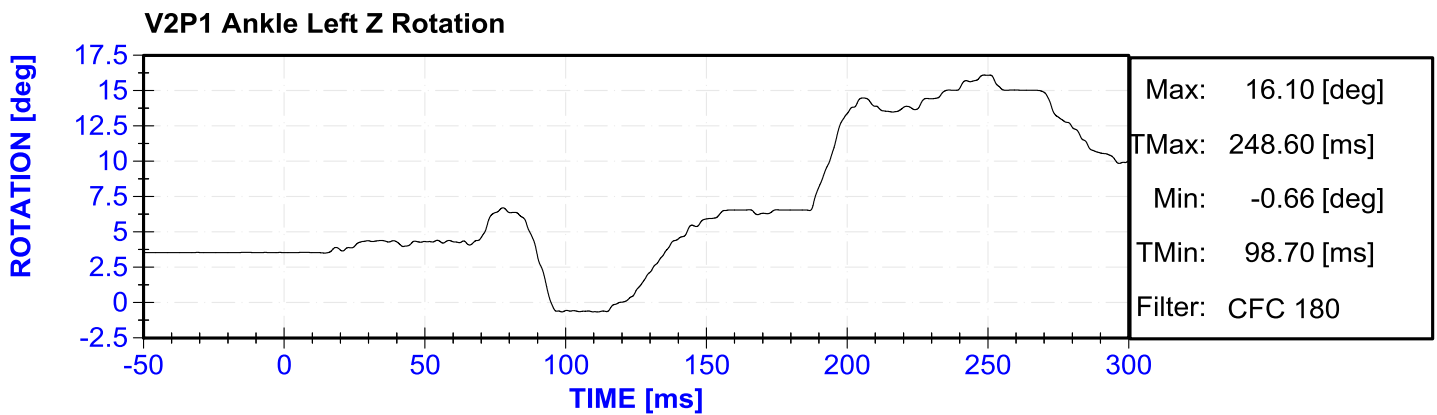
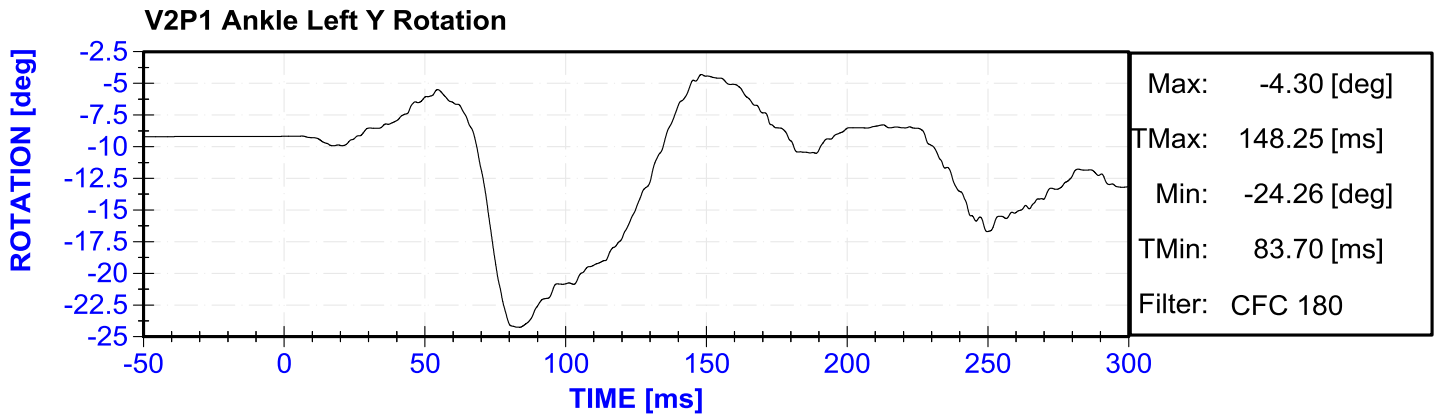

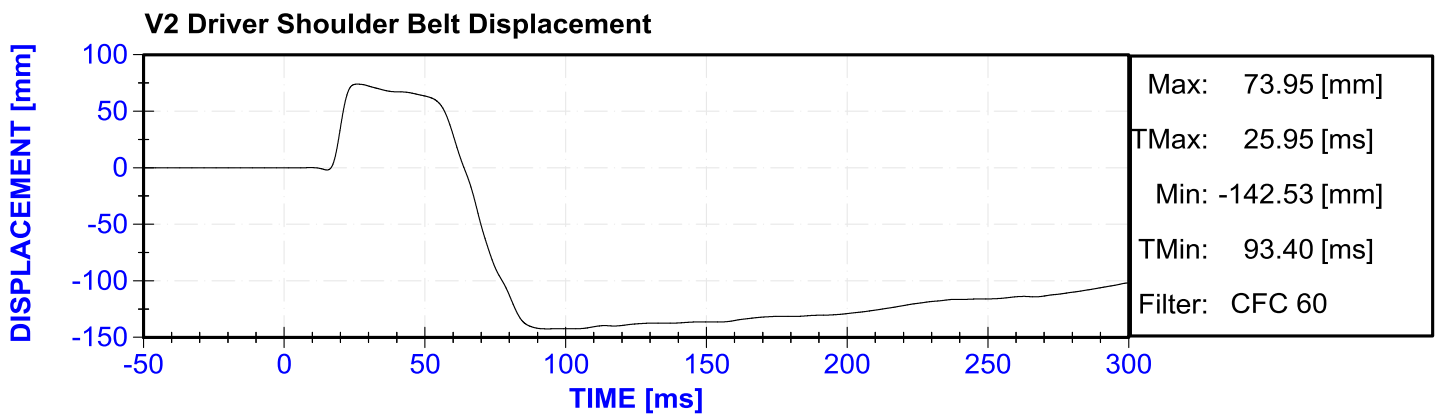
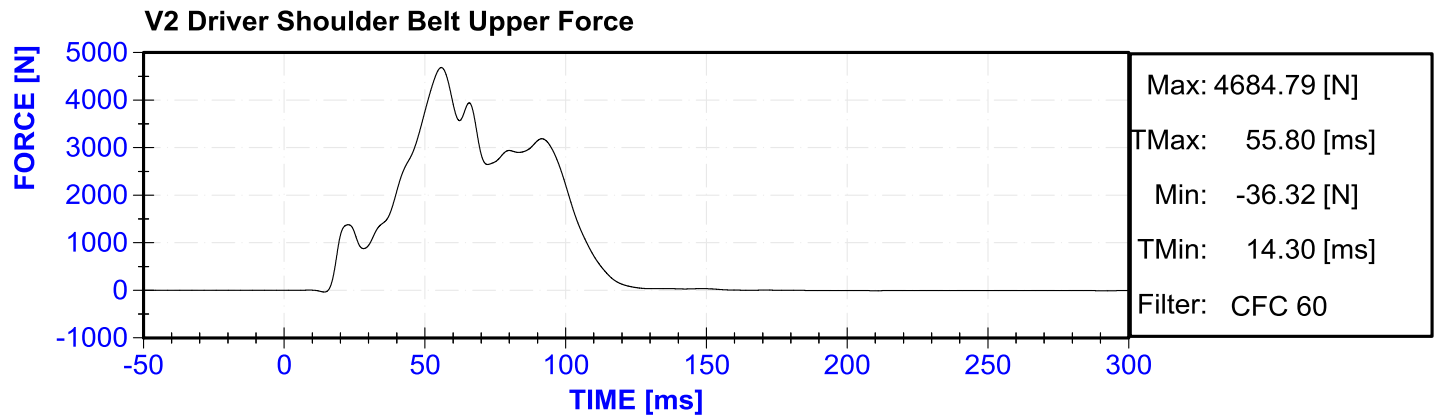
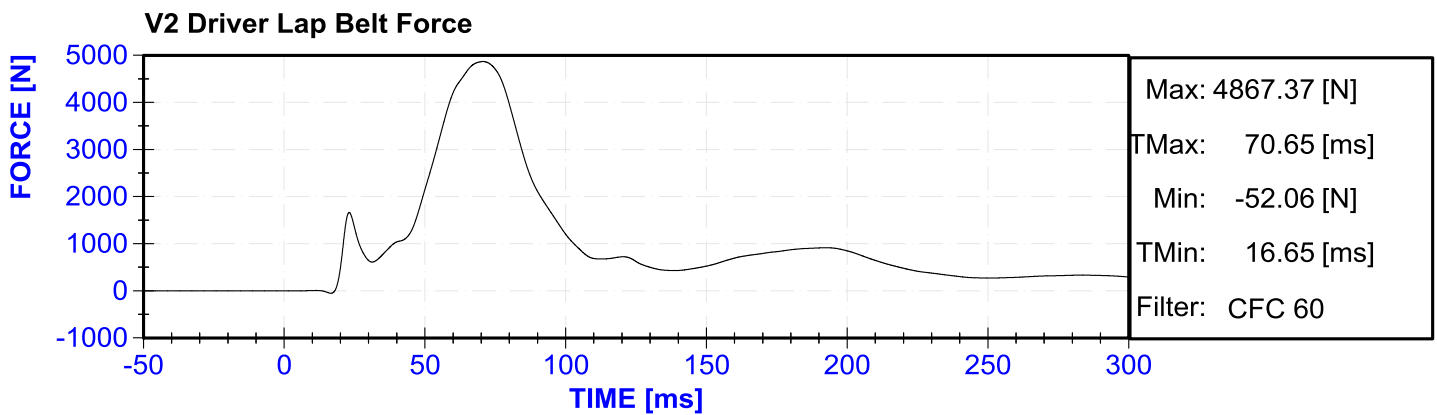
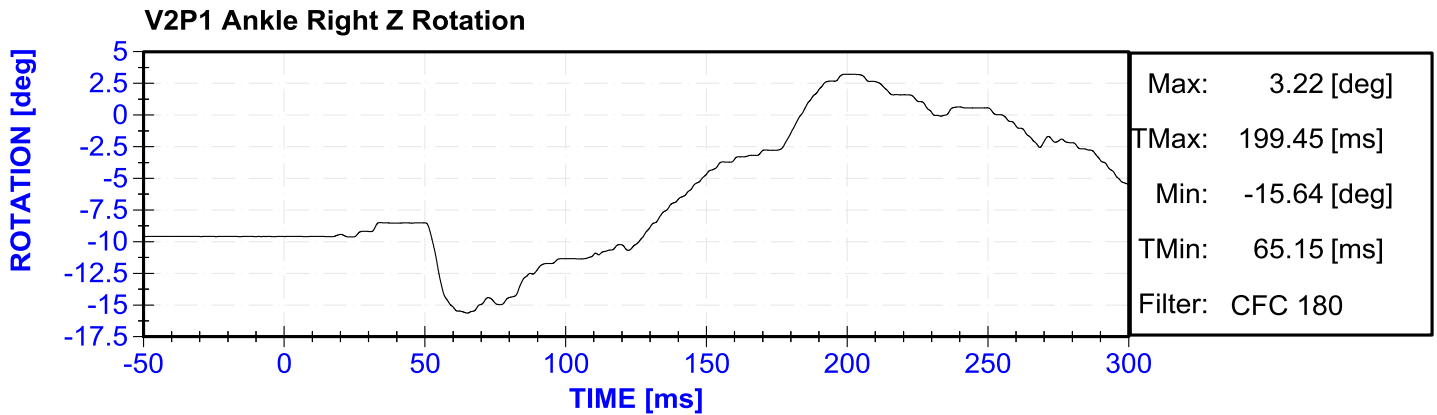

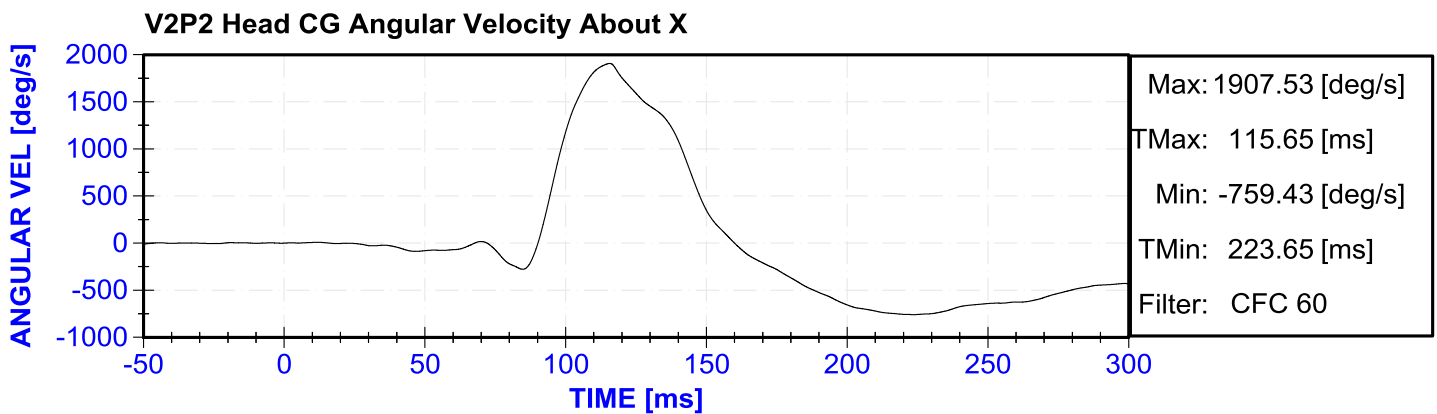
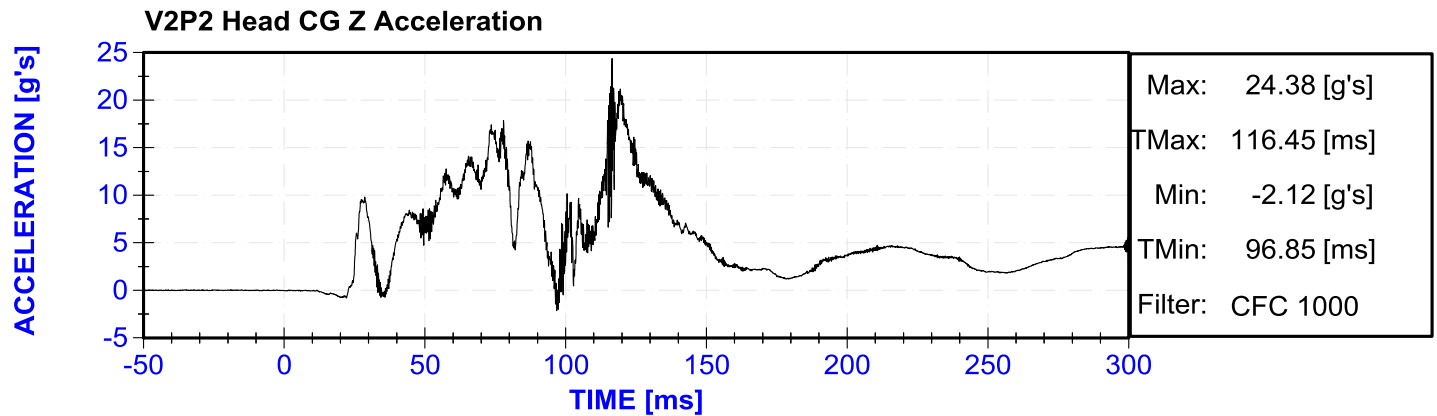
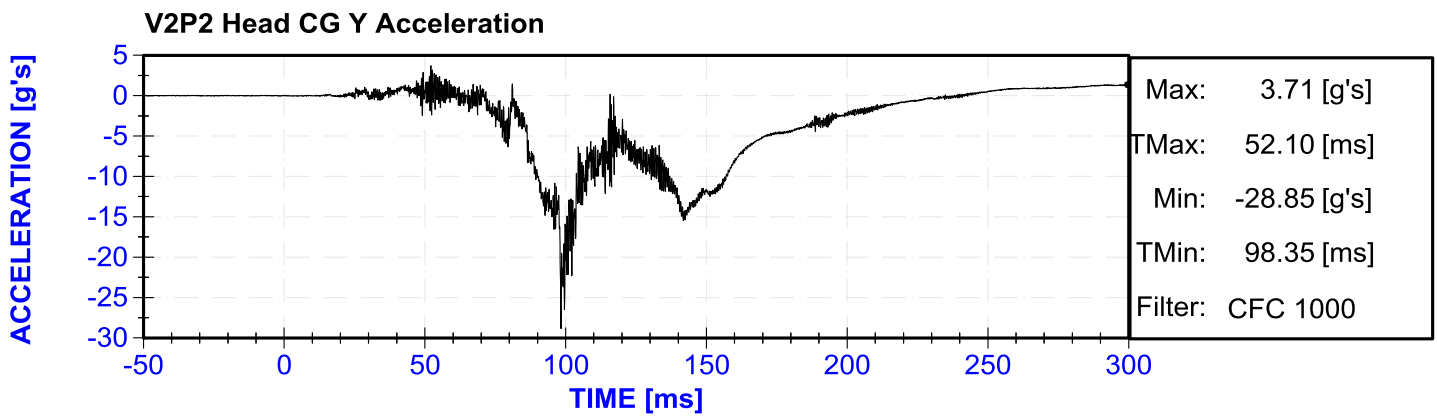
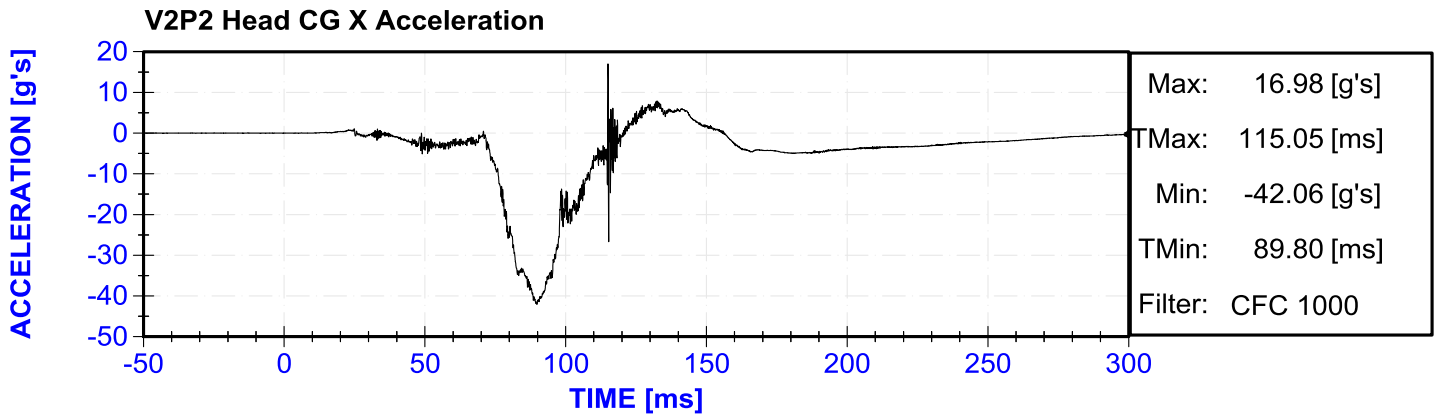

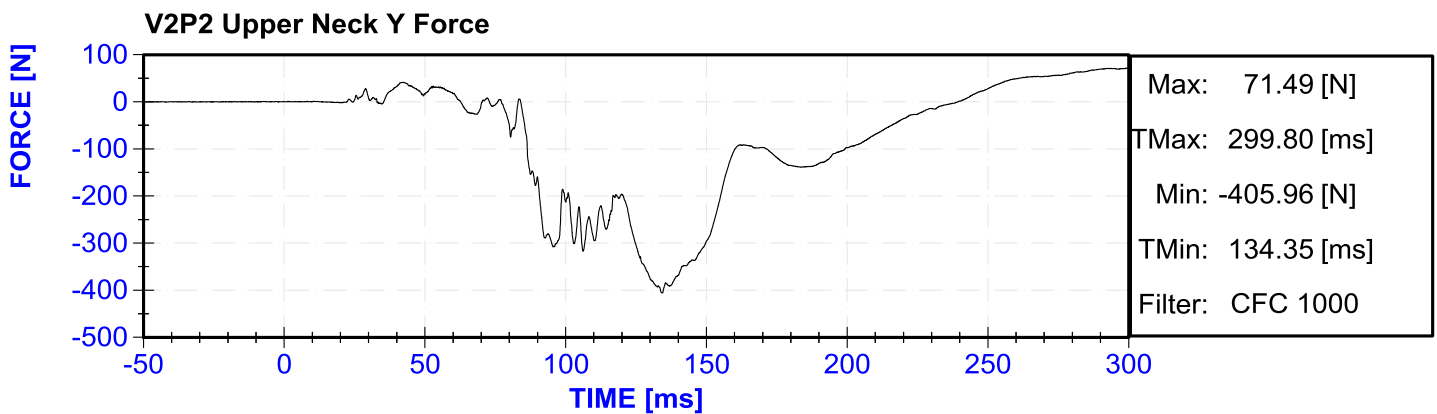
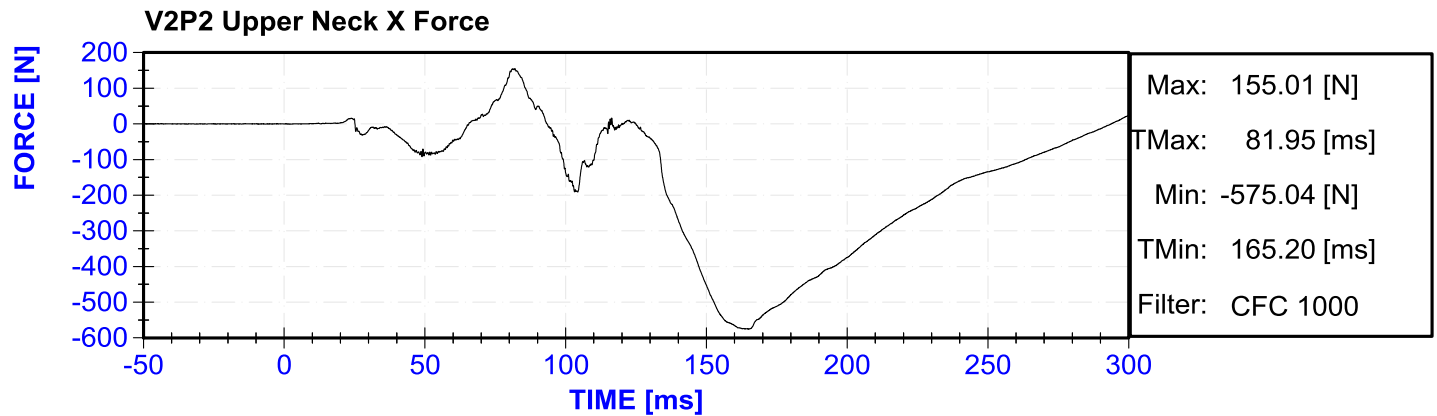
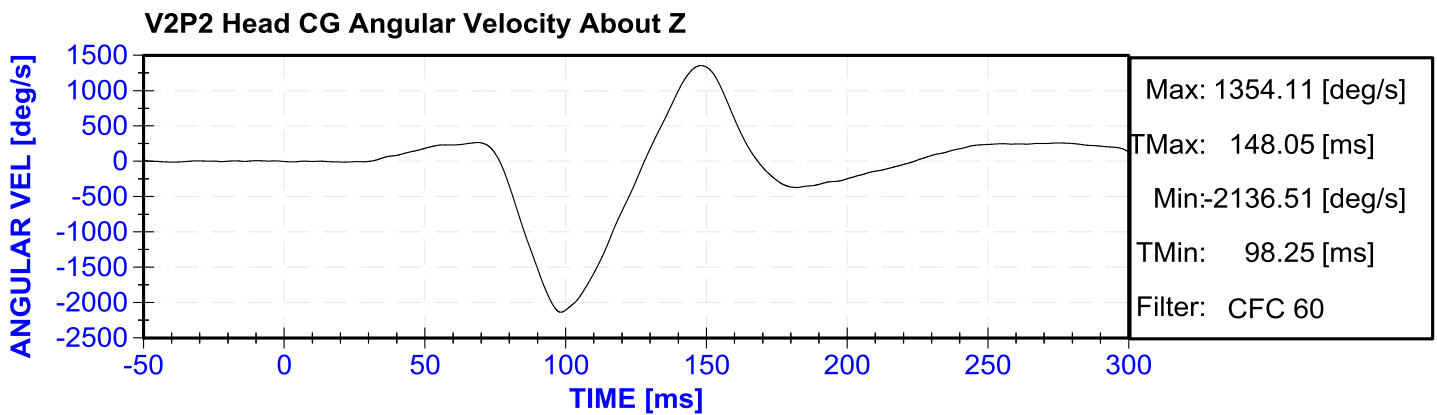
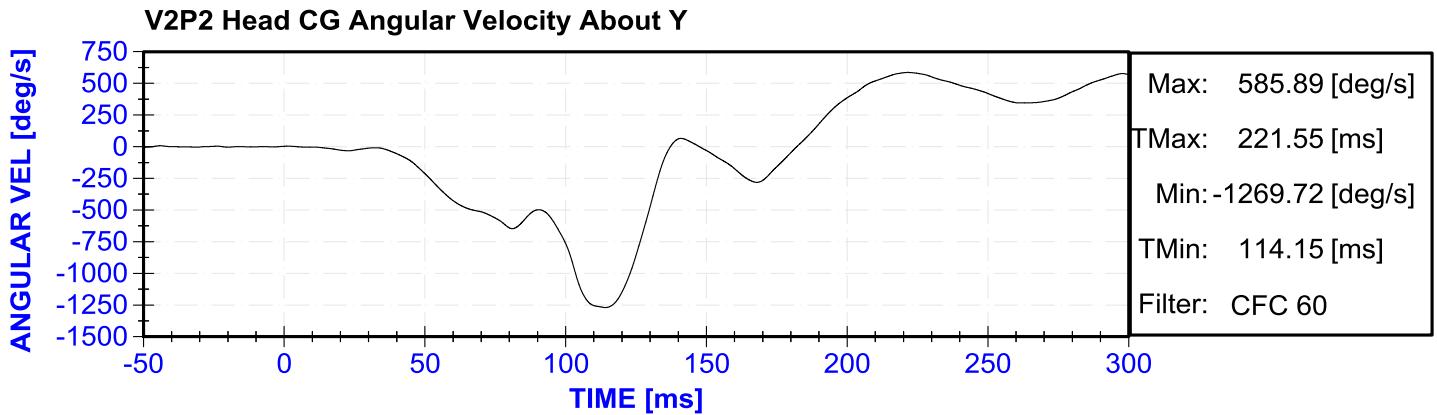

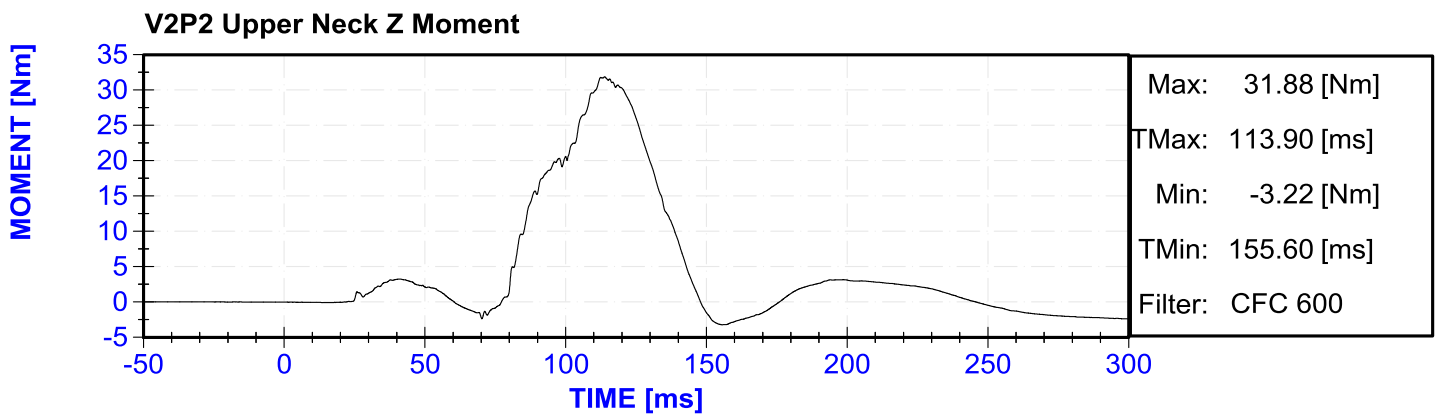
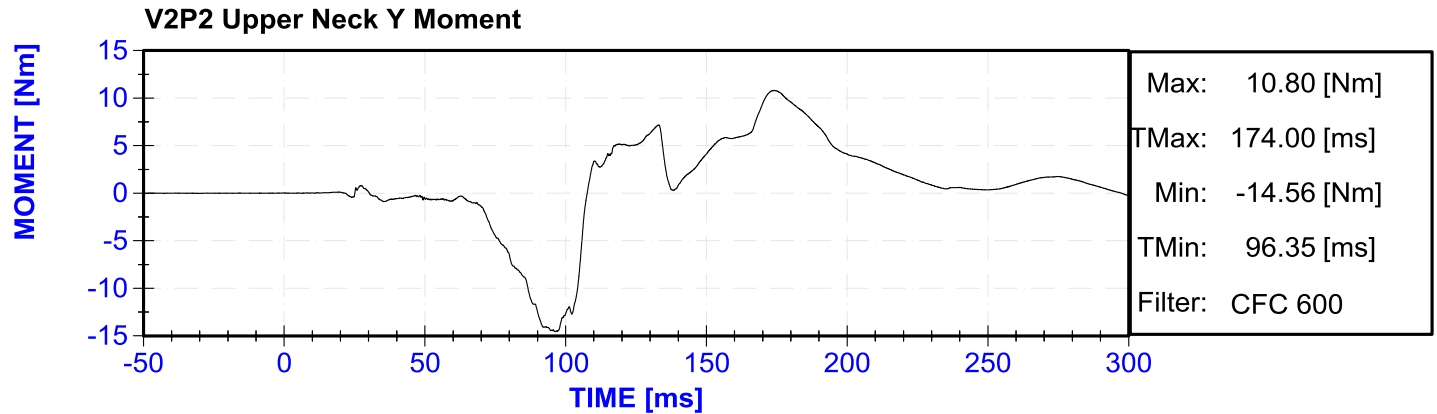
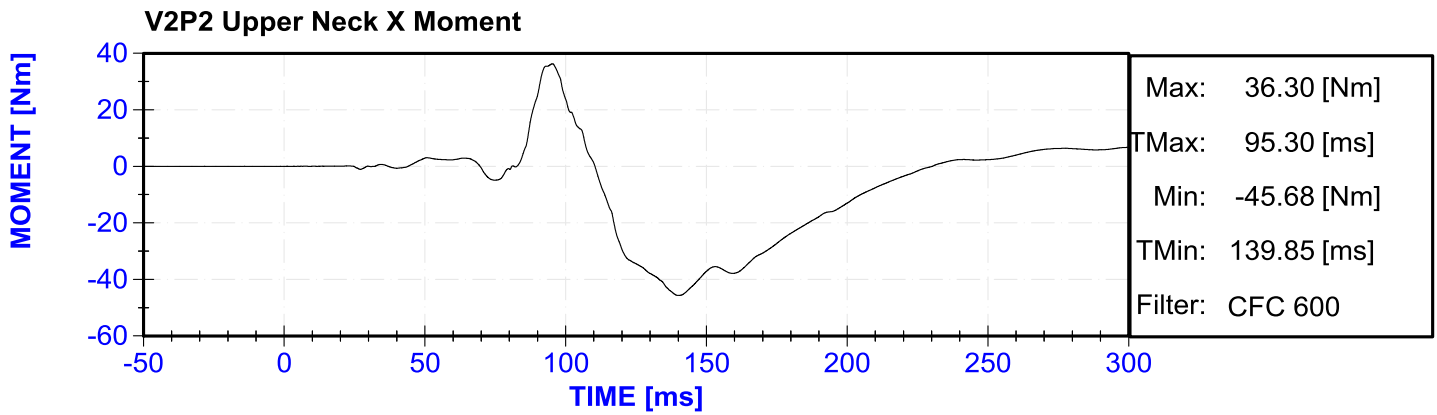
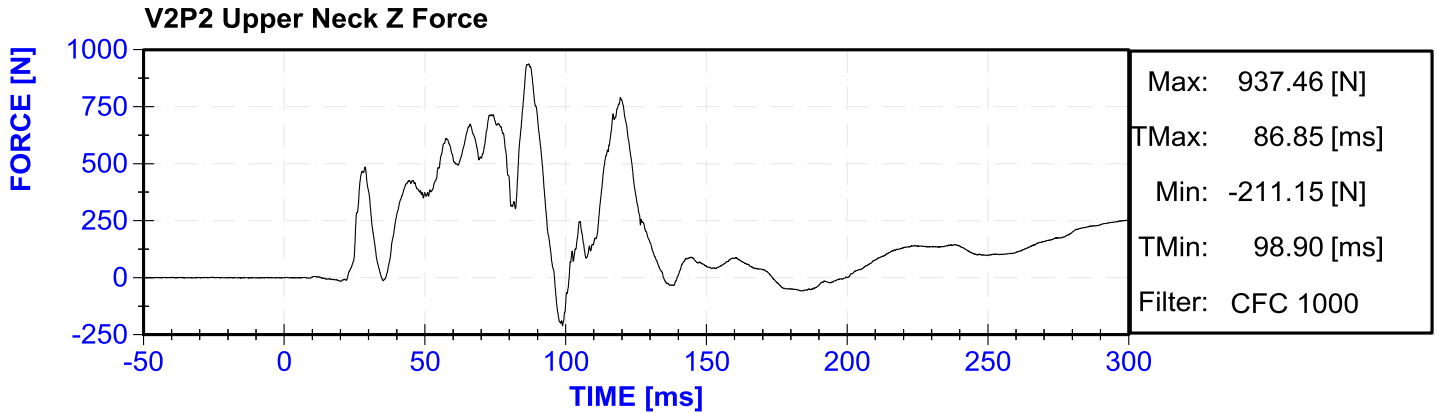

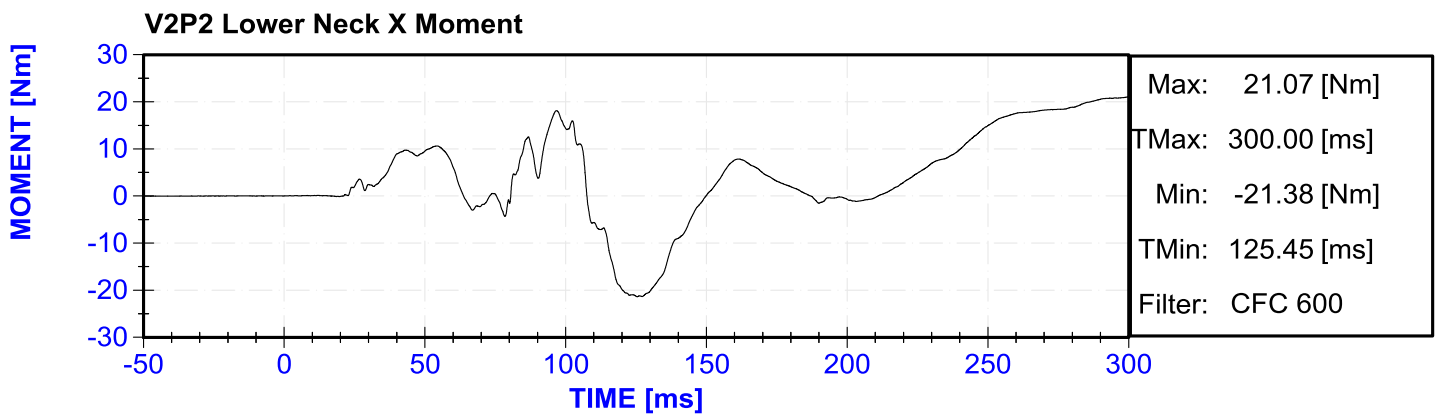
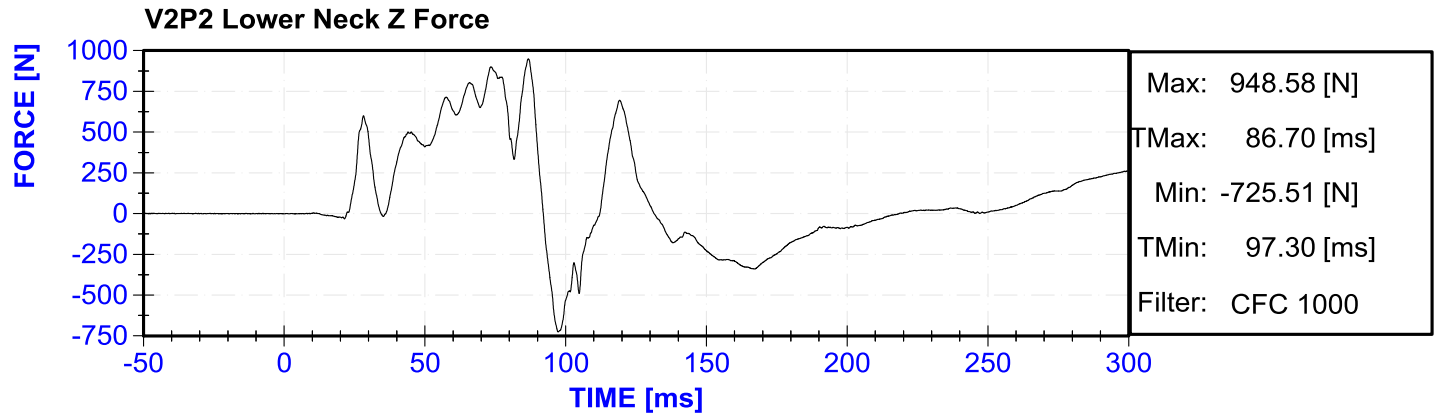
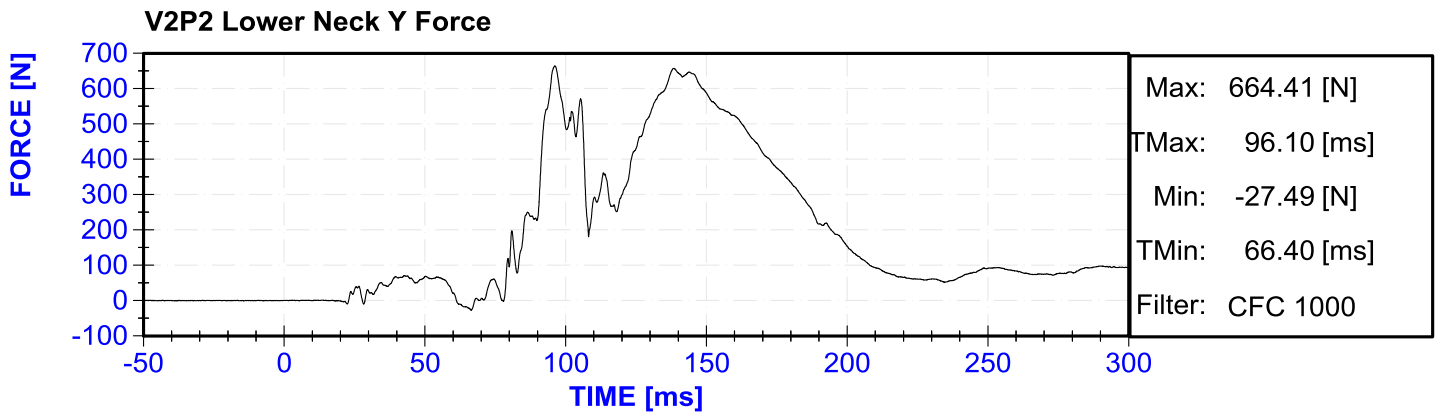
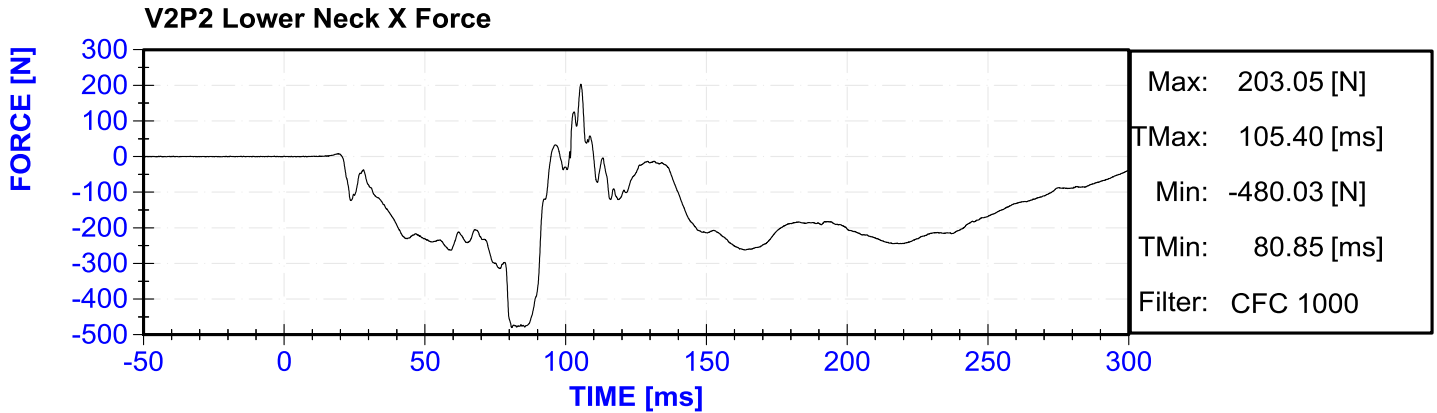

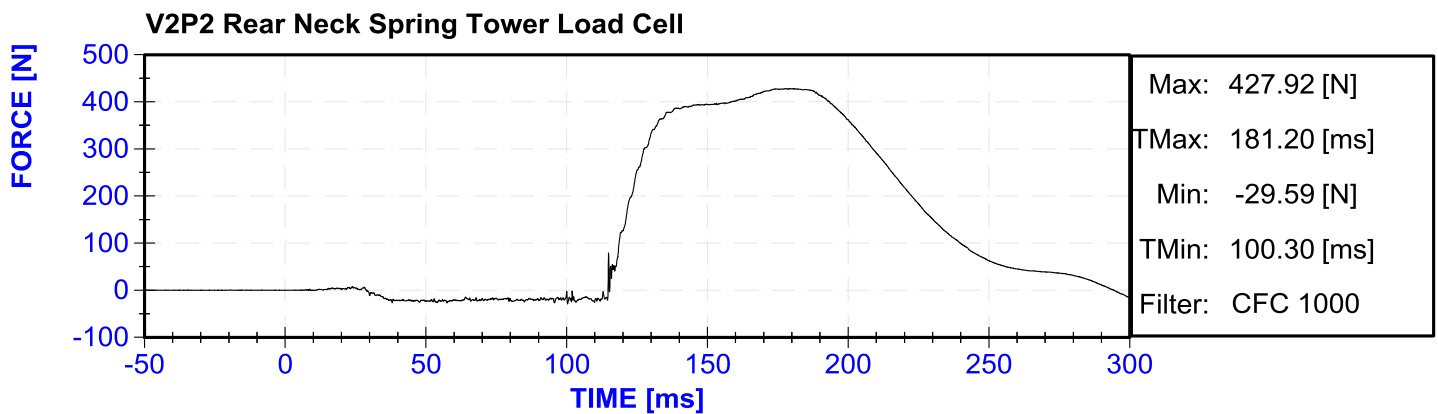
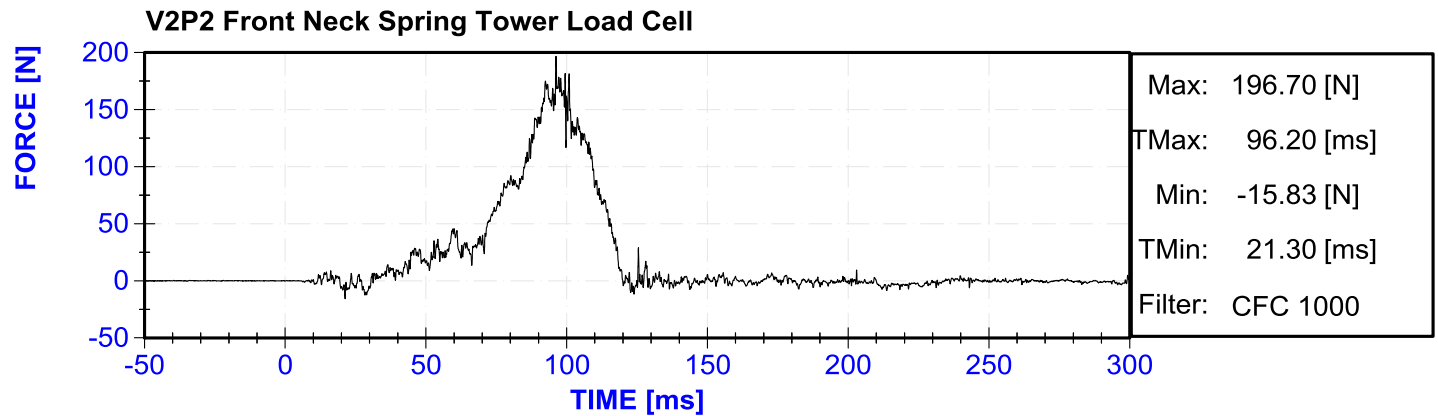
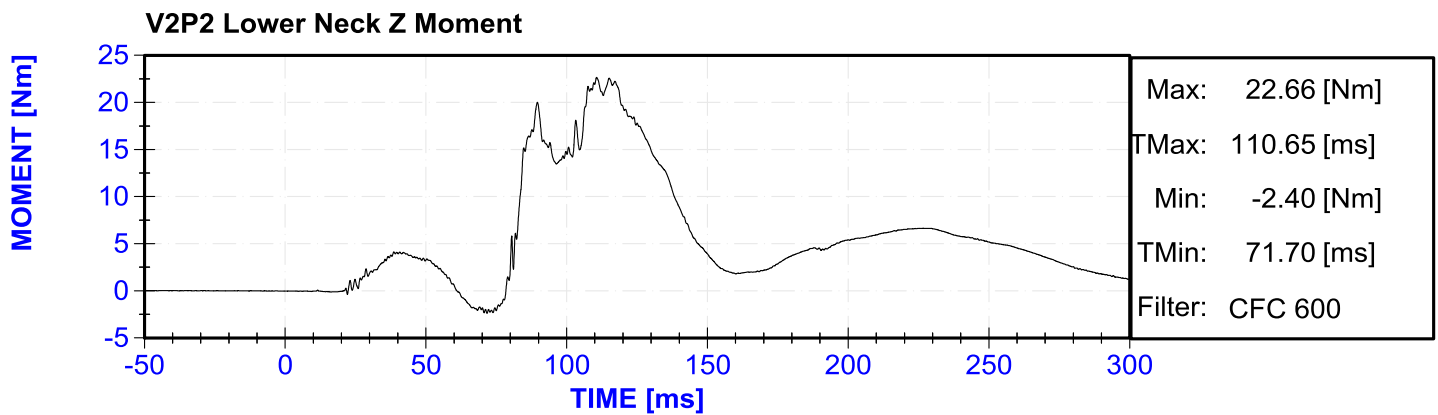
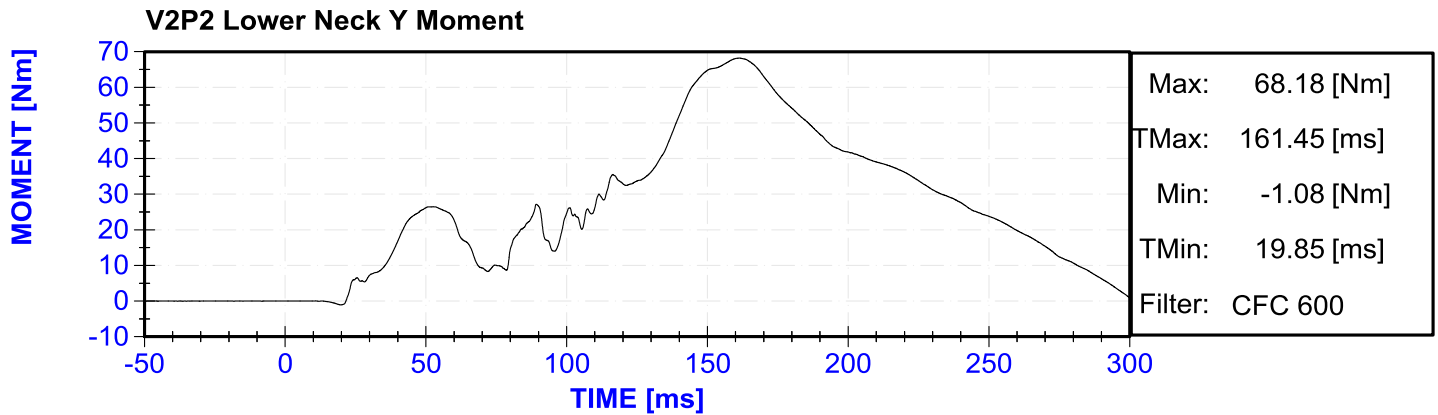

V2P2 Occipital Condyle Rotation Potentiometer

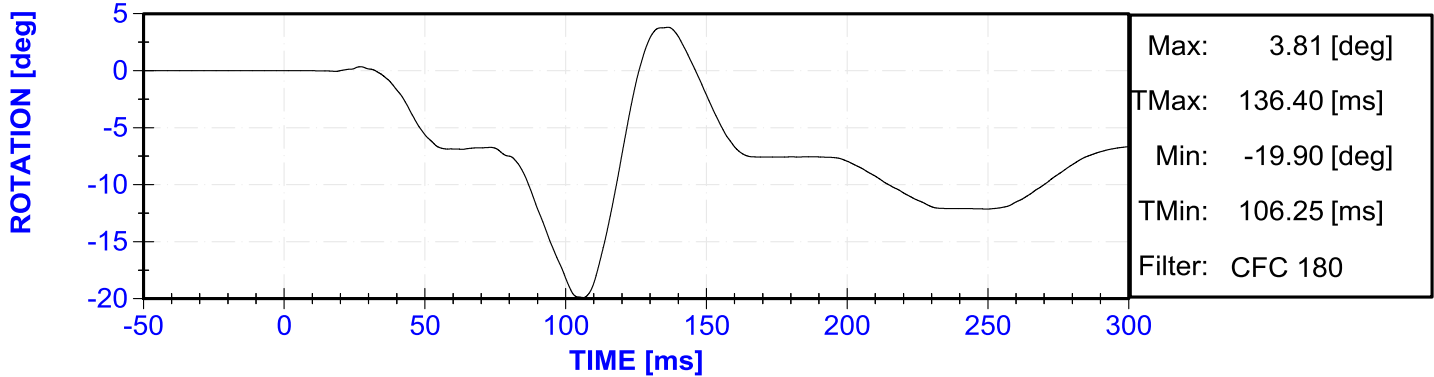

V2P2 Upper Left DGIR X Displacement

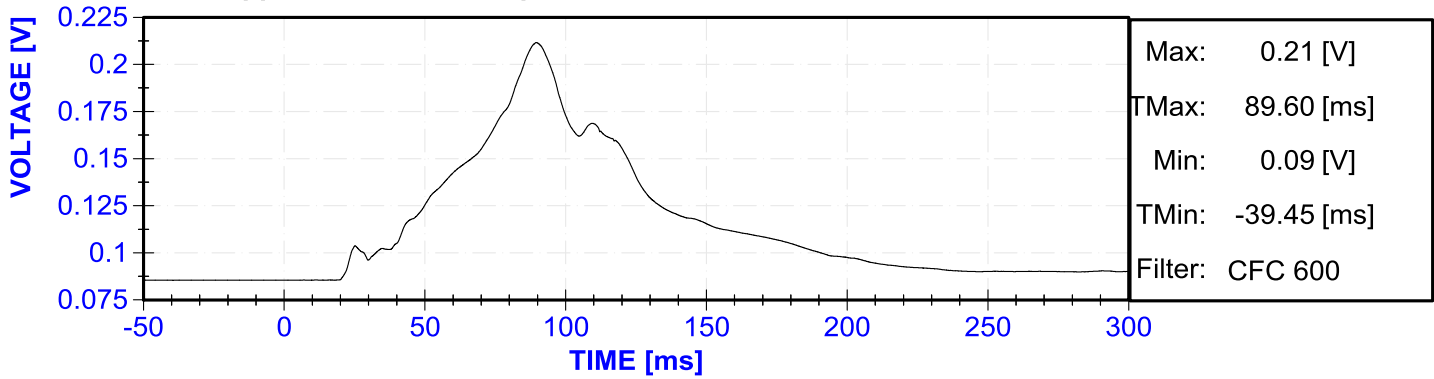

V2P2 Upper Left DGIR Y Rotation

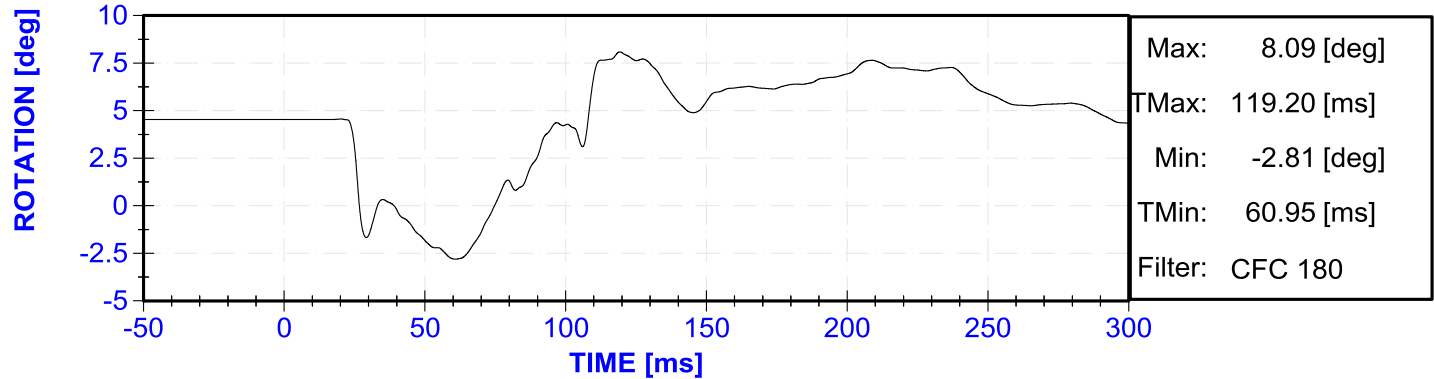

V2P2 Upper Left DGIR Z Rotation

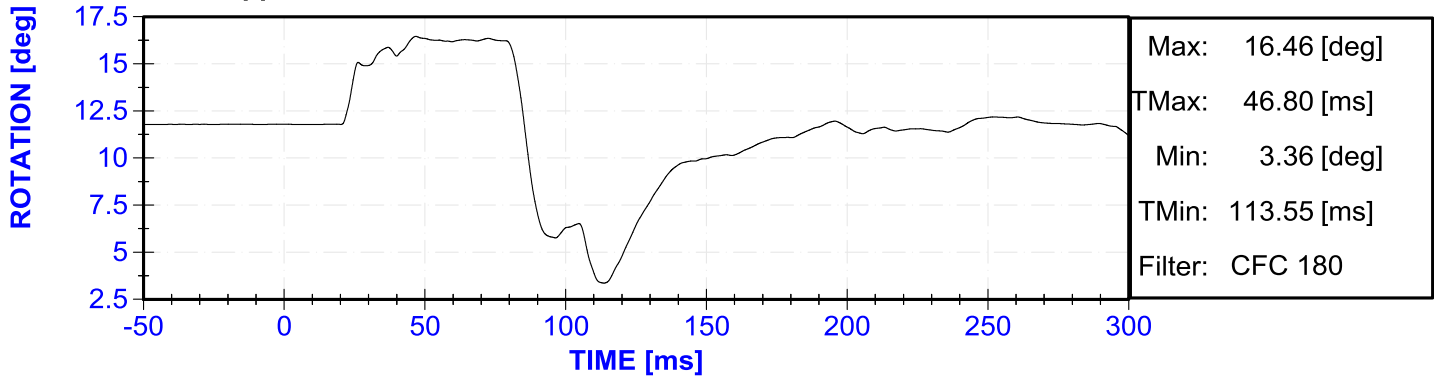

V2P2 Upper Right DGIR X Displacement

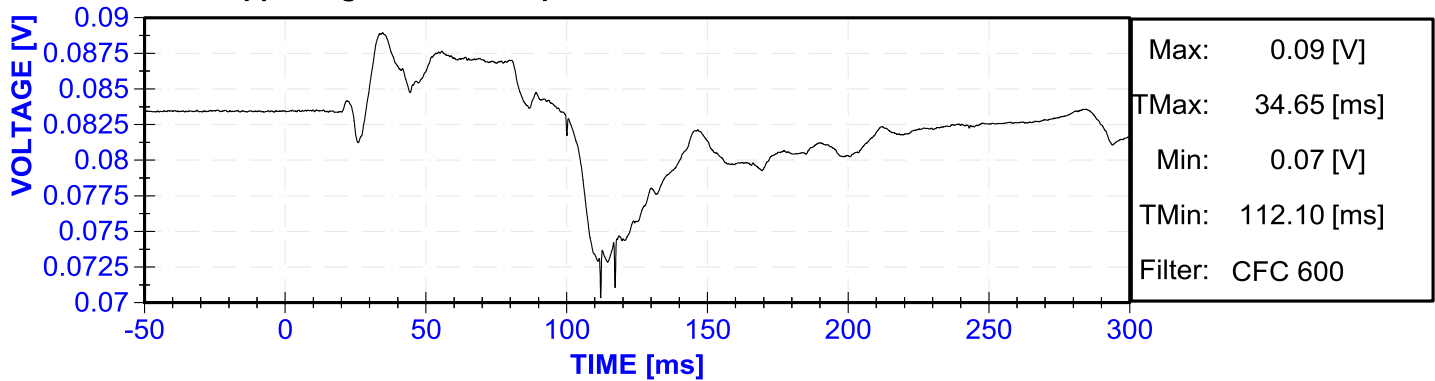

V2P2 Upper Right DGIR Y Rotation

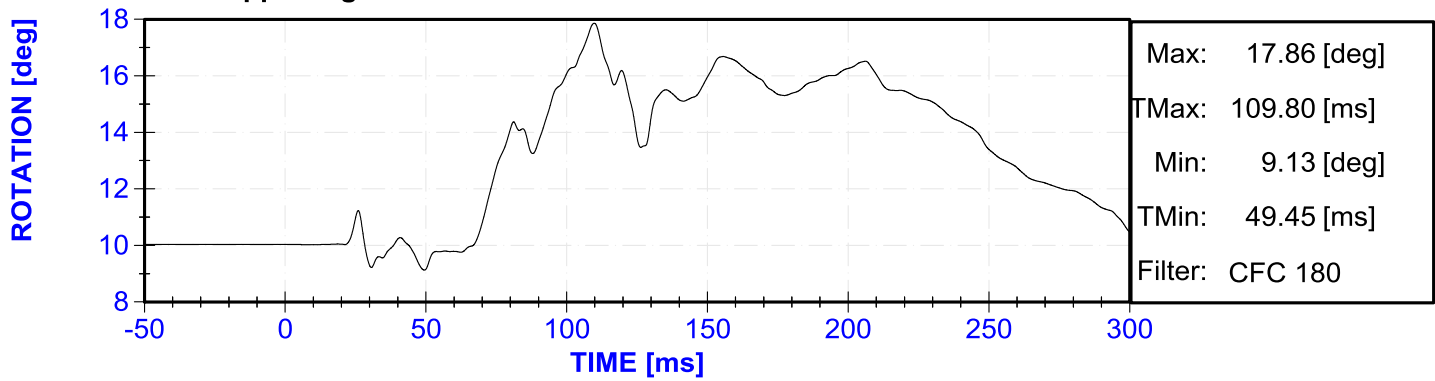

V2P2 Upper Right DGIR Z Rotation

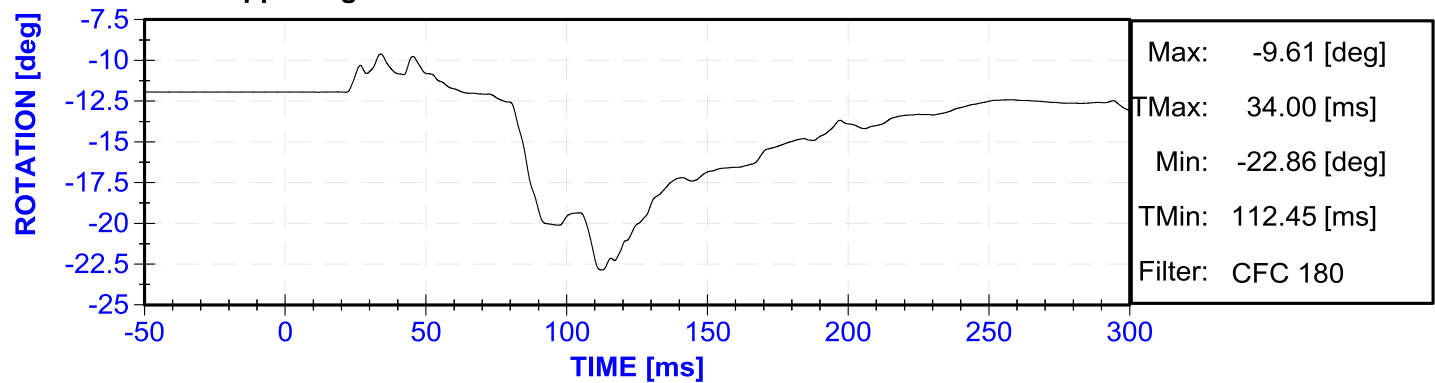

V2P2 Lower Left DGIR X Displacement

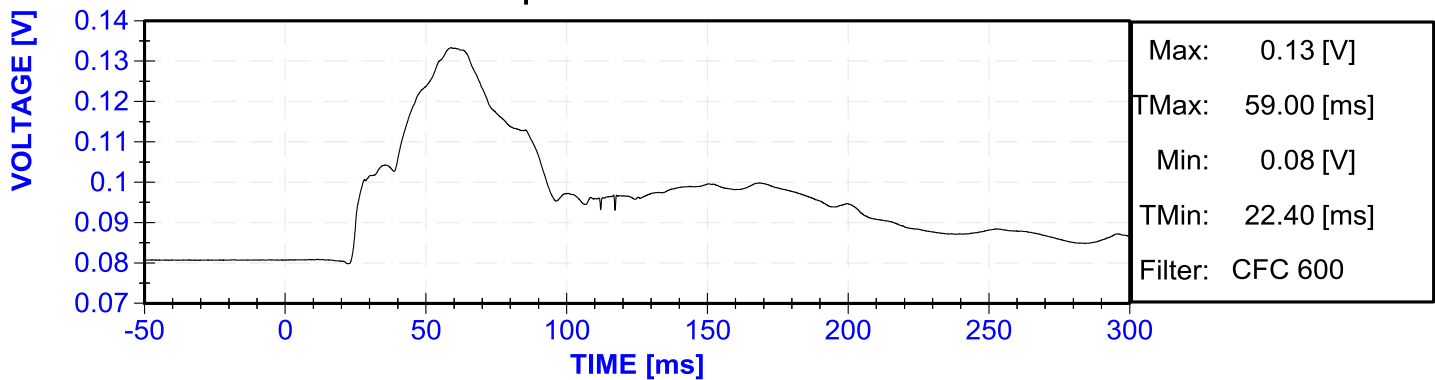

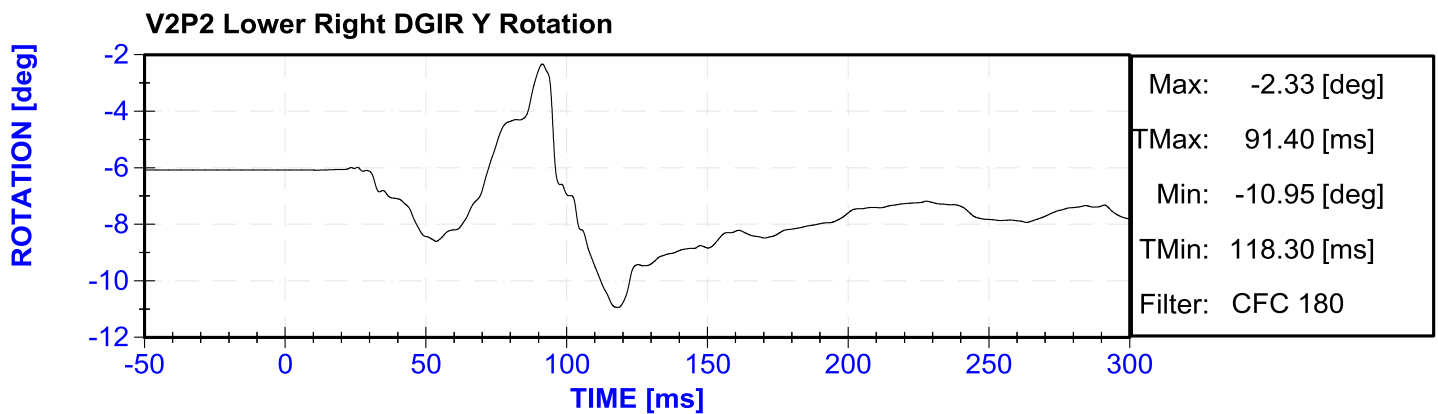
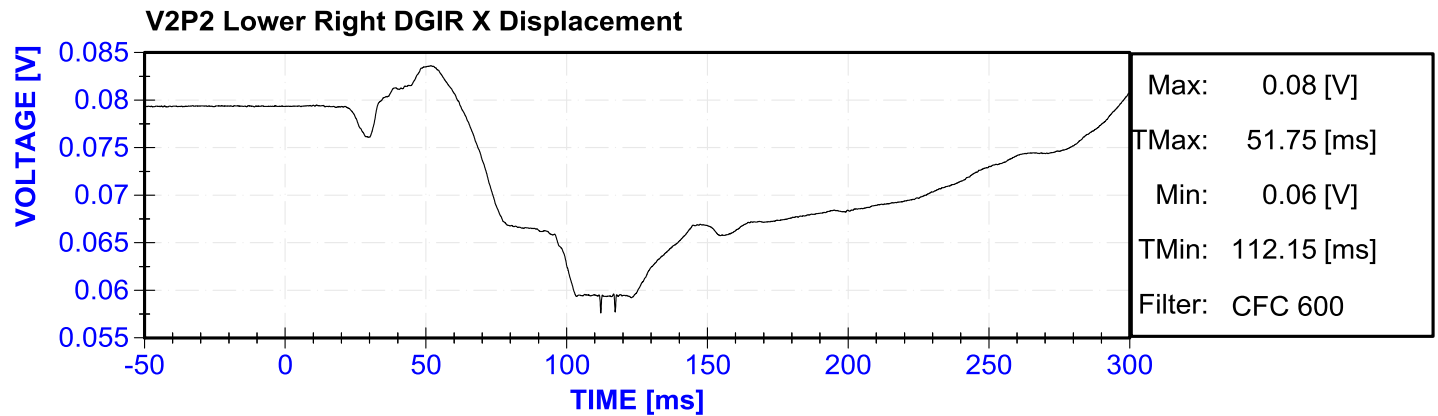
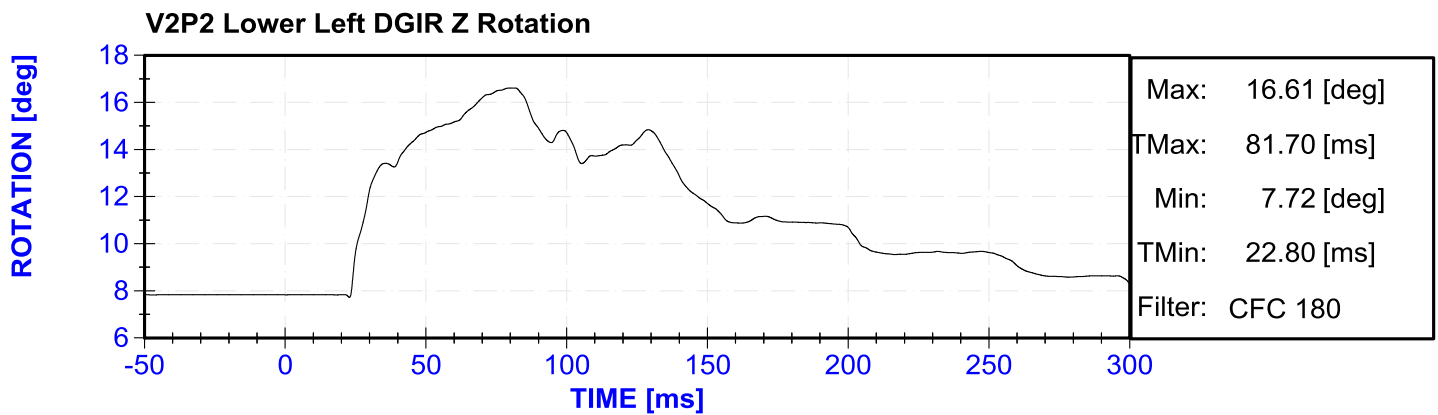
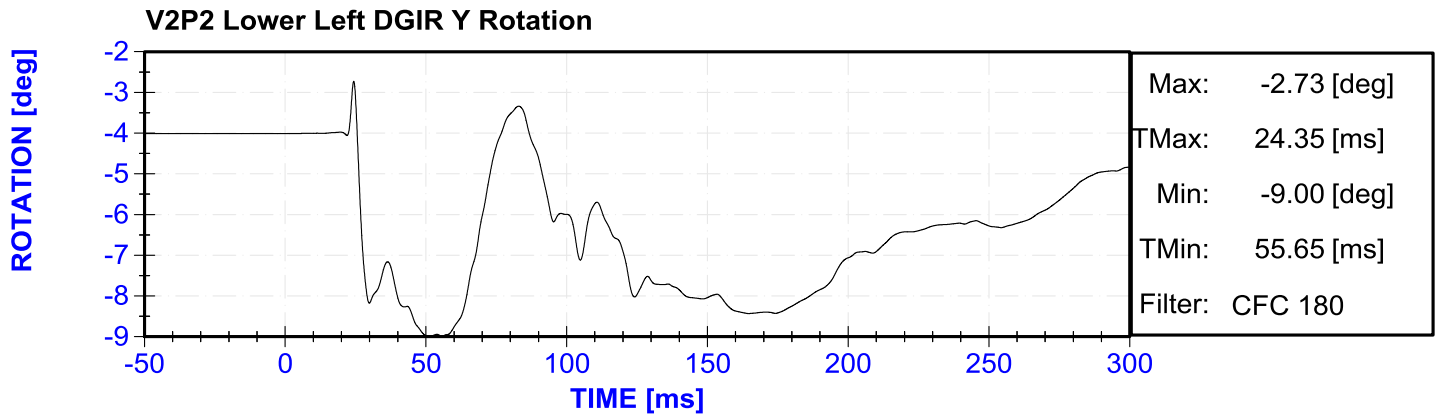

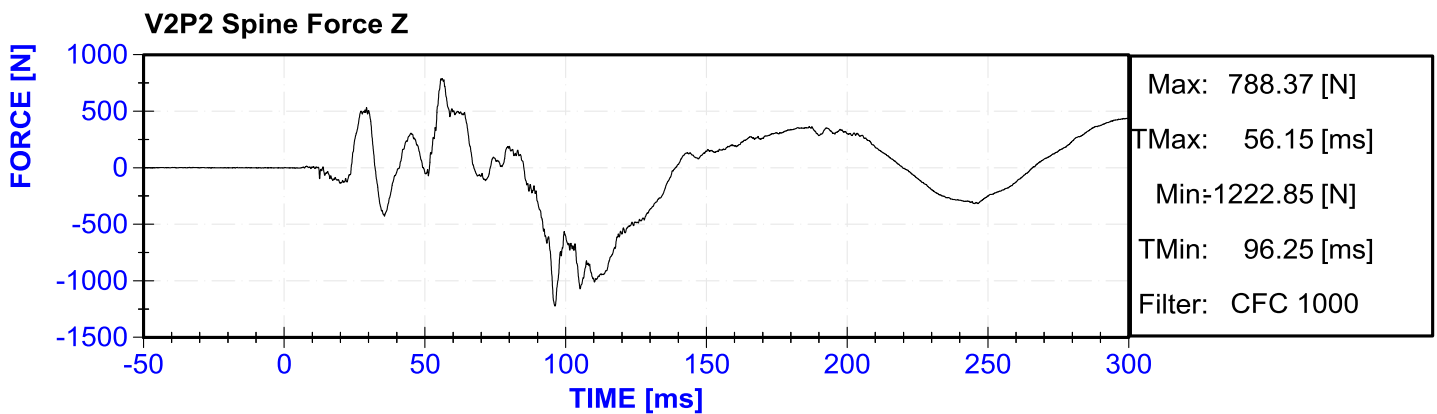
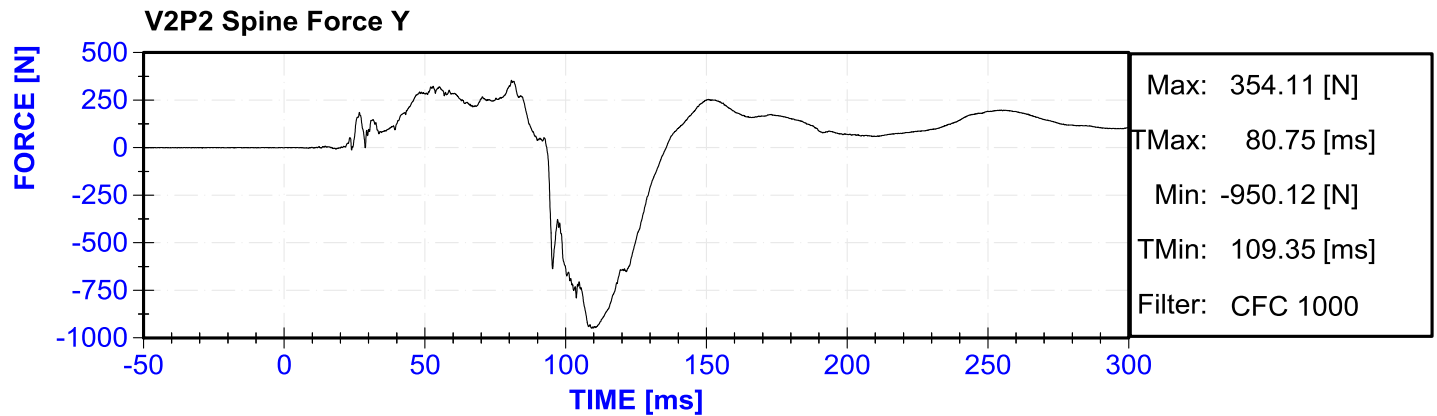
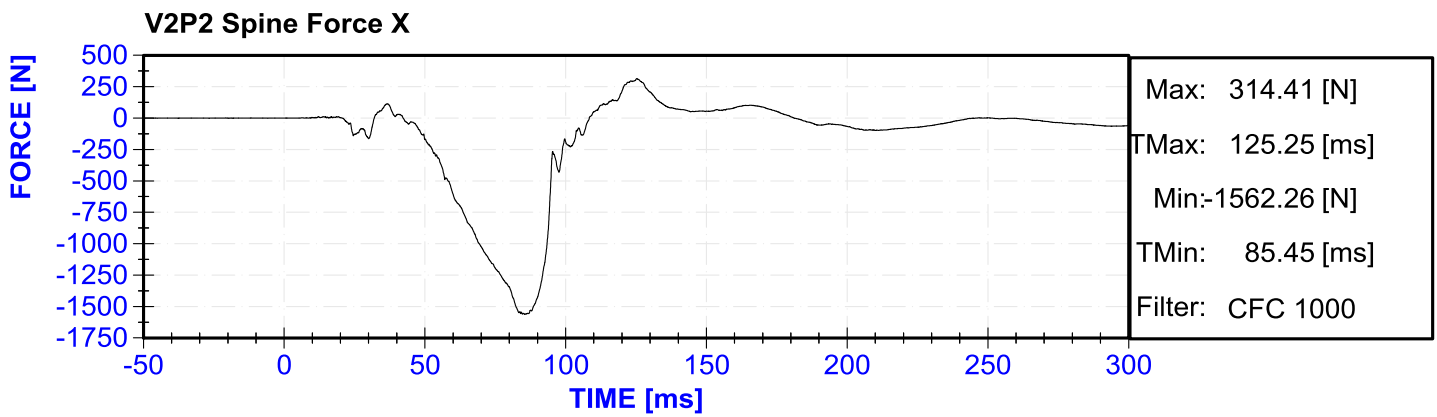
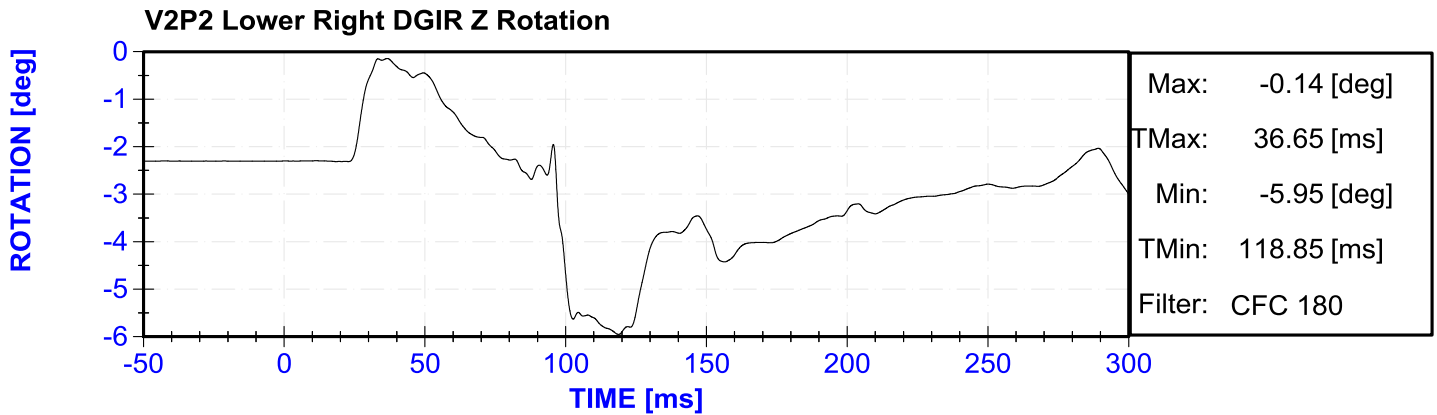

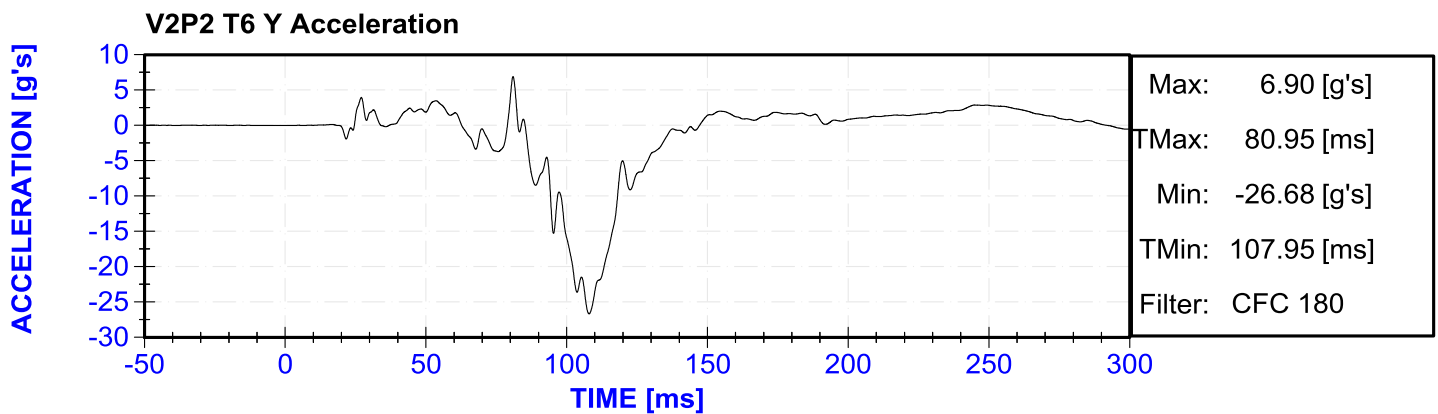
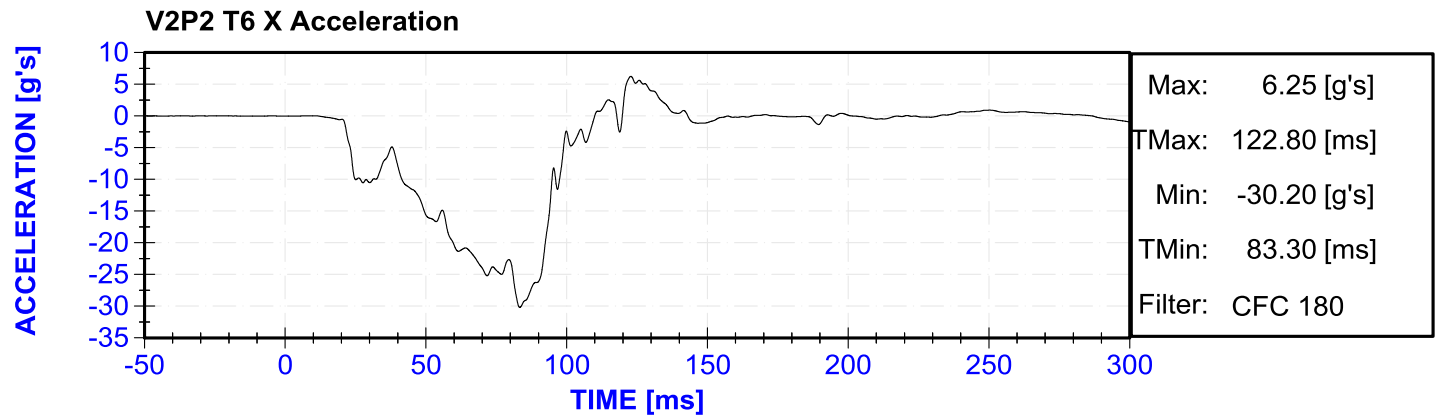
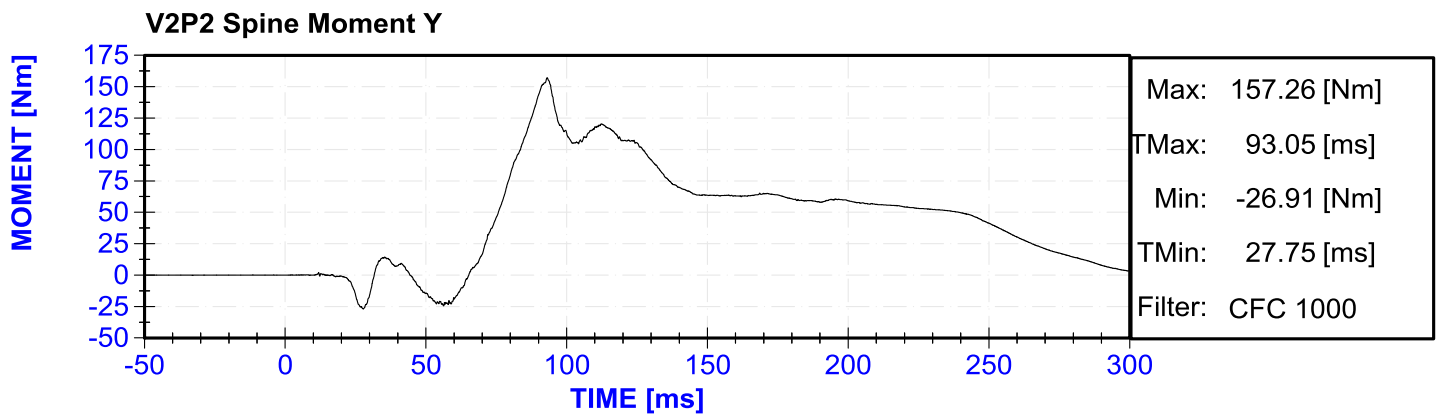
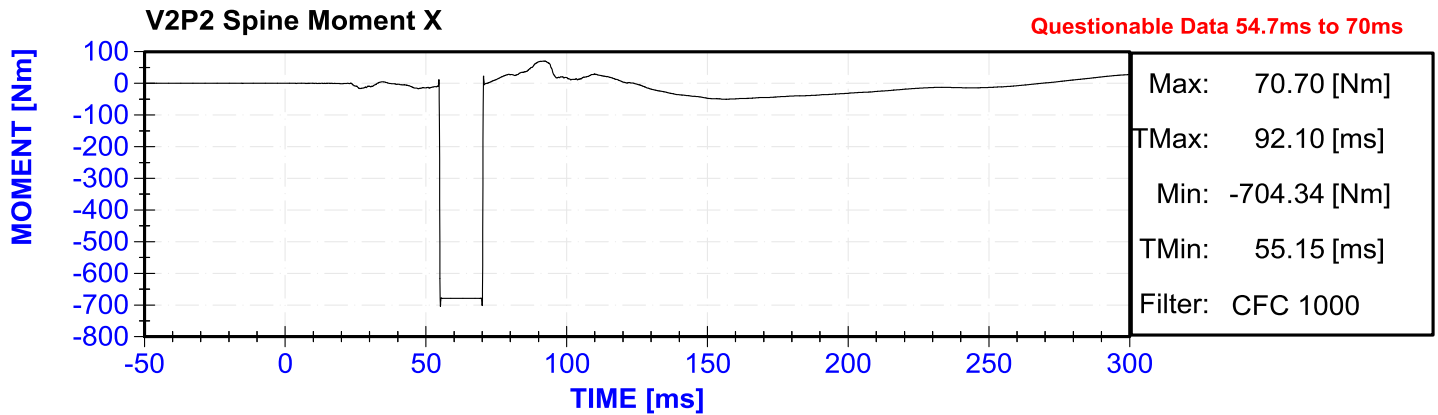

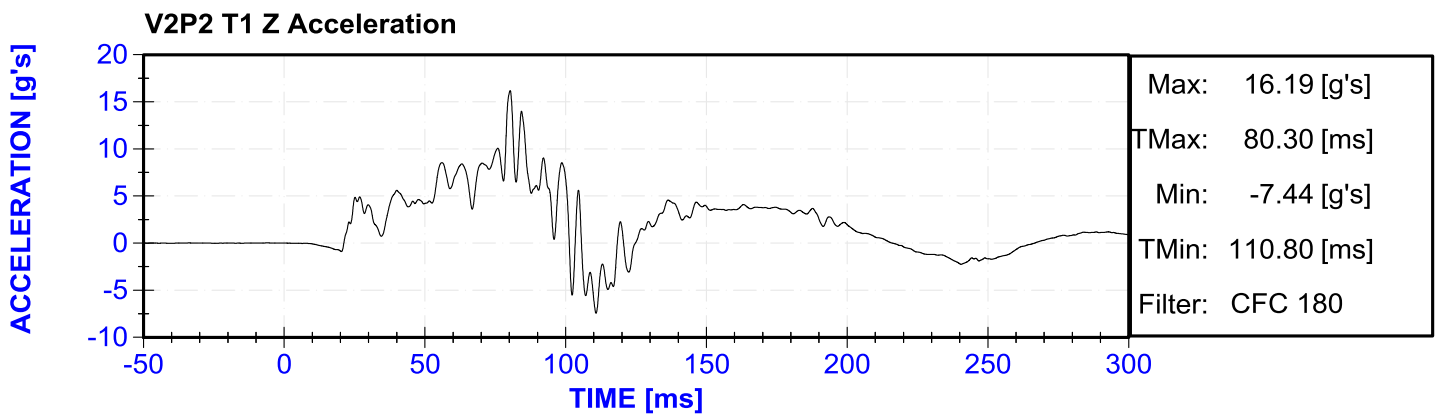
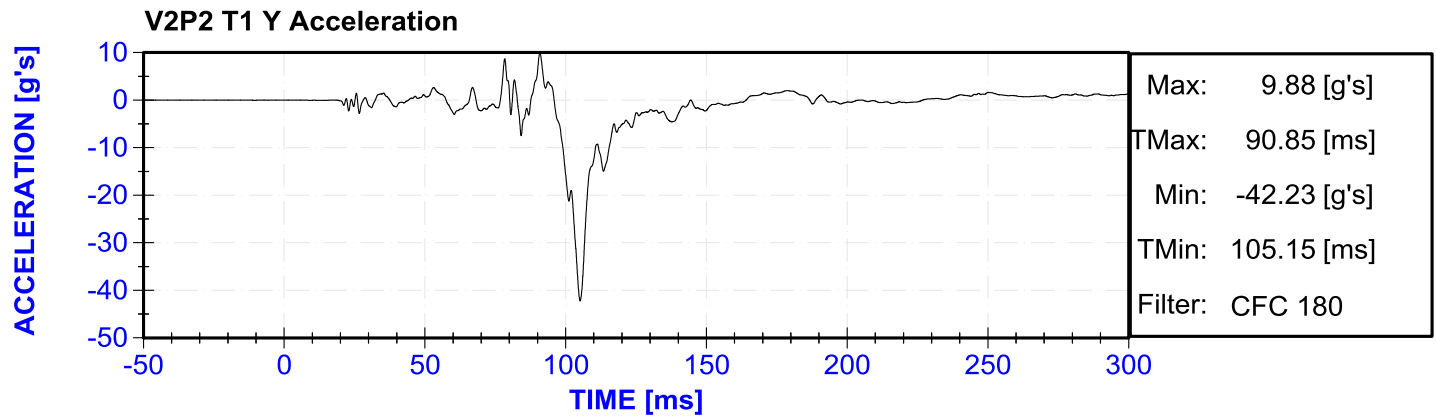
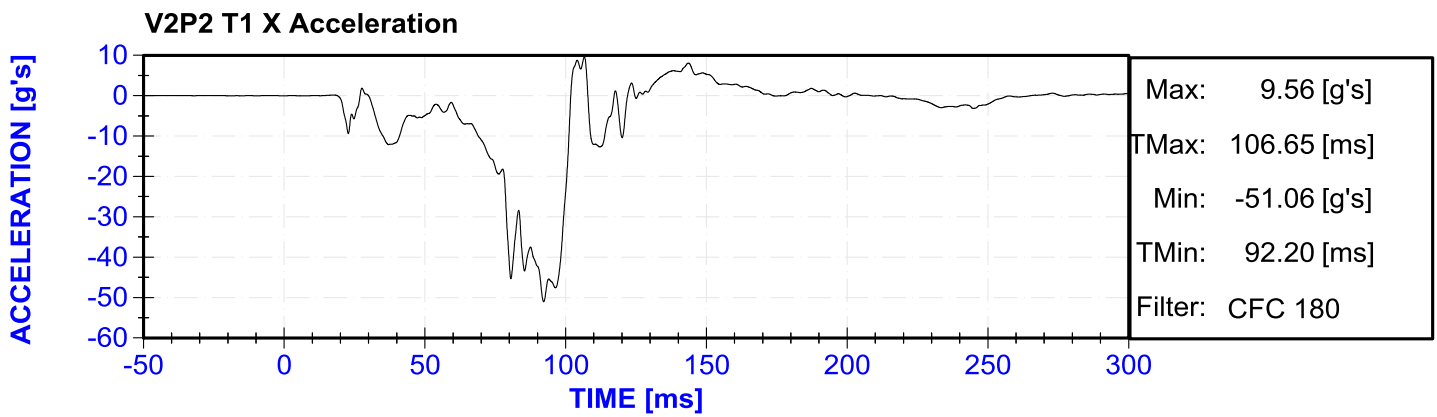
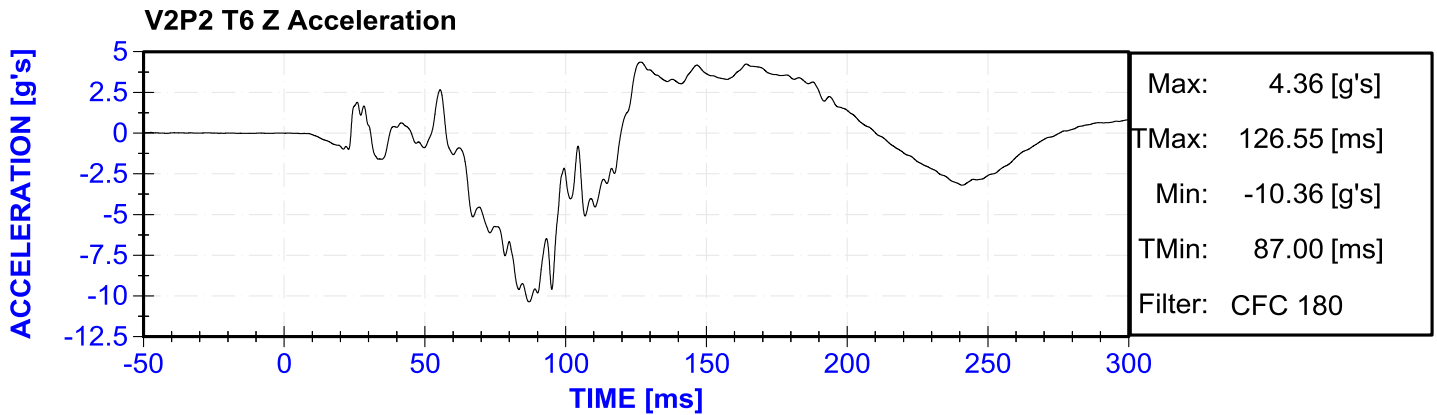

V2P2 Abdomen Left DGIR X Displacement

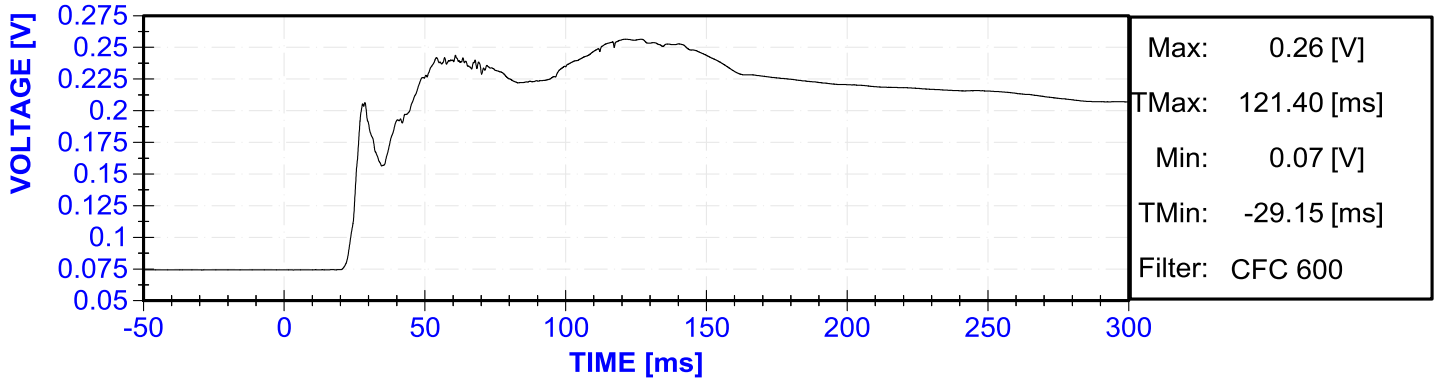

V2P2 Abdomen Left DGIR Y Rotation

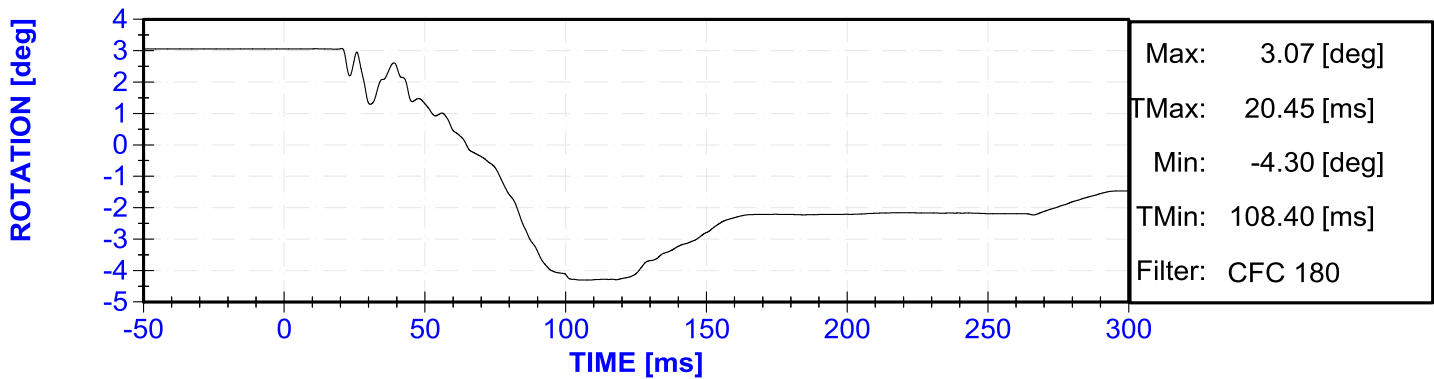

V2P2 Abdomen Left DGIR Z Rotation

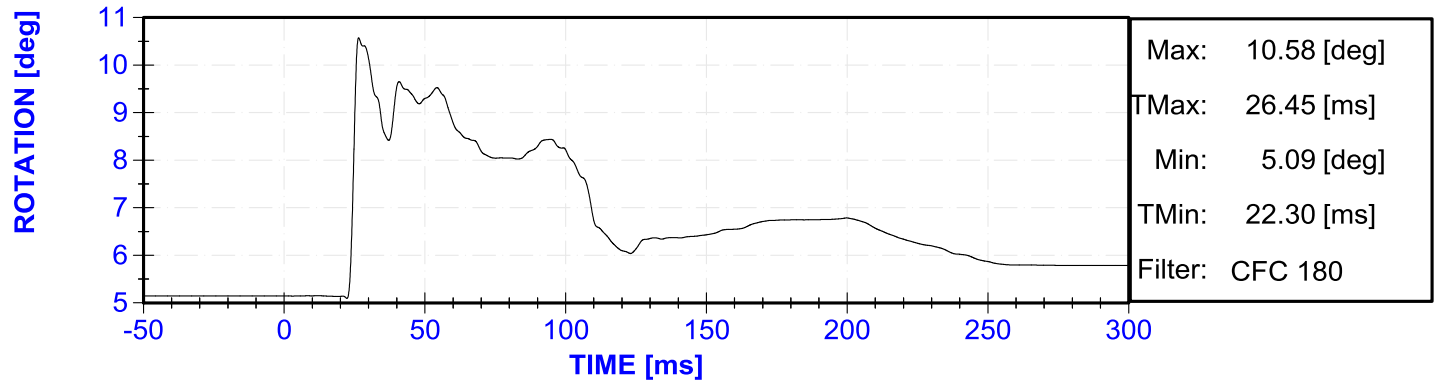

V2P2 Abdomen Right DGIR X Displacement

Questionable 21.6 to 53.3ms and 84.6 to 87ms

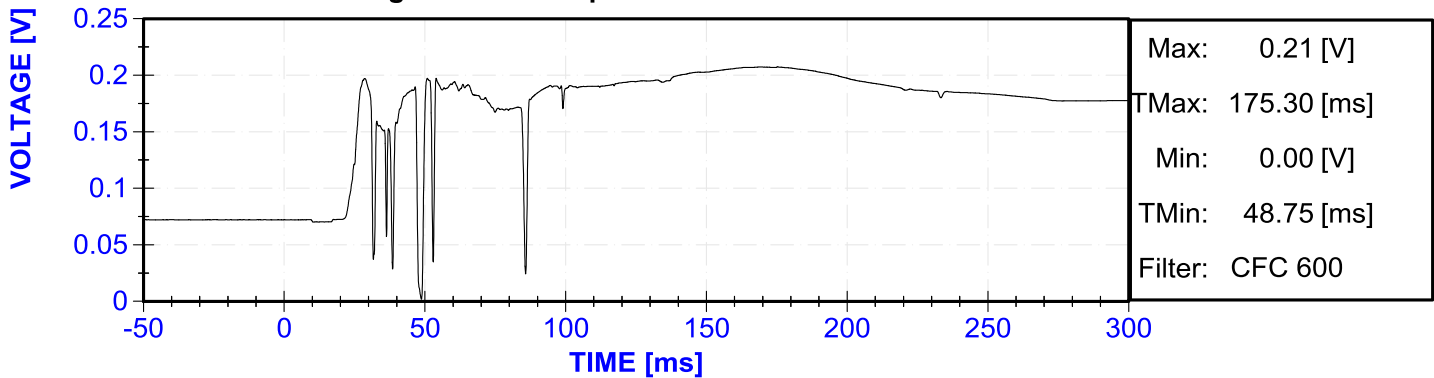

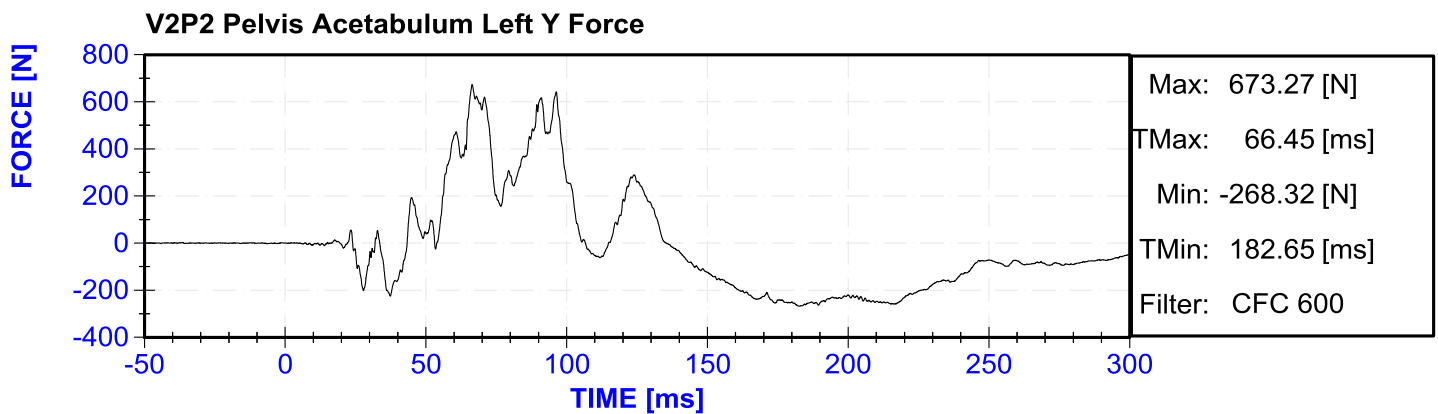
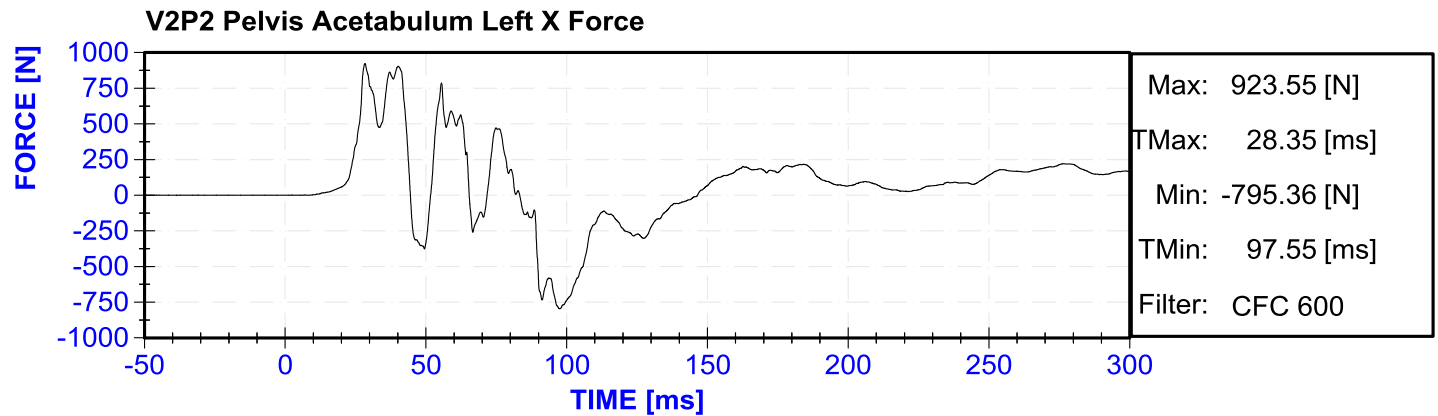
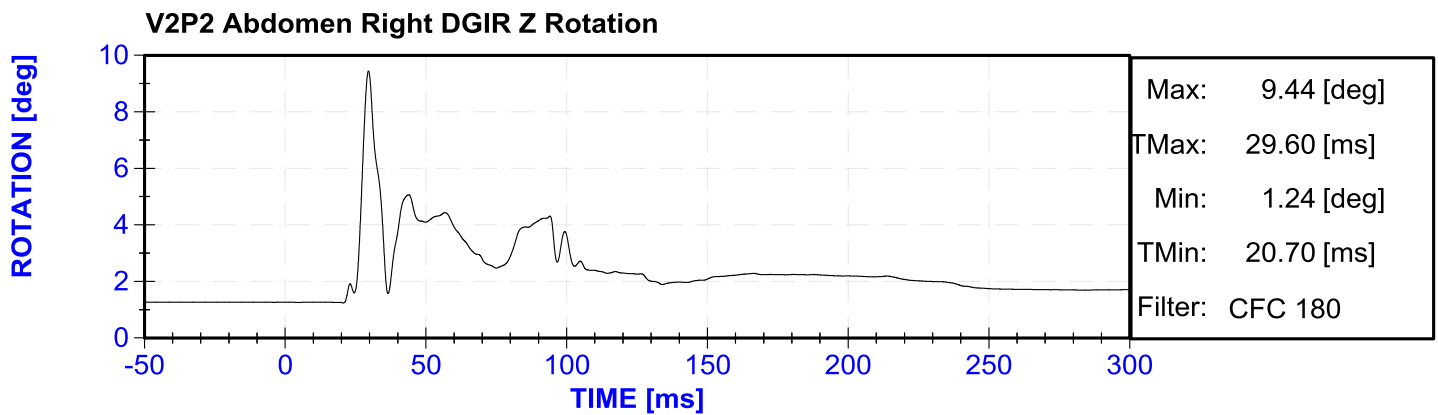
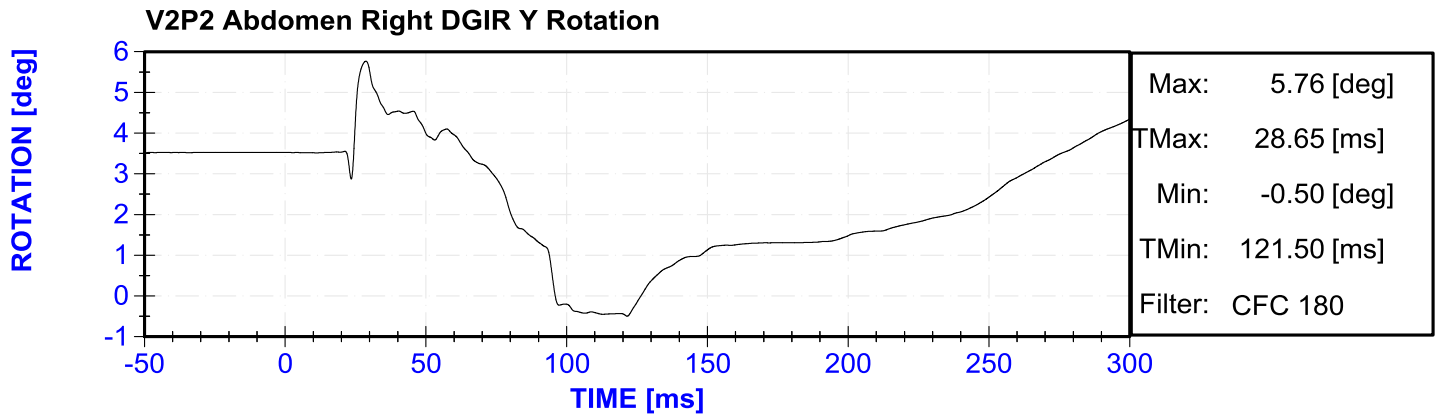

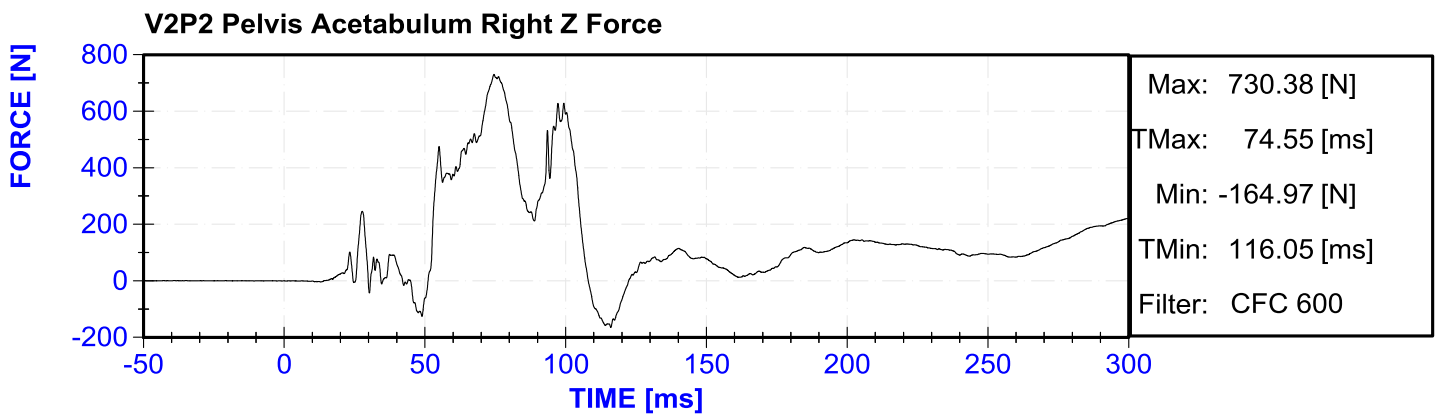
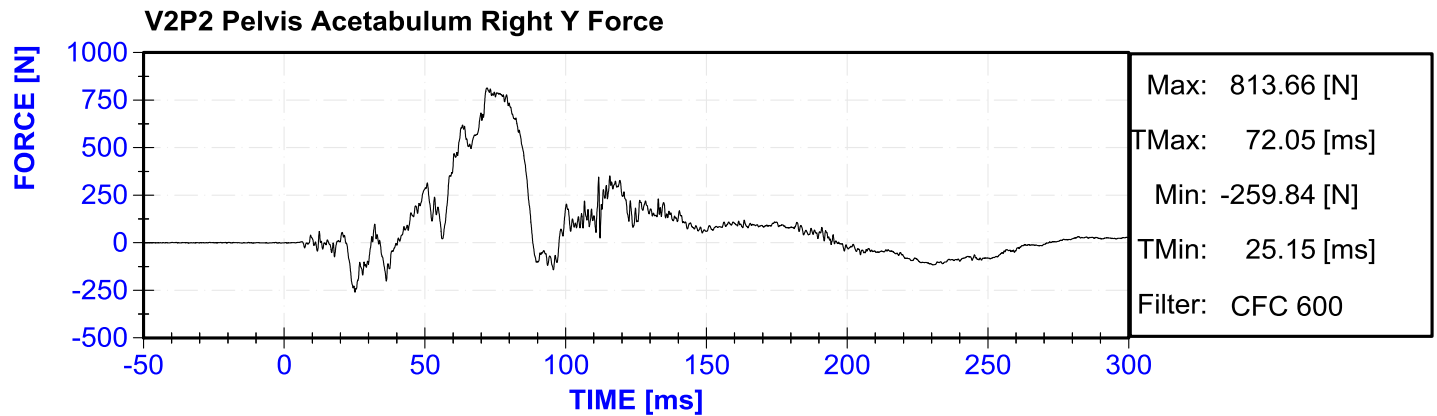
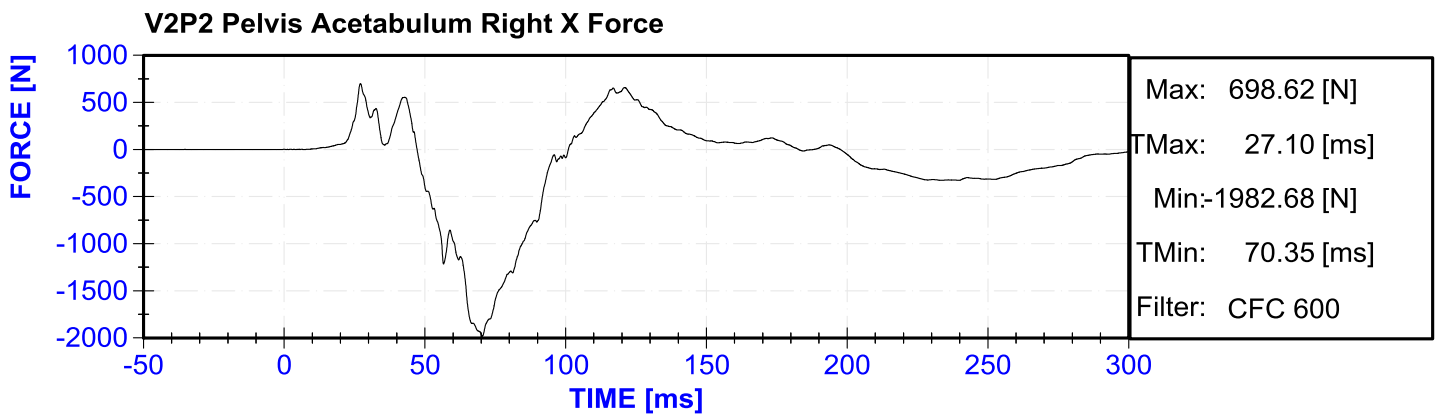
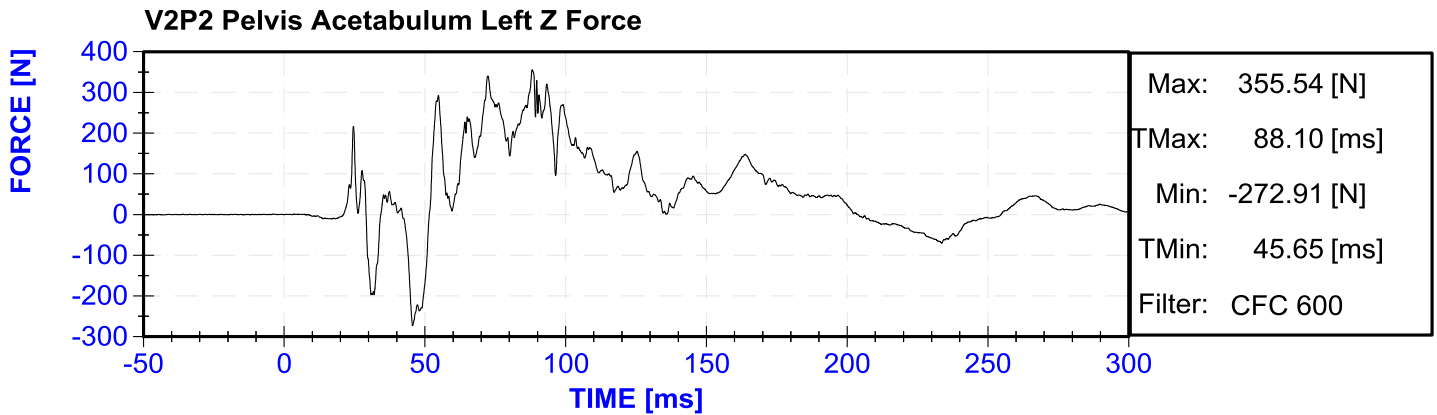

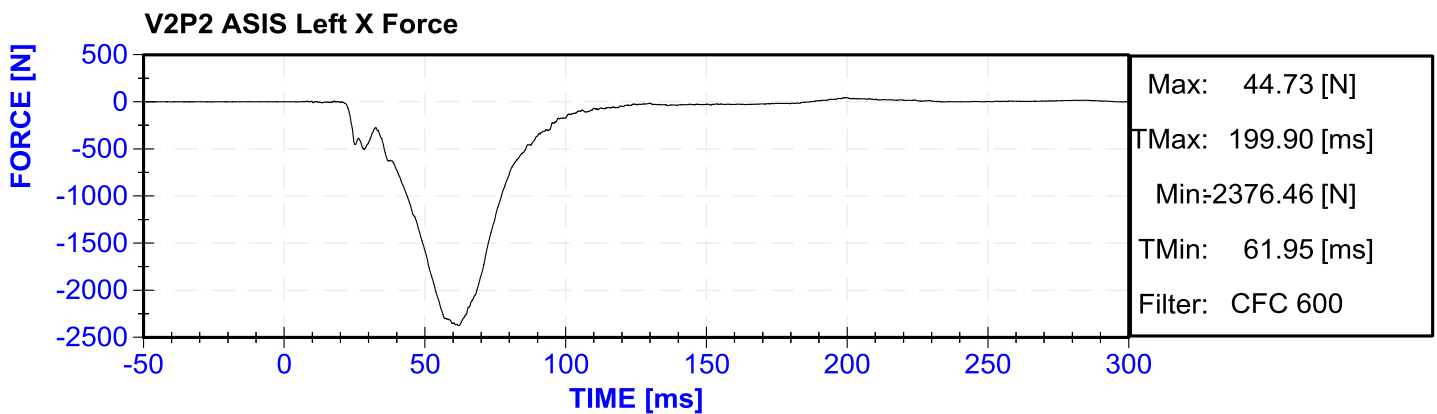
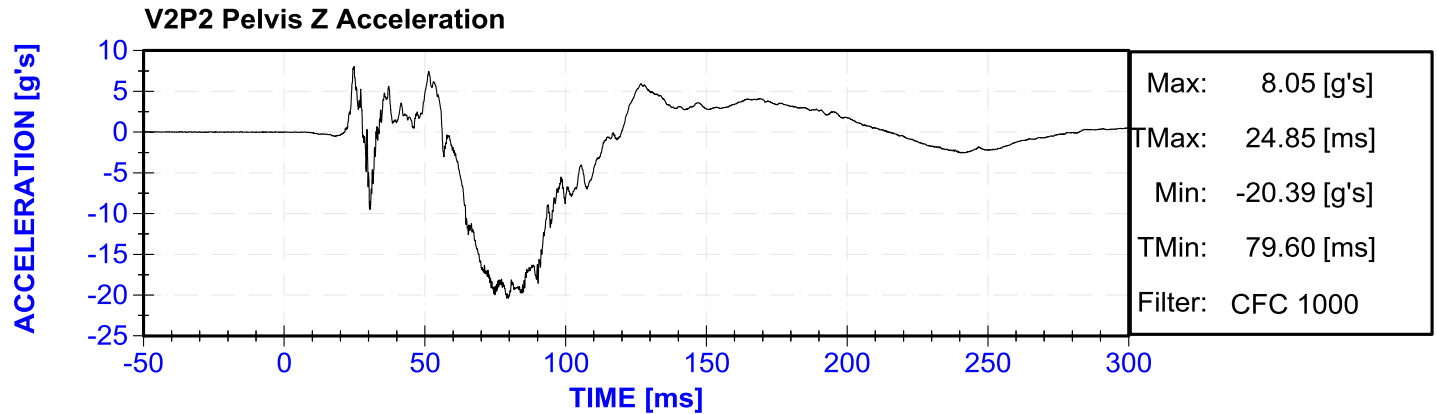
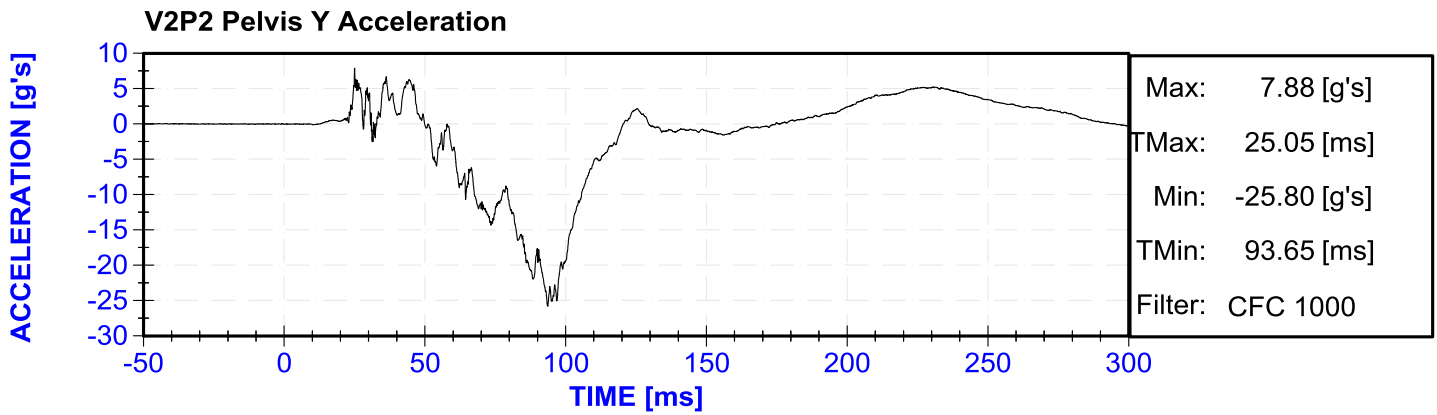
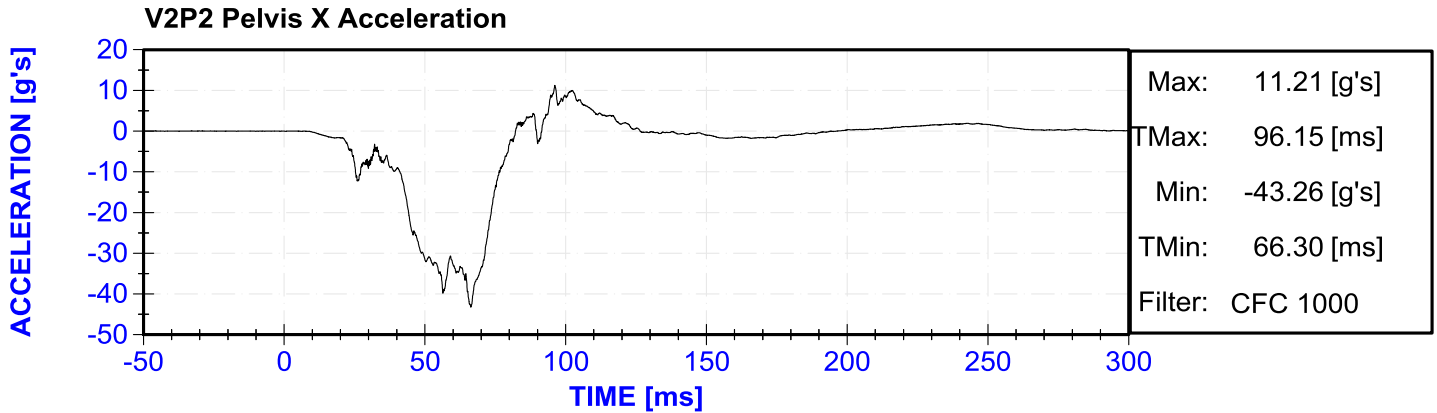

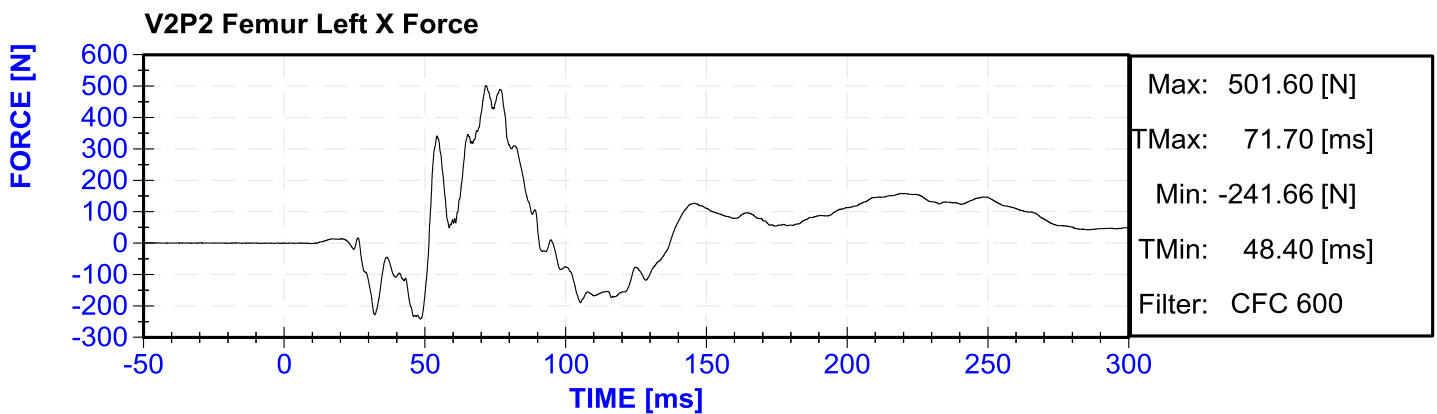
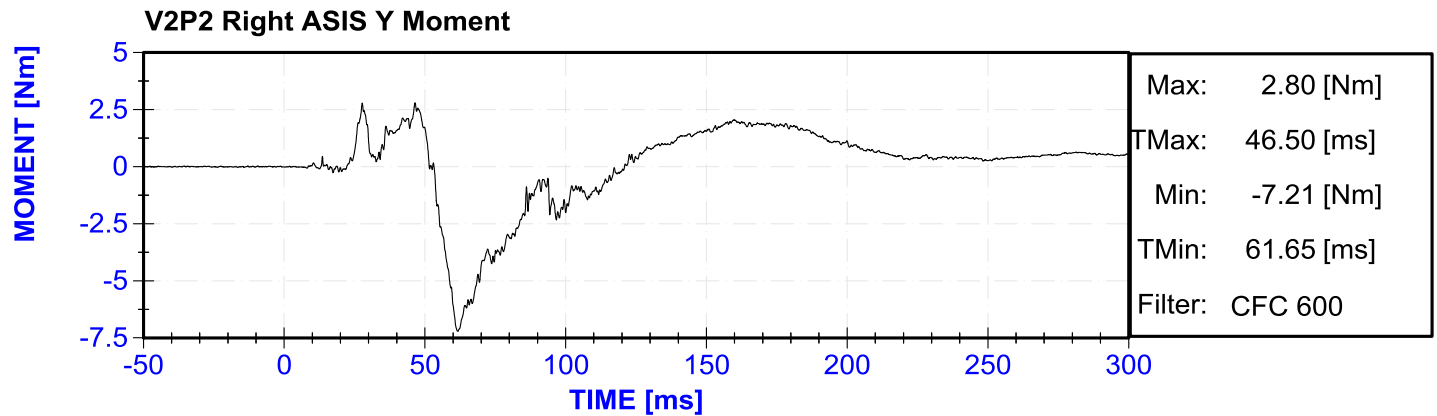
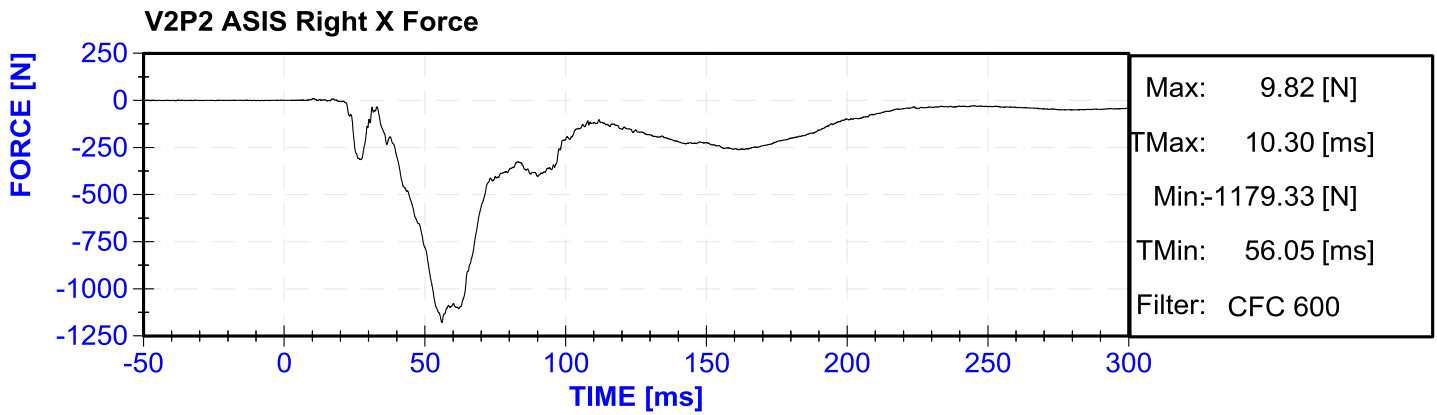
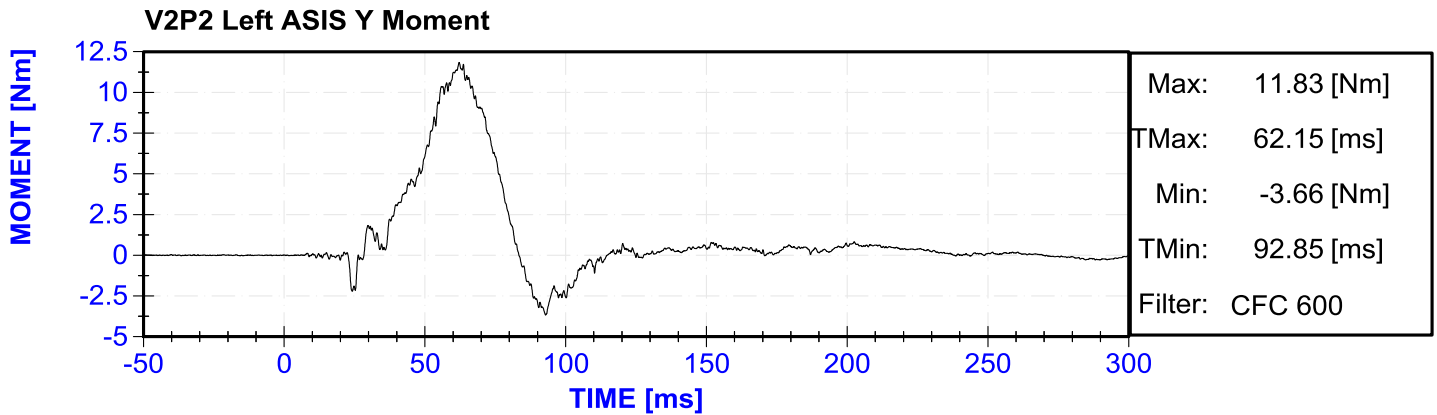

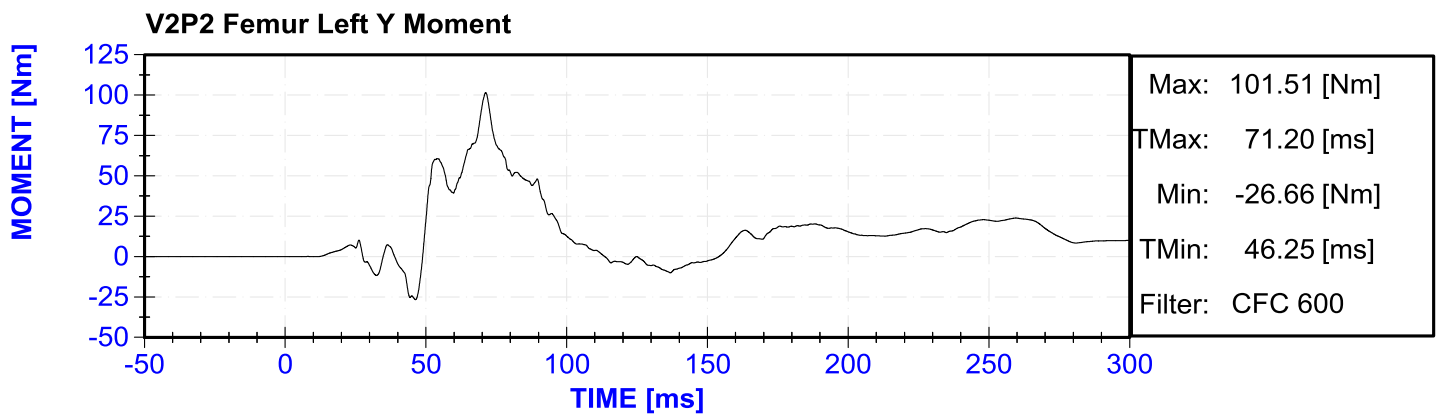
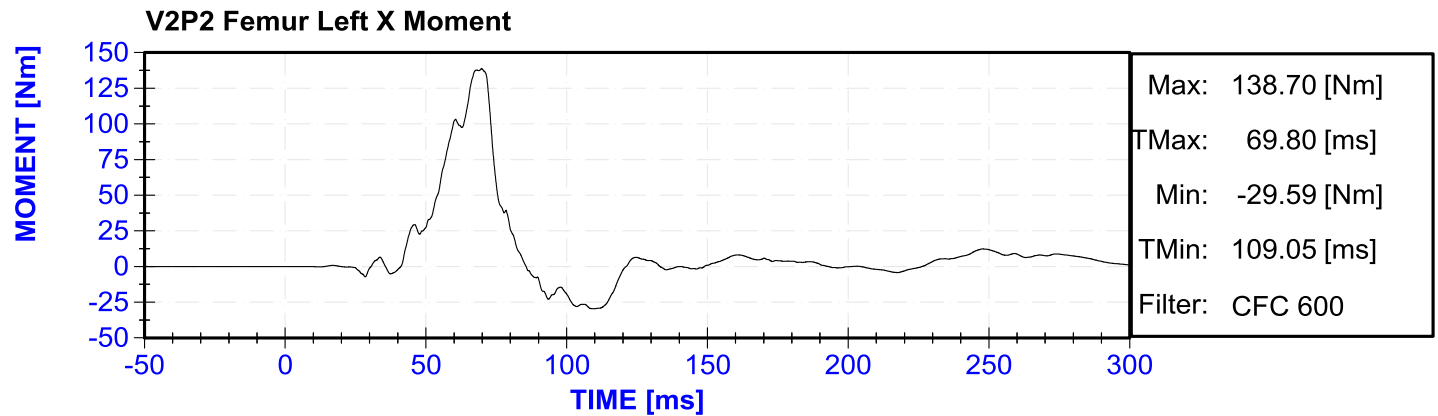
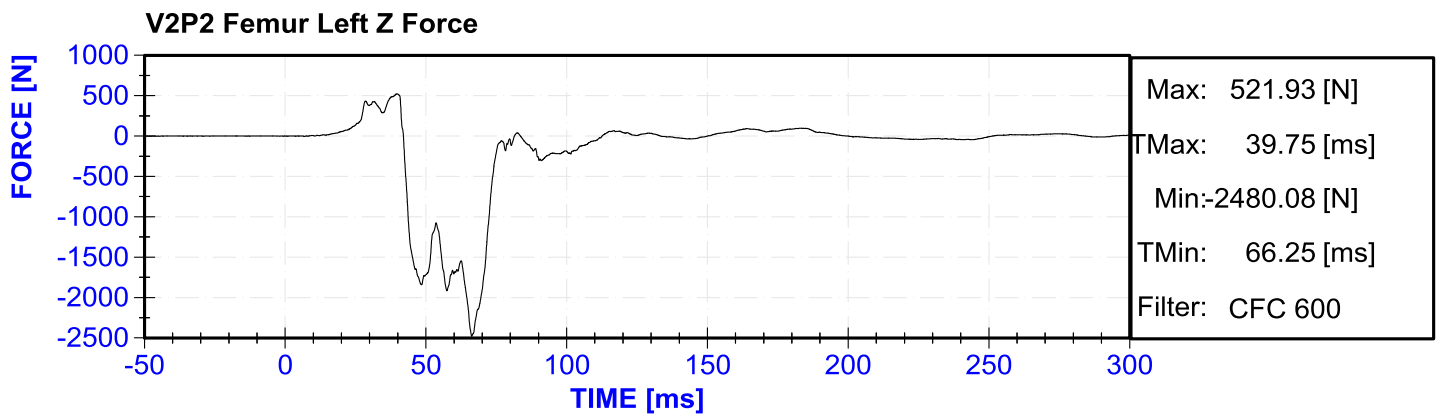
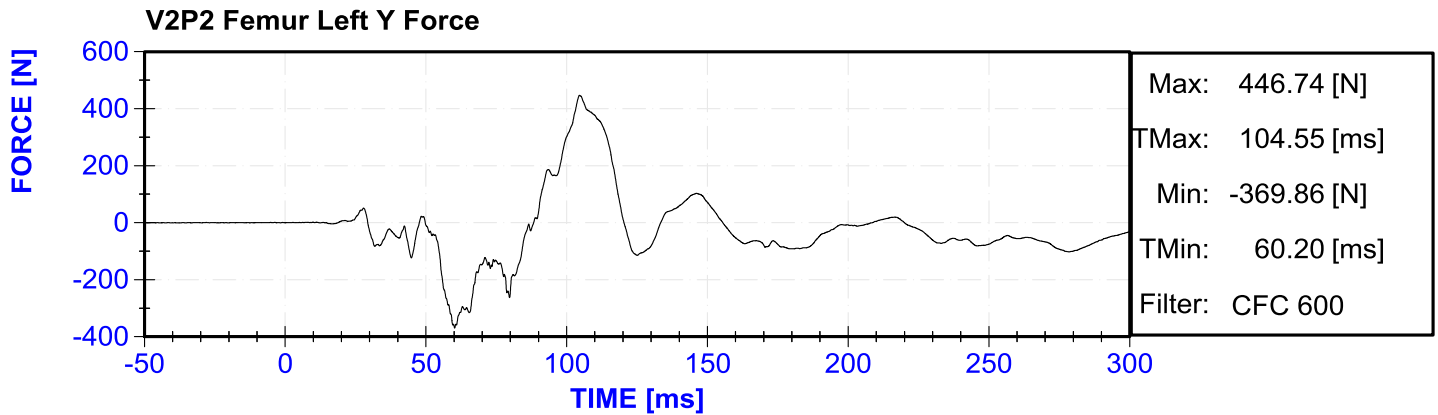

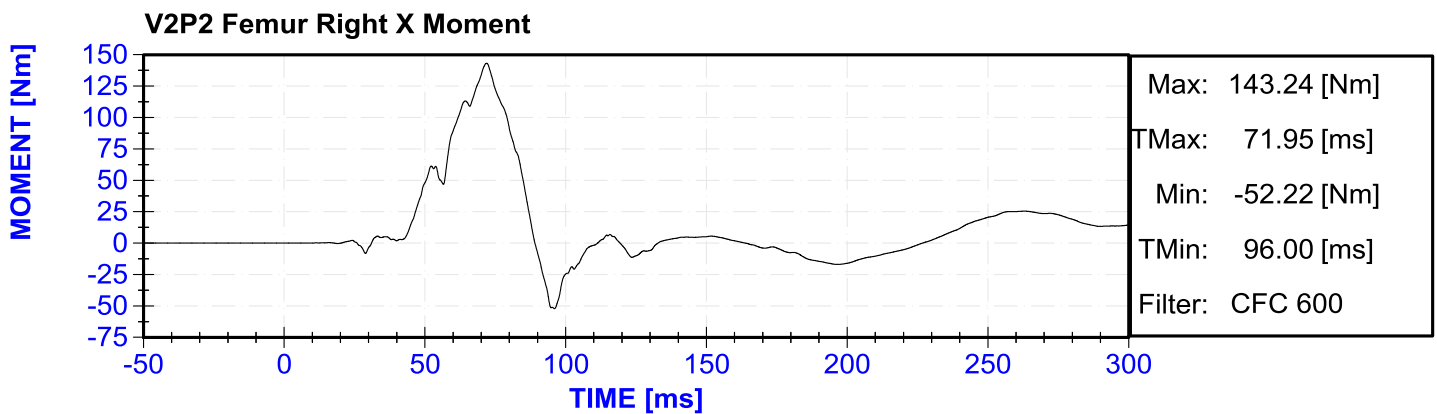
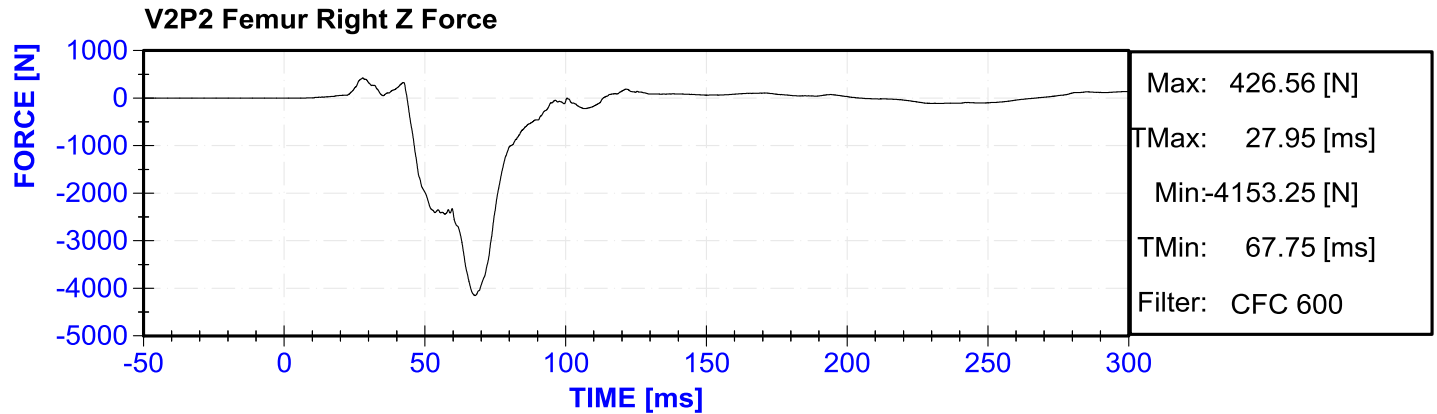
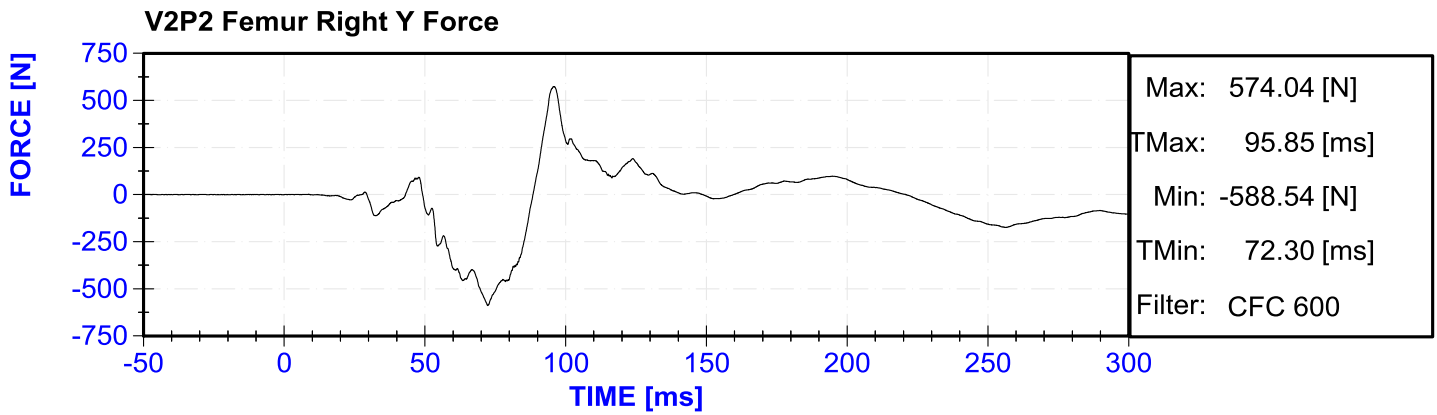
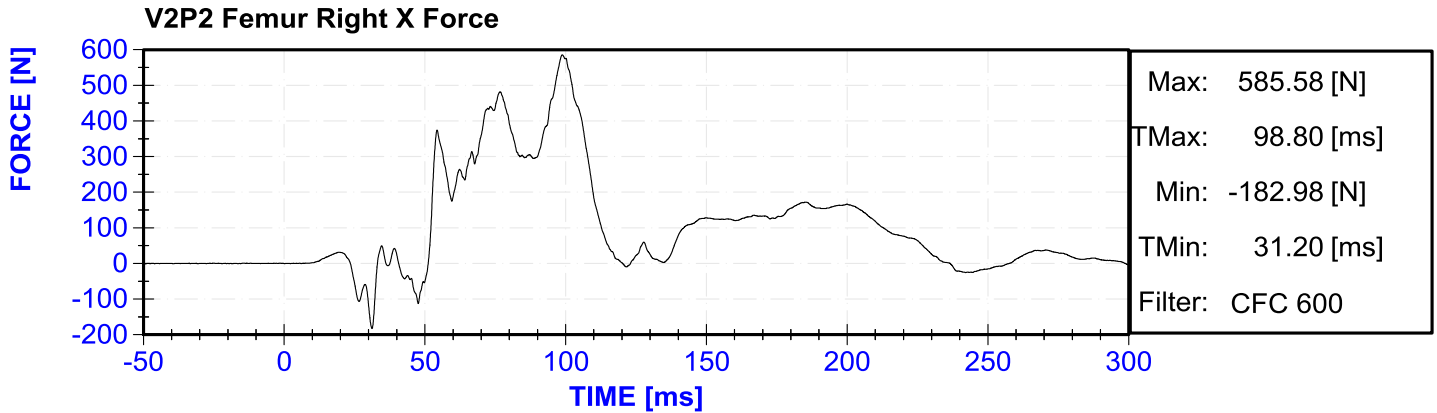

V2P2 Femur Right Y Moment

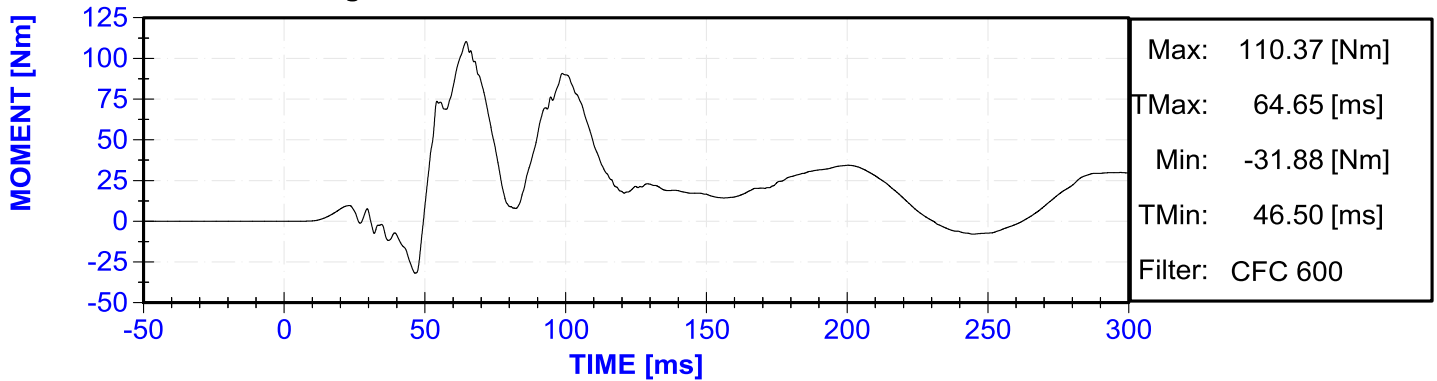

V2P2 Knee Left X Displacement

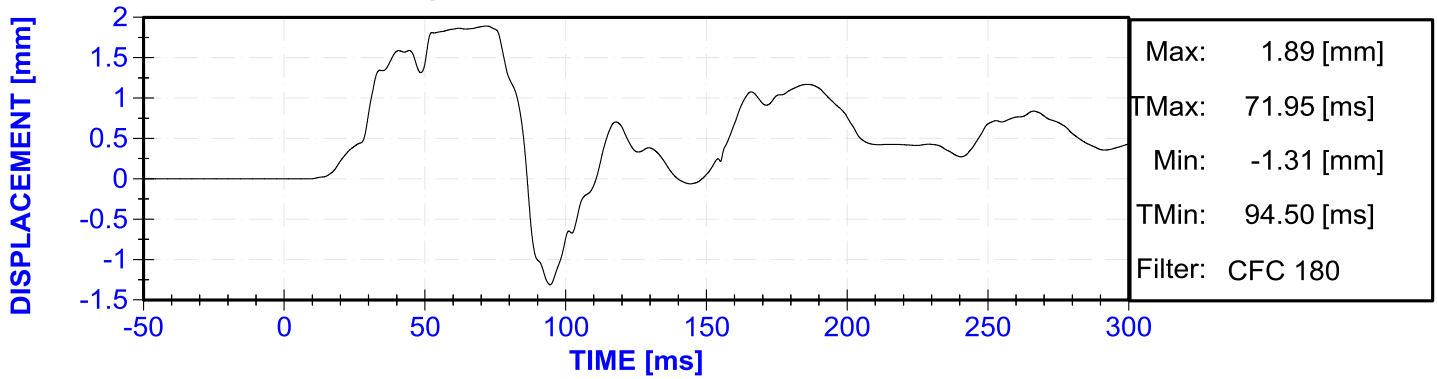

V2P2 Knee Right X Displacement

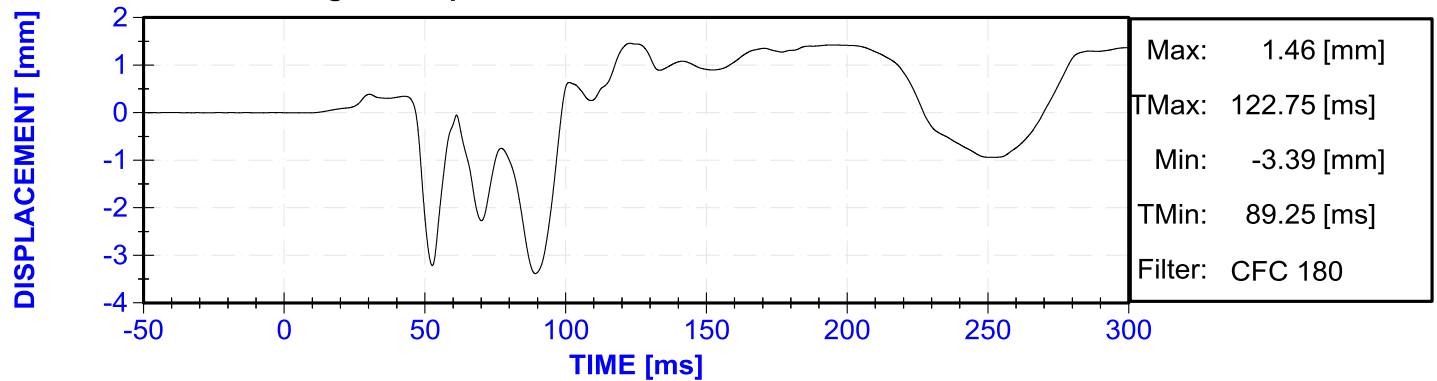

V2P2 Upper Tibia Left Z Force

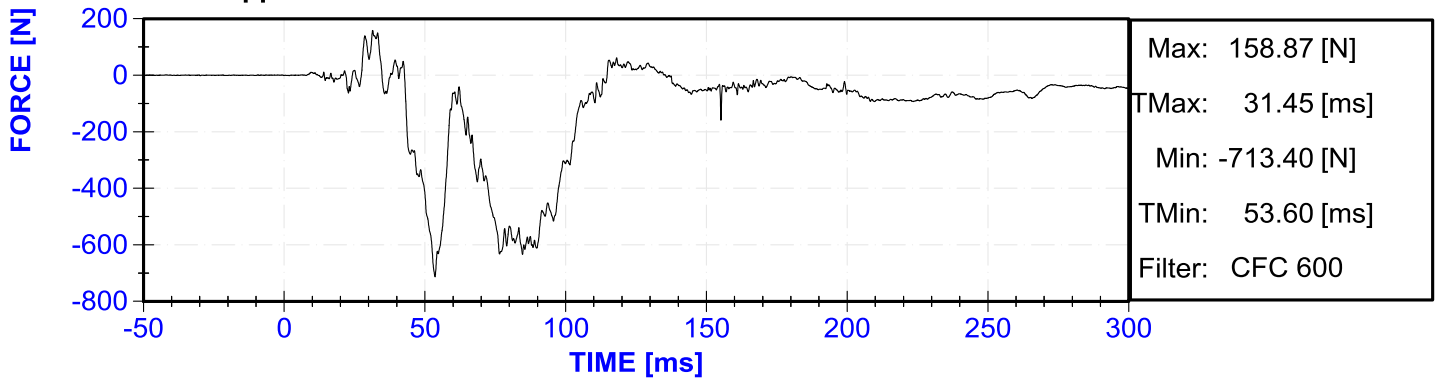

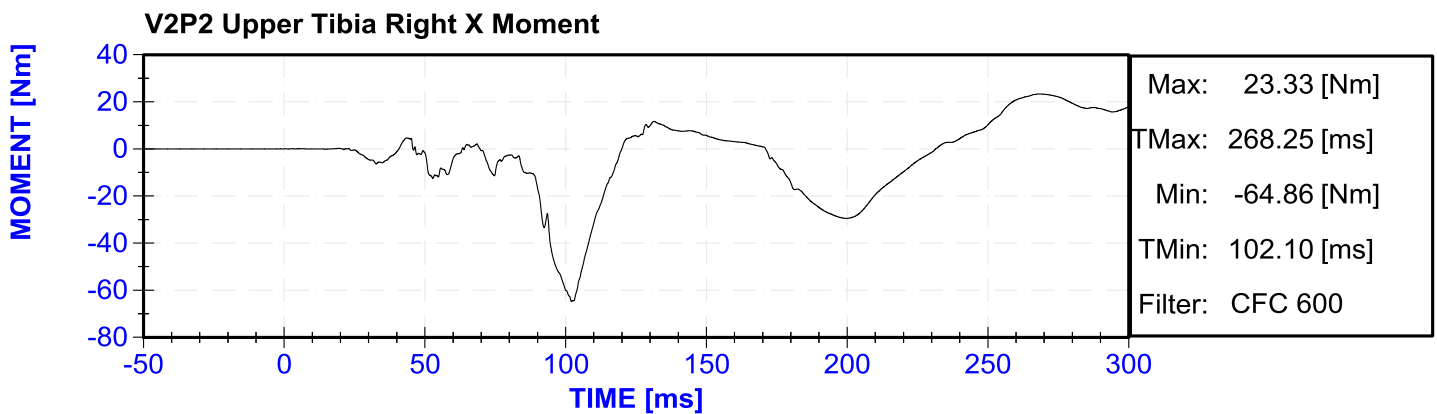
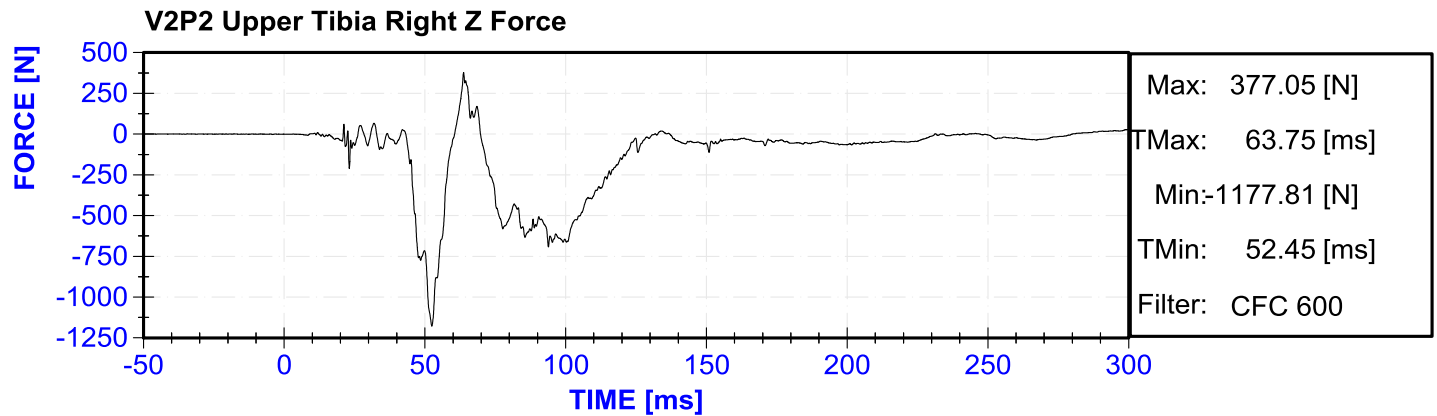
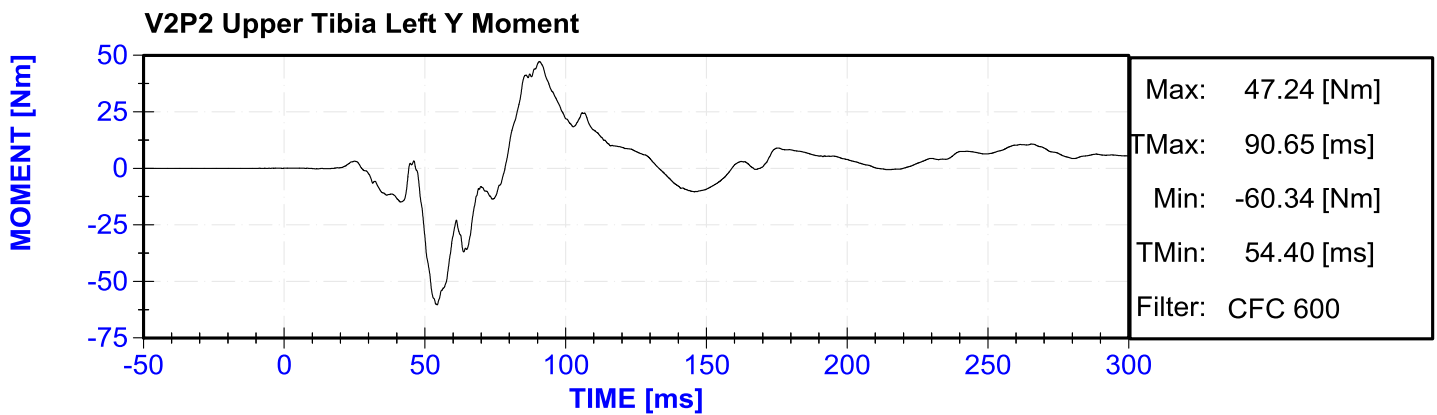
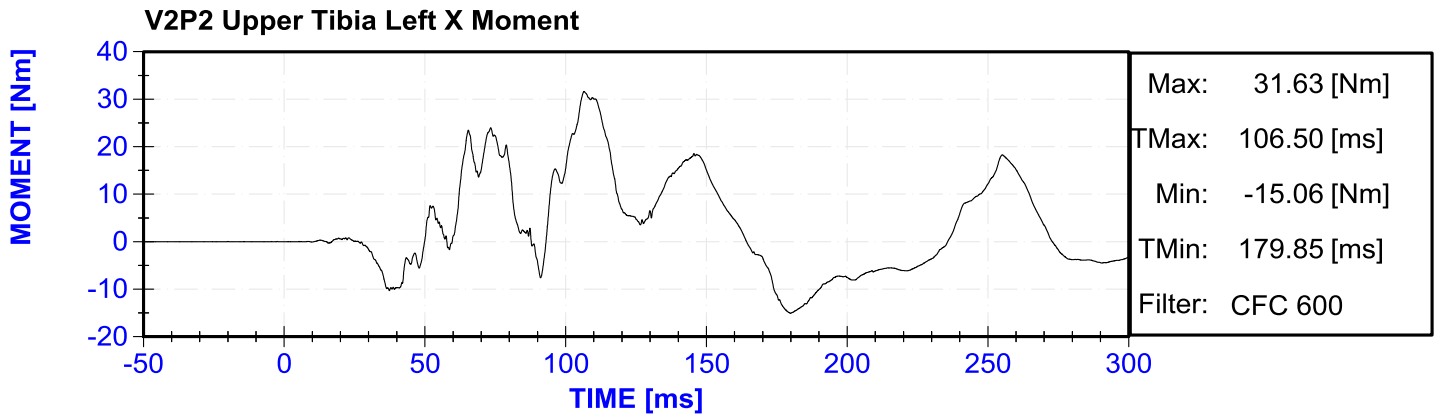

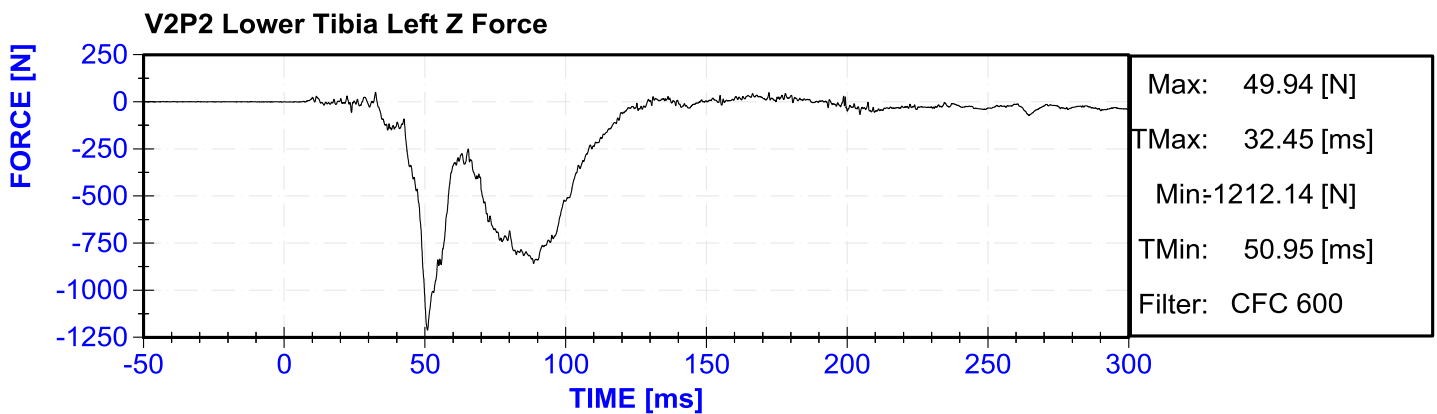
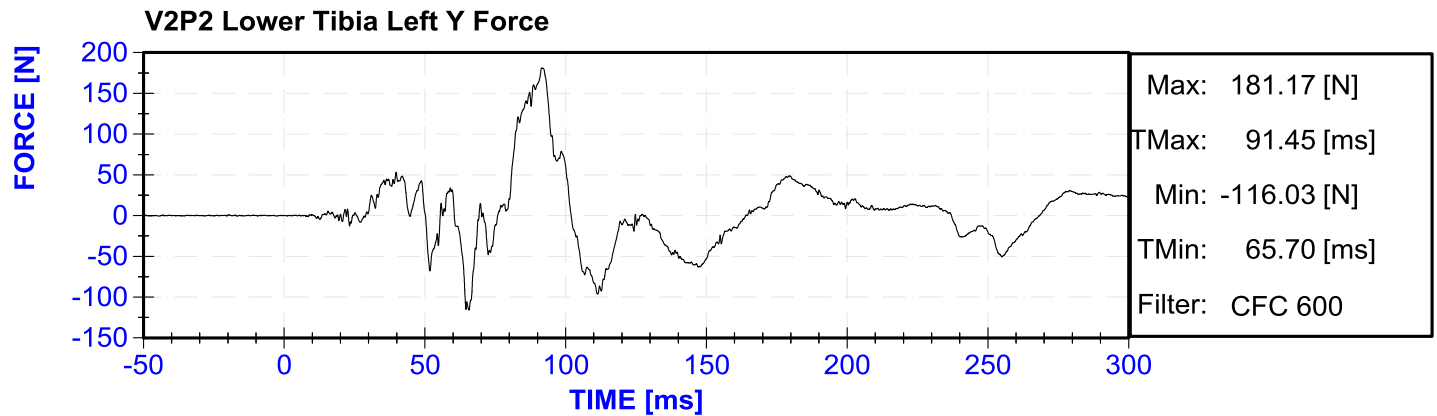
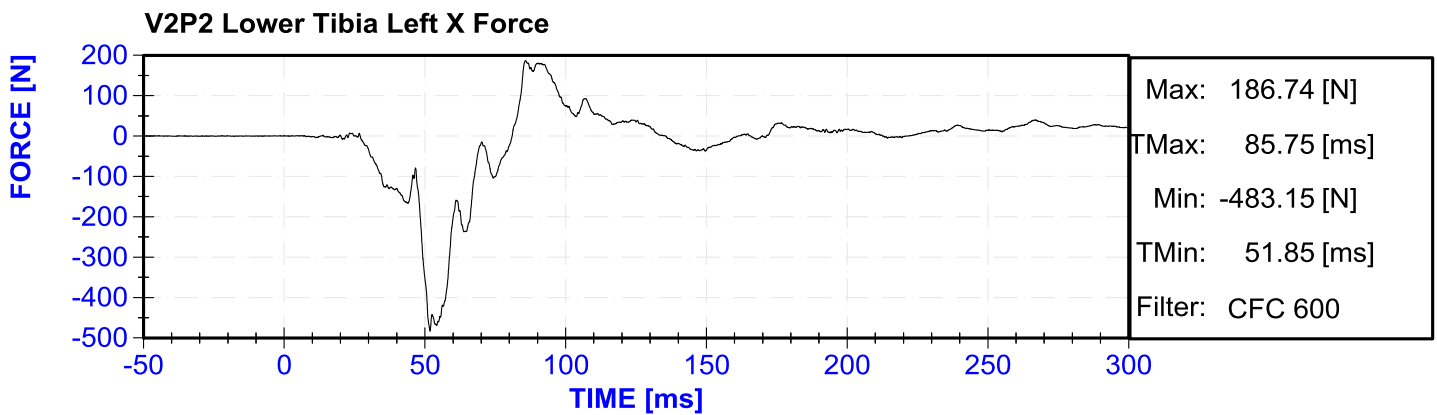
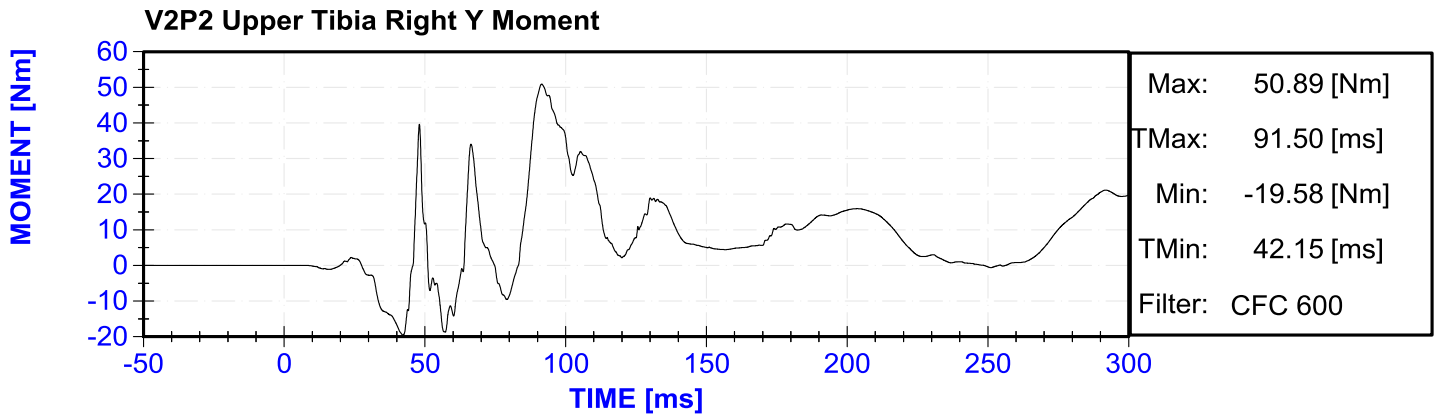

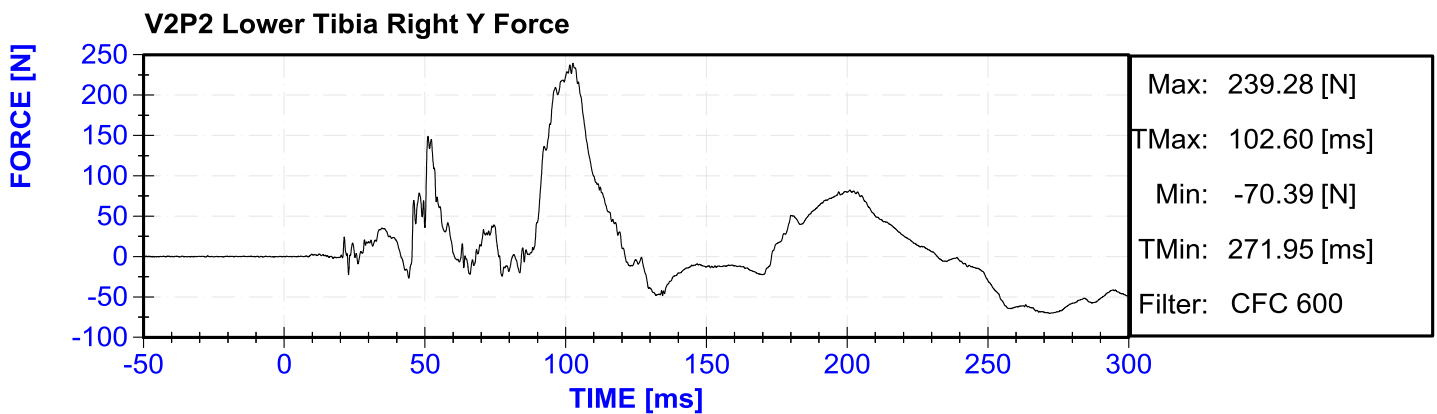
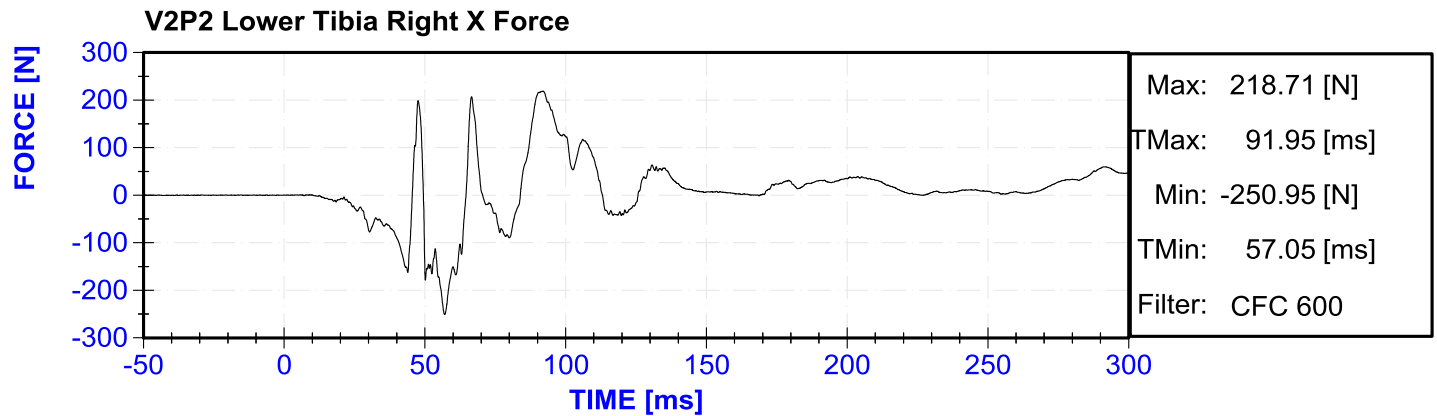
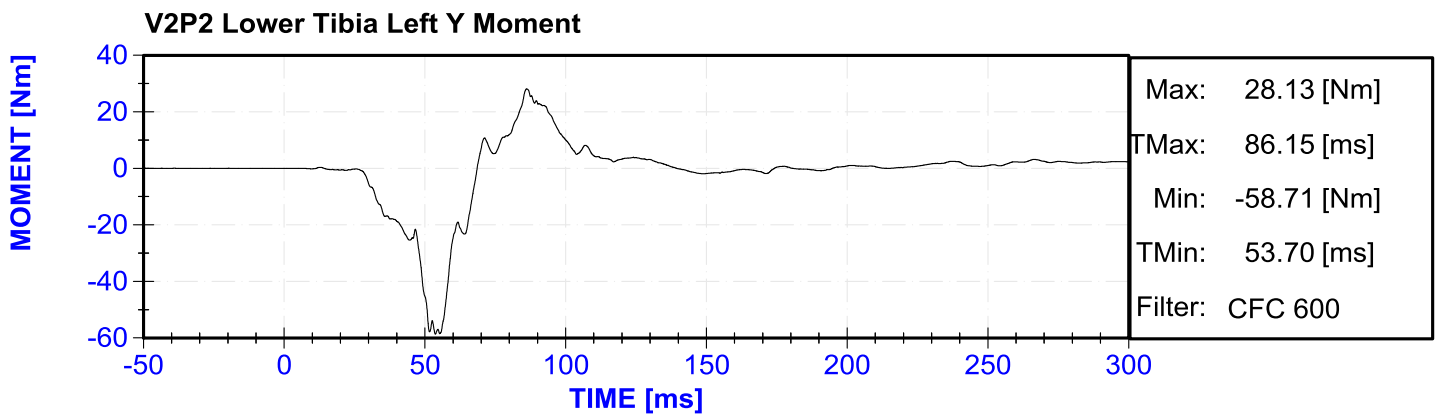
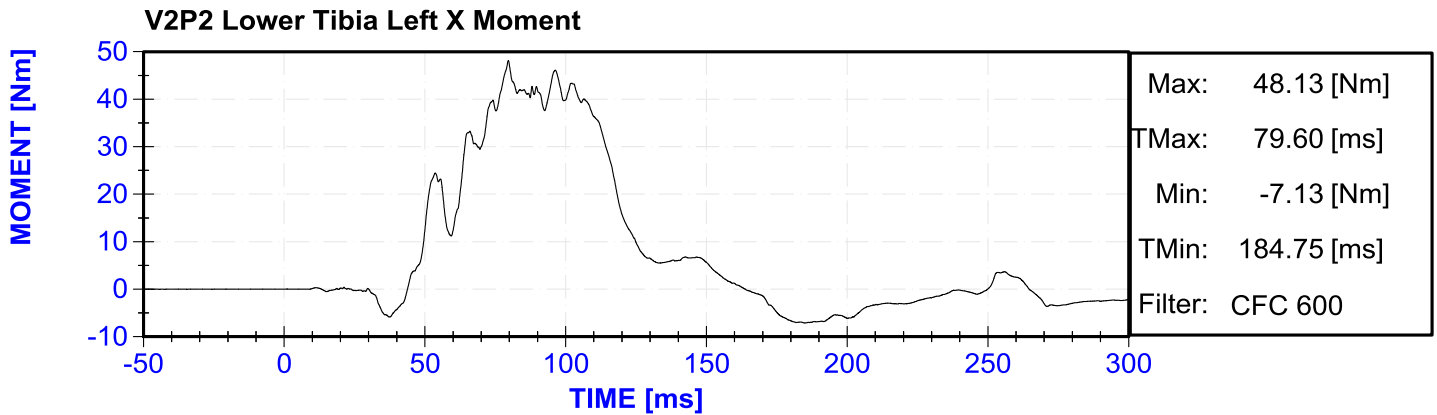

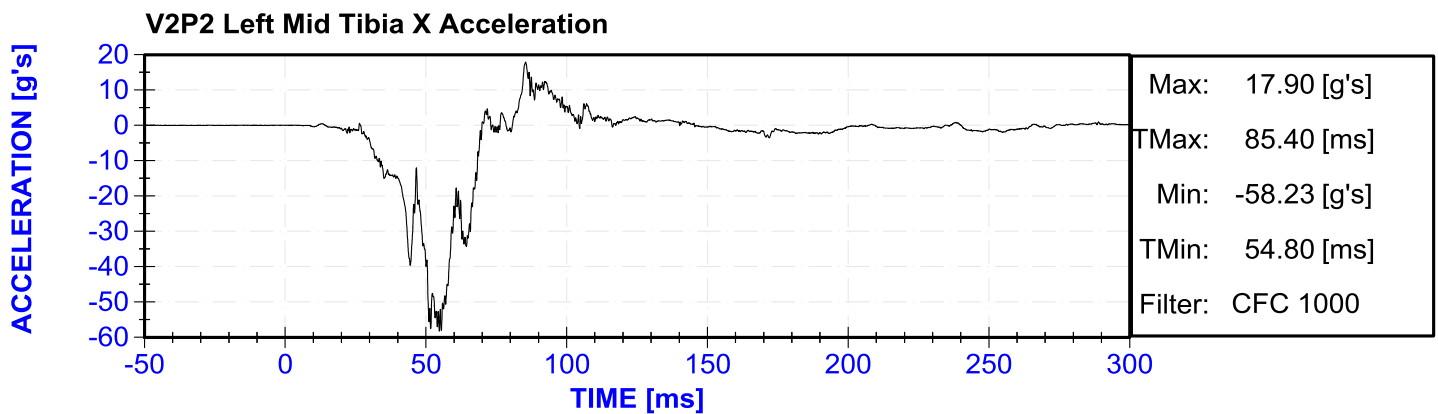
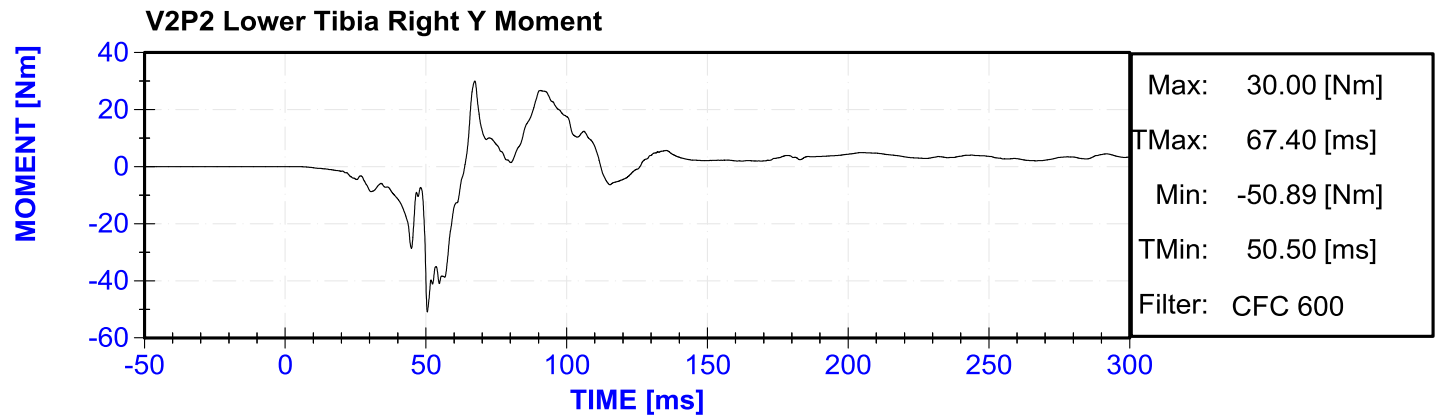
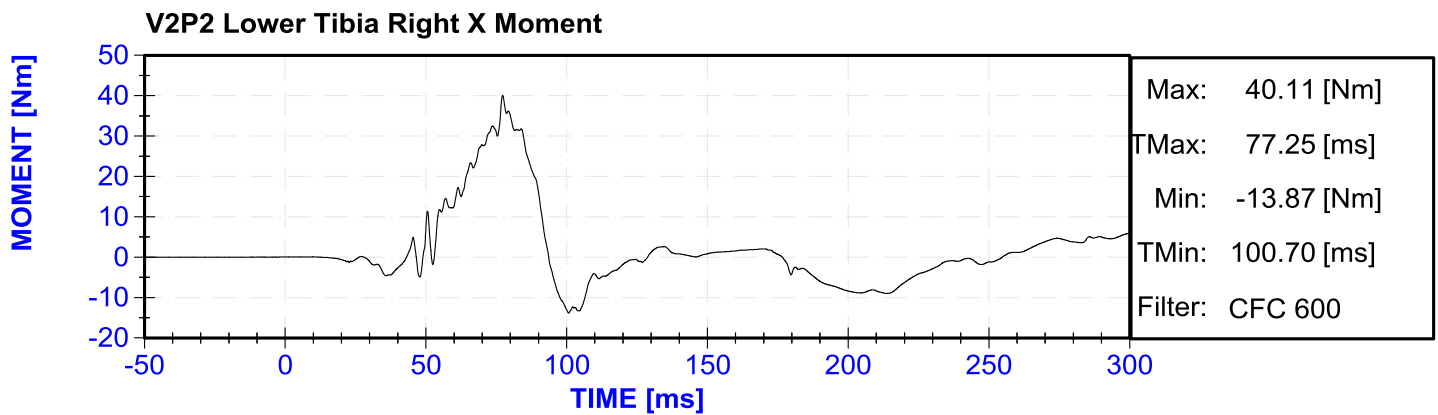
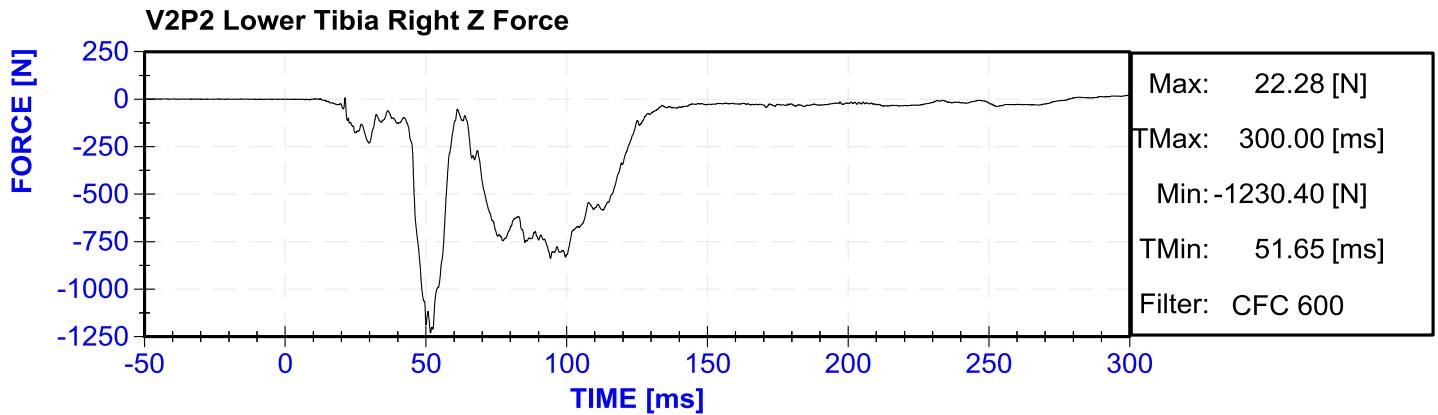

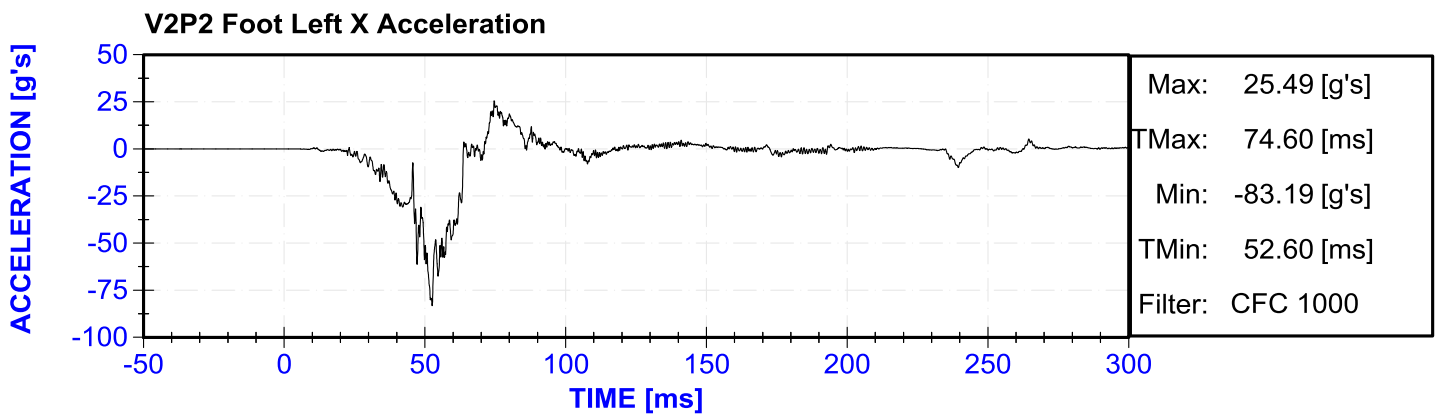
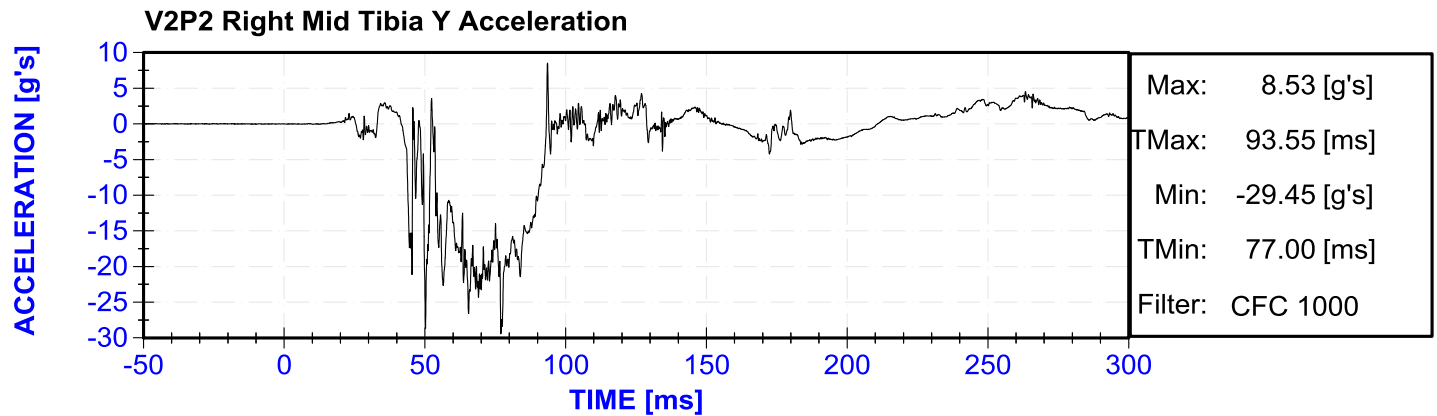
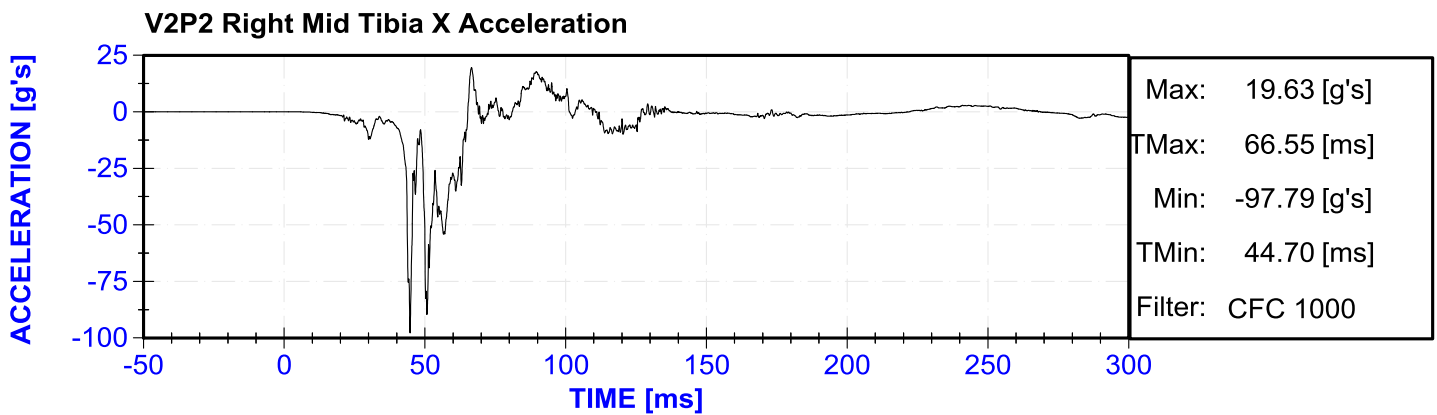
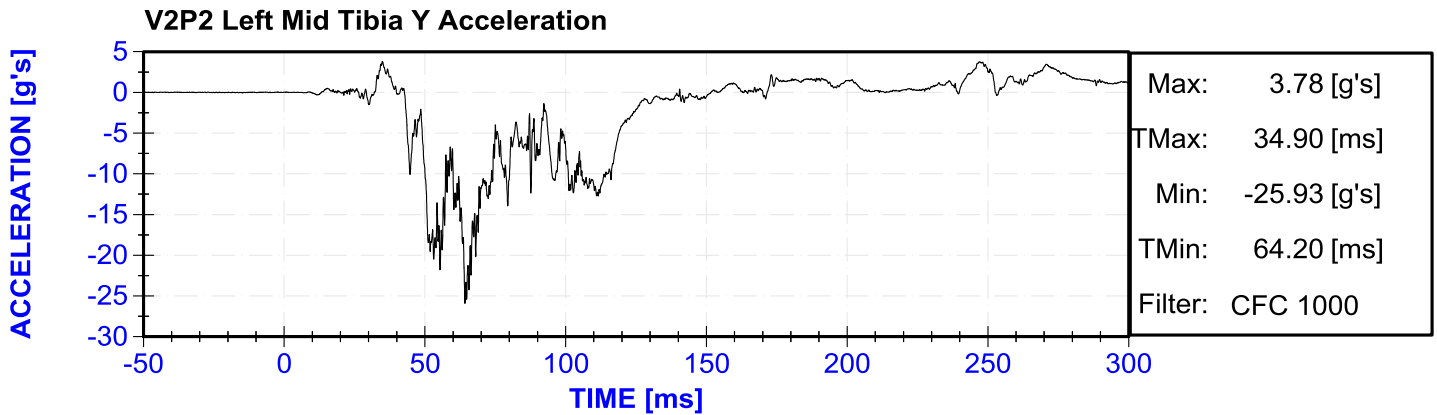

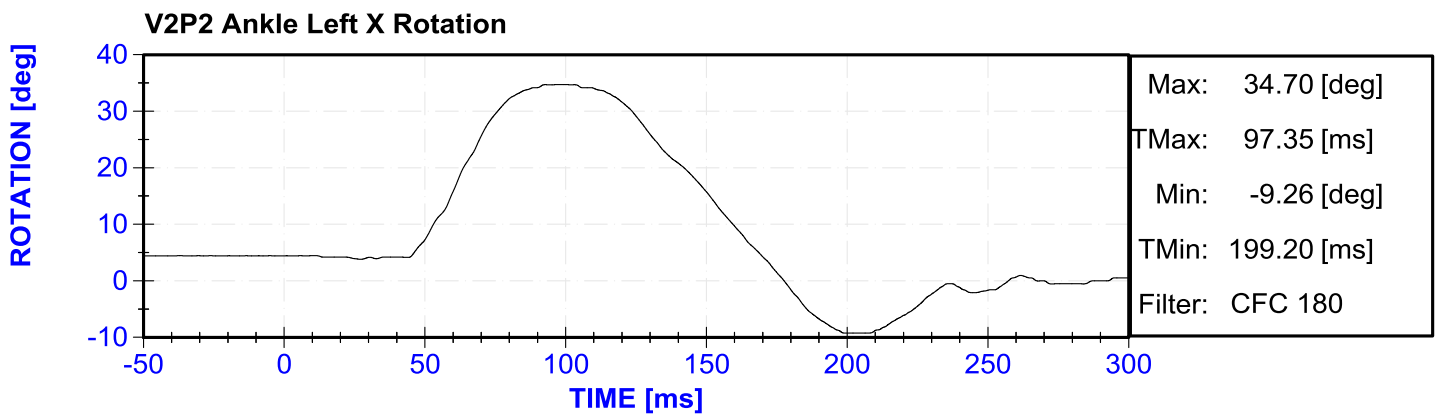
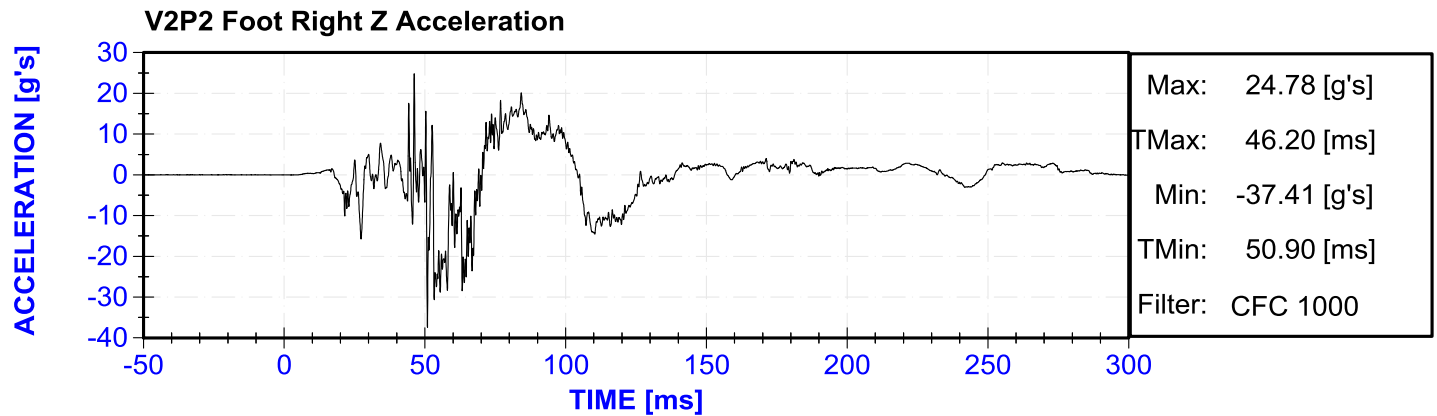
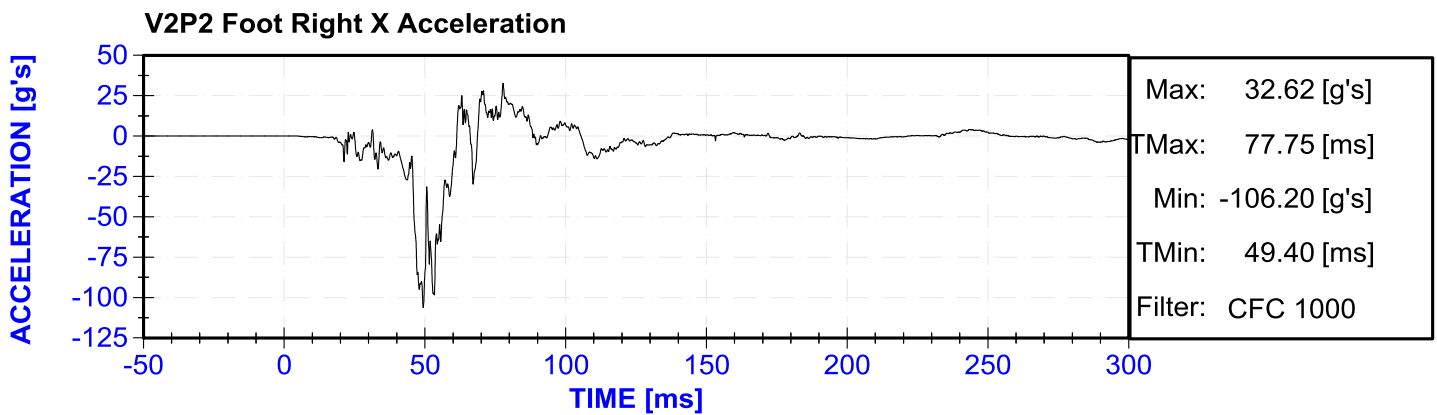
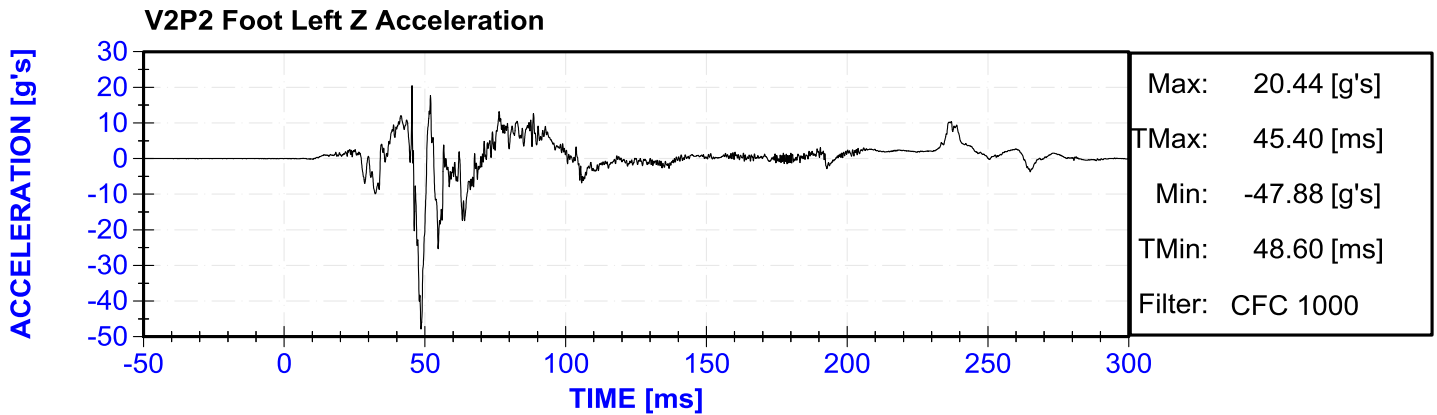

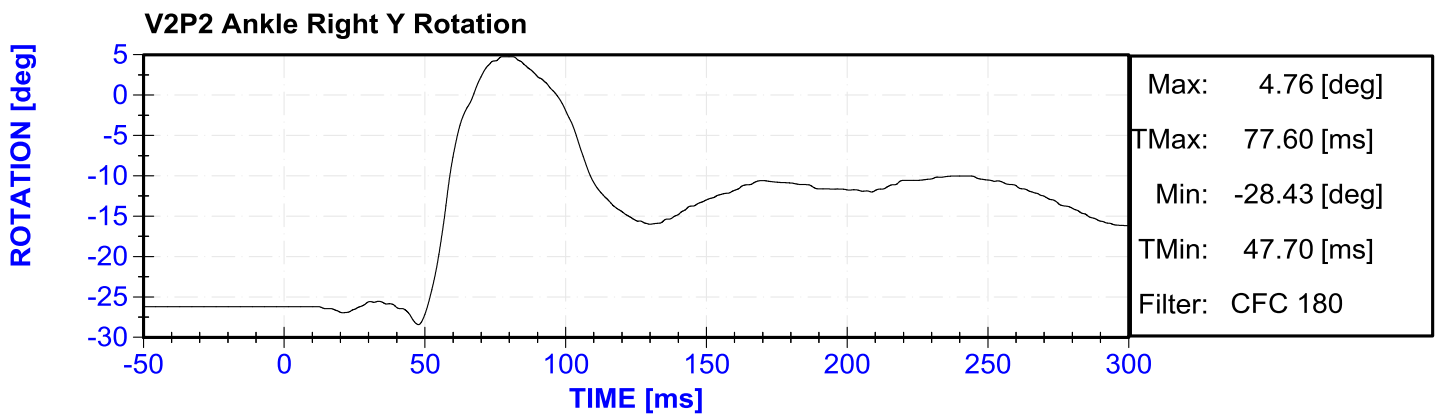
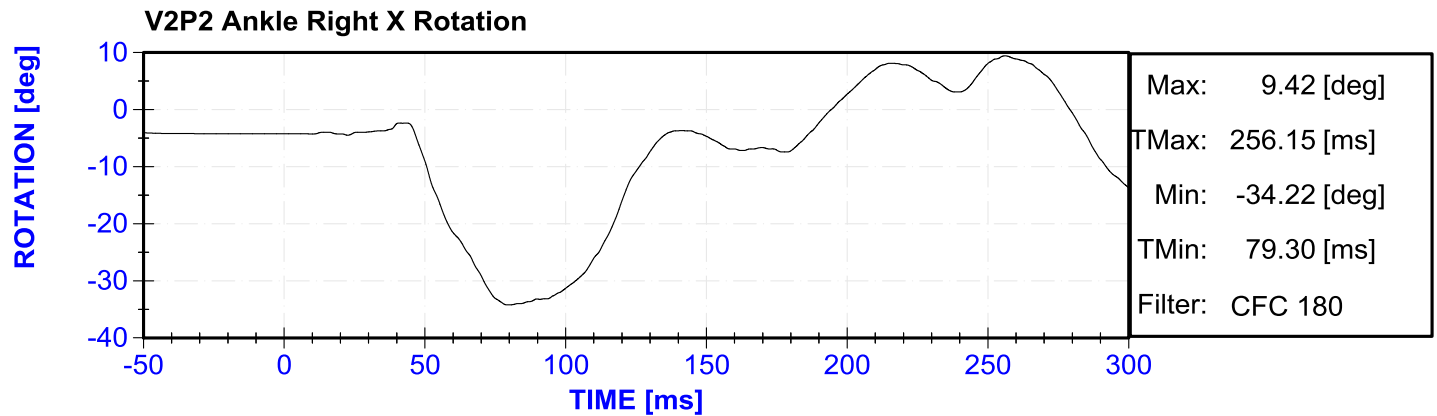
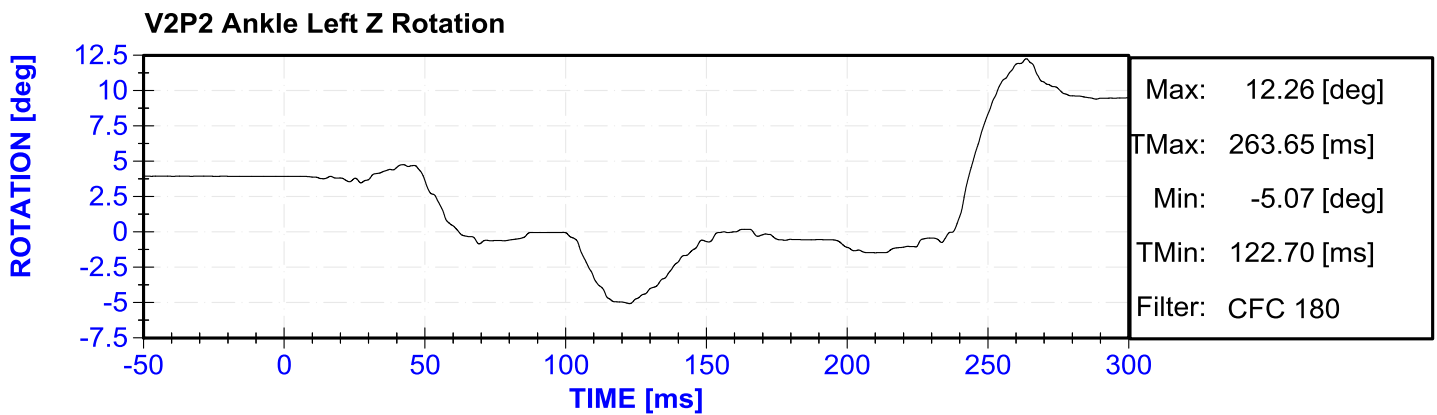
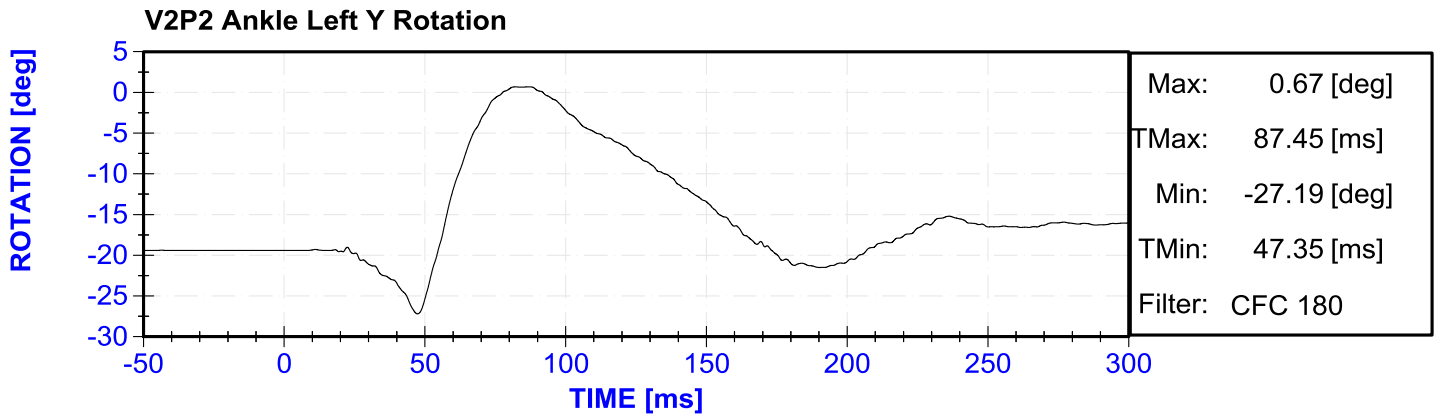

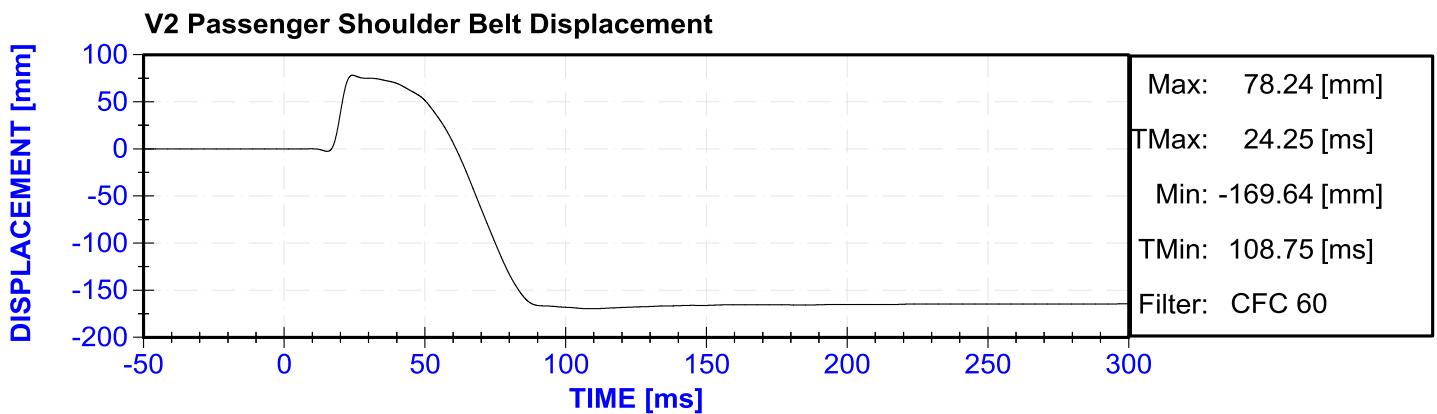
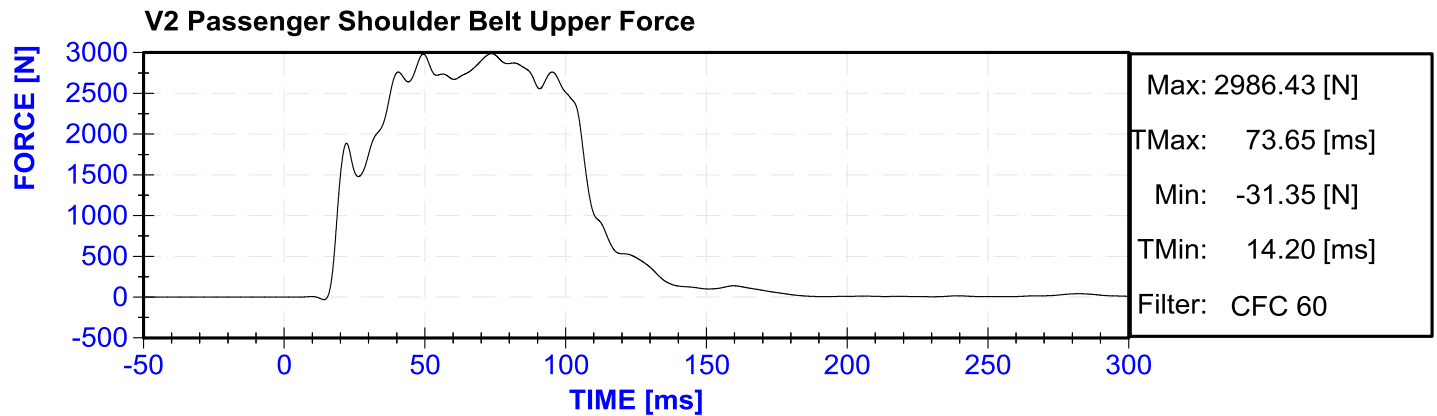
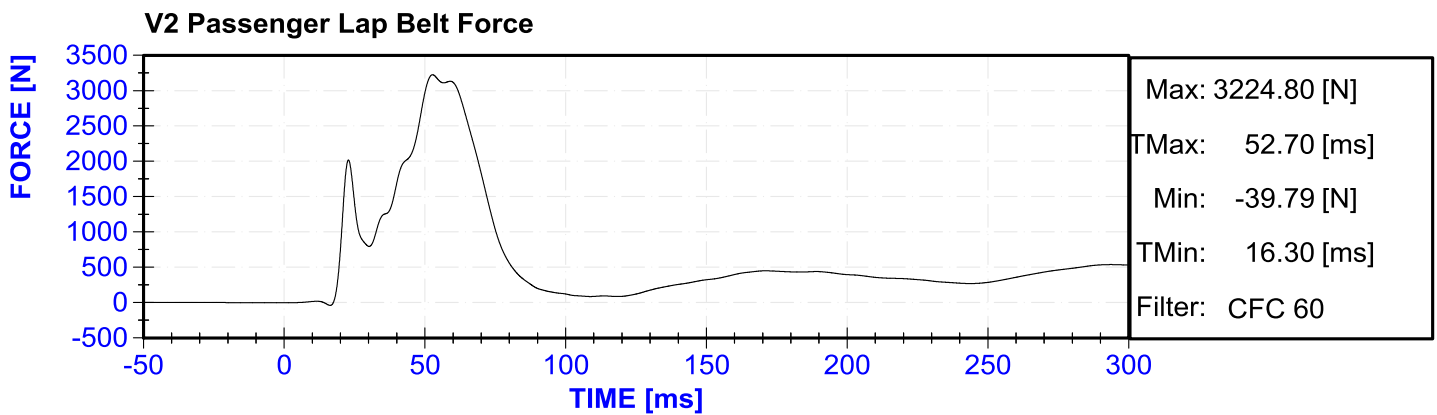
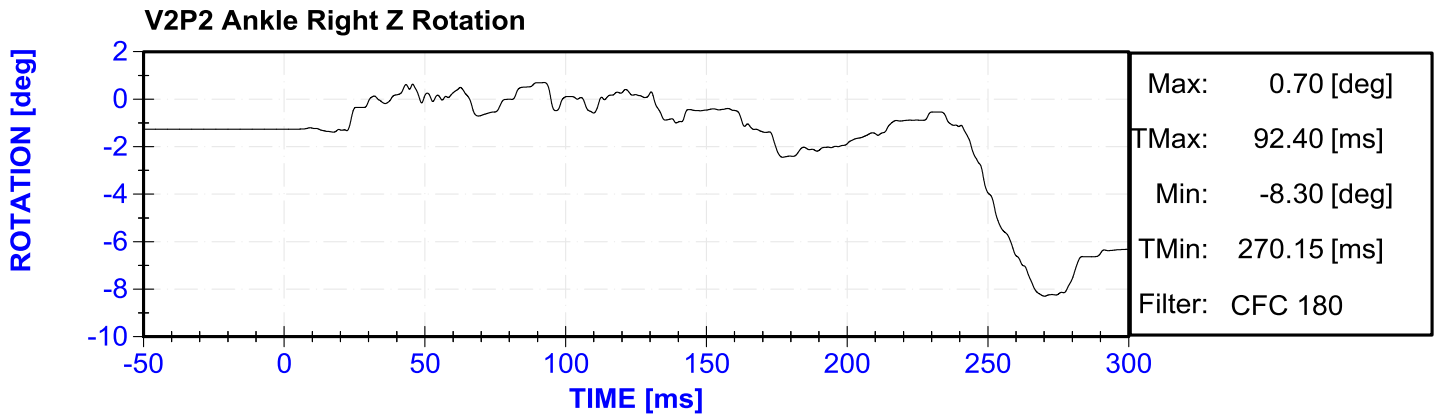

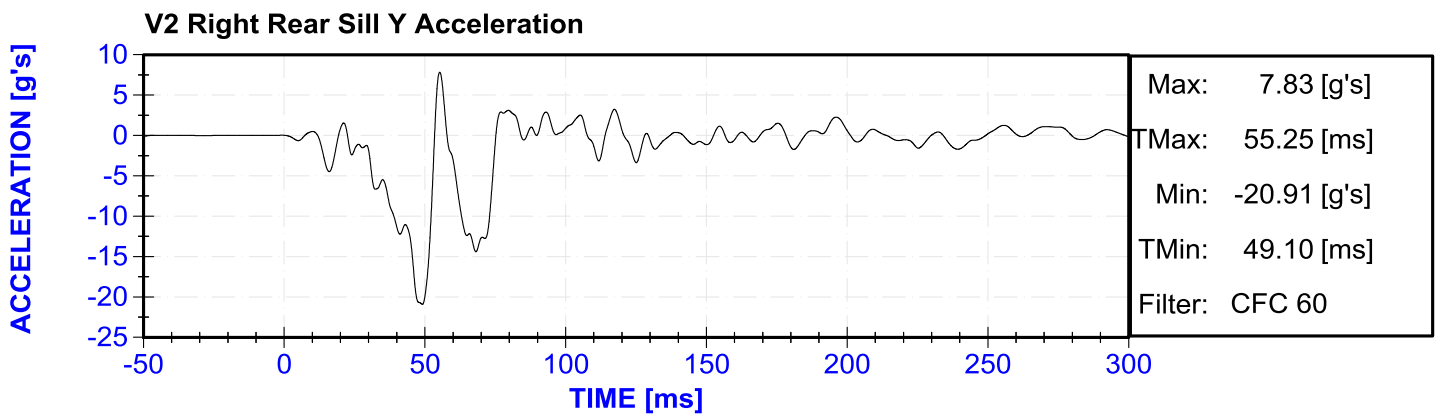
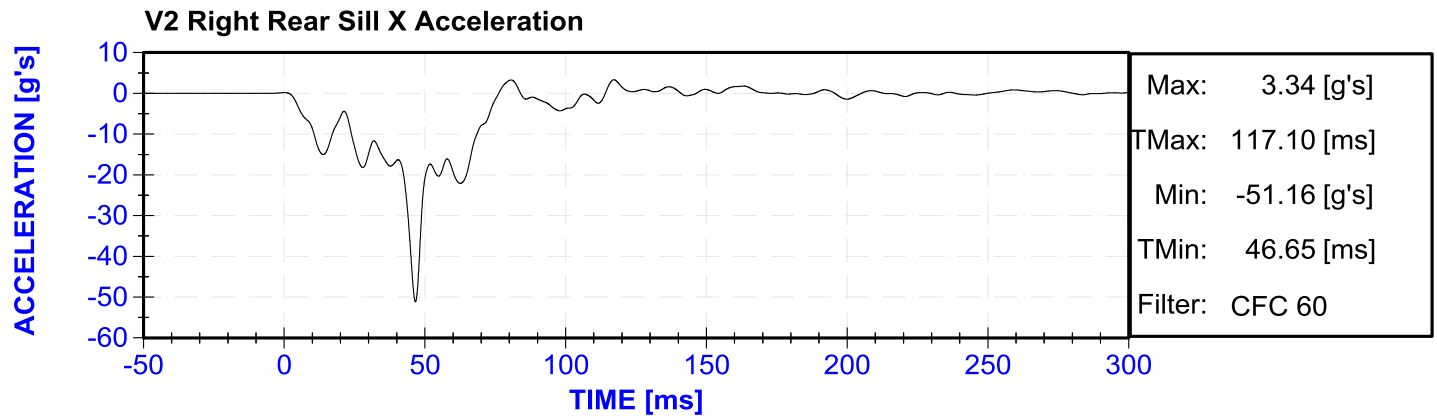
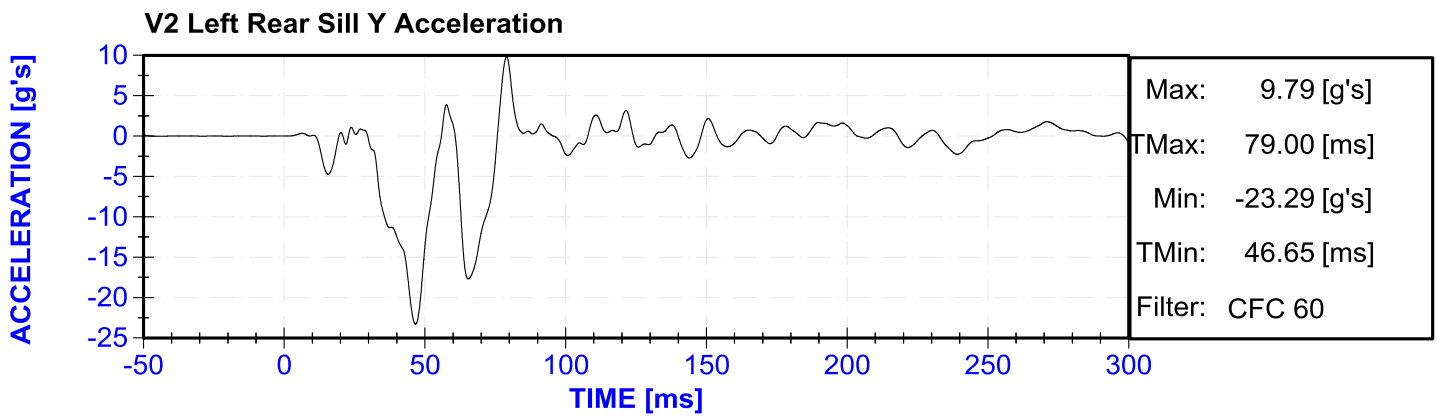
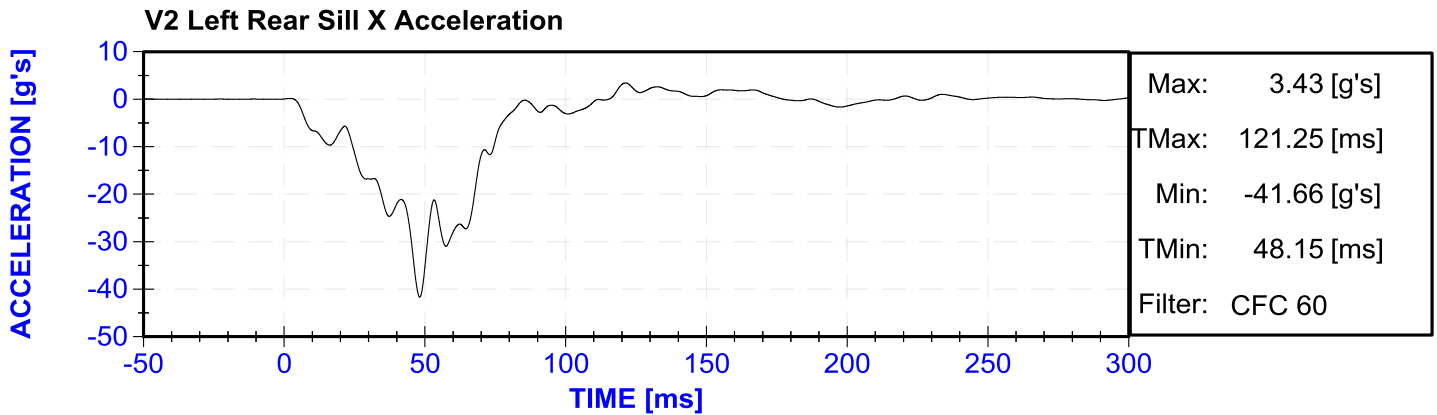

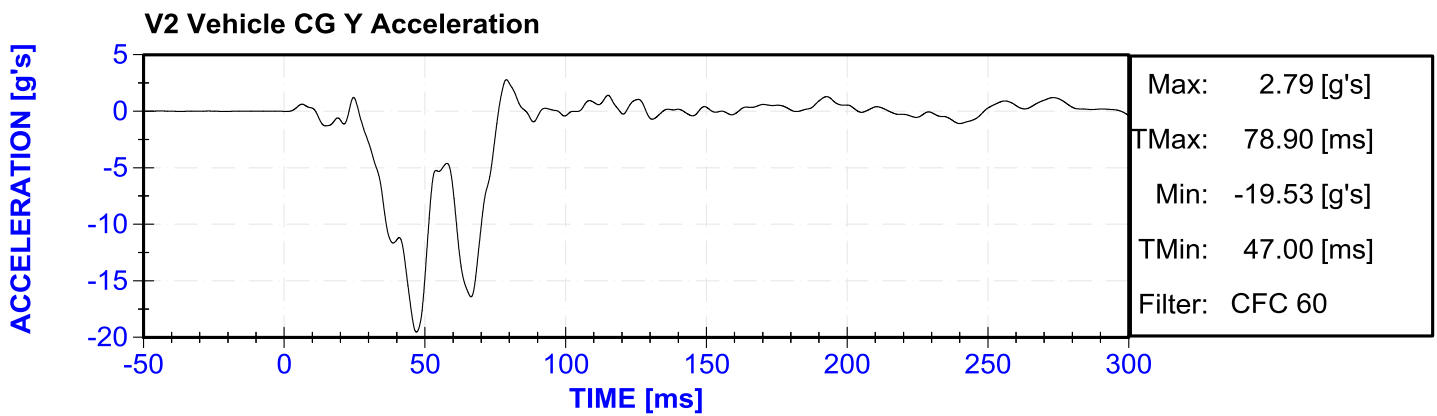
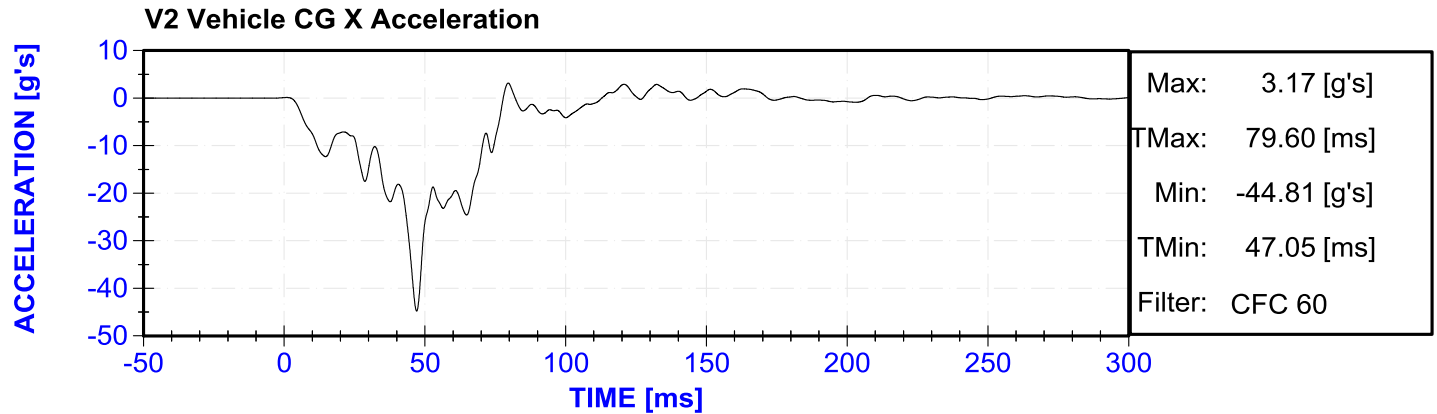
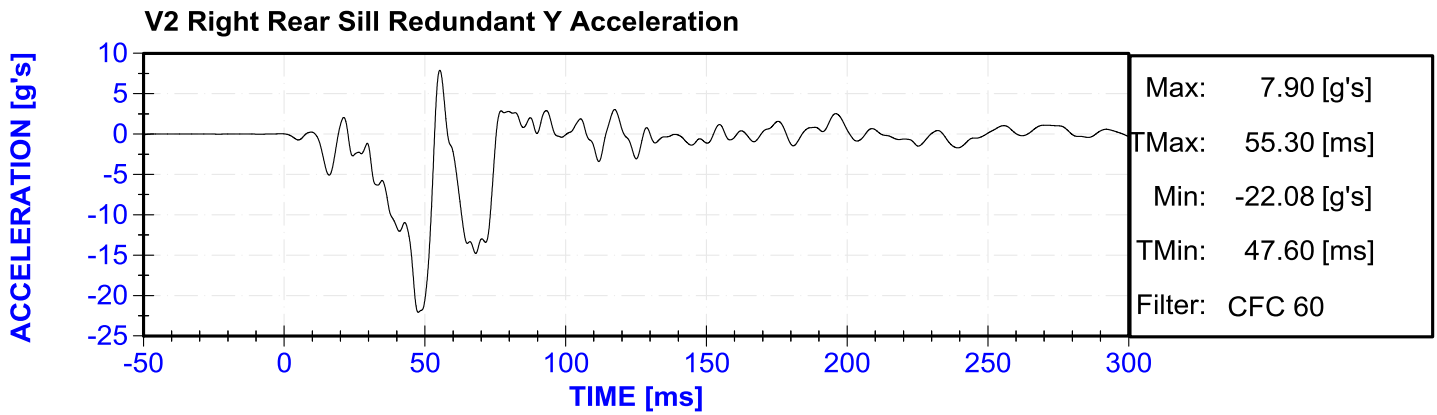
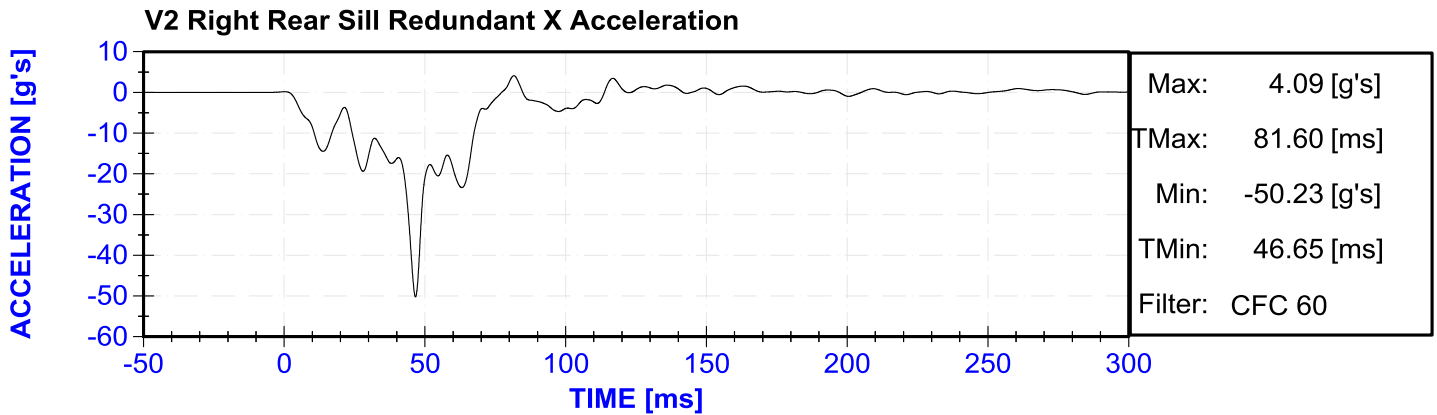

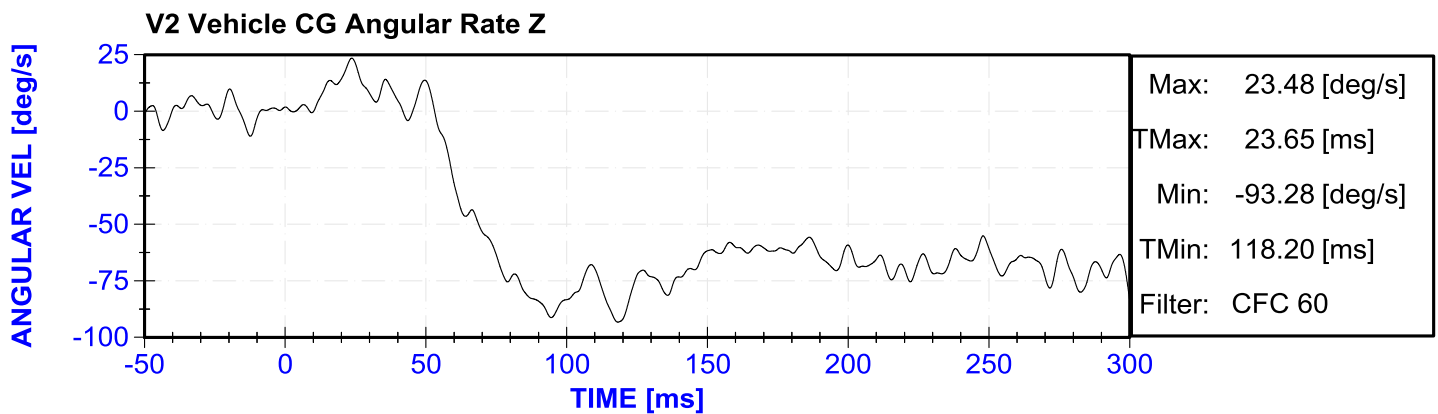
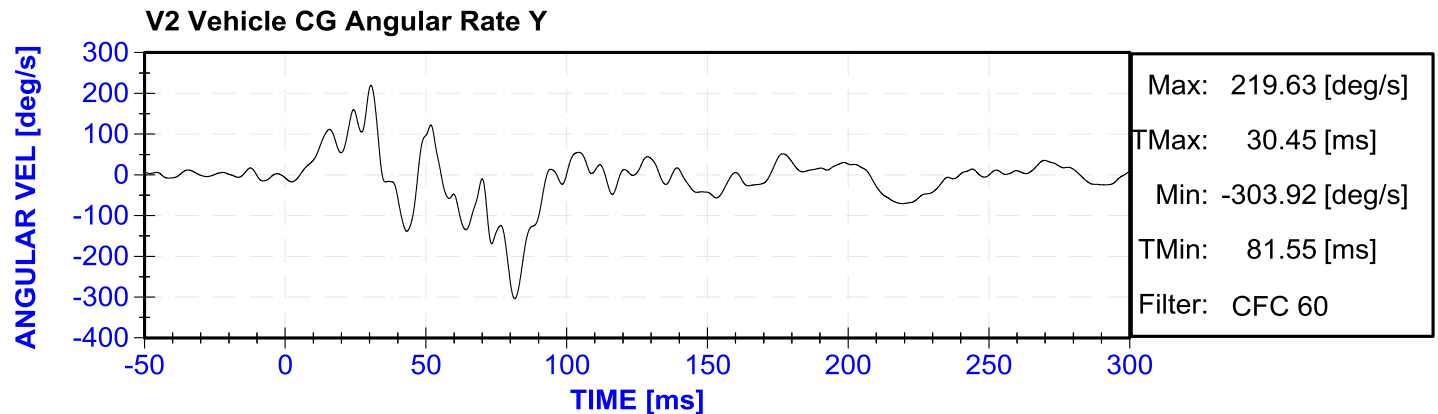
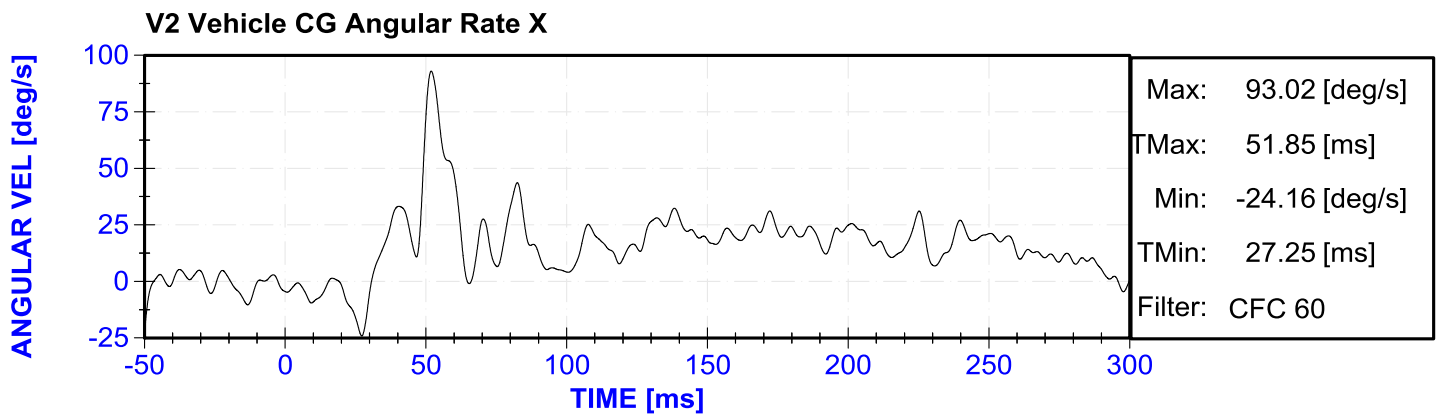
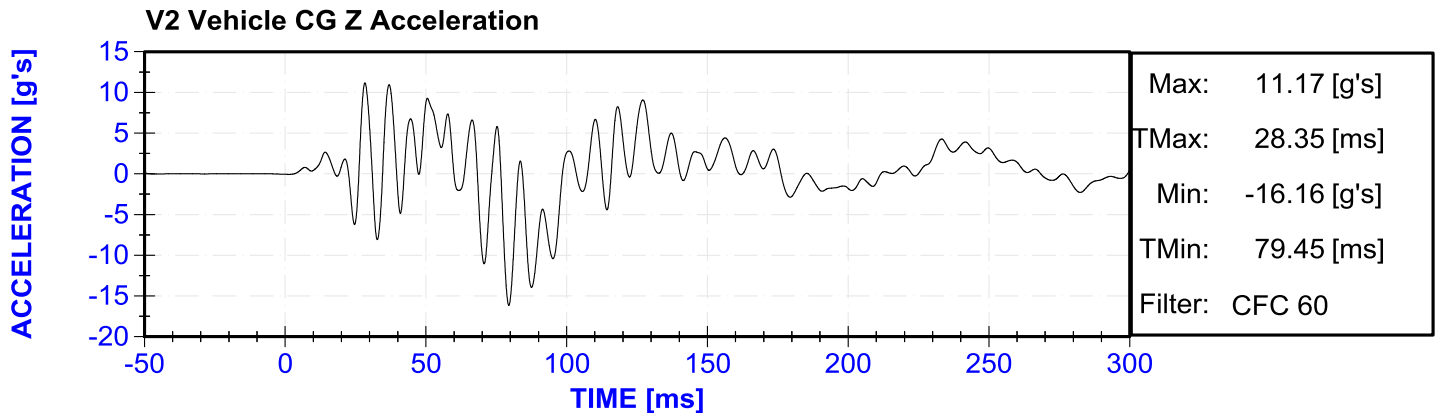

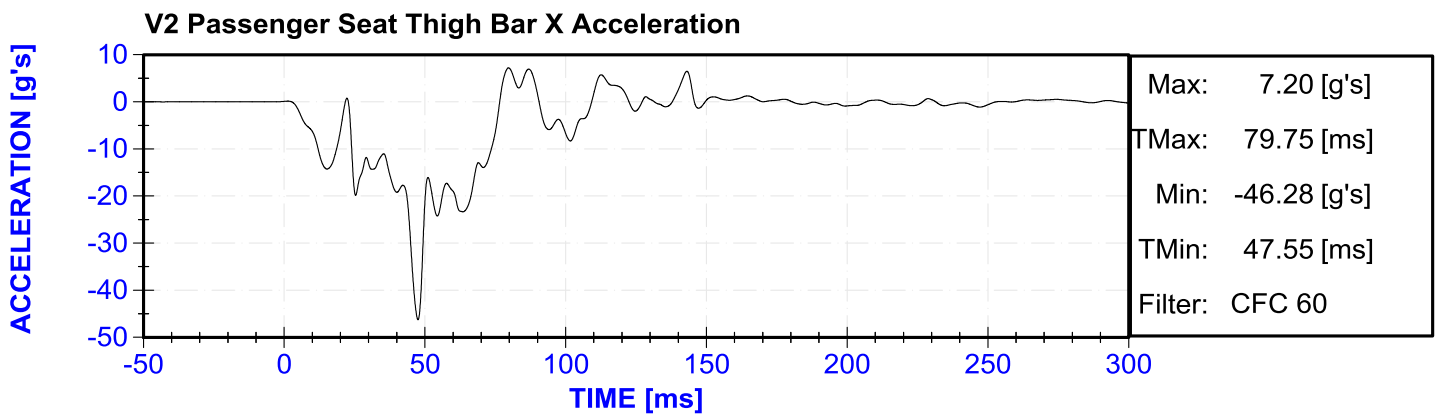
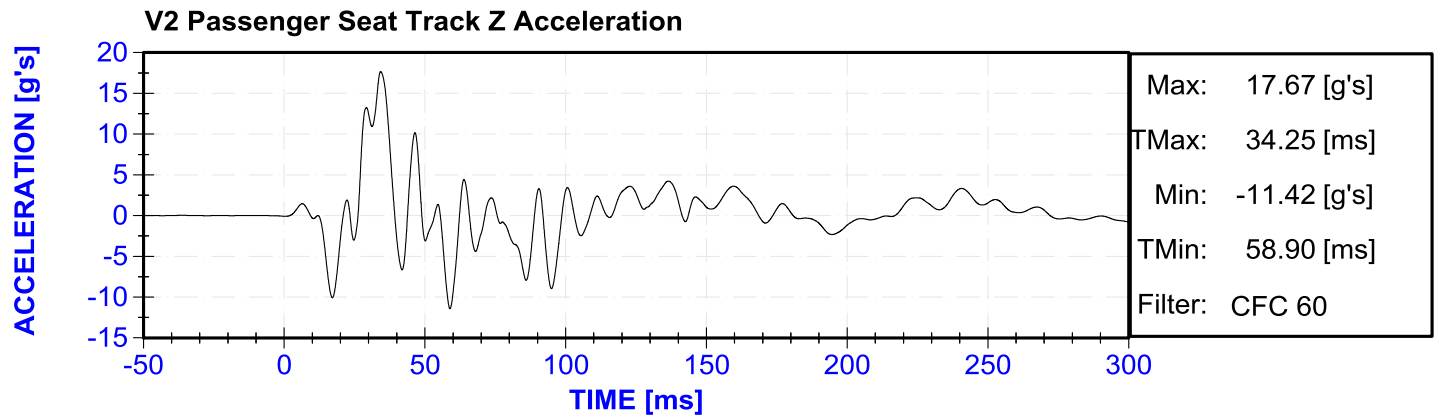
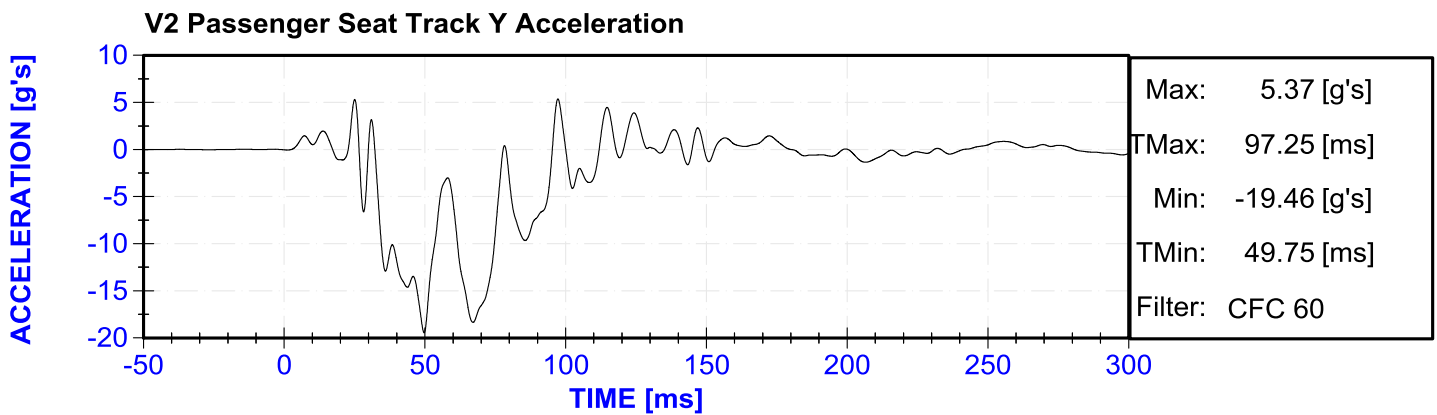
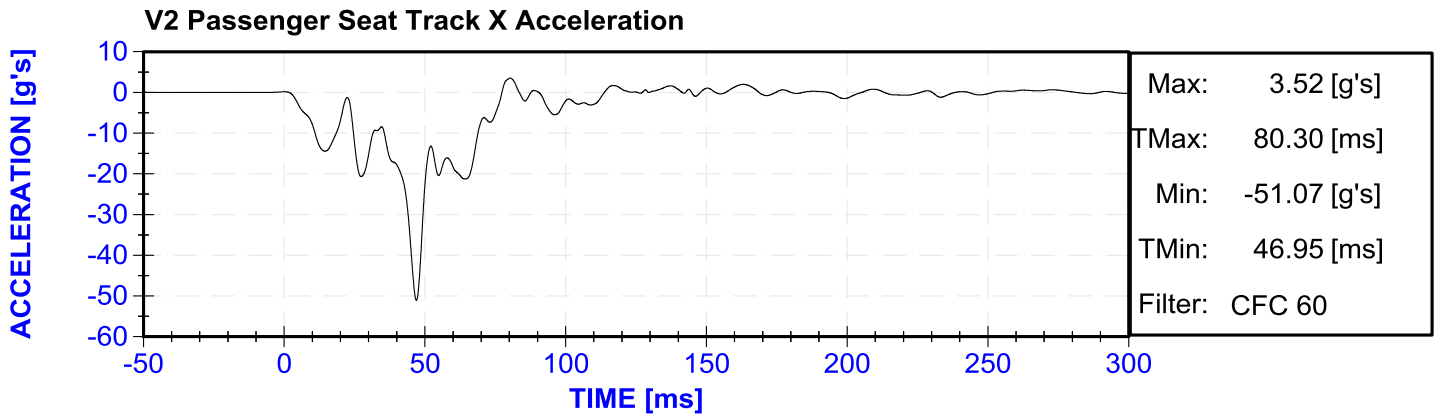

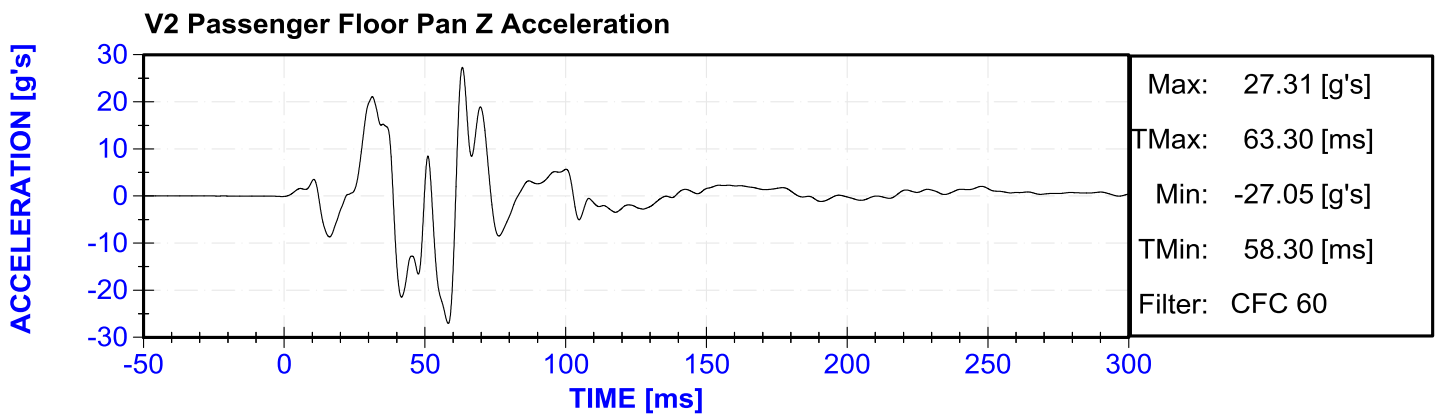
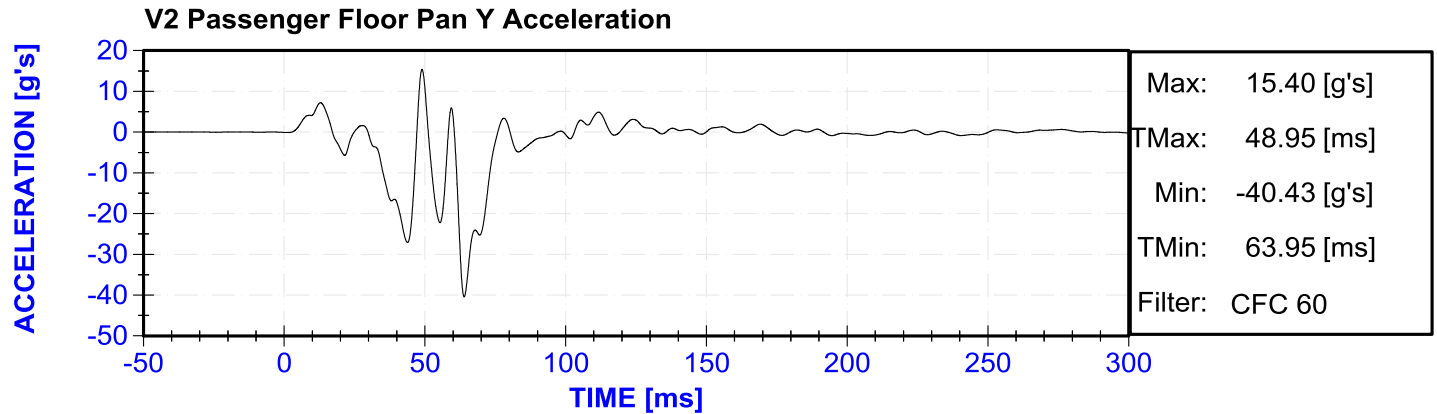
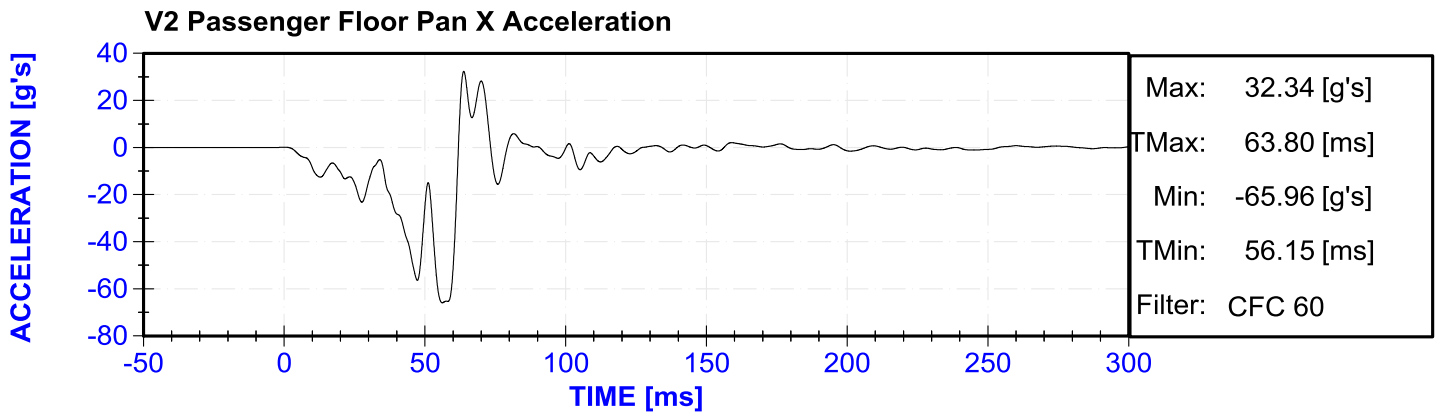
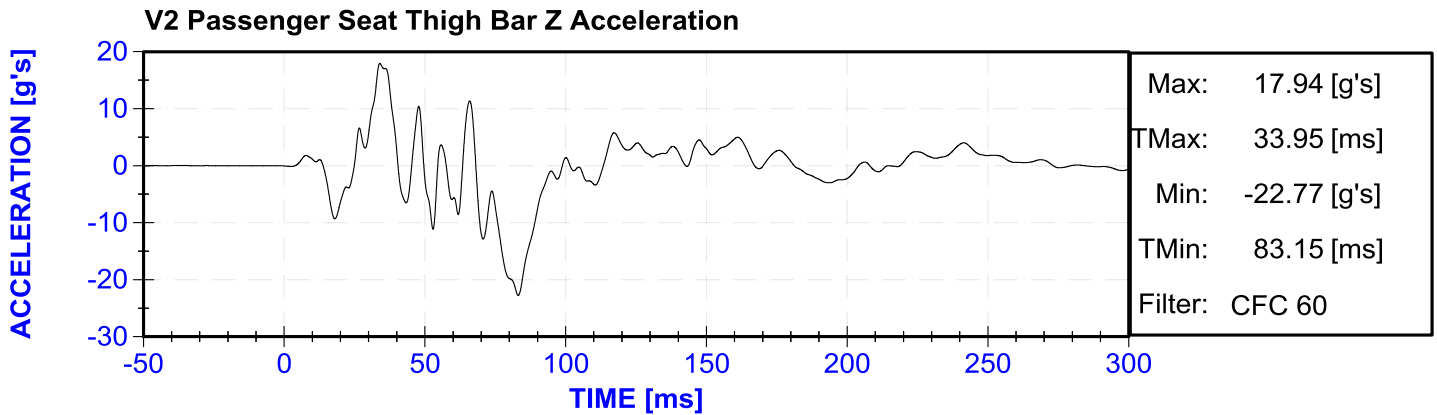

V2 Passenger Floor Pan X Deflection

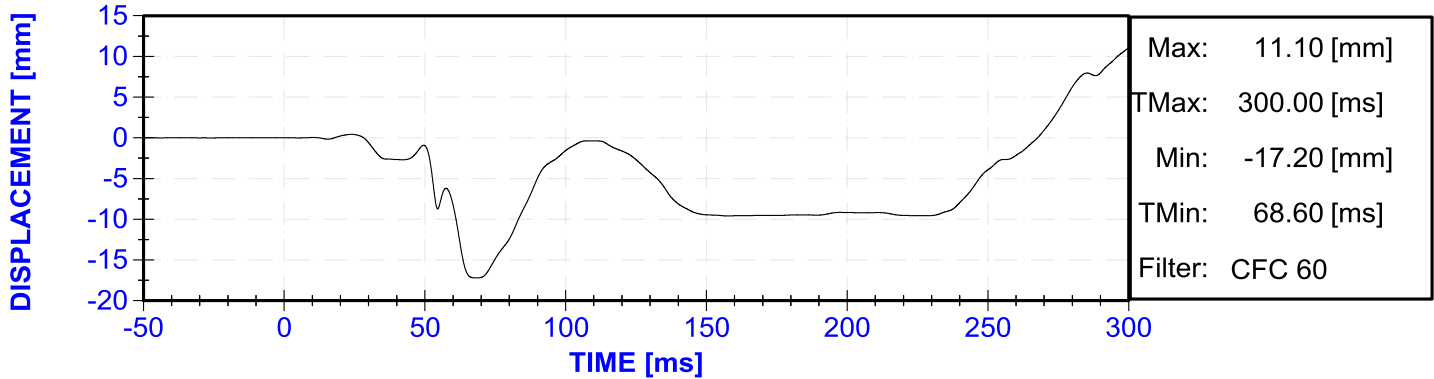

Driver Front Airbag Stage 1 Monitor

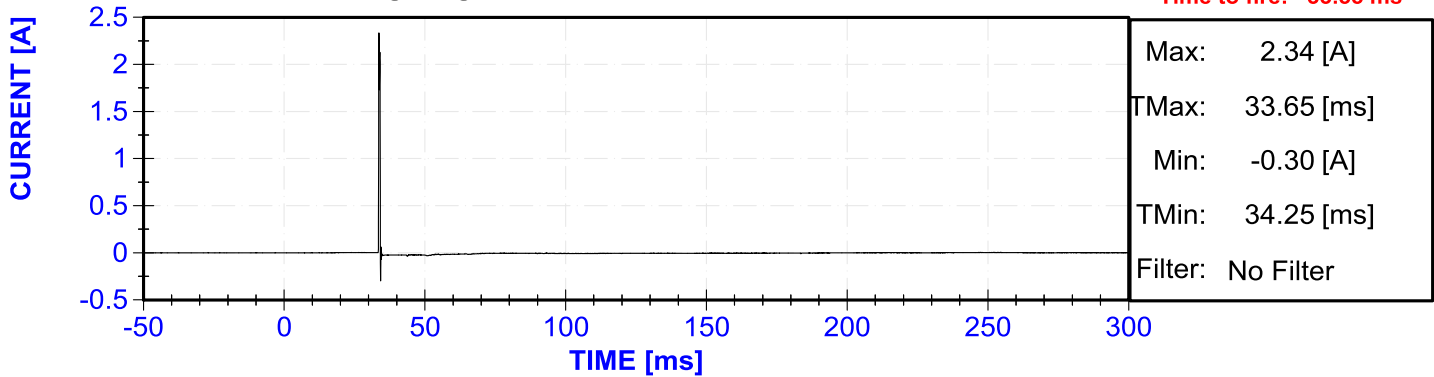

Driver Front Airbag Stage 2 Monitor

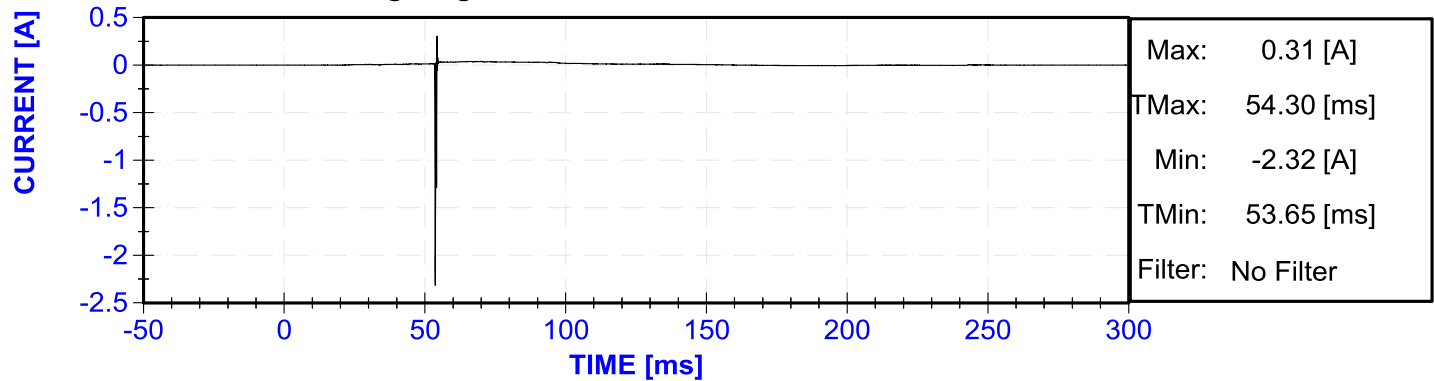

Driver Curtain Airbag Monitor

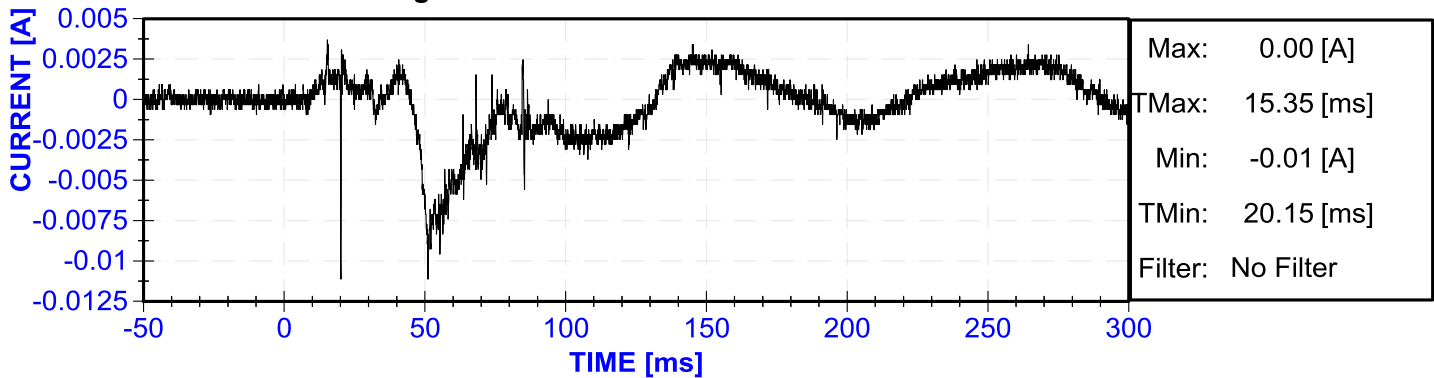

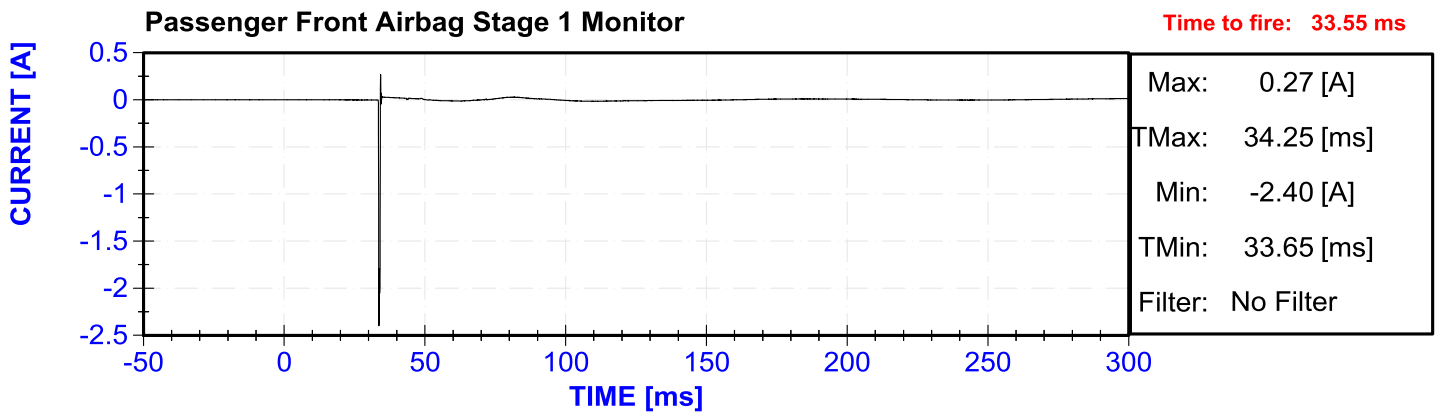
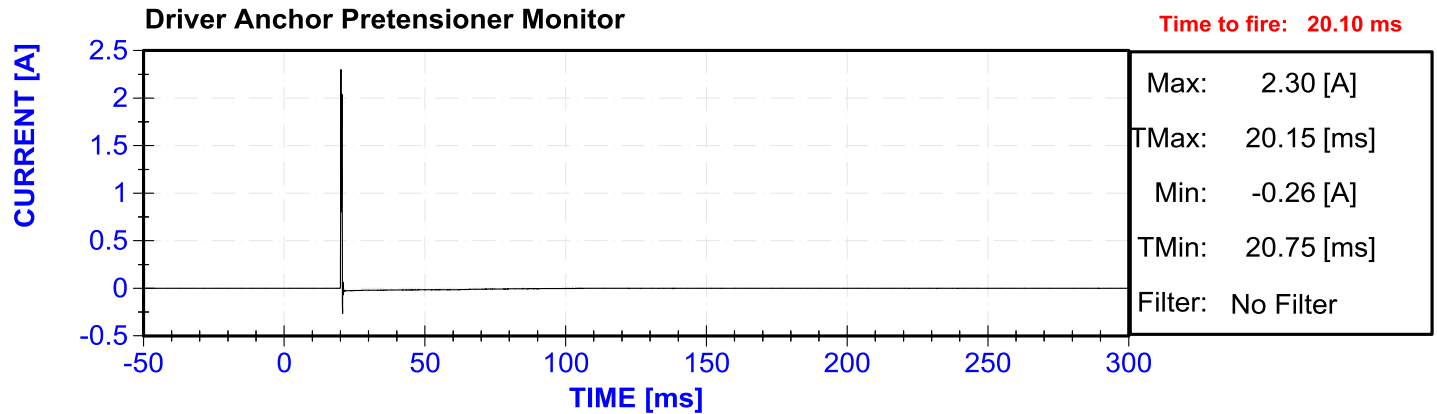
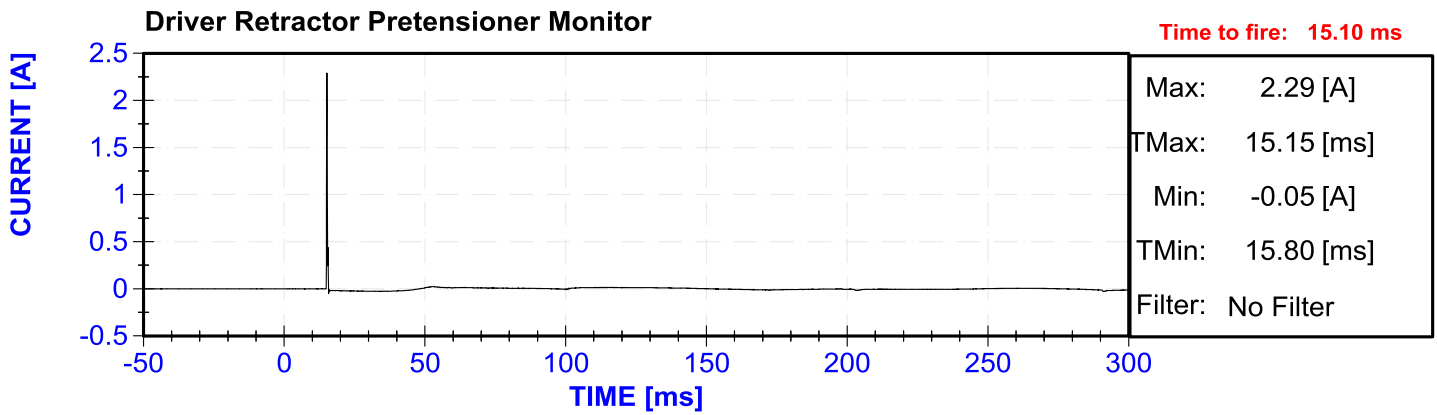
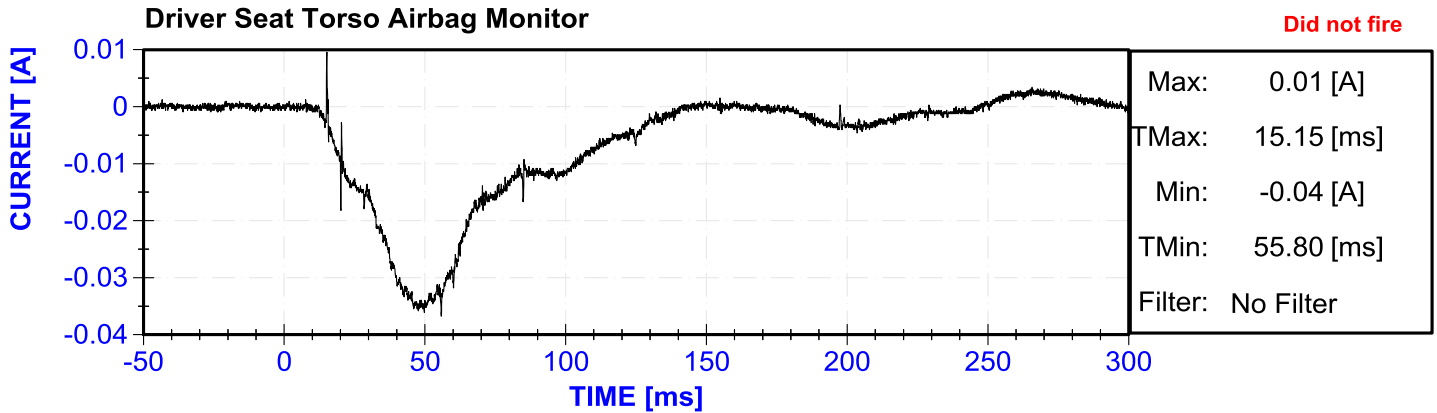

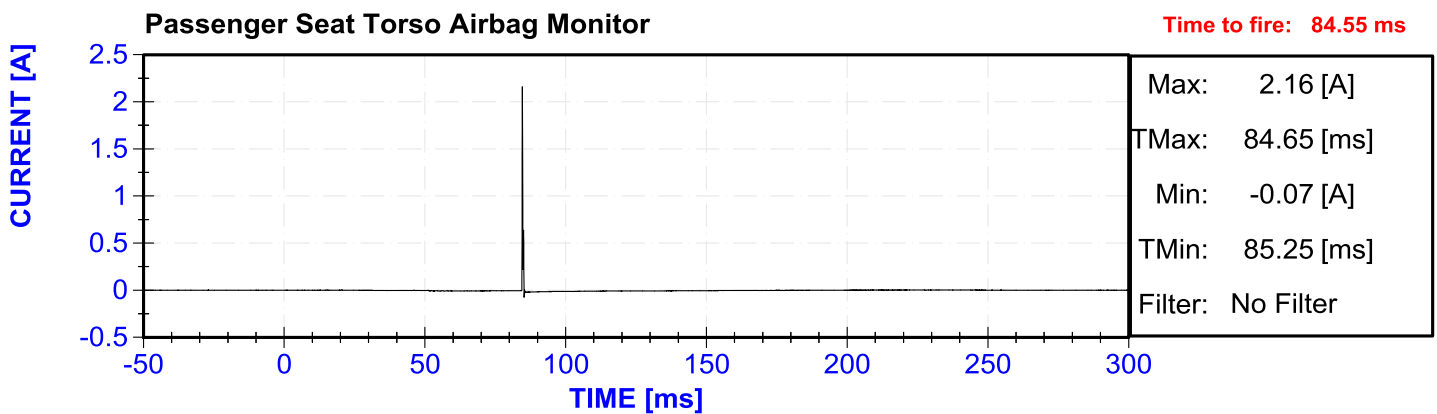
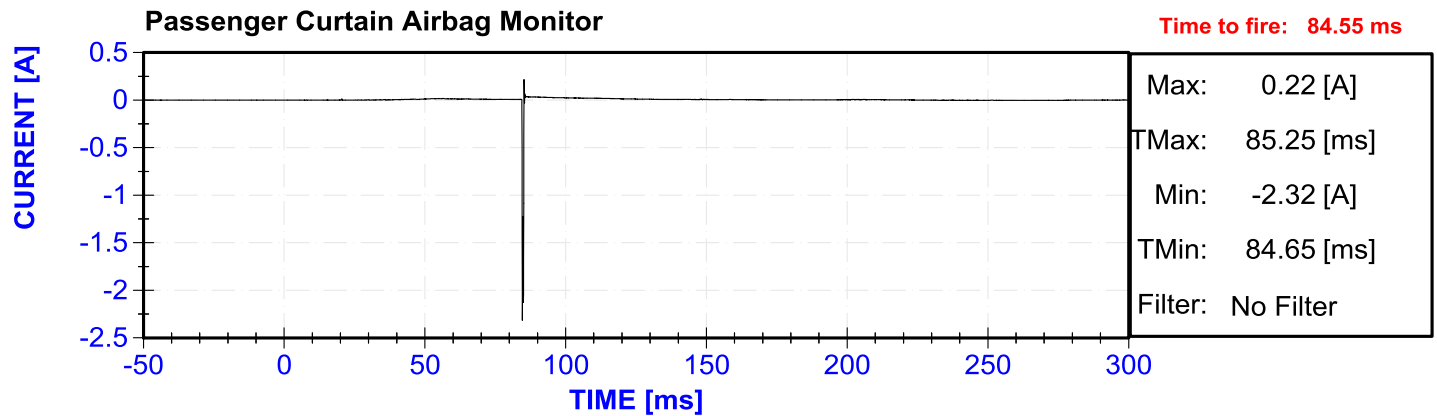
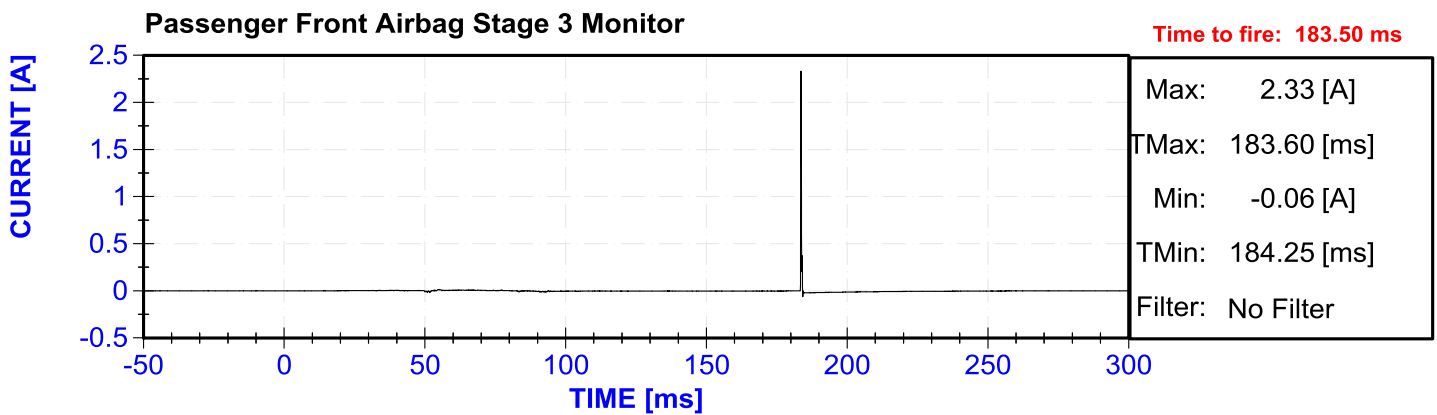
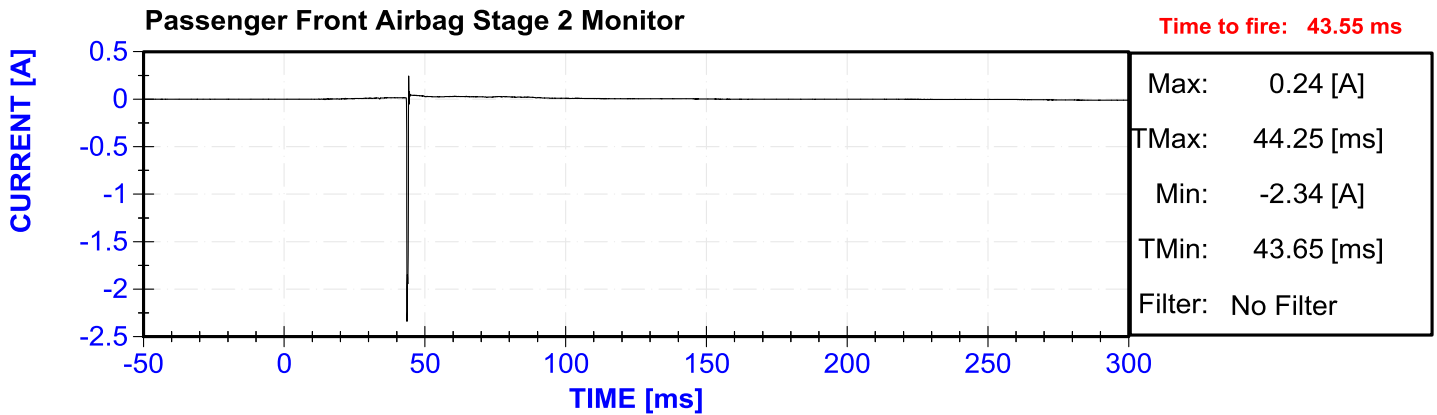

**Passenger Retractor Pretensioner Monitor**

Time to fire: 15.10 ms

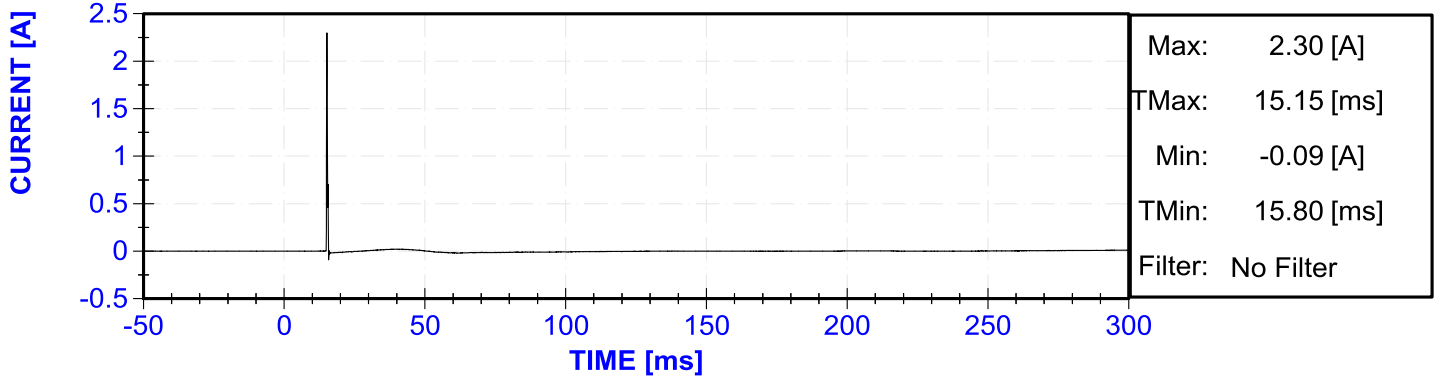

**Passenger Anchor Pretensioner Monitor**

Time to fire: 20.10 ms

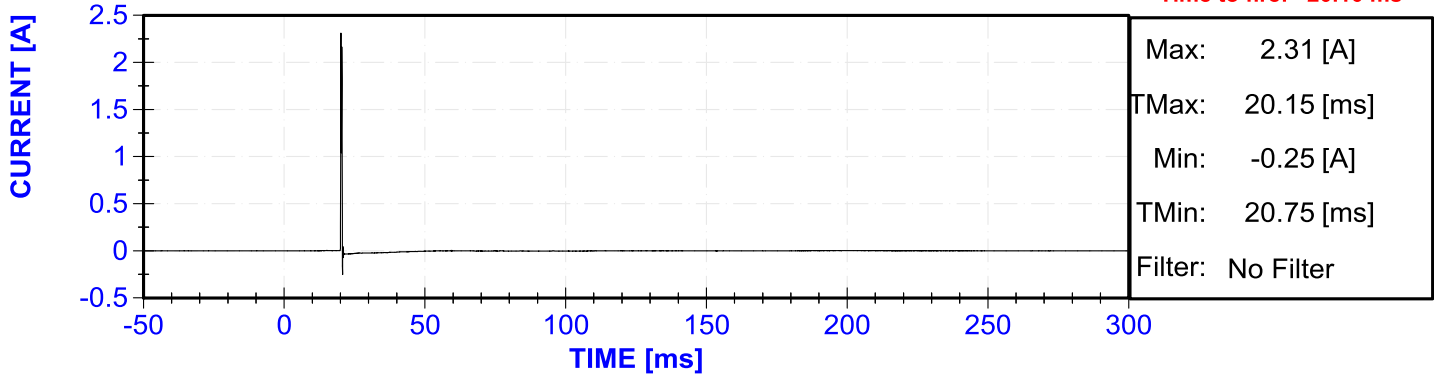

**V1 OMDB CG X Acceleration**

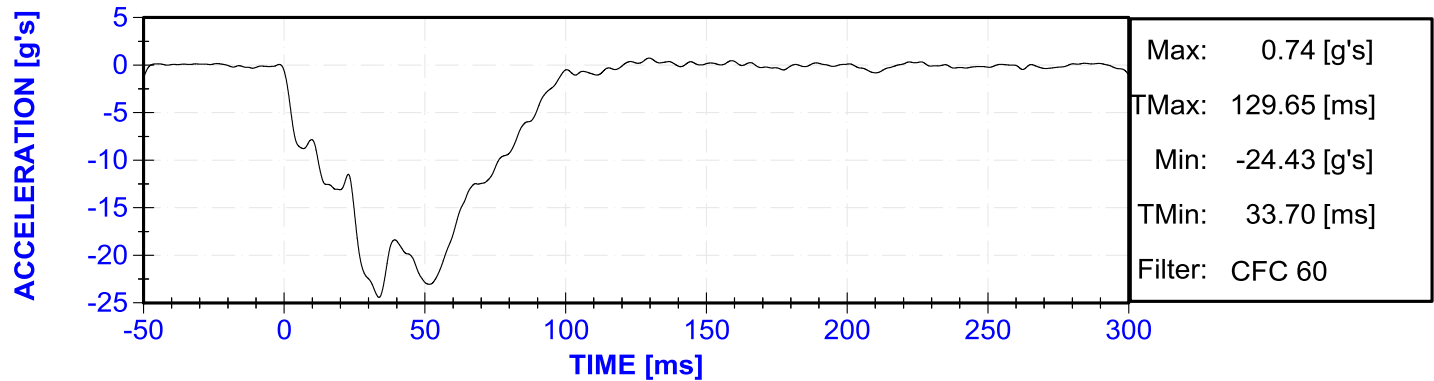

**V1 OMDB CG Y Acceleration**

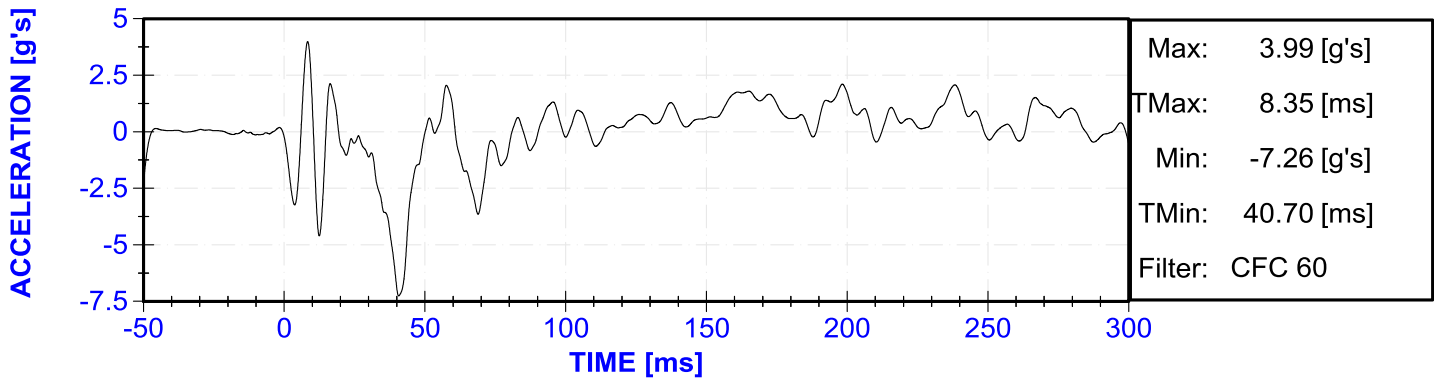

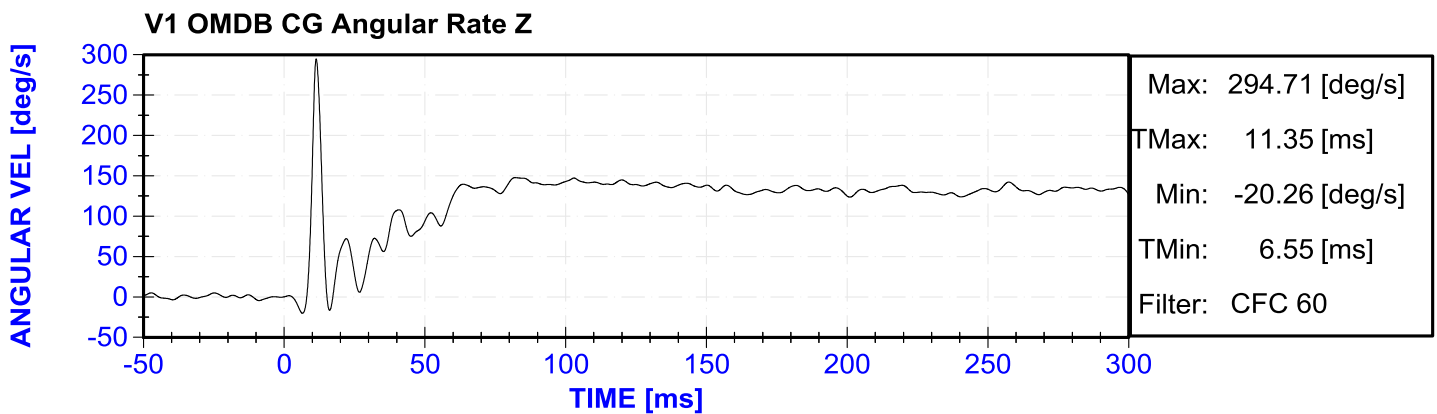
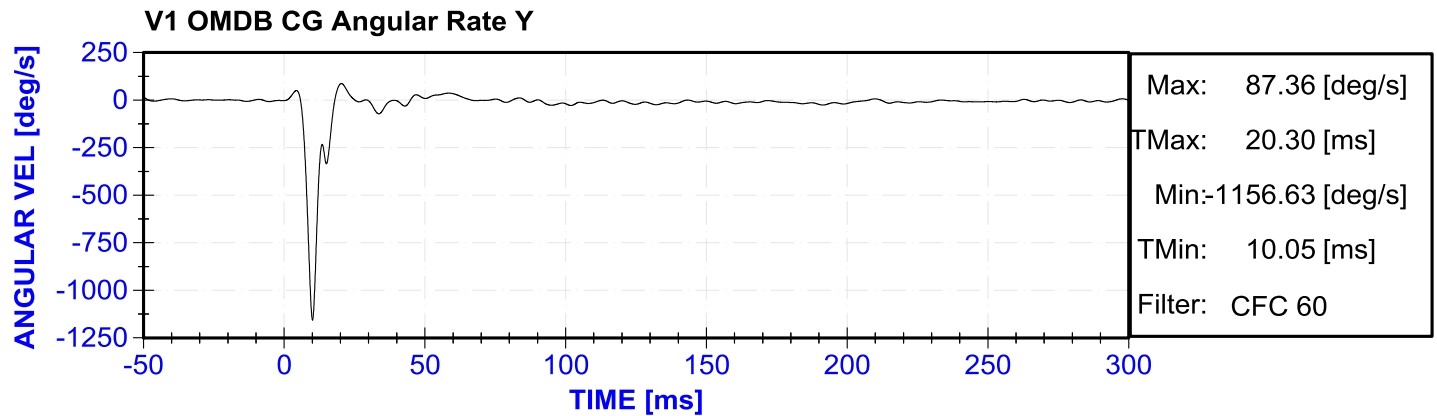
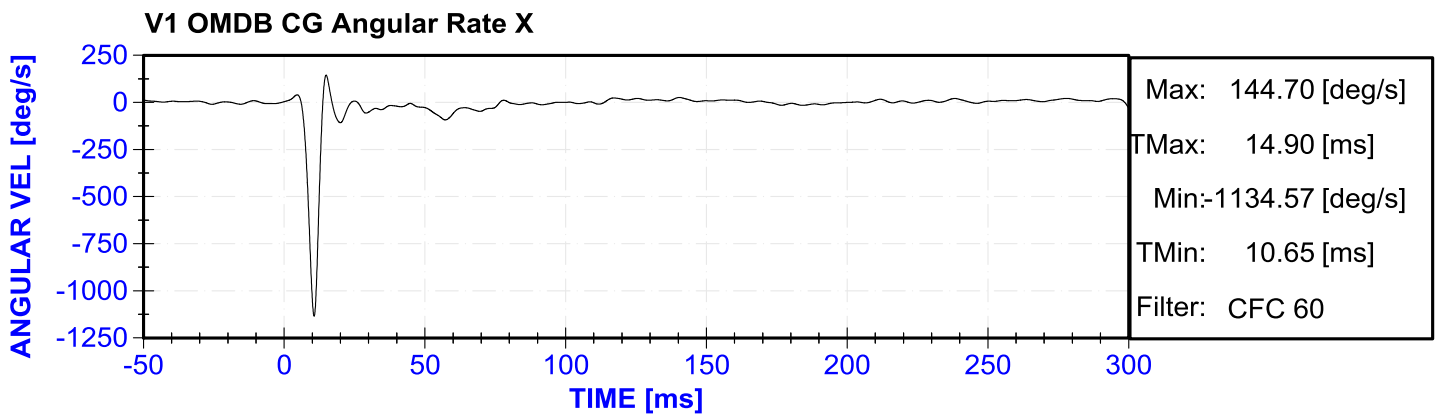
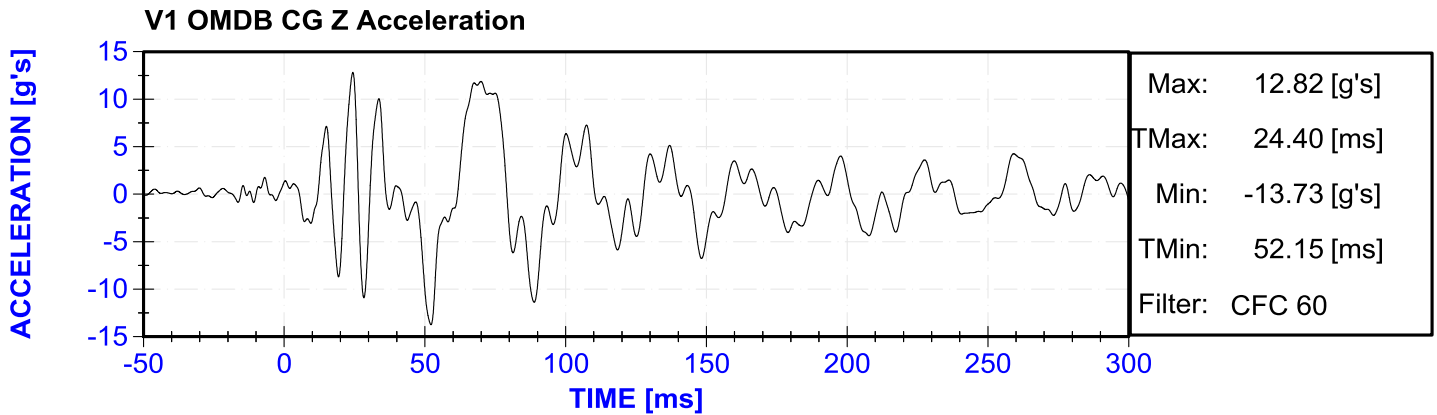

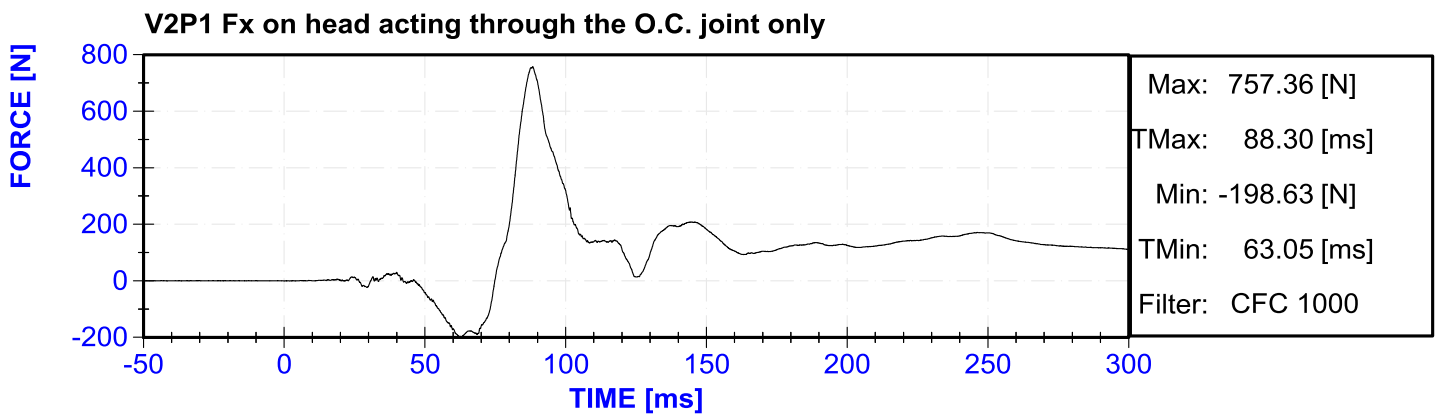
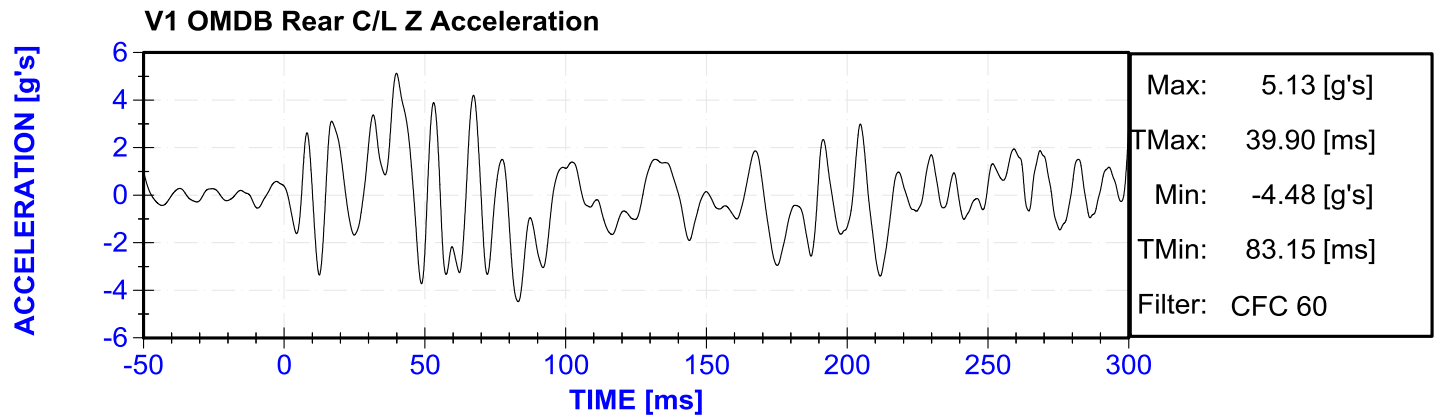
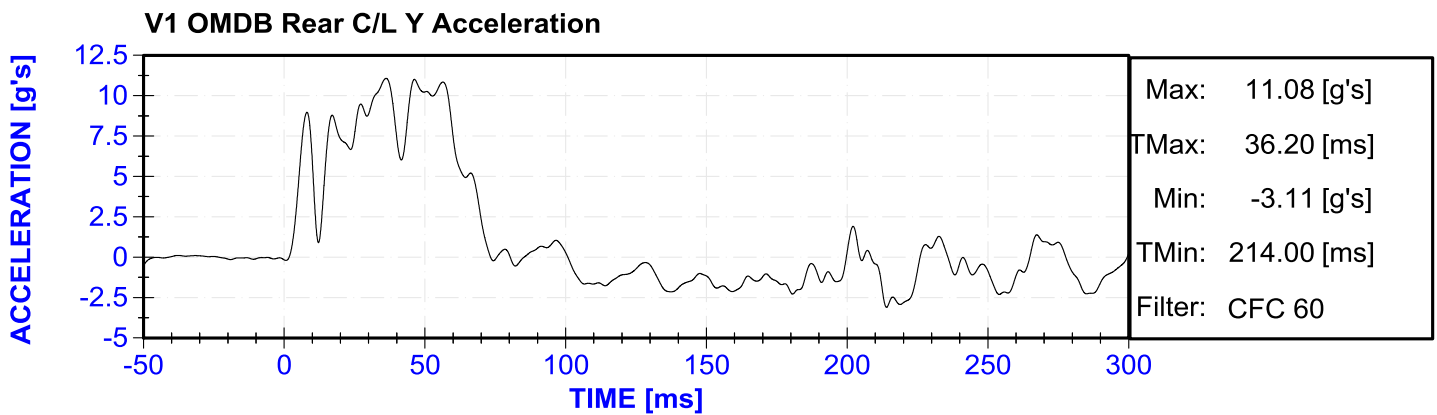
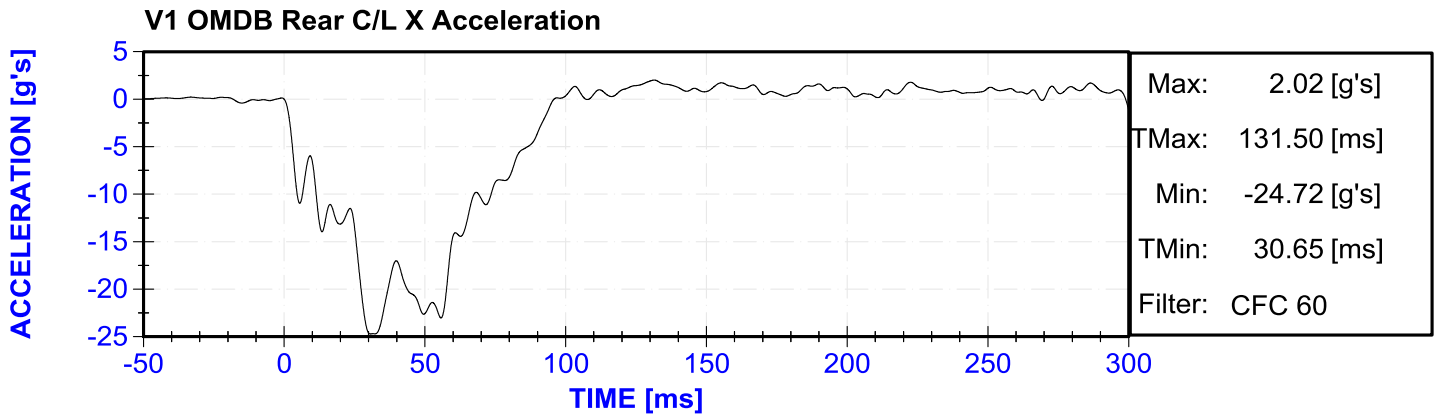

V2P1 Fz on head acting through the O.C. joint only

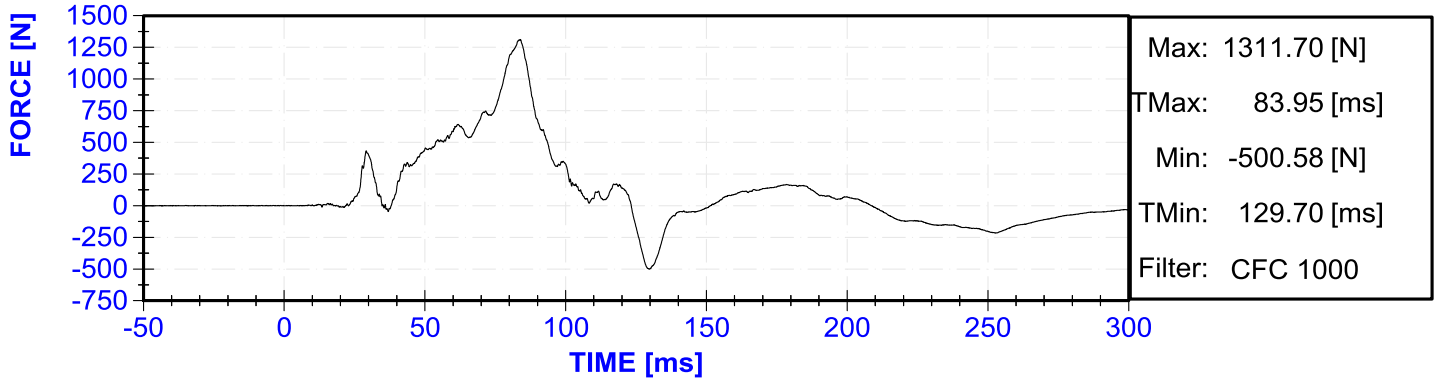

V2P1 My on head acting through the O.C. joint only

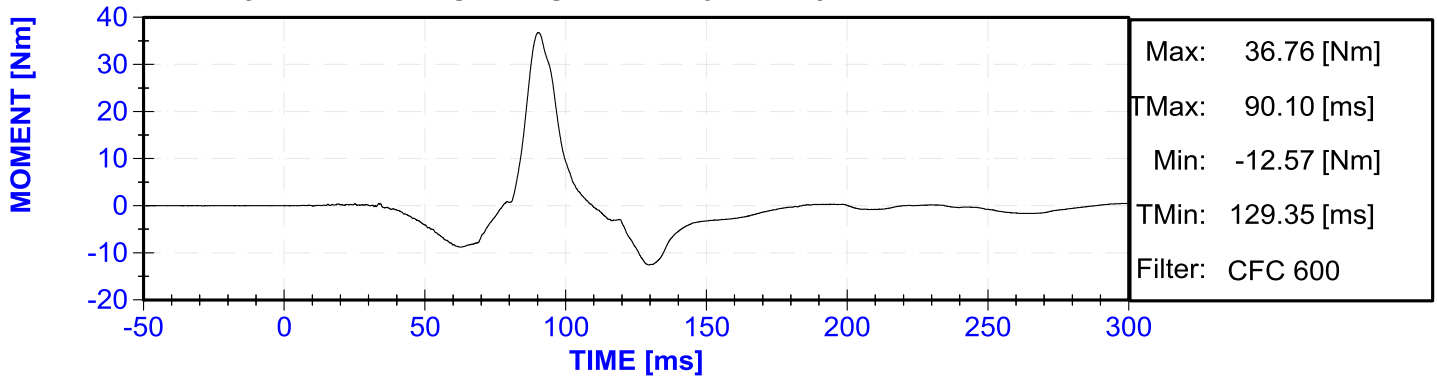

V2P1 Fx on head acting through the total neck section

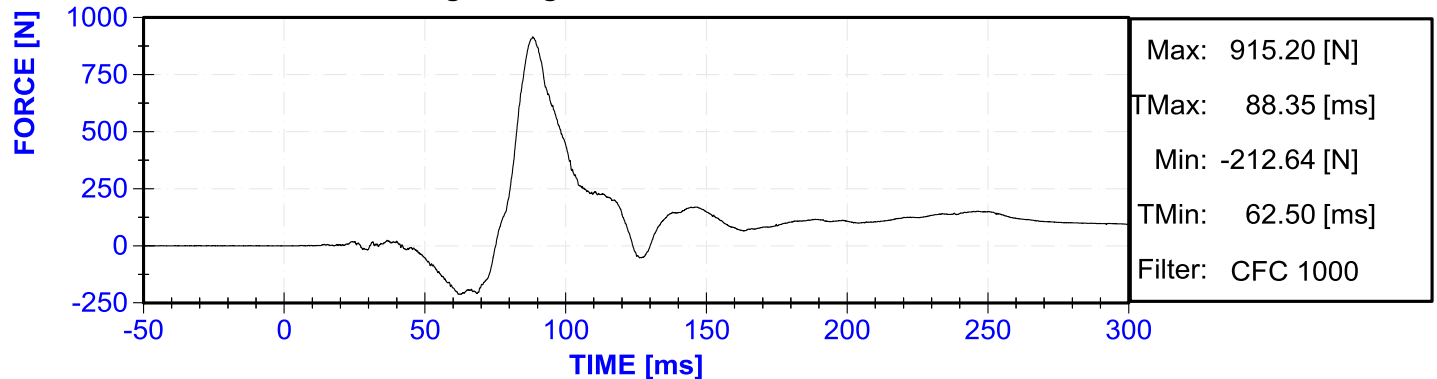

V2P1 Fy on head acting through the total neck section

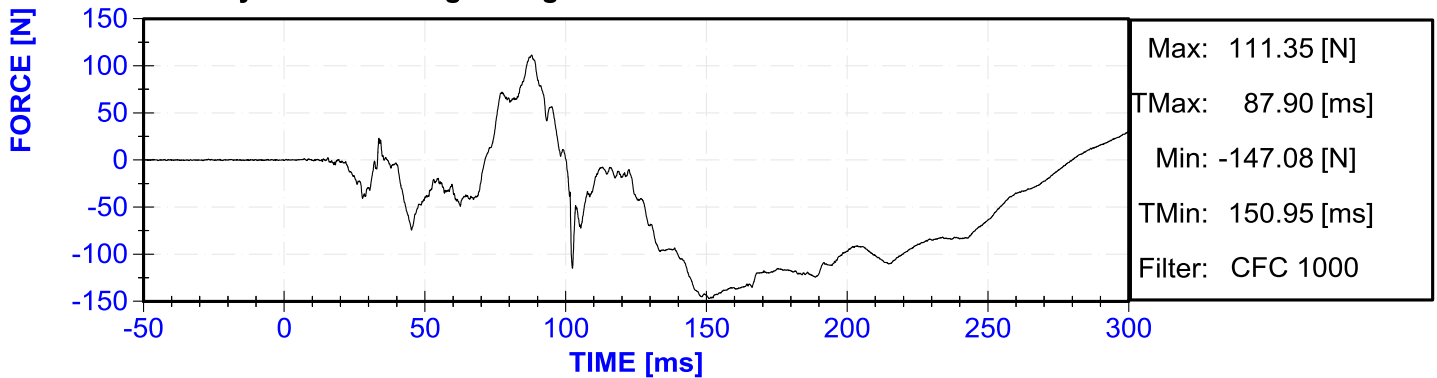

V2P1 Fz on head acting through the total neck section

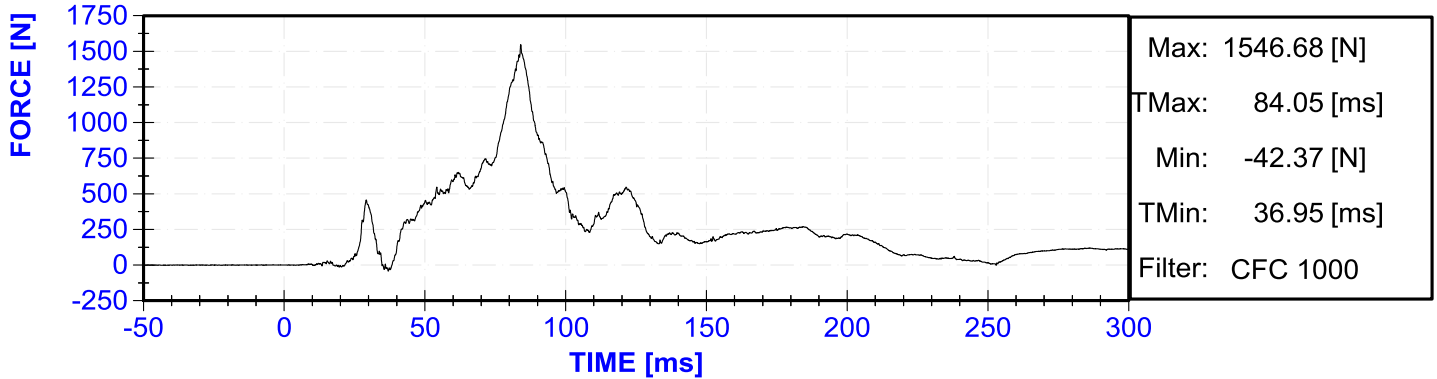

V2P1 Mx on head acting through the total neck section

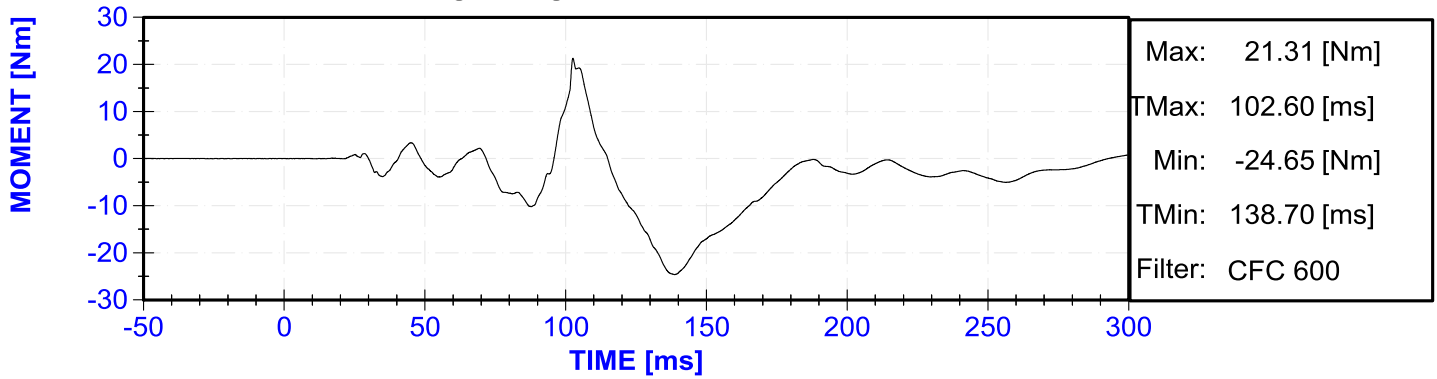

V2P1 My on head acting through the total neck section

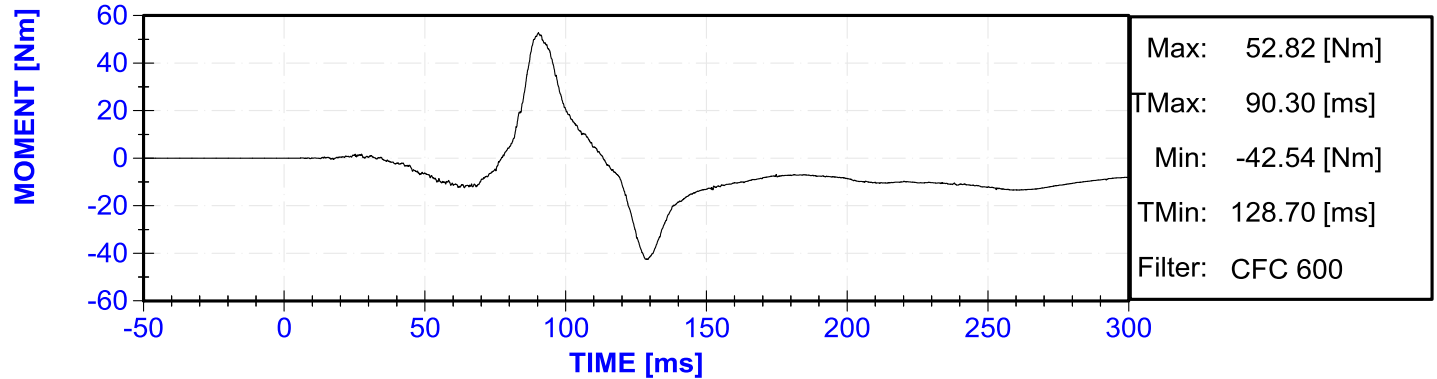

V2P1 Mz on head acting through the total neck section

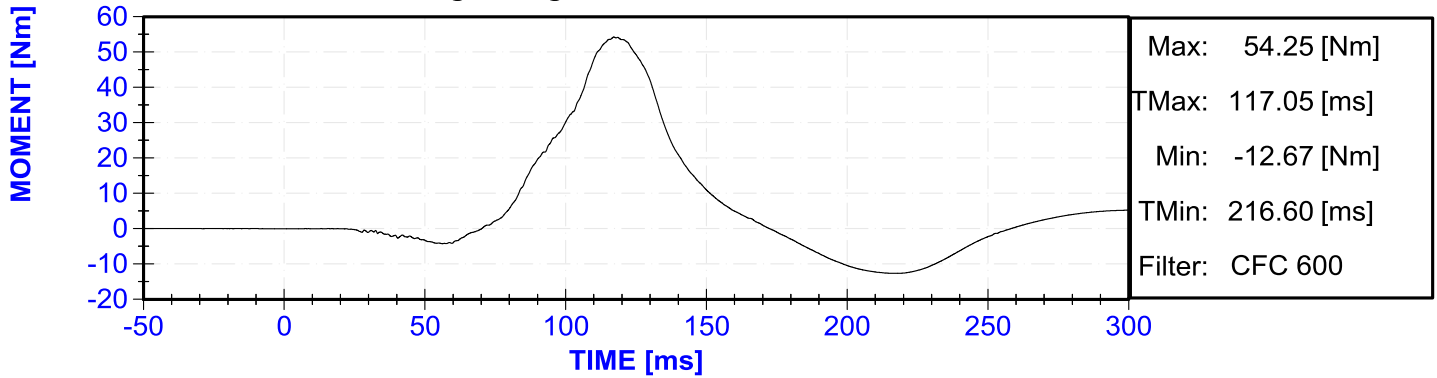

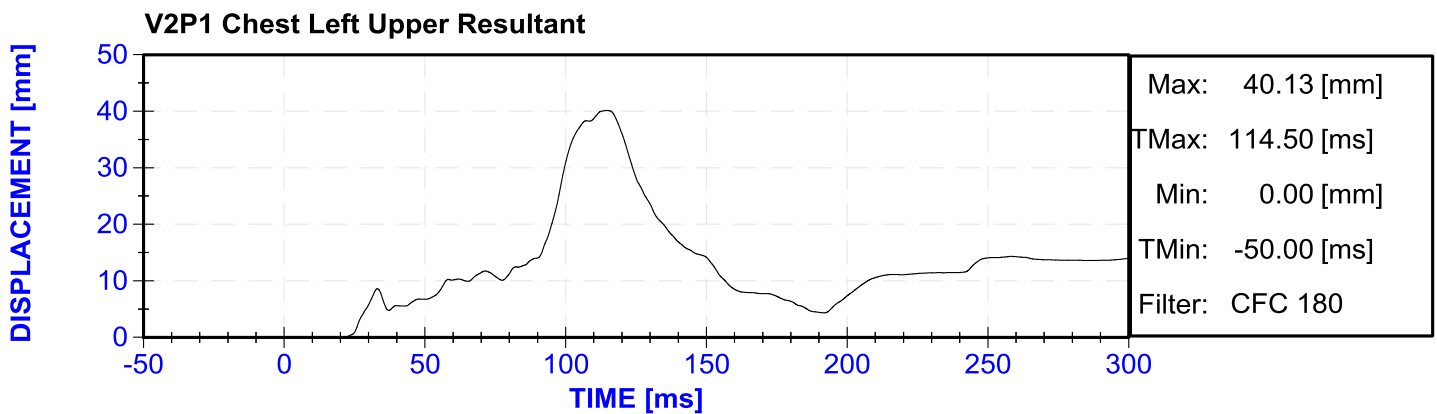
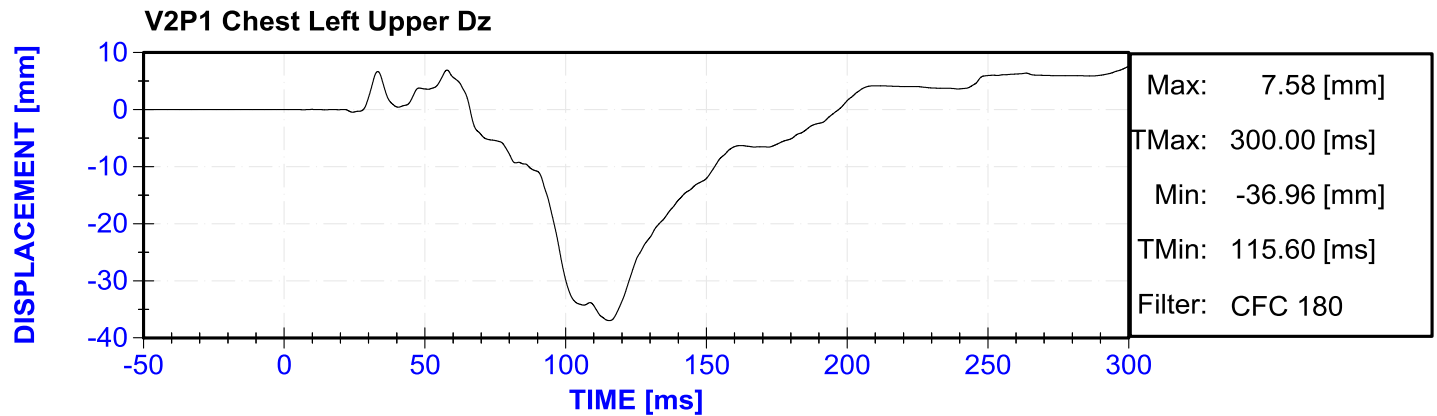
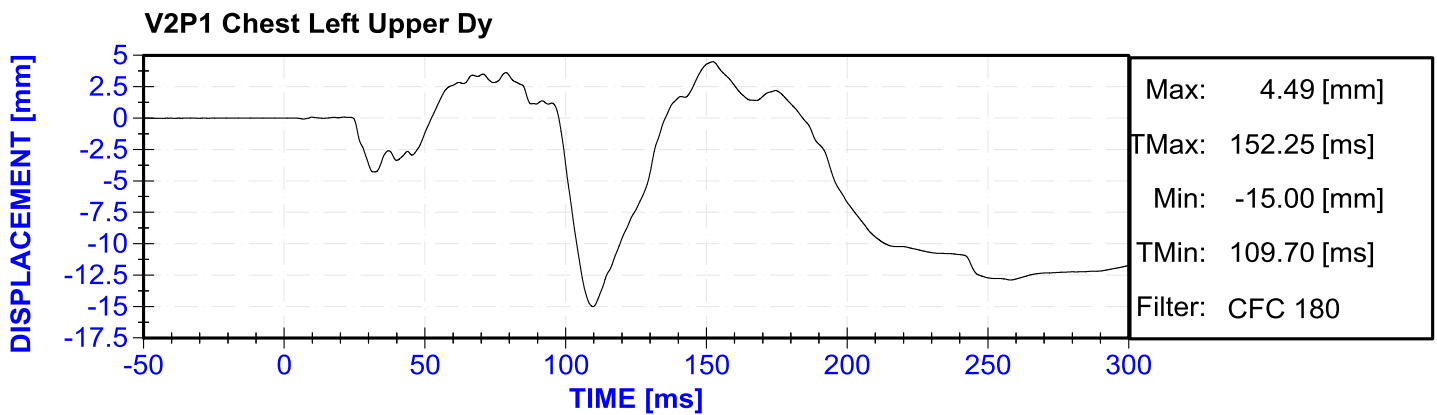
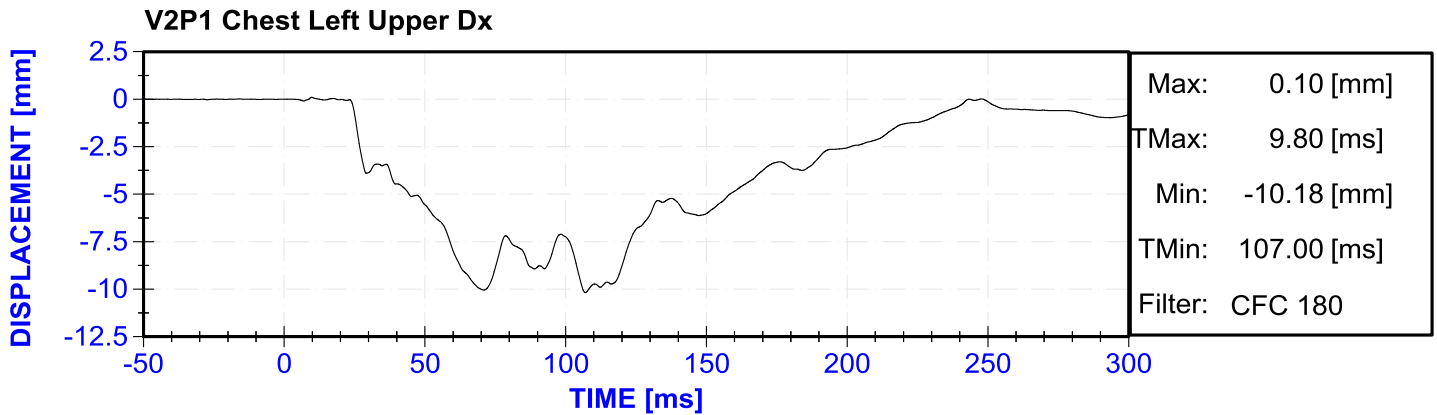

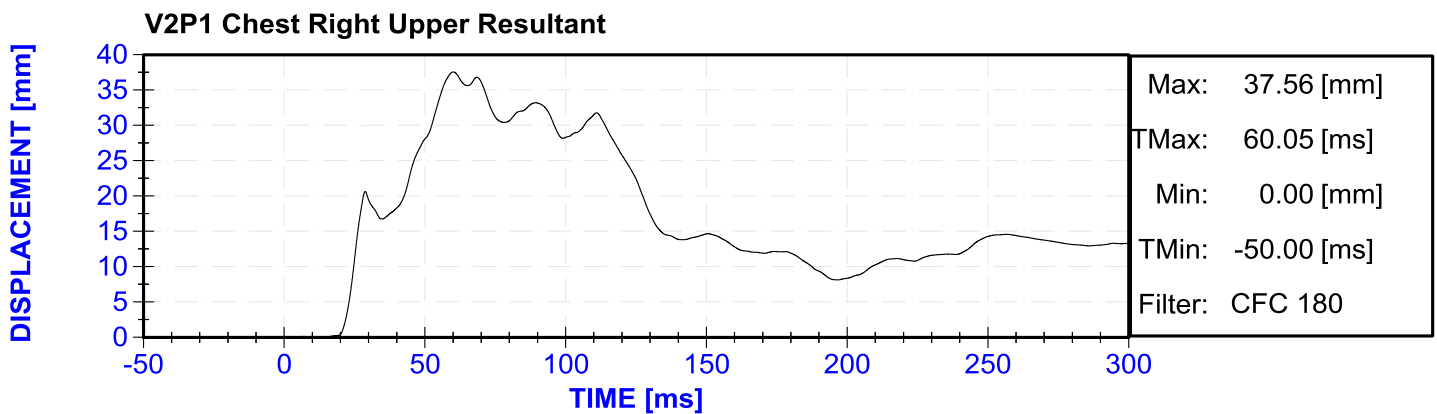
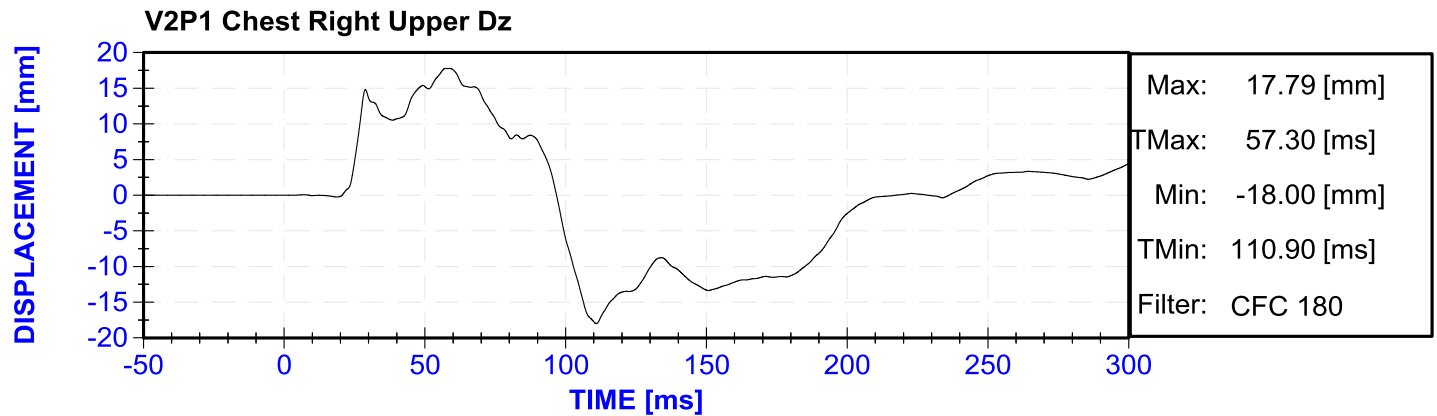
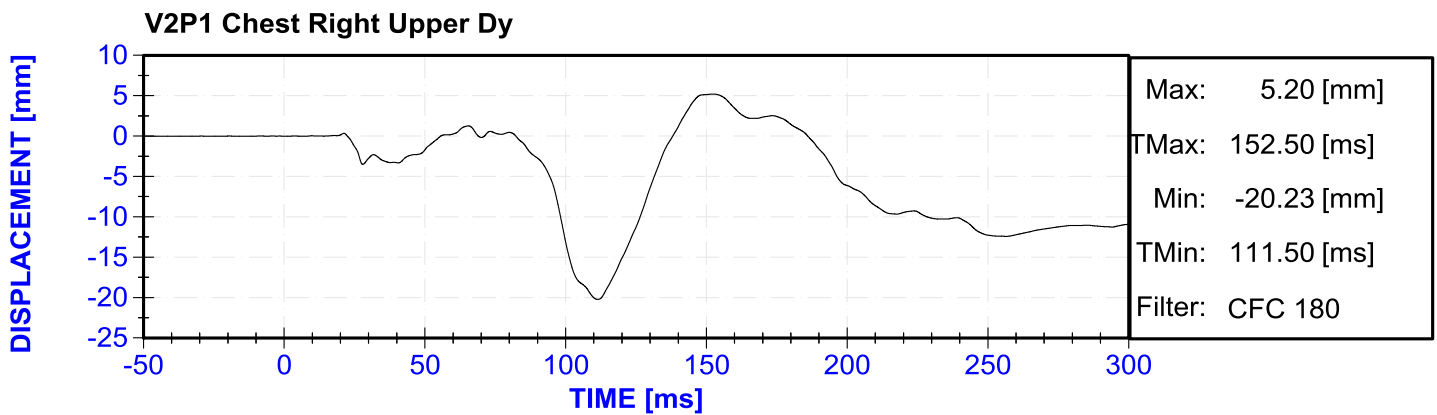
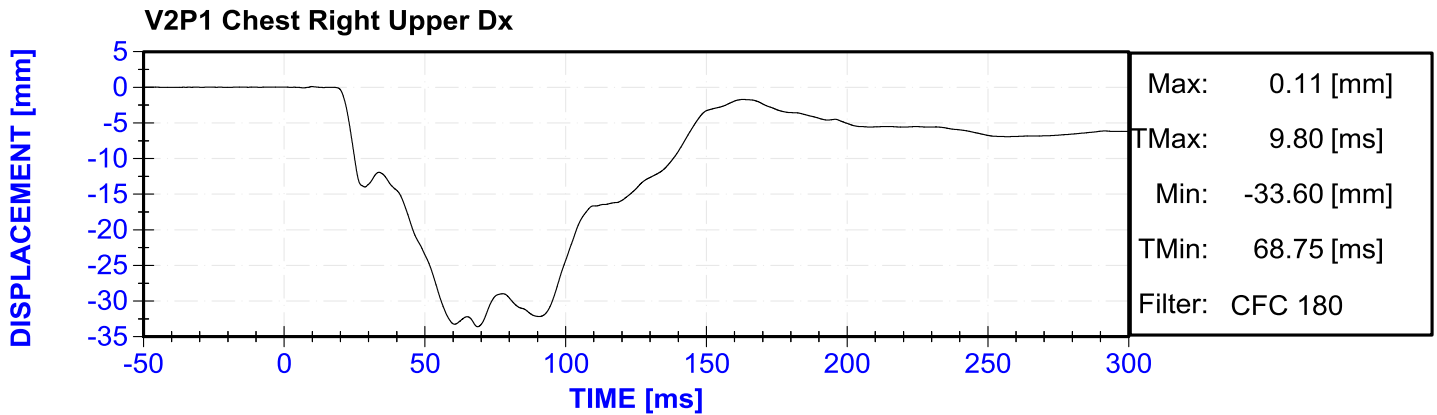

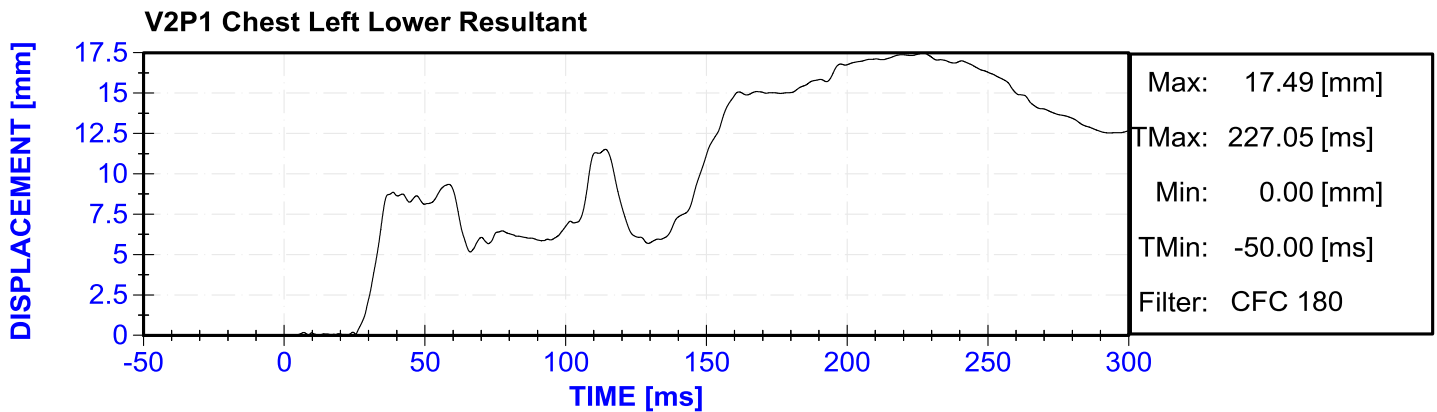
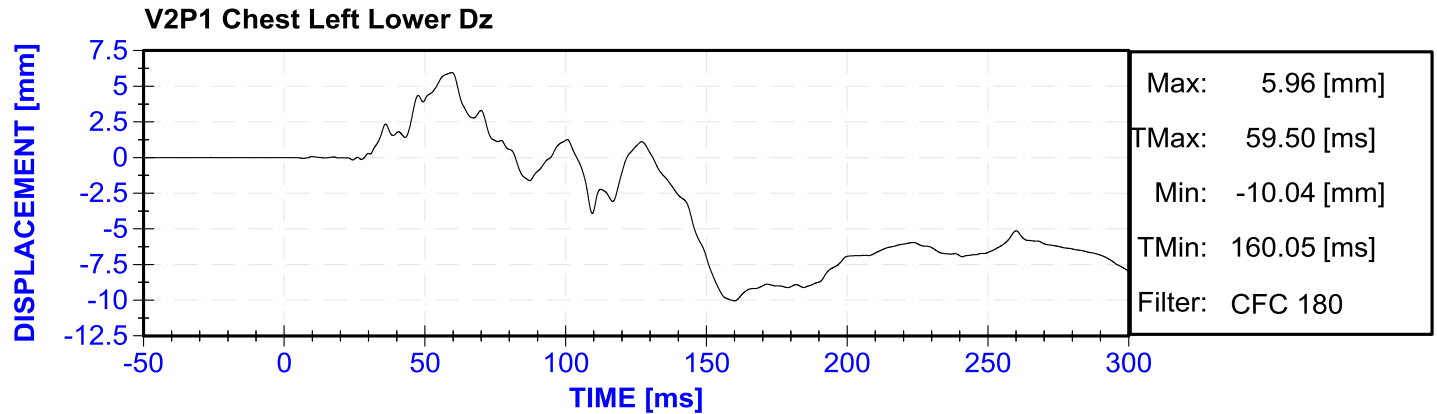
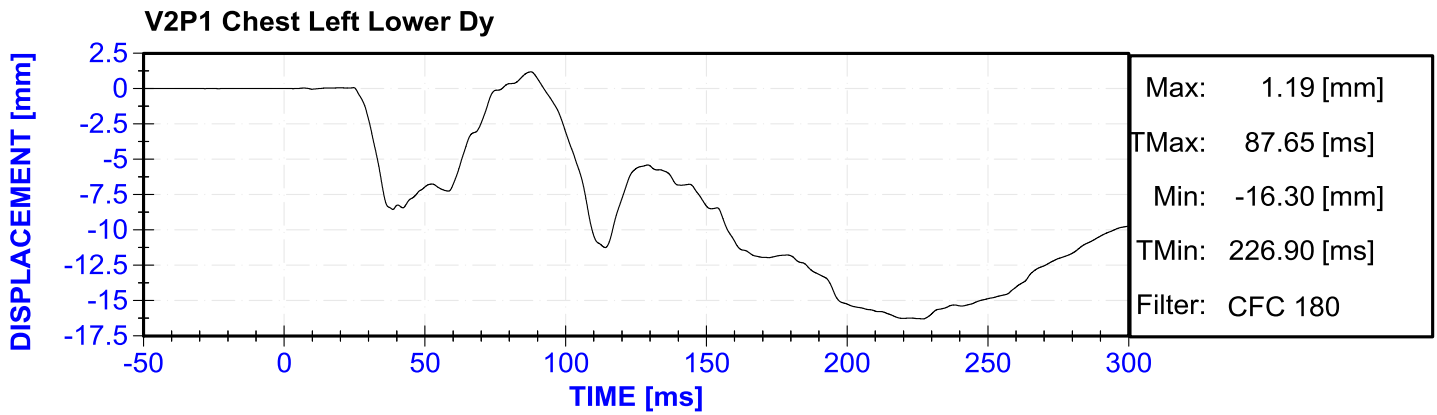
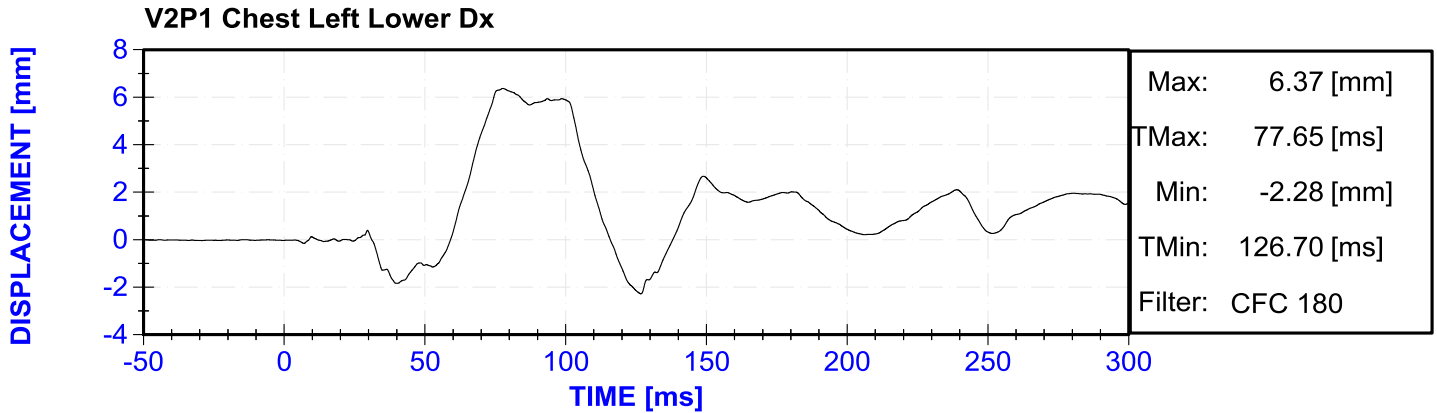

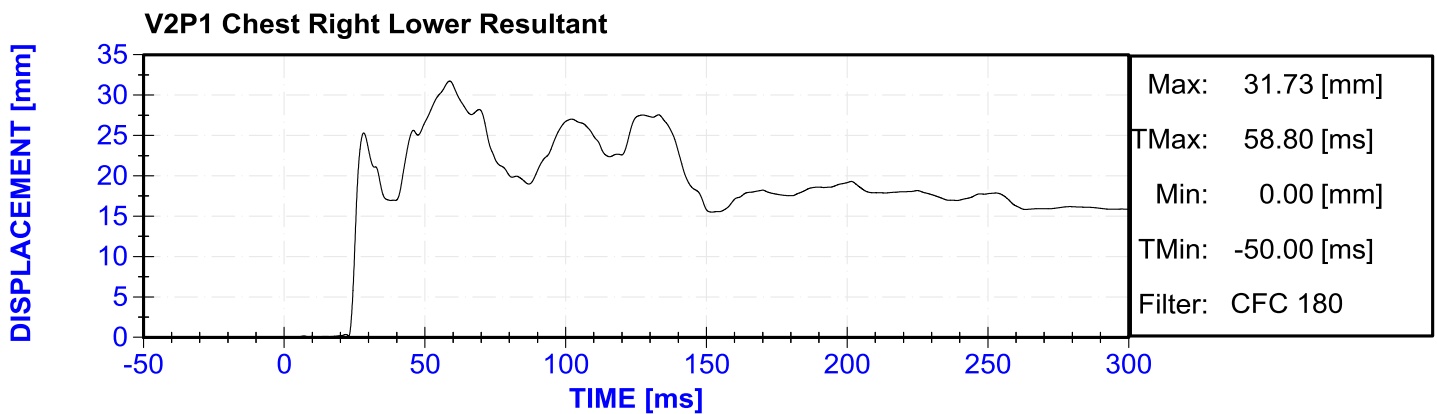
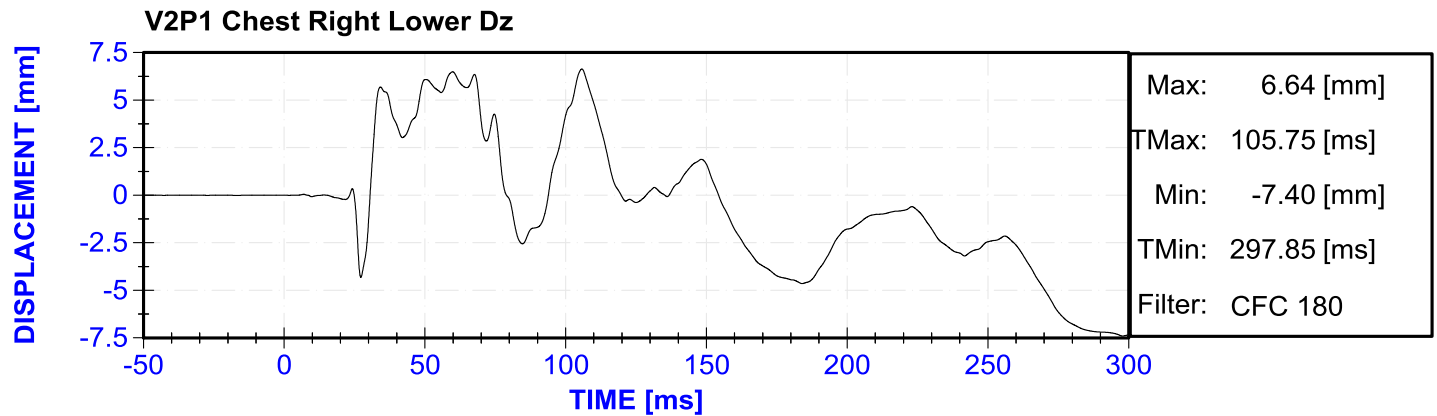
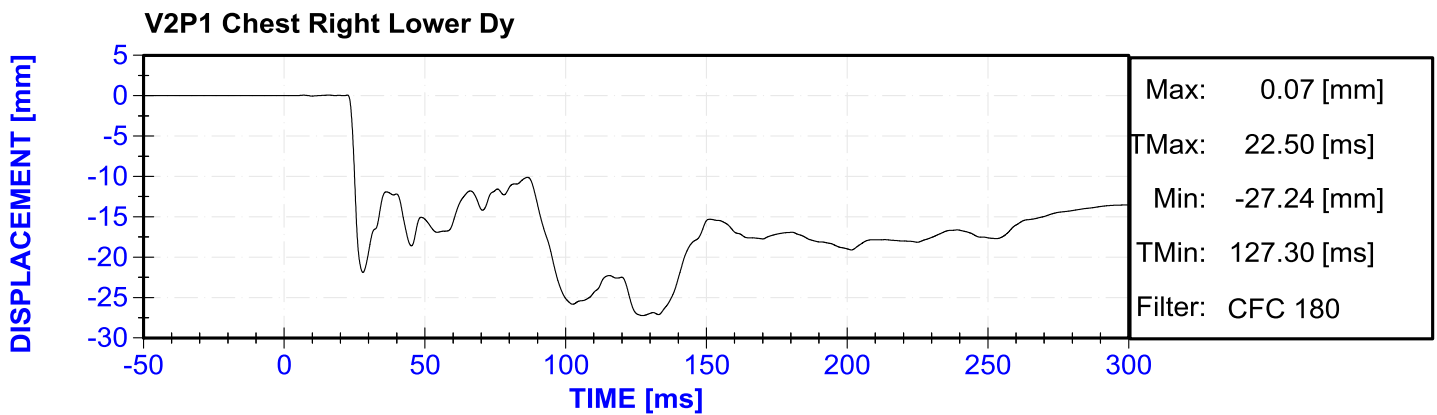
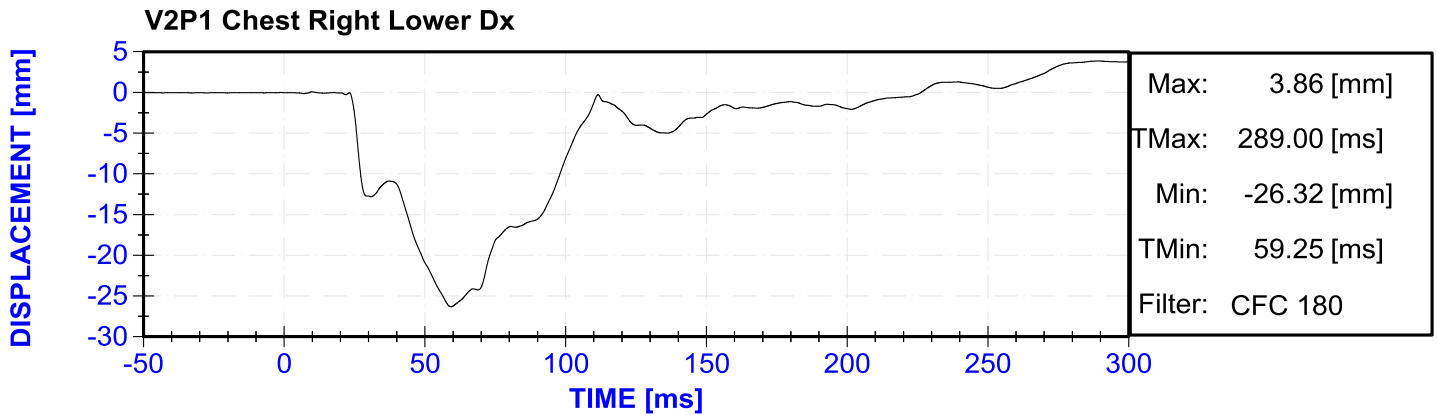

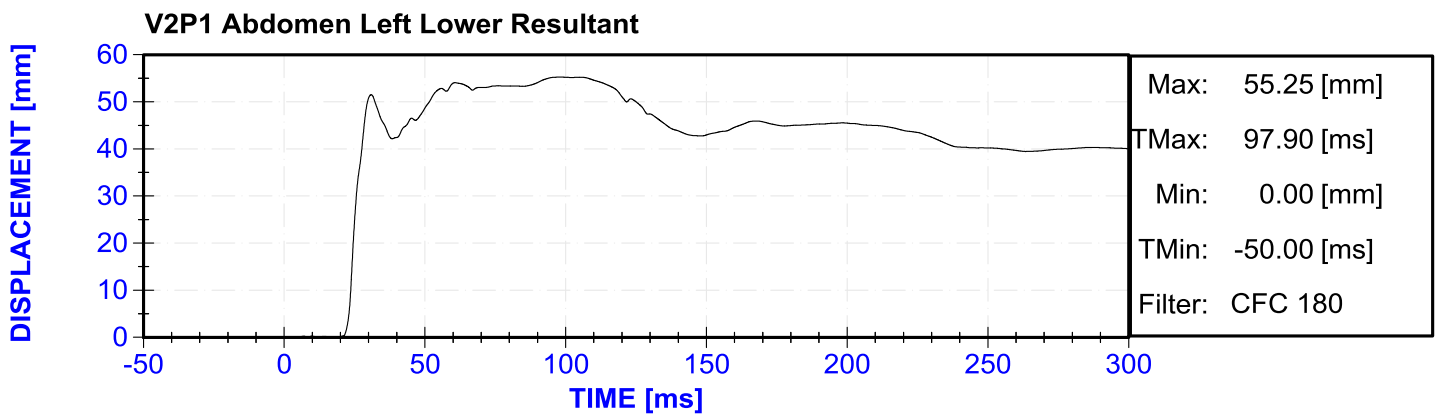
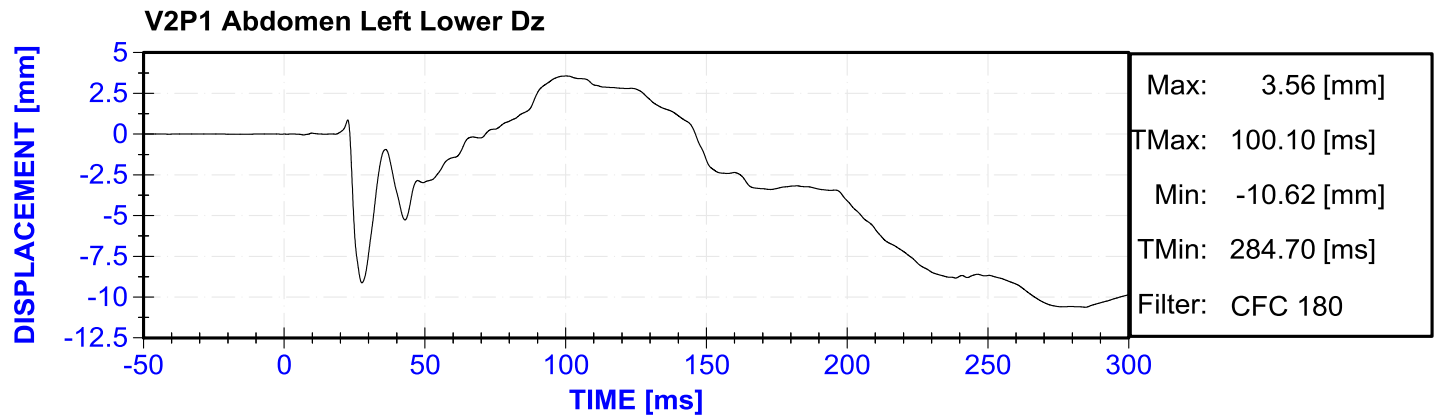
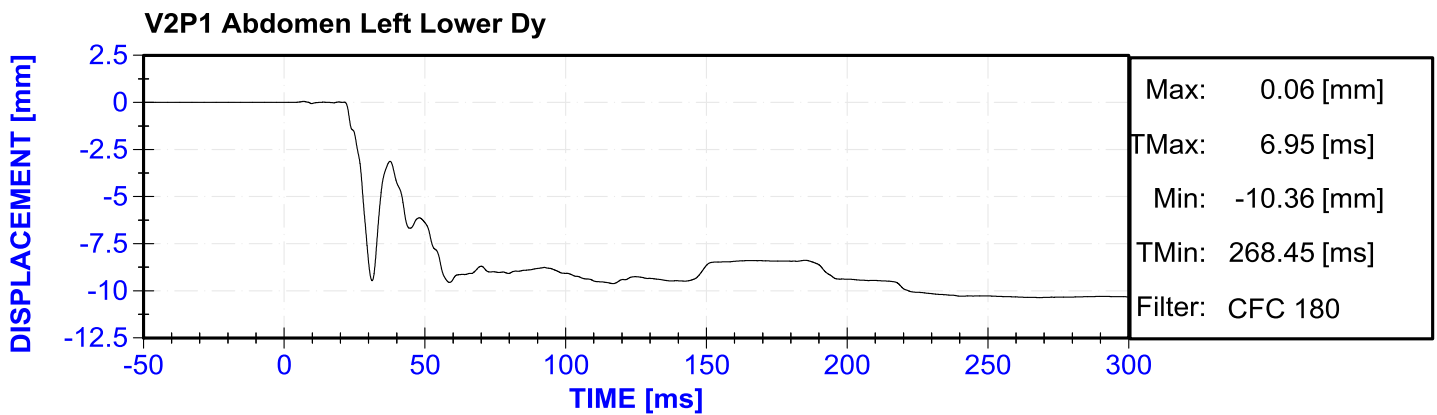
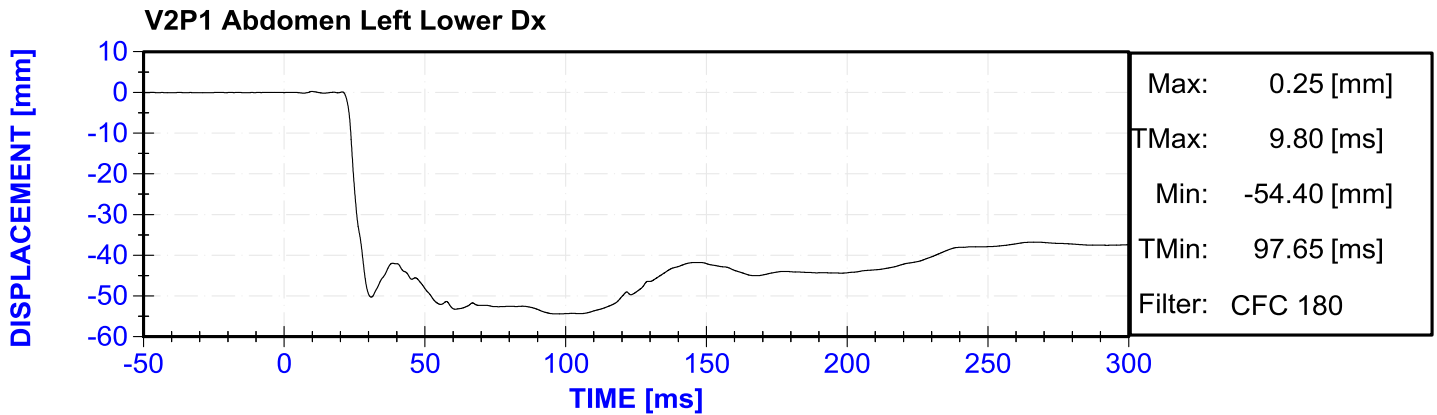

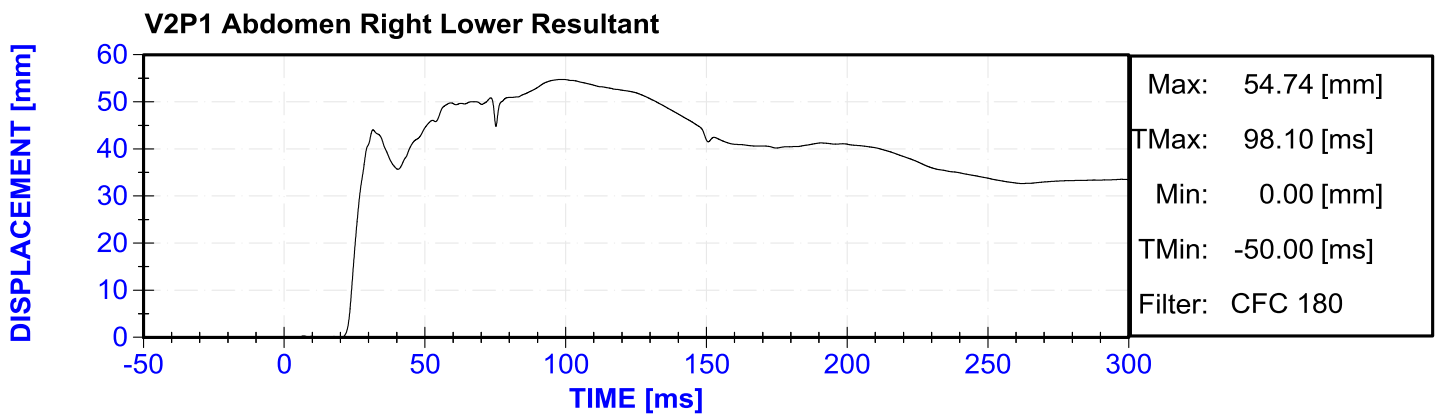
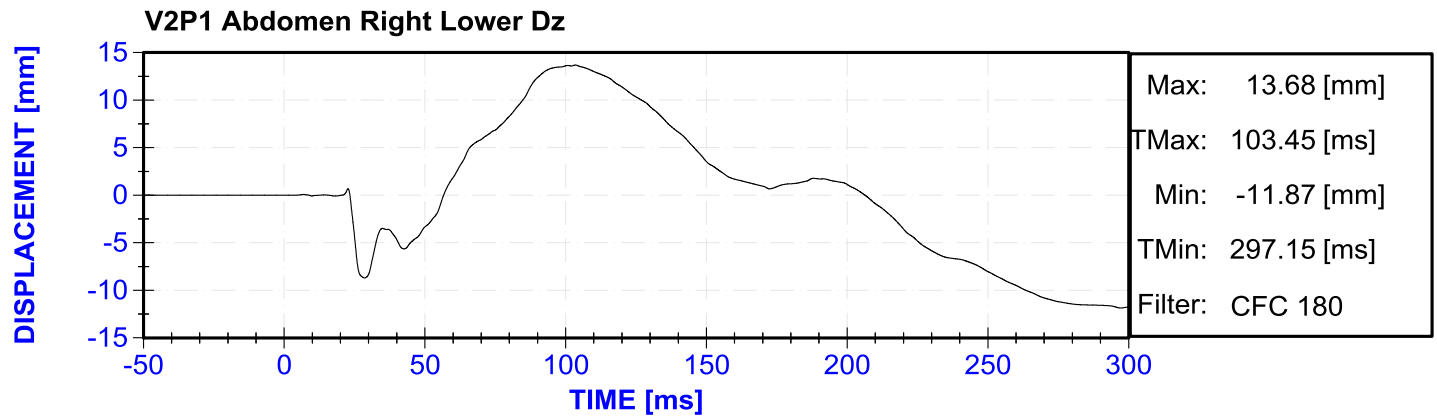
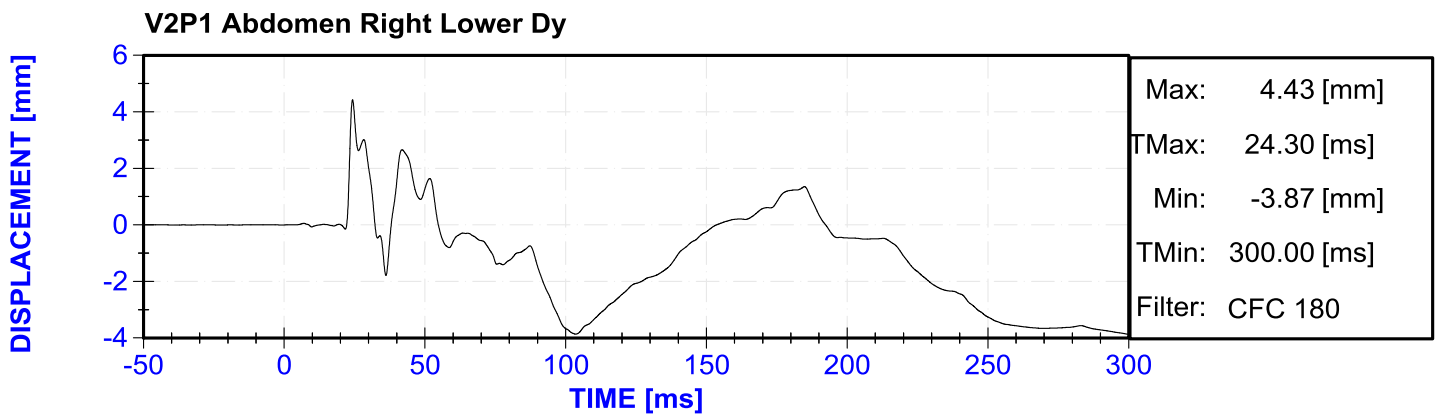
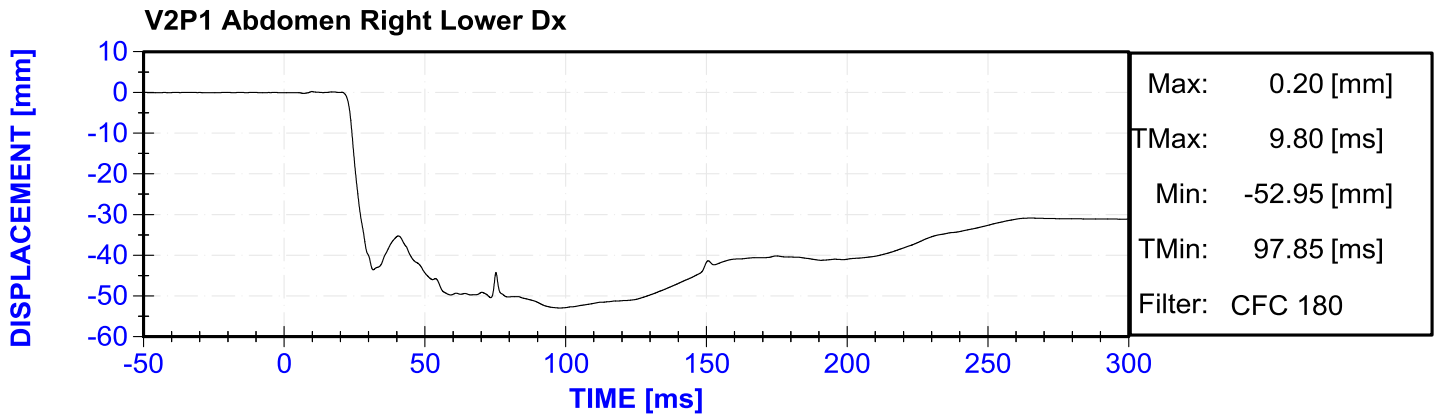

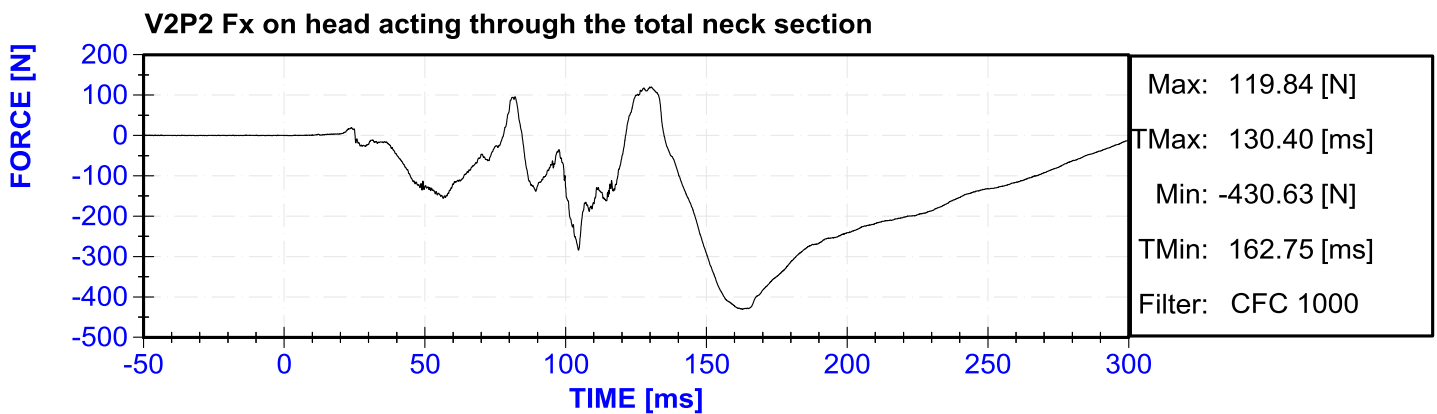
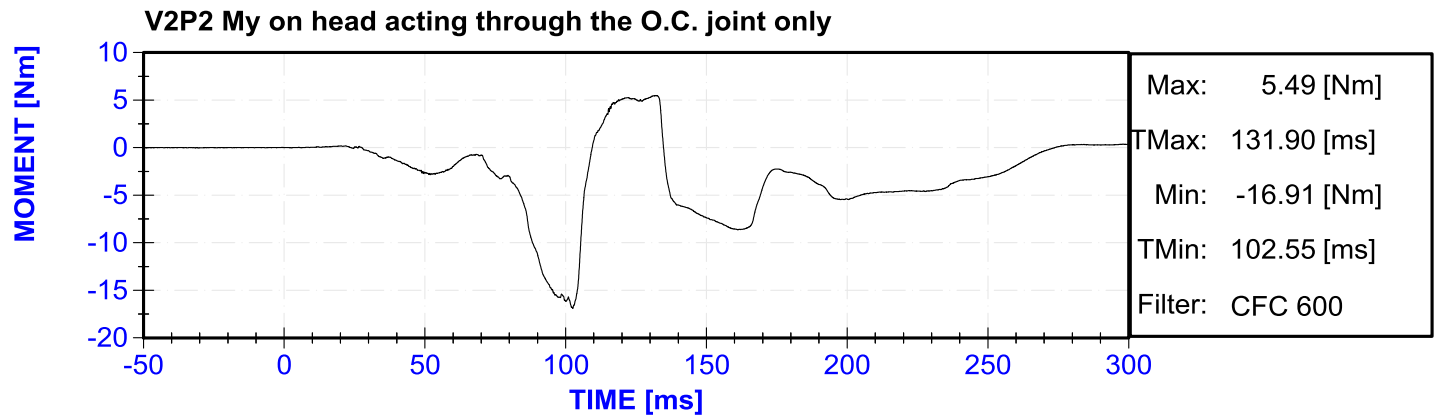
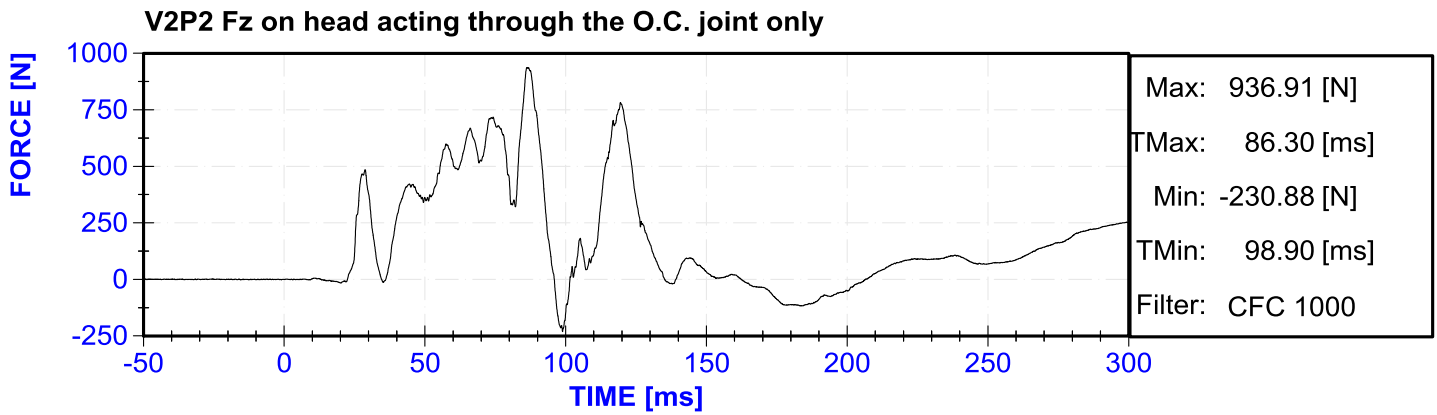
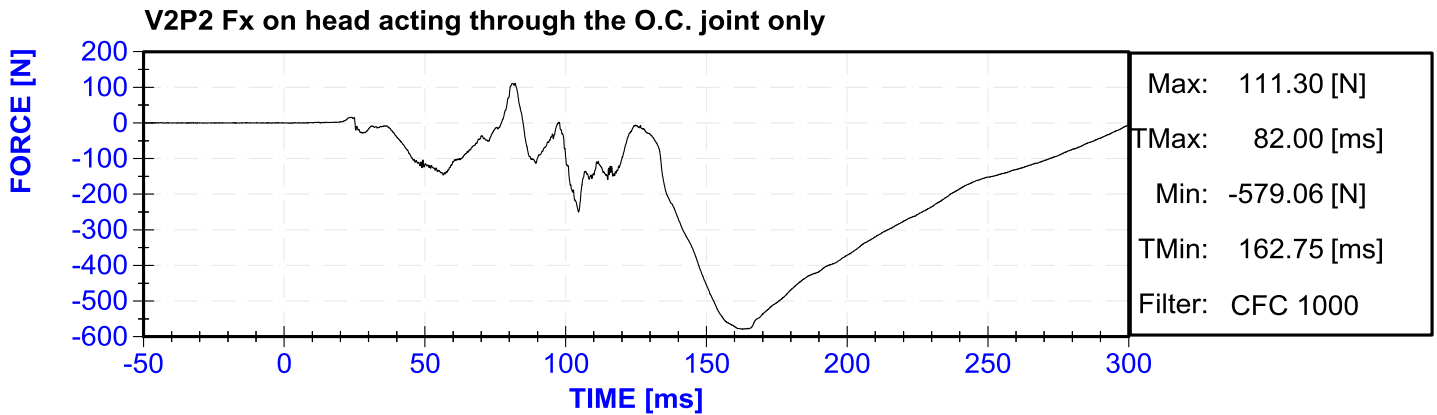

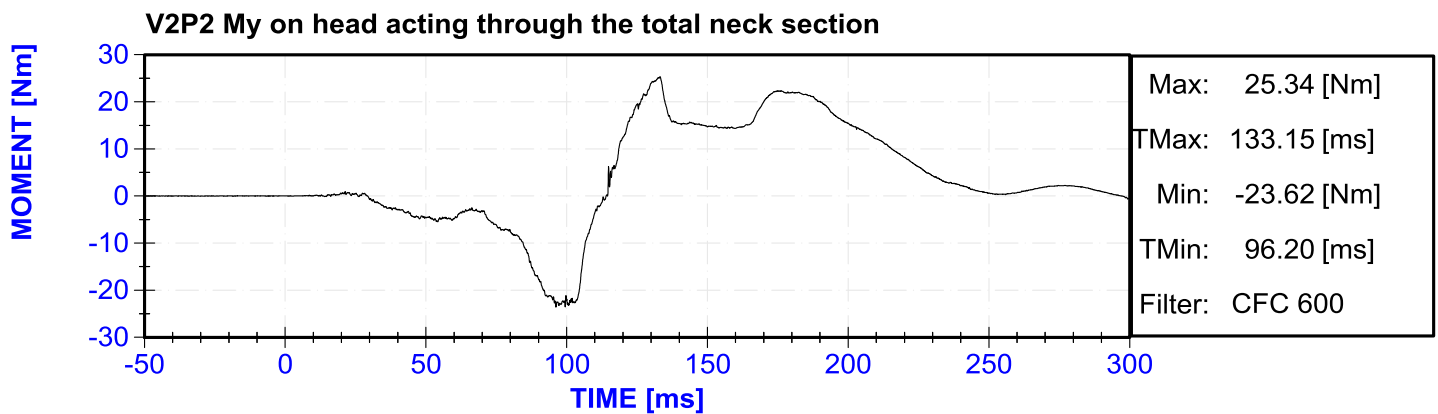
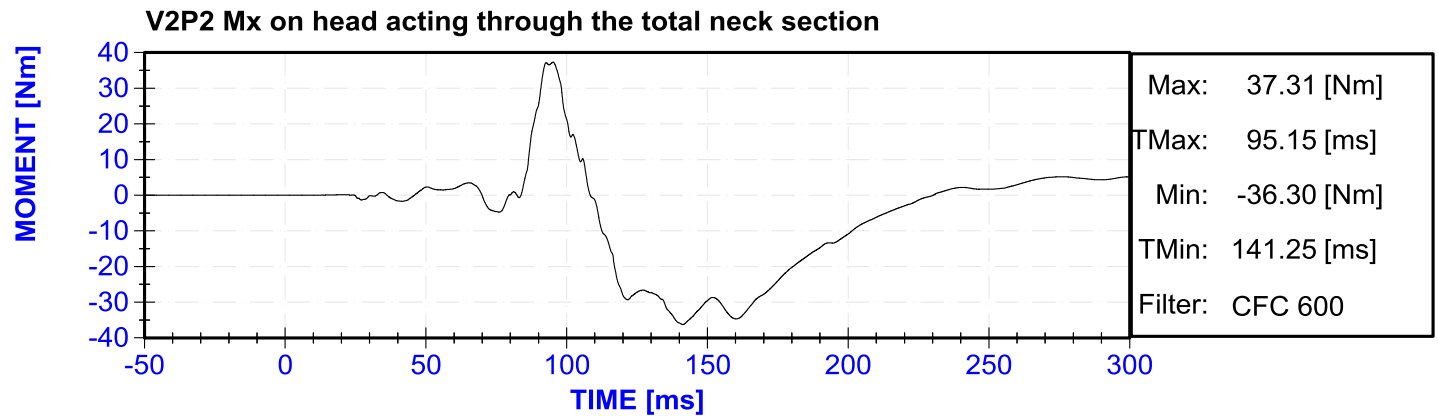
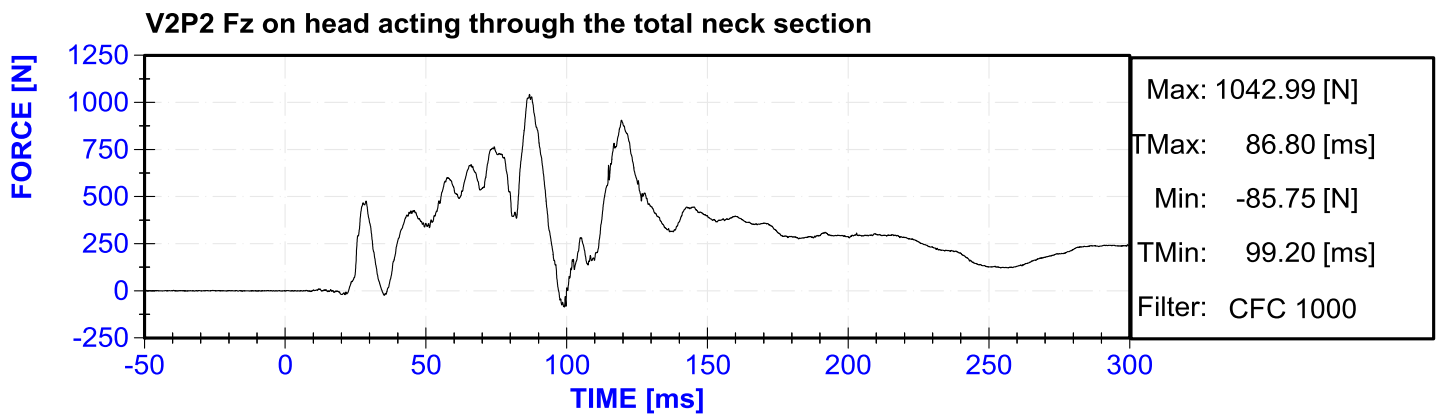
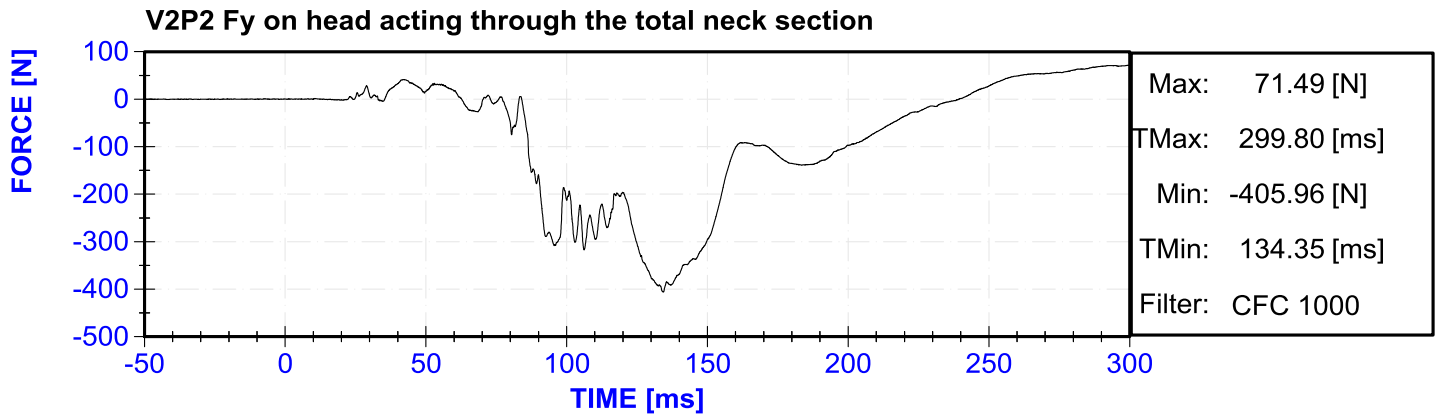

V2P2 Mz on head acting through the total neck section

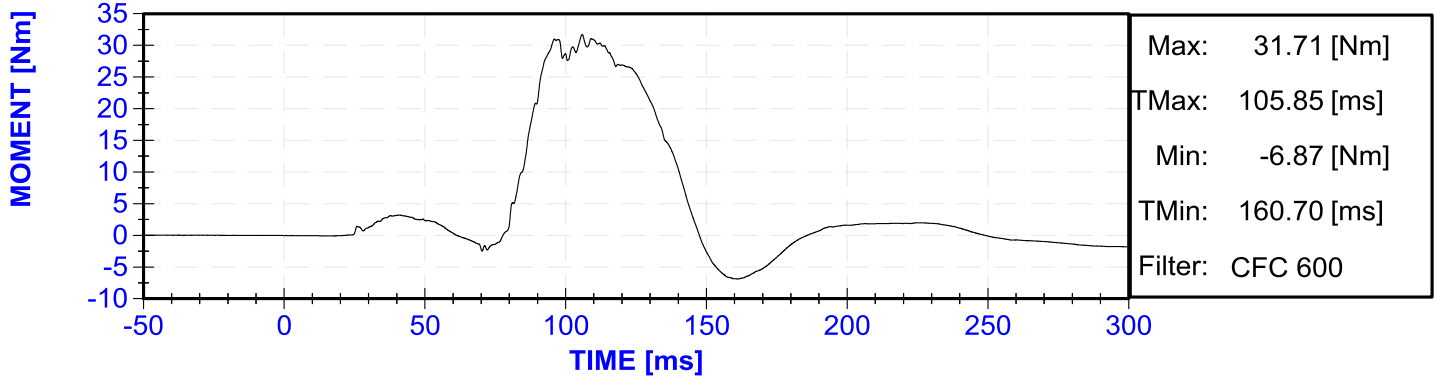

V2P2 Chest Left Upper Dx

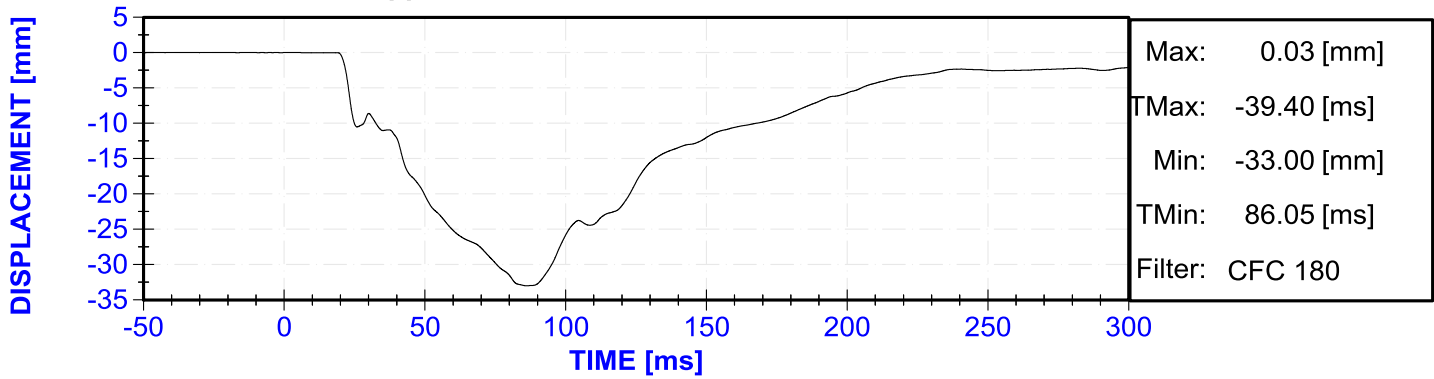

V2P2 Chest Left Upper Dy

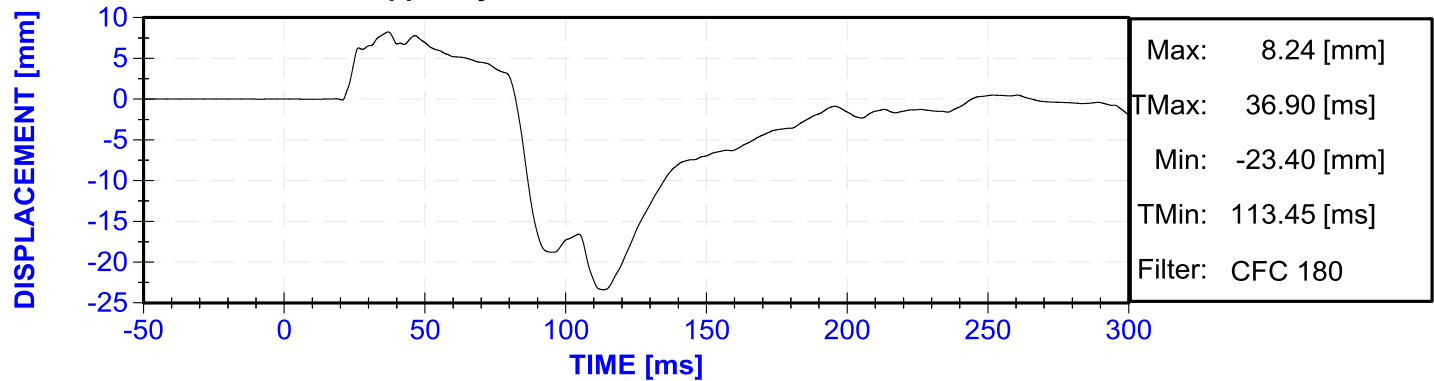

V2P2 Chest Left Upper Dz

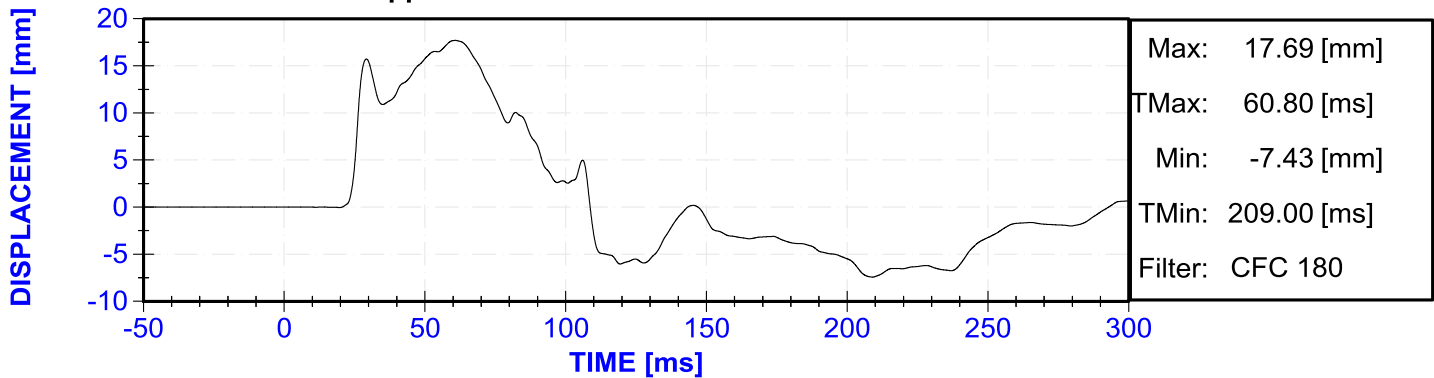

V2P2 Chest Left Upper Resultant

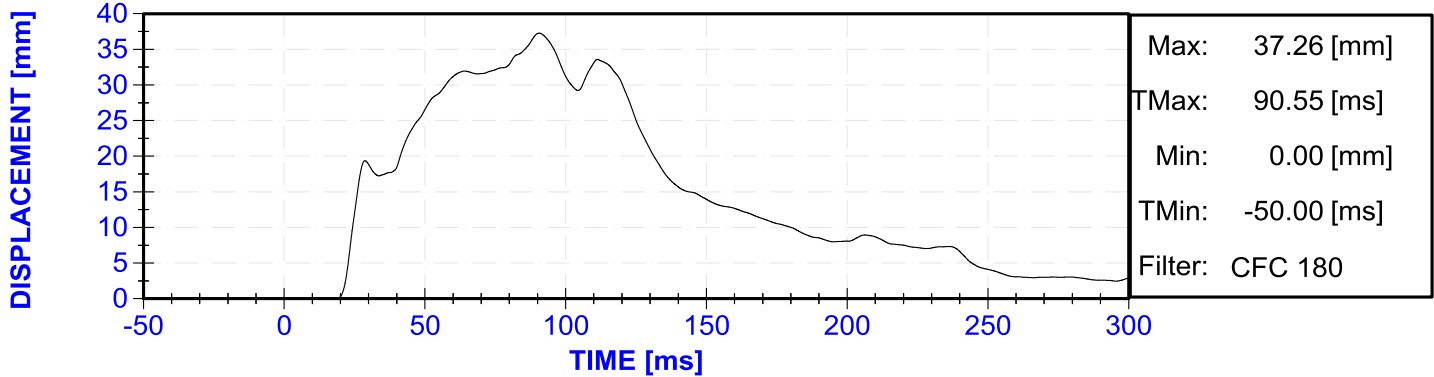

V2P2 Chest Right Upper Dx

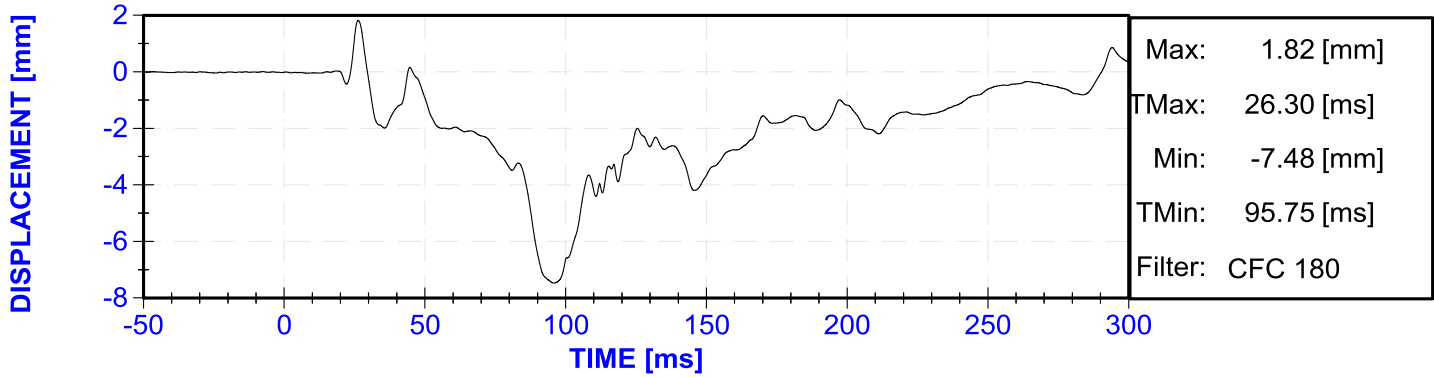

V2P2 Chest Right Upper Dy

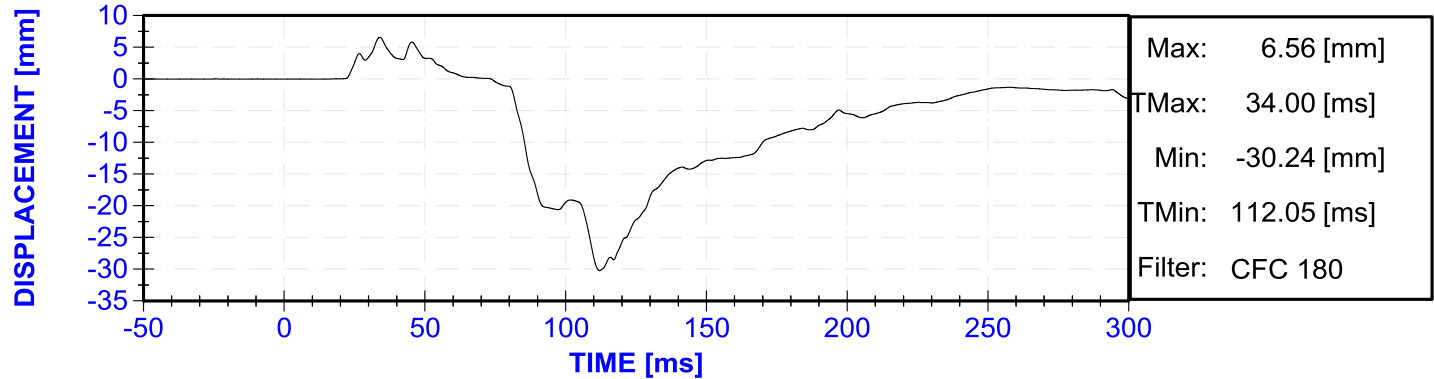

V2P2 Chest Right Upper Dz

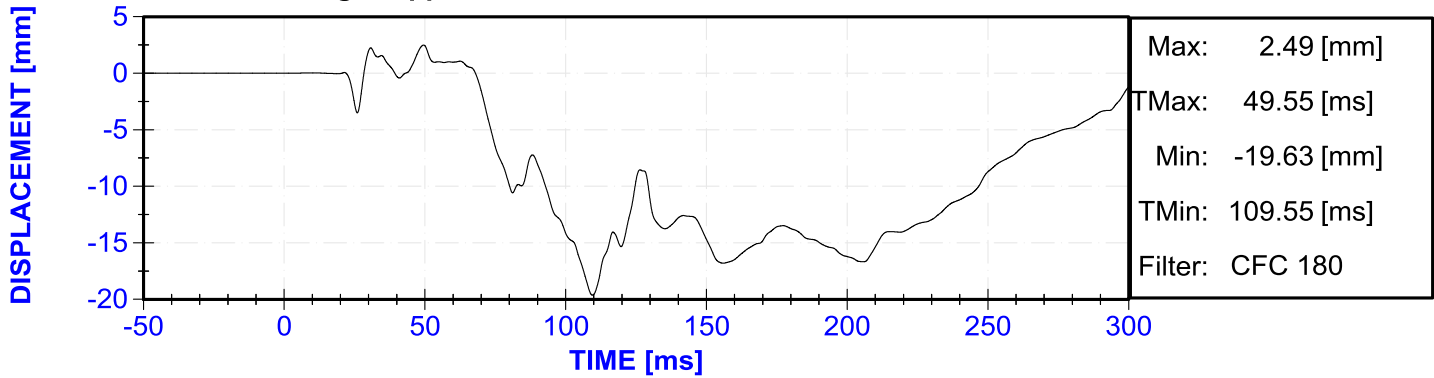

V2P2 Chest Right Upper Resultant

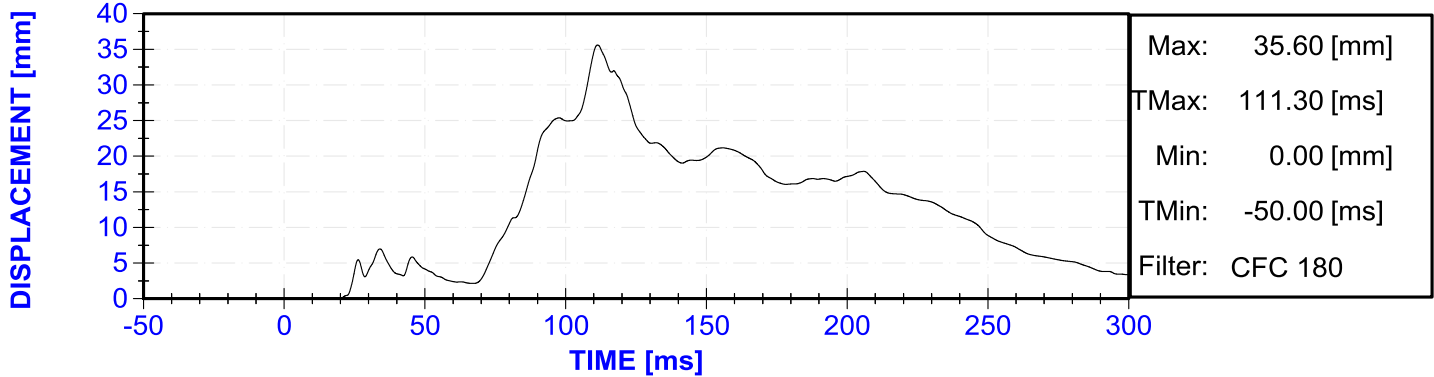

V2P2 Chest Left Lower Dx

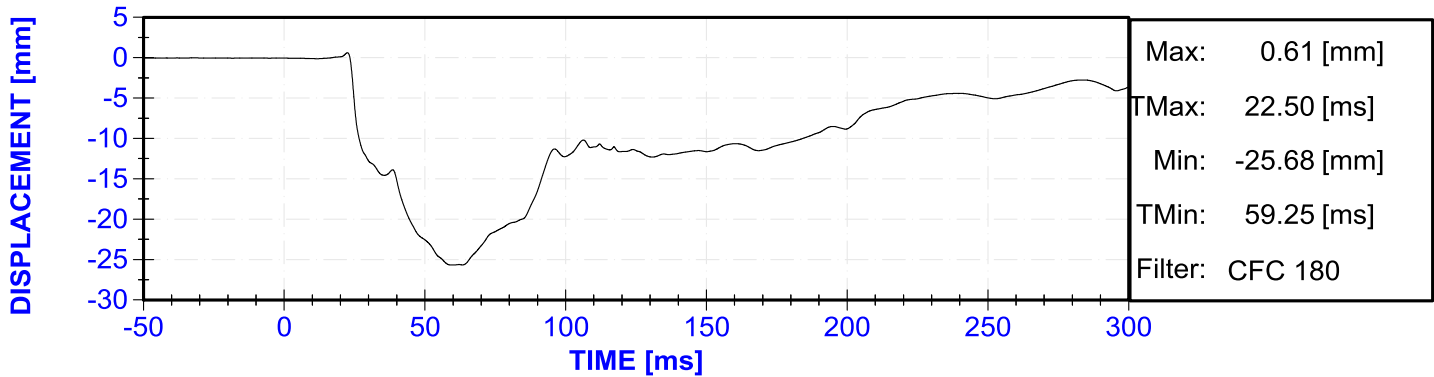

V2P2 Chest Left Lower Dy

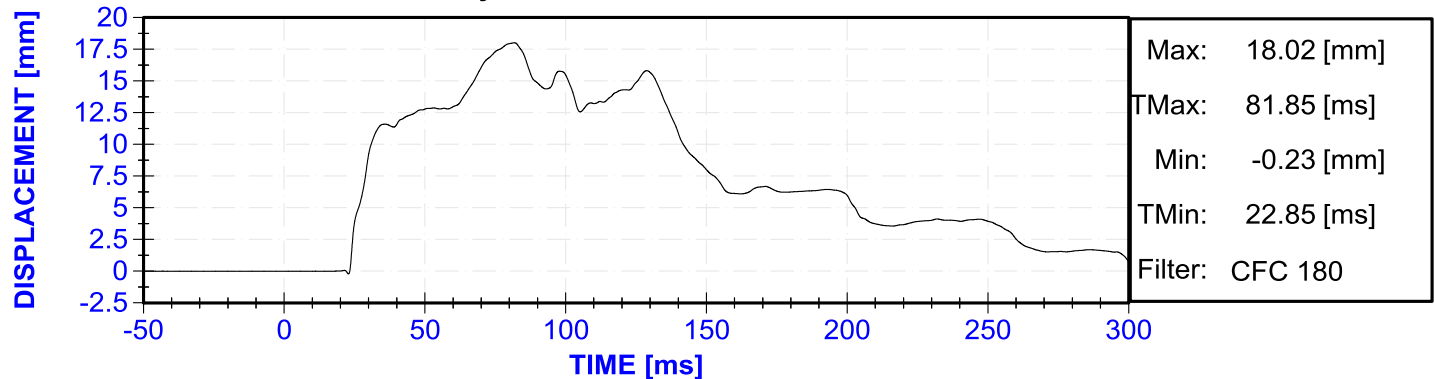

V2P2 Chest Left Lower Dz

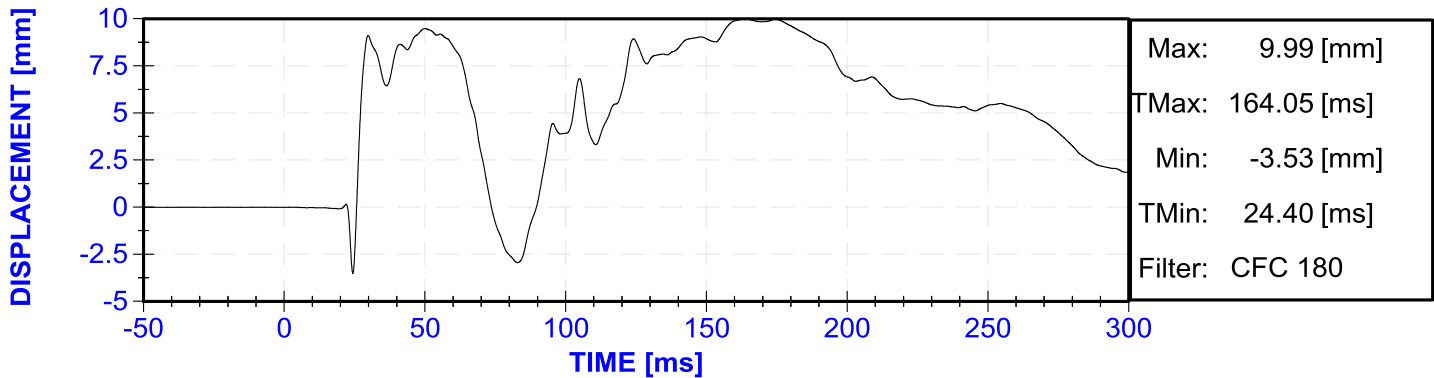

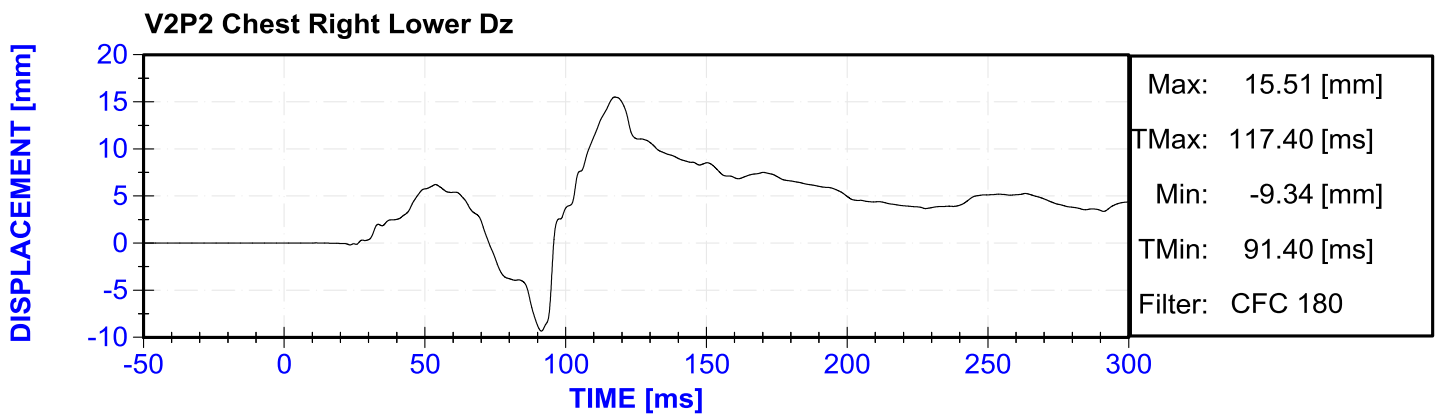
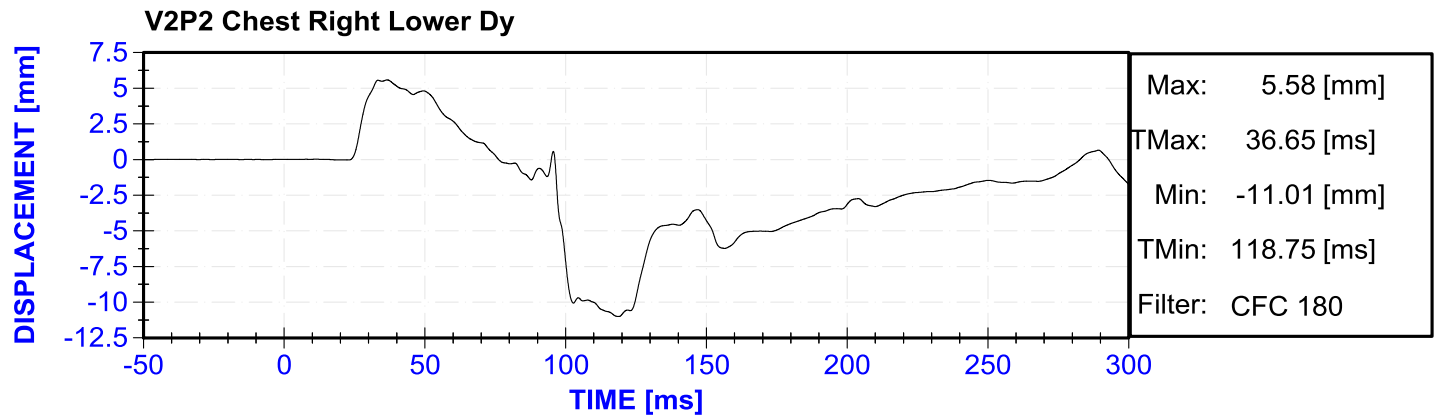
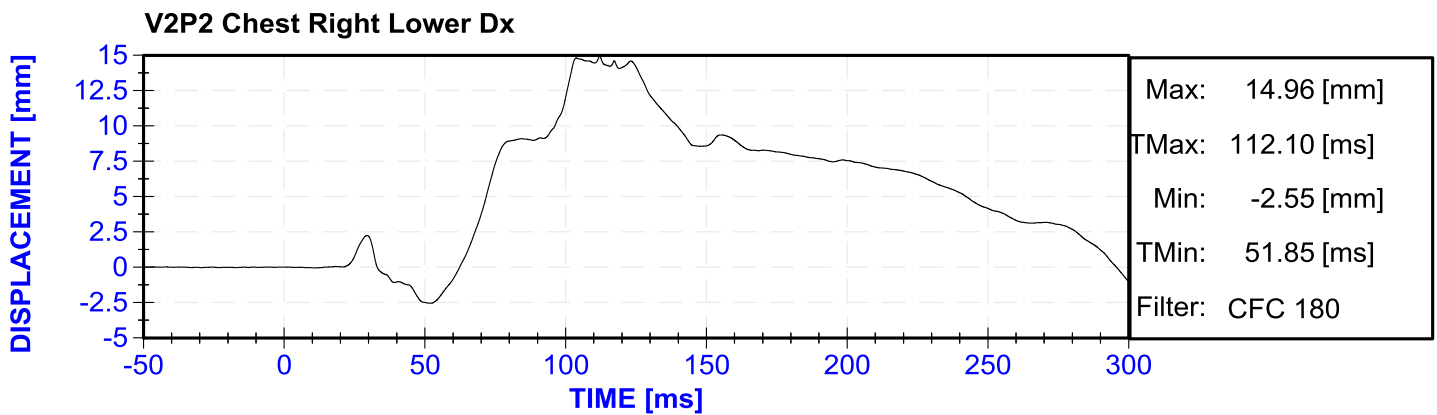
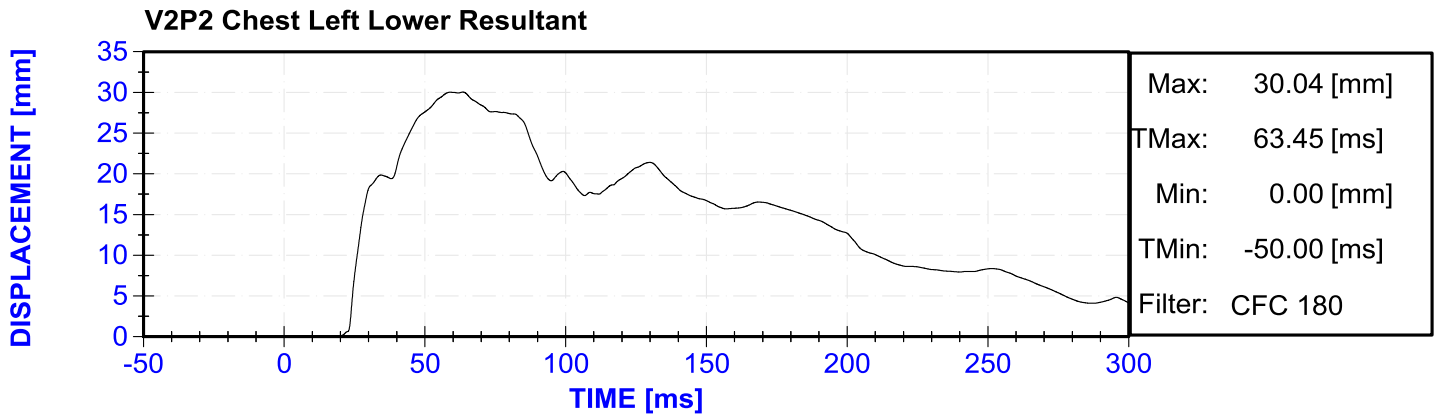

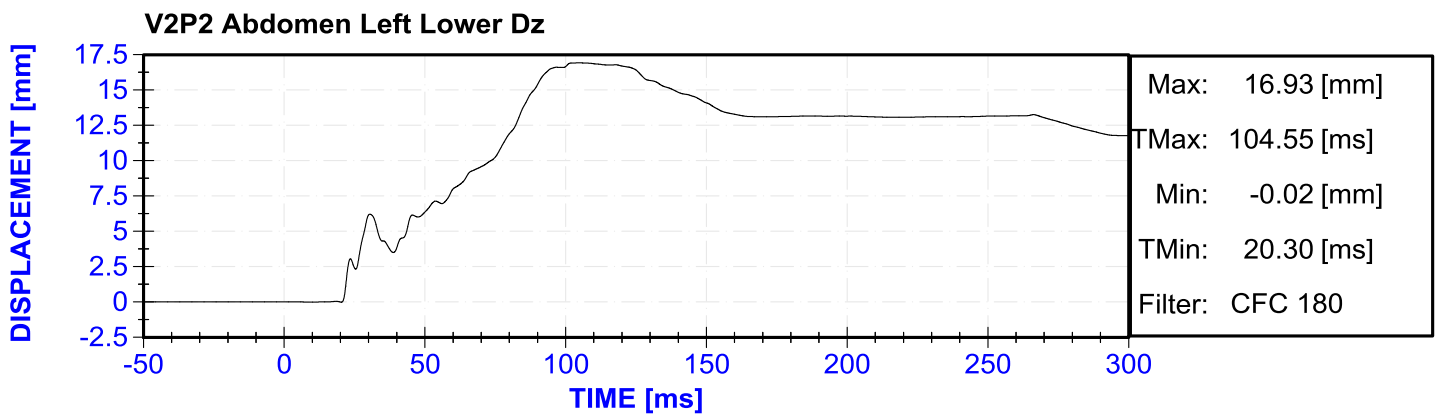
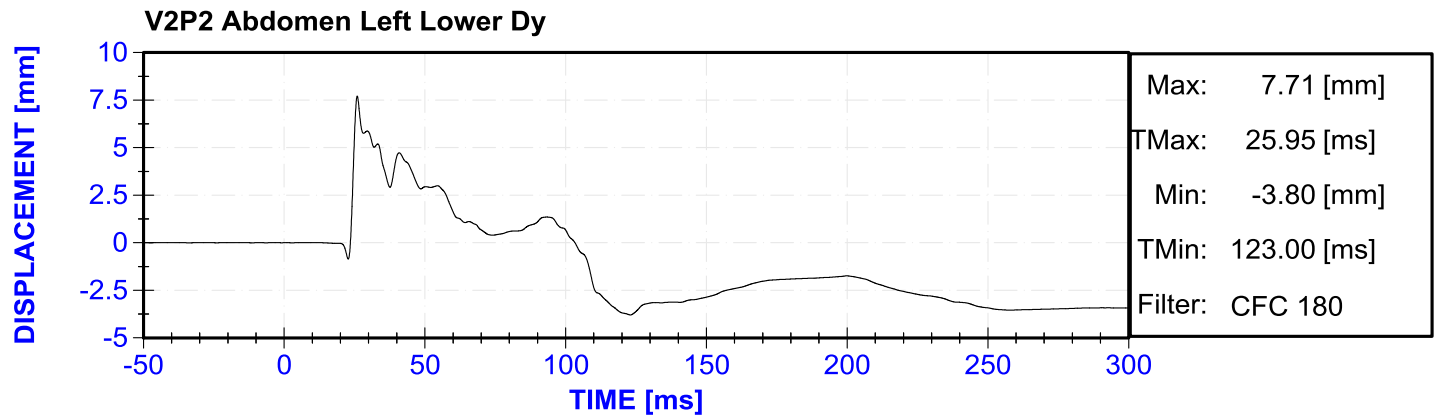
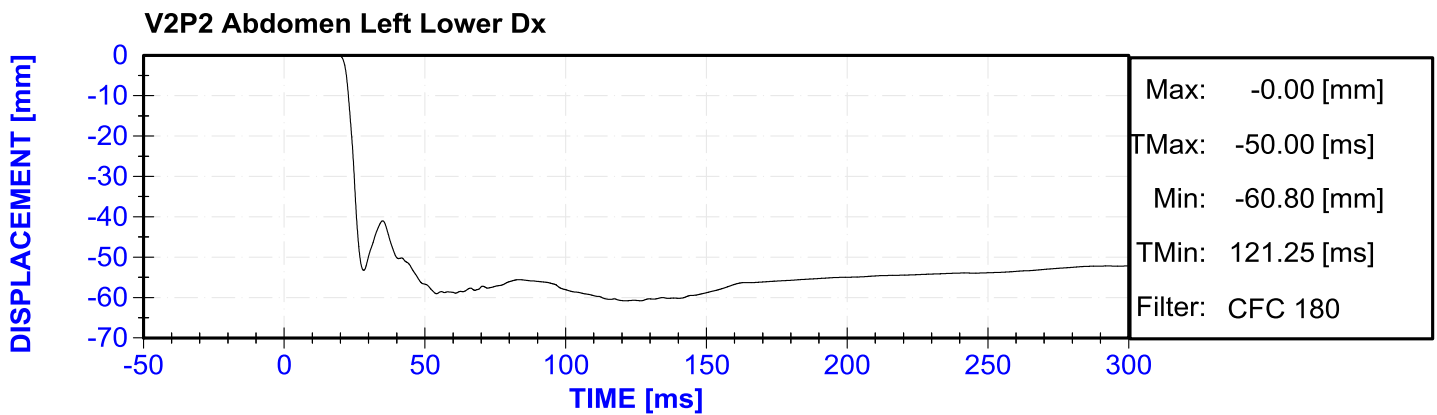
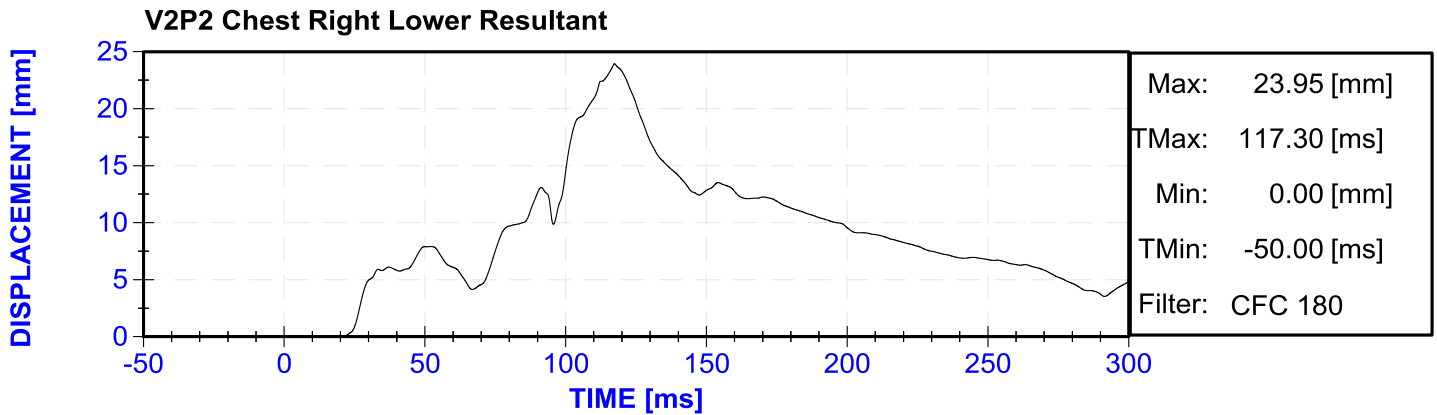

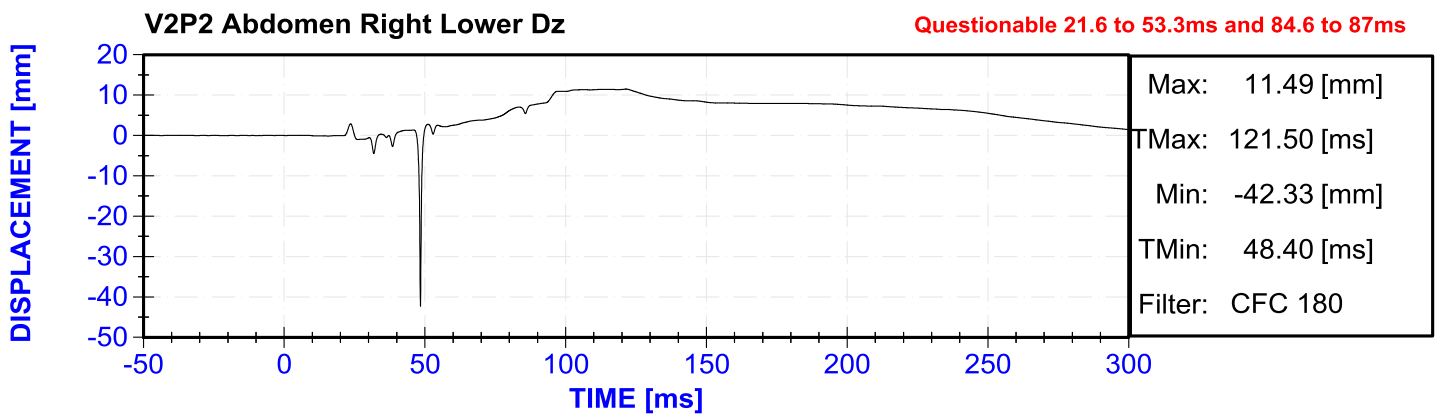
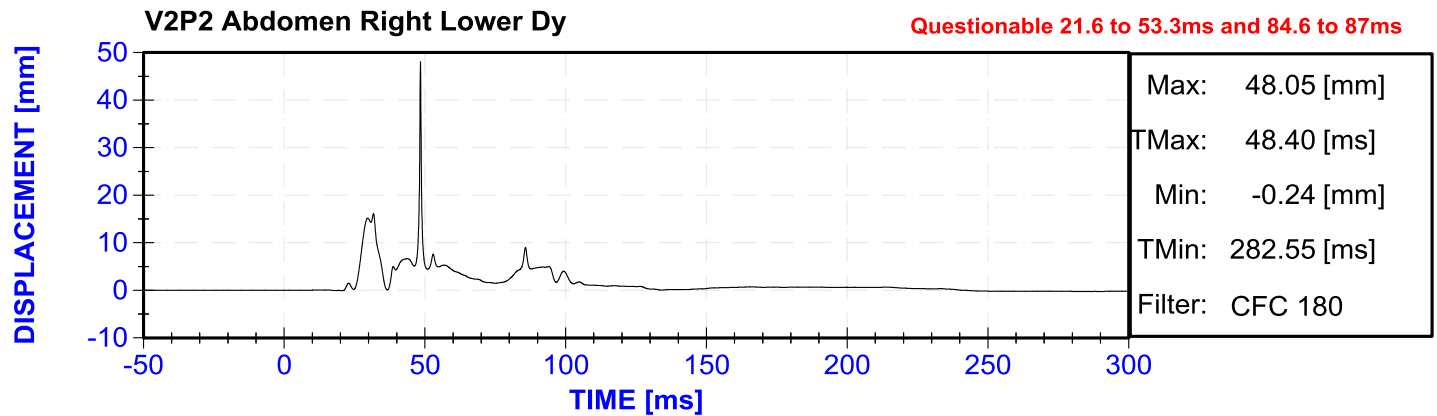
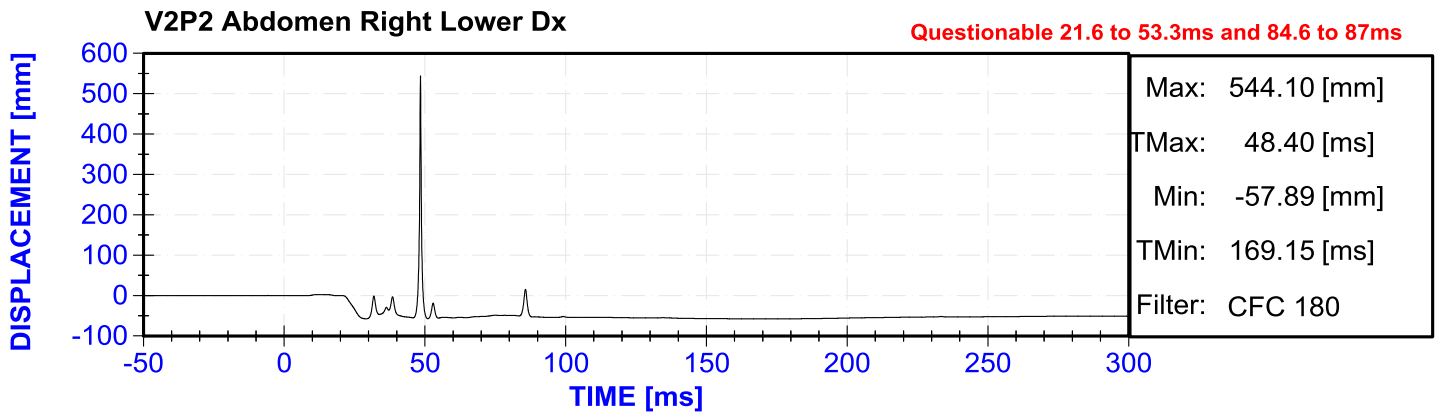
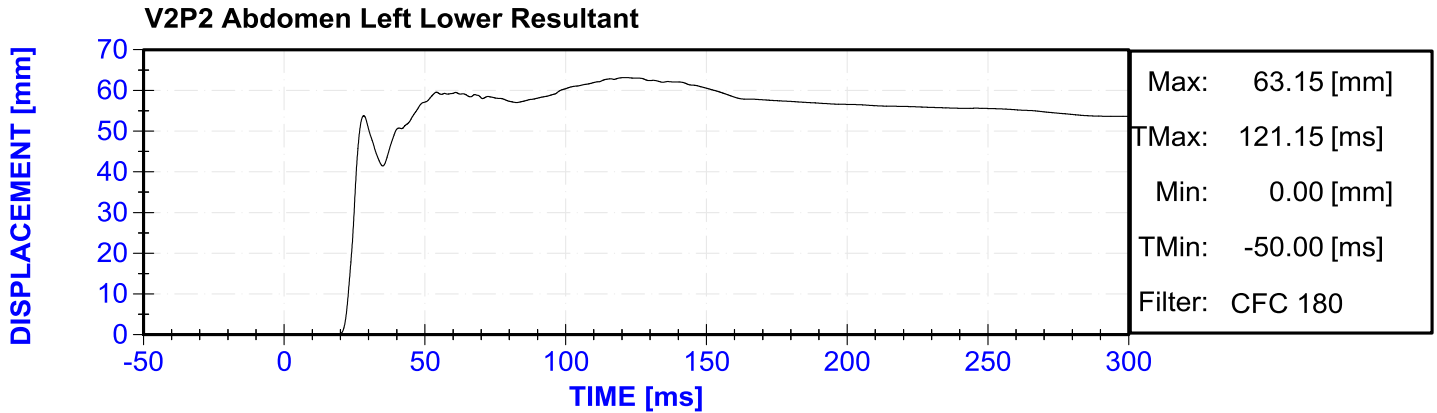

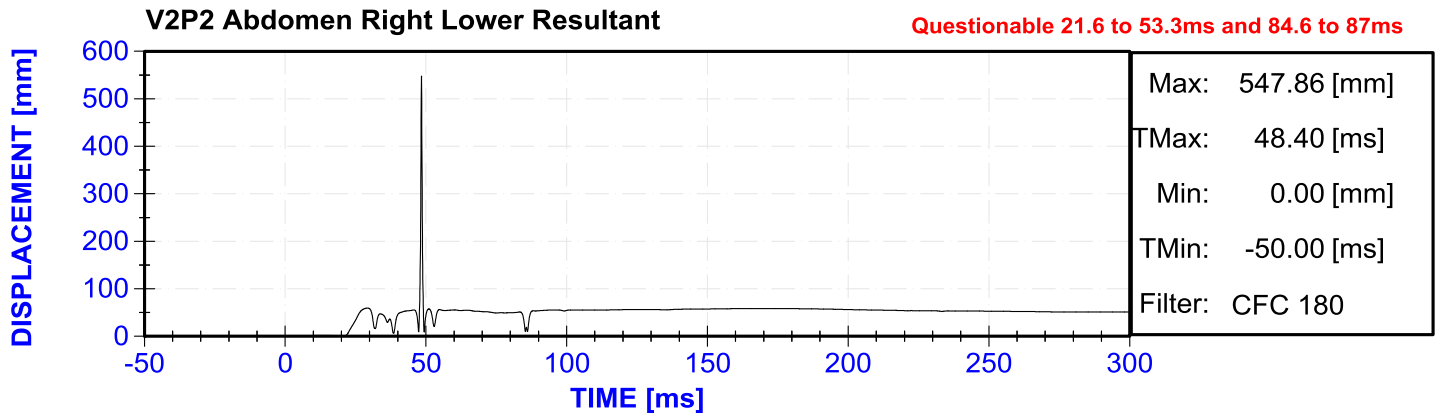

## APPENDIX C

### DUMMY CALIBRATION DATA

Table C-1: Dummy Information

TYPE	SERIAL NUMBER
THOR 50 <sup>TH</sup> Male	015
THOR 50 <sup>TH</sup> Male	016

Table C-2: THOR Ankle Zero Offset Information

THOR 50 <sup>th</sup> Male S/N: 015					
LFTX Left Ankle X	LFTY Left Ankle Y	LFTZ Left Ankle Z	RFTX Right Ankle X	RFTY Right Ankle Y	RFTZ Right Ankle Z
0.00893 deg	-15.7295 deg	-49.551 deg	-2.40521 deg	-12.1317 deg	-88.5479 deg
THOR 50 <sup>th</sup> Male S/N: 016					
LFTX Left Ankle X	LFTY Left Ankle Y	LFTZ Left Ankle Z	RFTX Right Ankle X	RFTY Right Ankle Y	RFTZ Right Ankle Z
2.16286 deg	-16.3445 deg	-44.58 deg	-3.53702 deg	-15.8108 deg	-46.565 deg

Table C- 3: THOR Dummy Initial Set-Up Information

THOR 50 <sup>th</sup> Male S/N: 015					
Sensor	Manufacturer	Serial Number	Range	Sensitivity	Sensitivity Units
Head CG Ax	Endevco	AC-P63993	2000	0.020850001	mV/V/g
Head CG Ay	Endevco	AC-P51641	2000	0.019360001	mV/V/g
Head CG Az	Endevco	AC-P52011	2000	0.019339999	mV/V/g
Head Wx	DTS	ARS-5921	18000	0.094919997	mV/deg/sec
Head Wy	DTS	ARS-6120	18000	0.093950002	mV/deg/sec
Head Wz	DTS	ARS-6640	18000	0.094540002	mV/deg/sec
Upper Neck Fx	Humanetics	LC-76Fx	8896.4	0.000231699	mV/V/N
Upper Neck Fy	Humanetics	LC-76Fy	8896.4	0.000234116	mV/V/N
Upper Neck Fz	Humanetics	LC-76Fz	13344.7	8.84E-05	mV/V/N
Upper Neck Mx	Humanetics	LC-76Mx	282.5	0.005946997	mV/V/Nm
Upper Neck My	Humanetics	LC-76My	282.5	0.005957618	mV/V/Nm
Upper Neck Mz	Humanetics	LC-76Mz	282.5	0.009966654	mV/V/Nm
Lower Neck Fx	Humanetics	LC-DM4552Fx	13344.7	0.00017042	mV/V/N
Lower Neck Fy	Humanetics	LC-DM4552Fy	13344.7	0.000169911	mV/V/N
Lower Neck Fz	Humanetics	LC-DM4552Fz	13344.7	7.10E-05	mV/V/N
Lower Neck Mx	Humanetics	LC-DM4552Mx	451.9	0.004082851	mV/V/Nm
Lower Neck My	Humanetics	LC-DM4552My	451.9	0.004110952	mV/V/Nm
Lower Neck Mz	Humanetics	LC-DM4552Mz	226	0.006743385	mV/V/Nm
Skull Spring Front Fz	Humanetics	LC-DI7617 Fz	4448.2	0.000498224	mV/V/N
Skull Spring Rear Fz	Humanetics	LC-80 Fz	4448.2	0.000868662	mV/V/N
Condyle Pot Ry	Sfernice	LC-DI7189	180	3.035299946	mV/V/deg
T1 Ax	Endevco	AC-P80336	2000	0.016559999	mV/V/g
T1 Ay	Endevco	AC-P80338	2000	0.01672	mV/V/g
T1 Az	Endevco	AC-P72696	2000	0.02044	mV/V/g

**THOR 50<sup>th</sup> Male (Continued) S/N: 015**

Sensor	Manufacturer	Serial Number	Range	Sensitivity	Sensitivity Units
T4 Ax	Endevco	AC-P80288	2000	0.020150001	mV/V/g
T4 Ay	Endevco	AC-P82328	2000	0.018279999	mV/V/g
T4 Az	Endevco	AC-P78985	2000	0.01835	mV/V/g
Thoracic Spine Fx	Denton	LC-92Fx	13344.7	0.000137193	mV/V/N
Thoracic Spine Fy	Denton	LC-92Fy	13344.7	0.000137958	mV/V/N
Thoracic Spine Fz	Denton	LC-92Fz	17792.9	5.26E-05	mV/V/N
Thoracic Spine Mx	Denton	LC-92Mx	677.9	0.002160616	mV/V/Nm
Thoracic Spine My	Denton	LC-92My	903.9	0.001779222	mV/V/Nm
Upper Left Thorax Dx	Humanetics	DS-DP1394	160 mm	Non-linear Scale	
Upper Left Thorax Ry	Sfernice	DS-DO7273	180	3.04979994	mV/V/deg
Upper Left Thorax Rz	Sfernice	DS-DP3884	180	3.048900049	mV/V/deg
Upper Right Thorax Dx	Humanetics	DS-DP1387	160 mm	Non-linear Scale	
Upper Right Thorax Ry	Sfernice	DS-DO7282	180	3.034099936	mV/V/deg
Upper Right Thorax Rz	Sfernice	DS-DO7285	180	3.021700075	mV/V/deg
Lower Left Thorax Dx	Humanetics	DS-DM1151	160 mm	Non-linear Scale	
Lower Left Thorax Ry	Sfernice	DS-DI2386	180	2.952900017	mV/V/deg
Lower Left Thorax Rz	Sfernice	DS-DI6129	180	3.087900113	mV/V/deg
Lower Right Thorax Dx	Humanetics	DS-DI4717	160 mm	Non-linear Scale	
Lower Right Thorax Ry	Sfernice	DS-DI2385	180	2.602899913	mV/V/deg
Lower Right Thorax Rz	Sfernice	DS-DO7286	180	3.08299996	mV/V/deg
Abdomen Left Dx	Humanetics	DS-DJ5441	192 mm	Non-linear Scale	
Abdomen Left Ry	Sfernice	DS-VR31	150	3.035200061	mV/V/deg
Abdomen Left Rz	Sfernice	DS-VR30	150	3.023399971	mV/V/deg
Abdomen Right Dx	Humanetics	DS-DI4778	192 mm	Non-linear Scale	
Abdomen Right Ry	Sfernice	DS-DI7754	150	3.015900031	mV/V/deg
Abdomen Right Rz	Sfernice	DS-DI7902	150	3.029200016	mV/V/deg
Pelvis Ax	Endevco	AC-P52130	2000	0.017099999	mV/V/g
Pelvis Ay	Endevco	AC-P51678	2000	0.020879999	mV/V/g
Pelvis Az	Endevco	AC-P63840	2000	0.0222	mV/V/g
Acetabulum Left Fx	Humanetics	LC-DM5055Fx	22241.1	0.000121887	mV/V/N
Acetabulum Left Fy	Humanetics	LC-DM5055Fy	13344.7	5.93E-05	mV/V/N
Acetabulum Left Fz	Humanetics	LC-DM5055Fz	13344.7	0.000163534	mV/V/N
Acetabulum Right Fx	Denton	LC-87Fx	22241.1	0.000124068	mV/V/N
Acetabulum Right Fy	Denton	LC-87Fy	13344.7	6.08E-05	mV/V/N
Acetabulum Right Fz	Denton	LC-87Fz	13344.7	0.000167363	mV/V/N
ASIS Left Fx	Humanetics	LC-DI4774 Fx	13000	6.84E-05	mV/V/N
ASIS Left My	Humanetics	LC-DI4774 My	325	0.003740923	mV/V/Nm
ASIS Right Fx	Humanetics	LC-DI4775 Fx	13000	6.77E-05	mV/V/N
ASIS Right My	Humanetics	LC-DI4775 My	325	0.003728923	mV/V/Nm
Femur Left Fx	Humanetics	LC-DT1833Fx	15000	0.000146287	mV/V/N
Femur Left Fy	Humanetics	LC-DT1833Fy	15000	0.000145733	mV/V/N
Femur Left Fz	Humanetics	LC-DT1833Fz	15000	7.36E-05	mV/V/N
Femur Left Mx	Humanetics	LC-DT1833Mx	350	0.006617429	mV/V/Nm
Femur Left My	Humanetics	LC-DT1833My	350	0.006614857	mV/V/Nm
Femur Right Fx	Humanetics	LC-DT1830Fx	15000	0.00014712	mV/V/N
Femur Right Fy	Humanetics	LC-DT1830Fy	15000	0.000147193	mV/V/N
Femur Right Fz	Humanetics	LC-DT1830Fz	15000	7.29E-05	mV/V/N
Femur Right Mx	Humanetics	LC-DT1830Mx	350	0.006648857	mV/V/Nm

THOR 50 <sup>th</sup> Male (Continued) S/N: 015					
Sensor	Manufacturer	Serial Number	Range	Sensitivity	Sensitivity Units
Femur Right My	Humanetics	LC-DT1830My	350	0.006598	mV/V/Nm
Knee Dx	Space Age	DS-D2103665B	33	23.88590015	mv/v/mm
Upper Tibia Fz	Denton	LC-DS8145 Fz	11120	9.56E-05	mv/v/N
Upper Tibia Mx	Denton	LC-DS8145 Mx	395	0.0074603	mv/v/Nm
Upper Tibia My	Denton	LC-DS8145 My	395	0.0074283	mv/v/Nm
Lower Tibia Fx	Denton	LC-78 Fx	11100	0.0001747	mv/v/N
Lower Tibia Fy	Denton	LC-78 Fy	11100	0.0001706	mv/v/N
Lower Tibia Fz	Denton	LC-78 Fz	11100	9.64E-05	mv/v/N
Lower Tibia Mx	Denton	LC-78 Mx	395	0.0074895	mv/v/Nm
Lower Tibia My	Denton	LC-78 My	395	0.007513	mv/v/Nm
Leg Ax	Endevco	AC-P74940	2000	0.016620001	mv/v/g
Leg Ay	Endevco	AC-P51732	2000	0.01896	mv/v/g
Ankle Rx	Contelec	DS-0382	180	3.178999992	mv/v/deg
Ankle Ry	Contelec	DS-0386	180	3.176100086	mv/v/deg
Ankle Rz	Contelec	DS-0543	180	3.198399907	mv/v/deg
Foot Ax	Endevco	AC-P68071	2000	0.02365	mv/v/g
Foot Az	Endevco	AC-P51294	2000	0.02195	mv/v/g
Knee Dx	Space Age	DS-D2103657B	30	24.01199937	mv/v/mm
Upper Tibia Fz	Denton	LC-DS8144 Fz	11120	9.63E-05	mv/v/N
Upper Tibia Mx	Denton	LC-DS8144 Mx	395	0.0074676	mv/v/Nm
Upper Tibia My	Denton	LC-DS8144 My	395	0.0074022	mv/v/Nm
Lower Tibia Fx	Denton	LC-77 Fx	11100	0.0001737	mv/v/N
Lower Tibia Fy	Denton	LC-77 Fy	11100	0.0001715	mv/v/N
Lower Tibia Fz	Denton	LC-77 Fz	11100	9.61E-05	mv/v/N
Lower Tibia Mx	Denton	LC-77 Mx	395	0.0074698	mv/v/Nm
Lower Tibia My	Denton	LC-77 My	395	0.0073378	mv/v/Nm
Leg Ax	Endevco	AC-P79622	2000	0.02118	mv/v/g
Leg Ay	Endevco	AC-P83316	2000	0.01946	mv/v/g
Ankle Rx	Contelec	DS-0385	180	3.178199986	mv/v/deg
Ankle Ry	Contelec	DS-0383	180	3.153099911	mv/v/deg
Ankle Rz	Contelec	DS-0401	180	3.186699934	mv/v/deg
Foot Ax	Endevco	AC-P72691	2000	0.02014	mv/v/g
Foot Az	Endevco	AC-P83310	2000	0.01946	mv/v/g

Table C- 3: THOR Dummy Initial Set-Up Information

THOR 50 <sup>th</sup> Male S/N: 016					
Sensor	Manufacturer	Serial Number	Range	Sensitivity	Sensitivity Units
Head CG Ax	Endevco	AC-P81382	2000	0.01759	mV/V/g
Head CG Ay	Endevco	AC-P80275	2000	0.020490001	mV/V/g
Head CG Az	Endevco	AC-P74947	2000	0.016690001	mV/V/g
Head Wx	DTS	ARS-6629	18000	0.094080002	mV/deg/sec
Head Wy	DTS	ARS-4735	18000	0.095700001	mV/deg/sec

THOR 50 <sup>th</sup> Male (Continued) S/N: 016					
Sensor	Manufacturer	Serial Number	Range	Sensitivity	Sensitivity Units
Head Wz	DTS	ARS-4069	18000	0.09311	mV/deg/sec
Upper Neck Fx	Humanetics	LC-75Fx	8896.4	0.000228159	mV/V/N
Upper Neck Fy	Humanetics	LC-75Fy	8896.4	0.000229418	mV/V/N
Upper Neck Fz	Humanetics	LC-75Fz	13344.7	8.76E-05	mV/V/N
Upper Neck Mx	Humanetics	LC-75Mx	282.5	0.005912656	mV/V/Nm
Upper Neck My	Humanetics	LC-75My	282.5	0.005966114	mV/V/Nm
Upper Neck Mz	Humanetics	LC-75Mz	282.5	0.009657586	mV/V/Nm
Lower Neck Fx	Humanetics	LC-79Fx	13344.7	0.000168262	mV/V/N
Lower Neck Fy	Humanetics	LC-79Fy	13344.7	0.000168472	mV/V/N
Lower Neck Fz	Humanetics	LC-79Fz	13344.7	7.02E-05	mV/V/N
Lower Neck Mx	Humanetics	LC-79Mx	451.9	0.003947435	mV/V/Nm
Lower Neck My	Humanetics	LC-79My	451.9	0.00396934	mV/V/Nm
Lower Neck Mz	Humanetics	LC-79Mz	226	0.006685855	mV/V/Nm
Skull Spring Front Fz	Humanetics	LC-130 Fz	4448.2	0.000493186	mV/V/N
Skull Spring Rear Fz	Humanetics	LC-DM2829Fz	4448.2	0.000514633	mV/V/N
Condyle Pot Ry	Sfernice	DS-0007	180	3.052179934	mV/V/deg
T1 Ax	Endevco	AC-P74948	2000	0.01686	mV/V/g
T1 Ay	Endevco	AC-P83429	2000	0.018139999	mV/V/g
T1 Az	Endevco	AC-P83430	2000	0.0177	mV/V/g
T4 Ax	Endevco	AC-P80268	2000	0.020920001	mV/V/g
T4 Ay	Endevco	AC-P81791	2000	0.01917	mV/V/g
T4 Az	Endevco	AC-P80269	2000	0.021170001	mV/V/g
Thoracic Spine Fx	Denton	LC-123Fx	13344.7	0.000139239	mV/V/N
Thoracic Spine Fy	Denton	LC-123Fy	13344.7	0.000140453	mV/V/N
Thoracic Spine Fz	Denton	LC-123Fz	17792.9	5.33E-05	mV/V/N
Thoracic Spine Mx	Denton	LC-123Mx	677.9	0.002083467	mV/V/Nm
Thoracic Spine My	Denton	LC-123My	903.9	0.001837305	mV/V/Nm
Upper Left Thorax Dx	Humanetics	DS-DS6356	160 mm	Non-linear Scale	
Upper Left Thorax Ry	Sfernice	DS-DJ4106	180	3.059499897	mV/V/deg
Upper Left Thorax Rz	Sfernice	DS-DJ4108	180	3.046100028	mV/V/deg
Upper Right Thorax Dx	Humanetics	DS-DM3232	160 mm	Non-linear Scale	
Upper Right Thorax Ry	Sfernice	DS-DI2381	180	3.058299888	mV/V/deg
Upper Right Thorax Rz	Sfernice	DS-DI2380	180	3.06040002	mV/V/deg
Lower Left Thorax Dx	Humanetics	DS-DP1389	160 mm	Non-linear Scale	
Lower Left Thorax Ry	Sfernice	DS-DP1972	180	3.044900019	mV/V/deg
Lower Left Thorax Rz	Sfernice	DS-DO7288	180	3.039200092	mV/V/deg
Lower Right Thorax Dx	Humanetics	DS-DP1393	160 mm	Non-linear Scale	
Lower Right Thorax Ry	Sfernice	DS-DO7275	180	3.038000083	mV/V/deg
Lower Right Thorax Rz	Sfernice	DS-DO7276	180	3.021999961	mV/V/deg
Abdomen Left Dx	Humanetics	DS-DJ5440	192 mm	Non-linear Scale	
Abdomen Left Ry	Sfernice	DS-DI7755	150	3.025599988	mV/V/deg
Abdomen Left Rz	Sfernice	DS-DI7901	150	3.057899885	mV/V/deg
Abdomen Right Dx	Humanetics	DS-DQ2304	192 mm	Non-linear Scale	
Abdomen Right Ry	Sfernice	DS-218	150	3.012799891	mV/V/deg
Abdomen Right Rz	Sfernice	DS-DI6580	150	2.744599944	mV/V/deg
Pelvis Ax	Endevco	AC-P82402	2000	0.01788	mV/V/g
Pelvis Ay	Endevco	AC-P82403	2000	0.01799	mV/V/g
Pelvis Az	Endevco	AC-P82332	2000	0.01715	mV/V/g

**THOR 50<sup>th</sup> Male (Continued) S/N: 016**

Sensor	Manufacturer	Serial Number	Range	Sensitivity	Sensitivity Units
Acetabulum Left Fx	Humanetics	LC-83Fx	22241.1	0.000120471	mV/V/N
Acetabulum Left Fy	Humanetics	LC-83Fy	13344.7	5.91E-05	mV/V/N
Acetabulum Left Fz	Humanetics	LC-83Fz	13344.7	0.000162964	mV/V/N
Acetabulum Right Fx	Denton	LC-84Fx	22241.1	0.000122579	mV/V/N
Acetabulum Right Fy	Denton	LC-84Fy	13344.7	5.82E-05	mV/V/N
Acetabulum Right Fz	Denton	LC-84Fz	13344.7	0.000165272	mV/V/N
ASIS Left Fx	Humanetics	LC-DT1000Fx	13000	6.88E-05	mV/V/N
ASIS Left My	Humanetics	LC-DT1000My	325	0.003827634	mV/V/Nm
ASIS Right Fx	Humanetics	LC-DT1001Fx	13000	6.94E-05	mV/V/N
ASIS Right My	Humanetics	LC-DT1001My	325	0.003849914	mV/V/Nm
Femur Left Fx	Humanetics	LC-DP4630Fx	15000	0.000142	mV/V/N
Femur Left Fy	Humanetics	LC-DP4630Fy	15000	0.0001419	mV/V/N
Femur Left Fz	Humanetics	LC-DP4630Fz	15000	7.16E-05	mV/V/N
Femur Left Mx	Humanetics	LC-DP4630Mx	350	0.0064409	mV/V/Nm
Femur Left My	Humanetics	LC-DP4630My	350	0.0064306	mV/V/Nm
Femur Right Fx	Humanetics	LC-DP3959Fx	15000	0.000142	mV/V/N
Femur Right Fy	Humanetics	LC-DP3959Fy	15000	0.0001422	mV/V/N
Femur Right Fz	Humanetics	LC-DP3959Fz	15000	7.24E-05	mV/V/N
Femur Right Mx	Humanetics	LC-DP3959Mx	350	0.006592	mV/V/Nm
Femur Right My	Humanetics	LC-DP3959My	350	0.0064729	mV/V/Nm
Knee Dx	Space Age	DS-017169	33	22.93870039	mv/v/mm
Upper Tibia Fz	Denton	LC-95 Fz	11120	9.60E-05	mv/v/N
Upper Tibia Mx	Denton	LC-95 Mx	395	0.0074226	mv/v/Nm
Upper Tibia My	Denton	LC-95 My	395	0.0073786	mv/v/Nm
Lower Tibia Fx	Denton	LC-139 Fx	11100	0.00017407	mv/v/N
Lower Tibia Fy	Denton	LC-139 Fy	11100	0.00017491	mv/v/N
Lower Tibia Fz	Denton	LC-139 Fz	11100	9.63E-05	mv/v/N
Lower Tibia Mx	Denton	LC-139 Mx	395	0.0074679	mv/v/Nm
Lower Tibia My	Denton	LC-139 My	395	0.007503	mv/v/Nm
Leg Ax	Endevco	AC-P67924	2000	0.02107	mv/v/g
Leg Ay	Endevco	AC-P51711	2000	0.01915	mv/v/g
Ankle Rx	Contelec	DS-0544	180	3.173100064	mv/v/deg
Ankle Ry	Contelec	DS-0527	180	3.160400083	mv/v/deg
Ankle Rz	Contelec	DS-0541	180	3.15340003	mv/v/deg
Foot Ax	Endevco	AC-P63979	2000	0.020310001	mv/v/g
Foot Az	Endevco	AC-P82182	2000	0.018090001	mv/v/g
Knee Dx	Space Age	DS-12070382	30	24.1260007	mv/v/mm
Upper Tibia Fz	Denton	LC-88 Fz	11120	9.33E-05	mv/v/N
Upper Tibia Mx	Denton	LC-88 Mx	395	0.0072837	mv/v/Nm
Upper Tibia My	Denton	LC-88 My	395	0.0071822	mv/v/Nm
Lower Tibia Fx	Denton	LC-140 Fx	11100	0.0001784	mv/v/N
Lower Tibia Fy	Denton	LC-140 Fy	11100	0.0001764	mv/v/N
Lower Tibia Fz	Denton	LC-140 Fz	11100	9.65E-05	mv/v/N
Lower Tibia Mx	Denton	LC-140 Mx	395	0.0076118	mv/v/Nm
Lower Tibia My	Denton	LC-140 My	395	0.0076405	mv/v/Nm
Leg Ax	Endevco	AC-P50100	2000	0.017660001	mv/v/g

THOR 50 <sup>th</sup> Male (Continued) S/N: 016					
Sensor	Manufacturer	Serial Number	Range	Sensitivity	Sensitivity Units
Leg Ay	Endevco	AC-P80922	2000	0.018160001	mv/v/g
Ankle Rx	Contelec	DS-0254	180	3.179399995	mv/v/deg
Ankle Ry	Contelec	DS-0525-1	180	3.179399995	mv/v/deg
Ankle Rz	Contelec	DS-0256	180	3.160899971	mv/v/deg
Foot Ax	Endevco	AC-P58836	2000	0.01903	mv/v/g
Foot Az	Endevco	AC-P72351	2000	0.021059999	mv/v/g

**Table 4 – THOR IR-TRACC Polarity**

In order to reduce the risk of damage to instrumentation, it is recommended that the 3D IR-TRACC units are not disconnected from the rib cage to conduct the polarity test. An alternate procedure for checking the IR-TRACC polarity is described below.

1. Using the data acquisition system control software, open a live view of each channel. If possible, view the DX, RY, and RZ components of a given quadrant simultaneously.
2. Record the initial reading of each channel
3. Perform the following motions on each of the four rib attachment locations and two abdomen attachment locations (specified by the hexagonal bolt attaching the blue ribs).
  - a. DX: Push inward (front-to-back). The IR-TRACC tube voltage should increase.
  - b. RY: Push downward (head-to-pelvis). The Y-axis potentiometer reading should decrease.
  - c. RZ: Push rightward (left-to-right). The Z-axis potentiometer should increase.
4. Record the final reading of each channel
5. If the “Measured” value (increase or decrease) does not match the “Expected” value, the polarity of the channel must be inverted.

## THOR 50<sup>th</sup> Male 015

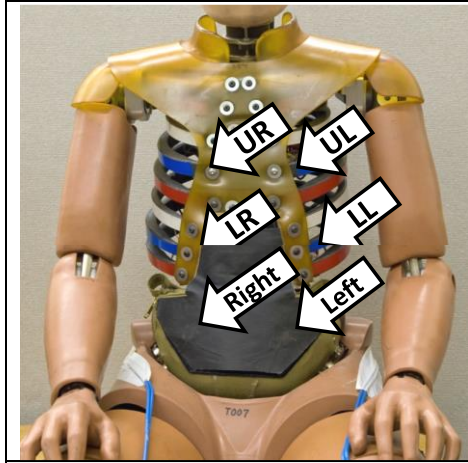

Figure 1. Manipulation to determine thoracic and abdominal IR-TRACC polarity.

Channel	Motion
DX	Push inward
RY	Push upward
RZ	Push rightward

Upper Right Thorax				Upper Left Thorax			
Channel	Initial Value	Expected Polarity	Recorded Polarity	Channel	Initial Value	Expected Polarity	Recorded Polarity
DX (V)	0.11203	+	+	DX (V)	0.10139	+	+
RY (Deg)	10.5792	+	+	RY (Deg)	11.7954	+	+
RZ (Deg)	-12.961	+	+	RZ (Deg)	13.0209	+	+
Lower Right Thorax				Lower Left Thorax			
Channel	Initial Value	Expected Polarity	Recorded Polarity	Channel	Initial Value	Expected Polarity	Recorded Polarity
DX (V)	0.09578	+	+	DX (V)	0.08445	+	+
RY (Deg)	-3.4367	+	+	RY (Deg)	-2.3055	+	+
RZ (Deg)	-5.1227	+	+	RZ (Deg)	5.23523	+	+
Abdomen Right				Abdomen Left			
Channel	Initial Value	Expected Polarity	Recorded Polarity	Channel	Initial Value	Expected Polarity	Recorded Polarity
DX (V)	0.06672	+	+	DX (V)	0.06328	+	+
RY (Deg)	2.86058	+	+	RY (Deg)	1.87899	+	+
RZ (Deg)	-0.8069	+	+	RZ (Deg)	1.53933	+	+

## THOR 50<sup>th</sup> Male 016

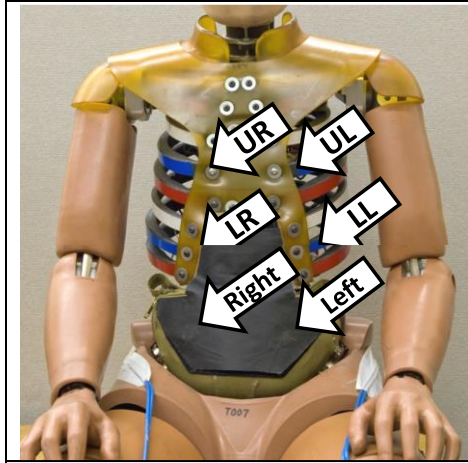

Figure 2. Manipulation to determine thoracic and abdominal IR-TRACC polarity.

Channel	Motion
DX	Push inward
RY	Push upward
RZ	Push rightward

Upper Right Thorax				Upper Left Thorax			
Channel	Initial Value	Expected Polarity	Recorded Polarity	Channel	Initial Value	Expected Polarity	Recorded Polarity
DX (V)	0.08380	+	+	DX (V)	0.85751	+	+
RY (Deg)	10.0137	+	+	RY (Deg)	4.55342	+	+
RZ (Deg)	-11.962	+	+	RZ (Deg)	11.7694	+	+
Lower Right Thorax				Lower Left Thorax			
Channel	Initial Value	Expected Polarity	Recorded Polarity	Channel	Initial Value	Expected Polarity	Recorded Polarity
DX (V)	0.08025	+	+	DX (V)	0.08125	+	+
RY (Deg)	-6.1346	+	+	RY (Deg)	-4.0026	+	+
RZ (Deg)	-2.2819	+	+	RZ (Deg)	7.84761	+	+
Abdomen Right				Abdomen Left			
Channel	Initial Value	Expected Polarity	Recorded Polarity	Channel	Initial Value	Expected Polarity	Recorded Polarity
DX (V)	0.07470	+	+	DX (V)	0.07571	+	+
RY (Deg)	3.52947	+	+	RY (Deg)	3.10074	+	+
RZ (Deg)	1.27844	+	+	RZ (Deg)	5.10226	+	+

**Test Data/Sensor Repair Notes**

# THOR Inspection Checklist

Date: <b>9/14/2015</b>	
NHTSA Representative: <b>James Saunders</b>	
Inspection Reporter: <b>Mike Hartung</b>	
Inspection type (check one): <input checked="" type="checkbox"/> Pre-Test <input type="checkbox"/> Post-Test	
Dummy S/N: <b>0015</b>	Legs S/N: <b>LX0038/LX0039</b>
Dummy Description: <b>THOR-M 50<sup>th</sup> Male</b>	
Date of last Certification: <b>July 2015</b>	
<u>Tests conducted:</u> <u>Since last inspection:</u> <b>R20150227- Forester</b> <u>Since last certification:</u> <b>R20150227- Forester</b>	
<u>Known errors in data channels (no data, clipping, unexpected drops):</u> <ul style="list-style-type: none"> <li>- <b>Tibia Left X Acceleration, Questionable spike at 81ms, SN:AC-P74940</b></li> <li>- <b>Tibia Left Y Acceleration, Questionable spike at 18.7ms and 81ms, SN:AC-P51732 - Both accelerometers check out fine. A grounding issue is the suspected cause.</b></li> </ul>	
<u>Physical evidence of damage:</u> <b>Zipper detaching left and right calf.</b>	
<u>Anecdotal evidence of damage:</u> <b>None</b>	
<u>Equipment delivered to Borrower:</u> <b>THOR 0015 ATD</b> <b>26 Accelerometers</b> <b>3 Angular Rate Sensors</b> <b>2 Skull Spring LC</b> <b>1 Condyle Pot</b> <b>1 Upper Neck LC</b> <b>6 IRTracs</b> <b>12 Rotational Pots</b> <b>1 Spine LC</b> <b>2 Acetabulum LC</b> <b>2 ASIS LC</b> <b>2 Femur LC</b>	<i>Continued</i> <b>2 LX Leg Assemblies</b> <b>2 Upper Tibia LC</b> <b>2 Lower Tibia LC</b> <b>6 Ankle Potentiometers</b> <b>2 Knee Sliders</b> <b>1 Neck Skin</b> <b>1 Neck Foam</b> <b>1 Tiltview Interface Cable</b> <b>4 Tilt Sensors</b> <b>1 H-Point Tool</b> <b>1 Tool Box</b> <b>1 Laptop</b>

**Note: New Damage is Noted in Red**

<b>HEAD</b>	
Y / N	Rear head cap mounts securely to head
Y / N	Head skin fits securely over skull
Y / N	Head skin shows no sign of tears or damage
Y / N	Interior components of skull cavity (ballast, accelerometer mount, accelerometers) securely attached
Y / N	Head securely mounted to OC joint
OTHER	
<b>NECK</b>	
Y / N	Neck cables slide freely through holes in neck plates
Y / N	Neck cables show no sign of fraying, broken strands, or kinking
Y / N	No evidence of de-bonding between neck pucks and plates
Y / N	No evidence of de-bonding or permanent compression in neck soft stop assemblies
Y / N	Neck securely attached to upper neck load cell
Y / N	Neck securely attached to lower neck load cell
Y / N	Neck pitch change joint mechanism mating teeth are engaged
OTHER	
<b>SHOULDER</b>	
Y / N	Urethane shoulder pads show no evidence of contact
Y / N	Clavicles securely attached to sternum and shoulder
Y / N	No evidence of de-bonding, tearing, or permanent compression of posterior soft stops
OTHER	
<b>SPINE</b>	
Y / N	No evidence of de-bonding between thoracic spine flex joint and metal plates
Y / N	No evidence of de-bonding between lumbar spine flex joint and metal plates
Y / N	Lumbar spine pitch change joint mechanism mating teeth are engaged
OTHER	
<b>THORAX</b>	
Y / N	No evidence of contact at top, bottom, or interior faces of rib damping material
Y / N	No evidence of de-bonding between rib damping material and ribs
Y / N	IRTRACCs securely attached to anterior ribs
Y / N	IRTRACCs securely attached to double gimbals, spine
Y / N	Urethane bib is securely attached to ribs with no sign of tearing or washer penetration
Y / N	Ribs securely attached to posterior spine
Y / N	Rib stiffeners show no evidence of bending (no gaps between ribs and stiffeners)
OTHER	
<b>ABDOMEN</b>	
Y / N	No evidence of tearing, cuts, or broken stitches in upper abdomen bag and zipper
Y / N	Upper abdomen insert securely attached to spine
Y / N	Upper abdomen insert shows no evidence of permanent set
Y / N	No evidence of tearing, cuts, or broken stitches in lower abdomen bag and zipper <b>Multiple tears and broken stitches in lower abdomen bag.</b>

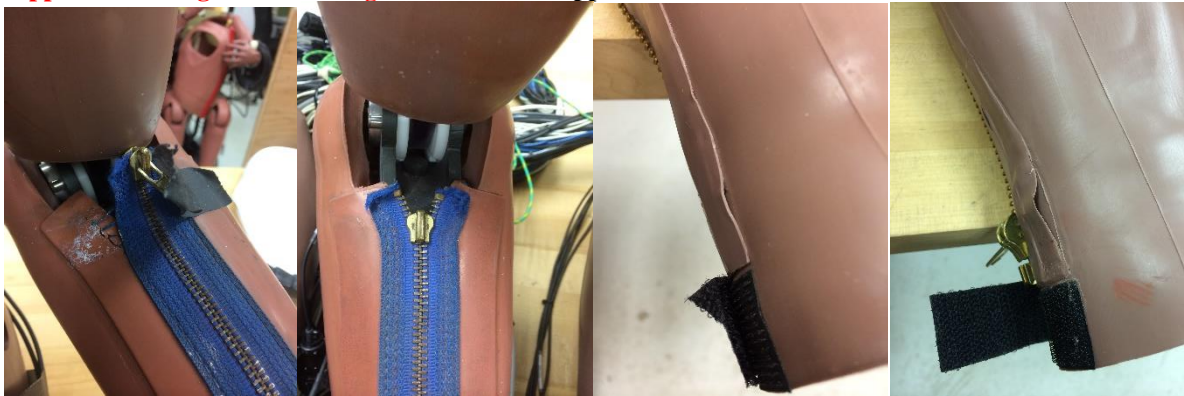

	
Y / N	Lower abdomen insert securely attached to spine
Y / N	Lower abdomen insert shows no evidence of permanent set
OTHER	<b>Zippers detaching on left and right calves. Torn zippers/flesh on L &amp; R forearms.</b>
	
<b>PELVIS</b>	
Y / N	Pelvis flesh fits securely over pelvis bones
Y / N	H-point tool fits securely into hole on both sides of pelvis
OTHER	
<b>FEMUR</b>	
Y / N	Acetabular load cells firmly attached
Y / N	Femur load cells firmly attached
Y / N	No evidence of deformation of knee slider bump stop
Y / N	No cuts, tears, or scuffing of knee flesh
OTHER	
<b>LOWER EXTREMITY (LX)</b>	
Y / N	Rotational potentiometers in ankle securely attached
Y / N	Achilles tendon provides resistance to dorsiflexion
Y / N	No evidence of de-bonding, tearing, or permanent compression of ankle soft stops
Y / N	No cuts, tears, or scuffing of leg flesh
OTHER	
<b>JACKET</b>	
Y / N	Rib stiffeners show no sign of permanent deformation
Y / N	No evidence of tears or holes in jacket fabric, Velcro, or zippers
OTHER	

# THOR Inspection Checklist

Date: <b>9/17/2015</b>	
NHTSA Representative: <b>James Saunders</b>	
Inspection Reporter: <b>Mike Hartung</b>	
Inspection type (check one): <input type="checkbox"/> Pre-Test <input checked="" type="checkbox"/> Post-Test	
Dummy S/N: <b>0015</b>	Legs S/N: <b>LX0038/LX0039</b>
Dummy Description: <b>THOR-M 50<sup>th</sup> Male</b>	
Date of last Certification: <b>July 2015</b>	
<u>Tests conducted:</u> <u>Since last inspection:</u> <b>R20150227-2015 Ford F-150</b> <u>Since last certification:</u> <b>R20155509- Forester</b> <b>R20150227-2015 Ford F-150</b>	
<u>Known errors in data channels (no data, clipping, unexpected drops):</u> <ul style="list-style-type: none"> <li>- <b>11TIBILELOTHFOXP, Tibia Lower Left X Force, Questionable spikes at 58ms, 90.8ms and 201ms, SN:LC-78 Fx</b></li> <li>- <b>11TIBILELOTHFOYP, Tibia Lower Left Y Force, Questionable Spikes at 57.6, 91.2 and 201 ms, SN:LC-78 Fy</b></li> <li>- <b>11TIBILELOTHFOZP, Tibia Lower Left Z Force, Questionable spikes throughout, SN:LC-78 Fz</b></li> </ul>	
<u>Physical evidence of damage:</u> <b>None New</b>	
<u>Anecdotal evidence of damage:</u> <b>None</b>	
<u>Equipment delivered to Borrower:</u> <b>THOR 0015 ATD</b> <b>26 Accelerometers</b> <b>3 Angular Rate Sensors</b> <b>2 Skull Spring LC</b> <b>1 Condyle Pot</b> <b>1 Upper Neck LC</b> <b>6 IRTraccs</b> <b>12 Rotational Pots</b> <b>1 Spine LC</b> <b>2 Acetabulum LC</b> <b>2 ASIS LC</b> <b>2 Femur LC</b>	<i>Continued</i> <b>2 LX Leg Assemblies</b> <b>2 Upper Tibia LC</b> <b>2 Lower Tibia LC</b> <b>6 Ankle Potentiometers</b> <b>2 Knee Sliders</b> <b>1 Neck Skin</b> <b>1 Neck Foam</b> <b>1 Tiltview Interface Cable</b> <b>4 Tilt Sensors</b> <b>1 H-Point Tool</b> <b>1 Tool Box</b> <b>1 Laptop</b>

**Note: New Damage is Noted in Red**



<b>HEAD</b>	
Y / N	Rear head cap mounts securely to head
Y / N	Head skin fits securely over skull
Y / N	Head skin shows no sign of tears or damage
Y / N	Interior components of skull cavity (ballast, accelerometer mount, accelerometers) securely attached
Y / N	Head securely mounted to OC joint
OTHER	
<b>NECK</b>	
Y / N	Neck cables slide freely through holes in neck plates
Y / N	Neck cables show no sign of fraying, broken strands, or kinking
Y / N	No evidence of de-bonding between neck pucks and plates
Y / N	No evidence of de-bonding or permanent compression in neck soft stop assemblies
Y / N	Neck securely attached to upper neck load cell
Y / N	Neck securely attached to lower neck load cell
Y / N	Neck pitch change joint mechanism mating teeth are engaged
OTHER	
<b>SHOULDER</b>	
Y / N	Urethane shoulder pads show no evidence of contact
Y / N	Clavicles securely attached to sternum and shoulder
Y / N	No evidence of de-bonding, tearing, or permanent compression of posterior soft stops
OTHER	
<b>SPINE</b>	
Y / N	No evidence of de-bonding between thoracic spine flex joint and metal plates
Y / N	No evidence of de-bonding between lumbar spine flex joint and metal plates
Y / N	Lumbar spine pitch change joint mechanism mating teeth are engaged
OTHER	
<b>THORAX</b>	
Y / N	No evidence of contact at top, bottom, or interior faces of rib damping material
Y / N	No evidence of de-bonding between rib damping material and ribs
Y / N	IRTRACCs securely attached to anterior ribs
Y / N	IRTRACCs securely attached to double gimbals, spine
Y / N	Urethane bib is securely attached to ribs with no sign of tearing or washer penetration
Y / N	Ribs securely attached to posterior spine
Y / N	Rib stiffeners show no evidence of bending (no gaps between ribs and stiffeners)
OTHER	
<b>ABDOMEN</b>	
Y / N	No evidence of tearing, cuts, or broken stitches in upper abdomen bag and zipper
Y / N	Upper abdomen insert securely attached to spine
Y / N	Upper abdomen insert shows no evidence of permanent set
Y / N	No evidence of tearing, cuts, or broken stitches in lower abdomen bag and zipper <b>Multiple tears and broken stitches in lower abdomen bag.</b>

	
Y / N	Lower abdomen insert securely attached to spine
Y / N	Lower abdomen insert shows no evidence of permanent set
OTHER	<b>Zippers detaching on left and right calves. Torn zippers/flesh on L &amp; R forearms.</b>
	
<b>PELVIS</b>	
Y / N	Pelvis flesh fits securely over pelvis bones
Y / N	H-point tool fits securely into hole on both sides of pelvis
OTHER	
<b>FEMUR</b>	
Y / N	Acetabular load cells firmly attached
Y / N	Femur load cells firmly attached
Y / N	No evidence of deformation of knee slider bump stop
Y / N	No cuts, tears, or scuffing of knee flesh
OTHER	
<b>LOWER EXTREMITY (LX)</b>	
Y / N	Rotational potentiometers in ankle securely attached
Y / N	Achilles tendon provides resistance to dorsiflexion
Y / N	No evidence of de-bonding, tearing, or permanent compression of ankle soft stops
Y / N	No cuts, tears, or scuffing of leg flesh
OTHER	
<b>JACKET</b>	
Y / N	Rib stiffeners show no sign of permanent deformation
Y / N	No evidence of tears or holes in jacket fabric, Velcro, or zippers
OTHER	

# THOR Inspection Checklist

Date: <b>09/14/2015</b>		
NHTSA Representative: <b>James Saunders</b>		
Inspection Reporter: <b>Mike Hartung</b>		
Inspection type (check one): <input checked="" type="checkbox"/> Pre-Test <input type="checkbox"/> Post-Test		
Dummy S/N: <b>0016</b>		Legs S/N: <b>LX0018/LX0019</b>
Dummy Description: <b>THOR 50<sup>th</sup> Male</b>		
Date of last Certification: <b>July 2015</b>		
<u>Tests conducted:</u> <u>Since last inspection:</u> <b>R20155509- Forester</b> <u>Since last certification:</u> <b>R20155509- Forester</b>		
<u>Known errors in data channels (no data, clipping, unexpected drops):</u> - 13THSP1200THMOXP, Spine Moment X, Questionable Data 54.7ms to 70ms, SN:LC-123Mx - 13ABDORI00THVO0P, Abdomen Right DGIR X Displacement, Questionable spikes throughout, SN:DS-DQ2304		
<u>Physical evidence of damage:</u> <b>See Report – Shoulder bumpers</b>		
<u>Anecdotal evidence of damage:</u> <b>N/A</b>		
<u>Equipment delivered to Borrower:</u> <b>THOR 0016 ATD</b> <b>2 LX Leg Assemblies 0018 &amp; 0019</b> <b>2 Lower Tibia Load Cells</b> <b>2 Upper Tibia Load Cells</b> <b>19 Rotational Potentiometers</b> <b>1 Left Knee Slider Potentiometer</b> <b>1 Right Knee Slider Potentiometer</b> <b>25 Accelerometers</b> <b>2 Achilles Load Cells</b>	<i>Continued</i> <b>3 Angular Rate Sensors</b> <b>2 Skull Spring Load Cells</b> <b>1 Upper Neck Load Cell</b> <b>1 Lower Neck Load Cell 6 IRTRACCs</b> <b>1 Thoracic Spine Load Cell</b> <b>1 Right Acetabulum Load Cell</b> <b>1 Left Acetabulum Load Cell</b>	<b>2 ASIS Load Cells</b> <b>2 Femur Load Cells</b> <b>1 Interface Cable</b> <b>1 IES Tilt Sensors</b> <b>1 Laptop</b> <b>1 H-Point Tool</b> <b>1 Neck Foam Assembly</b> <b>1 Neck Skin</b> <b>1 Toolbox</b>

**Note: New Damage is in Red**

HEAD	
Y / N	Rear head cap mounts securely to head
Y / N	Head skin fits securely over skull
Y / N	Head skin shows no sign of tears or damage
Y / N	Interior components of skull cavity (ballast, accelerometer mount, accelerometers) securely attached
Y / N	Head securely mounted to OC joint
OTHER	Rear head cap has a superficial cut and some scuffing. Head skin has scuffing. 
NECK	
Y / N	Neck cables slide freely through holes in neck plates
Y / N	Neck cables show no sign of fraying, broken strands, or kinking
Y / N	No evidence of de-bonding between neck pucks and plates
Y / N	No evidence of de-bonding or permanent compression in neck soft stop assemblies Permanent compression of the first neck soft stop 
Y / N	Neck securely attached to upper neck load cell
Y / N	Neck securely attached to lower neck load cell
Y / N	Neck pitch change joint mechanism mating teeth are engaged
OTHER	
SHOULDER	
Y / N	Urethane shoulder pads show no evidence of contact
Y / N	Clavicles securely attached to sternum and shoulder
Y / N	No evidence of de-bonding, tearing, or permanent compression of posterior soft stops
OTHER	Urethane Pads are both torn, completely through, near the neck. We put Gaffer's tape over the tears to protect. 

**LH shoulder bumper missing. RH shoulder bumper deformed**



**SPINE**

**Y / N** No evidence of de-bonding between thoracic spine flex joint and metal plates

**Y / N** No evidence of de-bonding between lumbar spine flex joint and metal plates

**Y / N** Lumbar spine pitch change joint mechanism mating teeth are engaged

**OTHER**

Small cut on the thoracic spine





Tears and rubbing damage to the front left Lumbar Spine. Tears also on rear sides – right side is pictured.



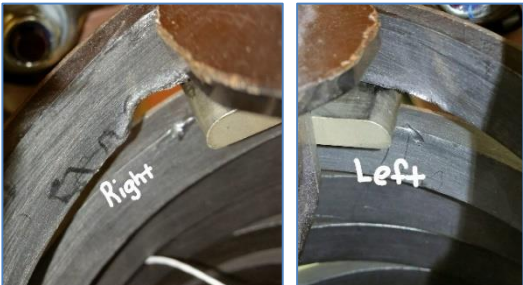

Damage is present on the surrounding metal structures of the Lumbar Spine

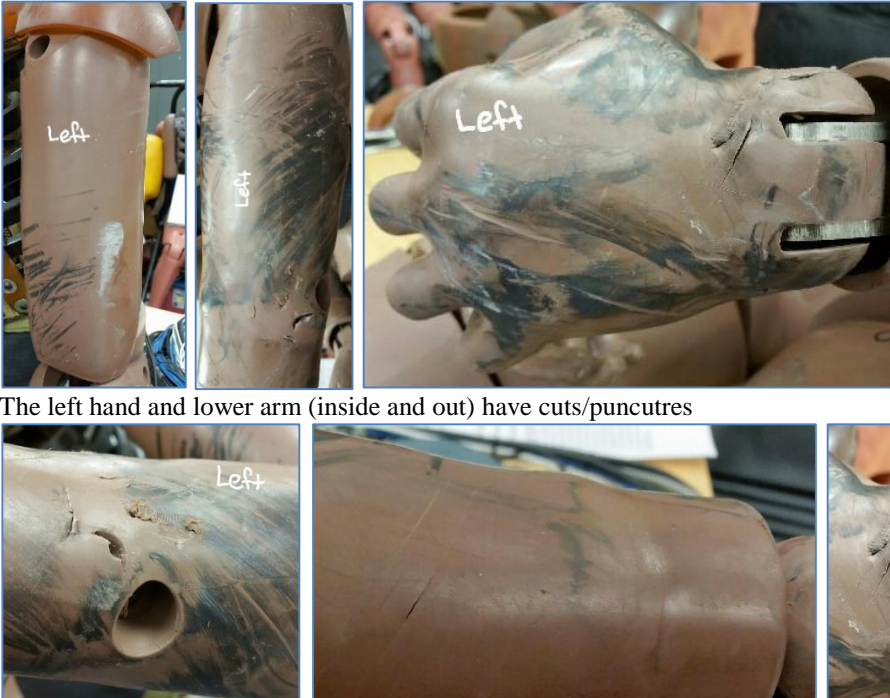

THORAX	
Y / N	<p>No evidence of contact at top, bottom, or interior faces of rib damping material Both of the top two ribs, left and right, have contact damage</p> 
Y / N	No evidence of de-bonding between rib damping material and ribs
Y / N	IRTRACCs securely attached to anterior ribs
Y / N	IRTRACCs securely attached to double gimbals, spine
Y / N	<p>Urethane bib is securely attached to ribs with no sign of tearing or washer penetration Urethane bib has signs of washer penetration repair and a tear</p> 
Y / N	Ribs securely attached to posterior spine
Y / N	Rib stiffeners show no evidence of bending (no gaps between ribs and stiffeners)
OTHER	<p>There is heavy scuffing to the left upper arm, lower arm, and hand</p>  <p>The left hand and lower arm (inside and out) have cuts/punctures</p>



	<p>The right lower arm (inside and out) has scuffing</p>  <p>The inside of the right hand has cuts and the thumb is tearing</p>  <p>The back of the right elbow has a small tear</p>
<b>ABDOMEN</b>	
Y / N	No evidence of tearing, cuts, or broken stitches in upper abdomen bag and zipper
Y / N	Upper abdomen insert securely attached to spine
Y / N	Upper abdomen insert shows no evidence of permanent set
Y / N	No evidence of tearing, cuts, or broken stitches in lower abdomen bag and zipper Both sides have tears on the lower portion of the bag, and right side is torn near top
	
Y / N	Lower abdomen insert securely attached to spine
Y / N	Lower abdomen insert shows no evidence of permanent set
<b>OTHER</b>	
<b>PELVIS</b>	
Y / N	Pelvis flesh fits securely over pelvis bones
Y / N	H-point tool fits securely into hole on both sides of pelvis
<b>OTHER</b>	
<b>FEMUR</b>	
Y / N	Acetabular load cells firmly attached
Y / N	Femur load cells firmly attached
Y / N	No evidence of deformation of knee slider bump stop
Y / N	No cuts, tears, or scuffing of knee flesh Scuffing to the right knee <b>Slice on Right knee</b>

	
OTHER	
<b>LOWER EXTREMITY (LX)</b>	
Y / N	Rotational potentiometers in ankle securely attached
Y / N	Achilles tendon provides resistance to dorsiflexion
Y / N	No evidence of de-bonding, tearing, or permanent compression of ankle soft stops
Y / N	No cuts, tears, or scuffing of leg flesh <b>Zipper pulling away from lower leg flesh of the left leg on both sides, and the front is scuffed.</b>
	
OTHER	
<b>JACKET</b>	
Y / N	Rib stiffeners show no sign of permanent deformation
Y / N	No evidence of tears or holes in jacket fabric, Velcro, or zippers
OTHER	

# THOR Inspection Checklist

Date: <b>09/17/2015</b>		
NHTSA Representative: <b>James Saunders</b>		
Inspection Reporter: <b>Mike Hartung</b>		
Inspection type (check one): <input type="checkbox"/> Pre-Test <input checked="" type="checkbox"/> Post-Test		
Dummy S/N: <b>0016</b>	Legs S/N: <b>LX0018/LX0019</b>	
Dummy Description: <b>THOR 50<sup>th</sup> Male</b>		
Date of last Certification: <b>July 2015</b>		
<u>Tests conducted:</u> Since last inspection: <b>R20150227-2015 Ford F-150</b> Since last certification: <b>R20155509- Forester</b> <b>R20150227-2015 Ford F-150</b>		
<u>Known errors in data channels (no data, clipping, unexpected drops):</u> - 13THSP1200THMOXP, Spine Moment X, Questionable Data 54.7ms to 70ms, SN:LC-123Mx - 13ABDORI00THVO0P, Abdomen Right DGIR X Displacement, Questionable spikes throughout, SN:DS-DQ2304		
<u>Physical evidence of damage:</u> See Report – Knee Cut		
<u>Anecdotal evidence of damage:</u> N/A		
<u>Equipment delivered to Borrower:</u> <b>THOR 0016 ATD</b> <b>2 LX Leg Assemblies 0018 &amp; 0019</b> <b>2 Lower Tibia Load Cells</b> <b>2 Upper Tibia Load Cells</b> <b>19 Rotational Potentiometers</b> <b>1 Left Knee Slider Potentiometer</b> <b>1 Right Knee Slider Potentiometer</b> <b>25 Accelerometers</b> <b>2 Achilles Load Cells</b>	<i>Continued</i> <b>3 Angular Rate Sensors</b> <b>2 Skull Spring Load Cells</b> <b>1 Upper Neck Load Cell</b> <b>1 Lower Neck Load Cell 6 IRTRACCs</b> <b>1 Thoracic Spine Load Cell</b> <b>1 Right Acetabulum Load Cell</b> <b>1 Left Acetabulum Load Cell</b>	<b>2 ASIS Load Cells</b> <b>2 Femur Load Cells</b> <b>1 Interface Cable</b> <b>1 IES Tilt Sensors</b> <b>1 Laptop</b> <b>1 H-Point Tool</b> <b>1 Neck Foam Assembly</b> <b>1 Neck Skin</b> <b>1 Toolbox</b>

**Note: New Damage is in Red**

HEAD	
Y / N	Rear head cap mounts securely to head
Y / N	Head skin fits securely over skull
Y / N	Head skin shows no sign of tears or damage
Y / N	Interior components of skull cavity (ballast, accelerometer mount, accelerometers) securely attached
Y / N	Head securely mounted to OC joint
OTHER	Rear head cap has a superficial cut and some scuffing. Head skin has scuffing. 
NECK	
Y / N	Neck cables slide freely through holes in neck plates
Y / N	Neck cables show no sign of fraying, broken strands, or kinking
Y / N	No evidence of de-bonding between neck pucks and plates
Y / N	No evidence of de-bonding or permanent compression in neck soft stop assemblies Permanent compression of the first neck soft stop 
Y / N	Neck securely attached to upper neck load cell
Y / N	Neck securely attached to lower neck load cell
Y / N	Neck pitch change joint mechanism mating teeth are engaged
OTHER	
SHOULDER	
Y / N	Urethane shoulder pads show no evidence of contact
Y / N	Clavicles securely attached to sternum and shoulder
Y / N	No evidence of de-bonding, tearing, or permanent compression of posterior soft stops
OTHER	Urethane Pads are both torn, completely through, near the neck. We put Gaffer's tape over the tears to protect. 
	<b>LH shoulder bumper missing. RH shoulder bumper deformed</b>



**SPINE**

**Y** / N No evidence of de-bonding between thoracic spine flex joint and metal plates

**Y** / N No evidence of de-bonding between lumbar spine flex joint and metal plates

**Y** / N Lumbar spine pitch change joint mechanism mating teeth are engaged

**OTHER**

Small cut on the thoracic spine







Tears and rubbing damage to the front left Lumbar Spine. Tears also on rear sides – right side is pictured.



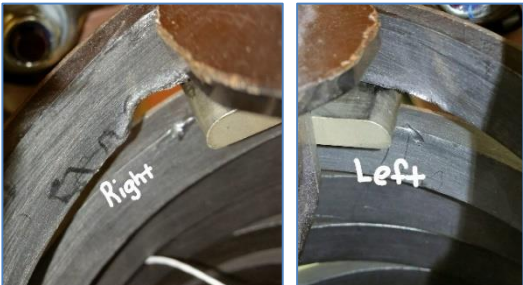

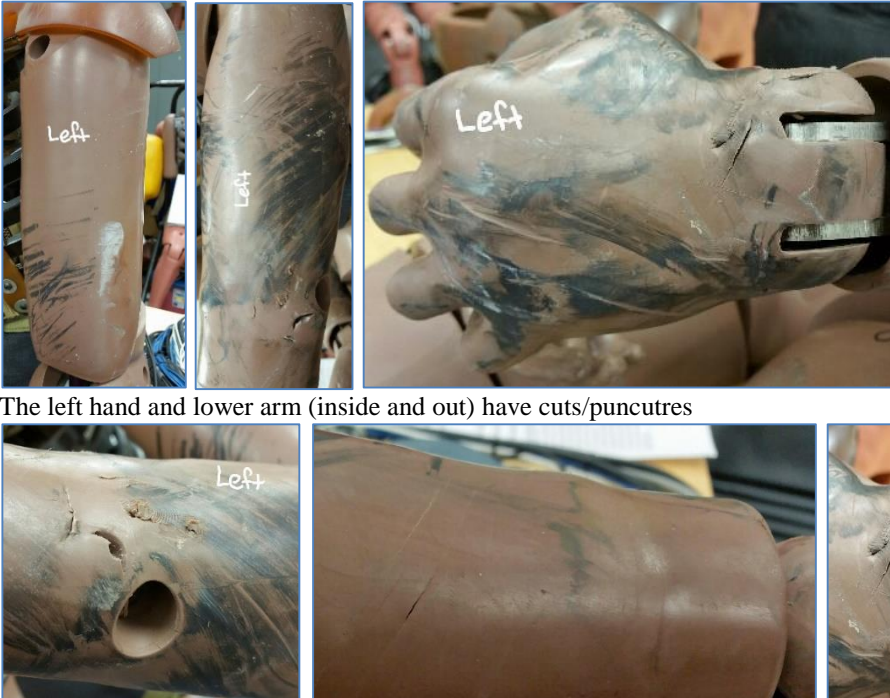
Damage is present on the surrounding metal structures of the Lumbar Spine



THORAX	
Y / N	<p>No evidence of contact at top, bottom, or interior faces of rib damping material Both of the top two ribs, left and right, have contact damage</p> 
Y / N	No evidence of de-bonding between rib damping material and ribs
Y / N	IRTRACCs securely attached to anterior ribs
Y / N	IRTRACCs securely attached to double gimbals, spine
Y / N	<p>Urethane bib is securely attached to ribs with no sign of tearing or washer penetration Urethane bib has signs of washer penetration repair and a tear</p> 
Y / N	Ribs securely attached to posterior spine
Y / N	Rib stiffeners show no evidence of bending (no gaps between ribs and stiffeners)
OTHER	<p>There is heavy scuffing to the left upper arm, lower arm, and hand</p>  <p>The left hand and lower arm (inside and out) have cuts/punctures</p>

	<p>The right lower arm (inside and out) has scuffing</p>  <p>The inside of the right hand has cuts and the thumb is tearing</p>  <p>The back of the right elbow has a small tear</p>
<b>ABDOMEN</b>	
Y / N	No evidence of tearing, cuts, or broken stitches in upper abdomen bag and zipper
Y / N	Upper abdomen insert securely attached to spine
Y / N	Upper abdomen insert shows no evidence of permanent set
Y / N	<p>No evidence of tearing, cuts, or broken stitches in lower abdomen bag and zipper Both sides have tears on the lower portion of the bag, and right side is torn near top</p> 
Y / N	Lower abdomen insert securely attached to spine
Y / N	Lower abdomen insert shows no evidence of permanent set
OTHER	
<b>PELVIS</b>	
Y / N	Pelvis flesh fits securely over pelvis bones
Y / N	H-point tool fits securely into hole on both sides of pelvis
OTHER	
<b>FEMUR</b>	
Y / N	Acetabular load cells firmly attached
Y / N	Femur load cells firmly attached
Y / N	No evidence of deformation of knee slider bump stop
Y / N	<p>No cuts, tears, or scuffing of knee flesh Scuffing to the right knee <b>Slice on Right knee</b></p>

	
OTHER	
<b>LOWER EXTREMITY (LX)</b>	
Y / N	Rotational potentiometers in ankle securely attached
Y / N	Achilles tendon provides resistance to dorsiflexion
Y / N	No evidence of de-bonding, tearing, or permanent compression of ankle soft stops
Y / N	No cuts, tears, or scuffing of leg flesh <b>Zipper pulling away from lower leg flesh of the left leg on both sides, and the front is scuffed.</b>
	
	
	<b>Velcro strap torn from LH tibia flesh at ankle.</b>
OTHER	
<b>JACKET</b>	
Y / N	Rib stiffeners show no sign of permanent deformation
Y / N	No evidence of tears or holes in jacket fabric, Velcro, or zippers
OTHER	

## DUMMY CALIBRATIONS

## 50% ADULT MALE THOR015 DUMMY CALIBRATIONS

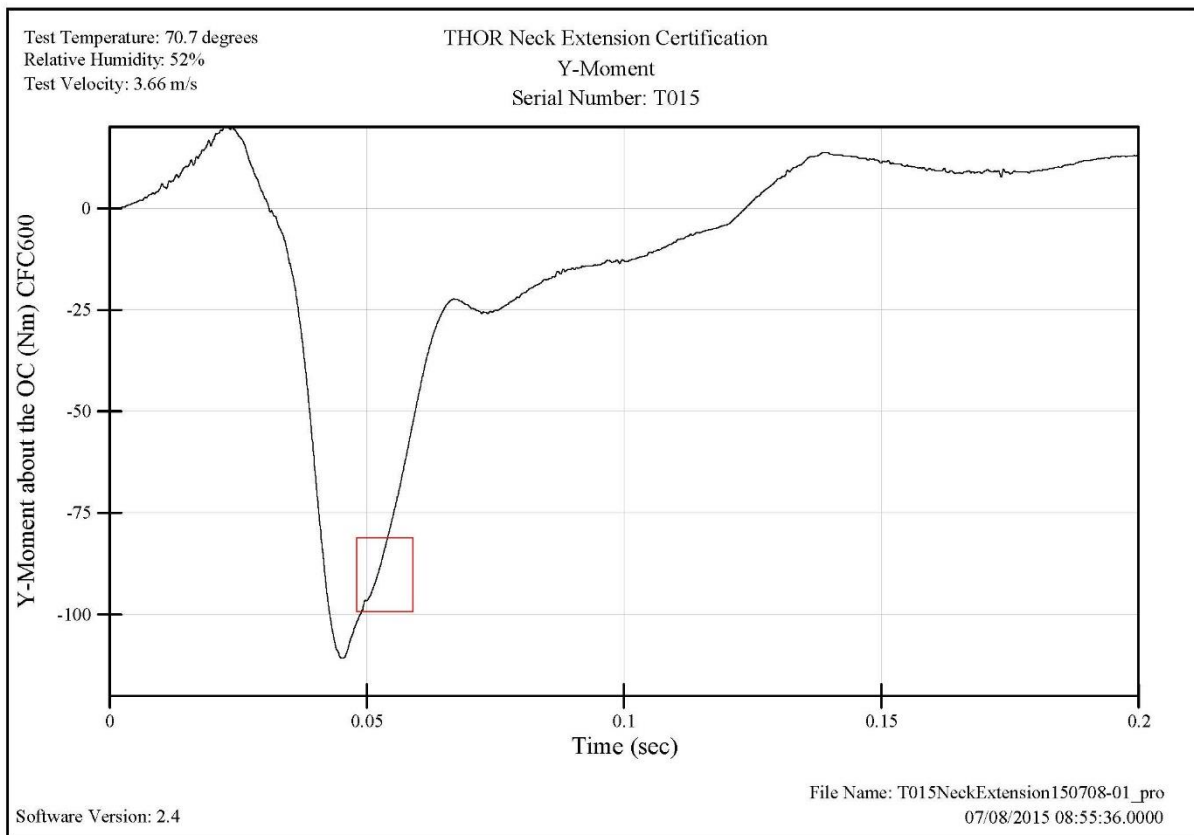
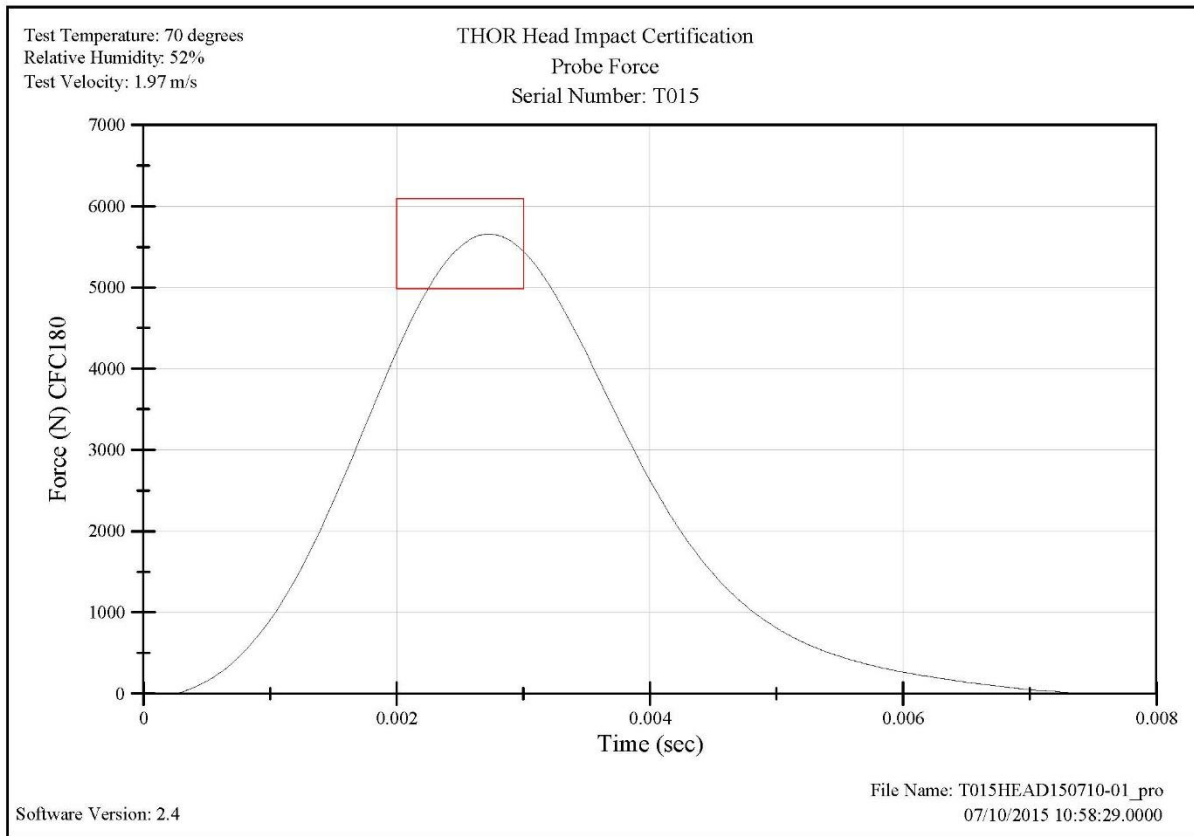

Test Temperature: 70.7 degrees  
Relative Humidity: 52%  
Test Velocity: 3.66 m/s

THOR Neck Extension Certification  
Probe Acceleration  
Serial Number: T015

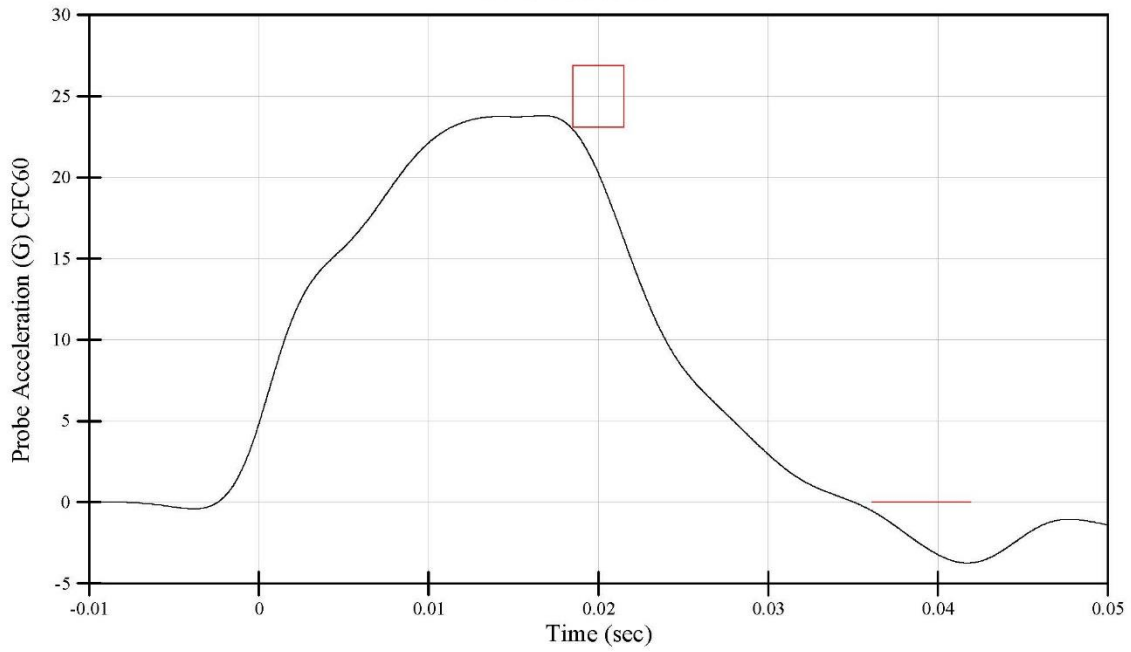

Software Version: 2.4

File Name: T015NeckExtension150708-01\_pro  
07/08/2015 08:55:36.0000

Test Temperature: 69.6 degrees  
Relative Humidity: 51%  
Test Velocity: 3.78 m/s

THOR Neck Flexion Certification  
Y-Moment  
Serial Number: T015

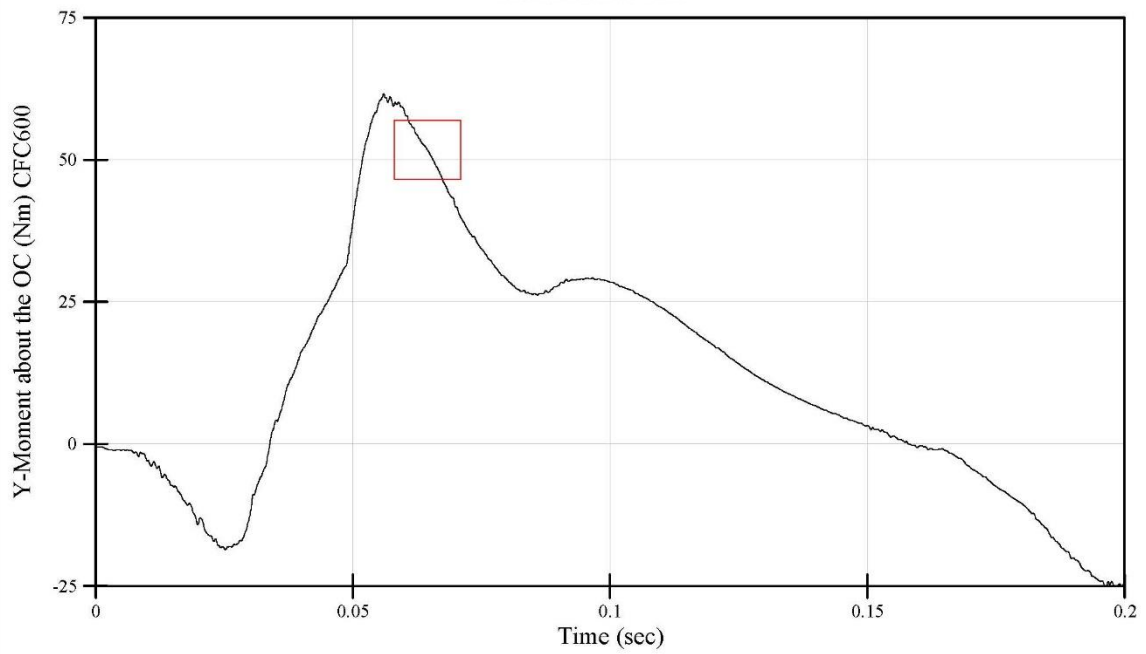

Software Version: 2.4

File Name: T015NeckFlexion150708-02\_pro  
07/08/2015 08:24:32.0000

Test Temperature: 69.6 degrees  
Relative Humidity: 51%  
Test Velocity: 3.78 m/s

THOR Neck Flexion Certification  
Probe Acceleration  
Serial Number: T015

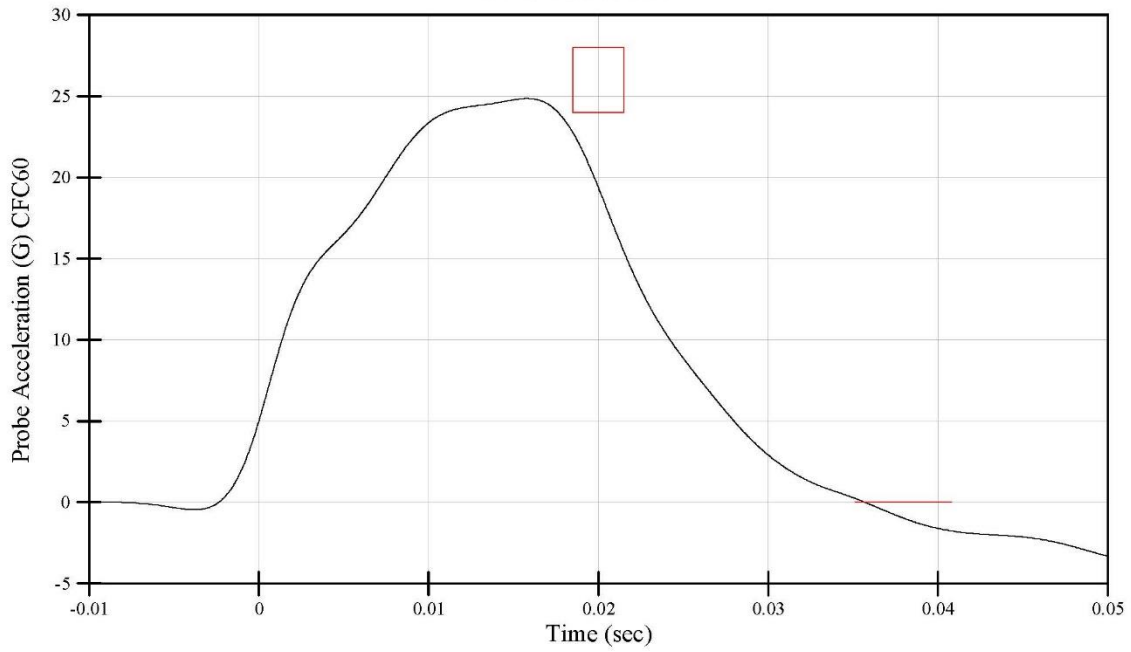

Software Version: 2.4

File Name: T015NeckFlexion150708-02\_pro  
07/08/2015 08:24:32.0000

Test Temperature: 70.5 degrees  
Relative Humidity: 51%  
Test Velocity: 2.86 m/s

THOR Neck Left Lateral Flexion Certification  
X-Moment  
Serial Number: T015

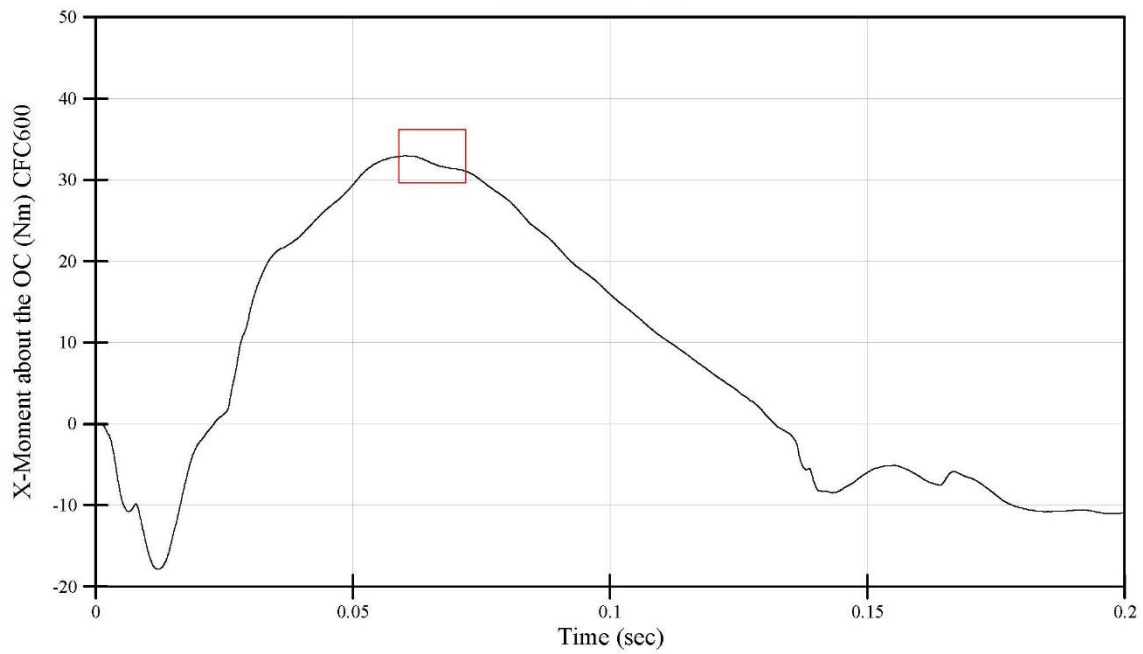

Software Version: 2.4

File Name: T015NeckLeft150708-01\_pro  
07/08/2015 09:59:03.0000

Test Temperature: 70.5 degrees  
Relative Humidity: 51%  
Test Velocity: 2.86 m/s

THOR Neck Left Lateral Flexion Certification  
Probe Acceleration  
Serial Number: T015

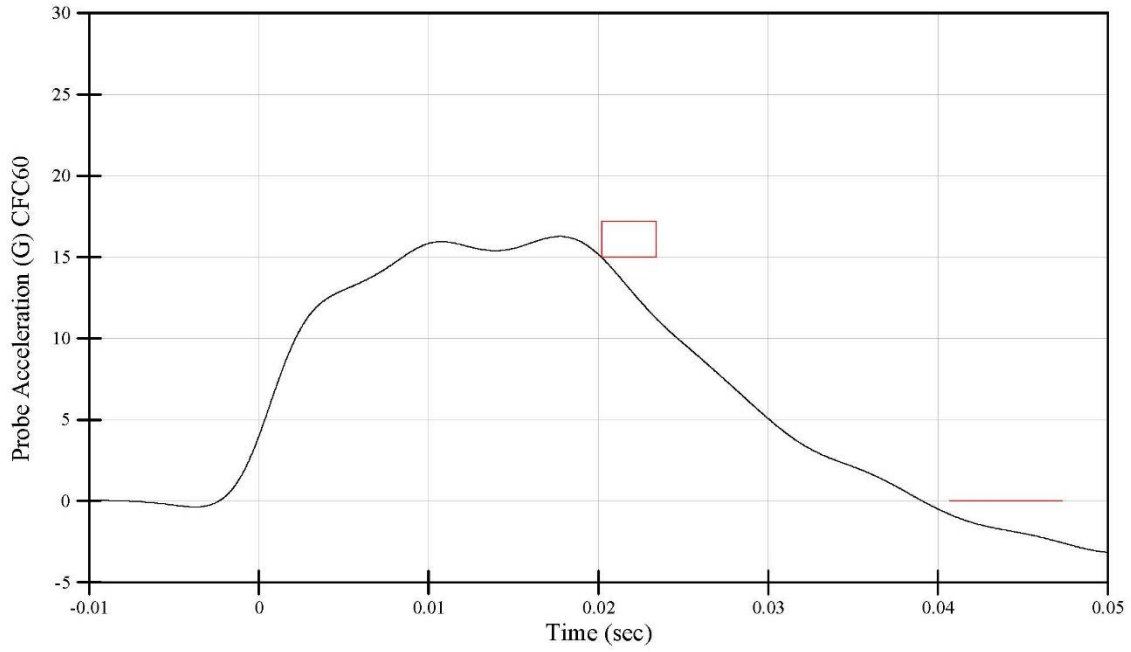

Software Version: 2.4

File Name: T015NeckLeft150708-01\_pro  
07/08/2015 09:59:03.0000

Test Temperature: 70.3 degrees  
Relative Humidity: 52%  
Test Velocity: 2.87 m/s

THOR Neck Right Lateral Flexion Certification  
X-Moment  
Serial Number: T015

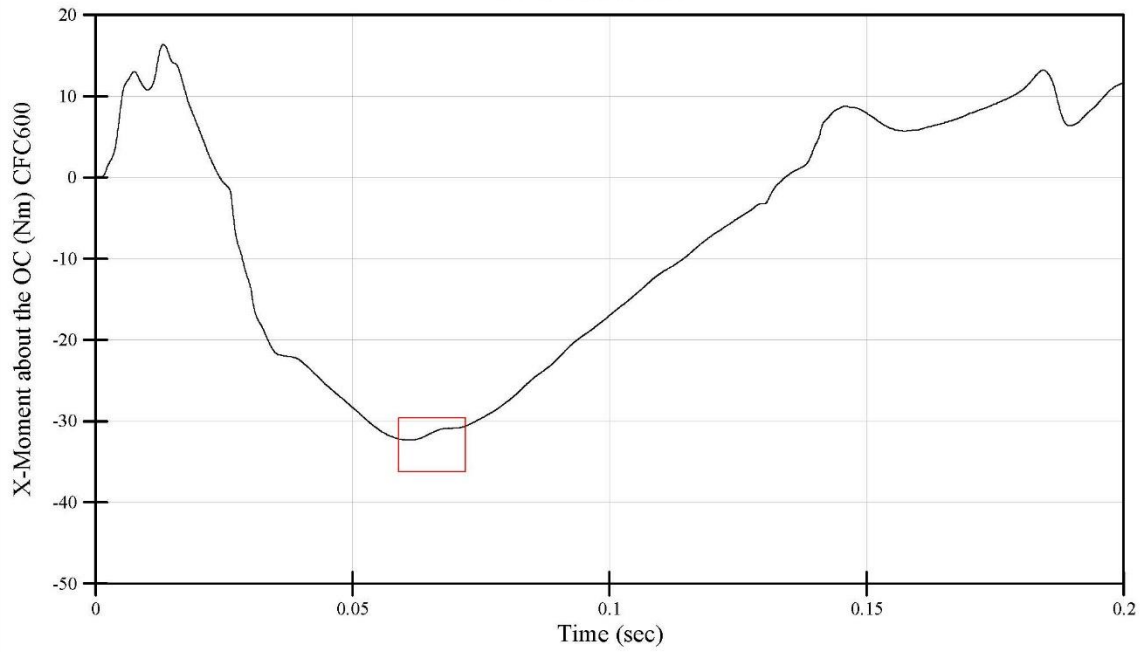

Software Version: 2.4

File Name: T015NeckRight150708-01\_pro  
07/08/2015 09:27:49.0000

Test Temperature: 70.3 degrees  
Relative Humidity: 52%  
Test Velocity: 2.87 m/s

### THOR Neck Right Lateral Flexion Certification

Probe Acceleration  
Serial Number: T015

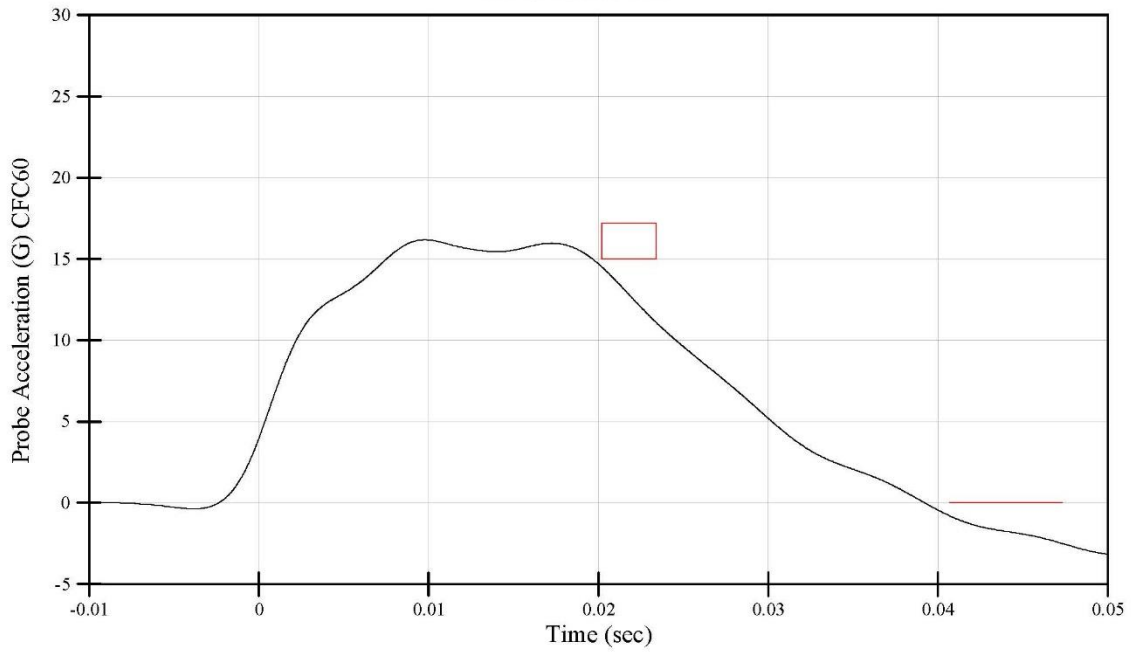

Software Version: 2.4

File Name: T015NeckRight150708-01\_pro  
07/08/2015 09:27:49.0000

Test Temperature: 70.2 degrees  
Relative Humidity: 51%  
Test Velocity: 6.63 m/s

### THOR Upper Abdomen Certification Abdomen Displacement vs. Probe Force Serial Number: T015

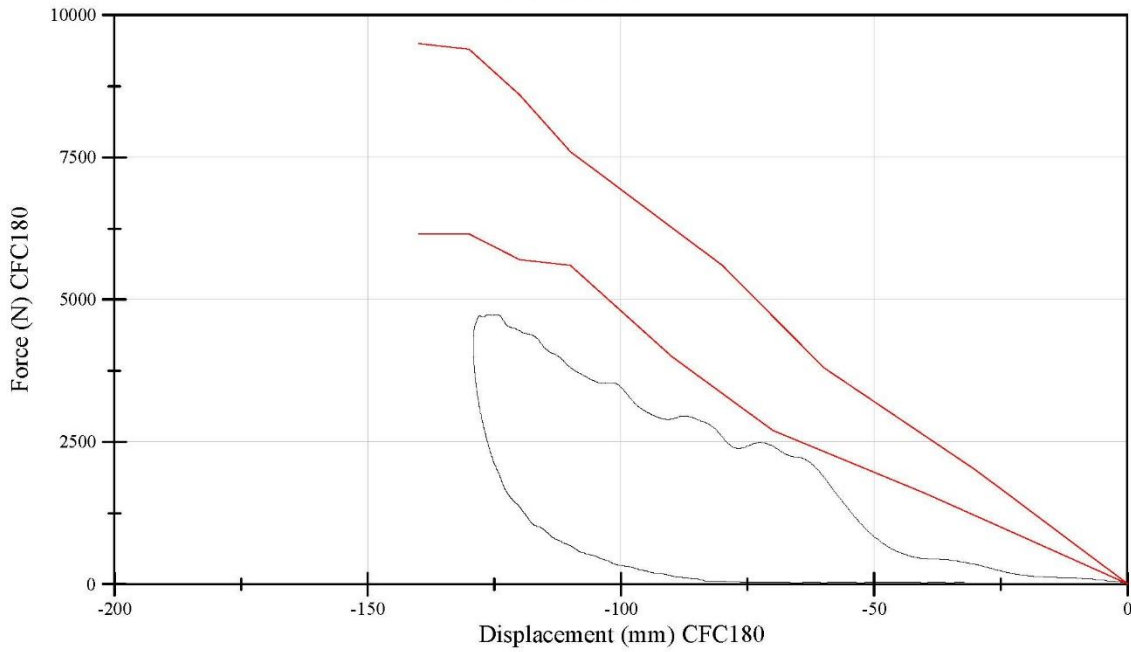

Software Version: 2.4

File Name: T015ABUP150709-01\_pro  
07/09/2015 15:52:54.0000

Test Temperature: 70.5 degrees  
Relative Humidity: 52%  
Test Velocity: 6.04 m/s

THOR Lower Abdomen Certification  
Abdomen Displacement vs. Probe Force  
Serial Number: T015

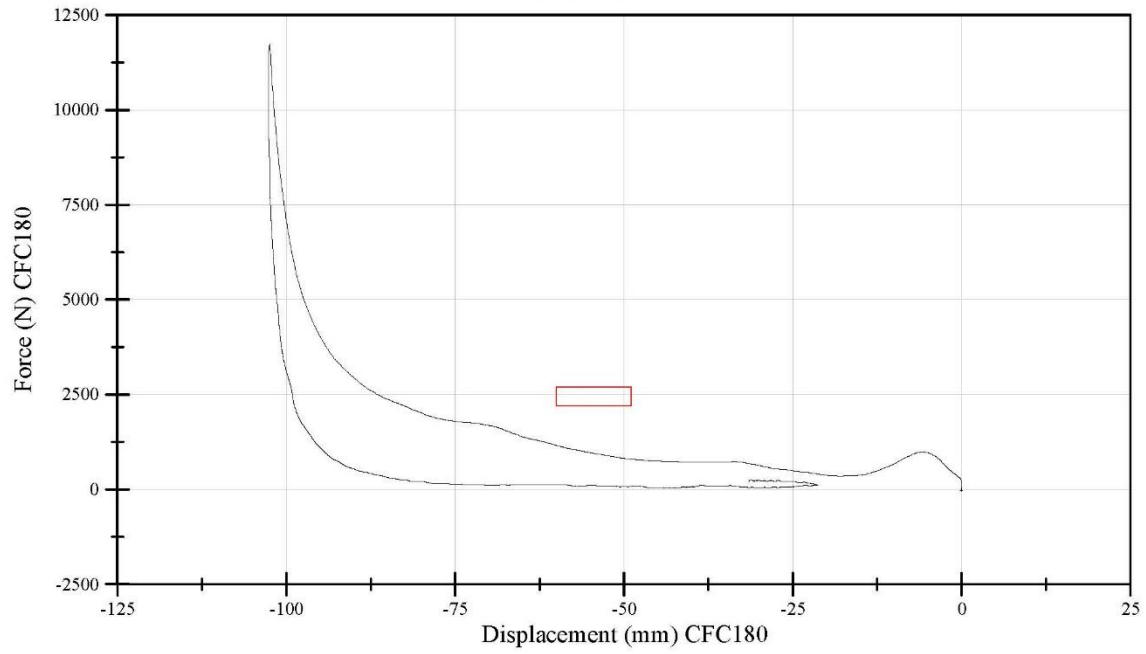

Software Version: 2.4

File Name: T015ABLR150709-04\_pro  
07/09/2015 14:46:27.0000

Test Temperature: 70.5 degrees  
Relative Humidity: 52%  
Test Velocity: 6.04 m/s

THOR Lower Abdomen Certification  
IRTRACC Displacement  
Serial Number: T015

Left Lower IR-TRACC  
Right Lower IR-TRACC

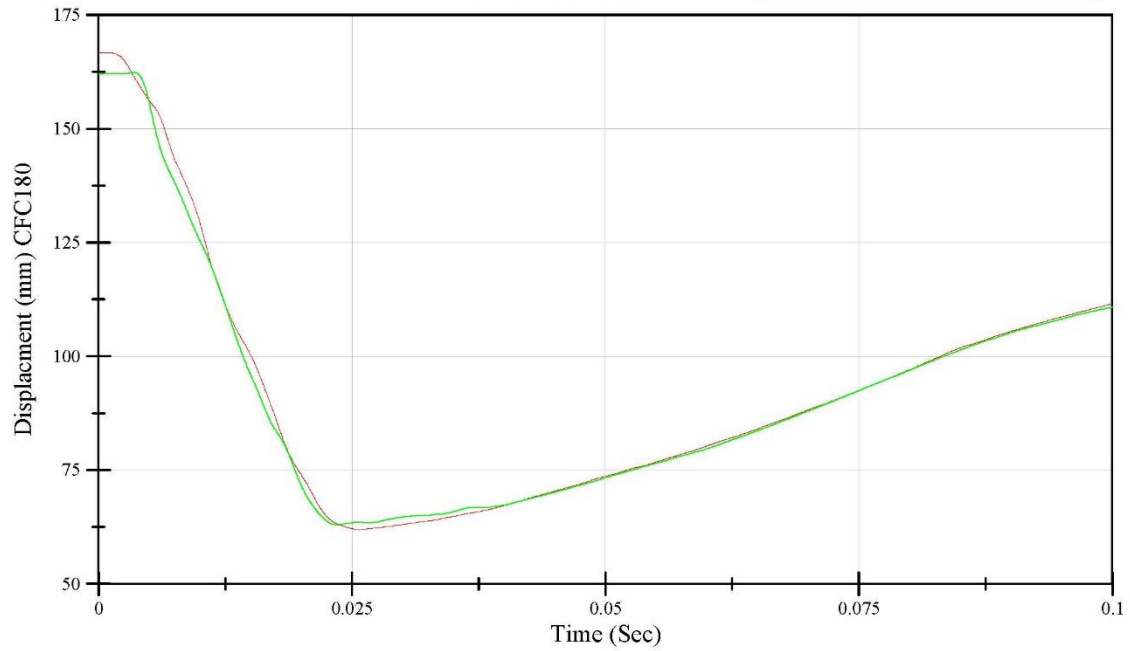

Software Version: 2.4

File Name: T015ABLR150709-04\_pro  
07/09/2015 14:46:27.0000

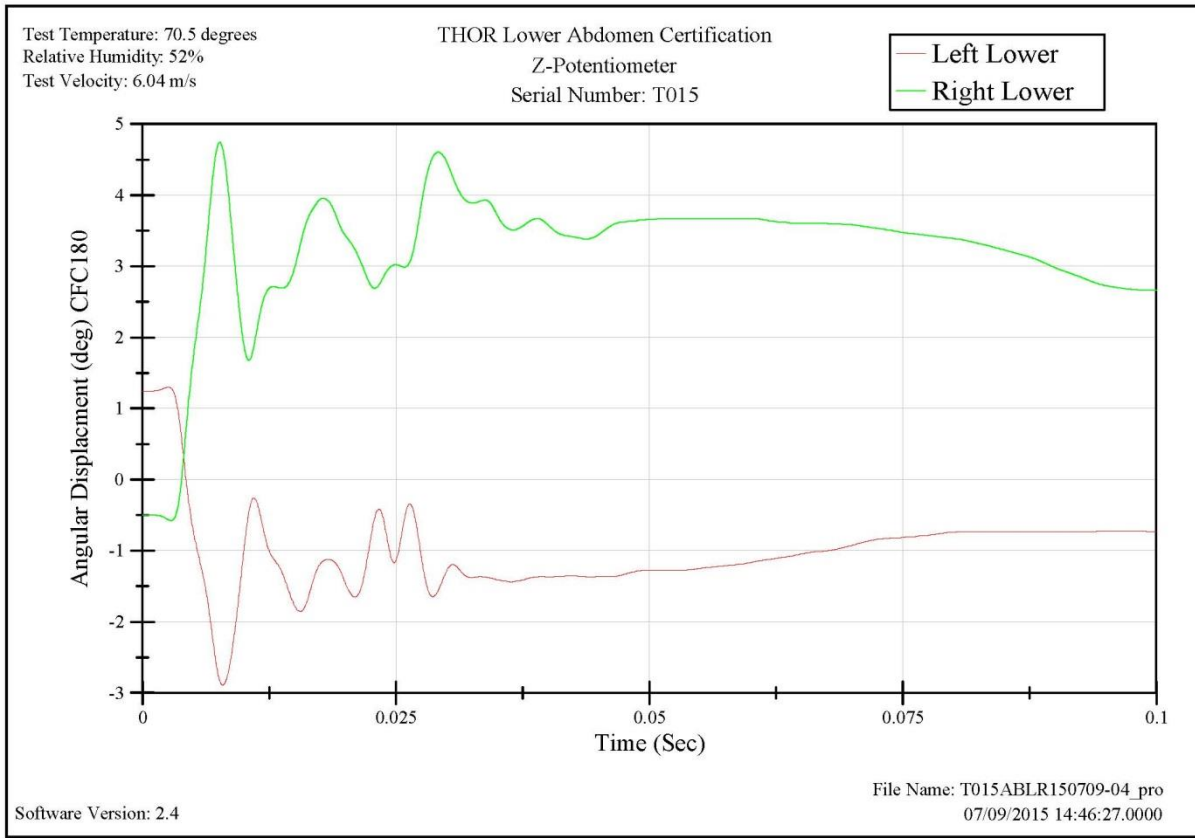
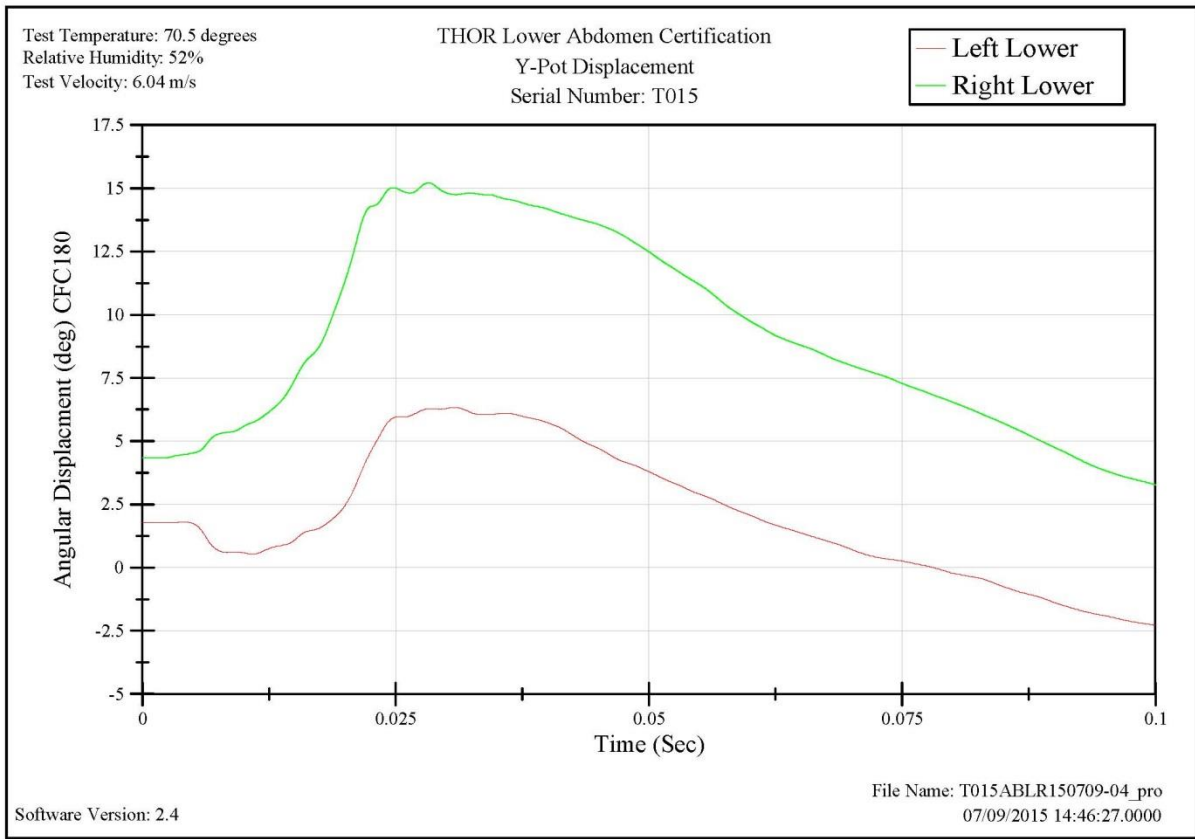

Test Temperature: 70.4 degrees  
Relative Humidity: 52%  
Test Velocity: 4.27 m/s

THOR Lower Left Oblique Thorax Certification  
Thorax Displacement vs. Probe Force  
Serial Number: T015

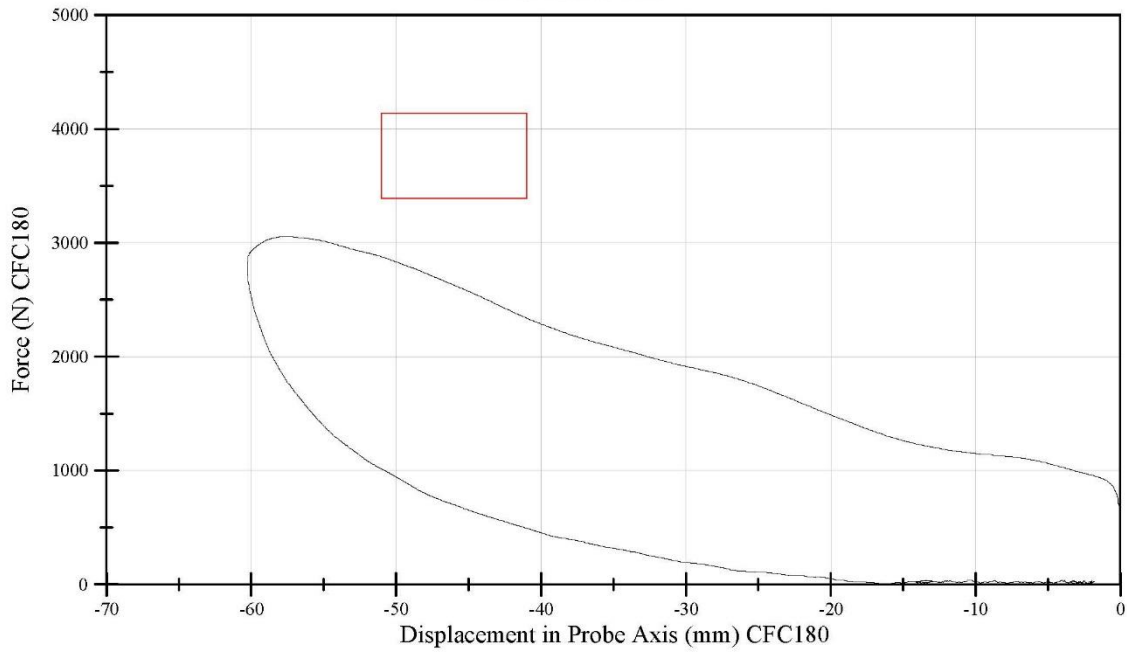

Software Version: 2.4

File Name: T015OBLE150710-01\_pro  
07/10/2015 14:01:12.0000

Test Temperature: 70.4 degrees  
Relative Humidity: 52%  
Test Velocity: 4.27 m/s

THOR Lower Left Oblique Thorax Certification  
Scaled IR-TRACC  
Serial Number: T015

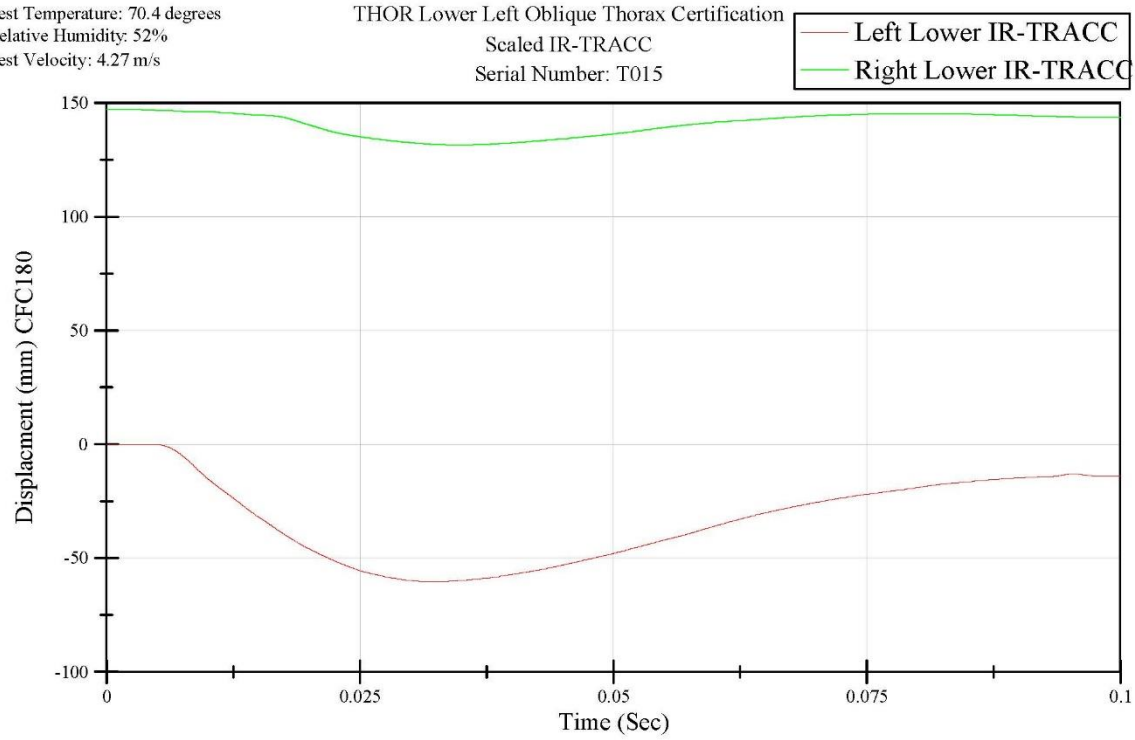

Software Version: 2.4

File Name: T015OBLE150710-01\_pro  
07/10/2015 14:01:12.0000

Test Temperature: 70.4 degrees  
Relative Humidity: 52%  
Test Velocity: 4.27 m/s

THOR Lower Left Oblique Thorax Certification  
Y-Potentiometer  
Serial Number: T015

Left Lower  
Right Lower

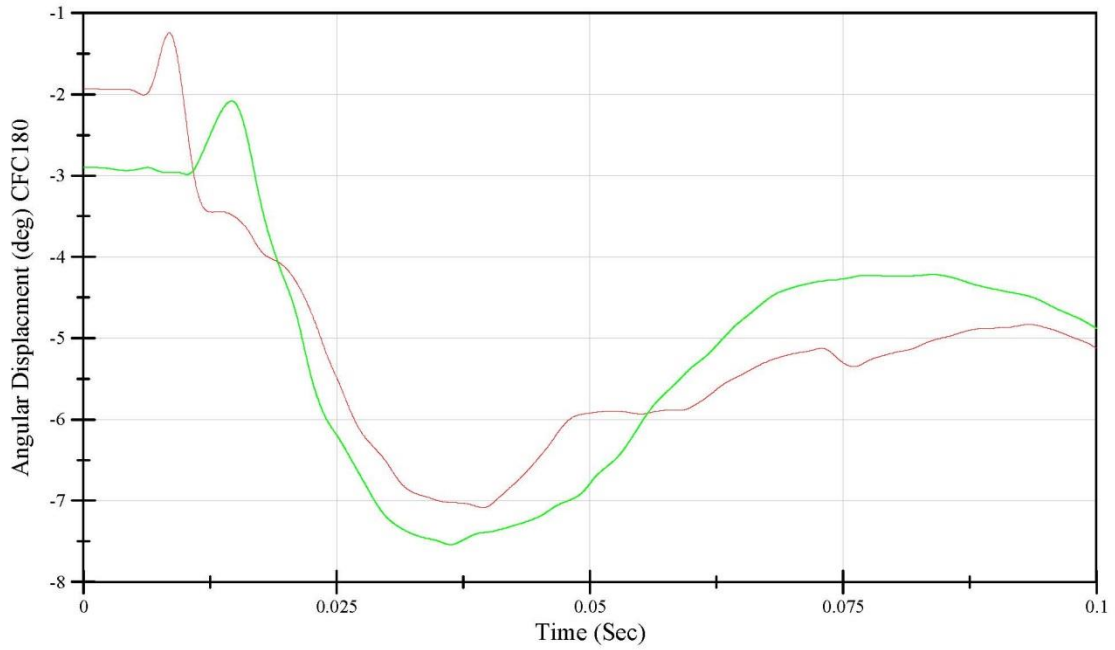

Software Version: 2.4

File Name: T015OBLE150710-01\_pro  
07/10/2015 14:01:12.0000

Test Temperature: 70.4 degrees  
Relative Humidity: 52%  
Test Velocity: 4.27 m/s

THOR Lower Left Oblique Thorax Certification  
Z-Potentiometer  
Serial Number: T015

Left Lower  
Right Lower

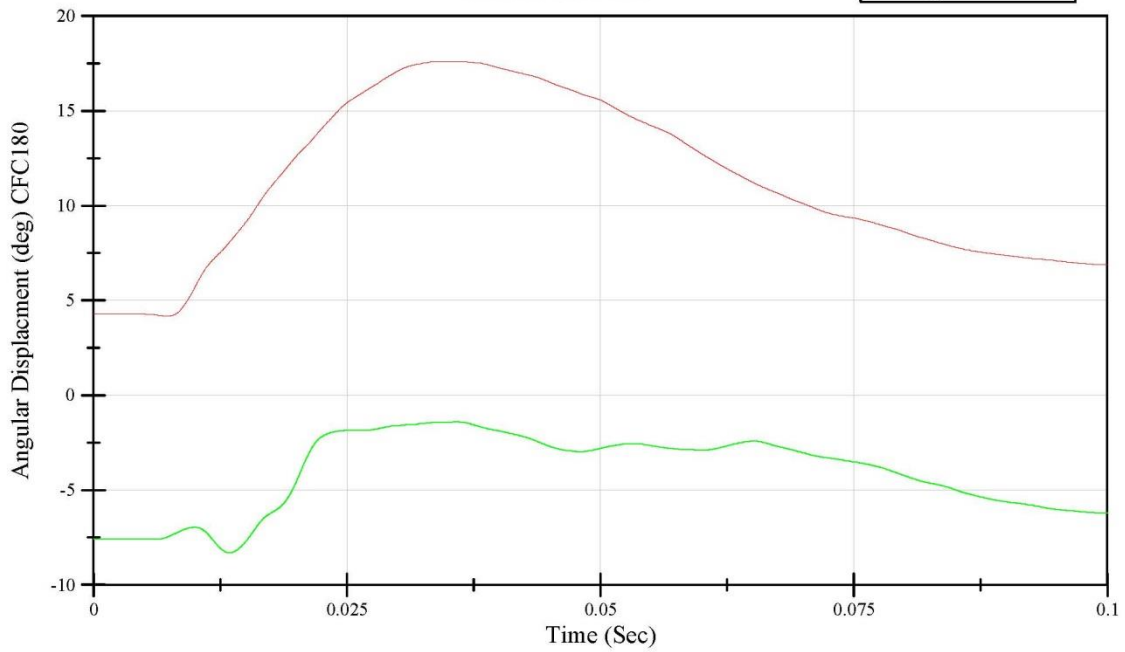

Software Version: 2.4

File Name: T015OBLE150710-01\_pro  
07/10/2015 14:01:12.0000

Test Temperature: 70.3 degrees  
Relative Humidity: 51%  
Test Velocity: 4.27 m/s

THOR Lower Right Oblique Thorax Certification  
Thorax Displacement vs. Probe Force  
Serial Number: T015

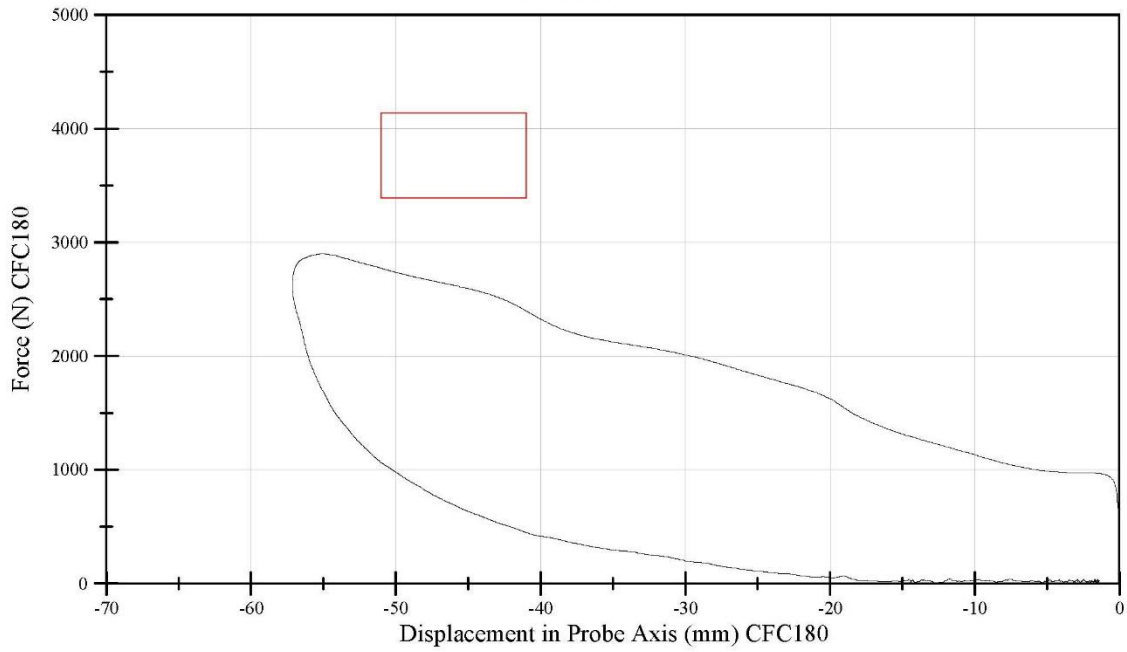

Software Version: 2.4

File Name: T015OBRI150710-01\_pro  
07/10/2015 12:55:35.0000

Test Temperature: 70.3 degrees  
Relative Humidity: 51%  
Test Velocity: 4.27 m/s

THOR Lower Right Oblique Thorax Certification  
Scaled IR-TRACC  
Serial Number: T015

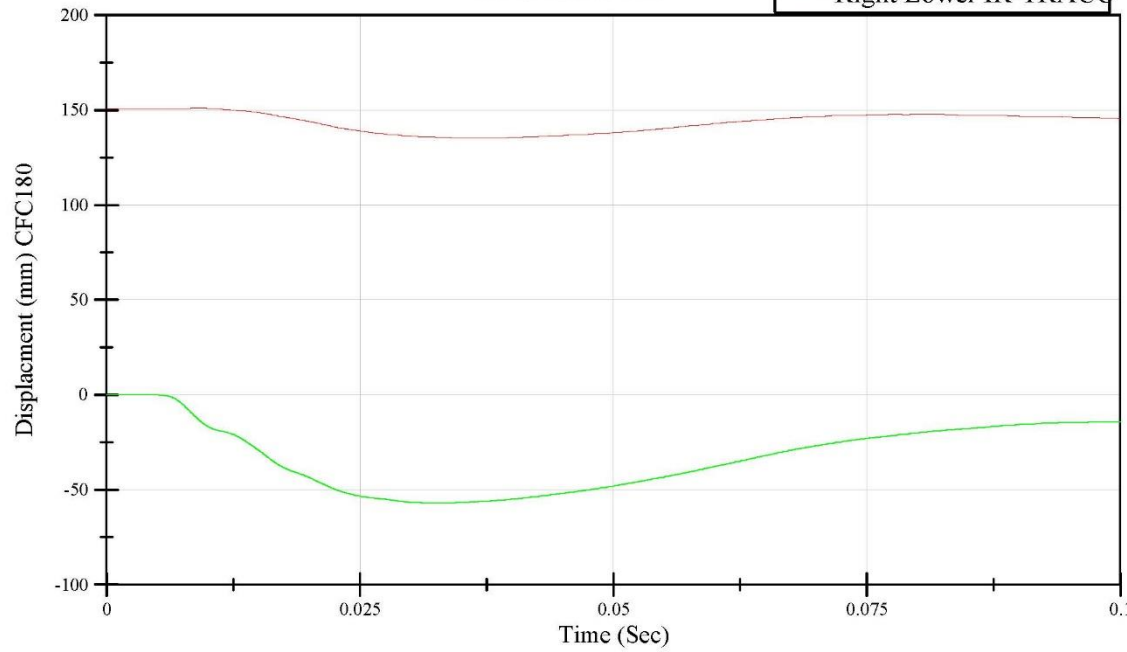

Software Version: 2.4

File Name: T015OBRI150710-01\_pro  
07/10/2015 12:55:35.0000

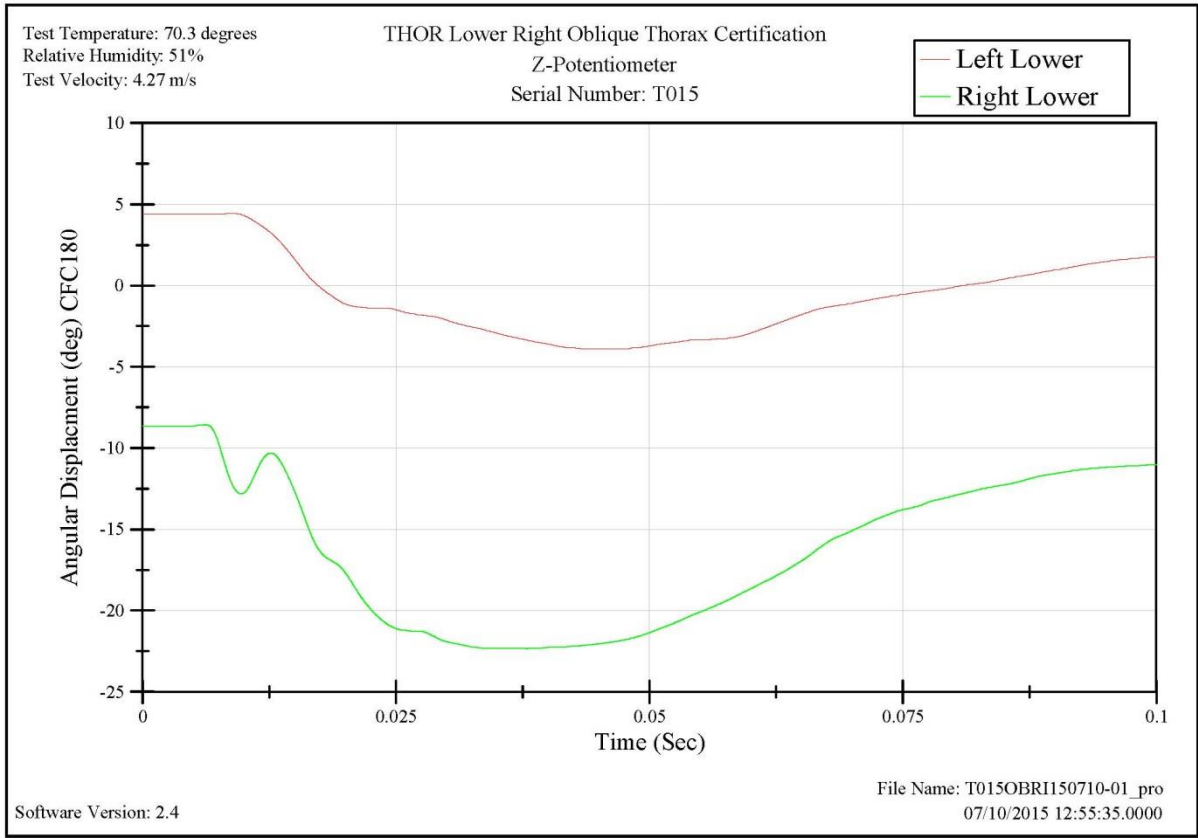
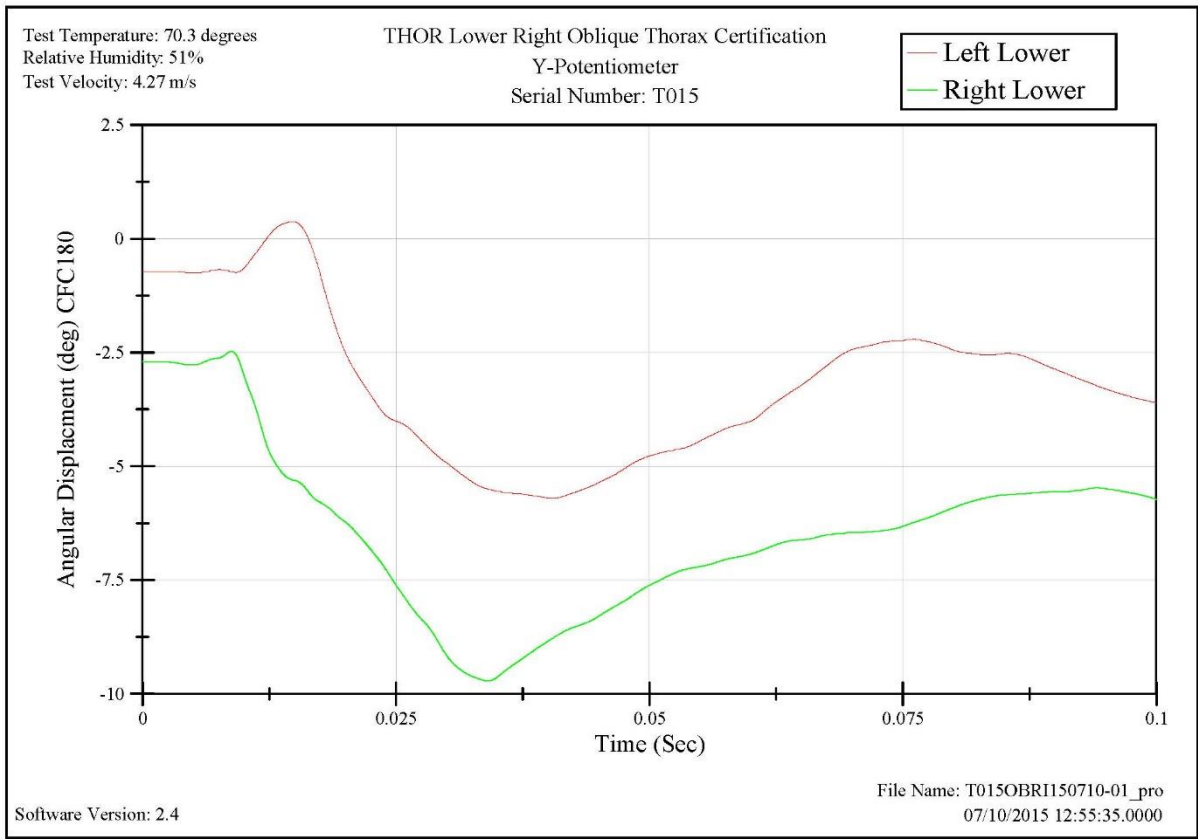

Test Temperature: 70.4 degrees  
Relative Humidity: 53%  
Test Velocity: 4.26 m/s

THOR Upper Thorax Certification  
Thorax Response With Kroell Corridor  
Serial Number: T015

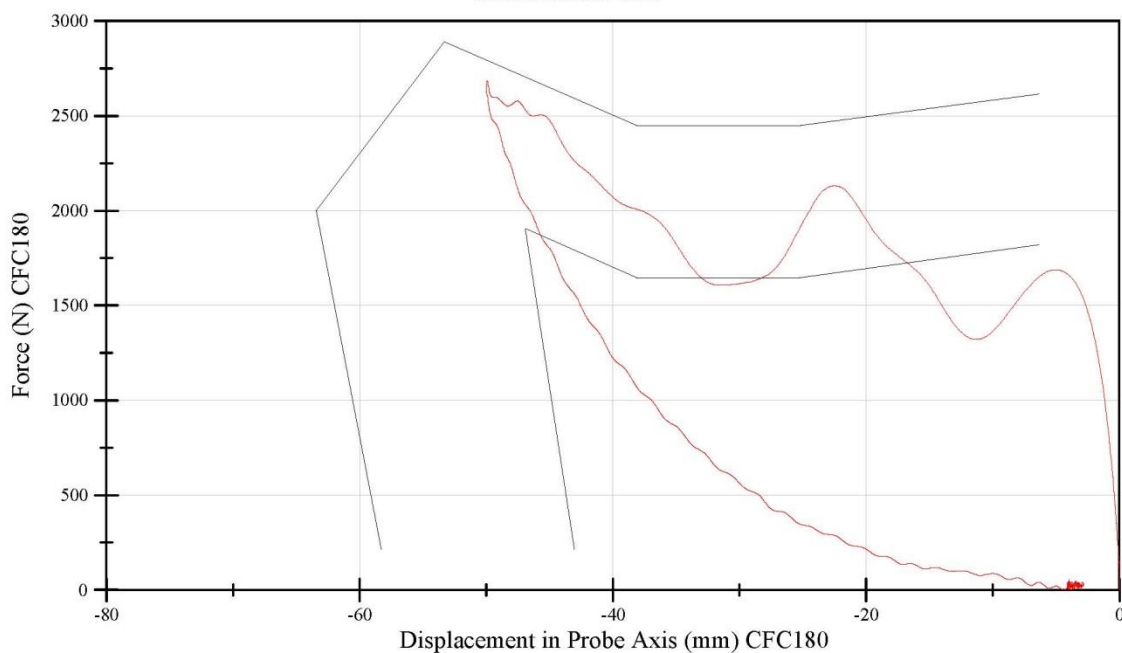

Software Version: 2.4

File Name: T015THUP150710-02\_pro.tdms  
07/10/2015 09:24:33.0000

Test Temperature: 70.4 degrees  
Relative Humidity: 53%  
Test Velocity: 4.26 m/s

THOR Upper Thorax Certification  
Scaled IR-TRACC  
Serial Number: T015

— Left Upper IR-TRACC  
— Right Upper IR-TRACC

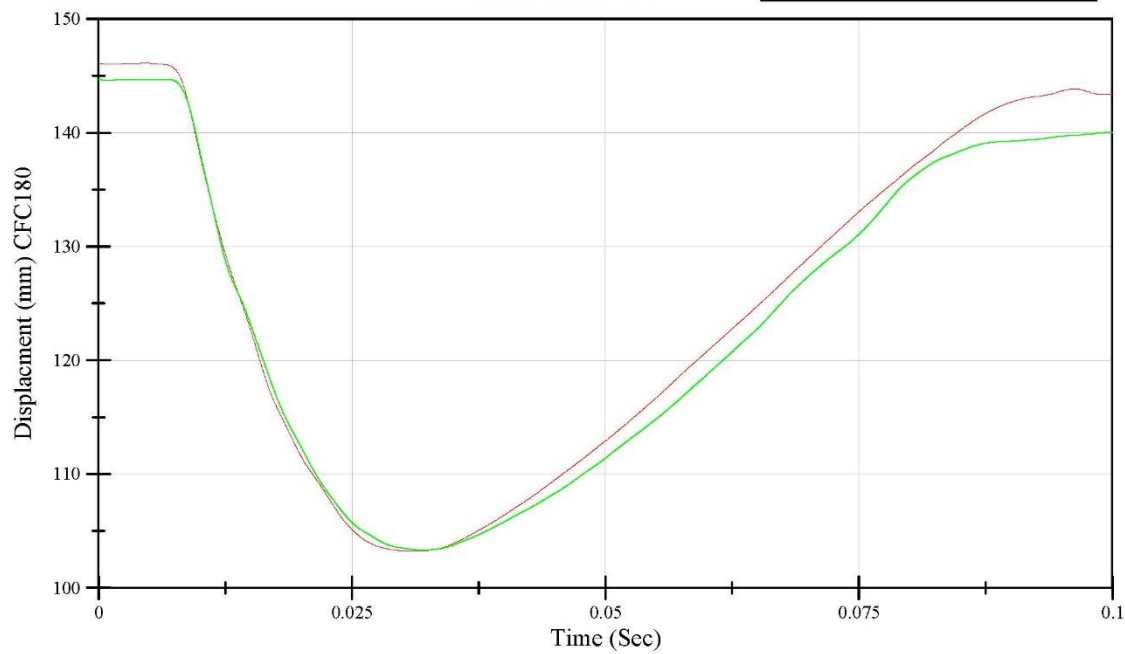

Software Version: 2.4

File Name: T015THUP150710-02\_pro.tdms  
07/10/2015 09:24:33.0000

Test Temperature: 70.4 degrees  
Relative Humidity: 53%  
Test Velocity: 4.26 m/s

THOR Upper Thorax Certification  
Y-Potentiometer  
Serial Number: T015

— Left Upper  
— Right Upper

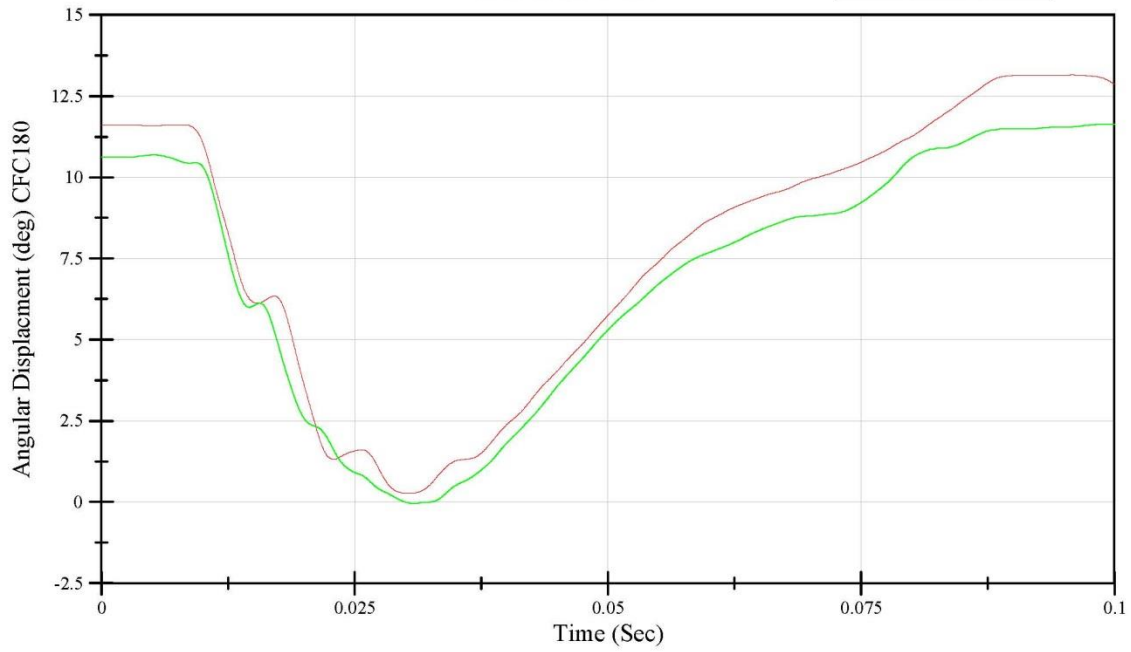

Software Version: 2.4

File Name: T015THUP150710-02\_pro.tdms  
07/10/2015 09:24:33.0000

Test Temperature: 70.4 degrees  
Relative Humidity: 53%  
Test Velocity: 4.26 m/s

THOR Upper Thorax Certification  
Z-Potentiometer  
Serial Number: T015

— Left Upper  
— Right Upper

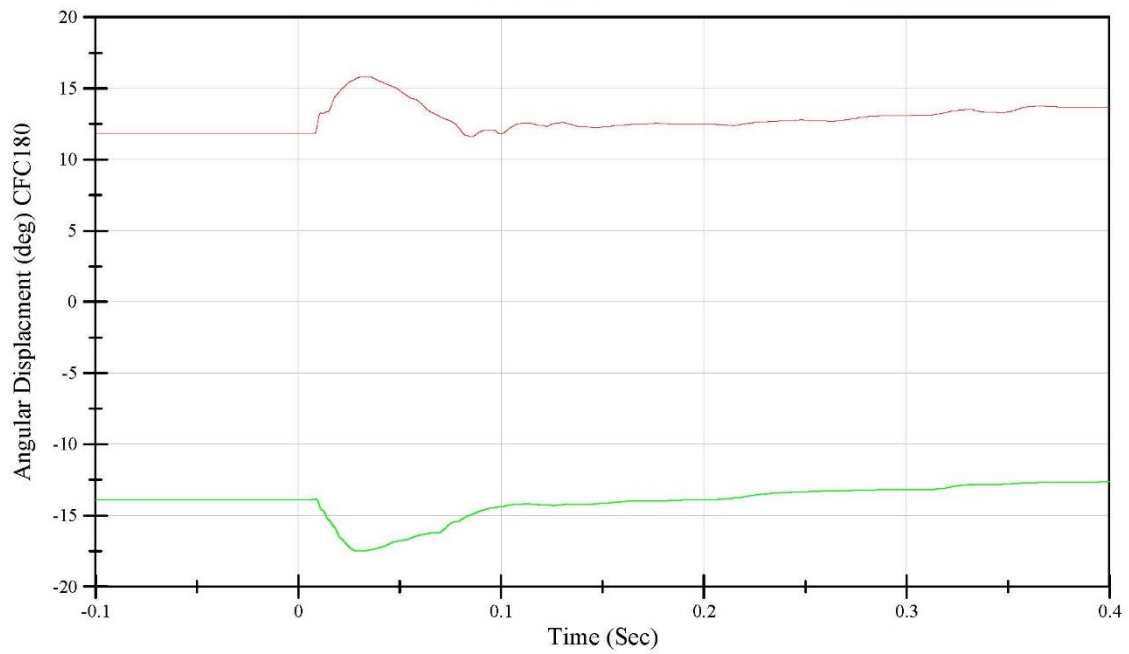

Software Version: 2.4

File Name: T015THUP150710-02\_pro.tdms  
07/10/2015 09:24:33.0000

Test Temperature: 71.4 degrees  
Relative Humidity: 48%  
Test Velocity: 2.77 m/s

THOR Right Knee Certification  
Femur Force vs. Knee Displacement  
Serial Number: D2103657B

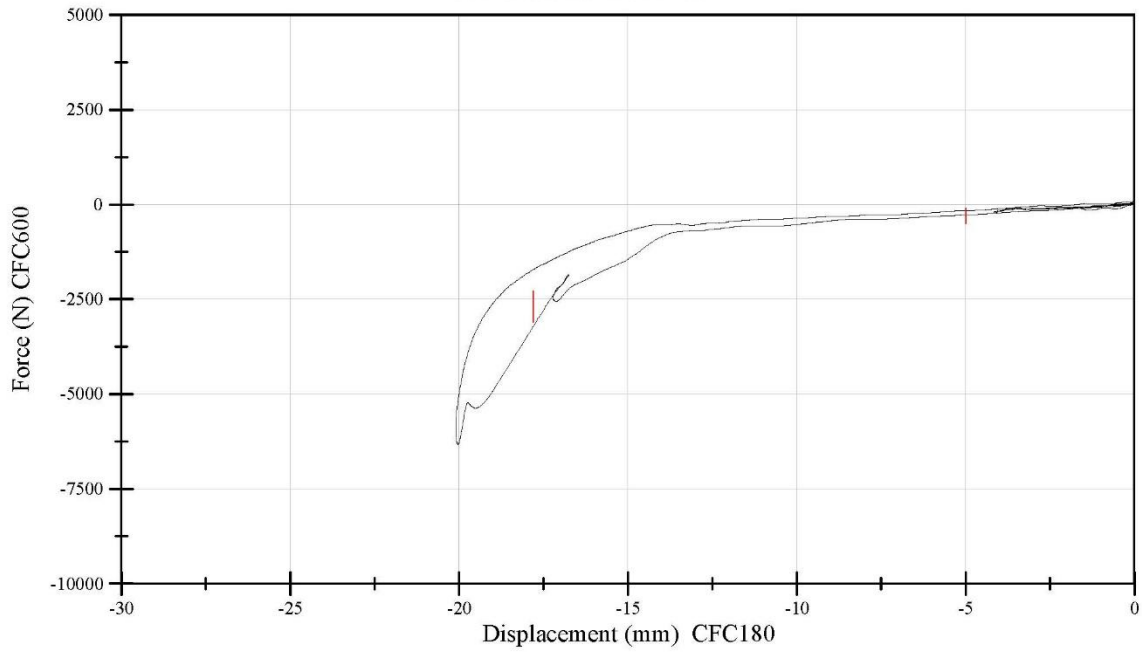

Software Version: 2.4

File Name: D2103657BKnee150407-01  
01/01/0000 00:00:00.0000

Test Temperature: 70.2 degrees  
Relative Humidity: 49%  
Test Velocity: 2.77 m/s

THOR Left Knee Certification  
Femur Force vs. Knee Displacement  
Serial Number: D2103665B

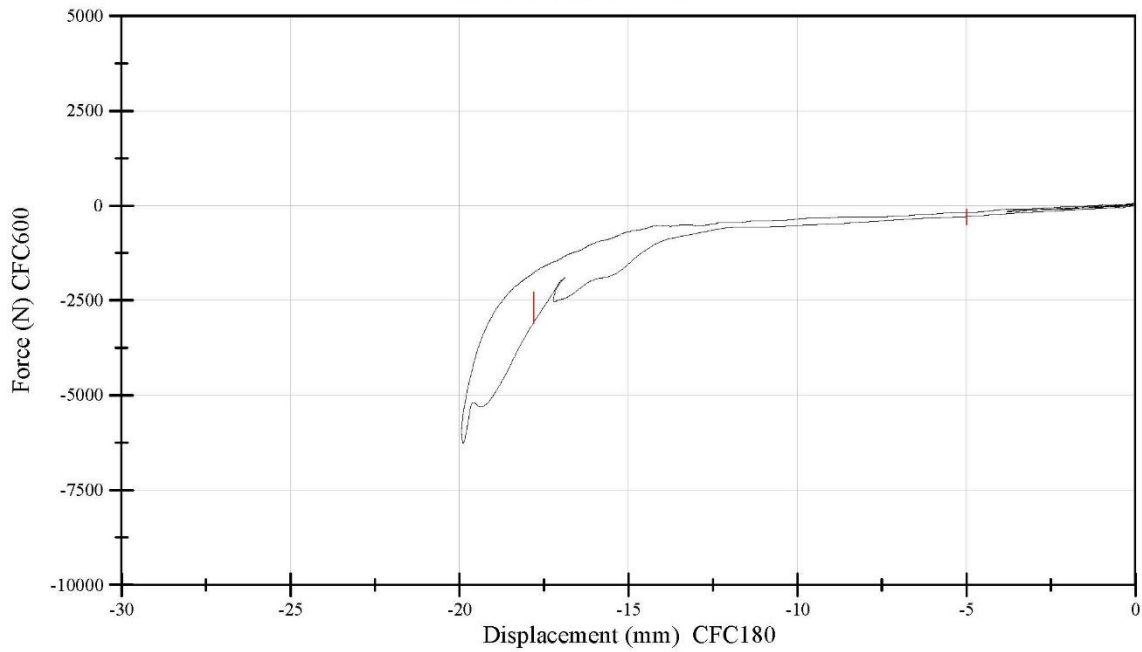

Software Version: 2.4

File Name: D2103665BKnee150407-01processed  
04/07/2015 13:14:07.0000

Test Temperature: 71.2 degrees  
Relative Humidity: 28.6%  
Test Velocity: 5.03 m/s

THOR Right Foot Dorsiflexion Certification  
Tibia Load  
Serial Number: LX0038

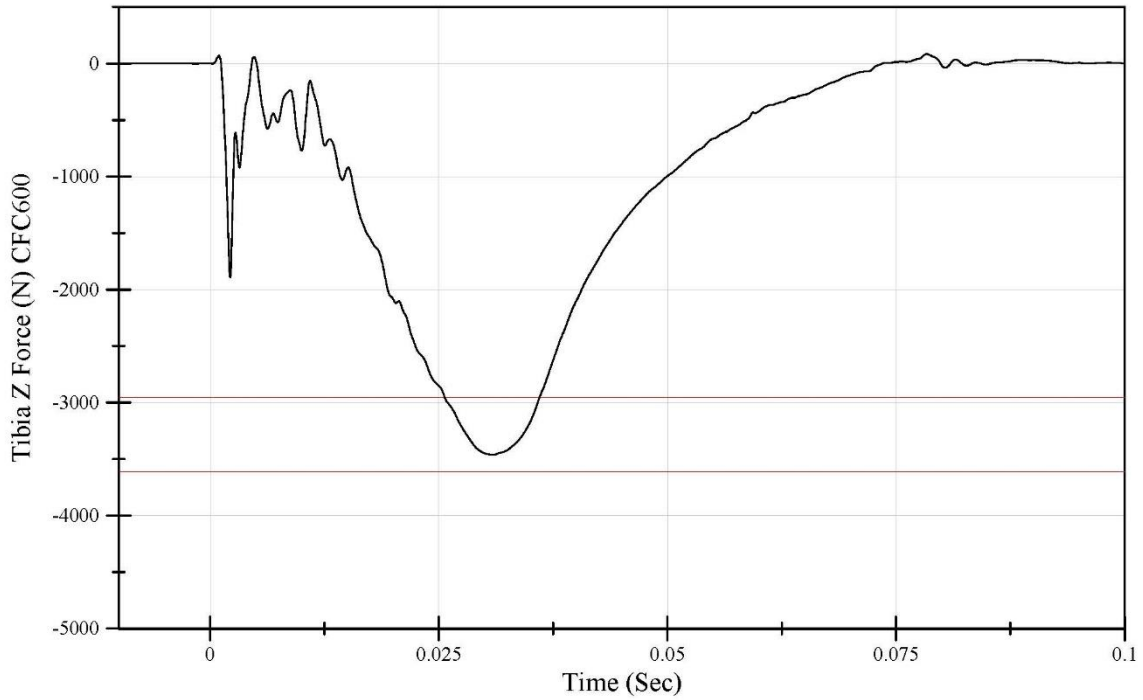

File Name: LX0038Ball150323\_06processed  
03/23/2015 09:51:34.0000

Software Version: 2.4

Test Temperature: 71.2 degrees  
Relative Humidity: 28.6%  
Test Velocity: 5.03 m/s

THOR Right Foot Dorsiflexion Certification  
Ankle Y-Moment  
Serial Number: LX0038

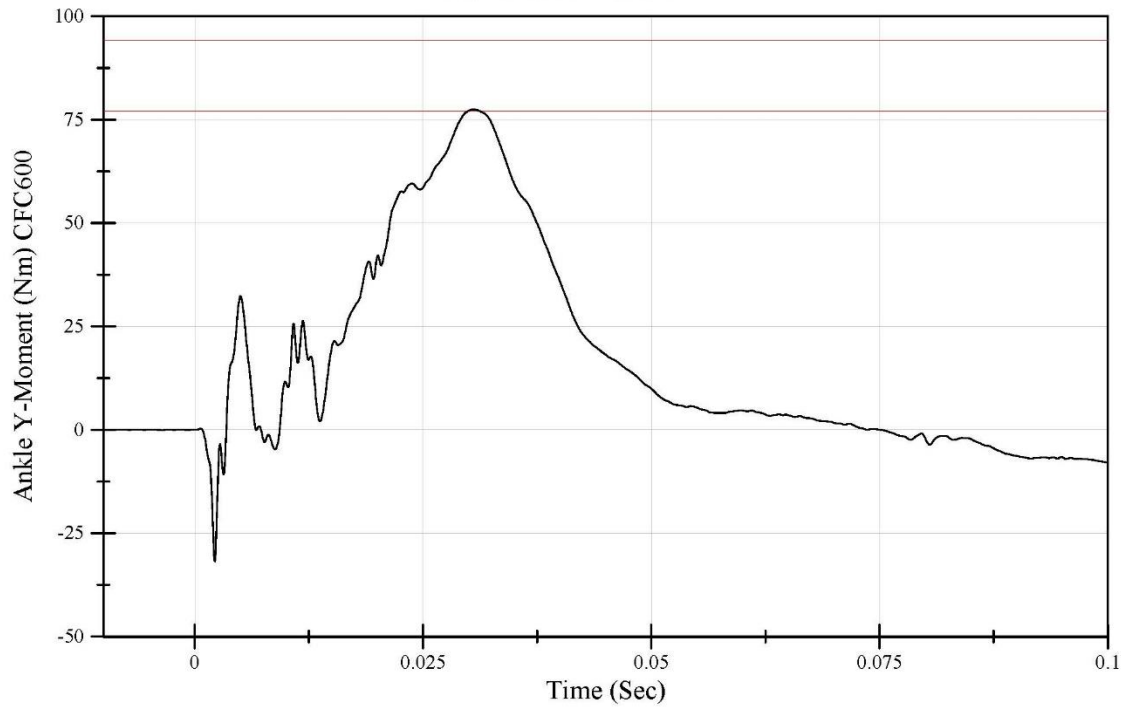

File Name: LX0038Ball150323\_06processed  
03/23/2015 09:51:34.0000

Software Version: 2.4

Test Temperature: 71.2 degrees  
Relative Humidity: 28.6%  
Test Velocity: 5.03 m/s

THOR Right Foot Dorsiflexion Certification  
Ankle Y-Rotation  
Serial Number: LX0038

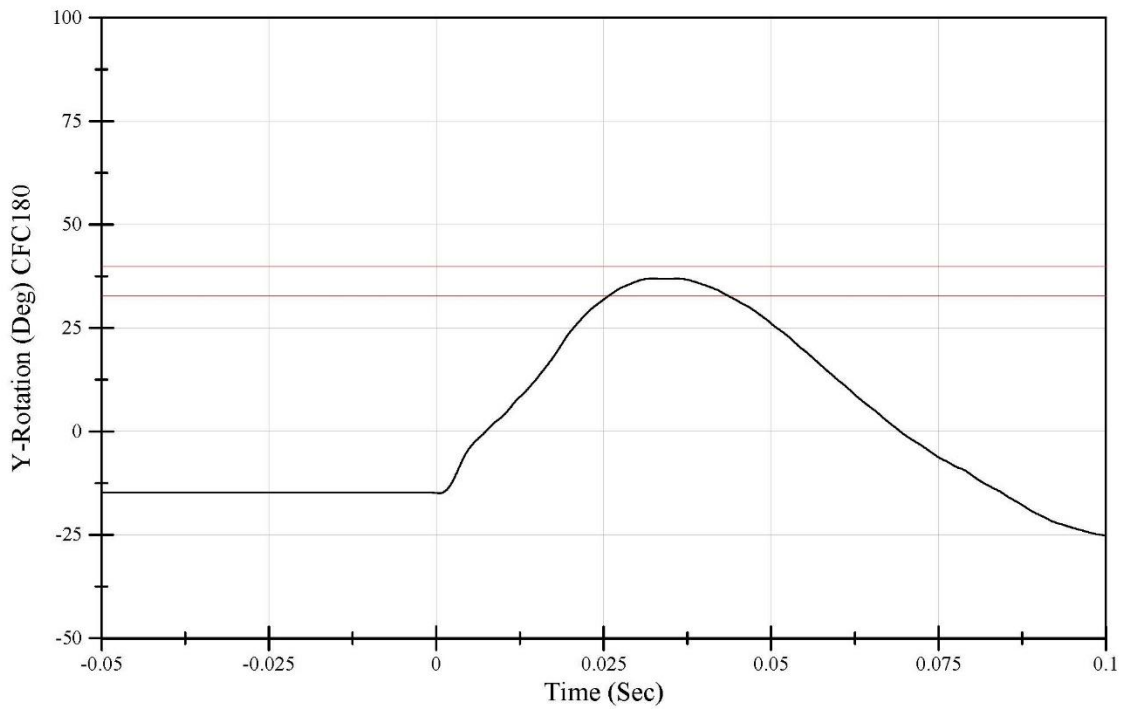

Software Version: 2.4

File Name: LX0038Ball150323\_06processed  
03/23/2015 09:51:34.0000

Test Temperature: 71 degrees  
Relative Humidity: 33.2%  
Test Velocity: 1.95 m/s

THOR Right Foot Eversion Certification  
Tibia Load  
Serial Number: LX0038

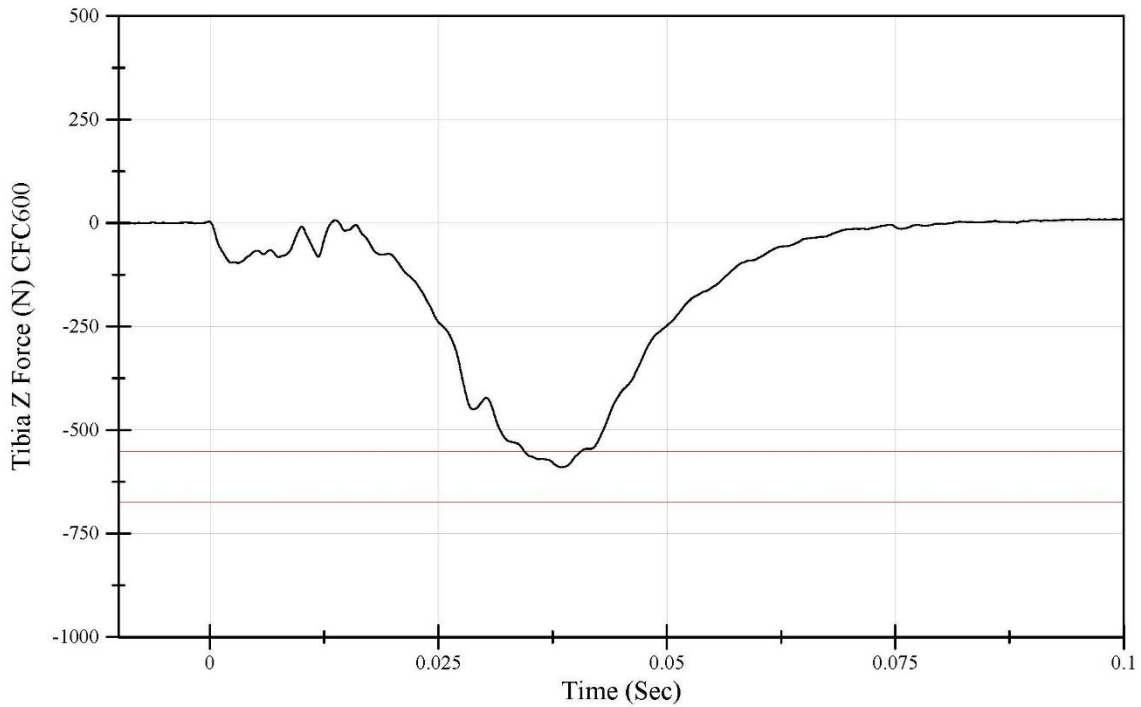

Software Version: 2.4

File Name: LX0038Eversion150319\_01processed  
03/19/2015 14:01:21.0000

Test Temperature: 71 degrees  
Relative Humidity: 33.2%  
Test Velocity: 1.95 m/s

THOR Right Foot Eversion Certification  
Ankle Moment  
Serial Number: LX0038

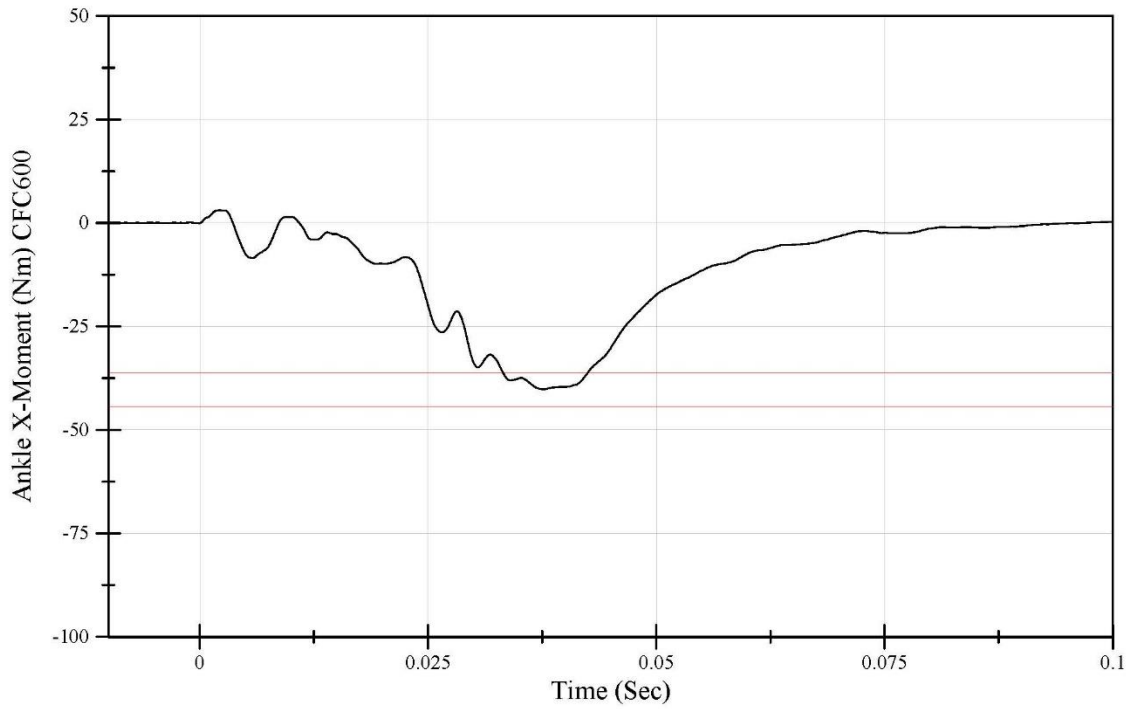

Software Version: 2.4

File Name: LX0038Eversion150319\_01processed  
03/19/2015 14:01:21.0000

Test Temperature: 71 degrees  
Relative Humidity: 33.2%  
Test Velocity: 1.95 m/s

THOR Right Foot Eversion Certification  
Ankle X-Rotation  
Serial Number: LX0038

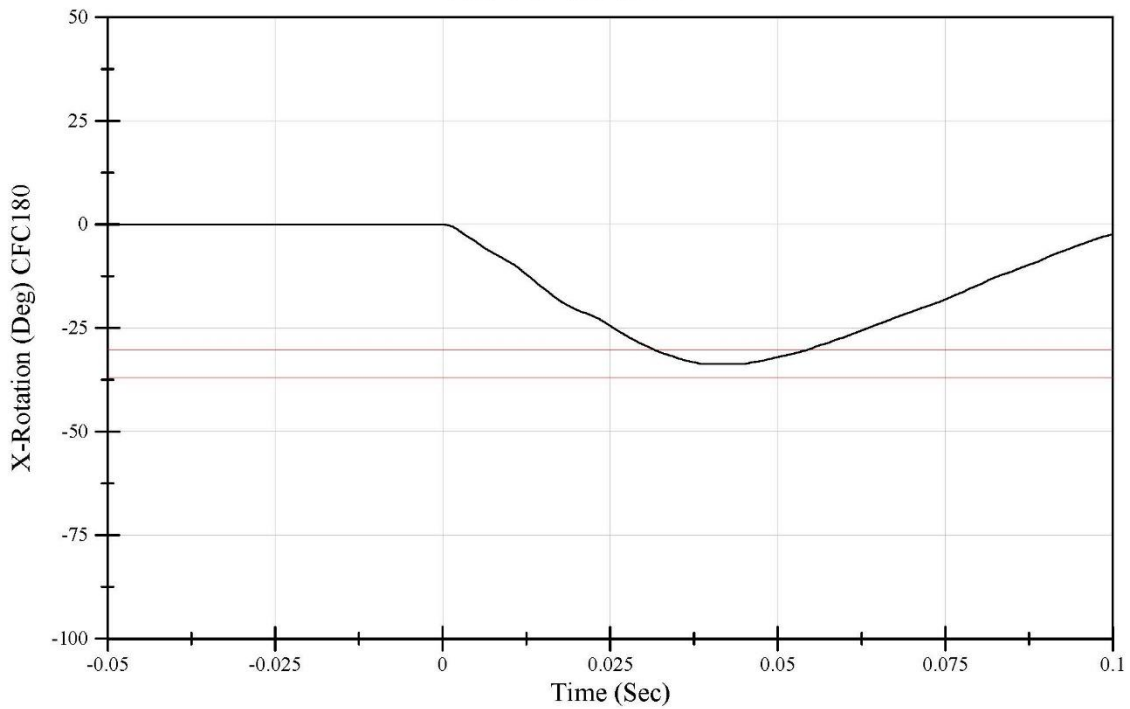

Software Version: 2.4

File Name: LX0038Eversion150319\_01processed  
03/19/2015 14:01:21.0000

Test Temperature: 71 degrees  
Relative Humidity: 28.4%  
Test Velocity: 3.91 m/s

### THOR Right Foot Heel Certification

Tibia Load  
Serial Number: LX0038

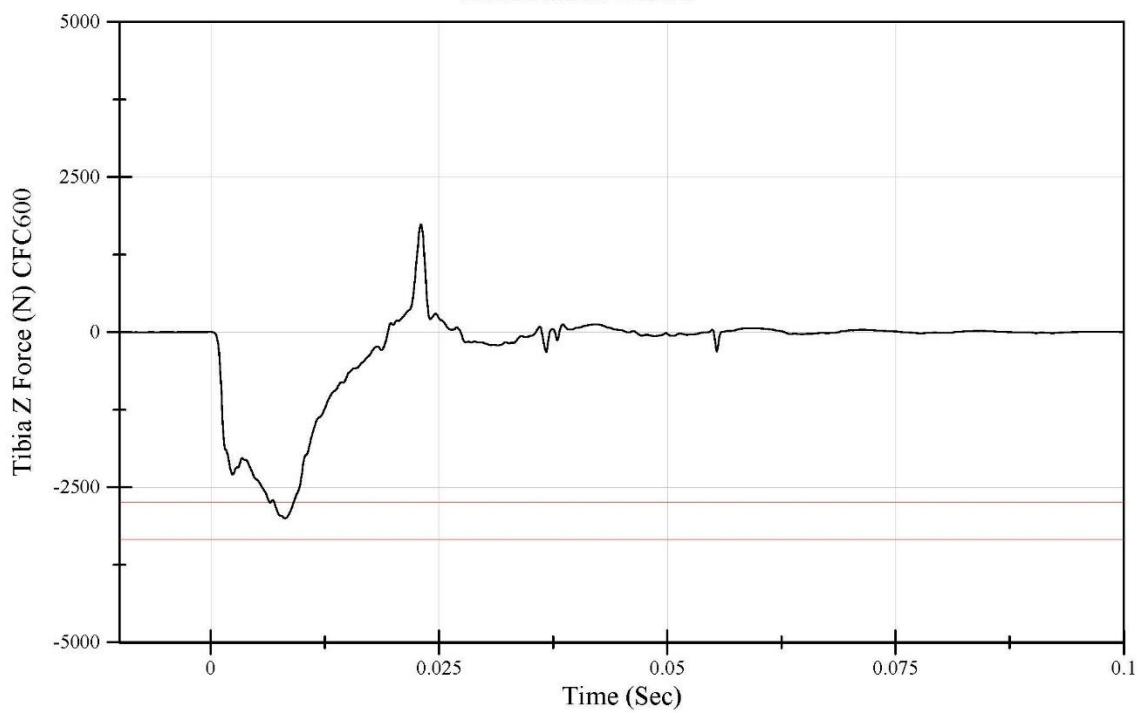

Software Version: 2.4

File Name: LX0038Heel150323\_02processed  
03/23/2015 13:53:13.0000

Test Temperature: 71.2 degrees  
Relative Humidity: 33.1%  
Test Velocity: 1.94 m/s

### THOR Right Foot Inversion Certification

Tibia Load  
Serial Number: LX0038

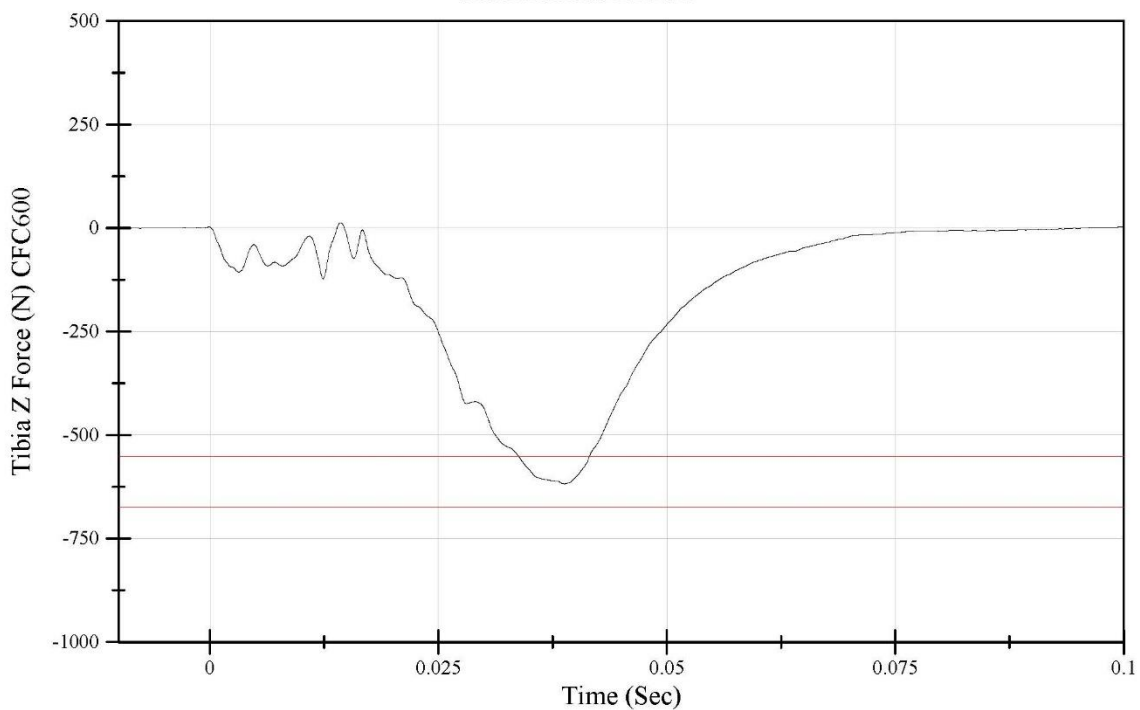

Software Version: 2.4

File Name: LX0038Inversion150319\_05processed  
03/19/2015 13:27:37.0000

Test Temperature: 71.2 degrees  
Relative Humidity: 33.1%  
Test Velocity: 1.94 m/s

THOR Right Foot Inversion Certification  
Ankle Moment  
Serial Number: LX0038

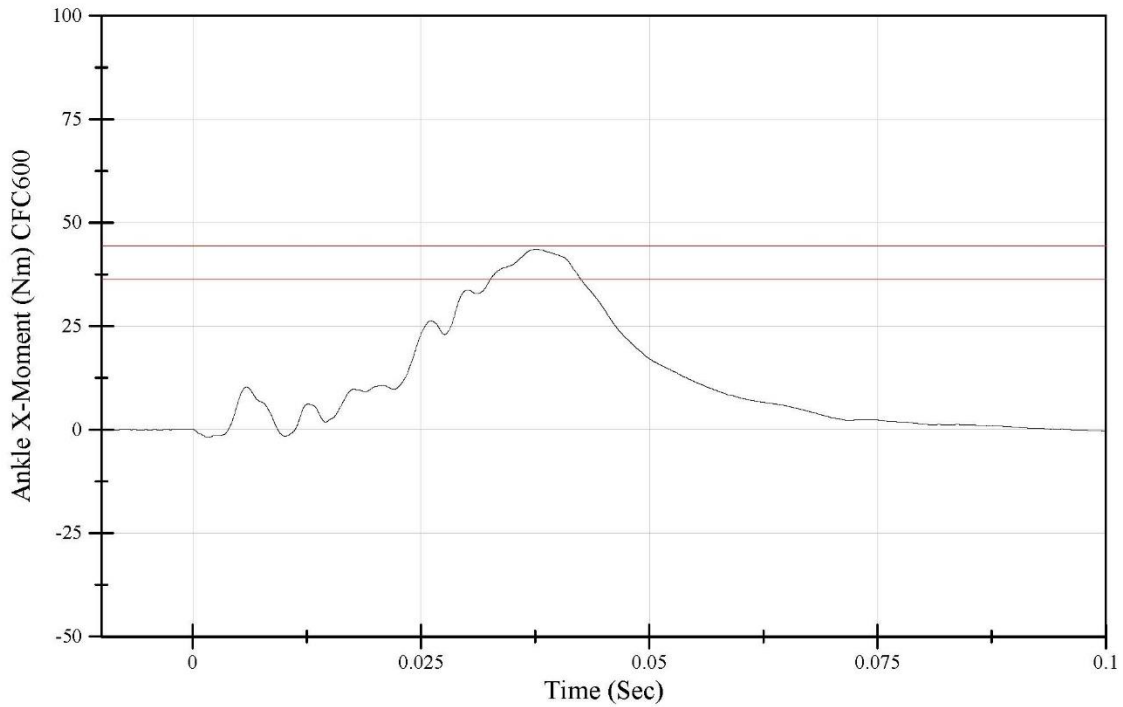

Software Version: 2.4

File Name: LX0038Inversion150319\_05processed  
03/19/2015 13:27:37.0000

Test Temperature: 71.2 degrees  
Relative Humidity: 33.1%  
Test Velocity: 1.94 m/s

THOR Right Foot Inversion Certification  
Ankle X-Rotation  
Serial Number: LX0038



Software Version: 2.4

File Name: LX0038Inversion150319\_05processed  
03/19/2015 13:27:37.0000

Test Temperature: 71 degrees  
Relative Humidity: 26.4%  
Test Velocity: 4.98 m/s

THOR Left Foot Dorsiflexion Certification  
Tibia Load  
Serial Number: LX0039

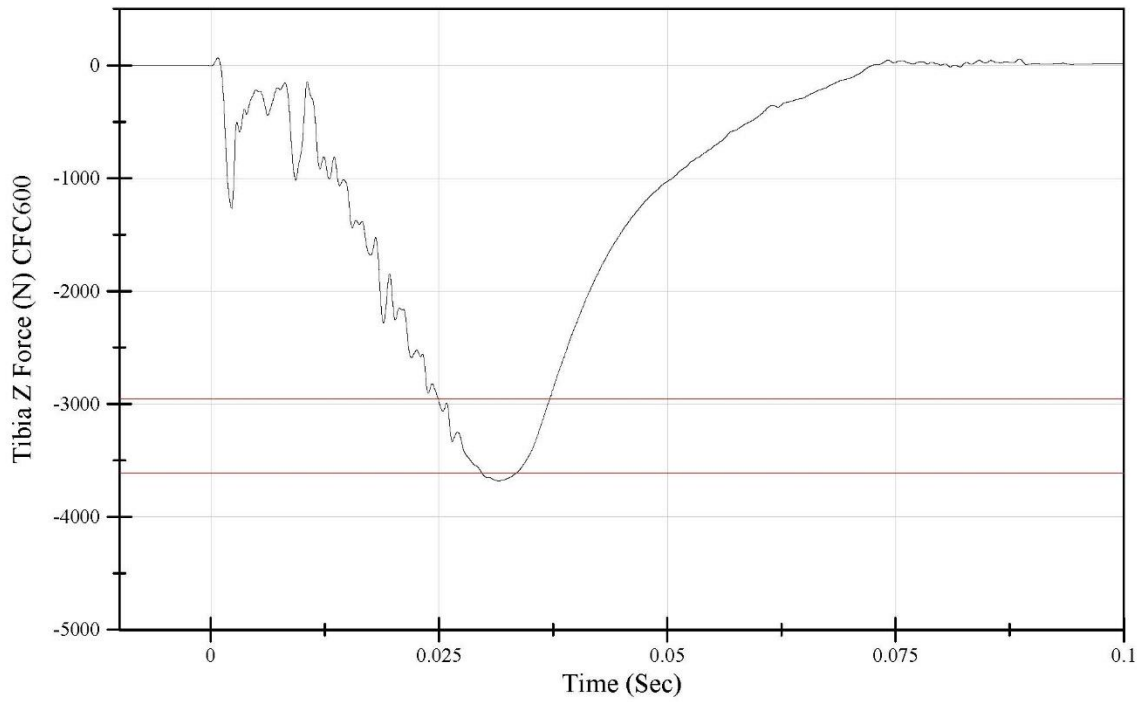

Software Version: 2.4

File Name: LX0039Ball1150324\_04processed  
03/24/2015 09:40:54.0000

Test Temperature: 71 degrees  
Relative Humidity: 26.4%  
Test Velocity: 4.98 m/s

THOR Left Foot Dorsiflexion Certification  
Ankle Y-Moment  
Serial Number: LX0039

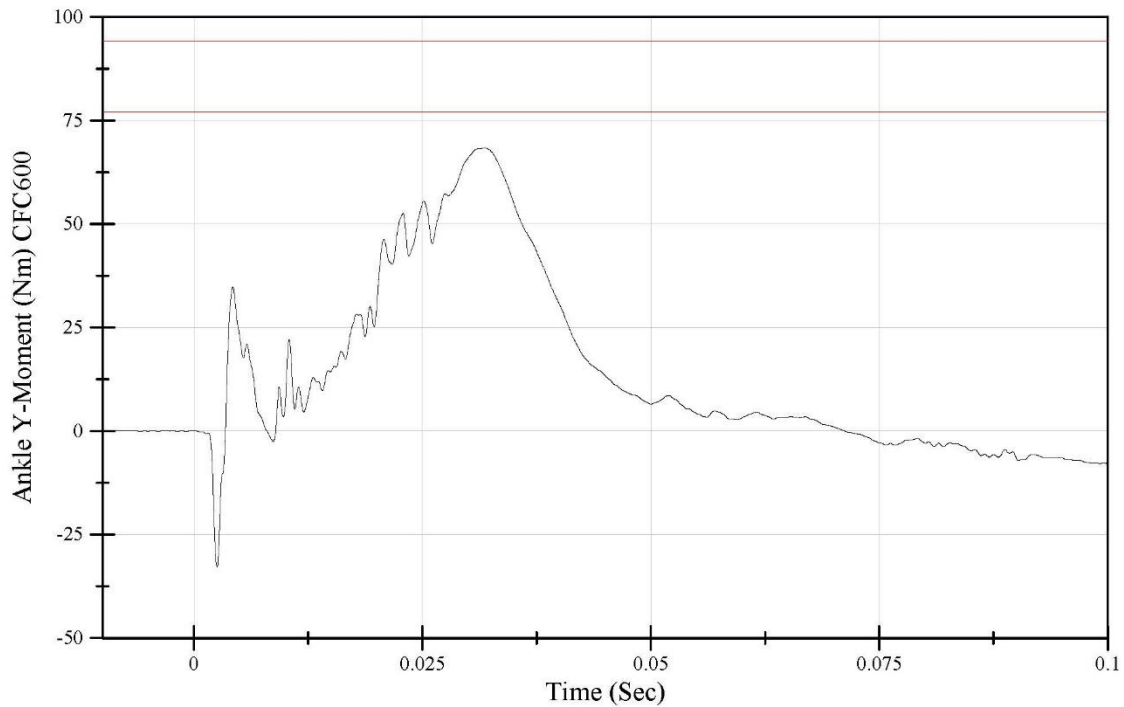

Software Version: 2.4

File Name: LX0039Ball1150324\_04processed  
03/24/2015 09:40:54.0000

Test Temperature: 71 degrees  
Relative Humidity: 26.4%  
Test Velocity: 4.98 m/s

THOR Left Foot Dorsiflexion Certification  
Ankle Y-Rotation  
Serial Number: LX0039

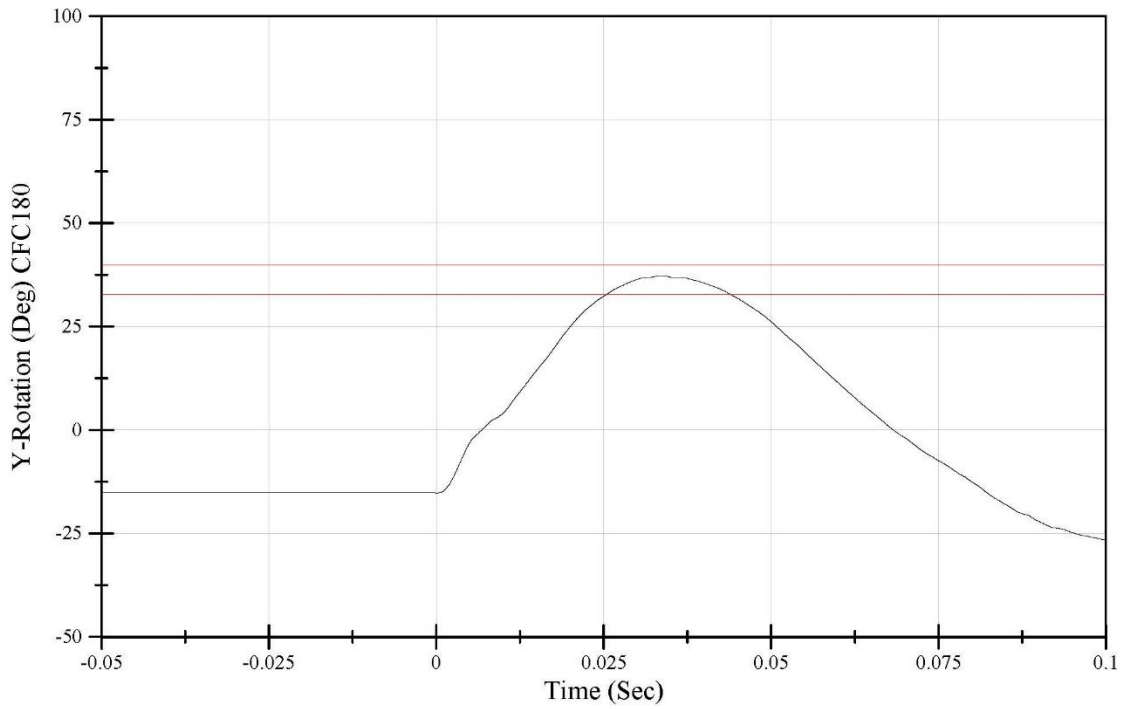

Software Version: 2.4

File Name: LX0039Ball150324\_04processed  
03/24/2015 09:40:54.0000

Test Temperature: 71 degrees  
Relative Humidity: 26.8%  
Test Velocity: 2.04 m/s

THOR Left Foot Eversion Certification  
Tibia Load  
Serial Number: LX0039

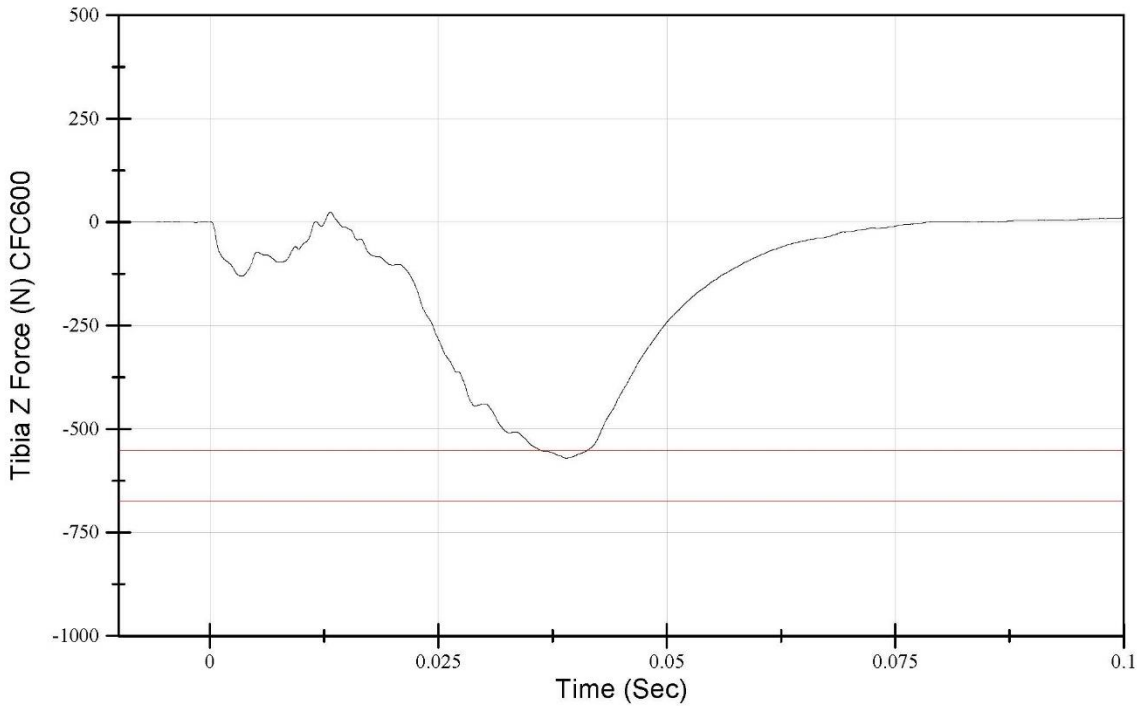

Software Version: 2.4

File Name: LX0039Eversion150324\_01processed  
03/24/2015 06:43:58.0000

Test Temperature: 71 degrees  
Relative Humidity: 26.8%  
Test Velocity: 2.04 m/s

THOR Left Foot Eversion Certification  
Ankle Moment  
Serial Number: LX0039

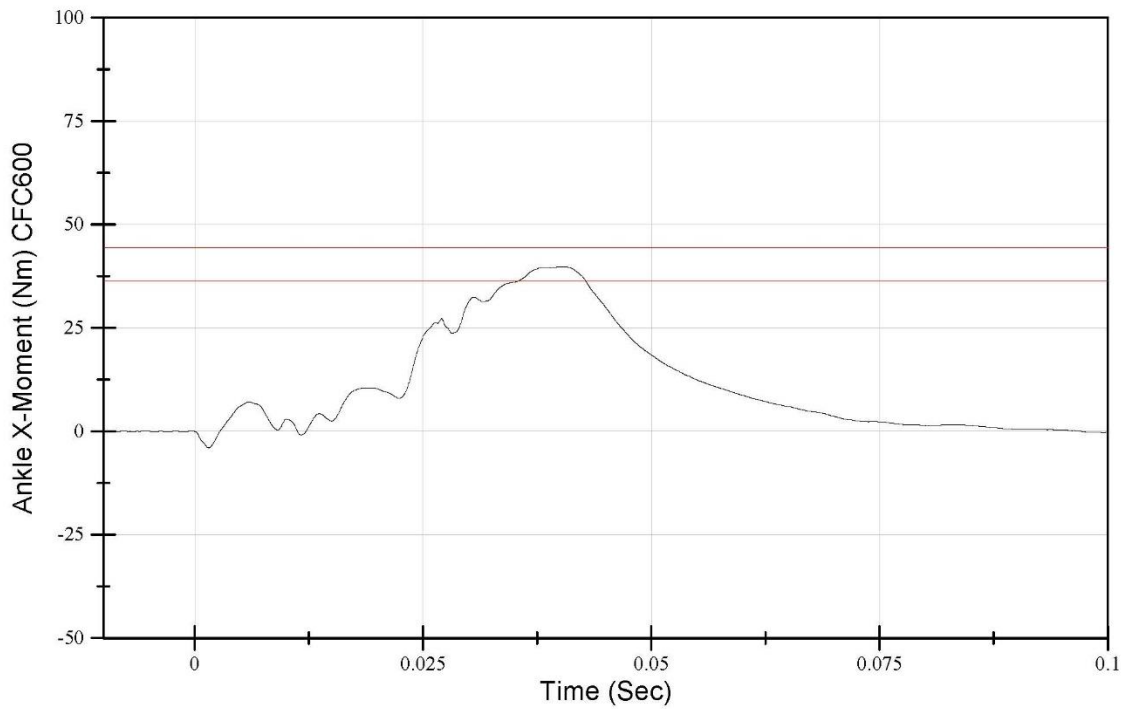

Software Version: 2.4

File Name: LX0039Eversion150324\_01processed  
03/24/2015 06:43:58.0000

Test Temperature: 71 degrees  
Relative Humidity: 26.8%  
Test Velocity: 2.04 m/s

THOR Left Foot Eversion Certification  
Ankle X-Rotation  
Serial Number: LX0039

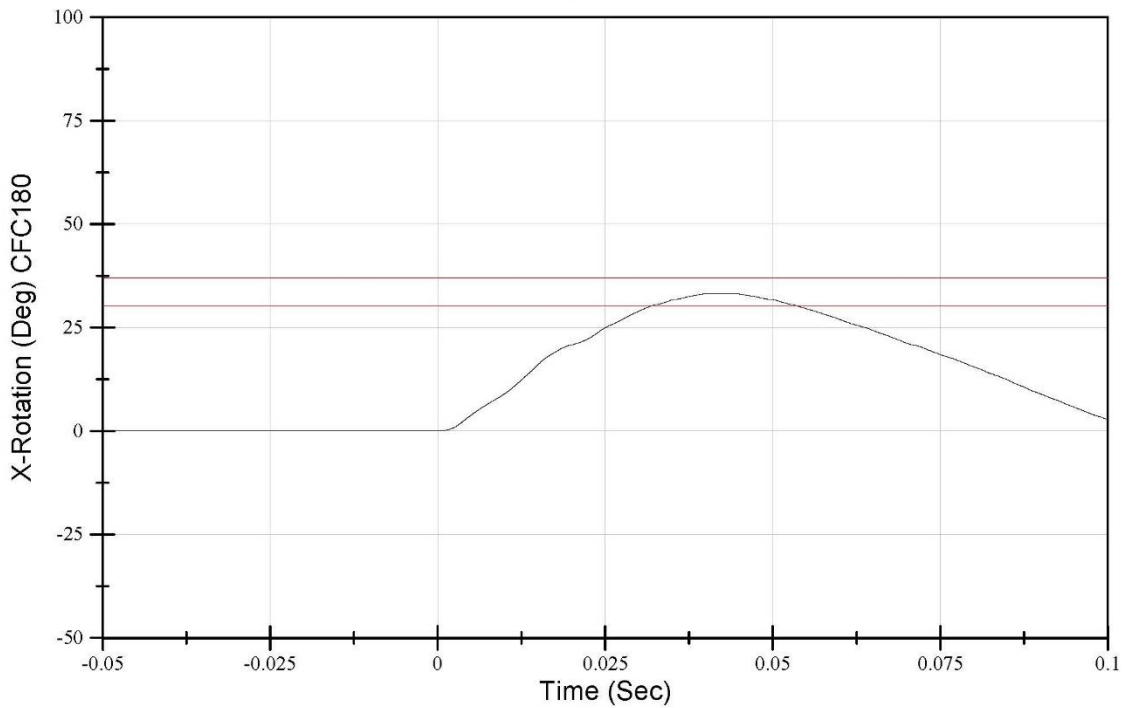

Software Version: 2.4

File Name: LX0039Eversion150324\_01processed  
03/24/2015 06:43:58.0000

Test Temperature: 71 degrees  
Relative Humidity: 26.4%  
Test Velocity: 3.96875 m/s

THOR Left Foot Heel Certification  
Tibia Load  
Serial Number: LX0039

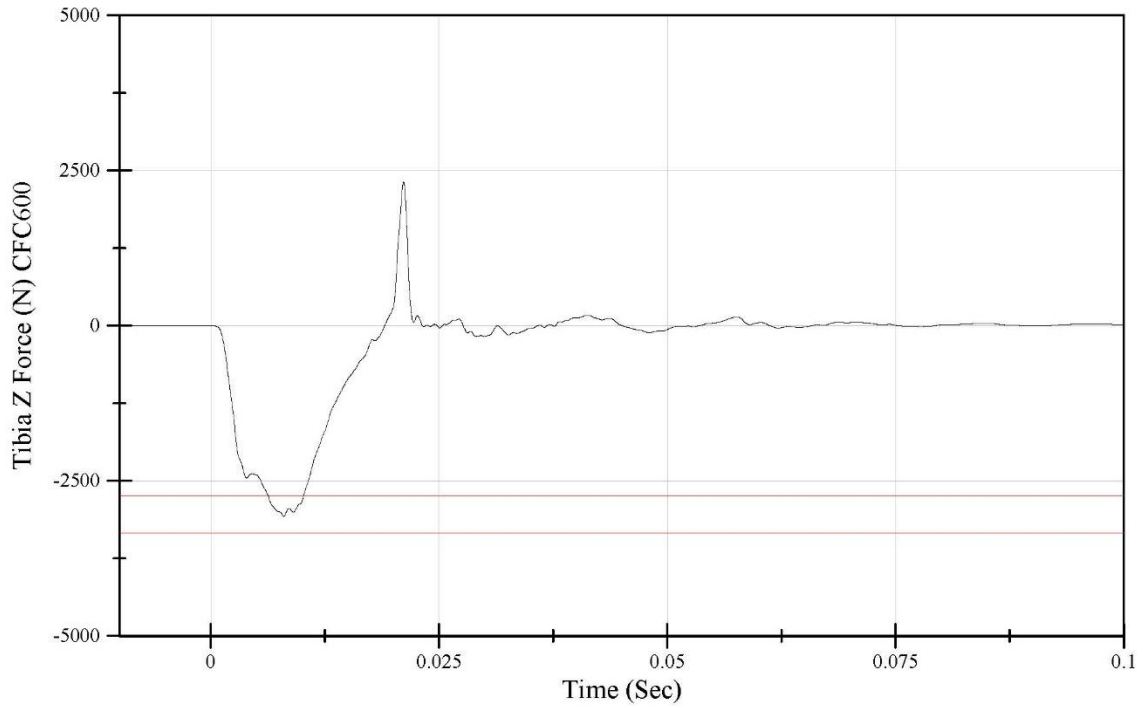

Software Version: 2.4

File Name: LX0039Heel150324\_01processed  
03/24/2015 10:54:09.0000

Test Temperature: 71 degrees  
Relative Humidity: 28.6%  
Test Velocity: 2 m/s

THOR Left Foot Inversion Certification  
Tibia Load  
Serial Number: LX0039

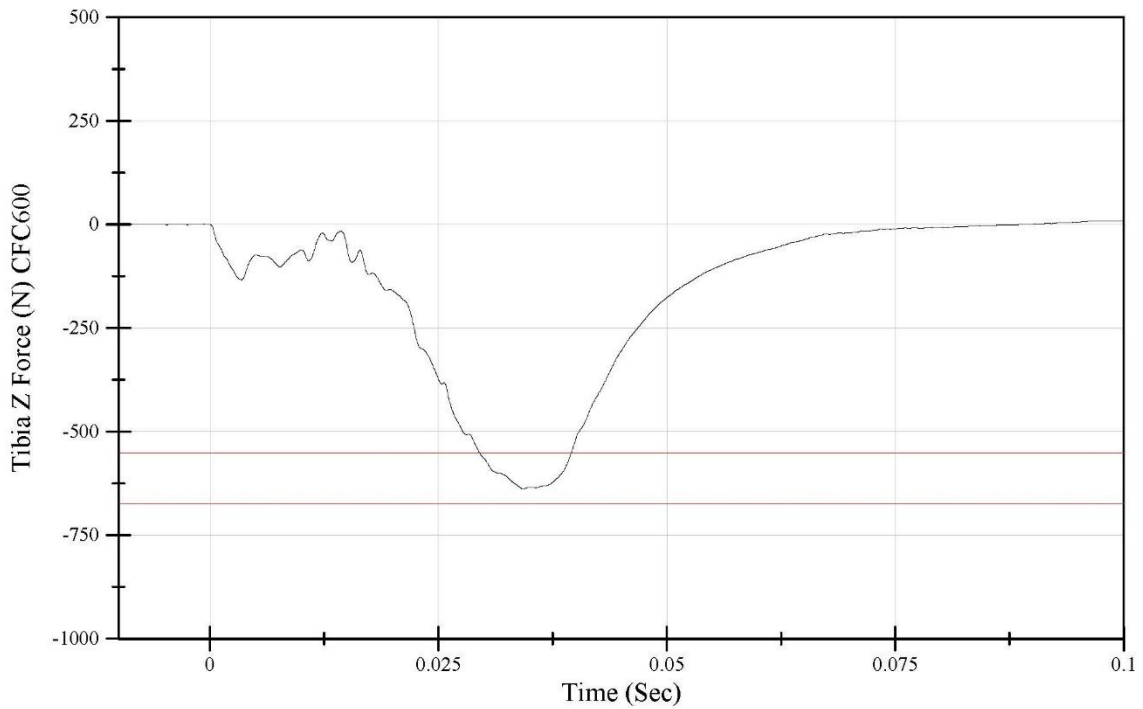

Software Version: 2.4

File Name: LX0039Inversion150323\_02processed  
03/23/2015 16:18:23.0000

Test Temperature: 71 degrees  
Relative Humidity: 28.6%  
Test Velocity: 2 m/s

THOR Left Foot Inversion Certification  
Ankle Moment  
Serial Number: LX0039

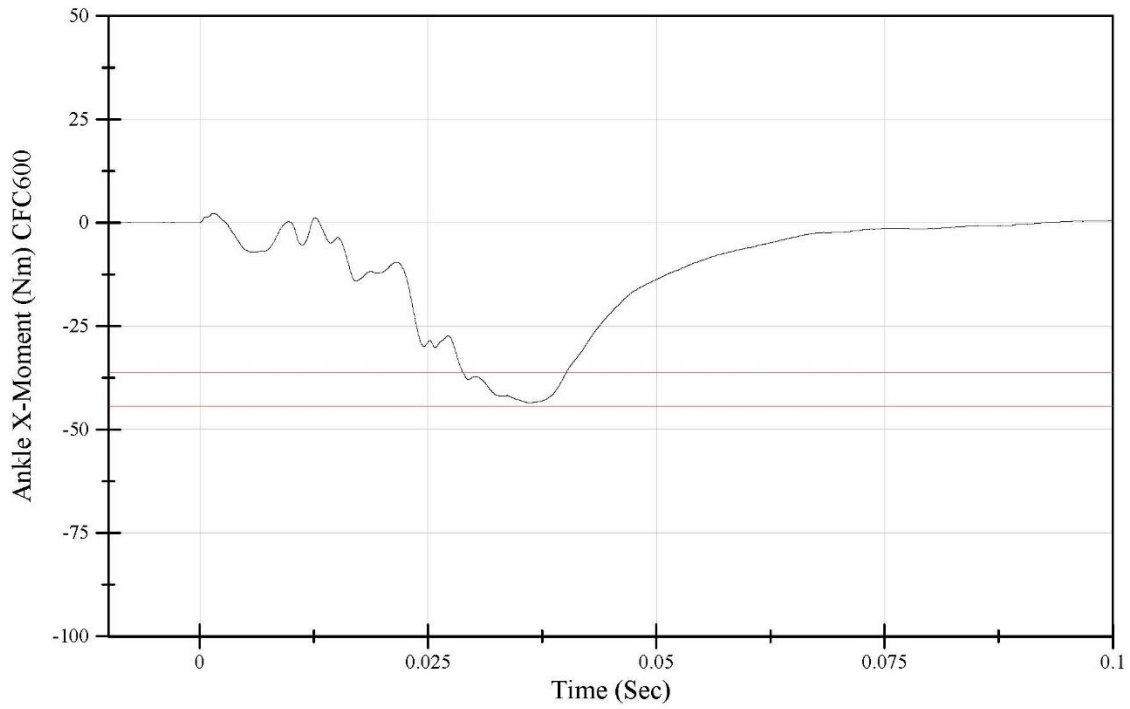

Software Version: 2.4

File Name: LX0039Inversion150323\_02processed  
03/23/2015 16:18:23.0000

Test Temperature: 71 degrees  
Relative Humidity: 28.6%  
Test Velocity: 2 m/s

THOR Left Foot Inversion Certification  
Ankle X-Rotation  
Serial Number: LX0039

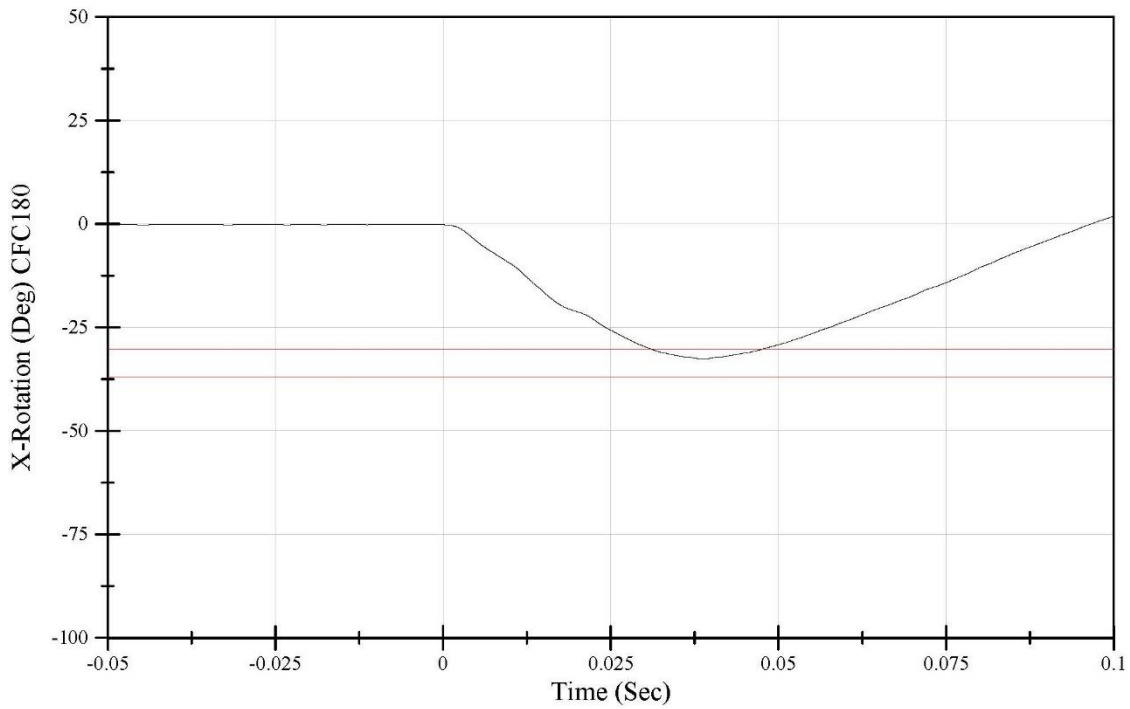

Software Version: 2.4

File Name: LX0039Inversion150323\_02processed  
03/23/2015 16:18:23.0000

Test Temperature: 70 degrees  
Relative Humidity: 52%  
Test Velocity: 2.64 m/s

THOR Left Femur Certification  
Probe Force  
Serial Number: T015

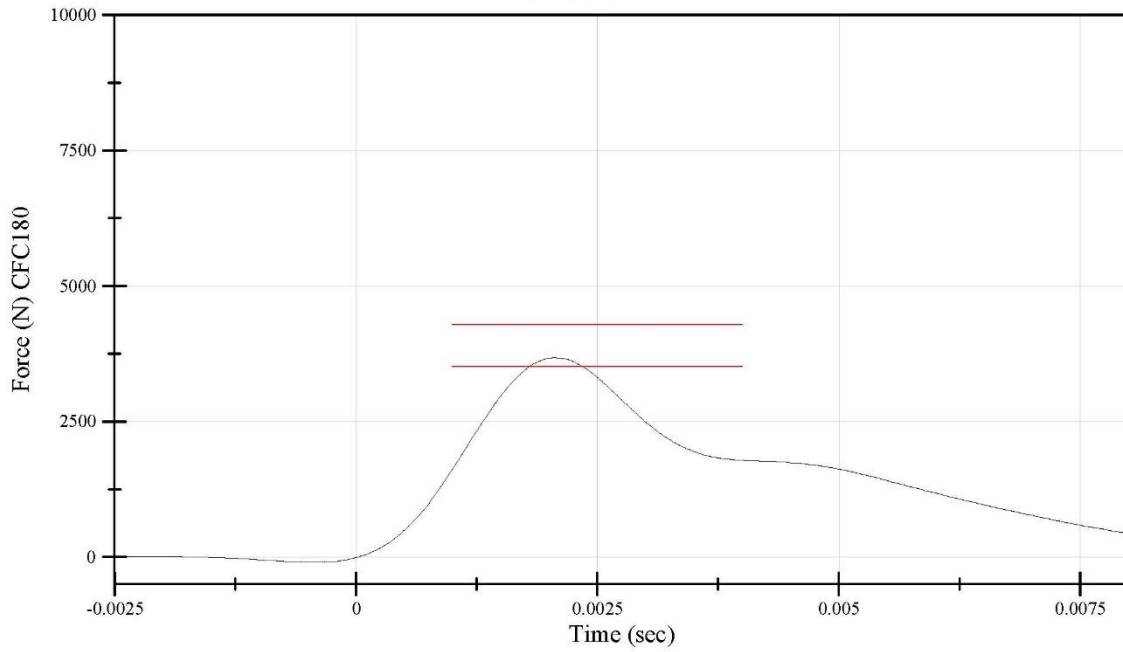

Software Version: 2.4

File Name: T015FELE150713-06\_pro  
07/13/2015 15:52:51.0000

Test Temperature: 69.9 degrees  
Relative Humidity: 52%  
Test Velocity: 2.64 m/s

THOR Right Femur Certification  
Probe Force  
Serial Number: T015

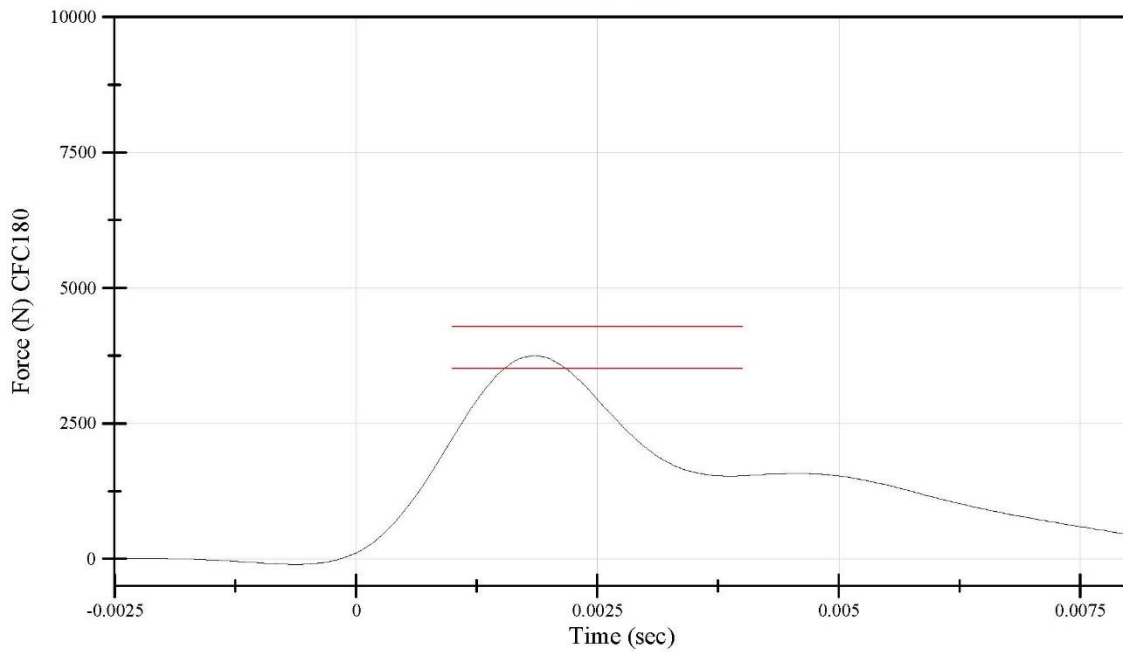

Software Version: 2.4

File Name: T015FERI150713-01\_pro  
07/13/2015 12:54:56.0000

Test Temperature: 69.6 degrees  
Relative Humidity: 52%  
Test Velocity: 0 m/s

THOR Occipital Condyle Quasi-Static Certification  
Displacement vs. Torque  
Serial Number: T015

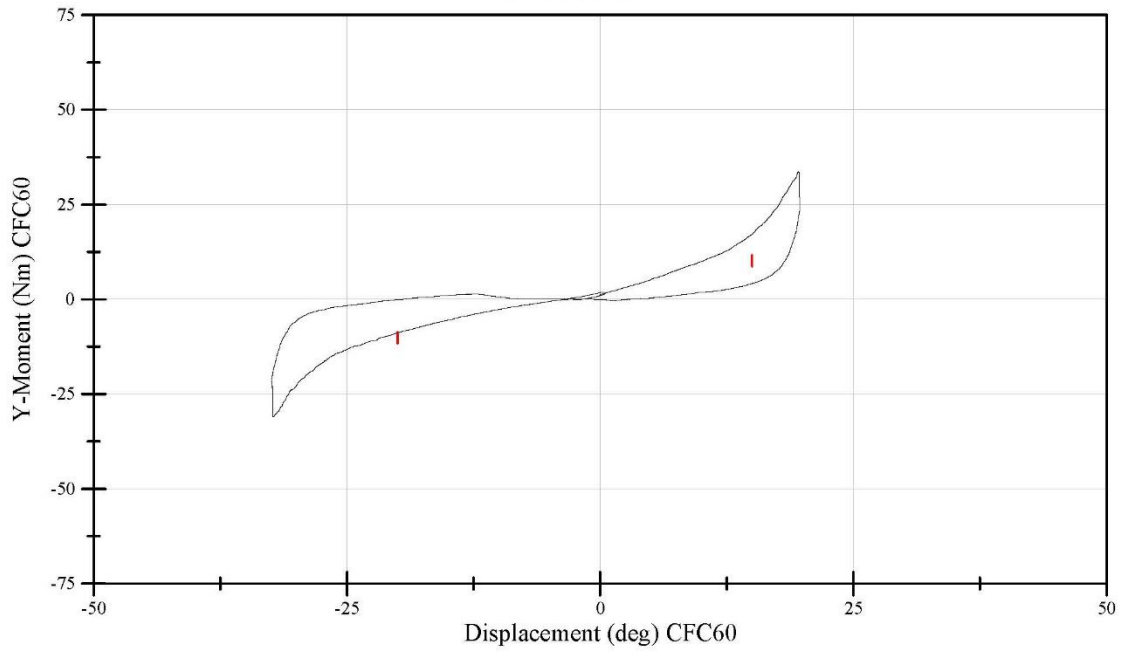

Software Version: 2.4

File Name: T015OCPot150701-03\_pro  
07/01/2015 13:24:58.0000

**50% ADULT MALE THOR016 DUMMY CALIBRATIONS**

Test Temperature: 69.8 degrees  
Relative Humidity: 53%  
Test Velocity: 1.98 m/s

THOR Head Impact Certification  
Probe Force  
Serial Number: T0016

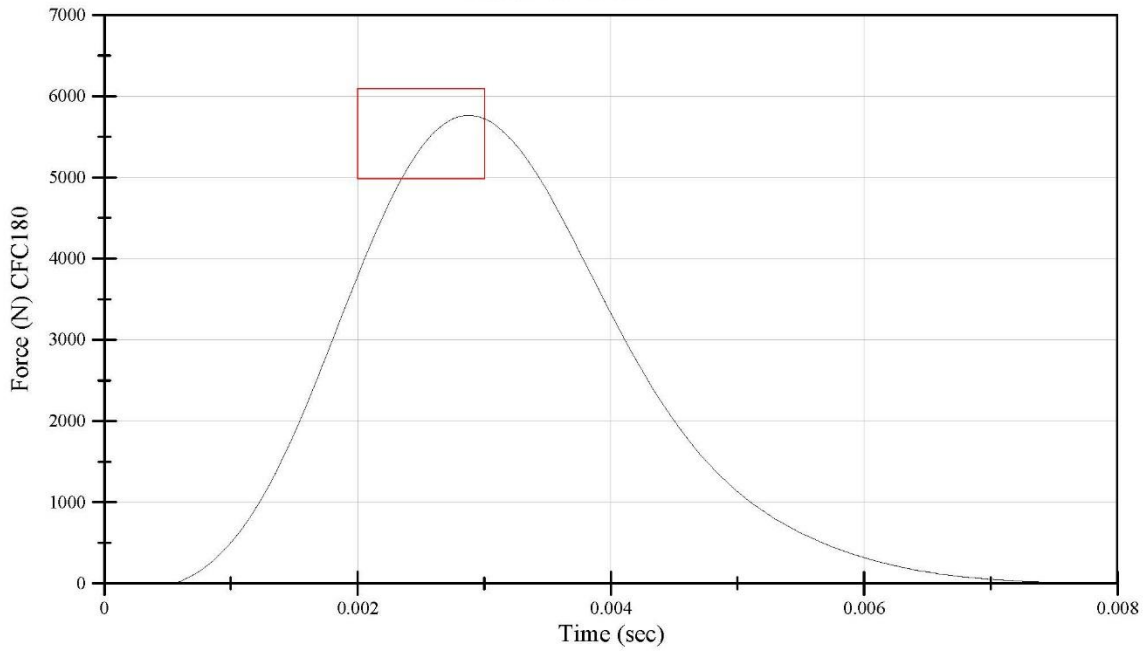

Software Version: 2.4

File Name: T0016HEAD150813-03\_pro tdms  
08/13/2015 12:52:18.0000

Test Temperature: 70.4 degrees  
Relative Humidity: 53%  
Test Velocity: 3.69 m/s

THOR Neck Extension Certification  
Y-Moment  
Serial Number: T0016

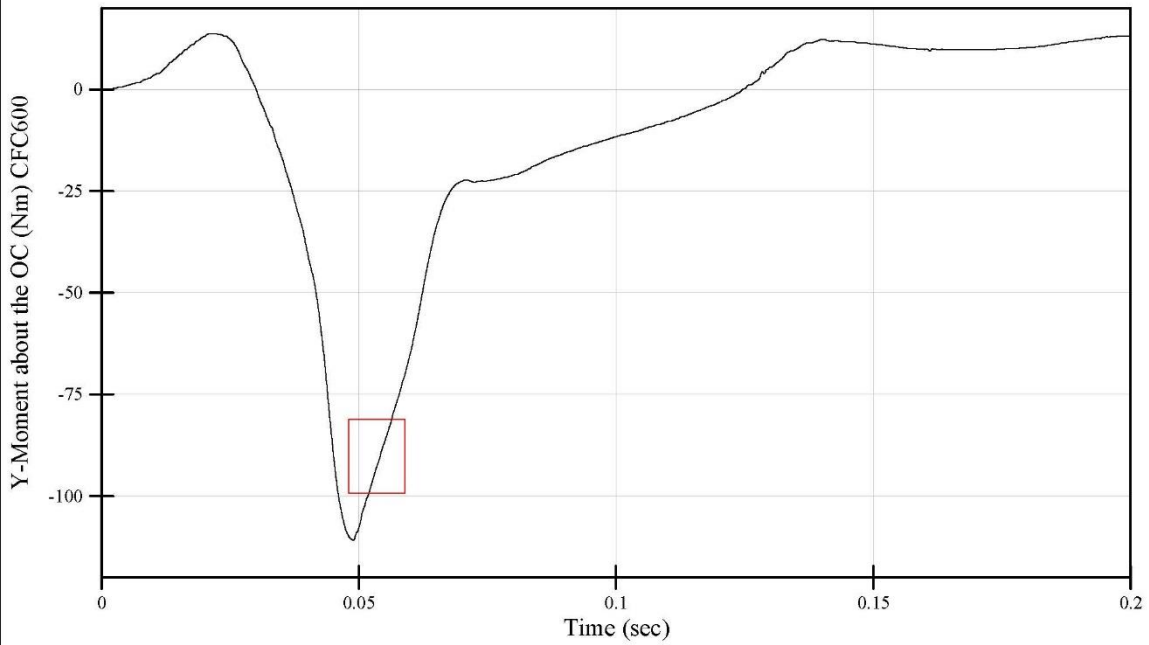

Software Version: 2.4

File Name: T0016NeckExtension150805-01\_pro  
08/05/2015 10:53:11.0000

Test Temperature: 70.4 degrees  
Relative Humidity: 53%  
Test Velocity: 3.69 m/s

THOR Neck Extension Certification  
Probe Acceleration  
Serial Number: T0016

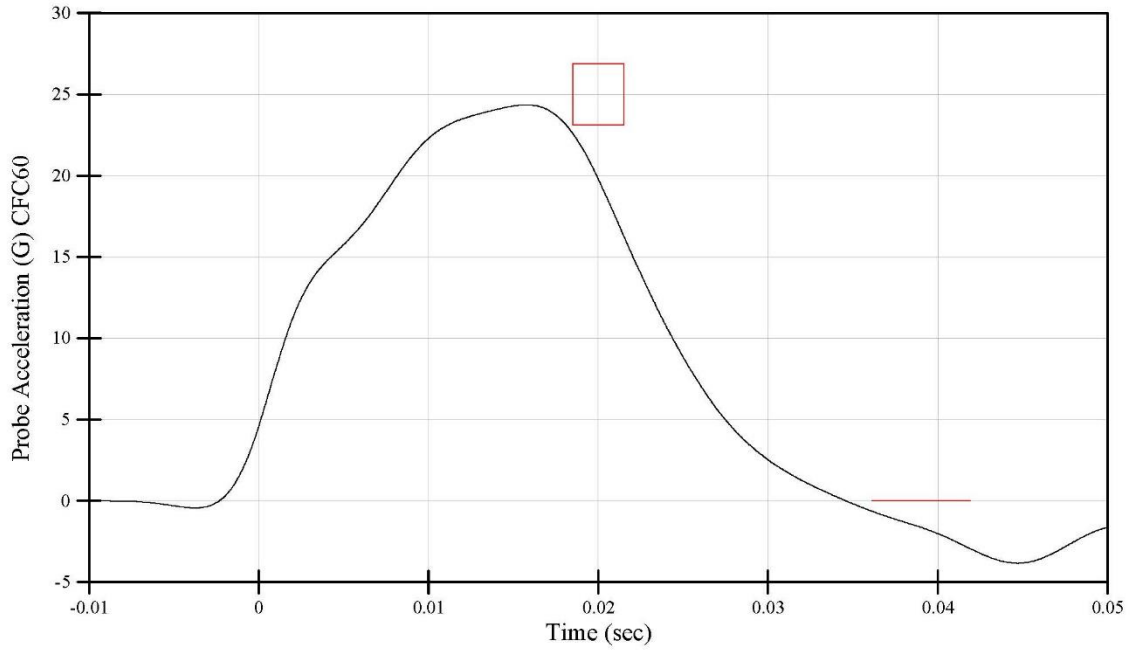

Software Version: 2.4

File Name: T0016NeckExtension150805-01\_pro  
08/05/2015 10:53:11.0000

Test Temperature: 70.6 degrees  
Relative Humidity: 52%  
Test Velocity: 3.78 m/s

THOR Neck Flexion Certification  
Y-Moment  
Serial Number: T0016

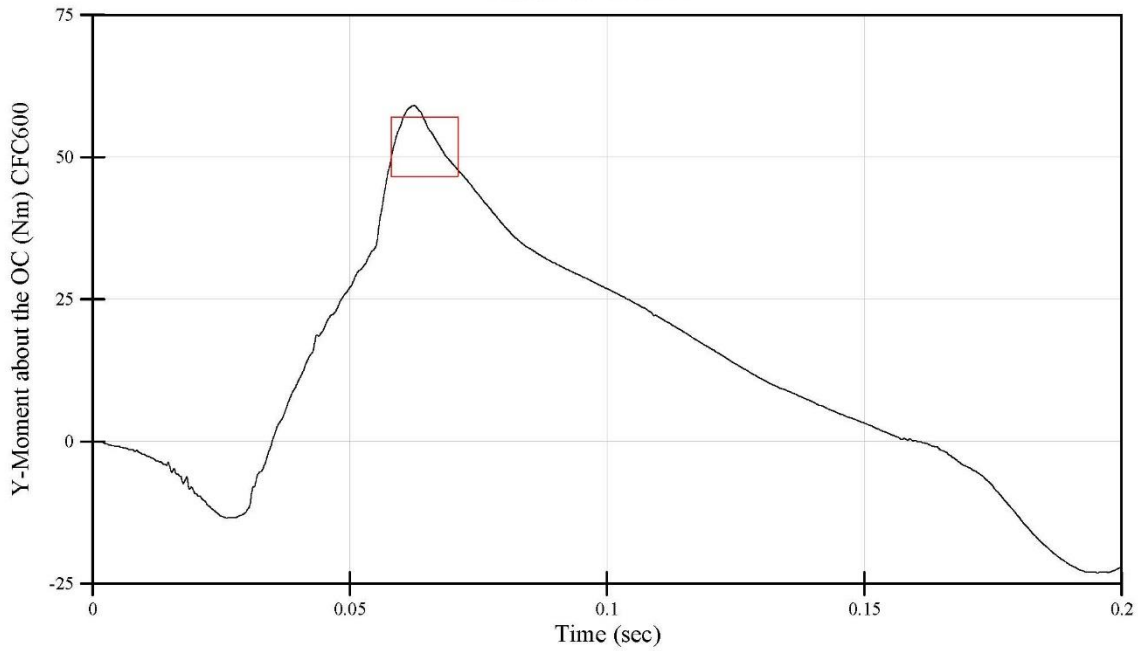

Software Version: 2.4

File Name: T0016NeckFlexion150805-01\_pro  
08/05/2015 10:24:56.0000

Test Temperature: 70.6 degrees  
Relative Humidity: 52%  
Test Velocity: 3.78 m/s

THOR Neck Flexion Certification  
Probe Acceleration  
Serial Number: T0016

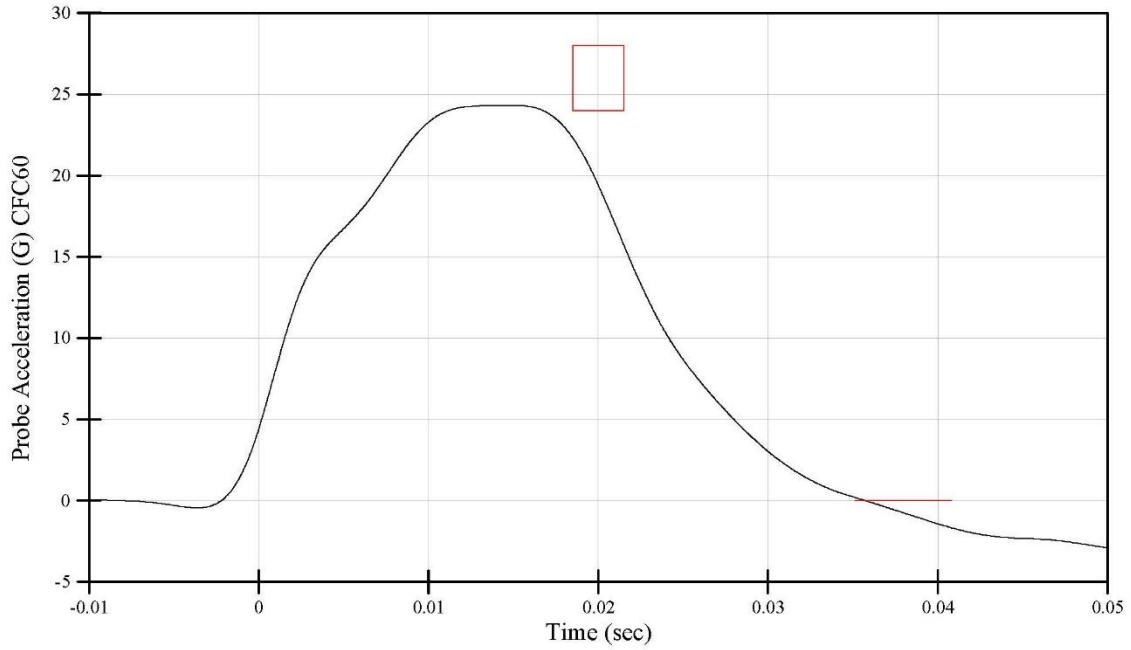

Software Version: 2.4

File Name: T0016NeckFlexion150805-01\_pro  
08/05/2015 10:24:56.0000

Test Temperature: 70.1 degrees  
Relative Humidity: 51%  
Test Velocity: 2.86 m/s

THOR Neck Left Lateral Flexion Certification  
X-Moment  
Serial Number: T0016

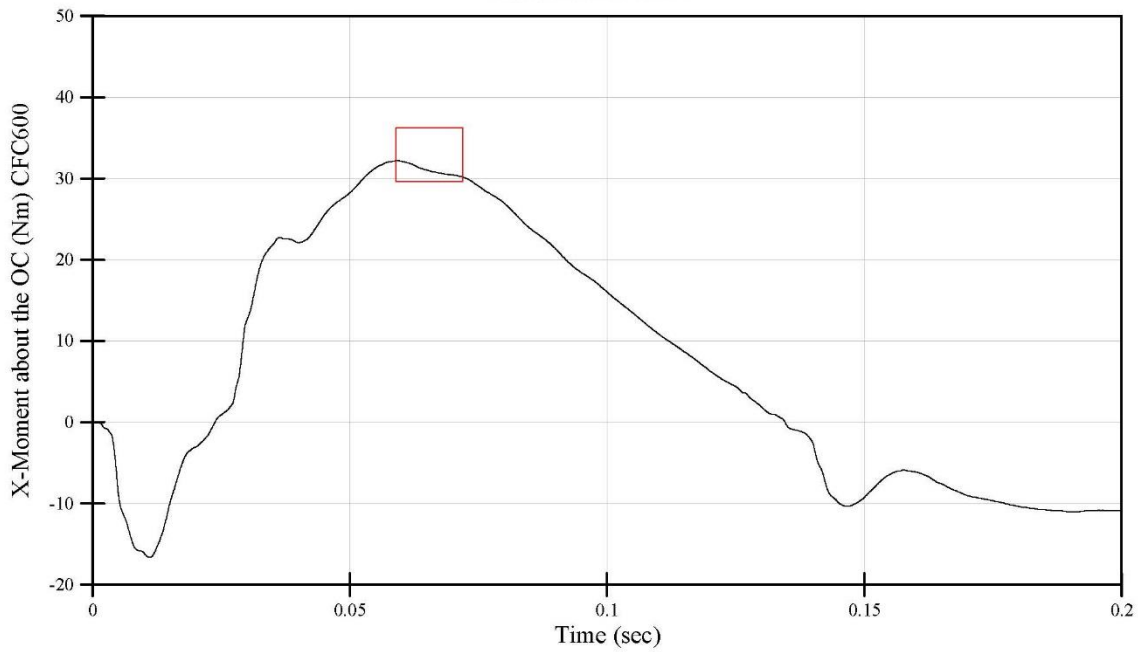

Software Version: 2.4

File Name: T0016NeckLeft150805-01\_pro  
08/05/2015 11:53:26.0000

Test Temperature: 70.1 degrees  
Relative Humidity: 51%  
Test Velocity: 2.86 m/s

THOR Neck Left Lateral Flexion Certification  
Probe Acceleration  
Serial Number: T0016

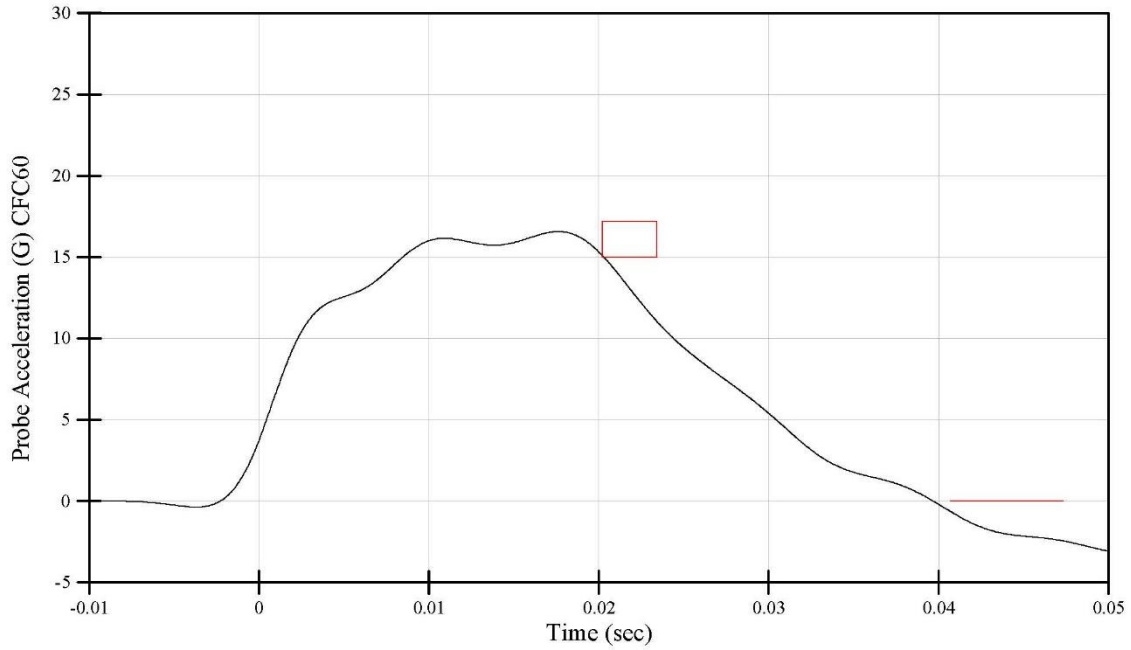

Software Version: 2.4

File Name: T0016NeckLeft150805-01\_pro  
08/05/2015 11:53:26.0000

Test Temperature: 70.2 degrees  
Relative Humidity: 52%  
Test Velocity: 2.87 m/s

THOR Neck Right Lateral Flexion Certification  
X-Moment  
Serial Number: T0016

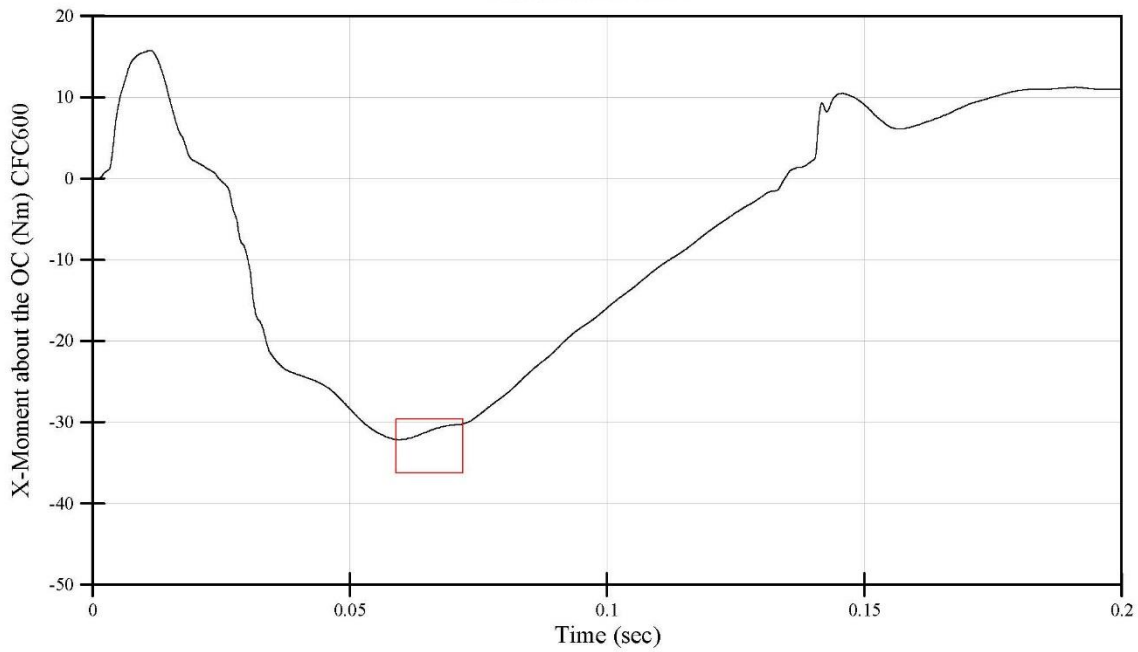

Software Version: 2.4

File Name: T0016NeckRight150805-01\_pro  
08/05/2015 11:24:43.0000

Test Temperature: 70.2 degrees  
Relative Humidity: 52%  
Test Velocity: 2.87 m/s

THOR Neck Right Lateral Flexion Certification  
Probe Acceleration  
Serial Number: T0016

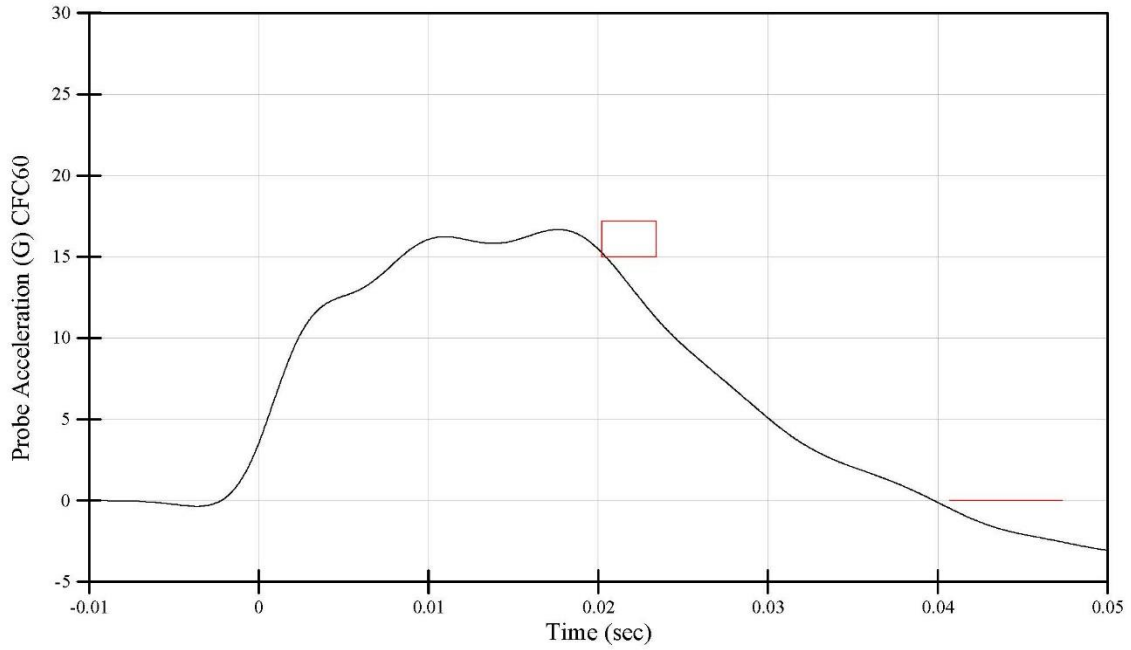

Software Version: 2.4

File Name: T0016NeckRight150805-01\_pro  
08/05/2015 11:24:43.0000

Test Temperature: 70.3 degrees  
Relative Humidity: 52%  
Test Velocity: 4.27 m/s

THOR Upper Thorax Certification  
Thorax Response With Kroell Corridor  
Serial Number: T0016

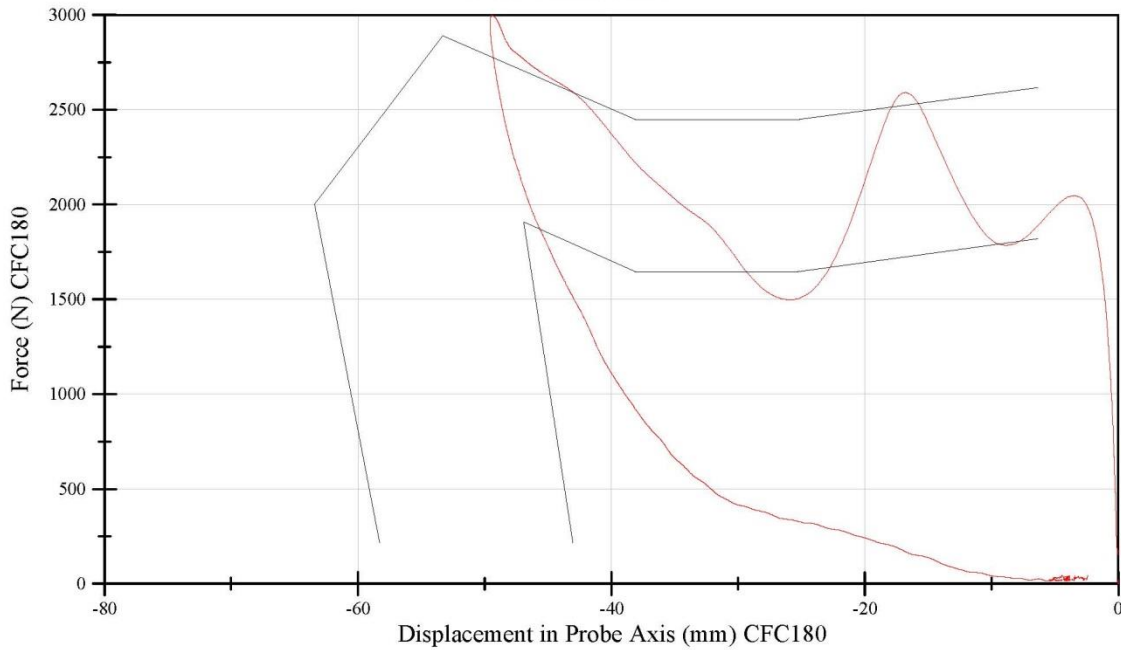

Software Version: 2.4

File Name: T0016ThoraxUpper150811-02\_pro.tdms  
08/11/2015 11:20:37.0000

Test Temperature: 70.3 degrees  
Relative Humidity: 52%  
Test Velocity: 4.27 m/s

THOR Upper Thorax Certification  
Sealed IR-TRACC  
Serial Number: T0016

— Left Upper IR-TRACC  
— Right Upper IR-TRACC

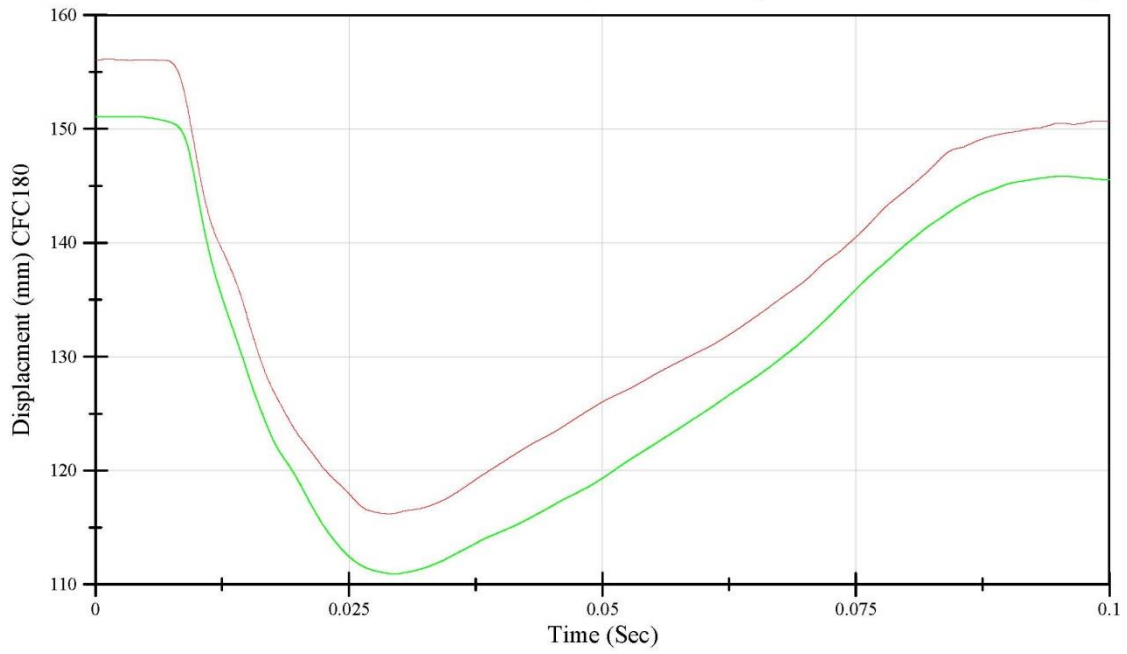

Software Version: 2.4

File Name: T0016ThoraxUpper150811-02\_pro tdms  
08/11/2015 11:20:37.0000

Test Temperature: 70.3 degrees  
Relative Humidity: 52%  
Test Velocity: 4.27 m/s

THOR Upper Thorax Certification  
Y-Potentiometer  
Serial Number: T0016

— Left Upper  
— Right Upper

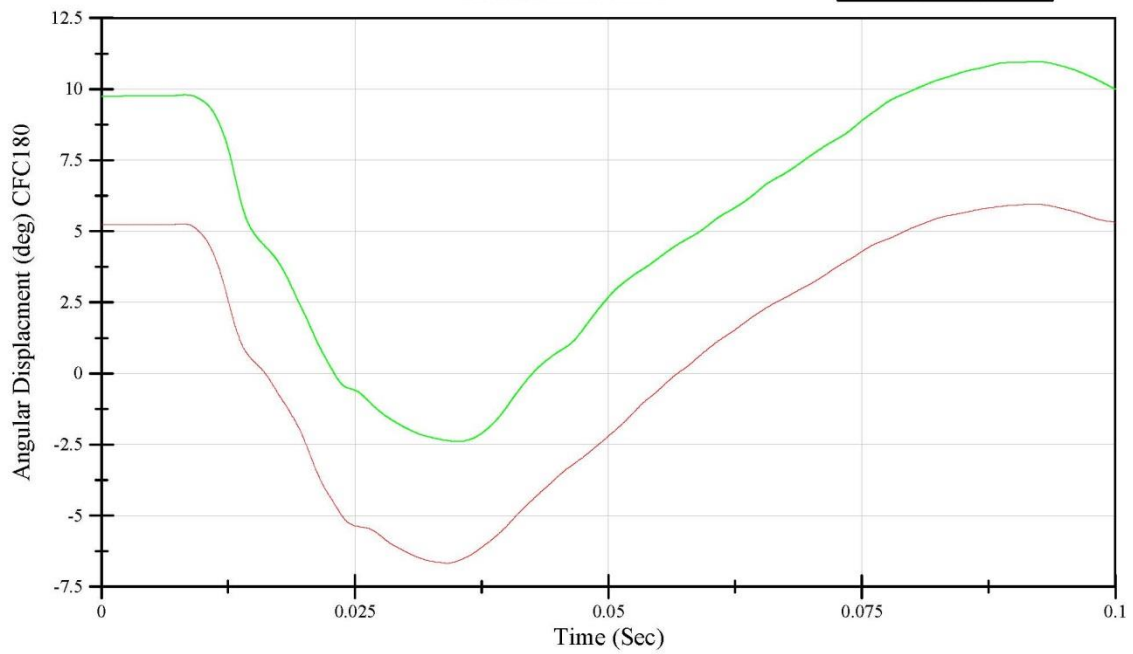

Software Version: 2.4

File Name: T0016ThoraxUpper150811-02\_pro tdms  
08/11/2015 11:20:37.0000

Test Temperature: 70.3 degrees  
Relative Humidity: 52%  
Test Velocity: 4.27 m/s

THOR Upper Thorax Certification  
Z-Potentiometer  
Serial Number: T0016

Left Upper  
Right Upper

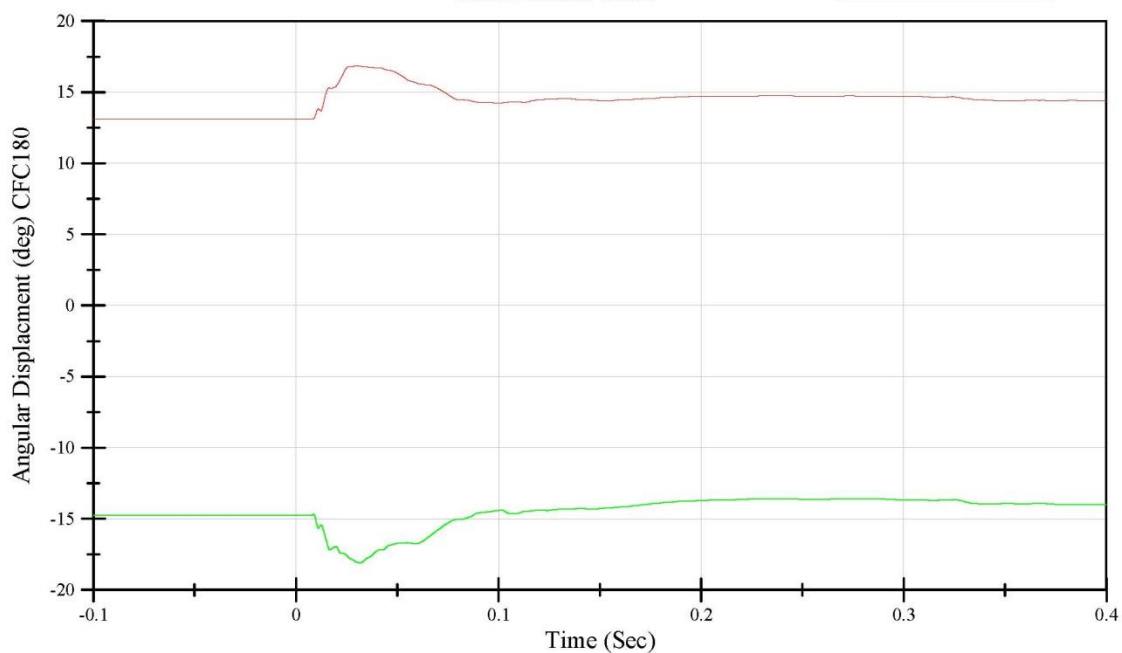

Software Version: 2.4

File Name: T0016ThoraxUpper150811-02\_pro tdms  
08/11/2015 11:20:37.0000

Test Temperature: 70.4 degrees  
Relative Humidity: 52%  
Test Velocity: 4.26 m/s

THOR Lower Left Oblique Thorax Certification  
Thorax Displacement vs. Probe Force  
Serial Number: T0016

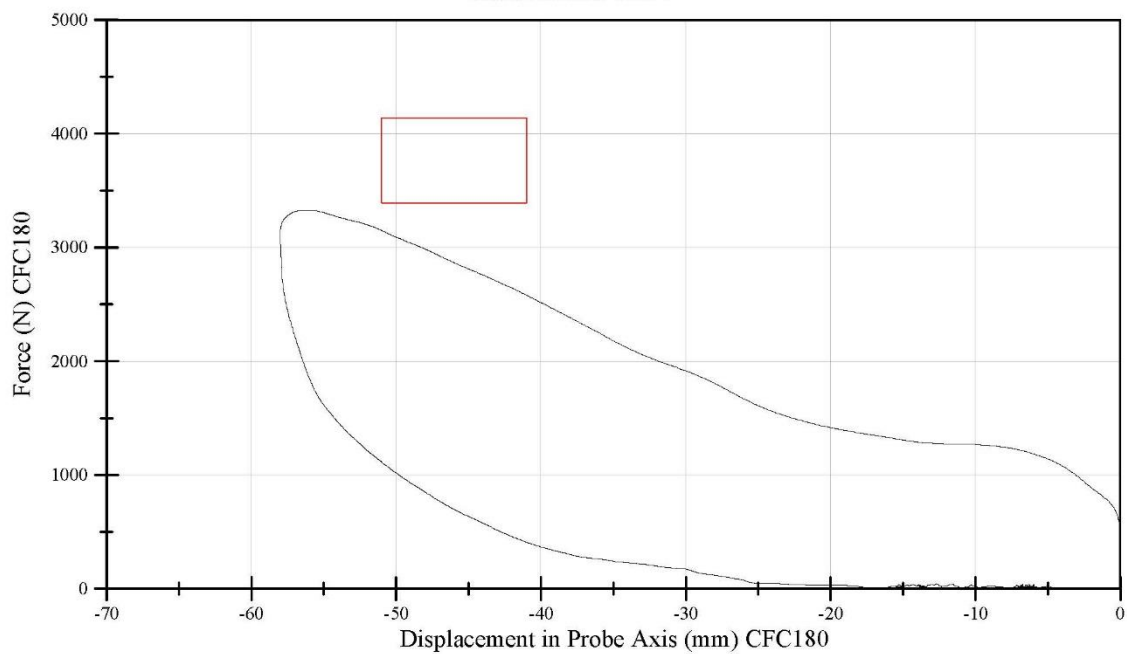

Software Version: 2.4

File Name: T0016ObliqueLeft150811-01\_pro tdms  
08/11/2015 14:14:26.0000

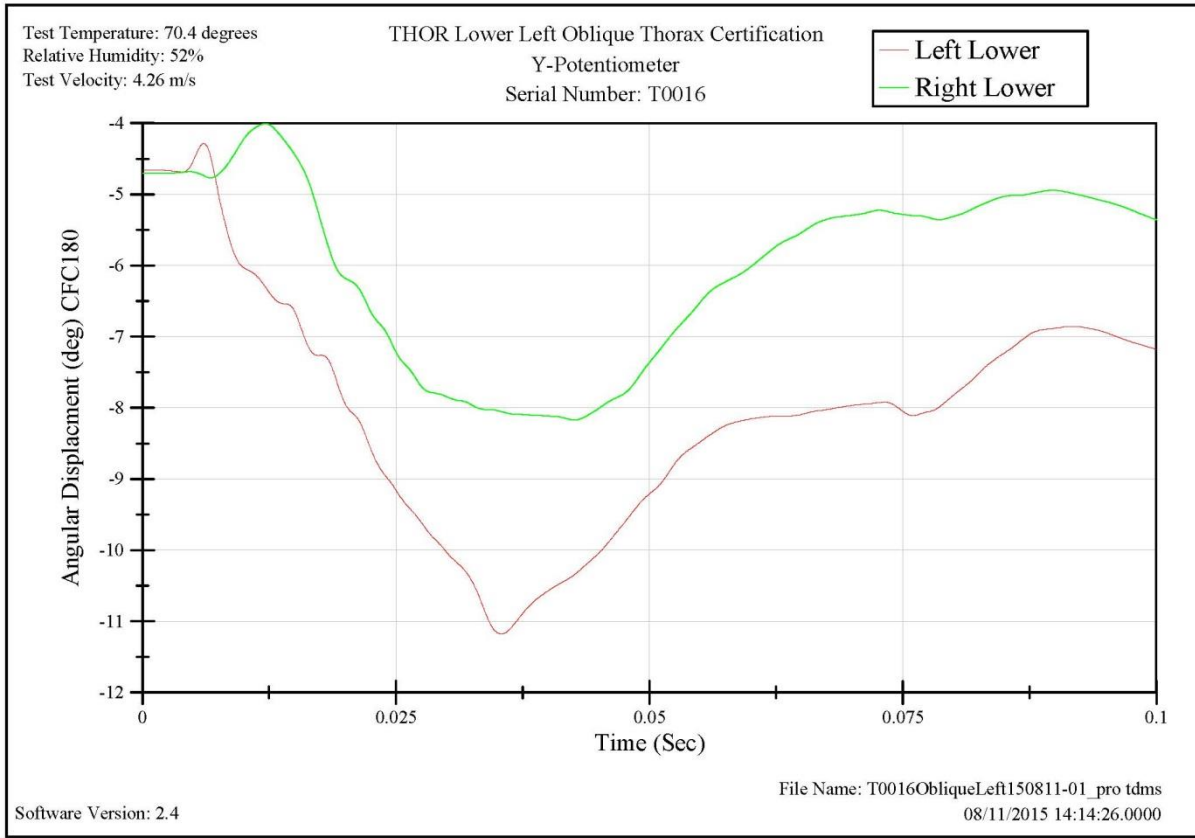
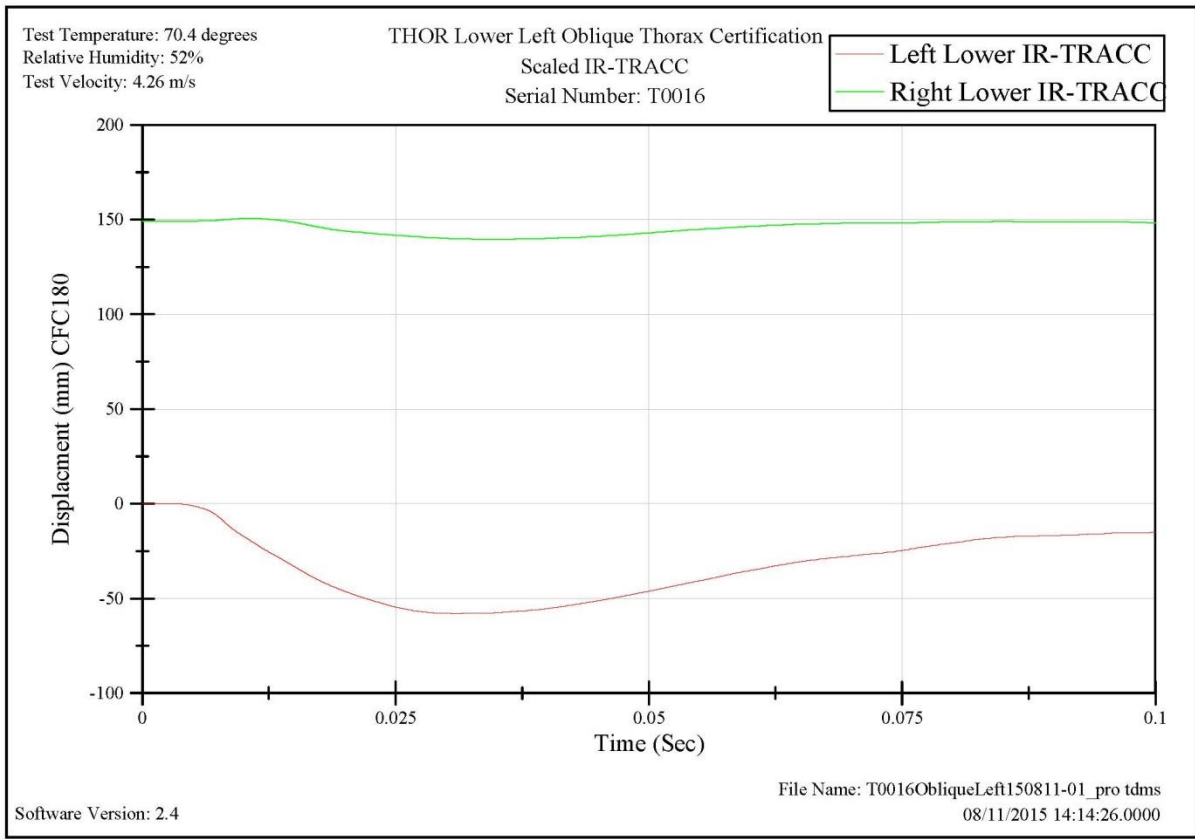

Test Temperature: 70.4 degrees  
Relative Humidity: 52%  
Test Velocity: 4.26 m/s

THOR Lower Left Oblique Thorax Certification  
Z-Potentiometer  
Serial Number: T0016

— Left Lower  
— Right Lower

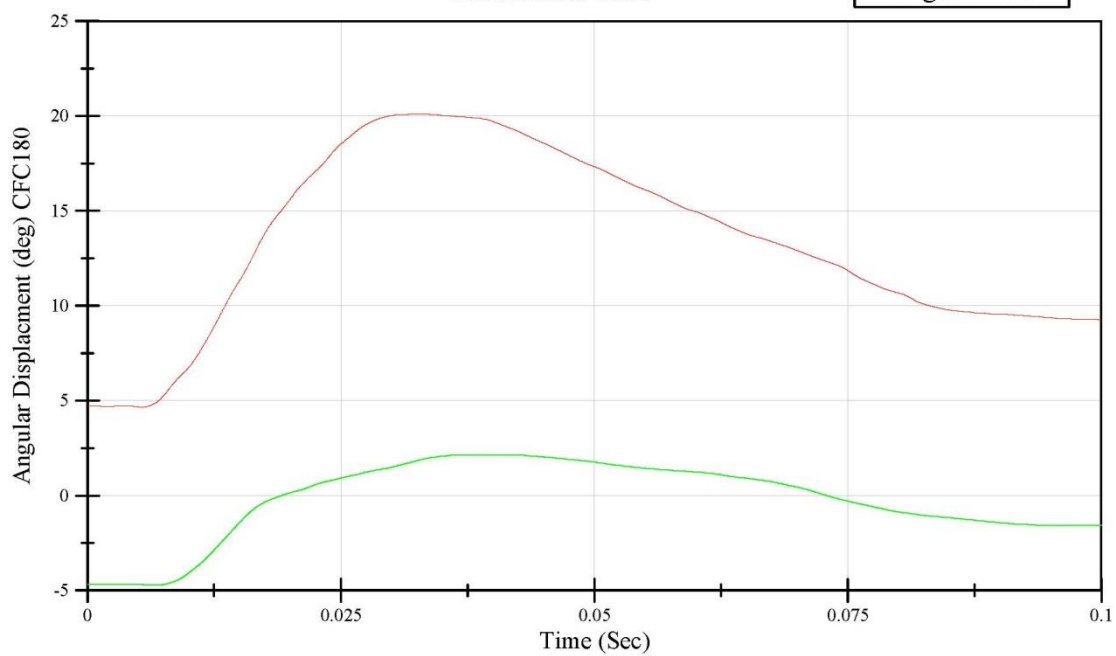

Software Version: 2.4

File Name: T0016ObliqueLeft150811-01\_pro tdms  
08/11/2015 14:14:26.0000

Test Temperature: 70.4 degrees  
Relative Humidity: 52%  
Test Velocity: 4.26 m/s

THOR Lower Left Oblique Thorax Certification  
Thorax Displacement vs. Probe Force  
Serial Number: T0116

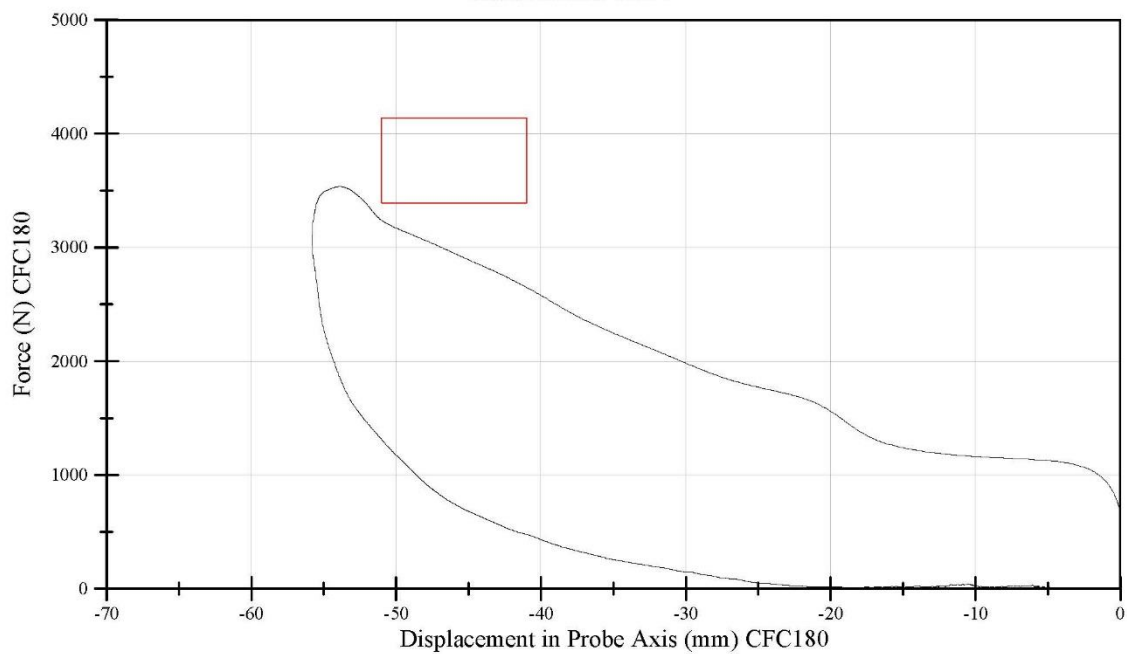

Software Version: 2.4

File Name: T0016ObliqueLeft150812-02  
08/12/2015 12:00:59.0000

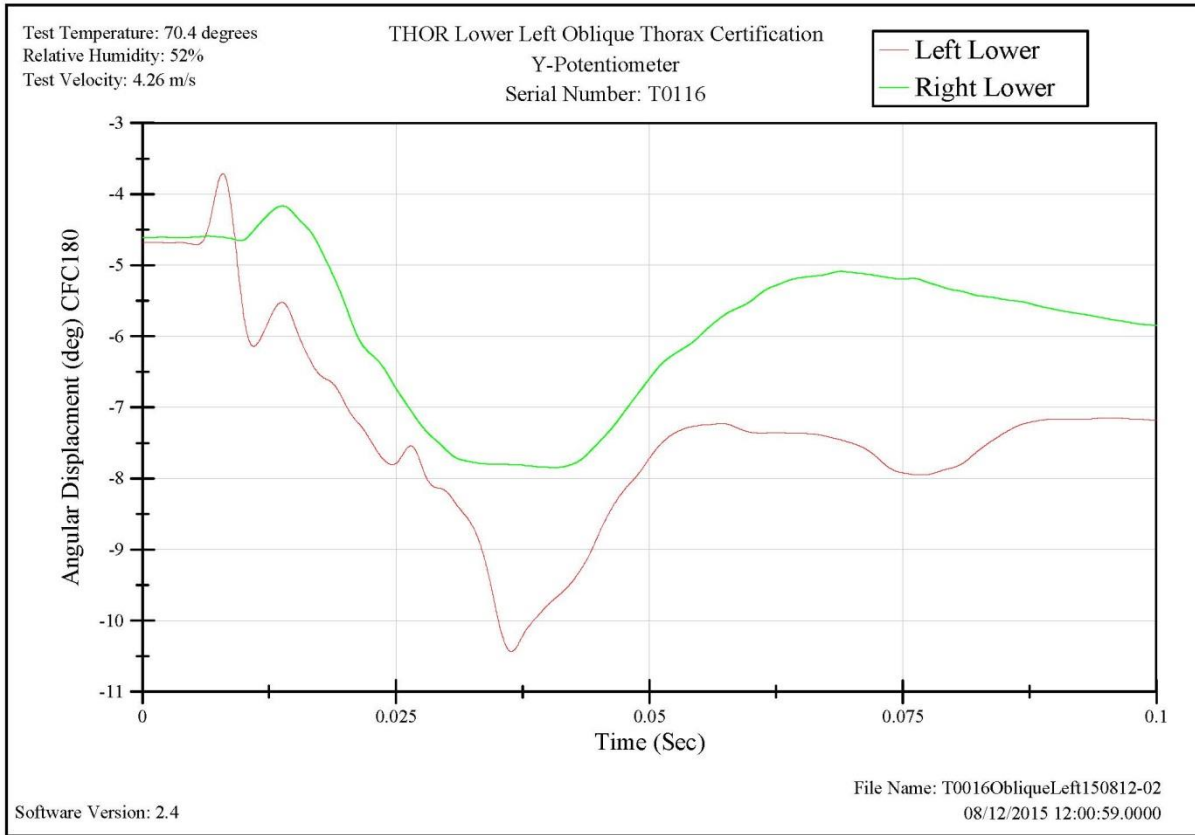
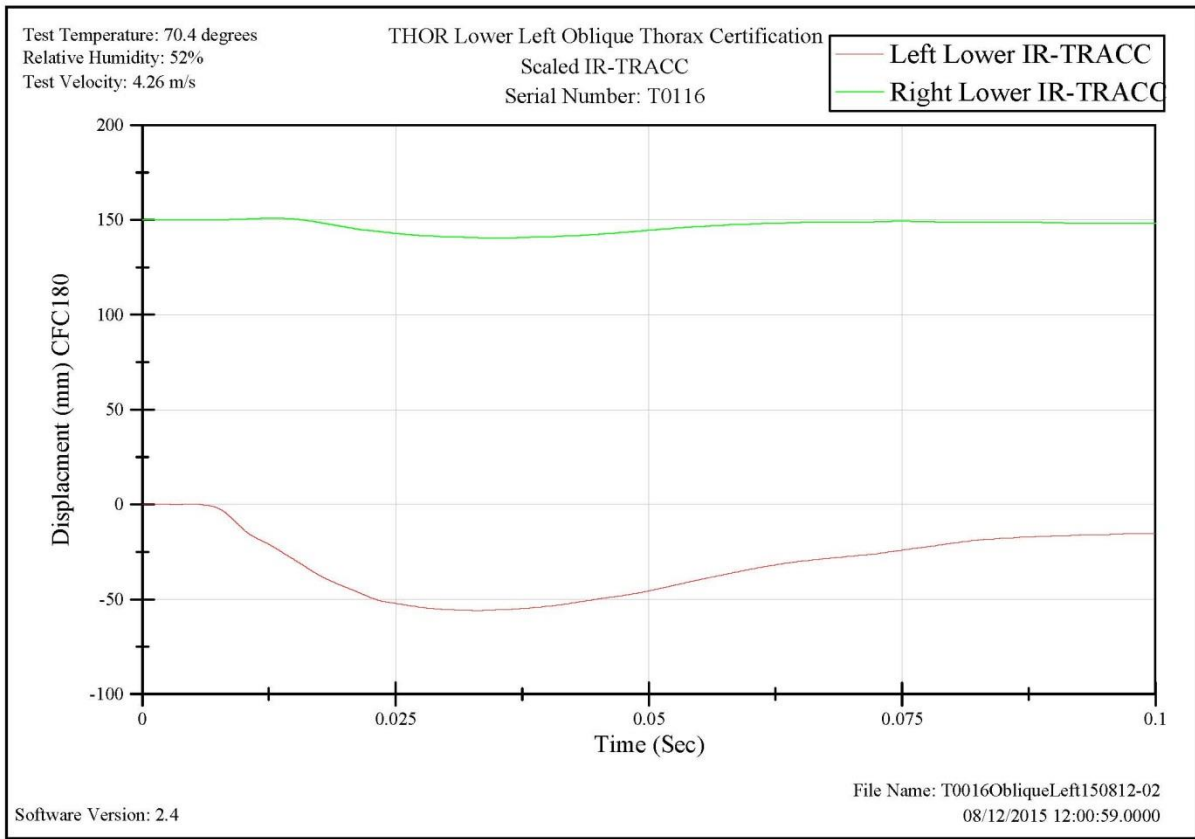

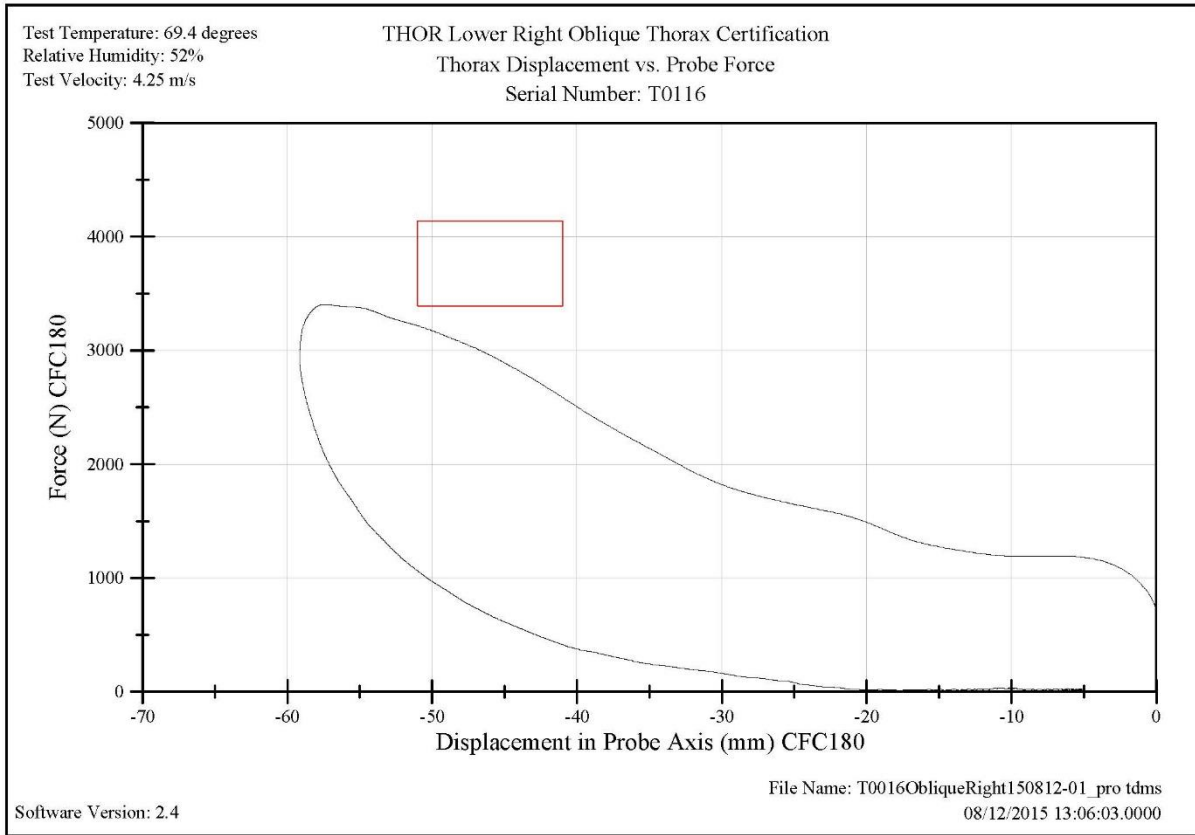
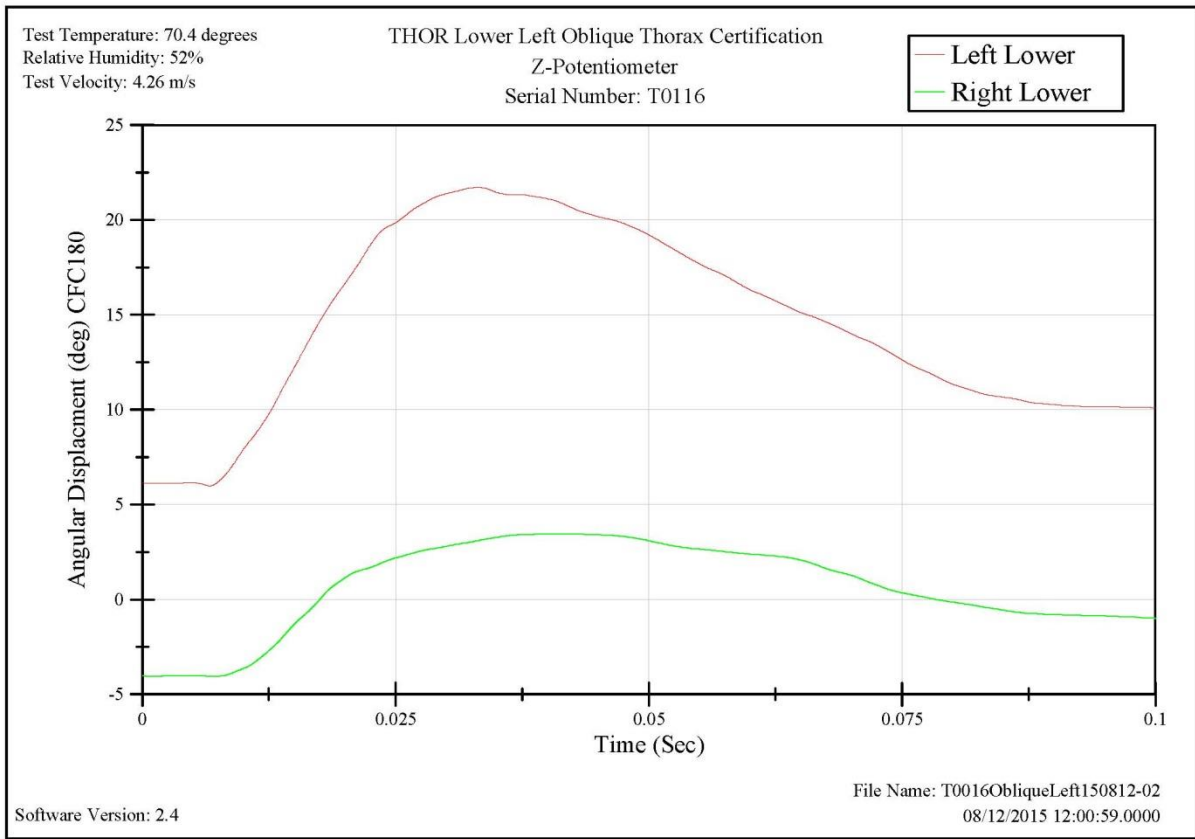

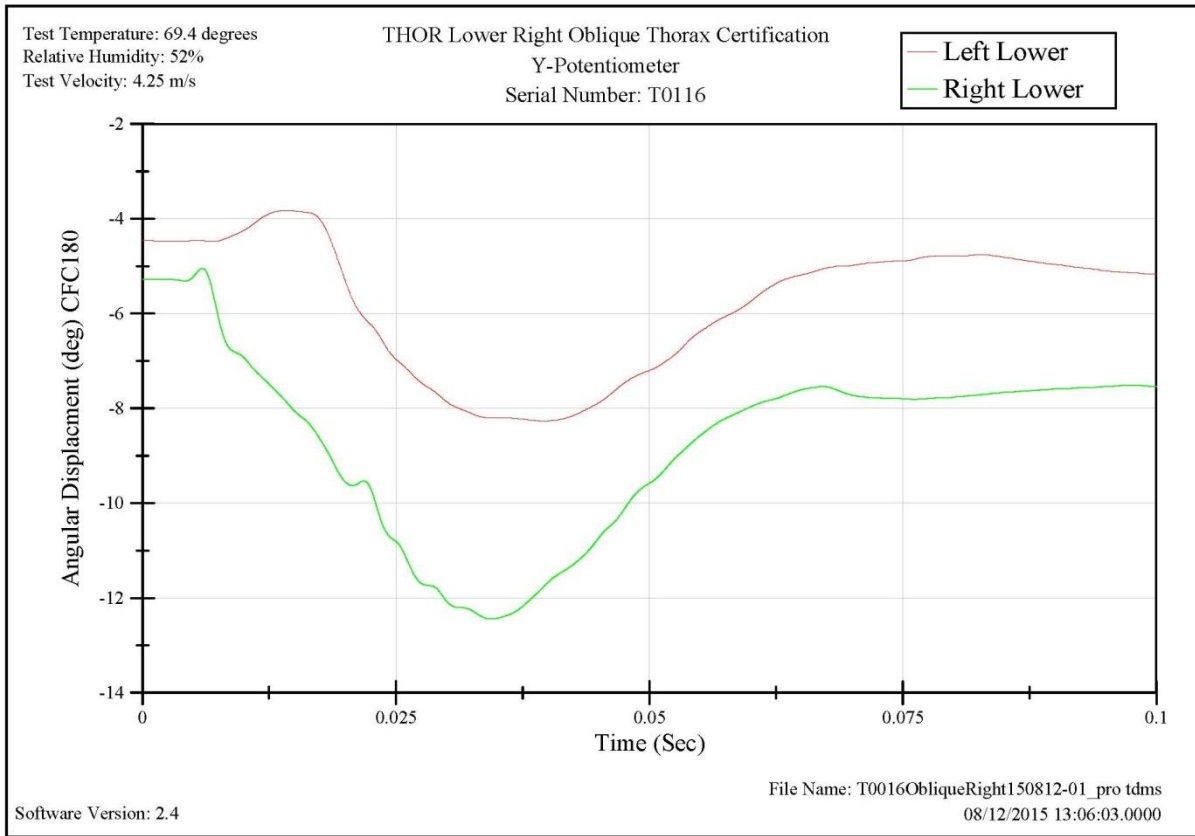
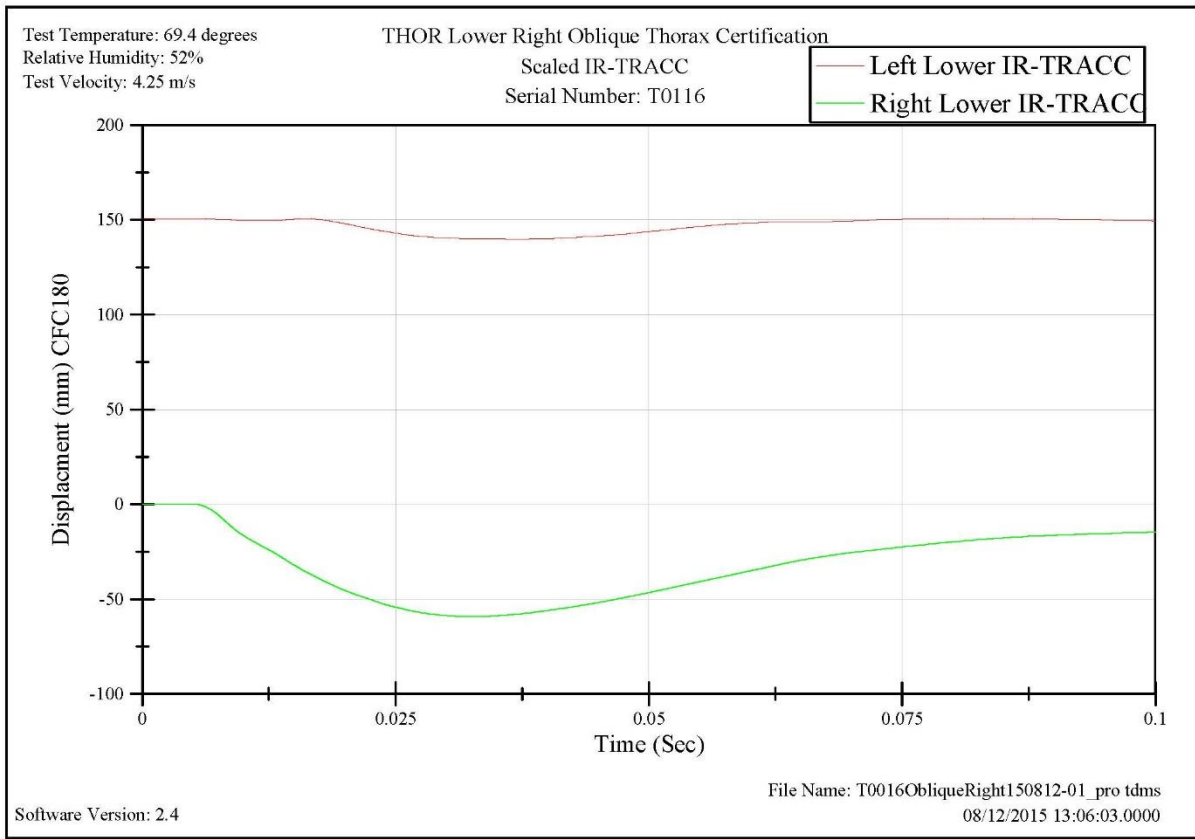

Test Temperature: 69.4 degrees  
Relative Humidity: 52%  
Test Velocity: 4.25 m/s

THOR Lower Right Oblique Thorax Certification  
Z-Potentiometer  
Serial Number: T0116

Left Lower  
Right Lower

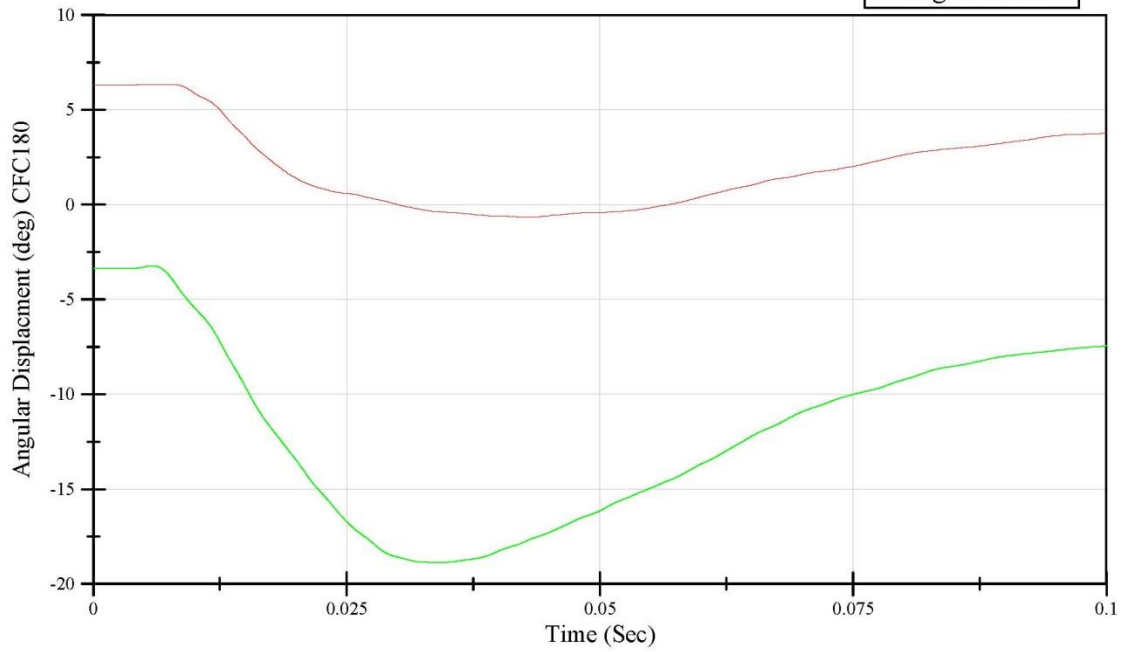

Software Version: 2.4

File Name: T0016ObliqueRight150812-01\_pro tdms  
08/12/2015 13:06:03.0000

Test Temperature: 70.6 degrees  
Relative Humidity: 53%  
Test Velocity: 6.04 m/s

THOR Lower Abdomen Certification  
Abdomen Displacement vs. Probe Force  
Serial Number: T0016

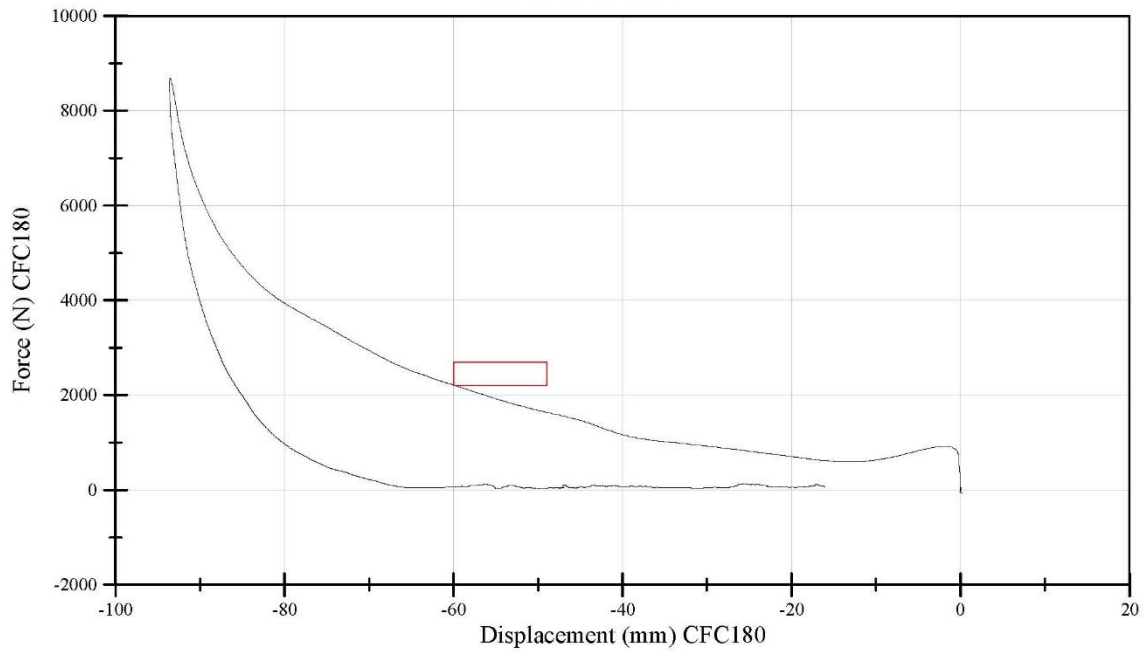

Software Version: 2.4

File Name: T0016ABLR150807-02\_proTDM  
08/07/2015 08:12:59.0000

Test Temperature: 70.6 degrees  
Relative Humidity: 53%  
Test Velocity: 6.04 m/s

THOR Lower Abdomen Certification  
IRTRACC Displacement  
Serial Number: T0016

— Left Lower IR-TRACC  
— Right Lower IR-TRACC

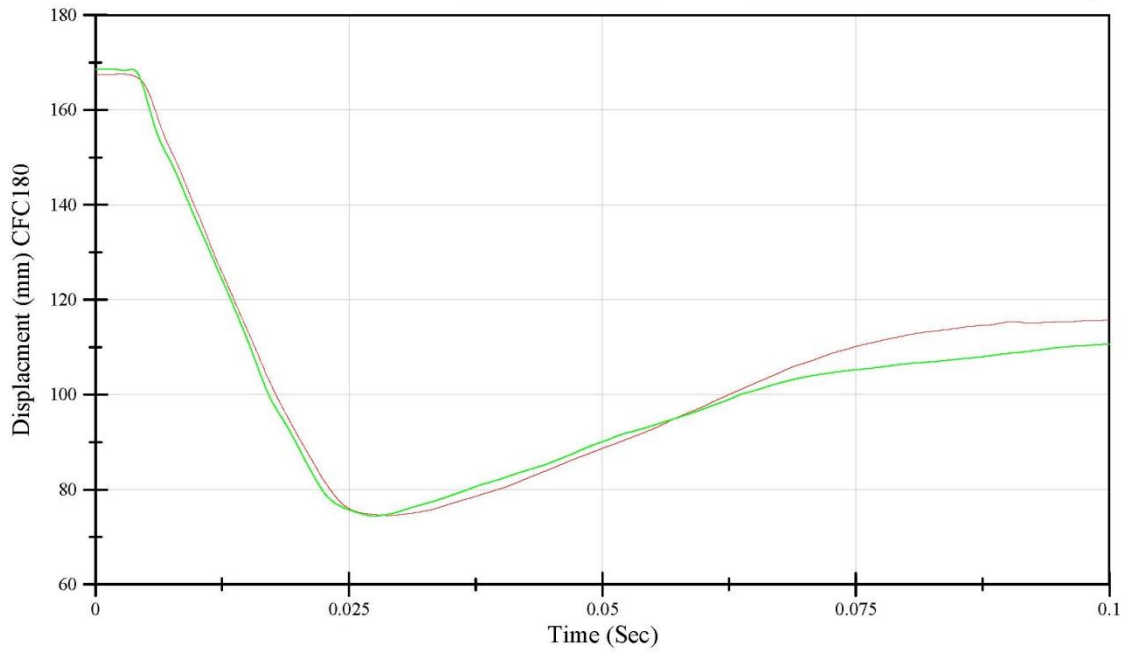

Software Version: 2.4

File Name: T0016ABLR150807-02\_proTDM  
08/07/2015 08:12:59.0000

Test Temperature: 70.6 degrees  
Relative Humidity: 53%  
Test Velocity: 6.04 m/s

THOR Lower Abdomen Certification  
Y-Pot Displacement  
Serial Number: T0016

— Left Lower  
— Right Lower

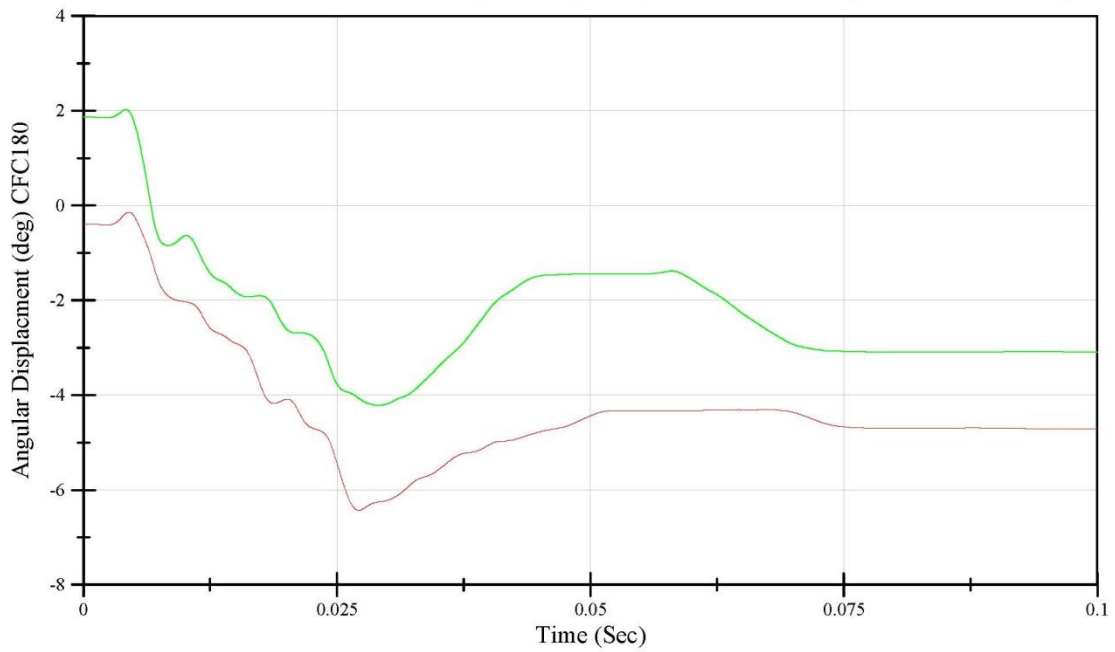

Software Version: 2.4

File Name: T0016ABLR150807-02\_proTDM  
08/07/2015 08:12:59.0000

Test Temperature: 70.6 degrees  
Relative Humidity: 53%  
Test Velocity: 6.04 m/s

THOR Lower Abdomen Certification  
Z-Potentiometer  
Serial Number: T0016

— Left Lower  
— Right Lower

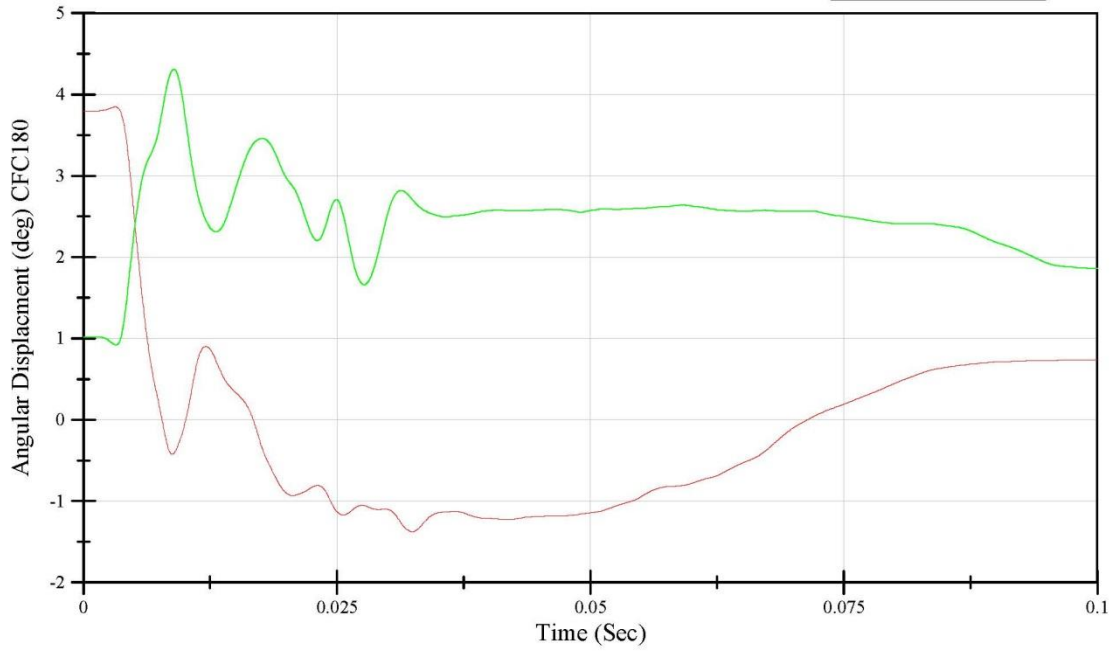

Software Version: 2.4

File Name: T0016ABLR150807-02\_proTDM  
08/07/2015 08:12:59.0000

Test Temperature: 70.6 degrees  
Relative Humidity: 52%  
Test Velocity: 6.57 m/s

THOR Upper Abdomen Certification  
Abdomen Displacement vs. Probe Force  
Serial Number: T0016

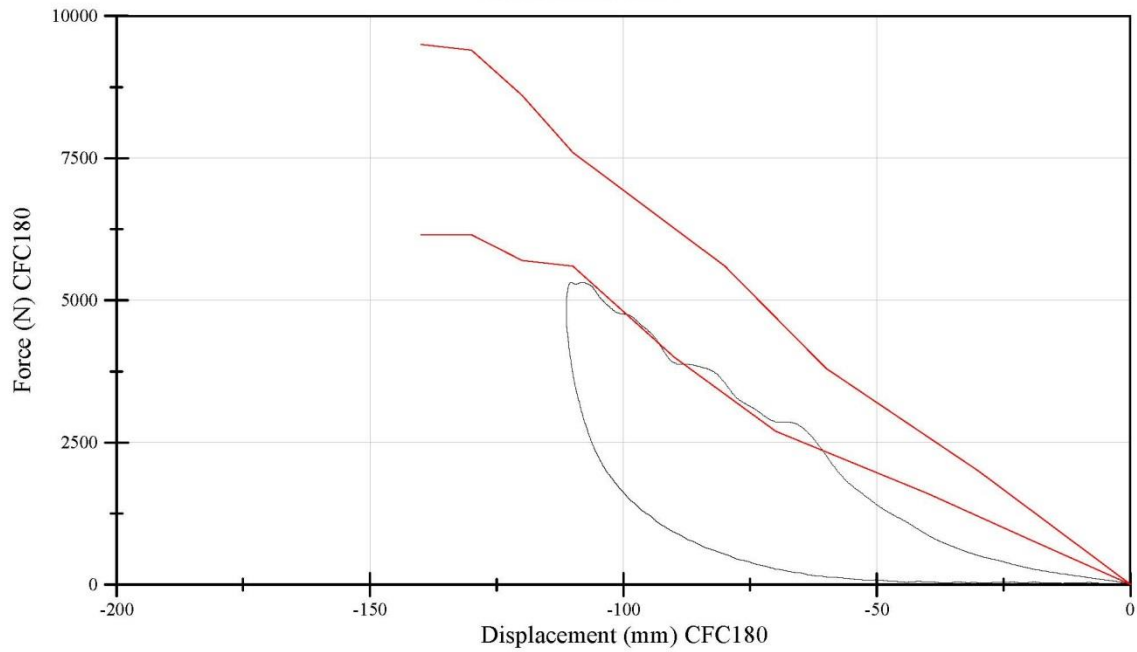

Software Version: 2.4

File Name: T0016ABUP150807-01\_proTDM  
08/07/2015 13:20:12.0000

Test Temperature: 70.1 degrees  
Relative Humidity: 53%  
Test Velocity: NOVALUE m/s

THOR Occipital Condyle Quasi-Static Certification  
Displacement vs. Torque  
Serial Number: T0016

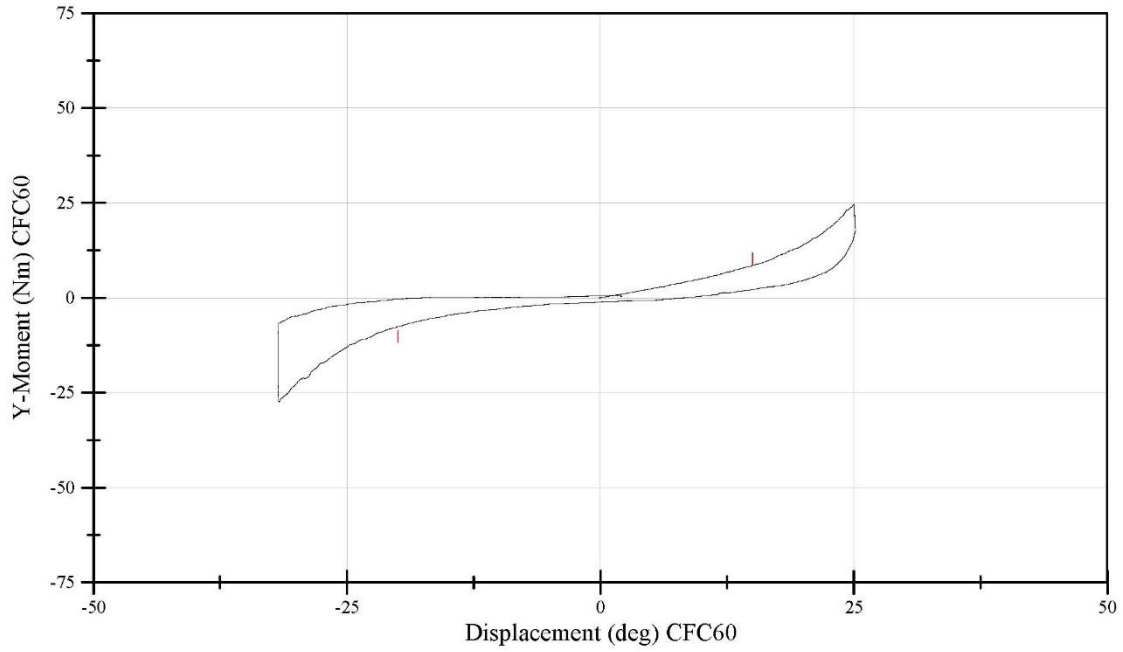

Software Version: 2.4

File Name: T0016OCPot150804-02\_pro  
08/04/2015 13:15:32.0000

Test Temperature: 70 degrees  
Relative Humidity: 52%  
Test Velocity: NOVALUE m/s

THOR Occipital Condyle Quasi-Static Certification  
Displacement vs. Torque  
Serial Number: T0016

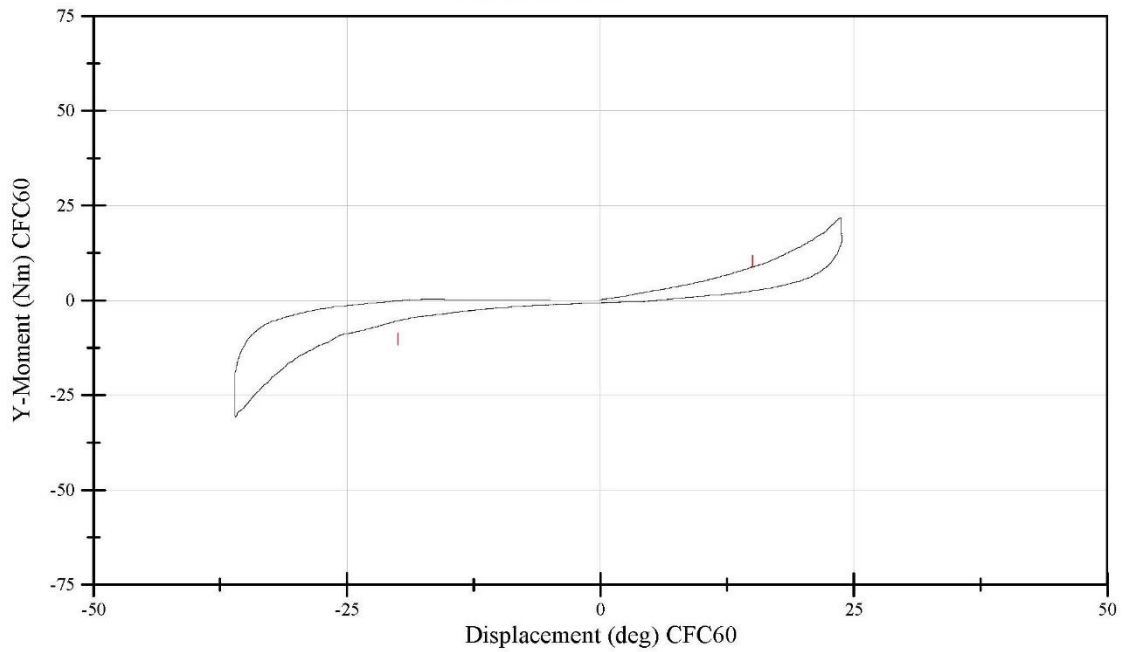

Software Version: 2.4

File Name: T0016OCPot150804-03\_pro  
08/04/2015 13:40:46.0000

Test Temperature: 70.2 degrees  
Relative Humidity: 53%  
Test Velocity: 2.63 m/s

THOR Left Femur Certification  
Probe Force  
Serial Number: T0016

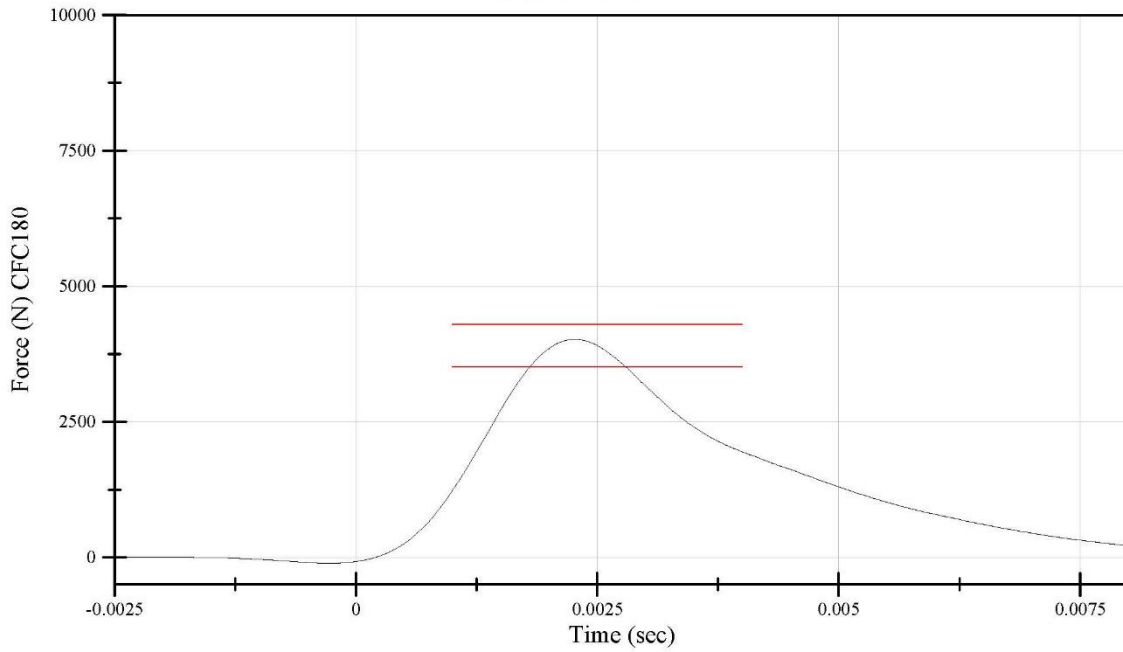

Software Version: 2.4

File Name: T0016LeftKnee150813-02\_pro  
08/14/2015 07:00:34.0000

Test Temperature: 71 degrees  
Relative Humidity: 51%  
Test Velocity: 2.76 m/s

THOR Left Knee Certification  
Femur Force vs. Knee Displacement  
Serial Number: 017169

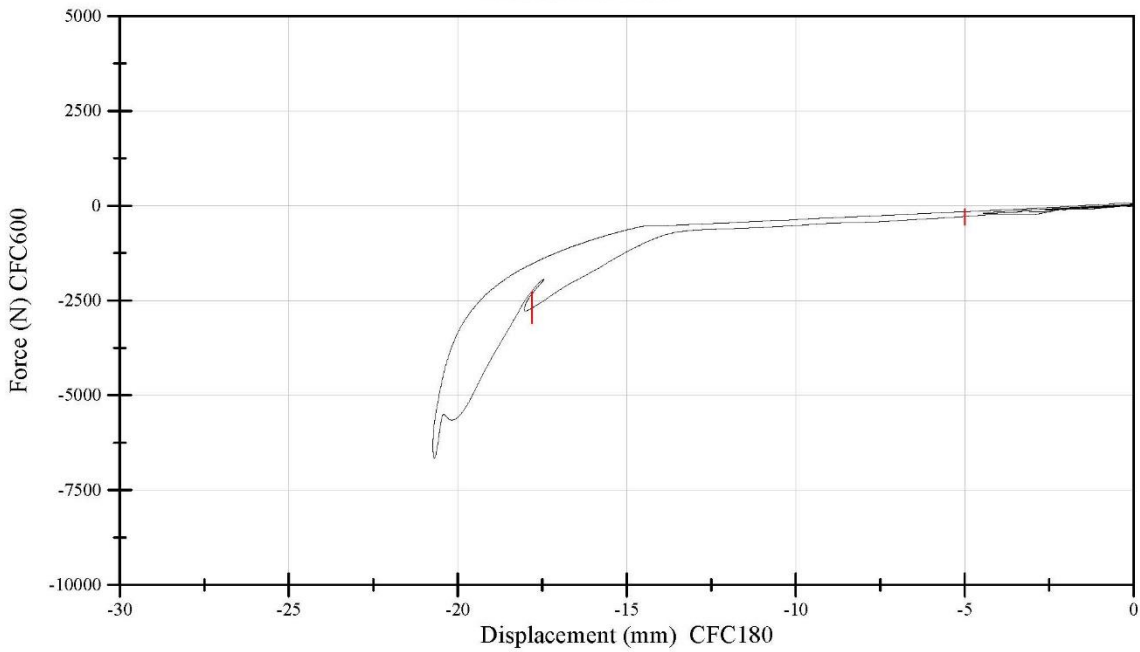

Software Version: 2.4

File Name: 017169Knee150708\_01processed  
07/08/2015 14:22:57.0000

Test Temperature: 69.7 degrees  
Relative Humidity: 52%  
Test Velocity: 2.63 m/s

THOR Right Femur Certification  
Probe Force  
Serial Number: T0016

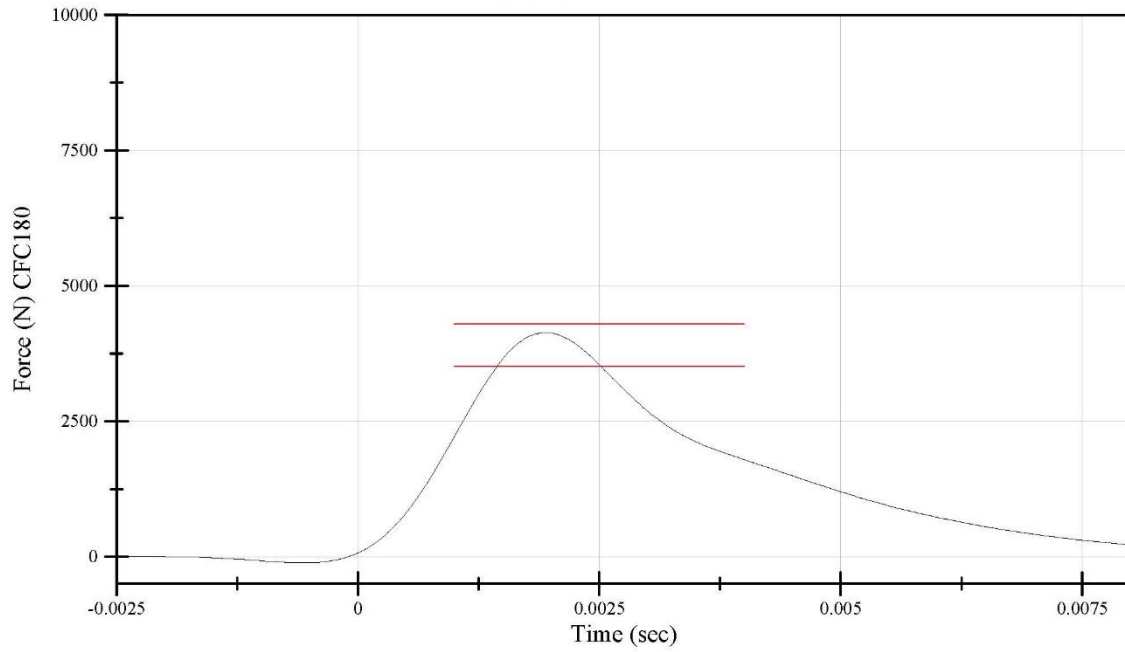

Software Version: 2.4

File Name: T0016RightKnee150814-01\_pro  
08/14/2015 07:48:52.0000

Test Temperature: 71 degrees  
Relative Humidity: 50%  
Test Velocity: 2.75 m/s

THOR Right Knee Certification  
Femur Force vs. Knee Displacement  
Serial Number: 12070382

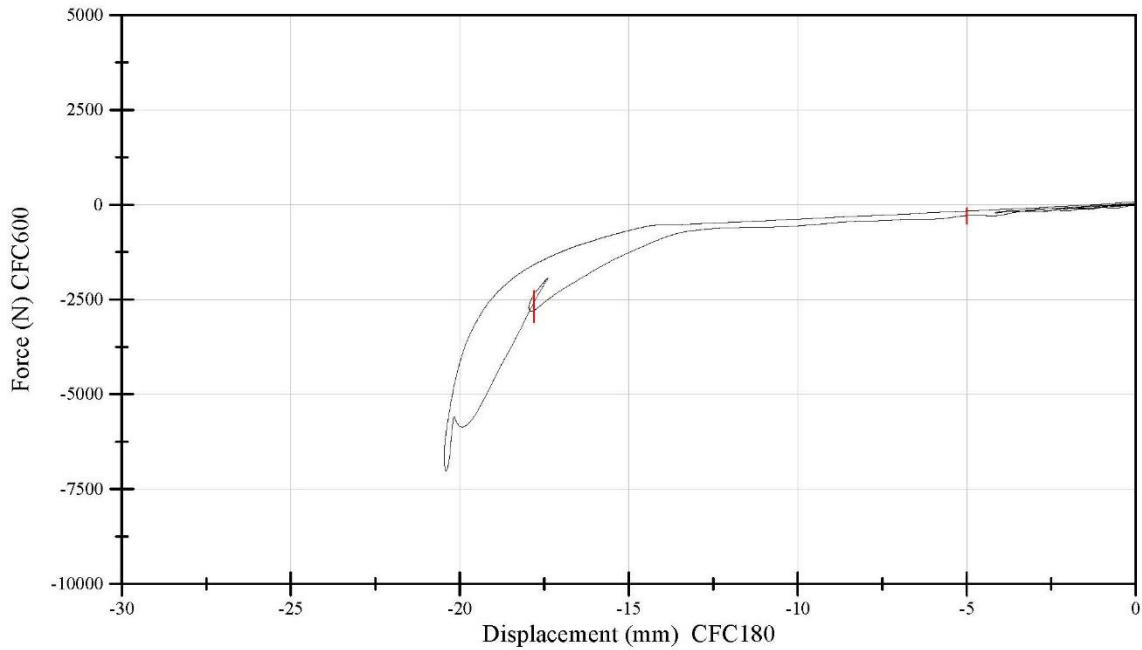

Software Version: 2.4

File Name: 12070382Knee150708\_01renamedprocessed  
07/09/2015 06:31:18.0000

Test Temperature: 71 degrees  
Relative Humidity: 51%  
Test Velocity: 5.03 m/s

THOR Right Foot Dorsiflexion Certification  
Tibia Load  
Serial Number: LX 0018

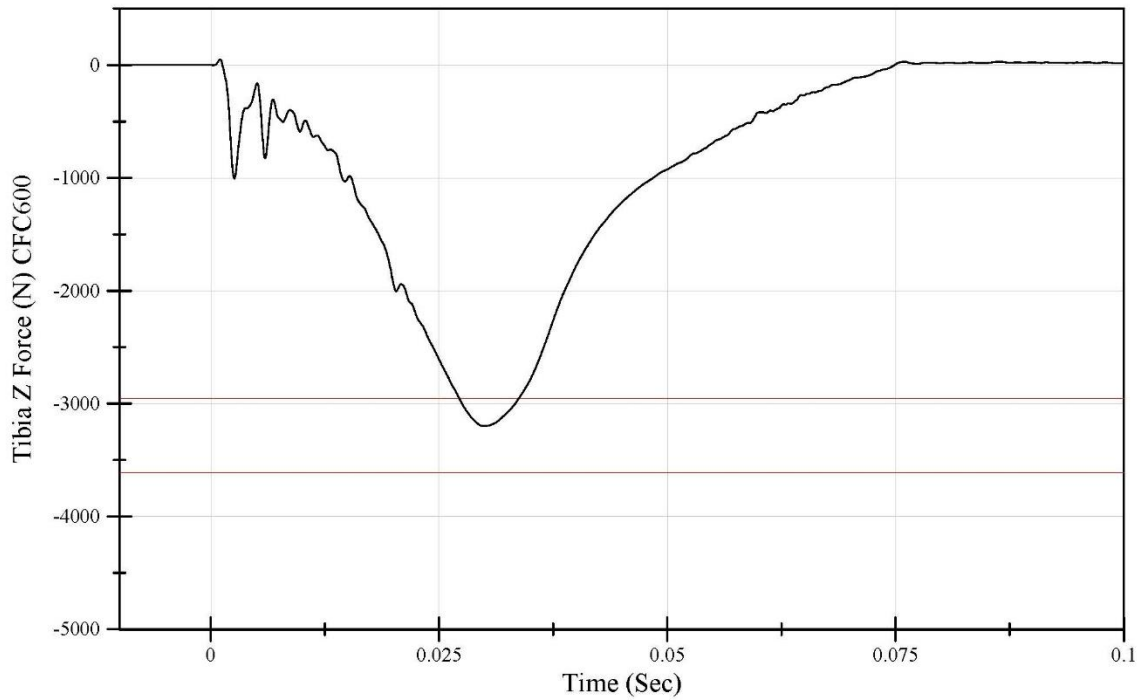

Software Version: 2.4

File Name: LX0018Ball1150707\_02processed  
07/07/2015 12:41:39.0000

Test Temperature: 71 degrees  
Relative Humidity: 51%  
Test Velocity: 5.03 m/s

THOR Right Foot Dorsiflexion Certification  
Ankle Y-Moment  
Serial Number: LX 0018

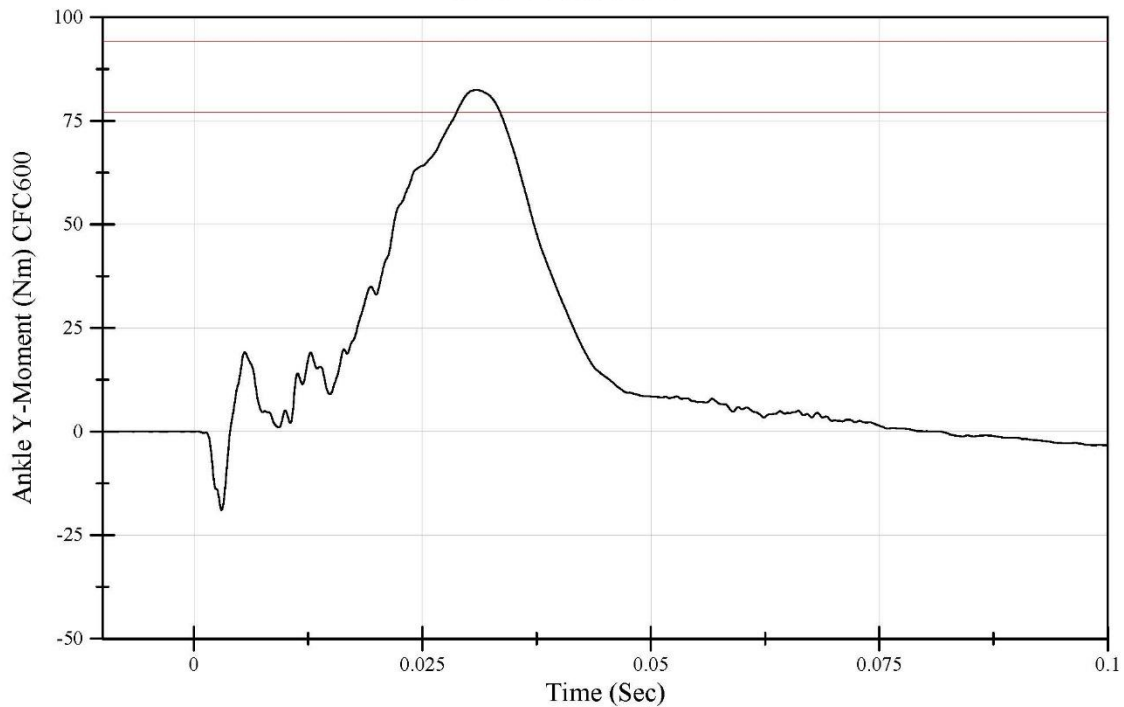

Software Version: 2.4

File Name: LX0018Ball1150707\_02processed  
07/07/2015 12:41:39.0000

Test Temperature: 71 degrees  
Relative Humidity: 51%  
Test Velocity: 5.03 m/s

### THOR Right Foot Dorsiflexion Certification

Ankle Y-Rotation  
Serial Number: LX 0018

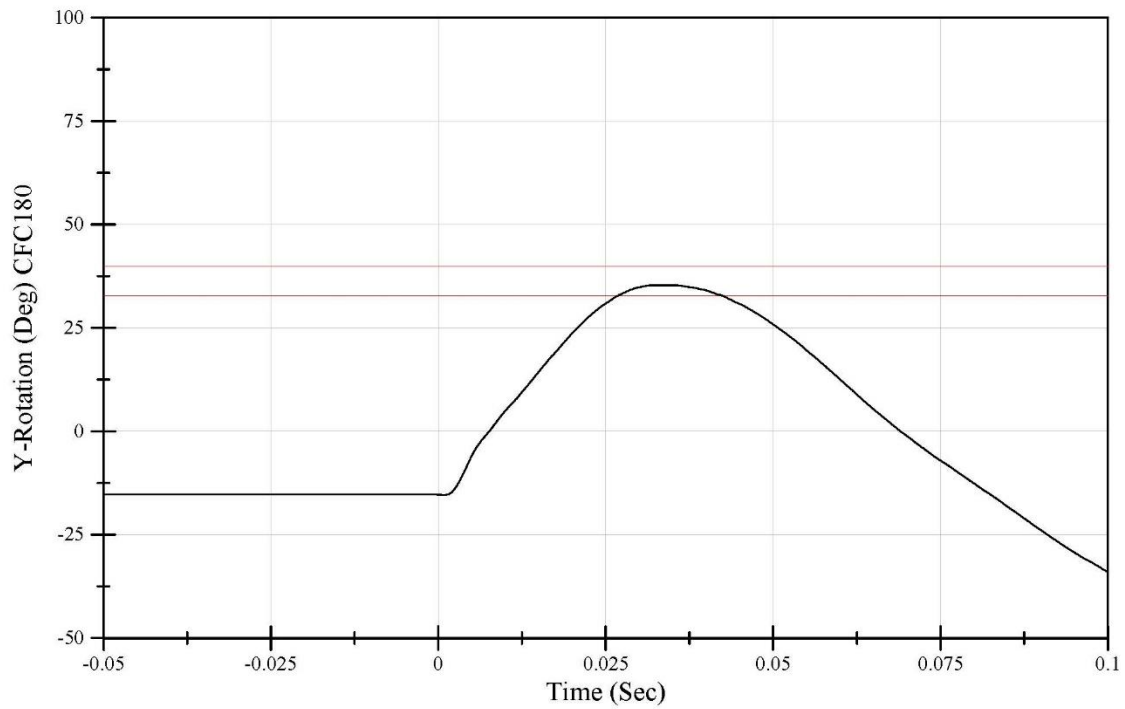

Software Version: 2.4

File Name: LX0018Ball150707\_02processed  
07/07/2015 12:41:39.0000

Test Temperature: 71 degrees  
Relative Humidity: 51%  
Test Velocity: 2 m/s

### THOR Right Foot Eversion Certification

Tibia Load  
Serial Number: LX 0018

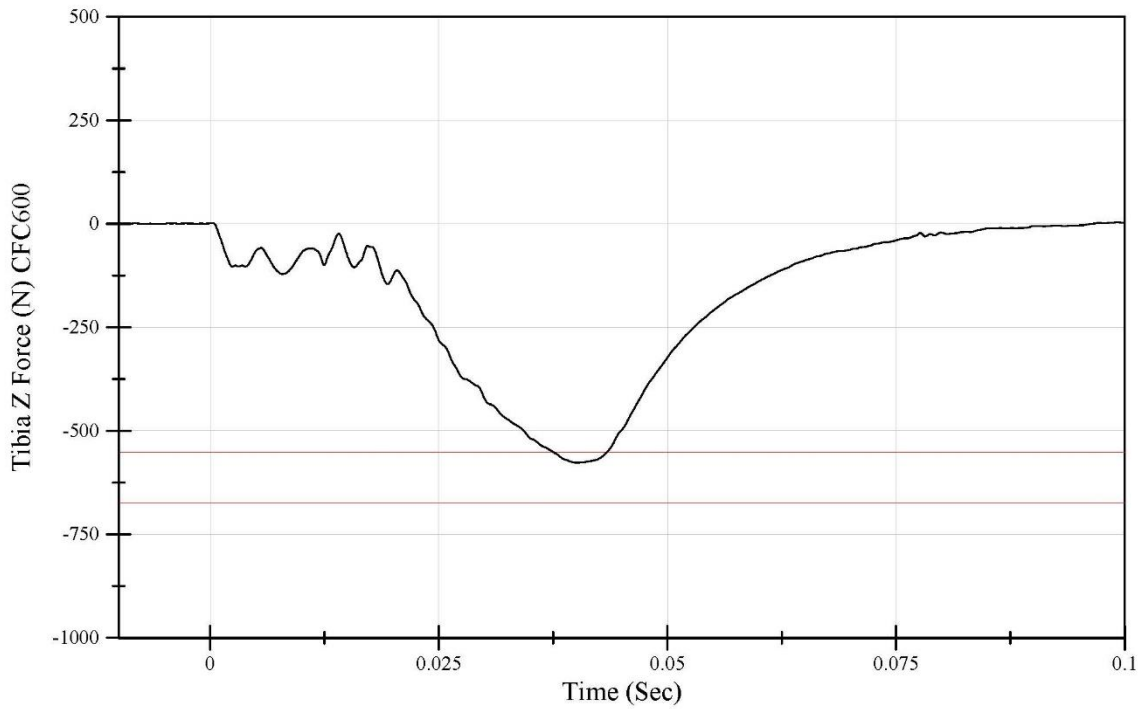

Software Version: 2.4

File Name: LX0018Eversion150707\_01processed  
07/07/2015 11:02:49.0000

Test Temperature: 71 degrees  
Relative Humidity: 51%  
Test Velocity: 2 m/s

THOR Right Foot Eversion Certification  
Ankle Moment  
Serial Number: LX 0018

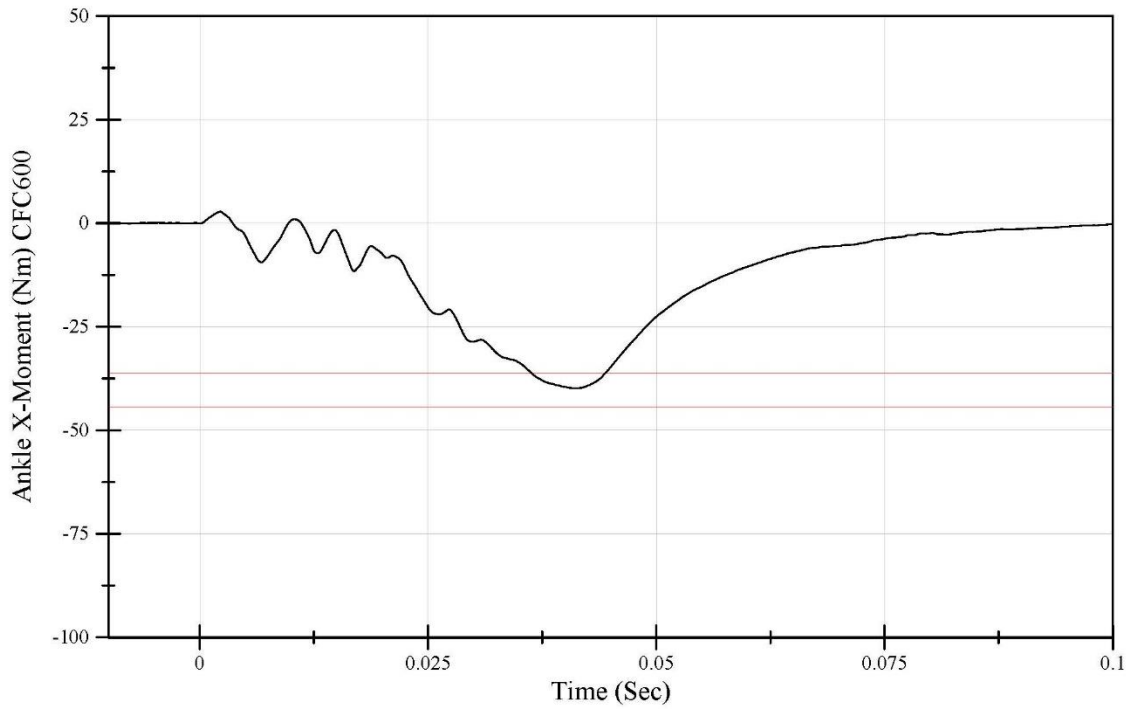

Software Version: 2.4

File Name: LX0018Eversion150707\_01processed  
07/07/2015 11:02:49.0000

Test Temperature: 71 degrees  
Relative Humidity: 51%  
Test Velocity: 2 m/s

THOR Right Foot Eversion Certification  
Ankle X-Rotation  
Serial Number: LX 0018

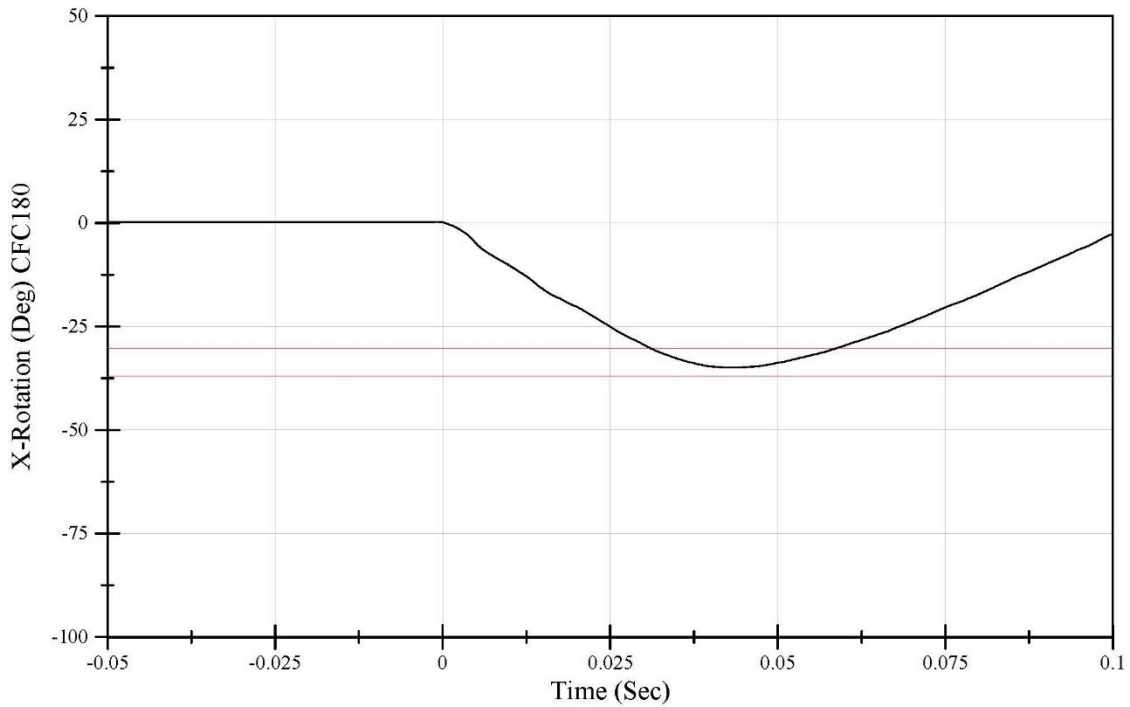

Software Version: 2.4

File Name: LX0018Eversion150707\_01processed  
07/07/2015 11:02:49.0000

Test Temperature: 71 degrees  
Relative Humidity: 51%  
Test Velocity: 3.91 m/s

THOR Right Foot Heel Certification  
Tibia Load  
Serial Number: LX 0018

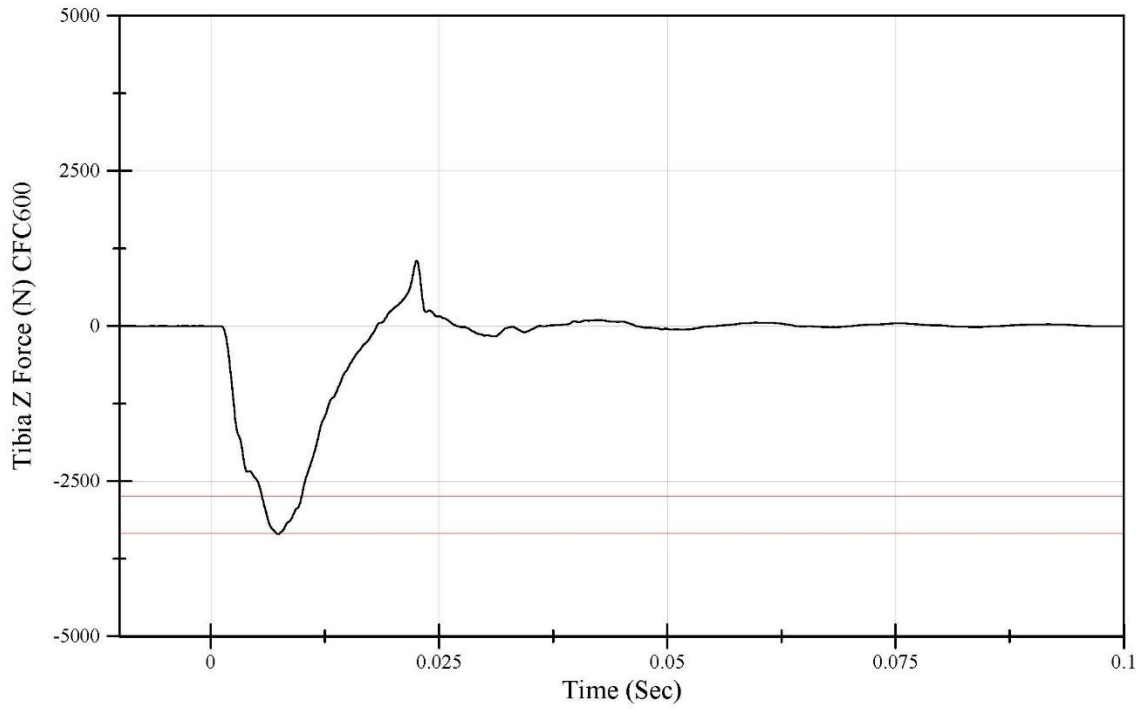

Software Version: 2.4

File Name: LX0018Heel150707\_01processed  
07/07/2015 13:34:11.0000

Test Temperature: 71 degrees  
Relative Humidity: 51%  
Test Velocity: 1.99 m/s

THOR Right Foot Inversion Certification  
Tibia Load  
Serial Number: LX 0018

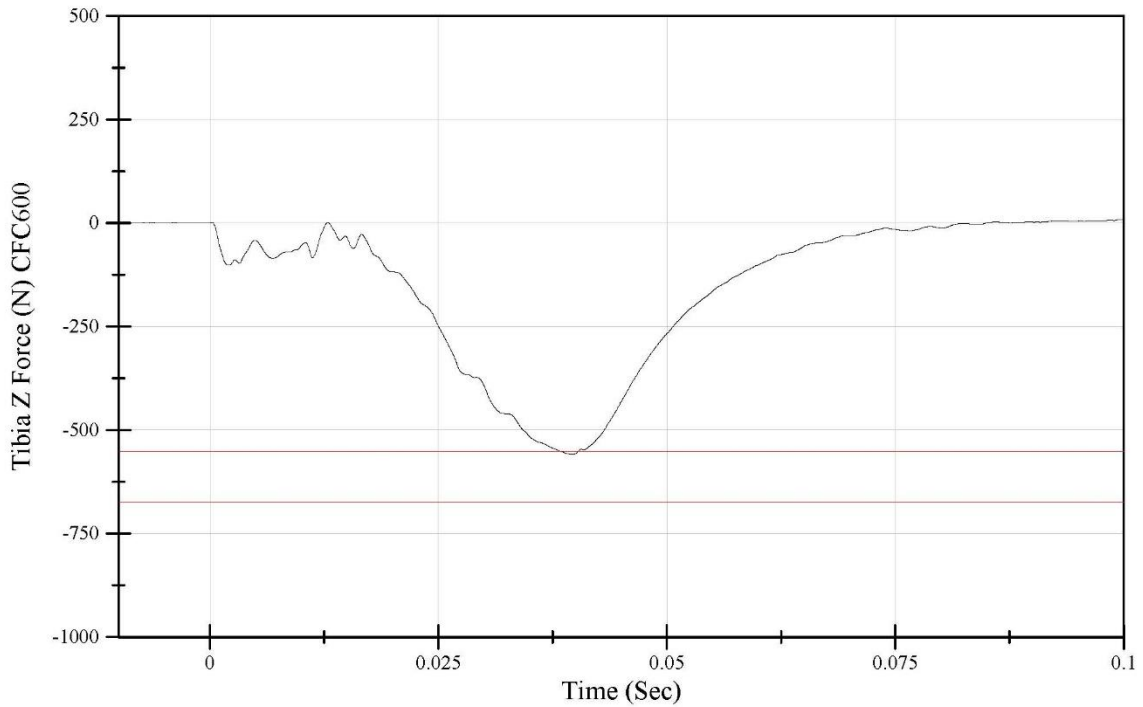

Software Version: 2.4

File Name: LX0018Inversion150707\_01renamedprocessed  
07/07/2015 10:04:43.0000

Test Temperature: 71 degrees  
Relative Humidity: 51%  
Test Velocity: 1.99 m/s

THOR Right Foot Inversion Certification  
Ankle Moment  
Serial Number: LX 0018

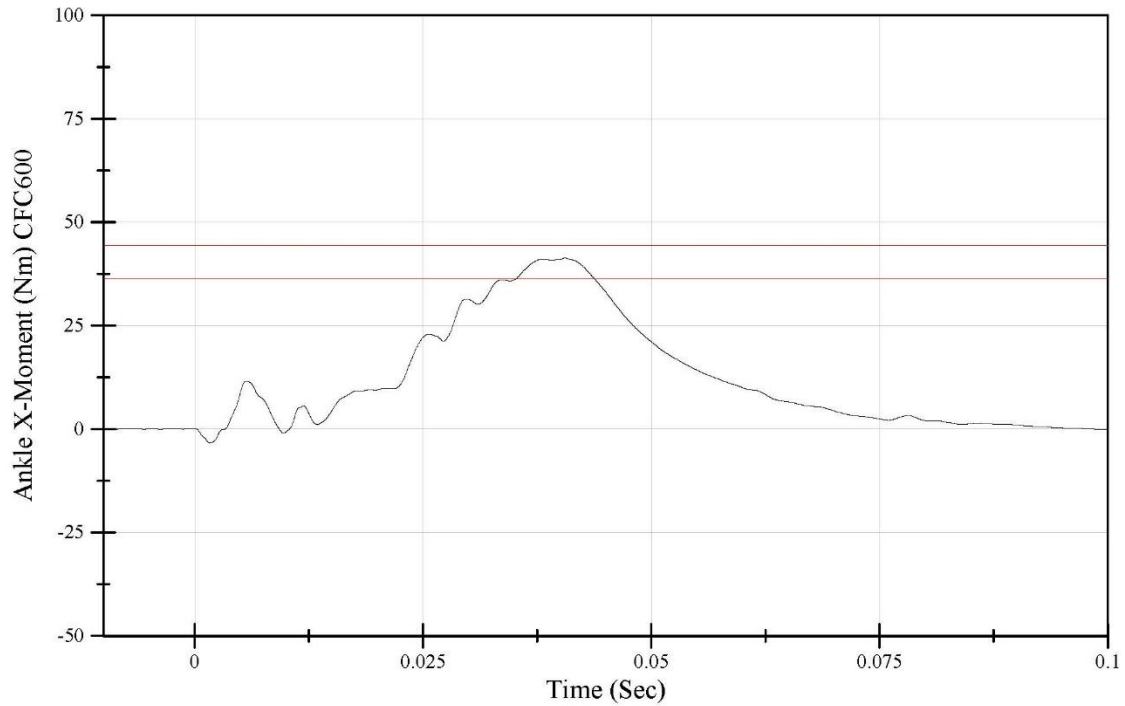

Software Version: 2.4

File Name: LX0018Inversion150707\_01renamedprocessed  
07/07/2015 10:04:43.0000

Test Temperature: 71 degrees  
Relative Humidity: 51%  
Test Velocity: 1.99 m/s

THOR Right Foot Inversion Certification  
Ankle X-Rotation  
Serial Number: LX 0018

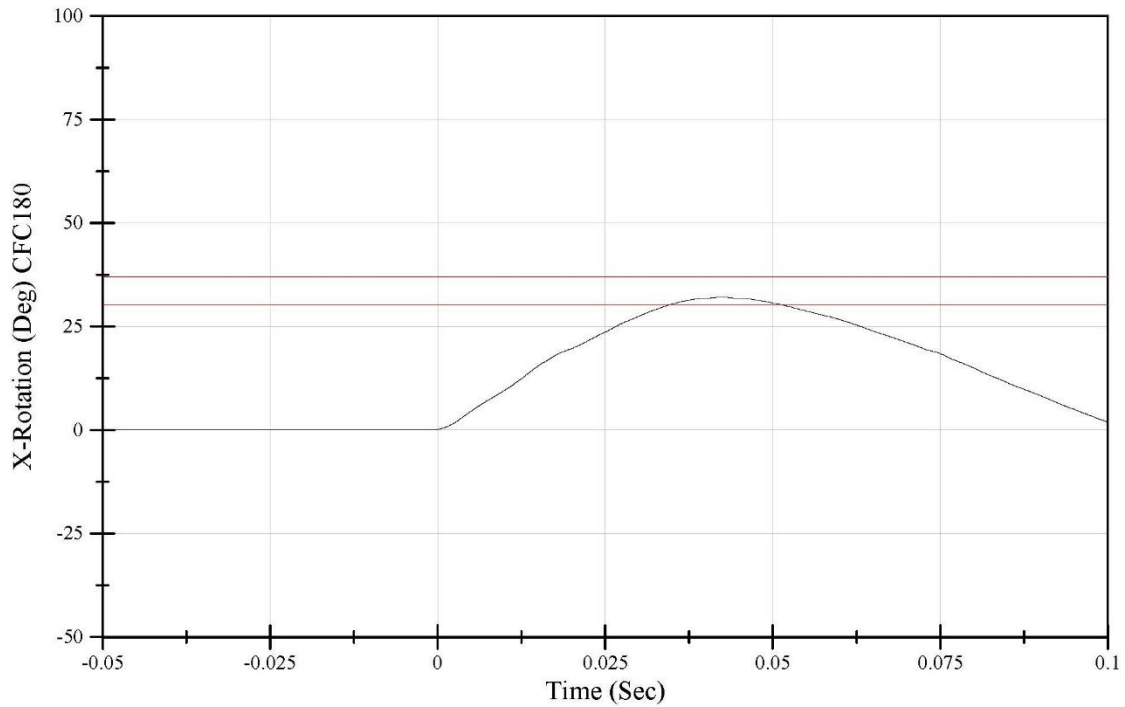

Software Version: 2.4

File Name: LX0018Inversion150707\_01renamedprocessed  
07/07/2015 10:04:43.0000

Test Temperature: 71 degrees  
Relative Humidity: 51%  
Test Velocity: 4.98 m/s

THOR Left Foot Dorsiflexion Certification  
Tibia Load  
Serial Number: LX 0019

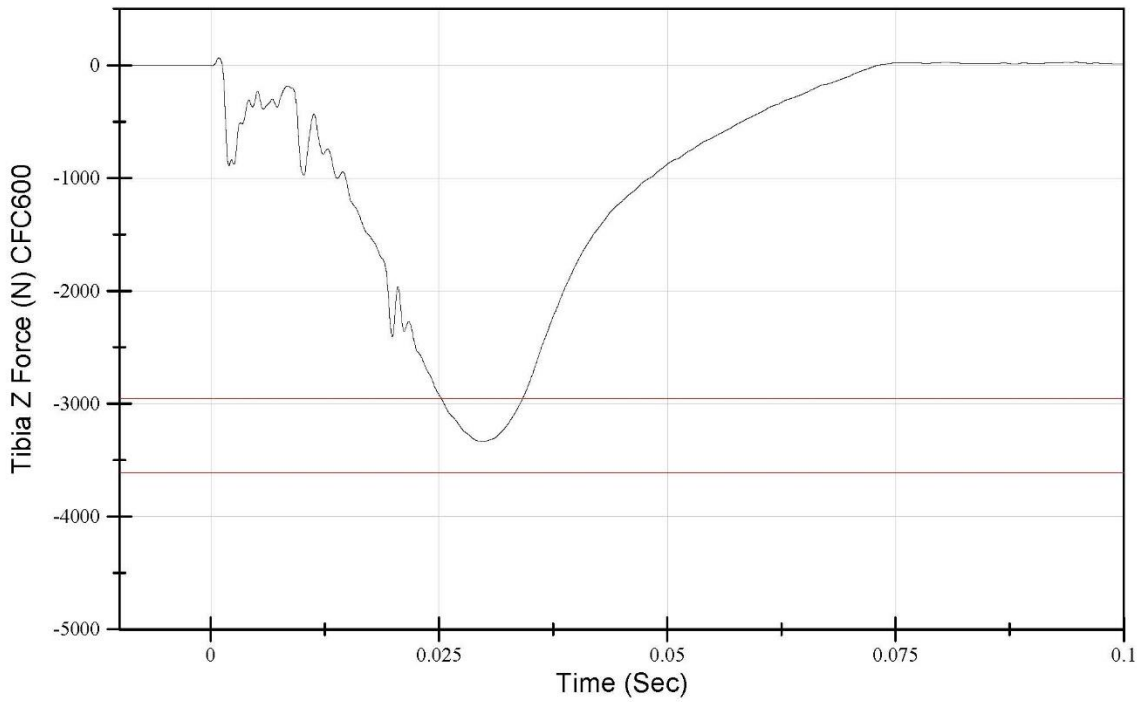

Software Version: 2.4

File Name: LX0019 Ball 150706\_01processed  
07/06/2015 07:34:13.0000

Test Temperature: 71 degrees  
Relative Humidity: 51%  
Test Velocity: 4.98 m/s

THOR Left Foot Dorsiflexion Certification  
Ankle Y-Moment  
Serial Number: LX 0019

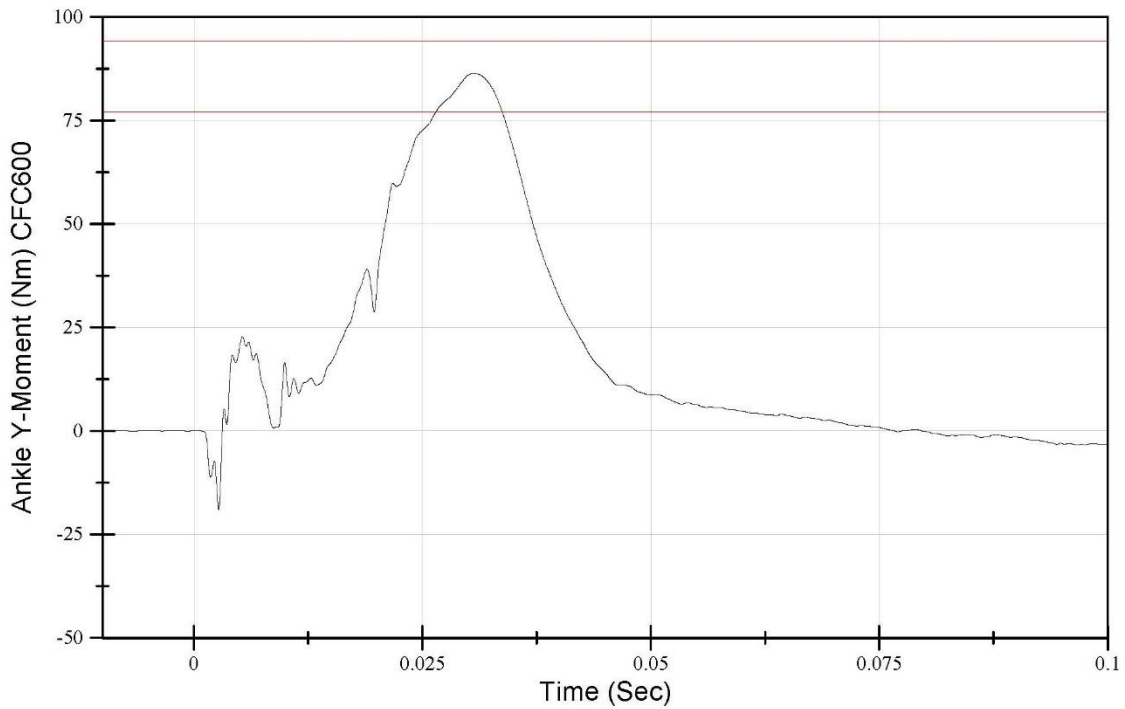

Software Version: 2.4

File Name: LX0019 Ball 150706\_01processed  
07/06/2015 07:34:13.0000

Test Temperature: 71 degrees  
Relative Humidity: 51%  
Test Velocity: 4.98 m/s

### THOR Left Foot Dorsiflexion Certification

Ankle Y-Rotation  
Serial Number: LX 0019

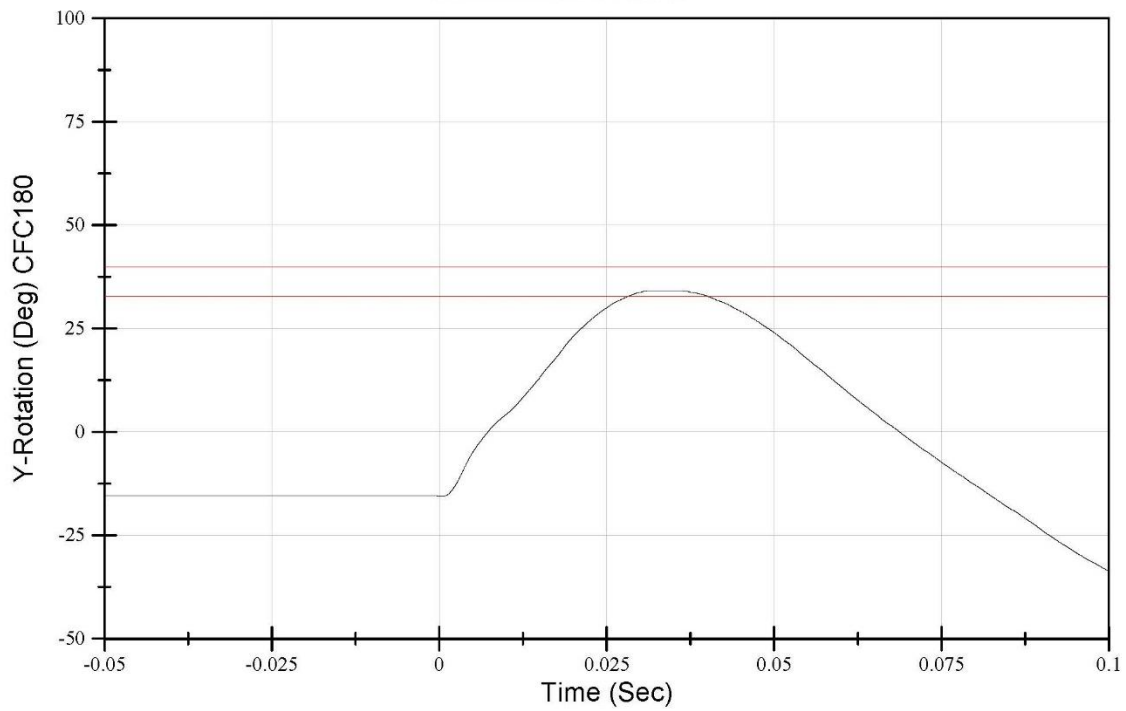

Software Version: 2.4

File Name: LX0019 Ball 150706\_01processed  
07/06/2015 07:34:13.0000

Test Temperature: 71 degrees  
Relative Humidity: 51%  
Test Velocity: 3.91 m/s

### THOR Left Foot Heel Certification

Tibia Load  
Serial Number: LX 0019

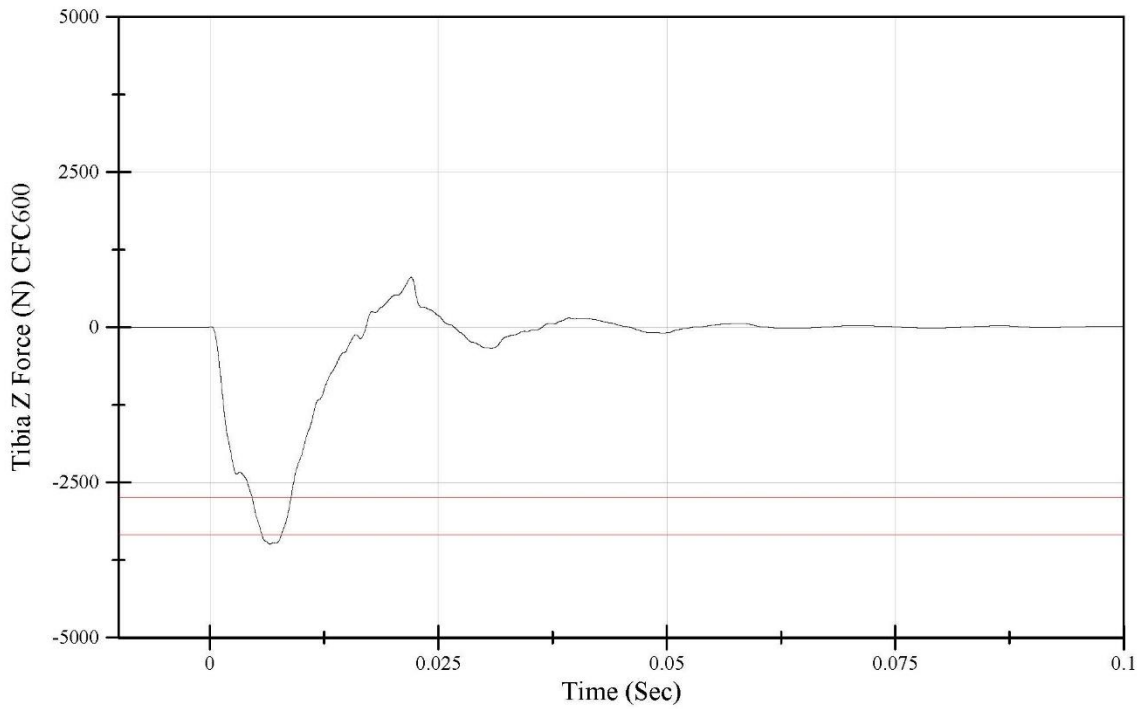

Software Version: 2.4

File Name: LX0019 Heel 150706\_01processed  
07/06/2015 11:35:49.0000

Test Temperature: 71 degrees  
Relative Humidity: 51%  
Test Velocity: 2.06 m/s

THOR Left Foot Eversion Certification  
Tibia Load  
Serial Number: LX0019

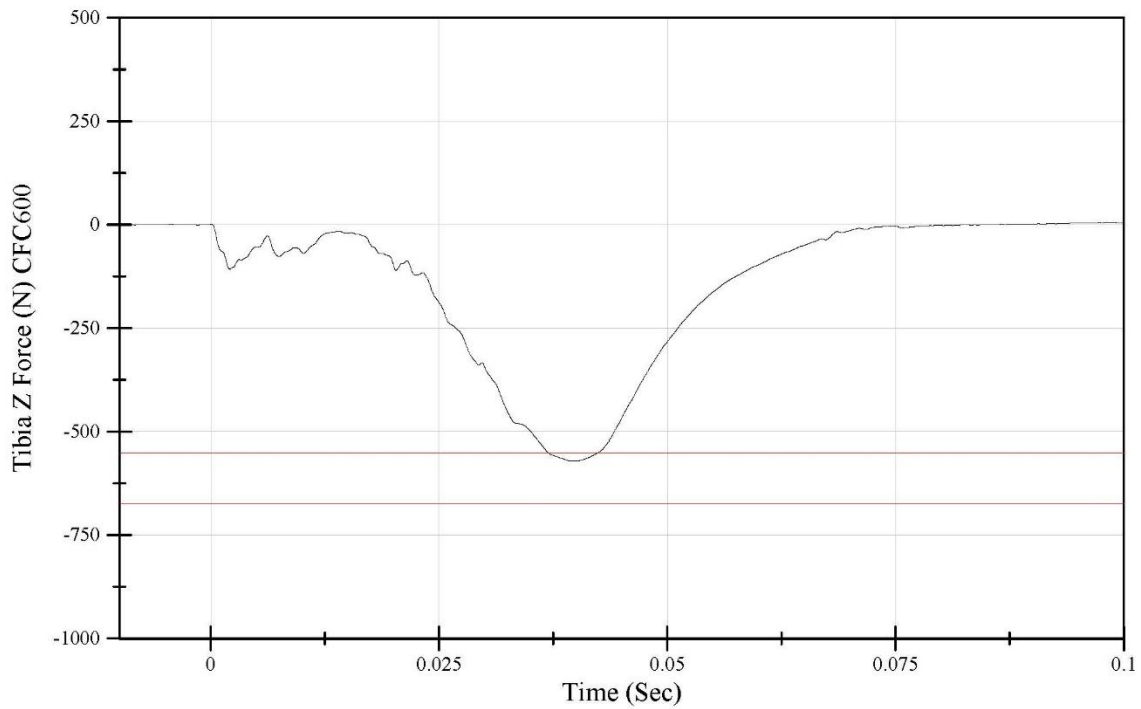

Software Version: 2.4

File Name: LX0019Eversion150702\_01processed  
07/02/2015 14:35:49.0000

Test Temperature: 71 degrees  
Relative Humidity: 51%  
Test Velocity: 2.06 m/s

THOR Left Foot Eversion Certification  
Ankle Moment  
Serial Number: LX0019

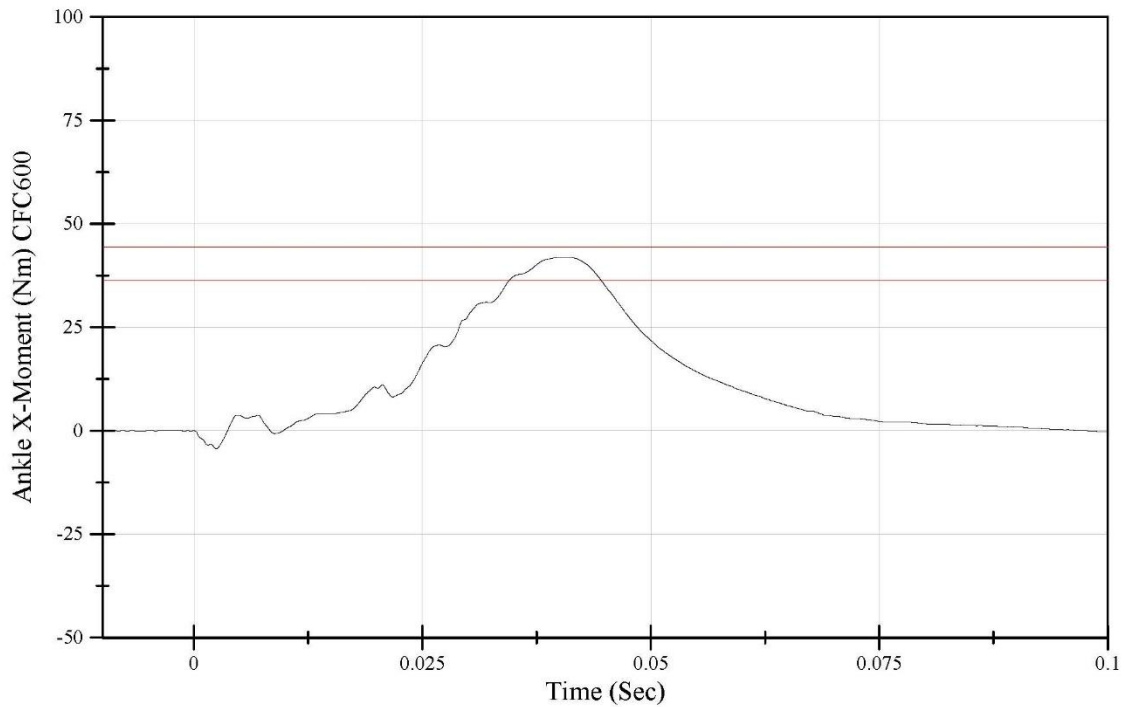

Software Version: 2.4

File Name: LX0019Eversion150702\_01processed  
07/02/2015 14:35:49.0000

Test Temperature: 71 degrees  
Relative Humidity: 51%  
Test Velocity: 2.06 m/s

THOR Left Foot Eversion Certification  
Ankle X-Rotation  
Serial Number: LX0019

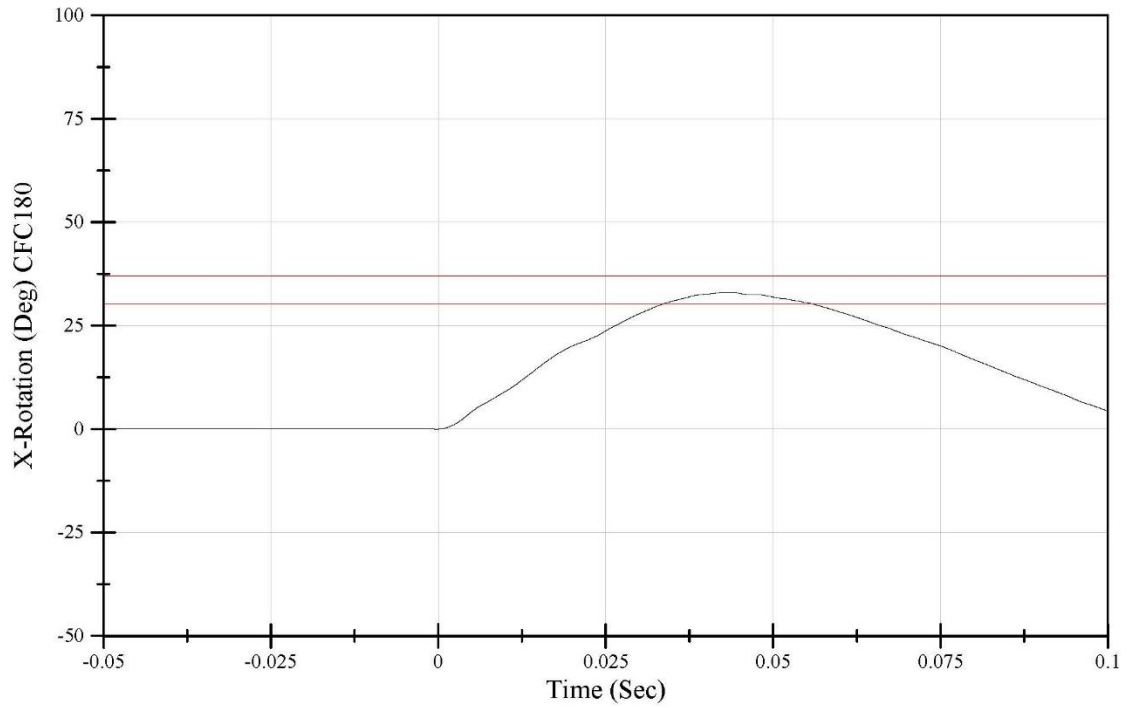

Software Version: 2.4

File Name: LX0019Eversion150702\_01processed  
07/02/2015 14:35:49.0000

Test Temperature: 71 degrees  
Relative Humidity: 51%  
Test Velocity: 1.98 m/s

THOR Left Foot Inversion Certification  
Tibia Load  
Serial Number: LX0019

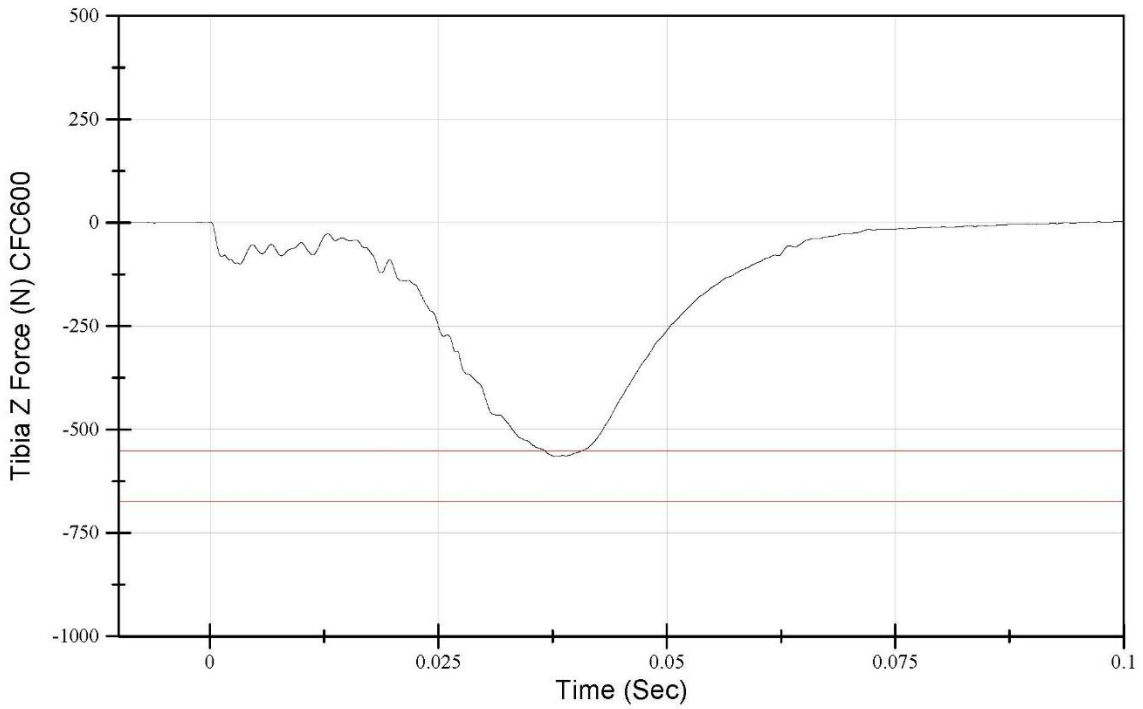

Software Version: 2.4

File Name: LX0019Inversion150702\_01processed  
07/02/2015 14:04:39.0000

Test Temperature: 71 degrees  
Relative Humidity: 51%  
Test Velocity: 1.98 m/s

THOR Left Foot Inversion Certification  
Ankle Moment  
Serial Number: LX0019

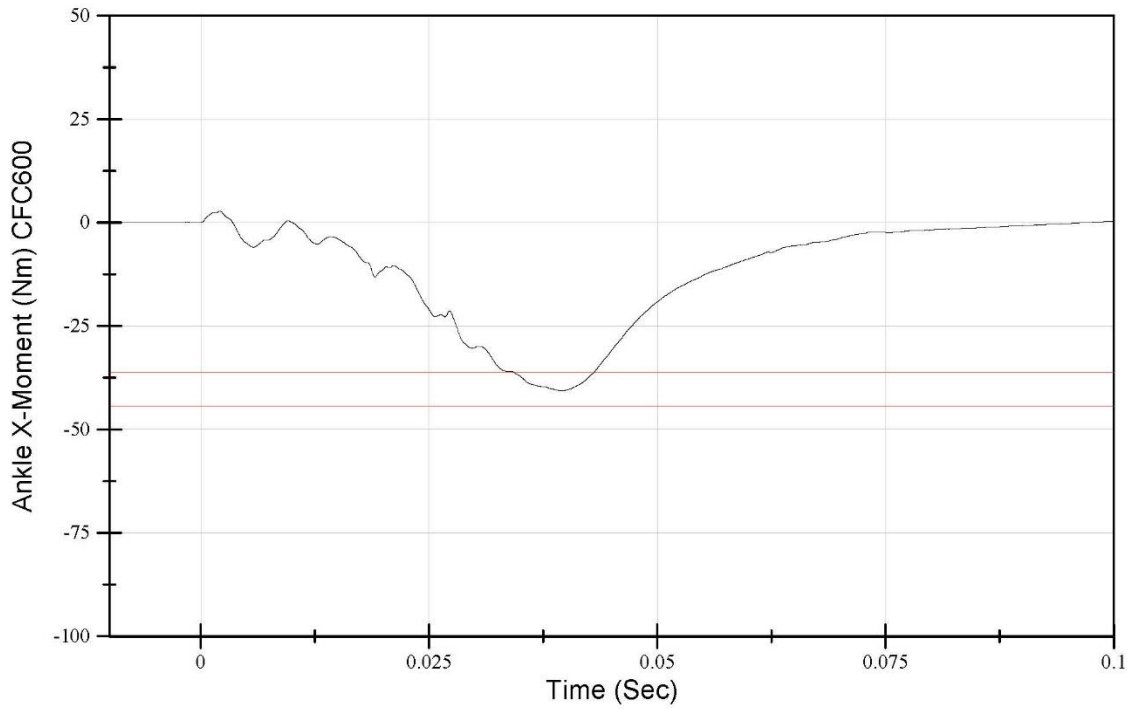

Software Version: 2.4

File Name: LX0019Inversion150702\_01processed  
07/02/2015 14:04:39.0000

Test Temperature: 71 degrees  
Relative Humidity: 51%  
Test Velocity: 1.98 m/s

THOR Left Foot Inversion Certification  
Ankle X-Rotation  
Serial Number: LX0019

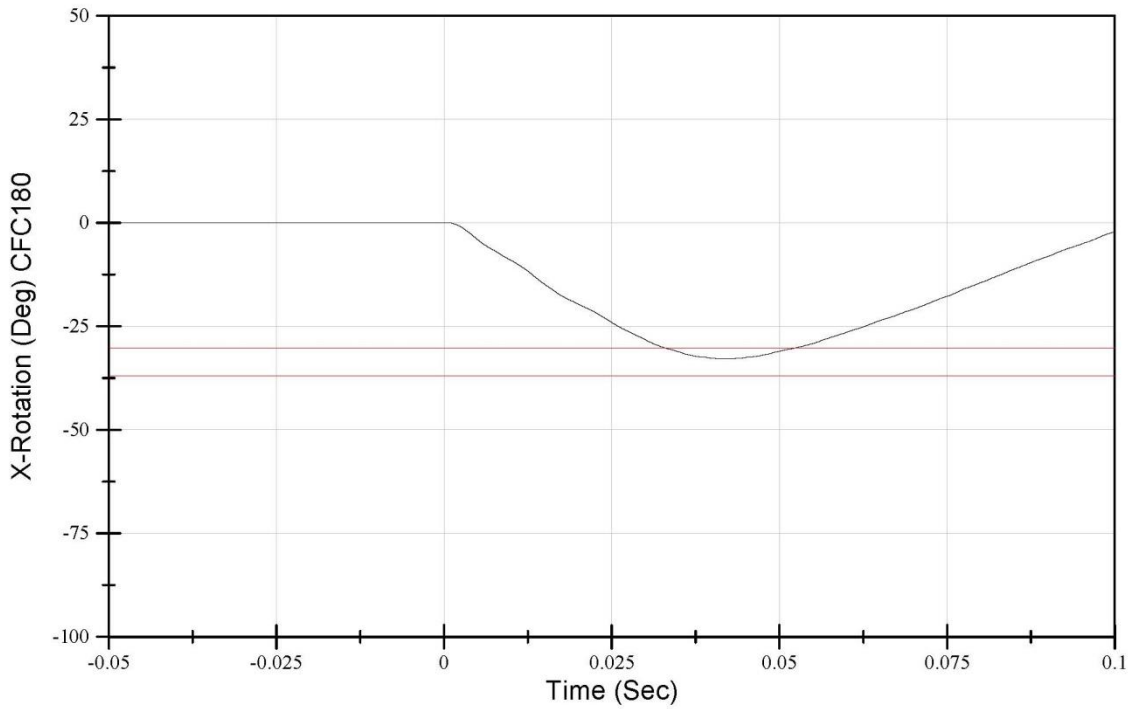

Software Version: 2.4

File Name: LX0019Inversion150702\_01processed  
07/02/2015 14:04:39.0000