

REPORT NUMBER: 208-MGA-2014-019

**VEHICLE SAFETY COMPLIANCE TESTING
FOR
FMVSS 208, OCCUPANT CRASH PROTECTION
FMVSS 212, WINDSHIELD MOUNTING
FMVSS 219, WINDSHIELD INTRUSION (PARTIAL)
FMVSS 301, FUEL SYSTEM INTEGRITY**

**FIAT GROUP AUTOS S.P.A.
2014 FIAT 500L MPV
NHTSA NO.: C20140306**

**PREPARED BY:
MGA RESEARCH CORPORATION
5000 WARREN ROAD
BURLINGTON, WI 53105**



TEST DATE: DECEMBER 16, 2014

FINAL REPORT DATE: MARCH 18, 2015

FINAL REPORT

**PREPARED FOR:
U.S. DEPARTMENT OF TRANSPORTATION
NATIONAL HIGHWAY TRAFFIC SAFETY ADMINISTRATION
OFFICE OF ENFORCEMENT
OFFICE OF VEHICLE SAFETY COMPLIANCE
1200 NEW JERSEY AVENUE, S.E., NVS-220
WASHINGTON, D.C. 20590**

This final test report was prepared for the U.S. Department of Transportation, National Highway Traffic Safety Administration, in response to Contract Number DTNH22-13-D-00313.

This publication is distributed by the U.S. Department of Transportation, National Highway Traffic Safety Administration, in the interest of information exchange. The opinions, findings and conclusions expressed in this publication are those of the author(s) and not necessarily those of the Department of Transportation or the National Highway Traffic Safety Administration. The United States Government assumes no liability for its contents or use thereof. If trade or manufacturers' names or products are mentioned it is only because they are considered essential to the object of the publication and should not be construed as an endorsement. The United States Government does not endorse products or manufacturers.

Prepared by: Jeff Lewandowski Date: March 18, 2015
Jeff Lewandowski, Project Engineer

Reviewed by: David Winkelbauer Date: March 18, 2015
David Winkelbauer, Facility Director

FINAL REPORT ACCEPTED BY OVSC:

Accepted By: 

Acceptance Date: March 18, 2015

Technical Report Documentation Page

1. Report No. 208-MGA-2014-019		2. Government Accession No.		3. Recipient's Catalog No.	
4. Title and Subtitle Final Report of FMVSS 208 Compliance Testing of a 2014 Fiat 500L NHTSA No.: C20140306				5. Report Date March 18, 2015	
				6. Performing Organization Code MGA	
7. Author(s) Jeff Lewandowski, Project Engineer				8. Performing Organization Report No. 208-MGA-2014-019	
9. Performing Organization Name and Address MGA Research Corporation 5000 Warren Road Burlington, WI 53105				10. Work Unit No.	
				11. Contract or Grant No. DTNH22-13-D-00313	
12. Sponsoring Agency Name and Address U.S. Department of Transportation National Highway Traffic Safety Administration Office of Enforcement Office of Vehicle Safety Compliance 1200 New Jersey Avenue, S.E., NVS-220 Washington, D.C. 20590				13. Type of Report and Period Covered 12/16/14 - 12/30/14	
				14. Sponsoring Agency Code NVS-220	
15. Supplementary Notes					
16. Abstract Compliance tests were conducted on the subject 2014 Fiat 500L in accordance with the specifications of the Office of Vehicle Safety Compliance Test Procedure No. TP208-14. Test failures identified were as follows: TEST FAILURES: None					
17. Key Words Frontal Impact 40 kmph Vehicle Safety Compliance Testing FMVSS 208, "Occupant Crash Protection" FMVSS 212, "Windshield Mounting" FMVSS 219, (partial), "Windshield Zone Intrusion" FMVSS 301, "Fuel System Integrity"				18. Distribution Statement Copies of this report are available from the following: U.S. Department of Transportation National Highway Traffic Safety Administration Technical Information Services (TIS), NPO-411 1200 New Jersey Avenue, S.E. (Room E12-100) Washington, DC 20590	
19. Security Classif. (of this report) Unclassified		20. Security Classif. (of this page) Unclassified		21. No. of Pages 154	22. Price

TABLE OF CONTENTS

<u>Section</u>		<u>Page No</u>
1	Purpose of Compliance Tests	1
2	Tests Performed	2
3	Injury Result Summary for FMVSS 208 Tests	4
4	Discussion of Tests (if applicable)	5
5	Test Data Sheets	6
 <u>Data Sheet</u>		
1	COTR Vehicle Work Order	7
2	Report of Vehicle Condition	12
3	Certification Label and Tire Placard Information	14
32	Vehicle Weight, Fuel Tank, and Attitude Data	15
33	Vehicle Accelerometer Locations and Measurements	19
34	Photographic Targets	22
35	Camera Locations	27
36	Dummy Positioning	29
37	Dummy Measurements	45
38	Crash Test	48
40	Accident Investigation Measurements	50
41	Windshield Mounting (FMVSS 212)	52
42	Windshield Zone Intrusion (FMVSS 219)	54
43	Fuel System Integrity (FMVSS 301)	56
 <u>Appendix</u>		
A	Crash Test Data	A-1
B	Crash Test Photographs	B-1
C	Instrumentation Calibration	C-1
D	Notice of Test Failure (If Applicable)	D-1

SECTION 1
PURPOSE OF COMPLIANCE TESTS

This Federal Motor Vehicle Safety Standard 208 compliance test is part of a program conducted for the National Highway Traffic Safety Administration (NHTSA) by MGA Research Corporation (MGA) under Contract No.: DTNH22-13-D-00313. The purpose of this test was to determine whether the subject vehicle, a 2014 Fiat 500L, NHTSA No.: C20140306, meets certain performance requirements of FMVSS 208, "Occupant Crash Protection"; FMVSS 212, "Windshield Mounting"; FMVSS 219, "Windshield Zone Intrusion"; and FMVSS 301, "Fuel System Integrity". The compliance test was conducted in accordance with OVSC Laboratory Test Procedure No.: TP208-14 dated April 16, 2008.

SECTION 2
TESTS PERFORMED

Test Vehicle: 2014 Fiat 500L
Test Program: FMVSS 208 Compliance

NHTSA No.: C20140306
Test Dates: 12/16/14

The following checked items indicate the tests that were performed:

- | | | |
|-------------------------------------|-----|--|
| <input type="checkbox"/> | 1. | Rear seating position seat belts |
| <input type="checkbox"/> | 2. | Air bag labels (S4.5.1) |
| <input type="checkbox"/> | 3. | Readiness indicator (S4.5.2) |
| <input type="checkbox"/> | 4. | Passenger air bag manual cut-off device (S4.5.4) |
| <input type="checkbox"/> | 5. | Lap belt lockability (S7.1.1.5) |
| <input type="checkbox"/> | 6. | Seat belt warning system (S7.3) |
| <input type="checkbox"/> | 7. | Seat belt contact force (S7.4.3) |
| <input type="checkbox"/> | 8. | Seat belt latch plate access (S7.4.4) |
| <input type="checkbox"/> | 9. | Seat belt retraction (S7.4.5) |
| <input type="checkbox"/> | 10. | Seat belt guides and hardware (S7.4.6) |
| <input type="checkbox"/> | 11. | Air bag suppression telltale (S19.2.2) |
| <input type="checkbox"/> | 12. | Suppression tests with 12-month-old CRABI dummy (Part 572, Subpart R) |
| <input type="checkbox"/> | 13. | Suppression tests with Newborn infant (Part 572, Subpart K) |
| <input type="checkbox"/> | 14. | Suppression tests with 3-year-old dummy |
| <input type="checkbox"/> | 15. | Suppression tests with 6-year-old dummy |
| <input type="checkbox"/> | 16. | Test of Reactivation of the passenger air bag system with an unbelted 5 th percentile female dummy |
| <input type="checkbox"/> | 17. | Low risk deployment test with 12-month-old dummy (Part 572, Subpart R) |
| <input type="checkbox"/> | 18. | Low risk deployment test with 3-year-old dummy (Part 572, Subpart P) |
| <input type="checkbox"/> | 19. | Low risk deployment test with 6-year-old dummy (Part 572, Subpart N) |
| <input type="checkbox"/> | 20. | Low risk deployment test with 5 th female dummy (Part 572, Subpart O) |
| <input type="checkbox"/> | 21. | Impact Tests |
| <input type="checkbox"/> | | <input type="checkbox"/> Frontal Oblique |
| | | <input type="checkbox"/> Belted 50 th male dummy driver and passenger (0 to 48 kmph) (S5.1.1(a)) |
| | | <input type="checkbox"/> Unbelted 50 th male dummy driver and passenger (0 to 48 kmph) (S5.1.2(a)(1)) |
| | | <input type="checkbox"/> Unbelted 50 th male dummy driver and passenger (32 to 40 kmph) (S5.1.2(a)(1) or S5.1.2(b)) |
| | | <input checked="" type="checkbox"/> Frontal 0° |
| | | <input type="checkbox"/> Belted 50 th male dummy driver (0 to 48 kmph) (S5.1.1.(b)(1) or S5.1.1(a)) |
| | | <input type="checkbox"/> Belted 50 th male dummy passenger (0 to 48 kmph) (S5.1.1.(b)(1) or S5.1.1(a)) |
| | | <input type="checkbox"/> Belted 5 th female dummy driver (0 to 48 kmph) (S16.1(a)) |
| | | <input type="checkbox"/> Belted 5 th female dummy passenger (0 to 48 kmph) (S16.1(a)) |
| | | <input type="checkbox"/> Belted 50 th male dummy driver and passenger (0 to 56 kmph) (S5.1.1.(b)(2)) |
| | | <input type="checkbox"/> Unbelted 50 th male dummy driver and passenger (0 to 48 kmph) (S5.1.2(a)(1)) |
| | | <input type="checkbox"/> Unbelted 50 th male dummy driver (32 to 40 kmph) (S5.1.2.(a)(2) or S5.1.2(b)) |
| | | <input type="checkbox"/> Unbelted 50 th male dummy passenger (32 to 40 kmph) (S5.1.2.(a)(2) or S5.1.2(b)) |
| | | <input checked="" type="checkbox"/> Unbelted 5 th female dummy driver (32 to 40 kmph) (S16.1(b)) |
| | | <input checked="" type="checkbox"/> Unbelted 5 th female dummy passenger (32 to 40 kmph) (S16.1(b)) |
| | | <input type="checkbox"/> 40% Offset 0° Belted 5 th female dummy driver and passenger (0 to 40 kmph) (S18.1) |
| <input type="checkbox"/> | 22. | FMVSS 204 Indicant Test |
| <input checked="" type="checkbox"/> | 23. | FMVSS 212 Test |
| <input checked="" type="checkbox"/> | 24. | FMVSS 219 Indicant Test |
| <input checked="" type="checkbox"/> | 25. | FMVSS 301 Frontal Test |
| <input type="checkbox"/> | 26. | FMVSS 305 Frontal Indicant Test |

For the crash tests, the vehicle was instrumented with 8 accelerometers. The data from the vehicle and dummies were sampled at 10,000 samples per second and processed as specified in SAE J211/1 MAR95 and FMVSS 208, S4.13.

The dynamic tests were recorded using high-speed digital video.

The vehicle appears to meet the performance requirements to which it was tested.

SECTION 3

INJURY RESULT SUMMARY FOR FMVSS 208 TESTS

Test Vehicle: 2014 Fiat 500L
 Test Program: FMVSS 208 Compliance

NHTSA No.: C20140306
 Test Date: 12/16/14

40 kmph Frontal Crash

Impact Angle:	0°			
Belted Dummies:		Yes	X	No

Speed Range:		0 to 40 kmph	X	32 to 40 kmph
		0 to 48 kmph		0 to 56 kmph

Test Speed (kmph):	39.8	Test Weight (kg):	1593.6
--------------------	------	-------------------	--------

Driver Dummy:	X	5 th female		50 th male
Passenger Dummy:	X	5 th female		50 th male

5th Percentile Female Frontal Crash Test Vehicles certified to S16.1 (a) (1), S16.1 (a) (2), S16.1 (b), or S18.1

Injury Criteria	Max. Allowable Injury Assessment Values	Driver	Passenger
HIC15	700	139	181
N _{te}	1.0	0.6	1.0
N _{tf}	1.0	0.1	0.2
N _{ce}	1.0	0.0	0.0
N _{cf}	1.0	0.2	0.1
Neck Tension	2620 N	1346	1020
Neck Compression	2520 N	70	213
Chest g	60 g	44	33
Chest Displacement	52 mm	15	1
Left Femur	6805 N	4687	4357
Right Femur	6805 N	3665	4535

SECTION 4
DISCUSSION OF TESTS

Test Vehicle: 2014 Fiat 500L
Test Program: FMVSS 208 Compliance

NHTSA No.: C20140306
Test Dates: 12/16/14

Two additional cameras were mounted onboard to the rear interior roof of the vehicle to view the driver knee air bag. The location is shown below.



One additional camera was mounted off-board of the vehicle to view the driver knee air bag. The location is shown below.



There was no valid data after 15 msec on the Left Brake Caliper (X) accelerometer during the frontal impact crash test.

SECTION 5
TEST DATA SHEETS

Test Vehicle: 2014 Fiat 500L
Test Program: FMVSS 208 Compliance

NHTSA No.: C20140306
Test Dates: 12/16/14

DATA SHEET 1
COTR VEHICLE WORK ORDER

Test Vehicle: 2014 Fiat 500L
Test Program: FMVSS 208 Compliance

NHTSA No.: C20140306
Test Dates: 12/16/14

COTR Signature: 

Test to be performed for this vehicle are checked below:

- | | |
|-------------------------------------|--|
| <input checked="" type="checkbox"/> | 1. Rear Seating Position Seat Belts |
| <input checked="" type="checkbox"/> | 2. Air Bag Labels (S4.5.1) |
| <input checked="" type="checkbox"/> | 3. Readiness Indicator (S4.5.2) |
| <input checked="" type="checkbox"/> | 4. Passenger Air Bag Manual Cut-off Device (S4.5.4) |
| <input checked="" type="checkbox"/> | 5. Lap Belt Lockability (S7.1.1.5) |
| <input checked="" type="checkbox"/> | 6. Seat Belt Warning System (S7.3) |
| <input checked="" type="checkbox"/> | 7. Seat Belt Contact Force (S7.4.3) |
| <input checked="" type="checkbox"/> | 8. Seat Belt Latch Plate Access (S7.4.4) |
| <input checked="" type="checkbox"/> | 9. Seat Belt Retraction (S7.4.5) |
| <input checked="" type="checkbox"/> | 10. Seat Belt Guides and Hardware (S7.4.6) |
| <input checked="" type="checkbox"/> | 11. Air bag suppression telltale (S19.2.2) |
| <input checked="" type="checkbox"/> | 12. Suppression tests with 12-month-old CRABI dummy (Part 572, Subpart R) using the following indicated child restraints (mid-height seat position): |

Section B – Rear Facing (unbelted and belted rear facing, unbelted forward facing)

<input checked="" type="checkbox"/>	Century Smart Fit 4543	<input checked="" type="checkbox"/>	Full Rearward	<input checked="" type="checkbox"/>	Mid Position	<input checked="" type="checkbox"/>	Full Forward
<input checked="" type="checkbox"/>	Cosco Arriva 22-013	<input checked="" type="checkbox"/>	Full Rearward	<input checked="" type="checkbox"/>	Mid Position	<input checked="" type="checkbox"/>	Full Forward
<input checked="" type="checkbox"/>	Evenflo Discovery Adjust Right 212	<input checked="" type="checkbox"/>	Full Rearward	<input checked="" type="checkbox"/>	Mid Position	<input checked="" type="checkbox"/>	Full Forward
<input checked="" type="checkbox"/>	Graco Infant 8457	<input checked="" type="checkbox"/>	Full Rearward	<input checked="" type="checkbox"/>	Mid Position	<input checked="" type="checkbox"/>	Full Forward
<input checked="" type="checkbox"/>	Graco Snugride 8645	<input checked="" type="checkbox"/>	Full Rearward	<input checked="" type="checkbox"/>	Mid Position	<input checked="" type="checkbox"/>	Full Forward
<input checked="" type="checkbox"/>	Peg Perego	<input checked="" type="checkbox"/>	Full Rearward	<input checked="" type="checkbox"/>	Mid Position	<input checked="" type="checkbox"/>	Full Forward

Section C – Convertible (unbelted and belted rear facing, unbelted and belted forward facing)

<input checked="" type="checkbox"/>	Britax Roundabout E9L02	<input checked="" type="checkbox"/>	Full Rearward	<input checked="" type="checkbox"/>	Mid Position	<input checked="" type="checkbox"/>	Full Forward
<input checked="" type="checkbox"/>	Cosco High Back Booster 22-209	<input checked="" type="checkbox"/>	Full Rearward	<input checked="" type="checkbox"/>	Mid Position	<input checked="" type="checkbox"/>	Full Forward
<input checked="" type="checkbox"/>	Cosco Summit Deluxe 22-262	<input checked="" type="checkbox"/>	Full Rearward	<input checked="" type="checkbox"/>	Mid Position	<input checked="" type="checkbox"/>	Full Forward
<input checked="" type="checkbox"/>	Cosco Touriva 02519	<input checked="" type="checkbox"/>	Full Rearward	<input checked="" type="checkbox"/>	Mid Position	<input checked="" type="checkbox"/>	Full Forward
<input checked="" type="checkbox"/>	Evenflo Generations 352	<input checked="" type="checkbox"/>	Full Rearward	<input checked="" type="checkbox"/>	Mid Position	<input checked="" type="checkbox"/>	Full Forward
<input checked="" type="checkbox"/>	Evenflo Medallion 254	<input checked="" type="checkbox"/>	Full Rearward	<input checked="" type="checkbox"/>	Mid Position	<input checked="" type="checkbox"/>	Full Forward
<input checked="" type="checkbox"/>	Evenflo Tribute V 379	<input checked="" type="checkbox"/>	Full Rearward	<input checked="" type="checkbox"/>	Mid Position	<input checked="" type="checkbox"/>	Full Forward
<input checked="" type="checkbox"/>	Graco ComfortSport	<input checked="" type="checkbox"/>	Full Rearward	<input checked="" type="checkbox"/>	Mid Position	<input checked="" type="checkbox"/>	Full Forward
<input checked="" type="checkbox"/>	Graco Platinum Cargo	<input checked="" type="checkbox"/>	Full Rearward	<input checked="" type="checkbox"/>	Mid Position	<input checked="" type="checkbox"/>	Full Forward
<input checked="" type="checkbox"/>	Graco Safeseat Step 2	<input checked="" type="checkbox"/>	Full Rearward	<input checked="" type="checkbox"/>	Mid Position	<input checked="" type="checkbox"/>	Full Forward

- | | |
|-------------------------------------|--|
| <input checked="" type="checkbox"/> | 13. Suppression tests with newborn infant (Part 572, Subpart K) using the following indicated child restraints (mid-height seat position). |
|-------------------------------------|--|

Section A – Car Bed (Belted)

<input checked="" type="checkbox"/>	Angel Guard Angel Ride	<input checked="" type="checkbox"/>	Full Rearward	<input checked="" type="checkbox"/>	Mid Position	<input checked="" type="checkbox"/>	Full Forward
-------------------------------------	------------------------	-------------------------------------	---------------	-------------------------------------	--------------	-------------------------------------	--------------

14. Suppression tests with 3-year-old dummy (Part 572, Subpart P) using the following indicated child restraints where a child restraint is required (mid-height seat position):

Section C – Convertible (Belted forward-facing)

Britax Roundabout E9L02	Full Rearward	Mid Position	Full Forward
Cosco High Back Booster 22-209	Full Rearward	Mid Position	Full Forward
Cosco Summit Deluxe 22-262	Full Rearward	Mid Position	Full Forward
Cosco Touriva 02519	Full Rearward	Mid Position	Full Forward
Evenflo Generations 352	Full Rearward	Mid Position	Full Forward
Evenflo Medallion 254	Full Rearward	Mid Position	Full Forward
Evenflo Tribute V 379	Full Rearward	Mid Position	Full Forward
Graco ComfortSport	Full Rearward	Mid Position	Full Forward
Graco Platinum Cargo	Full Rearward	Mid Position	Full Forward
Graco Safeseat Step 2	Full Rearward	Mid Position	Full Forward

Section D – Toddler/Belt Positioning Booster (Belted)

Britax Roadster 9004	Full Rearward	Mid Position	Full Forward
Cosco High Back Booster 22-209	Full Rearward	Mid Position	Full Forward
Cosco Summit Deluxe 22-262	Full Rearward	Mid Position	Full Forward
Evenflo Generations 352	Full Rearward	Mid Position	Full Forward
Evenflo Right Fit 245	Full Rearward	Mid Position	Full Forward
Graco Platinum Cargo	Full Rearward	Mid Position	Full Forward

15. Suppression tests with representative 3-year-old child using the following indicated child restraints where a child restraint is required (mid-height position). (Appendix H, Data Sheet 19H and 20H)

Section C – Convertible (Belted forward-facing)

Britax Roundabout E9L02	Full Rearward	Mid Position	Full Forward
Cosco High Back Booster 22-209	Full Rearward	Mid Position	Full Forward
Cosco Summit Deluxe 22-262	Full Rearward	Mid Position	Full Forward
Cosco Touriva 02519	Full Rearward	Mid Position	Full Forward
Evenflo Generations 352	Full Rearward	Mid Position	Full Forward
Evenflo Medallion 254	Full Rearward	Mid Position	Full Forward
Evenflo Tribute V 379	Full Rearward	Mid Position	Full Forward
Graco ComfortSport	Full Rearward	Mid Position	Full Forward
Graco Platinum Cargo	Full Rearward	Mid Position	Full Forward
Graco Safeseat Step 2	Full Rearward	Mid Position	Full Forward

Section D – Toddler/Belt Positioning Booster (Belted)

Britax Roadster 9004	Full Rearward	Mid Position	Full Forward
Cosco High Back Booster 22-209	Full Rearward	Mid Position	Full Forward
Cosco Summit Deluxe 22-262	Full Rearward	Mid Position	Full Forward
Evenflo Generations 352	Full Rearward	Mid Position	Full Forward
Evenflo Right Fit 245	Full Rearward	Mid Position	Full Forward
Graco Platinum Cargo	Full Rearward	Mid Position	Full Forward

16. Suppression tests with 3-year-old dummy (Part 572, Subpart P) in the following positions (mid-height seat position):
- Sitting on seat with back against seat back (S22.2.2.1)
 - Full Rearward Mid Position Full Forward
 - Sitting on seat with back against reclined seat back (S22.2.2.2)
 - Full Rearward Mid Position Full Forward
 - Sitting on seat with back not against seat back (S22.2.2.3)
 - Full Rearward Mid Position Full Forward
 - Sitting on seat edge, spine vertical, hands by the child's side (S22.2.2.4)
 - Full Rearward Mid Position Full Forward
 - Standing on seat, facing forward (S22.2.2.5)
 - Full Rearward Mid Position Full Forward
 - Kneeling on seat facing forward (S22.2.2.6)
 - Full Rearward Mid Position Full Forward
 - Kneeling on seat facing rearward (S22.2.2.7)
 - Full Rearward Mid Position Full Forward
 - Lying on seat (S22.2.2.8)
 - Full Rearward Mid Position Full Forward
17. Suppression tests with representative 3-year-old child in the following positions (mid-height seat position):
- Sitting on seat with back against seat back (S22.2.2.1)
 - Full Rearward Mid Position Full Forward
 - Sitting on seat with back against reclined seat back (S22.2.2.2)
 - Full Rearward Mid Position Full Forward
 - Sitting on seat with back not against seat back (S22.2.2.3)
 - Full Rearward Mid Position Full Forward
 - Sitting on seat edge, spine vertical, hands by the child's side (S22.2.2.4)
 - Full Rearward Mid Position Full Forward
 - Standing on seat, facing forward (S22.2.2.5)
 - Full Rearward Mid Position Full Forward
 - Kneeling on seat facing forward (S22.2.2.6)
 - Full Rearward Mid Position Full Forward
 - Kneeling on seat facing rearward (S22.2.2.7)
 - Full Rearward Mid Position Full Forward
 - Lying on seat (S22.2.2.8)
 - Full Rearward Mid Position Full Forward
18. Suppression tests with 6-year-old dummy (Part 572, Subpart N) using the following indicated child restraints where a child restraint is required (mid-height seat position):
- Section D
- | | | | |
|---|--|---------------------------------------|---------------------------------------|
| <input type="checkbox"/> Britax Roadster 9004 | <input type="checkbox"/> Full Rearward | <input type="checkbox"/> Mid Position | <input type="checkbox"/> Full Forward |
| <input type="checkbox"/> Cosco High Back Booster 22-209 | <input type="checkbox"/> Full Rearward | <input type="checkbox"/> Mid Position | <input type="checkbox"/> Full Forward |
| <input type="checkbox"/> Cosco Summit Deluxe 22-262 | <input type="checkbox"/> Full Rearward | <input type="checkbox"/> Mid Position | <input type="checkbox"/> Full Forward |
| <input type="checkbox"/> Evenflo Generations 352 | <input type="checkbox"/> Full Rearward | <input type="checkbox"/> Mid Position | <input type="checkbox"/> Full Forward |
| <input type="checkbox"/> Evenflo Right Fit 245 | <input type="checkbox"/> Full Rearward | <input type="checkbox"/> Mid Position | <input type="checkbox"/> Full Forward |
| <input type="checkbox"/> Graco Platinum Cargo | <input type="checkbox"/> Full Rearward | <input type="checkbox"/> Mid Position | <input type="checkbox"/> Full Forward |

19. Suppression tests with representative 6-year-old child using the following indicated child restraints where a child restraint is required (mid-height seat position):
- Section D
- | | | | | | | | |
|--------------------------|--------------------------------|--------------------------|---------------|--------------------------|--------------|--------------------------|--------------|
| <input type="checkbox"/> | Britax Roadster 9004 | <input type="checkbox"/> | Full Rearward | <input type="checkbox"/> | Mid Position | <input type="checkbox"/> | Full Forward |
| <input type="checkbox"/> | Cosco High Back Booster 22-209 | <input type="checkbox"/> | Full Rearward | <input type="checkbox"/> | Mid Position | <input type="checkbox"/> | Full Forward |
| <input type="checkbox"/> | Cosco Summit Deluxe 22-262 | <input type="checkbox"/> | Full Rearward | <input type="checkbox"/> | Mid Position | <input type="checkbox"/> | Full Forward |
| <input type="checkbox"/> | Evenflo Generations 352 | <input type="checkbox"/> | Full Rearward | <input type="checkbox"/> | Mid Position | <input type="checkbox"/> | Full Forward |
| <input type="checkbox"/> | Evenflo Right Fit 245 | <input type="checkbox"/> | Full Rearward | <input type="checkbox"/> | Mid Position | <input type="checkbox"/> | Full Forward |
| <input type="checkbox"/> | Graco Platinum Cargo | <input type="checkbox"/> | Full Rearward | <input type="checkbox"/> | Mid Position | <input type="checkbox"/> | Full Forward |
20. Suppression tests with 6-year-old dummy (Part 572, Subpart N) in the following positions (mid-height seat position):
- | | | | | | | | |
|--------------------------|--|--------------------------|---------------|--------------------------|--------------|--------------------------|--------------|
| <input type="checkbox"/> | Sitting on seat with back against seat back (S22.2.2.1) | <input type="checkbox"/> | Full Rearward | <input type="checkbox"/> | Mid Position | <input type="checkbox"/> | Full Forward |
| <input type="checkbox"/> | Sitting on seat with back against reclined seat back (S22.2.2.2) | <input type="checkbox"/> | Full Rearward | <input type="checkbox"/> | Mid Position | <input type="checkbox"/> | Full Forward |
| <input type="checkbox"/> | Sitting on seat edge, spine vertical, hands by the child's side (S22.2.2.4) | <input type="checkbox"/> | Full Rearward | <input type="checkbox"/> | Mid Position | <input type="checkbox"/> | Full Forward |
| <input type="checkbox"/> | Sitting back in the seat and leaning on the right front passenger door (S24.2.3) | <input type="checkbox"/> | Full Rearward | <input type="checkbox"/> | Mid Position | <input type="checkbox"/> | Full Forward |
21. Suppression tests with representative 6-year-old child in the following positions (mid-height seat position):
- | | | | | | | | |
|--------------------------|--|--------------------------|---------------|--------------------------|--------------|--------------------------|--------------|
| <input type="checkbox"/> | Sitting on seat with back against seat back (S22.2.2.1) | <input type="checkbox"/> | Full Rearward | <input type="checkbox"/> | Mid Position | <input type="checkbox"/> | Full Forward |
| <input type="checkbox"/> | Sitting on seat with back against reclined seat back (S22.2.2.2) | <input type="checkbox"/> | Full Rearward | <input type="checkbox"/> | Mid Position | <input type="checkbox"/> | Full Forward |
| <input type="checkbox"/> | Sitting on seat edge, spine vertical, hands by the child's side (S22.2.2.4) | <input type="checkbox"/> | Full Rearward | <input type="checkbox"/> | Mid Position | <input type="checkbox"/> | Full Forward |
| <input type="checkbox"/> | Sitting back in the seat and leaning on the right front passenger door (S24.2.3) | <input type="checkbox"/> | Full Rearward | <input type="checkbox"/> | Mid Position | <input type="checkbox"/> | Full Forward |
22. Test of Reactivation of the Passenger Air Bag System with an Unbelted 5th percentile female dummy (S20.3, 22.3, S24.3) (mid-height seat position). Perform this test after the following suppression tests: After each restraint.
23. Test of Reactivation of the Passenger Air Bag System with a representative 5th percentile female (S20.3, 22.3, S24.3) (mid-height seat position). Perform this test after the following suppression tests:
24. Low risk deployment test with 12-month-old dummy (Part 572, Subpart R) using the following indicated child restraints (full forward, mid-height seat position)(S20.4):
- Section B
- | | |
|--------------------------|------------------------------------|
| <input type="checkbox"/> | Century Smart Fit 4543 |
| <input type="checkbox"/> | Cosco Arriva 22-013 |
| <input type="checkbox"/> | Evenflo Discovery Adjust Right 212 |
| <input type="checkbox"/> | Graco Infant 8457 |
| <input type="checkbox"/> | Graco Snugride 8645 |
| <input type="checkbox"/> | Peg Perego |
- Section C
- | | |
|--------------------------|-------------------------|
| <input type="checkbox"/> | Britax Roundabout E9L02 |
| <input type="checkbox"/> | Cosco Touriva 02519 |
| <input type="checkbox"/> | Evenflo Medallion 254 |
| <input type="checkbox"/> | Evenflo Tribute V 379 |
| <input type="checkbox"/> | Graco ComfortSport |

- 25. Low risk deployment test with 3-year-old dummy (Part 572, Subpart P) in the following positions:
 - Position 1 (rearmost, lowest seat position)
 - Position 2 (mid-height seat position)
- 26. Low risk deployment test with 6-year-old dummy (Part 572, Subpart N) in the following positions:
 - Position 1 (rearmost, lowest seat position)
 - Position 2 (mid-height seat position)
- 27. Low risk deployment test with 5th female dummy (Part 572, Subpart O) in the following positions:
 - Position 1 (mid-height seat position)
 - Position 2 (mid-height seat position)
- 28. Impact Tests

<input type="checkbox"/>	Frontal Oblique	Impact Angle:	Test Speed:
<input type="checkbox"/>	Belted 50 th male dummy driver and passenger	(0 to 48 kmph)	(S5.1.1(a))
<input type="checkbox"/>	Unbelted 50 th male dummy driver and passenger	(0 to 48 kmph)	(S5.1.2(a)(1))
<input type="checkbox"/>	Unbelted 50 th male dummy driver and passenger	(32 to 40 kmph)	(S5.1.2(a)(2) or S5.1.2(b))
<input checked="" type="checkbox"/>	Frontal 0° - Test Speed: 39.8 kmph		
<input type="checkbox"/>	Belted 50 th male dummy driver	(0 to 48 kmph)	(S5.1.1.(b)(1) or S5.1.1(a))
<input type="checkbox"/>	Belted 50 th male dummy passenger	(0 to 48 kmph)	(S5.1.1.(b)(1) or S5.1.1(a))
<input type="checkbox"/>	Belted 5 th female dummy driver	(0 to 48 kmph)	(S16.1(a)(1))
<input type="checkbox"/>	Belted 5 th female dummy passenger	(0 to 48 kmph)	(S16.1(a)(1))
<input type="checkbox"/>	Belted 5 th female dummy driver and passenger	(0 to 56 kmph)	(S16.1(a)(2))
<input type="checkbox"/>	Belted 50 th male dummy driver and passenger	(0 to 56 kmph)	(S5.1.1.(b)(2))
<input type="checkbox"/>	Unbelted 50 th male dummy driver and passenger	(0 to 48 kmph)	(S5.1.2(a) (1))
<input type="checkbox"/>	Unbelted 50 th male dummy driver	(32 to 40 kmph)	(S5.1.2.(a)(2) or S5.1.2(b))
<input type="checkbox"/>	Unbelted 50 th male dummy passenger	(32 to 40 kmph)	(S5.1.2.(a)(2) or S5.1.2(b))
<input checked="" type="checkbox"/>	Unbelted 5 th female dummy driver	(32 to 40 kmph)	(S16.1(b))
<input checked="" type="checkbox"/>	Unbelted 5 th female dummy passenger	(32 to 40 kmph)	(S16.1(b))
<input type="checkbox"/>	40% Offset 0° Belted 5 th female dummy driver and passenger	(0 to 40 kmph)	(S18.1) Test Speed:
- 29. FMVSS 204 Indicant Test
- 30. FMVSS 212 Test
- 31. FMVSS 219 Indicant Test
- 32. FMVSS 301 Frontal Test

DATA SHEET 2
REPORT OF VEHICLE CONDITION

Test Vehicle: 2014 Fiat 500L
Test Program: FMVSS 208 Compliance

NHTSA No.: C20140306
Test Date: 12/16/14

CONTRACT NO.: DTNH22-13-D-00313

Date: 12/23/2014

FROM (Lab and rep name): MGA Research Corporation

TO: NHTSA, OVSC, NVS-220

PURPOSE: (X) Initial Receipt () Received via Transfer (X) Present vehicle condition

MODEL YEAR/MAKE/MODEL/BODY STYLE: 2014 Fiat 500L MPV

MANUFACTURE DATE: 4/13

NHTSA NO. C20140306 GVWR: 1950 kg (4299 lbs)

BODY COLOR: Nero (Black) GAWR (Fr): 1050 kg (2315 lbs)

VIN: ZFBCFAAH9EZ002194 GAWR (Rr): 915 kg (2017 lbs)

ODOMETER READINGS: ARRIVAL (miles): 104 DATE: 7/9/14

COMPLETION (miles): 106 DATE: 12/16/14

PURCHASE PRICE: (\$) 19,185

DEALER'S NAME: Whitten Fiat – 10745 Midlothian Turnpike
Richmond, VA 23235

- A. All options listed on window sticker are present on the test vehicle:
 Yes ___ No
- B. Tires and wheel rims are new and the same as listed: Yes ___ No
- C. There are no dents or other interior or exterior flaws: Yes ___ No
- D. The vehicle has been properly prepared and is in running condition:
 Yes ___ No
- E. Keyless remote is available and working: Yes ___ No
- F. The glove box contains an owner's manual, warranty document, consumer information, and extra set of keys: Yes ___ No
- G. Proper fuel filler cap is supplied on the test vehicle: Yes ___ No
- H. Using permanent marker, identify vehicle with NHTSA number and FMVSS test type(s) on roof line above driver door or for school buses, place a placard with NHTSA number inside the windshield and to the exterior front and rear side of bus:
 Yes ___ No
- I. Place vehicle in storage area: Yes ___ No
- J. Inspect the vehicle's interior and exterior, including all windows, seats, doors, etc. to confirm that each system is complete and functional per the manufacturer's specifications. Any damage, misadjustment, or other unusual condition that could influence the test program or test results shall be recorded. Report any abnormal condition to the NHTSA COTR before beginning any test:
 Vehicle OK ___ Conditions reported below in comment section

Identify the letter above to which any of the following comments apply.

Comments: _____

REPORT OF VEHICLE CONDITION AT THE COMPLETION OF TESTING

LIST OF FMVSS TESTS PERFORMED BY THIS LAB: FMVSS 208, 212, 219, 301

VEHICLE: 2014 Fiat 500L NHTSA NO.: C20140306

REMARKS:

Equipment that is no longer on the test vehicle as noted on previous page:

Hub Caps, Right Rear Tail Light, Flat Tire Kit, Cargo Divider, Cargo Sill Trim, Cargo Area Cover, LH/RH Mirrors, LH/RH Rear Door Panels and Windows, Rear Door Window Motors

Explanation for equipment removal:

Components removed for instrumentation installation and to meet target weight.

Test Vehicle Condition:

25 mph frontal impact damage- front suspension & structure damaged, hood & front quarter panels damaged, radiator damaged, air bags, Stoddard in fuel system

RECORDED BY: Jeff Lewandowski DATE: 12/23/2014

APPROVED BY: David Winkelbauer DATE: 12/23/2014

#####

RELEASE OF TEST VEHICLE

The vehicle described above is released from MGA to be delivered to:

Date: Time: Odometer:

Lab Rep's Signature:

Title:

Carrier/Customer Rep:

Date:

DATA SHEET 3

CERTIFICATION LABEL AND TIRE PLACARD INFORMATION

Test Vehicle: 2014 Fiat 500L
 Test Program: FMVSS 208 Compliance
 Test Technician: Alex Vanderheyden

NHTSA No.: C20140306
 Test Date: 12/16/14

Certification Label (Part 567)	
Manufacturer:	FIAT GROUP AUTOMOBILES S.P.A.
Date of Manufacture:	4/13
VIN:	ZFBCFAAH9EZ002194
Vehicle Certified As (Pass. Car/MPV/Truck/Bus):	MPV
Front Axle GVWR:	1050 kg (2315 lbs)
Rear Axle GVWR:	915 kg (2017 lbs)
Total GVWR:	1950 kg (4299 lbs)

Tire Placard for Motor Vehicles with GVWR of 10,000 lb or Less and Passenger Cars (571.110)	
Vehicle Capacity Weight:	390 kg (860 lbs)
Designated Seating Capacity Front:	2
Designated Seating Capacity Rear:	3
Total Designated Seating Capacity:	5
Recommended Cold Tire Inflation Pressure Front:	240 kpa (35 psi)
Recommended Cold Tire Inflation Pressure Rear:	230 kpa (33 psi)
Recommended Tire Size:	P205/55R16
Tire Size on Vehicle:	P205/55R16

Signature: 

Date: 12/16/14

DATA SHEET 32

VEHICLE WEIGHT, FUEL TANK, AND ATTITUDE DATA

Test Vehicle: 2014 Fiat 500L
 Test Program: FMVSS 208 Compliance
 Test Technician: Alex Vanderheyden

NHTSA No.: C20140306
 Test Date: 12/16/14

IMPACT ANGLE:	0°					
BELTED DUMMIES (YES/NO):	NO					
TEST SPEED:	X	32 to 40 kmph		0 to 48 kmph		0 to 56 kmph
DRIVER DUMMY:	X		5 th female		50 th male	
PASSENGER DUMMY:	X		5 th female		50 th male	

- 1. Fill the transmission with transmission fluid to the satisfactory range.
- 2. Drain fuel from vehicle.
- 3. Run the engine until fuel remaining in the fuel delivery system is used and the engine stops.
- 4. Record the useable fuel tank capacity supplied by the COTR.
- Useable Fuel Tank Capacity supplied by COTR: 50.0 liters (13.2 gallons).
- 5. Record the fuel tank capacity supplied in the owner's manual.
- Useable Fuel Tank Capacity in owner's manual: 50.0 liters (13.2 gallons).
- 6. Using purple dyed Stoddard solvent having the physical and chemical properties of Type 1 solvent or cleaning fluid, Table 1, ASTM Standard D484-71, "Standard Specifications for Hydrocarbon Dry-cleaning Solvents," or gasoline, fill the fuel tank.
- Amount Added: 50.0 liters (13.2 gallons)
- 7. Fill the coolant system to capacity.
- 8. Fill the engine with motor oil to the Max. mark on the dip stick.
- 9. Fill the brake reservoir with brake fluid to its normal level.
- 10. Fill the windshield washer reservoir to capacity.
- 11. Inflate the tires to the tire pressure on the tire placard. If no tire placard is available, inflate the tires to the recommended pressure in the owner's manual.

Tire placard pressure:	RF:	35 psi	LF:	35 psi	RR:	33 psi	LR:	33 psi
Owner's manual pressure:	RF:	35 psi	LF:	35 psi	RR:	33 psi	LR:	33 psi
Actual inflated pressure:	RF:	35 psi	LF:	35 psi	RR:	33 psi	LR:	33 psi

- 12. Record the vehicle weight at each wheel to determine the unloaded vehicle weight (UVW), i.e. "as delivered" weight).

Right Front (kg):	431.4	Right Rear (kg):	283.5
Left Front (kg):	444.1	Left Rear (kg):	293.5
Total Front (kg):	875.5	Total Rear (kg):	577.0
% Total Weight:	60.3	% Total Weight:	39.7
UVW = TOTAL FRONT PLUS TOTAL REAR (KG):	1452.5		

- 13. UVW Test Vehicle Attitude: (All dimensions in millimeters)
- 13.1 Mark a point on the vehicle above the center of each wheel.
- 13.2 Place the vehicle on a level surface.
- 13.3 Measure perpendicular to the level surface to the 4 points marked on the body and record the measurements.

RF:	680	LF:	678	RR:	700	LR:	691
-----	-----	-----	-----	-----	-----	-----	-----

14. Calculate the Rated Cargo and Luggage Weight (RCLW): 50 kg
- 14.1 Does the vehicle have the vehicle capacity weight (VCW) on the certification label or tire placard?
- Yes, go to 14.3
- No, go to 14.2
- 14.2 VCW = Gross Vehicle Weight - UVW

$$VCW = \underline{\hspace{2cm}} - \underline{\hspace{2cm}} = \underline{\hspace{2cm}}$$

- 14.3 VCW = 390 kg (860 lbs)
- 14.4 Does the certification or tire placard contain the Designated Seating Capacity (DSC)?

- Yes, go to 14.6
- No, go to 14.5 and skip 14.6

14.5 DSC = Total number of seat belt assemblies = _____

14.6 DSC = 5

14.7 RCLW = VCW - (68 kg x DSC) = 390 kg - (68 kg x 5) = 50 kg

14.8 Is the vehicle certified as a truck, MPV or bus (see the certification label on the door jamb)?

Yes, if the calculated RCLW is greater than 136 kg, use 136 kg as the RCLW. (S8.1.1)

No, use the RCLW calculated in 14.7

15. Fully Loaded Weight (100% fuel fill): 1600.3 kg

15.1 Place the appropriate test dummy in both front outboard seating positions.

Driver: 5th female 50th male
 Passenger: 5th female 50th male

15.2 Load the vehicle with the RCLW from 14.7 or 14.8 whichever is applicable.

15.3 Place the RCLW in the cargo area. Center the load over the longitudinal centerline of the vehicle. (S8.1.1 (d))

15.4 Record the vehicle weight at each wheel to determine the Fully Loaded Weight.

Right Front (kg):	459.5	Right Rear (kg):	337.9
Left Front (kg):	464.5	Left Rear (kg):	338.4
Total Front (kg):	924.0	Total Rear (kg):	676.3
% Total Weight:	57.7	% Total Weight:	42.3
% GVW	53.8	% GVW	46.9
(% GVW = Axle GVW divided by Vehicle GVW)			
Fully Loaded Weight = Total Front Plus Total Rear (kg):			1600.3

16. Fully Loaded Test Vehicle Attitude: (All dimensions in millimeters)

16.1 Place the vehicle on a level surface.

16.2 Measure perpendicular to the level surface to the 4 points marked on the body (see 13.1 above) and record the measurements

RF: 673 LF: 675 RR: 671 LR: 667

17. Drain the fuel system

18. Using purple dyed Stoddard solvent having the physical and chemical properties of Type 1 solvent or cleaning fluid, Table 1, ASTM Standard D484-71, "Standard Specifications for Hydrocarbon Dry-cleaning Solvents," fill the fuel tank to 92 - 94 percent of useable capacity.

Fuel tank capacity x .94 = 50.0 liters (13.2 gallons) x .94 = 47.0 liters (12.4 gallons)

Amount added: 46.3 liters (12.24 gallons) 92.7%

- 19. Crank the engine to fill the fuel delivery system with Stoddard solvent.
- 20. Calculate the test weight range.
- 20.1 Calculated Weight = UVW (see 12 above) + RCLW (see 14 above) + 2x(dummy weight)

$$\underline{1600.5 \text{ kg}} = \underline{1452.5 \text{ kg}} + \underline{50.0 \text{ kg}} + \underline{98.0 \text{ kg}}$$

- 20.2 Test Weight Range = Calculated Weight (- 4.5 kg, - 9 kg.)
 Max. Test Weight = Calculated Test Weight - 4.5 kg = 1596.0 kg
 Min. Test Weight = Calculated Test Weight - 9 kg = 1591.5 kg

- 21. Remove the RCLW from the cargo area.
- 22. Drain transmission fluid, engine coolant, motor oil, and windshield washer fluid from the test vehicle so that Stoddard solvent leakage from the fuel system will be evident.

- 23. Vehicle Components Removed For Weight Reduction:
Hub Caps, Right Rear Tail Light, Flat Tire Kit, Cargo Divider, Cargo Sill Trim, Cargo Area Cover, LH/RH Mirrors, LH/RH Rear Door Panels and Windows, Rear Door Window Motors

- 24. Secure the equipment and ballast in the load carrying area and distribute it, as nearly as possible, to obtain the proportion of axle weight indicated by the gross axle weight ratings and center it over the longitudinal centerline of the vehicle.

- 25. If necessary, add ballast to achieve the actual test weight.

N/A
 Weight of Ballast:

- 26. Ballast, including test equipment, must be contained so that it will not shift during the impact event or interfere with data collection or interfere with high-speed film recordings or affect the structural integrity of the vehicle or do anything else to affect test results. Care must be taken to assure that any attachment hardware added to the vehicle is not in the vicinity of the fuel tank or lines.

- 27. Record the vehicle weight at each wheel to determine the actual test weight.

Right Front (kg):	458.6	Right Rear (kg):	328.9
Left Front (kg):	475.4	Left Rear (kg):	330.7
Total Front (kg):	934.0	Total Rear (kg):	659.6
% Total Weight:	58.6	% Total Weight:	41.4
% GVW	53.8	% GVW	46.9
(% GVW = Axle GVW divided by Vehicle GVW)			
TOTAL FRONT PLUS TOTAL REAR (kg):			1593.6

- 28. Is the test weight between the Max. Weight and the Min. Weight (See 20.2)?

Yes
 No, explain why not.

- 29. Test Weight Vehicle Attitude: (all dimensions in millimeters)

- 29.1 Place the vehicle on a level surface.

- 29.2 Measure perpendicular to the level surface to the 4 points marked on the body (see 13 above) and record the measurements.

RF:	677	LF:	678	RR:	674	LR:	672
-----	-----	-----	-----	-----	-----	-----	-----

- 30. Summary of test attitude.
- 30.1 AS DELIVERED:

RF: 680 LF: 678 RR: 700 LR: 691

AS TESTED:

RF: 677 LF: 678 RR: 674 LR: 672

FULLY LOADED:

RF: 673 LF: 675 RR: 671 LR: 667

- 30.2 Is the "as tested" test attitude equal to or between the "fully loaded" and "as delivered" attitude?

- Yes
- No, explain why not.

REMARKS:

Signature:  Date: 12/16/14

I certify that I have read and performed each instruction.

DATA SHEET 33

VEHICLE ACCELEROMETER LOCATION AND MEASUREMENT

Test Vehicle: 2014 Fiat 500L
 Test Program: FMVSS 208 Compliance
 Test Technician: Alex Vanderheyden

NHTSA No.: C20140306
 Test Date: 12/16/14

IMPACT ANGLE:	0°					
BELTED DUMMIES (YES/NO):	NO					
TEST SPEED:	X	32 to 40 kmph		0 to 48 kmph		0 to 56 kmph
DRIVER DUMMY:	X		5 th female		50 th male	
PASSENGER DUMMY:	X		5 th female		50 th male	

- 1. Find the location where the vertical plane parallel to the longitudinal centerline of the vehicle and through the center of the left front outboard seating position intersects the left rear seat cross member. Install an accelerometer at this intersection on the rear seat cross member to record x-direction accelerations. Record the location on the following chart.
- 2. Find the location where the vertical plane parallel to the longitudinal centerline of the vehicle and through the center of the right front outboard seating position intersects the right rear seat cross member. Install an accelerometer at this intersection on the rear seat cross member to record x-direction accelerations. Record the location on the following chart.
- 3. Find the location where a vertical plane through the longitudinal centerline of the vehicle and a vertical transverse plane through the center of the two wheels on opposite sides of the engine intersect at the top of the engine. Install an accelerometer at this intersection to record x-direction accelerations. Record the location on the following chart.
- 4. Find the location where a vertical plane through the longitudinal centerline of the vehicle and a vertical transverse plane through the center of the two wheels on opposite sides of the engine intersect the bottom of the engine. Install an accelerometer at this intersection to record x-direction accelerations. Record the location on the following chart.
- 5. Install an accelerometer on the right front brake caliper to record x-direction accelerations. Record the location on the following chart.
- 6. Find the location where a vertical plane through the longitudinal centerline of the vehicle intersects the top of the instrument panel. Install an accelerometer at this intersection to record x-direction accelerations. Record the location on the following chart.
- 7. Install an accelerometer on the left front brake caliper to record x-direction accelerations. Record the location on the following chart.
- 8. Find the location where a vertical plane through the longitudinal centerline of the vehicle intersects the floor of the trunk. Install an accelerometer on the trunk floor at this intersection to record z-direction accelerations. Record the location on the following chart.

REMARKS:

I certify that I have read and performed each instruction.

Signature: 

Date: 12/16/14

VEHICLE ACCELEROMETER LOCATION AND DATA SUMMARY

CENTERLINE OF FRONT WHEELS

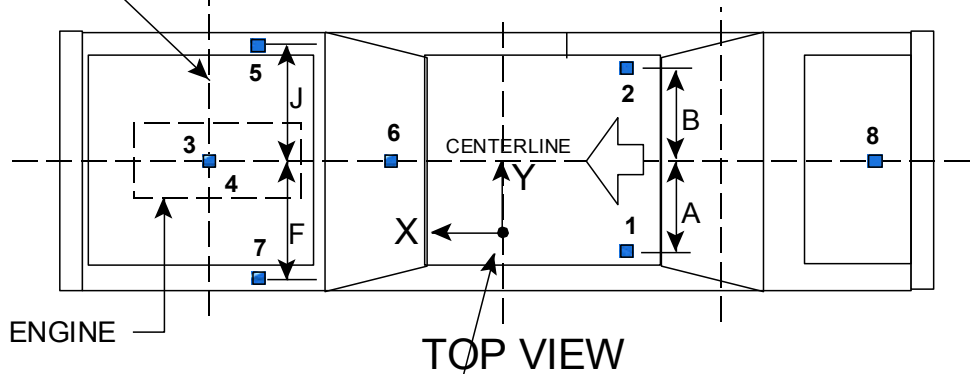

TOP VIEW

ACCELEROMETER COORDINATE SYSTEM (POSITIVE DIRECTION SHOWN)

REAR SEAT CUSHION ASSY. FRONT ATTACHMENT BRACKET SUPPORT

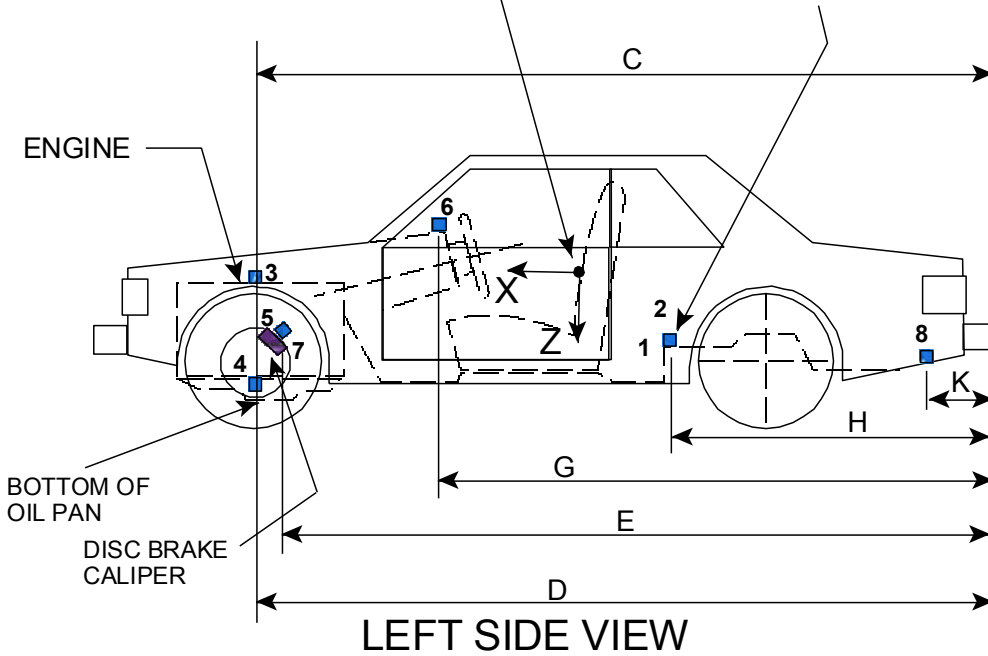

LEFT SIDE VIEW

Dimensions Corresponding To The Letters "A" Through "K" (Excluding "I") Are Recorded In The Table On The Following Page.

Accelerometers Corresponding To The Numbers 1 Through 8 Are Specified On The Preceding Page.

VEHICLE ACCELEROMETER LOCATION AND MEASUREMENTS

<u>DIMENSION</u>	<u>LENGTH (mm)</u>	
<u>PRETEST VALUES</u>		
<u>A</u> (LH Rear Seat Xmbr)	370	
<u>B</u> (RH Rear Seat Xmbr)	370	
<u>C</u> (Engine Top)	3462	
<u>D</u> (Engine Bottom)	3475	
<u>E</u> (Caliper)	Right Side: 3372	Left Side: 3372
<u>F</u> (Left Caliper)	690	
<u>G</u> (IP)	2865	
<u>H</u> (Seat)	1581	
<u>J</u> (Right Caliper)	690	
<u>K</u> (Trunk)	215	
<u>POST TEST VALUES</u>		
<u>A</u> (LH Rear Seat Xmbr)	370	
<u>B</u> (RH Rear Seat Xmbr)	370	
<u>C</u> (Engine Top)	3381	
<u>D</u> (Engine Bottom)	3450	
<u>E</u> (Caliper)	Right Side: 3338	Left Side: 3336
<u>F</u> (Left Caliper)	695	
<u>G</u> (IP)	2865	
<u>H</u> (Seat)	1581	
<u>J</u> (Right Caliper)	655	
<u>K</u> (Trunk)	215	

DATA SHEET 34
PHOTOGRAPHIC TARGETS

Test Vehicle: 2014 Fiat 500L
 Test Program: FMVSS 208 Compliance
 Test Technician: Alex Vanderheyden

NHTSA No.: C20140306
 Test Date: 12/16/14

IMPACT ANGLE:	0°		
BELTED DUMMIES (YES/NO):	NO		
TEST SPEED:	X	32 to 40 kmph	0 to 48 kmph
DRIVER DUMMY:	X	5 th female	50 th male
PASSENGER DUMMY:	X	5 th female	50 th male

- 1. **FMVSS 208 vehicle targeting requirements** (See Figures 28A and 28B)
- 1.1 Targets A1 and A2 are on flat rectangular panels.
- 1.2 Three circular targets at least 90 mm in diameter and with black and yellow quadrants are mounted at the front on the outboard sides of A1 and A2. The center of each circular target is 100 mm from the one next to it.
- Distance between targets (mm): 100 mm
- 1.3 Three circular targets at least 90 mm in diameter and with black and yellow quadrants are mounted at the back on the outboard sides of on A1 and A2. The center of each circular target is 100 mm from the one next to it.
- Distance between targets (mm): 100 mm
- 1.4 The distance between the first circular target at the front of A1 and A2 and the last circular target at the back of A1 and A2 is at least 915 mm.
- Distance between the first and last circular targets (mm): 915 mm
- 1.5 Firmly fix target A1 on the vehicle roof in the vertical longitudinal plane that is coincident with the midsagittal plane of the driver dummy.
- 1.6 Firmly fix target A2 on the vehicle roof in the vertical longitudinal plane that is coincident with the midsagittal plane of the passenger dummy.
- 1.7 Two circular targets (C1 and C2) at least 90 mm in diameter and with black and yellow quadrants are mounted on the outside of the driver door. The centers of each circular target are at least 610 mm apart.
- Distance between targets (mm): 610 mm
- 1.8 Two circular targets (C1 and C2) at least 90 mm in diameter and with black and yellow quadrants are mounted on the outside of the passenger door. The centers of each circular target are at least 610 mm apart.
- Distance between targets (mm): 610 mm
- 1.9 Place tape with squares having alternating colors on the top portion of the steering wheel.
- 1.10 Chalk the bottom portion of the steering wheel.
- 1.11 Is this an offset test?
- Yes, continue with this section**
- No, go to 2.**
- 1.12 Measure the width of the vehicle.
Vehicle width (mm):
- 1.13 Find the centerline of the vehicle. (½ of the vehicle width)
- 1.14 Find the line parallel to the centerline of the vehicle and 0.1 x vehicle width from the centerline of the vehicle.
- 1.15 Apply 25 mm wide tape with alternating black and yellow squares parallel to and on each side of the line found in 1.14. The edge of each tape shall be 50 mm from the line found in 1.14. The tape shall extend from the bottom of the bumper to the front edge of the windshield. (Figure 28D)

2. **Barrier Targeting**
- 2.1 Fix two stationary targets D1 and D2 to the barrier as shown in the Figure 28A. One target is in the vertical longitudinal plane that is coincident with the midsagittal plane of the driver dummy. The other is in the vertical longitudinal plane that is coincident with the midsagittal plane of the passenger dummy.
- 2.2 Targets D1 and D2 are on a rectangular panel.
- 2.3 Three circular targets at least 90 mm in diameter and with black and yellow quadrants are mounted on the sides of the rectangular panel away from the longitudinal centerline of the vehicle. The center of each circular target is 100 mm from the one next to it.
- Distance between circular targets on D1 (mm): 100 mm
- Distance between circular targets on D2 (mm): 100 mm
3. **FMVSS 208 Dummy Targeting Requirements**
- 3.1 Place a circular target with black and yellow quadrants on both sides of the driver dummy head as close as possible to the center of gravity of the head in the x and z direction (relative to the measuring directions of the accelerometers).
- 3.2 Place a circular target with black and yellow quadrants on both sides of the passenger dummy head as close as possible to the center of gravity of the head in the x and z direction (relative to the measuring directions of the accelerometers).
- 3.3 Place a circular target with black and yellow quadrants on the outboard shoulder of the driver dummy. Place the target as high up on the arm as possible at the intersection of the arm and shoulder. The sleeve of the shirt on the dummy may be cut to make the target visible, but do not remove any material.
- 3.4 Place a circular target with black and yellow quadrants on the outboard shoulder of the passenger dummy. Place the target as high up on the arm as possible at the intersection of the arm and shoulder. The sleeve of the shirt on the dummy may be cut to make the target visible, but do not remove any material.
4. **FMVSS 204 Targeting Requirements**
- 4.1 Is an FMVSS 204 indicant test ordered on the "COTR Vehicle Work Order?"
- Yes, continue with this form.
- No, this form is complete.
- 4.2 Resection panel (Figure 28C)
- 4.2.1 The panel deviates no more than 6 mm from perfect flatness when suspended vertically.
- 4.2.2 The 8 targets on the panel are circular targets at least 90 mm in diameter and with black and yellow quadrants.
- 4.2.3 The center of each of the 4 outer targets are placed within 1 mm of the corners of a square measuring 914 mm on each side.
- 4.2.4 Locate another square with 228 mm sides and with the center of this square coincident with the center of the 914 mm square.
- 4.2.5 The center of the 4 inner targets are placed at the midpoints of each of the 228 mm sides.
- 4.3 Place a circular target at least 90 mm in diameter and with black and yellow quadrants on a material (cardboard, metal, etc.) that can be taped to the top of the steering column.
- 4.4 Tape the target from 4.3 to the top of the steering column in a manner that does not interfere with the movement of the steering column in a crash.

REMARKS:

Signature: *Colex Vandenberg*

Date: 12/16/14

I certify that I have read and performed each instruction.

REFERENCE PHOTO TARGETS

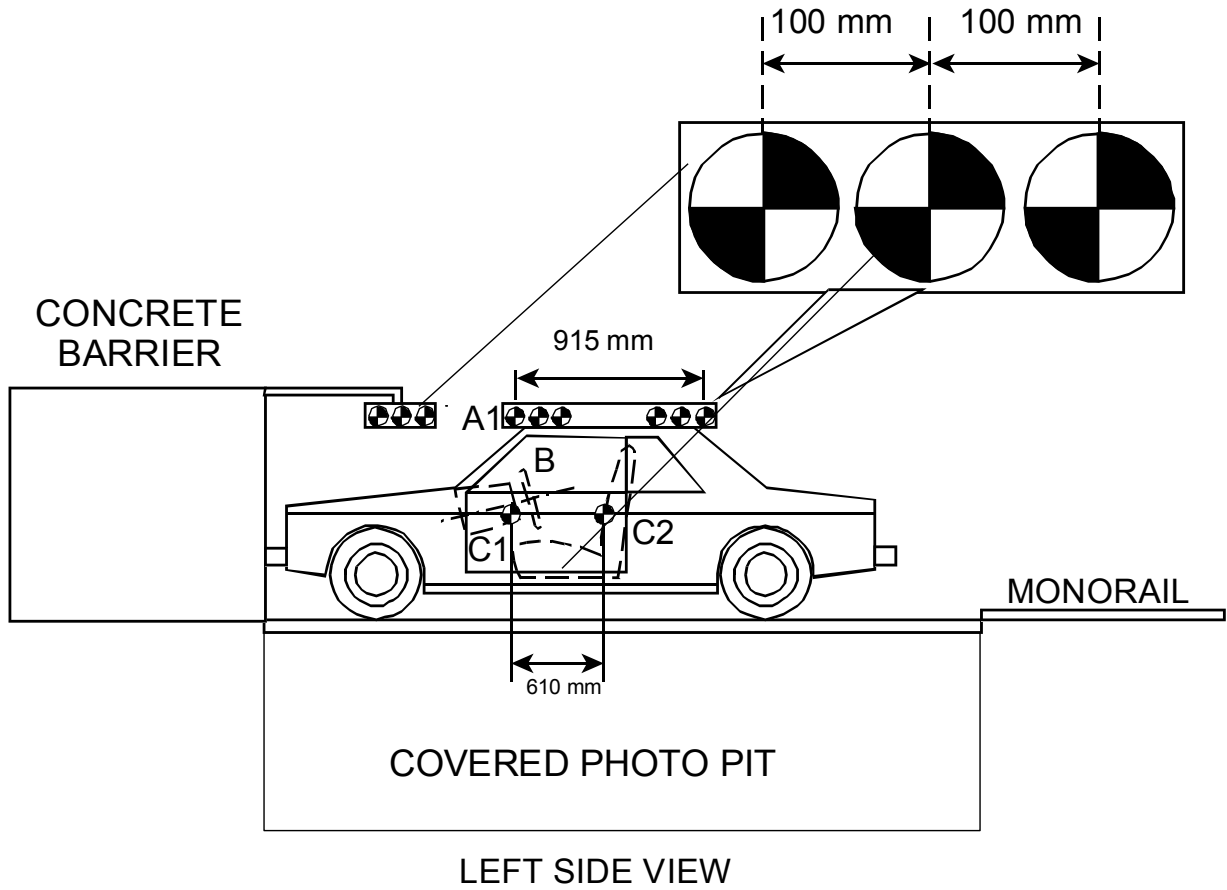

RESECTION PANEL TARGETING ALIGNMENT

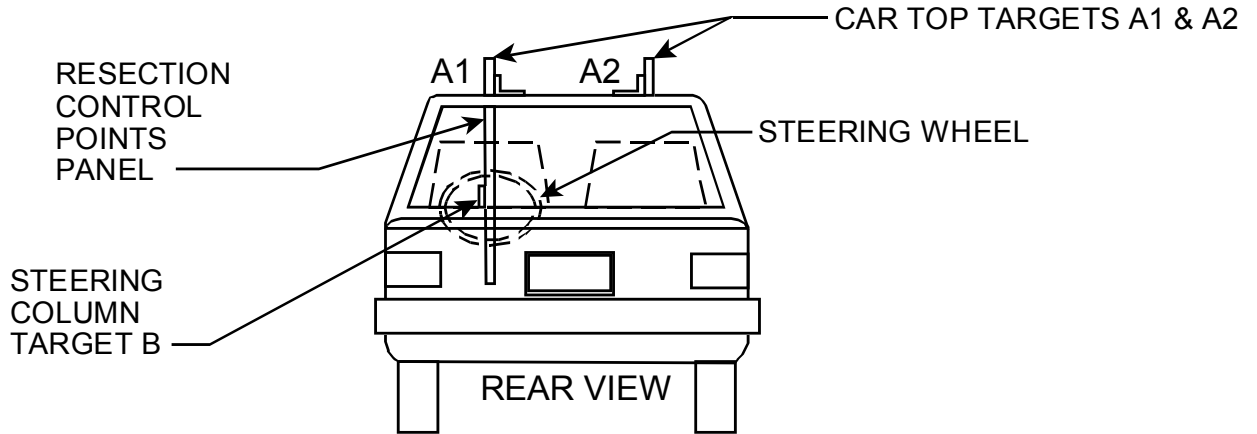

TEST RUN STEERING COLUMN CAMERA VIEW OF TYPICAL TIME ZERO VEHICLE POSITION

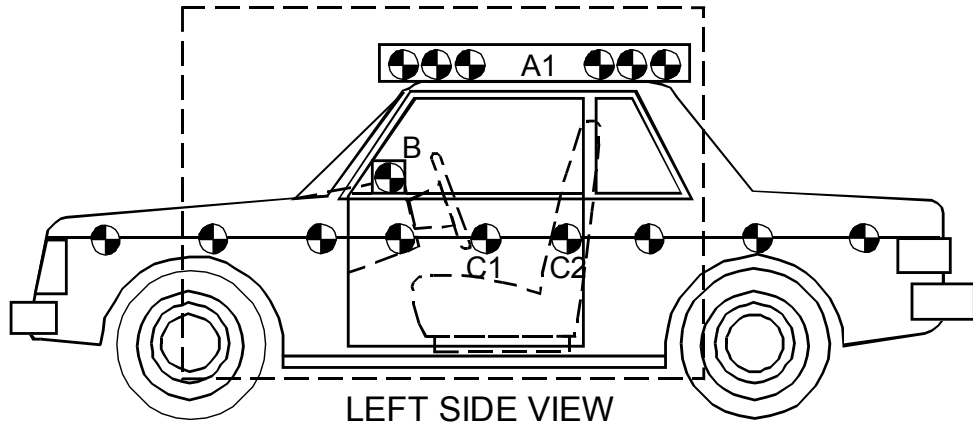

PRE-RUN STEERING COLUMN HIGH SPEED CAMERA VIEW

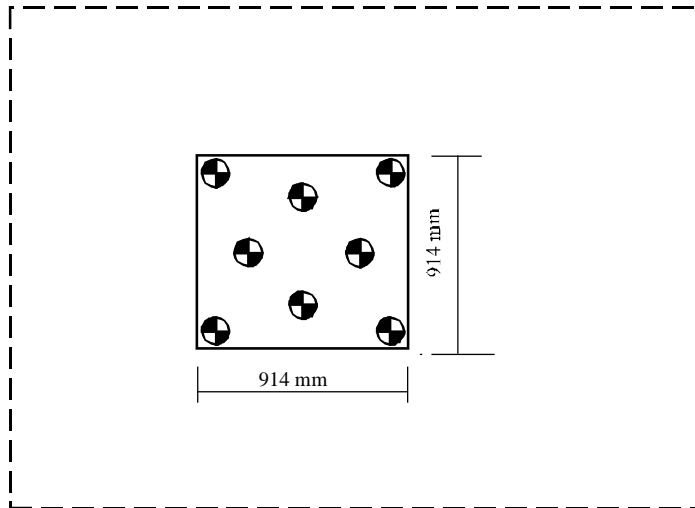

LEFT SIDE VIEW

DATA SHEET 35
CAMERA LOCATIONS

Test Vehicle: 2014 Fiat 500L
Test Program: FMVSS 208 Compliance

NHTSA No.: C20140306
Test Date: 12/16/14
Time: 10:19 AM

CAMERA NO.	VIEW	CAMERA POSITIONS (mm) *			LENS (mm)	SPEED (fps)
		X	Y	Z		
1	Real Time Left Side View				13	30
2	Left Side View (Barrier face to front seat backs)	1150	-4790	1230	24	1000
3	Left Side View (Driver)	1440	-6220	1900	35	1000
4	Left Side View (B-post aimed toward center of steering wheel)	5680	-4780	1970	50	1000
5	Left Side View (Steering Column)	680	-5070	1120	24	1000
6	Left Side View (Steering Column)	660	-5040	790	24	1000
7	Right Side View (Overall)	1800	5760	1300	20	1000
8	Right Side View (Passenger)	1480	6350	1910	35	1000
9	Right Side View (Angle)	5730	4850	1950	50	1000
10	Right Side View (Front door)	1150	4770	1360	24	1000
11	Front View Windshield	-210	0	2810	20	1000
12	Front View Driver	230	-450	2030	8.5	1000
13	Front View Passenger	230	450	2030	8.5	1000
14	Overhead Barrier Impact View	1970	0	4910	14	1000
15	Pit Camera Engine View	1250	0	-3150	24	1000
16	Pit Camera Fuel Tank View	3000	0	-3150	24	1000
17	Driver Overshoulder	1920	-2040	1770	24	1000

*COORDINATES:

- +X - forward of impact plane
- +Y - right of monorail centerline
- +Z - above ground level

CAMERA POSITIONS FOR FMVSS 208

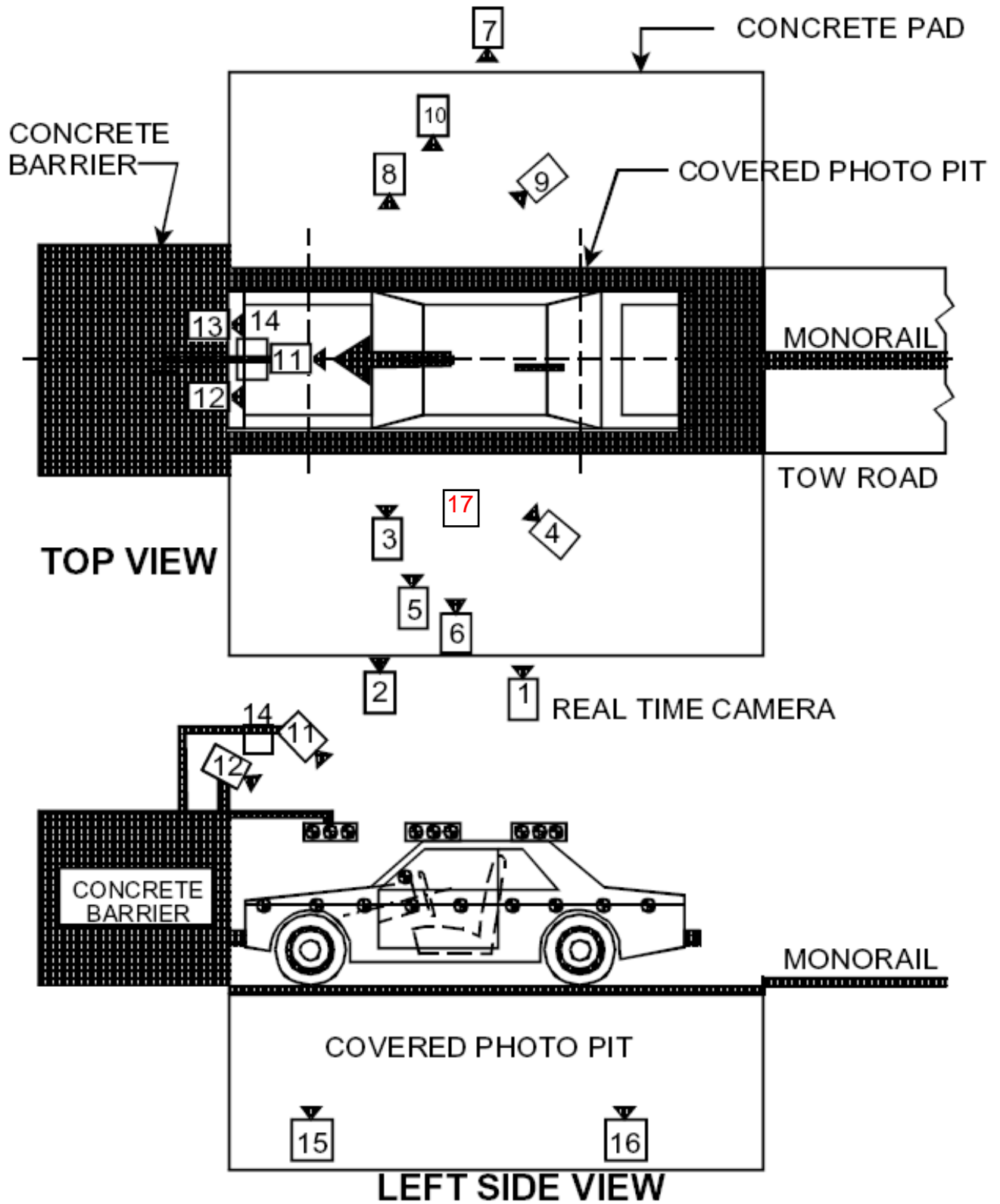

DATA SHEET 36 - APPENDIX G
DUMMY POSITIONING PROCEDURES
FOR 5th PERCENTILE FEMALE DRIVER TEST DUMMY
CONFORMING TO SUBPART O OF PART 572

Test Vehicle:	<u>2014 Fiat 500L</u>	NHTSA No.:	<u>C20140306</u>
Test Program:	<u>FMVSS 208 Compliance</u>	Test Date:	<u>12/16/14</u>
Test Technician:	<u>Jon Miller</u>		

IMPACT ANGLE:	0°					
BELTED DUMMIES (YES/NO):	NO					
TEST SPEED:	X	32 to 40 kmph		0 to 48 kmph		0 to 56 kmph
DRIVER DUMMY:	X	5 th female			50 th male	
PASSENGER DUMMY:	X	5 th female			50 th male	

1. Seat Position

- X 1.1 Position the seat's adjustable lumbar supports so that the lumbar supports are in the lowest, retracted or deflated adjustment positions. (S16.2.10.1, S20.1.9.1, S20.4.1, S22.1.7.1)
X N/A – No lumbar adjustment

- X 1.2 Position any adjustable parts of the seat that provide additional support so that they are in the lowest or most open adjustment position. (S16.2.10.2, S20.1.9.2, S20.4.1, S22.1.7.1, S22.4.2.1, S22.4.3.1, S24.4.2.1, S26.2.3, S26.3.1)
X N/A – No additional support adjustment

- X 1.3 Position an adjustable leg support system in its rearmost position. (8/27/04 interpretation to Toyota)
X N/A – No adjustable leg support system

- X 1.4 **Mark** a point (seat cushion reference point) on the side of the seat cushion that is between 150 mm and 250 mm from the front edge of the seat cushion. (S16.3.1.12)

- X 1.5 Draw a line (seat cushion reference line) through the seat cushion reference point. (S16.3.1.13)

- X 1.6 Use only the controls that primarily move the seat in the fore-aft direction to move the seat cushion reference point to the rearmost position. (S16.2.10.3.1, S22.1.7.3)

- X 1.7 If the seat cushion adjusts fore-aft, independent of the seat back, use only the controls that primarily move the seat cushion in the fore-aft direction to move the seat cushion reference point to the rearmost position. (S16.2.10.3.1, S20.1.9.3)
X N/A – No independent fore-aft seat cushion adjustment

- X 1.8 Use any part of any control, other than the parts just used for fore-aft positioning, to determine the range of angles of the seat cushion reference line and to set the seat cushion reference line at the mid-angle. (S16.2.10.3.1)
Maximum angle: 19.1° Nose Up
Minimum angle: 14.1° Nose Up
Mid-angle: 16.6° Nose Up

- 1.9 If the seat and/or seat cushion height is adjustable, use any part of any control other than the parts which primarily move the seat or seat cushion fore-aft, to put the seat cushion reference point in its lowest position with the seat cushion reference line angle at the mid-angle found in 1.8. (S16.2.10.3.1)
 N/A – No seat height adjustment
- 1.10 Use only the controls that primarily move the seat in the fore-aft direction to verify the seat is in the rearmost position.
- 1.11 Use only the controls that primarily move the seat in the fore-aft direction to **mark** the fore-aft seat positions. **Mark** each position so that there is a visual indication when the seat is at a particular position. For manual seats, move the seat forward one detent at a time and **mark** each detent. For power seats, **mark** only the rearmost, middle, and foremost positions. Label three of the positions with the following: F for foremost, M for mid-position (if there is no mid-position, label the closest adjustment position to the rear of the mid-point), and R for rearmost.
- 1.12 Use only the controls that primarily move the seat in the fore-aft direction to place the seat in the rearmost position.
- 1.13 Use any part of any control, other than the parts which primarily move the seat or seat cushion fore-aft, to find and visually **mark** the maximum, minimum, and middle height of the seat cushion reference point with the seat cushion reference line at the mid-angle determined in 1.8. (S20.1.9.4, S22.1.2, S22.1.7.4, S22.3.1, S22.4.3.1, S24.1.2, S24.3.1, S24.4.3.1, S26.2.3, S26.3.1)
 N/A – No seat height adjustment. Go to 1.18
- 1.14 Use only the controls that primarily move the seat and/or seat cushion in the fore-aft direction to place the seat in the mid-fore-aft position.
- 1.15 Use any part of any control, other than the parts which primarily move the seat or seat cushion fore-aft, to find and visually **mark** the maximum, minimum, and middle height of the seat cushion reference point with the seat cushion reference line at the mid-angle determined in 1.8. (S20.1.9.4, S22.1.2, S22.1.7.4, S22.3.1, S24.1.2, S24.3.1)
- 1.16 Use only the control that change the seat in the fore-aft direction to place the seat in the foremost position. (S16.2.10.3.2)
- 1.17 Use any part of any control, other than the parts which primarily move the seat or seat cushion fore-aft, to find and visually **mark** the maximum, minimum, and middle height of the seat cushion reference point with the seat cushion reference line at the mid-angle determined in 1.8. (S16.2.10.3.3, S20.1.9.4, S22.1.2, S22.1.7.4, S22.3.1, S24.1.2, S24.3.1)
- 1.18. Is the seat a bucket seat?
 Yes, go to 1.19 and skip 1.20
 No, go to 1.20 and skip 1.19
- 1.19 Bucket seats:
Locate and **mark** for future reference the longitudinal centerline of the seat cushion. The intersection of the vertical longitudinal plane that passes through the SgRP and the seat cushion upper surface determines the longitudinal centerline of a bucket seat cushion. (S16.3.1.10 & S20.1.10)

1.20 Bench seats (complete ONLY the one that is applicable to the seat being marked):
Locate and **mark** for future reference the longitudinal line on the seat cushion that marks the intersection of the vertical longitudinal plane through the centerline of the steering wheel and the seat cushion upper surface.

2. Head Restraint Position

N/A Vehicle contains automatic head restraints.

N/A, there is no head restraint adjustment Go to 3

2.1 Adjust the head restraint to its lowest position. (S16.2.10.2, S20.1.9.6, S20.4.1, S22.1.7.6, S22.4.2.1, S22.4.3.1, S24.4.3.1, S26.2.3, S26.3.1)

2.2 All adjustments of the head restraint shall be used to position it full forward. For example, if it rotates, rotate it such that the head restraint extends as far forward as possible.

Mark the foremost position. (S16.2.10.2 & S16.3.4.4 & S20.1.9.6, S20.4.1, S22.4.2.1, S22.4.3.1, S24.4.3.1, S26.2.3, S26.3.1)

2.3 Measure the vertical distance from the top most point of the head restraint to the bottom most point. Locate and **mark** a horizontal plane through the midpoint of this distance. (S16.3.4.3)

Vertical height of head restraint: 190 mm

Mid-point height: 95 mm

3. Is the **steering wheel** adjustable up and down and/or in and out?

Yes – go to 3.1

No – Go to 4

3.1. Find and **mark** for future reference each up and down position. Label three of the positions with the following: H for highest, M for mid-position (if there is no mid-position, label the next lowest adjustment position), and L for lowest.

N/A – steering wheel is not adjustable up and down

3.2. Find and **mark** for future references each in and out position. Label three of the Positions with the following: F for foremost, M for mid-position (if there is no mid-position, label the next rearmost adjustment position), and R for rearmost.

N/A – steering wheel is not adjustable in and out.

3.3. Use the markings to position the steering controls in the mid-position or if applicable next lowest detent position. (S16.2.9)

4. Place the SCRIP in the full rearward, mid-height position, and mid-seat cushion angle, determined in Item 1. (S16.3.2.1.1)

5. If the vehicle has an adjustable accelerator pedal, place it in the full forward position. (S16.3.2.2.1)

N/A accelerator pedal not adjustable

6. Fully recline the seat back. (S16.3.2.1.2)

N/A seat back not adjustable.

7. Place the dummy in the seat with the legs at an angle of 120 degrees to the thighs. The calves should not be touching the seat cushion. (S16.3.2.1.2)

8. Position the dummy in the seat such that the midsagittal plane is coincident with the longitudinal seat cushion markings as determined in Item 1.19 or 1.20. (S16.3.2.1.3 and S16.3.2.1.4)

9. Hold down the dummy's thighs and push rearward on the upper torso to maximize the pelvic angle. (S16.3.2.1.5)
10. Set the angle between the legs and the thighs to 120 degrees. (S16.3.2.1.6)
11. Set the transverse distance between the centers of the front of the knees at 160 to 170 mm. (6.3 to 6.7 inches) Center the knee separation with respect to the longitudinal seat cushion marking as determined in Item 1.19 or 1.20. (S16.3.2.1.6)
Record Knee Separation: 165 mm
12. Push rearward on the dummy's knees until the pelvis contacts the seat back, or the backs of the calves contact the seat cushion, whichever occurs first. (S16.3.2.1.6)
 Pelvis contacted seat back.
 Calves contacted seat cushion.
13. Gently rock the upper torso ± 5 degrees (approximately 51 mm (2 inches)) side-to-side three times. (S16.3.2.1.7)
14. If needed, extend the legs until the feet do not contact the floor pan. The thighs should be resting on the seat cushion. (S16.3.2.1.8)
15. Position the right foot until the foot is in line with a longitudinal vertical plane passing through the center of the accelerator pedal. Maintain the leg and thigh in a vertical plane. (S16.3.2.1.8)
16. Rotate the left leg and thigh laterally to equalize the distance between each knee and the longitudinal seat cushion marking as determined in Item 1.19 or 1.20. (S16.3.2.1.8)
17. Attempt to return the seat to the foremost fore-aft position, mid-height, and seat cushion mid-angle as determined in Item 1. The foot may contact and depress the accelerator and/or change the angle of the foot with respect to the leg. (S16.3.2.1.8)
 Foremost position achieved. Proceed to step 22.
 Foremost not achieved because of foot interference. Proceed to step 19.
 Foremost not achieved because of steering wheel contact.
18. If either of the dummy's legs contact the steering wheel, move the steering wheel up the minimum amount required to avoid contact. If the steering wheel is not adjustable separate the knees the minimum required to avoid contact. (S16.3.2.1.8)
 N/A- there was no leg contact
 Steering wheel repositioned
 Knees separated
19. If the left foot interferes with the clutch or brake pedals, rotate the left foot about the leg to provide clearance. If this is not sufficient, rotate the thigh outboard at the hip the minimum amount required for clearance. (S16.3.2.1.8)
 N/A, No foot interference with pedals.
 Foot adjusted to provide clearance.
 Foot and Thigh adjusted to provide clearance.

20. Continue to move the seat. Use seat controls to line up the seat markings determined during item 1 to set the foremost fore-aft position, mid-height position and the seat cushion mid-angle. If the dummy contacts the interior move the seat rearward until a maximum clearance of 5 mm (0.2 inches) is achieved or the seat is in the closest detent position that does not cause dummy contact. (S16.3.2.1.8)

Foremost, mid-height position and the seat cushion mid-angle reached

Dummy contact. Clearance set at maximum of 5 mm

Measured Clearance: _____

Dummy Contact. Seat set at nearest detent position.

Seat position: detent positions rearward of foremost
(foremost is position zero)

21. If the steering wheel was repositioned in step 18, return the steering wheel to the original position. If the steering wheel contacts the dummy before reaching the original position, position the wheel until a maximum clearance of 5 mm (.2 inches) is achieved, or the steering wheel is in the closest detent position that does not cause dummy contact. (S16.3.2.1.8)

N/A Steering wheel was not repositioned.

Original position achieved.

Dummy contact. Clearance set at maximum of 5 mm

Measured Clearance: _____

Dummy Contact. Steering wheel set at nearest detent position.

Steering wheel position: detent positions upward of original position.
(Original position is position zero)

22. If the seat back is adjustable, rotate the seat back forward while holding the thighs in place. Continue rotating the seat back forward until the transverse instrument platform of the dummy head is level ± 0.5 degrees. If the head cannot be leveled using the seat back adjustment, or the seat back is not adjustable, use the lower neck bracket adjustment to level the head. If a level position cannot be achieved, minimize the angle. (S16.3.2.1.9)

Head Level Achieved. (Check all that apply)

Head leveled using the adjustable seat back

Head leveled using the neck bracket.

Head Angle: 0.1 degrees

Head Level NOT Achieved. (Check all that apply)

Head adjusted using the adjustable seat back

Head adjusted using the neck bracket.

Head Angle: _____ degrees

23. Verify the pelvis is not interfering with the seat bight. (S16.3.2.1.9)

No interference

Pelvis moved forward the minimum amount so that it is not caught in the seat bight.

24. Verify the dummy abdomen is properly installed. (S16.3.2.1.9)

Abdomen still seated properly into dummy

Abdomen was adjusted because it was not seated properly into dummy

25. Head Angle

N/A, neither the pelvis nor the abdomen were adjusted.

25.1 Head still level (Go to 26)

25.2 Head level adjusted

 Head Level Achieved. (Check all that apply)

 Head leveled using the adjustable seat back

 Head leveled using the neck bracket.

Head Angle: _____ degrees

 Head Level NOT Achieved. (Check all that apply)

 Head level adjusted using the adjustable seat back

 Head level adjusted using the neck bracket.

Head Angle: _____ degrees

X 26. If the dummy torso contacts the steering wheel while performing step 22, reposition the steering wheel in the following order to eliminate contact. (S16.3.2.1.9)

X N/A, No dummy torso contact with the steering wheel.

 26.1 Adjust telescoping mechanism.

 N/A No telescoping adjustment.

 Adjustment performed (fill in appropriate change)

Steering wheel moved _____ detent positions in the forward direction.

Steering wheel moved _____ mm in the forward direction.

 26.2 Adjust tilt mechanism.

 N/A No tilt adjustment.

 No adjustment performed.

 Adjustment performed. (circle one)

Steering wheel moved _____ detent positions Upward/Downward.

Steering wheel moved _____ degrees Upward/Downward

 26.3 Adjust Seat in the aft direction.

 No Adjustment performed.

 Seat moved aft _____ mm from original position.

 Seat moved aft _____ detent positions from the original position.

X 27. Measure and set the pelvic angle using the pelvic angle gage TE-2504. The pelvic angle should be 20.0 degrees \pm 2.5 degrees. If the pelvic angle cannot be set to the specified range because the head will not be level or because the dummy will have need major repositioning, adjust the pelvis as closely as possible to the angle range, but keep the head level. (S16.3.2.1.11)

X Pelvic angle set to 20.0 degrees \pm 2.5 degrees.

 Pelvic angle of 20.0 degrees not achieved, the angular difference was minimized.

X Record the pelvic angle: 21.1 degrees

X 28. Check the dummy for contact with the interior after completing adjustments. (S16.3.2.1.12)

X No contact.

 Dummy in contact with interior.

 Seat moved aft _____ mm from the previous position.

 Seat moved aft _____ detent positions from the previous position.

X 29. Check the dummy to see if additional interior clearance is obtained, allowing the seat to be moved forward. (S16.3.2.1.12)

X N/A, Seat already at foremost position.

 Clearance unchanged. No adjustments required.

 Additional clearance available

 Seat moved Forward _____ mm from the previous position.

 Seat moved Forward _____ detent positions from the previous position.

30. Driver's foot positioning, right foot. Place the foot perpendicular to the leg and determine if the heel contacts the floor pan at any leg position. If the heel contacts the floor pan proceed to step 31 otherwise, proceed to step 32. (S16.3.2.2.1)
31. Perform the following steps until either all steps are completed, or the foot contacts the accelerator pedal. Step 31.6 shall be completed in all cases. (S16.3.2.2.1(a))
- 31.1 With the rear of the heel contacting the floor pan, move the foot forward until pedal contact occurs or the foot is at the full forward position.
- 31.2 If the vehicle has an adjustable accelerator pedal, move the pedals rearward until pedal contact occurs or the pedals reach the full rearward position.
- 31.3 Extend the leg, allowing the heel to lose contact with the floor until the foot contacts the pedal. Do not raise the toe of the foot higher than the top of the accelerator pedal. If the foot does not contact the pedal, proceed to the next step. If pedal contact does occur, place a tapered foam block as shown in Figure G1 under the heel with the shallow part of the taper facing forward. (S16.3.2.2.3)
- 31.4 Angle the foot to achieve contact between the foot and the pedal. If the foot does not contact the pedal, return the foot to the perpendicular orientation. If pedal contact does occur, place a tapered foam block as shown in Figure G1 under the heel with the shallow part of the taper facing forward. (S16.3.2.2.3)
- 31.5 Align the centerline of the foot with the vertical-longitudinal plane passing through the center of the accelerator pedal. Place a tapered foam block as shown in Figure G1 under the heel with the shallow part of the taper facing forward. (S16.3.2.2.3)
- 31.6 Record foot position
- Pedal Contact achieved. Contact occurred at step 31.1.
- Heel contacts floor pan
- Heel set _____ mm from floor pan.
- Pedal Contact not achieved. Heel set _____ mm from the floor pan.

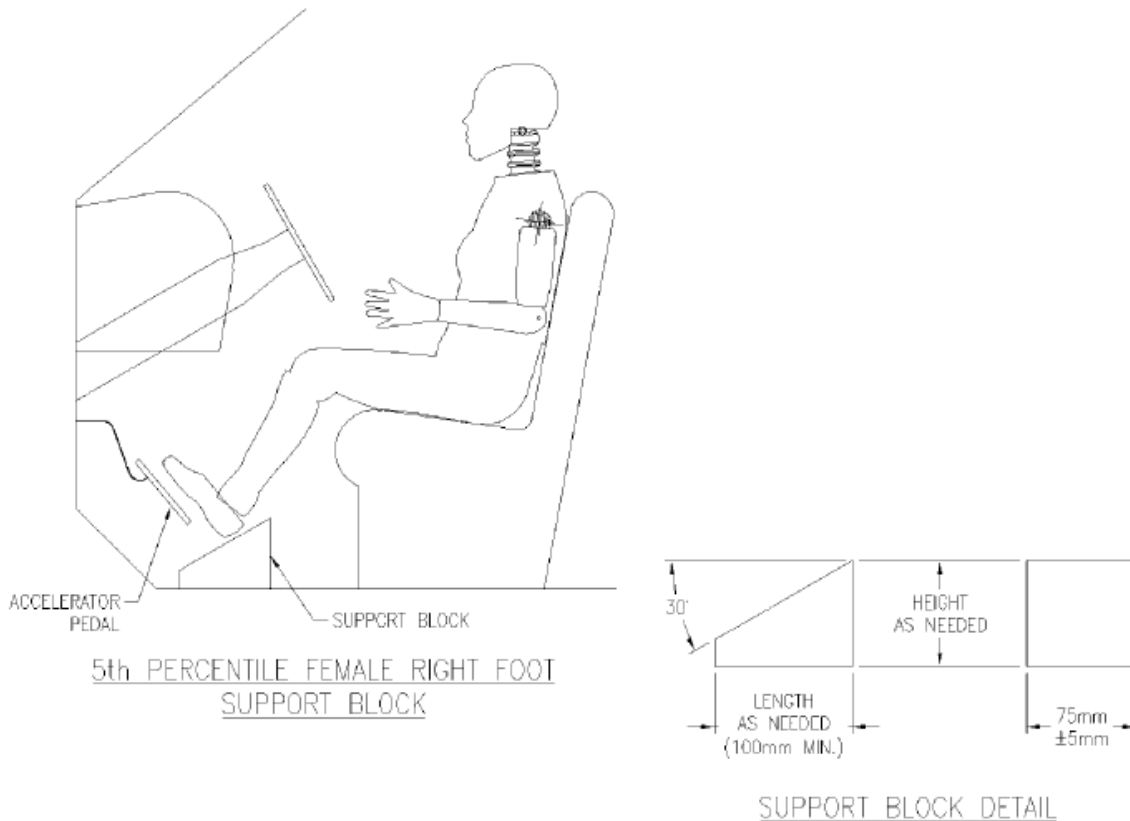

FIGURE G1

- __32. Perform the following steps until either all steps are completed, or the foot contacts the accelerator pedal. Step 30.5 shall be completed in all cases.
 - __32.1 Extend the leg until the foot contacts the pedal. Do not raise the toe of the foot higher than the top of the accelerator pedal. If the foot does not contact the pedal, proceed to the next step. If pedal contact does occur, place a tapered foam block as shown in Figure G1 under the heel with the shallow part of the taper facing forward. (S16.3.2.2.1(b) & S16.3.2.2.3)
 - __32.2 If the vehicle has an adjustable accelerator pedal, move the pedals rearward until pedal contact occurs or the pedals reach the full rearward position. If pedal contact does occur, place a tapered foam block as shown in Figure G1 under the heel with the shallow part of the taper facing forward. (S16.3.2.2.1(b) & S16.3.2.2.3)
 - __N/A No pedal adjustment
 - __32.3 Angle the foot to achieve contact between the foot and the pedal. If the foot does not contact the pedal, return the foot to the perpendicular orientation. If pedal contact does occur, place a tapered foam block as shown in Figure G1 under the heel with the shallow part of the taper facing forward. (S16.3.2.2.2 & S16.3.2.2.3)
 - __32.4 Align the centerline of the foot in the same horizontal plane as the centerline of the accelerator pedal. Place a tapered foam block as shown in Figure G1 under the heel with the shallow part of the taper facing forward. (S16.3.2.2.3)
 - __32.5 Record foot position
 - __Pedal Contact achieved. Contact occurred at step _____.
 - __Heel set _____ mm from floor pan.
 - __Pedal Contact not achieved. Heel set _____ mm from the floor pan.

X 33. Driver's foot positioning, left foot.

X 33.1 Place the foot perpendicular to the leg and determine if the heel contacts the floor pan at any leg position. If the heel contacts the floor pan proceed to step 33.2, otherwise position the leg as perpendicular to the thigh as possible with the foot parallel to the floor pan. (S16.2.2.6)

X 33.2 Place the foot on the toe board with the heel resting on the floor pan as close to the intersection of the floor pan and the toe board as possible. Adjust the angle of the foot if necessary to contact the toe board. If the foot will not contact the toe board, set the foot perpendicular to the leg, and set the heel on the floor pan as far forward as possible. Avoid contact with the brake pedal, clutch pedal, wheel well projection, and footrest. To avoid this contact use the following three manipulations in the order listed, with each subsequent option incorporating the previous, until contact is avoided: rotate the foot about the lower leg (abduction/adduction), plantar flex the foot, rotate the leg outboard about the hip. Movement should be the minimum amount necessary. If it is not possible to avoid all foot contact, give priority to avoiding brake or clutch pedal contact. (S16.2.2.4 & S16.2.2.5 & S16.2.2.7)

X No contact

 Foot rotated about the leg (abduction/adduction)

 Foot rotated about the leg, and foot plantar flexed

 Foot rotated about the leg, foot plantar flexed, and the leg rotated about the hip.

X 33.3 Record foot position.

 Heel does not contact floor pan.

 Heel on floor pan and foot on toe board.

X Heel on floor pan and foot not on toe board.

X 34. Driver arm/hand positioning.

X 34.1 Place the dummy's upper arms adjacent to the torso with the arm centerlines as close to a vertical longitudinal plane as possible. (S16.3.2.3.1)

X 34.2 Place the palms of the dummy in contact with the outer part of the steering wheel rim at its horizontal centerline with the thumbs over the steering wheel rim. (S16.3.2.3.2)

X 34.3 If it is not possible to position the thumbs inside the steering wheel rim at its horizontal centerline, then position them above and as close to the horizontal centerline of the steering wheel rim as possible. (S16.3.2.3.3)

X 34.4 Lightly tape the hands to the steering wheel rim so that if the hand of the test dummy is pushed upward by a force of not less than 9 N (2 lb) and not more than 22 N (5 lb), the tape releases the hand from the steering wheel rim. (S16.3.2.3.4)

X 35. Adjustable head restraints

 N/A, there is no head restraint adjustment

 35.1 If the head restraint has an automatic adjustment, leave it where the system positions the restraint after the dummy is placed in the seat. (S16.3.4.1) Go to 36.

X 35.2 Adjust each head restraint vertically so that the mid-horizontal plane determined in Item 2 is aligned with the center of gravity (CG) of the dummy head. (S16.3.4.3)

35.3 If the above position is not attainable, move the vertical center of the head restraint to the closest detent below the center of the head CG. (S16.3.4.3)

N/A midpoint position attained in previous step

Headrest set at nearest detent below the head CG

35.4 If the head restraint has a fore and aft adjustment, place the restraint in the foremost position or until contact with the head is made, whichever occurs first. (S16.3.4.4)

36. Driver and passenger manual belt adjustment (for tests conducted with a belted dummy). (S16.3.5)

N/A Dummies are unbelted for this test.

36.1 If an adjustable seat belt D-ring anchorage exists, place it in the manufacturer's design position for a 5th percentile adult female. (S16.3.5.1) **This information will be supplied by the COTR.**

Manufacturer's specified position:

Actual Position:

36.2 Place the Type 2 manual belt around the test dummy and fasten the latch. (S16.3.5.2)

36.3 Ensure that the dummy's head remains as level as possible. (S16.3.5.3)

36.4 Remove all slack from the lap belt. Pull the upper torso webbing out of the retractor and allow it to retract; repeat this operation four times. Apply a 9 N (2 lbf) to 18 N (4 lbf) tension load to the lap belt. If the belt system is equipped with a tension-relieving device, introduce the maximum amount of slack into the upper torso belt that is recommended by the manufacturer. If the belt system is not equipped with a tension-relieving device, allow the excess webbing in the shoulder belt to be retracted by the retractive force of the retractor. (S16.3.5.4)

I certify that I have read and performed each instruction.

Signature: 

Date: 12/16/14

DATA SHEET 36 - APPENDIX G
DUMMY POSITIONING PROCEDURES
FOR 5th PERCENTILE FEMALE PASSENGER TEST DUMMY
CONFORMING TO SUBPART O OF PART 572

Test Vehicle: 2014 Fiat 500L
 Test Program: FMVSS 208 Compliance
 Test Technician: Jon Miller

NHTSA No.: C20140306
 Test Date: 12/16/14

IMPACT ANGLE:	0°					
BELTED DUMMIES (YES/NO):	NO					
TEST SPEED:	X	32 to 40 kmph		0 to 48 kmph		0 to 56 kmph
DRIVER DUMMY:	X		5 th female		50 th male	
PASSENGER DUMMY:	X		5 th female		50 th male	

__ The passenger seat adjustments are controlled by the adjustments made to the driver's seat. Therefore, positioning of the passenger dummy is made simultaneously with the driver dummy. Adjustments made to the seat to position the driver will override any adjustments that would normally be made to position the passenger. (S16.2.10.3)

1. Seat Position

X 1.1 Position the seat's adjustable lumbar supports so that the lumbar supports are in the lowest, retracted or deflated adjustment positions. (S16.2.10.1, S20.1.9.1, S20.4.1, S22.1.7.1)

X N/A – No lumbar adjustment

X 1.2 Position any adjustable parts of the seat that provide additional support so that they are in the lowest or most open adjustment position. (S16.2.10.2, S20.1.9.2, S20.4.1, S22.1.7.1, S22.4.2.1, S22.4.3.1, S24.4.2.1, S26.2.3, S26.3.1)

X N/A – No additional support adjustment

X 1.3 Position an adjustable leg support system in its rearmost position. (8/27/04 interpretation to Toyota)

X N/A – No adjustable leg support system

X 1.4 **Mark** a point (seat cushion reference point) on the side of the seat cushion that is between 150 mm and 250 mm from the front edge of the seat cushion. (S16.3.1.12)

X 1.5 Draw a line (seat cushion reference line) through the seat cushion reference point. (S16.3.1.13)

X 1.6 Use only the controls that primarily move the seat in the fore-aft direction to move the seat cushion reference point to the rearmost position. (S16.2.10.3.1, S22.1.7.3)

X 1.7 If the seat cushion adjusts fore-aft, independent of the seat back, use only the controls that primarily move the seat cushion in the fore-aft direction to move the seat cushion reference point to the rearmost position. (S16.2.10.3.1, S20.1.9.3)

X N/A – No independent fore-aft seat cushion adjustment

- 1.8 Use any part of any control, other than the parts just used for fore-aft positioning, to determine the range of angles of the seat cushion reference line and to set the seat cushion reference line at the mid-angle. (S16.2.10.3.1)
Maximum angle: 18.0 Nose Up
Minimum angle: 12.8 Nose Up
Mid-angle: 15.4 Nose Up
- 1.9 If the seat and/or seat cushion height is adjustable, use any part of any control other than the parts which primarily move the seat or seat cushion fore-aft, to put the seat cushion reference point in its lowest position with the seat cushion reference line angle at the mid-angle found in 1.8. (S16.2.10.3.1)
 N/A – No seat height adjustment
- 1.10 Use only the controls that primarily move the seat in the fore-aft direction to verify the seat is in the rearmost position.
- 1.11 Use only the controls that primarily move the seat in the fore-aft direction to **mark** the fore-aft seat positions. **Mark** each position so that there is a visual indication when the seat is at a particular position. For manual seats, move the seat forward one detent at a time and **mark** each detent. For power seats, **mark** only the rearmost, middle, and foremost positions. Label three of the positions with the following: F for foremost, M for mid-position (if there is no mid-position, label the closest adjustment position to the rear of the mid-point), and R for rearmost.
- 1.12 Use only the controls that primarily move the seat in the fore-aft direction to place the seat in the rearmost position.
- 1.13 Use any part of any control, other than the parts which primarily move the seat or seat cushion fore-aft, to find and visually **mark** the maximum, minimum, and middle height of the seat cushion reference point with the seat cushion reference line at the mid-angle determined in 1.8. (S20.1.9.4, S22.1.2, S22.1.7.4, S22.3.1, S22.4.3.1, S24.1.2, S24.3.1, S24.4.3.1, S26.2.3, S26.3.1)
 N/A – No seat height adjustment. Go to 1.18
- 1.14 Use only the controls that primarily move the seat and/or seat cushion in the fore-aft direction to place the seat in the mid-fore-aft position.
- 1.15 Use any part of any control, other than the parts which primarily move the seat or seat cushion fore-aft, to find and visually **mark** the maximum, minimum, and middle height of the seat cushion reference point with the seat cushion reference line at the mid-angle determined in 1.8. (S20.1.9.4, S22.1.2, S22.1.7.4, S22.3.1, S24.1.2, S24.3.1)
- 1.16 Use only the controls that change the seat in the fore-aft direction to place the seat in the foremost position. (S16.2.10.3.2)
- 1.17 Use any part of any control, other than the parts which primarily move the seat or seat cushion fore-aft, to find and visually **mark** the maximum, minimum, and middle height of the seat cushion reference point with the seat cushion reference line at the mid-angle determined in 1.8. (S16.2.10.3.3, S20.1.9.4, S22.1.2, S22.1.7.4, S22.3.1, S24.1.2, S24.3.1)
- 1.18. Is the seat a bucket seat?
 Yes, go to 1.19 and skip 1.20
 No, go to 1.20 and skip 1.19

X 1.19 Bucket seats:

Locate and **mark** for future reference the longitudinal centerline of the seat cushion. The intersection of the vertical longitudinal plane that passes through the SgRP and the seat cushion upper surface determines the longitudinal centerline of a bucket seat cushion. (S16.3.1.10 & S20.1.10)

 1.20 Bench seats:

Locate and **mark** the longitudinal centerline of the passenger seat cushion. The longitudinal centerline is the same distance from the longitudinal centerline of the vehicle as the center of the steering wheel. (S20.2.1.4, S22.2.1.3, S24.2.3, S20.4.4, S22.2.2.1 (b), S22.2.2.3 (b), S22.2.2.4 (a), S22.2.2.5 (a), S22.2.2.6 (a), S22.2.2.7 (a), S24.2.3 (a))

Record the distance from the longitudinal centerline of the vehicle to the center of the steering wheel. _____

Record the distance from the longitudinal centerline of the vehicle to the longitudinal centerline of the seat cushion. (The vertical plane through this longitudinal centerline is Plane B for suppression.) _____

2. Head Restraint Position

 N/A Vehicle contains automatic head restraints.

 N/A, there is no head restraint adjustment Go to 3

X 2.1 Adjust the head restraint to its lowest position. (S16.2.10.2, S20.1.9.6, S20.4.1, S22.1.7.6, S22.4.2.1, S22.4.3.1, S24.4.3.1, S26.2.3, S26.3.1)

X 2.2 All adjustments of the head restraint shall be used to position it full forward. For example, if it rotates, rotate it such that the head restraint extends as far forward as possible. **Mark** the foremost position. (S16.2.10.2 & S16.3.4.4 & S20.1.9.6, S20.4.1, S22.4.2.1, S22.4.3.1, S24.4.3.1, S26.2.3, S26.3.1)

X 2.3 Measure the vertical distance from the top most point of the head restraint to the bottom most point. Locate and **mark** a horizontal plane through the midpoint of this distance. (S16.3.4.3)

Vertical height of head restraint: 190 mm

Mid-point height: 95 mm

X 3. Place the SCRIP in the full rearward, mid-height position, and mid-seat cushion angle. (S16.3.3.1.1)

X 4. Fully recline the seat back. (S16.3.3.1.2)

 N/A seat back not adjustable.

X 5. Place the dummy in the seat with the legs at an angle of 120 degrees to the thighs. The calves should not be touching the seat cushion. (S16.3.3.1.2)

X 6. Position the dummy in the seat such that the midsagittal plane is coincident with the longitudinal seat cushion marking that was determined in item 1.19 or 1.20. (S16.3.3.1.3 and S16.3.3.1.4)

X 7. Hold down the dummy's thighs and push rearward on the upper torso to maximize the pelvic angle. (S16.3.3.1.5)

X 8. Set the angle between the legs and the thighs to 120 degrees. (S16.3.3.1.6)

- X 9. Set the transverse distance between the centers of the front of the knees at 160 to 170 mm. (6.3 to 6.7 inches). Center the knee separation with respect to the longitudinal seat cushion marking that was determined in item 1.19 or 1.20. (S16.3.3.1.6)
Record Knee Separation: 165 mm
- X 10. Push rearward on the dummy's knees until the pelvis contacts the seat back, or the backs of the calves contact the seat cushion, whichever occurs first. (S16.3.3.1.6)
X Pelvis contacted seat back.
 Calves contacted seat cushion.
- X 11. Gently rock the upper torso ± 5 degrees (approximately 51 mm (2 inches)) side-to-side three times. (S16.3.3.1.7)
- X 12. If needed, extend the legs until the feet do not contact the floor pan. The thighs should be resting on the seat cushion. (S16.3.3.1.8)
- X 13. Use seat controls to line up the seat markings determined during the completion of item 1 to set the foremost fore-aft position, mid-height position and the seat cushion mid-angle. If the dummy contacts the interior move the seat rearward until a maximum clearance of 5 mm (0.2 inches) is achieved or the seat is in the closest detent position that does not cause dummy contact. (S16.3.3.1.8)
 Foremost, mid-height position and the seat cushion mid-angle reached
 Dummy contact. Clearance set at maximum of 5 mm
Measured Clearance: _____
X Dummy Contact. Seat set at nearest detent position.
Seat position 3 detent positions rearward of foremost
(foremost is position zero)
- X 14. If the seat back is adjustable, rotate the seat back forward while holding the thighs in place. Continue rotating the seat back forward until the transverse instrument platform of the dummy head is level ± 0.5 degrees. If head cannot be leveled using the seat back adjustment, or the seat back is not adjustable, use the lower neck bracket adjustment to level the head. If a level position cannot be achieved, adjust the head as closely as possible to the ± 0.5 degree range. (S16.3.3.1.9 and S16.3.3.1.10)
(Check All That Apply)
 Seat back not adjustable
 Seat back not independent of driver side seat back
X Head Level Achieved. (Check all that apply)
 Head leveled using the adjustable seat back
 Head leveled using the neck bracket.
Head Angle: 0.2 degrees
 Head Level NOT Achieved. (Check all that apply)
 Head adjusted using the adjustable seat back
 Head adjusted using the neck bracket.
Head Angle: _____ degrees
- X 15. Verify the pelvis is not interfering with the seat bight. (S16.3.3.1.9)
X No interference
 Pelvis moved forward the minimum amount so that it is not caught in the seat bight.
- X 16. Verify the dummy abdomen is properly installed. (S16.3.3.1.9)
X Abdomen still seated properly into dummy
 Abdomen was adjusted because it was not seated properly into dummy
- X 17. Head Angle
X N/A, neither the pelvis nor the abdomen were adjusted.

17.1 Head still level (Go to 18)

17.2 Head level adjusted

Head Level Achieved. (Check all that apply)

Head leveled using the adjustable seat back

Head leveled using the neck bracket.

Head Angle: _____ degrees

Head Level NOT Achieved. (Check all that apply)

Head adjusted using the adjustable seat back

Head adjusted using the neck bracket.

Head Angle: _____ degrees

18. Measure and set the pelvic angle using the pelvic angle gage TE-2504. The pelvic angle should be 20.0 degrees \pm 2.5 degrees. If the pelvic angle cannot be set to the specified range because the head will not be level or because the dummy will have need major repositioning, adjust the pelvis as closely as possible to the angle range, but keep the head level.

Pelvic angle set to 20.0 degrees \pm 2.5 degrees.

Pelvic angle of 20.0 degrees not achieved, the angular difference was minimized.

Record the pelvic angle: 21.7 degrees

19. Check the dummy for contact with the interior after completing adjustments.

No contact.

Dummy in contact with interior.

Seat moved aft _____ mm from the previous position.

Seat moved aft _____ detent positions from the previous position.

20. Verify the transverse instrument platform of the dummy head is level +/- 0.5 degrees. Use the lower neck bracket adjustment to level the head. If a level position cannot be achieved, minimize the angle. (S16.3.3.1.9, S16.3.3.1.10, and S16.3.3.1.11)

Head Level Achieved

Head Angle: 0.3 degrees

Head Level NOT Achieved.

Head Angle: _____ degrees

21. Check the dummy to see if additional interior clearance is obtained, allowing the seat to be moved forward. (S16.3.3.1.12)

N/A Bench Seat

N/A Seat already at full forward position.

Clearance unchanged. No adjustments required.

Additional clearance available

Seat moved Forward _____ mm from the previous position.

Seat moved Forward _____ detent positions from the previous position.

Seat moved Forward, Full Forward position reached.

22. Passenger foot positioning. (Indicate final position achieved) (S16.3.3.2)

22.1 Place feet flat on the toe board; OR (S16.3.3.2.1)

22.2 If the feet cannot be placed flat on the toe board, set the feet perpendicular to the lower leg, and rest the heel as far forward on the floor pan as possible; OR (S16.3.3.2.2)

22.3 If the heels do not touch the floor pan, set the legs as perpendicular to the thighs as possible and set the feet parallel to the floor pan. (S16.3.3.2.2)

23. Passenger arm/hand positioning. (S16.3.3.3)

23.1 Place the dummy's upper arms adjacent to the torso with the arm centerlines as close to a vertical longitudinal plane as possible. (S16.3.3.3.1)

23.2 Place the palms of the dummy in contact with the outer part of the thighs (S16.3.3.3.2)

23.3 Place the little fingers in contact with the seat cushion. (S16.3.3.3.3)

24. Adjustable head restraints (S16.3.4)
 N/A, there is no head restraint adjustment

24.1 If the head restraint has an automatic adjustment, leave it where the system positions the restraint after the dummy is placed in the seat. (S16.3.4.1) Go to 25.

24.2 Adjust each head restraint vertically so that the horizontal plane determined in Item 2 is aligned with the center of gravity (CG) of the dummy head. (S16.3.4.3)

24.3 If the above position is not attainable, move the vertical center of the head restraint to the closest detent below the center of the head CG. (S16.3.4.3)

N/A midpoint position attained in previous step

Headrest set at nearest detent below the head CG

24.4 If the head restraint has a fore and aft adjustment, place the restraint in the foremost position or until contact with the head is made, whichever occurs first. (S16.3.4.4)

25. Manual belt adjustment (for tests conducted with a belted dummy) (S16.3.5)
 N/A, Unbelted test

25.1 If an adjustable seat belt D-ring anchorage exists, place it in the manufacturer's design position for a 5th percentile adult female. **This information will be supplied by the COTR.** (S16.3.5.1)

Manufacturer's specified position:

Actual Position:

25.2 Place the Type 2 manual belt around the test dummy and fasten the latch. (S16.3.5.2)

25.3 Ensure that the dummy's head remains as level as possible. (S16.3.5.3)

25.4 Remove all slack from the lap belt. Pull the upper torso webbing out of the retractor and allow it to retract; repeat this operation four times. Apply a 9 N (2 lbf) to 18 N (4 lbf) tension load to the lap belt. If the belt system is equipped with a tension-relieving device, introduce the maximum amount of slack into the upper torso belt that is recommended by the manufacturer. If the belt system is not equipped with a tension-relieving device, allow the excess webbing in the shoulder belt to be retracted by the retractive force of the retractor. (S16.3.5.4)

I certify that I have read and performed each instruction.

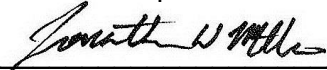
Signature: 

Date: 12/16/14

DATA SHEET 37

DUMMY MEASUREMENTS

Test Vehicle: 2014 Fiat 500L
 Test Program: FMVSS 208 Compliance
 Test Technician: Jon Miller

NHTSA No.: C20140306
 Test Date: 12/16/14

DUMMY MEASUREMENTS FOR FRONT SEAT OCCUPANTS

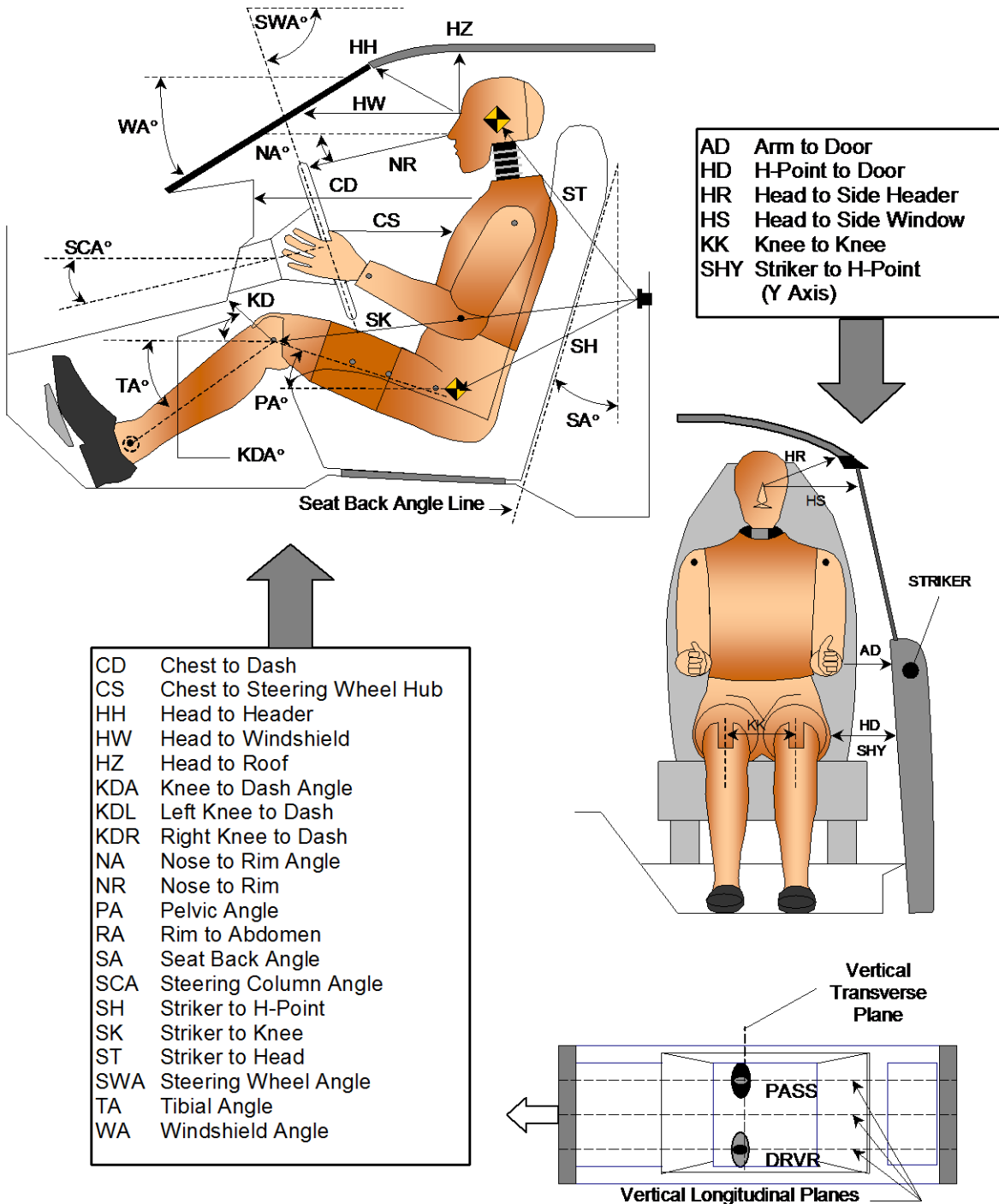

TEST DUMMY POSITION MEASUREMENTS

Code	Measurement Description	Driver SN 510		Passenger SN 511	
		Length (mm)	Angle (°)	Length (mm)	Angle (°)
WA	Windshield Angle		30.4		
SWA	Steering Wheel Angle		62.3		
SCA	Steering Column Angle		27.7		
SA	Seat Back Angle (On Headrest Post)		1.9		9.0
HZ	Head to Roof (Z)	318		305	
HH	Head to Header	474	31.3	450	26.8
HW	Head to Windshield	815	0.0	782	0.0
HR	Head to Side Header (Y)	328		303	
NR	Nose to Rim	321	3.4		
CD	Chest to Dash	498		402	
CS	Chest to Steering Hub	236	4.3		
RA	Rim to Abdomen	120	0.0		
KDL	Left Knee to Dash	119	30.5	72	
KDR	Right Knee to Dash	115		84	26.6
PA	Pelvic Angle		21.1		21.7
TA	Tibia Angle		55.9		61.1
KK	Knee to Knee (Y)	290		227	
SK	Striker to Knee	612	103.9	672	98.8
ST	Striker to Head	457	20.3	467	17.8
SH	Striker to H-Point	329	119.2	340	109.6
SHY	Striker to H-Point (Y)	313		308	
HS	Head to Side Window	390		365	
HD	H-Point to Door (Y)	203		196	
AD	Arm to Door (Y)	228		120	
AA	Ankle to Ankle	271		176	

SEAT BELT POSITIONING DATA

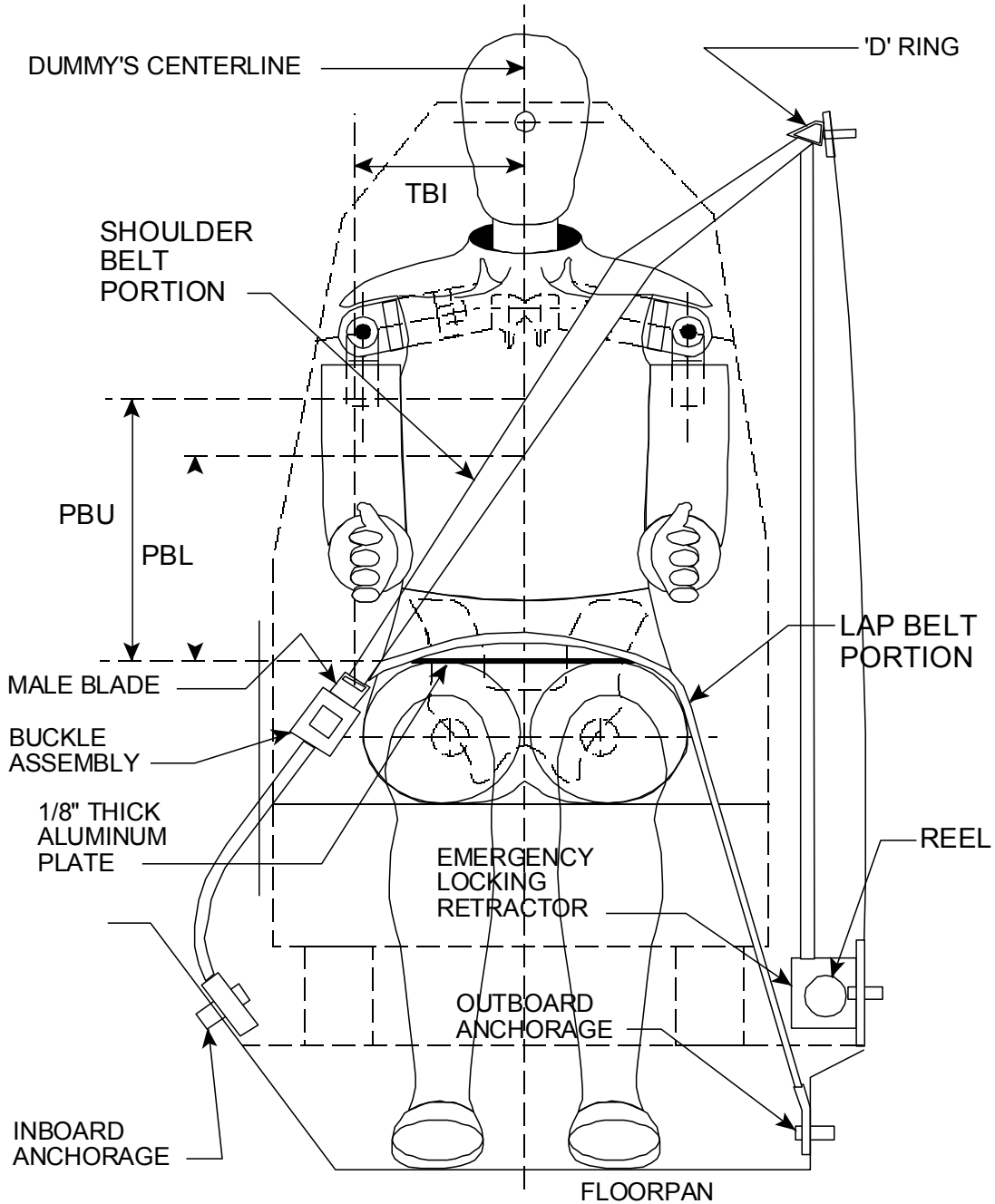

FRONT VIEW OF DUMMY

SEAT BELT POSITIONING MEASUREMENTS

Measurement Description	Units	Driver	Passenger
PBU - Top surface of reference to belt upper edge	mm	N/A	N/A
PBL - Top surface of reference to belt lower edge	mm	N/A	N/A

DATA SHEET 38

CRASH TEST

Test Vehicle: 2014 Fiat 500L
 Test Program: FMVSS 208 Compliance
 Test Technician: Alex Vanderheyden

NHTSA No.: C20140306
 Test Date: 12/16/14

IMPACT ANGLE:	0°					
BELTED DUMMIES (YES/NO):	NO					
TEST SPEED:	X	32 to 40 kmph		0 to 48 kmph		0 to 56 kmph
DRIVER DUMMY:	X		5 th female		50 th male	
PASSENGER DUMMY:	X		5 th female		50 th male	

- 1. Vehicle underbody painted.
- 2. The speed measuring devices are in place and functioning.
- 3. The speed measuring devices are 1.0 m from the barrier (spec. 1.5 m) and 30 cm from the barrier (spec. is 30 cm)
- 4. Convertible top is in the closed position.
 N/A, not a convertible
- 5. Instrumentation and wires are placed so motion of dummies during impact is not affected.
- 6. Tires inflated to pressure on tire placard or if it does not have a tire placard because it is not a passenger car, then inflated to the tire pressure specified in the owner information.

240 kpa front left tire 240 kpa specified on tire placard or in owner information
240 kpa front right tire 240 kpa specified on tire placard or in owner information
230 kpa rear left tire 230 kpa specified on tire placard or in owner information
230 kpa rear right tire 230 kpa specified on tire placard or in owner information
- 7. Time zero contacts on barrier in place.
- 8. Pre test zero and shunt calibration adjustments performed and recorded.
- 9. Dummy temperature meets requirements of section 12.2 of the test procedure.
- 10. Vehicle hood closed and latched.
- 11. Transmission placed in neutral.
- 12. Parking brake off.
- 13. Are the heads still level?
 Yes, go to 14
 No, Adjust dummy so that head is at the angle recorded in the Appendix F or G data sheets and then continue.
- 14. Ignition in the ON position.
- 15. Doors closed and latched but not locked.
- 16. Post test zero and shunt calibration checks performed and recorded.
- 17. Actual test speed 39.8 kmph
- 18. Vehicle rebound from the barrier 354 cm
- 19. Describe whether the doors open after the test and what method is used to open the doors.
 Left Front Door: Door remained closed and latched; Door opened without tools.
 Right Front Door: Door remained closed and latched; Door opened without tools.
 Left Rear Door: Door remained closed and latched; Door opened without tools.
 Right Rear Door: Door remained closed and latched; Door opened without tools.

20. Describe the contact points of the dummy with the interior of the vehicle.
- Driver Dummy: Head to Air Bag; Chest to Air Bag; Knees to Knee Air Bag.
 - Passenger Dummy: Head to Air Bag; Chest to Air Bag; Knees to Glove Box.

REMARKS:

Signature: *Chester Vandenberg*

Date: 12/16/14

I certify that I have read and performed each instruction.

DATA SHEET 40
ACCIDENT INVESTIGATION MEASUREMENTS

Test Vehicle: 2014 Fiat 500L
 Test Program: FMVSS 208 Compliance
 Test Technician: Alex Vanderheyden

NHTSA No.: C20140306
 Test Date: 12/16/14

IMPACT ANGLE:	0°					
BELTED DUMMIES (YES/NO):	NO					
TEST SPEED:	X	32 to 40 kmph		0 to 48 kmph		0 to 56 kmph
DRIVER DUMMY:	X		5 th female			50 th male
PASSENGER DUMMY:	X		5 th female			50 th male

Vehicle Year/Make/Model/Body Style:	2014 Fiat 500L MPV
VIN:	ZFBCFAAH9EZ002194
Wheelbase:	2624 mm
Build Date:	4/13
Vehicle Size Category:	3
Test Weight:	1593.6 kg
Front Overhang:	866 mm
Overall Width:	1745 mm
Overall Length Center:	4234 mm

Accelerometer Data	
Location:	As per measurements on Data Sheet 33
Linearity:	>99.9%

Integration Algorithm:	Trapezoidal
Vehicle Impact Speed:	39.8 kmph
Time of Separation:	65.0 ms
Velocity Change:	44.7 kmph

CRUSH PROFILE

Collision Deformation Classification: 12FDEW1
 Midpoint of Damage: Vehicle Longitudinal Centerline
 Damage Region Length (mm): 1440
 Impact Mode: Frontal Barrier

No.	Measurement Description	Units	Pre-Test	Post-Test	Difference
C1	Crush zone 1 at left side	mm	3974	3908	66
C2	Crush zone 2 at left side	mm	4102	3994	108
C3	Crush zone 3 at left side	mm	4137	4021	116
C4	Crush zone 4 at right side	mm	4137	3991	146
C5	Crush zone 5 at right side	mm	4102	3969	133
C6	Crush zone 6 at right side	mm	3974	3897	77

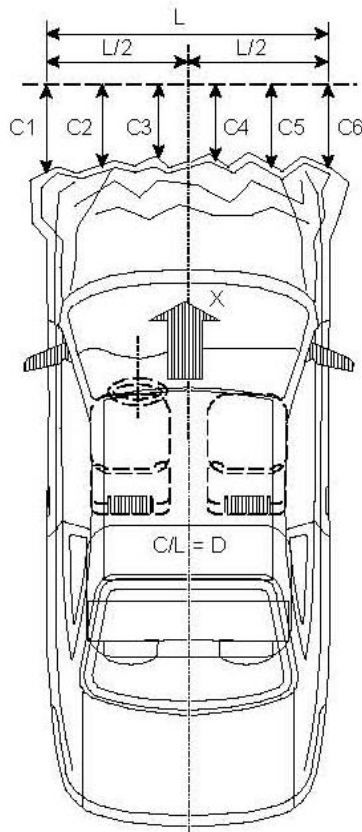

REMARKS:

Signature: *Colex Vandenbosch*

Date: 12/16/14

I certify that I have read and performed each instruction.

DATA SHEET 41
WINDSHIELD MOUNTING (FMVSS 212)

Test Vehicle: 2014 Fiat 500L
 Test Program: FMVSS 208 Compliance
 Test Technician: Alex Vanderheyden

NHTSA No.: C20140306
 Test Date: 12/16/14

IMPACT ANGLE:	0°					
BELTED DUMMIES (YES/NO):	NO					
TEST SPEED:	<input checked="" type="checkbox"/>	32 to 40 kmph	<input type="checkbox"/>	0 to 48 kmph	<input type="checkbox"/>	0 to 56 kmph
DRIVER DUMMY:	<input checked="" type="checkbox"/>		5 th female		50 th male	
PASSENGER DUMMY:	<input checked="" type="checkbox"/>		5 th female		50 th male	

1. Pre-Crash
- 1.1 Describe from visual inspection how the windshield is mounted and describe any trim material.
- Retained with glue, rubber and plastic trim
- 1.2 Mark the longitudinal centerline of the windshield.
- 1.3 Measure pre-crash A, B, and C for the left side and record in the chart below.
- 1.4 Measure pre-crash C, D, and E for the right side and record in the chart below.
- 1.5 Measure from the edge of the retainer or molding to the edge of the windshield.
- Dimension G (mm): 8 mm
2. Post Crash
- 2.1 Can a single thickness of copier type paper (as small a piece as necessary) slide between the windshield and the vehicle body?
- No - Pass. Skip to the table of measurements, complete it by repeating the pre-crash measurements in the post crash column, and calculate the retention percentage, which will be 100%.
- Yes, go to 2.2
- 2.2 Visibly mark the beginning and end of the portions of the periphery where the paper slides between the windshield and the vehicle body.
- 2.3 Measure and record post-crash A, B, C, D, E, and F such that the measurements do not include any of the parts of the windshield where the paper slides between the windshield and the vehicle body.
- 2.4 Calculate and record the percent retention for the right and left side of the windshield.
- 2.5 Is total right side percent retention less than 50%?
- Yes, Fail
- No, Pass
- 2.6 Is total left side percent retention less than 50%?
- Yes, Fail
- No, Pass

WINDSHIELD RETENTION MEASUREMENTS

	Dimension	Pre-Crash (mm)	Post-Crash (mm)	Percent Retention (Post-Test ÷ Pre-Crash)
Left Side	A	583	583	100%
	B	816	816	100%
	C	705	705	100%
	Total	2104	2104	100%
Right Side	D	583	583	100%
	E	816	816	100%
	F	705	705	100%
	Total	2104	2104	100%

Indicate area of mounting failure: NONE

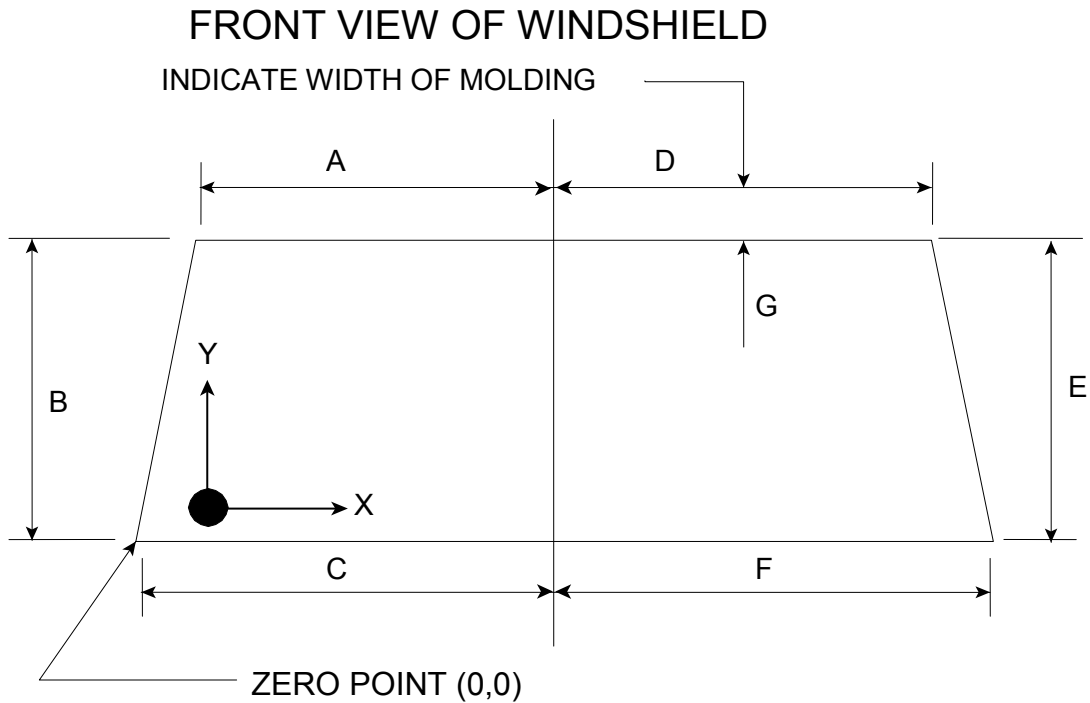

REMARKS:

Signature: *Chester Vandenberg*

Date: 12/16/14

I certify that I have read and performed each instruction.

DATA SHEET 42
WINDSHIELD ZONE INTRUSION (FMVSS 219)

Test Vehicle: 2014 Fiat 500L
 Test Program: FMVSS 208 Compliance
 Test Technician: Alex Vanderheyden

NHTSA No.: C20140306
 Test Date: 12/16/14

IMPACT ANGLE:	0°			
BELTED DUMMIES (YES/NO):	NO			
TEST SPEED:	X	32 to 40 kmph		0 to 56 kmph
DRIVER DUMMY:	X	5 th female		50 th male
PASSENGER DUMMY:	X	5 th female		50 th male

This standard specifies limits for the displacement of vehicle components into the windshield area during a frontal barrier impact test at any speed up to and including 48 kmph.

- 1. Place a 165 mm diameter rigid sphere, with a mass of 6.8 kg on the instrument panel so that it is simultaneously touching the instrument panel and the windshield. (571.219 S6.1(a))
- 2. Roll the sphere from one side of the windshield to the other while marking on the windshield where the sphere contacts the windshield. (571.219 S6.1(b))
- 3. From the outermost contactable points on the windshield draw a horizontal line to the edges of the windshield. (571.219 S6.1(b))
- 4. Draw a line on the inner surface of the windshield that is 13 mm below the line determined in items 2 and 3.
- 5. After the crash test, record any points where a part of the exterior of the vehicle has marked, penetrated, or broken the windshield.

Provide all dimensions necessary to reproduce the protected area.

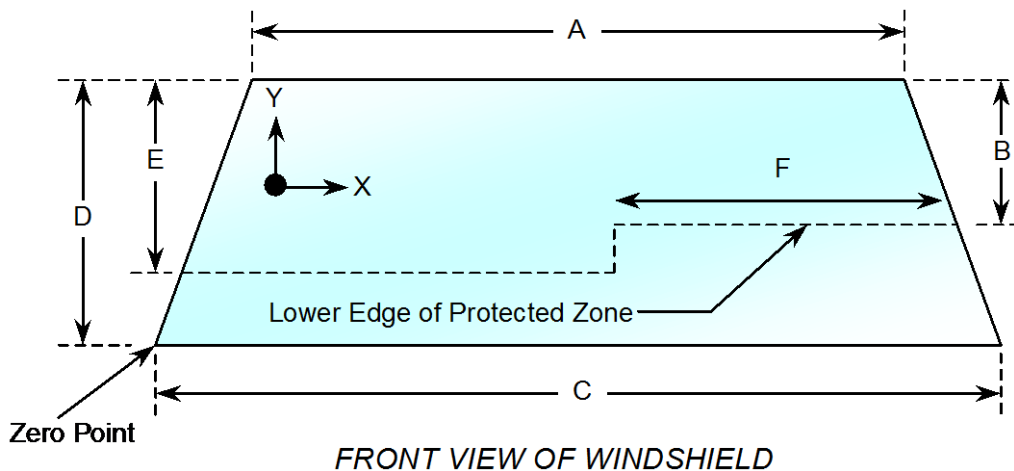

WINDSHIELD DIMENSIONS

Item	Units	Value
A	mm	1166
B	mm	525
C	mm	1410
D	mm	816
E	mm	525
F	mm	545

AREA OF PROTECTED ZONE FAILURES:

- B. Provide coordinates of the area that the protected zone was penetrated more than 0.25 inches by a vehicle component other than one which is normally in contact with the windshield.

X	Y
NONE	

- C. Provide coordinates of the area beneath the protected zone template that the inner surface of the windshield was penetrated by a vehicle component.

X	Y
NONE	

REMARKS: An assessment of FMVSS 219 was done for informational use only.

I certify that I have read and performed each instruction.

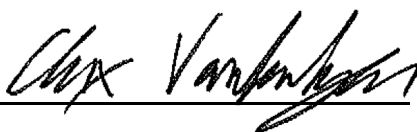
Signature: 

Date: 12/16/14

DATA SHEET 43
FUEL SYSTEM INTEGRITY (FMVSS 301)

Test Vehicle: 2014 Fiat 500L
Test Program: FMVSS 208 Compliance
Test Technician: Alex Vanderheyden

NHTSA No.: C20140306
Test Date: 12/16/14

TYPE OF IMPACT:	25 mph Unbelted
-----------------	-----------------

Stoddard Solvent Spillage Measurements

- A. From impact until vehicle motion ceases: 0 grams
(Maximum Allowable = 28 grams)
- B. For the 5 minute period after motion ceases: 0 grams
(Maximum Allowable = 142 grams)
- C. For the following 25 minutes: 0 grams
(Maximum Allowable = 28 grams/minute)
- D. Spillage: None

DATA SHEET 43

FMVSS 301 STATIC ROLLOVER DATA

Test Vehicle: 2014 Fiat 500L
 Test Program: FMVSS 208 Compliance

NHTSA No.: C20140306
 Test Date: 12/16/14

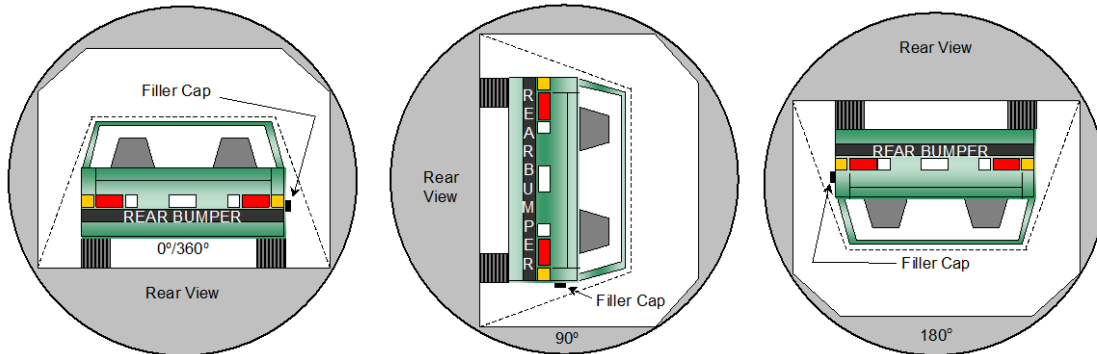

0° to 90°

90° to 180°

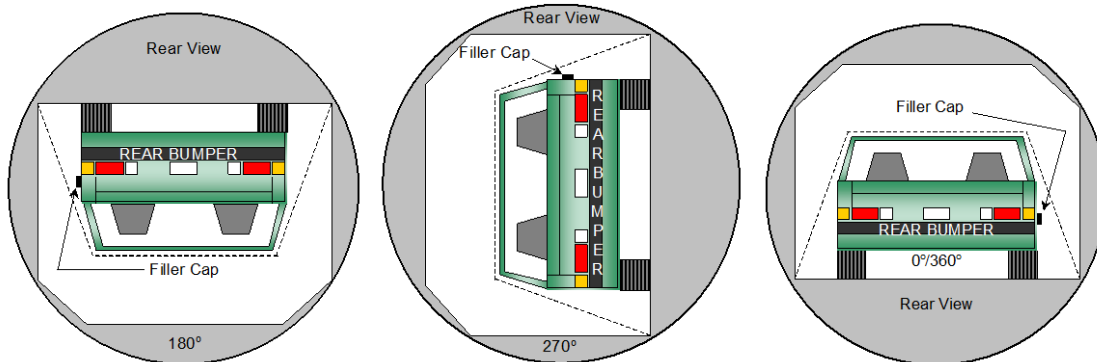

180° to 270°

270° to 360°

1. The specified fixture rollover rate for each 90° of rotation is 60 to 180 seconds.
2. The position hold time at each position is 300 seconds (minimum).
3. Details of Stoddard Solvent spillage locations: **None**

Test Phase	Rotation Time (sec.)	Hold Time (sec.)	Spillage (grams)
0° to 90°	110	300	0
90° to 180°	107	300	0
180° to 270°	106	300	0
270° to 360°	113	300	0

APPENDIX A

CRASH TEST DATA

TABLE OF DATA PLOTS

		<u>Page No.</u>
Figure No. 1.	Driver Head X Acceleration vs. Time	A-1
Figure No. 2.	Driver Head Y Acceleration vs. Time	A-1
Figure No. 3.	Driver Head Z Acceleration vs. Time	A-1
Figure No. 4.	Driver Head Resultant Acceleration vs. Time	A-1
Figure No. 5.	Driver Head X Velocity vs. Time	A-2
Figure No. 6.	Driver Head Y Velocity vs. Time	A-2
Figure No. 7.	Driver Head Z Velocity vs. Time	A-2
Figure No. 8.	Driver Neck Force X vs. Time	A-3
Figure No. 9.	Driver Neck Force Y vs. Time	A-3
Figure No. 10.	Driver Neck Force Z vs. Time	A-3
Figure No. 11.	Driver Neck Force Resultant vs. Time	A-3
Figure No. 12.	Driver Neck Moment X vs. Time	A-4
Figure No. 13.	Driver Neck Moment Y vs. Time	A-4
Figure No. 14.	Driver Neck Moment Z vs. Time	A-4
Figure No. 15.	Driver Neck Moment Resultant vs. Time	A-4
Figure No. 16.	Driver Chest X Acceleration vs. Time	A-5
Figure No. 17.	Driver Chest Y Acceleration vs. Time	A-5
Figure No. 18.	Driver Chest Z Acceleration vs. Time	A-5
Figure No. 19.	Driver Chest Resultant Acceleration vs. Time	A-5
Figure No. 20.	Driver Chest X Velocity vs. Time	A-6
Figure No. 21.	Driver Chest Y Velocity vs. Time	A-6
Figure No. 22.	Driver Chest Z Velocity vs. Time	A-6
Figure No. 23.	Driver Chest Displacement vs. Time	A-6
Figure No. 24.	Driver Left Femur Force vs. Time	A-7
Figure No. 25.	Driver Right Femur Force vs. Time	A-7
Figure No. 26.	Passenger Head X Acceleration vs. Time	A-8
Figure No. 27.	Passenger Head Y Acceleration vs. Time	A-8
Figure No. 28.	Passenger Head Z Acceleration vs. Time	A-8
Figure No. 29.	Passenger Head Resultant Acceleration vs. Time	A-8
Figure No. 30.	Passenger Head X Velocity vs. Time	A-9

	<u>Page No.</u>	
Figure No. 31.	Passenger Head Y Velocity vs. Time	A-9
Figure No. 32.	Passenger Head Z Velocity vs. Time	A-9
Figure No. 33.	Passenger Neck Force X vs. Time	A-10
Figure No. 34.	Passenger Neck Force Y vs. Time	A-10
Figure No. 35.	Passenger Neck Force Z vs. Time	A-10
Figure No. 36.	Passenger Neck Force Resultant vs. Time	A-10
Figure No. 37.	Passenger Neck Moment X vs. Time	A-11
Figure No. 38.	Passenger Neck Moment Y vs. Time	A-11
Figure No. 39.	Passenger Neck Moment Z vs. Time	A-11
Figure No. 40.	Passenger Neck Moment Resultant vs. Time	A-11
Figure No. 41.	Passenger Chest X Acceleration vs. Time	A-12
Figure No. 42.	Passenger Chest Y Acceleration vs. Time	A-12
Figure No. 43.	Passenger Chest Z Acceleration vs. Time	A-12
Figure No. 44.	Passenger Chest Resultant Acceleration vs. Time	A-12
Figure No. 45.	Passenger Chest X Velocity vs. Time	A-13
Figure No. 46.	Passenger Chest Y Velocity vs. Time	A-13
Figure No. 47.	Passenger Chest Z Velocity vs. Time	A-13
Figure No. 48.	Passenger Chest Displacement vs. Time	A-13
Figure No. 49.	Passenger Left Femur Force vs. Time	A-14
Figure No. 50.	Passenger Right Femur Force vs. Time	A-14
Figure No. 51.	Driver Nij (N_{TF}) vs. Time	A-15
Figure No. 52.	Driver Nij (N_{TE}) vs. Time	A-15
Figure No. 53.	Driver Nij (N_{CF}) vs. Time	A-15
Figure No. 54.	Driver Nij (N_{CE}) vs. Time	A-15
Figure No. 55.	Passenger Nij (N_{TF}) vs. Time	A-16
Figure No. 56.	Passenger Nij (N_{TE}) vs. Time	A-16
Figure No. 57.	Passenger Nij (N_{CF}) vs. Time	A-16
Figure No. 58.	Passenger Nij (N_{CE}) vs. Time	A-16
Figure No. 59.	Driver Occipital Condyle Moment vs. Time	A-17
Figure No. 60.	Passenger Occipital Condyle Moment vs. Time	A-17
Figure No. 61.	Left Rear Seat Crossmember X Acceleration vs. Time	A-18
Figure No. 62.	Left Rear Seat Crossmember X Velocity vs. Time	A-18
Figure No. 63.	Right Rear Seat Crossmember X Acceleration vs. Time	A-18
Figure No. 64.	Right Rear Seat Crossmember X Velocity vs. Time	A-18
Figure No. 65.	Top of Engine X Acceleration vs. Time	A-19

		<u>Page No.</u>
Figure No. 66.	Top of Engine X Velocity vs. Time	A-19
Figure No. 67.	Bottom of Engine X Acceleration vs. Time	A-19
Figure No. 68.	Bottom of Engine X Velocity vs. Time	A-19
Figure No. 69.	Left Brake Caliper X Acceleration vs. Time	A-20
Figure No. 70.	Left Brake Caliper X Velocity vs. Time	A-20
Figure No. 71.	Right Brake Caliper X Acceleration vs. Time	A-20
Figure No. 72.	Right Brake Caliper X Velocity vs. Time	A-20
Figure No. 73.	Instrument Panel X Acceleration vs. Time	A-21
Figure No. 74.	Instrument Panel X Velocity vs. Time	A-21
Figure No. 75.	Trunk Z Acceleration vs. Time	A-21
Figure No. 76.	Trunk Z Velocity vs. Time	A-21

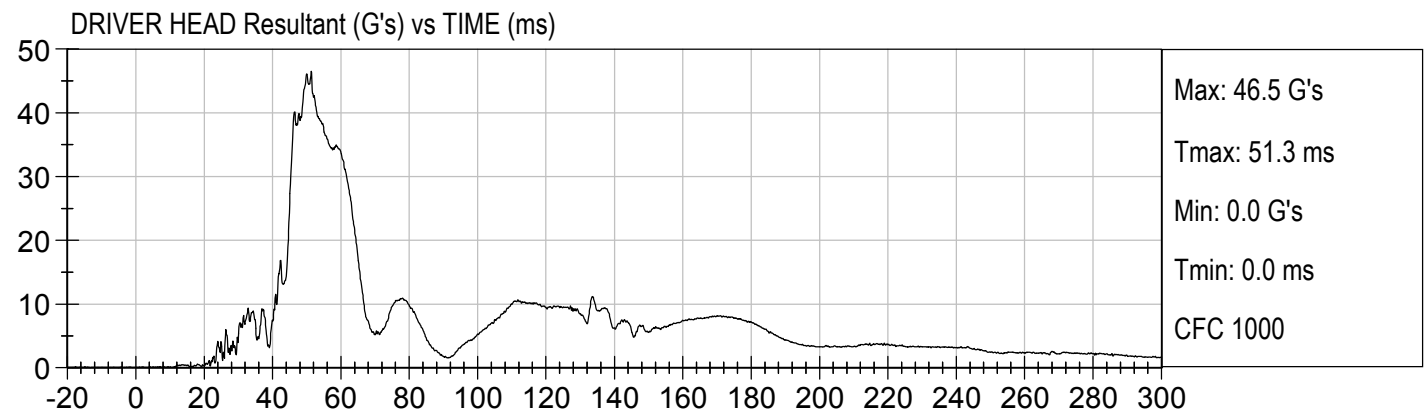
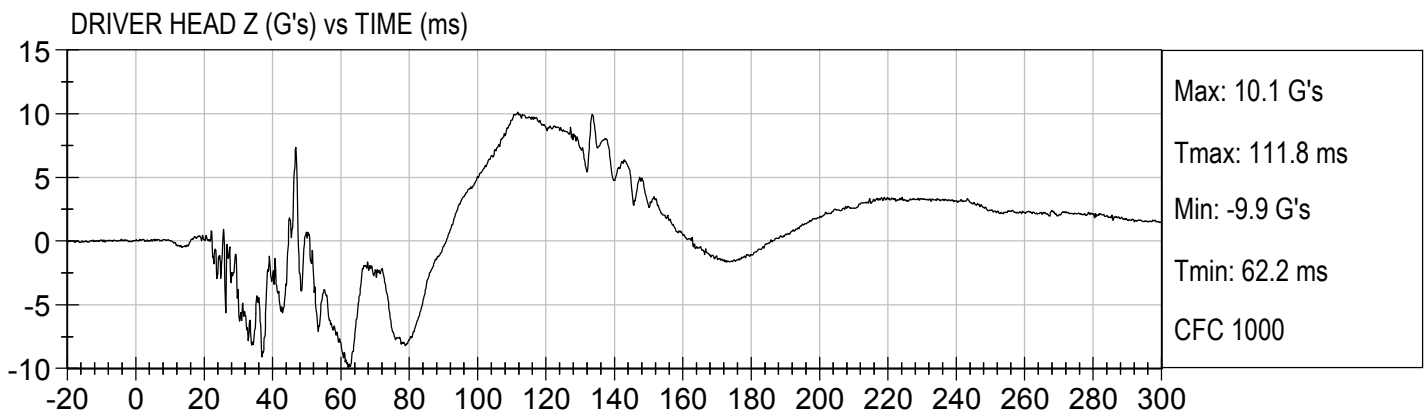
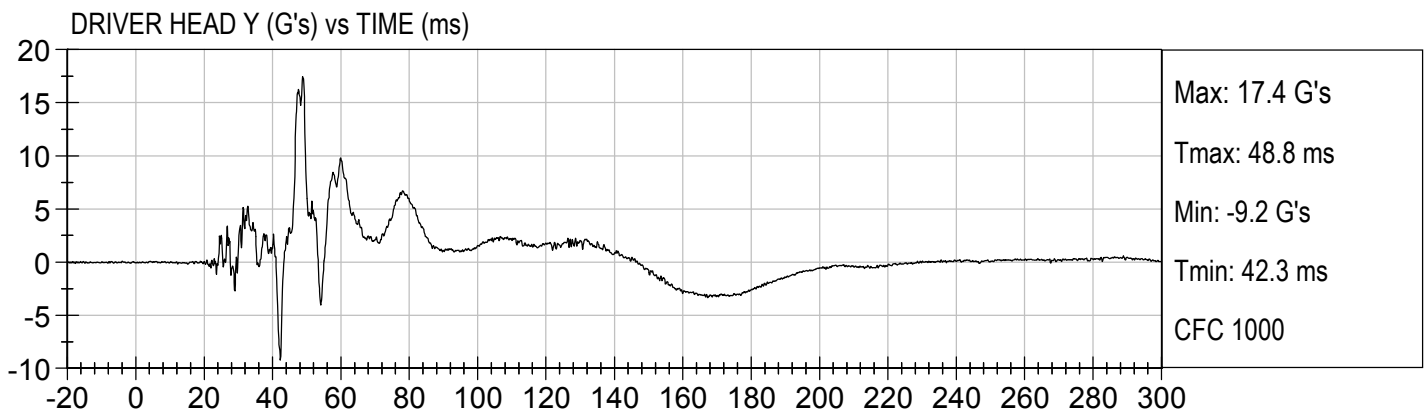
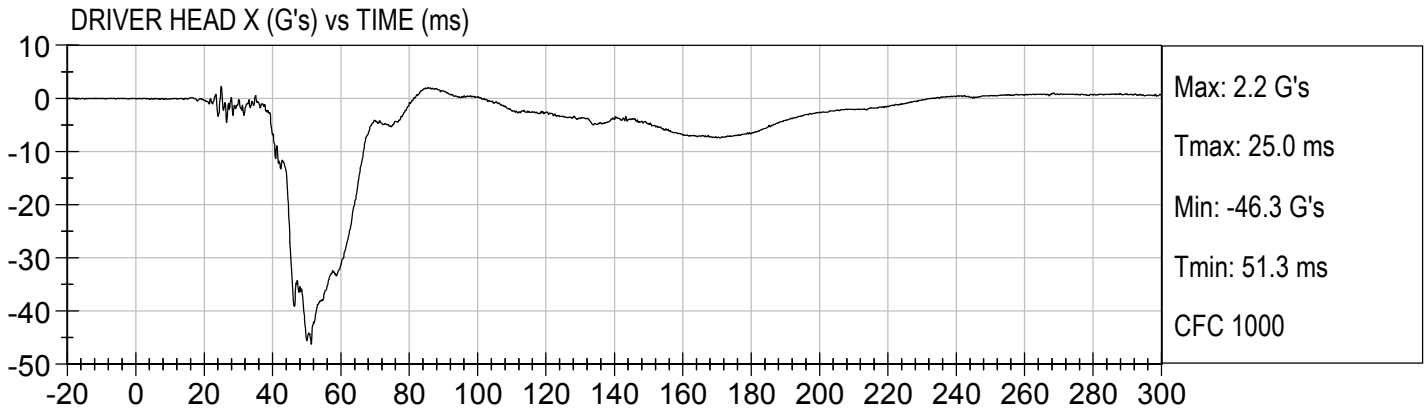

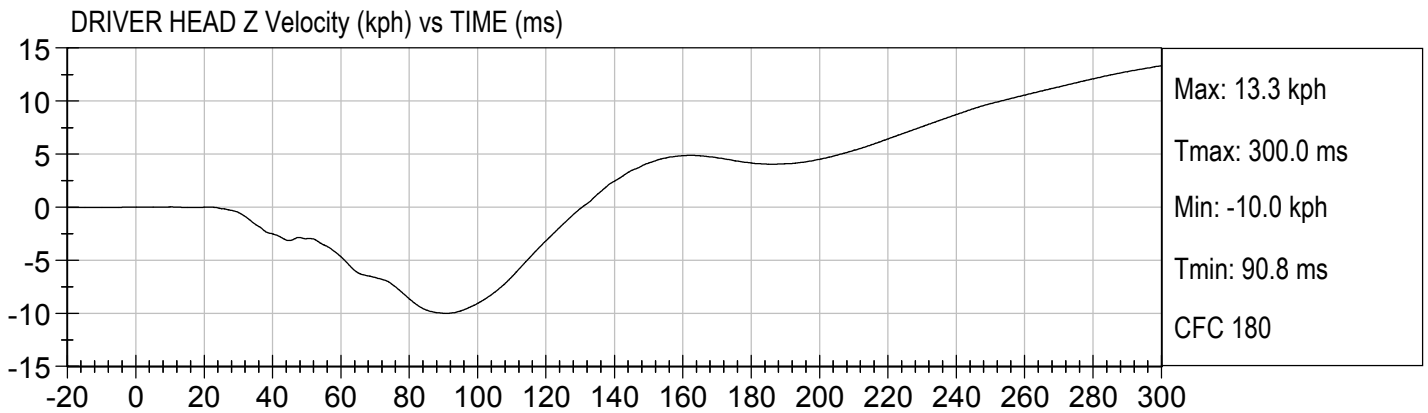
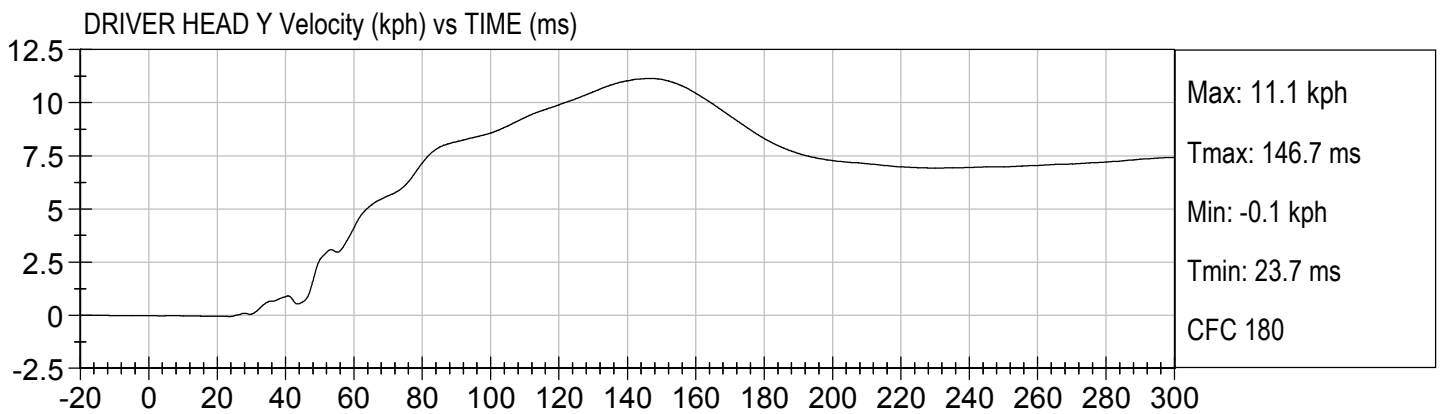
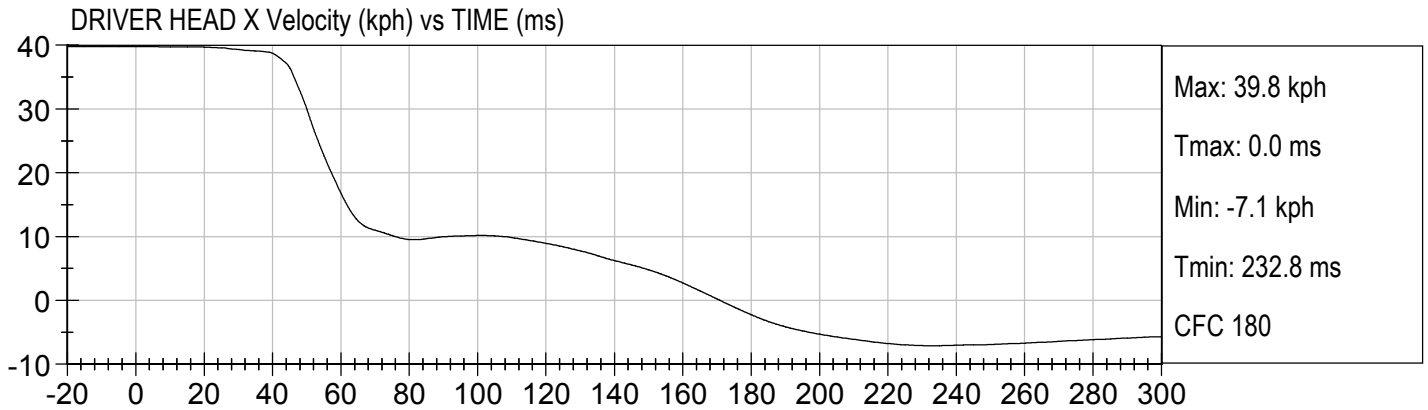

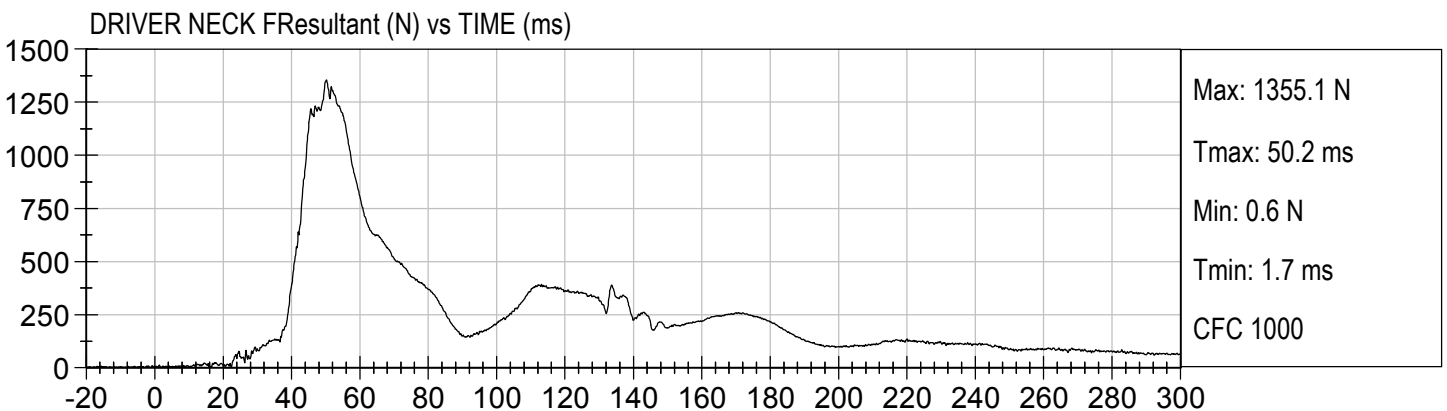
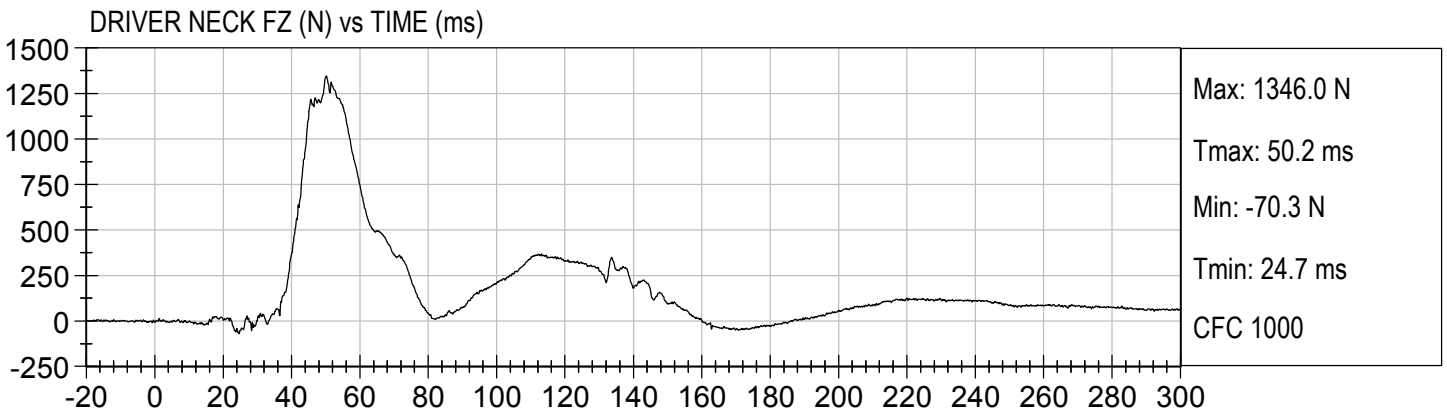
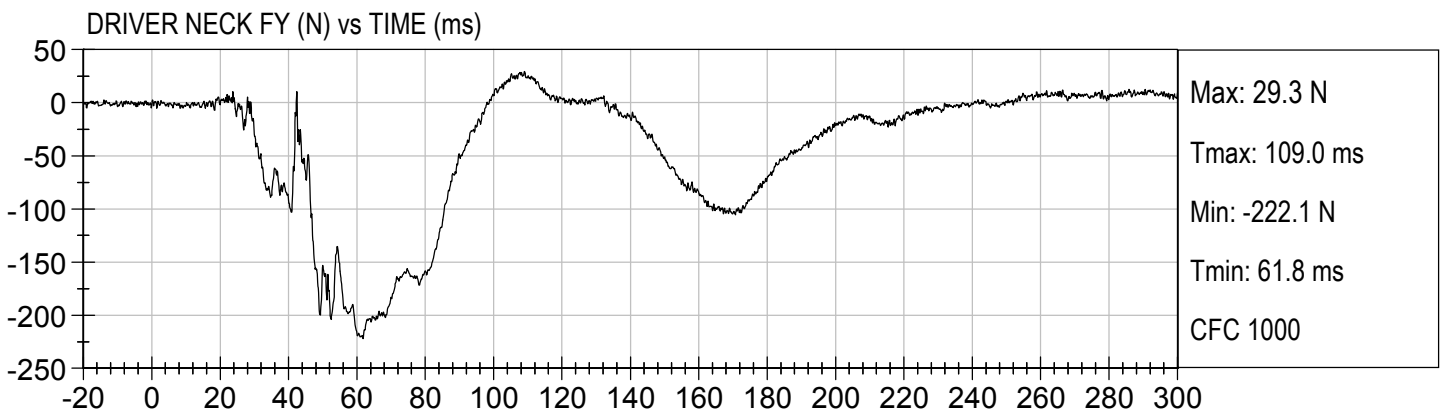
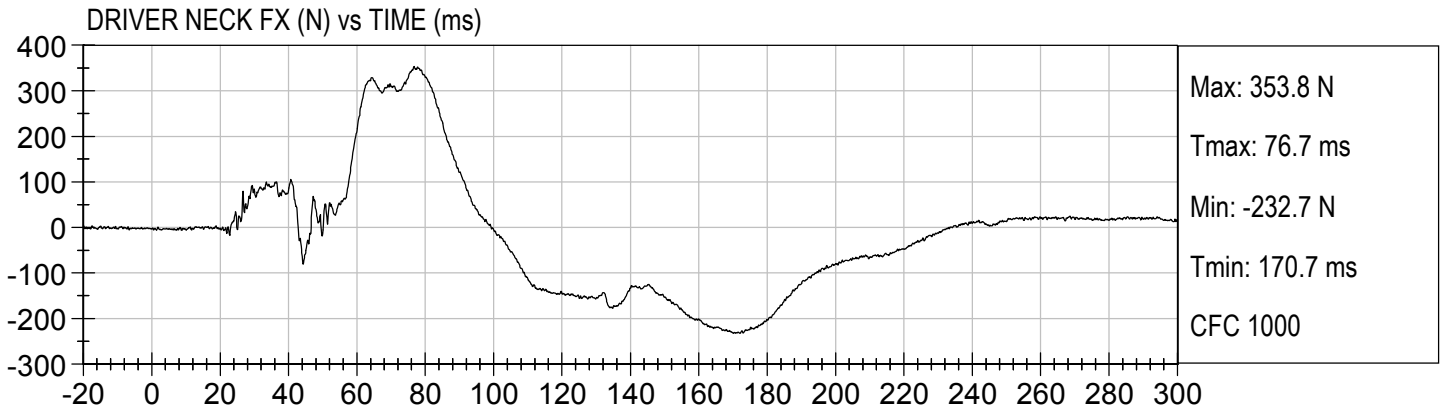

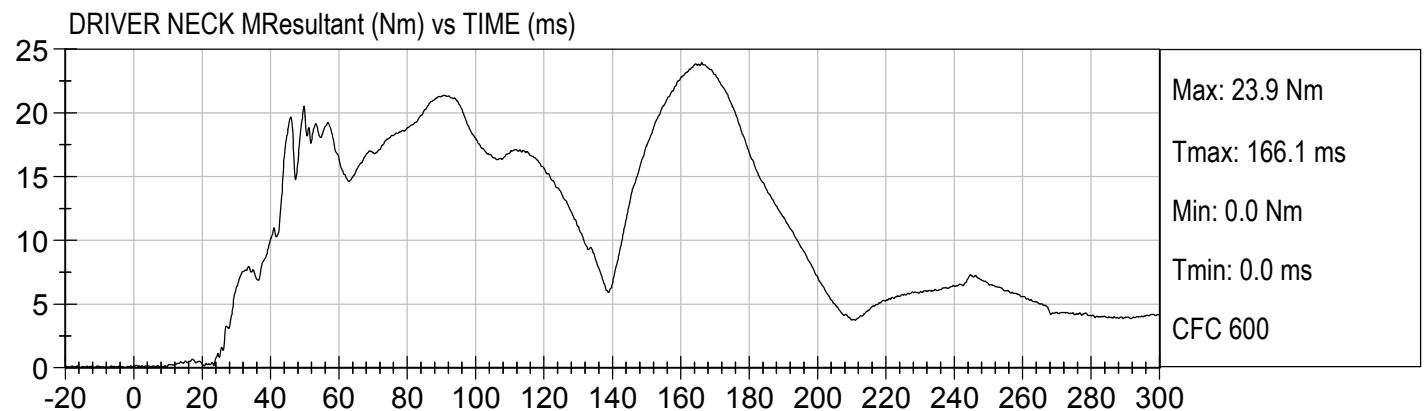
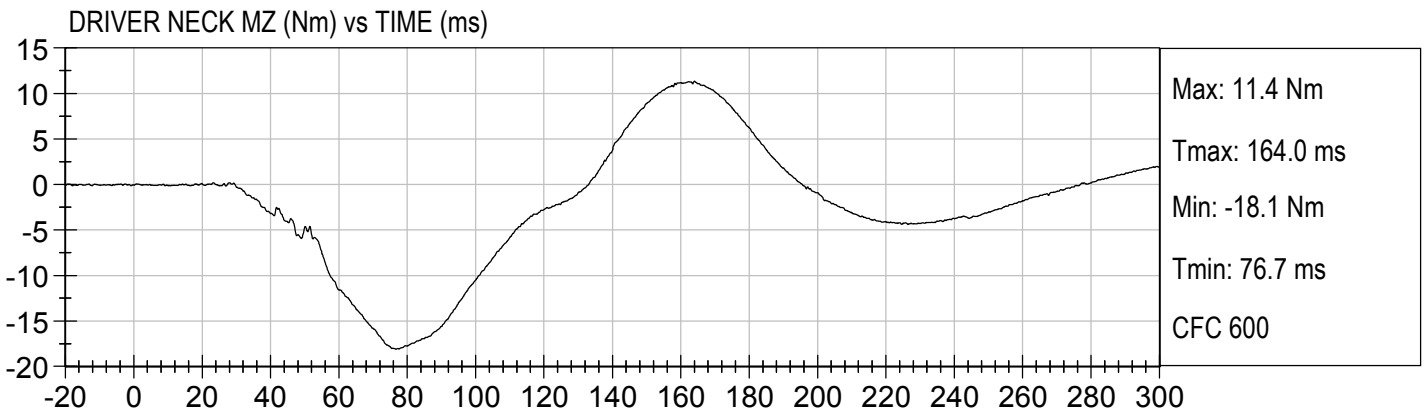
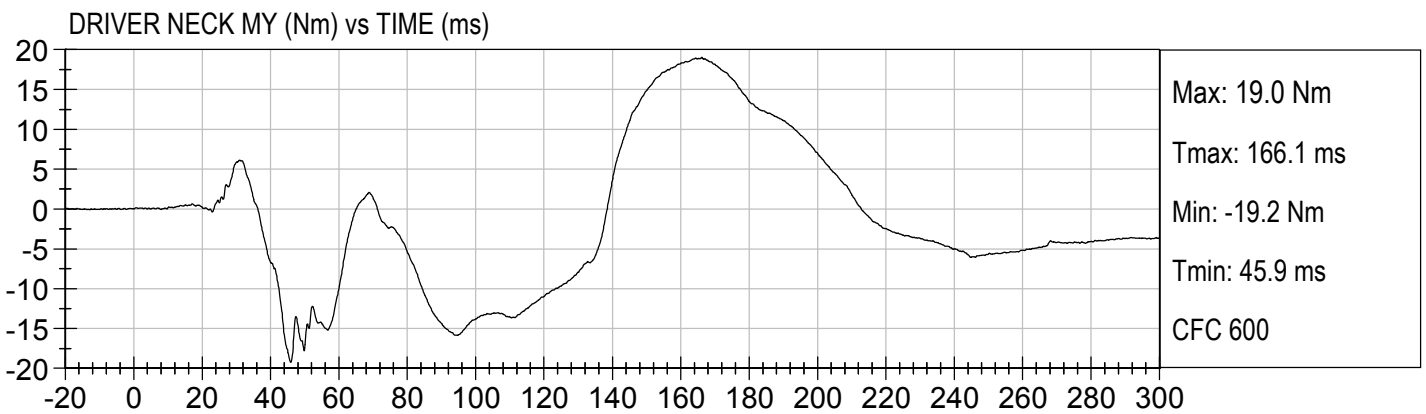
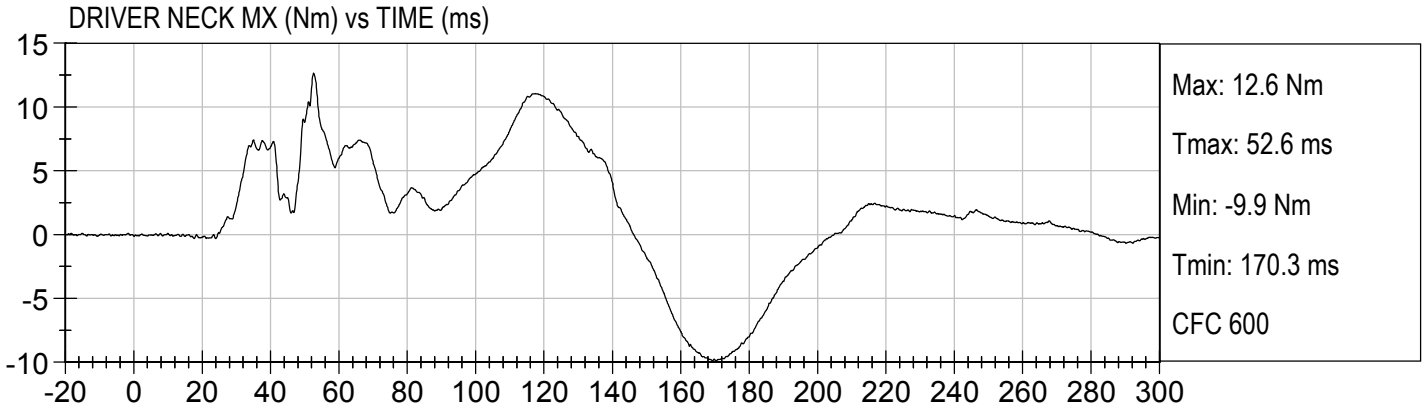

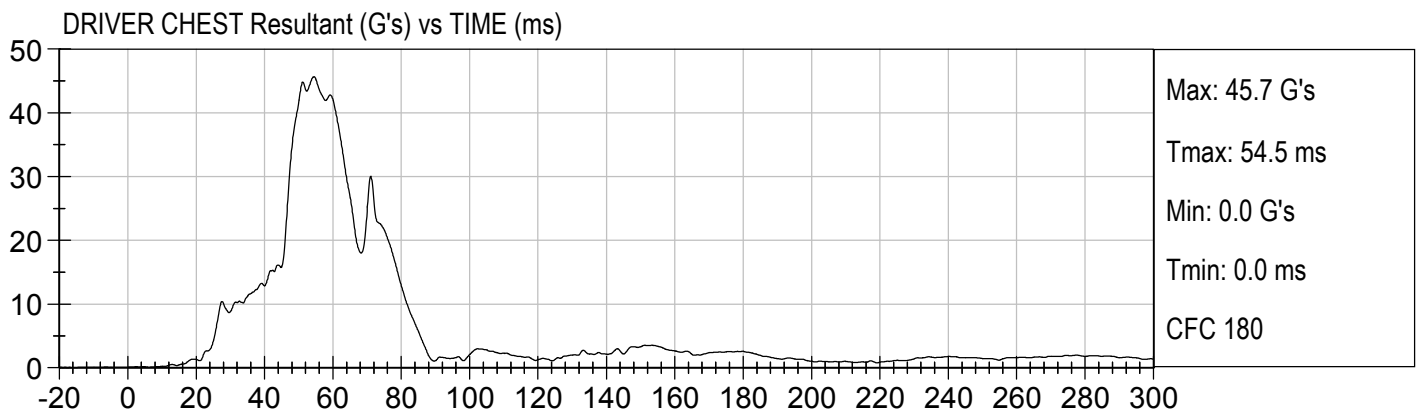
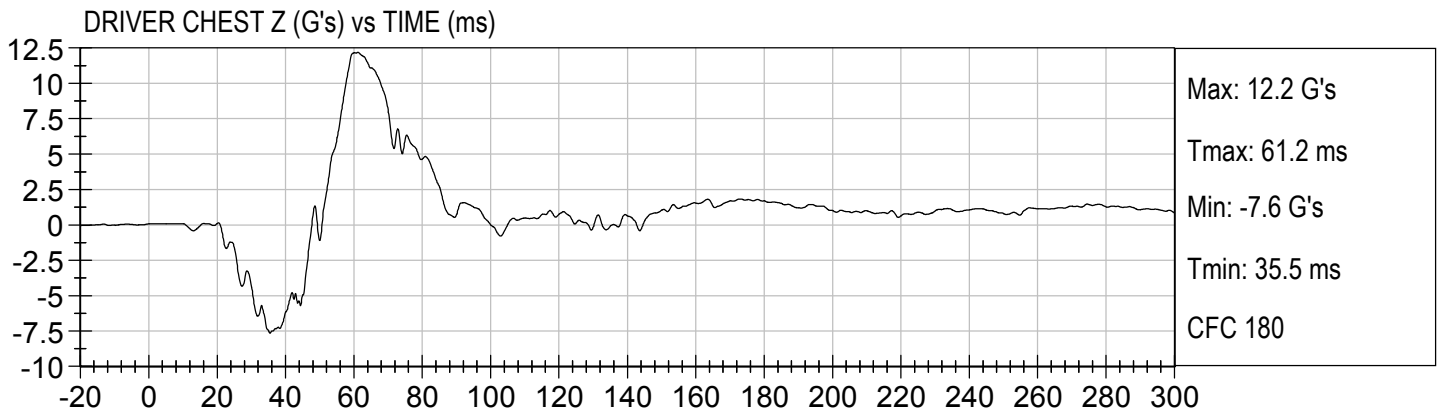
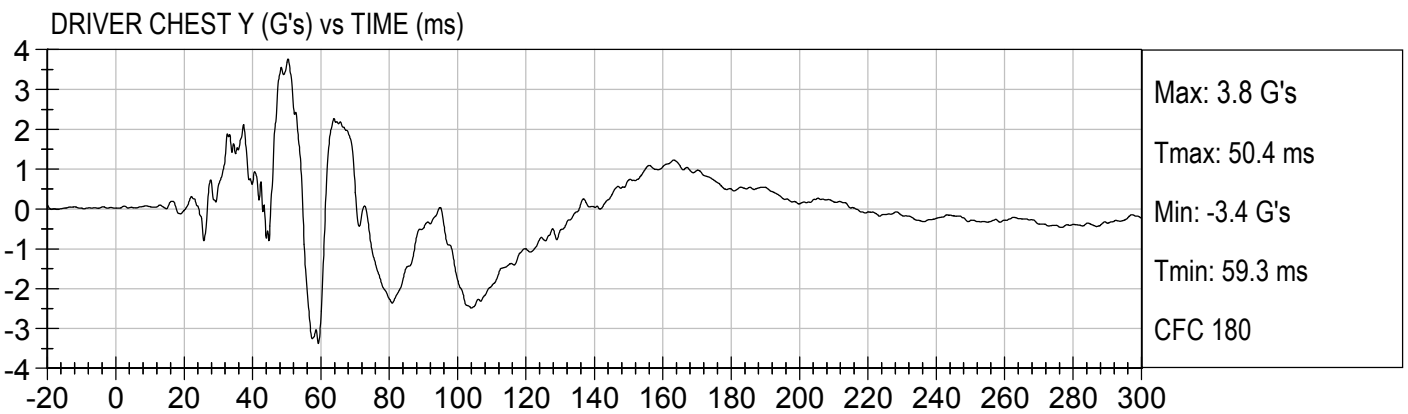
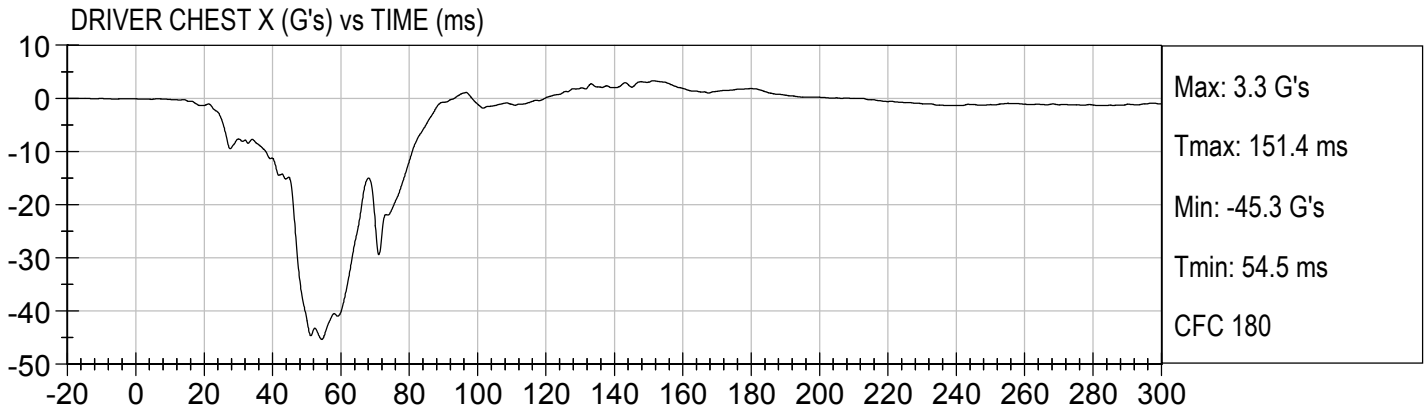

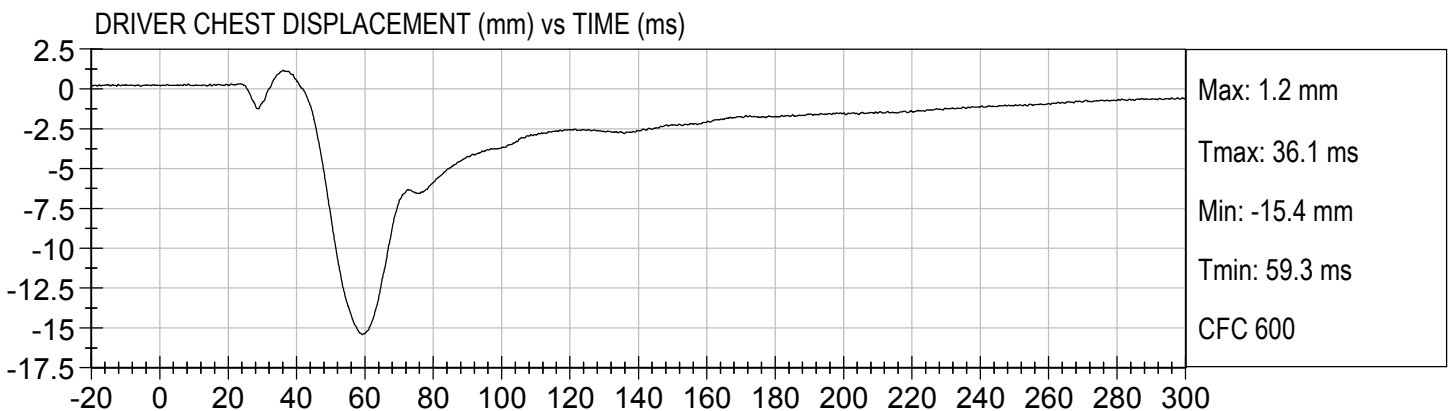
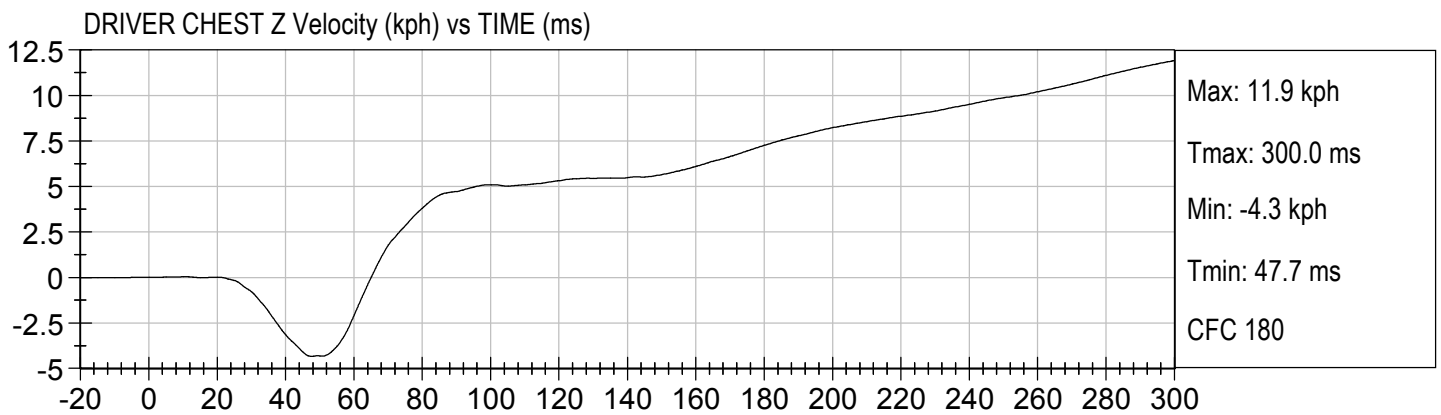
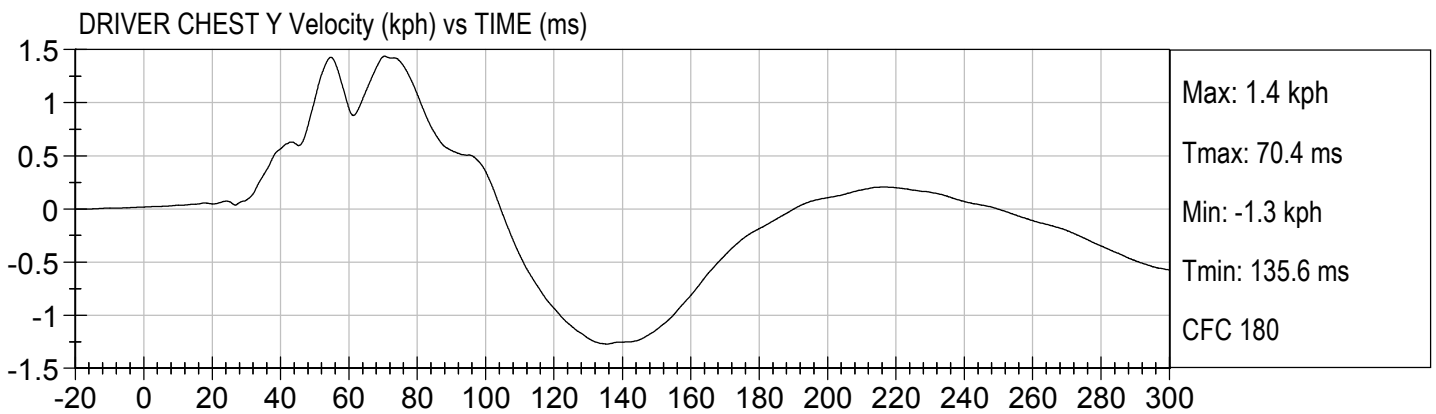
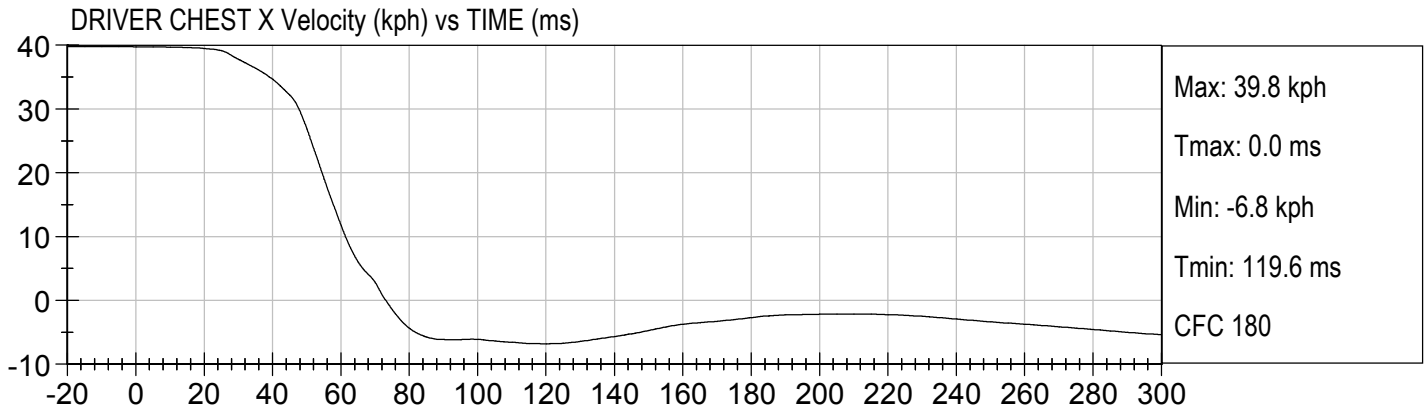

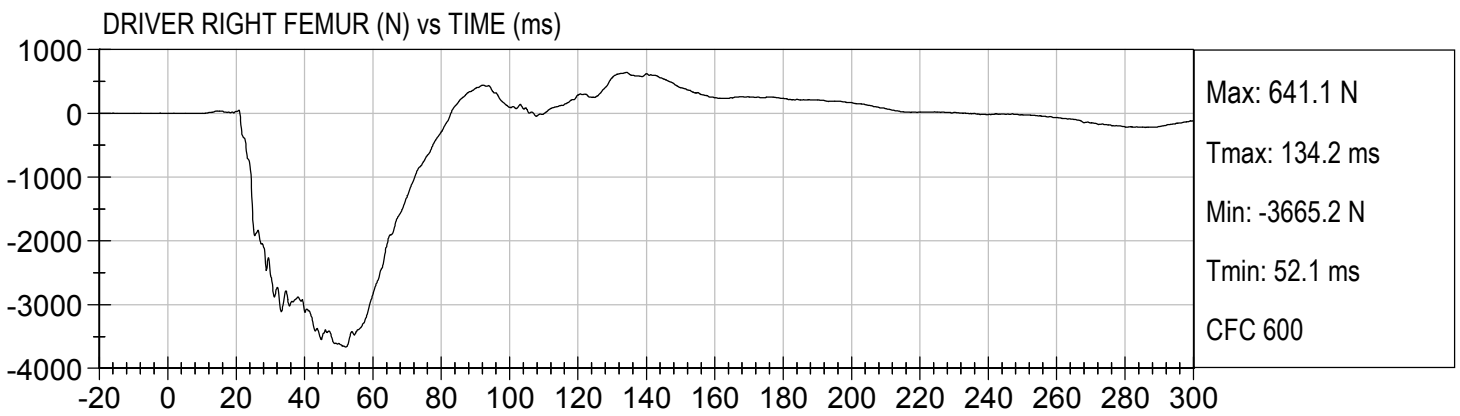
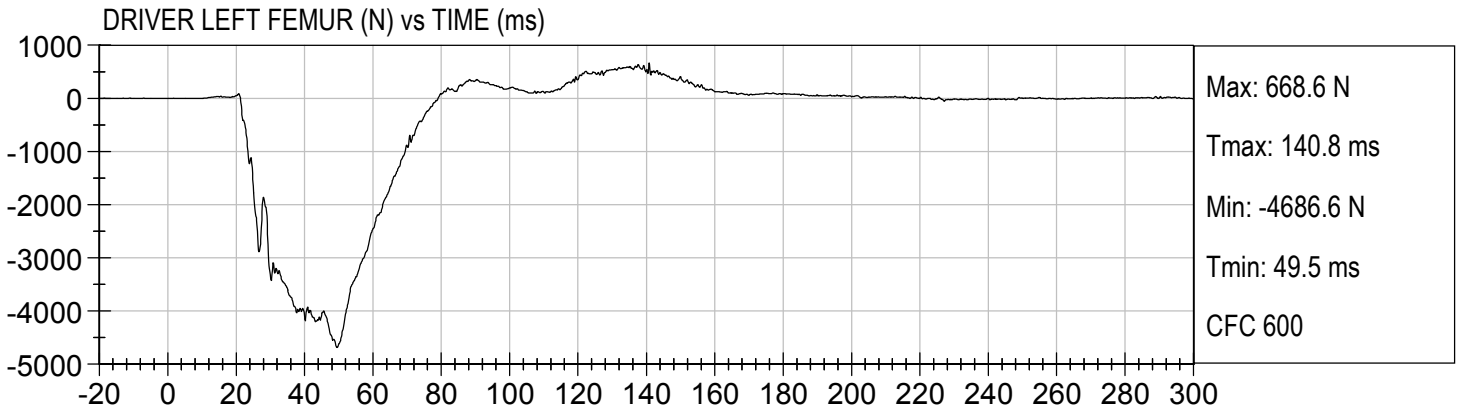

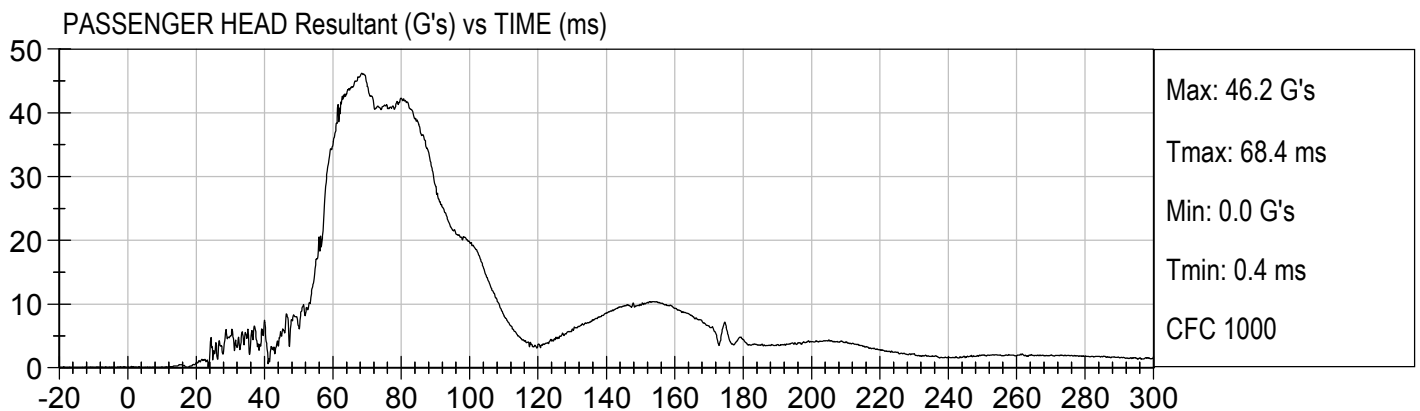
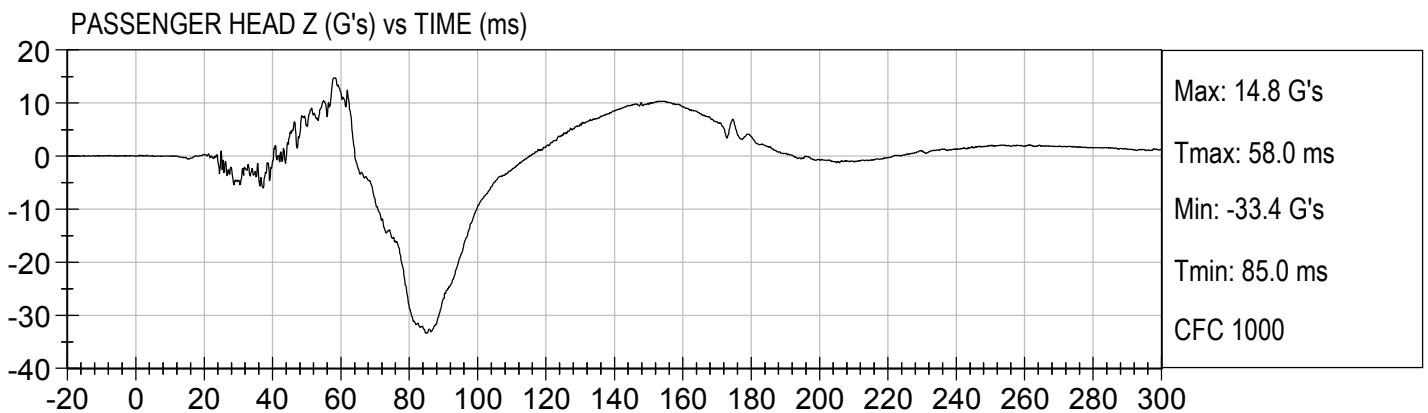
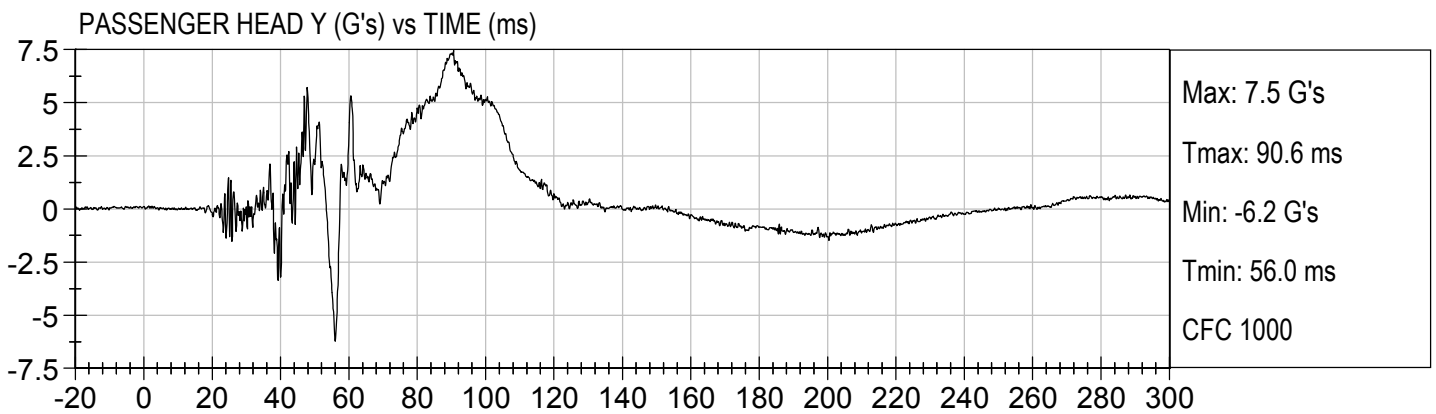
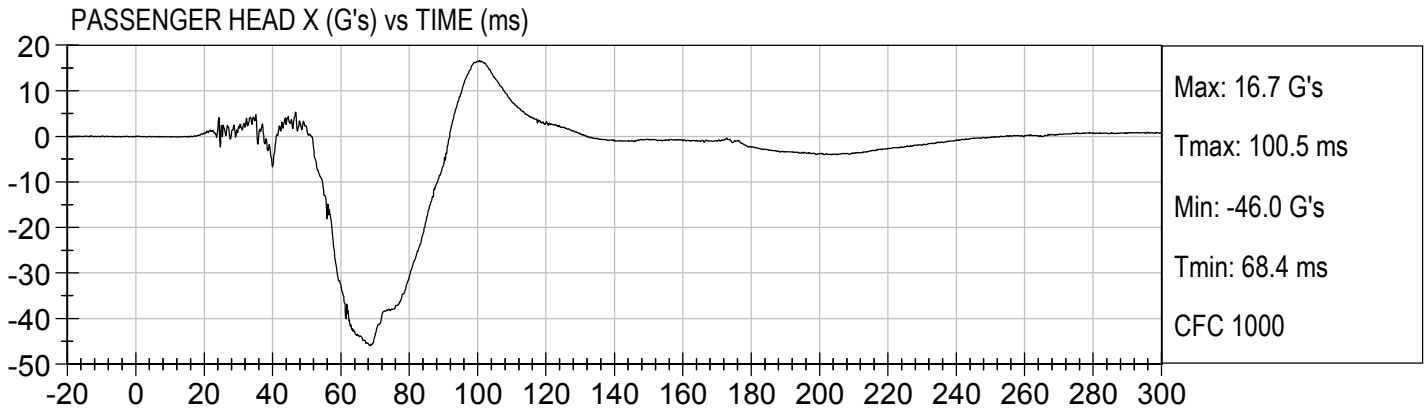

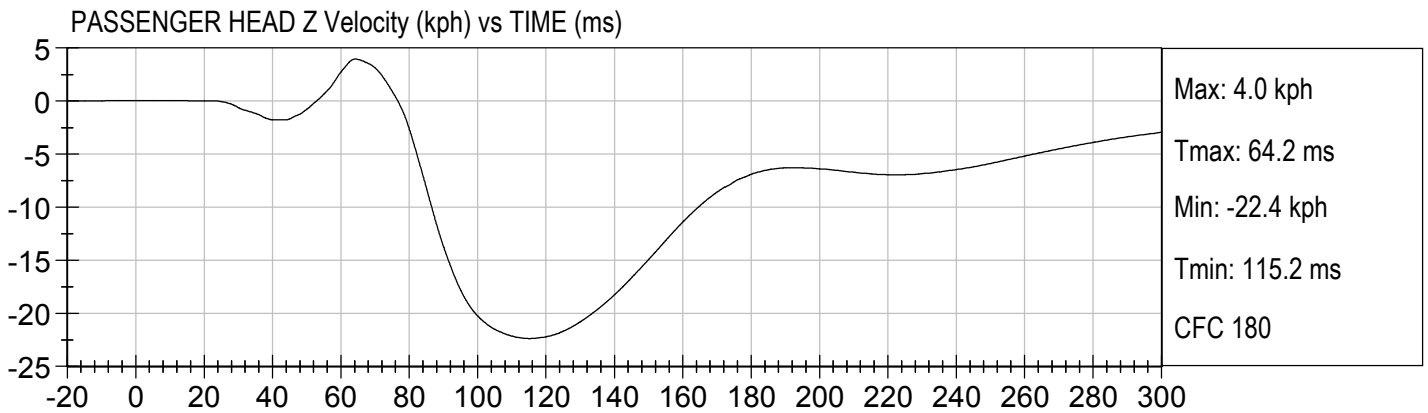
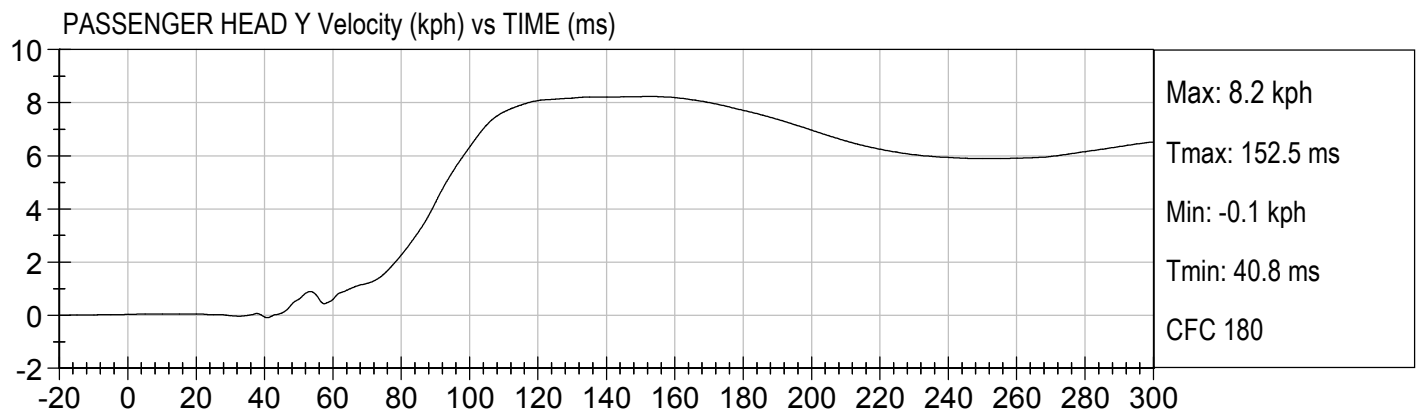
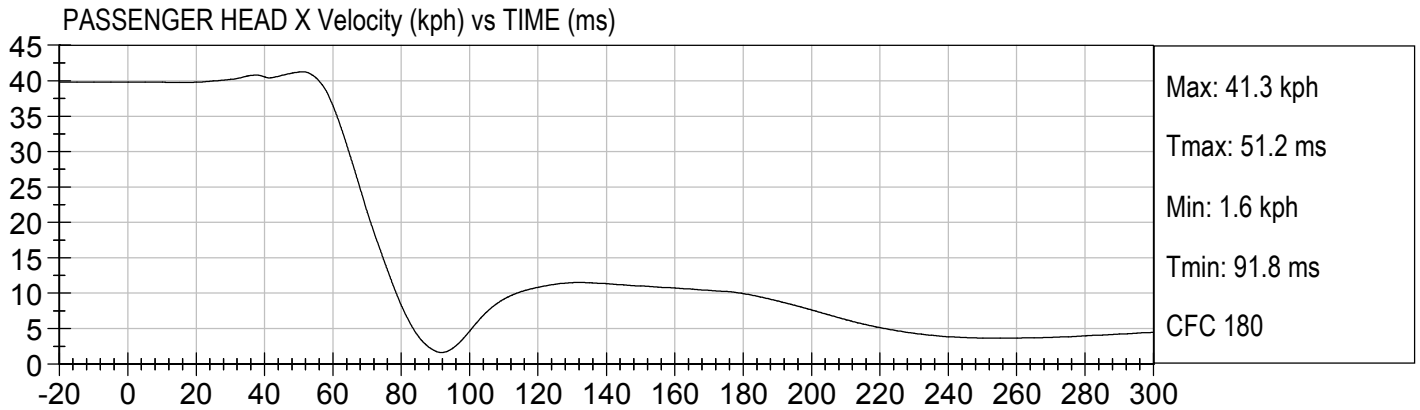

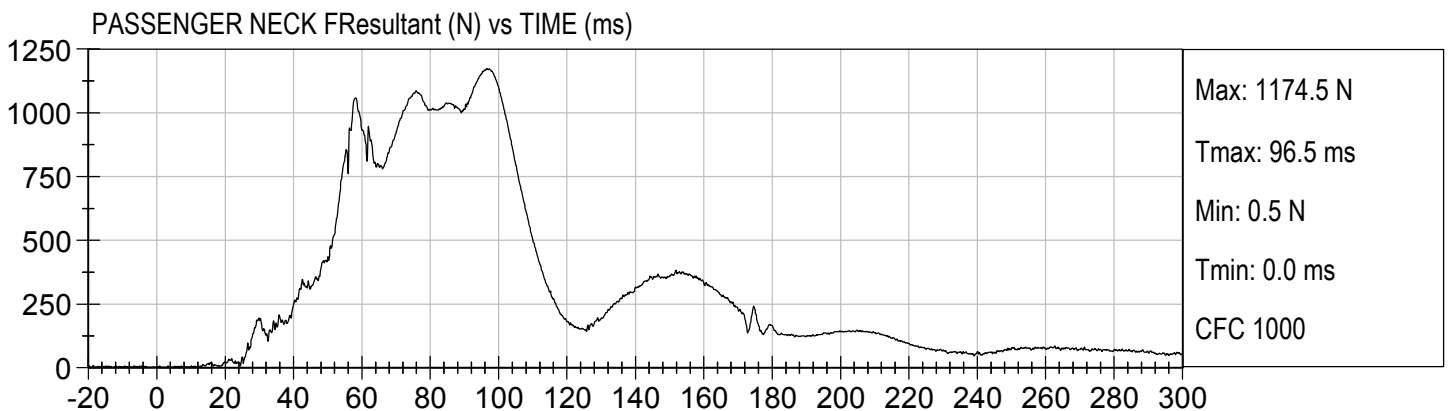
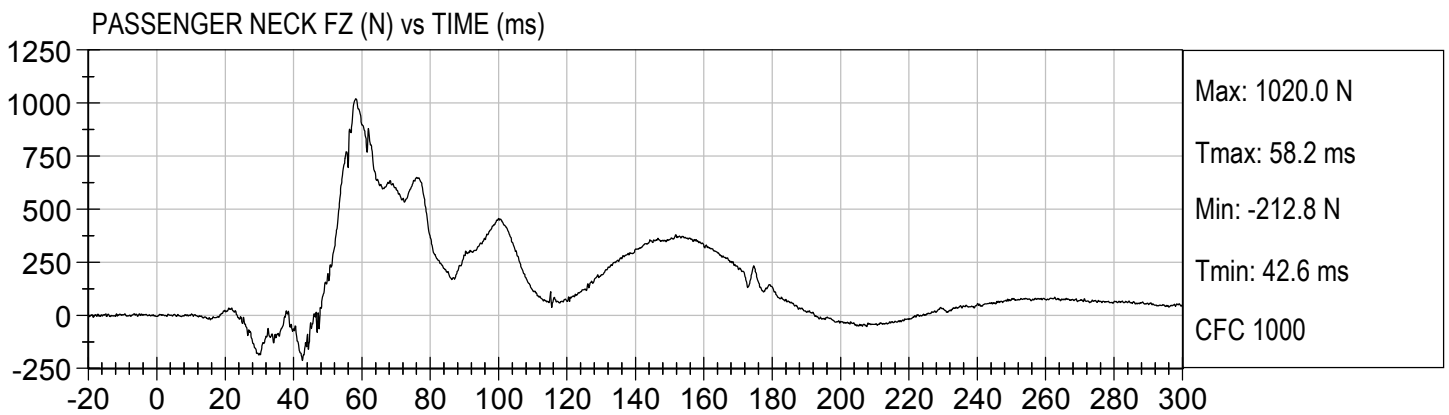
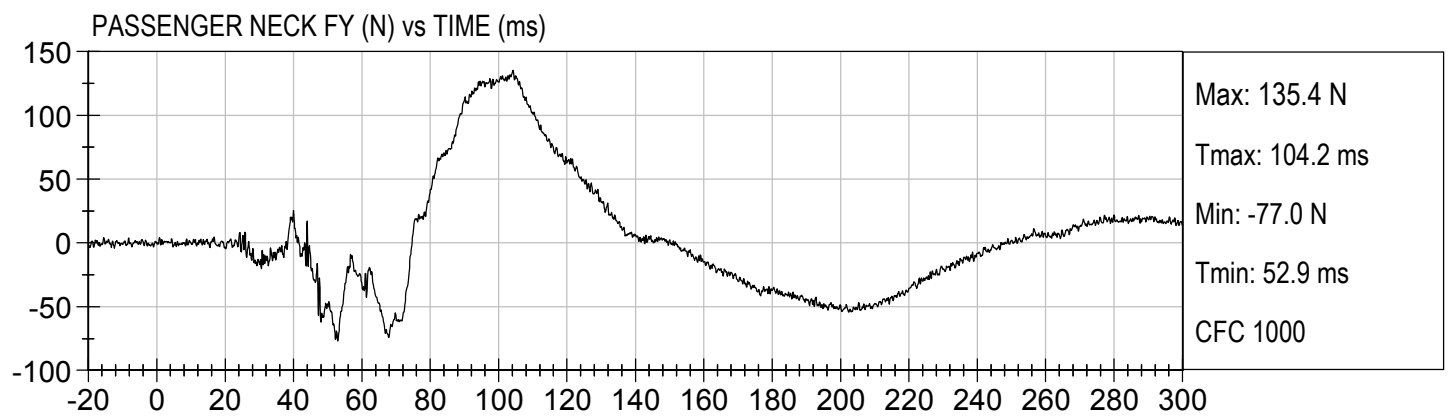
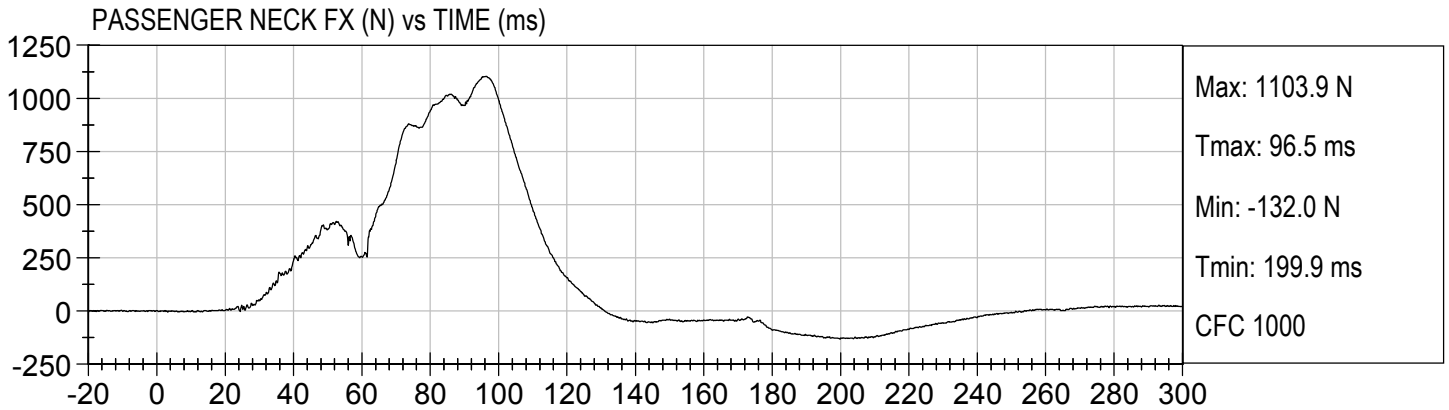

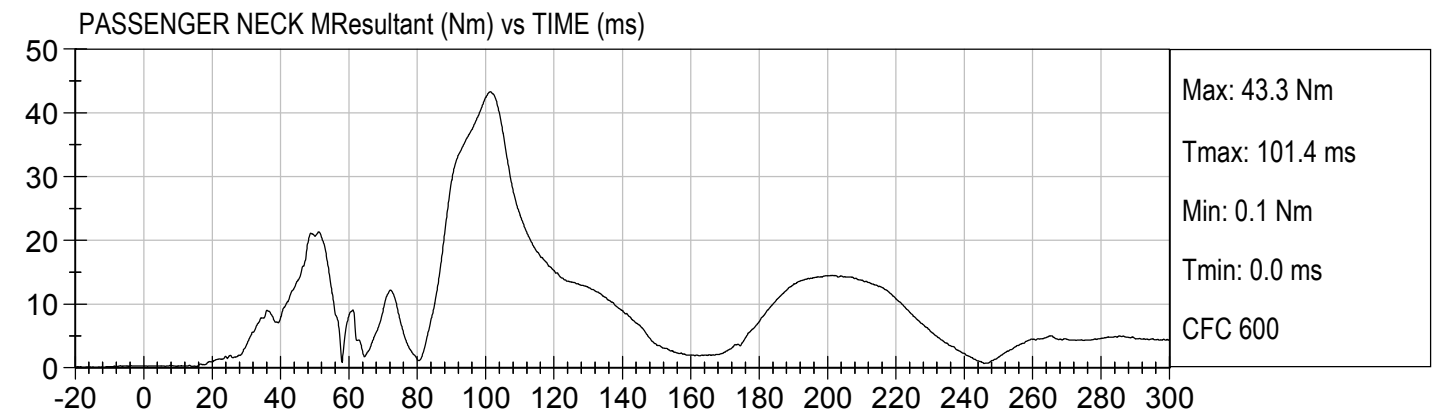
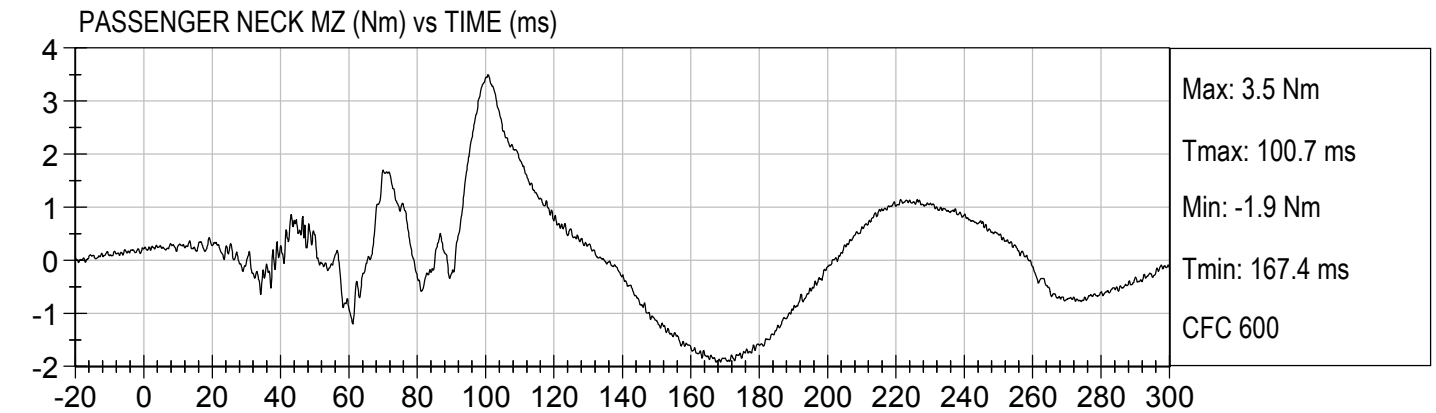
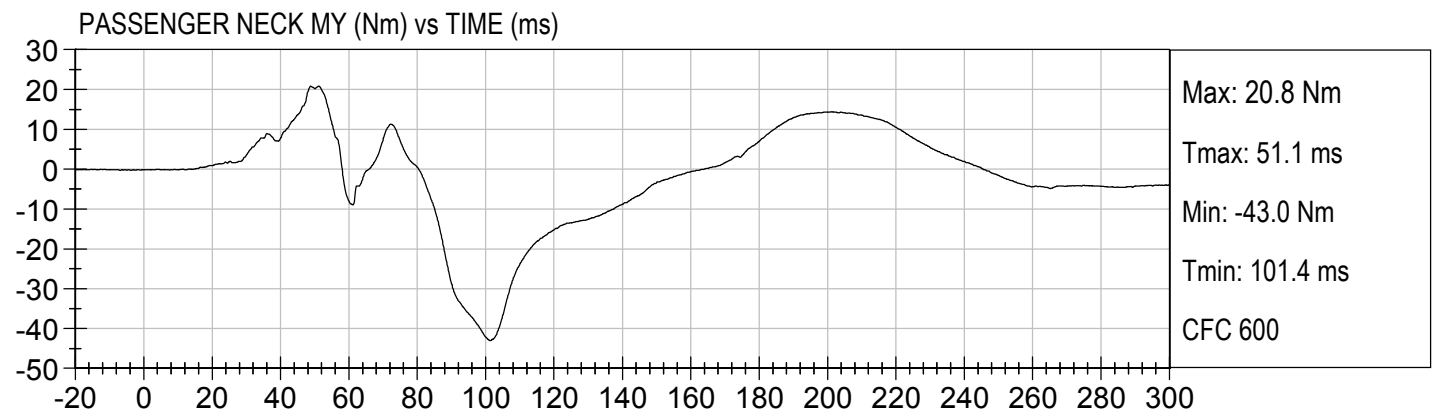
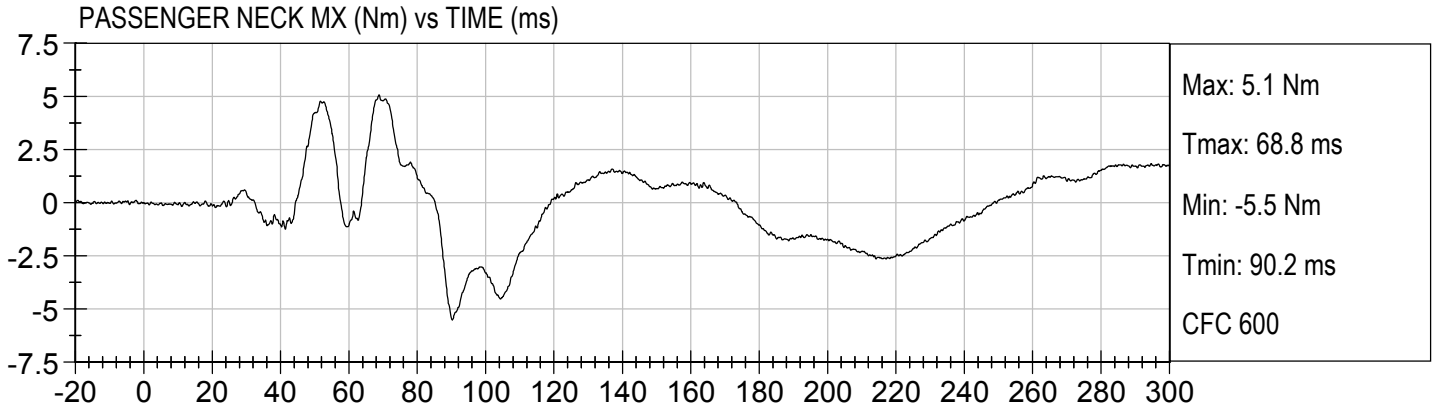

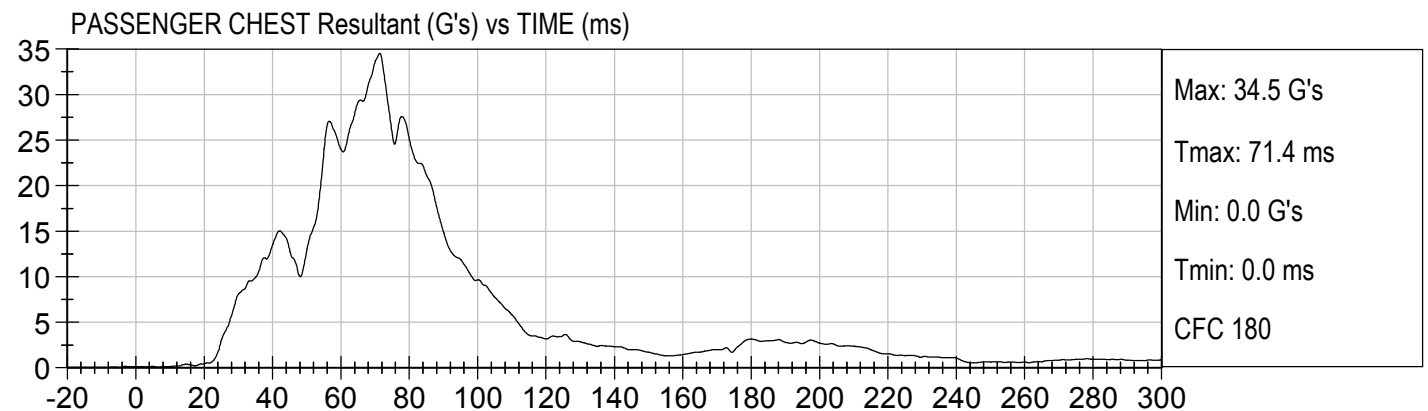
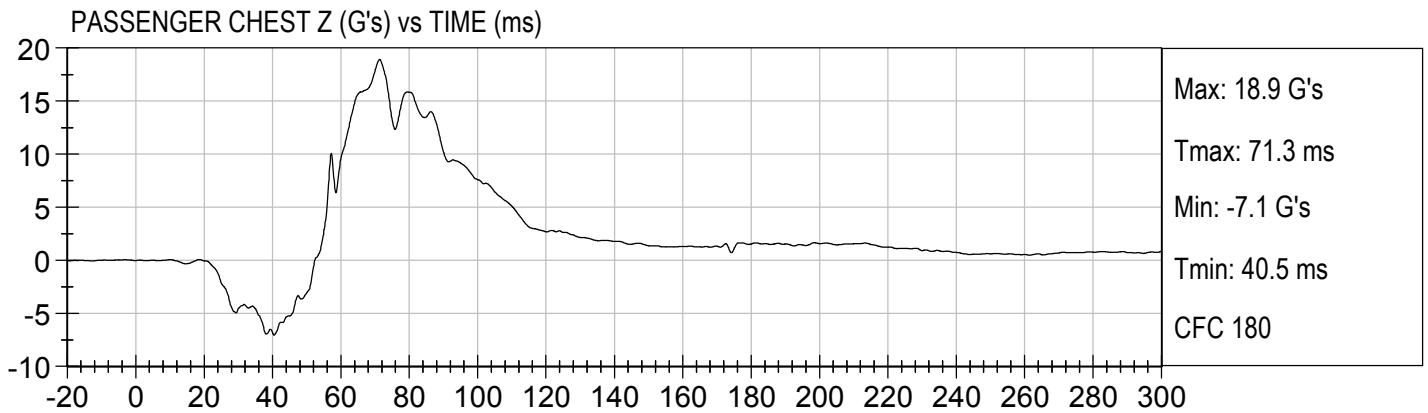
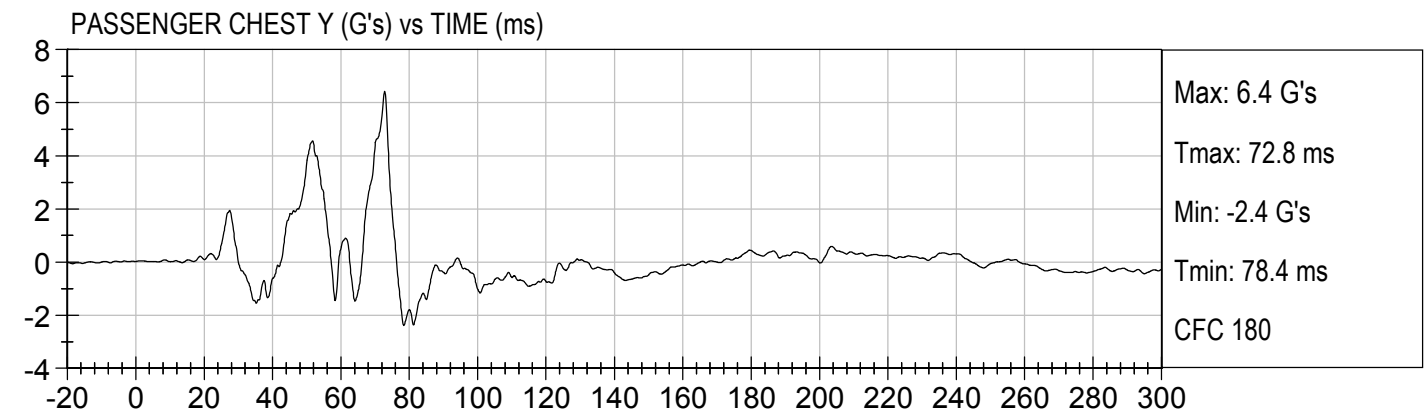
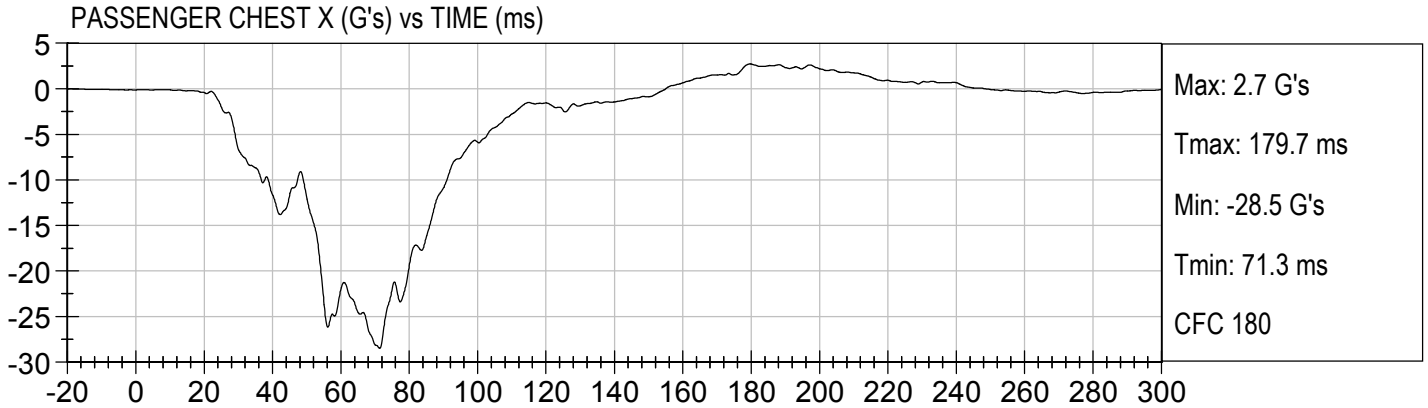

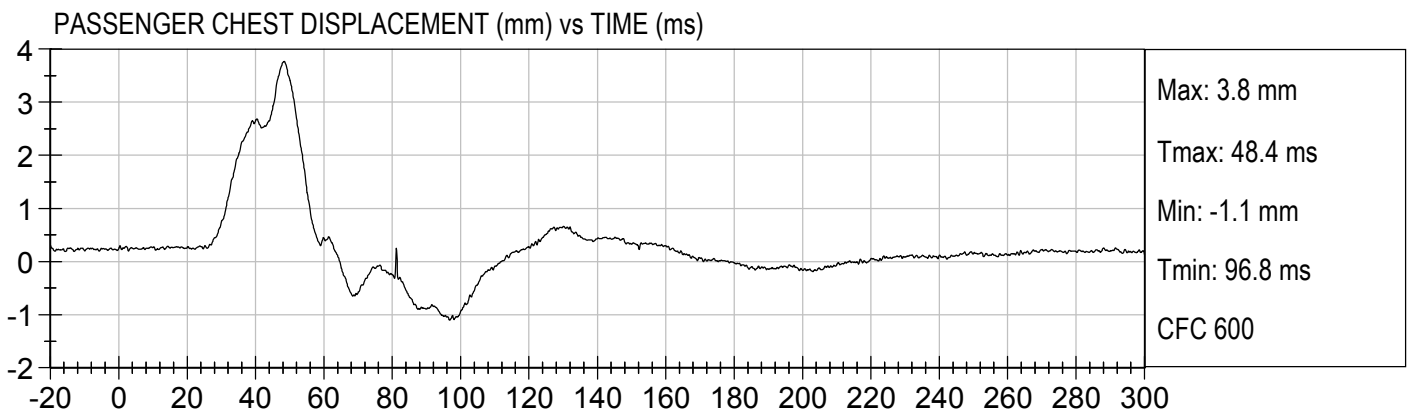
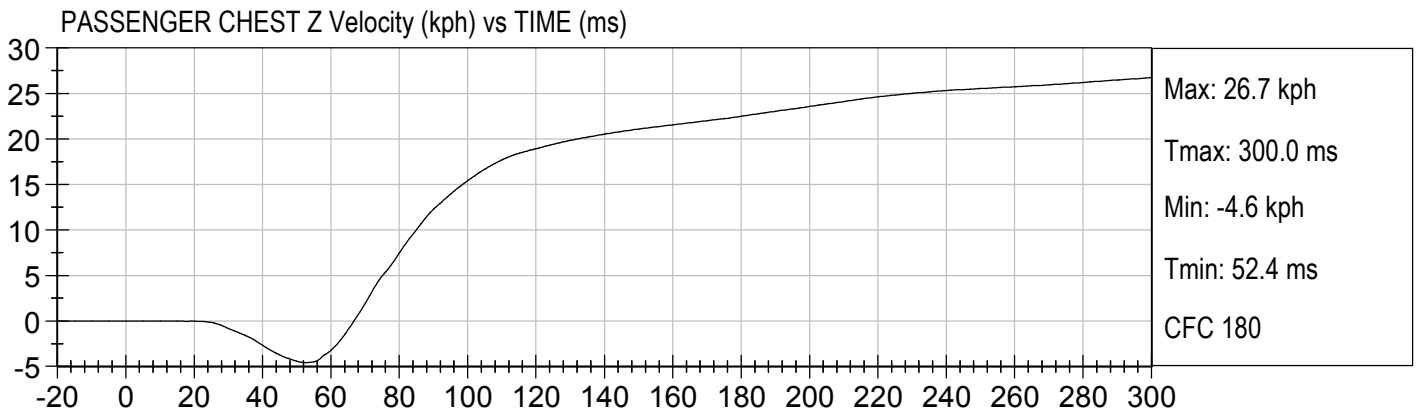
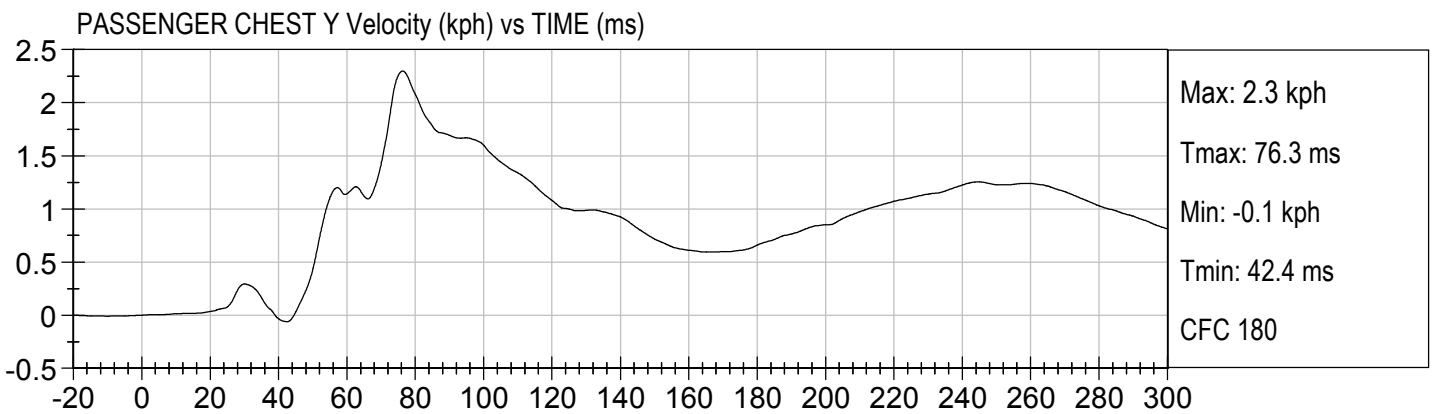
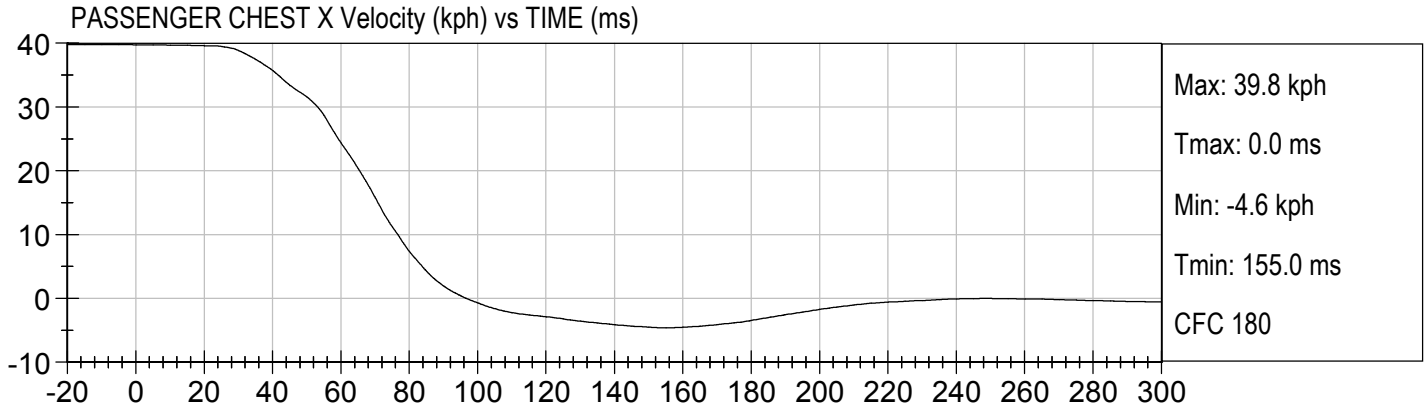

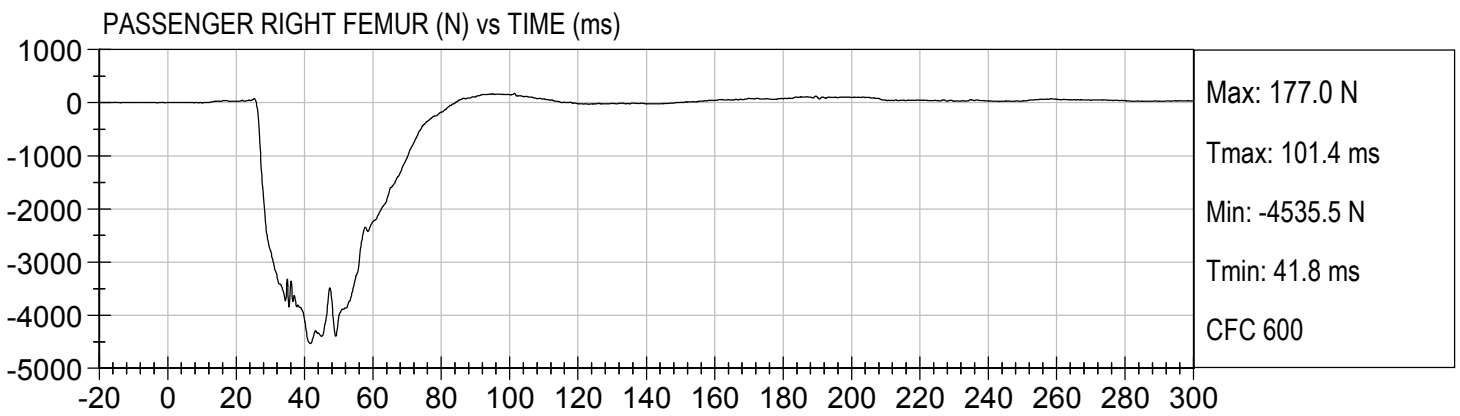
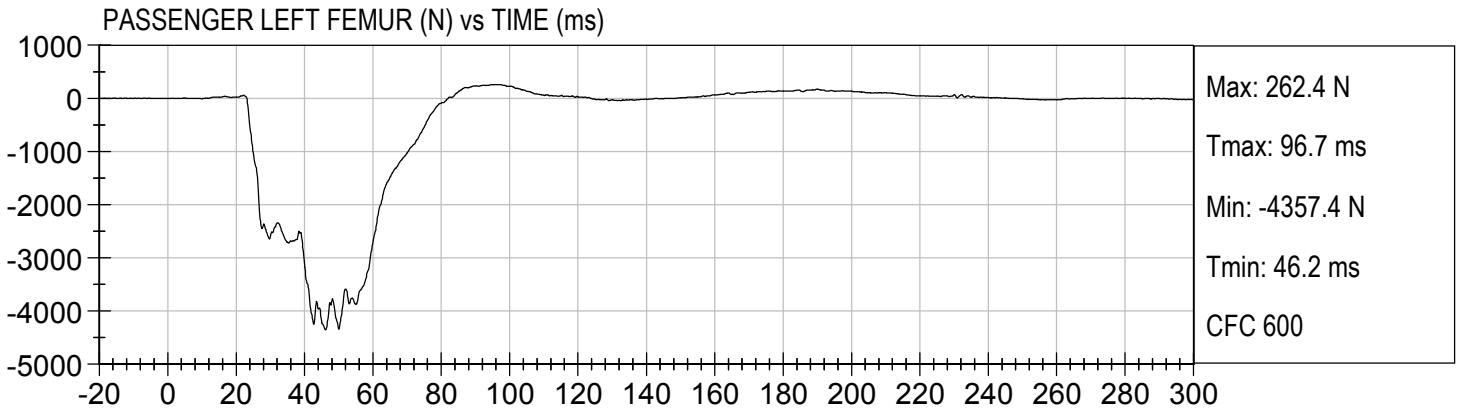

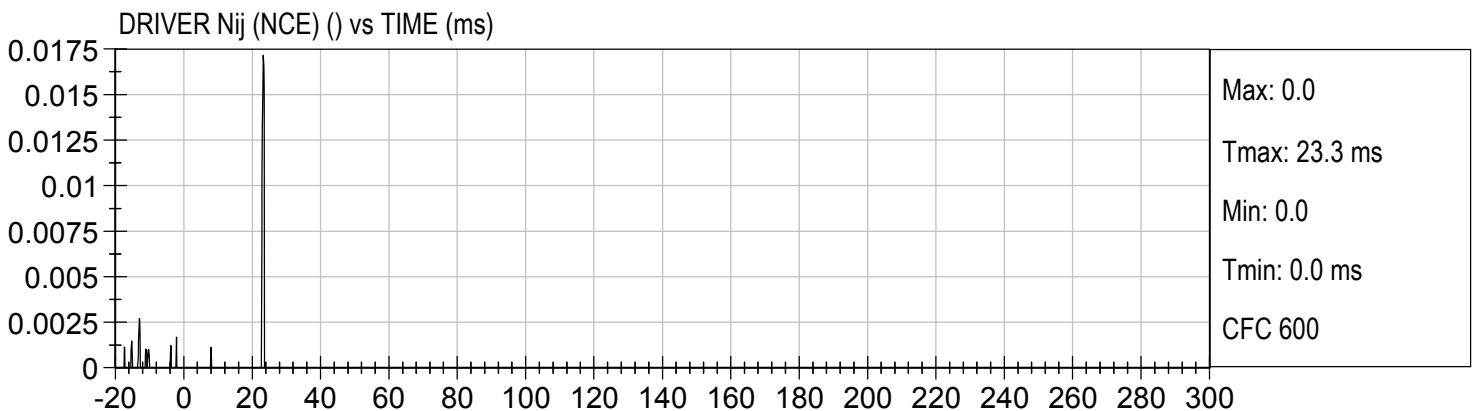
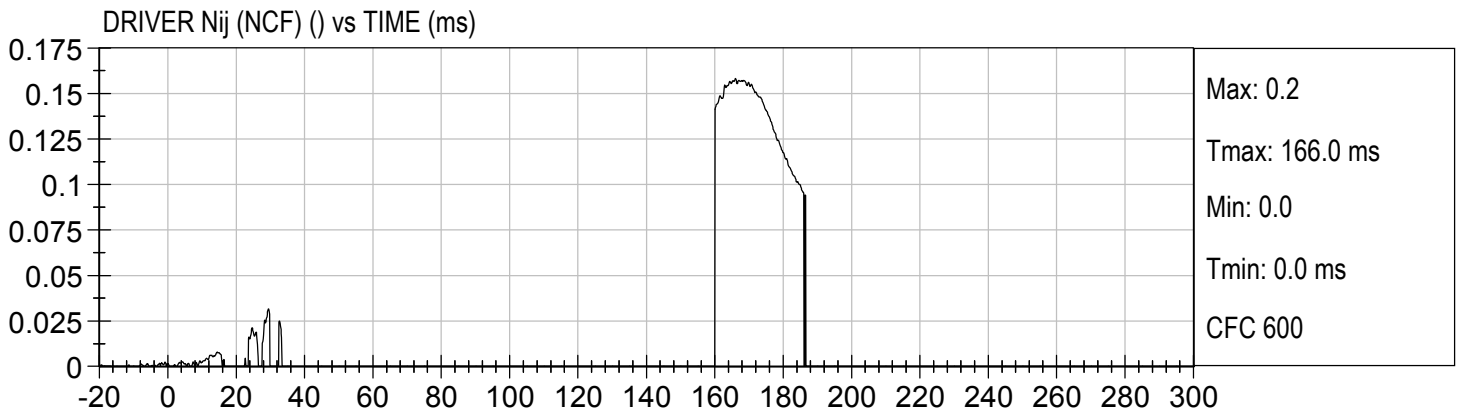
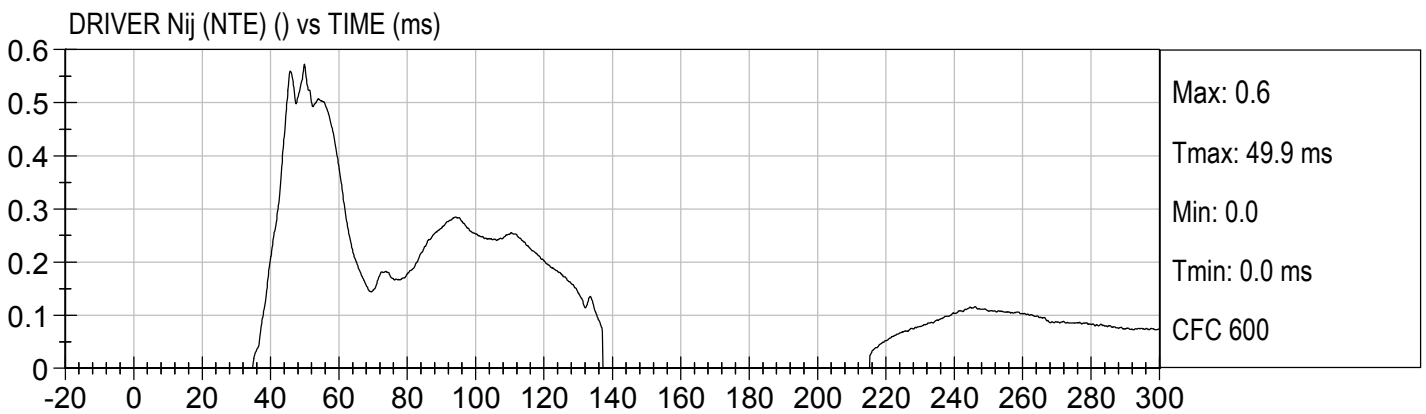
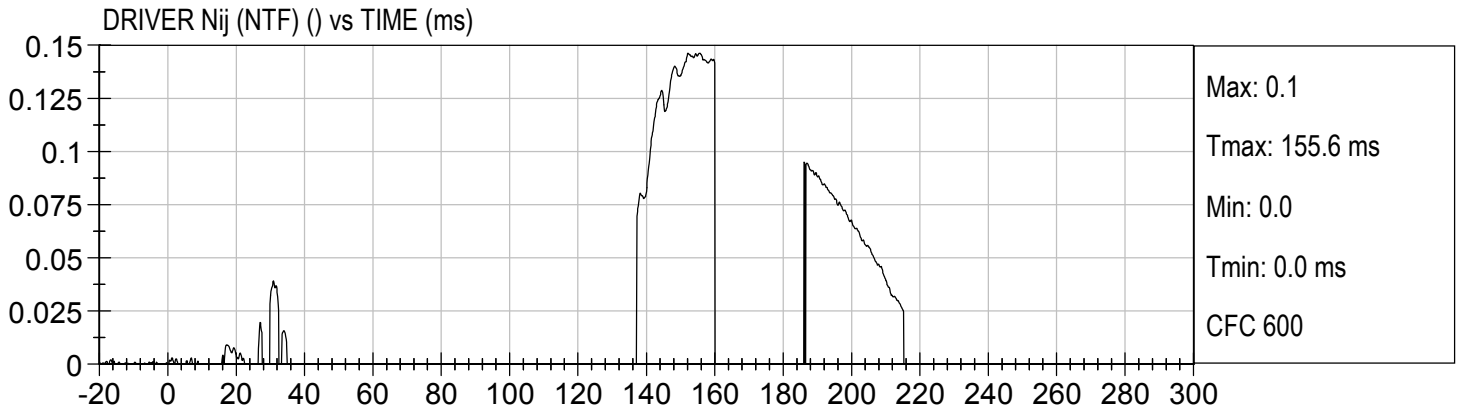

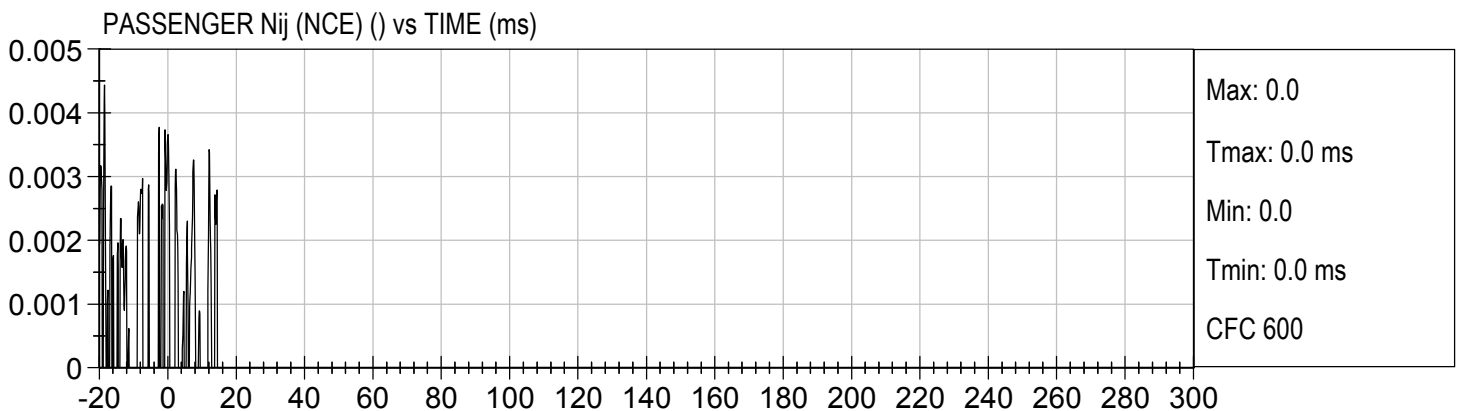
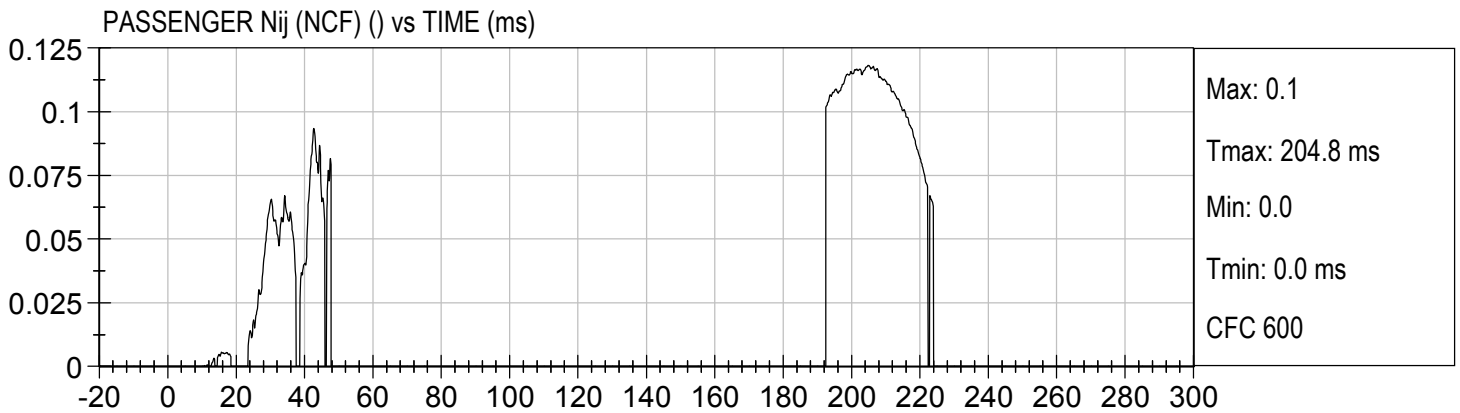
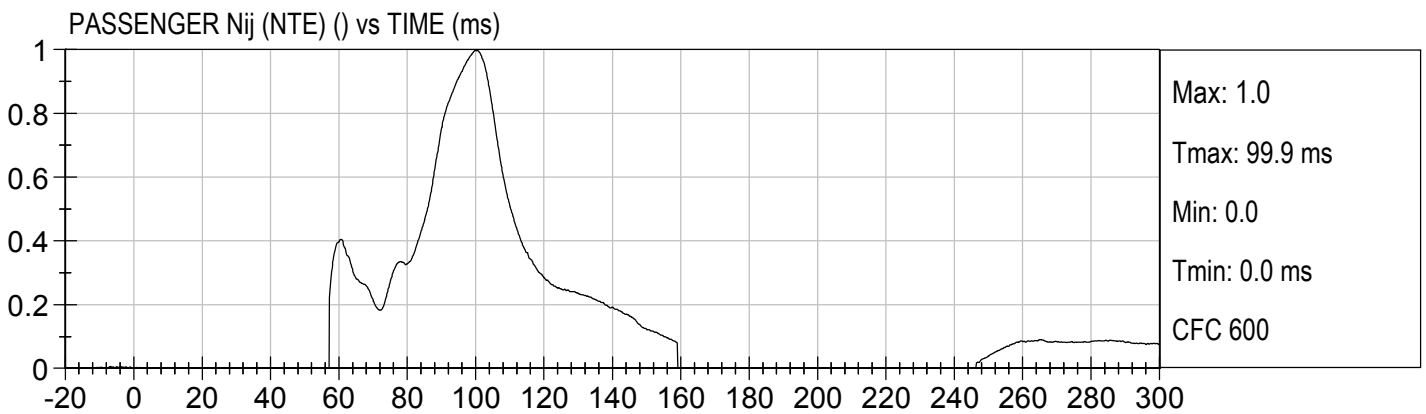
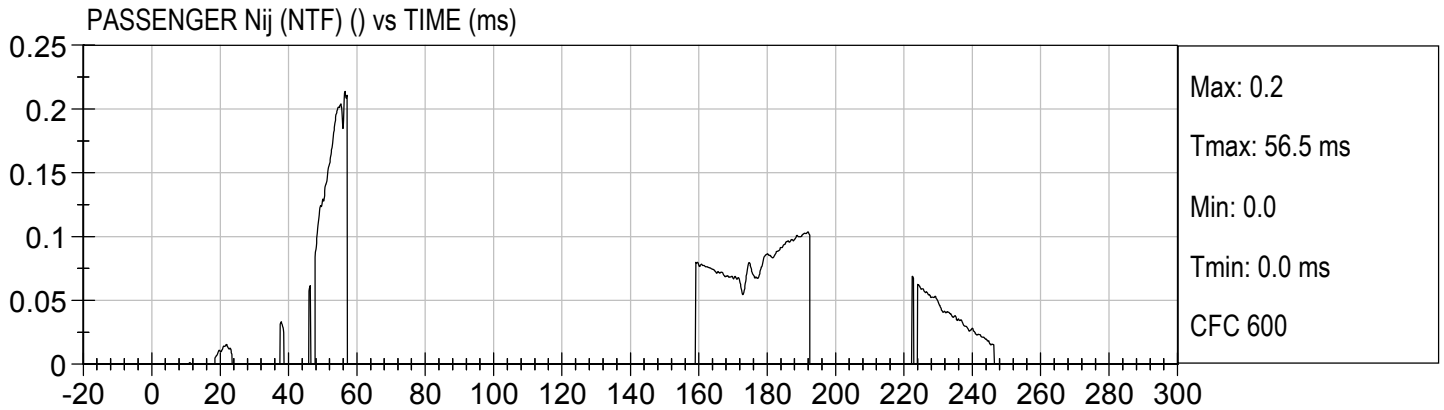

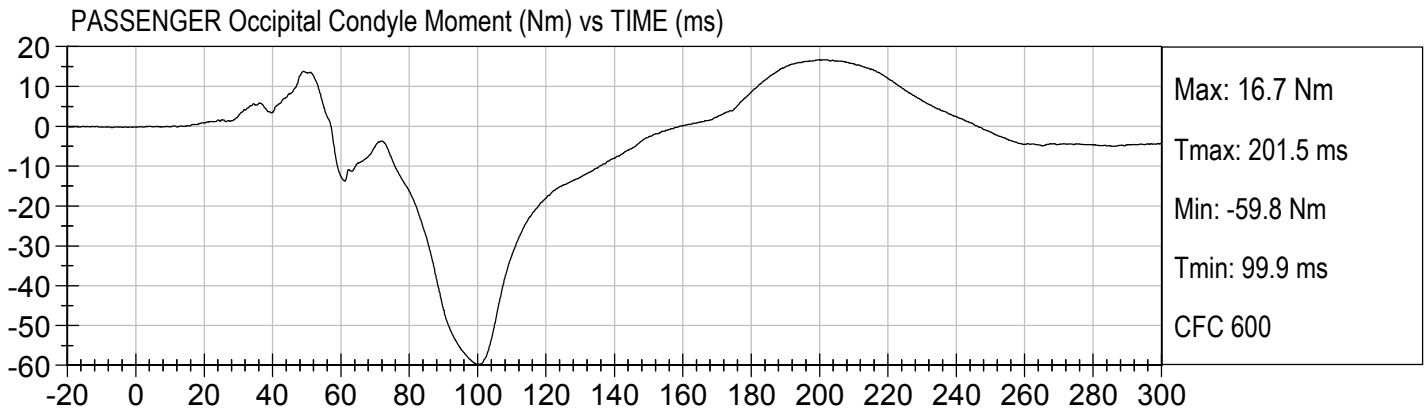
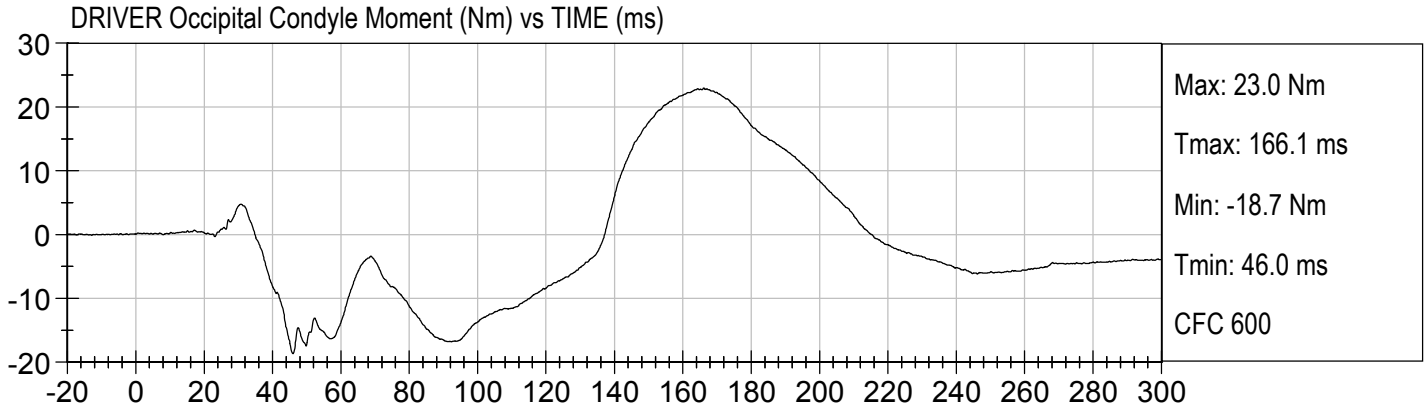

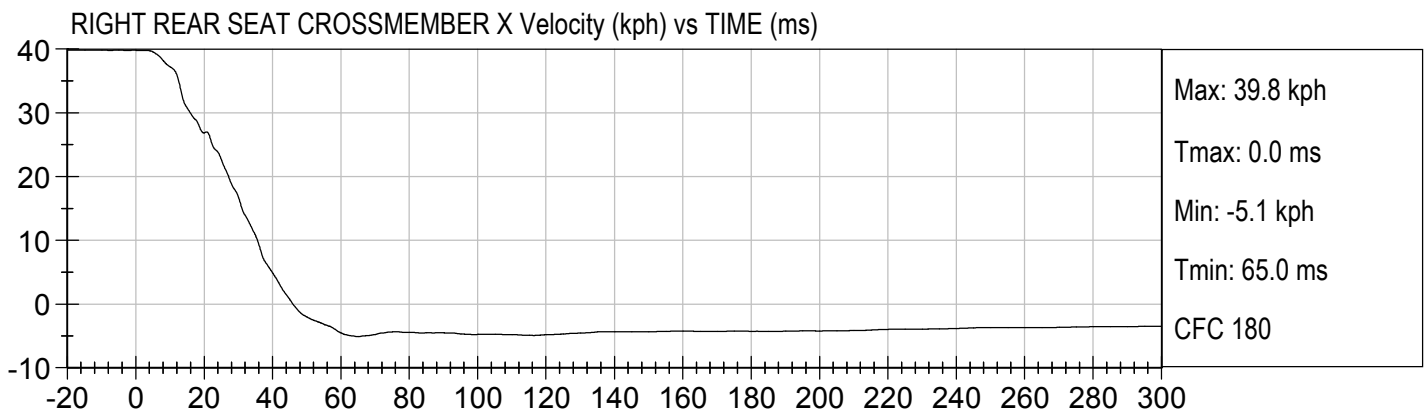
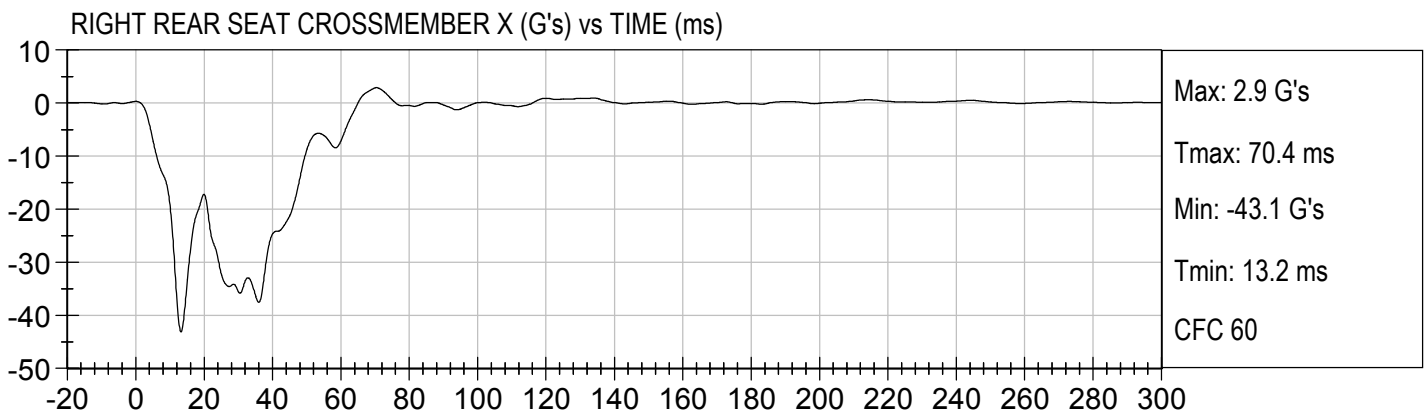
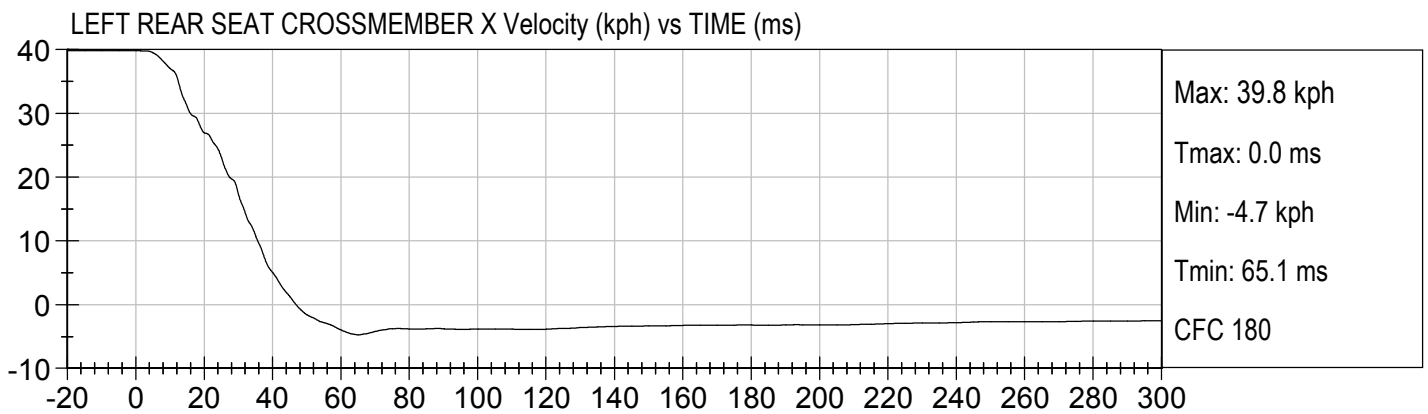
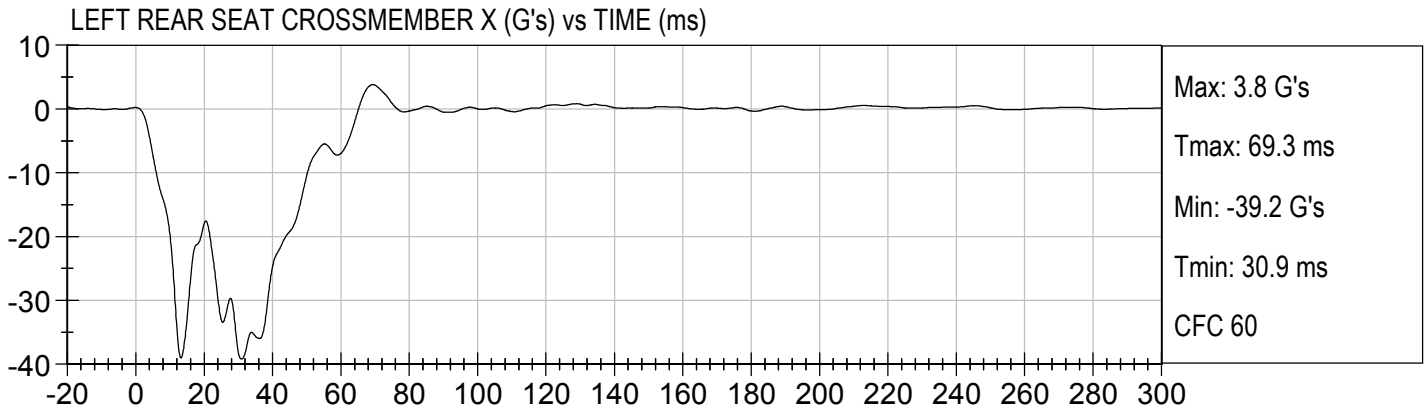

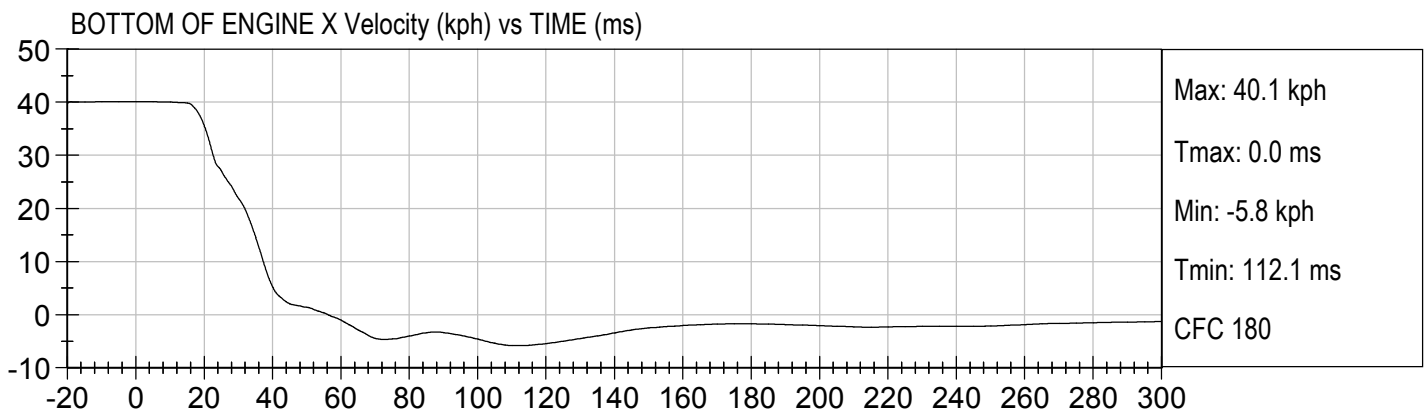
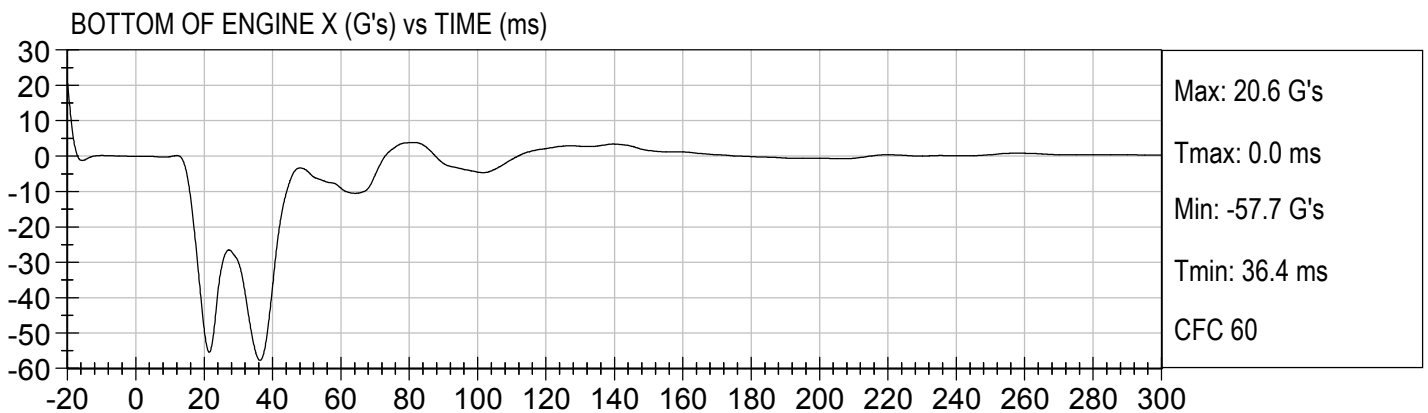
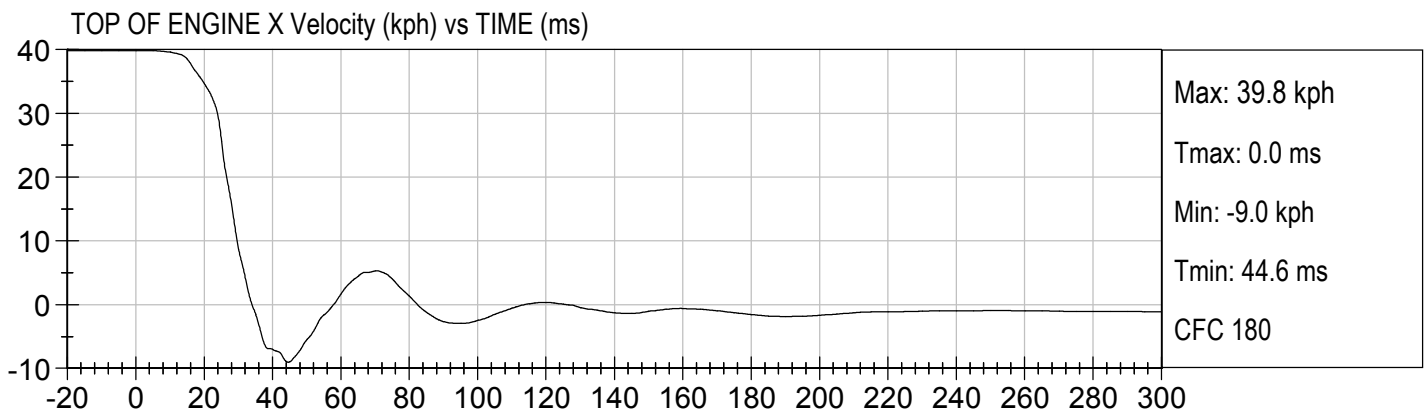
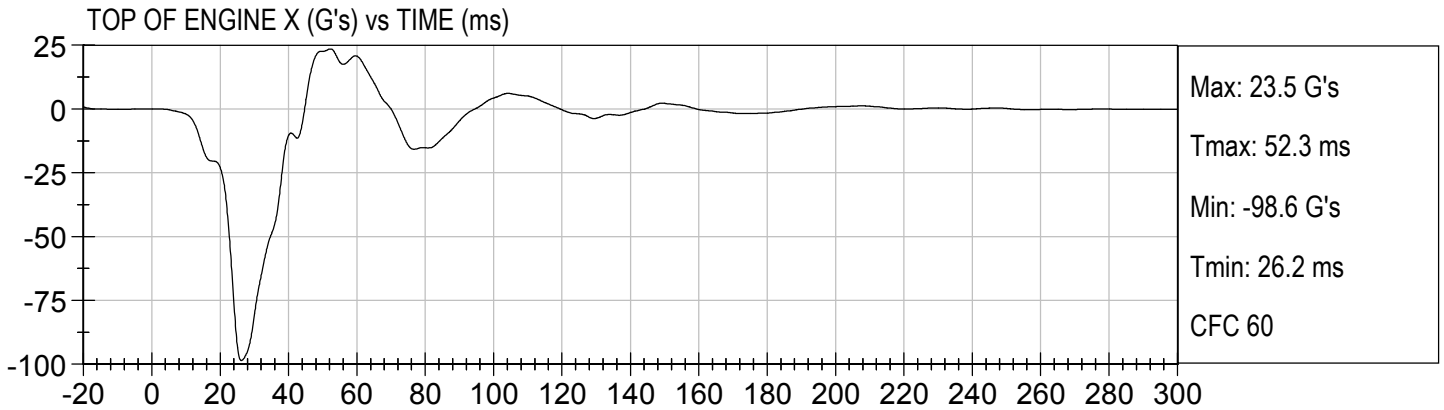

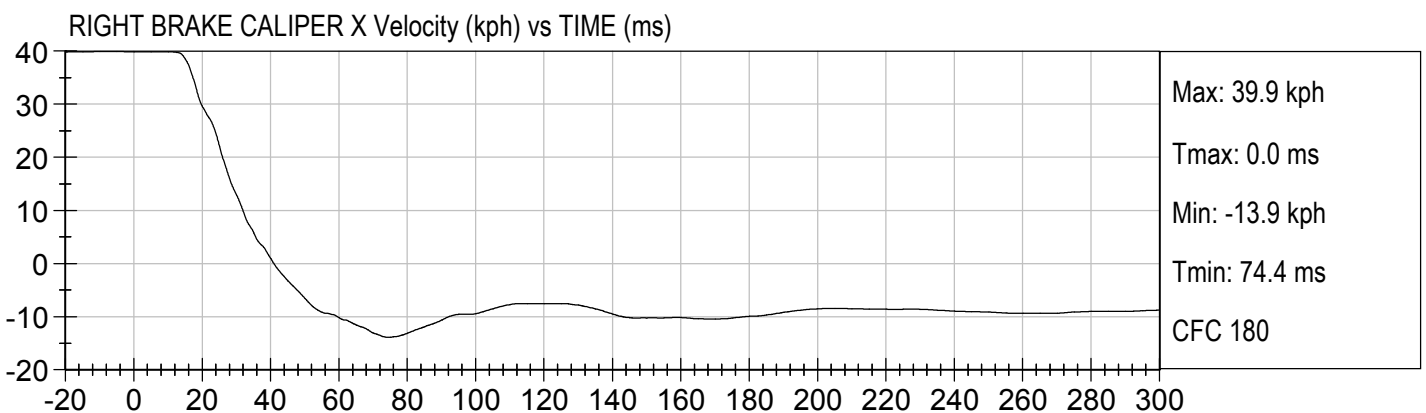
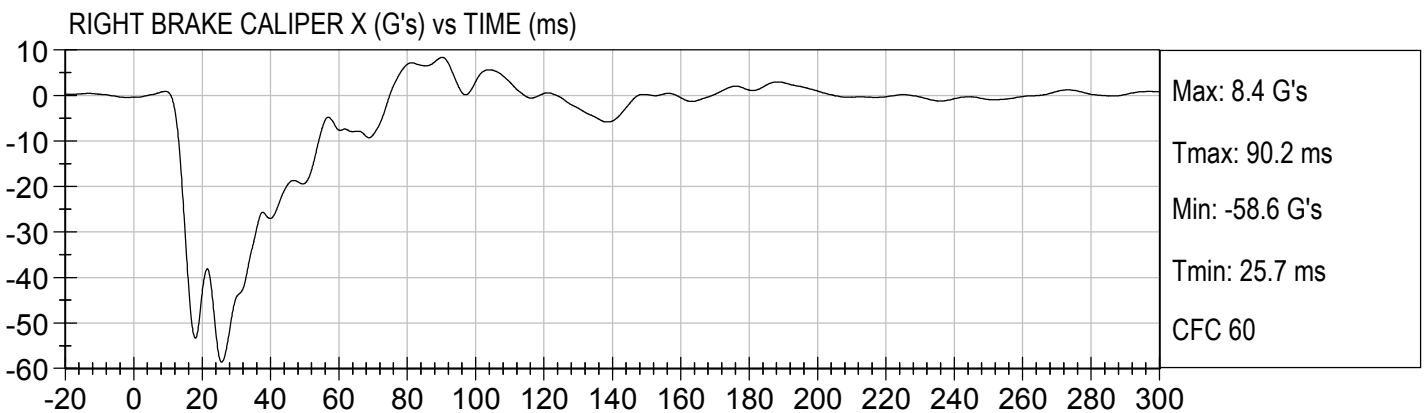
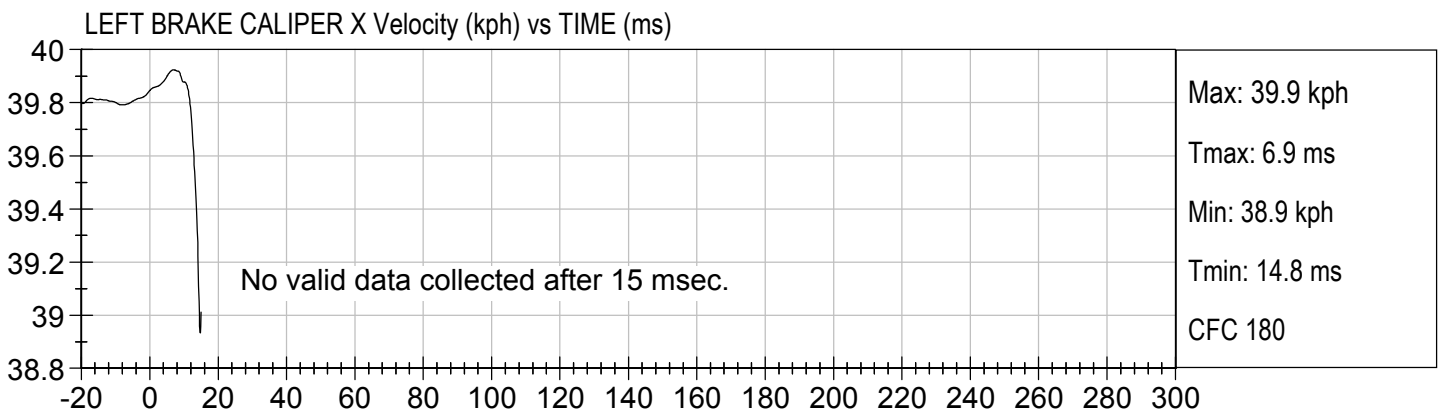
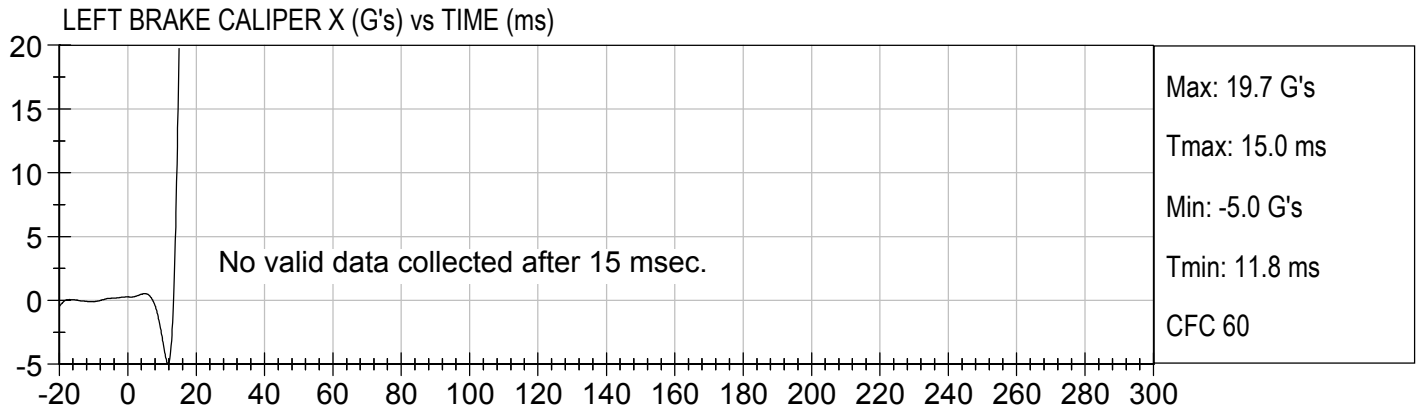

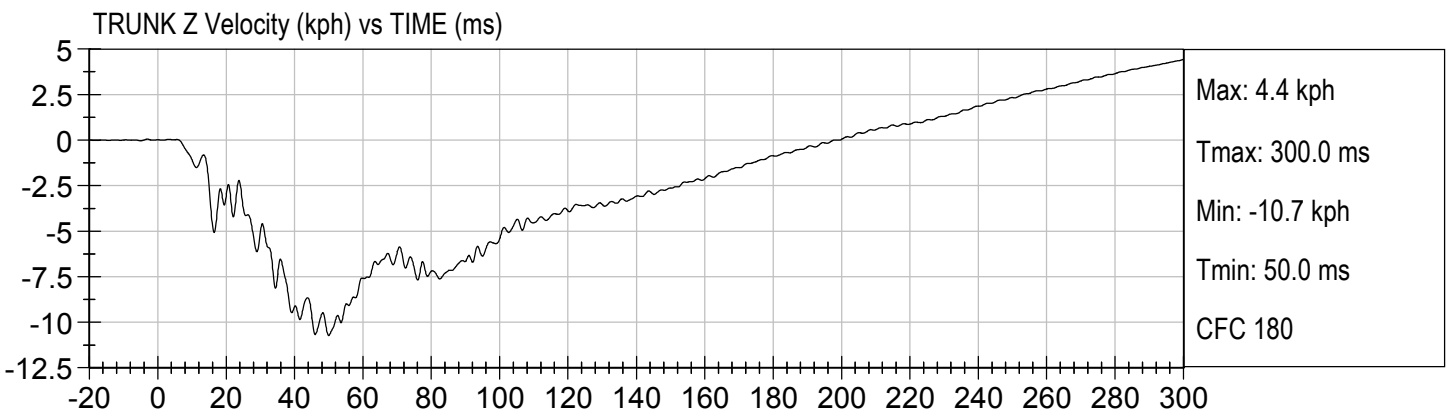
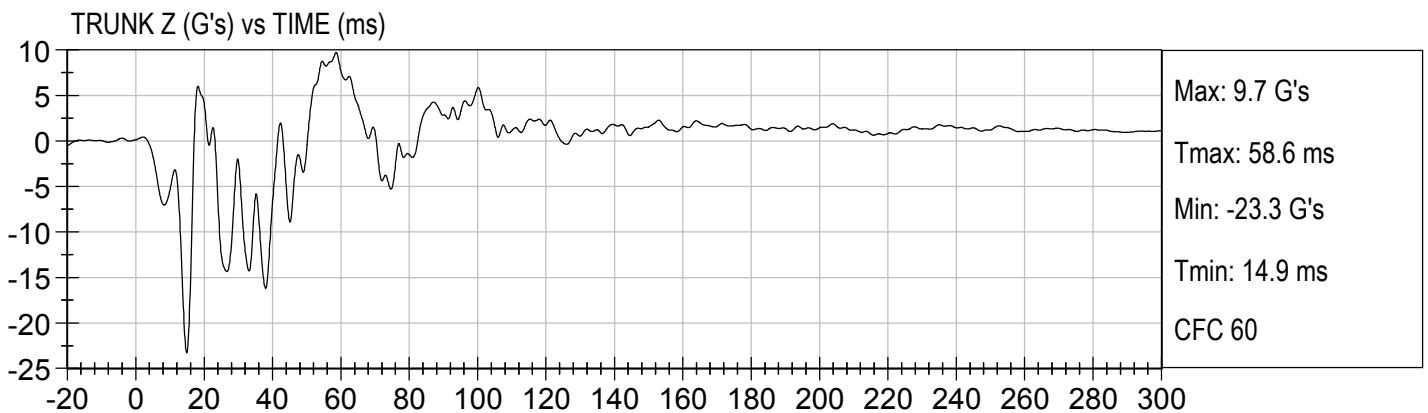
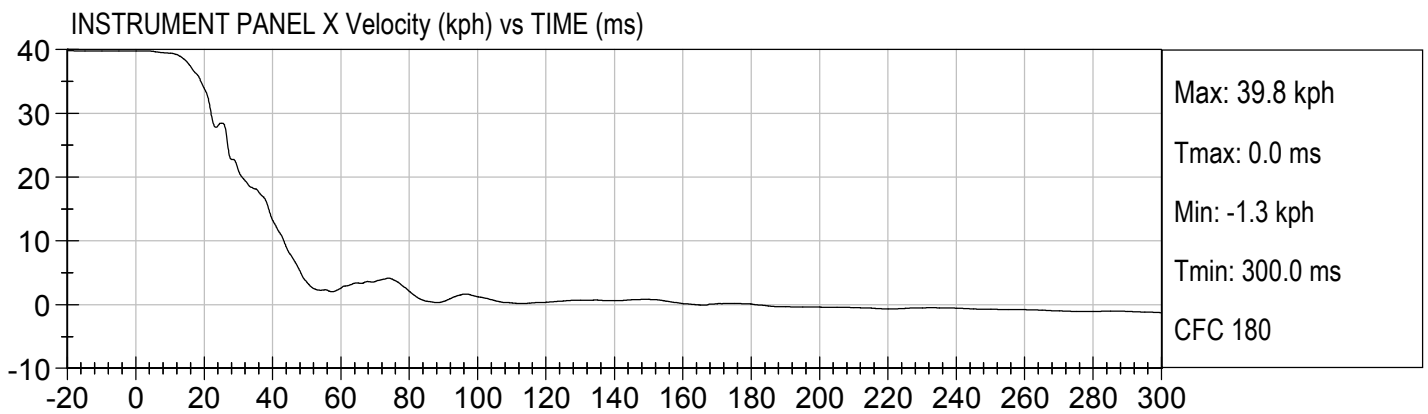
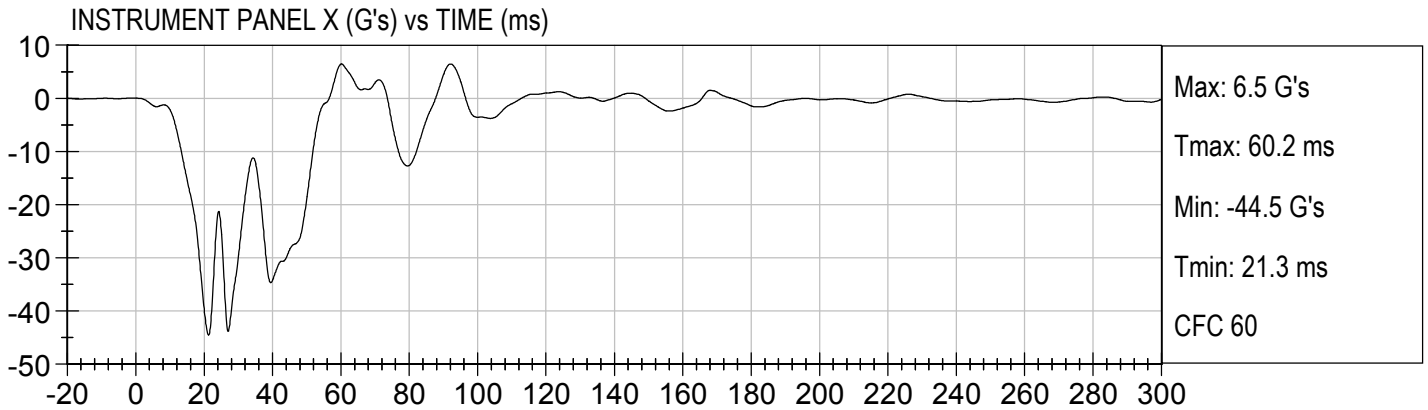

APPENDIX B

CRASH TEST PHOTOGRAPHS

TABLE OF PHOTOGRAPHS

	<u>Page No.</u>
Photo No. 1. Vehicle Certification Label	C-1
Photo No. 2. Tire Placard	C-2
Photo No. 3. Pre-Test Front View of Test Vehicle	C-3
Photo No. 4. Post-Test Front View of Test Vehicle	C-4
Photo No. 5. Pre-Test Left Side View of Test Vehicle	C-5
Photo No. 6. Post-Test Left Side View of Test Vehicle	C-6
Photo No. 7. Pre-Test Right Side View of Test Vehicle	C-7
Photo No. 8. Post-Test Right Side View of Test Vehicle	C-8
Photo No. 9. Pre-Test Left Front Three-Quarter View of Test Vehicle	C-9
Photo No. 10. Post-Test Left Front Three-Quarter View of Test Vehicle	C-10
Photo No. 11. Pre-Test Right Front Three-Quarter View of Test Vehicle	C-11
Photo No. 12. Post-Test Right Front Three-Quarter View of Test Vehicle	C-12
Photo No. 13. Pre-Test Right Rear Three-Quarter View of Test Vehicle	C-13
Photo No. 14. Post-Test Right Rear Three-Quarter View of Test Vehicle	C-14
Photo No. 15. Pre-Test Left Rear Three-Quarter View of Test Vehicle	C-15
Photo No. 16. Post-Test Left Rear Three-Quarter View of Test Vehicle	C-16
Photo No. 17. Pre-Test Rear View of Test Vehicle	C-17
Photo No. 18. Post-Test Rear View of Test Vehicle	C-18
Photo No. 19. Pre-Test Windshield View	C-19
Photo No. 20. Post-Test Windshield View	C-20
Photo No. 21. Pre-Test Engine Compartment View	C-21
Photo No. 22. Post-Test Engine Compartment View	C-22
Photo No. 23. Pre-Test Fuel Filler Cap View	C-23
Photo No. 24. Post-Test Fuel Filler Cap View	C-24
Photo No. 25. Pre-Test Front Underbody View	C-25
Photo No. 26. Post-Test Front Underbody View	C-26
Photo No. 27. Pre-Test Mid Underbody View	C-27
Photo No. 28. Post-Test Mid Underbody View	C-28
Photo No. 29. Pre-Test Mid Rear Underbody View	C-29
Photo No. 30. Post-Test Mid Rear Underbody View	C-30
Photo No. 31. Pre-Test Rear Underbody View	C-31
Photo No. 32. Post-Test Rear Underbody View	C-32
Photo No. 33. Pre-Test Driver Dummy Front View (head position)	C-33

Photo No. 34.	Post-Test Driver Dummy Front View (head position)	C-34
Photo No. 35.	Pre-Test Driver Dummy Position Left Side View	C-35
Photo No. 36.	Post-Test Driver Dummy Position Left Side View	C-36
Photo No. 37.	Pre-Test Driver Dummy Position Left Side View (door open)	C-37
Photo No. 38.	Post-Test Driver Dummy Position Left Side View (door open)	C-38
Photo No. 39.	Pre-Test Driver Dummy Seat Position	C-39
Photo No. 40.	Post-Test Driver Dummy Seat Position	C-40
Photo No. 41.	Pre-Test Driver Dummy Feet Position	C-41
Photo No. 42.	Post-Test Driver Dummy Feet Position	C-42
Photo No. 43.	Pre-Test Driver Side Knee Bolster View	C-43
Photo No. 44.	Post-Test Driver Side Knee Bolster View	C-44
Photo No. 45.	Post-Test Driver Dummy Airbag Contact	C-45
Photo No. 46.	Post-Test Driver Dummy Knee Contact (knee airbag)	C-46
Photo No. 47.	Pre-Test Passenger Dummy Front View (head position)	C-47
Photo No. 48.	Post-Test Passenger Dummy Front View (head position)	C-48
Photo No. 49.	Pre-Test Passenger Dummy Position Right Side View	C-49
Photo No. 50.	Post-Test Passenger Dummy Position Right Side View	C-50
Photo No. 51.	Pre-Test Passenger Dummy Position Right Side View (door open)	C-51
Photo No. 52.	Post-Test Passenger Dummy Position Right Side View (door open)	C-52
Photo No. 53.	Pre-Test Passenger Dummy Seat Position	C-53
Photo No. 54.	Post-Test Passenger Dummy Seat Position	C-54
Photo No. 55.	Pre-Test Passenger Dummy Feet Position	C-55
Photo No. 56.	Post-Test Passenger Dummy Feet Position	C-56
Photo No. 57.	Pre-Test Passenger Side Knee Bolster View	C-57
Photo No. 58.	Post-Test Passenger Side Knee Bolster View	C-58
Photo No. 59.	Post-Test Passenger Dummy Airbag Contact	C-59
Photo No. 60.	Post-Test Passenger Dummy Knee Contact (glove box)	C-60
Photo No. 61.	Rollover 90 Degrees	C-61
Photo No. 62.	Rollover 180 Degrees	C-62
Photo No. 63.	Rollover 270 Degrees	C-63
Photo No. 64.	Rollover 360 Degrees	C-64
Photo No. 65.	Temperature Plot	C-65

B-1

MFD BY FIAT GROUP AUTOMOBILES S.P.A.

DATE OF MFR: 4/13

GAWR FRONT: 1050 KG / 2315 LB

16X6

GAWR REAR: 915 KG / 2017 LB

16X6

GVWR: 1950 KG / 4299 LB

WITH: 205/55 R16 TIRES

RIMS AT: 240KPA/35PSI COLD

WITH: 205/55 R16 TIRES

RIMS AT: 230KPA/33PSI COLD

THIS VEHICLE CONFORMS TO ALL APPLICABLE U.S.A. FEDERAL MOTOR VEHICLE SAFETY AND THEFT PREVENTION STANDARDS IN EFFECT ON THE DATE OF MANUFACTURE SHOWN ABOVE

VIN: ZFBCFAAH9EZ002194 TYPE: MPV

VEHICLE MADE IN: SERBIA

TIRE AND LOADING INFORMATION

SEATING CAPACITY - TOTAL 5 FRONT 2 REAR 3

THE COMBINED WEIGHT OF OCCUPANTS AND CARGO SHOULD NEVER EXCEED 390 KG OR 860 LB

	FRONT	REAR	SPARE
USE ORIGINAL TIRE SIZE	205/55 R16	205/55 R16	none
FOR TIRE INFLATION	240 KPA/35 PSI	230 KPA/33 PSI	- KPA/- PSI

SEE OWNER'S MANUAL FOR ADDITIONAL INFORMATION

Photo No. 1 - Vehicle Certification Label

B-2

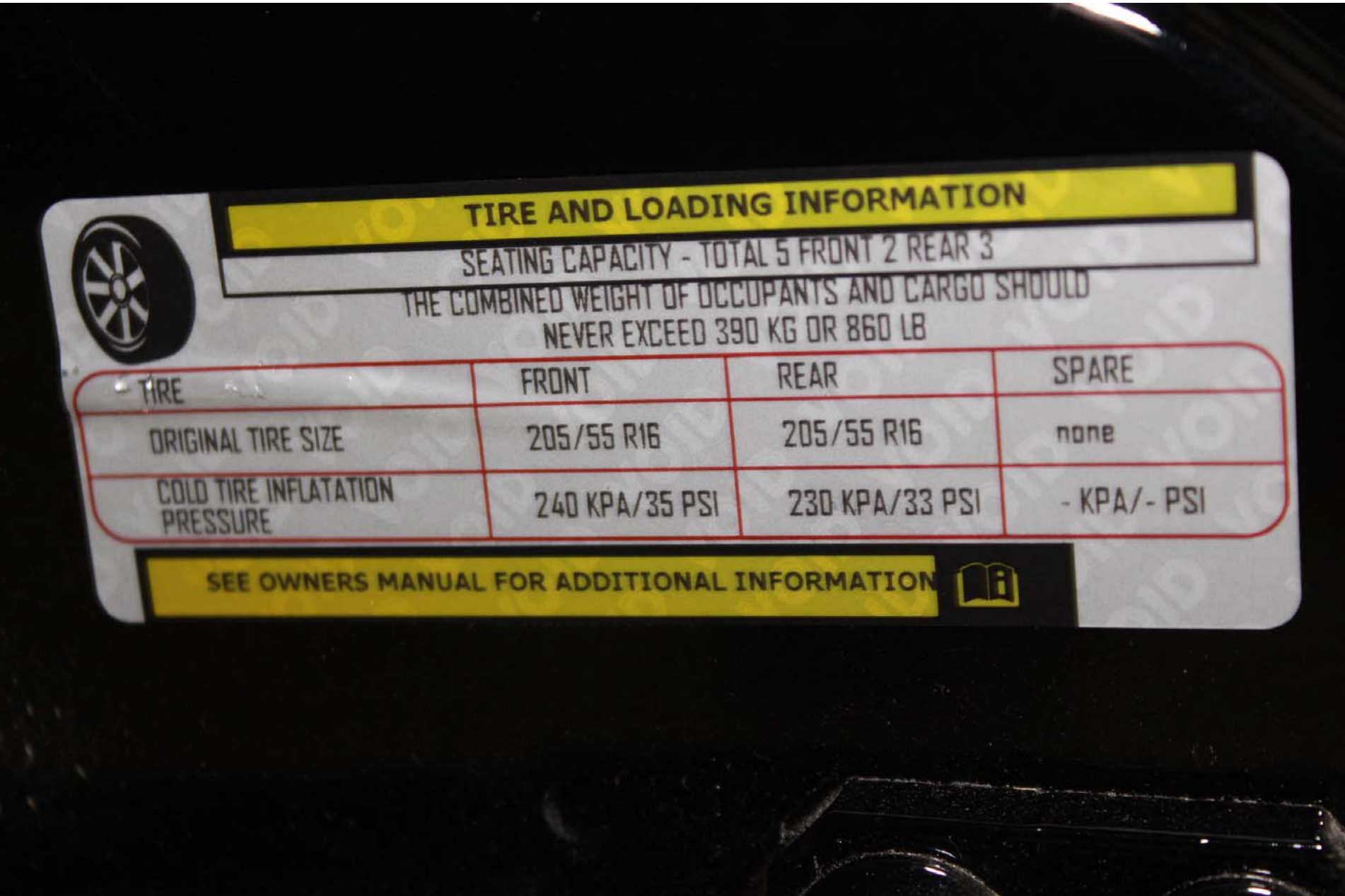

TIRE AND LOADING INFORMATION

SEATING CAPACITY - TOTAL 5 FRONT 2 REAR 3

THE COMBINED WEIGHT OF OCCUPANTS AND CARGO SHOULD NEVER EXCEED 390 KG OR 860 LB

TIRE	FRONT	REAR	SPARE
ORIGINAL TIRE SIZE	205/55 R16	205/55 R16	none
COLD TIRE INFLATATION PRESSURE	240 KPA/35 PSI	230 KPA/33 PSI	- KPA/- PSI

SEE OWNERS MANUAL FOR ADDITIONAL INFORMATION



Photo No. 2 - Tire Placard



Photo No. 3 - Pre-Test Front View of Test Vehicle



Photo No. 4 - Post-Test Front View of Test Vehicle



Photo No. 5 - Pre-Test Left Side View of Test Vehicle



Photo No. 6 - Post-Test Left Side View of Test Vehicle



Photo No. 7 - Pre-Test Right Side View of Test Vehicle



Photo No. 8 - Post-Test Right Side View of Test Vehicle



Photo No. 9 - Pre-Test Left Front Three-Quarter View of Test Vehicle



Photo No. 10 - Post-Test Left Front Three-Quarter View of Test Vehicle



B-11

Photo No. 11 - Pre-Test Right Front Three-Quarter View of Test Vehicle



Photo No. 12 - Post-Test Right Front Three-Quarter View of Test Vehicle



Photo No. 13 - Pre-Test Right Rear Three-Quarter View of Test Vehicle



Photo No. 14 - Post-Test Right Rear Three-Quarter View of Test Vehicle



Photo No. 15 - Pre-Test Left Rear Three-Quarter View of Test Vehicle



Photo No. 16 - Post-Test Left Rear Three-Quarter View of Test Vehicle



Photo No. 17 - Pre-Test Rear View of Test Vehicle



Photo No. 18 - Post-Test Rear View of Test Vehicle



Photo No. 19 - Pre-Test Windshield View



Photo No. 20 - Post-Test Windshield View



Photo No. 21 - Pre-Test Engine Compartment View



Photo No. 22 - Post-Test Engine Compartment View



B-23

Photo No. 23 - Pre-Test Fuel Filler Cap View



B-24

Photo No. 24 - Post-Test Fuel Filler Cap View

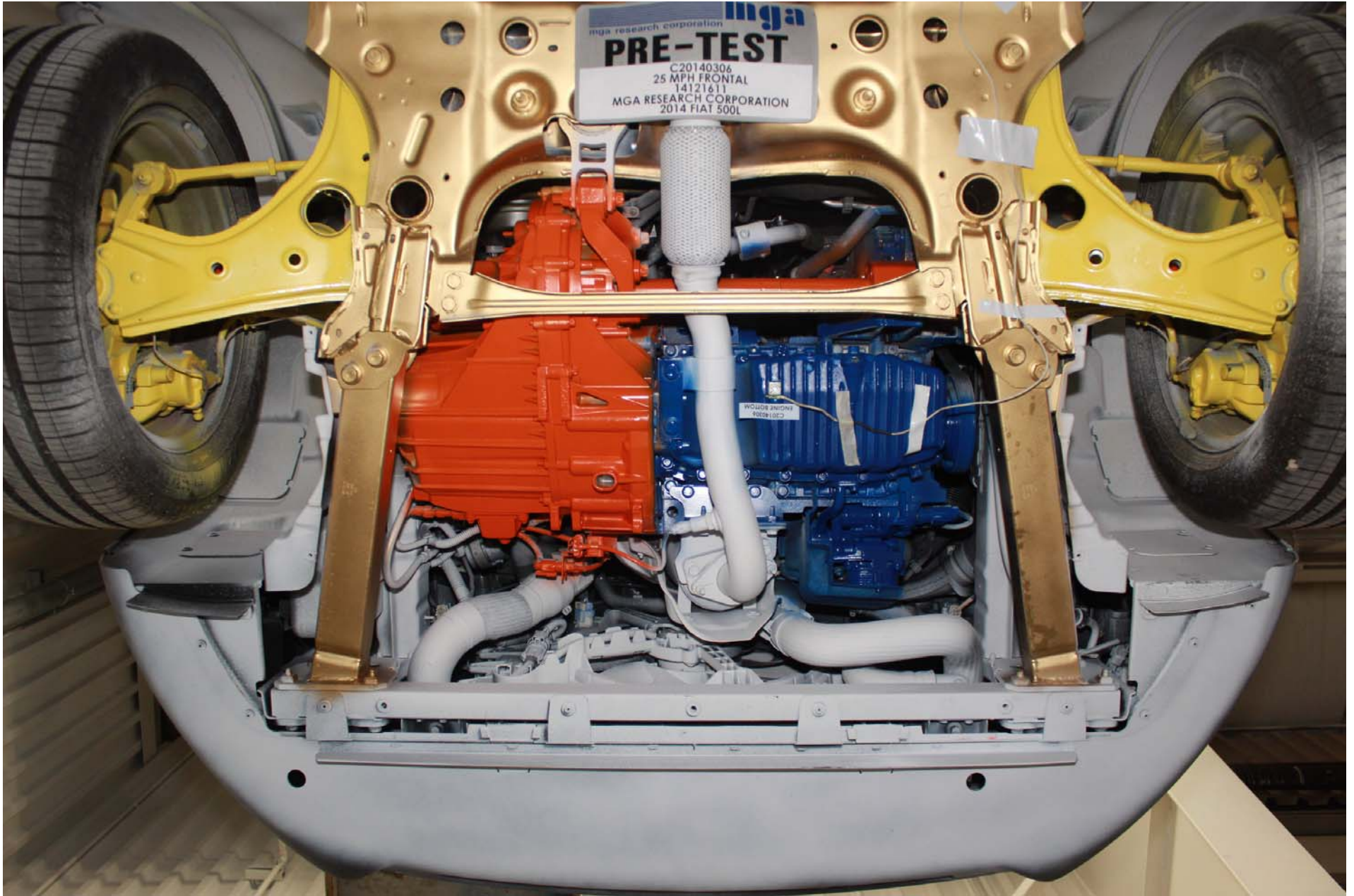
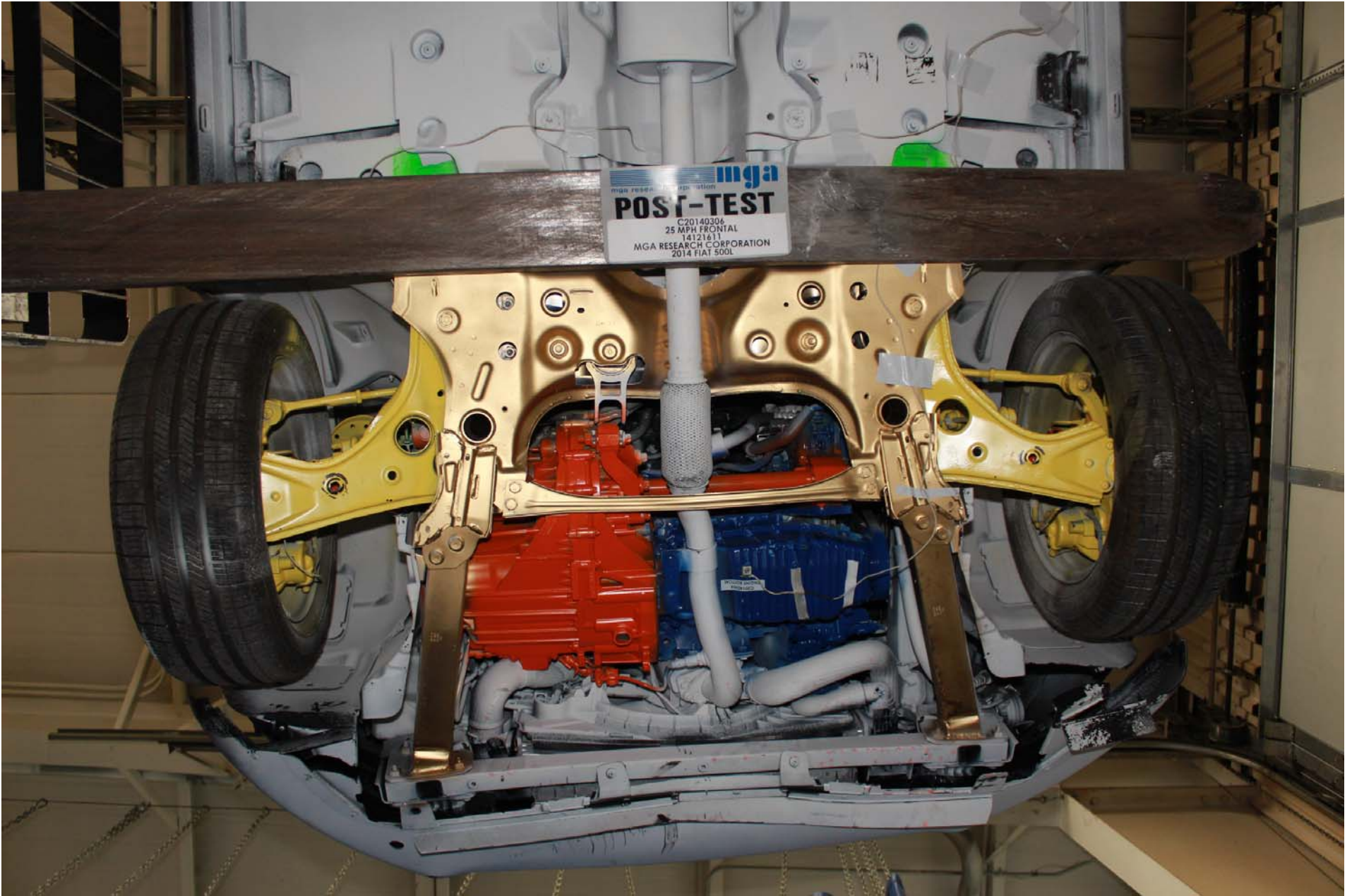

Photo No. 25 - Pre-Test Front Underbody View



B-26

Photo No. 26 - Post-Test Front Underbody View



Photo No. 27 - Pre-Test Mid Underbody View

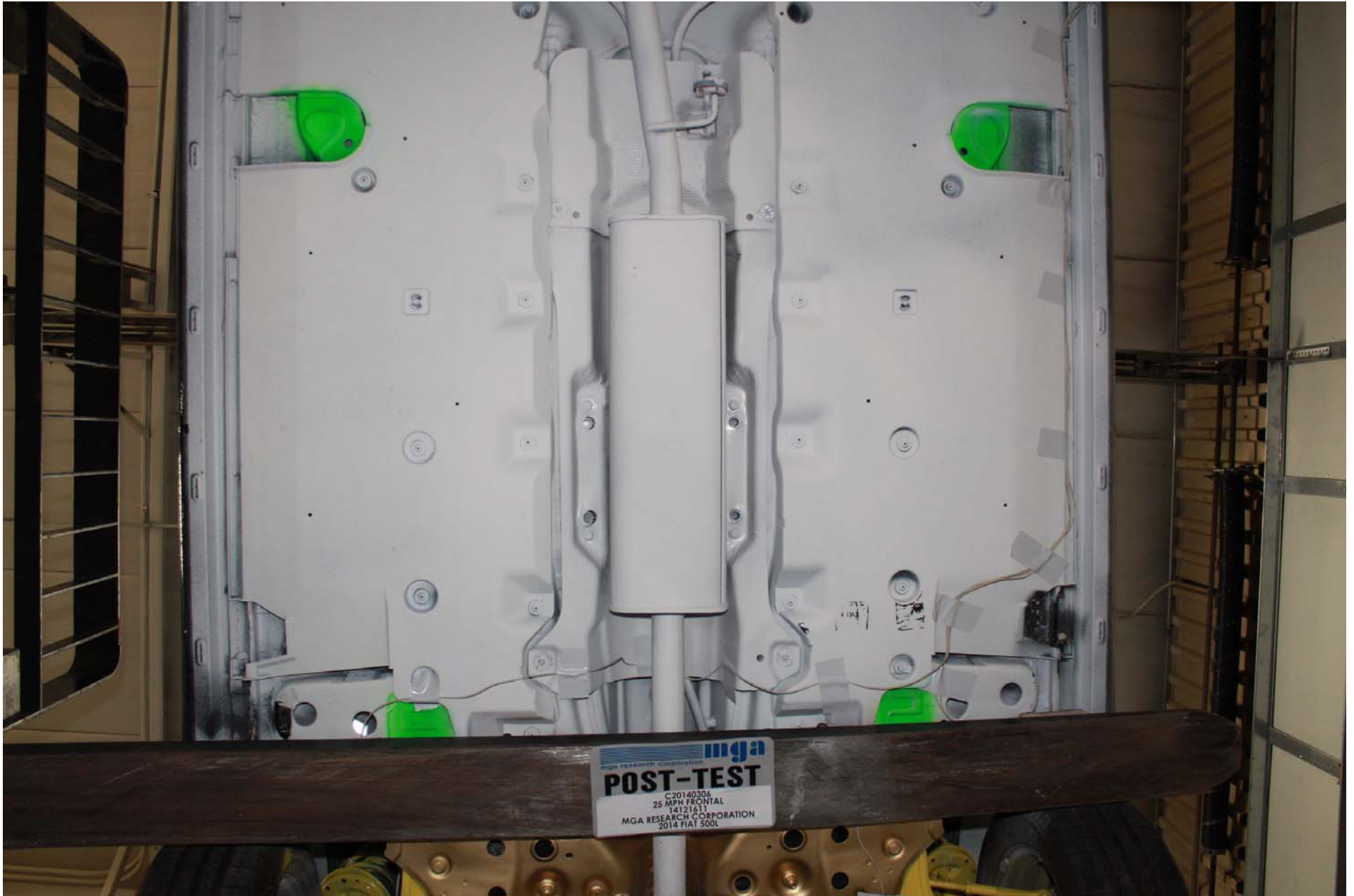
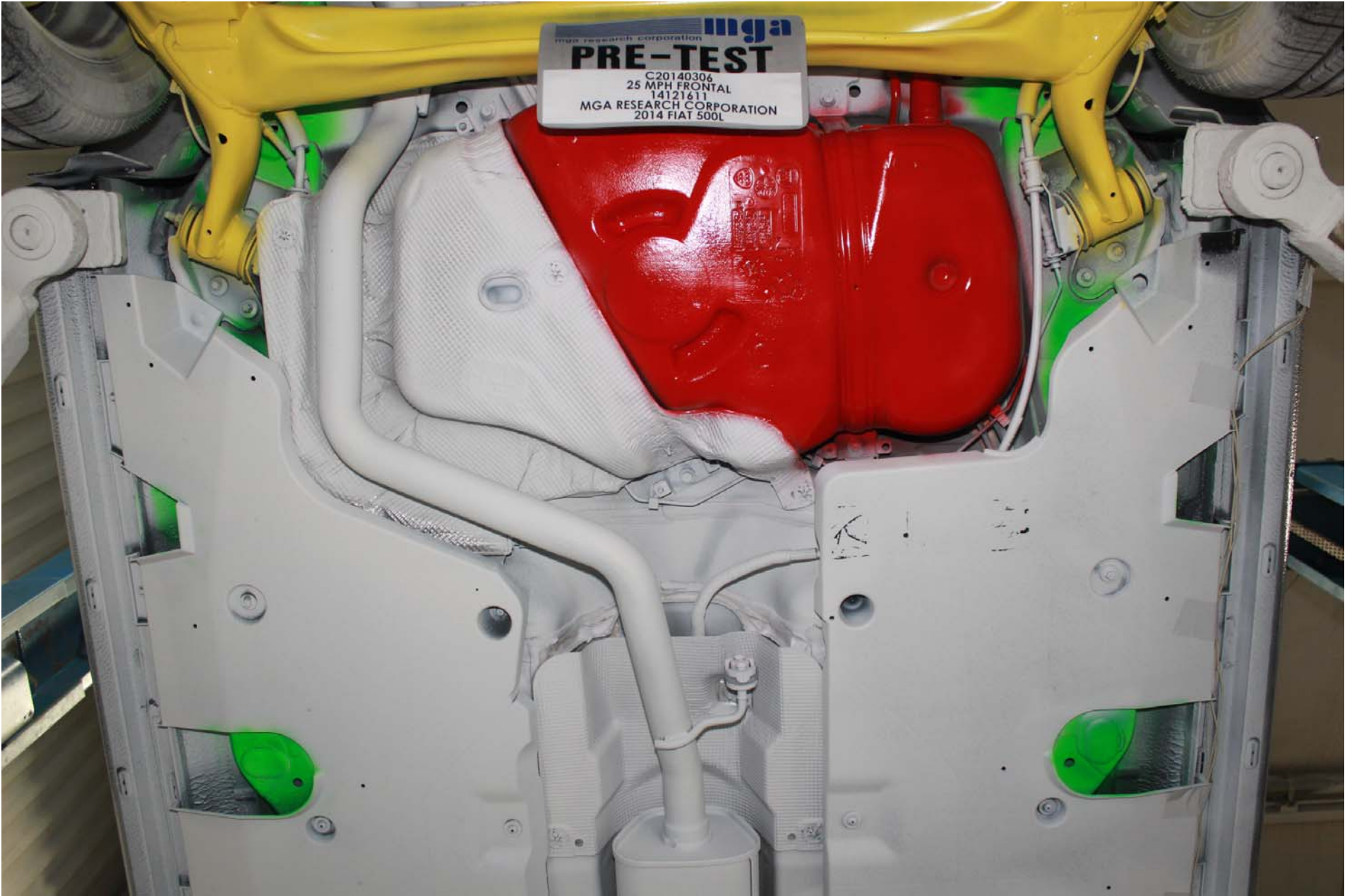

Photo No. 28 - Post-Test Mid Underbody View



B-29

Photo No. 29 - Pre-Test Mid Rear Underbody View



B-30

Photo No. 30 - Post-Test Mid Rear Underbody View

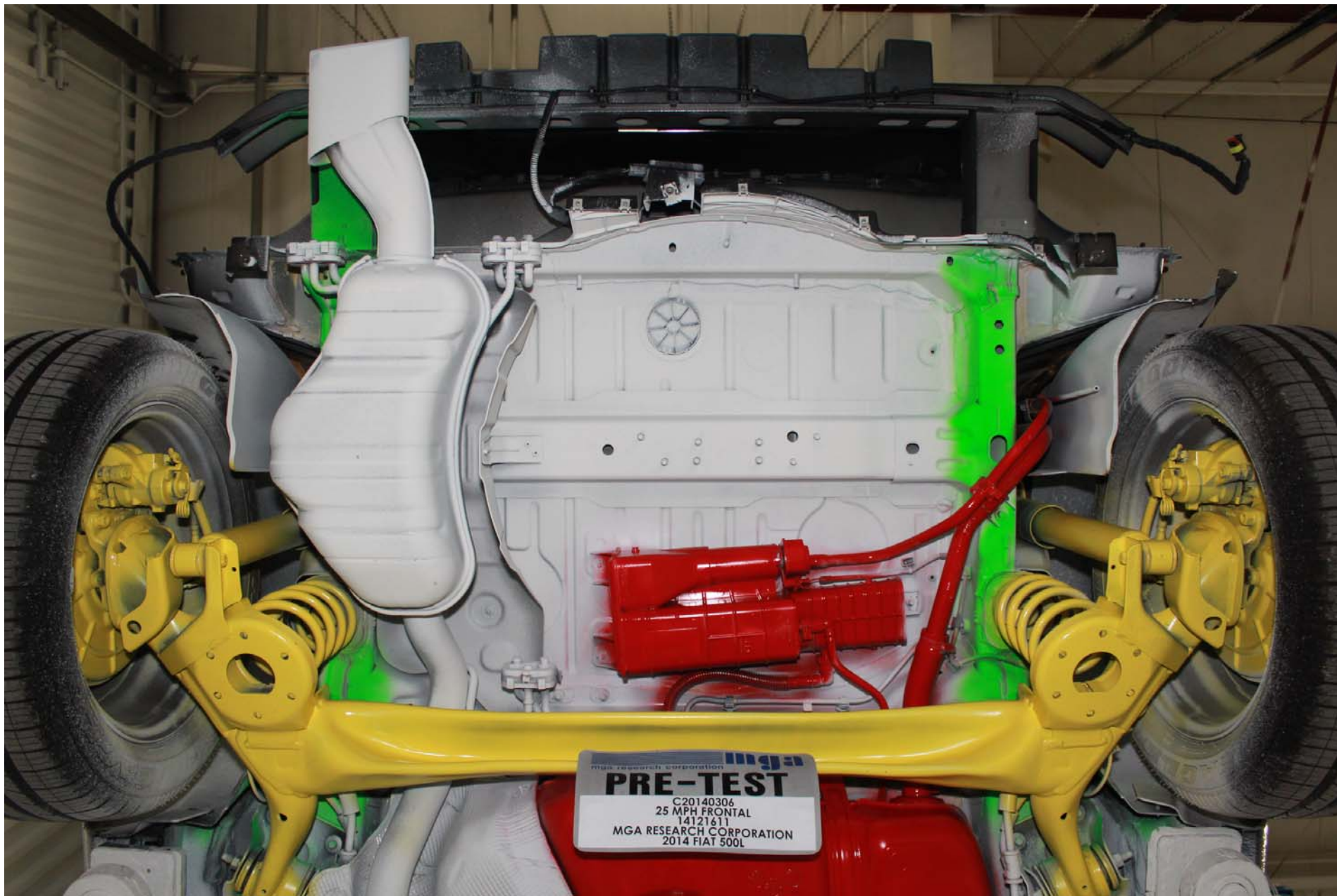

Photo No. 31 - Pre-Test Rear Underbody View

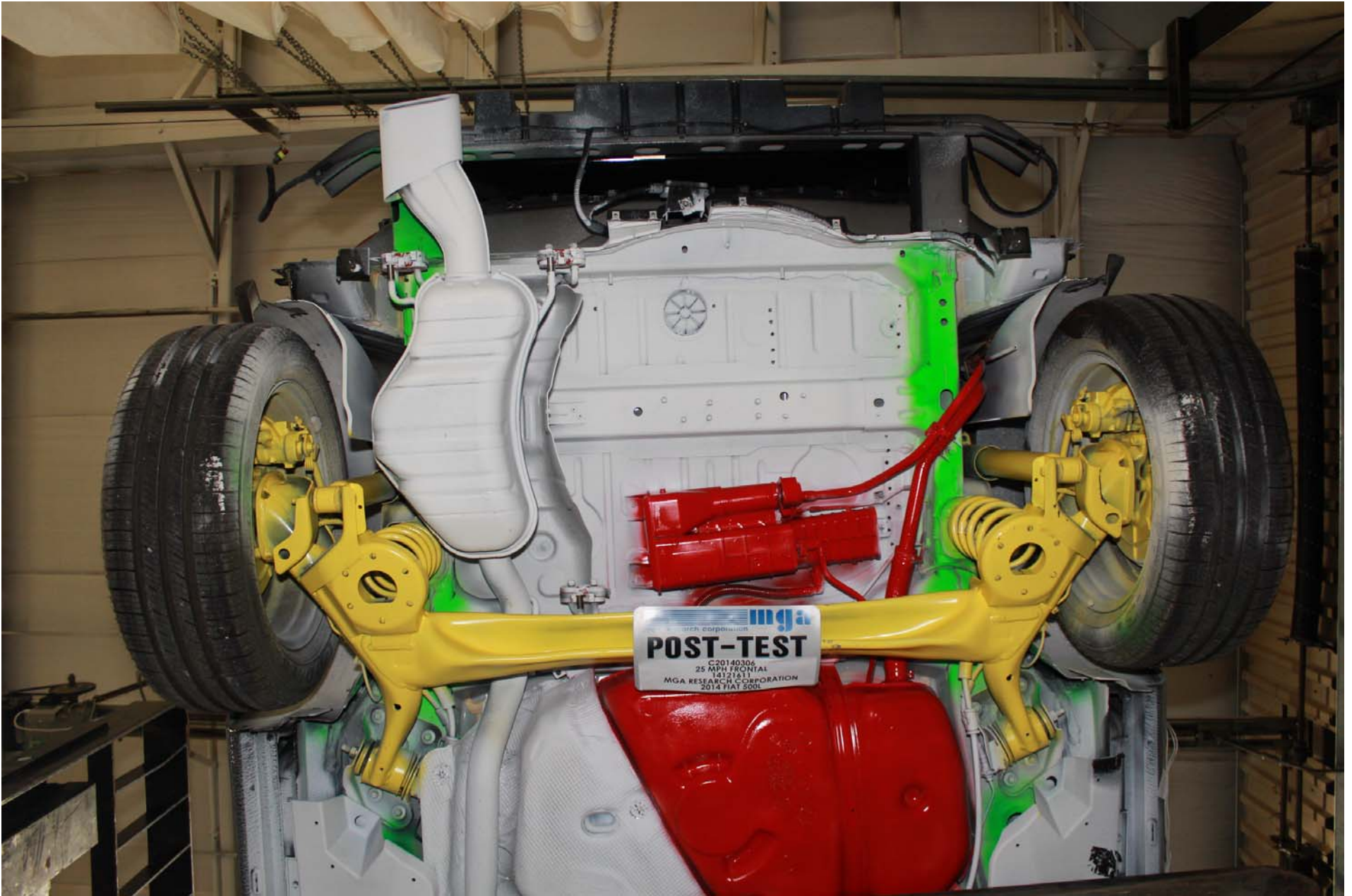

Photo No. 32 - Post-Test Rear Underbody View



B-33

Photo No. 33 - Pre-Test Driver Dummy Front View (head position)



B-34

Photo No. 34 - Post-Test Driver Dummy Front View (head position)



Photo No. 35 - Pre-Test Driver Dummy Position Left Side View



Photo No. 36 - Post-Test Driver Dummy Position Left Side View



Photo No. 37 - Pre-Test Driver Dummy Position Left Side View (door open)



Photo No. 38 - Post-Test Driver Dummy Position Left Side View (door open)



Photo No. 39 - Pre-Test Driver Dummy Seat Position



Photo No. 40 - Post-Test Driver Dummy Seat Position



Photo No. 41 - Pre-Test Driver Dummy Feet Position



Photo No. 42 - Post-Test Driver Dummy Feet Position

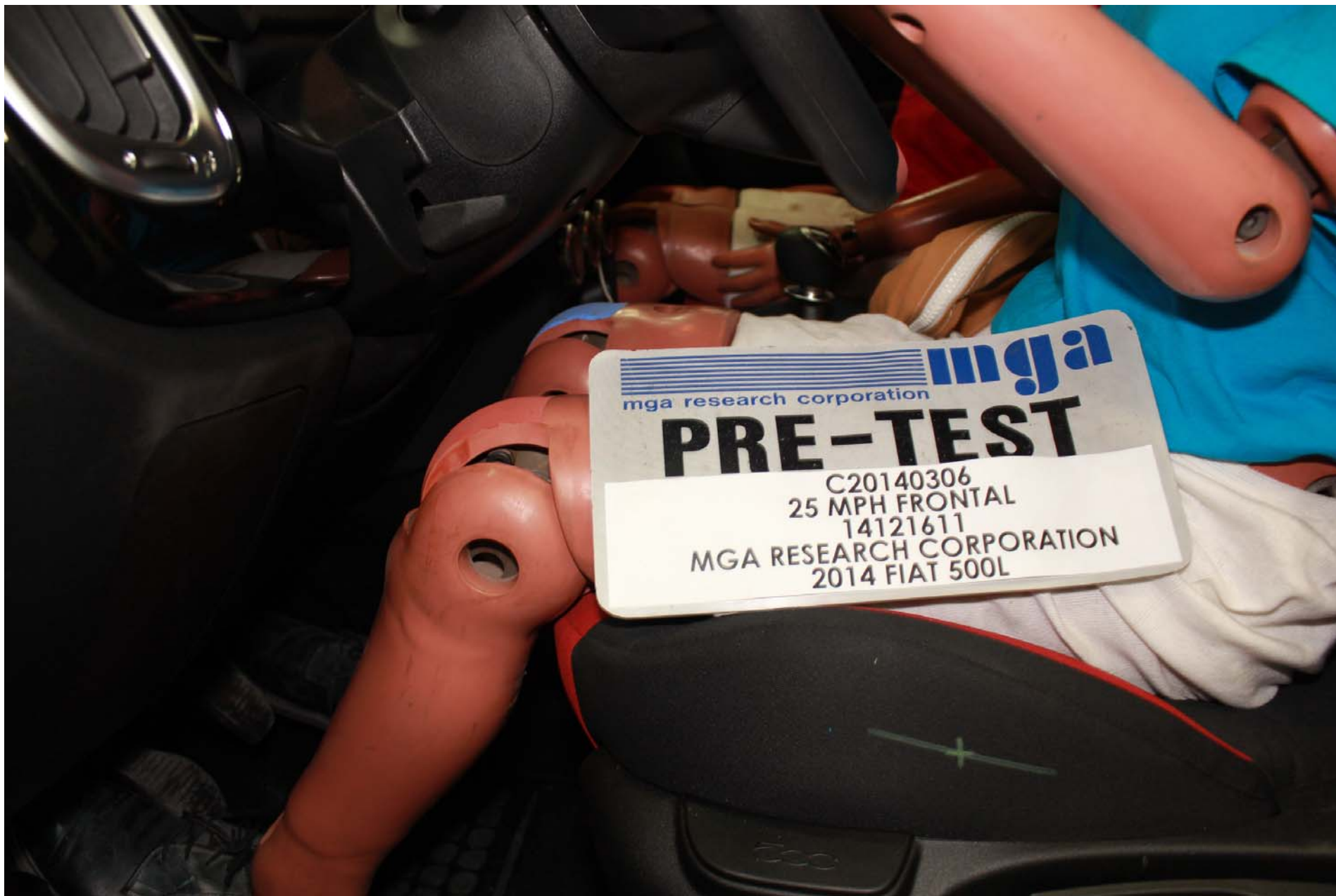

Photo No. 43 - Pre-Test Driver Side Knee Bolster View



Photo No. 44 - Post-Test Driver Side Knee Bolster View



Photo No. 45 - Post-Test Driver Dummy Airbag Contact

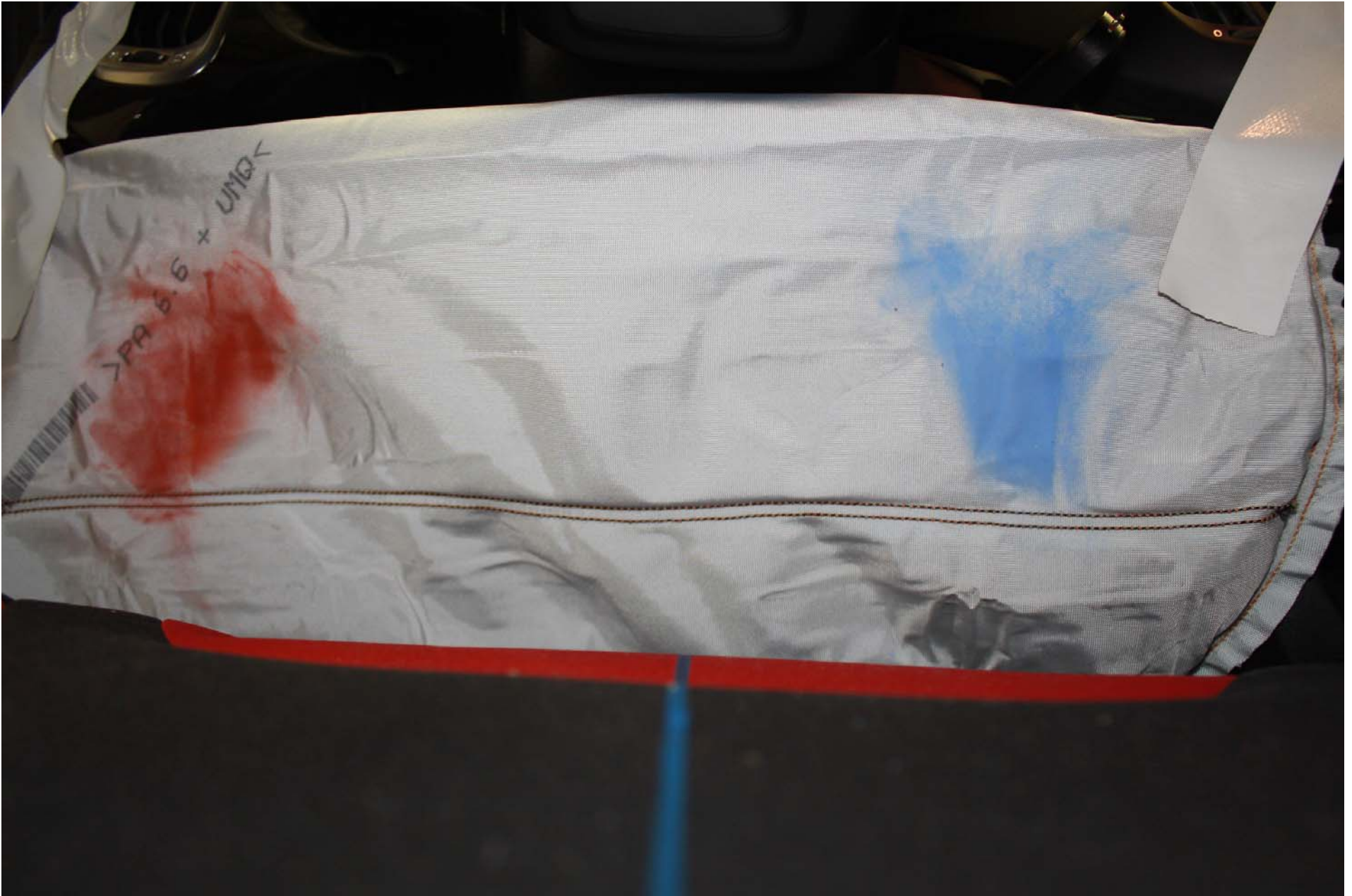

Photo No. 46 - Post-Test Driver Dummy Knee Contact (knee airbag)



Photo No. 47 - Pre-Test Passenger Dummy Front View (head position)



Photo No. 48 - Post-Test Passenger Dummy Front View (head position)



Photo No. 49 - Pre-Test Passenger Dummy Position Right Side View



Photo No. 50 - Post-Test Passenger Dummy Position Right Side View



Photo No. 51 - Pre-Test Passenger Dummy Position Right Side View (door open)



Photo No. 52 - Post-Test Passenger Dummy Position Right Side View (door open)



Photo No. 53 - Pre-Test Passenger Dummy Seat Position



Photo No. 54 - Post-Test Passenger Dummy Seat Position



Photo No. 55 - Pre-Test Passenger Dummy Feet Position



Photo No. 56 - Post-Test Passenger Dummy Feet Position



Photo No. 57 - Pre-Test Passenger Side Knee Bolster View

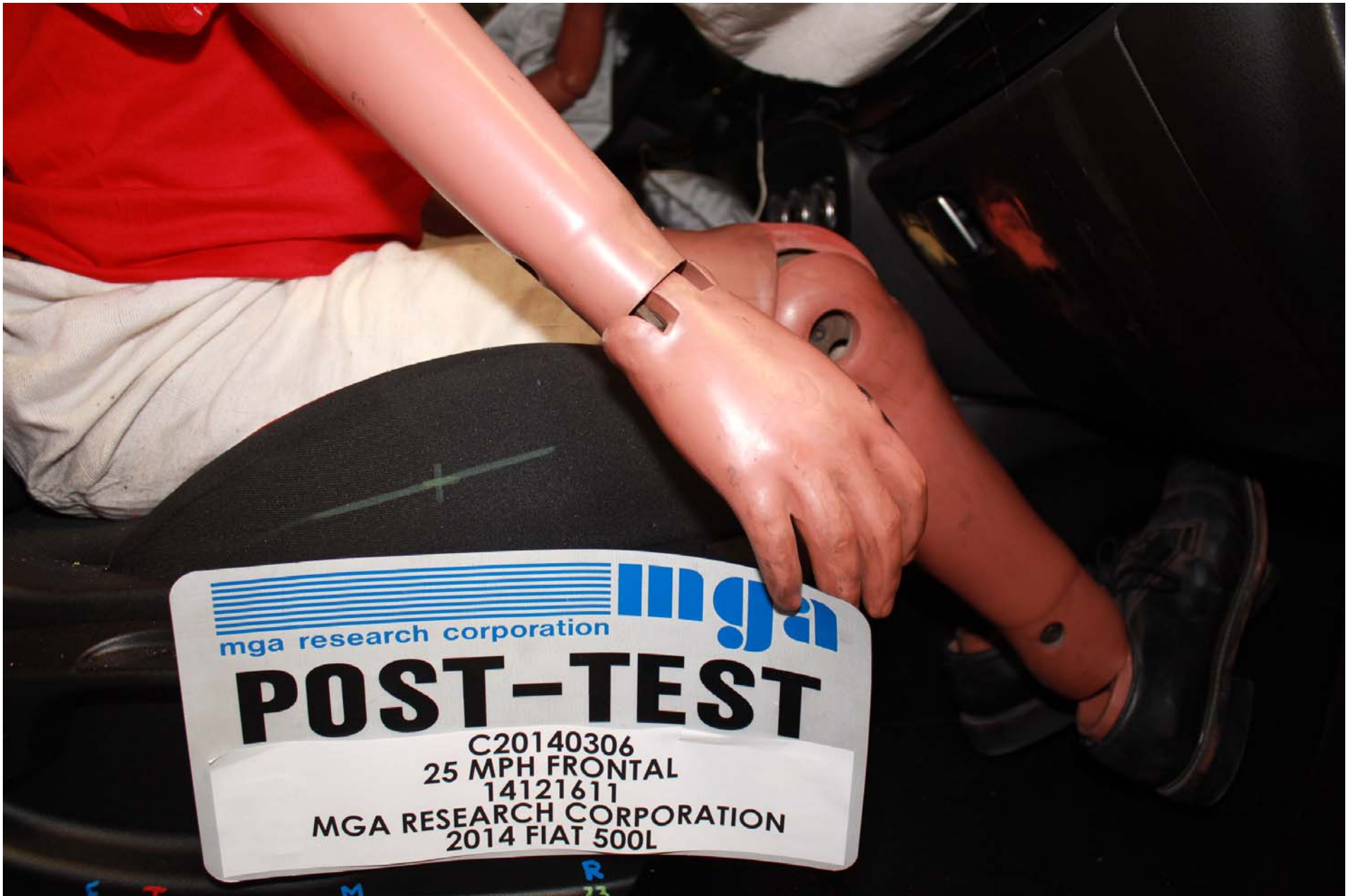

Photo No. 58 - Post-Test Passenger Side Knee Bolster View

B-59



Photo No. 59 - Post-Test Passenger Dummy Airbag Contact

B-60



Photo No. 60 - Post-Test Passenger Dummy Knee Contact (glove box)



Photo No. 61 - Rollover 90 Degrees



B-62

Photo No. 62 - Rollover 180 Degrees

B-63

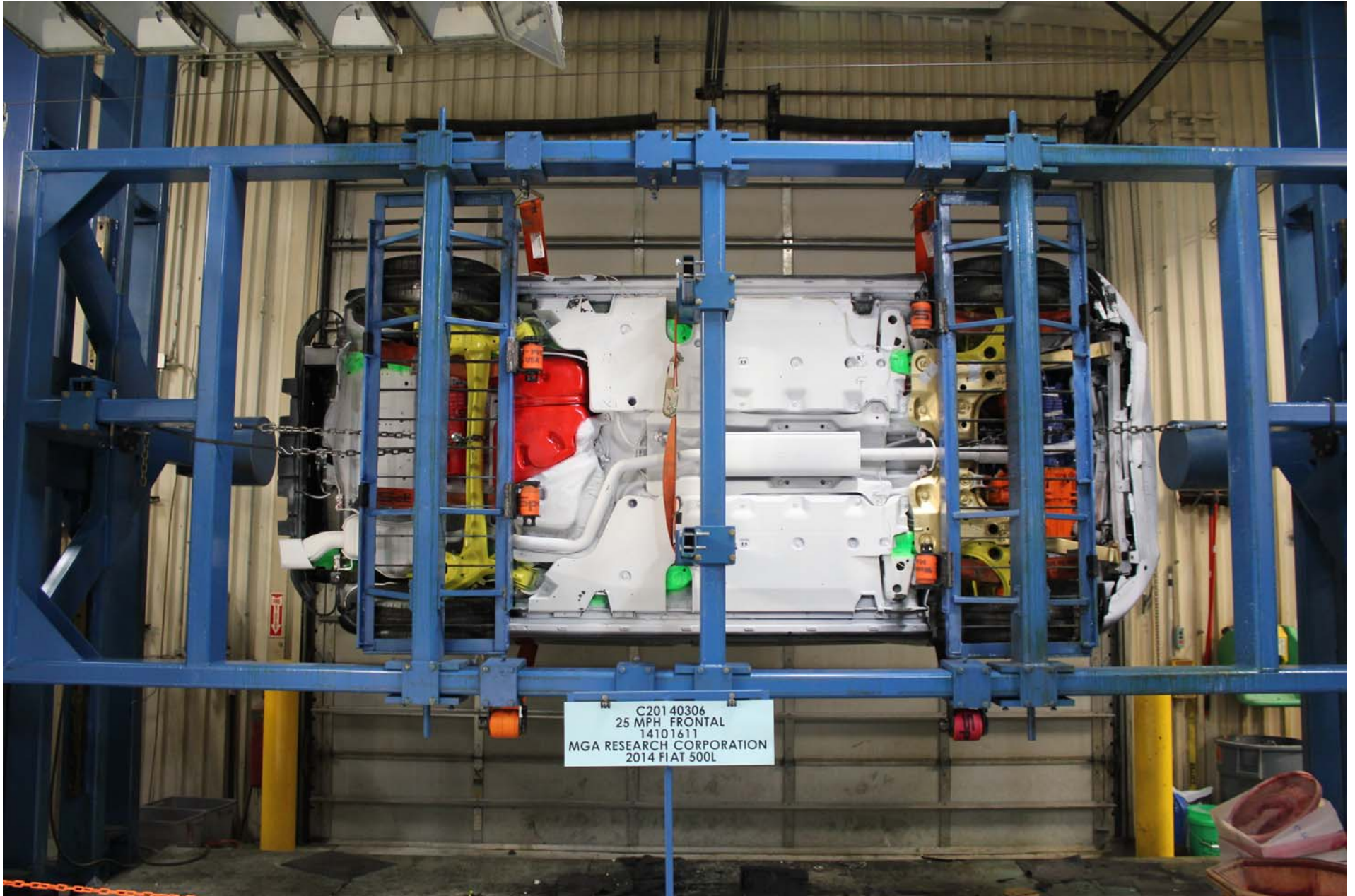
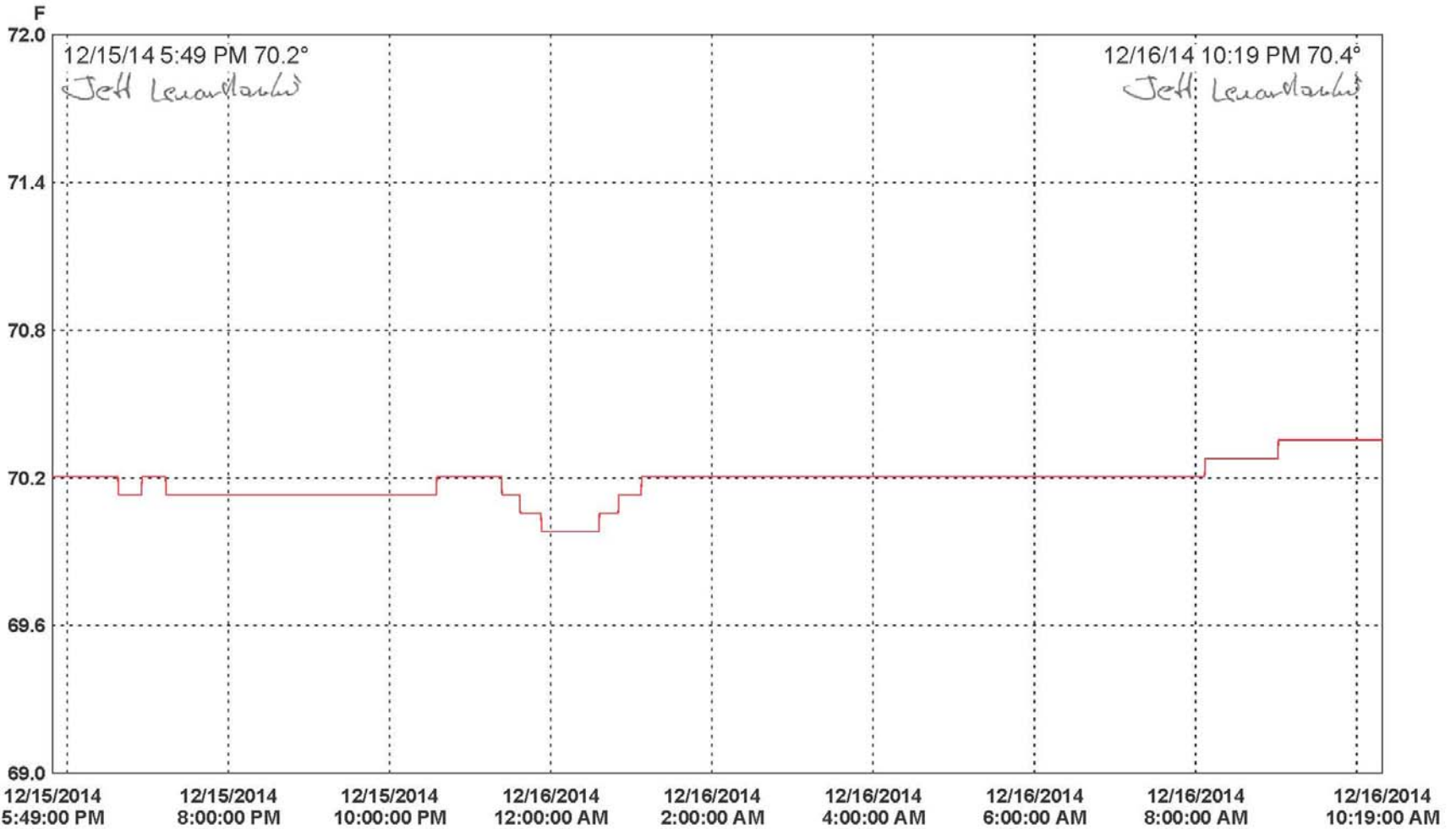

Photo No. 63 - Rollover 270 Degrees



Photo No. 64 - Rollover 360 Degrees



B-65

2 hours/div 16:30:00 (M/d/yyyy h:mm:ss tt) Central Time Graph file (truncated): 2014 Fiat 500L 208 12-16-14.spg

LN	Serial #	Description	CH	Value	Maximum	Average	Minimum	Units	CH description	Logger file
1	14182020	Crash1	1	70.35	70.19	69.98	F	Temperature	14182020_Crash1.spl	

LN	Logger file	ID #	Security	Created by	Creation time

LN	Serial #	Last calibrated by	Last calibration	Next calibration
1	14182020			

APPENDIX C

INSTRUMENTATION CALIBRATION

INSTRUMENTS FOR DRIVER DUMMY NO.: 510

	SERIAL NO.	MANUFACTURER	CALIBRATION DATE
Head X	P82668	Endevco	08/20/14
Head Y	P82669	Endevco	08/20/14
Head Z	P82670	Endevco	08/20/14
Neck Load Cell	N1159	Denton	08/26/14
Chest X	P79418	Endevco	08/20/14
Chest Y	P79439	Endevco	08/20/14
Chest Z	P79614	Endevco	08/20/14
Chest Displacement	510	Servo	08/20/14
Left Femur Load Cell	F799	Denton	07/11/14
Right Femur Load Cell	F737	Denton	07/11/14

INSTRUMENTS FOR PASSENGER DUMMY NO.: 511

	SERIAL NO.	MANUFACTURER	CALIBRATION DATE
Head X	P82661	Endevco	08/20/14
Head Y	P82662	Endevco	08/20/14
Head Z	P82663	Endevco	08/20/14
Neck Load Cell	N1673	Denton	11/19/14
Chest X	P79704	Endevco	08/20/14
Chest Y	P79705	Endevco	08/20/14
Chest Z	P82657	Endevco	08/20/14
Chest Displacement	511	Servo	08/20/14
Left Femur Load Cell	P643	Denton	07/10/14
Right Femur Load Cell	P639	Denton	07/11/14

VEHICLE INSTRUMENTS

	SERIAL NO.	MANUFACTURER	CALIBRATION DATE
Left Rear Seat Crossmember X	P68889	Endevco	09/08/14
Right Rear Seat Crossmember X	P63385	Endevco	10/31/14
Top of Engine X	P74298	Endevco	09/23/14
Bottom of Engine X	P73759	Endevco	07/28/14
Left Brake Caliper X	P73999	Endevco	09/23/14
Right Brake Caliper X	P59623	Endevco	07/15/14
Instrument Panel X	P73983	Endevco	08/25/14
Trunk Z	P85127	Endevco	09/08/14