

**OCAS-DRI-LDW-13-012**

**NCAP LANE DEPARTURE WARNING CONFIRMATION TEST**

**2013 Infiniti FX37**

**DYNAMIC RESEARCH, INC.**

355 Van Ness Avenue, STE 200  
Torrance, California 90501



**5 June 2013**

**Final Report**

**Prepared Under Contract No.:DTNH22-08-D-00095**

**U. S. DEPARTMENT OF TRANSPORTATION  
National Highway Traffic Safety Administration  
Office of Crash Avoidance Standards  
Mail Code: NVS-120  
1200 New Jersey Avenue SE  
Washington, DC 20590**

Prepared for the Department of Transportation, National Highway Traffic Safety Administration, under Contract No. DTNH22-08-D-00095.

This publication is distributed by the U.S. Department of Transportation, National Highway Traffic Safety Administration, in the interest of information exchange. The opinions, findings, and conclusions expressed in this publication are those of the author(s) and not necessarily those of the Department of Transportation or the National Highway Traffic Safety Administration. The United States Government assumes no liability for its contents or use thereof. If trade or manufacturer's names or products are mentioned, it is only because they are considered essential to the object of the publication and should not be construed as an endorsement. The United States Government does not endorse products of manufacturers.

Prepared By: John Lenkeit

Approved By: Brian Keschull

Approval Date: 5 June 2013

|   |  |   |           |
|---|--|---|-----------|
| 1. Report No.<br>OCAS-DRI-LDW-13-012  | 2. Government Accession No.                          | 3. Recipient's Catalog No.  |           |
| 4. Title and Subtitle<br>Final Report of Lane Departure Warning Testing of a 2013 Infiniti FX37.  |  | 5. Report Date<br>5 June 2013   |           |
|   |  | 6. Performing Organization Code<br>DRI  |           |
| 7. Author(s)<br>John F. Lenkeit, Technical Director<br>Brian Kebschull, Principal Engineer  |  | 8. Performing Organization Report No.<br>DRI-TM-12-99   |           |
| 9. Performing Organization Name and Address<br><br>Dynamic Research, Inc.<br>355 Van Ness Ave, STE 200<br>Torrance, CA 90501  |  | 10. Work Unit No.   |           |
|   |  | 11. Contract or Grant No.<br>DTNH22-08-D-00095  |           |
| 12. Sponsoring Agency Name and Address<br>U.S. Department of Transportation<br>National Highway Traffic Safety Administration<br>Office of Crash Avoidance Standards<br>1200 New Jersey Avenue, SE,<br>West Building, 4th Floor (NVS-120)<br>Washington, D.C. 20590   |  | 13. Type of Report and Period Covered<br><br>Final Test Report<br>April-June 2013   |           |
|   |  | 14. Sponsoring Agency Code<br>NVS-120   |           |
| 15. Supplementary Notes   |  |   |           |
| 16. Abstract<br><br>These tests were conducted on the subject 2013 Infiniti FX37 in accordance with the specifications of the Office of Crash Avoidance Standards most current Test Procedure in docket NHTSA-2006-26555 to confirm the performance of a lane departure warning system. The vehicle passed the requirements of the test for all three lane marking types and for both directions. |  |   |           |
| 17. Key Words<br><br>Lane Departure Warning,<br>LDW,<br>New Car Assessment Program,<br>NCAP   |  | 18. Distribution Statement<br><br>Copies of this report are available from the following:<br><br>NHTSA Technical Reference Division<br>National Highway Traffic Safety Administration<br>1200 New Jersey Avenue, SE<br>Washington, D.C. 20590 |           |
| 19. Security Classif. (of this report)<br>Unclassified  | 20. Security Classif. (of this page)<br>Unclassified | 21. No. of Pages<br>148   | 22. Price |

## TABLE OF CONTENTS

| <u>SECTION</u>  | <u>PAGE</u> |
|---|-------------|
| I. INTRODUCTION .....   | 1           |
| II. DATA SHEETS .....   | 2           |
| A. Data Sheet 1: Test Summary .....                           | 3           |
| B. Data Sheet 2: Vehicle Data.....                            | 4           |
| C. Data Sheet 3: Test Conditions.....                         | 6           |
| D. Data Sheet 4: Lane Departure Warning System Operation..... | 8           |
| III. TEST PROCEDURES .....                                    | 11          |
| A. Test Procedure Overview .....                              | 11          |
| B. Lane Delineation Markings .....                            | 12          |
| C. Test Validity .....  | 15          |
| D. Pass/Fail Criteria .....                                   | 15          |
| E. Instrumentation .....                                      | 16          |
| Appendix A Photographs .....                                  | A-1         |
| Appendix B Excerpts from Owner's Manual .....                 | B-1         |
| Appendix C Run Logs.....                                      | C-1         |
| Appendix D Time Histories.....                                | D-1         |

## Section I INTRODUCTION

The purpose of the testing reported herein was to confirm the performance of a Lane Departure Warning (LDW) system installed on a 2013 Infiniti FX37. The LDW system for this vehicle provides both visual and aural alerts.. The vehicle passed the requirements of the test for all three lane marking types and for both directions..

The test procedure is described in detail in the NHTSA Document "LANE DEPARTURE WARNING SYSTEM CONFIRMATION TEST" from March of 2010. Its purpose is to confirm the performance of Lane Departure Warning (LDW) systems installed on light vehicles with gross vehicle weight ratings (GVWR) of up to 10,000 lb. Current LDW technology relies on sensors to recognize a lane delimiting edge line. As such, the test procedures described in the document rely on painted or taped lines or Botts Dots being present on the test course to emulate those found on public roadways. Although it is impossible to predict what technologies could be used by future LDW systems (e.g., magnetic markers, RADAR reflective striping, ultra violet paint, infra red, etc.), it is believed that minor modifications to these procedures, when deemed appropriate, could be used to accommodate the evaluation of alternative or more advanced LDW systems.

Section II  
DATA SHEETS

**LANE DEPARTURE WARNING**  
**DATA SHEET 1: TEST SUMMARY**  
**2013 Infiniti FX37**

---

VIN: JN8CS1MUXDM1xxxx

Test Date: 5/1/2013

Lane Departure Warning setting: Nominal

Test 1 – Continuous White Line      Left: Pass                      Right: Pass

Test 2 – Dashed Yellow Line              Left: Pass                      Right: Pass

Test 3 – Botts Dots                      Left: Pass                      Right: Pass

**Overall: Pass**

**LANE DEPARTURE WARNING**  
**DATA SHEET 2: GENERAL TEST AND VEHICLE PARAMETER DATA**  
**(Page 1 of 2)**  
**2013 Infiniti FX37**

---

**TEST VEHICLE INFORMATION**

VIN: JN8CS1MUXDM1xxxx

Body Style: SUV

Color: Grey

Date Received: 4/24/2013

Odometer Reading: 59 mi

Engine: 3.7 L V-6

Transmission: Automatic

Final Drive: RWD

Is the vehicle equipped with:

ABS X Yes        No

Adaptive Cruise Control X Yes        No

Collision Mitigating Brake System X Yes        No

**DATA FROM VEHICLE'S CERTIFICATON LABEL**

Vehicle manufactured by: Nissan Motor Co., Ltd.

Date of manufacture: 02/13

**DATA FROM TIRE PLACARD:**

Tires size as stated on Tire Placard: Front: P265/50R20

Rear: P265/50R20

Recommended cold tire pressure: Front: 230 kPa (33 psi)

Rear: 230 kPa (33 psi)

**LANE DEPARTURE WARNING**  
**DATA SHEET 2: GENERAL TEST AND VEHICLE PARAMETER DATA**  
**(Page 2 of 2)**  
**2013 Infiniti FX37**

---

**TIRES**

Tire manufacturer and model: Bridgestone Dueler H/P 92A

Front tire size: P265/50R20

Rear tire size: P265/50R20

**VEHICLE ACCEPTANCE**

**Verify the following before accepting the vehicle**

- All options listed on the "window sticker" are present on the test vehicle
- Tires and wheel rims are the same as listed.
- There are no dents or other interior or exterior flaws.
- The vehicle has been properly prepared and is in running condition.
- Verify that spare tire, jack, lug wrench, and tool kit (if applicable) is located in the vehicle cargo area.

**LANE DEPARTURE WARNING**  
**DATA SHEET 3: TEST CONDITIONS (Page 1 of 2)**  
**2013 Infiniti FX37**

---

**GENERAL INFORMATION**

Test date: 5/1/2013

**AMBIENT CONDITIONS**

Air temperature: 30.0 C (86 F)

Wind speed: 4.6 m/s (10.4 mph)

- X Wind speed  $\leq$  10 m/s (22 mph)
- X Tests were not performed during periods of inclement weather. This includes, but is not limited to, rain, snow, hail, fog, smoke, or ash.
- X Tests were conducted during daylight hours with good atmospheric visibility (defined as an absence of fog and the ability to see clearly for more than 5000 meters). The tests were not conducted with the vehicle oriented into the sun during very low sun angle conditions, where the sun is oriented 15 degrees or less from horizontal, and camera "washout" or system inoperability results.

**VEHICLE PREPARATION**

**Verify the following:**

All non consumable fluids at 100 % capacity : X

Fuel tank is full: X

Tire pressures are set to manufacturer's recommended cold tire pressure: X

Front: 230 kPa (33 psi)

Rear: 230 kPa (33 psi)

**LANE DEPARTURE WARNING**  
**DATA SHEET 3: TEST CONDITIONS (Page 2 of 2)**  
**2013 Infiniti FX37**

---

**WEIGHT**

Weight of vehicle as tested including driver and instrumentation

Left Front: 542.5 kg (1196 lb)

Right Front 513.0 kg (1131 lb)

Left Rear 518.0 kg (1142 lb)

Right Rear 509.4 kg (1123 lb)

Total: 2082.9 kg (4592 lb)

## LANE DEPARTURE WARNING

### DATA SHEET 4: LANE DEPARTURE WARNING SYSTEM OPERATION

(Page 1 of 3)

2013 Infiniti FX37

---

How is the Forward Collision Warning presented to the driver?  
(Check all that apply)

Warning light

Buzzer or audible alarm

Vibration

Other

Describe the method by which the driver is alerted. For example, if the warning is a light, where is it located, its color, size, words or symbol, does it flash on and off, etc. If it is a sound, describe if it is constant beep or a repeated beep. If it is a vibration, describe where it is felt (e.g., pedals, steering wheel), the dominant frequency (and possibly magnitude).the type of warning (light, audible, vibration, or combination) etc.

The audible alert consists of 4 beeps, whose dominant tone is approximately 1000 Hz. The 4 beeps repeat if the vehicle continues to be near the lane edge.

The visual alert consists of an orange telltale located in the left side of the IP, in the upper left portion of the tachometer. The alert image is that of a vehicle in a lane. The image appears briefly, but does not flash on and off.(Figure A-10)



## LANE DEPARTURE WARNING

### DATA SHEET 4: LANE DEPARTURE WARNING SYSTEM OPERATION

(Page 3 of 3)

2013 Infiniti FX37

---

Are there other driving modes or conditions that render  Yes  
LDW inoperable or reduce its effectiveness?  No

If yes please provide a full description.

The system will not operate at speeds below approximately 45 mph or if it cannot detect lane markers.

The system may not function properly under the following conditions:

- On roads where there are multiple parallel lane markers; lane markers that are faded or not painted clearly; yellow painted lane markers; non standard lane markers; or lane markers covered with water, dirt, snow, etc.
- On roads where the discontinued lane markers are still detectable.
- On roads where there are sharp curves.
- On roads where there are sharply contrasting objects, such as shadows, snow, water, wheel ruts, seams, or lines remaining after road repairs (the LDW system could detect these items as lane markers).
- On roads where the travelling lane merges or separates
- When the vehicle's travelling direction does not align with the lane marker.
- When travelling close to the vehicle in front of you which obstructs the camera unit detection range.
- When rain, snow, or dirt adheres to the windshield in front of the lane camera unit.
- When the headlights are not bright due to dirt on the lens or if the aiming is not adjusted properly.
- When strong light enters the lane camera unit. (for example, the light directly shines on the front of the vehicle at sunrise or sunset).
- When a sudden change in brightness appears. (for example, when the vehicle enters or exits a tunnel or under a bridge).

Section III  
TEST PROCEDURES

**A. Test Procedure Overview**

Each LDW test involved one of three lane marking types: solid white lines, dashed yellow lines, or Botts Dots. Lane departures were done both to the left and to the right, and each test condition was repeated five times, as shown in Table 1.

**Table 1. – LDW Test Matrix**

| Lane Geometry | Line Type  | Departure Direction | Number of Trials |
|---------------|------------|---------------------|------------------|
| Straight      | Solid      | L                   | 5                |
|               |            | R                   | 5                |
|               | Dashed     | L                   | 5                |
|               |            | R                   | 5                |
|               | Botts Dots | L                   | 5                |
|               |            | R                   | 5                |

Prior to the start of a test series involving a given lane marking type and departure direction combination, the accuracy of the distance to lane marking measurement was verified. This was accomplished by driving the vehicle to the approximate location at which the lane departure would occur and placing the tire at the lane marking edge of interest (i.e., distance to lane marking = 0). The real-time display of distance to the lane marking was then observed to verify that the measured distance was within the tolerance (5 cm). If the measured distance was found to be greater than the tolerance, the instrumentation setup was checked and corrected, if necessary. If the measured distance was found to be within the tolerance, the instrumentation setup was considered appropriate and the test series was begun.

To begin the maneuver, the vehicle was accelerated from rest to a test speed of 72.4 km/h (45 mph), while being driven in a straight line parallel to the lane marking of interest, with the centerline of the vehicle approximately 1.83 m (6.0 ft) from the lane edge (i.e., such that the vehicle would pass through the center of the start gate). The test speed was achieved at least 60 m (200 ft) before the start gate was reached. Striking any start gate cones was not permitted, and any run in which a cone was struck was considered to be invalid. Also, during the initialization and test phases, the test driver avoided using turn

signals and avoided applying any sudden acceleration, sudden steering or sudden braking, and any use of the turn signals, sudden acceleration, sudden steering or sudden braking invalidated the test trial.

Data collection began with the vehicle at least 60 m (200 ft) from the start gate, which was configured using a pair of non-reflective, low-contrast color traffic cones. A second set of cones, placed 6 m (20 ft) longitudinally before the start gate, was used to guide the driver into the start gate. The lateral width between the cone pairs was 20 cm (8 in) greater than the width of the vehicle, and the centerline of each pair was laterally offset from the lane marking by 1.8 m (6 ft).

Once the driver passed the gate, the driver manually input sufficient steering to achieve a lane departure with a target lateral velocity of 0.5 m/s with respect to the lane line. As shown in Fig 1, two additional non-reflective cones were used to guide the driver in making this steering maneuver. Throughout the maneuver the driver modulated the throttle, or used cruise control, as appropriate, such that vehicle speed remained at constant speed. The test was considered complete when the vehicle crossed at least 1 m (3.3 ft) over the lane edge boundary.

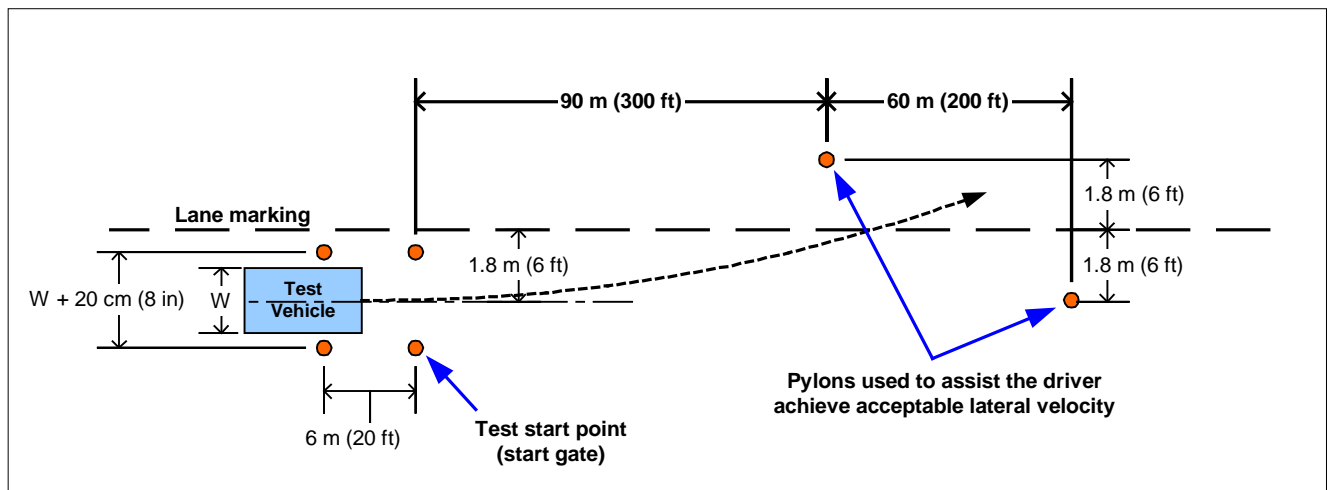

Figure 1. Position of Cones Used to Assist Driver

Data collected included vehicle speed, position, and yaw rate. In addition to cone strikes, vehicle speed and yaw rate data were used to identify invalid runs as described in Section C below. Data from trials where speed or yaw rate were outside of the performance specification were not considered valid.

## B. Lane Delineation Markings

The Office of Crash Avoidance Standards' Test Procedure for the confirmation of a lane departure warning system contains a requirement that all lane markings

meet USDOT specifications as described in the Manual on Uniform Traffic Control Devices (MUTCD) and be considered in “very good condition”.

### 1. Lane Marker Width

The width of the edge line marker was 10 to 15 cm (4 to 6 in). This is considered to be a normal width for longitudinal pavement markings under Section 3A.05 of the MUTCD.

### 2. Line Marking Color and Reflectivity

Lane marker color and reflectivity met all applicable standards. These standards include those from the International Commission of Illumination (CIE) for color and the American Society for Testing and Materials (ASTM) on lane marker reflectance.

### 3. Line Styles

The tests described in this document required the use of three lane line configurations: continuous solid white, discontinuous dashed yellow, and discontinuous with raised pavement markers.

- **Continuous White Line**  
A continuous white line is defined as a white line that runs for the entire length of the test course.
- **Dashed Yellow Line**  
As stated in the Manual on Uniform Traffic Control Devices (MUTCD), and as shown in Figure 2, a discontinuous dashed yellow line is defined as by a series of 3 m (10 ft) broken (dashed) yellow line segments, spaced 9.1 m (30 ft) apart.
- **Raised Pavement Marker Line (Botts Dots)**  
California Standard Plans indicates raised pavement markers are commonly used in lieu of painted strips for marking roads in California. Other states, mainly in the southern part of the United States, rely on them as well. These markers may be white or yellow, depending on the specific application, following the same basic colors of their analogous white and yellow painted lines. Following the California 2006 Standard Plans, three types of raised pavement markings are used to form roadway lines. It is believed that these types of roadway markings are the hardest for an LDW sensor system to process. Type A and Type AY are non-reflective circular domes that are approximately 10 cm (4 in) in diameter and approximately 1.8 cm (0.7

in) high. Type C and D are square markings that are retro reflective in two directions measuring approximately 10 x 10 x 5 cm (4 x 4 x 0.5 in), and Type G and H that are the same as C and D only retro reflective in a single direction.

For the tests described in this document, raised pavement markers were set up following California Standard Plan A20A, Detail 4 as shown in Figure 3. Note that in this figure, the squares are Type D yellow reflectors and the circles are yellow Type AY discs.

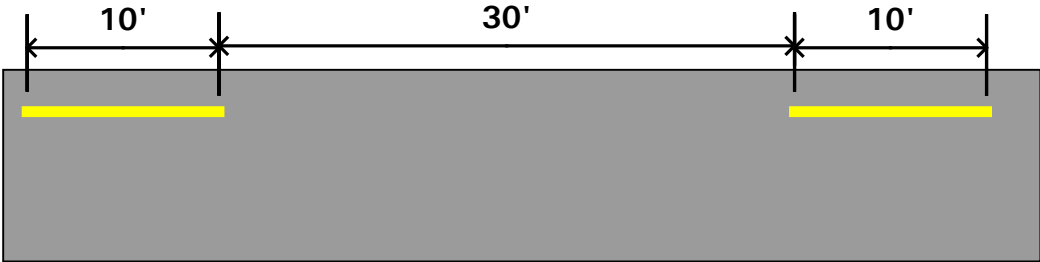

Figure 2. MUTCD Discontinuous Dashed Line Specifications

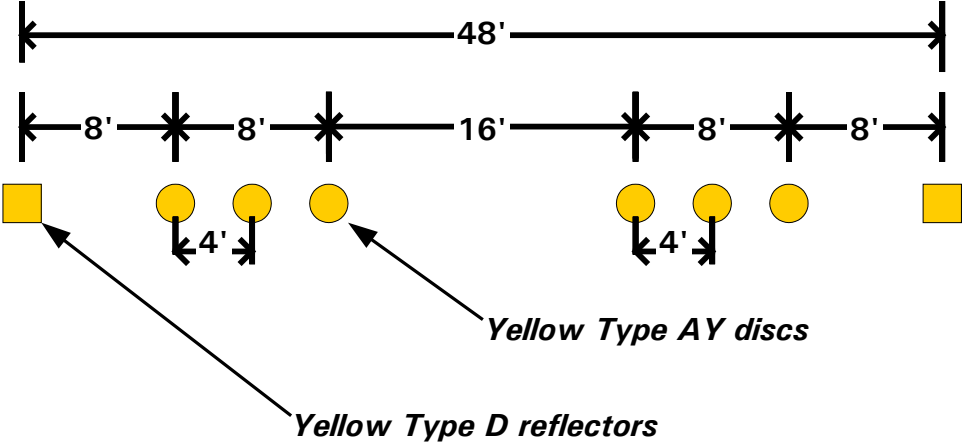

Figure 3. California Standard Plan A20A, Detail 4

## C. Test Validity

### 1. Speed

All LDW tests were conducted at 72.4 km/h (45 mph). Test speed was monitored and a test was considered valid if the test speed remained within  $\pm 2$  km/h ( $\pm 1.2$  mph) of the 72.4 km/h (45 mph) target speed. It was required that the speed must remain within this window from the start of the test until any part of the vehicle crossed a lane line by 1 m (3.3 ft) or more.

### 2. Lateral Velocity

All tests were conducted with a lateral velocity of 0.1 to 0.6 m/s (0.3 to 2.0 ft/s), measured with respect to the lane line at the time of the alert. To assist the test driver in being able to efficiently establish the target lateral velocity, cones were positioned in the manner shown in Figure 1.

### 3. Yaw Rate

It was required that the magnitude of the vehicle's yaw rate could not exceed 1.0 deg/sec at any time during lane departure maneuver, from the time the vehicle passes through the start gate to the instant the vehicle has crossed a lane line by 1 m (3.3 ft).

## D. Pass/Fail Criteria

The measured test data were used to determine the pass/fail outcome for each trial. The outcome was based on whether the LDW produced an appropriate alert during the maneuver. In the context of this test procedure, a lane departure is said to occur when any part of the two dimensional polygon used to represent the test vehicle breaches the inboard lane line edge (i.e., the edge of the line closed to the vehicle before the departure occurs). In the case of tests performed in this procedure, the front corner of the polygon, defined as the intersection of center of the front wheels (longitudinally) with the outboard edge of the front tire (laterally), crossed the line edge first. So, for example, if the vehicle departed its lane to the left, the left front corner of the polygon would first breach the lane line edge.

For an individual trial to be considered a "pass":

- Test speed, lateral velocity, and yaw rate validity conditions must be satisfied.
- The LDW alert must not occur when the lateral position of the vehicle

is greater than 0.75 m (2.5 ft) from the lane line edge (i.e., prior to the lane departure).

- The LDW alert must occur before the lane departure exceeds 0.3 m (1.0 ft).

For an overall “Pass” the LDW system must satisfy the pass criteria for 3 of 5 individual trials for each combination of departure direction and lane line type (60 percent), and pass 20 of the 30 trials overall (66 percent).

## **E. Instrumentation**

Table 2 lists the sensors, signal conditioning and data acquisition equipment used for these tests.

**Table 2. Test Instrumentation and Equipment**

| Type   | Output   | Range  | Accuracy, Other Primary Specs   | Mfr, Model  |
|--|--|--|---|---|
| Tire Pressure Gauge  | Vehicle Tire Pressure  | 0-100 psi<br>0-690 kPa   | 0.5 psi<br>3.45 kPa   | Ashcroft,<br>D1005PS  |
| Platform Scales  | Vehicle Total, Wheel,<br>and Axle Load   | 8000 lb<br>35.6 kN   | ± 1.0% of applied load  | Intercomp,<br>SWII  |
| Differential Global<br>Positioning System  | Position, Velocity   | Latitude: ± 90 deg<br>Longitude: ± 180 deg<br>Altitude: 0-18 km<br>Velocity: 0-1000 knots  | Horizontal Position: ± 1 cm<br>Vertical Position: ± 2 cm<br>Velocity: 0.05 km/h   | Trimble GPS<br>Receiver,<br>5700 (base station<br>and in-vehicle) |
| Multi-Axis Inertial<br>Sensing System  | Position;<br>Longitudinal, Lateral,<br>and Vertical Accels;<br>Lateral, Longitudinal and<br>Vertical Velocities;<br>Roll, Pitch, Yaw Rates;<br>Roll, Pitch, Yaw Angles | Latitude: ± 90 deg<br>Longitude: ± 180 deg<br>Altitude: 0-18 km<br>Velocity: 0-1000 knots<br>Accel: ± 100 m/s <sup>2</sup><br>Angular Rate: ± 100 deg/s<br>Angular Disp: ± 180 deg | Position: ± 2 cm<br>Velocity: 0.05 km/h<br>Accel: ≤ 0.01% of full range<br>Angular Rate: ≤ 0.01% of full<br>range<br>Roll/Pitch Angle: ± 0.03 deg<br>Heading Angle: ± 0.1 deg | Oxford Technical<br>Solutions (OXTS),<br>Inertial +               |
| Real-Time Calculation<br>of Position and<br>Velocity Relative to<br>Lane Markings (LDW)<br>and POV (FCW) | Distance and Velocity to<br>lane markings (LDW)<br>and POV (FCW)   | Lateral Lane Dist: ± 30 m<br>Lateral Lane Velocity:<br>± 20 m/sec<br>Longitudinal Range to POV:<br>± 200 m<br>Longitudinal Range Rate:<br>± 50 m/sec                               | Lateral Distance to Lane Marking:<br>± 2 cm<br>Lateral Velocity to Lane Marking:<br>± 0.02m/sec<br>Longitudinal Range: ± 3 cm<br>Longitudinal Range Rate: ± 0.02<br>m/sec     | Oxford Technical<br>Solutions (OXTS),<br>RT-Range                 |

**Table 2. Test Instrumentation and Equipment (Cont'd)**

| Type  | Output  | Range   | Accuracy, Other Primary Specs  | Mfr, Model                              |
|---|---|---|--|---|
| Data Acquisition System<br><br>[Includes amplification, anti-aliasing, and analog to digital conversion.] | Record Time; Position; Velocity; Distance to lane markings; Headway distance; Closing Velocity; Lateral, Longitudinal, and Vertical Accels; Roll, Yaw, and Pitch Rates; Roll, Yaw and Pitch Angles. | Sufficient to meet or exceed individual sensors           | Sound digitized at 10 kHz, all other channels digitized at 100 Hz. Accuracy is sufficient to meet or exceed individual sensors | SoMat, eDaq ECPU processor              |
|   |   |   |  | SoMat, High level Board EHLS            |
| Microphone  | Sound (to measure time at alert)  | Max SPL: 139 dB/SPL<br>Frequency Response: 40 Hz – 20 kHz | ≤ 3 dB over Freq. Resp. Range  | Sennheiser, e614                        |
| Light Sensor  | Light intensity (to measure time at alert)  | Spectral Bandwidth: 440-800 nm                            | Rise time < 10 msec  | DRI designed and developed Light Sensor |
| Accelerometer   | Acceleration (to measure time at alert)   | ± 5g  | ≤ 3% of full range   | Silicon Designs, 2210-005               |
| Coordinate Measurement Machine  | Inertial Sensing System Coordinates   | 0-8 ft<br>0-2.4 m   | ± .0020 in.<br>± .051 mm<br>(Single point articulation accuracy)   | Faro Arm, Fusion                        |

As part of the pre-test instrumentation verification process, the tonal frequency of the audible warning or the vibration frequency of the tactile warning (if present) was determined through use of the PSD (Power Spectral Density) function in Matlab. This was accomplished in order to identify the center frequency around which a band-pass filter was applied to subsequent audible or tactile warning data so that the beginning of such warnings could be programmatically determined. The bandpass filter used for these warning signals was a phaseless, forward-reverse pass, elliptical (Cauer) digital filter, with filter parameters as listed in Table 3.

**Table 3. Audible and Tactile Warning Filter Parameters**

| <b>Warning Type</b> | <b>Filter Order</b> | <b>Peak-to-Peak Ripple</b> | <b>Minimum Stop Band Attenuation</b> | <b>Pass-Band Frequency Range</b>      |
|---------------------|---------------------|----------------------------|--------------------------------------|---------------------------------------|
| Audible             | 5 <sup>th</sup>     | 3 dB                       | 60 dB                                | Identified Center Frequency $\pm$ 5%  |
| Tactile             | 5 <sup>th</sup>     | 3 dB                       | 60 dB                                | Identified Center Frequency $\pm$ 20% |

## APPENDIX A

### Photographs

## LIST OF FIGURES

|   | Page |
|---|------|
| Figure A1. Front View of Subject Vehicle.....                                   | A-3  |
| Figure A2. Rear View of Subject Vehicle.....                                    | A-4  |
| Figure A3. Window Sticker (Monroney Label).....                                 | A-5  |
| Figure A4. Vehicle Certification Label.....                                     | A-6  |
| Figure A5. DGPS and Inertial Measurement Unit Installed in Subject Vehicle..... | A-7  |
| Figure A6. Data Acquisition System Installed in Subject Vehicle.....            | A-8  |
| Figure A7. Computer Installed in Subject Vehicle.....                           | A-9  |
| Figure A8. Sensors for Visual and Acoustic Alerts.....                          | A-10 |
| Figure A9. LDW On-Off Switch.....   | A-11 |
| Figure A10. LDW Visual Display.....   | A-12 |



Figure A1. Front View of Subject Vehicle



Figure A2. Rear View of Subject Vehicle



# 2013 FX37

### Standard Equipment Included at No Extra Charge

#### PERFORMANCE:

3.7-liter V6 engine with VVEL  
 325 horsepower  
 267 lb-ft torque  
 Rear-wheel drive with Snow Mode  
 7-speed automatic transmission with Adaptive Shift Control (ASC) and manual shift mode with Downshift Rev Matching  
 18-inch, 5-spoke aluminum-alloy wheels with 265/60R18 all-season tires  
 Independent front and multi-link rear suspension  
 Front and rear stabilizer bars

#### LUXURY:

Leather-appointed seats  
 Heated 10-way power driver's seat including 2-way lumbar support  
 Heated 8-way power passenger front seat  
 Leather-wrapped steering wheel and shift knob  
 Automatic on/off High Intensity Discharge (HID) bi-functional xenon headlights  
 Front fog lights  
 Power sliding tinted glass moonroof with one-touch open/close, tilt feature and sliding sunshade  
 Dual Zone Automatic Temperature Control System with microfilter  
 Sequential welcome lighting  
 Auto-dimming inside mirror with compass and Homelink® Universal Transceiver  
 Power rear liftgate  
 Infiniti signature analog clock  
 Black lacquer interior trim  
 Power folding and heated outside mirrors

#### TECHNOLOGY:

RearView Monitor  
 7-inch color vehicle information display  
 Infiniti Intelligent Key with Illuminated Push Button Ignition  
 Bluetooth® Hands-free Phone System  
 Bose® 11-speaker Premium Sound System with AM/FM/CD with MP3 playback capability  
 USB connection port for iPod® interface and other compatible devices  
 SiriusXM Satellite Radio\*\*\*  
 Infiniti Controller for comfort and convenience features

#### SAFETY AND SECURITY:

Infiniti Advanced Air Bag System (AABS)  
 Driver and Front Passenger seat-mounted side-impact supplemental air bags  
 Roof-mounted curtain side-impact supplemental air bags with rollover sensor for front and rear seat outboard occupant head protection  
 3-point height adjustable front seat belts with pretensioners, and load limiters  
 Front-seat Active Head Restraints  
 Lower Anchors and Tethers for Children (LATCH)  
 4-wheel Anti-lock Braking System (ABS)  
 Brake Assist  
 Electronic Brake force Distribution  
 Vehicle Dynamic Control (VDC) with Traction Control System (TCS)  
 Tire Pressure Monitoring System (TPMS)  
 Vehicle Security System  
 Infiniti Vehicle Immobilizer System

\*\*\*3 months of SiriusXM Service included; subscription sold separately; not available to buyers in AK or HI; some features not available in all markets.

++ Optional equipment replaces standard equipment

Manufacturer's Suggested Retail Base Price: \$44,950.00

#### Options Included by Manufacturer

SPLASH GUARDS (4-piece) 170.00  
 ROOF RAIL CROSSBARS 330.00  
 TECHNOLOGY PACKAGE 2,950.00

Intelligent Cruise Control (full-speed range)  
 Lane Departure Warning & Prevention  
 Intelligent Brake Assist with Forward Collision Warning  
 Distance Control Assist  
 Adaptive Front lighting System with auto-leveling headlights++  
 Rain-sensing windshield wipers++  
 Front Pre-Crash Seat Belts

DELUXE TOURING PACKAGE 3,300.00

20-inch, aluminum-alloy wheels++  
 Quilted leather-appointed seating++  
 Climate-controlled front seats++  
 Maple interior accents++  
 Aluminum pedals++  
 Tonneau cover

ILLUMINATED KICK PLATES++ 300.00

PREMIUM PACKAGE 4,300.00

Infiniti Hard Drive Navigation  
 8-inch VGA color touch-screen display++  
 Infiniti Voice Recognition  
 NavTraffic and NavWeather\*\*\*\*  
 Zagat Survey® restaurant guide  
 Around View® Monitor with Moving Object Detection and Front and Rear Sonar  
 Streaming audio via Bluetooth®  
 Single in-dash CD/DVD player++  
 Dual occupant memory system  
 Entry/exit assist for driver's seat and steering wheel  
 Outside mirrors with reverse tilt-down  
 Power tilt/telescopic steering column  
 Aluminum Roof Rails  
 (Compass deleted in inside mirror)

FIRST AID KIT & CARGO NET 90.00

DESTINATION CHARGES 995.00

Total\* \$57,385.00

## EPA DOT Fuel Economy and Environment

Fuel Economy SMALL SUVs range from 16 to 30 MPG. The best vehicle rates 121 MPGe.

**19** MPG combined city/hwy  
 17 city 24 highway

5.3 gallons per 100 miles

You Save **\$3** m on co av

Annual fuel cost **\$3,000**

Fuel Economy & Greenhouse Gas Rating tailpipe

1 **4**

This vehicle emits 460 grams CO<sub>2</sub> per mile. The best emits 0 grams distributing fuel; also create emissions; learn more at fueleconomy.gov

Actual results will vary for many reasons, including driving conditions and how you drive and maintain your vehicle. The average new vehicle gets 23 MPG and costs \$11,600 to fuel over 5 years. Cost estimates are based on 15,000 miles per year at \$3.80 per gallon. MPGe is miles per gasoline gallon equivalent. Vehicle emissions are a significant cause of climate change and smog.

**fueleconomy.gov**  
 Calculate personalized estimates and compare vehicles

### GOVERNMENT 5-STAR SAFETY RATINGS

|  |                         |                        |                                |
|--|-------------------------|------------------------|--------------------------------|
| Overall Vehicle Score  | Not Rated               |                        | VEHIC<br>EXT<br>INT            |
| Based on the combined ratings of frontal, side and rollover. Should ONLY be compared to other vehicles of similar size and weight. |                         |                        |                                |
| Frontal Crash  | Driver Passenger        | Not Rated<br>Not Rated | FINA<br>LO:<br>TRA<br>TR       |
| Based on the risk of injury in a frontal impact. Should ONLY be compared to other vehicles of similar size and weight.             |                         |                        |                                |
| Side Crash   | Front seat<br>Rear seat | Not Rated<br>Not Rated | DEAI<br>KE:<br>467<br>SA<br>92 |
| Based on the risk of injury in a side impact.  |                         |                        |                                |
| Rollover   | Not Rated               |                        |                                |
| Based on the risk of rollover in a single-vehicle crash.   |                         |                        |                                |

Star ratings range from 1 to 5 stars (\*\*\*\*\*), with 5 being the highest.  
 Source: National Highway Traffic Safety Administration (NHTSA)  
[www.safercar.gov](http://www.safercar.gov) or 1-888-327-4236

**TOTAL OWNERSHIP EXPERIENCE**

Every Infiniti Vehicle includes Infiniti's:

- 4-Year/60,000 Mile Basic Limited Warranty Coverage \*\*
- 6-Year/70,000 Mile Powertrain Limited Warranty Coverage \*\*
- 7-Year/Unlimited Mileage Corrosion Limited Warranty Coverage \*\*
- 24-hour Roadside Assistance \*\*
- Complimentary Service Loan Car \*\*\*
- Infiniti Personal Assistant \*\*\*

\*\* Please see the Infiniti Warranty Information booklet for details.  
 \*\*\* Please ask your Infiniti retailer for details.

Figure A3. Window Sticker (Monroney Label)

MFD BY NISSAN MOTOR CO., LTD.  
 DATE 02/13  
 GVWR/PNBV 5301 LBS  
 GAWR/PNBE FR. 2464 LBS  
 WITH P265/50R20 TIRES,  
 20X8J RIMS. AT 33 PSI  
 COLD SINGLE.  
 GAWR/PNBE RR. 2855 LBS.  
 WITH P265/50R20 TIRES,  
 20X8J RIMS. AT 33 PSI  
 COLD SINGLE.  
 THIS VEHICLE CONFORMS  
 TO ALL APPLICABLE FED-  
 ERAL MOTOR VEHICLE SA-  
 FETY AND THEFT PREVEN-  
 TION STANDARDS IN EFF-  
 ECT ON THE DATE OF MA-  
 NUFACTURE SHOWN ABOVE.  
 VIN: JN8CS1MUXDM141994  
 TYPE: MPV  

| COLOR | TRIM      | TRANS   |
|-------|-----------|---------|
| KAD   | G         | RE7R01A |
| AXLE  | ENGINE    |         |
| RC33  | VQ37(VHR) | 3696CC  |

JN8CS1MUXDM14

Figure A4. Vehicle Certification Label

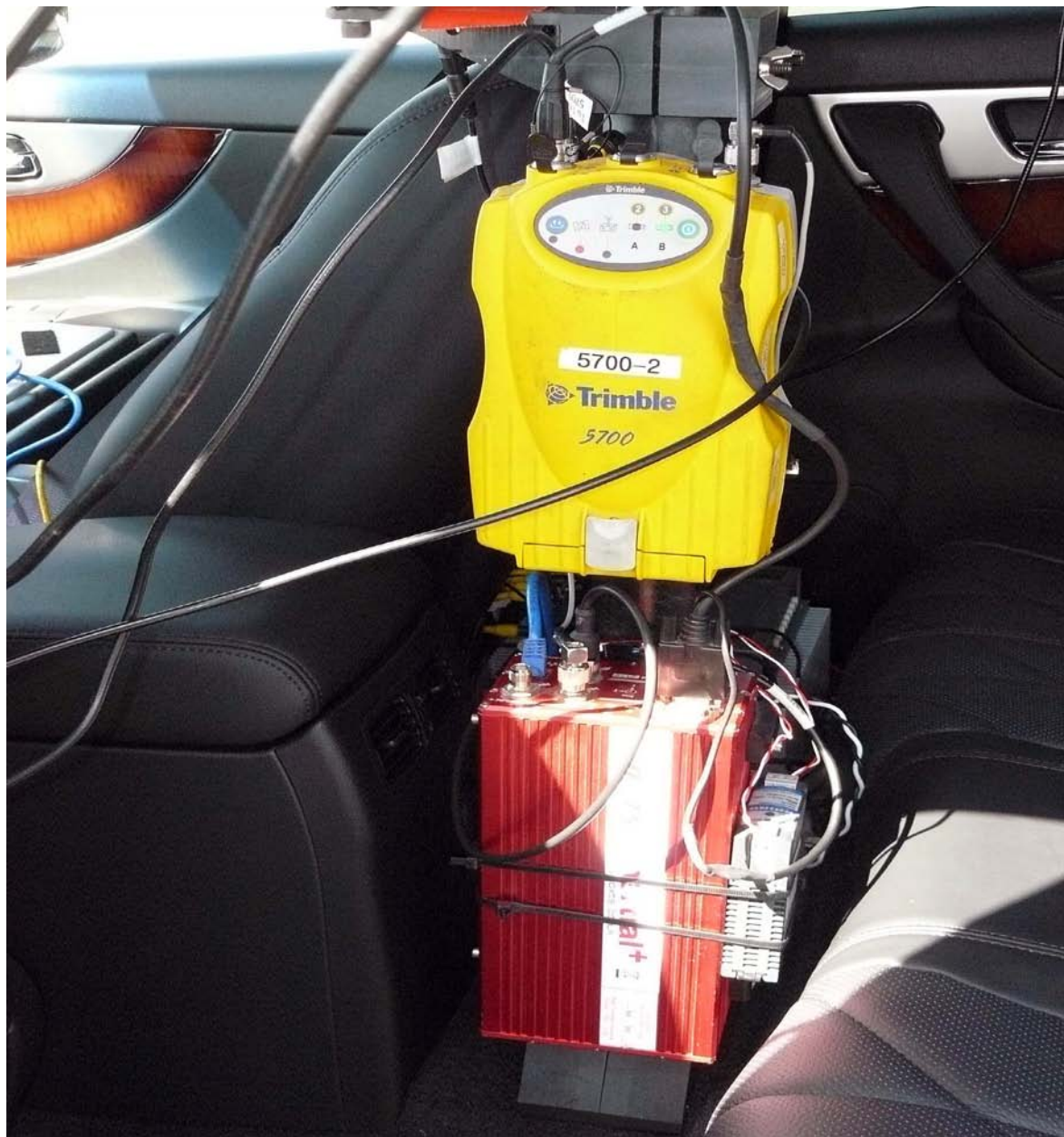

Figure A5. DGPS and Inertial Measurement Unit Installed in Subject Vehicle

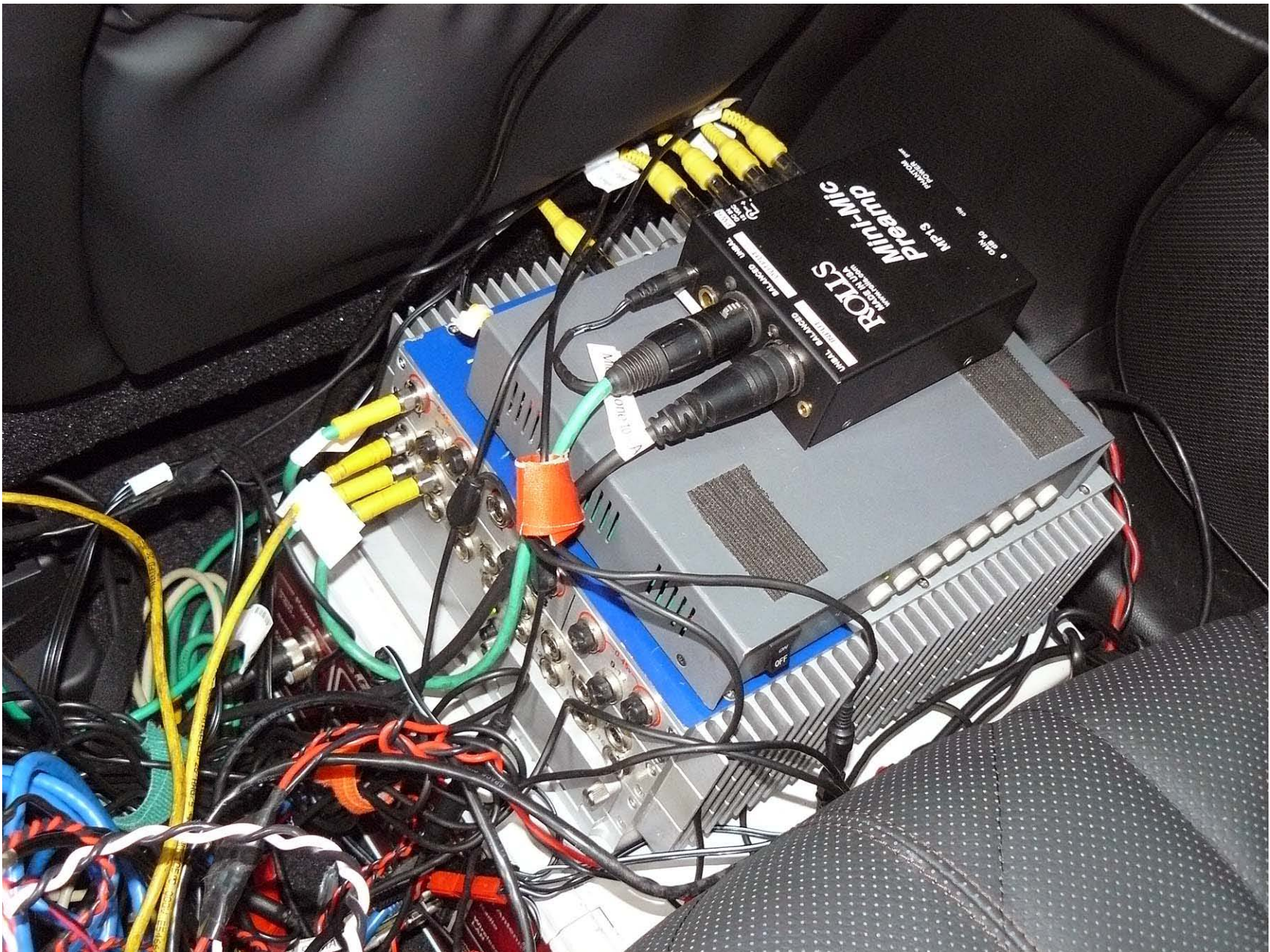

Figure A6. Data Acquisition System Installed in Subject Vehicle



Figure A7. Computer Installed in Subject Vehicle



Figure A8. Sensors for Visual and Acoustic Alerts



Figure A9. LDW On-Off Switch

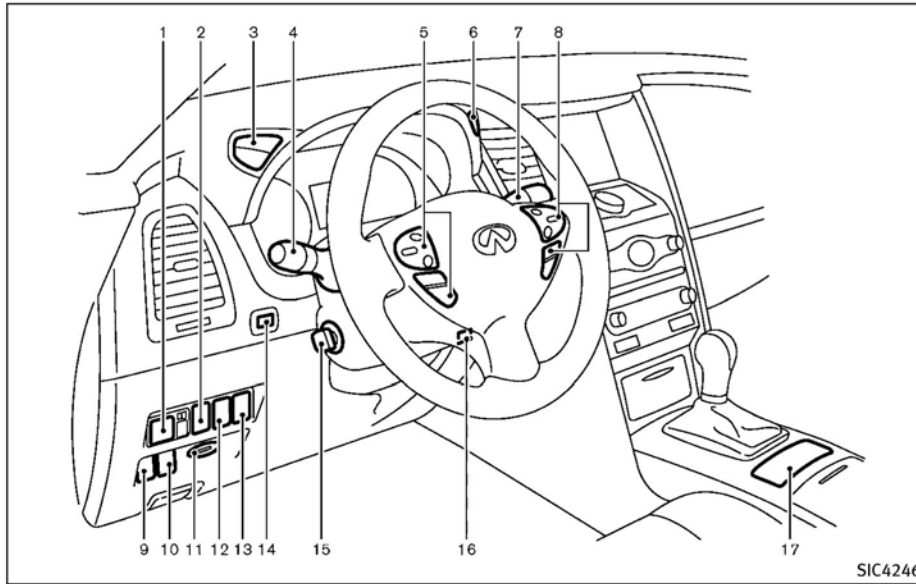

Figure A10. LDW Visual Display

## APPENDIX B

Excerpts from Owner's Manual

## COCKPIT



1. Outside mirror remote control switch (P.3-30)
2. Intelligent Brake Assist (IBA) off switch (if so equipped) (P.2-48)
3. Instrument brightness control switch (P.2-42)

4. Headlight, fog light and turn signal switch (P.2-37)
5. Steering-wheel-mounted controls (left side)
  - For audio system (P.4-54)
  - For Bluetooth® Hands-Free Phone

System (with navigation system)  
(P.4-94)















— For Bluetooth® Hands-Free Phone System (without navigation system)  
(P.4-104)

— For INFINITI Voice Recognition System (with navigation system)  
(P.4-119)



6. Trip computer switch (P.2-28)
7. Windshield wiper and washer switch (P.2-33)
8. Steering-wheel-mounted controls (right side)
  - Cruise control switches (if so equipped) (P.5-30)
  - Intelligent Cruise Control (ICC) switches (if so equipped) (P.5-32)
  - Dynamic Driver Assistance switch (if so equipped) (P.5-21, P.5-54)
9. Warning systems switch (if so equipped)
  - Forward Collision Warning (FCW) (P.2-46, P.5-67)
  - Lane Departure Warning (LDW) (P.2-46, P.5-21)
9. Headlight aiming control (if so equipped) (P.2-40)













0-6 Illustrated table of contents

## WARNING AND INDICATOR LIGHTS

| Warning light   | Name  | Page |
|---|---|------|
|    | All-Wheel Drive (AWD) warning light (AWD models)*               | 2-13 |
|    | Anti-lock Braking System (ABS) warning light                    | 2-13 |
|    | Automatic Transmission check warning light                      | 2-13 |
|    | Brake warning light   | 2-13 |
|    | Charge warning light  | 2-14 |
|    | Distance Control Assist (DCA) system warning light (orange)*    | 2-14 |
|    | Engine oil pressure warning light                               | 2-14 |
|    | Intelligent Cruise Control (ICC) system warning light (orange)* | 2-15 |
|    | Intelligent Key warning light                                   | 2-15 |
|    | Lane departure warning light (orange)*                          | 2-15 |
|    | Low tire pressure warning light                                 | 2-15 |
|   | Master warning light  | 2-17 |
|  | Preview Function warning light (orange)*                        | 2-17 |
|  | Rear Active Steer warning light*                                | 2-17 |

0-12 Illustrated table of contents

| Warning light   | Name  | Page |
|---|---|------|
|  | Seat belt warning light                     | 2-17 |
|  | Supplemental air bag warning light          | 2-17 |
|  | Vehicle Dynamic Control (VDC) warning light | 2-18 |

| Indicator light   | Name  | Page |
|---|---|------|
|  | Adaptive Front lighting System (AFS) indicator light*       | 2-18 |
|  | Automatic Transmission position indicator light             | 2-18 |
|  | Exterior light indicator                                    | 2-19 |
|  | Front passenger air bag status light                        | 2-19 |
|  | High beam indicator light                                   | 2-19 |
|  | Intelligent Brake Assist (IBA) off indicator light*         | 2-19 |
|  | Lane Departure Prevention (LDP) ON indicator light (green)* | 2-19 |
|  | Malfunction Indicator Light (MIL)                           | 2-19 |
|  | Security indicator light                                    | 2-20 |
|  | SPORT mode indicator light*                                 | 2-20 |
|  | Turn signal/hazard indicator lights                         | 2-20 |
|  | Vehicle Dynamic Control (VDC) off indicator light           | 2-20 |

\*: if so equipped

“Engine oil” (P.8-11.)

 **CAUTION**

Running the engine with the engine oil pressure warning light on could cause serious damage to the engine almost immediately. Such damage is not covered by warranty. Turn off the engine as soon as it is safe to do so.

 **Intelligent Cruise Control (ICC) system warning light (orange; if so equipped)**

This light comes on if there is a malfunction in the Intelligent Cruise Control (ICC) system.

If the warning light comes on, park the vehicle in a safe place. Turn the engine off, restart the engine, resume driving and set the ICC system again.

**If it is not possible to set the system or the indicator stays on, it may indicate that the system is malfunctioning. Although the vehicle is still driveable under normal conditions, have the vehicle checked at an INFINITI retailer.**

 **Intelligent Key warning light**

After the ignition switch is pushed to the ON position, this light comes on for about 2 seconds and then turns off.

This light warns of a malfunction with the Intelligent Key system.

If the light comes on while the engine is stopped, it may be impossible to start the engine. If the light comes on while the engine is running, you can drive the vehicle. However in these cases, contact an INFINITI retailer for repair as soon as possible.

 **Lane departure warning light (orange; if so equipped)**

When the ignition switch is pushed to the ON position, the light will come on in orange, turn green, and then turn off. This indicates that the Lane Departure Warning (LDW) and Lane Departure Prevention (LDP) systems are operational.

While the LDW and/or LDP system is on, the light will blink in orange and a warning chime will sound if the vehicle is traveling close to either the left or the right of a traveling lane with detectable lane markers.

If the light comes on in orange and remains on, it may indicate that the LDW and LDP systems are not functioning properly. Although the vehicle is still driveable, have the systems checked by an INFINITI retailer. See “Lane Departure Warning (LDW) system/Lane Departure Prevention (LDP) system” (P.5-21).

 **Low tire pressure warning light**

Your vehicle is equipped with a Tire Pressure Monitoring System (TPMS) that monitors the tire pressure of all tires except the spare.

The low tire pressure warning light warns of low tire pressure or indicates that the TPMS is not functioning properly.



After the ignition switch is pushed ON, this light illuminates for about 1 second and turns off.

**Low tire pressure warning:**

If the vehicle is being driven with low tire pressure, the warning light will illuminate. A CHECK TIRE PRESSURE warning also appears on the dot matrix liquid crystal display. If you select the tire pressure information in the display, the LOW PRES-

further details.

#### Exterior light indicator

This indicator illuminates when the headlight switch is turned to the AUTO,  or  position and the front parking lights, instrument panel lights, tail lights, license plate lights or headlights are on. The indicator turns off when these lights are turned off.

#### Front passenger air bag status light

The front passenger air bag status light () will be lit and the passenger front air bag will be OFF depending on how the front passenger seat is being used.

For front passenger air bag status light operation, see “INFINITI advanced air bag system (front seats)” (P.1-43) of this manual.

#### High beam indicator light

This light comes on when the headlight high beam is on and goes out when the low beam is selected.

#### Intelligent Brake Assist (IBA) off indicator light (if so equipped)

The light illuminates when the Intelligent Brake Assist (IBA) off switch is pushed to OFF. This indicates that the Intelligent Brake Assist (IBA) system is not operating.

When the IBA off indicator light illuminates while the system is turned on (without the warning chime sound), this light indicates that the system control is temporarily unavailable.

When the IBA off indicator light illuminates with the warning chime sound while the IBA system is turned on, this light indicates that the system may not be functioning properly. Park the vehicle in a safe place. Check to see if the laser sensor is clean. Turn the engine off, then restart the engine.

If the IBA off indicator light illuminates after following the procedures above, it may indicate that the system is malfunctioning. Although the vehicle is still driveable under normal conditions, have the vehicle checked at an INFINITI retailer. (See “Intelligent Brake Assist (IBA) system” (P.5-70).)

#### Lane Departure Prevention (LDP) ON indicator light (green; if so equipped)

The light comes on in green when the Lane Departure Prevention (LDP) system is turned on. The light turns off when the system is turned off.

#### **NOTE:**

**This light is common with the lane departure warning light (orange). (See “Lane departure warning light” (P.2-15).)**

For more details, see “Lane Departure Warning (LDW) system/Lane Departure Prevention (LDP) system” (P.5-21).

#### Malfunction Indicator Light (MIL)

If the malfunction indicator light comes on steady or blinks while the engine is running, it may indicate a potential emission control malfunction.

The malfunction indicator light may also come on steady if the fuel-filler cap is loose or missing, or if the vehicle runs out of fuel. Check to make sure the fuel-filler cap is installed and closed tightly, and that the vehicle has at least 3 US gallons (14 liters) of fuel in the fuel tank.

Instruments and controls 2-19



are not operating.

## AUDIBLE REMINDERS

### Key reminder chime

A chime will sound if the driver side door is opened while the ignition switch is pushed to the ACC position or pushed to the OFF or LOCK position with the Intelligent Key left in the Intelligent Key port. Make sure the ignition switch is pushed to the OFF position, and take the Intelligent Key with you when leaving the vehicle.

### Light reminder chime

A chime will sound when the driver side door is opened with the light switch in the  or  position and the ignition switch in the ACC, OFF or LOCK position.

Turn the light switch off when you leave the vehicle.

### Parking brake reminder chime

The chime will sound if the vehicle is driven at more than 4 MPH (7 km/h) with the parking brake applied. Stop the vehicle and release the parking brake.

### Brake pad wear warning

The disc brake pads have audible wear warnings. When a brake pad requires replacement, it will make a high pitched scraping sound when the vehicle is in motion. This scraping sound will first occur only when the brake pedal is depressed. After more wear of the brake pad, the sound will always be heard even if the brake pedal is not depressed. Have the brakes checked as soon as possible if the warning sound is heard.

### Lane departure warning chime (if so equipped)

When the Lane Departure Warning (LDW) or Lane Departure Prevention (LDP) system is on, the chime sounds if the vehicle is traveling close to either the left or the right of a traveling lane with detectable lane markers.

See “Lane Departure Warning (LDW) system/Lane Departure Prevention (LDP) system” (P.5-21) for more details.

## DOT MATRIX LIQUID CRYSTAL DISPLAY

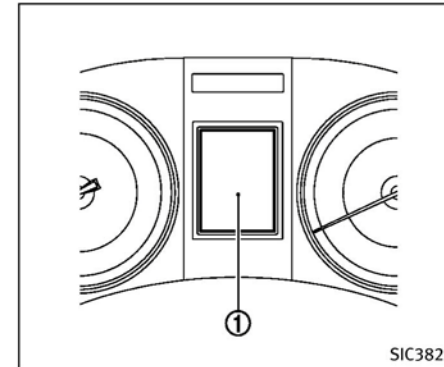

The dot matrix liquid crystal display ① is located between the tachometer and the speedometer, and it displays the automatic transmission position indicator, the Intelligent Cruise Control (ICC) system (if so equipped), the Distance Control Assist (DCA) system (if so equipped) information, the Intelligent Key operation information and other warnings and information.

For detailed information about each system, see the following sections:

- Automatic Transmission (AT)
  - “Warning/indicator lights and audible reminders” (P.2-12).

turn the switch off and have the system checked by an INFINITI retailer.

### WARNING SYSTEMS SWITCH (if so equipped)

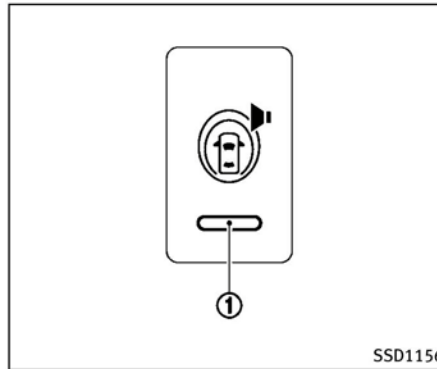

The warning systems switch will turn on and off the Lane Departure Warning (LDW) system and the Forward Collision Warning (FCW) system at the same time.

The LDW system will sound a warning chime and blink the lane departure warning light (orange) to alert the driver if the vehicle is traveling close to either the left or the right of a traveling lane with detectable lane markers. (See “Lane Departure Warning (LDW) system/Lane Departure Prevention (LDP) system” (P.5-21).)

The FCW system will sound a warning chime and the vehicle ahead detection indicator light blinks to alert the driver if

the vehicle is traveling close to the vehicle ahead. (See “Forward Collision Warning (FCW) system” (P.5-67).)

The warning systems switch is automatically turned on when the engine is started, and the warning systems ON indicator ① on the switch illuminates.

To cancel the warning systems, push the warning systems switch to turn off the system. The warning systems ON indicator will turn off.

#### NOTE:

**If you continue to push the warning systems switch from off to on for over 4 seconds, a chime will sound. This will change the default status of the LDW and FCW systems to OFF so that these systems will not automatically turn on when the engine is started. If this procedure is repeated, the default status will return to ON.**

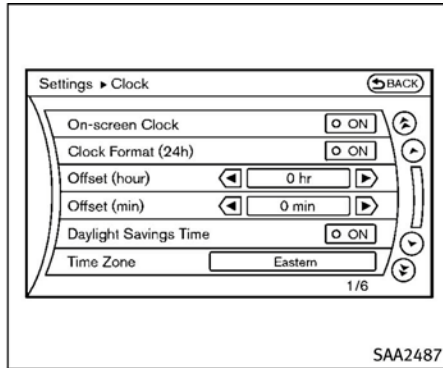

### Clock settings (models with navigation system)

The display as illustrated will appear when pushing the **SETTING** button and selecting the “Others” key, and then selecting the “Clock” key.

The clock settings display cannot be operated while driving. Stop the vehicle in a safe place and apply the parking brake before setting the clock.

#### **On-screen Clock:**

When this item is turned to ON, a clock is always displayed in the upper right corner of the screen.

This clock will indicate the time almost exactly because it is always adjusted by the GPS system (models with navigation system).

#### **Clock Format (24h):**

When this item is turned to ON, the 24-hour clock is displayed. When this item is not turned to ON, the 12-hour clock is displayed.

#### **Offset (hour)/(min):**

Adjust the time by increasing or decreasing per hour or per minute.

#### **Daylight Saving Time:**

Turn this item to ON for daylight saving time application.

#### **Time Zone:**

Choose the time zone from the following

- Pacific
- Mountain
- Central
- Eastern
- Atlantic
- Newfoundland
- Hawaii
- Alaska

### CAMERA settings

The “CAMERA” screen will appear when pushing the **SETTING** button, selecting the “Camera” key with the INFINITI controller and pushing the **ENTER** button.

For the details about the camera system operation, see “RearView monitor (models without navigation system)” (P.4-24) or “Around View™ Monitor (AVM) (models with navigation system)” (P.4-31).

### Driver Assistance settings (if so equipped)

For the details of the “Driver Assistance” settings, see the following items:

- “Lane Departure Prevention (LDP) system” (P.5-24).
- “Distance Control Assist (DCA) system” (P.5-54).

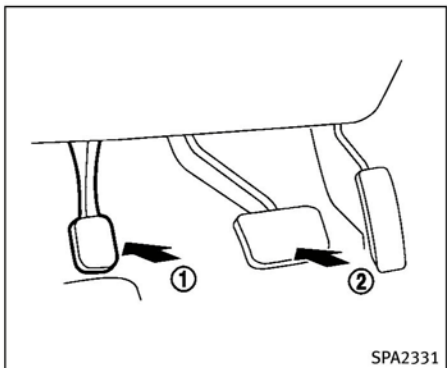

SPA2331

**To apply:** Fully depress the parking brake pedal ①.

**To release:**

1. Firmly apply the foot brake ②.
2. Depress the parking brake pedal ① and the parking brake will be released.
3. Before driving, be sure the brake warning light goes out.

### LANE DEPARTURE WARNING (LDW) SYSTEM/LANE DEPARTURE PREVENTION (LDP) SYSTEM (if so equipped)

The Lane Departure Warning (LDW) system/Lane Departure Prevention (LDP) system will operate when the vehicle is driven at speeds of approximately 45 MPH (70 km/h) and above, and when it is traveling close to either the left or the right of a traveling lane.

Each system functions as follows:

- Lane Departure Warning (LDW) system — warns the driver with a warning light and chime that the vehicle is beginning to leave the driving lane.
- Lane Departure Prevention (LDP) system — warns the driver with a warning light and chime, and helps assist the driver to return the vehicle to the center direction of the traveling lane by applying brake control to the left or right wheels individually (for a short period of time).

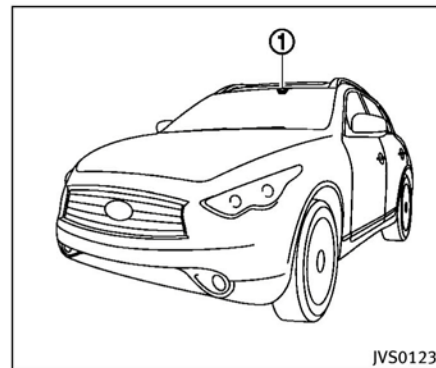

JVS0123X

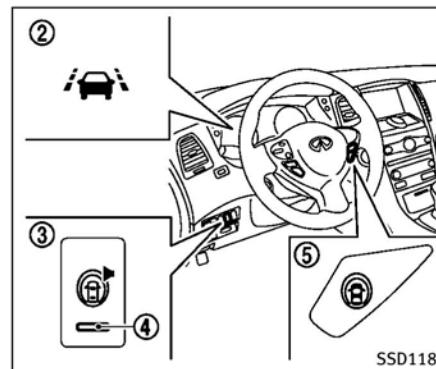

SSD1182

Starting and driving 5-21

The LDW and LDP systems monitor the lane markers on the traveling lane using the camera unit ① located above the inside mirror. When the camera unit detects that the vehicle is traveling close to either the left or the right of the traveling lane, the lane departure warning light ② on the instrument panel blinks in orange and a warning chime sounds. When the LDP system is on, it will automatically apply the brakes for a short period of time, using the function of the Vehicle Dynamic Control (VDC) system.

To turn on the LDW system, push the warning systems switch ③. The warning systems ON indicator light ④ on the switch will illuminate.

When the warning systems switch is pushed, the FCW system will also turn on or off simultaneously.

See “Forward Collision Warning (FCW) system” (P.5-67).

To turn on the LDP system, push the Dynamic driver assistance switch ⑤. The LDP ON indicator light ② will illuminate in green.

See “Lane Departure Prevention (LDP) system” (P.5-24).

## 5-22 Starting and driving

### LANE DEPARTURE WARNING (LDW) SYSTEM

#### Precautions on LDW system

#### WARNING

- This system is only a warning device to inform the driver of a potential unintended lane departure. It will not steer the vehicle or prevent loss of control. It is the driver's responsibility to stay alert, drive safely, keep the vehicle in the traveling lane, and be in control of the vehicle at all times.
- The system will not operate at speeds below approximately 45 MPH or if it cannot detect lane markers.
- If the LDW system malfunctions, it will cancel automatically, and the lane departure warning light (orange) will illuminate.
- If the lane departure warning light (orange) illuminates, pull off the road to a safe location and stop the vehicle. Turn the engine off and restart the engine. If the lane departure warning light (orange) continues to illuminate,

have the system checked by an INFINITI retailer.

- Excessive noise will interfere with the warning chime sound, and the chime may not be heard.

The system may not function properly under the following conditions:

- On roads where there are multiple parallel lane markers; lane markers that are faded or not painted clearly; yellow painted lane markers; non-standard lane markers; or lane markers covered with water, dirt, snow, etc.
- On roads where the discontinued lane markers are still detectable.
- On roads where there are sharp curves.
- On roads where there are sharply contrasting objects, such as shadows, snow, water, wheel ruts, seams or lines remaining after road repairs. (The LDW system could detect these items as lane markers.)
- On roads where the traveling lane merges or separates.
- When the vehicle's traveling direction does not align with the lane marker.

- When traveling close to the vehicle in front of you, which obstructs the lane camera unit detection range.
- When rain, snow or dirt adheres to the windshield in front of the lane camera unit.
- When the headlights are not bright due to dirt on the lens or if the aiming is not adjusted properly.
- When strong light enters the lane camera unit. (For example, the light directly shines on the front of the vehicle at sunrise or sunset.)
- When a sudden change in brightness occurs. (For example, when the vehicle enters or exits a tunnel or under a bridge.)

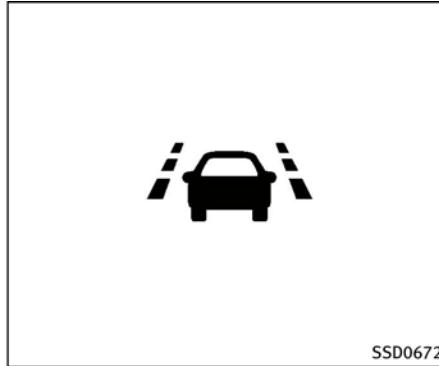

SSD0672

**Lane departure warning light (orange)**

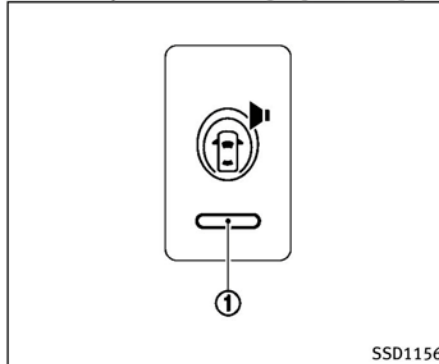

SSD1156

**Warning systems switch**

### LDW system operation

The LDW system provides a lane departure warning function when the vehicle is driven at speeds of approximately 45 MPH (70 km/h) and above. When the vehicle approaches either the left or the right side of the traveling lane, a warning chime will sound and the lane departure warning light (orange) on the instrument panel will blink to alert the driver.

The warning function will stop when the vehicle returns inside of the lane markers.

When you operate the lane change signal and change traveling lanes in the direction of the signal, the LDW system temporarily suspends operation. It will become operable again approximately 2 seconds after the lane change signal is turned off.

When the vehicle speed lowers to less than approximately 45 MPH (70 km/h), the LDW system will not provide a warning.

The LDW system has an automatic setting mode and a manual setting mode. The setting mode can be changed. In the automatic setting mode, the LDW system is automatically turned on when the ignition switch is pushed to the ON position. When the LDW system is on, the warning

systems ON indicator ① on the warning systems switch illuminates. To cancel the LDW system, push the warning systems switch. The warning systems ON indicator will turn off. To turn on the system, push the warning systems switch again.

When the warning systems switch is pushed, the FCW system will also turn on or off simultaneously. See “FCW system operation” (P.5-70)

In the manual setting mode, you need to push the warning systems switch to turn on the system after the ignition switch is pushed to the ON position.

The setting mode can be changed using the warning systems switch. To change the setting mode, push and hold the warning systems switch for more than 4 seconds when the warning systems ON indicator is off. When the mode is changed, a chime sounds and the lane departure warning light (orange) flashes.

### Temporary disabled status at high temperature

If the vehicle is parked in direct sunlight under high temperature conditions (over approximately 104°F (40°C) and then started, the LDW system may be deacti-

vated automatically. The warning systems ON indicator on the switch will flash.

When the interior temperature is reduced, the LDW system will resume operating automatically and the warning systems ON indicator will stop flashing.

## LANE DEPARTURE PREVENTION (LDP) SYSTEM

### Precautions on LDP system

#### WARNING

- The LDP system will not steer the vehicle or prevent loss of control. It is the driver's responsibility to stay alert, drive safely, keep the vehicle in the traveling lane, and be in control of vehicle at all times.
- The LDP system is primarily intended for use on well-developed freeways or highways. It may not detect the lane markers in certain roads, weather or driving conditions.
- Using the LDP system under some conditions of road, lane marker or weather, or when you change lanes without using the lane change signal

could lead to an unexpected system operation. In such conditions, you need to correct the vehicle's direction with your steering operation to avoid accidents.

- When the LDP system is operating, avoid excessive or sudden steering maneuvers. Otherwise, you could lose control of the vehicle.
- The LDP system will not operate at speeds below approximately 45 MPH (70 km/h) or if it cannot detect lane markers.
- The LDP system may not function properly under the following conditions, and do not use the LDP system:
  - During bad weather (rain, fog, snow, wind, etc.).
  - When driving on slippery roads, such as on ice or snow, etc.
  - When driving on winding or uneven roads.
  - When there is a lane closure due to road repairs.
  - When driving in a makeshift lane.

**Temporary disabled status at high temperature:**

If the vehicle is parked in direct sunlight under high temperature conditions (over approximately 104°F (40°C)) and then the LDP system is turned on, the LDP system may be deactivated automatically. The LDP ON indicator (green) will blink.

When the interior temperature is reduced, the system will resume operating automatically and the LDP ON indicator will stop blinking.

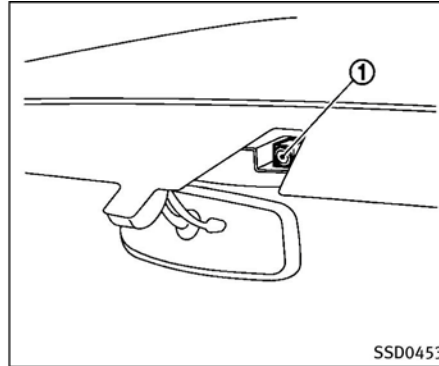

**LANE CAMERA UNIT MAINTENANCE**

The lane camera unit ① for the LDW/LDP system is located above the inside mirror. To keep the proper operation of the LDW/LDP systems and prevent a system malfunction, be sure to observe the following:

- Always keep the windshield clean.
- Do not attach a sticker (including transparent material) or install an accessory near the camera unit.
- Do not place reflective materials, such as white paper or a mirror, on the instrument panel. The reflection of sunlight may adversely affect the cam-

era unit's capability of detecting the lane markers.

- Do not strike or damage the areas around the camera unit. Do not touch the camera lens or remove the screw located on the camera unit. If the camera unit is damaged due to an accident, contact an INFINITI retailer.

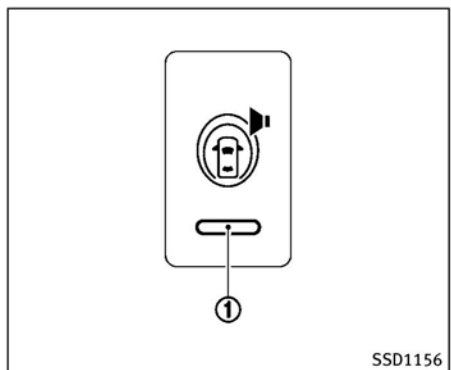

**Warning systems switch**

#### FCW system operation

The FCW system will function at speeds of approximately 10 MPH (15 km/h) and above, when the system turns on.

The FCW system has an automatic setting mode and a manual setting mode to turn the system on. The setting mode can be changed. In the automatic setting mode, the FCW system is automatically turned on when the ignition switch is pushed to the ON position. When the FCW system is on, the warning systems ON indicator light ① on the warning systems switch illuminates. To cancel the FCW system, push the

warning systems switch. The warning systems ON indicator light will turn off. To turn on the system, push the warning systems switch again.

When the warning systems switch is pushed, the LDW system will also turn on or off simultaneously. See “Lane Departure Warning (LDW) system/Lane Departure Prevention (LDP) system” (P.5-21).

In the manual setting mode, you need to push the warning systems switch to turn on the system after the ignition switch is pushed to the ON position.

The setting mode can be changed using the warning systems switch. To change the setting mode, push and hold the warning systems switch for more than 4 seconds when the warning systems ON indicator is off. When the mode is changed, a chime sounds and the lane departure warning light (orange) flashes.

For the sensor maintenance, see “Intelligent Cruise Control (ICC) system (FULL SPEED RANGE)” (P.5-32).

#### INTELLIGENT BRAKE ASSIST (IBA) SYSTEM (if so equipped)

The Intelligent Brake Assist (IBA) system warns the driver by a warning light and chime when there is a risk of a collision with the vehicle ahead in the traveling lane and the driver must take avoidance action immediately. The system helps reduce the rear-end collision speed by applying the brakes when the system judges that the collision cannot be prevented.

The IBA system will function when your vehicle is driven at speeds of approximately 10 MPH (15 km/h) and above, and when your vehicle is driven at speeds approximately 10 MPH (15 km/h) faster than the vehicle ahead.

## APPENDIX C

### Run Log

Subject Vehicle: **2013 Infiniti FX37**

Date: 5/1/2013

Driver: B Keschull

| Run | Lane Marking Type | Departure Direction | Valid Run? | Distance at Visual Alert (ft) | Distance at Audible Alert (ft) | Pass/Fail | Notes         |
|-----|-------------------|---------------------|------------|-------------------------------|--------------------------------|-----------|---------------|
| 1   | Botts             | Left                | Y          | -0.32                         | -0.23                          | Pass      |               |
| 2   |                   |                     | Y          | -0.24                         | -0.10                          | Pass      |               |
| 3   |                   |                     | Y          | -0.44                         | -0.30                          | Pass      |               |
| 4   |                   |                     | N          |                               |                                |           | Yaw rate high |
| 5   |                   |                     | Y          | -0.17                         | 0.04                           | Pass      |               |
| 6   |                   |                     | Y          | -0.20                         | -0.06                          | Pass      |               |
| 7   |                   |                     | Y          | -0.47                         | -0.32                          | Pass      |               |
| 8   |                   |                     | Y          | -0.08                         | 0.04                           | Pass      |               |
|     |                   |                     |            |                               |                                |           |               |
| 9   | Botts             | Right               | Y          | -0.37                         | -0.21                          | Pass      |               |
| 10  |                   |                     | Y          | -0.33                         | -0.19                          | Pass      |               |
| 11  |                   |                     | Y          | -0.35                         | -0.23                          | Pass      |               |
| 12  |                   |                     | Y          | -0.94                         | -0.79                          | Pass      |               |
| 13  |                   |                     | Y          | -0.37                         | -0.24                          | Pass      |               |
| 14  |                   |                     | Y          | -0.40                         | -0.26                          | Pass      |               |
| 15  |                   |                     | Y          | -0.36                         | -0.19                          | Pass      |               |
| 16  | Solid             | Right               | Y          | -0.23                         | -0.07                          | Pass      |               |

Driver: B Keschull

| Run | Lane Marking Type | Departure Direction | Valid Run? | Distance at Visual Alert (ft) | Distance at Audible Alert (ft) | Pass/Fail | Notes                       |
|-----|-------------------|---------------------|------------|-------------------------------|--------------------------------|-----------|-----------------------------|
| 17  |                   |                     | Y          | -0.23                         | -0.11                          | Pass      |                             |
| 18  |                   |                     | Y          | -0.19                         | -0.10                          | Pass      |                             |
| 19  |                   |                     | Y          | -0.12                         | -0.07                          | Pass      |                             |
| 20  |                   |                     | Y          | -0.31                         | -0.16                          | Pass      |                             |
| 21  |                   |                     | Y          | -0.25                         | -0.09                          | Pass      |                             |
| 22  |                   |                     | Y          | -0.23                         | -0.10                          | Pass      |                             |
|     |                   |                     |            |                               |                                |           |                             |
| 23  | Solid             | Left                | N          |                               |                                |           | Lateral position not zeroed |
| 24  |                   |                     | Y          | -0.10                         | -0.02                          | Pass      |                             |
| 25  |                   |                     | Y          | -0.20                         | -0.02                          | Pass      |                             |
| 26  |                   |                     | Y          | -0.30                         | -0.09                          | Pass      |                             |
| 27  |                   |                     | Y          | -0.25                         | -0.05                          | Pass      |                             |
| 28  |                   |                     | Y          | -0.24                         | -0.05                          | Pass      |                             |
| 29  |                   |                     | Y          | -0.15                         | -0.04                          | Pass      |                             |
| 30  |                   |                     | Y          | -0.16                         | -0.05                          | Pass      |                             |
|     |                   |                     |            |                               |                                |           |                             |
| 31  | Dashed            | Left                | Y          | 0.00                          | 0.14                           | Pass      |                             |
| 32  |                   |                     | Y          | 0.09                          | 0.17                           | Pass      |                             |

Driver: B Keschull

| Run | Lane Marking Type | Departure Direction | Valid Run? | Distance at Visual Alert (ft) | Distance at Audible Alert (ft) | Pass/Fail | Notes         |
|-----|-------------------|---------------------|------------|-------------------------------|--------------------------------|-----------|---------------|
| 33  |                   |                     | Y          | 0.00                          | 0.14                           | Pass      |               |
| 34  |                   |                     | Y          | 0.12                          | 0.25                           | Pass      |               |
| 35  |                   |                     | Y          | 0.01                          | 0.11                           | Pass      |               |
| 36  |                   |                     | Y          | 0.02                          | 0.13                           | Pass      |               |
| 37  |                   |                     | Y          | 0.07                          | 0.17                           | Pass      |               |
|     |                   |                     |            |                               |                                |           |               |
| 38  | Dashed            | Right               | Y          | 0.35                          | 0.48                           | Pass      |               |
| 39  |                   |                     | Y          |                               |                                | Fail      | No warning    |
| 40  |                   |                     | Y          | -0.13                         | 0.00                           | Pass      |               |
| 41  |                   |                     | Y          | -0.28                         | -0.15                          | Pass      |               |
| 42  |                   |                     | Y          | 0.21                          | 0.32                           | Pass      |               |
| 43  |                   |                     | N          |                               |                                |           | Yaw rate high |
| 44  |                   |                     | Y          | -0.20                         | -0.11                          | Pass      |               |
| 45  |                   |                     | Y          | -0.29                         | -0.19                          | Pass      |               |

## APPENDIX D

### Time History Plots

## LIST OF FIGURES

|   | Page |
|---|------|
| Figure D1. Example Time History for Lane Departure Warning Test, Passing .....  | D-9  |
| Figure D2. Example Time History for Lane Departure Warning Test, Failing, No<br>Warning Issued .....                  | D-10 |
| Figure D3. Example Time History for Lane Departure Warning Test, Invalid Run<br>Due to Subject Vehicle Yaw Rate ..... | D-11 |
| Figure D4. Time History for Run 1, Botts Dots, Left Departure, Audible Warning .....                                  | D-12 |
| Figure D5. Time History for Run 1, Botts Dots, Left Departure, Visual Warning .....                                   | D-13 |
| Figure D6. Time History for Run 2, Botts Dots, Left Departure, Audible Warning .....                                  | D-14 |
| Figure D7. Time History for Run 2, Botts Dots, Left Departure, Visual Warning .....                                   | D-15 |
| Figure D8. Time History for Run 3, Botts Dots, Left Departure, Audible Warning .....                                  | D-16 |
| Figure D9. Time History for Run 3, Botts Dots, Left Departure, Visual Warning .....                                   | D-17 |
| Figure D10. Time History for Run 5, Botts Dots, Left Departure, Audible Warning ....                                  | D-18 |
| Figure D11. Time History for Run 5, Botts Dots, Left Departure, Visual Warning .....                                  | D-19 |
| Figure D12. Time History for Run 6, Botts Dots, Left Departure, Audible Warning ....                                  | D-20 |
| Figure D13. Time History for Run 6, Botts Dots, Left Departure, Visual Warning .....                                  | D-21 |
| Figure D14. Time History for Run 7, Botts Dots, Left Departure, Audible Warning ....                                  | D-22 |
| Figure D15. Time History for Run 7, Botts Dots, Left Departure, Visual Warning .....                                  | D-23 |
| Figure D16. Time History for Run 8, Botts Dots, Left Departure, Audible Warning ....                                  | D-24 |
| Figure D17. Time History for Run 8, Botts Dots, Left Departure, Visual Warning .....                                  | D-25 |
| Figure D18. Time History for Run 9, Botts Dots, Right Departure, Audible<br>Warning .....                             | D-26 |
| Figure D19. Time History for Run 9, Botts Dots, Right Departure, Visual Warning.....                                  | D-27 |
| Figure D20. Time History for Run 10, Botts Dots, Right Departure, Audible<br>Warning .....                            | D-28 |
| Figure D21. Time History for Run 10, Botts Dots, Right Departure, Visual<br>Warning .....                             | D-29 |
| Figure D22. Time History for Run 11, Botts Dots, Right Departure, Audible<br>Warning .....                            | D-30 |
| Figure D23. Time History for Run 11, Botts Dots, Right Departure, Visual<br>Warning .....                             | D-31 |

|             |   |      |
|-------------|---|------|
| Figure D24. | Time History for Run 12, Botts Dots, Right Departure, Audible Warning ..... | D-32 |
| Figure D25. | Time History for Run 12, Botts Dots, Right Departure, Visual Warning .....  | D-33 |
| Figure D26. | Time History for Run 13, Botts Dots, Right Departure, Audible Warning ..... | D-34 |
| Figure D27. | Time History for Run 13, Botts Dots, Right Departure, Visual Warning .....  | D-35 |
| Figure D28. | Time History for Run 14, Botts Dots, Right Departure, Audible Warning ..... | D-36 |
| Figure D29. | Time History for Run 14, Botts Dots, Right Departure, Visual Warning .....  | D-37 |
| Figure D30. | Time History for Run 15, Botts Dots, Right Departure, Audible Warning ..... | D-38 |
| Figure D31. | Time History for Run 15, Botts Dots, Right Departure, Visual Warning .....  | D-39 |
| Figure D32. | Time History for Run 16, Solid Line, Right Departure, Audible Warning ..... | D-40 |
| Figure D33. | Time History for Run 16, Solid Line, Right Departure, Visual Warning ....   | D-41 |
| Figure D34. | Time History for Run 17, Solid Line, Right Departure, Audible Warning ..... | D-42 |
| Figure D35. | Time History for Run 17, Solid Line, Right Departure, Visual Warning ....   | D-43 |
| Figure D36. | Time History for Run 18, Solid Line, Right Departure, Audible Warning ..... | D-44 |
| Figure D37. | Time History for Run 18, Solid Line, Right Departure, Visual Warning ....   | D-45 |
| Figure D38. | Time History for Run 19, Solid Line, Right Departure, Audible Warning ..... | D-46 |
| Figure D39. | Time History for Run 19, Solid Line, Right Departure, Visual Warning ....   | D-47 |
| Figure D40. | Time History for Run 20, Solid Line, Right Departure, Audible Warning ..... | D-48 |
| Figure D41. | Time History for Run 20, Solid Line, Right Departure, Visual Warning ....   | D-49 |
| Figure D42. | Time History for Run 21, Solid Line, Right Departure, Audible Warning ..... | D-50 |
| Figure D43. | Time History for Run 21, Solid Line, Right Departure, Visual Warning ....   | D-51 |
| Figure D44. | Time History for Run 22, Solid Line, Right Departure, Audible Warning ..... | D-52 |

|             |  |      |
|-------------|--|------|
| Figure D45. | Time History for Run 22, Solid Line, Right Departure, Visual Warning ....      | D-53 |
| Figure D46. | Time History for Run 24, Solid Line, Left Departure, Audible Warning ....      | D-54 |
| Figure D47. | Time History for Run 24, Solid Line, Left Departure, Visual Warning .....      | D-55 |
| Figure D48. | Time History for Run 25, Solid Line, Left Departure, Audible Warning ....      | D-56 |
| Figure D49. | Time History for Run 25, Solid Line, Left Departure, Visual Warning .....      | D-57 |
| Figure D50. | Time History for Run 26, Solid Line, Left Departure, Audible Warning ....      | D-58 |
| Figure D51. | Time History for Run 26, Solid Line, Left Departure, Visual Warning .....      | D-59 |
| Figure D52. | Time History for Run 27, Solid Line, Left Departure, Audible Warning ....      | D-60 |
| Figure D53. | Time History for Run 27, Solid Line, Left Departure, Visual Warning .....      | D-61 |
| Figure D54. | Time History for Run 28, Solid Line, Left Departure, Audible Warning ....      | D-62 |
| Figure D55. | Time History for Run 28, Solid Line, Left Departure, Visual Warning .....      | D-63 |
| Figure D56. | Time History for Run 29, Solid Line, Left Departure, Audible Warning ....      | D-64 |
| Figure D57. | Time History for Run 29, Solid Line, Left Departure, Visual Warning .....      | D-65 |
| Figure D58. | Time History for Run 30, Solid Line, Left Departure, Audible Warning ....      | D-66 |
| Figure D59. | Time History for Run 30, Solid Line, Left Departure, Visual Warning .....      | D-67 |
| Figure D60. | Time History for Run 31, Dashed Line, Left Departure, Audible<br>Warning ..... | D-68 |
| Figure D61. | Time History for Run 31, Dashed Line, Left Departure, Visual<br>Warning .....  | D-69 |
| Figure D62. | Time History for Run 32, Dashed Line, Left Departure, Audible<br>Warning ..... | D-70 |
| Figure D63. | Time History for Run 32, Dashed Line, Left Departure, Visual<br>Warning .....  | D-71 |
| Figure D64. | Time History for Run 33, Dashed Line, Left Departure, Audible<br>Warning ..... | D-72 |
| Figure D65. | Time History for Run 33, Dashed Line, Left Departure, Visual<br>Warning .....  | D-73 |
| Figure D66. | Time History for Run 34, Dashed Line, Left Departure, Audible<br>Warning ..... | D-74 |
| Figure D67. | Time History for Run 34, Dashed Line, Left Departure, Visual<br>Warning .....  | D-75 |
| Figure D68. | Time History for Run 35, Dashed Line, Left Departure, Audible<br>Warning ..... | D-76 |
| Figure D69. | Time History for Run 35, Dashed Line, Left Departure, Visual<br>Warning .....  | D-77 |

|             |   |      |
|-------------|---|------|
| Figure D70. | Time History for Run 36, Dashed Line, Left Departure, Audible<br>Warning .....  | D-78 |
| Figure D71. | Time History for Run 36, Dashed Line, Left Departure, Visual<br>Warning .....   | D-79 |
| Figure D72. | Time History for Run 37, Dashed Line, Left Departure, Audible<br>Warning .....  | D-80 |
| Figure D73. | Time History for Run 37, Dashed Line, Left Departure, Visual<br>Warning .....   | D-81 |
| Figure D74. | Time History for Run 38, Dashed Line, Right Departure, Audible<br>Warning ..... | D-82 |
| Figure D75. | Time History for Run 38, Dashed Line, Right Departure, Visual<br>Warning .....  | D-83 |
| Figure D76. | Time History for Run 39, Dashed Line, Right Departure, Audible<br>Warning ..... | D-84 |
| Figure D77. | Time History for Run 39, Dashed Line, Right Departure, Visual<br>Warning .....  | D-85 |
| Figure D78. | Time History for Run 40, Dashed Line, Right Departure, Audible<br>Warning ..... | D-86 |
| Figure D79. | Time History for Run 40, Dashed Line, Right Departure, Visual<br>Warning .....  | D-87 |
| Figure D80. | Time History for Run 41, Dashed Line, Right Departure, Audible<br>Warning ..... | D-88 |
| Figure D81. | Time History for Run 41, Dashed Line, Right Departure, Visual<br>Warning .....  | D-89 |
| Figure D82. | Time History for Run 42, Dashed Line, Right Departure, Audible<br>Warning ..... | D-90 |
| Figure D83. | Time History for Run 42, Dashed Line, Right Departure, Visual<br>Warning .....  | D-91 |
| Figure D84. | Time History for Run 44, Dashed Line, Right Departure, Audible<br>Warning ..... | D-92 |
| Figure D85. | Time History for Run 44, Dashed Line, Right Departure, Visual<br>Warning .....  | D-93 |
| Figure D86. | Time History for Run 45, Dashed Line, Right Departure, Audible<br>Warning ..... | D-94 |
| Figure D87. | Time History for Run 45, Dashed Line, Right Departure, Visual<br>Warning .....  | D-95 |

## Description of Time History Plots

A set of time history plots is provided for each valid run in the test series. Each set of plots comprises time varying data from the Subject Vehicle, as well as pass/fail envelopes and thresholds. The following is a description of data types shown in the time history plots, as well as a description of the color code for data envelopes.

### Time History Plot Description

Time history figures include the following sub-plots:

- Event – indicates timing of warning issued by LDW system. Depending on the type of LDW alert or instrumentation used to measure the alert, this can be any of the following,:
  - Filtered and rectified sound signal
  - Filtered and rectified acceleration (e.g., steering wheel vibration)
  - Light sensor signal
  - Discrete on/off value
- Speed (mph) – speed of the Subject Vehicle
- Yaw Rate (deg/sec) – yaw rate of the Subject Vehicle
- Dist to Lane Edge (ft) – lateral distance (in lane coordinates) from the outer front tire bulge to the inside edge of the lane marking of interest for a given test (a positive value indicates the vehicle is completely within the lane while a negative value indicates that the outer front tire bulge has crossed over the inner lane marking edge)
- Lateral Velocity (ft/sec) – lateral velocity (in lane coordinates) of the outer front tire bulge
- Bird's Eye View – Indicates the position of the Subject Vehicle with respect to the lane marking of interest for a given test. Green rectangles represent the Subject Vehicle's position at approximately 2 second intervals, while the yellow rectangle indicates the position of the Subject Vehicle at the time of LDW warning issuance.

## Envelopes and Thresholds

Each of the time history plot figures can contain either green or yellow envelopes and/or black threshold lines. These envelopes and thresholds are used to programmatically and visually determine the validity of a given test run. Envelope and threshold exceedances are indicated with either red shading or red asterisks, and red text is placed to the right side of the plot indicating the type of exceedance.

Green envelopes indicate that the time-varying data should not exceed the envelope boundaries at any time within the envelope. Exceedances of a green envelope are indicated by red shading in the area between the measured time-varying data and the envelope boundaries.

Yellow envelopes indicate that the time-varying data should not exceed the envelope only at the right end. Exceedances at the right extent of a yellow envelope are indicated by red asterisks. Data within the boundaries at the right extent of a yellow envelope are indicated by green circles.

## Color Codes

Color codes have been adopted to easily identify the types of data, envelopes and thresholds used in the plots.

Color codes can be broken into three categories:

1. Validation envelopes and thresholds
2. Instantaneous samplings
3. Text

1. Validation envelope and threshold color codes:

- Green envelope = time varying data must be within the envelope at all times in order to be valid
- Yellow envelope = time varying data must be within limits at right end
- Black threshold (Solid) = time varying data must not exceed this threshold in order to be valid
- Black threshold (Dashed) = for reference only – this can include warning level thresholds which are used to determine the timing of the alert

2. Instantaneous sampling color codes:

- Green circle = passing or valid value at a given moment in time
- Red asterisk = failing or invalid value at a given moment in time

3. Text color codes:

- Green = passing or valid value
- Red = failing or invalid value

Examples of time history plots (including passing, failing and invalid runs) are shown in Figure D1 through Figure D3. Actual time history data plots for the vehicle under consideration are provided subsequently.

# LDW Test

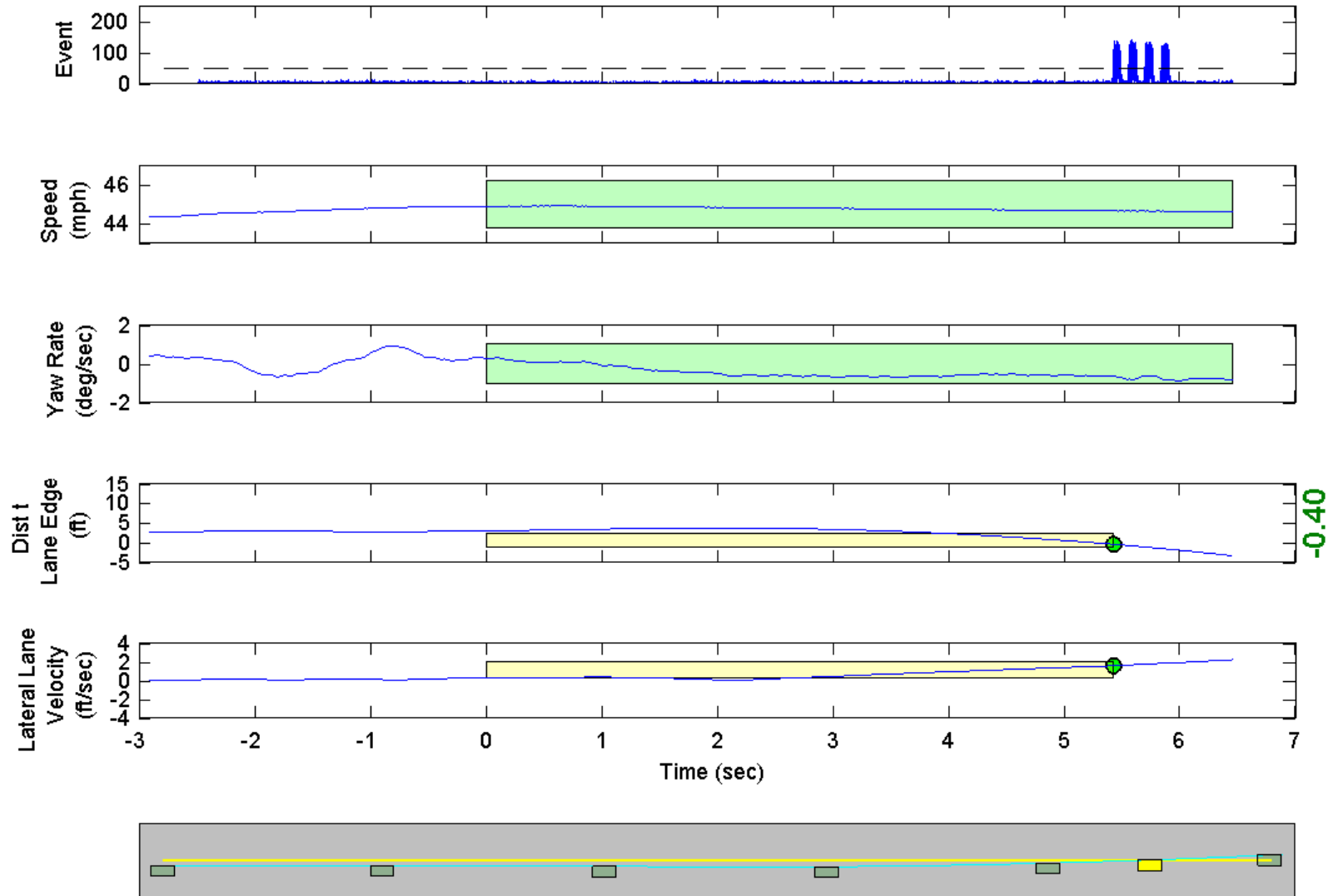

GPS Fix Type: RTK Fixed

Figure D1. Example Time History for Lane Departure Warning Test, Passing

### LDW Test

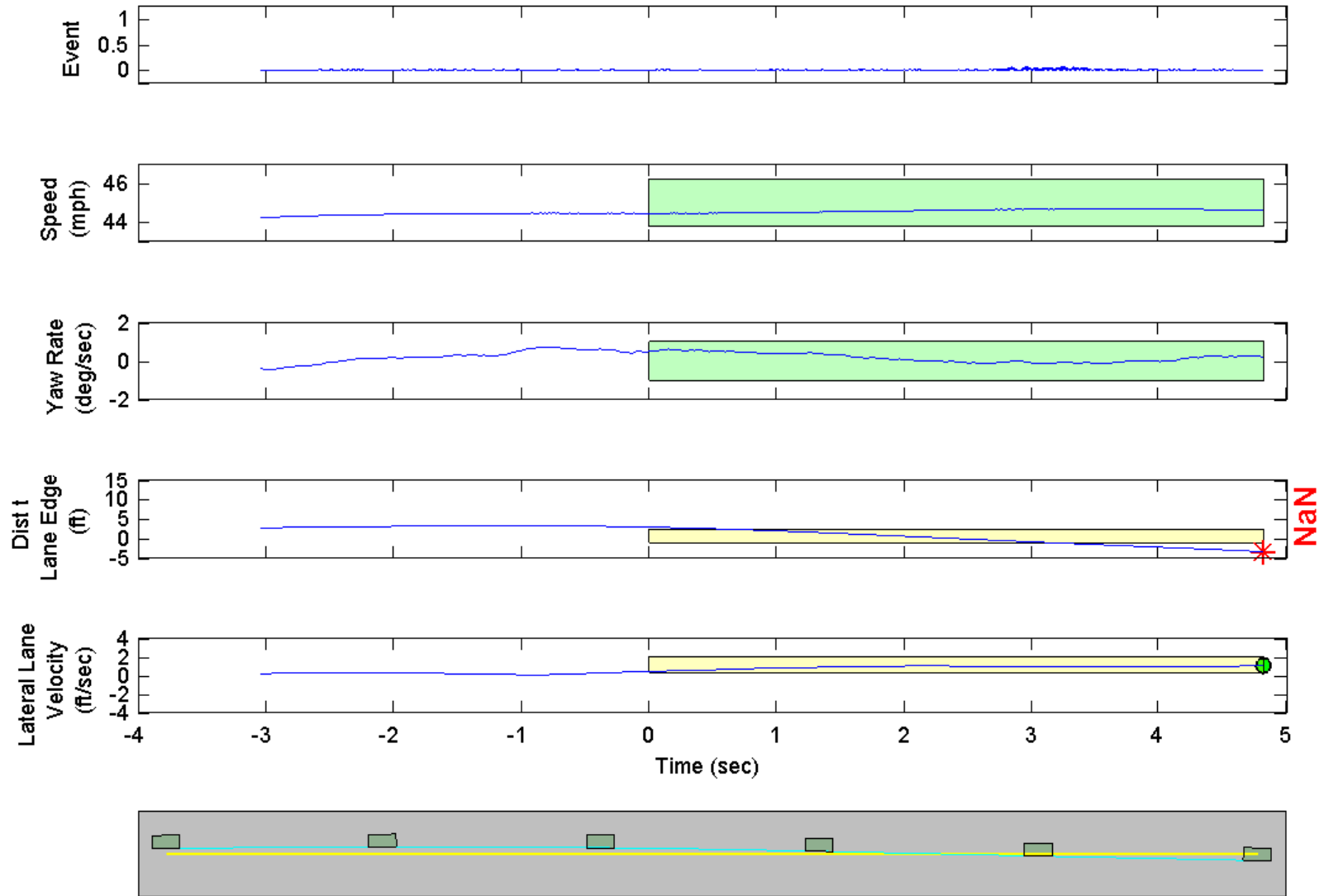

GPS Fix Type: RTK Fixed

Figure D2. Example Time History for Lane Departure Warning Test, Failing, No Warning Issued

### LDW Test

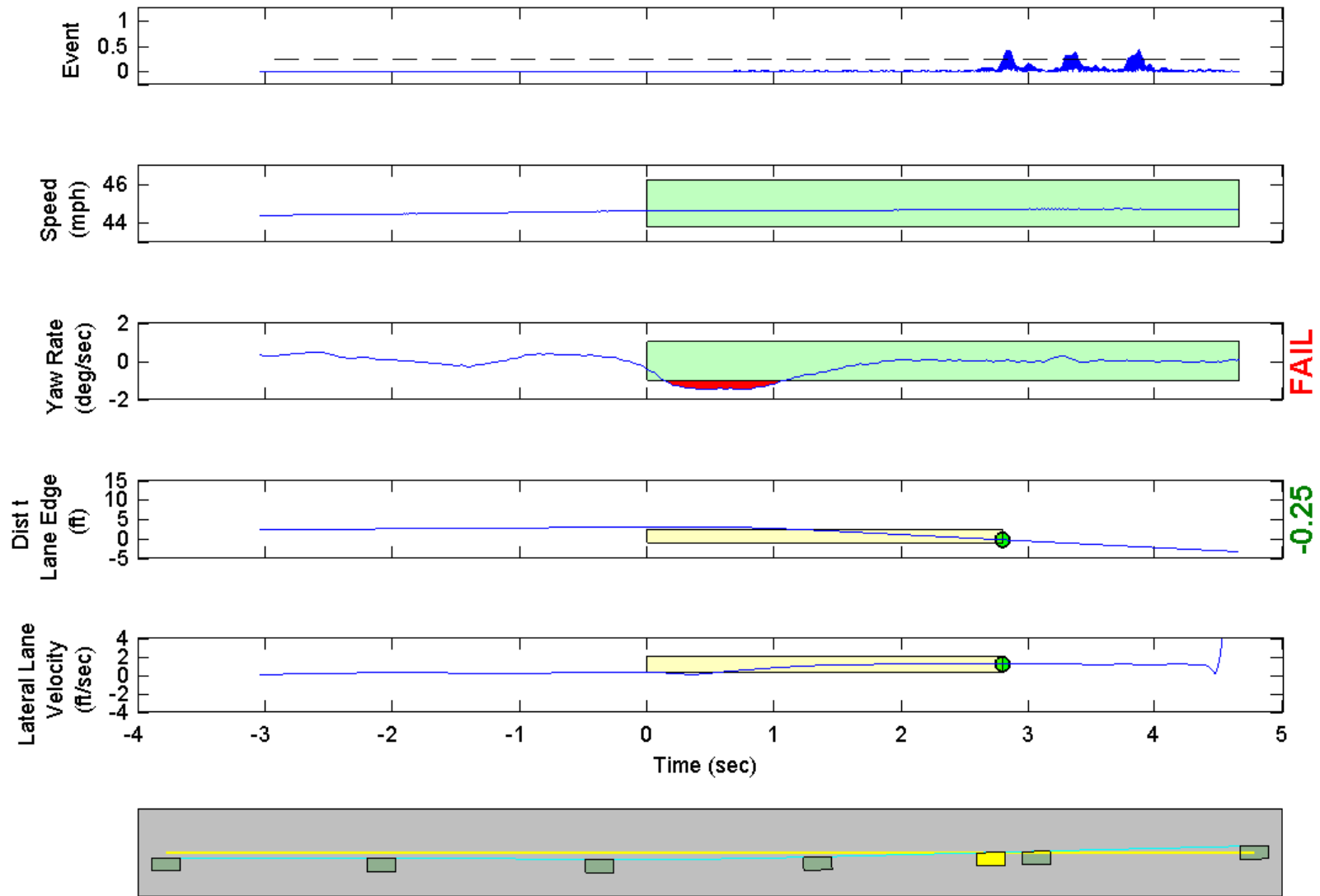

GPS Fix Type: RTK Fixed

Figure D3. Example Time History for Lane Departure Warning Test, Invalid Run Due to Subject Vehicle Yaw Rate

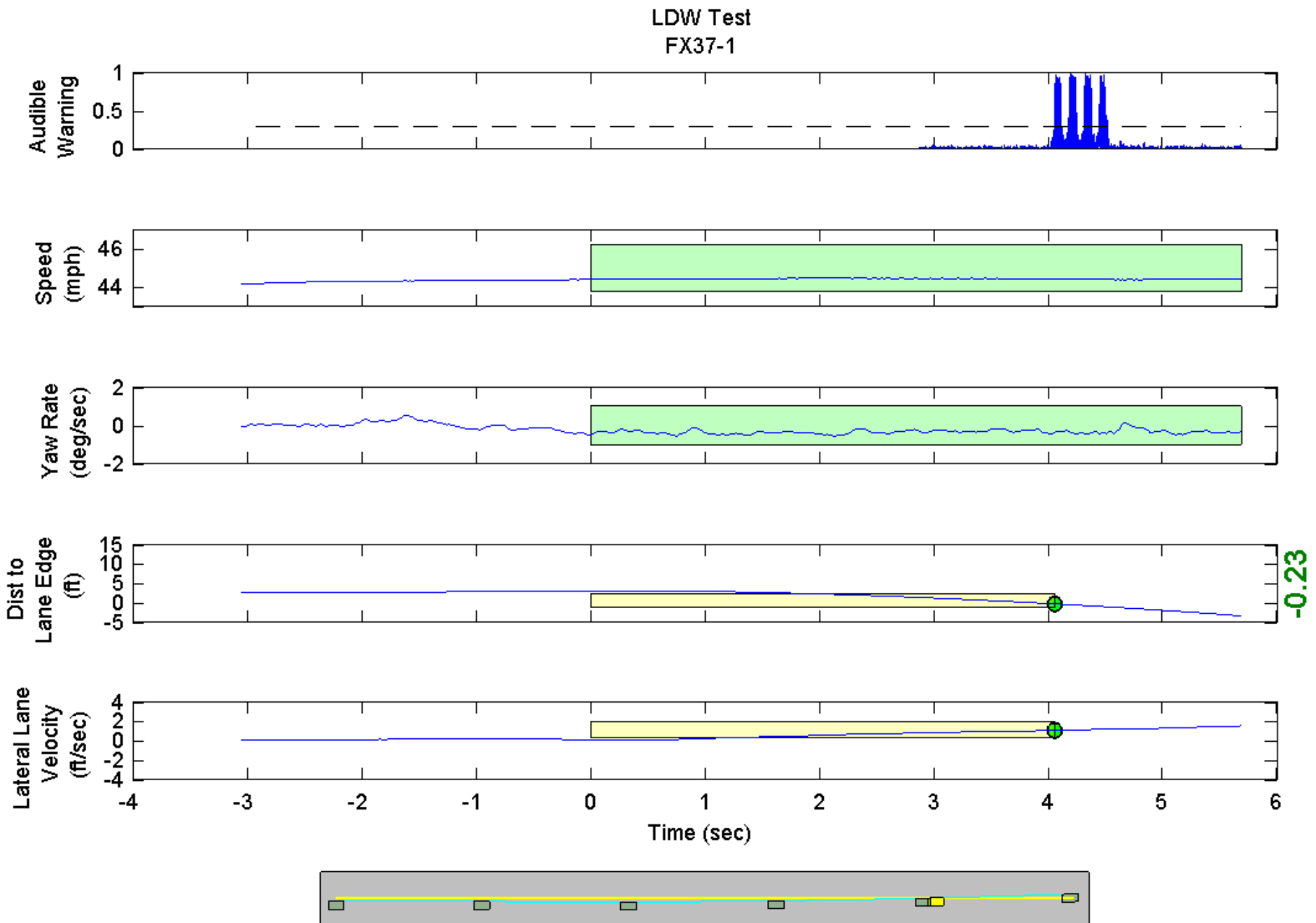

GPS Fix Type: RTK Fixed

Figure D4. Time History for Run 1, Botts Dots, Left Departure, Audible Warning

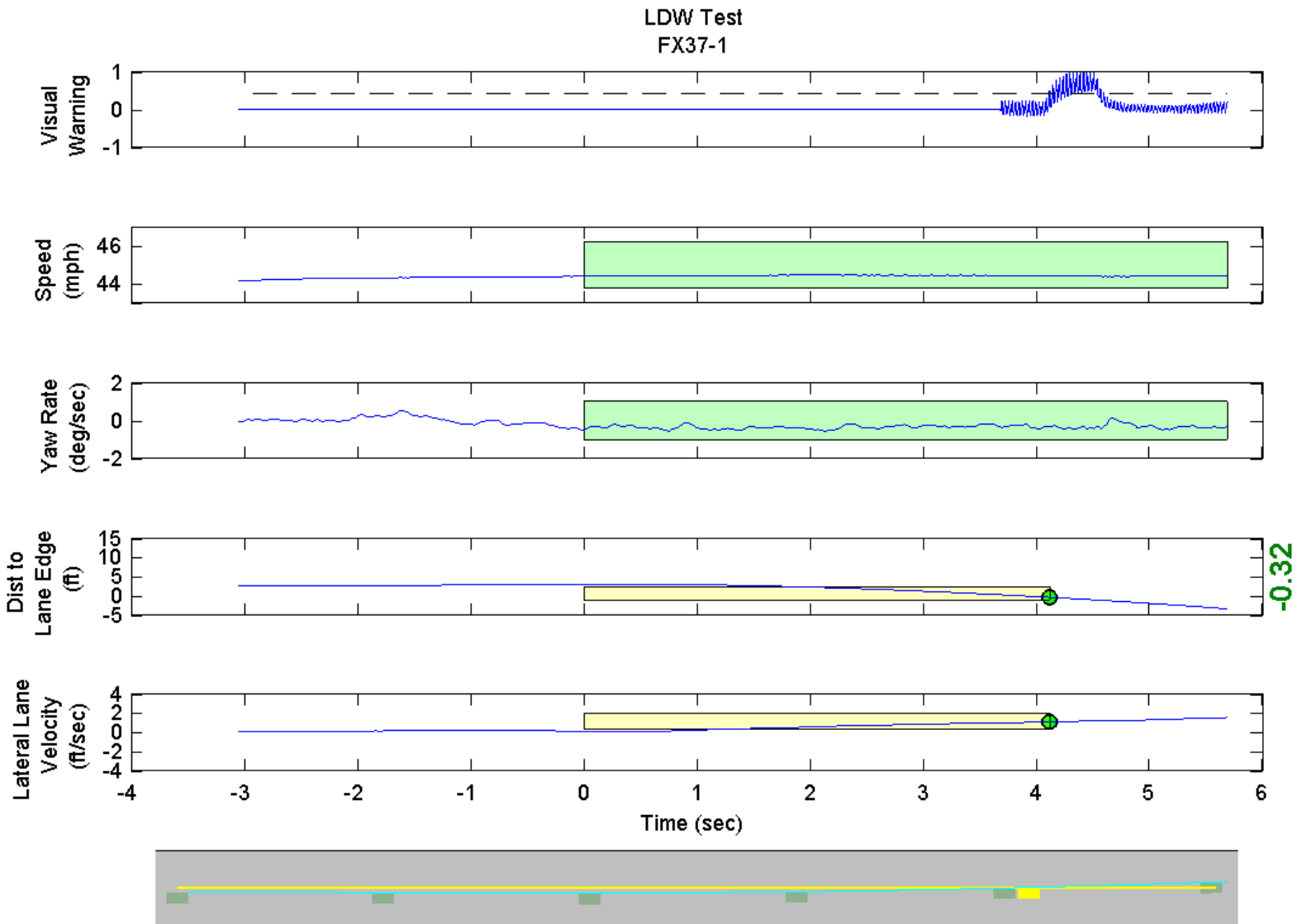

GPS Fix Type: RTK Fixed

Figure D5. Time History for Run 1, Botts Dots, Left Departure, Visual Warning

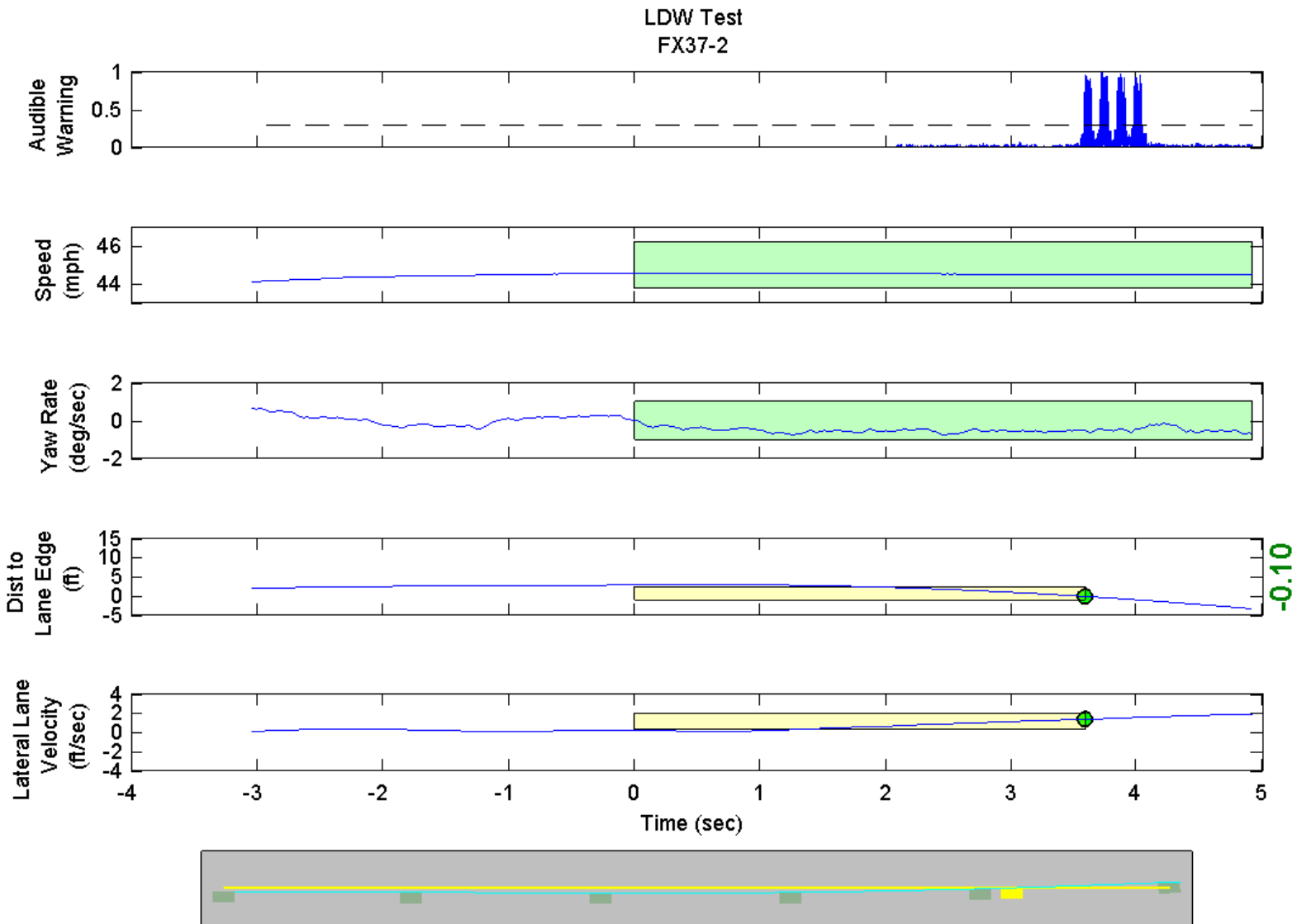

GPS Fix Type: RTK Fixed

Figure D6. Time History for Run 2, Botts Dots, Left Departure, Audible Warning

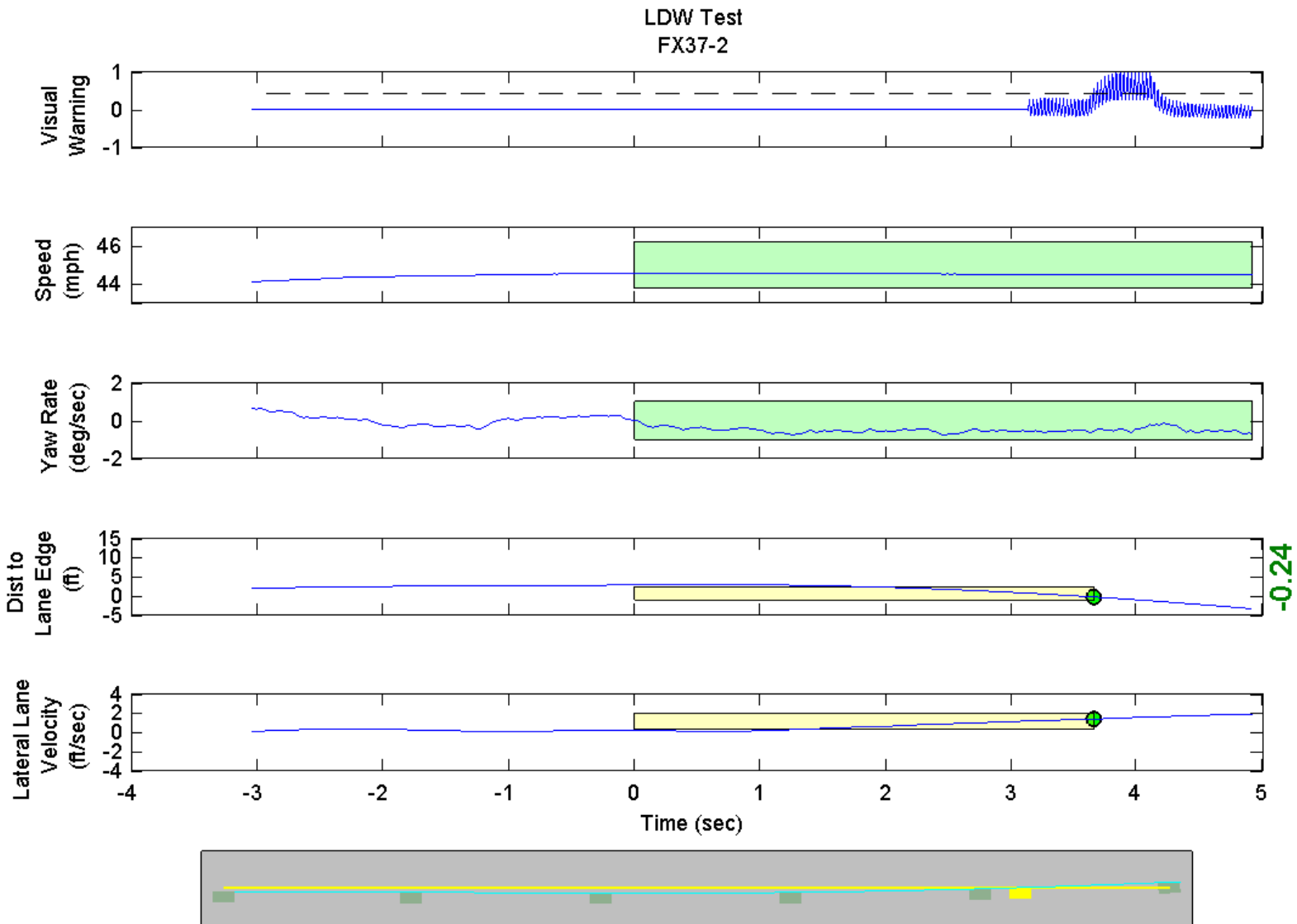

GPS Fix Type: RTK Fixed

Figure D7. Time History for Run 2, Botts Dots, Left Departure, Visual Warning

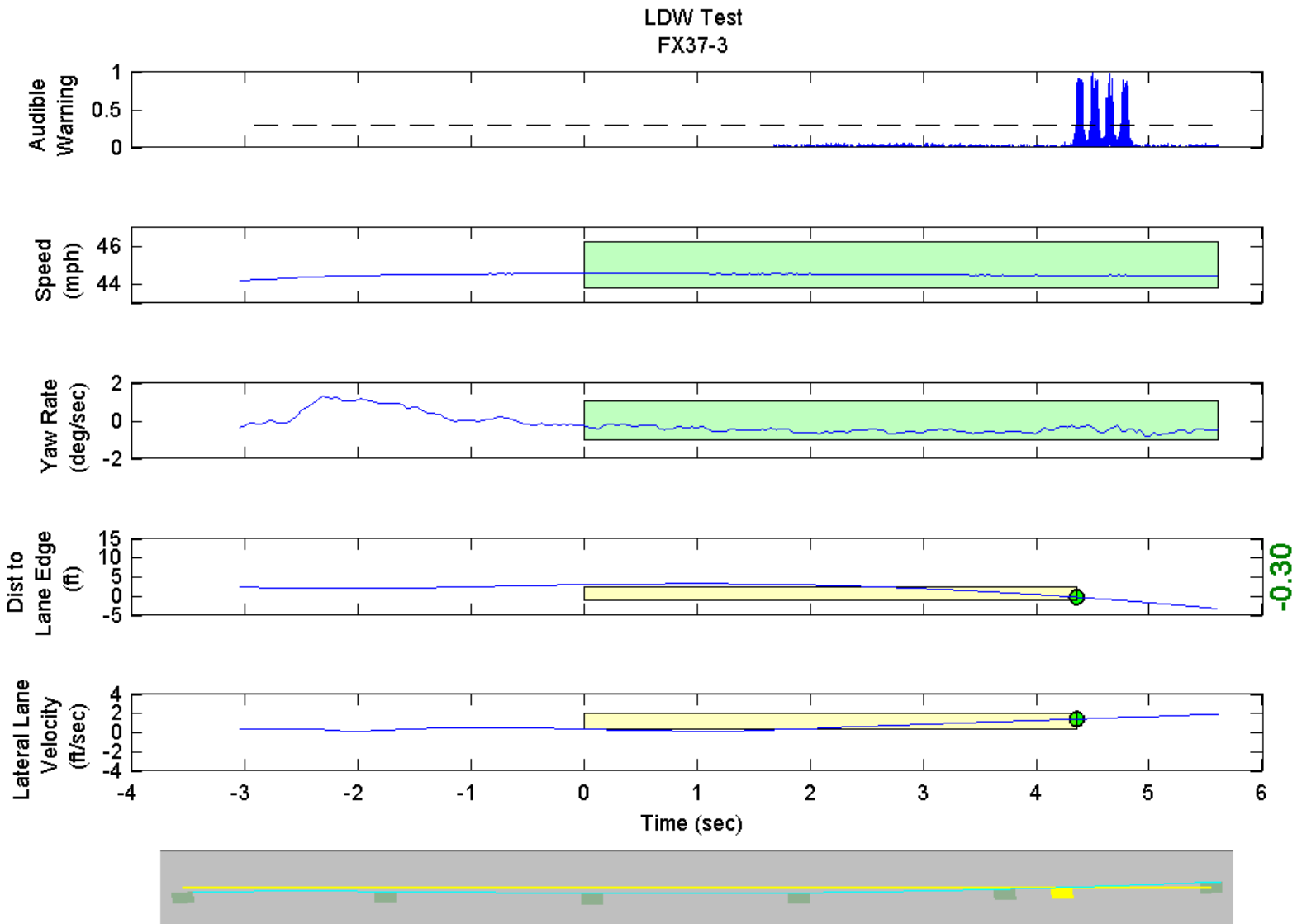

GPS Fix Type: RTK Fixed

Figure D8. Time History for Run 3, Botts Dots, Left Departure, Audible Warning

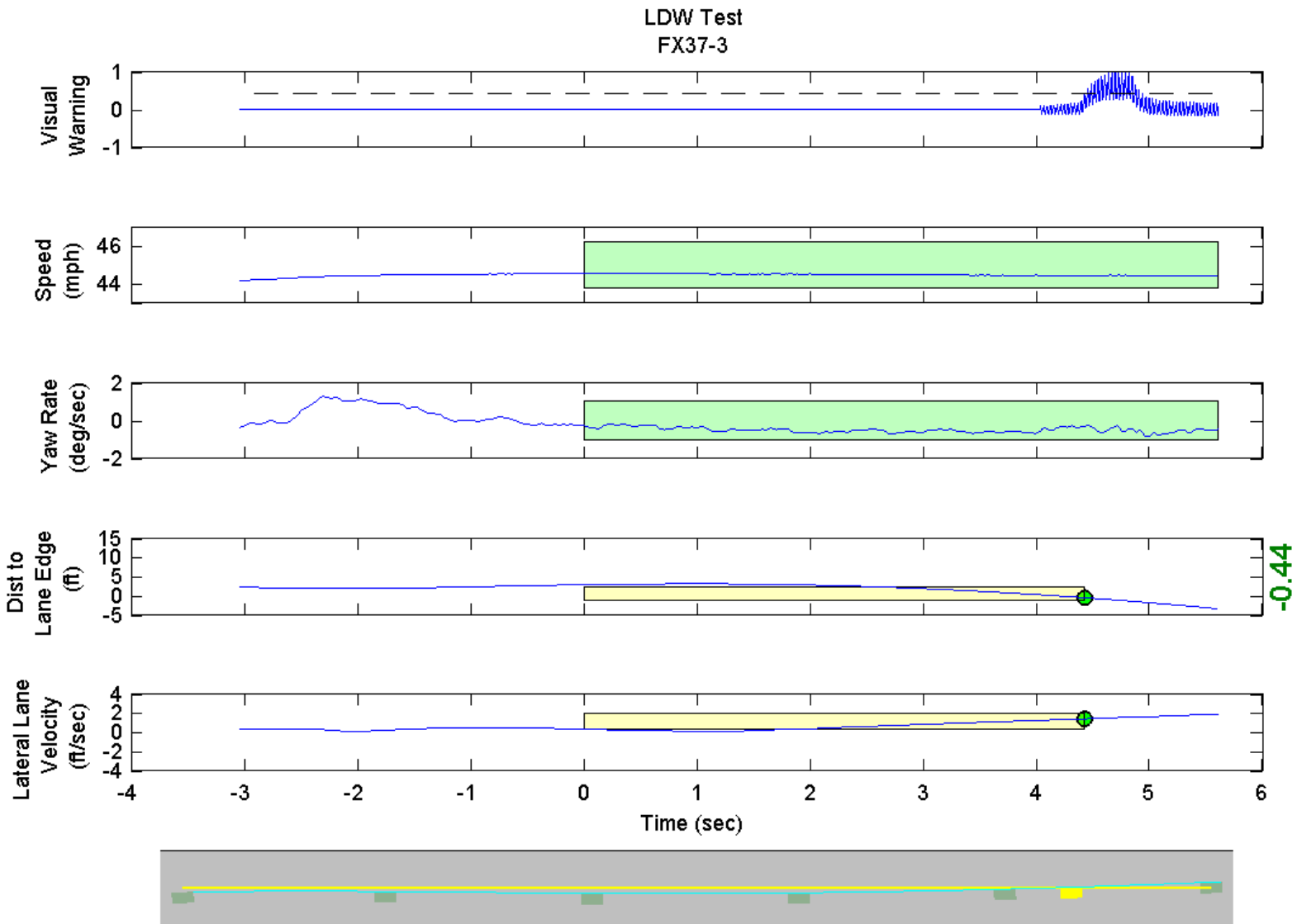

GPS Fix Type: RTK Fixed

Figure D9. Time History for Run 3, Botts Dots, Left Departure, Visual Warning

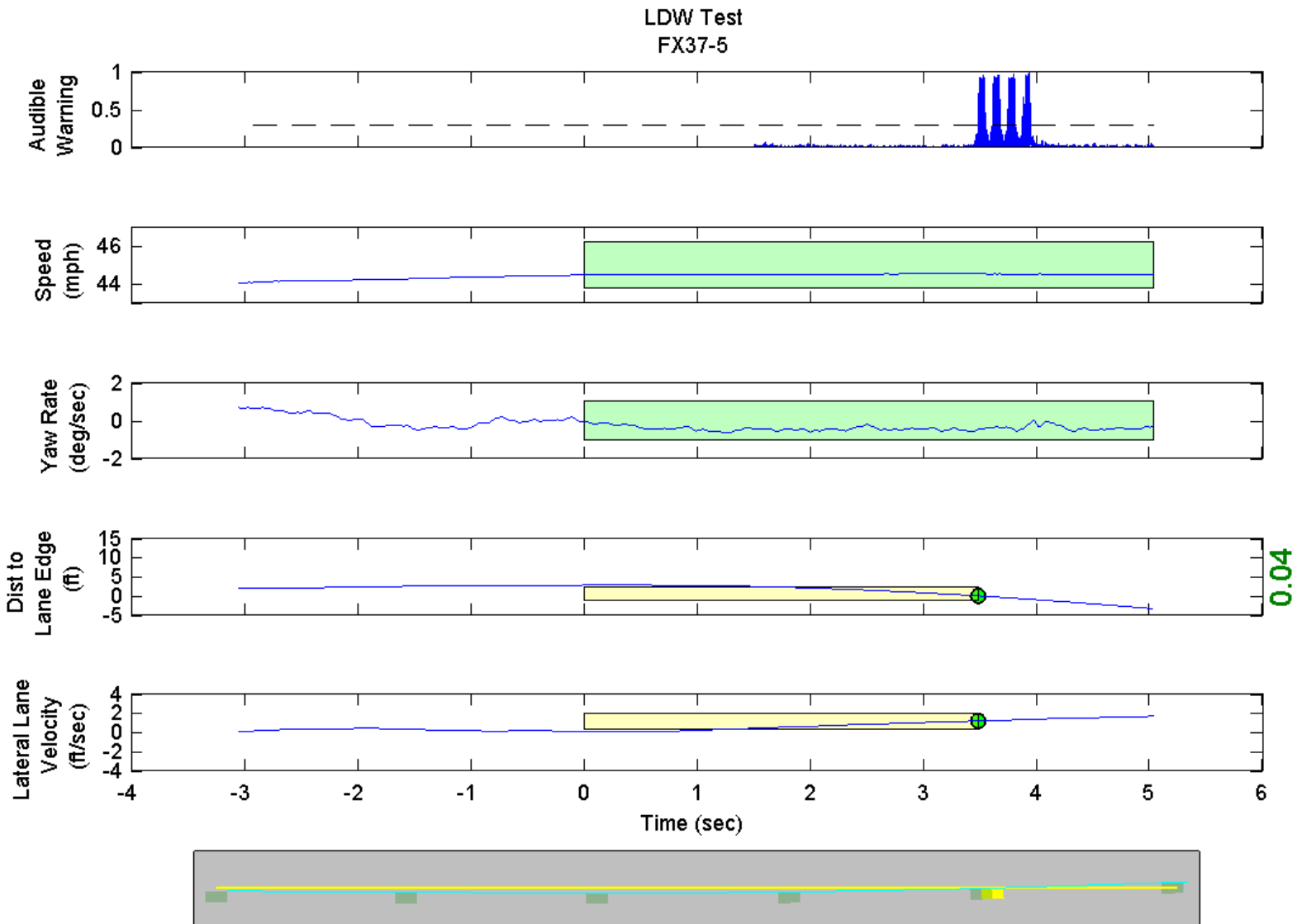

GPS Fix Type: RTK Fixed

Figure D10. Time History for Run 5, Botts Dots, Left Departure, Audible Warning

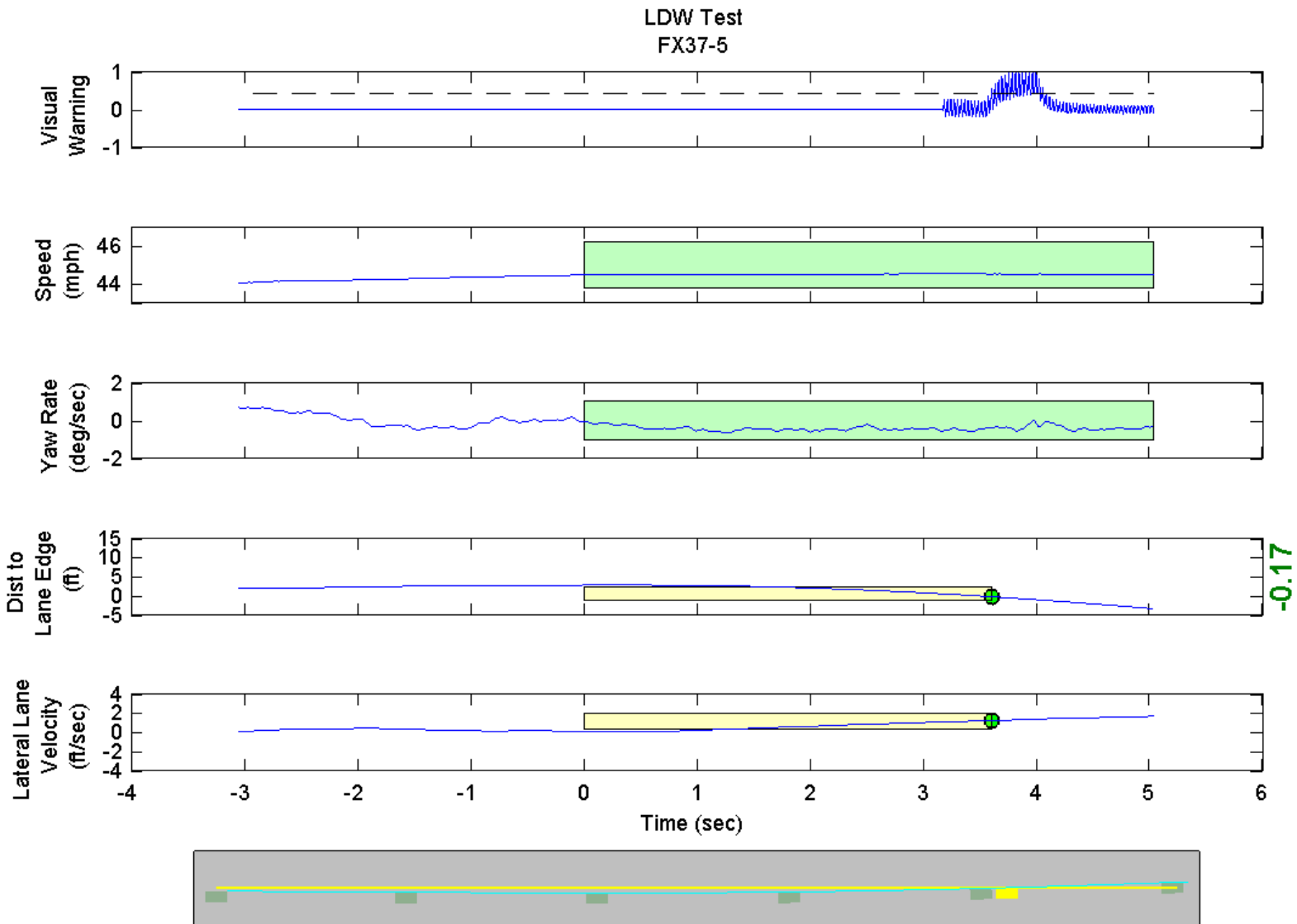

GPS Fix Type: RTK Fixed

Figure D11. Time History for Run 5, Botts Dots, Left Departure, Visual Warning

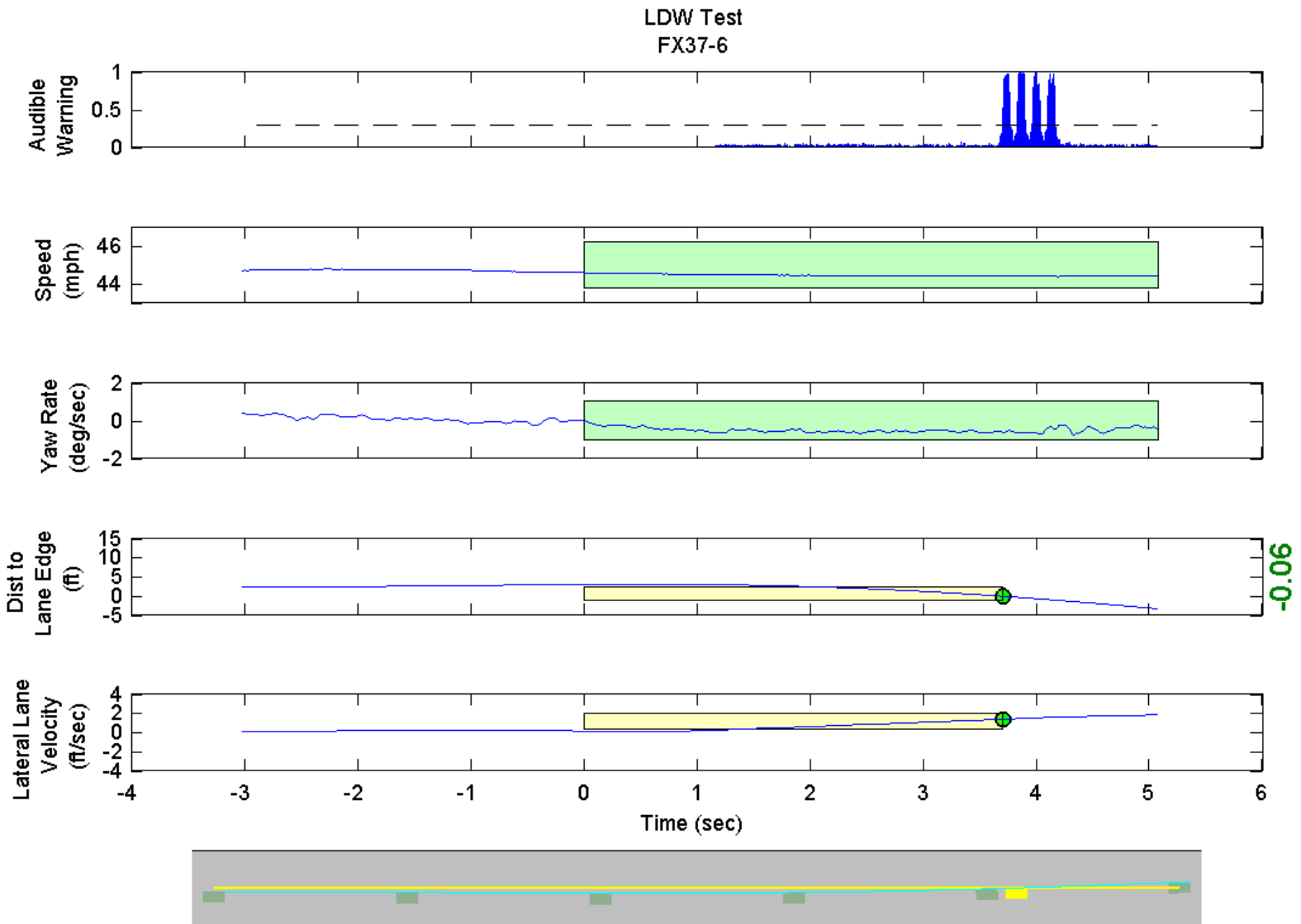

GPS Fix Type: RTK Fixed

Figure D12. Time History for Run 6, Botts Dots, Left Departure, Audible Warning

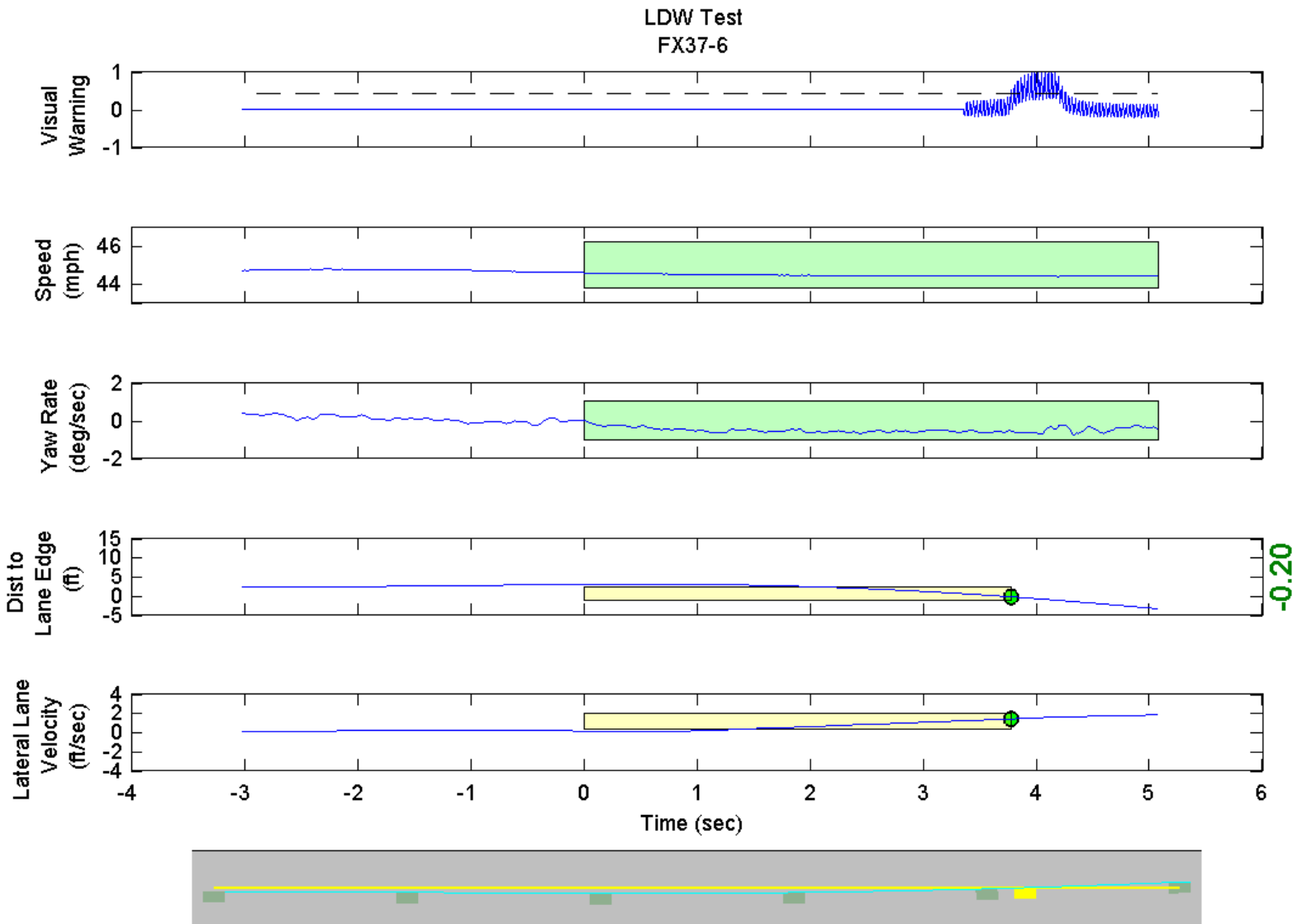

GPS Fix Type: RTK Fixed

Figure D13. Time History for Run 6, Botts Dots, Left Departure, Visual Warning

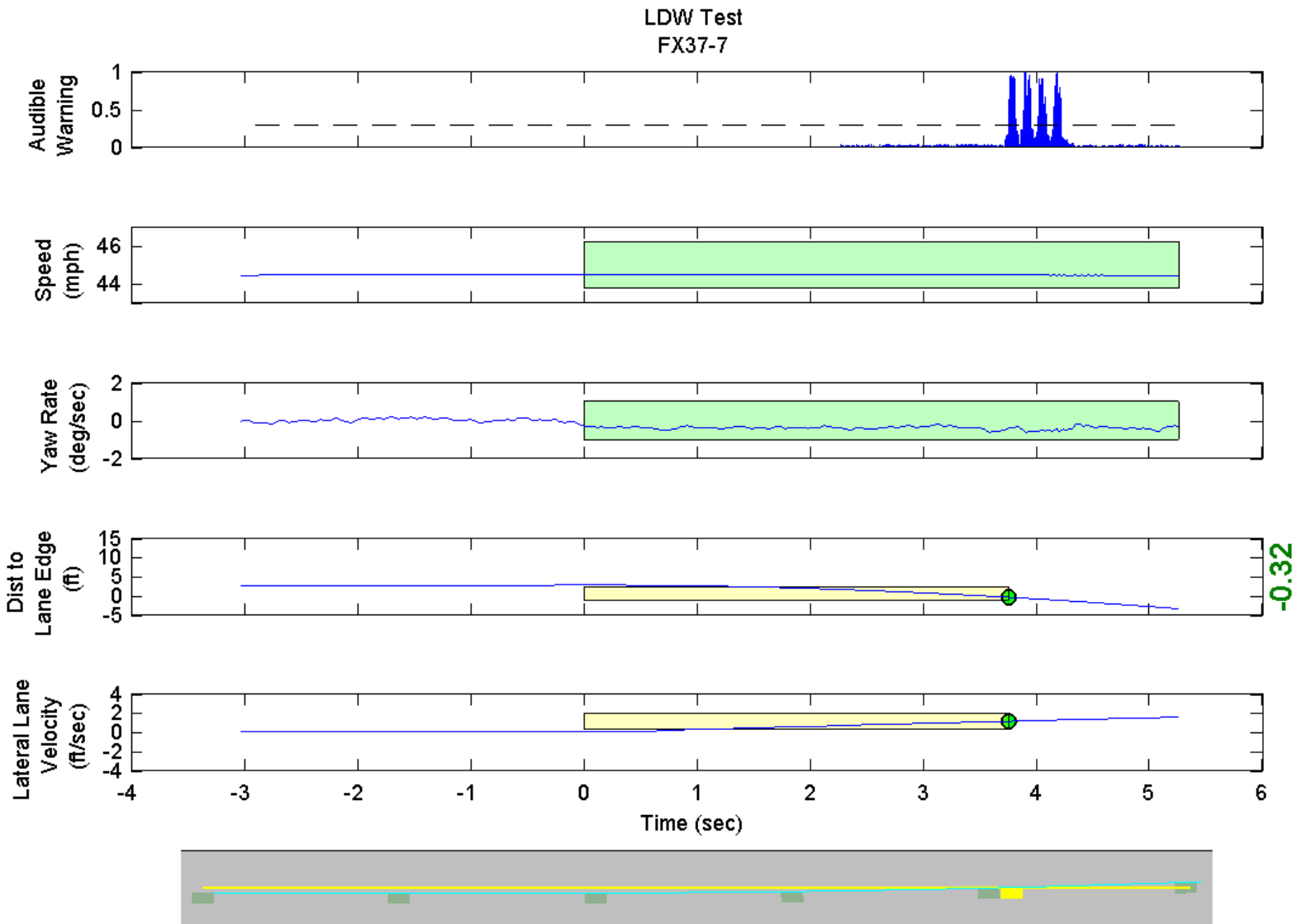

GPS Fix Type: RTK Fixed

Figure D14. Time History for Run 7, Botts Dots, Left Departure, Audible Warning

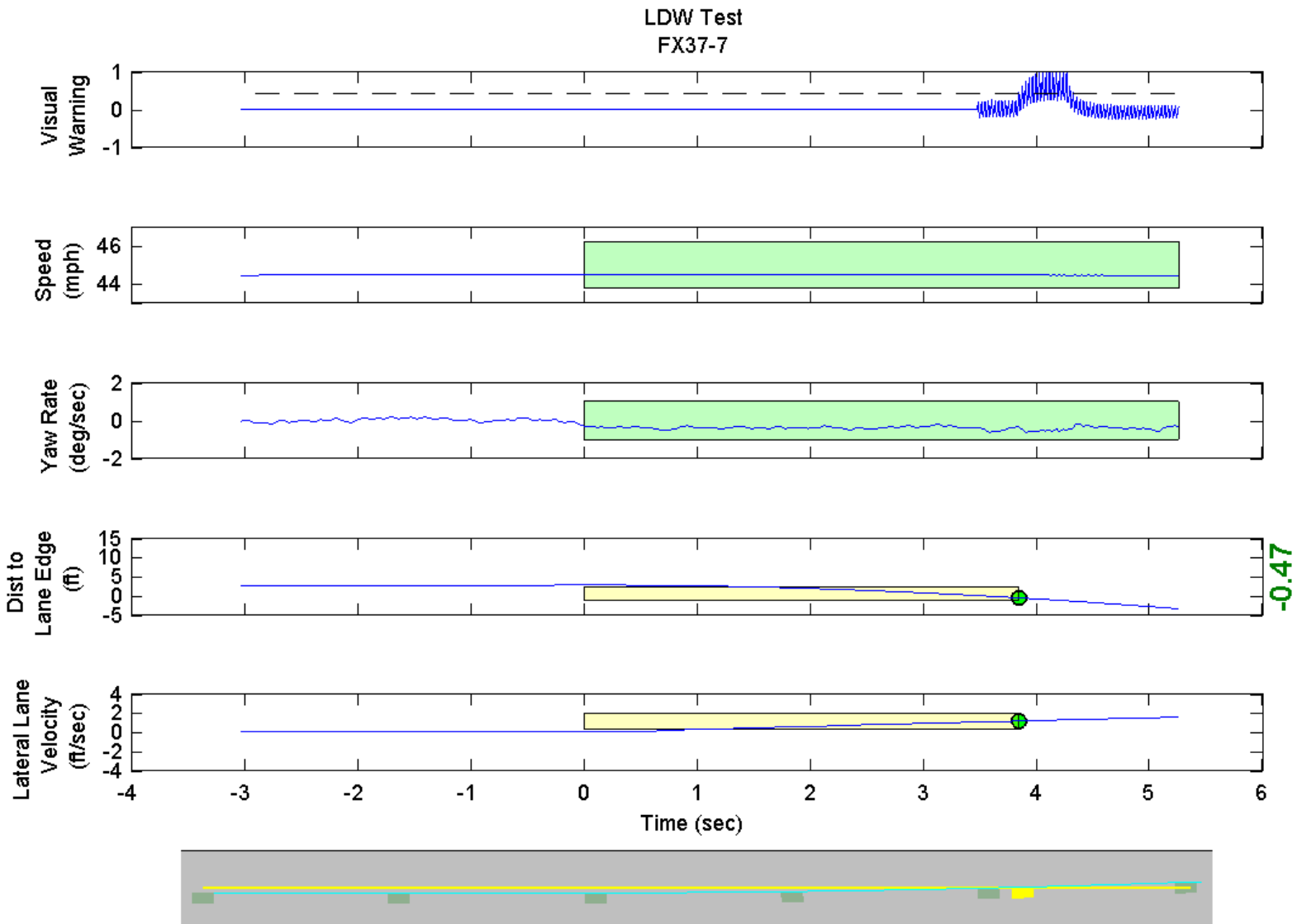

GPS Fix Type: RTK Fixed

Figure D15. Time History for Run 7, Botts Dots, Left Departure, Visual Warning

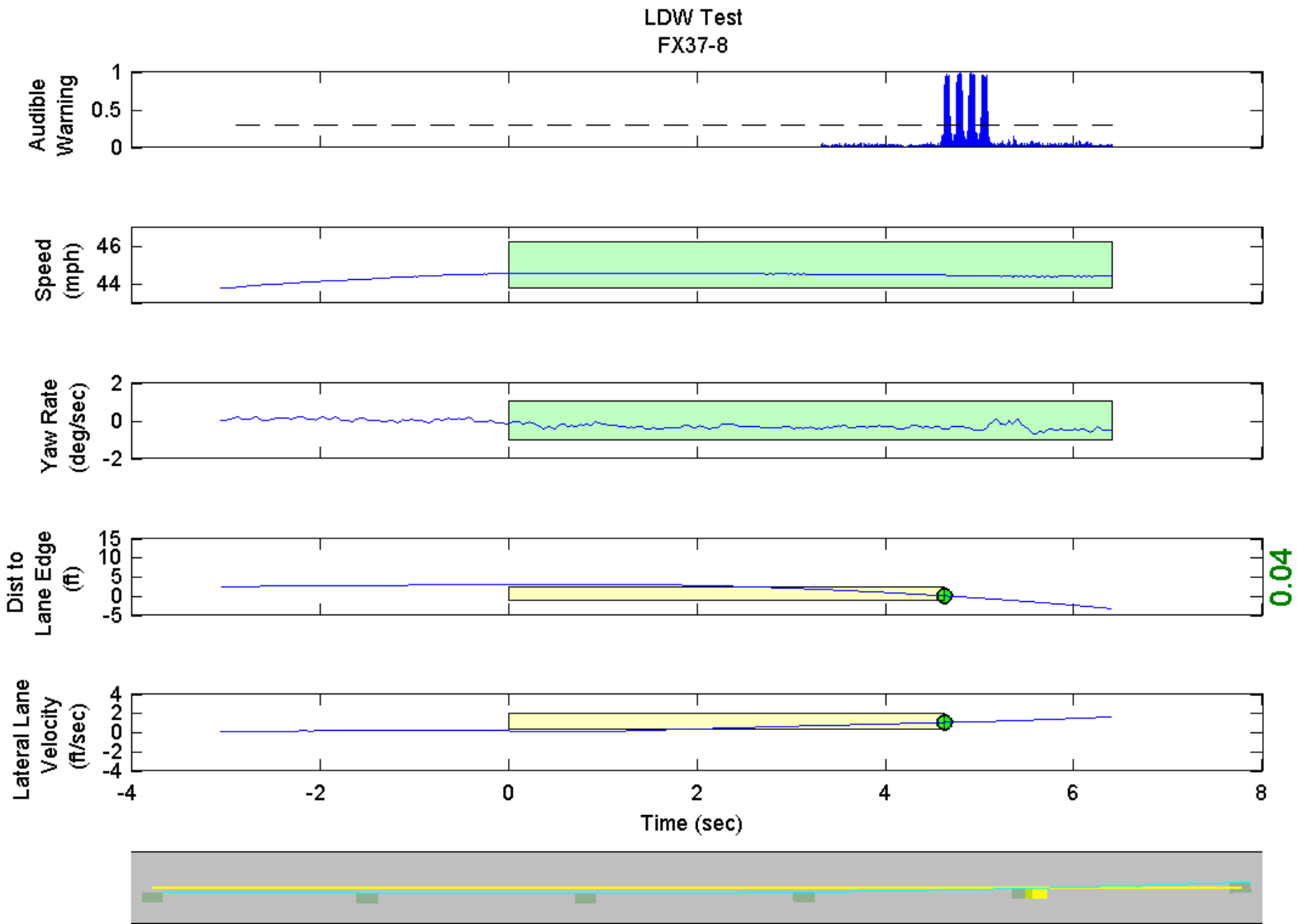

GPS Fix Type: RTK Fixed

Figure D16. Time History for Run 8, Botts Dots, Left Departure, Audible Warning

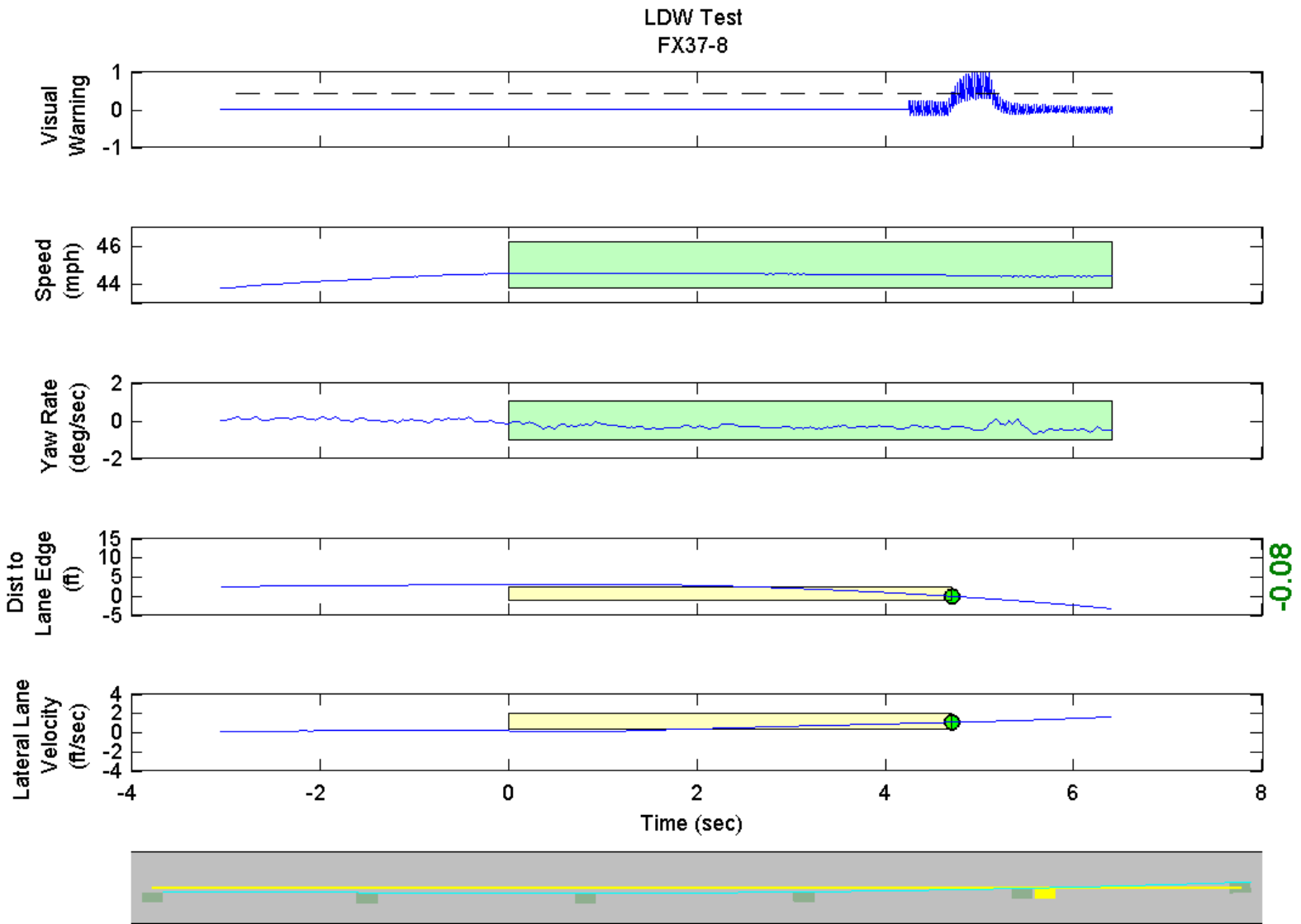

GPS Fix Type: RTK Fixed

Figure D17. Time History for Run 8, Botts Dots, Left Departure, Visual Warning

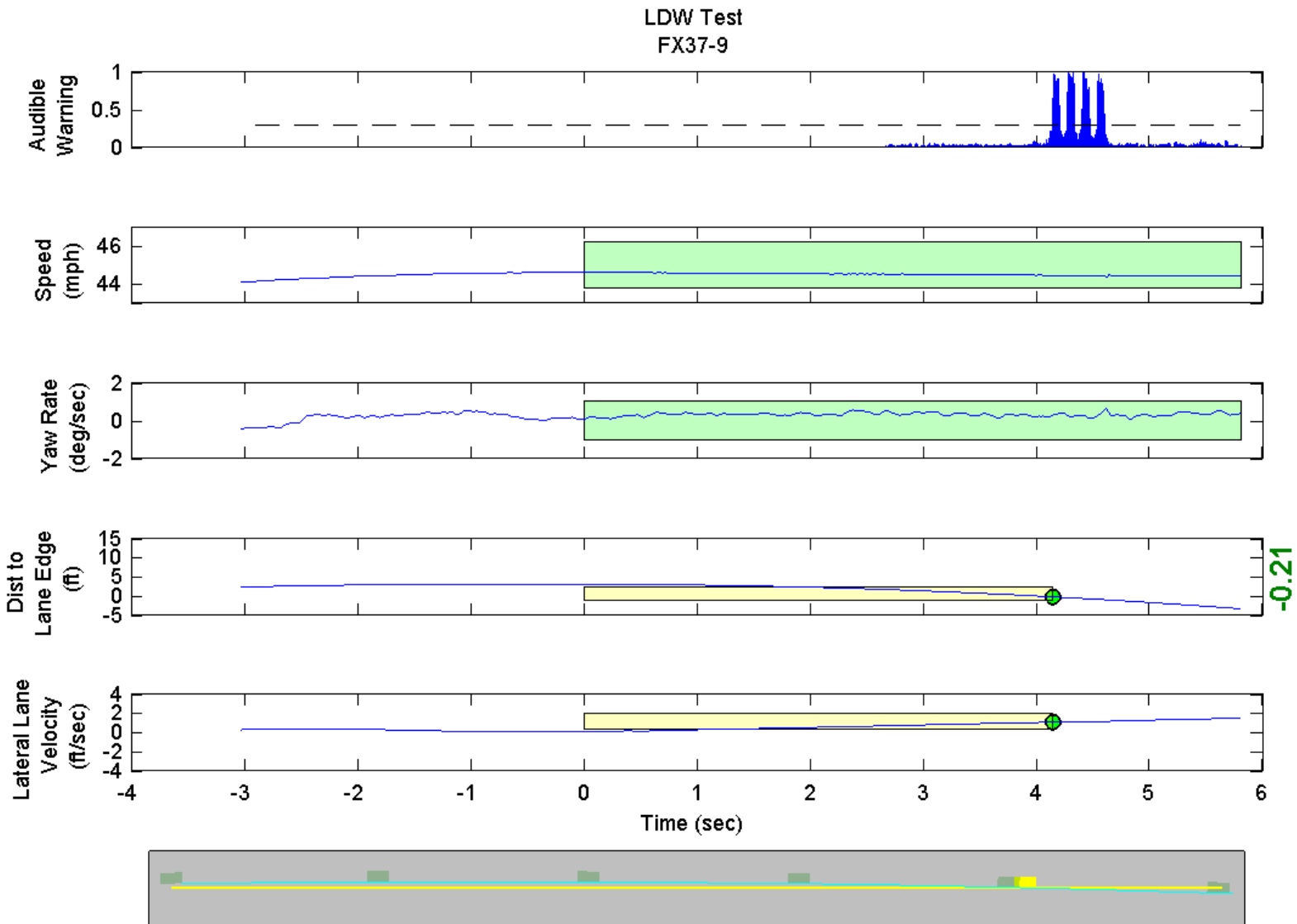

GPS Fix Type: RTK Fixed

Figure D18. Time History for Run 9, Botts Dots, Right Departure, Audible Warning

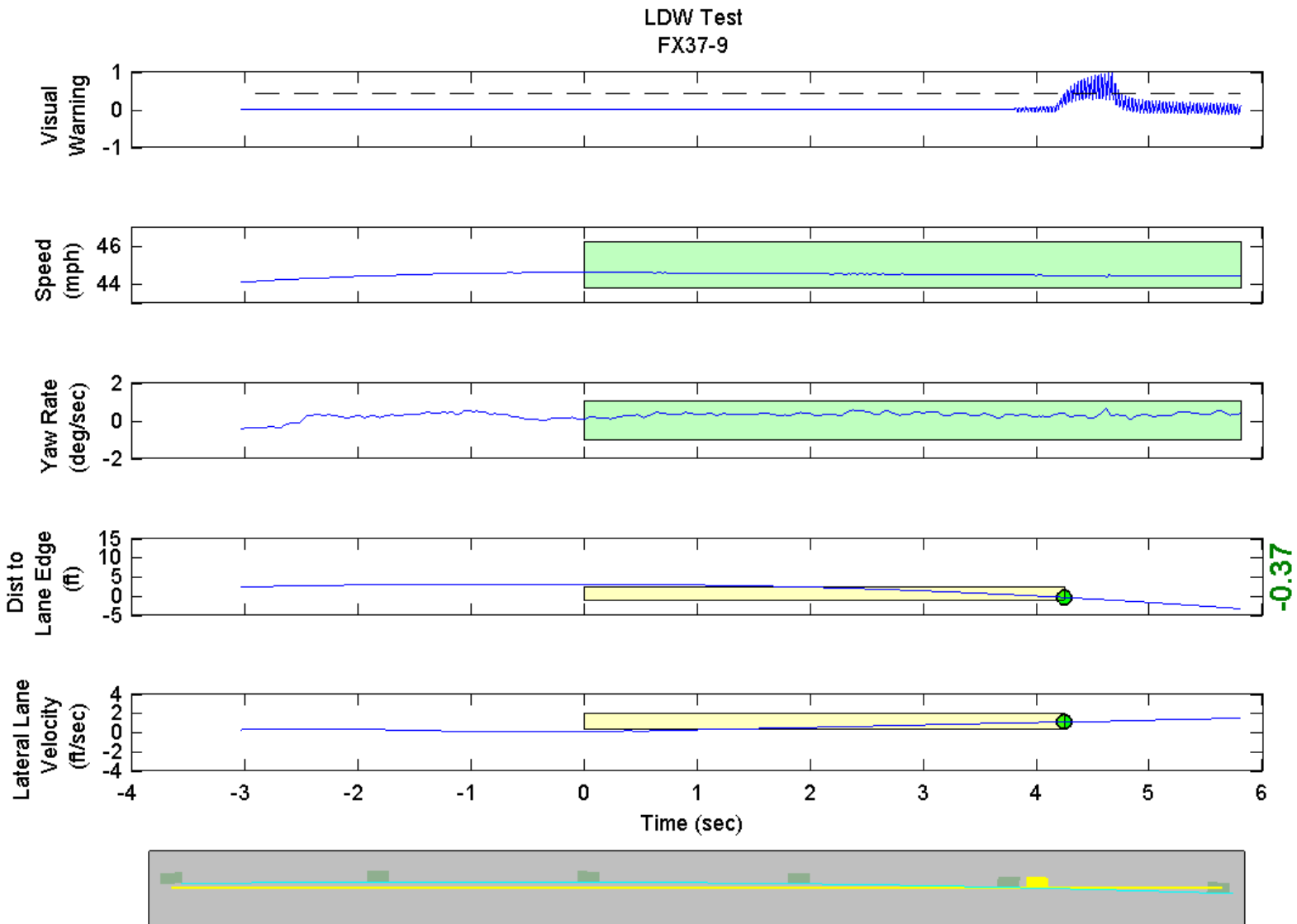

GPS Fix Type: RTK Fixed

Figure D19. Time History for Run 9, Botts Dots, Right Departure, Visual Warning

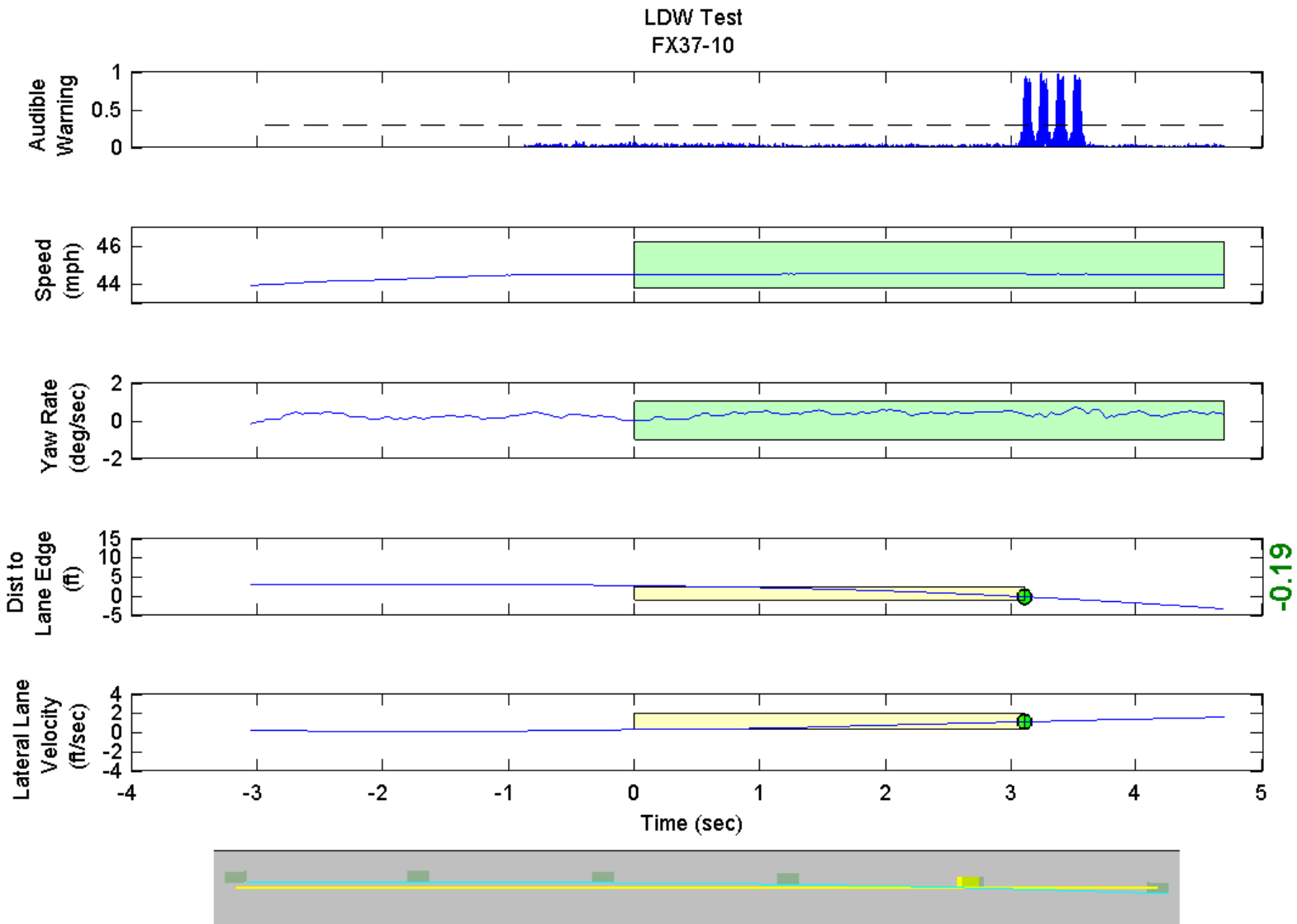

GPS Fix Type: RTK Fixed

Figure D20. Time History for Run 10, Botts Dots, Right Departure, Audible Warning

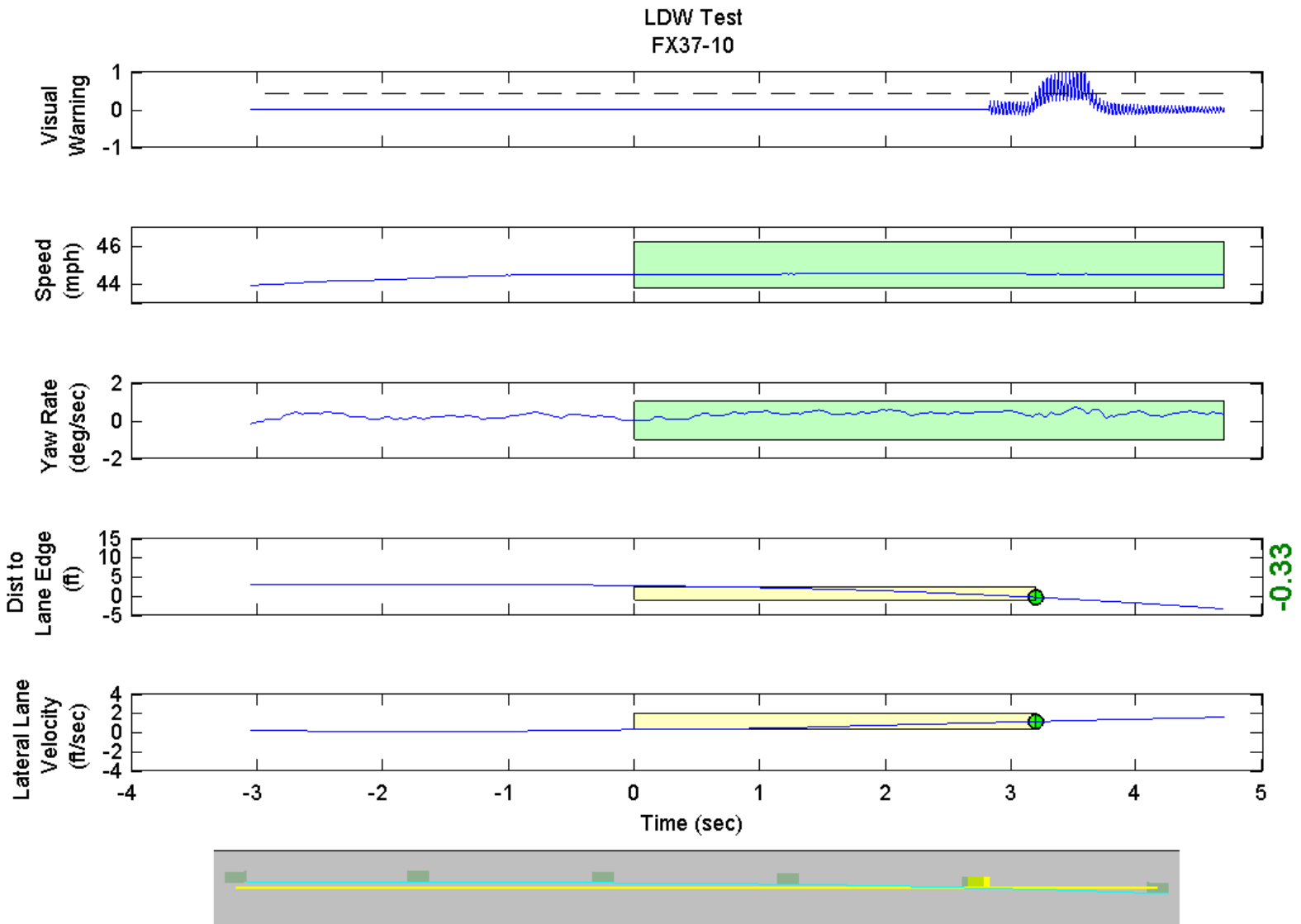

GPS Fix Type: RTK Fixed

Figure D21. Time History for Run 10, Botts Dots, Right Departure, Visual Warning

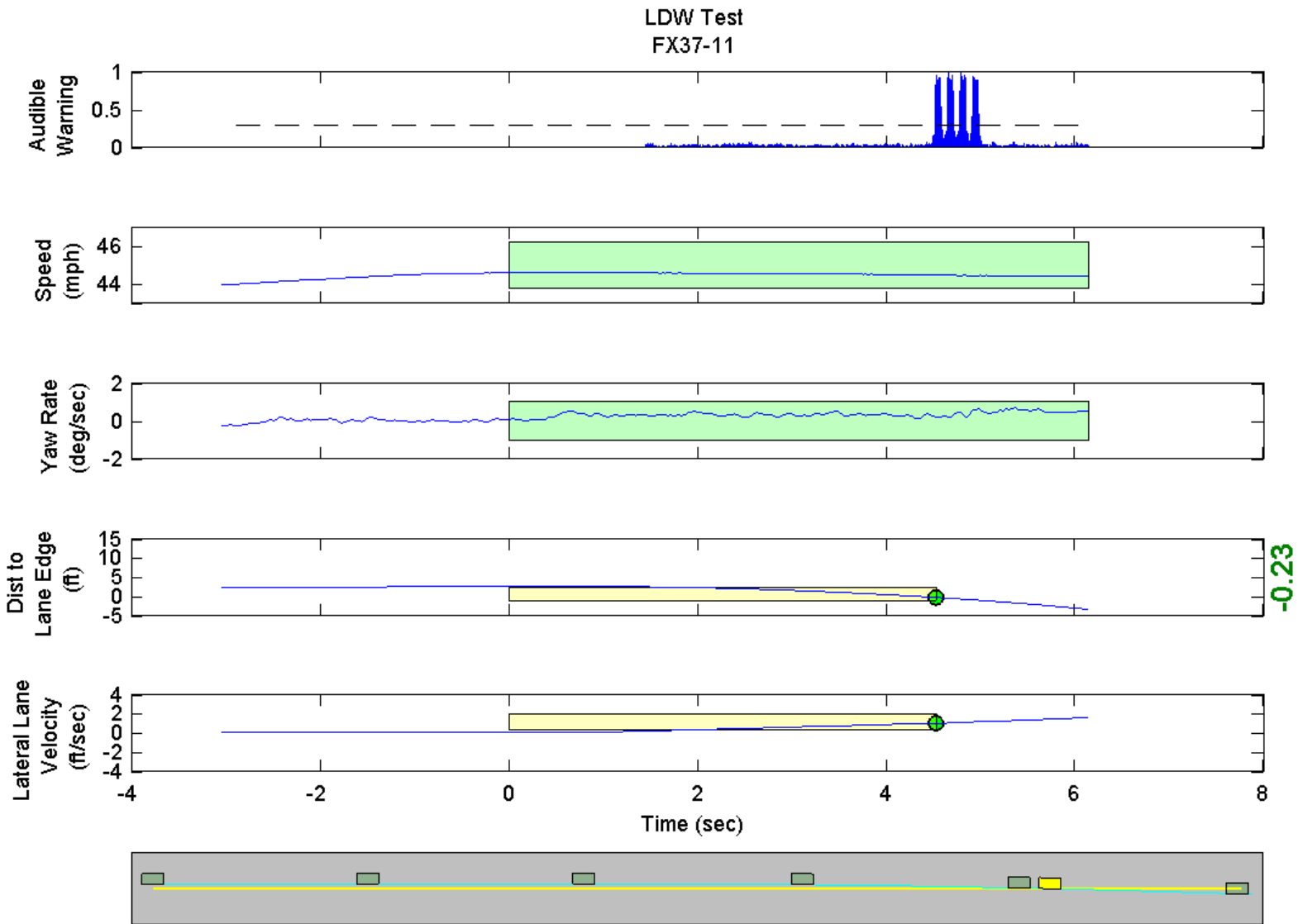

GPS Fix Type: RTK Fixed

Figure D22. Time History for Run 11, Botts Dots, Right Departure, Audible Warning

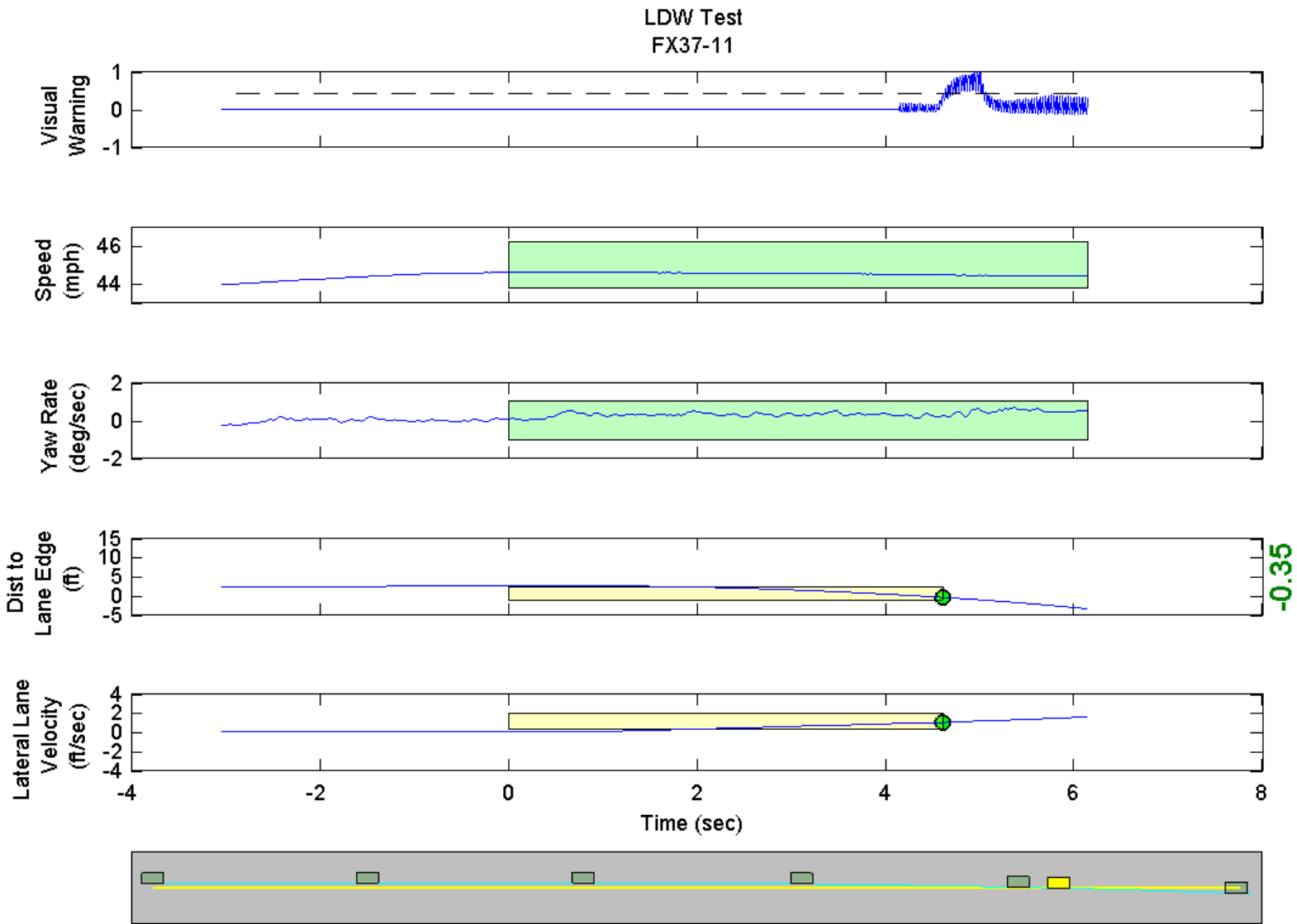

GPS Fix Type: RTK Fixed

Figure D23. Time History for Run 11, Botts Dots, Right Departure, Visual Warning

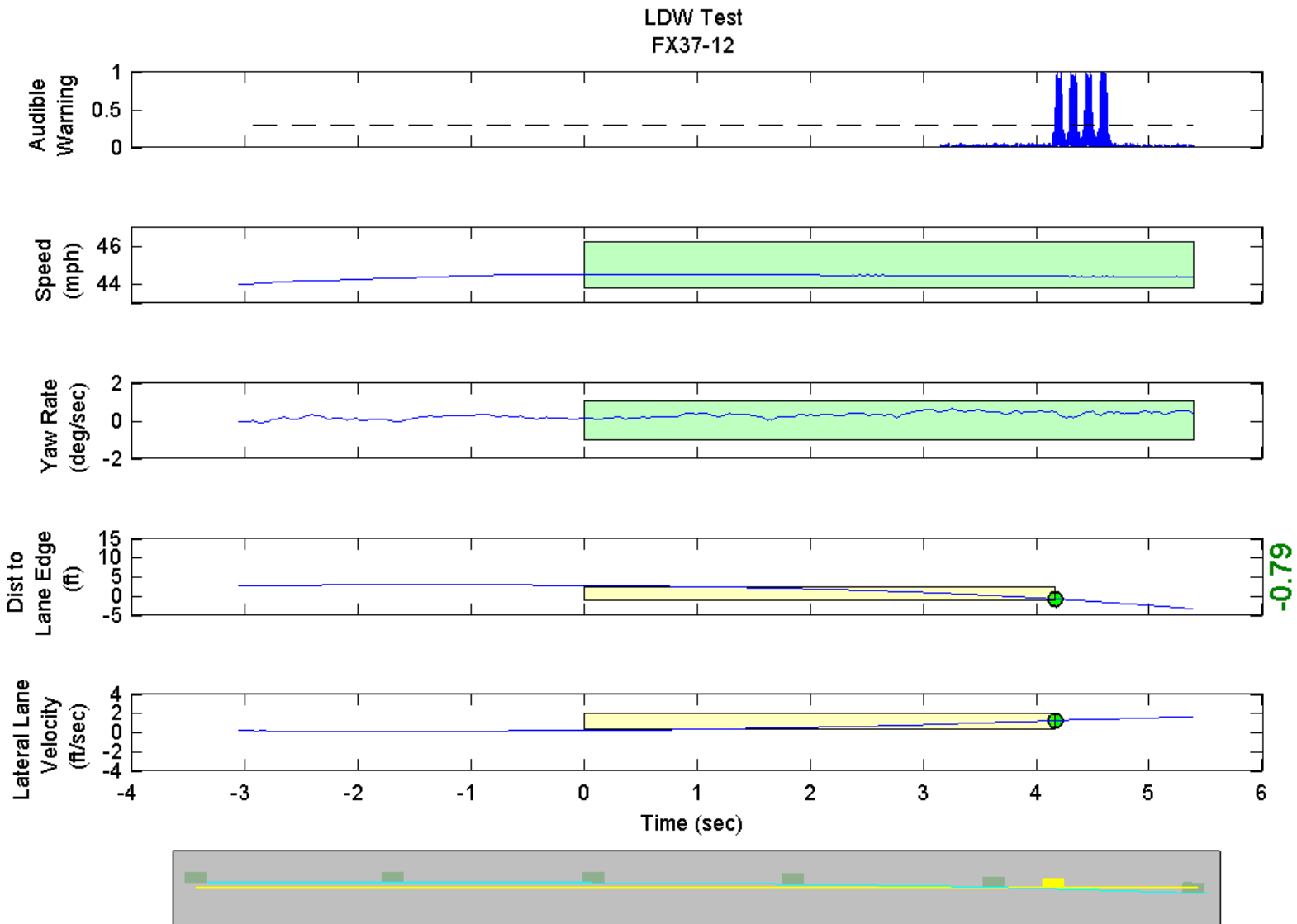

GPS Fix Type: RTK Fixed

Figure D24. Time History for Run 12, Botts Dots, Right Departure, Audible Warning

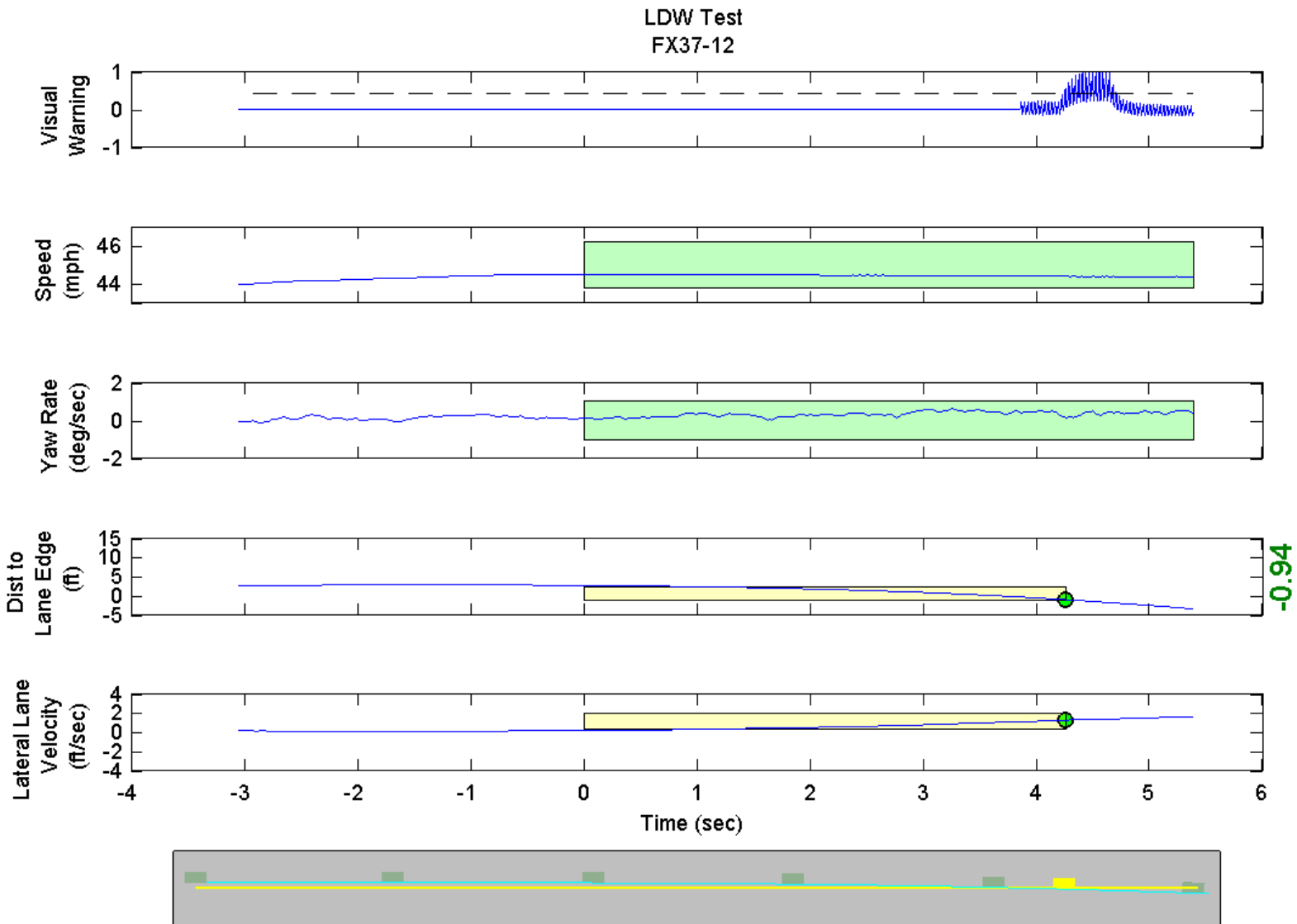

GPS Fix Type: RTK Fixed

Figure D25. Time History for Run 12, Botts Dots, Right Departure, Visual Warning

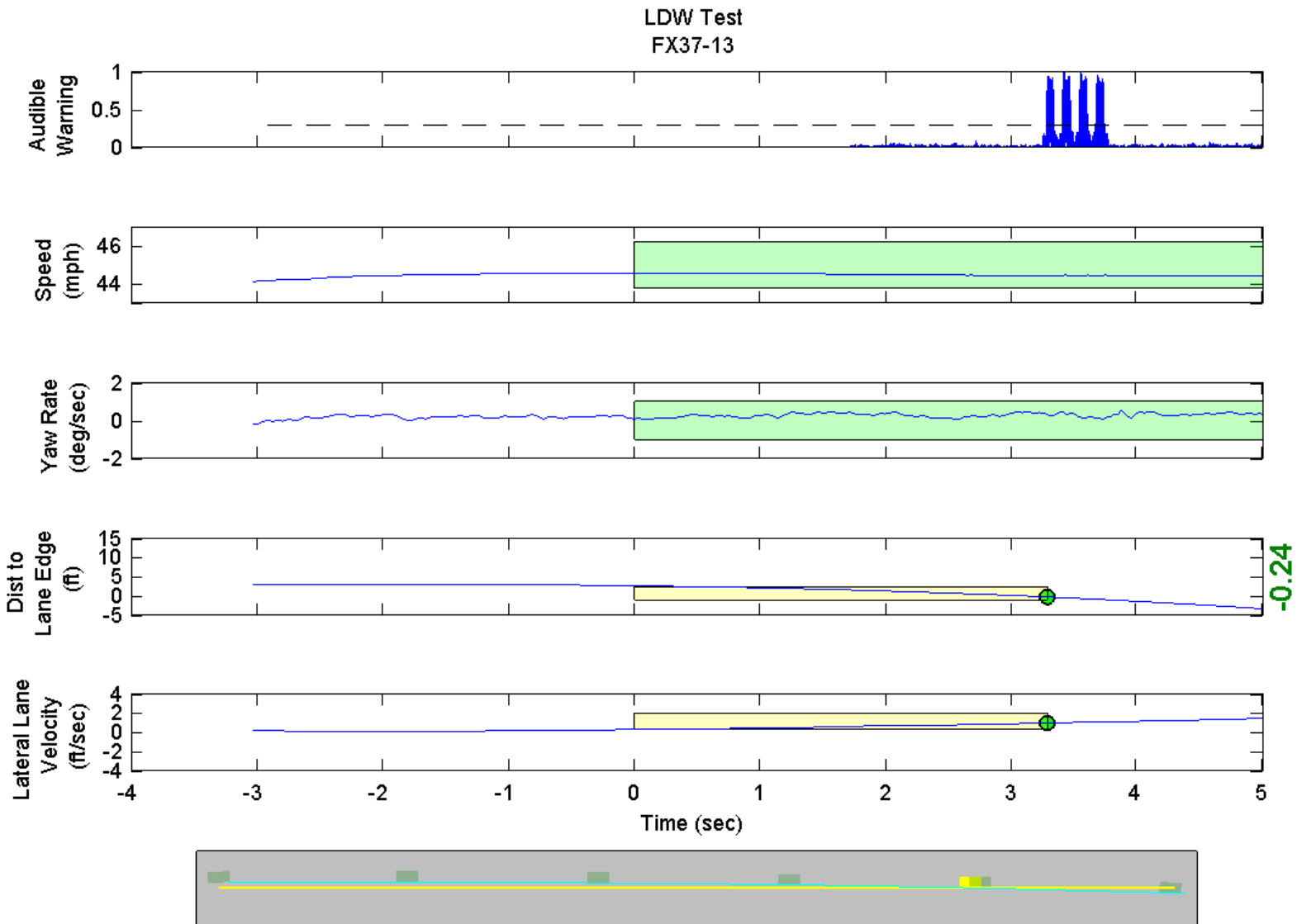

GPS Fix Type: RTK Fixed

Figure D26. Time History for Run 13, Botts Dots, Right Departure, Audible Warning

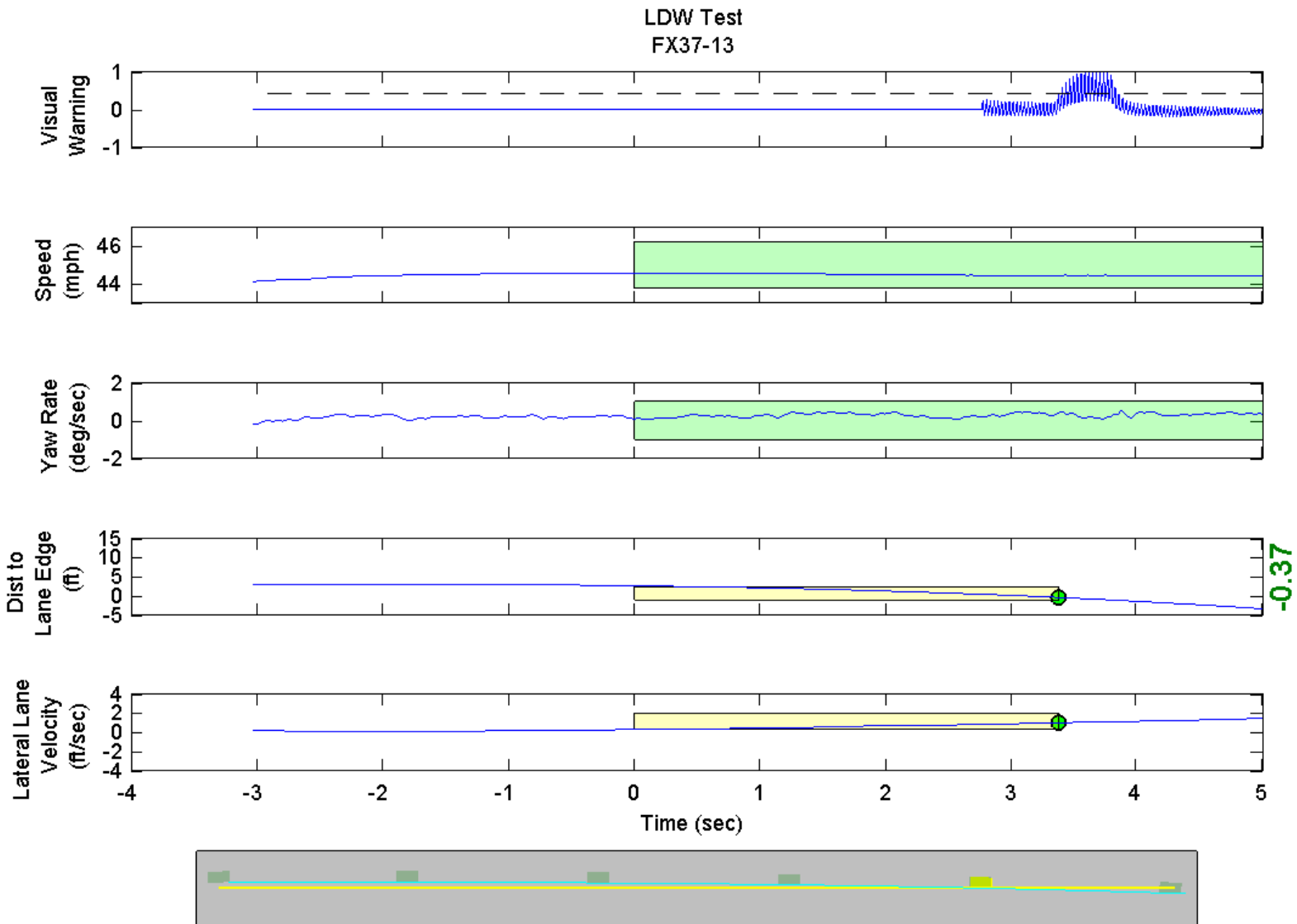

GPS Fix Type: RTK Fixed

Figure D27. Time History for Run 13, Botts Dots, Right Departure, Visual Warning

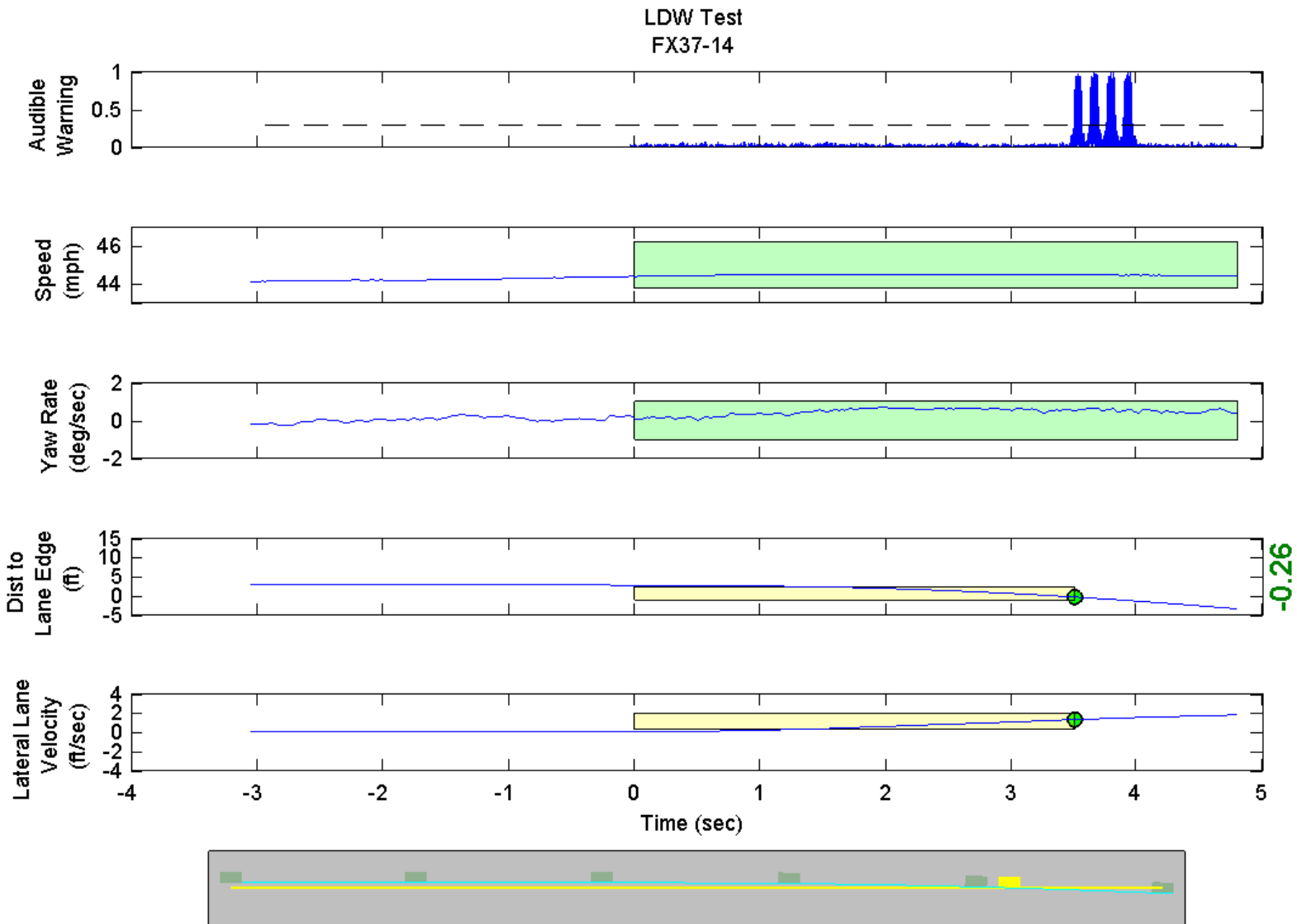

GPS Fix Type: RTK Fixed

Figure D28. Time History for Run 14, Botts Dots, Right Departure, Audible Warning

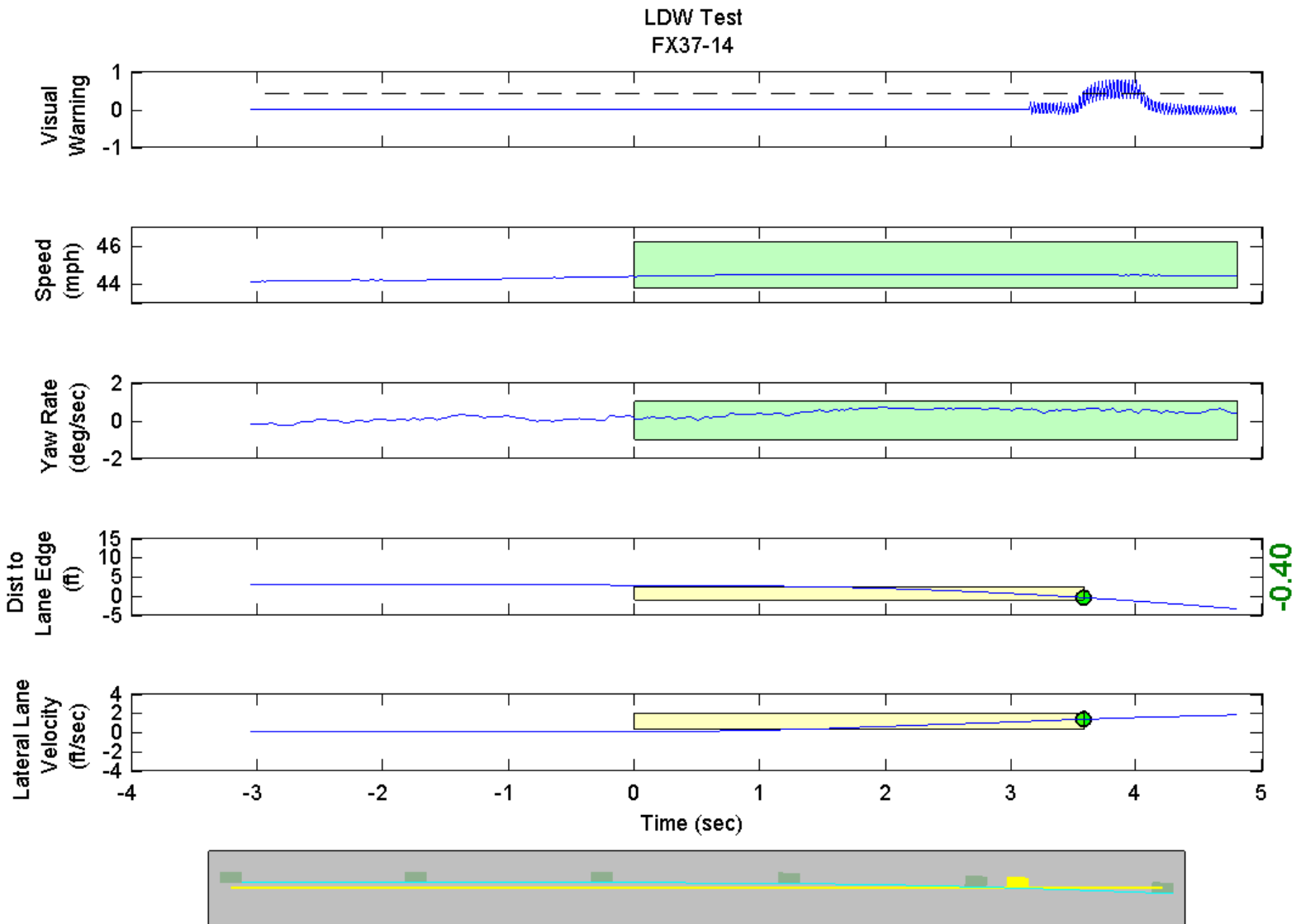

GPS Fix Type: RTK Fixed

Figure D29. Time History for Run 14, Botts Dots, Right Departure, Visual Warning

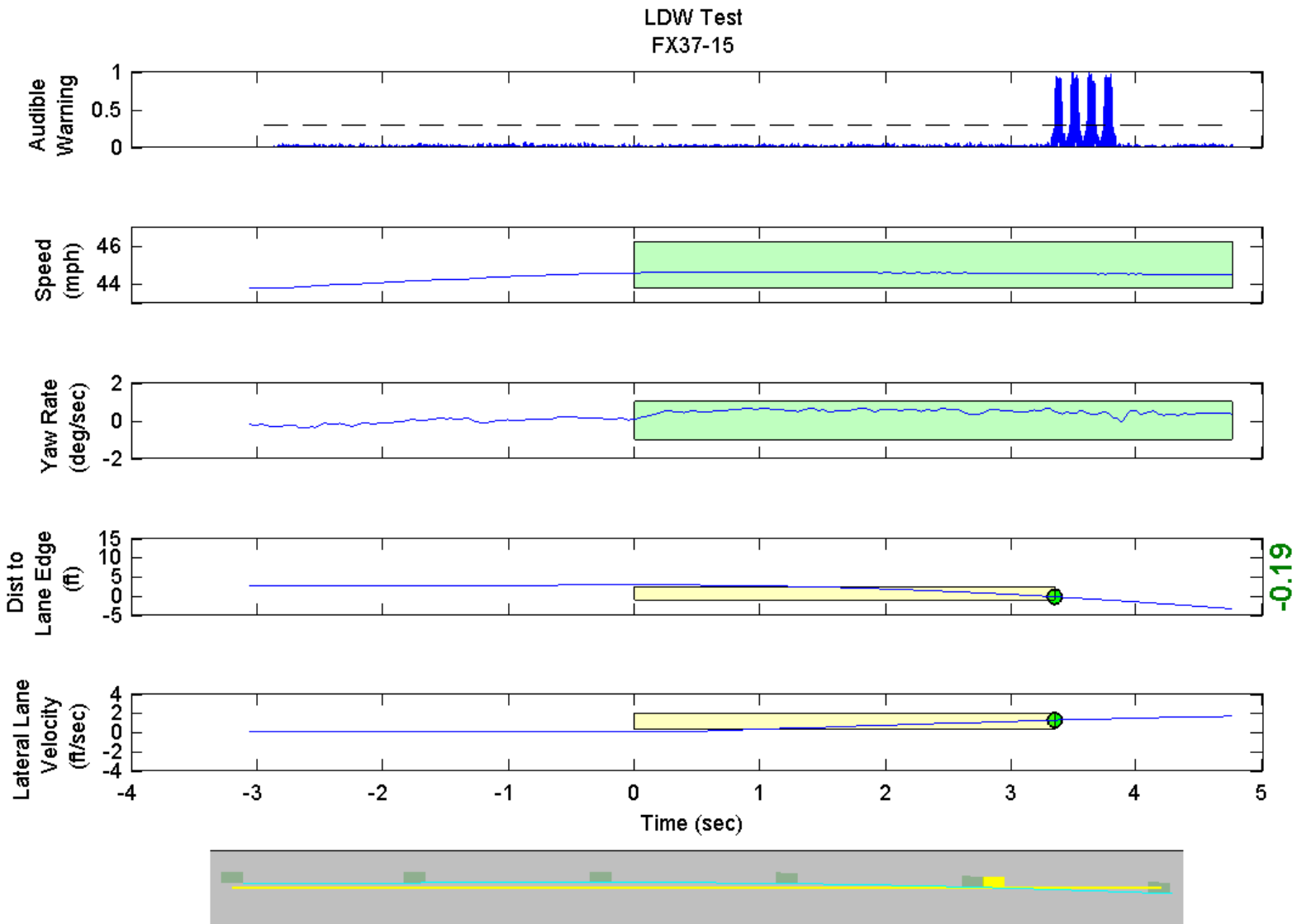

GPS Fix Type: RTK Fixed

Figure D30. Time History for Run 15, Botts Dots, Right Departure, Audible Warning

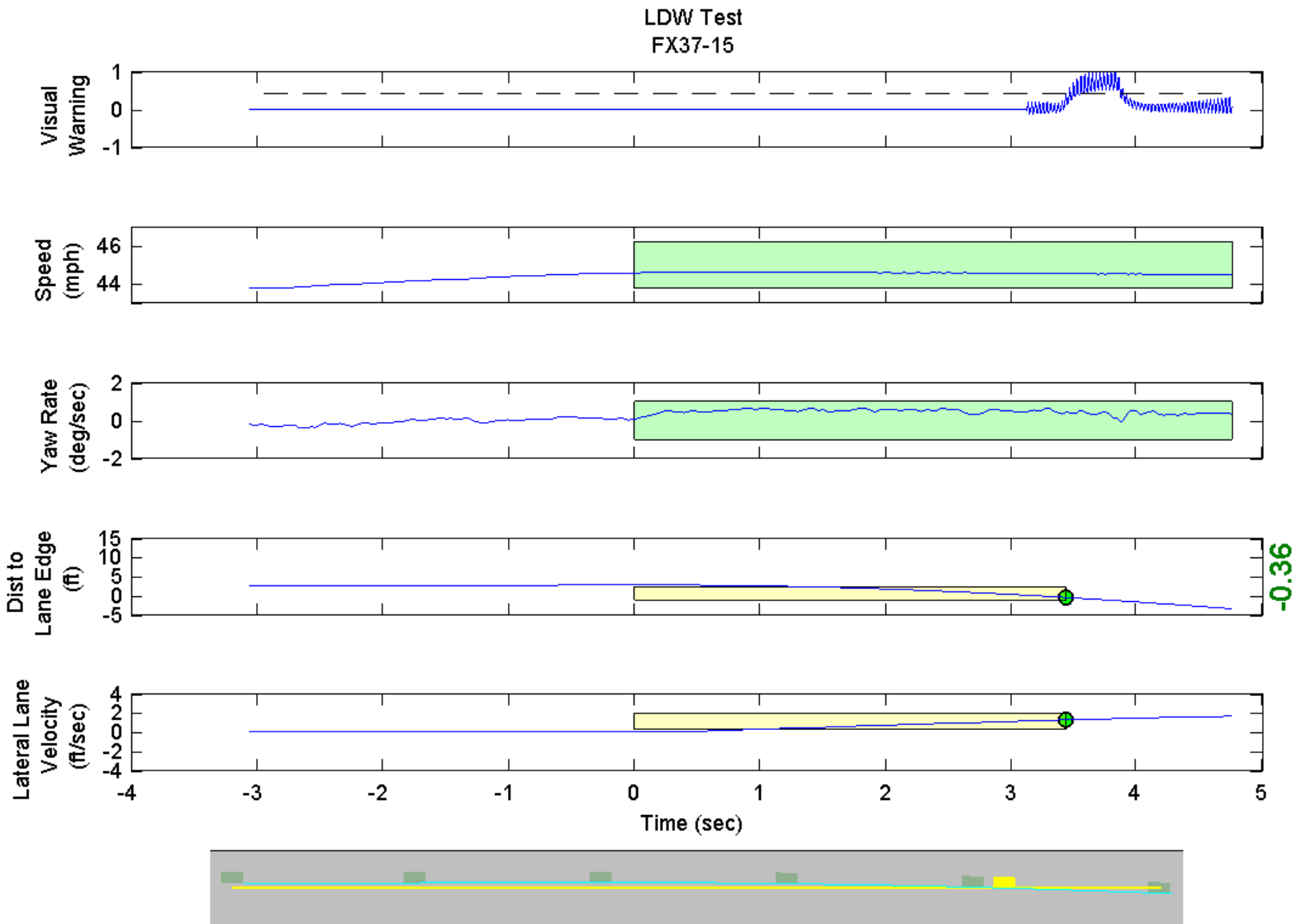

GPS Fix Type: RTK Fixed

Figure D31. Time History for Run 15, Botts Dots, Right Departure, Visual Warning

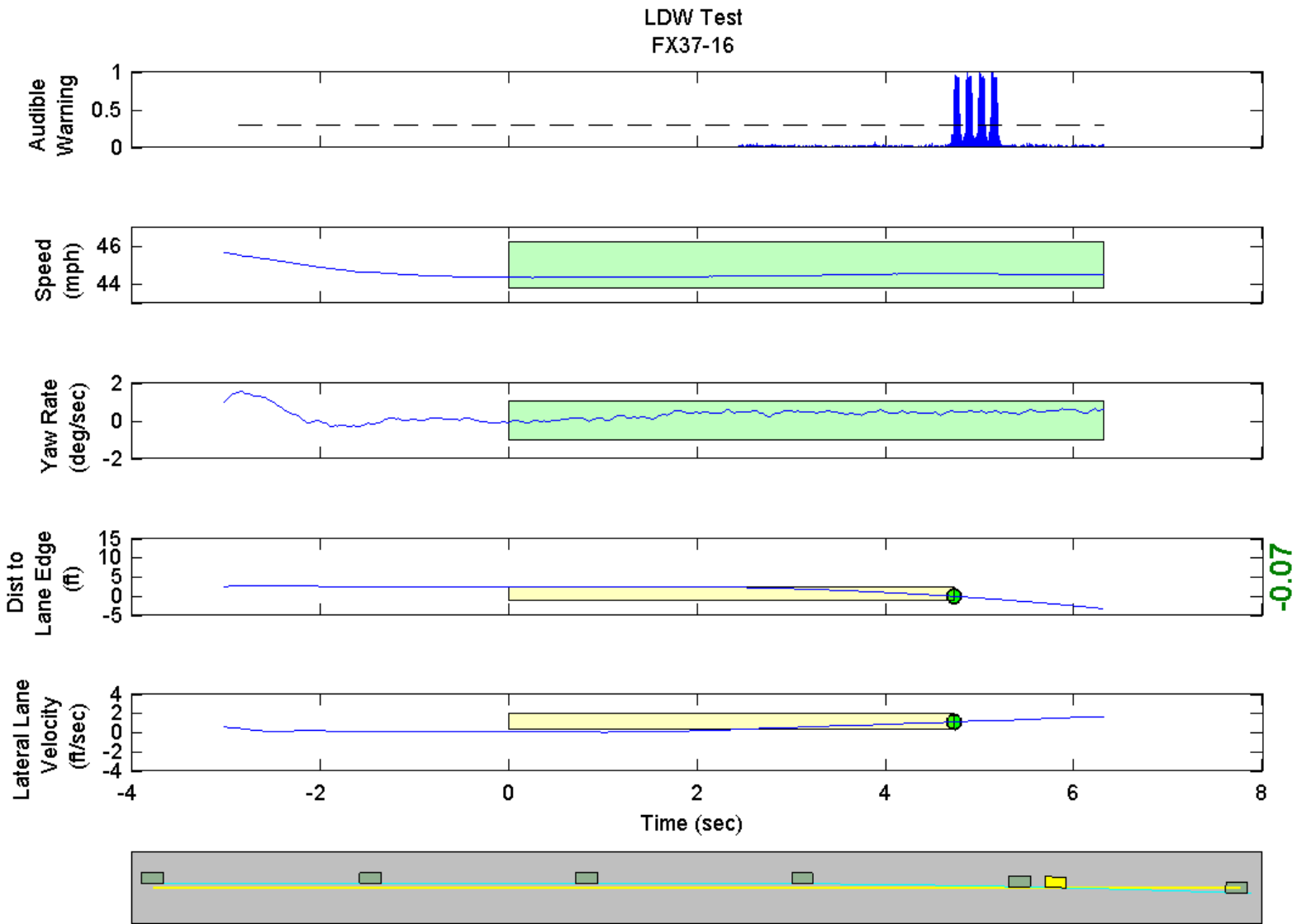

GPS Fix Type: RTK Fixed

Figure D32. Time History for Run 16, Solid Line, Right Departure, Audible Warning

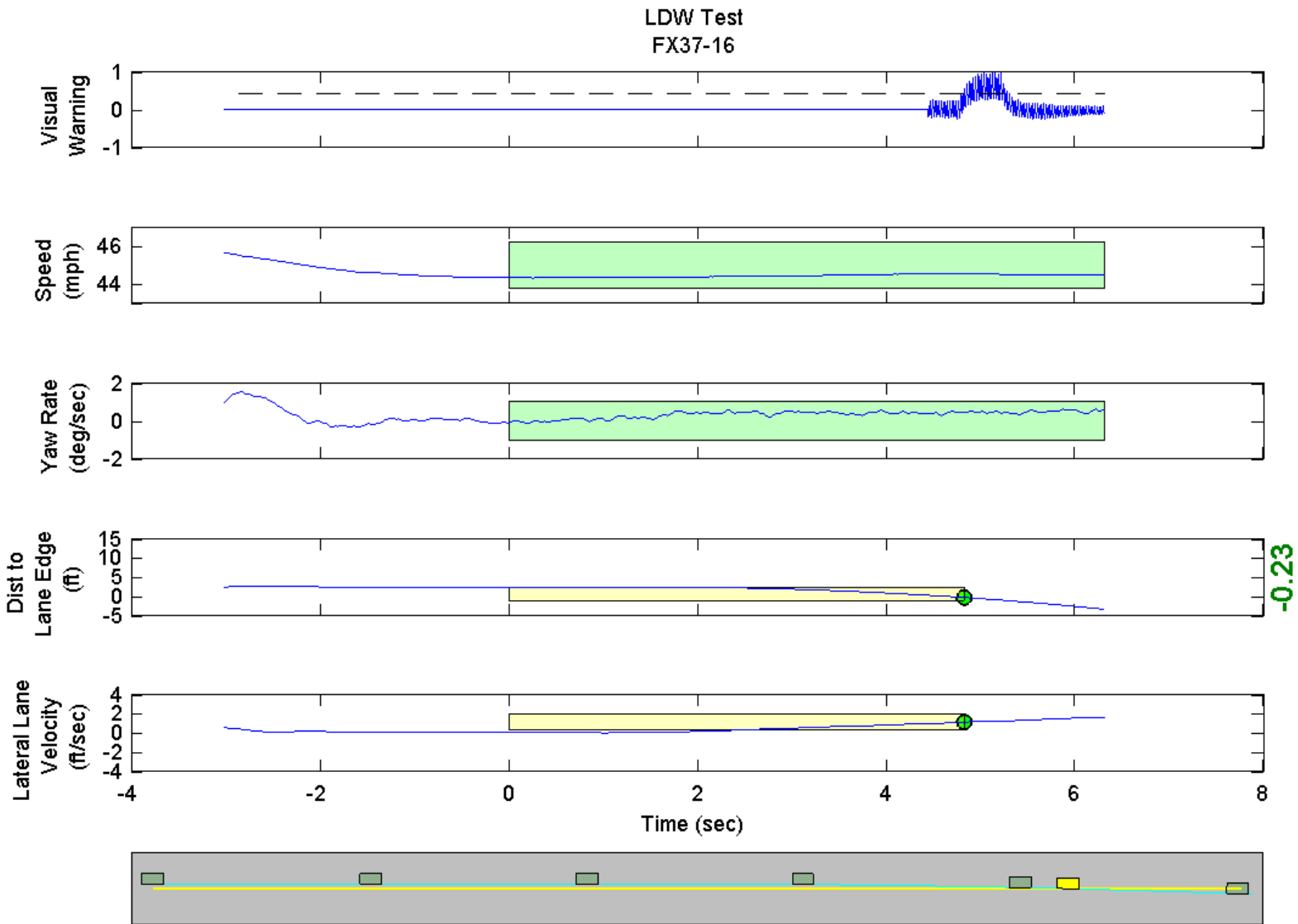

GPS Fix Type: RTK Fixed

Figure D33. Time History for Run 16, Solid Line, Right Departure, Visual Warning

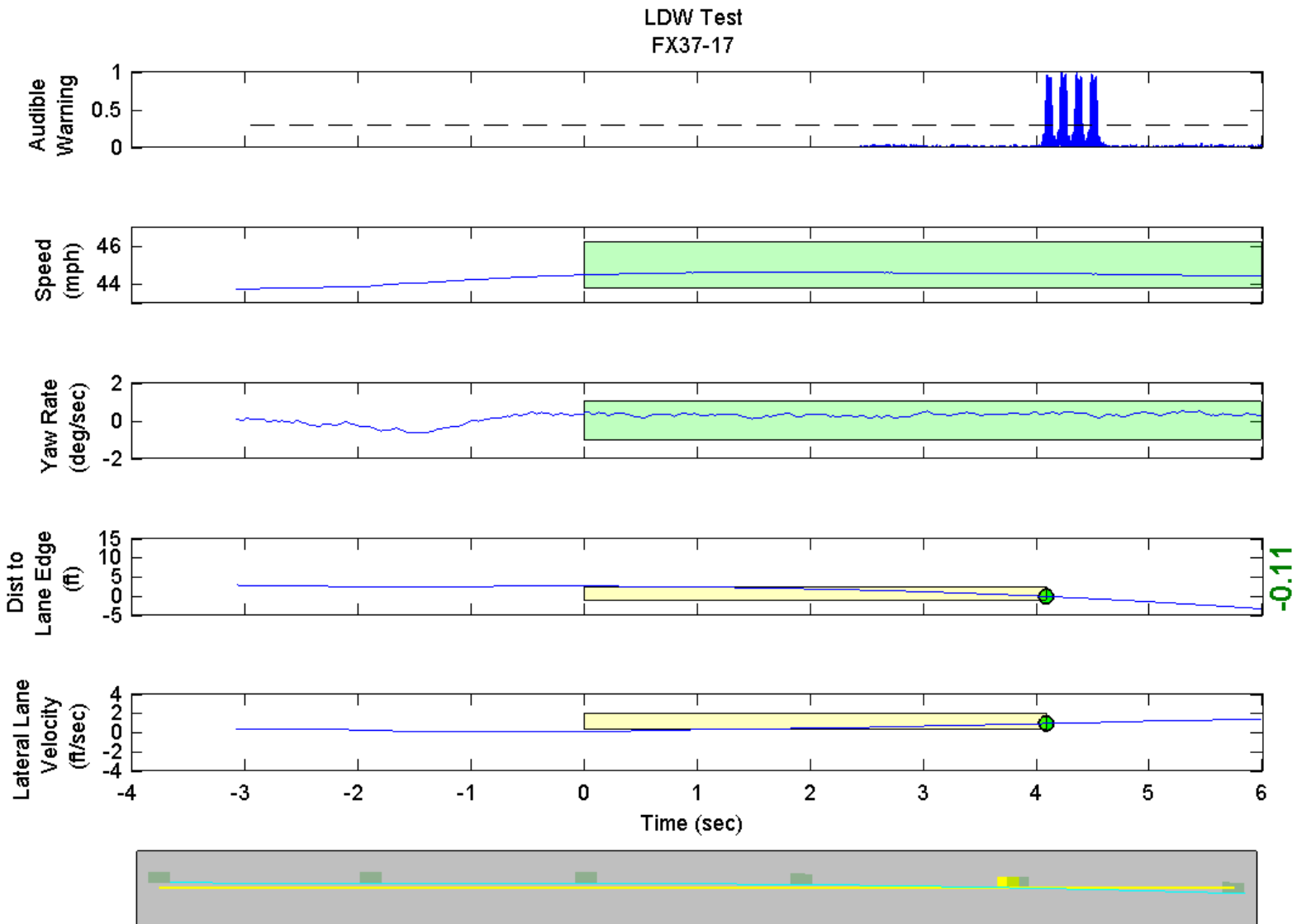

GPS Fix Type: RTK Fixed

Figure D34. Time History for Run 17, Solid Line, Right Departure, Audible Warning

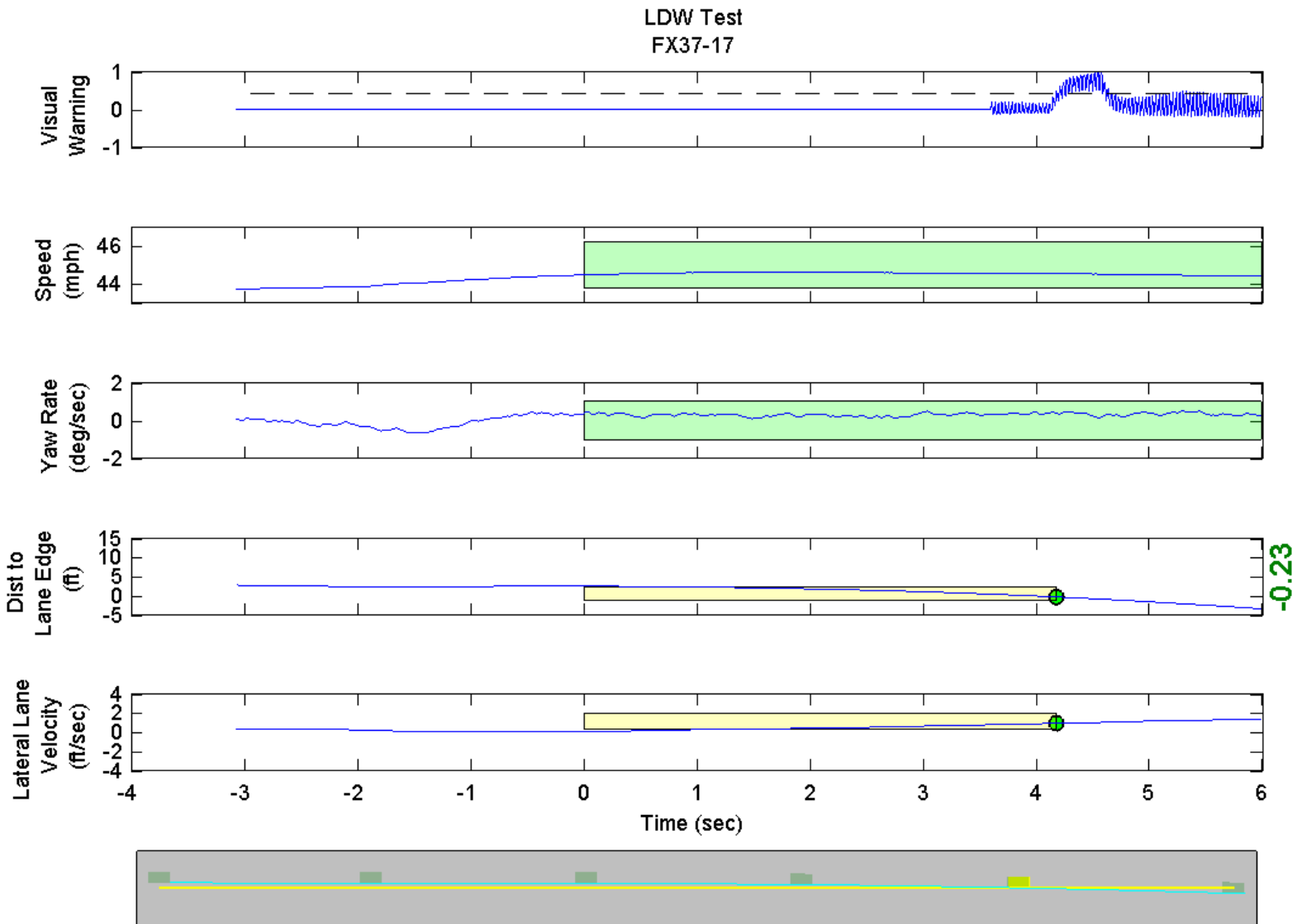

GPS Fix Type: RTK Fixed

Figure D35. Time History for Run 17, Solid Line, Right Departure, Visual Warning

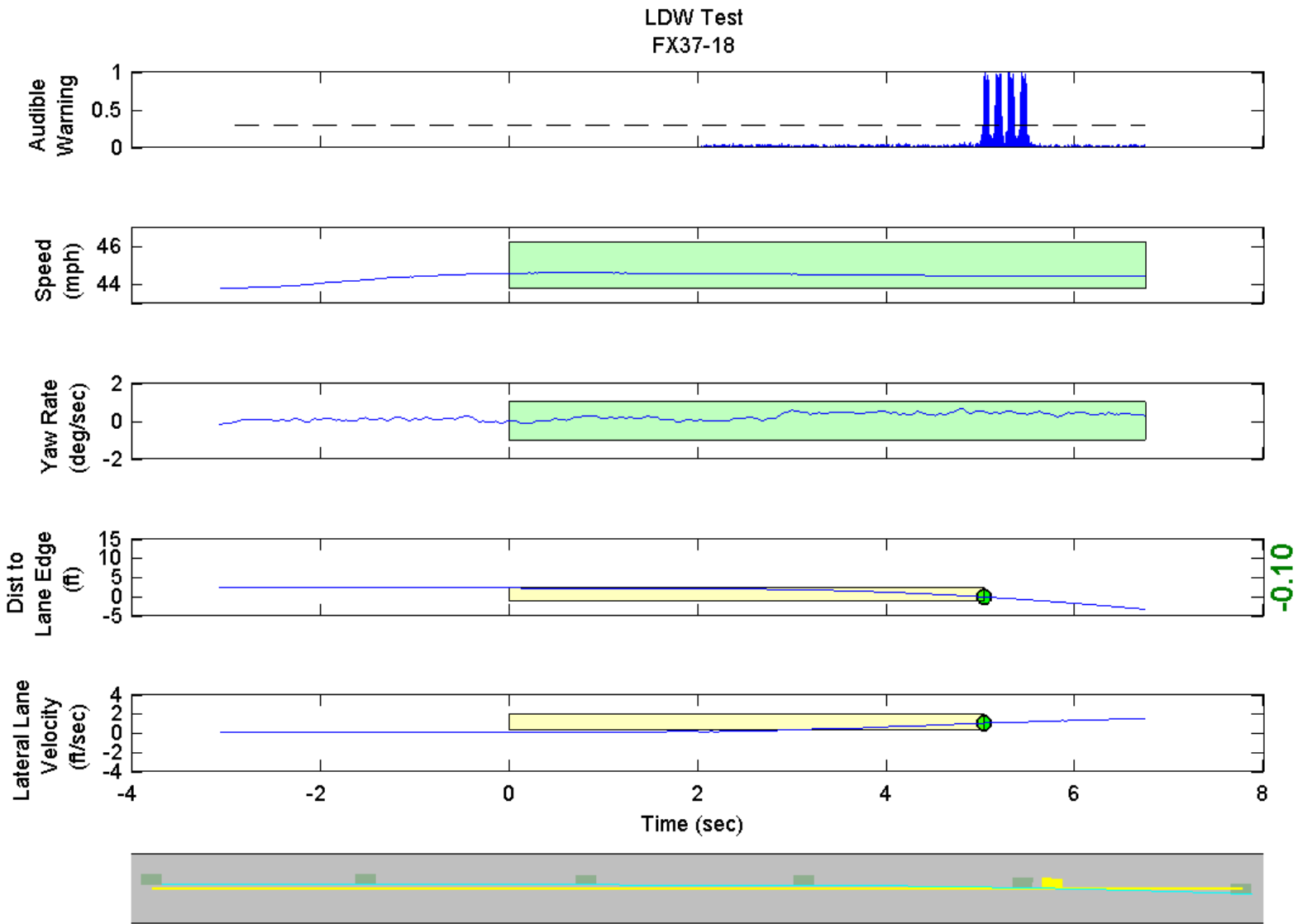

GPS Fix Type: RTK Fixed

Figure D36. Time History for Run 18, Solid Line, Right Departure, Audible Warning

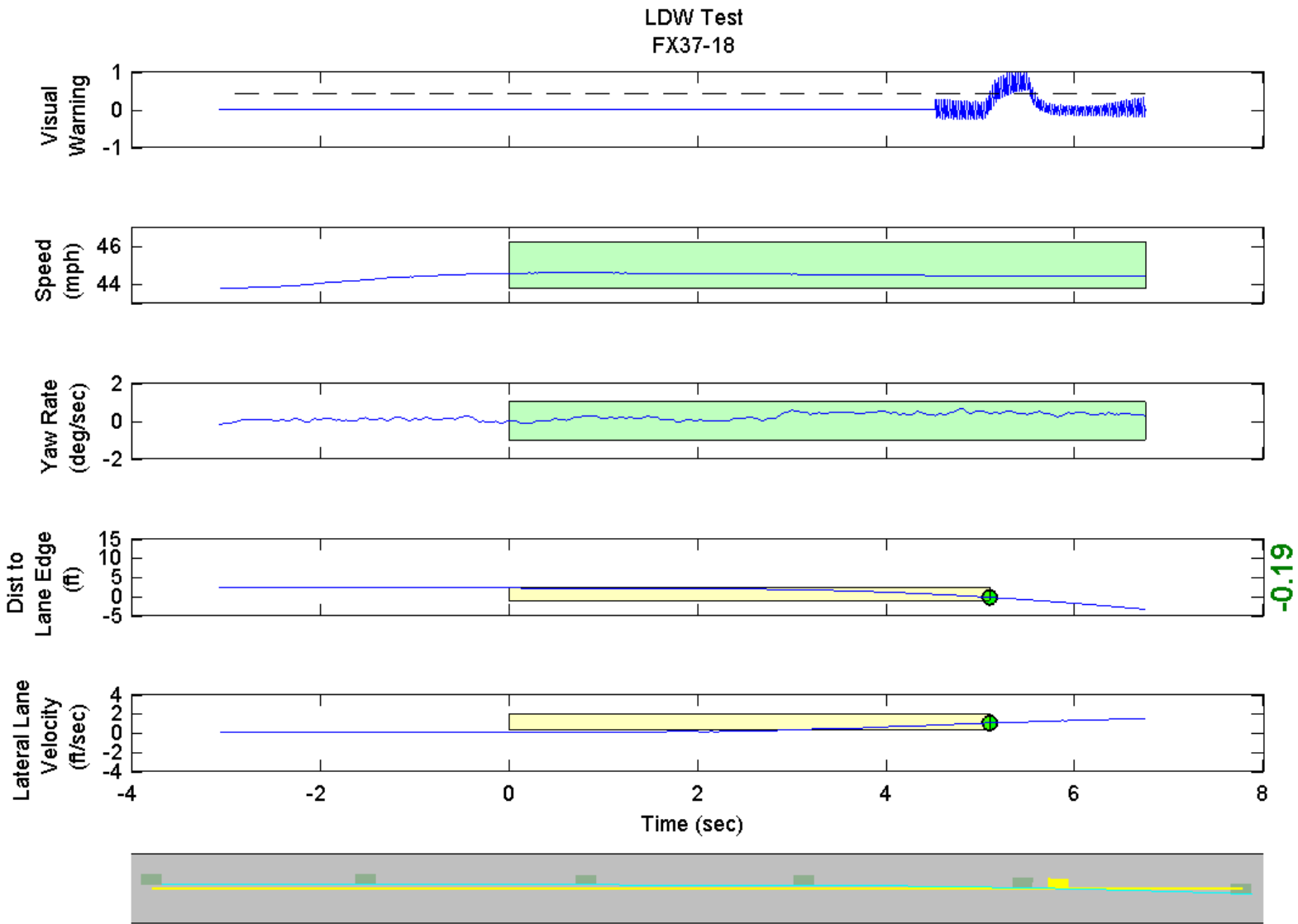

GPS Fix Type: RTK Fixed

Figure D37. Time History for Run 18, Solid Line, Right Departure, Visual Warning

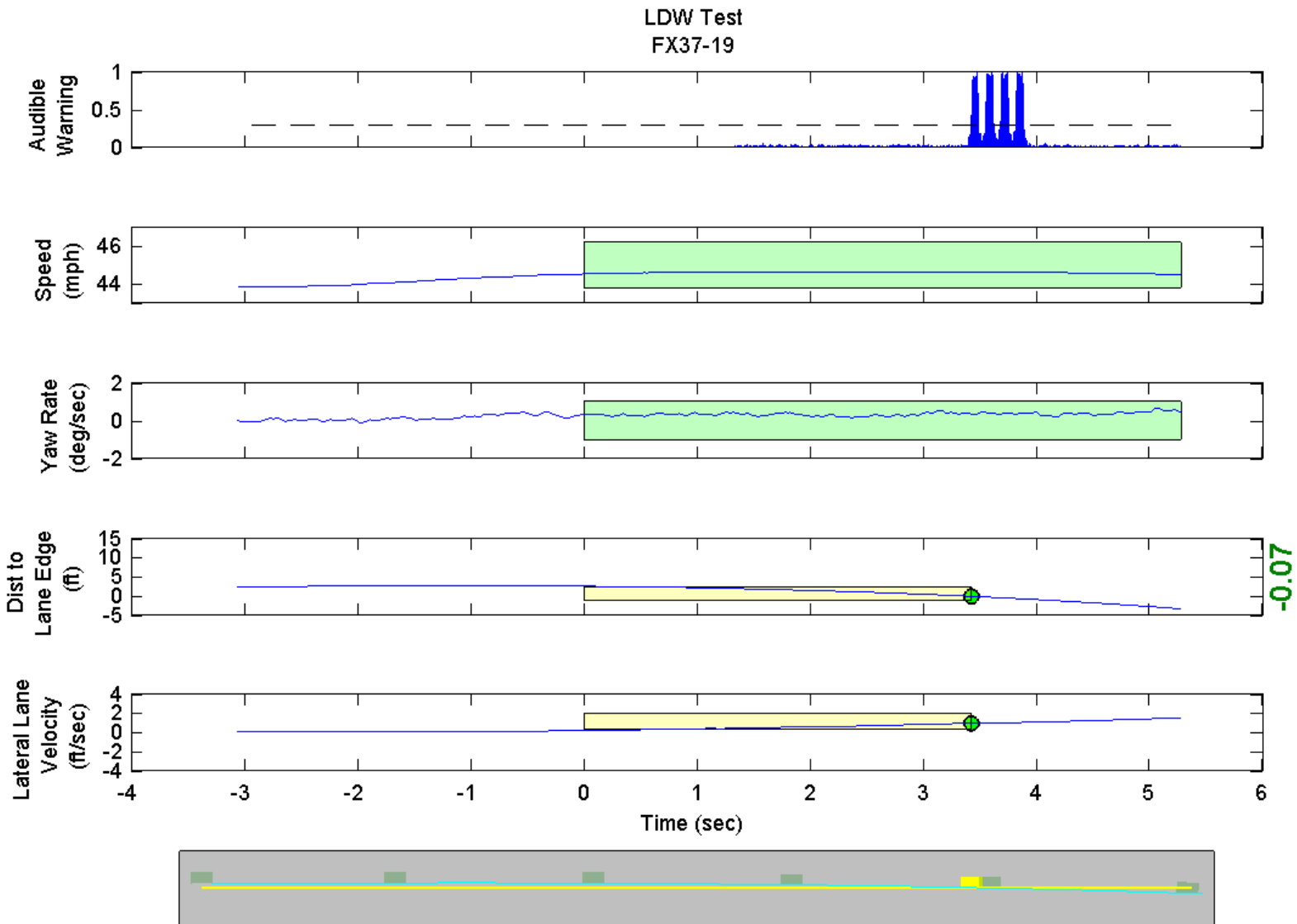

GPS Fix Type: RTK Fixed

Figure D38. Time History for Run 19, Solid Line, Right Departure, Audible Warning

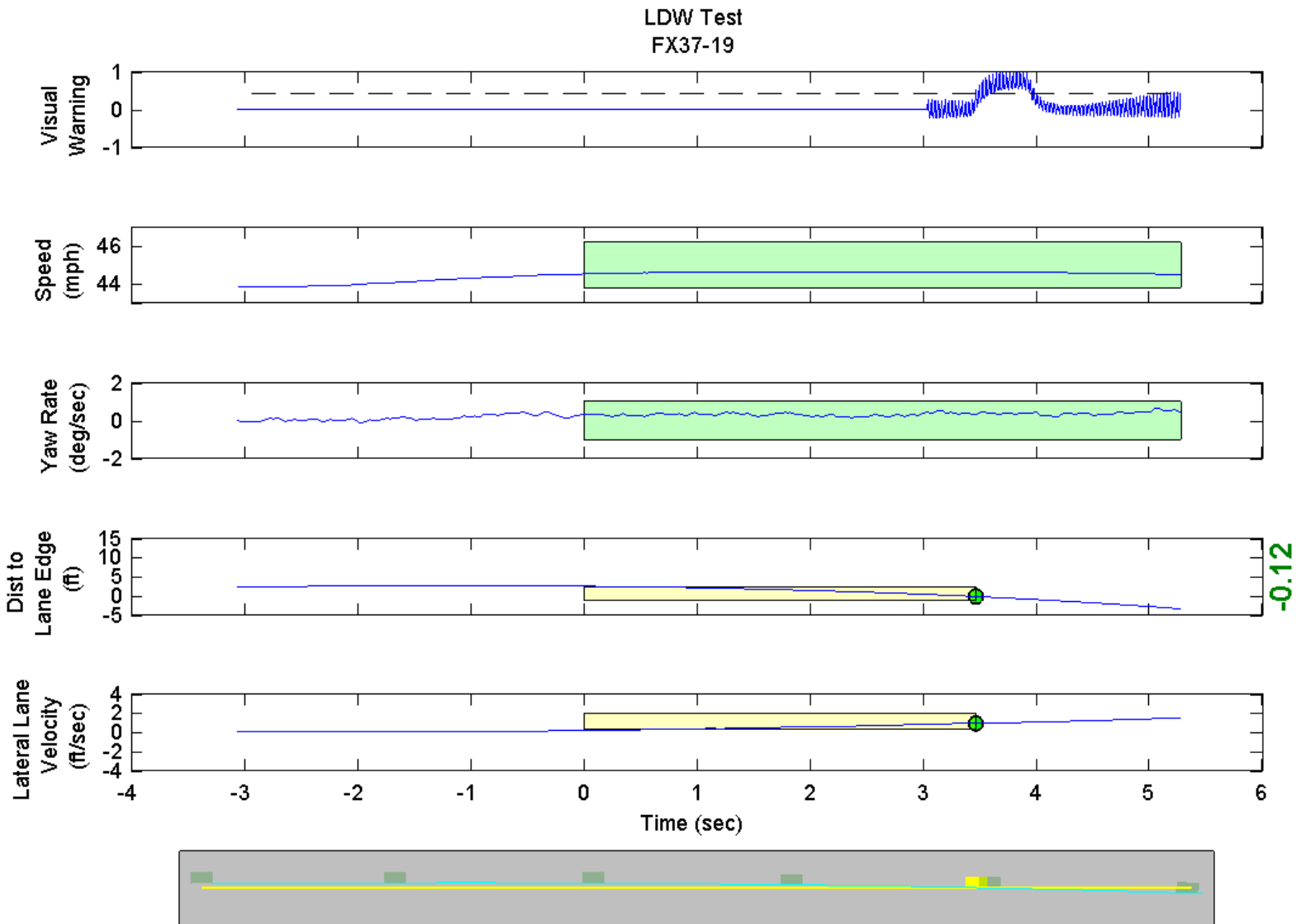

GPS Fix Type: RTK Fixed

Figure D39. Time History for Run 19, Solid Line, Right Departure, Visual Warning

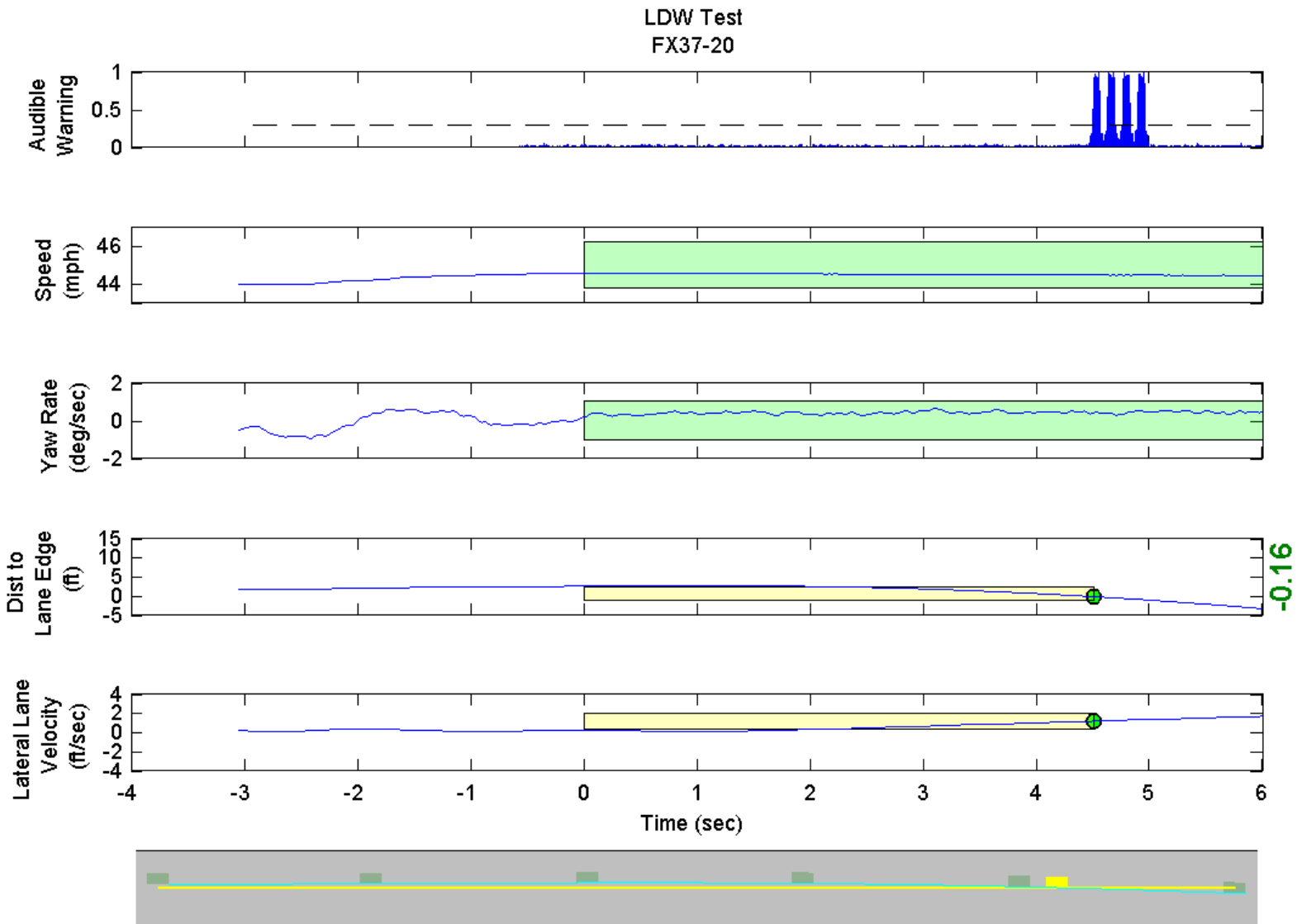

GPS Fix Type: RTK Fixed

Figure D40. Time History for Run 20, Solid Line, Right Departure, Audible Warning

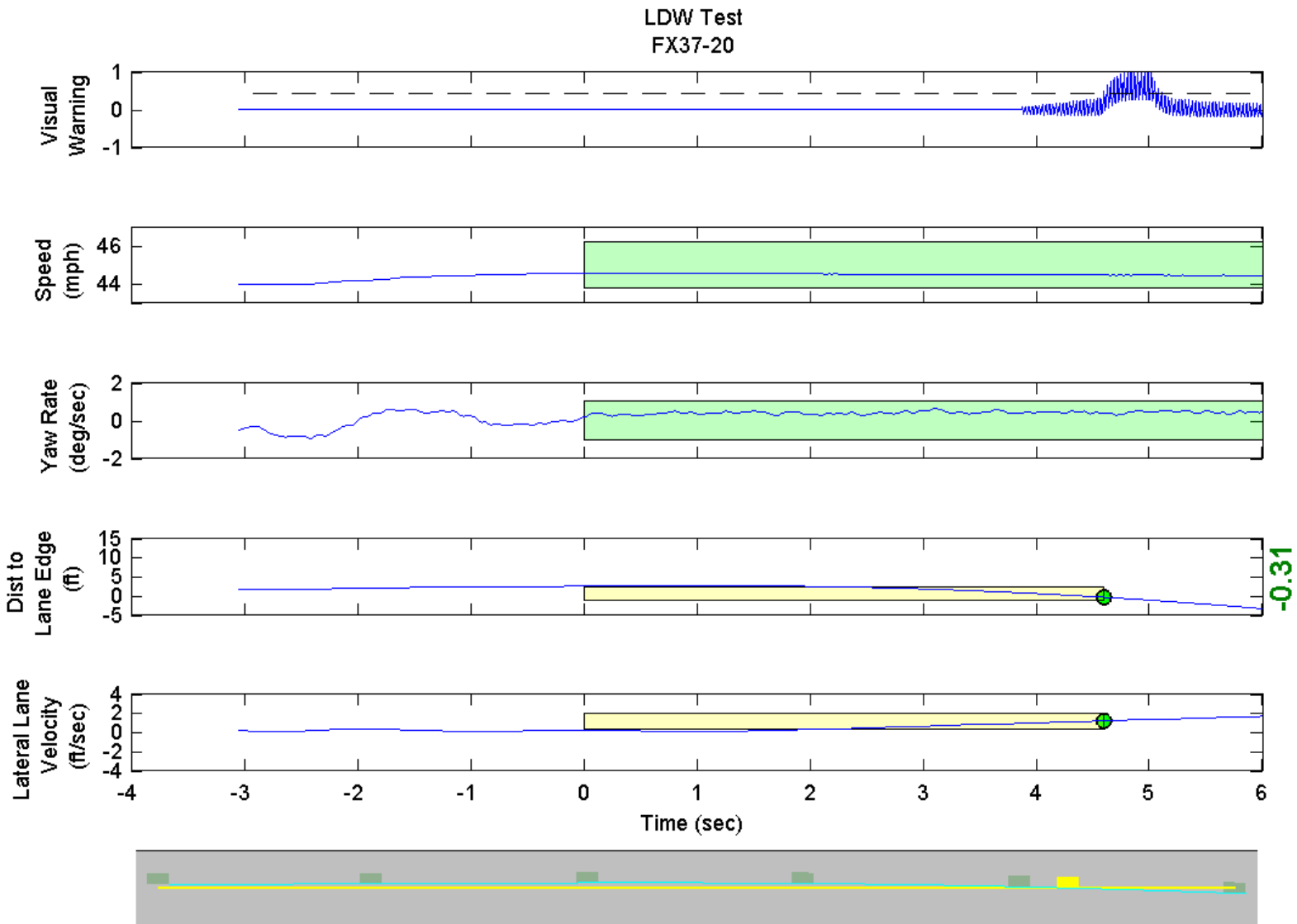

GPS Fix Type: RTK Fixed

Figure D41. Time History for Run 20, Solid Line, Right Departure, Visual Warning

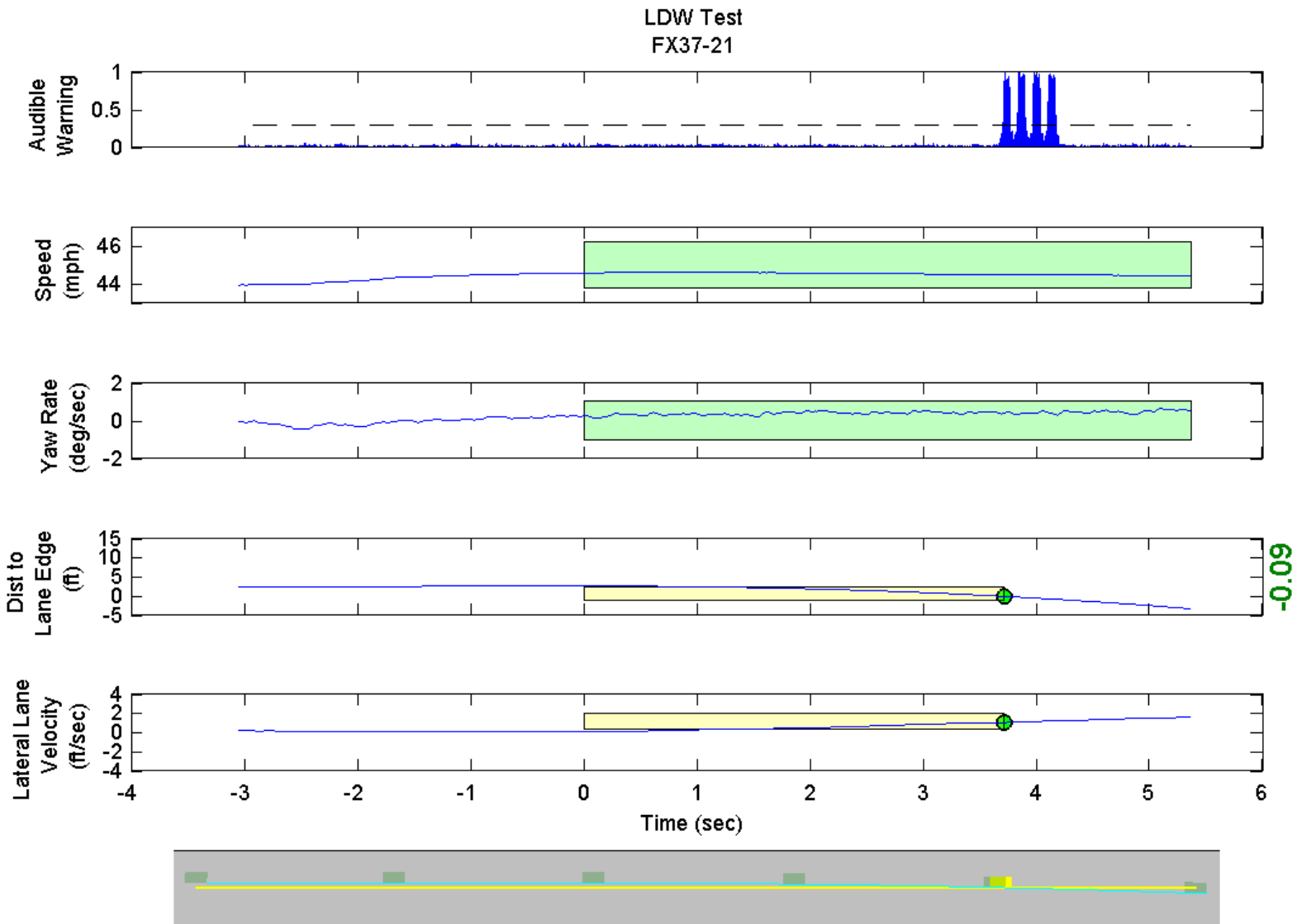

GPS Fix Type: RTK Fixed

Figure D42. Time History for Run 21, Solid Line, Right Departure, Audible Warning

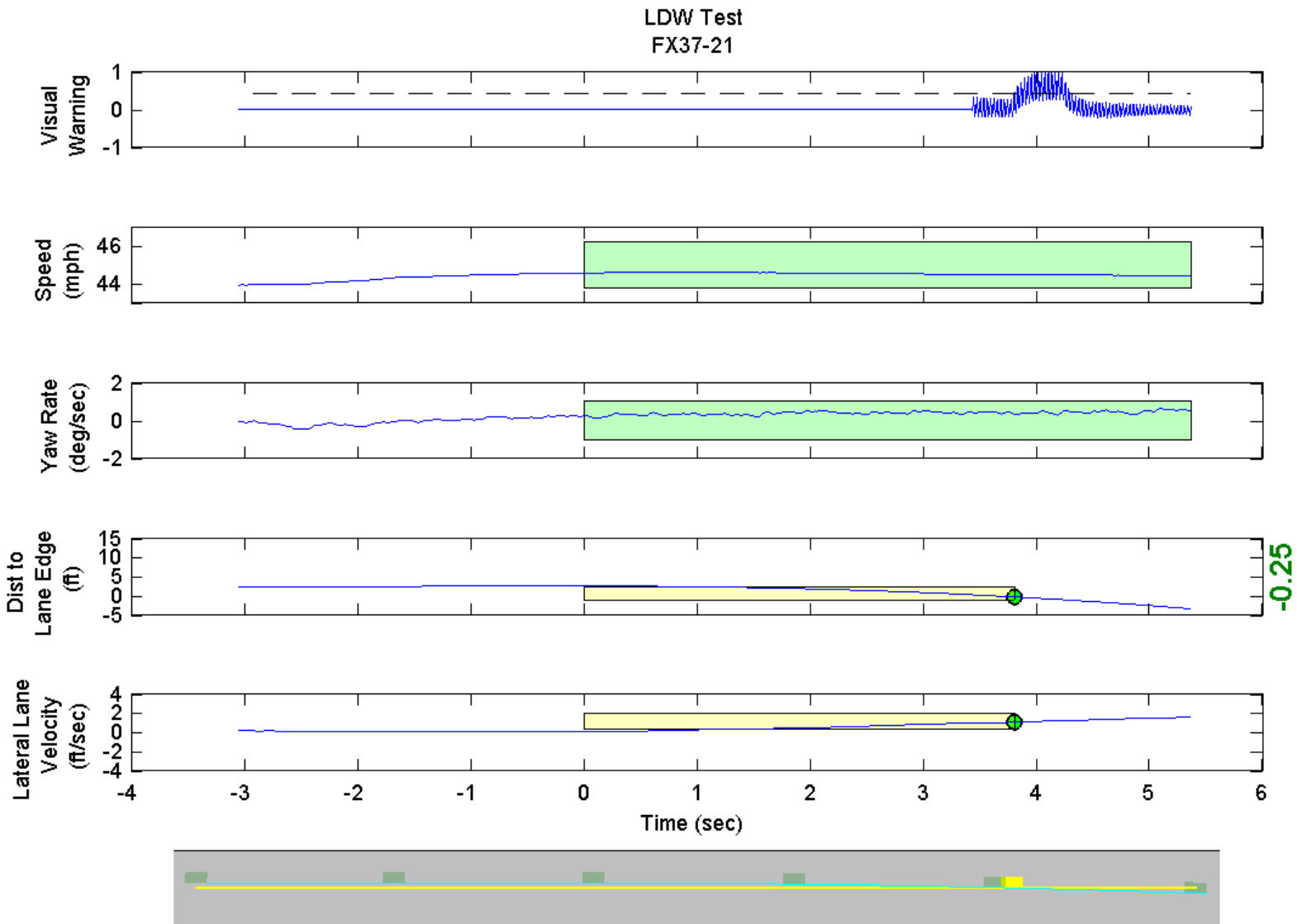

GPS Fix Type: RTK Fixed

Figure D43. Time History for Run 21, Solid Line, Right Departure, Visual Warning

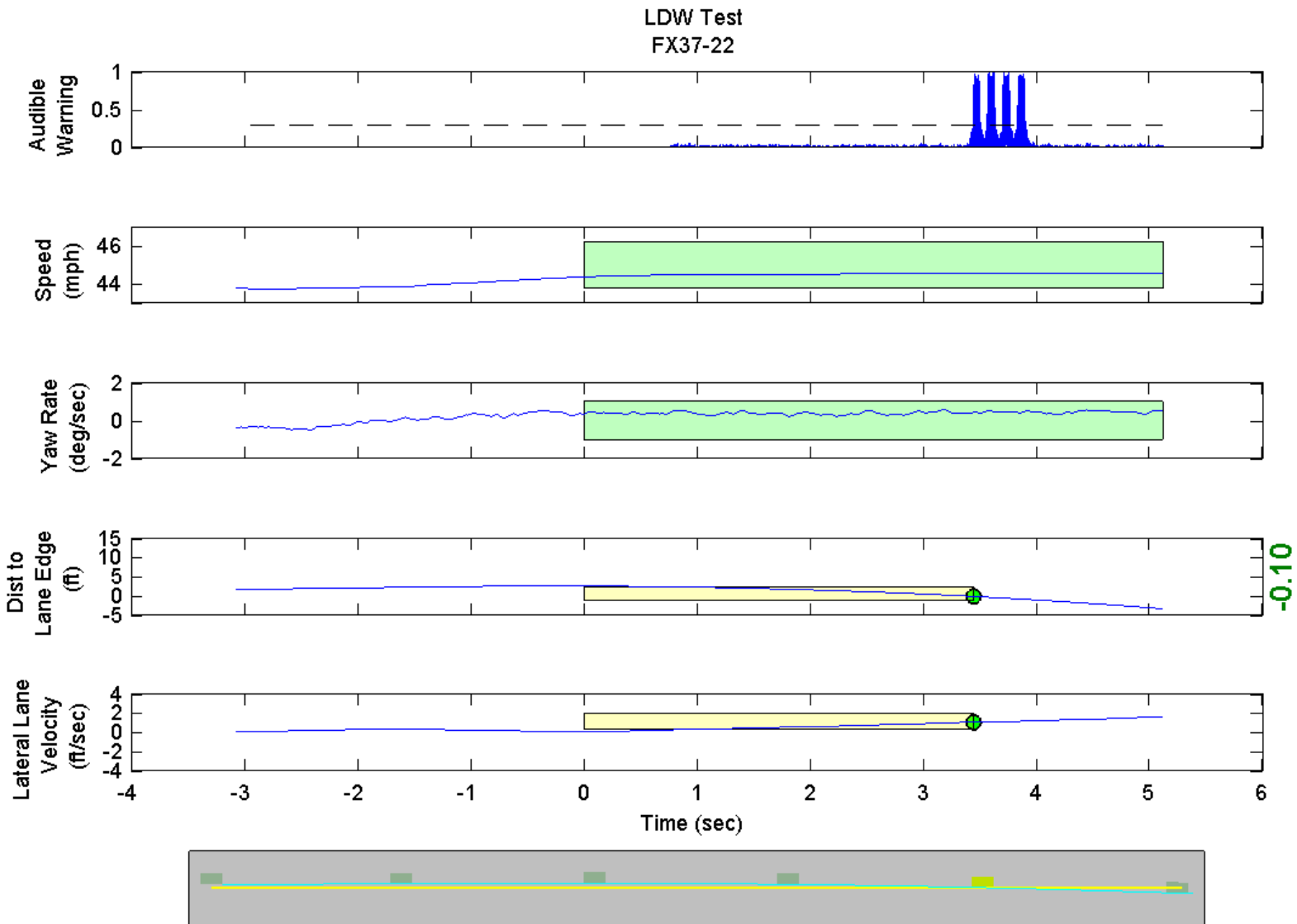

GPS Fix Type: RTK Fixed

Figure D44. Time History for Run 22, Solid Line, Right Departure, Audible Warning

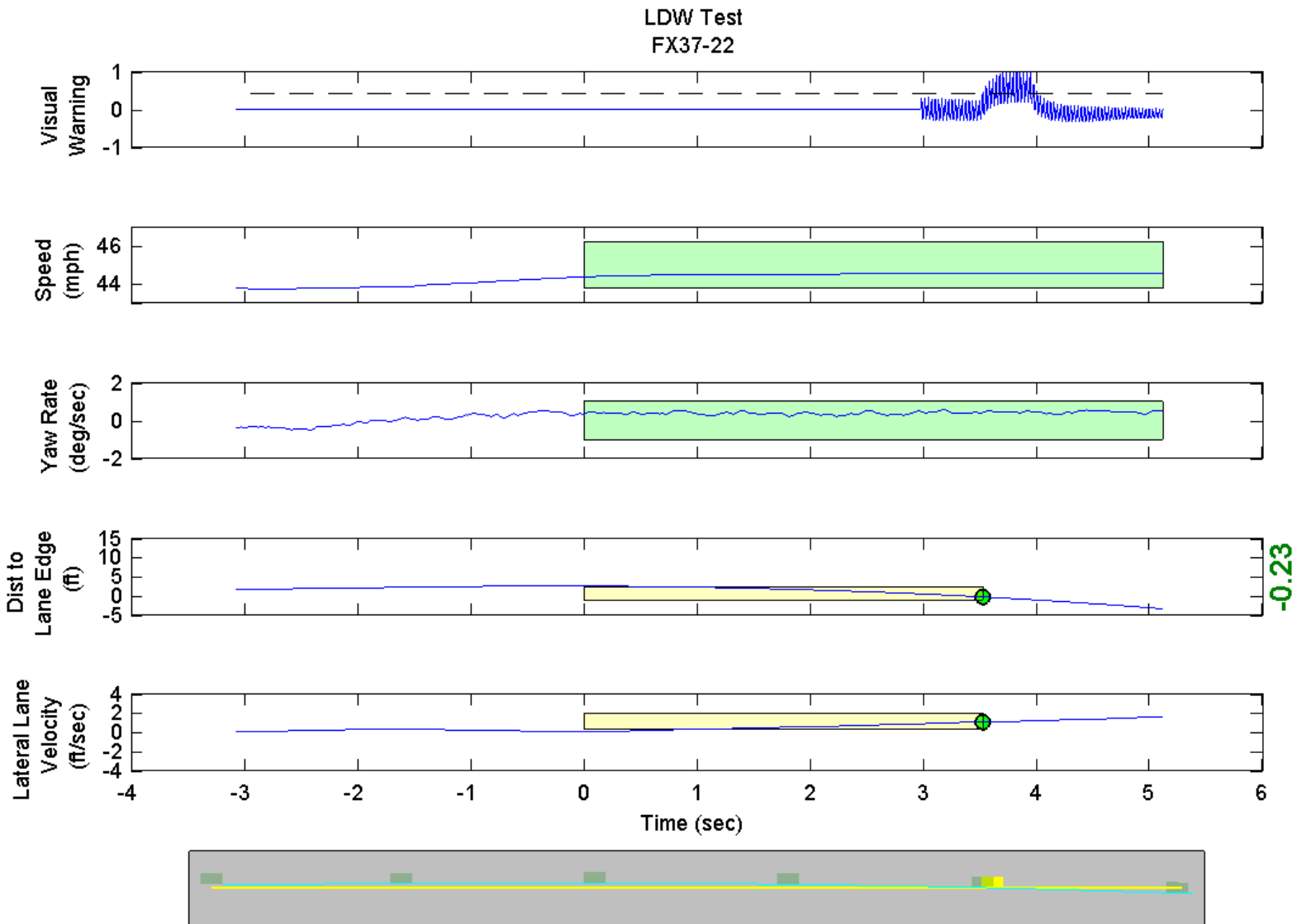

GPS Fix Type: RTK Fixed

Figure D45. Time History for Run 22, Solid Line, Right Departure, Visual Warning

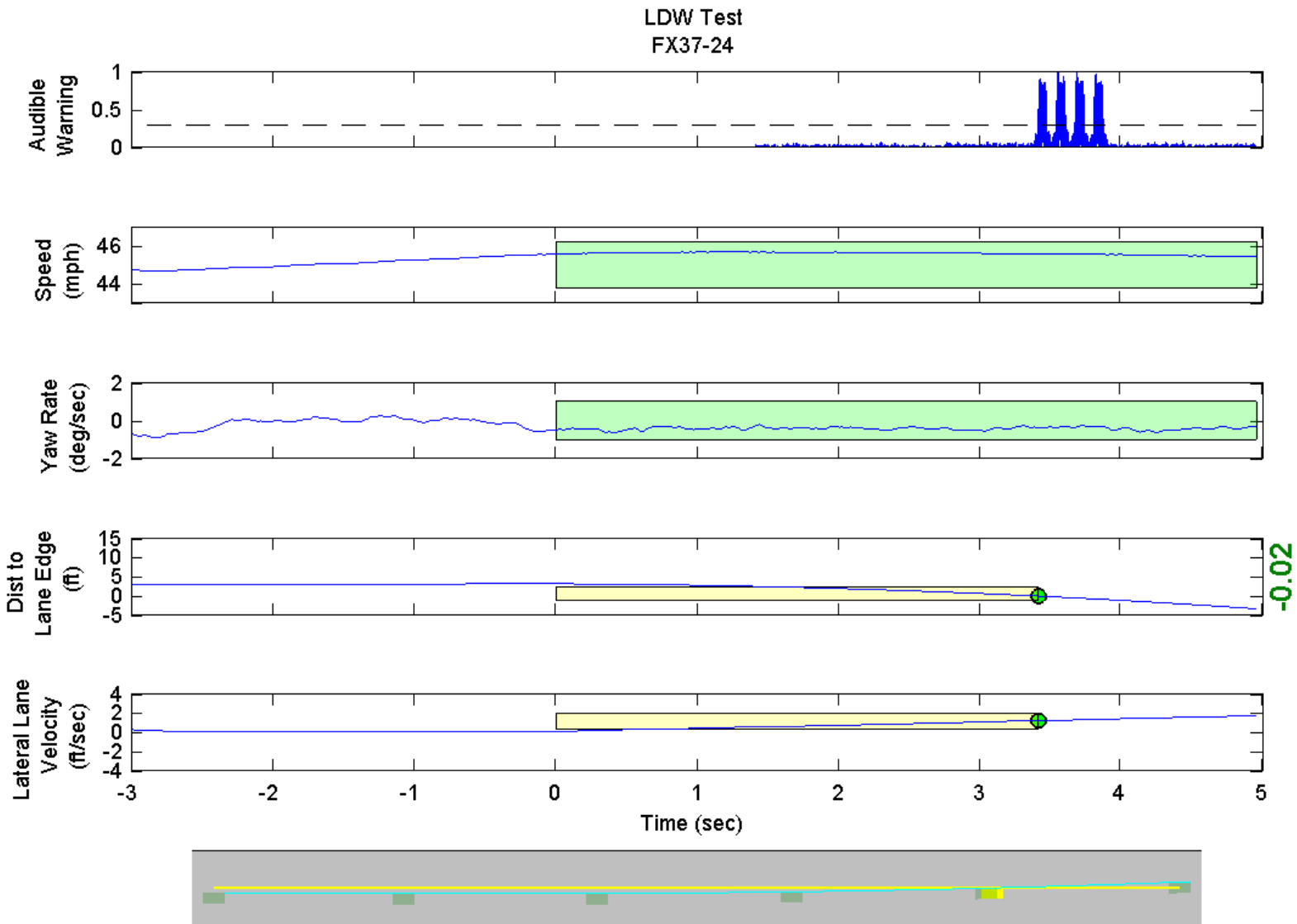

GPS Fix Type: RTK Fixed

Figure D46. Time History for Run 24, Solid Line, Left Departure, Audible Warning

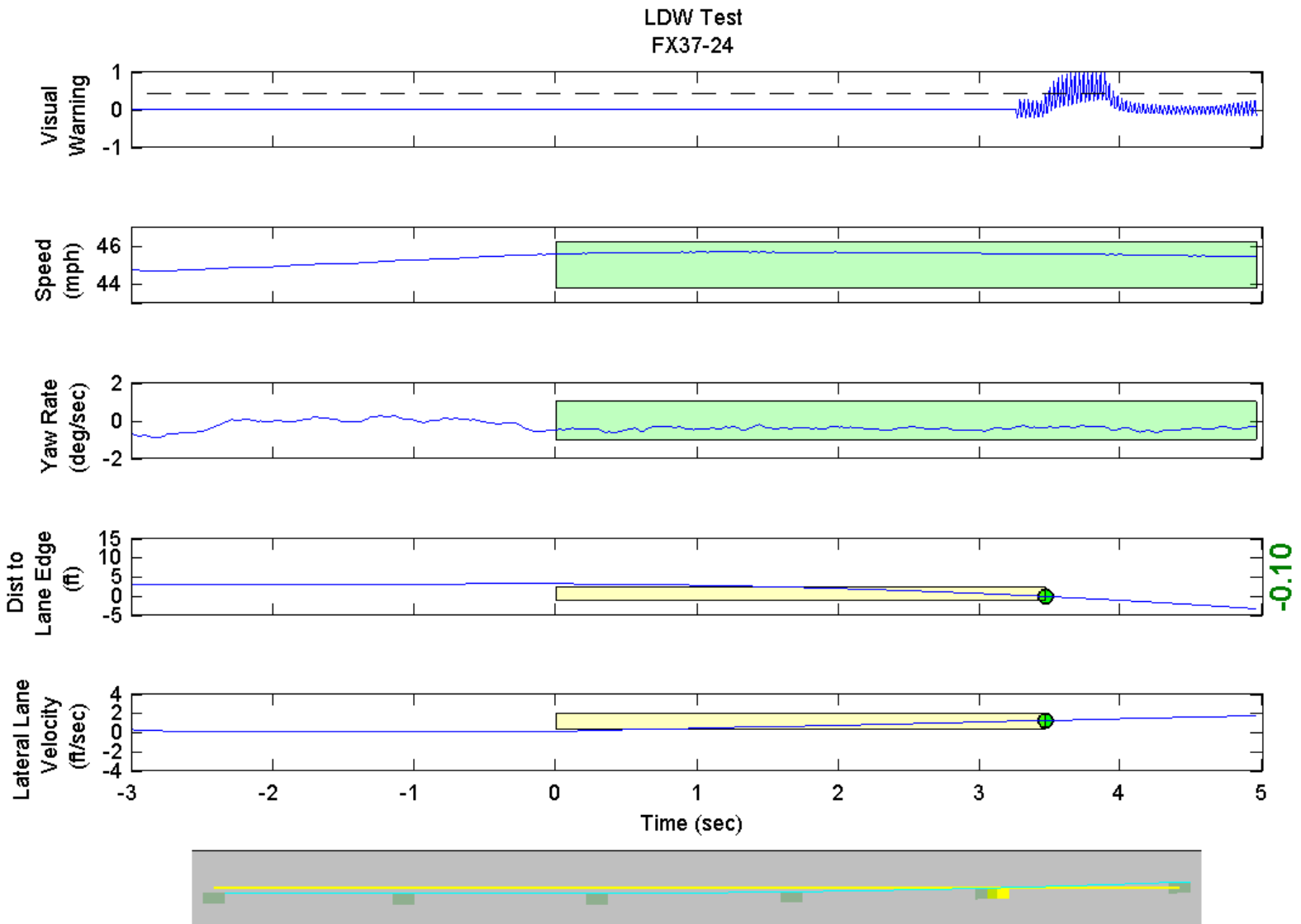

GPS Fix Type: RTK Fixed

Figure D47. Time History for Run 24, Solid Line, Left Departure, Visual Warning

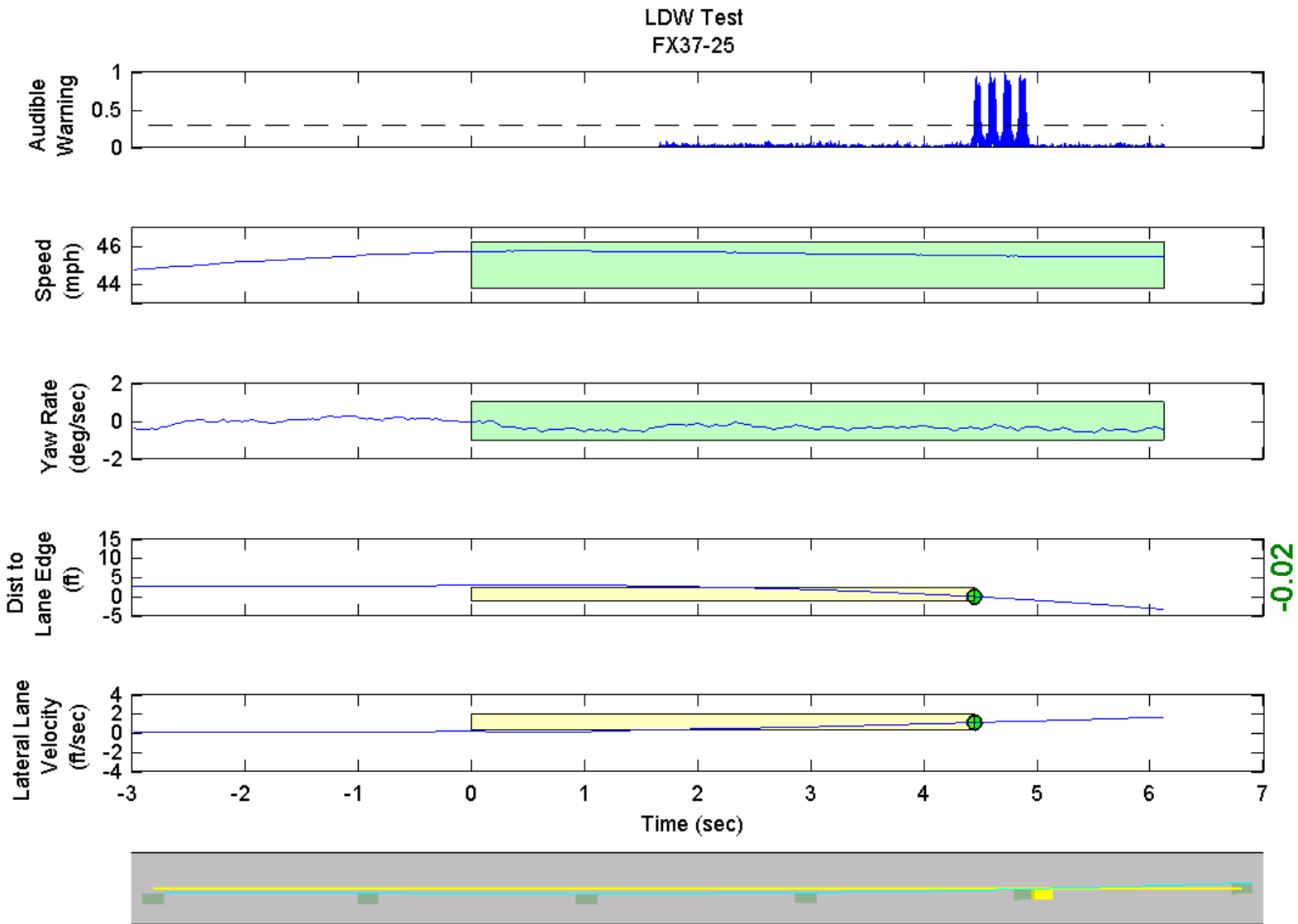

GPS Fix Type: RTK Fixed

Figure D48. Time History for Run 25, Solid Line, Left Departure, Audible Warning

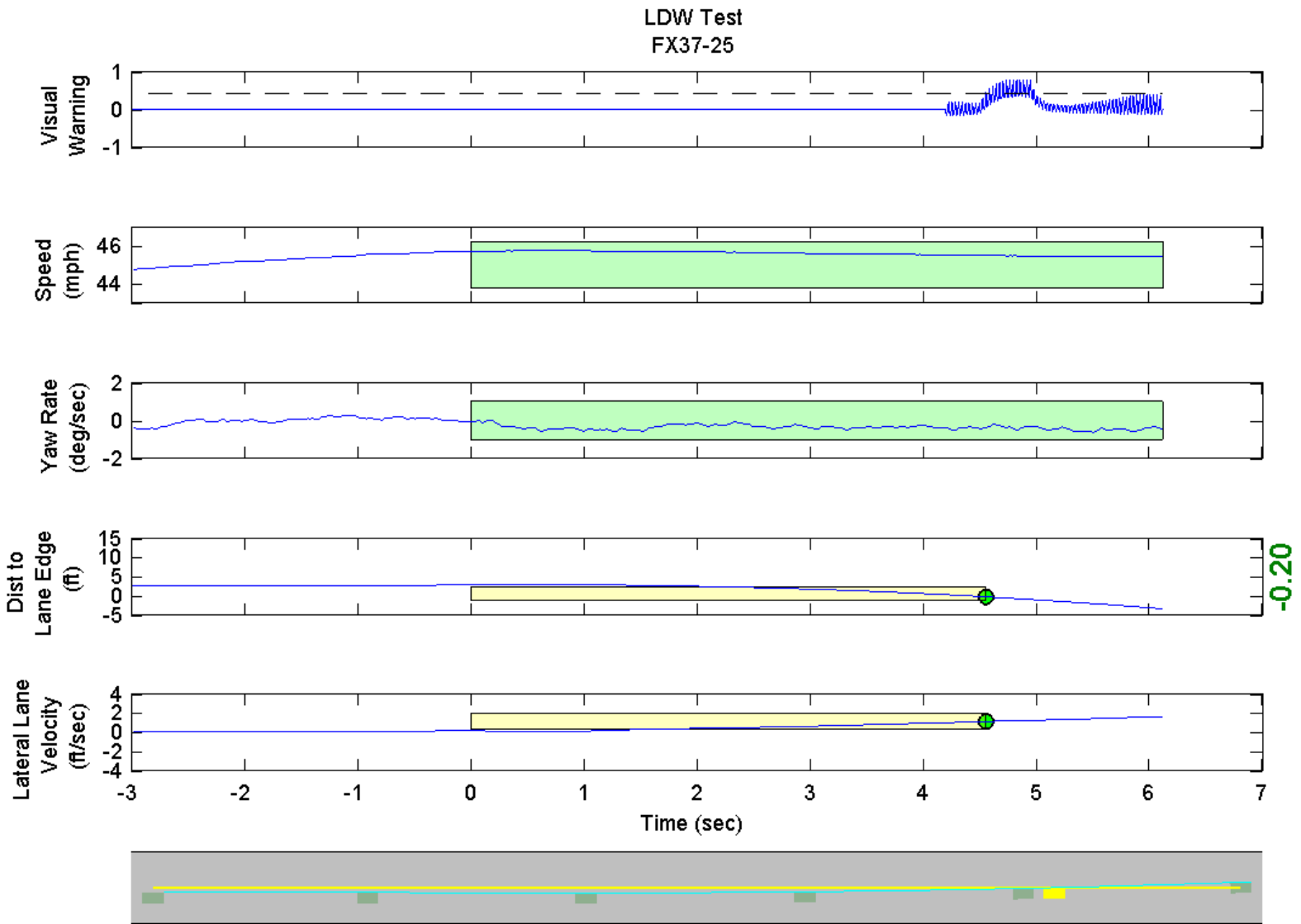

GPS Fix Type: RTK Fixed

Figure D49. Time History for Run 25, Solid Line, Left Departure, Visual Warning

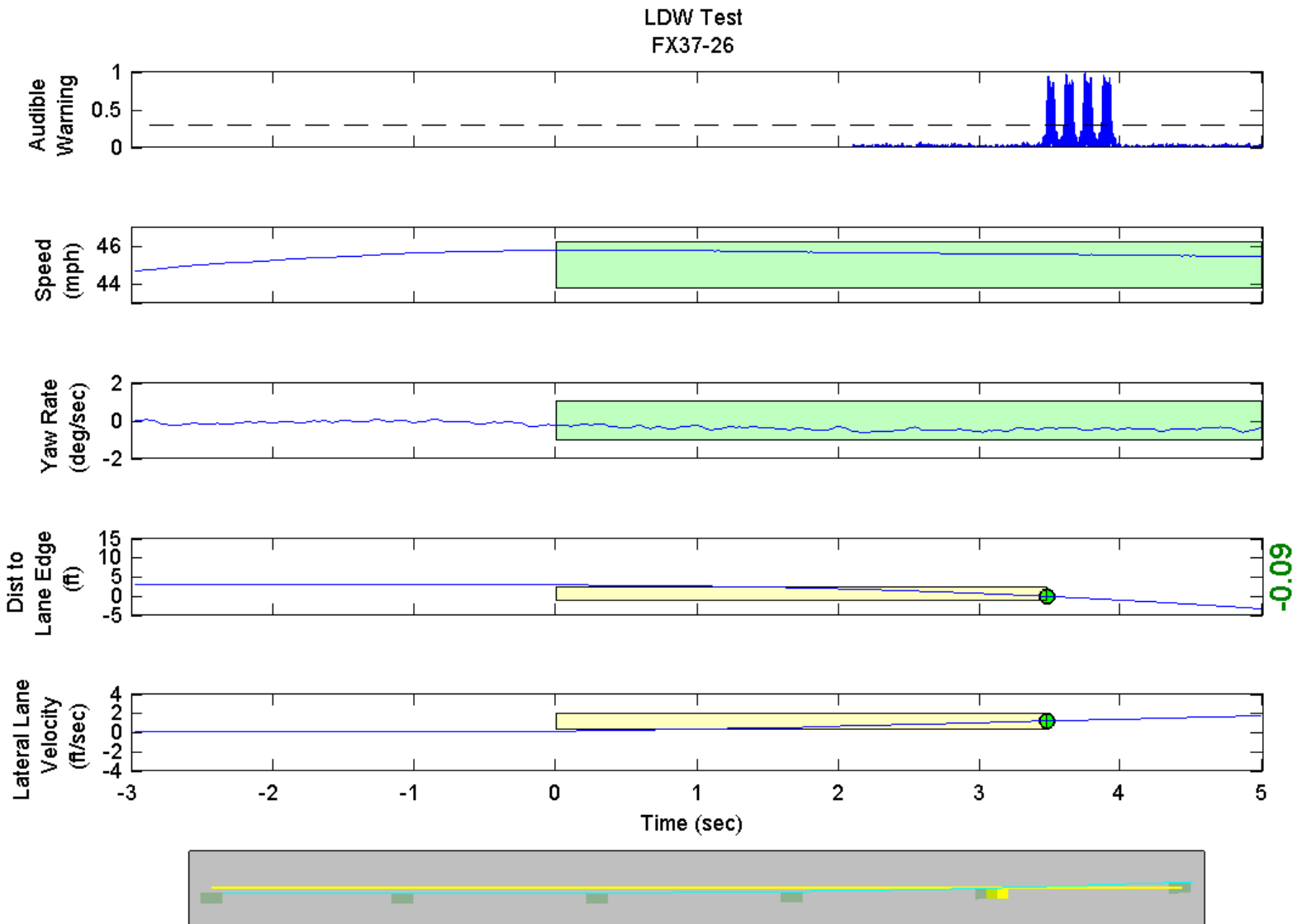

GPS Fix Type: RTK Fixed

Figure D50. Time History for Run 26, Solid Line, Left Departure, Audible Warning

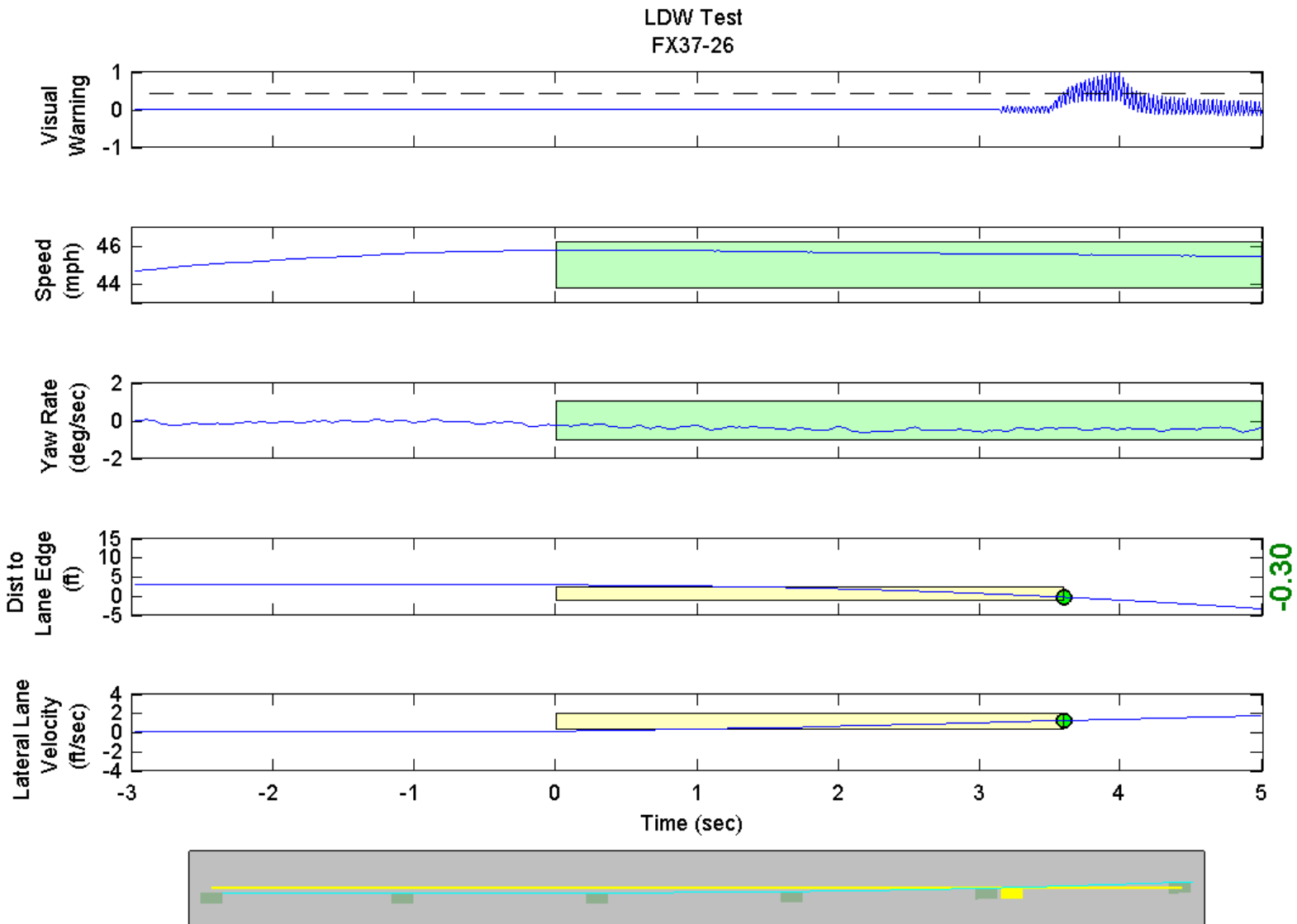

GPS Fix Type: RTK Fixed

Figure D51. Time History for Run 26, Solid Line, Left Departure, Visual Warning

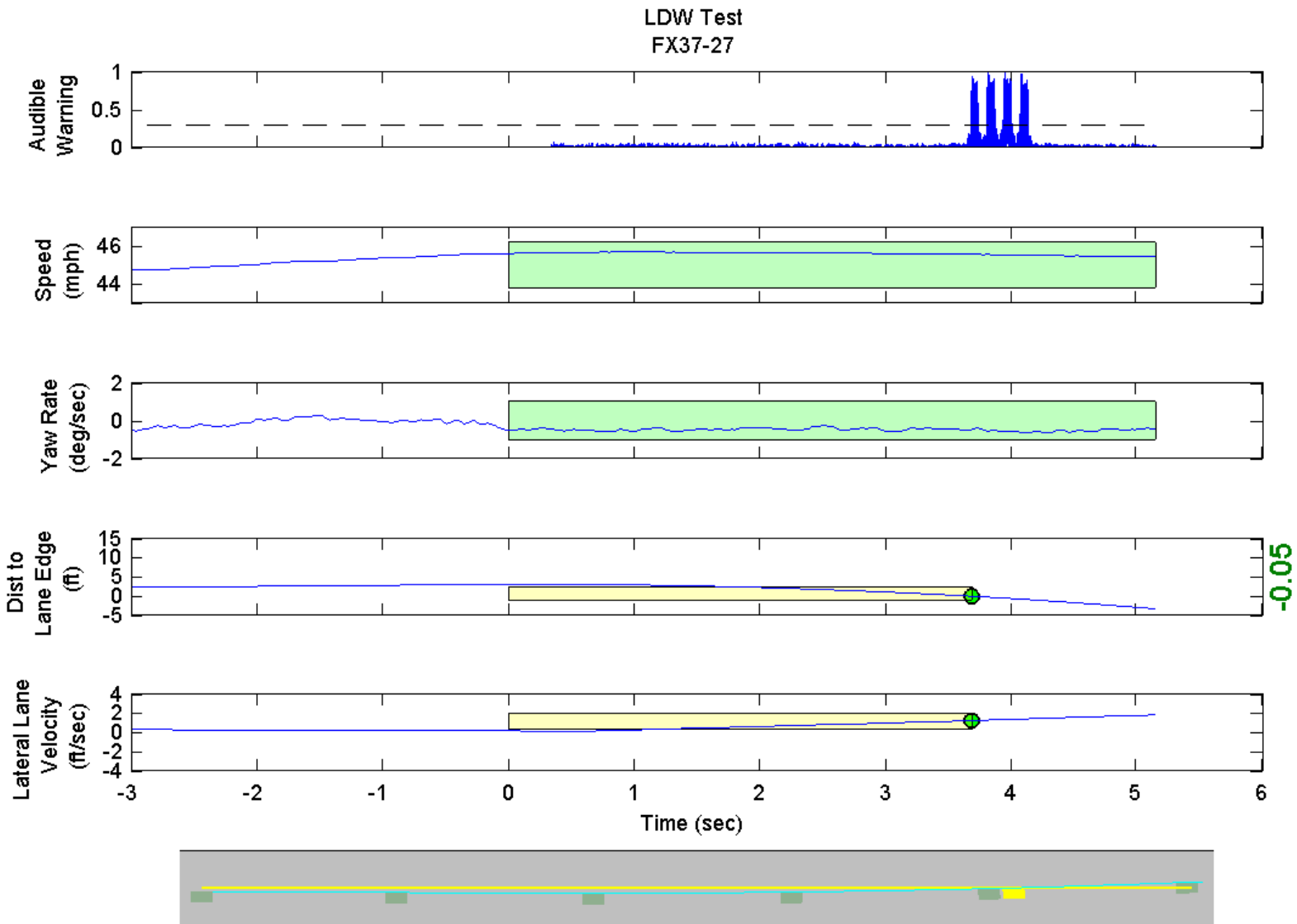

GPS Fix Type: RTK Fixed

Figure D52. Time History for Run 27, Solid Line, Left Departure, Audible Warning

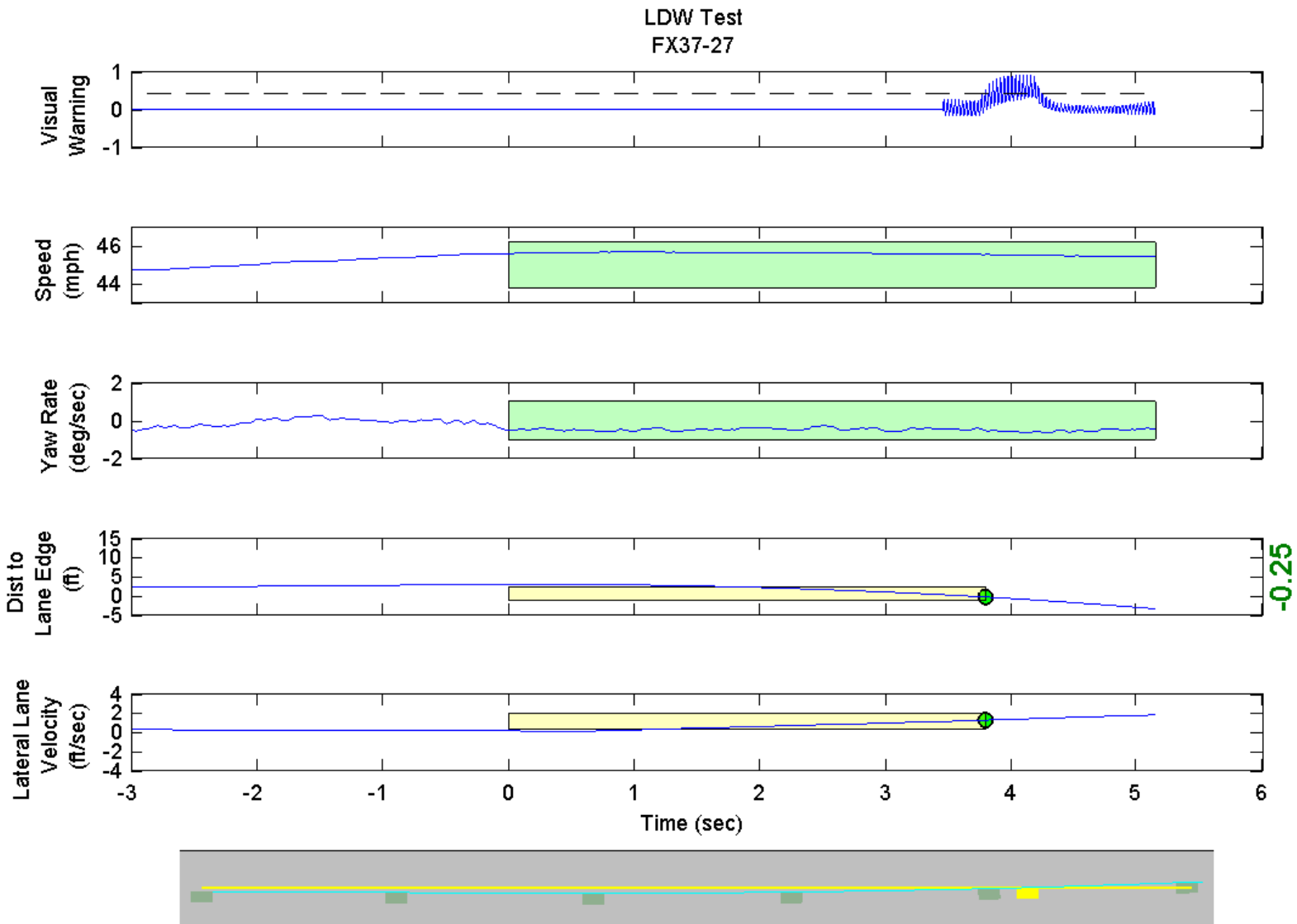

GPS Fix Type: RTK Fixed

Figure D53. Time History for Run 27, Solid Line, Left Departure, Visual Warning

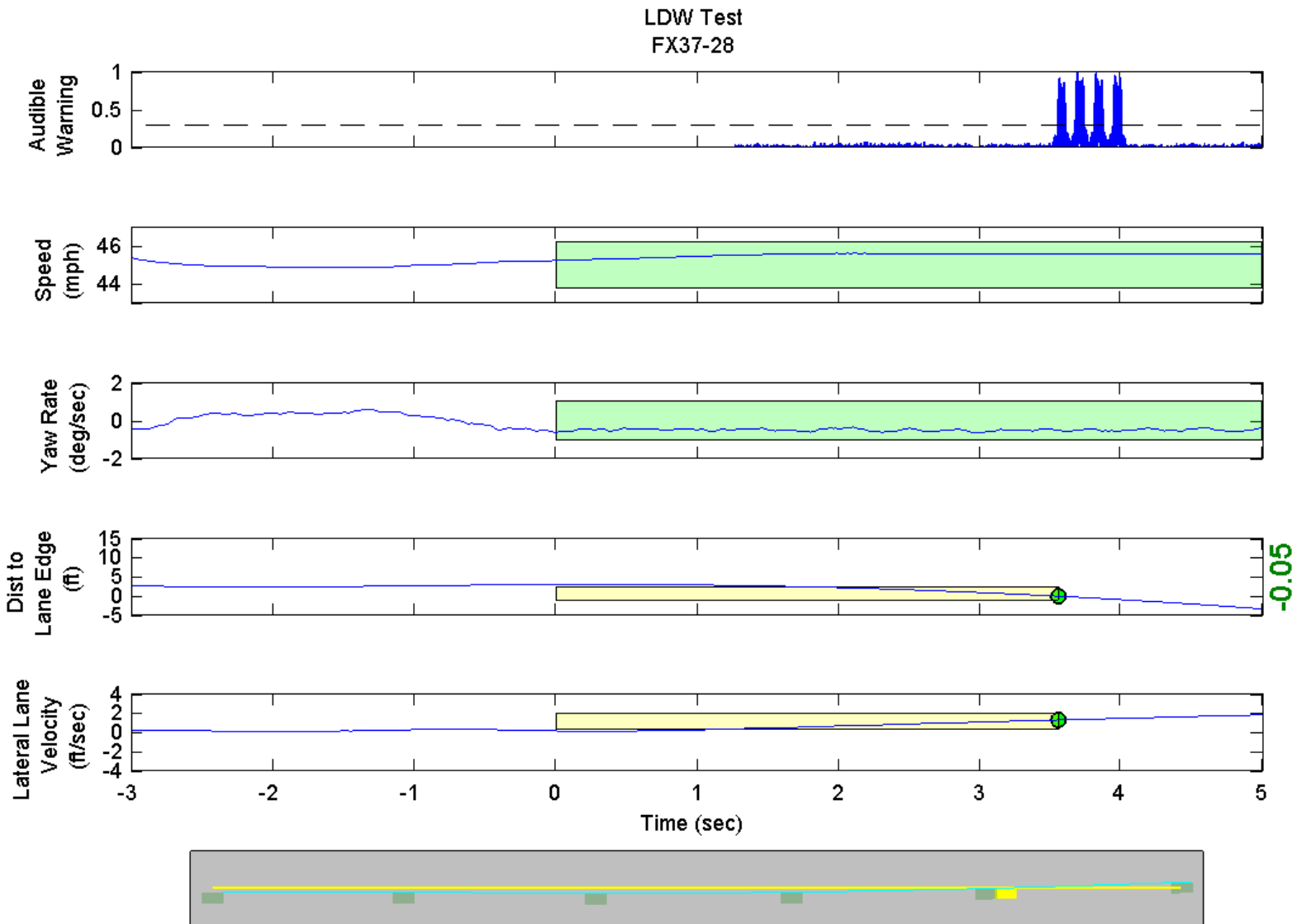

GPS Fix Type: RTK Fixed

Figure D54. Time History for Run 28, Solid Line, Left Departure, Audible Warning

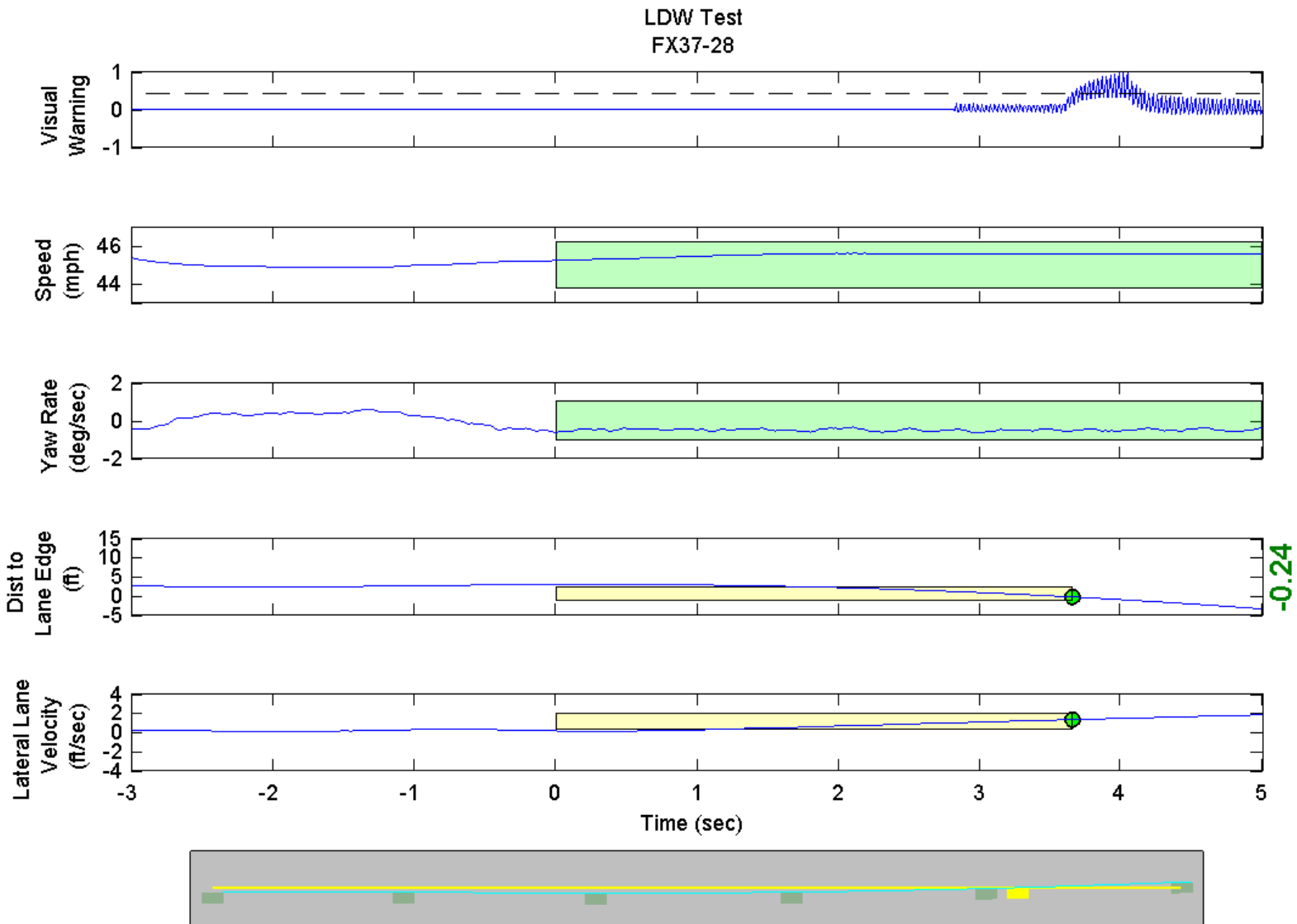

GPS Fix Type: RTK Fixed

Figure D55. Time History for Run 28, Solid Line, Left Departure, Visual Warning

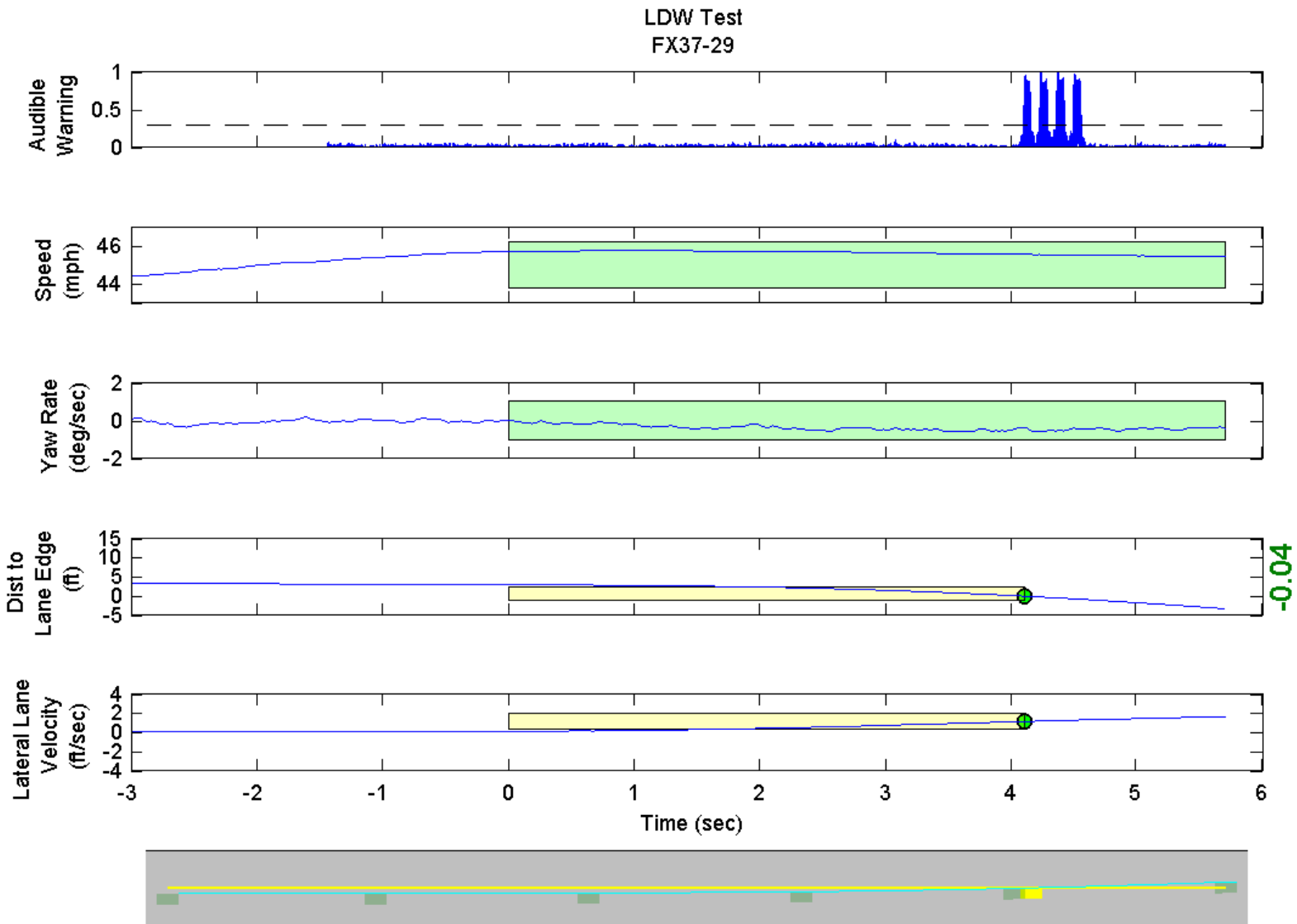

GPS Fix Type: RTK Fixed

Figure D56. Time History for Run 29, Solid Line, Left Departure, Audible Warning

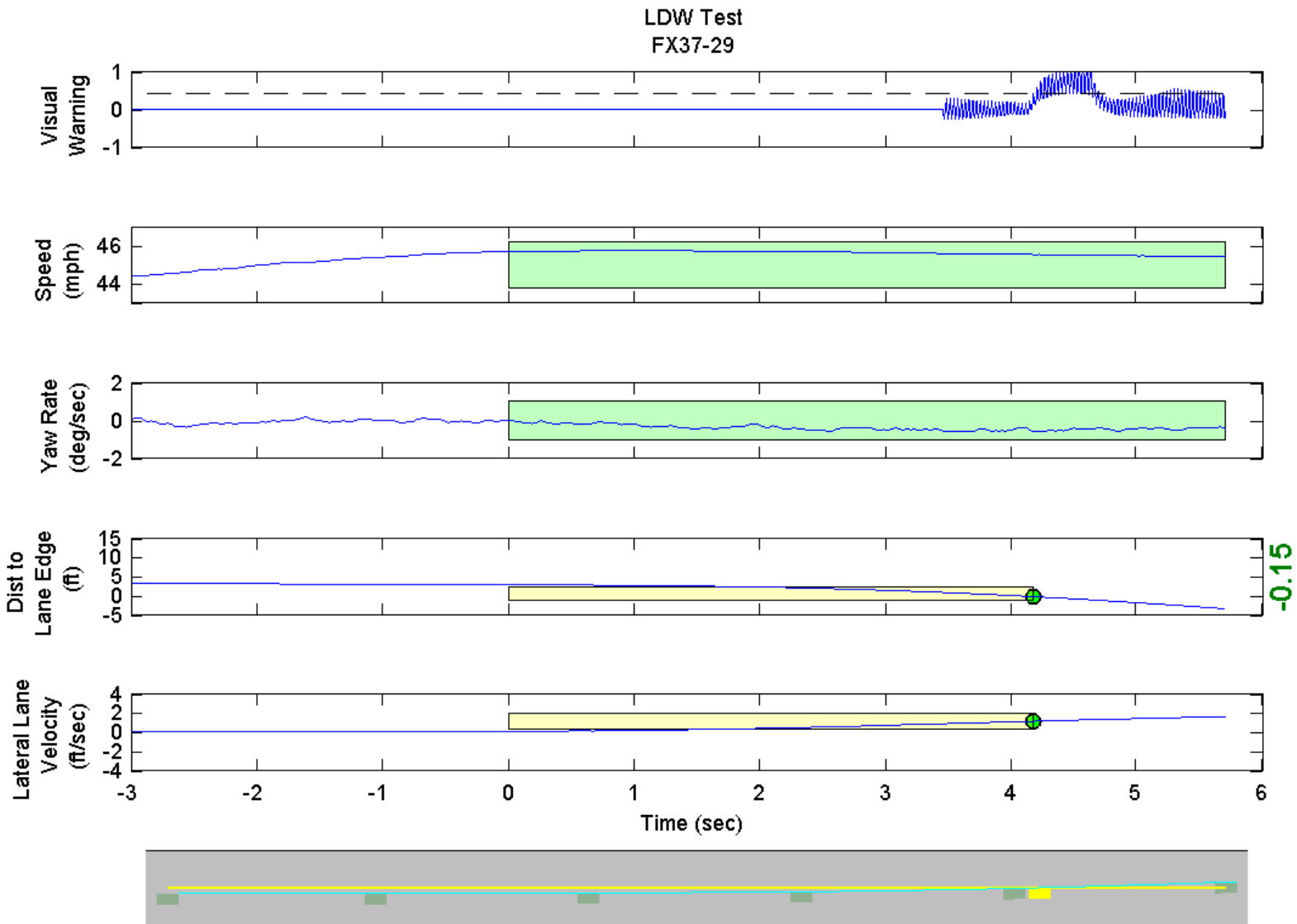

GPS Fix Type: RTK Fixed

Figure D57. Time History for Run 29, Solid Line, Left Departure, Visual Warning

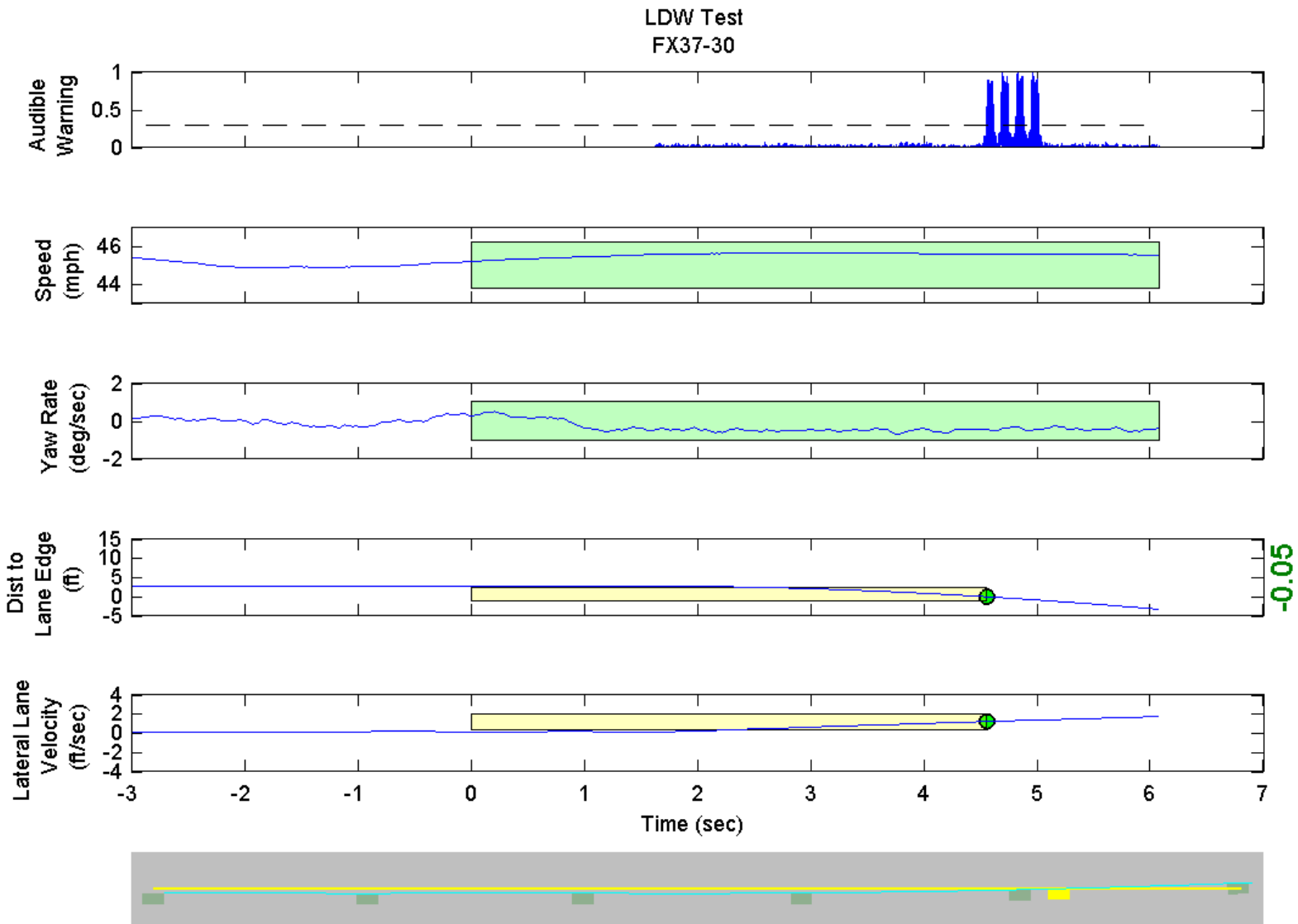

GPS Fix Type: RTK Fixed

Figure D58. Time History for Run 30, Solid Line, Left Departure, Audible Warning

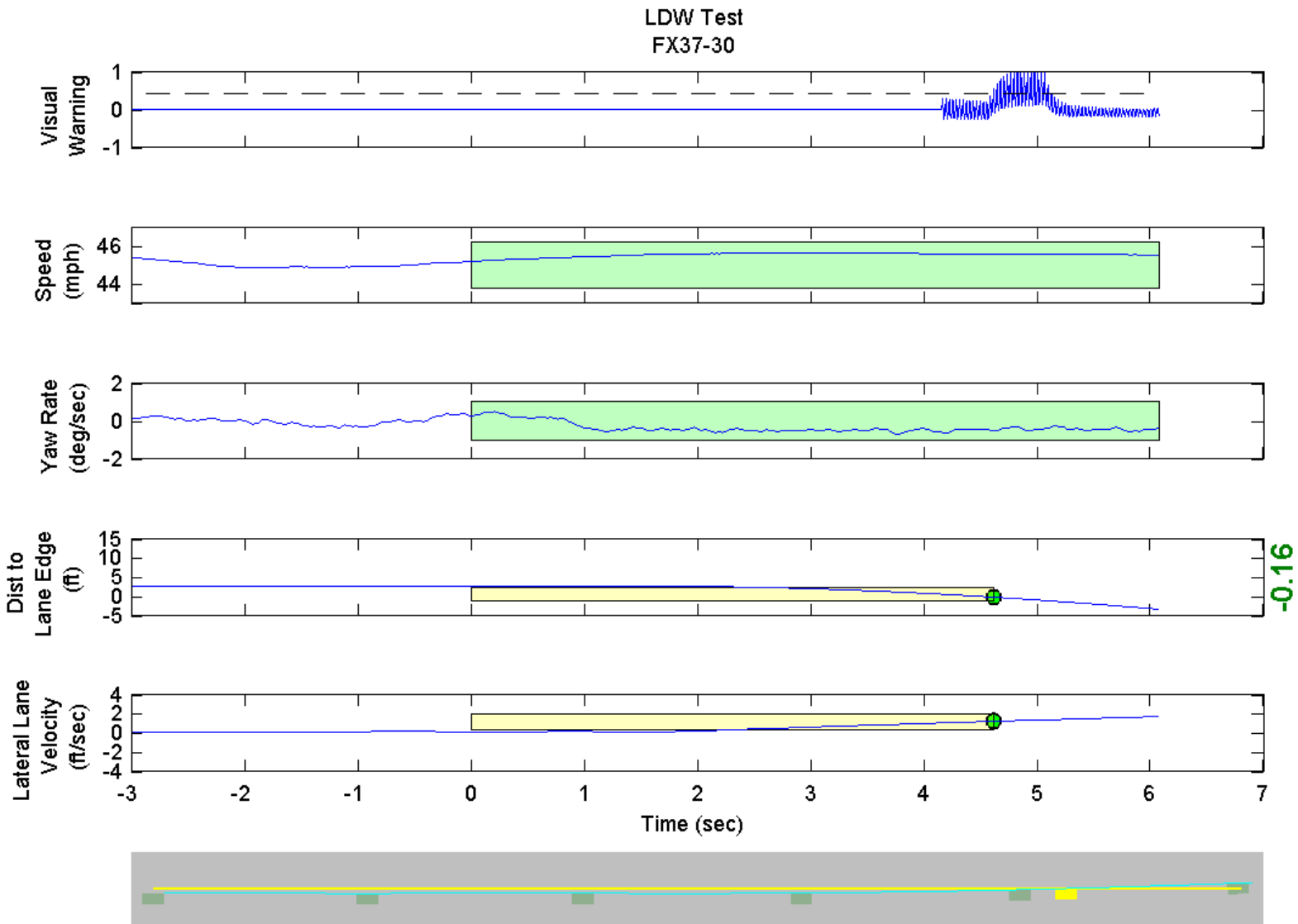

GPS Fix Type: RTK Fixed

Figure D59. Time History for Run 30, Solid Line, Left Departure, Visual Warning

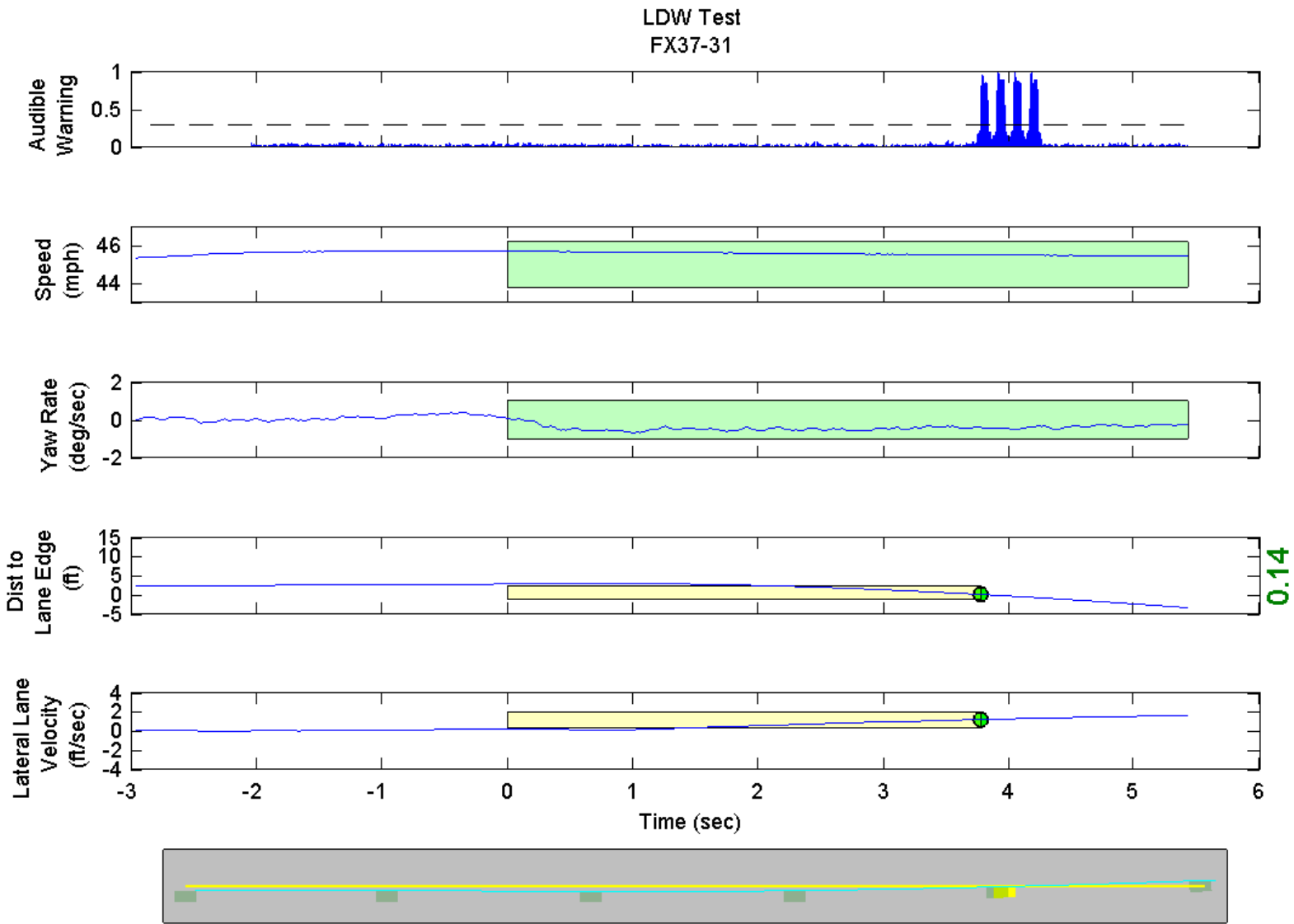

GPS Fix Type: RTK Fixed

Figure D60. Time History for Run 31, Dashed Line, Left Departure, Audible Warning

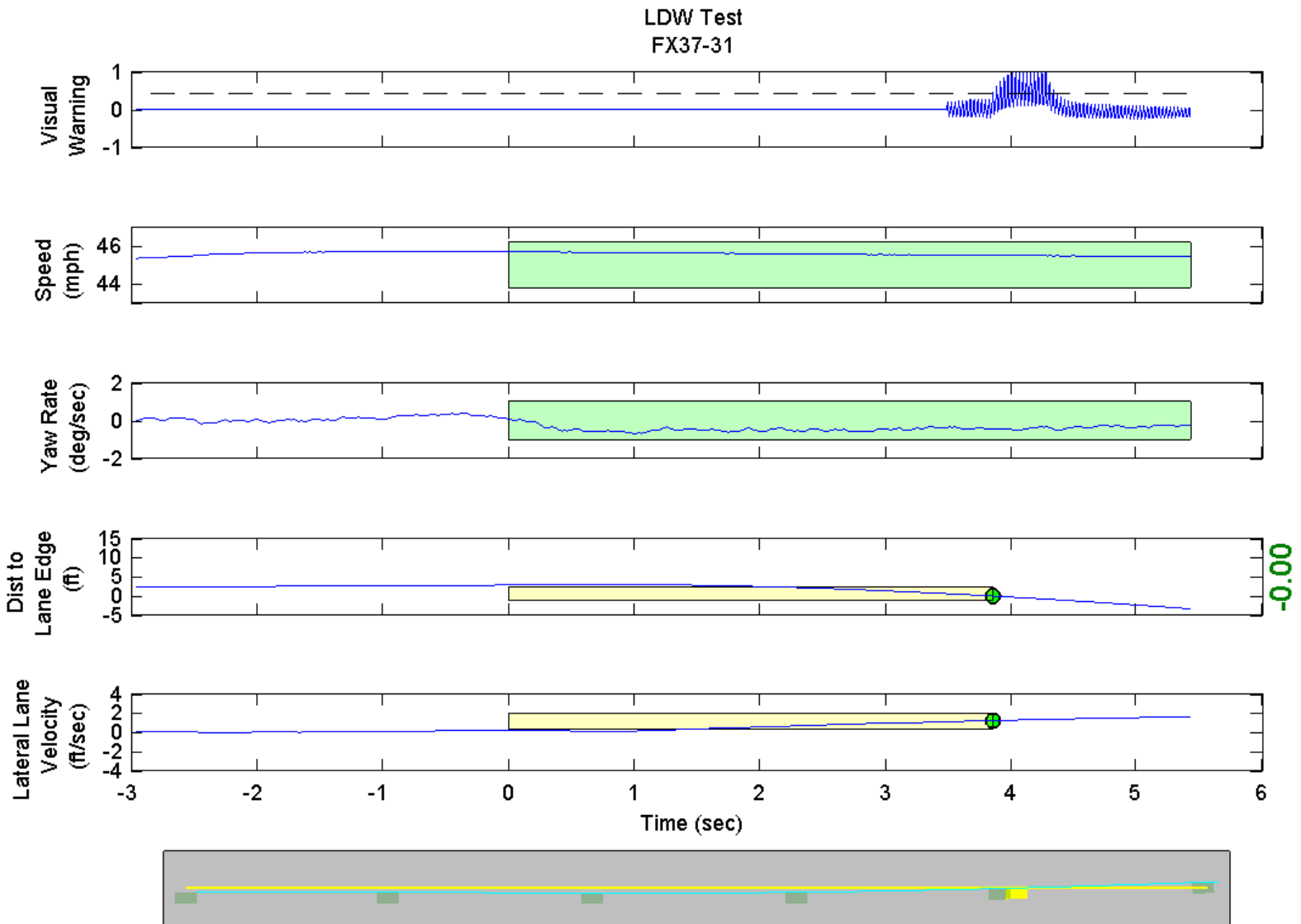

GPS Fix Type: RTK Fixed

Figure D61. Time History for Run 31, Dashed Line, Left Departure, Visual Warning

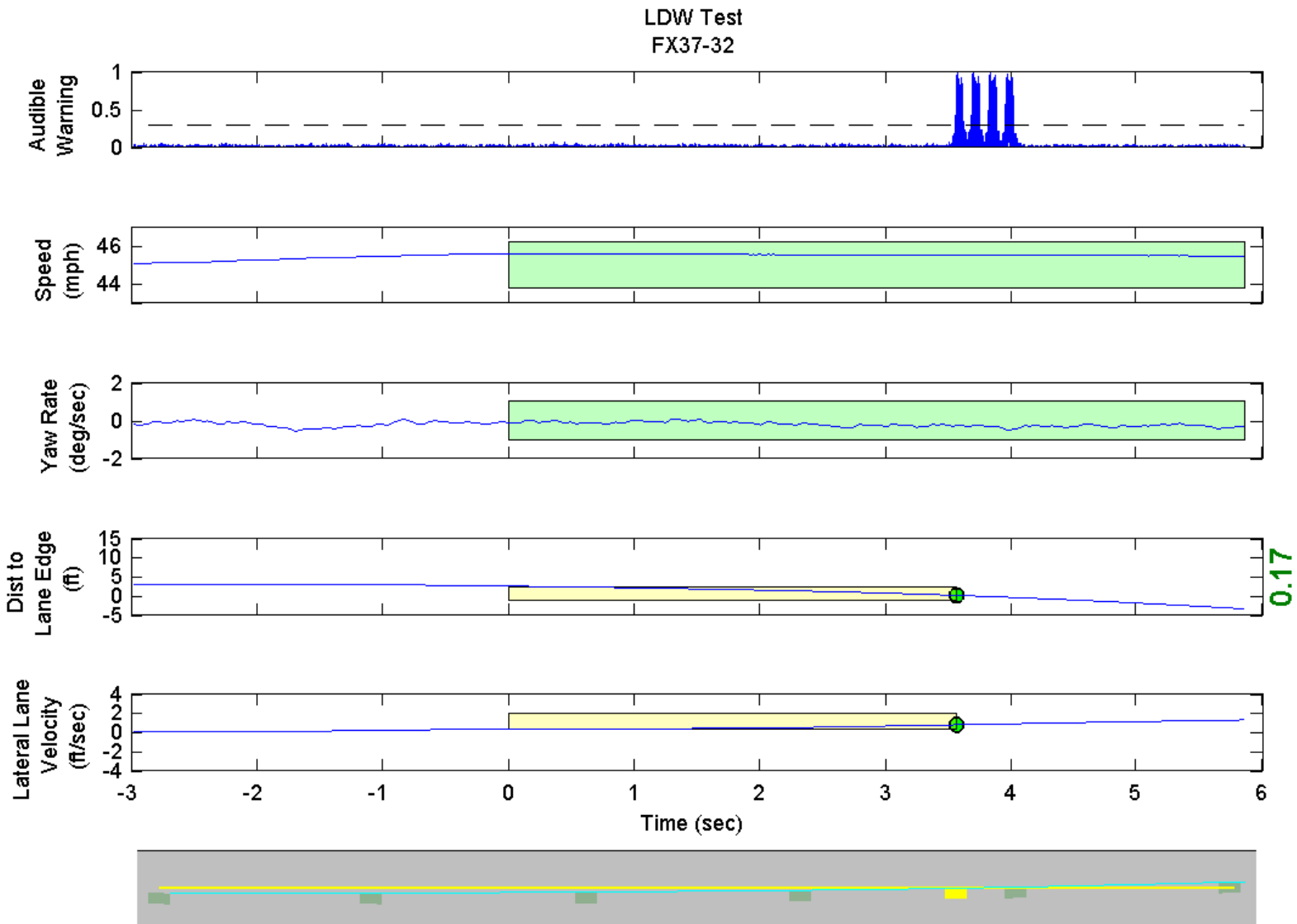

GPS Fix Type: RTK Fixed

Figure D62. Time History for Run 32, Dashed Line, Left Departure, Audible Warning

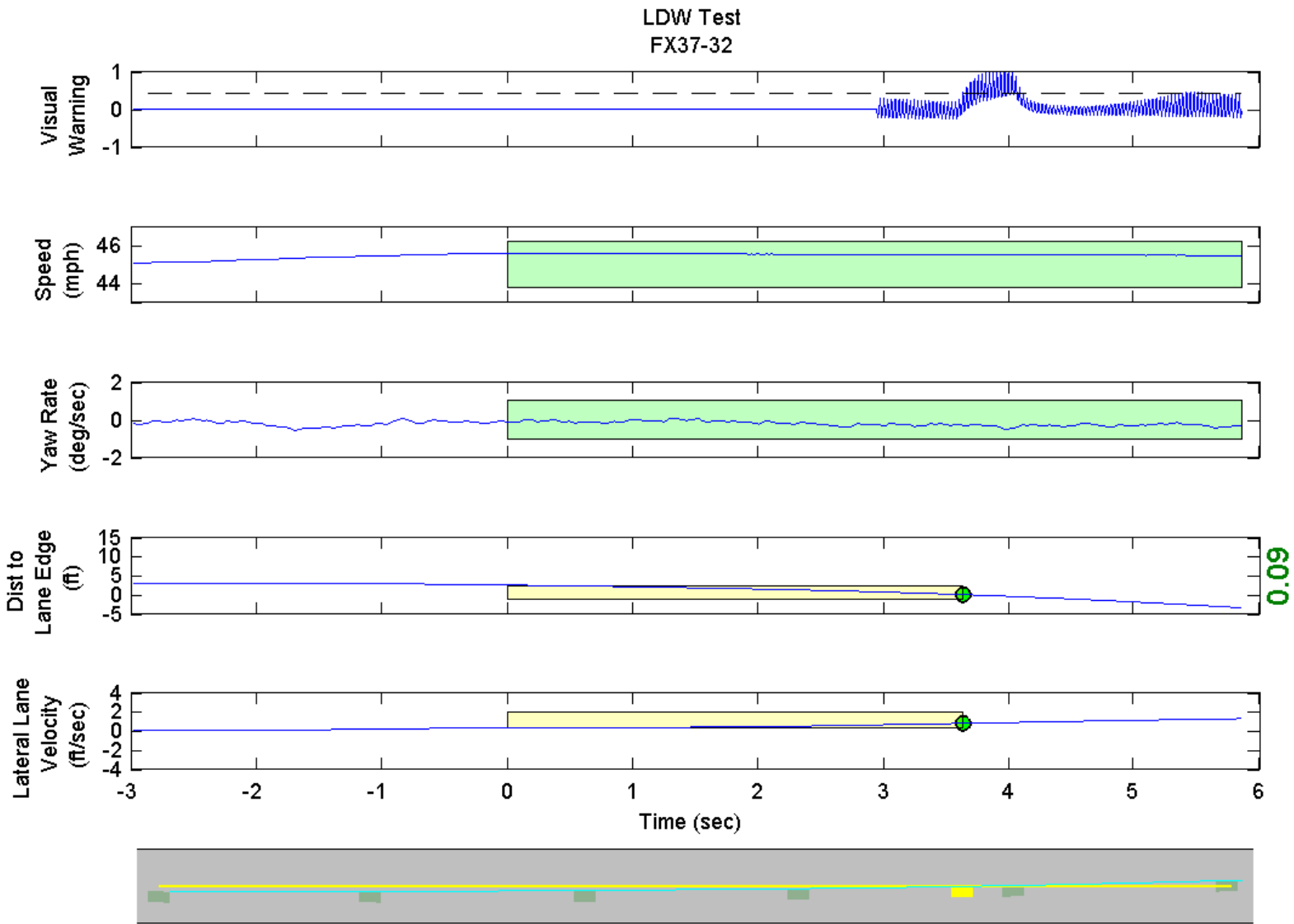

GPS Fix Type: RTK Fixed

Figure D63. Time History for Run 32, Dashed Line, Left Departure, Visual Warning

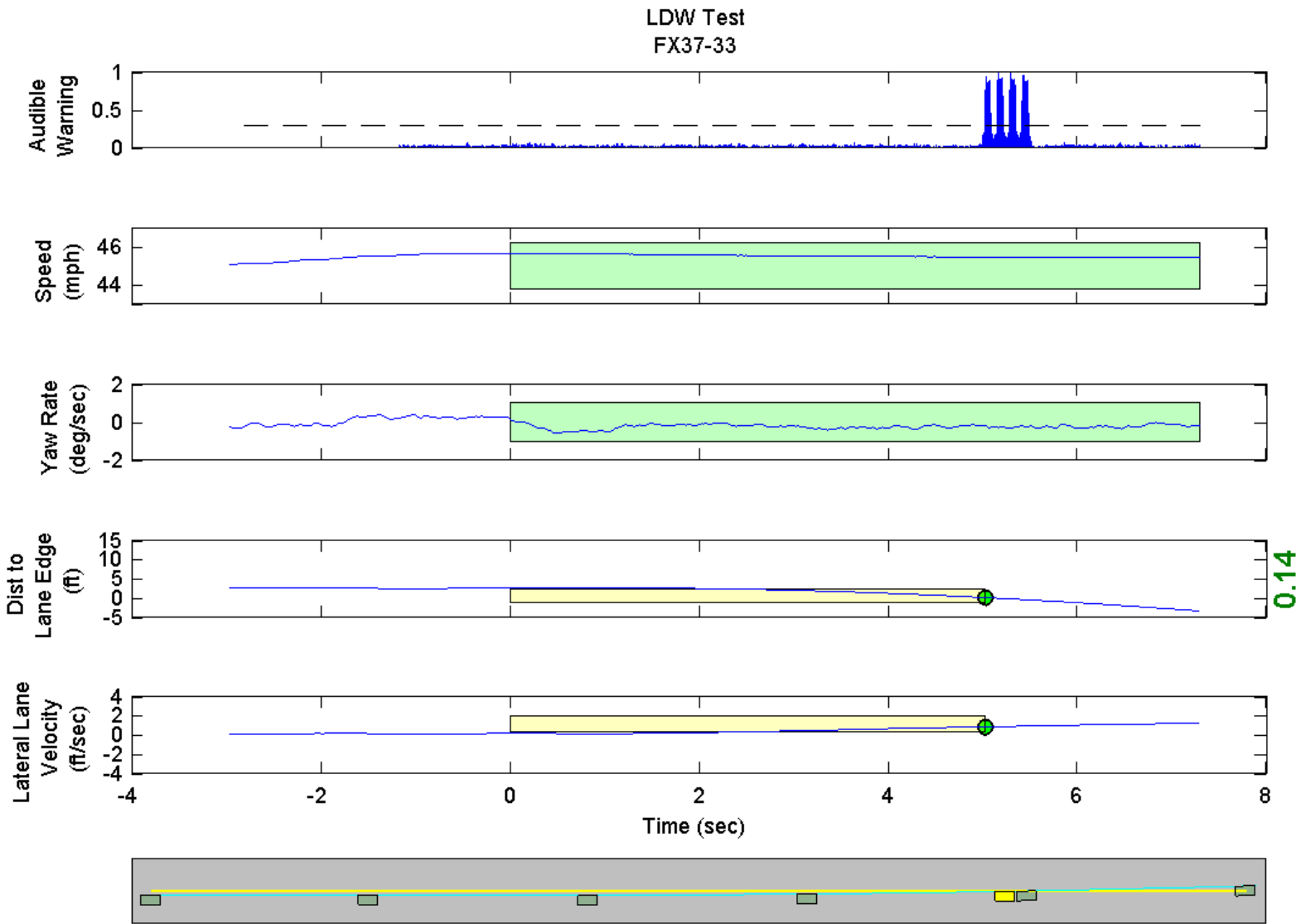

GPS Fix Type: RTK Fixed

Figure D64. Time History for Run 33, Dashed Line, Left Departure, Audible Warning

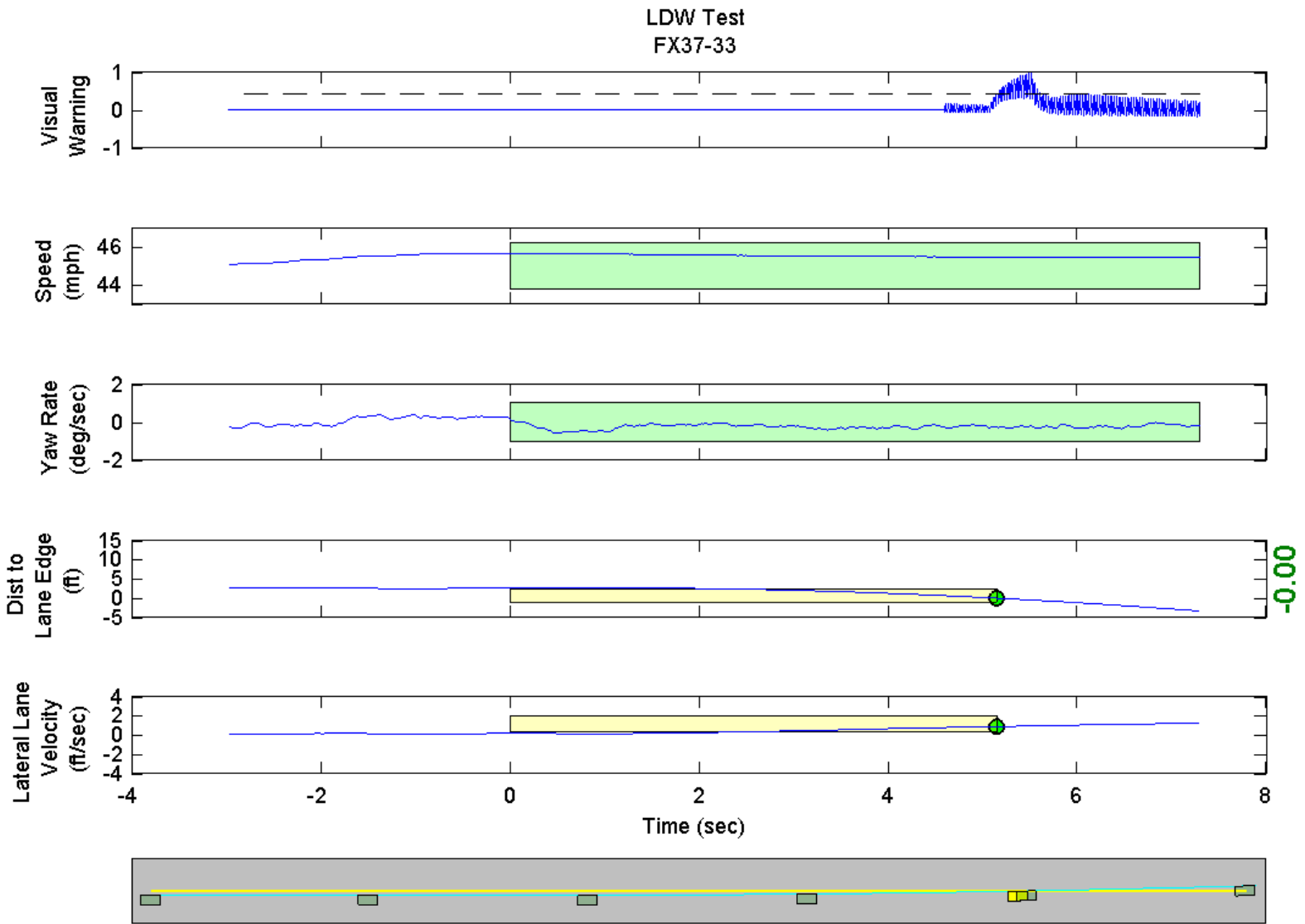

GPS Fix Type: RTK Fixed

Figure D65. Time History for Run 33, Dashed Line, Left Departure, Visual Warning

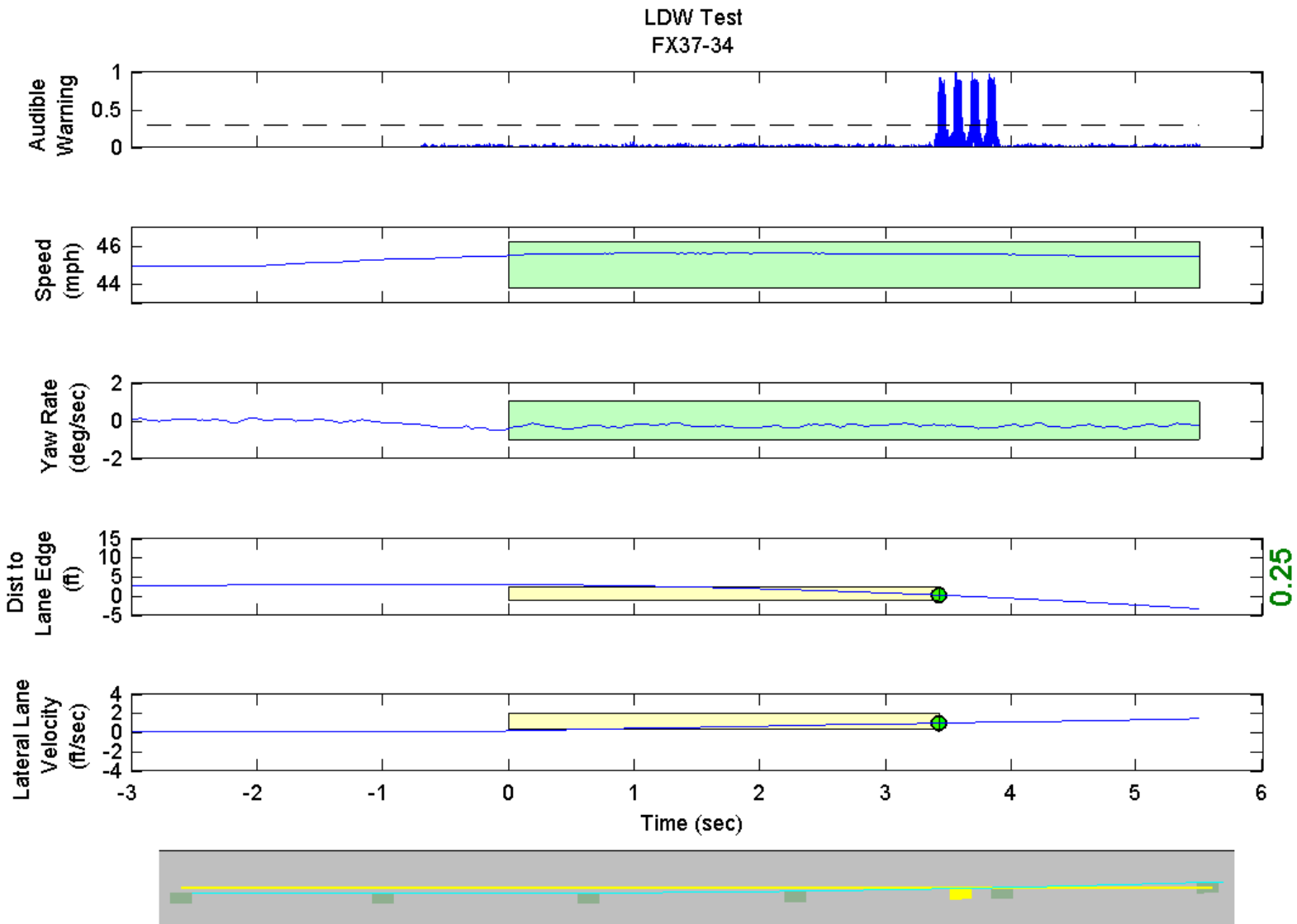

GPS Fix Type: RTK Fixed

Figure D66. Time History for Run 34, Dashed Line, Left Departure, Audible Warning

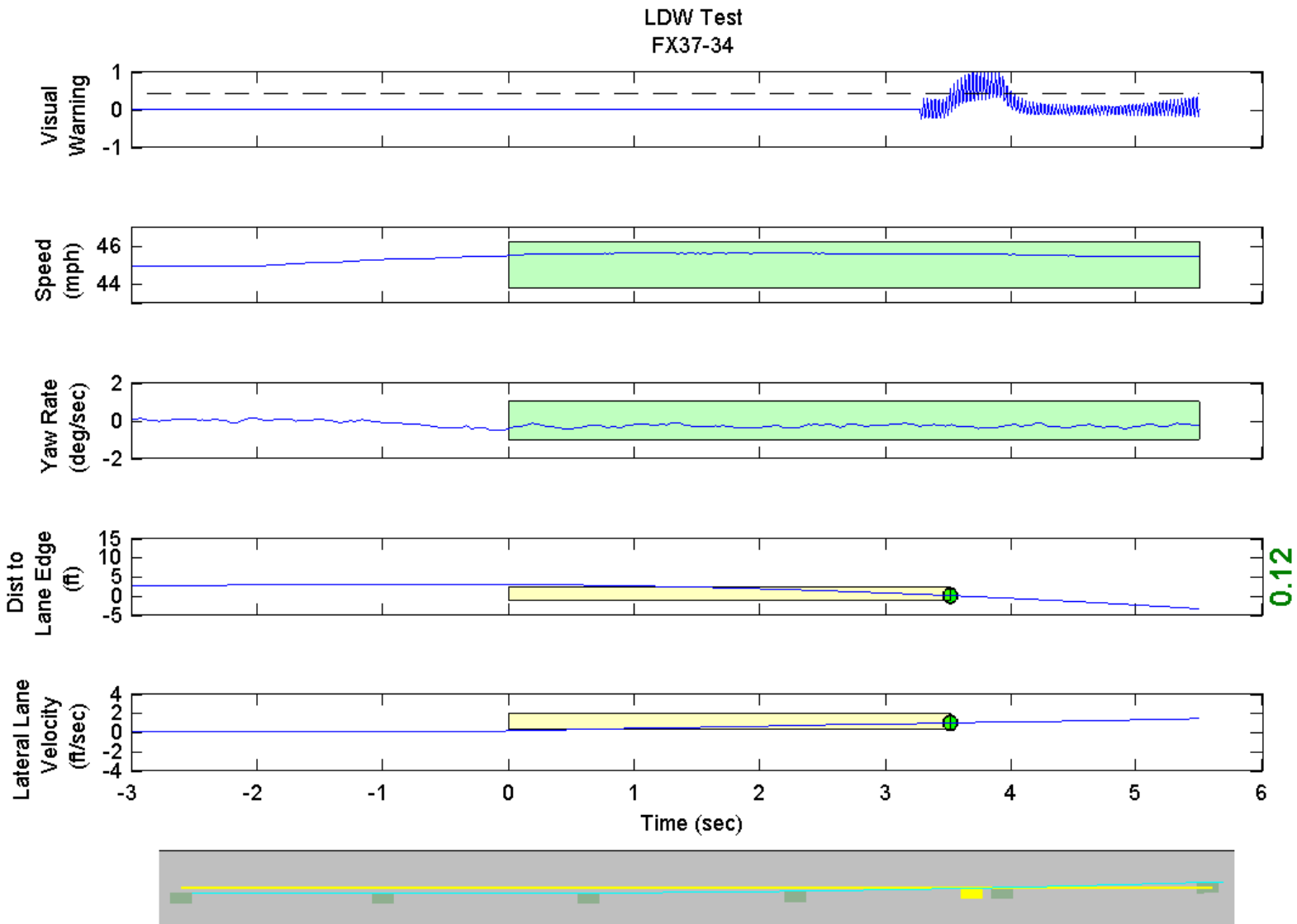

GPS Fix Type: RTK Fixed

Figure D67. Time History for Run 34, Dashed Line, Left Departure, Visual Warning

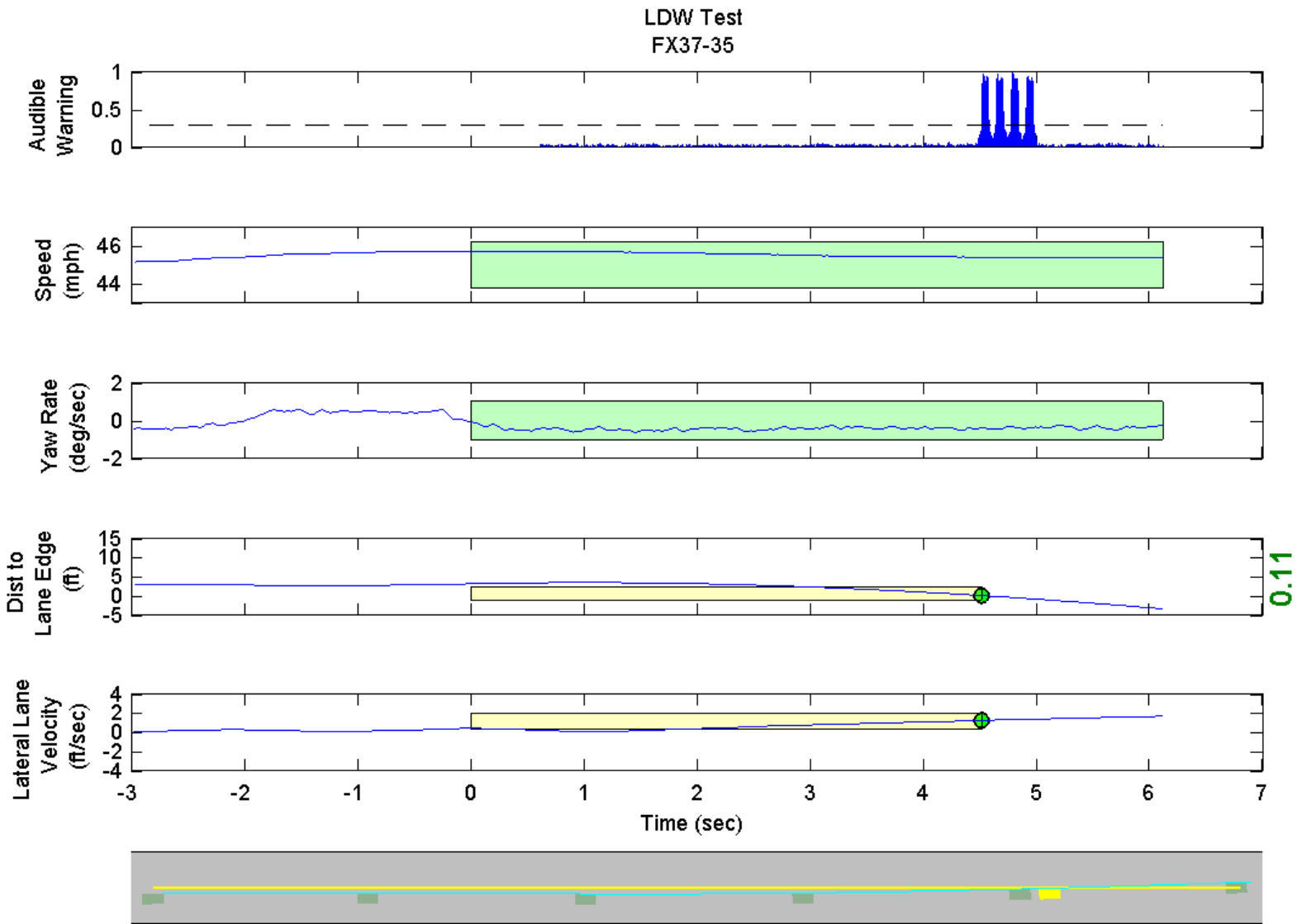

GPS Fix Type: RTK Fixed

Figure D68. Time History for Run 35, Dashed Line, Left Departure, Audible Warning

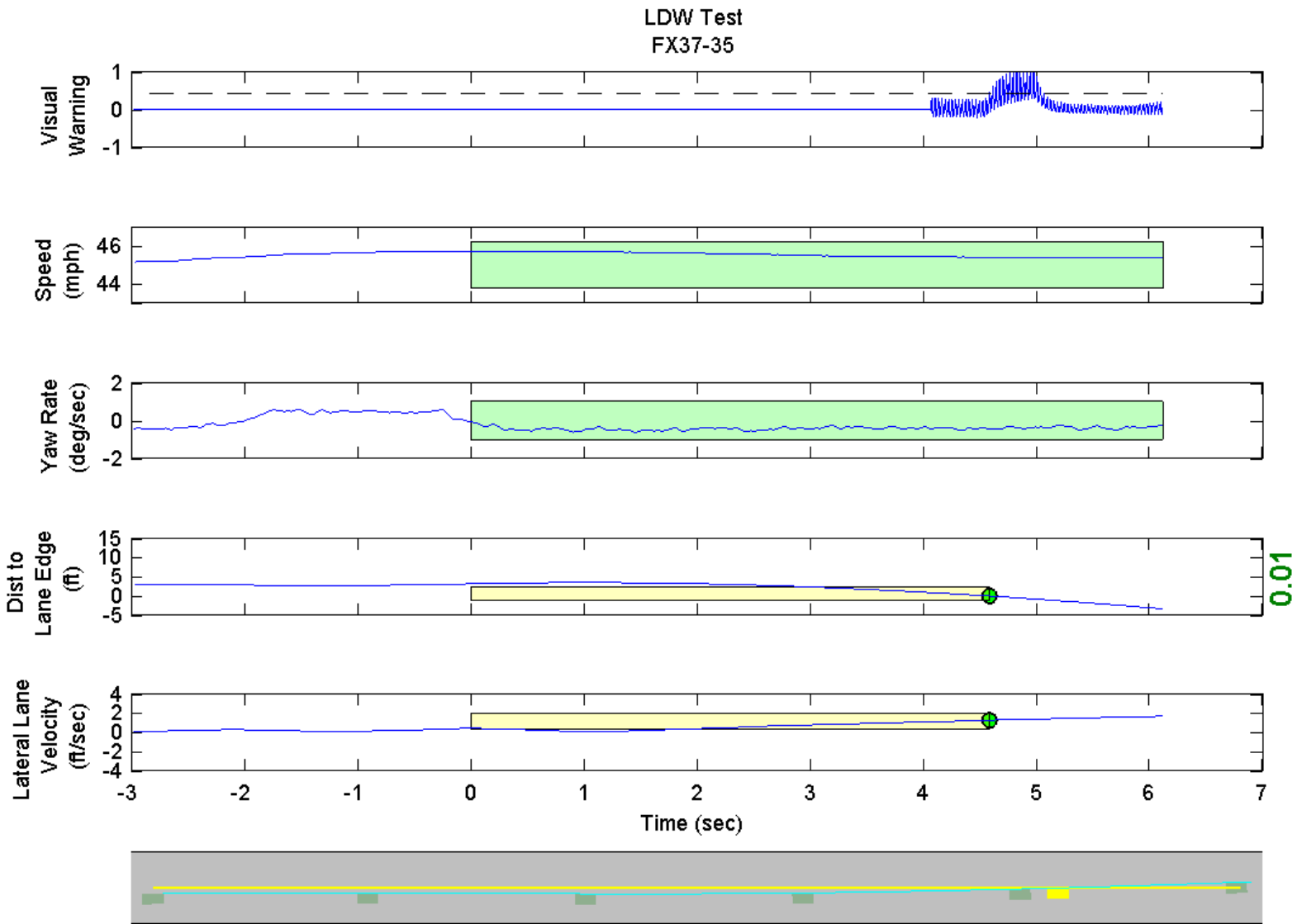

GPS Fix Type: RTK Fixed

Figure D69. Time History for Run 35, Dashed Line, Left Departure, Visual Warning

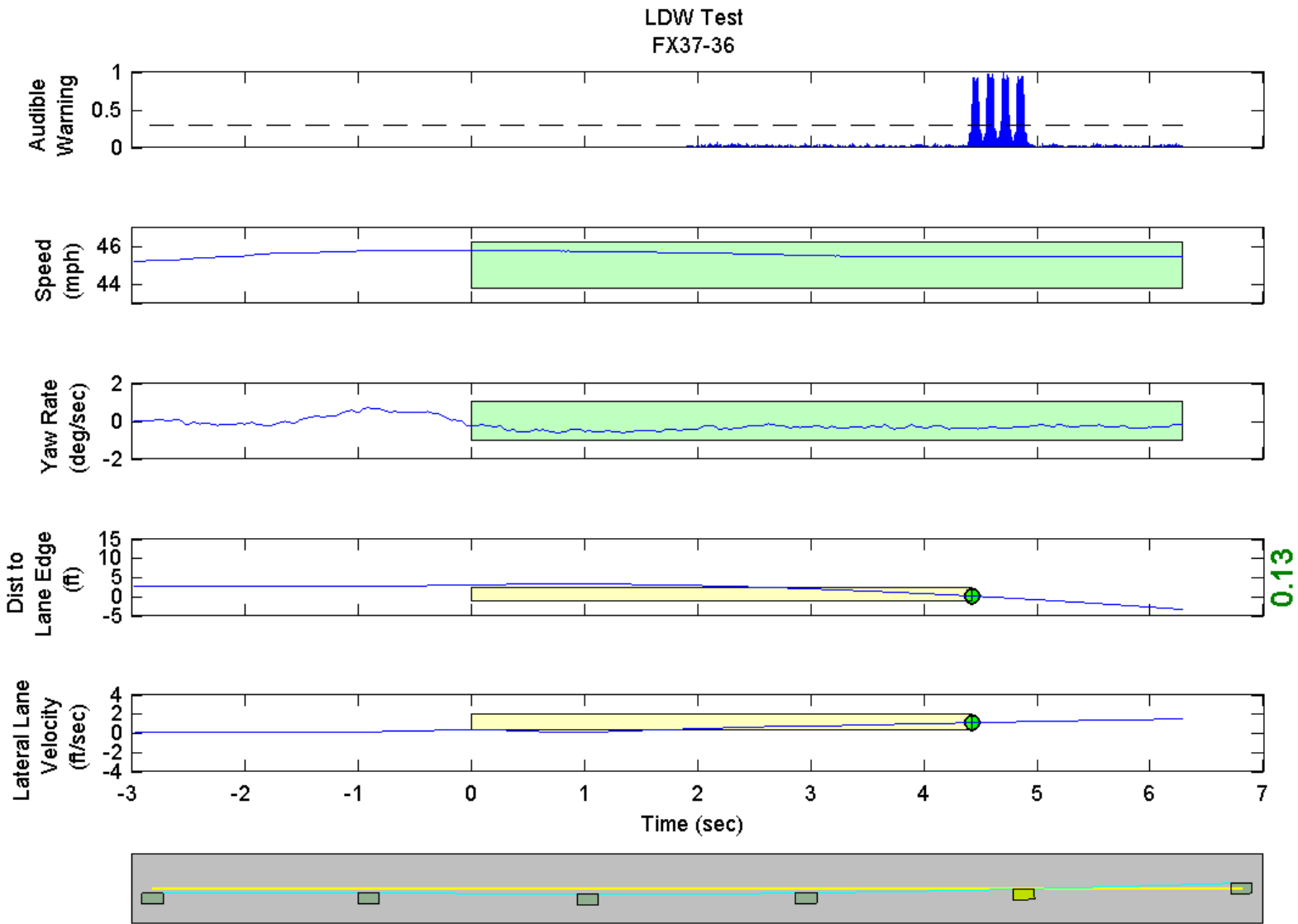

GPS Fix Type: RTK Fixed

Figure D70. Time History for Run 36, Dashed Line, Left Departure, Audible Warning

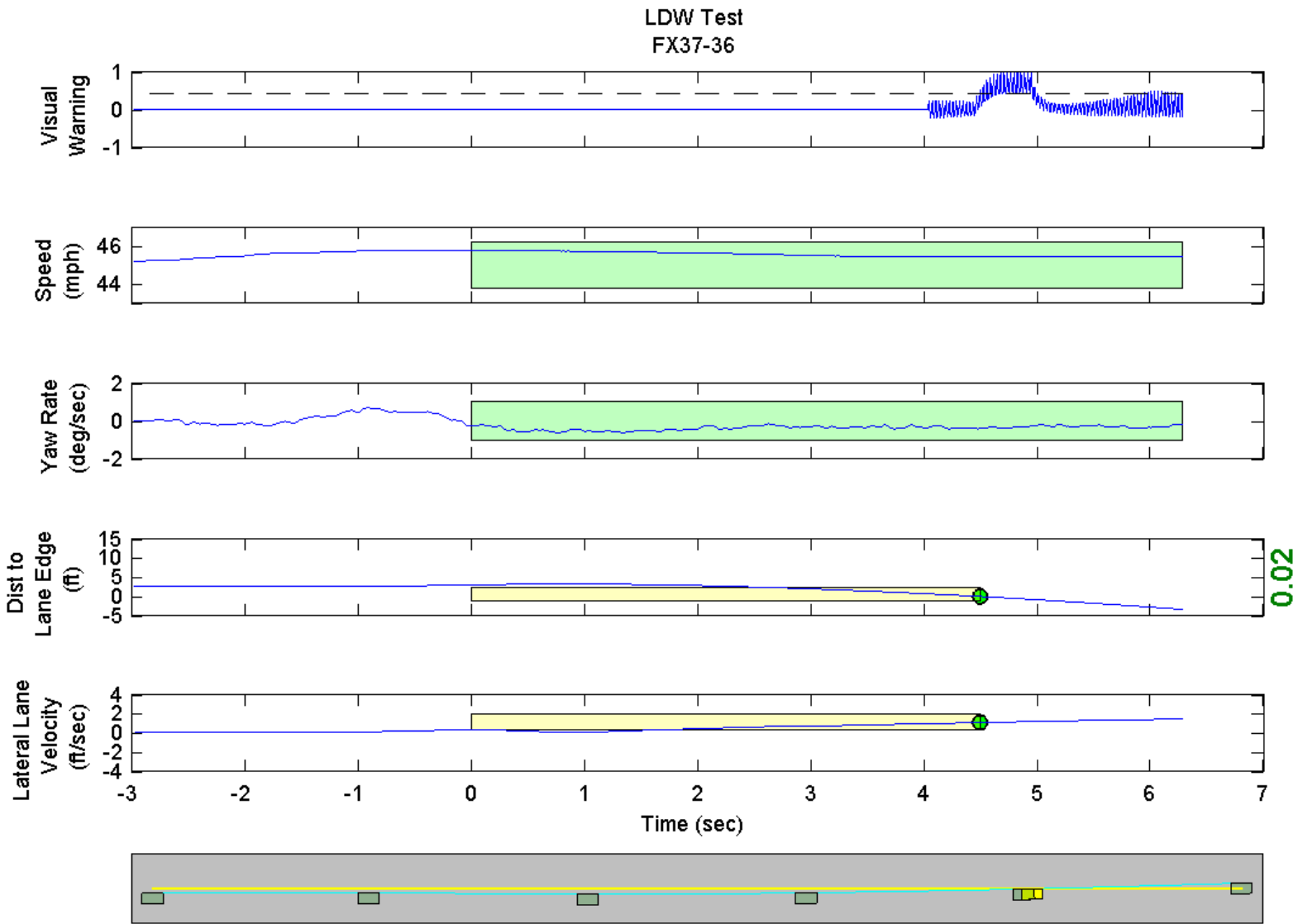

GPS Fix Type: RTK Fixed

Figure D71. Time History for Run 36, Dashed Line, Left Departure, Visual Warning

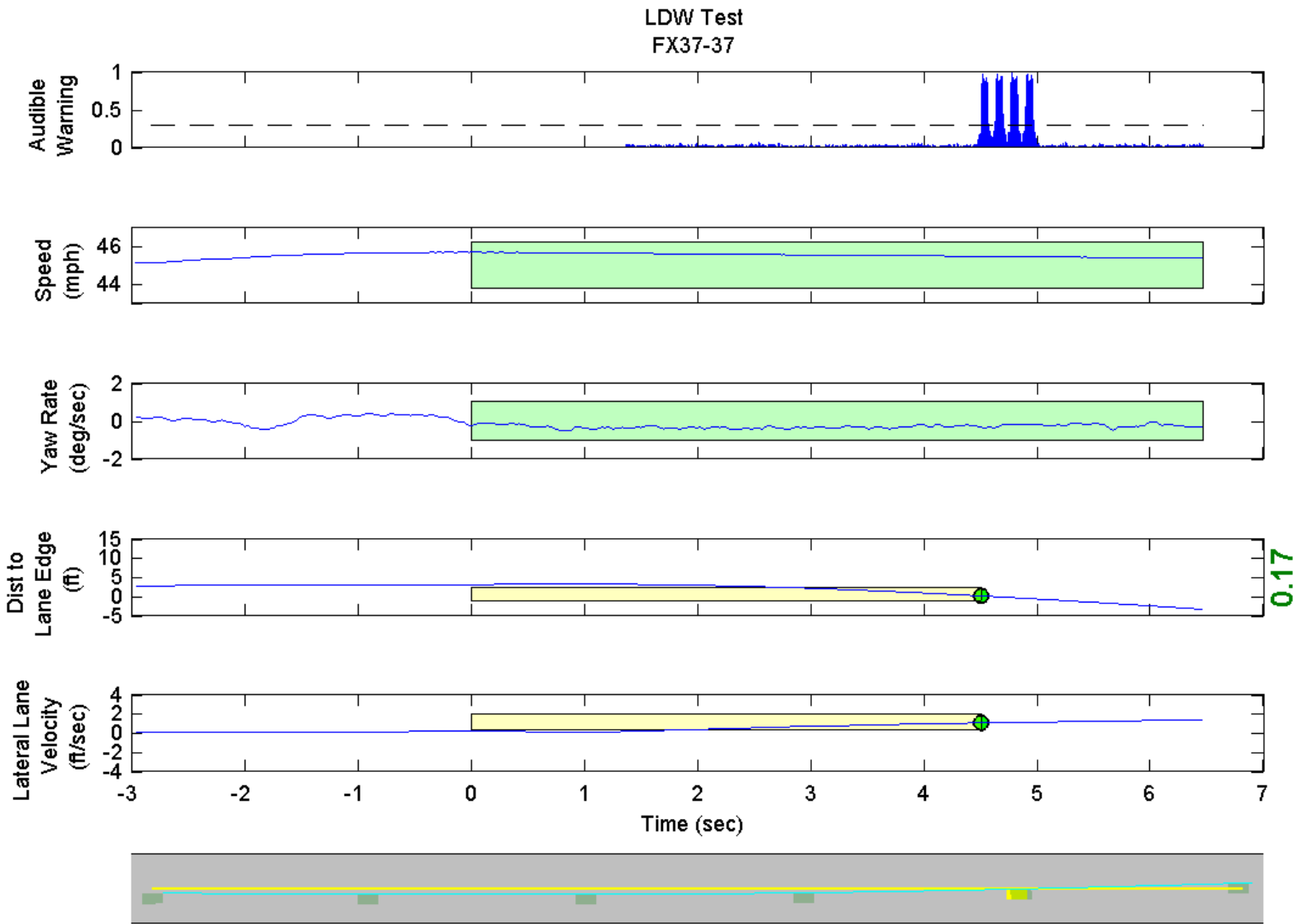

GPS Fix Type: RTK Fixed

Figure D72. Time History for Run 37, Dashed Line, Left Departure, Audible Warning

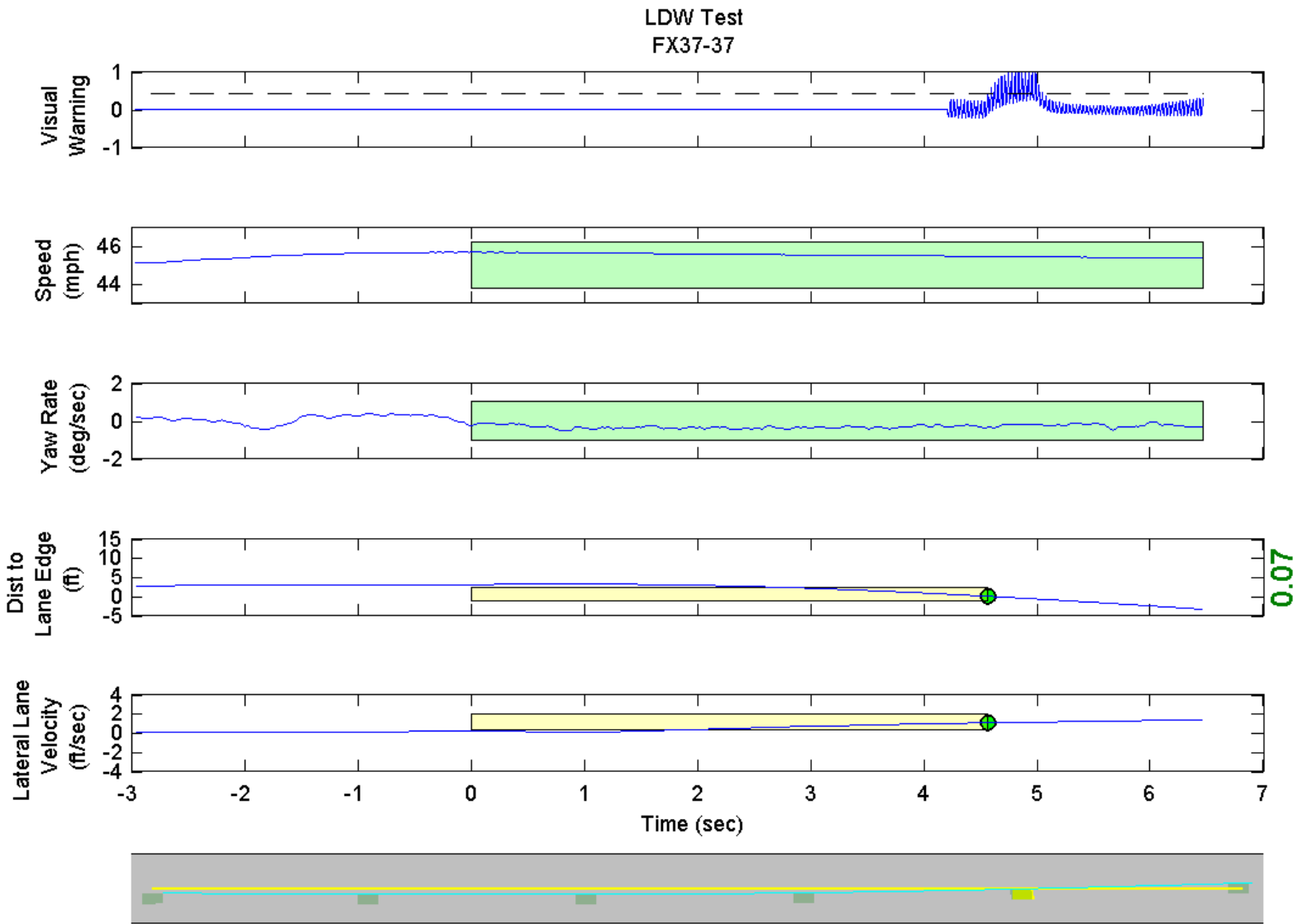

GPS Fix Type: RTK Fixed

Figure D73. Time History for Run 37, Dashed Line, Left Departure, Visual Warning

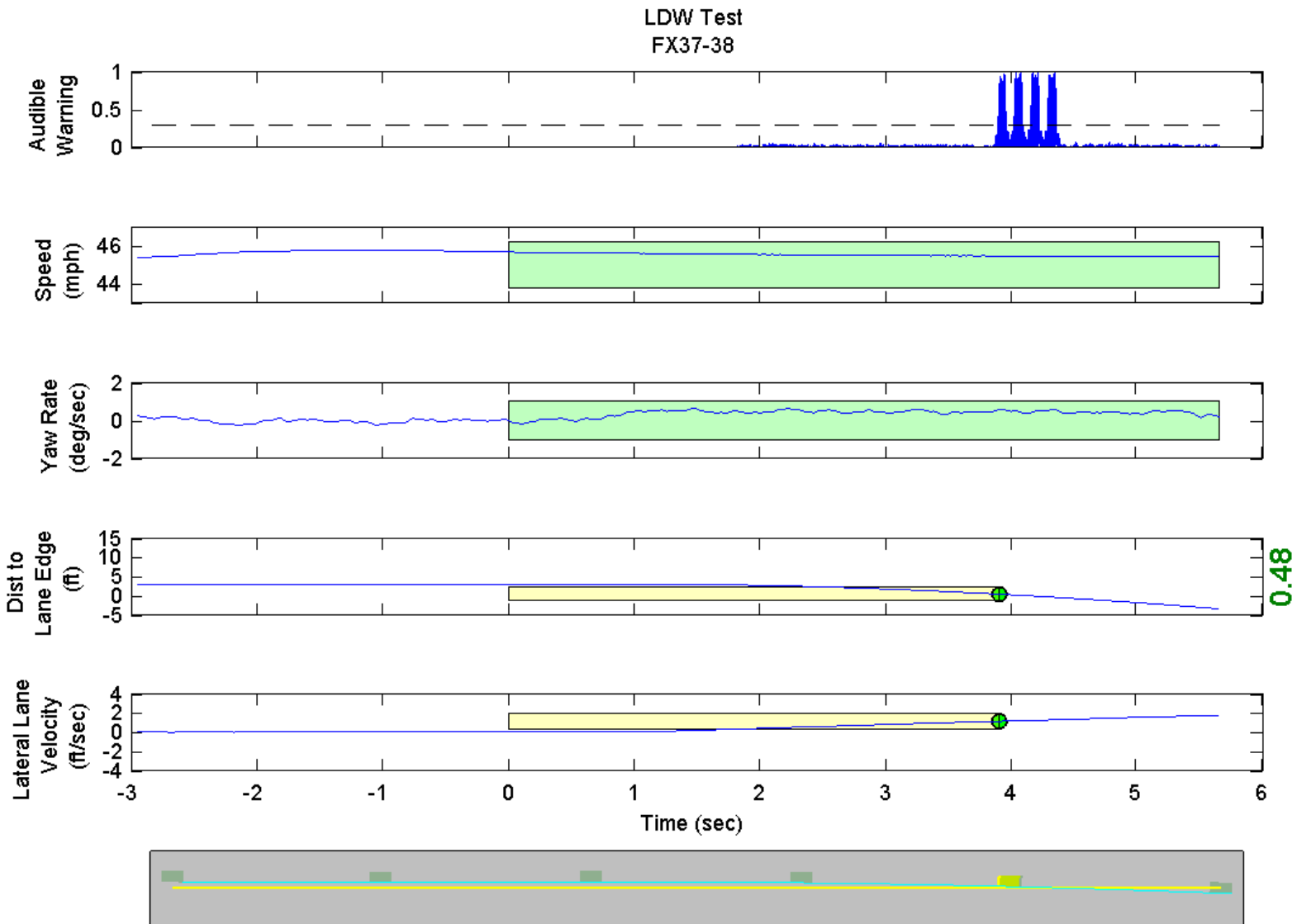

GPS Fix Type: RTK Fixed

Figure D74. Time History for Run 38, Dashed Line, Right Departure, Audible Warning

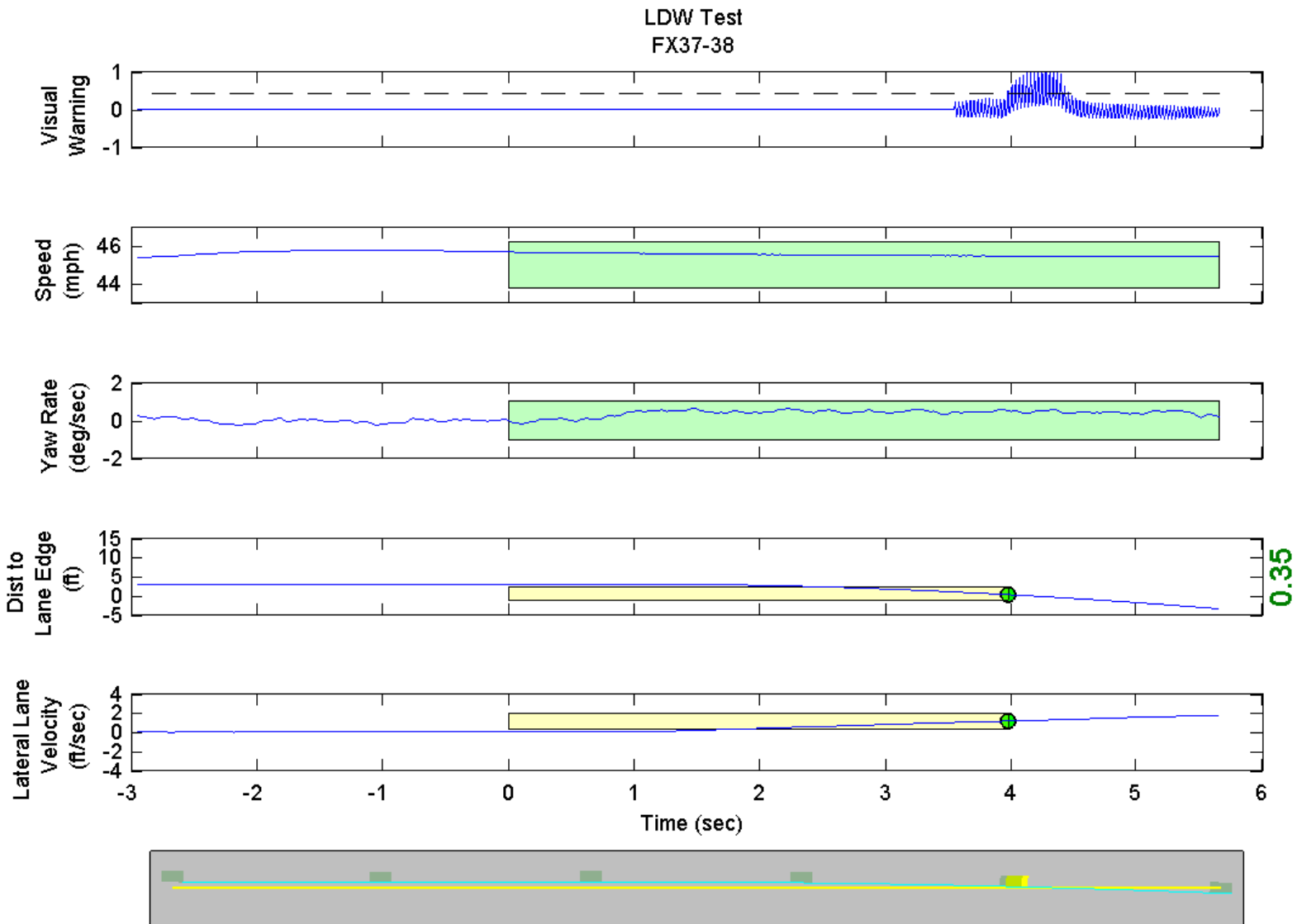

GPS Fix Type: RTK Fixed

Figure D75. Time History for Run 38, Dashed Line, Right Departure, Visual Warning

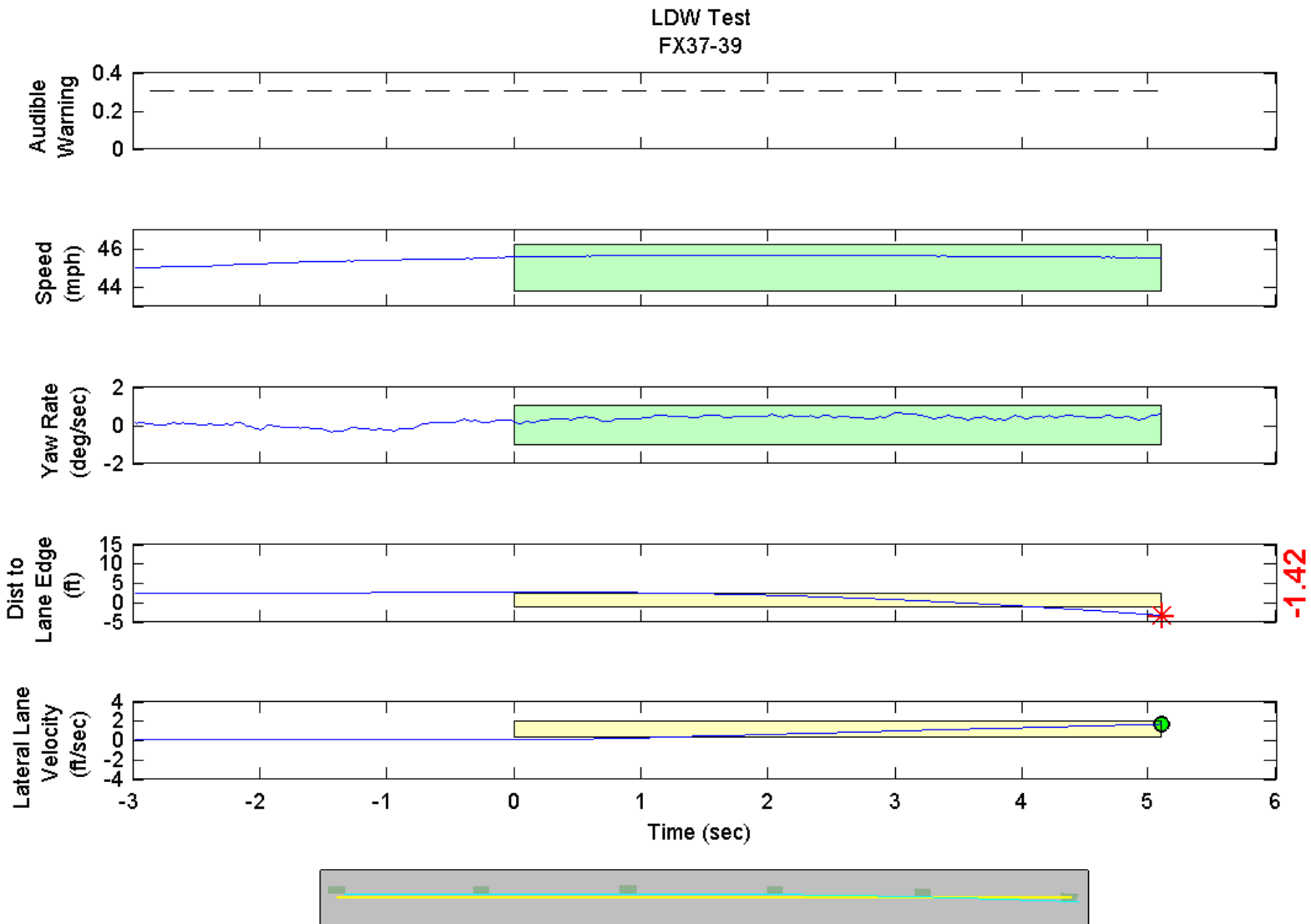

GPS Fix Type: RTK Fixed

Figure D76. Time History for Run 39, Dashed Line, Right Departure, Audible Warning

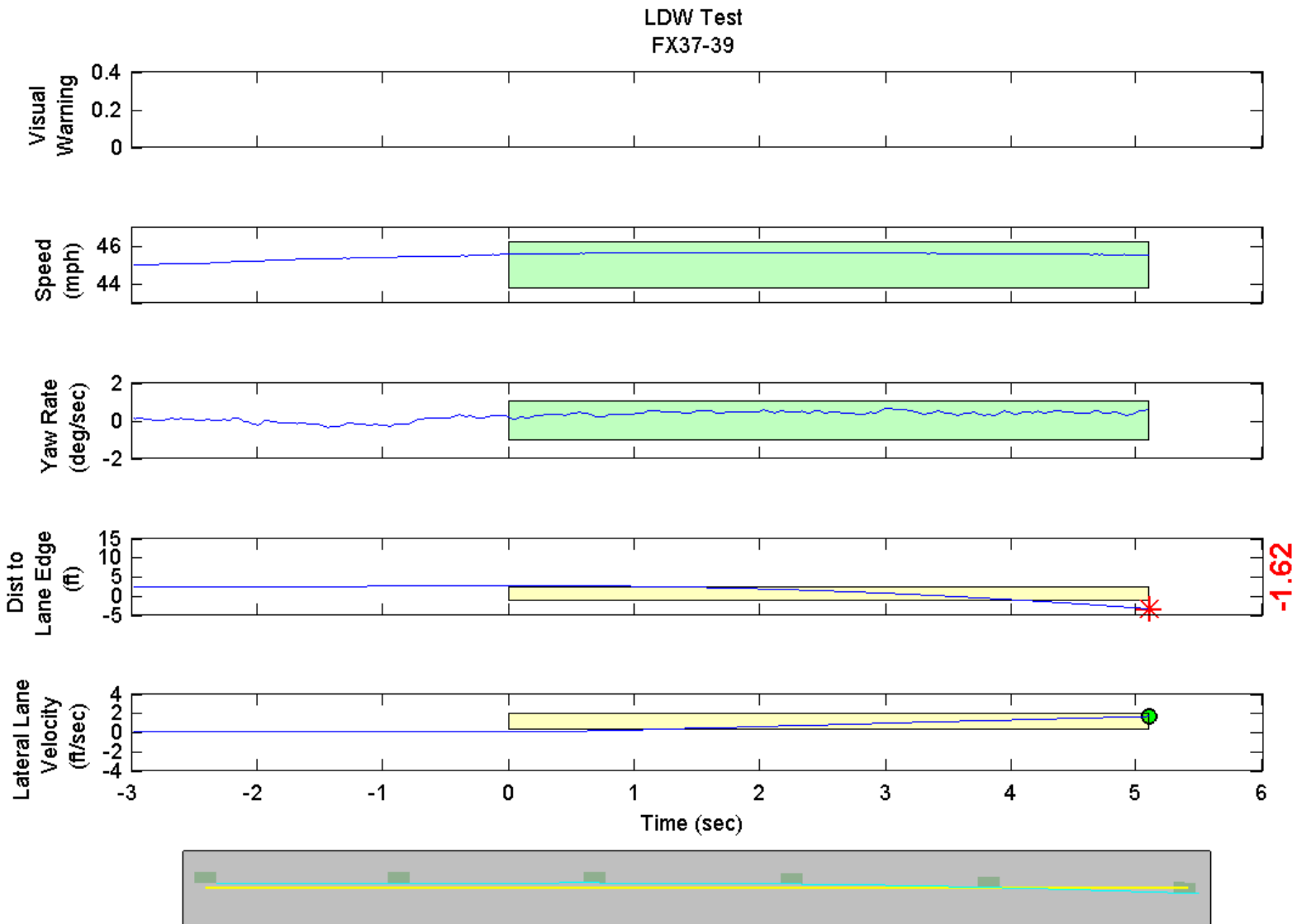

GPS Fix Type: RTK Fixed

Figure D77. Time History for Run 39, Dashed Line, Right Departure, Visual Warning

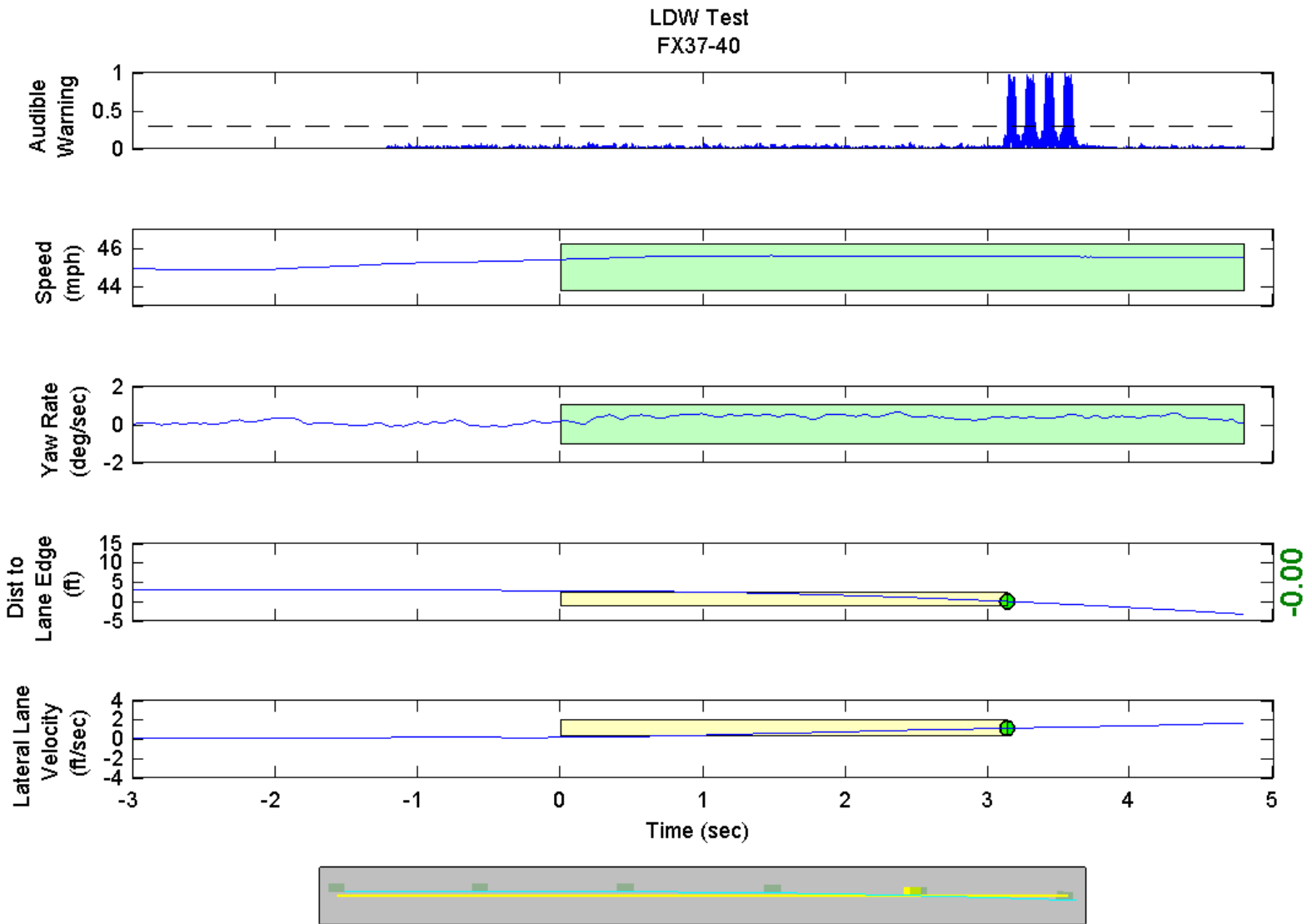

GPS Fix Type: RTK Fixed

Figure D78. Time History for Run 40, Dashed Line, Right Departure, Audible Warning

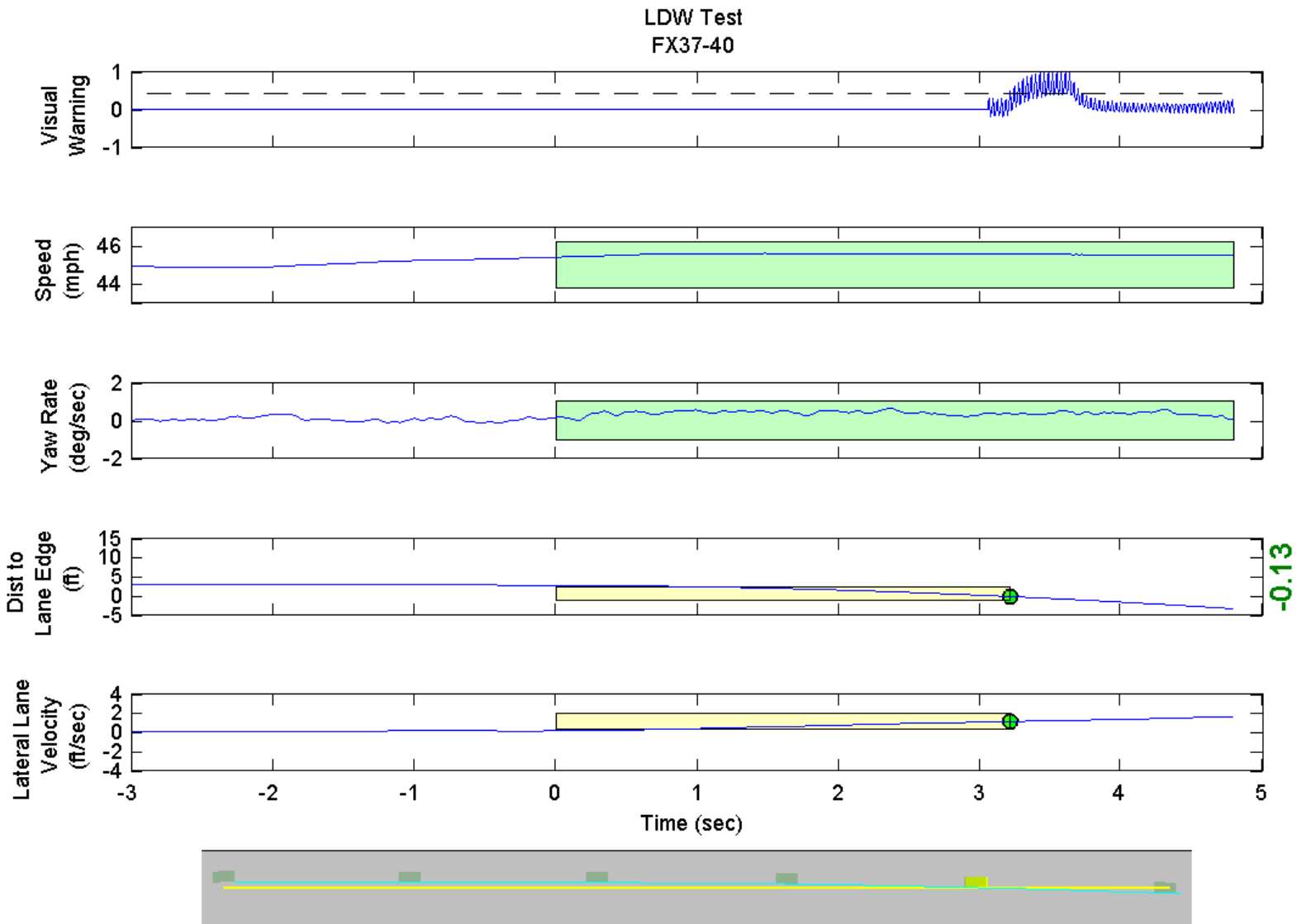

GPS Fix Type: RTK Fixed

Figure D79. Time History for Run 40, Dashed Line, Right Departure, Visual Warning

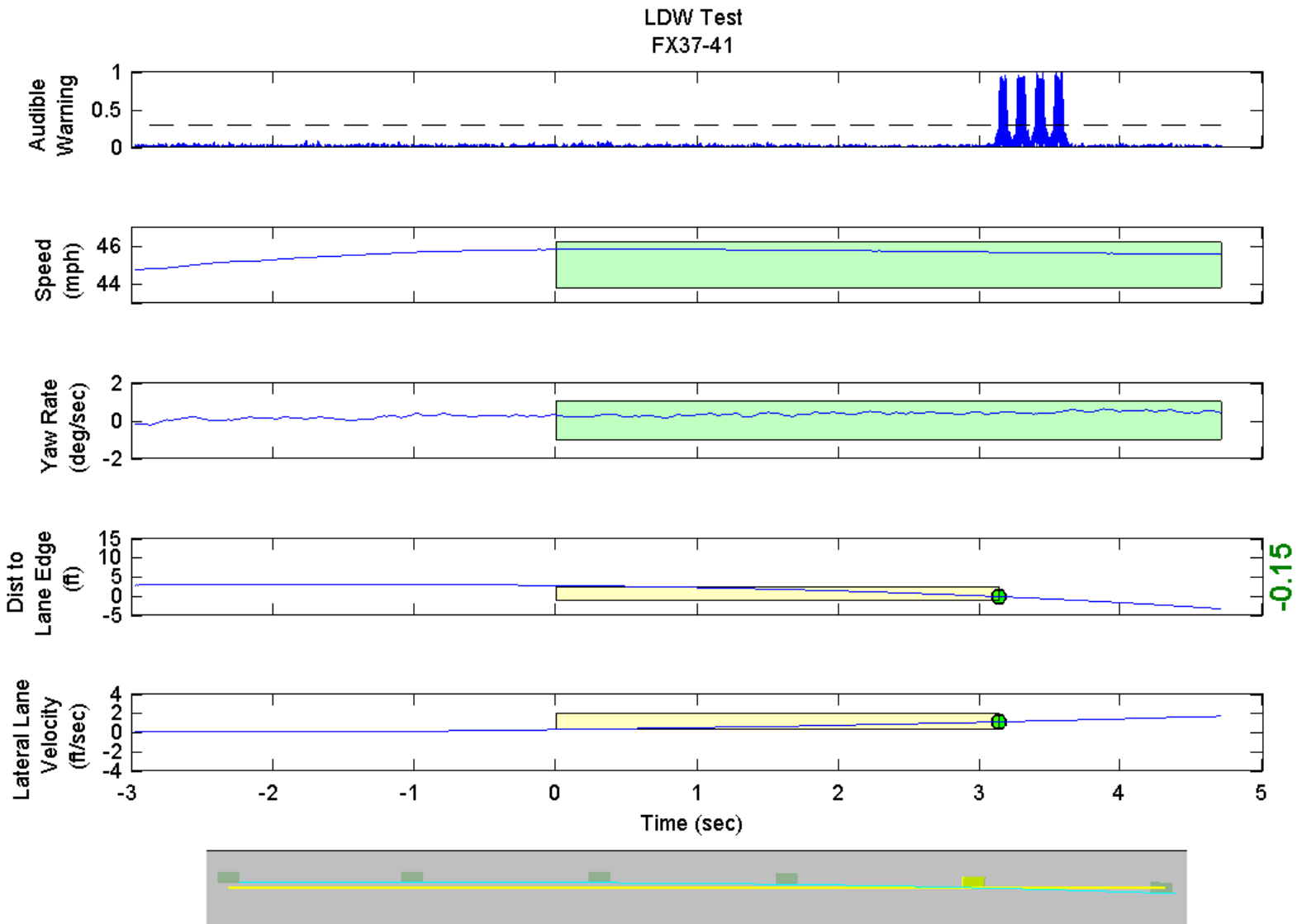

GPS Fix Type: RTK Fixed

Figure D80. Time History for Run 41, Dashed Line, Right Departure, Audible Warning

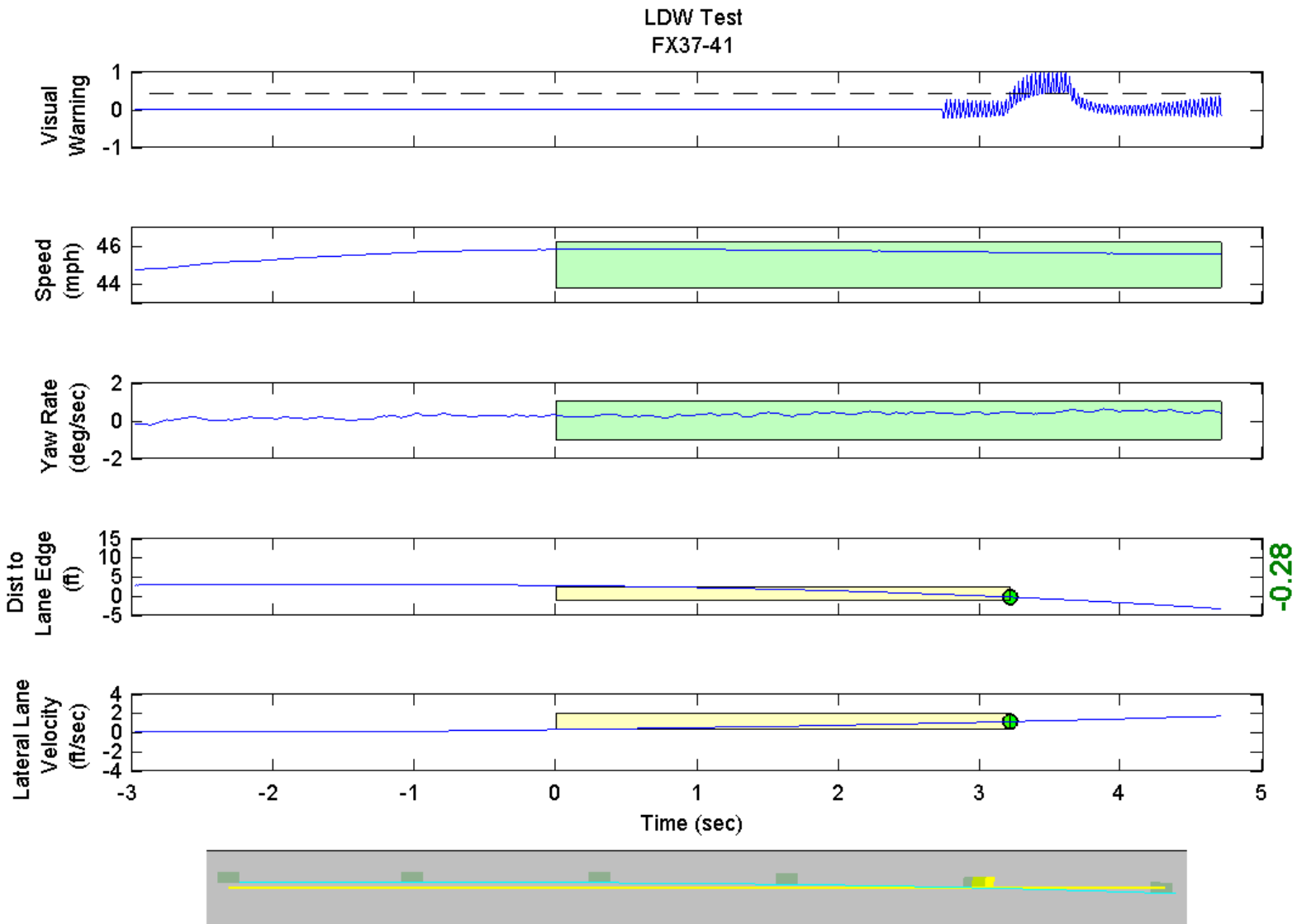

GPS Fix Type: RTK Fixed

Figure D81. Time History for Run 41, Dashed Line, Right Departure, Visual Warning

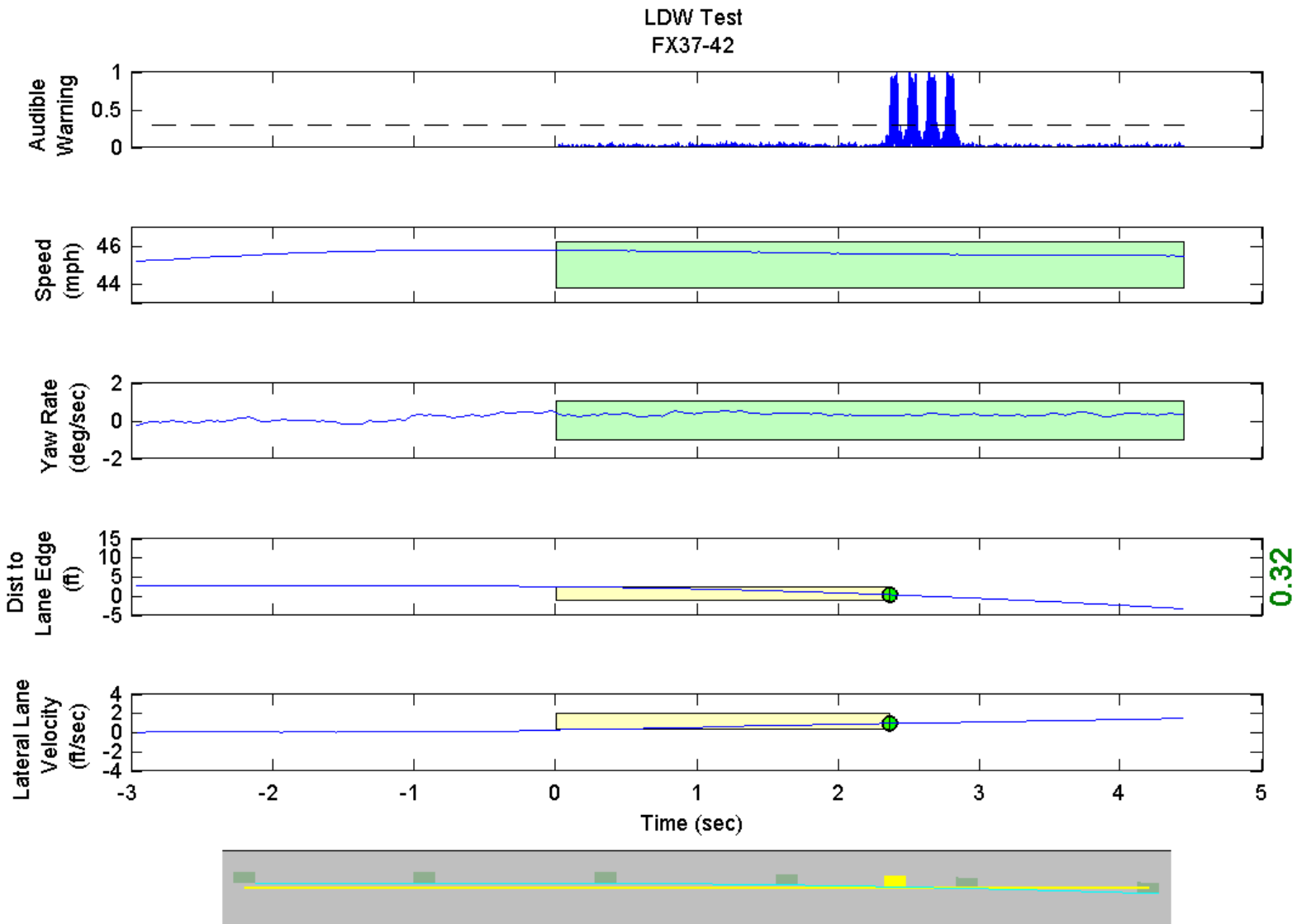

GPS Fix Type: RTK Fixed

Figure D82. Time History for Run 42, Dashed Line, Right Departure, Audible Warning

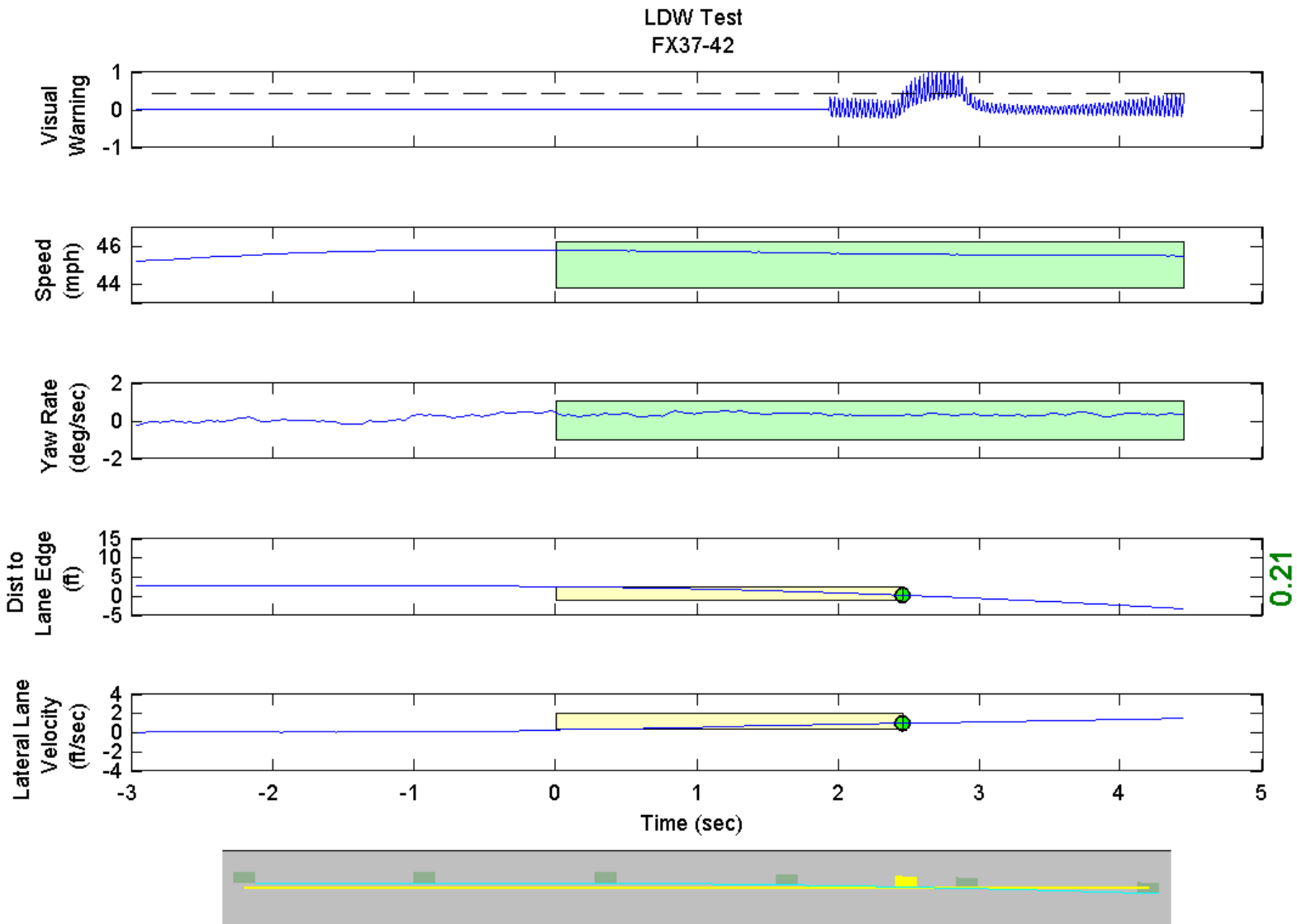

GPS Fix Type: RTK Fixed

Figure D83. Time History for Run 42, Dashed Line, Right Departure, Visual Warning

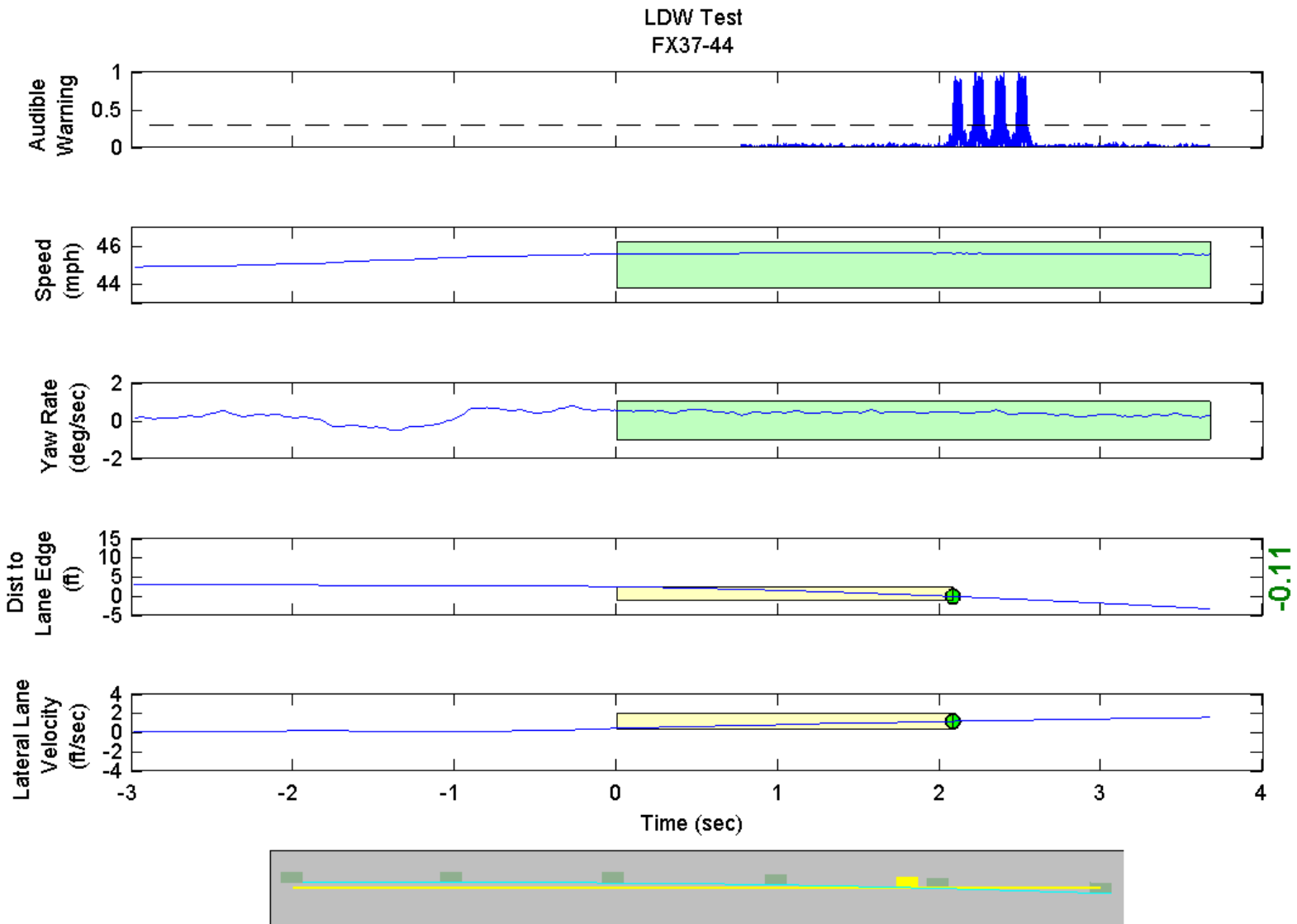

GPS Fix Type: RTK Fixed

Figure D84. Time History for Run 44, Dashed Line, Right Departure, Audible Warning

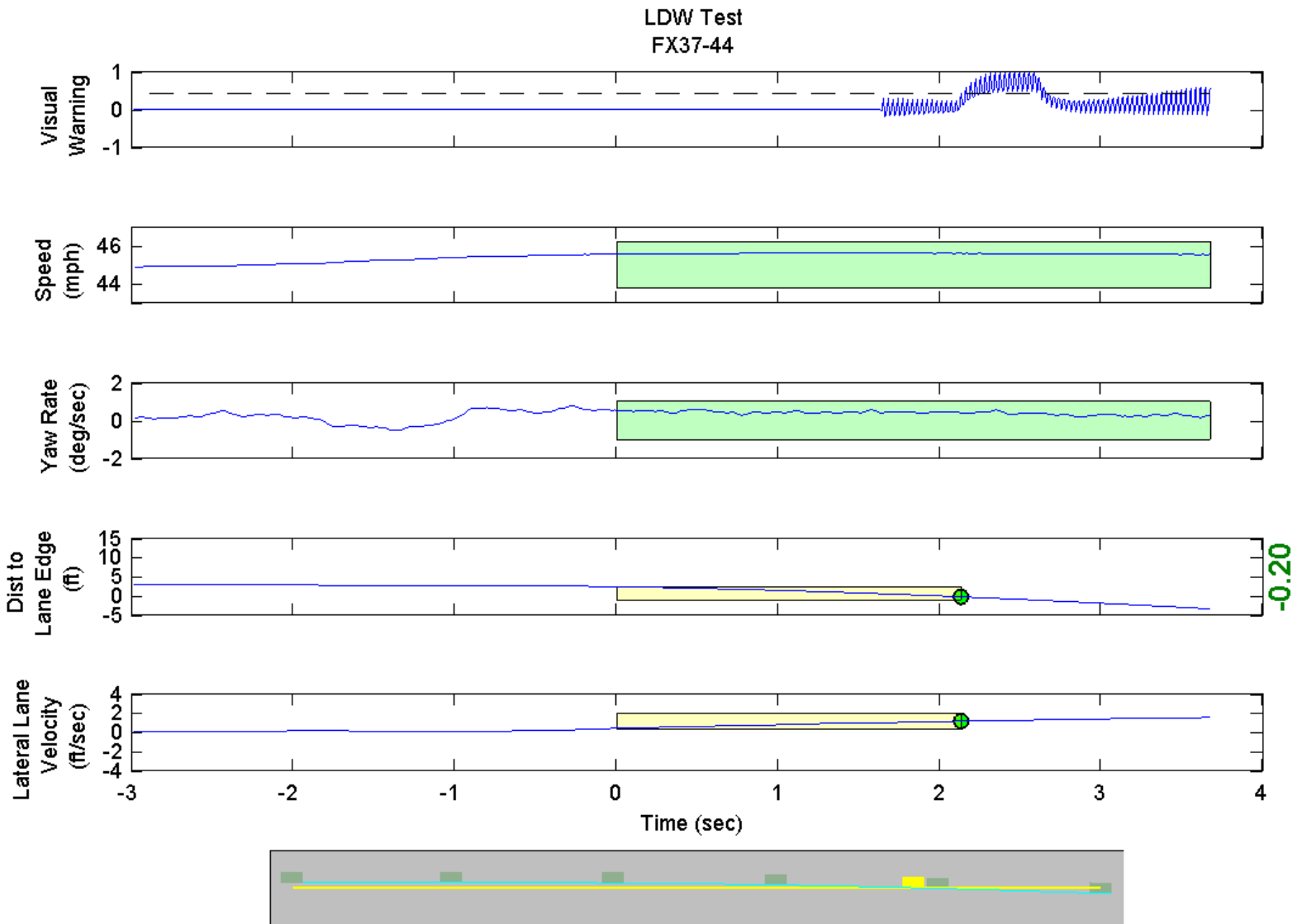

GPS Fix Type: RTK Fixed

Figure D85. Time History for Run 44, Dashed Line, Right Departure, Visual Warning

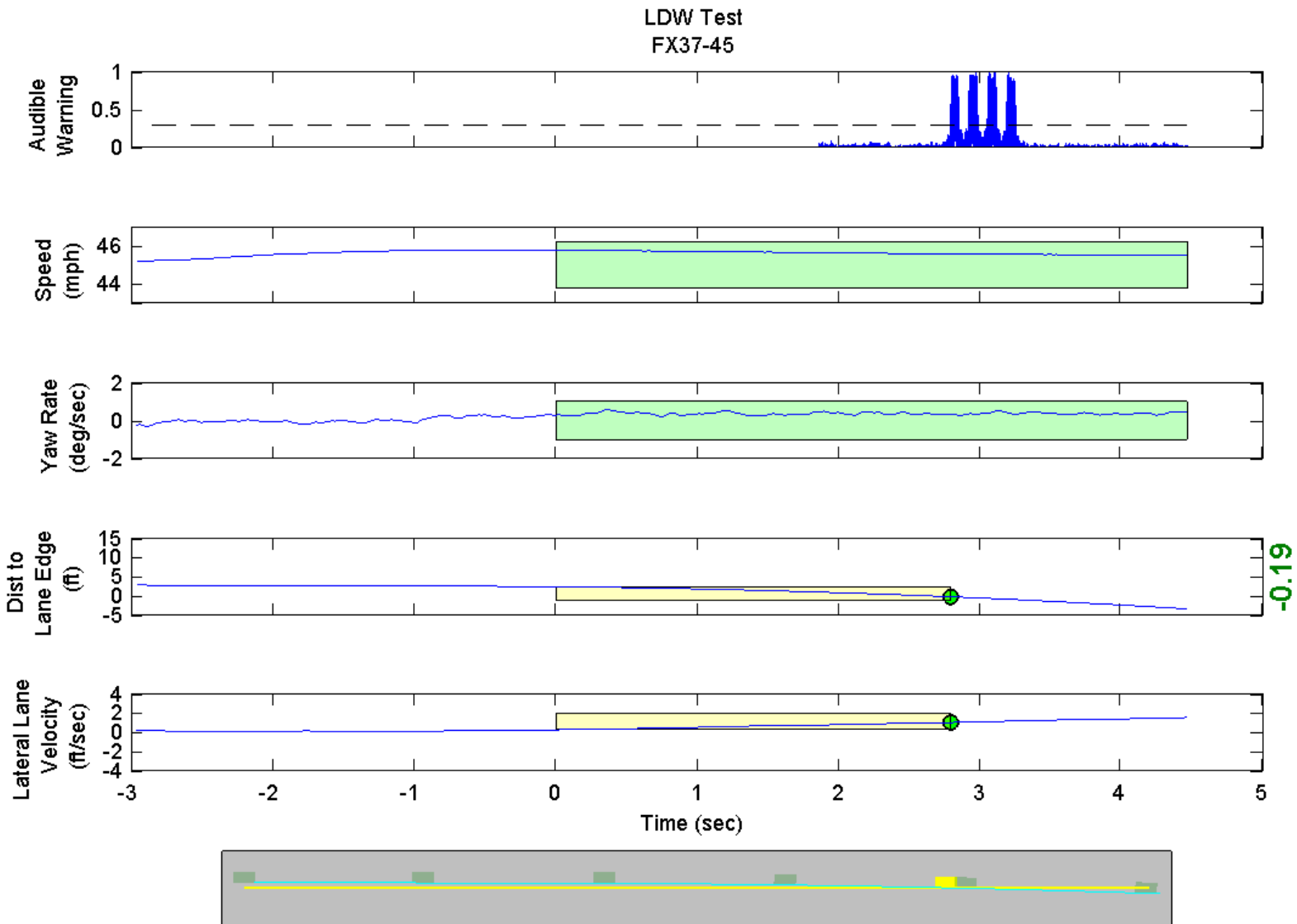

GPS Fix Type: RTK Fixed

Figure D86. Time History for Run 45, Dashed Line, Right Departure, Audible Warning

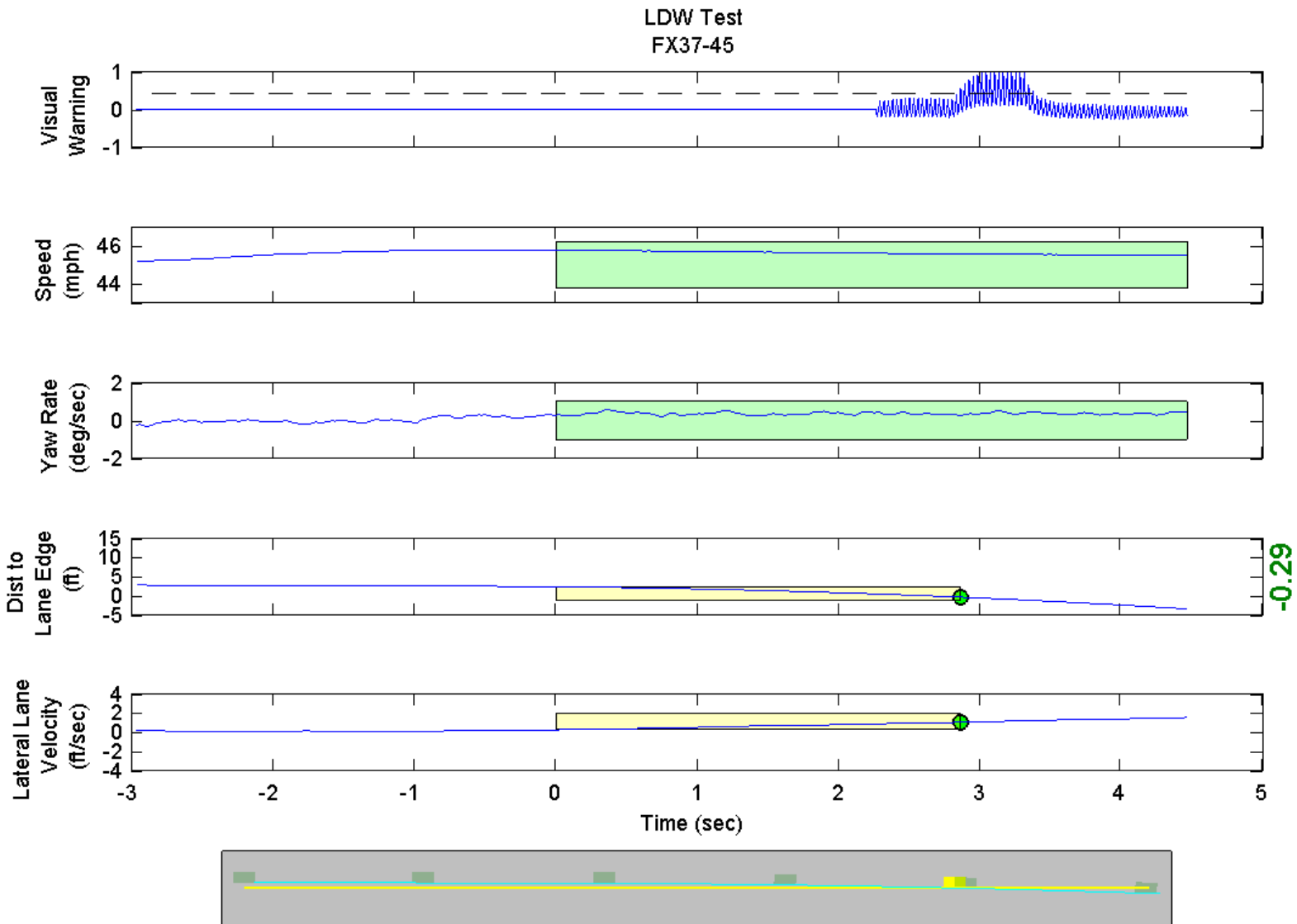

GPS Fix Type: RTK Fixed

Figure D87. Time History for Run 45, Dashed Line, Right Departure, Visual Warning