

REPORT NUMBER: 208-MGA-2014-015

**VEHICLE SAFETY COMPLIANCE TESTING
FOR
FMVSS 208, OCCUPANT CRASH PROTECTION
FMVSS 212, WINDSHIELD MOUNTING
FMVSS 219, WINDSHIELD INTRUSION (PARTIAL)
FMVSS 301, FUEL SYSTEM INTEGRITY**

**FORD MOTOR CO.
2014 FORD ESCAPE MPV
NHTSA NO.: C20140200**

**PREPARED BY:
MGA RESEARCH CORPORATION
5000 WARREN ROAD
BURLINGTON, WI 53105**



TEST DATES: JUNE 30, 2014 – AUGUST 25, 2014

FINAL REPORT DATE: NOVEMBER 5, 2014

FINAL REPORT

**PREPARED FOR:
U.S. DEPARTMENT OF TRANSPORTATION
NATIONAL HIGHWAY TRAFFIC SAFETY ADMINISTRATION
OFFICE OF ENFORCEMENT
OFFICE OF VEHICLE SAFETY COMPLIANCE
1200 NEW JERSEY AVENUE, S.E., NVS-220
WASHINGTON, D.C. 20590**

This final test report was prepared for the U.S. Department of Transportation, National Highway Traffic Safety Administration, in response to Contract Number DTNH22-13-D-00313.

This publication is distributed by the U.S. Department of Transportation, National Highway Traffic Safety Administration, in the interest of information exchange. The opinions, findings and conclusions expressed in this publication are those of the author(s) and not necessarily those of the Department of Transportation or the National Highway Traffic Safety Administration. The United States Government assumes no liability for its contents or use thereof. If trade or manufacturers' names or products are mentioned it is only because they are considered essential to the object of the publication and should not be construed as an endorsement. The United States Government does not endorse products or manufacturers.

Prepared by: Jeff Lewandowski Date: November 5, 2014
Jeff Lewandowski, Project Engineer

Reviewed by: David Winkelbauer Date: November 5, 2014
David Winkelbauer, Facility Director

FINAL REPORT ACCEPTED BY OVSC:

Accepted By: 

Acceptance Date: November 5, 2014

Technical Report Documentation Page

1. Report No. 208-MGA-2014-015		2. Government Accession No.		3. Recipient's Catalog No.	
4. Title and Subtitle Final Report of FMVSS 208 Compliance Testing of a 2014 Ford Escape NHTSA No.: C20140200				5. Report Date November 5, 2014	
				6. Performing Organization Code MGA	
7. Author(s) Jeff Lewandowski, Project Engineer				8. Performing Organization Report No. 208-MGA-2014-015	
9. Performing Organization Name and Address MGA Research Corporation 5000 Warren Road Burlington, WI 53105				10. Work Unit No.	
				11. Contract or Grant No. DTNH22-13-D-00313	
12. Sponsoring Agency Name and Address U.S. Department of Transportation National Highway Traffic Safety Administration Office of Enforcement Office of Vehicle Safety Compliance 1200 New Jersey Avenue, S.E., NVS-220 Washington, D.C. 20590				13. Type of Report and Period Covered 6/30/14 - 8/25/14	
				14. Sponsoring Agency Code NVS-220	
15. Supplementary Notes					
16. Abstract Compliance tests were conducted on the subject 2014 Ford Escape in accordance with the specifications of the Office of Vehicle Safety Compliance Test Procedure No. TP208-14 for the determination of FMVSS 208 compliance. Test failures identified were as follows: TEST FAILURES: None					
17. Key Words Frontal Impact 40 kmph Vehicle Safety Compliance Testing FMVSS 208, "Occupant Crash Protection" FMVSS 212, "Windshield Mounting" FMVSS 219, (partial), "Windshield Zone Intrusion" FMVSS 301, "Fuel System Integrity"				18. Distribution Statement Copies of this report are available from the following: U.S. Department of Transportation National Highway Traffic Safety Administration Technical Information Services (TIS), NPO-411 1200 New Jersey Avenue, S.E. (Room E12-100) Washington, DC 20590	
19. Security Classif. (of this report) Unclassified		20. Security Classif. (of this page) Unclassified		21. No. of Pages 333	22. Price

TABLE OF CONTENTS

<u>Section</u>		<u>Page No</u>
1	Purpose of Compliance Tests	1
2	Tests Performed	2
3	Injury Result Summary for FMVSS 208 Tests	4
4	Discussion of Tests (if applicable)	6
5	Test Data Sheets	7
<u>Data Sheet</u>		
1	COTR Vehicle Work Order	8
2	Report of Vehicle Condition	13
3	Certification Label and Tire Placard Information	15
4	Rear Seating Position Seat Belts	16
5	Air Bag Labels	17
6	FMVSS 208 Readiness Indicator	24
7	Passenger Air Bag Manual Cut-Off Device	25
8	Lap Belt Lockability	28
9	FMVSS 208 Seat Belt Warning System Check	40
10	Belt Contact Force	41
11	Latch Plate Access	51
12	Seat Belt Retraction	56
13	Seat Belt Guides and Hardware	62
15	H-Point Determination for 50 th Percentile Male Dummy	67
16	Air Bag Suppression Telltale	77
17	Suppression Test Using 12-Month CRABI Dummy	78
18	Suppression Test Using Newborn Infant Dummy	88
19	Suppression Test Using 3-YO Dummy and Booster Seats	89
20	Suppression Test Using 3-YO Dummy and Forward Facing Restraints	91
21	Suppression Test Using an Unbelted 3-YO Dummy	95
22	Suppression Test Using 6-YO Dummy and Booster Seats	96
23	Suppression Test Using an Unbelted 6-YO Dummy	98
29	Summary of Low Risk Deployment Using an Unbelted 5th% Dummy Position 1	99
30	Summary of Low Risk Deployment Using an Unbelted 5th% Dummy Position 2	100
32	Vehicle Weight, Fuel Tank, and Attitude Data	101
33	Vehicle Accelerometer Locations and Measurements	105
34	Photographic Targets	108

<u>Data Sheet</u>		<u>Page No</u>
35	Camera Locations	113
36	Dummy Positioning	115
37	Dummy Measurements	124
38	Crash Test	127
40	Accident Investigation Measurements	129
41	Windshield Mounting (FMVSS 212)	131
42	Windshield Zone Intrusion (FMVSS 219)	133
43	Fuel System Integrity (FMVSS 301)	135

Appendix

A	Crash Test Data	A-1
B	Low Risk Test Data	B-1
C	Crash Test Photographs	C-1
D	Low Risk Photographs	D-1
E	Suppression Photographs	E-1
F	Instrumentation Calibration	F-1
G	Notice of Test Failure (If Applicable)	G-1

SECTION 1
PURPOSE OF COMPLIANCE TESTS

This Federal Motor Vehicle Safety Standard 208 compliance test is part of a program conducted for the National Highway Traffic Safety Administration (NHTSA) by MGA Research Corporation (MGA) under Contract No.: DTNH22-13-D-00313. The purpose of this test was to determine whether the subject vehicle, a 2014 Ford Escape, NHTSA No.: C20140200, meets certain performance requirements of FMVSS 208, "Occupant Crash Protection"; FMVSS 212, "Windshield Mounting"; FMVSS 219, "Windshield Zone Intrusion"; and FMVSS 301, "Fuel System Integrity". The compliance test was conducted in accordance with OVSC Laboratory Test Procedure No.: TP208-14 dated April 16, 2008.

SECTION 2
TESTS PERFORMED

Test Vehicle: 2014 Ford Escape
Test Program: FMVSS 208 Compliance

NHTSA No.: C20140200
Test Dates: 6/30/14 - 8/25/14

The following checked items indicate the tests that were performed:

- | | | |
|-------------------------------------|-----|---|
| <input checked="" type="checkbox"/> | 1. | Rear seating position seat belts |
| <input checked="" type="checkbox"/> | 2. | Air bag labels (S4.5.1) |
| <input checked="" type="checkbox"/> | 3. | Readiness indicator (S4.5.2) |
| <input checked="" type="checkbox"/> | 4. | Passenger air bag manual cut-off device (S4.5.4) |
| <input checked="" type="checkbox"/> | 5. | Lap belt lockability (S7.1.1.5) |
| <input checked="" type="checkbox"/> | 6. | Seat belt warning system (S7.3) |
| <input checked="" type="checkbox"/> | 7. | Seat belt contact force (S7.4.3) |
| <input checked="" type="checkbox"/> | 8. | Seat belt latch plate access (S7.4.4) |
| <input checked="" type="checkbox"/> | 9. | Seat belt retraction (S7.4.5) |
| <input checked="" type="checkbox"/> | 10. | Seat belt guides and hardware (S7.4.6) |
| <input checked="" type="checkbox"/> | 11. | Air bag suppression telltale (S19.2.2) |
| <input checked="" type="checkbox"/> | 12. | Suppression tests with 12-month-old CRABI dummy (Part 572, Subpart R) |
| <input checked="" type="checkbox"/> | 13. | Suppression tests with Newborn infant (Part 572, Subpart K) |
| <input checked="" type="checkbox"/> | 14. | Suppression tests with 3-year-old dummy |
| <input checked="" type="checkbox"/> | 15. | Suppression tests with 6-year-old dummy |
| <input checked="" type="checkbox"/> | 16. | Test of Reactivation of the passenger air bag system with an unbelted 5 th percentile female dummy |
| <input type="checkbox"/> | 17. | Low risk deployment test with 12-month-old dummy (Part 572, Subpart R) |
| <input type="checkbox"/> | 18. | Low risk deployment test with 3-year-old dummy (Part 572, Subpart P) |
| <input type="checkbox"/> | 19. | Low risk deployment test with 6-year-old dummy (Part 572, Subpart N) |
| <input checked="" type="checkbox"/> | 20. | Low risk deployment test with 5 th female dummy (Part 572, Subpart O) |
| <input checked="" type="checkbox"/> | 21. | Impact Tests |
| <input checked="" type="checkbox"/> | | Frontal Oblique |
| <input type="checkbox"/> | | Belted 50 th male dummy driver and passenger (0 to 48 kmph) (S5.1.1(a)) |
| <input type="checkbox"/> | | Unbelted 50 th male dummy driver and passenger (0 to 48 kmph) (S5.1.2(a)(1)) |
| <input checked="" type="checkbox"/> | | Unbelted 50 th male dummy driver and passenger (32 to 40 kmph) (S5.1.2(a)(1) or S5.1.2(b)) |
| <input type="checkbox"/> | | Frontal 0° |
| <input type="checkbox"/> | | Belted 50 th male dummy driver (0 to 48 kmph) (S5.1.1.(b)(1) or S5.1.1(a)) |
| <input type="checkbox"/> | | Belted 50 th male dummy passenger (0 to 48 kmph) (S5.1.1.(b)(1) or S5.1.1(a)) |
| <input type="checkbox"/> | | Belted 5 th female dummy driver (0 to 48 kmph) (S16.1(a)) |
| <input type="checkbox"/> | | Belted 5 th female dummy passenger (0 to 48 kmph) (S16.1(a)) |
| <input type="checkbox"/> | | Belted 50 th male dummy driver and passenger (0 to 56 kmph) (S5.1.1.(b)(2)) |
| <input type="checkbox"/> | | Unbelted 50 th male dummy driver and passenger (0 to 48 kmph) (S5.1.2(a)(1)) |
| <input type="checkbox"/> | | Unbelted 50 th male dummy driver (32 to 40 kmph) (S5.1.2.(a)(2) or S5.1.2(b)) |
| <input type="checkbox"/> | | Unbelted 50 th male dummy passenger (32 to 40 kmph) (S5.1.2.(a)(2) or S5.1.2(b)) |
| <input type="checkbox"/> | | Unbelted 5 th female dummy driver (32 to 40 kmph) (S16.1(b)) |
| <input type="checkbox"/> | | Unbelted 5 th female dummy passenger (32 to 40 kmph) (S16.1(b)) |
| <input type="checkbox"/> | | 40% Offset 0° Belted 5 th female dummy driver and passenger (0 to 40 kmph) (S18.1) |
| <input type="checkbox"/> | 22. | FMVSS 204 Indicant Test |
| <input checked="" type="checkbox"/> | 23. | FMVSS 212 Test |
| <input checked="" type="checkbox"/> | 24. | FMVSS 219 Indicant Test |
| <input checked="" type="checkbox"/> | 25. | FMVSS 301 Frontal Test |

For the crash tests, the vehicle was instrumented with 8 accelerometers. The data from the vehicle and dummies were sampled at 10,000 samples per second and processed as specified in SAE J211/1 MAR95 and FMVSS 208, S4.13.

The dynamic tests were recorded using high-speed digital video.

The vehicle appears to meet the performance requirements to which it was tested.

SECTION 3

INJURY RESULT SUMMARY FOR FMVSS 208 TESTS

Test Vehicle: 2014 Ford Escape
 Test Program: FMVSS 208 Compliance

NHTSA No.: C20140200
 Test Date: 7/30/14

5th Percentile Female Low Risk Deployments

5th Percentile Female SN 124 Position 1 (Chin On Module) 7/30/14

Injury Criteria	Max. Allowable Injury Assessment Values	Measured Value
HIC15	700	39
Peak Nij (Nte)	1.0	0.4
Time (ms)	NA	86.9
Peak Nij (Ntf)	1.0	0.4
Time (ms)	NA	25.1
Peak Nij (Nce)	1.0	0.4
Time (ms)	NA	174.5
Peak Nij (Ncf)	1.0	0.1
Time (ms)	NA	8.2
Neck Tension	2070 N	845
Neck Compression	2520 N	306
Chest g	60 g	14
Chest Displacement	52 mm	5
Left Femur	6805 N	97
Right Femur	6805 N	85

Second stage fire time of 150 ms; Injuries calculated on 0 ms to 275 ms.

5th Percentile Female SN 124 Position 2 (Chin On Rim) 7/30/14

Injury Criteria	Max. Allowable Injury Assessment Values	Measured Value
HIC15	700	161
Peak Nij (Nte)	1.0	0.4
Time (ms)	NA	12.0
Peak Nij (Ntf)	1.0	0.3
Time (ms)	NA	61.9
Peak Nij (Nce)	1.0	0.1
Time (ms)	NA	250.6
Peak Nij (Ncf)	1.0	0.2
Time (ms)	NA	67.1
Neck Tension	2070 N	705
Neck Compression	2520 N	166
Chest g	60 g	17
Chest Displacement	52 mm	17
Left Femur	6805 N	66
Right Femur	6805 N	49

Second stage fire time of 150 ms; Injuries calculated on 0 ms to 275 ms.

SECTION 3

INJURY RESULT SUMMARY FOR FMVSS 208 TESTS

Test Vehicle: 2014 Ford Escape
 Test Program: FMVSS 208 Compliance

NHTSA No.: C20140200
 Test Date: 8/25/14

40 kmph Frontal Crash

Impact Angle:	30° LH Oblique			
Belted Dummies:		Yes	X	No
Speed Range:		0 to 40 kmph	X	32 to 40 kmph
		0 to 48 kmph		0 to 56 kmph
Test Speed (kmph):	39.7	Test Weight (kg):	1788.1	
Driver Dummy:		5 th female	X	50 th male
Passenger Dummy:		5 th female	X	50 th male

50th Percentile Male Frontal Crash Test

Vehicles certified to S5.1.1(b)(1), S5.1.1(b)(2), S5.1.2(a)(2), or S5.1.2(b)

Injury Criteria	Max. Allowable Injury Assessment Values	Driver	Passenger
HIC15	700	229	93
N _{te}	1.0	0.2	0.2
N _{tf}	1.0	0.2	0.2
N _{ce}	1.0	0.2	0.1
N _{cf}	1.0	0.0	0.1
Neck Tension	4170 N	1125	1319
Neck Compression	4000 N	639	419
Chest g	60 g	27	24
Chest Displacement	63 mm	11	3
Left Femur	10,000 N	3457	5027
Right Femur	10,000 N	1933	5501

SECTION 4
DISCUSSION OF TESTS

Test Vehicle: 2014 Ford Escape
Test Program: FMVSS 208 Compliance

NHTSA No.: C20140200
Test Dates: 6/30/14 - 8/25/14

A blanket and visor were not used in the suppression testing because they did not affect the sensing system used on the vehicle.

An assessment of FMVSS 212 and FMVSS 219 were done for informational use only.

SECTION 5
TEST DATA SHEETS

Test Vehicle: 2014 Ford Escape
Test Program: FMVSS 208 Compliance

NHTSA No.: C20140200
Test Dates: 6/30/14 - 8/25/14

DATA SHEET 1
COTR VEHICLE WORK ORDER

Test Vehicle: 2014 Ford Escape
Test Program: FMVSS 208 Compliance

NHTSA No.: C20140200
Test Dates: 6/30/14 - 8/25/14

COTR Signature: 

Test to be performed for this vehicle are checked below:

- | | |
|-------------------------------------|--|
| <input checked="" type="checkbox"/> | 1. Rear Seating Position Seat Belts |
| <input checked="" type="checkbox"/> | 2. Air Bag Labels (S4.5.1) |
| <input checked="" type="checkbox"/> | 3. Readiness Indicator (S4.5.2) |
| <input checked="" type="checkbox"/> | 4. Passenger Air Bag Manual Cut-off Device (S4.5.4) |
| <input checked="" type="checkbox"/> | 5. Lap Belt Lockability (S7.1.1.5) |
| <input checked="" type="checkbox"/> | 6. Seat Belt Warning System (S7.3) |
| <input checked="" type="checkbox"/> | 7. Seat Belt Contact Force (S7.4.3) |
| <input checked="" type="checkbox"/> | 8. Seat Belt Latch Plate Access (S7.4.4) |
| <input checked="" type="checkbox"/> | 9. Seat Belt Retraction (S7.4.5) |
| <input checked="" type="checkbox"/> | 10. Seat Belt Guides and Hardware (S7.4.6) |
| <input checked="" type="checkbox"/> | 11. Air bag suppression telltale (S19.2.2) |
| <input checked="" type="checkbox"/> | 12. Suppression tests with 12-month-old CRABI dummy (Part 572, Subpart R) using the following indicated child restraints (mid-height seat position): |

Section B – Rear Facing (unbelted and belted rear facing, unbelted forward facing)

<input type="checkbox"/>	Century Smart Fit 4543	<input type="checkbox"/>	Full Rearward	<input type="checkbox"/>	Mid Position	<input type="checkbox"/>	Full Forward
<input checked="" type="checkbox"/>	Cosco Arriva 22-013	<input checked="" type="checkbox"/>	Full Rearward	<input checked="" type="checkbox"/>	Mid Position	<input checked="" type="checkbox"/>	Full Forward
<input type="checkbox"/>	Evenflo Discovery Adjust Right 212	<input type="checkbox"/>	Full Rearward	<input type="checkbox"/>	Mid Position	<input type="checkbox"/>	Full Forward
<input type="checkbox"/>	Graco Infant 8457	<input type="checkbox"/>	Full Rearward	<input type="checkbox"/>	Mid Position	<input type="checkbox"/>	Full Forward
<input checked="" type="checkbox"/>	Graco Snugride	<input checked="" type="checkbox"/>	Full Rearward	<input checked="" type="checkbox"/>	Mid Position	<input checked="" type="checkbox"/>	Full Forward
<input checked="" type="checkbox"/>	Peg Perego Viaggio	<input checked="" type="checkbox"/>	Full Rearward	<input checked="" type="checkbox"/>	Mid Position	<input checked="" type="checkbox"/>	Full Forward

Section C – Convertible (unbelted and belted rear facing, unbelted and belted forward facing)

<input checked="" type="checkbox"/>	Britax Roundabout E9L02	<input checked="" type="checkbox"/>	Full Rearward	<input checked="" type="checkbox"/>	Mid Position	<input checked="" type="checkbox"/>	Full Forward
<input checked="" type="checkbox"/>	Cosco High Back Booster 22-209	<input checked="" type="checkbox"/>	Full Rearward	<input checked="" type="checkbox"/>	Mid Position	<input checked="" type="checkbox"/>	Full Forward
<input type="checkbox"/>	Cosco Summit Deluxe 22-262	<input type="checkbox"/>	Full Rearward	<input type="checkbox"/>	Mid Position	<input type="checkbox"/>	Full Forward
<input type="checkbox"/>	Cosco Touriva 02519	<input type="checkbox"/>	Full Rearward	<input type="checkbox"/>	Mid Position	<input type="checkbox"/>	Full Forward
<input checked="" type="checkbox"/>	Evenflo Generations 352	<input checked="" type="checkbox"/>	Full Rearward	<input checked="" type="checkbox"/>	Mid Position	<input checked="" type="checkbox"/>	Full Forward
<input type="checkbox"/>	Evenflo Medallion 254	<input type="checkbox"/>	Full Rearward	<input type="checkbox"/>	Mid Position	<input type="checkbox"/>	Full Forward
<input type="checkbox"/>	Evenflo Tribute V 379	<input type="checkbox"/>	Full Rearward	<input type="checkbox"/>	Mid Position	<input type="checkbox"/>	Full Forward
<input checked="" type="checkbox"/>	Graco ComfortSport	<input checked="" type="checkbox"/>	Full Rearward	<input checked="" type="checkbox"/>	Mid Position	<input checked="" type="checkbox"/>	Full Forward
<input type="checkbox"/>	Graco Platinum Cargo	<input type="checkbox"/>	Full Rearward	<input type="checkbox"/>	Mid Position	<input type="checkbox"/>	Full Forward
<input type="checkbox"/>	Graco Safeseat Step 2	<input type="checkbox"/>	Full Rearward	<input type="checkbox"/>	Mid Position	<input type="checkbox"/>	Full Forward

- | | |
|-------------------------------------|--|
| <input checked="" type="checkbox"/> | 13. Suppression tests with newborn infant (Part 572, Subpart K) using the following indicated child restraints (mid-height seat position). |
|-------------------------------------|--|

Section A – Car Bed (Belted)

<input checked="" type="checkbox"/>	Angel Guard Angel Ride	<input checked="" type="checkbox"/>	Full Rearward	<input checked="" type="checkbox"/>	Mid Position	<input checked="" type="checkbox"/>	Full Forward
-------------------------------------	------------------------	-------------------------------------	---------------	-------------------------------------	--------------	-------------------------------------	--------------

14. Suppression tests with 3-year-old dummy (Part 572, Subpart P) using the following indicated child restraints where a child restraint is required (mid-height seat position):

Section C – Convertible (Belted forward-facing)

<input checked="" type="checkbox"/>	Britax Roundabout E9L02	<input checked="" type="checkbox"/>	Full Rearward	<input checked="" type="checkbox"/>	Mid Position	<input checked="" type="checkbox"/>	Full Forward
<input checked="" type="checkbox"/>	Cosco High Back Booster 22-209	<input checked="" type="checkbox"/>	Full Rearward	<input checked="" type="checkbox"/>	Mid Position	<input checked="" type="checkbox"/>	Full Forward
<input type="checkbox"/>	Cosco Summit Deluxe 22-262	<input type="checkbox"/>	Full Rearward	<input type="checkbox"/>	Mid Position	<input type="checkbox"/>	Full Forward
<input type="checkbox"/>	Cosco Touriva 02519	<input type="checkbox"/>	Full Rearward	<input type="checkbox"/>	Mid Position	<input type="checkbox"/>	Full Forward
<input checked="" type="checkbox"/>	Evenflo Generations 352	<input checked="" type="checkbox"/>	Full Rearward	<input checked="" type="checkbox"/>	Mid Position	<input checked="" type="checkbox"/>	Full Forward
<input type="checkbox"/>	Evenflo Medallion 254	<input type="checkbox"/>	Full Rearward	<input type="checkbox"/>	Mid Position	<input type="checkbox"/>	Full Forward
<input type="checkbox"/>	Evenflo Tribute V 379	<input type="checkbox"/>	Full Rearward	<input type="checkbox"/>	Mid Position	<input type="checkbox"/>	Full Forward
<input checked="" type="checkbox"/>	Graco ComfortSport	<input checked="" type="checkbox"/>	Full Rearward	<input checked="" type="checkbox"/>	Mid Position	<input checked="" type="checkbox"/>	Full Forward
<input type="checkbox"/>	Graco Platinum Cargo	<input type="checkbox"/>	Full Rearward	<input type="checkbox"/>	Mid Position	<input type="checkbox"/>	Full Forward
<input type="checkbox"/>	Graco Safeseat Step 2	<input type="checkbox"/>	Full Rearward	<input type="checkbox"/>	Mid Position	<input type="checkbox"/>	Full Forward

Section D – Toddler/Belt Positioning Booster (Belted)

<input type="checkbox"/>	Britax Roadster 9004	<input type="checkbox"/>	Full Rearward	<input type="checkbox"/>	Mid Position	<input type="checkbox"/>	Full Forward
<input type="checkbox"/>	Cosco High Back Booster 22-209	<input type="checkbox"/>	Full Rearward	<input type="checkbox"/>	Mid Position	<input type="checkbox"/>	Full Forward
<input checked="" type="checkbox"/>	Cosco Summit Deluxe 22-262	<input checked="" type="checkbox"/>	Full Rearward	<input checked="" type="checkbox"/>	Mid Position	<input checked="" type="checkbox"/>	Full Forward
<input type="checkbox"/>	Evenflo Generations 352	<input type="checkbox"/>	Full Rearward	<input type="checkbox"/>	Mid Position	<input type="checkbox"/>	Full Forward
<input type="checkbox"/>	Evenflo Right Fit 245	<input type="checkbox"/>	Full Rearward	<input type="checkbox"/>	Mid Position	<input type="checkbox"/>	Full Forward
<input checked="" type="checkbox"/>	Graco Platinum Cargo	<input checked="" type="checkbox"/>	Full Rearward	<input checked="" type="checkbox"/>	Mid Position	<input checked="" type="checkbox"/>	Full Forward

15. Suppression tests with representative 3-year-old child using the following indicated child restraints where a child restraint is required (mid-height position).

(Appendix H, Data Sheet 19H and 20H)

Section C – Convertible (Belted forward-facing)

<input type="checkbox"/>	Britax Roundabout E9L02	<input type="checkbox"/>	Full Rearward	<input type="checkbox"/>	Mid Position	<input type="checkbox"/>	Full Forward
<input type="checkbox"/>	Cosco High Back Booster 22-209	<input type="checkbox"/>	Full Rearward	<input type="checkbox"/>	Mid Position	<input type="checkbox"/>	Full Forward
<input type="checkbox"/>	Cosco Summit Deluxe 22-262	<input type="checkbox"/>	Full Rearward	<input type="checkbox"/>	Mid Position	<input type="checkbox"/>	Full Forward
<input type="checkbox"/>	Cosco Touriva 02519	<input type="checkbox"/>	Full Rearward	<input type="checkbox"/>	Mid Position	<input type="checkbox"/>	Full Forward
<input type="checkbox"/>	Evenflo Generations 352	<input type="checkbox"/>	Full Rearward	<input type="checkbox"/>	Mid Position	<input type="checkbox"/>	Full Forward
<input type="checkbox"/>	Evenflo Medallion 254	<input type="checkbox"/>	Full Rearward	<input type="checkbox"/>	Mid Position	<input type="checkbox"/>	Full Forward
<input type="checkbox"/>	Evenflo Tribute V 379	<input type="checkbox"/>	Full Rearward	<input type="checkbox"/>	Mid Position	<input type="checkbox"/>	Full Forward
<input type="checkbox"/>	Graco ComfortSport	<input type="checkbox"/>	Full Rearward	<input type="checkbox"/>	Mid Position	<input type="checkbox"/>	Full Forward
<input type="checkbox"/>	Graco Platinum Cargo	<input type="checkbox"/>	Full Rearward	<input type="checkbox"/>	Mid Position	<input type="checkbox"/>	Full Forward
<input type="checkbox"/>	Graco Safeseat Step 2	<input type="checkbox"/>	Full Rearward	<input type="checkbox"/>	Mid Position	<input type="checkbox"/>	Full Forward

Section D – Toddler/Belt Positioning Booster (Belted)

<input type="checkbox"/>	Britax Roadster 9004	<input type="checkbox"/>	Full Rearward	<input type="checkbox"/>	Mid Position	<input type="checkbox"/>	Full Forward
<input type="checkbox"/>	Cosco High Back Booster 22-209	<input type="checkbox"/>	Full Rearward	<input type="checkbox"/>	Mid Position	<input type="checkbox"/>	Full Forward
<input type="checkbox"/>	Evenflo Right Fit 245	<input type="checkbox"/>	Full Rearward	<input type="checkbox"/>	Mid Position	<input type="checkbox"/>	Full Forward

16. Suppression tests with 3-year-old dummy (Part 572, Subpart P) in the following positions (mid-height seat position):
- | | | | | |
|-------------------------------------|---|-------------------------------------|-------------------------------------|-------------------------------------|
| <input checked="" type="checkbox"/> | Sitting on seat with back against seat back (S22.2.2.1) | <input checked="" type="checkbox"/> | <input checked="" type="checkbox"/> | <input checked="" type="checkbox"/> |
| | Full Rearward | Mid Position | Full Forward | |
| <input checked="" type="checkbox"/> | Sitting on seat with back against reclined seat back (S22.2.2.2) | <input checked="" type="checkbox"/> | <input checked="" type="checkbox"/> | <input checked="" type="checkbox"/> |
| | Full Rearward | Mid Position | Full Forward | |
| <input checked="" type="checkbox"/> | Sitting on seat with back not against seat back (S22.2.2.3) | <input checked="" type="checkbox"/> | <input checked="" type="checkbox"/> | <input checked="" type="checkbox"/> |
| | Full Rearward | Mid Position | Full Forward | |
| <input checked="" type="checkbox"/> | Sitting on seat edge, spine vertical, hands by the child's side (S22.2.2.4) | <input checked="" type="checkbox"/> | <input checked="" type="checkbox"/> | <input checked="" type="checkbox"/> |
| | Full Rearward | Mid Position | Full Forward | |
| <input checked="" type="checkbox"/> | Standing on seat, facing forward (S22.2.2.5) | <input checked="" type="checkbox"/> | <input checked="" type="checkbox"/> | <input checked="" type="checkbox"/> |
| | Full Rearward | Mid Position | Full Forward | |
| <input checked="" type="checkbox"/> | Kneeling on seat facing forward (S22.2.2.6) | <input checked="" type="checkbox"/> | <input checked="" type="checkbox"/> | <input checked="" type="checkbox"/> |
| | Full Rearward | Mid Position | Full Forward | |
| <input checked="" type="checkbox"/> | Kneeling on seat facing rearward (S22.2.2.7) | <input checked="" type="checkbox"/> | <input checked="" type="checkbox"/> | <input checked="" type="checkbox"/> |
| | Full Rearward | Mid Position | Full Forward | |
| <input type="checkbox"/> | Lying on seat (S22.2.2.8) | <input type="checkbox"/> | <input type="checkbox"/> | <input type="checkbox"/> |
| | Full Rearward | Mid Position | Full Forward | |
17. Suppression tests with representative 3-year-old child in the following positions (mid-height seat position):
- | | | | | |
|--------------------------|---|--------------------------|--------------------------|--------------------------|
| <input type="checkbox"/> | Sitting on seat with back against seat back (S22.2.2.1) | <input type="checkbox"/> | <input type="checkbox"/> | <input type="checkbox"/> |
| | Full Rearward | Mid Position | Full Forward | |
| <input type="checkbox"/> | Sitting on seat with back against reclined seat back (S22.2.2.2) | <input type="checkbox"/> | <input type="checkbox"/> | <input type="checkbox"/> |
| | Full Rearward | Mid Position | Full Forward | |
| <input type="checkbox"/> | Sitting on seat with back not against seat back (S22.2.2.3) | <input type="checkbox"/> | <input type="checkbox"/> | <input type="checkbox"/> |
| | Full Rearward | Mid Position | Full Forward | |
| <input type="checkbox"/> | Sitting on seat edge, spine vertical, hands by the child's side (S22.2.2.4) | <input type="checkbox"/> | <input type="checkbox"/> | <input type="checkbox"/> |
| | Full Rearward | Mid Position | Full Forward | |
| <input type="checkbox"/> | Standing on seat, facing forward (S22.2.2.5) | <input type="checkbox"/> | <input type="checkbox"/> | <input type="checkbox"/> |
| | Full Rearward | Mid Position | Full Forward | |
| <input type="checkbox"/> | Kneeling on seat facing forward (S22.2.2.6) | <input type="checkbox"/> | <input type="checkbox"/> | <input type="checkbox"/> |
| | Full Rearward | Mid Position | Full Forward | |
| <input type="checkbox"/> | Kneeling on seat facing rearward (S22.2.2.7) | <input type="checkbox"/> | <input type="checkbox"/> | <input type="checkbox"/> |
| | Full Rearward | Mid Position | Full Forward | |
| <input type="checkbox"/> | Lying on seat (S22.2.2.8) | <input type="checkbox"/> | <input type="checkbox"/> | <input type="checkbox"/> |
| | Full Rearward | Mid Position | Full Forward | |
18. Suppression tests with 6-year-old dummy (Part 572, Subpart N) using the following indicated child restraints where a child restraint is required (mid-height seat position):
- Section D
- | | | | | |
|-------------------------------------|--------------------------------|-------------------------------------|-------------------------------------|-------------------------------------|
| <input type="checkbox"/> | Britax Roadster 9004 | <input type="checkbox"/> | <input type="checkbox"/> | <input type="checkbox"/> |
| | Full Rearward | Mid Position | Full Forward | |
| <input type="checkbox"/> | Cosco High Back Booster 22-209 | <input type="checkbox"/> | <input type="checkbox"/> | <input type="checkbox"/> |
| | Full Rearward | Mid Position | Full Forward | |
| <input checked="" type="checkbox"/> | Cosco Summit Deluxe 22-262 | <input checked="" type="checkbox"/> | <input checked="" type="checkbox"/> | <input checked="" type="checkbox"/> |
| | Full Rearward | Mid Position | Full Forward | |
| <input type="checkbox"/> | Evenflo Generations 352 | <input type="checkbox"/> | <input type="checkbox"/> | <input type="checkbox"/> |
| | Full Rearward | Mid Position | Full Forward | |
| <input type="checkbox"/> | Evenflo Right Fit 245 | <input type="checkbox"/> | <input type="checkbox"/> | <input type="checkbox"/> |
| | Full Rearward | Mid Position | Full Forward | |
| <input checked="" type="checkbox"/> | Graco Platinum Cargo | <input checked="" type="checkbox"/> | <input checked="" type="checkbox"/> | <input checked="" type="checkbox"/> |
| | Full Rearward | Mid Position | Full Forward | |

19. Suppression tests with representative 6-year-old child using the following indicated child restraints where a child restraint is required (mid-height seat position):
- Section D
- | | | | | | | | |
|--------------------------|--------------------------------|--------------------------|---------------|--------------------------|--------------|--------------------------|--------------|
| <input type="checkbox"/> | Britax Roadster 9004 | <input type="checkbox"/> | Full Rearward | <input type="checkbox"/> | Mid Position | <input type="checkbox"/> | Full Forward |
| <input type="checkbox"/> | Cosco High Back Booster 22-209 | <input type="checkbox"/> | Full Rearward | <input type="checkbox"/> | Mid Position | <input type="checkbox"/> | Full Forward |
| <input type="checkbox"/> | Cosco Summit Deluxe 22-262 | <input type="checkbox"/> | Full Rearward | <input type="checkbox"/> | Mid Position | <input type="checkbox"/> | Full Forward |
| <input type="checkbox"/> | Evenflo Generations 352 | <input type="checkbox"/> | Full Rearward | <input type="checkbox"/> | Mid Position | <input type="checkbox"/> | Full Forward |
| <input type="checkbox"/> | Evenflo Right Fit 245 | <input type="checkbox"/> | Full Rearward | <input type="checkbox"/> | Mid Position | <input type="checkbox"/> | Full Forward |
| <input type="checkbox"/> | Graco Platinum Cargo | <input type="checkbox"/> | Full Rearward | <input type="checkbox"/> | Mid Position | <input type="checkbox"/> | Full Forward |
20. Suppression tests with 6-year-old dummy (Part 572, Subpart N) in the following positions (mid-height seat position):
- | | | | | | | | |
|-------------------------------------|--|-------------------------------------|--------------|-------------------------------------|--------------|--|--|
| <input checked="" type="checkbox"/> | Sitting on seat with back against seat back (S22.2.2.1) | | | | | | |
| <input checked="" type="checkbox"/> | Full Rearward | <input checked="" type="checkbox"/> | Mid Position | <input checked="" type="checkbox"/> | Full Forward | | |
| <input checked="" type="checkbox"/> | Sitting on seat with back against reclined seat back (S22.2.2.2) | | | | | | |
| <input checked="" type="checkbox"/> | Full Rearward | <input checked="" type="checkbox"/> | Mid Position | <input checked="" type="checkbox"/> | Full Forward | | |
| <input checked="" type="checkbox"/> | Sitting on seat edge, spine vertical, hands by the child's side (S22.2.2.4) | | | | | | |
| <input checked="" type="checkbox"/> | Full Rearward | <input checked="" type="checkbox"/> | Mid Position | <input checked="" type="checkbox"/> | Full Forward | | |
| <input checked="" type="checkbox"/> | Sitting back in the seat and leaning on the right front passenger door (S24.2.3) | | | | | | |
| <input checked="" type="checkbox"/> | Full Rearward | <input checked="" type="checkbox"/> | Mid Position | <input checked="" type="checkbox"/> | Full Forward | | |
21. Suppression tests with representative 6-year-old child in the following positions (mid-height seat position):
- | | | | | | | | |
|--------------------------|--|--------------------------|--------------|--------------------------|--------------|--|--|
| <input type="checkbox"/> | Sitting on seat with back against seat back (S22.2.2.1) | | | | | | |
| <input type="checkbox"/> | Full Rearward | <input type="checkbox"/> | Mid Position | <input type="checkbox"/> | Full Forward | | |
| <input type="checkbox"/> | Sitting on seat with back against reclined seat back (S22.2.2.2) | | | | | | |
| <input type="checkbox"/> | Full Rearward | <input type="checkbox"/> | Mid Position | <input type="checkbox"/> | Full Forward | | |
| <input type="checkbox"/> | Sitting on seat edge, spine vertical, hands by the child's side (S22.2.2.4) | | | | | | |
| <input type="checkbox"/> | Full Rearward | <input type="checkbox"/> | Mid Position | <input type="checkbox"/> | Full Forward | | |
| <input type="checkbox"/> | Sitting back in the seat and leaning on the right front passenger door (S24.2.3) | | | | | | |
22. Test of Reactivation of the Passenger Air Bag System with an Unbelted 5th percentile female dummy (S20.3, 22.3, S24.3) (mid-height seat position). Perform this test after the following suppression tests: After each restraint.
23. Test of Reactivation of the Passenger Air Bag System with a representative 5th percentile female (S20.3, 22.3, S24.3) (mid-height seat position). Perform this test after the following suppression tests:
24. Low risk deployment test with 12-month-old dummy (Part 572, Subpart R) using the following indicated child restraints (full forward, mid-height seat position)(S20.4):
- Section B
- | | |
|--------------------------|------------------------------------|
| <input type="checkbox"/> | Century Smart Fit 4543 |
| <input type="checkbox"/> | Cosco Arriva 22-013 |
| <input type="checkbox"/> | Evenflo Discovery Adjust Right 212 |
| <input type="checkbox"/> | Graco Infant 8457 |
| <input type="checkbox"/> | Graco Snugride |
| <input type="checkbox"/> | Peg Perego Viaggio |
- Section C
- | | |
|--------------------------|-------------------------|
| <input type="checkbox"/> | Britax Roundabout E9L02 |
| <input type="checkbox"/> | Cosco Touriva 02519 |
| <input type="checkbox"/> | Evenflo Medallion 254 |
| <input type="checkbox"/> | Evenflo Tribute V 379 |
| <input type="checkbox"/> | Graco ComfortSport |

- 25. Low risk deployment test with 3-year-old dummy (Part 572, Subpart P) in the following positions:
 - Position 1 (rearmost, lowest seat position)
 - Position 2 (mid-height seat position)
- 26. Low risk deployment test with 6-year-old dummy (Part 572, Subpart N) in the following positions:
 - Position 1 (rearmost, lowest seat position)
 - Position 2 (mid-height seat position)
- 27. Low risk deployment test with 5th female dummy (Part 572, Subpart O) in the following positions:
 - Position 1 (mid-height seat position)
 - Position 2 (mid-height seat position)
- 28. Impact Tests
 - Frontal Oblique Impact Angle: 30° Test Speed: 39.7 kmph
 - Belted 50th male dummy driver and passenger (0 to 48 kmph) (S5.1.1(a))
 - Unbelted 50th male dummy driver and passenger (0 to 48 kmph) (S5.1.2(a)(1))
 - Unbelted 50th male dummy driver and passenger (32 to 40 kmph) (S5.1.2(a)(2) or S5.1.2(b))
 - Frontal 0° - Test Speed:
 - Belted 50th male dummy driver (0 to 48 kmph) (S5.1.1.(b)(1) or S5.1.1(a))
 - Belted 50th male dummy passenger (0 to 48 kmph) (S5.1.1.(b)(1) or S5.1.1(a))
 - Belted 5th female dummy driver (0 to 48 kmph) (S16.1(a)(1))
 - Belted 5th female dummy passenger (0 to 48 kmph) (S16.1(a)(1))
 - Belted 5th female dummy driver and passenger (0 to 56 kmph) (S16.1(a)(2))
 - Belted 50th male dummy driver and passenger (0 to 56 kmph) (S5.1.1.(b)(2))
 - Unbelted 50th male dummy driver and passenger (0 to 48 kmph) (S5.1.2(a) (1))
 - Unbelted 50th male dummy driver (32 to 40 kmph) (S5.1.2.(a)(2) or S5.1.2(b))
 - Unbelted 50th male dummy passenger (32 to 40 kmph) (S5.1.2.(a)(2) or S5.1.2(b))
 - Unbelted 5th female dummy driver (32 to 40 kmph) (S16.1(b))
 - Unbelted 5th female dummy passenger (32 to 40 kmph) (S16.1(b))
 - 40% Offset 0° Belted 5th female dummy driver and passenger (0 to 40 kmph) (S18.1) Test Speed:
- 29. FMVSS 204 Indicant Test
- 30. FMVSS 212 Test
- 31. FMVSS 219 Indicant Test
- 32. FMVSS 301 Frontal Test
- 33. FMVSS 305 Indicant Test

DATA SHEET 2
REPORT OF VEHICLE CONDITION

Test Vehicle: 2014 Ford Escape
Test Program: FMVSS 208 Compliance

NHTSA No.: C20140200
Test Dates: 6/30/14 – 8/25/14

CONTRACT NO.: DTNH22-13-D-00313 Date: 9/1/2014
FROM (Lab and rep name): MGA Research Corporation
TO: NHTSA, OVSC, NVS-220

PURPOSE: (X) Initial Receipt () Received via Transfer (X) Present vehicle condition

MODEL YEAR/MAKE/MODEL/BODY STYLE: 2014 / Ford / Escape / MPV
MANUFACTURE DATE: 11/13
NHTSA NO. C20140200 GVWR: 2096 kg (4620 lbs)
BODY COLOR: Silver GAWR (Fr): 1098 kg (2420 lbs)
VIN: 1FMCU0F72EUB70023 GAWR (Rr): 1006 kg (2218 lbs)

ODOMETER READINGS: ARRIVAL (miles): 44 DATE: 6/12/14
COMPLETION (miles): 93 DATE: 8/25/14

PURCHASE PRICE: (\$) 22,902

DEALER'S NAME: Boucher Fleet Group, 1421 E. Moreland Blvd. Waukesha, WI
53186

- A. All options listed on window sticker are present on the test vehicle:
 Yes No
- B. Tires and wheel rims are new and the same as listed: Yes No
- C. There are no dents or other interior or exterior flaws: Yes No
- D. The vehicle has been properly prepared and is in running condition:
 Yes No
- E. Keyless remote is available and working: Yes No
- F. The glove box contains an owner's manual, warranty document, consumer information, and extra set of keys: Yes No
- G. Proper fuel filler cap is supplied on the test vehicle: Yes No
- H. Using permanent marker, identify vehicle with NHTSA number and FMVSS test type(s) on roof line above driver door or for school buses, place a placard with NHTSA number inside the windshield and to the exterior front and rear side of bus:
 Yes No
- I. Place vehicle in storage area: Yes No
- J. Inspect the vehicle's interior and exterior, including all windows, seats, doors, etc. to confirm that each system is complete and functional per the manufacturer's specifications. Any damage, misadjustment, or other unusual condition that could influence the test program or test results shall be recorded. Report any abnormal condition to the NHTSA COTR before beginning any test:
 Vehicle OK Conditions reported below in comment section

Identify the letter above to which any of the following comments apply.

Comments: _____

REPORT OF VEHICLE CONDITION AT THE COMPLETION OF TESTING

LIST OF FMVSS TESTS PERFORMED BY THIS LAB: FMVSS 208, 212, 219, 301
VEHICLE: 2014 Ford Escape NHTSA NO.: C20140200
REMARKS:

Equipment that is no longer on the test vehicle as noted on previous page:
Rear Floor Mats, Right Rear Tail Light, Spare Tire, Jack and Tools, Spare Tire Cover, Cargo Organizer

Explanation for equipment removal:
Components removed for instrumentation installation and to meet target weight.

Test Vehicle Condition:
25 mph frontal impact damage- front suspension & structure damaged, hood & front quarter panels damaged, radiator damaged, air bags deployed, Stoddard in fuel system

RECORDED BY: Jeff Lewandowski DATE: 9/1/2014
APPROVED BY: David Winkelbauer DATE: 9/1/2014

#####

RELEASE OF TEST VEHICLE

The vehicle described above is released from MGA to be delivered to:

Date: Time: Odometer:
Lab Rep's Signature:
Title:
Carrier/Customer Rep:
Date:

DATA SHEET 3

CERTIFICATION LABEL AND TIRE PLACARD INFORMATION

Test Vehicle: 2014 Ford Escape
 Test Program: FMVSS 208 Compliance
 Test Technician: Alex Vanderheyden

NHTSA No.: C20140200
 Test Date: 8/25/14

Certification Label (Part 567)	
Manufacturer:	Ford Motor Co.
Date of Manufacture:	11/13
VIN:	1FMCU0F72EUB70023
Vehicle Certified As (Pass. Car/MPV/Truck/Bus):	MPV
Front Axle GVWR:	1098 kg (2420 lbs)
Rear Axle GVWR:	1006 kg (2218 lbs)
Total GVWR:	2096 kg (4620 lbs)

Tire Placard for Motor Vehicles with GVWR of 10,000 lb or Less and Passenger Cars (571.110)	
Vehicle Capacity Weight:	375 kg (827 lbs)
Designated Seating Capacity Front:	2
Designated Seating Capacity Rear:	3
Total Designated Seating Capacity:	5
Recommended Cold Tire Inflation Pressure Front:	240 kpa (35 psi)
Recommended Cold Tire Inflation Pressure Rear:	240 kpa (35 psi)
Recommended Tire Size:	P235/55R17
Tire Size on Vehicle:	P235/55R17

Signature: 

Date: 8/25/14

DATA SHEET 4
REAR SEATING POSITION SEAT BELTS

Test Vehicle: 2014 Ford Escape
Test Program: FMVSS 208 Compliance
Test Technician: Nicholas Abels

NHTSA No.: C20140200
Test Date: 6/30/14

	Yes	No
Do all rear seating positions have Type 2 seat belts?	X	

If NO, describe the seat belt installed, the seat location, and any other information about the seat that would explain why a Type 2 seat belt was not installed.

REMARKS:

Signature: *Nicholas Abels*

Date: 6/30/14

DATA SHEET 5
AIR BAG LABELS (S4.5.1)

Test Vehicle: 2014 Ford Escape
Test Program: FMVSS 208 Compliance
Test Technician: Nicholas Abels

NHTSA No.: C20140200
Test Date: 6/30/14

1. Air Bag Maintenance Label and Owner's Manual Instructions: (S4.5.1(a))
- 1.1 Does the manufacturer recommend periodic maintenance or replacement of the air bag?
 Yes (Go to 1.2)
 No (Go to 2)
- 1.2 Does the vehicle have a label specifying air bag maintenance or replacement?
 Yes – Pass
 No – Fail
- 1.3 Does the label contain one of the following?
 Yes – Pass
 No – Fail
- Check applicable schedule:
___ Schedule on label specifies month and year (Record date _____)
___ Schedule on label specifies vehicle mileage (Record mileage _____)
___ Schedule on label specifies interval measured from date on certification label
(Record interval _____)
- 1.4 Is the label permanently affixed within the passenger compartment such that it cannot be removed without destroying or defacing the label or vehicle part? (3/19/01 legal interpretation to Todd Mitchell)
 Yes – Pass
 No – Fail
- 1.5 Is the label lettered in English?
 Yes – Pass
 No – Fail
- 1.6 Is the label in block capitals and numerals?
 Yes – Pass
 No – Fail
- 1.7 Are the letters and numerals at least 3/32 inches high?
 Yes – Pass
 No – Fail
- 1.8 Does the owner's manual set forth the recommended schedule for maintenance or replacement?
2. Does the owner's manual: (S4.5.1(f))
- 2.1 Include a description of the vehicle's air bag system in an easily understandable format?
 Yes – Pass
 No – Fail
- 2.2 Include a statement that the vehicle is equipped with an air bag and a lap/shoulder belt at the front outboard seating position?
 Yes – Pass
 No – Fail
- 2.3 Include a statement that the air bag is a supplemental restraint at the front outboard seating position?
 Yes – Pass
 No – Fail

- 2.4 Emphasize that all occupants, including the driver, should always wear their seat belts whether or not an air bag is also provided at their seating positions to minimize the risk of severe injury or death in the event of a crash?
 Yes – Pass
 No – Fail
- 2.5 Provide any necessary precautions regarding the proper positioning of occupants, including children, at seating positions equipped with air bags to ensure maximum safety protection for those occupants?
 Yes – Pass
 No – Fail
- 2.6 Explain that no objects should be placed over or near the air bag on the steering wheel or on the instrument panel, because any such objects could cause harm if the vehicle is in a crash severe enough to cause the air bag to inflate?
 Yes – Pass
 No – Fail
- 2.7 Is the vehicle certified to meet the requirements of S14.5, S15, S17, S19, S21, S23, and S25? (Obtain answer to this question from the COTR) (S4.5.1(f)(2))
 Yes – (Go to 2.7.1)
 No – (Go to 3.)
- 2.7.1 Explain the proper functioning of the advanced air bag system? (S4.5.1(f)(2))
 Yes – Pass
 No – Fail
- 2.7.2 Provide a summary of the actions that may affect the proper functioning of the system? (S4.5.1(f)(2))
 Yes – Pass
 No – Fail
- 2.7.3 Present and explain the main components of the advanced passenger air bag system? (S4.5.1(f)(2)(i))
 Yes – Pass
 No – Fail
- 2.7.4 Explain how the components function together as part of the advanced passenger air bag system? (S4.5.1(f)(2)(ii))
 Yes – Pass
 No – Fail
- 2.7.5 Contain the basic requirements for proper operation, including an explanation of the actions that may affect the proper functioning of the system? (S4.5.1(f)(2)(iii))
 Yes – Pass
 No – Fail
- 2.7.6 Is the vehicle certified to the requirements of S19.2, S21.2, or 23.2 (automatic suppression)?
 Yes, continue with 2.7.6
 No, go to 2.7.7
- 2.7.6.1 Contain a complete description of the passenger air bag suppression system installed in the vehicle, including a discussion of any suppression zone? (S4.5.1(f)(2)(iv))
 Yes – Pass
 No – Fail
- 2.7.6.2 Discuss the telltale light, specifying its location in the vehicle and explaining when the light is illuminated?
 Yes – Pass
 No – Fail
- 2.7.7 Explain the interaction of the advanced passenger air bag system with other vehicle components, such as seat belts, seats or other components? (S4.5.1(f)(2)(v))
 Yes – Pass
 No – Fail

- 2.7.8 Summarize the expected outcomes when child restraint systems, children and small teenagers or adults are both properly and improperly positioned in the passenger seat, including cautionary advice against improper placement of child restraint systems? (S4.5.1(f)(2)(vi))
- Yes – Pass
 No – Fail
- 2.7.9 Provide information on how to contact the vehicle manufacturer concerning modifications for persons with disabilities that may affect the advanced air bag system? (S4.5.1(f)(2)(vii))
- Yes – Pass
 No – Fail
3. Sun Visor Air Bag Warning Label (S4.5.1(b)): Vehicles certified to meet the requirements of S19, S21 and S23. (S4.5.1(b)(3))
- 3.1 Is the label permanently affixed (including permanent marking on the visor material or molding into the visor material) to either side of the sun visor at each front outboard seating position such that it cannot be removed without destroying or defacing the label or the sun visor? (S4.5.1(b)(3)) (3/19/01 legal interpretation to Todd Mitchell)
- Driver Side, Yes – Pass
 Driver Side, No – Fail
 Passenger Side, Yes – Pass
 Passenger Side, No – Fail
- 3.2 Does the label conform in content to the label shown in Figure 11 at each front outboard seating position? (S4.5.1(b)(2)) **(Vehicles without back seats or the back seat is too small to accommodate a rear-facing child restraint may omit the statement: “Never put a rear-facing child seat in the front.” (S4.5.1(b)(3)(v)))**



Figure 11. Sun Visor Label Visible when Visor is in Down Position.



Figure 6b. Sun Visor Label Visible When Visor is in Down Position.

- Driver Side, Yes – Pass
 Driver Side, No – Fail
 Passenger Side, Yes – Pass
 Passenger Side, No – Fail

- 3.3 Is the label heading area yellow with the word "WARNING" and the alert symbol in black? (S4.5.1(b)(3)(i))
- Driver Side, Yes – Pass
 Driver Side, No – Fail
 Passenger Side, Yes – Pass
 Passenger Side, No – Fail
- 3.4 Is the message area white with black text? (S4.5.1(b)(3)(ii))
- Driver Side, Yes – Pass
 Driver Side, No – Fail
 Passenger Side, Yes – Pass
 Passenger Side, No – Fail
- 3.5 Is the message area at least 30 cm²? (S4.5.1(b)(3)(ii))
- The message area consists of the total label area minus the yellow heading area and the pictogram. The pictogram is enclosed on the left side and bottom by the edge of the label. The top edge of the pictogram area is defined by a horizontal line midway between the uppermost edge of the pictogram and the lowermost edge of the text. The right side of the pictogram is defined by a vertical line midway between the rightmost edge of the pictogram and the left most edge of the text, including any bullets. (See 5/6/03 interpretation to Gerald Plante on behalf of Subaru)**
- Driver Side: Length 97 mm, Width 36 mm
Passenger Side: Length 97 mm, Width 36 mm
Driver actual message area 34.9 cm²
Passenger actual message area 34.9 cm²
- Driver Side, Yes – Pass
 Driver Side, No – Fail
 Passenger Side, Yes – Pass
 Passenger Side, No – Fail
- 3.6 Is the pictogram black on a white background? (S4.5.1(b)(3)(iii))
- Driver Side, Yes – Pass
 Driver Side, No – Fail
 Passenger Side, Yes – Pass
 Passenger Side, No – Fail
- 3.7 Is the pictogram at least 30 mm in length? (S4.5.1(b)(3)(iii))
- Driver side: Length: 31 mm
Passenger side: Length: 31 mm
- Driver Side, Yes – Pass
 Driver Side, No – Fail
 Passenger Side, Yes – Pass
 Passenger Side, No – Fail
- 3.8 Is the same side of the sun visor that contains the air bag warning label free of other information with the exception of the air bag maintenance label and/or the rollover-warning label? (S4.5.1(b)(5)(i))
- Driver Side, Yes – Pass
 Driver Side, No – Fail
 Passenger Side, Yes – Pass
 Passenger Side, No – Fail
- 3.9 Is the sun visor free of other information about air bags or the need to wear seat belts with the exception of the air bag alert label and/or the rollover-warning label? (S4.5.1(b)(5)(ii))
- Driver Side, Yes – Pass
 Driver Side, No – Fail
 Passenger Side, Yes – Pass
 Passenger Side, No – Fail

- 3.10 Does the driver side visor contain a rollover-warning label on the same side of the visor as the air bag warning label?
 ___ Yes (go to 3.10.1)
 No (go to 4., skipping 3.10.1 through 3.10.3)
- 3.10.1 Are both the rollover-warning label and the air bag warning label surrounded by a continuous solid-lined border?
 Yes (go to 3.10.2 and skip 3.10.3)
 ___ No (go to 3.10.3 and skip 3.10.2)
- 3.10.2 Is the shortest distance from the border of the rollover label to the border of the air bag warning label at least 1 cm? (575.105 (d)(1)(iv)(B))
 _____ 1.2 cm _____ actual distance
 Yes-Pass ___ **No-FAIL**
- 3.10.3 Is the shortest distance from any of the lettering or graphics on the rollover-warning label to any of the lettering or graphics of the air bag warning label at least 3 cm? (575.105 (d)(1)(iv)(A))
 _____ actual distance
 ___ Yes-Pass ___ **No-FAIL**
4. Air Bag Alert Label (S4.5.1(c) (A “Rollover Warning Label” or “Rollover Alert Label” may be on the same side of the driver’s sun visor as the “Air Bag Alert Label.” 575.105(d))
- 4.1 Is the Sun Visor Warning Label visible when the sun visor is in the stowed position?
 If yes for driver and passenger, go to 5.
 Driver Side, Yes
 Driver Side, No
 Passenger Side, Yes
 Passenger Side, No
- 4.2 Is the air bag alert label permanently affixed (including permanent marking on the visor material or molding into the visor material) to the sun visor at each front outboard seating position such that it cannot be removed without destroying or defacing the label or the sun visor? (S4.5.1(c)) (3/19/01 legal interpretation to Todd Mitchell)
 Driver Side, Yes – Pass
 Driver Side, No – Fail
 Passenger Side, Yes – Pass
 Passenger Side, No – Fail
- 4.3 Is the air bag alert label visible when the visor is in the stowed position? (S4.5.1(c))
 Driver Side, Yes – Pass
 Driver Side, No – Fail
 Passenger Side, Yes – Pass
 Passenger Side, No – Fail

4.4 Does the label conform in content to the label shown in Figure 6C? (S4.5.1(c))

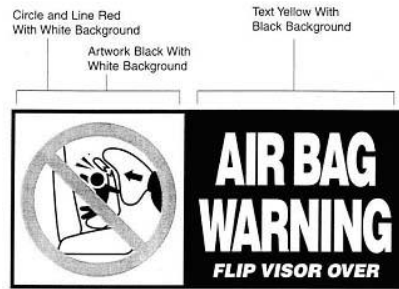

Figure 6c. Sun Visor Label Visible When Visor is in Up Position.

- Driver Side, Yes – Pass
- Driver Side, No – Fail
- Passenger Side, Yes – Pass
- Passenger Side, No – Fail

4.5 Is the message area black with yellow text? (S4.5.1(c)(1))

- Driver Side, Yes – Pass
- Driver Side, No – Fail
- Passenger Side, Yes – Pass
- Passenger Side, No – Fail

4.6 Is the message area at least 20 cm²? (S4.5.1(c)(1)) **The message area consists of the black part of the label.**

Driver Side: Length _____, Width _____
Passenger Side: Length _____, Width _____
Actual message area _____ cm²

- Driver Side, Yes – Pass
- Driver Side, No – Fail
- Passenger Side, Yes – Pass
- Passenger Side, No – Fail

4.7 Is the pictogram black with a red circle and slash on a white background? (S4.5.1(c)(2))

- Driver Side, Yes – Pass
- Driver Side, No – Fail
- Passenger Side, Yes – Pass
- Passenger Side, No – Fail

4.8 Is the pictogram at least 20 mm in diameter? (S4.5.1(c)(2))

Driver Side: Diameter _____mm
Passenger Side: Diameter _____mm

- Driver Side, Yes – Pass
- Driver Side, No – Fail
- Passenger Side, Yes – Pass
- Passenger Side, No – Fail

5. Label on the Dashboard: Vehicles certified to meet the requirements of S19, S21 and S23?

5.1 Does the vehicle have a label on the dash or steering wheel hub? (S4.5.1(e)(3))

- Yes – Pass **The label was missing and it could not be determined when it was removed. Therefore it was not evaluated.**
- No – Fail

5.2 Is the label clearly visible from all front seating positions? (S4.5.1(e)(3))

- Yes – Pass
- No - Fail

- 5.3 Does the label conform in content to the label shown in Figure 12? (S4.5.1(e)(3)) **Vehicles without back seats may omit the statement: “The back seat is the safest place for children.” Vehicles without back seats or too small to accommodate a rear-facing child restraint consistent with S4.5.4.1 as determined in DATA SHEET 7 may omit the statement “Never put a rear-facing child seat in the front.” (S4.5.1(e)(3)(iii))**
- Yes – Pass
 No - Fail

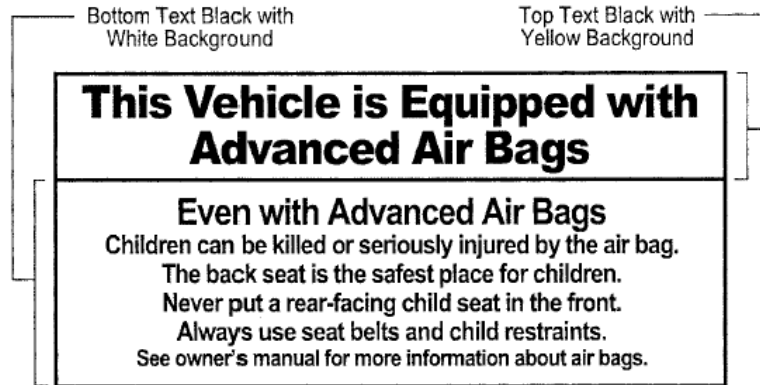

Figure 12. Removable Label on Dash.

- 5.4 Is the heading area yellow with black text? (S4.5.1(e)(3)(i))
- Yes – Pass
 No - Fail
- 5.5 Is the message white with black text? (S4.5.1(e)(3)(ii))
- Yes – Pass
 No - Fail
- 5.6 Is the message area at least 30 cm²? (S4.5.1(e)(3)(ii)) **The message area consists of the total label area minus the yellow heading area. (See 5/6/03 interpretation to Gerald Plante on behalf of Subaru)**
- Length ___ mm, Width ___ mm
 Actual message area ___ cm²
- Yes – Pass
 No - Fail

I certify that I have read and performed each instruction.

Signature: Nicholas Steets

Date: 6/30/14

DATA SHEET 6
FMVSS 208 READINESS INDICATOR (S4.5.2)

Test Vehicle: 2014 Ford Escape
Test Program: FMVSS 208 Compliance
Test Technician: Nicholas Abels

NHTSA No.: C20140200
Test Date: 6/30/14

An occupant restraint system that deploys in the event of a crash shall have a monitoring system with a readiness indicator. A totally mechanical system is exempt from this requirement. (11/8/94 legal interpretation to Lawrence F. Hennegerger on behalf of Breed)

1. Is the system totally mechanical? **(If Yes, this Data Sheet is complete).**
 Yes
 No
2. Describe the location of the readiness indicator: *Left of Instrument Cluster*
3. Is the readiness indicator clearly visible to the driver?
 Yes – Pass
 No - Fail
4. Is a list of the elements in the occupant restraint system, being monitored by the readiness indicator, provided on a label or in the owner's manual?
 Yes – Pass
 No - Fail
5. Does the vehicle have an on-off switch for the passenger air bag?
 If Yes (go to 6)
 If No (this form is complete)
6. Is the air bag readiness indicator off when the passenger air bag switch is in the off position?
 Yes – Pass
 No - Fail

REMARKS:

I certify that I have read and performed each instruction.

Signature: Nicholas Abels

Date: 6/30/14

DATA SHEET 7

PASSENGER AIR BAG MANUAL CUT-OFF DEVICE (S4.5.4)

Test Vehicle: 2014 Ford Escape
 Test Program: FMVSS 208 Compliance
 Test Technician: Nicholas Abels

NHTSA No.: C20140200
 Test Date: 6/30/14

- 1. Is the vehicle equipped with an on-off switch that deactivates the air bag installed at the right front outboard seating position?
 Yes, go to 2
 No, this sheet is complete
- 2. Does the vehicle have any forward-facing rear designated seating positions? (S4.5.4.1(a))
 Yes, go to 3
 No, go to 4
- 3. Verification there is room for a child restraint in the rear seat behind the driver's seat. (S4.5.4.1(b))
- 3.1 Using all the controls that affect the fore-aft movement of the seat, move the seat to the rearmost position. Mark this position.
 N/A – the seat does not have fore-aft adjustment
- 3.2 Using all the controls that affect the fore-aft movement of the seat, move the seat to the foremost position. Mark this position.
 N/A – the seat does not have fore-aft adjustment
- 3.3 Move the seat to the middle of the foremost and rearmost positions. (S8.1.2)
 N/A – the seat does not have a fore-aft adjustment
- 3.4 If the driver's seat height is adjustable, use all the controls that affect height to put it in the lowest position while maintaining the middle fore-aft position. (S8.1.2)
 N/A – No seat height adjustment
- 3.5 Position the driver's seat adjustable lumbar supports so that the lumbar support is in its lowest, retracted or deflated adjustment position. (S8.1.3)
 N/A – No lumbar adjustment
- 3.6 The driver's seat back angle, if adjustable, is set at the manufacturer's nominal design riding position for a 50th percentile adult male in the manner specified by the manufacturer. (S4.5.4.1(b) and S8.1.3)
 N/A – No seat back angle adjustment
 Manufacturer's design driver's seat back angle _____
 Tested driver's seat back angle _____
- 3.7 Is the driver seat a bucket seat?
 ___ Yes, go to 3.7.1 and skip 3.7.2.
 ___ No, go to 3.7.2 and skip 3.7.1.
- 3.7.1 Bucket seats:
- 3.7.1.1 Locate and mark a vertical Plane B through the longitudinal centerline of the driver's seat cushion. The longitudinal centerline of a bucket seat cushion is determined at SgRP. (S16.3.1.10) (S4.5.4.1(b)(1))
- 3.7.1.2 Locate the longitudinal horizontal line in plane B that is tangent to the highest point of the rear seat cushion behind the driver's seat. Measure along this line from the front of the seat back of the rear seat to the rear of the seat back of the driver's seat.
 _____ mm distance
 _____ less than 720 mm – Pass
 _____ more than 720 mm – **FAIL**
 Go to 4
- 3.7.2 Bench seats (including split bench seats):
- 3.7.2.1 Locate and mark a vertical Plane B through the center of the steering wheel parallel to the vehicle longitudinal centerline. (S4.5.4.1(b)(2))

- 3.7.2.2 Locate the longitudinal horizontal line in plane B that is tangent to the highest point of the rear seat cushion. Measure along this line from the front of the seat back of the rear seat to the rear of the seat back of the front seat.
 _____ mm distance
 _____ less than 720 mm – Pass
 _____ more than 720 mm - **FAIL**
 Go to 4
4. Does the device turn the air bag on and off using the vehicle's ignition key? (S4.5.4.2)
 Yes – Pass
 No – Fail
5. Is the on-off device separate from the ignition switch? (S4.5.4.2)
 Yes – Pass
 No – Fail
6. Is there a telltale light that comes on when the passenger air bag is turned off? (S4.5.4.2)
 Yes – Pass
 No – Fail
7. Telltale light (S4.5.4.3)
- 7.1 Is the light yellow? (S4.5.4.3(a))
 Yes – Pass
 No – Fail
- 7.2 Are the words "PASSENGER AIR BAG OFF" or "PASS AIR BAG OFF" (S4.5.4.3(b))
 7.2.1 on the telltale?
 Yes – Pass, go to 7.3
 No – go to 7.2.2
- 7.2.2 Within 25 mm of the telltale?
 Measurement from the edge of the telltale (mm):
 Yes – Pass
 No – Fail
- 7.3 Does the telltale remain illuminated while the air bag is turned off? (S4.5.4.3c)
 (Leave the air bag off for 5 minutes.)
 Yes – Pass
 No – Fail
- 7.4 Is the telltale illuminated while the air bag is turned on? (S4.5.4.3(d))
 Yes – Fail
 No – Pass
- 7.5 Is the telltale combined with the air bag readiness indicator? (S4.5.4.3(e))
 Yes – Fail
 No – Pass
8. Owner's Manual
- 8.1 Does the owner's manual contain complete instructions on the operation of the on-off switch? (S4.5.4.4(a))
 Yes – Pass
 No – Fail

- 8.2 Does the owner's manual contain a statement that the on-off switch should only be used when a member of one of the following risk groups is occupying the right front passenger seating position? (S4.5.4.4(b))
- Infants: there is no back seat
 the rear seat is too small to accommodate a child restraint
 there is a medical condition that must be monitored constantly
- Children aged 1 to 12: there is no back seat
 space is not always available in the rear seat
 there is a medical condition that must be monitored constantly
- Medical condition: medical risk causes special risk for passenger
 greater risk for harm than with the air bag on

- Yes – Pass
 No – Fail

- 8.3 Does the owner's manual contain a warning about the safety consequences of using the on-off switch at other times?

- Yes – Pass
 No – Fail

REMARKS:

I certify that I have read and performed each instruction.

Signature: Nicholas Atte

Date: 6/30/14

DATA SHEET 8

LAP BELT LOCKABILITY

Passenger cars, trucks, buses, and multipurpose passenger Vehicles with a GVWR of 10,000 pounds or less. (S7.1.1.5)

Test Vehicle: 2014 Ford Escape
Test Program: FMVSS 208 Compliance
Test Technician: Nicholas Abels

NHTSA No.: C20140200
Test Date: 6/30/14

Complete one of these forms for **each** designated seating position that can be adjusted to forward-facing or that is a forward-facing seat, other than the driver's seat (S7.1.1.5(a), **and** that has seat belt retractors that are not solely automatic locking retractors. (S7.1.1.5(c))

DESIGNATED SEATING POSITION: **Front Passenger**

- N/A – No retractor is at this position
 N/A – The retractor is an automatic locking retractor ONLY
1. Record test fore-aft seat position: **REAR**
(S7.1.1.5(c)(1)) (Any position is acceptable)
2. Does the lap belt portion of the seat belt in the forward-facing seat or seat that can be adjusted to forward-facing consist of a locking device that does **NOT** have to be attached by the vehicle user to the seat belt webbing, retractor, or any other part of the vehicle. (S7.1.1.5(a))
 Yes – Pass
 No – Fail
3. Does the lap belt portion of the seat belt in the forward-facing seat or seat that can be adjusted to forward-facing consist of a locking device that does **NOT** require inverting, twisting or deforming of the belt webbing. (S7.1.1.5(a))
 Yes – Pass
 No – Fail
4. Place any adjustable seat belt anchorage in the lowest adjustment position.
 N/A The anchorage is not adjustable.
5. Buckle the seat belt. (S7.1.1.5(c)(1))
6. Locate a reference point A on the seat belt buckle. (S7.1.1.5(c)(2))
7. Locate a reference point B on the attachment hardware or retractor assembly at the other end of the lap belt or lap belt portion of the seat belt assembly. (S7.1.1.5(c)(2))
8. Does the vehicle user need to take some action to activate the locking feature on the lap belt portion of the seat belt in any forward-facing seat or seat that can be adjusted to forward-facing?
 Yes (go to 8.1)
 No (go to 9)
- 8.1 Does the vehicle owner's manual include a description in words and/or diagrams describing how to activate the locking feature so that the seat belt assembly can tightly secure a child restraint system and how to deactivate the locking feature to remove the child restraint system? (S7.1.1.5(b))
 Yes – Pass
 No – Fail
9. Adjust the lap belt or lap belt portion of the seat belt assembly according to any procedures recommended in the vehicle owner's manual to activate any locking feature so that the webbing between points A and B is at the maximum length allowed by the belt system. (S7.1.1.5(c)(2) & S7.1.1.5(c)(1))

10. Measure and record the distance between points A and B along the longitudinal centerline of the webbing for the lap belt or lap belt portion of the seat belt assembly. (S7.1.1.5(c)(2))
Measured distance between A and B (inches): 59 ½
11. Readjust the belt system so that the webbing between points A and B is at ½ the maximum length of the webbing. (S7.1.1.5(c)(3))
12. To the lap belt or lap belt portion of the seat belt assembly, apply a preload of 10 pounds using the webbing tension pull device in Figure 5. Apply the load in a vertical plane parallel to the longitudinal axis of the vehicle and passing through the seating reference point of the designated seating position. Apply the preload in a horizontal direction toward the front of the vehicle with a force application angle of not less than 5 degrees nor more than 15 degrees above the horizontal. (S7.1.1.5(c)(4))
Measured force application angle: 10° (spec. 5 - 15 degrees)
13. Measure the length between points A and B along the longitudinal centerline of the webbing while the preload is being applied. (S7.1.1.5(c)(4))
Measured distance between A and B: 33 ½ inches
14. Increase the load to 50 pounds at a rate of no more than 50 pounds per second. Attain the load in not more than 5 seconds. (If webbing sensitive emergency locking retractors are installed as part of the lap belt or lap belt portion of the seat belt assembly, apply the load at a rate less than the threshold value for lock-up specified by the manufacturer.) Maintain the load for at least 5 seconds. Measure and record the distance between points A and B along the longitudinal centerline of the webbing. (S7.1.1.5(c)(5))
Record onset rate: 15 lb/sec (spec. 10 to 50 lb/sec) (S7.1.1.5(c)(5))
Measured distance between A and B: 33 ½ inches (S7.1.1.5(c)(6))
15. Let the seat belt webbing retract to its minimum length with the seat belt still buckled.
16. To the lap belt or lap belt portion of the seat belt assembly, apply a preload of 10 pounds using the webbing tension pull device in Figure 5. Apply the load in a vertical plane parallel to the longitudinal axis of the vehicle and passing through the seating reference point of the designated seating position. Apply the preload in a horizontal direction toward the front of the vehicle with a force application angle of not less than 5 degrees nor more than 15 degrees above the horizontal. (S7.1.1.5(c)(4))
Measured force application angle: 10° (spec. 5 - 15 degrees)
17. Measure the length between points A and B along the longitudinal centerline of the webbing while the preload is being applied. (S7.1.1.5(c)(4))
Measured distance between A and B: 21 ½ inches
18. Increase the load to 50 pounds at a rate of no more than 50 pounds per second. Attain the load in not more than 5 seconds. (If webbing sensitive emergency locking retractors are installed as part of the lap belt or lap belt portion of the seat belt assembly, apply the load at a rate less than the threshold value for lock-up specified by the manufacturer.) Maintain the load for at least 5 seconds. Measure and record the distance between points A and B along the longitudinal centerline of the webbing. (S7.1.1.5(c)(5))
Record onset rate: 15 lb/sec (spec. 10 to 50 lb/sec) (S7.1.1.5(c)(5))
Measured distance between A and B: 21 ½ inches (S7.1.1.5(c)(6))
19. Subtract the measurement in 13 from the measurement in 14 and the measurement in 17 from the measurement in 18. Is the difference 2 inches or less for both? (S7.1.1.5(c)(7))
14 – 13 = 33 ½ - 33 ½ = 0 inches;
18 – 17 = 21 ½ - 21 ½ = 0 inches;
- Yes – Pass
 No – Fail

20. Subtract the measurement in 14 from the measurement in 10 and the measurement in 18 from the measurement in 10. Is the difference 3 inches or more for both?
(S7.1.1.5(c)(8))
- 10-14 = $59 \frac{1}{2} - 33 \frac{1}{2} = 26$ inches;
- 10-18 = $59 \frac{1}{2} - 21 \frac{1}{2} = 38$ inches
- Yes – Pass
- No – Fail

REMARKS:

Signature: Nicholas Heets

Date: 6/30/14

I certify that I have read and performed each instruction.

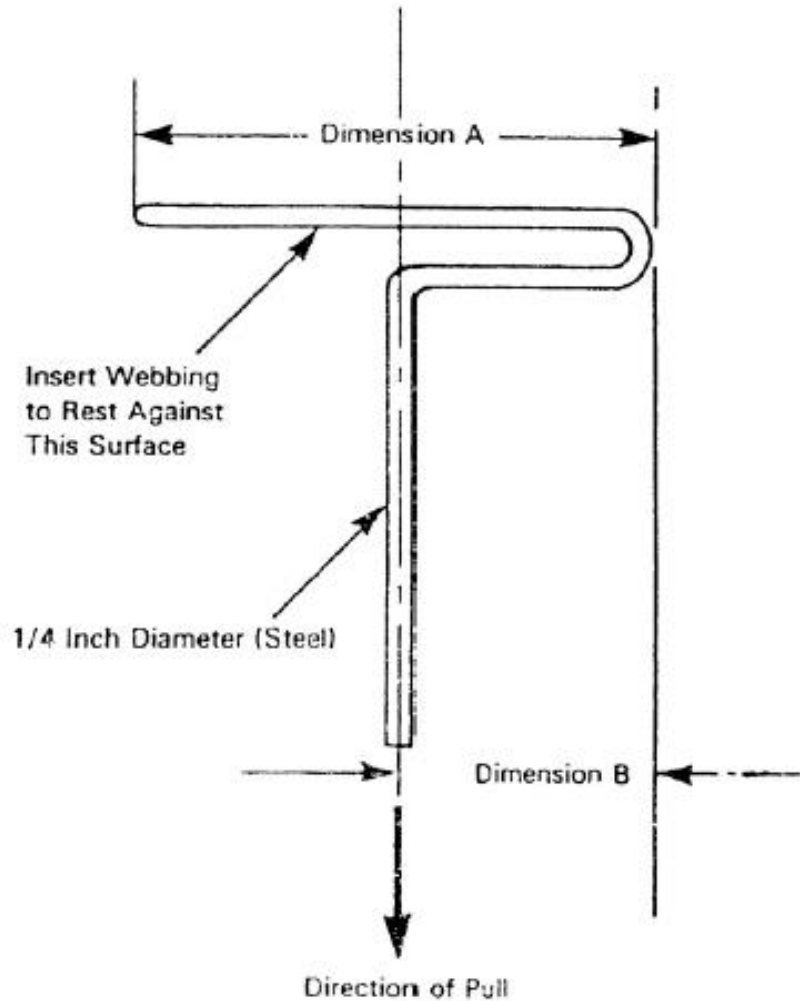

Dimension A - Width of Webbing Plus 1/2 Inch

Dimension B - 1/2 of Dimension A

Figure 5. - Webbing Tension Pull Device

DATA SHEET 8

LAP BELT LOCKABILITY

Passenger cars, trucks, buses, and multipurpose passenger
Vehicles with a GVWR of 10,000 pounds or less. (S7.1.1.5)

Test Vehicle: 2014 Ford Escape
Test Program: FMVSS 208 Compliance
Test Technician: Nicholas Abels

NHTSA No.: C20140200
Test Date: 6/30/14

Complete one of these forms for **each** designated seating position that can be adjusted to forward-facing or that is a forward-facing seat, other than the driver's seat (S7.1.1.5(a), **and** that has seat belt retractors that are not solely automatic locking retractors. (S7.1.1.5(c))

DESIGNATED SEATING POSITION: **Left Rear Passenger**

- N/A – No retractor is at this position
- N/A – The retractor is an automatic locking retractor ONLY
- 1. Record test fore-aft seat position: **FIXED**
(S7.1.1.5(c)(1)) (Any position is acceptable)
- 2. Does the lap belt portion of the seat belt in the forward-facing seat or seat that can be adjusted to forward-facing consist of a locking device that does **NOT** have to be attached by the vehicle user to the seat belt webbing, retractor, or any other part of the vehicle. (S7.1.1.5(a))
 - Yes – Pass
 - No – Fail
- 3. Does the lap belt portion of the seat belt in the forward-facing seat or seat that can be adjusted to forward-facing consist of a locking device that does **NOT** require inverting, twisting or deforming of the belt webbing. (S7.1.1.5(a))
 - Yes – Pass
 - No – Fail
- 4. Place any adjustable seat belt anchorage in the lowest adjustment position.
 - N/A The anchorage is not adjustable.
- 5. Buckle the seat belt. (S7.1.1.5(c)(1))
- 6. Locate a reference point A on the seat belt buckle. (S7.1.1.5(c)(2))
- 7. Locate a reference point B on the attachment hardware or retractor assembly at the other end of the lap belt or lap belt portion of the seat belt assembly. (S7.1.1.5(c)(2))
- 8. Does the vehicle user need to take some action to activate the locking feature on the lap belt portion of the seat belt in any forward-facing seat or seat that can be adjusted to forward-facing?
 - Yes (go to 8.1)
 - No (go to 9)
- 8.1 Does the vehicle owner's manual include a description in words and/or diagrams describing how to activate the locking feature so that the seat belt assembly can tightly secure a child restraint system and how to deactivate the locking feature to remove the child restraint system? (S7.1.1.5(b))
 - Yes – Pass
 - No – Fail
- 9. Adjust the lap belt or lap belt portion of the seat belt assembly according to any procedures recommended in the vehicle owner's manual to activate any locking feature so that the webbing between points A and B is at the maximum length allowed by the belt system. (S7.1.1.5(c)(2) & S7.1.1.5(c)(1))

10. Measure and record the distance between points A and B along the longitudinal centerline of the webbing for the lap belt or lap belt portion of the seat belt assembly. (S7.1.1.5(c)(2))
Measured distance between A and B (inches): 71 ¼
11. Readjust the belt system so that the webbing between points A and B is at ½ the maximum length of the webbing. (S7.1.1.5(c)(3))
12. To the lap belt or lap belt portion of the seat belt assembly, apply a preload of 10 pounds using the webbing tension pull device in Figure 5. Apply the load in a vertical plane parallel to the longitudinal axis of the vehicle and passing through the seating reference point of the designated seating position. Apply the preload in a horizontal direction toward the front of the vehicle with a force application angle of not less than 5 degrees nor more than 15 degrees above the horizontal. (S7.1.1.5(c)(4))
Measured force application angle: 10° (spec. 5 - 15 degrees)
13. Measure the length between points A and B along the longitudinal centerline of the webbing while the preload is being applied. (S7.1.1.5(c)(4))
Measured distance between A and B: 45 ½ inches
14. Increase the load to 50 pounds at a rate of no more than 50 pounds per second. Attain the load in not more than 5 seconds. (If webbing sensitive emergency locking retractors are installed as part of the lap belt or lap belt portion of the seat belt assembly, apply the load at a rate less than the threshold value for lock-up specified by the manufacturer.) Maintain the load for at least 5 seconds. Measure and record the distance between points A and B along the longitudinal centerline of the webbing. (S7.1.1.5(c)(5))
Record onset rate: 15 lb/sec (spec. 10 to 50 lb/sec) (S7.1.1.5(c)(5))
Measured distance between A and B: 45 ¾ inches (S7.1.1.5(c)(6))
15. Let the seat belt webbing retract to its minimum length with the seat belt still buckled.
16. To the lap belt or lap belt portion of the seat belt assembly, apply a preload of 10 pounds using the webbing tension pull device in Figure 5. Apply the load in a vertical plane parallel to the longitudinal axis of the vehicle and passing through the seating reference point of the designated seating position. Apply the preload in a horizontal direction toward the front of the vehicle with a force application angle of not less than 5 degrees nor more than 15 degrees above the horizontal. (S7.1.1.5(c)(4))
Measured force application angle: 10° (spec. 5 - 15 degrees)
17. Measure the length between points A and B along the longitudinal centerline of the webbing while the preload is being applied. (S7.1.1.5(c)(4))
Measured distance between A and B: 23 inches
18. Increase the load to 50 pounds at a rate of no more than 50 pounds per second. Attain the load in not more than 5 seconds. (If webbing sensitive emergency locking retractors are installed as part of the lap belt or lap belt portion of the seat belt assembly, apply the load at a rate less than the threshold value for lock-up specified by the manufacturer.) Maintain the load for at least 5 seconds. Measure and record the distance between points A and B along the longitudinal centerline of the webbing. (S7.1.1.5(c)(5))
Record onset rate: 15 lb/sec (spec. 10 to 50 lb/sec) (S7.1.1.5(c)(5))
Measured distance between A and B: 23 ½ inches (S7.1.1.5(c)(6))
19. Subtract the measurement in 13 from the measurement in 14 and the measurement in 17 from the measurement in 18. Is the difference 2 inches or less for both? (S7.1.1.5(c)(7))
14 – 13 = 45 ¾ - 45 ½ = ¼ inches;
18 – 17 = 23 ½ - 23 = ½ inches;
- Yes – Pass
 No – Fail

20. Subtract the measurement in 14 from the measurement in 10 and the measurement in 18 from the measurement in 10. Is the difference 3 inches or more for both?
(S7.1.1.5(c)(8))

$10-14 = 71 \frac{1}{4} - 45 \frac{3}{4} = 25 \frac{1}{2}$ inches;

$10-18 = 71 \frac{1}{4} - 23 \frac{1}{2} = 47 \frac{3}{4}$ inches;

Yes – Pass

No – Fail

REMARKS:

Signature: *Nicholas Heets*

Date: 6/30/14

I certify that I have read and performed each instruction.

DATA SHEET 8
LAP BELT LOCKABILITY

**Passenger cars, trucks, buses, and multipurpose passenger
Vehicles with a GVWR of 10,000 pounds or less. (S7.1.1.5)**

Test Vehicle: 2014 Ford Escape
Test Program: FMVSS 208 Compliance
Test Technician: Nicholas Abels

NHTSA No.: C20140200
Test Date: 6/30/14

Complete one of these forms for **each** designated seating position that can be adjusted to forward-facing or that is a forward-facing seat, other than the driver's seat (S7.1.1.5(a), **and** that has seat belt retractors that are not solely automatic locking retractors. (S7.1.1.5(c))

DESIGNATED SEATING POSITION:	Center Rear Passenger
------------------------------	-----------------------

- | | | |
|-------------------------------------|-----|---|
| <input type="checkbox"/> | | N/A – No retractor is at this position |
| <input type="checkbox"/> | | N/A – The retractor is an automatic locking retractor ONLY |
| <input checked="" type="checkbox"/> | 1. | Record test fore-aft seat position: FIXED
(S7.1.1.5(c)(1)) (Any position is acceptable) |
| <input checked="" type="checkbox"/> | 2. | Does the lap belt portion of the seat belt in the forward-facing seat or seat that can be adjusted to forward-facing consist of a locking device that does NOT have to be attached by the vehicle user to the seat belt webbing, retractor, or any other part of the vehicle. (S7.1.1.5(a)) |
| | | <input checked="" type="checkbox"/> Yes – Pass |
| | | <input type="checkbox"/> No – Fail |
| <input checked="" type="checkbox"/> | 3. | Does the lap belt portion of the seat belt in the forward-facing seat or seat that can be adjusted to forward-facing consist of a locking device that does NOT require inverting, twisting or deforming of the belt webbing. (S7.1.1.5(a)) |
| | | <input checked="" type="checkbox"/> Yes – Pass |
| | | <input type="checkbox"/> No – Fail |
| <input checked="" type="checkbox"/> | 4. | Place any adjustable seat belt anchorage in the lowest adjustment position. |
| | | <input type="checkbox"/> N/A The anchorage is not adjustable. |
| <input checked="" type="checkbox"/> | 5. | Buckle the seat belt. (S7.1.1.5(c)(1)) |
| <input checked="" type="checkbox"/> | 6. | Locate a reference point A on the seat belt buckle. (S7.1.1.5(c)(2)) |
| <input checked="" type="checkbox"/> | 7. | Locate a reference point B on the attachment hardware or retractor assembly at the other end of the lap belt or lap belt portion of the seat belt assembly. (S7.1.1.5(c)(2)) |
| <input checked="" type="checkbox"/> | 8. | Does the vehicle user need to take some action to activate the locking feature on the lap belt portion of the seat belt in any forward-facing seat or seat that can be adjusted to forward-facing? |
| | | <input checked="" type="checkbox"/> Yes (go to 8.1) |
| | | <input type="checkbox"/> No (go to 9) |
| <input checked="" type="checkbox"/> | 8.1 | Does the vehicle owner's manual include a description in words and/or diagrams describing how to activate the locking feature so that the seat belt assembly can tightly secure a child restraint system and how to deactivate the locking feature to remove the child restraint system? (S7.1.1.5(b)) |
| | | <input checked="" type="checkbox"/> Yes – Pass |
| | | <input type="checkbox"/> No – Fail |
| <input checked="" type="checkbox"/> | 9. | Adjust the lap belt or lap belt portion of the seat belt assembly according to any procedures recommended in the vehicle owner's manual to activate any locking feature so that the webbing between points A and B is at the maximum length allowed by the belt system. (S7.1.1.5(c)(2) & S7.1.1.5(c)(1)) |

10. Measure and record the distance between points A and B along the longitudinal centerline of the webbing for the lap belt or lap belt portion of the seat belt assembly. (S7.1.1.5(c)(2))
Measured distance between A and B (inches): 71
11. Readjust the belt system so that the webbing between points A and B is at $\frac{1}{2}$ the maximum length of the webbing. (S7.1.1.5(c)(3))
12. To the lap belt or lap belt portion of the seat belt assembly, apply a preload of 10 pounds using the webbing tension pull device in Figure 5. Apply the load in a vertical plane parallel to the longitudinal axis of the vehicle and passing through the seating reference point of the designated seating position. Apply the preload in a horizontal direction toward the front of the vehicle with a force application angle of not less than 5 degrees nor more than 15 degrees above the horizontal. (S7.1.1.5(c)(4))
Measured force application angle: 10° (spec. 5 - 15 degrees)
13. Measure the length between points A and B along the longitudinal centerline of the webbing while the preload is being applied. (S7.1.1.5(c)(4))
Measured distance between A and B: 42 $\frac{3}{4}$ inches
14. Increase the load to 50 pounds at a rate of no more than 50 pounds per second. Attain the load in not more than 5 seconds. (If webbing sensitive emergency locking retractors are installed as part of the lap belt or lap belt portion of the seat belt assembly, apply the load at a rate less than the threshold value for lock-up specified by the manufacturer.) Maintain the load for at least 5 seconds. Measure and record the distance between points A and B along the longitudinal centerline of the webbing. (S7.1.1.5(c)(5))
Record onset rate: 15 lb/sec (spec. 10 to 50 lb/sec) (S7.1.1.5(c)(5))
Measured distance between A and B: 43 $\frac{1}{4}$ inches (S7.1.1.5(c)(6))
15. Let the seat belt webbing retract to its minimum length with the seat belt still buckled.
16. To the lap belt or lap belt portion of the seat belt assembly, apply a preload of 10 pounds using the webbing tension pull device in Figure 5. Apply the load in a vertical plane parallel to the longitudinal axis of the vehicle and passing through the seating reference point of the designated seating position. Apply the preload in a horizontal direction toward the front of the vehicle with a force application angle of not less than 5 degrees nor more than 15 degrees above the horizontal. (S7.1.1.5(c)(4))
Measured force application angle: 10° (spec. 5 - 15 degrees)
17. Measure the length between points A and B along the longitudinal centerline of the webbing while the preload is being applied. (S7.1.1.5(c)(4))
Measured distance between A and B: 10 $\frac{1}{4}$ inches
18. Increase the load to 50 pounds at a rate of no more than 50 pounds per second. Attain the load in not more than 5 seconds. (If webbing sensitive emergency locking retractors are installed as part of the lap belt or lap belt portion of the seat belt assembly, apply the load at a rate less than the threshold value for lock-up specified by the manufacturer.) Maintain the load for at least 5 seconds. Measure and record the distance between points A and B along the longitudinal centerline of the webbing. (S7.1.1.5(c)(5))
Record onset rate: 15 lb/sec (spec. 10 to 50 lb/sec) (S7.1.1.5(c)(5))
Measured distance between A and B: 10 $\frac{3}{4}$ inches (S7.1.1.5(c)(6))
19. Subtract the measurement in 13 from the measurement in 14 and the measurement in 17 from the measurement in 18. Is the difference 2 inches or less for both? (S7.1.1.5(c)(7))
14 – 13 = 43 $\frac{1}{4}$ - 42 $\frac{3}{4}$ = $\frac{1}{2}$ inch;
18 – 17 = 10 $\frac{3}{4}$ - 10 $\frac{1}{4}$ = $\frac{1}{2}$ inch;
- Yes – Pass
 No – Fail

20. Subtract the measurement in 14 from the measurement in 10 and the measurement in 18 from the measurement in 10. Is the difference 3 inches or more for both?
(S7.1.1.5(c)(8))

$10-14 = 71 - 43 \frac{1}{4} = 27 \frac{3}{4}$ inches;

$10-18 = 71 - 10 \frac{3}{4} = 60 \frac{1}{4}$ inches

Yes – Pass

No – Fail

REMARKS:

Signature: *Nicholas Atte*

Date: 6/30/14

I certify that I have read and performed each instruction.

DATA SHEET 8

LAP BELT LOCKABILITY

Passenger cars, trucks, buses, and multipurpose passenger
Vehicles with a GVWR of 10,000 pounds or less. (S7.1.1.5)

Test Vehicle: 2014 Ford Escape
Test Program: FMVSS 208 Compliance
Test Technician: Nicholas Abels

NHTSA No.: C20140200
Test Date: 6/30/14

Complete one of these forms for **each** designated seating position that can be adjusted to forward-facing or that is a forward-facing seat, other than the driver's seat (S7.1.1.5(a), **and** that has seat belt retractors that are not solely automatic locking retractors. (S7.1.1.5(c))

DESIGNATED SEATING POSITION: **Right Rear Passenger**

- N/A – No retractor is at this position
- N/A – The retractor is an automatic locking retractor ONLY
- 1. Record test fore-aft seat position: **FIXED**
(S7.1.1.5(c)(1)) (Any position is acceptable)
- 2. Does the lap belt portion of the seat belt in the forward-facing seat or seat that can be adjusted to forward-facing consist of a locking device that does **NOT** have to be attached by the vehicle user to the seat belt webbing, retractor, or any other part of the vehicle. (S7.1.1.5(a))
 - Yes – Pass
 - No – Fail
- 3. Does the lap belt portion of the seat belt in the forward-facing seat or seat that can be adjusted to forward-facing consist of a locking device that does **NOT** require inverting, twisting or deforming of the belt webbing. (S7.1.1.5(a))
 - Yes – Pass
 - No – Fail
- 4. Place any adjustable seat belt anchorage in the lowest adjustment position.
 - N/A The anchorage is not adjustable.
- 5. Buckle the seat belt. (S7.1.1.5(c)(1))
- 6. Locate a reference point A on the seat belt buckle. (S7.1.1.5(c)(2))
- 7. Locate a reference point B on the attachment hardware or retractor assembly at the other end of the lap belt or lap belt portion of the seat belt assembly. (S7.1.1.5(c)(2))
- 8. Does the vehicle user need to take some action to activate the locking feature on the lap belt portion of the seat belt in any forward-facing seat or seat that can be adjusted to forward-facing?
 - Yes (go to 8.1)
 - No (go to 9)
- 8.1 Does the vehicle owner's manual include a description in words and/or diagrams describing how to activate the locking feature so that the seat belt assembly can tightly secure a child restraint system and how to deactivate the locking feature to remove the child restraint system? (S7.1.1.5(b))
 - Yes – Pass
 - No – Fail
- 9. Adjust the lap belt or lap belt portion of the seat belt assembly according to any procedures recommended in the vehicle owner's manual to activate any locking feature so that the webbing between points A and B is at the maximum length allowed by the belt system. (S7.1.1.5(c)(2) & S7.1.1.5(c)(1))

10. Measure and record the distance between points A and B along the longitudinal centerline of the webbing for the lap belt or lap belt portion of the seat belt assembly. (S7.1.1.5(c)(2))
Measured distance between A and B (inches): 71 1/2
11. Readjust the belt system so that the webbing between points A and B is at 1/2 the maximum length of the webbing. (S7.1.1.5(c)(3))
12. To the lap belt or lap belt portion of the seat belt assembly, apply a preload of 10 pounds using the webbing tension pull device in Figure 5. Apply the load in a vertical plane parallel to the longitudinal axis of the vehicle and passing through the seating reference point of the designated seating position. Apply the preload in a horizontal direction toward the front of the vehicle with a force application angle of not less than 5 degrees nor more than 15 degrees above the horizontal. (S7.1.1.5(c)(4))
Measured force application angle: 10° (spec. 5 - 15 degrees)
13. Measure the length between points A and B along the longitudinal centerline of the webbing while the preload is being applied. (S7.1.1.5(c)(4))
Measured distance between A and B: 42 1/4 inches
14. Increase the load to 50 pounds at a rate of no more than 50 pounds per second. Attain the load in not more than 5 seconds. (If webbing sensitive emergency locking retractors are installed as part of the lap belt or lap belt portion of the seat belt assembly, apply the load at a rate less than the threshold value for lock-up specified by the manufacturer.) Maintain the load for at least 5 seconds. Measure and record the distance between points A and B along the longitudinal centerline of the webbing. (S7.1.1.5(c)(5))
Record onset rate: 15 lb/sec (spec. 10 to 50 lb/sec) (S7.1.1.5(c)(5))
Measured distance between A and B: 43 inches (S7.1.1.5(c)(6))
15. Let the seat belt webbing retract to its minimum length with the seat belt still buckled.
16. To the lap belt or lap belt portion of the seat belt assembly, apply a preload of 10 pounds using the webbing tension pull device in Figure 5. Apply the load in a vertical plane parallel to the longitudinal axis of the vehicle and passing through the seating reference point of the designated seating position. Apply the preload in a horizontal direction toward the front of the vehicle with a force application angle of not less than 5 degrees nor more than 15 degrees above the horizontal. (S7.1.1.5(c)(4))
Measured force application angle: 10° (spec. 5 - 15 degrees)
17. Measure the length between points A and B along the longitudinal centerline of the webbing while the preload is being applied. (S7.1.1.5(c)(4))
Measured distance between A and B: 23 inches
18. Increase the load to 50 pounds at a rate of no more than 50 pounds per second. Attain the load in not more than 5 seconds. (If webbing sensitive emergency locking retractors are installed as part of the lap belt or lap belt portion of the seat belt assembly, apply the load at a rate less than the threshold value for lock-up specified by the manufacturer.) Maintain the load for at least 5 seconds. Measure and record the distance between points A and B along the longitudinal centerline of the webbing. (S7.1.1.5(c)(5))
Record onset rate: 15 lb/sec (spec. 10 to 50 lb/sec) (S7.1.1.5(c)(5))
Measured distance between A and B: 23 3/4 inches (S7.1.1.5(c)(6))
19. Subtract the measurement in 13 from the measurement in 14 and the measurement in 17 from the measurement in 18. Is the difference 2 inches or less for both? (S7.1.1.5(c)(7))
14 – 13 = 43 - 42 1/4 = 3/4 inches;
18 – 17 = 23 3/4 - 23 = 3/4 inches;
- Yes – Pass
 No – Fail

20. Subtract the measurement in 14 from the measurement in 10 and the measurement in 18 from the measurement in 10. Is the difference 3 inches or more for both?
(S7.1.1.5(c)(8))

$10-14 = 71 \frac{1}{2} - 43 = 28 \frac{1}{2}$ inches;

$10-18 = 71 \frac{1}{2} - 23 \frac{3}{4} = 47 \frac{3}{4}$ inches

Yes – Pass

No – Fail

REMARKS:

Signature: *Nicholas Atte*

Date: 6/30/14

I certify that I have read and performed each instruction.

DATA SHEET 9

FMVSS 208 SEAT BELT WARNING SYSTEM CHECK (S7.3)

Test Vehicle: 2014 Ford Escape
 Test Program: FMVSS 208 Compliance
 Test Technician: Nicholas Abels

NHTSA No.: C20140200
 Test Date: 6/30/14

- 1. The occupant is in the driver's seat.
- 2. The seat belt is in the stowed position.
- 3. The key is in the "on" or "start" position.
- 4. The time duration of the audible signal beginning with key "on" or "start" is 6 seconds.
- 5. The occupant is in the driver's seat.
- 6. The seat belt is in the stowed position.
- 7. The key is in the "on" or "start" position.
- 8. The time duration of the warning light beginning with key "on" or "start" is 60 seconds.
- 9. The occupant is in the driver's seat.
- 10. The seat belt is in the latched position and with at least 4 inches of belt webbing extended.
- 11. The key is in the "on" or "start" position.
- 12. The time duration of the warning light beginning with key "on" or "start" is 0 seconds.
- 13. Complete the following table with the data from 4, 8, and 12 to determine which option is used.

		Warning light	Warning light specification	Audible signal	Audible signal specification*
S7.3 (a)(1)	Belt stowed & key on or start	Item 8: <u>60</u>	60 seconds minimum	Item 4: <u>6</u>	4 to 8 seconds
S7.3 (a)(2)	Belt latched & key on or start	Item 12: <u>0</u>	4 to 8 seconds		
	Belt stowed & key on or start	Item 8: <u>60</u>	4 to 8 seconds	Item 4: <u>6</u>	4 to 8 seconds

* 49 USCS @ 30124 does NOT allow an audible signal to operate for more than 8 seconds.

A voluntary audible signal after the 4 to 8 second required signal may be provided. It must be differentiated from the required signal (5/25/2001 legal interpretation to Longacre and Associates).

- 14. The seat belt warning system meets the requirements of (manufacturers may comply with either section).
 - S7.3 (a)(1)
 - S7.3 (a)(2)
 - FAIL – Does NOT meet the requirements of either option.
- 15. Note wording of visual warning: (S7.3(a)(1) and S7.3(a)(2))
 - Fasten Seat Belts
 - Fasten Belts
 - Symbol 101 - 
 - FAIL – Does not use any of the above wording or symbol.

REMARKS:

I certify that I have read and performed each instruction.

Signature: Nicholas Abels

Date: 6/30/14

DATA SHEET 10
BELT CONTACT FORCE (S7.4.3)

Test Vehicle: 2014 Ford Escape
 Test Program: FMVSS 208 Compliance
 Test Technician: Nicholas Abels

NHTSA No.: C20145403
 Test Date: 6/30/14

Test all Type 2 seat belts other than those in walk-in van-type vehicles and those at front outboard designated seating positions in passenger cars. Complete a form for each applicable seat belt.

DESIGNATED SEATING POSITION:	Left Front Driver
------------------------------	-------------------

- | | | | |
|-------------------------------------|--|----|---|
| <input checked="" type="checkbox"/> | | 1. | Does the vehicle incorporate a webbing tension-relieving device? |
| | | | <input type="checkbox"/> Yes (this form is complete) |
| | | | <input checked="" type="checkbox"/> No (continue with this check sheet) |
- | | | | |
|-------------------------------------|--|----|---|
| <input checked="" type="checkbox"/> | | 2. | Position the seat's adjustable lumbar supports so that the lumbar support is in its lowest, retracted or deflated adjustment position. (S8.1.3) |
| | | | <input checked="" type="checkbox"/> N/A – No lumbar adjustment |
- | | | | |
|-------------------------------------|--|----|---|
| <input checked="" type="checkbox"/> | | 3. | Position any adjustable parts of the seat that provide additional support so that they are in the lowest or most open adjustment position. (S16.2.10.2) |
| | | | <input checked="" type="checkbox"/> N/A – No additional support adjustment |
- | | | | |
|-------------------------------------|--|----|---|
| <input checked="" type="checkbox"/> | | 4. | Is the fore-aft position of the seat adjustable? |
| | | | <input type="checkbox"/> No – go to 5 |
| | | | <input checked="" type="checkbox"/> Yes – go to 4.1 |
- | | | | |
|-------------------------------------|--|-----|---|
| <input checked="" type="checkbox"/> | | 4.1 | Use all the seat controls that have any affect on the fore-aft movement of the seat to move the seat cushion to the rearmost position. Mark this position. (8/31/95 legal interpretation to Hogan and Hartson) |
|-------------------------------------|--|-----|---|
- | | | | |
|-------------------------------------|--|-----|--|
| <input checked="" type="checkbox"/> | | 4.2 | Use all the seat controls that have any affects on the fore-aft movement of the seat to move the seat cushion to the foremost position. Mark this position. (8/31/95 legal interpretation to Hogan and Hartson) |
|-------------------------------------|--|-----|--|
- | | | | |
|-------------------------------------|--|-----|---|
| <input checked="" type="checkbox"/> | | 4.3 | Mark each fore-aft position so that there is a visual indication when the seat is at a particular position. For manual seats, mark each detent. For power seats, mark only the rearmost, middle and foremost positions. Label three of the positions with the following: F for foremost, M for mid-position (if there is no mid-position, label the closest adjustment position to the rear of the mid-point), and R for rearmost. Determine the mid fore-aft seat position based on the foremost and rearmost positions determined in items 4.1 and 4.2. (8/31/95 legal interpretation to Hogan and Hartson) |
|-------------------------------------|--|-----|---|
- | | | | |
|-------------------------------------|--|-----|------------------------------------|
| <input checked="" type="checkbox"/> | | 4.4 | Move the seat to the mid position. |
|-------------------------------------|--|-----|------------------------------------|
- | | | | |
|-------------------------------------|--|-----|--|
| <input checked="" type="checkbox"/> | | 4.5 | While maintaining the mid position, move the seat to its lowest position. For seats with adjustable seat cushions, use the manufacturer's recommended seat cushion angle for determining the lowest height position. |
|-------------------------------------|--|-----|--|
- | | | | |
|-------------------------------------|--|----|--|
| <input checked="" type="checkbox"/> | | 5. | Is the seat back angle adjustable? |
| | | | <input type="checkbox"/> No- go to 6 |
| | | | <input checked="" type="checkbox"/> Yes- go to 5.1 |
- | | | | |
|-------------------------------------|--|-----|---|
| <input checked="" type="checkbox"/> | | 5.1 | Set and mark seat back angle, if adjustable, at the manufacturer's nominal design riding position for a 50 th percentile adult male in the manner specified by the manufacturer. |
| | | | <input type="checkbox"/> N/A – No seat back angle adjustment |
| | | | <input checked="" type="checkbox"/> Manufacturer's design seat back angle: <u>4.1° on Headrest Post</u> |
| | | | <input checked="" type="checkbox"/> Tested seat back angle: <u>4.3° on Headrest Post</u> |

6. Is the seat a bucket seat?
 Yes, go to 6.1 and skip 6.2
 No, go to 6.2 and skip 6.1
- 6.1 Bucket seats:
 Locate and mark the longitudinal centerline of the seat cushion. The intersection of the vertical longitudinal plane that passes through the SgRP and the seat cushion upper surface determines the longitudinal centerline of a bucket seat cushion. (S10.4.1.2 and S16.3.1.10)
- 6.2 Bench seats (complete ONLY the one that is applicable to the seat being tested):
- 6.2.1 Driver Seat
 Locate and **mark** the longitudinal line on the seat cushion that marks the intersection of the vertical longitudinal plane through the centerline of the steering wheel and the seat cushion upper surface. (S10.4.1.1)
- 6.2.2 Front Outboard Passenger Seat
 Locate and **mark** the longitudinal centerline of the passenger seat cushion. The longitudinal centerline is the same distance from the longitudinal centerline of the vehicle as the center of the steering wheel. (S10.4.1.1)
 Record the distance from the longitudinal centerline of the vehicle to the center of the steering wheel. _____
 Record the distance from the longitudinal centerline of the vehicle to the longitudinal centerline of the seat cushion. _____
- 6.2.3 Rear designated seating positions
 Locate and **mark** the longitudinal centerline of the seat cushion. The intersection of the vertical longitudinal plane that passes through the SgRP and the seat cushion upper surface determines the longitudinal centerline.
7. Position the test dummies according to dummy position placement instructions in Appendix F. **Complete the Appendix F check sheets, but include them in the test report ONLY if there is a test failure.**
8. Fasten the seat belt latch.
9. Pull either 12 inches of belt webbing or the maximum available amount of belt webbing, whichever is less, from the retractor and then release it, allowing the belt webbing to return to the dummy's chest.
10. Locate the point where the centerline of the upper torso belt webbing crosses the midsagittal line on the dummy's chest. At that point pull the belt webbing out 3 inches from the dummy's chest and release until it is within one inch from the dummy's chest. (S10.8) Using a force measuring gage with a full scale range of no more than 1.5 pounds, measure the contact force perpendicular to the dummy's chest exerted by the belt webbing.
 Contact Force (lb): **0.5**
 0.0 to 0.7 pounds – Pass
 Greater than 0.7 pounds - FAIL

REMARKS:

Signature: *Nicholas Atch*

Date: 6/30/14

I certify that I have read and performed each instruction.

DATA SHEET 10
BELT CONTACT FORCE (S7.4.3)

Test Vehicle: 2014 Ford Escape
 Test Program: FMVSS 208 Compliance
 Test Technician: Nicholas Abels

NHTSA No.: C20145403
 Test Date: 6/30/14

Test all Type 2 seat belts other than those in walk-in van-type vehicles and those at front outboard designated seating positions in passenger cars. Complete a form for each applicable seat belt.

DESIGNATED SEATING POSITION:	Right Front Passenger
------------------------------	-----------------------

- | | | |
|-------------------------------------|----|---|
| <input checked="" type="checkbox"/> | 1. | Does the vehicle incorporate a webbing tension-relieving device? |
| | | <input type="checkbox"/> Yes (this form is complete) |
| | | <input checked="" type="checkbox"/> No (continue with this check sheet) |
- | | | |
|-------------------------------------|----|---|
| <input checked="" type="checkbox"/> | 2. | Position the seat's adjustable lumbar supports so that the lumbar support is in its lowest, retracted or deflated adjustment position. (S8.1.3) |
| | | <input checked="" type="checkbox"/> N/A – No lumbar adjustment |
- | | | |
|-------------------------------------|----|---|
| <input checked="" type="checkbox"/> | 3. | Position any adjustable parts of the seat that provide additional support so that they are in the lowest or most open adjustment position. (S16.2.10.2) |
| | | <input checked="" type="checkbox"/> N/A – No additional support adjustment |
- | | | |
|-------------------------------------|----|---|
| <input checked="" type="checkbox"/> | 4. | Is the fore-aft position of the seat adjustable? |
| | | <input type="checkbox"/> No – go to 5 |
| | | <input checked="" type="checkbox"/> Yes – go to 4.1 |
- | | | |
|-------------------------------------|-----|---|
| <input checked="" type="checkbox"/> | 4.1 | Use all the seat controls that have any effect on the fore-aft movement of the seat to move the seat cushion to the rearmost position. Mark this position. (8/31/95 legal interpretation to Hogan and Hartson) |
|-------------------------------------|-----|---|
- | | | |
|-------------------------------------|-----|--|
| <input checked="" type="checkbox"/> | 4.2 | Use all the seat controls that have any effects on the fore-aft movement of the seat to move the seat cushion to the foremost position. Mark this position. (8/31/95 legal interpretation to Hogan and Hartson) |
|-------------------------------------|-----|--|
- | | | |
|-------------------------------------|-----|---|
| <input checked="" type="checkbox"/> | 4.3 | Mark each fore-aft position so that there is a visual indication when the seat is at a particular position. For manual seats, mark each detent. For power seats, mark only the rearmost, middle and foremost positions. Label three of the positions with the following: F for foremost, M for mid-position (if there is no mid-position, label the closest adjustment position to the rear of the mid-point), and R for rearmost. Determine the mid fore-aft seat position based on the foremost and rearmost positions determined in items 4.1 and 4.2. (8/31/95 legal interpretation to Hogan and Hartson) |
|-------------------------------------|-----|---|
- | | | |
|-------------------------------------|-----|------------------------------------|
| <input checked="" type="checkbox"/> | 4.4 | Move the seat to the mid position. |
|-------------------------------------|-----|------------------------------------|
- | | | |
|-------------------------------------|-----|--|
| <input checked="" type="checkbox"/> | 4.5 | While maintaining the mid position, move the seat to its lowest position. For seats with adjustable seat cushions, use the manufacturer's recommended seat cushion angle for determining the lowest height position. |
|-------------------------------------|-----|--|
- | | | |
|-------------------------------------|----|--|
| <input checked="" type="checkbox"/> | 5. | Is the seat back angle adjustable? |
| | | <input type="checkbox"/> No- go to 6 |
| | | <input checked="" type="checkbox"/> Yes- go to 5.1 |
- | | | |
|-------------------------------------|-----|---|
| <input checked="" type="checkbox"/> | 5.1 | Set and mark seat back angle, if adjustable, at the manufacturer's nominal design riding position for a 50 th percentile adult male in the manner specified by the manufacturer. |
| | | <input type="checkbox"/> N/A – No seat back angle adjustment |
| | | <input checked="" type="checkbox"/> Manufacturer's design seat back angle: <u>4.1° on Headrest Post</u> |
| | | <input checked="" type="checkbox"/> Tested seat back angle: <u>4.3° on Headrest Post</u> |

6. Is the seat a bucket seat?
 Yes, go to 6.1 and skip 6.2
 No, go to 6.2 and skip 6.1
- 6.1 Bucket seats:
 Locate and mark the longitudinal centerline of the seat cushion. The intersection of the vertical longitudinal plane that passes through the SgRP and the seat cushion upper surface determines the longitudinal centerline of a bucket seat cushion. (S10.4.1.2 and S16.3.1.10)
- 6.2 Bench seats (complete ONLY the one that is applicable to the seat being tested):
- 6.2.1 Driver Seat
 Locate and **mark** the longitudinal line on the seat cushion that marks the intersection of the vertical longitudinal plane through the centerline of the steering wheel and the seat cushion upper surface. (S10.4.1.1)
- 6.2.2 Front Outboard Passenger Seat
 Locate and **mark** the longitudinal centerline of the passenger seat cushion. The longitudinal centerline is the same distance from the longitudinal centerline of the vehicle as the center of the steering wheel. (S10.4.1.1)
 Record the distance from the longitudinal centerline of the vehicle to the center of the steering wheel. _____
 Record the distance from the longitudinal centerline of the vehicle to the longitudinal centerline of the seat cushion. _____
- 6.2.3 Rear designated seating positions
 Locate and **mark** the longitudinal centerline of the seat cushion. The intersection of the vertical longitudinal plane that passes through the SgRP and the seat cushion upper surface determines the longitudinal centerline.
7. Position the test dummies according to dummy position placement instructions in Appendix F. **Complete the Appendix F check sheets, but include them in the test report ONLY if there is a test failure.**
8. Fasten the seat belt latch.
9. Pull either 12 inches of belt webbing or the maximum available amount of belt webbing, whichever is less, from the retractor and then release it, allowing the belt webbing to return to the dummy's chest.
10. Locate the point where the centerline of the upper torso belt webbing crosses the midsagittal line on the dummy's chest. At that point pull the belt webbing out 3 inches from the dummy's chest and release until it is within one inch from the dummy's chest. (S10.8) Using a force measuring gage with a full scale range of no more than 1.5 pounds, measure the contact force perpendicular to the dummy's chest exerted by the belt webbing.
 Contact Force (lb): **0.5**
 0.0 to 0.7 pounds – Pass
 Greater than 0.7 pounds - FAIL

REMARKS:

Signature: Nicholas Hertz

Date: 6/30/14

I certify that I have read and performed each instruction.

DATA SHEET 10
BELT CONTACT FORCE (S7.4.3)

Test Vehicle: 2014 Ford Escape
 Test Program: FMVSS 208 Compliance
 Test Technician: Nicholas Abels

NHTSA No.: C20140200
 Test Date: 6/30/14

Test all Type 2 seat belts other than those in walk-in van-type vehicles and those at front outboard designated seating positions in passenger cars. Complete a form for each applicable seat belt.

DESIGNATED SEATING POSITION:	Left Rear Passenger
------------------------------	---------------------

- | | | |
|-------------------------------------|----|---|
| <input checked="" type="checkbox"/> | 1. | Does the vehicle incorporate a webbing tension-relieving device? |
| | | <input type="checkbox"/> Yes (this form is complete) |
| | | <input checked="" type="checkbox"/> No (continue with this check sheet) |
- | | | |
|-------------------------------------|----|---|
| <input checked="" type="checkbox"/> | 2. | Position the seat's adjustable lumbar supports so that the lumbar support is in its lowest, retracted or deflated adjustment position. (S8.1.3) |
| | | <input checked="" type="checkbox"/> N/A – No lumbar adjustment |
- | | | |
|-------------------------------------|----|---|
| <input checked="" type="checkbox"/> | 3. | Position any adjustable parts of the seat that provide additional support so that they are in the lowest or most open adjustment position. (S16.2.10.2) |
| | | <input checked="" type="checkbox"/> N/A – No additional support adjustment |
- | | | |
|-------------------------------------|----|--|
| <input checked="" type="checkbox"/> | 4. | Is the fore-aft position of the seat adjustable? |
| | | <input checked="" type="checkbox"/> No – go to 5 |
| | | <input type="checkbox"/> Yes – go to 4.1 |
- | | | |
|--------------------------|-----|---|
| <input type="checkbox"/> | 4.1 | Use all the seat controls that have any effect on the fore-aft movement of the seat to move the seat cushion to the rearmost position. Mark this position. (8/31/95 legal interpretation to Hogan and Hartson) |
|--------------------------|-----|---|
- | | | |
|--------------------------|-----|--|
| <input type="checkbox"/> | 4.2 | Use all the seat controls that have any effects on the fore-aft movement of the seat to move the seat cushion to the foremost position. Mark this position. (8/31/95 legal interpretation to Hogan and Hartson) |
|--------------------------|-----|--|
- | | | |
|--------------------------|-----|---|
| <input type="checkbox"/> | 4.3 | Mark each fore-aft position so that there is a visual indication when the seat is at a particular position. For manual seats, mark each detent. For power seats, mark only the rearmost, middle and foremost positions. Label three of the positions with the following: F for foremost, M for mid-position (if there is no mid-position, label the closest adjustment position to the rear of the mid-point), and R for rearmost. Determine the mid fore-aft seat position based on the foremost and rearmost positions determined in items 4.1 and 4.2. (8/31/95 legal interpretation to Hogan and Hartson) |
|--------------------------|-----|---|
- | | | |
|--------------------------|-----|------------------------------------|
| <input type="checkbox"/> | 4.4 | Move the seat to the mid position. |
|--------------------------|-----|------------------------------------|
- | | | |
|--------------------------|-----|--|
| <input type="checkbox"/> | 4.5 | While maintaining the mid position, move the seat to its lowest position. For seats with adjustable seat cushions, use the manufacturer's recommended seat cushion angle for determining the lowest height position. |
|--------------------------|-----|--|
- | | | |
|-------------------------------------|----|---|
| <input checked="" type="checkbox"/> | 5. | Is the seat back angle adjustable? |
| | | <input checked="" type="checkbox"/> No- go to 6 |
| | | <input type="checkbox"/> Yes- go to 5.1 |
- | | | |
|--------------------------|-----|---|
| <input type="checkbox"/> | 5.1 | Set and mark seat back angle, if adjustable, at the manufacturer's nominal design riding position for a 50 th percentile adult male in the manner specified by the manufacturer. |
| | | <input type="checkbox"/> N/A – No seat back angle adjustment |
| | | <input type="checkbox"/> Manufacturer's design seat back angle: <u>22.0°</u> |
| | | <input type="checkbox"/> Tested seat back angle: <u>21.9°</u> |

6. Is the seat a bucket seat?
 Yes, go to 6.1 and skip 6.2
 No, go to 6.2 and skip 6.1
- 6.1 Bucket seats:
 Locate and mark the longitudinal centerline of the seat cushion. The intersection of the vertical longitudinal plane that passes through the SgRP and the seat cushion upper surface determines the longitudinal centerline of a bucket seat cushion. (S10.4.1.2 and S16.3.1.10)
- 6.2 Bench seats (complete ONLY the one that is applicable to the seat being tested):
- 6.2.1 Driver Seat
 Locate and **mark** the longitudinal line on the seat cushion that marks the intersection of the vertical longitudinal plane through the centerline of the steering wheel and the seat cushion upper surface. (S10.4.1.1)
- 6.2.2 Front Outboard Passenger Seat
 Locate and **mark** the longitudinal centerline of the passenger seat cushion. The longitudinal centerline is the same distance from the longitudinal centerline of the vehicle as the center of the steering wheel. (S10.4.1.1)
 Record the distance from the longitudinal centerline of the vehicle to the center of the steering wheel. _____
 Record the distance from the longitudinal centerline of the vehicle to the longitudinal centerline of the seat cushion. _____
- 6.2.3 Rear designated seating positions
 Locate and **mark** the longitudinal centerline of the seat cushion. The intersection of the vertical longitudinal plane that passes through the SgRP and the seat cushion upper surface determines the longitudinal centerline.
7. Position the test dummies according to dummy position placement instructions in Appendix F. **Complete the Appendix F check sheets, but include them in the test report ONLY if there is a test failure.**
8. Fasten the seat belt latch.
9. Pull either 12 inches of belt webbing or the maximum available amount of belt webbing, whichever is less, from the retractor and then release it, allowing the belt webbing to return to the dummy's chest.
10. Locate the point where the centerline of the upper torso belt webbing crosses the midsagittal line on the dummy's chest. At that point pull the belt webbing out 3 inches from the dummy's chest and release until it is within one inch from the dummy's chest. (S10.8) Using a force measuring gage with a full scale range of no more than 1.5 pounds, measure the contact force perpendicular to the dummy's chest exerted by the belt webbing.
 Contact Force (lb): **0.5**
 0.0 to 0.7 pounds – Pass
 Greater than 0.7 pounds - FAIL

REMARKS:

Signature: Nicholas Atch

Date: 6/30/14

I certify that I have read and performed each instruction.

DATA SHEET 10
BELT CONTACT FORCE (S7.4.3)

Test Vehicle: 2014 Ford Escape
 Test Program: FMVSS 208 Compliance
 Test Technician: Nicholas Abels

NHTSA No.: C20140200
 Test Date: 6/30/14

Test all Type 2 seat belts other than those in walk-in van-type vehicles and those at front outboard designated seating positions in passenger cars. Complete a form for each applicable seat belt.

DESIGNATED SEATING POSITION:	Center Rear Passenger
------------------------------	-----------------------

- | | | |
|-------------------------------------|----|---|
| <input checked="" type="checkbox"/> | 1. | Does the vehicle incorporate a webbing tension-relieving device? |
| | | <input type="checkbox"/> Yes (this form is complete) |
| | | <input checked="" type="checkbox"/> No (continue with this check sheet) |
- | | | |
|-------------------------------------|----|---|
| <input checked="" type="checkbox"/> | 2. | Position the seat's adjustable lumbar supports so that the lumbar support is in its lowest, retracted or deflated adjustment position. (S8.1.3) |
| | | <input checked="" type="checkbox"/> N/A – No lumbar adjustment |
- | | | |
|-------------------------------------|----|---|
| <input checked="" type="checkbox"/> | 3. | Position any adjustable parts of the seat that provide additional support so that they are in the lowest or most open adjustment position. (S16.2.10.2) |
| | | <input checked="" type="checkbox"/> N/A – No additional support adjustment |
- | | | |
|-------------------------------------|----|--|
| <input checked="" type="checkbox"/> | 4. | Is the fore-aft position of the seat adjustable? |
| | | <input checked="" type="checkbox"/> No – go to 5 |
| | | <input type="checkbox"/> Yes – go to 4.1 |
- | | | |
|--------------------------|-----|---|
| <input type="checkbox"/> | 4.1 | Use all the seat controls that have any effect on the fore-aft movement of the seat to move the seat cushion to the rearmost position. Mark this position. (8/31/95 legal interpretation to Hogan and Hartson) |
|--------------------------|-----|---|
- | | | |
|--------------------------|-----|--|
| <input type="checkbox"/> | 4.2 | Use all the seat controls that have any effects on the fore-aft movement of the seat to move the seat cushion to the foremost position. Mark this position. (8/31/95 legal interpretation to Hogan and Hartson) |
|--------------------------|-----|--|
- | | | |
|--------------------------|-----|---|
| <input type="checkbox"/> | 4.3 | Mark each fore-aft position so that there is a visual indication when the seat is at a particular position. For manual seats, mark each detent. For power seats, mark only the rearmost, middle and foremost positions. Label three of the positions with the following: F for foremost, M for mid-position (if there is no mid-position, label the closest adjustment position to the rear of the mid-point), and R for rearmost. Determine the mid fore-aft seat position based on the foremost and rearmost positions determined in items 4.1 and 4.2. (8/31/95 legal interpretation to Hogan and Hartson) |
|--------------------------|-----|---|
- | | | |
|--------------------------|-----|------------------------------------|
| <input type="checkbox"/> | 4.4 | Move the seat to the mid position. |
|--------------------------|-----|------------------------------------|
- | | | |
|--------------------------|-----|--|
| <input type="checkbox"/> | 4.5 | While maintaining the mid position, move the seat to its lowest position. For seats with adjustable seat cushions, use the manufacturer's recommended seat cushion angle for determining the lowest height position. |
|--------------------------|-----|--|
- | | | |
|-------------------------------------|----|---|
| <input checked="" type="checkbox"/> | 5. | Is the seat back angle adjustable? |
| | | <input checked="" type="checkbox"/> No- go to 6 |
| | | <input type="checkbox"/> Yes- go to 5.1 |
- | | | |
|--------------------------|-----|---|
| <input type="checkbox"/> | 5.1 | Set and mark seat back angle, if adjustable, at the manufacturer's nominal design riding position for a 50 th percentile adult male in the manner specified by the manufacturer. |
| | | <input type="checkbox"/> N/A – No seat back angle adjustment |
| | | <input type="checkbox"/> Manufacturer's design seat back angle: <u>22.0°</u> |
| | | <input type="checkbox"/> Tested seat back angle: <u>21.9°</u> |

6. Is the seat a bucket seat?
 Yes, go to 6.1 and skip 6.2
 No, go to 6.2 and skip 6.1
- 6.1 Bucket seats:
 Locate and mark the longitudinal centerline of the seat cushion. The intersection of the vertical longitudinal plane that passes through the SgRP and the seat cushion upper surface determines the longitudinal centerline of a bucket seat cushion. (S10.4.1.2 and S16.3.1.10)
- 6.2 Bench seats (complete ONLY the one that is applicable to the seat being tested):
- 6.2.1 Driver Seat
 Locate and **mark** the longitudinal line on the seat cushion that marks the intersection of the vertical longitudinal plane through the centerline of the steering wheel and the seat cushion upper surface. (S10.4.1.1)
- 6.2.2 Front Outboard Passenger Seat
 Locate and **mark** the longitudinal centerline of the passenger seat cushion. The longitudinal centerline is the same distance from the longitudinal centerline of the vehicle as the center of the steering wheel. (S10.4.1.1)
 Record the distance from the longitudinal centerline of the vehicle to the center of the steering wheel. _____
 Record the distance from the longitudinal centerline of the vehicle to the longitudinal centerline of the seat cushion. _____
- 6.2.3 Rear designated seating positions
 Locate and **mark** the longitudinal centerline of the seat cushion. The intersection of the vertical longitudinal plane that passes through the SgRP and the seat cushion upper surface determines the longitudinal centerline.
7. Position the test dummies according to dummy position placement instructions in Appendix F. **Complete the Appendix F check sheets, but include them in the test report ONLY if there is a test failure.**
8. Fasten the seat belt latch.
9. Pull either 12 inches of belt webbing or the maximum available amount of belt webbing, whichever is less, from the retractor and then release it, allowing the belt webbing to return to the dummy's chest.
10. Locate the point where the centerline of the upper torso belt webbing crosses the midsagittal line on the dummy's chest. At that point pull the belt webbing out 3 inches from the dummy's chest and release until it is within one inch from the dummy's chest. (S10.8) Using a force measuring gage with a full scale range of no more than 1.5 pounds, measure the contact force perpendicular to the dummy's chest exerted by the belt webbing.
 Contact Force (lb): **0.6**
 0.0 to 0.7 pounds – Pass
 Greater than 0.7 pounds - FAIL

REMARKS:

Signature: Nicholas Steets

Date: 6/30/14

I certify that I have read and performed each instruction.

DATA SHEET 10
BELT CONTACT FORCE (S7.4.3)

Test Vehicle: 2014 Ford Escape
 Test Program: FMVSS 208 Compliance
 Test Technician: Nicholas Abels

NHTSA No.: C20140200
 Test Date: 6/30/14

Test all Type 2 seat belts other than those in walk-in van-type vehicles and those at front outboard designated seating positions in passenger cars. Complete a form for each applicable seat belt.

DESIGNATED SEATING POSITION: **Right Rear Passenger**

1. Does the vehicle incorporate a webbing tension-relieving device?
 Yes (this form is complete)
 No (continue with this check sheet)
2. Position the seat's adjustable lumbar supports so that the lumbar support is in its lowest, retracted or deflated adjustment position. (S8.1.3)
 N/A – No lumbar adjustment
3. Position any adjustable parts of the seat that provide additional support so that they are in the lowest or most open adjustment position. (S16.2.10.2)
 N/A – No additional support adjustment
4. Is the fore-aft position of the seat adjustable?
 No – go to 5
 Yes – go to 4.1
- 4.1 Use all the seat controls that have any effect on the fore-aft movement of the seat to move the seat cushion to the rearmost position. **Mark** this position. (8/31/95 legal interpretation to Hogan and Hartson)
- 4.2 Use all the seat controls that have any effects on the fore-aft movement of the seat to move the seat cushion to the foremost position. **Mark** this position. (8/31/95 legal interpretation to Hogan and Hartson)
- 4.3 **Mark** each fore-aft position so that there is a visual indication when the seat is at a particular position. For manual seats, **mark** each detent. For power seats, mark only the rearmost, middle and foremost positions. Label three of the positions with the following: F for foremost, M for mid-position (if there is no mid-position, label the closest adjustment position to the rear of the mid-point), and R for rearmost. Determine the mid fore-aft seat position based on the foremost and rearmost positions determined in items 4.1 and 4.2. (8/31/95 legal interpretation to Hogan and Hartson)
- 4.4 Move the seat to the mid position.
- 4.5 While maintaining the mid position, move the seat to its lowest position. For seats with adjustable seat cushions, use the manufacturer's recommended seat cushion angle for determining the lowest height position.
5. Is the seat back angle adjustable?
 No- go to 6
 Yes- go to 5.1
- 5.1 Set and mark seat back angle, if adjustable, at the manufacturer's nominal design riding position for a 50th percentile adult male in the manner specified by the manufacturer.
 N/A – No seat back angle adjustment
 Manufacturer's design seat back angle: 22.0°
 Tested seat back angle: 21.9°

6. Is the seat a bucket seat?
 Yes, go to 6.1 and skip 6.2
 No, go to 6.2 and skip 6.1
- 6.1 Bucket seats:
 Locate and mark the longitudinal centerline of the seat cushion. The intersection of the vertical longitudinal plane that passes through the SgRP and the seat cushion upper surface determines the longitudinal centerline of a bucket seat cushion. (S10.4.1.2 and S16.3.1.10)
- 6.2 Bench seats (complete ONLY the one that is applicable to the seat being tested):
- 6.2.1 Driver Seat
 Locate and **mark** the longitudinal line on the seat cushion that marks the intersection of the vertical longitudinal plane through the centerline of the steering wheel and the seat cushion upper surface. (S10.4.1.1)
- 6.2.2 Front Outboard Passenger Seat
 Locate and **mark** the longitudinal centerline of the passenger seat cushion. The longitudinal centerline is the same distance from the longitudinal centerline of the vehicle as the center of the steering wheel. (S10.4.1.1)
 Record the distance from the longitudinal centerline of the vehicle to the center of the steering wheel. _____
 Record the distance from the longitudinal centerline of the vehicle to the longitudinal centerline of the seat cushion. _____
- 6.2.3 Rear designated seating positions
 Locate and **mark** the longitudinal centerline of the seat cushion. The intersection of the vertical longitudinal plane that passes through the SgRP and the seat cushion upper surface determines the longitudinal centerline.
7. Position the test dummies according to dummy position placement instructions in Appendix F. **Complete the Appendix F check sheets, but include them in the test report ONLY if there is a test failure.**
8. Fasten the seat belt latch.
9. Pull either 12 inches of belt webbing or the maximum available amount of belt webbing, whichever is less, from the retractor and then release it, allowing the belt webbing to return to the dummy's chest.
10. Locate the point where the centerline of the upper torso belt webbing crosses the midsagittal line on the dummy's chest. At that point pull the belt webbing out 3 inches from the dummy's chest and release until it is within one inch from the dummy's chest. (S10.8) Using a force measuring gage with a full scale range of no more than 1.5 pounds, measure the contact force perpendicular to the dummy's chest exerted by the belt webbing.
 Contact Force (lb): **0.5**
 0.0 to 0.7 pounds – Pass
 Greater than 0.7 pounds - FAIL

REMARKS:

Signature: Nicholas Atteb

Date: 6/30/14

I certify that I have read and performed each instruction.

DATA SHEET 11
LATCH PLATE ACCESS (S7.4.4)

Test Vehicle: 2014 Ford Escape
 Test Program: FMVSS 208 Compliance
 Test Technician: Nicholas Abels

NHTSA No.: C20145403
 Test Date: 6/30/14

Test all front outboard seat belts **other than those in** walk-in van-type vehicles and those at front outboard designated seating positions in **passenger cars**. Complete a form for each applicable seat belt.

DESIGNATED SEATING POSITION:	Left Front Driver
------------------------------	-------------------

- | | | |
|-------------------------------------|----|---|
| <input checked="" type="checkbox"/> | 1. | Position the seat's adjustable lumbar supports so that the lumbar support is in its lowest, retracted or deflated adjustment position. (S8.1.3) |
| | | <input checked="" type="checkbox"/> N/A – No lumbar adjustment |
- | | | |
|-------------------------------------|----|---|
| <input checked="" type="checkbox"/> | 2. | Position any adjustable parts of the seat that provide additional support so that they are in the lowest or most open adjustment position. (S16.2.10.2) |
| | | <input checked="" type="checkbox"/> N/A – No additional support adjustment |
- | | | |
|-------------------------------------|----|---|
| <input checked="" type="checkbox"/> | 3. | Is the fore-aft position of the seat adjustable? |
| | | <input type="checkbox"/> No – go to 4 |
| | | <input checked="" type="checkbox"/> Yes – go to 3.1 |
- | | | |
|-------------------------------------|-----|---|
| <input checked="" type="checkbox"/> | 3.1 | Use all the seat controls that have any affect on the fore-aft movement of the seat to move the seat cushion to the rearmost position. Mark this position. (8/31/95 legal interpretation to Hogan and Hartson) |
|-------------------------------------|-----|---|
- | | | |
|-------------------------------------|-----|---|
| <input checked="" type="checkbox"/> | 3.2 | While maintaining the forward most position, move the seat to its lowest position. For seats with adjustable seat cushions, use the manufacturer's recommended seat cushion angle for determining the lowest height position. |
|-------------------------------------|-----|---|
- | | | |
|-------------------------------------|----|--|
| <input checked="" type="checkbox"/> | 4. | Is the seat back angle adjustable? |
| | | <input type="checkbox"/> No- go to 5 |
| | | <input checked="" type="checkbox"/> Yes- go to 4.1 |
- | | | |
|-------------------------------------|-----|---|
| <input checked="" type="checkbox"/> | 4.1 | Set and mark seat back angle, if adjustable, at the manufacturer's nominal design riding position for a 50th percentile adult male in the manner specified by the manufacturer. |
| | | <input type="checkbox"/> N/A – No seat back angle adjustment |
| | | <input checked="" type="checkbox"/> Manufacturer's design seat back angle: <u>4.1° on Headrest Post</u> |
| | | <input checked="" type="checkbox"/> Tested seat back angle: <u>4.3° on Headrest Post</u> |
- | | | |
|-------------------------------------|----|---|
| <input checked="" type="checkbox"/> | 5. | Is the seat a bucket seat? |
| | | <input checked="" type="checkbox"/> Yes, go to 5.1 and skip 5.2 |
| | | <input type="checkbox"/> No, go to 5.2 and skip 5.1 |
- | | | |
|-------------------------------------|-----|--|
| <input checked="" type="checkbox"/> | 5.1 | Bucket seats:
Locate and mark the longitudinal centerline of the seat cushion. The intersection of the vertical longitudinal plane that passes through the SgRP and the seat cushion upper surface determines the longitudinal centerline of a bucket seat cushion. (S10.4.1.2 and S16.3.1.10) |
|-------------------------------------|-----|--|
- | | | |
|--------------------------|-------|---|
| <input type="checkbox"/> | 5.2 | Bench seats (complete ONLY the one that is applicable to the seat being tested): |
| <input type="checkbox"/> | 5.2.1 | Driver Seat
Locate and mark the longitudinal line on the seat cushion that marks the intersection of the vertical longitudinal plane through the centerline of the steering wheel and the seat cushion upper surface. (S10.4.1.1) |

- 5.2.2 Front Outboard Passenger Seat
 Locate and **mark** the longitudinal centerline of the passenger seat cushion.
 The longitudinal centerline is the same distance from the longitudinal centerline of the vehicle as the center of the steering wheel. (S10.4.1.1)
- Record the distance from the longitudinal centerline of the vehicle to the center of the steering wheel. _____
- Record the distance from the longitudinal centerline of the vehicle to the longitudinal centerline of the seat cushion. _____
6. Position the test dummy using the procedures in Appendix F. (Some modifications to the positioning procedure may need to be made because the seat is in the forward most position. Note on the Appendix F positioning check sheet any deviations necessary to position the Part 572, Subpart E dummy). **Complete the Appendix F check sheets, but include them in the test report ONLY if there is a test failure.**
7. Position the adjustable seat belt anchorage in the manufacturer's nominal design position for a 50th percentile adult male occupant.
8. Attach the inboard reach string to the base of the head following the instructions on Figure 3.
9. Attach the outboard reach string to the torso sheath following the instructions on Figure 3.
10. Place the latch plate in the stowed position.
11. Extend the inboard reach string in front of the dummy and then backward and outboard to the latch plate to generate arcs of the reach envelope of the test dummy's arms. Is the latch plate within the reach envelope?
- Yes – Pass
 No
12. Extend the outboard reach string in front of the dummy and then backward and outboard to the latch plate to generate arcs of the reach envelope of the test dummy's arms. Is the latch plate within the reach envelope?
- Yes – Pass
 No
13. Is the latch plate within the inboard (item 11) or outboard (item 12) reach envelope?
- Yes – Pass
 No – Fail
14. Using the clearance test block, specified in Figure 4, is there sufficient clearance between the vehicle seat and the side of vehicle interior to allow the test block to move unhindered to the latch plate or buckle?
- Yes – Pass
 No – Fail

REMARKS:

Signature: Nicholas Huet

Date: 6/30/14

I certify that I have read and performed each instruction.

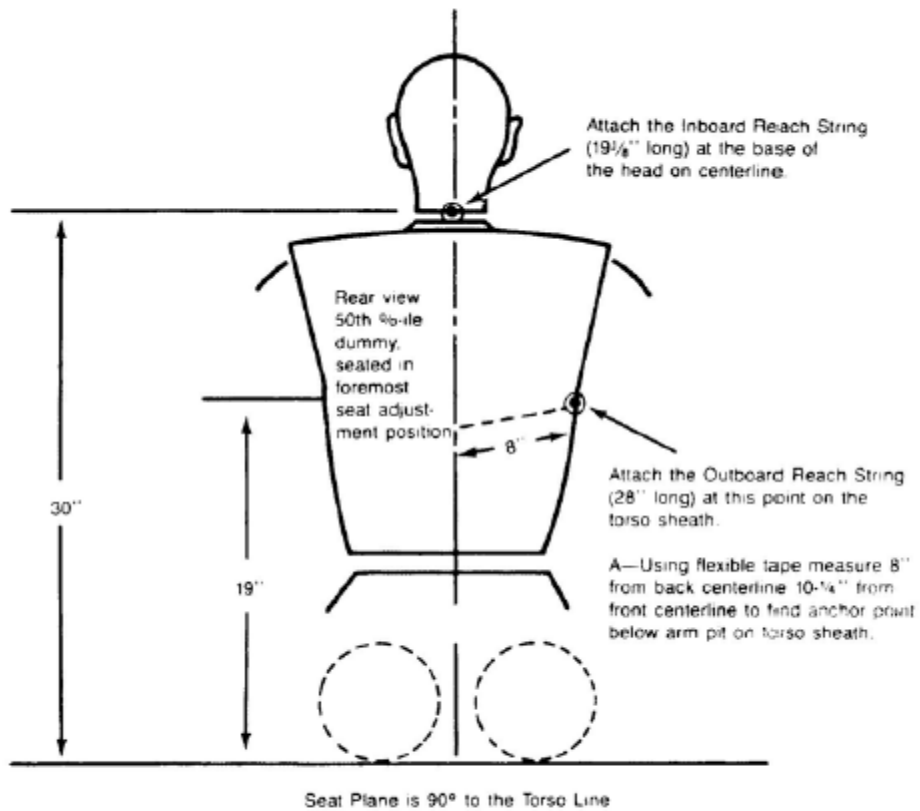

Figure 3. Location of Anchoring Points for Latchplate Reach Limiting Chains or Strings to Test for Latchplate Accessibility Using Subpart E Test Device

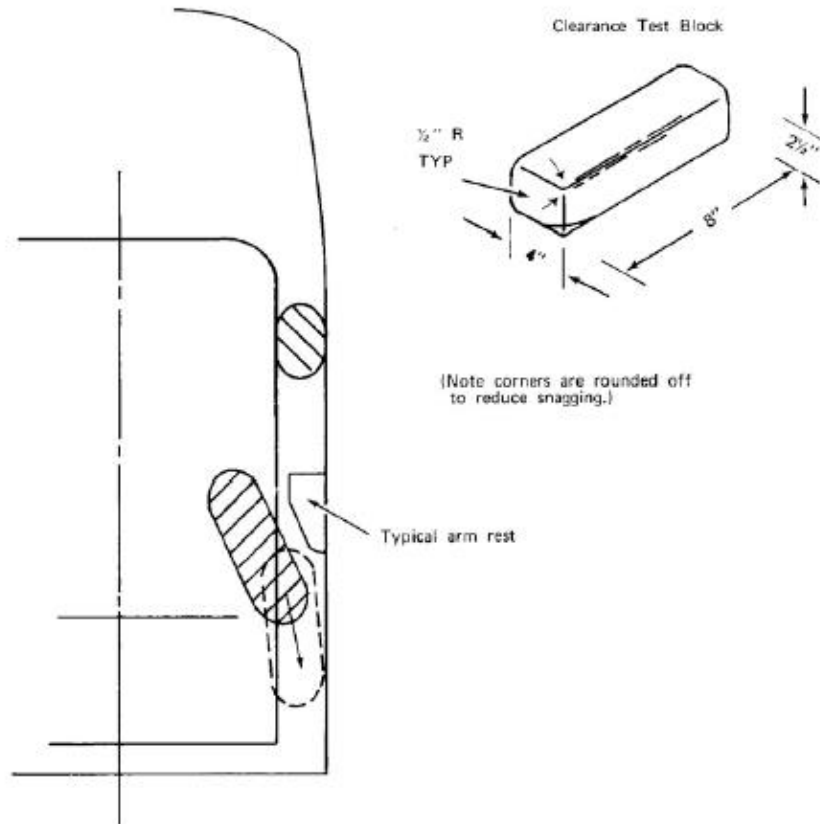

Figure 4—USE OF CLEARANCE TEST BLOCK TO DETERMINE HAND/ARM ACCESS

DATA SHEET 11
LATCH PLATE ACCESS (S7.4.4)

Test Vehicle: 2014 Ford Escape
 Test Program: FMVSS 208 Compliance
 Test Technician: Nicholas Abels

NHTSA No.: C20145403
 Test Date: 6/30/14

Test all front outboard seat belts **other than those in** walk-in van-type vehicles and those at front outboard designated seating positions in **passenger cars**. Complete a form for each applicable seat belt.

DESIGNATED SEATING POSITION:	Right Front Passenger
------------------------------	-----------------------

- | | | |
|-------------------------------------|-------------------------------------|---|
| <input checked="" type="checkbox"/> | 1. | Position the seat's adjustable lumbar supports so that the lumbar support is in its lowest, retracted or deflated adjustment position. (S8.1.3) |
| | <input checked="" type="checkbox"/> | N/A – No lumbar adjustment |
- | | | |
|-------------------------------------|-------------------------------------|---|
| <input checked="" type="checkbox"/> | 2. | Position any adjustable parts of the seat that provide additional support so that they are in the lowest or most open adjustment position. (S16.2.10.2) |
| | <input checked="" type="checkbox"/> | N/A – No additional support adjustment |
- | | | |
|-------------------------------------|-------------------------------------|--|
| <input checked="" type="checkbox"/> | 3. | Is the fore-aft position of the seat adjustable? |
| | <input type="checkbox"/> | No – go to 4 |
| | <input checked="" type="checkbox"/> | Yes – go to 3.1 |
- | | | |
|-------------------------------------|-----|---|
| <input checked="" type="checkbox"/> | 3.1 | Use all the seat controls that have any effect on the fore-aft movement of the seat to move the seat cushion to the rearmost position. Mark this position. (8/31/95 legal interpretation to Hogan and Hartson) |
|-------------------------------------|-----|---|
- | | | |
|-------------------------------------|-----|---|
| <input checked="" type="checkbox"/> | 3.2 | While maintaining the forward most position, move the seat to its lowest position. For seats with adjustable seat cushions, use the manufacturer's recommended seat cushion angle for determining the lowest height position. |
|-------------------------------------|-----|---|
- | | | |
|-------------------------------------|-------------------------------------|------------------------------------|
| <input checked="" type="checkbox"/> | 4. | Is the seat back angle adjustable? |
| | <input type="checkbox"/> | No- go to 5 |
| | <input checked="" type="checkbox"/> | Yes- go to 4.1 |
- | | | |
|-------------------------------------|-------------------------------------|---|
| <input checked="" type="checkbox"/> | 4.1 | Set and mark seat back angle, if adjustable, at the manufacturer's nominal design riding position for a 50th percentile adult male in the manner specified by the manufacturer. |
| | <input type="checkbox"/> | N/A – No seat back angle adjustment |
| | <input checked="" type="checkbox"/> | Manufacturer's design seat back angle: <u>4.1° on Headrest Post</u> |
| | <input checked="" type="checkbox"/> | Tested seat back angle: <u>4.3° on Headrest Post</u> |
- | | | |
|-------------------------------------|-------------------------------------|-----------------------------|
| <input checked="" type="checkbox"/> | 5. | Is the seat a bucket seat? |
| | <input checked="" type="checkbox"/> | Yes, go to 5.1 and skip 5.2 |
| | <input type="checkbox"/> | No, go to 5.2 and skip 5.1 |
- | | | |
|-------------------------------------|-----|--|
| <input checked="" type="checkbox"/> | 5.1 | Bucket seats:
Locate and mark the longitudinal centerline of the seat cushion. The intersection of the vertical longitudinal plane that passes through the SgRP and the seat cushion upper surface determines the longitudinal centerline of a bucket seat cushion. (S10.4.1.2 and S16.3.1.10) |
|-------------------------------------|-----|--|
- | | | |
|--------------------------|-------|---|
| <input type="checkbox"/> | 5.2 | Bench seats (complete ONLY the one that is applicable to the seat being tested): |
| <input type="checkbox"/> | 5.2.1 | Driver Seat
Locate and mark the longitudinal line on the seat cushion that marks the intersection of the vertical longitudinal plane through the centerline of the steering wheel and the seat cushion upper surface. (S10.4.1.1) |

- 5.2.2 Front Outboard Passenger Seat
 Locate and **mark** the longitudinal centerline of the passenger seat cushion.
 The longitudinal centerline is the same distance from the longitudinal centerline of the vehicle as the center of the steering wheel. (S10.4.1.1)
- Record the distance from the longitudinal centerline of the vehicle to the center of the steering wheel. _____
- Record the distance from the longitudinal centerline of the vehicle to the longitudinal centerline of the seat cushion. _____
6. Position the test dummy using the procedures in Appendix F. (Some modifications to the positioning procedure may need to be made because the seat is in the forward most position. Note on the Appendix F positioning check sheet any deviations necessary to position the Part 572, Subpart E dummy). **Complete the Appendix F check sheets, but include them in the test report ONLY if there is a test failure.**
7. Position the adjustable seat belt anchorage in the manufacturer's nominal design position for a 50th percentile adult male occupant.
8. Attach the inboard reach string to the base of the head following the instructions on Figure 3.
9. Attach the outboard reach string to the torso sheath following the instructions on Figure 3.
10. Place the latch plate in the stowed position.
11. Extend the inboard reach string in front of the dummy and then backward and outboard to the latch plate to generate arcs of the reach envelope of the test dummy's arms. Is the latch plate within the reach envelope?
- Yes – Pass
 No
12. Extend the outboard reach string in front of the dummy and then backward and outboard to the latch plate to generate arcs of the reach envelope of the test dummy's arms. Is the latch plate within the reach envelope?
- Yes – Pass
 No
13. Is the latch plate within the inboard (item 11) or outboard (item 12) reach envelope?
- Yes – Pass
 No – Fail
14. Using the clearance test block, specified in Figure 4, is there sufficient clearance between the vehicle seat and the side of vehicle interior to allow the test block to move unhindered to the latch plate or buckle?
- Yes – Pass
 No – Fail

REMARKS:

Signature: Nicholas Heets

Date: 6/30/14

I certify that I have read and performed each instruction.

DATA SHEET 12
SEAT BELT RETRACTION (S7.4.5)

Test Vehicle: 2014 Ford Escape
 Test Program: FMVSS 208 Compliance
 Test Technician: Nicholas Abels

NHTSA No.: C20145403
 Test Date: 6/30/14

Test all front outboard seat belts, except those in walk-in van-type vehicles and those at front outboard designated seating positions in passenger cars. Complete a form for each applicable seat belt.

DESIGNATED SEATING POSITION:	Left Front Driver
------------------------------	-------------------

- | | | |
|-------------------------------------|----|---|
| <input checked="" type="checkbox"/> | 1. | Is the vehicle a passenger car or walk-in van-type vehicle? |
| | | <input type="checkbox"/> Yes, this form is complete |
| | | <input checked="" type="checkbox"/> No |
- | | | |
|-------------------------------------|----|---|
| <input checked="" type="checkbox"/> | 2. | Position the seat's adjustable lumbar supports so that the lumbar support is in its lowest, retracted or deflated adjustment position. (S8.1.3) |
| | | <input checked="" type="checkbox"/> N/A – No lumbar adjustment |
- | | | |
|-------------------------------------|----|---|
| <input checked="" type="checkbox"/> | 3. | Position any adjustable parts of the seat that provide additional support so that they are in the lowest or most open adjustment position. (S16.2.10.2) |
| | | <input checked="" type="checkbox"/> N/A – No additional support adjustment |
- | | | |
|-------------------------------------|----|---|
| <input checked="" type="checkbox"/> | 4. | Is the fore-aft position of the seat adjustable? |
| | | <input type="checkbox"/> No – go to 5 |
| | | <input checked="" type="checkbox"/> Yes – go to 4.1 |
- | | | |
|-------------------------------------|-----|---|
| <input checked="" type="checkbox"/> | 4.1 | Use all the seat controls that have any affect on the fore-aft movement of the seat to move the seat cushion to the rearmost position. Mark this position. (8/31/95 legal interpretation to Hogan and Hartson) |
|-------------------------------------|-----|---|
- | | | |
|-------------------------------------|-----|--|
| <input checked="" type="checkbox"/> | 4.2 | Use all the seat controls that have any affects on the fore-aft movement of the seat to move the seat cushion to the foremost position. Mark this position. (8/31/95 legal interpretation to Hogan and Hartson) |
|-------------------------------------|-----|--|
- | | | |
|-------------------------------------|-----|---|
| <input checked="" type="checkbox"/> | 4.3 | Mark each fore-aft position so that there is a visual indication when the seat is at a particular position. For manual seats, mark each detent. For power seats, mark only the rearmost, middle and foremost positions. Label three of the positions with the following: F for foremost, M for mid-position (if there is no mid-position, label the closest adjustment position to the rear of the mid-point), and R for rearmost. Determine the mid fore-aft seat position based on the foremost and rearmost positions determined in items 4.1 and 4.2. (8/31/95 legal interpretation to Hogan and Hartson) |
|-------------------------------------|-----|---|
- | | | |
|-------------------------------------|-----|------------------------------------|
| <input checked="" type="checkbox"/> | 4.4 | Move the seat to the mid position. |
|-------------------------------------|-----|------------------------------------|
- | | | |
|-------------------------------------|-----|--|
| <input checked="" type="checkbox"/> | 4.5 | While maintaining the mid position, move the seat to its lowest position. For seats with adjustable seat cushions, use the manufacturer's recommended seat cushion angle for determining the lowest height position. |
|-------------------------------------|-----|--|
- | | | |
|-------------------------------------|----|--|
| <input checked="" type="checkbox"/> | 5. | Is the seat back angle adjustable? |
| | | <input type="checkbox"/> No- go to 6 |
| | | <input checked="" type="checkbox"/> Yes- go to 5.1 |
- | | | |
|-------------------------------------|-----|---|
| <input checked="" type="checkbox"/> | 5.1 | Set and mark seat back angle, if adjustable, at the manufacturer's nominal design riding position for a 50th percentile adult male in the manner specified by the manufacturer. |
| | | <input type="checkbox"/> N/A – No seat back angle adjustment |
| | | <input checked="" type="checkbox"/> Manufacturer's design seat back angle: <u>4.1° on Headrest Post</u> |
| | | <input checked="" type="checkbox"/> Tested seat back angle: <u>4.3° on Headrest Post</u> |
- | | | |
|-------------------------------------|----|---|
| <input checked="" type="checkbox"/> | 6. | Is the seat a bucket seat? |
| | | <input checked="" type="checkbox"/> Yes, go to 6.1 and skip 6.2 |
| | | <input type="checkbox"/> No, go to 6.2 and skip 6.1 |

- 6.1 Bucket Seats:
Locate and **mark** the longitudinal centerline of the seat cushion. The intersection of the vertical longitudinal plane that passes through the SgRP and the seat cushion upper surface determines the longitudinal centerline of a bucket seat cushion. (S10.4.1.2 and S16.3.1.10)
- 6.2 Bench seats (complete ONLY the one that is applicable to the seat being tested):
- 6.2.1 Driver Seat
Locate and **mark** the longitudinal line on the seat cushion that marks the intersection of the vertical longitudinal plane through the centerline of the steering wheel and the seat cushion upper surface. (S10.4.1.1)
- 6.2.2 Front Outboard Passenger Seat
Locate and **mark** the longitudinal centerline of the passenger seat cushion. The longitudinal centerline is the same distance from the longitudinal centerline of the vehicle as the center of the steering wheel. (S10.4.1.1)
- Record the distance from the longitudinal centerline of the vehicle to the center of the steering wheel. _____
- Record the distance from the longitudinal centerline of the vehicle to the longitudinal centerline of the seat cushion. _____
7. Position the Part 572 Subpart E test dummy according to dummy position placement instructions in Appendix F. **Complete the Appendix F check sheets, but include them in the test report ONLY if there is a test failure.**
8. Fasten the seat belt around the dummy.
9. Remove all slack from the lap belt portion. (S10.9)
- N/A, the seat does not have a fore-aft adjustment
10. Pull the upper torso webbing out of the retractor and allow it to retract; repeat this four times. (S10.9)
11. Apply a 2 to 4 pound tension load to the lap belt. (S10.9)
Pound load applied: 3
12. Is the belt system equipped with a tension relieving device?
- Yes, continue
- No, go to 14
13. Introduce the maximum amount of slack into the upper torso belt that is recommended by the vehicle manufacturer in the vehicle owner's manual. (S10.9).
14. Check the statement that applies to this test vehicle:
- 14.1 The torso and lap belt webbing of the seat belt system automatically retracts to a stowed position when the adjacent vehicle door is in an open position and the seat belt latch plate is released.
- Yes – Pass go to 16
- No – go to 14.2
- 14.2 The torso and lap belt webbing of the seat belt system automatically retracts when the seat belt latch plate is released.
- Yes – Pass go to 15
- No – go to 14.3
- 14.3 Neither 14.1 nor 14.2 apply. - Fail
15. With the webbing and hardware in the stowed position are the webbing and hardware prevented from being pinched when the door is closed?
- Yes – Pass
- No – Fail

16. If this test vehicle has an open body (without doors) and has a belt system with a tension relieving device, does the belt system fully retract when the tension-relieving device is deactivated?

N/A – Not an open body vehicle

Yes – Pass

No – Fail

REMARKS:

Signature: *Nicholas Atte*

Date: 6/30/14

I certify that I have read and performed each instruction.

DATA SHEET 12
SEAT BELT RETRACTION (S7.4.5)

Test Vehicle: 2014 Ford Escape
 Test Program: FMVSS 208 Compliance
 Test Technician: Nicholas Abels

NHTSA No.: C20145403
 Test Date: 6/30/14

Test all front outboard seat belts, except those in walk-in van-type vehicles and those at front outboard designated seating positions in passenger cars. Complete a form for each applicable seat belt.

DESIGNATED SEATING POSITION:	Right Front Passenger
------------------------------	-----------------------

- | | |
|-------------------------------------|--|
| <input checked="" type="checkbox"/> | 1. Is the vehicle a passenger car or walk-in van-type vehicle? |
| | <input type="checkbox"/> Yes, this form is complete |
| | <input checked="" type="checkbox"/> No |
- | | |
|-------------------------------------|--|
| <input checked="" type="checkbox"/> | 2. Position the seat's adjustable lumbar supports so that the lumbar support is in its lowest, retracted or deflated adjustment position. (S8.1.3) |
| | <input checked="" type="checkbox"/> N/A – No lumbar adjustment |
- | | |
|-------------------------------------|--|
| <input checked="" type="checkbox"/> | 3. Position any adjustable parts of the seat that provide additional support so that they are in the lowest or most open adjustment position. (S16.2.10.2) |
| | <input checked="" type="checkbox"/> N/A – No additional support adjustment |
- | | |
|-------------------------------------|---|
| <input checked="" type="checkbox"/> | 4. Is the fore-aft position of the seat adjustable? |
| | <input type="checkbox"/> No – go to 5 |
| | <input checked="" type="checkbox"/> Yes – go to 4.1 |
- | | |
|-------------------------------------|---|
| <input checked="" type="checkbox"/> | 4.1 Use all the seat controls that have any effect on the fore-aft movement of the seat to move the seat cushion to the rearmost position. Mark this position. (8/31/95 legal interpretation to Hogan and Hartson) |
|-------------------------------------|---|
- | | |
|-------------------------------------|--|
| <input checked="" type="checkbox"/> | 4.2 Use all the seat controls that have any effects on the fore-aft movement of the seat to move the seat cushion to the foremost position. Mark this position. (8/31/95 legal interpretation to Hogan and Hartson) |
|-------------------------------------|--|
- | | |
|-------------------------------------|---|
| <input checked="" type="checkbox"/> | 4.3 Mark each fore-aft position so that there is a visual indication when the seat is at a particular position. For manual seats, mark each detent. For power seats, mark only the rearmost, middle and foremost positions. Label three of the positions with the following: F for foremost, M for mid-position (if there is no mid-position, label the closest adjustment position to the rear of the mid-point), and R for rearmost. Determine the mid fore-aft seat position based on the foremost and rearmost positions determined in items 4.1 and 4.2. (8/31/95 legal interpretation to Hogan and Hartson) |
|-------------------------------------|---|
- | | |
|-------------------------------------|--|
| <input checked="" type="checkbox"/> | 4.4 Move the seat to the mid position. |
|-------------------------------------|--|
- | | |
|-------------------------------------|--|
| <input checked="" type="checkbox"/> | 4.5 While maintaining the mid position, move the seat to its lowest position. For seats with adjustable seat cushions, use the manufacturer's recommended seat cushion angle for determining the lowest height position. |
|-------------------------------------|--|
- | | |
|-------------------------------------|--|
| <input checked="" type="checkbox"/> | 5. Is the seat back angle adjustable? |
| | <input type="checkbox"/> No- go to 6 |
| | <input checked="" type="checkbox"/> Yes- go to 5.1 |
- | | |
|-------------------------------------|---|
| <input checked="" type="checkbox"/> | 5.1 Set and mark seat back angle, if adjustable, at the manufacturer's nominal design riding position for a 50th percentile adult male in the manner specified by the manufacturer. |
| | <input type="checkbox"/> N/A – No seat back angle adjustment |
| | <input checked="" type="checkbox"/> Manufacturer's design seat back angle: <u>4.1° on Headrest Post</u> |
| | <input checked="" type="checkbox"/> Tested seat back angle: <u>4.3° on Headrest Post</u> |
- | | |
|-------------------------------------|---|
| <input checked="" type="checkbox"/> | 6. Is the seat a bucket seat? |
| | <input checked="" type="checkbox"/> Yes, go to 6.1 and skip 6.2 |
| | <input type="checkbox"/> No, go to 6.2 and skip 6.1 |

- 6.1 Bucket Seats:
Locate and **mark** the longitudinal centerline of the seat cushion. The intersection of the vertical longitudinal plane that passes through the SgRP and the seat cushion upper surface determines the longitudinal centerline of a bucket seat cushion. (S10.4.1.2 and S16.3.1.10)
- 6.2 Bench seats (complete ONLY the one that is applicable to the seat being tested):
- 6.2.1 Driver Seat
Locate and **mark** the longitudinal line on the seat cushion that marks the intersection of the vertical longitudinal plane through the centerline of the steering wheel and the seat cushion upper surface. (S10.4.1.1)
- 6.2.2 Front Outboard Passenger Seat
Locate and **mark** the longitudinal centerline of the passenger seat cushion. The longitudinal centerline is the same distance from the longitudinal centerline of the vehicle as the center of the steering wheel. (S10.4.1.1)
- Record the distance from the longitudinal centerline of the vehicle to the center of the steering wheel. _____
- Record the distance from the longitudinal centerline of the vehicle to the longitudinal centerline of the seat cushion. _____
7. Position the Part 572 Subpart E test dummy according to dummy position placement instructions in Appendix F. **Complete the Appendix F check sheets, but include them in the test report ONLY if there is a test failure.**
8. Fasten the seat belt around the dummy.
9. Remove all slack from the lap belt portion. (S10.9)
- N/A, the seat does not have a fore-aft adjustment
10. Pull the upper torso webbing out of the retractor and allow it to retract; repeat this four times. (S10.9)
11. Apply a 2 to 4 pound tension load to the lap belt. (S10.9)
Pound load applied: 3
12. Is the belt system equipped with a tension relieving device?
- Yes, continue
- No, go to 14
13. Introduce the maximum amount of slack into the upper torso belt that is recommended by the vehicle manufacturer in the vehicle owner's manual. (S10.9).
14. Check the statement that applies to this test vehicle:
- 14.1 The torso and lap belt webbing of the seat belt system automatically retracts to a stowed position when the adjacent vehicle door is in an open position and the seat belt latch plate is released.
- Yes – Pass go to 16
- No – go to 14.2
- 14.2 The torso and lap belt webbing of the seat belt system automatically retracts when the seat belt latch plate is released.
- Yes – Pass go to 15
- No – go to 14.3
- 14.3 Neither 14.1 nor 14.2 apply. - Fail
15. With the webbing and hardware in the stowed position are the webbing and hardware prevented from being pinched when the door is closed?
- Yes – Pass
- No – Fail

16. If this test vehicle has an open body (without doors) and has a belt system with a tension relieving device, does the belt system fully retract when the tension-relieving device is deactivated?
- N/A – Not an open body vehicle
 Yes – Pass
 No – Fail

REMARKS:

Signature: *Nicholas Atte*

Date: 6/30/14

I certify that I have read and performed each instruction.

DATA SHEET 13

SEAT BELT GUIDES AND HARDWARE (S7.4.6)

Test Vehicle: 2014 Ford Escape
Test Program: FMVSS 208 Compliance
Test Technician: Nicholas Abels

NHTSA No.: C20145403
Test Date: 6/30/14

Test seat belts except those in walk-in van-type vehicles and those at front outboard designated seating positions in passenger cars. Complete a form for each applicable seat belt.

DESIGNATED SEATING POSITION: Left Front Driver

- 1. Is the seat cushion movable so that the seat back serves a function other than seating? (S7.4.6.1(b))
2. Is the seat removable? (S7.4.6.1(b))
3. Is the seat movable so that the space formerly occupied by the seat can be used for a secondary function? (S7.4.6.1(b))
4. Is the webbing designed to pass through the seat cushion or between the seat cushion and seat back? (S7.4.6.1(a))
5. Does one of the following three parts, the seat belt latch plate, the buckle, or the seat belt webbing, stay on top of or above the seat cushion under normal conditions...
6. Are the remaining two seat belt parts accessible under normal conditions?
7. The buckle and latch plate do not pass through the guides or conduits provided and fall behind the seat when the belt is completely retracted...
8. The buckle and latch plate do not pass through the guides or conduits provided and fall behind the seat when the seat is moved to any position to which it is designed to be adjusted...
9. The buckle and latch plate do not pass through the guides or conduits provided and fall behind the seat when the seat back, if foldable, is folded forward as far as possible...
10. Is the inboard receptacle end of the seat belt assembly, installed in the front outboard designated seating position, accessible with the center armrest in any position to which it can be adjusted (without moving the armrest)? (S7.4.6.2)

REMARKS:

Signature: Nicholas Abels

Date: 6/30/14

I certify that I have read and performed each instruction.

DATA SHEET 13

SEAT BELT GUIDES AND HARDWARE (S7.4.6)

Test Vehicle: 2014 Ford Escape
Test Program: FMVSS 208 Compliance
Test Technician: Nicholas Abels

NHTSA No.: C20145403
Test Date: 6/30/14

Test seat belts except those in walk-in van-type vehicles and those at front outboard designated seating positions in passenger cars. Complete a form for each applicable seat belt.

DESIGNATED SEATING POSITION: Right Front Passenger

- 1. Is the seat cushion movable so that the seat back serves a function other than seating? (S7.4.6.1(b))
2. Is the seat removable? (S7.4.6.1(b))
3. Is the seat movable so that the space formerly occupied by the seat can be used for a secondary function? (S7.4.6.1(b))
4. Is the webbing designed to pass through the seat cushion or between the seat cushion and seat back? (S7.4.6.1(a))
5. Does one of the following three parts, the seat belt latch plate, the buckle, or the seat belt webbing, stay on top of or above the seat cushion under normal conditions...
6. Are the remaining two seat belt parts accessible under normal conditions?
7. The buckle and latch plate do not pass through the guides or conduits provided and fall behind the seat when the belt is completely retracted...
8. The buckle and latch plate do not pass through the guides or conduits provided and fall behind the seat when the seat is moved to any position...
9. The buckle and latch plate do not pass through the guides or conduits provided and fall behind the seat when the seat back, if foldable, is folded forward...
10. Is the inboard receptacle end of the seat belt assembly, installed in the front outboard designated seating position, accessible with the center armrest in any position to which it can be adjusted (without moving the armrest)? (S7.4.6.2)

REMARKS:

Signature: Nicholas Abels

Date: 6/30/14

I certify that I have read and performed each instruction.

DATA SHEET 13

SEAT BELT GUIDES AND HARDWARE (S7.4.6)

Test Vehicle: 2014 Ford Escape
Test Program: FMVSS 208 Compliance
Test Technician: Nicholas Abels

NHTSA No.: C20140200
Test Date: 6/30/14

Test seat belts except those in walk-in van-type vehicles and those at front outboard designated seating positions in passenger cars. Complete a form for each applicable seat belt.

DESIGNATED SEATING POSITION: Left Rear Passenger

- 1. Is the seat cushion movable so that the seat back serves a function other than seating? (S7.4.6.1(b))
2. Is the seat removable? (S7.4.6.1(b))
3. Is the seat movable so that the space formerly occupied by the seat can be used for a secondary function? (S7.4.6.1(b))
4. Is the webbing designed to pass through the seat cushion or between the seat cushion and seat back? (S7.4.6.1(a))
5. Does one of the following three parts, the seat belt latch plate, the buckle, or the seat belt webbing, stay on top of or above the seat cushion under normal conditions...? (S7.4.6.1(a))
6. Are the remaining two seat belt parts accessible under normal conditions?
7. The buckle and latch plate do not pass through the guides or conduits provided and fall behind the seat when the belt is completely retracted or, if the belt is nonretractable, the belt is unlatched. (S7.4.6.2)
8. The buckle and latch plate do not pass through the guides or conduits provided and fall behind the seat when the seat is moved to any position to which it is designed to be adjusted. (S7.4.6.2)
9. The buckle and latch plate do not pass through the guides or conduits provided and fall behind the seat when the seat back, if foldable, is folded forward as far as possible and then moved backward into position. (S7.4.6.2)
10. Is the inboard receptacle end of the seat belt assembly, installed in the front outboard designated seating position, accessible with the center armrest in any position to which it can be adjusted (without moving the armrest)? (S7.4.6.2)

REMARKS:

Signature: Nicholas Abels

Date: 6/30/14

I certify that I have read and performed each instruction.

DATA SHEET 13

SEAT BELT GUIDES AND HARDWARE (S7.4.6)

Test Vehicle: 2014 Ford Escape
 Test Program: FMVSS 208 Compliance
 Test Technician: Nicholas Abels

NHTSA No.: C20140200
 Test Date: 6/30/14

Test seat belts except those in walk-in van-type vehicles and those at front outboard designated seating positions in passenger cars. Complete a form for each applicable seat belt.

DESIGNATED SEATING POSITION: **Center Rear Passenger**

- | | | | | | |
|-------------------------------------|--|-----|--|--|---|
| <input checked="" type="checkbox"/> | | 1. | Is the seat cushion movable so that the seat back serves a function other than seating? (S7.4.6.1(b)) | <input type="checkbox"/> Yes, this form is complete | <input checked="" type="checkbox"/> No, go to 2 |
| <input checked="" type="checkbox"/> | | 2. | Is the seat removable? (S7.4.6.1(b)) | <input type="checkbox"/> Yes, this form is complete | <input checked="" type="checkbox"/> No, go to 3 |
| <input checked="" type="checkbox"/> | | 3. | Is the seat movable so that the space formerly occupied by the seat can be used for a secondary function? (S7.4.6.1(b)) | <input checked="" type="checkbox"/> Yes, this form is complete | <input type="checkbox"/> No, go to 4 |
| <input type="checkbox"/> | | 4. | Is the webbing designed to pass through the seat cushion or between the seat cushion and seat back? (S7.4.6.1(a)) | <input type="checkbox"/> Yes, go to 5 | <input type="checkbox"/> No, this form is complete |
| <input type="checkbox"/> | | 5. | Does one of the following three parts, the seat belt latch plate, the buckle, or the seat belt webbing, stay on top of or above the seat cushion under normal conditions (i.e., conditions other than when belt hardware is intentionally pushed behind the seat by a vehicle occupant)? (S7.4.6.1(a)) | <input type="checkbox"/> Yes – Pass | <input type="checkbox"/> No – Fail |
| | | | Identify the part(s) on top or above the seat. | <input type="checkbox"/> Seat belt latch plate | <input type="checkbox"/> Buckle <input type="checkbox"/> Seat belt webbing |
| <input type="checkbox"/> | | 6. | Are the remaining two seat belt parts accessible under normal conditions? | <input type="checkbox"/> Yes – Pass | <input type="checkbox"/> No – Fail |
| <input type="checkbox"/> | | 7. | The buckle and latch plate do not pass through the guides or conduits provided and fall behind the seat when the belt is completely retracted or, if the belt is nonretractable, the belt is unlatched. (S7.4.6.2) | <input type="checkbox"/> Yes – Pass | <input type="checkbox"/> No – Fail |
| <input type="checkbox"/> | | 8. | The buckle and latch plate do not pass through the guides or conduits provided and fall behind the seat when the seat is moved to any position to which it is designed to be adjusted. (S7.4.6.2) | <input type="checkbox"/> Yes – Pass | <input type="checkbox"/> No – Fail |
| <input type="checkbox"/> | | 9. | The buckle and latch plate do not pass through the guides or conduits provided and fall behind the seat when the seat back, if foldable, is folded forward as far as possible and then moved backward into position. (S7.4.6.2) | <input type="checkbox"/> Yes – Pass | <input type="checkbox"/> No – Fail |
| <input type="checkbox"/> | | 10. | Is the inboard receptacle end of the seat belt assembly, installed in the front outboard designated seating position, accessible with the center armrest in any position to which it can be adjusted (without moving the armrest)? (S7.4.6.2) | <input type="checkbox"/> Yes – Pass | <input type="checkbox"/> No – Fail <input type="checkbox"/> N/A – Rear seat |

REMARKS:

Signature: Nicholas Abels

Date: 6/30/14

I certify that I have read and performed each instruction.

DATA SHEET 13

SEAT BELT GUIDES AND HARDWARE (S7.4.6)

Test Vehicle: 2014 Ford Escape
Test Program: FMVSS 208 Compliance
Test Technician: Nicholas Abels

NHTSA No.: C20140200
Test Date: 6/30/14

Test seat belts except those in walk-in van-type vehicles and those at front outboard designated seating positions in passenger cars. Complete a form for each applicable seat belt.

DESIGNATED SEATING POSITION: Right Rear Passenger

- 1. Is the seat cushion movable so that the seat back serves a function other than seating? (S7.4.6.1(b))
2. Is the seat removable? (S7.4.6.1(b))
3. Is the seat movable so that the space formerly occupied by the seat can be used for a secondary function? (S7.4.6.1(b))
4. Is the webbing designed to pass through the seat cushion or between the seat cushion and seat back? (S7.4.6.1(a))
5. Does one of the following three parts, the seat belt latch plate, the buckle, or the seat belt webbing, stay on top of or above the seat cushion under normal conditions...? (S7.4.6.1(a))
6. Are the remaining two seat belt parts accessible under normal conditions?
7. The buckle and latch plate do not pass through the guides or conduits provided and fall behind the seat when the belt is completely retracted or, if the belt is nonretractable, the belt is unlatched. (S7.4.6.2)
8. The buckle and latch plate do not pass through the guides or conduits provided and fall behind the seat when the seat is moved to any position to which it is designed to be adjusted. (S7.4.6.2)
9. The buckle and latch plate do not pass through the guides or conduits provided and fall behind the seat when the seat back, if foldable, is folded forward as far as possible and then moved backward into position. (S7.4.6.2)
10. Is the inboard receptacle end of the seat belt assembly, installed in the front outboard designated seating position, accessible with the center armrest in any position to which it can be adjusted (without moving the armrest)? (S7.4.6.2)

REMARKS:

Signature: Nicholas Abels

Date: 6/30/14

I certify that I have read and performed each instruction.

DATA SHEET 15

H-POINT DETERMINATION FOR 50TH PERCENTILE MALE DUMMY

Test Vehicle: 2014 Ford Escape
Test Program: FMVSS 208 Compliance
Test Technician: Jon Miller

NHTSA No.: C20140200
Test Date: 8/25/14

Driver Designated Seating Position Passenger Designated Seating Position

1. Position the seat's adjustable lumbar supports so that the lumbar support is in its lowest, retracted or deflated adjustment position. (S8.1.3)
 N/A – No lumbar adjustment
2. Position any adjustable parts of the seat that provide additional support so that they are in the lowest or most open adjustment position. (S16.2.10.2)
 N/A – No additional support adjustment
3. Use all the seat controls that have any effect on the fore-aft movement of the seat to move the seat cushion to the rearmost position. **Mark** this position. (8/31/95 legal interpretation to Hogan and Hartson)
4. Use all the seat controls that have any effect on the fore-aft movement of the seat to move the seat cushion to the foremost position. **Mark** this position. (8/31/95 legal interpretation to Hogan and Hartson)
5. **Mark** each fore-aft position so that there is a visual indication when the seat is at a particular position. For manual seats, **mark** each detent. For power seats, **mark** only the rearmost, middle, and foremost positions. Label three of the positions with the following: F for foremost, M for mid-position (if there is no mid-position, label the closest adjustment position to the rear of the mid-point), and R for rearmost. Determine the mid fore-aft seat position based on the foremost and rearmost positions determined in items 3 and 4. (8/31/95 legal interpretation to Hogan and Hartson)
6. Move the seat to the mid position.
7. While maintaining the mid position, move the seat to its lowest position. **Mark** the height position. For seats with adjustable seat cushions, use the manufacturer's recommended seat cushion angle for determining the lowest height position.
8. Visually **mark** the seat back angle, if adjustable, at the manufacturer's nominal design riding position for a **50th percentile adult male** in the manner specified by the manufacturer.
 N/A – No seat back angle adjustment
Manufacturer's design seat back angle 4.1° on Headrest Post
9. Is the seat a bucket seat?
 Yes, go to 10 and skip 11
 No, go to 11 and skip 10
10. Bucket seats:
Locate and **mark** for future reference the longitudinal centerline of the seat cushion. The intersection of the vertical longitudinal plane that passes through the SgRP and the seat cushion upper surface determines the longitudinal centerline of a bucket seat cushion. (S10.4.1.2 and S16.3.1.10)

11. Bench seats (complete ONLY the one that is applicable to the seat being marked):
- 11.1 Driver Seat
Locate and **mark** for future reference the longitudinal line on the seat cushion that marks the intersection of the vertical longitudinal plane through the centerline of the steering wheel and the seat cushion upper surface. (S10.4.1.1)
- 11.2 Passenger Seat
Locate and **mark** for future reference the longitudinal centerline of the passenger seat cushion. The longitudinal centerline is the same distance from the longitudinal centerline of the vehicle as the center of the steering wheel. (S10.4.1.1)
Record the distance from the longitudinal centerline of the vehicle to the center of the steering wheel. _____
Record the distance from the longitudinal centerline of the vehicle to the longitudinal centerline of the seat cushion. _____
12. Place a 910 mm² piece of muslin cotton cloth over the seat area. (The muslin cloth shall be comparable to 48 threads/in² and density of 2.85 lb/yd.) Tuck the muslin cloth in a sufficient amount to prevent hammocking of the material.
13. Place the seat and back assembly of the H-Point machine at the centerline of the seat as determined in item 10 or 11.
14. Install the lower leg, and foot segments.
15. Set the length of the lower leg segment at 16.3 inches and the length of the thigh bar at 15.8 inches.
16. Leg and foot placement.
- 16.1 Driver Designated Seating Position.
- 16.1.1 Insert the pin so that the foot angle is never less than 87 degrees.
- 16.1.2 Place the right foot on the undepressed accelerator pedal with the sole of the foot on the pedal and the heel as far forward as allowable. Do not place the heel on the toe board.
- 16.1.3 Adjust the left leg to be the same distance from H-point machine centerline as the right leg.
- 16.1.4 With the T-bar level, place the left foot on the toe board with the rearmost point of the heel resting on the floor pan as close as possible to the point of intersection of the planes described by the toe board and the floor pan and not on the wheel well projection. If the foot cannot be positioned on the toe board, set it on the floor pan.
- Foot on toe board.
 Foot on floor pan.
- 16.2 Passenger Designated Seating Position.
- 16.2.1 Insert the pin so that the foot angle is never less than 87 degrees.
- 16.2.2 Space the lower legs 10.6 inches apart, equally spaced about the centerline of the H-point machine.

- 16.2.3 With the T-bar level, place the left foot on the toe board with the rearmost point of the heel resting on the floor pan as close as possible to the point of intersection of the planes described by the toe board and the floor pan and not on the wheel well projection. If the foot cannot be positioned on the toe board, set it on the floor pan.
- Foot on toe board.
 - Foot on floor pan.
- 16.2.4 With the T-bar level, place the right foot on the toe board with the rearmost point of the heel resting on the floor pan as close as possible to the point of intersection of the planes described by the toe board and the floor pan and not on the wheel well projection. If the foot cannot be positioned on the toe board, set it on the floor pan.
- Foot on toe board.
 - Foot on floor pan.
17. Apply the lower leg weights.
18. Apply the thigh weights.
19. Tilt the back pan forward against the forward stop and draw the H-point machine away from the seatback using the T-bar.
20. Repositioning the back pan.
- 20.1 Allow the H-point machine to slide rearward until a forward horizontal restraining load on the T-bar is no longer required due to the seat pan contacting the seat back.
- The seat pan does not slide rearward. Go to 20.2
- 20.2 Slide the H-point machine rearward by a horizontal rearward load applied at the T-bar until the seat pan contacts the seat back.
21. Apply a 10 kg load at the intersection of the hip angle quadrant and the T-bar housing along a line from the above intersection to a point just above the thigh bar housing.
22. Again apply a 10 kg load at the intersection of the hip angle quadrant and the T-bar housing along a line from the above intersection to a point just above the thigh bar housing.
23. Carefully return the back pan to the seat back.
24. Install the right and left buttock weights.
25. Install the eight torso weights alternately the installation between right and left.
26. Tilt the back pan forward until the stop is contacted.
27. Rock the H-point from side to side over a 10 degree arc (5 degrees to each side of the vertical centerline) for three complete cycles. Restrain the T-bar during rocking so that the seat pan does not change position. Minimize any inadvertent exterior loads applied in a vertical or fore-aft direction. The feet are free to move during this rocking motion.
28. Without applying a forward or lateral load lift the right foot off the floor the minimum amount necessary until no additional forward foot movement is obtained.
29. Lower the right foot until the heel is in contact with the floor pan and the ball of the foot is in contact with the floor, toe board, or undepressed accelerator pedal.

- X 30. Without applying a forward or lateral load lift the left foot off the floor the minimum amount necessary until no additional forward foot movement is obtained.
- X 31. Lower the left foot until the heel is in contact with the floor pan and the ball of the foot is in contact with the floor or toe board.
- X 32. Is the seat pan level?
 ___ Yes. Go to 34
 X No. Go to 33
- X 33. Apply a sufficient lateral load to the top of the seatback pan to level the H-point machine seat pan on the seat.
- X 34. Holding the T-bar to prevent the H-point from sliding forward on the seat cushion, return the seatback pan to the seatback.
- X 35. Holding the T-bar to prevent the H-point from sliding forward on the seat cushion, apply sufficient rearward force perpendicular to the back angle bar just above the torso weights to increase the hip angle 3 degrees. Minimize the exterior downward or side forces applied to the H-point machine. Release the force. Repeat this step until the hip angle readout is identical. Complete as many force applications as necessary and record the results in the following table:

Force Application	Hip Angle
1	95
2	96
3	94
4	
5	

- X 36. Is the H-point machine level?
 X Yes, go to 37.
 ___ No, re-level. Go back to item 26 and repeat using a new data sheet.

X_37. Record the H-point location.
Describe and mark the measuring reference point.

Driver H-Point	
HP to Floor Z	270
HP to Hinge X	710
HP to Sill Y	230
HP to Striker X	190
HP to Dash X	517
HP to Header Z	826

H-Point Machine	
Left Knee	111
Right Knee	112
Left Foot Angle	95°
Right Foot Angle	89°
Left Leg	180
Right Leg	178
Hip Angle	96°
Back Angle	22°

Signature: 

Date: 8/25/14

I certify that I have read and performed each instruction.

DATA SHEET 15

H-POINT DETERMINATION FOR 50TH PERCENTILE MALE DUMMY

Test Vehicle: 2014 Ford Escape
Test Program: FMVSS 208 Compliance
Test Technician: Jon Miller

NHTSA No.: C20140200
Test Date: 8/25/14

Driver Designated Seating Position Passenger Designated Seating Position

1. Position the seat's adjustable lumbar supports so that the lumbar support is in its lowest, retracted or deflated adjustment position. (S8.1.3)
 N/A – No lumbar adjustment
2. Position any adjustable parts of the seat that provide additional support so that they are in the lowest or most open adjustment position. (S16.2.10.2)
 N/A – No additional support adjustment
3. Use all the seat controls that have any effect on the fore-aft movement of the seat to move the seat cushion to the rearmost position. **Mark** this position. (8/31/95 legal interpretation to Hogan and Hartson)
4. Use all the seat controls that have any effect on the fore-aft movement of the seat to move the seat cushion to the foremost position. **Mark** this position. (8/31/95 legal interpretation to Hogan and Hartson)
5. **Mark** each fore-aft position so that there is a visual indication when the seat is at a particular position. For manual seats, **mark** each detent. For power seats, **mark** only the rearmost, middle, and foremost positions. Label three of the positions with the following: F for foremost, M for mid-position (if there is no mid-position, label the closest adjustment position to the rear of the mid-point), and R for rearmost. Determine the mid fore-aft seat position based on the foremost and rearmost positions determined in items 3 and 4. (8/31/95 legal interpretation to Hogan and Hartson)
6. Move the seat to the mid position.
7. While maintaining the mid position, move the seat to its lowest position. **Mark** the height position. For seats with adjustable seat cushions, use the manufacturer's recommended seat cushion angle for determining the lowest height position.
8. Visually **mark** the seat back angle, if adjustable, at the manufacturer's nominal design riding position for a **50th percentile adult male** in the manner specified by the manufacturer.
 N/A – No seat back angle adjustment
Manufacturer's design seat back angle 4.1° on Headrest Post
9. Is the seat a bucket seat?
 Yes, go to 10 and skip 11
 No, go to 11 and skip 10
10. Bucket seats:
Locate and **mark** for future reference the longitudinal centerline of the seat cushion. The intersection of the vertical longitudinal plane that passes through the SgRP and the seat cushion upper surface determines the longitudinal centerline of a bucket seat cushion. (S10.4.1.2 and S16.3.1.10)

11. Bench seats (complete ONLY the one that is applicable to the seat being marked):
- 11.1 Driver Seat
Locate and **mark** for future reference the longitudinal line on the seat cushion that marks the intersection of the vertical longitudinal plane through the centerline of the steering wheel and the seat cushion upper surface. (S10.4.1.1)
- 11.2 Passenger Seat
Locate and **mark** for future reference the longitudinal centerline of the passenger seat cushion. The longitudinal centerline is the same distance from the longitudinal centerline of the vehicle as the center of the steering wheel. (S10.4.1.1)
Record the distance from the longitudinal centerline of the vehicle to the center of the steering wheel. _____
Record the distance from the longitudinal centerline of the vehicle to the longitudinal centerline of the seat cushion. _____
12. Place a 910 mm² piece of muslin cotton cloth over the seat area. (The muslin cloth shall be comparable to 48 threads/in² and density of 2.85 lb/yd.) Tuck the muslin cloth in a sufficient amount to prevent hammocking of the material.
13. Place the seat and back assembly of the H-Point machine at the centerline of the seat as determined in item 10 or 11.
14. Install the lower leg, and foot segments.
15. Set the length of the lower leg segment at 16.3 inches and the length of the thigh bar at 15.8 inches.
16. Leg and foot placement.
- 16.1 Driver Designated Seating Position.
- 16.1.1 Insert the pin so that the foot angle is never less than 87 degrees.
- 16.1.2 Place the right foot on the undepressed accelerator pedal with the sole of the foot on the pedal and the heel as far forward as allowable. Do not place the heel on the toe board.
- 16.1.3 Adjust the left leg to be the same distance from H-point machine centerline as the right leg.
- 16.1.4 With the T-bar level, place the left foot on the toe board with the rearmost point of the heel resting on the floor pan as close as possible to the point of intersection of the planes described by the toe board and the floor pan and not on the wheel well projection. If the foot cannot be positioned on the toe board, set it on the floor pan.
 Foot on toe board.
 Foot on floor pan.
- 16.2 Passenger Designated Seating Position.
- 16.2.1 Insert the pin so that the foot angle is never less than 87 degrees.
- 16.2.2 Space the lower legs 10.6 inches apart, equally spaced about the centerline of the H-point machine.

- X 16.2.3 With the T-bar level, place the left foot on the toe board with the rearmost point of the heel resting on the floor pan as close as possible to the point of intersection of the planes described by the toe board and the floor pan and not on the wheel well projection. If the foot cannot be positioned on the toe board, set it on the floor pan.
X Foot on toe board.
 Foot on floor pan.
- X 16.2.4 With the T-bar level, place the right foot on the toe board with the rearmost point of the heel resting on the floor pan as close as possible to the point of intersection of the planes described by the toe board and the floor pan and not on the wheel well projection. If the foot cannot be positioned on the toe board, set it on the floor pan.
X Foot on toe board.
 Foot on floor pan.
- X 17. Apply the lower leg weights.
- X 18. Apply the thigh weights.
- X 19. Tilt the back pan forward against the forward stop and draw the H-point machine away from the seatback using the T-bar.
- X 20. Repositioning the back pan.
- X 20.1 Allow the H-point machine to slide rearward until a forward horizontal restraining load on the T-bar is no longer required due to the seat pan contacting the seat back.
 The seat pan does not slide rearward. Go to 20.2
- 20.2 Slide the H-point machine rearward by a horizontal rearward load applied at the T-bar until the seat pan contacts the seat back.
- X 21. Apply a 10 kg load at the intersection of the hip angle quadrant and the T-bar housing along a line from the above intersection to a point just above the thigh bar housing.
- X 22. Again apply a 10 kg load at the intersection of the hip angle quadrant and the T-bar housing along a line from the above intersection to a point just above the thigh bar housing.
- X 23. Carefully return the back pan to the seat back.
- X 24. Install the right and left buttock weights.
- X 25. Install the eight torso weights alternately the installation between right and left.
- X 26. Tilt the back pan forward until the stop is contacted.
- X 27. Rock the H-point from side to side over a 10 degree arc (5 degrees to each side of the vertical centerline) for three complete cycles. Restrain the T-bar during rocking so that the seat pan does not change position. Minimize any inadvertent exterior loads applied in a vertical or fore-aft direction. The feet are free to move during this rocking motion.
- X 28. Without applying a forward or lateral load lift the right foot off the floor the minimum amount necessary until no additional forward foot movement is obtained.
- X 29. Lower the right foot until the heel is in contact with the floor pan and the ball of the foot is in contact with the floor, toe board, or undepressed accelerator pedal.

- X 30. Without applying a forward or lateral load lift the left foot off the floor the minimum Amount necessary until no additional forward foot movement is obtained.
- X 31. Lower the left foot until the heel is in contact with the floor pan and the ball of the foot is In contact with the floor or toe board.
- X 32. Is the seat pan level?
 ___ Yes. Go to 34
 X No. Go to 33
- X 33. Apply a sufficient lateral load to the top of the seatback pan to level the H-point machine seat pan on the seat.
- X 34. Holding the T-bar to prevent the H-point from sliding forward on the seat cushion, return the seatback pan to the seatback.
- X 35. Holding the T-bar to prevent the H-point from sliding forward on the seat cushion, apply sufficient rearward force perpendicular to the back angle bar just above the torso weights to increase the hip angle 3 degrees. Minimize the exterior downward or side forces applied to the H-point machine. Release the force. Repeat this step until the hip angle readout is identical. Complete as many force applications as necessary and record the results in the following table:

Force Application	Hip Angle
1	104
2	105
3	105
4	
5	

- X 36. Is the H-point machine level?
 X Yes, go to 37.
 ___ No, re-level. Go back to item 26 and repeat using a new data sheet.

X37. Record the H-point location.
Describe and mark the measuring reference point.

Passenger H-Point	
HP to Floor Z	423
HP to Hinge X	712
HP to Sill Y	237
HP to Striker X	188
HP to Dash X	543
HP to Header Z	791

H-Point Machine	
Left Knee	120
Right Knee	120
Left Foot Angle	100°
Right Foot Angle	100°
Left Leg	131
Right Leg	132
Hip Angle	105°
Back Angle	25°

Signature: 

Date: 8/25/14

I certify that I have read and performed each instruction.

DATA SHEET 16

AIR BAG SUPPRESSION TELLTALE (S19.2.2)

Test Vehicle: 2014 Ford Escape
Test Program: FMVSS 208 Compliance
Test Technician: Nicholas Abels

NHTSA No.: C20140200
Test Date: 7/21/14

- 1. Is the vehicle certified to any suppression performance standards of FMVSS 208?
 Yes - go to 2
 No - this form is complete
- 2. Does telltale emit yellow light when the air bag is suppressed? (S19.2.2(a))
 Yes - Pass **NO - FAIL**
- 3. Are the words "PASSENGER AIR BAG OFF" or "PASS AIR BAG OFF" (S19.2.2(b))
 3.1 on the telltale? (S19.2.2(b))
 Yes - Pass, go to 4
 No - go to 3.2
- 3.2 Within 25 mm of the telltale? (S19.2.2 (b)) 5 mm from the edge of the telltale light?
 Yes - Pass **NO - FAIL**
- 4. Is the telltale separate from the air bag readiness indicator? (S19.2.2(c))
 Yes - Pass **NO - FAIL**
- 5. Is the telltale within the interior of the vehicle? (S19.2.2 (d))
 Yes - Pass **NO - FAIL**
- 6. Is the telltale forward of and above the design H-point of both the driver's and the front outboard passenger's seat when the seats are in their forward most seating positions? (S19.2.2 (d))
 Yes - Pass **NO - FAIL**
- 7. Is the telltale away from surfaces that can be used for temporary or permanent storage of objects that could obscure the telltale from either the driver's or front outboard passenger's view? (S19.2.2 (d))
 Yes - Pass **NO - FAIL**
- 8. Is the telltale located so that it is not obscured from the driver or front outboard passenger by a rear-facing child restraint in Appendix A installed in the front outboard passenger seat? (S19.2.2 (d))
 Yes - Pass **NO - FAIL**
- 9. Is the telltale visible or recognizable during the night? (S19.2.2 (e))
 Yes - Pass **NO - FAIL**
- 10. Is the telltale visible or recognizable during the day? (S19.2.2 (e))
 Yes - Pass **NO - FAIL**
- 11. If there is a visibility adjustment, do all the adjustment levels make the telltale visible and recognizable? (S19.2.2 (g))
 N/A-No visibility adjustment
 Yes - Pass **NO - FAIL**
- 12. Does the telltale remain illuminated while the air bag is suppressed? (S19.2.2 (h)) (Leave the air bag suppressed for 5 minutes.)
 Yes - Pass **NO - FAIL**
- 13. Is the telltale off while the air bag is activated? (S19.2.2 (h)) (Leave the air bag activated for 5 minutes.)
 Yes - Pass **NO - FAIL**

Signature: *Nicholas Abels*

Date: 7/21/14

I certify that I have read and performed each instruction.

DATA SHEET 17 SUMMARY

Suppression Test Using 12-Month-Old CRABI Dummy (Part 572, Subpart R)
Section B Rear Facing CRS

NHTSA NO.:	C20140200	TEST DATE:	7/21/14
LABORATORY:	MGA	TECHNICIAN(S):	MT
DUMMY TYPE:	12 Month Old	DUMMY SERIAL NO.:	062

CHILD RESTRAINT NAME:	Cosco
CHILD RESTRAINT MODEL:	Arriva 22-049 (same as model 22-013)
DATE OF MANUFACTURE:	8-20-2008

Base: X On Off N/A-Constraint does not have a removable base

Manufacturer’s design seat back angle: 4.1° on Headrest Post
 Tested seat back angle: 3.8° on Headrest Post
 Manufacturer’s specified anchorage position: 0 of 4; Upper-most defined as 0
 Tested anchorage position: 0 of 4; Upper-most defined as 0

A blanket and visor were not used in the suppression testing because they did not affect the weight sensing system used on the vehicle.

Test Summary

Seat Belt	Seat Slide	Cinch Load (N)	Result
Belted Rear Facing	Forward 16*	127	Suppressed
	Middle	127	Suppressed
	Rearward	127	Suppressed
Unbelted Rear Facing	Forward 17*	N/A	Suppressed
	Middle	N/A	Suppressed
	Rearward	N/A	Suppressed
Unbelted Forward Facing	Forward 9*	N/A	Suppressed
	Middle	N/A	Suppressed
	Rearward	N/A	Suppressed

* The CRS would not fit in this forward seat slide position. If there is a number in the seat slide column, it indicates the fore-aft detent position with respect to the foremost position. (1 = Full Forward; 40 = Full Rearward; 40 total Seat Slide detents)

DATA SHEET 17 SUMMARY

Suppression Test Using 12-Month-Old CRABI Dummy (Part 572, Subpart R)
Section B Rear Facing CRS

NHTSA NO.:	C20140200	TEST DATE:	7/21/14
LABORATORY:	MGA	TECHNICIAN(S):	MT
DUMMY TYPE:	12 Month Old	DUMMY SERIAL NO.:	062

CHILD RESTRAINT NAME:	Cosco
CHILD RESTRAINT MODEL:	Arriva 22-049 (same as model 22-013)
DATE OF MANUFACTURE:	8-20-2008

Base: On Off N/A-Constraint does not have a removable base

Manufacturer's design seat back angle: 4.1° on Headrest Post
 Tested seat back angle: 3.8° on Headrest Post
 Manufacturer's specified anchorage position: 0 of 4; Upper-most defined as 0
 Tested anchorage position: 0 of 4; Upper-most defined as 0

A blanket and visor were not used in the suppression testing because they did not affect the weight sensing system used on the vehicle.

Test Summary

Seat Belt	Seat Slide	Cinch Load (N)	Result
Belted Rear Facing	Forward 16*	130	Suppressed
	Middle	129	Suppressed
	Rearward	129	Suppressed
Unbelted Rear Facing	Forward 17*	N/A	Suppressed
	Middle	N/A	Suppressed
	Rearward	N/A	Suppressed
Unbelted Forward Facing	Forward 7*	N/A	Suppressed
	Middle	N/A	Suppressed
	Rearward	N/A	Suppressed

* The CRS would not fit in this forward seat slide position. If there is a number in the seat slide column, it indicates the fore-aft detent position with respect to the foremost position. (1 = Full Forward; 40 = Full Rearward; 40 total Seat Slide detents)

Successful Unbelted 5th percentile Female Dummy Reactivation was performed with the seat in the Rearward position. (SN 506)

DATA SHEET 17 SUMMARY

Suppression Test Using 12-Month-Old CRABI Dummy (Part 572, Subpart R) Section B Rear Facing CRS

NHTSA NO.:	C20140200	TEST DATE:	7/21/14
LABORATORY:	MGA	TECHNICIAN(S):	MT
DUMMY TYPE:	12 Month Old	DUMMY SERIAL NO.:	062

CHILD RESTRAINT NAME:	Graco
CHILD RESTRAINT MODEL:	Snugride
DATE OF MANUFACTURE:	5-24-2007

Base: On Off N/A-Constraint does not have a removable base

Manufacturer's design seat back angle: 4.1° on Headrest Post
 Tested seat back angle: 3.8° on Headrest Post
 Manufacturer's specified anchorage position: 0 of 4; Upper-most defined as 0
 Tested anchorage position: 0 of 4; Upper-most defined as 0

A blanket and visor were not used in the suppression testing because they did not affect the weight sensing system used on the vehicle.

Test Summary

Seat Belt	Seat Slide	Cinch Load (N)	Result
Belted Rear Facing	Forward 11*	133	Suppressed
	Middle	133	Suppressed
	Rearward	131	Suppressed
Unbelted Rear Facing	Forward	N/A	Won't Fit
	Middle	N/A	Suppressed
	Rearward	N/A	Suppressed
Unbelted Forward Facing	Forward 4*	N/A	Suppressed
	Middle	N/A	Suppressed
	Rearward	N/A	Suppressed

* The CRS would not fit in this Forward Seat Slide position. If there is a number in the Seat Slide column, it indicates the fore-aft detent position with respect to the foremost position. (1 = Full Forward; 40 = Full Rearward; 40 total Seat Slide detents)

DATA SHEET 17 SUMMARY

Suppression Test Using 12-Month-Old CRABI Dummy (Part 572, Subpart R)
Section B Rear Facing CRS

NHTSA NO.:	C20140200	TEST DATE:	7/21/14
LABORATORY:	MGA	TECHNICIAN(S):	MT
DUMMY TYPE:	12 Month Old	DUMMY SERIAL NO.:	062

CHILD RESTRAINT NAME:	Graco
CHILD RESTRAINT MODEL:	Snugride
DATE OF MANUFACTURE:	5-24-2007

Base: __ On X Off __ N/A-Constraint does not have a removable base

Manufacturer’s design seat back angle: 4.1° on Headrest Post
 Tested seat back angle: 3.8° on Headrest Post
 Manufacturer’s specified anchorage position: 0 of 4; Upper-most defined as 0
 Tested anchorage position: 0 of 4; Upper-most defined as 0

A blanket and visor were not used in the suppression testing because they did not affect the weight sensing system used on the vehicle.

Test Summary

Seat Belt	Seat Slide	Cinch Load (N)	Result
Belted Rear Facing	Forward 10*	127	Suppressed
	Middle	131	Suppressed
	Rearward	127	Suppressed
Unbelted Rear Facing	Forward 15*	N/A	Suppressed
	Middle	N/A	Suppressed
	Rearward	N/A	Suppressed
Unbelted Forward Facing	Forward 10*	N/A	Suppressed
	Middle	N/A	Suppressed
	Rearward	N/A	Suppressed

* The CRS would not fit in this forward or middle seat slide position. If there is a number in the seat slide column, it indicates the fore-aft detent position with respect to the foremost position. (1 = Full Forward; 40 = Full Rearward; 40 total Seat Slide detents)

Successful Unbelted 5th percentile Female Dummy Reactivation was performed with the seat in the Middle position. (SN 506)

DATA SHEET 17 SUMMARY

Suppression Test Using 12-Month-Old CRABI Dummy (Part 572, Subpart R)
Section B Rear Facing CRS

NHTSA NO.:	C20140200	TEST DATE:	7/21/14
LABORATORY:	MGA	TECHNICIAN(S):	MT
DUMMY TYPE:	12 Month Old	DUMMY SERIAL NO.:	062

CHILD RESTRAINT NAME:	Peg Perego
CHILD RESTRAINT MODEL:	Viaggio
DATE OF MANUFACTURE:	8-27-2007

Base: On Off N/A-Constraint does not have a removable base

Manufacturer's design seat back angle: 4.1° on Headrest Post
 Tested seat back angle: 3.8° on Headrest Post
 Manufacturer's specified anchorage position: 0 of 4; Upper-most defined as 0
 Tested anchorage position: 0 of 4; Upper-most defined as 0

A blanket and visor were not used in the suppression testing because they did not affect the weight sensing system used on the vehicle.

Test Summary

Seat Belt	Seat Slide	Cinch Load (N)	Result
Belted Rear Facing	Forward	132	Suppressed
	Middle	131	Suppressed
	Rearward	128	Suppressed
Unbelted Rear Facing	Forward 6*	N/A	Suppressed
	Middle	N/A	Suppressed
	Rearward	N/A	Suppressed
Unbelted Forward Facing	Forward	N/A	Suppressed
	Middle	N/A	Suppressed
	Rearward	N/A	Suppressed

* The CRS would not fit in this forward seat slide position. If there is a number in the seat slide column, it indicates the fore-aft detent position with respect to the foremost position. (1 = Full Forward; 40 = Full Rearward; 40 total Seat Slide detents)

DATA SHEET 17 SUMMARY

Suppression Test Using 12-Month-Old CRABI Dummy (Part 572, Subpart R) Section B Rear Facing CRS

NHTSA NO.:	C20140200	TEST DATE:	7/21/14
LABORATORY:	MGA	TECHNICIAN(S):	MT
DUMMY TYPE:	12 Month Old	DUMMY SERIAL NO.:	062

CHILD RESTRAINT NAME:	Peg Perego
CHILD RESTRAINT MODEL:	Viaggio
DATE OF MANUFACTURE:	8-27-2007

Base: __On X Off __N/A-Constraint does not have a removable base

Manufacturer's design seat back angle: 4.1° on Headrest Post
 Tested seat back angle: 3.8° on Headrest Post
 Manufacturer's specified anchorage position: 0 of 4; Upper-most defined as 0
 Tested anchorage position: 0 of 4; Upper-most defined as 0

A blanket and visor were not used in the suppression testing because they did not affect the weight sensing system used on the vehicle.

Test Summary

Seat Belt	Seat Slide	Cinch Load (N)	Result
Belted Rear Facing	Forward 10*	130	Suppressed
	Middle	131	Suppressed
	Rearward	129	Suppressed
Unbelted Rear Facing	Forward 12*	N/A	Suppressed
	Middle	N/A	Suppressed
	Rearward	N/A	Suppressed
Unbelted Forward Facing	Forward	N/A	Suppressed
	Middle	N/A	Suppressed
	Rearward	N/A	Suppressed

* The CRS would not fit in this forward seat slide position. If there is a number in the seat slide column, it indicates the fore-aft detent position with respect to the foremost position. (1 = Full Forward; 40 = Full Rearward; 40 total Seat Slide detents)

Successful Unbelted 5th percentile Female Dummy Reactivation was performed with the seat in the Forward position. (SN 506)

DATA SHEET 17 SUMMARY

Suppression Test Using 12-Month-Old CRABI Dummy (Part 572, Subpart R)
Section C Forward Facing Convertible CRS

NHTSA NO.:	C20140200	TEST DATE:	7/22/14
LABORATORY:	MGA	TECHNICIAN(S):	JL
DUMMY TYPE:	12 Month Old	DUMMY SERIAL NO.:	062

CHILD RESTRAINT NAME:	Britax
CHILD RESTRAINT MODEL:	Roundabout E9L02
DATE OF MANUFACTURE:	7-2-2008

Base: On Off N/A-Constraint does not have a removable base

Manufacturer's design seat back angle: 4.1° on Headrest Post
 Tested seat back angle: 3.8° on Headrest Post
 Manufacturer's specified anchorage position: 0 of 4; Upper-most defined as 0
 Tested anchorage position: 0 of 4; Upper-most defined as 0

A blanket was not used in the suppression testing because it did not affect the weight sensing system used on the vehicle.

Test Summary

Seat Belt	Seat Slide	Cinch Load (N)	Result
Belted Forward Facing	Forward	131	Suppressed
	Middle	133	Suppressed
	Rearward	128	Suppressed
Unbelted Forward Facing	Forward	N/A	Suppressed
	Middle	N/A	Suppressed
	Rearward	N/A	Suppressed
Belted Rear Facing	Forward 11*	130	Suppressed
	Middle	127	Suppressed
	Rearward	127	Suppressed
Unbelted Rear Facing	Forward 14*	N/A	Suppressed
	Middle	N/A	Suppressed
	Rearward	N/A	Suppressed

* The CRS would not fit in this forward seat slide position. If there is a number in the seat slide column, it indicates the fore-aft detent position with respect to the foremost position. (1 = Full Forward; 40 = Full Rearward; 40 total Seat Slide detents)

Successful Unbelted 5th percentile Female Dummy Reactivation was performed with the seat in the Forward position. (SN 506)

DATA SHEET 17 SUMMARY

Suppression Test Using 12-Month-Old CRABI Dummy (Part 572, Subpart R)
Section C Forward Facing Convertible CRS

NHTSA NO.:	C20140200	TEST DATE:	7/22/14
LABORATORY:	MGA	TECHNICIAN(S):	JL
DUMMY TYPE:	12 Month Old	DUMMY SERIAL NO.:	062

CHILD RESTRAINT NAME:	Cosco
CHILD RESTRAINT MODEL:	High Back Booster 22-209
DATE OF MANUFACTURE:	10-7-2008

Base: __On __Off N/A-Constraint does not have a removable base

Manufacturer's design seat back angle: 4.1° on Headrest Post
 Tested seat back angle: 3.8° on Headrest Post
 Manufacturer's specified anchorage position: 0 of 4; Upper-most defined as 0
 Tested anchorage position: 0 of 4; Upper-most defined as 0

A blanket was not used in the suppression testing because it did not affect the weight sensing system used on the vehicle.

Test Summary

Seat Belt	Seat Slide	Cinch Load (N)	Result
Belted Forward Facing	Forward	129	Suppressed
	Middle	131	Suppressed
	Rearward	130	Suppressed
Unbelted Forward Facing	Forward	N/A	Suppressed
	Middle	N/A	Suppressed
	Rearward	N/A	Suppressed
Unbelted Rear Facing	Forward	N/A	Suppressed
	Middle	N/A	Suppressed
	Rearward	N/A	Suppressed

Successful Unbelted 5th percentile Female Dummy Reactivation was performed with the seat in the Middle position. (SN 506)

The Cosco High Back Booster 22-209 does not have a rear facing belt path.

DATA SHEET 17 SUMMARY

Suppression Test Using 12-Month-Old CRABI Dummy (Part 572, Subpart R)
Section C Forward Facing Convertible CRS

NHTSA NO.:	C20140200	TEST DATE:	7/22/14
LABORATORY:	MGA	TECHNICIAN(S):	JL
DUMMY TYPE:	12 Month Old	DUMMY SERIAL NO.:	062

CHILD RESTRAINT NAME:	Evenflo
CHILD RESTRAINT MODEL:	Generations 352
DATE OF MANUFACTURE:	10-5-2006

Base: __On __Off N/A-Constraint does not have a removable base

Manufacturer's design seat back angle: 4.1° on Headrest Post
 Tested seat back angle: 3.8° on Headrest Post
 Manufacturer's specified anchorage position: 0 of 4; Upper-most defined as 0
 Tested anchorage position: 0 of 4; Upper-most defined as 0

A blanket was not used in the suppression testing because it did not affect the weight sensing system used on the vehicle.

Test Summary

Seat Belt	Seat Slide	Cinch Load (N)	Result
Belted Forward Facing	Forward	132	Suppressed
	Middle	130	Suppressed
	Rearward	132	Suppressed
Unbelted Forward Facing	Forward	N/A	Suppressed
	Middle	N/A	Suppressed
	Rearward	N/A	Suppressed
Unbelted Rear Facing	Forward	N/A	Suppressed
	Middle	N/A	Suppressed
	Rearward	N/A	Suppressed

Successful Unbelted 5th percentile Female Dummy Reactivation was performed with the seat in the Rearward position. (SN 506)

The Evenflo Generations 352 does not have a rear facing belt path.

DATA SHEET 17 SUMMARY

Suppression Test Using 12-Month-Old CRABI Dummy (Part 572, Subpart R)
Section C Forward Facing Convertible CRS

NHTSA NO.:	C20140200	TEST DATE:	7/22/14
LABORATORY:	MGA	TECHNICIAN(S):	JL
DUMMY TYPE:	12 Month Old	DUMMY SERIAL NO.:	062

CHILD RESTRAINT NAME:	Graco
CHILD RESTRAINT MODEL:	ComfortSport
DATE OF MANUFACTURE:	6-15-2009

Base: __On __Off X N/A-Constraint does not have a removable base

Manufacturer's design seat back angle: 4.0° on Headrest Post
 Tested seat back angle: 3.8° on Headrest Post
 Manufacturer's specified anchorage position: Upper-most
 Tested anchorage position: Upper-most

A blanket was not used in the suppression testing because it did not affect the weight sensing system used on the vehicle.

Test Summary

Seat Belt	Seat Slide	Cinch Load (N)	Result
Belted Forward Facing	Forward	128	Suppressed
	Middle	130	Suppressed
	Rearward	133	Suppressed
Unbelted Forward Facing	Forward	N/A	Suppressed
	Middle	N/A	Suppressed
	Rearward	N/A	Suppressed
Belted Rear Facing	Forward 4*	129	Suppressed
	Middle	132	Suppressed
	Rearward	127	Suppressed
Unbelted Rear Facing	Forward 9*	N/A	Suppressed
	Middle	N/A	Suppressed
	Rearward	N/A	Suppressed

* The CRS would not fit in this forward seat slide position. If there is a number in the seat slide column, it indicates the fore-aft detent position with respect to the foremost position. (1 = Full Forward; 40 = Full Rearward; 40 total Seat Slide detents)

Successful Unbelted 5th percentile Female Dummy Reactivation was performed with the seat in the Forward position. (SN 506)

DATA SHEET 18 SUMMARY

Suppression Test Using Newborn Infant Dummy (Part 572, Subpart K) Section A Car Bed

NHTSA NO.:	C20140200	TEST DATE:	7/21/14
LABORATORY:	MGA	TECHNICIAN(S):	MT
DUMMY TYPE:	Newborn Infant	DUMMY SERIAL NO.:	003

CAR BED NAME:	Angel Guard
CAR BED MODEL:	Angel Ride
DATE OF MANUFACTURE:	4-15-2008

Base: On Off N/A-Constraint does not have a removable base
 (A car bed with a removable base shall be treated as two separate models, i.e. this form and test procedure will be completed with the base on and then repeated on a new form with the base off.

Manufacturer's design seat back angle: 4.1° on Headrest Post
 Tested seat back angle: 3.8° on Headrest Post
 Manufacturer's specified anchorage position: 0 of 4; Upper-most defined as 0
 Tested anchorage position: 0 of 4; Upper-most defined as 0

A blanket and visor were not used in the suppression testing because they did not affect the weight sensing system used on the vehicle.

Test Summary

Seat Belt	Seat Slide	Result
Belted	Forward	Suppressed
	Middle	Suppressed
	Rearward	Suppressed

Successful Unbelted 5th percentile Female Dummy Reactivation was performed with the seat in the Forward position. (SN 506)

DATA SHEET 19 SUMMARY

Suppression Test Using 3 Year Old Dummy And Booster Seats (Part 572, Subpart P)
Section D Forward Facing Belt Positioning Booster

NHTSA NO.:	C20140200	TEST DATE:	7/22/14
LABORATORY:	MGA	TECHNICIAN(S):	JL
DUMMY TYPE:	3 Year Old	DUMMY SERIAL NO.:	032

BOOSTER SEAT NAME:	Cosco
BOOSTER SEAT MODEL:	Summit Deluxe High Back Booster 22-262
DATE OF MANUFACTURE:	8-9-2007

Manufacturer's design seat back angle:	<u>4.1° on Headrest Post</u>
Tested seat back angle:	<u>3.8° on Headrest Post</u>
Manufacturer's specified anchorage position:	<u>0 of 4; Upper-most defined as 0</u>
Tested anchorage position:	<u>0 of 4; Upper-most defined as 0</u>

Test Summary

Seat Belt	Seat Slide	Cinch Load (N)	Result
Belted Forward Facing Without Harness	Forward	11	Suppressed
	Middle	12	Suppressed
	Rearward	16	Suppressed
Belted Forward Facing Cinched With Harness	Forward	129	Suppressed
	Middle	128	Suppressed
	Rearward	128	Suppressed

Successful Unbelted 5th percentile Female Dummy Reactivation was performed with the seat in the Middle position. (SN 506)

DATA SHEET 19 SUMMARY

Suppression Test Using 3 Year Old Dummy And Booster Seats (Part 572, Subpart P)
Section D Forward Facing Toddler Belt Positioning Booster Seat

NHTSA NO.:	C20140200	TEST DATE:	7/22/14
LABORATORY:	MGA	TECHNICIAN(S):	JL
DUMMY TYPE:	3 Year Old	DUMMY SERIAL NO.:	032

BOOSTER SEAT NAME:	Graco
BOOSTER SEAT MODEL:	Platinum Cargo
DATE OF MANUFACTURE:	6-24-2008

Manufacturer's design seat back angle:	<u>4.1° on Headrest Post</u>
Tested seat back angle:	<u>3.8° on Headrest Post</u>
Manufacturer's specified anchorage position:	<u>0 of 4; Upper-most defined as 0</u>
Tested anchorage position:	<u>0 of 4; Upper-most defined as 0</u>

Test Summary

Seat Belt	Seat Slide	Cinch Load (N)	Result
Belted Forward Facing Without Harness	Forward	17	Suppressed
	Middle	14	Suppressed
	Rearward	14	Suppressed
Belted Forward Facing Cinched With Harness	Forward	130	Suppressed
	Middle	128	Suppressed
	Rearward	131	Suppressed

Successful Unbelted 5th percentile Female Dummy Reactivation was performed with the seat in the Rearward position. (SN 506)

DATA SHEET 20 SUMMARY

Suppression Test Using 3 Year Old Dummy And Convertible Restraints (Part 572, Subpart P)
Section C Forward Facing Convertible CRS

NHTSA NO.:	C20140200	TEST DATE:	7/22/14
LABORATORY:	MGA	TECHNICIAN(S):	JL
DUMMY TYPE:	3 Year Old	DUMMY SERIAL NO.:	032

CHILD RESTRAINT NAME:	Britax
CHILD RESTRAINT MODEL:	Roundabout E9L02
DATE OF MANUFACTURE:	7-2-2008

Manufacturer's design seat back angle: 4.1° on Headrest Post
Tested seat back angle: 3.8° on Headrest Post
Manufacturer's specified anchorage position: 0 of 4; Upper-most defined as 0
Tested anchorage position: 0 of 4; Upper-most defined as 0

Test Summary

Seat Belt	Seat Slide	Cinch Load (N)	Result
Belted	Forward	130	Suppressed
	Middle	127	Suppressed
	Rearward	132	Suppressed

Successful Unbelted 5th percentile Female Dummy Reactivation was performed with the seat in the Forward position. (SN 506)

DATA SHEET 20 SUMMARY

Suppression Test Using 3 Year Old Dummy And Convertible Restraints (Part 572, Subpart P)
Section C Forward Facing Convertible CRS

NHTSA NO.:	C20140200	TEST DATE:	7/22/14
LABORATORY:	MGA	TECHNICIAN(S):	JL
DUMMY TYPE:	3 Year Old	DUMMY SERIAL NO.:	032

CHILD RESTRAINT NAME:	Cosco
CHILD RESTRAINT MODEL:	High Back Booster 22-209
DATE OF MANUFACTURE:	10-7-2008

Manufacturer's design seat back angle:	<u>4.1° on Headrest Post</u>
Tested seat back angle:	<u>3.8° on Headrest Post</u>
Manufacturer's specified anchorage position:	<u>0 of 4; Upper-most defined as 0</u>
Tested anchorage position:	<u>0 of 4; Upper-most defined as 0</u>

Test Summary

Seat Belt	Seat Slide	Cinch Load (N)	Result
Belted (Without Harness)	Forward	9	Suppressed
	Middle	12	Suppressed
	Rearward	17	Suppressed
Belted (Cinched with Harness)	Forward	132	Suppressed
	Middle	132	Suppressed
	Rearward	128	Suppressed

Successful Unbelted 5th percentile Female Dummy Reactivation was performed with the seat in the Middle position. (SN 506)

DATA SHEET 20 SUMMARY

Suppression Test Using 3 Year Old Dummy And Convertible Restraints (Part 572, Subpart P)
Section C Forward Facing Convertible CRS

NHTSA NO.:	C20140200	TEST DATE:	7/22/14
LABORATORY:	MGA	TECHNICIAN(S):	JL
DUMMY TYPE:	3 Year Old	DUMMY SERIAL NO.:	032

CHILD RESTRAINT NAME:	Evenflo
CHILD RESTRAINT MODEL:	Generations 352
DATE OF MANUFACTURE:	10-5-2006

Manufacturer's design seat back angle:	<u>4.1° on Headrest Post</u>
Tested seat back angle:	<u>3.8° on Headrest Post</u>
Manufacturer's specified anchorage position:	<u>0 of 4; Upper-most defined as 0</u>
Tested anchorage position:	<u>0 of 4; Upper-most defined as 0</u>

Test Summary

Seat Belt	Seat Slide	Cinch Load (N)	Result
Belted (Without Harness)	Forward	10	Suppressed
	Middle	15	Suppressed
	Rearward	12	Suppressed
Belted (Cinched with Harness)	Forward	130	Suppressed
	Middle	130	Suppressed
	Rearward	131	Suppressed

Successful Unbelted 5th percentile Female Dummy Reactivation was performed with the seat in the Rearward position. (SN 506)

DATA SHEET 20 SUMMARY

Suppression Test Using 3 Year Old Dummy And Convertible Restraints (Part 572, Subpart P)
Section C Forward Facing Convertible CRS

NHTSA NO.:	C20140200	TEST DATE:	7/22/14
LABORATORY:	MGA	TECHNICIAN(S):	JL
DUMMY TYPE:	3 Year Old	DUMMY SERIAL NO.:	032

CHILD RESTRAINT NAME:	Graco
CHILD RESTRAINT MODEL:	Comfort Sport
DATE OF MANUFACTURE:	6-15-2009

Manufacturer's design seat back angle:	<u>4.1° on Headrest Post</u>
Tested seat back angle:	<u>3.8° on Headrest Post</u>
Manufacturer's specified anchorage position:	<u>0 of 4; Upper-most defined as 0</u>
Tested anchorage position:	<u>0 of 4; Upper-most defined as 0</u>

Test Summary

Seat Belt	Seat Slide	Cinch Load (N)	Result
Belted	Forward	132	Suppressed
	Middle	129	Suppressed
	Rearward	130	Suppressed

Successful Unbelted 5th percentile Female Dummy Reactivation was performed with the seat in the Rearward position. (SN 506)

DATA SHEET 21 SUMMARY

Suppression Test Using An Unbelted 3 Year Old Dummy (Part 572, Subpart P)
No CRS

NHTSA NO.:	C20140200	TEST DATE:	7/22/14
LABORATORY:	MGA	TECHNICIAN(S):	JL
DUMMY TYPE:	3 Year Old	DUMMY SERIAL NO.:	032

Test Summary

Position	Seat Slide	Seat Back Angle **	Result
Position 1 Sitting on seat with back against seat back	Forward	3.8° on HRP	Suppressed
	Middle	3.8° on HRP	Suppressed
	Rearward	3.8° on HRP	Suppressed
Position 2 Sitting on seat with back against reclined seat back	Forward	27.4° on HRP**	Suppressed
	Middle	27.4° on HRP**	Suppressed
	Rearward	27.4° on HRP**	Suppressed
Position 3 Sitting on seat with back not against seat back	Forward	3.8° on HRP	Suppressed
	Middle	3.8° on HRP	Suppressed
	Rearward	3.8° on HRP	Suppressed
Position 4 Sitting on seat edge, spine vertical, hands at dummy's sides	Forward	3.8° on HRP	Suppressed
	Middle	3.8° on HRP	Suppressed
	Rearward	3.8° on HRP	Suppressed
Position 5 Standing on seat, facing forward	Forward	3.8° on HRP	Suppressed
	Middle	3.8° on HRP	Suppressed
	Rearward	3.8° on HRP	Suppressed
Position 6 Kneeling on seat, facing forward	Forward	3.8° on HRP	Suppressed
	Middle	3.8° on HRP	Suppressed
	Rearward	3.8° on HRP	Suppressed
Position 7 Kneeling on seat, facing rearward	Forward	3.8° on HRP	Suppressed
	Middle	3.8° on HRP	Suppressed
	Rearward	3.8° on HRP	Suppressed
Position 8 Lying on seat. (Three designated seating positions only)	Forward	N/A	N/A
	Middle	N/A	N/A
	Rearward	N/A	N/A

Successful Unbelted 5th percentile Female Dummy Reactivation was performed with the seat in the Forward position. (SN 506)

** The manufacturer's design seat back angle of 4.1° on Headrest Post; equaled 3.8° on the head rest post (HRP). When the vehicle passenger seat was reclined 25° the seat back angle on the head rest post was 27.4°.

DATA SHEET 22 SUMMARY

Suppression Test Using 6 Year Old Dummy And Booster Seats (Part 572, Subpart N)
Section D Forward Facing Toddler Belt Positioning Booster Seat

NHTSA NO.:	C20140200	TEST DATE:	7/22/14
LABORATORY:	MGA	TECHNICIAN(S):	JL
DUMMY TYPE:	6 Year Old	DUMMY SERIAL NO.:	153

CHILD RESTRAINT NAME:	Cosco
CHILD RESTRAINT MODEL:	Summit Deluxe High Back Booster 22-262
DATE OF MANUFACTURE:	8-9-2007

Manufacturer's design seat back angle:	<u>4.1° on Headrest Post</u>
Tested seat back angle:	<u>3.8° on Headrest Post</u>
Manufacturer's specified anchorage position:	<u>0 of 4; Upper-most defined as 0</u>
Tested anchorage position:	<u>0 of 4; Upper-most defined as 0</u>

Test Summary

Seat Belt	Seat Slide	Cinch Load (N)	Result
Belted (9-18N)	Forward	13	Suppressed
	Middle	17	Suppressed
	Rearward	15	Suppressed

Successful Unbelted 5th percentile Female Dummy Reactivation was performed with the seat in the Middle position. (SN 506)

DATA SHEET 22 SUMMARY

Suppression Test Using 6 Year Old Dummy And Booster Seats (Part 572, Subpart N)
Section D Forward Facing Toddler Belt Positioning Booster Seat

NHTSA NO.:	C20140200	TEST DATE:	7/22/14
LABORATORY:	MGA	TECHNICIAN(S):	JL
DUMMY TYPE:	6 Year Old	DUMMY SERIAL NO.:	153

CHILD RESTRAINT NAME:	Graco
CHILD RESTRAINT MODEL:	Platinum Cargo
DATE OF MANUFACTURE:	6-24-2008

Manufacturer's design seat back angle:	<u>4.1° on Headrest Post</u>
Tested seat back angle:	<u>3.8° on Headrest Post</u>
Manufacturer's specified anchorage position:	<u>0 of 4; Upper-most defined as 0</u>
Tested anchorage position:	<u>0 of 4; Upper-most defined as 0</u>

Test Summary

Seat Belt	Seat Slide	Cinch Load (N)	Result
Belted (9-18N)	Forward	11	Suppressed
	Middle	16	Suppressed
	Rearward	15	Suppressed

Successful Unbelted 5th percentile Female Dummy Reactivation was performed with the seat in the Rearward position. (SN 506)

DATA SHEET 23 SUMMARY

Suppression Tests Using an Unbelted 6 Year Old Dummy (Part 572, Subpart N) (S24.2.1)
No CRS

NHTSA NO.:	C20140200	TEST DATE:	7/22/14
LABORATORY:	MGA	TECHNICIAN(S):	JL
DUMMY TYPE:	6 Year Old	DUMMY SERIAL NO.:	153

Test Summary

Position	Seat Slide	Seat Back Angle **	Result
Position 1 Sitting on seat with back against seat back	Forward	3.8° on HRP	Suppressed
	Middle	3.8° on HRP	Suppressed
	Rearward	3.8° on HRP	Suppressed
Position 2 Sitting on seat with back against reclined seat back	Forward	27.4° on HRP**	Suppressed
	Middle	27.4° on HRP**	Suppressed
	Rearward	27.4° on HRP**	Suppressed
Position 3 Sitting on seat edge, spine vertical, hands at dummy's sides	Forward	3.8° on HRP	Suppressed
	Middle	3.8° on HRP	Suppressed
	Rearward	3.8° on HRP	Suppressed
Position 4 Sitting on seat with back against seat back then leaning on the door	Forward	3.8° on HRP	Suppressed
	Middle	3.8° on HRP	Suppressed
	Rearward	3.8° on HRP	Suppressed

Successful Unbelted 5th percentile Female Dummy Reactivation was performed with the seat in the middle position. (SN 506)

** The manufacturer's design seat back angle of 4.1° on Headrest Post; equaled 3.8° on the head rest post (HRP). When the vehicle passenger seat was reclined 25° the seat back angle on the head rest post was 27.4°.

DATA SHEET 29 SUMMARY

Low Risk Deployment Tests Using an Unbelted 5th Percentile Female
Dummy (Part 572, Subpart O) (S26) Position 1 - Chin On Module (S26.2)

NHTSA NO.:	C20140200	TEST DATE:	7/30/14
LABORATORY:	MGA	TECHNICIAN(S):	NA / JL
DUMMY TYPE:	5 th Percentile Female	DUMMY SERIAL NO.:	124

Manufacturer's design seat back angle: 4.1° on Headrest Post
 Tested seat back angle: 4.3° on Headrest Post
 Tested seat position: Full Aft

Tested steering wheel angle: 27.5°
 Thorax cavity angle: 33.3°
 Bottom of chin height: 3 mm – Above Plane F Module Height

Air Bag Deployment Timing

Stage No.	Firing time (ms)	Recorded firing time (ms)
1	0.0	0.0
2	150.0	150.0

5th Percentile Female SN 124 Position 1 (Chin On Module) 7/30/14

Injury Criteria	Max. Allowable Injury Assessment Values	Measured Value
HIC15	700	39
Peak Nij (Nte)	1.0	0.4
Time (ms)	NA	86.9
Peak Nij (Ntf)	1.0	0.4
Time (ms)	NA	25.1
Peak Nij (Nce)	1.0	0.4
Time (ms)	NA	174.5
Peak Nij (Ncf)	1.0	0.1
Time (ms)	NA	8.2
Neck Tension	2070 N	845
Neck Compression	2520 N	306
Chest g	60 g	14
Chest Displacement	52 mm	5
Left Femur	6805 N	97
Right Femur	6805 N	85

Calculated on data recorded for 125 ms after the initiation of the final stage of air bag deployment designed to deploy in any full frontal rigid barrier crash up to 26 km/h. (S4.11 (d))
 Second stage fire time of 150 ms; Injuries calculated on 0 ms to 275 ms.

The original equipment parts and a new air bag were used for this deployment.

DATA SHEET 30 SUMMARY

Low Risk Deployment Tests Using an Unbelted 5th Percentile Female Dummy (Part 572, Subpart O) (S26) Position 2 - Chin On Rim (S26.3)

NHTSA NO.:	C20140200	TEST DATE:	7/30/14
LABORATORY:	MGA	TECHNICIAN(S):	NA / JL
DUMMY TYPE:	5 th Percentile Female	DUMMY SERIAL NO.:	124

Manufacturer's design seat back angle: 4.1° on Headrest Post
 Tested seat back angle: 4.3° on Headrest Post
 Tested seat position: Full Aft

Tested steering wheel angle: 27.5°
 Thorax cavity angle: 33.5°
 Chin Point height: 1 mm Above Steering Wheel Target
Note: The chin on rim steering wheel target is 10 mm below the highest point on the steering wheel.

Air Bag Deployment Timing

Stage No.	Firing time (ms)	Recorded firing time (ms)
1	0.0	0.0
2	150.0	150.0

5th Percentile Female SN 124 Position 2 (Chin On Rim) 7/30/14

Injury Criteria	Max. Allowable Injury Assessment Values	Measured Value
HIC15	700	161
Peak Nij (Nte)	1.0	0.4
Time (ms)	NA	12.0
Peak Nij (Ntf)	1.0	0.3
Time (ms)	NA	61.9
Peak Nij (Nce)	1.0	0.1
Time (ms)	NA	250.6
Peak Nij (Ncf)	1.0	0.2
Time (ms)	NA	67.1
Neck Tension	2070 N	705
Neck Compression	2520 N	166
Chest g	60 g	17
Chest Displacement	52 mm	17
Left Femur	6805 N	66
Right Femur	6805 N	49

Calculated on data recorded for 125 ms after the initiation of the final stage of air bag deployment designed to deploy in any full frontal rigid barrier crash up to 26 km/h. (S4.11 (d))
 Second stage fire time of 150 ms; Injuries calculated on 0 ms to 275 ms.

A new air bag; and original equipment steering column and steering wheel were used for this deployment.

DATA SHEET 32

VEHICLE WEIGHT, FUEL TANK, AND ATTITUDE DATA

Test Vehicle: 2014 Ford Escape
 Test Program: FMVSS 208 Compliance
 Test Technician: Alex Vanderheyden

NHTSA No.: C20140200
 Test Date: 8/25/14

IMPACT ANGLE:	30° Left Oblique					
BELTED DUMMIES (YES/NO):	NO					
TEST SPEED:	X	32 to 40 kmph		0 to 48 kmph		0 to 56 kmph
DRIVER DUMMY:			5 th female	X		50 th male
PASSENGER DUMMY:			5 th female	X		50 th male

- 1. Fill the transmission with transmission fluid to the satisfactory range.
- 2. Drain fuel from vehicle.
- 3. Run the engine until fuel remaining in the fuel delivery system is used and the engine stops.
- 4. Record the useable fuel tank capacity supplied by the COTR.
Useable Fuel Tank Capacity supplied by COTR: 57.0 liters (15.06 gallons)
- 5. Record the fuel tank capacity supplied in the owner's manual.
Useable Fuel Tank Capacity in owner's manual: 57.0 liters (15.06 gallons)
- 6. Using purple dyed Stoddard solvent having the physical and chemical properties of Type 1 solvent or cleaning fluid, Table 1, ASTM Standard D484-71, "Standard Specifications for Hydrocarbon Dry-cleaning Solvents," or gasoline, fill the fuel tank.
Amount Added: 57.0 liters (15.06 gallons)
- 7. Fill the coolant system to capacity.
- 8. Fill the engine with motor oil to the Max. Mark on the dip stick.
- 9. Fill the brake reservoir with brake fluid to its normal level.
- 10. Fill the windshield washer reservoir to capacity.
- 11. Inflate the tires to the tire pressure on the tire placard. If no tire placard is available, inflate the tires to the recommended pressure in the owner's manual.

Tire placard pressure:	RF:	35 psi	LF:	35 psi	RR:	35 psi	LR:	35 psi
Owner's manual pressure:	RF:	35 psi	LF:	35 psi	RR:	35 psi	LR:	35 psi
Actual inflated pressure:	RF:	35 psi	LF:	35 psi	RR:	35 psi	LR:	35 psi

- 12. Record the vehicle weight at each wheel to determine the unloaded vehicle weight (UVW), i.e. "as delivered" weight).

Right Front (kg):	464.0	Right Rear (kg):	338.4
Left Front (kg):	474.5	Left Rear (kg):	327.0
Total Front (kg):	938.5	Total Rear (kg):	665.4
% Total Weight:	58.5	% Total Weight:	41.5
UVW = TOTAL FRONT PLUS TOTAL REAR (KG):	1603.9		

- 13. UVW Test Vehicle Attitude: (All dimensions in millimeters)
- 13.1 Mark a point on the vehicle above the center of each wheel.
- 13.2 Place the vehicle on a level surface.
- 13.3 Measure perpendicular to the level surface to the 4 points marked on the body and record the measurements.

RF:	740	LF:	743	RR:	784	LR:	785
-----	-----	-----	-----	-----	-----	-----	-----

- 14. Calculate the Rated Cargo and Luggage Weight (RCLW): 35 kg

- 14.1 Does the vehicle have the vehicle capacity weight (VCW) on the certification label or tire placard?
- Yes, go to 14.3
 No, go to 14.2
- 14.2 VCW = Gross Vehicle Weight - UVW
- VCW = _____ - _____ = _____
- 14.3 VCW = 375 kg (827 lbs)
- 14.4 Does the certification or tire placard contain the Designated Seating Capacity (DSC)?
- Yes, go to 14.6
 No, go to 14.5 and skip 14.6
- 14.5 DSC = Total number of seat belt assemblies = _____
- 14.6 DSC = 5
- 14.7 RCLW = VCW - (68 kg x DSC) = 375 kg - (68 kg x 5) = 35 kg
- 14.8 Is the vehicle certified as a truck, MPV or bus (see the certification label on the door jamb)?
- Yes, if the calculated RCLW is greater than 136 kg, use 136 kg as the RCLW. (S8.1.1)
 No, use the RCLW calculated in 14.7
15. Fully Loaded Weight (100% fuel fill): 1794.9 kg
- 15.1 Place the appropriate test dummy in both front outboard seating positions.
- Driver: _ 5th female 50th male
Passenger: _ 5th female 50th male
- 15.2 Load the vehicle with the RCLW from 14.7 or 14.8 whichever is applicable.
- 15.3 Place the RCLW in the cargo area. Center the load over the longitudinal centerline of the vehicle. (S8.1.1(d))
- 15.4 Record the vehicle weight at each wheel to determine the Fully Loaded Weight.
- | | | | |
|---|--------|------------------|--------|
| Right Front (kg): | 502.6 | Right Rear (kg): | 394.2 |
| Left Front (kg): | 514.8 | Left Rear (kg): | 383.3 |
| Total Front (kg): | 1017.4 | Total Rear (kg): | 777.5 |
| % Total Weight: | 56.7 | % Total Weight: | 43.3 |
| % GVW | 52.4 | % GVW | 48.0 |
| (% GVW = Axle GVW divided by Vehicle GVW) | | | |
| Fully Loaded Weight = Total Front Plus Total Rear (kg): | | | 1794.9 |
16. Fully Loaded Test Vehicle Attitude: (All dimensions in millimeters)
- 16.1 Place the vehicle on a level surface.
- 16.2 Measure perpendicular to the level surface to the 4 points marked on the body (see 13.1 above) and record the measurements.
- | | | | | | | | |
|-----|-----|-----|-----|-----|-----|-----|-----|
| RF: | 733 | LF: | 734 | RR: | 767 | LR: | 773 |
|-----|-----|-----|-----|-----|-----|-----|-----|
17. Drain the fuel system.
18. Using purple dyed Stoddard solvent having the physical and chemical properties of Type 1 solvent or cleaning fluid, Table 1, ASTM Standard D484-71, "Standard Specifications for Hydrocarbon Dry-cleaning Solvents," fill the fuel tank to 92 - 94 percent of useable capacity. Fuel tank capacity x .94 = 57.0 liters (15.06 gallons) x .94 = 53.6 liters (14.2 gallons)
Amount added: 53.0 liters (14.0 gallons) 93.0%
19. Crank the engine to fill the fuel delivery system with Stoddard solvent.
20. Calculate the test weight range.

- 20.1 Calculated Weight = UVW (see 12 above) + RCLW (see 14 above) + 2x(dummy weight)
1794.9 kg = 1603.9 kg + 35.0 kg + 156.0 kg
- 20.2 Test Weight Range = Calculated Weight (- 4.5 kg, - 9 kg.)
 Max. Test Weight = Calculated Test Weight - 4.5 kg = 1790.4 kg
 Min. Test Weight = Calculated Test Weight - 9 kg = 1785.9 kg
21. Remove the RCLW from the cargo area.
22. Drain transmission fluid, engine coolant, motor oil, and windshield washer fluid from the test vehicle so that Stoddard solvent leakage from the fuel system will be evident.
23. Vehicle Components Removed For Weight Reduction:
Rear Floor Mats, Right Rear Tail Light, Spare Tire, Jack and Tools, Spare Tire Cover, Cargo Organizer
24. Secure the equipment and ballast in the load carrying area and distribute it, as nearly as possible, to obtain the proportion of axle weight indicated by the gross axle weight ratings and center it over the longitudinal centerline of the vehicle.
25. If necessary, add ballast to achieve the actual test weight.
 N/A
 Weight of Ballast: 27.7 kg
26. Ballast, including test equipment, must be contained so that it will not shift during the impact event or interfere with data collection or interfere with high-speed film recordings or affect the structural integrity of the vehicle or do anything else to affect test results. Care must be taken to assure that any attachment hardware added to the vehicle is not in the vicinity of the fuel tank or lines.
27. Record the vehicle weight at each wheel to determine the actual test weight.
- | | | | |
|---|--------|------------------|--------|
| Right Front (kg): | 500.3 | Right Rear (kg): | 392.8 |
| Left Front (kg): | 511.7 | Left Rear (kg): | 383.3 |
| Total Front (kg): | 1012.0 | Total Rear (kg): | 776.1 |
| % Total Weight: | 56.6 | % Total Weight: | 43.4 |
| % GVW | 52.4 | % GVW | 48.0 |
| (% GVW = Axle GVW divided by Vehicle GVW) | | | |
| TOTAL FRONT PLUS TOTAL REAR (kg): | | | 1788.1 |
28. Is the test weight between the Max Weight and the Min. Weight (See 20.2)?
 Yes
 No, explain why not.
29. Test Weight Vehicle Attitude: (all dimensions in millimeters)
- 29.1 Place the vehicle on a level surface.
- 29.2 Measure perpendicular to the level surface to the 4 points marked on the body (see 13 above) and record the measurements.
- | | | | | | | | |
|-----|-----|-----|-----|-----|-----|-----|-----|
| RF: | 734 | LF: | 735 | RR: | 774 | LR: | 777 |
|-----|-----|-----|-----|-----|-----|-----|-----|
30. Summary of test attitude
- 30.1 AS DELIVERED:
- | | | | | | | | |
|-----|-----|-----|-----|-----|-----|-----|-----|
| RF: | 740 | LF: | 743 | RR: | 784 | LR: | 785 |
|-----|-----|-----|-----|-----|-----|-----|-----|
- AS TESTED:
- | | | | | | | | |
|-----|-----|-----|-----|-----|-----|-----|-----|
| RF: | 734 | LF: | 735 | RR: | 774 | LR: | 777 |
|-----|-----|-----|-----|-----|-----|-----|-----|
- FULLY LOADED:
- | | | | | | | | |
|-----|-----|-----|-----|-----|-----|-----|-----|
| RF: | 733 | LF: | 734 | RR: | 767 | LR: | 773 |
|-----|-----|-----|-----|-----|-----|-----|-----|

30.2 Is the "as tested" test attitude equal to or between the "fully loaded" and "as delivered" attitude?

Yes

No, explain why not.

REMARKS:

Signature: *Chex Vandenberg* Date: 8/25/14

I certify that I have read and performed each instruction.

DATA SHEET 33

VEHICLE ACCELEROMETER LOCATION AND MEASUREMENT

Test Vehicle: 2014 Ford Escape
 Test Program: FMVSS 208 Compliance
 Test Technician: Alex Vanderheyden

NHTSA No.: C20140200
 Test Date: 8/25/14

IMPACT ANGLE:	30° Left Oblique					
BELTED DUMMIES (YES/NO):	NO					
TEST SPEED:	X	32 to 40 kmph		0 to 48 kmph		0 to 56 kmph
DRIVER DUMMY:			5 th female	X		50 th male
PASSENGER DUMMY:			5 th female	X		50 th male

- 1. Find the location where the vertical plane parallel to the longitudinal centerline of the vehicle and through the center of the left front outboard seating position intersects the left rear seat cross member. Install an accelerometer at this intersection on the rear seat cross member to record x-direction accelerations. Record the location on the following chart.
- 2. Find the location where the vertical plane parallel to the longitudinal centerline of the vehicle and through the center of the right front outboard seating position intersects the right rear seat cross member. Install an accelerometer at this intersection on the rear seat cross member to record x-direction accelerations. Record the location on the following chart.
- 3. Find the location where a vertical plane through the longitudinal centerline of the vehicle and a vertical transverse plane through the center of the two wheels on opposite sides of the engine intersect at the top of the engine. Install an accelerometer at this intersection to record x-direction accelerations. Record the location on the following chart.
- 4. Find the location where a vertical plane through the longitudinal centerline of the vehicle and a vertical transverse plane through the center of the two wheels on opposite sides of the engine intersect the bottom of the engine. Install an accelerometer at this intersection to record x-direction accelerations. Record the location on the following chart.
- 5. Install an accelerometer on the right front brake caliper to record x-direction accelerations. Record the location on the following chart.
- 6. Find the location where a vertical plane through the longitudinal centerline of the vehicle intersects the top of the instrument panel. Install an accelerometer at this intersection to record x-direction accelerations. Record the location on the following chart.
- 7. Install an accelerometer on the left front brake caliper to record x-direction accelerations. Record the location on the following chart.
- 8. Find the location where a vertical plane through the longitudinal centerline of the vehicle intersects the floor of the trunk. Install an accelerometer on the trunk floor at this intersection to record z-direction accelerations. Record the location on the following chart.

REMARKS:

I certify that I have read and performed each instruction.

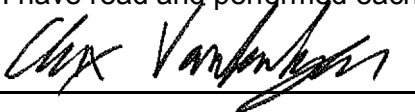
Signature: 

Date: 8/25/14

VEHICLE ACCELEROMETER LOCATION AND DATA SUMMARY

CENTERLINE OF FRONT WHEELS

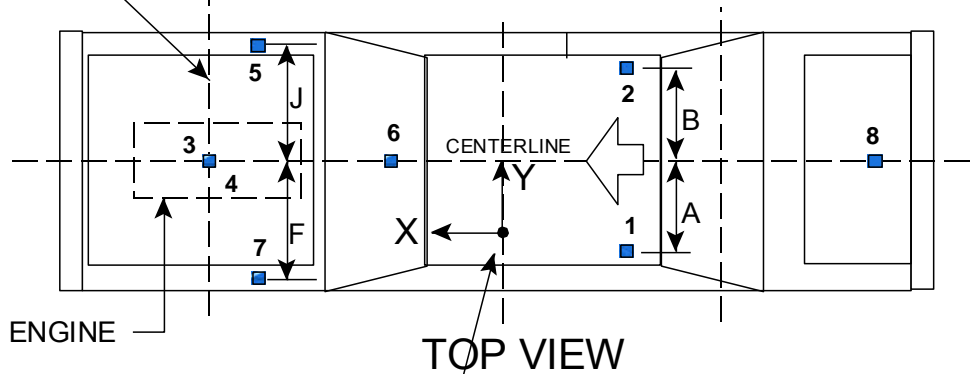

TOP VIEW

ACCELEROMETER COORDINATE SYSTEM (POSITIVE DIRECTION SHOWN)

REAR SEAT CUSHION ASSY. FRONT ATTACHMENT BRACKET SUPPORT

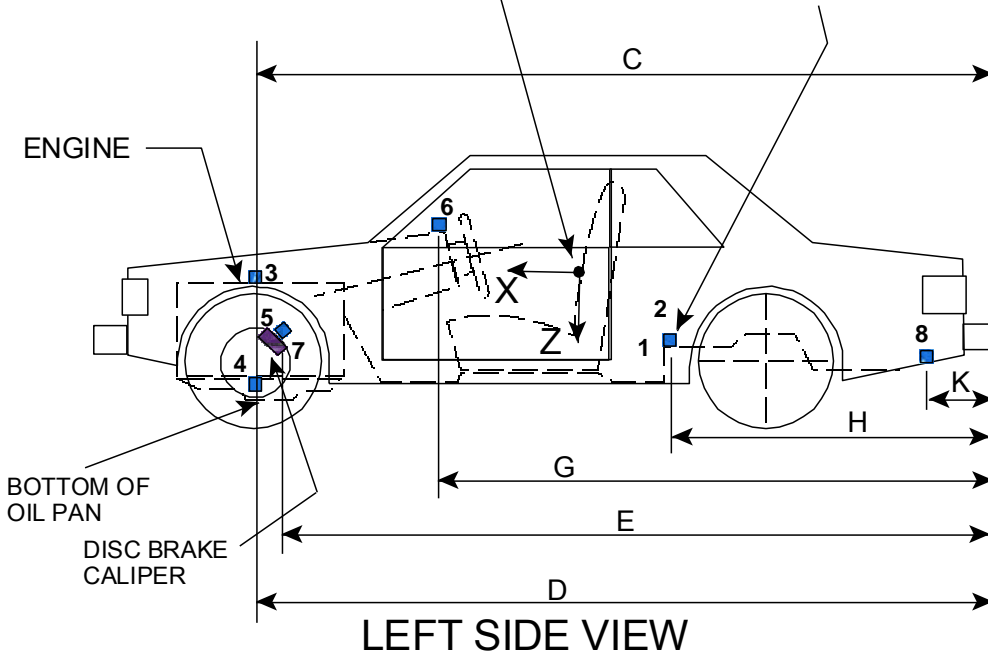

LEFT SIDE VIEW

Dimensions Corresponding To The Letters "A" Through "K" (Excluding "I") Are Recorded In The Table On The Following Page.

Accelerometers Corresponding To The Numbers 1 Through 8 Are Specified On The Preceding Page.

VEHICLE ACCELEROMETER LOCATION AND MEASUREMENTS

<u>DIMENSION</u>	<u>LENGTH (mm)</u>	
<u>PRETEST VALUES</u>		
<u>A</u> (LH Rear Seat Xmbr)	373	
<u>B</u> (RH Rear Seat Xmbr)	375	
<u>C</u> (Engine Top)	3765	
<u>D</u> (Engine Bottom)	3660	
<u>E</u> (Caliper)	Right Side: 3710	Left Side: 3710
<u>F</u> (Left Caliper)	775	
<u>G</u> (IP)	2940	
<u>H</u> (Seat)	1870	
<u>J</u> (Right Caliper)	775	
<u>K</u> (Trunk)	900	
<u>POST TEST VALUES</u>		
<u>A</u> (LH Rear Seat Xmbr)	373	
<u>B</u> (RH Rear Seat Xmbr)	375	
<u>C</u> (Engine Top)	3752	
<u>D</u> (Engine Bottom)	3648	
<u>E</u> (Caliper)	Right Side: 3672	Left Side: 3576
<u>F</u> (Left Caliper)	695	
<u>G</u> (IP)	2937	
<u>H</u> (Seat)	1870	
<u>J</u> (Right Caliper)	775	
<u>K</u> (Trunk)	900	

DATA SHEET 34
PHOTOGRAPHIC TARGETS

Test Vehicle: 2014 Ford Escape
 Test Program: FMVSS 208 Compliance
 Test Technician: Alex Vanderheyden

NHTSA No.: C20140200
 Test Date: 8/25/14

IMPACT ANGLE:	30° Left Oblique		
BELTED DUMMIES (YES/NO):	NO		
TEST SPEED:	X	32 to 40 kmph	0 to 48 kmph
DRIVER DUMMY:		5 th female	X
PASSENGER DUMMY:		5 th female	X

- 1. **FMVSS 208 vehicle targeting requirements** (See Figures 28A and 28B)
- 1.1 Targets A1 and A2 are on flat rectangular panels.
- 1.2 Three circular targets at least 90 mm in diameter and with black and yellow quadrants are mounted at the front on the outboard sides of A1 and A2. The center of each circular target is 100 mm from the one next to it.
- Distance between targets (mm): 100 mm
- 1.3 Three circular targets at least 90 mm in diameter and with black and yellow quadrants are mounted at the back on the outboard sides of on A1 and A2. The center of each circular target is 100 mm from the one next to it.
- Distance between targets (mm): 100 mm
- 1.4 The distance between the first circular target at the front of A1 and A2 and the last circular target at the back of A1 and A2 is at least 915 mm.
- Distance between the first and last circular targets (mm): 915 mm
- 1.5 Firmly fix target A1 on the vehicle roof in the vertical longitudinal plane that is coincident with the midsagittal plane of the driver dummy.
- 1.6 Firmly fix target A2 on the vehicle roof in the vertical longitudinal plane that is coincident with the midsagittal plane of the passenger dummy.
- 1.7 Two circular targets (C1 and C2) at least 90 mm in diameter and with black and yellow quadrants are mounted on the outside of the driver door. The centers of each circular target are at least 610 mm apart.
- Distance between targets (mm): 610 mm
- 1.8 Two circular targets (C1 and C2) at least 90 mm in diameter and with black and yellow quadrants are mounted on the outside of the passenger door. The centers of each circular target are at least 610 mm apart.
- Distance between targets (mm): 610 mm
- 1.9 Place tape with squares having alternating colors on the top portion of the steering wheel.
- 1.10 Chalk the bottom portion of the steering wheel.
- 1.11 Is this an offset test?
- Yes, continue with this section**
- No, go to 2.**
- 1.12 Measure the width of the vehicle.
Vehicle width (mm):
- 1.13 Find the centerline of the vehicle. ($\frac{1}{2}$ of the vehicle width)
- 1.14 Find the line parallel to the centerline of the vehicle and 0.1 x vehicle width from the centerline of the vehicle.
- 1.15 Apply 25 mm wide tape with alternating black and yellow squares parallel to and on each side of the line found in 1.14. The edge of each tape shall be 50 mm from the line found in 1.14. The tape shall extend from the bottom of the bumper to the front edge of the windshield. (Figure 28D)

2. **Barrier Targeting**
- 2.1 Fix two stationary targets D1 and D2 to the barrier as shown in the Figure 28A. One target is in the vertical longitudinal plane that is coincident with the midsagittal plane of the driver dummy. The other is in the vertical longitudinal plane that is coincident with the midsagittal plane of the passenger dummy.
- 2.2 Targets D1 and D2 are on a rectangular panel.
- 2.3 Three circular targets at least 90 mm in diameter and with black and yellow quadrants are mounted on the sides of the rectangular panel away from the longitudinal centerline of the vehicle. The center of each circular target is 100 mm from the one next to it.
- Distance between circular targets on D1 (mm): 100 mm
- Distance between circular targets on D2 (mm): 100 mm
3. **FMVSS 208 Dummy Targeting Requirements**
- 3.1 Place a circular target with black and yellow quadrants on both sides of the driver dummy head as close as possible to the center of gravity of the head in the x and z direction (relative to the measuring directions of the accelerometers).
- 3.2 Place a circular target with black and yellow quadrants on both sides of the passenger dummy head as close as possible to the center of gravity of the head in the x and z direction (relative to the measuring directions of the accelerometers).
- 3.3 Place a circular target with black and yellow quadrants on the outboard shoulder of the driver dummy. Place the target as high up on the arm as possible at the intersection of the arm and shoulder. The sleeve of the shirt on the dummy may be cut to make the target visible, but do not remove any material.
- 3.4 Place a circular target with black and yellow quadrants on the outboard shoulder of the passenger dummy. Place the target as high up on the arm as possible at the intersection of the arm and shoulder. The sleeve of the shirt on the dummy may be cut to make the target visible, but do not remove any material.
4. **FMVSS 204 Targeting Requirements**
- 4.1 Is an FMVSS 204 indicant test ordered on the "COTR Vehicle Work Order?"
- Yes, continue with this form.
- No, this form is complete.
- 4.2 Resection panel (Figure 28C)
- 4.2.1 The panel deviates no more than 6 mm from perfect flatness when suspended vertically.
- 4.2.2 The 8 targets on the panel are circular targets at least 90 mm in diameter and with black and yellow quadrants.
- 4.2.3 The center of each of the 4 outer targets are placed within 1 mm of the corners of a square measuring 914 mm on each side.
- 4.2.4 Locate another square with 228 mm sides and with the center of this square coincident with the center of the 914 mm square.
- 4.2.5 The center of the 4 inner targets are placed at the midpoints of each of the 228 mm sides.
- 4.3 Place a circular target at least 90 mm in diameter and with black and yellow quadrants on a material (cardboard, metal, etc.) that can be taped to the top of the steering column.
- 4.4 Tape the target from 4.3 to the top of the steering column in a manner that does not interfere with the movement of the steering column in a crash.

REMARKS:

Signature: *Colex Vandenberg*

Date: 8/25/14

I certify that I have read and performed each instruction.

REFERENCE PHOTO TARGETS

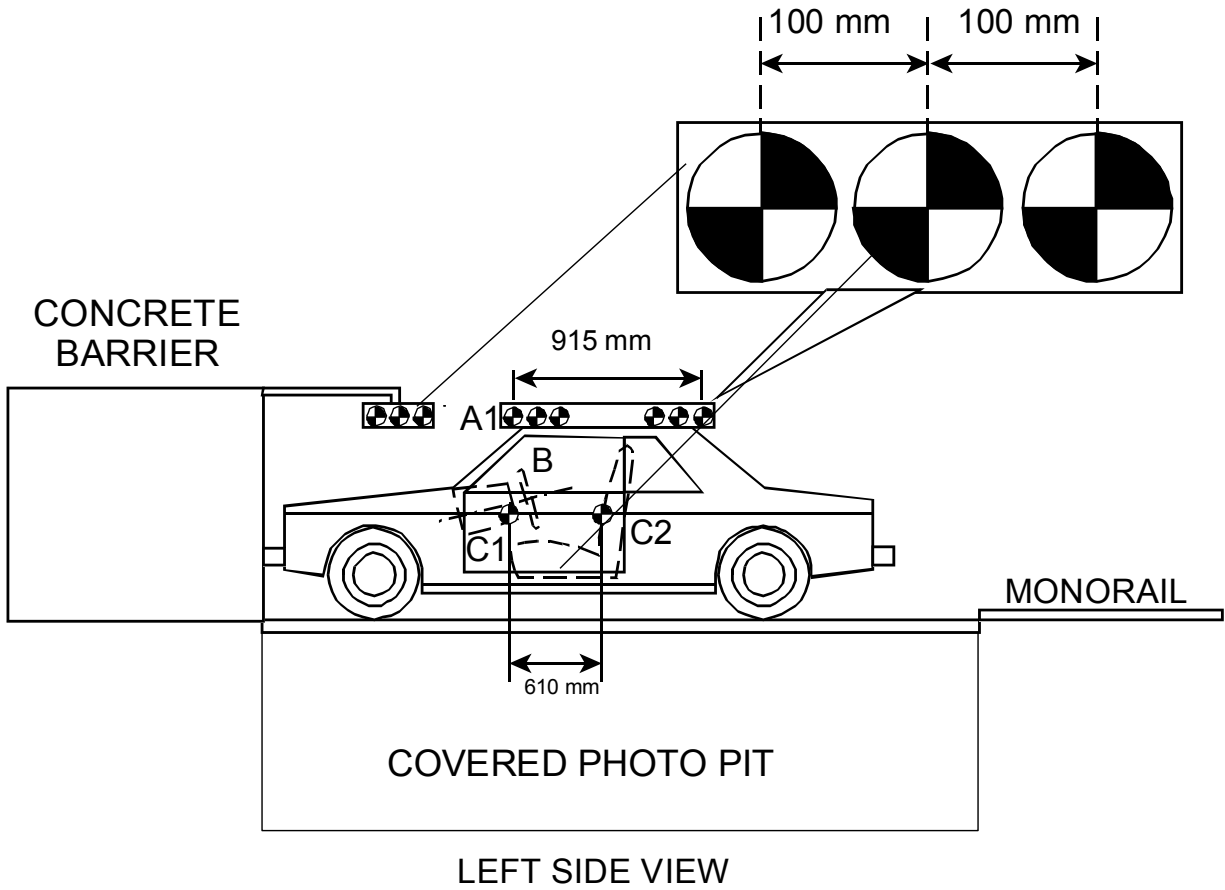

RESECTION PANEL TARGETING ALIGNMENT

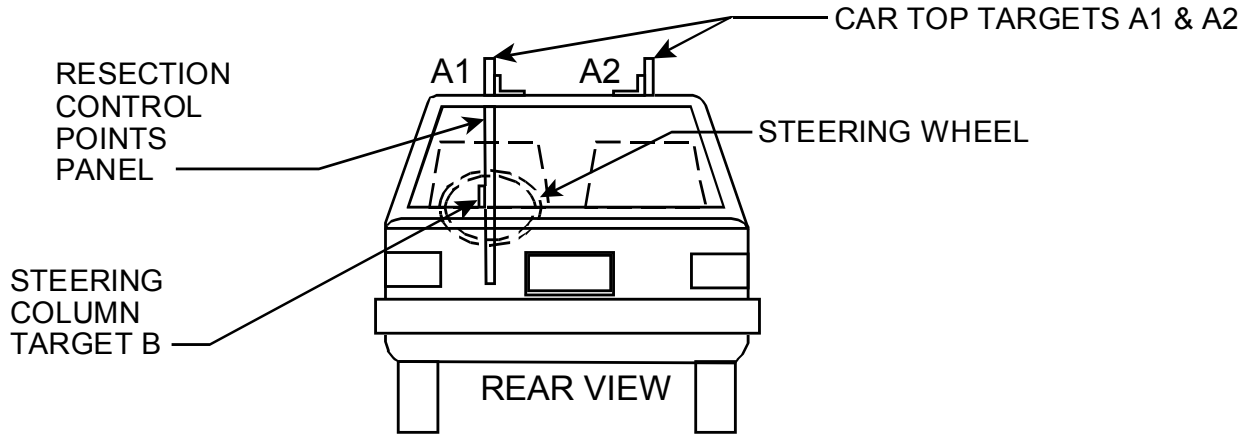

TEST RUN STEERING COLUMN CAMERA VIEW OF TYPICAL TIME ZERO VEHICLE POSITION

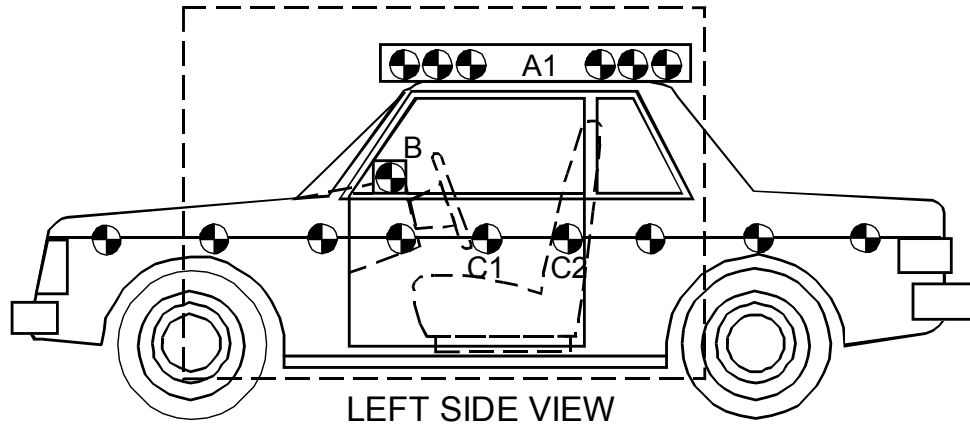

PRE-RUN STEERING COLUMN HIGH SPEED CAMERA VIEW

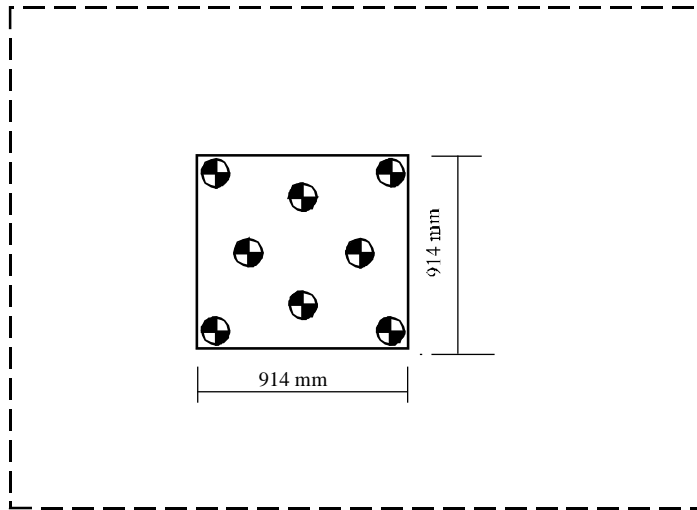

LEFT SIDE VIEW

DATA SHEET 35
CAMERA LOCATIONS

Test Vehicle: 2014 Ford Escape
Test Program: FMVSS 208 Compliance

NHTSA No.: C20140200
Test Date: 8/25/14
Time: 11:00 am

CAMERA NO.	VIEW	CAMERA POSITIONS (mm) *			LENS (mm)	SPEED (fps)
		X	Y	Z		
1	Real Time Left Side View				13	30
2	Left Side View (Barrier face to front seat backs)	1330	-4860	1260	24	1000
3	Left Side View (Driver)	1250	-6730	1790	35	1000
4	Left Side View (B-post aimed toward center of steering wheel)	4590	-5430	1870	50	1000
5	Left Side View (Steering Column)	990	-5070	1180	24	1000
6	Left Side View (Steering Column)	980	-5080	790	24	1000
7	Right Side View (Overall)	1670	7000	1270	20	1000
8	Right Side View (Passenger)	1360	6770	1790	35	1000
9	Right Side View (Angle)	4830	5000	1960	50	1000
10	Right Side View (Front door)	680	5830	1230	24	1000
11	Front View Windshield	-1760	0	2810	24	1000
12	Front View Driver	-1410	-450	2030	12.5	1000
13	Front View Passenger	1410	450	2030	12.5	1000
14	Overhead Barrier Impact View	920	0	4910	14	1000
15	Pit Camera Engine View	520	0	-3150	24	1000
16	Pit Camera Fuel Tank View	2420	0	-3150	24	1000

*COORDINATES:

- +X - forward of impact plane
- +Y - right of monorail centerline
- +Z - above ground level

CAMERA POSITIONS FOR FMVSS 208

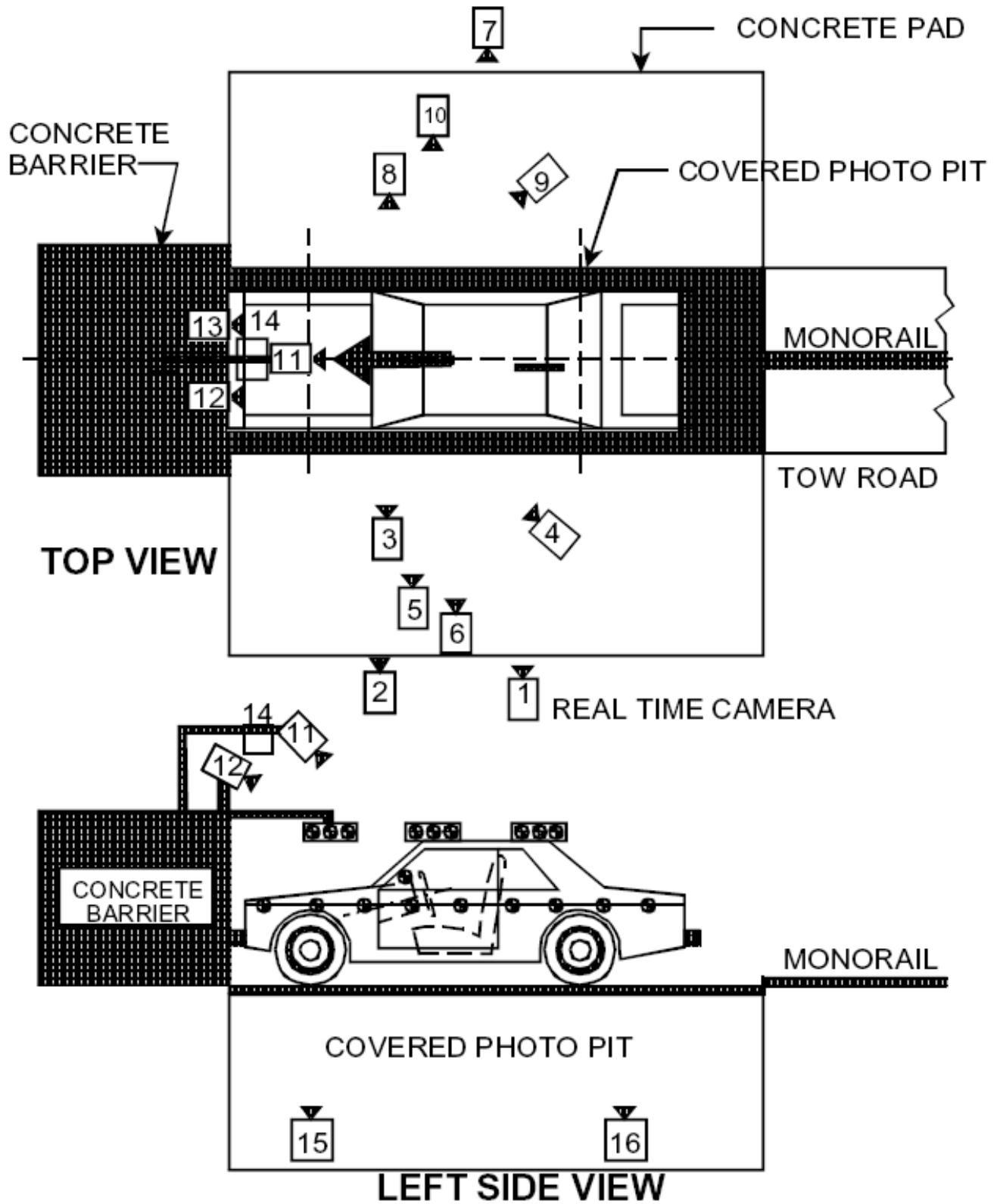

DATA SHEET 36

APPENDIX F

**DUMMY POSITIONING PROCEDURES FOR DRIVER TEST DUMMY CONFORMING TO
SUBPART E OF PART 572**

Test Vehicle: 2014 Ford Escape
 Test Program: FMVSS 208 Compliance
 Test Technician: Jon Miller

NHTSA No.: C20140200
 Test Date: 8/25/14

IMPACT ANGLE:	30° Left Oblique				
BELTED DUMMIES (YES/NO):	NO				
TEST SPEED:	X	32 to 40 kmph		0 to 48 kmph	0 to 56 kmph
DRIVER DUMMY:			5 th female	X	50 th male
PASSENGER DUMMY:			5 th female	X	50 th male

- X 1. Position the seat's adjustable lumbar supports so that the lumbar support is in its lowest, retracted or deflated adjustment position. (S8.1.3)
X N/A – No lumbar adjustment

- X 2. Position any adjustable parts of the seat that provide additional support so that they are in the lowest or most open adjustment position. (S16.2.10.2)
X N/A – No additional support adjustment

- X 3. Use all the seat controls that have any affect on the fore-aft movement of the seat to move the seat cushion to the rearmost position. **Mark** this position. (8/31/95 legal interpretation to Hogan and Hartson)

- X 4. Use all the seat controls that have any affect on the fore-aft movement of the seat to move the seat cushion to the foremost position. **Mark** this position. (8/31/95 legal interpretation to Hogan and Hartson)

- X 5. **Mark** each fore-aft position so that there is a visual indication when the seat is at a particular position. For manual seats, **mark** each detent. For power seats, **mark** only the rearmost, middle, and foremost positions. Label three of the positions with the following: F for foremost, M for mid-position (if there is no mid-position, label the closest adjustment position to the rear of the mid-point), and R for rearmost. Determine the mid fore-aft seat position based on the foremost and rearmost positions determined in items 3 and 4. (8/31/95 legal interpretation to Hogan and Hartson)

- X 6. Move the seat to the mid position.

- X 7. While maintaining the mid position, move the seat to its lowest position. **Mark** the height position. For seats with adjustable seat cushions, use the manufacturer's recommended seat cushion angle for determining the lowest height position.
 N/A- No cushion angle adjustment
 Manufacturer's seat cushion angle: Full down
 Tested seat cushion angle: Full down

- X 8. Visually **mark** the seat back angle, if adjustable, at the manufacturer's nominal design riding position for a **50th percentile adult male** in the manner specified by the manufacturer.
 N/A – No seat back angle adjustment
 Manufacturer's design seat back angle: 4.1° on Headrest Post
 Tested seat back angle: 4.5° on Headrest Post

9. Is the seat a bucket seat?
 Yes, go to 10 and skip 11
 No, go to 11 and skip 10
10. Bucket seats:
Locate and **mark** the longitudinal centerline of the seat cushion. The intersection of the vertical longitudinal plane that passes through the SgRP and the seat cushion upper surface determines the longitudinal centerline of a bucket seat cushion. (S10.4.1.2 and S16.3.1.10)
11. Bench seats:
Locate and **mark** the longitudinal line on the seat cushion that marks the intersection of the vertical longitudinal plane through the centerline of the steering wheel and the seat cushion upper surface. (S10.4.1.1)
12. If adjustable, set the head restraint at the full up position. (S8.1.3) If there are adjustments other than vertical, adjust them as recommended by the manufacturer.
 N/A – No head restraint adjustment
13. Place any adjustable seat belt anchorages at the vehicle manufacturer's nominal design position for a 50th percentile adult male occupant (S8.1.3)
 N/A – No adjustable upper seat belt anchorage
Manufacturer's specified anchorage position: 0 of 4; Upper-most defined as 0
Tested anchorage position: 0 of 4; Upper-most defined as 0
14. Place adjustable pedals in the full forward position.
 N/A – the pedals are not adjustable.
15. Is the steering wheel adjustable up and down and/or in and out?
 Yes – go to 16
 No – go to 19
16. Find and **mark** each up and down position. Label three of the positions with the following: H for highest, M for mid-position (if there is no mid-position, label the next lowest adjustment position), and L for lowest.
 N/A – steering wheel is not adjustable up and down
17. Find and **mark** each in and out position. Label three of the positions with the following: F for foremost, M for mid-position (if there is no mid-position, label the next rearmost adjustment position), and R for rearmost.
 N/A – steering wheel is not adjustable in and out.
18. Set the steering wheel hub at the geometric center of the full range of driving positions including any telescoping positions.
19. Place the dummy in the seat such that the midsagittal plane is coincident with the longitudinal seat cushion markings as determined in item 10 or 11 and the upper torso rests against the seat back. (S10.4.1.1 & S10.4.1.2)
20. Rest the thighs on the seat cushion. (S10.5)

21. Position the H-point of the dummy within 0.5 inch of the vertical dimension and 0.5 inch of the horizontal dimension of a point 0.25 inch below the H-point determined in Data Sheet 15. (S10.4.2.1) Then measure the pelvic angle with respect to the horizontal using the pelvic angle gage. Adjust the dummy position until these three measurements are within the specifications. (S10.4.2.1 and S10.4.2.2)

0.394" horizontal inches from the point 0.25 below the determined H-point (0.5" max.) (S10.4.2.1)

0.315" vertical inches from the point 0.25 below the determined H-point (0.5" max.) (S10.4.2.1)

24.9° pelvic angle (20° to 25°)

22. Is the head level within $\pm 0.5^\circ$? (S10.1)

Yes, go to 23

No, go to 22.1

22.1 Adjust the position of the H-point. (S10.1)

22.2 Is the head level within $\pm 0.5^\circ$? (S10.1)

Yes, record the following, then go to 23. No, go to 22.3

horizontal inches from the point 0.25 below the determined H-point (0.5" max.) (S10.4.2.1)

vertical inches from the point 0.25 below the determined H-point (0.5" max.) (S10.4.2.1)

pelvic angle (20° to 25°) (S10.4.2.2)

22.3 Adjust the pelvic angle. (S10.1)

22.4 Is the head level within $\pm 0.5^\circ$? (S10.1)

Yes, record the following, then go to 23. No, go to 22.5

horizontal inches from the point 0.25 below the determined H-point (0.5 inch max.) (S10.4.2.1)

vertical inches from the point 0.25 below the determined H-point (0.5 inch max.) (S10.4.2.1)

pelvic angle (20° to 25°) (S10.4.2.2)

22.5 Adjust the neck bracket of the dummy the minimum amount necessary from the nonadjusted "0" setting until the head is level within $\pm 0.5^\circ$. (S10.1) Record the following, then go to 23. (Adjusted 2 Notches)

0.197" horizontal inches from the point 0.25 below the determined H-point (0.5" max.) (S10.4.2.1)

0.276" vertical inches from the point 0.25 below the determined H-point (0.5" max.) (S10.4.2.1)

23.9° pelvic angle (20° to 25°)

23. Set the distance between the outboard knee clevis flange surfaces at 10.6 inches.

10.6" measured distance (10.6 inches) (S10.5)

24. Can the right foot be placed on the accelerator?

Yes, go to 24.1 and skip 24.2

No, go to 24.2

24.1. To the extent practicable keep the right thigh and the leg in a vertical plane (S10.5) while resting the foot on the undepressed accelerator pedal with the rearmost point of the heel on the floor pan in the plane of the pedal. (S10.6.1.1)

24.2 Initially set the foot perpendicular to the leg and then place it as far forward as possible in the direction of the pedal centerline with the rearmost point of the heel resting on the floor pan. (S10.6.1.1)

24.2.1 Move the adjustable pedal to its most rearward position or until the right foot is flat on the pedal, whichever occurs first. (S10.6.1.1)

N/A – the accelerator pedal is not adjustable

25. Does the vehicle have a foot rest?

Yes, go to 25.1

No, go to 25.2

25.1 With the left thigh and leg in a vertical plane, place the left foot on the foot rest with the heel resting on the floor pan. (S10.6.1.2)

25.1.1 Is the left foot elevated above the right foot?

Yes, go to 25.2 and position the foot off the foot rest

No, go to 26

25.2 Check the ONLY one of the following that applies

The left foot reaches the toeboard without adjusting the foot or leg. To the extent practicable keep the left thigh and the leg in a vertical longitudinal plane (S10.5) and place the foot on the toeboard, skip 25.3 (S10.6.1.2)

The left foot reaches the toeboard but contacts the brake or clutch pedal and must be rotated to avoid pedal contact. To the extent practicable keep the left thigh and the leg in a vertical longitudinal plane (S10.5) and place the foot on the toeboard. The foot was rotated about the leg to avoid pedal contact, skip 25.3 (S10.6.1.2)

The left foot reaches the toeboard but contacts the brake or clutch pedal and the foot and leg must be rotated to avoid pedal contact. To the extent practicable keep the left thigh and the leg in a vertical longitudinal plane (S10.5) and place the foot on the toeboard. The foot was rotated about the leg and the leg was rotated outboard about the hip the minimum distance necessary to avoid pedal contact, skip 12.3 (S10.6.1.2)

N/A – the foot does not reach the toeboard, go to 25.3

25.3 Check the ONLY one of the following that applies

The left foot did not contact the brake or clutch pedal. To the extent practicable keep the left thigh and the leg in a vertical longitudinal plane (S10.5). Set the foot perpendicular to the leg and place it as far forward as possible with the heel resting on the floor pan. (S10.6.1.2)

The left foot did contact the brake or clutch pedal and the foot was rotated to avoid contact. To the extent practicable keep the left thigh and the leg in a vertical longitudinal plane (S10.5). Set the foot perpendicular to the leg and place it as far forward as possible with the heel resting on the floor pan and rotate the foot the minimum amount to avoid pedal contact. (S10.6.1.2)

The left foot did contact the brake or clutch pedal and the foot was rotated about the leg and the leg was rotated outboard about the hip the minimum distance necessary to avoid pedal contact. Set the foot perpendicular to the leg and place it as far forward as possible with the heel resting on the floor pan and rotate the foot about the leg and the thigh and leg outboard about the hip the minimum distance necessary to avoid pedal contact. (S10.6.1.2)

26. Place the right upper arm adjacent to the torso with the centerline as close to a vertical plane as possible. (S10.2.1)

27. Is the driver seat belt used for this test?

Yes, continue

No, go to 28

27.1 Fasten the seat belt around the dummy.

27.2 Remove all slack from the lap belt portion. (S10.9)

27.3 Pull the upper torso webbing out of the retractor and allow it to retract; repeat this four times. (S10.9)

27.4 Apply a 2 to 4 pound tension load to the lap belt. (S10.9)

pound load applied

27.5 Is the belt system equipped with a tension-relieving device?

Yes, continue

No, go to 28

27.6 Introduce the maximum amount of slack into the upper torso bet that is recommended by the vehicle manufacturer in the vehicle owner's manual. (S10.9).

28. Place the left upper arm adjacent to the torso with the centerline as close to a vertical plane as possible. (S10.2.1)

29. Place the right hand with the palm in contact with the steering wheel at the rim's horizontal centerline and with the thumb over the steering wheel. (S10.3.1)

30. Place the left hand with the palm in contact with the steering wheel at the rim's horizontal centerline and with the thumb over the steering wheel. (S10.3.1)

31. Tape the thumb of each hand to the steering wheel by using masking tape with a width of 0.25 inch. The length of the tape shall only be enough to go around the thumb and steering wheel one time.

Signature: 

Date: 8/25/14

I certify that I have read and performed each instruction.

DATA SHEET 36
APPENDIX F
DUMMY POSITIONING PROCEDURES FOR PASSENGER TEST DUMMY
CONFORMING TO SUBPART E OF PART 572

Test Vehicle: 2014 Ford Escape
 Test Program: FMVSS 208 Compliance
 Test Technician: Jon Miller

NHTSA No.: C20140200
 Test Date: 8/25/14

IMPACT ANGLE:	30° Left Oblique					
BELTED DUMMIES (YES/NO):	NO					
TEST SPEED:	<input checked="" type="checkbox"/>	32 to 40 kmph	<input type="checkbox"/>	0 to 48 kmph	<input type="checkbox"/>	0 to 56 kmph
DRIVER DUMMY:			5 th female	<input checked="" type="checkbox"/>	50 th male	
PASSENGER DUMMY:			5 th female	<input checked="" type="checkbox"/>	50 th male	

- X 1. The seat is a bench seat for which the adjustments have already been made for the driver and there are no independent adjustments that can be made for the passenger. Go to 12.
X N/A- the passenger seat adjusts independently of the driver seat.
- X 2. Position the seat's adjustable lumbar supports so that the lumbar support is in its lowest, retracted or deflated adjustment position. (S8.1.3)
X N/A – No lumbar adjustment
- X 3. Position any adjustable parts of the seat that provide additional support so that they are in the lowest or most open adjustment position. (S16.2.10.2)
X N/A – No additional support adjustment
- X 4. Use all the seat controls that have any affect on the fore-aft movement of the seat to move the seat cushion to the rearmost position. **Mark** this position. (8/31/95 legal interpretation to Hogan and Hartson)
- X 5. Use all the seat controls that have any affect on the fore-aft movement of the seat to move the seat cushion to the foremost position. **Mark** this position. (8/31/95 legal interpretation to Hogan and Hartson)
- X 6. **Mark** each fore-aft position so that there is a visual indication when the seat is at a particular position. For manual seats, **mark** each detent. For power seats, **mark** only the rearmost, middle, and foremost positions. Label three of the positions with the following: F for foremost, M for mid-position (if there is no mid-position, label the closest adjustment position to the rear of the mid-point), and R for rearmost. Determine the mid fore-aft seat position based on the foremost and rearmost positions determined in items 3 and 4. (8/31/95 legal interpretation to Hogan and Hartson)
- X 7. Move the seat to the mid position.
- X 8. While maintaining the mid position, move the seat to its lowest position. **Mark** the height position. For seats with adjustable seat cushions, use the manufacturer's recommended seat cushion angle for determining the lowest height position.
X N/A- No cushion angle adjustment
 Manufacturers seat cushion angle: _____
 Tested seat cushion angle: _____

9. Visually **mark** the seat back angle, if adjustable, at the manufacturer's nominal design riding position for a **50th percentile adult male** in the manner specified by the manufacturer.
 Manufacturer's design seat back angle: 4.1° on Headrest Post
 Tested seat back angle: 4.3° on Headrest Post
10. Is the seat a bucket seat?
 Yes, go to 11 and skip 12
 No, go to 12 and skip 11
11. Bucket seats:
 Locate and **mark** for future reference the longitudinal centerline of the seat cushion. The intersection of the vertical longitudinal plane that passes through the SgRP and the seat cushion upper surface determines the longitudinal centerline of a bucket seat cushion. (S10.4.1.2 and S16.3.1.10)
12. Bench seats:
 Locate and **mark** for future reference the longitudinal centerline of the passenger seat cushion. The longitudinal centerline is the same distance from the longitudinal centerline of the vehicle as the center of the steering wheel. (S10.4.1.1)
 Record the distance from the longitudinal centerline of the vehicle to the center of the steering wheel. _____
 Record the distance from the longitudinal centerline of the vehicle to the longitudinal centerline of the seat cushion. _____
13. If adjustable, set the head restraint at the full up position. (S8.1.3) If there are adjustments other than vertical, adjust them as recommended by the manufacturer.
 N/A – No head restraint adjustment
14. Place any adjustable seat belt anchorages at the vehicle manufacturer's nominal design position for a 50th percentile adult male occupant (S8.1.3)
 N/A – No adjustable upper seat belt anchorage
 Manufacturer's specified anchorage position: 0 of 4; Upper-most defined as 0
 Tested anchorage position: 0 of 4; Upper-most defined as 0
15. Place the dummy in the seat such that the midsagittal plane is coincident with the longitudinal seat cushion markings as determined in item 11 or 12 and the upper torso rests against the seat back. (S10.4.1.1 & S10.4.1.2)
16. Rest the thighs on the seat cushion. (S10.5)
17. Position the H-point of the dummy within 0.5 inch of the vertical dimension and 0.5 inch of the horizontal dimension of a point 0.25 inch below the H-point determined by using the equipment and procedures specified in SAE J826 (APR 1980). (S10.4.2.1) Then measure the pelvic angle with respect to the horizontal using the pelvic angle gage. Adjust the dummy position until these three measurements are within the specifications. (S10.4.2.1 and S10.4.2.2)
0.393" horizontal inches from the point 0.25 below the determined H-point (0.5" max.) (S10.4.2.1)
0.171" vertical inches from the point 0.25 below the determined H-point (0.5" max.) (S10.4.2.1)
24.1° pelvic angle (20° to 25°)
18. Is the head level within $\pm 0.5^\circ$? (S10.1)
 Yes, go to 19
 No, go to 18.1

- 18.1 Adjust the position of the H-point. (S10.1 and S10.4.2.1)
- 18.2 Is the head level within $\pm 0.5^\circ$? (S10.1)
- Yes, record the following, then go to 19. No, go to 18.3
 - Horizontal inches from the point 0.25 below the determined H-point (0.5" max.) (S10.4.2.1)
 - Vertical inches from the point 0.25 below the determined H-point (0.5" max.) (S10.4.2.1)
 - Pelvic angle (20° to 25°) (S10.4.2.2)
- 18.3 Adjust the pelvic angle. (S10.1)
- 18.4 Is the head level within $\pm 0.5^\circ$? (S10.1)
- Yes, record the following, then go to 19. No, go to 18.5
 - Horizontal inches from the point 0.25 below the determined H-point (0.5" max.) (S10.4.2.1)
 - Vertical inches from the point 0.25 below the determined H-point (0.5" max.) (S10.4.2.1)
 - Pelvic angle (20° to 25°) (S10.4.2.2)
- 18.5 Adjust the neck bracket of the dummy the minimum amount necessary from the nonadjusted "0" setting until the head is level within $\pm 0.5^\circ$. (S10.1) Record the following, then go to 19.
- Horizontal inches from the point 0.25 below the determined H-point (0.5" max.) (S10.4.2.1)
 - Vertical inches from the point 0.25 below the determined H-point (0.5" max.) (S10.4.2.1)
 - Pelvic angle (20° to 25°) (S10.4.2.2)
19. Set the distance between the outboard knee clevis flange surfaces at 10.6 inches.
- 10.6" measured distance (10.6 inches) (S10.5)
20. Check the only one of the following that applies:
- To the extent practicable keep the left thigh and leg in a vertical plane and the right thigh and leg in a vertical plane, place the feet on the toeboard with the heels resting on the floor pan as close as possible to the intersection of the floor pan and toeboard.
 - The feet cannot be placed flat on the toeboard. To the extent practicable keep the left thigh and leg in a vertical plane and the right thigh and leg in a vertical plane, set the feet perpendicular to the legs and place them as far forward as possible with the heels resting on the floor pan.
 - The vehicle has a wheelhouse projection. To the extent practicable keep the left thigh and leg in a vertical plane and the right thigh and leg in a vertical plane, set the feet perpendicular to the legs and place them as far forward as possible with the heels resting on the floor pan. Do not set the feet on the wheelhouse projection.
 - The vehicle has a wheelhouse projection and the feet cannot be placed on the toeboard. To the extent practicable keep the left thigh and leg in a vertical plane and the right thigh and leg in a vertical plane, set the feet perpendicular to the legs and place them as far forward as possible with the heel resting on the floor pan. Do not set the feet on the wheelhouse projection.
21. Place the left upper arm in contact with the seat back and side of the torso. (S10.2.2)

22. Is the passenger seat belt used for this test?

Yes, continue

No, go to 23

22.1 Fasten the seat belt around the dummy.

22.2 Remove all slack from the lap belt portion. (S10.9)

22.3 Pull the upper torso webbing out of the retractor and allow it to retract; repeat this four times. (S10.9)

22.4 Apply a 2 to 4 pound tension load to the lap belt. (S10.9)
_____pound load applied

22.5 Is the belt system equipped with a tension relieving device?

Yes, continue

No, go to 23

22.6 Introduce the maximum amount of slack into the upper torso bet that is recommended by the vehicle manufacturer in the vehicle owner's manual. (S10.9). Go to 23.

23. Place the right upper arm in contact with the seat back and side of the torso. (S10.2.2)

24. Place the left hand palm in contact with the outside of the left thigh and the little finger in contact with the seat cushion. (S10.3.2)

25. Place the right hand palm in contact with the outside of the right thigh and the little finger in contact with the seat cushion. (S10.3.2)

Signature: _____



Date: 8/25/14

I certify that I have read and performed each instruction.

DATA SHEET 37

DUMMY MEASUREMENTS

Test Vehicle: 2014 Ford Escape
 Test Program: FMVSS 208 Compliance
 Test Technician: Jon Miller

NHTSA No.: C20140200
 Test Date: 8/25/14

DUMMY MEASUREMENTS FOR FRONT SEAT OCCUPANTS

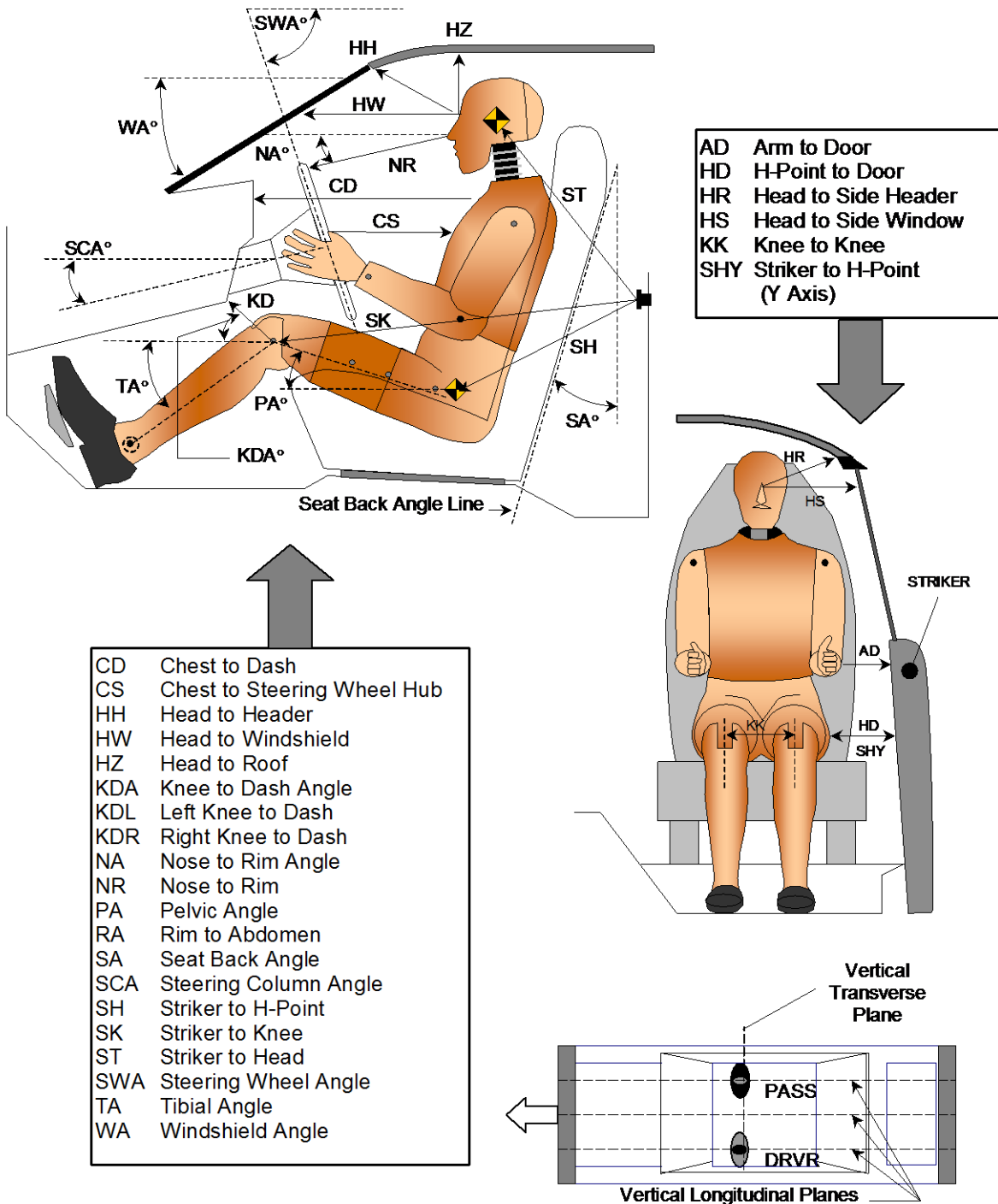

TEST DUMMY POSITION MEASUREMENTS

Code	Measurement Description	Driver SN 401		Passenger SN 403	
		Length (mm)	Angle (°)	Length (mm)	Angle (°)
WA	Windshield Angle		23.6		
SWA	Steering Wheel Angle		63.1		
SCA	Steering Column Angle		26.9		
SA	Seat Back Angle (On Headrest Post)		4.5		4.3
HZ	Head to Roof (Z)	262		240	
HH	Head to Header	400	28.2	393	27.1
HW	Head to Windshield	772	0.0	731	0.0
HR	Head to Side Header (Y)	275		251	
NR	Nose to Rim	444	9.1		
CD	Chest to Dash	576		542	
CS	Chest to Steering Hub	571	2.8		
RA	Rim to Abdomen	222	0.0		
KDL	Left Knee to Dash	166	27.2	134	
KDR	Right Knee to Dash	194		161	27.8
PA	Pelvic Angle		23.9		24.1
TA	Tibia Angle		57.4		57.2
KK	Knee to Knee (Y)	345		272	
SK	Striker to Knee	559	87.7	588	92.1
ST	Striker to Head	528	6.8	567	8.5
SH	Striker to H-Point	233	128.3	208	116.2
SHY	Striker to H-Point (Y)	270		292	
HS	Head to Side Window	370		355	
HD	H-Point to Door (Y)	147		149	
AD	Arm to Door (Y)	120		53	
AA	Ankle to Ankle	321		206	

SEAT BELT POSITIONING DATA

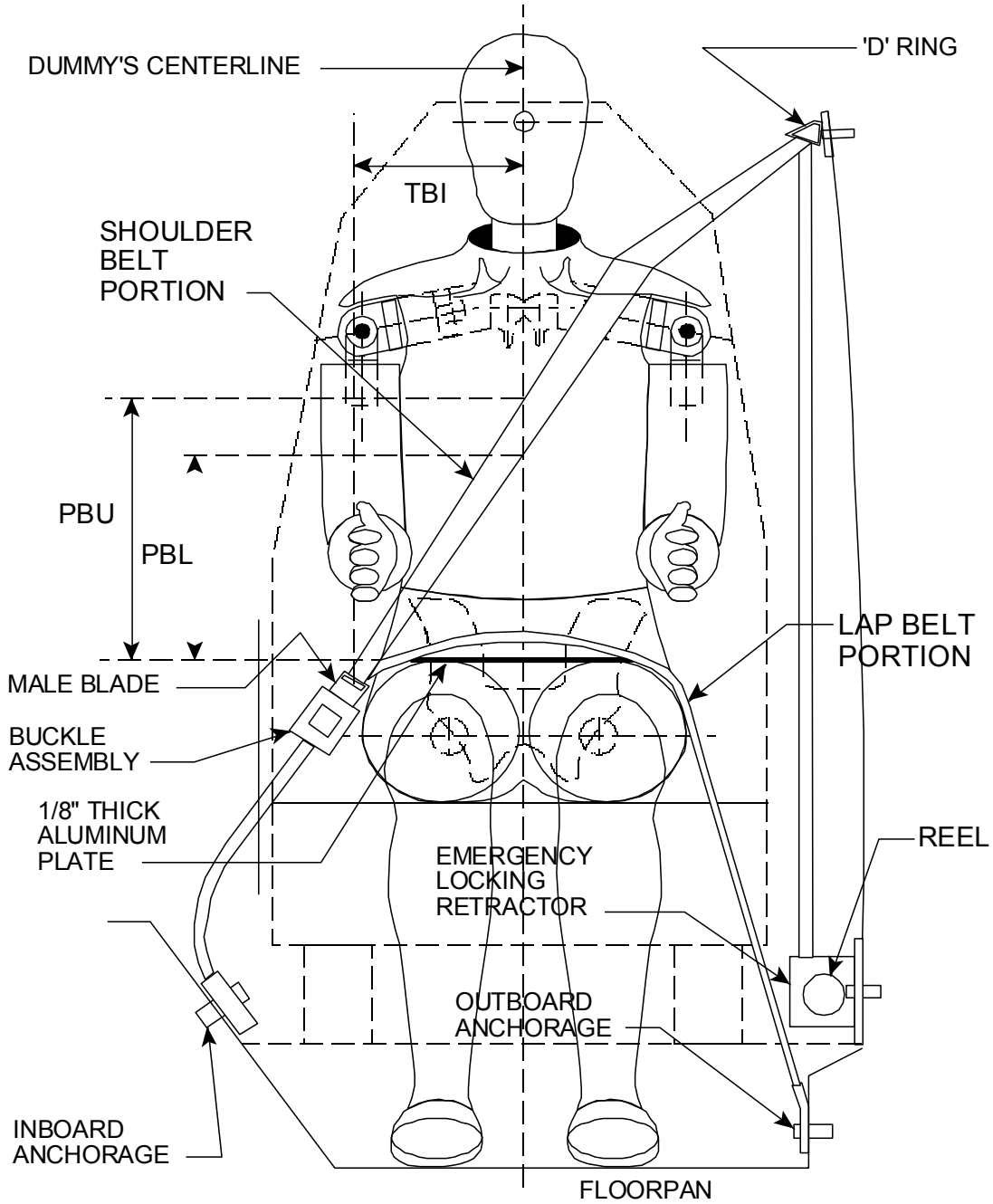

FRONT VIEW OF DUMMY

SEAT BELT POSITIONING MEASUREMENTS

Measurement Description	Units	Driver	Passenger
PBU - Top surface of reference to belt upper edge	mm	N/A	N/A
PBL - Top surface of reference to belt lower edge	mm	N/A	N/A

DATA SHEET 38

CRASH TEST

Test Vehicle: 2014 Ford Escape
 Test Program: FMVSS 208 Compliance
 Test Technician: Alex Vanderheyden

NHTSA No.: C20140200
 Test Date: 8/25/14

IMPACT ANGLE:	30° Left Oblique					
BELTED DUMMIES (YES/NO):	NO					
TEST SPEED:	X	32 to 40 kmph		0 to 48 kmph		0 to 56 kmph
DRIVER DUMMY:			5 th female	X		50 th male
PASSENGER DUMMY:			5 th female	X		50 th male

- 1. Vehicle underbody painted.
- 2. The speed measuring devices are in place and functioning.
- 3. The speed measuring devices are 1.0 m from the barrier (spec. 1.5 m) and 30 cm from the barrier (spec. is 30 cm)
- 4. Convertible top is in the closed position.
 - N/A, not a convertible
- 5. Instrumentation and wires are placed so motion of dummies during impact is not affected.
- 6. Tires inflated to pressure on tire placard or if it does not have a tire placard because it is not a passenger car, then inflated to the tire pressure specified in the owner information.
 - 240 kpa front left tire 240 kpa specified on tire placard or in owner information
 - 240 kpa front right tire 240 kpa specified on tire placard or in owner information
 - 240 kpa rear left tire 240 kpa specified on tire placard or in owner information
 - 240 kpa rear right tire 240 kpa specified on tire placard or in owner information
- 7. Time zero contacts on barrier in place.
- 8. Pre test zero and shunt calibration adjustments performed and recorded.
- 9. Dummy temperature meets requirements of section 12.2 of the test procedure.
- 10. Vehicle hood closed and latched.
- 11. Transmission placed in neutral.
- 12. Parking brake off.
- 13. Are the heads still level?
 - Yes, go to 14
 - No, Adjust dummy so that head is at the angle recorded in the Appendix F or G data sheets and then continue.
- 14. Ignition in the ON position.
- 15. Doors closed and latched but not locked.
- 16. Post test zero and shunt calibration checks performed and recorded.
- 17. Actual test speed 39.7 kmph
- 18. Vehicle rebound from the barrier 35.1 cm
- 19. Describe whether the doors open after the test and what method is used to open the doors.
 - Left Front Door: Door remained closed and latched; Door opened without tools.
 - Right Front Door: Door remained closed and latched; Door opened without tools.
 - Left Rear Door: Door remained closed and latched; Door opened without tools.
 - Right Rear Door: Door remained closed and latched; Door opened without tools.

20. Describe the contact points of the dummy with the interior of the vehicle.

Driver Dummy: Head to Air Bag, Curtain Air Bag, A-Pillar, Windshield, Headliner; Chest to Air Bag; Knees to Knee Air Bag.

Passenger Dummy: Head to Air Bag, Shifter; Chest to Air Bag; Knees to Glove Box.

REMARKS:

Signature: _____



Date: 8/25/14

I certify that I have read and performed each instruction.

DATA SHEET 40

ACCIDENT INVESTIGATION MEASUREMENTS

Test Vehicle: 2014 Ford Escape
 Test Program: FMVSS 208 Compliance
 Test Technician: Alex Vanderheyden

NHTSA No.: C20140200
 Test Date: 8/25/14

IMPACT ANGLE:	30° Left Oblique					
BELTED DUMMIES (YES/NO):	NO					
TEST SPEED:	X	32 to 40 kmph		0 to 48 kmph		0 to 56 kmph
DRIVER DUMMY:			5 th female	X		50 th male
PASSENGER DUMMY:			5 th female	X		50 th male

Vehicle Year/Make/Model/Body Style:	2014 Ford Escape MPV
VIN:	1FMCU0F72EUB70023
Wheelbase:	2686 mm
Build Date:	11/13
Vehicle Size Category:	3
Test Weight:	1788.1 kg
Front Overhang:	928 mm
Overall Width:	1819 mm
Overall Length Center:	4532 mm

Accelerometer Data	
Location:	As per measurements on Data Sheet 33
Linearity:	>99.9%

Integration Algorithm:	Trapezoidal
Vehicle Impact Speed:	39.7 kmph
Time of Separation:	132.3 ms
Velocity Change:	41.6 kmph

CRUSH PROFILE

Collision Deformation Classification: 11FDEW2
 Midpoint of Damage: Vehicle Longitudinal Centerline
 Damage Region Length (mm): 1801
 Impact Mode: Frontal Barrier

No.	Measurement Description	Units	Pre-Test	Post-Test	Difference
C1	Crush zone 1 at left side	mm	4343	3932	411
C2	Crush zone 2 at left side	mm	4467	4111	356
C3	Crush zone 3 at left side	mm	4493	4253	240
C4	Crush zone 4 at right side	mm	4493	4462	31
C5	Crush zone 5 at right side	mm	4467	4498	-31
C6	Crush zone 6 at right side	mm	4343	4356	-13

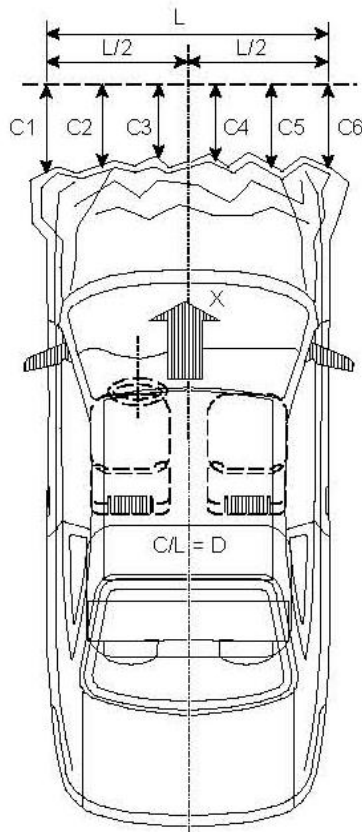

REMARKS:

Signature: *Clois Vandenberg*

Date: 8/25/14

I certify that I have read and performed each instruction.

DATA SHEET 41
WINDSHIELD MOUNTING (FMVSS 212)

Test Vehicle: 2014 Ford Escape
 Test Program: FMVSS 208 Compliance
 Test Technician: Alex Vanderheyden

NHTSA No.: C20140200
 Test Date: 8/25/14

IMPACT ANGLE:	30° Left Oblique					
BELTED DUMMIES (YES/NO):	NO					
TEST SPEED:	<input checked="" type="checkbox"/>	32 to 40 kmph	<input type="checkbox"/>	0 to 48 kmph	<input type="checkbox"/>	0 to 56 kmph
DRIVER DUMMY:			5 th female	<input checked="" type="checkbox"/>	50 th male	
PASSENGER DUMMY:			5 th female	<input checked="" type="checkbox"/>	50 th male	

1. Pre-Crash
 - 1.1 Describe from visual inspection how the windshield is mounted and describe any trim material.

Retained with glue, rubber and plastic trim
 - 1.2 Mark the longitudinal centerline of the windshield.
 - 1.3 Measure pre-crash A, B, and C for the left side and record in the chart below.
 - 1.4 Measure pre-crash C, D, and E for the right side and record in the chart below.
 - 1.5 Measure from the edge of the retainer or molding to the edge of the windshield.
Dimension G (mm): 8 mm
2. Post Crash
 - 2.1 Can a single thickness of copier type paper (as small a piece as necessary) slide between the windshield and the vehicle body?
 - No - Pass. Skip to the table of measurements, complete it by repeating the pre-crash measurements in the post crash column, and calculate the retention percentage, which will be 100%.
 - Yes, go to 2.2
 - 2.2 Visibly mark the beginning and end of the portions of the periphery where the paper slides between the windshield and the vehicle body.
 - 2.3 Measure and record post-crash A, B, C, D, E, and F such that the measurements do not include any of the parts of the windshield where the paper slides between the windshield and the vehicle body.
 - 2.4 Calculate and record the percent retention for the right and left side of the windshield.
 - 2.5 Is total right side percent retention less than 50%?
 - Yes, Fail
 - No, Pass
 - 2.6 Is total left side percent retention less than 50%?
 - Yes, Fail
 - No, Pass

WINDSHIELD RETENTION MEASUREMENTS

	Dimension	Pre-Crash (mm)	Post-Crash (mm)	Percent Retention (Post-Test ÷ Pre-Crash)
Left Side	A	635	635	100%
	B	930	930	100%
	C	736	736	100%
	Total	2301	2301	100%
Right Side	D	635	635	100%
	E	930	930	100%
	F	736	736	100%
	Total	2301	2301	100%

Indicate area of mounting failure: NONE

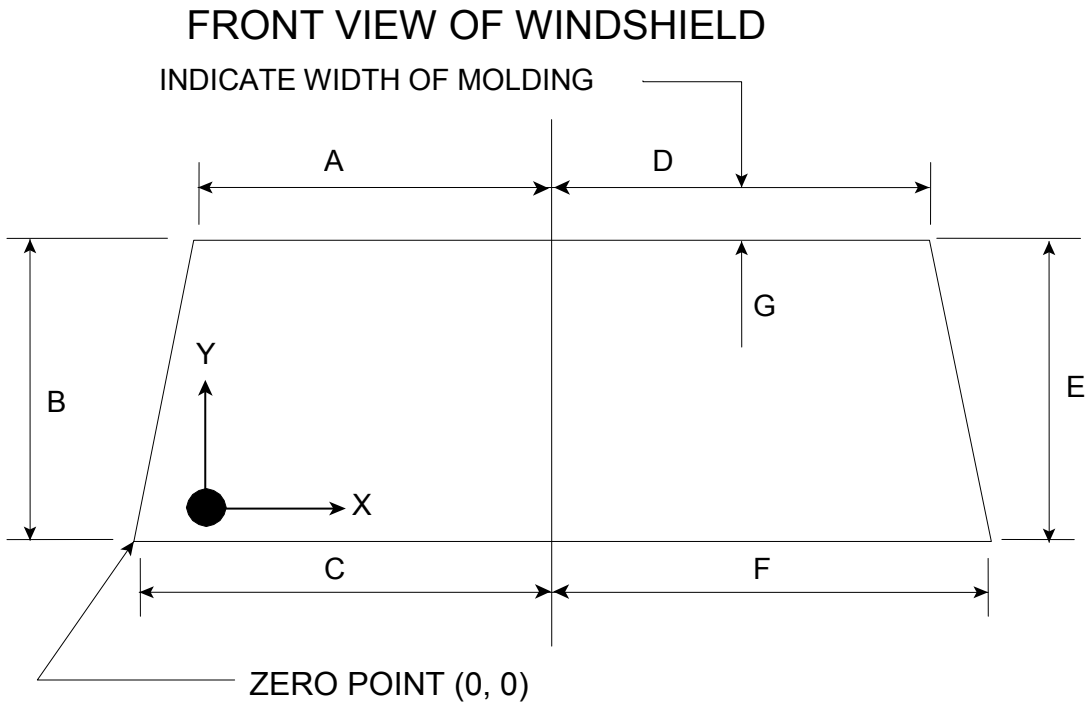

REMARKS:

Signature: *Alex Vandenberg*

Date: 8/25/14

I certify that I have read and performed each instruction.

DATA SHEET 42
WINDSHIELD ZONE INTRUSION (FMVSS 219)

Test Vehicle: 2014 Ford Escape
 Test Program: FMVSS 208 Compliance
 Test Technician: Alex Vanderheyden

NHTSA No.: C20140200
 Test Date: 8/25/14

IMPACT ANGLE:	30° Left Oblique			
BELTED DUMMIES (YES/NO):	NO			
TEST SPEED:	X	32 to 40 kmph		0 to 56 kmph
DRIVER DUMMY:		5 th female	X	50 th male
PASSENGER DUMMY:		5 th female	X	50 th male

This standard specifies limits for the displacement of vehicle components into the windshield area during a frontal barrier impact test at any speed up to and including 48 kmph.

- 1. Place a 165 mm diameter rigid sphere, with a mass of 6.8 kg on the instrument panel so that it is simultaneously touching the instrument panel and the windshield. (571.219 S6.1(a))
- 2. Roll the sphere from one side of the windshield to the other while marking on the windshield where the sphere contacts the windshield. (571.219 S6.1(b))
- 3. From the outermost contactable points on the windshield draw a horizontal line to the edges of the windshield. (571.219 S6.1(b))
- 4. Draw a line on the inner surface of the windshield that is 13 mm below the line determined in items 2 and 3.
- 5. After the crash test, record any points where a part of the exterior of the vehicle has marked, penetrated, or broken the windshield.

Provide all dimensions necessary to reproduce the protected area.

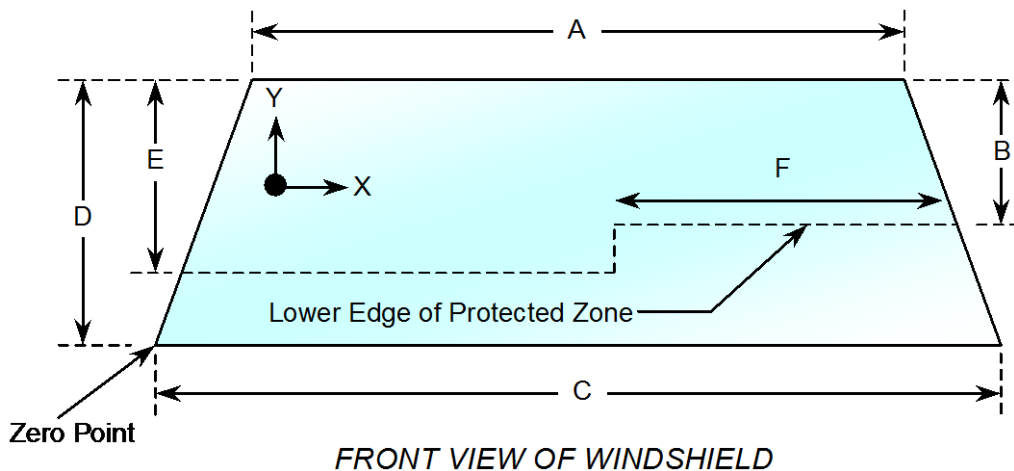

WINDSHIELD DIMENSIONS

Item	Units	Value
A	mm	1270
B	mm	602
C	mm	1472
D	mm	930
E	mm	594
F	mm	622

AREA OF PROTECTED ZONE FAILURES:

- B. Provide coordinates of the area that the protected zone was penetrated more than 0.25 inches by a vehicle component other than one which is normally in contact with the windshield.

X	Y
NONE	

- C. Provide coordinates of the area beneath the protected zone template that the inner surface of the windshield was penetrated by a vehicle component.

X	Y
NONE	

REMARKS:

I certify that I have read and performed each instruction.

Signature: *Chap VanDerKam*

Date: 8/25/14

DATA SHEET 43
FUEL SYSTEM INTEGRITY (FMVSS 301)

Test Vehicle: 2014 Ford Escape
Test Program: FMVSS 208 Compliance
Test Technician: Jon Miller

NHTSA No.: C20140200
Test Date: 8/25/14

TYPE OF IMPACT:	25 mph Unbelted 30° Left Oblique
-----------------	----------------------------------

Stoddard Solvent Spillage Measurements

- A. From impact until vehicle motion ceases: 0 grams
(Maximum Allowable = 28 grams)
- B. For the 5 minute period after motion ceases: 0 grams
(Maximum Allowable = 142 grams)
- C. For the following 25 minutes: 0 grams
(Maximum Allowable = 28 grams/minute)
- D. Spillage: None

DATA SHEET 43

FMVSS 301 STATIC ROLLOVER DATA

Test Vehicle: 2014 Ford Escape
 Test Program: FMVSS 208 Compliance

NHTSA No.: C20140200
 Test Date: 8/25/14

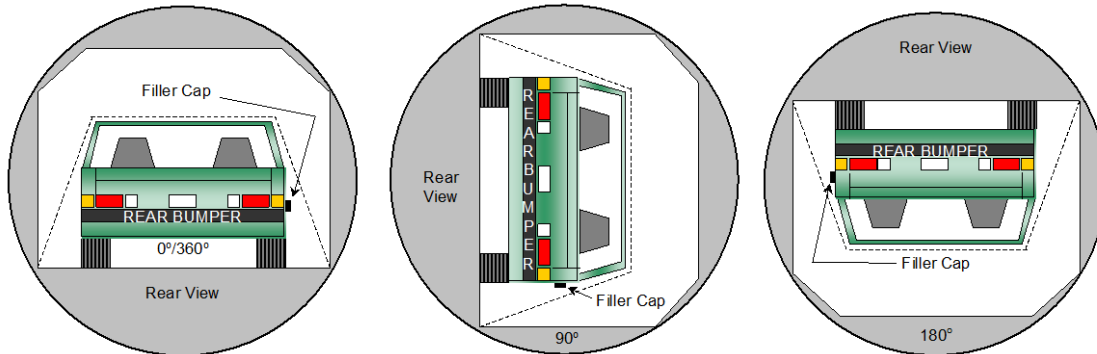

0° to 90°

90° to 180°

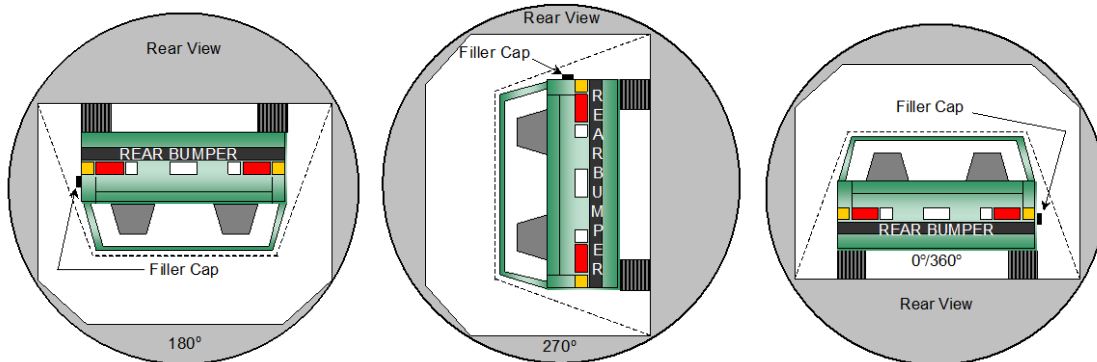

180° to 270°

270° to 360°

1. The specified fixture rollover rate for each 90° of rotation is 60 to 180 seconds.
2. The position hold time at each position is 300 seconds (minimum).
3. Details of Stoddard Solvent spillage locations: **None**

Test Phase	Rotation Time (sec.)	Hold Time (sec.)	Spillage (grams)
0° to 90°	113	300	0
90° to 180°	108	300	0
180° to 270°	107	300	0
270° to 360°	112	300	0

APPENDIX A
CRASH TEST DATA
TABLE OF DATA PLOTS

		<u>Page No.</u>
Figure No. 1.	Driver Head X Acceleration vs. Time	A-1
Figure No. 2.	Driver Head Y Acceleration vs. Time	A-1
Figure No. 3.	Driver Head Z Acceleration vs. Time	A-1
Figure No. 4.	Driver Head Resultant Acceleration vs. Time	A-1
Figure No. 5.	Driver Head X Velocity vs. Time	A-2
Figure No. 6.	Driver Head Y Velocity vs. Time	A-2
Figure No. 7.	Driver Head Z Velocity vs. Time	A-2
Figure No. 8.	Driver Neck Force X vs. Time	A-3
Figure No. 9.	Driver Neck Force Y vs. Time	A-3
Figure No. 10.	Driver Neck Force Z vs. Time	A-3
Figure No. 11.	Driver Neck Force Resultant vs. Time	A-3
Figure No. 12.	Driver Neck Moment X vs. Time	A-4
Figure No. 13.	Driver Neck Moment Y vs. Time	A-4
Figure No. 14.	Driver Neck Moment Z vs. Time	A-4
Figure No. 15.	Driver Neck Moment Resultant vs. Time	A-4
Figure No. 16.	Driver Chest X Acceleration vs. Time	A-5
Figure No. 17.	Driver Chest Y Acceleration vs. Time	A-5
Figure No. 18.	Driver Chest Z Acceleration vs. Time	A-5
Figure No. 19.	Driver Chest Resultant Acceleration vs. Time	A-5
Figure No. 20.	Driver Chest X Velocity vs. Time	A-6
Figure No. 21.	Driver Chest Y Velocity vs. Time	A-6
Figure No. 22.	Driver Chest Z Velocity vs. Time	A-6
Figure No. 23.	Driver Chest Displacement vs. Time	A-6
Figure No. 24.	Driver Left Femur Force vs. Time	A-7
Figure No. 25.	Driver Right Femur Force vs. Time	A-7
Figure No. 26.	Passenger Head X Acceleration vs. Time	A-8
Figure No. 27.	Passenger Head Y Acceleration vs. Time	A-8
Figure No. 28.	Passenger Head Z Acceleration vs. Time	A-8
Figure No. 29.	Passenger Head Resultant Acceleration vs. Time	A-8
Figure No. 30.	Passenger Head X Velocity vs. Time	A-9

	<u>Page No.</u>	
Figure No. 31.	Passenger Head Y Velocity vs. Time	A-9
Figure No. 32.	Passenger Head Z Velocity vs. Time	A-9
Figure No. 33.	Passenger Neck Force X vs. Time	A-10
Figure No. 34.	Passenger Neck Force Y vs. Time	A-10
Figure No. 35.	Passenger Neck Force Z vs. Time	A-10
Figure No. 36.	Passenger Neck Force Resultant vs. Time	A-10
Figure No. 37.	Passenger Neck Moment X vs. Time	A-11
Figure No. 38.	Passenger Neck Moment Y vs. Time	A-11
Figure No. 39.	Passenger Neck Moment Z vs. Time	A-11
Figure No. 40.	Passenger Neck Moment Resultant vs. Time	A-11
Figure No. 41.	Passenger Chest X Acceleration vs. Time	A-12
Figure No. 42.	Passenger Chest Y Acceleration vs. Time	A-12
Figure No. 43.	Passenger Chest Z Acceleration vs. Time	A-12
Figure No. 44.	Passenger Chest Resultant Acceleration vs. Time	A-12
Figure No. 45.	Passenger Chest X Velocity vs. Time	A-13
Figure No. 46.	Passenger Chest Y Velocity vs. Time	A-13
Figure No. 47.	Passenger Chest Z Velocity vs. Time	A-13
Figure No. 48.	Passenger Chest Displacement vs. Time	A-13
Figure No. 49.	Passenger Left Femur Force vs. Time	A-14
Figure No. 50.	Passenger Right Femur Force vs. Time	A-14
Figure No. 51.	Driver Nij (N_{TF}) vs. Time	A-15
Figure No. 52.	Driver Nij (N_{TE}) vs. Time	A-15
Figure No. 53.	Driver Nij (N_{CF}) vs. Time	A-15
Figure No. 54.	Driver Nij (N_{CE}) vs. Time	A-15
Figure No. 55.	Passenger Nij (N_{TF}) vs. Time	A-16
Figure No. 56.	Passenger Nij (N_{TE}) vs. Time	A-16
Figure No. 57.	Passenger Nij (N_{CF}) vs. Time	A-16
Figure No. 58.	Passenger Nij (N_{CE}) vs. Time	A-16
Figure No. 59.	Driver Occipital Condyle Moment vs. Time	A-17
Figure No. 60.	Passenger Occipital Condyle Moment vs. Time	A-17
Figure No. 61.	Left Rear Seat Crossmember X Acceleration vs. Time	A-18
Figure No. 62.	Left Rear Seat Crossmember X Velocity vs. Time	A-18
Figure No. 63.	Right Rear Seat Crossmember X Acceleration vs. Time	A-18
Figure No. 64.	Right Rear Seat Crossmember X Velocity vs. Time	A-18
Figure No. 65.	Top of Engine X Acceleration vs. Time	A-19

		<u>Page No.</u>
Figure No. 66.	Top of Engine X Velocity vs. Time	A-19
Figure No. 67.	Bottom of Engine X Acceleration vs. Time	A-19
Figure No. 68.	Bottom of Engine X Velocity vs. Time	A-19
Figure No. 69.	Left Brake Caliper X Acceleration vs. Time	A-20
Figure No. 70.	Left Brake Caliper X Velocity vs. Time	A-20
Figure No. 71.	Right Brake Caliper X Acceleration vs. Time	A-20
Figure No. 72.	Right Brake Caliper X Velocity vs. Time	A-20
Figure No. 73.	Instrument Panel X Acceleration vs. Time	A-21
Figure No. 74.	Instrument Panel X Velocity vs. Time	A-21
Figure No. 75.	Trunk Z Acceleration vs. Time	A-21
Figure No. 76.	Trunk Z Velocity vs. Time	A-21

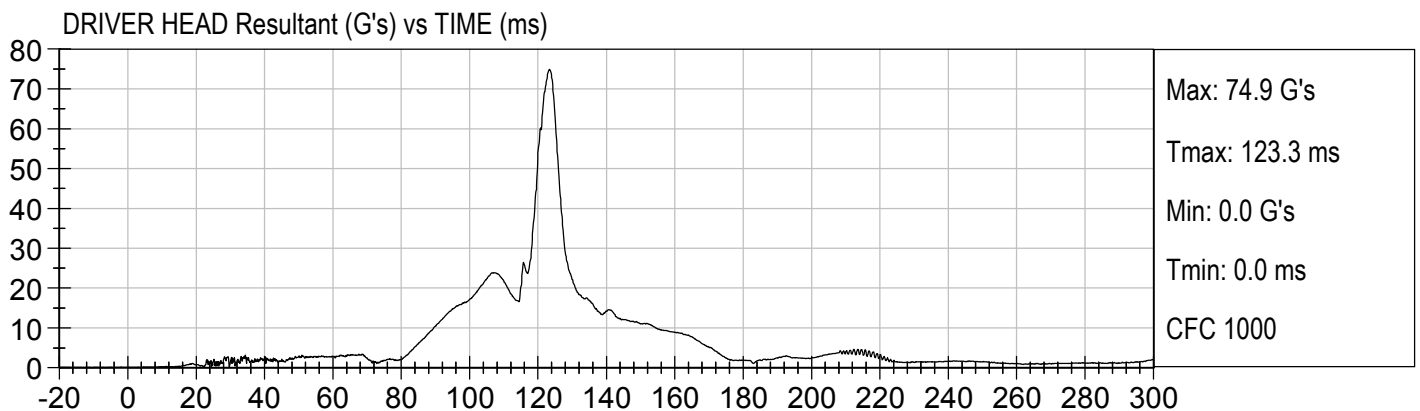
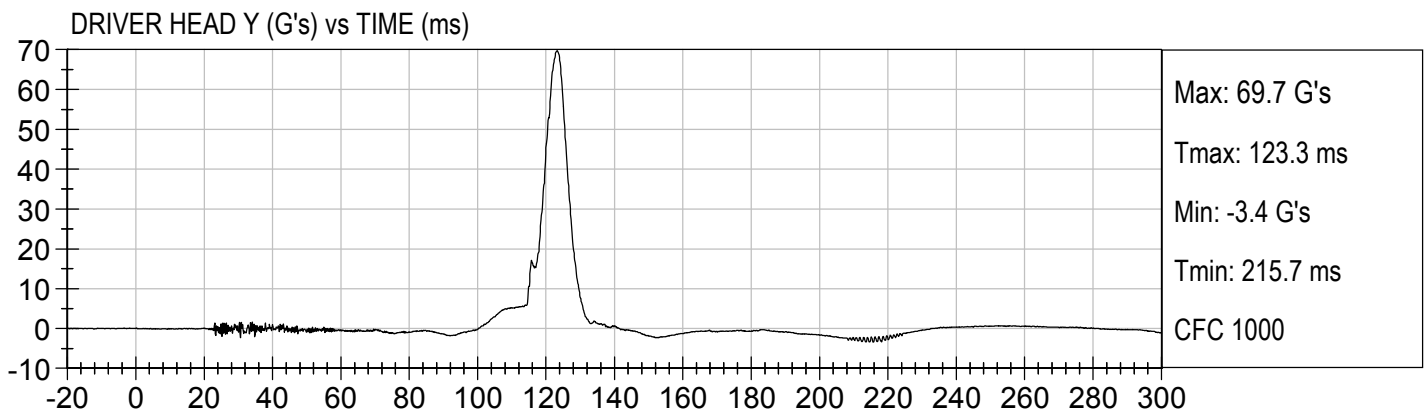
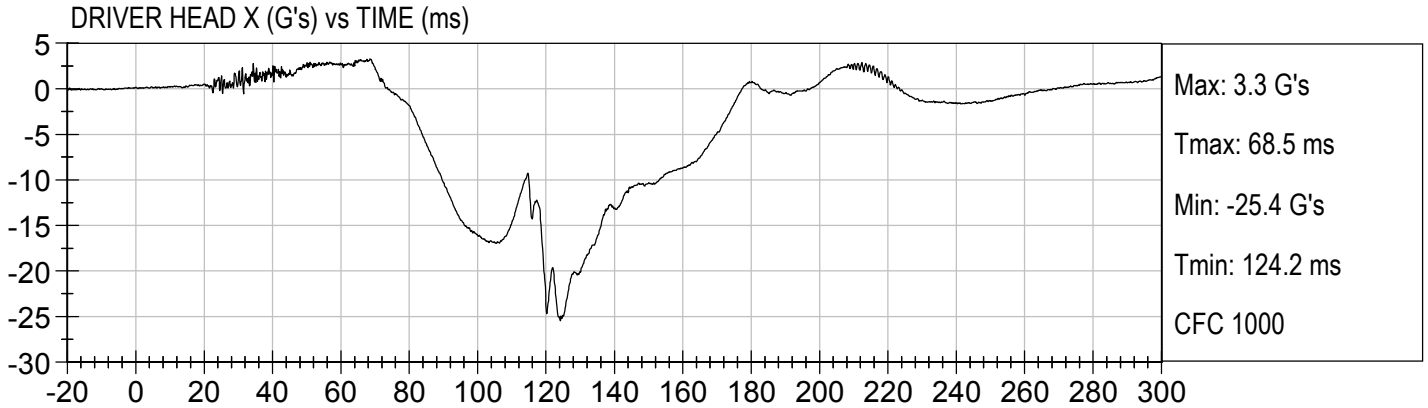

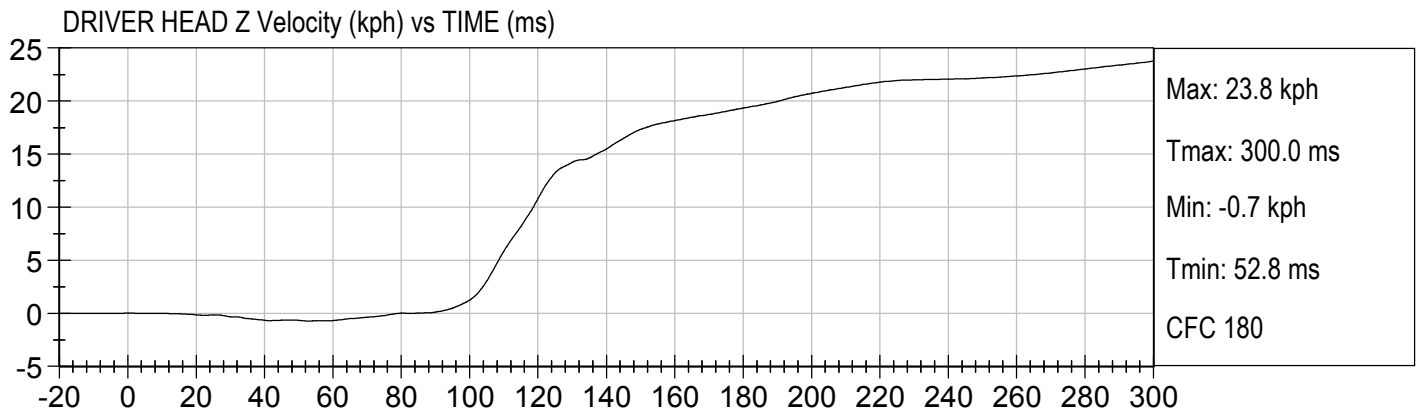
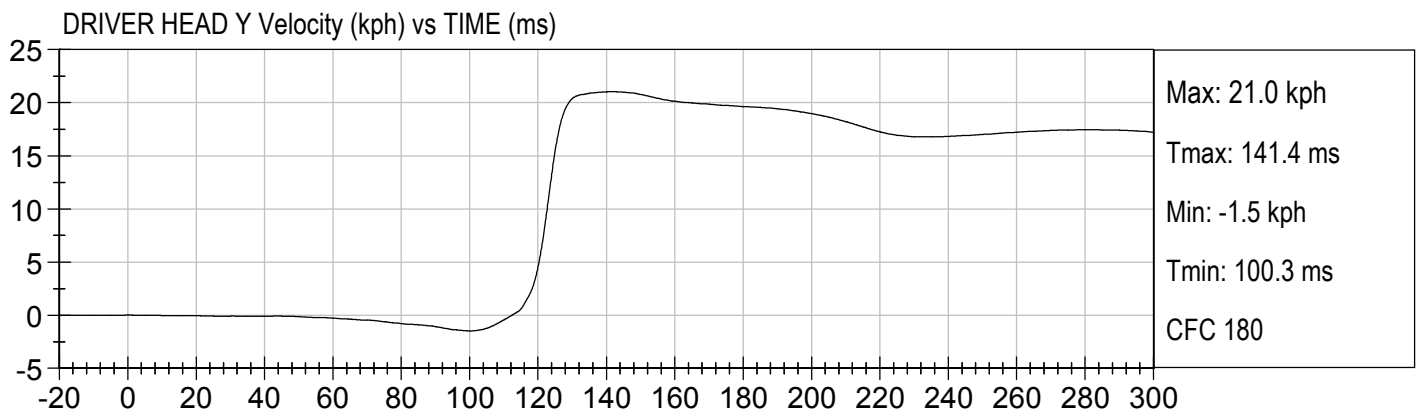
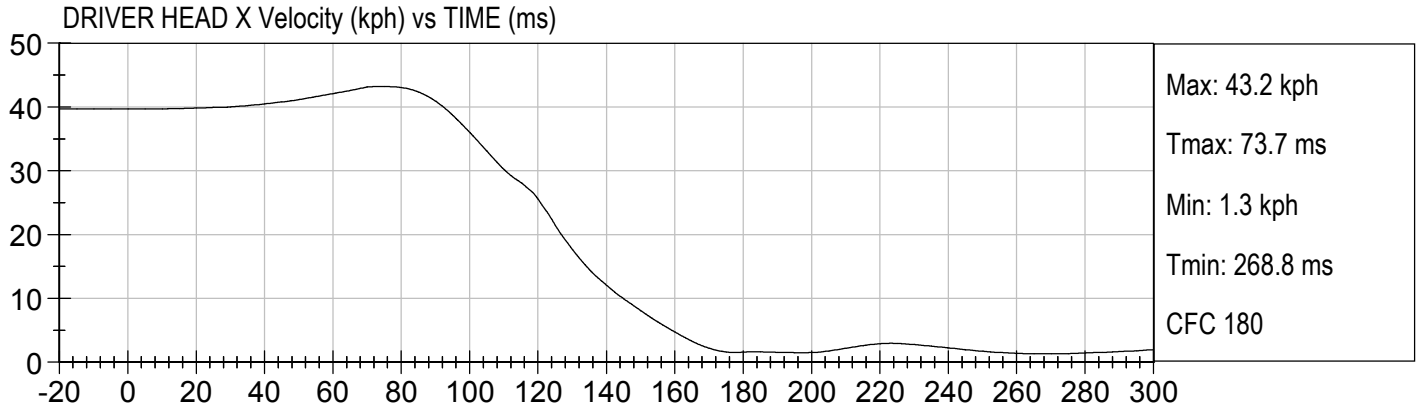

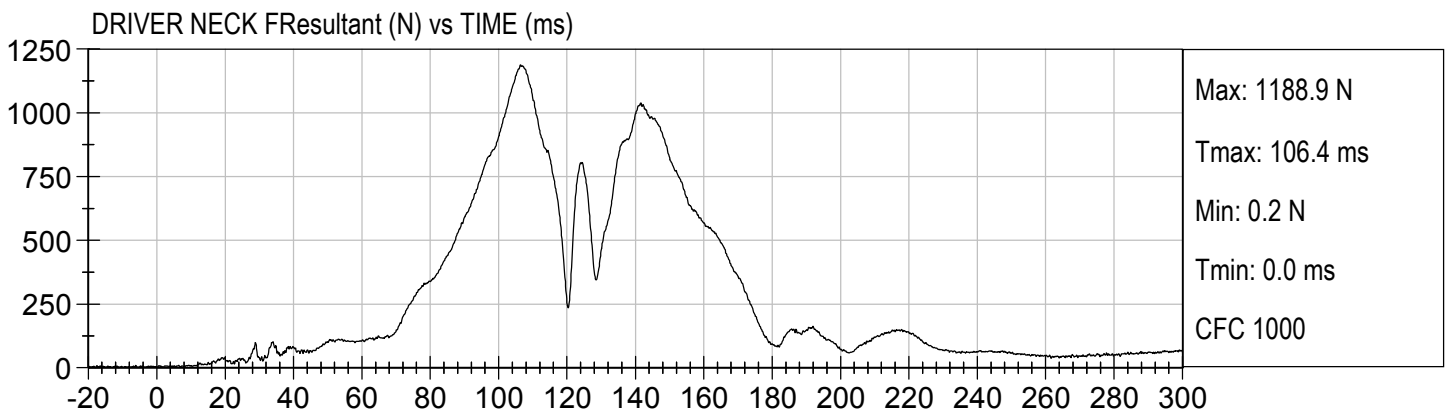
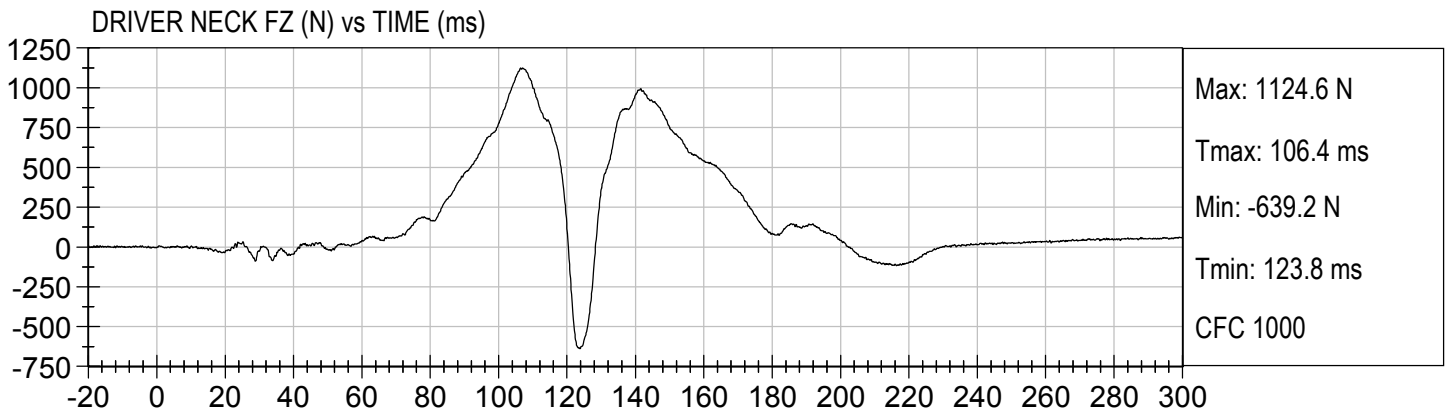
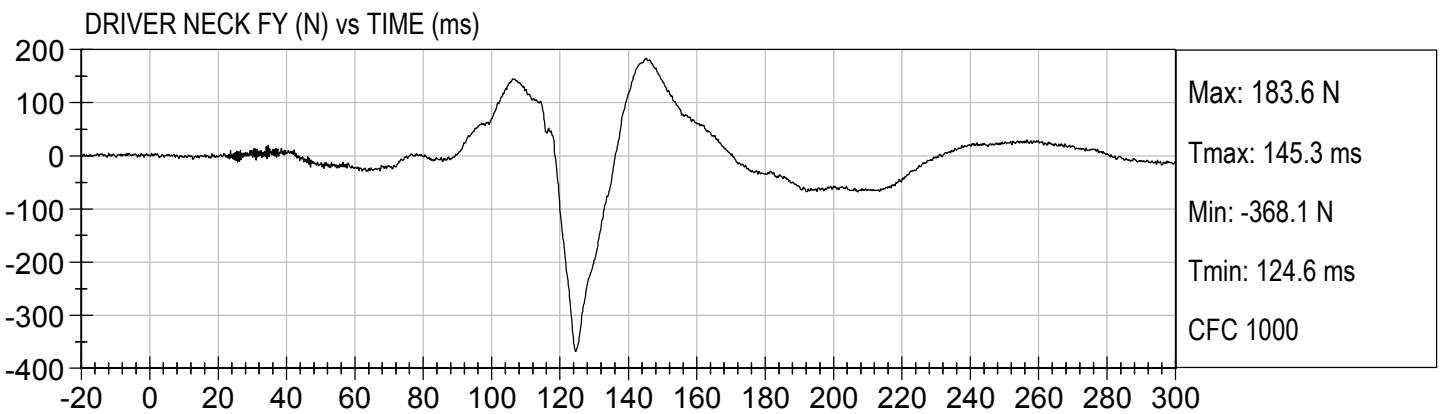
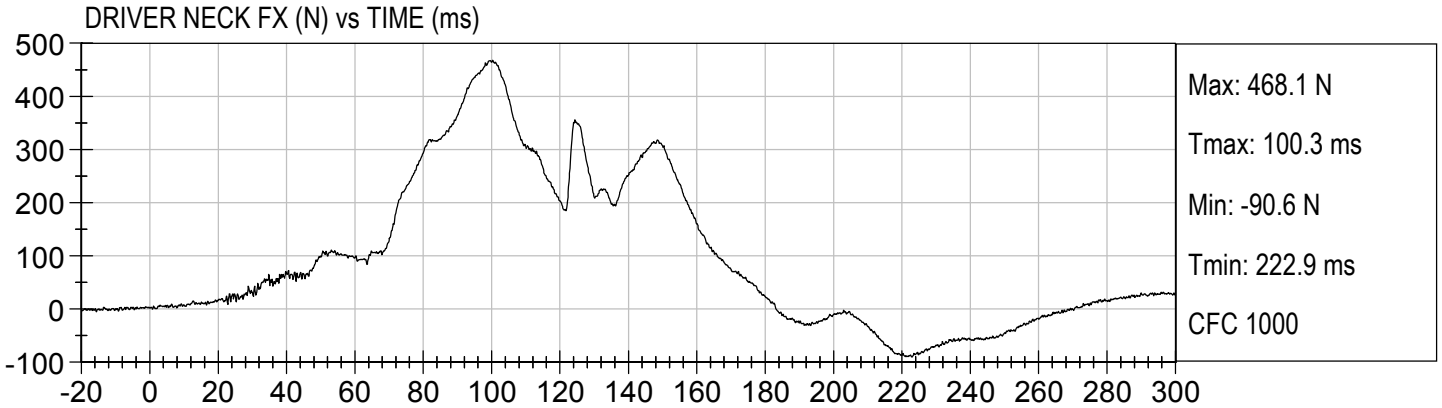

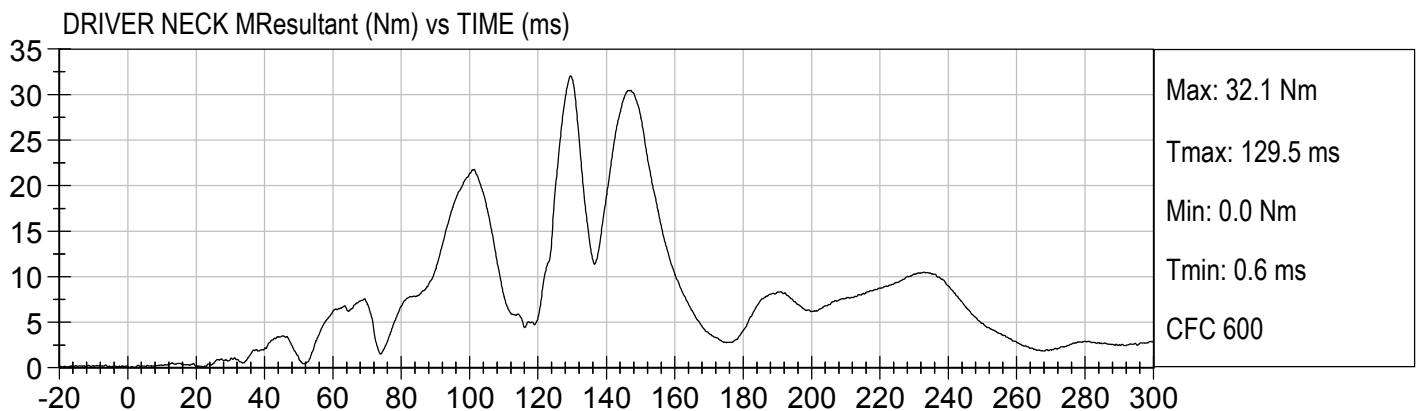
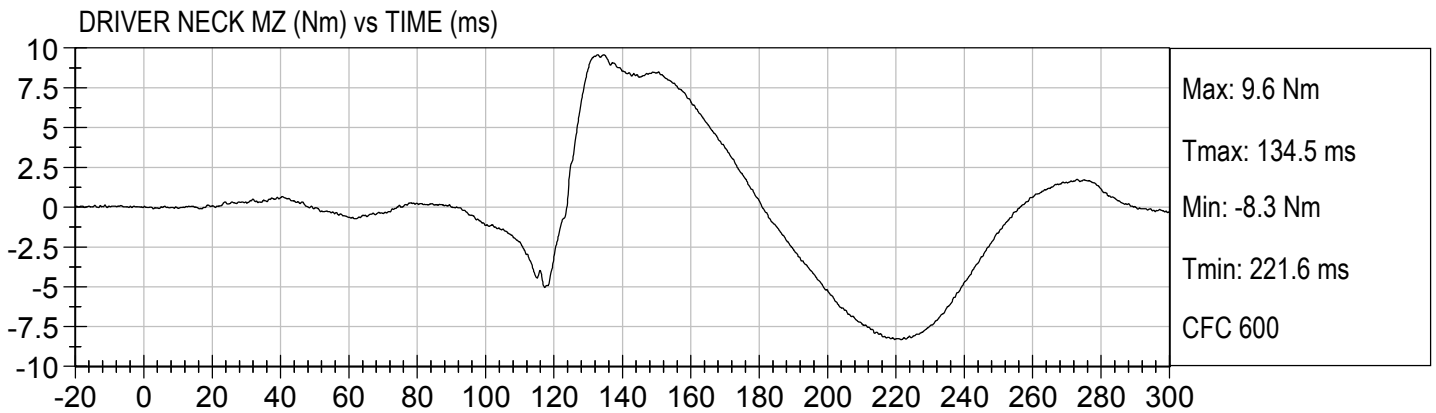
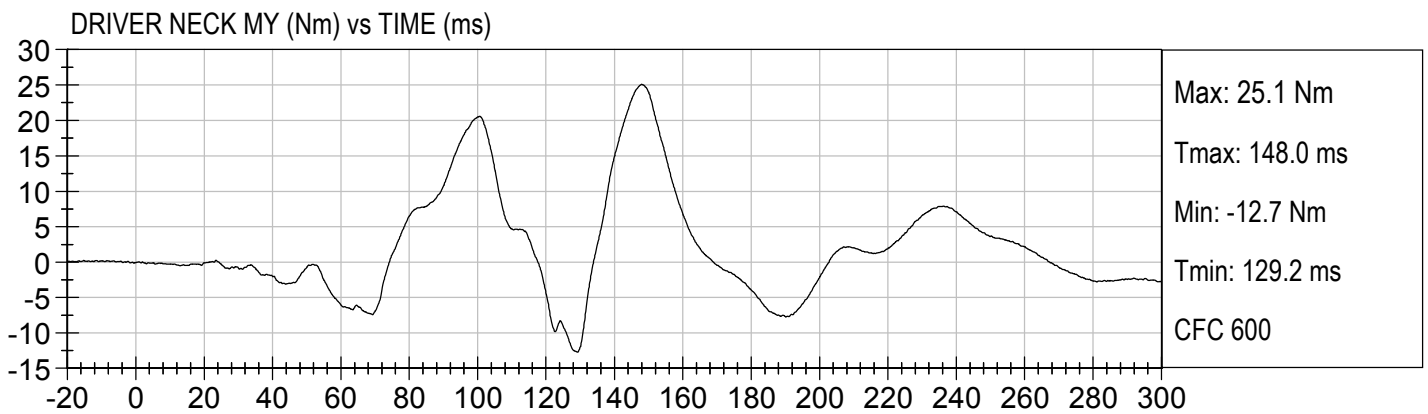
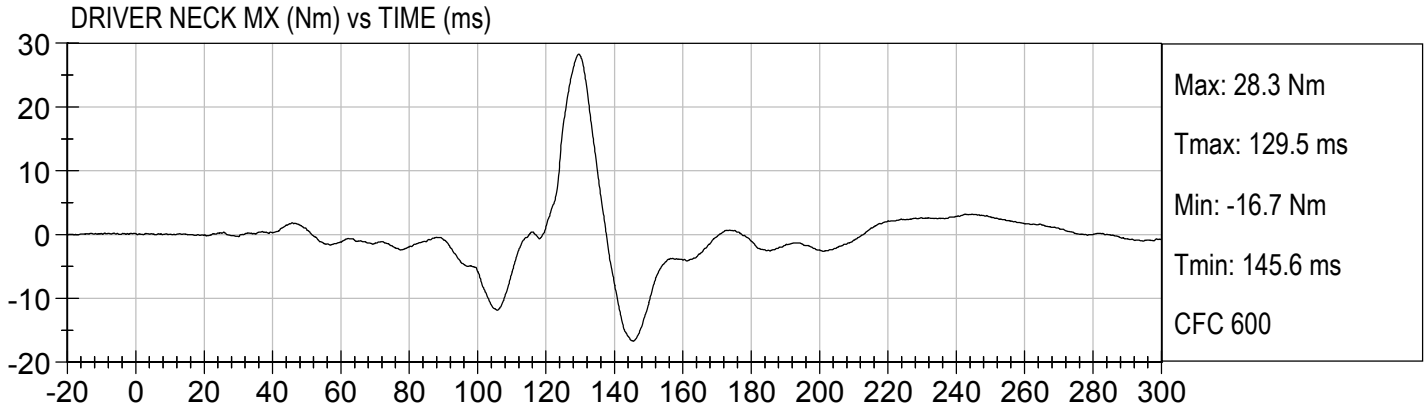

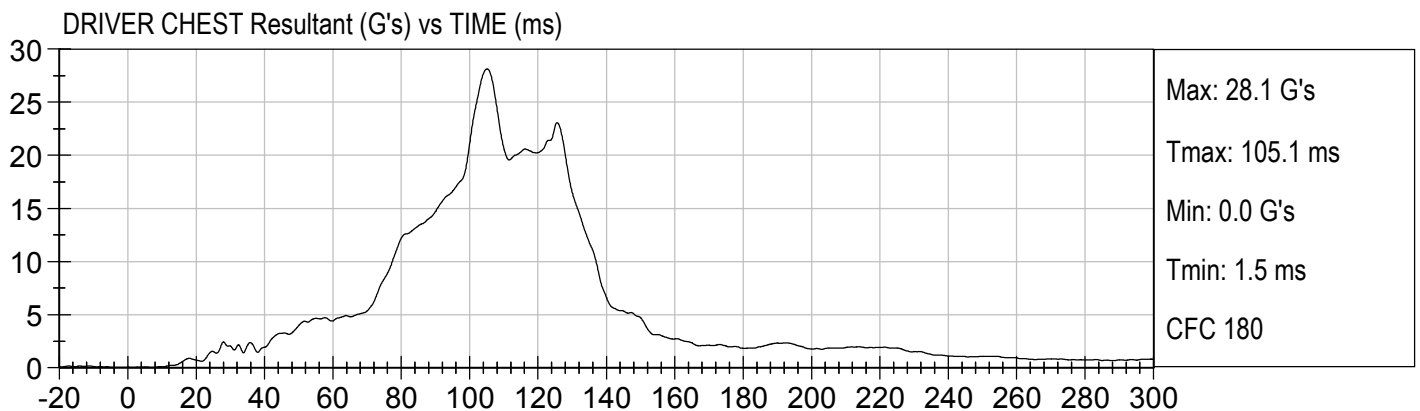
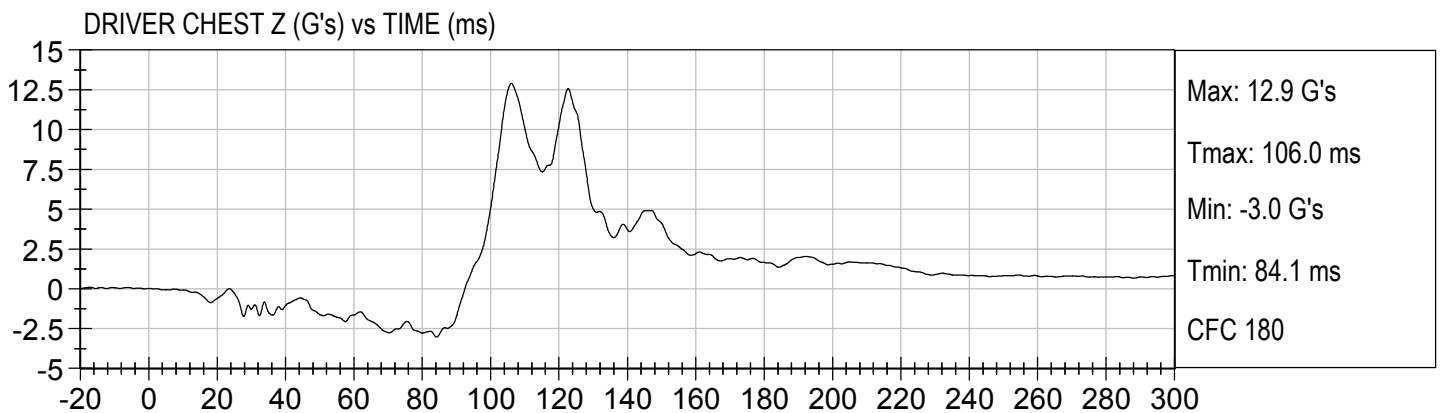
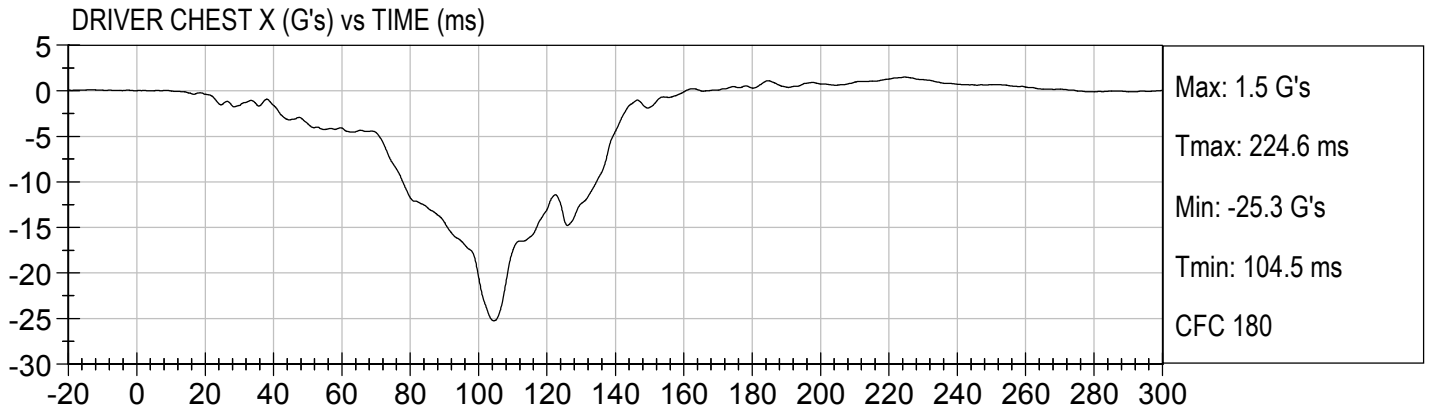

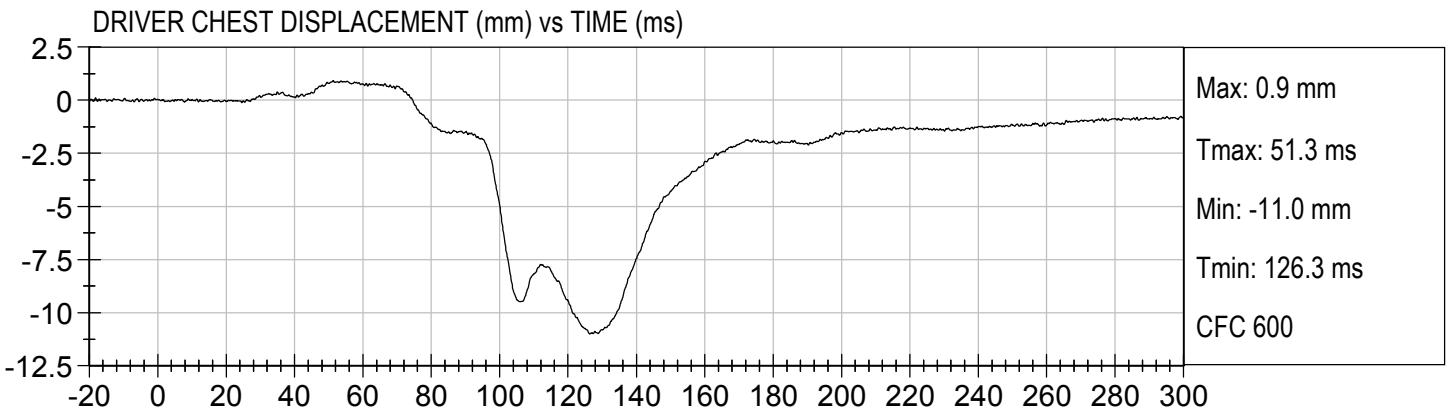
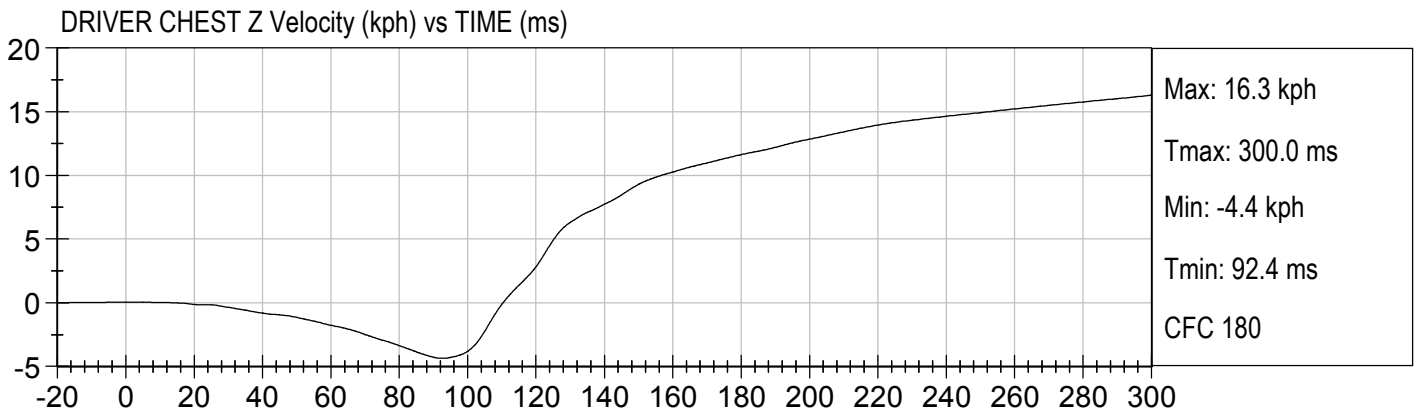
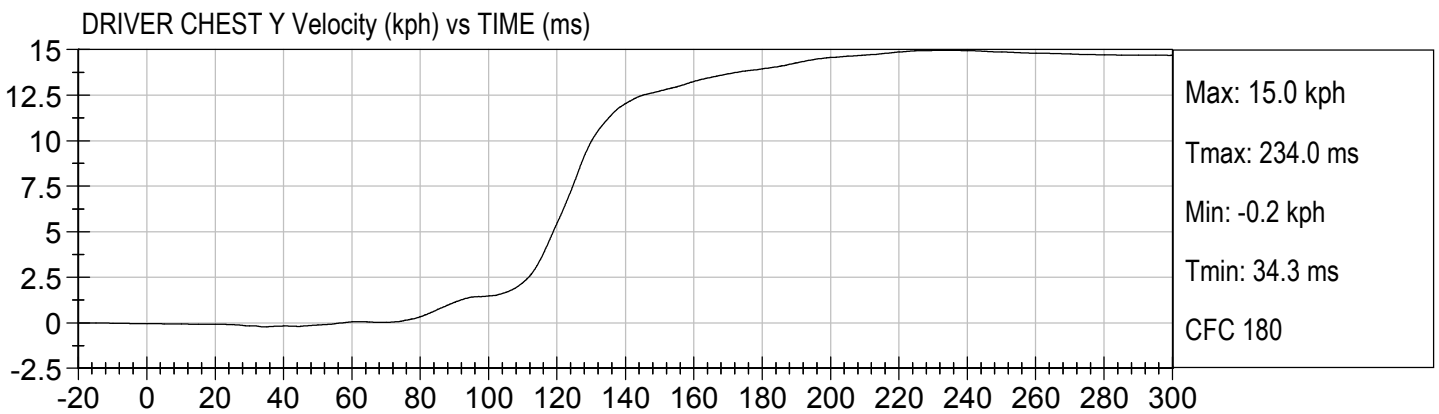
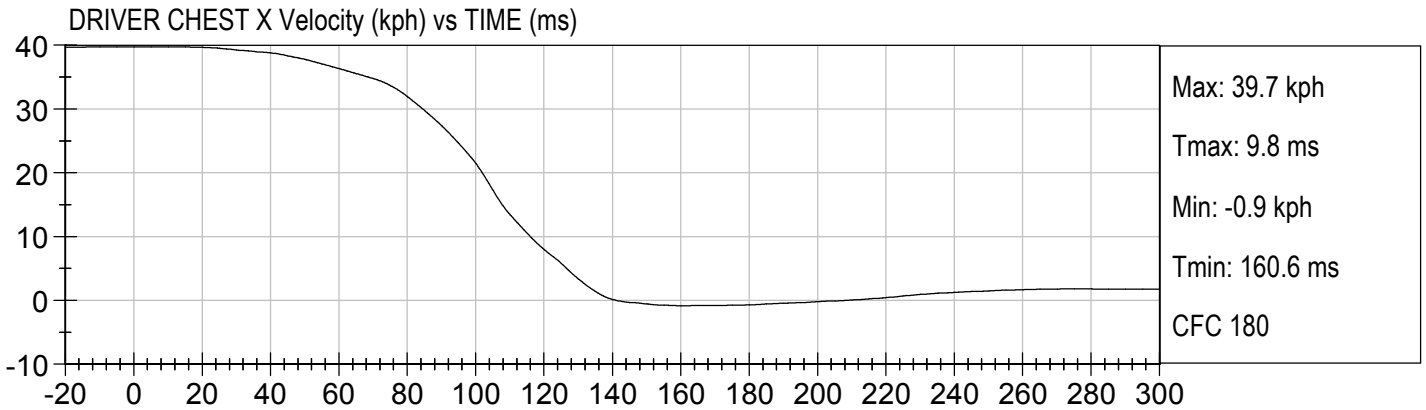

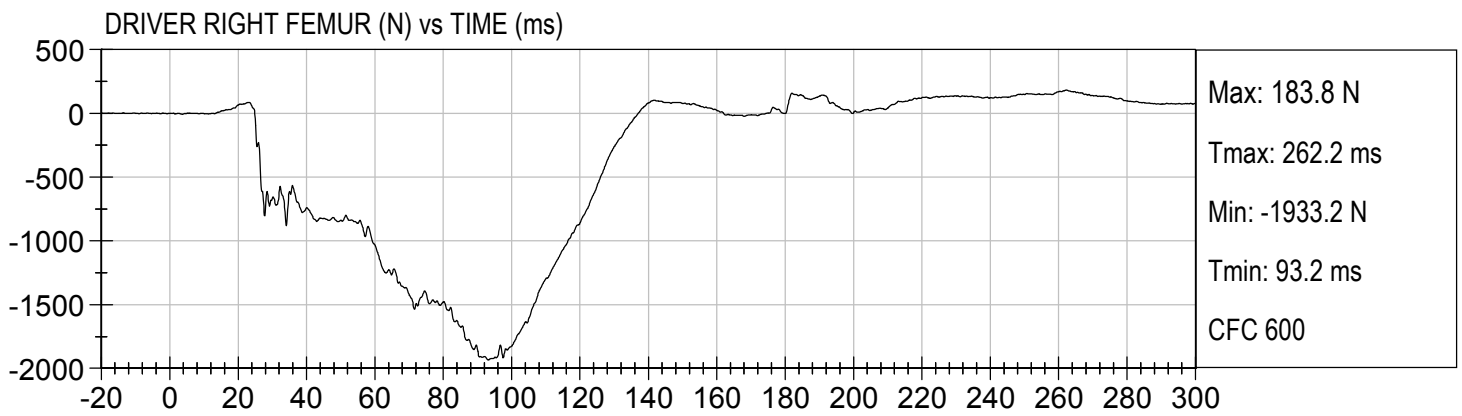
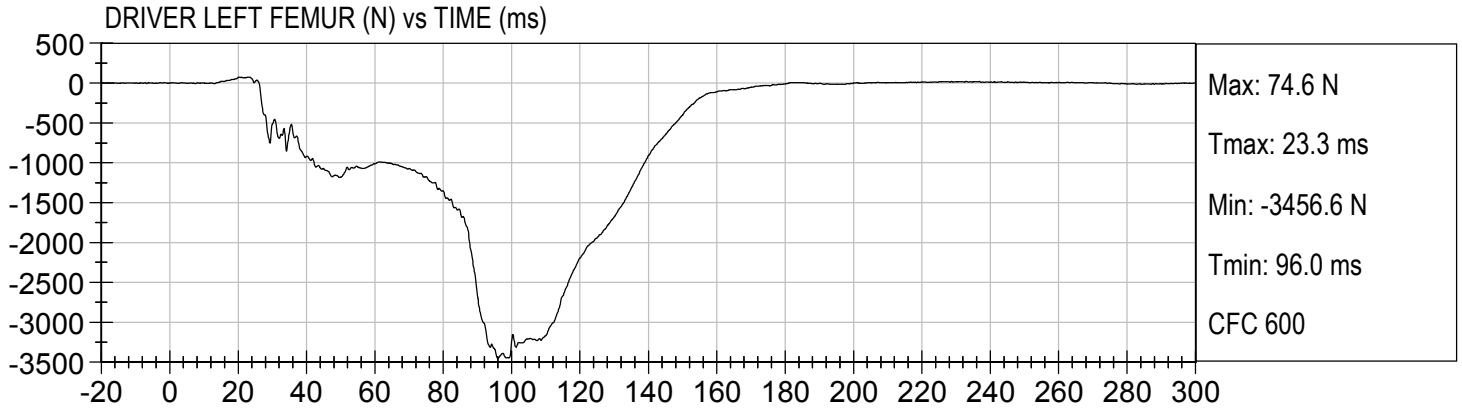

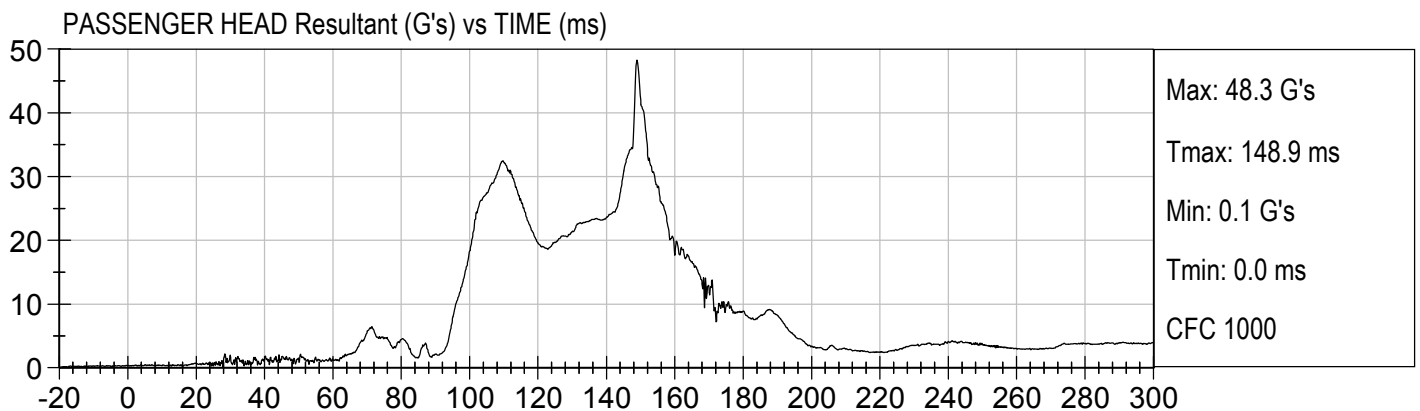
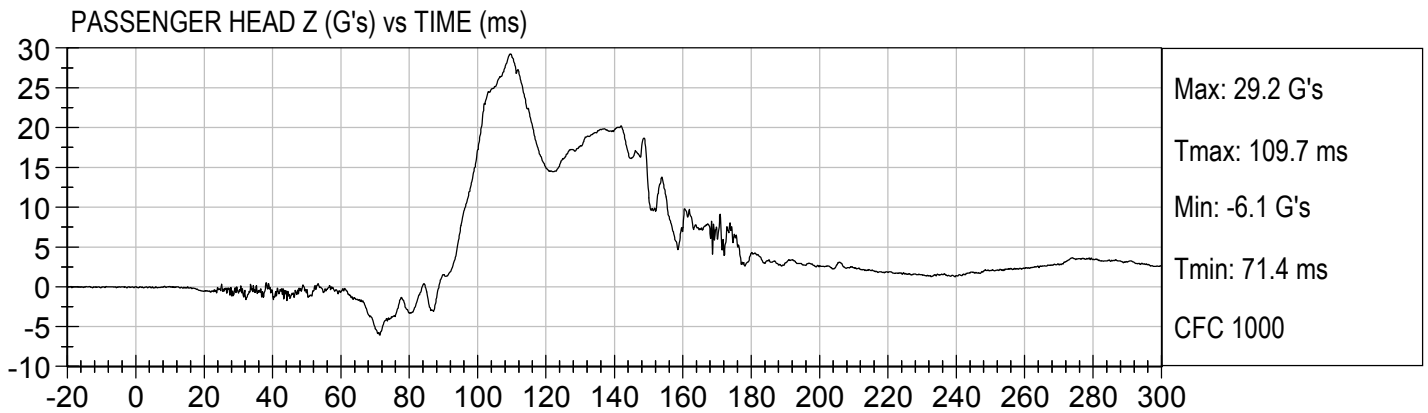
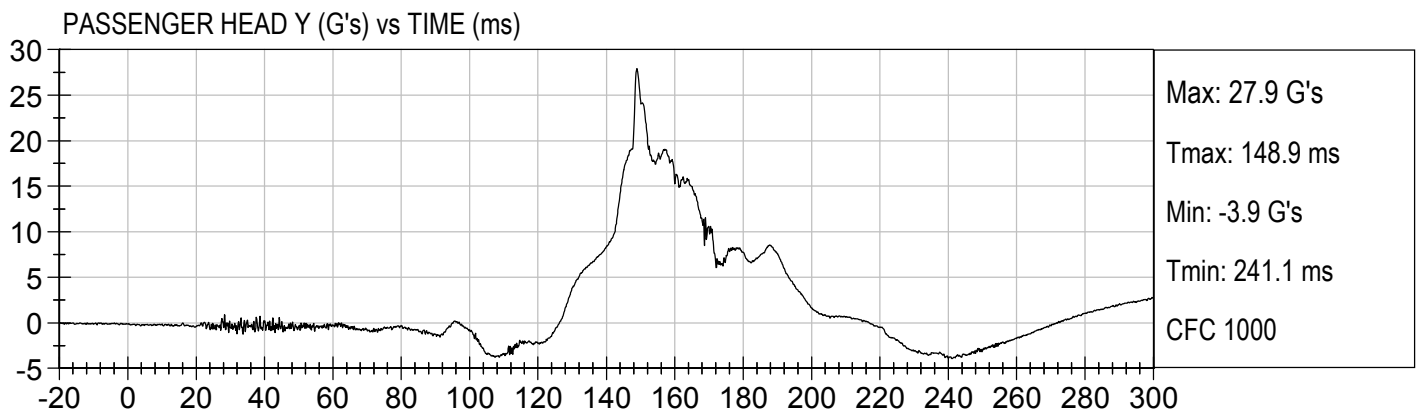
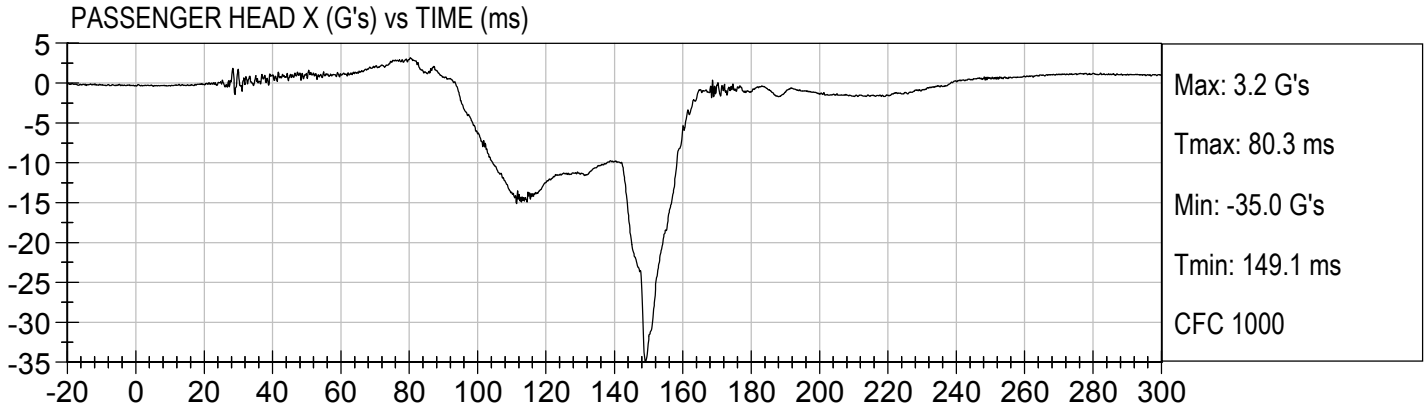

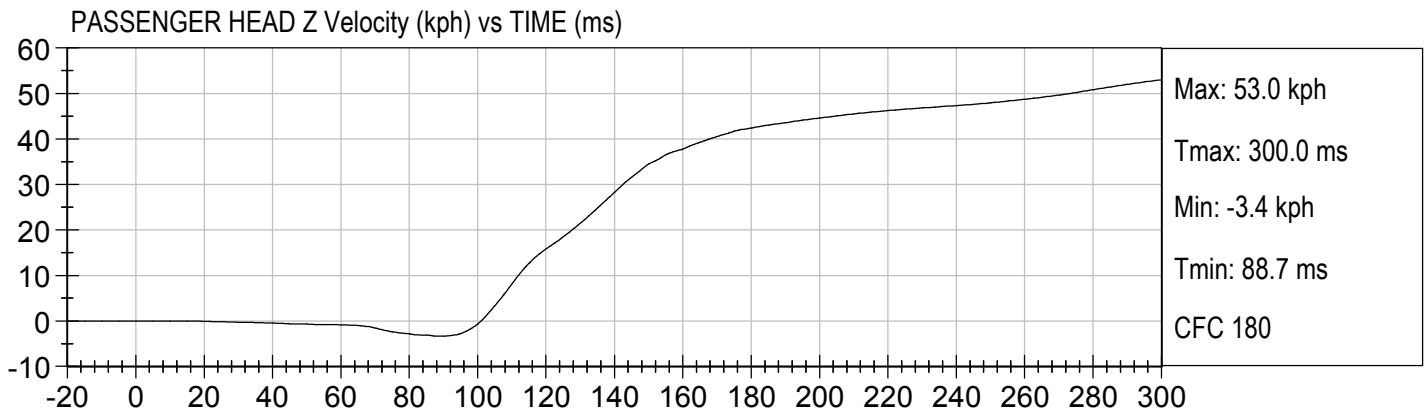
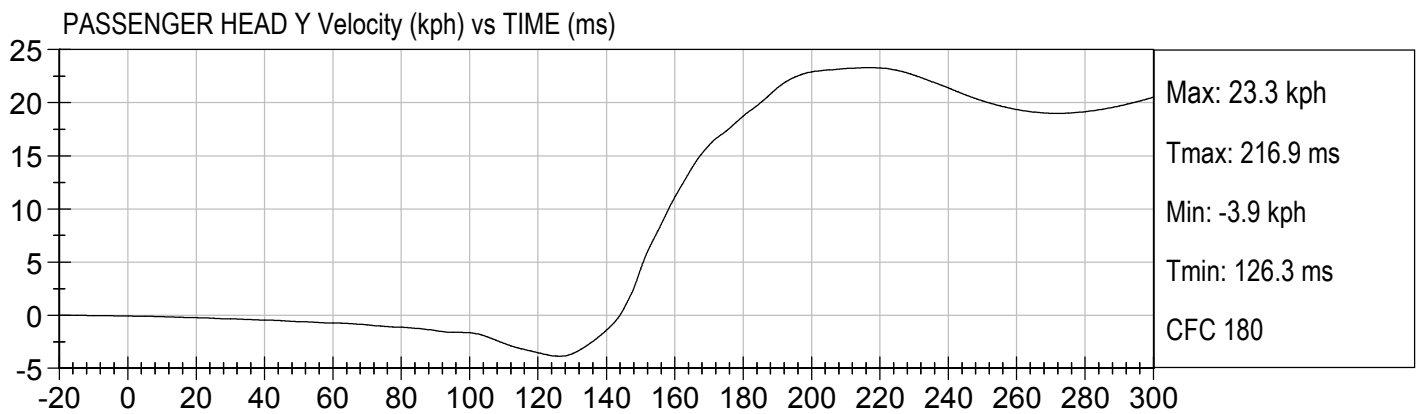
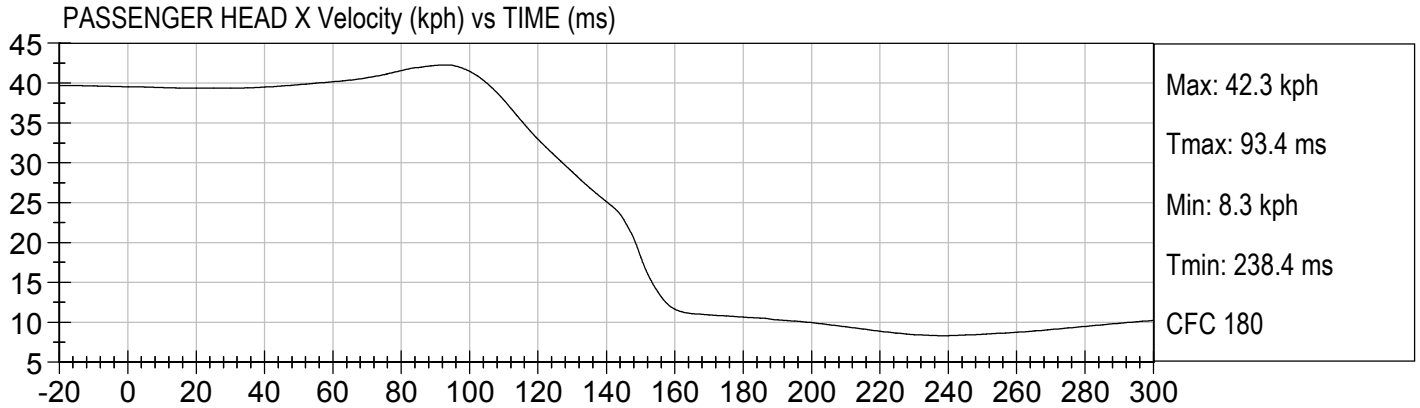

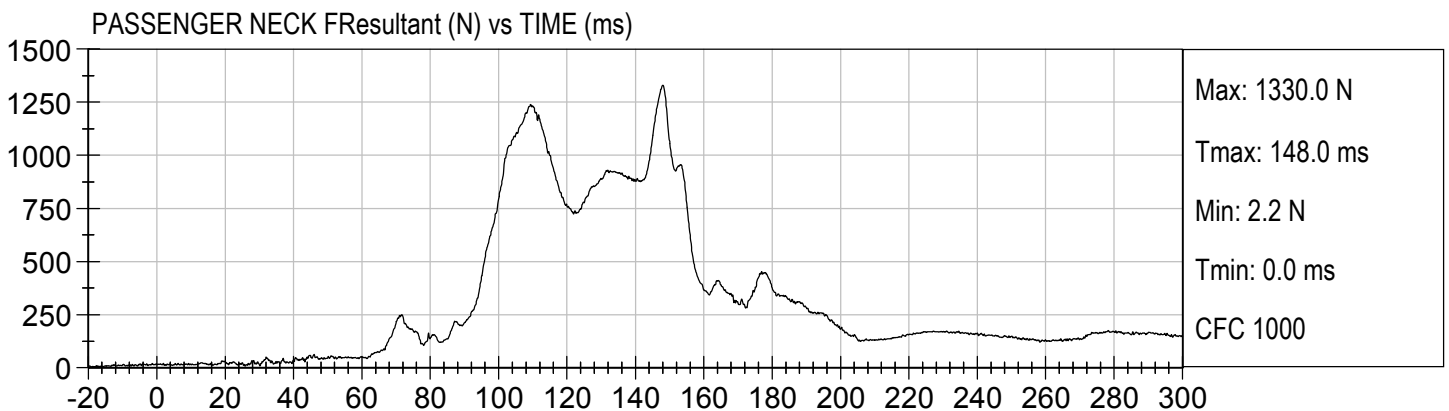
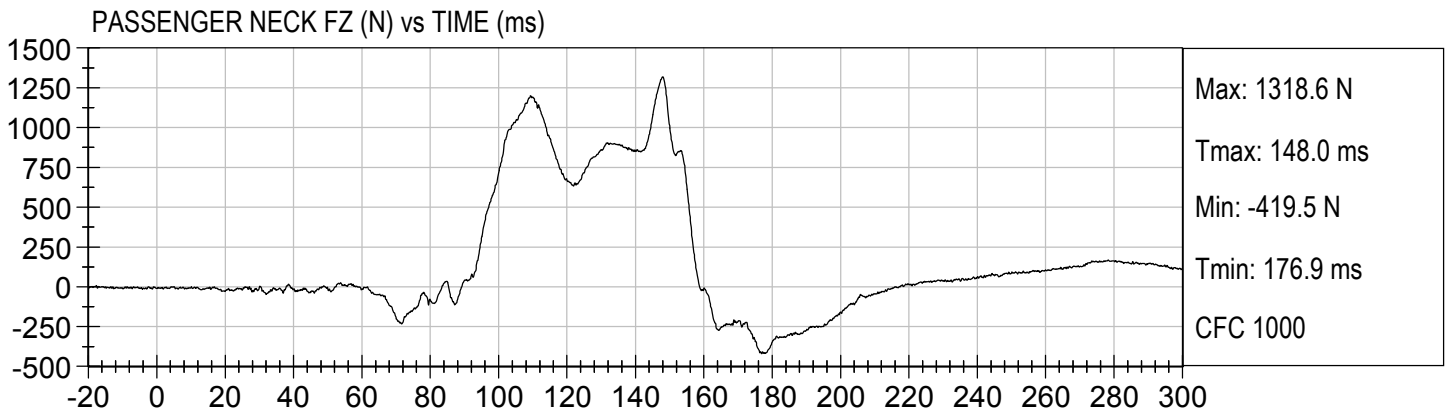
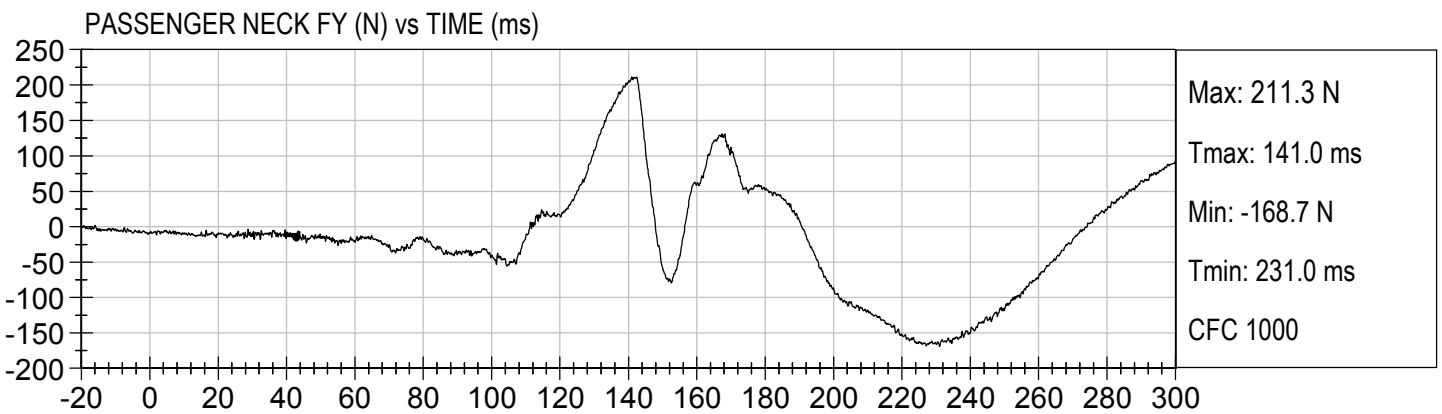
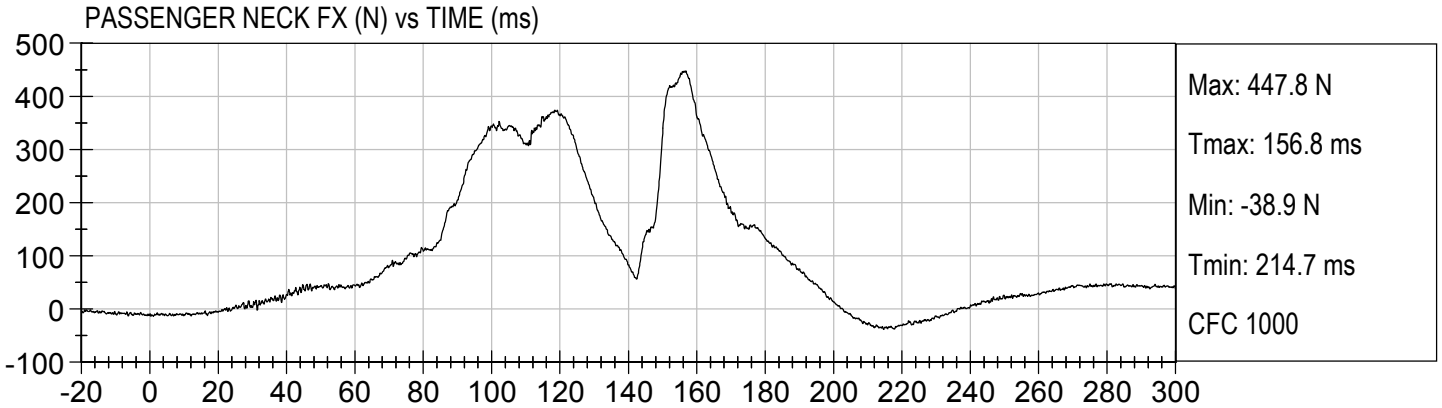

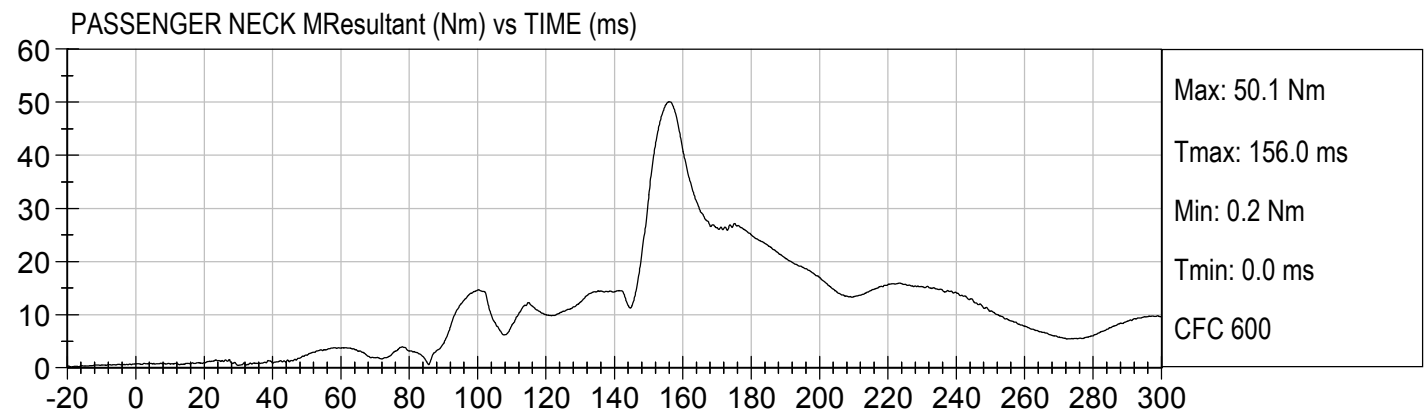
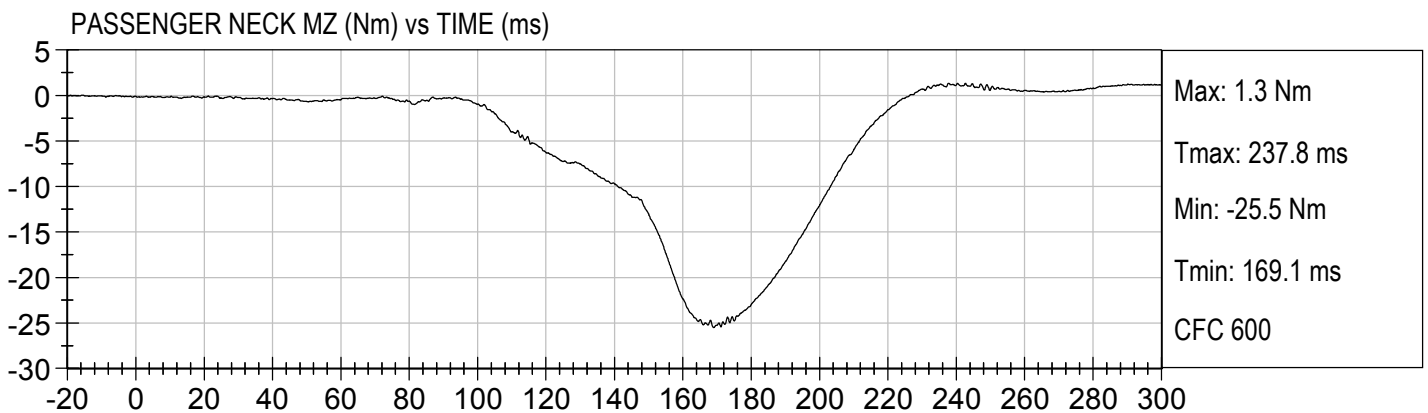
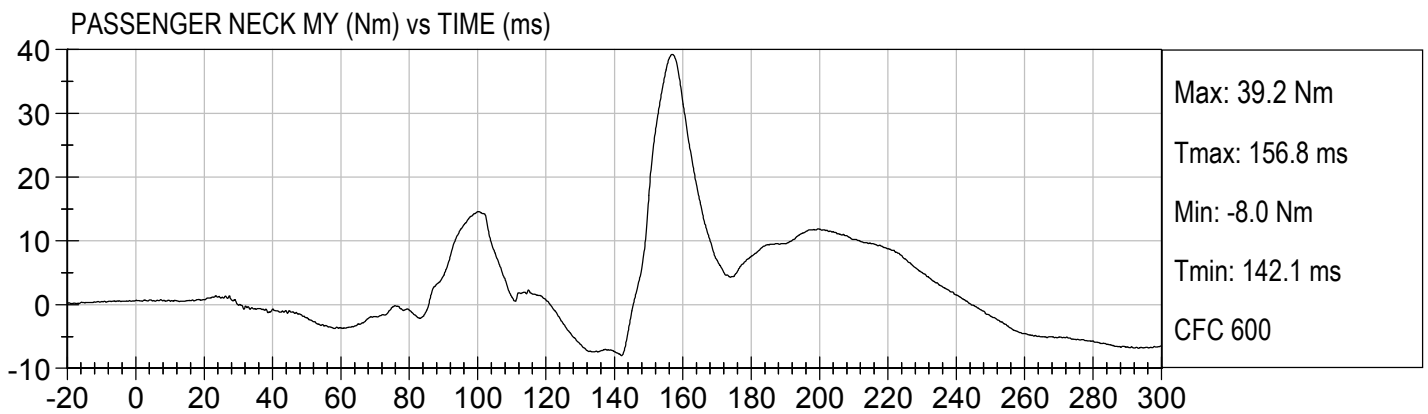
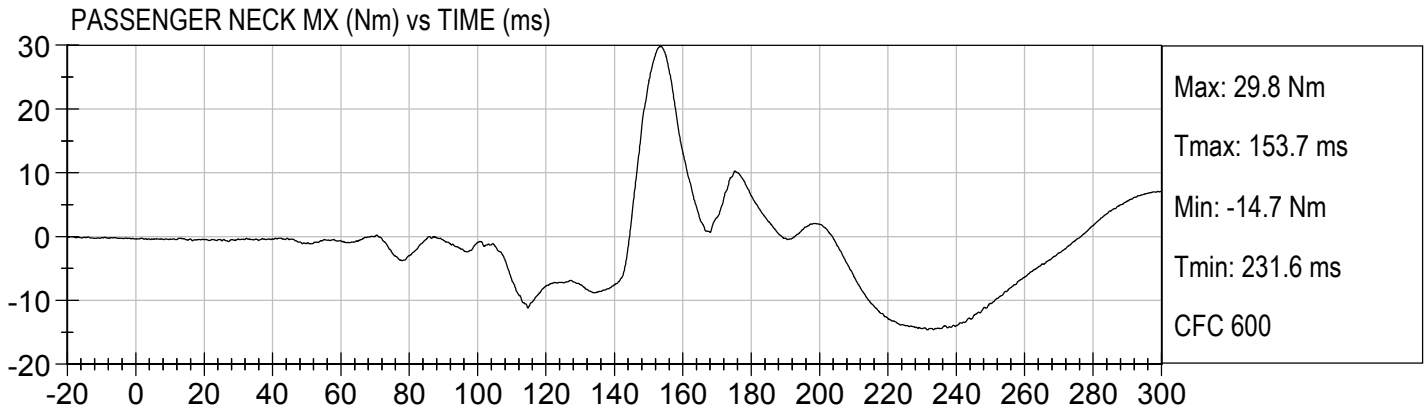

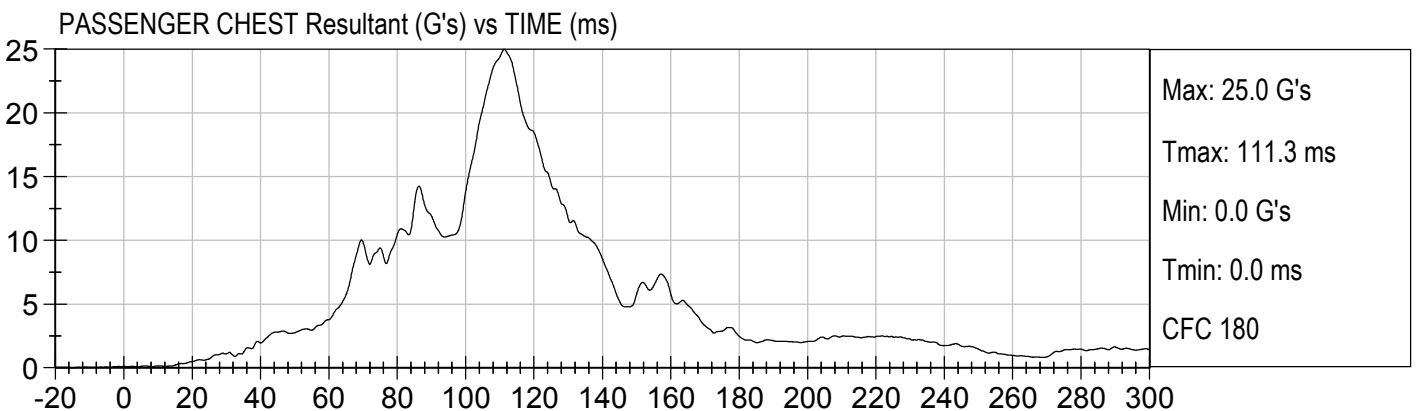
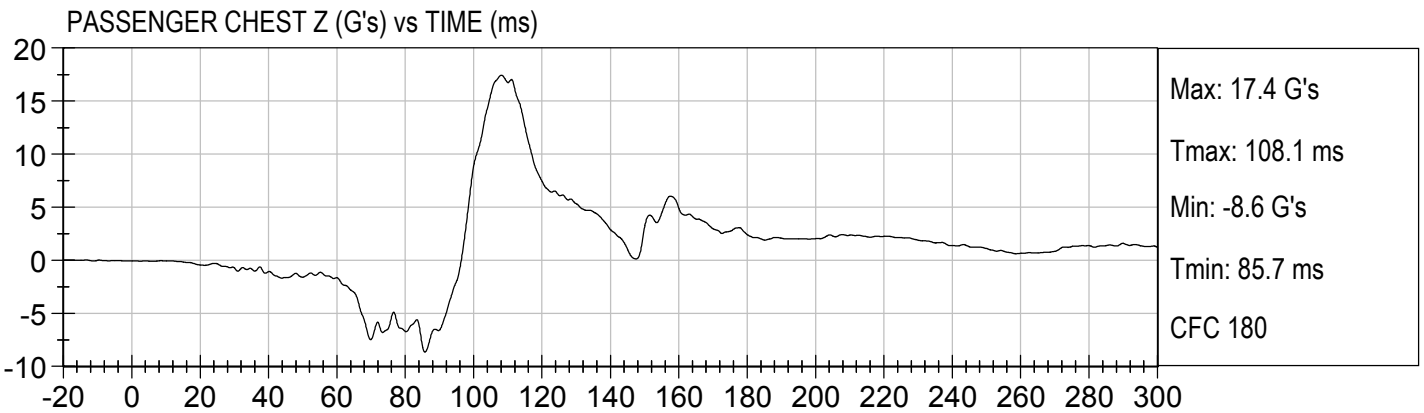
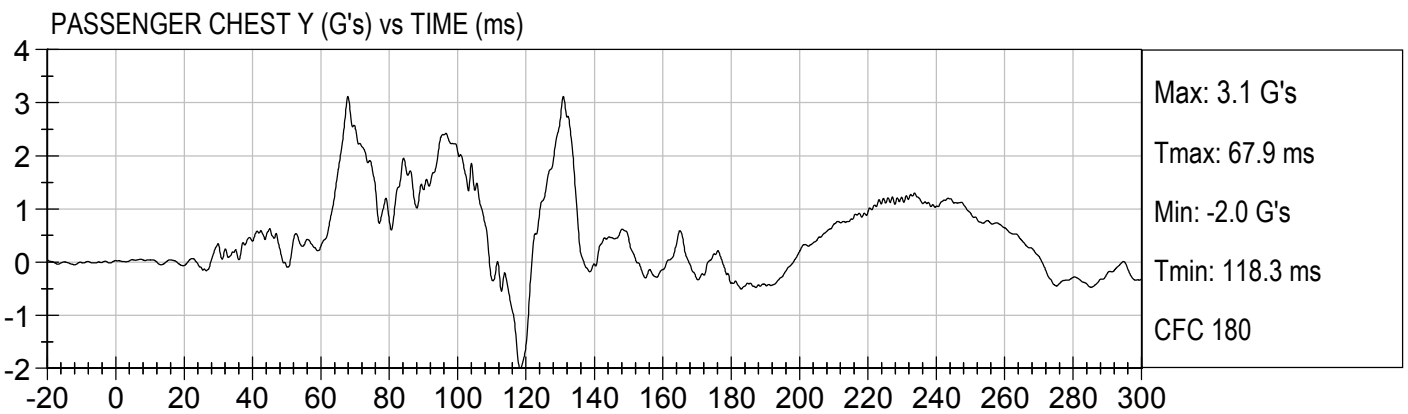
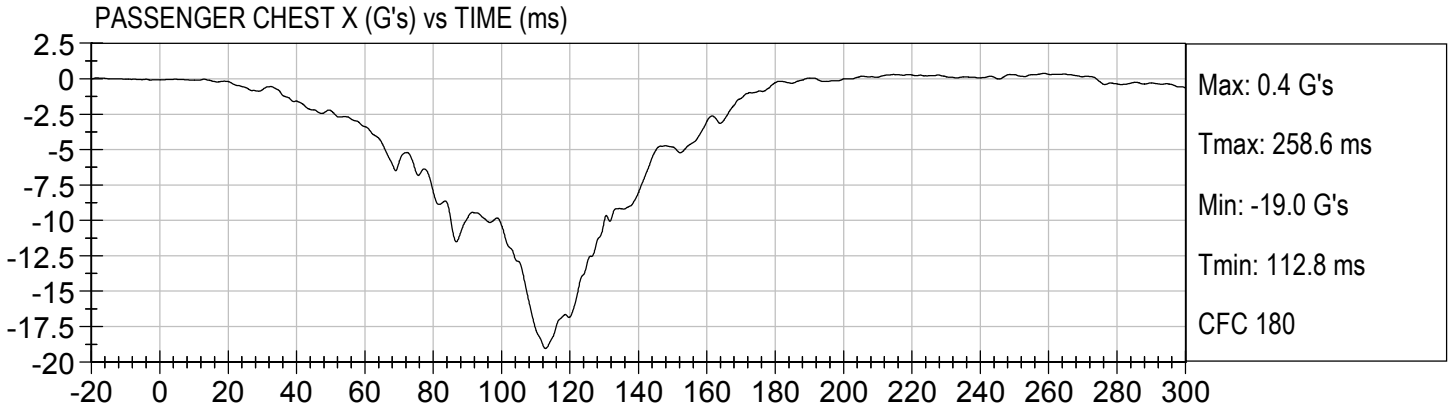

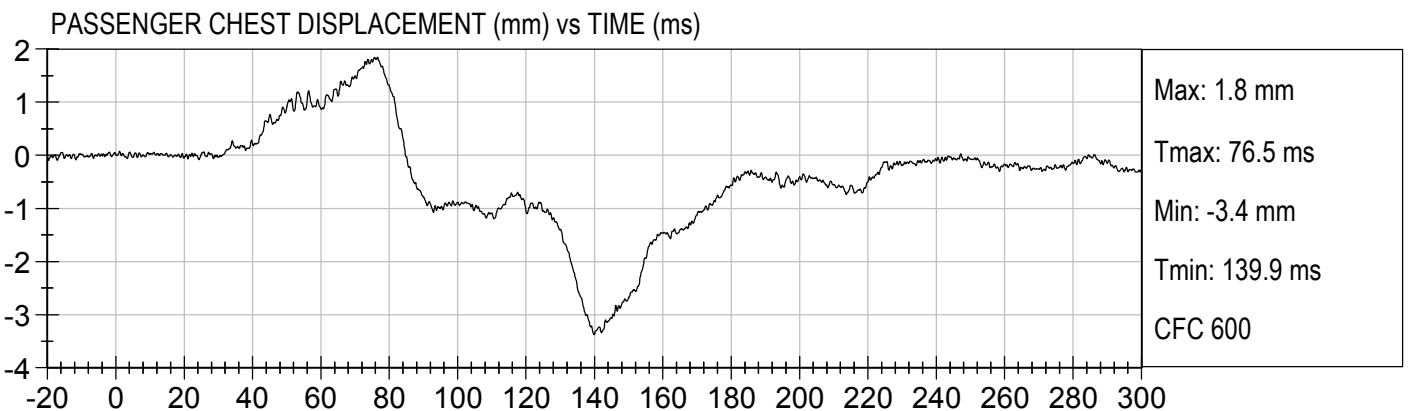
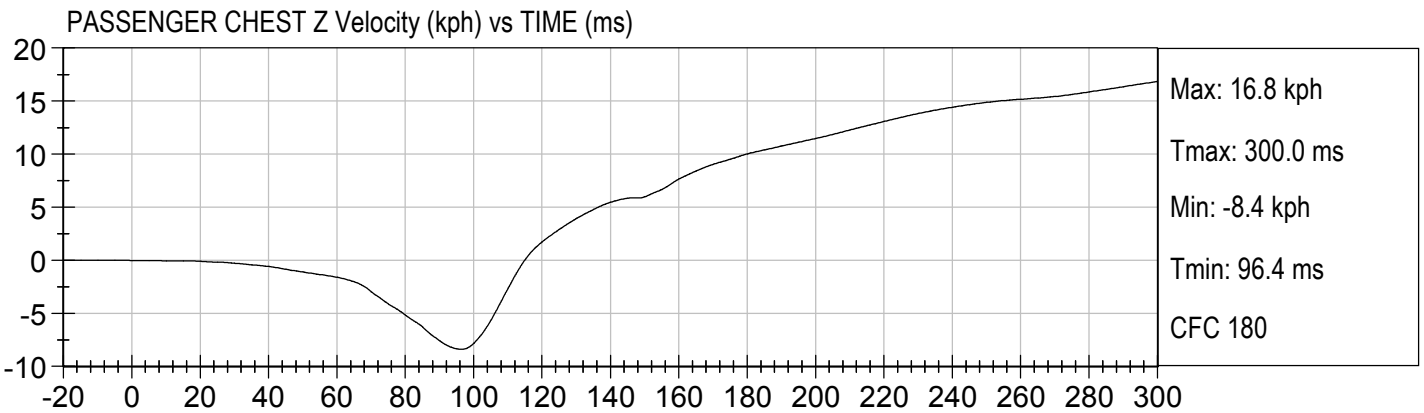
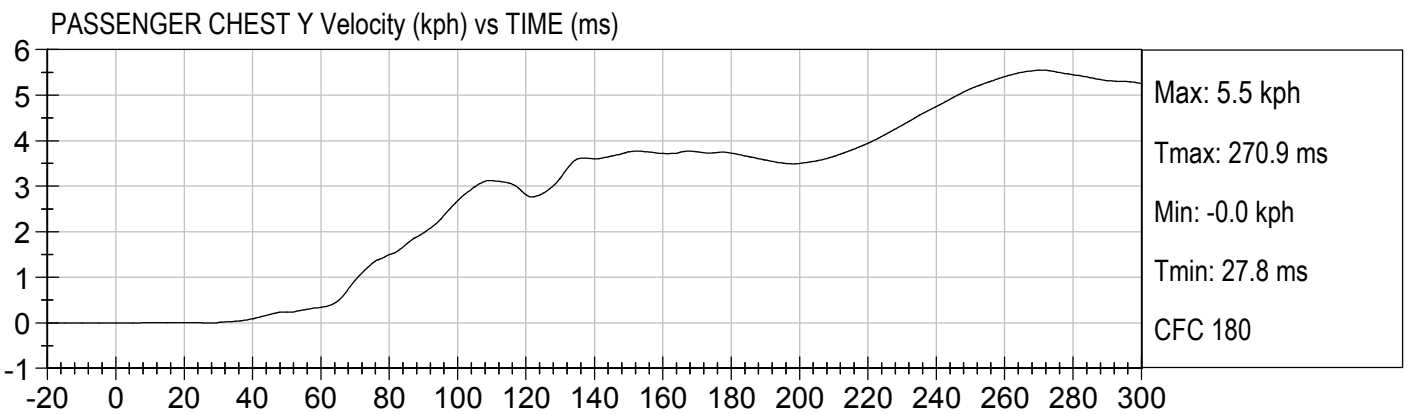
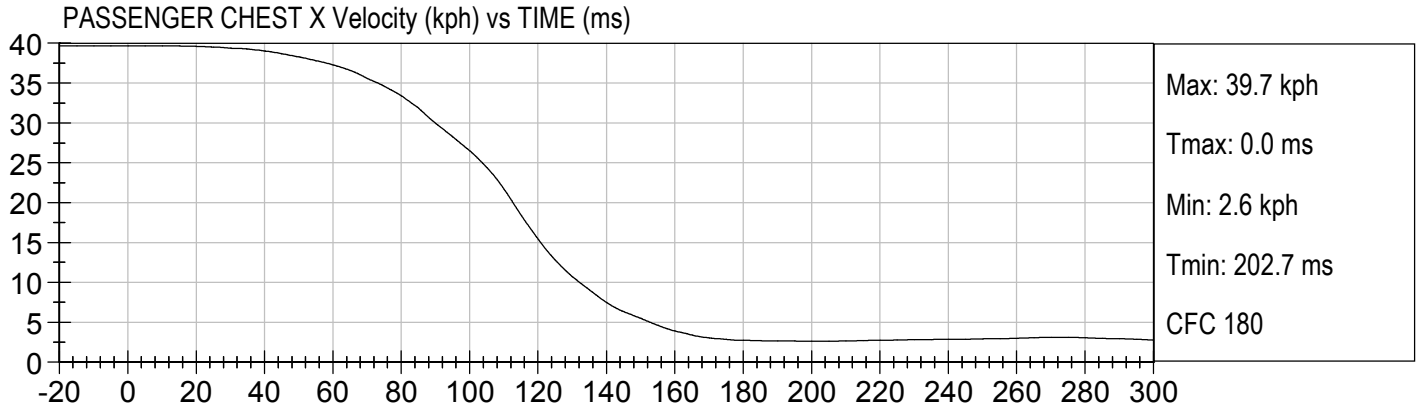

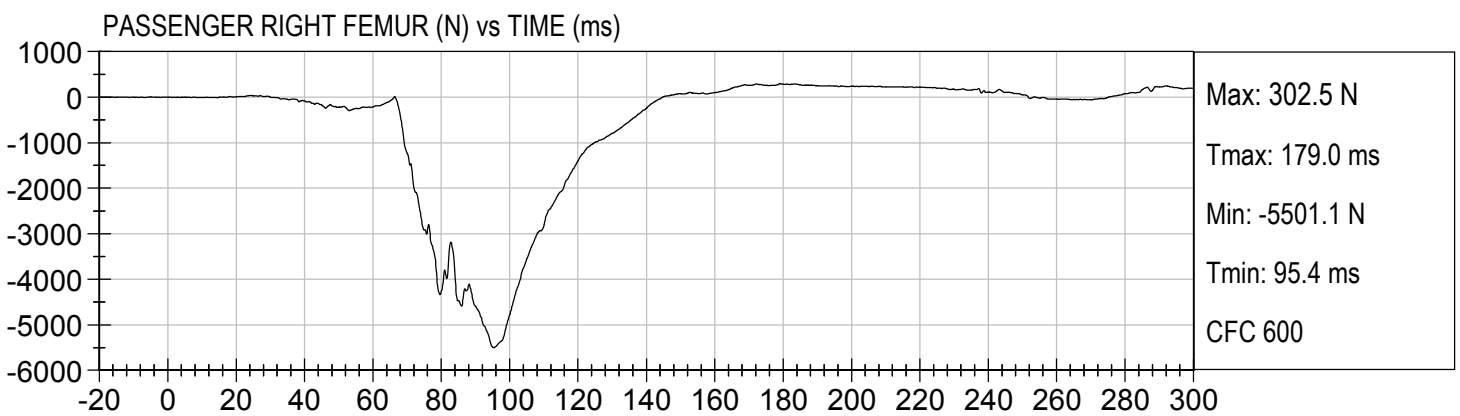
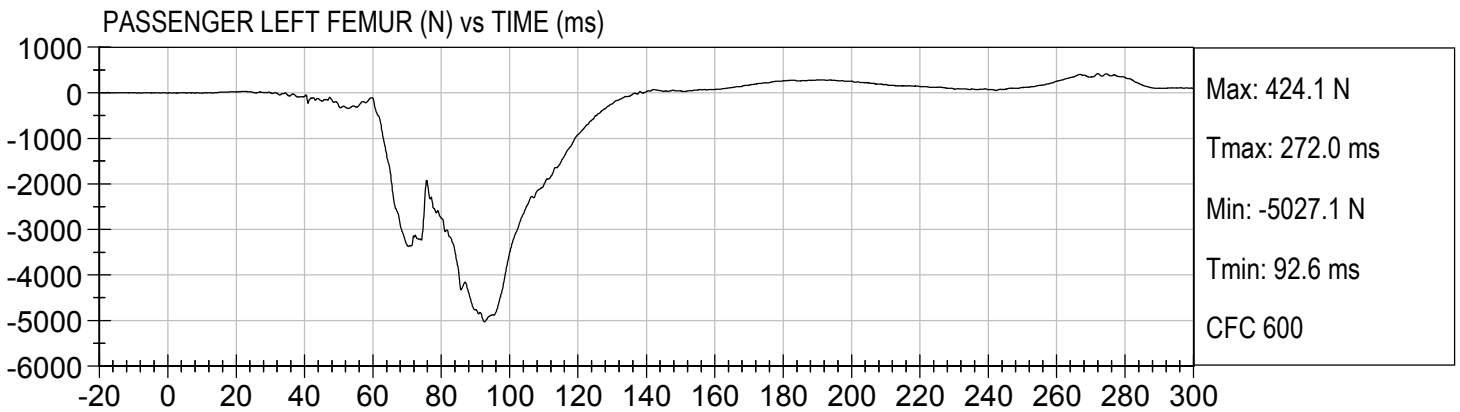

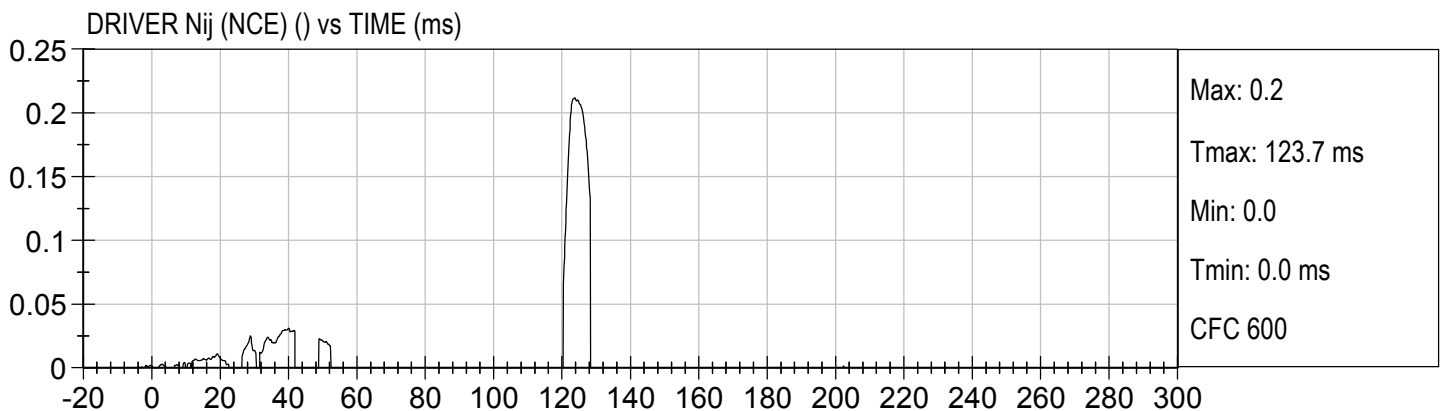
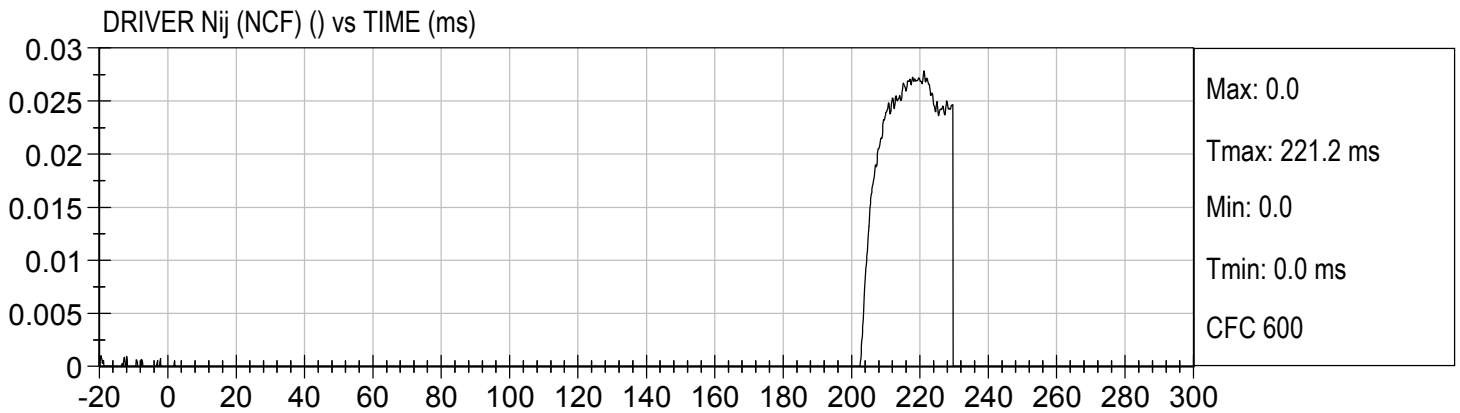
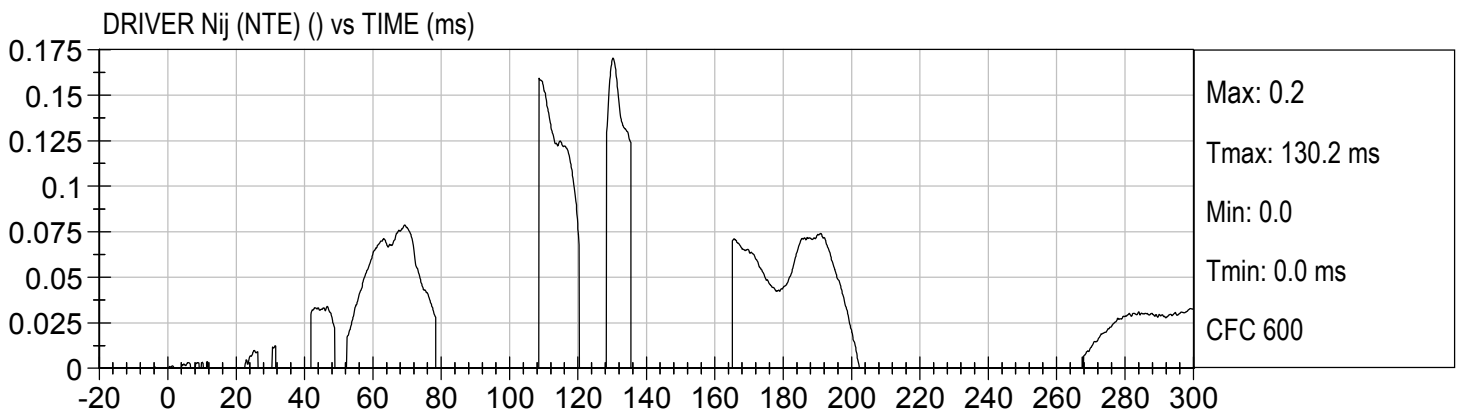
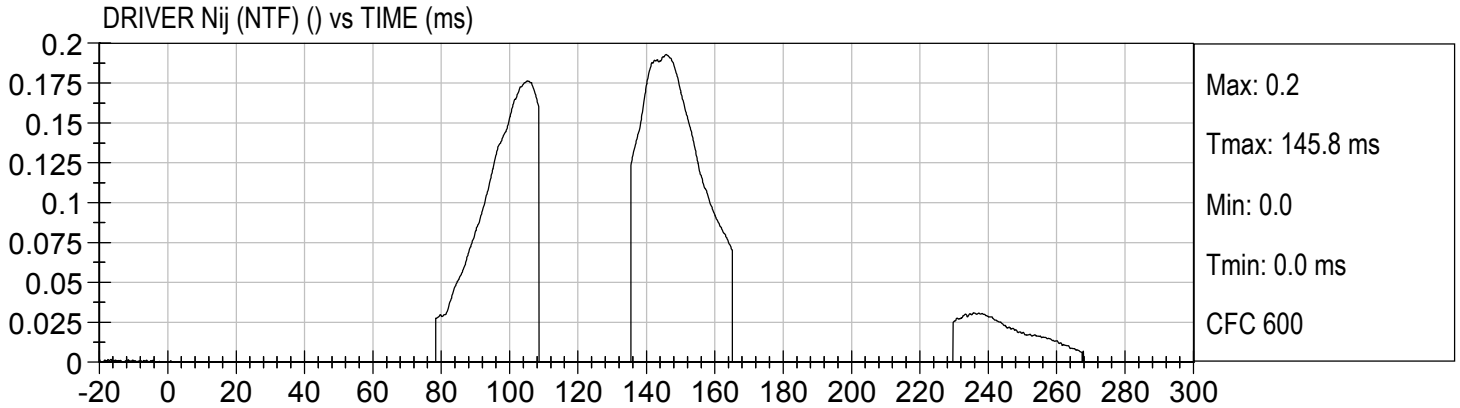

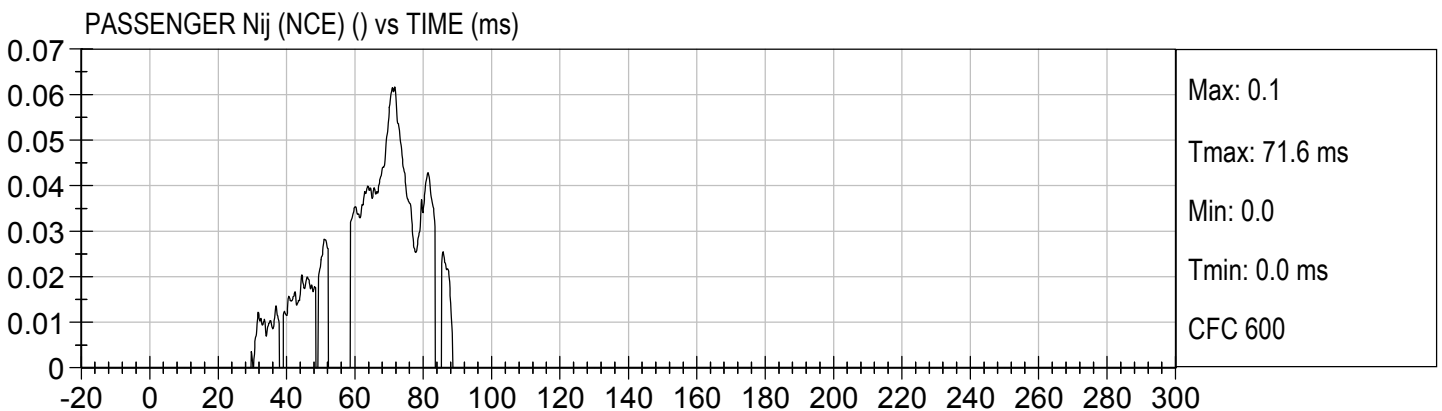
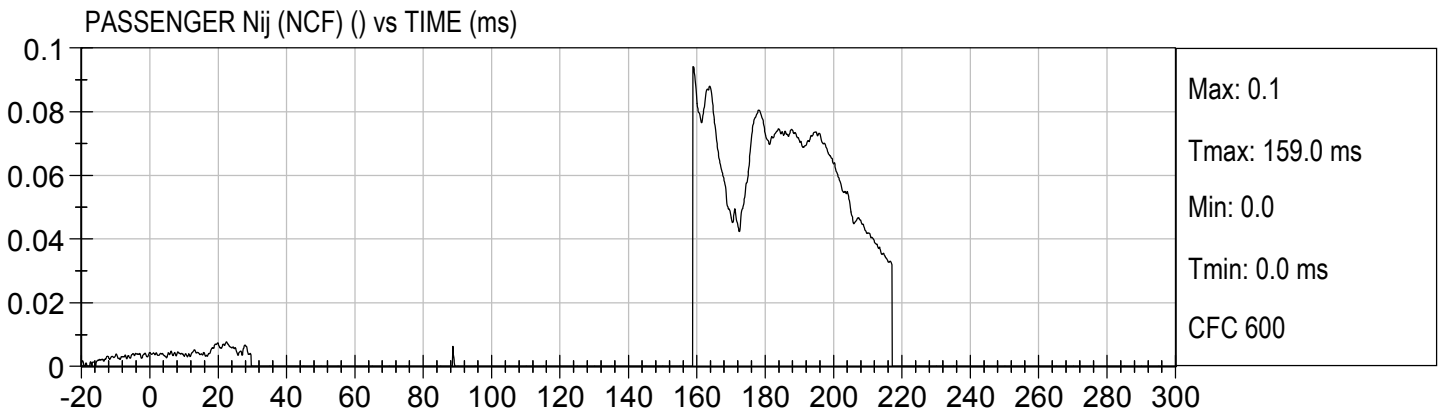
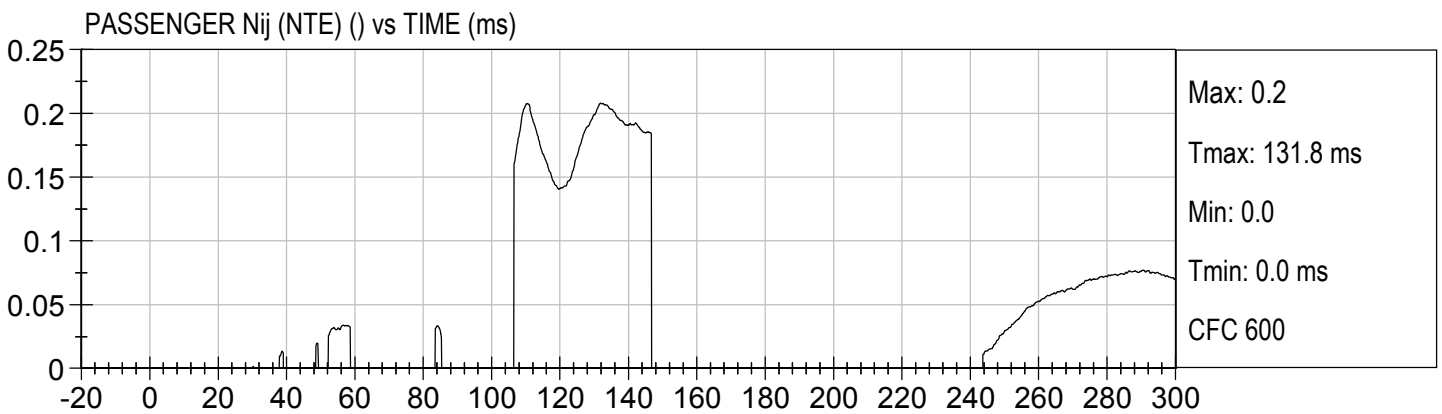
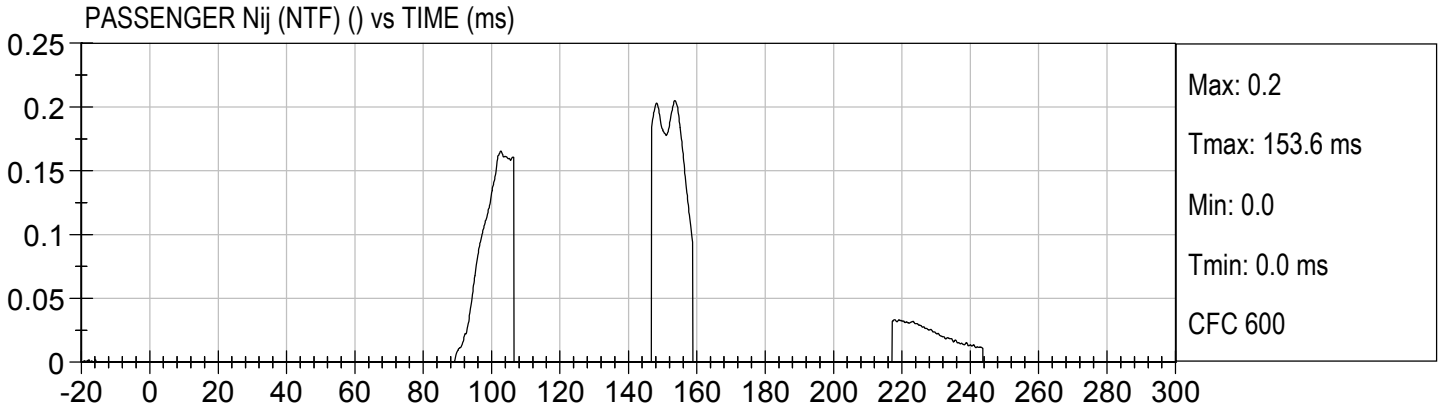

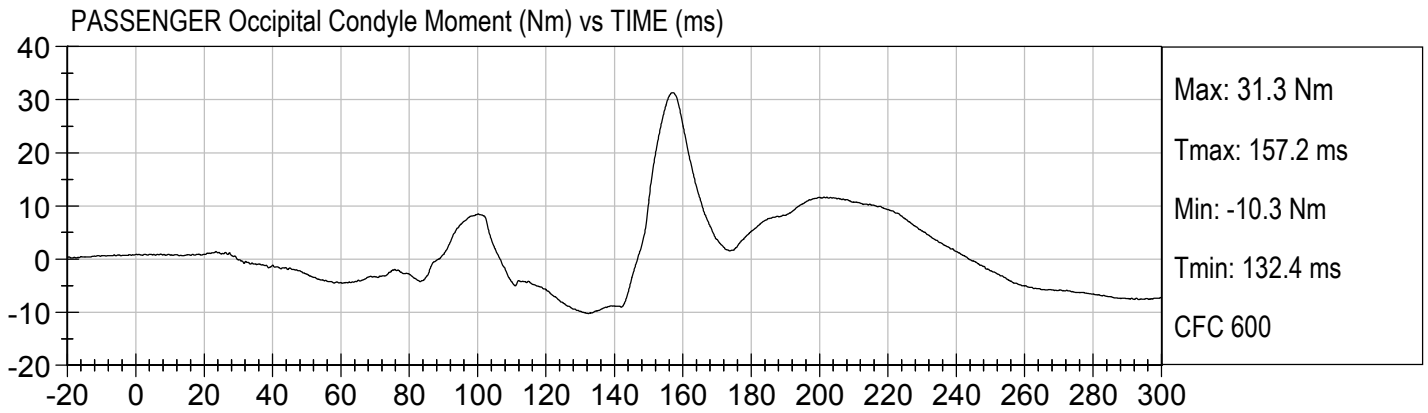
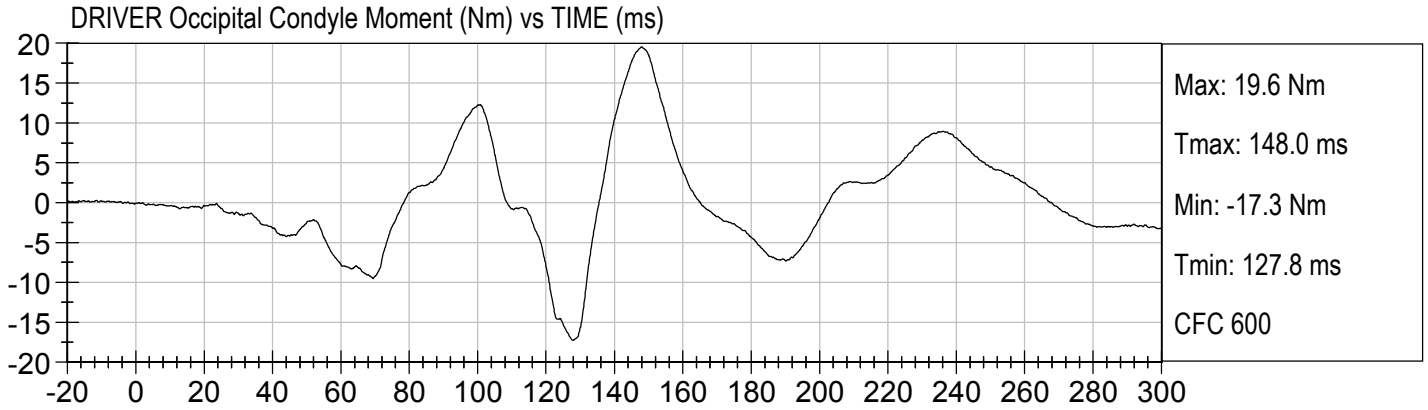

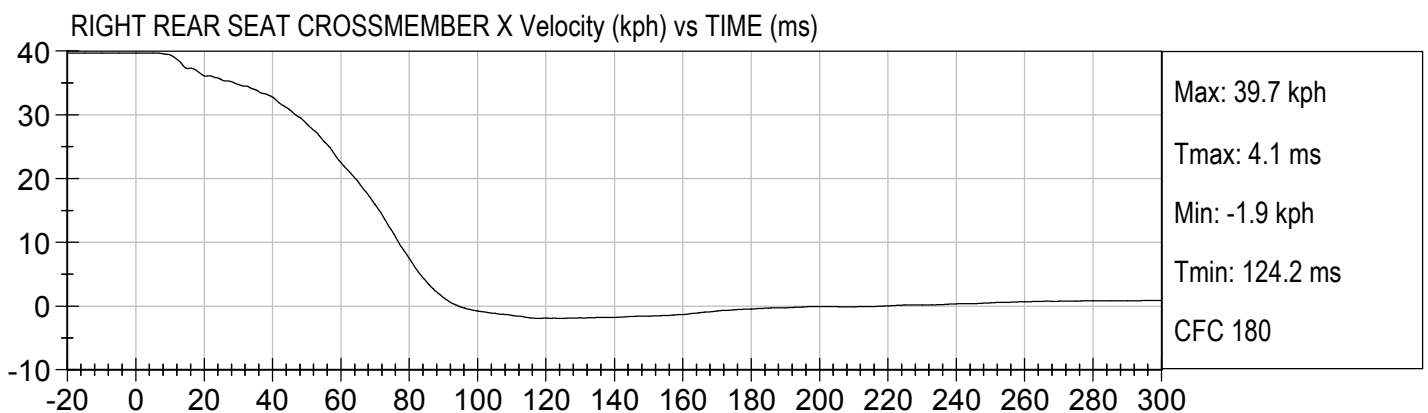
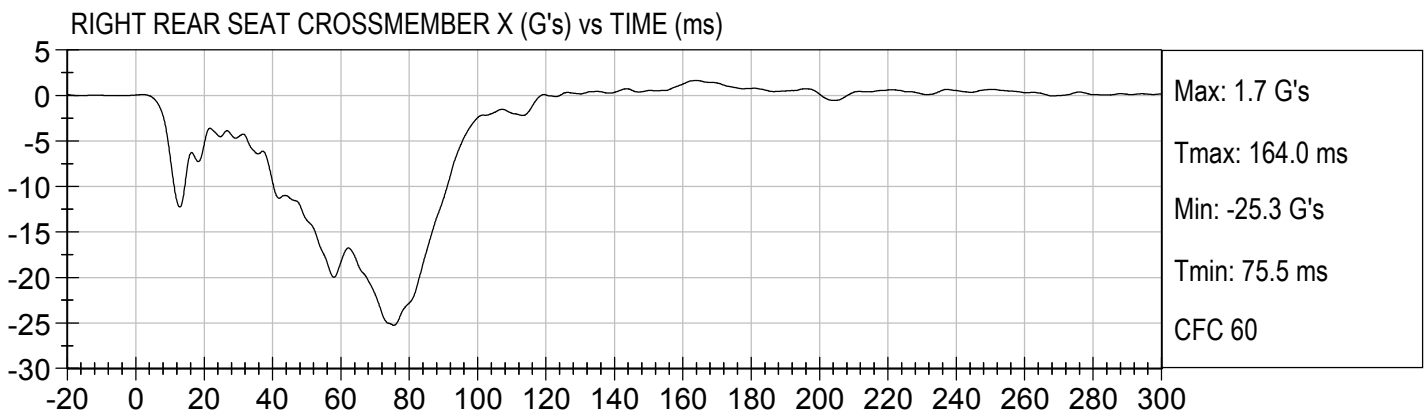
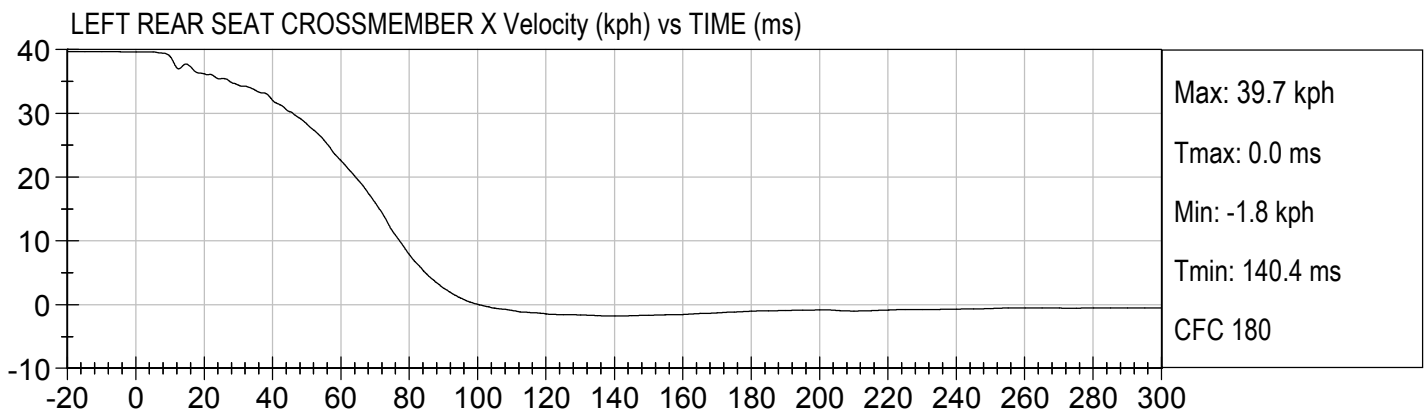
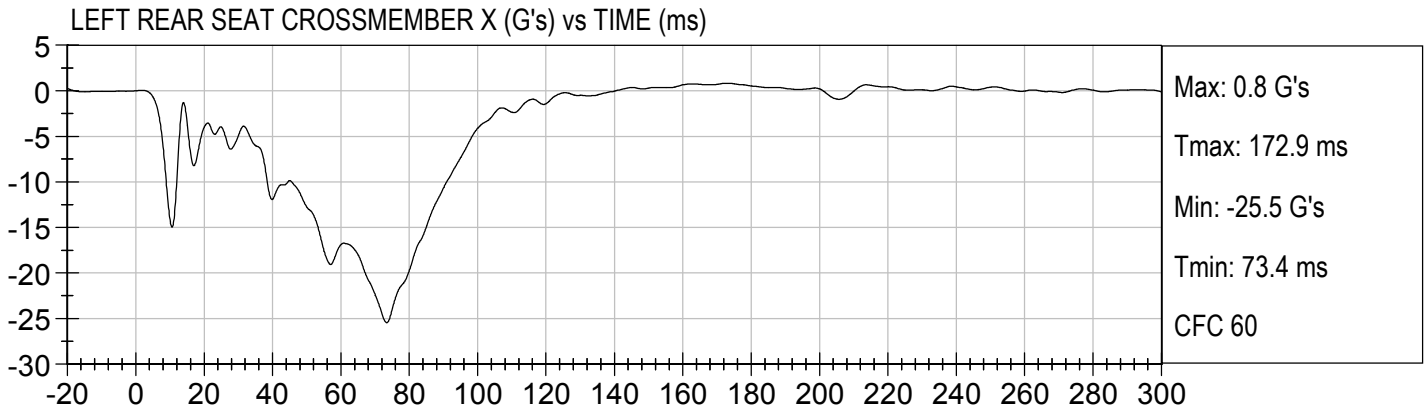

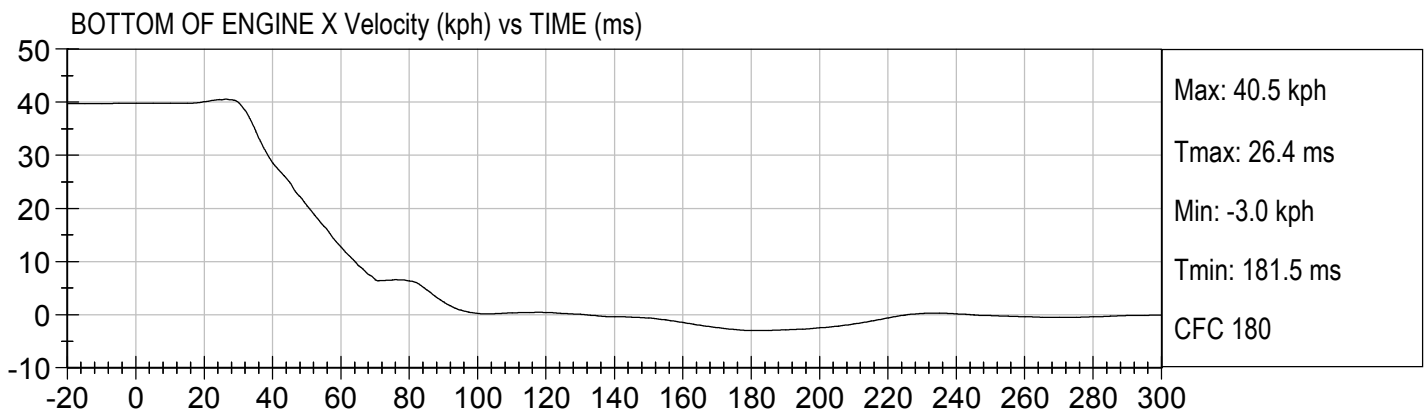
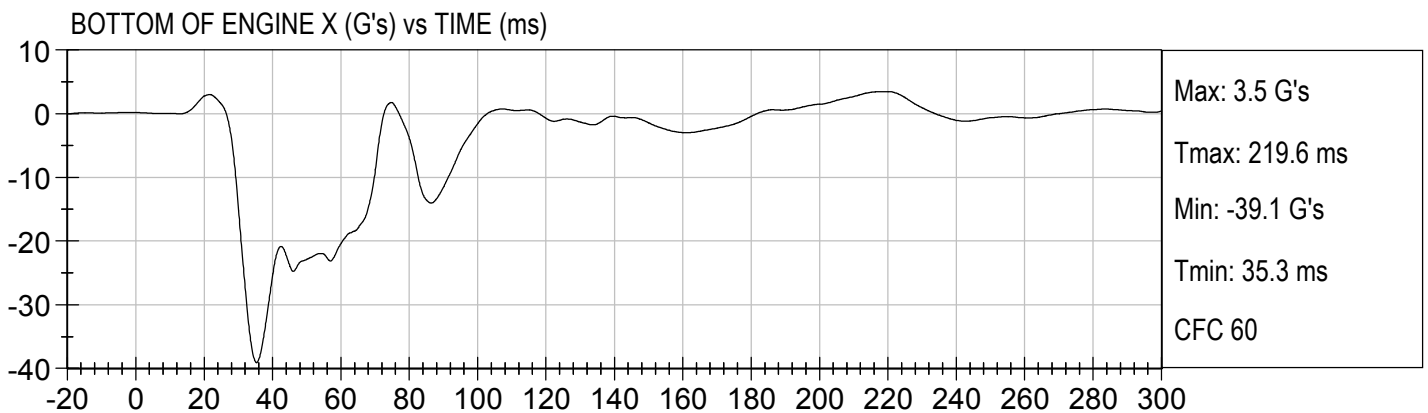
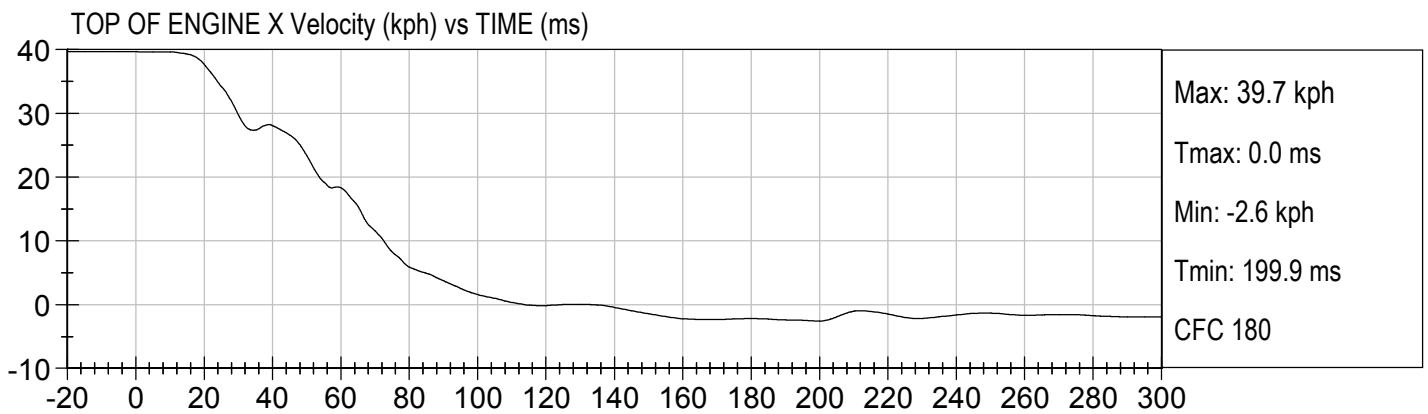
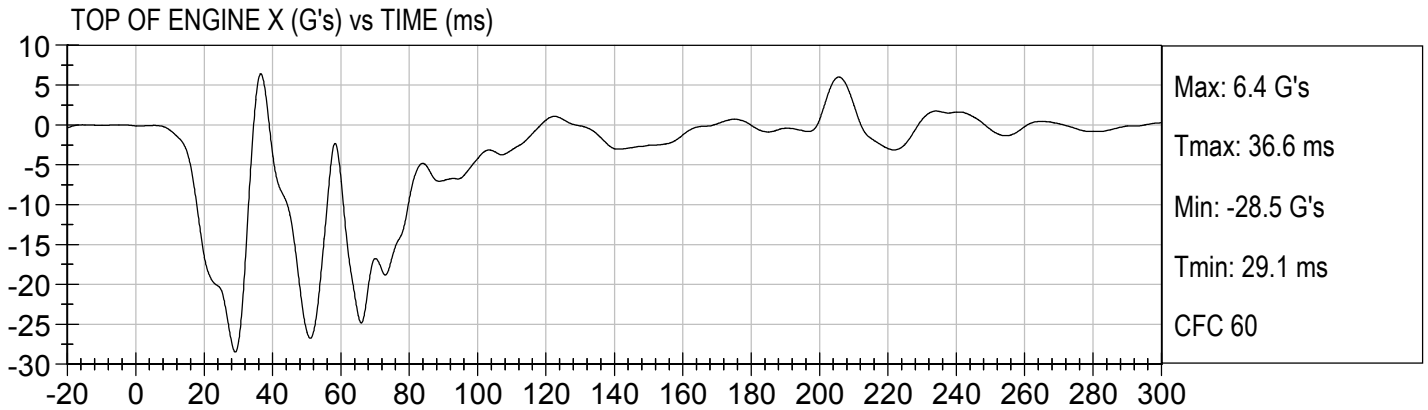

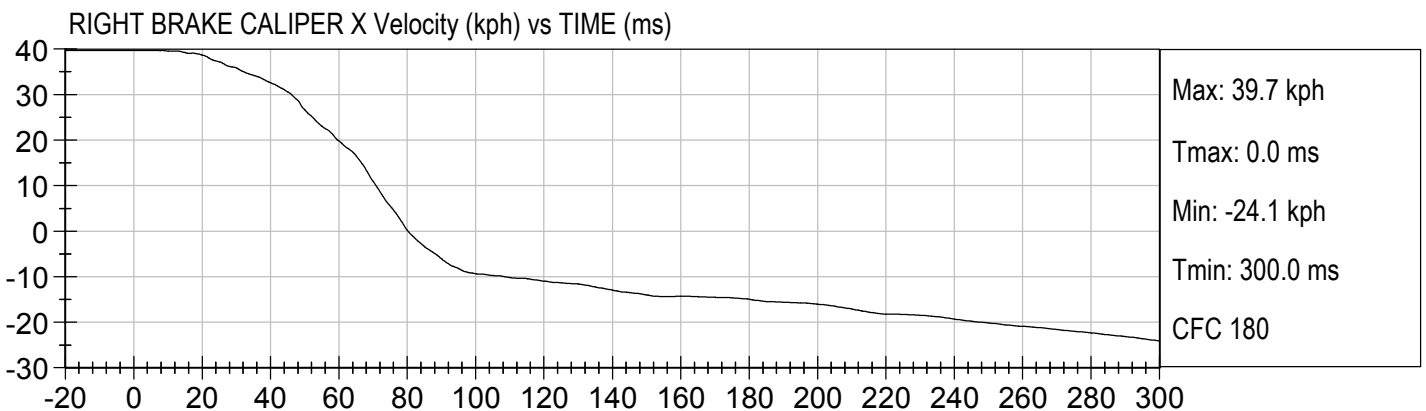
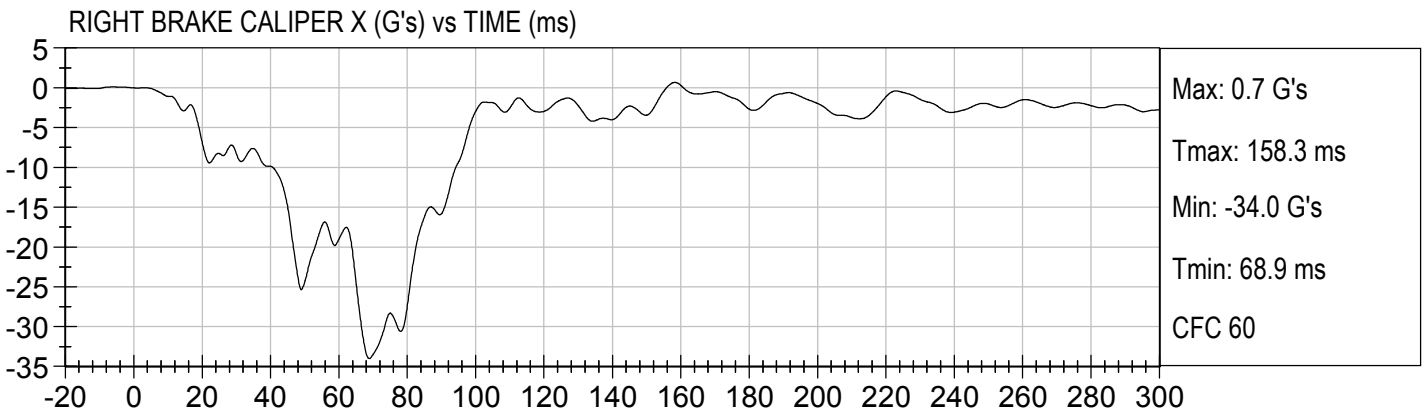
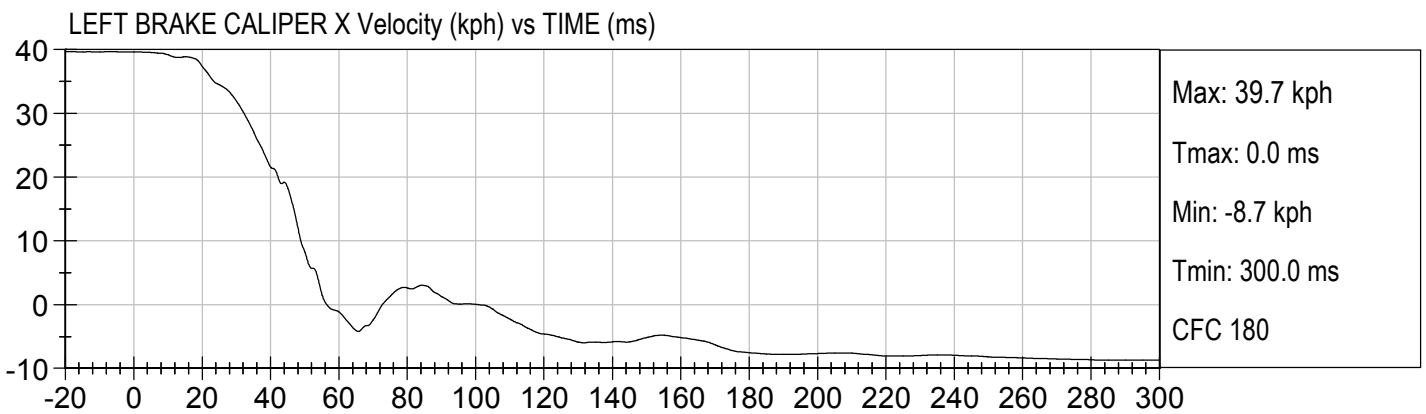
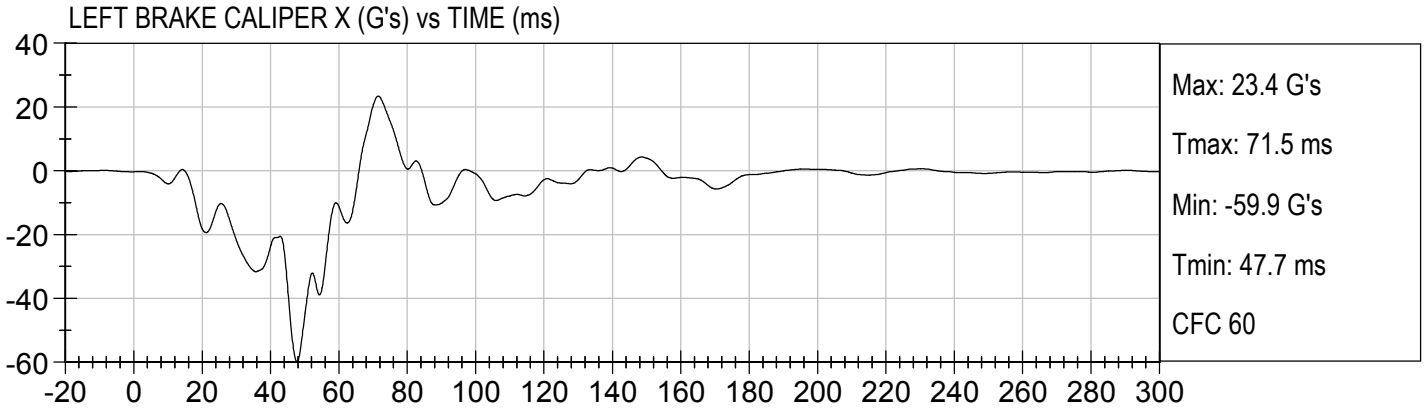

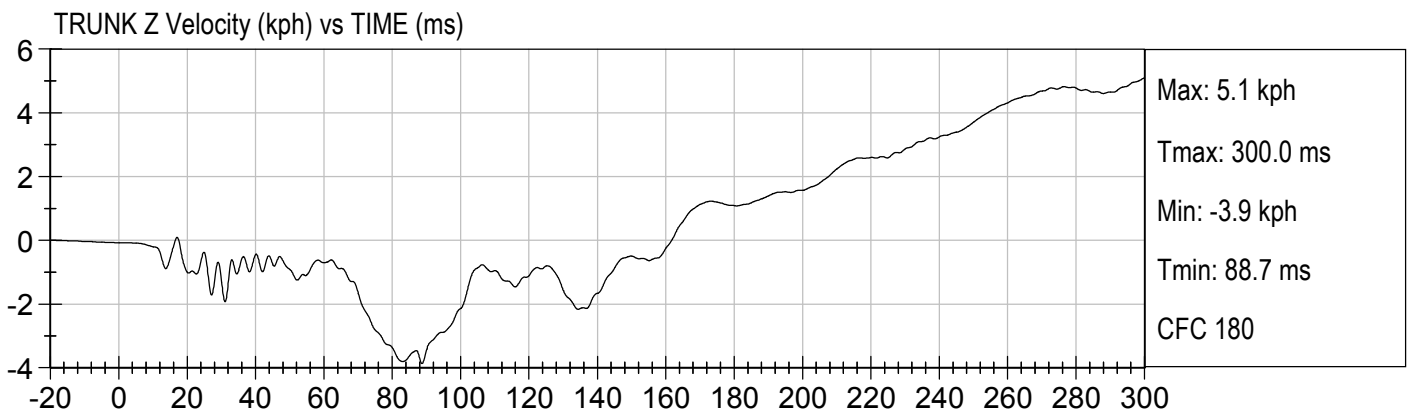
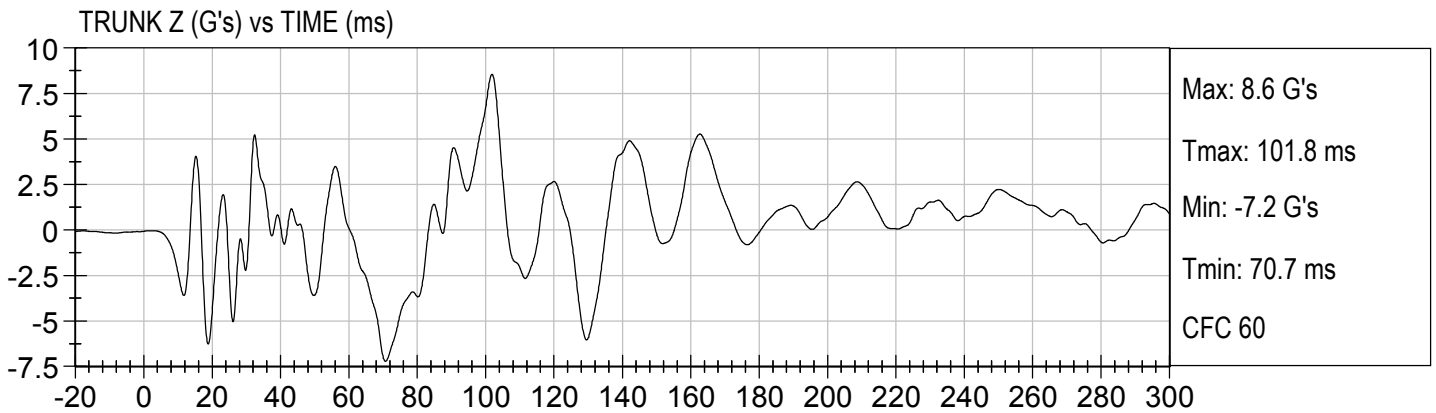
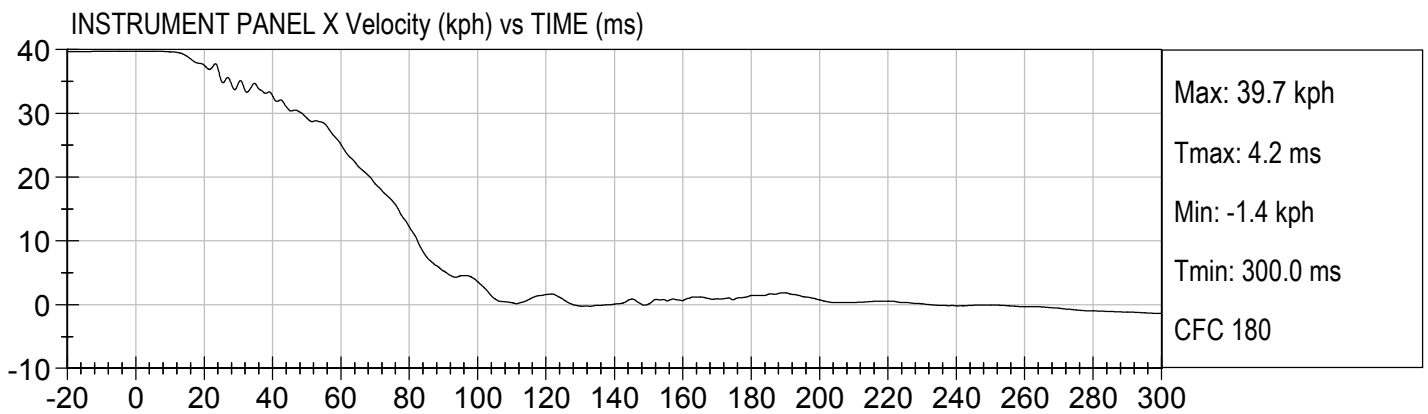
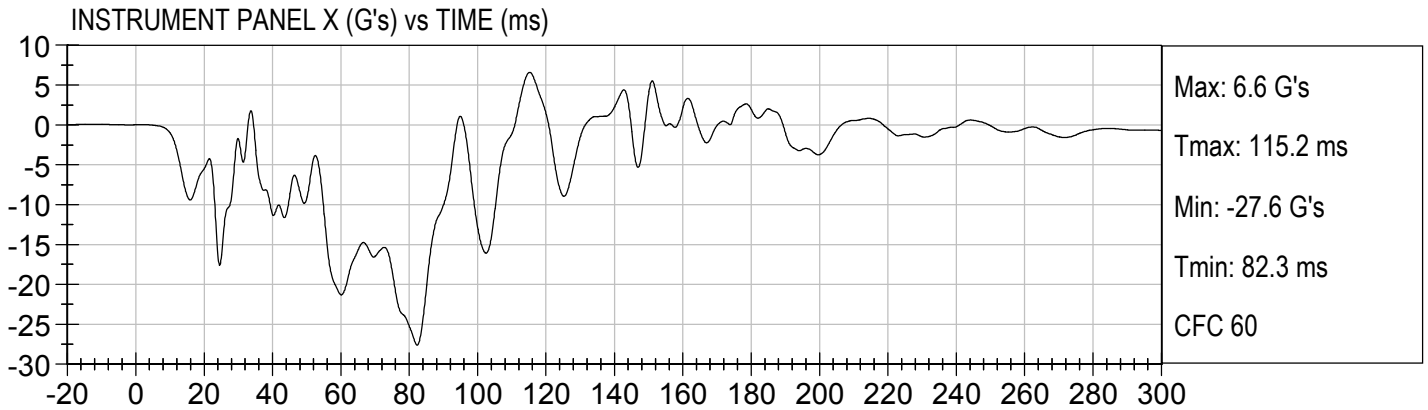

APPENDIX B

LOW RISK TEST DATA

TABLE OF DATA PLOTS

		<u>Page No.</u>
Figure No. 1.	5 th Fem. P1 Driver Head X Acceleration vs. Time	B-1
Figure No. 2.	5 th Fem. P1 Driver Head Y Acceleration vs. Time	B-1
Figure No. 3.	5 th Fem. P1 Driver Head Z Acceleration vs. Time	B-1
Figure No. 4.	5 th Fem. P1 Driver Head Resultant Acceleration vs. Time	B-1
Figure No. 5.	5 th Fem. P1 Driver Head X Velocity vs. Time	B-2
Figure No. 6.	5 th Fem. P1 Driver Head Y Velocity vs. Time	B-2
Figure No. 7.	5 th Fem. P1 Driver Head Z Velocity vs. Time	B-2
Figure No. 8.	5 th Fem. P1 Driver Neck Force X vs. Time	B-3
Figure No. 9.	5 th Fem. P1 Driver Neck Force Y vs. Time	B-3
Figure No. 10.	5 th Fem. P1 Driver Neck Force Z vs. Time	B-3
Figure No. 11.	5 th Fem. P1 Driver Neck Force Resultant vs. Time	B-3
Figure No. 12.	5 th Fem. P1 Driver Neck Moment X vs. Time	B-4
Figure No. 13.	5 th Fem. P1 Driver Neck Moment Y vs. Time	B-4
Figure No. 14.	5 th Fem. P1 Driver Neck Moment Z vs. Time	B-4
Figure No. 15.	5 th Fem. P1 Driver Occipital Condyle Moment vs. Time	B-4
Figure No. 16.	5 th Fem. P1 Driver Chest X Acceleration vs. Time	B-5
Figure No. 17.	5 th Fem. P1 Driver Chest Y Acceleration vs. Time	B-5
Figure No. 18.	5 th Fem. P1 Driver Chest Z Acceleration vs. Time	B-5
Figure No. 19.	5 th Fem. P1 Driver Chest Resultant Acceleration vs. Time	B-5
Figure No. 20.	5 th Fem. P1 Driver Chest X Velocity vs. Time	B-6
Figure No. 21.	5 th Fem. P1 Driver Chest Y Velocity vs. Time	B-6
Figure No. 22.	5 th Fem. P1 Driver Chest Z Velocity vs. Time	B-6
Figure No. 23.	5 th Fem. P1 Driver Chest Displacement vs. Time	B-6
Figure No. 24.	5 th Fem. P1 Driver Left Femur Force vs. Time	B-7
Figure No. 25.	5 th Fem. P1 Driver Right Femur Force vs. Time	B-7
Figure No. 26.	Fire Voltage #1 vs. Time	B-8
Figure No. 27.	Fire Current #1 vs. Time	B-8
Figure No. 28.	Fire Voltage #2 vs. Time	B-8
Figure No. 29.	Fire Current #2 vs. Time	B-8
Figure No. 30.	5 th Fem. P1 Driver Nij (N_{TF}) vs. Time	B-9
Figure No. 31.	5 th Fem. P1 Driver Nij (N_{TE}) vs. Time	B-9

	<u>Page No.</u>
Figure No. 32. 5 th Fem. P1 Driver Nij (N_{CF}) vs. Time	B-9
Figure No. 33. 5 th Fem. P1 Driver Nij (N_{CE}) vs. Time	B-9
Figure No. 34. 5 th Fem. P2 Driver Head X Acceleration vs. Time	B-10
Figure No. 35. 5 th Fem. P2 Driver Head Y Acceleration vs. Time	B-10
Figure No. 36. 5 th Fem. P2 Driver Head Z Acceleration vs. Time	B-10
Figure No. 37. 5 th Fem. P2 Driver Head Resultant Acceleration vs. Time	B-10
Figure No. 38. 5 th Fem. P2 Driver Head X Velocity vs. Time	B-11
Figure No. 39. 5 th Fem. P2 Driver Head Y Velocity vs. Time	B-11
Figure No. 40. 5 th Fem. P2 Driver Head Z Velocity vs. Time	B-11
Figure No. 41. 5 th Fem. P2 Driver Neck Force X vs. Time	B-12
Figure No. 42. 5 th Fem. P2 Driver Neck Force Y vs. Time	B-12
Figure No. 43. 5 th Fem. P2 Driver Neck Force Z vs. Time	B-12
Figure No. 44. 5 th Fem. P2 Driver Neck Force Resultant vs. Time	B-12
Figure No. 45. 5 th Fem. P2 Driver Neck Moment X vs. Time	B-13
Figure No. 46. 5 th Fem. P2 Driver Neck Moment Y vs. Time	B-13
Figure No. 47. 5 th Fem. P2 Driver Neck Moment Z vs. Time	B-13
Figure No. 48. 5 th Fem. P2 Driver Occipital Condyle Moment vs. Time	B-13
Figure No. 49. 5 th Fem. P2 Driver Chest X Acceleration vs. Time	B-14
Figure No. 50. 5 th Fem. P2 Driver Chest Y Acceleration vs. Time	B-14
Figure No. 51. 5 th Fem. P2 Driver Chest Z Acceleration vs. Time	B-14
Figure No. 52. 5 th Fem. P2 Driver Chest Resultant Acceleration vs. Time	B-14
Figure No. 53. 5 th Fem. P2 Driver Chest X Velocity vs. Time	B-15
Figure No. 54. 5 th Fem. P2 Driver Chest Y Velocity vs. Time	B-15
Figure No. 55. 5 th Fem. P2 Driver Chest Z Velocity vs. Time	B-15
Figure No. 56. 5 th Fem. P2 Driver Chest Displacement vs. Time	B-15
Figure No. 57. 5 th Fem. P2 Driver Left Femur Force vs. Time	B-16
Figure No. 58. 5 th Fem. P2 Driver Right Femur Force vs. Time	B-16
Figure No. 59. Fire Voltage #1 vs. Time	B-17
Figure No. 60. Fire Current #1 vs. Time	B-17
Figure No. 61. Fire Voltage #2 vs. Time	B-17
Figure No. 62. Fire Current #2 vs. Time	B-17
Figure No. 63. 5 th Fem. P2 Driver Nij (N_{TF}) vs. Time	B-18
Figure No. 64. 5 th Fem. P2 Driver Nij (N_{TE}) vs. Time	B-18
Figure No. 65. 5 th Fem. P2 Driver Nij (N_{CF}) vs. Time	B-18
Figure No. 66. 5 th Fem. P2 Driver Nij (N_{CE}) vs. Time	B-18



Injury Values Calculated between 0ms and 275ms

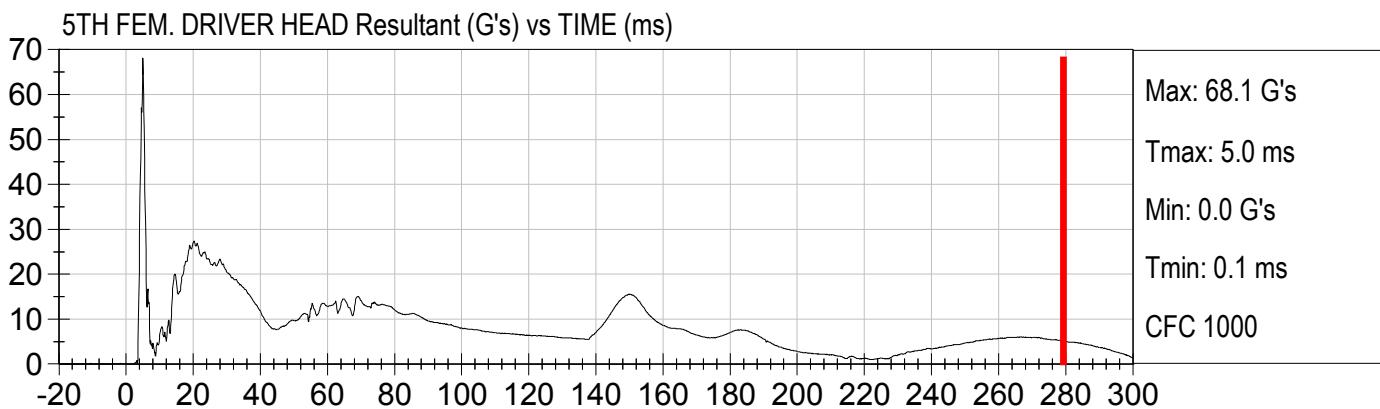
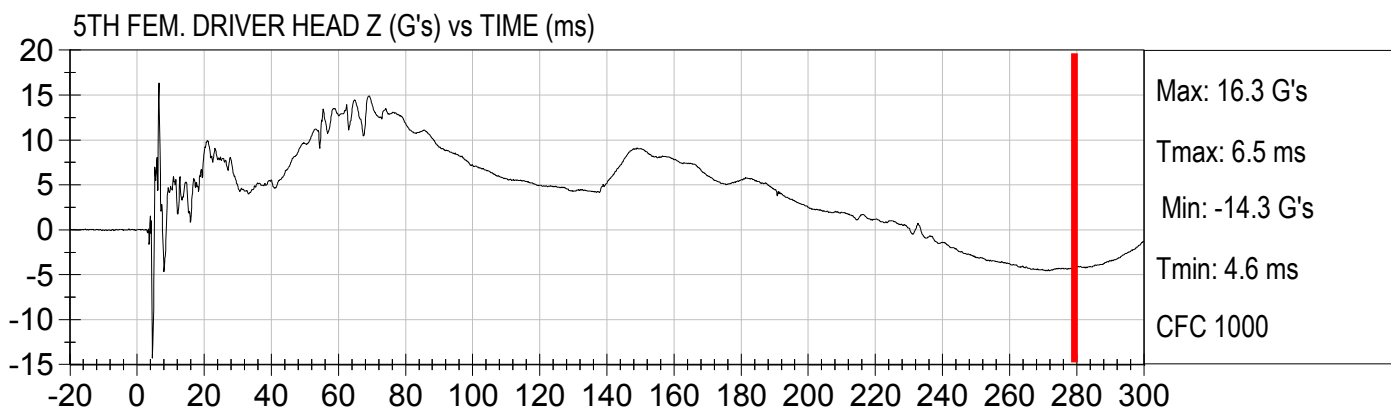
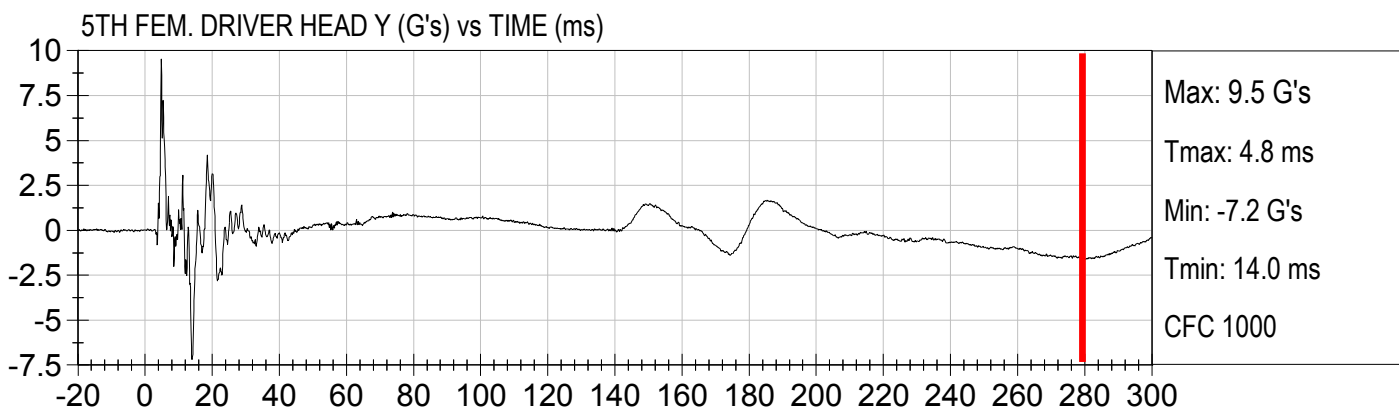
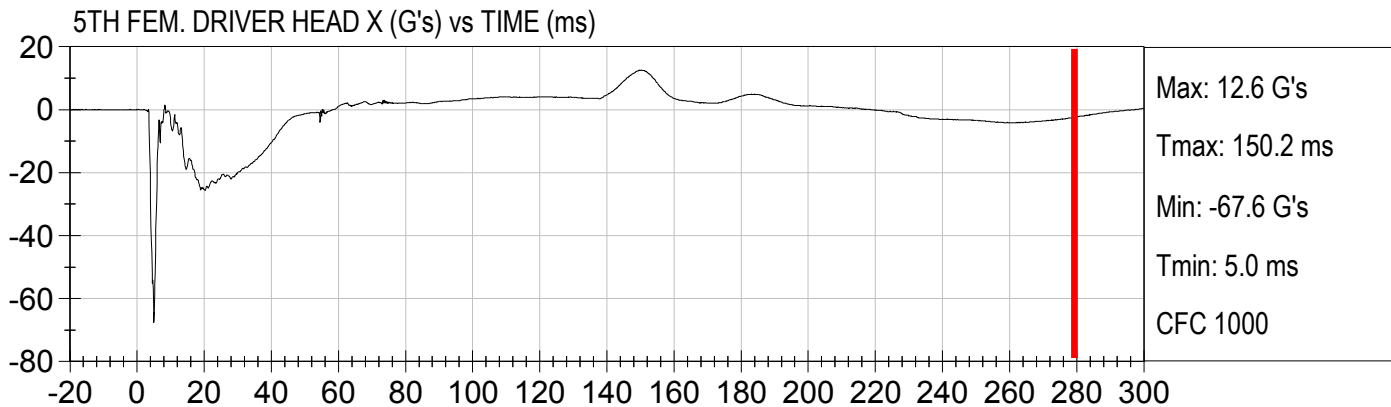



Injury Values Calculated between 0ms and 275ms

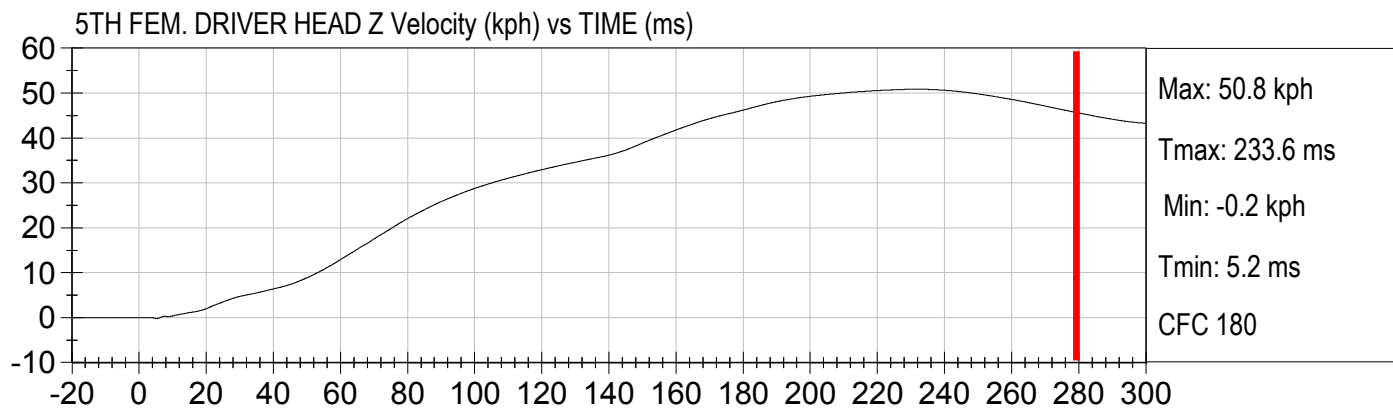
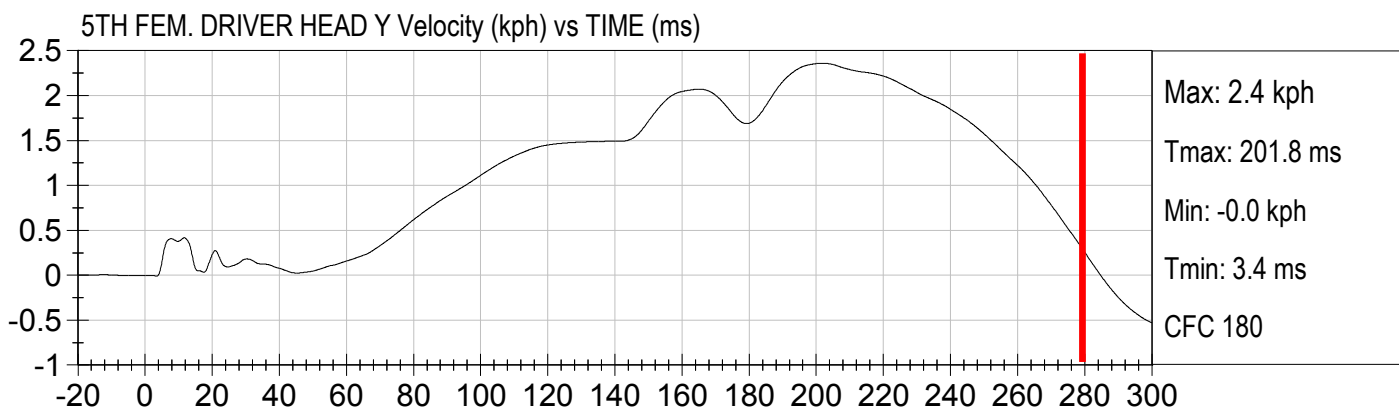
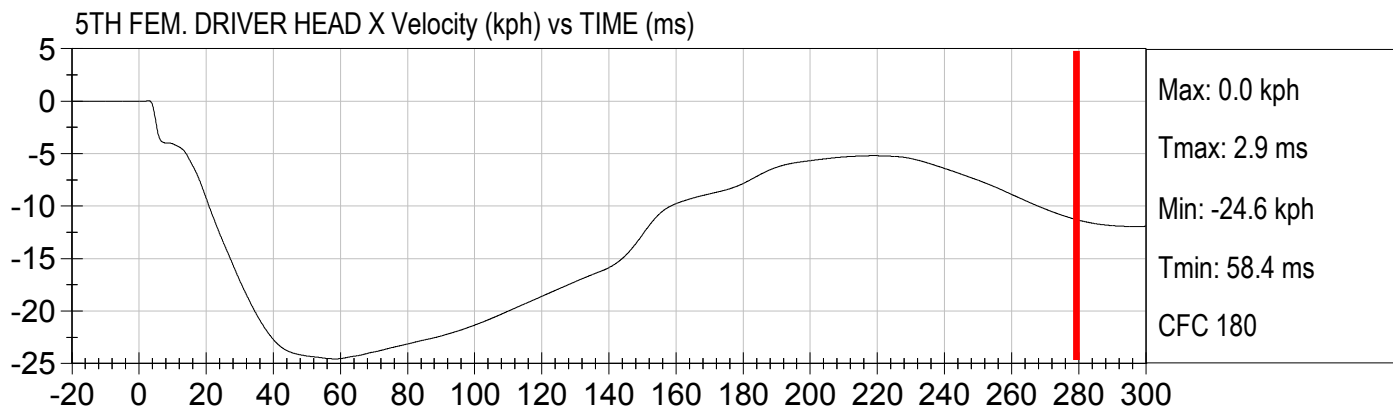



Injury Values Calculated between 0ms and 275ms

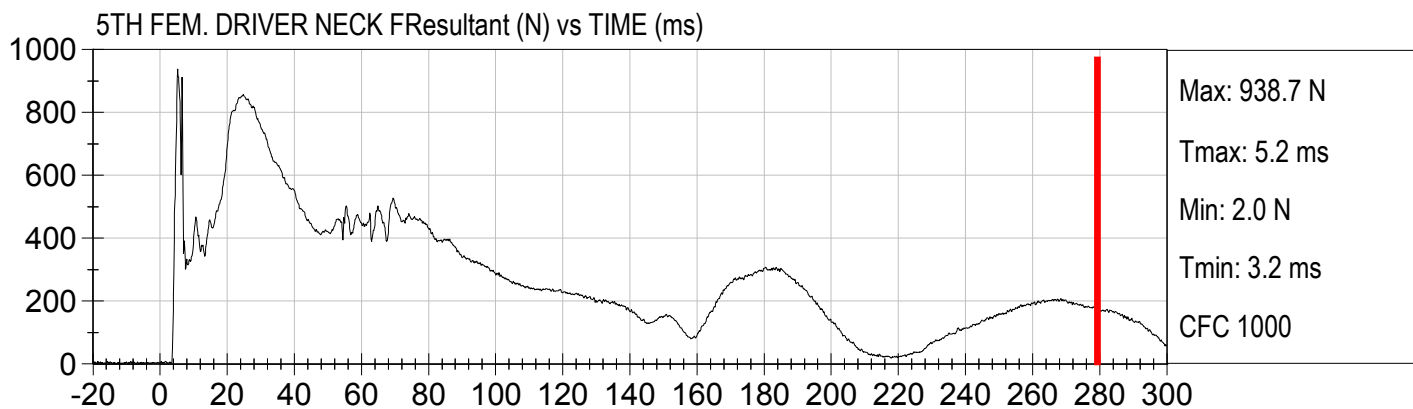
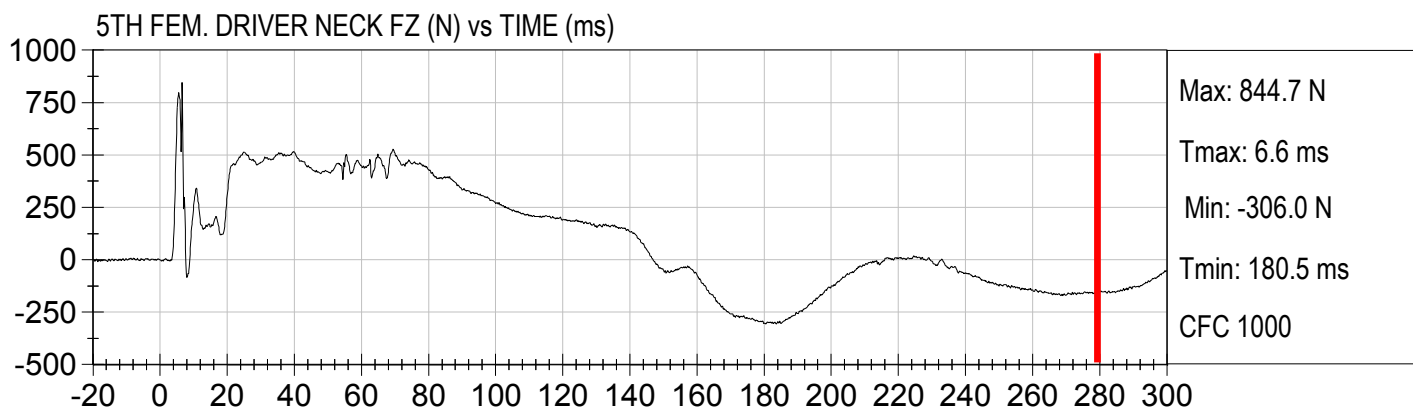
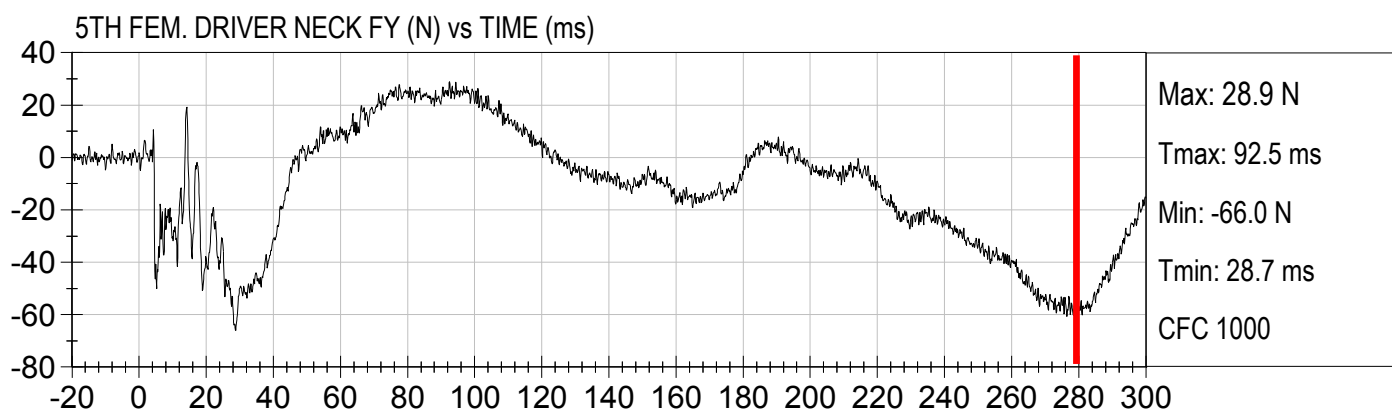
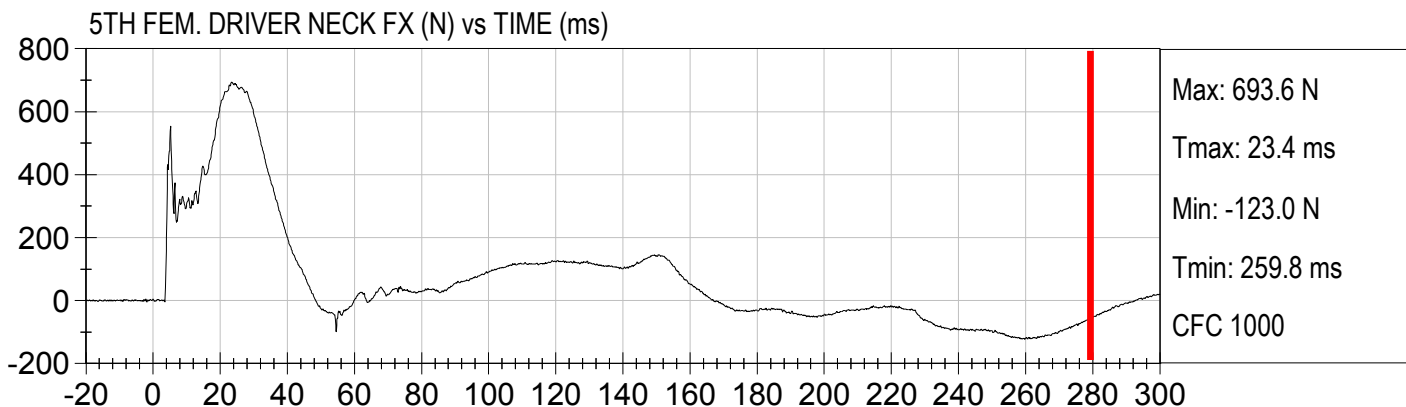



Injury Values Calculated between 0ms and 275ms

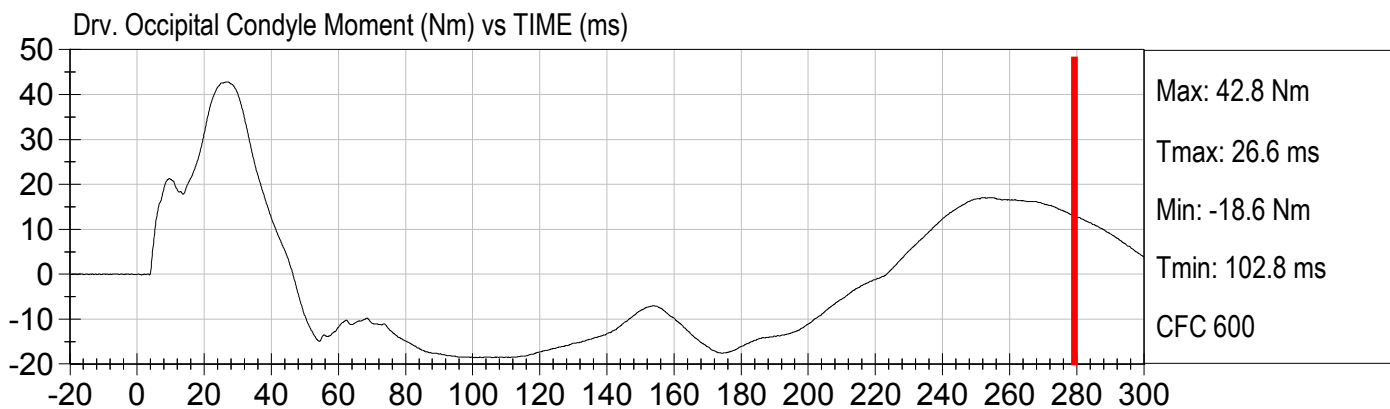
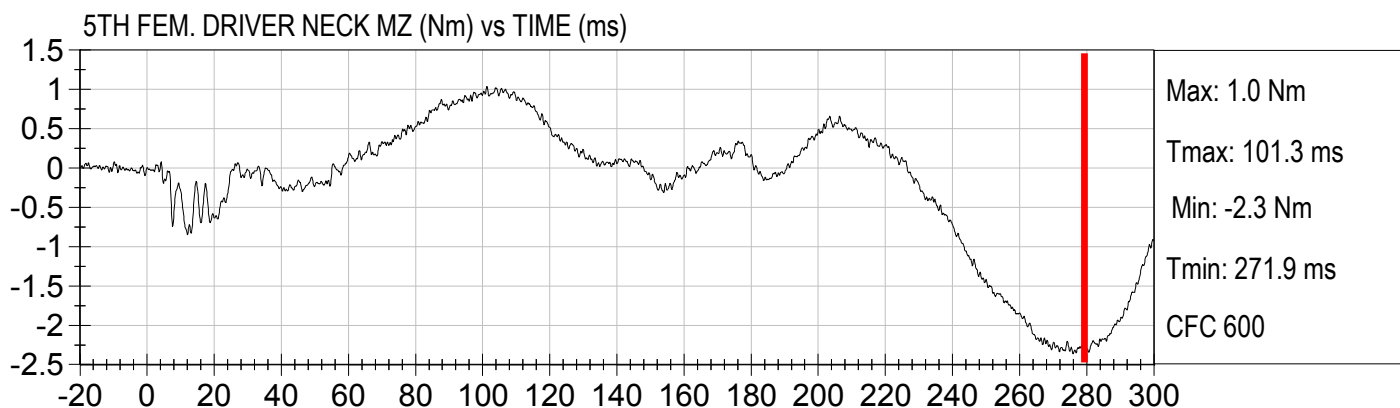
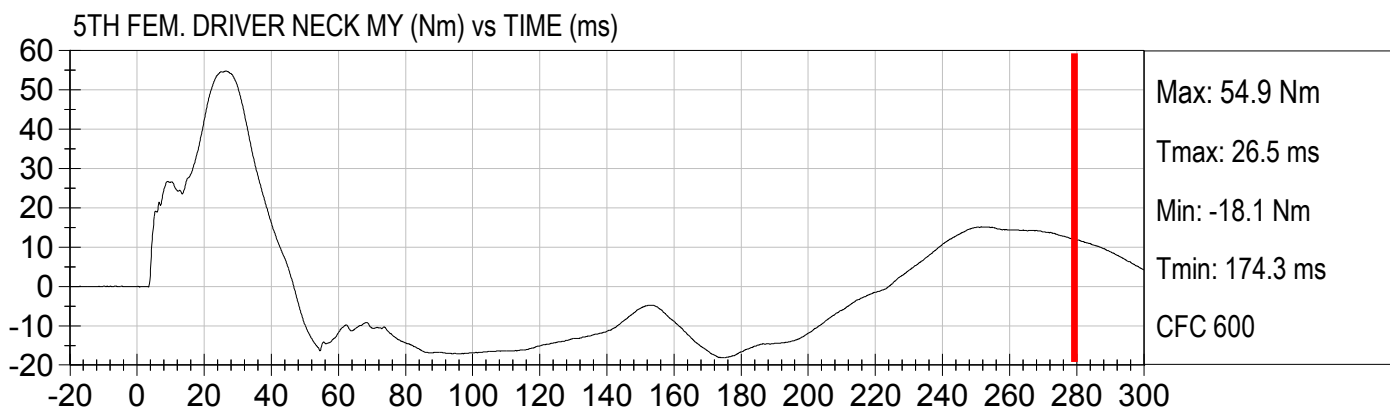
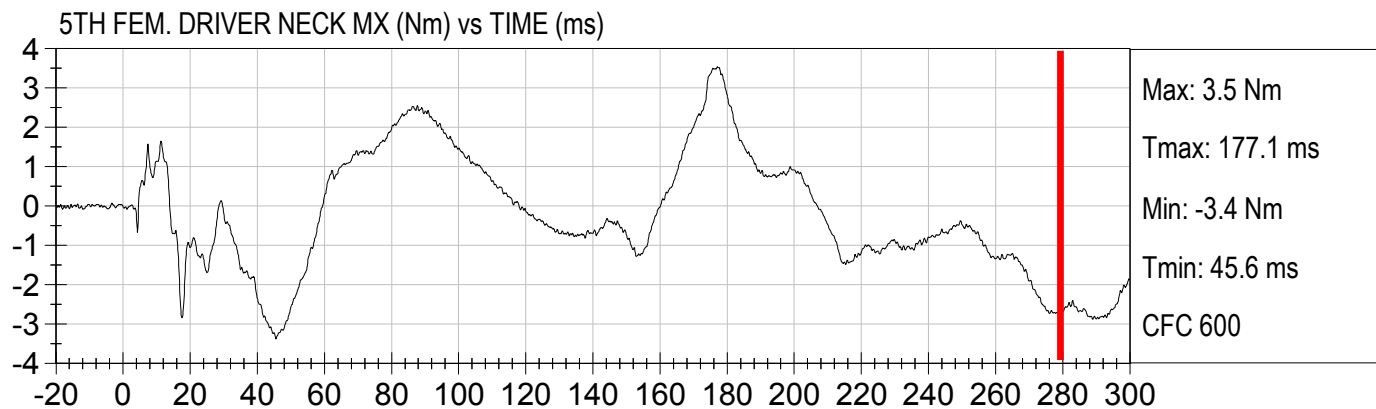



Injury Values Calculated between 0ms and 275ms

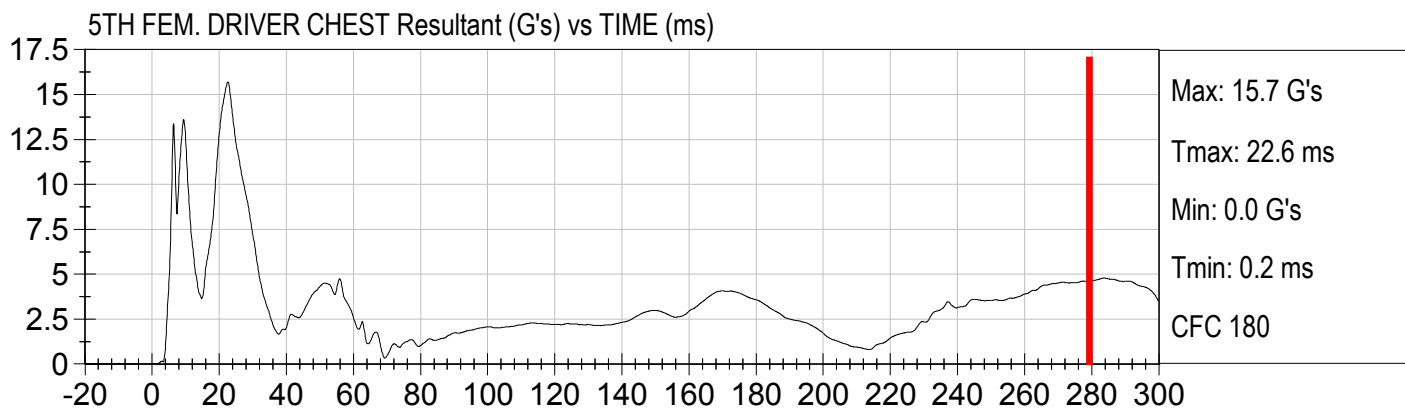
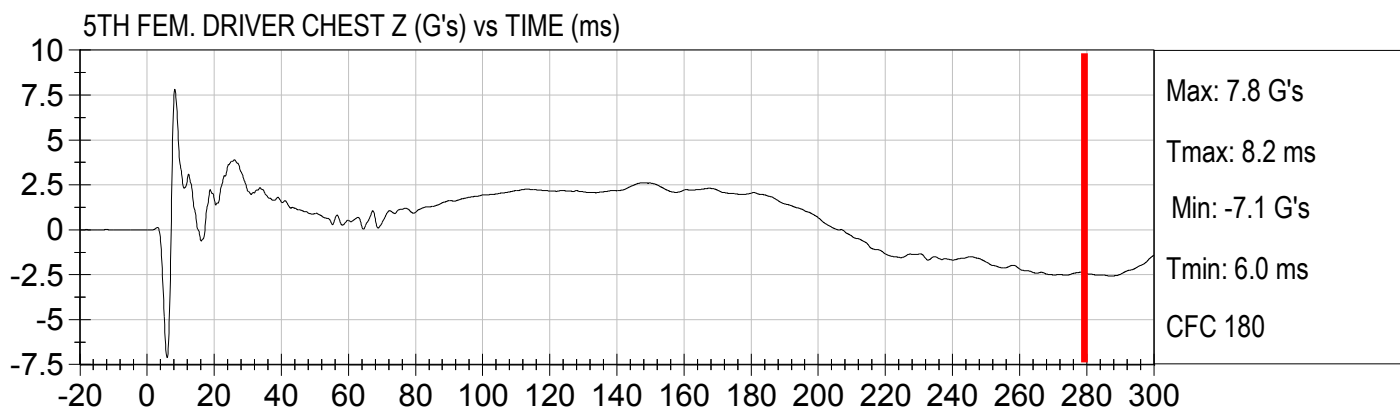
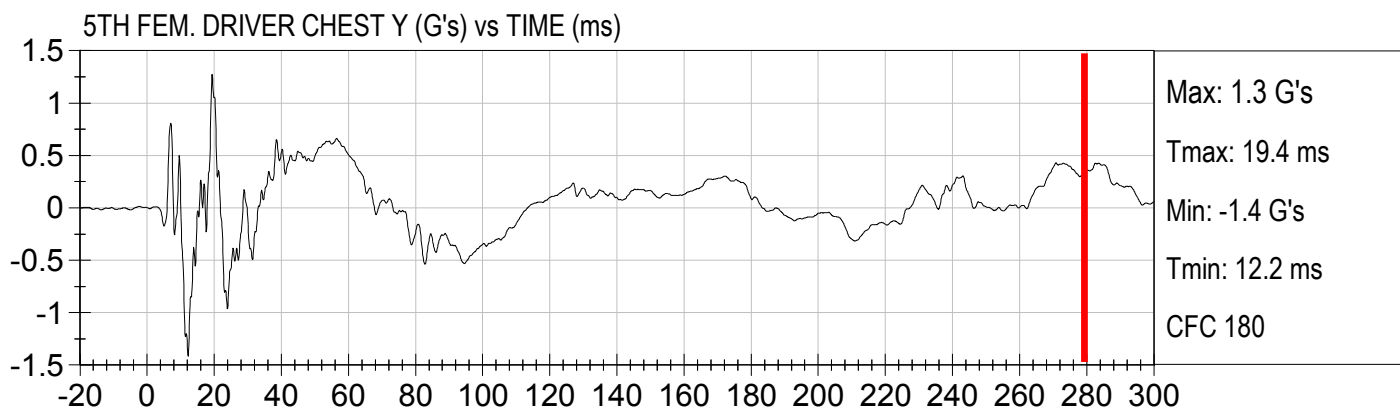
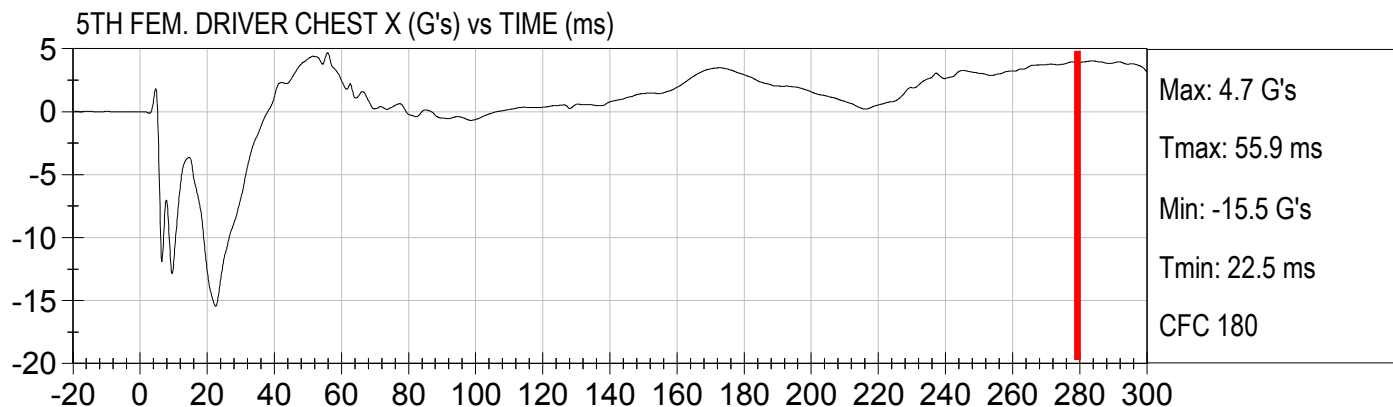



Injury Values Calculated between 0ms and 275ms

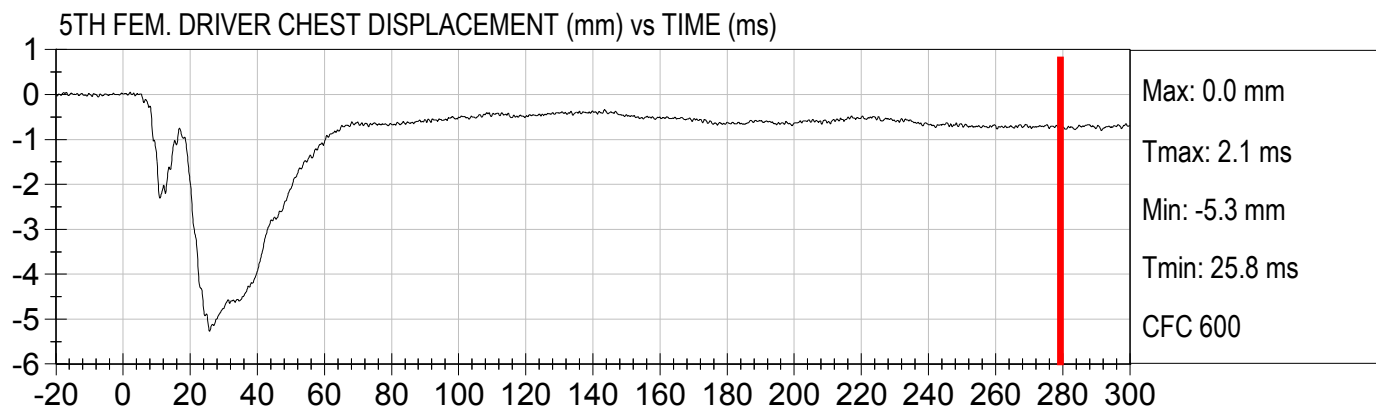
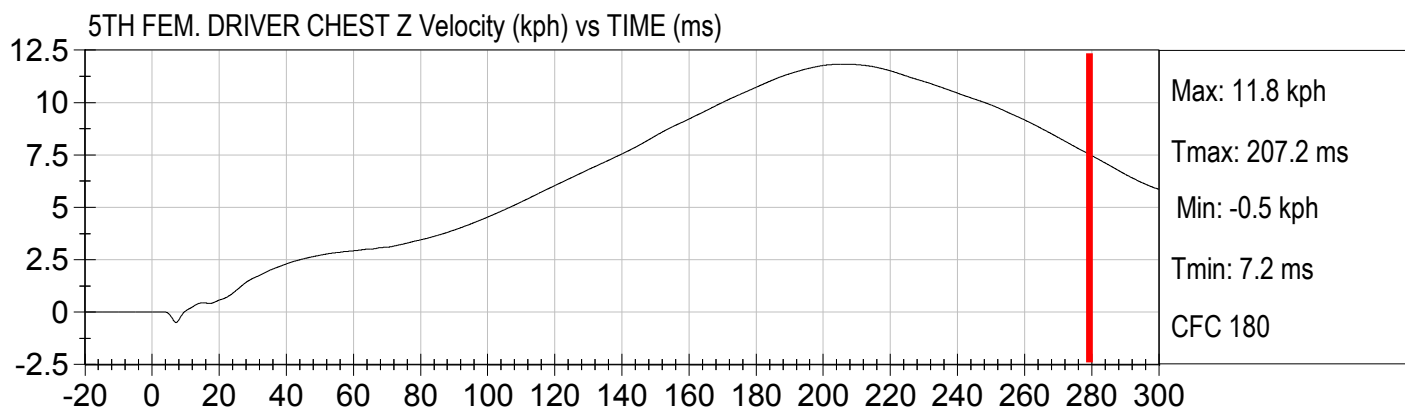
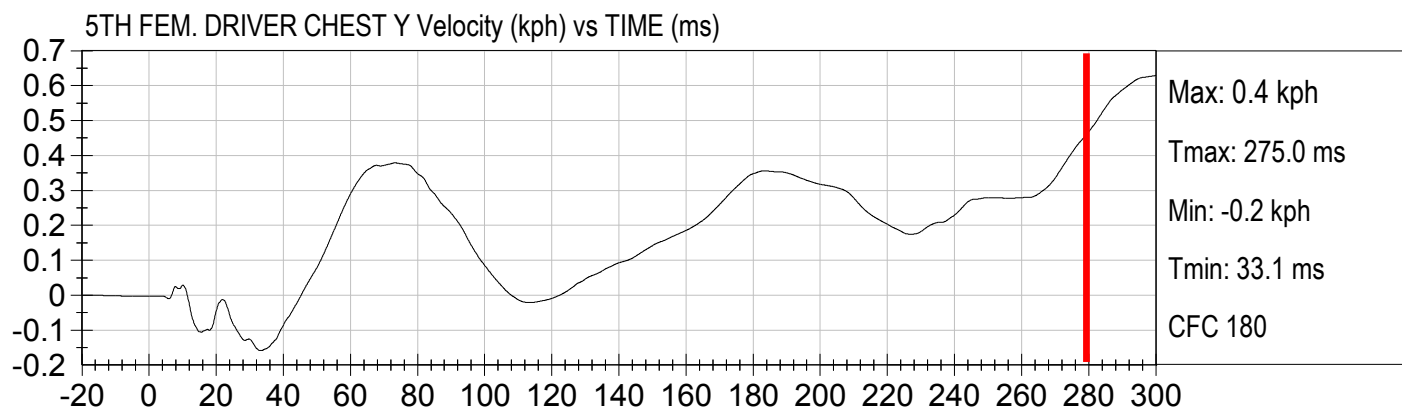
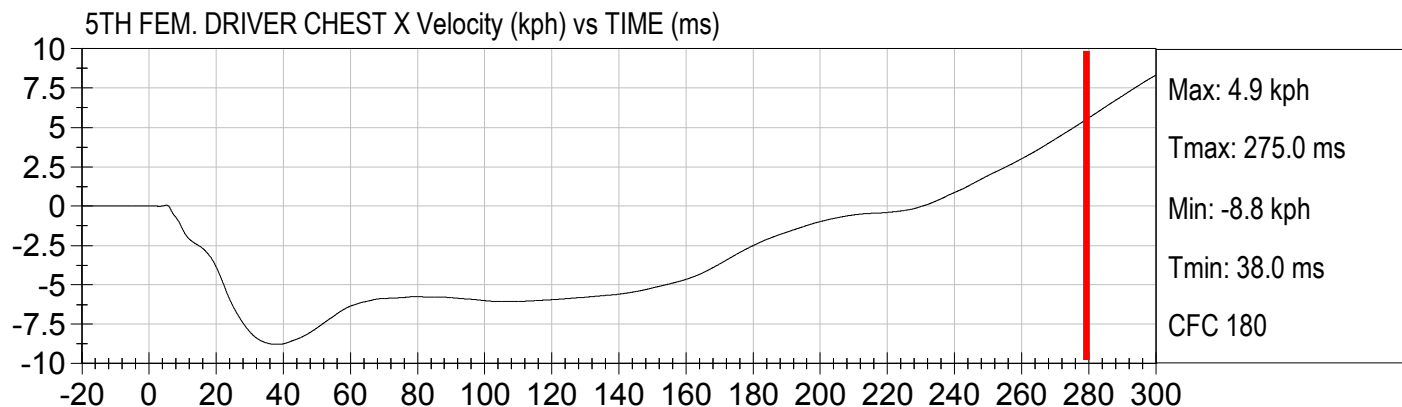



Injury Values Calculated between 0ms and 275ms

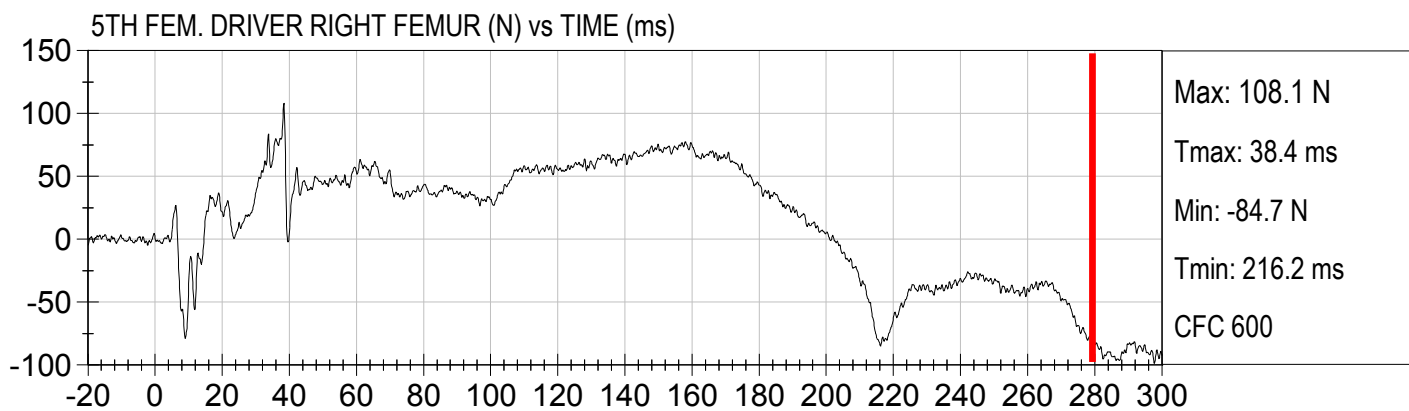
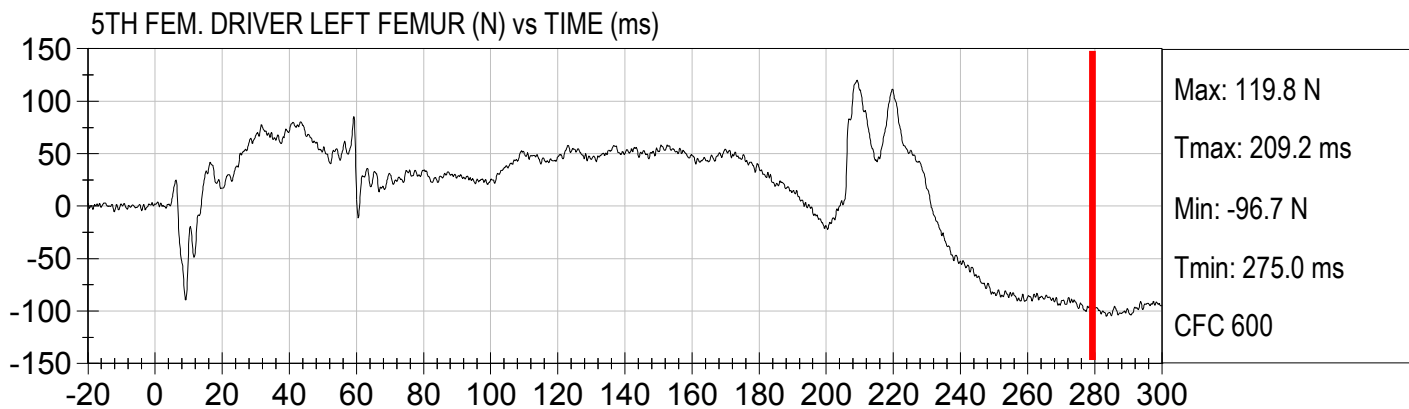



Injury Values Calculated between 0ms and 275ms

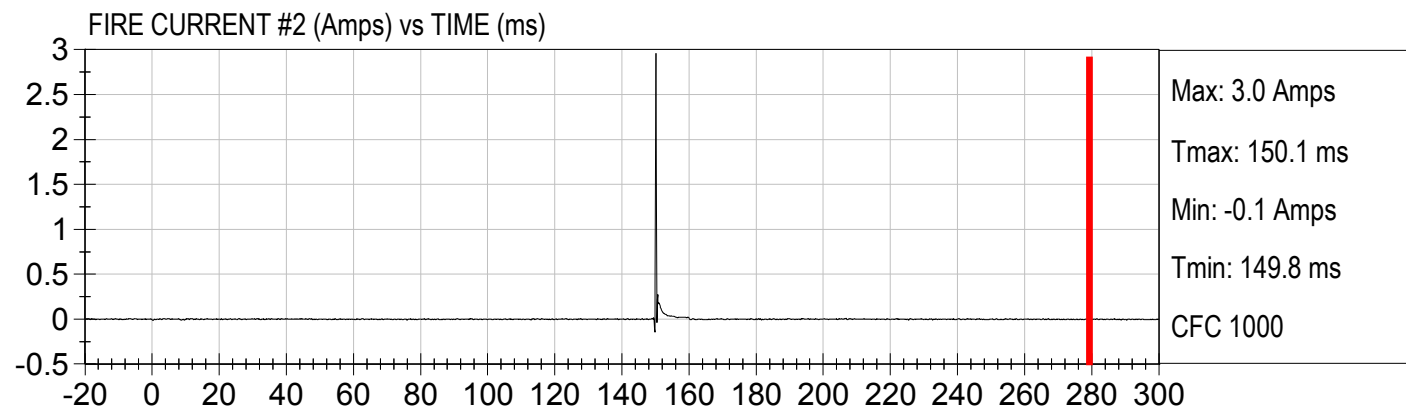
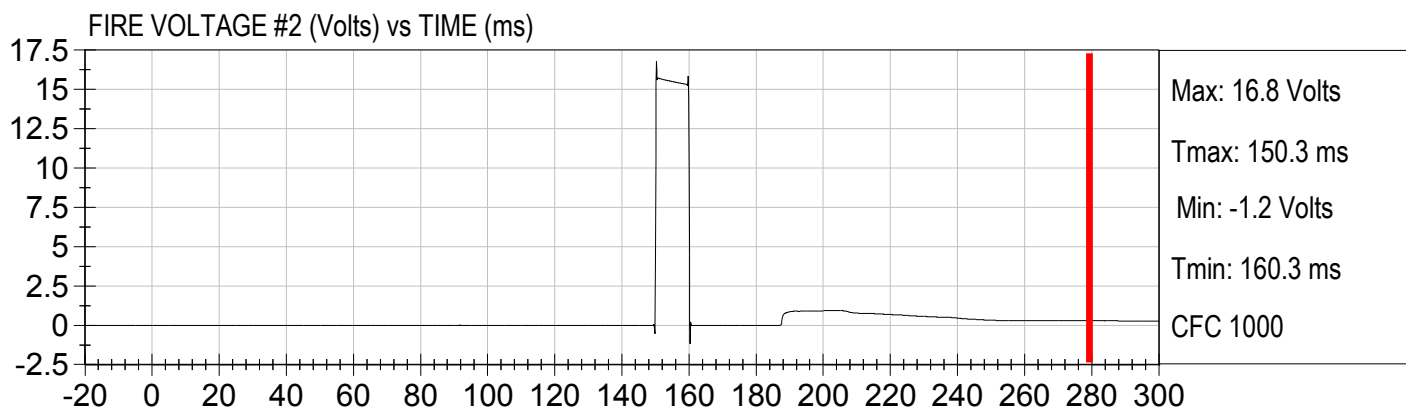
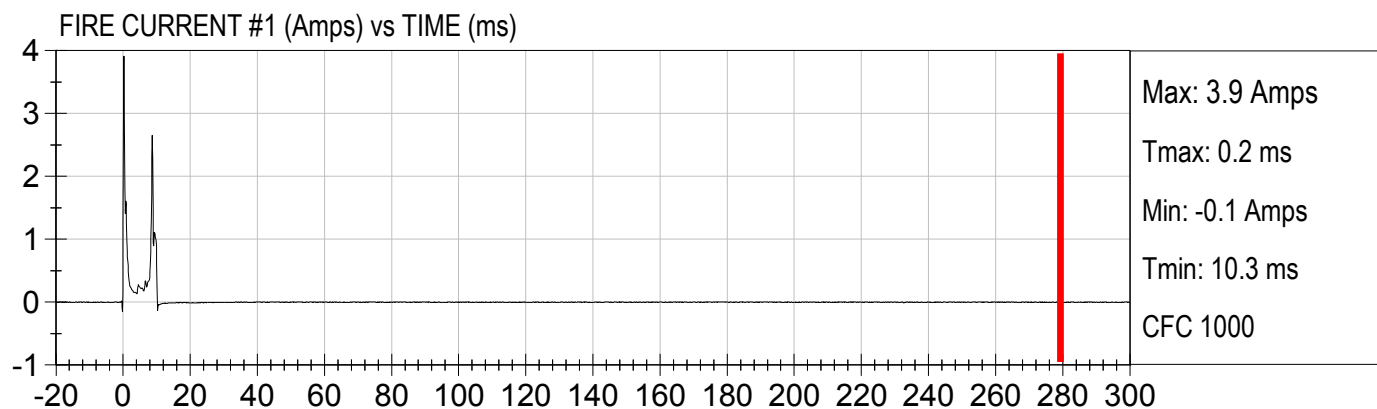
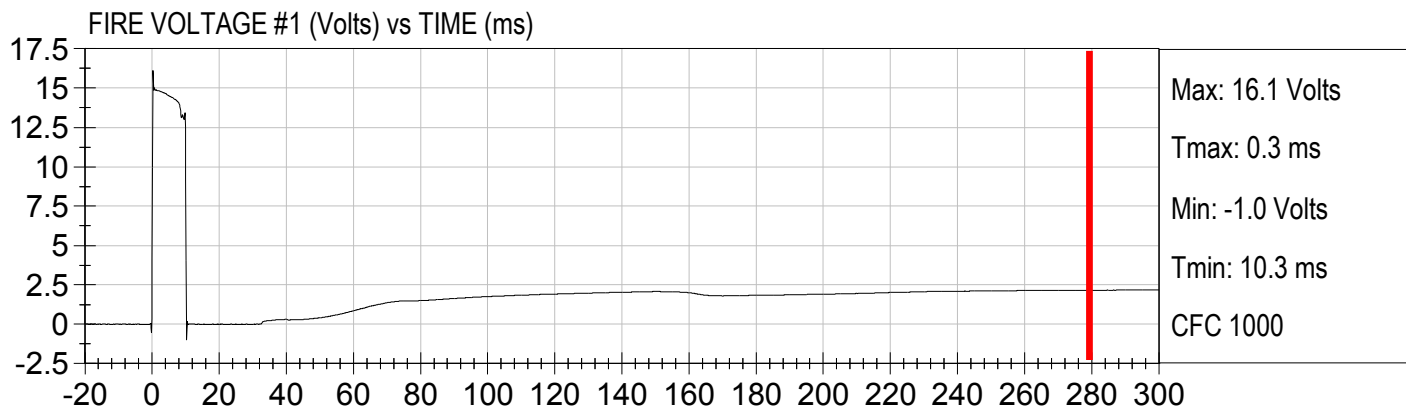



Drv. nij (NTF) () vs TIME SPECIAL CHS (ms)

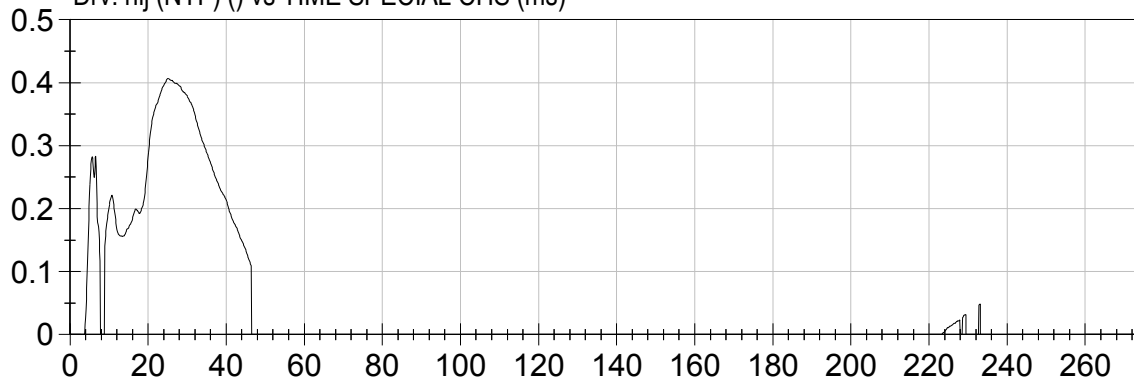

Max: 0.4
Tmax: 25.1 ms
Min: 0.0
Tmin: 0.1 ms
CFC 600

Drv. nij (NTE) () vs TIME SPECIAL CHS (ms)

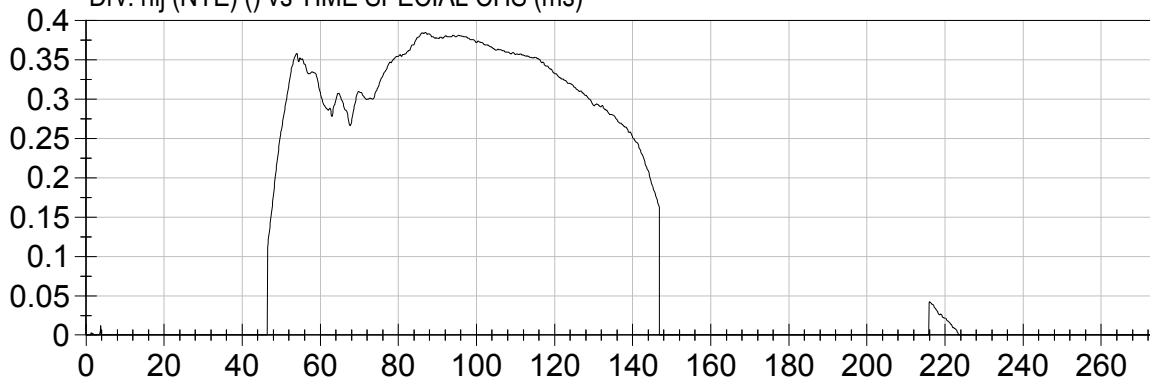

Max: 0.4
Tmax: 86.9 ms
Min: 0.0
Tmin: 0.1 ms
CFC 600

Drv. nij (NCF) () vs TIME SPECIAL CHS (ms)

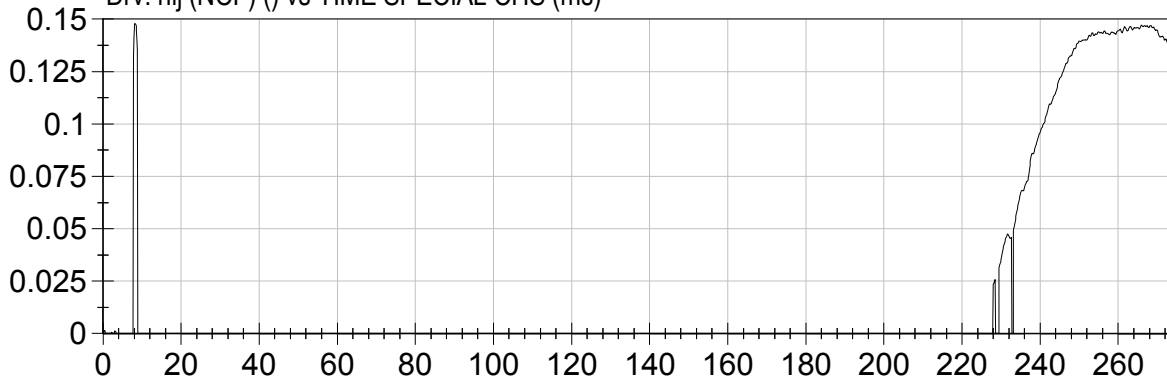

Max: 0.1
Tmax: 8.2 ms
Min: 0.0
Tmin: 0.1 ms
CFC 600

Drv. nij (NCE) () vs TIME SPECIAL CHS (ms)

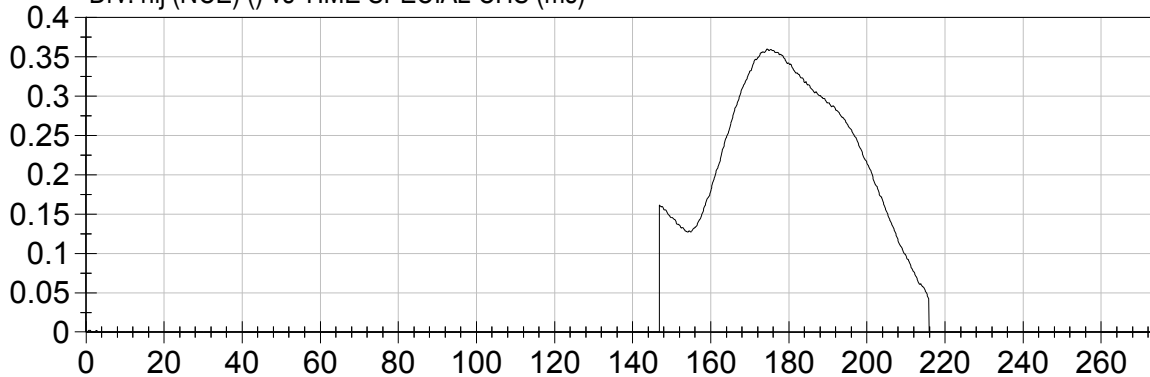

Max: 0.4
Tmax: 174.5 ms
Min: 0.0
Tmin: 0.2 ms
CFC 600



Injury Values Calculated between 0ms and 275ms

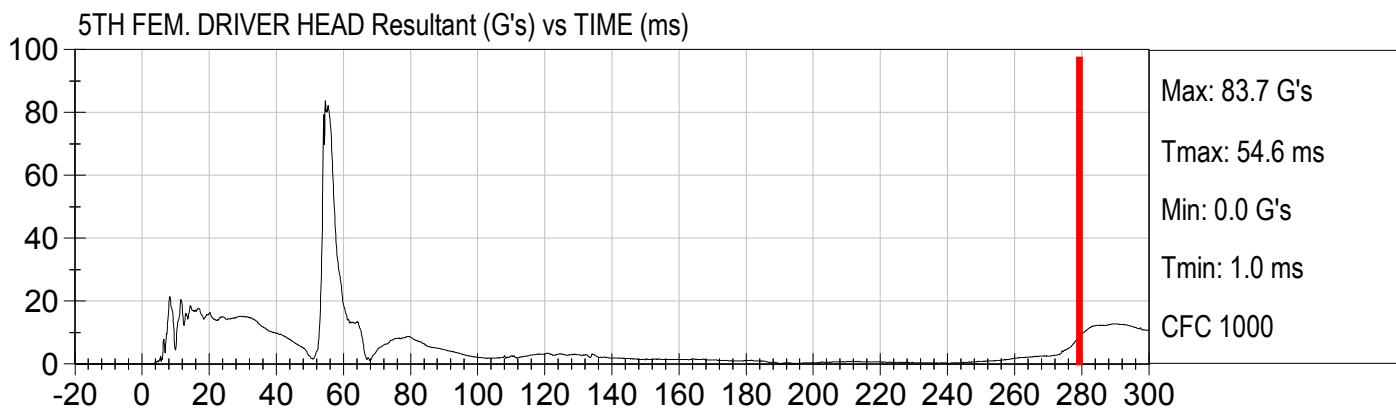
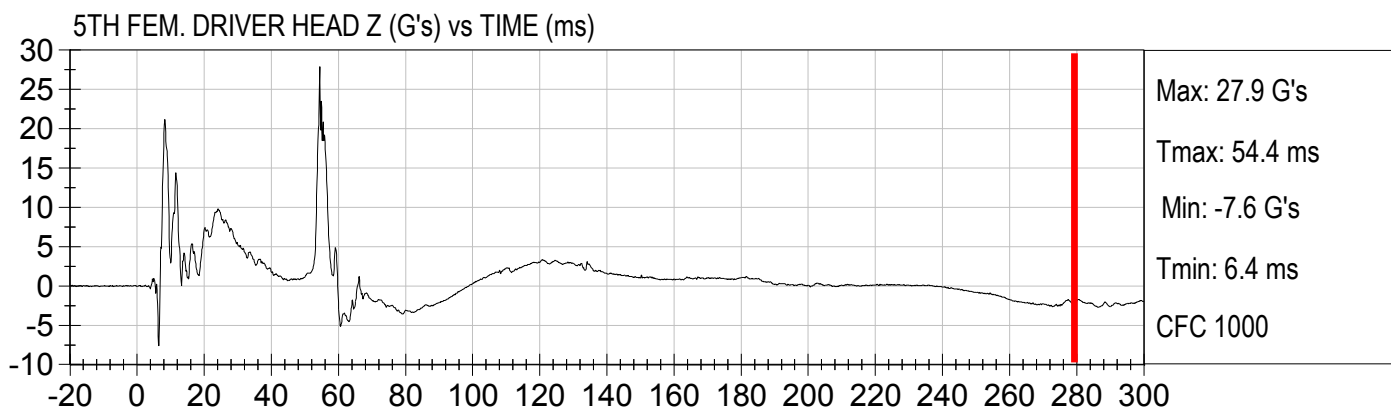
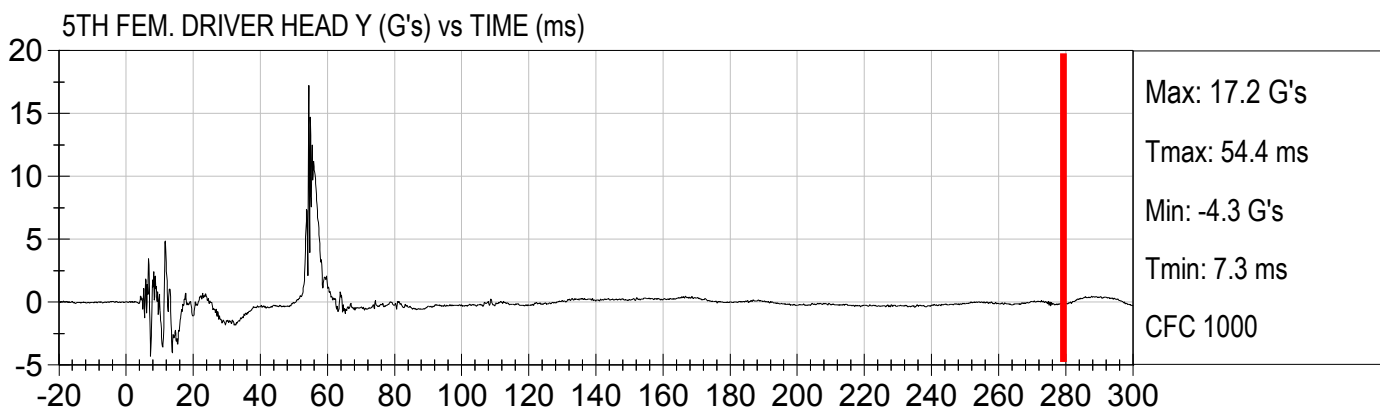
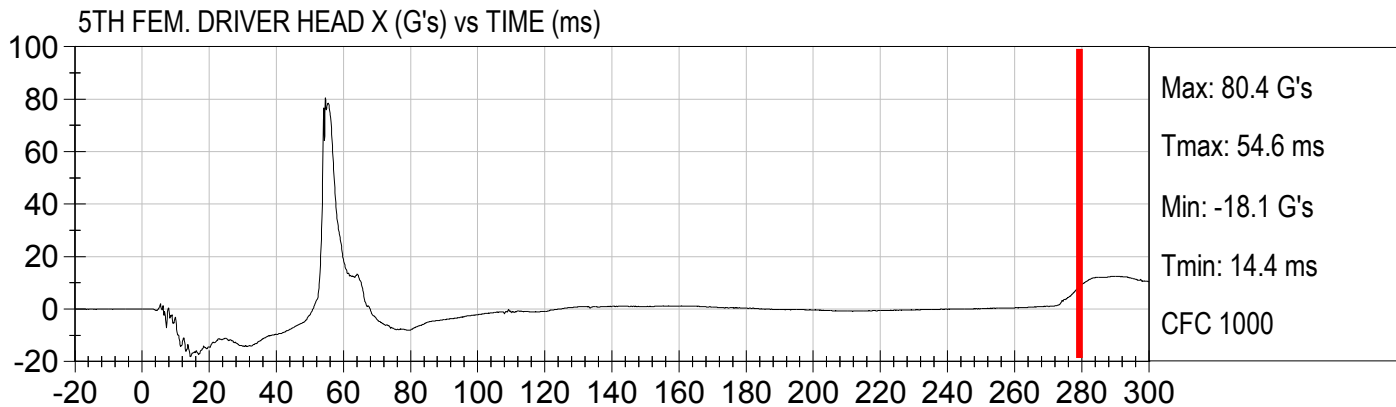



Injury Values Calculated between 0ms and 275ms

5TH FEM. DRIVER HEAD X Velocity (kph) vs TIME (ms)

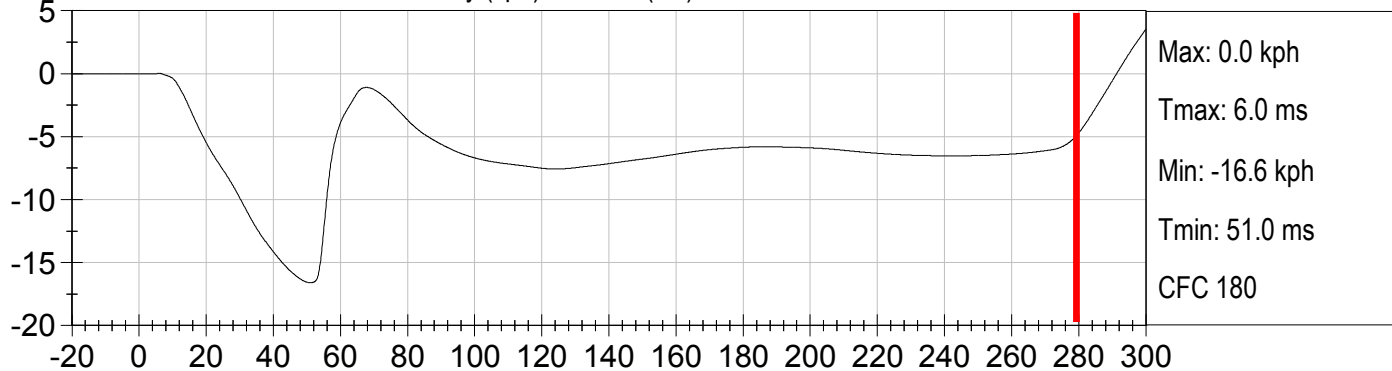

5TH FEM. DRIVER HEAD Y Velocity (kph) vs TIME (ms)

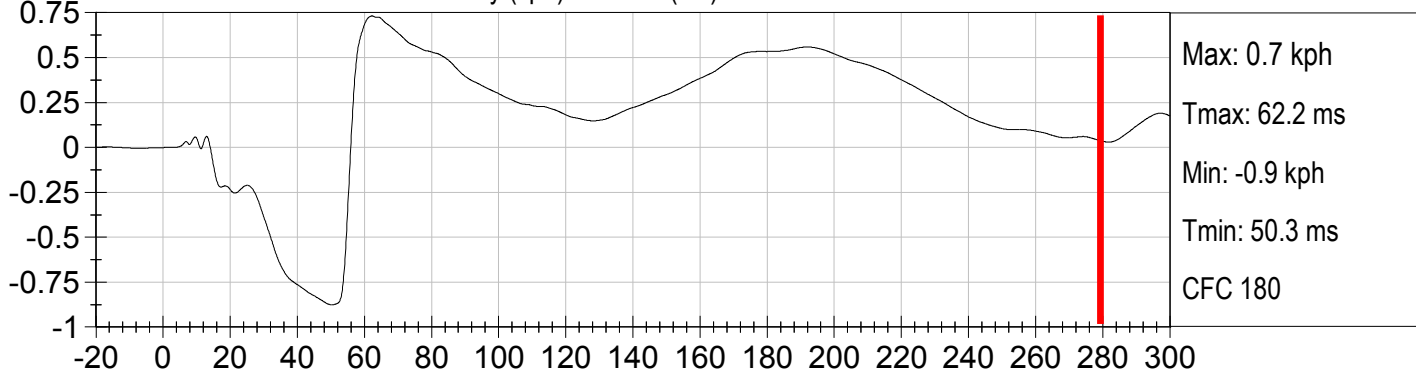

5TH FEM. DRIVER HEAD Z Velocity (kph) vs TIME (ms)

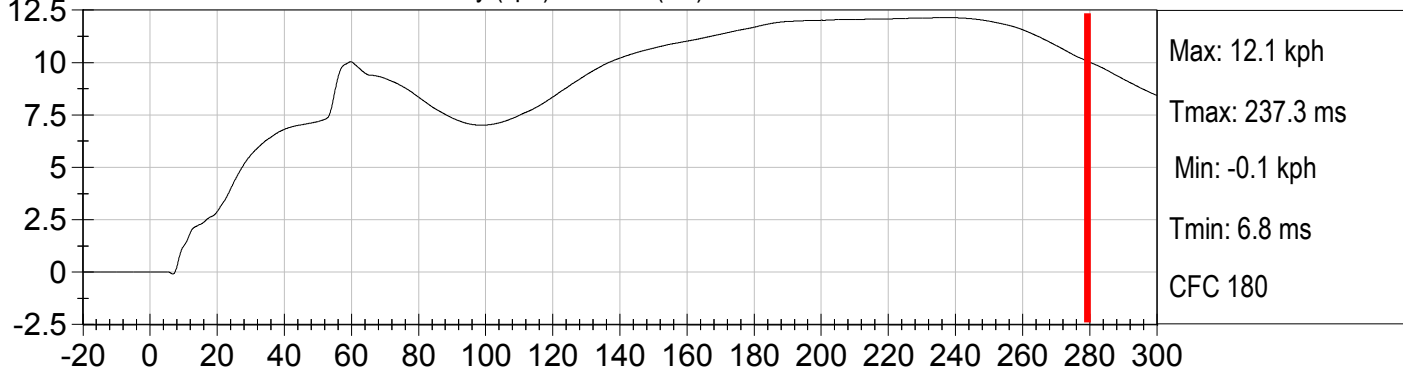



Injury Values Calculated between 0ms and 275ms

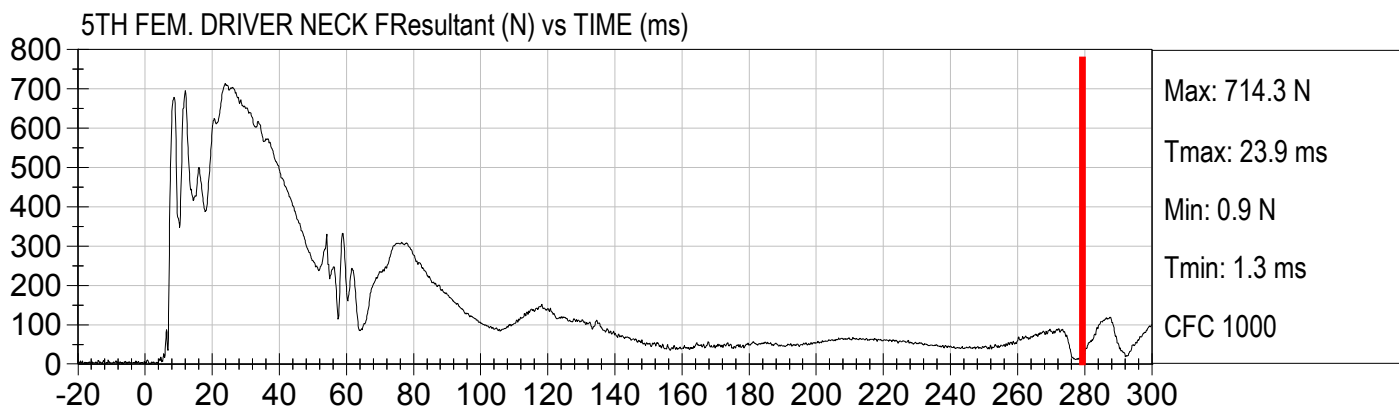
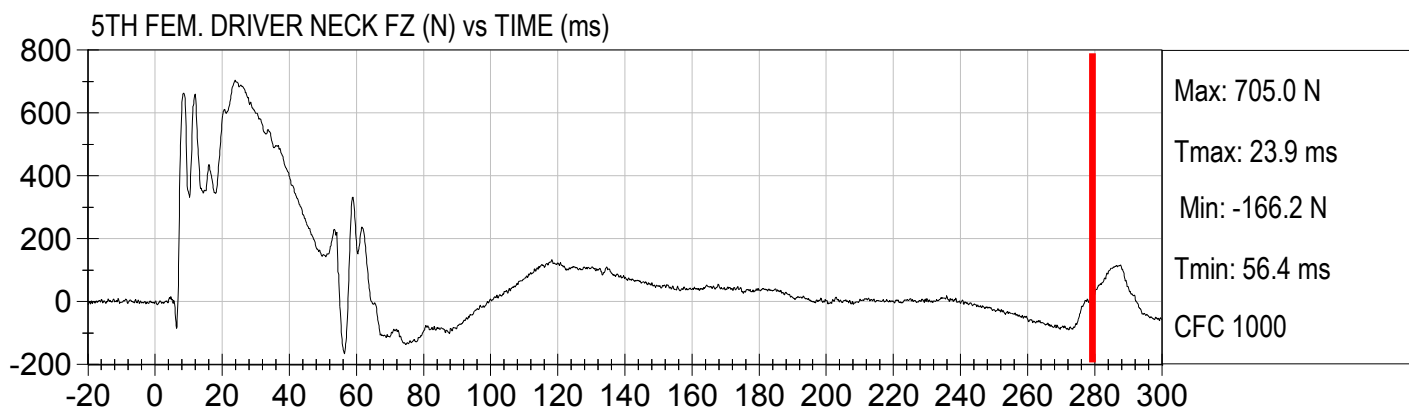
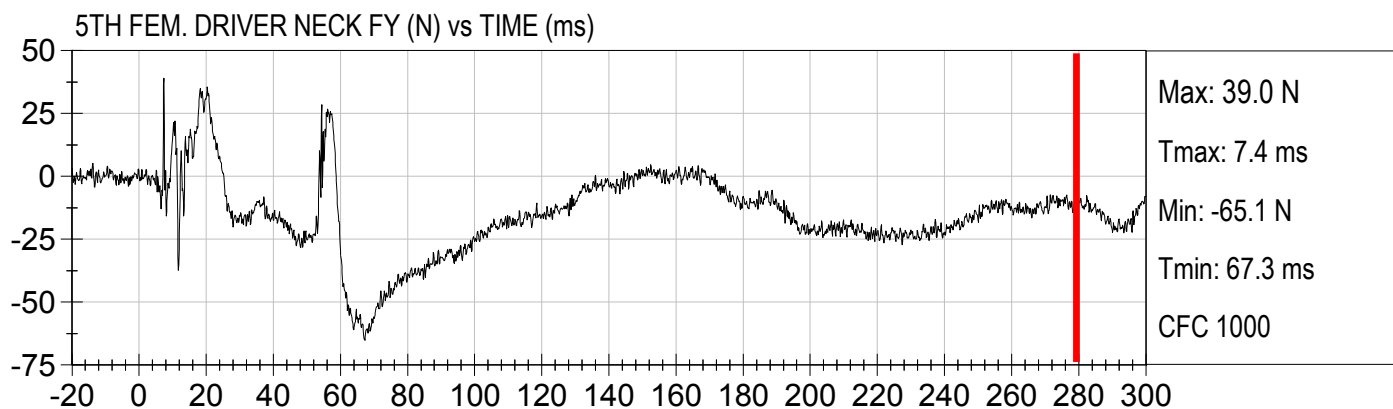
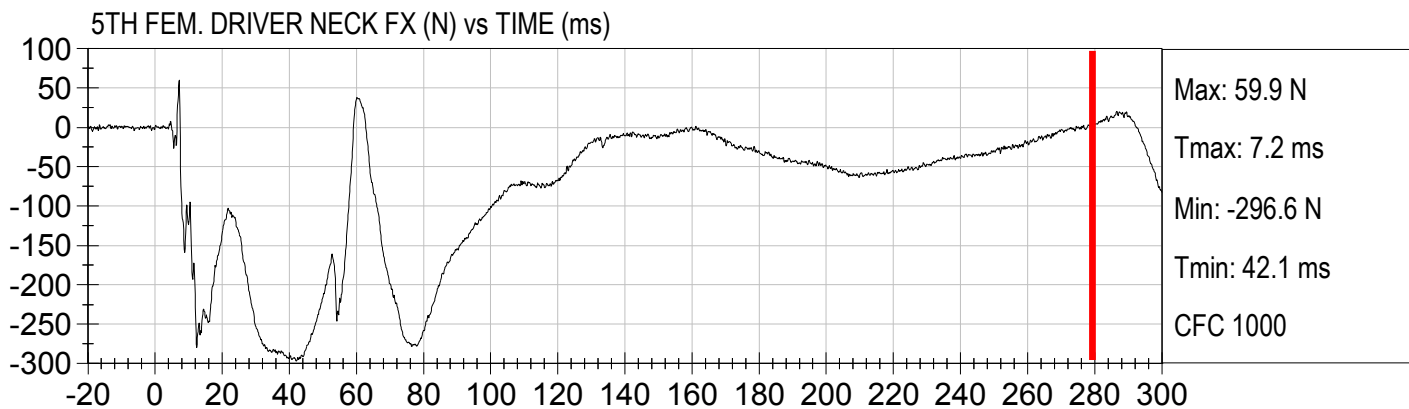



Injury Values Calculated between 0ms and 275ms

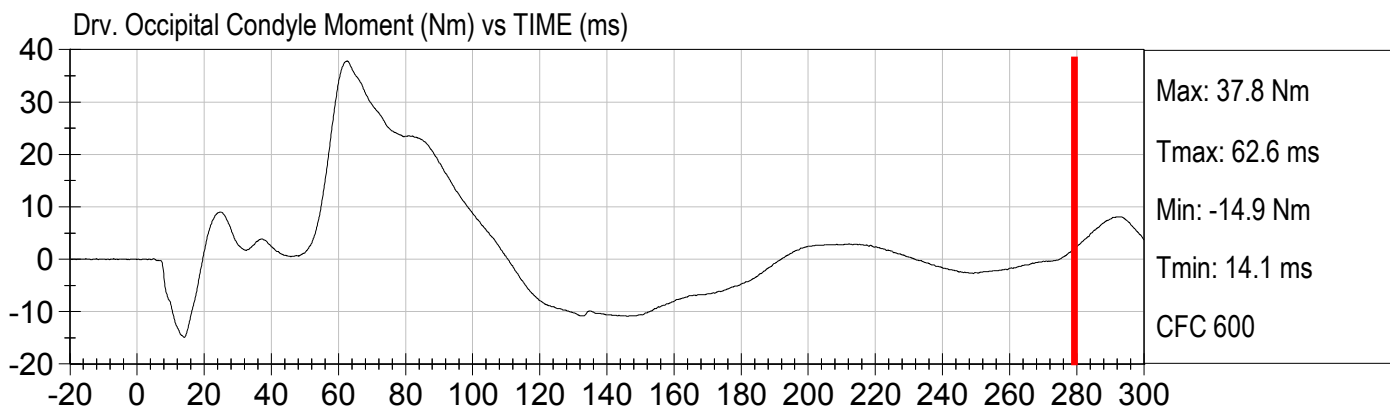
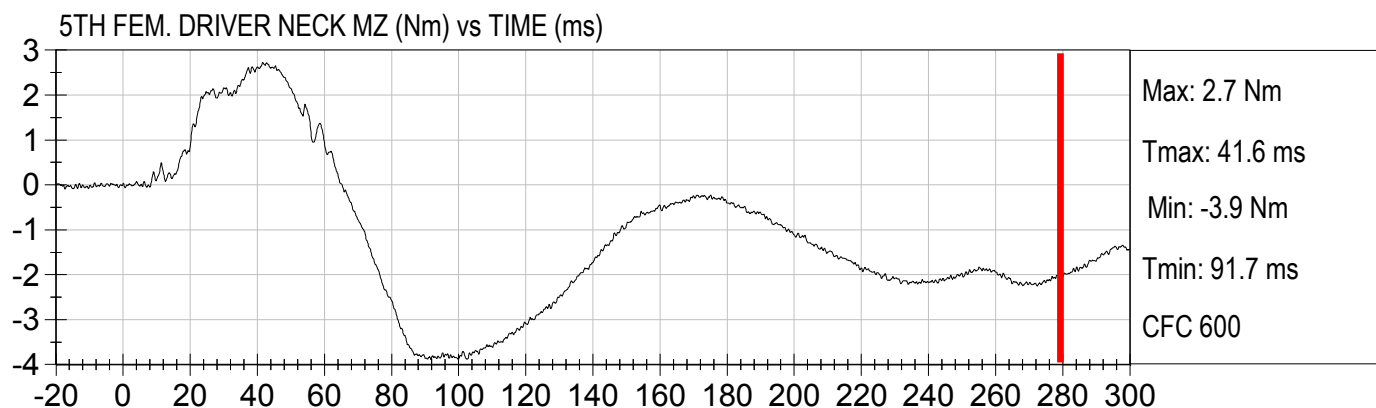
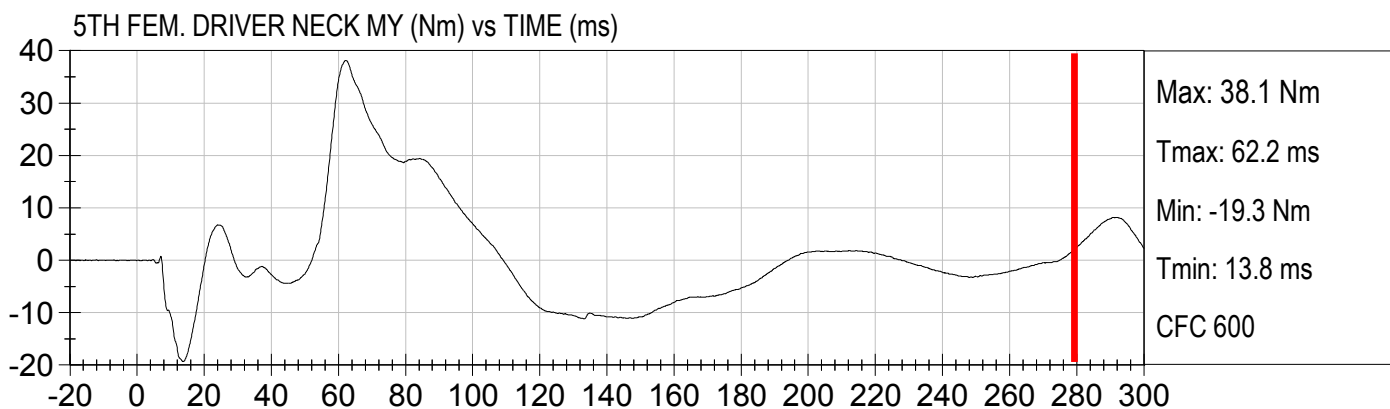
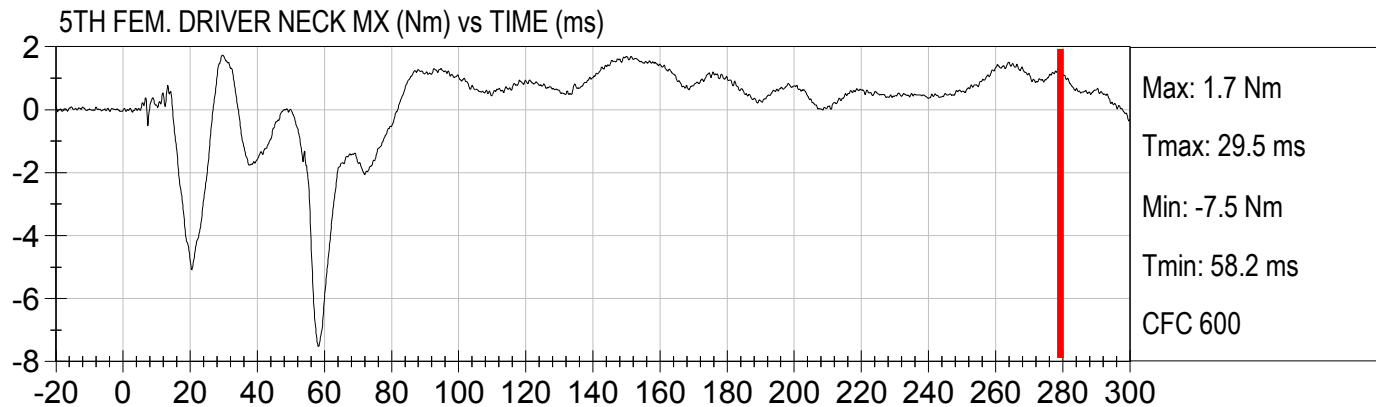



Injury Values Calculated between 0ms and 275ms

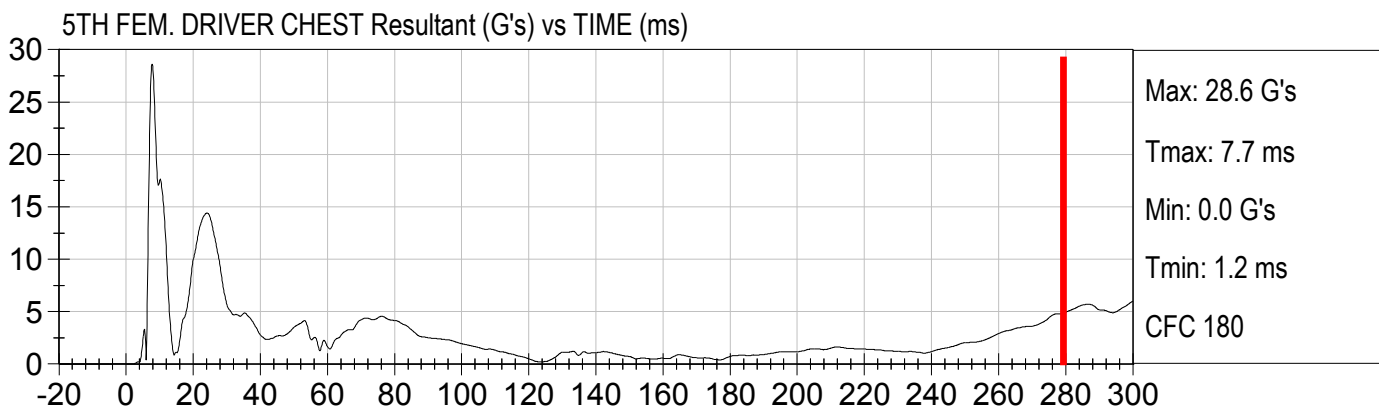
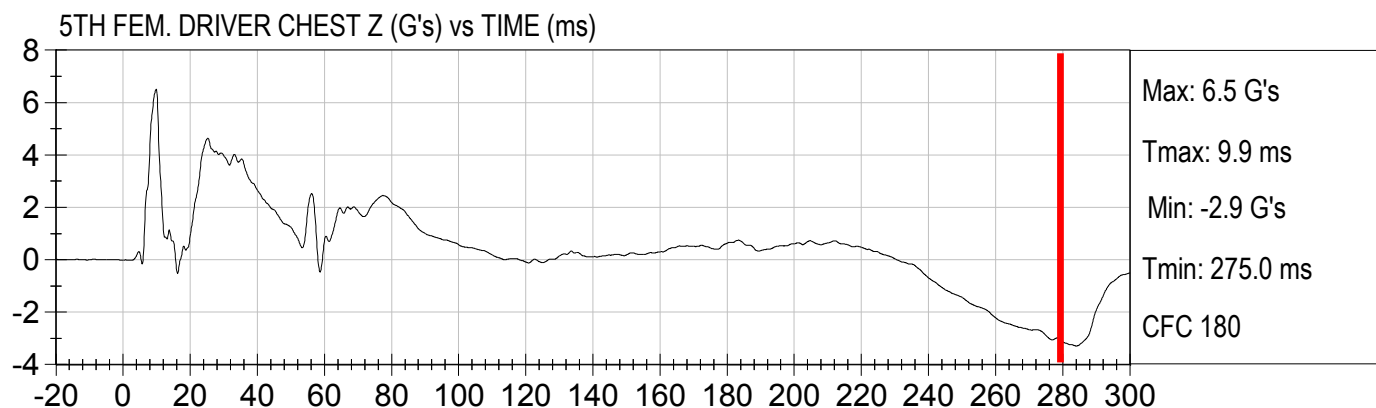
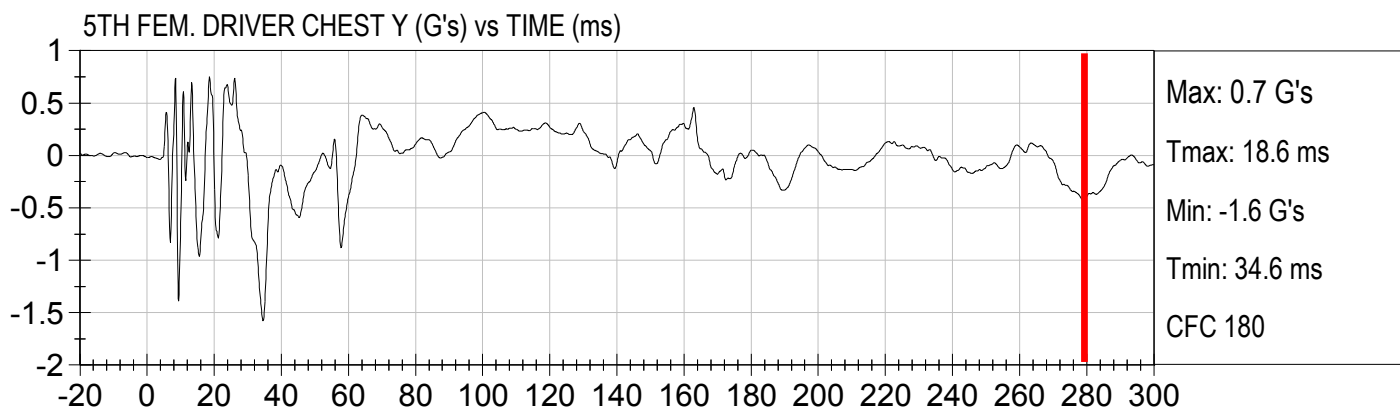
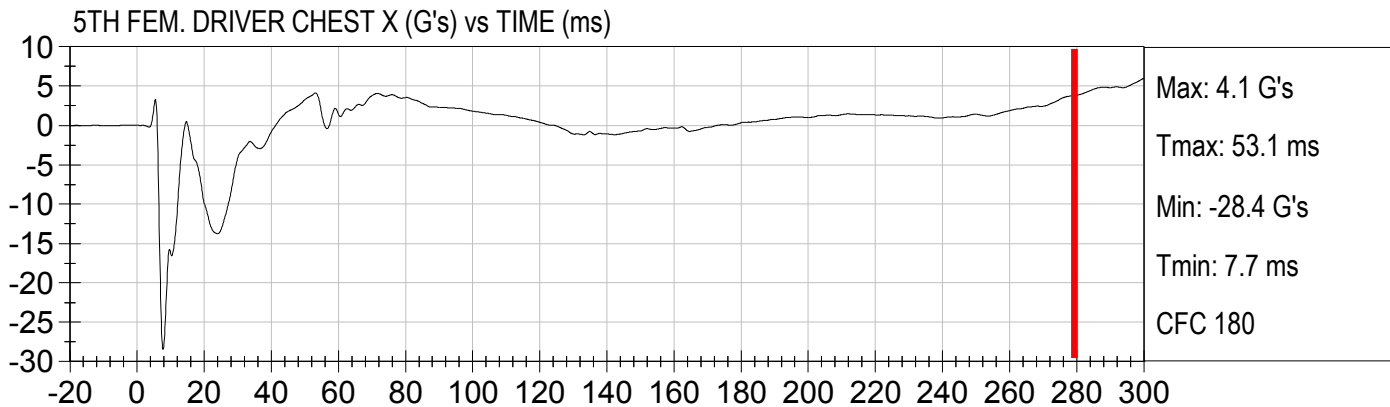



Injury Values Calculated between 0ms and 275ms

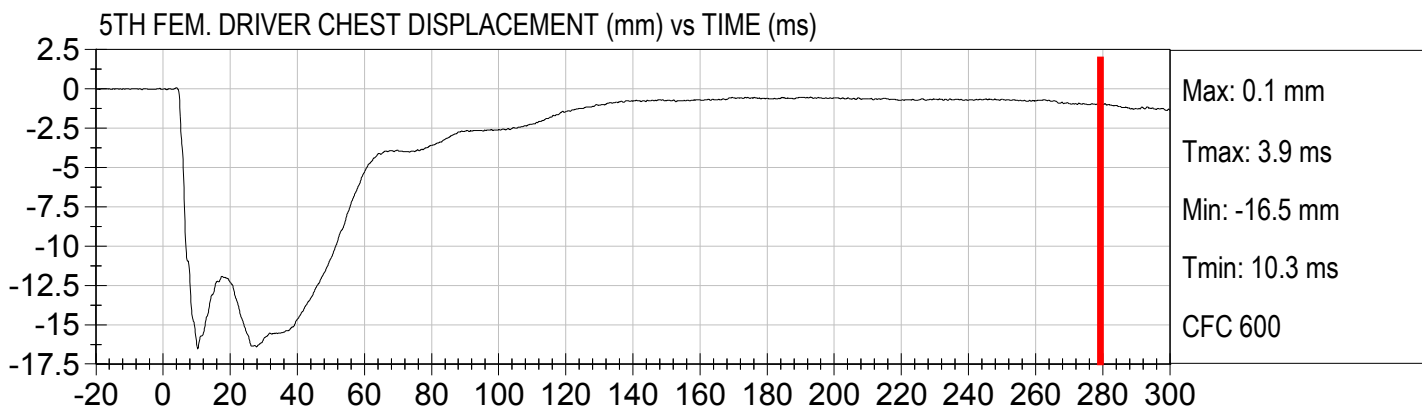
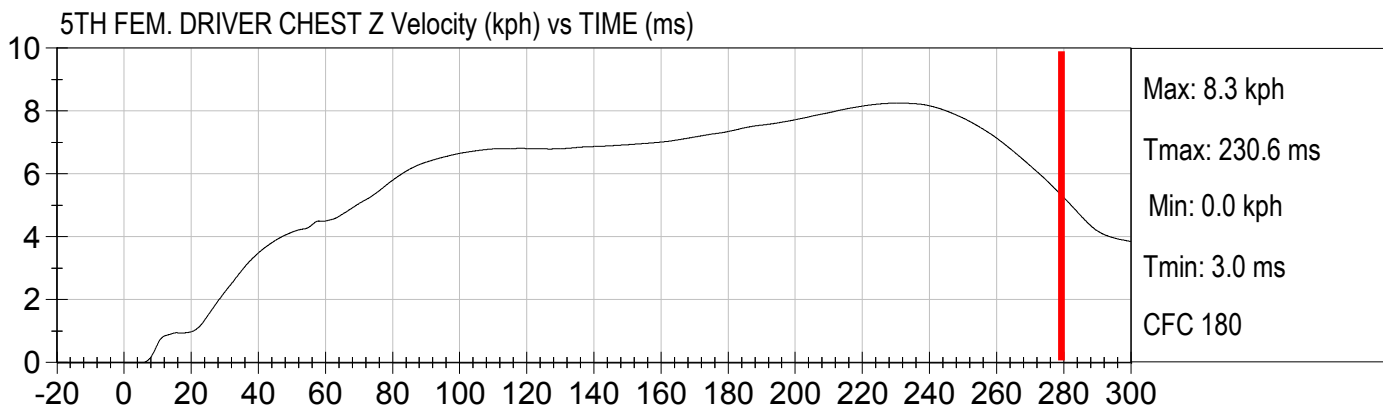
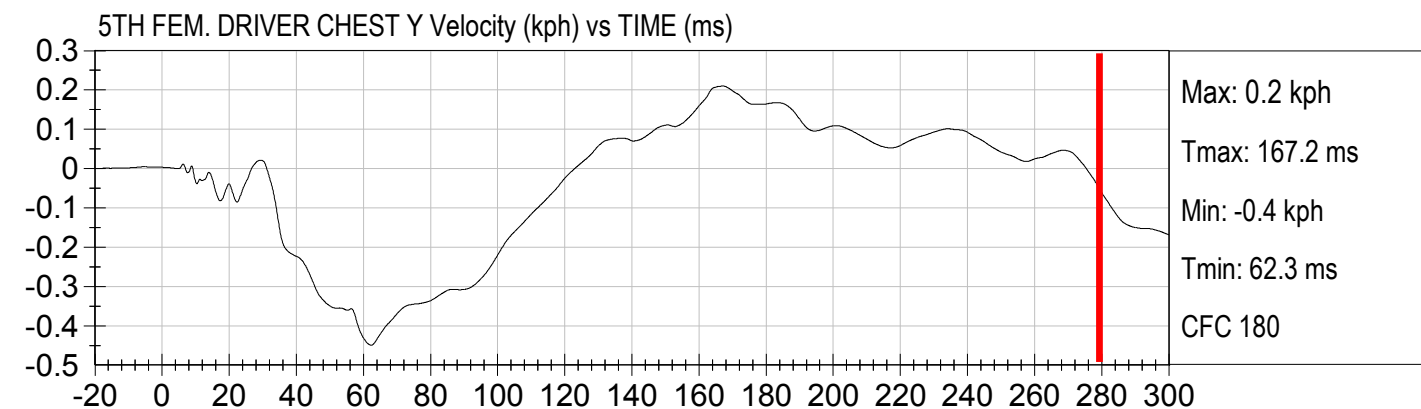
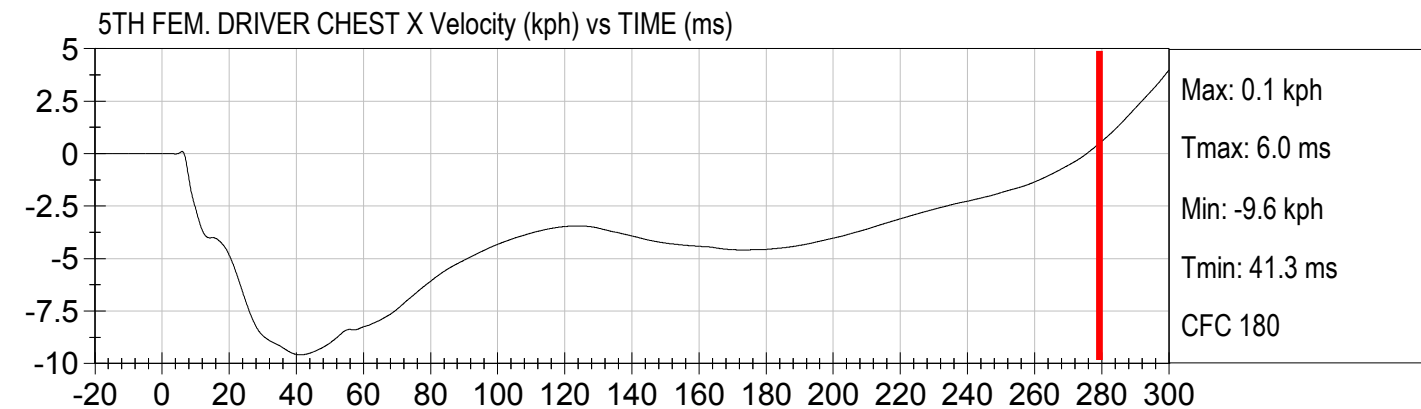



Injury Values Calculated between 0ms and 275ms

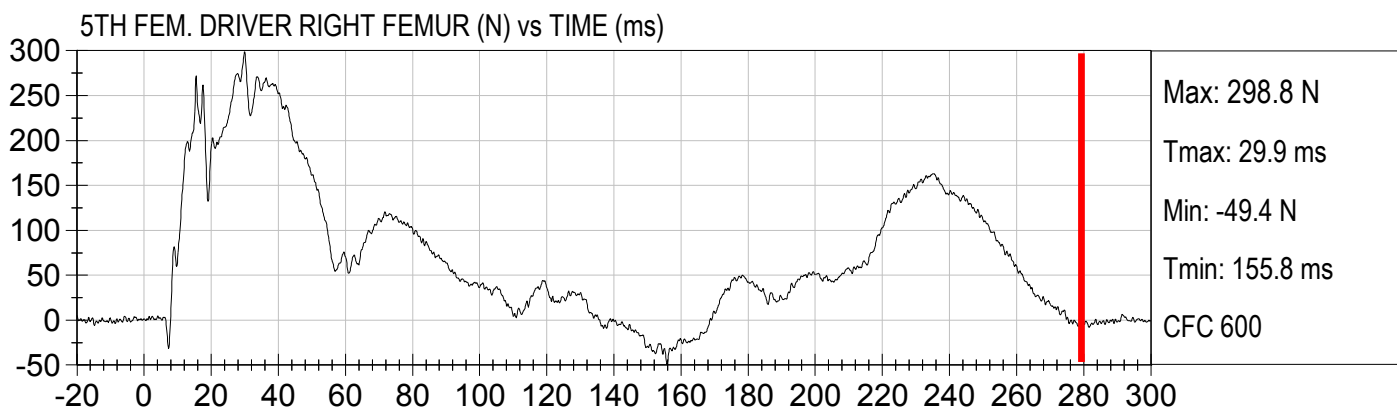
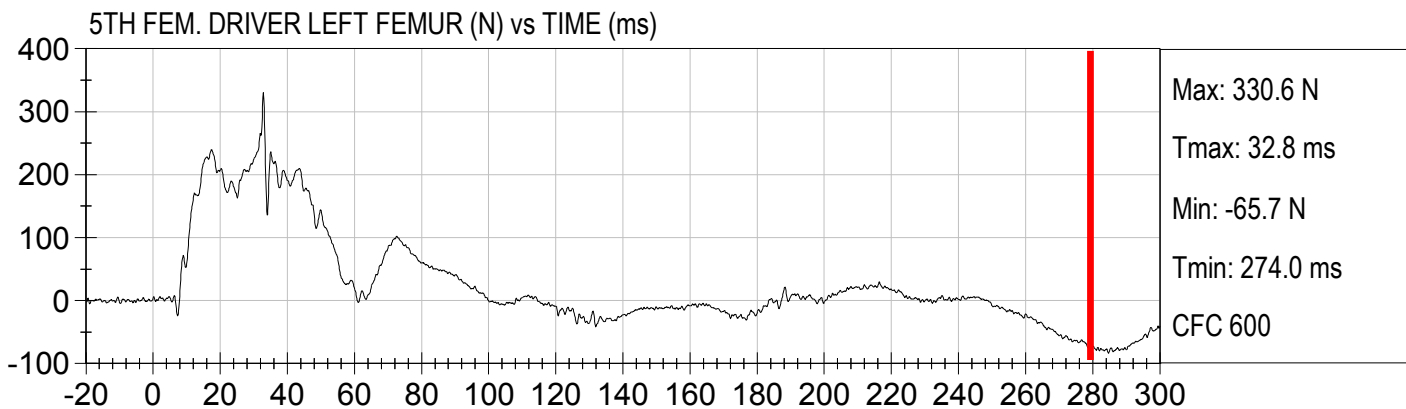



Injury Values Calculated between 0ms and 275ms

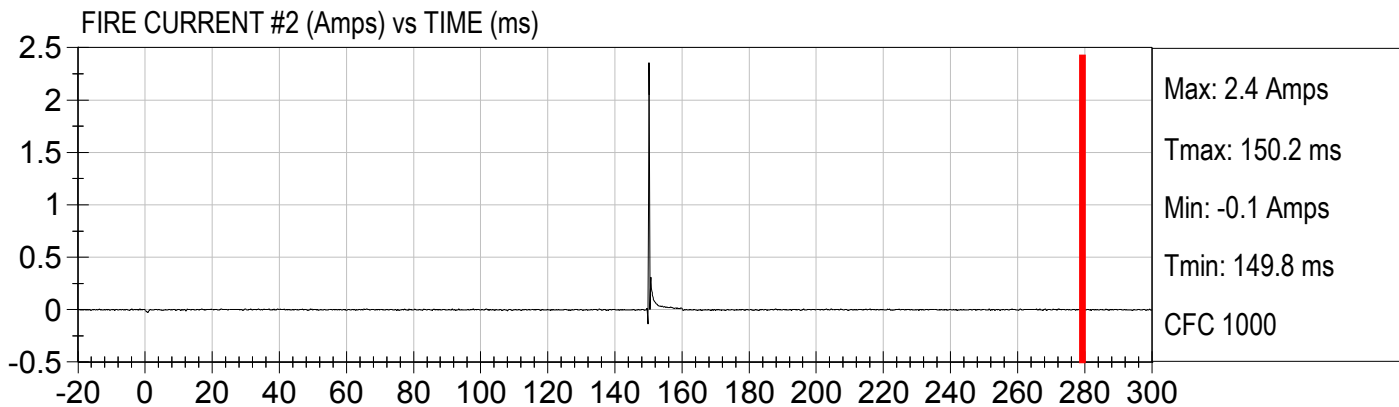
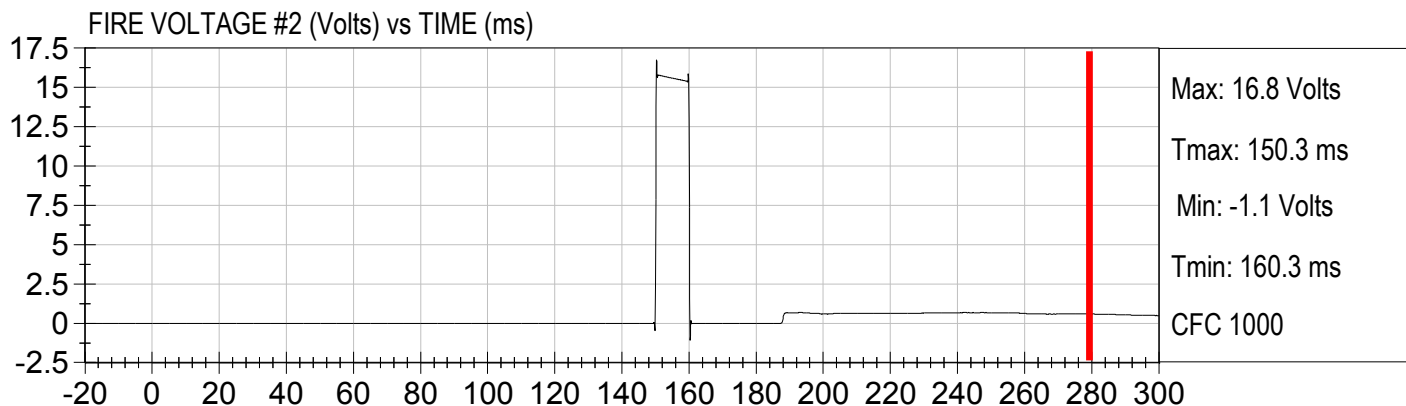
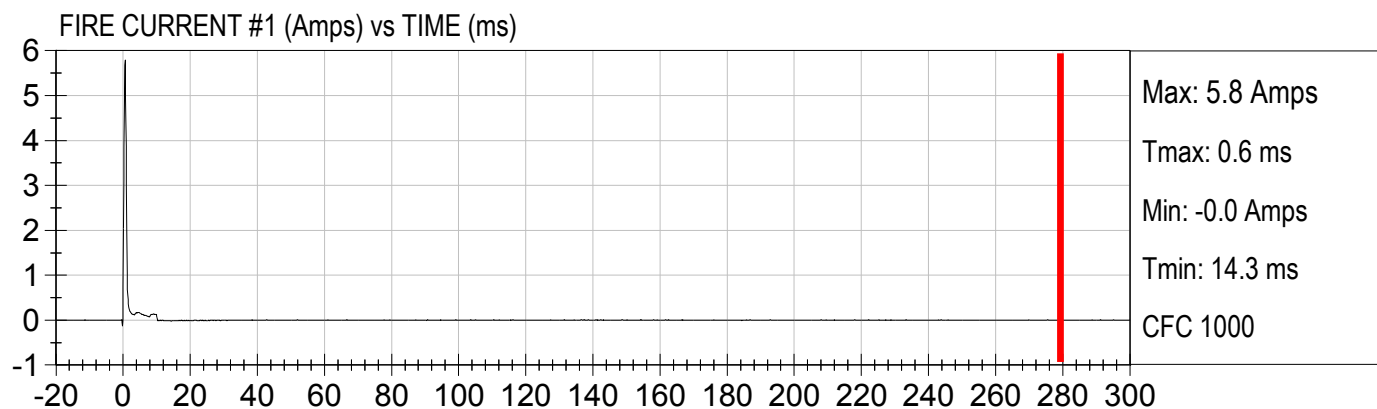
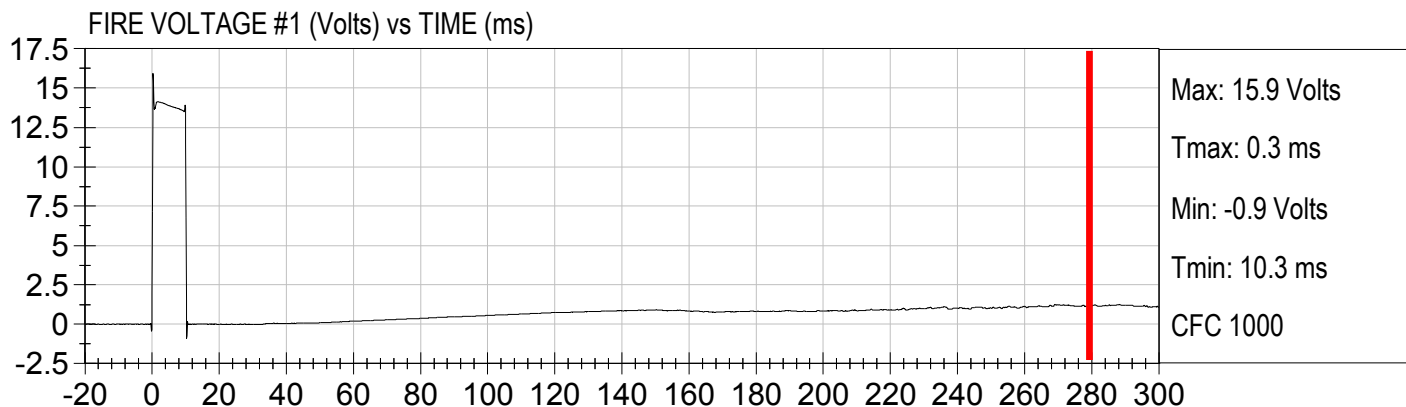

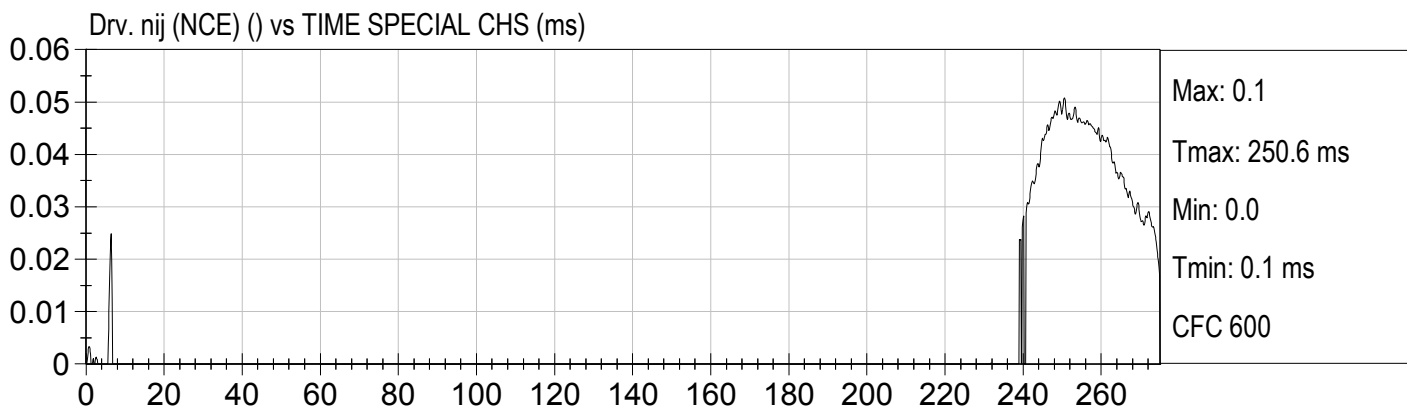
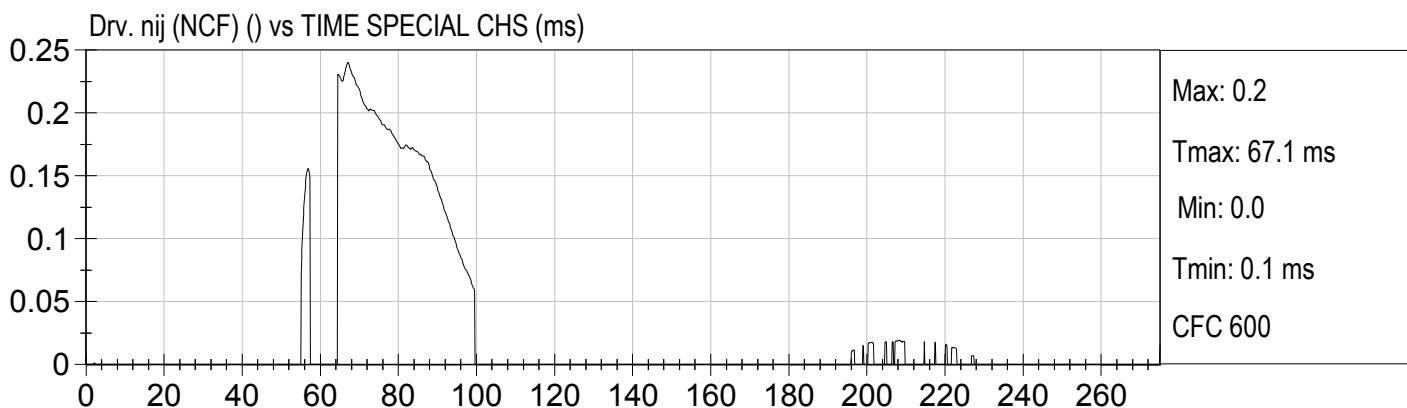
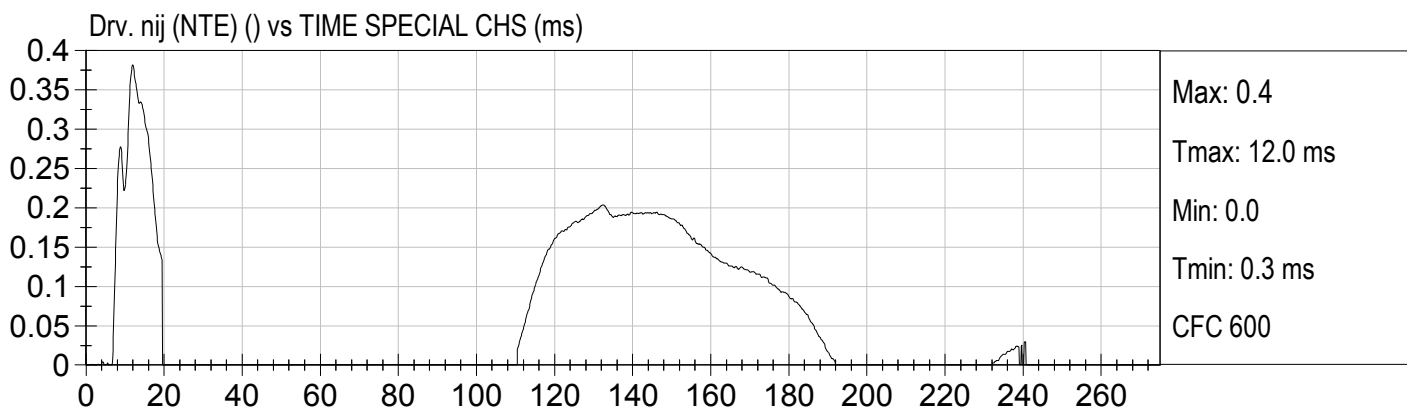
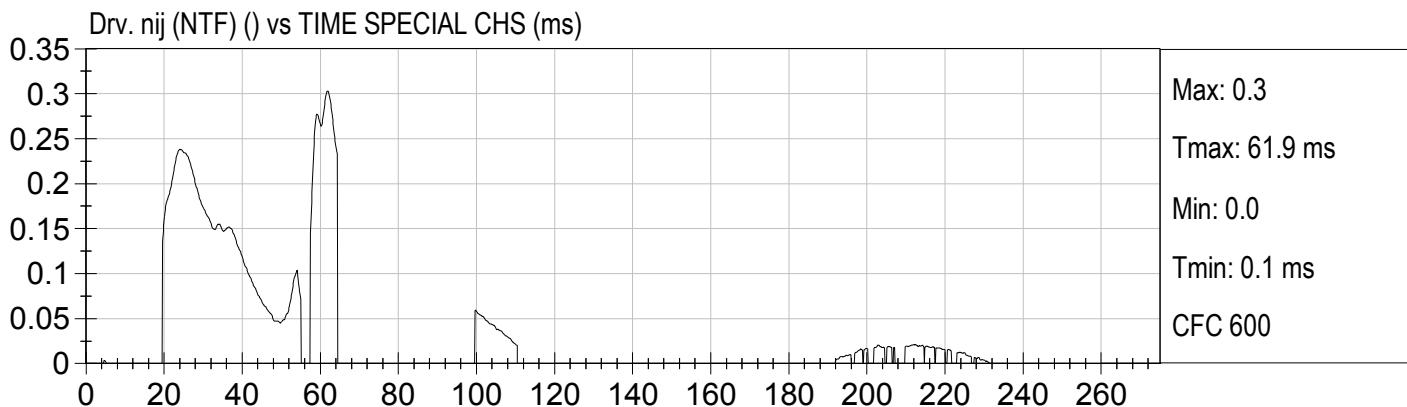

APPENDIX C

CRASH TEST PHOTOGRAPHS

TABLE OF PHOTOGRAPHS

	<u>Page No.</u>
Photo No. 1. Vehicle Certification Label	C-1
Photo No. 2. Tire Placard	C-2
Photo No. 3. Pre-Test Front View of Test Vehicle	C-3
Photo No. 4. Post-Test Front View of Test Vehicle	C-4
Photo No. 5. Pre-Test Left Side View of Test Vehicle	C-5
Photo No. 6. Post-Test Left Side View of Test Vehicle	C-6
Photo No. 7. Pre-Test Right Side View of Test Vehicle	C-7
Photo No. 8. Post-Test Right Side View of Test Vehicle	C-8
Photo No. 9. Pre-Test Left Front Three-Quarter View of Test Vehicle	C-9
Photo No. 10. Post-Test Left Front Three-Quarter View of Test Vehicle	C-10
Photo No. 11. Pre-Test Right Front Three-Quarter View of Test Vehicle	C-11
Photo No. 12. Post-Test Right Front Three-Quarter View of Test Vehicle	C-12
Photo No. 13. Pre-Test Right Rear Three-Quarter View of Test Vehicle	C-13
Photo No. 14. Post-Test Right Rear Three-Quarter View of Test Vehicle	C-14
Photo No. 15. Pre-Test Left Rear Three-Quarter View of Test Vehicle	C-15
Photo No. 16. Post-Test Left Rear Three-Quarter View of Test Vehicle	C-16
Photo No. 17. Pre-Test Rear View of Test Vehicle	C-17
Photo No. 18. Post-Test Rear View of Test Vehicle	C-18
Photo No. 19. Pre-Test Windshield View	C-19
Photo No. 20. Post-Test Windshield View	C-20
Photo No. 21. Pre-Test Engine Compartment View	C-21
Photo No. 22. Post-Test Engine Compartment View	C-22
Photo No. 23. Pre-Test Fuel Filler Cap View	C-23
Photo No. 24. Post-Test Fuel Filler Cap View	C-24
Photo No. 25. Pre-Test Front Underbody View	C-25
Photo No. 26. Post-Test Front Underbody View	C-26
Photo No. 27. Pre-Test Mid Underbody View	C-27
Photo No. 28. Post-Test Mid Underbody View	C-28
Photo No. 29. Pre-Test Mid Rear Underbody View	C-29
Photo No. 30. Post-Test Mid Rear Underbody View	C-30
Photo No. 31. Pre-Test Rear Underbody View	C-31
Photo No. 32. Post-Test Rear Underbody View	C-32
Photo No. 33. Pre-Test Driver Dummy Front View (head position)	C-33

Photo No. 34.	Post-Test Driver Dummy Front View (head position)	C-34
Photo No. 35.	Pre-Test Driver Dummy Position Left Side View	C-35
Photo No. 36.	Post-Test Driver Dummy Position Left Side View	C-36
Photo No. 37.	Pre-Test Driver Dummy Position Left Side View (door open)	C-37
Photo No. 38.	Post-Test Driver Dummy Position Left Side View (door open)	C-38
Photo No. 39.	Pre-Test Driver Dummy Seat Position	C-39
Photo No. 40.	Post-Test Driver Dummy Seat Position	C-40
Photo No. 41.	Pre-Test Driver Dummy Feet Position	C-41
Photo No. 42.	Post-Test Driver Dummy Feet Position	C-42
Photo No. 43.	Pre-Test Driver Side Knee Bolster View	C-43
Photo No. 44.	Post-Test Driver Side Knee Bolster View	C-44
Photo No. 45.	Post-Test Driver Dummy Airbag Contact	C-45
Photo No. 46.	Post-Test Driver Dummy Knee Contact (knee airbag)	C-46
Photo No. 47.	Post-Test Driver Dummy Head Contact (curtain airbag)	C-47
Photo No. 48.	Post-Test Driver Dummy Head Contact (A-pillar)	C-48
Photo No. 49.	Post-Test Driver Dummy Head Contact (windshield)	C-49
Photo No. 50.	Post-Test Driver Dummy Head Contact (headliner)	C-50
Photo No. 51.	Pre-Test Passenger Dummy Front View (head position)	C-51
Photo No. 52.	Post-Test Passenger Dummy Front View (head position)	C-52
Photo No. 53.	Pre-Test Passenger Dummy Position Right Side View	C-53
Photo No. 54.	Post-Test Passenger Dummy Position Right Side View	C-54
Photo No. 55.	Pre-Test Passenger Dummy Position Right Side View (door open)	C-55
Photo No. 56.	Post-Test Passenger Dummy Position Right Side View (door open)	C-56
Photo No. 57.	Pre-Test Passenger Dummy Seat Position	C-57
Photo No. 58.	Post-Test Passenger Dummy Seat Position	C-58
Photo No. 59.	Pre-Test Passenger Dummy Feet Position	C-59
Photo No. 60.	Post-Test Passenger Dummy Feet Position	C-60
Photo No. 61.	Pre-Test Passenger Side Knee Bolster View	C-61
Photo No. 62.	Post-Test Passenger Side Knee Bolster View	C-62
Photo No. 63.	Post-Test Passenger Dummy Airbag Contact	C-63
Photo No. 64.	Post-Test Passenger Dummy Knee Contact (glovebox)	C-64
Photo No. 65.	Post-Test Passenger Dummy Head Contact (shifter)	C-65
Photo No. 66.	Rollover 90 Degrees	C-66
Photo No. 67.	Rollover 180 Degrees	C-67
Photo No. 68.	Rollover 270 Degrees	C-68
Photo No. 69.	Rollover 360 Degrees	C-69
Photo No. 70.	Temperature Plot	C-70

C20140200

MFD. BY FORD MOTOR CO. DATE: 11/13 GVWR: 2096 KG (4620 LB)
FRONT GAWR: 1098 KG (2420 LB) REAR GAWR: 1006 KG (2218 LB)
WITH 235/55R17 99H TIRES WITH 235/55R17 99H TIRES
17X7.5J RIMS AT 17X7.5J RIMS
AT 240 kPa/ 35 PSI COLD
THIS VEHICLE CONFORMS TO ALL APPLICABLE FEDERAL MOTOR VEHICLE SAFETY AND THEFT
PREVENTION STANDARDS IN EFFECT ON THE DATE OF MANUFACTURE SHOWN ABOVE.
VIN: 1FMCU0F72EUB70023 TYPE: MPV

EXT PNT: UX RC: 41 DSO: F0079
WB INT TR TP/PS R AXLE TR SPR EM21A T0318
105 7B 3 35 6 MMPP 50A
MADE IN U.S.A. 1201311183350 ULC 5USA-3520472-AA

C-1

Photo No. 1 - Vehicle Certification Label

C20140200

TIRE AND LOADING INFORMATION



SEATING CAPACITY TOTAL : 5 FRONT: 2 REAR: 3
The combined weight of occupants and cargo should never exceed : 375 kg or 827 lbs.

5USA-1532-AA (TLU)

TIRE	SIZE	COLD TIRE PRESSURE
FRONT	235/55R17 99H	240 KPA, 35 PSI
REAR	235/55R17 99H	240 KPA, 35 PSI
SPARE	T155/70R17 110M	420 KPA, 60 PSI

**SEE OWNERS
MANUAL FOR
ADDITIONAL
INFORMATION**

1FMCU0F72EUB70023



C-2

Photo No. 2 - Tire Placard



Photo No. 3 - Pre-Test Front View of Test Vehicle



Photo No. 4 - Post-Test Front View of Test Vehicle



Photo No. 5 - Pre-Test Left Side View of Test Vehicle



Photo No. 6 - Post-Test Left Side View of Test Vehicle



Photo No. 7 - Pre-Test Right Side View of Test Vehicle



Photo No. 8 - Post-Test Right Side View of Test Vehicle



Photo No. 9 - Pre-Test Left Front Three-Quarter View of Test Vehicle



Photo No. 10 - Post-Test Left Front Three-Quarter View of Test Vehicle



Photo No. 11 - Pre-Test Right Front Three-Quarter View of Test Vehicle



Photo No. 12 - Post-Test Right Front Three-Quarter View of Test Vehicle



Photo No. 13 - Pre-Test Right Rear Three-Quarter View of Test Vehicle



Photo No. 14 - Post-Test Right Rear Three-Quarter View of Test Vehicle



Photo No. 15 - Pre-Test Left Rear Three-Quarter View of Test Vehicle



Photo No. 16 - Post-Test Left Rear Three-Quarter View of Test Vehicle



Photo No. 17 - Pre-Test Rear View of Test Vehicle



Photo No. 18 - Post-Test Rear View of Test Vehicle



C-19

Photo No. 19 - Pre-Test Windshield View



Photo No. 20 - Post-Test Windshield View



Photo No. 21 - Pre-Test Engine Compartment View



Photo No. 22 - Post-Test Engine Compartment View

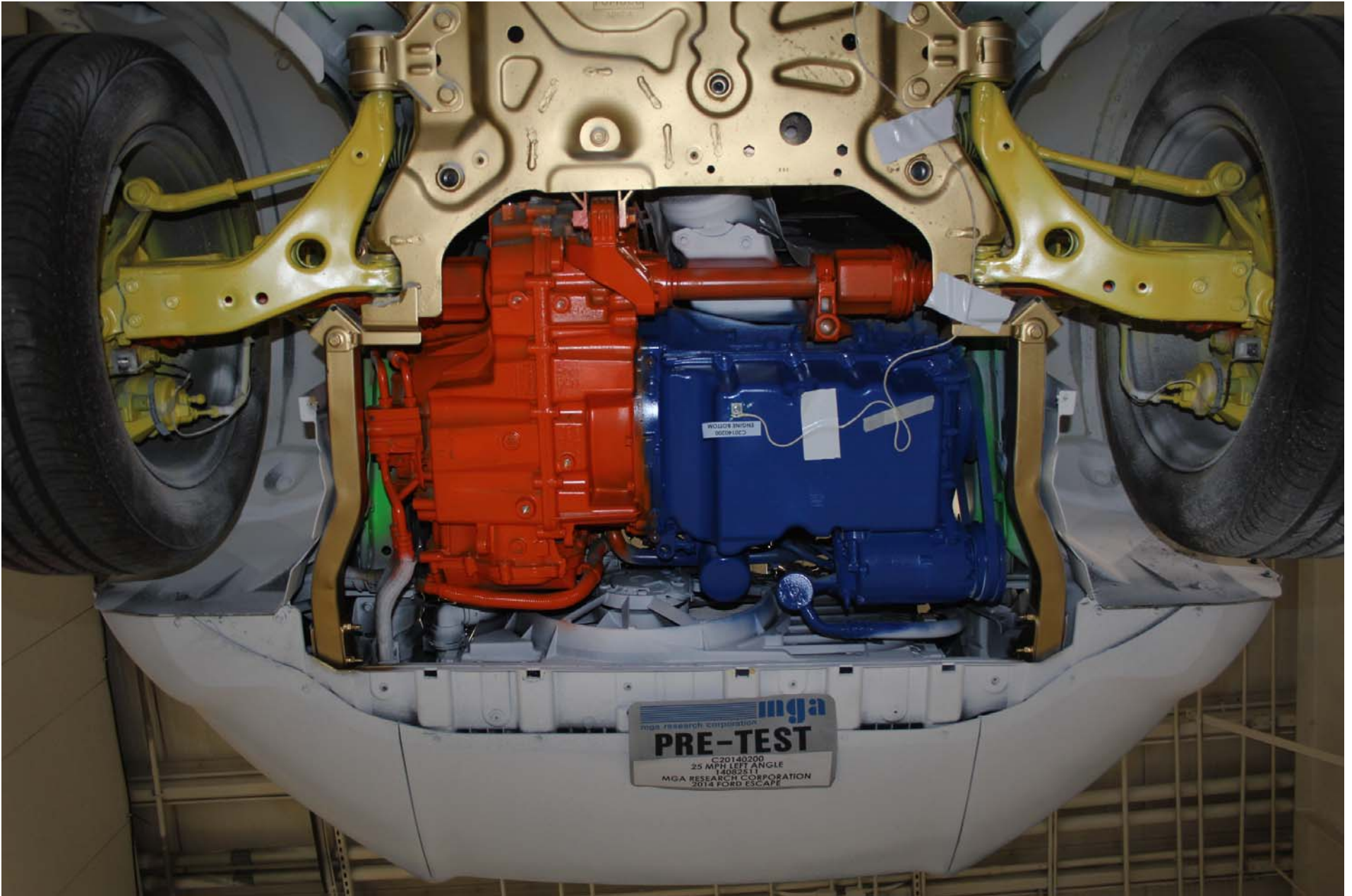

Photo No. 23 - Pre-Test Fuel Filler Cap View



C-24

Photo No. 24 - Post-Test Fuel Filler Cap View



mga
mga research corporation
PRE-TEST
C20140200
25 MPH LEFT ANGLE
14082511
MGA RESEARCH CORPORATION
2014 FORD ESCAPE

Photo No. 25 - Pre-Test Front Underbody View

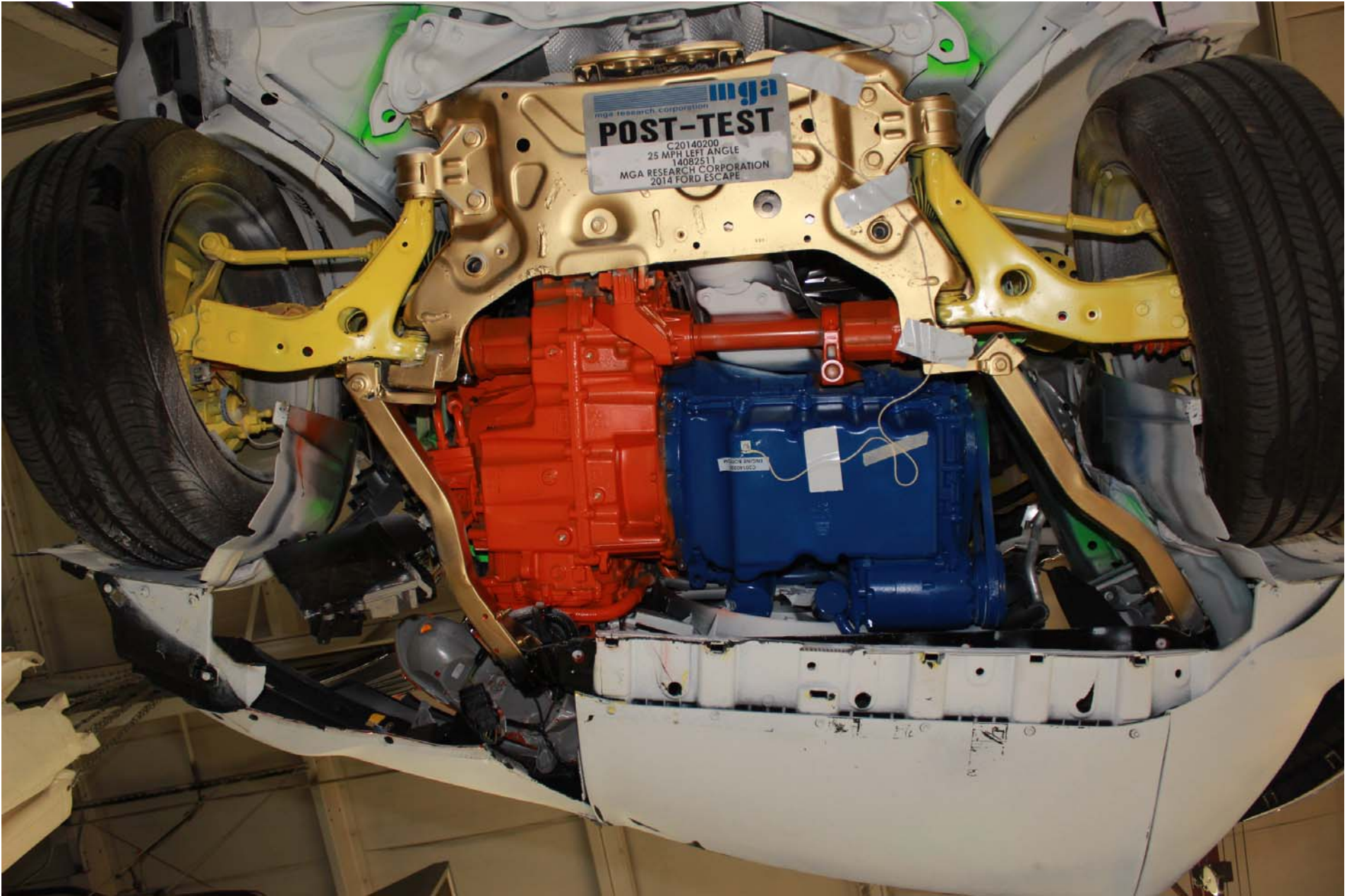

C-26

Photo No. 26 - Post-Test Front Underbody View



Photo No. 27 - Pre-Test Mid Underbody View

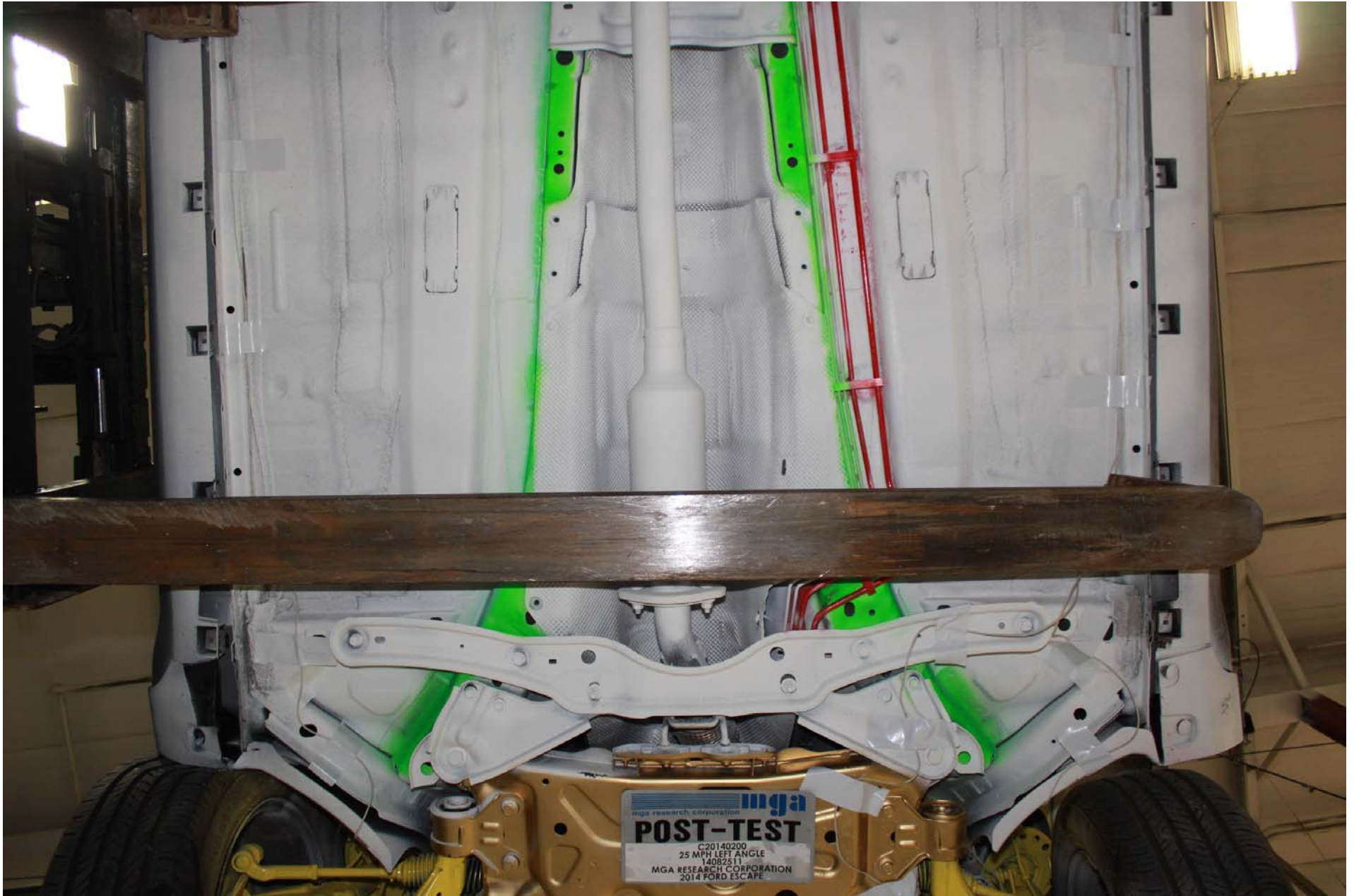

Photo No. 28 - Post-Test Mid Underbody View

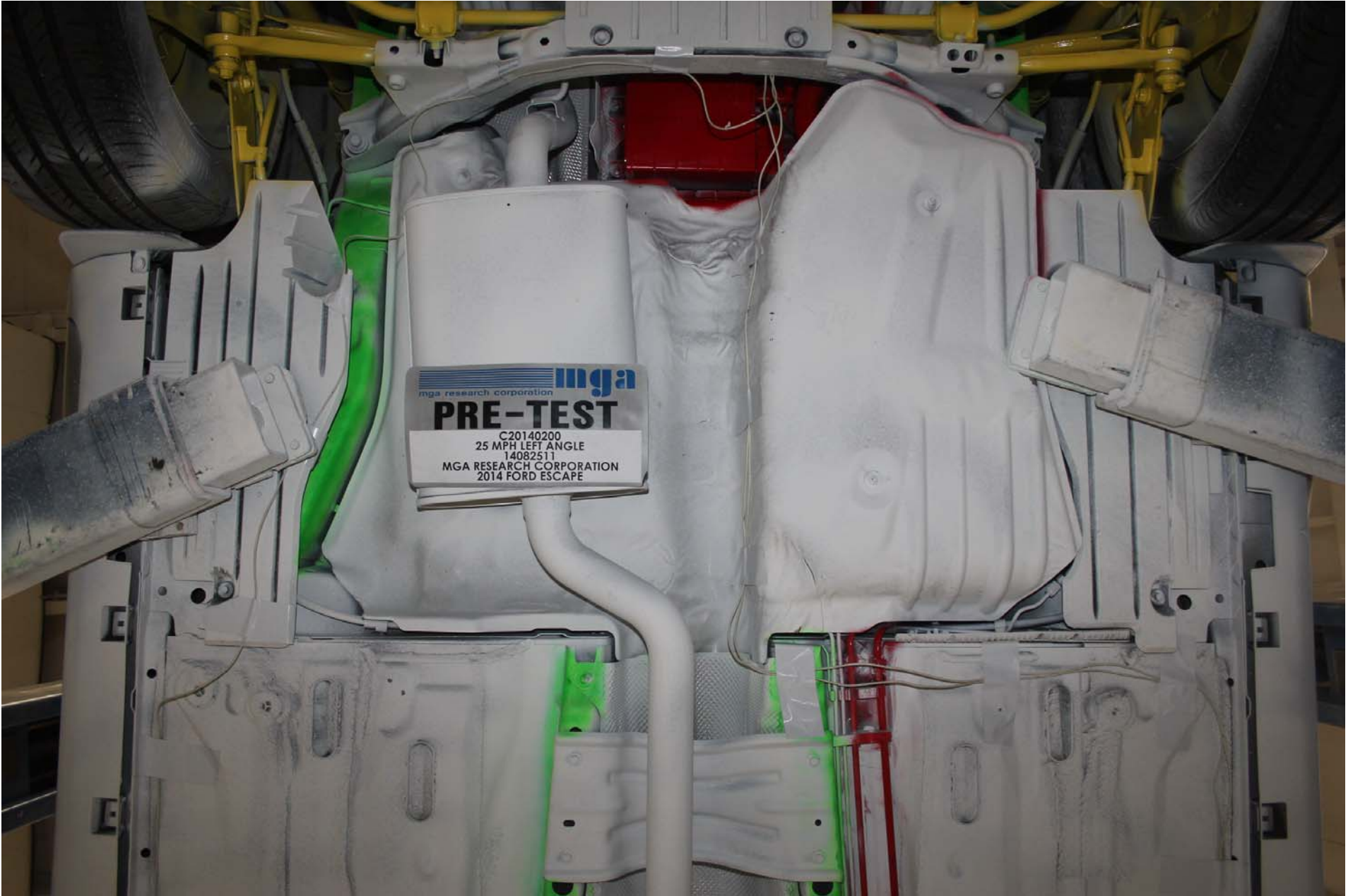

Photo No. 29 - Pre-Test Mid Rear Underbody View

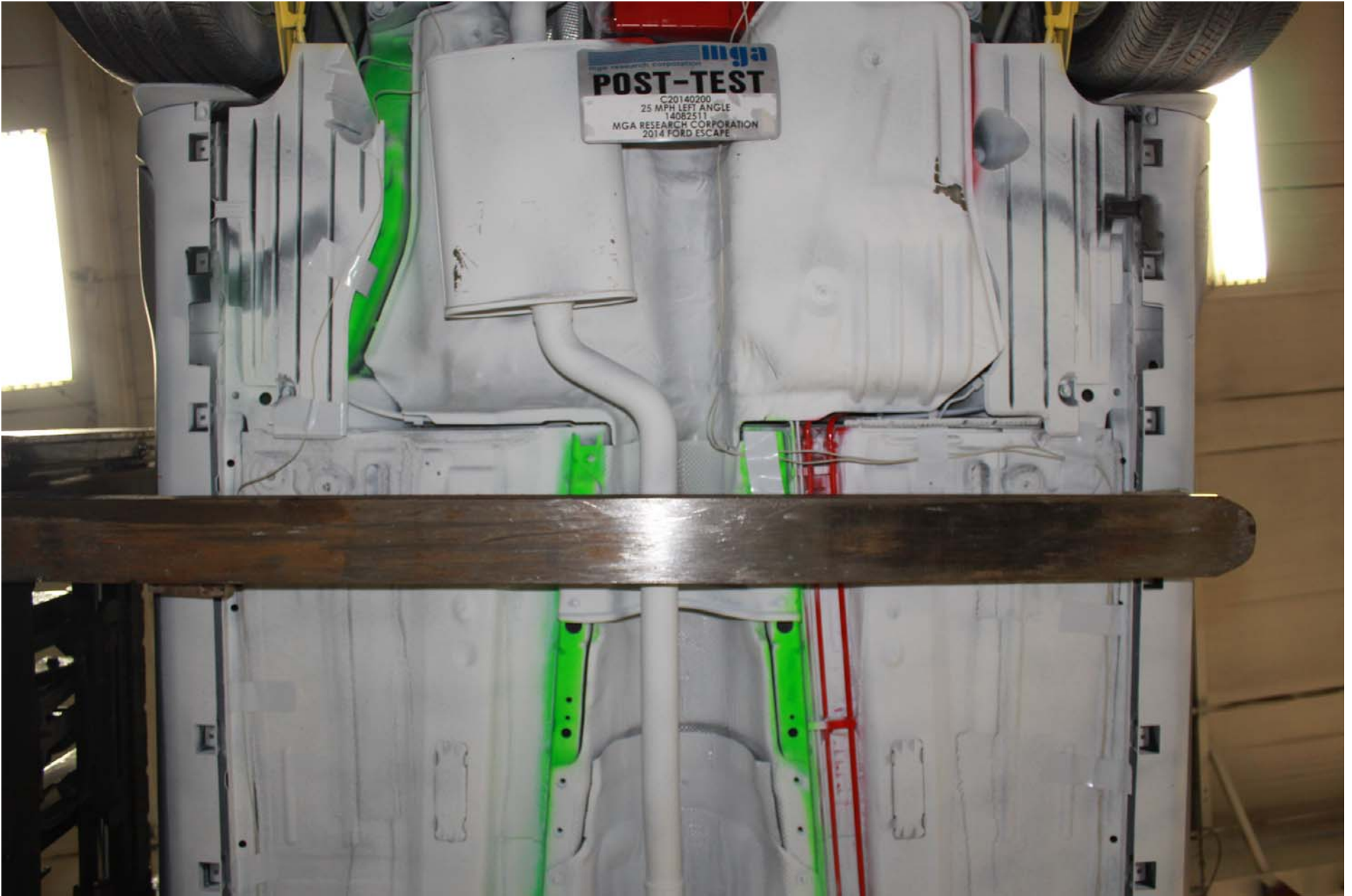

Photo No. 30 - Post-Test Mid Rear Underbody View

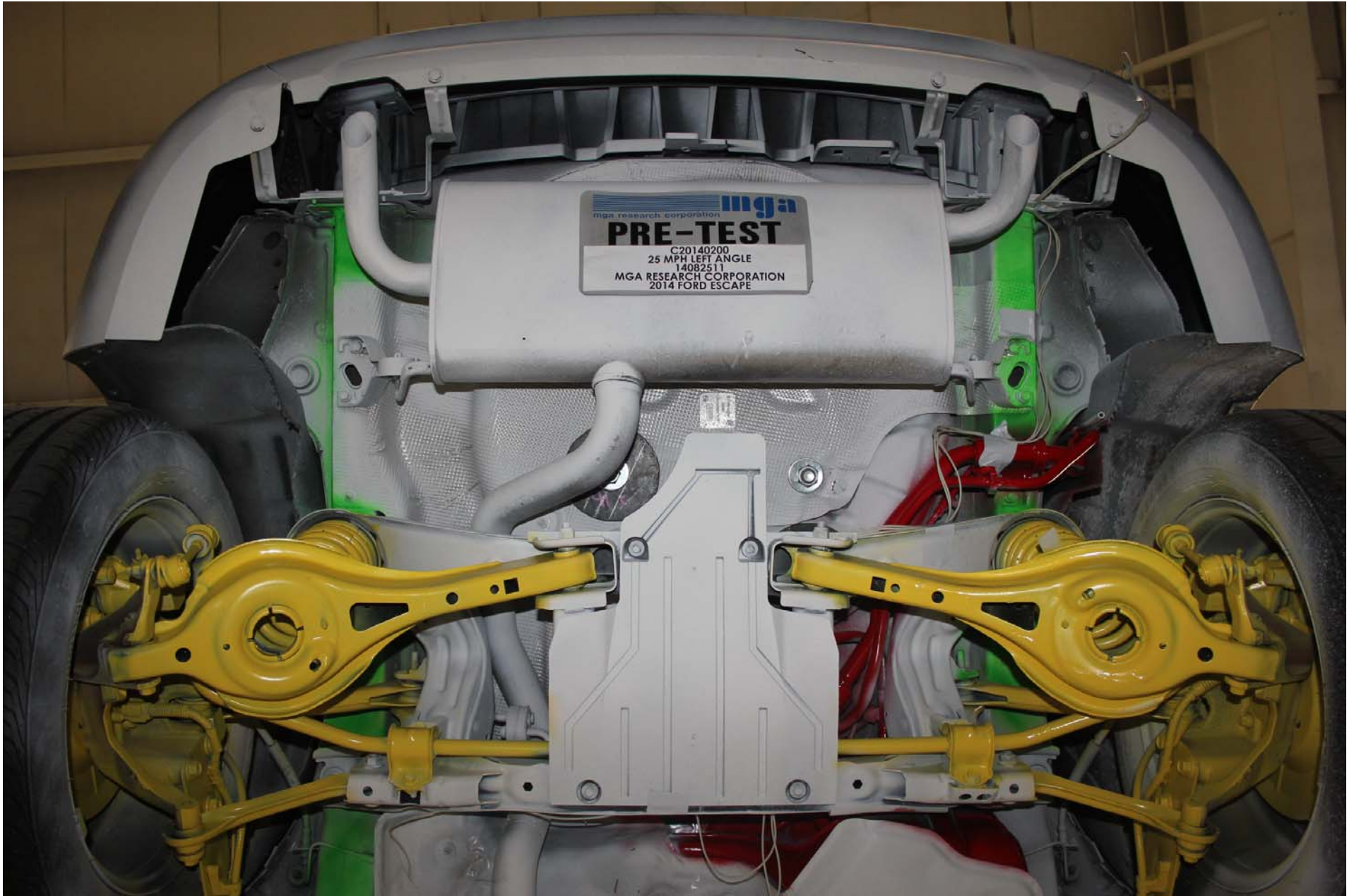

Photo No. 31 - Pre-Test Rear Underbody View

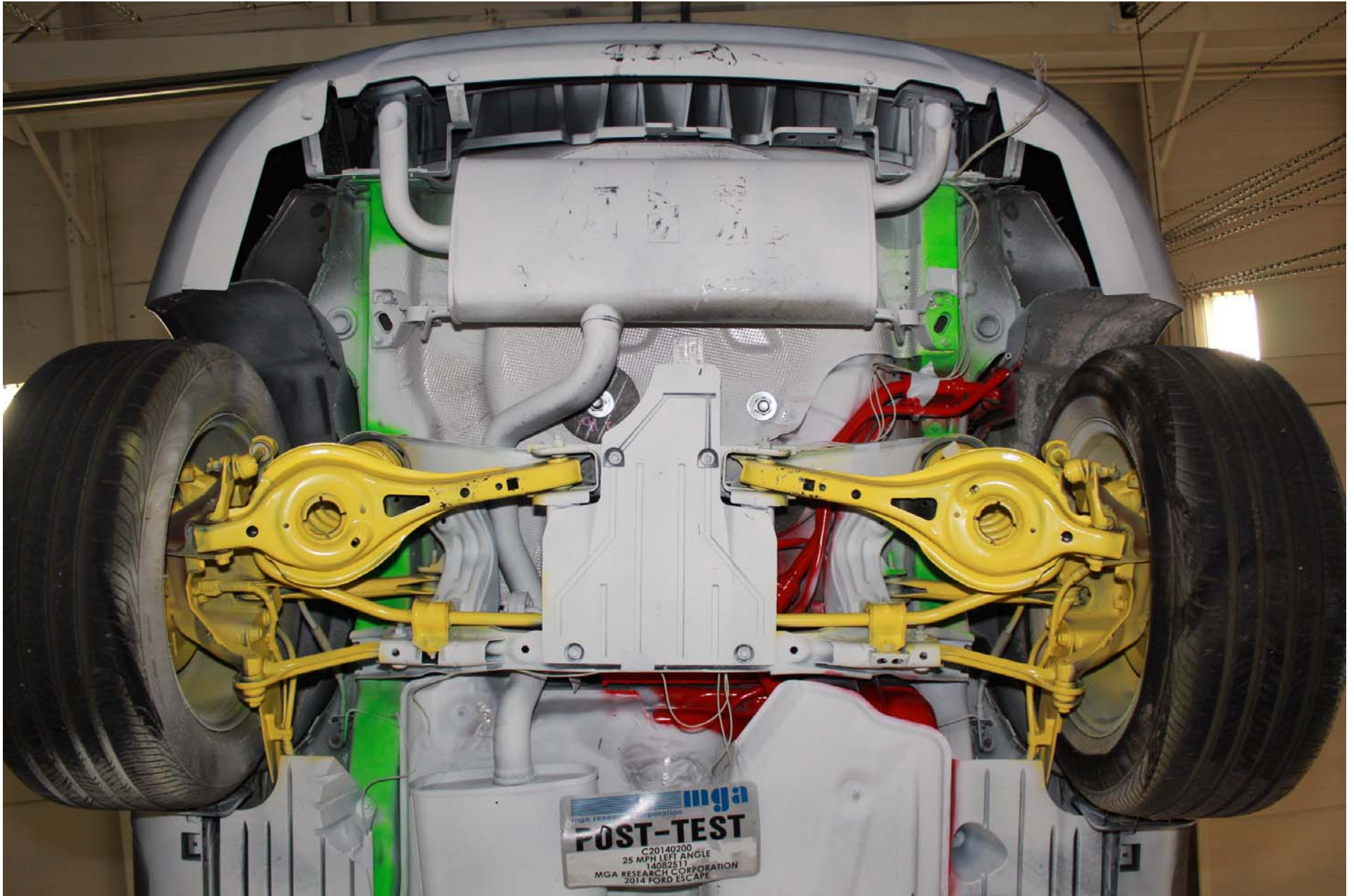

Photo No. 32 - Post-Test Rear Underbody View



Photo No. 33 - Pre-Test Driver Dummy Front View (head position)



Photo No. 34 - Post-Test Driver Dummy Front View (head position)



Photo No. 35 - Pre-Test Driver Dummy Position Left Side View



Photo No. 36 - Post-Test Driver Dummy Position Left Side View



Photo No. 37 - Pre-Test Driver Dummy Position Left Side View (door open)



Photo No. 38 - Post-Test Driver Dummy Position Left Side View (door open)



Photo No. 39 - Pre-Test Driver Dummy Seat Position

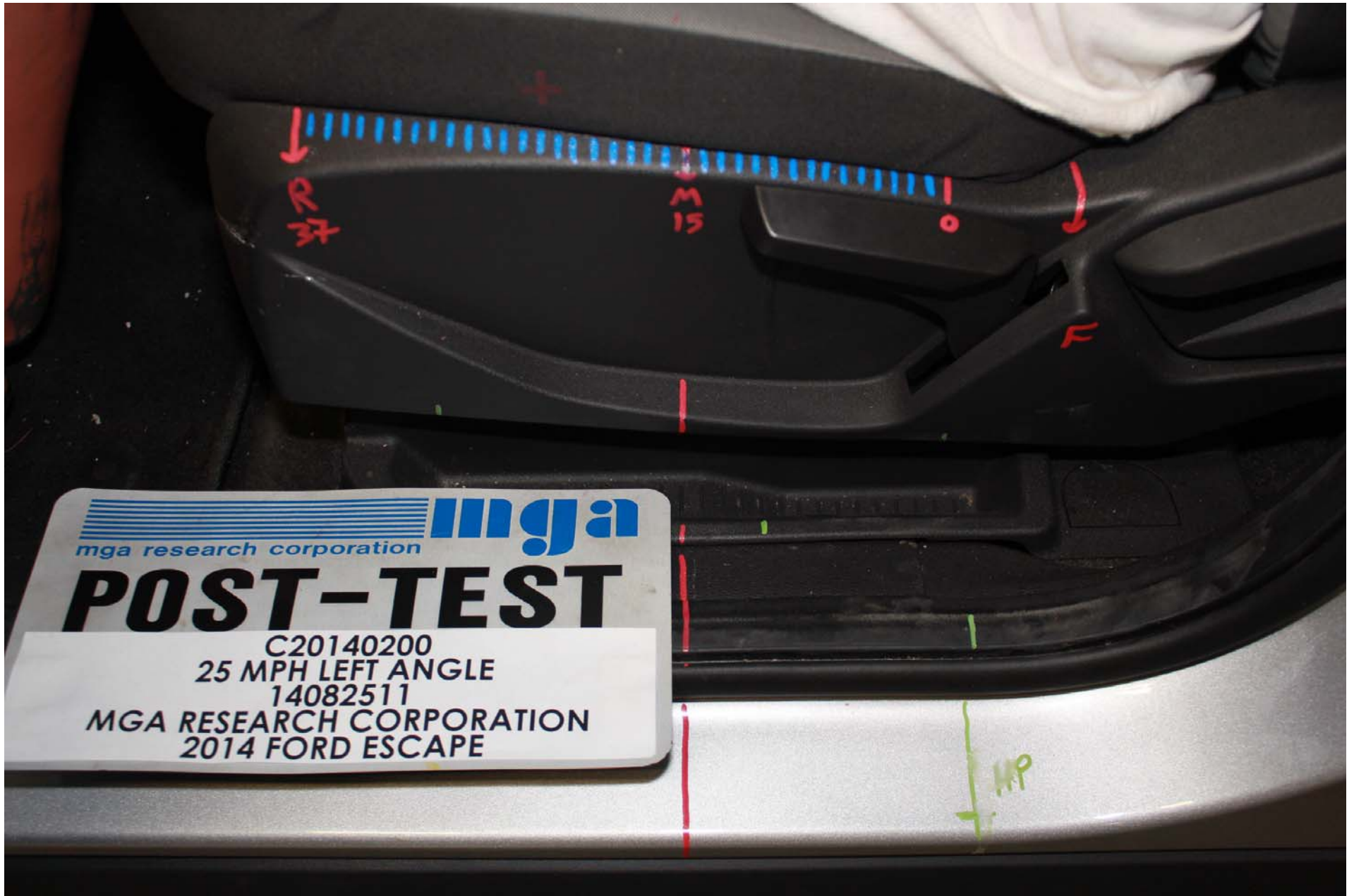

Photo No. 40 - Post-Test Driver Dummy Seat Position



Photo No. 41 - Pre-Test Driver Dummy Feet Position



Photo No. 42 - Post-Test Driver Dummy Feet Position

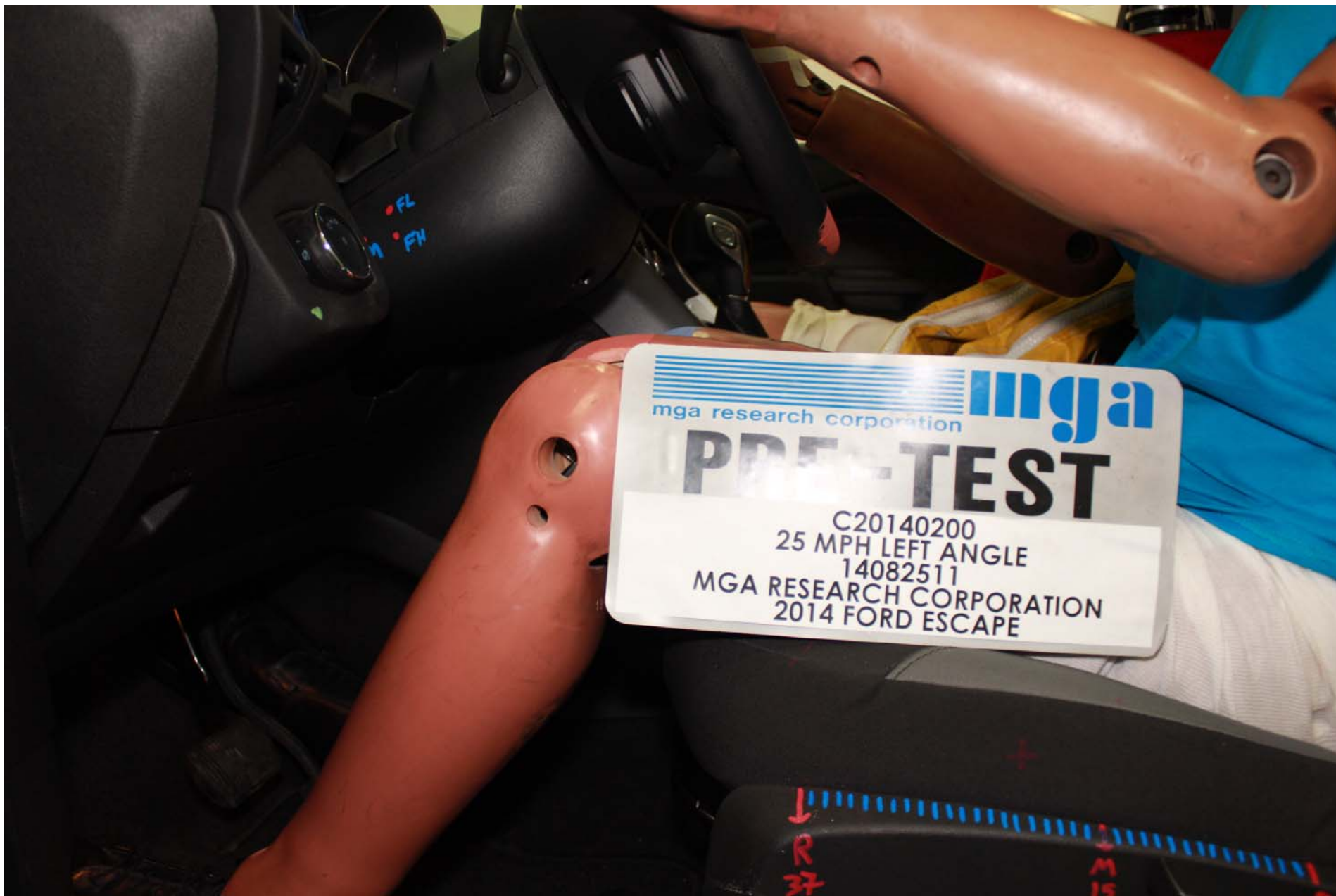

Photo No. 43 - Pre-Test Driver Side Knee Bolster View



Photo No. 44 - Post-Test Driver Side Knee Bolster View



Photo No. 45 - Post-Test Driver Dummy Airbag Contact



Photo No. 46 - Post-Test Driver Dummy Knee Contact (knee airbag)



Photo No. 47 - Post-Test Driver Dummy Head Contact (curtain airbag)



Photo No. 48 - Post-Test Driver Dummy Head Contact (A-pillar)



Photo No. 49 - Post-Test Driver Dummy Head Contact (windshield)



Photo No. 50 - Post-Test Driver Dummy Head Contact (headliner)



Photo No. 51 - Pre-Test Passenger Dummy Front View (head position)



Photo No. 52 - Post-Test Passenger Dummy Front View (head position)



Photo No. 53 - Pre-Test Passenger Dummy Position Right Side View



Photo No. 54 - Post-Test Passenger Dummy Position Right Side View



Photo No. 55 - Pre-Test Passenger Dummy Position Right Side View (door open)



Photo No. 56 - Post-Test Passenger Dummy Position Right Side View (door open)



Photo No. 57 - Pre-Test Passenger Dummy Seat Position



Photo No. 58 - Post-Test Passenger Dummy Seat Position



Photo No. 59 - Pre-Test Passenger Dummy Feet Position



Photo No. 60 - Post-Test Passenger Dummy Feet Position



Photo No. 61 - Pre-Test Passenger Side Knee Bolster View



Photo No. 62 - Post-Test Passenger Side Knee Bolster View



Photo No. 63 - Post-Test Passenger Dummy Airbag Contact



Photo No. 64 - Post-Test Passenger Dummy Knee Contact (glovebox)



Photo No. 65 - Post-Test Passenger Dummy Head Contact (shifter)



C20140200
25 MPH LEFT ANGLE
14082511
MGA RESEARCH CORPORATION
2014 FORD ESCAPE

Photo No. 66 - Rollover 90 Degrees



Photo No. 67 - Rollover 180 Degrees

C-68

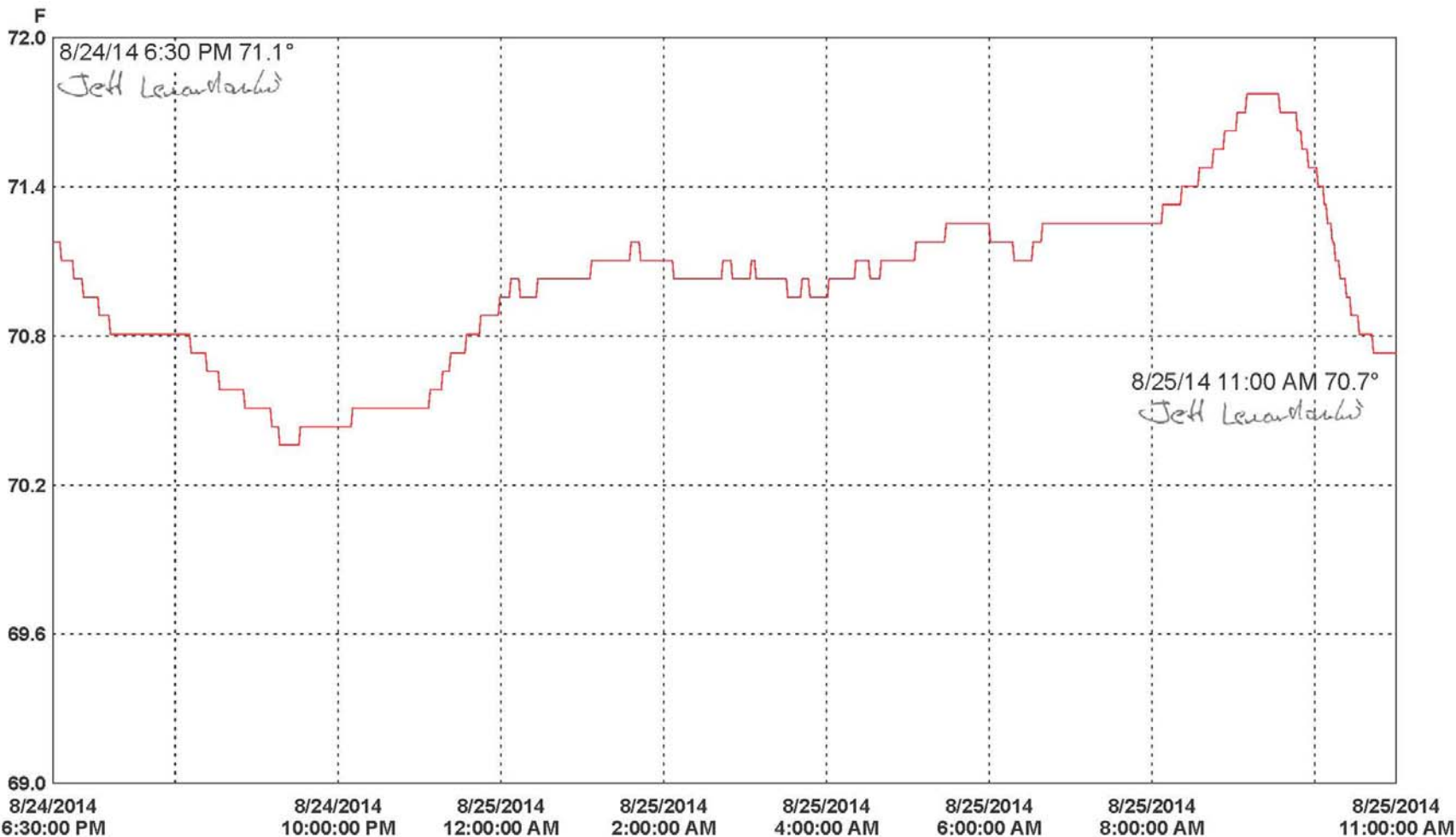

Photo No. 68 - Rollover 270 Degrees



Photo No. 69 - Rollover 360 Degrees

C-70



2 hours/div 16:30:00 (M/d/yyyy h:mm:ss tt) Central Time Graph file (truncated): 2014 Ford Escape 208 8-25-14.spg

LN	Serial #	Description	CH	Value	Maximum	Average	Minimum	Units	CH description	Logger file
1	10102162	MGATemp_10102162	1	71.77	71.01	70.36	F	Temperature	10102162_MGATemp_10102162.spl	

LN	Logger file	ID #	Security	Created by	Creation time
1	C:\Program Files (x86)\Veriteq Instruments\vlLog 4.4\Prep 2014\10102162_MGATemp_10102162.spl				

LN	Serial #	Last calibrated by	Last calibration	Next calibration
1	10102162			

APPENDIX D

LOW RISK PHOTOGRAPHS

TABLE OF PHOTOGRAPHS

		<u>Page No.</u>
Photo No. 1.	Pre-Test 5 th Fem. P1 Driver Dummy Left Side View	D-1
Photo No. 2.	Post-Test 5 th Fem. P1 Driver Dummy Left Side View	D-2
Photo No. 3.	Pre-Test 5 th Fem. P1 Driver Dummy Right Side View	D-3
Photo No. 4.	Post-Test 5 th Fem. P1 Driver Dummy Right Side View	D-4
Photo No. 5.	Post-Test 5 th Fem. P1 Driver Dummy Airbag Left Side View	D-5
Photo No. 6.	Post-Test 5 th Fem. P1 Driver Dummy Airbag Right Side View	D-6
Photo No. 7.	Post-Test 5 th Fem. P1 Driver Dummy Head Contact (headrest/seat back)	D-7
Photo No. 8.	Pre-Test 5 th Fem. P2 Driver Dummy Left Side View	D-8
Photo No. 9.	Post-Test 5 th Fem. P2 Driver Dummy Left Side View	D-9
Photo No. 10.	Pre-Test 5 th Fem. P2 Driver Dummy Right Side View	D-10
Photo No. 11.	Post-Test 5 th Fem. P2 Driver Dummy Right Side View	D-11
Photo No. 12.	Post-Test 5 th Fem. P2 Driver Dummy Airbag Left Side View	D-12
Photo No. 13.	Post-Test 5 th Fem. P2 Driver Dummy Airbag Right Side View	D-13
Photo No. 14.	Post-Test 5 th Fem. P2 Driver Dummy Head Contact (headrest)	D-14
Photo No. 15.	Post-Test 5 th Fem. P2 Driver Dummy Head Contact (headliner/visor)	D-15



Photo No. 1 - Pre-Test 5th Fem. P1 Driver Dummy Left Side View



Photo No. 2 - Post-Test 5th Fem. P1 Driver Dummy Left Side View



Photo No. 3 - Pre-Test 5th Fem. P1 Driver Dummy Right Side View



Photo No. 4 - Post-Test 5th Fem. P1 Driver Dummy Right Side View



Photo No. 5 - Post-Test 5th Fem. P1 Driver Dummy Airbag Left Side View



Photo No. 6 - Post-Test 5th Fem. P1 Driver Dummy Airbag Right Side View



Photo No. 7 - Post-Test 5th Fem. P1 Driver Dummy Head Contact (headrest-seat back)



Photo No. 8 - Pre-Test 5th Fem. P2 Driver Dummy Left Side View



Photo No. 9 - Post-Test 5th Fem. P2 Driver Dummy Left Side View



Photo No. 10 - Pre-Test 5th Fem. P2 Driver Dummy Right Side View



Photo No. 11 - Post-Test 5th Fem. P2 Driver Dummy Right Side View



Photo No. 12 - Post-Test 5th Fem. P2 Driver Dummy Airbag Left Side View



Photo No. 13 - Post-Test 5th Fem. P2 Driver Dummy Airbag Right Side View



Photo No. 14 - Post-Test 5th Fem. P2 Driver Dummy Head Contact (headrest)



Photo No. 15 - Post-Test 5th Fem. P2 Driver Dummy Head Contact (headliner-visor)

APPENDIX E
SUPPRESSION PHOTOGRAPHS

TABLE OF PHOTOGRAPHS

		<u>Page #</u>
Photo No. 1.	Angel Guard Angel Ride Car Bed Belted, Forward Seat Track	E-1
Photo No. 2.	Angel Guard Angel Ride Car Bed Belted, Middle Seat Track	E-1
Photo No. 3.	Angel Guard Angel Ride Car Bed Belted, Rearward Seat Track	E-1
Photo No. 4.	Unbelted 5 th Percentile Female Dummy Reactivation, Forward Seat Track	E-1
Photo No. 5.	Cosco Arriva W/Base, Belted, Rear Facing, Forward Seat Track	E-2
Photo No. 6.	Cosco Arriva W/Base, Belted, Rear Facing, Middle Seat Track	E-2
Photo No. 7.	Cosco Arriva W/Base, Belted, Rear Facing, Rearward Seat Track	E-2
Photo No. 8.	Cosco Arriva W/Base, Unbelted, Rear Facing, Forward Seat Track	E-2
Photo No. 9.	Cosco Arriva W/Base, Unbelted, Rear Facing, Middle Seat Track	E-3
Photo No. 10.	Cosco Arriva W/Base, Unbelted, Rear Facing, Rearward Seat Track	E-3
Photo No. 11.	Cosco Arriva W/Base, Unbelted, Forward Facing, Forward Seat Track	E-3
Photo No. 12.	Cosco Arriva W/Base, Unbelted, Forward Facing, Middle Seat Track	E-3
Photo No. 13.	Cosco Arriva W/Base, Unbelted, Forward Facing, Rearward Seat Track	E-4
Photo No. 14.	Cosco Arriva W/Out Base, Belted, Rear Facing, Forward Seat Track	E-4
Photo No. 15.	Cosco Arriva W/Out Base, Belted, Rear Facing, Middle Seat Track	E-4
Photo No. 16.	Cosco Arriva W/Out Base, Belted, Rear Facing, Rearward Seat Track	E-4
Photo No. 17.	Cosco Arriva W/Out Base, Unbelted, Rear Facing, Forward Seat Track	E-5
Photo No. 18.	Cosco Arriva W/Out Base, Unbelted, Rear Facing, Middle Seat Track	E-5
Photo No. 19.	Cosco Arriva W/Out Base, Unbelted, Rear Facing, Rearward Seat Track	E-5
Photo No. 20.	Cosco Arriva W/Out Base, Unbelted, Forward Facing, Forward Seat Track	E-5
Photo No. 21.	Cosco Arriva W/Out Base, Unbelted, Forward Facing, Middle Seat Track	E-6
Photo No. 22.	Cosco Arriva W/Out Base, Unbelted, Forward Facing, Rearward Seat Track	E-6
Photo No. 23.	Unbelted 5 th Percentile Female Dummy Reactivation, Rearward Seat Track	E-6
Photo No. 24.	Graco Snugride W/Base, Belted, Rear Facing, Forward Seat Track	E-7
Photo No. 25.	Graco Snugride W/Base, Belted, Rear Facing, Middle Seat Track	E-7
Photo No. 26.	Graco Snugride W/Base, Belted, Rear Facing, Rearward Seat Track	E-7
Photo No. 27.	Graco Snugride W/Base, Unbelted, Rear Facing, Middle Seat Track	E-7
Photo No. 28.	Graco Snugride W/Base, Unbelted, Rear Facing, Rearward Seat Track	E-8
Photo No. 29.	Graco Snugride W/Base, Unbelted, Forward Facing, Forward Seat Track	E-8
Photo No. 30.	Graco Snugride W/Base, Unbelted, Forward Facing, Middle Seat Track	E-8
Photo No. 31.	Graco Snugride W/Base, Unbelted, Forward Facing, Rearward Seat Track	E-8
Photo No. 32.	Graco Snugride W/Out Base, Belted, Rear Facing, Forward Seat Track	E-9

	<u>Page #</u>	
Photo No. 33.	Graco Snugride W/Out Base, Belted, Rear Facing, Middle Seat Track	E-9
Photo No. 34.	Graco Snugride W/Out Base, Belted, Rear Facing, Rearward Seat Track	E-9
Photo No. 35.	Graco Snugride W/Out Base, Unbelted, Rear Facing, Forward Seat Track	E-9
Photo No. 36.	Graco Snugride W/Out Base, Unbelted, Rear Facing, Middle Seat Track	E-10
Photo No. 37.	Graco Snugride W/Out Base, Unbelted, Rear Facing, Rearward Seat Track	E-10
Photo No. 38.	Graco Snugride W/Out Base, Unbelted, Forward Facing, Forward Seat Track	E-10
Photo No. 39.	Graco Snugride W/Out Base, Unbelted, Forward Facing, Middle Seat Track	E-10
Photo No. 40.	Graco Snugride W/Out Base, Unbelted, Forward Facing, Rearward Seat Track	E-11
Photo No. 41.	Unbelted 5 th Percentile Female Dummy Reactivation, Middle Seat Track	E-11
Photo No. 42.	Peg Perego Viaggio W/Base, Belted, Rear Facing, Forward Seat Track	E-12
Photo No. 43.	Peg Perego Viaggio W/Base, Belted, Rear Facing, Middle Seat Track	E-12
Photo No. 44.	Peg Perego Viaggio W/Base, Belted, Rear Facing, Rearward Seat Track	E-12
Photo No. 45.	Peg Perego Viaggio W/Base, Unbelted, Rear Facing, Forward Seat Track	E-12
Photo No. 46.	Peg Perego Viaggio W/Base, Unbelted, Rear Facing, Middle Seat Track	E-13
Photo No. 47.	Peg Perego Viaggio W/Base, Unbelted, Rear Facing, Rearward Seat Track	E-13
Photo No. 48.	Peg Perego Viaggio W/Base, Unbelted, Forward Facing, Forward Seat Track	E-13
Photo No. 49.	Peg Perego Viaggio W/Base, Unbelted, Forward Facing, Middle Seat Track	E-13
Photo No. 50.	Peg Perego Viaggio W/Base, Unbelted, Forward Facing, Rearward Seat Track	E-14
Photo No. 51.	Peg Perego Viaggio W/Out Base, Belted, Rear Facing, Forward Seat Track	E-14
Photo No. 52.	Peg Perego Viaggio W/Out Base, Belted, Rear Facing, Middle Seat Track	E-14
Photo No. 53.	Peg Perego Viaggio W/Out Base, Belted, Rear Facing, Rearward Seat Track	E-14
Photo No. 54.	Peg Perego Viaggio W/Out Base, Unbelted, Rear Facing, Forward Seat Track	E-15
Photo No. 55.	Peg Perego Viaggio W/Out Base, Unbelted, Rear Facing, Middle Seat Track	E-15
Photo No. 56.	Peg Perego Viaggio W/Out Base, Unbelted, Rear Facing, Rearward Seat Track	E-15
Photo No. 57.	Peg Perego Viaggio W/Out Base, Unbelted, Forward Facing, Forward Seat Track	E-15
Photo No. 58.	Peg Perego Viaggio W/Out Base, Unbelted, Forward Facing, Middle Seat Track	E-16
Photo No. 59.	Peg Perego Viaggio W/Out Base, Unbelted, Forward Facing, Rearward Seat Track	E-16
Photo No. 60.	Unbelted 5 th Percentile Female Dummy Reactivation, Forward Seat Track	E-16
Photo No. 61.	Britax Roundabout Forward Facing Belted, Forward Seat Track	E-17
Photo No. 62.	Britax Roundabout Forward Facing Belted, Middle Seat Track	E-17
Photo No. 63.	Britax Roundabout Forward Facing Belted, Rearward Seat Track	E-17
Photo No. 64.	Britax Roundabout Forward Facing Unbelted, Forward Seat Track	E-17
Photo No. 65.	Britax Roundabout Forward Facing Unbelted, Middle Seat Track	E-18
Photo No. 66.	Britax Roundabout Forward Facing Unbelted, Rearward Seat Track	E-18
Photo No. 67.	Britax Roundabout Rear Facing Belted, Forward Seat Track	E-18
Photo No. 68.	Britax Roundabout Rear Facing Belted, Middle Seat Track	E-18

	<u>Page #</u>	
Photo No. 69.	Britax Roundabout Rear Facing Belted, Rearward Seat Track	E-19
Photo No. 70.	Britax Roundabout Rear Facing Unbelted, Forward Seat Track	E-19
Photo No. 71.	Britax Roundabout Rear Facing Unbelted, Middle Seat Track	E-19
Photo No. 72.	Britax Roundabout Rear Facing Unbelted, Rearward Seat Track	E-19
Photo No. 73.	Unbelted 5 th Percentile Female Dummy Reactivation, Forward Seat Track	E-20
Photo No. 74.	Cosco High Back Booster Forward Facing Belted, Forward Seat Track	E-21
Photo No. 75.	Cosco High Back Booster Forward Facing Belted, Middle Seat Track	E-21
Photo No. 76.	Cosco High Back Booster Forward Facing Belted, Rearward Seat Track	E-21
Photo No. 77.	Cosco High Back Booster Forward Facing Unbelted, Forward Seat Track	E-21
Photo No. 78.	Cosco High Back Booster Forward Facing Unbelted, Middle Seat Track	E-22
Photo No. 79.	Cosco High Back Booster Forward Facing Unbelted, Rearward Seat Track	E-22
Photo No. 80.	Cosco High Back Booster Rear Facing Unbelted, Forward Seat Track	E-22
Photo No. 81.	Cosco High Back Booster Rear Facing Unbelted, Middle Seat Track	E-22
Photo No. 82.	Cosco High Back Booster Rear Facing Unbelted, Rearward Seat Track	E-23
Photo No. 83.	Unbelted 5 th Percentile Female Dummy Reactivation, Rearward Seat Track	E-23
Photo No. 84.	Evenflo Generations Forward Facing Belted, Forward Seat Track	E-24
Photo No. 85.	Evenflo Generations Forward Facing Belted, Middle Seat Track	E-24
Photo No. 86.	Evenflo Generations Forward Facing Belted, Rearward Seat Track	E-24
Photo No. 87.	Evenflo Generations Forward Facing Unbelted, Forward Seat Track	E-24
Photo No. 88.	Evenflo Generations Forward Facing Unbelted, Middle Seat Track	E-25
Photo No. 89.	Evenflo Generations Forward Facing Unbelted, Rearward Seat Track	E-25
Photo No. 90.	Evenflo Generations Rear Facing Unbelted, Forward Seat Track	E-25
Photo No. 91.	Evenflo Generations Rear Facing Unbelted, Middle Seat Track	E-25
Photo No. 92.	Evenflo Generations Rear Facing Unbelted, Rearward Seat Track	E-26
Photo No. 93.	Unbelted 5 th Percentile Female Dummy Reactivation, Forward Seat Track	E-26
Photo No. 94.	Graco Comfortsport Forward Facing Belted, Forward Seat Track	E-27
Photo No. 95.	Graco Comfortsport Forward Facing Belted, Middle Seat Track	E-27
Photo No. 96.	Graco Comfortsport Forward Facing Belted, Rearward Seat Track	E-27
Photo No. 97.	Graco Comfortsport Forward Facing Unbelted, Forward Seat Track	E-27
Photo No. 98.	Graco Comfortsport Forward Facing Unbelted, Middle Seat Track	E-28
Photo No. 99.	Graco Comfortsport Forward Facing Unbelted, Rearward Seat Track	E-28
Photo No. 100.	Graco Comfortsport Rear Facing Belted, Forward Seat Track	E-28
Photo No. 101.	Graco Comfortsport Rear Facing Belted, Middle Seat Track	E-28
Photo No. 102.	Graco Comfortsport Rear Facing Belted, Rearward Seat Track	E-29
Photo No. 103.	Graco Comfortsport Rear Facing Unbelted, Forward Seat Track	E-29
Photo No. 104.	Graco Comfortsport Rear Facing Unbelted, Middle Seat Track	E-29

	<u>Page #</u>
Photo No. 105. Graco Comfortsport Rear Facing Unbelted, Rearward Seat Track	E-29
Photo No. 106. Unbelted 5 th Percentile Female Dummy Reactivation, Middle Seat Track	E-30
Photo No. 107. 3-Year-Old Forward Facing Britax Roundabout Cinched With Harness, Forward Seat Track	E-31
Photo No. 108. 3-Year-Old Forward Facing Britax Roundabout Cinched With Harness, Middle Seat Track	E-31
Photo No. 109. 3-Year-Old Forward Facing Britax Roundabout Cinched With Harness, Rearward Seat Track	E-31
Photo No. 110. Unbelted 5 th Percentile Female Dummy Reactivation, Rearward Seat Track	E-31
Photo No. 111. 3-Year-Old Forward Facing Cosco High Back Booster Belted, Forward Seat Track	E-32
Photo No. 112. 3-Year-Old Forward Facing Cosco High Back Booster Belted, Middle Seat Track	E-32
Photo No. 113. 3-Year-Old Forward Facing Cosco High Back Booster Belted, Rearward Seat Track	E-32
Photo No. 114. 3-Year-Old Forward Facing Cosco High Back Booster Cinched With Harness, Forward Seat Track	E-32
Photo No. 115. 3-Year-Old Forward Facing Cosco High Back Booster Cinched With Harness, Middle Seat Track	E-33
Photo No. 116. 3-Year-Old Forward Facing Cosco High Back Booster Cinched With Harness, Rearward Seat Track	E-33
Photo No. 117. Unbelted 5 th Percentile Female Dummy Reactivation, Middle Seat Track	E-33
Photo No. 118. 3-Year-Old Forward Facing Evenflo Generations Belted, Forward Seat Track	E-34
Photo No. 119. 3-Year-Old Forward Facing Evenflo Generations Belted, Middle Seat Track	E-34
Photo No. 120. 3-Year-Old Forward Facing Evenflo Generations Belted, Rearward Seat Track	E-34
Photo No. 121. 3-Year-Old Forward Facing Evenflo Generations Cinched With Harness, Forward Seat Track	E-34
Photo No. 122. 3-Year-Old Forward Facing Evenflo Generations Cinched With Harness, Middle Seat Track	E-35
Photo No. 123. 3-Year-Old Forward Facing Evenflo Generations Cinched With Harness, Rearward Seat Track	E-35
Photo No. 124. Unbelted 5 th Percentile Female Dummy Reactivation, Rearward Seat Track	E-35
Photo No. 125. 3-Year-Old Forward Facing Graco Comfortsport Cinched With Harness, Forward Seat Track	E-36
Photo No. 126. 3-Year-Old Forward Facing Graco Comfortsport Cinched With Harness, Middle Seat Track	E-36
Photo No. 127. 3-Year-Old Forward Facing Graco Comfortsport Cinched With Harness, Rearward Seat Track	E-36
Photo No. 128. Unbelted 5 th Percentile Female Dummy Reactivation, Middle Seat Track	E-36
Photo No. 129. 3-Year-Old Cosco Summit Deluxe Belted, Forward Seat Track	E-37
Photo No. 130. 3-Year-Old Cosco Summit Deluxe Belted, Middle Seat Track	E-37
Photo No. 131. 3-Year-Old Cosco Summit Deluxe Belted, Rearward Seat Track	E-37
Photo No. 132. 3-Year-Old Cosco Summit Deluxe Cinched With Harness, Forward Seat Track	E-37
Photo No. 133. 3-Year-Old Cosco Summit Deluxe Cinched With Harness, Middle Seat Track	E-38
Photo No. 134. 3-Year-Old Cosco Summit Deluxe Cinched With Harness, Rearward Seat Track	E-38
Photo No. 135. Unbelted 5 th Percentile Female Dummy Reactivation, Rearward Seat Track	E-38
Photo No. 136. 3-Year-Old Graco Platinum Cargo Belted, Forward Seat Track	E-39
Photo No. 137. 3-Year-Old Graco Platinum Cargo Belted, Middle Seat Track	E-39
Photo No. 138. 3-Year-Old Graco Platinum Cargo Belted, Rearward Seat Track	E-39
Photo No. 139. 3-Year-Old Graco Platinum Cargo Cinched With Harness, Forward Seat Track	E-39
Photo No. 140. 3-Year-Old Graco Platinum Cargo Cinched With Harness, Middle Seat Track	E-40

	<u>Page #</u>
Photo No. 141. 3-Year-Old Graco Platinum Cargo Cinched With Harness, Rearward Seat Track	E-40
Photo No. 142. Unbelted 5 th Percentile Female Dummy Reactivation, Middle Seat Track	E-40
Photo No. 143. 6-Year-Old Cosco Summit Deluxe Belted, Forward Seat Track	E-41
Photo No. 144. 6-Year-Old Cosco Summit Deluxe Belted, Middle Seat Track	E-41
Photo No. 145. 6-Year-Old Cosco Summit Deluxe Belted, Rearward Seat Track	E-41
Photo No. 146. Unbelted 5 th Percentile Female Dummy Reactivation, Forward Seat Track	E-41
Photo No. 147. 6-Year-Old Graco Platinum Cargo Belted, Forward Seat Track	E-42
Photo No. 148. 6-Year-Old Graco Platinum Cargo Belted, Middle Seat Track	E-42
Photo No. 149. 6-Year-Old Graco Platinum Cargo Belted, Rearward Seat Track	E-42
Photo No. 150. Unbelted 5 th Percentile Female Dummy Reactivation, Middle Seat Track	E-42
Photo No. 151. 3-Year-Old Unbelted, Forward Seat Track, Position 1	E-43
Photo No. 152. 3-Year-Old Unbelted, Forward Seat Track, Position 2	E-43
Photo No. 153. 3-Year-Old Unbelted, Forward Seat Track, Position 3	E-43
Photo No. 154. 3-Year-Old Unbelted, Forward Seat Track, Position 4	E-43
Photo No. 155. 3-Year-Old Unbelted, Forward Seat Track, Position 5	E-44
Photo No. 156. 3-Year-Old Unbelted, Forward Seat Track, Position 6	E-44
Photo No. 157. 3-Year-Old Unbelted, Forward Seat Track, Position 7	E-44
Photo No. 158. 3-Year-Old Unbelted, Middle Seat Track, Position 1	E-44
Photo No. 159. 3-Year-Old Unbelted, Middle Seat Track, Position 2	E-45
Photo No. 160. 3-Year-Old Unbelted, Middle Seat Track, Position 3	E-45
Photo No. 161. 3-Year-Old Unbelted, Middle Seat Track, Position 4	E-45
Photo No. 162. 3-Year-Old Unbelted, Middle Seat Track, Position 5	E-45
Photo No. 163. 3-Year-Old Unbelted, Middle Seat Track, Position 6	E-46
Photo No. 164. 3-Year-Old Unbelted, Middle Seat Track, Position 7	E-46
Photo No. 165. 3-Year-Old Unbelted, Rearward Seat Track, Position 1	E-46
Photo No. 166. 3-Year-Old Unbelted, Rearward Seat Track, Position 2	E-46
Photo No. 167. 3-Year-Old Unbelted, Rearward Seat Track, Position 3	E-47
Photo No. 168. 3-Year-Old Unbelted, Rearward Seat Track, Position 4	E-47
Photo No. 169. 3-Year-Old Unbelted, Rearward Seat Track, Position 5	E-47
Photo No. 170. 3-Year-Old Unbelted, Rearward Seat Track, Position 6	E-47
Photo No. 171. 3-Year-Old Unbelted, Rearward Seat Track, Position 7	E-48
Photo No. 172. Unbelted 5 th Percentile Female Dummy Reactivation, Forward Seat Track	E-48
Photo No. 173. 6-Year-Old Unbelted, Forward Seat Track, Position 1	E-49
Photo No. 174. 6-Year-Old Unbelted, Forward Seat Track, Position 2	E-49
Photo No. 175. 6-Year-Old Unbelted, Forward Seat Track, Position 3	E-49
Photo No. 176. 6-Year-Old Unbelted, Forward Seat Track, Position 4	E-49

		<u>Page #</u>
Photo No. 177.	6-Year-Old Unbelted, Middle Seat Track, Position 1	E-50
Photo No. 178.	6-Year-Old Unbelted, Middle Seat Track, Position 2	E-50
Photo No. 179.	6-Year-Old Unbelted, Middle Seat Track, Position 3	E-50
Photo No. 180.	6-Year-Old Unbelted, Middle Seat Track, Position 4	E-50
Photo No. 181.	6-Year-Old Unbelted, Rearward Seat Track, Position 1	E-51
Photo No. 182.	6-Year-Old Unbelted, Rearward Seat Track, Position 2	E-51
Photo No. 183.	6-Year-Old Unbelted, Rearward Seat Track, Position 3	E-51
Photo No. 184.	6-Year-Old Unbelted, Rearward Seat Track, Position 4	E-51
Photo No. 185.	Unbelted 5 th Percentile Female Dummy Reactivation, Rearward Seat Track	E-52



Angel Guard Angel Ride Car Bed Belted, Forward Seat Track



Angel Guard Angel Ride Car Bed Belted, Middle Seat Track



Angel Guard Angel Ride Car Bed Belted, Rearward Seat Track



Unbelted 5th Percentile Female Dummy Reactivation, Forward Seat Track



Cosco Arriva WBBase, Belted, Rear Facing, Forward Seat Track



Cosco Arriva WBBase, Belted, Rear Facing, Middle Seat Track



Cosco Arriva WBBase, Belted, Rear Facing, Rearward Seat Track



Cosco Arriva WBBase, Unbelted, Rear Facing, Forward Seat Track



Cosco Arriva WBBase, Unbelted, Rear Facing, Middle Seat Track



Cosco Arriva WBBase, Unbelted, Rear Facing, Rearward Seat Track



Cosco Arriva WBBase, Unbelted, Forward Facing, Forward Seat Track



Cosco Arriva WBBase, Unbelted, Forward Facing, Middle Seat Track



Cosco Arriva WBase, Unbelted, Forward Facing, Rearward Seat Track



Cosco Arriva WOut Base, Belted, Rear Facing, Forward Seat Track



Cosco Arriva WOut Base, Belted, Rear Facing, Middle Seat Track



Cosco Arriva WOut Base, Belted, Rear Facing, Rearward Seat Track



Cosco Arriva WOut Base, Unbelted, Rear Facing, Forward Seat Track



Cosco Arriva WOut Base, Unbelted, Rear Facing, Middle Seat Track



Cosco Arriva WOut Base, Unbelted, Rear Facing, Rearward Seat Track



Cosco Arriva WOut Base, Unbelted, Forward Facing, Forward Seat Track



Cosco Arriva W/Out Base, Unbelted, Forward Facing, Middle Seat Track



Cosco Arriva W/Out Base, Unbelted, Forward Facing, Rearward Seat Track



Unbelted 5th Percentile Female Dummy Reactivation, Rearward Seat Track



Graco Snugride WBase, Belted, Rear Facing, Forward Seat Track



Graco Snugride WBase, Belted, Rear Facing, Middle Seat Track



Graco Snugride WBase, Belted, Rear Facing, Rearward Seat Track



Graco Snugride WBase, Unbelted, Rear Facing, Middle Seat Track



Graco Snugride WBase, Unbelted, Rear Facing, Rearward Seat Track



Graco Snugride WBase, Unbelted, Forward Facing, Forward Seat Track



Graco Snugride WBase, Unbelted, Forward Facing, Middle Seat Track



Graco Snugride WBase, Unbelted, Forward Facing, Rearward Seat Track



Graco Snugride WOut Base, Belted, Rear Facing, Forward Seat Track



Graco Snugride WOut Base, Belted, Rear Facing, Middle Seat Track



Graco Snugride WOut Base, Belted, Rear Facing, Rearward Seat Track



Graco Snugride WOut Base, Unbelted, Rear Facing, Forward Seat Track



Graco Snuggly W/Out Base, Unbelted, Rear Facing, Middle Seat Track



Graco Snuggly W/Out Base, Unbelted, Rear Facing, Rearward Seat Track



Graco Snuggly W/Out Base, Unbelted, Forward Facing, Forward Seat Track



Graco Snuggly W/Out Base, Unbelted, Forward Facing, Middle Seat Track



Graco Snugride WOut Base, Unbelted, Forward Facing, Rearward Seat Track



Unbelted 5th Percentile Female Dummy Reactivation, Middle Seat Track



Peg Perego Viaggio WBase, Belted, Rear Facing, Forward Seat Track



Peg Perego Viaggio WBase, Belted, Rear Facing, Middle Seat Track



Peg Perego Viaggio WBase, Belted, Rear Facing, Rearward Seat Track



Peg Perego Viaggio WBase, Unbelted, Rear Facing, Forward Seat Track



Peg Perego Viaggio WBBase, Unbelted, Rear Facing, Middle Seat Track



Peg Perego Viaggio WBBase, Unbelted, Rear Facing, Rearward Seat Track



Peg Perego Viaggio WBBase, Unbelted, Forward Facing, Forward Seat Track



Peg Perego Viaggio WBBase, Unbelted, Forward Facing, Middle Seat Track



Peg Perego Viaggio WBase, Unbelted, Forward Facing, Rearward Seat Track



Peg Perego Viaggio WOut Base, Belted, Rear Facing, Forward Seat Track



Peg Perego Viaggio WOut Base, Belted, Rear Facing, Middle Seat Track



Peg Perego Viaggio WOut Base, Belted, Rear Facing, Rearward Seat Track



Peg Perego Viaggio WOut Base, Unbelted, Rear Facing, Forward Seat Track



Peg Perego Viaggio WOut Base, Unbelted, Rear Facing, Middle Seat Track



Peg Perego Viaggio WOut Base, Unbelted, Rear Facing, Rearward Seat Track



Peg Perego Viaggio WOut Base, Unbelted, Forward Facing, Forward Seat Track



Peg Perego Viaggio WOut Base, Unbelted, Forward Facing, Middle Seat Track



Peg Perego Viaggio WOut Base, Unbelted, Forward Facing, Rearward Seat Track



Unbelted 5th Percentile Female Dummy Reactivation, Forward Seat Track



Britax Roundabout Forward Facing, Belted, Forward Seat Track



Britax Roundabout Forward Facing, Belted, Middle Seat Track



Britax Roundabout Forward Facing, Belted, Rearward Seat Track



Britax Roundabout Forward Facing, Unbelted, Forward Seat Track



Britax Roundabout Forward Facing, Unbelted, Middle Seat Track



Britax Roundabout Forward Facing, Unbelted, Rearward Seat Track



Britax Roundabout Rear Facing, Belted, Forward Seat Track

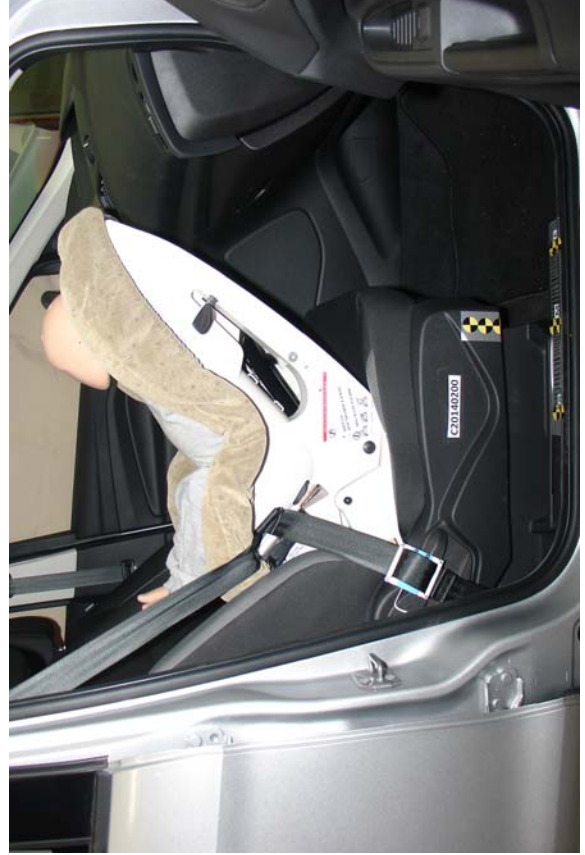

Britax Roundabout Rear Facing, Belted, Middle Seat Track



Britax Roundabout Rear Facing, Belted, Rearward Seat Track



Britax Roundabout Rear Facing, Unbelted, Forward Seat Track



Britax Roundabout Rear Facing, Unbelted, Middle Seat Track



Britax Roundabout Rear Facing, Unbelted, Rearward Seat Track



Unbelted 5th Percentile Female Dummy Reactivation, Forward Seat Track



Cosco High Back Booster Forward Facing, Belted, Forward Seat Track



Cosco High Back Booster Forward Facing, Belted, Middle Seat Track



Cosco High Back Booster Forward Facing, Belted, Rearward Seat Track



Cosco High Back Booster Forward Facing, Unbelted, Forward Seat Track



Cosco High Back Booster Forward Facing, Unbelted, Middle Seat Track



Cosco High Back Booster Forward Facing, Unbelted, Rearward Seat Track



Cosco High Back Booster Rear Facing, Unbelted, Forward Seat Track



Cosco High Back Booster Rear Facing, Unbelted, Middle Seat Track



Cosco High Back Booster Rear Facing, Unbelted, Rearward Seat Track



Unbelted 5th Percentile Female Dummy Reactivation, Middle Seat Track



Evenflo Generations Forward Facing, Belted, Forward Seat Track



Evenflo Generations Forward Facing, Belted, Middle Seat Track



Evenflo Generations Forward Facing, Belted, Rearward Seat Track



Evenflo Generations Forward Facing, Unbelted, Forward Seat Track



Eventflo Generations Forward Facing, Unbelted, Middle Seat Track



Eventflo Generations Forward Facing, Unbelted, Rearward Seat Track



Eventflo Generations Rear Facing, Unbelted, Forward Seat Track



Eventflo Generations Rear Facing, Unbelted, Middle Seat Track



Evenflo Generations Rear Facing, Unbelted, Rearward Seat Track



Unbelted 5th Percentile Female Dummy Reactivation, Rearward Seat Track



Graco ComfortSport Forward Facing, Belted, Forward Seat Track



Graco ComfortSport Forward Facing, Belted, Middle Seat Track



Graco ComfortSport Forward Facing, Belted, Rearward Seat Track



Graco ComfortSport Forward Facing, Unbelted, Forward Seat Track



Graco ComfortSport Forward Facing, Unbelted, Middle Seat Track



Graco ComfortSport Forward Facing, Unbelted, Rearward Seat Track



Graco ComfortSport Rear Facing, Belted, Forward Seat Track



Graco ComfortSport Rear Facing, Belted, Middle Seat Track



Graco ComfortSport Rear Facing, Belted, Rearward Seat Track



Graco ComfortSport Rear Facing, Unbelted, Forward Seat Track



Graco ComfortSport Rear Facing, Unbelted, Middle Seat Track



Graco ComfortSport Rear Facing, Unbelted, Rearward Seat Track



Unbelted 5th Percentile Female Dummy Reactivation, Forward Seat Track



3-Year-Old Forward Facing Britax Roundabout Cinched With Harness, Forward Seat Track



3-Year-Old Forward Facing Britax Roundabout Cinched With Harness, Middle Seat Track



3-Year-Old Forward Facing Britax Roundabout Cinched With Harness, Rearward Seat



Unbelted 5th Percentile Female Dummy Reactivation, Forward Seat Track



3-Year-Old Forward Facing Cosco High Back Belted, Forward Seat Track



3-Year-Old Forward Facing Cosco High Back Belted, Middle Seat Track



3-Year-Old Forward Facing Cosco High Back Belted, Rearward Seat Track



3-Year-Old Forward Facing Cosco High Back Cinched With Harness, Forward Seat Track



3-Year-Old Forward Facing Cosco High Back Cinched With Harness, Middle Seat Track



3-Year-Old Forward Facing Cosco High Back Cinched With Harness, Rearward Seat



Unbelted 5th Percentile Female Dummy Reactivation, Middle Seat Track



3-Year-Old Forward Facing Evenflo Generations Belted, Forward Seat Track



3-Year-Old Forward Facing Evenflo Generations Belted, Middle Seat Track



3-Year-Old Forward Facing Evenflo Generations Belted, Rearward Seat Track



3-Year-Old Forward Facing Evenflo Generations Cinched With Harness, Forward Seat



3-Year-Old Forward Facing Evenflo Generations Cinched With Harness, Middle Seat



3-Year-Old Forward Facing Evenflo Generations Cinched With Harness, Rearward Seat



Unbelted 5th Percentile Female Dummy Reactivation, Rearward Seat Track



3-Year-Old Forward Facing Graco ComfortSport Cinched With Harness, Forward Seat



3-Year-Old Forward Facing Graco ComfortSport Cinched With Harness, Middle Seat Track



3-Year-Old Forward Facing Graco ComfortSport Cinched With Harness, Rearward Seat



Unbelted 5th Percentile Female Dummy Reactivation, Rearward Seat Track



3-Year-Old Cosco Summit Deluxe Belted, Forward Seat Track



3-Year-Old Cosco Summit Deluxe Belted, Middle Seat Track



3-Year-Old Cosco Summit Deluxe Belted, Rearward Seat Track



3-Year-Old Cosco Summit Deluxe Cinched With Harness, Forward Seat Track



3-Year-Old Cosco Summit Deluxe Cinched With Harness, Middle Seat Track



3-Year-Old Cosco Summit Deluxe Cinched With Harness, Rearward Seat Track



Unbelted 5th Percentile Female Dummy Reactivation, Middle Seat Track



3-Year-Old Graco Platinum Cargo Belted, Forward Seat Track



3-Year-Old Graco Platinum Cargo Belted, Middle Seat Track



3-Year-Old Graco Platinum Cargo Belted, Rearward Seat Track



3-Year-Old Graco Platinum Cargo Cinched With Harness, Forward Seat Track



3-Year-Old Graco Platinum Cargo Cinched With Harness, Middle Seat Track



3-Year-Old Graco Platinum Cargo Cinched With Harness, Rearward Seat Track



Unbelted 5th Percentile Female Dummy Reactivation, Rearward Seat Track



6-Year-Old Cosco Summit Deluxe Belted, Forward Seat Track



6-Year-Old Cosco Summit Deluxe Belted, Middle Seat Track



6-Year-Old Cosco Summit Deluxe Belted, Rearward Seat Track



Unbelted 5th Percentile Female Dummy Reactivation, Middle Seat Track



6-Year-Old Graco Platinum Cargo Belted, Forward Seat Track



6-Year-Old Graco Platinum Cargo Belted, Middle Seat Track



6-Year-Old Graco Platinum Cargo Belted, Rearward Seat Track



Unbelted 5th Percentile Female Dummy Reactivation, Rearward Seat Track

DOT/NHTSA 208 Suppression Test - 2014 Ford Escape (C20140200)
3 Year Old No CRS



3-Year-Old Unbelted, Forward Seat Track Position 1



3-Year-Old Unbelted, Forward Seat Track Position 2



3-Year-Old Unbelted, Forward Seat Track Position 3



3-Year-Old Unbelted, Forward Seat Track Position 4

DOT/NHTSA 208 Suppression Test - 2014 Ford Escape (C20140200)
3 Year Old No CRS



3-Year-Old Unbelted, Forward Seat Track Position 5



3-Year-Old Unbelted, Forward Seat Track Position 6



3-Year-Old Unbelted, Forward Seat Track Position 7



3-Year-Old Unbelted, Middle Seat Track Position 1

DOT/NHTSA 208 Suppression Test - 2014 Ford Escape (C20140200)
3 Year Old No CRS



3-Year-Old Unbelted, Middle Seat Track Position 2



3-Year-Old Unbelted, Middle Seat Track Position 3



3-Year-Old Unbelted, Middle Seat Track Position 4



3-Year-Old Unbelted, Middle Seat Track Position 5

DOT/NHTSA 208 Suppression Test - 2014 Ford Escape (C20140200)
3 Year Old No CRS



3-Year-Old Unbelted, Middle Seat Track Position 6



3-Year-Old Unbelted, Middle Seat Track Position 7



3-Year-Old Unbelted, Rearward Seat Track Position 1



3-Year-Old Unbelted, Rearward Seat Track Position 2

DOT/NHTSA 208 Suppression Test - 2014 Ford Escape (C20140200)
3 Year Old No CRS



3-Year-Old Unbelted, Rearward Seat Track Position 3



3-Year-Old Unbelted, Rearward Seat Track Position 4



3-Year-Old Unbelted, Rearward Seat Track Position 5



3-Year-Old Unbelted, Rearward Seat Track Position 6

DOT/NHTSA 208 Suppression Test - 2014 Ford Escape (C20140200)
3 Year Old No CRS



3-Year-Old Unbelted, Rearward Seat Track Position 7



Unbelted 5th Percentile Female Dummy Reactivation, Forward Seat Track

DOT/NHTSA 208 Suppression Test - 2014 Ford Escape (C20140200)
6 Year Old No CRS



6-Year-Old Unbelted, Forward Seat Track Position 1



6-Year-Old Unbelted, Forward Seat Track Position 2



6-Year-Old Unbelted, Forward Seat Track Position 3



6-Year-Old Unbelted, Forward Seat Track Position 4

DOT/NHTSA 208 Suppression Test - 2014 Ford Escape (C20140200)
6 Year Old No CRS



6-Year-Old Unbelted, Middle Seat Track Position 1



6-Year-Old Unbelted, Middle Seat Track Position 2



6-Year-Old Unbelted, Middle Seat Track Position 3



6-Year-Old Unbelted, Middle Seat Track Position 4

DOT/NHTSA 208 Suppression Test - 2014 Ford Escape (C20140200)
6 Year Old
No CRS



6-Year-Old Unbelted, Rearward Seat Track Position 1



6-Year-Old Unbelted, Rearward Seat Track Position 2



6-Year-Old Unbelted, Rearward Seat Track Position 3



6-Year-Old Unbelted, Rearward Seat Track Position 4

DOT/NHTSA 208 Suppression Test - 2014 Ford Escape (C20140200)
6 Year Old No CRS



Unbelted 5th Percentile Female Dummy Reactivation, Middle Seat Track

APPENDIX F

INSTRUMENTATION CALIBRATION

INSTRUMENTS FOR DRIVER DUMMY NO.: 401

	SERIAL NO.	MANUFACTURER	CALIBRATION DATE
Head X	AGH74	Endevco	04/10/14
Head Y	C10686	Endevco	04/10/14
Head Z	C13046	Endevco	04/10/14
Neck Load Cell	N1021	Denton	08/07/14
Chest X	AH5D9	Endevco	04/10/14
Chest Y	AH5L1	Endevco	04/10/14
Chest Z	AH5N9	Endevco	04/10/14
Chest Displacement	401	Servo	04/08/14
Left Femur Load Cell	F8807	Denton	04/14/14
Right Femur Load Cell	F8806	Denton	04/14/14

INSTRUMENTS FOR PASSENGER DUMMY NO.: 403

	SERIAL NO.	MANUFACTURER	CALIBRATION DATE
Head X	AGH70	Endevco	04/10/14
Head Y	AH5E5	Endevco	04/10/14
Head Z	C10591	Endevco	04/10/14
Neck Load Cell	N1865	Denton	08/04/14
Chest X	AGH55	Endevco	04/10/14
Chest Y	AGH79	Endevco	04/10/14
Chest Z	C12863	Endevco	04/10/14
Chest Displacement	403	Servo	04/08/14
Left Femur Load Cell	F8805	Denton	05/07/14
Right Femur Load Cell	F8804	Denton	05/07/14

INSTRUMENTS FOR LOW RISK 5TH FEMALE DUMMY NO.: 124 (P1 & P2)

	SERIAL NO.	MANUFACTURER	CALIBRATION DATE
Head X	P78702	Endevco	07/02/14
Head Y	P78777	Endevco	07/02/14
Head Z	P78781	Endevco	07/02/14
Neck Load Cell	N2320	Denton	05/30/14
Chest X	P79695	Endevco	07/02/14
Chest Y	P79696	Endevco	07/02/14
Chest Z	P79740	Endevco	07/02/14
Chest Displacement	124	Servo	07/08/14
Left Femur Load Cell	F1362	Denton	04/23/14
Right Femur Load Cell	F1361	Denton	04/23/14

VEHICLE INSTRUMENTS

	SERIAL NO.	MANUFACTURER	CALIBRATION DATE
Left Rear Seat Crossmember X	P74653	Endevco	07/16/14
Right Rear Seat Crossmember X	P67878	Endevco	07/28/14
Top of Engine X	P73894	Endevco	05/16/14
Bottom of Engine X	P75553	Endevco	07/28/14
Left Brake Caliper X	P74002	Endevco	03/14/14
Right Brake Caliper X	P74003	Endevco	03/14/14
Instrument Panel X	P67886	Endevco	07/28/14
Trunk Z	P72776	Endevco	05/30/14