

REPORT NUMBER: TR-P32096-08-NC

**RESEARCH AND DEVELOPMENT
80 KM/H 70% OVERLAP REAR IMPACT**

**FORD MOTOR CO.
2000 FORD CONTOUR 4-DOOR SEDAN**

NHTSA NUMBER: PY0200

**PREPARED BY:
KARCO ENGINEERING, LLC.
9270 HOLLY ROAD
ADELANTO, CA 92301**



**TEST DATE:
SEPTEMBER 10, 2012**

**REPORT DATE:
SEPTEMBER 19, 2012**

FINAL REPORT

**U.S. DEPARTMENT OF TRANSPORTATION
NATIONAL HIGHWAY TRAFFIC SAFETY ADMINISTRATION
NATIONAL CENTER FOR STATISTICS AND ANALYSIS
OFFICE OF REGULATORY ANALYSIS AND EVALUATION
1200 NEW JERSEY AVE, SE
ROOM W53-469
WASHINGTON, DC 20590**

This publication is distributed by the U.S. Department of Transportation, National Highway Traffic Safety Administration, in the interest of information exchange. The opinions, findings and conclusions expressed in this publication are those of the author(s) and not necessarily those of the Department of Transportation or the National Highway Traffic Safety Administration. The United States Government assumes no liability for its contents or use thereof. If trade or manufacturers' names or products are mentioned, it is only because they are considered essential to the object of the publication and should not be construed as an endorsement. The United States Government does not endorse products or manufacturers.

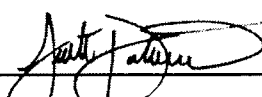
Prepared By: 
Ms. Sweta P. Dedania, Project Engineer
KARCO Engineering, LLC.

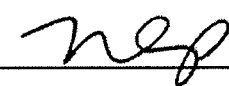
Reviewed By: 
Mr. Michael L. Dunlap, Director of Operations
KARCO Engineering, LLC.

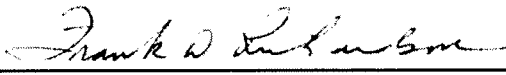
Approved By: 
Mr. Frank D. Richardson, Program Manager
KARCO Engineering, LLC.

Approval Date: September 19, 2012

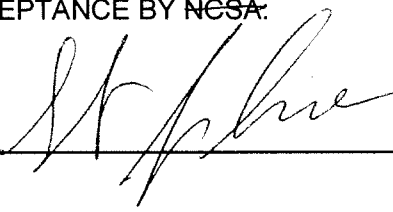
^{COTR}
FINAL REPORT ACCEPTANCE BY NCSA:

Date: 9/27/12

TECHNICAL REPORT DOCUMENTATION PAGE

1. Report No. TR-P32096-08-NC	2. Government Accession No.	3. Recipient's Catalog No.	
4. Title and Subtitle Final Report of FMVSS 301R Overlap Rear Impact Testing of 2000 Ford Contour 4-Door Sedan NHTSA No. PY0200		5. Report Date September 19, 2012	
		6. Performing Organization Code KAR	
7. Authors Ms. Sweta P. Dedania, Project Engineer, KARCO Mr. Frank Richardson, Program Manager, KARCO		8. Performing Organization Report No. TR-P32096-08-NC	
9. Performing Organization Name and Address KARCO Engineering, LLC. 9270 Hdly Rd. Adelanto, CA 92301		10. Work Unit No.	
		11. Contract or Grant No. DTNH22-11-D-00245	
12. Sponsoring Agency Name and Address U. S. Department of Transportation National Highway Traffic Safety Administration National Center for Statistics and Analysis Office of Regulatory Analysis and Evaluation 1200 New Jersey Ave., SE, Room W53-469 Washington, D.C. 20590		13. Type of Report and Period Covered Final Test Report, Sept. 10 - Sept. 19, 2012	
		14. Sponsoring Agency Code	
15. Supplementary Notes			
16. Abstract An 80 km/h 70% overlap rear impact test was conducted on the subject 2000 Ford Contour 4-door sedan in accordance with the specifications of the Office of Vehicle Compliance Laboratory Test Procedure for FMVSS 301R. The test was conducted at the KARCO Engineering, LLC. facility in Adelanto, California on September 10, 2012. The impact velocity was 79.54 km/h and the outside ambient temperature was 36.0 deg. C. The vehicle's doors remained closed throughout the event. There was no Stoddard solvent leakage immediately after the impact event. Stoddard solvent leaked from the fuel filler neck area on the left rear fender of the vehicle throughout the static rollover test at every position from 0°-360°. The amount of solvent collected at each interval exceeded the allowable limits.			
17. Key Words FMVSS 301R Overlap Rear Impact MDB 2000 Ford Contour		18. Distribution Statement	
19. Security Classification of this report UNCLASSIFIED	20. Security Classification of this page UNCLASSIFIED	21. No. of Pages 38	22. Price

TABLE OF CONTENTS

<u>Section</u>		<u>Page No.</u>
1	Summary of the Test	1
2	Data Sheets	2
3	Laboratory Notice of Apparent Test Failure	15

<u>Data Sheet No.</u>		<u>Page No.</u>
1	Test Vehicle Specification	3
2	Pre-Test Inspection	5
3	Pre-Test Data	6
4	Moving Barrier Data	10
5	Post-Test Data	11
6	FMVSS 301 Data	13
7	Static Rollover Test Data	14

<u>Appendix</u>		<u>Page No.</u>
A	Photographs	A

SECTION 1 SUMMARY OF TEST

SUMMARY

The purpose of this rear impact test series is to measure the performance of the subject vehicle, a 2000 Ford Contour 4-door sedan, for FMVSS 301R '*Fuel System Integrity – Rear Impact*'.

This 80 km/h 70% Overlap Rear Impact is sponsored by the National Highway Traffic Safety Administration (NHTSA) under contract number DTNH22-11-D-00245. It was conducted in accordance with the Office of Vehicle Compliance Laboratory Test Procedure for FMVSS 301R '*Fuel System Integrity – Rear Impact*', dated January, 2007.

A 2000 Ford Contour 4-door sedan was impacted by a moving deformable barrier at a velocity of 79.54 km/h. The test was performed at KARCO Engineering, LLC. on September 10, 2012. Pre- and post-test photographs of the vehicle and dummies can be found in Appendix A of this report.

Two (2) real-time cameras and three (3) high-speed cameras were used to document the rear impact event.

Two Part 572E 50th percentile male anthropomorphic test devices (ATD) were placed in the driver and right front passenger seating positions. Both ATD's were un-instrumented for this test.

Both the driver and passenger side doors remained closed during the impact event and after the impact.

There was no Stoddard solvent leakage immediately after the impact event. Stoddard solvent leaked from the fuel filler neck area on the left rear fender of the vehicle throughout the static rollover test at every position from 0°-360°. The amount of solvent collected at each interval exceeded the allowable limits. All solvent leakage appeared to come from the fuel filler neck portion that is contained within the left rear fender. Solvent leakage is summarized in Data Sheets 6 and 7. Photographs of the damaged area are presented in Appendix A.

SECTION 2
DATA SHEETS

Test Vehicle: 2000 Ford Contour 4-Door Sedan NHTSA No.: PY0200
 Test Program: 70% Overlap Rear Impact Test Date: 09/10/12

CONVERSION FACTORS

Quantity	Typical Application	Std Units	Metric Unit	Multiply By
Mass	Vehicle Weight	lb	kg	0.4536
Linear Velocity	Impact Velocity	miles/hr	km/hr	1.609344
Length or Distance	Measurements	in	mm	25.4
Volume	Fuel Systems	gal	liter	3.785
Volume	Small Fluids	oz	mL	29.574
Pressure	Tire Pressures	lbf/in ²	kPa	6.895
Temperature	General Use	°F	°C	$=(T_f - 32)/1.8$
Force	Dynamic Forces	lbf	N	4.448
Moment	Torque	lbf-ft	N•m	1.355

DATA SHEET NO. 1

TEST VEHICLE SPECIFICATIONS

Test Vehicle: 2000 Ford Contour 4-Door Sedan NHTSA No.: PY0200
 Test Program: 70% Overlap Rear Impact Test Date: 09/10/12

TEST VEHICLE INFORMATION AND OPTIONS

NHTSA Number	PY0200
Model Year	2000
Make	Ford
Model	Contour
Body Style	4-Door Sedan
VIN	1FAFP66L3YK1
Date Received	8/2/2012
Body Color	White
Odometer Reading (km / mi)	166,578 / 103,507
Engine Displacement (L)	2.5
Engine Placement	Transverse
Transmission Type	Automatic
Transmission Speeds	4
Overdrive	Yes
Final Drive	Front
Roof Rack	No
Sunroof / T-Top	No
Tinted Glass	Yes
Traction Control	No
Power Brakes	Yes
Front Disc Brakes	Yes
Rear Disc Brakes	No
Anti-Lock Brakes (ABS)	Yes

All Wheel Drive	No
Power Steering	Yes
Driver Front Airbag	Yes
Driver Side Airbag	No
Driver Head Airbag	No
Driver Curtain Airbag	No
Driver Combo Airbag	No
Driver Knee Airbag	No
Passenger Front Airbag	Yes
Passenger Side Airbag	No
Passenger Head Airbag	No
Passenger Curtain Airbag	No
Passenger Combo Airbag	No
Passenger Knee Airbag	No
Seat Belt Pre-Tensioners	Yes
Load Limiters	Yes
Bucket Seats	Yes
Air Conditioning	Yes
AM/FM CD	Yes
Tilt Steering	Yes
Automatic Door Locks	No
Power Windows	Yes
Power Seats	No

Does Owner's Manual provide instructions to turn off automatic door locks?

DATA FROM CERTIFICATION LABEL

Manufactured By	Ford Motor Co.
Date of Manufacture	Jan-00

GVWR (kg)	1925
GAWR Front (kg)	1038
GAWR Rear (kg)	899

VEHICLE SEATING AND CAPACITY WEIGHT INFORMATION

Measured Parameter	Front	Rear	Third	Total
Type of Seats	Bucket	Bench		
Designated Seating Capacity	2	3		5
Capacity Weight (VCW) (kg)				400.0
DSC x 68.04 (kg)				340.0
Cargo Weight (RCLW) (kg)				60.0

A

B

A-B

DATA SHEET NO. 1 ... (CONTINUED)

TEST VEHICLE SPECIFICATIONS

Test Vehicle: 2000 Ford Contour 4-Door Sedan

NHTSA No.: PY0200

Test Program: 70% Overlap Rear Impact

Test Date: 09/10/12

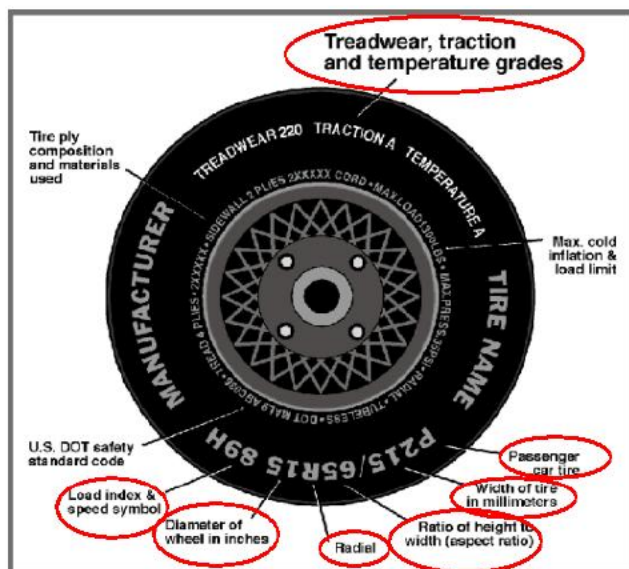

VEHICLE TIRE INFORMATION

Measured Parameter	Front	Rear
Max Tire Pressure (kPa)	300	300
Cold Tire Pressure (kPa)	235	235
Max Load Tire Pressure (kPa)	235	235
Recommended Tire Size	P185/70R14	P185/70R14
Tire Size on Vehicle	P185/70R14	P185/70R14
Tire Manufacturer	Bridgestone	Bridgestone
Tire Model	Insignia SE200	Insignia SE200
Load Range	545	545
Treadwear Rating	560	560
Traction Rating	A	A
Temperature Grades	B	B
Tire Plies Sidewall	1 Polyester	1 Polyester
Tire Plies Body	1 Polyester, 2 Steel	1 Polyester, 2 Steel
Load Index/Speed Symbol	87S	87S
Tire Material	Polyester, Steel	Polyester, Steel
DOT Safety Code Left	WBRV E20 1911	WBRV E20 1911
DOT Safety Code Right	WBRV E20 1911	WBRV E20 1911
Type of Spare Tire	T125/90R15	
Location of Tire Placard on Vehicle	Trunk	

DATA SHEET NO. 2
PRE-TEST INSPECTION

Test Vehicle: 2000 Ford Contour 4-Door Sedan

NHTSA No.: PY0200

Test Program: 70% Overlap Rear Impact

Test Date: 09/10/12

Feature	Yes	No	Comments
Is the vehicle totally complete?	X		None
Does the vehicle run and drive?	X		None
Is there any sign that the vehicle has ever been in a crash?		X	None
Are the bumpers damaged?		X	None
Do the doors open and close properly?	X		None
Are the doors properly aligned so that there are no gaps when closed?	X		None
Does the battery hold a charge so that electrical accessories in the vehicle may be operated without starting the engine?	X		None
Does the vehicle sag or have a raised or lowered suspension?		X	None
Are any of the control arms or other suspension components damaged or distorted?		X	None
Do the tires have some usable tread remaining and hold pressure?	X		None
Are the radiator and/or its supporting cross members damaged?		X	None
Is the cooling system able to retain its coolant and are the proper fluid levels maintained?	X		None
Does the fuel tank leak?		X	None
Does the fuel tank have any damages or dents that would reduce its internal capacity?		X	None
Is the fuel tank located behind the rear axle?		X	None
Is the fuel tank located between the front and rear axle?	X		None
Is the vehicle attitude "as tested" between "as delivered" and "fully loaded" before running the test?	X		None

Equipment	Present		Proper Place		Operate Properly	
	Yes	No	Yes	No	Yes	No
Engine	X		X		X	
Transmission	X		X		X	
Drive Axles	X		X		X	
Battery	X		X		X	
Alternator	X		X		X	
Radiator	X		X		X	

DATA SHEET NO. 3

PRE-TEST DATA

Test Vehicle: 2000 Ford Contour 4-Door Sedan NHTSA No.: PY0200
 Test Program: 70% Overlap Rear Impact Test Date: 09/10/12

TEST VEHICLE AXLE WEIGHTS

	Units	As Delivered (UVW)			As Tested (ATW)			Fully Loaded		
		Front	Rear	Total	Front	Rear	Total	Front	Rear	Total
Left	kg	437.5	247.0		490.5	299.0		471.5	317.5	
Right	kg	434.0	230.5		477.5	282.5		467.0	302.5	
Ratio	%	64.6%	35.4%	100.0%	62.5%	37.5%	100.0%	60.2%	39.8%	100.0%
Total	kg	871.5	477.5	1349.0	968.0	581.5	1549.5	938.5	620.0	1558.5

TARGET TEST WEIGHT CALCULATION

Measured Parameter	Units	Value	
Total Delivered Weight (UVW)	kg	1349.0	A
Actual Weight of 2 P572 ATDs Used	kg	148.0	B
Rated Cargo/Luggage Wt (RCLW)	kg	60.0	C
Calculated Vehicle Target Wt (TVTWT)	kg	1557.0	A+B+C

TEST VEHICLE ATTITUDES

Condition	Units	LF	RF	LR	RR	CG Aft of Front Axle
As Delivered	mm	675	680	668	677	956
As Tested	mm	648	659	645	651	1013
Fully Loaded	mm	646	650	630	632	1074
Post-Test	mm	693	612		552	

GENERAL TEST VEHICLE DATA

Measurement Description	Units	Value
Total Vehicle Wheel Base	mm	2700
Total Vehicle Length	mm	4680
Amount of Stoddard Solvent in Fuel Tank	L	54.21

DATA SHEET NO. 3 ... (CONTINUED)

PRE-TEST DATA

Test Vehicle: 2000 Ford Contour 4-Door Sedan NHTSA No.: PY0200
 Test Program: 70% Overlap Rear Impact Test Date: 09/10/12

BALLAST DATA

Description	Value
Type of Ballast	Ballast Dummy
Method of Securing Ballast	Seat Belt
Weight of Ballast in Cargo Area	37.5 kg
Weight of Vehicle Components Removed	0 kg

VEHICLE COMPONENTS REMOVED TO MEET TEST WEIGHT:

No vehicle components were removed

FUEL TANK CAPACITY

Description	Liters
Fuel System Capacity Listed in Owners Manual	58.29
Usable Capacity of "Standard Tank"	58.29
91 - 94% of Usable Capacity	53.04 - 54.79
Actual Amount of Stoddard Solvent Used	54.21

FUEL PUMP

The vehicle is equipped with an electric fuel pump. The fuel pump is activated when the ignition is turned on.

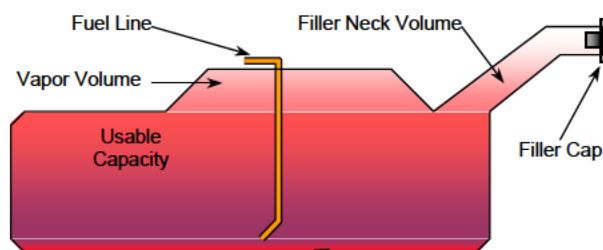

VEHICLE FUEL TANK ASSEMBLY

TEST FLUID

Description	Value
Test Fluid Type	Stoddard Solvent
Test Fluid Specific Gravity	0.97
Test Fluid Kinematic Viscosity	
Test Fluid Color	Purple

DATA SHEET NO. 3 ... (CONTINUED)

PRE-TEST DATA

Test Vehicle: 2000 Ford Contour 4-Door Sedan
 Test Program: 70% Overlap Rear Impact

NHTSA No.: PY0200
 Test Date: 09/10/12

NOMINAL DESIGN RIDING POSITION

Seat back angle is measured at the headrest post using a digital inclinometer.

SEAT BACK ANGLE

Seating Position	Degrees
Driver Seat Back Angle	16.7
Passenger Seat Back Angle	16.8

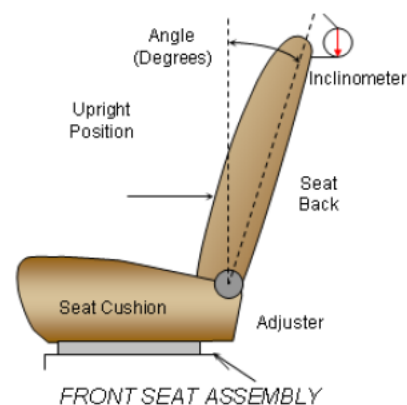

SEAT FORE / AFT POSITIONING

The total seat travel is measured from the forward most possible position to the rear most possible position. The driver's seat is set to the middle of the fore-aft travel. The passenger's seat is set to the middle of the fore-aft travel.

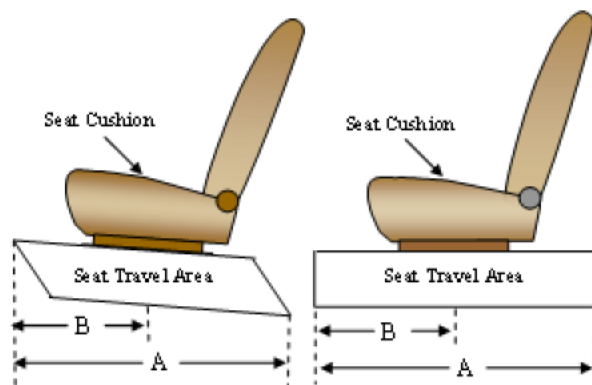

SEAT FORE/AFT POSITIONS

Seating Position	Total Fore-Aft Travel	Placed in Position
Driver Seat	210 mm	110 mm
Passenger Seat	210 mm	110 mm

DATA SHEET NO. 3 ... (CONTINUED)

PRE-TEST DATA

Test Vehicle: 2000 Ford Contour 4-Door Sedan

NHTSA No.: PY0200

Test Program: 70% Overlap Rear Impact

Test Date: 09/10/12

STEERING COLUMN ADJUSTMENT

Steering wheel and column adjustments are made so that the steering wheel hub is at the geometric center of the locus it describes when moved through its full range of motion. A digital inclinometer is used to measure a plate which is placed across the rim of the steering wheel for angular measurements. A tape measure is used to measure telescoping steering wheel travel.

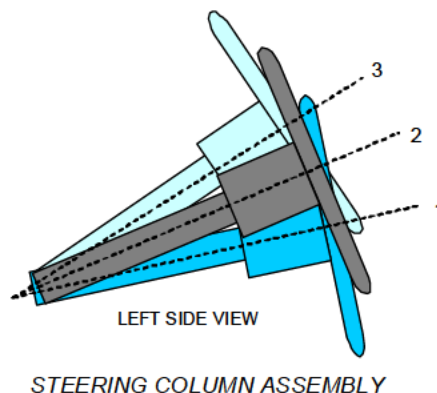

STEERING COLUMN POSITIONING

	Degrees	Fore-Aft Position (mm)
Lowermost Position, No. 1	19.9	
Geometric Center Position, No. 2	21.9	
Uppermost Position, No. 3	24.0	
Telescoping Steering Wheel Travel		
Test Position	21.9	

DATA SHEET NO. 4
MOVING BARRIER DATA

Test Vehicle: 2000 Ford Contour 4-Door Sedan NHTSA No.: PY0200
 Test Program: 70% Overlap Rear Impact Test Date: 09/10/12

MOVING BARRIER TEST WEIGHT

	Units	As Delivered Weights (UVW)		
		Front Axle	Rear Axle	Total
Left	kg	401.8	298.0	699.8
Right	kg	376.9	291.6	668.5
Ratio	%	56.9%	43.1%	100.0%
Total	kg	778.7	589.6	1368.3

MOVING BARRIER TIRE INFORMATION

Measured Parameter	Front	Rear
Recommended Tire Size	205/75R15	205/75R15
Tire Size on Vehicle	205/75R15	205/75R15
Tire Manufacturer	Pacemark	Pacemark
Tire Model	All Weather	All Weather
Treadwear	420	420
Traction	A	A
Temperature Grades	B	B
Tire Pressure - Front	220	220
Tire Pressure - Rear	220	220

MOVING BARRIER DIMENSIONS

Measurement Description	Length (mm)
Overall Width	1676
Overall Height	559
Honeycomb Depth	381
Overall Depth	483
Bottom Honeycomb to Bottom Bumper	51
Bumper Height	203
Ground to Top of MDB	788
Ground to Bottom of MDB	229
Ground to Bottom of Bumper	280
Ground to Top of Bumper	483

DATA SHEET NO. 5**POST-TEST DATA**Test Vehicle: 2000 Ford Contour 4-Door Sedan NHTSA No.: PY0200Test Program: 70% Overlap Rear Impact Test Date: 09/10/12Temperature at Time of Impact: 36.0°C Test Time: 1:41 PMVIN: 1FAFP66L3YK1**IMPACT VELOCITY DATA**

Measured Parameter	Units	Value
Trap No. 1 Velocity (Primary)	km/h	79.54
Trap No. 2 Velocity (Redundant)	km/h	79.67

IMPACT POINT LOCATION DATA

Measured Parameter	Units	Tolerance	Value
Vehicle Width	mm		1740
Vertical Impact Reference Line (Left of Vehicle Center Line)	mm		348
Actual Impact Point (Left of Vehicle Center Line)	mm		369
Horizontal Offset (+ right / - left)	mm	± 50 of Intended Impact Point	21
Vertical Offset (+ down / - up)	mm	± 40 of Intended Impact Point	-5

TARGET VEHICLE PRE- AND POST- TEST STRUCTURAL MEASUREMENTS

No.	Description	Pre-Test	Post-Test	Difference
1	Total Length at Centerline	4680	4120	-560
2	Total Length	4680	4410	-270
3	Total Width	1740	1800	60
4	Left Side Wheelbase	2700	2670	-30
5	Right Side Wheelbase	2700	2500	-200

MAXIMUM STATIC CRUSH OF HONEYCOMB FACE

Row	Vertical Location		From Centerline		Max. Crush (mm)
	Description	Height (mm)	Distance (mm)	Direction	
A	Center of Bumper	432	800	Left	194
B	Top of Bumper	533	800	Left	227
C	Mid Level	686	800	Left	177
D	Top of Stack	813	800	Left	117

DATA SHEET NO. 5 ... (CONTINUED)

POST-TEST DATA

Test Vehicle: 2000 Ford Contour 4-Door Sedan NHTSA No.: PY0200
Test Program: 70% Overlap Rear Impact Test Date: 09/10/12

DOOR OPENING AND SEAT TRACK INFORMATION

Description	Driver	Passenger
Front Door Opening	Remained closed and latched	Remained closed and latched
Rear Door Opening	Jammed Shut	Jammed Shut
Hatch	Jammed Shut	

DATA SHEET NO. 6

FMVSS 301 DATA

Test Vehicle: 2000 Ford Contour 4-Door Sedan NHTSA No.: PY0200

Test Program: 70% Overlap Rear Impact Test Date: 09/10/12

FMVSS 301 FUEL SYSTEM INTEGRITY POST-IMPACT DATA

Stoddard Solvent Spillage Measurements

- A. From impact until vehicle motion ceases: 0 g
(Maximum allowable = 28 g)
- B. For the 5 minute period after motion ceases: 0 g
(Maximum allowable = 28 g)
- C. For the following 25 minutes: 0 g
(Maximum allowable = 28 g/minute)
- D. Spillage: No Stoddard Solvent leakage

DATA SHEET NO. 7
STATIC ROLLOVER TEST DATA

Test Vehicle: 2000 Ford Contour 4-Door Sedan
 Test Program: 70% Overlap Rear Impact

NHTSA No.: PY0200
 Test Date: 09/10/12

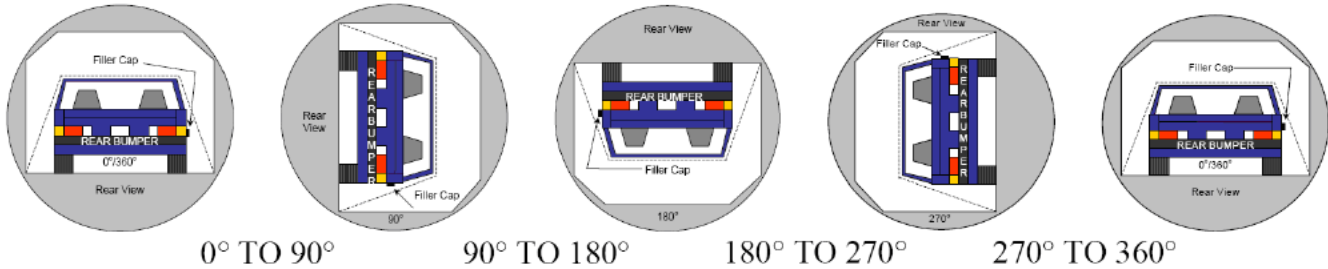

1. The specified fixture rollover rate for each 90° of rotation is 60 to 180 seconds.
2. The position hold time at each position is 300 seconds (minimum).
3. Details of Stoddard solvent spillage: Stoddard solvent leaked from the fuel filler neck area on the left rear of the vehicle.

SOLVENT COLLECTION TIME TABLE IN SECONDS

Test Phase	Rotation Time	Hold Time	Total Time
0° To 90°	81	306	387
90° To 180°	84	305	389
180° To 270°	79	300	379
270° To 360°	80	300	380

FMVSS 301 SPILLAGE TABLE

Test Phase	First 5 Minutes	Sixth Minute	Seventh Minute	Eighth Minute
0° To 90°	4131 g	1061 g	373 g	
90° To 180°	2065 g	1520 g	488 g	
180° To 270°	17614 g	114 g		
270° To 360°	287 g			

SOLVENT SPILLAGE LOCATION TABLE

Test Phase	Spillage Location
0° To 90°	Fuel Filler Neck
90° To 180°	Fuel Filler Neck
180° To 270°	Fuel Filler Neck
270° To 360°	Fuel Filler Neck

SECTION 3

LABORATORY NOTICE OF APPARENT TEST FAILURE

TEST INFORMATION:

Test Date	9/10/2012
Laboratory	KARCO Engineering, LLC.
Contract No.	DTNH22-11-D-00245
Delivery Order No.	
Lab Project Engineer's Name	Steven Matsusaka
NHTSA No.	PY0200
Test Vehicle	
Year	2000
Make	Ford
Model	Contour
Body Style	4-Door Sedan
VIN	1FAFP66L3YK1
Manufacturer	Ford Motor Co. in U.S.A.

TEST FAILURE DESCRIPTION:

There was no stoddard solvent leakage immediately after the impact event. Stoddard solvent leaked from the fuel filler neck area on the left rear fender of the vehicle throughout the static rollover test at every position from 0°-360°. The amount of solvent collected at each interval exceeded the allowable limits.

FMVSS REQUIREMENT, PARAGRAPHS:

5.3 Static Rollover

NOTIFICATION TO NHTSA

Date: 9/10/12 By: Kelsey Chiu

REMARKS:

None.

**APPENDIX A
PHOTOGRAPHS**

TABLE OF PHOTOGRAPHS

<u>Figure</u>		<u>Page</u>
1	Vehicle Certification Label	A-1
2	Vehicle Tire Placard	A-1
3	Pre-Test Front View of Test Vehicle	A-2
4	Post-Test Front View of Test Vehicle	A-2
5	Pre-Test Left Front 3-4 View	A-3
6	Post-Test Left Front 3-4 View	A-3
7	Pre-Test Left View of Test Vehicle	A-4
8	Post-Test Left View of Test Vehicle	A-4
9	Pre-Test Left Rear 3-4 View of Test Vehicle	A-5
10	Post-Test Left Rear 3-4 View of Test Vehicle	A-5
11	Pre-Test Rear View of Test Vehicle	A-6
12	Post-Test Rear View of Test Vehicle	A-6
13	Pre-Test Right Rear 3-4 View of Test Vehicle	A-7
14	Post-Test Right Rear 3-4 View of Test Vehicle	A-7
15	Pre-Test Right View of Test Vehicle	A-8
16	Post-Test Right View of Test Vehicle	A-8
17	Pre-Test Right Front 3-4 View	A-9
18	Post-Test Right Front 3-4 View	A-9
19	Pre-Test Underbody, Fuel Tank Location	A-10
20	Post-Test Underbody, Fuel Tank Location	A-10
21	Pre-Test Underbody, Fuel Filler Neck Location	A-11
22	Post-Test Underbody, Fuel Filler Neck Location	A-11
23	Pre-Test Underbody, Fuel Line Location	A-12
24	Post-Test Underbody, Fuel Line Location	A-12
25	Vehicle at 0° on Static Rollover Device	A-13
26	Vehicle at 90° on Static Rollover Device	A-13
27	Vehicle at 180° on Static Rollover Device	A-14
28	Vehicle at 270° on Static Rollover Device	A-14
29	Vehicle at 360° on Static Rollover Device	A-15
30	Post-Test Stoddard Solvent Spillage Location View	A-15
31	Post-Test Stoddard Solvent Spillage Location View	A-16
32	Post-Test Stoddard Solvent Spillage Location View	A-16
33	Post-Test Stoddard Solvent Spillage Location View	A-17
34	Post-Test Stoddard Solvent Spillage Location View	A-17

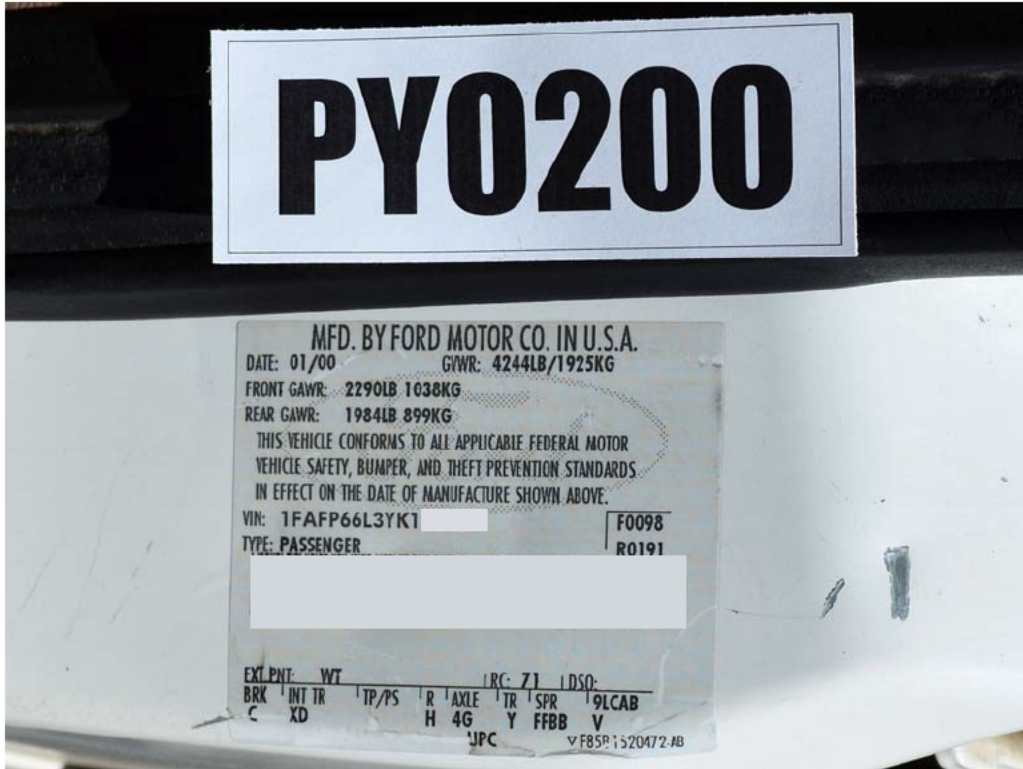

FIGURE 1. Vehicle Certification Label

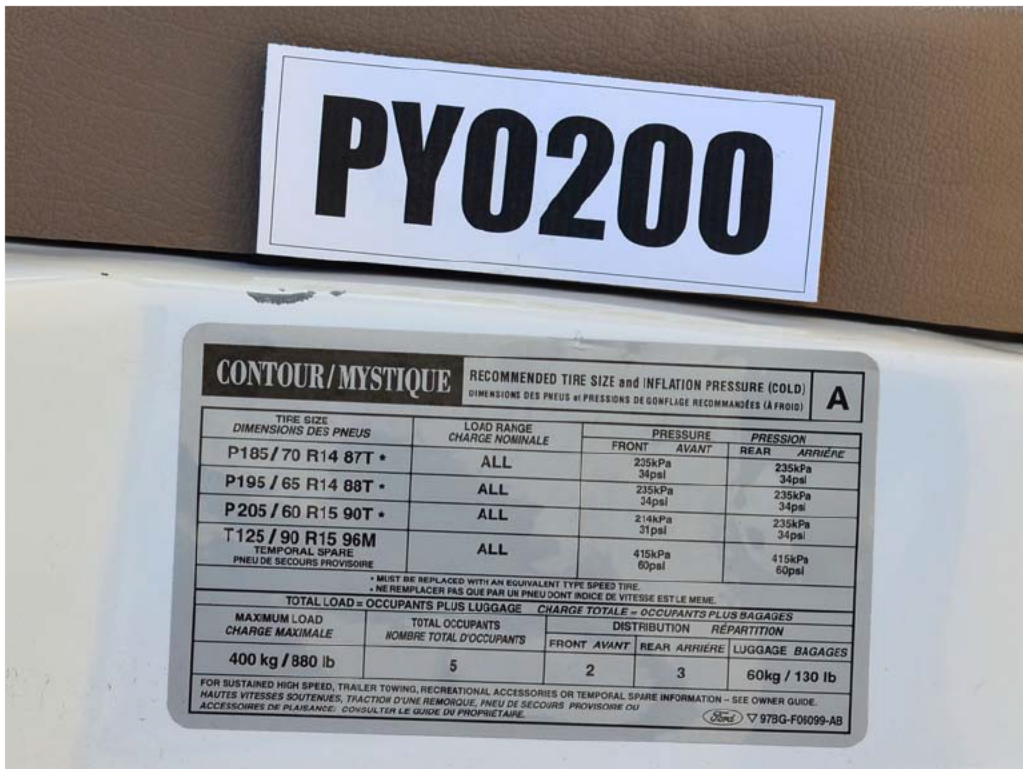

FIGURE 2. Vehicle Tire Placard



FIGURE 3. Pre-Test Front of Test Vehicle



FIGURE 4. Post-Test Front of Test Vehicle



FIGURE 5. Pre-Test Left Front $\frac{3}{4}$ View of Test Vehicle



FIGURE 6. Post-Test Left Front $\frac{3}{4}$ View of Test Vehicle



FIGURE 7. Pre-Test Left View of Test Vehicle



FIGURE 8. Post-Test Left View of Test Vehicle



FIGURE 9. Pre-Test Left Rear $\frac{3}{4}$ View of Test Vehicle



FIGURE 10. Post-Test Left Rear $\frac{3}{4}$ View of Test Vehicle



FIGURE 11. Pre-Test Rear View of Test Vehicle

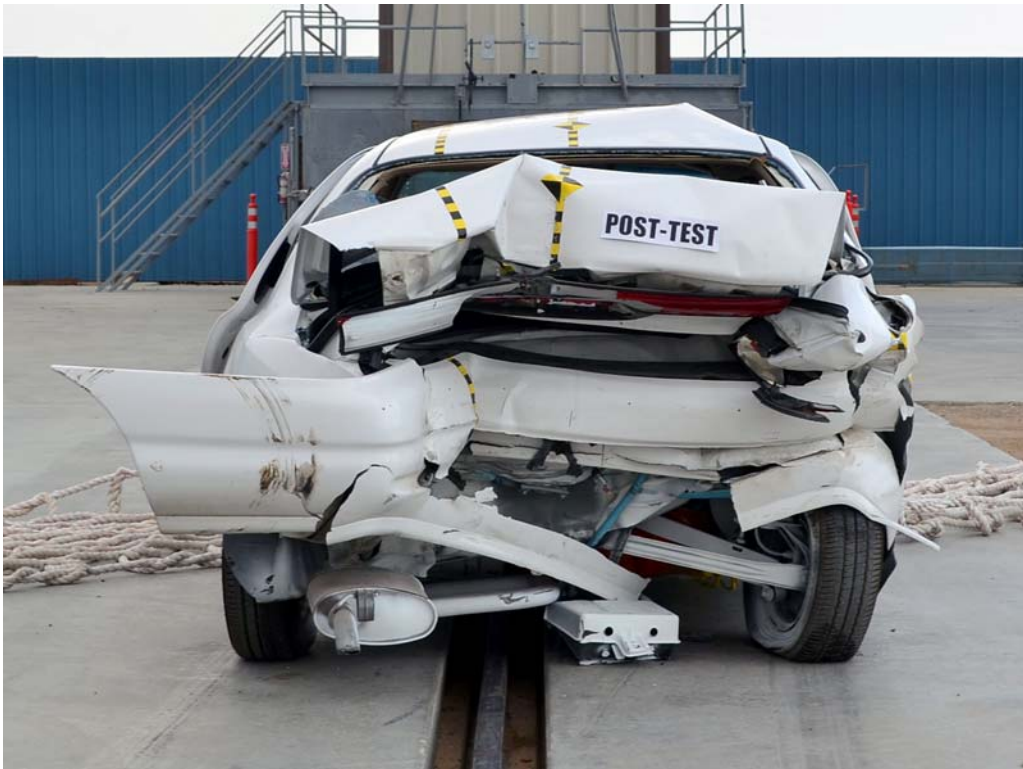

FIGURE 12. Post-Test Rear View of Test Vehicle



FIGURE 13. Pre-Test Right Rear $\frac{3}{4}$ View of Test Vehicle



FIGURE 14. Post-Test Right Rear $\frac{3}{4}$ View of Test Vehicle



FIGURE 15. Pre-Test Right View of Test Vehicle



FIGURE 16. Post-Test Right View of Test Vehicle



FIGURE 17. Pre-Test Right Front $\frac{3}{4}$ View of Test Vehicle



FIGURE 18. Post-Test Right Front $\frac{3}{4}$ View of Test Vehicle



FIGURE 19. Pre-Test Underbody, Fuel Tank Location



FIGURE 20. Post-Test Underbody, Fuel Tank Location



FIGURE 21. Pre-Test Underbody, Fuel Filler Neck Location



FIGURE 22. Post-Test Underbody, Fuel Filler Neck Location



FIGURE 23. Pre-Test Underbody, Fuel Line Location



FIGURE 24. Post-Test Underbody, Fuel Line Location



FIGURE 25. Vehicle at 0° on Static Rollover Device

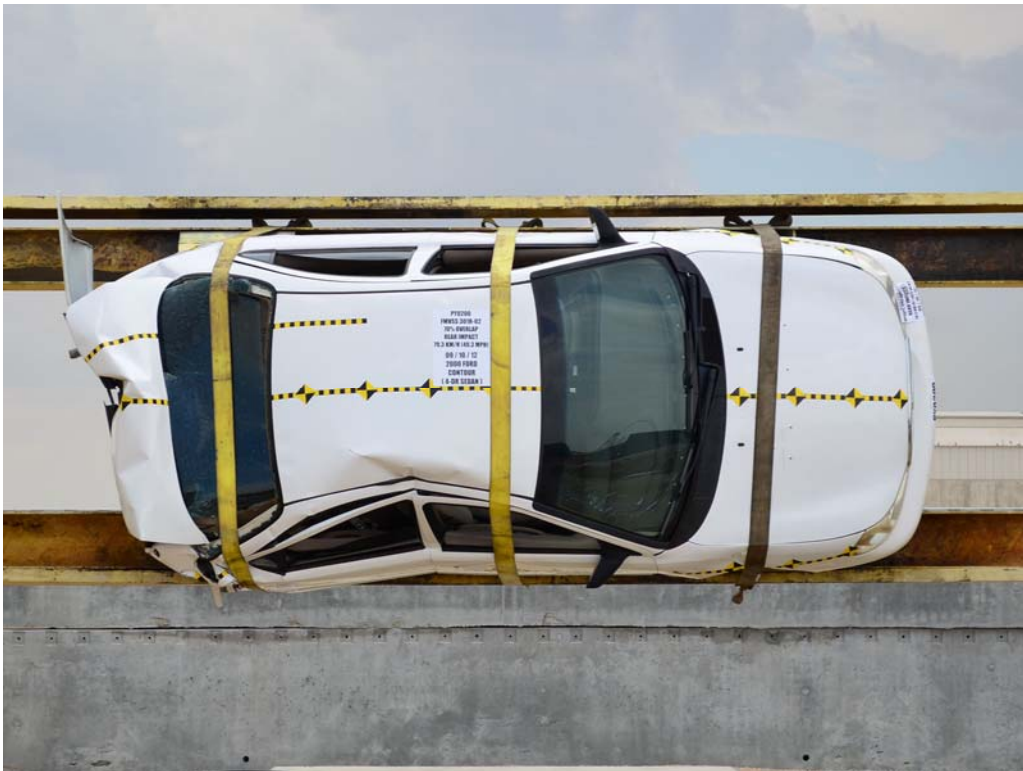

FIGURE 26. Vehicle at 90° on Static Rollover Device



FIGURE 27. Vehicle at 180° on Static Rollover Device

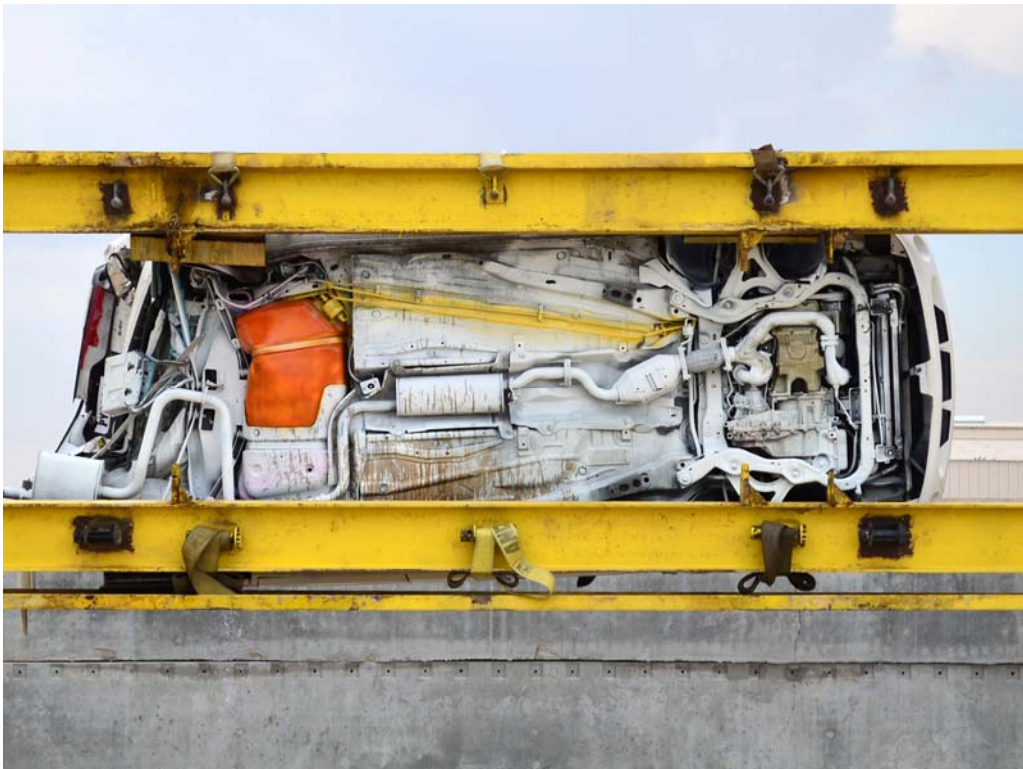

FIGURE 28. Vehicle at 270° on Static Rollover Device



FIGURE 29. Vehicle at 360° on Static Rollover Device



FIGURE 30. Post-Test Stoddard Solvent Spillage Location View



FIGURE 31. Post-Test Stoddard Solvent Spillage Location View



FIGURE 32. Post-Test Stoddard Solvent Spillage Location View



FIGURE 33. Post-Test Stoddard Solvent Spillage Location View



FIGURE 34. Post-Test Stoddard Solvent Spillage Location View