

REPORT NUMBER: NCAP-MGA-2014-013

**NEW CAR ASSESSMENT PROGRAM (NCAP)
Frontal Barrier Impact Test**

**TOYOTA MOTOR MANUFACTURING CANADA INC.
2013 Toyota RAV4 LE AWD SUV
NHTSA No.: YD5112**

**MGA RESEARCH CORPORATION
5000 Warren Road
Burlington, WI 53105**



Test Date: September 6, 2013

Final Report Date: October 21, 2013

FINAL REPORT

**U.S. DEPARTMENT OF TRANSPORTATION
National Highway Traffic Safety Administration
Office of Crashworthiness Standards
Mail Code: NVS-111
1200 New Jersey Ave, SE
Room W43-410
Washington, DC 20590**

This publication is distributed by the U.S. Department of Transportation, National Highway Traffic Safety Administration, in the interest of information exchange. The opinions, findings and conclusions expressed in this publication are those of the author(s) and not necessarily those of the Department of Transportation or the National Highway Traffic Safety Administration. The United States Government assumes no liability for its contents or use thereof. If trade or manufacturers' names or products are mentioned, it is only because they are considered essential to the object of the publication and should not be construed as an endorsement. The United States Government does not endorse products or manufacturers.

Prepared by: 
Donna Janovicz, Project Manager

Approved by: 
Ben Fischer, Project Engineer

Approval Date: October 21, 2013

FINAL REPORT ACCEPTANCE BY OCWS:

Division Chief, New Car Assessment Program
NHTSA, Office of Crashworthiness Standards

Date: _____

COTR, New Car Assessment Program
NHTSA, Office of Crashworthiness Standards

Date: _____

Technical Report Documentation Page

| 1. Report No. NCAP-MGA-2014-013 | 2. Government Accession No. | 3. Recipient's Catalog No. | | | | | | | | | | | | | | | | | | | | | | | | | | | | | | | | | | | | | | | | | | | | | | | | | | | |
|---|--|--|------------------|-------------------------|-------|------------|---------------|------------|---------------|------------------|-----------------|---|-----|-----|-----|-----|-----|---------------------------|----|----|----|----|----|-----|-----|---|---|------|------|--------------|---|------|------|------|------|------------------|---|------|------|----|-----|------------------|---|-------|------|------|------|-------------------|---|-------|------|------|------|
| 4. Title and Subtitle Final Report of New Car Assessment Program Frontal Impact Testing of a 2013 Toyota RAV4 LE AWD SUV, NHTSA No.: YD5112 | | 5. Report Date October 21, 2013 | | | | | | | | | | | | | | | | | | | | | | | | | | | | | | | | | | | | | | | | | | | | | | | | | | | |
| | | 6. Performing Organization Code MGA | | | | | | | | | | | | | | | | | | | | | | | | | | | | | | | | | | | | | | | | | | | | | | | | | | | |
| 7. Author(s) Donna Janovicz, Project Manager Ben Fischer, Project Engineer | | 8. Performing Organization Report No. NCAP-MGA-2014-013 | | | | | | | | | | | | | | | | | | | | | | | | | | | | | | | | | | | | | | | | | | | | | | | | | | | |
| | | 10. Work Unit No. | | | | | | | | | | | | | | | | | | | | | | | | | | | | | | | | | | | | | | | | | | | | | | | | | | | |
| 9. Performing Organization Name and Address MGA Research Corporation 5000 Warren Road Burlington, WI 53105 | | 11. Contract or Grant No. DTNH22-12-D-00258 | | | | | | | | | | | | | | | | | | | | | | | | | | | | | | | | | | | | | | | | | | | | | | | | | | | |
| | | 13. Type of Report and Period Covered Final Test Report September 6, 2013 to October 21, 2013 | | | | | | | | | | | | | | | | | | | | | | | | | | | | | | | | | | | | | | | | | | | | | | | | | | | |
| 12. Sponsoring Agency Name and Address U.S. Department of Transportation National Highway Traffic Safety Administration Office of Crashworthiness Standards (NVS-111) 1200 New Jersey Ave, SE, Room W43-410 Washington, D.C. 20590 | | 14. Sponsoring Agency Code NVS-111 | | | | | | | | | | | | | | | | | | | | | | | | | | | | | | | | | | | | | | | | | | | | | | | | | | | |
| | | 15. Supplementary Notes | | | | | | | | | | | | | | | | | | | | | | | | | | | | | | | | | | | | | | | | | | | | | | | | | | | |
| 16. Abstract A 56.3 km/h NCAP Frontal Impact Test was conducted on a 2013 Toyota RAV4 LE AWD SUV in accordance with the specifications of the Office of Crashworthiness Standards Frontal NCAP Laboratory Test Procedure. This test was conducted to obtain data indicant of FMVSS 208, 212, 219 (partial), 301, and foot well intrusion performance. The test was conducted at MGA Research Corporation in Burlington, Wisconsin, on September 6, 2013. The impact velocity was 56.6 km/h and the ambient temperature at the barrier face at the time of impact was 20.8°C. The target vehicle post-test maximum crush was 452 mm located at the vehicle's centerline. The test vehicle's performance was as follows: | | | | | | | | | | | | | | | | | | | | | | | | | | | | | | | | | | | | | | | | | | | | | | | | | | | | | |
| <table border="1" style="width: 100%; border-collapse: collapse; background-color: #ffff00;"> <thead> <tr> <th rowspan="2">Measurement Description</th> <th rowspan="2">Units</th> <th colspan="2">Threshold</th> <th rowspan="2">Driver ATD</th> <th rowspan="2">Passenger ATD</th> </tr> <tr> <th>50th</th> <th>5th</th> </tr> </thead> <tbody> <tr> <td>Head Injury Criteria (HIC₁₅)</td> <td>N/A</td> <td>700</td> <td>700</td> <td>300</td> <td>493</td> </tr> <tr> <td>Maximum Chest Compression</td> <td>mm</td> <td>63</td> <td>52</td> <td>14</td> <td>12</td> </tr> <tr> <td>Nij</td> <td>N/A</td> <td>1</td> <td>1</td> <td>0.46</td> <td>0.50</td> </tr> <tr> <td>Neck Tension</td> <td>N</td> <td>4170</td> <td>2620</td> <td>1871</td> <td>1266</td> </tr> <tr> <td>Neck Compression</td> <td>N</td> <td>4000</td> <td>2520</td> <td>86</td> <td>441</td> </tr> <tr> <td>Left Femur Force</td> <td>N</td> <td>10008</td> <td>6805</td> <td>1948</td> <td>1556</td> </tr> <tr> <td>Right Femur Force</td> <td>N</td> <td>10008</td> <td>6805</td> <td>2525</td> <td>1062</td> </tr> </tbody> </table> | | | | Measurement Description | Units | Threshold | | Driver ATD | Passenger ATD | 50 th | 5 th | Head Injury Criteria (HIC ₁₅) | N/A | 700 | 700 | 300 | 493 | Maximum Chest Compression | mm | 63 | 52 | 14 | 12 | Nij | N/A | 1 | 1 | 0.46 | 0.50 | Neck Tension | N | 4170 | 2620 | 1871 | 1266 | Neck Compression | N | 4000 | 2520 | 86 | 441 | Left Femur Force | N | 10008 | 6805 | 1948 | 1556 | Right Femur Force | N | 10008 | 6805 | 2525 | 1062 |
| Measurement Description | Units | Threshold | | | | Driver ATD | Passenger ATD | | | | | | | | | | | | | | | | | | | | | | | | | | | | | | | | | | | | | | | | | | | | | | |
| | | 50 th | 5 th | | | | | | | | | | | | | | | | | | | | | | | | | | | | | | | | | | | | | | | | | | | | | | | | | | |
| Head Injury Criteria (HIC ₁₅) | N/A | 700 | 700 | 300 | 493 | | | | | | | | | | | | | | | | | | | | | | | | | | | | | | | | | | | | | | | | | | | | | | | | |
| Maximum Chest Compression | mm | 63 | 52 | 14 | 12 | | | | | | | | | | | | | | | | | | | | | | | | | | | | | | | | | | | | | | | | | | | | | | | | |
| Nij | N/A | 1 | 1 | 0.46 | 0.50 | | | | | | | | | | | | | | | | | | | | | | | | | | | | | | | | | | | | | | | | | | | | | | | | |
| Neck Tension | N | 4170 | 2620 | 1871 | 1266 | | | | | | | | | | | | | | | | | | | | | | | | | | | | | | | | | | | | | | | | | | | | | | | | |
| Neck Compression | N | 4000 | 2520 | 86 | 441 | | | | | | | | | | | | | | | | | | | | | | | | | | | | | | | | | | | | | | | | | | | | | | | | |
| Left Femur Force | N | 10008 | 6805 | 1948 | 1556 | | | | | | | | | | | | | | | | | | | | | | | | | | | | | | | | | | | | | | | | | | | | | | | | |
| Right Femur Force | N | 10008 | 6805 | 2525 | 1062 | | | | | | | | | | | | | | | | | | | | | | | | | | | | | | | | | | | | | | | | | | | | | | | | |
| 17. Key Words 35 mph Frontal Barrier Impact Test New Car Assessment Program (NCAP) | | 18. Distribution Statement Copies of this report are available from: National Highway Traffic Safety Administration Technical Information Services Division, NPO-411 1200 New Jersey Ave, SE Washington, DC 20590 Email: tis@nhtsa.dot.gov FAX: 202-493-2833 | | | | | | | | | | | | | | | | | | | | | | | | | | | | | | | | | | | | | | | | | | | | | | | | | | | |
| 19. Security Classification of Report Unclassified | 20. Security Classification of Page Unclassified | 21. No. of Pages 168 | 22. Price | | | | | | | | | | | | | | | | | | | | | | | | | | | | | | | | | | | | | | | | | | | | | | | | | | |

TABLE OF CONTENTS

| <u>Section</u> | | <u>Page No.</u> |
|----------------|--|-----------------|
| 1 | Purpose and Summary of Test | 1 |
| 2 | Occupant and Vehicle Information / Data Sheets | 3 |

| <u>Data Sheet No.</u> | | <u>Page No.</u> |
|-----------------------|--|-----------------|
| 1 | General Test and Vehicle Parameter Data | 4 |
| 2 | Seat Adjustment, Fuel System, and Steering Wheel Data | 8 |
| 3 | Dummy Longitudinal Clearance Dimensions | 10 |
| 4 | Dummy Lateral Clearance Dimensions | 11 |
| 5 | Seat Belt Positioning Data | 12 |
| 6 | High-Speed Camera Locations and Data | 13 |
| 7 | Vehicle Accelerometer Locations | 15 |
| 8 | Photographic Reference Target Locations | 16 |
| 9 | Load Cell Locations on Fixed Barrier | 17 |
| 10 | Test Vehicle Summary of Results | 18 |
| 11 | Post-Test Observations | 19 |
| 12 | Vehicle Profile Measurements | 20 |
| 13 | Accident Investigation Division Data | 22 |
| 14 | Vehicle Intrusion Measurements | 23 |
| 15 | Summary of FMVSS 212, FMVSS 219 (Partial) Data, and 301 Data | 25 |
| 16 | FMVSS 301 Static Rollover Results | 27 |
| 17 | Dummy/Vehicle Temperature Stabilization Data | 28 |

Appendix

| | | |
|---|---|---|
| A | Photographs | A |
| B | Dummy Response Data Traces | B |
| C | Dummy Calibration and Performance Verification Data | C |

SECTION 1 PURPOSE AND SUMMARY OF TEST

PURPOSE

This 56.3 km/h frontal barrier impact test is part of the Vehicle Barrier Impact Testing Program sponsored by the National Highway Traffic Safety Administration (NHTSA) under contract number DTNH22-12-D-00258. The purpose of this test was to obtain vehicle crashworthiness and occupant restraint system performance data for consumer information purposes.

The 56.3 km/h frontal barrier impact was conducted in accordance with the Office of Crashworthiness Standards Frontal NCAP Laboratory Test Procedure.

SUMMARY

A load cell barrier consisting of 176 load cells was impacted by a 2013 Toyota RAV4 LE AWD SUV at a velocity of 56.6 km/h. The test was performed at MGA Research Corporation on September 6, 2013. Pre-test and post-test photographs of the vehicle and dummies can be found in Appendix A.

Two (2) real-time cameras and fourteen (14) high-speed cameras were used to document the frontal barrier impact event. Camera locations and other pertinent camera information can be found in this report.

One Part 572E 50th percentile male anthropomorphic test device (ATD), was placed in the driver seating position and one Part 572O 5th percentile female test device (ATD) was placed in the right-front passenger seating position according to dummy placement instructions specified in the Frontal NCAP Laboratory Test Procedure.

Both ATDs were fully instrumented with head, chest and pelvis tri-axial accelerometers, chest displacement potentiometers, upper neck transducers, right/left femur load cells, and lower leg instrumentation. Seat belt load cells were also installed on the driver's and passenger's lap belts to measure dummy pelvic section loading.

The driver (position 1) ATD (Serial No. 036) and the right-front passenger (position 2) ATD (Serial No. 138) were calibrated previous to this test. Certification details, along with instrumentation calibration data, are found in Appendix C of this report.

The 628 channels of data were recorded on an on-board data acquisition system. Appendix B contains the dummy response data traces.

There was 100 percent windshield retention and no intrusion into the protected zone of the windshield during the event. There was no Stoddard Solvent leakage after the event or during any phase of the static rollover.

The maximum static crush of the vehicle was 452 mm and both the driver and passenger side doors remained closed during the impact event and were operable after the impact.

The driver's visible contact points were as follows: The driver's head and chest contacted the airbag. The driver's head also contacted the headrest. The driver's knees contacted the knee airbag. The passenger's visible contact points were as follows: The passenger's head and chest contacted the airbag. The passenger's head also contacted the headrest and seatback. The passenger's knees contacted the glove box.

The occupant data is summarized below:

| ATD position | HIC ₁₅ | Nij | Neck Tension (N) | Neck Comp. (N) | 3ms Chest Clip (Gs) | Chest Disp. (mm) | Left Femur (N) | Right Femur (N) |
|------------------------------|-------------------|------|------------------|----------------|---------------------|------------------|----------------|-----------------|
| Driver (50 th) | 300 | 0.46 | 1871 | 86 | 56 | 14 | 1948 | 2525 |
| Passenger (5 th) | 493 | 0.50 | 1266 | 441 | 55 | 12 | 1556 | 1062 |

The test data can be found on the NHTSA website at www.nhtsa.dot.gov.

TEST NOTES

Load Cell K-16 MY has questionable data.

MGA does not endorse or certify products. The manufacturer's name appears solely for identification purposes.

SECTION 2
OCCUPANT AND VEHICLE INFORMATION / DATA SHEETS

**DATA SHEET NO. 1
GENERAL TEST AND VEHICLE PARAMETER DATA**

Test Vehicle: 2013 Toyota RAV4 LE AWD SUV
 Test Program: NCAP Frontal Barrier Impact Test

NHTSA No.: YD5112
 Test Date: 09/06/2013

TEST VEHICLE INFORMATION AND OPTIONS

| | | | |
|-----------------------------|------------------------|---------------------------------|-----|
| NHTSA No. | YD5112 | Traction Control System (TCS) | Yes |
| Model Year | 2013 | Power Steering | Yes |
| Make | Toyota | Power Window Auto-Reverse | No |
| Model | RAV4 | Driver Frontal Airbag | Yes |
| Body Style | SUV | Driver Curtain Airbag | Yes |
| VIN | 2T3BFREVDW070736 | Driver Head/Torso Airbag | No |
| Body Color | Barcelona Red Metallic | Driver Torso Airbag | No |
| Odometer (km/mi) | 113 / 70 | Driver Torso/Pelvis Airbag | Yes |
| Engine Displacement (L) | 2.5 | Driver Pelvis Airbag | No |
| Type/No. Cylinders | 4 | Driver Knee Airbag | Yes |
| Engine Placement | Lateral | Front Pass. Frontal Airbag | Yes |
| Transmission Type | Automatic | Front Pass. Curtain Airbag | Yes |
| Transmission Speeds | 6 | Front Pass. Head/Torso Airbag | No |
| Overdrive | Yes | Front Pass. Torso Airbag | No |
| Final Drive | AWD | Front Pass. Torso/Pelvis Airbag | Yes |
| Roof Rack | Yes | Front Pass. Pelvis Airbag | No |
| Sunroof/T-Top | No | Front Pass. Knee Airbag | No |
| Running Boards | No | Driver Pretensioner | Yes |
| Tilt Steering Wheel | Yes | Driver Load Limiter | Yes |
| Power Seats | No | Front Pass. Pretensioner | Yes |
| Anti-Lock Brakes (ABS) | Yes | Front Pass. Load Limiter | Yes |
| Automatic Door Locks (ADLs) | Yes | RF Pass. Seat Cushion Airbag | Yes |

| | |
|--|-----|
| Does owner's manual provide instructions to turn off automatic door locks? | Yes |
|--|-----|

DATA FROM CERTIFICATION LABEL

| | | | |
|---------------------|--|-----------------|------|
| Manufactured By | Toyota Motor Manufacturing Canada Inc. | GVWR (kg) | 2085 |
| Date of Manufacture | 07/13 | GAWR Front (kg) | 1150 |
| | | GAWR Rear (kg) | 1150 |

VEHICLE SEATING AND WEIGHT CAPACITY DATA

| Measured Parameter | Front | Rear | Third | Total |
|-----------------------------------|--------|-------------|-------|-------|
| Type of Seats | Bucket | Split Bench | | |
| Designated Seating Capacity (DSC) | 2 | 3 | | 5 |
| Capacity Weight (VCW) (kg) | | | | 405 |
| Cargo Weight (RCLW) (kg) | | | | 65 |

DATA SHEET NO. 1 (CONTINUED)
GENERAL TEST AND VEHICLE PARAMETER DATA

Test Vehicle: 2013 Toyota RAV4 LE AWD SUV
 Test Program: NCAP Frontal Barrier Impact Test

NHTSA No.: YD5112
 Test Date: 09/06/2013

VEHICLE TIRE INFORMATION

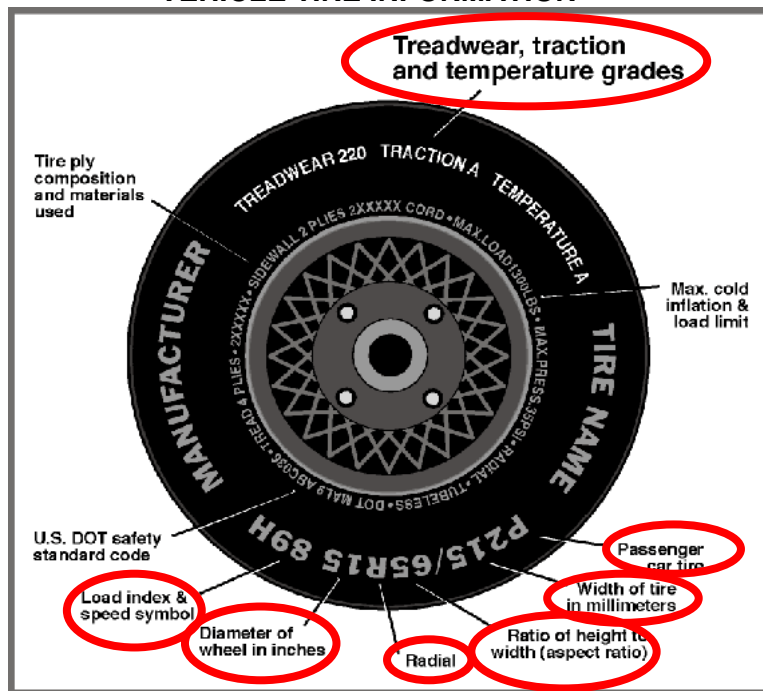

| Measured Parameter | Front | Rear |
|--------------------------|-------------------------------|-------------------------|
| Max. Tire Pressure (kPa) | 350 | 350 |
| Cold Pressure (kPa) | 230 | 230 |
| Recommended Tire Size | P225/65R17 | P225/65R17 |
| Tire Size on Vehicle | P225/65R17 | P225/65R17 |
| Tire Manufacturer | Dunlop | Dunlop |
| Tire Model | Grandtrek | Grandtrek |
| Treadwear | 360 | 360 |
| Traction | A | A |
| Temperature Grade | A | A |
| Tire Plies Sidewall | 2 Polyester | 2 Polyester |
| Tire Plies Body | 2 Polyester, 2 Steel, 1 Nylon | 2 Polyester, 2 Steel, 1 |
| Load Index/Speed Symbol | 102H | 102H |
| Tire Material | Rubber | Rubber |
| DOT Safety Code Left | U2F5 3M5R 1213 | U2F5 3M5R 1213 |
| DOT Safety Code Right | U2F5 3M5R 1213 | U2F5 3M5R 1213 |

**DATA SHEET NO. 1 (CONTINUED)
GENERAL TEST AND VEHICLE PARAMETER DATA**

Test Vehicle: 2013 Toyota RAV4 LE AWD SUV
Test Program: NCAP Frontal Barrier Impact Test

NHTSA No.: YD5112
Test Date: 09/06/2013

TEST VEHICLE WEIGHTS

| | Units | As Delivered (UVW) | | | As Tested (ATW) | | |
|--------|-------|--------------------|-------|--------|-----------------|-------|--------|
| | | Front | Rear | Total | Front | Rear | Total |
| Left | kg | 472.6 | 351.1 | | 506.7 | 426.4 | |
| Right | kg | 462.2 | 331.6 | | 481.7 | 400.5 | |
| Ratio | % | 57.8 | 42.2 | | 54.4 | 45.6 | |
| Totals | kg | 934.8 | 682.7 | 1617.5 | 988.4 | 826.9 | 1815.3 |

TARGET TEST WEIGHT CALCULATION

| Measured Parameter | Units | Value |
|--|-------|--------|
| Total Delivered Weight (UVW) | kg | 1617.5 |
| Weight of 1 P572E ATD & 1 P572O ATD | kg | 140.6 |
| Rated Cargo/Luggage Weight (RCLW) | kg | 65 |
| Calculated Vehicle Target Weight (TVTWT) | kg | 1823.1 |

TEST VEHICLE ATTITUDES AND CG

| | Units | LF | RF | LR | RR | CG (aft of front axle) |
|--------------|-------|-----|-----|-----|-----|------------------------|
| As Delivered | mm | 806 | 806 | 822 | 828 | 1124 |
| As Tested | mm | 795 | 801 | 795 | 800 | 1213 |
| Post Test | mm | 763 | 788 | 794 | 800 | |

GENERAL TEST VEHICLE DATA

| Measurement Description | Units | Value |
|---|-------|-------|
| Total Vehicle Wheel Base | mm | 2662 |
| Total Vehicle Length at Left Side | mm | 4451 |
| Total Vehicle Length at Centerline | mm | 4566 |
| Total Vehicle Length at Right Side | mm | 4451 |
| Weight of Ballast in Cargo Area | kg | 67.1 |
| Weight of Vehicle Components Removed | kg | 36.3 |
| Amount of Stoddard Solvent in Fuel Tank | L | 55.9 |

List of components removed to meet test weight: Right taillight, spare tire, spare tire cover, jack and tool kit, cargo area carpet, cargo divider, wheel covers, right lower c-pillar cover, and rear sill plastic trim.

DATA SHEET NO. 1 (CONTINUED)
GENERAL TEST AND VEHICLE PARAMETER DATA

Test Vehicle: 2013 Toyota RAV4 LE AWD SUV
 Test Program: NCAP Frontal Barrier Impact Test

NHTSA No.: YD5112
 Test Date: 09/06/2013

TARGET VEHICLE STRUCTURAL MEASUREMENT

| | Elements | Pre-Test (mm) |
|----|---------------------------------------|---------------|
| 1 | Total Length | 4566 |
| 2 | Total Width | 1737 |
| 3 | Bumper Top Height | 604 |
| 4 | Bumper Bottom Height | 488 |
| 5 | Longitudinal Member Top Height | 588 |
| 6 | Distance between Longitudinal Members | 917 |
| 7 | Longitudinal Member Width | 64 |
| 8 | Engine Top Height | 938 |
| 9 | Engine Bottom Height | 214 |
| 10 | Engine and Gearbox Width | 875 |
| 11 | Front Bumper-Engine Distance | 343 |
| 12 | Front Shock Absorber Fixing Height | 940 |
| 13 | Bonnet Leading Edge Height | 906 |
| 14 | Front Shock Absorber Fixing Width | 1203 |
| 15 | Front Bumper – Front Axle Distance | 895 |
| 16 | Front Axle – A-Pillar Distance | 472 |
| 17 | A-Pillar – B-Pillar Distance | 1083 |
| 18 | B-Pillar – Rear Axle Distance | 1105 |
| 19 | B-Pillar – C-Pillar Distance | 635 |
| 20 | Roof Sill Bottom Height | 1495 |
| 21 | Roof Sill Top Height | 1681 |
| 22 | Floor Sill Bottom Height | 271 |
| 23 | Floor Sill Top Height | 456 |

**DATA SHEET NO. 2
SEAT ADJUSTMENT, FUEL SYSTEM, AND STEERING WHEEL DATA**

Test Vehicle: 2013 Toyota RAV4 LE AWD SUV
 Test Program: NCAP Frontal Barrier Impact Test

NHTSA No.: YD5112
 Test Date: 09/06/2013

NOMINAL DESIGN RIDING POSITION

The driver seat back is positioned as close as possible to the manufacturer's design angle. For the passenger seat back, seat back is adjusted following Appendix F, "Driver & Passenger Dummy Seating & Positioning Procedures" in the NCAP Test Procedure dated September 2012.

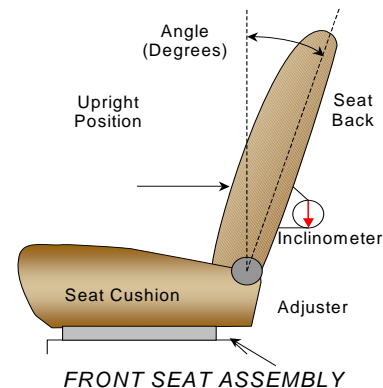

| | Degrees |
|---------------------------|-----------------------|
| Driver Seat Back Angle | 4.1° on headrest post |
| Passenger Seat Back Angle | 4.3° on headrest post |

SEAT FORE/AFT POSITIONS

The driver and passenger seat fore/aft positions are adjusted following Appendix F, "Driver & Passenger Dummy Seating & Positioning Procedures" in the NCAP Test Procedure dated September 2012.

| | Total Fore/Aft Travel | Placed in Position # |
|----------------|-----------------------------------|---|
| Driver Seat | 25 Detents (1 st as 1) | 9 th Detent (1 st as 0) |
| Passenger Seat | 27 Detents (1 st as 1) | 0 Detent (1 st as 0) |

SEAT BELT UPPER ANCHORAGES

The seat belt upper anchorages are positioning following the manufacturer's specified position as listed in Form 1.

| | Total # of Positions | Placed in Position # |
|----------------|--------------------------|----------------------|
| Driver Seat | 4 (1 st as 1) | 0 (uppermost as 0) |
| Passenger Seat | 4 (1 st as 1) | 0 (uppermost as 0) |

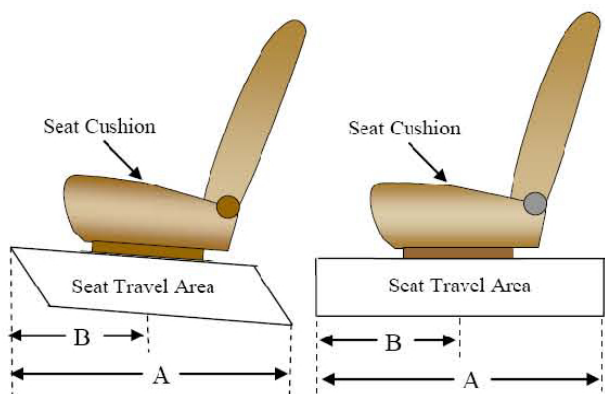

DATA SHEET NO. 2 (CONTINUED)
SEAT ADJUSTMENT, FUEL SYSTEM, AND STEERING WHEEL DATA

Test Vehicle: 2013 Toyota RAV4 LE AWD SUV
 Test Program: NCAP Frontal Barrier Impact Test

NHTSA No.: YD5112
 Test Date: 09/06/2013

FUEL TANK CAPACITY DATA

| | Liters |
|------------------------------------|--------------|
| Usable Capacity of "Standard Tank" | 60.2 |
| Usable Capacity of "Optional Tank" | |
| 92-94% of Usable Capacity | 55.4 to 56.6 |
| Actual Amount of Solvent used | 55.9 |
| 1/3 of Usable Capacity | 20.1 |

FUEL PUMP

Describe the fuel pump type, its behavior, and the location of the fuel filler pipe.

The vehicle is equipped with an electric fuel pump. The fuel pump is activated when the ignition is turned on. The fuel pipe is on the left side.

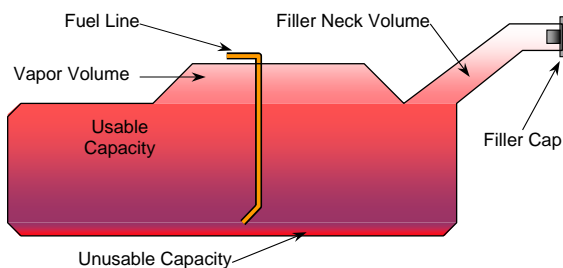

VEHICLE FUEL TANK ASSEMBLY

STEERING COLUMN ADJUSTMENT

Steering wheel and column adjustments are made so that the steering wheel hub is at the geometric center of the locus it describes when moved through its full range of motion. An aluminum plate is placed across the rim of the steering wheel, an inclinometer is placed on the plate and the angle is measured.

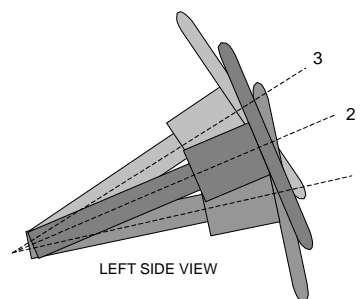

STEERING COLUMN ASSEMBLY

STEERING COLUMN POSITION

| | Degrees | Fore/Aft Position (mm) |
|-----------------------------------|---------|------------------------|
| Lowermost Position 1 | 66.1 | 235 |
| Geometric Center Position 2 | 64.1 | 215 |
| Uppermost Position 3 | 62.1 | 195 |
| Telescoping Steering Wheel Travel | | 40 |
| Test Position | 64.1 | 215 |

**DATA SHEET NO. 3
DUMMY LONGITUDINAL CLEARANCE DIMENSIONS**

Test Vehicle: 2013 Toyota RAV4 LE AWD SUV
 Test Program: NCAP Frontal Barrier Impact Test

NHTSA No.: YD5112
 Test Date: 09/06/2013

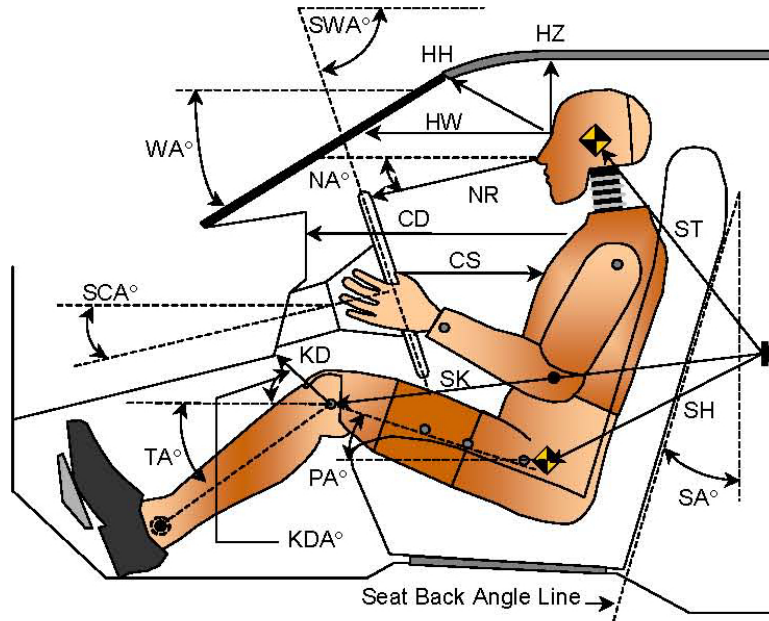

LEFT SIDE VIEW

| Code | Measurement Description | Driver S/N 036 | | Passenger S/N 138 | |
|------|------------------------------------|----------------|-----------|-------------------|-----------|
| | | Length (mm) | Angle (°) | Length (mm) | Angle (°) |
| WA° | Windshield Angle | | 27.2 | | |
| SWA° | Steering Wheel Angle | | 64.1 | | |
| SCA° | Steering Column Angle | | 25.9 | | |
| SA° | Seat Back Angle (on headrest post) | | 4.1 | | 4.3 |
| HZ | Head to Roof (Z) | 226 | 90.0 | 223 | 90.0 |
| HH | Head to Header | 342 | 27.7 | 270 | 46.3 |
| HW | Head to Windshield | 654 | 0.0 | 615 | 0.0 |
| NR | Nose to Rim | 398 | 13.2 | | |
| CD | Chest to Dash | 535 | | 345 | |
| CS | Chest to Steering Hub | 331 | 5.7 | | |
| RA | Rim to Abdomen | 200 | 0.0 | | |
| KDL | Left Knee to Dash | 145 | 26.2 | 72 | 34.0 |
| KDR | Right Knee to Dash | 143 | 21.8 | 80 | 35.6 |
| PA° | Pelvic Angle | | 23.2 | | 19.7 |
| TA° | Tibia Angle | | 51.3 | | 51.1 |
| SK | Striker to Knee | 587 | 99.9 | 890 | 107.8 |
| ST | Striker to Head | 423 | 10.3 | 452 | 32.8 |
| SH | Striker to H-Point | 308 | 137.9 | 402 | 118.0 |

**DATA SHEET NO. 4
DUMMY LATERAL CLEARANCE DIMENSIONS**

Test Vehicle: 2013 Toyota RAV4 LE AWD SUV
 Test Program: NCAP Frontal Barrier Impact Test

NHTSA No.: YD5112
 Test Date: 09/06/2013

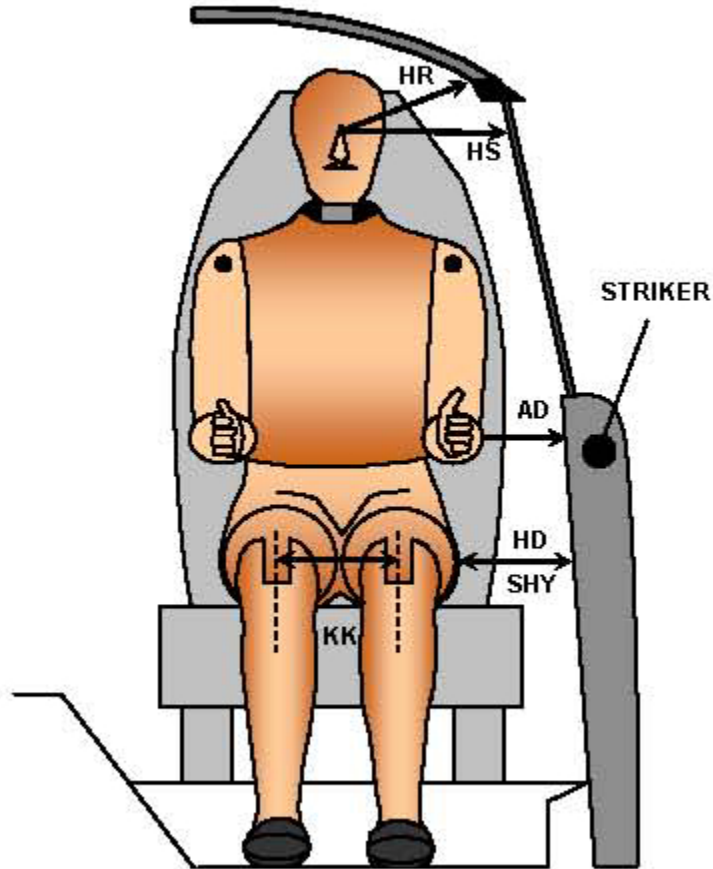

FRONT VIEW OF DUMMY

| Code | Measurement Description | Driver S/N 036 | Passenger S/N 138 |
|------|----------------------------------|----------------|-------------------|
| | | Length (mm) | |
| AD | Arm to Door | 156 | 92 |
| HD | H-Point to Door | 155 | 174 |
| HR | Head to Side Header | 231 | 268 |
| HS | Head to Side Window | 325 | 360 |
| KK | Knee to Knee | 385 | 214 |
| SHY | Striker to H-Point (Y Direction) | 285 | 350 |
| AA | Ankle to Ankle | 360 | 185 |

**DATA SHEET NO. 5
SEAT BELT POSITIONING DATA**

Test Vehicle: 2013 Toyota RAV4 LE AWD SUV
 Test Program: NCAP Frontal Barrier Impact Test

NHTSA No.: YD5112
 Test Date: 09/06/2013

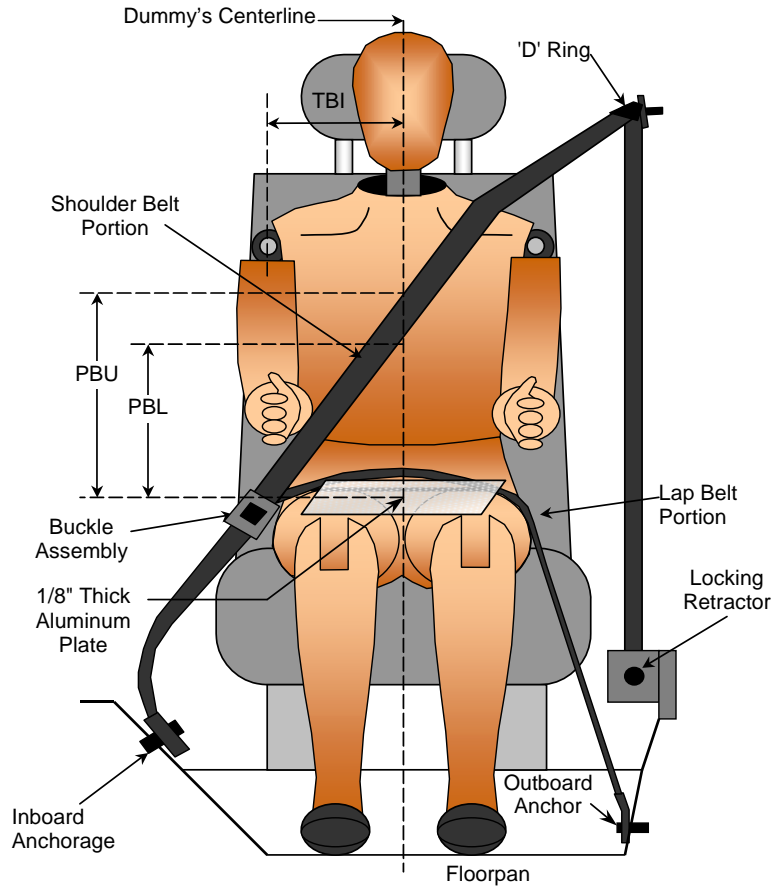

FRONT VIEW OF DUMMY

SEAT BELT POSITIONING MEASUREMENTS

| Measurement Description | Units | Driver | Passenger |
|---|-------|--------|-----------|
| PBU - Top surface of reference to belt upper edge | mm | 365 | 310 |
| PBL - Top surface of reference to belt lower edge | mm | 290 | 220 |

BELT LENGTH DATA

| Measurement Description | Units | Driver | Passenger |
|--|-------|--------|-----------|
| Shoulder Belt Length as measured on ATD | mm | 900 | 975 |
| Lap Belt Length as measured on ATD | mm | 770 | 885 |
| Remainder of belt on reel | mm | 1630 | 1440 |
| Total Belt Length for Continuous Webbing Systems | mm | 3300 | 3300 |

**DATA SHEET NO. 6
HIGH-SPEED CAMERA LOCATIONS AND DATA**

Test Vehicle: 2013 Toyota RAV4 LE AWD SUV
Test Program: NCAP Frontal Barrier Impact Test

NHTSA No.: YD5112
Test Date: 09/06/2013

CAMERA POSITIONS FOR FRONTAL IMPACTS

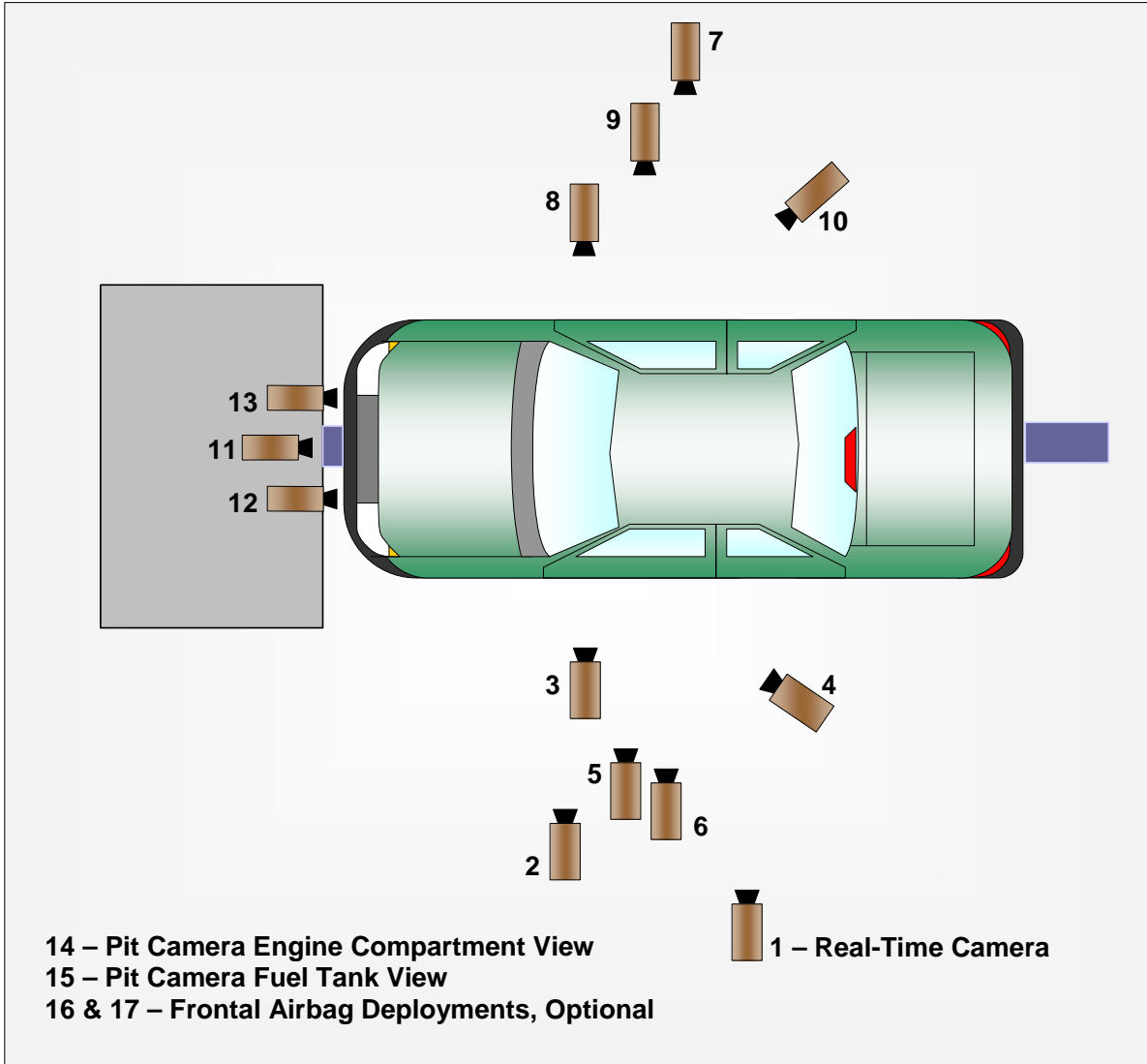

**DATA SHEET NO. 6 (CONTINUED)
CAMERA LOCATIONS AND DATA**

Test Vehicle: 2013 Toyota RAV4 LE AWD SUV
Test Program: NCAP Frontal Barrier Impact Test

NHTSA No.: YD5112
Test Date: 09/06/2013

CAMERA LOCATIONS

| No. | Camera View | Coordinates (mm) | | | Lens (mm) | Speed (fps) |
|-----|-----------------------------------|------------------|-------|-------|-----------|-------------|
| | | X* | Y* | Z* | | |
| 1 | Real-Time Left Overall | | | | | 30 |
| 2 | Driver Close-Up | 1170 | -6490 | -1900 | 35 | 1000 |
| 3 | Left Front Half | 1060 | -4950 | -1270 | 24 | 1000 |
| 4 | Left Angle | 5250 | -5470 | -2030 | 50 | 1000 |
| 5 | Steering Column - Top | 560 | -5070 | -1170 | 24 | 1000 |
| 6 | Steering Column - Bottom | 540 | -5040 | -770 | 24 | 1000 |
| 7 | Right Overall | 2090 | 6400 | -1240 | 20 | 1000 |
| 8 | Passenger Close-Up | 1530 | 6480 | -1840 | 35 | 1000 |
| 9 | Right Front Half | 1260 | 5140 | -1200 | 24 | 1000 |
| 10 | Right Angle | 5630 | 4800 | -1980 | 50 | 1000 |
| 11 | Windshield | -50 | 0 | -2810 | 24 | 1000 |
| 12 | Driver Windshield | 30 | -450 | -2030 | 8.5 | 1000 |
| 13 | Passenger Windshield | 30 | 450 | -2030 | 8.5 | 1000 |
| 14 | Pit Front | 960 | 0 | 3150 | 24 | 1000 |
| 15 | Pit Rear | 2880 | 0 | 3150 | 24 | 1000 |
| 16 | Onboard Driver Side (optional) | | | | | |
| 17 | Onboard Passenger Side (optional) | | | | | |
| 18 | Real-Time Pan View | | | | | 30 |

***COORDINATES:**

- +X = forward of impact plane
- +Y = right of monorail centerline
- +Z = below ground level

Cameras 16 & 17 were not used for this test.

**DATA SHEET NO. 7
VEHICLE ACCELEROMETER LOCATIONS**

Test Vehicle: 2013 Toyota RAV4 LE AWD SUV
 Test Program: NCAP Frontal Barrier Impact Test

NHTSA No.: YD5112
 Test Date: 09/06/2013

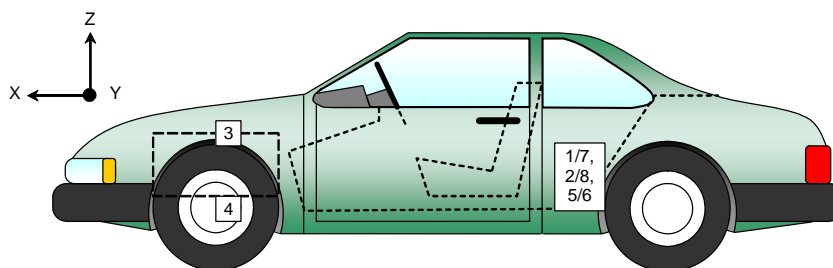
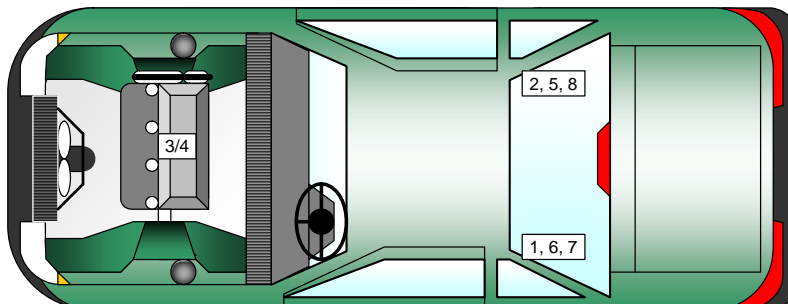

VEHICLE ACCELEROMETER PRE-TEST LOCATIONS

| No. | Accelerometer Location | Measurements (mm) | | |
|-----|--|-------------------|------|------|
| | | X | Y | Z |
| 1 | Left Rear Crossmember Accelerometer – X Direction | 1675 | -568 | -462 |
| 2 | Right Rear Crossmember Accelerometer – X Direction | 1692 | 573 | -464 |
| 3 | Engine Top X | 3833 | 0 | -924 |
| 4 | Engine Bottom X | 3807 | 145 | -205 |
| 5 | Left Rear Crossmember Accelerometer – Z Direction | 1683 | -477 | -456 |
| 6 | Right Rear Crossmember Accelerometer – Z Direction | 1700 | 474 | -461 |
| 7 | Left Rear Crossmember Accelerometer Redundant – X Direction | 1675 | -568 | -462 |
| 8 | Right Rear Crossmember Accelerometer Redundant – X Direction | 1692 | 573 | -464 |

Reference Points: X - Rear Surface of Vehicle (+ forward)
 Y - Vehicle Centerline (+ to right)
 Z - Ground Plane (+ down)

DATA SHEET NO. 8
PHOTOGRAPHIC REFERENCE TARGET LOCATIONS

Test Vehicle: 2013 Toyota RAV4 LE AWD SUV
 Test Program: NCAP Frontal Barrier Impact Test

NHTSA No.: YD5112
 Test Date: 09/06/2013

| Item | Value (mm) |
|------|------------|
| A | 380 |
| B | 869 |
| C | 2260 |
| D | 664 |
| E | 1642 |
| F | 90 |
| G | |
| H | 1184 |
| I | 1370 |
| J | 862 |
| K | 862 |
| L | 1472 |
| M | 1184 |
| N | 1472 |
| O | 862 |
| P | 862 |
| Q | 1370 |

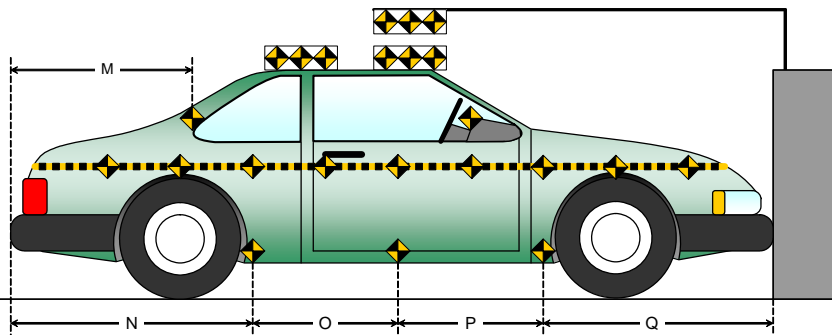
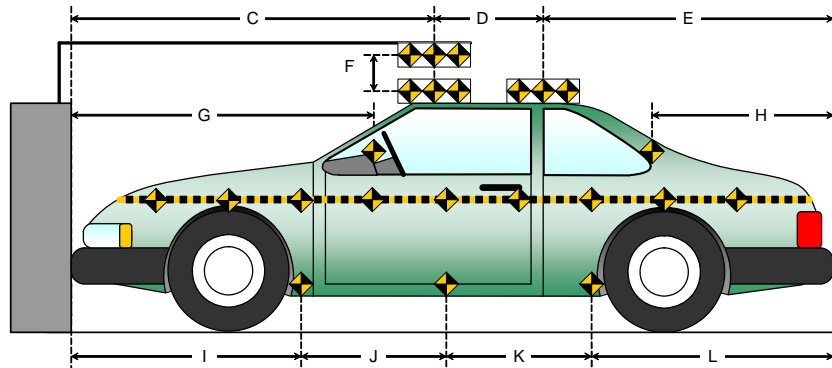
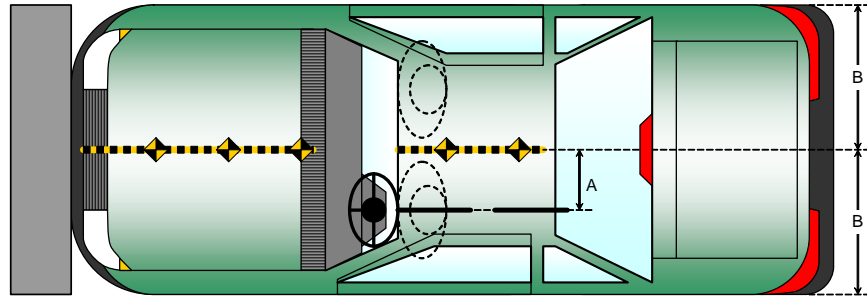

**DATA SHEET NO. 9
LOAD CELL LOCATIONS ON FIXED BARRIER**

Test Vehicle: 2013 Toyota RAV4 LE AWD SUV
 Test Program: NCAP Frontal Barrier Impact Test

NHTSA No.: YD5112
 Test Date: 09/06/2013

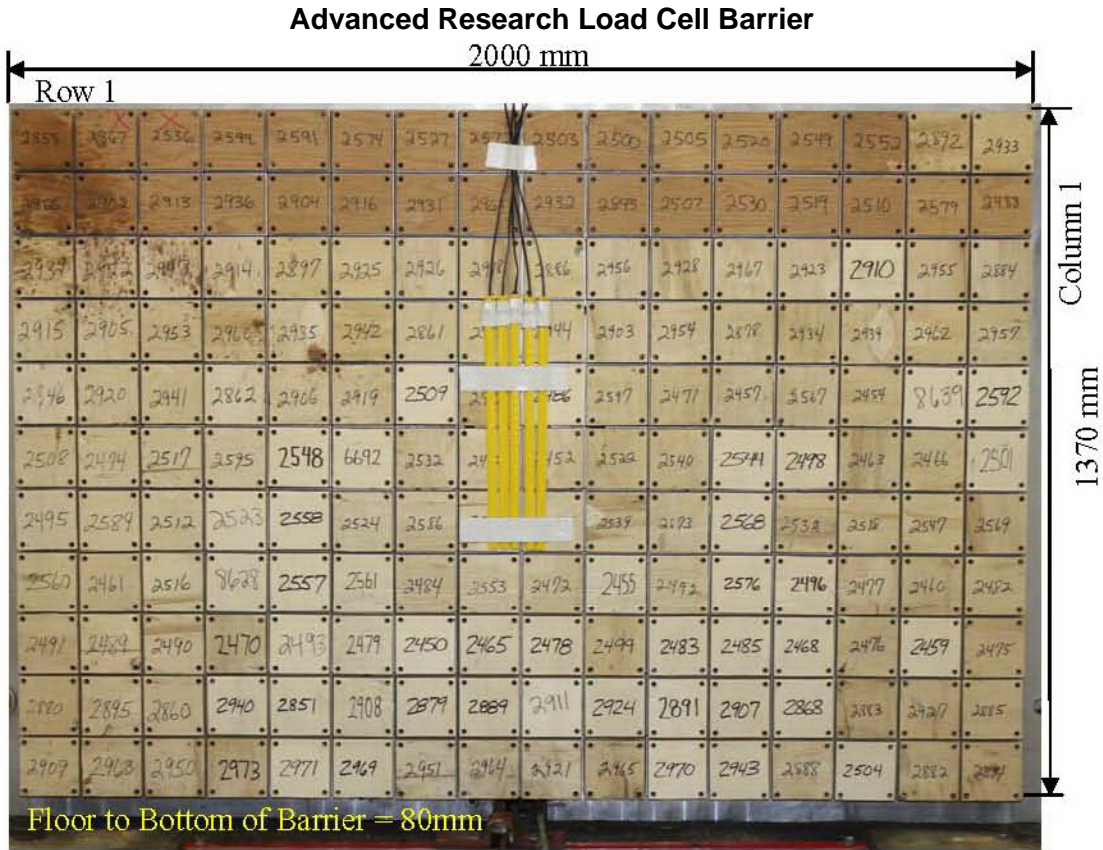

Photo for Reference Only

| | | | | | | | | Centerline | | | | | | | | |
|------|------|------|------|------|------|------|------|------------|------|------|------|------|------|------|------|--|
| A-16 | A-15 | A-14 | A-13 | A-12 | A-11 | A-10 | A-09 | A-08 | A-07 | A-06 | A-05 | A-04 | A-03 | A-02 | A-01 | |
| B-16 | B-15 | B-14 | B-13 | B-12 | B-11 | B-10 | B-09 | B-08 | B-07 | B-06 | B-05 | B-04 | B-03 | B-02 | B-01 | |
| C-16 | C-15 | C-14 | C-13 | C-12 | C-11 | C-10 | C-09 | C-08 | C-07 | C-06 | C-05 | C-04 | C-03 | C-02 | C-01 | |
| D-16 | D-15 | D-14 | D-13 | D-12 | D-11 | D-10 | D-09 | D-08 | D-07 | D-06 | D-05 | D-04 | D-03 | D-02 | D-01 | |
| E-16 | E-15 | E-14 | E-13 | E-12 | E-11 | E-10 | E-09 | E-08 | E-07 | E-06 | E-05 | E-04 | E-03 | E-02 | E-01 | |
| F-16 | F-15 | F-14 | F-13 | F-12 | F-11 | F-10 | F-09 | F-08 | F-07 | F-06 | F-05 | F-04 | F-03 | F-02 | F-01 | |
| G-16 | G-15 | G-14 | G-13 | G-12 | G-11 | G-10 | G-09 | G-08 | G-07 | G-06 | G-05 | G-04 | G-03 | G-02 | G-01 | |
| H-16 | H-15 | H-14 | H-13 | H-12 | H-11 | H-10 | H-09 | H-08 | H-07 | H-06 | H-05 | H-04 | H-03 | H-02 | H-01 | |
| I-16 | I-15 | I-14 | I-13 | I-12 | I-11 | I-10 | I-09 | I-08 | I-07 | I-06 | I-05 | I-04 | I-03 | I-02 | I-01 | |
| J-16 | J-15 | J-14 | J-13 | J-12 | J-11 | J-10 | J-09 | J-08 | J-07 | J-06 | J-05 | J-04 | J-03 | J-02 | J-01 | |
| K-16 | K-15 | K-14 | K-13 | K-12 | K-11 | K-10 | K-09 | K-08 | K-07 | K-06 | K-05 | K-04 | K-03 | K-02 | K-01 | |

Load Cells are 121 mm x 121 mm with a 7 mm gap in between each load cell.

**DATA SHEET NO. 10
TEST VEHICLE SUMMARY OF RESULTS**

Test Vehicle: 2013 Toyota RAV4 LE AWD SUV
Test Program: NCAP Frontal Barrier Impact Test

NHTSA No.: YD5112
Test Date: 09/06/2013

INSTRUMENTATION

| | |
|----------------------------------|-----|
| Driver Dummy Data Channels | 46 |
| Passenger Dummy Data Channels | 46 |
| Vehicle Structure Accelerometers | 8 |
| Barrier Channels | 528 |
| Total | 628 |

CAMERA COVERAGE

| | |
|----------------------------|----|
| High-Speed Vehicle Onboard | 0 |
| High-Speed Offboard | 14 |
| Real-Time | 2 |
| Total | 16 |

**DATA SHEET NO. 11
POST-TEST OBSERVATIONS**

Test Vehicle: 2013 Toyota RAV4 LE AWD SUV
 Test Program: NCAP Frontal Barrier Impact Test

NHTSA No.: YD5112
 Test Date: 09/06/2013

TEST DUMMY INFORMATION AND CONTACT LOCATIONS

| Description | Driver | Passenger |
|-------------------------|------------------|----------------------------|
| Dummy Type / Serial No. | HIII 50% / 036 | HIII 5% / 138 |
| Head Contact | Airbag, Headrest | Airbag, Headrest, Seatback |
| Upper Torso Contact | Airbag | Airbag |
| Lower Torso Contact | None | None |
| Left Knee Contact | Knee Airbag | Glove Box |
| Right Knee Contact | Knee Airbag | Glove Box |

DOOR OPENING AND SEAT TRACK INFORMATION

| Description | Driver | Passenger |
|-----------------------|--|--|
| Locked/Unlocked Doors | Doors were unlocked | Doors were unlocked |
| Front Door Opening | Door remained closed and latched; Door opened without tools | Door remained closed and latched; Door opened without tools |
| Rear Door Opening | Door remained closed and latched; Door opened without tools | Door remained closed and latched; Door opened without tools |
| Seat Track Shift (mm) | 0 | 0 |
| Seat Back Failure | None | None |

POST TEST STRUCTURAL OBSERVATIONS

| Critical Areas of Performance | Observations and Conclusions |
|-------------------------------|------------------------------|
| Windshield Damage | None |
| Window Damage | None |
| Other Notable Effects | None |

VEHICLE REBOUND FROM BARRIER

| Measured Parameter | Units | Value |
|--------------------|-------|-------|
| Left Side | mm | 730 |
| Center | mm | 675 |
| Right Side | mm | 735 |
| Average | mm | 713 |

SUPPLEMENTAL RESTRAINT SYSTEM INFORMATION

| Restraint Type | Left Front (Driver) P1 | | Right Front (Passenger) P2 | |
|--------------------------|------------------------|----------|----------------------------|----------|
| | Mounted | Deployed | Mounted | Deployed |
| Frontal Airbag | Yes | Yes | Yes | Yes |
| Curtain Side Airbag | Yes | No | Yes | No |
| Torso/Pelvis Side Airbag | Yes | No | Yes | No |
| Knee Airbag | Yes | Yes | No | |
| Seat Belt Pretensioner | Yes | Yes | Yes | Yes |
| Seat Belt Load Limiter | Yes | | Yes | |

DATA SHEET NO. 12 VEHICLE PROFILE MEASUREMENTS

Test Vehicle: 2013 Toyota RAV4 LE AWD SUV
 Test Program: NCAP Frontal Barrier Impact Test

NHTSA No.: YD5112
 Test Date: 09/06/2013

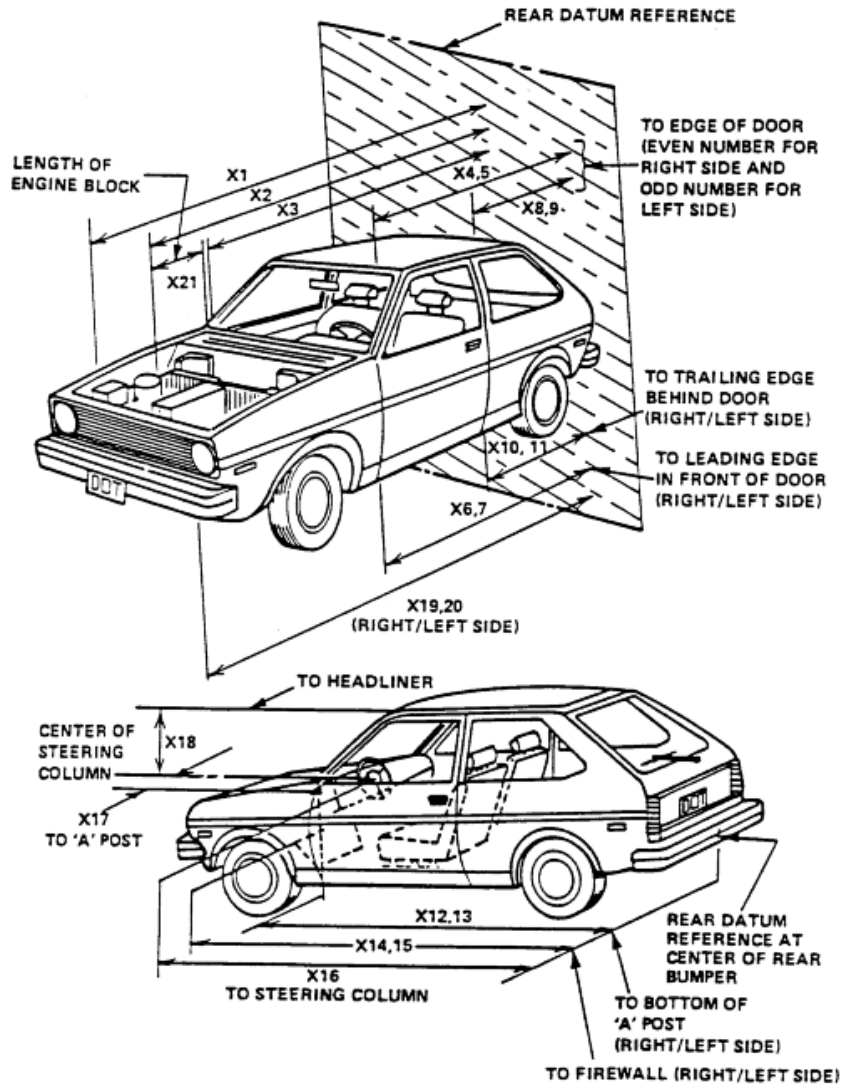

**DATA SHEET NO. 12 (CONTINUED)
VEHICLE PROFILE MEASUREMENTS**

Test Vehicle: 2013 Toyota RAV4 LE AWD SUV
Test Program: NCAP Frontal Barrier Impact Test

NHTSA No.: YD5112
Test Date: 09/06/2013

RSOV (Rear Surface of Vehicle)

| No. | Measurement Description | Units | Pre-Test | Post-Test | Difference |
|-----|---|-------|----------|-----------|------------|
| 1 | Total Length of Vehicle at Centerline | mm | 4566 | 4114 | 452 |
| 2 | RSOV to Front of Engine | mm | 4092 | 3815 | 277 |
| 3 | RSOV to Firewall | mm | 3372 | 3370 | 2 |
| 4 | RSOV to Upper Leading Edge of Right Door | mm | 3130 | 3128 | 2 |
| 5 | RSOV to Upper Leading Edge of Left Door | mm | 3130 | 3130 | 0 |
| 6 | RSOV to Lower Leading Edge of Right Door | mm | 3099 | 3095 | 4 |
| 7 | RSOV to Lower Leading Edge of Left Door | mm | 3099 | 3095 | 4 |
| 8 | RSOV to Upper Trailing Edge of Right Door | mm | 2072 | 2072 | 0 |
| 9 | RSOV to Upper Trailing Edge of Left Door | mm | 2072 | 2071 | 1 |
| 10 | RSOV to Lower Trailing Edge of Right Door | mm | 2078 | 2078 | 0 |
| 11 | RSOV to Lower Trailing Edge of Left Door | mm | 2078 | 2075 | 3 |
| 12 | RSOV to Bottom of "A" Post of Right Side | mm | 3092 | 3089 | 3 |
| 13 | RSOV to Bottom of "A" Post of Left Side | mm | 3092 | 3089 | 3 |
| 14 | RSOV to Firewall, Right Side | mm | 3278 | 3275 | 3 |
| 15 | RSOV to Firewall, Left Side | mm | 3278 | 3274 | 4 |
| 16 | RSOV to Steering Column | mm | 2683 | 2755 | -72 |
| 17 | Center of Steering Column to "A" Post | mm | 404 | 414 | -10 |
| 18 | Center of Steering Column to Headliner | mm | 456 | 491 | -35 |
| 19 | RSOV to Right Side of Front Bumper | mm | 4451 | 4065 | 386 |
| 20 | RSOV to Left Side of Front Bumper | mm | 4451 | 4051 | 400 |
| 21 | Length of Engine Block | mm | 524 | 524 | 0 |
| RD | RSOV to Right Side of Dash Panel | mm | 2977 | 2989 | -12 |
| CD | RSOV to Center of Dash Panel | mm | 2990 | 2995 | -5 |
| LD | RSOV to Left Side of Dash Panel | mm | 2978 | 2990 | -12 |

DATA SHEET NO. 13
ACCIDENT INVESTIGATION DIVISION DATA

Test Vehicle: 2013 Toyota RAV4 LE AWD SUV
Test Program: NCAP Frontal Barrier Impact Test

NHTSA No.: YD5112
Test Date: 09/06/2013

VEHICLE INFORMATION

VIN: 2T3BFREVDW070736 Wheelbase (mm): 2662
Vehicle Size Category: MPV Test Weight (kg): 1815.3

ACCELEROMETER DATA

Accelerometer Locations: As per measurements on Page 15

Cal. Procedure/Interval: MGA procedure / 6 month

Integration Algorithm: Trapezoidal

Linearity: > 99%

Impact Velocity (km/h): 56.6

Velocity Change (km/h): 63.8

Time of Separation (msec): 79.0

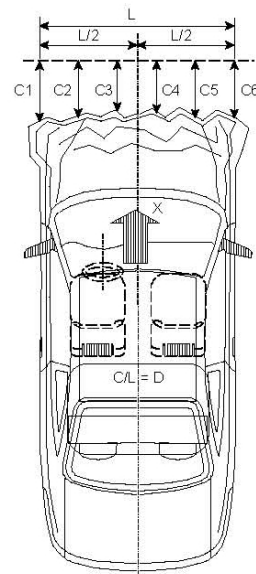

CRUSH PROFILE

Collision Deformation Classification: Frontal

Midpoint of Damage: Centerline

Damage Region Length (mm): 1228

Impact Mode: Frontal

| No. | Measurement Description | Units | Pre-Test | Post-Test | Difference |
|-----|----------------------------|-------|----------|-----------|------------|
| C1 | Crush zone 1 at left side | mm | 4451 | 4051 | 400 |
| C2 | Crush zone 2 at left side | mm | 4511 | 4096 | 415 |
| C3 | Crush zone 3 at left side | mm | 4530 | 4115 | 415 |
| C4 | Crush zone 4 at right side | mm | 4530 | 4110 | 420 |
| C5 | Crush zone 5 at right side | mm | 4511 | 4099 | 412 |
| C6 | Crush zone 6 at right side | mm | 4451 | 4065 | 386 |
| L | C1 TO C6 | mm | 1228 | 1226 | 2 |

**DATA SHEET NO. 14
VEHICLE INTRUSION MEASUREMENTS**

Test Vehicle: 2013 Toyota RAV4 LE AWD SUV
 Test Program: NCAP Frontal Barrier Impact Test

NHTSA No.: YD5112
 Test Date: 09/06/2013

DOOR OPENING WIDTH

| Item | Description | Units | Pre-Test | Post-Test | Difference |
|------|------------------|-------|----------|-----------|------------|
| A | Left Side Upper | mm | 975 | 975 | 0 |
| B | Left Side Lower | mm | 880 | 880 | 0 |
| D | Right Side Upper | mm | 975 | 975 | 0 |
| E | Right Side Lower | mm | 880 | 880 | 0 |

WHEELBASE MEASUREMENTS

| Item | Description | Units | Pre-Test | Post-Test | Difference |
|------|----------------------|-------|----------|-----------|------------|
| C | Left Side Wheelbase | mm | 2662 | 2614 | 48 |
| F | Right Side Wheelbase | mm | 2662 | 2671 | -9 |

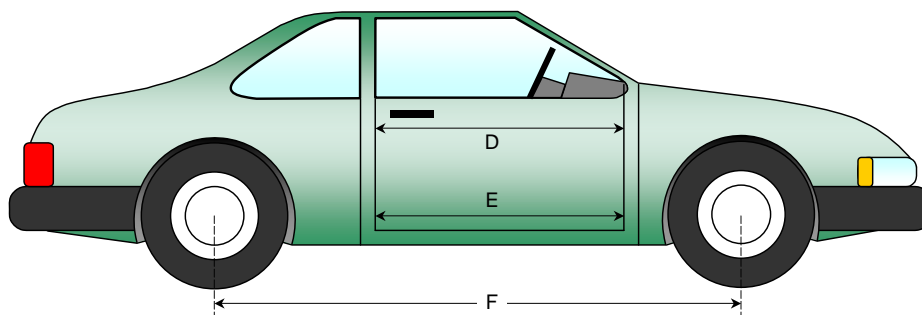
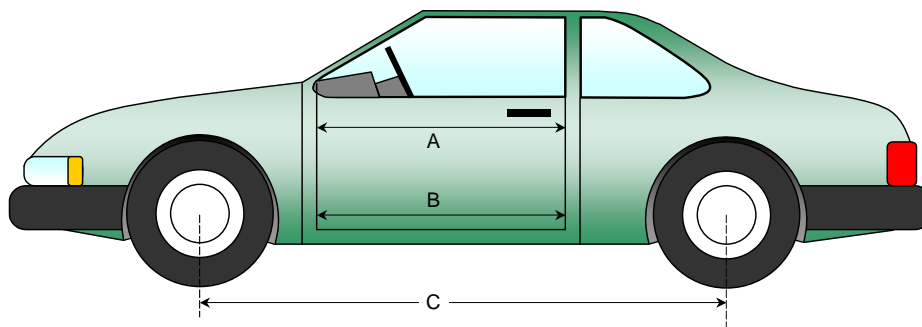

**DATA SHEET NO. 14 (CONTINUED)
VEHICLE INTRUSION MEASUREMENTS**

Test Vehicle: 2013 Toyota RAV4 LE AWD SUV
 Test Program: NCAP Frontal Barrier Impact Test

NHTSA No.: YD5112
 Test Date: 09/06/2013

DRIVER COMPARTMENT INTRUSION

| Item | Description | Units | Pre-Test | Post-Test | Difference |
|------|--|-------|----------|-----------|------------|
| AB | Door Opening (Inside Window Jam) | mm | 819 | 819 | 0 |
| CX | Left Knee Bolster to X | mm | 271 | 288 | -17 |
| DX | Right Knee Bolster to X | mm | 183 | 208 | -25 |
| EX | Brake Pedal to X | mm | 572 | 555 | 17 |
| FX | Foot Rest to X | mm | 578 | 559 | 19 |
| GX | Center of Steering Column Wheel Hub to X | mm | 89 | 180 | -91 |

X = Front of Seat Track (stationary)

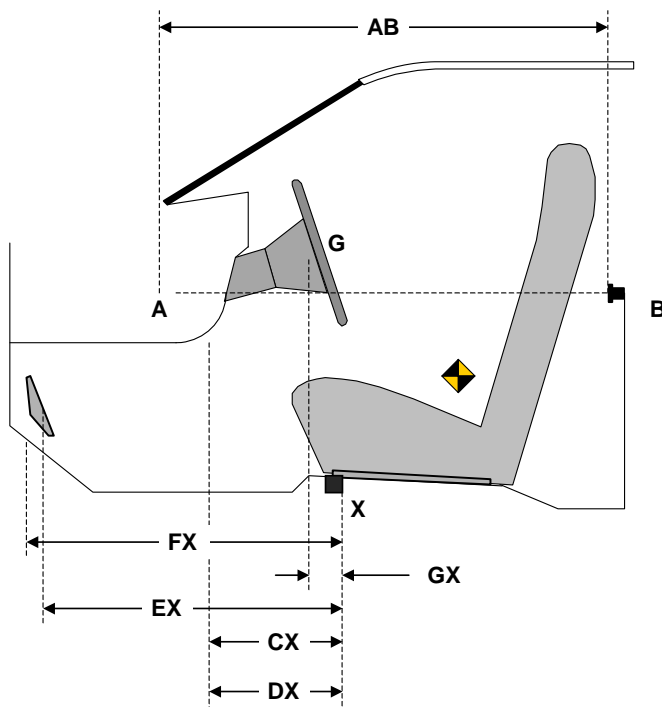

DRIVER COMPARTMENT

DATA SHEET NO. 15
SUMMARY OF FMVSS 212, FMVSS 219 (PARTIAL) DATA, AND 301 DATA

Test Vehicle: 2013 Toyota RAV4 LE AWD SUV
 Test Program: NCAP Frontal Barrier Impact Test

NHTSA No.: YD5112
 Test Date: 09/06/2013

Windshield Mounting Details:

Windshield glass is secured to the vehicle frame with a rubber trim and glue.

The standard requires that the post-test retention measurement be a minimum of 75 percent of the pre-test total periphery measurement for vehicles not equipped with occupant passive restraints and 50 percent for each side of the windshield for vehicles which are equipped with occupant passive restraints.

Temperature of windshield molding during test: 20.8°C

WINDSHIELD PERIPHERY MEASUREMENTS

| Measurement | Pre-Test (mm) | Post-Test (mm) | % of Retention |
|-------------|---------------|----------------|----------------|
| Left Side | 2113 | 2113 | 100 |
| Right Side | 2113 | 2113 | 100 |
| Total | 4226 | 4226 | 100 |

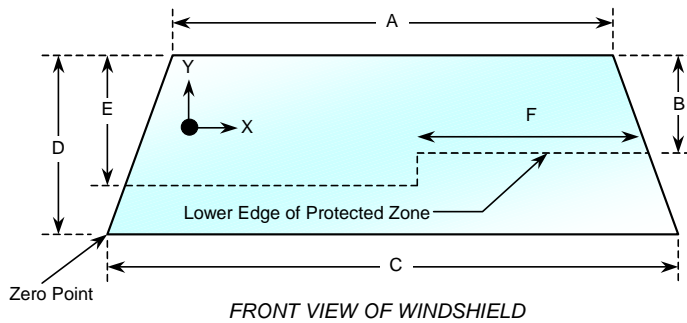

| Item | Units | Value |
|------|-------|-------|
| A | mm | 1198 |
| B | mm | 490 |
| C | mm | 1368 |
| D | mm | 830 |
| E | mm | 490 |
| F | mm | 538 |

AREA OF PROTECTED ZONE FAILURES - NONE

A. Provide coordinates of the area that the protected zone was penetrated more than 0.25 inches by a vehicle component other than one that is normally in contact with the windshield. **None**

| X | Y |
|---|---|
| | |
| | |
| | |
| | |

B. Provide coordinates of the area beneath the protected zone that the inner surface of the windshield was penetrated by a vehicle component. **None**

| X | Y |
|---|---|
| | |
| | |
| | |
| | |

DATA SHEET NO. 15 (CONTINUED)
SUMMARY OF FMVSS 212, FMVSS 219 (PARTIAL), AND 301 DATA

Test Vehicle: 2013 Toyota RAV4 LE AWD SUV
Test Program: NCAP Frontal Barrier Impact Test

NHTSA No.: YD5112
Test Date: 09/06/2013

FMVSS 301 FUEL SYSTEM INTEGRITY POST IMPACT DATA

Temperature at Time of Impact: 20.8°C Test Time: 10:37 a.m.

- A. From impact until vehicle motion ceases: 0 oz.
(Maximum allowable = 1 oz.)
- B. For the 5 minute period after motion ceases: 0 oz.
(Maximum allowable = 5 oz.)
- C. For the following 25 minutes: 0 oz.
(Maximum allowable = 1 oz./minute)
- D. Spillage: None

**DATA SHEET NO. 16
FMVSS 301 STATIC ROLLOVER RESULTS**

Test Vehicle: 2013 Toyota RAV4 LE AWD SUV
 Test Program: NCAP Frontal Barrier Impact Test

NHTSA No.: YD5112
 Test Date: 09/06/2013

1. The specified fixture rollover rate for each 90° of rotation is 60 to 180 seconds.
2. The position hold time at each position is 300 seconds (minimum).
3. Details of Stoddard Solvent spillage: **None**

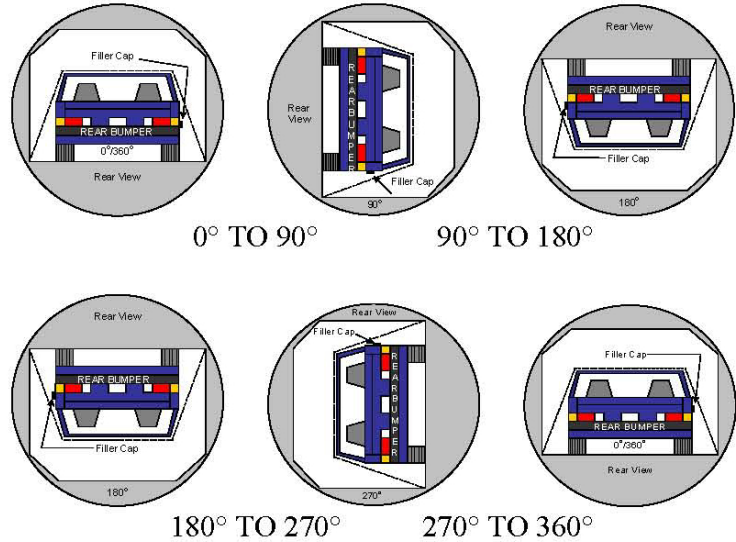

SOLVENT COLLECTION TIME TABLE IN SECONDS

| Test Phase | Rotation Time | Hold Time | Total Time |
|--------------|---------------|-----------|------------|
| 0° to 90° | 111 | 300 | 411 |
| 90° to 180° | 111 | 300 | 411 |
| 180° to 270° | 108 | 300 | 408 |
| 270° to 360° | 108 | 300 | 408 |

FMVSS 301 SPILLAGE TABLE (units in ounces)

| Test Phase | First 5 Minutes | Sixth Minute | Seventh Minute | Eight Minute |
|--------------|-----------------|--------------|----------------|--------------|
| 0° to 90° | 0 | 0 | 0 | 0 |
| 90° to 180° | 0 | 0 | 0 | 0 |
| 180° to 270° | 0 | 0 | 0 | 0 |
| 270° to 360° | 0 | 0 | 0 | 0 |

SOLVENT SPILLAGE LOCATION TABLE

| Test Phase | Spillage Location |
|--------------|-------------------|
| 0° to 90° | |
| 90° to 180° | |
| 180° to 270° | |
| 270° to 360° | |

DATA SHEET NO. 17
DUMMY/VEHICLE TEMPERATURE STABILIZATION DATA

Test Vehicle: 2013 Toyota RAV4 LE AWD SUV
 Test Program: NCAP Frontal Barrier Impact Test

NHTSA No.: YD5112
 Test Date: 09/06/2013

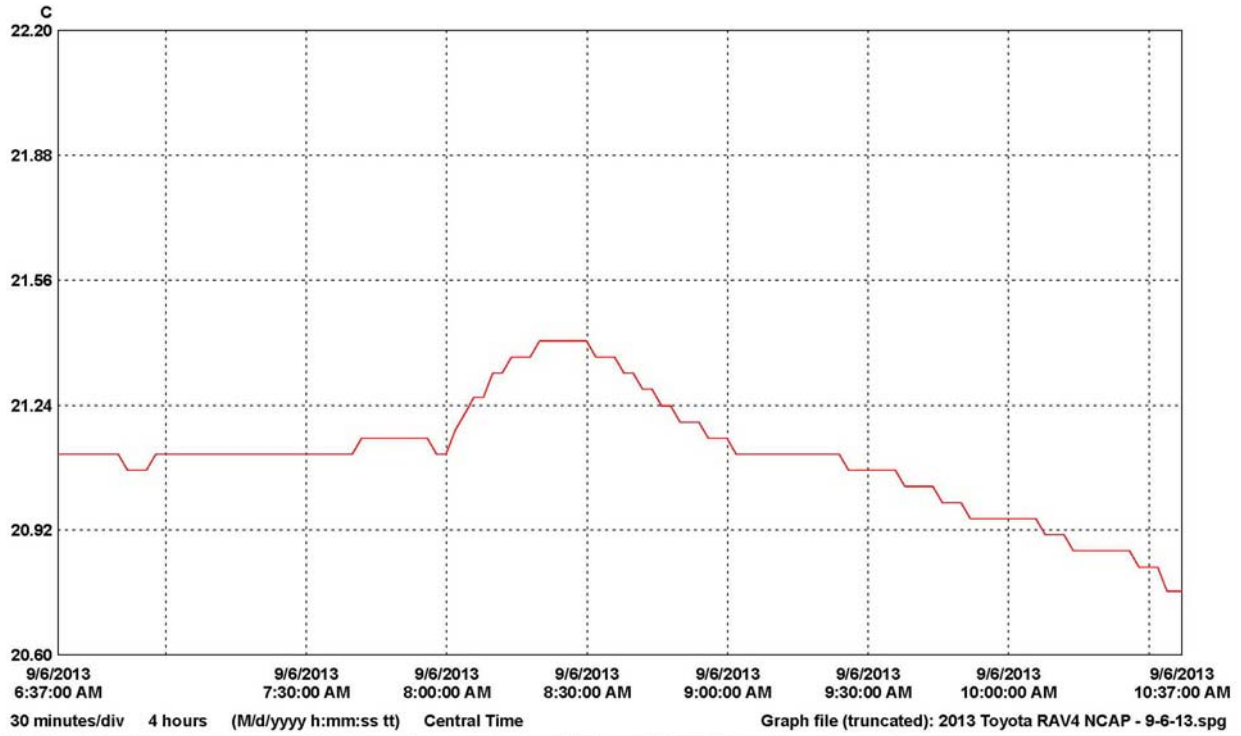

| LN | Serial # | Description | CH | Value | Maximum | Average | Minimum | Units | CH description | Logger file |
|----|----------|------------------|----|-------|---------|---------|---------|-------|----------------|-------------------------------|
| 1 | 10102162 | MGATemp_10102162 | 1 | | 21.40 | 21.11 | 20.76 | C | Temperature | 10102162_MGATemp_10102162.spl |

**APPENDIX A
PHOTOGRAPHS**

TABLE OF PHOTOGRAPHS

| | | <u>Page No.</u> |
|---------------|---|-----------------|
| Photo No. 1. | Load Cell Location | A-1 |
| Photo No. 2. | Load Cell Wall | A-1 |
| Photo No. 3. | Manufacturer's Label | A-2 |
| Photo No. 4. | Reduced Load Carrying Capacity Label | A-2 |
| Photo No. 5. | Tire Placard | A-3 |
| Photo No. 6. | 2013 Toyota RAV4 SUV Frontal As Delivered | A-3 |
| Photo No. 7. | Left Rear 3-4 View, As Received | A-4 |
| Photo No. 8. | Pre-Test Front View of Test Vehicle | A-4 |
| Photo No. 9. | Post-Test Front View of Test Vehicle | A-5 |
| Photo No. 10. | Pre-Test Left View of Test Vehicle | A-5 |
| Photo No. 11. | Post-Test Left View of Test Vehicle | A-6 |
| Photo No. 12. | Pre-Test Right View of Test Vehicle | A-6 |
| Photo No. 13. | Post-Test Right View of Test Vehicle | A-7 |
| Photo No. 14. | Pre-Test Right Front 3-4 View | A-7 |
| Photo No. 15. | Post-Test Right Front 3-4 View | A-8 |
| Photo No. 16. | Pre-Test Left Rear 3-4 View | A-8 |
| Photo No. 17. | Post-Test Left Rear 3-4 View | A-9 |
| Photo No. 18. | Pre-Test Windshield View | A-9 |
| Photo No. 19. | Post-Test Windshield View | A-10 |
| Photo No. 20. | Pre-Test Engine Compartment View | A-10 |
| Photo No. 21. | Post-Test Engine Compartment View | A-11 |
| Photo No. 22. | Pre-Test Fuel Filler Cap View | A-11 |
| Photo No. 23. | Post-Test Fuel Filler Cap View | A-12 |
| Photo No. 24. | Pre-Test Front Underbody View | A-12 |
| Photo No. 25. | Post-Test Front Underbody View | A-13 |
| Photo No. 26. | Pre-Test Mid Front Underbody View | A-13 |
| Photo No. 27. | Post-Test Mid Front Underbody View | A-14 |
| Photo No. 28. | Pre-Test Mid Rear Underbody View | A-14 |
| Photo No. 29. | Post-Test Mid Rear Underbody View | A-15 |
| Photo No. 30. | Pre-Test Rear Underbody View | A-15 |

| | | <u>Page No.</u> |
|---------------|---|-----------------|
| Photo No. 31. | Post-Test Rear Underbody View | A-16 |
| Photo No. 32. | Pre-Test Dummy Cable Routing | A-16 |
| Photo No. 33. | Post-Test Dummy Cable Routing | A-17 |
| Photo No. 34. | Pre-Test Driver Dummy Front View | A-17 |
| Photo No. 35. | Post-Test Driver Dummy Front View | A-18 |
| Photo No. 36. | Pre-Test Driver Dummy Window View | A-18 |
| Photo No. 37. | Post-Test Driver Dummy Window View | A-19 |
| Photo No. 38. | Pre-Test Driver Dummy and Vehicle Interior (Door Open) | A-19 |
| Photo No. 39. | Post-Test Driver Dummy and Vehicle Interior (Door Open) | A-20 |
| Photo No. 40. | Pre-Test Driver's Seat Fore-Aft Markings | A-20 |
| Photo No. 41. | Post-Test Driver's Seat Fore-Aft Markings | A-21 |
| Photo No. 42. | Pre-Test View of Belt Anchorage for Driver Dummy | A-21 |
| Photo No. 43. | Post-Test View of Belt Anchorage for Driver Dummy | A-22 |
| Photo No. 44. | Pre-Test Driver Dummy Feet | A-22 |
| Photo No. 45. | Post-Test Driver Dummy Feet | A-23 |
| Photo No. 46. | Pre-Test Driver's Side Knee Bolster (without dummy) | A-23 |
| Photo No. 47. | Post-Test Driver's Side Knee Bolster (without dummy) | A-24 |
| Photo No. 48. | Pre-Test Driver's Side Floorpan | A-24 |
| Photo No. 49. | Post-Test Driver's Side Floorpan | A-25 |
| Photo No. 50. | Post-Test Driver Dummy Face | A-25 |
| Photo No. 51. | Post-Test Driver Dummy Contact with Airbag | A-26 |
| Photo No. 52. | Post-Test Driver Dummy Contact with Headrest | A-26 |
| Photo No. 53. | Post-Test Driver Dummy Contact with Knee Airbag | A-27 |
| Photo No. 54. | Pre-Test View of the Steering Wheel | A-27 |
| Photo No. 55. | Post-Test View of the Steering Wheel | A-28 |
| Photo No. 56. | Pre-Test Passenger Dummy Front View | A-28 |
| Photo No. 57. | Post-Test Passenger Dummy Front View | A-29 |
| Photo No. 58. | Pre-Test Passenger Dummy Window View | A-29 |
| Photo No. 59. | Post-Test Passenger Dummy Window View | A-30 |
| Photo No. 60. | Pre-Test Passenger Dummy and Vehicle Interior (Door Open) | A-30 |

| | | <u>Page No.</u> |
|---------------|--|-----------------|
| Photo No. 61. | Post-Test Passenger Dummy and Vehicle Interior (Door Open) | A-31 |
| Photo No. 62. | Pre-Test Passenger's Seat Fore-Aft Markings | A-31 |
| Photo No. 63. | Post-Test Passenger's Seat Fore-Aft Markings | A-32 |
| Photo No. 64. | Pre-Test View of Belt Anchorage for Passenger Dummy | A-32 |
| Photo No. 65. | Post-Test View of Belt Anchorage for Passenger Dummy | A-33 |
| Photo No. 66. | Pre-Test Passenger Dummy Feet | A-33 |
| Photo No. 67. | Post-Test Passenger Dummy Feet | A-34 |
| Photo No. 68. | Pre-Test Passenger's Side Knee Bolster (without dummy) | A-34 |
| Photo No. 69. | Post-Test Passenger's Side Knee Bolster (without dummy) | A-35 |
| Photo No. 70. | Pre-Test Passenger's Side Floorpan | A-35 |
| Photo No. 71. | Post-Test Passenger's Side Floorpan | A-36 |
| Photo No. 72. | Post-Test Passenger Dummy Contact with Airbag | A-36 |
| Photo No. 73. | Post-Test Passenger Dummy Contact with Headrest and Seatback | A-37 |
| Photo No. 74. | Post-Test Passenger Dummy Contact with Glovebox | A-37 |
| Photo No. 75. | Ballast Installed in Vehicle | A-38 |
| Photo No. 76. | Post-Test Stoddard Solvent Spillage Location View | A-38 |
| Photo No. 77. | Post-Test Speed Trap Read-Out | A-39 |
| Photo No. 78. | Vehicle at 0 Degree on Static Rollover Device | A-39 |
| Photo No. 79. | Vehicle at 90 Degrees on Static Rollover Device | A-40 |
| Photo No. 80. | Vehicle at 180 Degrees on Static Rollover Device | A-40 |
| Photo No. 81. | Vehicle at 270 Degrees on Static Rollover Device | A-41 |
| Photo No. 82. | Vehicle at 360 Degrees on Static Rollover Device | A-41 |
| Photo No. 83. | 2013 Toyota RAV4 SUV Frontal Impact Event | A-42 |
| Photo No. 84. | Monroney Label | A-42 |

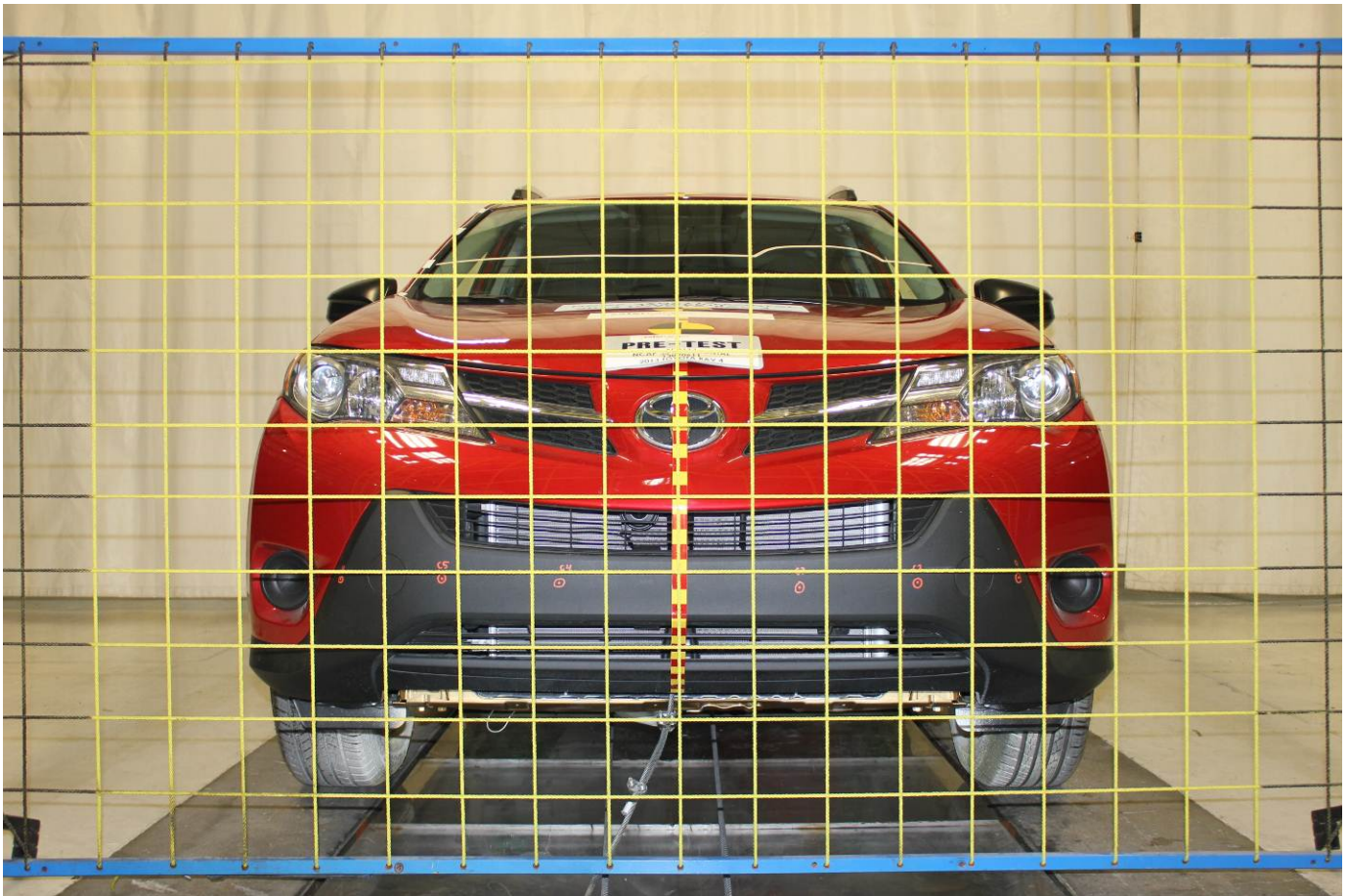

Load Cell Location

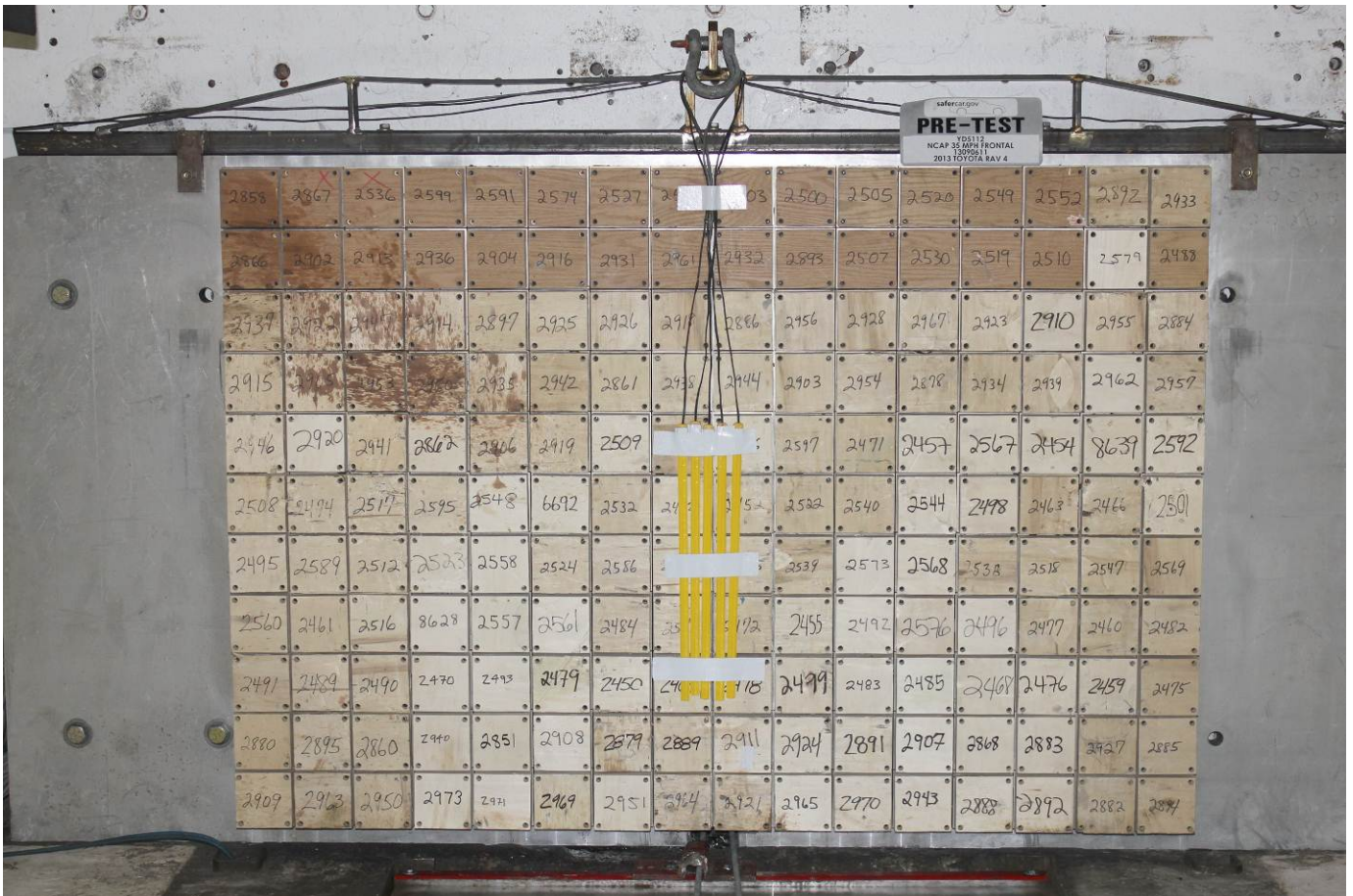

Load Cell Wall



Manufacturer's Label



Reduced Load Carrying Capacity Label

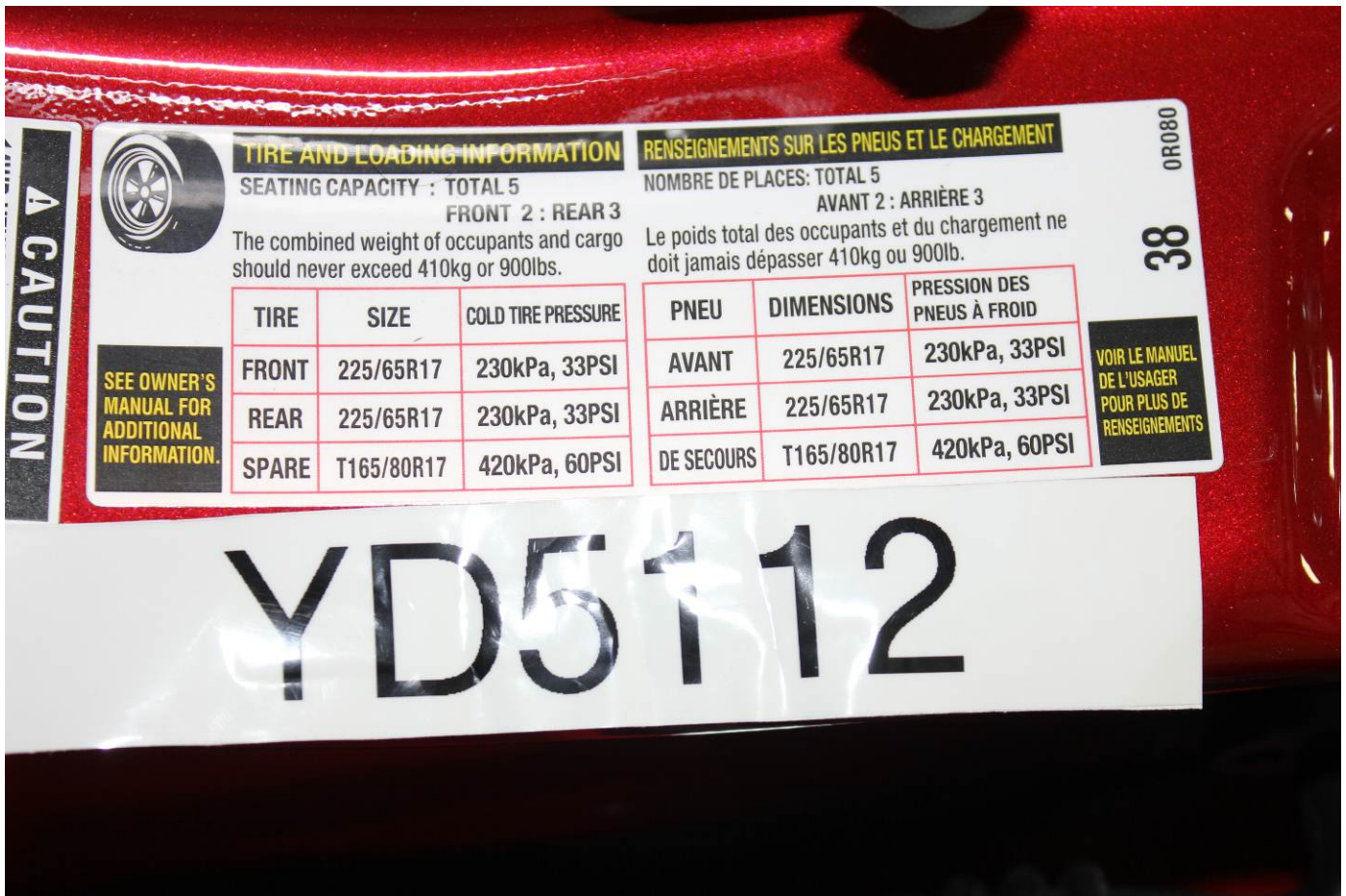

Tire Placard



2013 Toyota RAV4 SUV Frontal As Delivered



Left Rear 3-4 View, As Received



Pre-Test Front View of Test Vehicle



Post-Test Front View of Test Vehicle



Pre-Test Left View of Test Vehicle



Post-Test Left View of Test Vehicle



Pre-Test Right View of Test Vehicle



Post-Test Right View of Test Vehicle



Pre-Test Right Front 3-4 View



Post-Test Right Front 3-4 View



Pre-Test Left Rear 3-4 View



Post-Test Left Rear 3-4 View



Pre-Test Windshield View



Post-Test Windshield View



Pre-Test Engine Compartment View



Post-Test Engine Compartment View



Pre-Test Fuel Filler Cap View



Post-Test Fuel Filler Cap View

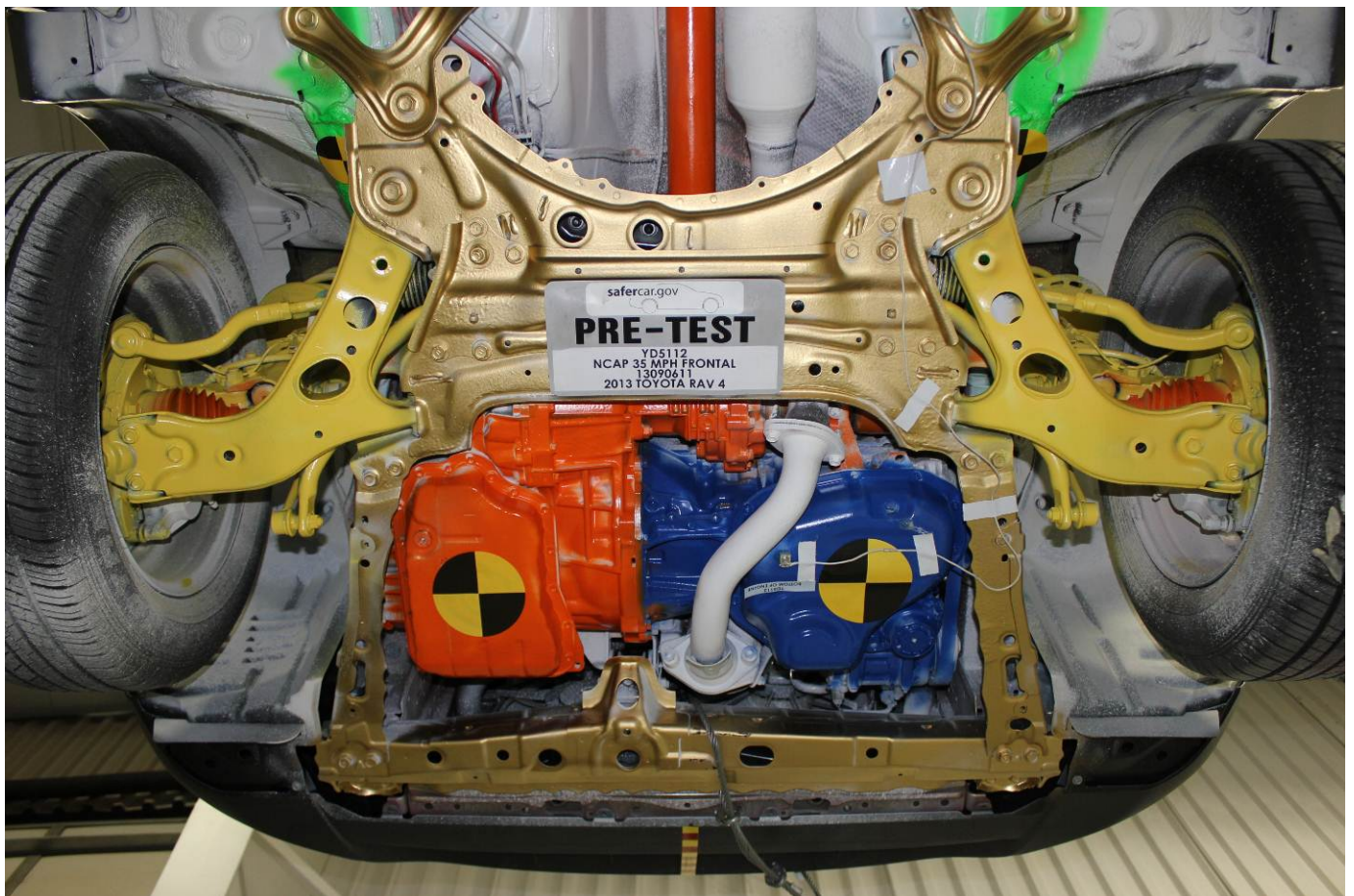

Pre-Test Front Underbody View

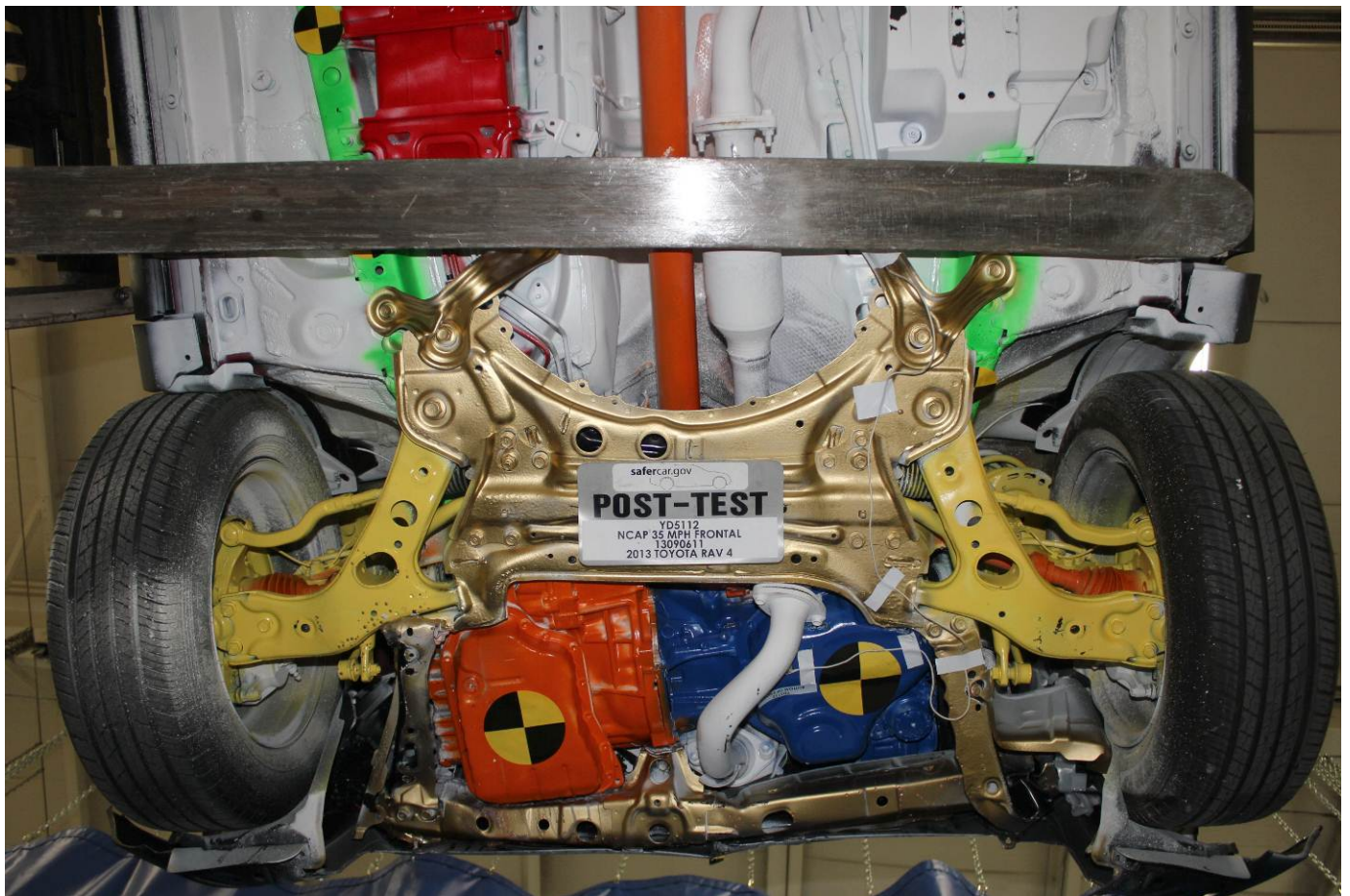

Post-Test Front Underbody View



Pre-Test Mid Front Underbody View



Post-Test Mid Front Underbody View



Pre-Test Mid Rear Underbody View



Post-Test Mid Rear Underbody View

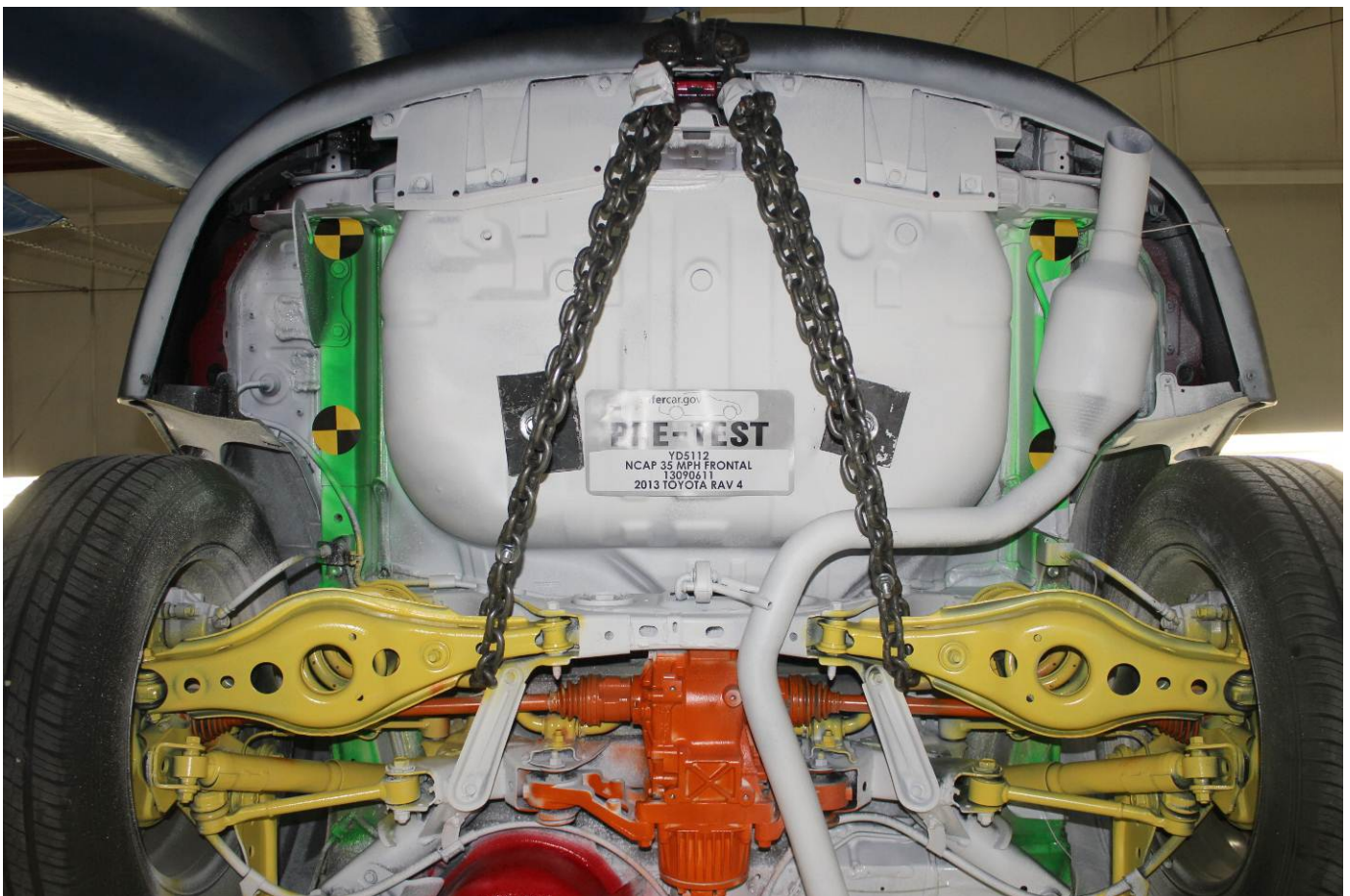

Pre-Test Rear Underbody View

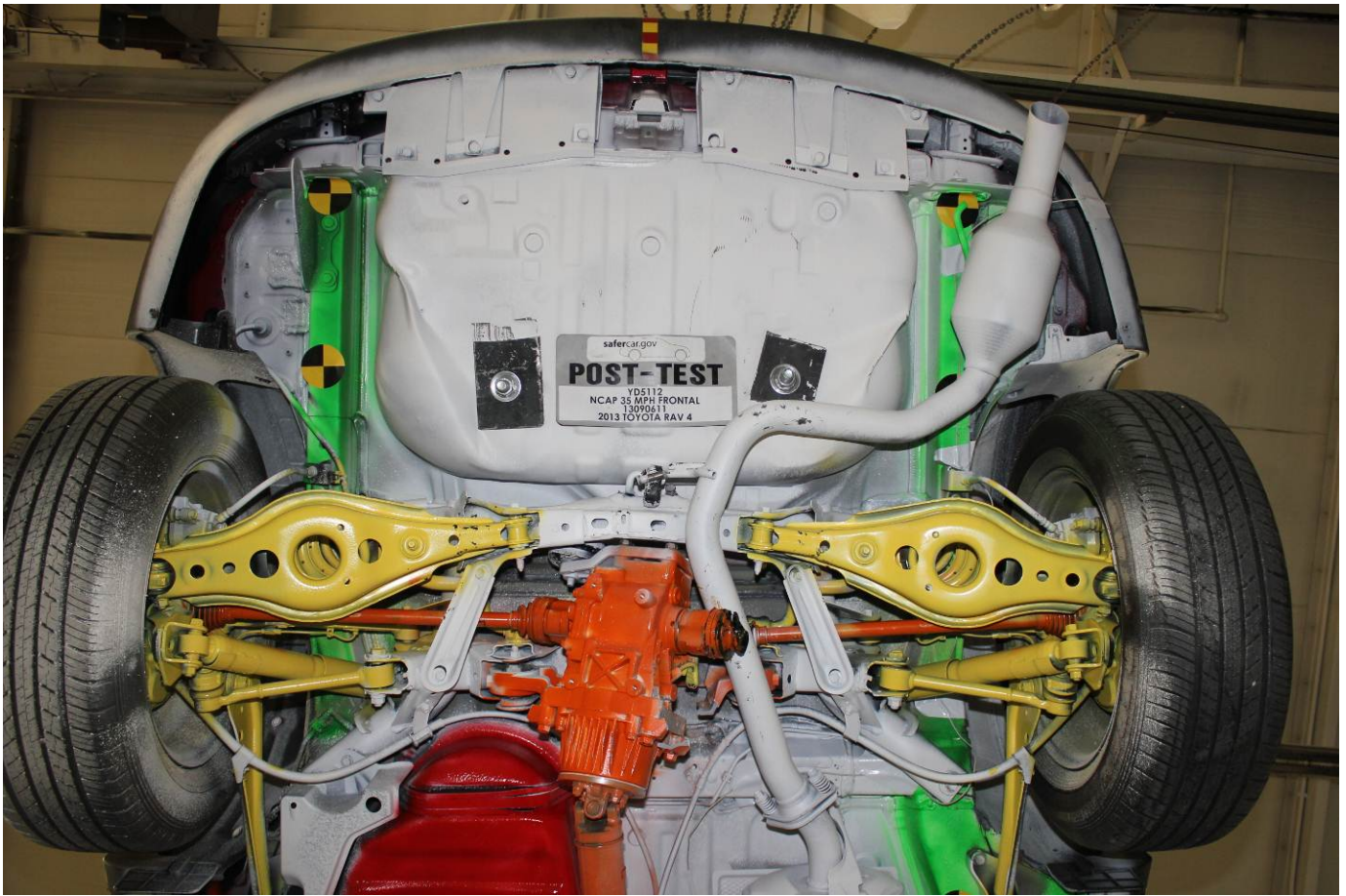

Post-Test Rear Underbody View



Pre-Test Dummy Cable Routing



Post-Test Dummy Cable Routing



Pre-Test Driver Dummy Front View



Post-Test Driver Dummy Front View



Pre-Test Driver Dummy Window View



Post-Test Driver Dummy Window View



Pre-Test Driver Dummy and Vehicle Interior (Door Open)



Post-Test Driver Dummy and Vehicle Interior (Door Open)



Pre-Test Driver's Seat Fore-Aft Markings



Post-Test Driver's Seat Fore-Aft Markings



Pre-Test View of Belt Anchorage for Driver Dummy



Post-Test View of Belt Anchorage for Driver Dummy



Pre-Test Driver Dummy Feet



Post-Test Driver Dummy Feet



Pre-Test Driver's Side Knee Bolster (without dummy)



Post-Test Driver's Side Knee Bolster (without dummy)



Pre-Test Driver's Side Floorpan



Post-Test Driver's Side Floorpan



Post-Test Driver Dummy Face



Post-Test Driver Dummy Contact with Airbag



Post-Test Driver Dummy Contact with Headrest



Post-Test Driver Dummy Contact with Knee Airbag



Pre-Test View of the Steering Wheel



Post-Test View of the Steering Wheel



Pre-Test Passenger Dummy Front View



Post-Test Passenger Dummy Front View



Pre-Test Passenger Dummy Window View



Post-Test Passenger Dummy Window View



Pre-Test Passenger Dummy and Vehicle Interior (Door Open)



Post-Test Passenger Dummy and Vehicle Interior (Door Open)



Pre-Test Passenger's Seat Fore-Aft Markings



Post-Test Passenger's Seat Fore-Aft Markings



Pre-Test View of Belt Anchorage for Passenger Dummy



Post-Test View of Belt Anchorage for Passenger Dummy



Pre-Test Passenger Dummy Feet



Post-Test Passenger Dummy Feet



Pre-Test Passenger's Side Knee Bolster (without dummy)



Post-Test Passenger's Side Knee Bolster (without dummy)



Pre-Test Passenger's Side Floorpan



Post-Test Passenger's Side Floorpan



Post-Test Passenger Dummy Contact with Airbag



Post-Test Passenger Dummy Contact with Headrest and Seatback



Post-Test Passenger Dummy Contact with Glovebox

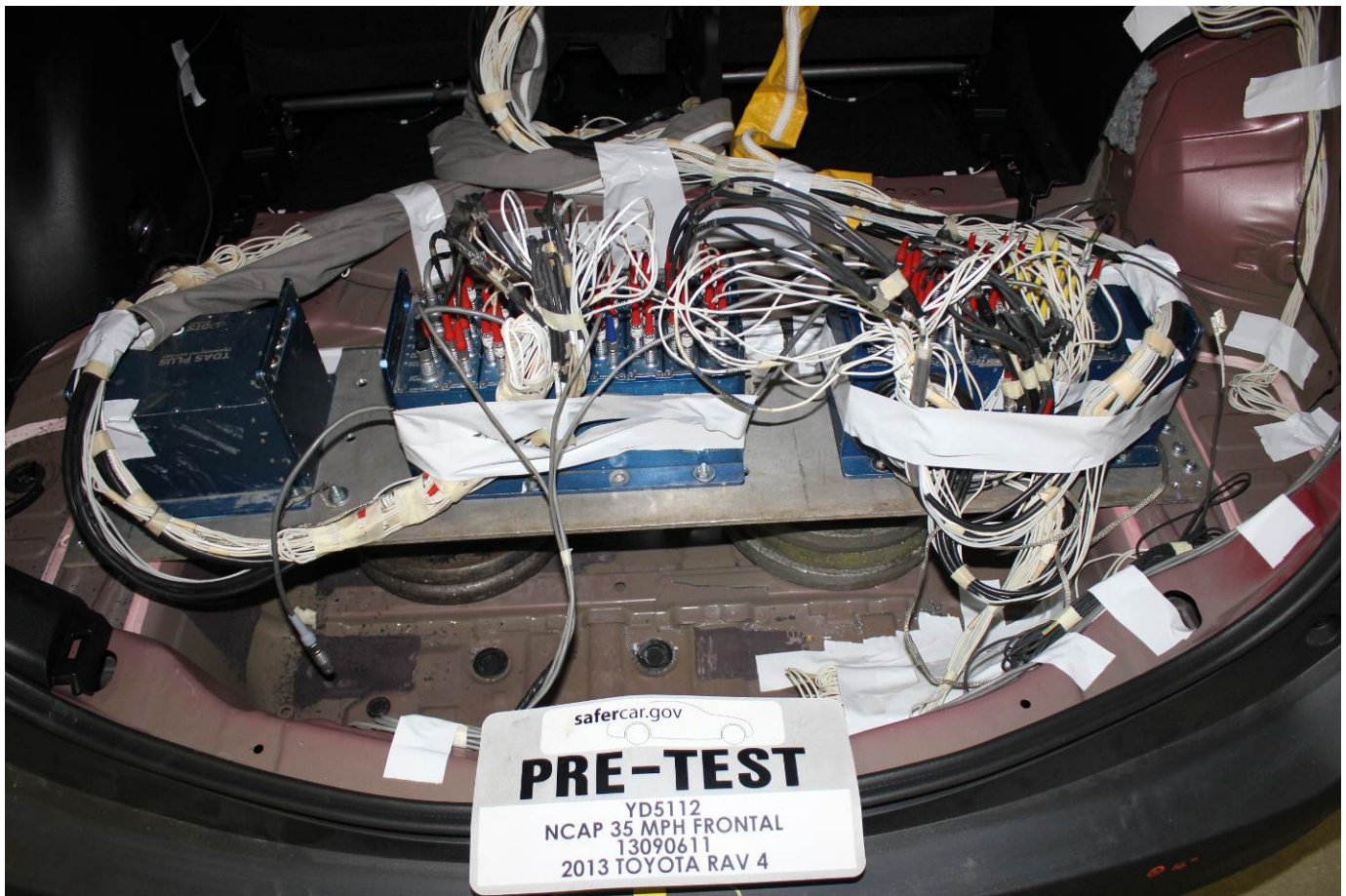

Ballast Installed in Vehicle

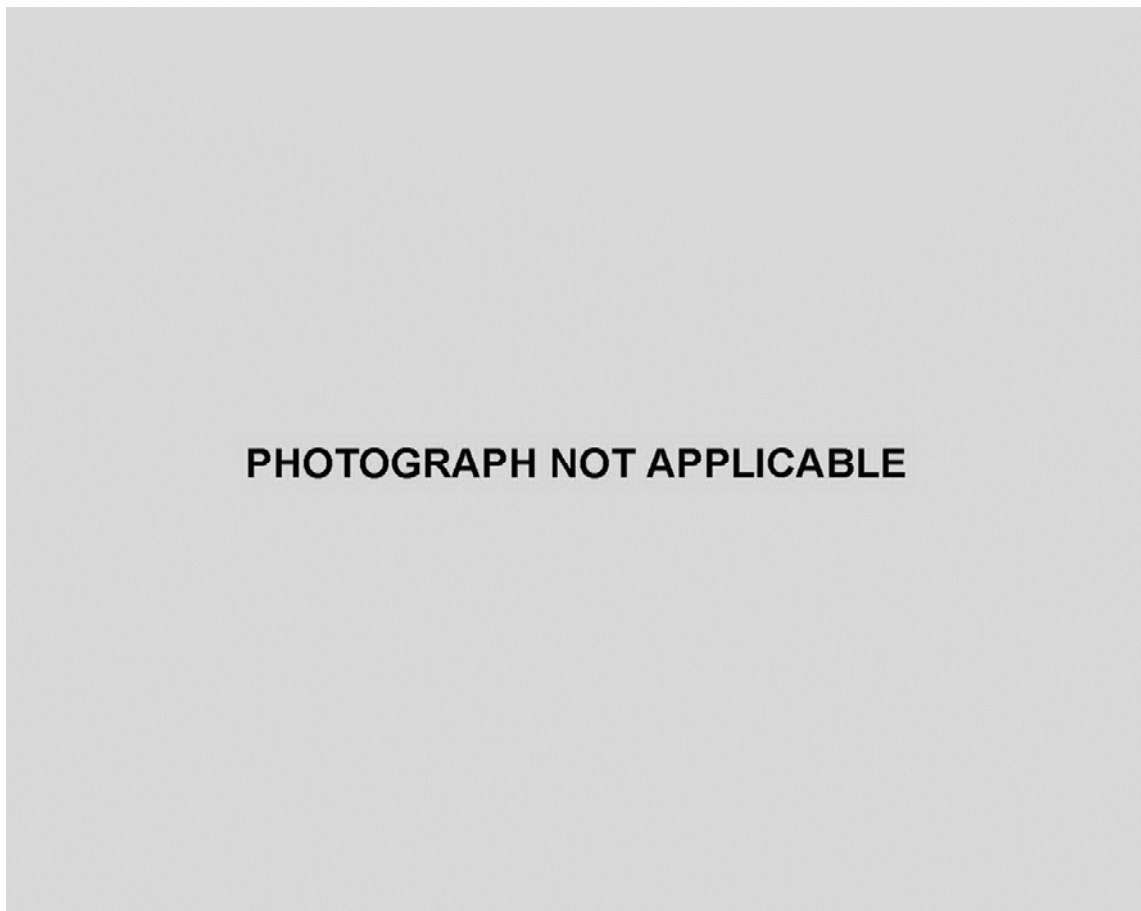

Post-Test Stoddard Solvent Spillage Location View

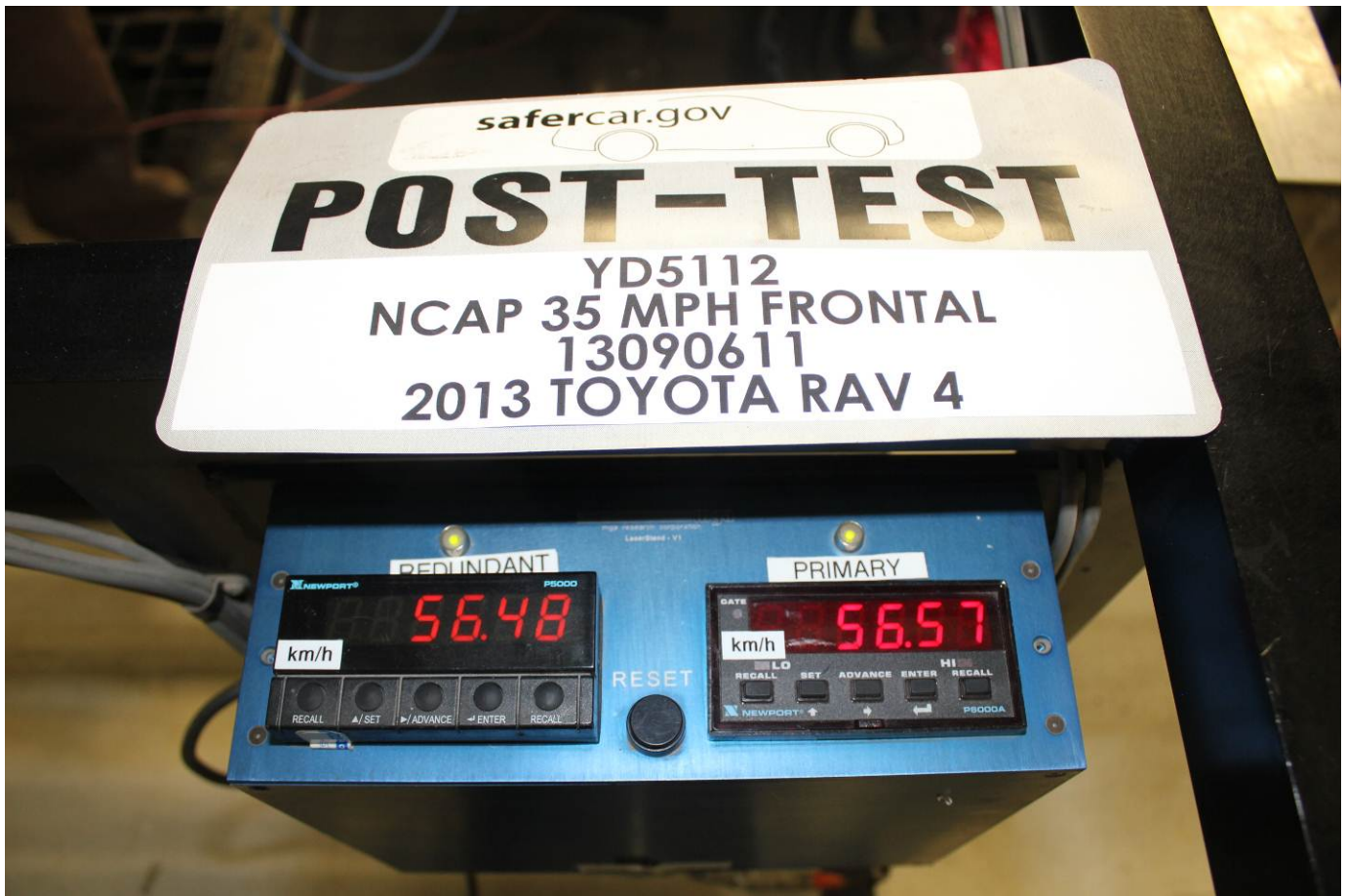

Post-Test Speed Trap Read-Out



Vehicle at 0 Degree on Static Rollover Device



Vehicle at 90 Degrees on Static Rollover Device

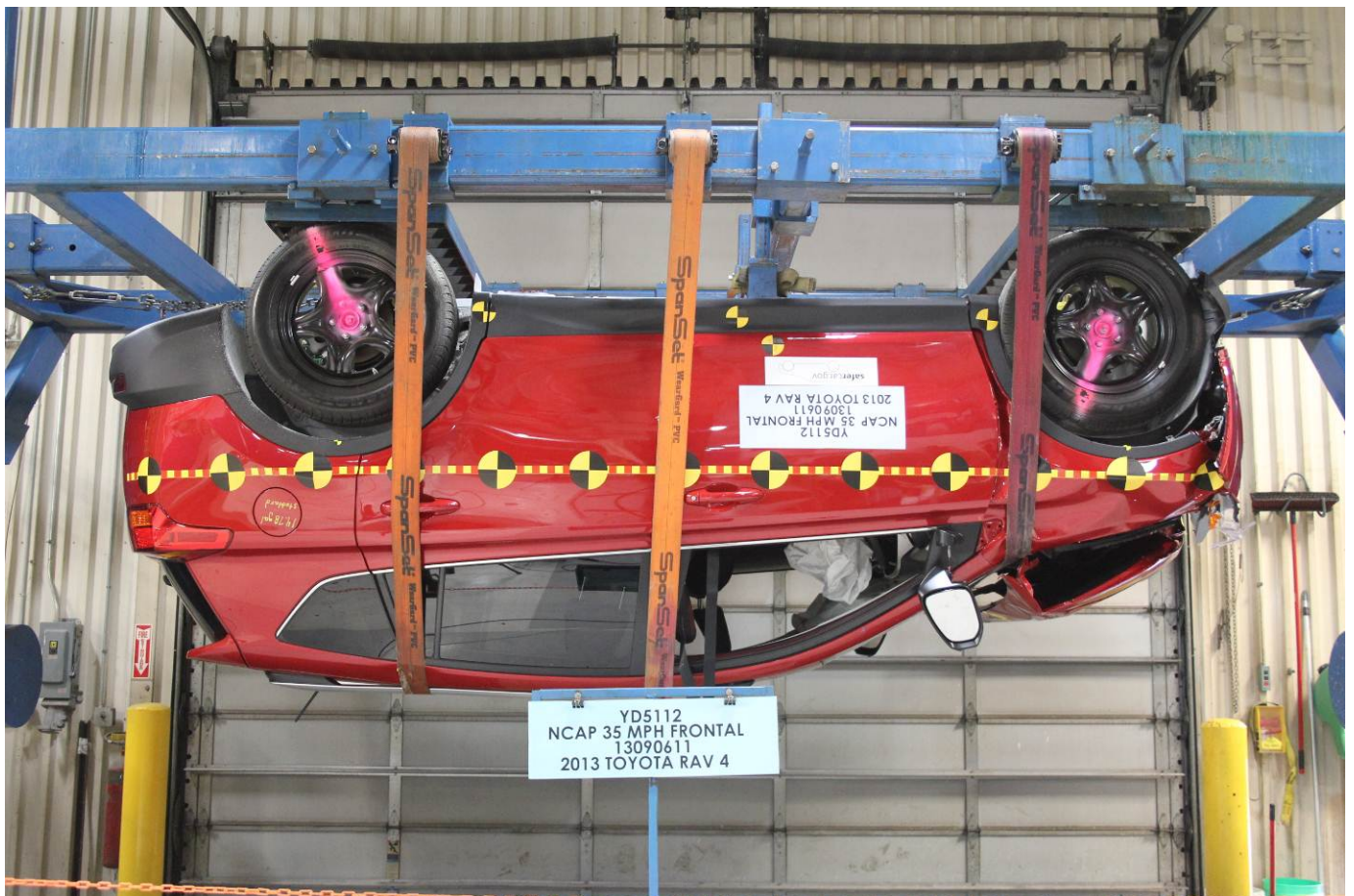

Vehicle at 180 Degrees on Static Rollover Device



Vehicle at 270 Degrees on Static Rollover Device



Vehicle at 360 Degrees on Static Rollover Device



2013 Toyota RAV4 SUV Frontal Impact Event



TOYOTA
Let's Go Places

DESC: **RAV4** LE AWD SUV
VIN: **2T3BFREVXDW070736**
YR/MDL: 2013/4432A
CLR: BARCELONA RED MET.FFB10 (03R3110)
PORT/PLANT: Detroit, MI/TJMC RAILHEAD:

GOVERNMENT 5-STAR SAFETY RATINGS

Overall Vehicle Score ★★★★★
Based on the combined ratings of frontal, side and rollover. Should ONLY be compared to other vehicles of similar size and weight.

| | | |
|---|------------|-------|
| Frontal Crash | Driver | ★★★★★ |
| | Passenger | ★★★★★ |
| <small>Based on the risk of injury in a frontal impact. Should ONLY be compared to other vehicles of similar size and weight.</small> | | |
| Side Crash | Front seat | ★★★★★ |
| | Rear seat | ★★★★★ |
| <small>Based on the risk of injury in a side impact.</small> | | |
| Rollover | | ★★★★★ |
| <small>Based on the risk of rollover in a single-vehicle crash.</small> | | |

Star ratings range from 1 to 5 stars (★★★★★) with 5 being the highest. Source: National Highway Traffic Safety Administration (NHTSA) www.safercar.gov or 1-888-327-4236

STANDARD EQUIPMENT

MECHANICAL & PERFORMANCE

- 2.5L DOHC 18V 4-Cyl Engine w/Dual VVT-i
- 178 hp @ 6000 rpm / 172 lb-ft @ 4100 rpm
- 6-Speed Automatic Transmission
- Dynamic Torque Control AWD
- 4-Wheel Independent Suspension
- Electronic Power Steering System
- 4-Wheel Disc Brakes
- 17" Steel Wheel Covers, P225/65R17 Tires

SAFETY

- Star Safety System: Enhanced Vehicle Stability Control, Traction Control, Anti-Lock Brakes, Electronic Brake Force Distribution, Brake Assist and Smart Stop Technology
- Eight Standard Airbags
- Driver and Front Passenger Whiplash-Injury-Mitigating (WII) Seats
- LATCH Lower Anchor & Tether for Children
- Child Protector Rear Door Locks
- Tire Pressure Monitoring System

EXTERIOR

- Projector Beam Headlamps
- Rear Spoiler, Power Outside Mirrors
- Daytime Running Lights, Privacy Glass
- Acoustic Front Windshield
- Intermittent Windshield Wipers

COMFORT & CONVENIENCE

- Air Conditioning with Air Filter
- Display Audio w/6 Spkrs, Aux, USB, BT
- Backup Camera, Tilt/Telescopic Steering Wheel w/Audio and Bluetooth Controls
- Fabric-Trimmed 8-Way Adj. DR Seat
- 4-Way Adj. FR Pass Seat, 8-Way Split Reclining Fold-Flat 2nd Row Seats
- Remote Keyless Entry System
- Illuminated Entry System
- Power Windows, Power Door Locks
- Center Armrest Console Storage Box
- EcoSport Mode, Cruise Control
- Digital Clock
- 12V Auxiliary Power Outlets (2)

Full Tank of Gas

MANUFACTURER'S SUGGESTED RETAIL PRICE \$24,700.00

OPTIONAL EQUIPMENT

| | | |
|----|-----------------------------|--------|
| FE | 80 State Emissions | 150.00 |
| RR | Roof Rails | 90.00 |
| TC | Towbars Cover | 225.00 |
| CF | Carpet Floor Mats/Cargo Mat | |

EPA DOT Fuel Economy and Environment Gasoline Vehicle

| | |
|-----------------------------------|--|
| Fuel Economy | You save \$850 |
| 25 MPG (combined city/hwy) | in fuel costs over 5 years |
| 22 (city) 29 (highway) | compared to the average new vehicle |
| 4.0 gallons per 100 miles | |

Annual fuel cost \$2,150

Fuel Economy & Greenhouse Gas Rating (EPA est.) Smog Rating (EPA est.)

TOTAL \$26,010.00

DELIVERY PROCESSING AND HANDLING FEE 845.00

The New Vehicle Limited Warranty provides 3-year/50,000-mile basic coverage, 5-year/60,000-mile powertrain coverage, and 2-year/unlimited-mile combined performance coverage. See Warranty and Maintenance Guide for details. An extended service contract may be available for the vehicle. Ask Dealer for details. Manufacturer's suggested retail price includes manufacturer's recommended pre-delivery service. Capable, license and title fees, applicable federal, state and local taxes and dealer and distributor selected options are not included in the manufacturer's suggested retail price. Toyota Care, which covers actual factory scheduled maintenance for two years or 25,000 miles, whichever occurs first, is included as part of the sales price of the vehicle for qualifying buyers.

Dealer Name / Address: 46012 Ship Co.
JACK SAFRO TOYOTA
3042 WEST CAPITOL DRIVE
BROOKFIELD WIS3045

fuelconomy.gov Calculate personalized estimates and compare vehicles

Monroney Label

APPENDIX B
DUMMY RESPONSE DATA TRACES

TABLE OF DATA PLOTS

Page No.

List of Data Plots Provided in the Test Report

| | | |
|----------------|---|-----|
| Figure No. 1. | Driver Head X Acceleration vs. Time | B-1 |
| Figure No. 2. | Driver Head Y Acceleration vs. Time | B-1 |
| Figure No. 3. | Driver Head Z Acceleration vs. Time | B-1 |
| Figure No. 4. | Driver Head Resultant Acceleration vs. Time | B-1 |
| Figure No. 5. | Driver Chest Displacement vs. Time | B-2 |
| Figure No. 6. | Driver Chest X Acceleration vs. Time | B-3 |
| Figure No. 7. | Driver Chest Y Acceleration vs. Time | B-3 |
| Figure No. 8. | Driver Chest Z Acceleration vs. Time | B-3 |
| Figure No. 9. | Driver Chest Resultant Acceleration vs. Time | B-3 |
| Figure No. 10. | Driver Neck Force X vs. Time | B-4 |
| Figure No. 11. | Driver Neck Force Z vs. Time | B-4 |
| Figure No. 12. | Driver Neck Moment Y vs. Time | B-4 |
| Figure No. 13. | Driver Nij (NTF) vs. Time | B-5 |
| Figure No. 14. | Driver Nij (NTE) vs. Time | B-5 |
| Figure No. 15. | Driver Nij (NCF) vs. Time | B-5 |
| Figure No. 16. | Driver Nij (NCE) vs. Time | B-5 |
| Figure No. 17. | Driver Left Femur Force vs. Time | B-6 |
| Figure No. 18. | Driver Right Femur Force vs. Time | B-6 |
| Figure No. 19. | Passenger Head X Acceleration vs. Time | B-7 |
| Figure No. 20. | Passenger Head Y Acceleration vs. Time | B-7 |
| Figure No. 21. | Passenger Head Z Acceleration vs. Time | B-7 |
| Figure No. 22. | Passenger Head Resultant Acceleration vs. Time | B-7 |
| Figure No. 23. | Passenger Chest Displacement vs. Time | B-8 |
| Figure No. 24. | Passenger Chest X Acceleration vs. Time | B-9 |
| Figure No. 25. | Passenger Chest Y Acceleration vs. Time | B-9 |
| Figure No. 26. | Passenger Chest Z Acceleration vs. Time | B-9 |
| Figure No. 27. | Passenger Chest Resultant Z Acceleration vs. Time | B-9 |

| | <u>Page No.</u> |
|---|-----------------|
| Figure No. 28. Passenger Neck Force X vs. Time | B-10 |
| Figure No. 29. Passenger Neck Force Z vs. Time | B-10 |
| Figure No. 30. Passenger Neck Moment Y vs. Time | B-10 |
| Figure No. 31. Passenger Nij (NTF) vs. Time | B-11 |
| Figure No. 32. Passenger Nij (NTE) vs. Time | B-11 |
| Figure No. 33. Passenger Nij (NCF) vs. Time | B-11 |
| Figure No. 34. Passenger Nij (NCE) vs. Time | B-11 |
| Figure No. 35. Passenger Left Femur Force vs. Time | B-12 |
| Figure No. 36. Passenger Right Femur Force vs. Time | B-12 |

The following additional dummy and vehicle response data can be found in the R&D section of the NHTSA website at www.nhtsa.dot.gov

Driver Head X Redundant
 Driver Head Y Redundant
 Driver Head Z Redundant
 Driver Upper Neck Force Y
 Driver Upper Neck Moment X
 Driver Upper Neck Moment Z
 Driver Chest X Redundant
 Driver Chest Y Redundant
 Driver Chest Z Redundant
 Driver Pelvis X
 Driver Pelvis Y
 Driver Pelvis Z
 Driver Left Femur Redundant
 Driver Right Femur Redundant
 Driver Left Upper Tibia Moment X
 Driver Left Upper Tibia Moment Y
 Driver Left Upper Tibia Force Z
 Driver Left Lower Tibia Moment X

Driver Left Lower Tibia Moment Y
Driver Left Lower Tibia Force Z
Driver Right Upper Tibia Moment X
Driver Right Upper Tibia Moment Y
Driver Right Upper Tibia Force Z
Driver Right Lower Tibia Moment X
Driver Right Lower Tibia Moment Y
Driver Right Lower Tibia Force Z
Driver Left Foot Fore Z
Driver Left Foot Aft X
Driver Left Foot Aft Z
Driver Right Foot Fore Z
Driver Right Foot Aft X
Driver Right Foot Aft Z
Driver Lap Belt Force
Driver Shoulder Belt Force
Passenger Head X Redundant
Passenger Head Y Redundant
Passenger Head Z Redundant
Passenger Upper Neck Force Y
Passenger Upper Neck Moment X
Passenger Upper Neck Moment Z
Passenger Chest X Redundant
Passenger Chest Y Redundant
Passenger Chest Z Redundant
Passenger Pelvis X
Passenger Pelvis Y
Passenger Pelvis Z
Passenger Left Femur Redundant
Passenger Right Femur Redundant
Passenger Left Upper Tibia Moment X

Passenger Left Upper Tibia Moment Y
Passenger Left Upper Tibia Force Z
Passenger Left Lower Tibia Moment X
Passenger Left Lower Tibia Moment Y
Passenger Left Lower Tibia Force Z
Passenger Right Upper Tibia Moment X
Passenger Right Upper Tibia Moment Y
Passenger Right Upper Tibia Force Z
Passenger Right Lower Tibia Moment X
Passenger Right Lower Tibia Moment Y
Passenger Right Lower Tibia Force Z
Passenger Left Foot Fore Z
Passenger Left Foot Aft X
Passenger Left Foot Aft Z
Passenger Right Foot Fore Z
Passenger Right Foot Aft X
Passenger Right Foot Aft Z
Passenger Lap Belt Force
Passenger Shoulder Belt Force
Left Rear Seat Crossmember X
Right Rear Seat Crossmember X
Vehicle Engine Top X
Vehicle Engine Bottom X
Left Rear Seat Crossmember Z
Right Rear Seat Crossmember Z
Left Rear Seat Crossmember Xr
Right Rear Seat Crossmember Xr
Advanced Research Load Cell Barrier – 528 channels

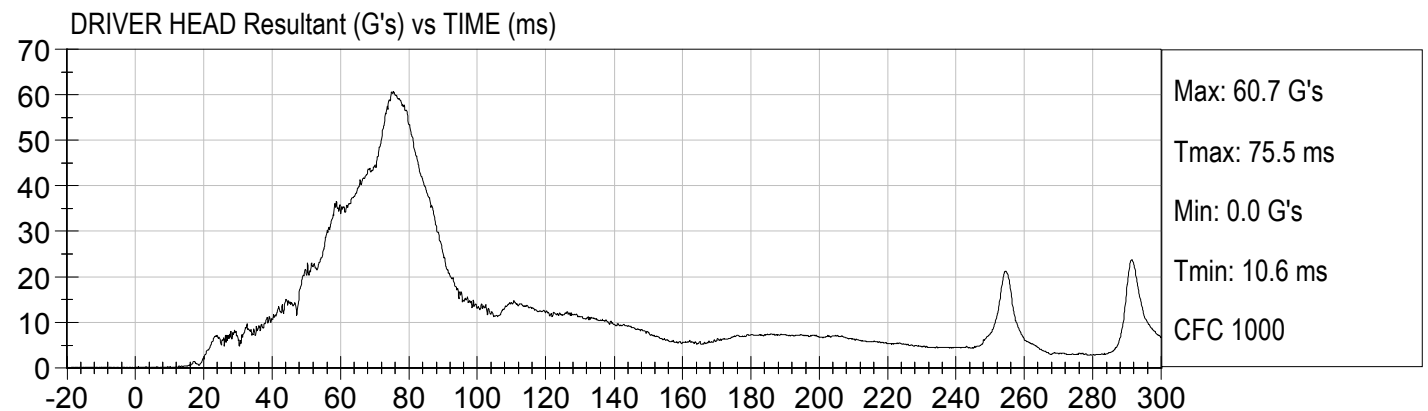
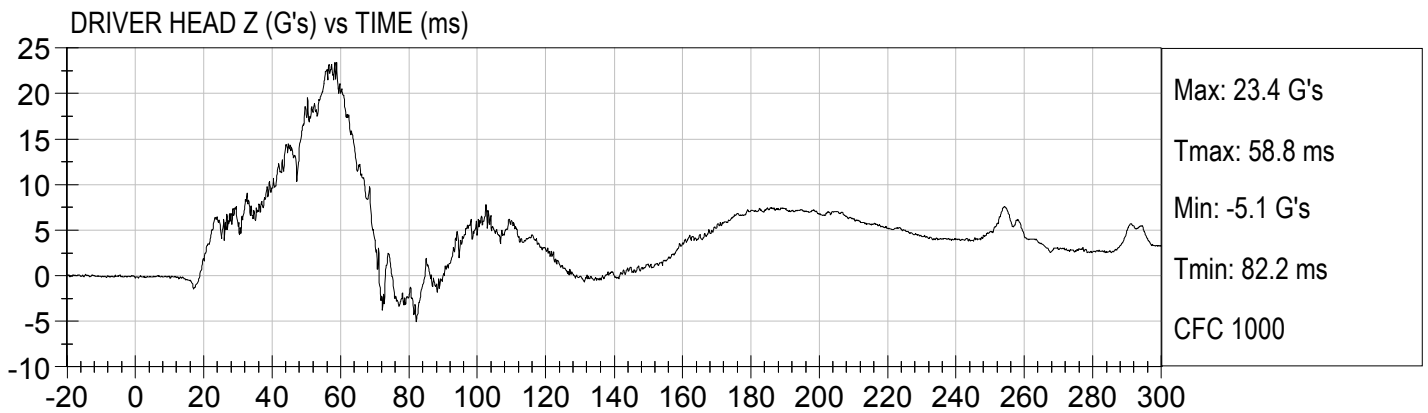
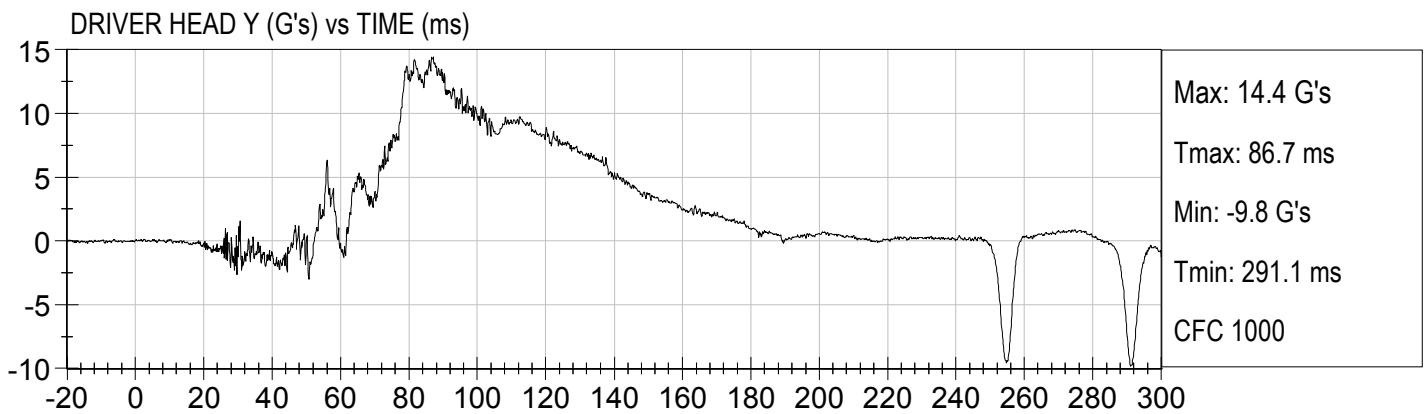
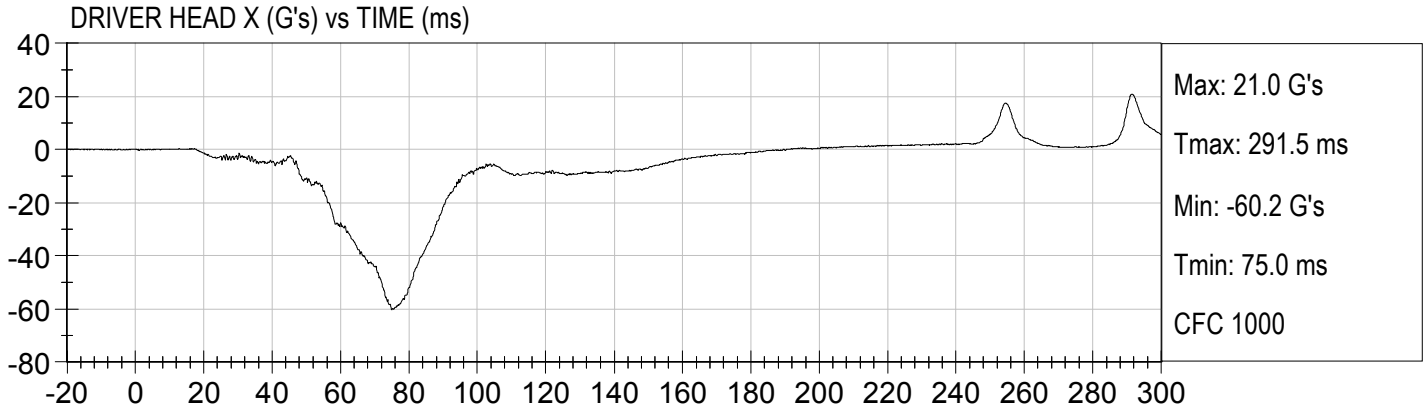

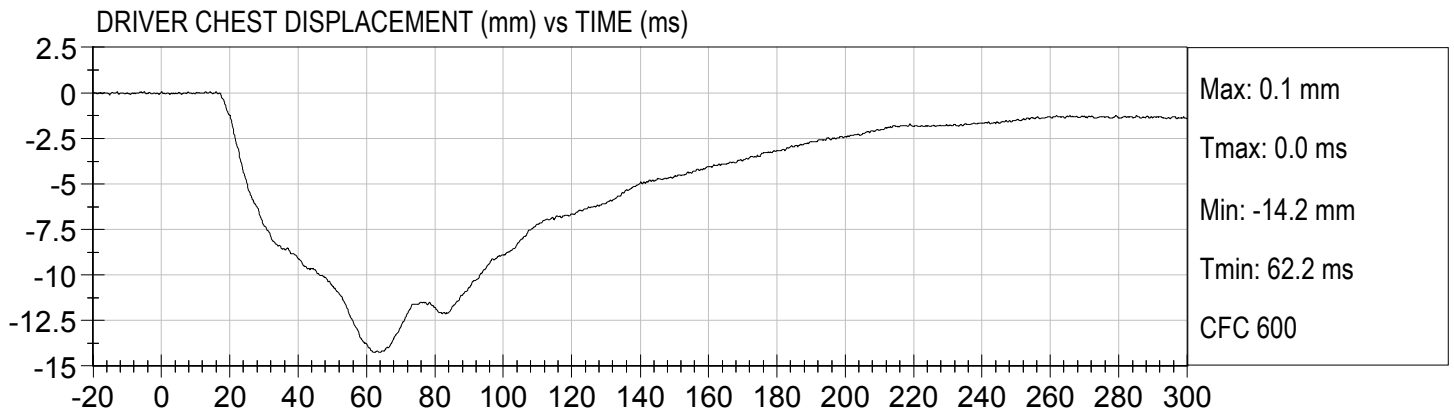

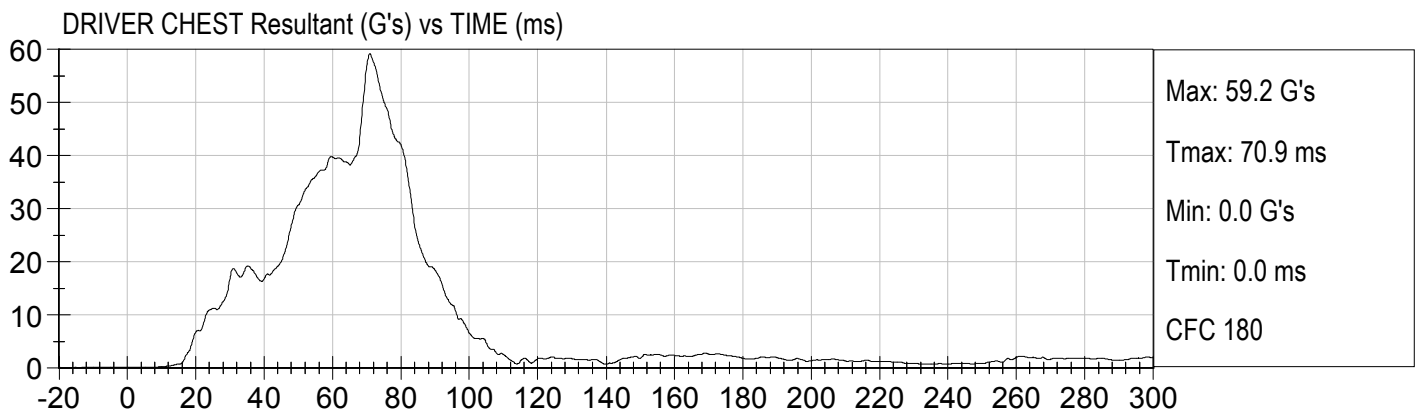
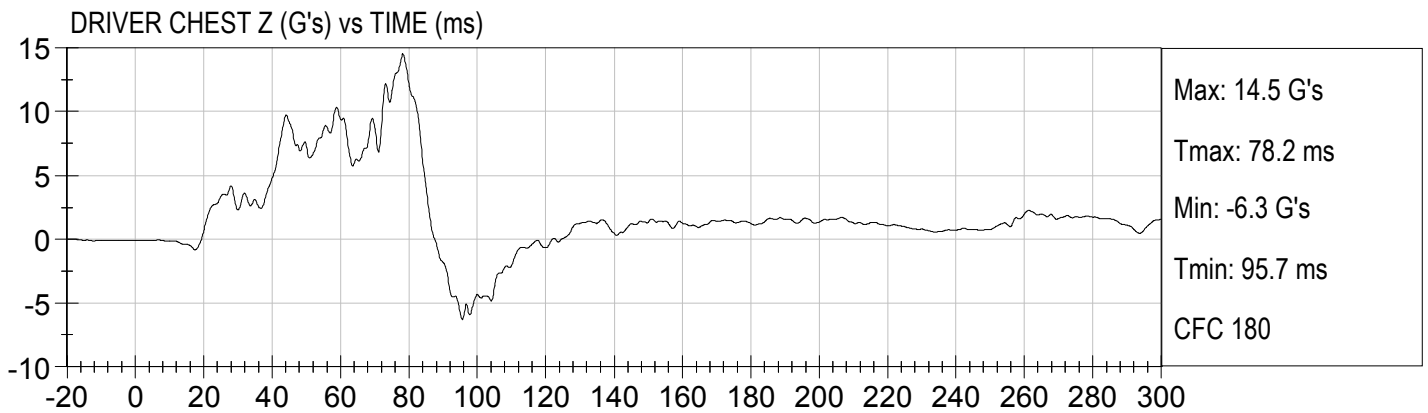
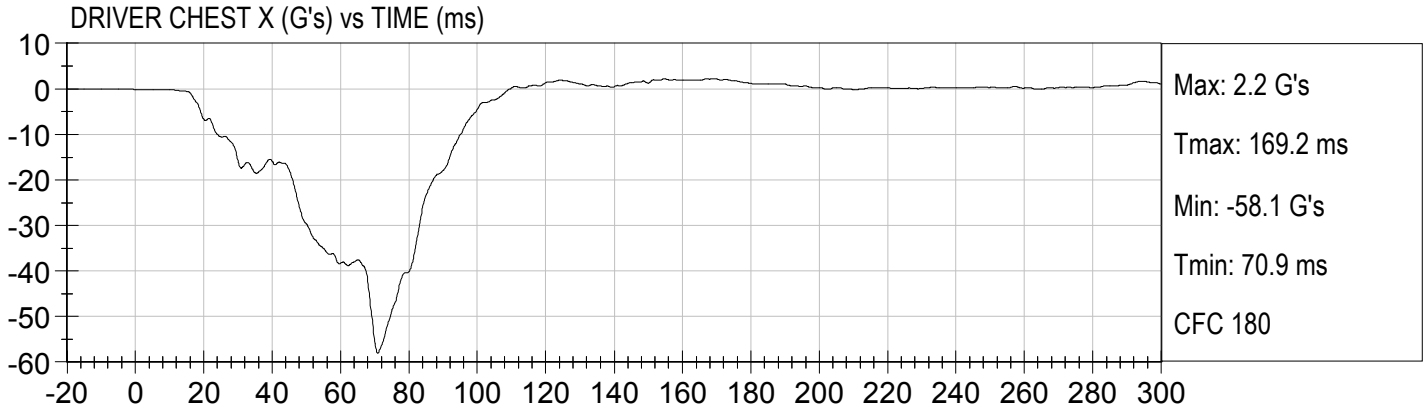

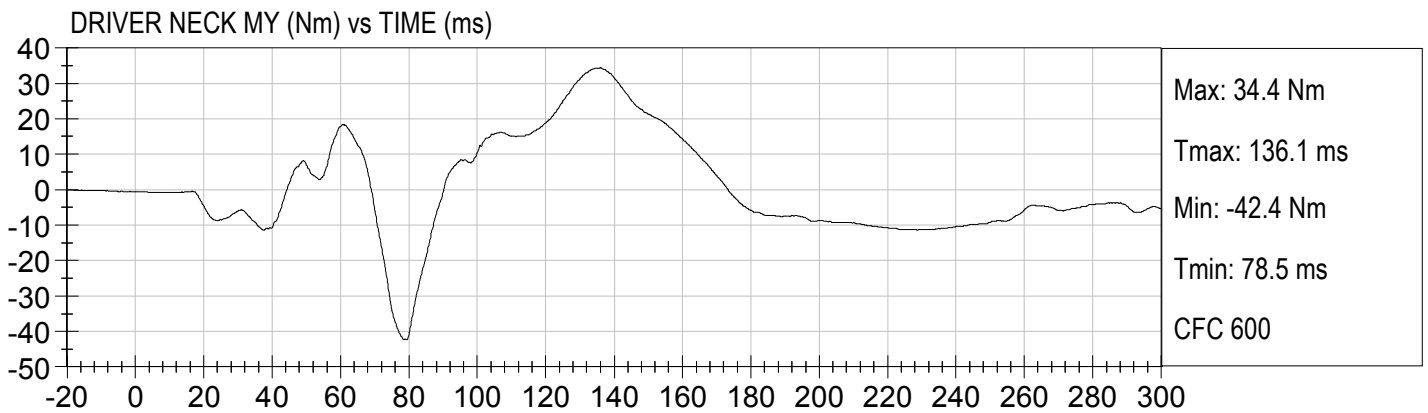
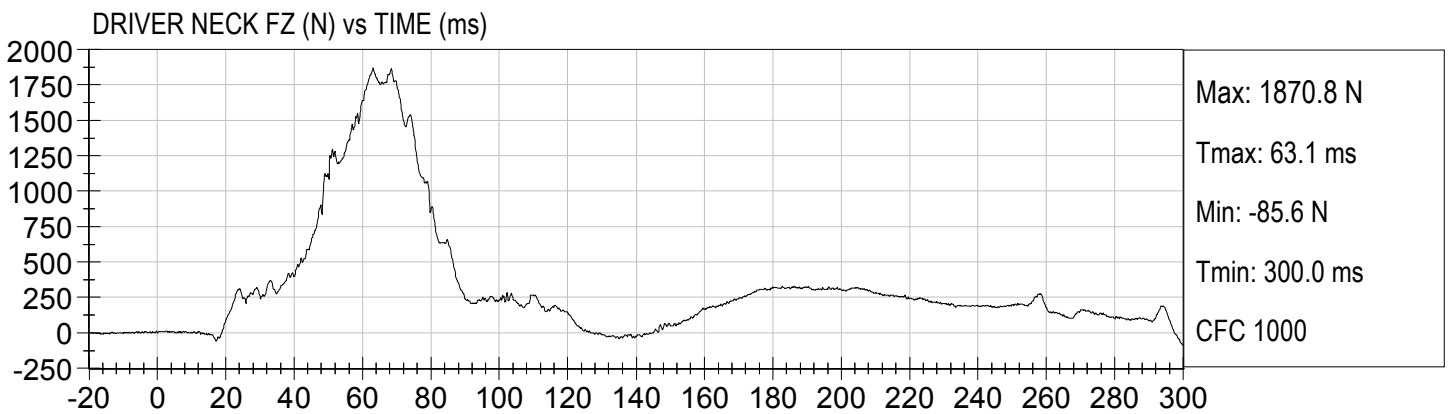
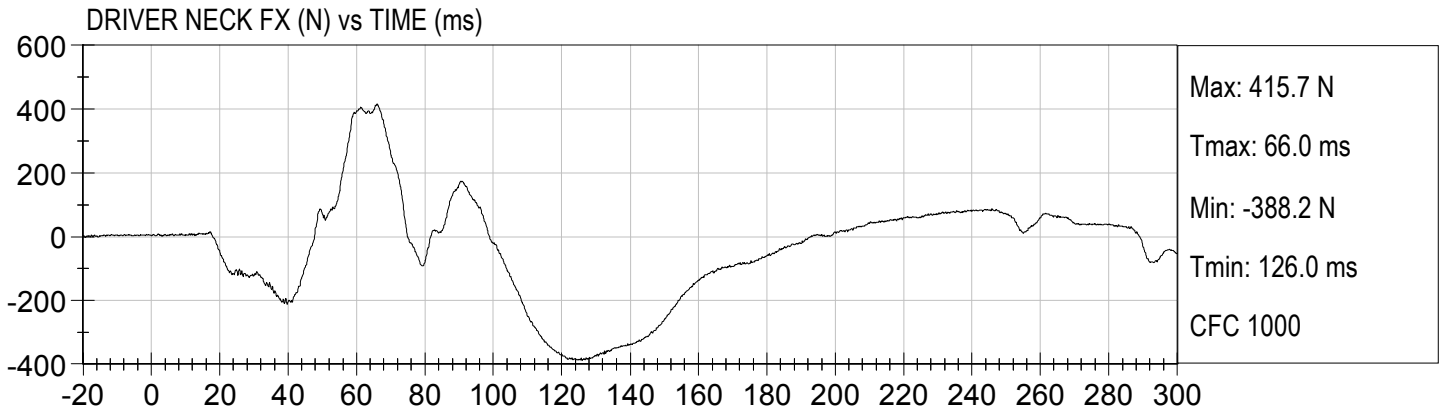

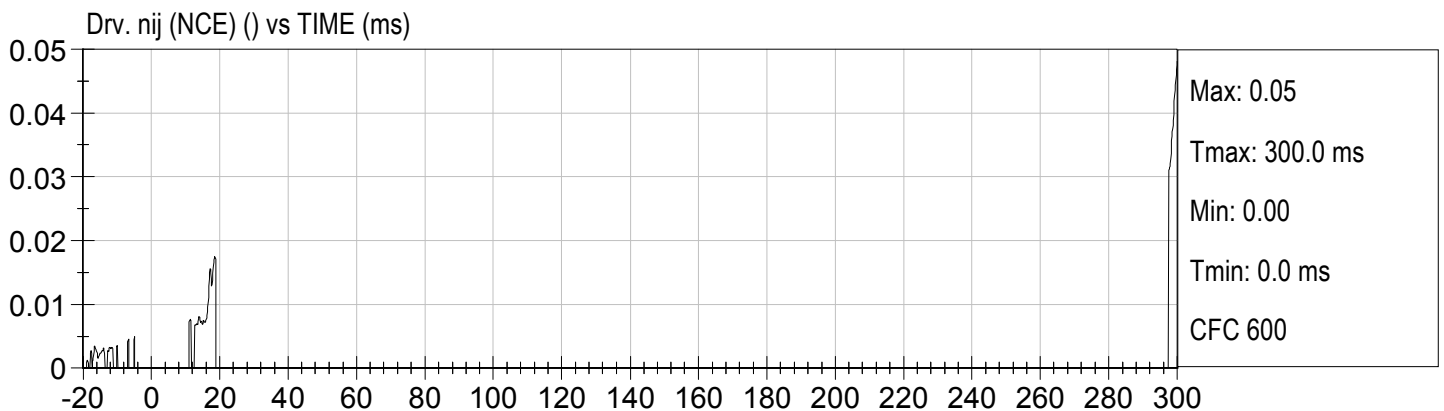
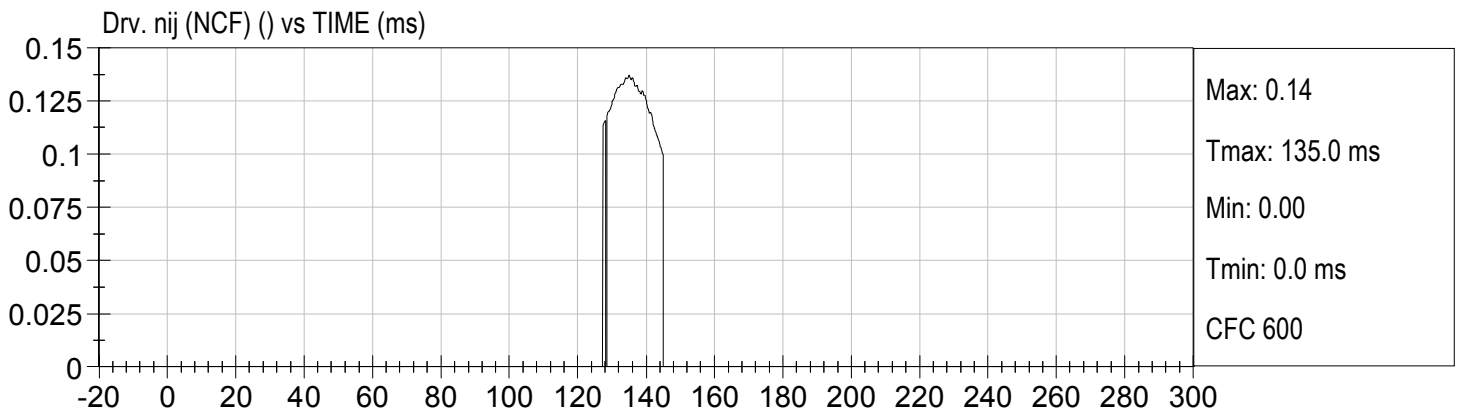
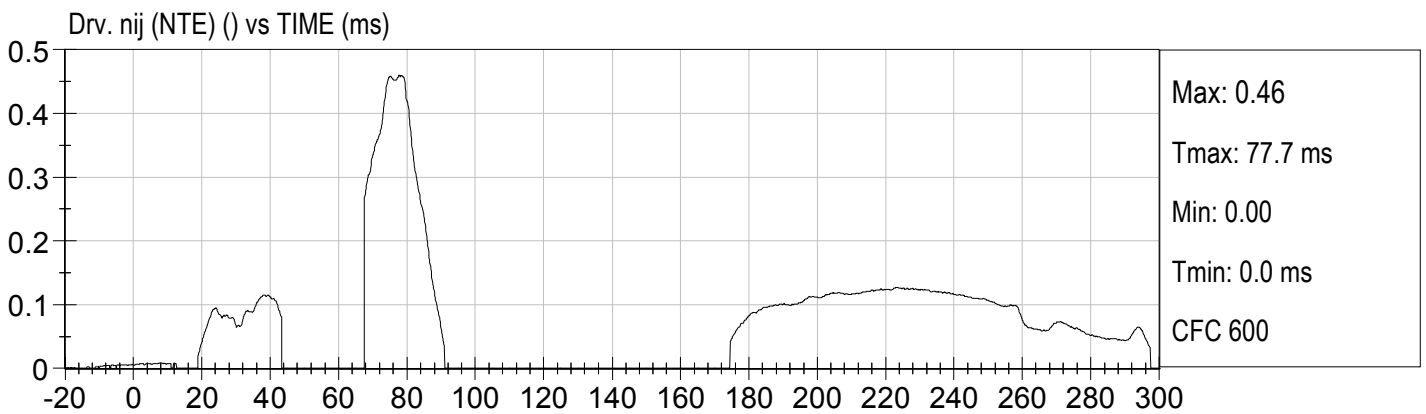
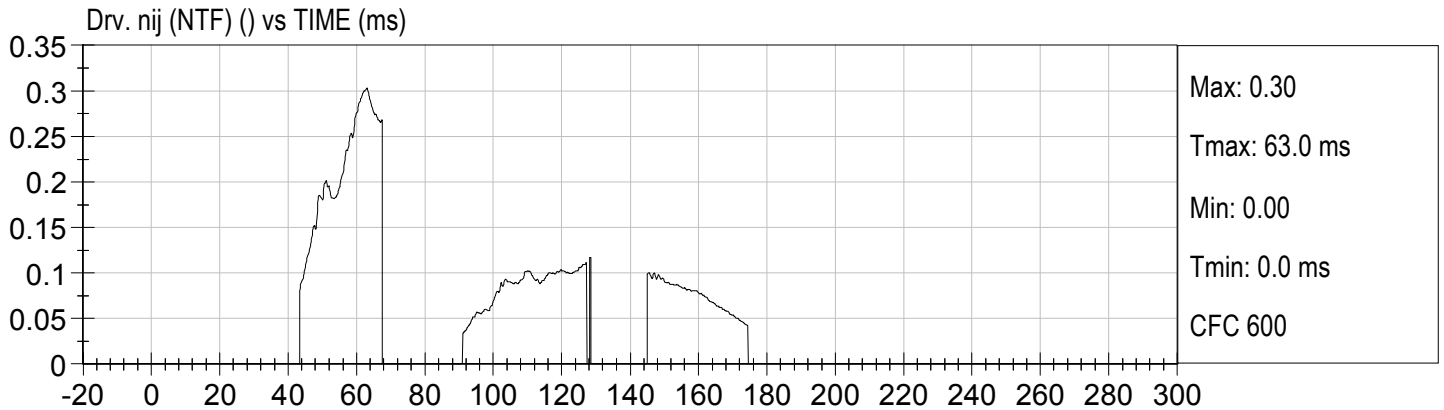

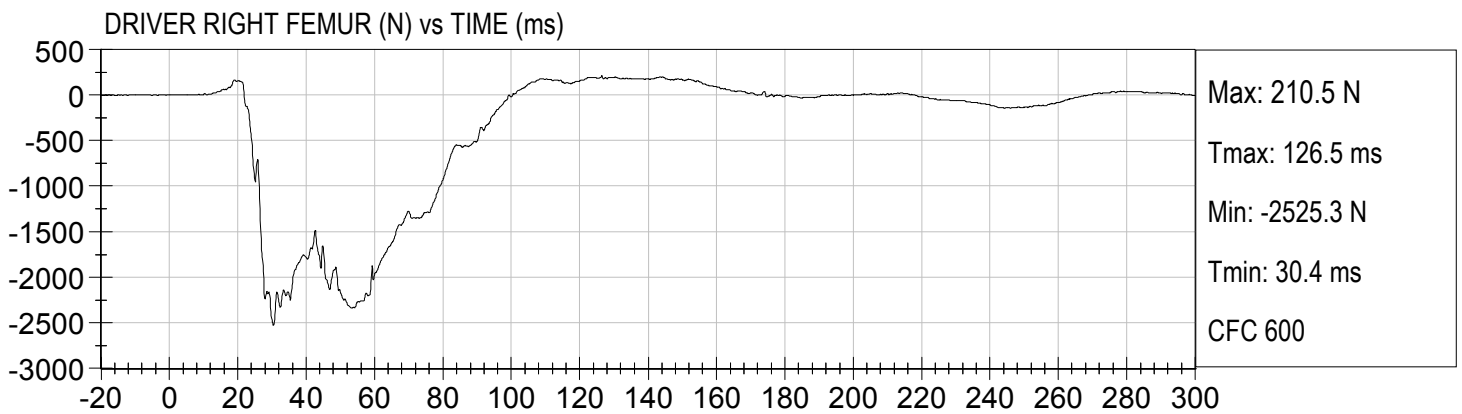
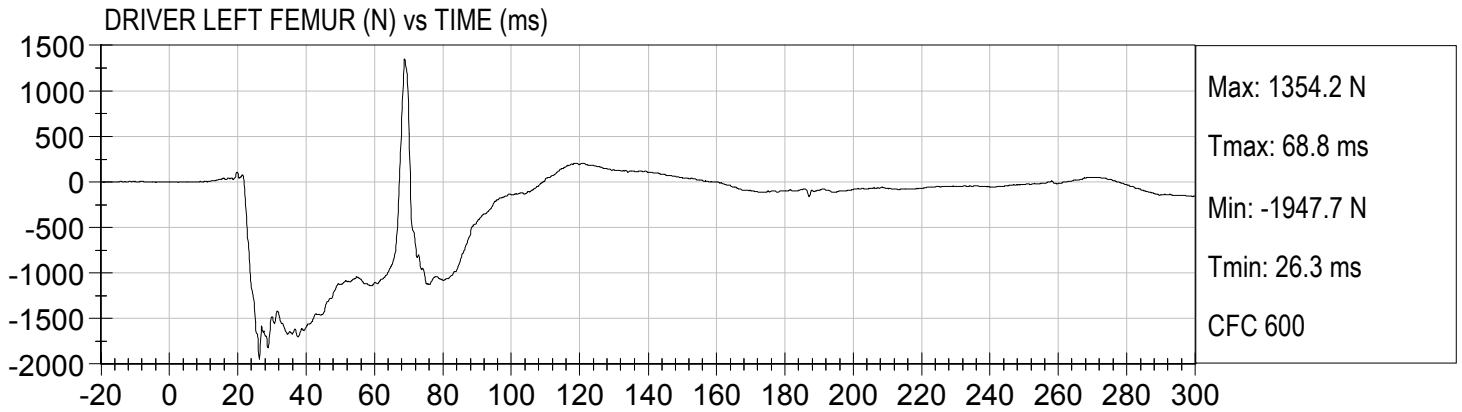

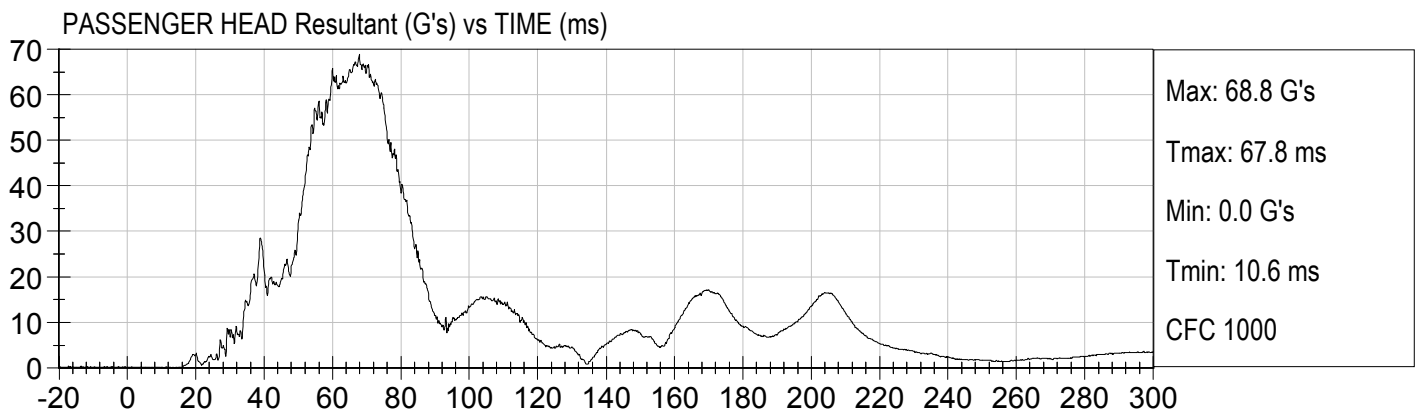
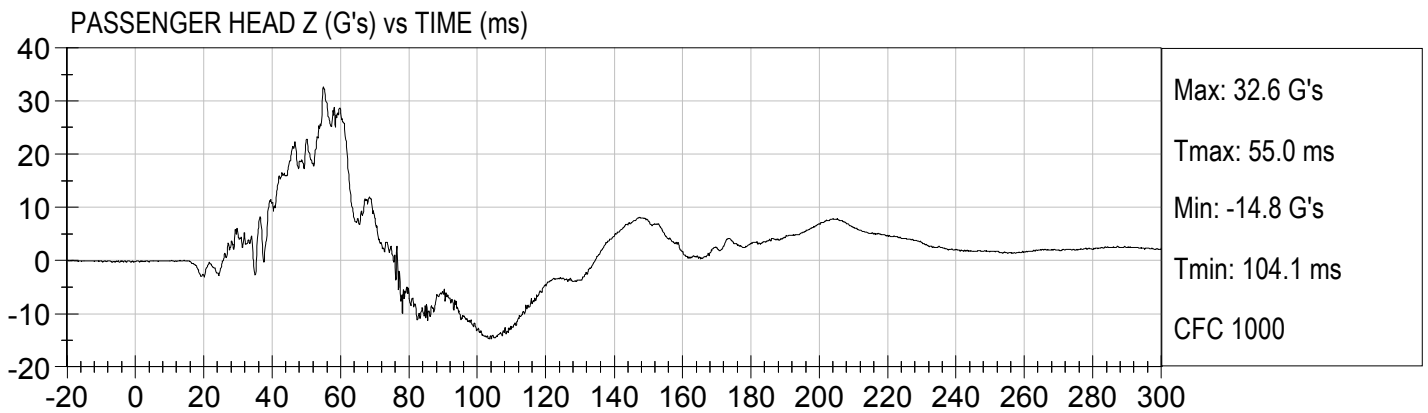
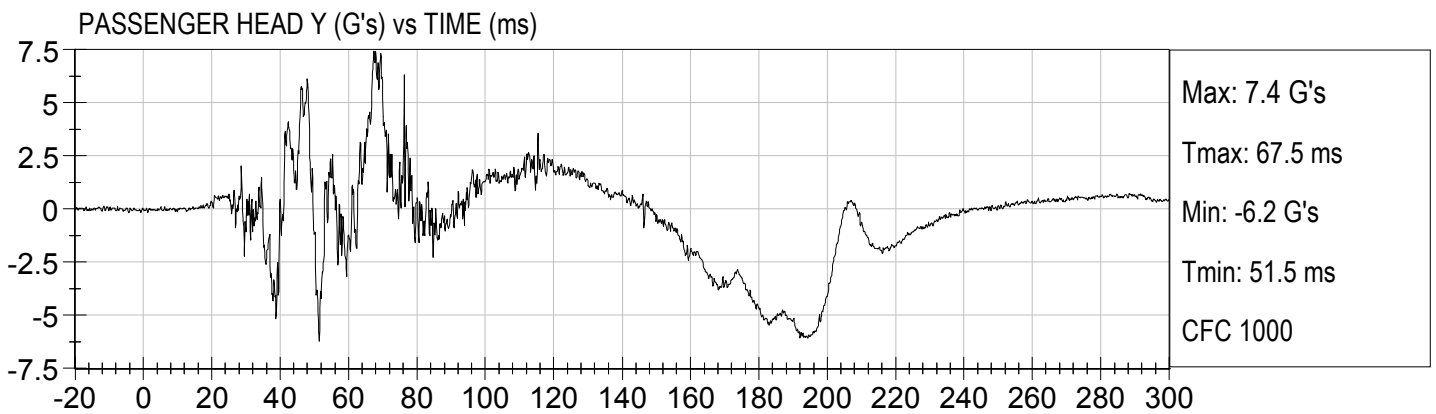
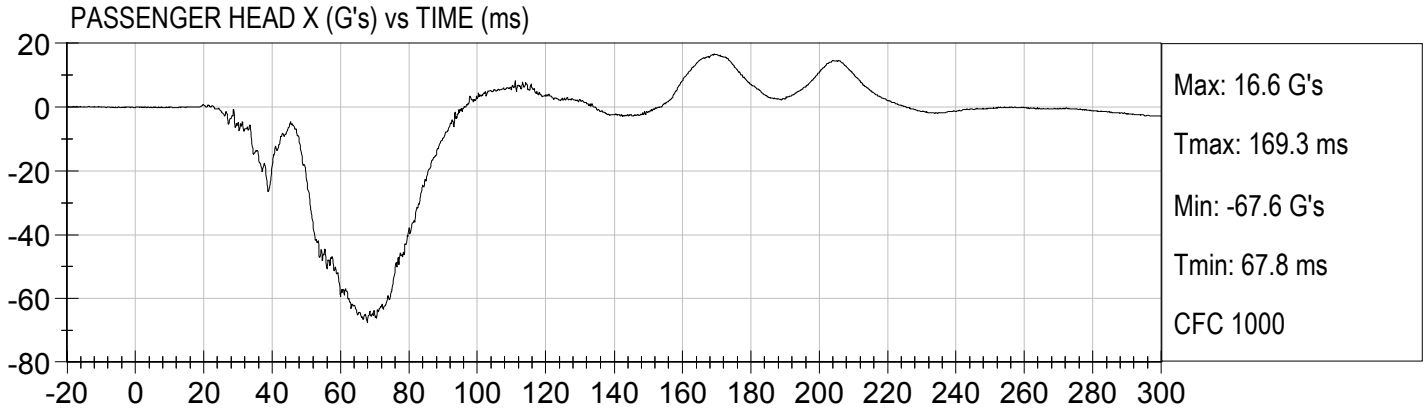

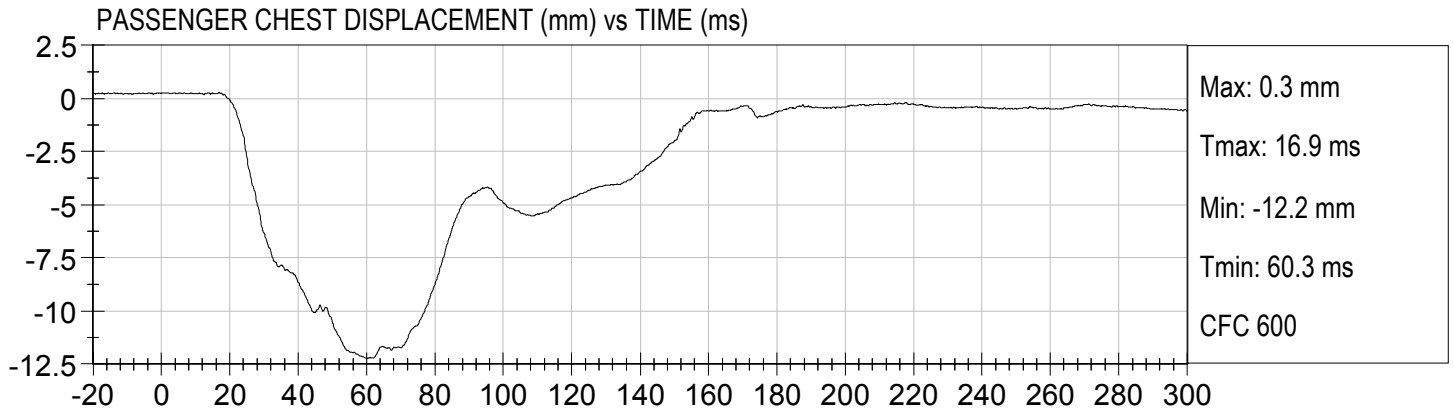

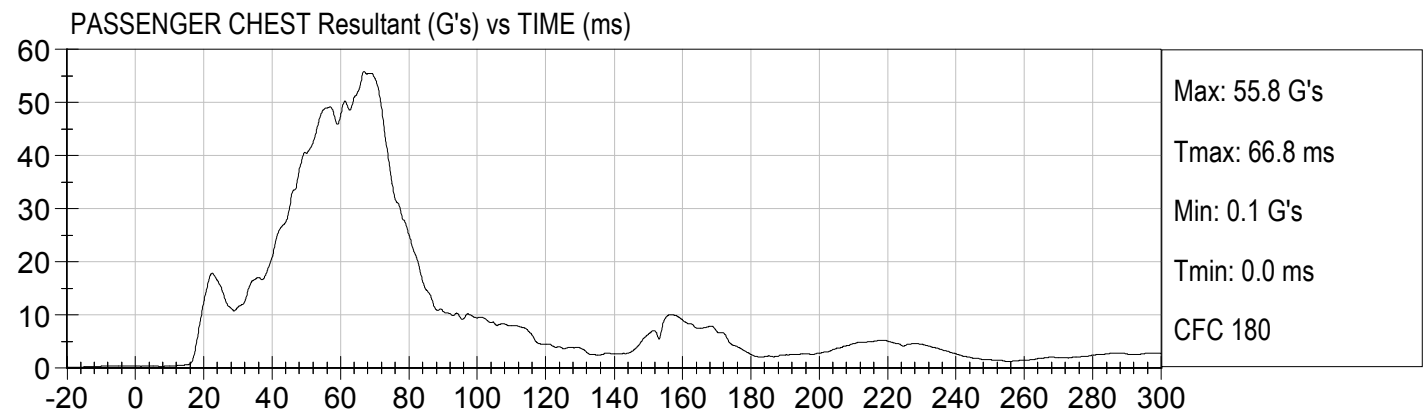
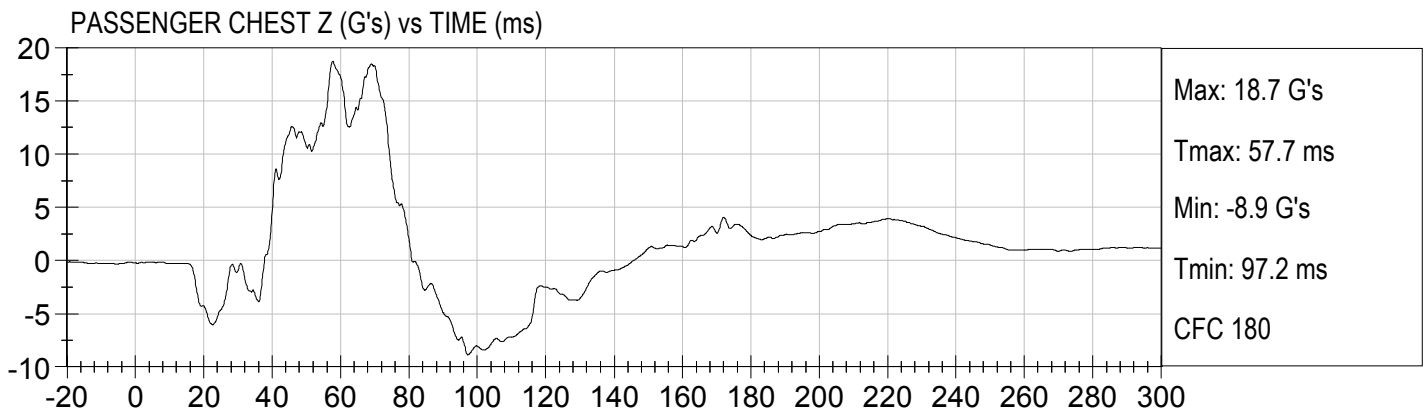
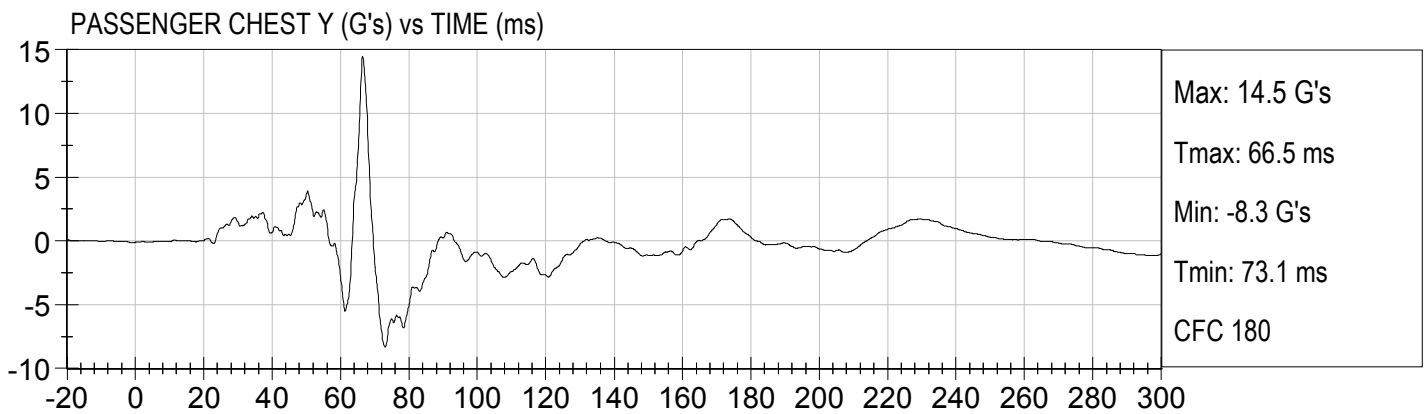
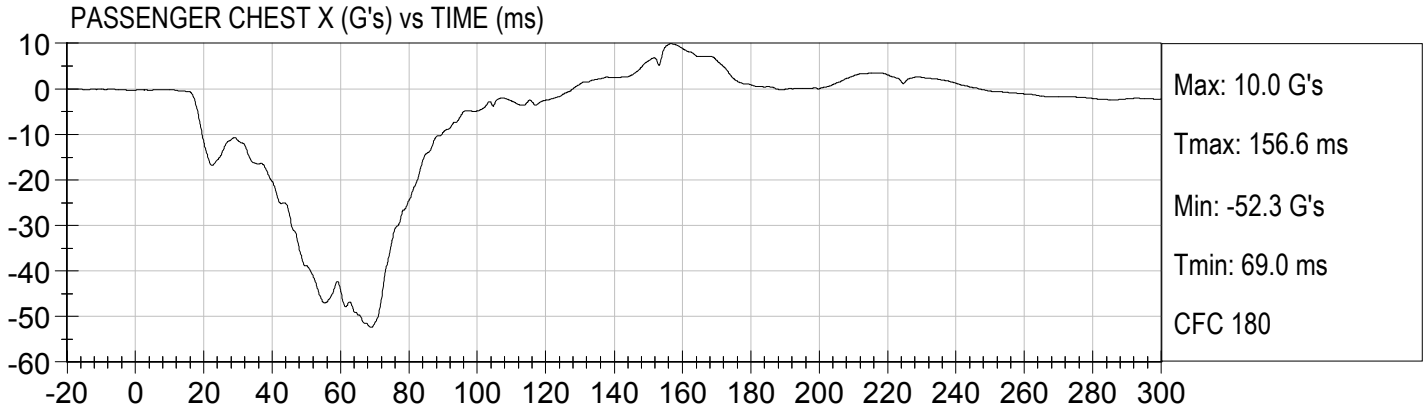

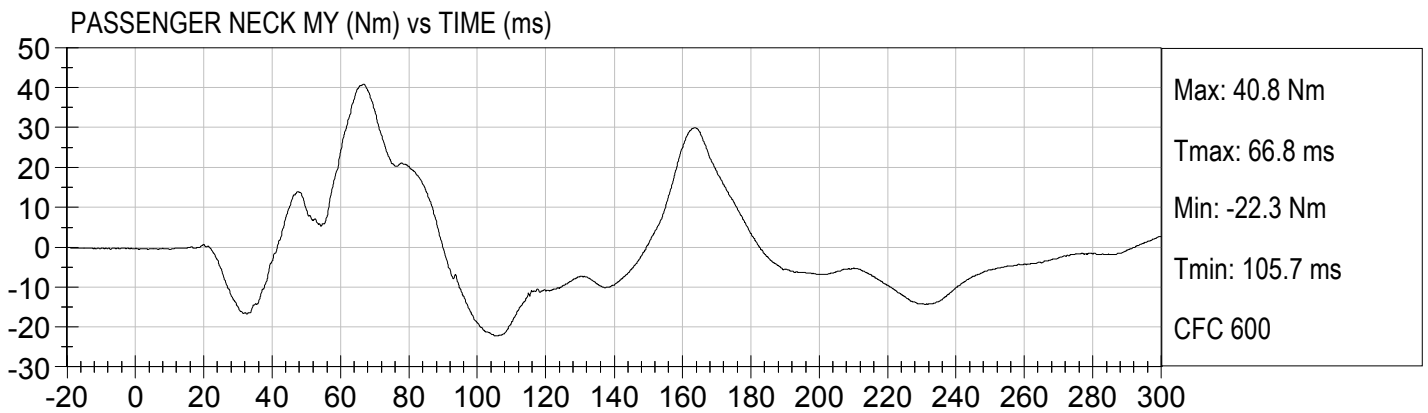
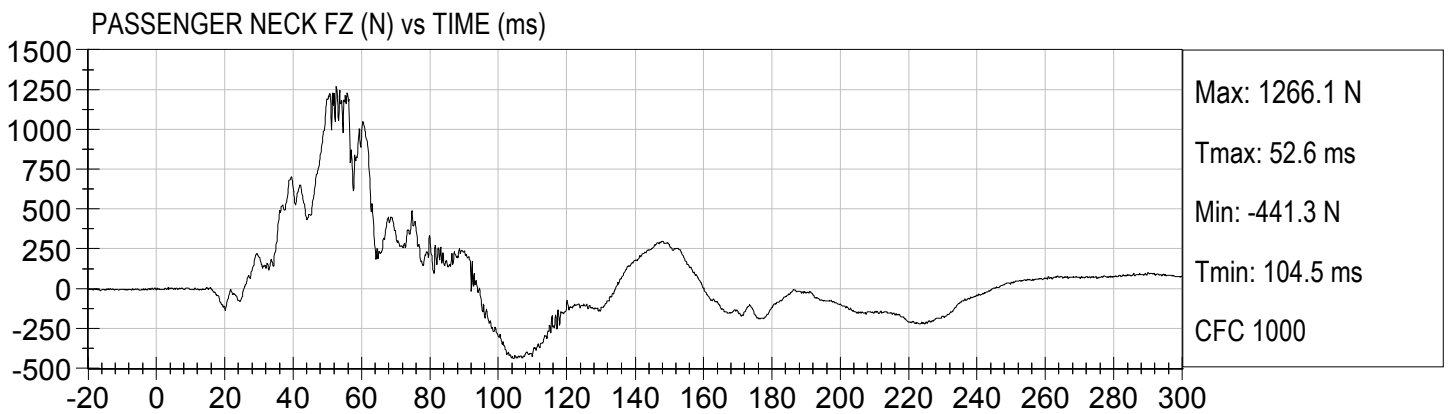
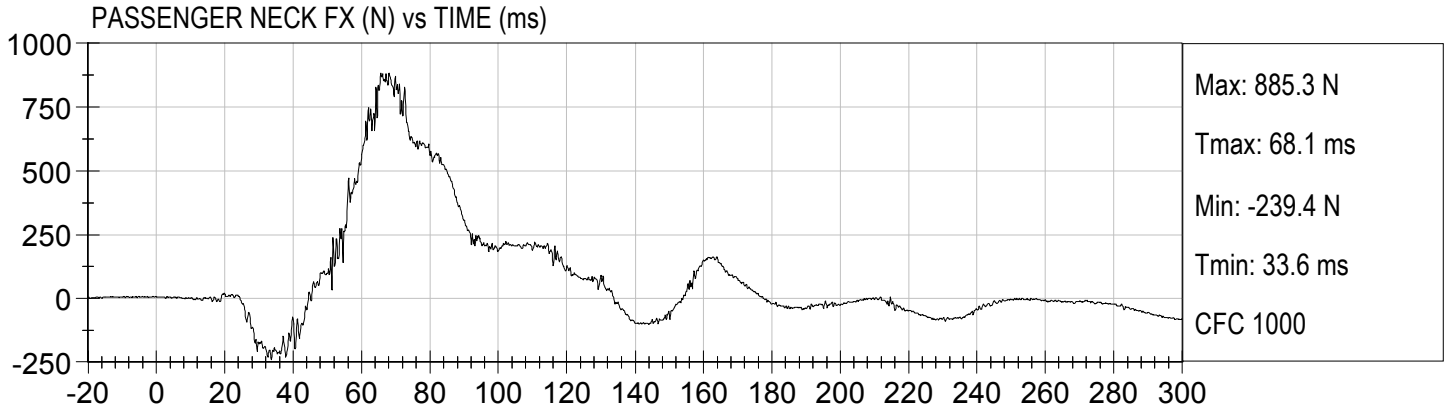

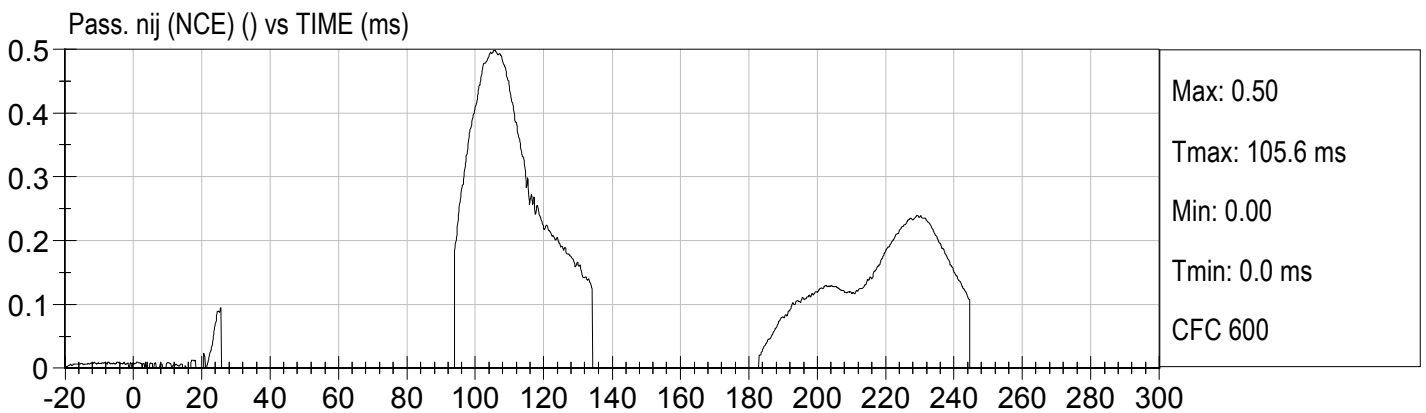
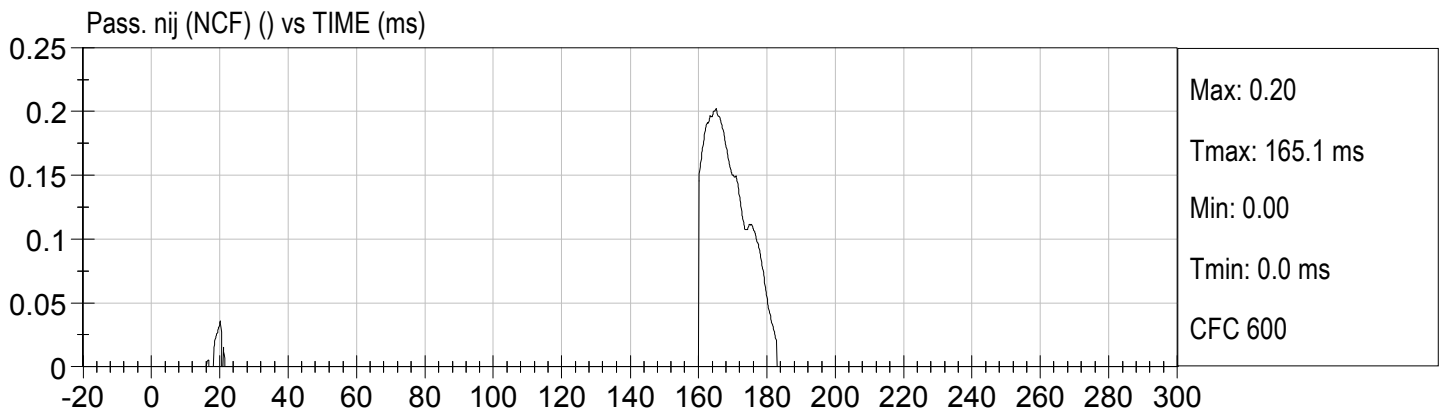
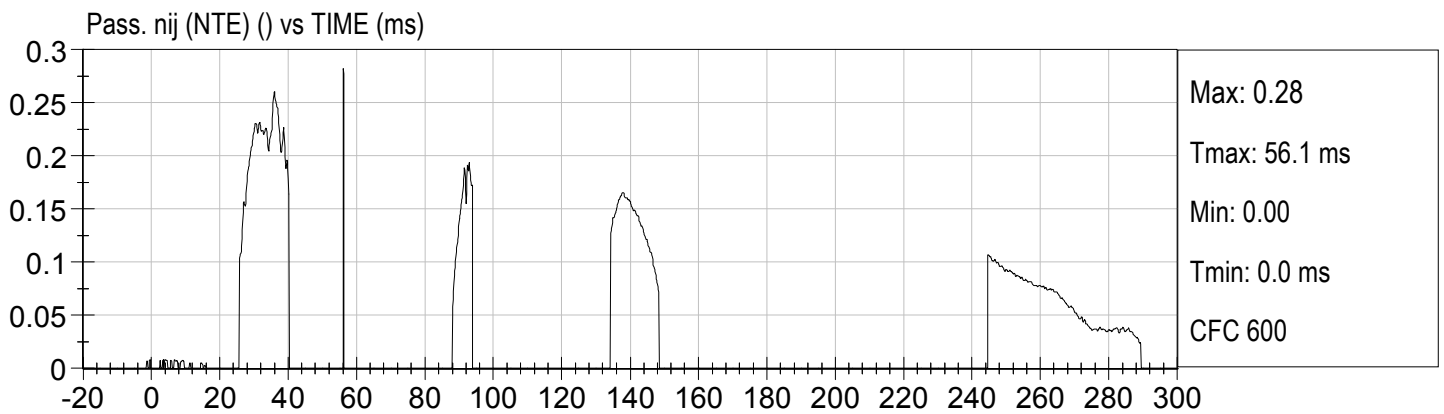
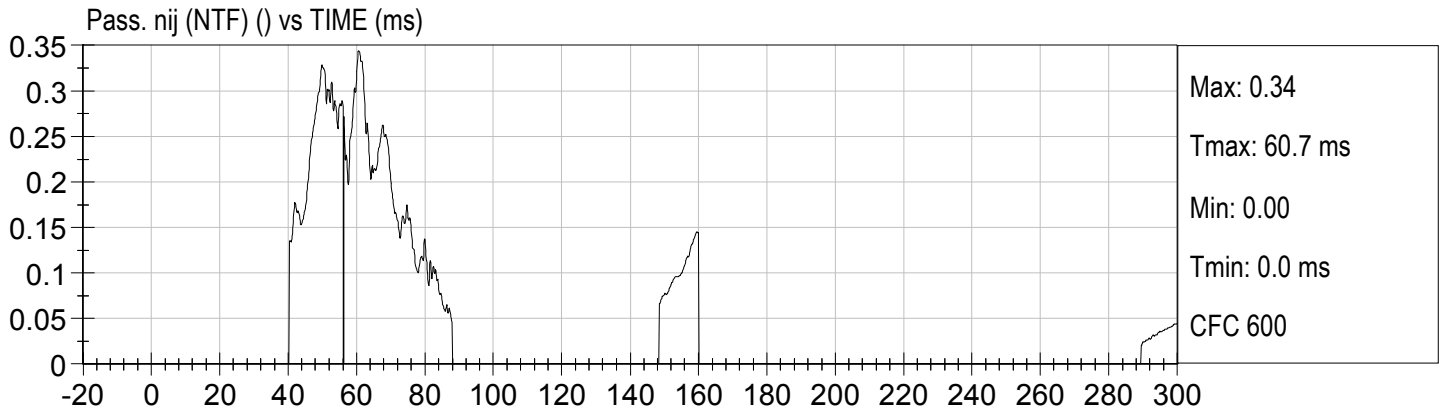

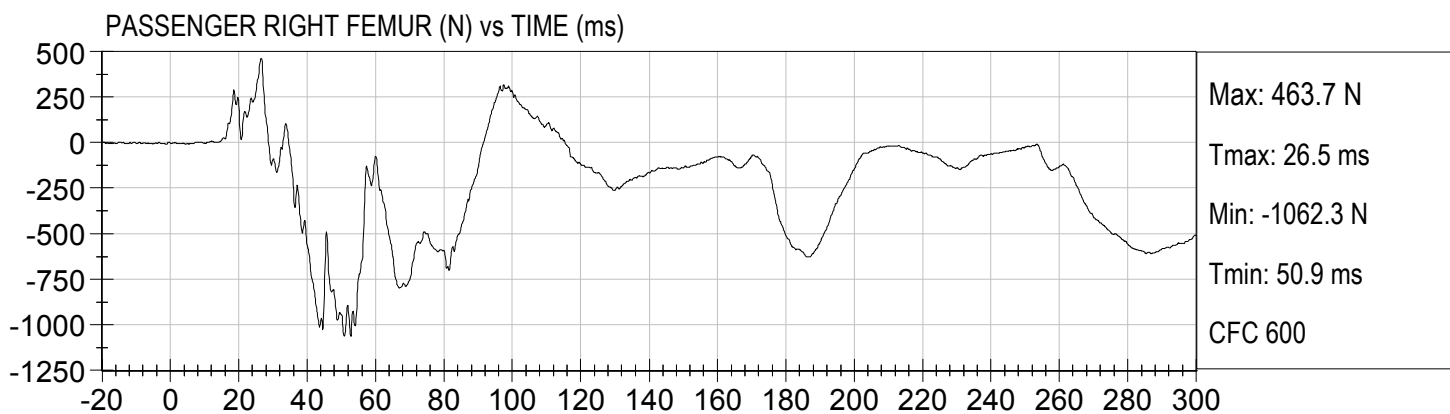
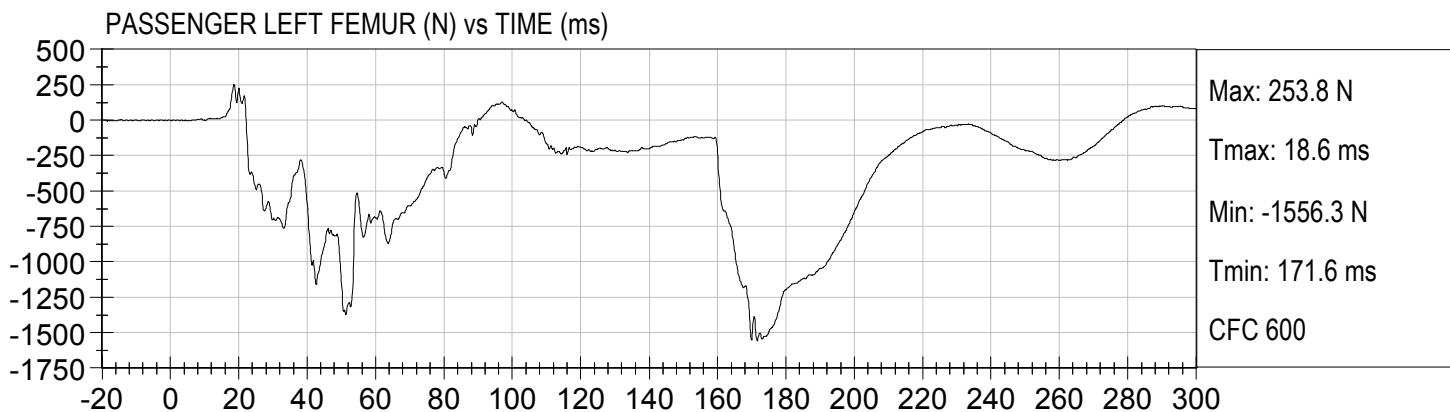

APPENDIX C
DUMMY CALIBRATION AND PERFORMANCE VERIFICATION DATA

**Hybrid III, 50th External Measurements
SN: 036**

| HYBRID III, PART 572, SUBPART E EXTERNAL DIMENSIONS | | | | |
|---|--------------------------------|--|-----------------------------|--------------------|
| DIMENSION | DESCRIPTION | DETAILS | ASSEMBLY DIMENSION (inches) | ACTUAL MEASUREMENT |
| A | TOTAL SITTING HEIGHT | Seat surface to highest point on top of the head. | 34.6–35.0 | 34.7 |
| B | SHOULDER PIVOT HEIGHT | Centerline of shoulder pivot bolt to the seat surface. | 19.9-20.5 | 20.0 |
| C | H-POINT HEIGHT | Reference | 3.3-3.5 | 3.4 |
| D | H-POINT LOCATION FROM BACKLINE | Reference | 5.3-5.5 | 5.4 |
| E | SHOULDER PIVOT FROM BACKLINE | Center of the shoulder clevis to the rear vertical surface of the fixture. | 3.3-3.7 | 3.6 |
| F | THIGH CLEARANCE | Measured at the highest point on the upper femur segment. | 5.5-6.1 | 5.8 |
| G | BACK OF ELBOW TO WRIST PIVOT | back of the elbow flesh to the wrist pivot in line with the elbow and wrist pivots | 11.4-12.0 | 11.5 |
| H | HEAD BACK TO BACKLINE | Back of Skull cap skin to seat rear vertical surface (Reference) | 1.6-1.8 | 1.7 |
| I | SHOULDER TO- ELBOW LENGTH | Measure from the highest point on top of the shoulder clevis to the lowest part of the flesh on the elbow in line with the elbow pivot bolt. | 13.0-13.6 | 13.0 |
| J | ELBOW REST HEIGHT | Measure from the flesh below the elbow pivot bolt to the seat surface. | 7.5-8.3 | 7.9 |
| K | BUTTOCK TO KNEE LENGTH | The forward most part of the knee flesh to the rear vertical surface of the fixture. | 22.8-23.8 | 23.8 |
| L | POPLITEAL HEIGHT | Seat surface to the plane of the horizontal plane of the bottom of the feet. | 16.9-17.9 | 17.3 |
| M | KNEE PIVOT HEIGHT | Centerline of knee pivot bolt to the horizontal plane of the bottom of the feet. | 19.1-19.7 | 19.5 |
| N | BUTTOCK POPLITEAL LENGTH | The rearmost surface of the lower leg to the same point on the rear surface of the buttocks used for dim. "K". | 17.8-18.8 | 17.9 |

HYBRID III, SUBPART E EXTERIOR DIMENSIONS, continued

| DIMENSION | DESCRIPTION | DETAILS | | ACTUAL MEASUREMENT |
|-----------|---|---|-----------|--------------------|
| O | CHEST DEPTH WITHOUT JACKET | Measured 16.9-17.1 in. above seat surface | 8.4-9.0 | 8.8 |
| P | FOOT LENGTH | Tip of toe to rear of heel | 9.9-10.5 | 10.0 |
| V | SHOULDER BREADTH | Outside edges of right and left shoulder clevises | 16.3-17.2 | 16.4 |
| W | FOOT BREADTH | The widest part of the foot | 3.6-4.2 | 4.1 |
| Y | CHEST CIRCUMFERENCE (WITH CHEST JACKET) | Measured 16.9-17.1 in. above seat surface | 38.2-39.4 | 38.4 |
| Z | WAIST CIRCUMFERENCE | Measured 8.9-9.1 in. above seat surface | 32.9-34.1 | 34.0 |
| AA | REFERENCE LOCATION FOR MEASUREMENT OF CHEST CIRCUMFERENCE | Reference | 16.9-17.1 | 17.0 |
| BB | REFERENCE LOCATION FOR MEASUREMENT OF WAIST CIRCUMFERENCE | Reference | 8.9-9.1 | 9.0 |

NOTE: THE H-POINT IS LOCATED 1.83 INCHES FORWARD AND 2.57 INCHES DOWN FROM THE CENTER OF THE PELVIS ANGLE REFERENCE HOLE.

**MGA RESEARCH CORPORATION
HEAD DROP TEST
HYBRID III 50TH PERCENTILE MALE**

ATD Serial No: 036

Test ID: D132721

| Tested Parameter | Units | Specification | Result | Pass/Fail |
|------------------------------|-------|--------------------|--------|-------------|
| Laboratory Temperature | deg C | 18.9 to 25.6 | 21.3 | Pass |
| Laboratory Relative Humidity | % | 10 to 70 | 46 | Pass |
| Peak Resultant Acceleration | G's | 225 to 275 | 271 | Pass |
| Peak Lateral Acceleration | G's | <= +/- 15.0 | -4.2 | Pass |
| Unimodal | N/A | Yes | Yes | Pass |
| Oscillations | N/A | within 10% of peak | Yes | Pass |
| Overall Test Results | | | | Pass |

Jessica Gall
Laboratory Technician

08/14/2013
Test Date

David Winkelbauer
Approved By

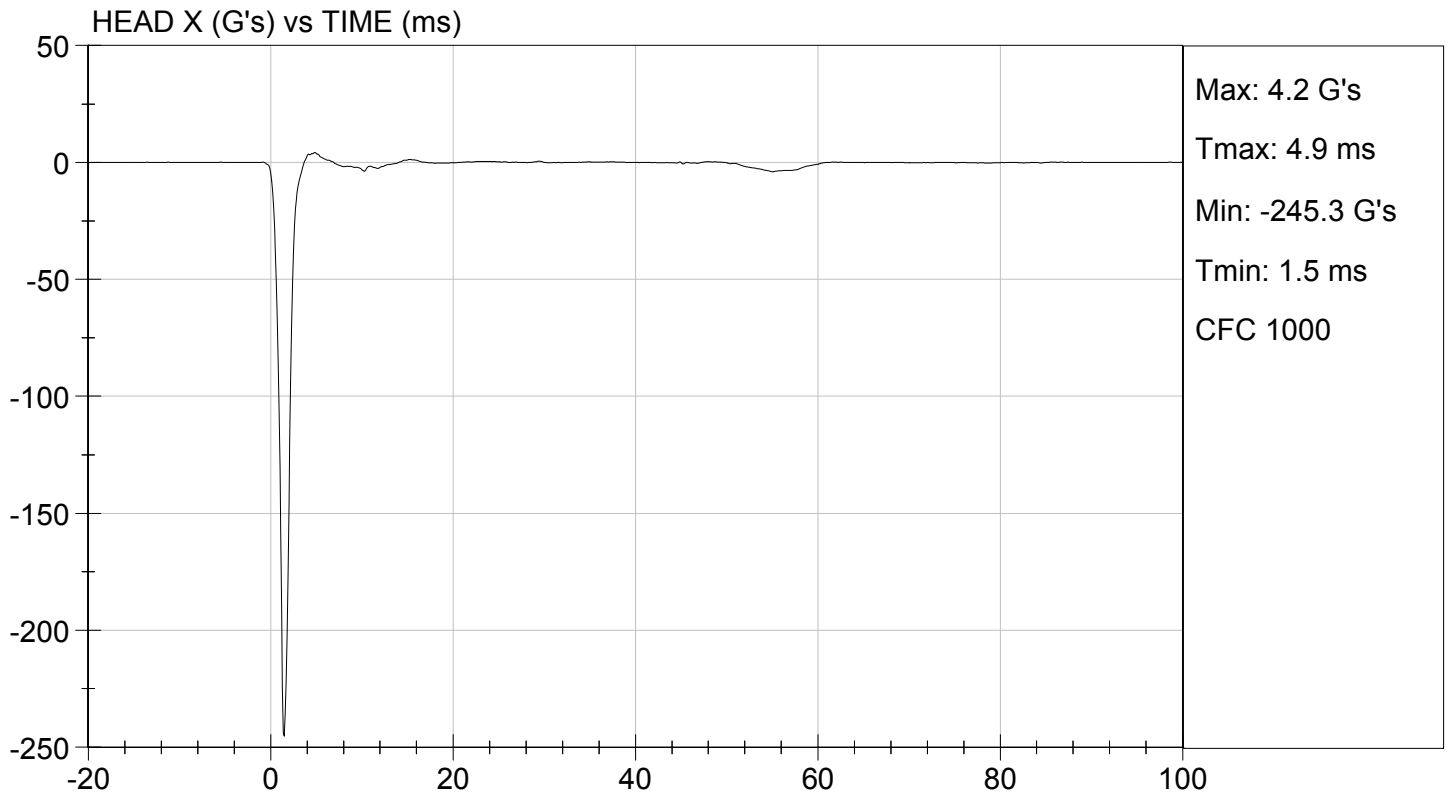
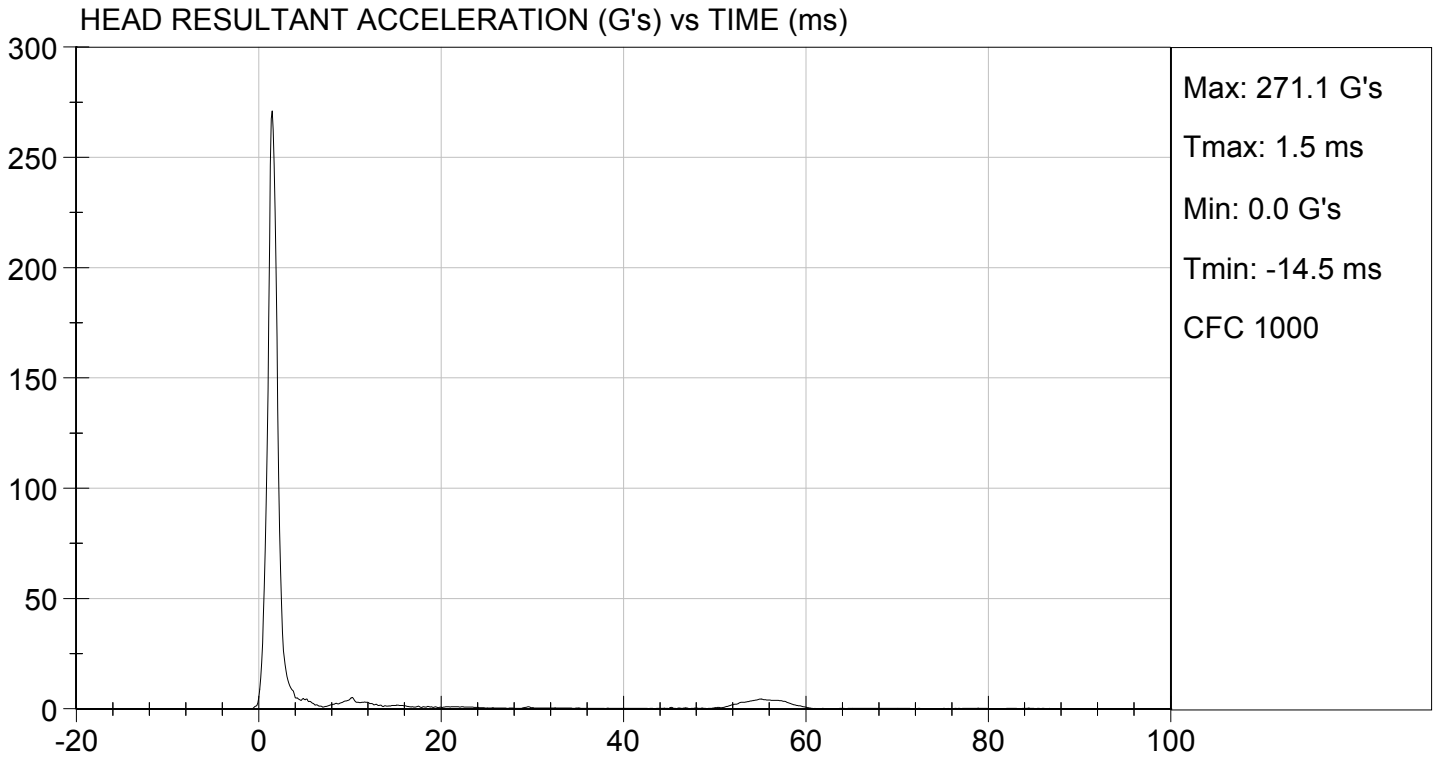

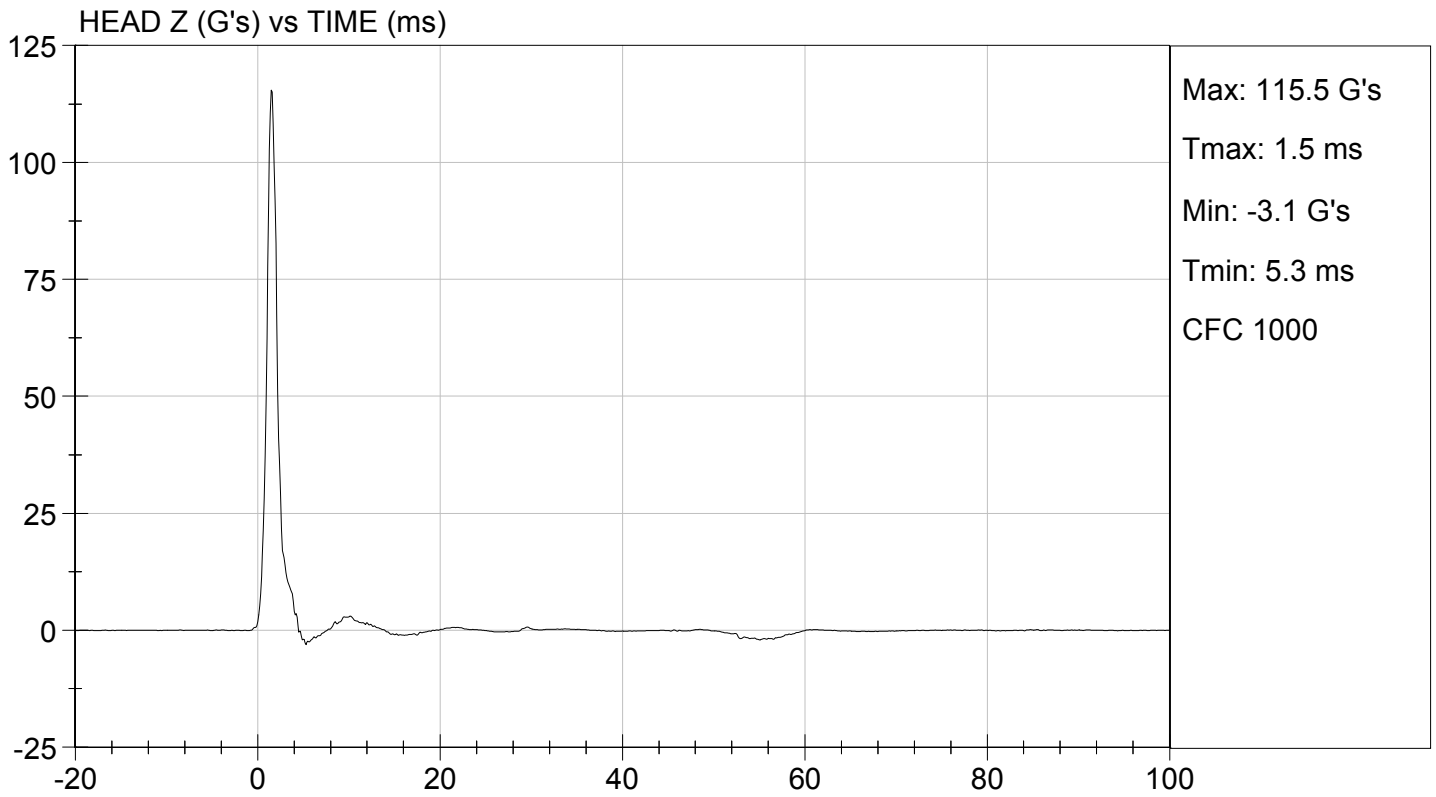
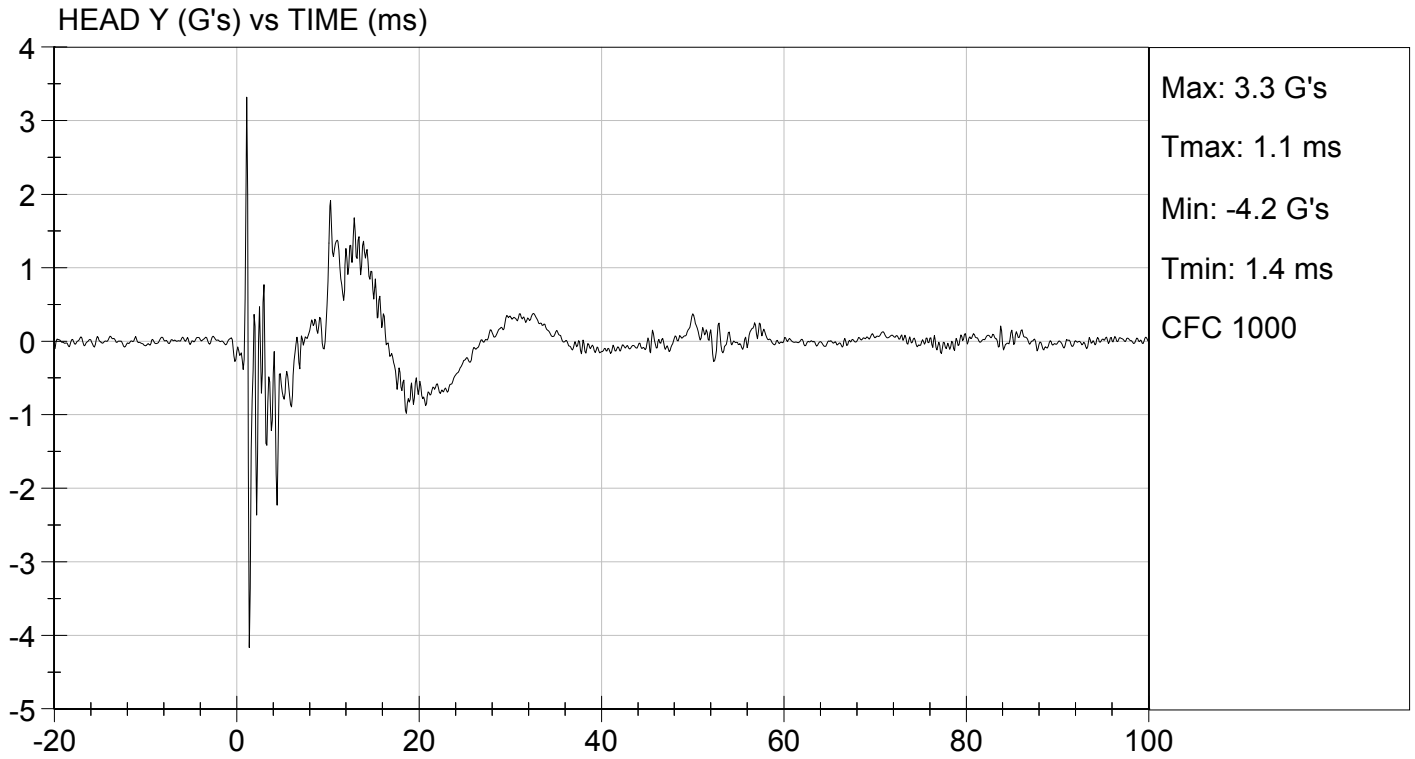

MGA RESEARCH CORPORATION
NECK FLEXION TEST
HYBRID III 50TH PERCENTILE MALE

ATD Serial No: 036

Test I.D: D132722

| Tested Parameter | | Units | Specification | Result | Pass/Fail |
|--|---------|-------|----------------|--------|-------------|
| Laboratory Temperature | | deg C | 20.6 to 22.2 | 21.4 | Pass |
| Laboratory Relative Humidity | | % | 10 to 70 | 42 | Pass |
| Pendulum Velocity | | m/s | 6.89 to 7.13 | 6.96 | Pass |
| Pendulum Deceleration | 10 ms | G's | 22.50 to 27.50 | 23.19 | Pass |
| | 20 ms | G's | 17.60 to 22.60 | 19.35 | Pass |
| | 30 ms | G's | 12.50 to 18.50 | 13.8 | Pass |
| Peak Pendulum Deceleration After 30 ms | | G's | <= 29.0 | 14.1 | Pass |
| Deceleration Decay Time to Cross 5 G's | | ms | 34.0 to 42.0 | 36.9 | Pass |
| Maximum "D" Plane Rotation | Maximum | Deg | 64.0 to 78.0 | 73.4 | Pass |
| | Time | ms | 57.0 to 64.0 | 61.1 | Pass |
| "D" Plane Rotation Decay Time To Zero Crossing | | ms | 113.0 to 128.0 | 119.6 | Pass |
| Moment About Occipital Condyle | Maximum | Nm | 88.1 to 108.5 | 90.6 | Pass |
| | Time | ms | 47.0 to 58.0 | 50.8 | Pass |
| Positive Moment Decay Time To Zero Crossing | | ms | 97.0 to 107.0 | 99.7 | Pass |
| Overall Test Results | | | | | Pass |

Jessica Hall
 Laboratory Technician

08/14/2013
 Test Date

David Winkelbauer
 Approved By

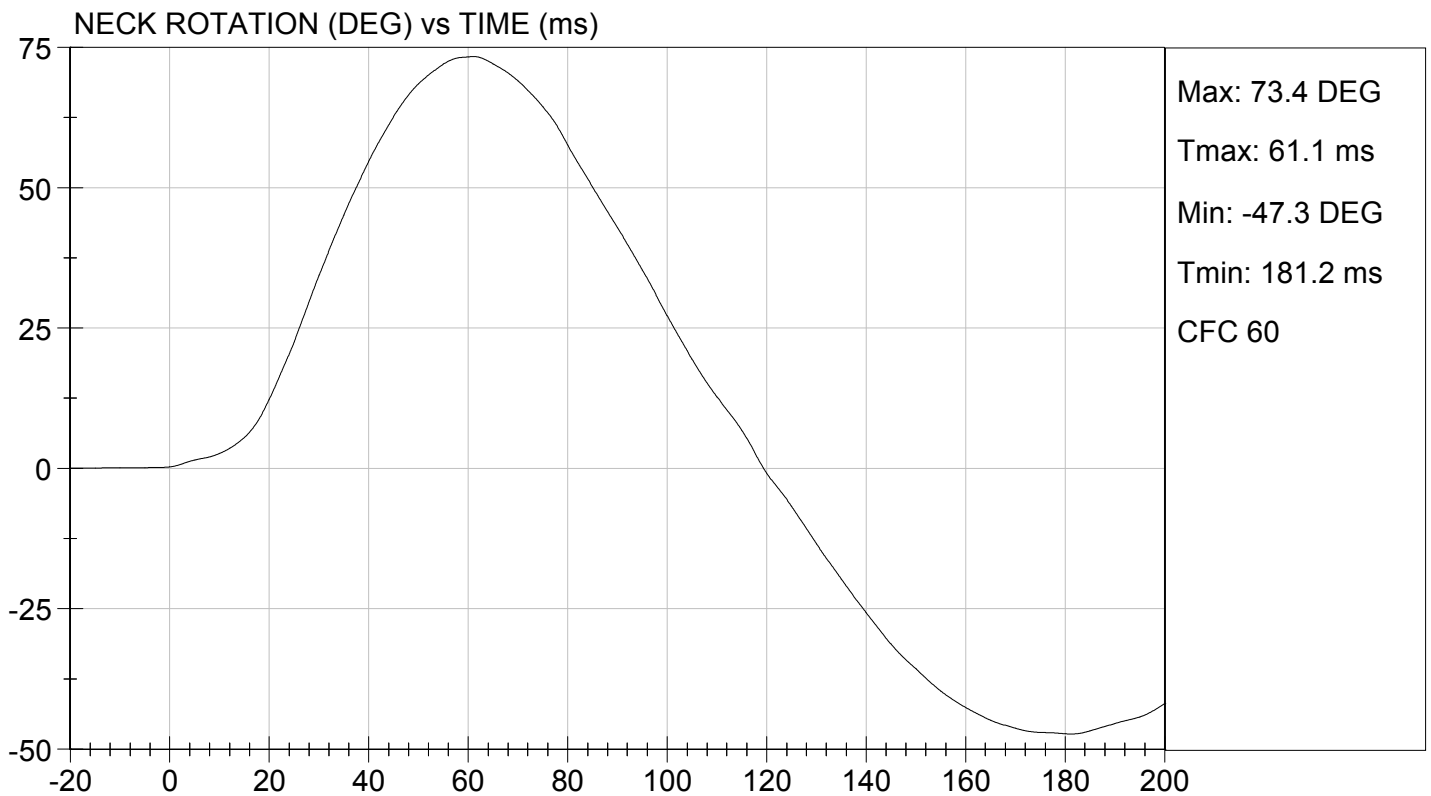
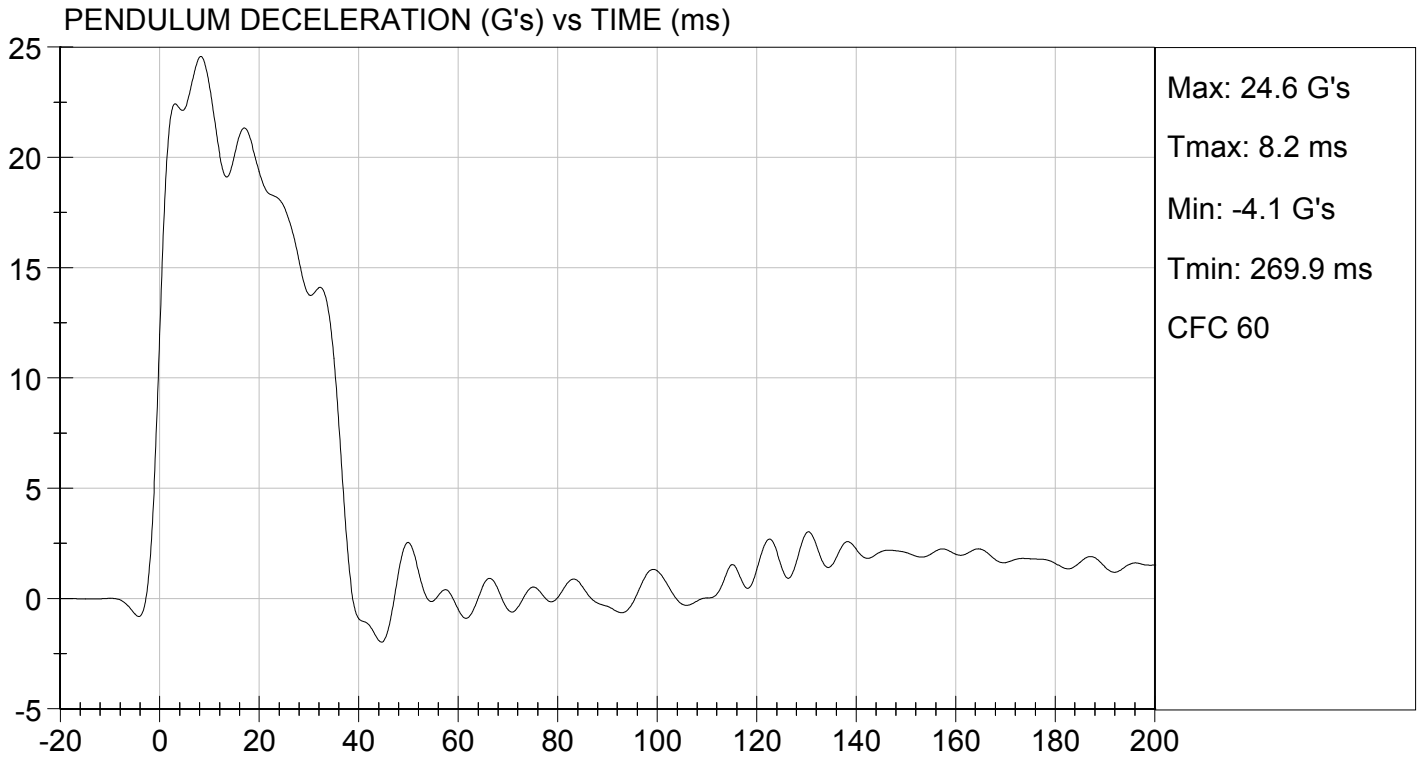

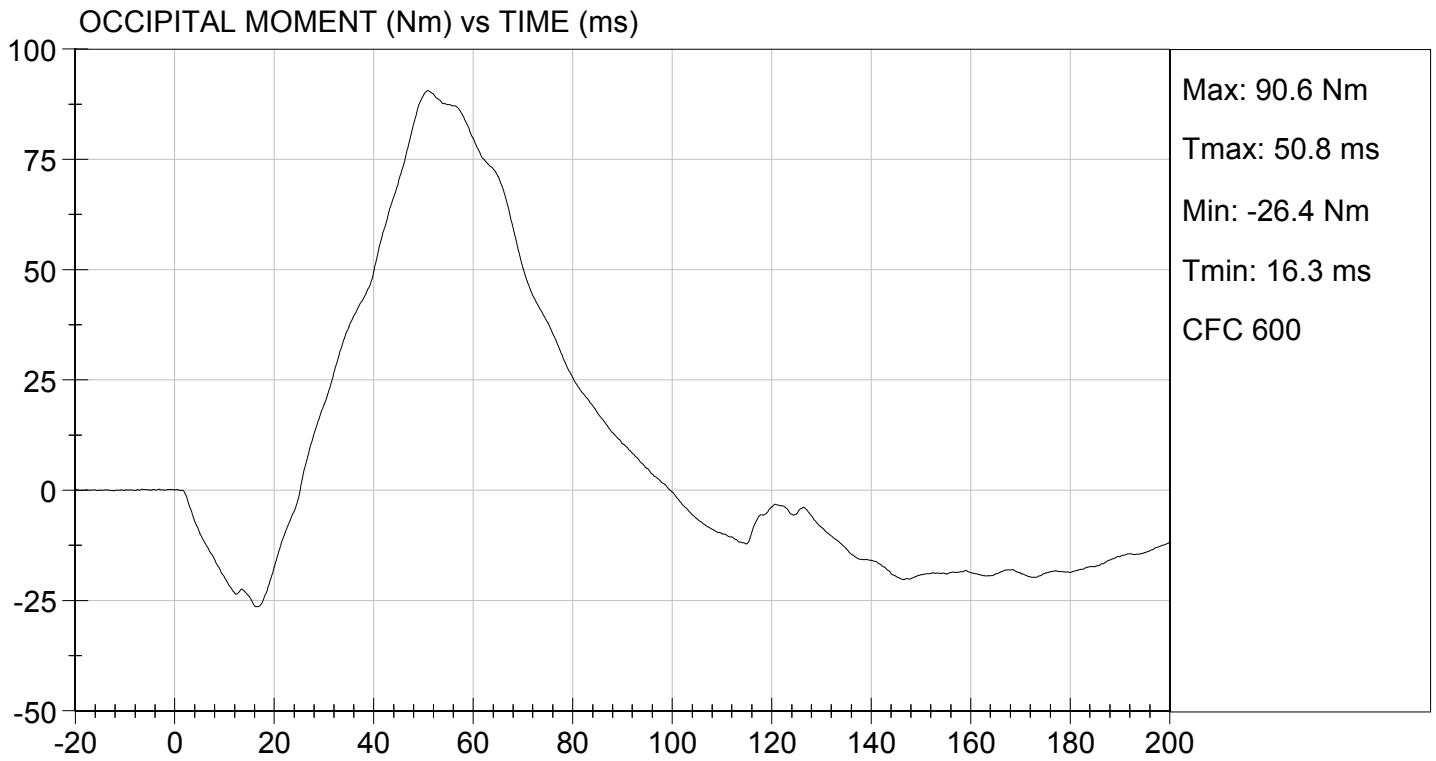

**MGA RESEARCH CORPORATION
NECK EXTENSION TEST
HYBRID III 50TH PERCENTILE MALE**

ATD Serial No: 036

Test I.D.: D132723

| Tested Parameter | | Units | Specification | Result | Pass/Fail |
|--|---------|---------|----------------|--------|-------------|
| Laboratory Temperature | | deg C | 20.6 to 22.2 | 21.4 | Pass |
| Laboratory Relative Humidity | | % | 10 to 70 | 42 | Pass |
| Pendulum Velocity | | m/s | 5.95 to 6.19 | 6.05 | Pass |
| Pendulum Deceleration | 10 ms | G's | 17.20 to 21.20 | 18.52 | Pass |
| | 20 ms | G's | 14.00 to 19.00 | 15.77 | Pass |
| | 30 ms | G's | 11.00 to 16.00 | 13.29 | Pass |
| Peak Pendulum Deceleration After 30 ms | | G's | <= 22.0 | 13.9 | Pass |
| Deceleration Decay Time to Cross 5 G's | | ms | 38.0 to 46.0 | 38.2 | Pass |
| Maximum "D" Plane Rotation | Maximum | Degrees | 81.0 to 106.0 | 94.2 | Pass |
| | Time | ms | 72.0 to 82.0 | 77.5 | Pass |
| "D" Plane Rotation Decay Time To Zero Crossing | | ms | 147.0 to 174.0 | 159.7 | Pass |
| Moment About Occipital Condyle | Maximum | Nm | -52.9 to -79.9 | -62.2 | Pass |
| | Time | ms | 65.0 to 79.0 | 72.6 | Pass |
| Negative Moment Decay Time To Zero Crossing | | ms | 120.0 to 148.0 | 143.9 | Pass |
| Overall Test Results | | | | | Pass |

Jessica Hall
Laboratory Technician

08/14/2013
Test Date

David Winkelbauer
Approved By

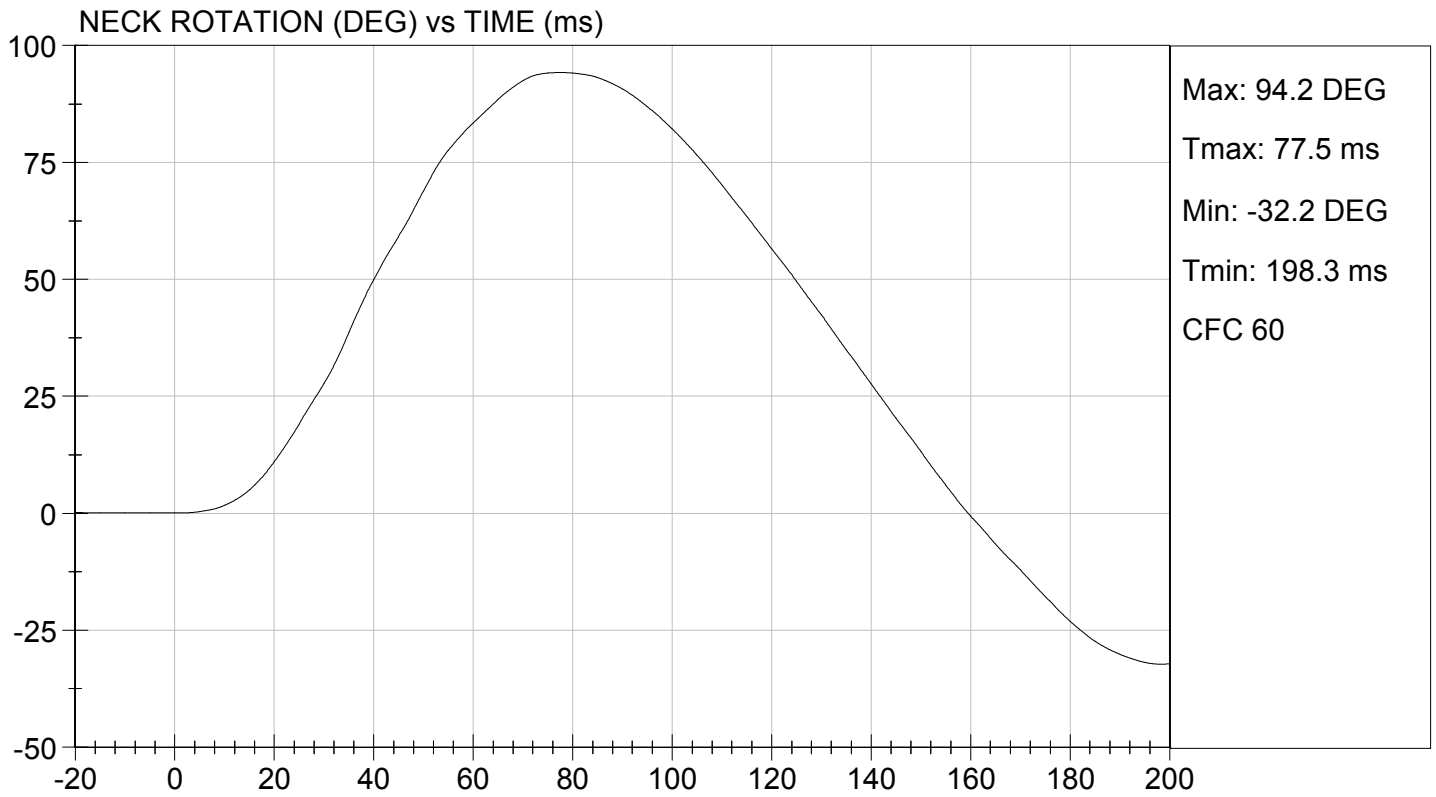
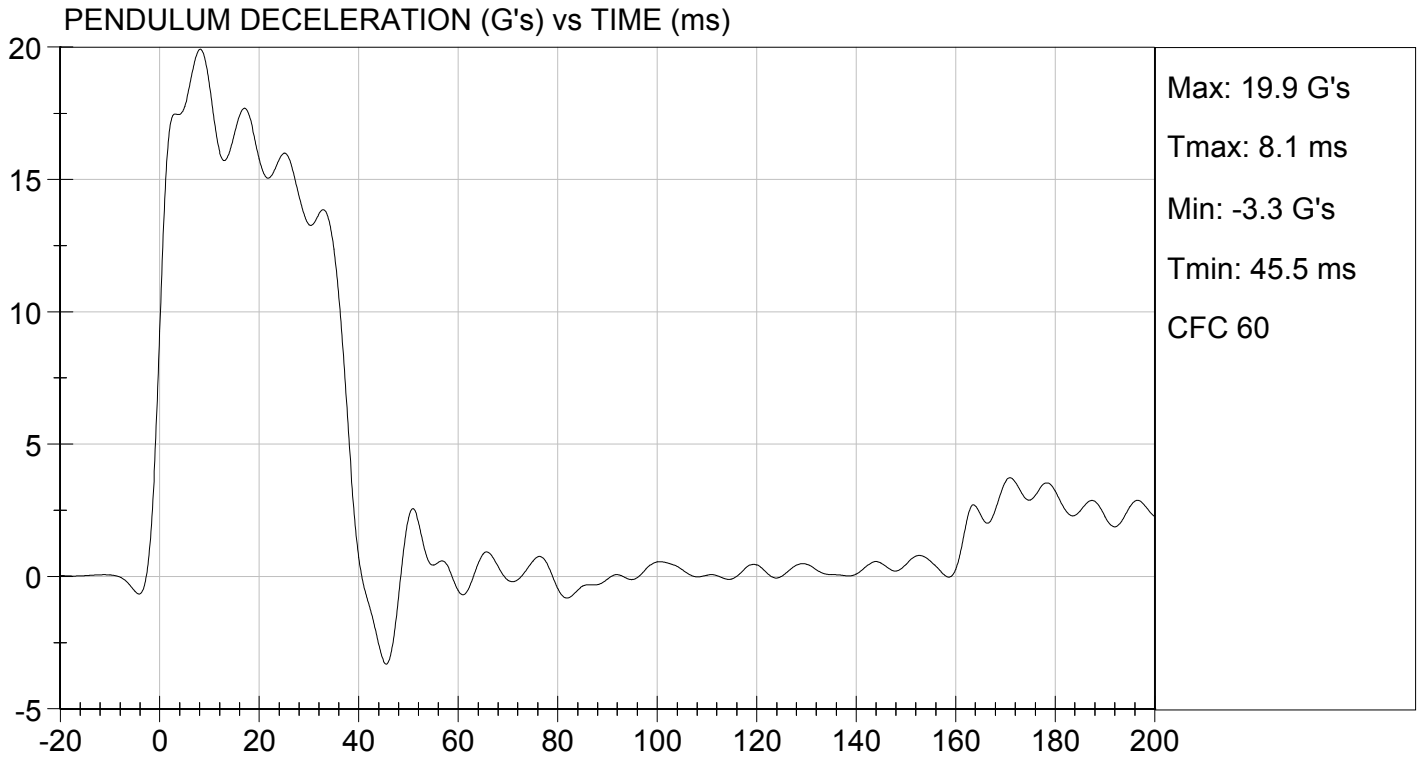

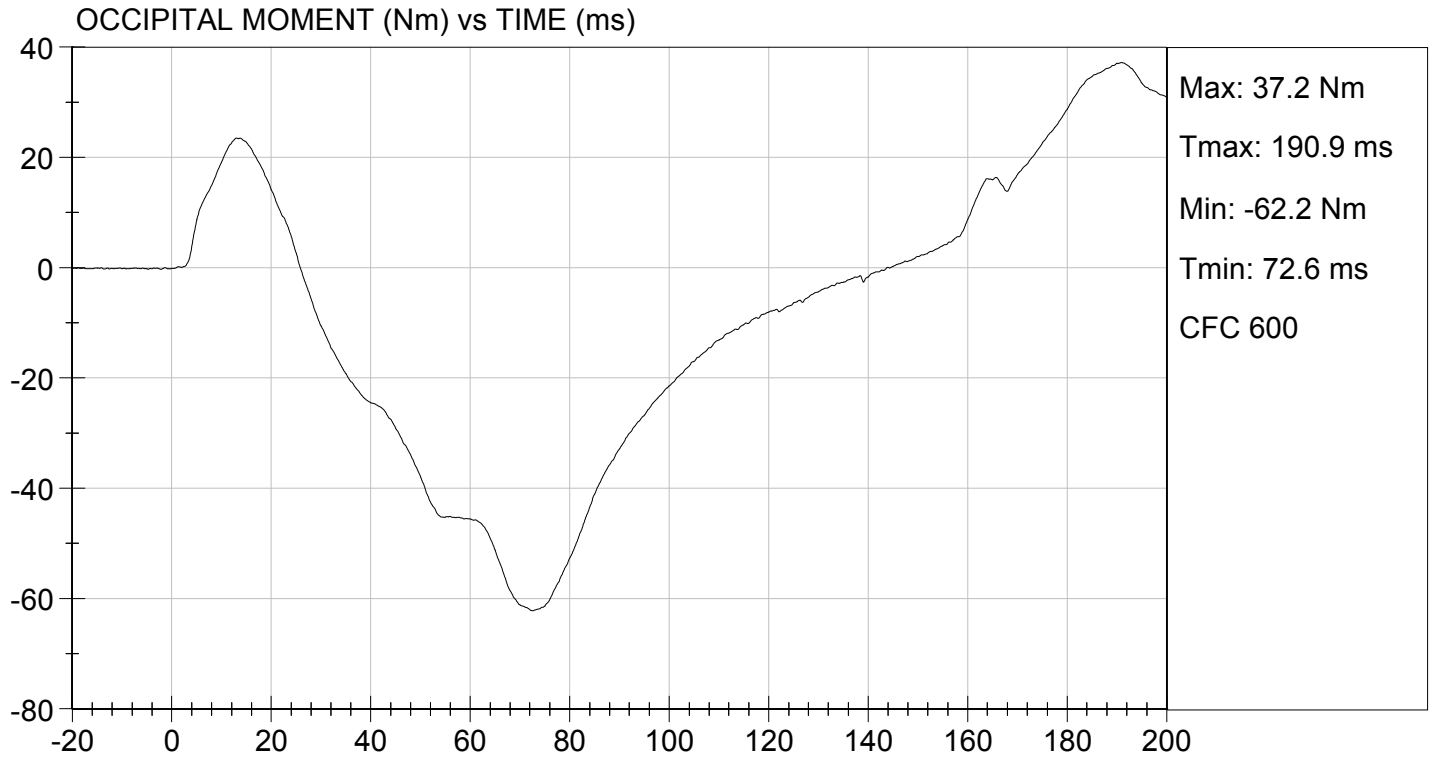

**MGA RESEARCH CORPORATION
THORAX IMPACT
HYBRID III 50TH PERCENTILE MALE**

ATD Serial No: 036

Test I.D.: D132724

| Tested Parameter | Units | Specification | Result | Pass/Fail |
|------------------------------|-------|---------------|--------|-------------|
| Laboratory Temperature | deg C | 20.6 to 22.2 | 21.6 | Pass |
| Laboratory Relative Humidity | % | 10 to 70 | 44 | Pass |
| Probe Velocity | m/s | 6.58 to 6.82 | 6.68 | Pass |
| Peak Probe Force | N | 5159 to 5893 | 5,454 | Pass |
| Peak Sternum Displacement | cm | 6.35 to 7.26 | 6.40 | Pass |
| Internal Hysteresis | % | 69 to 85 | 72 | Pass |
| Overall Test Results | | | | Pass |

Laboratory Technician

08/15/2013
Test Date

Approved By

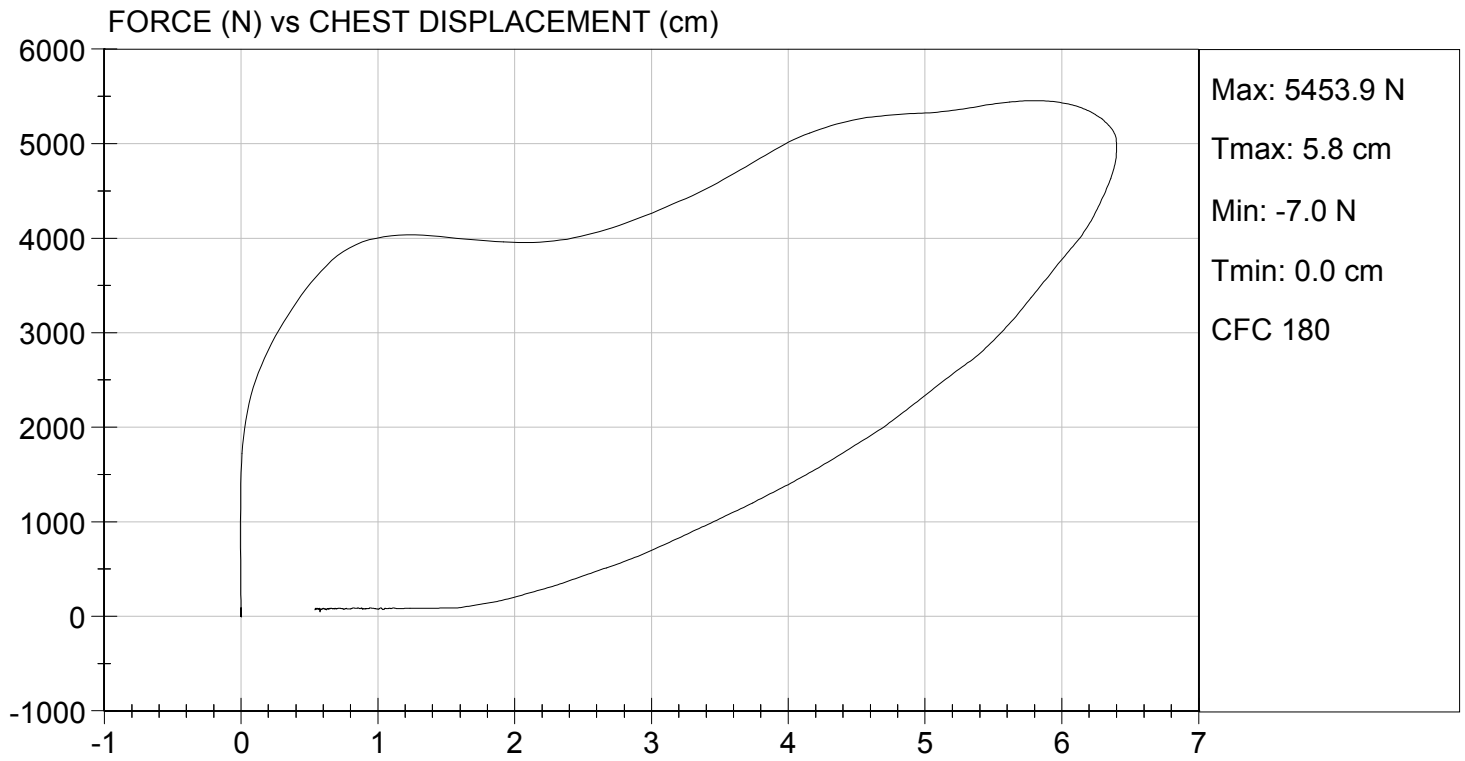

MGA RESEARCH CORPORATION
RIGHT KNEE IMPACT TEST
HYBRID III 50TH PERCENTILE MALE

ATD Serial No: 036

Test I.D: D132725

| Tested Parameter | Units | Specification | Result | Pass/Fail |
|------------------------------|-------|---------------|--------|-----------|
| Laboratory Temperature | deg C | 18.9 to 25.6 | 21.4 | Pass |
| Laboratory Relative Humidity | % | 10 to 70 | 45 | Pass |
| Probe Velocity | m/s | 2.07 to 2.13 | 2.07 | Pass |
| Peak Probe Force | N | 4715 to 5782 | 4,956 | Pass |
| Overall Test Results | | | | Pass |

 Laboratory Technician

08/15/2013
 Test Date

 Approved By



TEST DESC: RIGHT KNEE
VELOCITY: 6.80 ft/s, 2.07 m/s

TEST DATE: 08/15/2013
TEST #: D132725

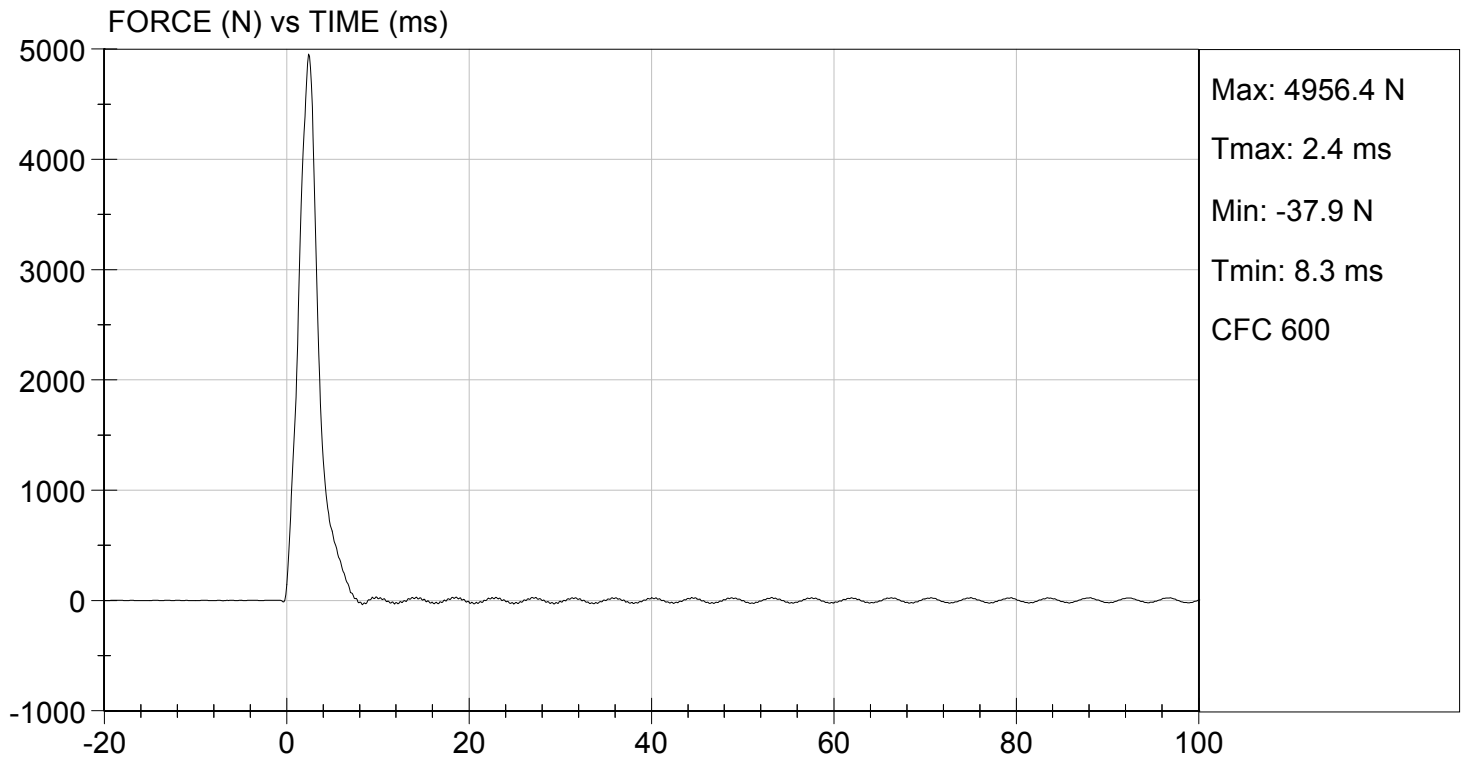

MGA RESEARCH CORPORATION
LEFT KNEE IMPACT TEST
HYBRID III 50TH PERCENTILE MALE

ATD Serial No: 036

Test I.D: D132726

| Tested Parameter | Units | Specification | Result | Pass/Fail |
|------------------------------|-------|---------------|--------|-------------|
| Laboratory Temperature | deg C | 18.9 to 25.6 | 21.4 | Pass |
| Laboratory Relative Humidity | % | 10 to 70 | 45 | Pass |
| Probe Velocity | m/s | 2.07 to 2.13 | 2.08 | Pass |
| Peak Probe Force | N | 4715 to 5782 | 4,950 | Pass |
| Overall Test Results | | | | Pass |

 Laboratory Technician

08/15/2013
 Test Date

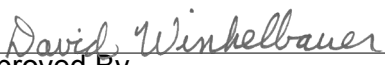
 Approved By



TEST DESC: LEFT KNEE
VELOCITY: 6.81 ft/s, 2.08 m/s

TEST DATE: 08/15/2013
TEST #: D132726

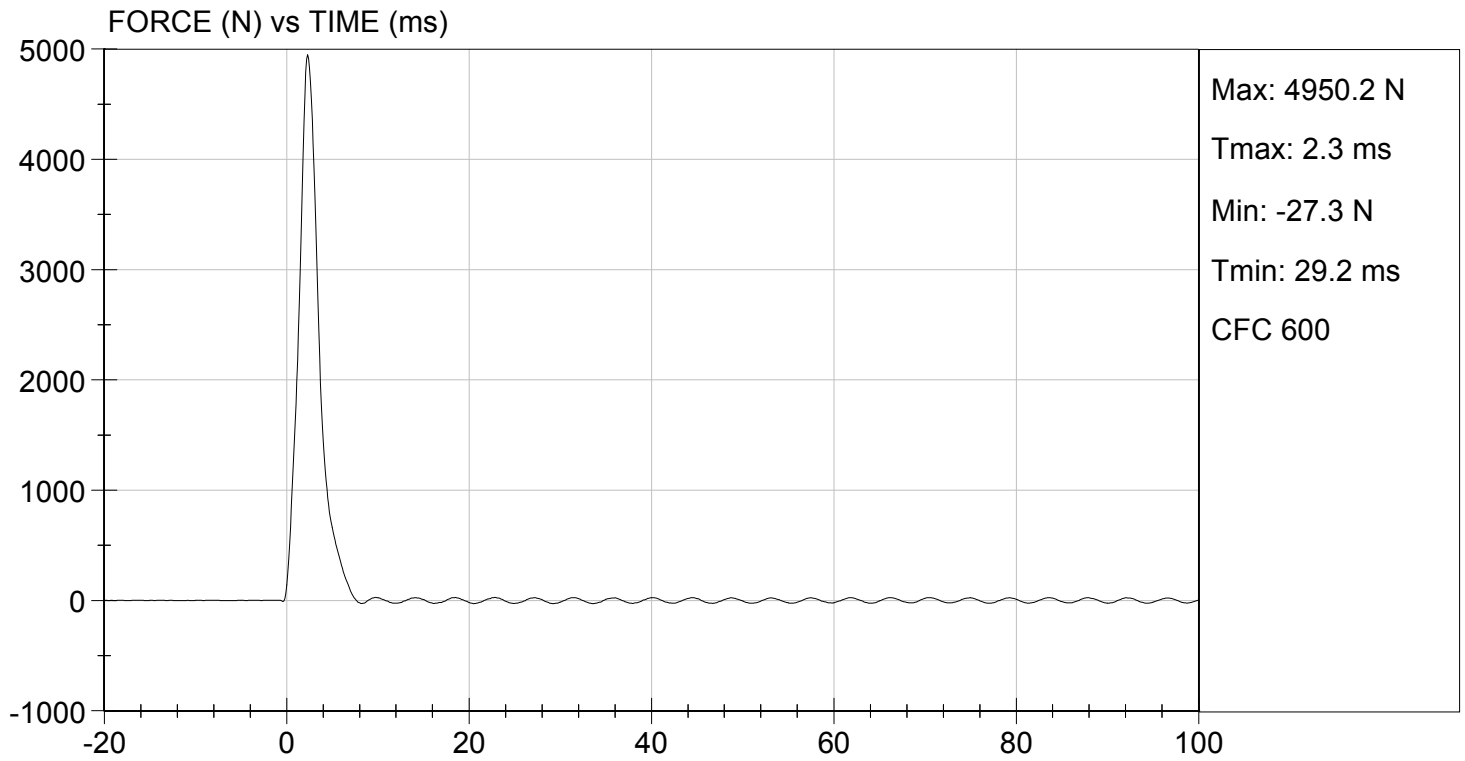

MGA RESEARCH CORPORATION
HIP-FEMUR FLEXION TEST
HYBRID III 50TH PERCENTILE MALE

ATD Serial No: 036

Test I.D: D132720

| Tested Parameter | Units | Specification | Result | | Pass/Fail |
|------------------------------|-------|-------------------------------------|--------|------|-----------|
| | | | Right | Left | |
| Laboratory Temperature | deg C | 18.9 to 25.6 | 21.3 | 21.3 | Pass |
| Laboratory Relative Humidity | % | 10 to 70 | 46 | 46 | Pass |
| Rotation Rate | deg/s | 5.0 to 10.0 | 6.1 | 6.2 | Pass |
| 30 Degrees | Nm | 94.9 Nm Max | 92.9 | 93.8 | Pass |
| 150 ft-lbf / 203.4 Nm | Deg | 40.0 to 50.0 Degree Max Rotation | 40.9 | 40.5 | Pass |
| Overall Test Results | | | | | Pass |

Jessica Hall
 Laboratory Technician

08/14/2013
 Test Date

David Winkelbauer
 Approved By

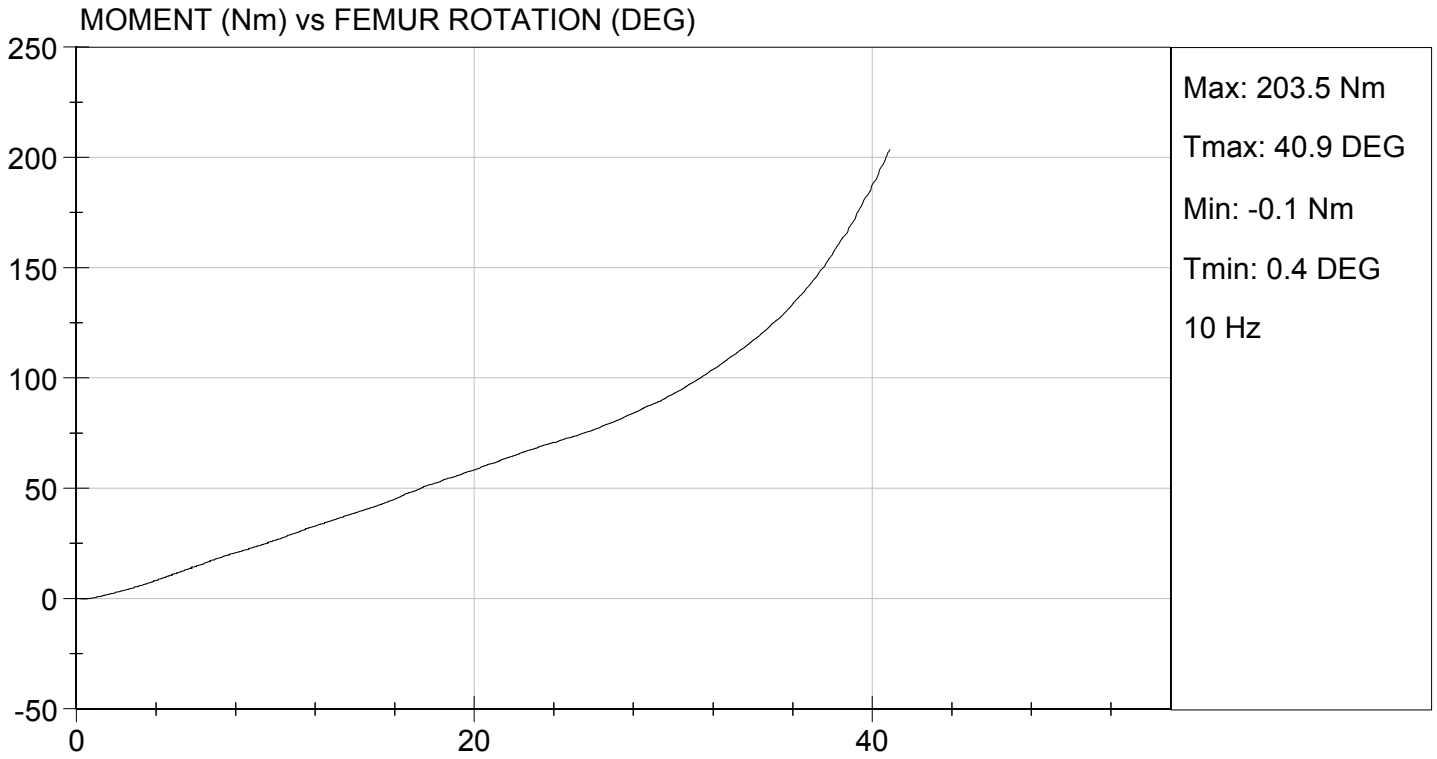

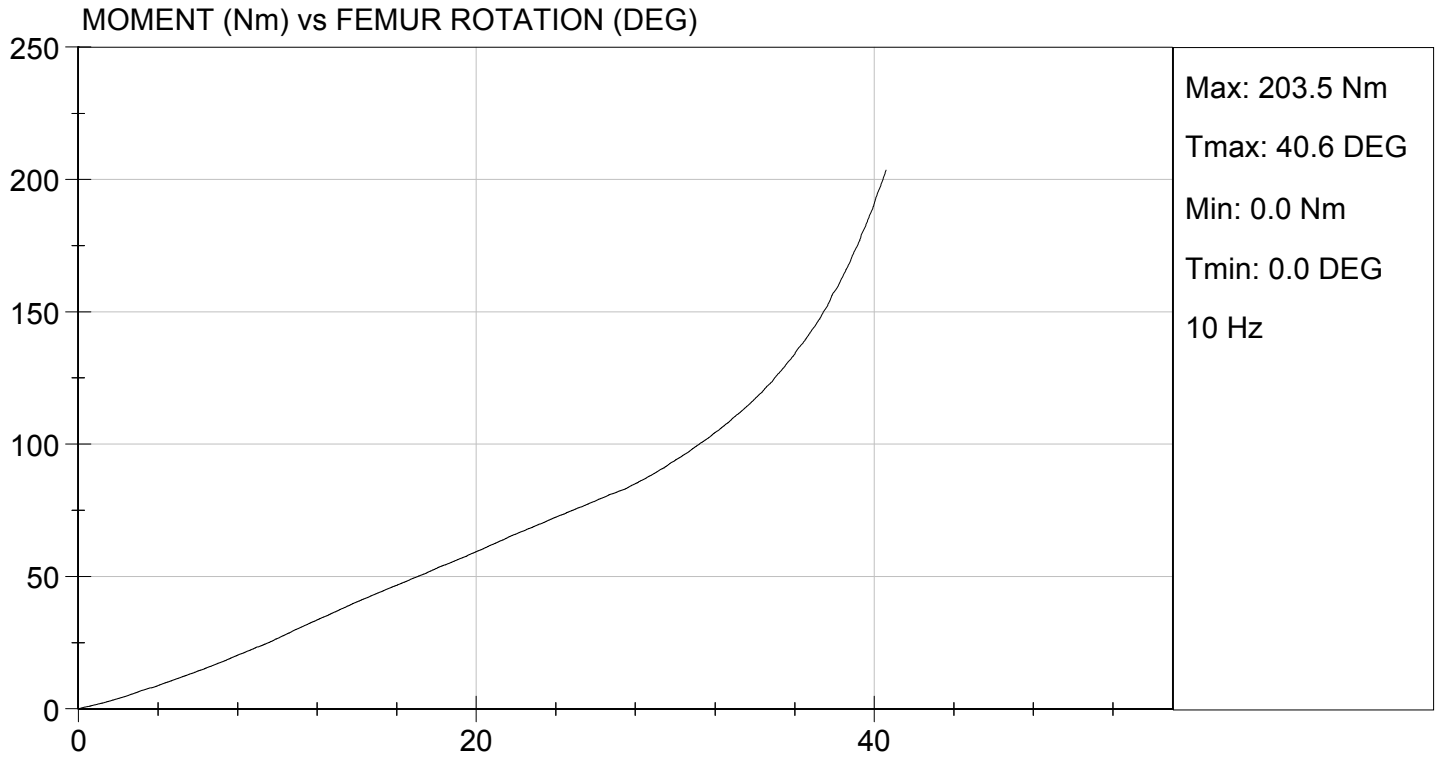

**MGA RESEARCH CORPORATION
HEAD DROP TEST
HYBRID III 50TH PERCENTILE MALE**

ATD Serial No: 036

Test ID: D132981

| Tested Parameter | Units | Specification | Result | Pass/Fail |
|------------------------------|-------|--------------------|--------|-------------|
| Laboratory Temperature | deg C | 18.9 to 25.6 | 21.0 | Pass |
| Laboratory Relative Humidity | % | 10 to 70 | 49 | Pass |
| Peak Resultant Acceleration | G's | 225 to 275 | 253 | Pass |
| Peak Lateral Acceleration | G's | <= +/- 15.0 | -7.4 | Pass |
| Unimodal | N/A | Yes | Yes | Pass |
| Oscillations | N/A | within 10% of peak | Yes | Pass |
| Overall Test Results | | | | Pass |

Jessica Hall
Laboratory Technician

09/06/2013
Test Date

David Winkelbauer
Approved By

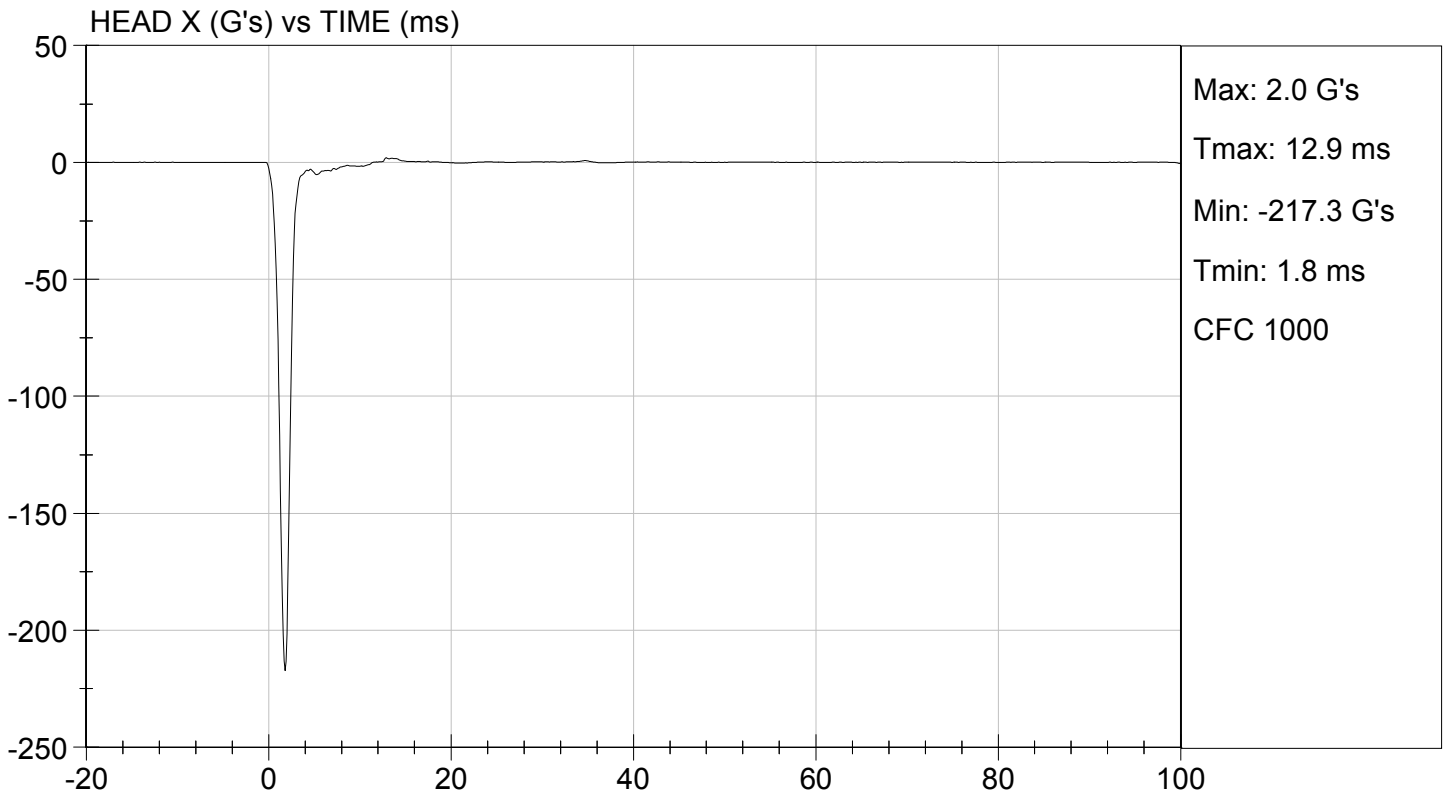
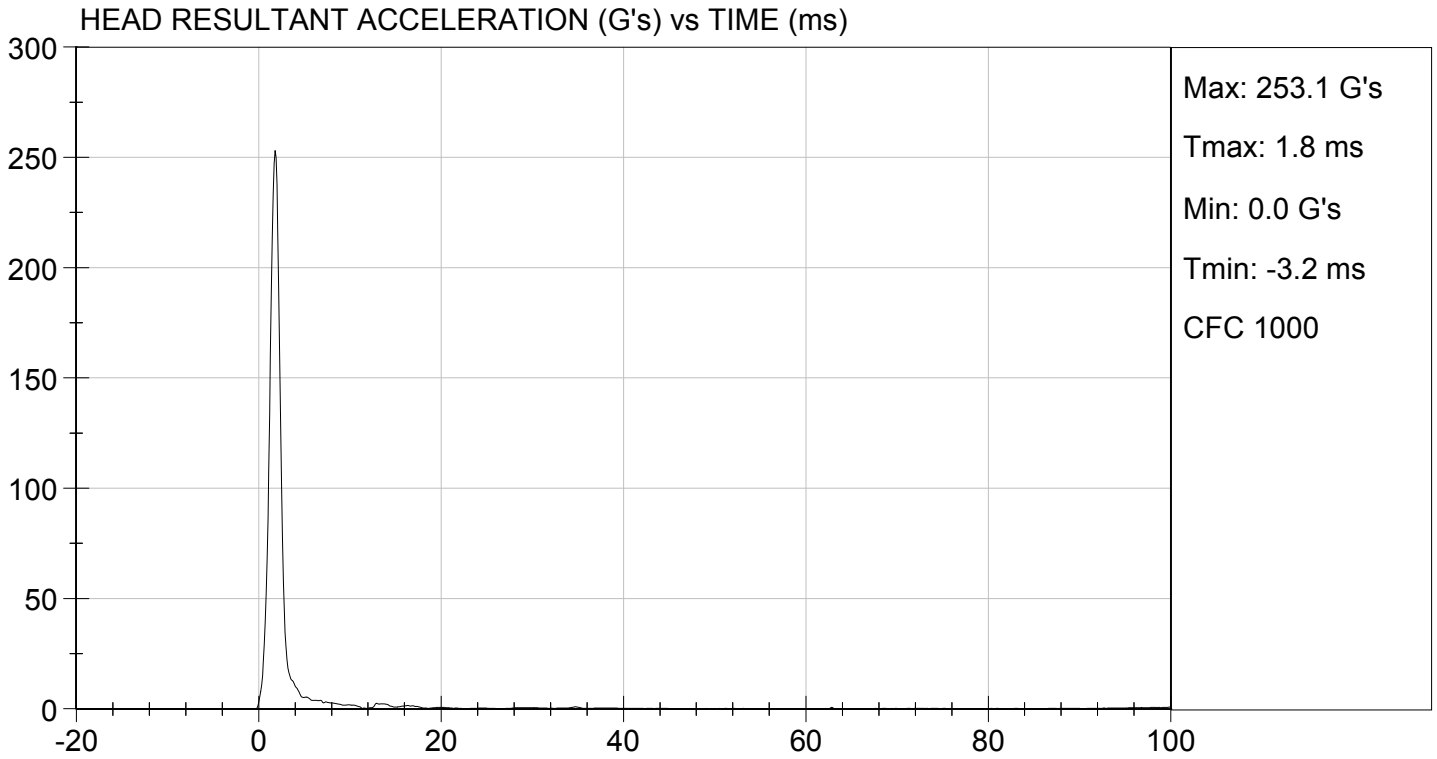

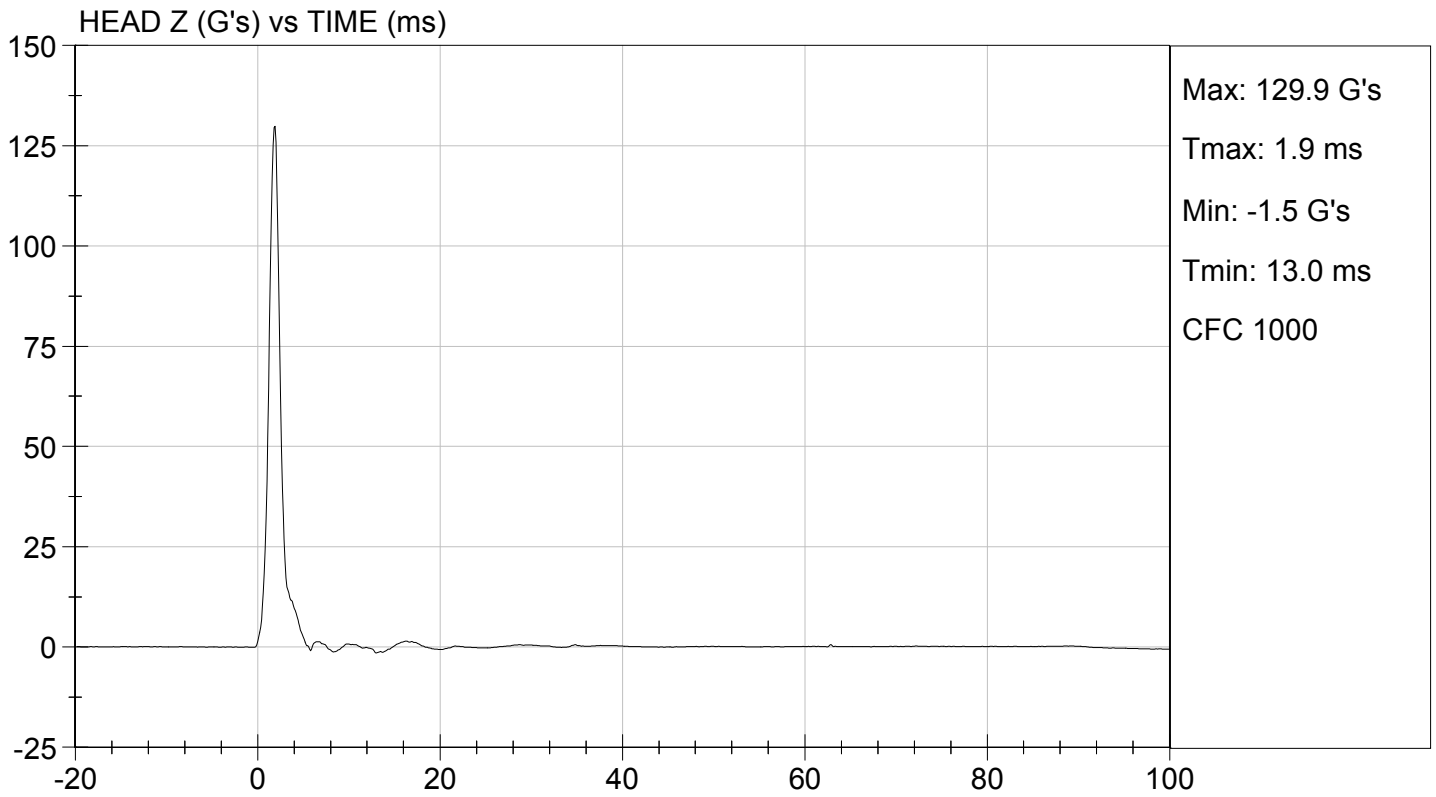
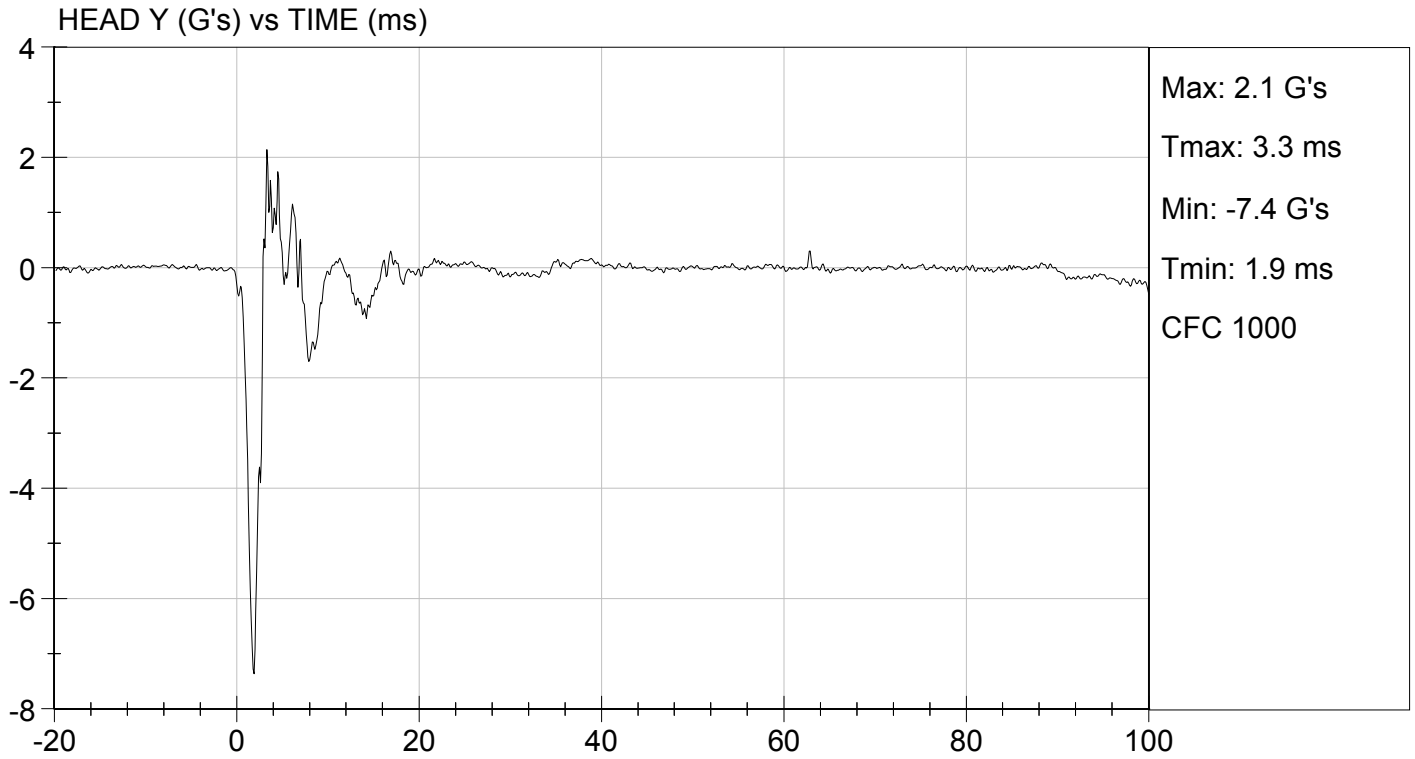

**MGA RESEARCH CORPORATION
NECK FLEXION TEST
HYBRID III 50TH PERCENTILE MALE**

ATD Serial No: 036

Test I.D.: D132982

| Tested Parameter | | Units | Specification | Result | Pass/Fail |
|--|---------|-------|----------------|--------|-------------|
| Laboratory Temperature | | deg C | 20.6 to 22.2 | 21.2 | Pass |
| Laboratory Relative Humidity | | % | 10 to 70 | 52 | Pass |
| Pendulum Velocity | | m/s | 6.89 to 7.13 | 6.96 | Pass |
| Pendulum Deceleration | 10 ms | G's | 22.50 to 27.50 | 23.17 | Pass |
| | 20 ms | G's | 17.60 to 22.60 | 20.36 | Pass |
| | 30 ms | G's | 12.50 to 18.50 | 16.11 | Pass |
| Peak Pendulum Deceleration After 30 ms | | G's | <= 29.0 | 16.0 | Pass |
| Deceleration Decay Time to Cross 5 G's | | ms | 34.0 to 42.0 | 35.0 | Pass |
| Maximum "D" Plane Rotation | Maximum | Deg | 64.0 to 78.0 | 71.4 | Pass |
| | Time | ms | 57.0 to 64.0 | 57.3 | Pass |
| "D" Plane Rotation Decay Time To Zero Crossing | | ms | 113.0 to 128.0 | 115.0 | Pass |
| Moment About Occipital Condyle | Maximum | Nm | 88.1 to 108.5 | 97.8 | Pass |
| | Time | ms | 47.0 to 58.0 | 50.4 | Pass |
| Positive Moment Decay Time To Zero Crossing | | ms | 97.0 to 107.0 | 98.2 | Pass |
| Overall Test Results | | | | | Pass |

Jessica Gall
Laboratory Technician

09/06/2013
Test Date

David Winkelbauer
Approved By

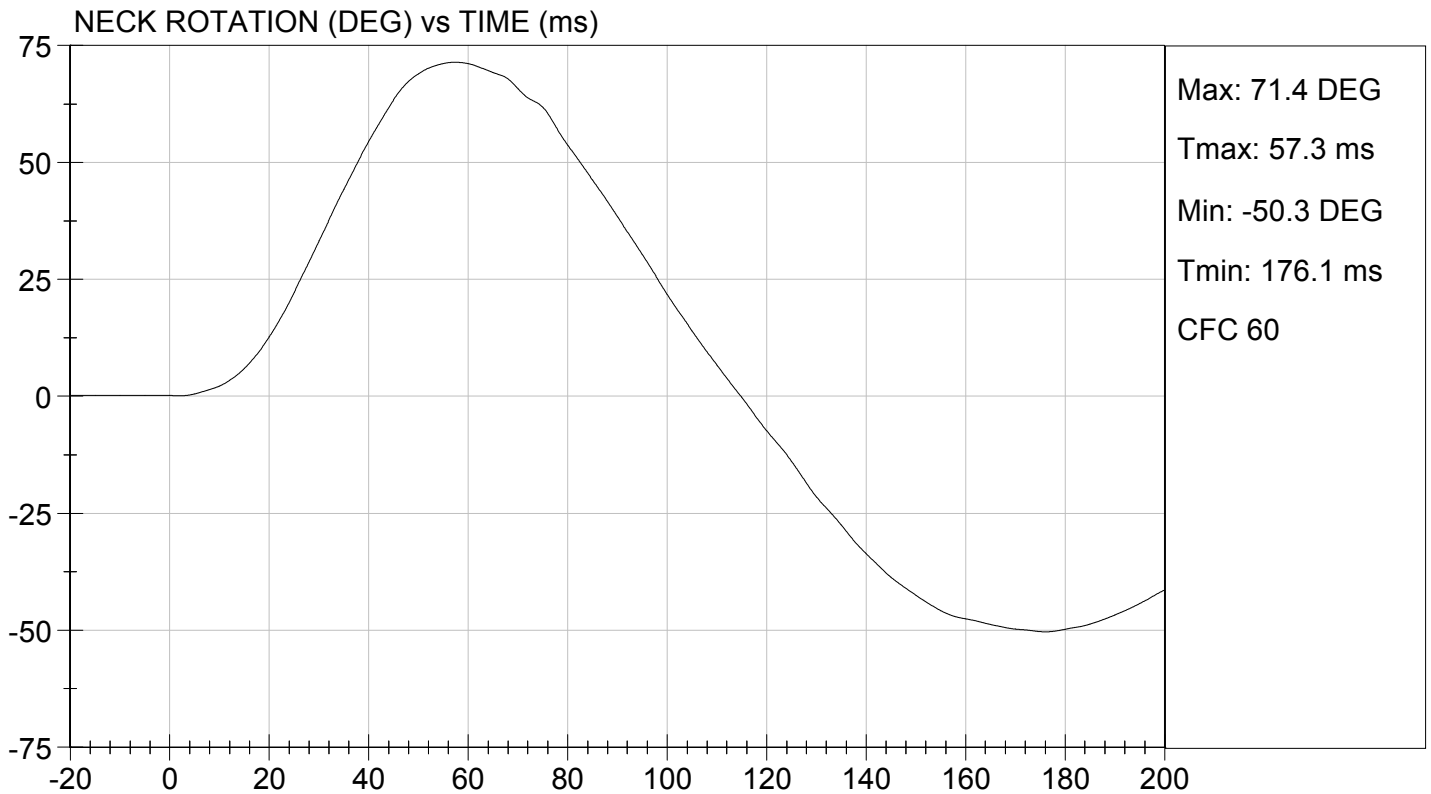
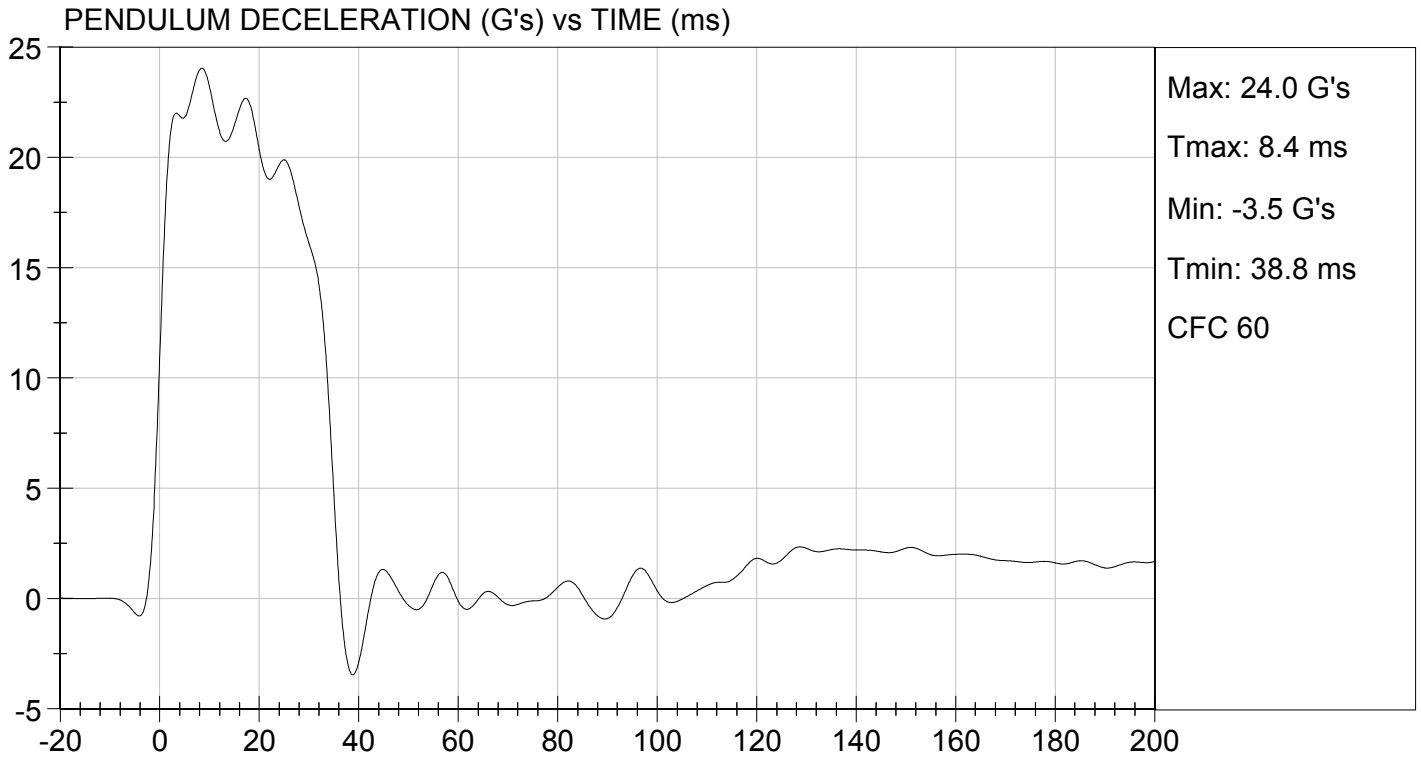



TEST DESC: NECK FLEXION
VELOCITY: 22.83 ft/s, 6.96 m/s

TEST DATE: 09/06/2013
TEST #: D132982

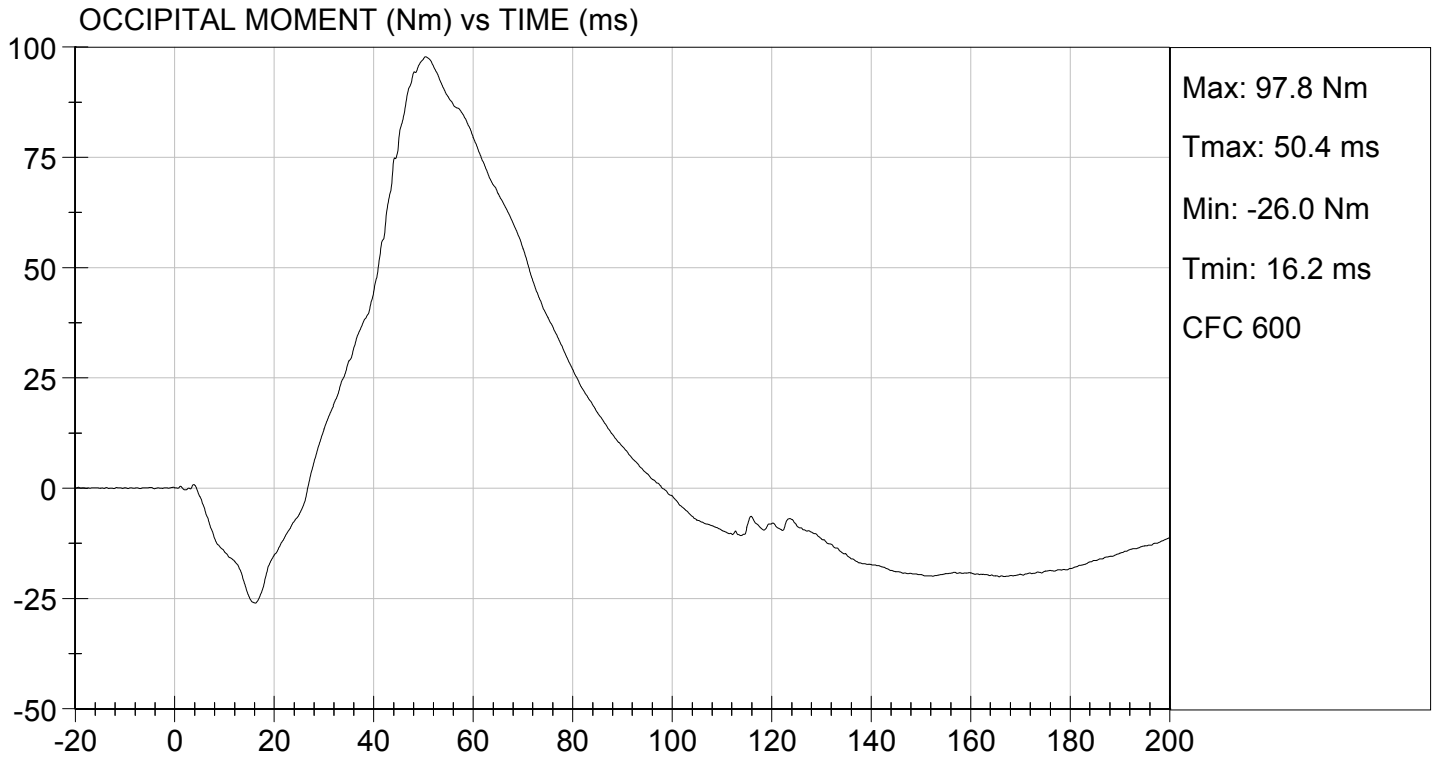

MGA RESEARCH CORPORATION
NECK EXTENSION TEST
HYBRID III 50TH PERCENTILE MALE

ATD Serial No: 036

Test I.D.: D132983

| Tested Parameter | | Units | Specification | Result | Pass/Fail |
|--|---------|---------|----------------|--------|-------------|
| Laboratory Temperature | | deg C | 20.6 to 22.2 | 21.2 | Pass |
| Laboratory Relative Humidity | | % | 10 to 70 | 52 | Pass |
| Pendulum Velocity | | m/s | 5.95 to 6.19 | 6.05 | Pass |
| Pendulum Deceleration | 10 ms | G's | 17.20 to 21.20 | 18.35 | Pass |
| | 20 ms | G's | 14.00 to 19.00 | 16.15 | Pass |
| | 30 ms | G's | 11.00 to 16.00 | 11.92 | Pass |
| Peak Pendulum Deceleration After 30 ms | | G's | <= 22.0 | 13.3 | Pass |
| Deceleration Decay Time to Cross 5 G's | | ms | 38.0 to 46.0 | 39.5 | Pass |
| Maximum "D" Plane Rotation | Maximum | Degrees | 81.0 to 106.0 | 96.4 | Pass |
| | Time | ms | 72.0 to 82.0 | 76.1 | Pass |
| "D" Plane Rotation Decay Time To Zero Crossing | | ms | 147.0 to 174.0 | 156.5 | Pass |
| Moment About Occipital Condyle | Maximum | Nm | -52.9 to -79.9 | -66.9 | Pass |
| | Time | ms | 65.0 to 79.0 | 71.3 | Pass |
| Negative Moment Decay Time To Zero Crossing | | ms | 120.0 to 148.0 | 143.5 | Pass |
| Overall Test Results | | | | | Pass |

Jessica Hall
 Laboratory Technician

09/06/2013
 Test Date

David Winkelbauer
 Approved By

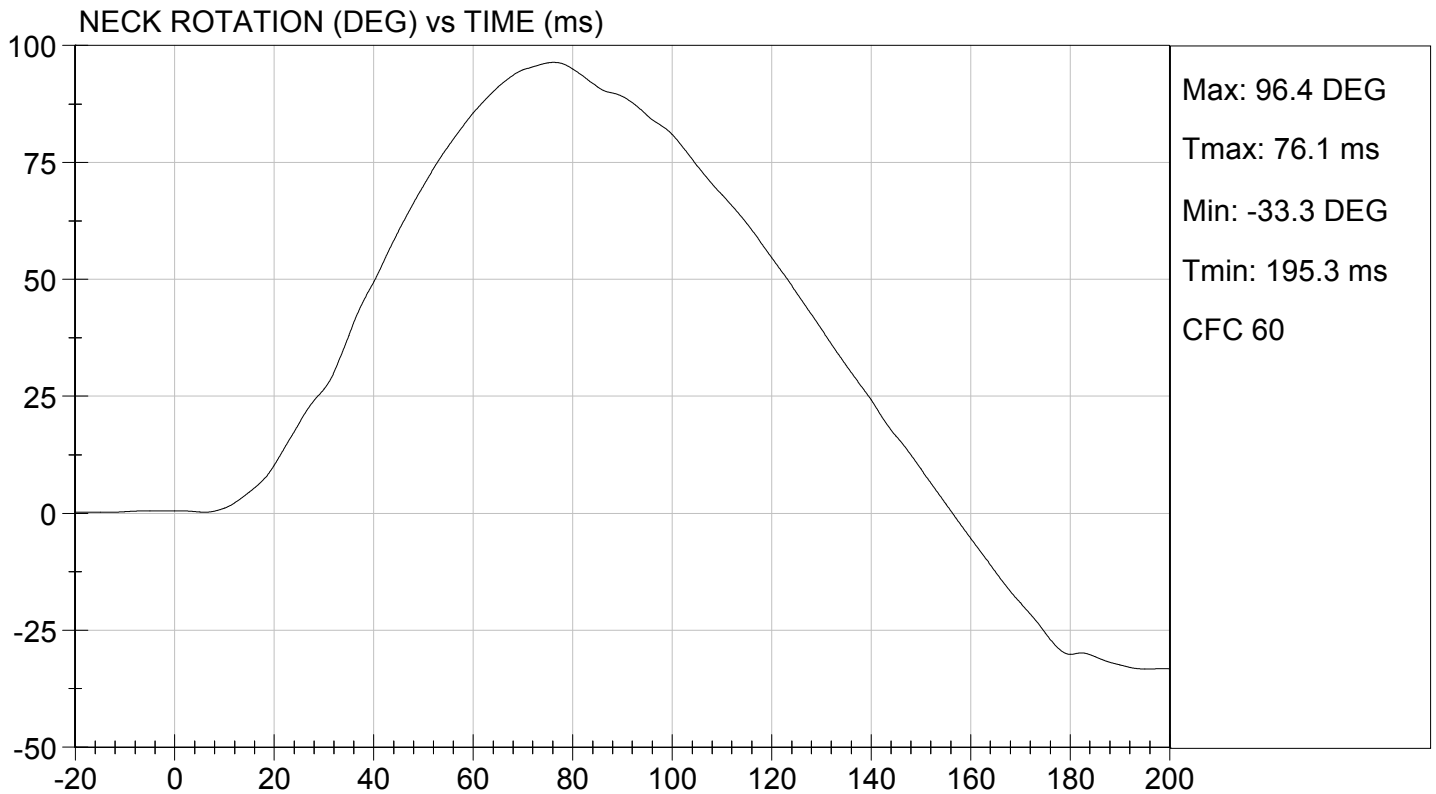
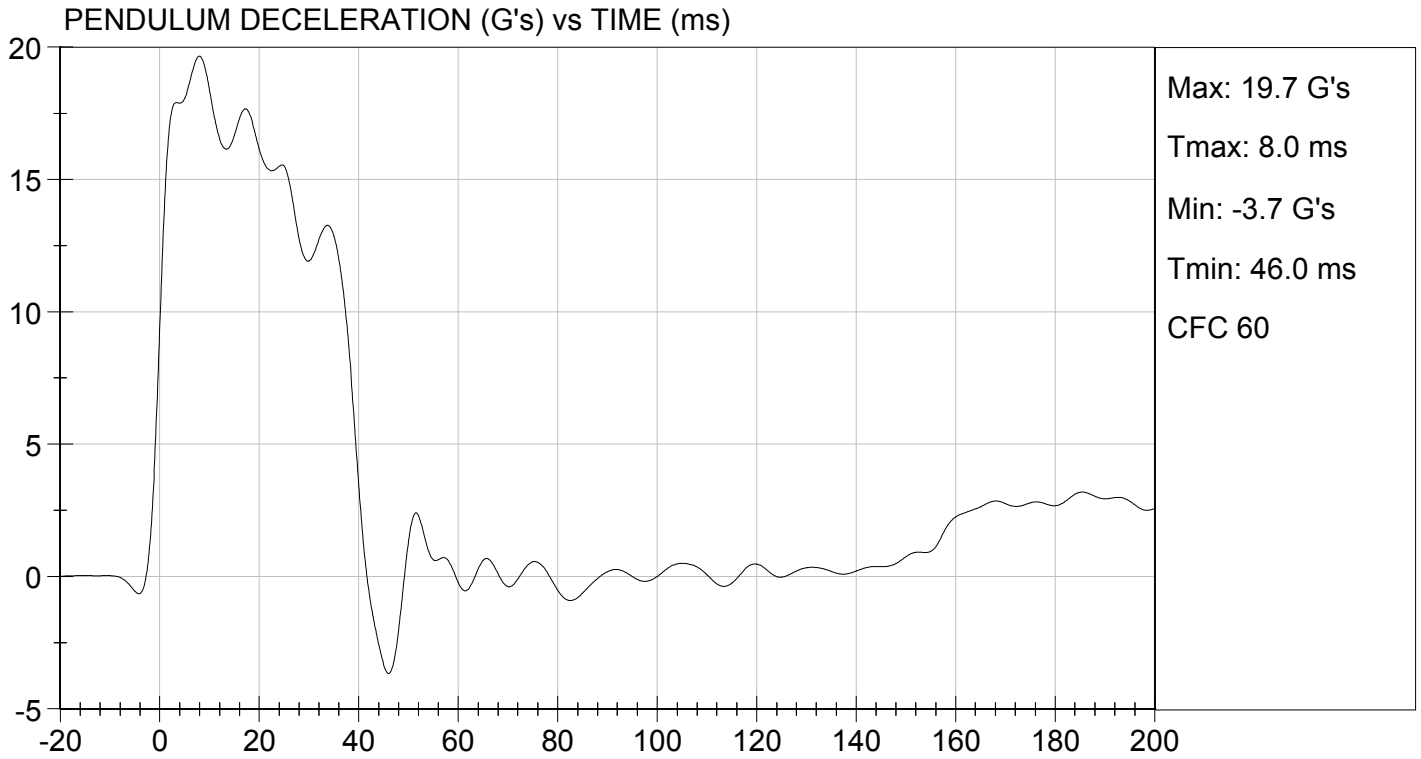

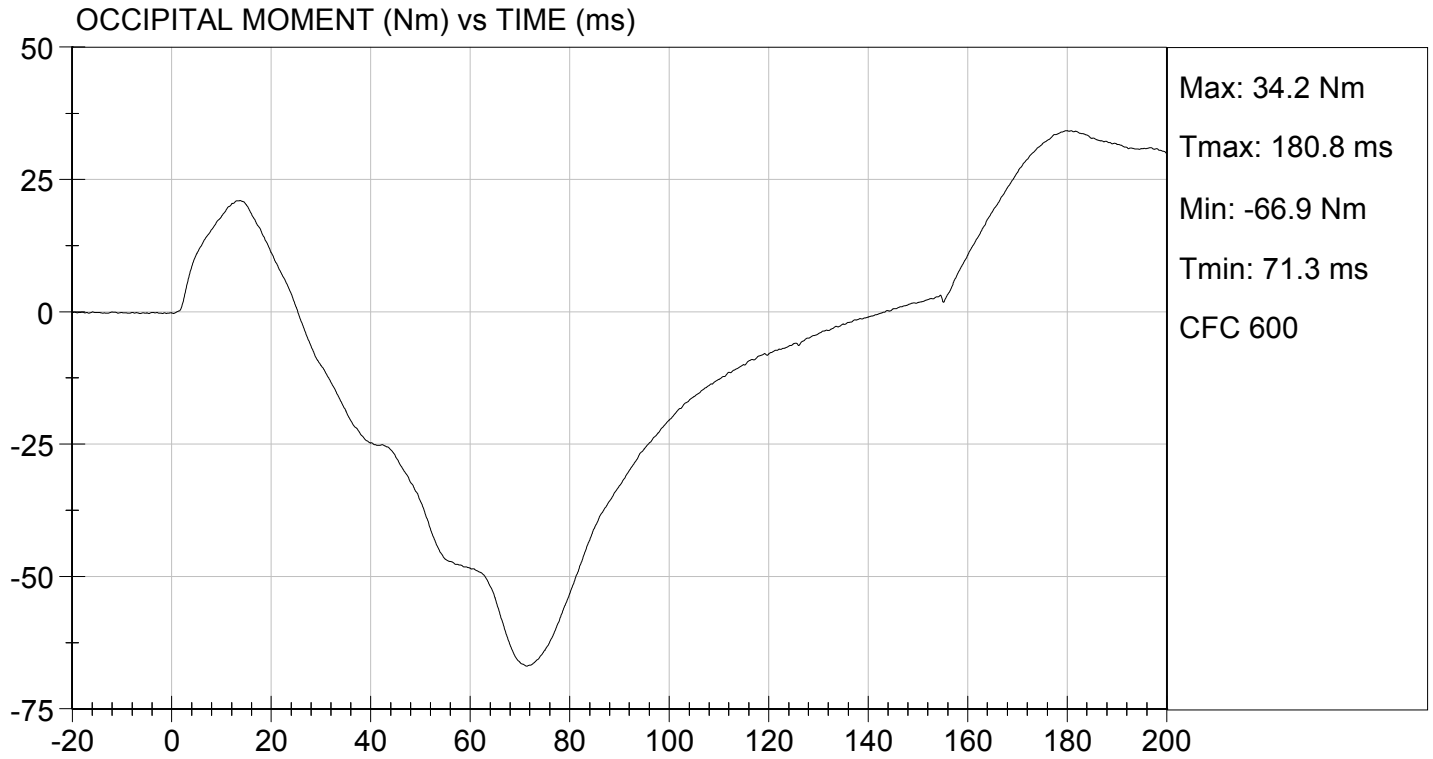

**MGA RESEARCH CORPORATION
THORAX IMPACT
HYBRID III 50TH PERCENTILE MALE**

ATD Serial No: 036

Test I.D: D132984

| Tested Parameter | Units | Specification | Result | Pass/Fail |
|------------------------------|-------|---------------|--------|-------------|
| Laboratory Temperature | deg C | 20.6 to 22.2 | 21.6 | Pass |
| Laboratory Relative Humidity | % | 10 to 70 | 50 | Pass |
| Probe Velocity | m/s | 6.58 to 6.82 | 6.77 | Pass |
| Peak Probe Force | N | 5159 to 5893 | 5,432 | Pass |
| Peak Sternum Displacement | cm | 6.35 to 7.26 | 6.36 | Pass |
| Internal Hysteresis | % | 69 to 85 | 70 | Pass |
| Overall Test Results | | | | Pass |

Laboratory Technician

09/09/2013
Test Date

Approved By

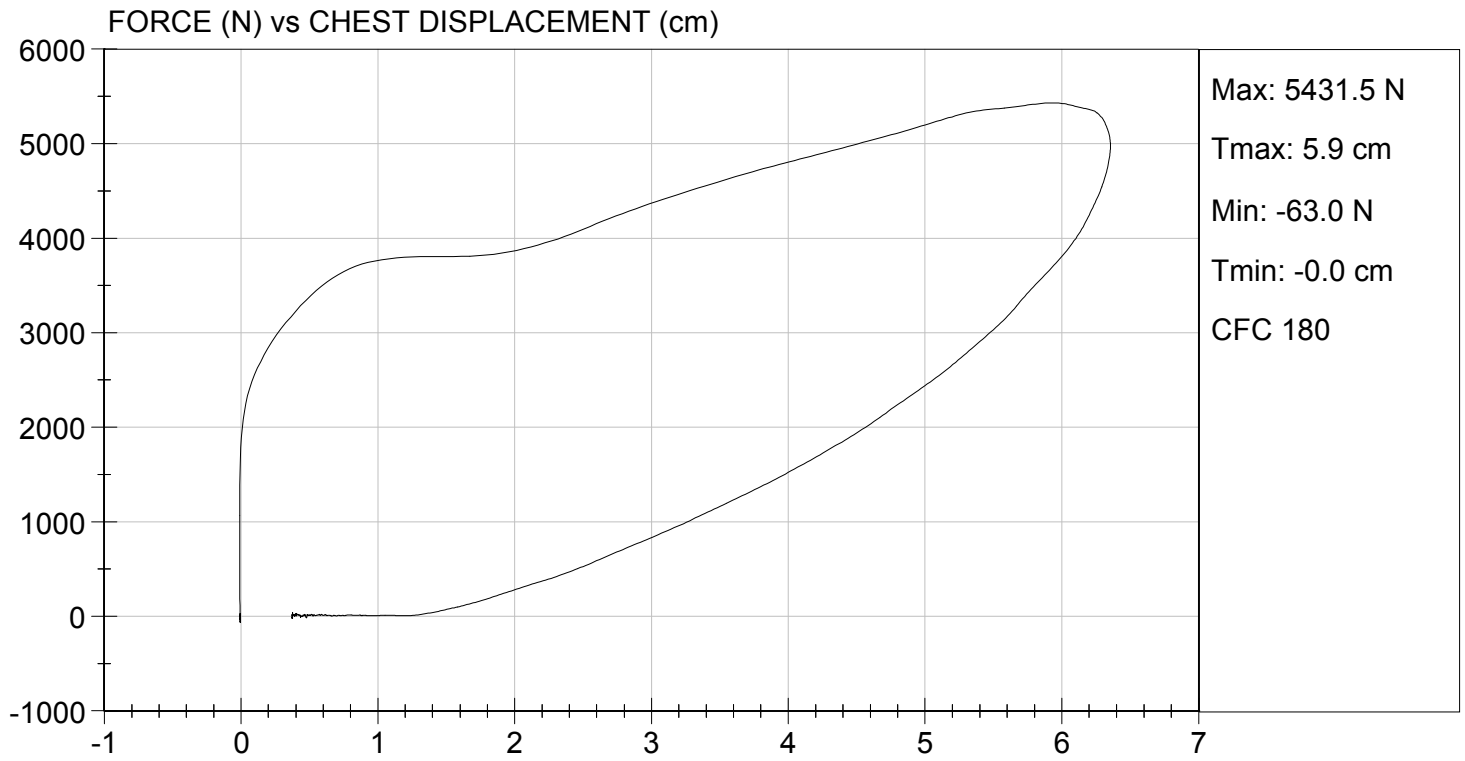

MGA RESEARCH CORPORATION
RIGHT KNEE IMPACT TEST
HYBRID III 50TH PERCENTILE MALE

ATD Serial No: 036

Test I.D: D132985

| Tested Parameter | Units | Specification | Result | Pass/Fail |
|------------------------------|-------|---------------|--------|-----------|
| Laboratory Temperature | deg C | 18.9 to 25.6 | 21.1 | Pass |
| Laboratory Relative Humidity | % | 10 to 70 | 53 | Pass |
| Probe Velocity | m/s | 2.07 to 2.13 | 2.11 | Pass |
| Peak Probe Force | N | 4715 to 5782 | 5,091 | Pass |
| Overall Test Results | | | | Pass |

Jessica Gall
 Laboratory Technician

09/06/2013
 Test Date

David Winkelbauer
 Approved By

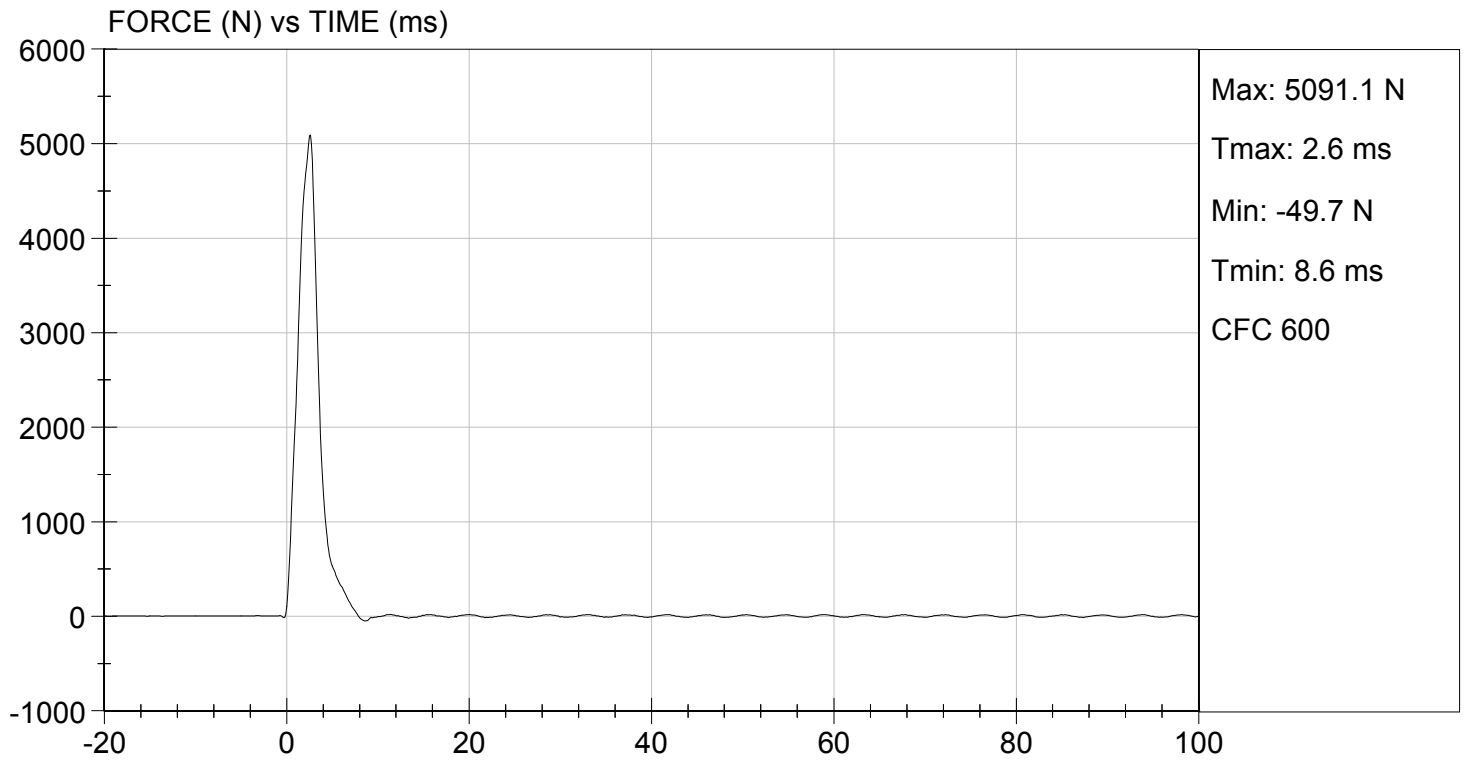

MGA RESEARCH CORPORATION
LEFT KNEE IMPACT TEST
HYBRID III 50TH PERCENTILE MALE

ATD Serial No: 036

Test I.D: D132986

| Tested Parameter | Units | Specification | Result | Pass/Fail |
|------------------------------|-------|---------------|--------|-------------|
| Laboratory Temperature | deg C | 18.9 to 25.6 | 21.1 | Pass |
| Laboratory Relative Humidity | % | 10 to 70 | 53 | Pass |
| Probe Velocity | m/s | 2.07 to 2.13 | 2.07 | Pass |
| Peak Probe Force | N | 4715 to 5782 | 4,887 | Pass |
| Overall Test Results | | | | Pass |

Jessica Gall
 Laboratory Technician

09/06/2013
 Test Date

David Winkelbauer
 Approved By



TEST DESC: LEFT KNEE
VELOCITY: 6.8 ft/s, 2.07 m/s

TEST DATE: 09/06/2013
TEST #: D132986

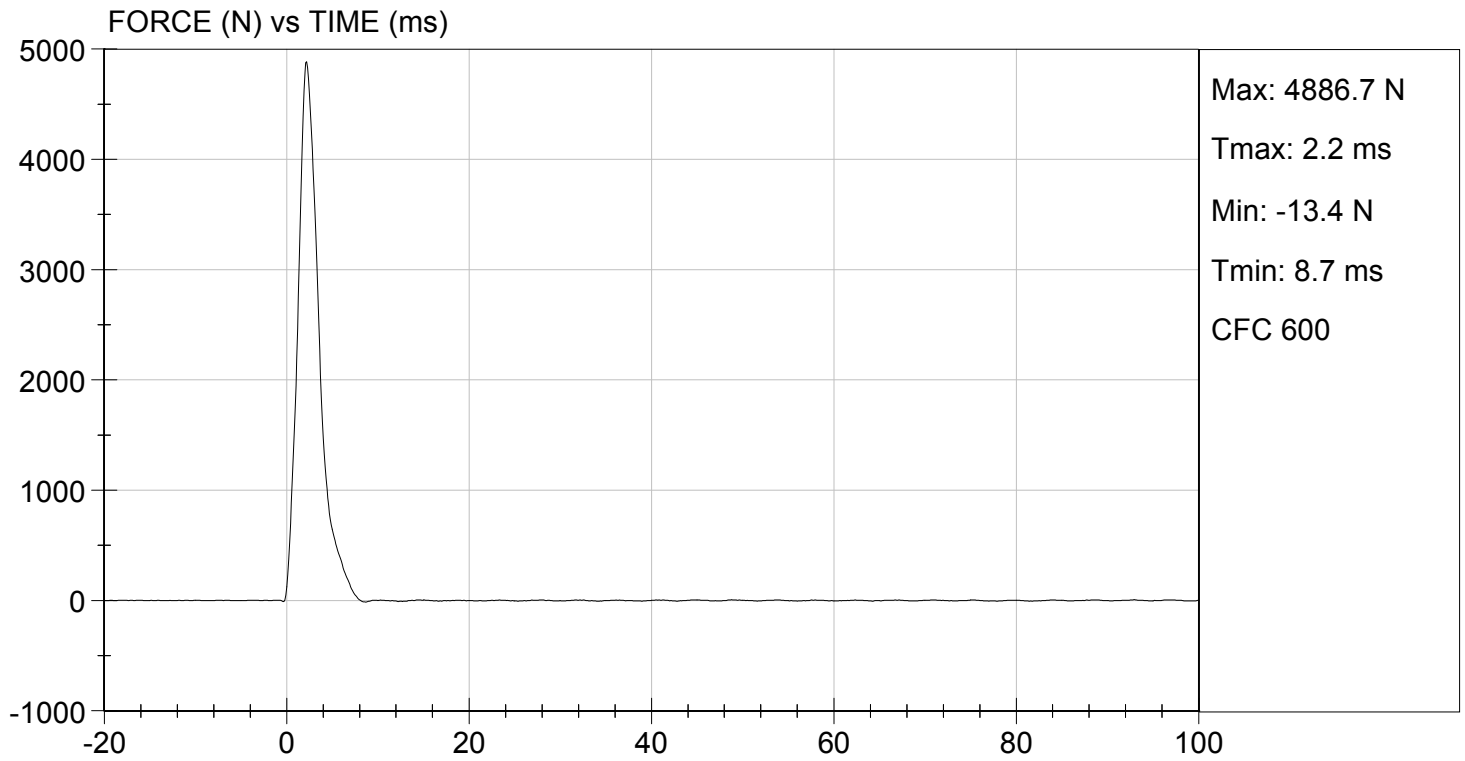

MGA RESEARCH CORPORATION
HIP-FEMUR FLEXION TEST
HYBRID III 50TH PERCENTILE MALE

ATD Serial No: 036

Test I.D: D132980

| Tested Parameter | Units | Specification | Result | | Pass/Fail |
|------------------------------|-------|-------------------------------------|--------|------|-----------|
| | | | Right | Left | |
| Laboratory Temperature | deg C | 18.9 to 25.6 | 21.0 | 21.0 | Pass |
| Laboratory Relative Humidity | % | 10 to 70 | 49 | 49 | Pass |
| Rotation Rate | deg/s | 5.0 to 10.0 | 6.2 | 6.2 | Pass |
| 30 Degrees | Nm | 94.9 Nm Max | 91.2 | 89.5 | Pass |
| 150 ft-lbf / 203.4 Nm | Deg | 40.0 to 50.0 Degree Max Rotation | 41.0 | 40.7 | Pass |
| Overall Test Results | | | | | Pass |

Jessica Gall
 Laboratory Technician

09/06/2013
 Test Date

David Winkelbauer
 Approved By

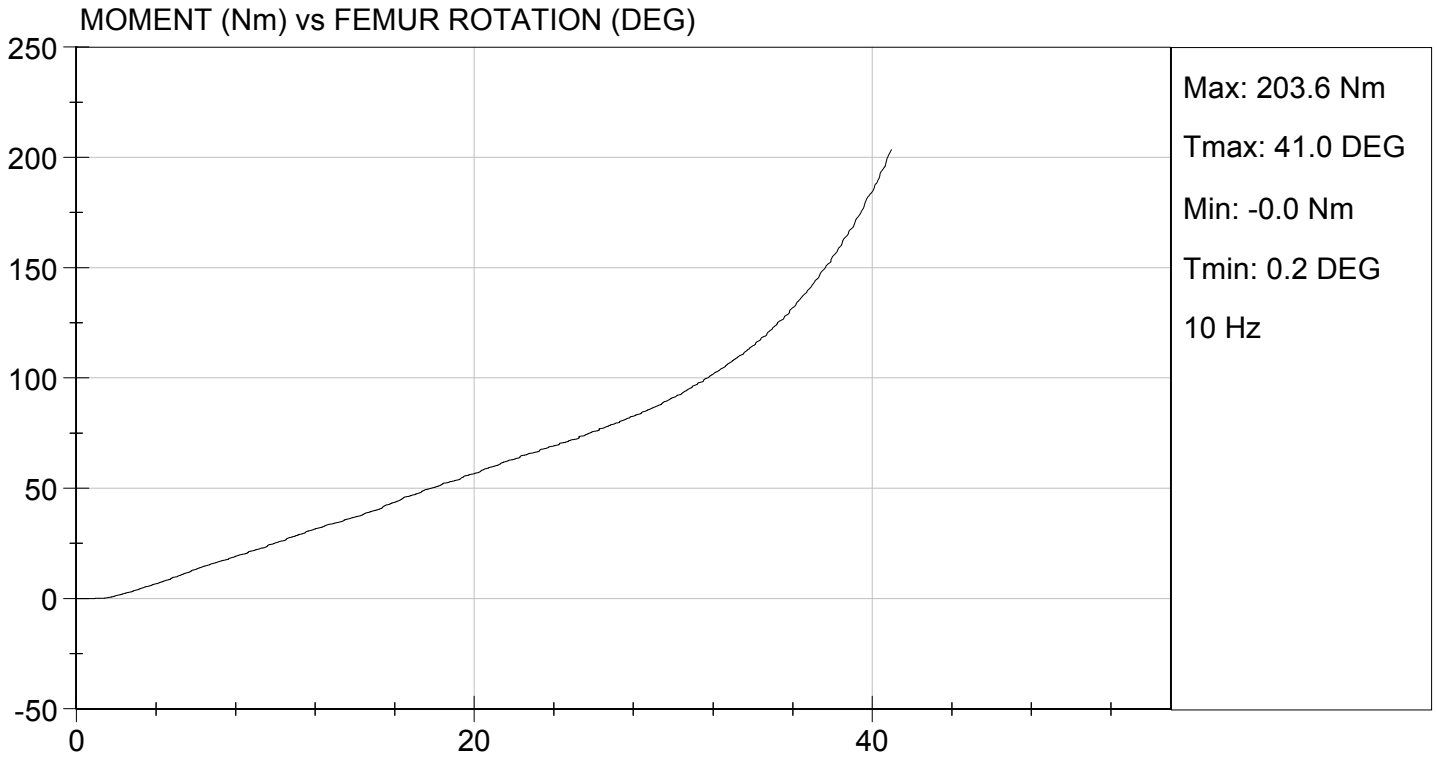

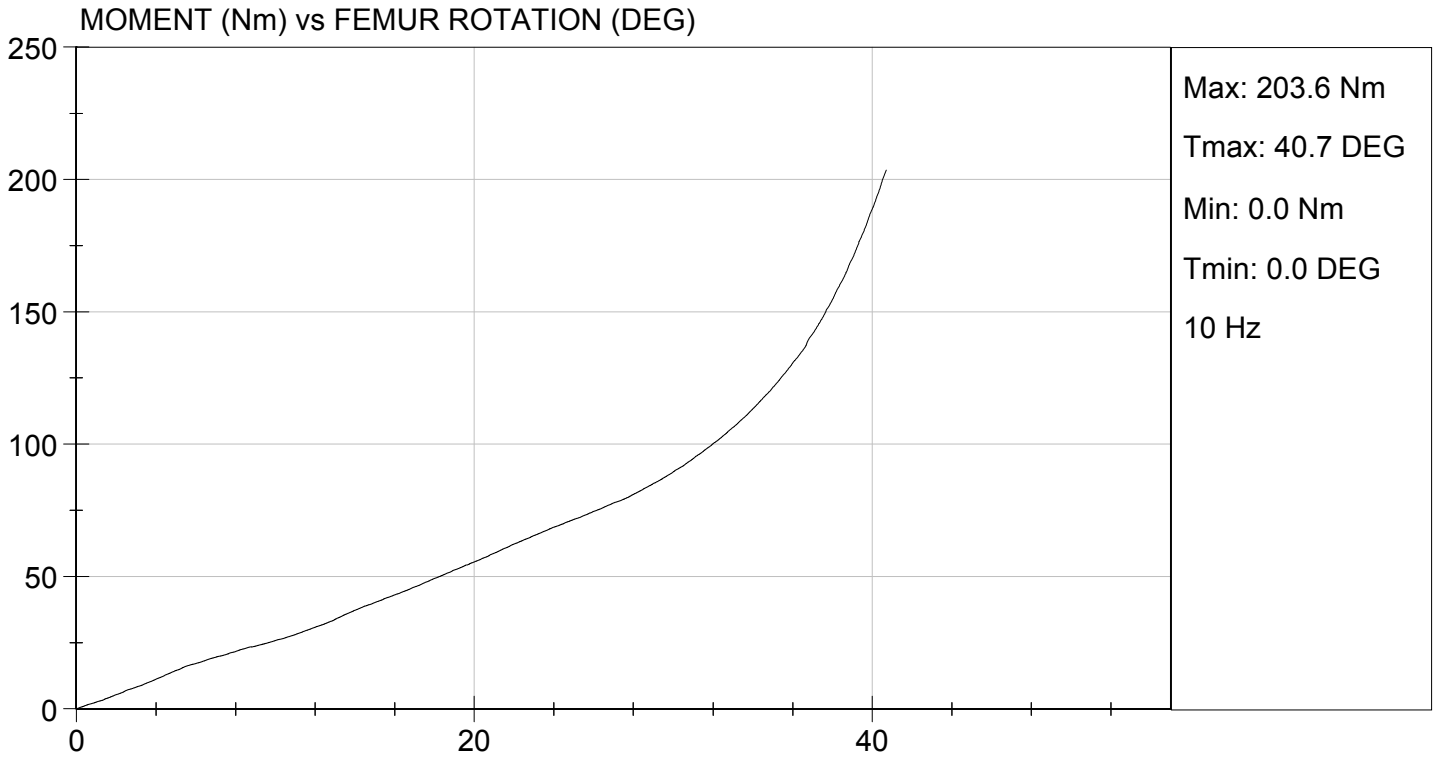

**Hybrid III, 5th External Measurements
SN: 138**

| HYBRID III, PART 572, SUBPART O EXTERNAL DIMENSIONS | | | | |
|---|--------------------------------|--|-------------------------|--------------------|
| DIMENSION | DESCRIPTION | DETAILS | ASSEMBLY DIMENSION (mm) | ACTUAL MEASUREMENT |
| A | TOTAL SITTING HEIGHT | Seat surface to highest point on top of the head. | 774.7-800.1 | 785.1 |
| B | SHOULDER PIVOT HEIGHT | Centerline of shoulder pivot bolt to the seat surface. | 431.8-457.2 | 456.8 |
| C | H-POINT HEIGHT | Reference | 81.3-86.3 | 84.0 |
| D | H-POINT LOCATION FROM BACKLINE | Reference | 144.8-149.8 | 146.2 |
| E | SHOULDER PIVOT FROM BACKLINE | Center of the shoulder clevis to the rear vertical surface of the fixture. | 68.6-83.8 | 78.0 |
| F | THIGH CLEARANCE | Measured at the highest point on the upper femur segment. | 119.4-134.6 | 127.5 |
| G | BACK OF ELBOW TO WRIST PIVOT | back of the elbow flesh to the wrist pivot in line with the elbow and wrist pivots | 243.9-259.1 | 249.6 |
| H | HEAD BACK TO BACKLINE | Back of Skull cap skin to seat rear vertical surface (Reference) | 43.2-48.2 | 45.0 |
| I | SHOULDER TO- ELBOW LENGTH | Measure from the highest point on top of the shoulder clevis to the lowest part of the flesh on the elbow in line with the elbow pivot bolt. | 276.8-297.2 | 280.2 |
| J | ELBOW REST HEIGHT | Measure from the flesh below the elbow pivot bolt to the seat surface. | 182.8-203.2 | 201.9 |
| K | BUTTOCK TO KNEE LENGTH | The forward most part of the knee flesh to the rear vertical surface of the fixture. | 520.7-546.1 | 526.7 |
| L | POPLITEAL HEIGHT | Seat surface to the plane of the horizontal plane of the bottom of the feet. | 355.6-376.0 | 362.3 |
| M | KNEE PIVOT HEIGHT | Centerline of knee pivot bolt to the horizontal plane of the bottom of the feet. | 393.7-419.1 | 398.0 |
| N | BUTTOCK POPLITEAL LENGTH | The rearmost surface of the lower leg to the same point on the rear surface of the buttocks used for dim. "K". | 414-439.4 | 430.5 |

| HYBRID III, SUBPART O EXTERNAL DIMENSIONS, continued | | | | |
|--|---|---|-------------------------|--------------------|
| DIMENSION | DESCRIPTION | DETAILS | ASSEMBLY DIMENSION (mm) | ACTUAL MEASUREMENT |
| O | CHEST DEPTH WITHOUT JACKET | Measured 304.8 ± 5.1 mm above seat surface | 175.3-190.5 | 184.6 |
| P | FOOT LENGTH | Tip of toe to rear of heel | 218.5-233.7 | 221.0 |
| Q | STANDING HEIGHT | (THEORETICAL) | 1501.1 | N/A |
| R | BUTTOCK TO KNEE PIVOT LENGTH | The rear surface of the buttocks to the knee pivot bolt | 457.2-482.6 | 472.6 |
| S | HEAD BREADTH | The widest part of the head | 137.1-147.3 | 141.9 |
| T | HEAD DEPTH | Back of the head to the forehead | 177.8-188.0 | 184.2 |
| U | HIP BREADTH | The widest part of the hip | 299.7-314.9 | 307.4 |
| V | SHOULDER BREADTH | Outside edges of right and left shoulder clevises | 350.5-365.7 | 360.5 |
| W | FOOT BREADTH | The widest part of the foot | 78.8-94.0 | 85.0 |
| X | HEAD CIRCUMFERENCE | Measured at the point as in dim. "T" | 528.3-548.7 | 546.2 |
| Y | CHEST CIRCUMFERENCE (WITH CHEST JACKET) | Measured 345.4 ± 12.7 mm above seat surface | 850.9-881.3 | 875.1 |
| Z | WAIST CIRCUMFERENCE | Measured 165.1 ± 5.1 mm above seat surface | 759.5-789.9 | 785.4 |
| AA | REFERENCE LOCATION FOR MEASUREMENT OF CHEST CIRCUMFERENCE | Reference | 332.7-358.1 | 345.4 |
| BB | REFERENCE LOCATION FOR MEASUREMENT OF WAIST CIRCUMFERENCE | Reference | 160.1-170.2 | 165.1 |

**MGA RESEARCH CORPORATION
HEAD DROP TEST
HYBRID III 5TH PERCENTILE**

ATD Serial No: 138

Test ID: D132731

| Tested Parameter | Units | Specification | Result | Pass/Fail |
|------------------------------|-------|--------------------|--------|-------------|
| Laboratory Temperature | deg C | 18.9 to 25.6 | 21.4 | Pass |
| Laboratory Relative Humidity | % | 10 to 70 | 42 | Pass |
| Peak Resultant Acceleration | G's | 250 to 300 | 266 | Pass |
| Peak Lateral Acceleration | G's | <= +/- 15.0 | -10.4 | Pass |
| Unimodal | N/A | Yes | Yes | Pass |
| Oscillations | N/A | within 10% of peak | Yes | Pass |
| Overall Test Results | | | | Pass |

Jessica Gall

 Laboratory Technician

08/14/2013

 Test Date

David Winkelbauer

 Approved By

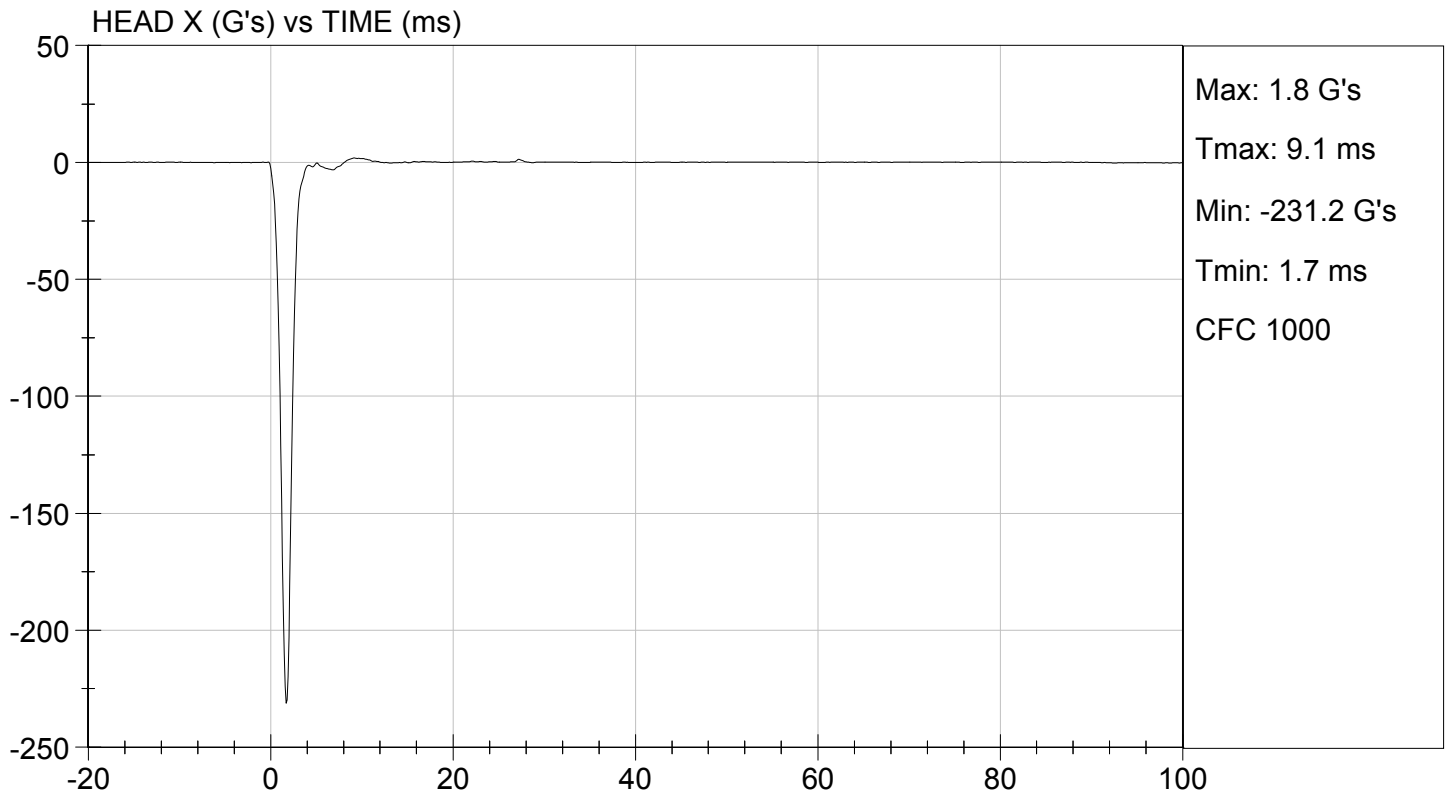
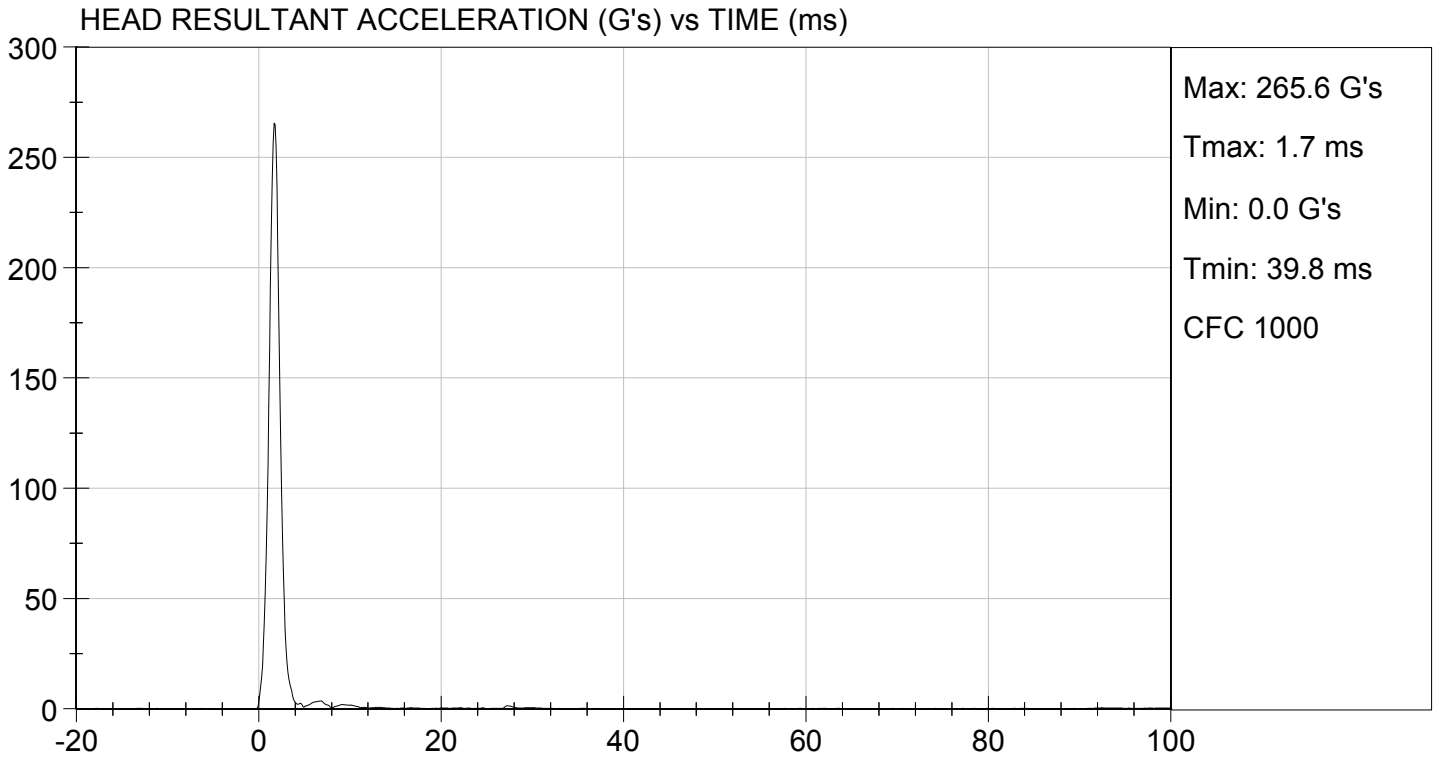

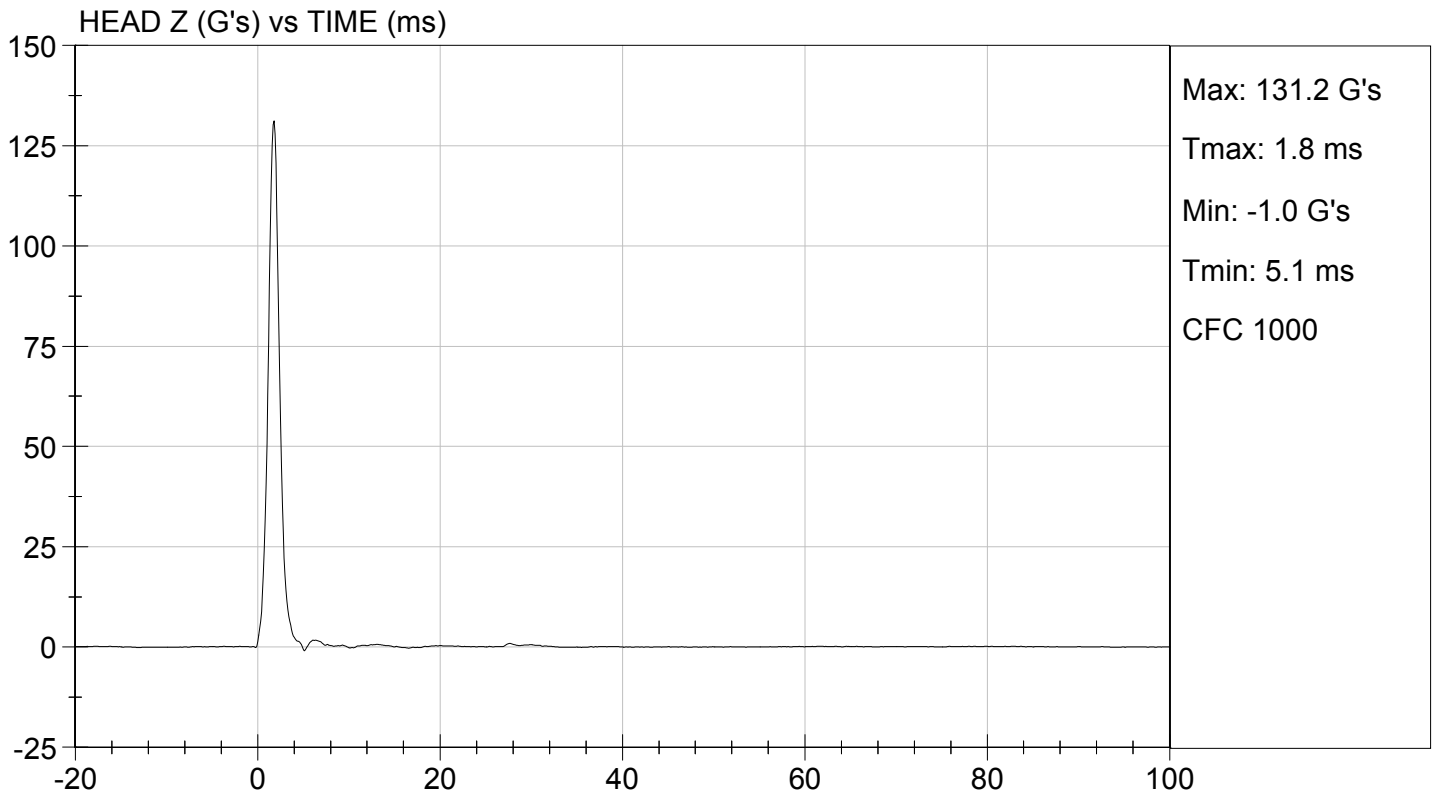
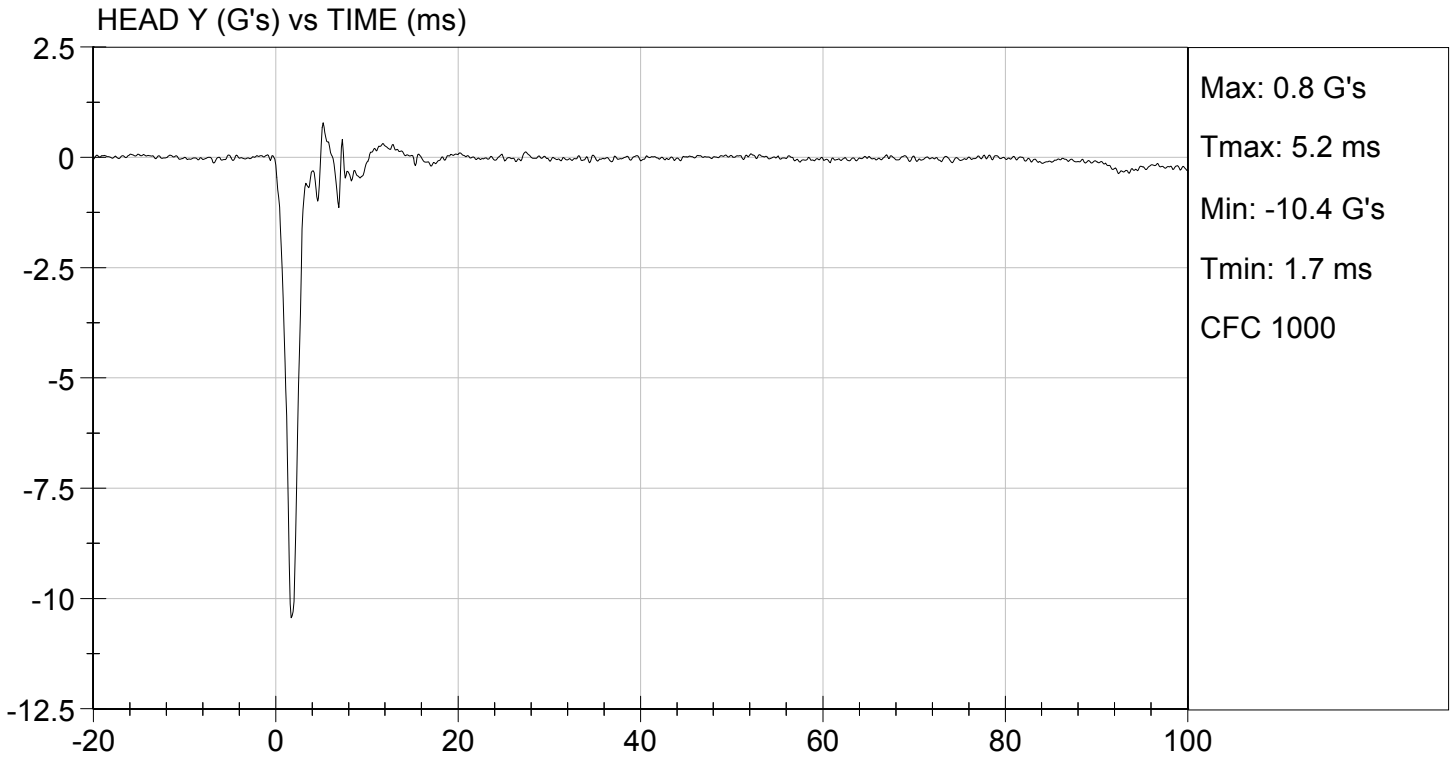

MGA RESEARCH CORPORATION

NECK FLEXION TEST

HYBRID III 5TH PERCENTILE

ATD Serial No: 138

Test I.D.: D132732

| Tested Parameter | | Units | Specification | Result | Pass/Fail |
|---|-------|-------|---------------|--------|-----------|
| Laboratory Temperature | | deg C | 20.6 to 22.2 | 21.1 | Pass |
| Laboratory Relative Humidity | | % | 10 to 70 | 42 | Pass |
| Pendulum Speed | | m/s | 6.89 to 7.13 | 7.10 | Pass |
| Pendulum Velocity | 10 ms | m/s | 2.1 to 2.5 | 2.3 | Pass |
| | 20 ms | m/s | 4.0 to 5.0 | 4.4 | Pass |
| | 30 ms | m/s | 5.8 to 7.0 | 6.3 | Pass |
| D Plane Rotation | Max | deg | 77 to 91 | 81 | Pass |
| Occipital Condyle Moment within Rotation Corridor | | Nm | 69 to 83 | 73.2 | Pass |
| Positive Moment Time Curve Decay to 10 Nm | | ms | 80 to 100 | 88 | Pass |
| Overall Results | | | | | Pass |

Jessica Hall
Laboratory Technician

08/14/2013
Test Date

David Winkelbauer
Approved By

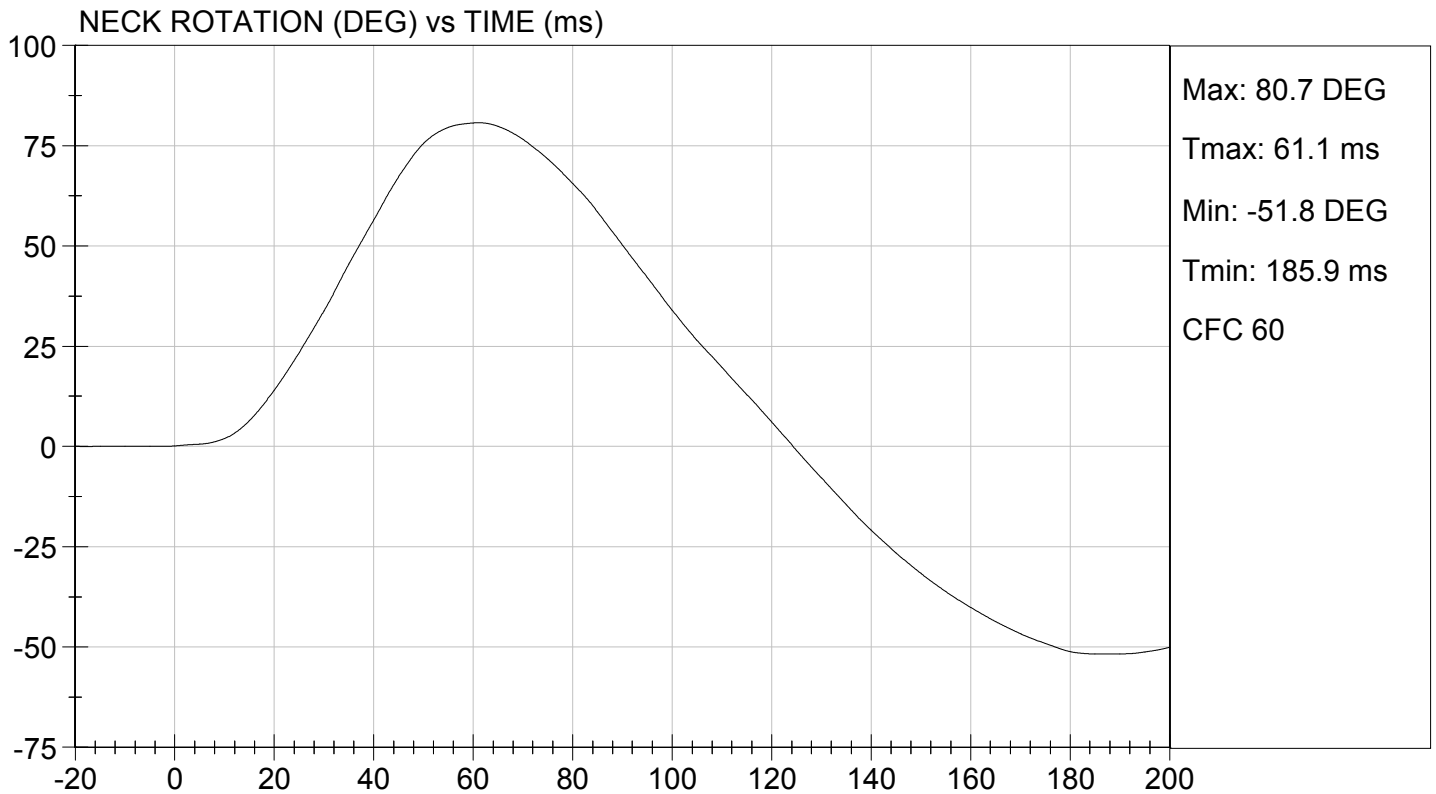
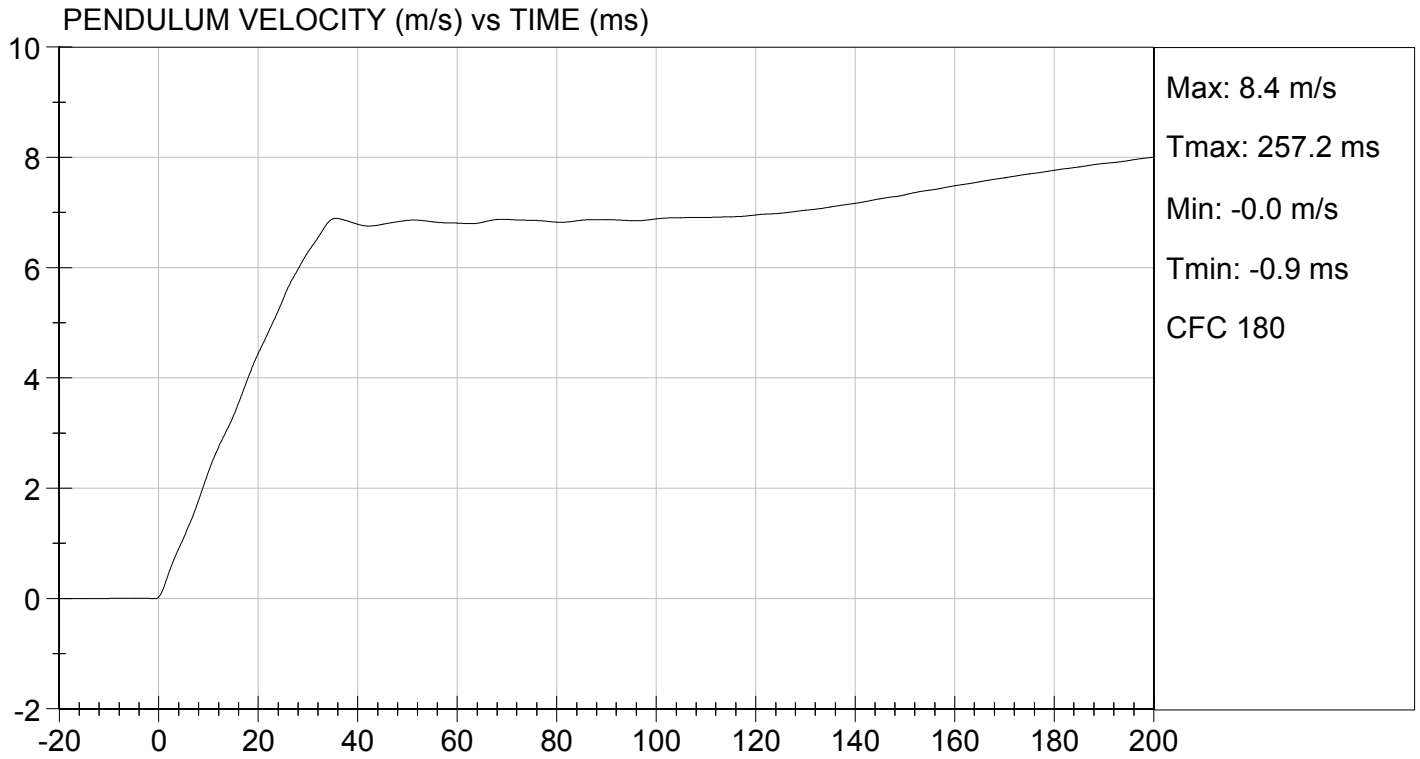

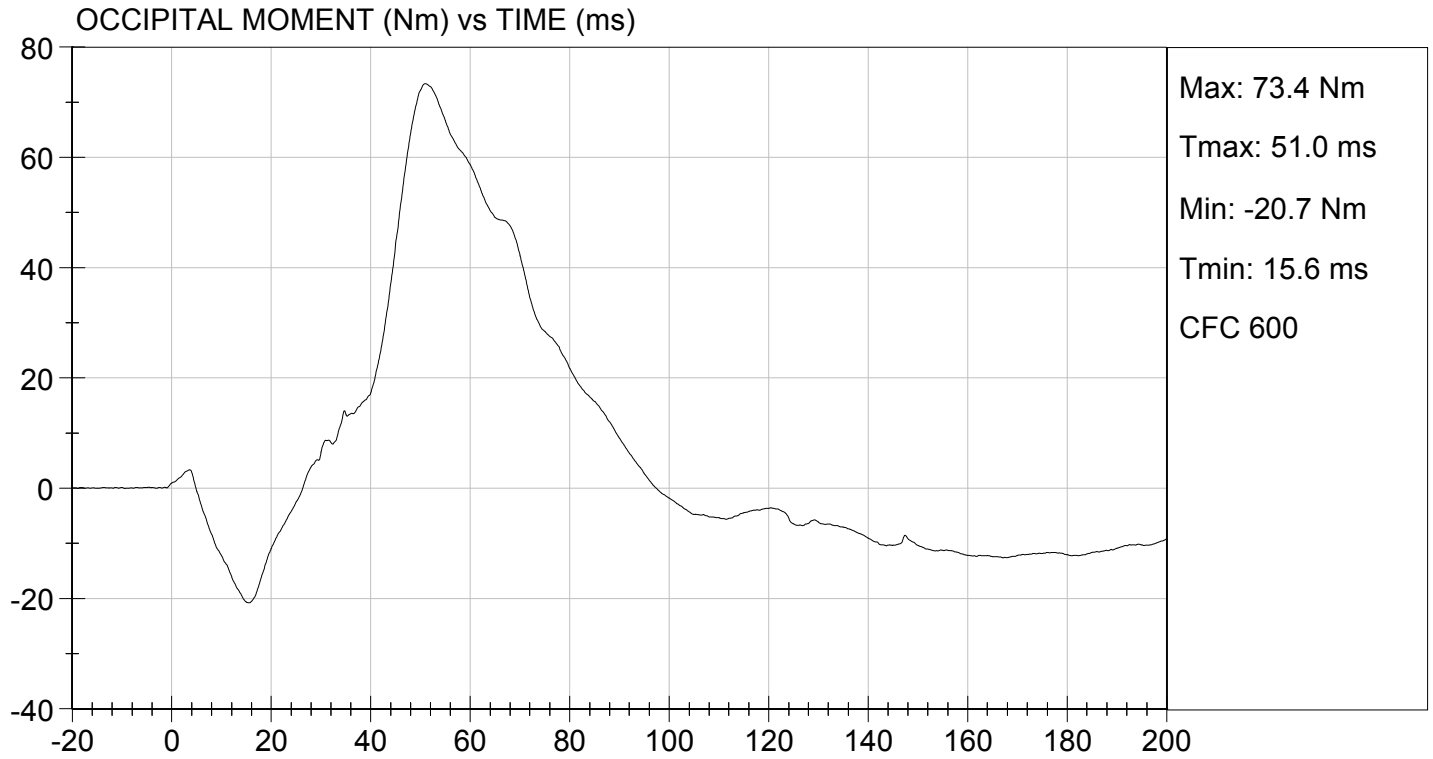

MGA RESEARCH CORPORATION
NECK EXTENSION TEST
HYBRID III 5TH PERCENTILE

ATD Serial No: 138

Test I.D: D132733

| Tested Parameter | | Units | Specification | Result | Pass/Fail |
|---|-------|-------|---------------|--------|-----------|
| Laboratory Temperature | | deg C | 20.6 to 22.2 | 21.1 | Pass |
| Laboratory Relative Humidity | | % | 10 to 70 | 42 | Pass |
| Pendulum Speed | | m/s | 5.95 to 6.19 | 6.16 | Pass |
| Pendulum Velocity | 10 ms | m/s | 1.5 to 1.9 | 1.7 | Pass |
| | 20 ms | m/s | 3.1 to 3.9 | 3.5 | Pass |
| | 30 ms | m/s | 4.6 to 5.6 | 5.1 | Pass |
| D Plane Rotation | Max | deg | 99 to 114 | 105 | Pass |
| Occipital Condyle Moment within Rotation Corridor | | Nm | -65 to -53 | -54.2 | Pass |
| Negative Moment Time Curve Decay to -10 Nm | | ms | 94 to 114 | 100 | Pass |
| Overall Results | | | | | Pass |

Jessica Gall
Laboratory Technician

08/14/2013
Test Date

David Winkelbauer
Approved By

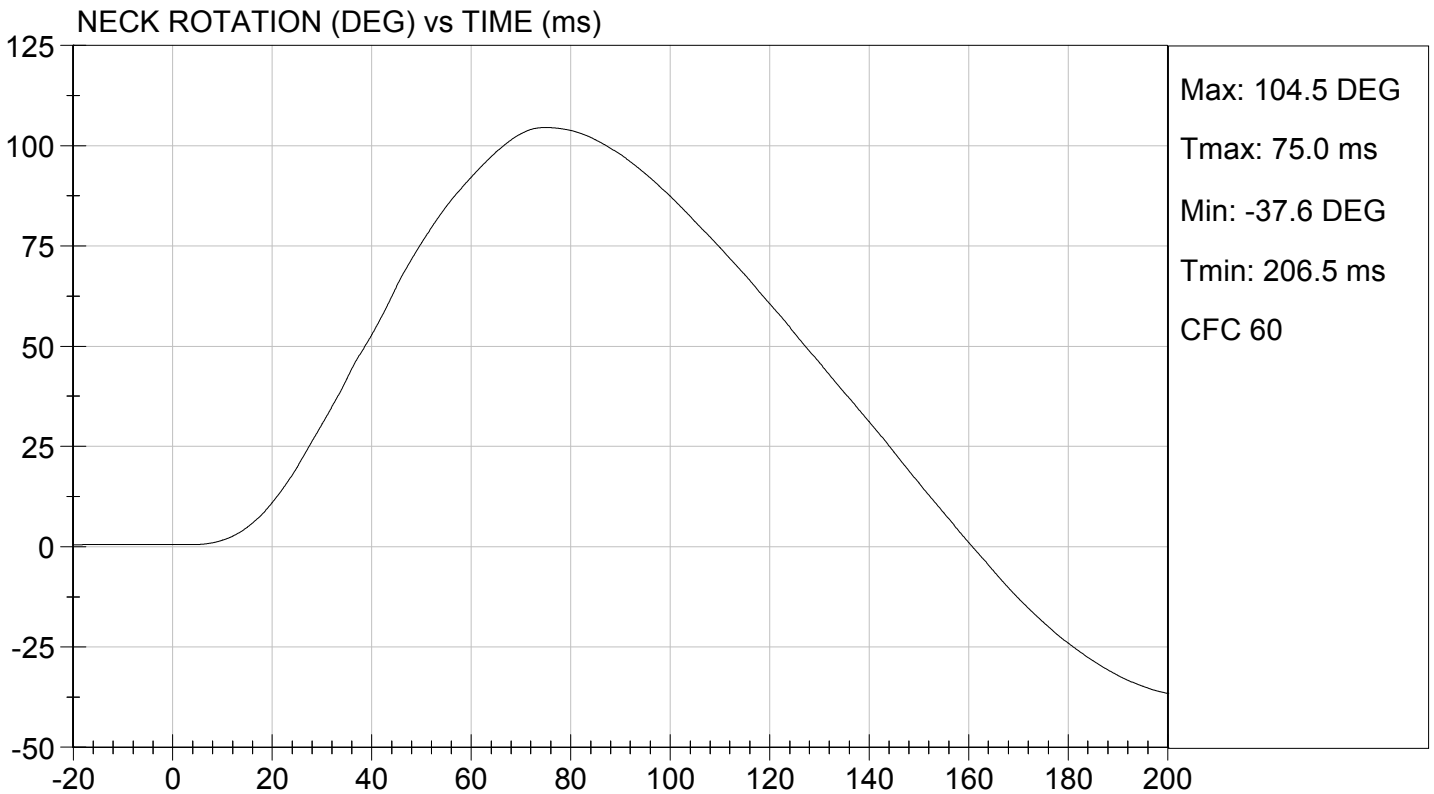
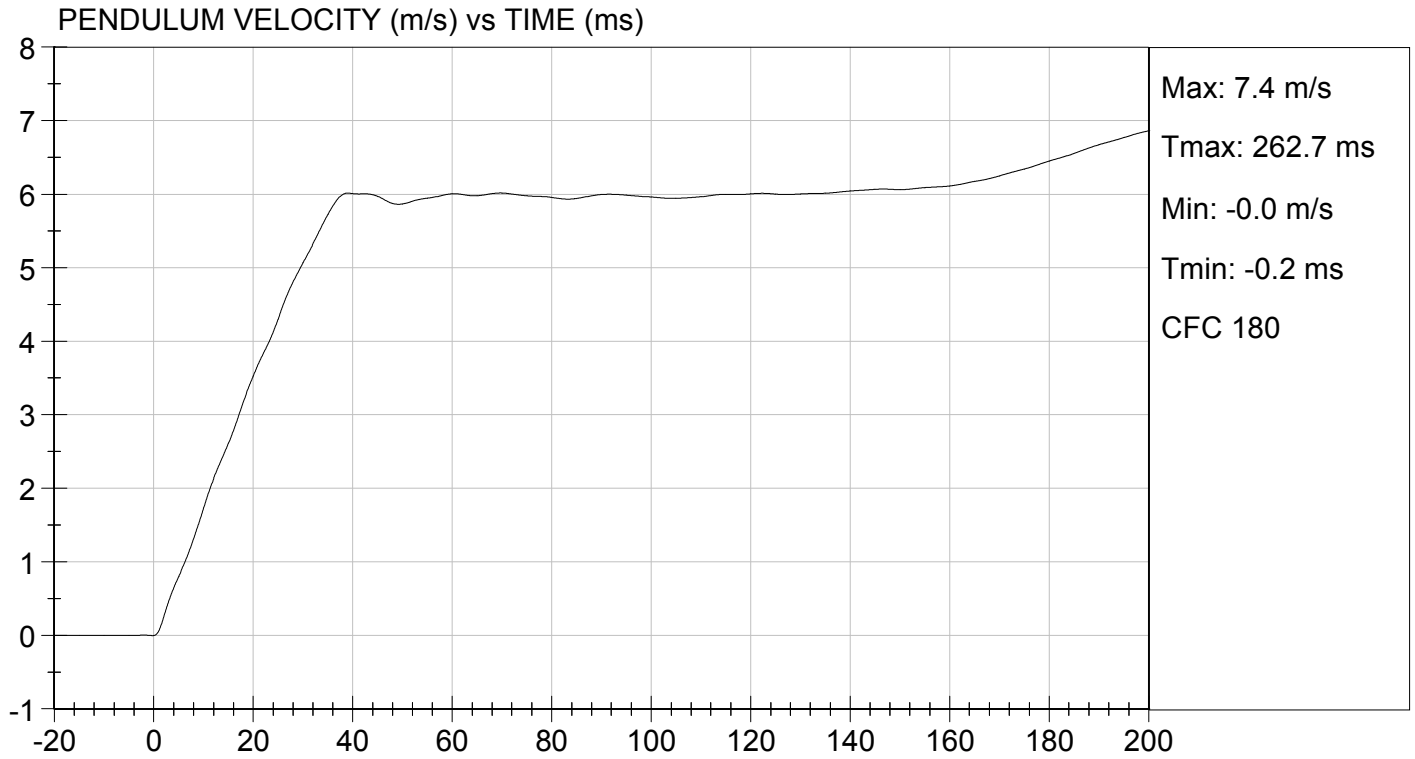

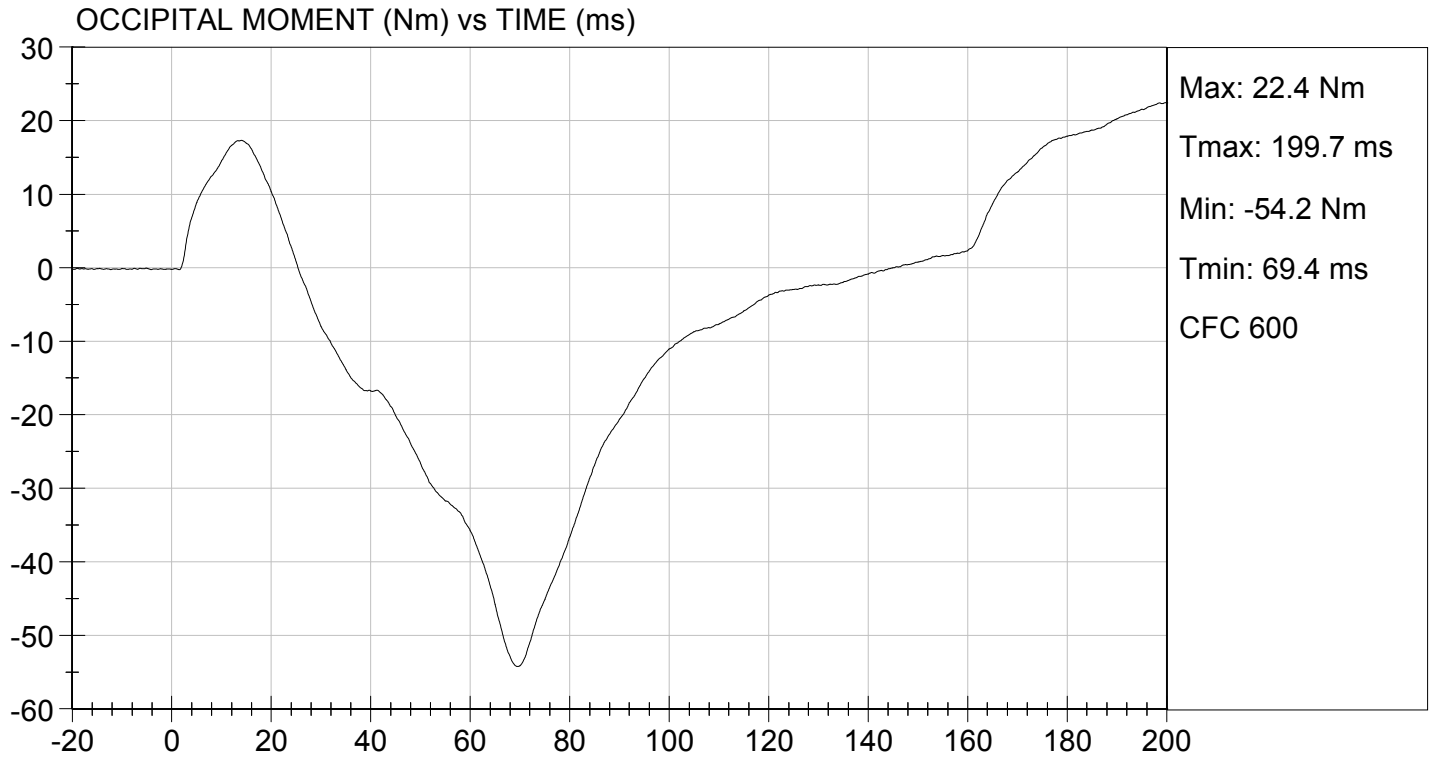

MGA RESEARCH CORPORATION
THORAX IMPACT
HYBRID III 5TH PERCENTILE

ATD Serial No: 138

Test I.D: D132734

| Tested Parameter | Units | Specification | Result | Pass/Fail |
|---|-------|---------------|--------|-------------|
| Temperature | deg C | 20.6 to 22.2 | 21.6 | Pass |
| Relative Humidity | % | 10 to 70 | 47 | Pass |
| Probe Speed | m/s | 6.59 to 6.83 | 6.68 | Pass |
| Peak Deflection | mm | 50 to 58 | 57 | Pass |
| Peak Resistive Force w/in Deflection Corridor | N | 3900 to 4400 | 4087 | Pass |
| Internal Hysteresis | % | 69 to 85 | 70 | Pass |
| Peak Force 18 mm - 50 mm | N | <= 4600 | 3854 | Pass |
| Overall Test Results | | | | Pass |

Jessica Gall
 Laboratory Technician

08/15/2013
 Test Date

David Winkelbauer
 Approved By

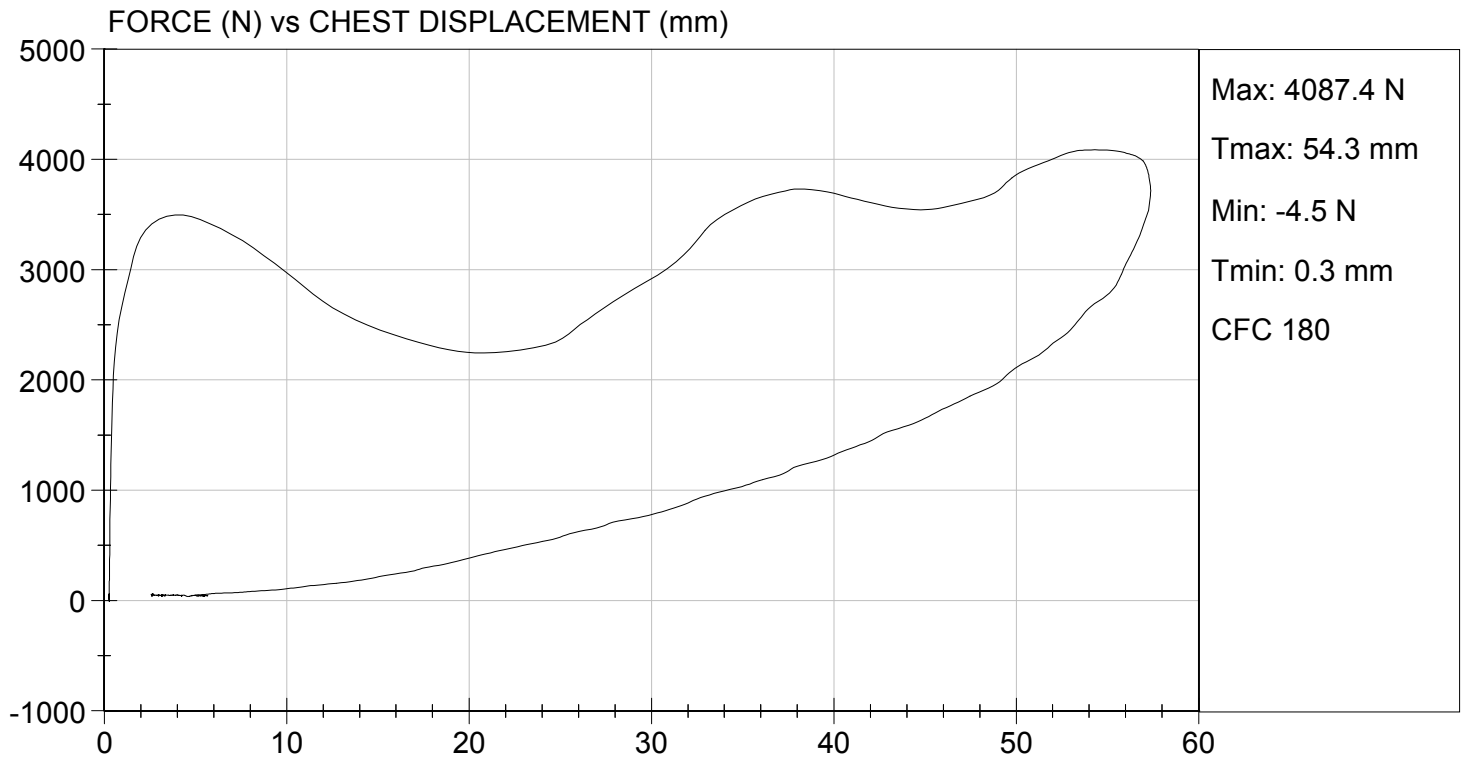

MGA RESEARCH CORPORATION
RIGHT KNEE IMPACT TEST
HYBRID III 5TH PERCENTILE

ATD Serial No: 138

Test I.D.: D132735

| Tested Parameter | Units | Specification | Result | Pass/Fail |
|------------------------------|-------|---------------|--------|-----------|
| Laboratory Temperature | deg C | 18.9 to 25.6 | 21.1 | Pass |
| Laboratory Relative Humidity | % | 10 to 70 | 42 | Pass |
| Probe Speed | m/s | 2.07 to 2.13 | 2.12 | Pass |
| Maximum Force | N | 3450 to 4060 | 3570 | Pass |
| Overall Test Results | | | | Pass |

Jessica Hall
 Laboratory Technician

08/14/2013
 Test Date

David Winkelbauer
 Approved By



TEST DESC: RIGHT KNEE
VELOCITY: 6.97 ft/s, 2.12 m/s

TEST DATE: 08/14/2013
TEST #: D132735

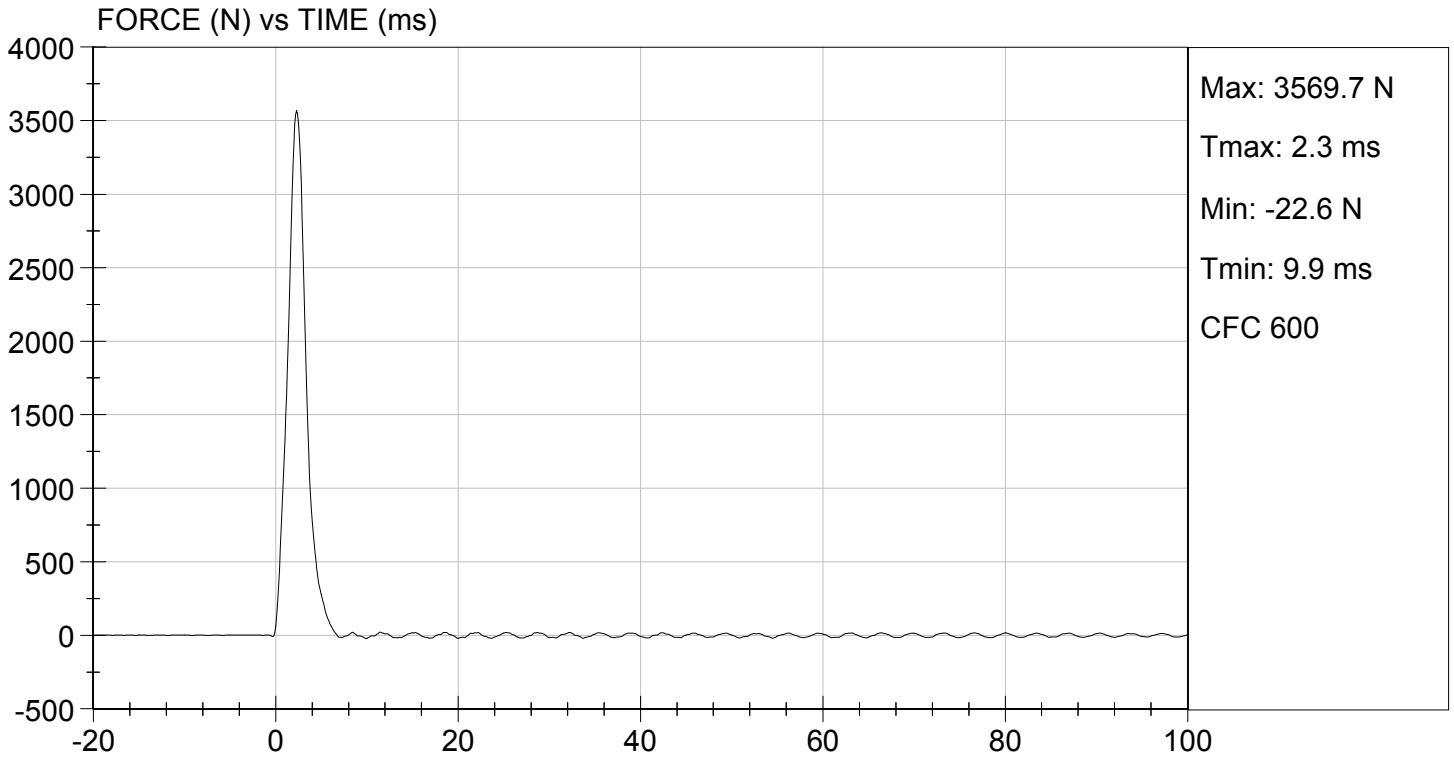

MGA RESEARCH CORPORATION
LEFT KNEE IMPACT TEST
HYBRID III 5TH PERCENTILE

ATD Serial No: 138

Test I.D: D132736

| Tested Parameter | Units | Specification | Result | Pass/Fail |
|------------------------------|-------|---------------|--------|-----------|
| Laboratory Temperature | deg C | 18.9 to 25.6 | 21.1 | Pass |
| Laboratory Relative Humidity | % | 10 to 70 | 42 | Pass |
| Probe Speed | m/s | 2.07 to 2.13 | 2.12 | Pass |
| Maximum Force | N | 3450 to 4060 | 3614 | Pass |
| Overall Test Results | | | | Pass |

Jessica Gall
Laboratory Technician

08/14/2013
Test Date

David Winkelbauer
Approved By



TEST DESC: LEFT KNEE
VELOCITY: 6.97 ft/s, 2.12 m/s

TEST DATE: 08/14/2013
TEST #: D132736

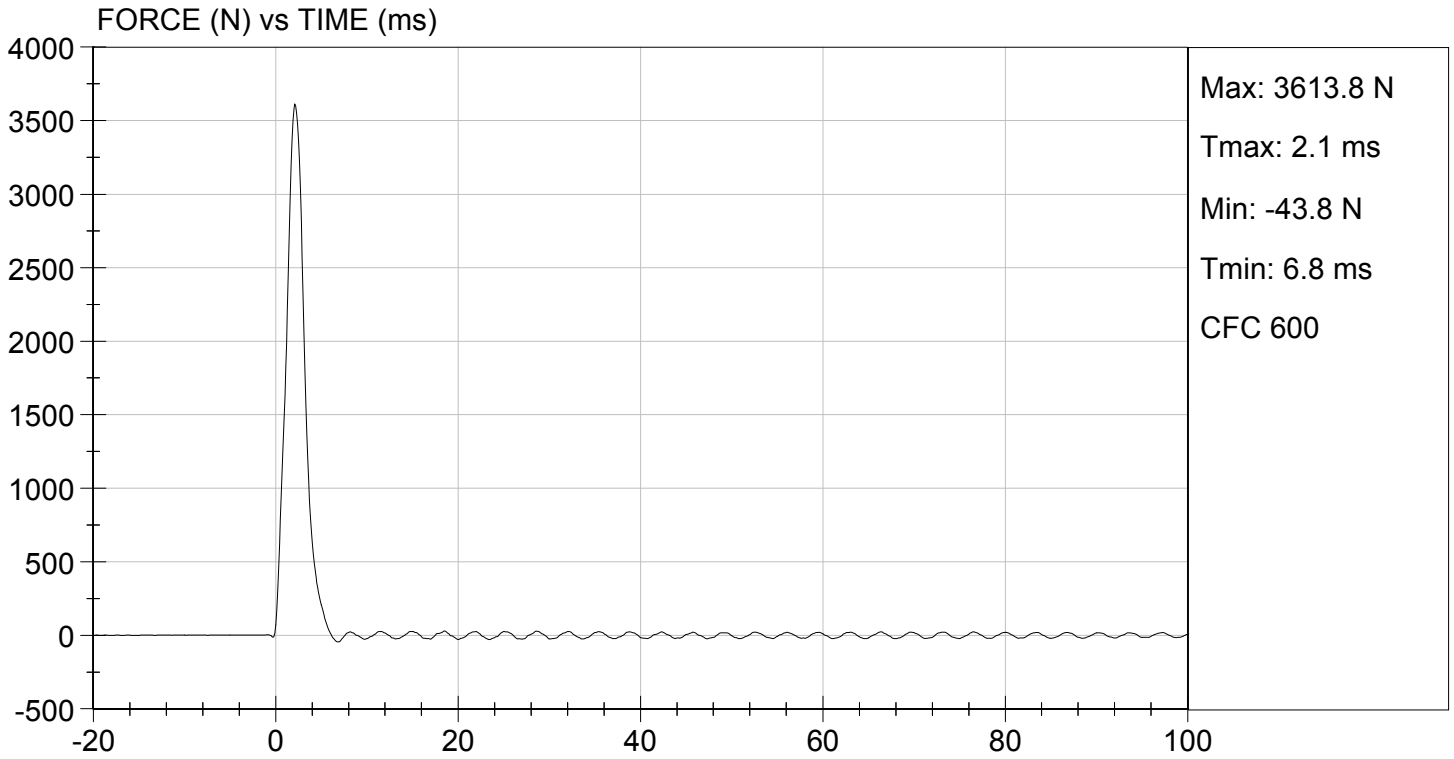

MGA RESEARCH CORPORATION
TORSO FLEXION TEST
HYBRID III 5TH PERCENTILE

ATD Serial No: 138

Test I.D.: D132737

| Tested Parameter | Units | Specification | Result | Pass/Fail |
|------------------------------|-------|---------------|--------|-------------|
| Laboratory Temperature | deg C | 18.9 to 25.6 | 21.1 | Pass |
| Laboratory Relative Humidity | % | 10 to 70 | 41 | Pass |
| Initial Angle | deg | 0 to 20 | 19 | Pass |
| Return Angle | deg | +/- 8 | 1 | Pass |
| Force at 45 deg | N | 320 to 390 | 383 | Pass |
| Upper Torso Deflection Rate | deg/s | 0.5 to 1.5 | 0.9 | Pass |
| Overall Result | | | | Pass |

Jessica Hall
 Laboratory Technician

08/14/2013
 Test Date

David Winkelbauer
 Approved By

**MGA RESEARCH CORPORATION
HEAD DROP TEST
HYBRID III 5TH PERCENTILE**

ATD Serial No: 138

Test ID: D132991

| Tested Parameter | Units | Specification | Result | Pass/Fail |
|------------------------------|-------|--------------------|--------|-------------|
| Laboratory Temperature | deg C | 18.9 to 25.6 | 21.0 | Pass |
| Laboratory Relative Humidity | % | 10 to 70 | 49 | Pass |
| Peak Resultant Acceleration | G's | 250 to 300 | 254 | Pass |
| Peak Lateral Acceleration | G's | <= +/- 15.0 | -10.8 | Pass |
| Unimodal | N/A | Yes | Yes | Pass |
| Oscillations | N/A | within 10% of peak | Yes | Pass |
| Overall Test Results | | | | Pass |



 Laboratory Technician

09/06/2013

 Test Date



 Approved By

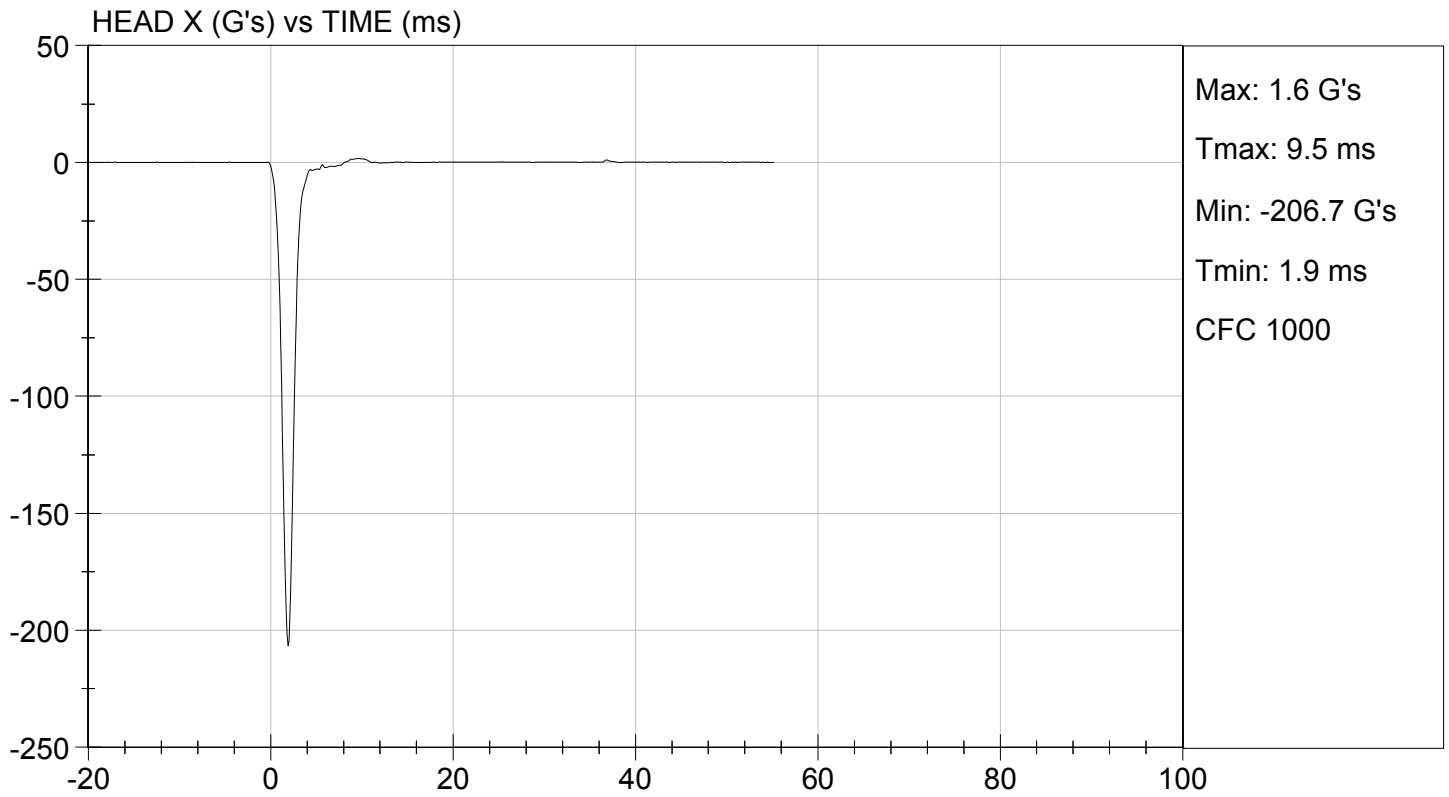
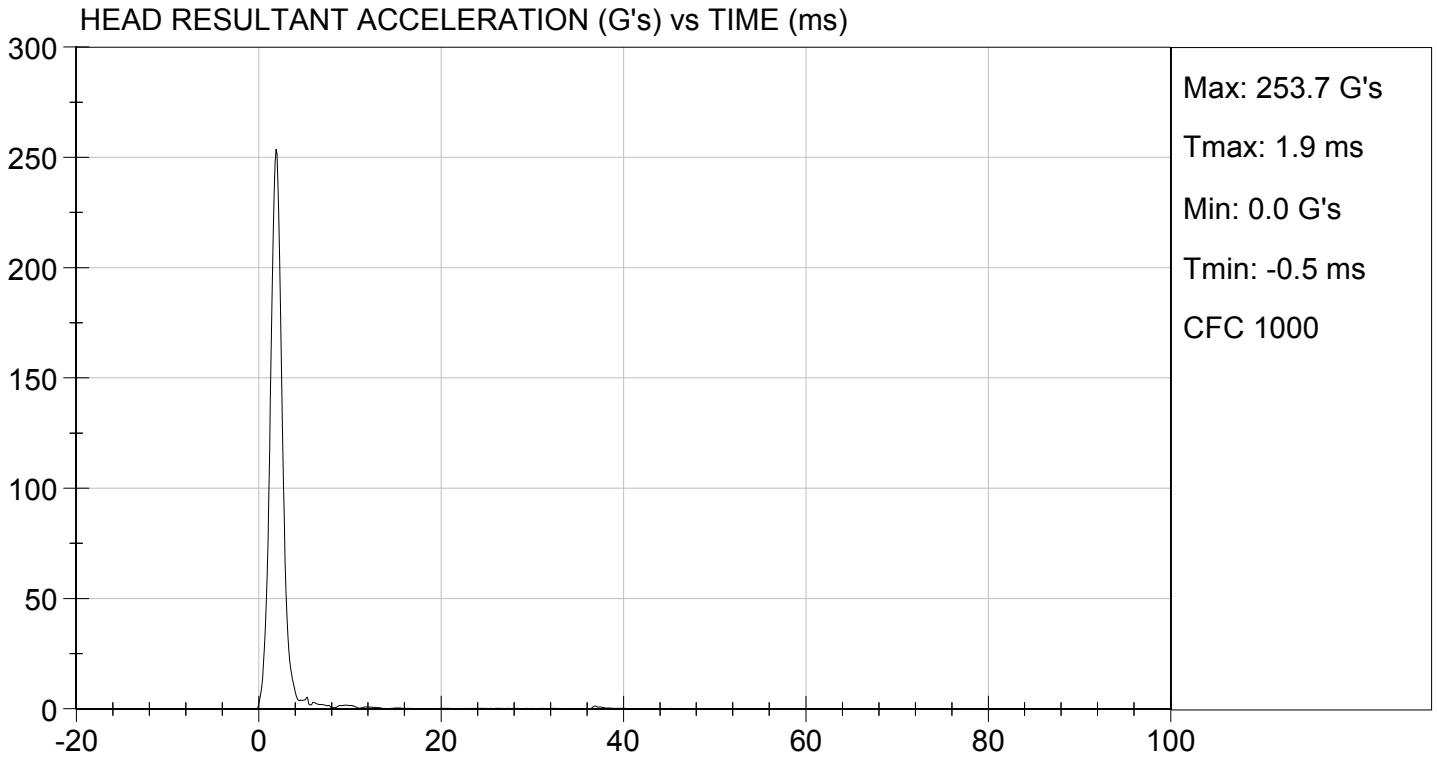

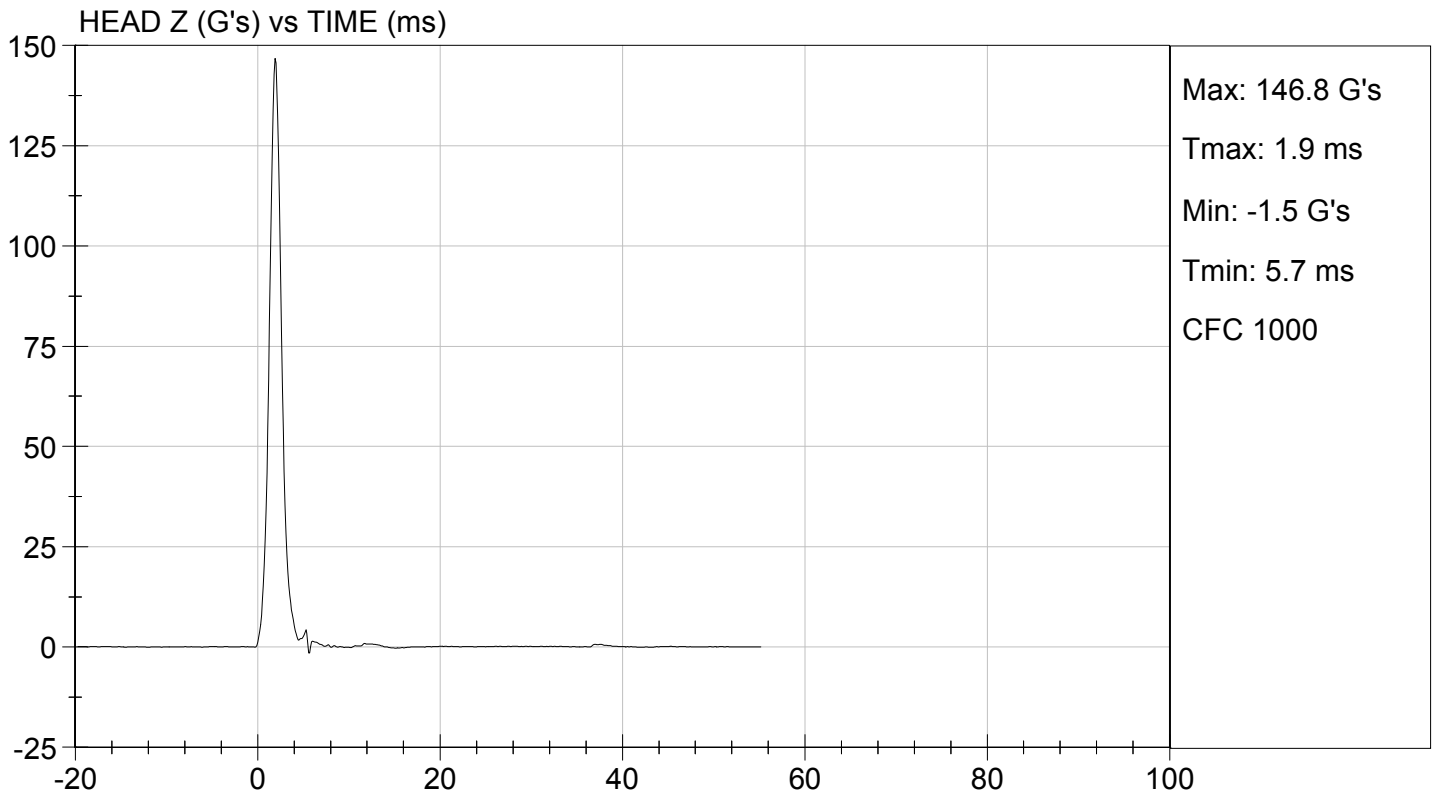
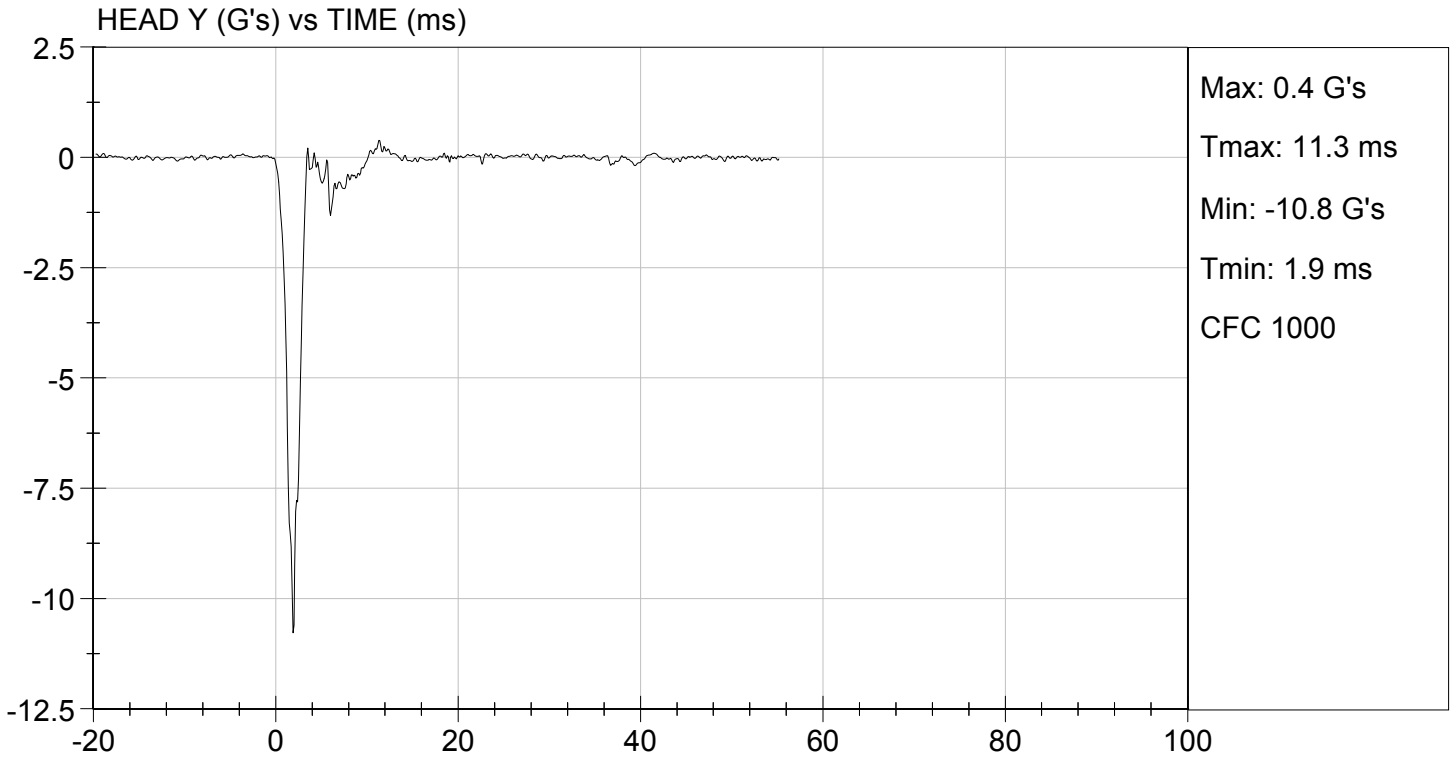

MGA RESEARCH CORPORATION

NECK FLEXION TEST

HYBRID III 5TH PERCENTILE

ATD Serial No: 138

Test I.D.: D132992

| Tested Parameter | Units | Specification | Result | Pass/Fail | |
|---|-------|---------------|------------|-----------|------|
| Laboratory Temperature | deg C | 20.6 to 22.2 | 21.2 | Pass | |
| Laboratory Relative Humidity | % | 10 to 70 | 52 | Pass | |
| Pendulum Speed | m/s | 6.89 to 7.13 | 7.06 | Pass | |
| Pendulum Velocity | 10 ms | m/s | 2.1 to 2.5 | 2.5 | Pass |
| | 20 ms | m/s | 4.0 to 5.0 | 4.7 | Pass |
| | 30 ms | m/s | 5.8 to 7.0 | 6.7 | Pass |
| D Plane Rotation | Max | deg | 77 to 91 | 81 | Pass |
| Occipital Condyle Moment within Rotation Corridor | Nm | 69 to 83 | 71 | Pass | |
| Positive Moment Time Curve Decay to 10 Nm | ms | 80 to 100 | 84 | Pass | |
| Overall Results | | | | Pass | |

Jessica Hall
Laboratory Technician

09/06/2013
Test Date

David Winkelbauer
Approved By

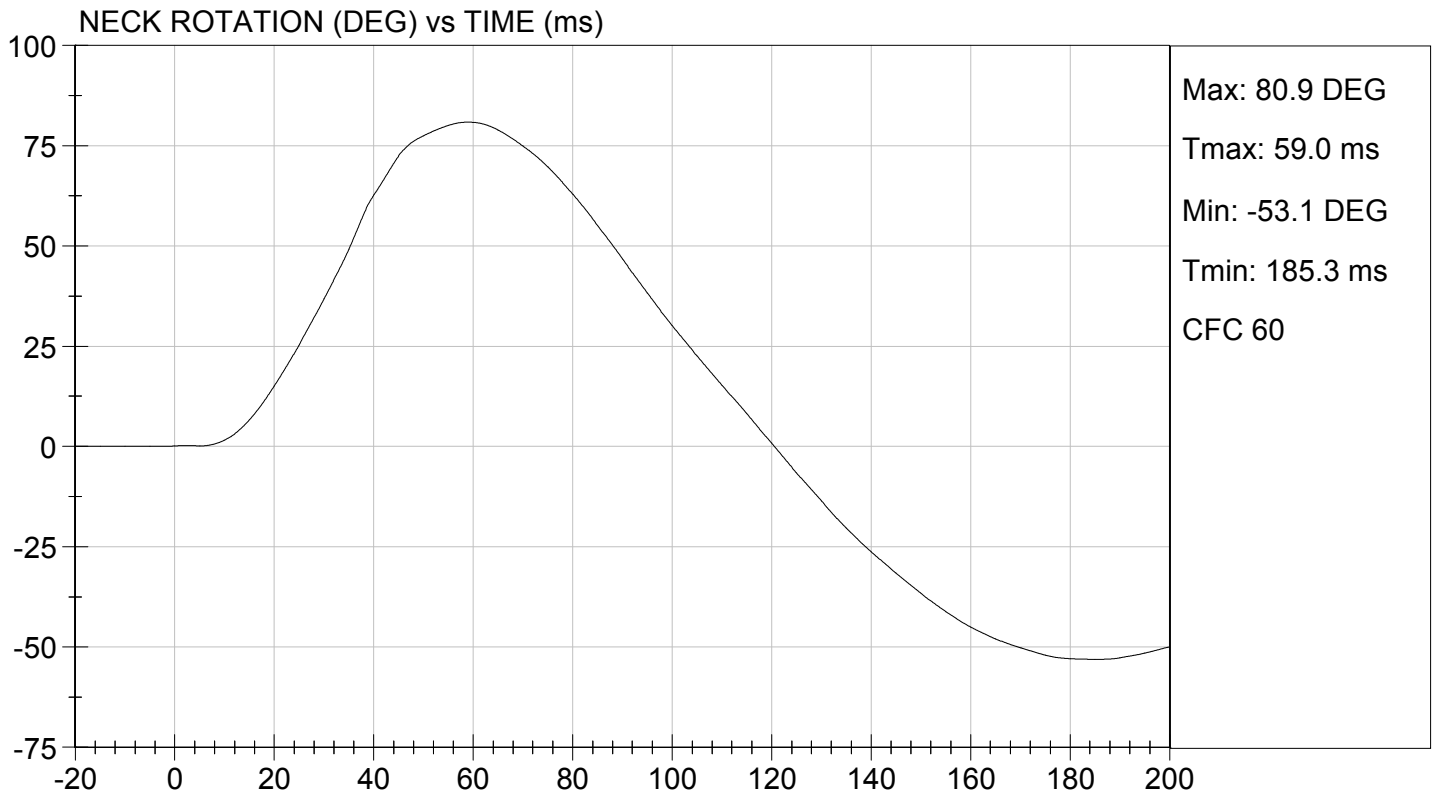
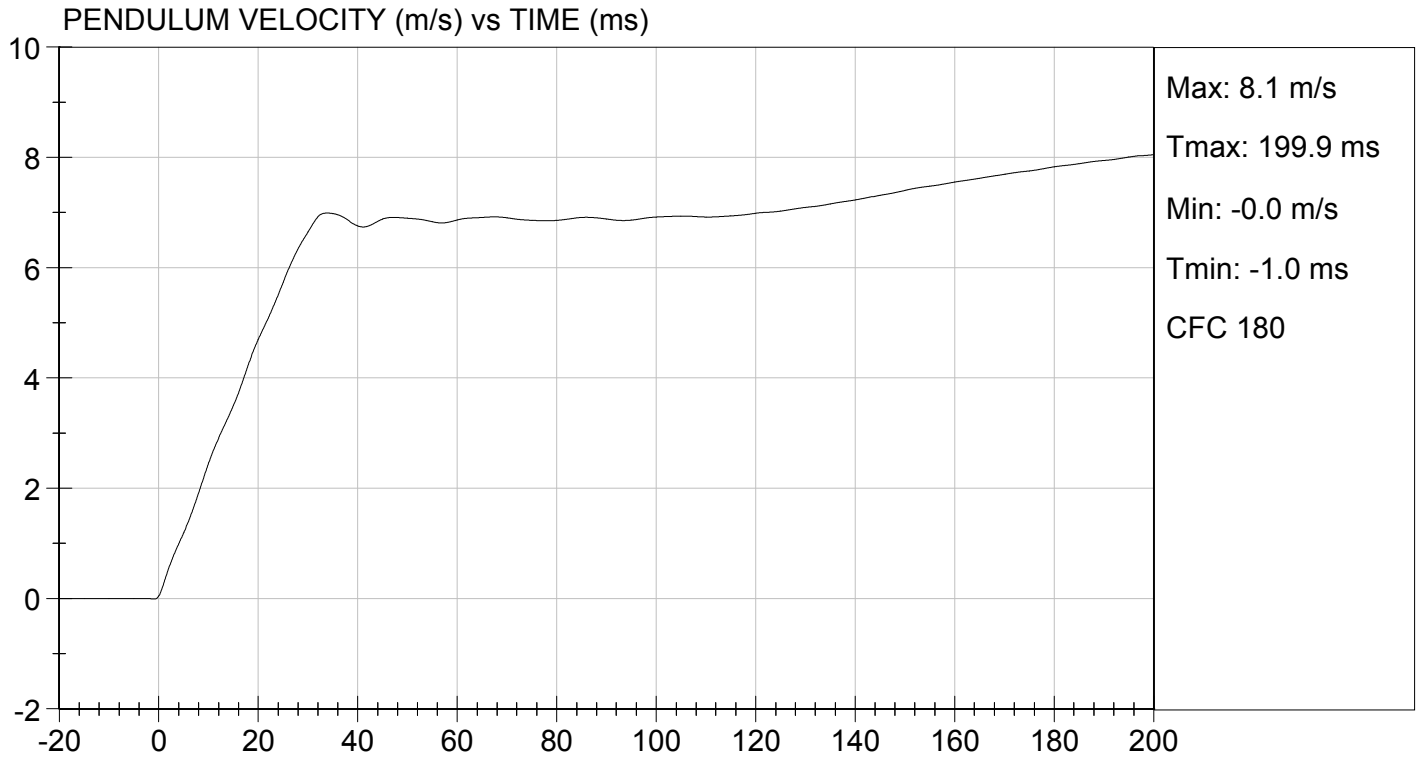



TEST DESC: NECK FLEXION
VELOCITY: 23.15 ft/s, 7.06 m/s

TEST DATE: 09/06/2013
TEST #: D132992

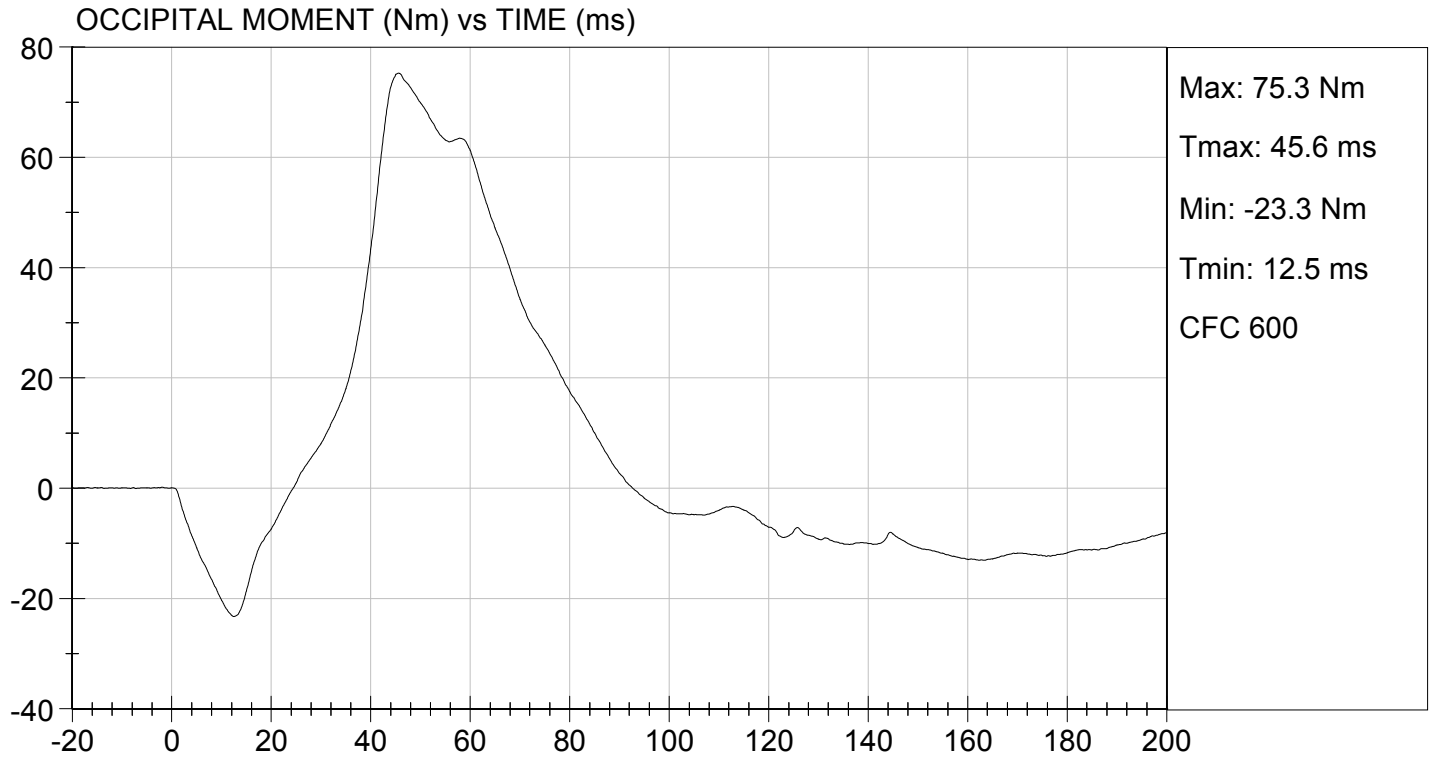

MGA RESEARCH CORPORATION
NECK EXTENSION TEST
HYBRID III 5TH PERCENTILE

ATD Serial No: 138

Test I.D: D132993

| Tested Parameter | | Units | Specification | Result | Pass/Fail |
|---|-------|-------|---------------|--------|-----------|
| Laboratory Temperature | | deg C | 20.6 to 22.2 | 21.2 | Pass |
| Laboratory Relative Humidity | | % | 10 to 70 | 52 | Pass |
| Pendulum Speed | | m/s | 5.95 to 6.19 | 6.12 | Pass |
| Pendulum Velocity | 10 ms | m/s | 1.5 to 1.9 | 1.6 | Pass |
| | 20 ms | m/s | 3.1 to 3.9 | 3.3 | Pass |
| | 30 ms | m/s | 4.6 to 5.6 | 4.9 | Pass |
| D Plane Rotation | Max | deg | 99 to 114 | 104 | Pass |
| Occipital Condyle Moment within Rotation Corridor | | Nm | -65 to -53 | -56 | Pass |
| Negative Moment Time Curve Decay to -10 Nm | | ms | 94 to 114 | 100 | Pass |
| Overall Results | | | | | Pass |

Jessica Hall
Laboratory Technician

09/06/2013
Test Date

David Winkelbauer
Approved By

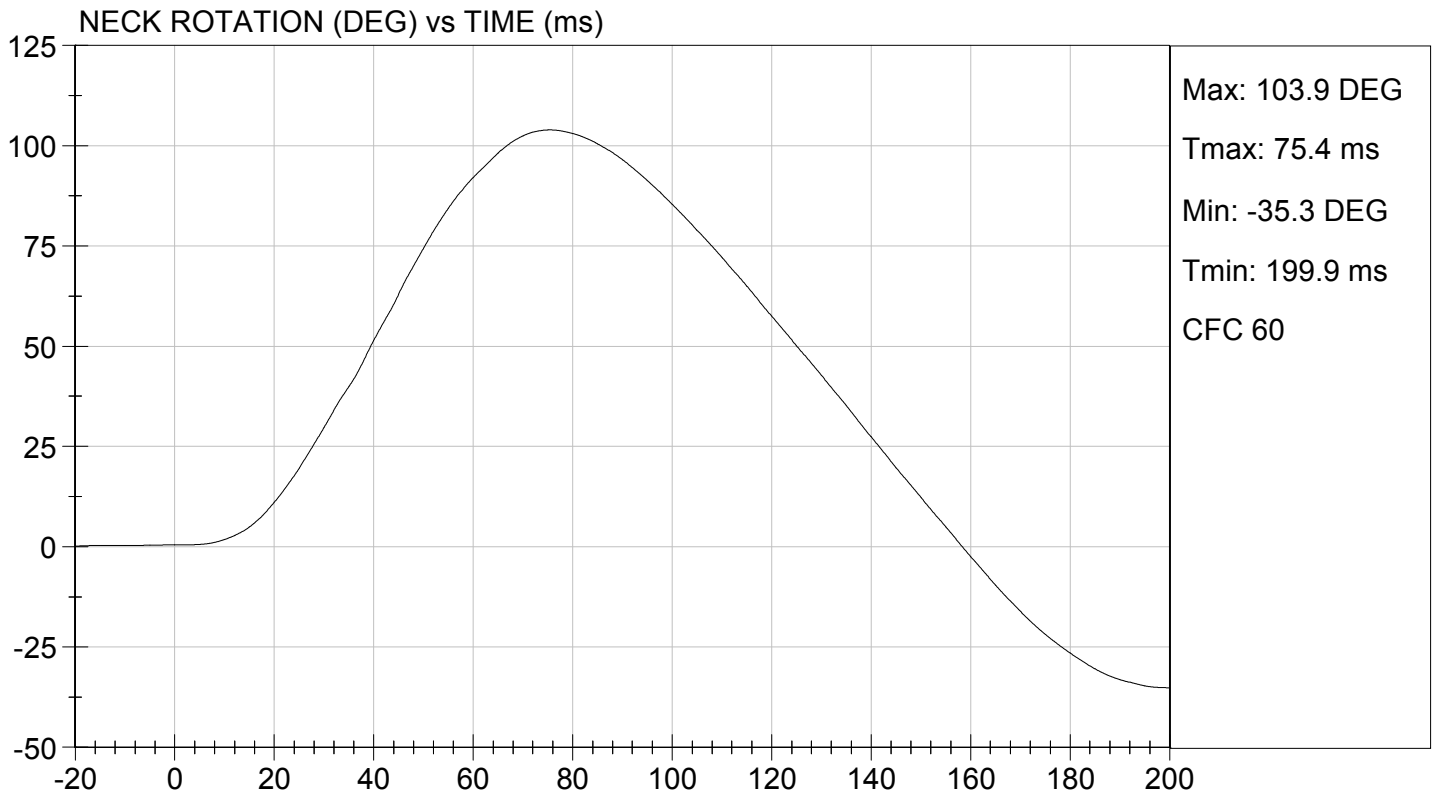
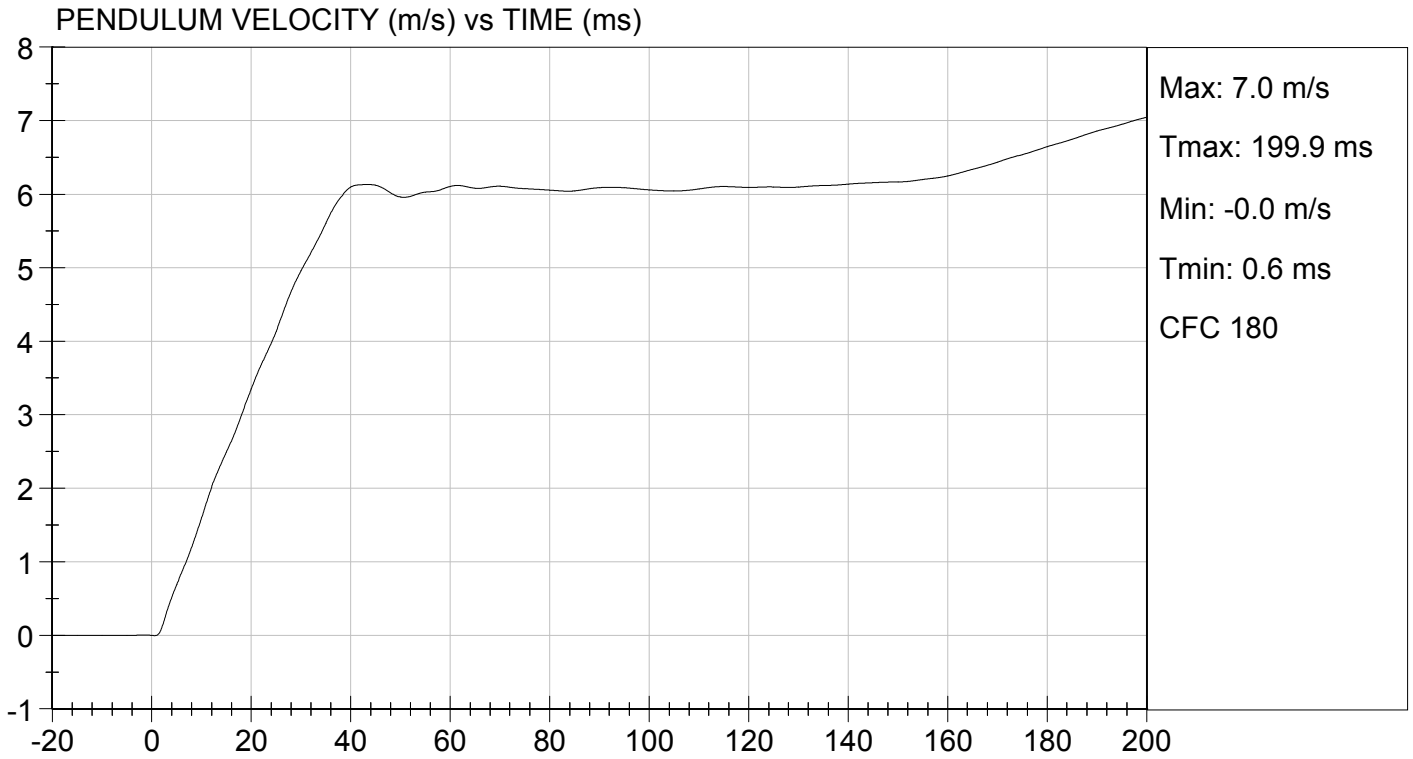

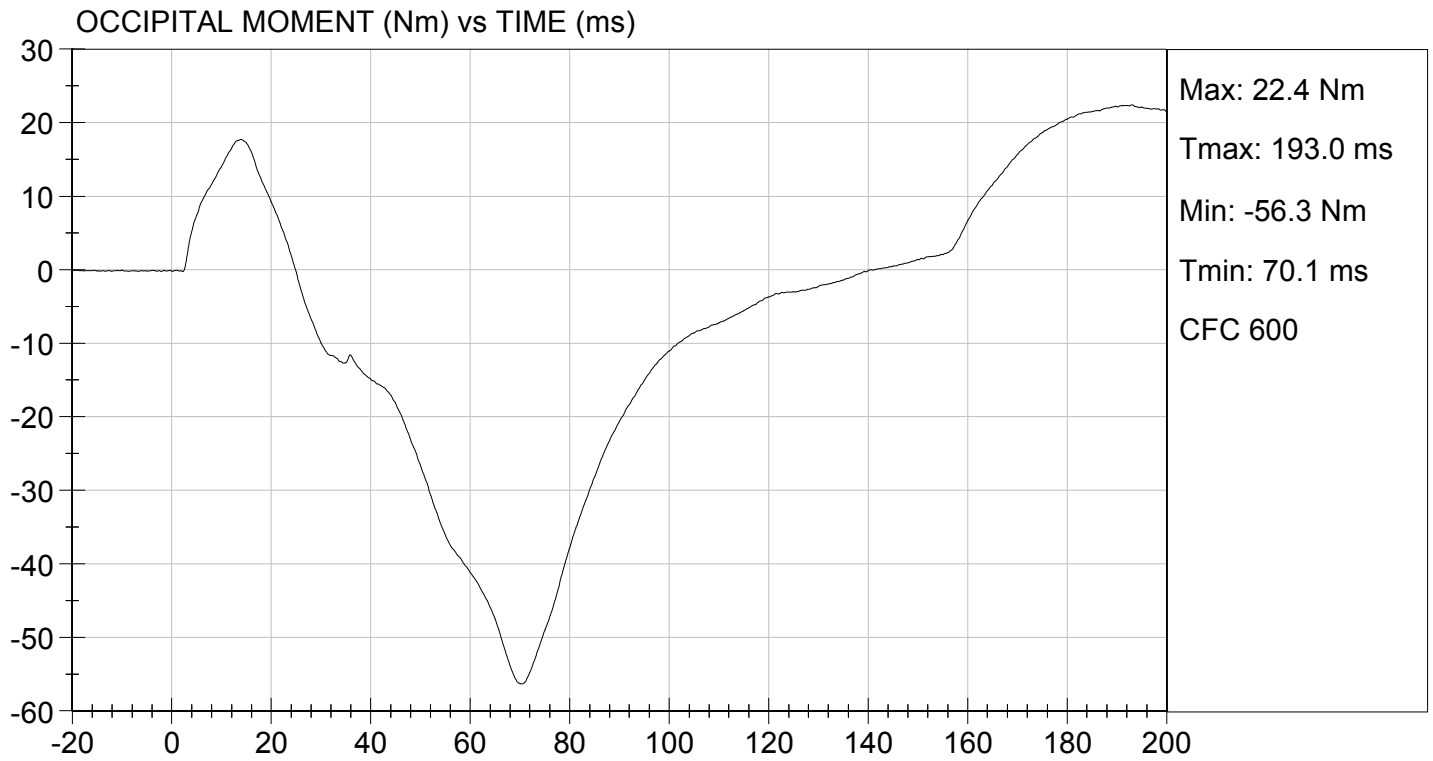

MGA RESEARCH CORPORATION
THORAX IMPACT
HYBRID III 5TH PERCENTILE

ATD Serial No: 138

Test I.D: D132994

| Tested Parameter | Units | Specification | Result | Pass/Fail |
|---|-------|---------------|--------|-------------|
| Temperature | deg C | 20.6 to 22.2 | 21.0 | Pass |
| Relative Humidity | % | 10 to 70 | 49 | Pass |
| Probe Speed | m/s | 6.59 to 6.83 | 6.77 | Pass |
| Peak Deflection | mm | 50 to 58 | 55 | Pass |
| Peak Resistive Force w/in Deflection Corridor | N | 3900 to 4400 | 4180 | Pass |
| Internal Hysteresis | % | 69 to 85 | 70 | Pass |
| Peak Force 18 mm - 50 mm | N | <= 4600 | 4137 | Pass |
| Overall Test Results | | | | Pass |

Jessica Gall
 Laboratory Technician

09/06/2013
 Test Date

David Winkelbauer
 Approved By

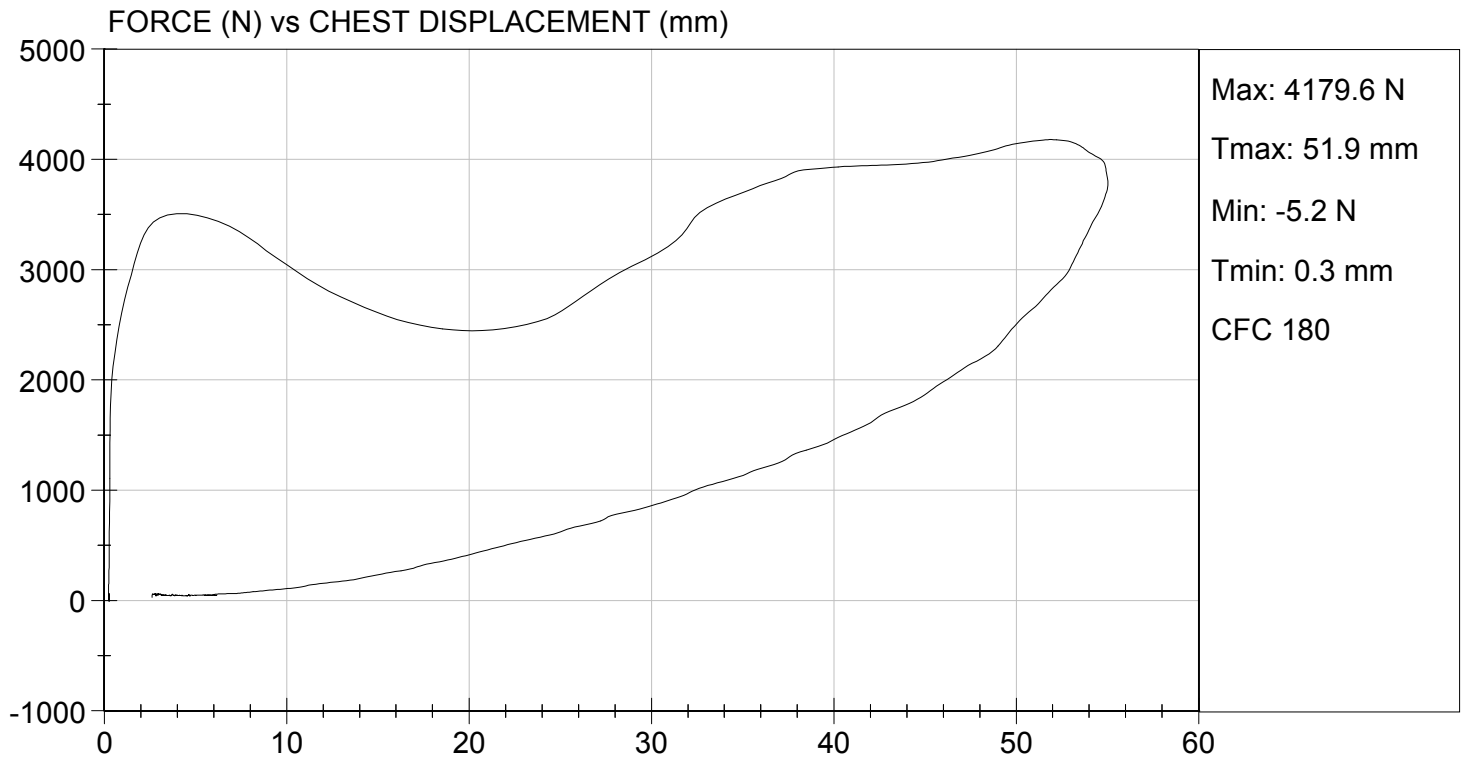

MGA RESEARCH CORPORATION
RIGHT KNEE IMPACT TEST
HYBRID III 5TH PERCENTILE

ATD Serial No: 138

Test I.D.: D132995

| Tested Parameter | Units | Specification | Result | Pass/Fail |
|------------------------------|-------|---------------|--------|-------------|
| Laboratory Temperature | deg C | 18.9 to 25.6 | 21.2 | Pass |
| Laboratory Relative Humidity | % | 10 to 70 | 52 | Pass |
| Probe Speed | m/s | 2.07 to 2.13 | 2.13 | Pass |
| Maximum Force | N | 3450 to 4060 | 3472 | Pass |
| Overall Test Results | | | | Pass |

Jessica Gall
 Laboratory Technician

09/06/2013
 Test Date

David Winkelbauer
 Approved By



TEST DESC: RIGHT KNEE
VELOCITY: 7.00 ft/s, 2.13 m/s

TEST DATE: 09/06/2013
TEST #: D132995

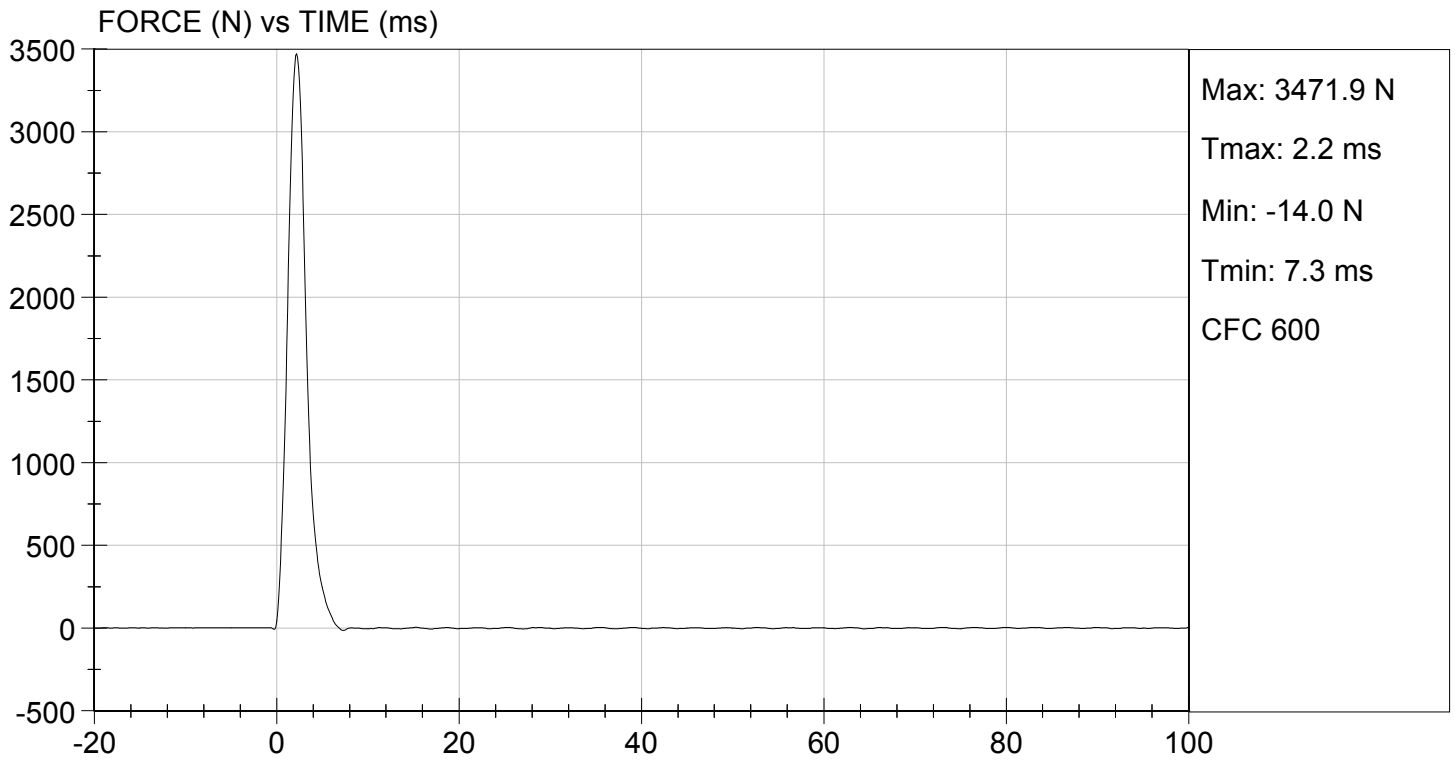

MGA RESEARCH CORPORATION

LEFT KNEE IMPACT TEST
HYBRID III 5TH PERCENTILE

ATD Serial No: 138

Test I.D: D132996

| Tested Parameter | Units | Specification | Result | Pass/Fail |
|------------------------------|-------|---------------|--------|-----------|
| Laboratory Temperature | deg C | 18.9 to 25.6 | 21.2 | Pass |
| Laboratory Relative Humidity | % | 10 to 70 | 52 | Pass |
| Probe Speed | m/s | 2.07 to 2.13 | 2.13 | Pass |
| Maximum Force | N | 3450 to 4060 | 3625 | Pass |
| Overall Test Results | | | | Pass |

Jessica Gall
Laboratory Technician

09/06/2013
Test Date

David Winkelbauer
Approved By



TEST DESC: LEFT KNEE
VELOCITY: 7.00 ft/s, 2.13 m/s

TEST DATE: 09/06/2013
TEST #: D132996

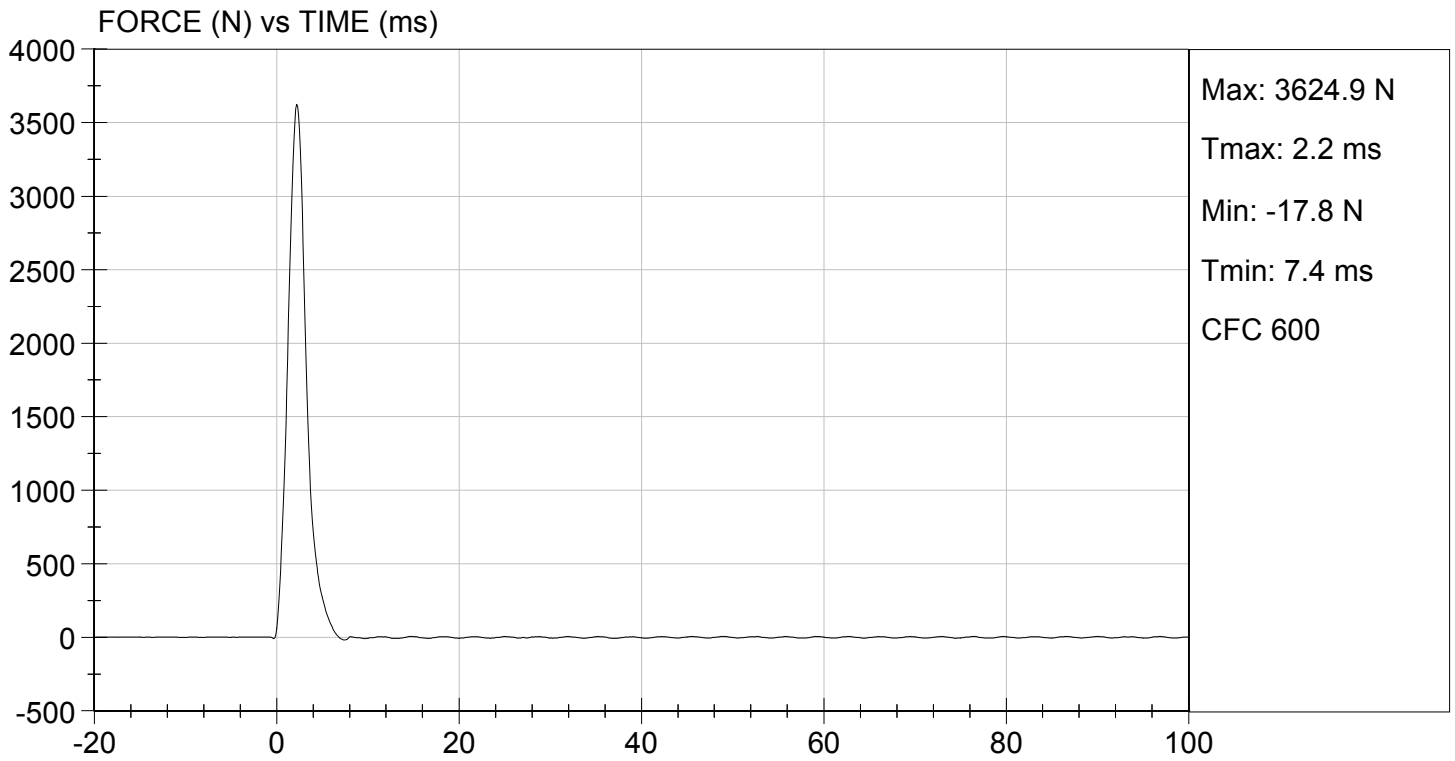

MGA RESEARCH CORPORATION
TORSO FLEXION TEST
HYBRID III 5TH PERCENTILE

ATD Serial No: 138

Test I.D.: D132997

| Tested Parameter | Units | Specification | Result | Pass/Fail |
|------------------------------|-------|---------------|--------|-------------|
| Laboratory Temperature | deg C | 18.9 to 25.6 | 21.0 | Pass |
| Laboratory Relative Humidity | % | 10 to 70 | 49 | Pass |
| Initial Angle | deg | 0 to 20 | 17 | Pass |
| Return Angle | deg | +/- 8 | 3 | Pass |
| Force at 45 deg | N | 320 to 390 | 385 | Pass |
| Upper Torso Deflection Rate | deg/s | 0.5 to 1.5 | 0.9 | Pass |
| Overall Result | | | | Pass |

Jessica Hall
 Laboratory Technician

09/06/2013
 Test Date

David Winkelbauer
 Approved By