

REPORT NUMBER: SPNCAP-MGA-2013-051

**NEW CAR ASSESSMENT PROGRAM (NCAP)
Side Impact Pole Test**

**FORD MOTOR COMPANY
2013 Ford C-MAX Energi SEL 5-Dr Hatchback
NHTSA No.: MD0209**

**MGA RESEARCH CORPORATION
5000 Warren Road
Burlington, WI 53105**



Test Date: February 22, 2013

Final Report Date: March 19, 2013

FINAL REPORT

**U.S. DEPARTMENT OF TRANSPORTATION
National Highway Traffic Safety Administration
Office of Crashworthiness Standards
Mail Code: NVS-111
1200 New Jersey Ave, SE
Room W43-410
Washington, DC 20590**

This publication is distributed by the U.S. Department of Transportation, National Highway Traffic Safety Administration, in the interest of information exchange. The opinions, findings and conclusions expressed in this publication are those of the author(s) and not necessarily those of the Department of Transportation or the National Highway Traffic Safety Administration. The United States Government assumes no liability for its contents or use thereof.

If trade or manufacturers' names or products are mentioned, it is only because they are considered essential to the object of the publication and should not be construed as an endorsement. The United States Government does not endorse products or manufacturers.

Prepared by: 
Donna Janovicz, Project Manager

Approved by: 
Ben Fischer, Project Engineer

Approval Date: March 19, 2013

FINAL REPORT ACCEPTANCE BY OCWS:

Division Chief, New Car Assessment Program
NHTSA, Office of Crashworthiness Standards

Date: _____

COTR, New Car Assessment Program
NHTSA, Office of Crashworthiness Standards

Date: _____

Technical Report Documentation Page

1. Report No. SPNCAP-MGA-2013-051	2. Government Accession No.	3. Recipient's Catalog No.																												
4. Title and Subtitle Final Report of New Car Assessment Program Side Impact Pole Testing of a 2013 Ford C-MAX Energi SEL 5-Dr Hatchback, NHTSA No.: MD0209		5. Report Date March 19, 2013																												
		6. Performing Organization Code MGA																												
7. Author(s) Donna Janovicz, Project Manager Ben Fischer, Project Engineer		8. Performing Organization Report No. SPNCAP-MGA-2013-051																												
9. Performing Organization Name and Address MGA Research Corporation 5000 Warren Road Burlington, WI 53105		10. Work Unit No.																												
		11. Contract or Grant No. DTNH22-09-D-00124																												
12. Sponsoring Agency Name and Address United States Department of Transportation National Highway Traffic Safety Administration Office of Crashworthiness Standards (NVS-111) 1200 New Jersey Ave, SE, Room W43-410 Washington, DC 20590		13. Type of Report and Period Covered: Final Test Report February 22, 2013 to March 19, 2013																												
		14. Sponsoring Agency Code NVS-111																												
15. Supplementary Notes																														
16. Abstract A 32.20 km/h, 75° oblique impact Side NCAP Test was conducted on the subject 2013 Ford C-MAX Energi SEL 5-Dr Hatchback in accordance with the specifications of the Office of Crashworthiness Standards Side NCAP Pole Laboratory Test Procedure for the generation of consumer information on vehicle side pole crash protection. The test was conducted at MGA Research Corporation, in Burlington, Wisconsin, on February 22, 2013. The impact velocity was 32.1 km/h, and the ambient temperature at the struck (driver's) side of the target vehicle at the time of impact was 21.0°C. The test vehicle post-test maximum crush was 393 mm at level 3. The test vehicle's performance was as follows:																														
<table border="1" style="margin: auto; border-collapse: collapse;"> <thead> <tr> <th rowspan="2" style="text-align: left;">Measurement Description</th> <th colspan="3" style="text-align: center;">Driver ATD (SID-IIs)</th> </tr> <tr> <th style="text-align: center;">Units</th> <th style="text-align: center;">Threshold</th> <th style="text-align: center;">Result</th> </tr> </thead> <tbody> <tr> <td>Head Injury Criteria (HIC₃₆)</td> <td style="text-align: center;">N/A</td> <td style="text-align: center;">1000</td> <td style="text-align: center;">270</td> </tr> <tr> <td>Resultant Lower Spine Acceleration</td> <td style="text-align: center;">Gs</td> <td style="text-align: center;">82</td> <td style="text-align: center;">46</td> </tr> <tr> <td>Total Pelvic Force (sum of acetabular and iliac forces)</td> <td style="text-align: center;">N</td> <td style="text-align: center;">5525</td> <td style="text-align: center;">4198</td> </tr> <tr> <td>Maximum Thoracic Rib Deflection</td> <td style="text-align: center;">mm</td> <td style="text-align: center;">38*</td> <td style="text-align: center;">17</td> </tr> <tr> <td>Maximum Abdomen Rib Deflection</td> <td style="text-align: center;">mm</td> <td style="text-align: center;">45*</td> <td style="text-align: center;">12</td> </tr> </tbody> </table>				Measurement Description	Driver ATD (SID-IIs)			Units	Threshold	Result	Head Injury Criteria (HIC ₃₆)	N/A	1000	270	Resultant Lower Spine Acceleration	Gs	82	46	Total Pelvic Force (sum of acetabular and iliac forces)	N	5525	4198	Maximum Thoracic Rib Deflection	mm	38*	17	Maximum Abdomen Rib Deflection	mm	45*	12
Measurement Description	Driver ATD (SID-IIs)																													
	Units	Threshold	Result																											
Head Injury Criteria (HIC ₃₆)	N/A	1000	270																											
Resultant Lower Spine Acceleration	Gs	82	46																											
Total Pelvic Force (sum of acetabular and iliac forces)	N	5525	4198																											
Maximum Thoracic Rib Deflection	mm	38*	17																											
Maximum Abdomen Rib Deflection	mm	45*	12																											
*Proposed IARV																														
The two doors on the struck side of the vehicle did not separate from the body at the hinges or latches and the opposite doors did not open during the side impact event.																														
17. Key Words New Car Assessment Program (NCAP) Side Impact Pole Part 572V SID-IIs		18. Distribution Statement Copies of this report are available from: National Highway Traffic Safety Administration Technical Information Services Division, NPO-411 1200 New Jersey Ave, SE Washington, DC 20590 e-mail: tis@nhtsa.dot.gov FAX: 202-493-2833																												
19. Security Classification of Report Unclassified	20. Security Classification of Page Unclassified	21. No. of Pages 138	22. Price																											

TABLE OF CONTENTS

<u>Section</u>		<u>Page No.</u>
1	Test Purpose and Procedure	1
2	Summary of Test Results	2
3	Occupant and Vehicle Information	4

<u>Data Sheet No.</u>		<u>Page No.</u>
1	General Test and Vehicle Parameter Data	5
2	Seat, Seat Belt, Steering Wheel Adjustment and Fuel System Data	8
3	Dummy Longitudinal Clearance Dimensions	11
4	Dummy Lateral Clearance Dimensions	12
5	Camera and Instrumentation Data	13
6	Vehicle Accelerometer Data	14
7	Rigid Pole Load Cell Data	15
8	Post-Test Observations	16
9	Vehicle Profile Measurements	18
10	Vehicle Exterior Crush Measurements	19
11	FMVSS No. 301 Static Rollover Results	22
12	Dummy/Vehicle Temperature Stabilization Data	23

Appendix

A	Photographs	A
B	Vehicle and Dummy Response Data Plots	B
C	Dummy Configuration and Performance Verification Data	C
D	Test Equipment and Instrumentation Calibration Data	D

SECTION 1
TEST PURPOSE AND PROCEDURE

This side impact test is part of the MY 2013 New Car Assessment Program Side Impact Test Program, sponsored by the National Highway Traffic Safety Administration (NHTSA), under Contract No. DTNH22-09-D-00124. The purpose of this test is to generate comparative side impact performance in a 2013 Ford C-MAX Energi SEL 5-Dr Hatchback. The side impact test was conducted in accordance with the Office of Crashworthiness Standard's Side NCAP Pole Laboratory Test Procedure, dated September 2012.

SECTION 2 SUMMARY OF TEST RESULTS

A rigid pole side impact test was conducted on a 2013 Ford C-MAX Energi SEL 5-Dr Hatchback. The subject vehicle was towed into the rigid pole at an angle of 75° and a velocity of 32.1 km/h. The test was conducted by MGA Research Corporation in Burlington, Wisconsin, on February 22, 2013. Pre-test and post-test photographs of the test vehicle and side impact dummy (SID-IIs) are included in Appendix A of this report.

One Part 572V (SID-IIs) dummy was placed in the driver designated seating position according to instructions specified in the OCWS Side NCAP Pole Laboratory Test Procedure dated September 2012. Camera locations and other pertinent camera information are included in this report.

The Part 572V (SID-IIs) dummy was instrumented accordingly:

- Primary and Redundant Head CG Triaxial Accelerometers
- Thorax Upper, Middle, and Lower Rib Displacement Potentiometers
- Abdomen Upper Rib and Lower Rib Displacement Potentiometers
- Lower Spine (T12) Triaxial Accelerometers
- Iliac Load Cell
- Acetabulum Load Cell

Appendix B contains the vehicle and dummy response data. Dummy configuration and performance verification data can be found in Appendix C of this report. Appendix D contains the test equipment and instrumentation calibration data.

Injury readings for the SID-IIs dummy were recorded as follows:

Measurement Description	Driver ATD (SID-IIs)		
	Units	Threshold	Result
Head Injury Criteria (HIC ₃₆)	N/A	1000	270
Resultant Lower Spine Acceleration	Gs	82	46
Total Pelvic Force (sum of acetabular and iliac forces)	N	5525	4198
Maximum Thoracic Rib Deflection	mm	38*	17
Maximum Abdominal Rib Deflection	mm	45*	12

*Proposed IARV

Supplemental restraint information is given below:

Restraint Type	Left Front (Driver) Occupant Location 1		Left Rear (Passenger) Occupant Location 4	
	Mounted	Deployed	Mounted	Deployed
Frontal Airbag	Yes	No		
Knee Airbag	Yes	No		
Side Curtain Airbag	Yes	Yes	Yes	Yes
Side Torso/Abdomen/Pelvis Airbag	Yes	Yes	No	
Seat Belt Pretensioner	Yes	Yes	No	
Seat Belt Load Limiter	Yes	Yes	No	
Other				

The test data can be found on the NHTSA website at www.nhtsa.dot.gov

GENERAL COMMENTS

There was no valid data collected for:

Left Floor Sill Y after 20ms

Left A-Post @ Sill Y after 66ms

Left Mid B-Post Y is questionable from 15-21 and 45-53ms

Driver Seat Track Y after 88ms

Firewall Y after 35ms

MGA does not endorse or certify products. The manufacturer's name appears solely for identification purposes.

**SECTION 3
OCCUPANT AND VEHICLE INFORMATION**

**DATA SHEET NO. 1
GENERAL TEST AND VEHICLE PARAMETER DATA**

Test Vehicle: 2013 Ford C-MAX Energi SEL 5-Dr Hatchback
 Test Program: NCAP Side Pole Impact Test

NHTSA No. MD0209
 Test Date: 2/22/2013

TEST VEHICLE INFORMATION AND OPTIONS

NHTSA No.	MD0209	Traction Control System (TCS)	Yes
Model Year	2013	Auto-Leveling System	No
Make	Ford	Automatic Door Locks (ADL)	Yes
Model	C-MAX Energi	Power Window Auto-Reverse	Yes
Body Style	5-Dr Hatchback	Other Optional Feature	N/A
VIN	1FADP5CU1DL519349	Driver Front Airbag	Yes
Body Color	Sterling Gray Metallic	Driver Curtain Airbag	Yes
Odometer Reading (km/mi)	11 / 7	Driver Head/Torso Airbag	No
Engine Displacement (L)	2.0	Driver Torso Airbag	No
Type/No. Cylinders	4	Driver Torso/Pelvis Airbag	Yes
Engine Placement	Lateral	Driver Pelvis Airbag	No
Transmission Type	Automatic	Driver Knee Airbag	Yes
Transmission Speeds	CVT	Rear Pass. Curtain Airbag	Yes
Overdrive	NA	Rear Pass. Head/Torso Airbag	No
Final Drive	Front	Rear Pass. Torso Airbag	No
Roof Rack	No	Rear Pass. Torso/Pelvis Airbag	No
Sunroof/T-Top	No	Rear Pass. Pelvis Airbag	No
Running Boards	No	Driver Seat Belt Pretensioner	Yes
Tilt Steering Wheel	Yes	Rear Pass. Seat Belt Pretensioner	No
Power Seats	Yes – Driver Only	Driver Load Limiter	Yes
Anti-Lock Brakes (ABS)	Yes	Rear Pass. Load Limiter	No
		Other Safety Restraint	N/A

Does owner's manual provide instructions to turn off automatic door locks? **Yes**

DATA FROM CERTIFICATION LABEL

Manufactured By	Ford Motor Company	GVWR (kg)	2250
Date of Manufacture	12/12	GAWR Front (kg)	1119
Vehicle Type	Passenger Car	GAWR Rear (kg)	1131

VEHICLE SEATING AND WEIGHT CAPACITY DATA

Measured Parameter	Front	Rear	Third	Total	
Designated Seating Capacity (DSC)	2	3		5	
Capacity Weight (VCW) (kg)				374	(A)
DSC x 68.04 kg				340	(B)
Rated Cargo and Luggage Weight (RCLW) (kg)				34	(A-B)

VEHICLE SEAT TYPE

Seating Location	Type of Seat Pan				Type of Seat Back		
	Bucket	Bench	Split Bench	Contoured	Fixed	Adjustable	
						Manual	Power
Front Seat	X						X
Rear or Second Row			X		X	w/lever	
Third Row Seat							

DATA SHEET NO. 1 (CONTINUED)
GENERAL TEST AND VEHICLE PARAMETER DATA

Test Vehicle: 2013 Ford C-MAX Energi SEL 5-Dr Hatchback
 Test Program: NCAP Side Pole Impact Test

NHTSA No. MD0209
 Test Date: 2/22/2013

VEHICLE TIRE INFORMATION

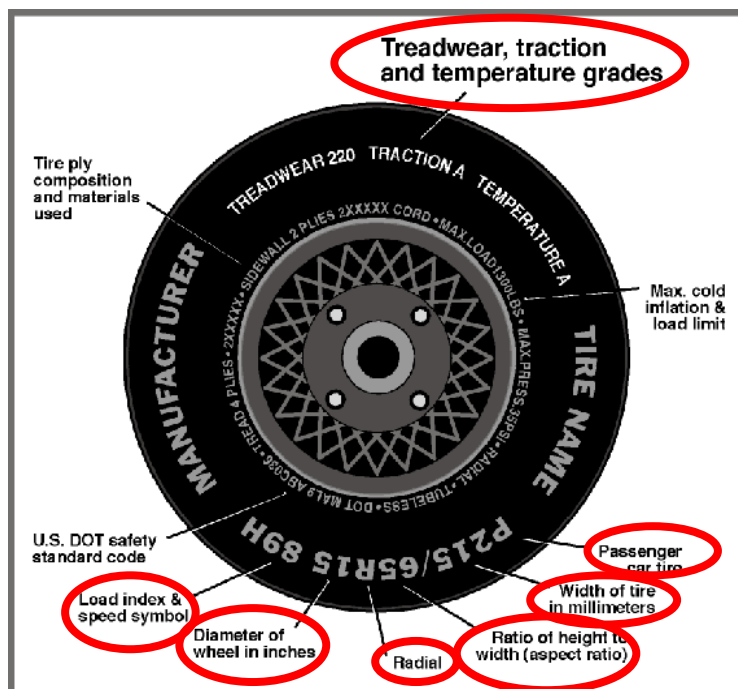

Measured Parameter	Front	Rear
Max. Tire Pressure (kPa)	350	350
Cold Pressure (kPa)	260	260
Recommended Tire Size	P225/50R17	P225/50R17
Tire Size on Vehicle	P225/50R17	P225/50R17
Tire Manufacturer	Michelin	Michelin
Tire Model	Energy Saver A/S	Energy Saver A/S
Treadwear	480	480
Traction	A	A
Temperature Grade	A	A
Tire Plies Sidewall	1 polyester	1 polyester
Tire Plies Body	1 polyester, 1 polyamid, 2 steel	1 polyester, 1 polyamid, 2 steel
Load Index/Speed Symbol	93V	93V
Tire Material	Rubber	Rubber
DOT Safety Code Left	B90A 00NX 4312	B90A 00NX 4312
DOT Safety Code Right	B90A 00NX 4312	B90A 00NX 4312

DATA SHEET NO. 1 (CONTINUED)
GENERAL TEST AND VEHICLE PARAMETER DATA

Test Vehicle: 2013 Ford C-MAX Energi SEL 5-Dr Hatchback
 Test Program: NCAP Side Pole Impact Test

NHTSA No. MD0209
 Test Date: 2/22/2013

TEST PRESSURES

	Units	LF	RF	LR	RR
As Delivered	kpa	260	260	260	260
Tire Placard	kpa	260	260	260	260
Owner's Manual	kpa				
As Tested	kpa	260	260	260	260

TEST VEHICLE WEIGHTS

	Units	As Delivered (UVW)			As Tested (ATW)			Fully Loaded		
		Front	Rear	Total	Front	Rear	Total	Front	Rear	Total
Left	kg	487.2	409.1		517.1	423.2		504.4	448.6	
Right	kg	474.9	397.8		491.7	415.5		477.6	426.0	
Ratio	%	54.4	45.6		54.6	45.4		52.9	47.1	
Totals	kg	962.1	806.9	1769.0	1008.8	838.7	1847.5	982.0	874.6	1856.6

TARGET TEST WEIGHT CALCULATION

Measured Parameter	Units	Value	
Total Delivered Weight (UVW)	kg	1769.0	(A)
Actual Weight of 1 P572V ATD (SID-IIs) ATD Used	kg	52.2	(B)
Rated Cargo/Luggage Weight (RCLW)	kg	34	(C)
Calculated Vehicle Target Weight (TVT _W)	kg	1855.2	(A+B+C)

Does the measured As Tested Vehicle Weight lie within the required weight range (i.e. Calculated Test Vehicle Target Weight – 4.5 kg to 9 kg)? **YES**

TEST VEHICLE ATTITUDES AND CG

	Units	As Delivered	As Tested	Fully Loaded	Meets Requirement***
Driver Door Sill Angle (front-to-rear)*	deg	-0.2	-0.3	-0.3	Yes
Front Pass. Sill Angle (front-to-rear)*	deg	-0.1	-0.1	0.0	Yes
Front Bumper Angle (left-to-right)**	deg	-0.2	-0.2	-0.3	Yes
Rear Bumper Angle (left-to-right)**	deg	-0.2	-0.2	-0.1	Yes
Vehicle CG (Aft of Front Axle)	mm	1208	1202	1247	
Vehicle CG (Left (+) / Right (-) from Longitudinal Centerline)	mm	10	14	20	

*ND=Nose Down (-), NU=Nose Up (+) ** LD=Left Down (-), LU=Left Up (+)

*** The "As Tested" vehicle attitude measurements must be equal to or between the "As Delivered" and "Fully Loaded" vehicle attitude measurements.

WEIGHT OF BALLAST AND VEHICLE COMPONENTS REMOVED TO MEET TVT_W

Component Description	Weight (kg)
Ballast (if any)	0.0
Taillights, right side mirror, jack & tool kit, cargo cover/carpet/divider, right rear window glass/motor/track, hatch wiper/motor/trim, rear headrests, right front passenger headrest, right rear speaker, floor mats.	30.8

DATA SHEET NO. 2
SEAT, SEAT BELT, STEERING WHEEL ADJUSTMENT AND FUEL SYSTEM DATA

Test Vehicle: 2013 Ford C-MAX Energi SEL 5-Dr Hatchback
 Test Program: NCAP Side Pole Impact Test

NHTSA No. MD0209
 Test Date: 2/22/2013

SEAT POSITIONING

The driver's seat, front center seat (if applicable), and right front passenger's seat should be set to the forward-most, mid-height, mid-angle position. The struck-side rear passenger's seat, rear center seat, and non-struck side rear passenger's seats should be set to the rear-most, lowest, mid-angle position.

SCRL ANGLE RANGE

Seat	SCRL (°)		
	Max	Min	Mid
Driver Seat	22.5	12.7	17.6
Front Passenger Seat	Fixed	Fixed	Fixed
Front Center Seat			
Struck Side Rear Seat	Fixed	Fixed	Fixed
Non-Struck Side Rear Seat	Fixed	Fixed	Fixed
Rear Center Seat	Fixed	Fixed	Fixed

SEAT HEIGHT AND ANGLE

Seat	As Tested SCRL Angle (Mid) (°)	As Tested SCRP Height (mm)	SCRP Height Position	SCRP Height (mm)		
				Rear-most	Mid-Fore/Aft	Forward-Most
Driver Seat	17.6	22	Max	44	44	44
	17.6	22	Mid	22	22	22
	17.6	22	Min	0	0	0
Front Passenger Seat	Fixed	Fixed	Max	Fixed	Fixed	Fixed
	Fixed	Fixed	Mid	Fixed	Fixed	Fixed
	Fixed	Fixed	Min	Fixed	Fixed	Fixed
Front Center Seat			Max			
			Mid			
			Min			
Struck Side Rear Seat	Fixed	Fixed	Max	Fixed	Fixed	Fixed
	Fixed	Fixed	Mid	Fixed	Fixed	Fixed
	Fixed	Fixed	Min	Fixed	Fixed	Fixed
Non-Struck Side Rear Seat	Fixed	Fixed	Max	Fixed	Fixed	Fixed
	Fixed	Fixed	Mid	Fixed	Fixed	Fixed
	Fixed	Fixed	Min	Fixed	Fixed	Fixed
Rear Center Seat	Fixed	Fixed	Max	Fixed	Fixed	Fixed
	Fixed	Fixed	Mid	Fixed	Fixed	Fixed
	Fixed	Fixed	Min	Fixed	Fixed	Fixed

DATA SHEET NO. 2 (CONTINUED)
SEAT, SEAT BELT, STEERING WHEEL ADJUSTMENT, AND FUEL SYSTEM DATA

Test Vehicle: 2013 Ford C-MAX Energi SEL 5-Dr Hatchback
 Test Program: NCAP Side Pole Impact Test

NHTSA No. MD0209
 Test Date: 2/22/2013

SEAT FORE/AFT POSITIONS

Seat	Total Fore/Aft Travel		Test Position from Forward-most Position	
	mm	Detents	mm	Detent
Driver Seat	254		0	
Front Passenger Seat	274	39 (1 st as 0)	0	0 (1 st as 0)
Front Center Seat				
Struck Side Rear Seat	Fixed	Fixed	Fixed	Fixed
Non-Struck Side Rear Seat	Fixed	Fixed	Fixed	Fixed
Rear Center Seat	Fixed	Fixed	Fixed	Fixed

SEAT BACK ANGLE ADJUSTMENT

The driver's seat back is positioned such that the dummy's head is level. The front center and front passenger's seat backs are positioned in a similar manner as the driver's seat back. The struck-side rear passenger seat back is positioned in accordance with the information provided by the manufacturer on Form No. 1 for the 5th percentile female dummy in a Side NCAP MDB test. The rear center and non-struck side rear passenger's seat back is set to match the struck-side rear seat back.

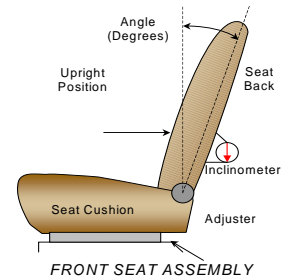

Seat	Total Seat Back Angle Range		Test Position from Vertical	
	Degrees	Detents	Degree	Detent
Driver Seat w/Seated Dummy	57.4		-4.4	
Front Passenger Seat	52.1		-4.2	6 th (1 st as 0)
Front Center Seat				
Struck Side Rear Seat	Fixed		Fixed	
Non-Struck Side Rear Seat	Fixed		Fixed	
Rear Center Seat	Fixed		Fixed	

SEAT BELT ANCHORAGE ADJUSTMENT

Seat belt anchorages are adjusted in accordance with the information provided by the manufacturer on Form No. 1.

	Total # of Positions	Placed in Position #
Driver Seat	4 detents (1 st as 1)	0 (uppermost as 0)

HEAD RESTRAINT ADJUSTMENT

Head restraints are adjusted to the lowest and most full forward in-use position.

	Total # of Positions	Placed in Position #
Driver Seat	3	Lowest/Full Forward

DATA SHEET NO. 2 (CONTINUED)
SEAT, SEAT BELT, STEERING WHEEL ADJUSTMENT, AND FUEL SYSTEM DATA

Test Vehicle: 2013 Ford C-MAX Energi SEL 5-Dr Hatchback
 Test Program: NCAP Side Pole Impact Test

NHTSA No. MD0209
 Test Date: 2/22/2013

STEERING COLUMN ADJUSTMENT

Steering wheel and column adjustments are made so that the steering wheel geometric locus is described when it moves through its full range of motion.

	Degrees	Fore/Aft Position (mm)
Lowermost, Position 1	65.6	222
Geometric Center, Position 2	62.8	197
Uppermost, Position 3	60.0	172
Telescoping Steering Wheel Travel		50
Test Position	62.8	197

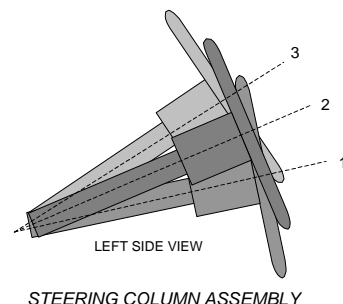

FUEL PUMP

Describe the fuel pump type, details about how it operates and the location of the fuel filler pipe.

The vehicle is equipped with an electric fuel pump. The electric fuel pump operates for a prescribed amount of time to pressurize the fuel system following the actuation of the ignition. If no attempt has been made to start the engine within 450ms following ignition operation, the fuel pump will shut off. The fuel pump operates continuously while the engine is running. If the engine stalls, the fuel pump is deactivated. Also, fuel pump shut-off is provided, which is designed to stop the fuel flow to the engine if the vehicle sustains an impact above a certain magnitude. The fuel pipe is on the right side.

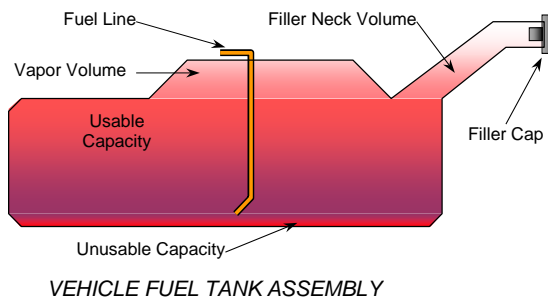

FUEL TANK CAPACITY DATA

	Liters
Usable Capacity of "Standard Tank" (see Form No. 1)	51.1
Usable Capacity of "Optional Tank" (see Form No. 1)	53.0
Usable Capacity of Standard Tank as Specified in Owner's Manual	51.1
Usable Capacity of Optional Tank as Specified in Owner's Manual	53.0
93% of Usable Capacity	49.3
Actual Amount of Solvent Used	49.3
1/3 of Usable Capacity	17.7

Is the actual amount of solvent used in the test equal to 93% ± 1% of the Usable Capacity stated in Form No. 1? **YES**

**.DATA SHEET NO. 3
DUMMY LONGITUDINAL CLEARANCE DIMENSIONS**

Test Vehicle: 2013 Ford C-MAX Energi SEL 5-Dr Hatchback
 Test Program: NCAP Side Pole Impact Test

NHTSA No. MD0209
 Test Date: 2/22/2013

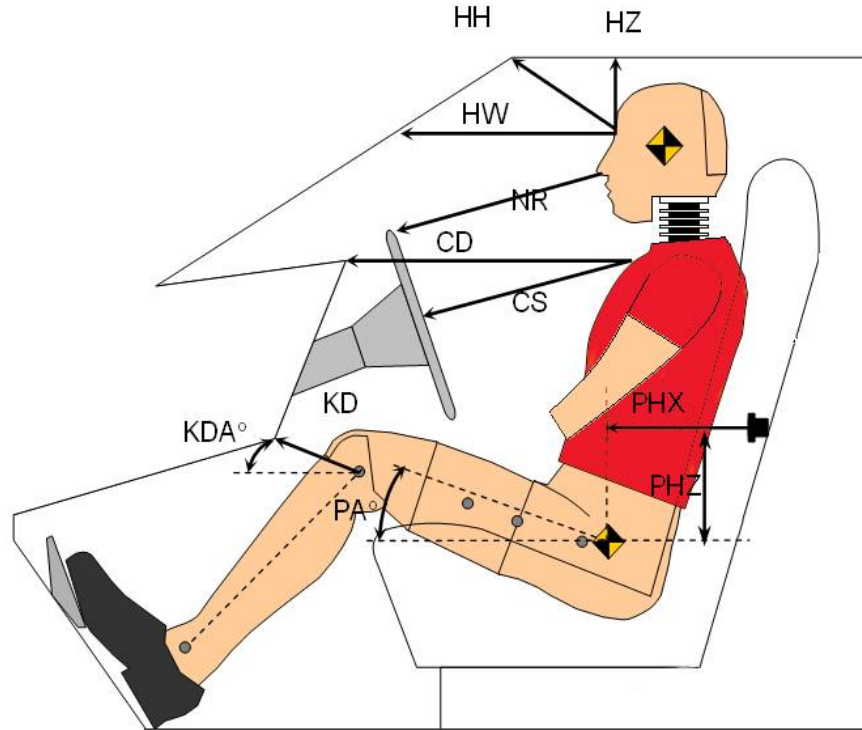

LEFT SIDE VIEW

Code	Measurement Description	Driver S/N 296	
		Length (mm)	Angle (°)
HH	Head to Header	247	
HW	Head to Windshield	710	
HZ	Head to Roof Liner	223	
NR	Nose to Rim	265	
CD	Chest to Dashboard	417	
CS	Chest to Steering Wheel	209	
KDL/KDAL°	Left Knee to Dash	112	32.0
KDR/KDAR°	Right Knee to Dash	116	28.4
PAX°	Pelvic Tilt Angle (X-Axis)		20.3
PAY°	Pelvic Tilt Angle (Y-Axis)		-0.1
PHX	Hip Point to Striker (X-Axis)	336	
PHZ	Hip Point to Striker (Z-Axis)	56	

**DATA SHEET NO. 4
DUMMY LATERAL CLEARANCE DIMENSIONS**

Test Vehicle: 2013 Ford C-MAX Energi SEL 5-Dr Hatchback
 Test Program: NCAP Side Pole Impact Test

NHTSA No. MD0209
 Test Date: 2/22/2013

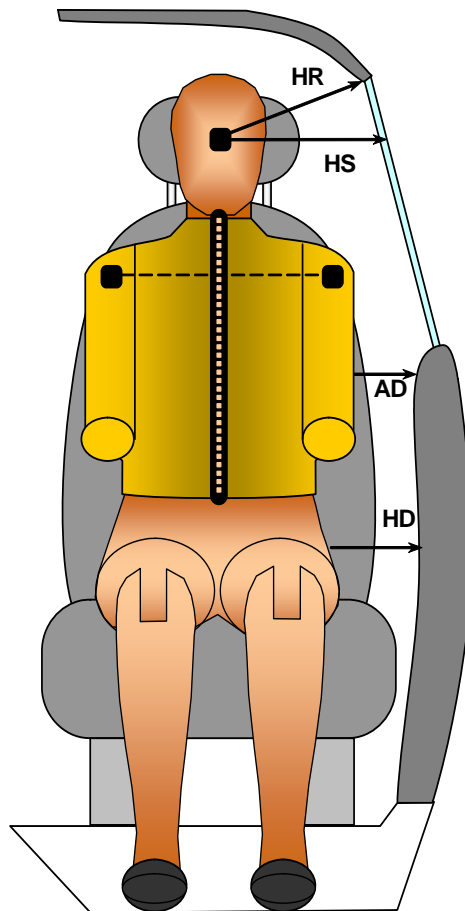

FRONT VIEW OF DUMMY

Code	Measurement Description	Driver S/N 296 Length (mm)
HR	Head to Side Header	275
HS	Head to Side Window	387
AD	Arm to Door	170
HD	Hip Point to Door	173

**DATA SHEET NO. 5
CAMERA AND INSTRUMENTATION DATA**

Test Vehicle: 2013 Ford C-MAX Energi SEL 5-Dr Hatchback
 Test Program: NCAP Side Pole Impact Test

NHTSA No. MD0209
 Test Date: 2/22/2013

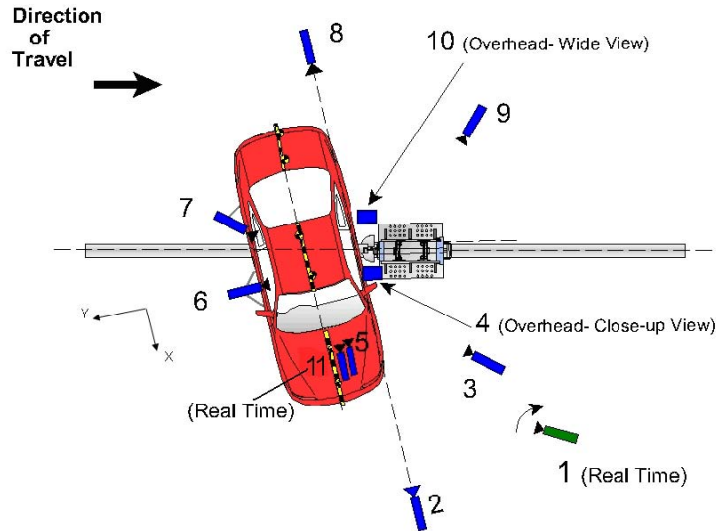

Reference: (from Point of Impact for X and Y; from Ground for Z):
 +X = Forward of Impact, + Y = Right of Impact, +Z = Down

Camera No.	View	Coordinates (mm)			Lens (mm)	Film Speed (fps)
		X*	Y*	Z*		
1	Real-Time Pan View					30
2	Front Ground Level	-90	6030	-1840	24	1000
3	Impact Side 45° Forward	-2530	5180	-1910	20	1000
4	Overhead Closeup	110	0	-4430	50	1000
5	Onboard – Driver Front				16	
6	Onboard – Driver Side				8	
7	Onboard – Driver Rear				8	
8	Rear Ground Level	-80	-6740	-1810	24	1000
9	Impact Side 45° Rearward	-4510	-3910	-2020	20	1000
10	Overhead Wide View	260	0	-4630	14	1000
11	Real-Time Dummy Front View					30

* All measurements accurate to ± 6 mm

Note: Vehicle was at a 75° angle to the rigid pole.

Explain why camera(s) did not operate as intended: Not Applicable

INSTRUMENTATION

	Number of Channels
Driver Dummy	16
Vehicle Structure	18
Pole Load Cells	8
TOTAL	42

DATA SHEET NO. 6
VEHICLE ACCELEROMETER DATA

Test Vehicle: 2013 Ford C-MAX Energi SEL 5-Dr Hatchback
Test Program: NCAP Side Pole Impact Test

NHTSA No. MD0209
Test Date: 2/22/2013

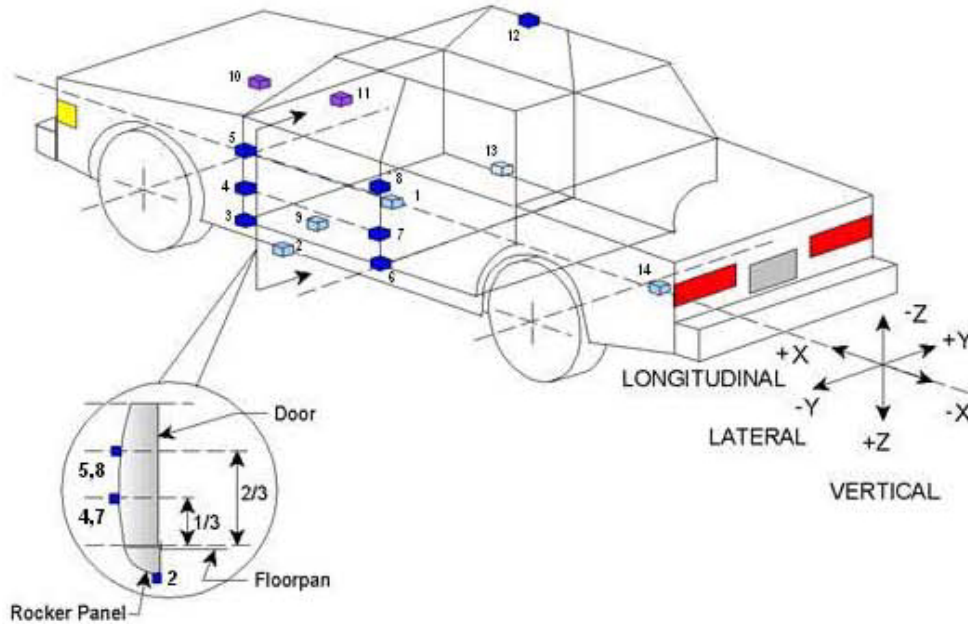

	Accelerometer Location			
	ID	Coordinates (mm)		
		X	Y	Z
1	Vehicle CG	2241	195	-172
2	Left Floor Sill	2571	-697	-175
3	A Pillar Sill	2959	-697	-174
4	A Pillar Low	2982	-802	-566
5	A Pillar Mid	2982	-810	-847
6	B Pillar Sill	1905	-695	-178
7	B Pillar Low	1903	-730	-651
8	B Pillar Mid	1903	-727	-854
9	Driver Seat Track	2174	-388	-216
10	Engine Top	3908	22	-725
11	Firewall	3438	28	-811
12	Right Roof	1878	590	-1612
13	Right Floor Sill	2639	697	-176
14	Rear Floorpan	853	0	-834

Reference:

- X – Test Vehicle Rear Bumper (+forward)
- Y – Test Vehicle Centerline (+ to right)
- Z – Ground Plane (+ down)

DATA SHEET NO. 7
RIGID POLE LOAD CELL DATA

Test Vehicle: 2013 Ford C-MAX Energi SEL 5-Dr Hatchback
Test Program: NCAP Side Pole Impact Test

NHTSA No. MD0209
Test Date: 2/22/2013



254 mm Diameter Rigid Pole

Load Cell Locations	
ID	Height From Impact Surface (mm)
1	182
2	470
3	698
4	986
5	1212
6	1641
7	1854
8	2053

**DATA SHEET NO. 8
POST-TEST OBSERVATIONS**

Test Vehicle: 2013 Ford C-MAX Energi SEL 5-Dr Hatchback
 Test Program: NCAP Side Pole Impact Test

NHTSA No. MD0209
 Test Date: 2/22/2013

TEST DUMMY INFORMATION AND CONTACT POINTS

Description	Driver SID-IIs Dummy
Face	Curtain Airbag
Top of Head	Curtain Airbag
Left Side of Head	Curtain Airbag
Back of Head	Curtain Airbag, Headrest, Seatback
Left Shoulder	Side Airbag, Seatback
Upper Torso	Side Airbag, Seatback
Lower Torso	Side Airbag, Seatback
Left Hip	Side Airbag, Seatpan
Left Knee	Door Panel

POST-TEST DOOR PERFORMANCE

Description	Struck Side		Non-Struck Side		Rear Hatch/ Other Door
	Front	Rear	Front	Rear	
Remained Closed and Operational	No	No	Yes	Yes	Yes
Total Separation from Vehicle at Hinges or Latches	No	No	No	No	No
Latch or Hinge Systems Pulled Out of Their Anchorages	No	No	No	No	No
Disengaged from Latched Position	No	No	No	No	No
Latch Separated from Striker	No	No	No	No	No
Jammed Shut	Yes	Yes	No	No	No
If Door Opened at Striker, Record Width of Opening at Striker (mm)	N/A	N/A	N/A	N/A	N/A

POST-TEST SEAT PERFORMANCE

Description	Struck Side		Non-Struck Side	
	Front	Rear	Front	Rear
Seat Movement Along Seat Track	No	No	No	No
Seat Disengagement from Floor Pan	No	No	No	No
Seat Back Movement from Initial Position	No	No	No	No
Seat Back Collapse	No	No	No	No

POST-TEST STRUCTURAL OBSERVATIONS

Critical Areas of Performance	Observations and Conclusions
Pillar Performance	No Separation
Sill Separation	None
Windshield Damage	Cracked
Side Window Damage	Left Front Window Broken
Other Notable Effects	Roof and Windshield Separations (photo on page A-39)

**DATA SHEET NO. 8 (CONTINUED)
POST-TEST OBSERVATIONS**

Test Vehicle: 2013 Ford C-MAX Energi SEL 5-Dr Hatchback
 Test Program: NCAP Side Pole Impact Test

NHTSA No. MD0209
 Test Date: 2/22/2013

SUPPLEMENTAL RESTRAINT SYSTEM INFORMATION

Restraint Type	Left Front (Driver) Occupant Location 1		Left Rear (Passenger) Occupant Location 4	
	Mounted	Deployed	Mounted	Deployed
Frontal Airbag	Yes	No		
Knee Airbag	Yes	No		
Side Curtain Airbag	Yes	Yes	Yes	Yes
Side Torso/Abdomen/Pelvis Airbag	Yes	Yes	No	
Seat Belt Pretensioner	Yes	Yes	No	
Seat Belt Load Limiter	Yes	Yes	No	
Other				

VEHICLE SPEED, VEHICLE ANGLE AT IMPACT, AND IMPACT POINT LOCATION DATA

Measured Parameter	Units	Tolerance	Value
Vertical Impact Reference Line (Aft of Front Axle) (Intended Impact Point)	mm		1090
Actual Impact Point (Aft of Front Axle)	mm		1101
Horizontal Offset (+forward / -rearward)	mm	+/- 38 of Intended Impact Point	-11
Angle Between Vehicle's Longitudinal Centerline and Line of Forward Motion	deg	75 +/- 3	75
Trap No. 1 Velocity (Primary)	km/h	31.4 to 33.0	32.1
Trap No. 2 Velocity (Redundant)	km/h	31.4 to 33.0	32.2

**DATA SHEET NO. 9
VEHICLE PROFILE MEASUREMENTS**

Test Vehicle: 2013 Ford C-MAX Energi SEL 5-Dr Hatchback
 Test Program: NCAP Side Pole Impact Test

NHTSA No. MD0209
 Test Date: 2/22/2013

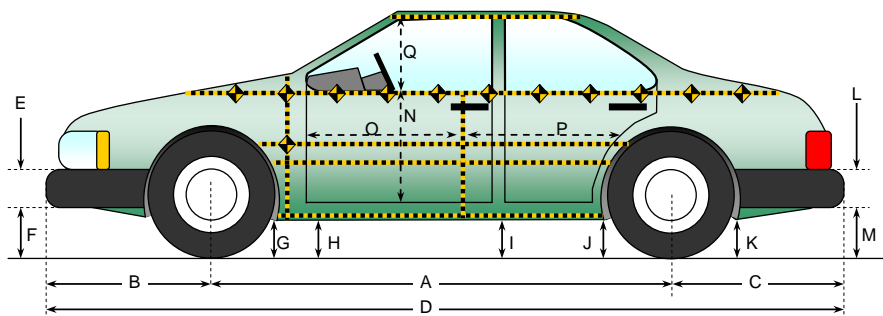

All measurements in (mm) with tolerance of ± 3 mm

LEFT SIDE VIEW

VEHICLE PRE- AND POST-TEST MEASUREMENT INFORMATION

Code	Measurement Description	Pre-Test	Post-Test	Difference
A	Wheelbase	2648	2498	150
B	Front Axle to FSOV	900	900	0
C	Rear Axle to RSOV	862	862	0
D	Total Vehicle Length at Centerline	4410	4260	150
E	Front Bumper Thickness	115	115	0
F	Front Bumper Bottom to Ground	220	244	-24
G	Sill Height at Front Wheel Well	172	155	17
H	Sill Height at Front Door Leading Edge	175	153	22
I	Sill Height at B-Pillar	192	172	20
J1	Sill Height at Rear Wheel Well	203	200	3
J2	Pinch Weld Height at Rear Wheel Well	200	186	14
K	Sill Height Aft of Rear Wheel Well	306	283	23
L	Rear Bumper Thickness	117	117	0
M	Rear Bumper Bottom to Ground	383	356	27
N	Sill Height to Bottom of Front Window Sill	791	807	-16
O	Front Door Leading Edge to Impact CL	639	640	-1
P	Rear Door Trailing Edge to Impact CL	1329	1319	10
Q	Front Window Opening	488	474	14
R	Right Side Length	3184	3196	-12
S	Left Side Length	3184	3013	171
T	Vehicle Width at B-Pillars	1772	1654	118

DATA SHEET NO. 10
VEHICLE EXTERIOR CRUSH MEASUREMENTS

Test Vehicle: 2013 Ford C-MAX Energi SEL 5-Dr Hatchback
 Test Program: NCAP Side Pole Impact Test

NHTSA No. MD0209
 Test Date: 2/22/2013

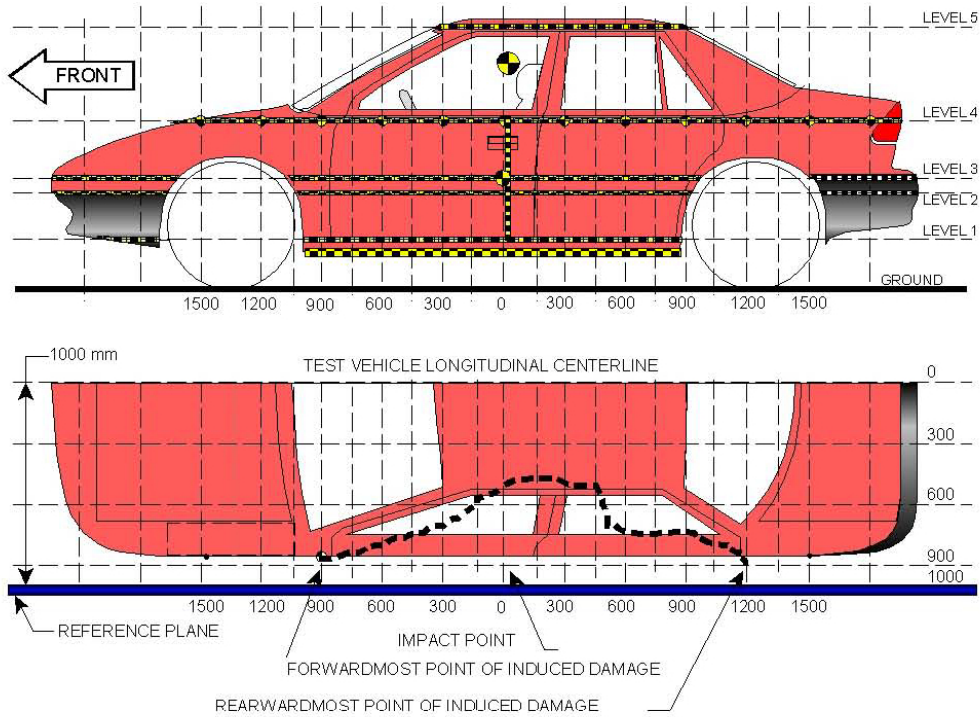

NOTE: The measurements are taken along the vertical impact reference line. Vehicle measurements forward of the vertical impact reference line are negative.

MAXIMUM EXTERIOR CRUSH MEASUREMENTS

Level	Measurement Description	Height Above Ground (mm)	Maximum Exterior Static Crush	Distance from Impact
1	Sill Top	230	317	0
2	Occupant Hip Point	642	391	75
3	Mid Door	668	393	75
4	Window Sill	952	385	75
5	Window Top	1540	215	75

DATA SHEET NO. 10 (CONTINUED)
VEHICLE EXTERIOR CRUSH MEASUREMENTS

Test Vehicle: 2013 Ford C-MAX Energi SEL 5-Dr Hatchback
 Test Program: NCAP Side Pole Impact Test

NHTSA No. MD0209
 Test Date: 2/22/2013

	Pre-Test					Post-Test					Difference				
	1	2	3	4	5	1	2	3	4	5	1	2	3	4	5
-1200				309					293					-16	
-1050				290					297					7	
-900			199	273				190	267				-9	-6	
-750		204	205	261			194	195	255			-10	-10	-6	
-600	255	213	212	253		194	238	245	235		-61	25	33	-18	
-525	254	213	213	249		230	220	224	264		-24	7	11	15	
-450	254	212	212	246		277	255	253	299		23	43	41	53	
-375	254	212	212	241		315	300	302	336		61	88	90	95	
-300	255	212	211	238		357	349	351	377		102	137	140	139	
-225	255	213	211	235		410	430	430	428		155	217	219	193	
-150	255	213	211	233		465	477	476	484		210	264	265	251	
-75	256	213	211	230	490	525	530	538	548	640	269	317	327	318	150
0	257	213	212	228	467	574	583	583	593	668	317	370	371	365	201
75	258	214	213	226	458	566	605	606	611	673	308	391	393	385	215
150	258	214	213	226	451	523	572	573	584	625	265	358	360	358	174
225	258	215	214	224	447	462	519	520	533	604	204	304	306	309	157
300	259	216	215	222	444	401	449	454	461	576	142	233	239	239	132
375	260	216	215	221	444	334	391	337	398	552	74	175	122	177	108
450	261	217	216	220	445	291	344	312	344	532	30	127	96	124	87
525	264	217	216	218	445	314	316	316	321	508	50	99	100	103	63
600	265	218	217	218	447	297	300	298	305	490	32	82	81	87	43
750	272	221	220	218	453	282	277	276	283	484	10	56	56	65	31
900	272	223	222	223	460	261	256	253	259	485	-11	33	31	36	25
1050	270	226	224	228	470	238	235	230	247	491	-32	9	6	19	21
1200		217	216	237	481		211	203	235	505		-6	-13	-2	24
1350			207	238	495			212	222	525			5	-16	30
1500				245	513				255	535				10	22
1650				255	534				261	552				6	18

NOTE: Pre-test measurements are taken when the vehicle is in the "As Tested" weight condition. Vehicle measurements forward of the vertical impact reference line are negative. The crush profile grid is established prior to the test based on an estimated impact point. The final distance from impact is determined after the final dummy positioning and the pole is aligned with the center of gravity of the dummy's head.

DATA SHEET NO. 10 (CONTINUED)
VEHICLE EXTERIOR CRUSH MEASUREMENTS

Test Vehicle: 2013 Ford C-MAX Energi SEL 5-Dr Hatchback
 Test Program: NCAP Side Pole Impact Test

NHTSA No. MD0209
 Test Date: 2/22/2013

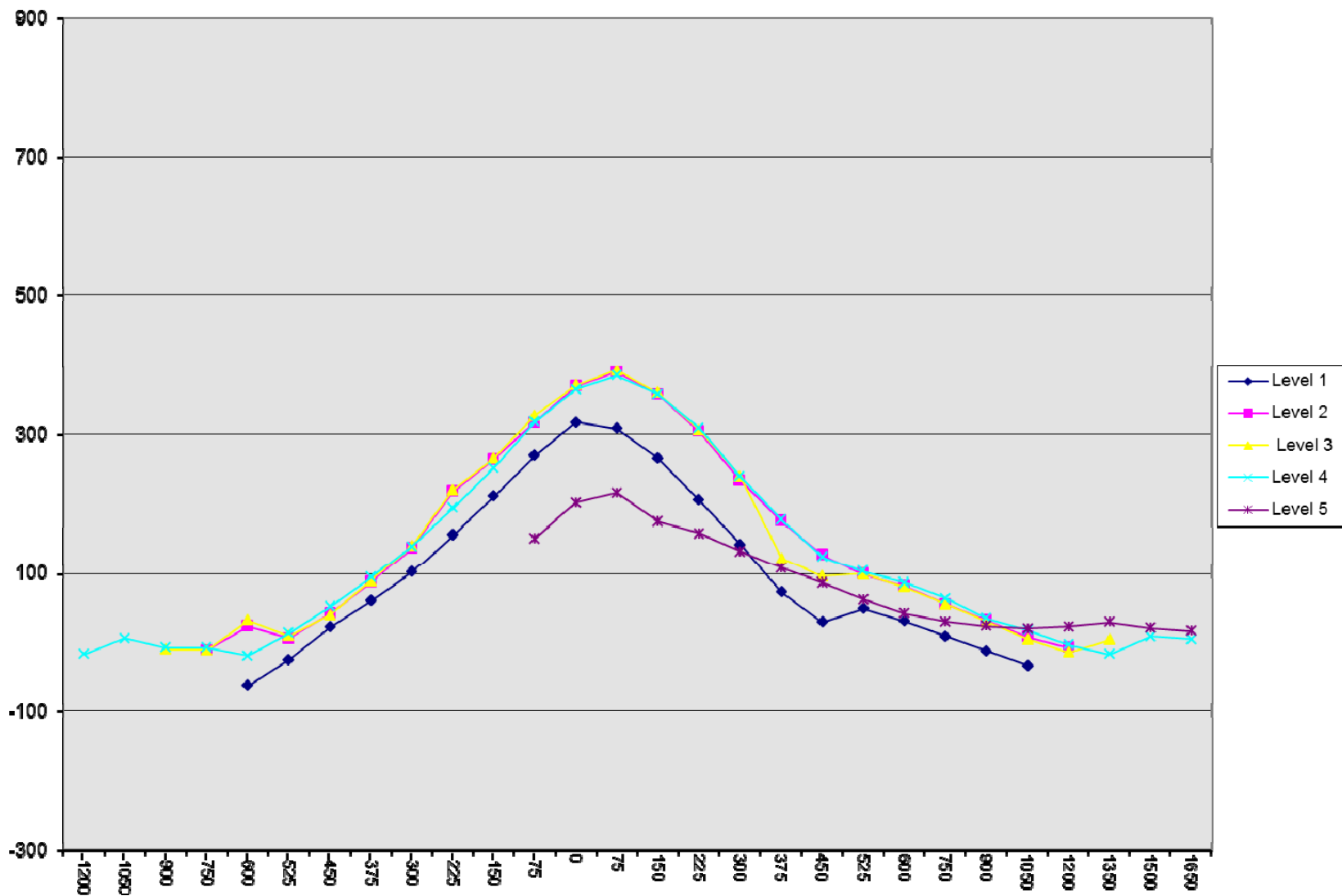

DATA SHEET NO. 11
FMVSS NO. 301 STATIC ROLLOVER RESULTS

Test Vehicle: 2013 Ford C-MAX Energi SEL 5-Dr Hatchback
 Test Program: NCAP Side Pole Impact Test

NHTSA No. MD0209
 Test Date: 2/22/2013

Test Time: 11:05 am

Temperature: 21.0° C

- A. From impact until vehicle motion ceases: 0 oz.
 (Maximum Allowable = 1 ounce)
- B. For the 5 minute period after motion ceases: None
 (Maximum allowable = 5 ounces)
- C. For the following 25 minutes: None
 (Maximum allowable = 1 oz./minute)
- D. Spillage Details: None

FMVSS 301 STATIC ROLLOVER DATA

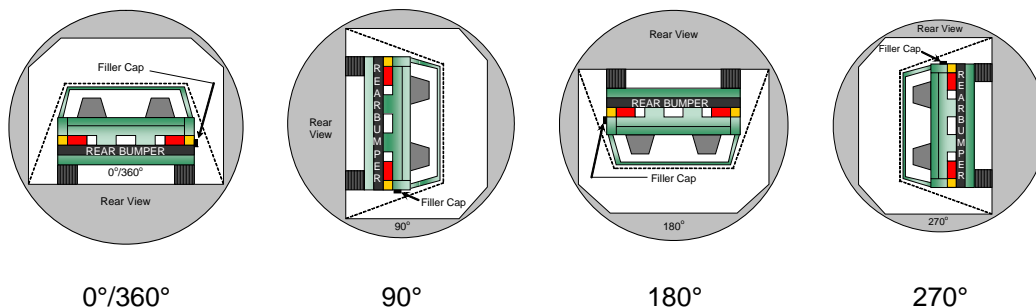

ROLLOVER SOLVENT COLLECTION TIME TABLE IN SECONDS

Test Phase	Rotation Time	Hold Time	Total Time
0° to 90°	114	300	414
90° to 180°	111	300	411
180° to 270°	107	300	407
270° to 360°	111	300	411

FMVSS 301 ROLLOVER SPILLAGE TABLE (units in ounces)

Test Phase	First 5 Minutes	Sixth Minute	Seventh Minute	Eight Minute
0° to 90°	0	0	0	0
90° to 180°	0	0	0	0
180° to 270°	0	0	0	0
270° to 360°	0	0	0	0

ROLLOVER SOLVENT SPILLAGE LOCATION TABLE

Test Phase	Spillage Location
0° to 90°	
90° to 180°	
180° to 270°	
270° to 360°	

DATA SHEET NO. 12
DUMMY/VEHICLE TEMPERATURE STABILIZATION DATA

Test Vehicle: 2013 Ford C-MAX Energi SEL 5-Dr Hatchback
 Test Program: NCAP Side Pole Impact Test

NHTSA No. MD0209
 Test Date: 2/22/2013

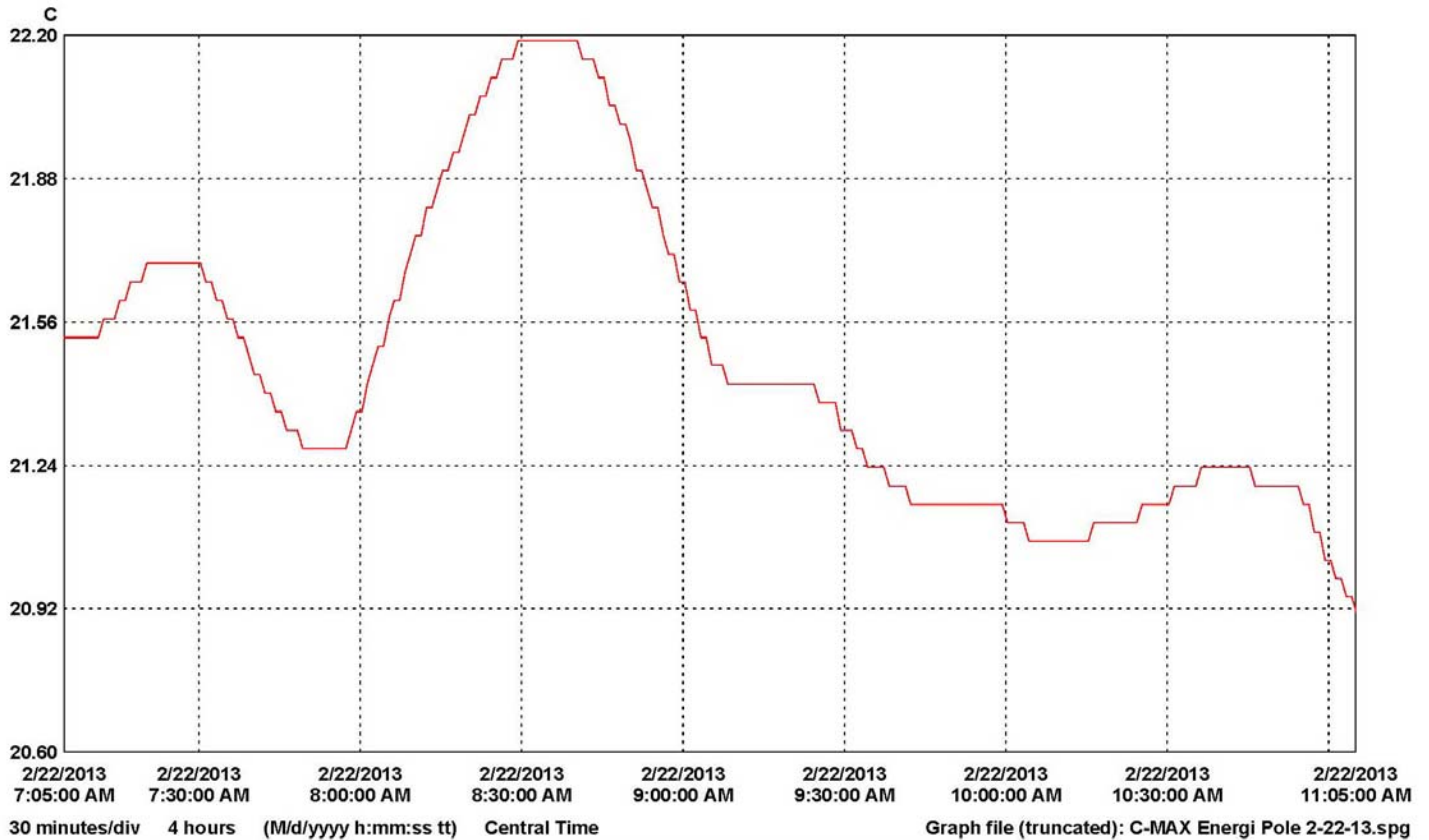

LN	Serial #	Description	CH	Value	Maximum	Average	Minimum	Units	CH description	Logger file
1	10102056	Crash Prep 1	1		22.19	21.46	20.95	C	Temperature	10102056_Crash_Prep_1.spl

APPENDIX A
PHOTOGRAPHS

TABLE OF PHOTOGRAPHS

		<u>Page No.</u>
Photo No. 1.	As Delivered Right Front $\frac{3}{4}$ View of Test Vehicle	A-1
Photo No. 2.	As Delivered Left Rear $\frac{3}{4}$ View of Test Vehicle	A-1
Photo No. 3.	Pre-Test Frontal View of Test Vehicle	A-2
Photo No. 4.	Post-Test Frontal View of Test Vehicle	A-2
Photo No. 5.	Pre-Test Left Front $\frac{3}{4}$ View of Test Vehicle	A-3
Photo No. 6.	Post-Test Left Front $\frac{3}{4}$ View of Test Vehicle	A-3
Photo No. 7.	Pre-Test Left Side View of Test Vehicle	A-4
Photo No. 8.	Post-Test Left Side View of Test Vehicle	A-4
Photo No. 9.	Pre-Test Left Rear $\frac{3}{4}$ View of Test Vehicle	A-5
Photo No. 10.	Post-Test Left Rear $\frac{3}{4}$ View of Test Vehicle	A-5
Photo No. 11.	Pre-Test Rear View of Test Vehicle	A-6
Photo No. 12.	Post-Test Rear View of Test Vehicle	A-6
Photo No. 13.	Pre-Test Right Side View of Test Vehicle	A-7
Photo No. 14.	Post-Test Right Side View of Test Vehicle	A-7
Photo No. 15.	Pre-Test Overhead View of Test Area	A-8
Photo No. 16.	Post-Test Overhead View of Test Area	A-8
Photo No. 17.	Post-Test Overhead View of Test Area	A-9
Photo No. 18.	Pre-Test Left Side View of Pole Positioned Against Side of Vehicle	A-9
Photo No. 19.	Pre-Test Right Side View of Pole Positioned Against Side of Vehicle	A-10
Photo No. 20.	Pre-Test Close-Up View of Impact Point Target	A-10
Photo No. 21.	Post-Test Close-Up View of Impact Point Target Showing Impact Location	A-11
Photo No. 22.	Pre-Test Front Close-Up View of Dummy Head and Chest	A-11
Photo No. 23.	Post-Test Front Close-Up View of Dummy	A-12

	<u>Page No.</u>
Photo No. 24. Pre-Test Left Side View of Dummy Showing Belt and Chalking	A-12
Photo No. 25. Pre-Test Left Side View of Dummy Shoulder and Door Top View	A-13
Photo No. 26. Post-Test Left Side View of Dummy Shoulder and Door Top View	A-13
Photo No. 27. Pre-Test Front View of Seat Back Prior to Dummy Positioning	A-14
Photo No. 28. Pre-Test Front View of Seat Back Prior to Dummy Positioning	A-14
Photo No. 29. Pre-Test Front Close-Up View of Dummy Head and Shoulders in Relation to Head Restraint	A-15
Photo No. 30. Pre-Test Front View of Seat Pan Prior to Dummy Positioning	A-15
Photo No. 31. Pre-Test Overhead View of Dummy Thighs on Seat Pan	A-16
Photo No. 32. Pre-Test Left Side View of Dummy's Neck Showing Position of Adjustable Neck Bracket	A-16
Photo No. 33. Pre-Test Left Side View of Dummy's Head Showing Dummy's Head is Level	A-17
Photo No. 34. Pre-Test Placement of Dummy's Feet	A-17
Photo No. 35. Pre-Test View of Belt Anchorage for Dummy	A-18
Photo No. 36. Pre-Test Left Side View of Steering Wheel	A-18
Photo No. 37. Pre-Test View of Disengaged Parking Brake	A-19
Photo No. 38. Pre-Test View of Parking Brake	A-19
Photo No. 39. Pre-Test Close-Up Left Side View of Driver Seat Track	A-20
Photo No. 40. Pre-Test Close-Up Left Side View of Driver Seat Back	A-20
Photo No. 41. Pre-Test Close-Up View of Driver Seat Back or Head Restraint	A-21
Photo No. 42. Pre-Test Dummy and Door Clearance View	A-21
Photo No. 43. Post-Test Dummy and Door Clearance View	A-22
Photo No. 44. Pre-Test Right Side View of Dummy and Front Seat of Occupant Compartment	A-22
Photo No. 45. Post-Test Right Side View of Dummy and Front Seat of Occupant Compartment	A-23
Photo No. 46. Pre-Test Inner Door Panel View	A-23
Photo No. 47. Post-Test Inner Door Panel View Showing Dummy Contact Location	A-24
Photo No. 48. Post-Test Dummy Close-Up Head Contact with Vehicle Interior View	A-24

	<u>Page No.</u>
Photo No. 49. Post-Test Dummy Close-Up Head Contact with Vehicle Interior View	A-25
Photo No. 50. Post-Test Dummy Close-Up Head Contact with Side Air Bag View	A-25
Photo No. 51. Post-Test Dummy Close-Up Torso Contact with Vehicle Interior View	A-26
Photo No. 52. Post-Test Dummy Close-Up Torso Contact with Vehicle Interior View	A-26
Photo No. 53. Post-Test Dummy Close-Up Torso Contact with Side Air Bag View	A-27
Photo No. 54. Post-Test Dummy Close-Up Pelvis Contact with Vehicle Interior View	A-27
Photo No. 55. Post-Test Dummy Close-Up Pelvis Contact with Side Air Bag View	A-28
Photo No. 56. Post-Test Dummy Close-Up Knee Contact with Vehicle Interior View	A-28
Photo No. 57. Pre-Test View of Fuel Filler Cap or Fuel Filler Neck	A-29
Photo No. 58. Post-Test View of Fuel Filler Cap or Fuel Filler Neck	A-29
Photo No. 59. Close-Up View of Vehicle's Certification Label	A-30
Photo No. 60. Close-Up View of Vehicle's Tire Information Placard or Label	A-30
Photo No. 61. Pre-Test Pole Barrier Front View	A-31
Photo No. 62. Post-Test Pole Barrier Front View	A-31
Photo No. 63. Pre-Test Pole Barrier Side View	A-32
Photo No. 64. Post-Test Pole Barrier Side View	A-32
Photo No. 65. Pre-Test Ballast View	A-33
Photo No. 66. Post-Test Primary and Redundant Speed Trap Read-Out	A-33
Photo No. 67. FMVSS No. 301 Static Rollover 0 Degrees	A-34
Photo No. 68. FMVSS No. 301 Static Rollover 90 Degrees	A-34
Photo No. 69. FMVSS No. 301 Static Rollover 180 Degrees	A-35
Photo No. 70. FMVSS No. 301 Static Rollover 270 Degrees	A-35
Photo No. 71. FMVSS No. 301 Static Rollover 360 Degrees	A-36
Photo No. 72. Impact Event	A-36
Photo No. 73. Monroney Label	A-37

		<u>Page No.</u>
Photo No. 74.	Head Restraint Use and Adjustment Information from Vehicle Owner's Manual	A-37
Photo No. 75.	Head Restraint Use and Adjustment Information from Vehicle Owner's Manual	A-38
Photo No. 76.	Head Restraint Use and Adjustment Information from Vehicle Owner's Manual	A-38
Photo No. 77.	Post-Test View of Shattered Vehicle Inner Door Panel	A-39
Photo No. 78.	Post-Test Roof and Windshield Separations	A-39



As Delivered Right Front ¾ View of Test Vehicle



As Delivered Left Rear ¾ View of Test Vehicle



Pre-Test Frontal View of Test Vehicle



Post-Test Frontal View of Test Vehicle



Pre-Test Left Front 3/4 View of Test Vehicle



Post-Test Left Front 3/4 View of Test Vehicle



Pre-Test Left Side View of Test Vehicle



Post-Test Left Side View of Test Vehicle



Pre-Test Left Rear $\frac{3}{4}$ View of Test Vehicle



Post-Test Left Rear $\frac{3}{4}$ View of Test Vehicle



Pre-Test Rear View of Test Vehicle



Post-Test Rear View of Test Vehicle



Pre-Test Right Side View of Test Vehicle



Post-Test Right Side View of Test Vehicle



Pre-Test Overhead View of Test Area

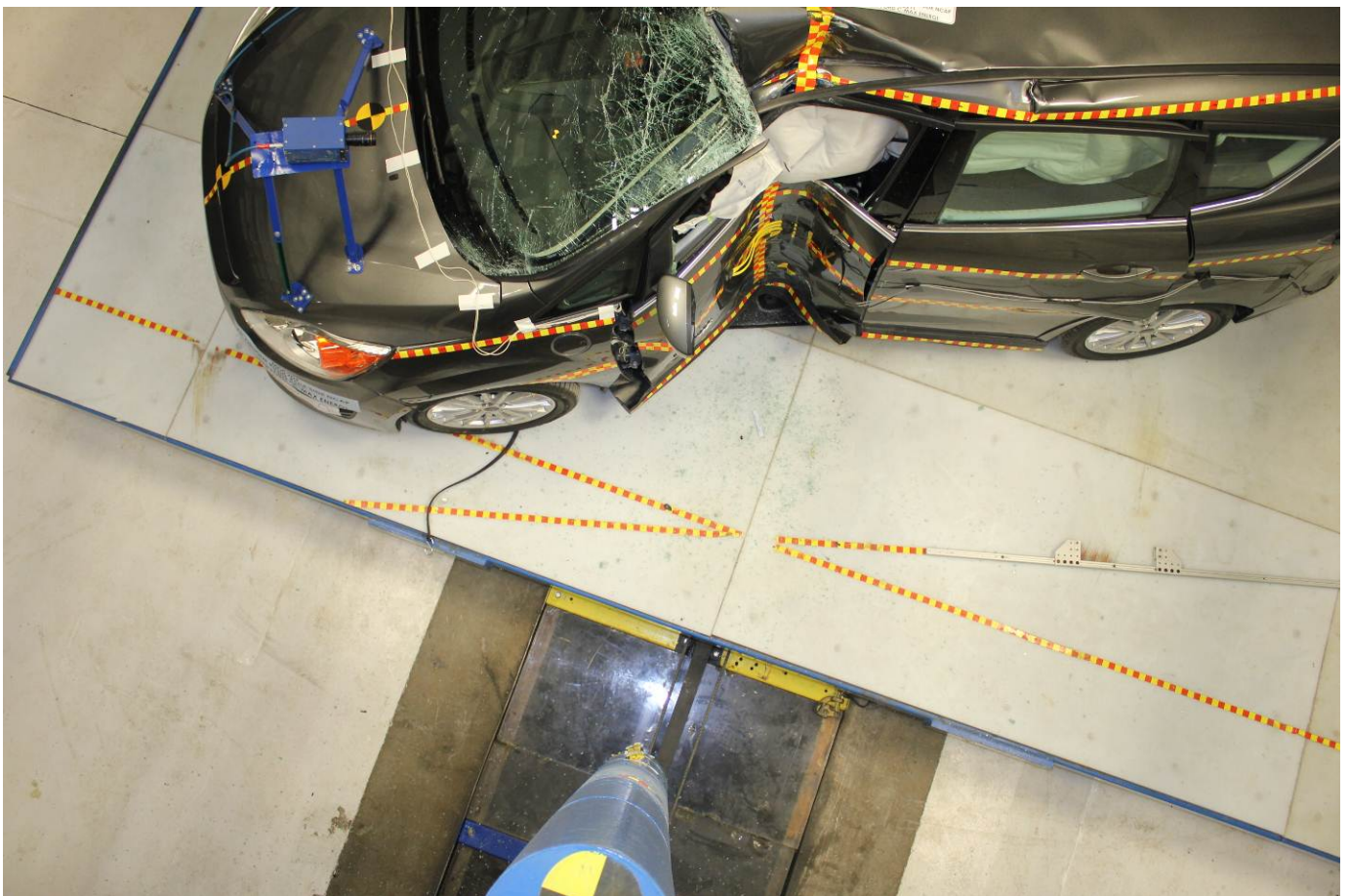

Post-Test Overhead View of Test Area



Post-Test Overhead View of Test Area



Pre-Test Left Side View of Pole Positioned Against Side of Vehicle



Pre-Test Right Side View of Pole Positioned Against Side of Vehicle



Pre-Test Close-Up View of Impact Point Target



Post-Test Close-Up View of Impact Point Target Showing Impact Location



Pre-Test Front Close-Up View of Dummy Head and Chest



Post-Test Front Close-Up View of Dummy



Pre-Test Left Side View of Dummy Showing Belt and Chalking



Pre-Test Left Side View of Dummy Shoulder and Door Top View



Post-Test Left Side View of Dummy Shoulder and Door Top View



Pre-Test Front View of Seat Back Prior to Dummy Positioning



Pre-Test Front View of Seat Back Prior to Dummy Positioning



Pre-Test Front Close-Up View of Dummy Head and Shoulders in Relation to Head Restraint



Pre-Test Front View of Seat Pan Prior to Dummy Positioning



Pre-Test Overhead View of Dummy Thighs on Seat Pan



Pre-Test Left Side View of Dummy's Neck Showing Position of Adjustable Neck Bracket



Pre-Test Left Side View of Dummy's Head Showing Dummy's Head is Level



Pre-Test Placement of Dummy's Feet



Pre-Test View of Belt Anchorage for Dummy



Pre-Test Left Side View of Steering Wheel

PHOTOGRAPH NOT AVAILABLE

Pre-Test View of Disengaged Parking Brake



Pre-Test View of Parking Brake



Pre-Test Close-Up Left Side View of Driver Seat Track



Pre-Test Close-Up Left Side View of Driver Seat Back



Pre-Test Close-Up View of Driver Seat Back or Head Restraint



Pre-Test Dummy and Door Clearance View

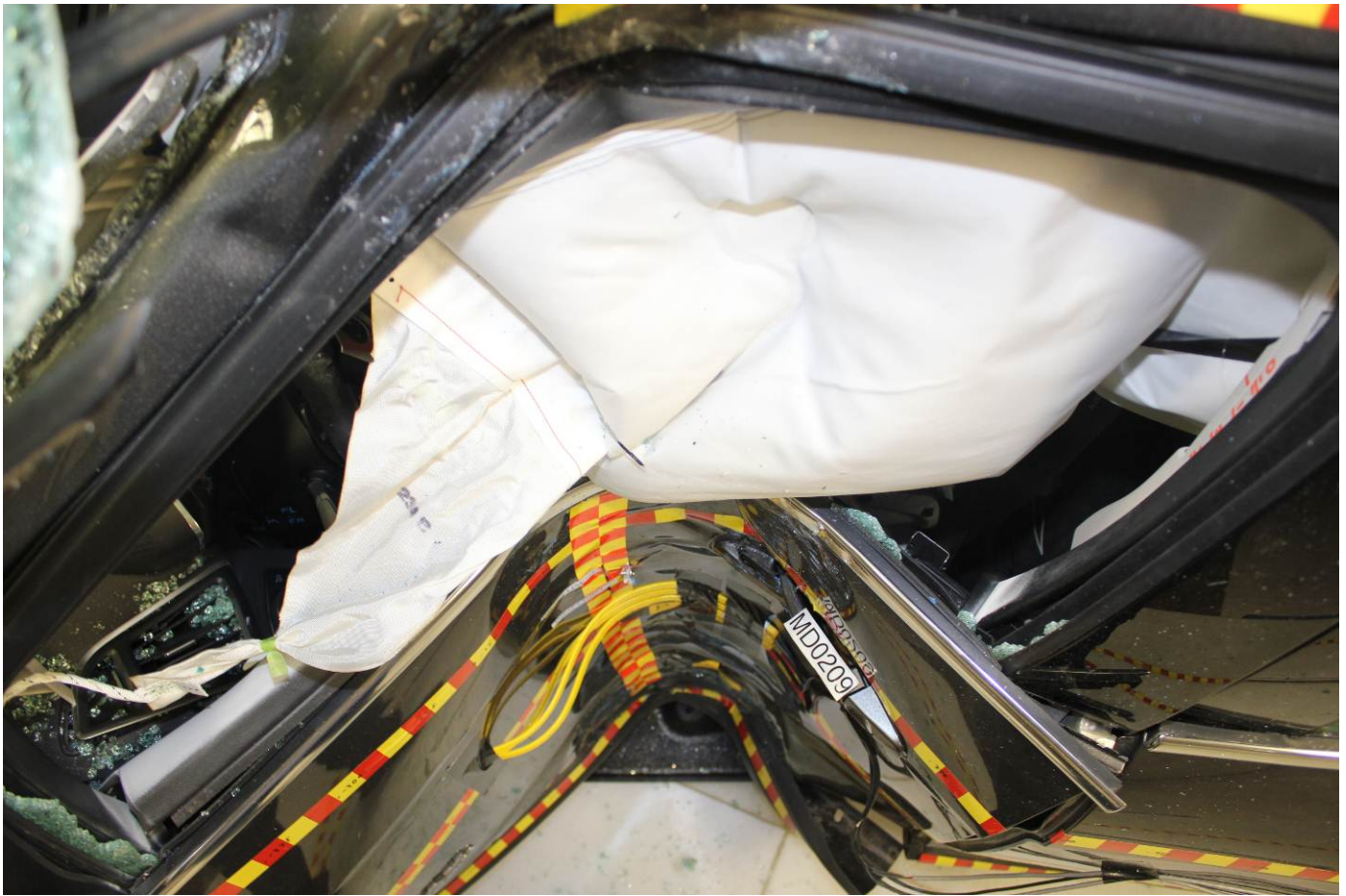

Post-Test Dummy and Door Clearance View



Pre-Test Right Side View of Dummy and Front Seat of Occupant Compartment



Post-Test Right Side View of Dummy and Front Seat of Occupant Compartment



Pre-Test Inner Door Panel View



Post-Test Inner Door Panel View Showing Dummy Contact Location



Post-Test Dummy Close-Up Head Contact with Vehicle Interior View



Post-Test Dummy Close-Up Head Contact with Vehicle Interior View

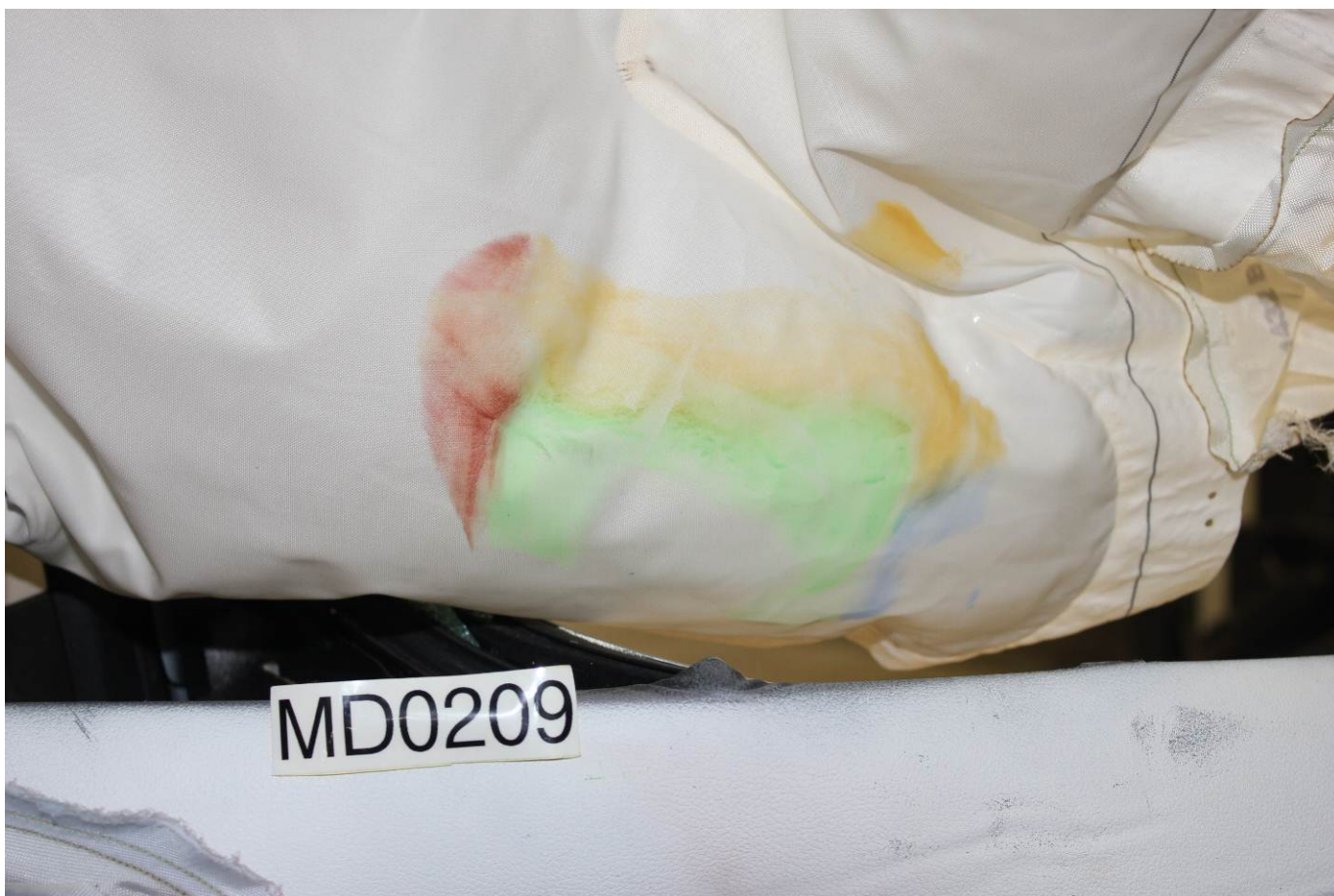

Post-Test Dummy Close-Up Head Contact with Side Air Bag View



Post-Test Dummy Close-Up Torso Contact with Vehicle Interior View



Post-Test Dummy Close-Up Torso Contact with Vehicle Interior View



Post-Test Dummy Close-Up Torso Contact with Side Air Bag View



Post-Test Dummy Close-Up Pelvis Contact with Vehicle Interior View



Post-Test Dummy Close-Up Pelvis Contact with Side Air Bag View



Post-Test Dummy Close-Up Knee Contact with Vehicle Interior View



Pre-Test View of Fuel Filler Cap or Fuel Filler Neck



Post-Test View of Fuel Filler Cap or Fuel Filler Neck



Close-Up View of Vehicle's Certification Label



Close-Up View of Vehicle's Tire Information Placard or Label



Pre-Test Pole Barrier Front View



Post-Test Pole Barrier Front View

PHOTOGRAPH NOT APPLICABLE

Pre-Test Ballast View



Post-Test Primary and Redundant Speed Trap Read-Out



FMVSS No. 301 Static Rollover 0 Degrees



FMVSS No. 301 Static Rollover 90 Degrees



FMVSS No. 301 Static Rollover 180 Degrees



FMVSS No. 301 Static Rollover 270 Degrees



FMVSS No. 301 Static Rollover 360 Degrees



Impact Event



C-MAX ENERGY

2013 5-DR ENERGY SEL
5-PASSENGER
2.0L I4 ATK 110CT ENGINE
CVT TRANSMISSION

EXTERIOR: STERLING GRAY METALLIC
INTERIOR: CHARCOAL BLACK LEATHER SEAT

DL 519349

EPA Fuel Economy and Environment

Midsize cars range from 13 to 100 MPGe. The best vehicle rates 112 MPGe.

Electricity + Gasoline
Charge Time 2.5 hours (240V)
100 MPGe combined city/highway

Gasoline Only
43 MPG combined city/highway

You save \$6,850 in fuel costs over 5 years compared to the average new vehicle.

STANDARD EQUIPMENT INCLUDED AT NO EXTRA CHARGE

EXTERIOR

- 17 MACHINED ALUMINUM WHEELS
- BLIND SPOT MIRRORS
- FOG LAMPS
- MIRRORS-MAN FOLD DUAL PWR HEATED WITH APPROACH LAMP

INTERIOR

- SMART GAUGE WITH ECO GUIDE
- 5-PASS SEATING
- 2ND ROW 60/40 FOLD FLAT
- AMBIENT LIGHTING
- DUAL-ZONE ELECTRONIC AUTO CLIMATE CONTROL
- N-FLOOR STORAGE - REAR
- LEATHER TRIM HEATED 10-WAY POWER DRIVER SEAT
- LEATHER WRAPPED SHIFT KNOB
- LEATHER WRAPPED STR WHEEL
- REAR A/C DUCTS

FUNCTIONAL

- ELECTRONIC PWR ASST STEER
- FRONT WHEEL DRIVE
- HOMELINK
- INTELLIGENT ACCESS W/PUSH BUTTON START
- LITHIUM ION BATTERY
- MYKEY
- REGENERATIVE BRAKING SYS
- REMOTE KEYLESS ENTRY
- SPEED CONTROL
- SYNC W/ MYFORD TOUCH
- 110V OUTLET

SAFETY/SECURITY

- ADVANCED TRAC WITH RSC
- AIRBAG - DRIVER KNEE
- AIRBAGS - FRONT AND SIDE
- 1ST AND 2ND ROW CURTAIN AIRBAGS
- BRAKES - ABS/ESP/RSC
- PERIMETER ALARM
- REVERSE SENSING SYSTEM
- SECURITY ANTI-THEFT ENGINE IMMOBILIZER
- 30S POST CRASH ALERT SYS
- TIRE PRESSURE MONITOR SYS
- TURN SIGNAL MIRRORS

WARRANTY

- EXTENDED HYBRID WARRANTY

INCLUDED ON THIS VEHICLE (MSRP)

EQUIPMENT GROUP 300A

OPTIONAL EQUIPMENT

FRONT LICENSE PLATE BRACKET	NO CHARGE
50 STATE EMISSIONS CHARGE CORD BAG *DLR-INSTL	NO CHARGE
EXT PROTECTION PKG *DLR-INSTL	245.00

PRICE INFORMATION (MSRP)

BASE PRICE \$32,950.00

TOTAL OPTIONS 304.00

TOTAL VEHICLE & OPTIONS \$33,254.00

DESTINATION & DELIVERY 795.00

INCLUDED ON THIS VEHICLE (MSRP)

EQUIPMENT GROUP 300A				
OPTIONAL EQUIPMENT				
FRONT LICENSE PLATE BRACKET	NO CHARGE			
50 STATE EMISSIONS CHARGE CORD BAG *DLR-INSTL	NO CHARGE			
EXT PROTECTION PKG *DLR-INSTL	245.00			

PRICE INFORMATION (MSRP)

BASE PRICE \$32,950.00

TOTAL OPTIONS 304.00

TOTAL VEHICLE & OPTIONS \$33,254.00

DESTINATION & DELIVERY 795.00

TOTAL MSRP \$34,049.00

SOLD TO

Route 23 Auto Mall, LLC
1301 Route 23
Butler NJ 07406

RAMP ONE

RA41

DEALER NO.

13D 155

RAMP TWO

RA41

FINAL ASSEMBLY PLANT

MICHIGAN

ITEM #: 13-B207 O/T 2

CMI141 N RA 2X 325 000528 12 14 12

SHIP TO (IF OTHER THAN SOLD TO)

Route 23 Auto Mall, LLC
1301 Route 23
Butler NJ 07406

SHIP THROUGH

RAIL

SHIP TO (IF OTHER THAN SOLD TO)

Route 23 Auto Mall, LLC
1301 Route 23
Butler NJ 07406

SHIP THROUGH

RAIL

SHIP TO (IF OTHER THAN SOLD TO)

Route 23 Auto Mall, LLC
1301 Route 23
Butler NJ 07406

SHIP THROUGH

RAIL

SHIP TO (IF OTHER THAN SOLD TO)

Route 23 Auto Mall, LLC
1301 Route 23
Butler NJ 07406

SHIP THROUGH

RAIL

SHIP TO (IF OTHER THAN SOLD TO)

Route 23 Auto Mall, LLC
1301 Route 23
Butler NJ 07406

SHIP THROUGH

RAIL

SHIP TO (IF OTHER THAN SOLD TO)

Route 23 Auto Mall, LLC
1301 Route 23
Butler NJ 07406

SHIP THROUGH

RAIL

SHIP TO (IF OTHER THAN SOLD TO)

Route 23 Auto Mall, LLC
1301 Route 23
Butler NJ 07406

SHIP THROUGH

RAIL

SHIP TO (IF OTHER THAN SOLD TO)

Route 23 Auto Mall, LLC
1301 Route 23
Butler NJ 07406

SHIP THROUGH

RAIL

SHIP TO (IF OTHER THAN SOLD TO)

Route 23 Auto Mall, LLC
1301 Route 23
Butler NJ 07406

SHIP THROUGH

RAIL

SHIP TO (IF OTHER THAN SOLD TO)

Route 23 Auto Mall, LLC
1301 Route 23
Butler NJ 07406

SHIP THROUGH

RAIL

SHIP TO (IF OTHER THAN SOLD TO)

Route 23 Auto Mall, LLC
1301 Route 23
Butler NJ 07406

SHIP THROUGH

RAIL

SHIP TO (IF OTHER THAN SOLD TO)

Route 23 Auto Mall, LLC
1301 Route 23
Butler NJ 07406

SHIP THROUGH

RAIL

SHIP TO (IF OTHER THAN SOLD TO)

Route 23 Auto Mall, LLC
1301 Route 23
Butler NJ 07406

SHIP THROUGH

RAIL

SHIP TO (IF OTHER THAN SOLD TO)

Route 23 Auto Mall, LLC
1301 Route 23
Butler NJ 07406

SHIP THROUGH

RAIL

SHIP TO (IF OTHER THAN SOLD TO)

Route 23 Auto Mall, LLC
1301 Route 23
Butler NJ 07406

SHIP THROUGH

RAIL

SHIP TO (IF OTHER THAN SOLD TO)

Route 23 Auto Mall, LLC
1301 Route 23
Butler NJ 07406

SHIP THROUGH

RAIL

SHIP TO (IF OTHER THAN SOLD TO)

Route 23 Auto Mall, LLC
1301 Route 23
Butler NJ 07406

SHIP THROUGH

RAIL

SHIP TO (IF OTHER THAN SOLD TO)

Route 23 Auto Mall, LLC
1301 Route 23
Butler NJ 07406

SHIP THROUGH

RAIL

SHIP TO (IF OTHER THAN SOLD TO)

Route 23 Auto Mall, LLC
1301 Route 23
Butler NJ 07406

SHIP THROUGH

RAIL

SHIP TO (IF OTHER THAN SOLD TO)

Route 23 Auto Mall, LLC
1301 Route 23
Butler NJ 07406

SHIP THROUGH

RAIL

SHIP TO (IF OTHER THAN SOLD TO)

Route 23 Auto Mall, LLC
1301 Route 23
Butler NJ 07406

SHIP THROUGH

RAIL

SHIP TO (IF OTHER THAN SOLD TO)

Route 23 Auto Mall, LLC
1301 Route 23
Butler NJ 07406

SHIP THROUGH

RAIL

SHIP TO (IF OTHER THAN SOLD TO)

Route 23 Auto Mall, LLC
1301 Route 23
Butler NJ 07406

SHIP THROUGH

RAIL

SHIP TO (IF OTHER THAN SOLD TO)

Route 23 Auto Mall, LLC
1301 Route 23
Butler NJ 07406

SHIP THROUGH

RAIL

SHIP TO (IF OTHER THAN SOLD TO)

Route 23 Auto Mall, LLC
1301 Route 23
Butler NJ 07406

SHIP THROUGH

RAIL

SHIP TO (IF OTHER THAN SOLD TO)

Route 23 Auto Mall, LLC
1301 Route 23
Butler NJ 07406

SHIP THROUGH

RAIL

SHIP TO (IF OTHER THAN SOLD TO)

Route 23 Auto Mall, LLC
1301 Route 23
Butler NJ 07406

SHIP THROUGH

RAIL

SHIP TO (IF OTHER THAN SOLD TO)

Route 23 Auto Mall, LLC
1301 Route 23
Butler NJ 07406

SHIP THROUGH

RAIL

SHIP TO (IF OTHER THAN SOLD TO)

Route 23 Auto Mall, LLC
1301 Route 23
Butler NJ 07406

SHIP THROUGH

RAIL

SHIP TO (IF OTHER THAN SOLD TO)

Route 23 Auto Mall, LLC
1301 Route 23
Butler NJ 07406

SHIP THROUGH

RAIL

SHIP TO (IF OTHER THAN SOLD TO)

Route 23 Auto Mall, LLC
1301 Route 23
Butler NJ 07406

SHIP THROUGH

RAIL

SHIP TO (IF OTHER THAN SOLD TO)

Route 23 Auto Mall, LLC
1301 Route 23
Butler NJ 07406

SHIP THROUGH

RAIL

SHIP TO (IF OTHER THAN SOLD TO)

Route 23 Auto Mall, LLC
1301 Route 23
Butler NJ 07406

SHIP THROUGH

RAIL

SHIP TO (IF OTHER THAN SOLD TO)

Route 23 Auto Mall, LLC
1301 Route 23
Butler NJ 07406

SHIP THROUGH

RAIL

SHIP TO (IF OTHER THAN SOLD TO)

Route 23 Auto Mall, LLC
1301 Route 23
Butler NJ 07406

SHIP THROUGH

RAIL

SHIP TO (IF OTHER THAN SOLD TO)

Route 23 Auto Mall, LLC
1301 Route 23
Butler NJ 07406

SHIP THROUGH

RAIL

SHIP TO (IF OTHER THAN SOLD TO)

Route 23 Auto Mall, LLC
1301 Route 23
Butler NJ 07406

SHIP THROUGH

RAIL

SHIP TO (IF OTHER THAN SOLD TO)

Route 23 Auto Mall, LLC
1301 Route 23
Butler NJ 07406

SHIP THROUGH

RAIL

SHIP TO (IF OTHER THAN SOLD TO)

Route 23 Auto Mall, LLC
1301 Route 23
Butler NJ 07406

SHIP THROUGH

RAIL

SHIP TO (IF OTHER THAN SOLD TO)

Route 23 Auto Mall, LLC
1301 Route 23
Butler NJ 07406

SHIP THROUGH

RAIL

SHIP TO (IF OTHER THAN SOLD TO)

Route 23 Auto Mall, LLC
1301 Route 23
Butler NJ 07406

SHIP THROUGH

RAIL

SHIP TO (IF OTHER THAN SOLD TO)

Route 23 Auto Mall, LLC
1301 Route 23
Butler NJ 07406

SHIP THROUGH

RAIL

SHIP TO (IF OTHER THAN SOLD TO)

Route 23 Auto Mall, LLC
1301 Route 23
Butler NJ 07406

SHIP THROUGH

RAIL

SHIP TO (IF OTHER THAN SOLD TO)

Route 23 Auto Mall, LLC
1301 Route 23
Butler NJ 07406

SHIP THROUGH

RAIL

SHIP TO (IF OTHER THAN SOLD TO)

Route 23 Auto Mall, LLC
1301 Route 23
Butler NJ 07406

SHIP THROUGH

RAIL

SHIP TO (IF OTHER THAN SOLD TO)

Route 23 Auto Mall, LLC
1301 Route 23
Butler NJ 07406

SHIP THROUGH

RAIL

SHIP TO (IF OTHER THAN SOLD TO)

Route 23 Auto Mall, LLC
1301 Route 23
Butler NJ 07406

SHIP THROUGH

RAIL

SHIP TO (IF OTHER THAN SOLD TO)

Route 23 Auto Mall, LLC
1301 Route 23
Butler NJ 07406

SHIP THROUGH

RAIL

SHIP TO (IF OTHER THAN SOLD TO)

Route 23 Auto Mall, LLC
1301 Route 23
Butler NJ 07406

SHIP THROUGH

RAIL

SHIP TO (IF OTHER THAN SOLD TO)

Route 23 Auto Mall, LLC
1301 Route 23
Butler NJ 07406

SHIP THROUGH

RAIL

SHIP TO (IF OTHER THAN SOLD TO)

Route 23 Auto Mall, LLC
1301 Route 23
Butler NJ 07406

SHIP THROUGH

RAIL

SHIP TO (IF OTHER THAN SOLD TO)

Route 23 Auto Mall, LLC
1301 Route 23
Butler NJ 07406

SHIP THROUGH

RAIL

SHIP TO (IF OTHER THAN SOLD TO)

Route 23 Auto Mall, LLC
1301 Route 23
Butler NJ 07406

SHIP THROUGH

RAIL

SHIP TO (IF OTHER THAN SOLD TO)

Route 23 Auto Mall, LLC
1301 Route 23
Butler NJ 07406

SHIP THROUGH

RAIL

SHIP TO (IF OTHER THAN SOLD TO)

Route 23 Auto Mall, LLC
1301 Route 23
Butler NJ 07406

SHIP THROUGH

RAIL

SHIP TO (IF OTHER THAN SOLD TO)

Route 23 Auto Mall, LLC
1301 Route 23
Butler NJ 07406

SHIP THROUGH

RAIL

SHIP TO (IF OTHER THAN SOLD TO)

Route 23 Auto Mall, LLC
1301 Route 23
Butler NJ 07406

SHIP THROUGH

RAIL

SHIP TO (IF OTHER THAN SOLD TO)

Route 23 Auto Mall, LLC
1301 Route 23
Butler NJ 07406

SHIP THROUGH

RAIL

SHIP TO (IF OTHER THAN SOLD TO)

Route 23 Auto Mall, LLC
1301 Route 23
Butler NJ 07406

SHIP THROUGH

RAIL

SHIP TO (IF OTHER THAN SOLD TO)

Route 23 Auto Mall, LLC
1301 Route 23
Butler NJ 07406

SHIP THROUGH

RAIL

SHIP TO (IF OTHER THAN SOLD TO)

Route 23 Auto Mall, LLC
1301 Route 23
Butler NJ 07406

SHIP THROUGH

RAIL

SHIP TO (IF OTHER THAN SOLD TO)

Route 23 Auto Mall, LLC
1301 Route 23
Butler NJ 07406

SHIP THROUGH

RAIL

SHIP TO (IF OTHER THAN SOLD TO)

Route 23 Auto Mall, LLC
1301 Route 23
Butler NJ 07406

SHIP THROUGH

RAIL

SHIP TO (IF OTHER THAN SOLD TO)

Route 23 Auto Mall, LLC
1301 Route 23
Butler NJ 07406

SHIP THROUGH

RAIL

SHIP TO (IF OTHER THAN SOLD TO)

Route 23 Auto Mall, LLC
1301 Route 23
Butler NJ 07406

SHIP THROUGH

RAIL

SHIP TO (IF OTHER THAN SOLD TO)

Route 23 Auto Mall, LLC
1301 Route 23
Butler NJ 07406

SHIP THROUGH

RAIL

SHIP TO (IF OTHER THAN SOLD TO)

Route 23 Auto Mall, LLC
1301 Route 23
Butler NJ 07406

SHIP THROUGH

RAIL

SHIP TO (IF OTHER THAN SOLD TO)

Route 23 Auto Mall, LLC
1301 Route 23
Butler NJ 07406

SHIP THROUGH

RAIL

SHIP TO (IF OTHER THAN SOLD TO)

Route 23 Auto Mall, LLC
1301 Route 23
Butler NJ 07406

SHIP THROUGH

RAIL

SHIP TO (IF OTHER THAN SOLD TO)

Route 23 Auto Mall, LLC
1301 Route 23
Butler NJ 07406

SHIP THROUGH

RAIL

SHIP TO (IF OTHER THAN SOLD TO)

Route 23 Auto Mall, LLC
1301 Route 23
Butler NJ 07406

SHIP THROUGH

RAIL

SHIP TO (IF OTHER THAN SOLD TO)

Route 23 Auto Mall, LLC
1301 Route 23
Butler NJ 07406

SHIP THROUGH

RAIL

SHIP TO (IF OTHER THAN SOLD TO)

Route 23 Auto Mall, LLC
1301 Route 23
Butler NJ 07406

SHIP THROUGH

RAIL

SHIP TO (IF OTHER THAN SOLD TO)

Route 23 Auto Mall, LLC
1301 Route 23
Butler NJ 07406

SHIP THROUGH

RAIL

SHIP TO (IF OTHER THAN SOLD TO)

Route 23 Auto Mall, LLC
1301 Route 23
Butler NJ 07406

SHIP THROUGH

RAIL

SHIP TO (IF OTHER THAN SOLD TO)

Route 23 Auto Mall, LLC
1301 Route 23
Butler NJ 07406

SHIP THROUGH

RAIL

SHIP TO (IF OTHER THAN SOLD TO)

Route 23 Auto Mall, LLC
1301 Route 23
Butler NJ 07406

SHIP THROUGH

RAIL

SHIP TO (IF OTHER THAN SOLD TO)

Route 23 Auto Mall, LLC
1301 Route 23
Butler NJ 07406

SHIP THROUGH

RAIL

SHIP TO (IF OTHER THAN SOLD TO)

Route 23 Auto Mall, LLC
1301 Route 23
Butler NJ 07406

SHIP THROUGH

RAIL

SHIP TO (IF OTHER THAN SOLD TO)

Route 23 Auto Mall, LLC
1301 Route 23
Butler NJ 07406

SHIP THROUGH

RAIL

SHIP TO (IF OTHER THAN SOLD TO)

Route 23 Auto Mall, LLC
1301 Route 23
Butler NJ 07406

SHIP THROUGH

RAIL

SHIP TO (IF OTHER THAN SOLD TO)

Route 23 Auto Mall, LLC
1301 Route 23
Butler NJ 07406

SHIP THROUGH

RAIL

SHIP TO (IF OTHER THAN SOLD TO)

Route 23 Auto Mall, LLC
1301 Route 23
Butler NJ 07406

SHIP THROUGH

RAIL

SHIP TO (IF OTHER THAN SOLD TO)

Route 23 Auto Mall, LLC
1301 Route 23
Butler NJ 07406

SHIP THROUGH

RAIL

SHIP TO (IF OTHER THAN SOLD TO)

Route 23 Auto Mall, LLC
1301 Route 23
Butler NJ 07406

SHIP THROUGH

RAIL

SHIP TO (IF OTHER THAN SOLD TO)

Route 23 Auto Mall, LLC
1301 Route 23
Butler NJ 07406

SHIP THROUGH

RAIL

SHIP TO (IF OTHER THAN SOLD TO)

Route 23 Auto Mall, LLC
1301 Route 23
Butler NJ 07406

SHIP THROUGH

RAIL

SHIP TO (IF OTHER THAN SOLD TO)

Route 23 Auto Mall, LLC
1301 Route 23
Butler NJ 07406

SHIP THROUGH

RAIL

SHIP TO (IF OTHER THAN SOLD TO)

Route 23 Auto Mall, LLC
1301 Route 23
Butler NJ 07406

SHIP THROUGH

RAIL

SHIP TO (IF OTHER THAN SOLD TO)

Route 23 Auto Mall, LLC
1301 Route 23

The head restraints consist of:

- A. An energy absorbing head restraint
- B. Two steel stems
- C. Guide sleeve adjust and release button
- D. Guide sleeve unlock and remove button

Adjusting the Head Restraint

Raise: Pull up the head restraint.

Lower:

1. Press and hold button C.
2. Push the head restraint down.

Remove:

1. Pull up the head restraint until it reaches the highest adjustment position.
2. Press and hold buttons C and D.
3. Pull the head restraint up.

Install: Align the steel stems into the guide sleeves and push the head restraint down until it locks.

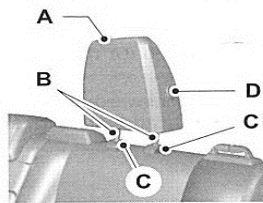

Rear Seat Outboard Head Restraints

The head restraints consist of:

- A. An energy absorbing head restraint
- B. Two steel stems
- C. Guide sleeve unlock and remove button
- D. Fold button

Head Restraint Use and Adjustment Information from Vehicle Owner's Manual

Remove:

1. Press and hold buttons C.
2. Pull the head restraint up.

Install: Align the steel stems into the guide sleeves and push the head restraint down until it locks.

Fold:

1. Press and hold button D.
2. Pull it back up to reset.

Tilting Head Restraints (If Equipped)

The front head restraints may have a tilting feature for extra comfort. To tilt the head restraint, do the following:

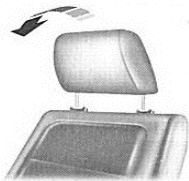

1. Adjust the seat back to an upright driving or riding position.
2. Tilt the head restraint forward by gently pulling the top of the head restraint.

Once it is in its forward-most position, tilt it forward once more to release it to the upright position.

Note: Do not attempt to force the head restraint backward after it is tilted. Instead, continue tilting it forward until the head restraint releases to the upright position.

Head Restraint Use and Adjustment Information from Vehicle Owner's Manual



Post-Test View of Shattered Vehicle Inner Door Panel



Post-Test Roof and Windshield Separations

APPENDIX B

VEHICLE AND DUMMY RESPONSE DATA PLOTS

TABLE OF DATA PLOTS
Driver Dummy Instrumentation Plots

		<u>Page No.</u>
Figure No. 1.	Driver Head CG Acceleration (X) vs. Time	B-1
Figure No. 2.	Driver Head CG Acceleration (Y) vs. Time	B-1
Figure No. 3.	Driver Head CG Acceleration (Z) vs. Time	B-1
Figure No. 4.	Driver Head CG Resultant Acceleration (X) vs. Time	B-1
Figure No. 5.	Driver Lower Spine T12 Acceleration (X) vs. Time	B-2
Figure No. 6.	Driver Lower Spine T12 Acceleration (Y) vs. Time	B-2
Figure No. 7.	Driver Lower Spine T12 Acceleration (Z) vs. Time	B-2
Figure No. 8.	Driver Lower Spine T12 Resultant Acceleration vs. Time	B-2
Figure No. 9.	Driver Iliac Wing Force on Impact Side (Y) vs. Time	B-3
Figure No. 10.	Driver Acetabulum Force on Impact Side (Y) vs. Time	B-3
Figure No. 11.	Driver Total Pelvis Force on Impact Side (Y) vs. Time	B-3

The following additional data for this test can be obtained from the Research and Development section of the NHTSA website. The website can be found at www.NHTSA.dot.gov

Additional Driver Dummy Instrumentation Data

Driver Head CG Redundant Acceleration (X) vs. Time

Driver Head CG Redundant Acceleration (Y) vs. Time

Driver Head CG Redundant Acceleration (Z) vs. Time

Driver Upper Thorax Rib Deflection (Y)

Driver Middle Thorax Rib Deflection (Y)

Driver Lower Thorax Rib Deflection (Y)

Driver Upper Abdomen Rib Deflection (Y)

Driver Lower Abdomen Rib Deflection (Y)

Vehicle Instrumentation Data

Vehicle Center of Gravity Acceleration (X)

Vehicle Center of Gravity Acceleration (Y)

Vehicle Center of Gravity Acceleration (Z)

Left Floor Sill Acceleration (Y)

Left A-Pillar Sill Acceleration (Y)

Left Lower A-Pillar Acceleration (Y)

Left Mid A-Pillar Acceleration (Y)

Left B-Pillar Sill Acceleration (Y)

Left Lower B-Pillar Acceleration (Y)

Left Mid B-Pillar Acceleration (Y)

Driver Seat Track at Dummy Hip Point Acceleration (Y)

Engine Top Acceleration (X)

Engine Top Acceleration (Y)

Firewall Center Acceleration (Y)

Right Roof at Vertical Impact Reference Line Acceleration (Y)

Right Sill at Vertical Impact Reference Line Acceleration (Y)

Rear Floorpan Behind Rear Axle at Centerline Acceleration (X)

Rear Floorpan Behind Rear Axle at Centerline Acceleration (Y)

Pole Instrumentation Data

Load Cell Pole Barrier #1 Force (Y)

Load Cell Pole Barrier #2 Force (Y)

Load Cell Pole Barrier #3 Force (Y)

Load Cell Pole Barrier #4 Force (Y)

Load Cell Pole Barrier #5 Force (Y)

Load Cell Pole Barrier #6 Force (Y)

Load Cell Pole Barrier #7 Force (Y)

Load Cell Pole Barrier #8 Force (Y)

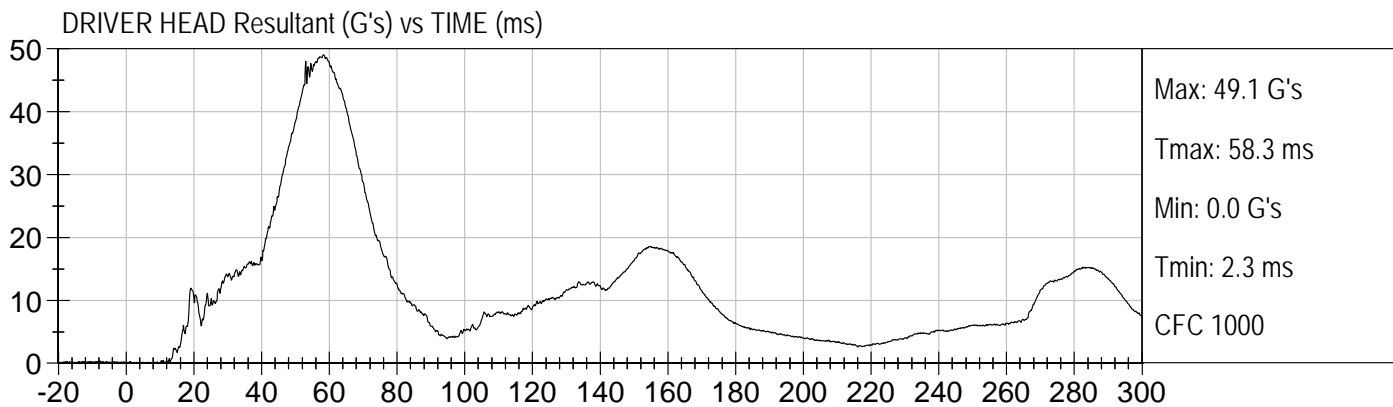
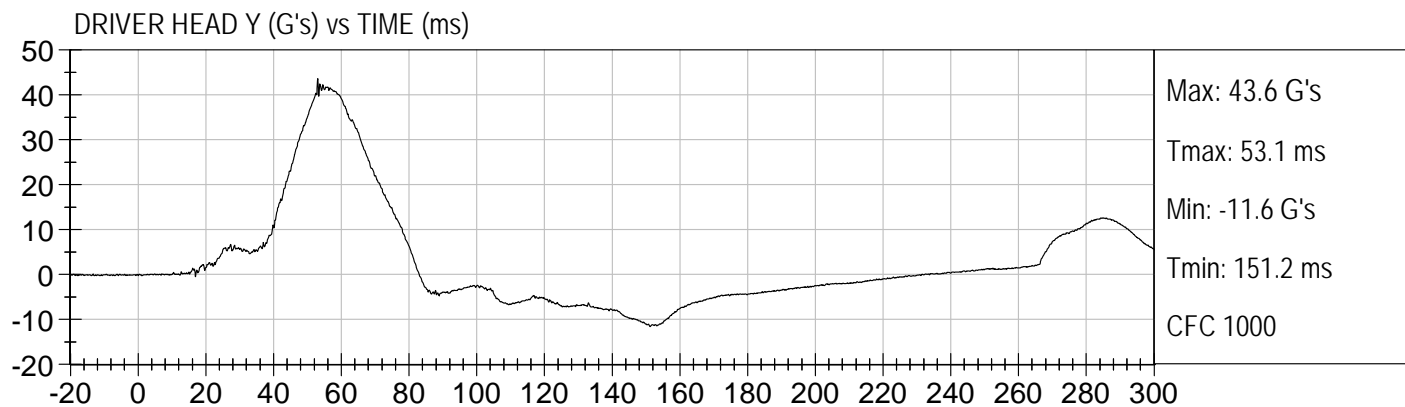
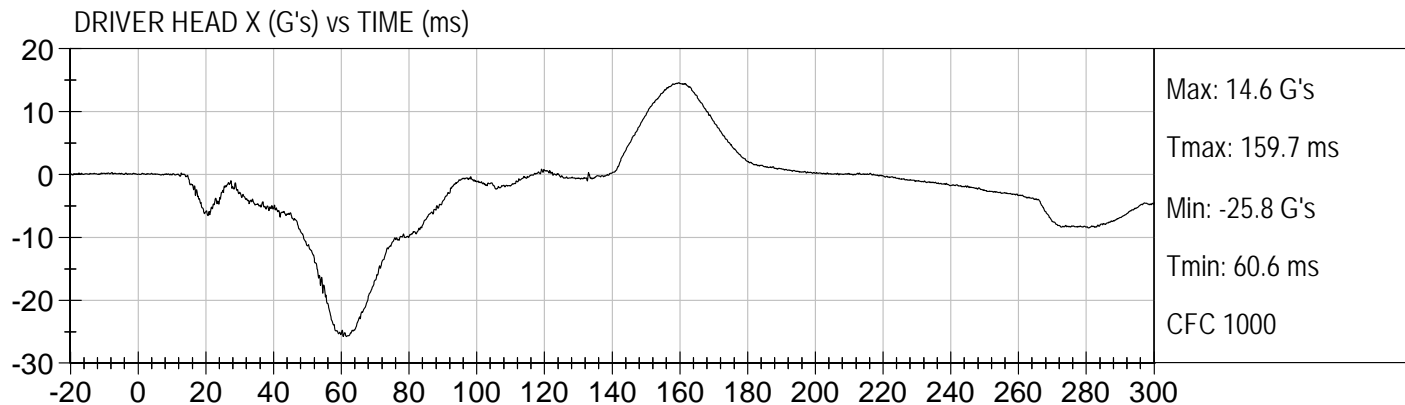

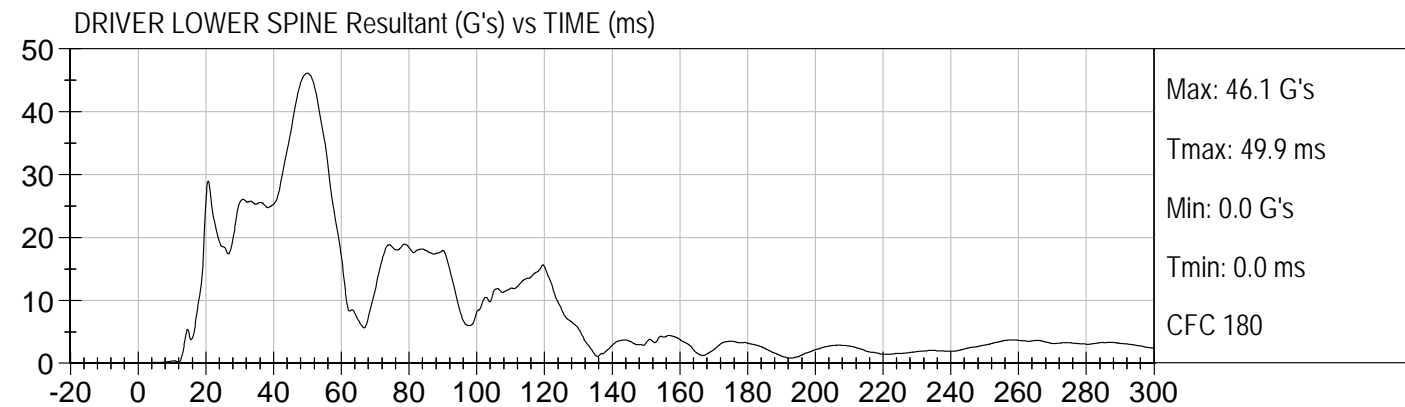
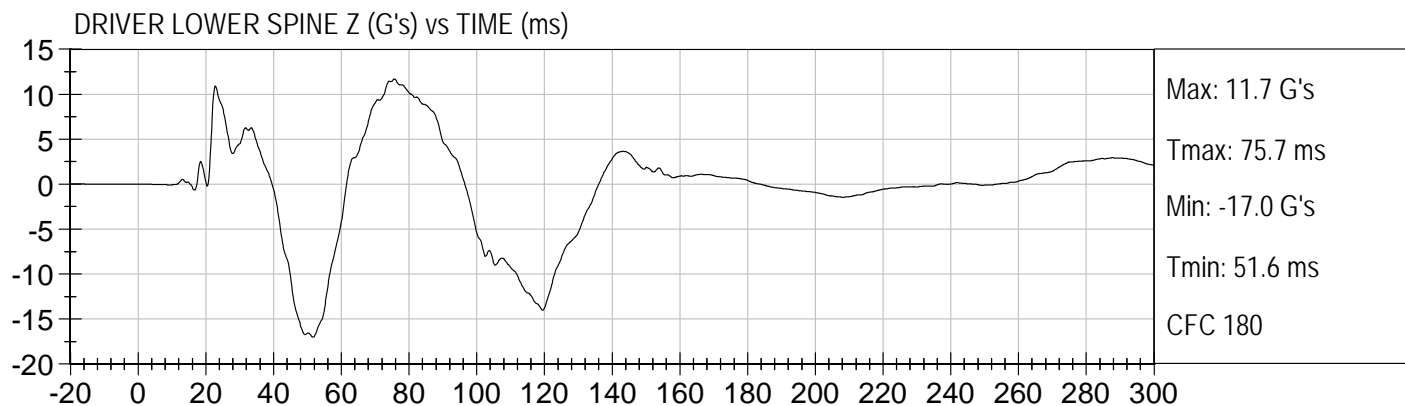
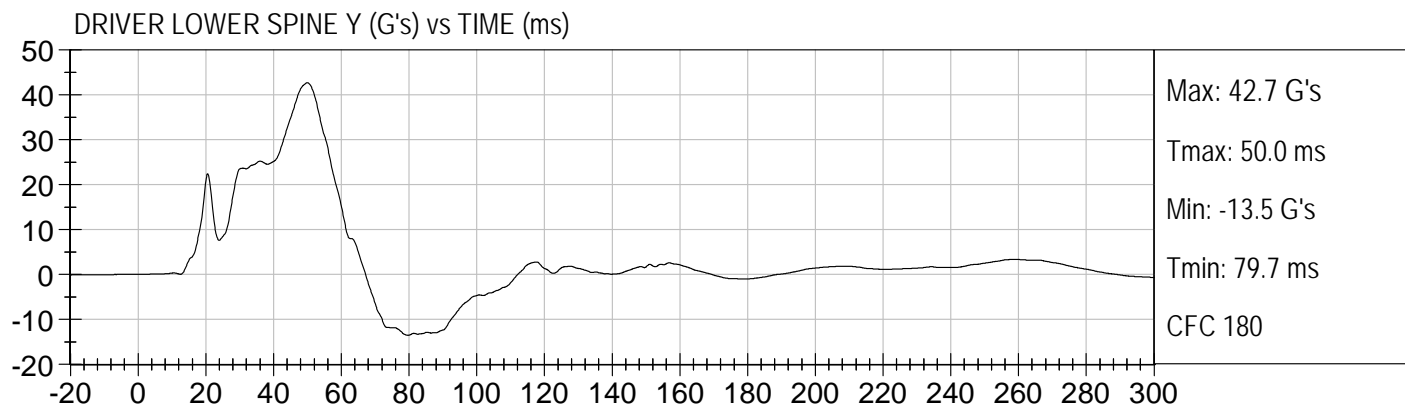
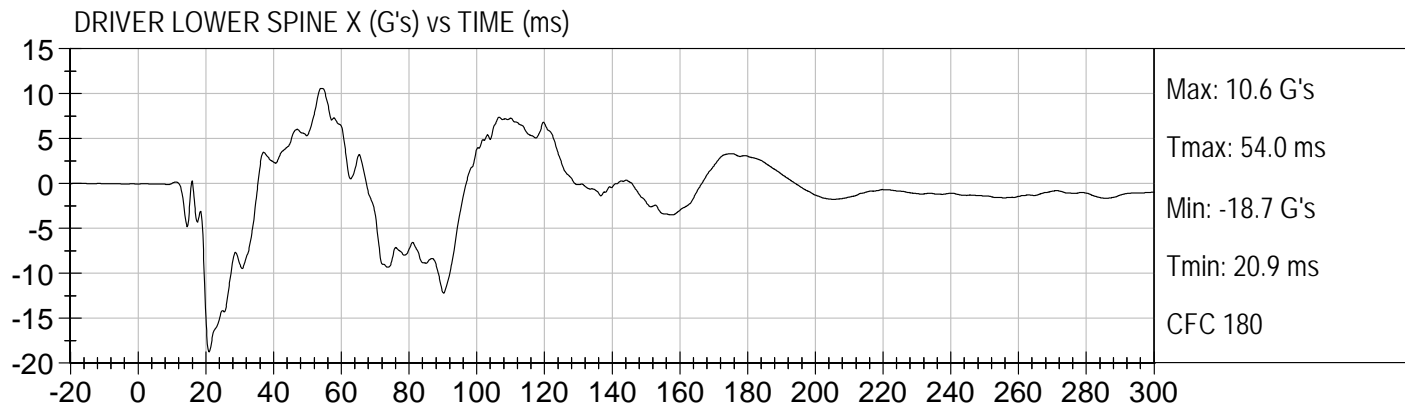

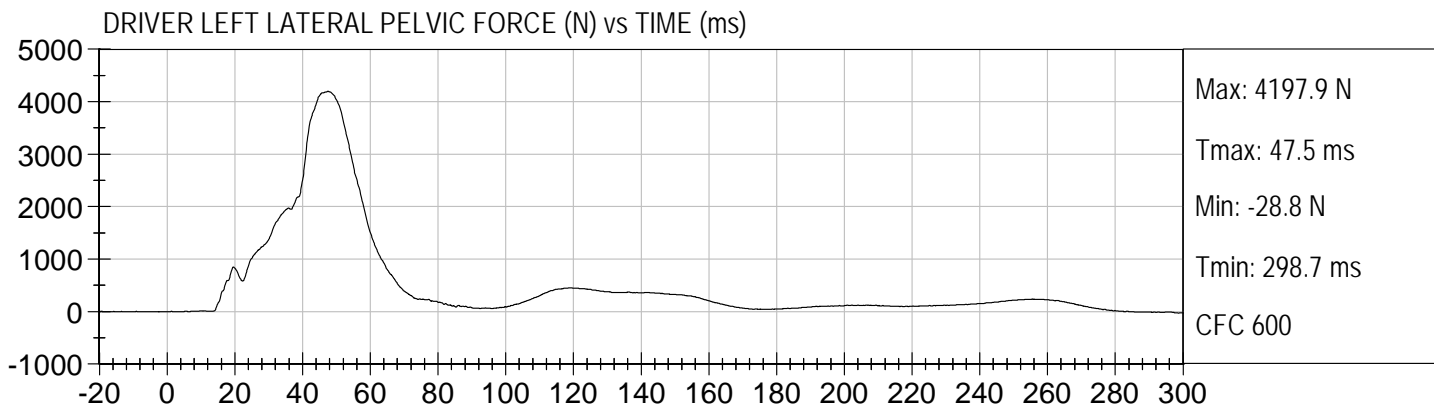
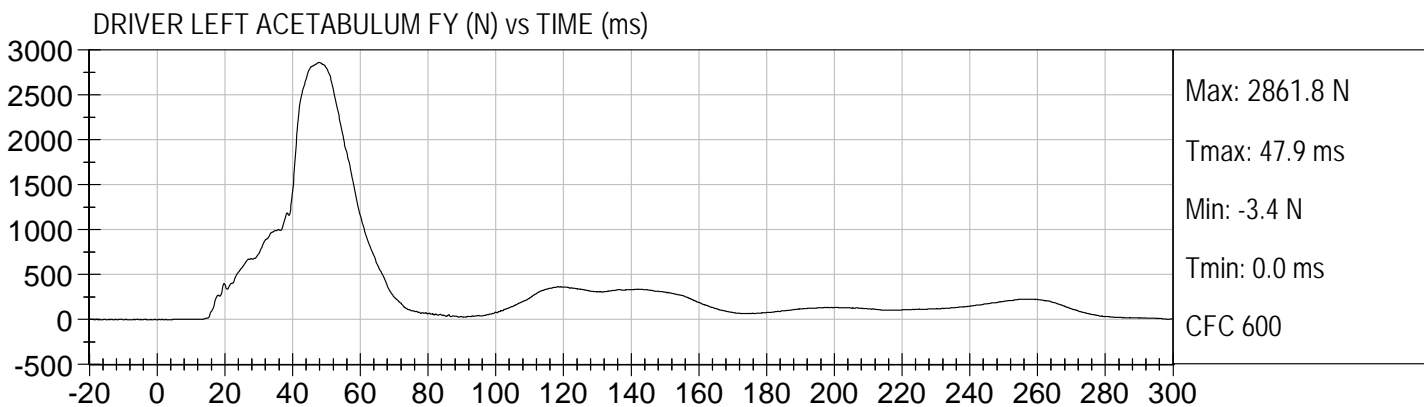
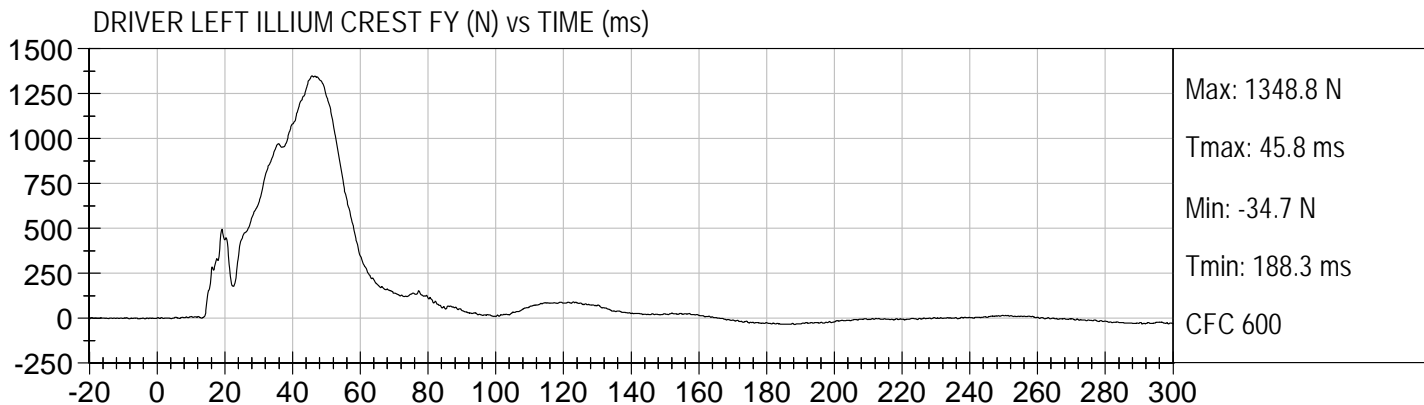

APPENDIX C

DUMMY CONFIGURATION AND PERFORMANCE VERIFICATION DATA

SID-IIsD External Measurements
SN: 296

No.	Name	Spec. (mm)	Result	Pass/Fail
A	Sitting Height	772 - 788	784	Pass
B	Shoulder Pivot Height	437 - 453	442	Pass
C	H-point Height	79 - 89	83	Pass
D	H-point from Seatback	141 - 151	145	Pass
E	Shoulder Pivot from Backline	97 - 107	99	Pass
F	Thigh Clearance	119 - 135	121	Pass
G	Head Breadth	140 - 148	142	Pass
H	Head Back from Backline	40 - 46	45	Pass
I	Head Depth	178 - 188	180	Pass
J	Head Circumference	541 - 551	548	Pass
K	Buttock to Knee Length	514 - 540	535	Pass
L	Popliteal Height	343 - 369	358	Pass
M	Knee Pivot to Floor Height	392 - 409	404	Pass
N	Buttock Popliteal Length	416 - 442	435	Pass
O	Chest Depth w/o Jacket	195 - 211	206	Pass
P	Foot Length	216 - 232	219	Pass
Q	Hip Breadth (w/ pelvic plugs)	313 - 323	316	Pass
R	Arm Length	249 - 259	250	Pass
S	Knee Joint to Seatback	477 - 493	481	Pass
V	Shoulder Width	341 - 357	346	Pass
W	Foot Width	78 - 94	85	Pass
Y	Chest Circumference w/ jacket	851 - 881	870	Pass
Z	Waist Circumference	761 - 791	772	Pass

**MGA RESEARCH CORPORATION
HEAD DROP TEST
SID-IIs BUILD LEVEL D DUMMY**

ATD Serial No: 296

Test ID: D13091

Tested Parameter	Units	Specification	Result	Pass/Fail
Laboratory Temperature	deg C	20.6 to 22.2	21.5	Pass
Laboratory Relative Humidity	%	10 to 70	37	Pass
Peak Resultant Acceleration	G's	115 to 137	123	Pass
Peak Longitudinal Acceleration	G's	+/- 15	2.2	Pass
Unimodal	N/A	Yes	Yes	Pass
Oscillations	N/A	<15%	Yes	Pass
Overall Test Results				Pass

Jessica Hall
Laboratory Technician

01/11/2013
Test Date

David Winkelbauer
Approved By

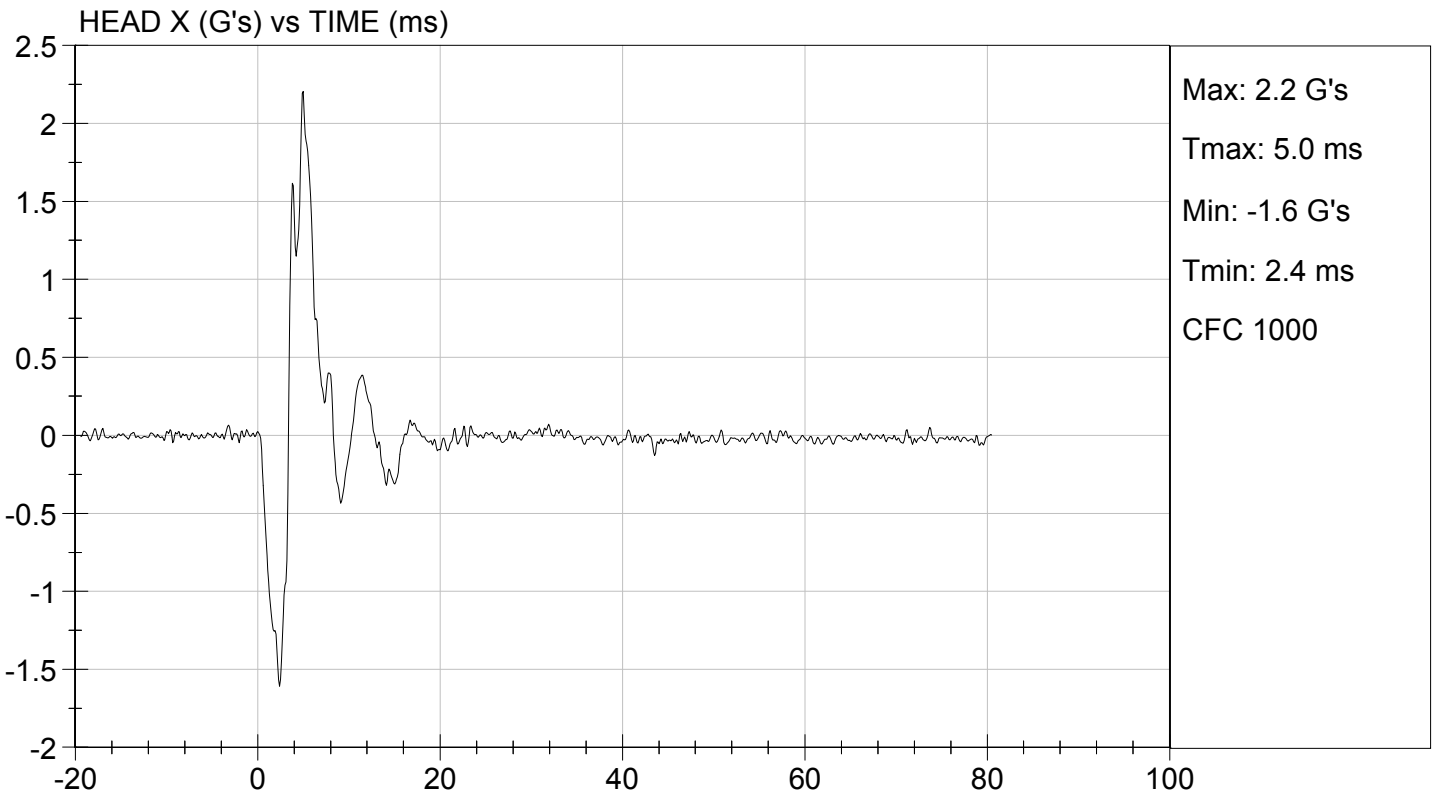
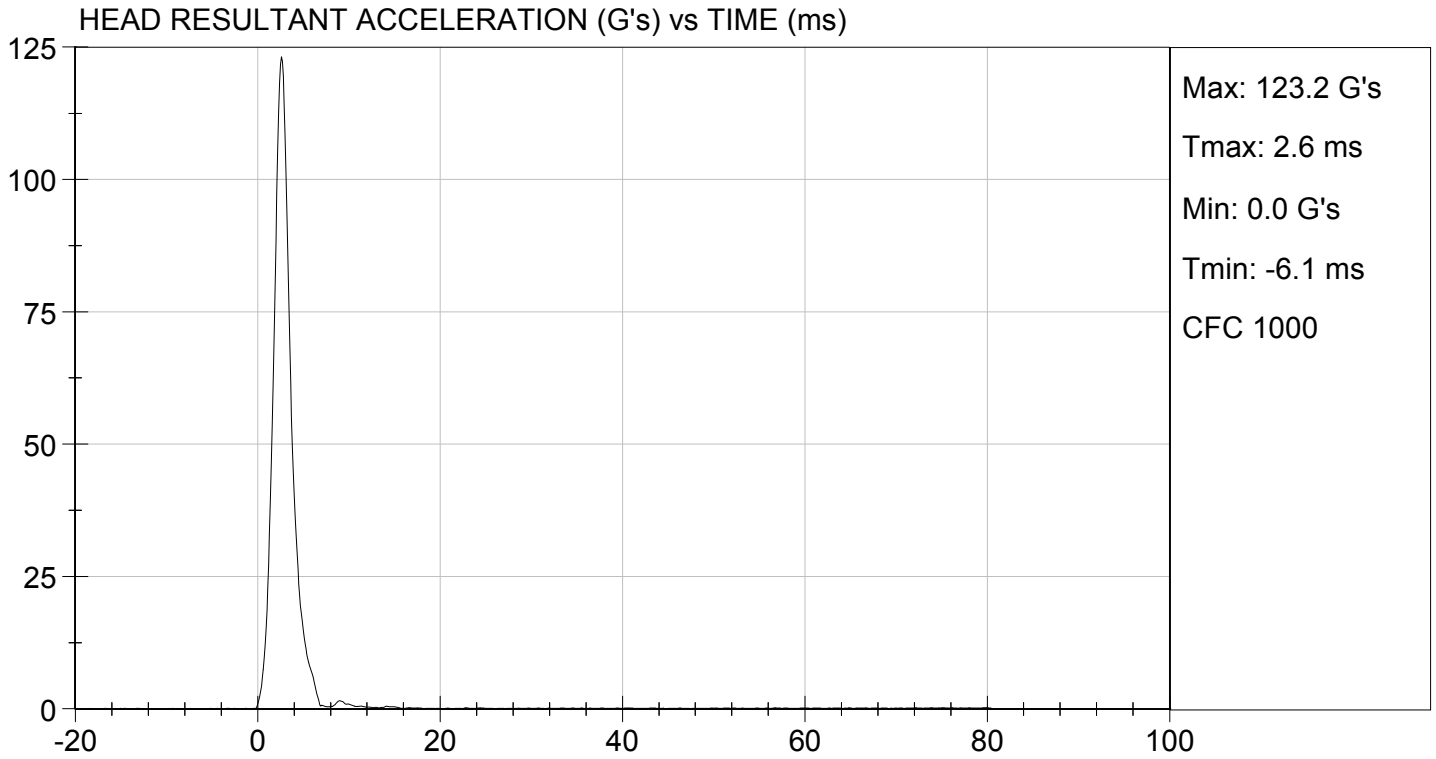

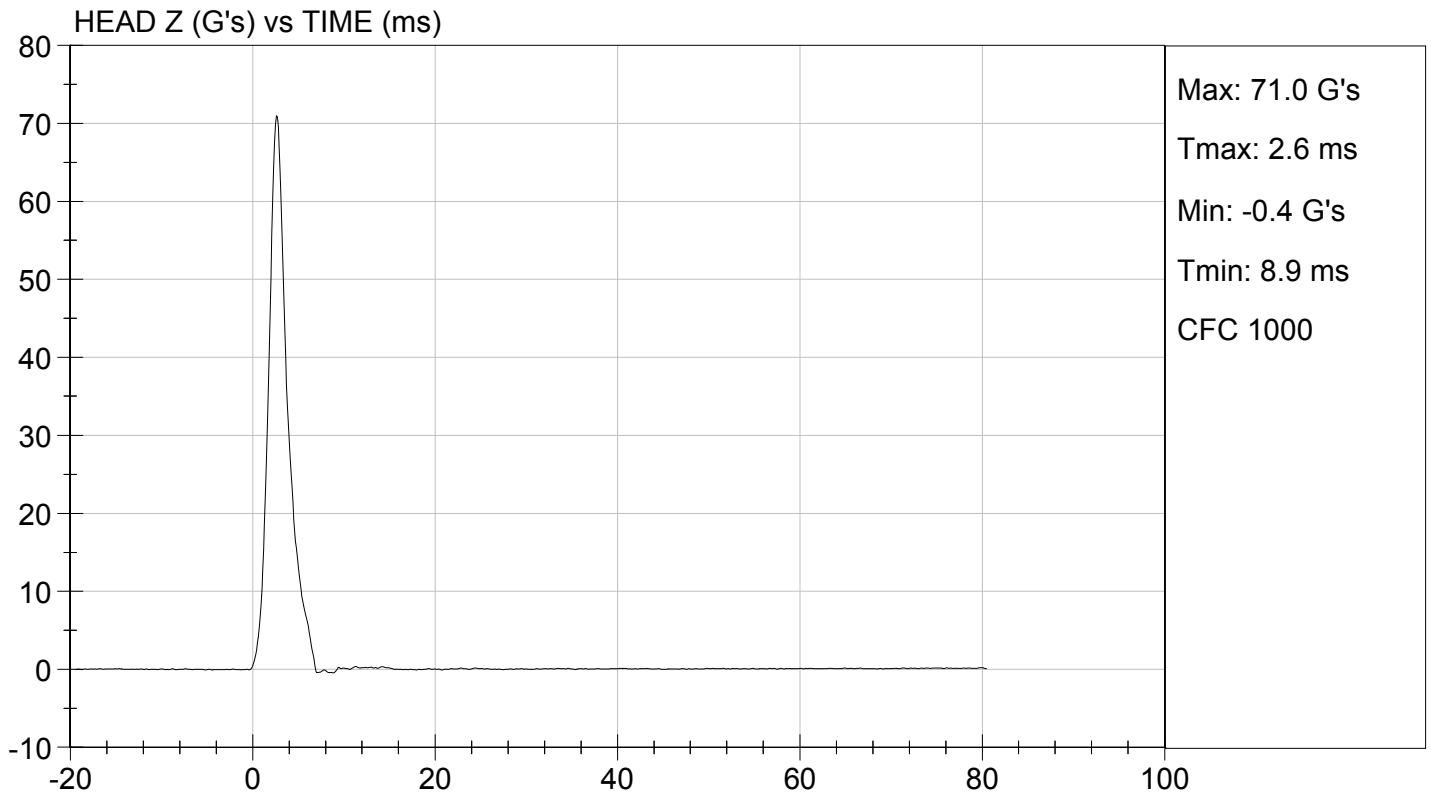
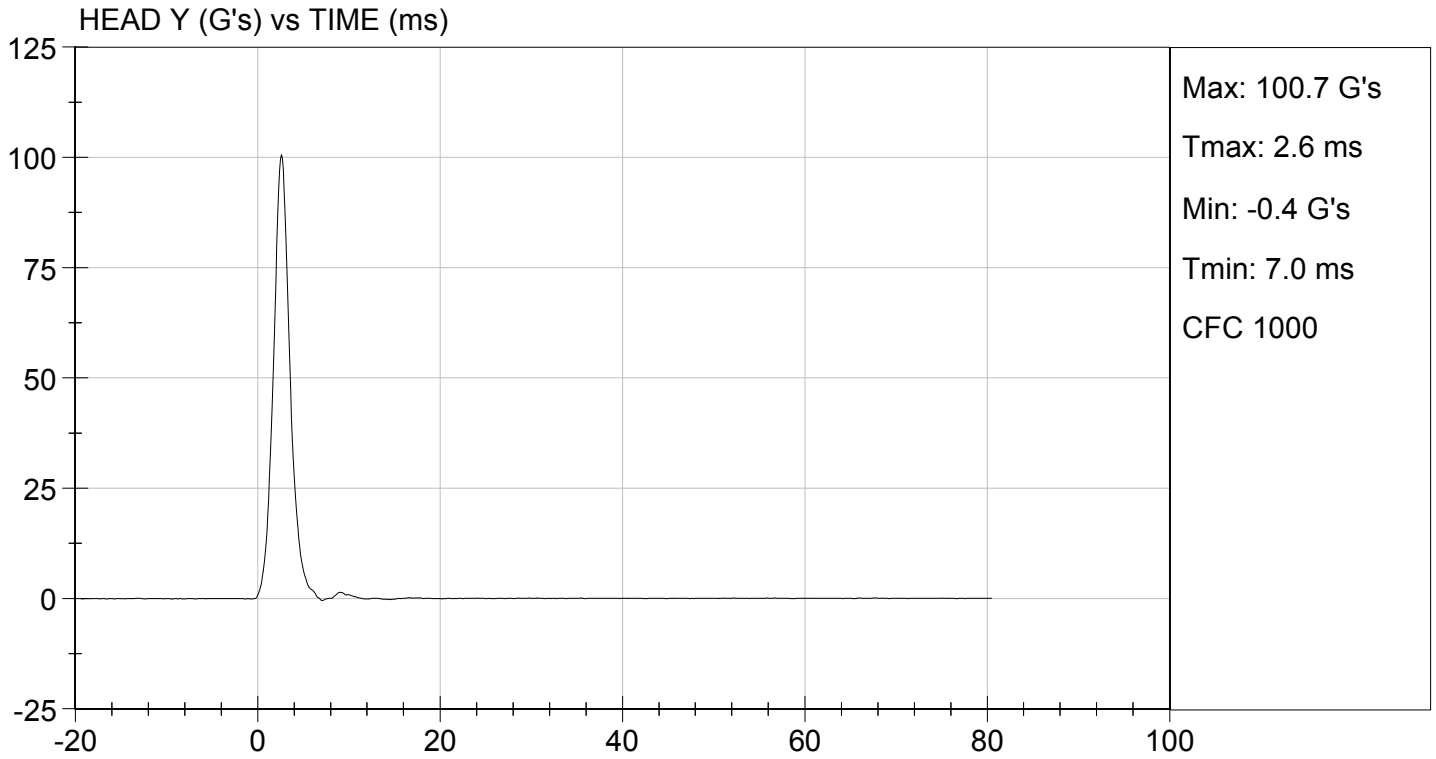

**MGA RESEARCH CORPORATION
LATERAL NECK PENDULUM TEST
SID-IIs BUILD LEVEL D DUMMY**

ATD Serial No: 296

Test I.D.: D13092

Tested Parameter	Units	Specification	Result	Pass/Fail	
Temperature	deg C	20.6 to 22.2	21.6	Pass	
Humidity	%	10 to 70	37	Pass	
Impact Velocity	m/s	5.51 to 5.63	5.58	Pass	
Pendulum Velocity	10 ms	m/s	2.20 to 2.80	2.39	Pass
	15 ms	m/s	3.30 to 4.10	3.46	Pass
	20 ms	m/s	4.40 to 5.40	4.67	Pass
	25 ms	m/s	5.40 to 6.10	5.47	Pass
	25-100 ms	m/s	5.50 to 6.20	5.67	Pass
Maximum D-Plane Rotation	deg	71 to 81	73	Pass	
Time of Maximum D-Plane Rotation	ms	50 to 70	61	Pass	
Maximum Occipital Condyle Moment	Nm	-44 to -36	-39	Pass	
Time of Moment Decay to 0 Nm	ms	102 to 126	118	Pass	
Overall Test Results				Pass	

Jessica Hall
Laboratory Technician

01/11/2013

Test Date

David Winkelbauer
Approved By

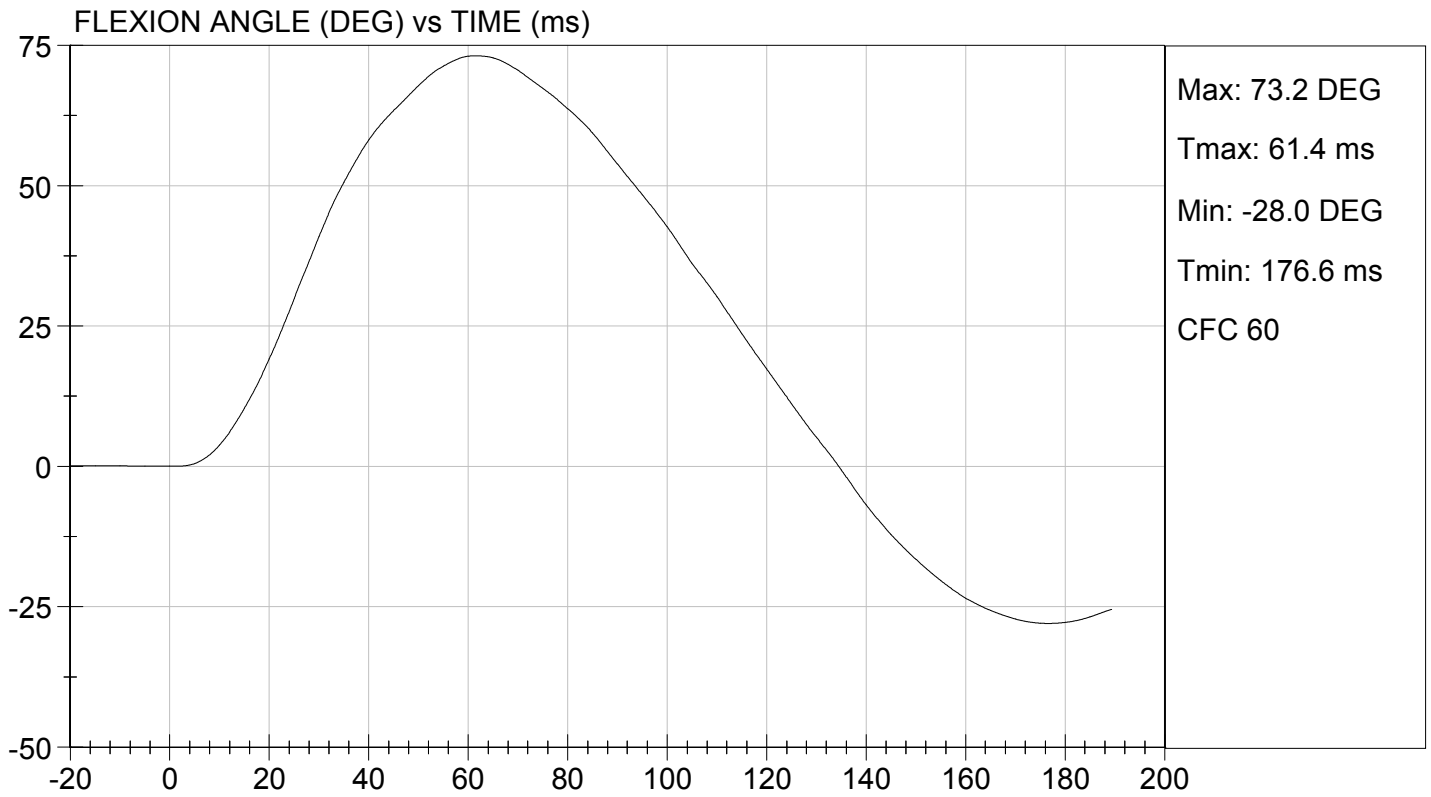
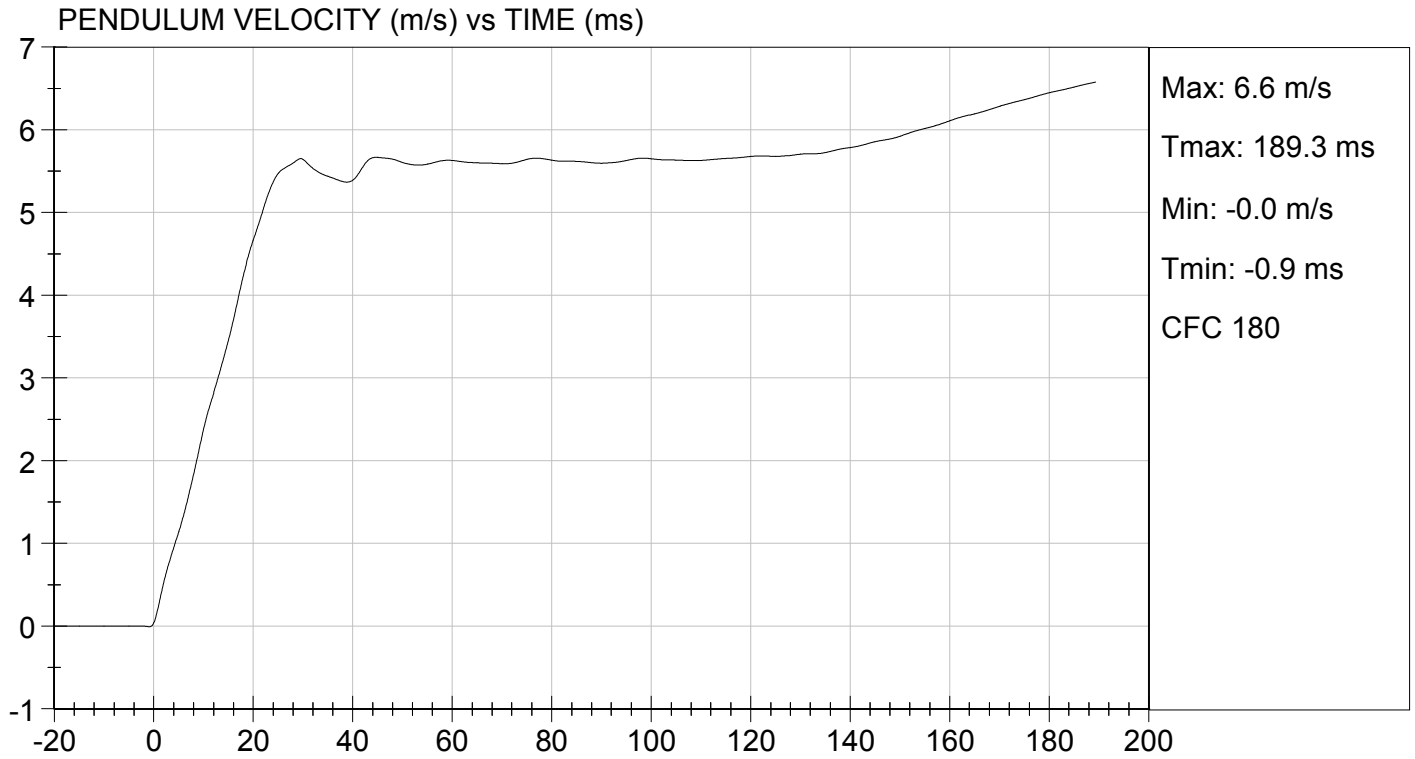



TEST DESC: NECK BENDING
VELOCITY: 18.31 ft/s, 5.58 m/s

TEST DATE: 01/11/2013
TEST #: D13092

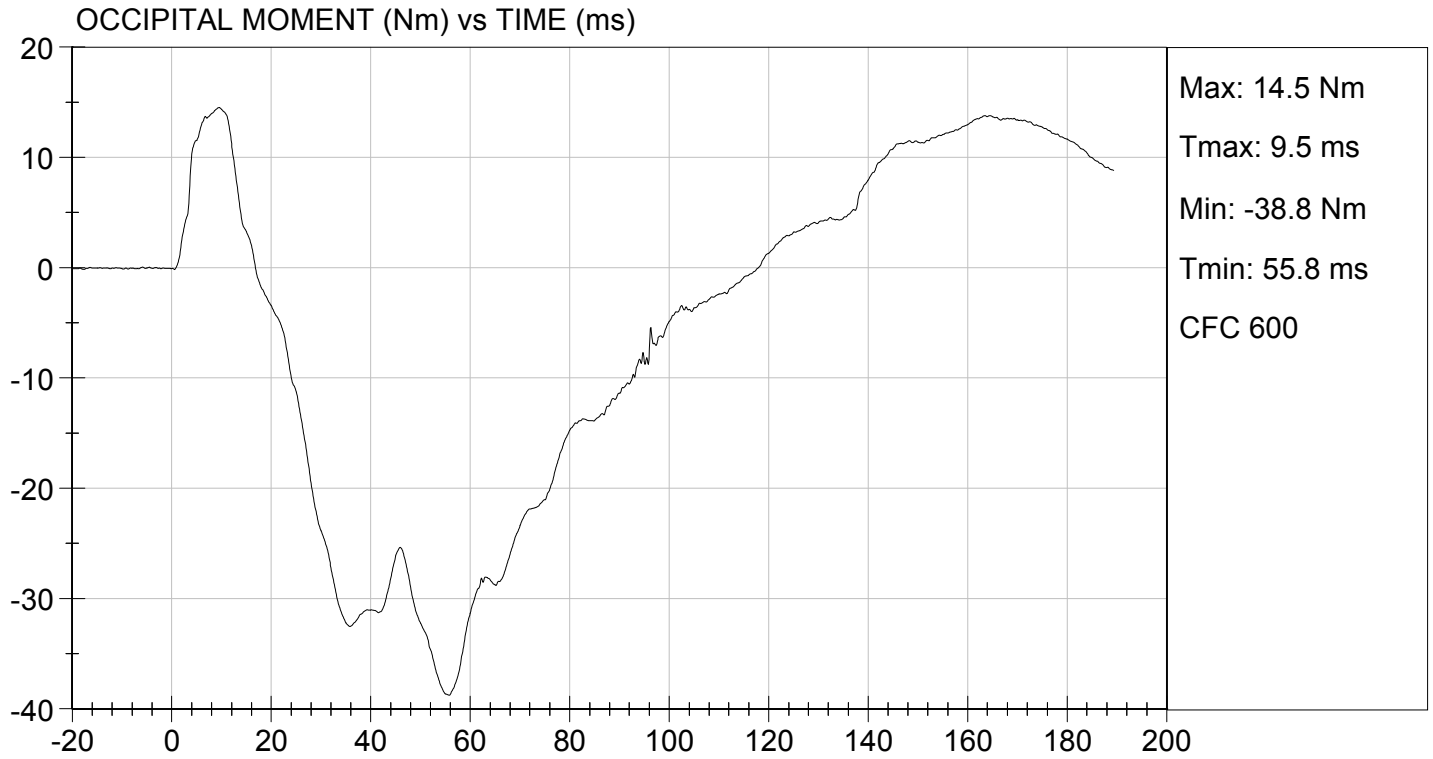

**MGA RESEARCH CORPORATION
SHOULDER IMPACT TEST
SID-IIs BUILD LEVEL D DUMMY**

ATD Serial No: 296

Test ID: D13093

Tested Parameter	Units	Specification	Result	Pass/Fail
Laboratory Temperature	deg C	20.6 to 22.2	21.5	Pass
Laboratory Relative Humidity	%	10 to 70	37	Pass
Impact Velocity	m/s	4.20 to 4.40	4.34	Pass
Maximum Probe Acceleration	G's	13 to 18	15	Pass
Shoulder Displacement	mm	28 to 37	32	Pass
Upper Spine (T1) Y Acceleration	G's	17 to 22	18	Pass
Overall Test Results				Pass

Jessica Hall
Laboratory Technician

01/11/2013
Test Date

David Winkelbauer
Approved By

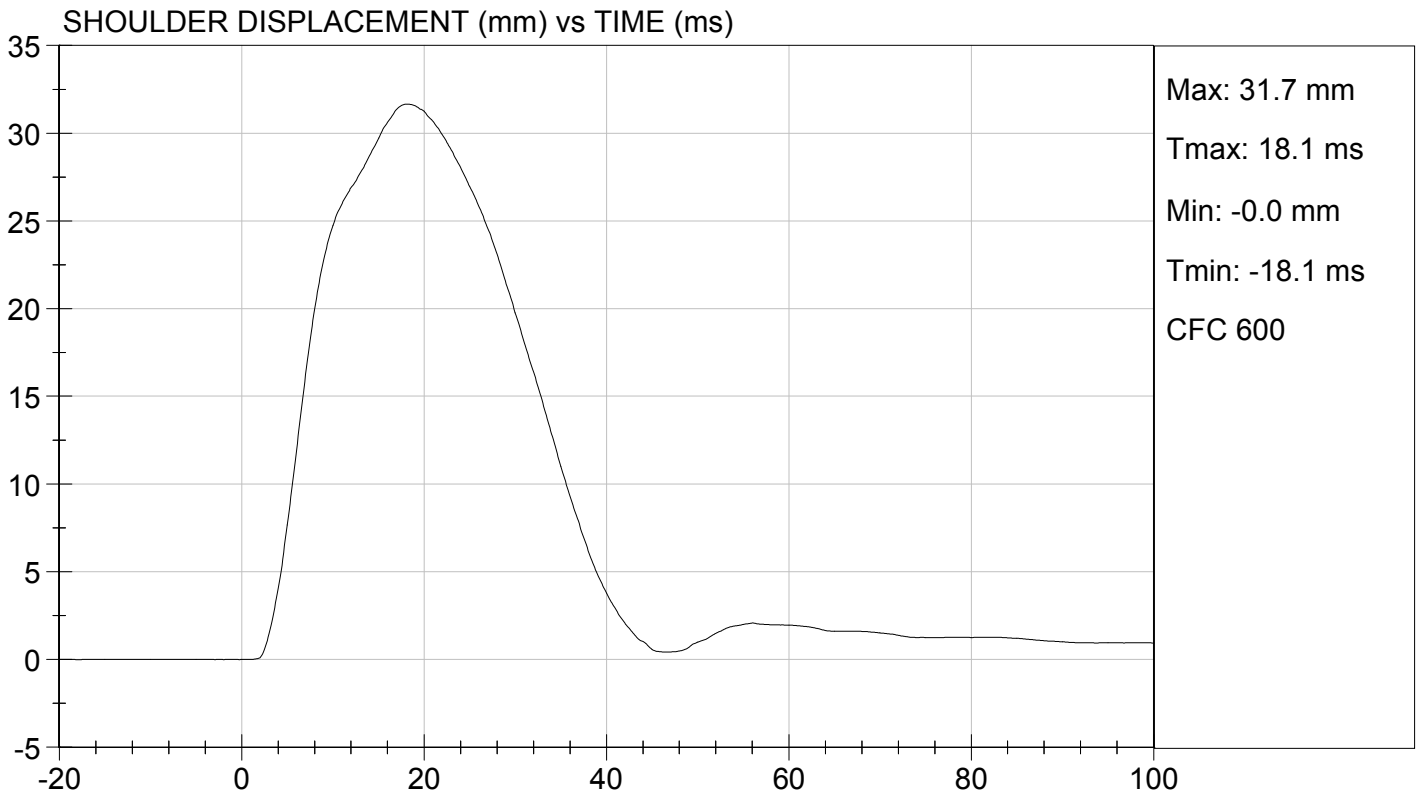
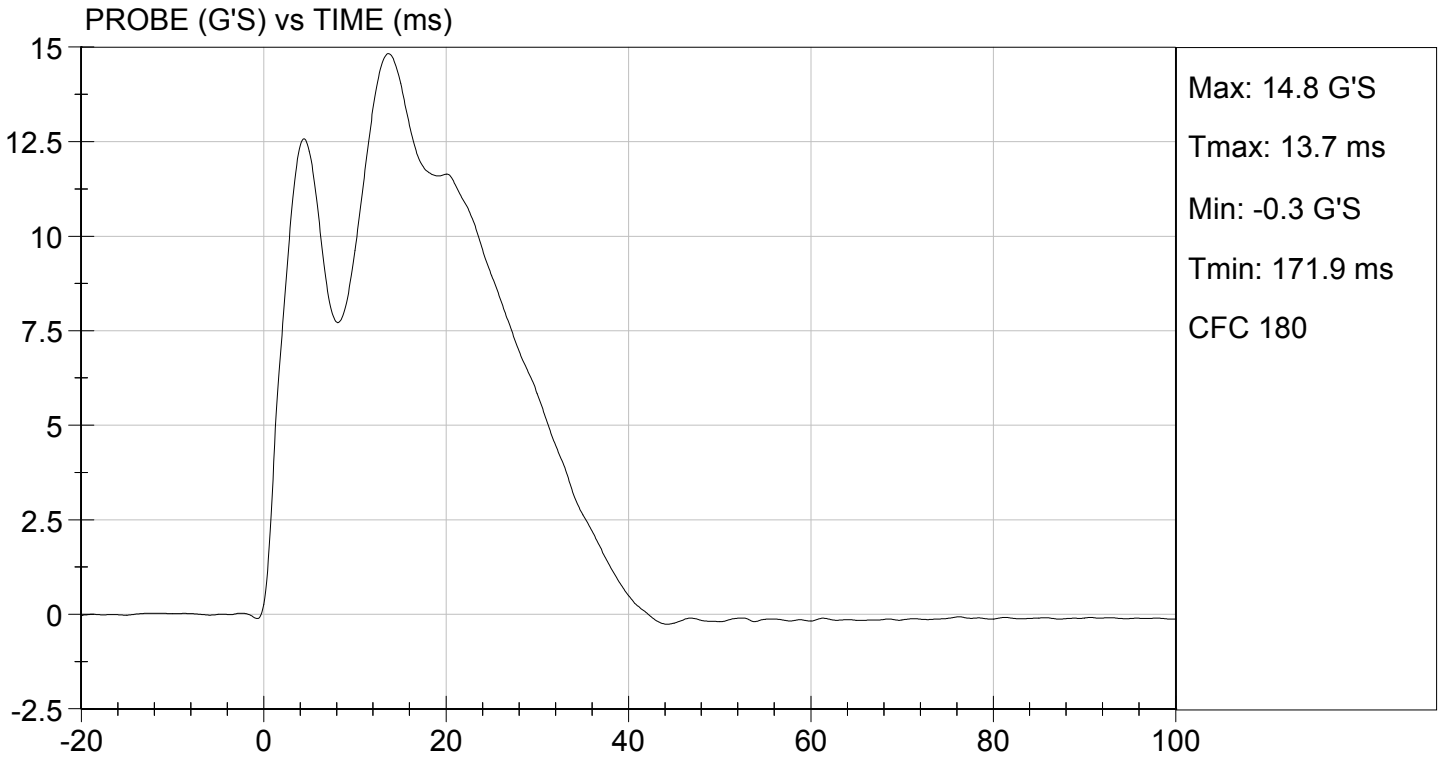



TEST DESC: SHOULDER IMPACT
VELOCITY: 14.24 ft/s, 4.34 m/s

TEST DATE: 01/11/2013
TEST #: D13093

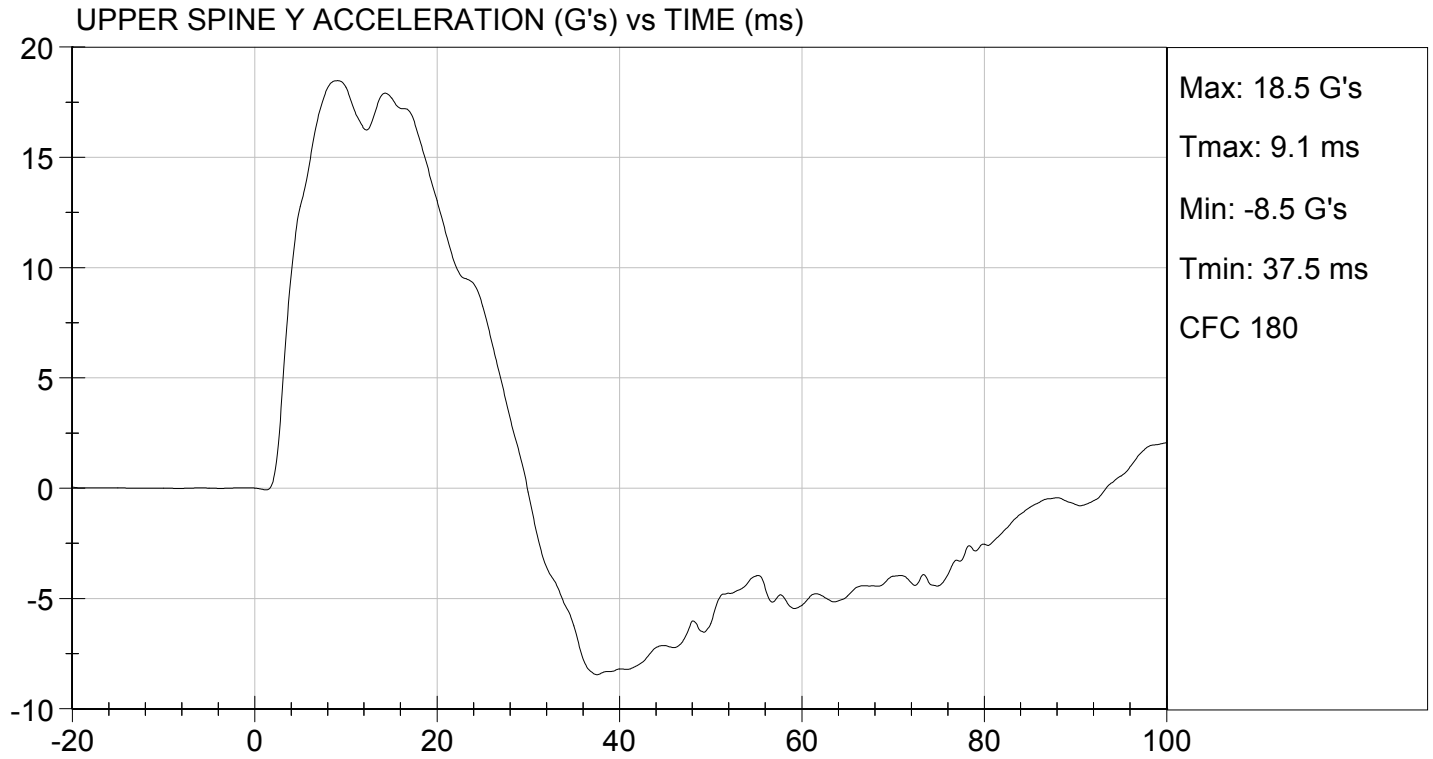

**MGA RESEARCH CORPORATION
THORAX (WITH ARM) IMPACT TEST
SID-IIs BUILD LEVEL D DUMMY**

ATD Serial No: 296

Test I.D.: D13094

Tested Parameter	Units	Specification	Result	Pass/Fail
Temperature	deg C	20.6 to 22.2	21.5	Pass
Humidity	%	10 to 70	37	Pass
Impact Velocity	m/s	6.60 to 6.80	6.77	Pass
Maximum Probe Acceleration	G's	30 to 36	30	Pass
Shoulder Displacement	mm	31 to 40	36	Pass
Upper Rib Displacement	mm	25 to 32	28	Pass
Middle Rib Displacement	mm	30 to 36	32	Pass
Lower Rib Displacement	mm	32 to 38	34	Pass
Upper Spine (T1) Y Acceleration	G's	34 to 43	36	Pass
Lower Spine (T12) Y Acceleration	G's	29 to 37	31	Pass
Overall Test Results				Pass

Jessica Hall
Laboratory Technician

01/11/2013
Test Date

David Winkelbauer
Approved By

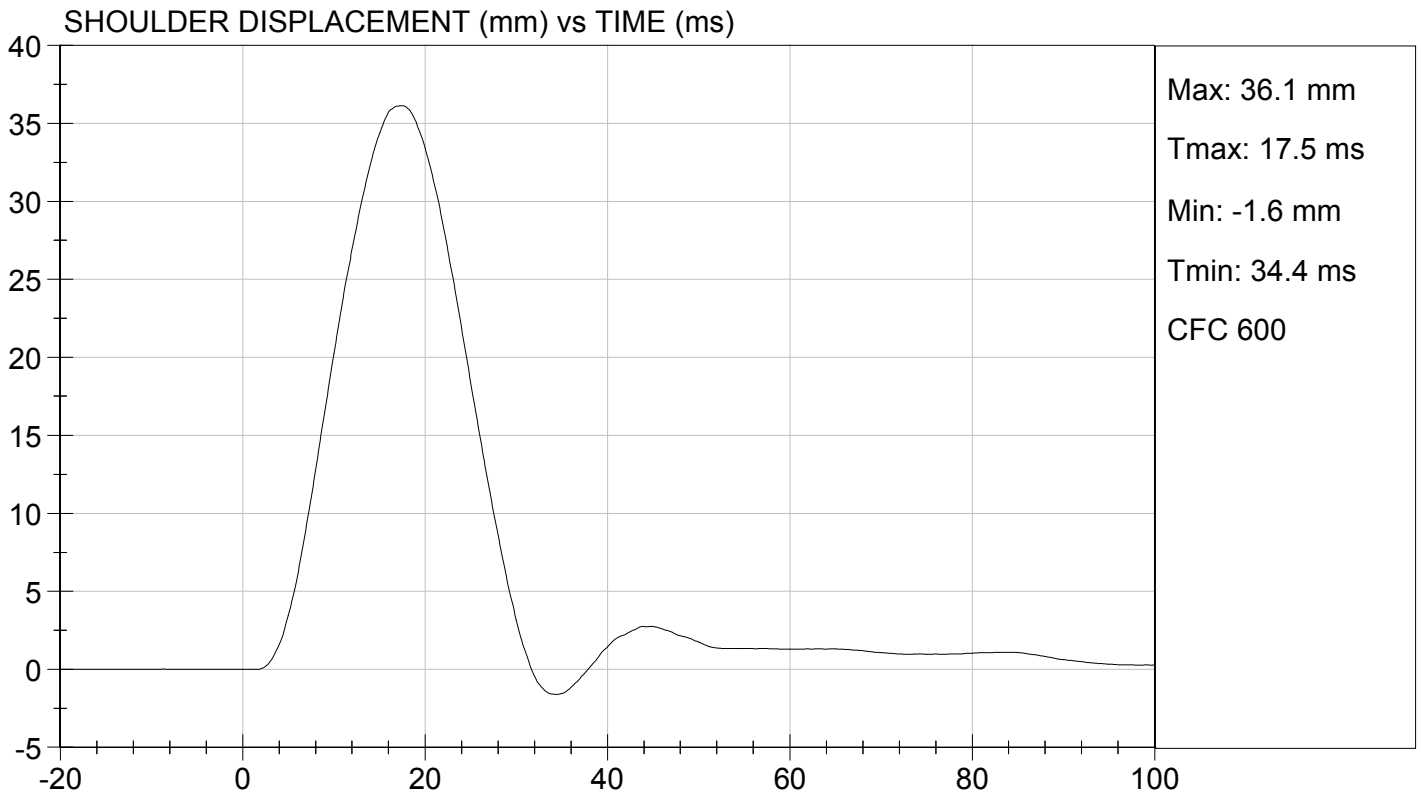
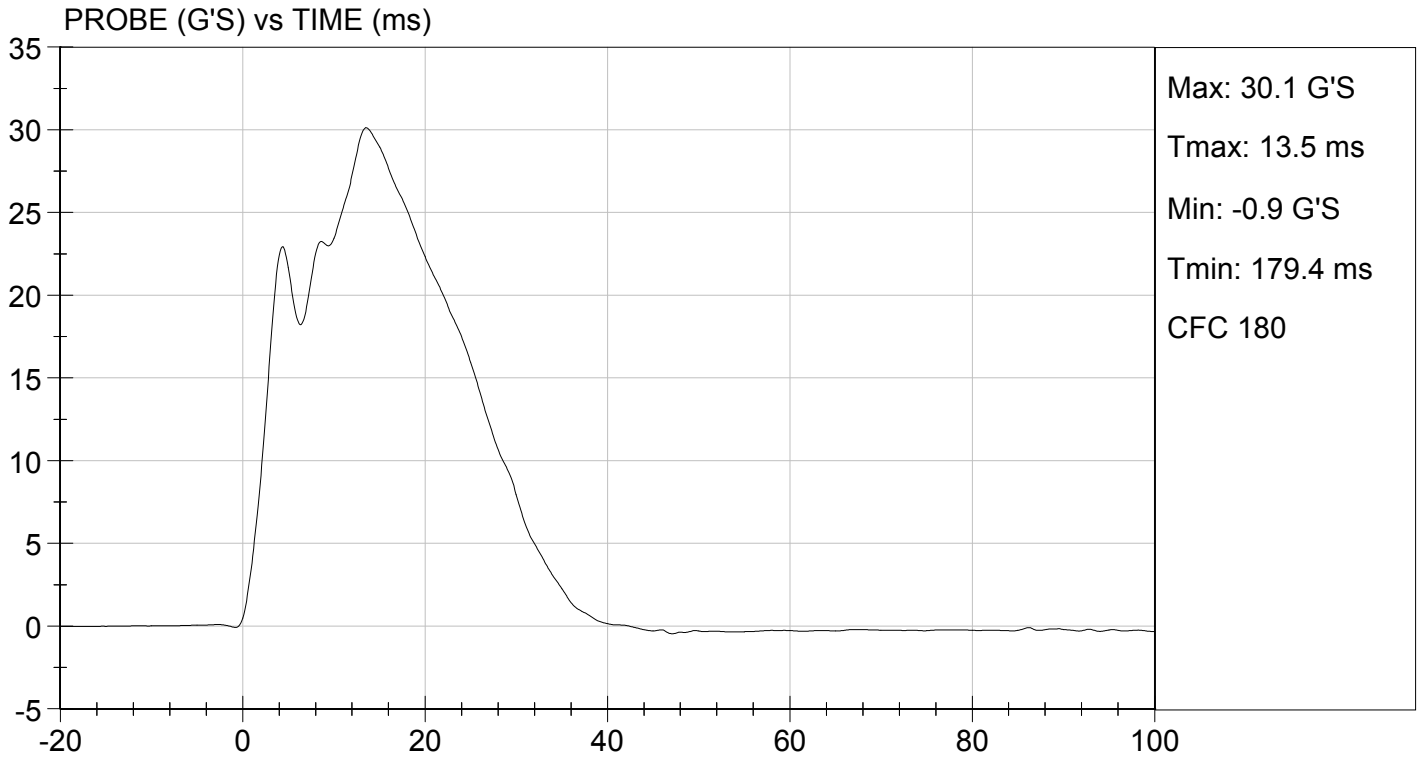

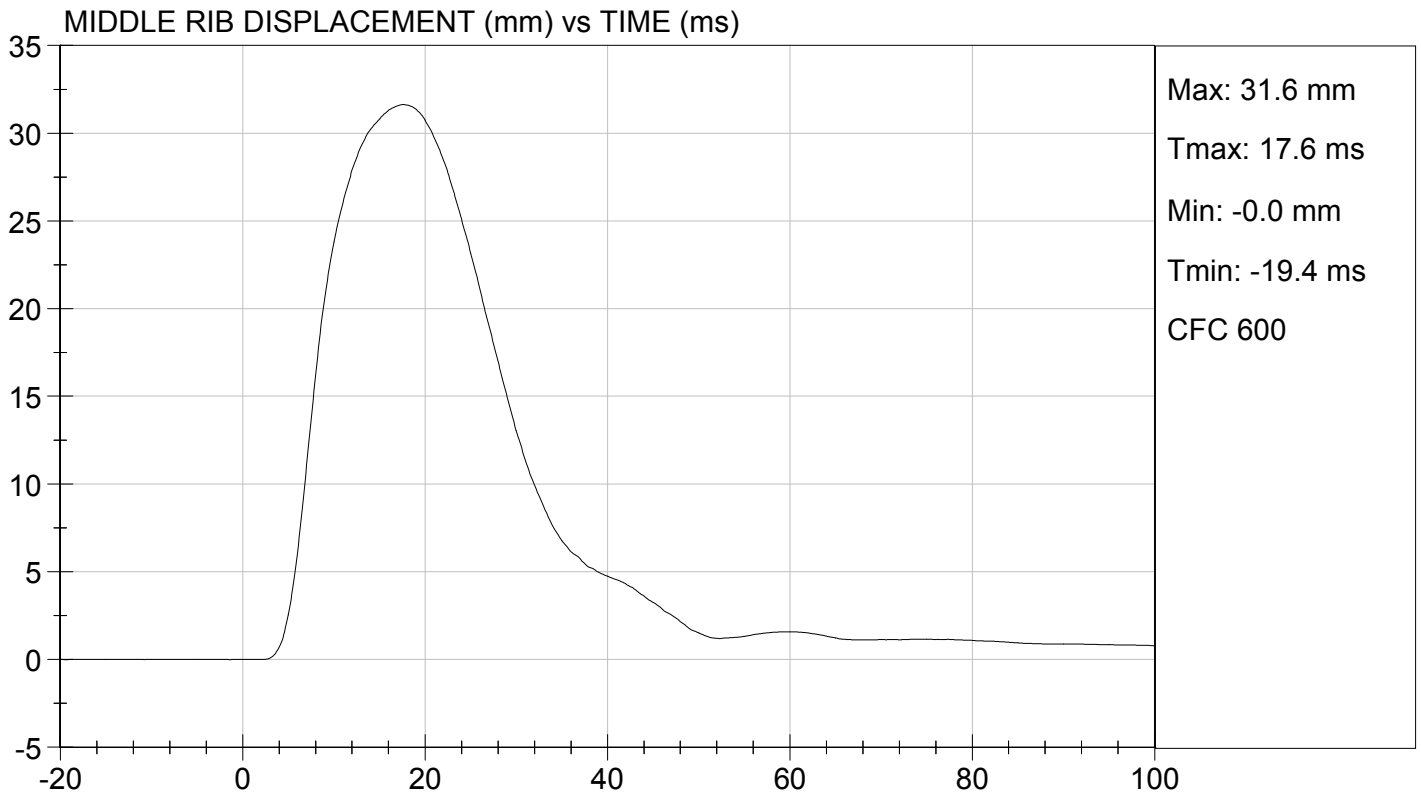
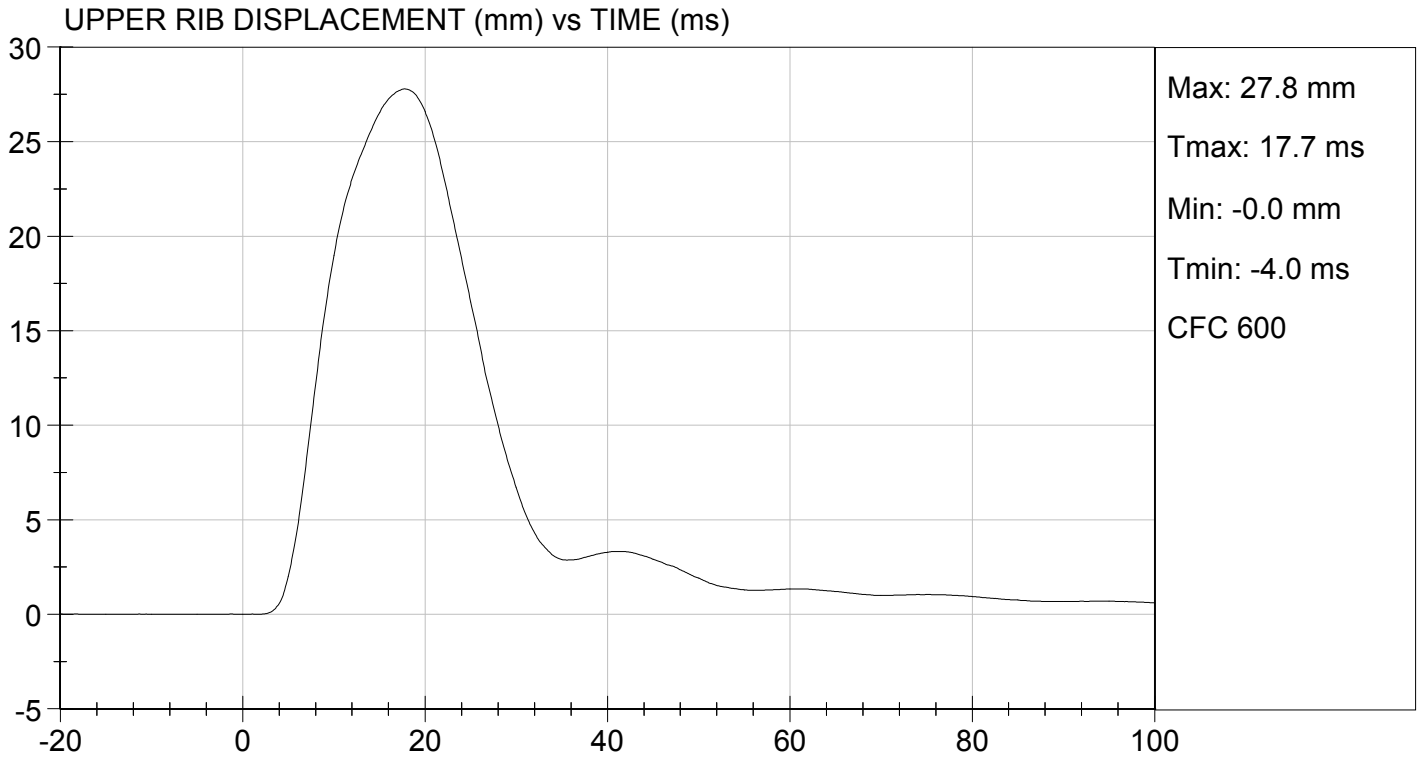

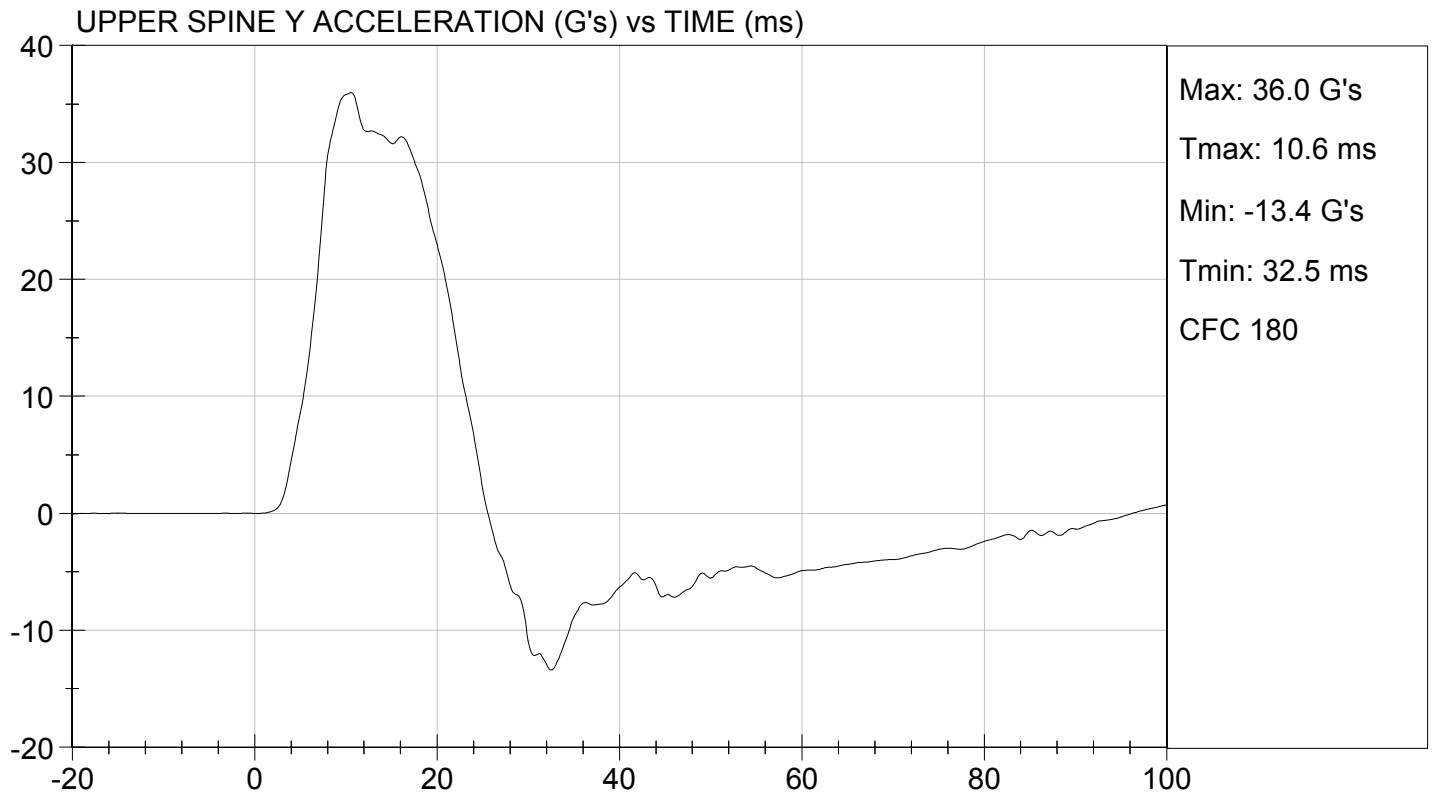
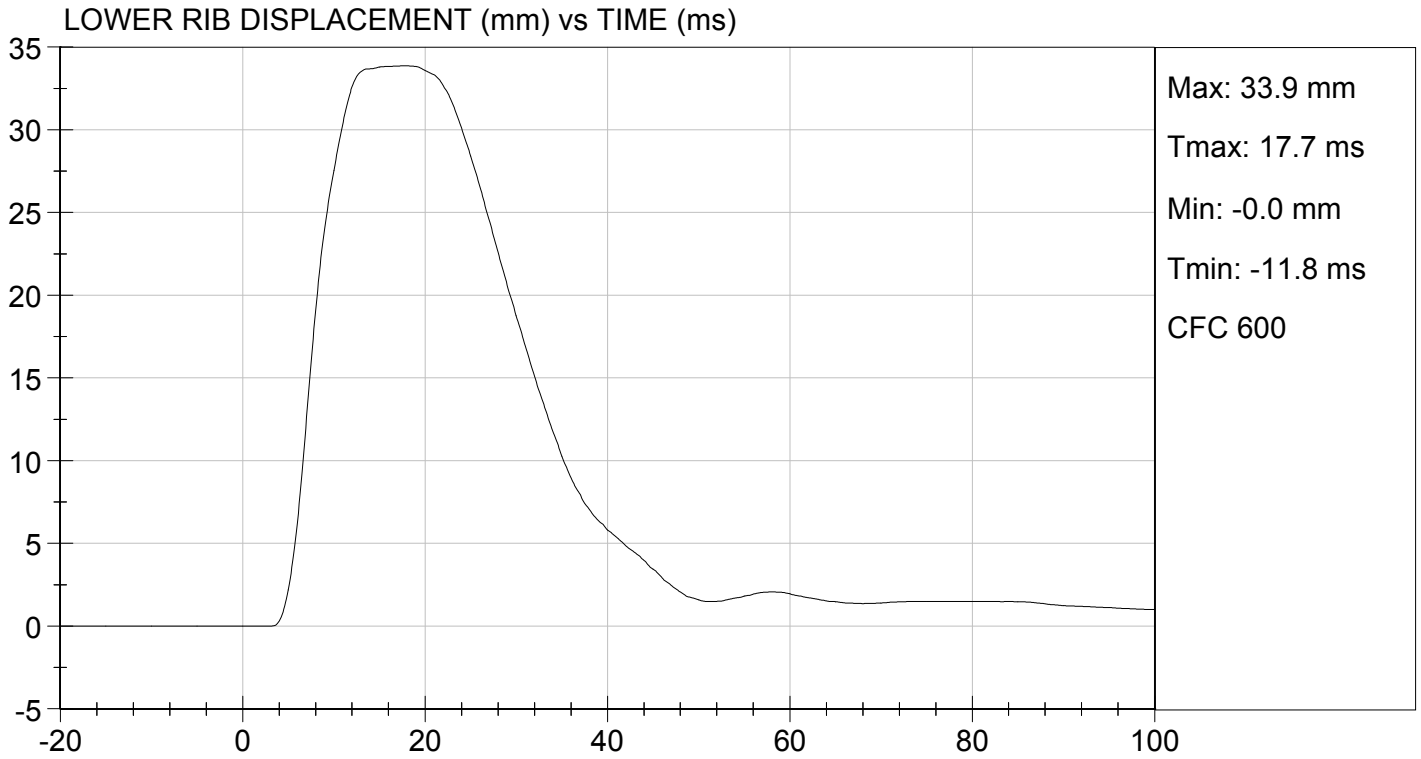

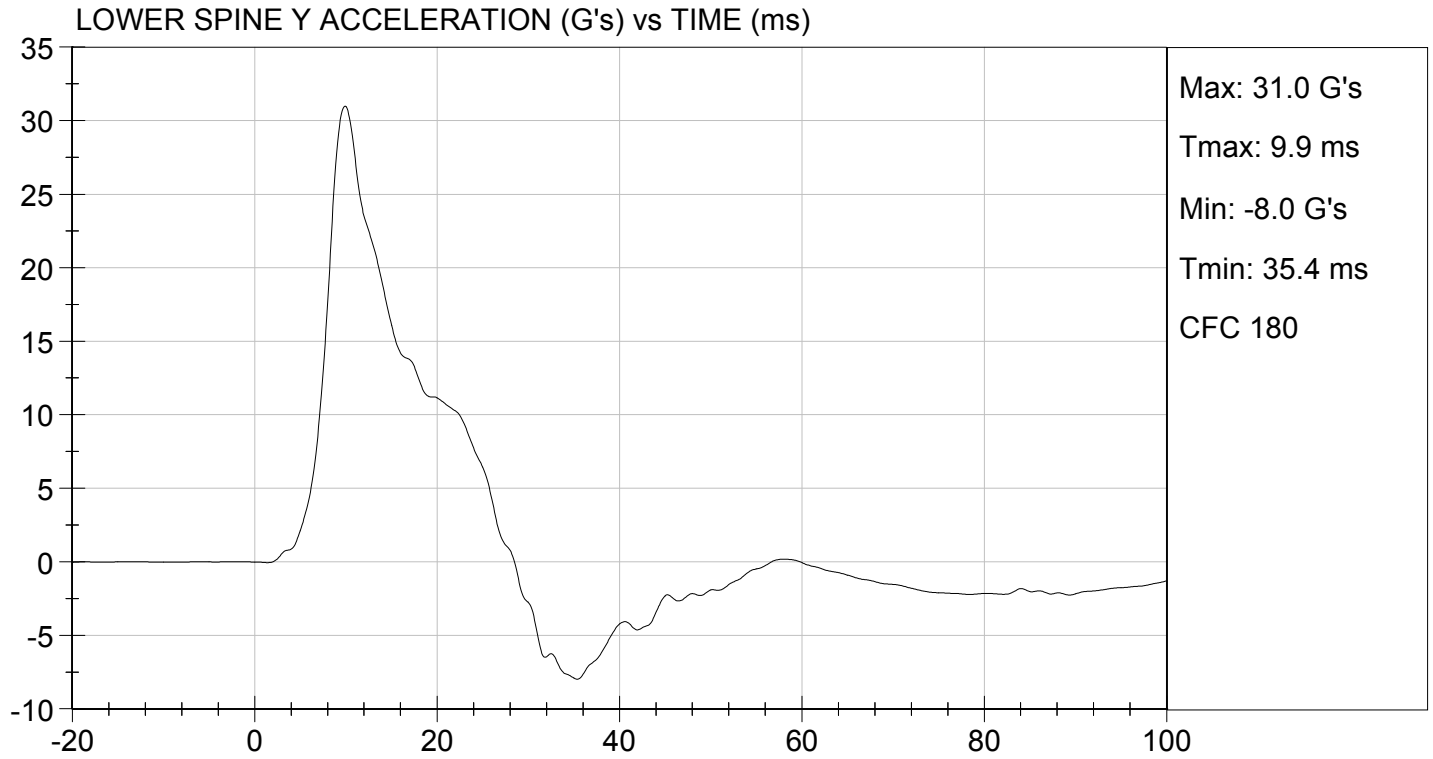

MGA RESEARCH CORPORATION
THORAX (WITHOUT ARM) IMPACT TEST
SID-IIs BUILD LEVEL D DUMMY

ATD Serial No: 296

Test I.D: D13095

Tested Parameter	Units	Specification	Result	Pass/Fail
Temperature	deg C	20.6 to 22.2	21.5	Pass
Humidity	%	10 to 70	37	Pass
Impact Velocity	m/s	4.20 to 4.40	4.30	Pass
Maximum Probe Acceleration	G's	14 to 18	14	Pass
Upper Rib Displacement	mm	32 to 40	35	Pass
Middle Rib Displacement	mm	39 to 45	41	Pass
Lower Rib Displacement	mm	35 to 43	40	Pass
Upper Spine (T1) Y Acceleration	G's	13 to 17	14	Pass
Lower Spine (T12) Y Acceleration	G's	7 to 11	8	Pass
Overall Test Results				Pass

Jessica Hall
 Laboratory Technician

01/11/2013
 Test Date

David Winkelbauer
 Approved By

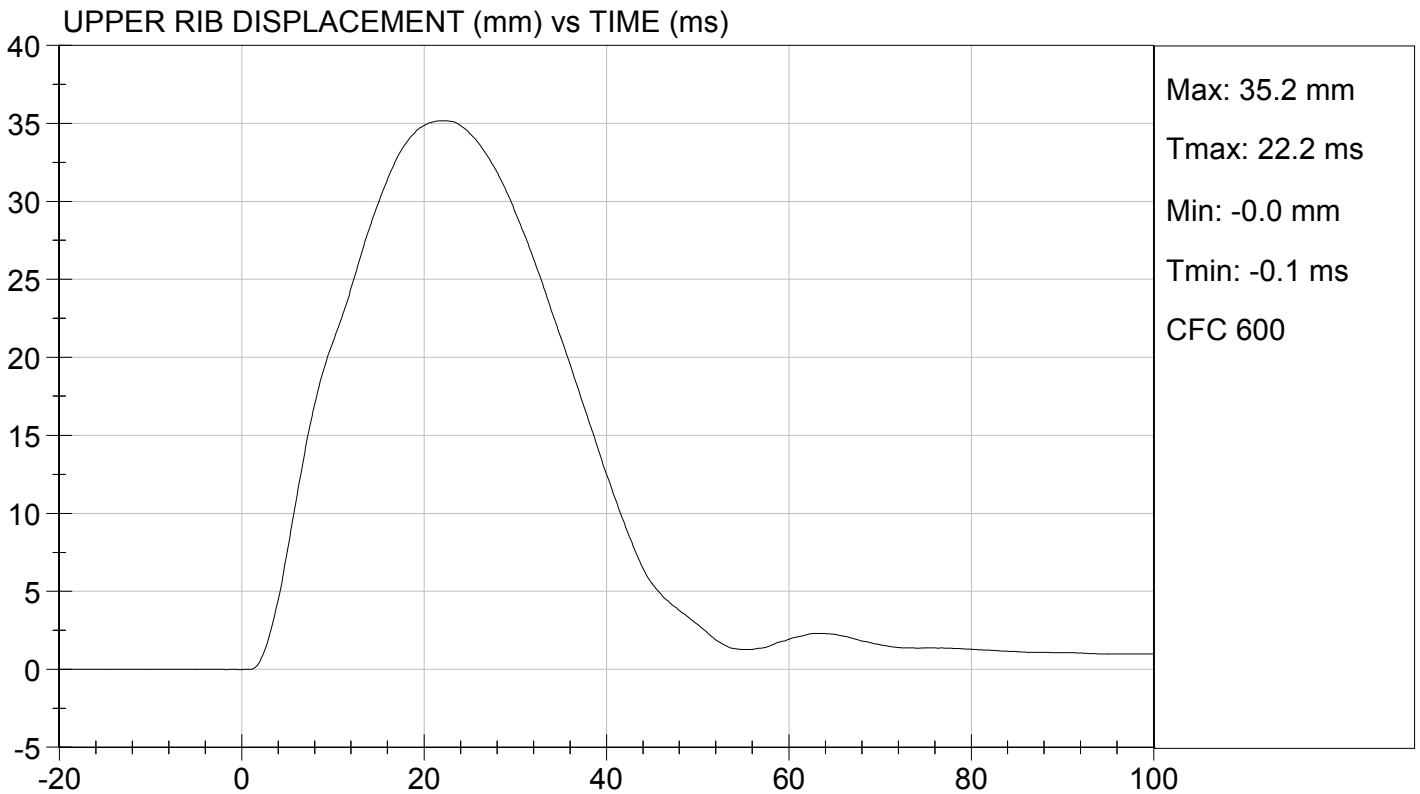
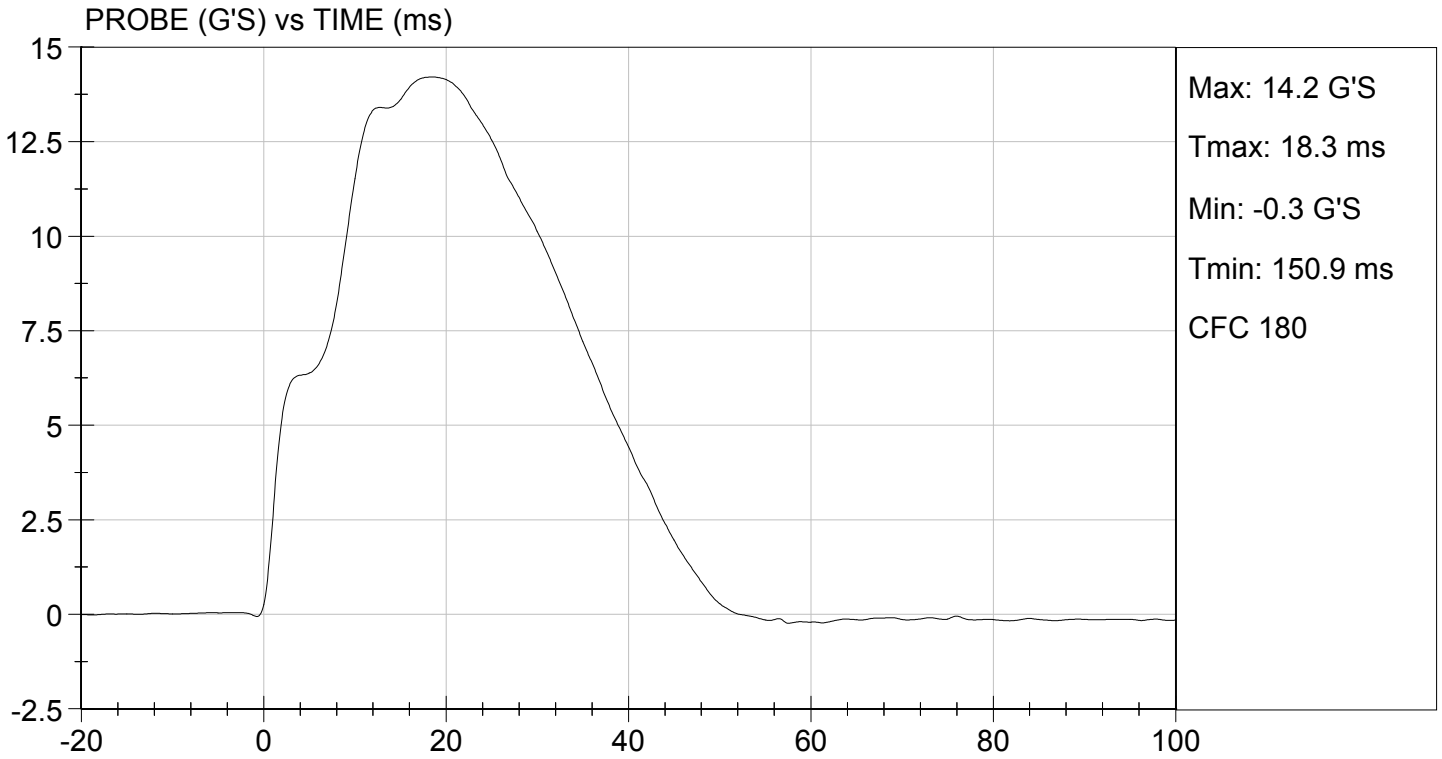

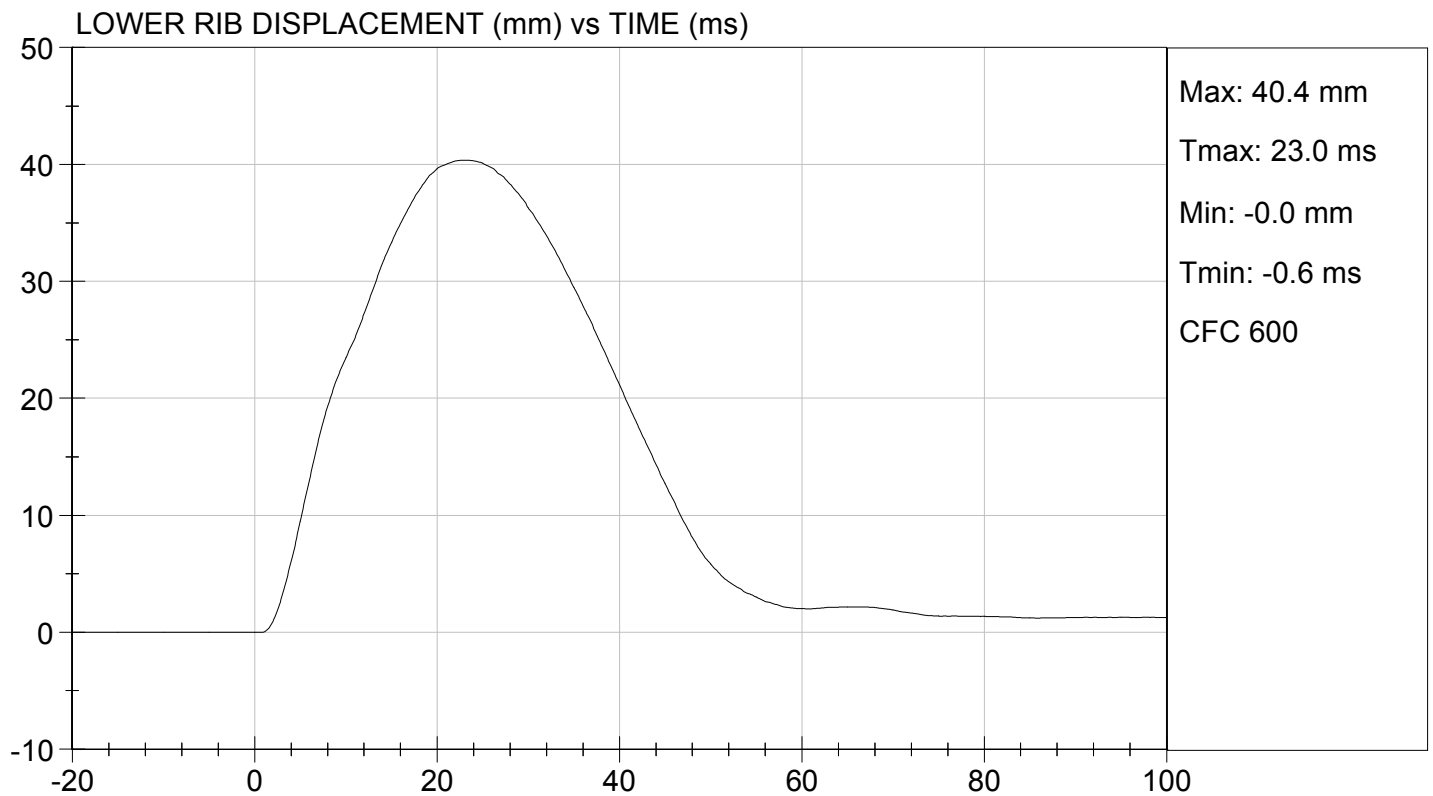
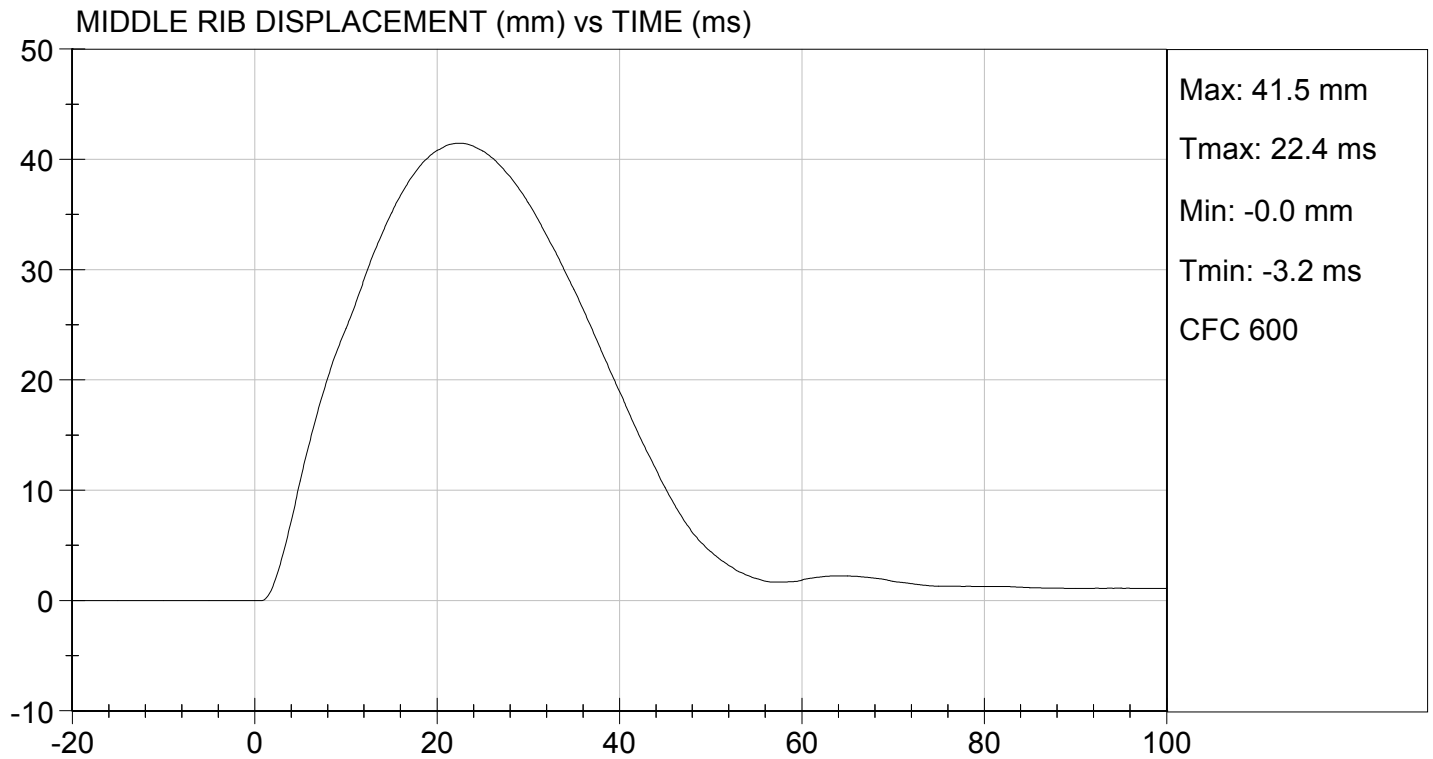

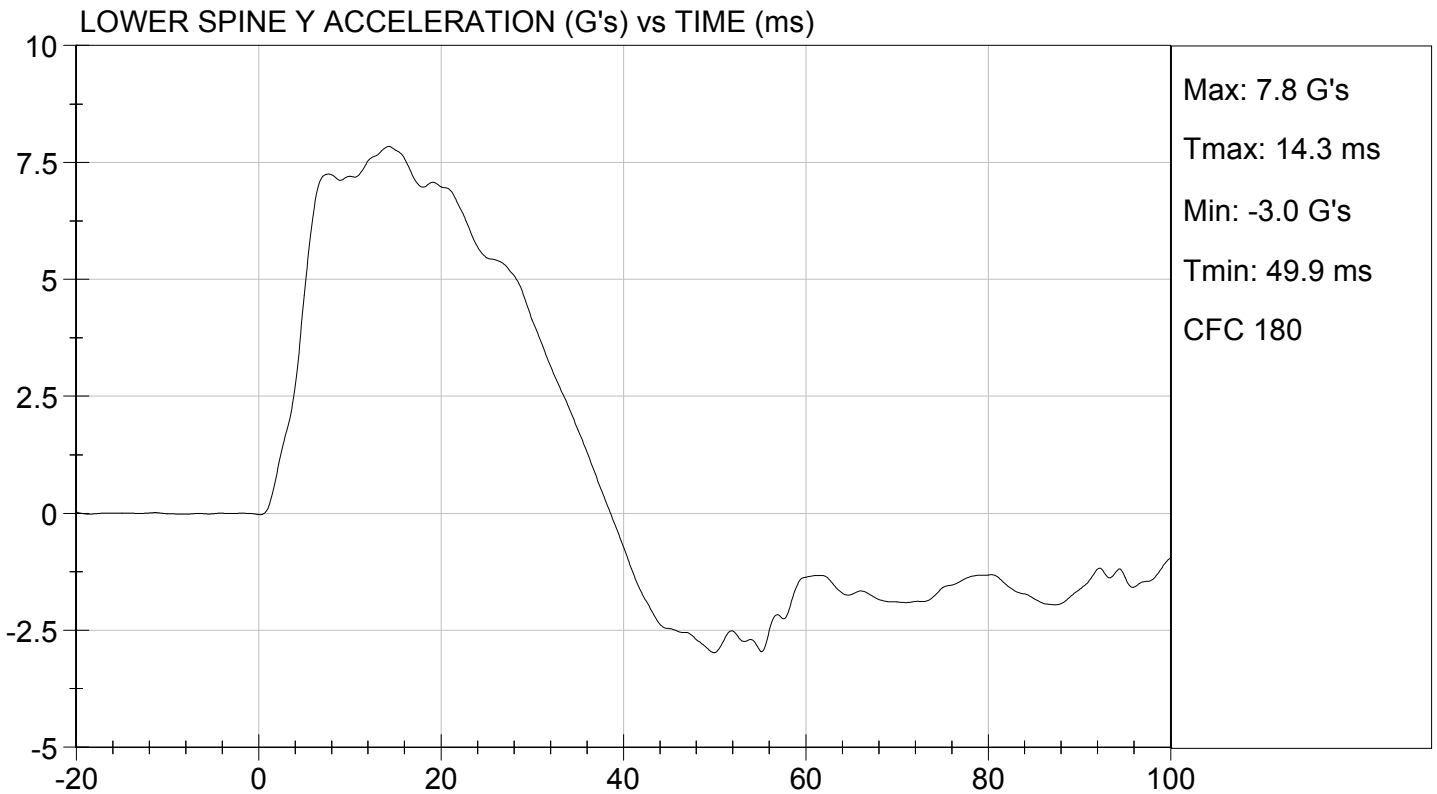
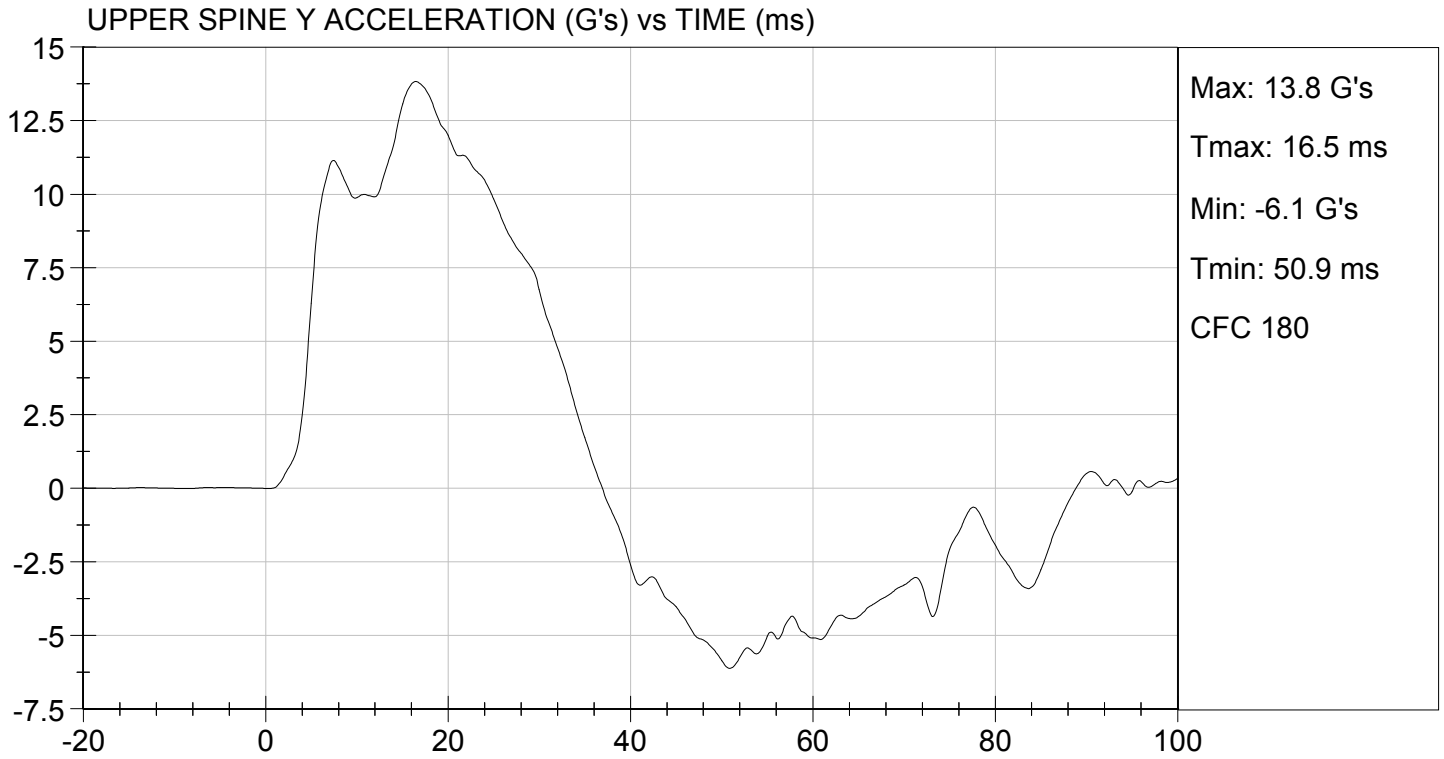

MGA RESEARCH CORPORATION
ABDOMINAL IMPACT TEST
SID-IIs BUILD LEVEL D DUMMY

ATD Serial No: 296

Test I.D: D13096

Tested Parameter	Units	Specification	Result	Pass/Fail
Temperature	deg C	20.6 to 22.2	21.6	Pass
Humidity	%	10 to 70	39	Pass
Impact Velocity	m/s	4.20 to 4.40	4.30	Pass
Maximum Probe Acceleration	G's	12 to 16	13	Pass
Upper Abdomen Rib Displacement	mm	36 to 47	44	Pass
Lower Abdomen Rib Displacement	mm	33 to 44	41	Pass
Lower Spine (T12) Y Acceleration	G's	9 to 14	10	Pass
Overall Test Results				Pass

Jessica Hall
 Laboratory Technician

01/11/2013
 Test Date

David Winkelbauer
 Approved By

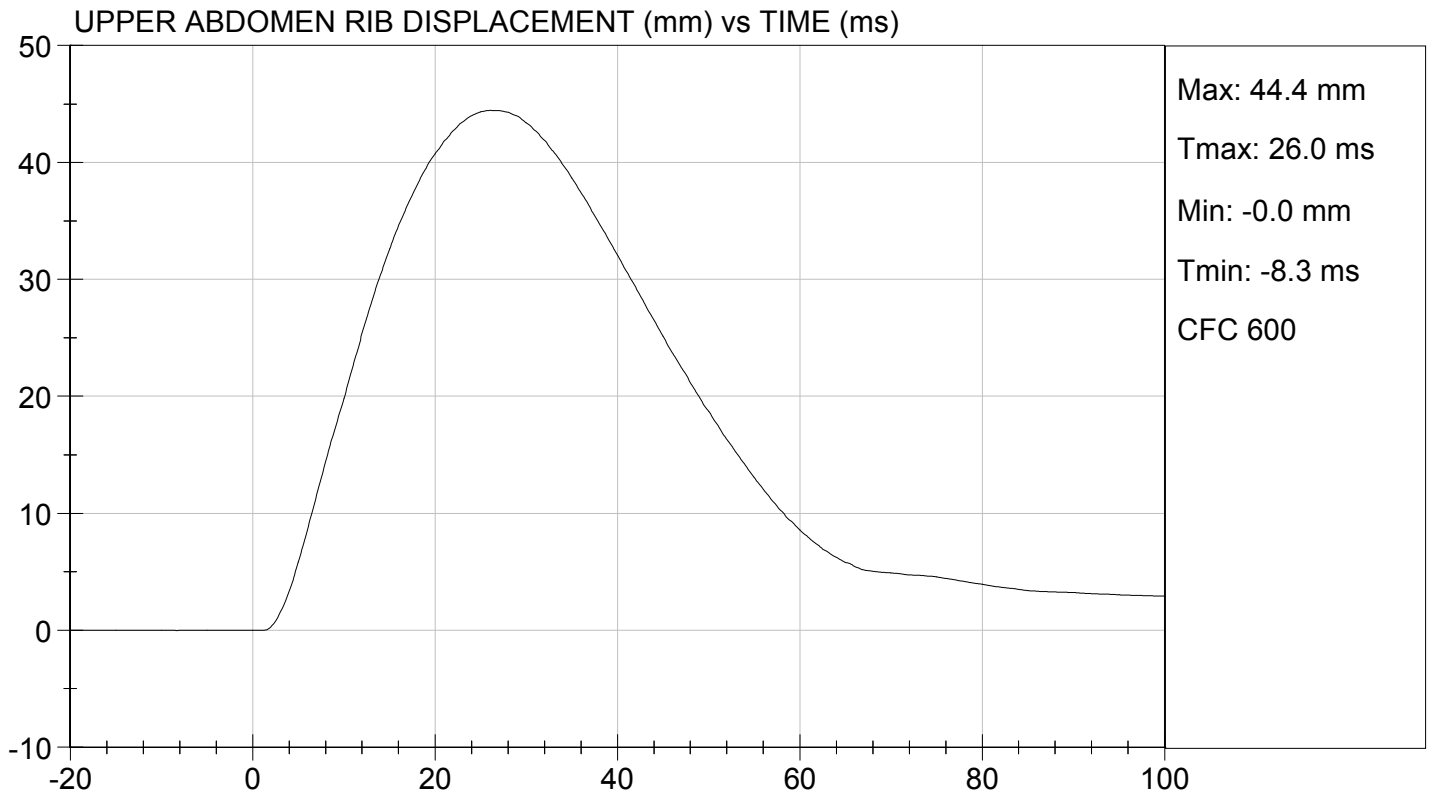
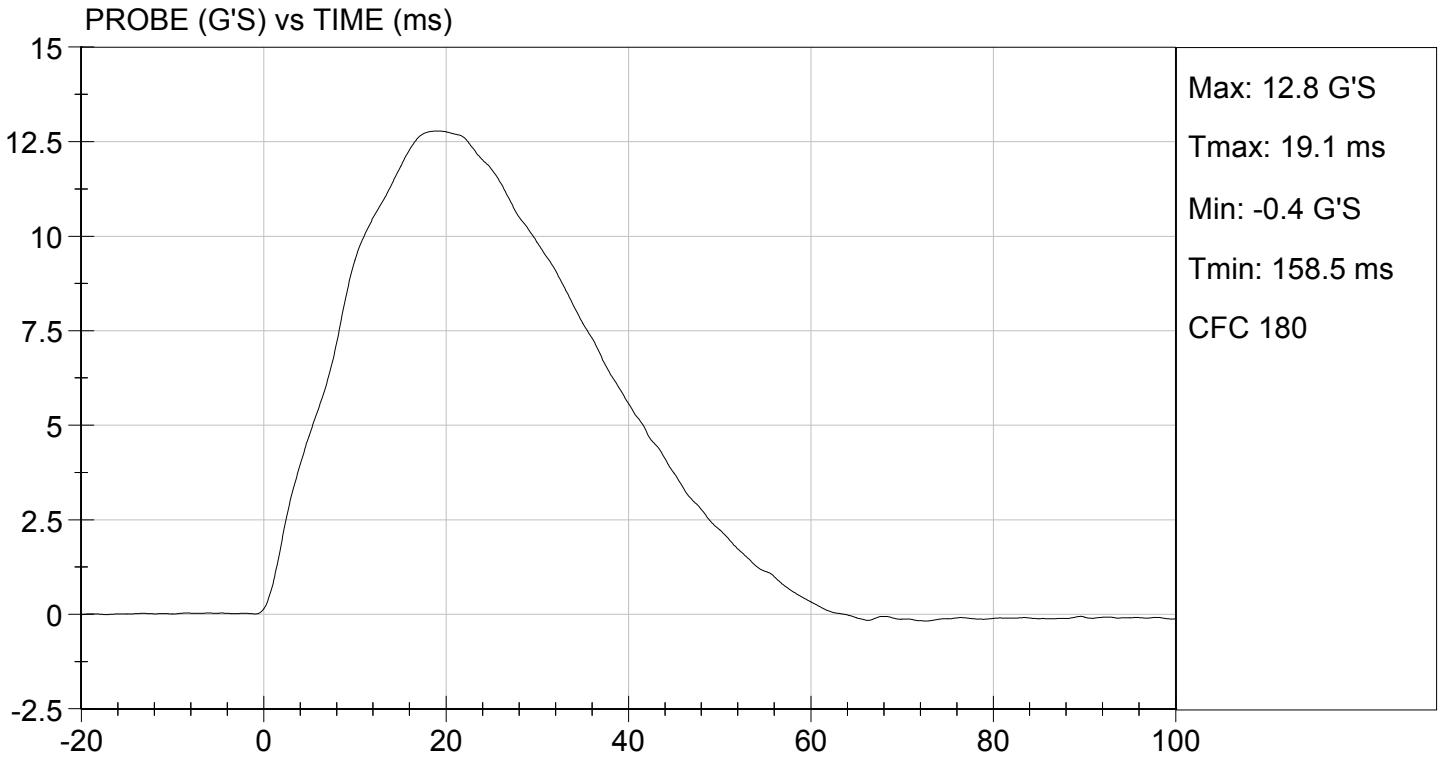



LOWER ABDOMEN RIB DISPLACEMENT (mm) vs TIME (ms)

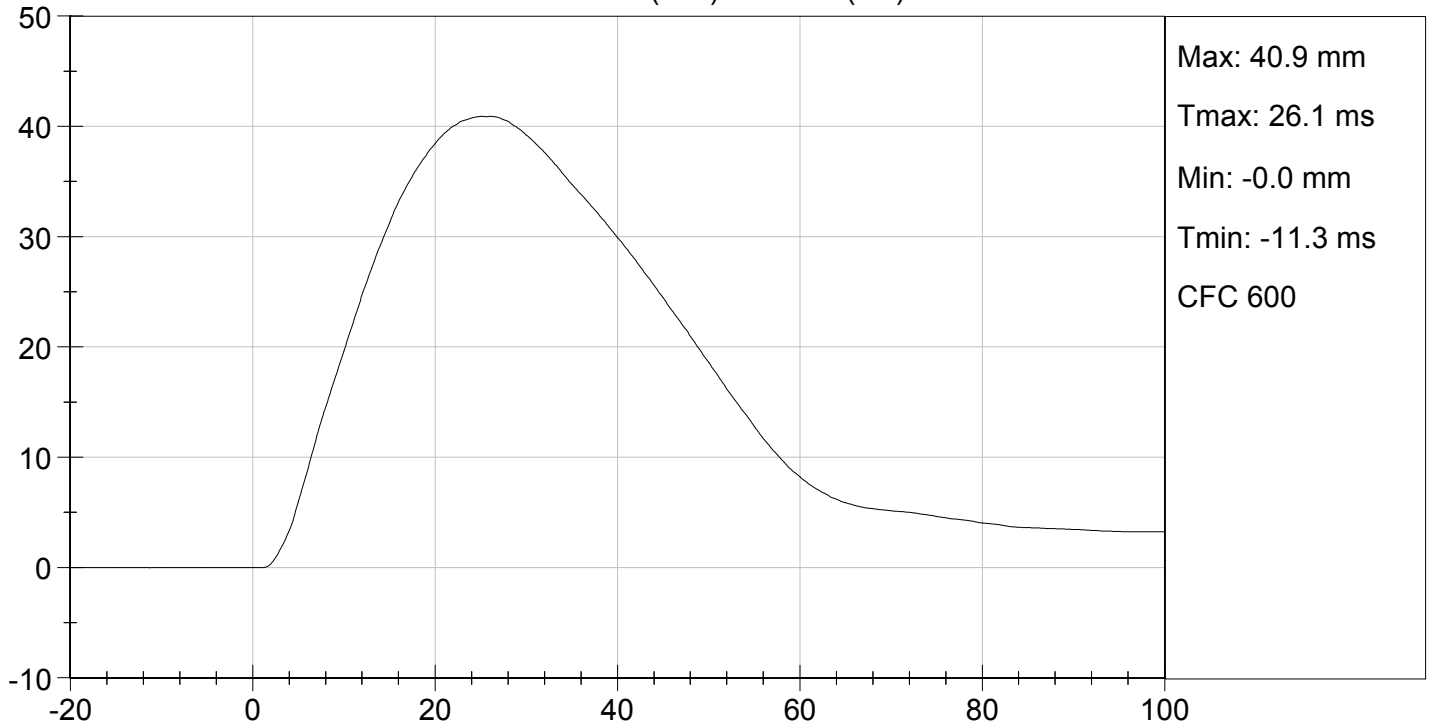

LOWER SPINE ACCELERATION (G's) vs TIME (ms)

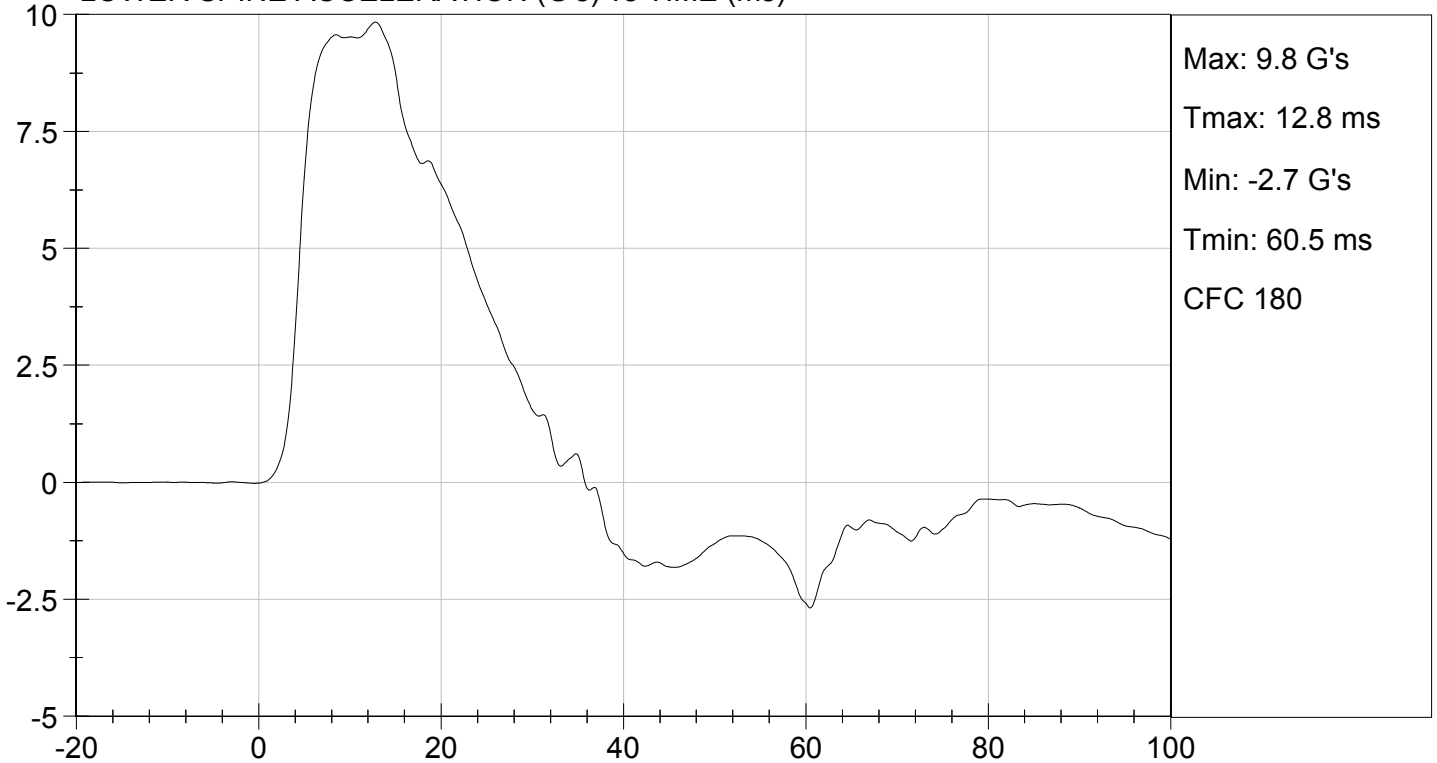

**MGA RESEARCH CORPORATION
 PELVIS IMPACT TEST
 SID-IIs BUILD LEVEL D DUMMY**

ATD Serial No: 296

Test I.D.: D13097

Tested Parameter	Units	Specification	Result	Pass/Fail
Temperature	deg C	20.6 to 22.2	21.6	Pass
Humidity	%	10 to 70	39	Pass
Impact Velocity	m/s	6.60 to 6.80	6.77	Pass
Maximum Probe Acceleration	G's	38 to 47	43	Pass
Pelvis Y Acceleration After 6 ms	G's	34 to 42	41	Pass
Peak Acetabulum Force	N	3600 to 4300	3,871	Pass
Overall Test Results				Pass

Jessica Gall
 Laboratory Technician

01/11/2013
 Test Date

David Winkelbauer
 Approved By

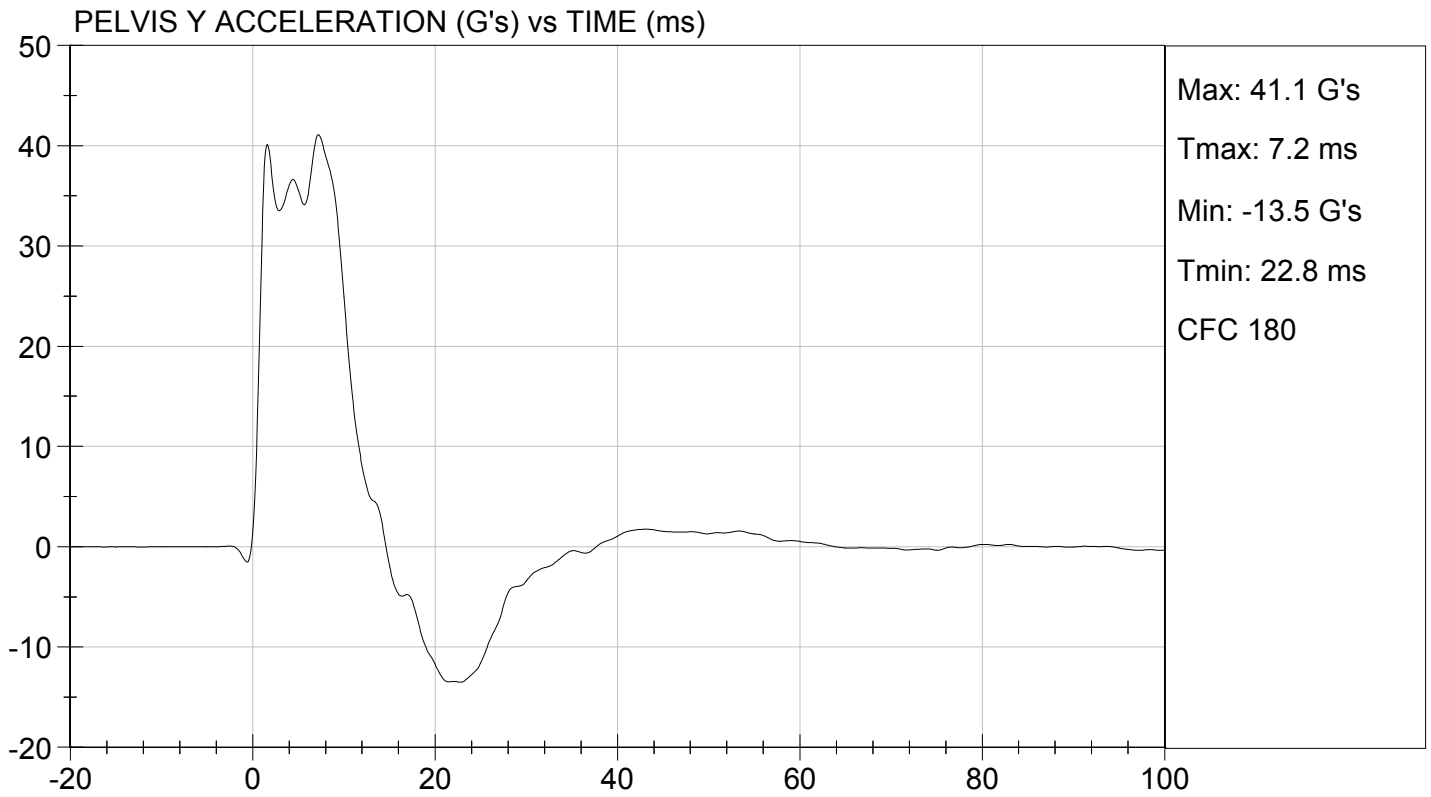
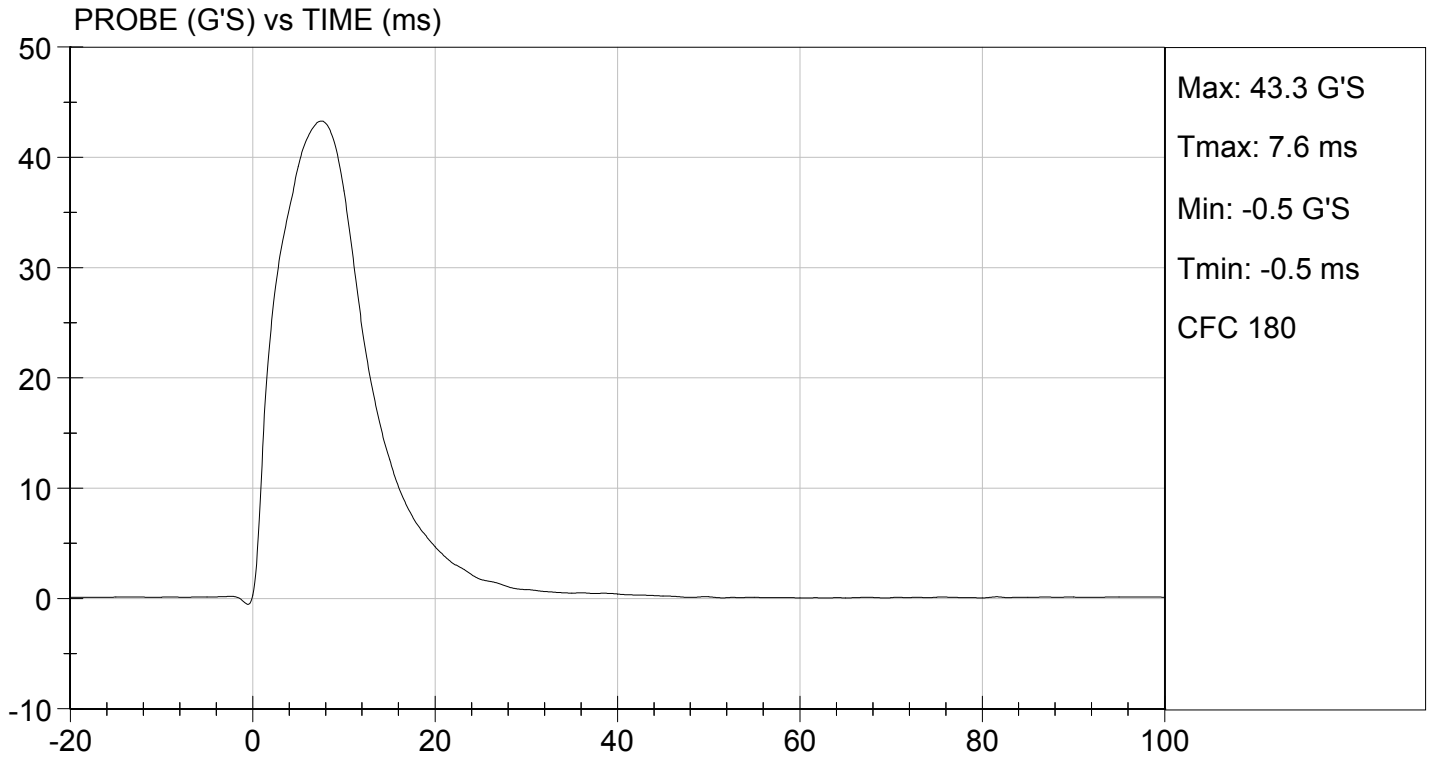

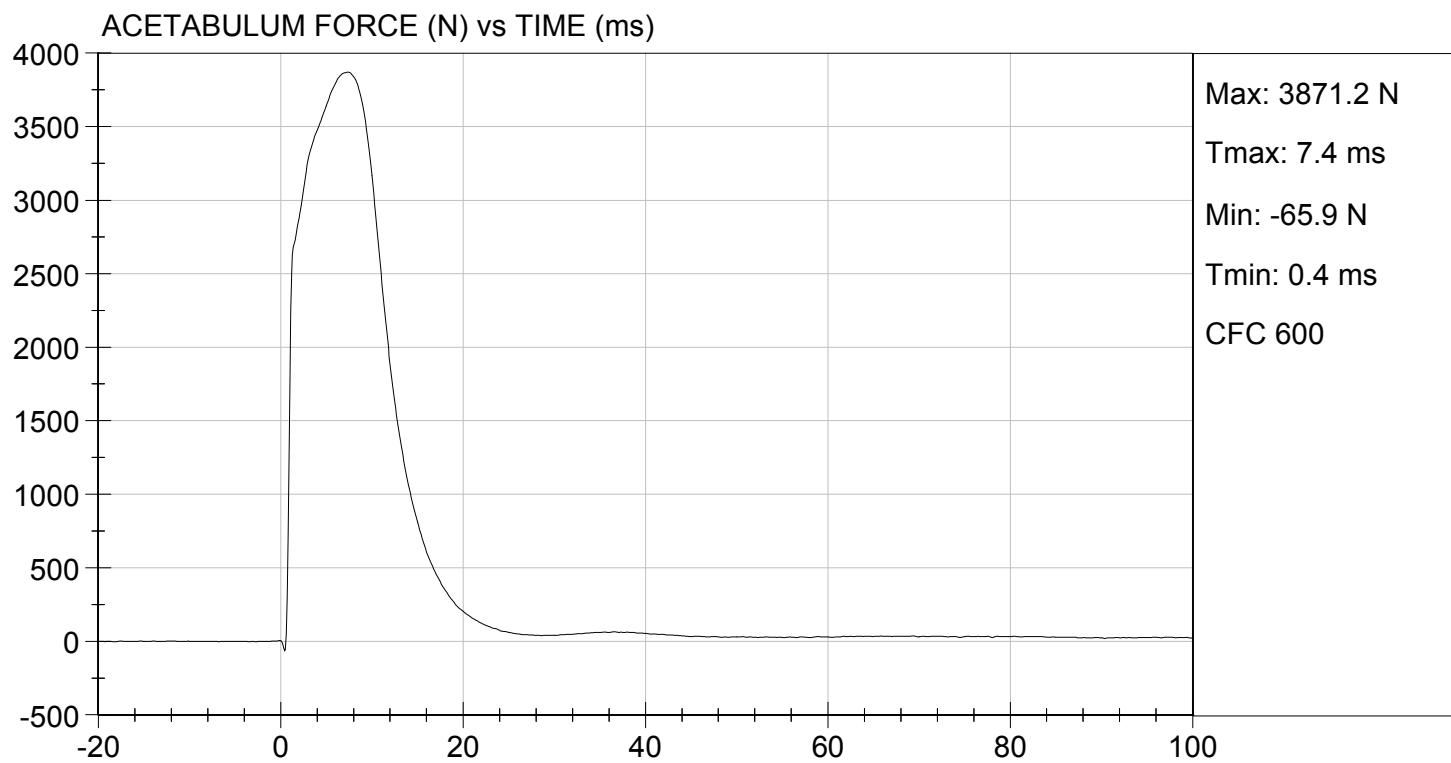

MGA RESEARCH CORPORATION
ILIAC IMPACT TEST
SID-IIs BUILD LEVEL D DUMMY

ATD Serial No: 296

Test I.D: D13098

Tested Parameter	Units	Specification	Result	Pass/Fail
Temperature	deg C	20.6 to 22.2	21.6	Pass
Humidity	%	10 to 70	39	Pass
Impact Velocity	m/s	4.20 to 4.40	4.34	Pass
Maximum Probe Acceleration	G's	36 to 45	38	Pass
Pelvis Y Acceleration	G's	28 to 39	33	Pass
Peak Pelvis Iliac Force	N	4100 to 5100	4,677	Pass
Overall Test Results				Pass

Jessica Gall
 Laboratory Technician

01/11/2013
 Test Date

David Winkelbauer
 Approved By

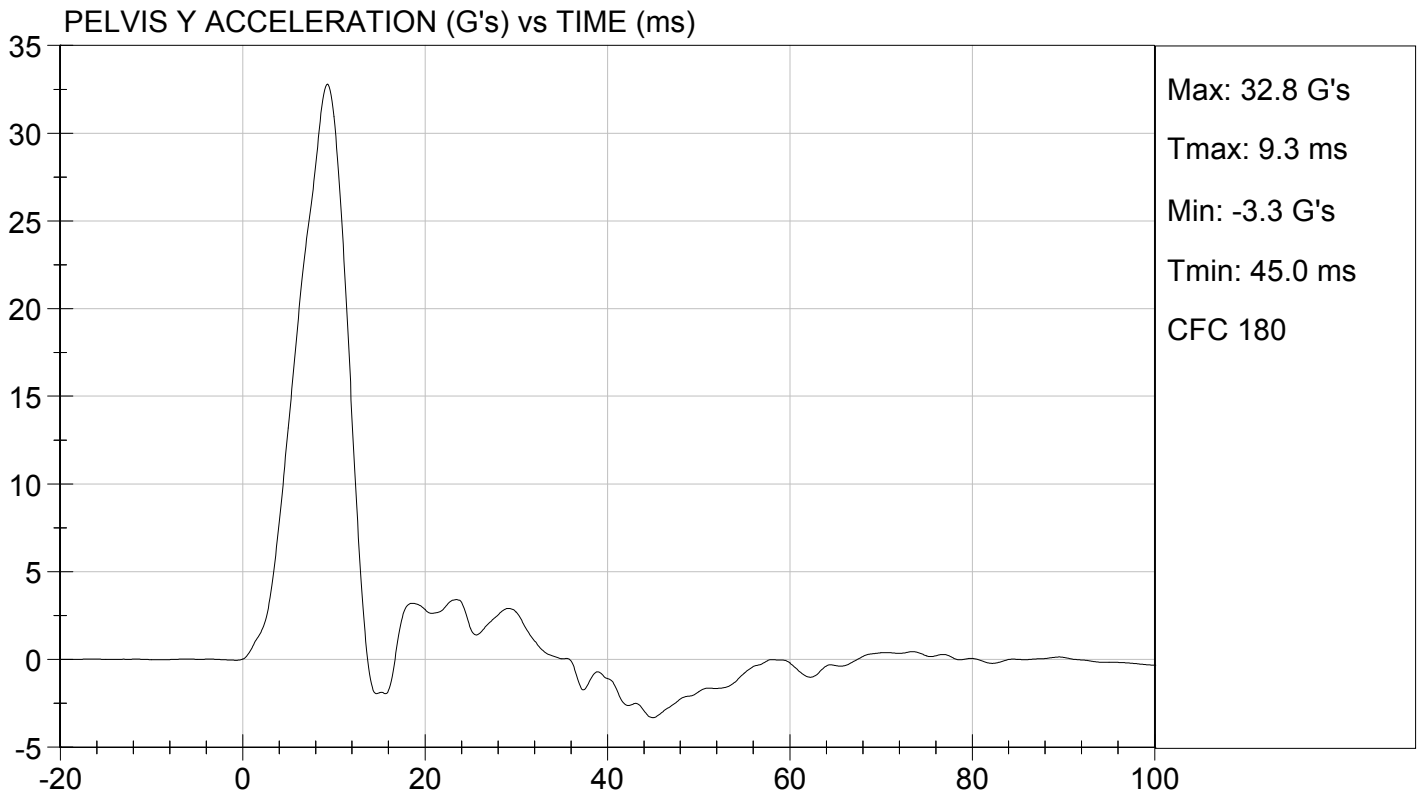
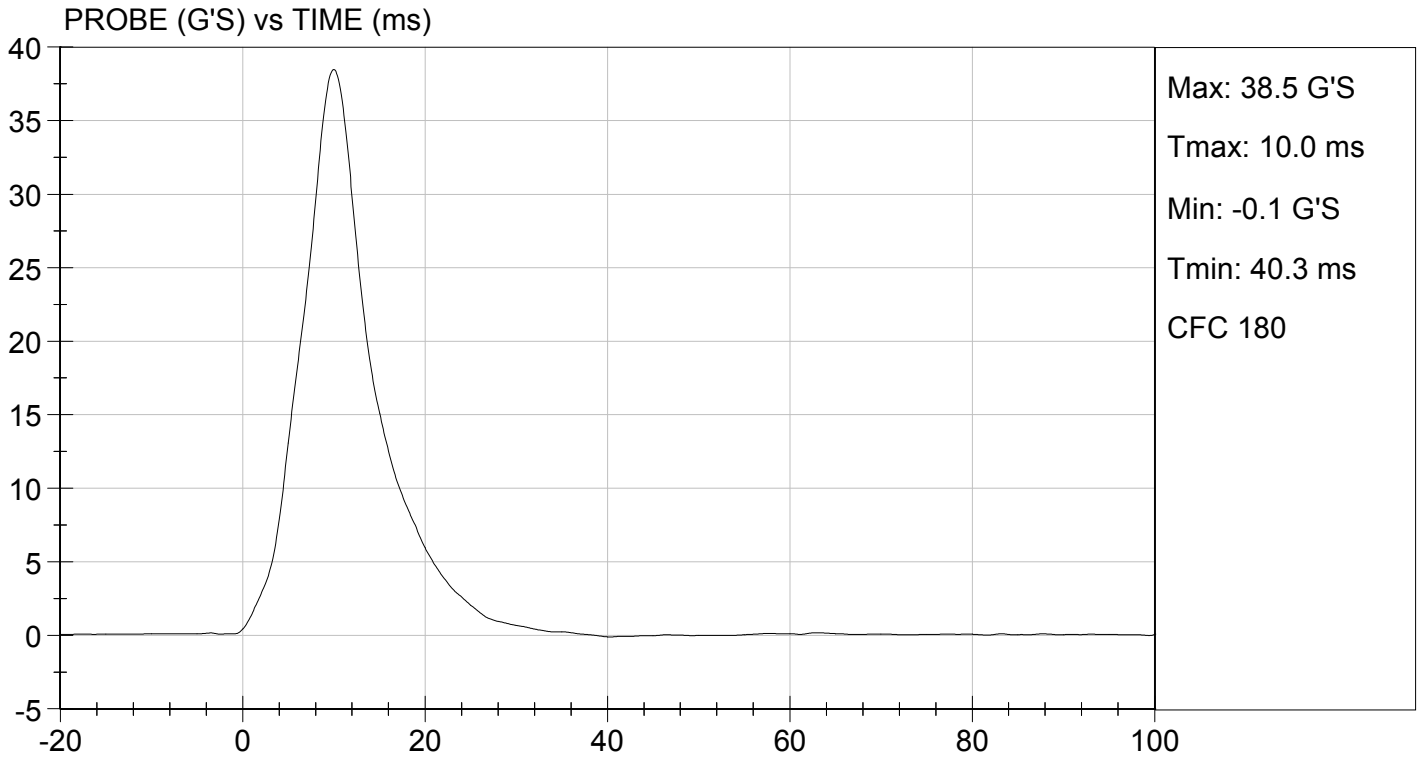



TEST DESC: ILLIAC
VELOCITY: 14.25 ft/s, 4.34 m/s

TEST DATE: 01/11/2013
TEST #: D13098

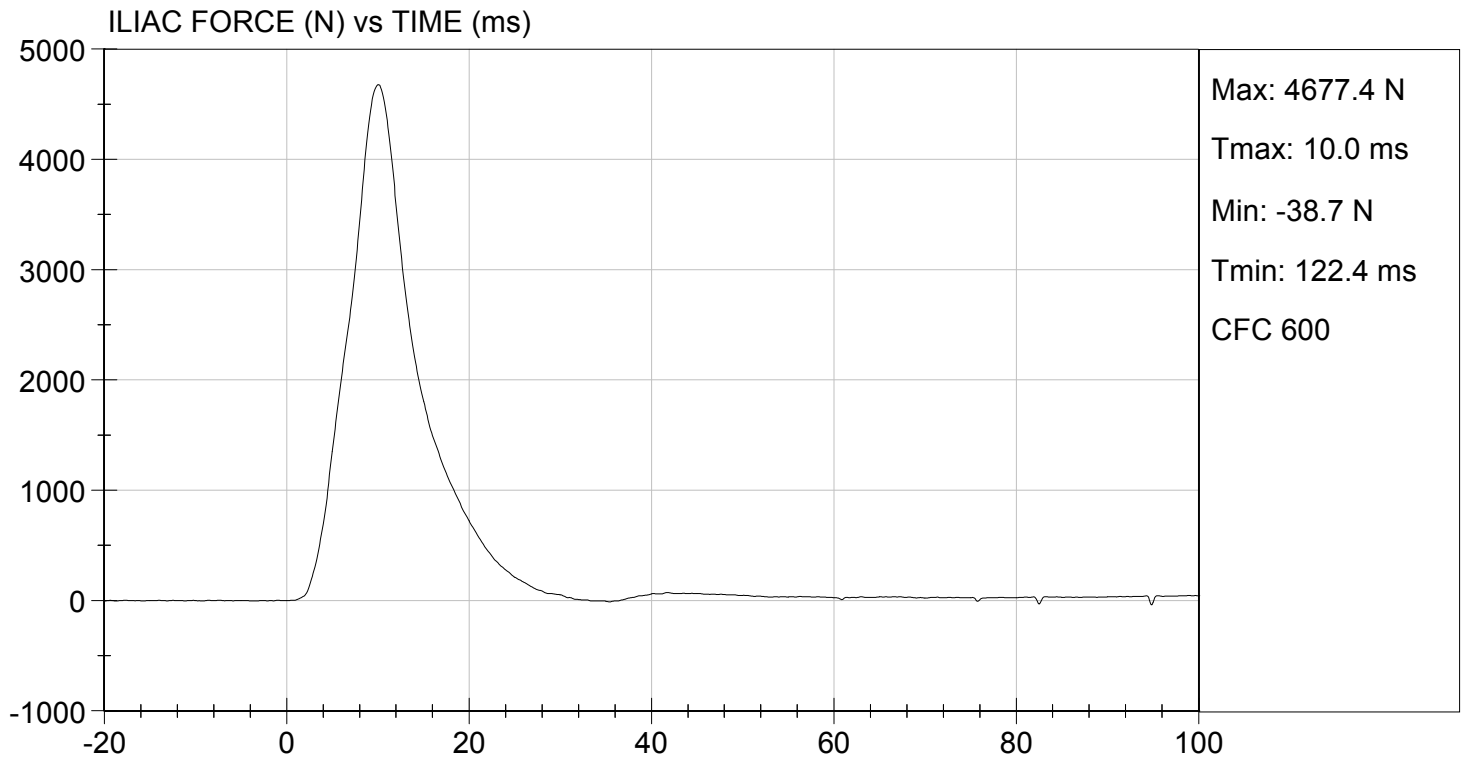

**MGA RESEARCH CORPORATION
HEAD DROP TEST
SID-IIs BUILD LEVEL D DUMMY**

ATD Serial No: 296

Test ID: D13531

Tested Parameter	Units	Specification	Result	Pass/Fail
Laboratory Temperature	deg C	20.6 to 22.2	21.2	Pass
Laboratory Relative Humidity	%	10 to 70	28	Pass
Peak Resultant Acceleration	G's	115 to 137	122	Pass
Peak Longitudinal Acceleration	G's	+/- 15	-5.3	Pass
Unimodal	N/A	Yes	Yes	Pass
Oscillations	N/A	<15%	Yes	Pass
Overall Test Results				Pass

Jessica Gall

 Laboratory Technician

02/22/2013

 Test Date

David Winkelbauer

 Approved By

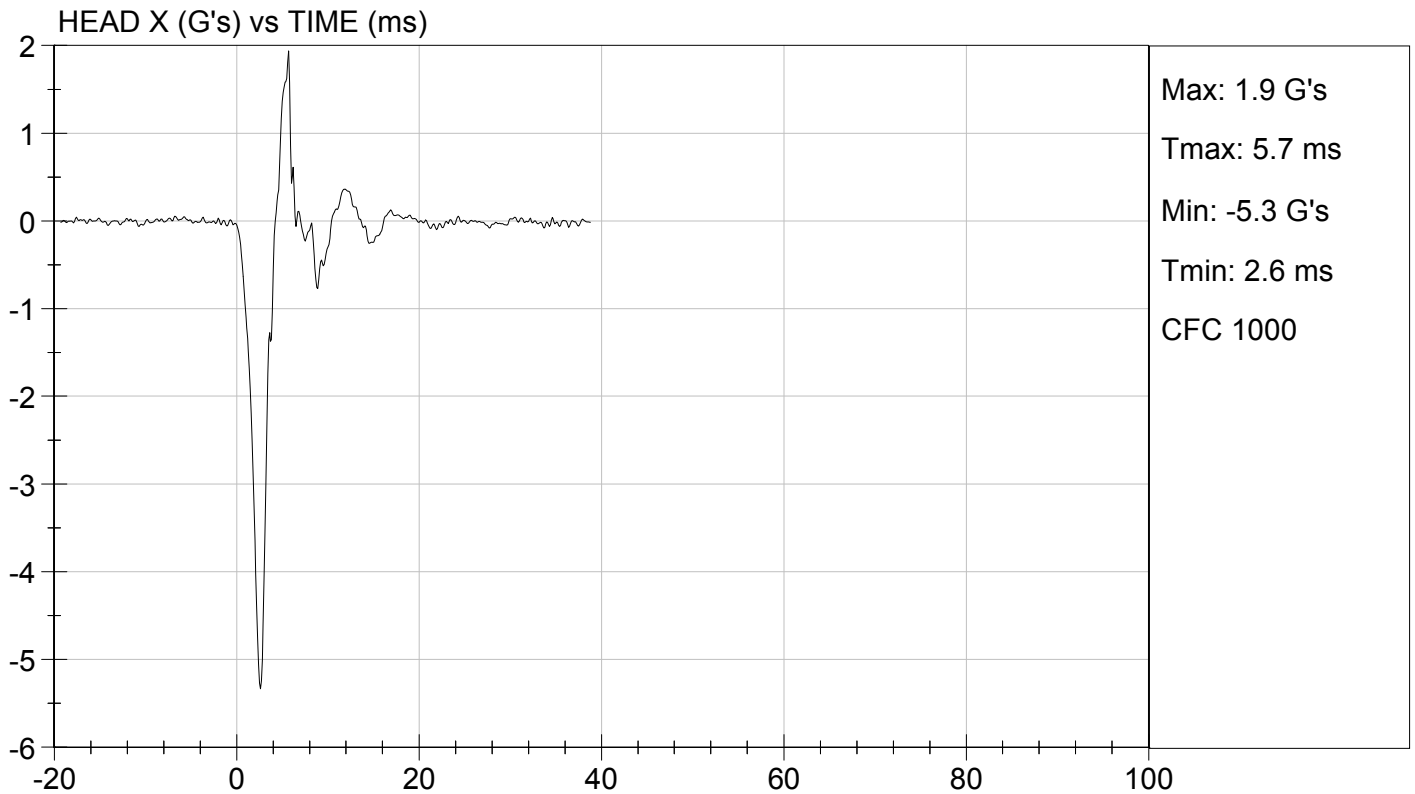
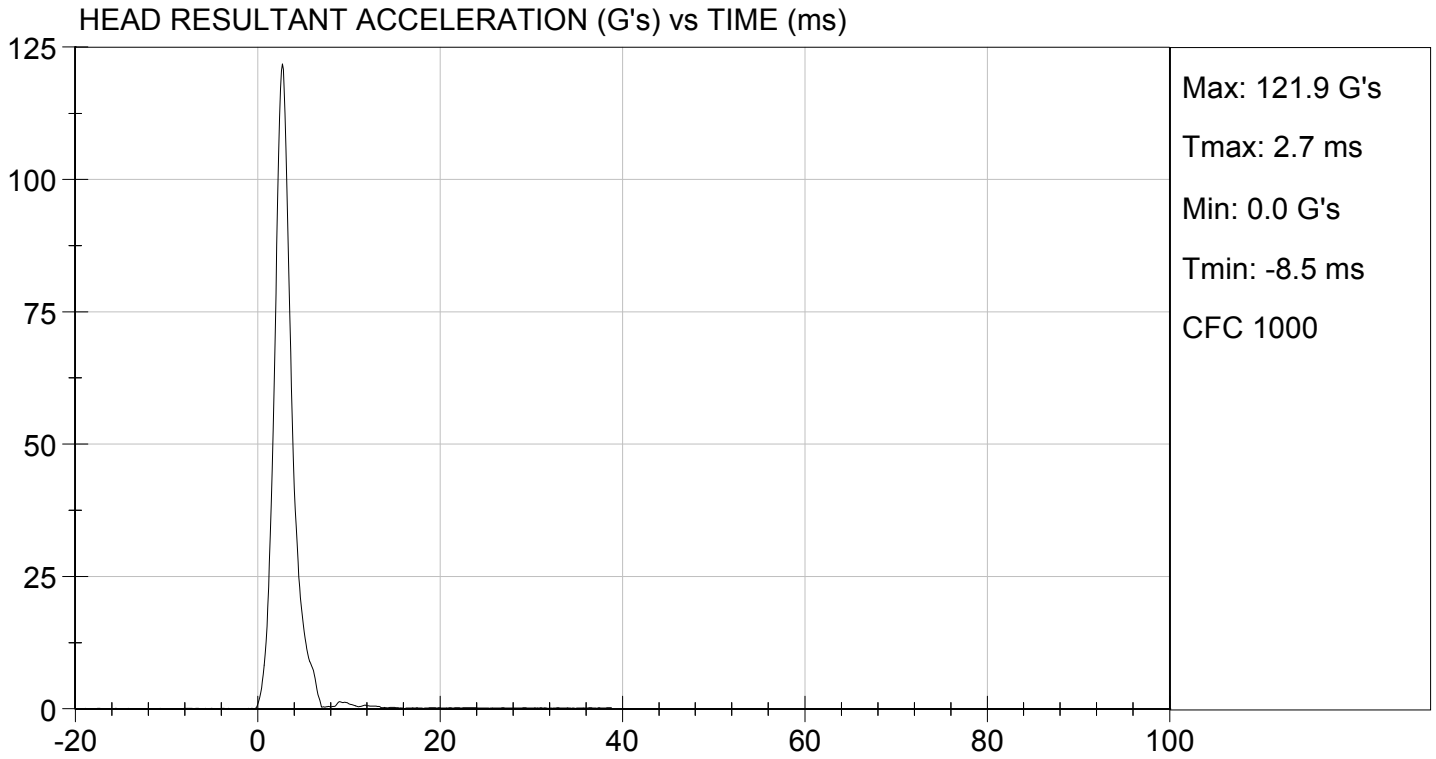

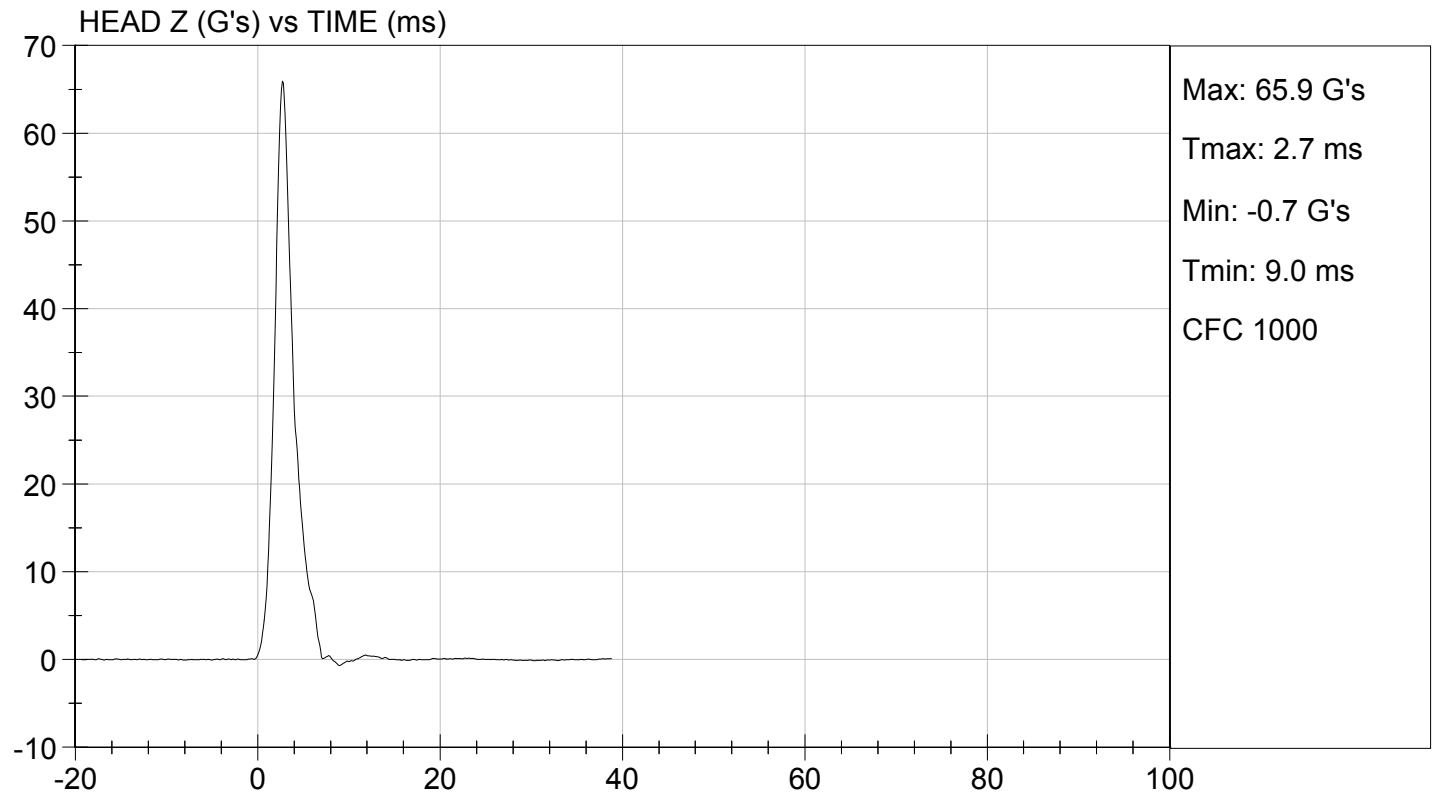
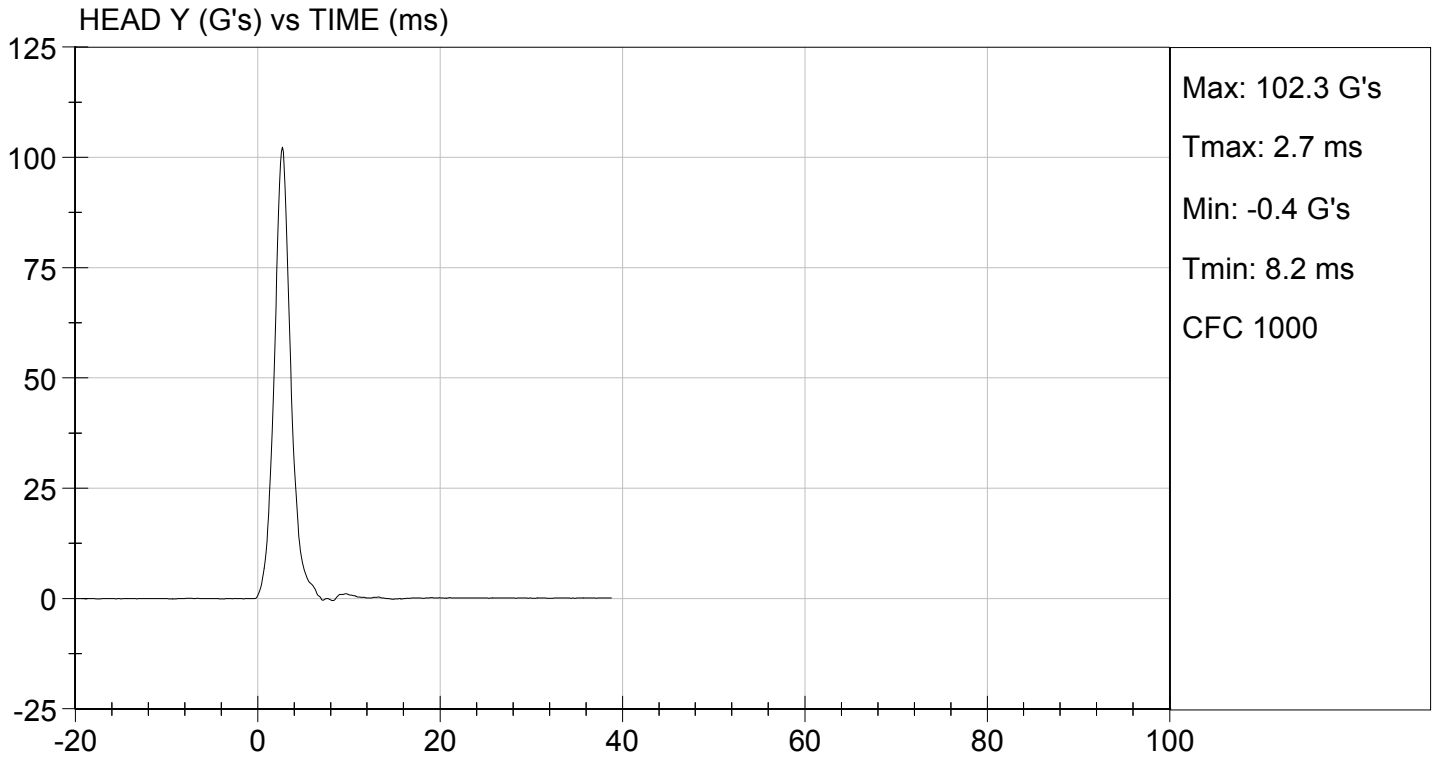

**MGA RESEARCH CORPORATION
LATERAL NECK PENDULUM TEST
SID-IIs BUILD LEVEL D DUMMY**

ATD Serial No: 296

Test I.D.: D13532

Tested Parameter		Units	Specification	Result	Pass/Fail
Temperature		deg C	20.6 to 22.2	20.8	Pass
Humidity		%	10 to 70	17	Pass
Impact Velocity		m/s	5.51 to 5.63	5.52	Pass
Pendulum Velocity	10 ms	m/s	2.20 to 2.80	2.66	Pass
	15 ms	m/s	3.30 to 4.10	3.77	Pass
	20 ms	m/s	4.40 to 5.40	5.00	Pass
	25 ms	m/s	5.40 to 6.10	5.50	Pass
	25-100 ms	m/s	5.50 to 6.20	5.52	Pass
Maximum D-Plane Rotation		deg	71 to 81	72	Pass
Time of Maximum D-Plane Rotation		ms	50 to 70	60	Pass
Maximum Occipital Condyle Moment		Nm	-44 to -36	-41	Pass
Time of Moment Decay to 0 Nm		ms	102 to 126	114	Pass
Overall Test Results					Pass

Jessica Hall
Laboratory Technician

02/25/2013

Test Date

David Winkelbauer
Approved By

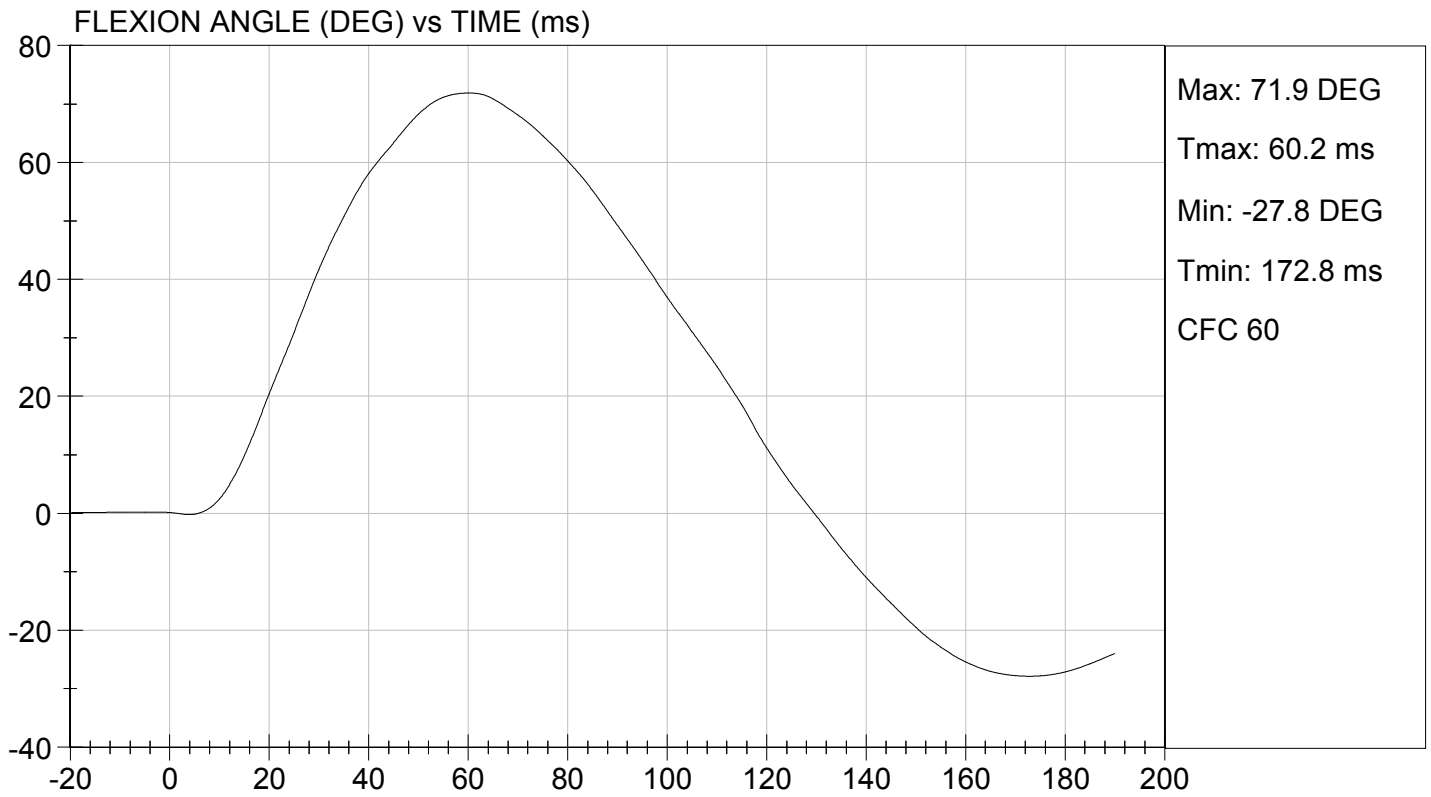
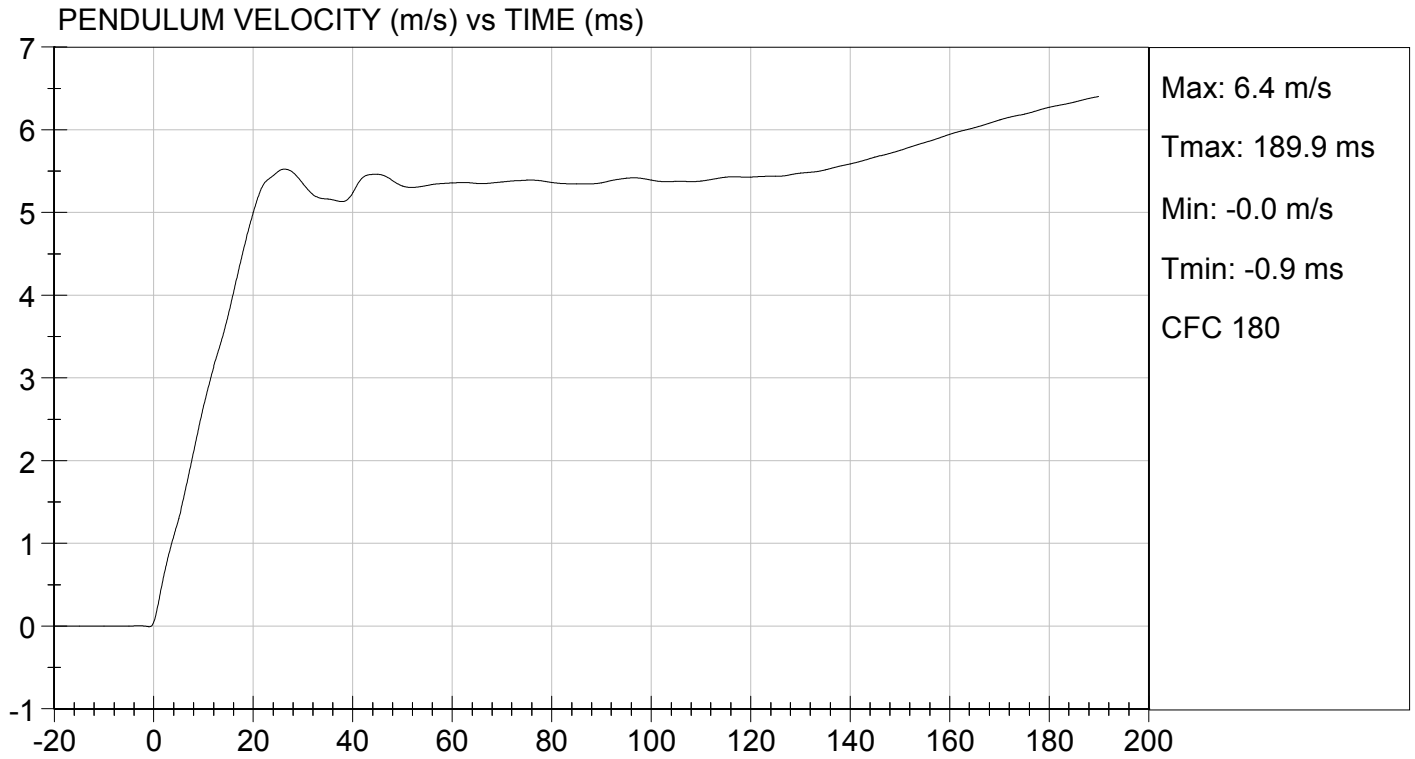

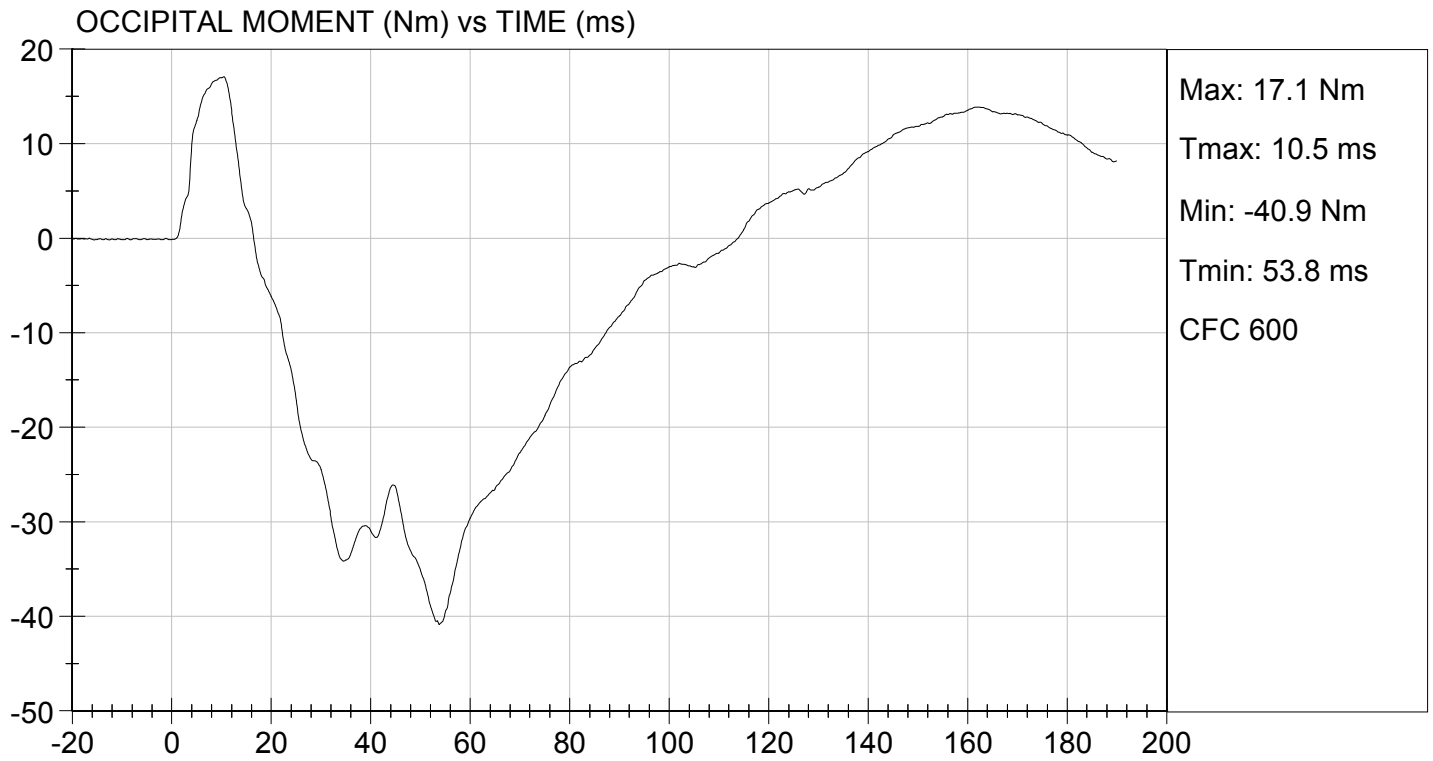

MGA RESEARCH CORPORATION
SHOULDER IMPACT TEST
SID-IIs BUILD LEVEL D DUMMY

ATD Serial No: 296

Test ID: D13533

Tested Parameter	Units	Specification	Result	Pass/Fail
Laboratory Temperature	deg C	20.6 to 22.2	21.7	Pass
Laboratory Relative Humidity	%	10 to 70	28	Pass
Impact Velocity	m/s	4.20 to 4.40	4.30	Pass
Maximum Probe Acceleration	G's	13 to 18	15	Pass
Shoulder Displacement	mm	28 to 37	31	Pass
Upper Spine (T1) Y Acceleration	G's	17 to 22	19	Pass
Overall Test Results				Pass

Jessica Hall
 Laboratory Technician

02/22/2013
 Test Date

David Winkelbauer
 Approved By

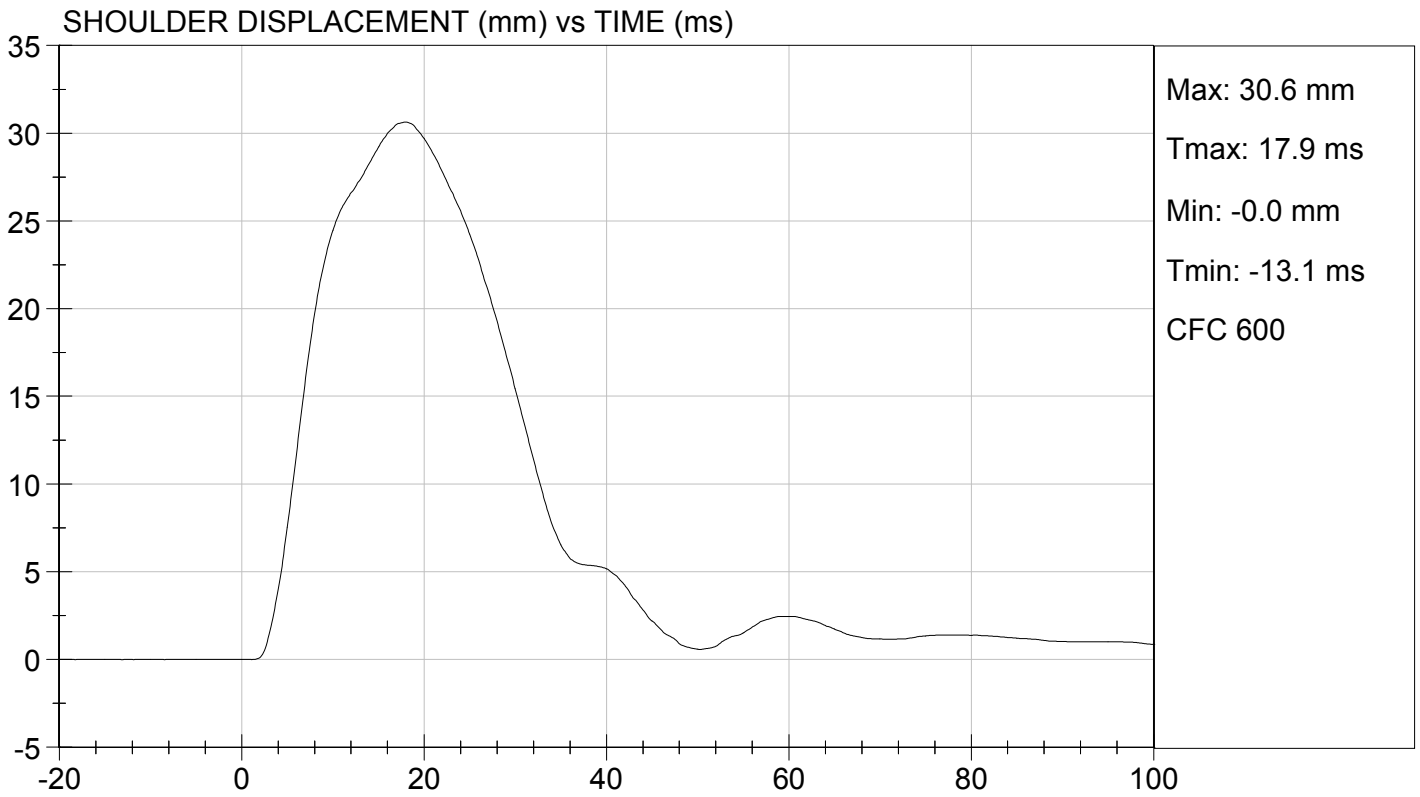
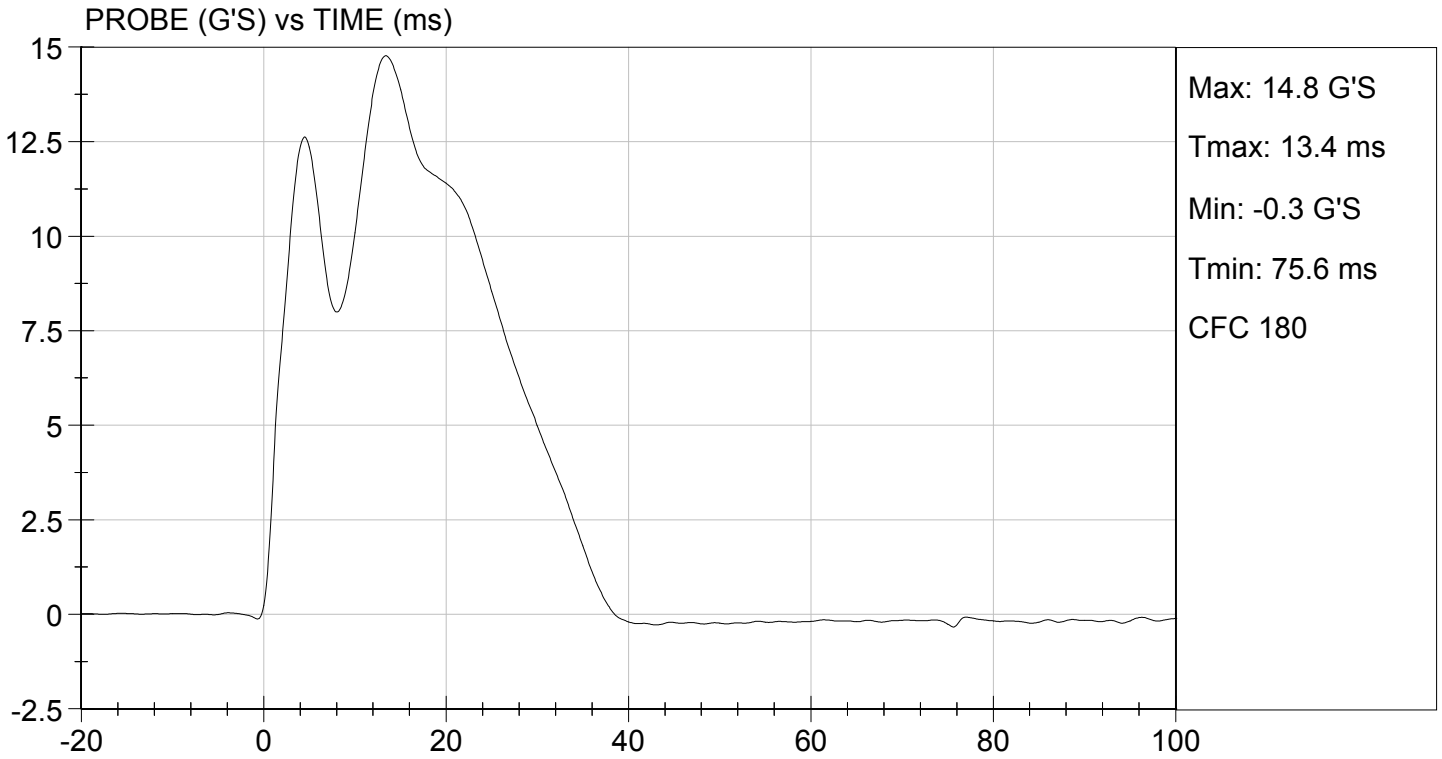

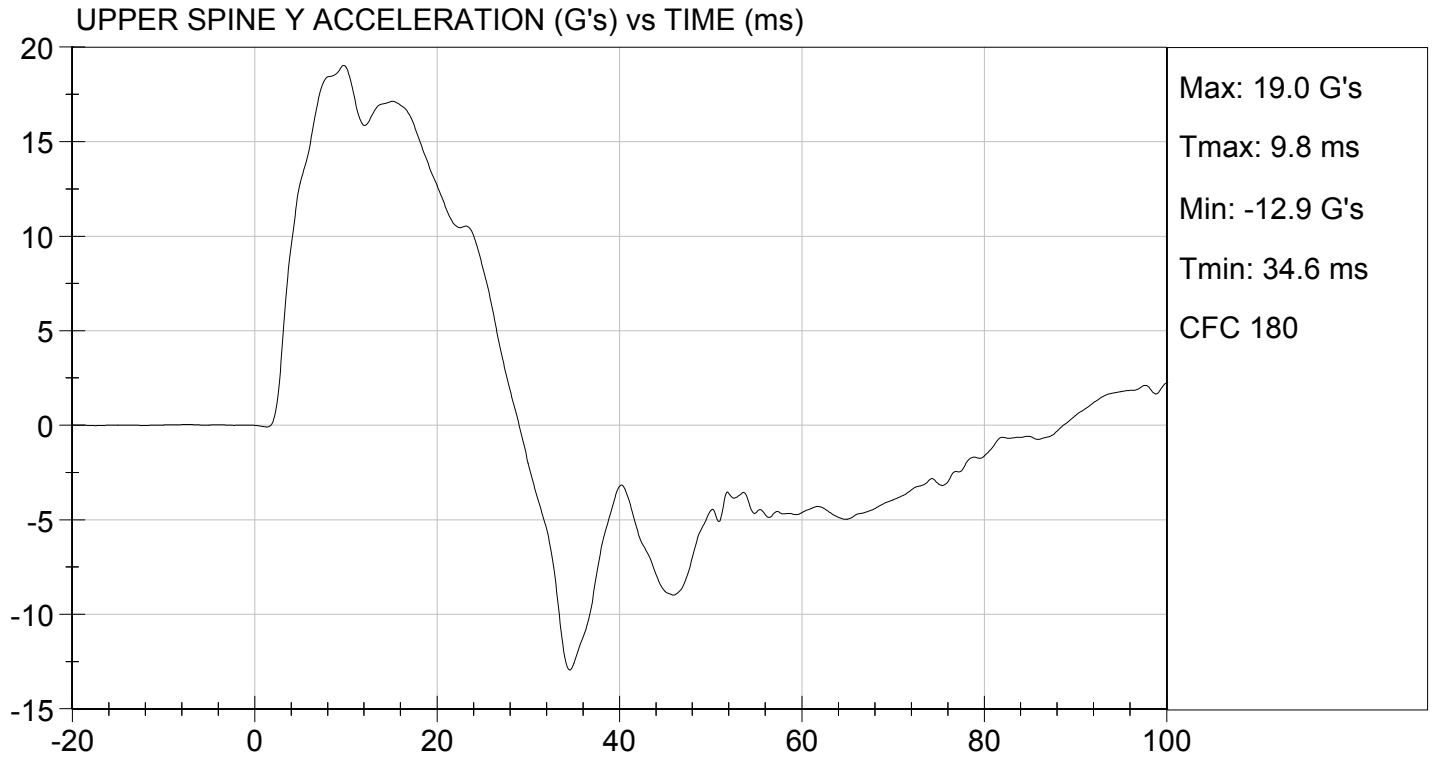

**MGA RESEARCH CORPORATION
THORAX (WITH ARM) IMPACT TEST
SID-IIs BUILD LEVEL D DUMMY**

ATD Serial No: 296

Test I.D.: D13534

Tested Parameter	Units	Specification	Result	Pass/Fail
Temperature	deg C	20.6 to 22.2	21.7	Pass
Humidity	%	10 to 70	28	Pass
Impact Velocity	m/s	6.60 to 6.80	6.77	Pass
Maximum Probe Acceleration	G's	30 to 36	31	Pass
Shoulder Displacement	mm	31 to 40	37	Pass
Upper Rib Displacement	mm	25 to 32	29	Pass
Middle Rib Displacement	mm	30 to 36	33	Pass
Lower Rib Displacement	mm	32 to 38	35	Pass
Upper Spine (T1) Y Acceleration	G's	34 to 43	37	Pass
Lower Spine (T12) Y Acceleration	G's	29 to 37	33	Pass
Overall Test Results				Pass

Jessica Hall
Laboratory Technician

02/22/2013
Test Date

David Winkelbauer
Approved By

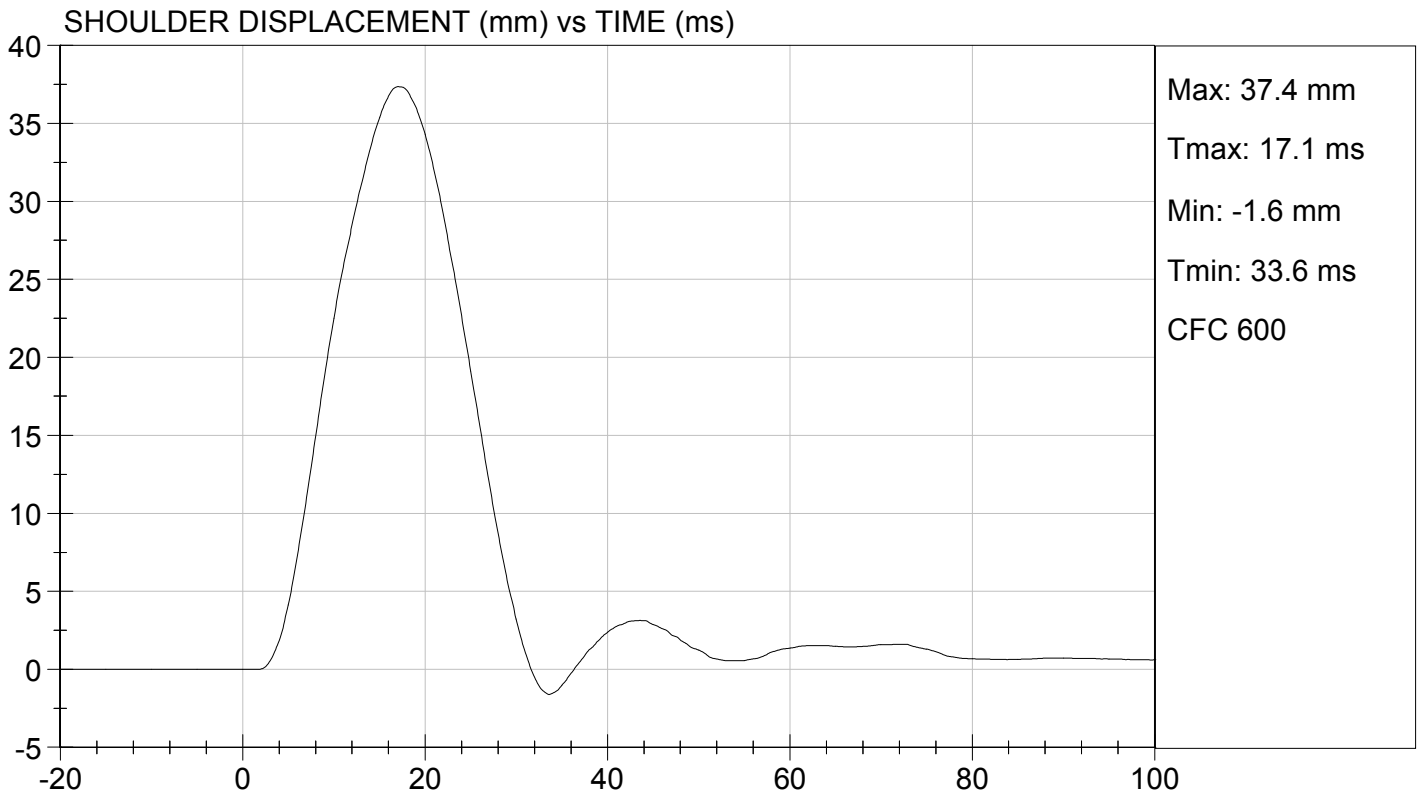
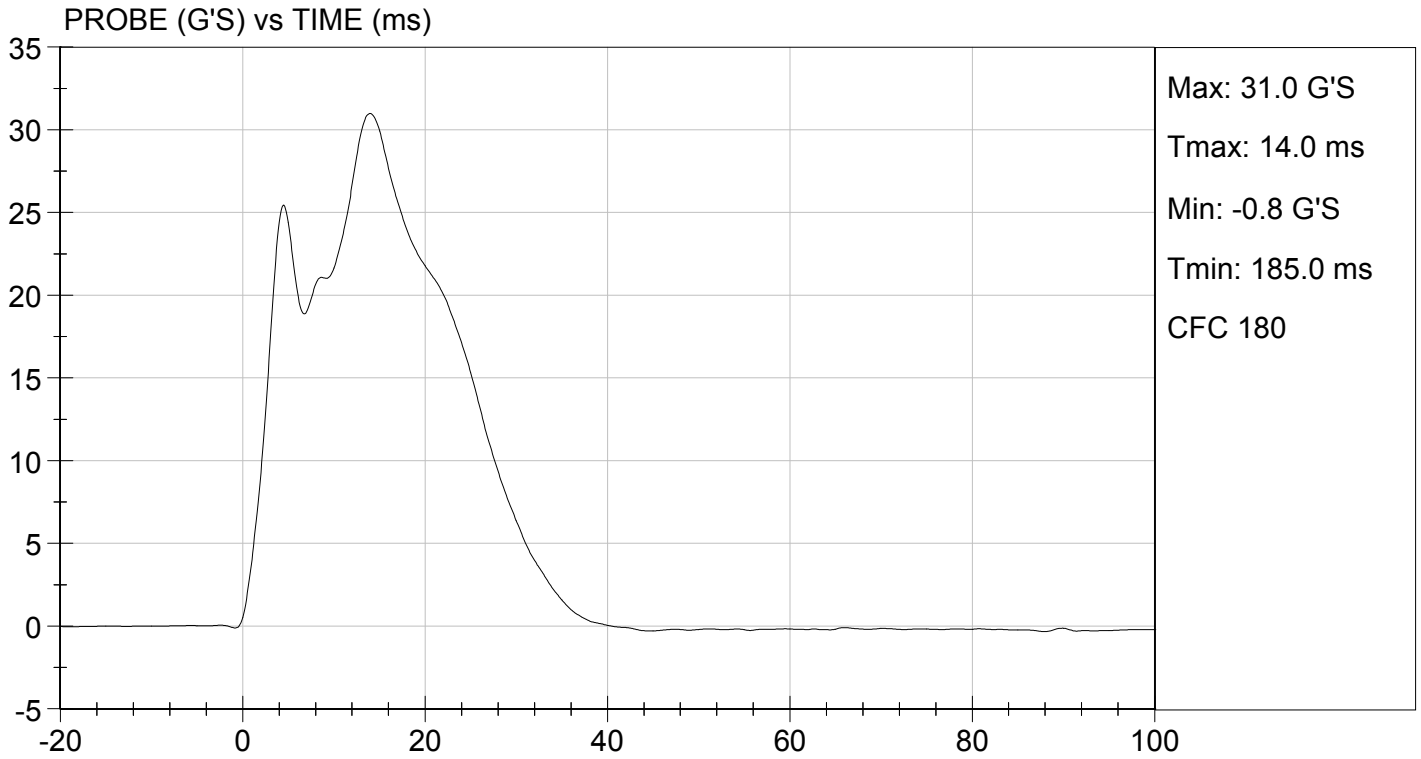

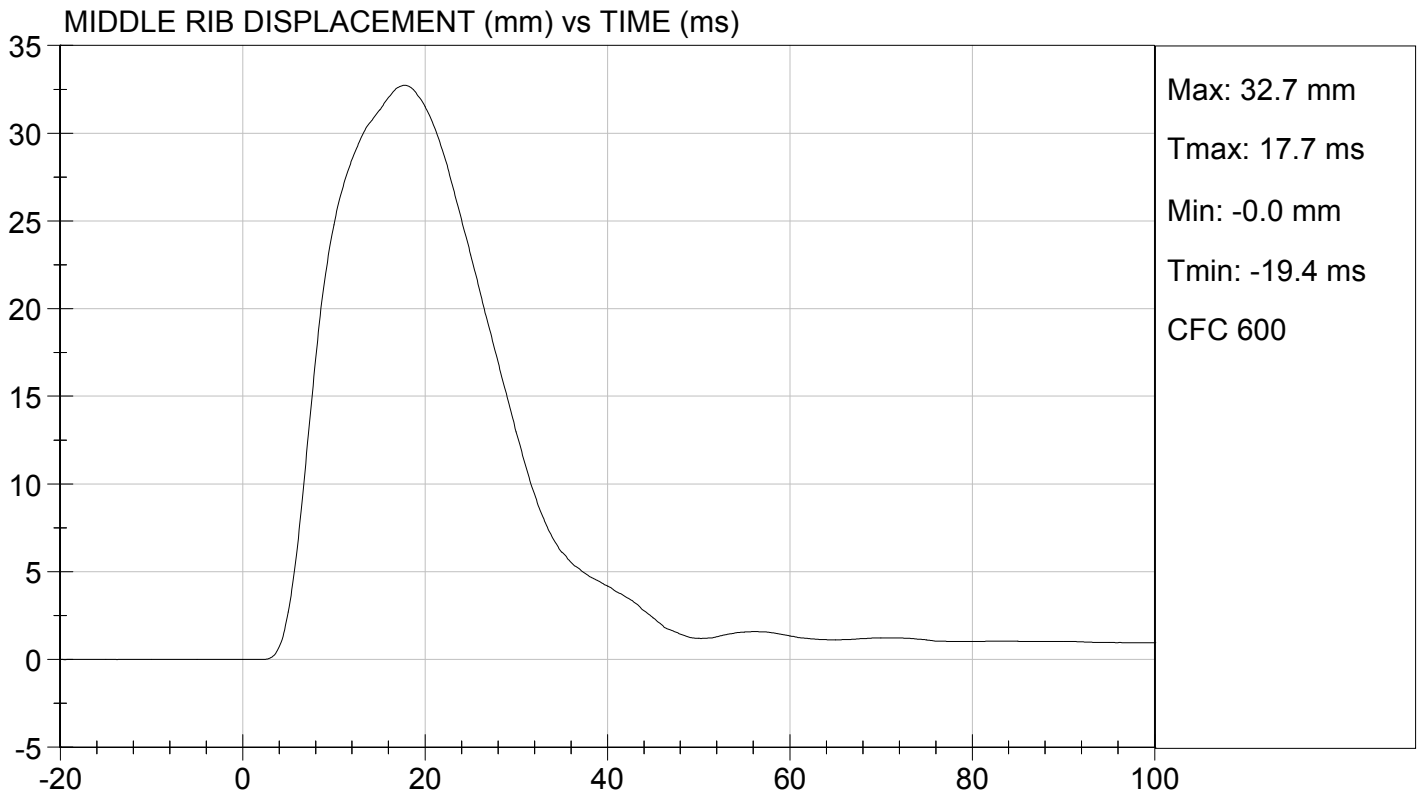
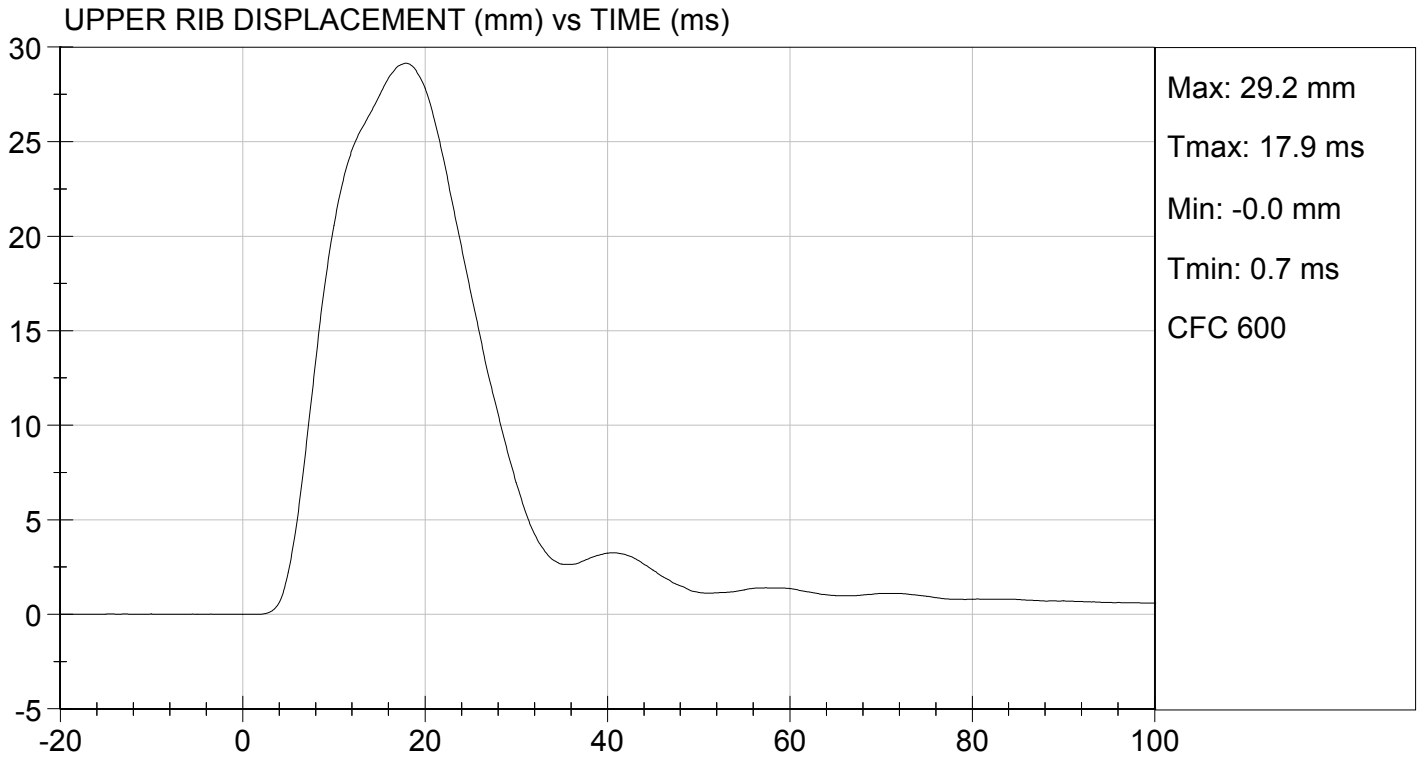

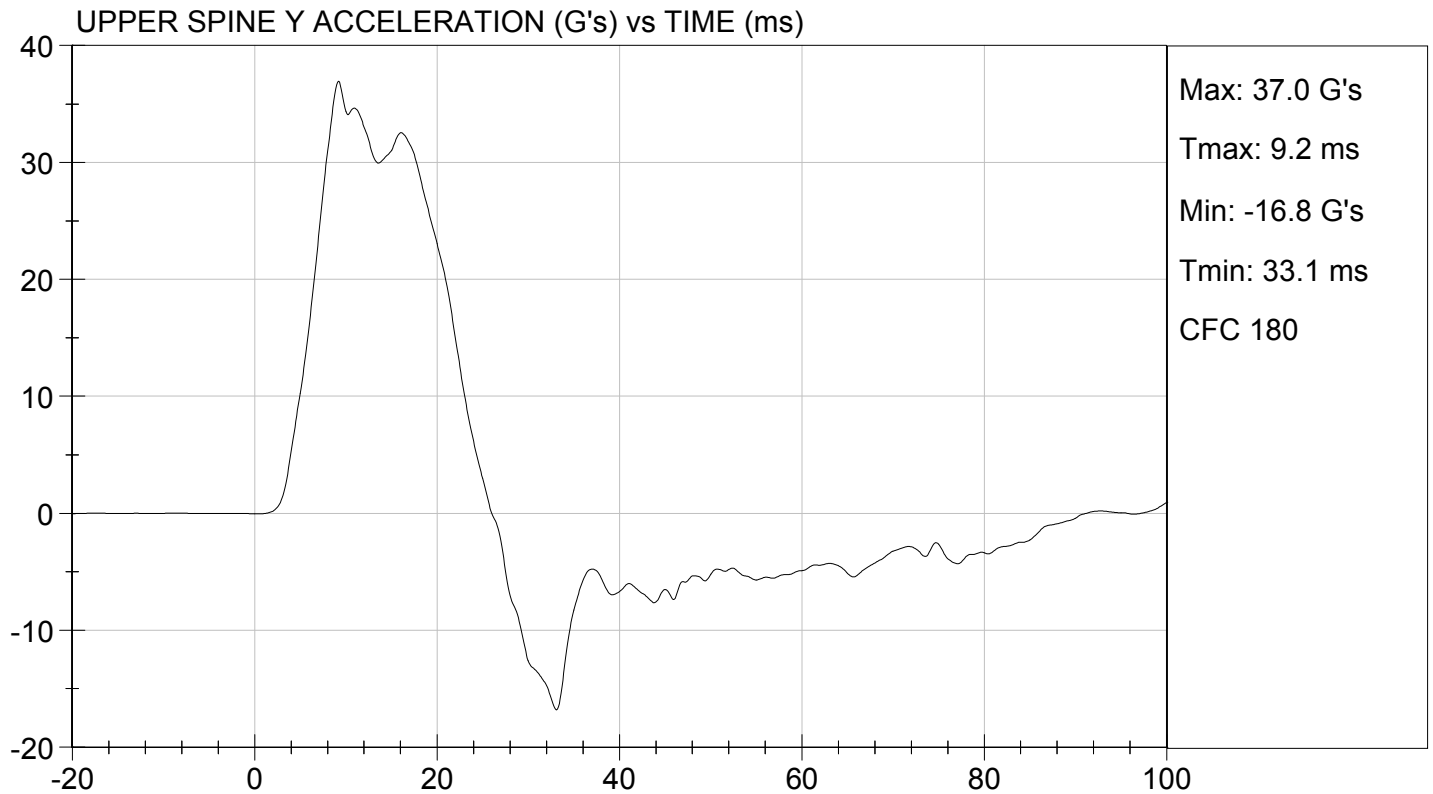
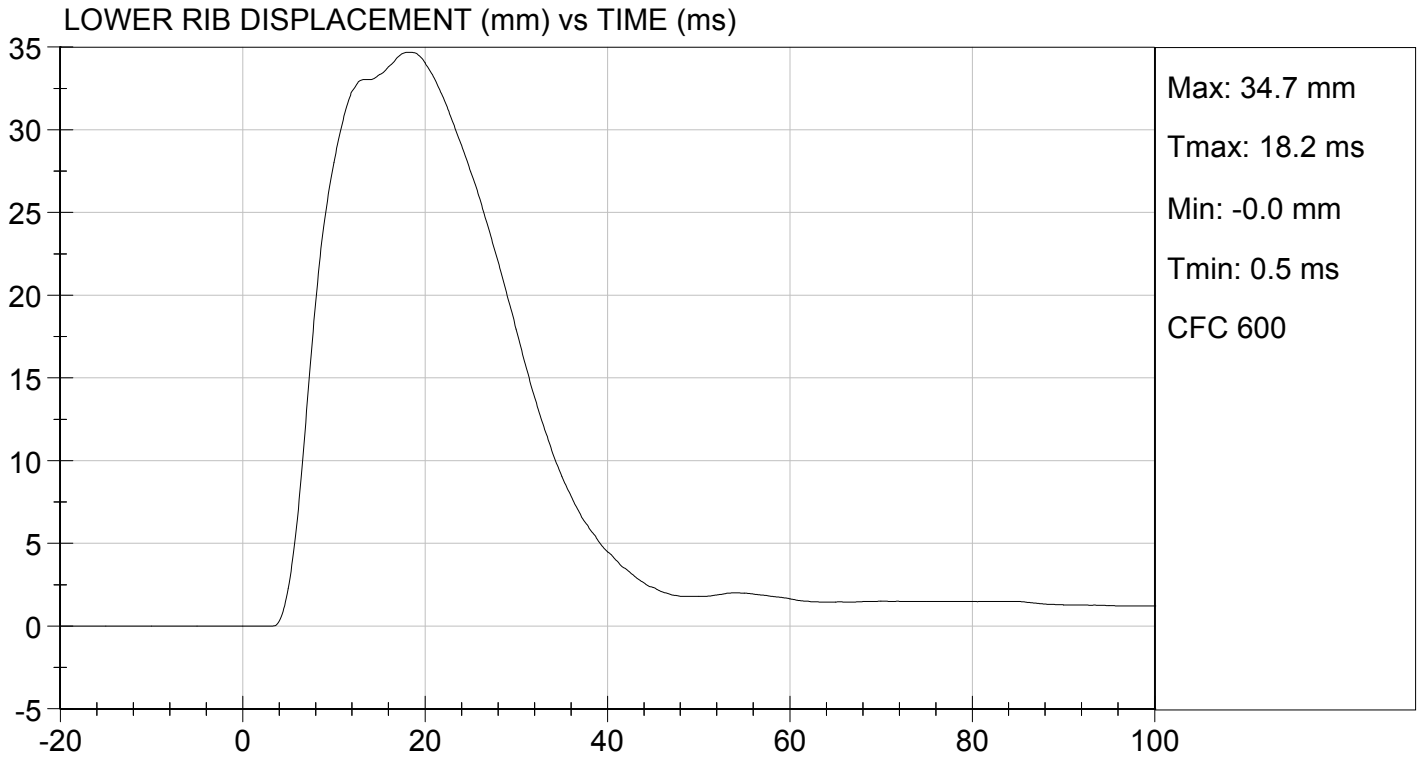

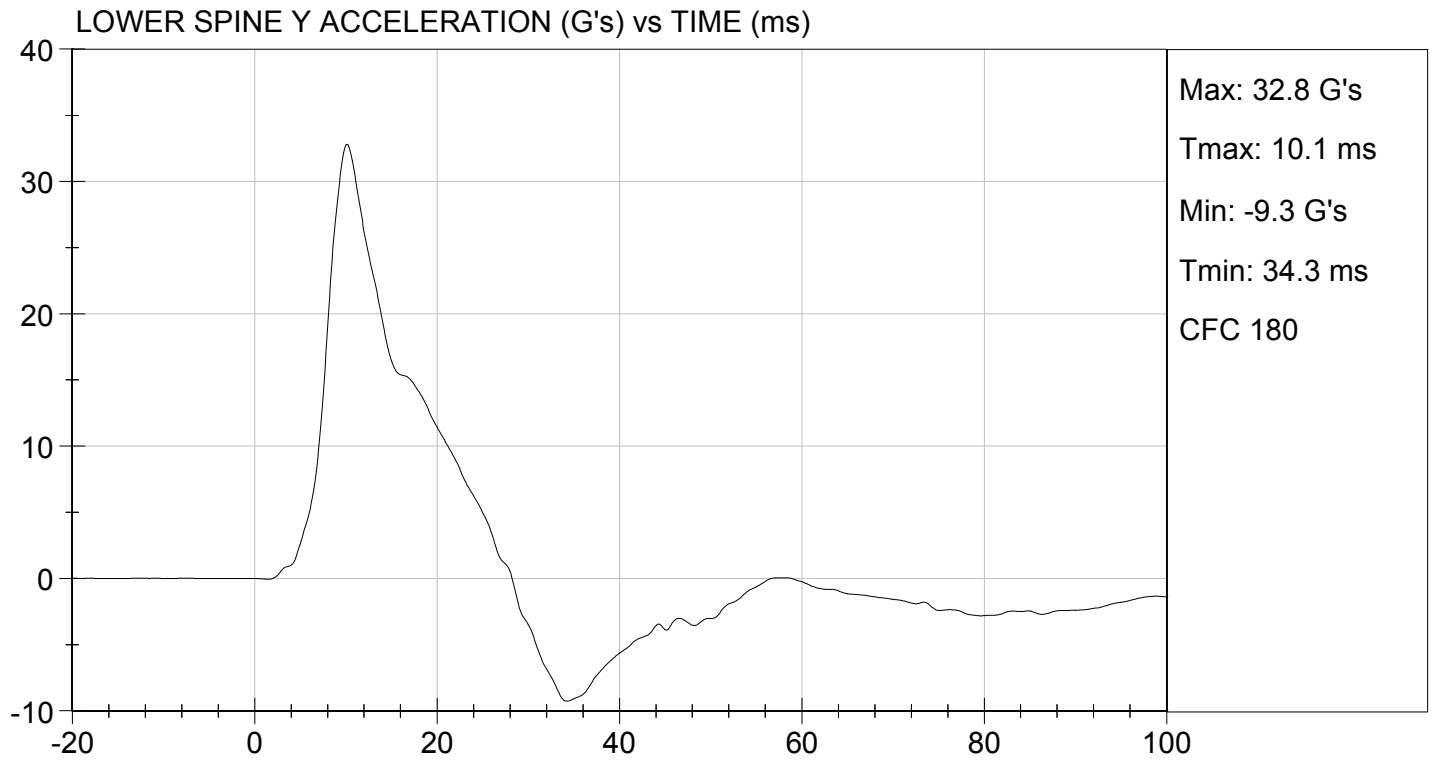

MGA RESEARCH CORPORATION
THORAX (WITHOUT ARM) IMPACT TEST
SID-IIs BUILD LEVEL D DUMMY

ATD Serial No: 296

Test I.D: D13535

Tested Parameter	Units	Specification	Result	Pass/Fail
Temperature	deg C	20.6 to 22.2	21.7	Pass
Humidity	%	10 to 70	28	Pass
Impact Velocity	m/s	4.20 to 4.40	4.30	Pass
Maximum Probe Acceleration	G's	14 to 18	15	Pass
Upper Rib Displacement	mm	32 to 40	36	Pass
Middle Rib Displacement	mm	39 to 45	43	Pass
Lower Rib Displacement	mm	35 to 43	42	Pass
Upper Spine (T1) Y Acceleration	G's	13 to 17	13	Pass
Lower Spine (T12) Y Acceleration	G's	7 to 11	9	Pass
Overall Test Results				Pass

Jessica Hall
 Laboratory Technician

02/22/2013
 Test Date

David Winkelbauer
 Approved By

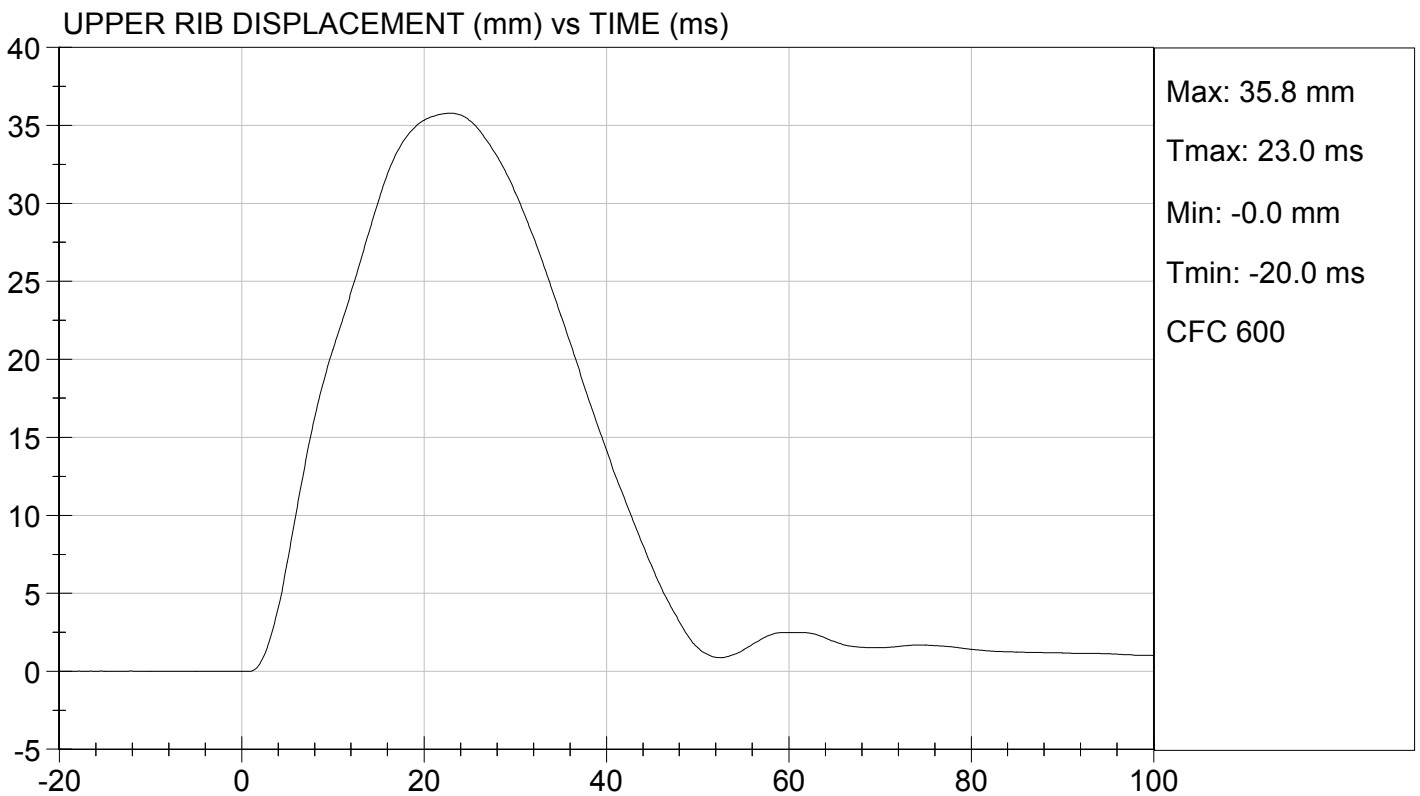
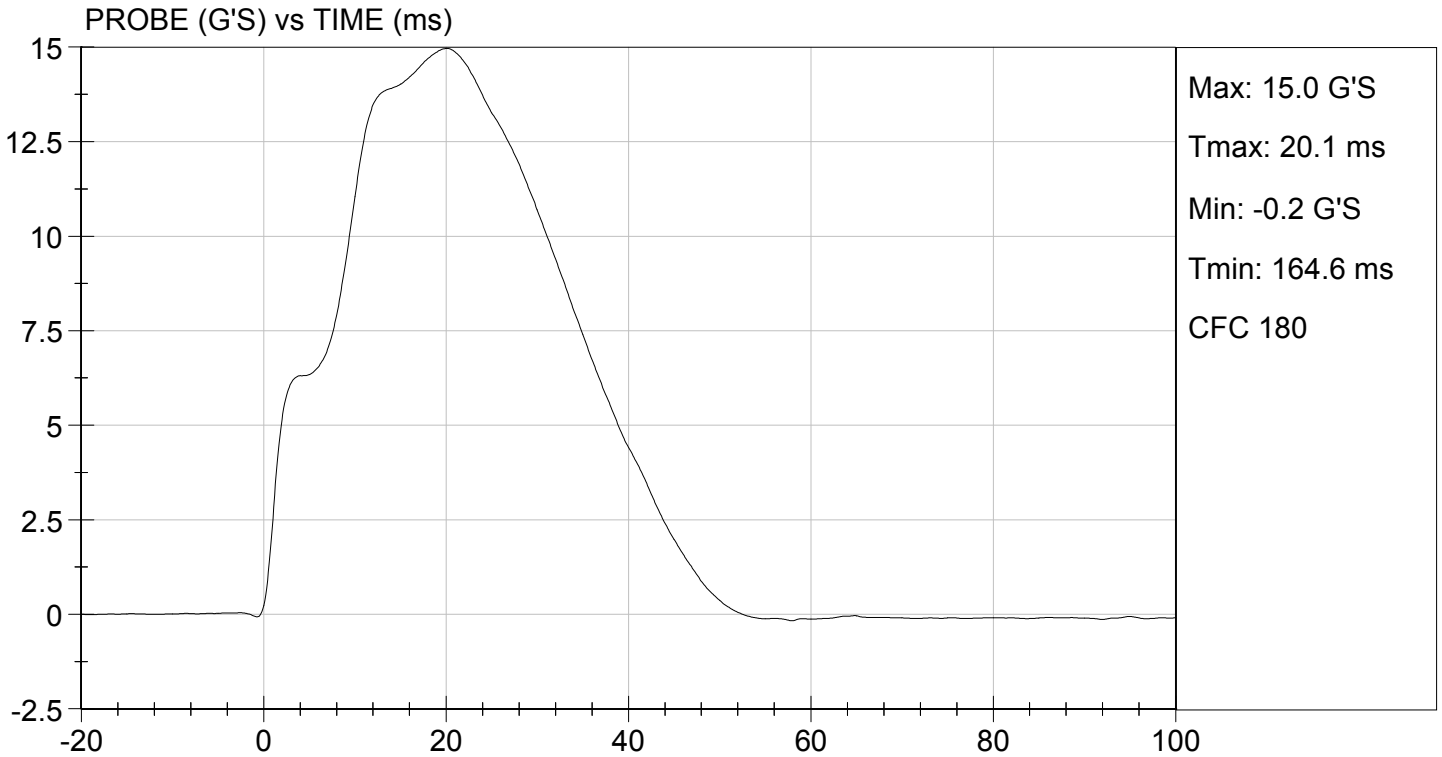

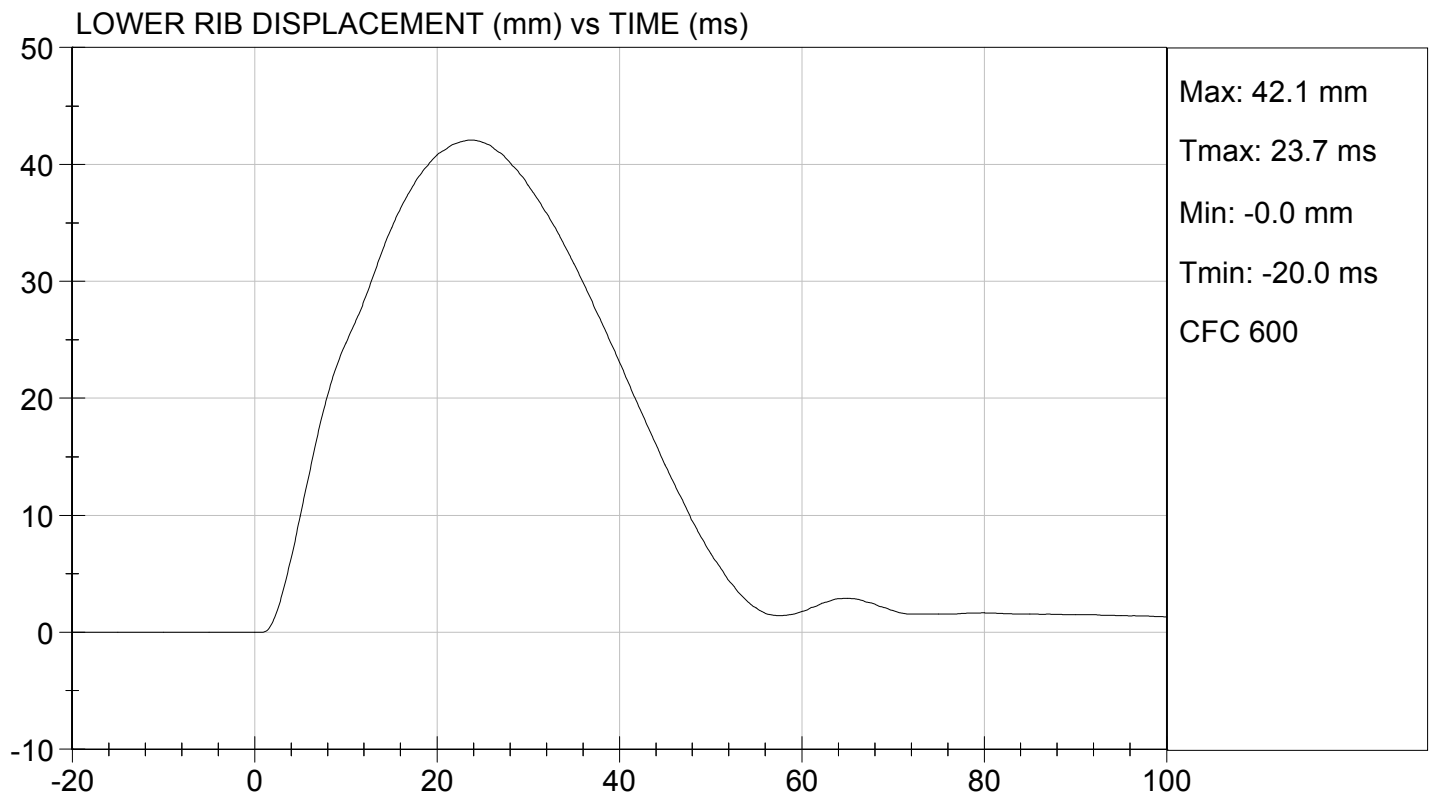
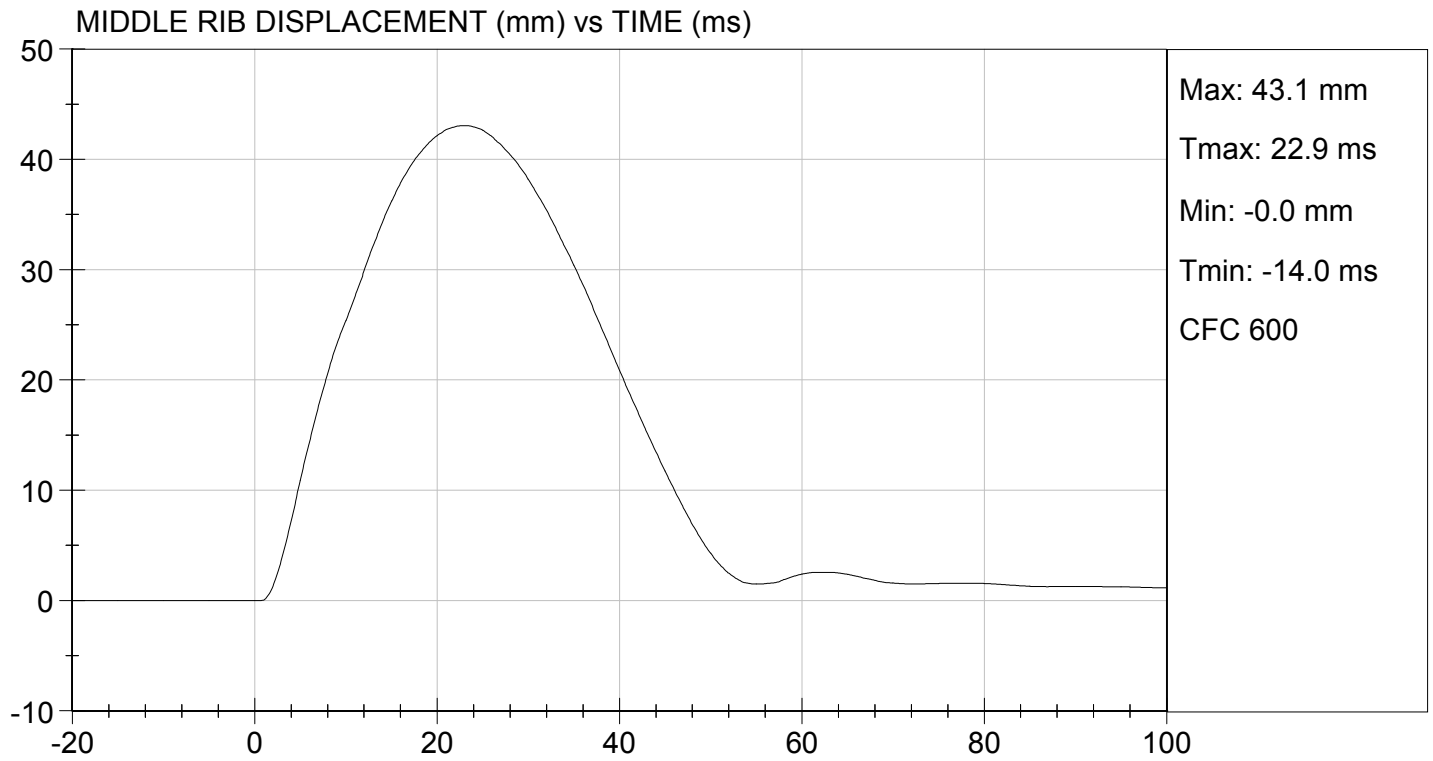

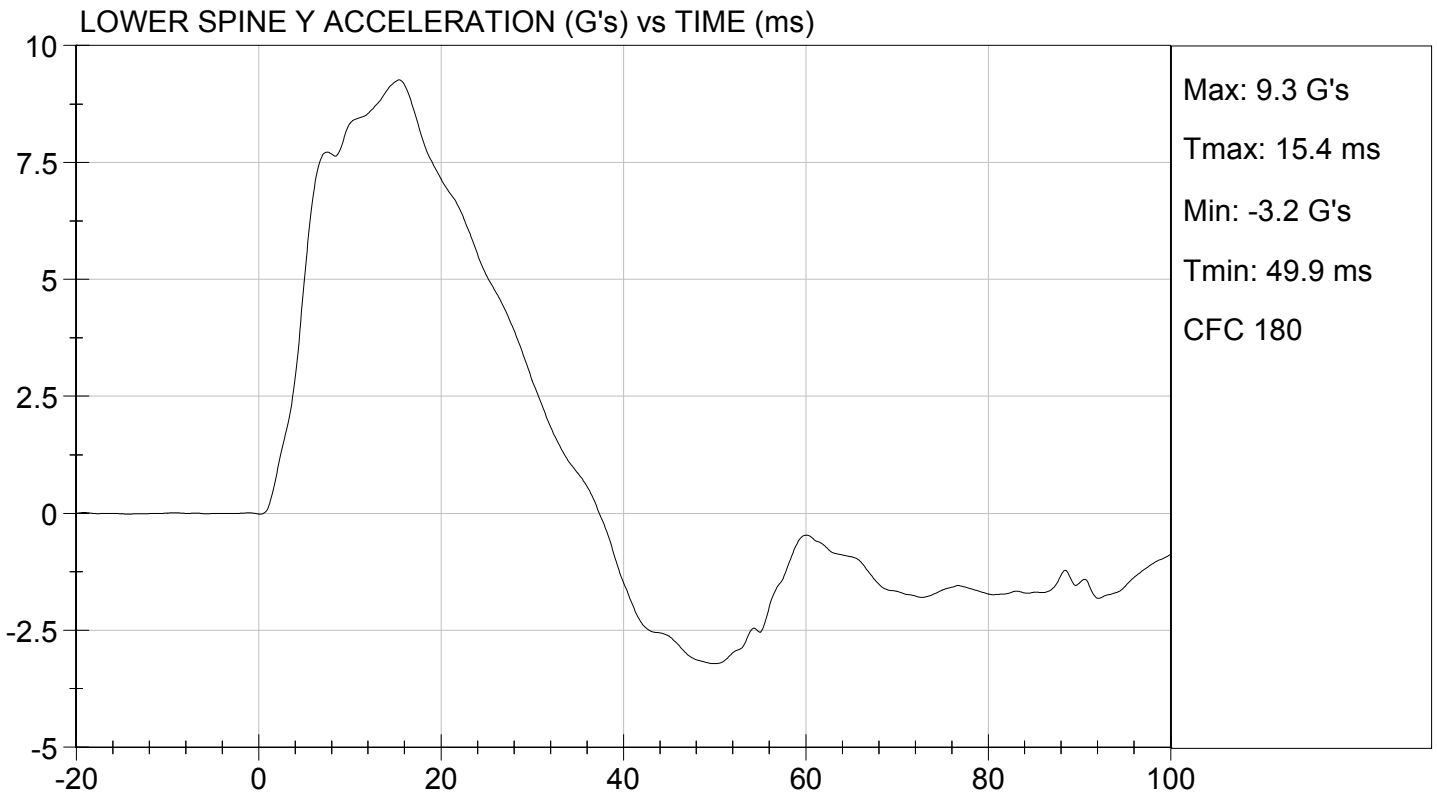
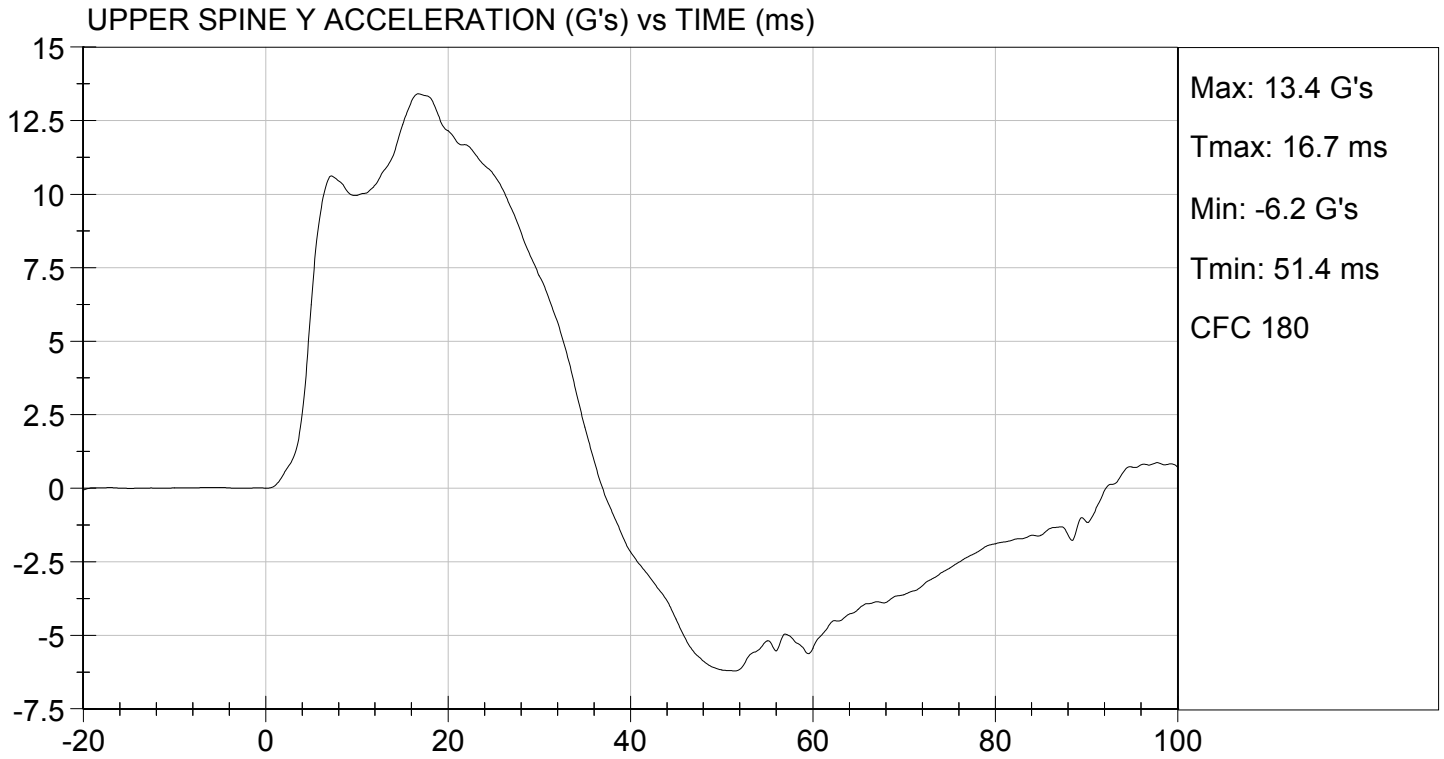

MGA RESEARCH CORPORATION
ABDOMINAL IMPACT TEST
SID-IIs BUILD LEVEL D DUMMY

ATD Serial No: 296

Test I.D: D13536

Tested Parameter	Units	Specification	Result	Pass/Fail
Temperature	deg C	20.6 to 22.2	21.7	Pass
Humidity	%	10 to 70	28	Pass
Impact Velocity	m/s	4.20 to 4.40	4.34	Pass
Maximum Probe Acceleration	G's	12 to 16	13	Pass
Upper Abdomen Rib Displacement	mm	36 to 47	45	Pass
Lower Abdomen Rib Displacement	mm	33 to 44	40	Pass
Lower Spine (T12) Y Acceleration	G's	9 to 14	10	Pass
Overall Test Results				Pass

Jessica Hall
 Laboratory Technician

02/22/2013
 Test Date

David Winkelbauer
 Approved By

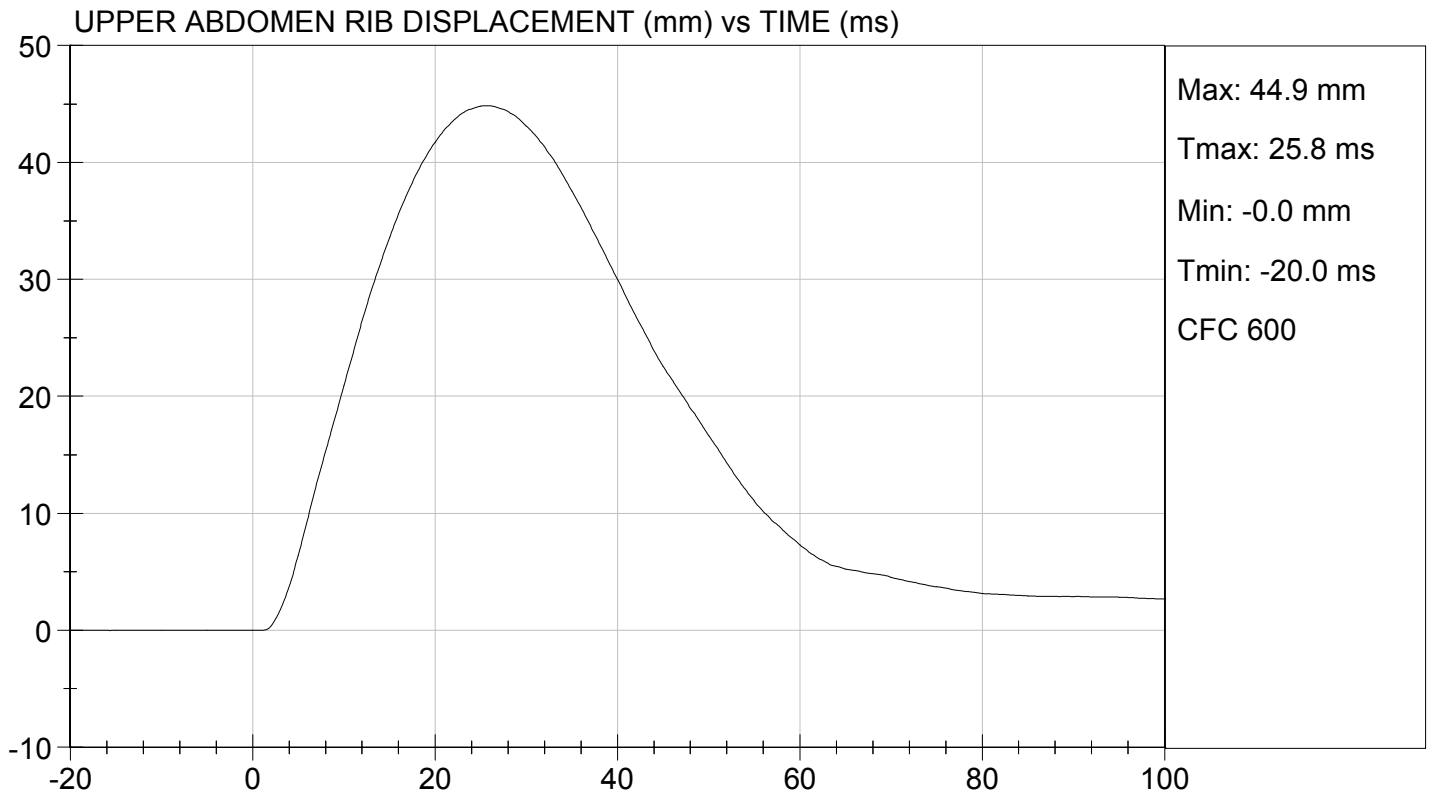
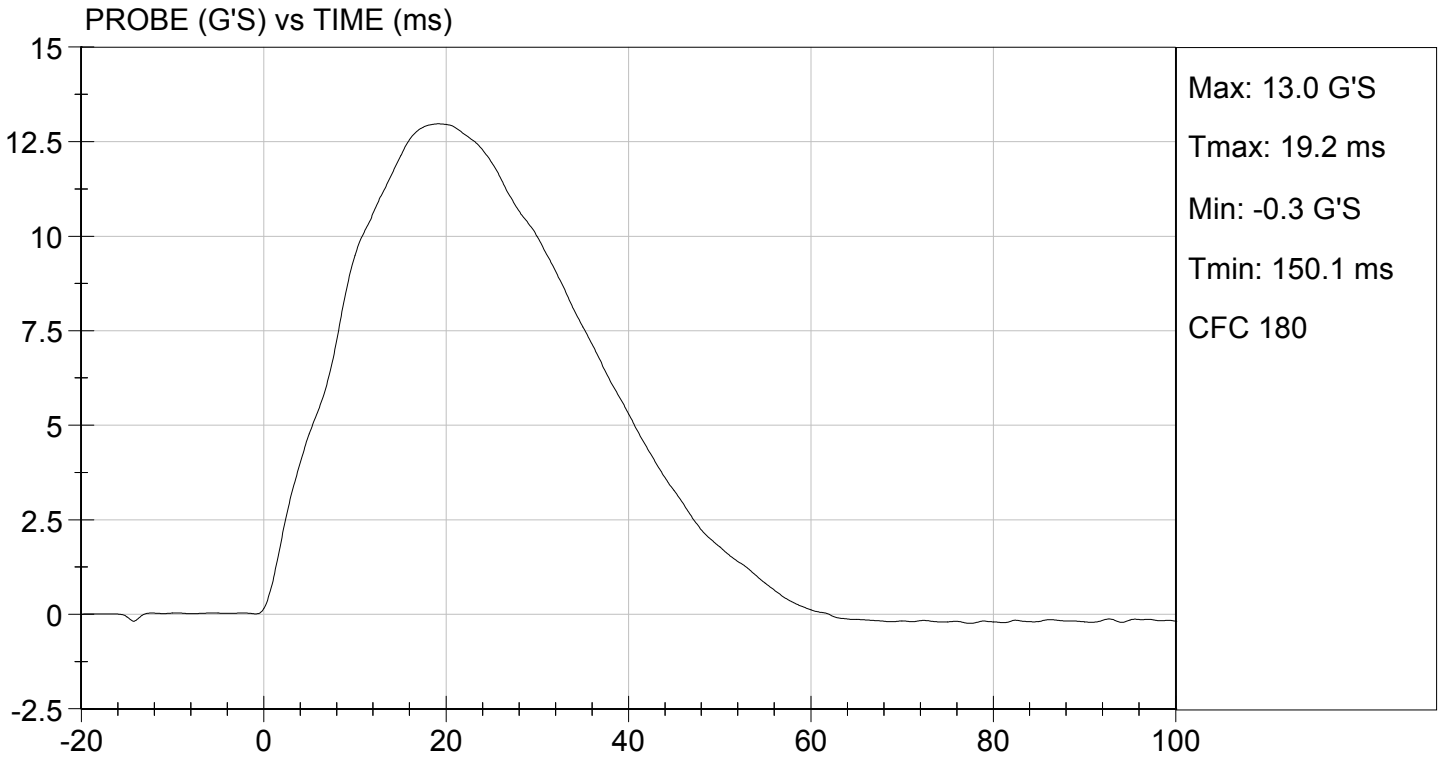

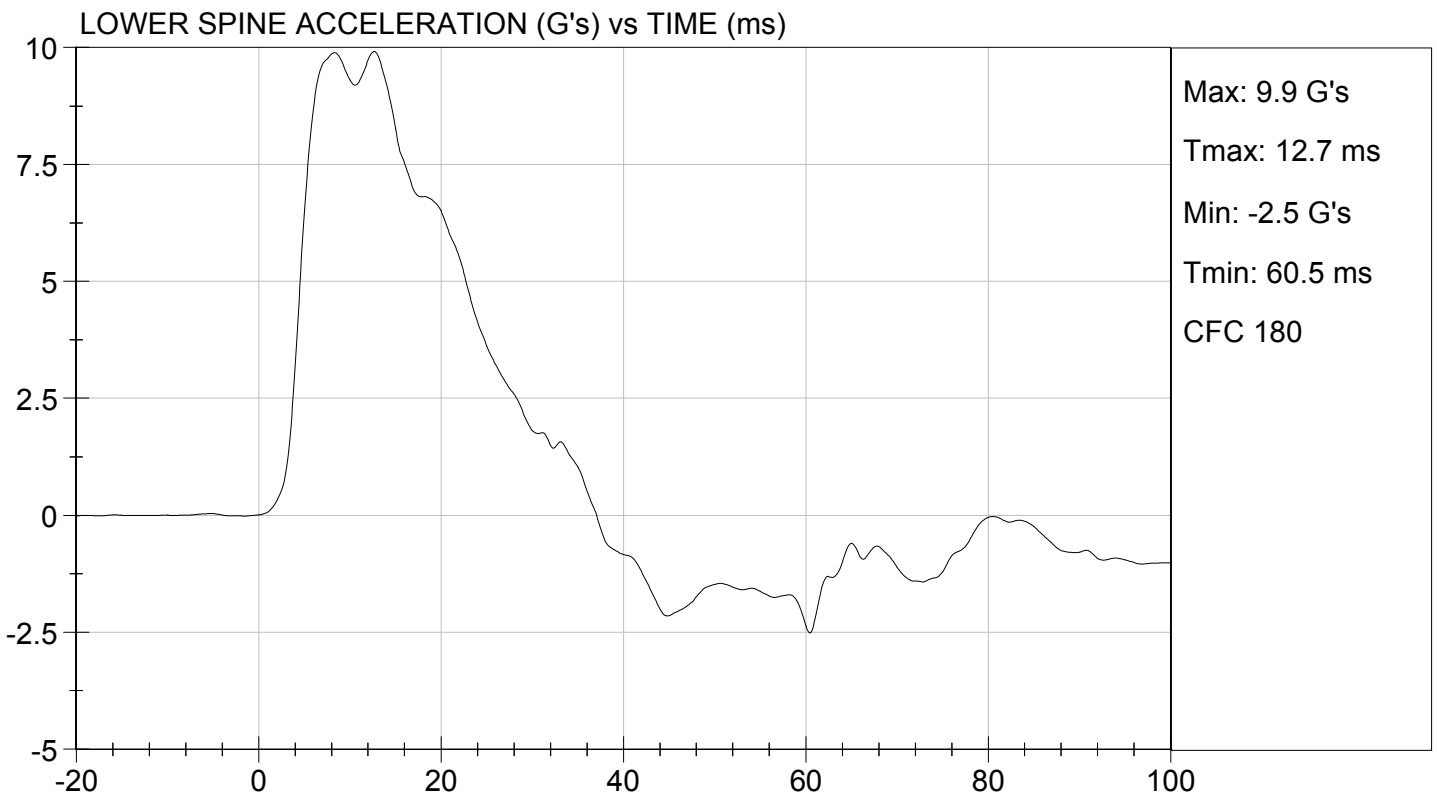
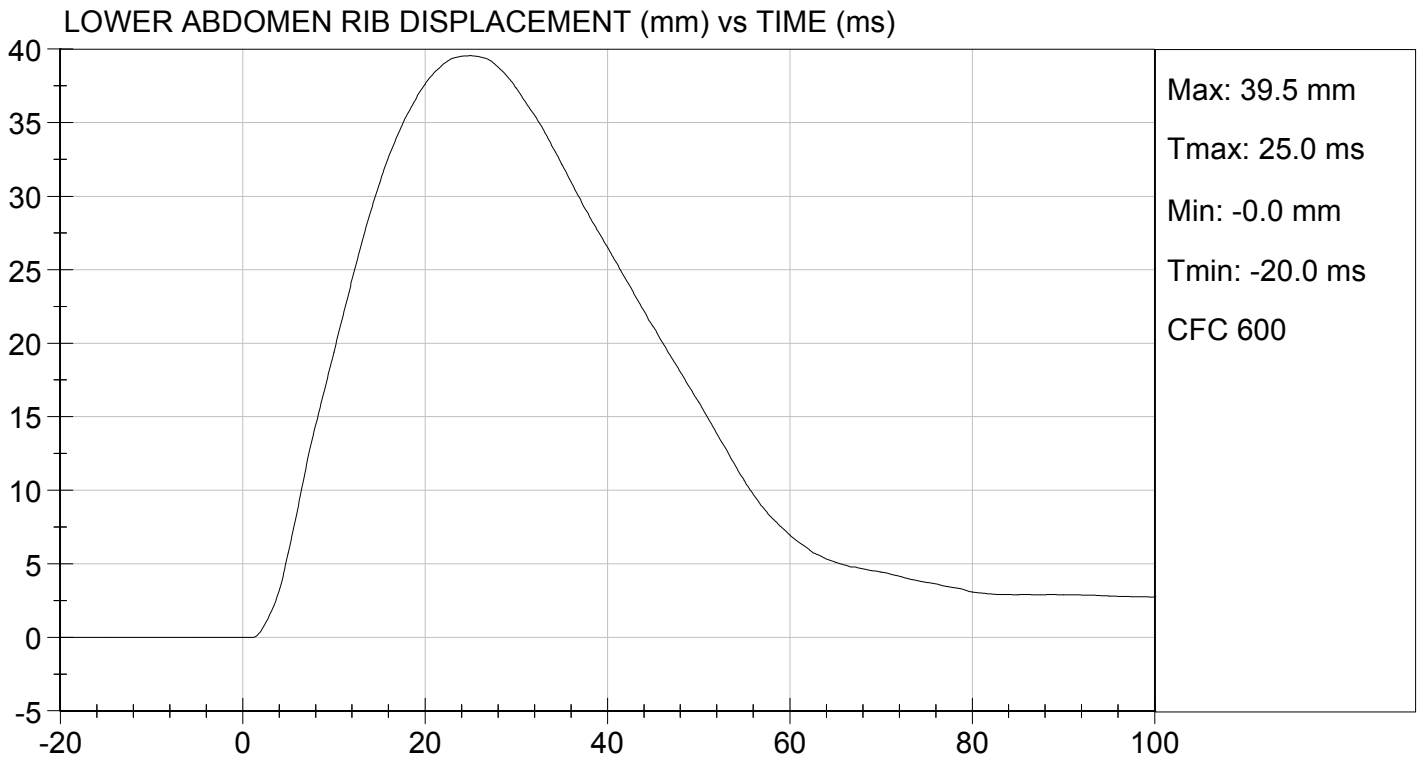

MGA RESEARCH CORPORATION
PELVIS IMPACT TEST
SID-IIs BUILD LEVEL D DUMMY

ATD Serial No: 296

Test I.D: D13537

Tested Parameter	Units	Specification	Result	Pass/Fail
Temperature	deg C	20.6 to 22.2	21.7	Pass
Humidity	%	10 to 70	28	Pass
Impact Velocity	m/s	6.60 to 6.80	6.68	Pass
Maximum Probe Acceleration	G's	38 to 47	44	Pass
Pelvis Y Acceleration After 6 ms	G's	34 to 42	41	Pass
Peak Acetabulum Force	N	3600 to 4300	3,938	Pass
Overall Test Results				Pass

Jessica Hall
 Laboratory Technician

02/22/2013
 Test Date

David Winkelbauer
 Approved By

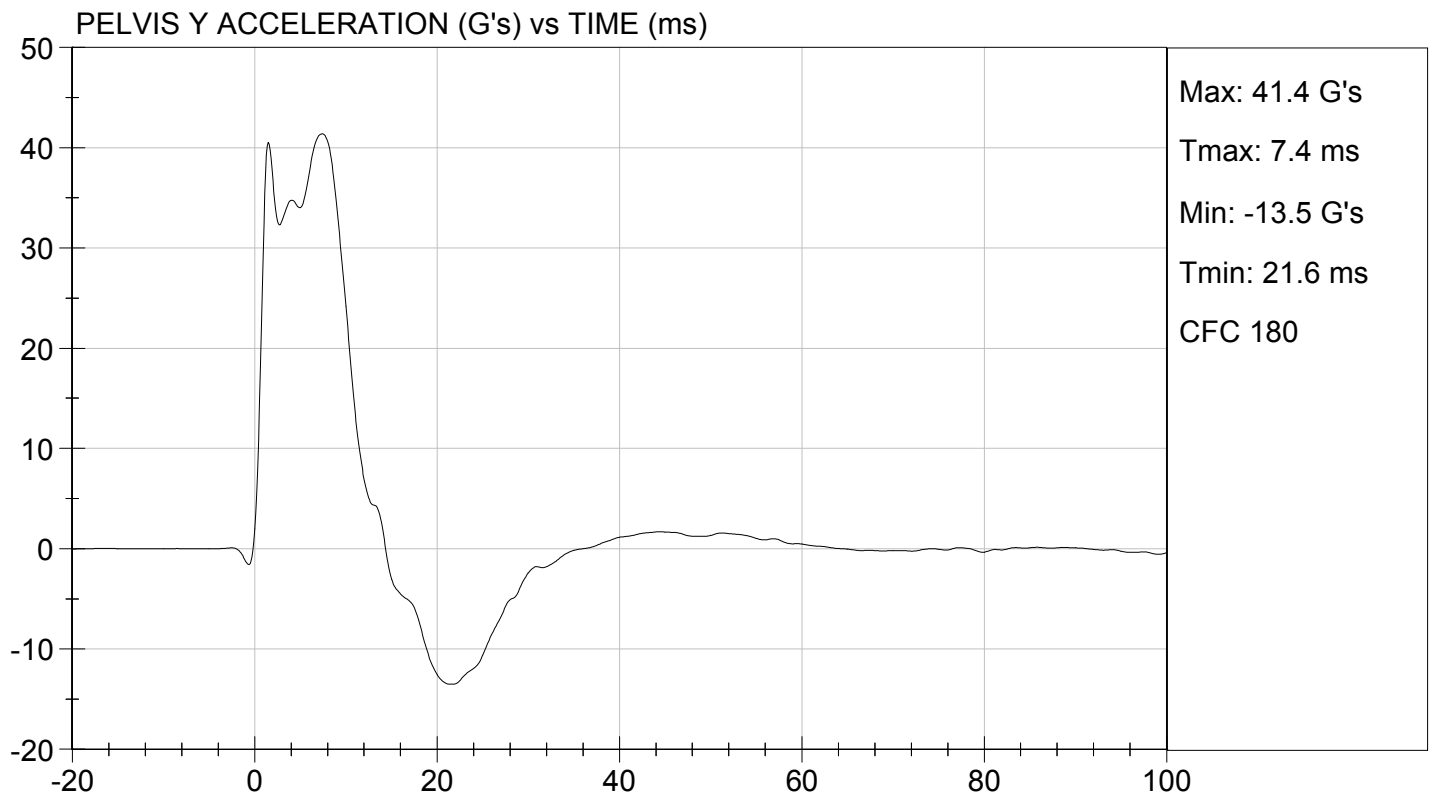
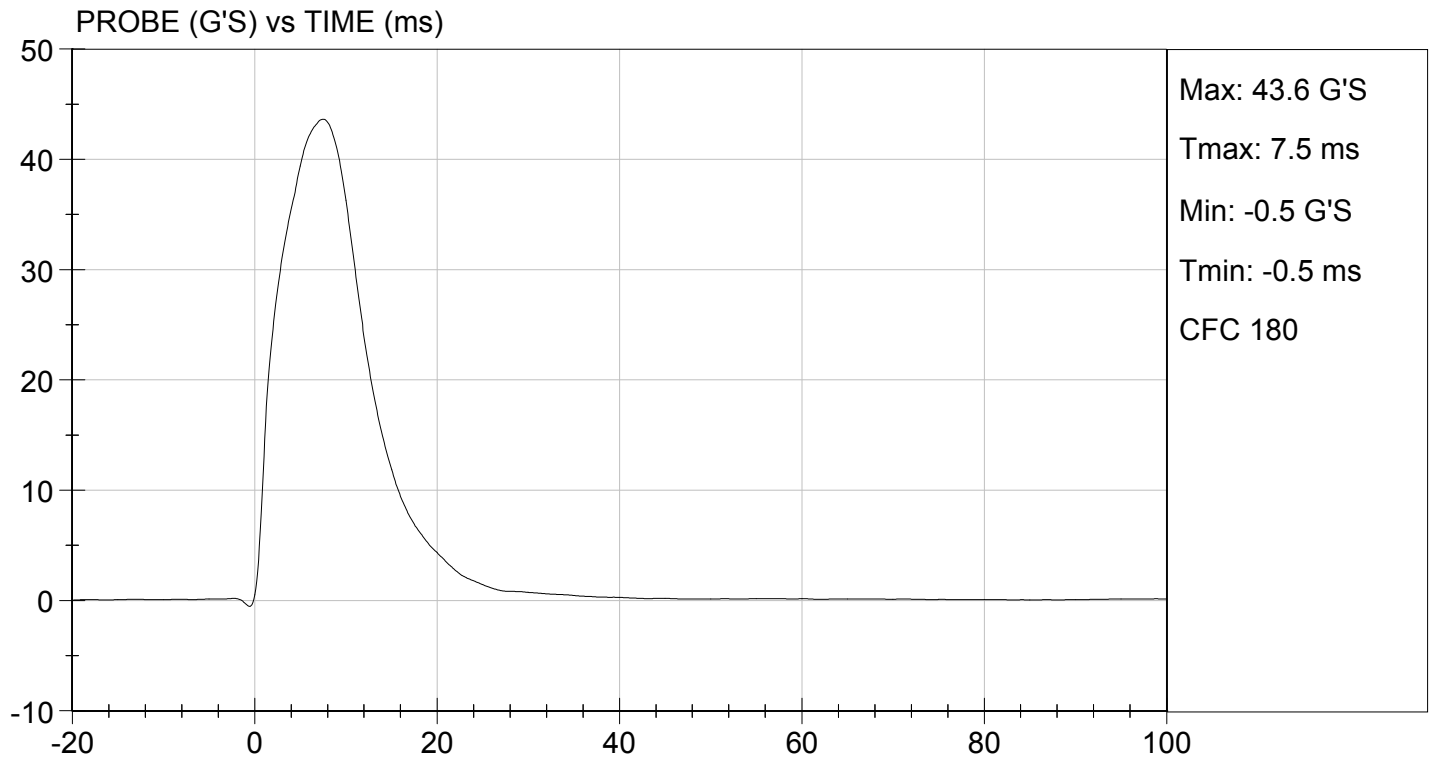



TEST DESC: PELVIS IMPACT
VELOCITY: 21.90 ft/s, 6.68 m/s

TEST DATE: 02/22/2013
TEST #: D13537

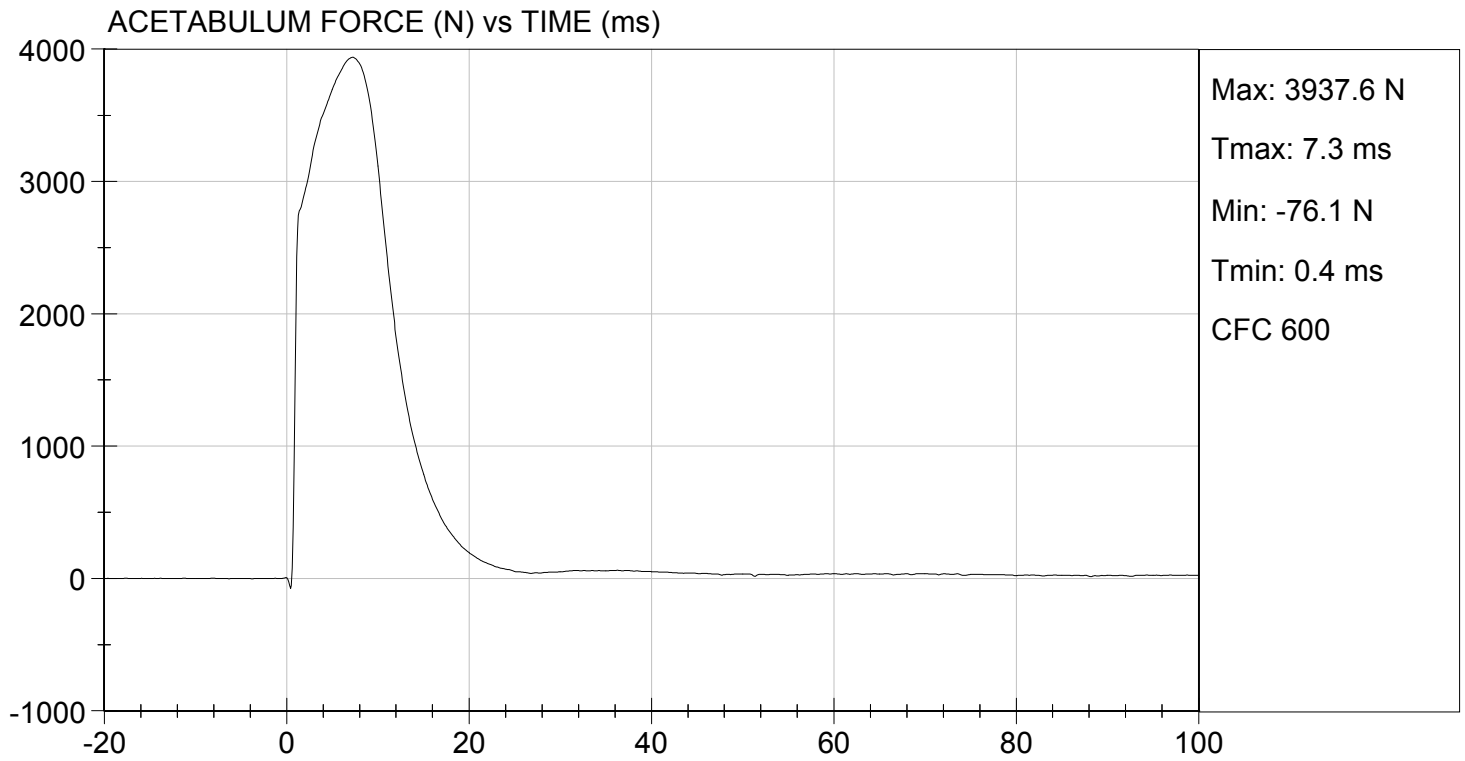

MGA RESEARCH CORPORATION
ILIAC IMPACT TEST
SID-IIs BUILD LEVEL D DUMMY

ATD Serial No: 296

Test I.D: D13538

Tested Parameter	Units	Specification	Result	Pass/Fail
Temperature	deg C	20.6 to 22.2	21.7	Pass
Humidity	%	10 to 70	28	Pass
Impact Velocity	m/s	4.20 to 4.40	4.30	Pass
Maximum Probe Acceleration	G's	36 to 45	38	Pass
Pelvis Y Acceleration	G's	28 to 39	32	Pass
Peak Pelvis Iliac Force	N	4100 to 5100	4,661	Pass
Overall Test Results				Pass

Jessica Gall
 Laboratory Technician

02/22/2013
 Test Date

David Winkelbauer
 Approved By

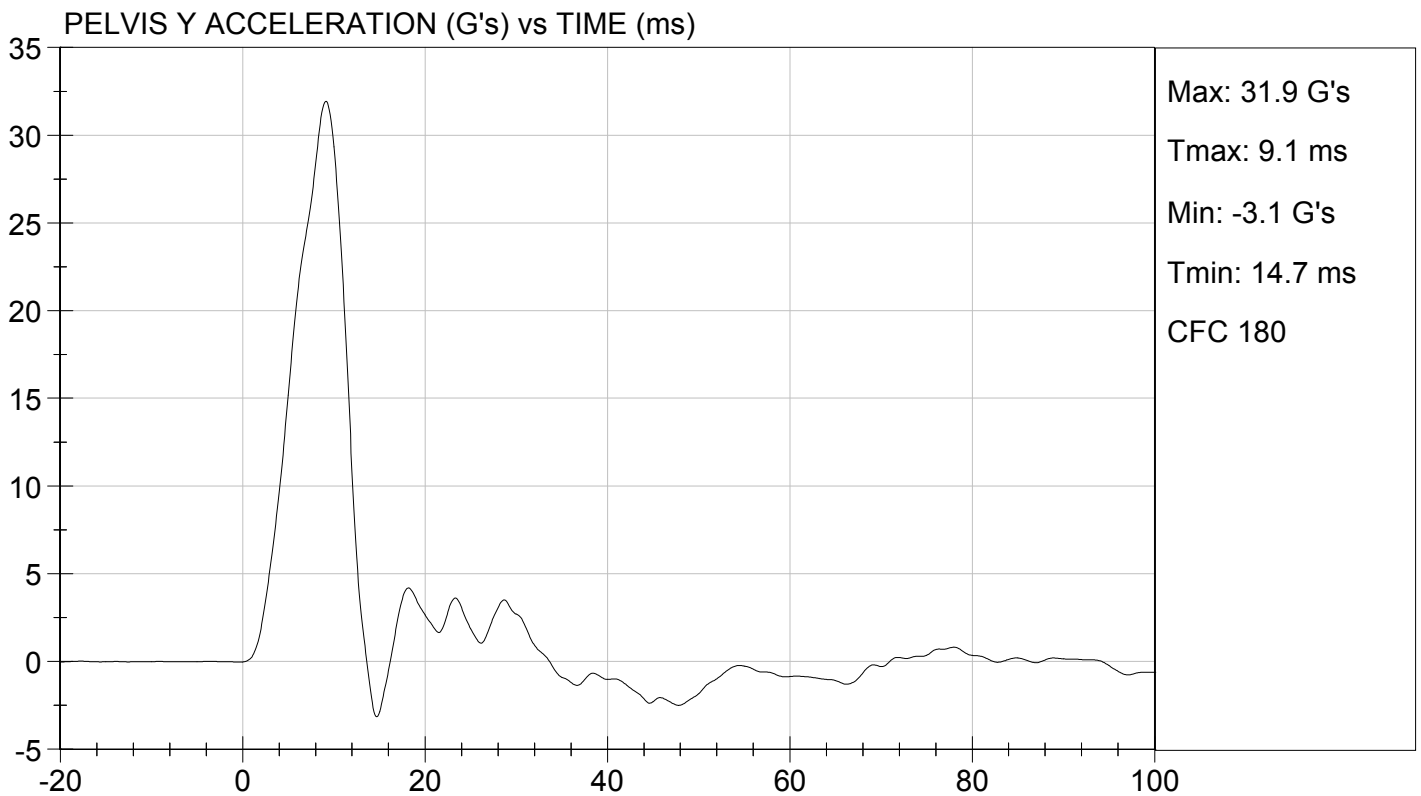
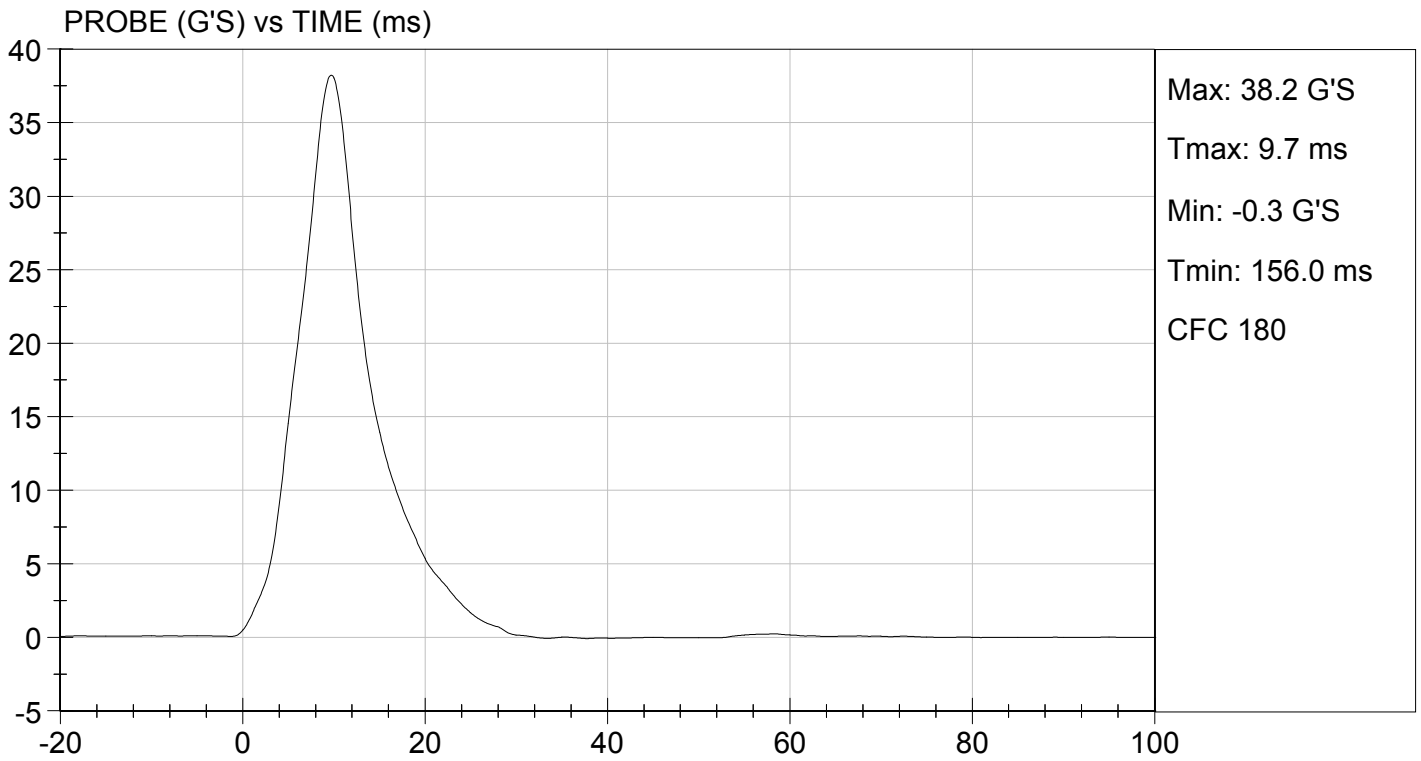



TEST DESC: ILLIAC
VELOCITY: 14.12 ft/s, 4.30 m/s

TEST DATE: 02/22/2013
TEST #: D13538

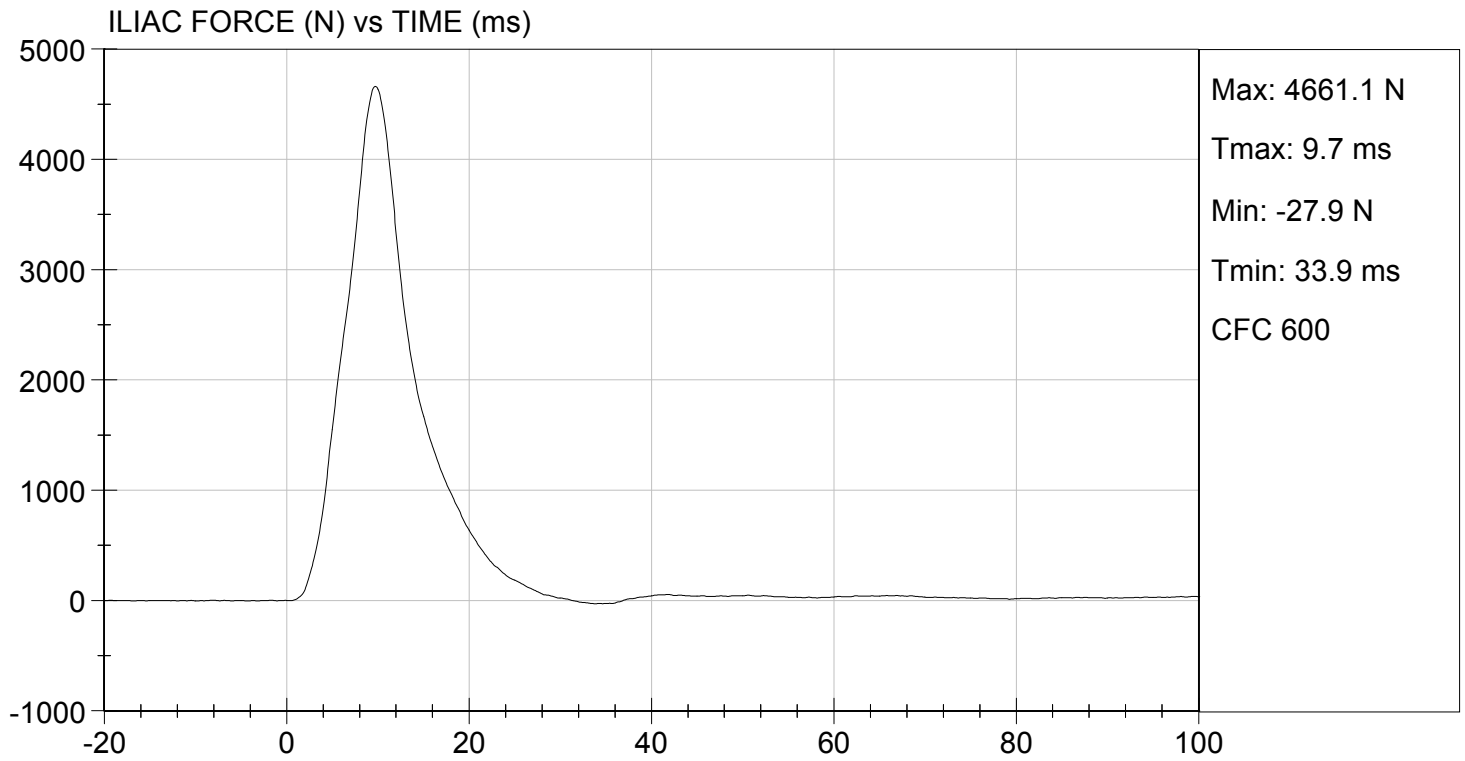

Resultant Data - SIDIIs Plug Compression

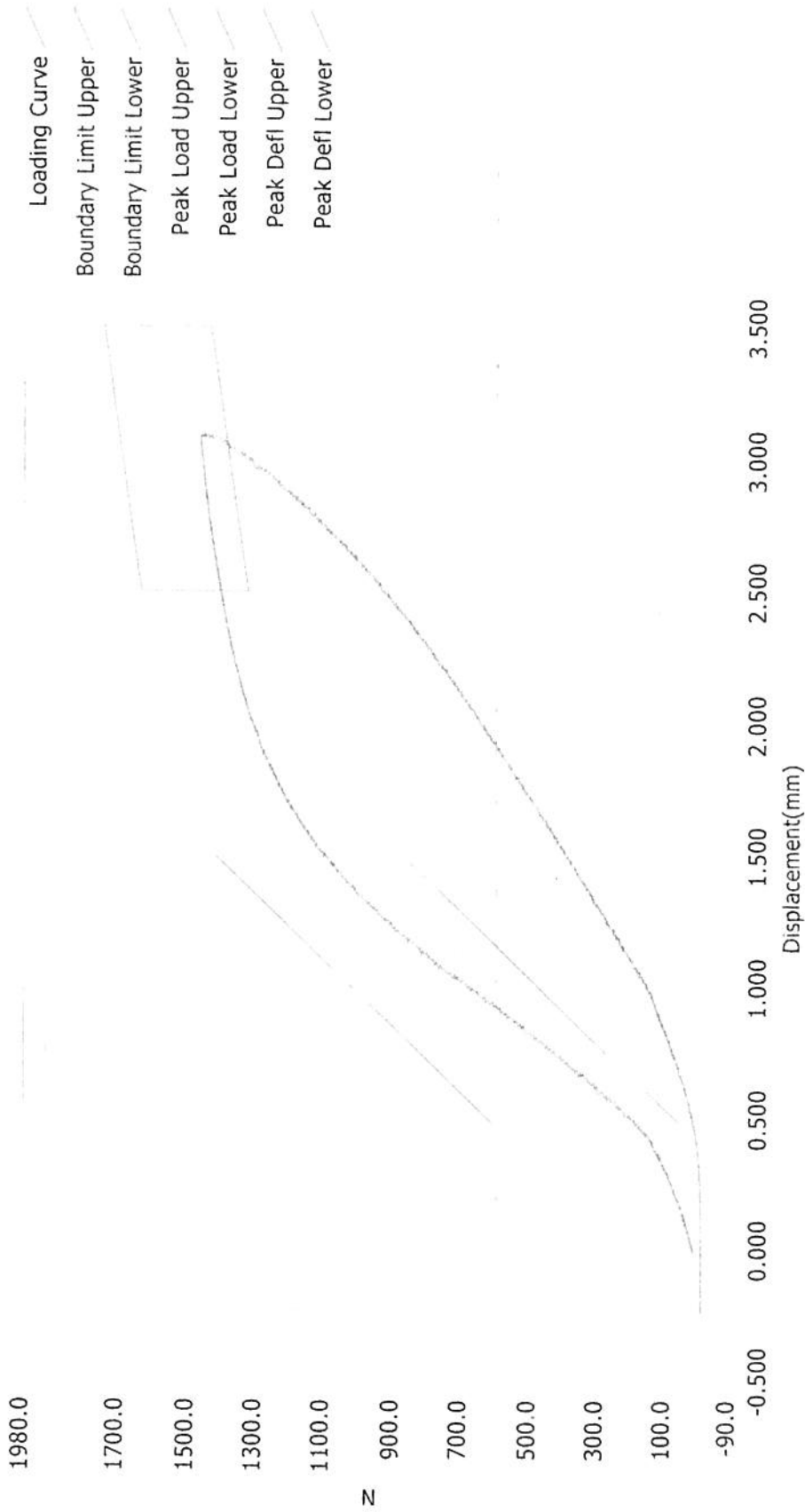

ATD Calibration Lab

<u>Test ID</u>	<u>Part Serial Number</u>	<u>Test Date</u>	<u>Test Time</u>
	47956	10/31/2011	9:22 PM
<u>Cert ID</u>	<u>ATD Serial Number</u>	<u>ATD Type</u>	
	N/A	SIDIIs	

Current Date : 10/31/2011

Current Time : 21:23:26

Resultant Data - SIDIIs Plug Compression

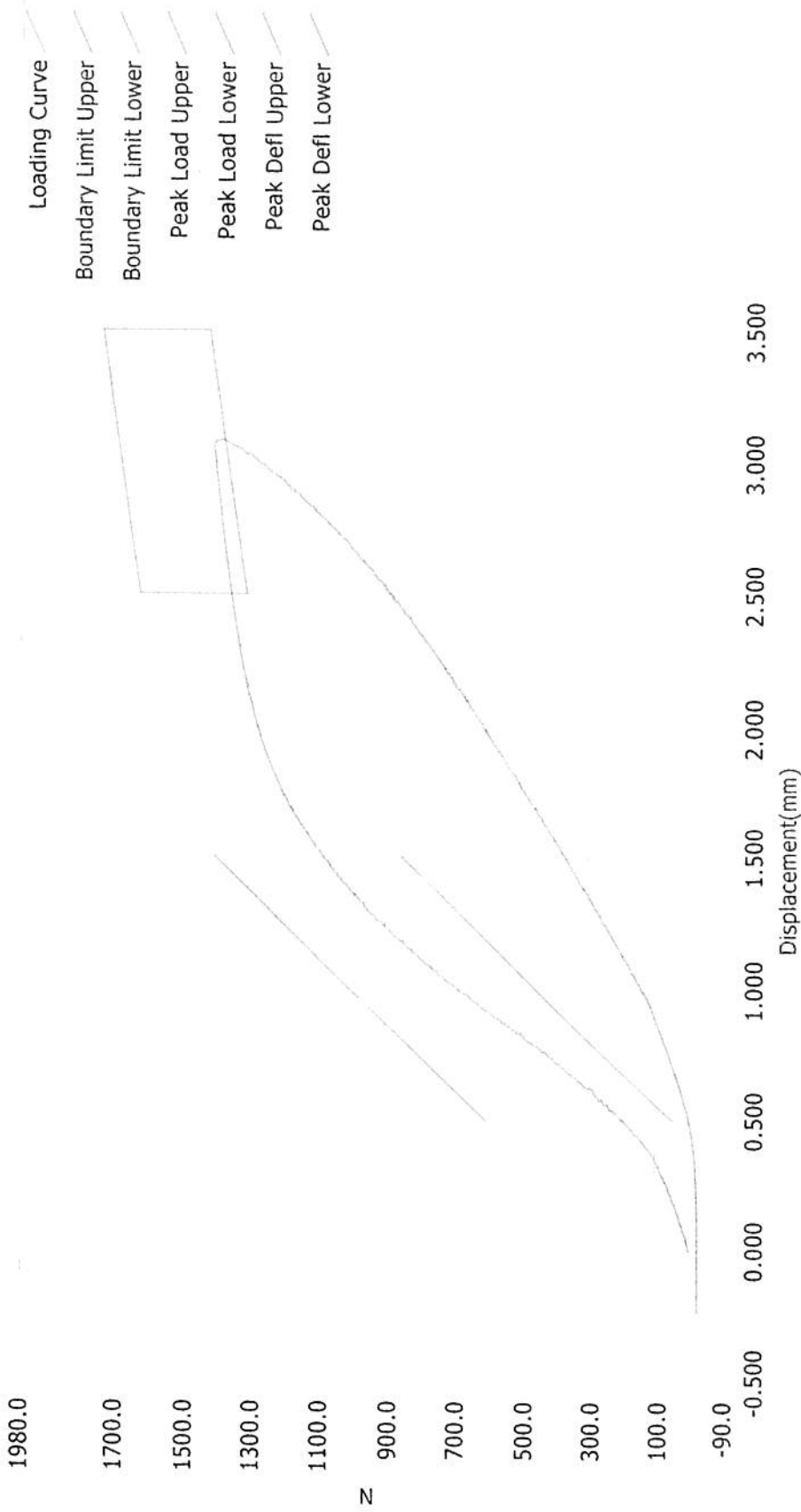

ATD Calibration Lab

Test ID	Part Serial Number	Test Date	Test Time
	45941	9/20/2011	7:56 PM
Cert ID	ATD Serial Number	ATD Type	SIDIIs
	N/A		

Current Date : 9/20/2011

Current Time : 19:57:25

APPENDIX D

TEST EQUIPMENT AND INSTRUMENTATION CALIBRATION DATA

Table 1 – Dummy Instrumentation

				SID-IIs S/N 296		
				Serial Number	Manufacturer	Calibration Date
Head CG Accelerometers			X	P78696	Endevco	10/12/12
			Y	P78698	Endevco	10/12/12
			Z	P78699	Endevco	10/12/12
			Xr	P78700	Endevco	10/12/12
			Yr	P78701	Endevco	10/12/12
			Zr	P78708	Endevco	10/12/12
Displacement Potentiometers	Thoracic Rib	Upper	Y	G012	Servo	10/15/12
		Middle	Y	G1163	FTSS	10/15/12
		Lower	Y	G1158	FTSS	10/15/12
	Abdominal Rib	Upper	Y	G1146	FTSS	10/15/12
		Lower	Y	G1126	FTSS	10/15/12
Lower Spine Accelerometers (T12)			X	P78690	Endevco	10/12/12
			Y	P78693	Endevco	10/12/12
			Z	P78694	Endevco	10/12/12
Acetabulum Load Cell			Y	ACG268	Denton	01/03/13
Iliac Wing Load Cell			Y	IWG282	Denton	01/03/13
Pelvis Plug (struck side)				48931	FTSS	12/05/11
Pelvis Plug (non-struck side)				47745	FTSS	10/28/11

Table 2 – Vehicle Instrumentation

		Serial Number	Manufacturer	Calibration Date
Vehicle Center of Gravity	X	P66633	Endevco	12/27/12
Vehicle Center of Gravity	Y	P66634	Endevco	12/27/12
Vehicle Center of Gravity	Z	P66632	Endevco	12/27/12
Left Floor Sill	Y	P78895	Endevco	12/26/12
A-Pillar Sill	Y	P59238	Endevco	01/04/13
A-Pillar Low	Y	P63925	Endevco	12/26/12
A-Pillar Mid	Y	P47889	Endevco	12/03/12
B-Pillar Sill	Y	P78947	Endevco	11/03/12
B-Pillar Low	Y	P63534	Endevco	12/26/12
B-Pillar Mid	V	P63346	Endevco	12/26/12
Driver Seat	Y	P63391	Endevco	10/06/12
Engine Top	X	P63336	Endevco	10/18/12
Engine Top	Y	P63337	Endevco	10/18/12
Firewall	Y	P63353	Endevco	12/26/12
Right Roof	Y	P66627	Endevco	11/02/12
Right Floor Sill	Y	P59260	Endevco	12/26/12
Rear Floorpan	X	P63923	Endevco	10/18/12
Rear Floorpan	Y	P63922	Endevco	10/18/12

Table 3 – Pole Instrumentation

	Serial Number	Manufacturer	Calibration Date
Load Cell 1	DG6277	FTSS	09/05/12
Load Cell 2	DG6278	FTSS	09/05/12
Load Cell 3	DG6279	FTSS	09/05/12
Load Cell 4	DG6280	FTSS	09/05/12
Load Cell 5	DG6281	FTSS	09/05/12
Load Cell 6	DG6283	FTSS	09/05/12
Load Cell 7	DG6284	FTSS	09/05/12
Load Cell 8	DG6582	FTSS	09/05/12