

**REPORT NUMBER: NCAP-KAR-13-033**

**NEW CAR ASSESSMENT PROGRAM (NCAP)  
FRONTAL BARRIER IMPACT TEST**

**DAIMLER AG STUTT GART  
2013 MERCEDES-BENZ C300 4MATIC AWD 4-DOOR SEDAN**

**NHTSA NUMBER: MD0506**

**PREPARED BY:  
KARCO ENGINEERING, LLC.  
9270 HOLLY ROAD  
ADELANTO, CA 92301**



**DECEMBER 28, 2012**

**FINAL REPORT**

**U.S. DEPARTMENT OF TRANSPORTATION  
NATIONAL HIGHWAY TRAFFIC SAFETY ADMINISTRATION  
SAFETY PERFORMANCE STANDARDS  
OFFICE OF CRASHWORTHINESS STANDARDS  
1200 NEW JERSEY AVE, SE  
ROOM W43-410  
WASHINGTON, DC 20590**

This publication is distributed by the U.S. Department of Transportation, National Highway Traffic Safety Administration, in the interest of information exchange. The opinions, findings and conclusions expressed in this publication are those of the author(s) and not necessarily those of the Department of Transportation or the National Highway Traffic Safety Administration. The United States Government assumes no liability for its contents or use thereof. If trade or manufacturers' names or products are mentioned, it is only because they are considered essential to the object of the publication and should not be construed as an endorsement. The United States Government does not endorse products or manufacturers.

Prepared By:   
Mr. Kelsey A. Chiu, Engineering Department Supervisor  
KARCO Engineering, LLC.

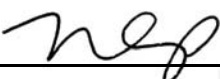
Reviewed By:   
Mr. Michael L. Dunlap, Director of Operations  
KARCO Engineering, LLC.

Approved By:   
Mr. Frank D. Richardson, Program Manager  
KARCO Engineering, LLC.

Approval Date: December 28, 2012

FINAL REPORT ACCEPTANCE BY OCWS:

\_\_\_\_\_  
Division Chief, New Car Assessment Program  
NHTSA, Office of Crashworthiness Standards

Date: \_\_\_\_\_

\_\_\_\_\_  
COTR, New Car Assessment Program  
NHTSA, Office of Crashworthiness Standards

Date: \_\_\_\_\_

## TECHNICAL REPORT DOCUMENTATION PAGE

<b>1. Report No.</b> NCAP-KAR-13-033	<b>2. Government Accession No.</b>	<b>3. Recipient's Catalog No.</b>																																																					
<b>4. Title and Subtitle</b> Final Report of New Car Assessment Program Testing of a 2013 Mercedes-Benz C300 4Matic AWD 4-Door Sedan NHTSA No. MD0506		<b>5. Report Date</b> December 28, 2012																																																					
		<b>6. Performing Organization Code</b> KAR																																																					
<b>7. Authors</b> Mr. Kelsey A. Chiu, Engineering Department Supervisor, KARCO Mr. Frank Richardson, Program Manager, KARCO		<b>8. Performing Organization Report No.</b> TR-P33001-08-NC																																																					
		<b>10. Work Unit No.</b>																																																					
<b>9. Performing Organization Name and Address</b> KARCO Engineering, LLC. 9270 Holly Rd. Adelanto, CA 92301				<b>11. Contract or Grant No.</b> DTNH22-12-D-00259																																																			
		<b>12. Sponsoring Agency Name and Address</b> U. S. Department of Transportation National Highway Traffic Safety Administration Office of Crashworthiness Standards 1200 New Jersey Ave., SE, Room W43-410 Washington, D.C. 20590		<b>13. Type of Report and Period Covered</b> Final Test Report, Dec. 14 - 28, 2012																																																			
<b>14. Sponsoring Agency Code</b> NVS-111																																																							
<b>15. Supplementary Notes</b>																																																							
<b>16. Abstract</b> <p>A 56.3 km/h NCAP Frontal Impact Test was conducted on a 2013 Mercedes-Benz C300 4Matic AWD 4-door sedan in accordance with the specifications of the Office of Crashworthiness Standards Frontal NCAP Laboratory Test Procedure. This test was conducted to obtain data indicant of FMVSS 208, 212, 219 (partial), 301, and footwell intrusion performance. The test was conducted at the KARCO Engineering, LLC. facility in Adelanto, California on December 14, 2012.</p> <p>The impact velocity of the vehicle was 56.16 km/h and the ambient temperature at the barrier face at the time of impact was 10.9 deg. C. The target vehicle's post-test maximum crush was 437 mm at the vehicle's centerline. The test vehicle's performance is as follows:</p> <table border="1" style="width: 100%; border-collapse: collapse; margin-top: 10px;"> <thead> <tr> <th rowspan="2">Measurement Description</th> <th rowspan="2">Units</th> <th colspan="2">Driver ATD</th> <th colspan="2">Passenger ATD</th> </tr> <tr> <th>Threshold</th> <th>Result</th> <th>Threshold</th> <th>Result</th> </tr> </thead> <tbody> <tr> <td>Head Injury Criteria (HIC<sub>15</sub>)</td> <td>N/A</td> <td>700.0</td> <td>244.2</td> <td>700.0</td> <td>276.7</td> </tr> <tr> <td>Maximum Chest Compression</td> <td>mm</td> <td>63</td> <td>-20</td> <td>52</td> <td>-24</td> </tr> <tr> <td>Nij</td> <td>N/A</td> <td>1</td> <td>0.34</td> <td>1</td> <td>0.35</td> </tr> <tr> <td>Neck Tension</td> <td>N</td> <td>4170</td> <td>1804.3</td> <td>2620</td> <td>539.1</td> </tr> <tr> <td>Neck Compression</td> <td>N</td> <td>4000</td> <td>-172.4</td> <td>2520</td> <td>-737.6</td> </tr> <tr> <td>Left Femur Force</td> <td>N</td> <td>10008</td> <td>-3285.2</td> <td>6805</td> <td>-3111.4</td> </tr> <tr> <td>Right Femur Force</td> <td>N</td> <td>10008</td> <td>-3574.5</td> <td>6805</td> <td>-1722.3</td> </tr> </tbody> </table>				Measurement Description	Units	Driver ATD		Passenger ATD		Threshold	Result	Threshold	Result	Head Injury Criteria (HIC <sub>15</sub> )	N/A	700.0	244.2	700.0	276.7	Maximum Chest Compression	mm	63	-20	52	-24	Nij	N/A	1	0.34	1	0.35	Neck Tension	N	4170	1804.3	2620	539.1	Neck Compression	N	4000	-172.4	2520	-737.6	Left Femur Force	N	10008	-3285.2	6805	-3111.4	Right Femur Force	N	10008	-3574.5	6805	-1722.3
Measurement Description	Units	Driver ATD				Passenger ATD																																																	
		Threshold	Result	Threshold	Result																																																		
Head Injury Criteria (HIC <sub>15</sub> )	N/A	700.0	244.2	700.0	276.7																																																		
Maximum Chest Compression	mm	63	-20	52	-24																																																		
Nij	N/A	1	0.34	1	0.35																																																		
Neck Tension	N	4170	1804.3	2620	539.1																																																		
Neck Compression	N	4000	-172.4	2520	-737.6																																																		
Left Femur Force	N	10008	-3285.2	6805	-3111.4																																																		
Right Femur Force	N	10008	-3574.5	6805	-1722.3																																																		
<b>17. Key Words</b> 35 mph Frontal Barrier Impact Test New Car Assessment Program (NCAP)		<b>18. Distribution Statement</b> Copies of this report are available from: National Highway Traffic Safety Admin. Technical Information Services Division, NPO-411 1200 New Jersey Ave., SE Washington, DC 20590 e-mail: tis@nhtsa.dot.gov FAX: 202-493-2833																																																					
		<b>19. Security Classification of this report</b> UNCLASSIFIED	<b>20. Security Classification of this page</b> UNCLASSIFIED	<b>21. No. of Pages</b> 134	<b>22. Price</b>																																																		

## TABLE OF CONTENTS

<u>Section</u>		<u>Page No.</u>
1	Purpose and Summary of the Test	1
2	Occupant and Vehicle Information / Data Sheets	3
<u>Data Sheet No.</u>		<u>Page No.</u>
1	General Test and Vehicle Parameter Data	4
2	Seat Adjustment, Fuel Systems, and Steering Wheel Data	8
3	Dummy Longitudinal Clearance Dimensions	10
4	Dummy Lateral Clearance Dimensions	11
5	Seat Belt Positioning Data	12
6	High-Speed Camera Locations and Data	13
7	Vehicle Accelerometer Locations	15
8	Photographic Reference Target Locations	16
9	Load Cell Locations on Fixed Barrier	17
10	Test Vehicle Camera and Instrumentation Summary	18
11	Post-Test Observations	19
12	Vehicle Profile Measurements	20
13	Accident Investigation Division Data	22
14	Vehicle Intrusion Measurements	23
15	Summary of FMVSS 212 and FMVSS 219 (Partial) Data	28
16	FMVSS 301 Fuel Static Rollover Data	30
17	Dummy / Vehicle Temperature Stabilization	31
<u>Appendix</u>		<u>Page No.</u>
A	Photographs	A
B	Dummy Response Data Traces	B
C	Dummy Calibration and Performance Verification Data	C

## **SECTION 1**

### **PURPOSE AND SUMMARY OF TEST**

#### **PURPOSE**

This 56.3 km/h frontal barrier impact test is part of the Vehicle Barrier Impact Testing Program, sponsored by the National Highway Traffic Safety Administration (NHTSA) under contract number DTNH22-12-D-00259. The purpose of this test was to obtain vehicle crashworthiness and occupant restraint system performance data for consumer information purposes.

The 56.3 km/h frontal barrier impact test was conducted in accordance with the Office of Crashworthiness Standards Frontal NCAP Laboratory Test Procedure, dated September 2012.

#### **SUMMARY**

A load cell barrier consisting of 36 load cells was impacted by a 2013 Mercedes-Benz C300 4Matic AWD 4-door sedan at a velocity of 56.16 km/h. The test was performed at KARCO Engineering, LLC. on December 14, 2012. Pre- and post-test photographs of the vehicle and dummies can be found in Appendix A of this report.

Three (3) real-time cameras and sixteen (16) high-speed cameras were used to document the frontal barrier impact event. Camera locations and other pertinent camera information can be found in Data Sheet 6 of this report.

One Part 572E 50<sup>th</sup> percentile male anthropomorphic test device (ATD) was placed in the driver seating position and one Part 572O 5<sup>th</sup> percentile female ATD was placed in the right-front passenger seating position according to dummy placement instructions specified in the Frontal NCAP Laboratory Test Procedure.

Both ATDs were fully instrumented with head, chest and pelvis tri-axial accelerometers, chest displacement potentiometers, upper neck force transducers, right / left femur load cells, and lower leg instrumentation. Seat belt load cells were placed on the driver and passenger's shoulder belts and lap belts to measure the dummy torso and pelvic section loading. The driver (position 1) ATD (Serial No. 034) and the right-front passenger (position 2) ATD (Serial No. 635) were calibrated prior to this test. Certification details, along with instrumentation calibration data, are found in Appendix C of this report.

The 148 channels of data were recorded on an on-board data acquisition system. Appendix B contains the dummy response data traces.

There was 100% windshield retention and no intrusion into the protected zone of the windshield during the event. There was no Stoddard solvent leakage after the event or during any phase of the static rollover.

The maximum static crush of the test vehicle was 437 mm located at the vehicle's centerline. Both the driver and passenger side doors remained closed during the impact event and were operable after the impact.

The driver's visible contact points were as follows: The driver ATD's head contacted the airbag and the headrest. The upper torso contacted the airbag. Both the left and right knees contacted the knee airbag.

The passenger's visible contact points were as follows: The passenger ATD's head contacted the airbag, headrest, and side header. The upper torso contacted the airbag. The left and right knee contacted the glove box.

The occupant data is summarized below:

ATD Position	HIC <sub>15</sub>	T <sup>1</sup>	T <sup>2</sup>	Chest Disp. (mm)	Nij	Neck Tension (N)	Neck Comp. (N)	Left Femur (N)	Right Femur (N)
Driver (50th)	244.2	62.1	77.1	-20	0.34	1804.3	-172.4	-3285.2	-3574.5
Passenger (5th)	276.7	57.3	72.3	-24	0.35	539.1	-737.6	-3111.4	-1722.3

**SECTION 2**  
**DATA SHEETS**

Test Vehicle: 2013 Mercedes-Benz C300 4Matic AWD 4-Door Sedan NHTSA No.: MD0506  
 Test Program: 56 km/h Frontal Impact NCAP Test Test Date: 12/14/12

**CONVERSION FACTORS**

Quantity	Typical Application	Std Units	Metric Unit	Multiply By
Mass	Vehicle Weight	lb	kg	0.4536
Linear Velocity	Impact Velocity	miles/hr	km/hr	1.609344
Length or Distance	Measurements	in	mm	25.4
Volume	Fuel Systems	gal	liter	3.785
Volume	Small Fluids	oz	mL	29.574
Pressure	Tire Pressures	lbf/in <sup>2</sup>	kPa	6.895
Temperature	General Use	°F	°C	$=(T_f - 32)/1.8$
Force	Dynamic Forces	lbf	N	4.448
Moment	Torque	lbf-ft	N•m	1.355

**DATA SHEET NO. 1**

**GENERAL TEST AND VEHICLE PARAMETER DATA**

Test Vehicle: 2013 Mercedes-Benz C300 4Matic AWD 4-Door Sedan NHTSA No.: MD0506  
 Test Program: 56 km/h Frontal Impact NCAP Test Test Date: 12/14/12

**TEST VEHICLE INFORMATION AND OPTIONS**

NHTSA Number	MD0506
Model Year	2013
Make	Mercedes-Benz
Model	C300
Body Style	4-Door Sedan
VIN	WDDGF8AB5DR252927
Body Color	Steel Grey
Odometer Reading (km / mi)	26 / 16
Engine Displacement (L)	3.5
Type / No. of Cylinders	V6
Engine Placement	Longitudinal
Transmission Type	Automatic
Transmission Speeds	7
Overdrive	Yes
Final Drive	AWD
Roof Rack	No
Sunroof / T-Top	Yes
Running Boards	No
Tilt Steering Wheel	Yes
Power Seats	Yes
Anti-Lock Brakes (ABS)	Yes
Automatic Door Locks (ADLs)	Yes

Traction Control System	Yes
Power Steering	Yes
Power Window Auto-Reverse	Yes
Driver Frontal Airbag	Yes
Driver Curtain Airbag	Yes
Driver Head/Torso Airbag	No
Driver Torso Airbag	Yes
Driver Torso/Pelvis Airbag	No
Driver Pelvis Airbag	Yes
Driver Knee Airbag	Yes
Front Pass. Frontal Airbag	Yes
Front Pass. Curtain Airbag	Yes
Front Pass. Head/Torso Airbag	No
Front Pass. Torso Airbag	Yes
Front Pass. Torso/Pelvis Airbag	No
Front Pass. Pelvis Airbag	Yes
Front Pass. Knee Airbag	No
Driver Seat Belt Pretensioner	Yes
Driver Load Limiter	Yes
Front Pass. Seat Belt Pretensioner	Yes
Front Pass. Load Limiter	Yes
Other	None

Does Owner's Manual provide instructions to turn off automatic door locks? Yes

**DATA FROM CERTIFICATION LABEL**

Manufactured By	Daimler Ag Stuttgart
Date of Manufacture	Aug-12

GVWR (kg)	2185
GAWR Front (kg)	1075
GAWR Rear (kg)	1140

**VEHICLE SEATING AND CAPACITY WEIGHT INFORMATION**

Measured Parameter	Front	Rear	Third	Total	
Type of Seats	Bucket	Bench			
Designated Seating Capacity	2	3		5	
Capacity Weight (VCW) (kg)				400.0	A
DSC x 68.04 (kg)				340.2	B
Cargo Weight (RCLW) (kg)				59.8	A-B

## DATA SHEET NO. 1 ... (CONTINUED)

### GENERAL TEST AND VEHICLE PARAMETER DATA

Test Vehicle: 2013 Mercedes-Benz C300 4Matic AWD 4-Door Sedan NHTSA No.: MD0506  
 Test Program: 56 km/h Frontal Impact NCAP Test Test Date: 12/14/12

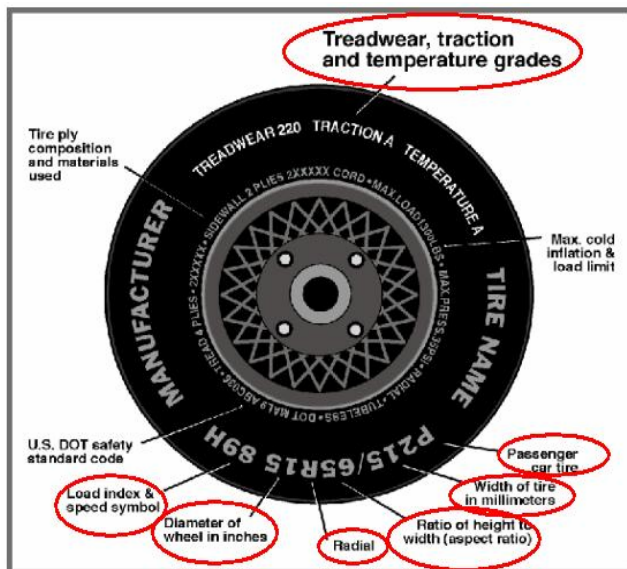

### VEHICLE TIRE INFORMATION

Measured Parameter	Front	Rear
Max. Tire Pressure (kPa)	350	350
Cold Pressure (kPa)	250	280
Recommended Tire Size	225/45R17	245/40R17
Tire Size on Vehicle	225/45R17	245/40R17
Tire Manufacturer	Continental	Continental
Tire Model	Conti Pro Contact	Conti Pro Contact
Treadwear	500	500
Traction	AA	AA
Temperature Grades	A	A
Tire Plies Sidewall	1 Polyester	1 Rayon
Tire Plies Body	1 Polyester, 1 Nylon, 2 Steel	1 Polyamide, 1 Rayon, 2 Steel
Load Index / Speed Symbol	91H	91H
Tire Material	Polyester, Steel, Nylon	Polyamide, Rayon, Steel
DOT Safety Code Left	1L7R PXH6 2712	1L8N PXH6 2612
DOT Safety Code Right	1L7R PXH6 2712	1L8N PXH6 2612

**DATA SHEET NO. 1 ... (CONTINUED)**

**GENERAL TEST AND VEHICLE PARAMETER DATA**

Test Vehicle: 2013 Mercedes-Benz C300 4Matic AWD 4-Door Sedan NHTSA No.: MD0506  
 Test Program: 56 km/h Frontal Impact NCAP Test Test Date: 12/14/12

**TEST VEHICLE WEIGHTS**

	Units	As Delivered Weights (UVW)			As Tested Weights (ATW)		
		Front Axle	Rear Axle	Total	Front Axle	Rear Axle	Total
Left	kg	473.5	379.5		499.5	461.5	
Right	kg	456.5	395.5		468.0	470.5	
Ratio	%	54.5%	45.5%	100.0%	50.9%	49.1%	100.0%
Total	kg	930.0	775.0	1705.0	967.5	932.0	1899.5

**TARGET TEST WEIGHT CALCULATION**

Measured Parameter	Units	Value	
Total Delivered Weight (UVW)	kg	1705.0	A
Weight of 1 P572E ATD & 1 P572O ATD	kg	141.0	B
Rated Cargo/Luggage Weight (RCLW)	kg	59.8	C
Calculated Vehicle Target Weight (TVTW)	kg	1905.8	A+B+C

**TEST VEHICLE ATTITUDES**

Condition	Units	LF	RF	LR	RR	CG Aft of Front Axle
As Delivered	mm	652	655	667	663	1256
As Tested	mm	645	645	643	647	1356
Post-Test	mm	657	666	644	640	

**GENERAL TEST VEHICLE DATA**

Measurement Description	Units	Value
Total Vehicle Wheel Base	mm	2763
Total Vehicle Length at Left Side	mm	3997
Total Vehicle Length at Centerline	mm	4630
Total Vehicle Length at Right Side	mm	4003
Weight of Ballast in Cargo Area	kg	89.0
Weight of Vehicle Components Removed	kg	20.0
Amount of Stoddard Solvent in Fuel Tank	L	61.60

**VEHICLE COMPONENTS REMOVED TO MEET TEST WEIGHT:**

Spare Tire and Tools (14.5 kg), Trunk Trim (5.5)

---



---



---

**DATA SHEET NO. 1 ... (CONTINUED)****GENERAL TEST AND VEHICLE PARAMETER DATA**

Test Vehicle: 2013 Mercedes-Benz C300 4Matic AWD 4-Door Sedan NHTSA No.: MD0506  
Test Program: 56 km/h Frontal Impact NCAP Test Test Date: 12/14/12

**TARGET VEHICLE STRUCTURAL MEASUREMENTS**

No.	Description	Pre-Test
1	Total Length	4630
2	Total Width	1775
3	Bumper Top Height	520
4	Bumper Bottom Height	395
5	Longitudinal Member Top Height	505
6	Distance Between Longitudinal Members	800
7	Longitudinal Member Width	55
8	Engine Top Height	850
9	Engine Bottom Height	183
10	Engine and Gearbox Width	710
11	Front Bumper to Engine Distance	440
12	Front Shock Absorber Fixing Height	825
13	Bonnet Leading Edge Height	715
14	Front Shock Absorber Fixing Width	1175
15	Front Bumper to Front Axle Distance	787
16	Front Axle to A-Pillar Distance	615
17	A-Pillar to B-Pillar Distance	916
18	B-Pillar to Rear Axle Distance	1060
19	B-Pillar to C-Pillar Distance	820
20	Roof Sill Bottom Height	1260
21	Roof Sill Top Height	1377
22	Floor Sill Bottom Height	160
23	Floor Sill Top Height	315

All measurements in millimeters.

## DATA SHEET NO. 2

### SEAT ADJUSTMENT, FUEL SYSTEMS, AND STEERING WHEEL DATA

Test Vehicle: 2013 Mercedes-Benz C300 4Matic AWD 4-Door Sedan NHTSA No.: MD0506  
 Test Program: 56 km/h Frontal Impact NCAP Test Test Date: 12/14/12

#### NOMINAL DESIGN RIDING POSITION

The procedure for the driver is as follows: the seat back is set to the manufacturer's designated angle. The procedure for the passenger is as follows: the seat back is set to position the transverse instrumentation platform of the dummy's head at  $0^\circ \pm 0.5^\circ$ . Seat back angle is measured at the seat back using a digital inclinometer.

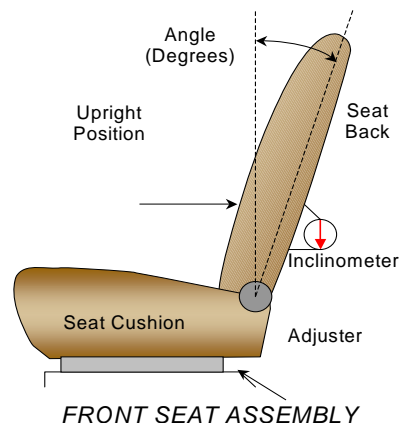

#### SEAT BACK ANGLE

Seating Position	Degrees
Driver Seat Back Angle	21.3
Passenger Seat Back Angle	20.6

#### SEAT FORE / AFT POSITIONING

The total seat travel is measured from the forward most possible position to the rear most possible position. The driver's seat is set to the middle of the fore-aft travel. The passenger's seat is set to the forward most position where the ATD will not contact any interior panels.

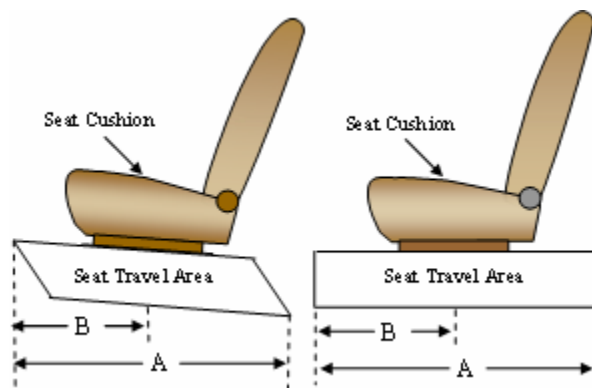

#### SEAT FORE/AFT POSITIONS

Seating Position	Total Fore-Aft Travel	Placed in Position
Driver Seat	286 mm	143 mm
Passenger Seat	222 mm	0 mm

#### SEAT BELT UPPER ANCHORAGE

The seat belt upper anchorage is positioned to the manufacturer's design position for a 50<sup>th</sup> percentile adult male ATD for the driver, and a 5<sup>th</sup> percentile adult female ATD for the passenger. Position "H" is the uppermost position, followed by position "M1". Position "L" is the lowermost position.

#### SEAT BELT UPPER ANCHORAGES

Seating Position	Total No. of Positions	Placed in Position
Driver Seat	5	H
Passenger Seat	5	H

**DATA SHEET NO. 2 ... (CONTINUED)**

**SEAT ADJUSTMENT, FUEL SYSTEMS, AND STEERING WHEEL DATA**

Test Vehicle: 2013 Mercedes-Benz C300 4Matic AWD 4-Door Sedan NHTSA No.: MD0506  
 Test Program: 56 km/h Frontal Impact NCAP Test Test Date: 12/14/12

**FUEL TANK CAPACITY**

Description	Liters
Usable Capacity of "Standard Tank"	66.24
Usable Capacity of "Optional Tank"	
92 - 94% of Usable Capacity	60.94 to 62.27
Actual Amount of Stoddard Solvent Used	61.60
1/3 of Usable Capacity	22.08

**FUEL PUMP**

The vehicle is equipped with an electric fuel pump. The fuel pump operates when the ignition is switched to the "ON" position. After about 15 seconds the pump switches to standby mode if the engine is not started.

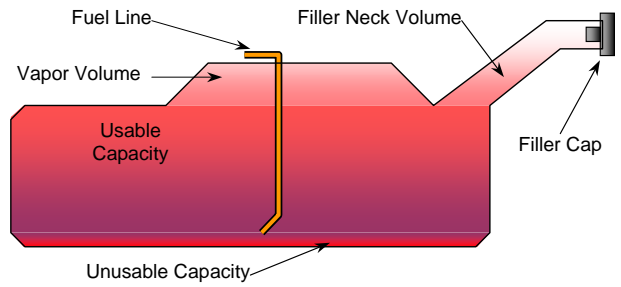

VEHICLE FUEL TANK ASSEMBLY

**STEERING COLUMN ADJUSTMENT**

Steering wheel and column adjustments are made so that the steering wheel hub is at the geometric center of the locus it describes when moved through its full range of motion. A digital inclinometer is used to measure a plate which is placed across the rim of the steering wheel for angular measurements. A tape measure is used to measure telescoping steering wheel travel.

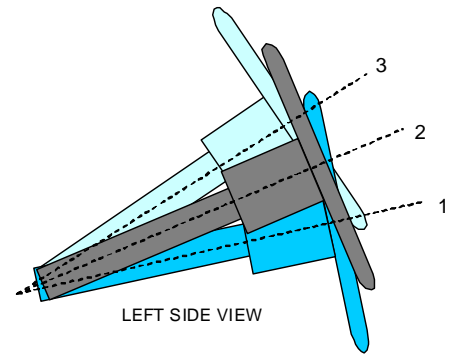

STEERING COLUMN ASSEMBLY

**STEERING COLUMN POSITIONING**

	Degrees	Fore-Aft Position (mm)
Lowermost Position, No. 1	19.7	73
Geometric Center Position, No. 2	22.2	104
Uppermost Position, No. 3	24.7	135
Telescoping Steering Wheel Travel		62
Test Position	22.2	104

### DATA SHEET NO. 3

### DUMMY LONGITUDINAL CLEARANCE DIMENSIONS

Test Vehicle: 2013 Mercedes-Benz C300 4Matic AWD 4-Door Sedan NHTSA No.: MD0506  
 Test Program: 56 km/h Frontal Impact NCAP Test Test Date: 12/14/12

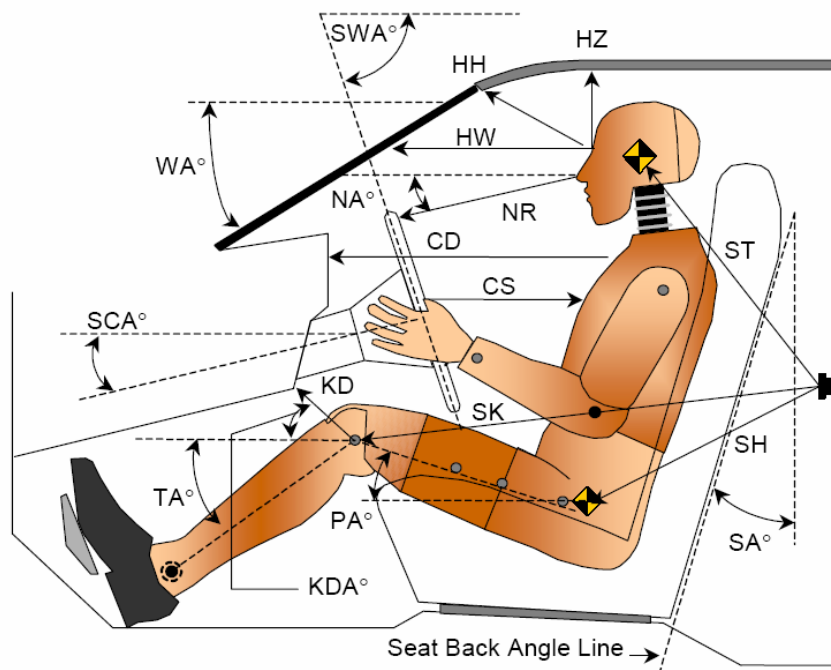

**LEFT SIDE VIEW**

Code	Measurement Description	Driver		Passenger	
		Length (mm)	Angle (°)	Length (mm)	Angle (°)
WA°	Windshield Angle		26.5		
SWA°	Steering Wheel Angle		67.8		
SCA°	Steering Column Angle		22.2		
SA°	Seat Back Angle (On Headrest Post)		21.3		20.6
HZ	Head to Roof	171	90.0	182	90.0
HH	Head to Header	328	29.6	282	50.0
HW	Head to Windshield	567	0.0	571	0.0
NR	Nose to Rim	373	11.0	460	28.5
CD	Chest to Dash	515	12.9	405	3.3
CS	Chest to Steering Hub	286	0.0		
RA	Rim to Abdomen	189	0.0		
KDL	Left Knee to Dash	183	36.2	108	40.2
KDR	Right Knee to Dash	155	34.5	110	46.6
PA°	Pelvic Angle		20.6		20.5
TA°	Tibia Angle		37.1		45.9
SK	Striker to Knee	556	15.0	644	10.9
ST	Striker to Head	430	79.9	410	68.1
SH	Striker to H-Point	295	56.2	359	34.9

## DATA SHEET NO. 4

### DUMMY LATERAL CLEARANCE DIMENSIONS

Test Vehicle: 2013 Mercedes-Benz C300 4Matic AWD 4-Door Sedan NHTSA No.: MD0506

Test Program: 56 km/h Frontal Impact NCAP Test Test Date: 12/14/12

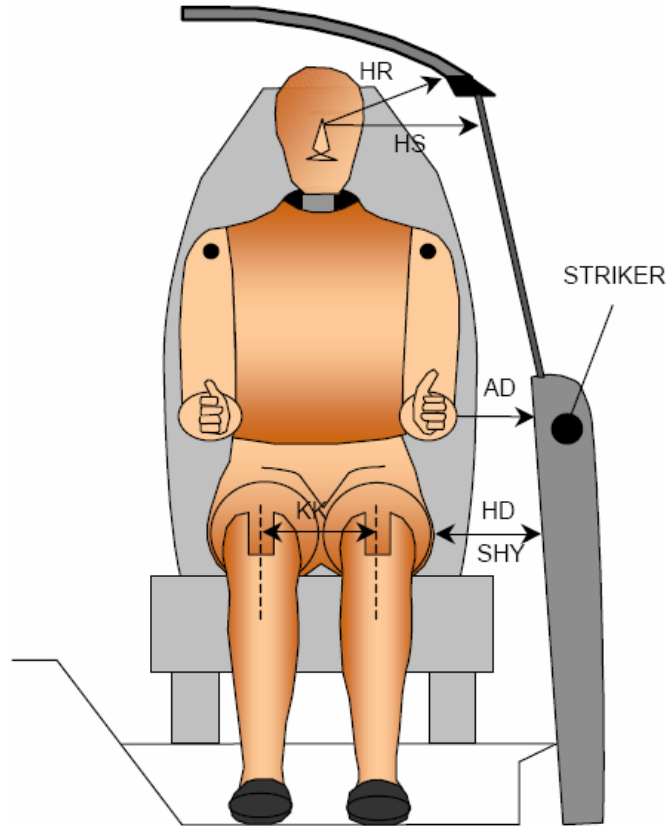

Code	Description	Driver (mm)	Passenger (mm)
AD	Arm to Door	101	55
HD	H-Point to Door	130	211
HR	Head to Side Header	213	228
HS	Head to Side Window	310	320
KK	Knee to Knee	327	223
SHY	Striker to H-Point (Y-Direction)	205	240
AA	Ankle to Ankle	310	170

**DATA SHEET NO. 5**  
**SEAT BELT POSITIONING DATA**

Test Vehicle: 2013 Mercedes-Benz C300 4Matic AWD 4-Door Sedan NHTSA No.: MD0506  
 Test Program: 56 km/h Frontal Impact NCAP Test Test Date: 12/14/12

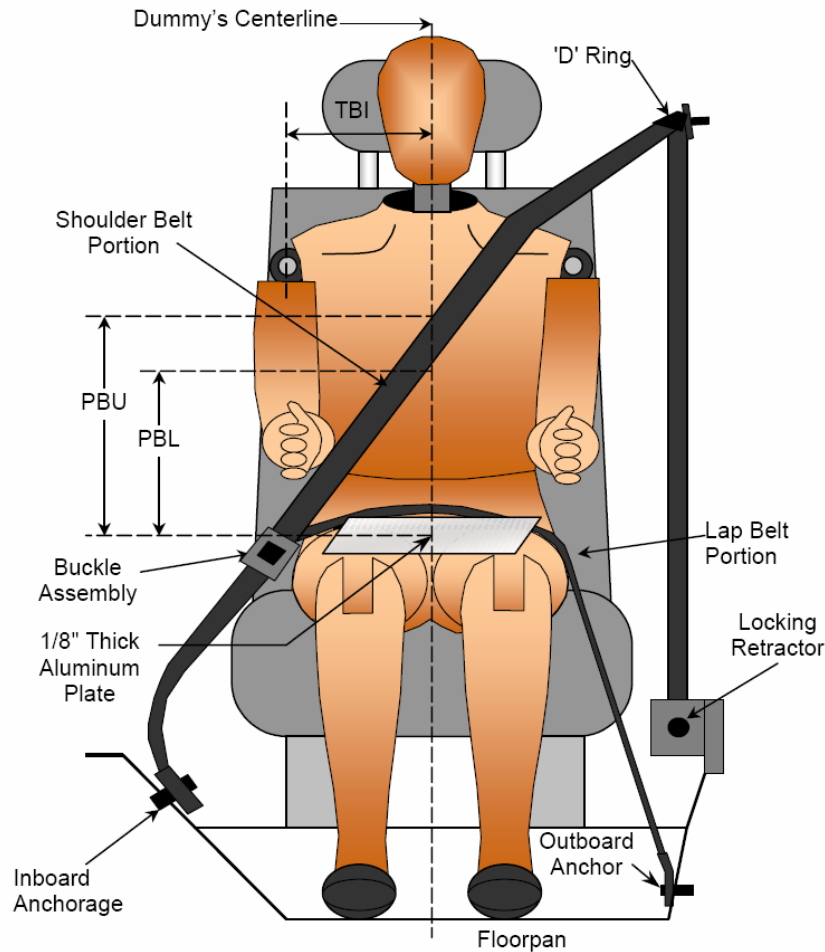

**FRONT VIEW OF DUMMY**

**SEAT BELT POSITIONING MEASUREMENTS**

Code	Measurement Description	Units	Driver	Passenger
PBU	Top Surface of Aluminum Plate to Belt Upper Edge	mm	399	305
PBL	Top Surface of Aluminum Plate to Belt Lower Edge	mm	314	220

**BELT LENGTH DATA**

Measurement Description	Units	Driver	Passenger
Shoulder Belt Length as Measured on ATD	mm	915	935
Lap Belt Length as Measured on ATD	mm	572	560
Remainder of Belt on Reel	mm	849	818
Total Belt Length for Continuous Webbing Systems	mm	2336	2313

DATA SHEET NO. 6

HIGH-SPEED CAMERA LOCATIONS AND DATA

Test Vehicle: 2013 Mercedes-Benz C300 4Matic AWD 4-Door Sedan NHTSA No.: MD0506

Test Program: 56 km/h Frontal Impact NCAP Test Test Date: 12/14/12

CAMERA POSITIONS FOR FRONTAL IMPACTS

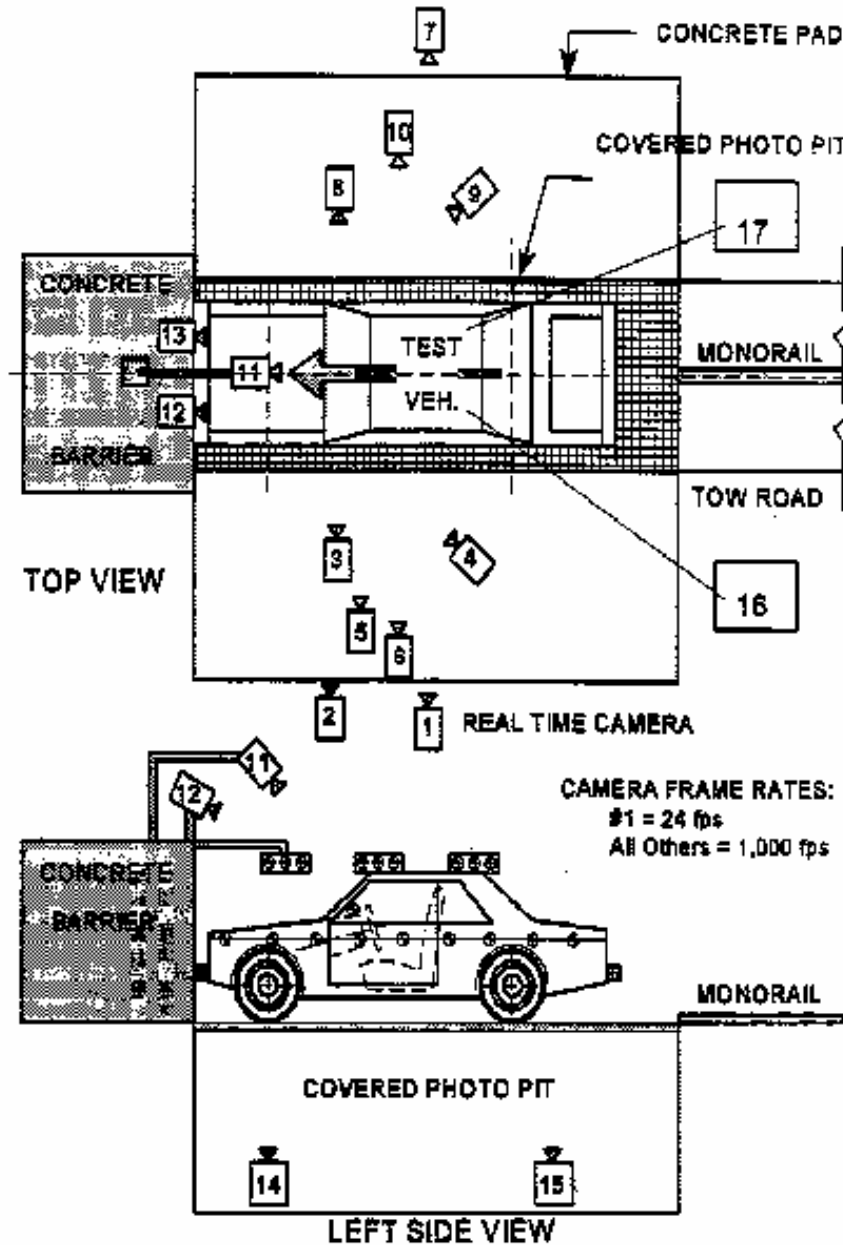

**DATA SHEET NO. 6 ... (CONTINUED)**

**HIGH-SPEED CAMERA LOCATIONS AND DATA**

Test Vehicle: 2013 Mercedes-Benz C300 4Matic AWD 4-Door Sedan NHTSA No.: MD0506  
 Test Program: 56 km/h Frontal Impact NCAP Test Test Date: 12/14/12

**CAMERA LOCATIONS**

No.	Description	Location (mm)			Lens (mm)	Speed (fps)
		X	Y	Z		
1	Real-Time Left Overall	-11412	-8150	-1484		30
2	Driver Close-Up	-2590	-7950	-1371	24	1000
3	Left Front Half	-1701	-6197	-1701	50	1000
4	Left Angle	-6696	-10308	-3211	ZOOM	1000
5	Steering Column - Top	-1966	-10412	-3688	50	1000
6	Steering Column - Bottom	-1972	-10412	-3379	50	1000
7	Right Overall	-2336	7569	-1012	24	1000
8	Passenger Close-Up	-1733	7581	-1408	50	1000
9	Right Front Half	-1600	8214	-1811	ZOOM	1000
10	Right Angle	-6217	9516	-4830	ZOOM	1000
11	Windshield	-354	0	-5749	12	1000
12	Driver Windshield	297	-366	-2460	12	1000
13	Passenger Windshield	297	366	-2460	24	1000
14	Pit Front	-756	0	1495	12	1000
15	Pit Rear	-3398	0	1495	8	1000
16	Onboard Driver Airbag (Optional)	-3080	220	-1220	12	1000
17	Onboard Passenger Airbag (Optional)	-3080	-220	-1220	12	1000
18	Real-Time Left View of Impact					
19	Real-Time Right View of Impact					

Coordinates:      +X = forward impact plane  
                          +Y = right of monorail center  
                          +Z = into ground

**DATA SHEET NO. 7**

**VEHICLE ACCELEROMETER LOCATIONS**

Test Vehicle: 2013 Mercedes-Benz C300 4Matic AWD 4-Door Sedan NHTSA No.: MD0506  
 Test Program: 56 km/h Frontal Impact NCAP Test Test Date: 12/14/12

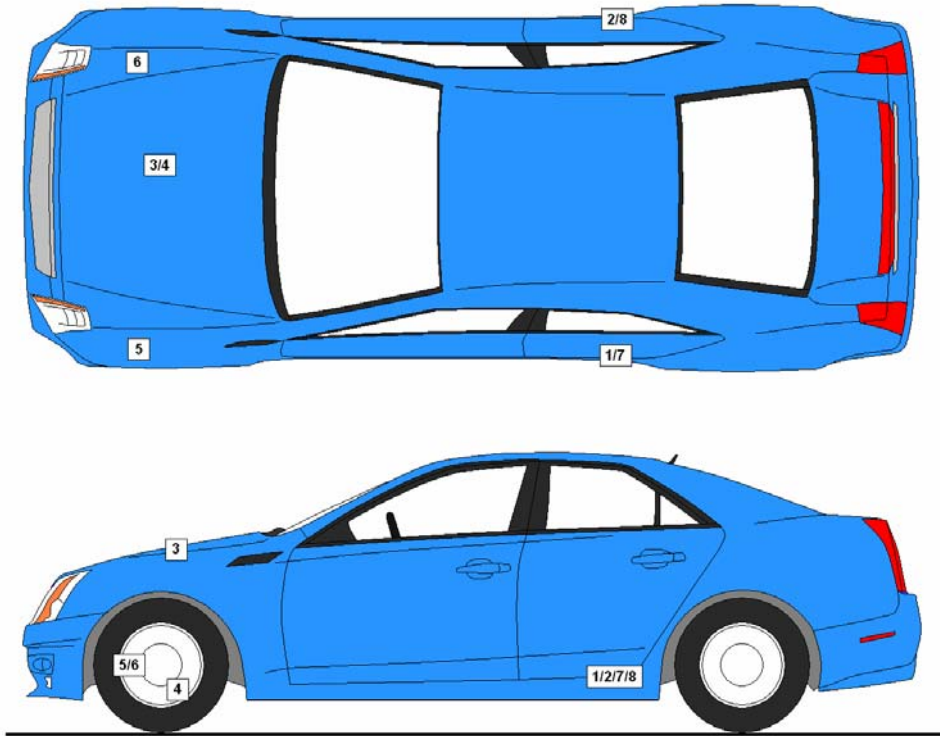

**VEHICLE ACCELEROMETER PRE-TEST LOCATIONS**

No.	Description	Location		
		X	Y	Z
1	Left Rear Accelerometer X-Direction	1810	-720	-380
2	Right Rear Accelerometer X-Direction	1810	720	-380
3	Engine Top X	3990	125	-785
4	Engine Bottom X	3870	0	-130
5	Left Rear Accelerometer Z-Direction	n/a	n/a	n/a
6	Right Rear Accelerometer Z-Direction	n/a	n/a	n/a

Reference Points: X – Rear Surface of Vehicle (+ forward)  
 Y – Vehicle Centerline (+ to right)  
 Z – Ground Plane (+ down)

**DATA SHEET NO. 8**

**PHOTOGRAPHIC REFERENCE TARGET LOCATIONS**

Test Vehicle: 2013 Mercedes-Benz C300 4Matic AWD 4-Door Sedan NHTSA No.: MD0506

Test Program: 56 km/h Frontal Impact NCAP Test Test Date: 12/14/12

Item	Value
A	
B	887
C	2060
D	610
E	1960
F	305
G	1840
H	955
I	1232
J	936
K	936
L	1522
M	985
N	1540
O	929
P	929
Q	1220

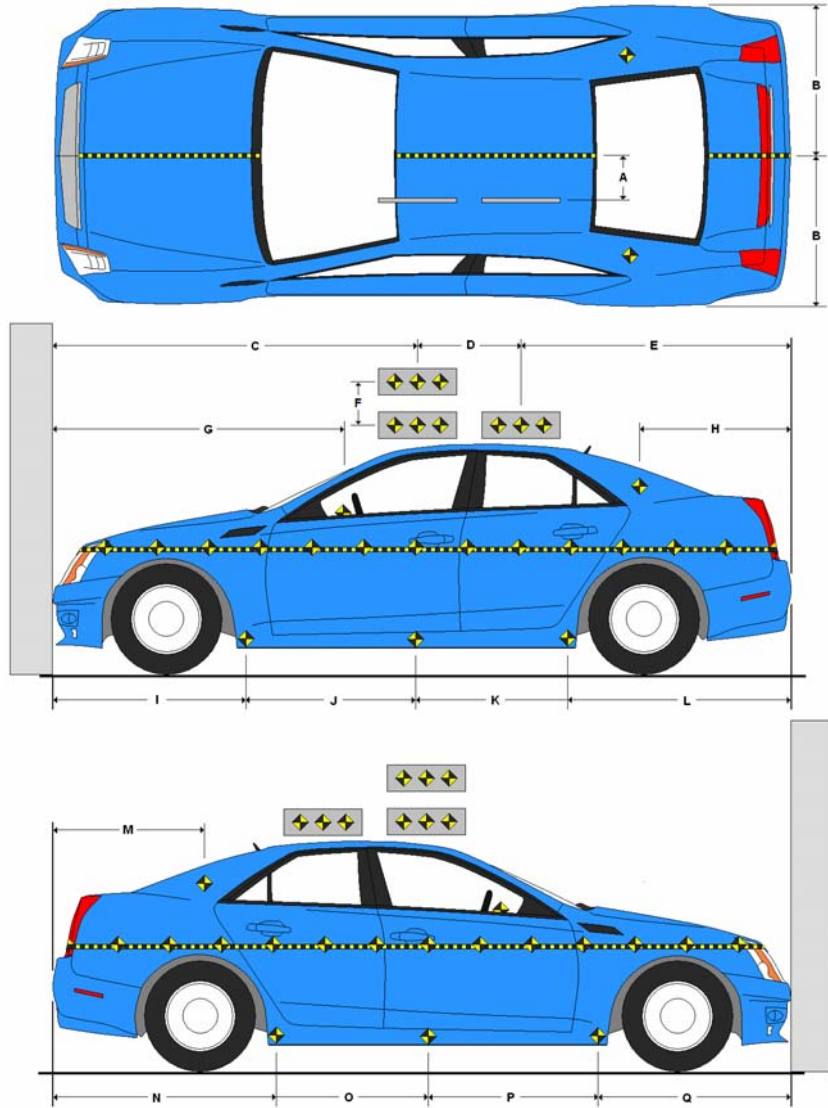

All measurements in millimeters.

**DATA SHEET NO. 9**

**LOAD CELL LOCATIONS ON FIXED BARRIER**

Test Vehicle: 2013 Mercedes-Benz C300 4Matic AWD 4-Door Sedan NHTSA No.: MD0506

Test Program: 56 km/h Frontal Impact NCAP Test Test Date: 12/14/12

**36 Load Cell Rigid Barrier (NHTSA Standard)  
Load Cell Locations on Fixed Barrier**

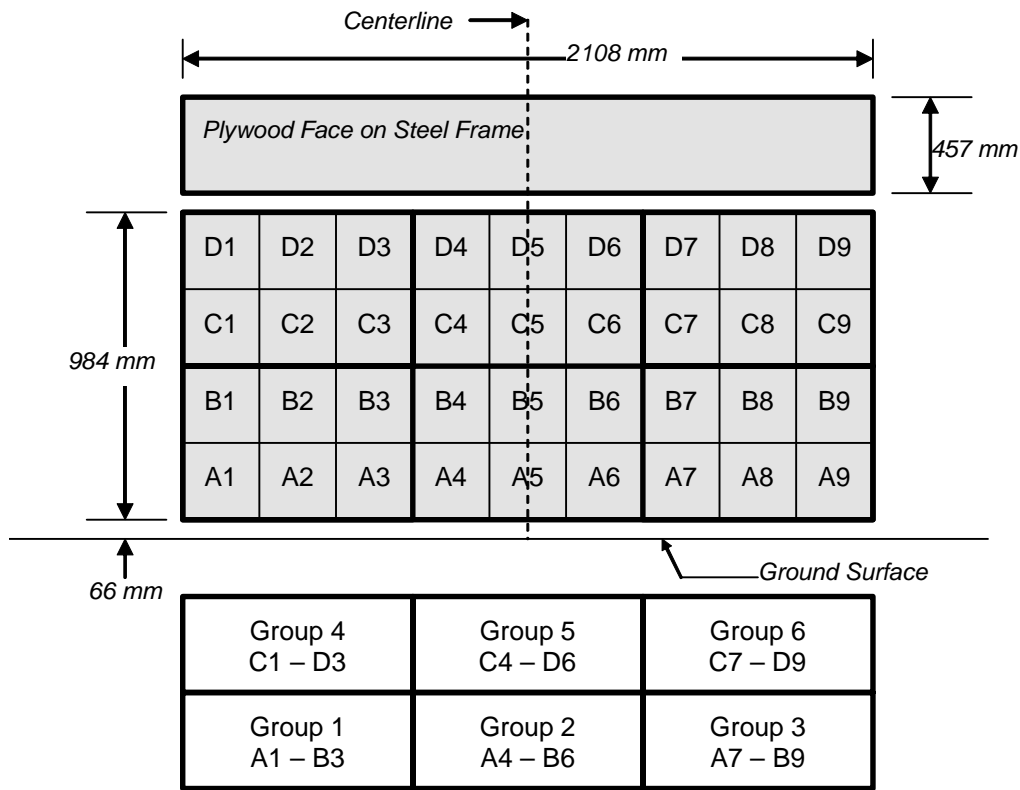

6 Groups of 6 Load Cells Each

**DATA SHEET NO. 10**

**TEST VEHICLE CAMERA AND INSTRUMENTATION SUMMARY**

Test Vehicle: 2013 Mercedes-Benz C300 4Matic AWD 4-Door Sedan NHTSA No.: MD0506  
Test Program: 56 km/h Frontal Impact NCAP Test Test Date: 12/14/12

**INSTRUMENTATION**

Driver Dummy Accelerometers	50
Passenger Dummy Accelerometers	50
Vehicle Structure Accelerometers	8
Seat Belt Load Cells	4
Load Cell Barrier	36
Total	148

**CAMERA COVERAGE**

High-Speed Vehicle On Board	2
High-Speed Off board	14
Real Time	3
Total	19

**DATA SHEET NO. 11**  
**POST-TEST OBSERVATIONS**

Test Vehicle: 2013 Mercedes-Benz C300 4Matic AWD 4-Door Sedan NHTSA No.: MD0506  
 Test Program: 56 km/h Frontal Impact NCAP Test Test Date: 12/14/12

Description	Driver	Passenger
Dummy Type/Serial No.	P572E 50th Percentile Male ATD / 034	P572O 5th Percentile Female ATD / 635
Head Contact	Airbag, Headrest	Airbag, Headrest, Side Header
Upper Torso Contact	Airbag	Airbag
Lower Torso Contact	None	None
Left Knee Contact	Knee Airbag	Glovebox
Right Knee Contact	Knee Airbag	Glovebox

**DOOR OPENING AND SEAT TRACK INFORMATION**

Description	Driver	Passenger
Locked / Unlocked Doors	Unlocked	Unlocked
Front Door Opening	Remained closed and latched, operational	Remained closed and latched, operational
Rear Door Opening	Remained closed and latched, operational	Remained closed and latched, operational
Seat Track Shift (mm)	36	20
Seat Back Failure	None	None
Glazing Damage	None	None

**POST TEST STRUCTURAL OBSERVATIONS**

Critical Areas of Performance	Observations and Conclusions
Windshield Damage	Cracked
Window Damage	None
Other Notable Effects	None

**VEHICLE REBOUND FROM BARRIER**

Measured Parameter	Units	Value
Left Side	mm	980
Center	mm	995
Right Side	mm	973
Average	mm	983

**SUPPLEMENTAL RESTRAINT SYSTEM INFORMATION**

Restraint Type	Driver		Passenger	
	Installed	Operated	Installed	Operated
Front Airbag	Yes	Yes	Yes	Yes
Side Airbag 1 (Curtain)	Yes	No	Yes	No
Side Airbag 2 (Torso)	Yes	No	Yes	No
Side Airbag 3 (Pelvis)	Yes	No	Yes	No
Knee Airbag	Yes	Yes	No	
Seat Belt Pretensioner	Yes	Yes	Yes	Yes
Seat Belt Load Limiter	Yes	Yes	Yes	Yes

**DATA SHEET NO. 12**  
**VEHICLE PROFILE MEASUREMENTS**

Test Vehicle: 2013 Mercedes-Benz C300 4Matic AWD 4-Door Sedan NHTSA No.: MD0506  
 Test Program: 56 km/h Frontal Impact NCAP Test Test Date: 12/14/12

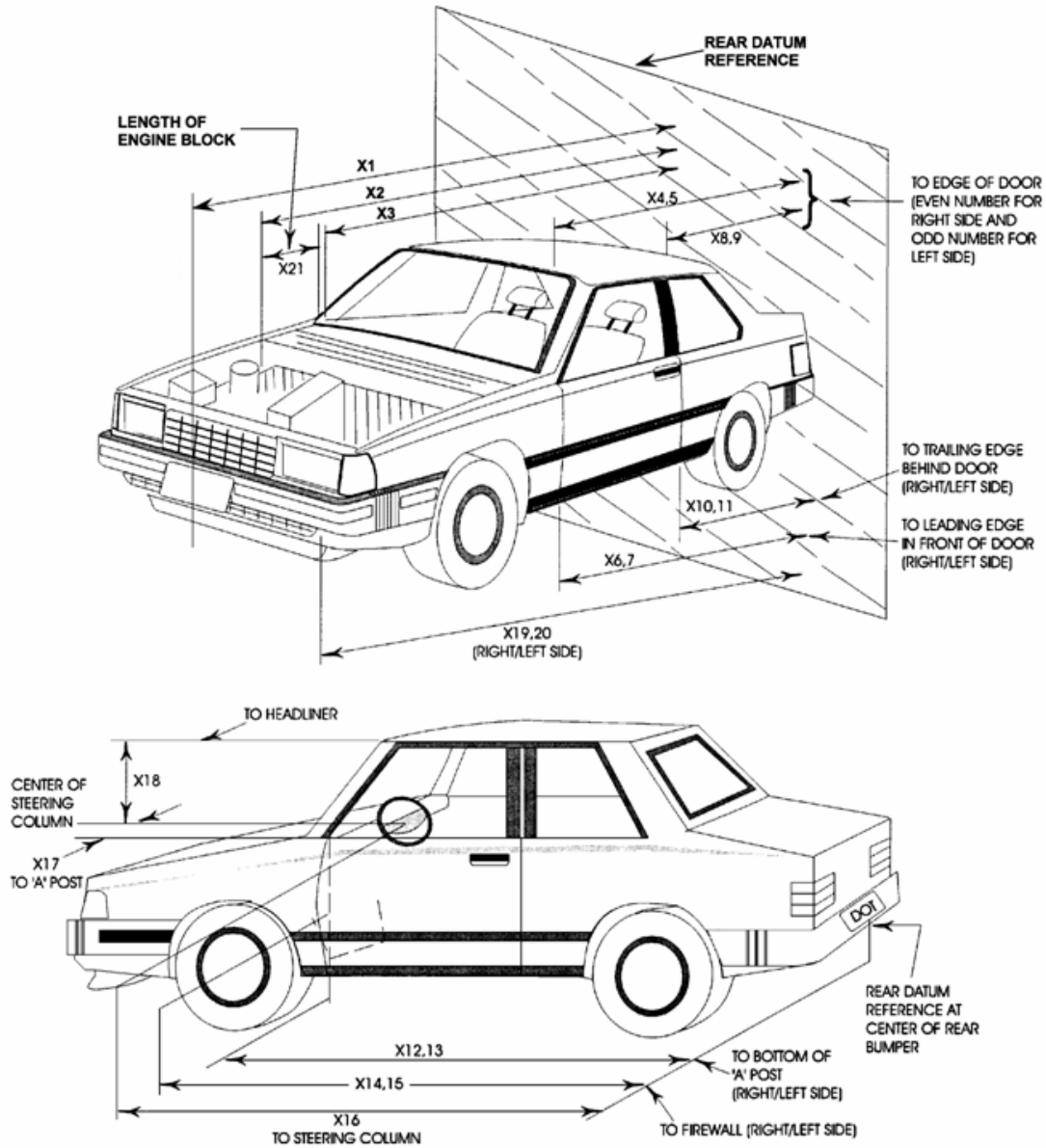

**DATA SHEET NO. 12 ... (CONTINUED)****VEHICLE PROFILE MEASUREMENTS**

Test Vehicle: 2013 Mercedes-Benz C300 4Matic AWD 4-Door Sedan NHTSA No.: MD0506  
Test Program: 56 km/h Frontal Impact NCAP Test Test Date: 12/14/12

No.	Description	Pre-Test	Post-Test	Difference
1	Total Length of Vehicle at Centerline	4630	4193	-437
2	Rear Surface of Vehicle to Front of Engine	4190	4049	-141
3	RSOV to Firewall	3495	3461	-34
4	RSOV to Upper Leading Edge of Right Door	3246	3255	9
5	RSOV to Upper Leading Edge of Left Door	3233	3248	15
6	RSOV to Lower Leading Edge of Right Door	3226	3226	0
7	RSOV to Lower Leading Edge of Left Door	3222	3228	6
8	RSOV to Upper Trailing Edge of Right Door	2107	2118	11
9	RSOV to Upper Trailing Edge of Left Door	2095	2112	17
10	RSOV to Lower Trailing Edge of Right Door	2147	2146	-1
11	RSOV to Lower Trailing Edge of Left Door	2142	2149	7
12	RSOV to Bottom of A-Pillar, Right Side	3000	3088	88
13	RSOV to Bottom of A-Pillar, Left Side	3073	3081	8
14	RSOV to Firewall, Right Side	3295	3319	24
15	RSOV to Firewall, Left Side	3365	3343	-22
16	RSOV to Steering Column	2680	2728	48
17	Center of Steering Column to A-Pillar	420	425	5
18	Center of Steering Column to Headliner	430	404	-26
19	RSOV to Right Side of Front Bumper	4003	3910	-93
20	RSOV to Left Side of Front Bumper	3997	3940	-57
21	Length of Engine Block	610	610	0
RD	RSOV to Right Side of Dash Panel	2875	2881	6
CD	RSOV to Center of Dash Panel	2815	2838	23
LD	RSOV to Left Side of Dash Panel	2865	2868	3

All measurements in millimeters.

**DATA SHEET NO. 13**  
**ACCIDENT INVESTIGATION DATA**

Test Vehicle: 2013 Mercedes-Benz C300 4Matic AWD 4-Door Sedan NHTSA No.: MD0506  
 Test Program: 56 km/h Frontal Impact NCAP Test Test Date: 12/14/12

**VEHICLE INFORMATION**

VIN: WDDGF8AB5DR252927 Wheelbase (mm): 2763  
 Vehicle Size Category: 4-Door Sedan Test Weight (kg): 1899.5

**ACCELEROMETER DATA**

Accelerometer Locations: Left Rear Crossmember  
 Cal. Procedure/Interval: Drop Test / 6 months  
 Integration Algorithm: NHTSA Standard  
 Impact Velocity (km/h): 56.16  
 Velocity Change (km/h): 68.4  
 Time of Separation (msec): 59.7

Linearity: Good

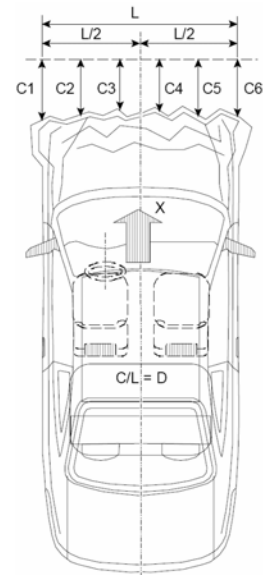

**CRUSH PROFILE**

Collision Deformation Classification: 12FDEW2  
 Midpoint of Damage: Vehicle Centerline  
 Damage Region Length (mm): 1452  
 Impact Mode: Full Frontal

No.	Measurement Description	Units	Pre-Test	Post-Test	Difference
C1	Crush Zone 1 at Left Side	mm	195	376	181
C2	Crush Zone 2 at Left Side	mm	122	467	345
C3	Crush Zone 3 at Left Side	mm	55	448	393
C4	Crush Zone 4 at Right Side	mm	55	445	390
C5	Crush Zone 5 at Right Side	mm	122	480	358
C6	Crush Zone 6 at Right Side	mm	196	421	225
L	C1 to C6	mm	1452		

## DATA SHEET NO. 14

### VEHICLE INTRUSION MEASUREMENTS

Test Vehicle: 2013 Mercedes-Benz C300 4Matic AWD 4-Door Sedan NHTSA No.: MD0506  
 Test Program: 56 km/h Frontal Impact NCAP Test Test Date: 12/14/12

#### DOOR OPENING WIDTH

Item	Description	Units	Pre-Test	Post-Test	Difference
A	Left Side Upper	mm	920	909	11
B	Left Side Lower	mm	808	801	7
D	Right Side Upper	mm	920	914	6
E	Right Side Lower	mm	805	800	5

#### WHEELBASE MEASUREMENTS

Item	Description	Units	Pre-Test	Post-Test	Difference
C	Left Side Wheelbase	mm	2763	2646	117
F	Right Side Wheelbase	mm	2763	2650	113

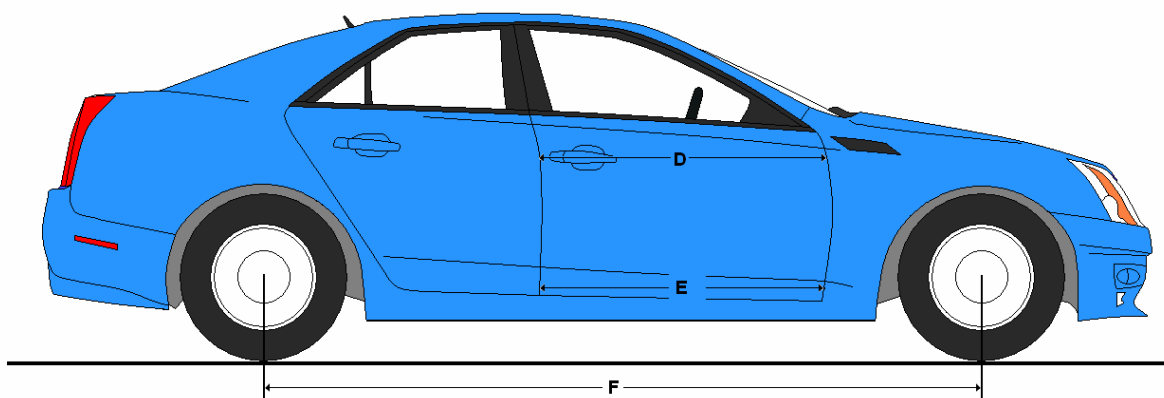
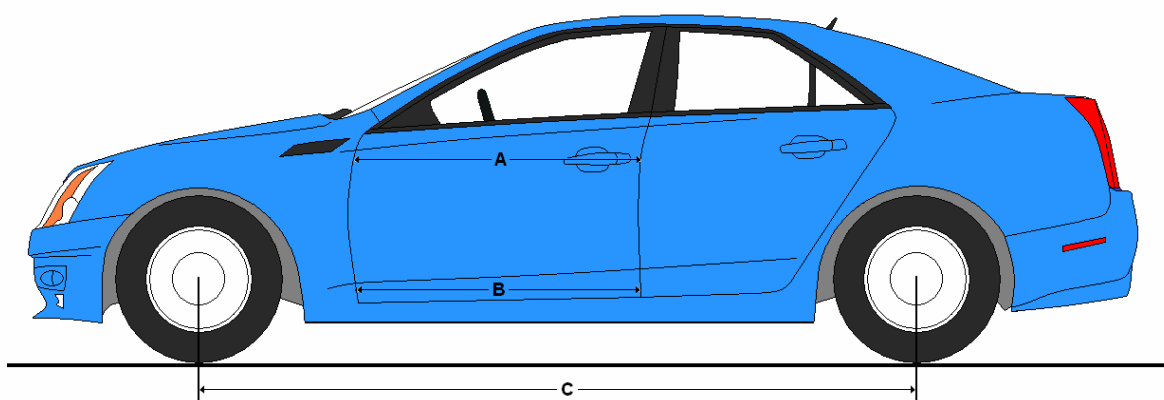

**DATA SHEET NO. 14 ... (CONTINUED)**  
**VEHICLE INTRUSION MEASUREMENTS**

Test Vehicle: 2013 Mercedes-Benz C300 4Matic AWD 4-Door Sedan NHTSA No.: MD0506  
 Test Program: 56 km/h Frontal Impact NCAP Test Test Date: 12/14/12

**DRIVER COMPARTMENT INTRUSION**

Item	Description	Units	Pre-Test	Post-Test	Difference
AB	Door Opening (Inside Window Jam)	mm	833	819	14
CX	Left Knee Bolster to X	mm	340	364	-24
DX	Right Knee Bolster to X	mm	330	368	-38
EX	Brake Pedal to X	mm	580	587	-7
FX	Foot Rest to X	mm	620	615	5
GX	Center of Steering Wheel Hub to X	mm	70	111	-41

X = Front of Seat Track (Stationary)

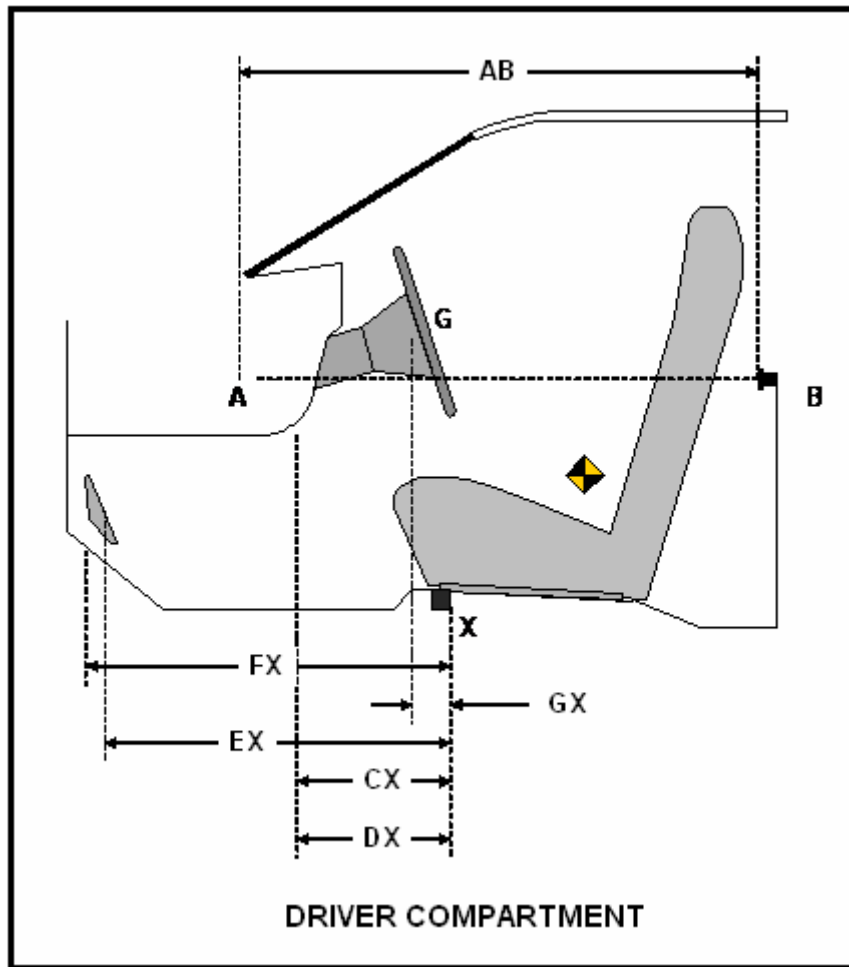

**DATA SHEET NO. 15**

**SUMMARY OF FMVSS 212 AND 219 (PARTIAL) DATA**

Test Vehicle: 2013 Mercedes-Benz C300 4Matic AWD 4-Door Sedan NHTSA No.: MD0506

Test Program: 56 km/h Frontal Impact NCAP Test Test Date: 12/14/12

Windshield Mounting Details: Windshield glass is secured to the vehicle frame with plastic molding and rubber cement.

The standard requires that the post-test retention measurement be a minimum of 75% of the pre-test total periphery measurement for vehicles not equipped with occupant passive restraints and 50% for each side of the windshield for vehicles which are equipped with occupant passive restraints.

Temperature of windshield molding during test: 21.2 ° C

**WINDSHIELD PERIPHERY MEASUREMENTS**

Measurement	Pre-Test (mm)	Post-Test (mm)	% Retention
Left Side	2157	2157	100.0%
Right Side	2157	2157	100.0%
Total	4314	4314	100.0%

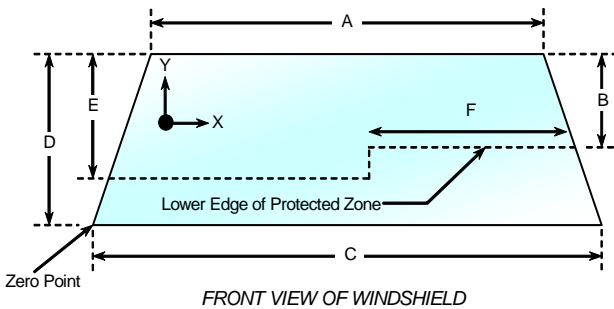

Item	Units	Value
A	mm	1154
B	mm	330
C	mm	1420
D	mm	870
E	mm	500
F	mm	520

**AREAS OF PROTECTED ZONE FAILURES**

A. Provide Coordinates of the area that the protected zone was penetrated more than 0.25 inches by a vehicle component other than one that is normally in contact with the windshield.

X	Y

B. Provide coordinates of the area beneath the protected zone that the inner surface of the windshield was penetrated by a vehicle component.

X	Y

**DATA SHEET NO. 15 ... (CONTINUED)**

**SUMMARY OF FMVSS 212 AND 219 (PARTIAL) DATA**

Test Vehicle: 2013 Mercedes-Benz C300 4Matic AWD 4-Door Sedan NHTSA No.: MD0506

Test Program: 56 km/h Frontal Impact NCAP Test Test Date: 12/14/12

**FMVSS 301 FUEL SYSTEM INTEGRITY POST IMPACT DATA**

Temperature at Time of Impact: 10.9° C Test Time: 12:54 PM

**Stoddard Solvent Spillage Measurements**

- A. From impact until vehicle motion ceases: 0 oz.  
(Maximum allowable = 1 oz.)
- B. For the 5 minute period after motion ceases: 0 oz.  
(Maximum allowable = 5 oz.)
- C. For the following 25 minutes: 0 oz.  
(Maximum allowable = 1 oz./minute)
- D. Spillage: There was no Stoddard solvent spillage.  
\_\_\_\_\_  
\_\_\_\_\_  
\_\_\_\_\_

**DATA SHEET NO. 16**

**FMVSS 301 STATIC ROLLOVER**

Test Vehicle: 2013 Mercedes-Benz C300 4Matic AWD 4-Door Sedan NHTSA No.: MD0506

Test Program: 56 km/h Frontal Impact NCAP Test Test Date: 12/14/12

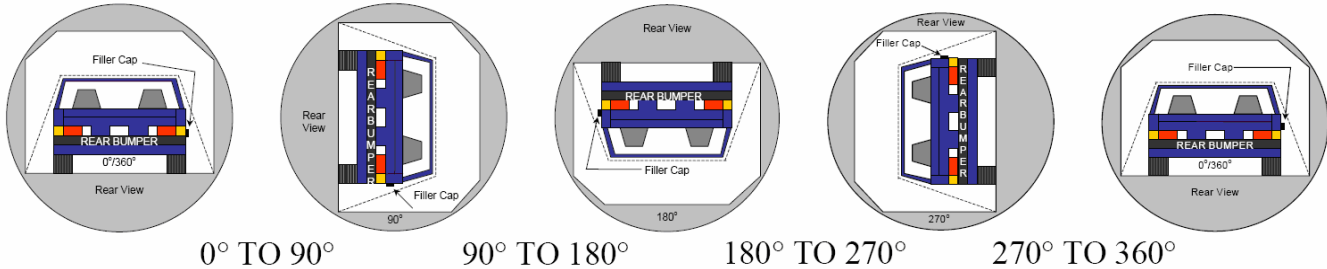

1. The specified fixture rollover rate for each 90° of rotation is 60 to 180 seconds.
2. The position hold time at each position is 300 seconds (minimum).
3. Details of Stoddard solvent spillage: There was no Stoddard solvent spillage.

**SOLVENT COLLECTION TIME TABLE IN SECONDS**

Test Phase	Rotation Time	Hold Time	Total Time
0° To 90°	82	300	382
90° To 180°	82	300	382
180° To 270°	80	300	380
270° To 360°	81	300	381

**FMVSS 301 SPILLAGE TABLE**

Test Phase	First 5 Minutes	Sixth Minute	Seventh Minute	Eighth Minute
0° To 90°	0			
90° To 180°	0			
180° To 270°	0			
270° To 360°	0			

**SOLVENT SPILLAGE LOCATION TABLE**

Test Phase	Spillage Location
0° To 90°	
90° To 180°	
180° To 270°	
270° To 360°	

**DATA SHEET NO. 17**

**DUMMY / VEHICLE TEMPERATURE STABILIZATION CHART**

Test Vehicle: 2013 Mercedes-Benz C300 4Matic AWD 4-Door Sedan NHTSA No.: MD0506

Test Program: 56 km/h Frontal Impact NCAP Test Test Date: 12/14/12

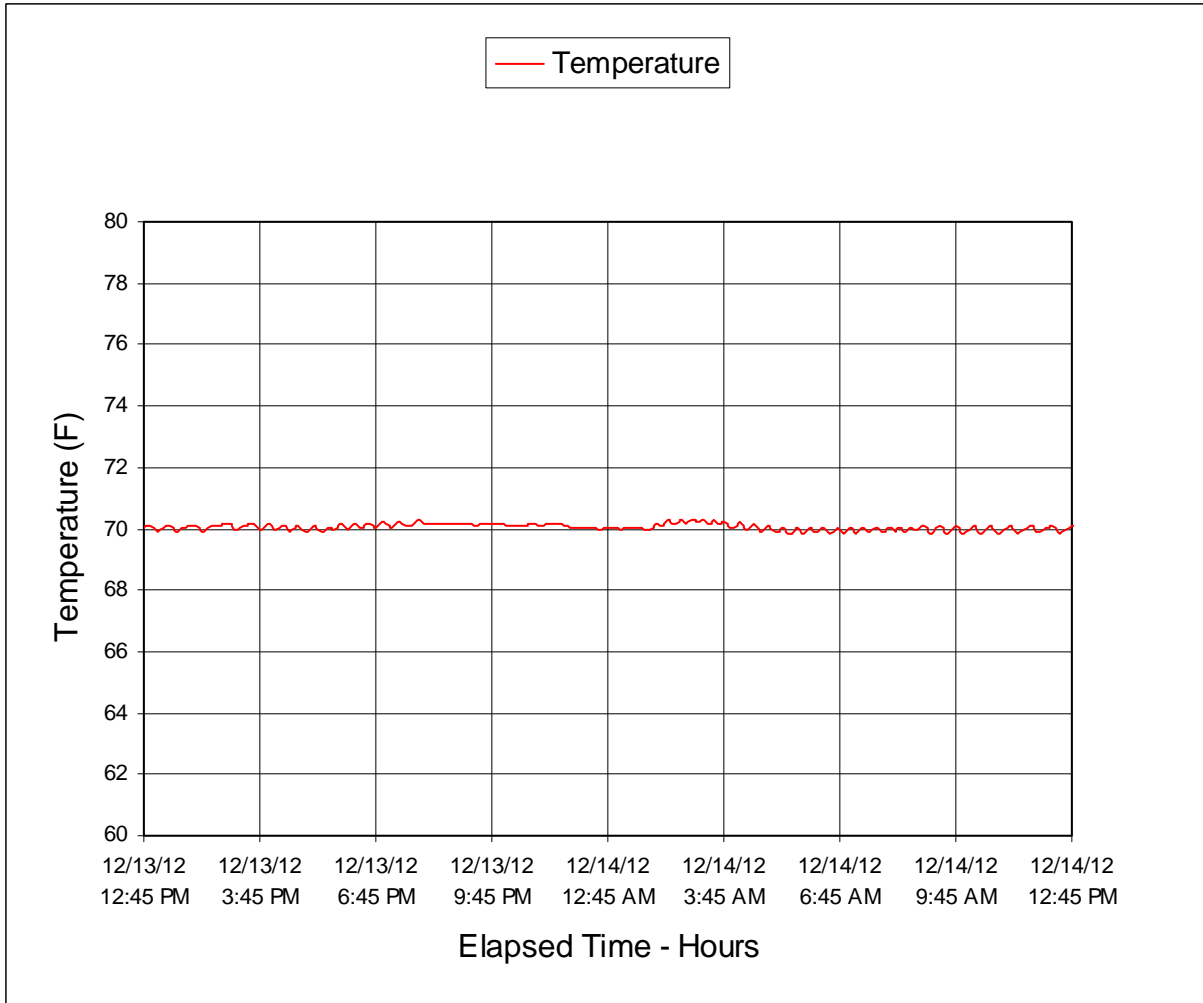

**APPENDIX A  
PHOTOGRAPHS**

## TABLE OF PHOTOGRAPHS

Figure		Page
1	Load Cell Location	A-1
2	Load Cell Wall	A-1
3	Manufacturer's Label	A-2
4	Tire Placard	A-2
5	2013 Mercedes-Benz C300 Frontal as Delivered	A-3
6	Left Rear $\frac{3}{4}$ View, as Received	A-3
7	Pre-Test Front View of Test Vehicle	A-4
8	Post-Test Front View of Test Vehicle	A-4
9	Pre-Test Left View of Test Vehicle	A-5
10	Post-Test Left View of Test Vehicle	A-5
11	Pre-Test Right View of Test Vehicle	A-6
12	Post-Test Right View of Test Vehicle	A-6
13	Pre-Test Right Front $\frac{3}{4}$ View	A-7
14	Post-Test Right Front $\frac{3}{4}$ View	A-7
15	Pre-Test Left Rear $\frac{3}{4}$ View	A-8
16	Post-Test Left Rear $\frac{3}{4}$ View	A-8
17	Pre-Test Windshield View	A-9
18	Post-Test Windshield View	A-9
19	Pre-Test Engine Compartment View	A-10
20	Post-Test Engine Compartment View	A-10
21	Pre-Test Fuel Filler Cap View	A-11
22	Post-Test Fuel Filler Cap View	A-11
23	Pre-Test Front Underbody View	A-12
24	Post-Test Front Underbody View	A-12
25	Pre-Test Rear Underbody View	A-13
26	Post-Test Rear Underbody View	A-13
27	Pre-Test Dummy Cable Routing	A-14
28	Post-Test Dummy Cable Routing	A-14
29	Pre-Test Driver Dummy Front View	A-15
30	Post-Test Driver Dummy Front View	A-15
31	Pre-Test Driver Dummy Window View	A-16
32	Post-Test Driver Dummy Window View	A-16
33	Pre-Test Driver Dummy and Vehicle Interior View	A-17
34	Post-Test Driver Dummy and Vehicle Interior View	A-17
35	Pre-Test Driver's Seat Fore-Aft Markings	A-18

## TABLE OF PHOTOGRAPHS ... (CONTINUED)

<u>Figure</u>		<u>Page</u>
36	Post-Test Driver's Seat Fore-Aft Markings	A-18
37	Pre-Test View of Belt Anchorage for Driver Dummy	A-19
38	Post-Test View of Belt Anchorage for Driver Dummy	A-19
39	Pre-Test Driver Dummy Feet	A-20
40	Post-Test Driver Dummy Feet	A-20
41	Pre-Test Driver's Side Knee Bolster	A-21
42	Post-Test Driver's Side Knee Bolster	A-21
43	Pre-Test Driver's Side Floorpan	A-22
44	Post-Test Driver's Side Floorpan	A-22
45	Post-Test Driver Dummy Face	A-23
46	Post-Test Driver Dummy Contact With Airbag	A-23
47	Post-Test Driver Dummy Contact With Headrest	A-24
47a	Post-Test Driver Dummy Contact With Knee Airbag	A-24
48	Pre-Test View of the Steering Wheel	A-25
49	Post-Test View of the Steering Wheel	A-25
50	Pre-Test Passenger Dummy Front View	A-26
51	Post-Test Passenger Dummy Front View	A-26
52	Pre-Test Passenger Dummy Window View	A-27
53	Post-Test Passenger Dummy Window View	A-27
54	Pre-Test Passenger Dummy and Vehicle Interior View	A-28
55	Post-Test Passenger Dummy and Vehicle Interior View	A-28
56	Pre-Test Passenger's Seat Fore-Aft Markings	A-29
57	Post-Test Passenger's Seat Fore-Aft Markings	A-29
58	Pre-Test View of Belt Anchorage for Passenger Dummy	A-30
59	Post-Test View of Belt Anchorage for Passenger Dummy	A-30
60	Pre-Test Passenger Dummy Feet	A-31
61	Post-Test Passenger Dummy Feet	A-31
62	Pre-Test Passenger's Side Knee Bolster	A-32
63	Post-Test Passenger's Side Knee Bolster	A-32
64	Pre-Test Passenger's Side Floorpan	A-33
65	Post-Test Passenger's Side Floorpan	A-33
66	Post-Test Passenger Dummy Contact With Airbag	A-34
66a	Post-Test Passenger Dummy Contact With Headrest	A-34
66b	Post-Test Passenger Dummy Contact With Glove Box	A-35
66c	Post-Test Passenger Dummy Head Contact With Side Header	A-35

## TABLE OF PHOTOGRAPHS ... (CONTINUED)

<u>Figure</u>		<u>Page</u>
67	Photograph of Ballast Installed in Vehicle	A-36
68	Post-Test Stoddard Solvent Spillage Location View	A-36
69	Post-Test Speed Trap Read-Out	A-37
70	Vehicle at 0° on Static Rollover Device	A-37
71	Vehicle at 90° on Static Rollover Device	A-38
72	Vehicle at 180° on Static Rollover Device	A-38
73	Vehicle at 270° on Static Rollover Device	A-39
74	Vehicle at 360° on Static Rollover Device	A-39
75	2013 Mercedes-Benz C300 Frontal Impact Event	A-40
76	Monroney Label Photograph	A-40



FIGURE 1. Load Cell Location



FIGURE 2. Load Cell Wall



FIGURE 3. Manufacturer's Label

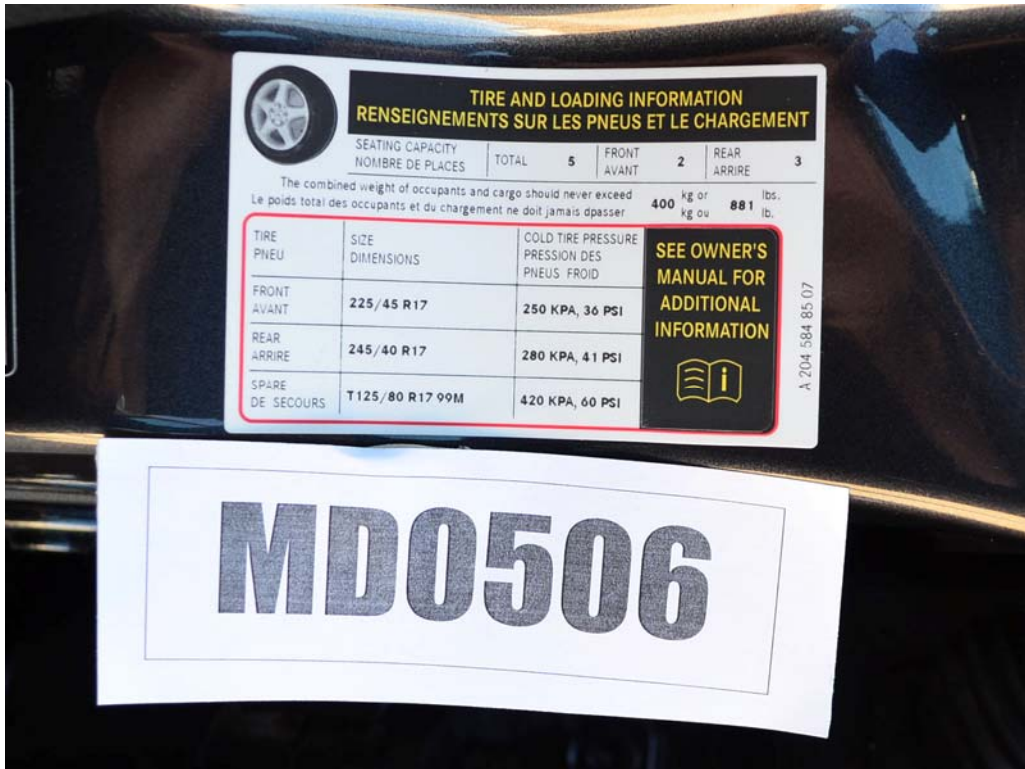

FIGURE 4. Tire Placard



FIGURE 5. 2013 Mercedes-Benz C300 Frontal As Delivered



FIGURE 6. Left Rear ¾ View, As Received



FIGURE 7. Pre-Test Front View of Test Vehicle



FIGURE 8. Post-Test Front View of Test Vehicle



FIGURE 9. Pre-Test Left View of Test Vehicle



FIGURE 10. Post-Test Left View of Test Vehicle



FIGURE 11. Pre-Test Right View of Test Vehicle



FIGURE 12. Post-Test Right View of Test Vehicle



FIGURE 13. Pre-Test Right Front 3/4 View



FIGURE 14. Post-Test Right Front 3/4 View



FIGURE 15. Pre-Test Left Rear  $\frac{3}{4}$  View



FIGURE 16. Post-Test Left Rear  $\frac{3}{4}$  View

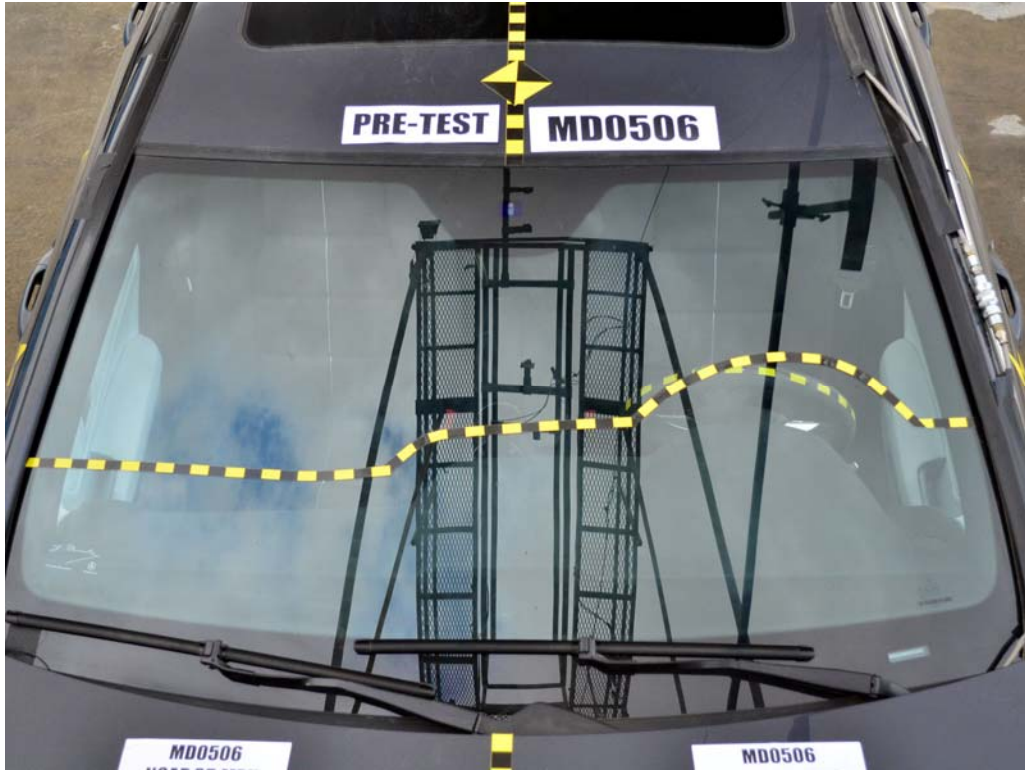

FIGURE 17. Pre-Test Windshield View



FIGURE 18. Post-Test Windshield View



FIGURE 19. Pre-Test Engine Compartment View



FIGURE 20. Post-Test Engine Compartment View



FIGURE 21. Pre-Test Fuel Filler Cap View



FIGURE 22. Post-Test Fuel Filler Cap View

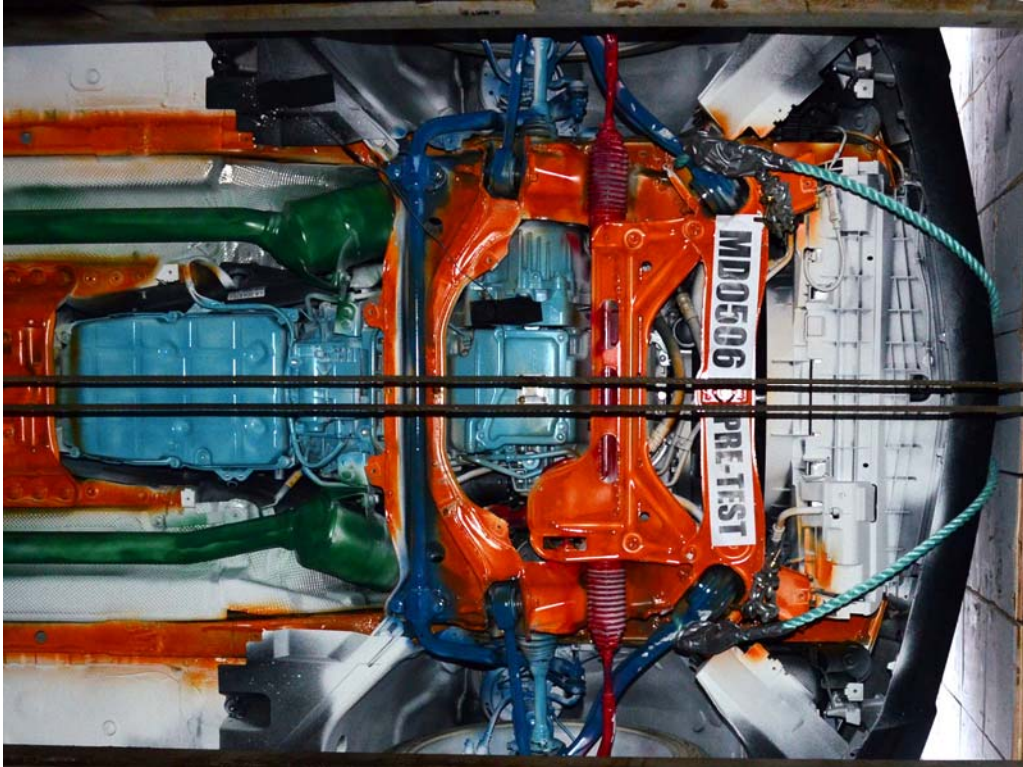

FIGURE 23. Pre-Test Front Underbody View

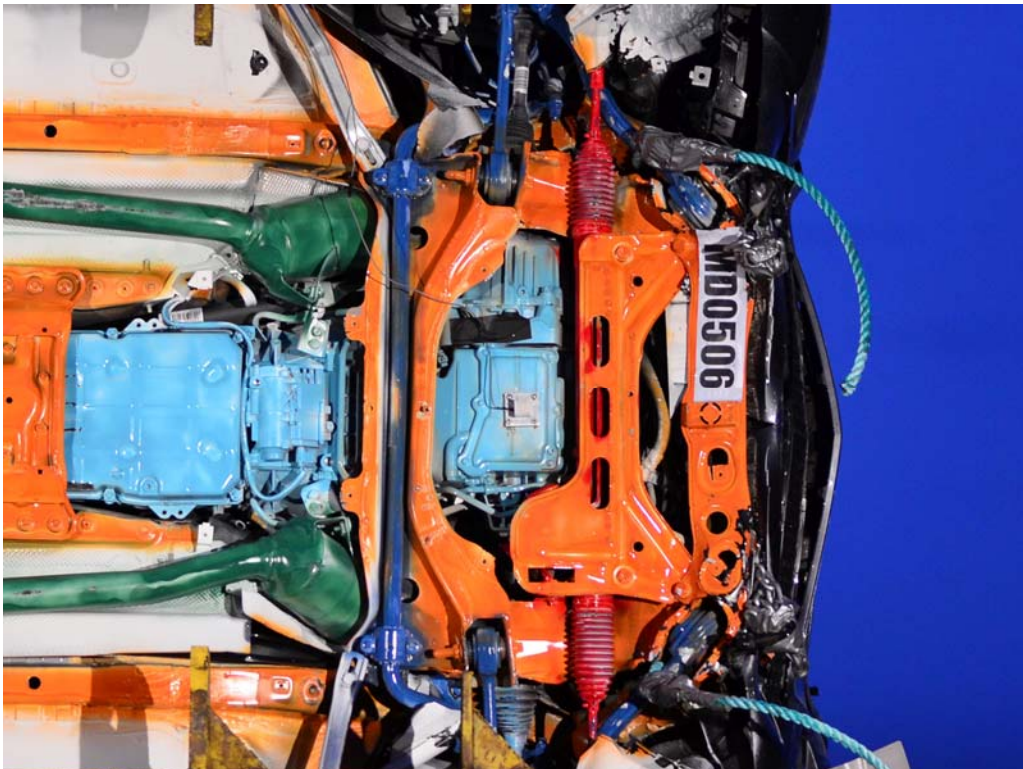

FIGURE 24. Post-Test Front Underbody View

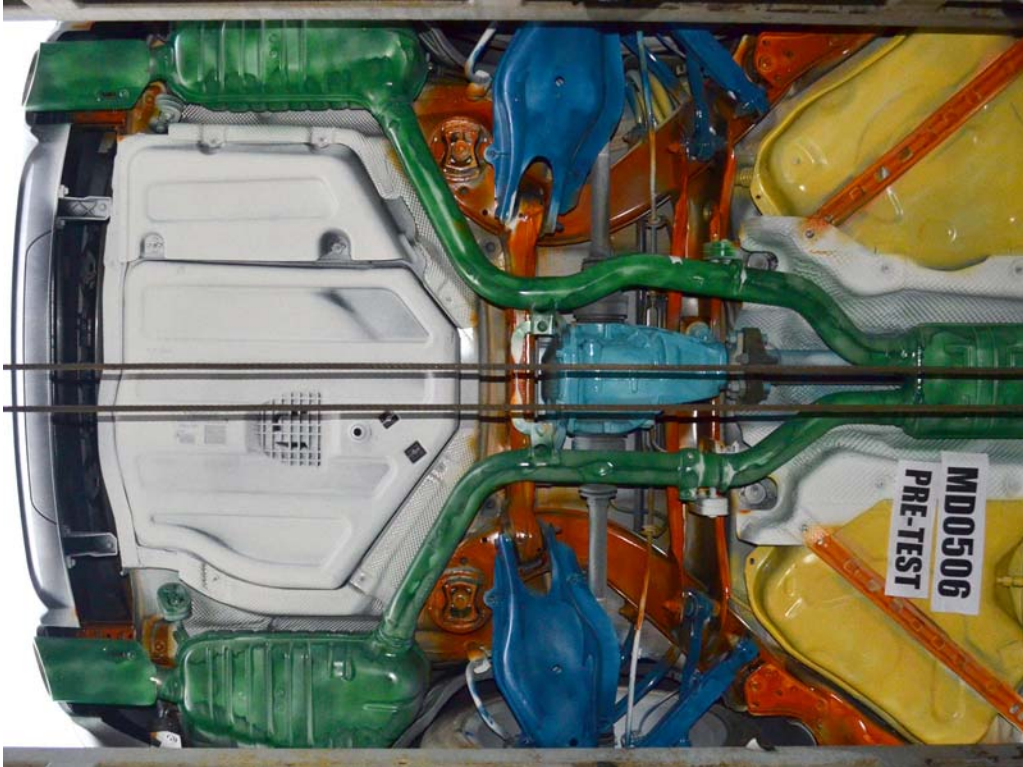

FIGURE 25. Pre-Test Rear Underbody View

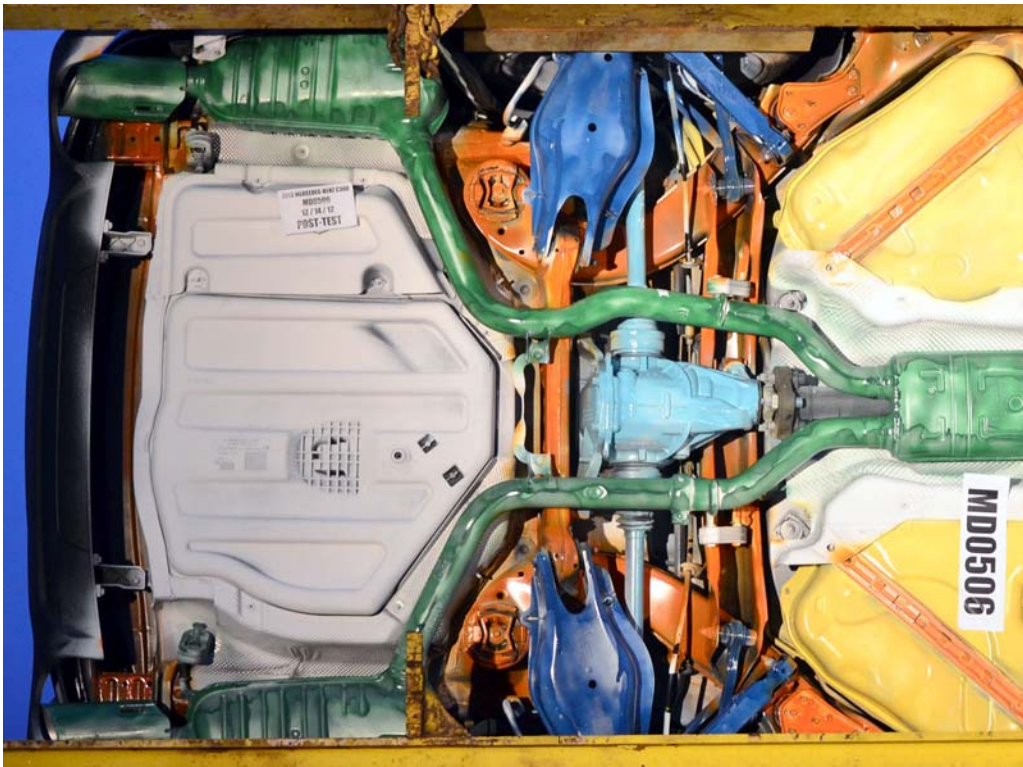

FIGURE 26. Post-Test Rear Underbody View



FIGURE 27. Pre-Test Dummy Cable Routing



FIGURE 28. Post-Test Dummy Cable Routing

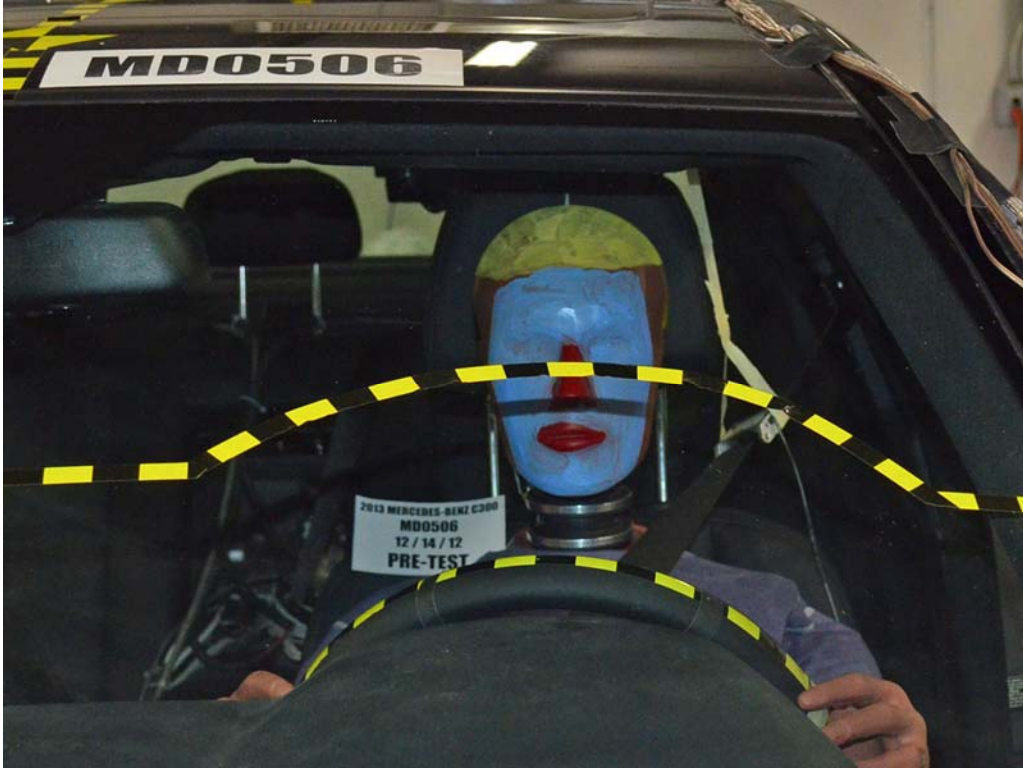

FIGURE 29. Pre-Test Driver Dummy Front View



FIGURE 30. Post-Test Driver Dummy Front View



FIGURE 31. Pre-Test Driver Dummy Window View



FIGURE 32. Post-Test Driver Dummy Window View

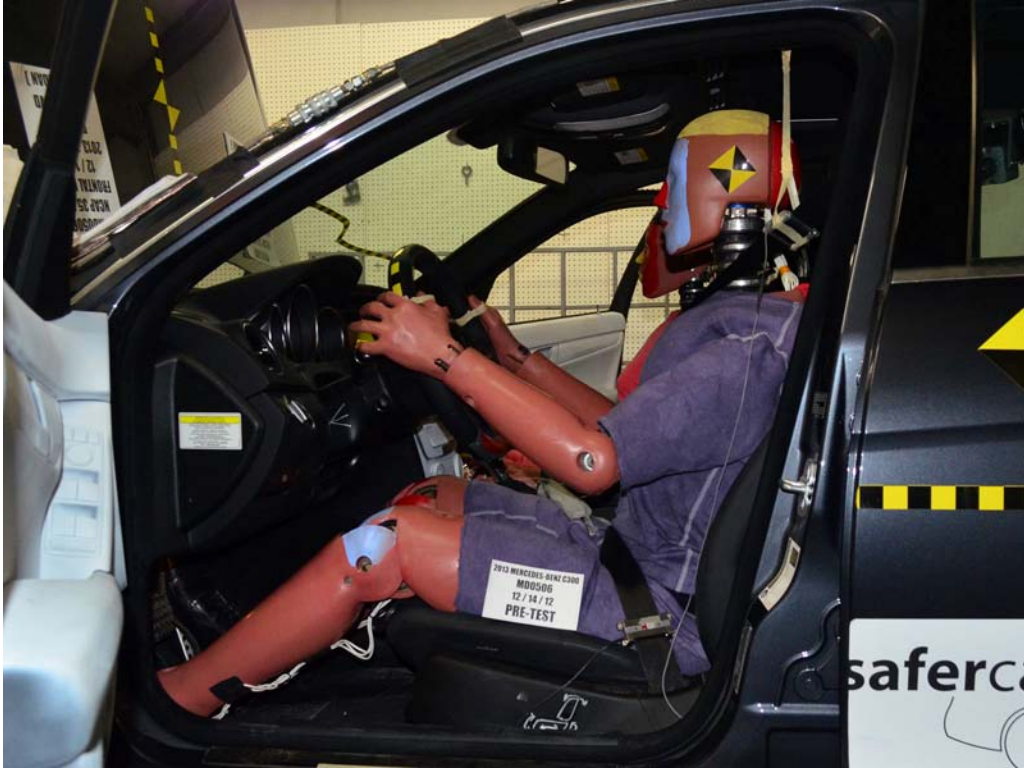

FIGURE 33. Pre-Test Driver Dummy and Vehicle Interior View



FIGURE 34. Post-Test Driver Dummy and Vehicle Interior View

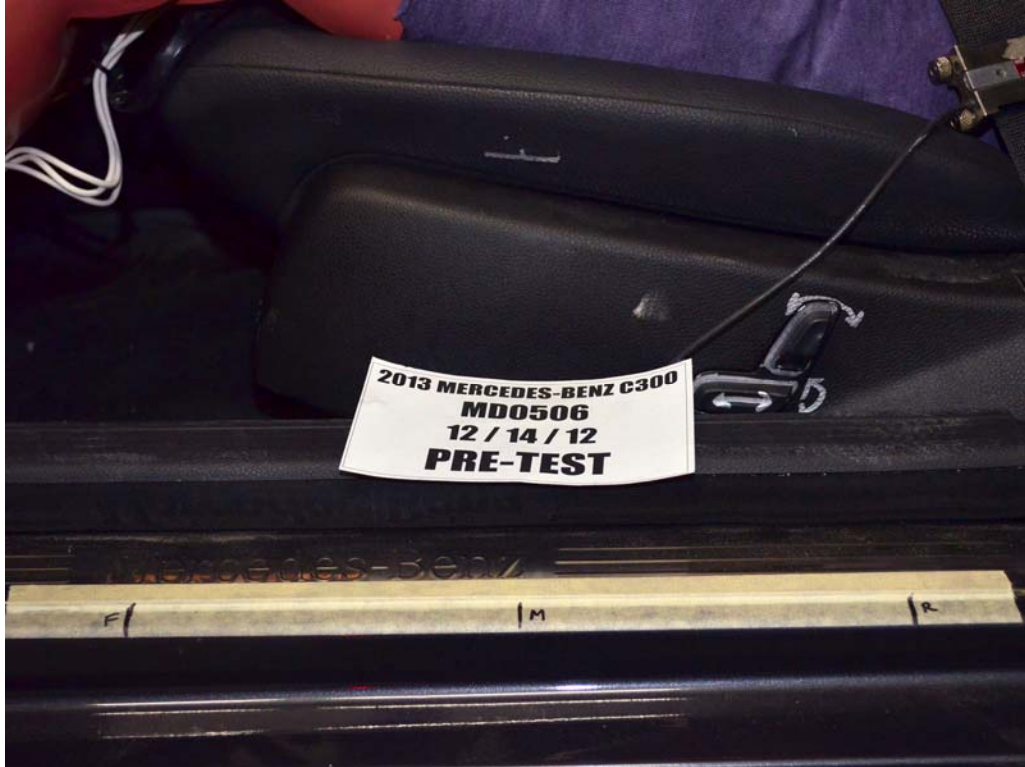

FIGURE 35. Pre-Test Driver's Seat Fore-Aft Markings



FIGURE 36. Post-Test Driver's Seat Fore-Aft Markings



FIGURE 37. Pre-Test View of Belt Anchorage for Driver Dummy



FIGURE 38. Post-Test View of Belt Anchorage for Driver Dummy



FIGURE 39. Pre-Test Driver Dummy Feet



FIGURE 40. Post-Test Driver Dummy Feet



FIGURE 41. Pre-Test Driver's Side Knee Bolster



FIGURE 42. Post-Test Driver's Side Knee Bolster

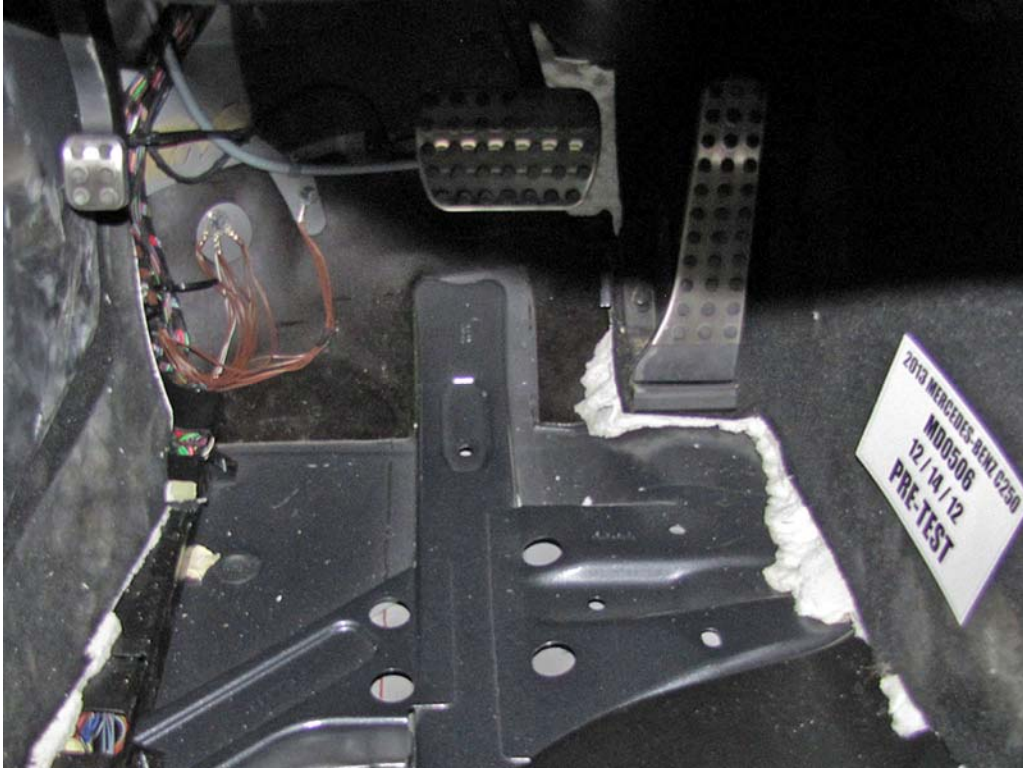

FIGURE 43. Pre-Test Driver's Side Floorpan



FIGURE 44. Post-Test Driver's Side Floorpan



FIGURE 45. Post-Test Driver Dummy Face



FIGURE 46. Post-Test Driver Dummy Contact With Airbag



FIGURE 47. Post-Test Driver Dummy Contact With Headrest



FIGURE 47a. Post-Test Driver Dummy Contact With Knee Airbag



FIGURE 48. Pre-Test View of the Steering Wheel



FIGURE 49. Post-Test View of the Steering Wheel



FIGURE 50. Pre-Test Passenger Dummy Front View



FIGURE 51. Post-Test Passenger Dummy Front View

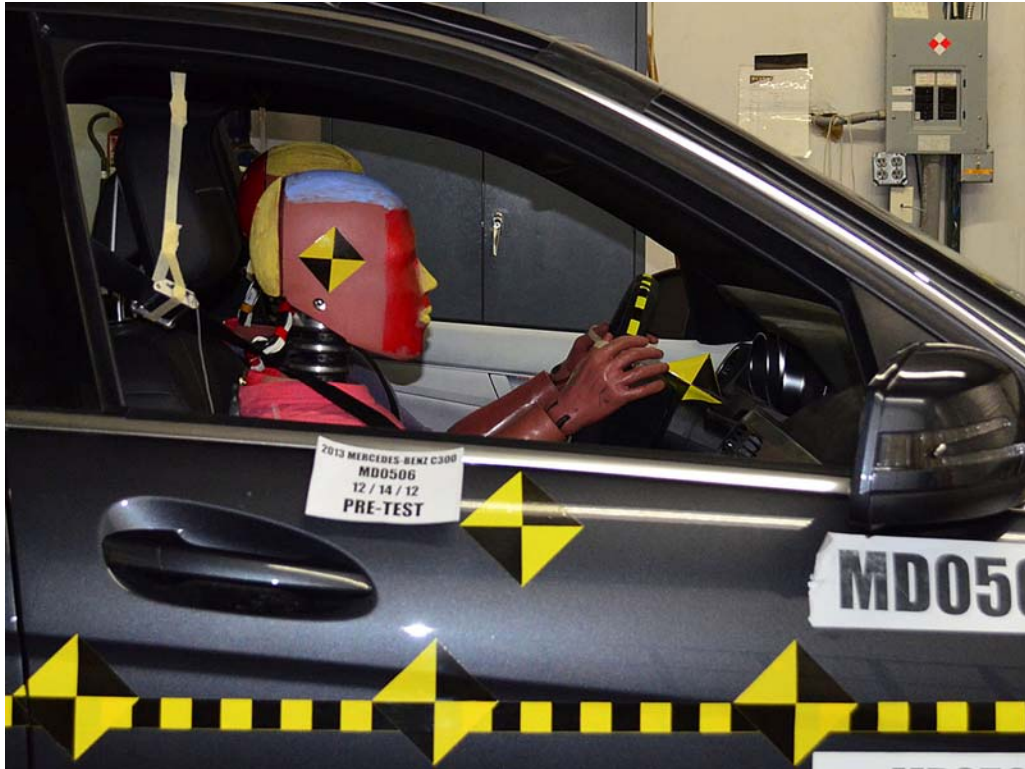

FIGURE 52. Pre-Test Passenger Dummy Window View



FIGURE 53. Post-Test Passenger Dummy Window View



FIGURE 54. Pre-Test Passenger Dummy and Vehicle Interior View



FIGURE 55. Post-Test Passenger Dummy and Vehicle Interior View



FIGURE 56. Pre-Test Passenger's Seat Fore-Aft Markings



FIGURE 57. Post-Test Passenger's Seat Fore-Aft Markings



FIGURE 58. Pre-Test View of Belt Anchorage for Passenger Dummy



FIGURE 59. Post-Test View of Belt Anchorage for Passenger Dummy



FIGURE 60. Pre-Test Passenger Dummy Feet



FIGURE 61. Post-Test Passenger Dummy Feet



FIGURE 62. Pre-Test Passenger's Side Knee Bolster



FIGURE 63. Post-Test Passenger's Side Knee Bolster



FIGURE 64. Pre-Test Passenger's Side Floorpan



FIGURE 65. Post-Test Passenger's Side Floorpan

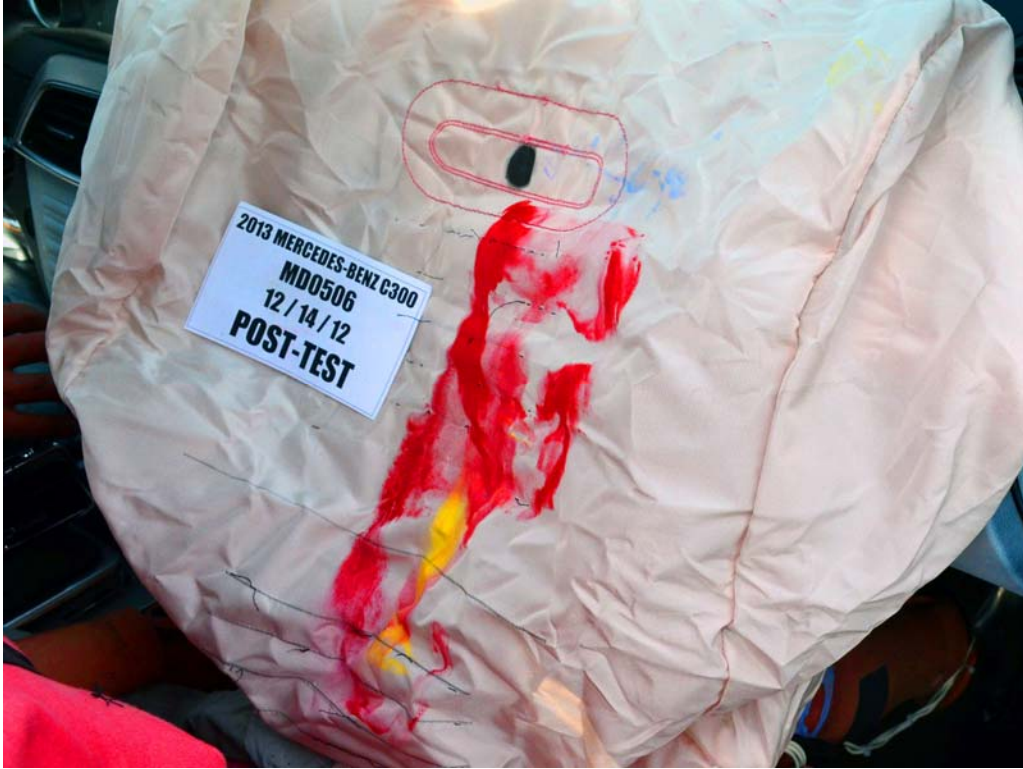

FIGURE 66. Post-Test Passenger Dummy Contact With Airbag



FIGURE 66a. Post-Test Passenger Dummy Contact With Headrest



FIGURE 66b. Post-Test Passenger Dummy Contact With Glovebox



FIGURE 66c. Post-Test Passenger Dummy Head Contact With Side Header



FIGURE 67. Photograph of Ballast Installed In Vehicle

Photograph Not Applicable

No Stoddard  
Solvent Leakage

FIGURE 68. Post-Test Stoddard Solvent Spillage Location View



FIGURE 69. Post-Test Speed Trap Read-Out

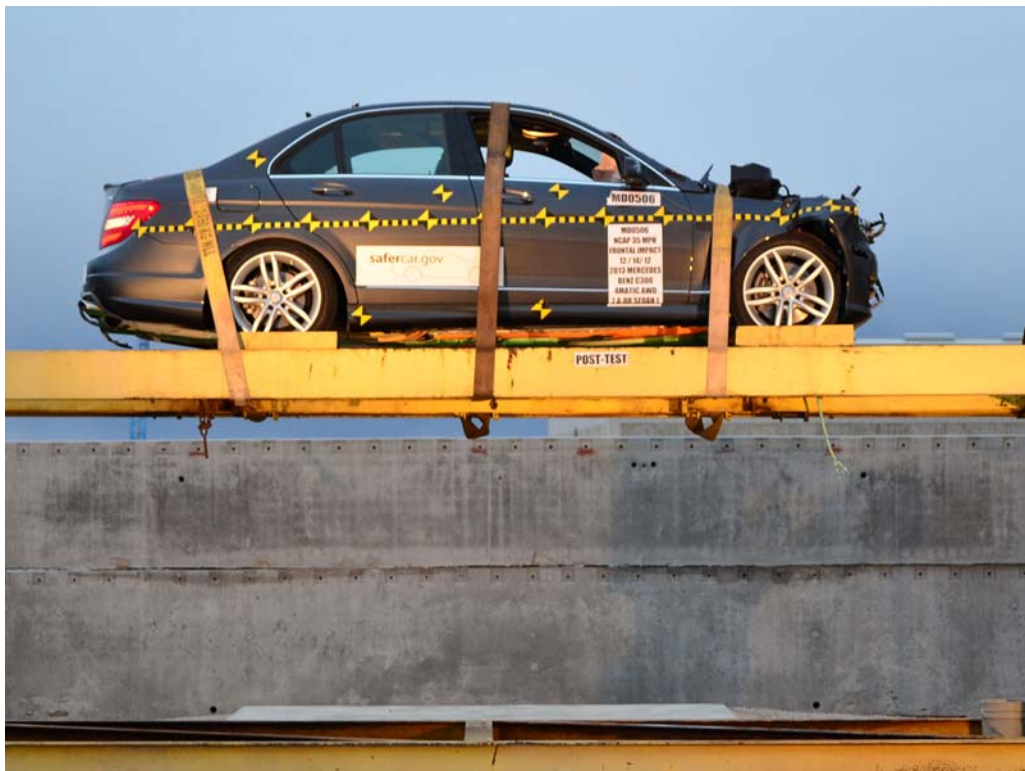

FIGURE 70. Vehicle at 0° on Static Rollover Device



FIGURE 71. Vehicle at 90° on Static Rollover Device

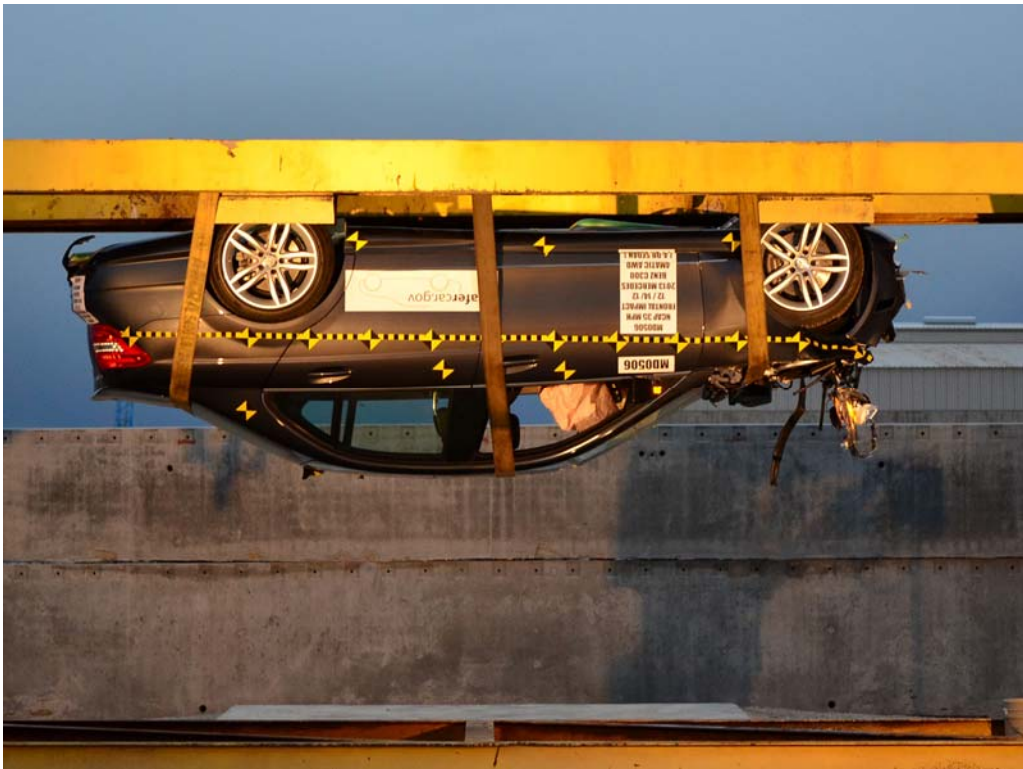

FIGURE 72. Vehicle at 180° on Static Rollover Device

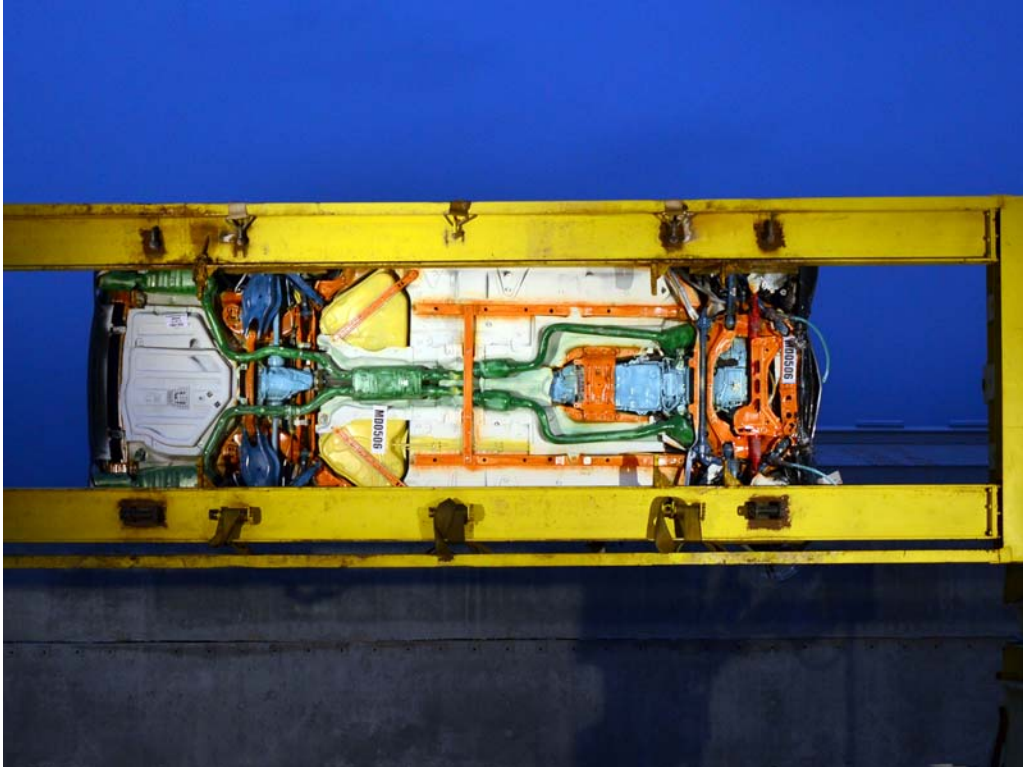

FIGURE 73. Vehicle at 270° on Static Rollover Device

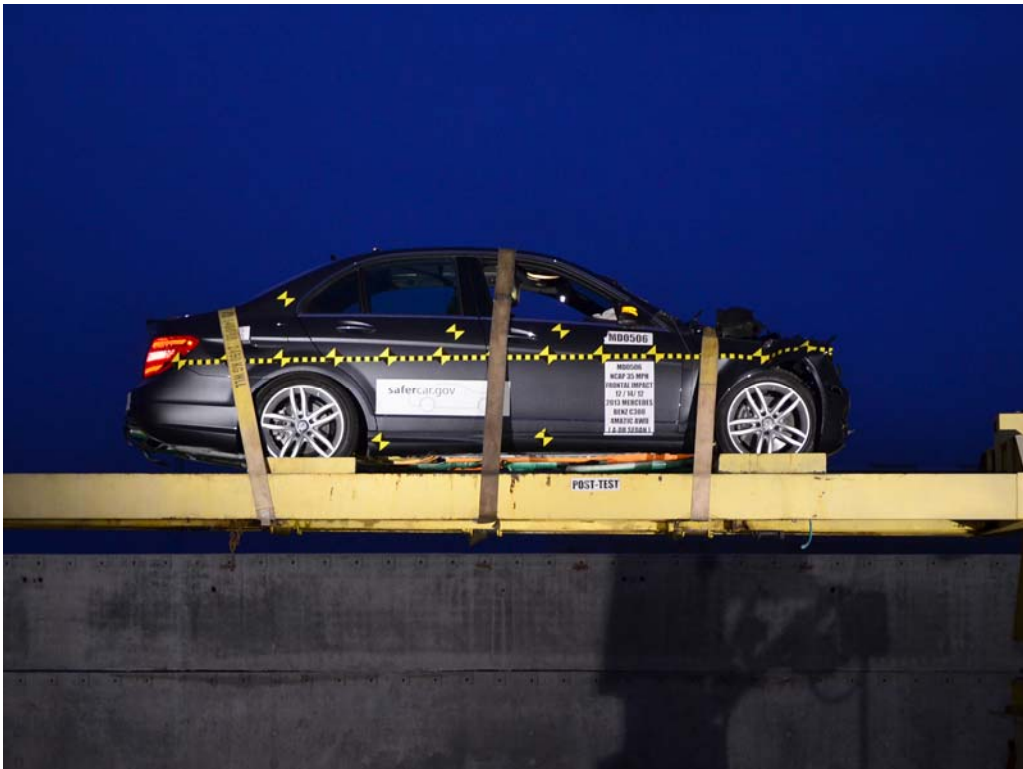

FIGURE 74. Vehicle at 360° on Static Rollover Device



**APPENDIX B**  
**DUMMY RESPONSE DATA TRACES**

## TABLE OF DATA PLOTS

<u>Plot</u>		<u>Page</u>
1	Driver Head X Acceleration vs. Time Primary	B-1
2	Driver Head Y Acceleration vs. Time Primary	B-1
3	Driver Head Z Acceleration vs. Time Primary	B-1
4	Driver Head Resultant Acceleration vs. Time Primary	B-1
5	Driver Chest X Deflection vs. Time	B-2
6	Driver Chest X Acceleration vs. Time Primary	B-3
7	Driver Chest Y Acceleration vs. Time Primary	B-3
8	Driver Chest Z Acceleration vs. Time Primary	B-3
9	Driver Chest Resultant Acceleration vs. Time Primary	B-3
10	Driver Upper Neck Force X vs. Time Primary	B-4
11	Driver Upper Neck Force Z vs. Time Primary	B-4
12	Driver Upper Neck Moment Y vs. Time Primary	B-4
13	Driver Nij vs. Time Primary	B-4
14	Driver Left Femur Force vs. Time	B-5
15	Driver Right Femur Force vs. Time	B-5
16	Passenger Head X Acceleration vs. Time Primary	B-6
17	Passenger Head Y Acceleration vs. Time Primary	B-6
18	Passenger Head Z Acceleration vs. Time Primary	B-6
19	Passenger Head Resultant Acceleration vs. Time Primary	B-6
20	Passenger Chest X Deflection vs. Time	B-7
21	Passenger Chest X Acceleration vs. Time Primary	B-8
22	Passenger Chest Y Acceleration vs. Time Primary	B-8
23	Passenger Chest Z Acceleration vs. Time Primary	B-8
24	Passenger Chest Resultant Acceleration vs. Time Primary	B-8
25	Passenger Upper Neck Force X vs. Time Primary	B-9
26	Passenger Upper Neck Force Z vs. Time Primary	B-9
27	Passenger Upper Neck Moment Y vs. Time Primary	B-9
28	Passenger Nij vs. Time Primary	B-9
29	Passenger Left Femur Force vs. Time	B-10
30	Passenger Right Femur Force vs. Time	B-10

The following additional dummy and vehicle response data can be found in the R&D section of the NHTSA website at [www.nhtsa.dot.gov](http://www.nhtsa.dot.gov)

Driver Head X Acceleration Redundant  
Driver Head Y Acceleration Redundant  
Driver Head Z Acceleration Redundant  
Driver Head Front Y Acceleration  
Driver Head Front Z Acceleration  
Driver Head Top X Acceleration  
Driver Head Top Y Acceleration  
Driver Head Left X Acceleration  
Driver Head Left Z Acceleration  
Driver Upper Neck Force Y  
Driver Upper Neck Moment X  
Driver Upper Neck Moment Z  
Driver Chest X Acceleration Redundant  
Driver Chest Y Acceleration Redundant  
Driver Chest Z Acceleration Redundant  
Driver Pelvis X  
Driver Pelvis Y  
Driver Pelvis Z  
Driver Left Femur Force Z Redundant  
Driver Right Femur Force Z Redundant  
Driver Shoulder Belt Force  
Driver Lap Belt Force  
Driver Left Upper Tibia Moment X  
Driver Left Upper Tibia Moment Y  
Driver Left Upper Tibia Force Z  
Driver Left Lower Tibia Moment X  
Driver Left Lower Tibia Moment Y  
Driver Left Lower Tibia Force Z  
Driver Right Upper Tibia Moment X  
Driver Right Upper Tibia Moment Y  
Driver Right Upper Tibia Force Z  
Driver Right Lower Tibia Moment X  
Driver Right Lower Tibia Moment Y

Driver Right Lower Tibia Force Z  
Driver Left Foot Fore Z  
Driver Left Foot Aft X  
Driver Left Foot Aft Z  
Driver Right Foot Fore Z  
Driver Right Foot Aft X  
Driver Right Foot Aft Z  
Passenger Head X Acceleration Redundant  
Passenger Head Y Acceleration Redundant  
Passenger Head Z Acceleration Redundant  
Passenger Head Front Y Acceleration  
Passenger Head Front Z Acceleration  
Passenger Head Top X Acceleration  
Passenger Head Top Y Acceleration  
Passenger Head Left X Acceleration  
Passenger Head Left Z Acceleration  
Passenger Upper Neck Force X  
Passenger Upper Neck Force Z  
Passenger Upper Neck Moment Y  
Passenger Chest X Acceleration Redundant  
Passenger Chest Y Acceleration Redundant  
Passenger Chest Z Acceleration Redundant  
Passenger Pelvis X  
Passenger Pelvis Y  
Passenger Pelvis Z  
Passenger Left Femur Force Z Redundant  
Passenger Right Femur Force Z Redundant  
Passenger Shoulder Belt Force  
Passenger Lap Belt Force  
Passenger Left Upper Tibia Moment X  
Passenger Left Upper Tibia Moment Y  
Passenger Left Upper Tibia Force Z  
Passenger Left Lower Tibia Moment X  
Passenger Left Lower Tibia Moment Y  
Passenger Left Lower Tibia Force Z  
Passenger Right Upper Tibia Moment X

Passenger Right Upper Tibia Moment Y  
Passenger Right Upper Tibia Force Z  
Passenger Right Lower Tibia Moment X  
Passenger Right Lower Tibia Moment Y  
Passenger Right Lower Tibia Force Z  
Passenger Left Foot Fore Z  
Passenger Left Foot Aft X  
Passenger Left Foot Aft Z  
Passenger Right Foot Fore Z  
Passenger Right Foot Aft X  
Passenger Right Foot Aft Z  
Left Rear Seat Crossmember X  
Left Rear Seat Crossmember Z  
Right Rear Seat Crossmember X  
Right Rear Seat Crossmember Z  
Vehicle Engine Top X  
Vehicle Engine Bottom X  
Vehicle Left Rear Z  
Vehicle Right Rear Z  
Load Cell Barrier A1-A9  
Load Cell Barrier B1-B9  
Load Cell Barrier C1-C9  
Load Cell Barrier D1-D9

Test Vehicle: 2013 Mercedes-Benz C300 4MATIC AWD 4-Door Sedan  
 Test Program: 56 km/h Frontal Impact NCAP Test

NHTSA No.: MD0506  
 Test Date: 12/14/12

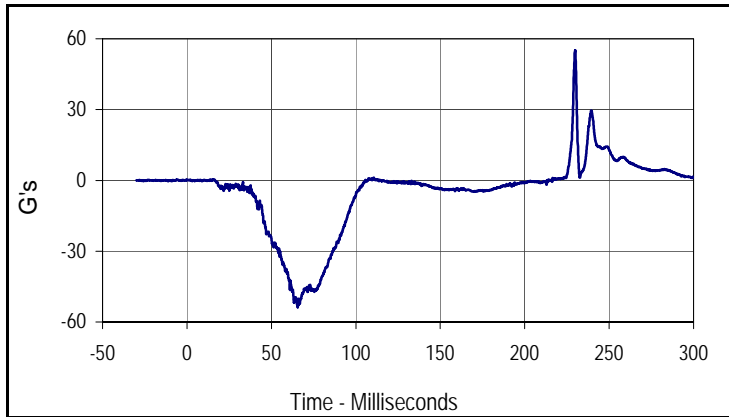

Curve Description			
Driver Head Acceleration X Primary			
Plot No.	Type	SAE Class	Units
001	FIL	1000	G's
Max	Time	Min	Time
55.1	229.9	-53.8	65.6

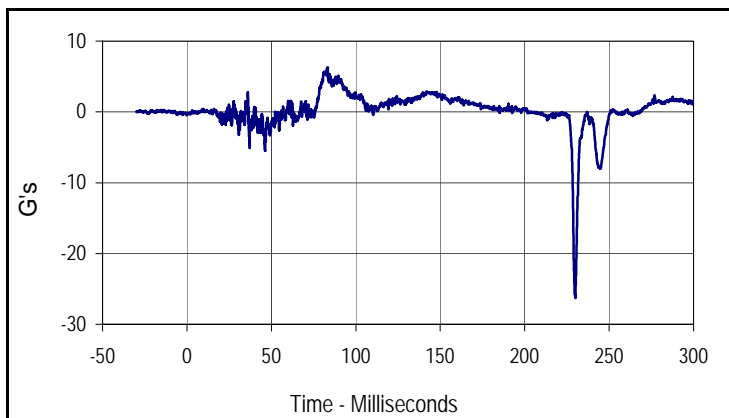

Curve Description			
Driver Head Acceleration Y Primary			
Plot No.	Type	SAE Class	Units
002	FIL	1000	G's
Max	Time	Min	Time
6.3	83.4	-26.3	230.0

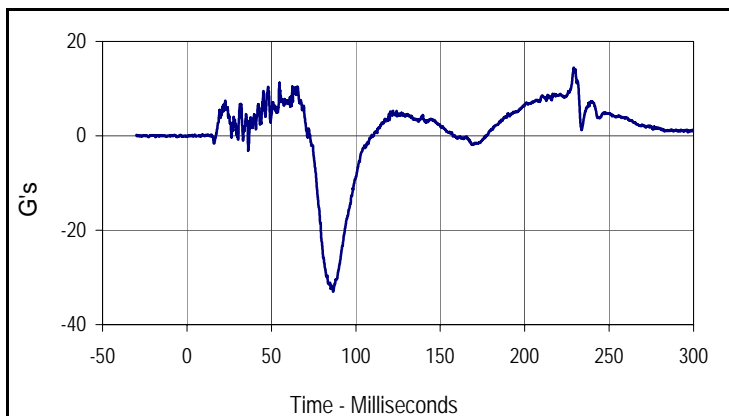

Curve Description			
Driver Head Acceleration Z Primary			
Plot No.	Type	SAE Class	Units
003	FIL	1000	G's
Max	Time	Min	Time
14.5	229.0	-33.0	86.6

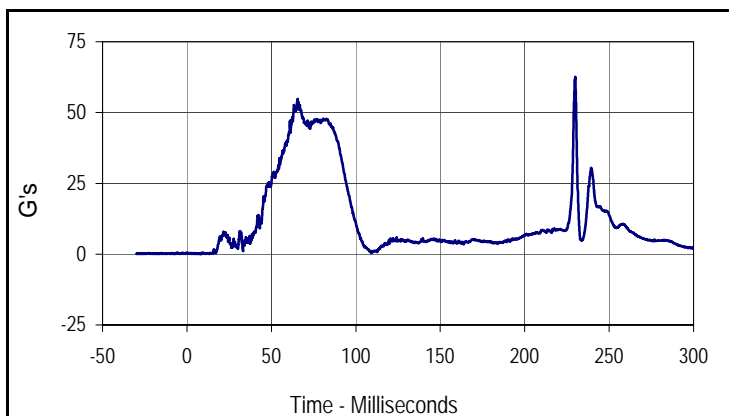

Curve Description			
Driver Head Resultant Acceleration Primary			
Plot No.	Type	SAE Class	Units
004	RES	1000	G's
Max	Time	Min	Time
62.6	229.9	0.0	8.3

Test Vehicle: 2013 Mercedes-Benz C300 4MATIC AWD 4-Door Sedan

NHTSA No.: MD0506

Test Program: 56 km/h Frontal Impact NCAP Test

Test Date: 12/14/12

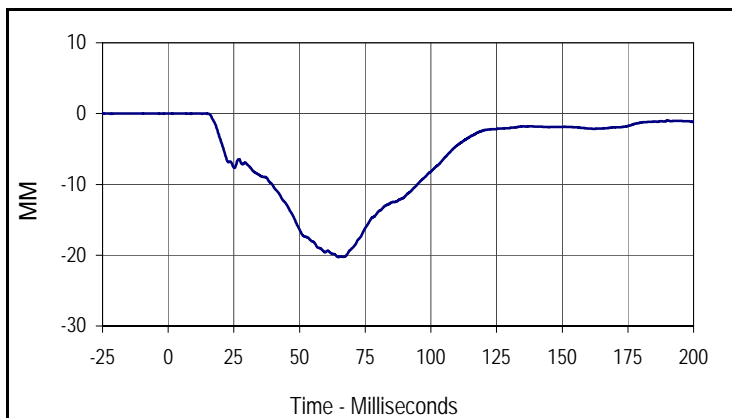

Curve Description			
Driver Chest Deflection			
Plot No.	Type	SAE Class	Units
005	FIL	600	MM
Max	Time	Min	Time
0.0	3.3	-20.3	64.8

Test Vehicle: 2013 Mercedes-Benz C300 4MATIC AWD 4-Door Sedan  
 Test Program: 56 km/h Frontal Impact NCAP Test

NHTSA No.: MD0506  
 Test Date: 12/14/12

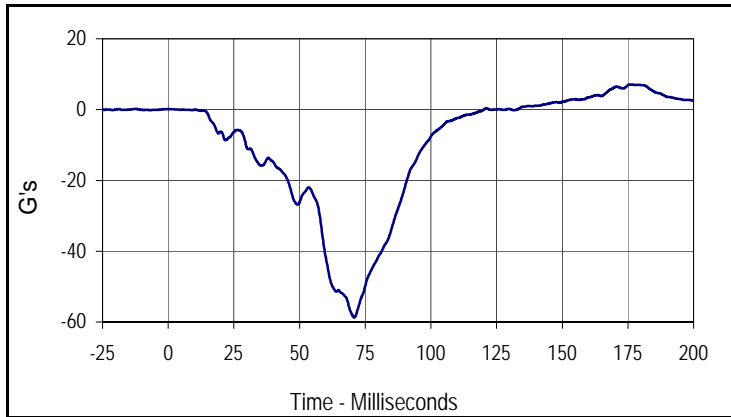

Curve Description			
Driver Chest Acceleration X Primary			
Plot No.	Type	SAE Class	Units
006	FIL	180	G's
Max	Time	Min	Time
7.1	175.9	-58.7	70.9

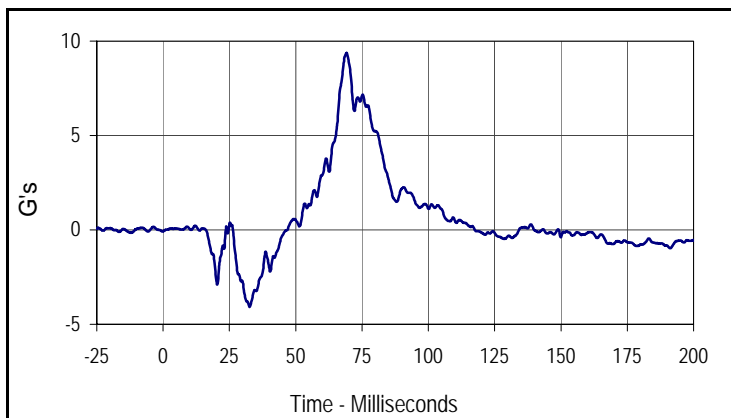

Curve Description			
Driver Chest Acceleration Y Primary			
Plot No.	Type	SAE Class	Units
007	FIL	180	G's
Max	Time	Min	Time
9.4	69.2	-4.1	32.6

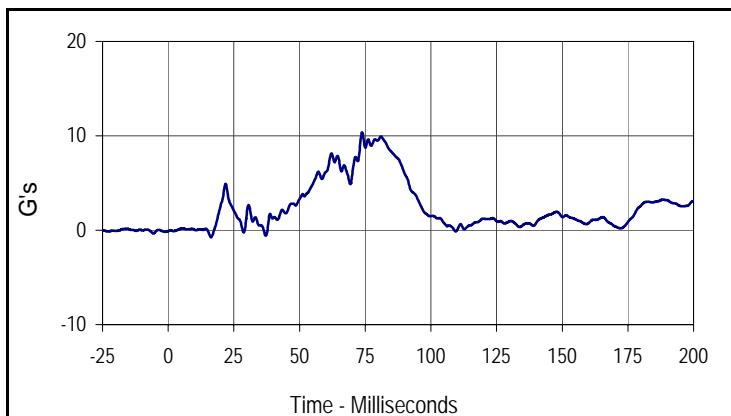

Curve Description			
Driver Chest Acceleration Z Primary			
Plot No.	Type	SAE Class	Units
008	FIL	180	G's
Max	Time	Min	Time
10.4	73.8	-0.7	16.3

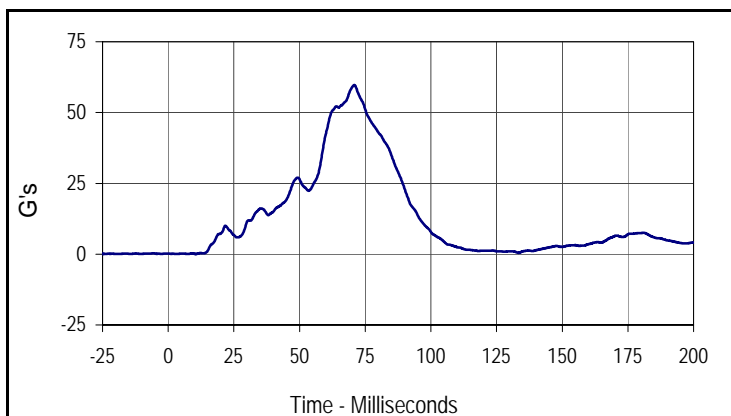

Curve Description			
Driver Chest Resultant Acceleration Primary			
Plot No.	Type	SAE Class	Units
009	RES	180	G's
Max	Time	Min	Time
59.7	70.8	0.0	10.5

Test Vehicle: 2013 Mercedes-Benz C300 4MATIC AWD 4-Door Sedan  
 Test Program: 56 km/h Frontal Impact NCAP Test

NHTSA No.: MD0506  
 Test Date: 12/14/12

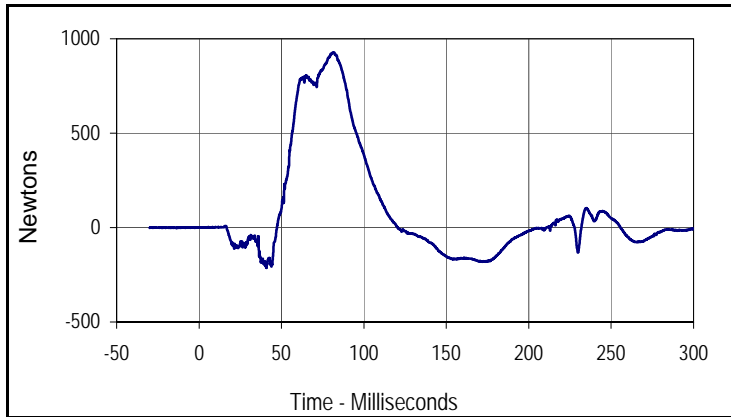

Curve Description			
Driver Upper Neck Force X			
Plot No.	Type	SAE Class	Units
010	FIL	1000	Newtons
Max	Time	Min	Time
928.1	81.9	-214.3	40.9

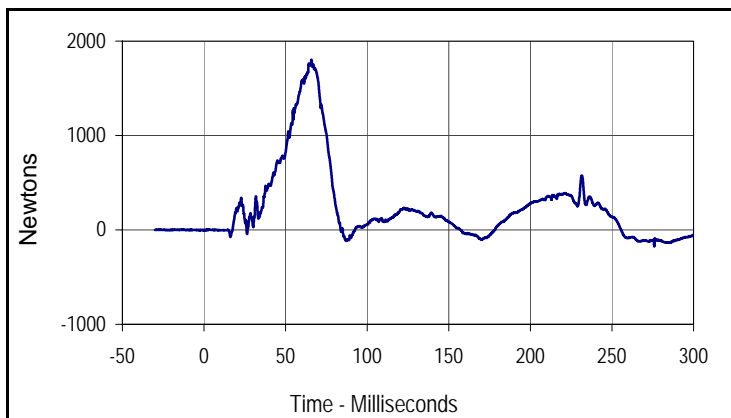

Curve Description			
Driver Upper Neck Force Z			
Plot No.	Type	SAE Class	Units
011	FIL	1000	Newtons
Max	Time	Min	Time
1804.3	65.8	-172.4	275.9

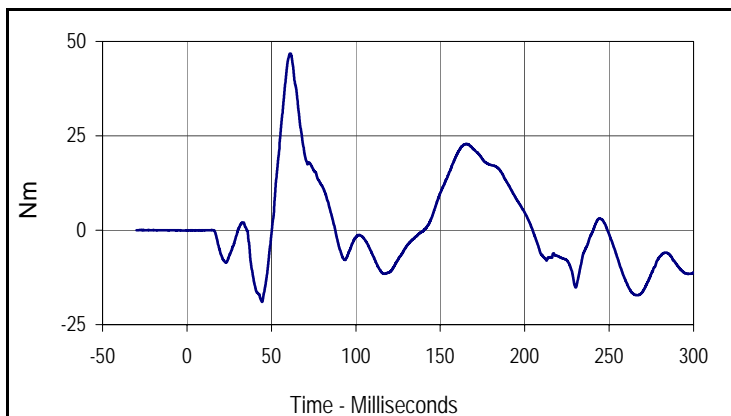

Curve Description			
Driver Upper Neck Moment Y			
Plot No.	Type	SAE Class	Units
012	FIL	600	Nm
Max	Time	Min	Time
46.8	61.1	-19.0	44.5

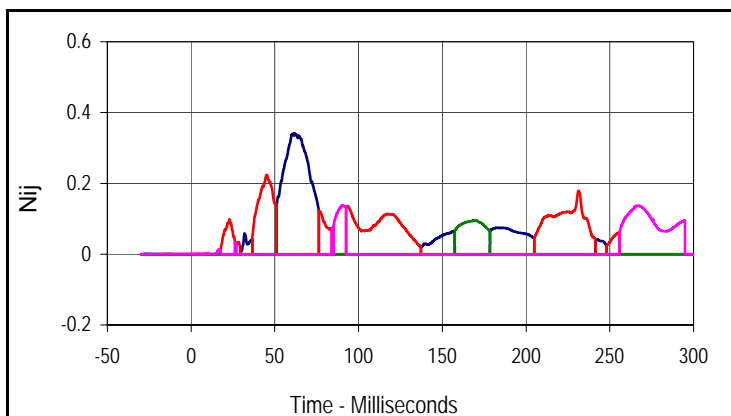

Curve Description			
Driver Nij			
Units	Type	Max	Time
Ntf	FIL	0.34	61.8
Nte	FIL	0.22	45.2
Ncf	FIL	0.10	169.1
Nce	FIL	0.14	90.2

Test Vehicle: 2013 Mercedes-Benz C300 4MATIC AWD 4-Door Sedan  
 Test Program: 56 km/h Frontal Impact NCAP Test

NHTSA No.: MD0506  
 Test Date: 12/14/12

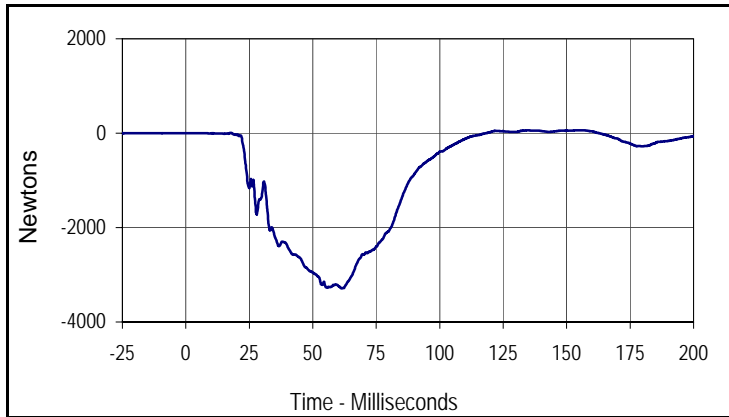

Curve Description			
Driver Left Femur Force Z			
Plot No.	Type	SAE Class	Units
013	FIL	600	Newtons
Max	Time	Min	Time
62.7	155.1	-3285.2	61.3

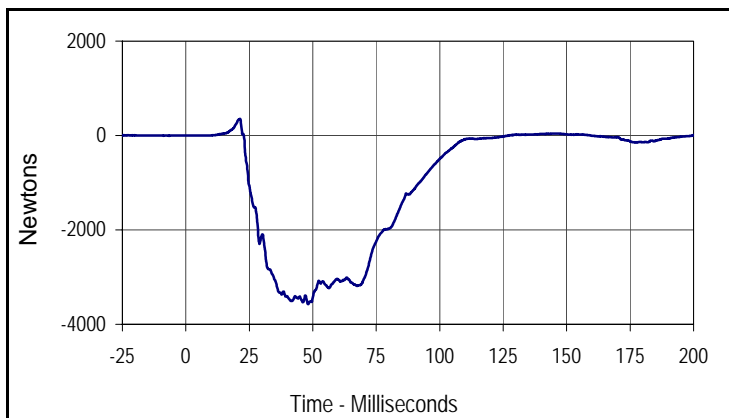

Curve Description			
Driver Right Femur Force Z			
Plot No.	Type	SAE Class	Units
014	FIL	600	Newtons
Max	Time	Min	Time
352.4	21.3	-3574.5	48.1

Test Vehicle: 2013 Mercedes-Benz C300 4MATIC AWD 4-Door Sedan  
 Test Program: 56 km/h Frontal Impact NCAP Test

NHTSA No.: MD0506  
 Test Date: 12/14/12

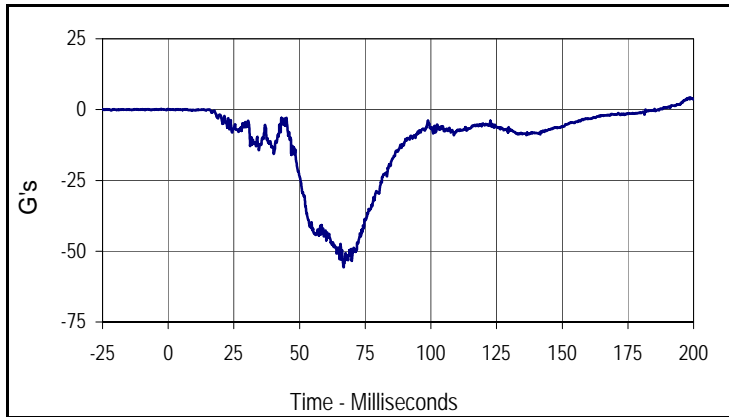

Curve Description			
Passenger Head Acceleration X Primary			
Plot No.	Type	SAE Class	Units
015	FIL	1000	G's
Max	Time	Min	Time
4.2	198.7	-55.7	66.7

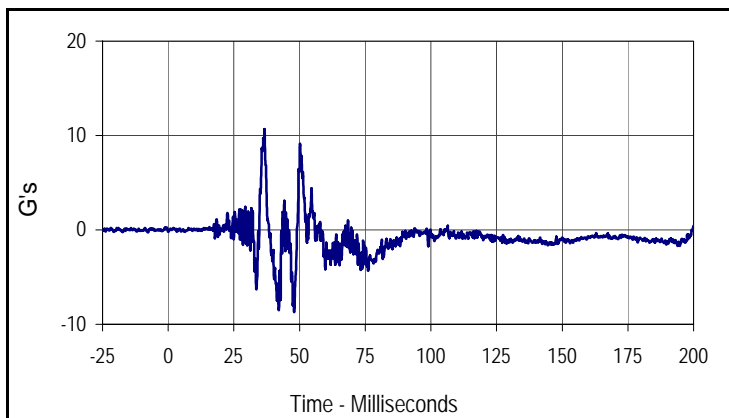

Curve Description			
Passenger Head Acceleration Y Primary			
Plot No.	Type	SAE Class	Units
016	FIL	1000	G's
Max	Time	Min	Time
10.7	36.7	-8.7	48.0

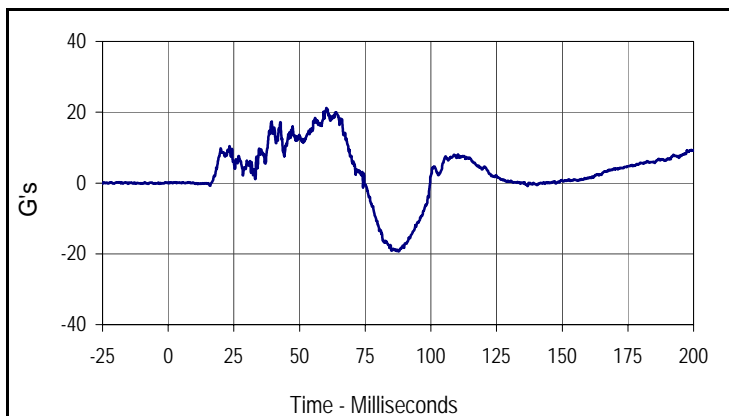

Curve Description			
Passenger Head Acceleration Z Primary			
Plot No.	Type	SAE Class	Units
017	FIL	1000	G's
Max	Time	Min	Time
21.2	60.2	-19.3	87.6

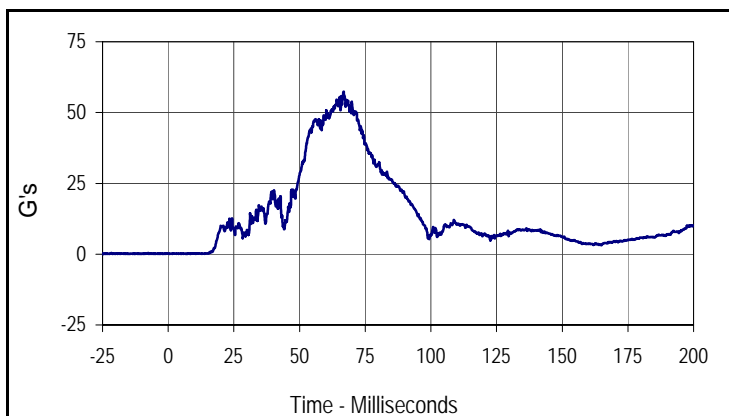

Curve Description			
Passenger Head Resultant Acceleration Primary			
Plot No.	Type	SAE Class	Units
018	RES	1000	G's
Max	Time	Min	Time
57.3	66.7	0.1	8.4

Test Vehicle: 2013 Mercedes-Benz C300 4MATIC AWD 4-Door Sedan

NHTSA No.: MD0506

Test Program: 56 km/h Frontal Impact NCAP Test

Test Date: 12/14/12

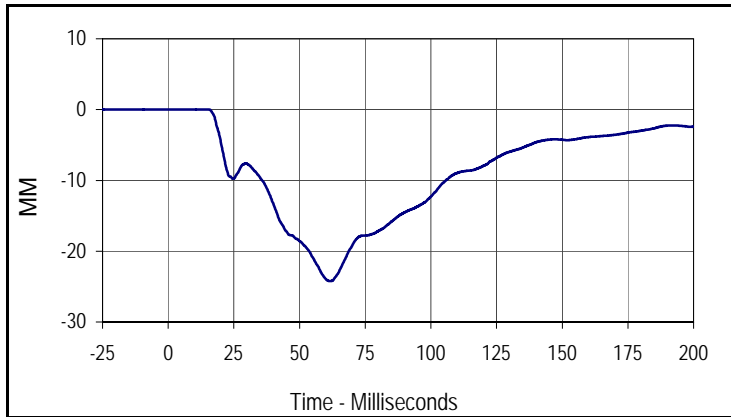

Curve Description			
Passenger Chest Deflection			
Plot No.	Type	SAE Class	Units
019	FIL	600	MM
Max	Time	Min	Time
0.0	13.6	-24.2	61.6

Test Vehicle: 2013 Mercedes-Benz C300 4MATIC AWD 4-Door Sedan  
 Test Program: 56 km/h Frontal Impact NCAP Test

NHTSA No.: MD0506  
 Test Date: 12/14/12

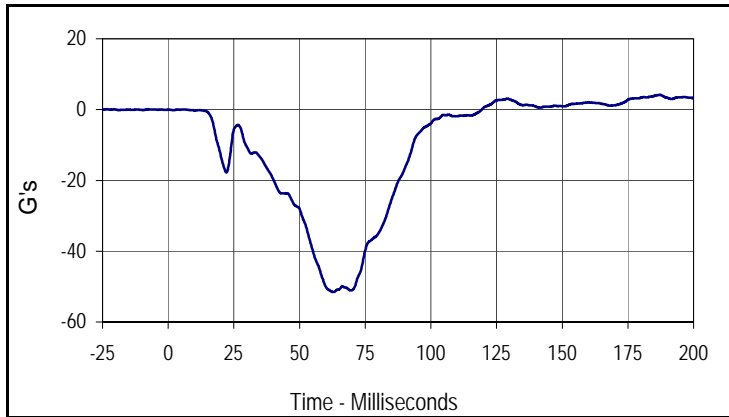

Curve Description			
Passenger Chest Acceleration X Primary			
Plot No.	Type	SAE Class	Units
020	FIL	180	G's
Max	Time	Min	Time
4.2	187.1	-51.5	62.8

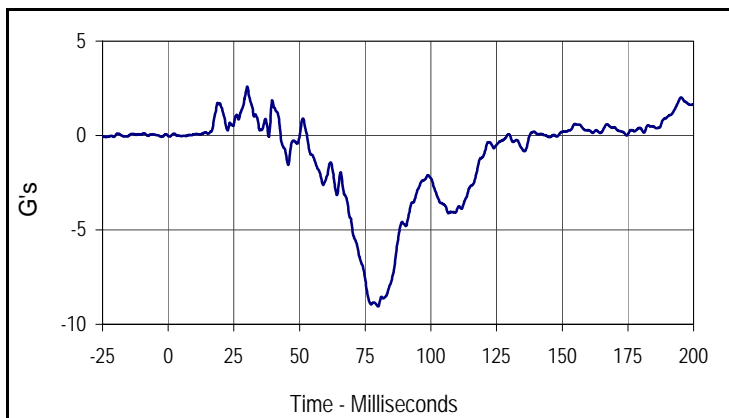

Curve Description			
Passenger Chest Acceleration Y Primary			
Plot No.	Type	SAE Class	Units
021	FIL	180	G's
Max	Time	Min	Time
2.6	30.1	-9.1	79.9

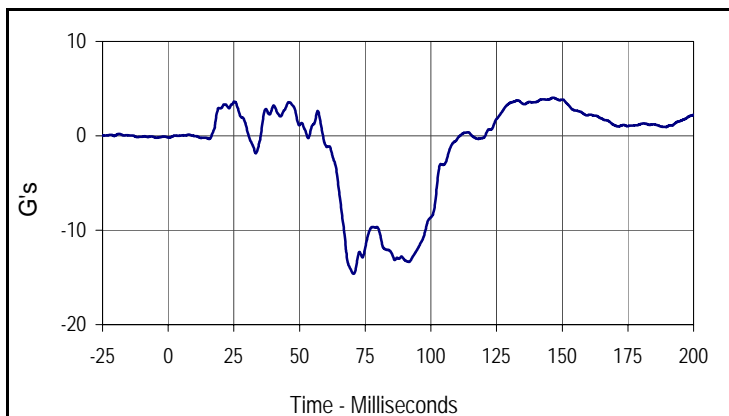

Curve Description			
Passenger Chest Acceleration Z Primary			
Plot No.	Type	SAE Class	Units
022	FIL	180	G's
Max	Time	Min	Time
4.0	146.5	-14.6	70.5

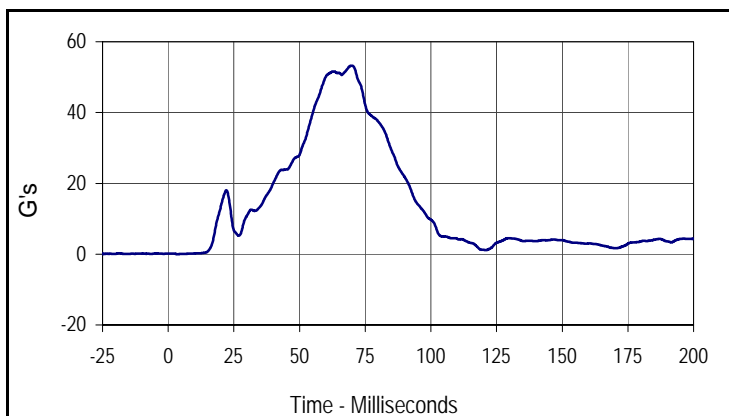

Curve Description			
Passenger Chest Resultant Acceleration Primary			
Plot No.	Type	SAE Class	Units
023	RES	180	G's
Max	Time	Min	Time
53.2	70.0	0.0	3.4

Test Vehicle: 2013 Mercedes-Benz C300 4MATIC AWD 4-Door Sedan  
 Test Program: 56 km/h Frontal Impact NCAP Test

NHTSA No.: MD0506  
 Test Date: 12/14/12

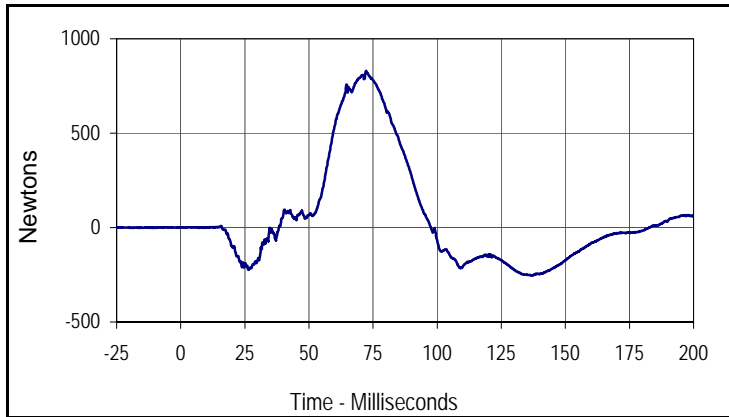

Curve Description			
Passenger Upper Neck Force X			
Plot No.	Type	SAE Class	Units
024	FIL	1000	Newtons
Max	Time	Min	Time
830.6	72.3	-254.6	137.3

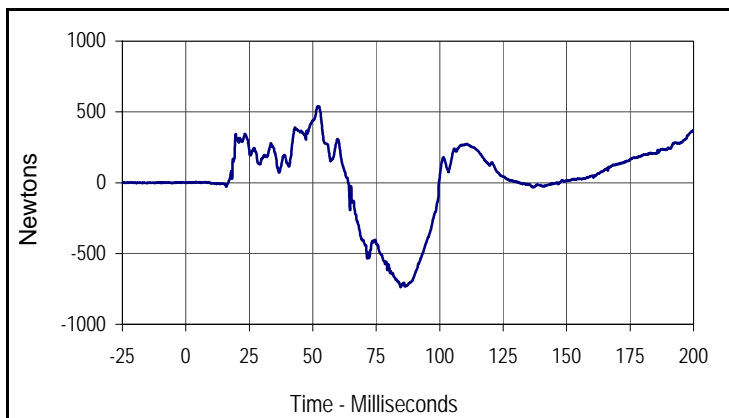

Curve Description			
Passenger Upper Neck Force Z			
Plot No.	Type	SAE Class	Units
025	FIL	1000	Newtons
Max	Time	Min	Time
539.1	52.5	-737.6	84.7

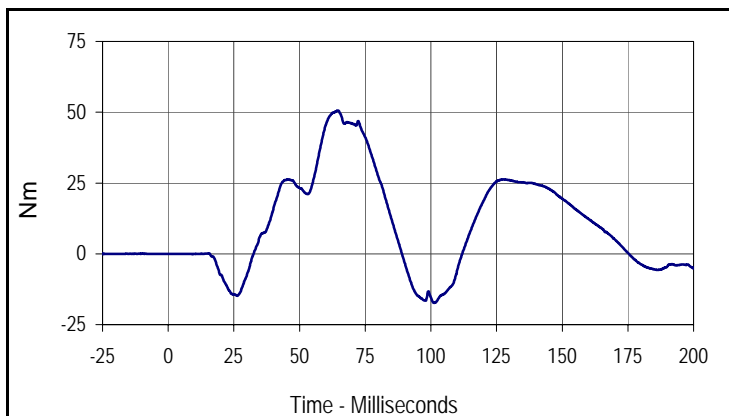

Curve Description			
Passenger Upper Neck Moment Y			
Plot No.	Type	SAE Class	Units
026	FIL	600	Nm
Max	Time	Min	Time
50.6	64.6	-17.3	101.2

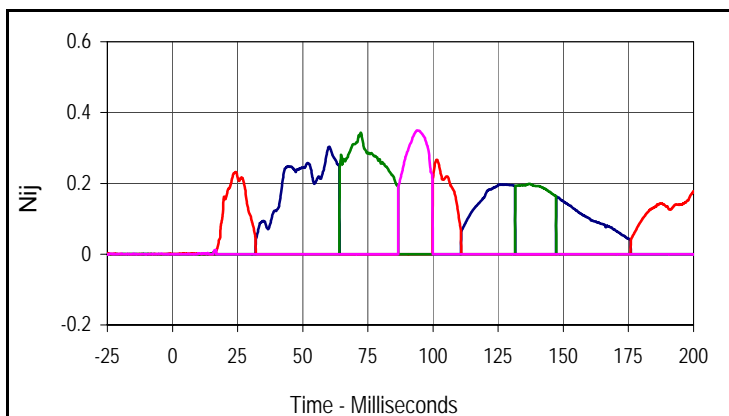

Curve Description			
Passenger Nij			
Units	Type	Max	Time
Ntf	FIL	0.30	60.1
Units	Type	Max	Time
Nte	FIL	0.29	218.6
Units	Type	Max	Time
Ncf	FIL	0.34	72.3
Units	Type	Max	Time
Nce	FIL	0.35	93.9

Test Vehicle: 2013 Mercedes-Benz C300 4MATIC AWD 4-Door Sedan  
 Test Program: 56 km/h Frontal Impact NCAP Test

NHTSA No.: MD0506  
 Test Date: 12/14/12

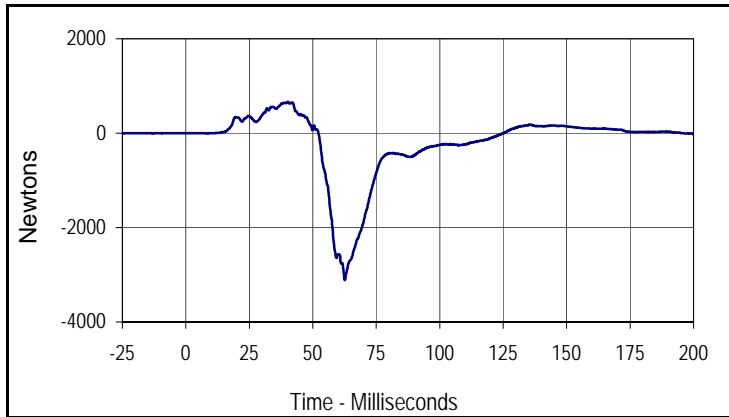

Curve Description			
Passenger Left Femur Force Z			
Plot No.	Type	SAE Class	Units
027	FIL	600	Newtons
Max	Time	Min	Time
664.7	40.2	-3111.4	62.6

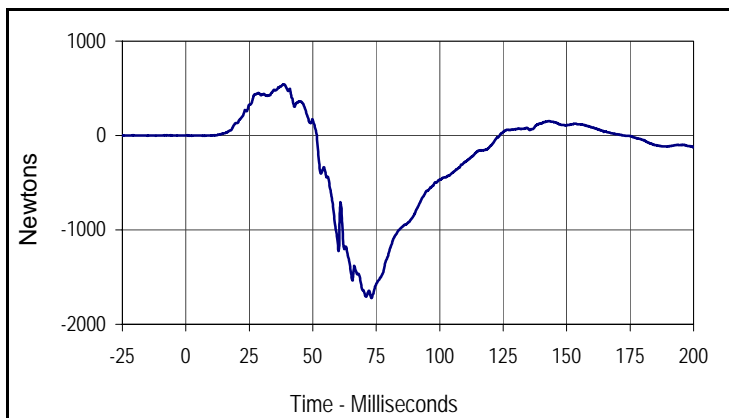

Curve Description			
Passenger Right Femur Force Z			
Plot No.	Type	SAE Class	Units
028	FIL	600	Newtons
Max	Time	Min	Time
542.8	38.7	-1722.3	73.1

**APPENDIX C**  
**DUMMY CALIBRATION AND PERFORMANCE VERIFICATION DATA**

**APPENDIX C**  
**PRE-TEST / ATD CONFIGURATION AND PERFORMANCE VERIFICATION DATA**

Test Program: Hybrid III 50th Percentile Male Dummy Damage Checklist

Test Date: 12/5/12



ATD Serial No.: 034

Test I.D.: N/A

Dummy Item	Inspect for	Comments	Damaged	OK
Entire Dummy	Perform general cleaning			X
Outer Skin	Gashes, rips, cracks			X
Head	Ballast secure			X
	General appearance			X
Neck	Broken or cracked rubber			X
	Upper neck bracket firmly attached to the lower neck bracket			X
	Looseness at the condyle joint			X
	Nodding blocks cracked or out of position			X
Spine	Broken or cracks in rubber			X
Ribs	Broken or bent ribs			X
	Broken or bent rib supports			X
	Damping material separated or cracked			X
	Rubber bumpers in place			X
Chest Displacement Assembly	Bent shaft			X
	Slider arm riding in track			X
Transducer Leads	Torn cables			X
Accelerometer Mountings	Head mounting secure			X
	Chest mounting secure			X
Knees	Skin condition			X
	Insert (do not remove)			X
	Casting			X
Limbs	Normal movement and adjustment			X
Knee Sliders	Wires intact			X
	Rubber returned to "at rest" position			X
Pelvis	Broken			X
Other				X

Describe the repair on repair or replacement of parts:

---



---



---

Test Program: Hybrid III 50th Percentile Male External Measurements

Test Date: 12/5/12



ATD Serial No.: 034

Test I.D.: N/A

Tested Parameter	Units	Specification	Result	Pass/Fail
Laboratory Temperature	°C	20.6 to 22.2	21.13	Pass
Laboratory Relative Humidity	%	10 to 70	29.8	Pass
A - Total sitting height	mm	879 to 889	884	Pass
B - Shoulder pivot height	mm	505 to 521	512	Pass
C - H point height	mm	84 to 89	85	Pass
D - H point location from backline	mm	135 to 140	137	Pass
E - Shoulder pivot from backline	mm	84 to 94	89	Pass
F - Thigh clearance	mm	140 to 155	146	Pass
G - Back of elbow to wrist pivot	mm	290 to 305	297	Pass
H - Head back to backline	mm	41 to 46	43	Pass
I - Shoulder to elbow length	mm	330 to 345	336	Pass
J - Elbow rest height	mm	190 to 211	201	Pass
K - Buttock to knee length	mm	579 to 604	586	Pass
L - Popliteal length	mm	429 to 455	438	Pass
M - Knee pivot height	mm	485 to 500	493	Pass
N - Buttock popliteal length	mm	452 to 477	472	Pass
O - Chest depth without jacket	mm	213 to 229	225	Pass
P - Foot length	mm	251 to 267	260	Pass
V - Shoulder breadth	mm	422 to 437	433	Pass
W - Foot breadth	mm	91 to 107	99	Pass
Y - Chest circumference (with chest jacket)	mm	970 to 1001	981	Pass
Z - Waist circumference	mm	836 to 866	864	Pass
AA - Location for chest circumference	mm	429 to 434	429	Pass
BB - Location for waist circumference	mm	226 to 231	230	Pass
Overall Test Results				Pass

Test Program: Hybrid III 50th Percentile Male Head Drop Test

Test Date: 12/5/12



ATD Serial No.: 034

Test I.D.: M034HD037

Tested Parameter	Units	Specification	Result	Pass/Fail
Head Assembly Soak Time	Minutes	≥240	255	Pass
Temperature During Soak	Max	18.9 to 25.6	21.6	Pass
	Min		20.7	Pass
Humidity During Soak	Max	10.0 to 70.0	31.4	Pass
	Min		29.3	Pass
Laboratory Temperature During Test	°C	18.9 to 25.6	21.2	Pass
Laboratory Humidity During Test	%	10.0 to 70.0	29.5	Pass
Peak Resultant Acceleration	G's	225.0 to 275.0	260.8	Pass
Peak Lateral Acceleration	G's	≤15.0	2.5	Pass
Oscillations After Main Pulse	%	<10% of peak Res. Acceleration	4.3	Pass
Is Acceleration Unimodal?	Yes/No	Yes	Yes	Pass
<b>Overall Test Results</b>				<b>Pass</b>

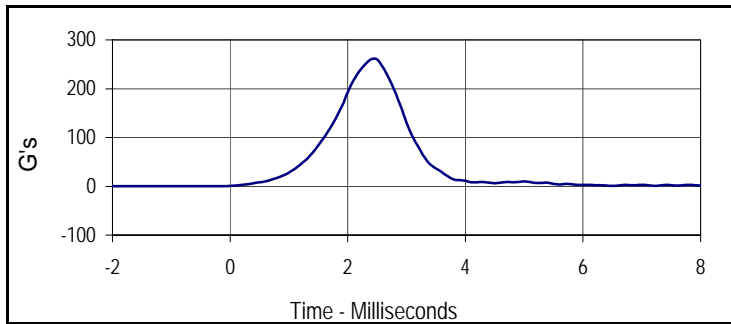

Curve Description			
Head Resultant			
Plot No.	Type	SAE Class	Units
001	RES	1000	G's
Max	Time	Min	Time
260.8	2.4	0.0	-0.8

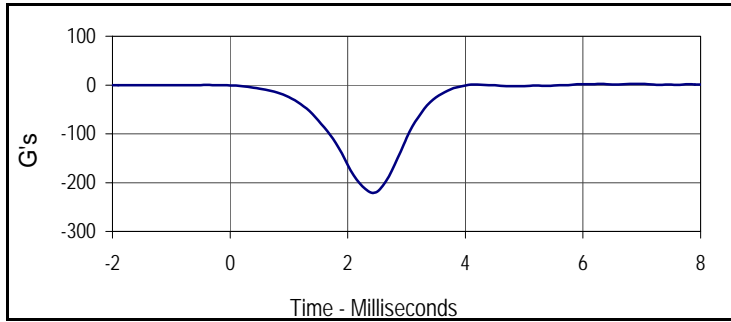

Curve Description			
Head X			
Plot No.	Type	SAE Class	Units
002	FIL	1000	G's
Max	Time	Min	Time
1.9	6.0	-220.7	2.4

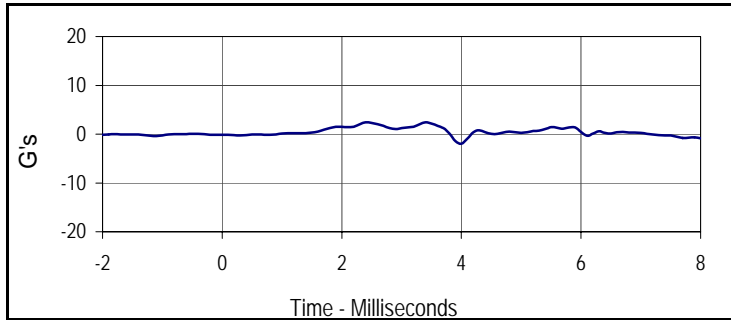

Curve Description			
Head Y			
Plot No.	Type	SAE Class	Units
003	FIL	1000	G's
Max	Time	Min	Time
2.5	2.4	-2.0	4.0

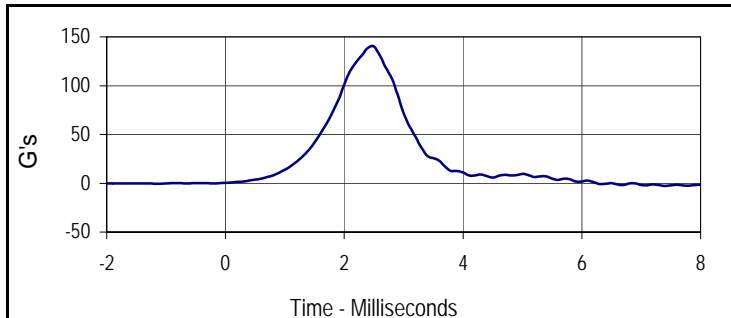

Curve Description			
Head Z			
Plot No.	Type	SAE Class	Units
004	FIL	1000	G's
Max	Time	Min	Time
140.2	2.5	-0.4	-1.2

Test Program: Hybrid III 50th Percentile Male Neck Flexion Test

Test Date: 12/5/12



ATD Serial No.: 034

Test I.D.: M034NF037

Tested Parameter	Units	Specification	Result	Pass/Fail	
Neck Assembly Soak Time	Minutes	≥240	305	Pass	
Temperature During Soak	Max	20.6 to 22.2	21.6	Pass	
	Min		20.7	Pass	
Humidity During Soak	Max	10.0 to 70.0	31.4	Pass	
	Min		29.3	Pass	
Laboratory Temperature During Test	°C	20.6 to 22.2	21.1	Pass	
Laboratory Humidity During Test	%	10.0 to 70.0	29.8	Pass	
Pendulum Velocity	m/s	6.89 to 7.13	6.91	Pass	
Pendulum Deceleration	10 Msec.	G's	22.5 to 27.5	23.0	Pass
	20 Msec.	G's	17.6 to 22.6	20.7	Pass
	30 Msec.	G's	12.5 to 18.5	18.4	Pass
Peak Pendulum Decel. after 30 Msec.	G's	≤ 29.0	18.4	Pass	
Deceleration Decay, Time to Cross 5 G's	Msec.	34.0 to 42.0	37	Pass	
Maximum "D" Plane Rotation	Max	Degrees	64.0 to 78.0	76.5	Pass
	Time	Msec.	57.0 to 64.0	62.7	Pass
"D" Plane Rotation Decay, Time To Zero Crossing	Msec.	113.0 to 128.0	119.4	Pass	
Moment About Occ. Condyle	Max	Nm	84.1 to 108.5	91.1	Pass
	Time	Msec.	47.0 to 58.0	54.0	Pass
Positive Moment Decay, Time To Zero Crossing	Msec.	97.0 to 107.0	97.2	Pass	
<b>Overall Test Results</b>				<b>Pass</b>	

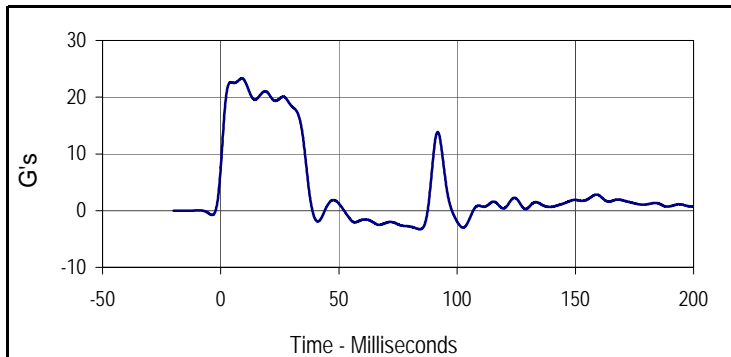

Curve Description			
Pendulum Deceleration			
Plot No.	Type	SAE Class	Units
001	FIL	60	G's
Max	Time	Min	Time
23.3	8.9	-3.3	84.3

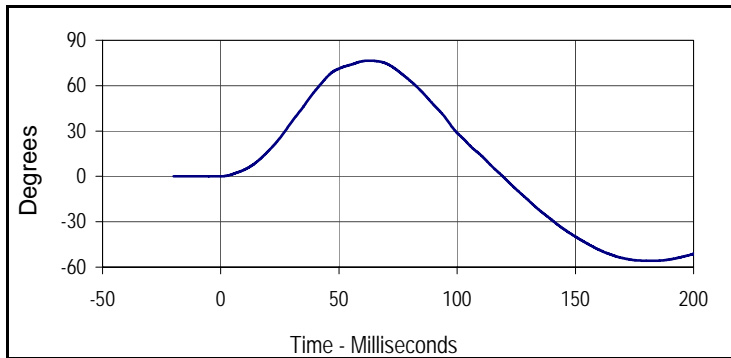

Curve Description			
"D" Plane Rotation			
Plot No.	Type	SAE Class	Units
002	FIL	60	Degrees
Max	Time	Min	Time
76.5	62.7	-55.7	183.7

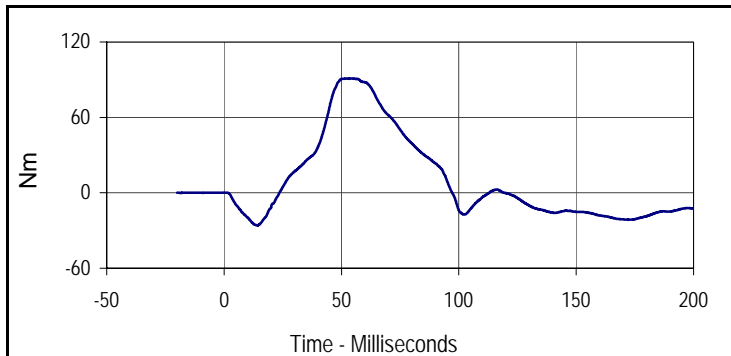

Curve Description			
Moment About Occipital Condyle			
Plot No.	Type	SAE Class	Units
003	FIL	600	Nm
Max	Time	Min	Time
91.1	54.0	-26.0	14.2

Test Program: Hybrid III 50th Percentile Male Neck Flexion Test

Test Date: 12/5/12



ATD Serial No.: 034

Test I.D.: M034NF037

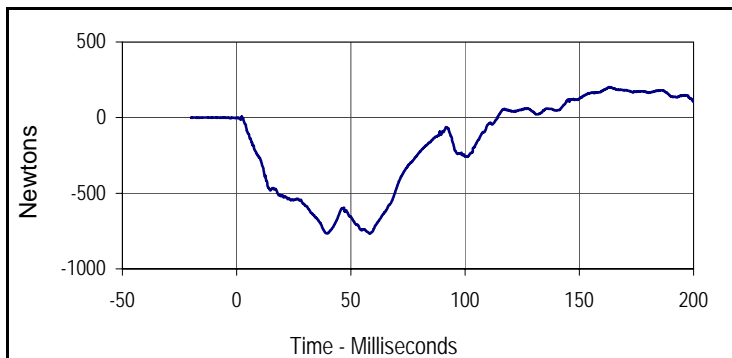

Curve Description			
Neck Force X			
Plot No.	Type	SAE Class	Units
004	FIL	1000	Newtons
Max	Time	Min	Time
201.0	162.9	-766.2	39.5

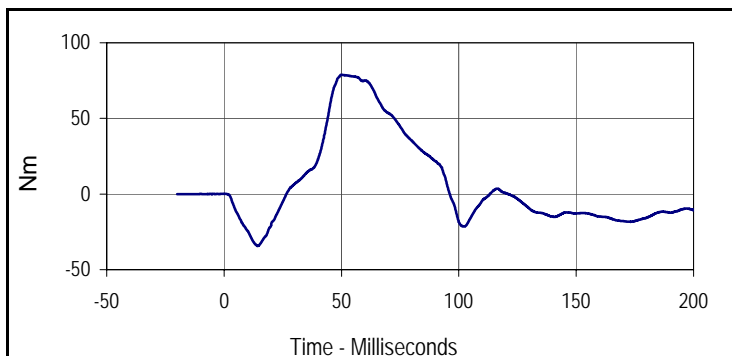

Curve Description			
Neck Moment Y			
Plot No.	Type	SAE Class	Units
005	FIL	600	Nm
Max	Time	Min	Time
78.9	50.1	-34.4	14.3

Test Program: Hybrid III 50th Percentile Male Neck Extension Test

Test Date: 12/5/12



ATD Serial No.: 034

Test I.D.: M034NE037

Tested Parameter	Units	Specification	Result	Pass/Fail	
Neck Assembly Soak Time	Minutes	≥240	340	Pass	
Temperature During Soak	Max	20.6 to 22.2	21.6	Pass	
	Min		20.7	Pass	
Humidity During Soak	Max	10.0 to 70.0	31.4	Pass	
	Min		29.3	Pass	
Laboratory Temperature During Test	°C	20.6 to 22.2	21.1	Pass	
Laboratory Humidity During Test	%	10.0 to 70.0	29.8	Pass	
Pendulum Velocity	m/s	5.94 to 6.19	6.08	Pass	
Pendulum Deceleration	10 Msec.	G's	17.2 to 21.2	19.6	Pass
	20 Msec.	G's	14.0 to 19.0	17.9	Pass
	30 Msec.	G's	11.0 to 16.0	15.0	Pass
Peak Pendulum Decel. after 30 Msec.	G's	≤ 22.0	15.0	Pass	
Deceleration Decay, Time to Cross 5 G's	Msec.	38.0 to 46.0	38.2	Pass	
Maximum "D" Plane Rotation	Max	Degrees	81.0 to 106.0	96.6	Pass
	Time	Msec.	72.0 to 82.0	72.1	Pass
"D" Plane Rotation Decay, Time To Zero Crossing	Msec.	147.0 to 174.0	151.6	Pass	
Moment About Occ. Condyle	Max	Nm	-52.9 to -79.9	-65.3	Pass
	Time	Msec.	65.0 to 79.0	67.5	Pass
Positive Moment Decay, Time To Zero Crossing	Msec.	120.0 to 148.0	138.3	Pass	
<b>Overall Test Results</b>				<b>Pass</b>	

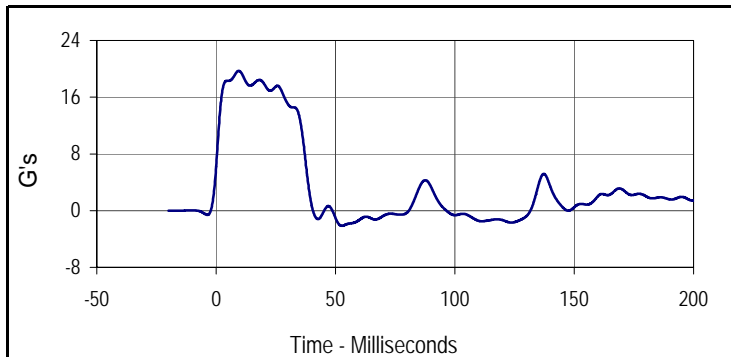

Curve Description			
Pendulum Deceleration			
Plot No.	Type	SAE Class	Units
001	FIL	60	G's
Max	Time	Min	Time
19.7	9.5	-2.2	52.7

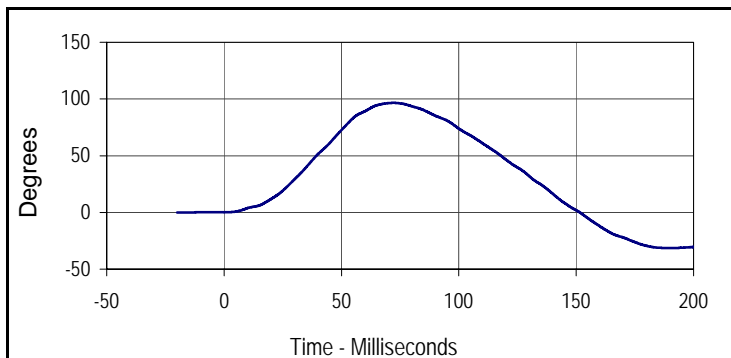

Curve Description			
"D" Plane Rotation			
Plot No.	Type	SAE Class	Units
002	FIL	60	Degrees
Max	Time	Min	Time
96.6	72.1	-31.5	190.4

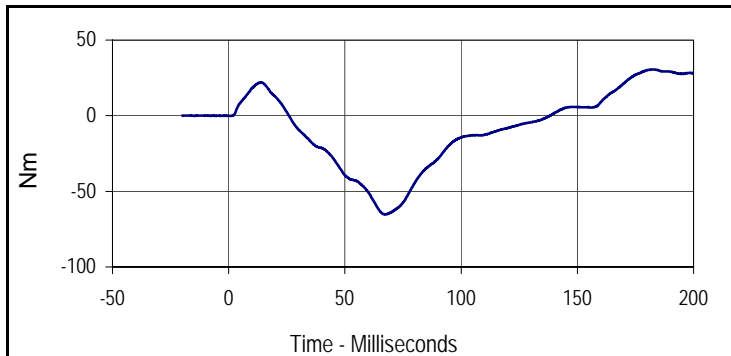

Curve Description			
Moment About Occipital Condyle			
Plot No.	Type	SAE Class	Units
003	FIL	600	Nm
Max	Time	Min	Time
30.6	182.8	-65.3	67.5

Test Program: Hybrid III 50th Percentile Male Neck Extension Test

Test Date: 12/5/12



ATD Serial No.: 034

Test I.D.: M034NE037

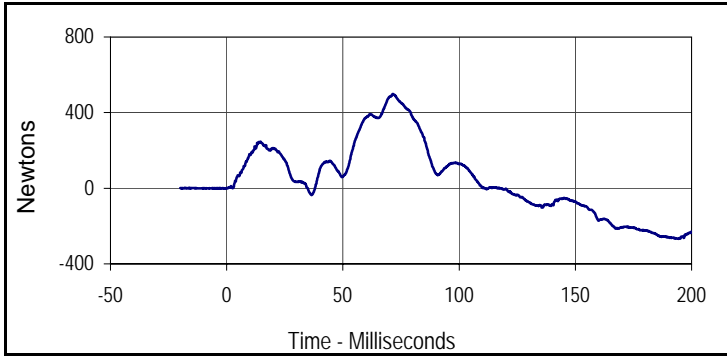

Curve Description			
Neck Force X			
Plot No.	Type	SAE Class	Units
004	FIL	1000	Newtons
Max	Time	Min	Time
499.2	71.5	-267.3	194.3

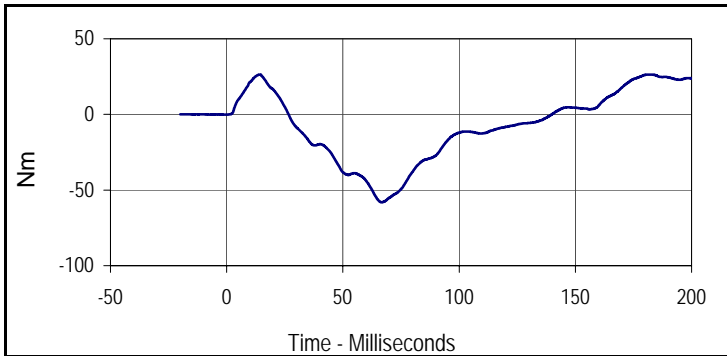

Curve Description			
Neck Moment Y			
Plot No.	Type	SAE Class	Units
005	FIL	600	Nm
Max	Time	Min	Time
26.4	14.2	-58.1	66.5

Test Program: Hybrid III 50th Percentile Male Thorax Impact Test

Test Date: 12/5/12



ATD Serial No.: 034

Test I.D.: M034CH037

Tested Parameter	Units	Specification	Result	Pass/Fail
Dummy Soak Time	Minutes	≥240	390	Pass
Temperature During Soak	Max	20.6 to 22.2	21.6	Pass
	Min		20.7	Pass
Humidity During Soak	Max	10.0 to 70.0	31.4	Pass
	Min		29.3	Pass
Laboratory Temperature During Test	°C	20.6 to 22.2	21.1	Pass
Laboratory Humidity During Test	%	10.0 to 70.0	29.7	Pass
Probe Velocity	m/s	6.58 to 6.82	6.63	Pass
Peak Probe Force	Newtons	5159 to 5893	5686	Pass
Peak Sternum Deflection	CM	6.35 to 7.26	6.43	Pass
Internal Hysteresis	%	69 to 85	70.6	Pass
Overall Test Results				Pass

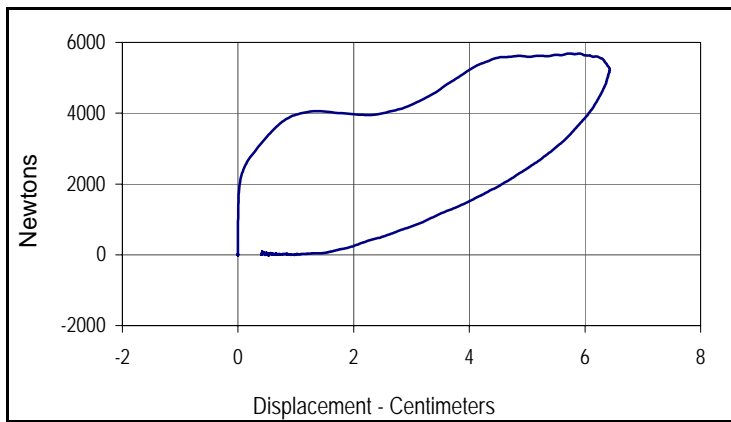

Curve Description			
Probe Force vs. Chest Deflection			
Plot No.	Type	SAE Class	Hysteresis
001	FIL	180	70.6
Peak Probe Force		Peak Chest Deflection	
5686		6.43	

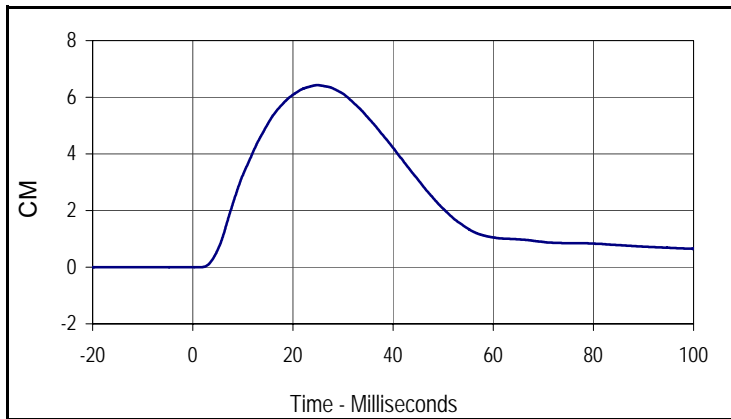

Curve Description			
Chest Deflection			
Plot No.	Type	SAE Class	Units
002	FIL	180	CM
Max	Time	Min	Time
6.4	24.9	0.0	1.3

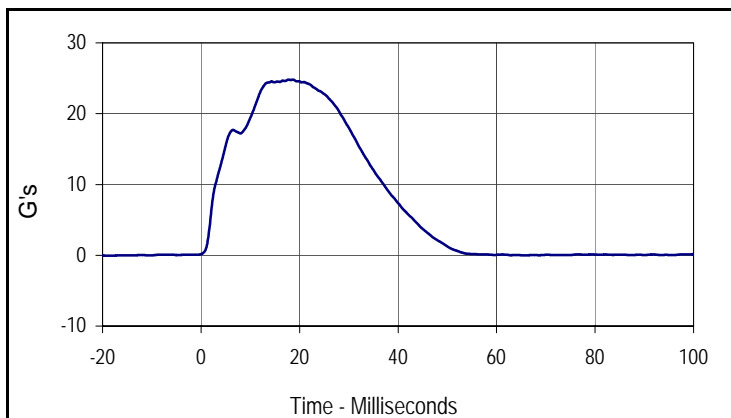

Curve Description			
Impactor Acceleration			
Plot No.	Type	SAE Class	Units
003	FIL	180	G's
Max	Time	Min	Time
24.8	17.7	-0.1	-20.0

Test Program: Hybrid III 50th Percentile Male Knee Impact Test

Test Date: 12/5/12



ATD Serial No.: 034

Test I.D.: M034LK037, M034RK037

**Left Knee**

Tested Parameter	Units	Specification	Result	Pass/Fail
Knee Assembly Soak Time	Minutes	≥240	425	Pass
Temperature During Soak	Max	18.9 to 25.6	21.6	Pass
	Min		20.7	Pass
Humidity During Soak	Max	10.0 to 70.0	31.4	Pass
	Min		29.3	Pass
Laboratory Temperature During Test	°C	18.9 to 25.6	21.2	Pass
Laboratory Humidity During Test	%	10.0 to 70.0	29.8	Pass
Pendulum Velocity at T=0	m/sec	2.07 to 2.13	2.11	Pass
Peak Probe Force	Newtons	4715 to 5782	4959	Pass
<b>Overall Test Results</b>				<b>Pass</b>

**Right Knee**

Pendulum Velocity at T=0	m/sec	2.07 to 2.13	2.09	Pass
Peak Probe Force	Newtons	4715 to 5782	4944	Pass
<b>Overall Test Results</b>				<b>Pass</b>



Curve Description			
Left Knee Probe Force			
Plot No.	Type	SAE Class	Units
001	FIL	600	Newtons
Max	Time	Min	Time
4958.6	4.4	-44.5	10.0

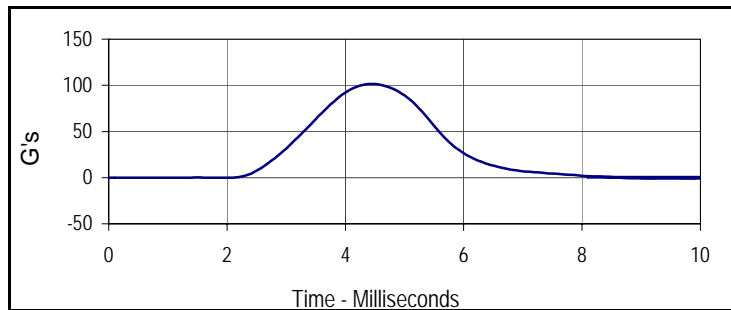

Curve Description			
Left Knee Acceleration			
Plot No.	Type	SAE Class	Units
002	FIL	600	G's
Max	Time	Min	Time
101.3	4.4	-0.9	10.0

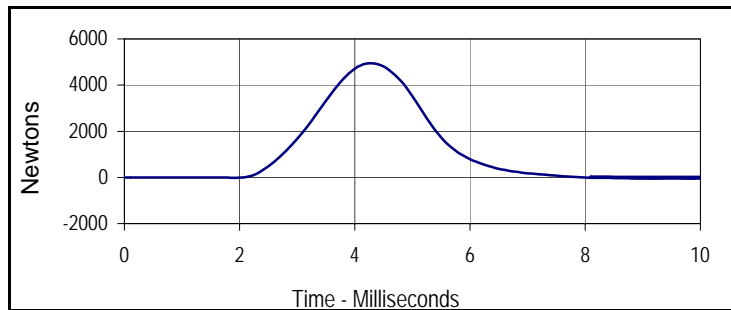

Curve Description			
Right Knee Probe Force			
Plot No.	Type	SAE Class	Units
003	FIL	600	Newtons
Max	Time	Min	Time
4943.9	4.3	-51.3	9.9



Curve Description			
Right Knee Acceleration			
Plot No.	Type	SAE Class	Units
004	FIL	600	G's
Max	Time	Min	Time
101.0	4.3	-1.0	9.9

Test Program: Hybrid III 50th Percentile Male Hip Joint-Femur Flexion Test

Test Date: 12/5/12



ATD Serial No.: 034

Test I.D.: M034LF037, M034RF037

**Left Hip Joint-Femur Results**

Tested Parameter	Units	Specification	Result	Pass/Fail
Hip Joint-Femur Assembly Soak Time	Minutes	≥240	475	Pass
Temperature During Soak	Max	18.9 to 25.6	21.6	Pass
	Min		20.7	Pass
Humidity During Soak	Max	10.0 to 70.0	31.4	Pass
	Min		29.3	Pass
Laboratory Temperature During Test	°C	18.9 to 25.6	21.1	Pass
Laboratory Humidity During Test	%	10.0 to 70.0	29.8	Pass
Rotation Rate	deg/sec	5 to 10	7.8	Pass
Femur Torque at 30°	Nm	≤ 95	94.8	Pass
Rotation at 203 Nm	Degrees	40.0 to 50.0	49.1	Pass
<b>Overall Test Results</b>				<b>Pass</b>

**Right Hip Joint-Femur Results**

Rotation Rate	deg/sec	5 to 10	7.6	Pass
Femur Torque at 30°	Nm	≤ 95	94.2	Pass
Rotation at 203 Nm	Degrees	40.0 to 50.0	48.5	Pass
<b>Overall Test Results</b>				<b>Pass</b>

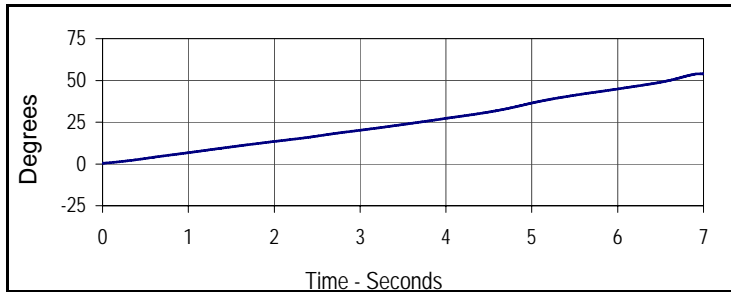

Curve Description			
Left Hip-Femur Rotation			
Plot No.	Type	SAE Class	Units
001	FIL	60	Degrees
Max	Time	Min	Time
54.0	7.0	0.4	0.0

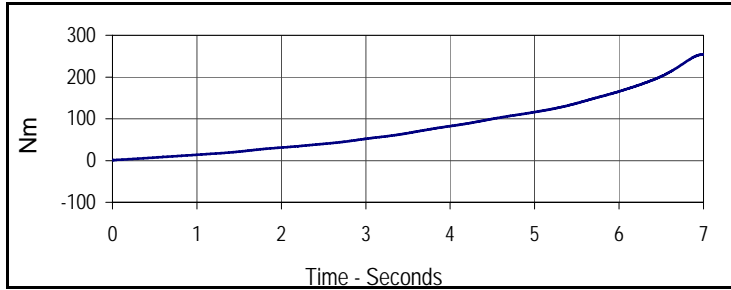

Curve Description			
Left Femur Torque			
Plot No.	Type	SAE Class	Units
002	FIL	600	Nm
Max	Time	Min	Time
254.0	7.0	1.1	0.0

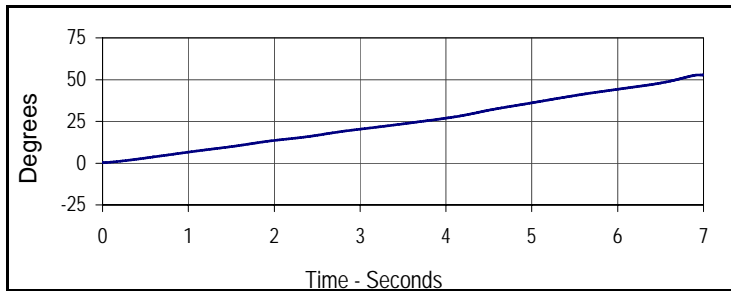

Curve Description			
Right Hip-Femur Rotation			
Plot No.	Type	SAE Class	Units
003	FIL	60	Degrees
Max	Time	Min	Time
52.9	7.0	0.2	0.0

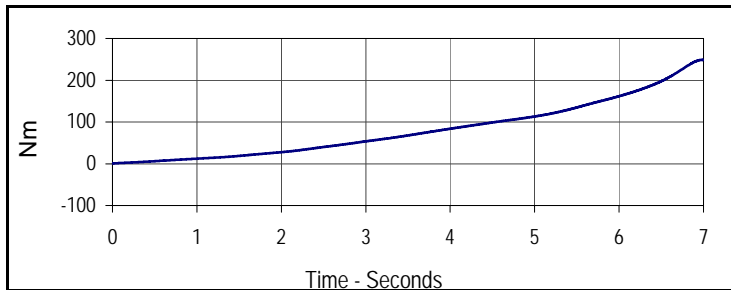

Curve Description			
Right Femur Torque			
Plot No.	Type	SAE Class	Units
004	FIL	600	Nm
Max	Time	Min	Time
249.0	7.0	1.0	0.0

Test Program: Hybrid III 5th Percentile Female Dummy Damage Checklist

Test Date: 12/10/12



ATD Serial No.: 635

Test I.D.: N/A

Dummy Item	Inspect for	Comments	Damaged	OK
Entire Dummy	Perform general cleaning			X
Outer Skin	Gashes, rips, cracks			X
Head	Ballast secure			X
	General appearance			X
Neck	Broken or cracked rubber			X
	Upper neck bracket firmly attached to the lower neck bracket			X
	Looseness at the condyle joint			X
	Nodding blocks cracked or out of position			X
Spine	Broken or cracks in rubber			X
Ribs	Broken or bent ribs			X
	Broken or bent rib supports			X
	Damping material separated or cracked			X
	Rubber bumpers in place			X
Chest Displacement Assembly	Bent shaft			X
	Slider arm riding in track			X
Transducer Leads	Torn cables			X
Accelerometer Mountings	Head mounting secure			X
	Chest mounting secure			X
Knees	Skin condition			X
	Insert (do not remove)			X
	Casting			X
Limbs	Normal movement and adjustment			X
Knee Sliders	Wires intact			X
	Rubber returned to "at rest" position			X
Pelvis	Broken			X
Other				X

Describe the repair on repair or replacement of parts:

---



---



---

Test Program: Hybrid III 5th Percentile Female External Measurements

Test Date: 12/10/12



ATD Serial No.: 635

Test I.D.: N/A

Tested Parameter	Units	Specification	Result	Pass/Fail
Laboratory Temperature	°C	20.6 to 22.2	21.19	Pass
Laboratory Relative Humidity	%	10 to 70	29.8	Pass
A - Total sitting height	mm	774.7 to 800.1	786	Pass
B - Shoulder pivot height	mm	431.8 to 457.2	450	Pass
C - H point height	mm	81.3 to 86.3	85	Pass
D - H point location from backline	mm	144.8 to 149.8	146	Pass
E - Shoulder pivot from backline	mm	68.6 to 83.8	77	Pass
F - Thigh clearance	mm	119.4 to 134.6	126	Pass
G - Back of elbow to wrist pivot	mm	243.9 to 259.1	250	Pass
H - Head back to backline	mm	40.7 to 45.7	44	Pass
I - Shoulder to elbow length	mm	276.8 to 297.2	285	Pass
J - Elbow rest height	mm	182.8 to 203.2	198	Pass
K - Buttock to knee length	mm	520.7 to 546.1	531	Pass
L - Popliteal length	mm	355.6 to 376.0	371	Pass
M - Knee pivot height	mm	393.7 to 419.1	402	Pass
N - Buttock popliteal length	mm	414.0 to 439.4	420	Pass
O - Chest depth without jacket	mm	175.3 to 190.5	186	Pass
P - Foot length	mm	218.5 to 233.7	221	Pass
R - Buttock to Knee Pivot Length	mm	457.2 to 482.6	473	Pass
S - Head Breadth	mm	137.1 to 147.3	144	Pass
T - Head Depth	mm	177.8 to 188.0	180	Pass
U - Hip Breadth	mm	299.7 to 314.9	302	Pass
V - Shoulder breadth	mm	350.5 to 365.7	359	Pass
W - Foot breadth	mm	78.8 to 94.0	90	Pass
X - Head circumference	mm	528.3 to 548.7	541	Pass
Y - Chest circumference (with chest jacket)	mm	850.8 to 881.3	864	Pass
Z - Waist circumference	mm	759.5 to 789.9	766	Pass
AA - Location for chest circumference	mm	299.7 to 309.9	300	Pass
BB - Location for waist circumference	mm	160.1 to 170.2	164	Pass
Overall Test Results				Pass

Test Program: Hybrid III 5th Percentile Female Head Drop Test

Test Date: 12/10/12



ATD Serial No.: 635

Test I.D.: F635HD035

Tested Parameter	Units	Specification	Result	Pass/Fail
Head Assembly Soak Time	Minutes	≥240	265	Pass
Temperature During Soak	Max	18.9 to 25.6	21.5	Pass
	Min		20.8	Pass
Humidity During Soak	Max	10.0 to 70.0	32.4	Pass
	Min		29.5	Pass
Laboratory Temperature During Test	°C	18.9 to 25.6	21.2	Pass
Laboratory Humidity During Test	%	10.0 to 70.0	30.1	Pass
Peak Resultant Acceleration	G's	250.0 to 300.0	273.1	Pass
Peak Lateral Acceleration	G's	≤15.0	5.7	Pass
Oscillations After Main Pulse	%	<10% of peak Res. Acceleration	1.7	Pass
Is Acceleration Unimodal?	Yes/No	Yes	Yes	Pass
<b>Overall Test Results</b>				<b>Pass</b>

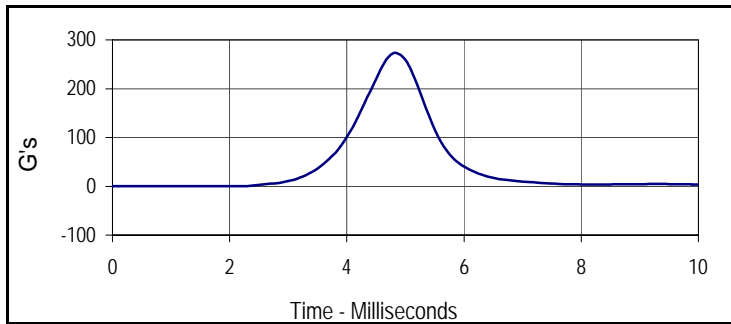

Curve Description			
Head Resultant			
Plot No.	Type	SAE Class	Units
001	RES	1000	G's
Max	Time	Min	Time
273.1	4.8	0.1	0.5

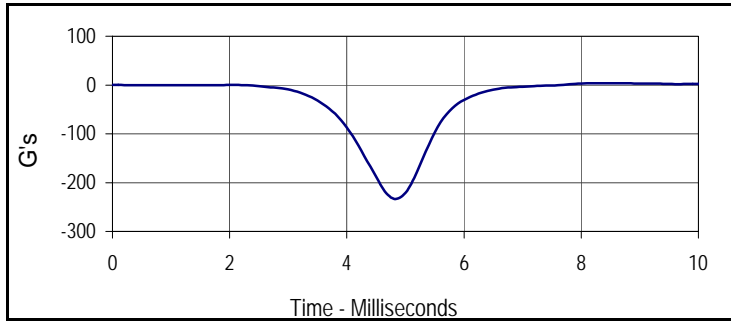

Curve Description			
Head X			
Plot No.	Type	SAE Class	Units
002	FIL	1000	G's
Max	Time	Min	Time
3.0	8.0	-233.4	4.8

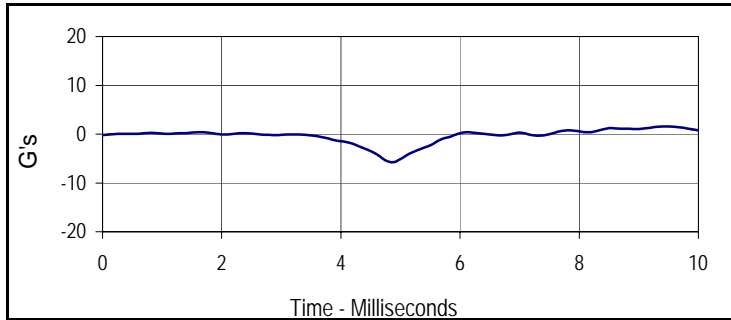

Curve Description			
Head Y			
Plot No.	Type	SAE Class	Units
003	FIL	1000	G's
Max	Time	Min	Time
0.8	7.8	-5.7	4.9

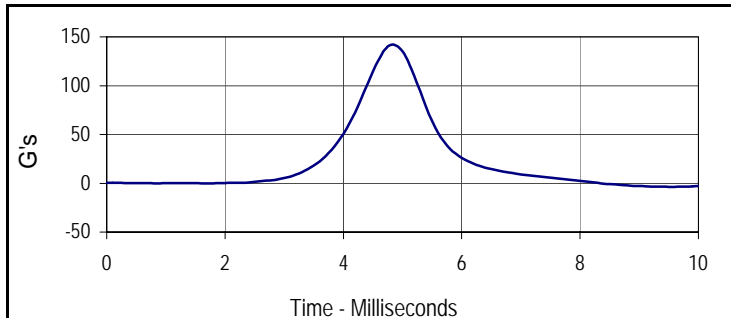

Curve Description			
Head Z			
Plot No.	Type	SAE Class	Units
004	FIL	1000	G's
Max	Time	Min	Time
141.7	4.8	-0.1	1.7

Test Program: Hybrid III 5th Percentile Female Neck Flexion Test

Test Date: 12/10/12



ATD Serial No.: 635

Test I.D.: F635NF035

Tested Parameter	Units	Specification	Result	Pass/Fail	
Neck Assembly Soak Time	Minutes	≥240	320	Pass	
Temperature During Soak	Max	20.6 to 22.2	21.5	Pass	
	Min		20.8	Pass	
Humidity During Soak	Max	10.0 to 70.0	32.4	Pass	
	Min		29.5	Pass	
Laboratory Temperature During Test	°C	20.6 to 22.2	21.2	Pass	
Laboratory Humidity During Test	%	10.0 to 70.0	30.1	Pass	
Pendulum Velocity	m/s	6.89 to 7.13	7.07	Pass	
Pendulum Deceleration	10 Msec.	m/s	2.1 to 2.5	2.4	Pass
	20 Msec.	m/s	4.0 to 5.0	4.7	Pass
	30 Msec.	m/s	5.8 to 7.0	6.8	Pass
"D" Plane Rotation	Max	Degrees	77.0 to 91.0	82.2	Pass
Peak Moment in Rotation	Max	Nm	69.0 to 83.0	73.4	Pass
Positive Moment Decay, Time To 10 Nm	Msec.	80.0 to 100.0	87.1	Pass	
Overall Test Results				Pass	

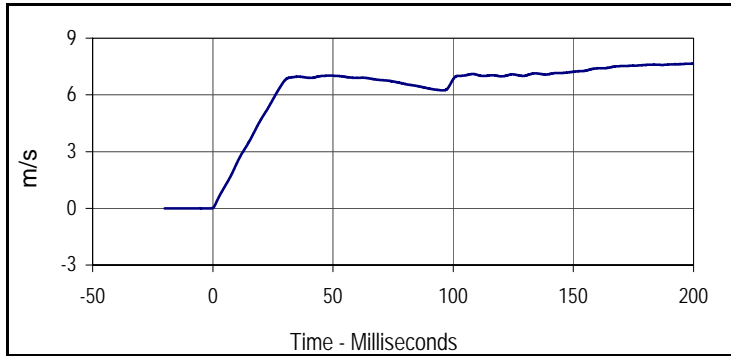

Curve Description			
Pendulum Velocity			
Plot No.	Type	SAE Class	Units
001	FIL	180	m/s
Max	Time	Min	Time
7.7	200.0	0.0	-0.8

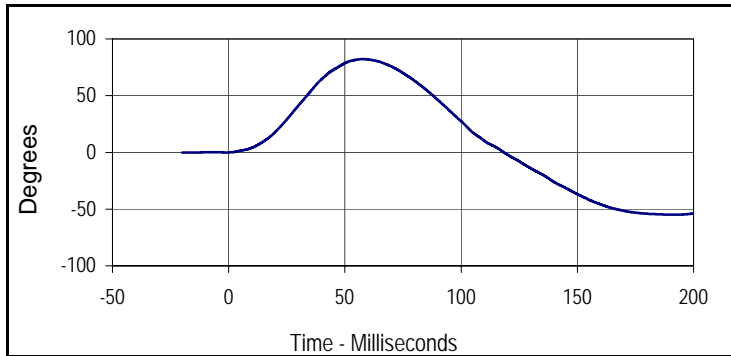

Curve Description			
"D" Plane Rotation			
Plot No.	Type	SAE Class	Units
002	FIL	60	Degrees
Max	Time	Min	Time
82.2	57.6	-54.9	192.5

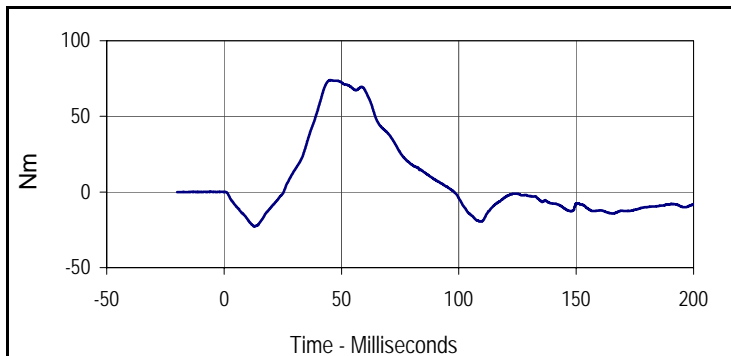

Curve Description			
Moment About Occipital Condyle			
Plot No.	Type	SAE Class	Units
003	FIL	600	Nm
Max	Time	Min	Time
74.0	45.2	-22.9	12.8

Test Program: Hybrid III 5th Percentile Female Neck Flexion Test

Test Date: 12/10/12



ATD Serial No.: 635

Test I.D.: F635NF035

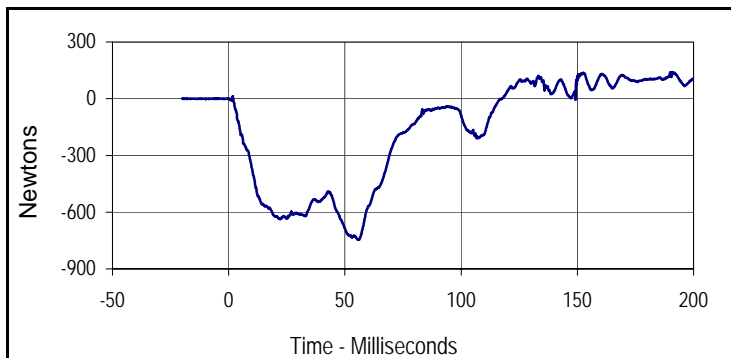

Curve Description			
Upper Neck Force X			
Plot No.	Type	SAE Class	Units
004	FIL	1000	Newtons
Max	Time	Min	Time
141.7	191.0	-745.9	55.6

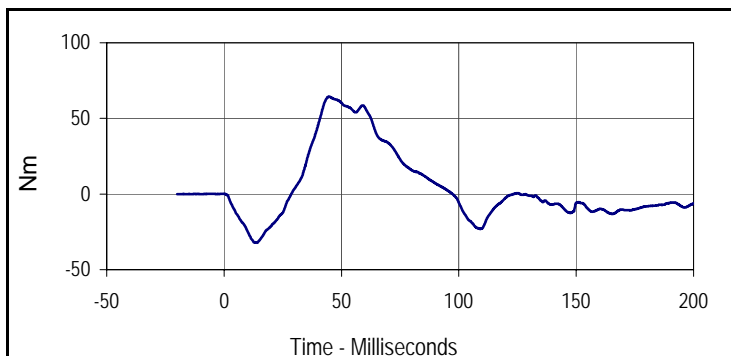

Curve Description			
Neck Moment Y			
Plot No.	Type	SAE Class	Units
005	FIL	600	Nm
Max	Time	Min	Time
64.4	44.9	-32.2	14.0

Test Program: Hybrid III 5th Percentile Female Neck Extension Test

Test Date: 12/10/12



ATD Serial No.: 635

Test I.D.: F635NE035

Tested Parameter	Units	Specification	Result	Pass/Fail	
Neck Assembly Soak Time	Minutes	≥240	355	Pass	
Temperature During Soak	Max	20.6 to 22.2	21.5	Pass	
	Min		20.8	Pass	
Humidity During Soak	Max	10.0 to 70.0	32.4	Pass	
	Min		29.5	Pass	
Laboratory Temperature During Test	°C	20.6 to 22.2	21.2	Pass	
Laboratory Humidity During Test	%	10.0 to 70.0	30.2	Pass	
Pendulum Velocity	m/s	5.95 to 6.19	6.05	Pass	
Pendulum Deceleration	10 Msec.	m/s	1.5 to 1.9	1.7	Pass
	20 Msec.	m/s	3.1 to 3.9	3.4	Pass
	30 Msec.	m/s	4.6 to 5.6	4.9	Pass
"D" Plane Rotation	Max	Degrees	99.0 to 114.0	107.2	Pass
Peak Moment in Rotation	Max	Nm	-53.0 to -65.0	-61.6	Pass
Positive Moment Decay, Time To -10 Nm	Msec.	94.0 to 114.0	100.3	Pass	
<b>Overall Test Results</b>				<b>Pass</b>	

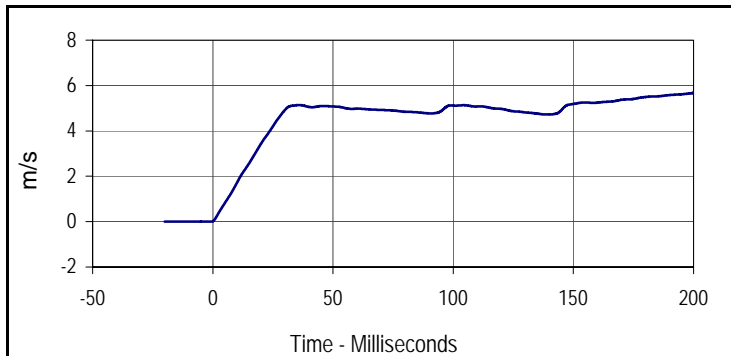

Curve Description			
Pendulum Velocity			
Plot No.	Type	SAE Class	Units
001	FIL	180	m/s
Max	Time	Min	Time
5.7	200.0	0.0	-0.9

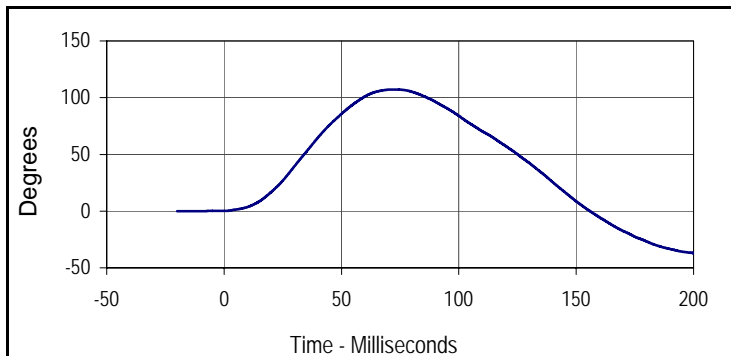

Curve Description			
"D" Plane Rotation			
Plot No.	Type	SAE Class	Units
002	FIL	60	Degrees
Max	Time	Min	Time
107.2	72.3	-37.0	200.0

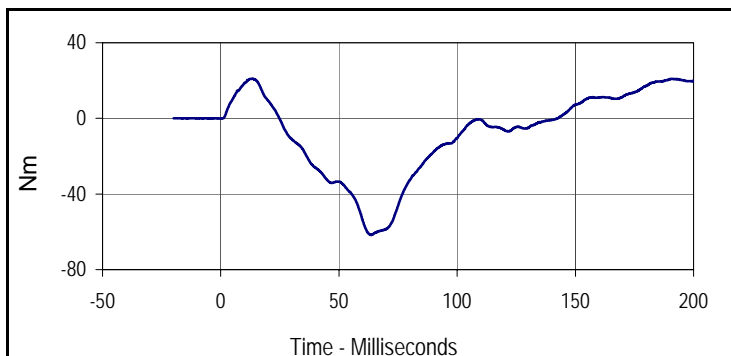

Curve Description			
Moment About Occipital Condyle			
Plot No.	Type	SAE Class	Units
003	FIL	600	Nm
Max	Time	Min	Time
21.1	13.5	-61.6	63.6

Test Program: Hybrid III 5th Percentile Female Neck Extension Test

Test Date: 12/10/12



ATD Serial No.: 635

Test I.D.: F635NE035

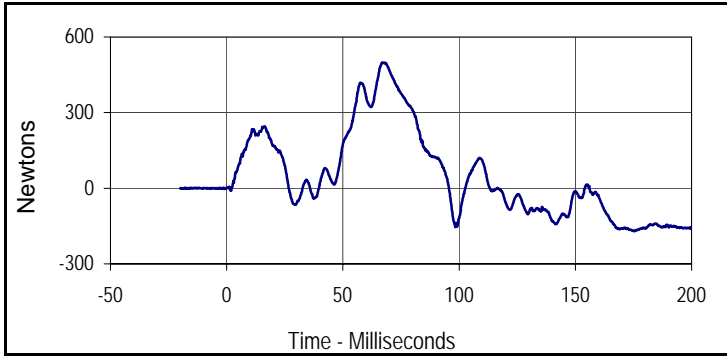

Curve Description			
Upper Neck Force X			
Plot No.	Type	SAE Class	Units
004	FIL	1000	Newtons
Max	Time	Min	Time
498.6	67.2	-170.3	175.5

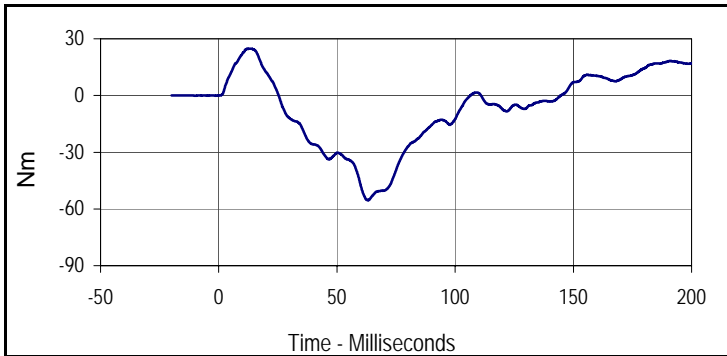

Curve Description			
Neck Moment Y			
Plot No.	Type	SAE Class	Units
005	FIL	600	Nm
Max	Time	Min	Time
24.8	13.5	-55.4	63.1

Test Program: Hybrid III 5th Percentile Female Thorax Impact Test

Test Date: 12/10/12



ATD Serial No.: 635

Test I.D.: F635CH035

Tested Parameter	Units	Specification	Result	Pass/Fail
Dummy Soak Time	Minutes	≥240	405	Pass
Temperature During Soak	Max	20.6 to 22.2	21.5	Pass
	Min		20.8	Pass
Humidity During Soak	Max	10.0 to 70.0	32.4	Pass
	Min		29.5	Pass
Laboratory Temperature During Test	°C	20.6 to 22.2	21.2	Pass
Laboratory Humidity During Test	%	10.0 to 70.0	30.2	Pass
Probe Velocity	m/s	6.59 to 6.83	6.69	Pass
Peak Chest Deflection	mm	50.0 to 58.0	55.2	Pass
Peak Force Between 50 and 58 MM	Newtons	3900 to 4400	4117	Pass
Peak Force Between 18 and 50 MM	Newtons	≤4600	4143	Pass
Internal Hysteresis	%	69 to 85	72.1	Pass
Overall Test Results				Pass

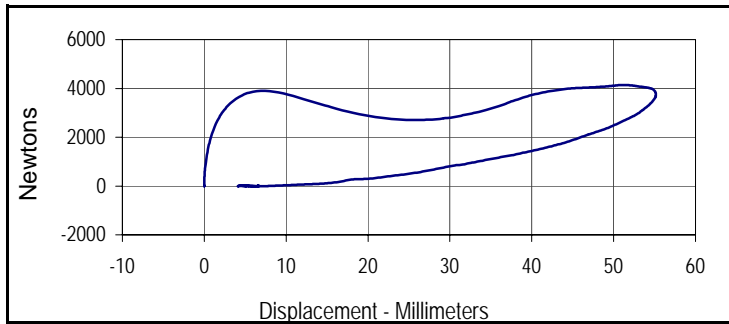

Curve Description			
Probe Force vs. Chest Deflection			
Plot No.	Type	SAE Class	Hysteresis
001	FIL	180	72.1
Peak Probe Force		Peak Chest Deflection	
4143.0		55.2	

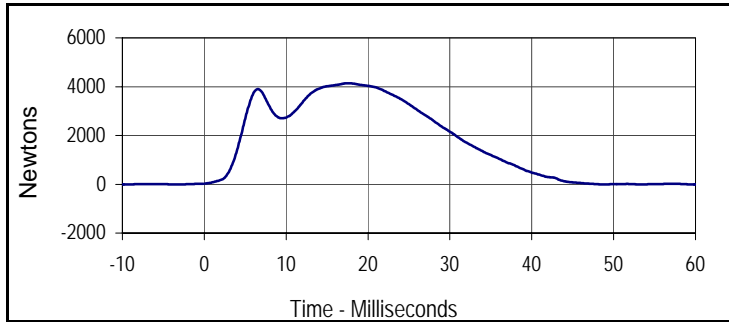

Curve Description			
Probe Force			
Plot No.	Type	SAE Class	Units
002	FIL	180	Newtons
Max	Time	Min	Time
4143.0	17.7	-23.5	69.7

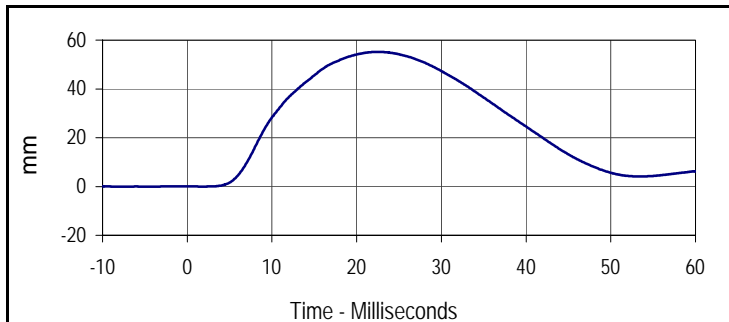

Curve Description			
Chest Deflection			
Plot No.	Type	SAE Class	Units
003	FIL	180	mm
Max	Time	Min	Time
55.2	22.5	0.0	1.9

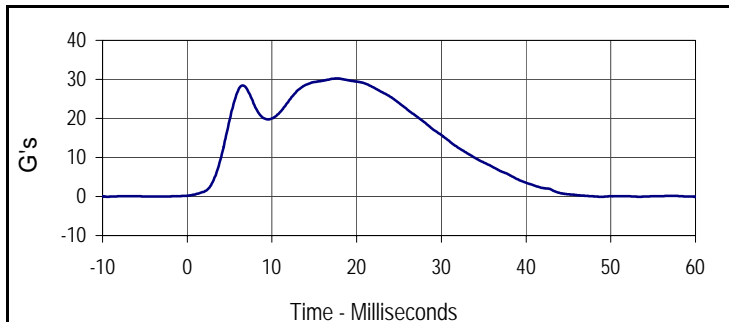

Curve Description			
Impactor Acceleration			
Plot No.	Type	SAE Class	Units
004	FIL	180	G's
Max	Time	Min	Time
30.2	17.7	-0.2	69.7

Test Program: Hybrid III 5th Percentile Female Knee Impact Test

Test Date: 12/10/12



ATD Serial No.: 635

Test I.D.: F635LK035, F635RK035

**Left Knee**

Tested Parameter	Units	Specification	Result	Pass/Fail
Knee Assembly Soak Time	Minutes	≥240	435	Pass
Temperature During Soak	Max	18.9 to 25.6	21.5	Pass
	Min		20.8	Pass
Humidity During Soak	Max	10.0 to 70.0	32.4	Pass
	Min		29.5	Pass
Laboratory Temperature During Test	°C	18.9 to 25.6	21.2	Pass
Laboratory Humidity During Test	%	10.0 to 70.0	30.1	Pass
Pendulum Velocity at T=0	m/sec	2.07 to 2.13	2.09	Pass
Peak Probe Force	Newtons	3450 to 4060	3813	Pass
<b>Overall Test Results</b>				<b>Pass</b>

**Right Knee**

Pendulum Velocity at T=0	m/sec	2.07 to 2.13	2.10	Pass
Peak Probe Force	Newtons	3450 to 4060	3807	Pass
<b>Overall Test Results</b>				<b>Pass</b>



Curve Description			
Left Knee Probe Force			
Plot No.	Type	SAE Class	Units
001	FIL	600	Newtons
Max	Time	Min	Time
3813.3	4.3	-25.4	7.7

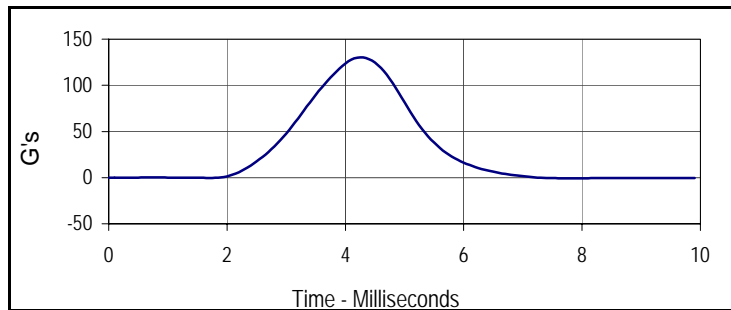

Curve Description			
Left Knee Acceleration			
Plot No.	Type	SAE Class	Units
002	FIL	600	G's
Max	Time	Min	Time
130.1	4.3	-0.9	7.7

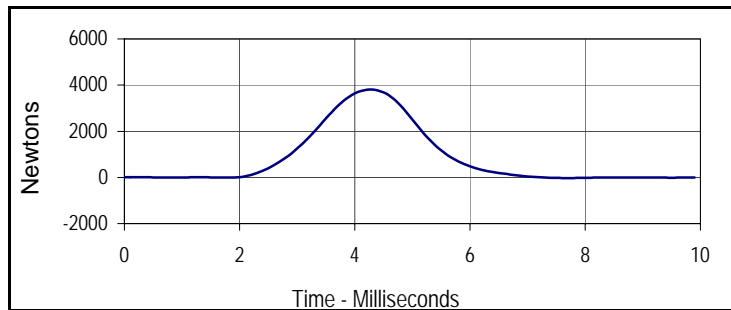

Curve Description			
Right Knee Probe Force			
Plot No.	Type	SAE Class	Units
003	FIL	600	Newtons
Max	Time	Min	Time
3807.5	4.3	-29.4	7.7

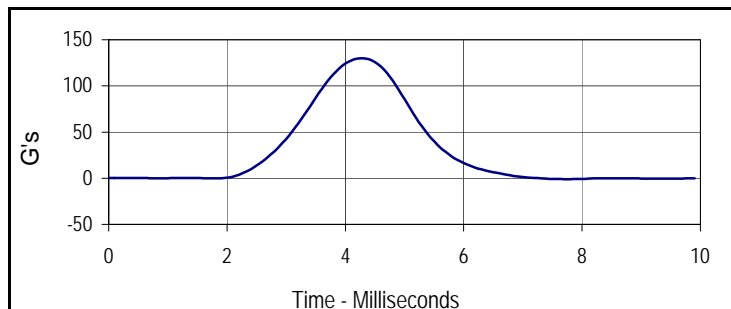

Curve Description			
Right Knee Acceleration			
Plot No.	Type	SAE Class	Units
004	FIL	600	G's
Max	Time	Min	Time
129.9	4.3	-1.0	7.7

Test Program: Hybrid III 5th Percentile Female Torso Flexion Test

Test Date: 12/10/12



ATD Serial No.: 635

Test I.D.: F635TF035

**Left Hip Joint-Femur Results**

Tested Parameter		Units	Specification	Result	Pass/Fail
Dummy Soak Time		Minutes	≥240	460	Pass
Temperature During Soak	Max	°C	18.9 to 25.6	21.5	Pass
	Min	°C		20.8	Pass
Humidity During Soak	Max	%	10.0 to 70.0	32.4	Pass
	Min	%		29.5	Pass
Laboratory Temperature During Test		°C	18.9 to 25.6	21.2	Pass
Laboratory Humidity During Test		%	10.0 to 70.0	30.1	Pass
Initial Reference Plane Angle		Degrees	≤ 20	0.8	Pass
Peak Force at 45° +/-0.5°		Newtons	320.0 to 390.0	346.4	Pass
Torso Rotation Rate		deg/sec	0.5 to 1.5	1.1	Pass
Final Reference Plane Angle		Degrees	+/-8	2.3	Pass
<b>Overall Test Results</b>					<b>Pass</b>

**APPENDIX C**  
**POST-TEST / ATD CONFIGURATION AND PERFORMANCE VERIFICATION DATA**

Test Program: Hybrid III 50th Percentile Male Dummy Damage Checklist

Test Date: 12/15/12



ATD Serial No.: 034

Test I.D.: N/A

Dummy Item	Inspect for	Comments	Damaged	OK
Entire Dummy	Perform general cleaning			X
Outer Skin	Gashes, rips, cracks			X
Head	Ballast secure			X
	General appearance			X
Neck	Broken or cracked rubber			X
	Upper neck bracket firmly attached to the lower neck bracket			X
	Looseness at the condyle joint			X
	Nodding blocks cracked or out of position			X
Spine	Broken or cracks in rubber			X
Ribs	Broken or bent ribs			X
	Broken or bent rib supports			X
	Damping material separated or cracked			X
	Rubber bumpers in place			X
Chest Displacement Assembly	Bent shaft			X
	Slider arm riding in track			X
Transducer Leads	Torn cables			X
Accelerometer Mountings	Head mounting secure			X
	Chest mounting secure			X
Knees	Skin condition			X
	Insert (do not remove)			X
	Casting			X
Limbs	Normal movement and adjustment			X
Knee Sliders	Wires intact			X
	Rubber returned to "at rest" position			X
Pelvis	Broken			X
Other				X

Describe the repair on repair or replacement of parts:

---



---



---

Test Program: Hybrid III 50th Percentile Male External Measurements

Test Date: 12/15/12



ATD Serial No.: 034

Test I.D.: N/A

Tested Parameter	Units	Specification	Result	Pass/Fail
Laboratory Temperature	°C	20.6 to 22.2	21.17	Pass
Laboratory Relative Humidity	%	10 to 70	29.9	Pass
A - Total sitting height	mm	879 to 889	884	Pass
B - Shoulder pivot height	mm	505 to 521	512	Pass
C - H point height	mm	84 to 89	85	Pass
D - H point location from backline	mm	135 to 140	137	Pass
E - Shoulder pivot from backline	mm	84 to 94	89	Pass
F - Thigh clearance	mm	140 to 155	146	Pass
G - Back of elbow to wrist pivot	mm	290 to 305	297	Pass
H - Head back to backline	mm	41 to 46	43	Pass
I - Shoulder to elbow length	mm	330 to 345	336	Pass
J - Elbow rest height	mm	190 to 211	201	Pass
K - Buttock to knee length	mm	579 to 604	586	Pass
L - Popliteal length	mm	429 to 455	438	Pass
M - Knee pivot height	mm	485 to 500	493	Pass
N - Buttock popliteal length	mm	452 to 477	472	Pass
O - Chest depth without jacket	mm	213 to 229	225	Pass
P - Foot length	mm	251 to 267	260	Pass
V - Shoulder breadth	mm	422 to 437	433	Pass
W - Foot breadth	mm	91 to 107	99	Pass
Y - Chest circumference (with chest jacket)	mm	970 to 1001	981	Pass
Z - Waist circumference	mm	836 to 866	864	Pass
AA - Location for chest circumference	mm	429 to 434	429	Pass
BB - Location for waist circumference	mm	226 to 231	230	Pass
Overall Test Results				Pass

Test Program: Hybrid III 50th Percentile Male Head Drop Test

Test Date: 12/15/12



ATD Serial No.: 034

Test I.D.: M034HD038

Tested Parameter	Units	Specification	Result	Pass/Fail
Head Assembly Soak Time	Minutes	≥240	305	Pass
Temperature During Soak	Max	18.9 to 25.6	21.8	Pass
	Min		20.8	Pass
Humidity During Soak	Max	10.0 to 70.0	32.1	Pass
	Min		29.5	Pass
Laboratory Temperature During Test	°C	18.9 to 25.6	21.2	Pass
Laboratory Humidity During Test	%	10.0 to 70.0	29.9	Pass
Peak Resultant Acceleration	G's	225.0 to 275.0	261.6	Pass
Peak Lateral Acceleration	G's	≤15.0	2.4	Pass
Oscillations After Main Pulse	%	<10% of peak Res. Acceleration	7.2	Pass
Is Acceleration Unimodal?	Yes/No	Yes	Yes	Pass
<b>Overall Test Results</b>				<b>Pass</b>

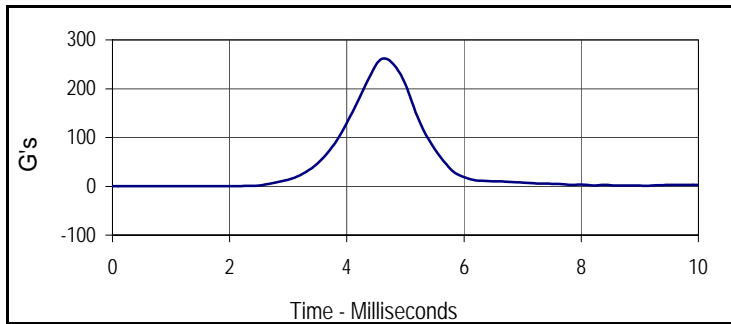

Curve Description			
Head Resultant			
Plot No.	Type	SAE Class	Units
001	RES	1000	G's
Max	Time	Min	Time
261.6	4.6	0.0	0.3

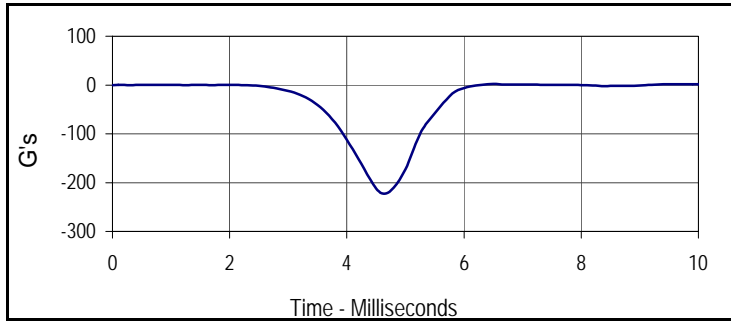

Curve Description			
Head X			
Plot No.	Type	SAE Class	Units
002	FIL	1000	G's
Max	Time	Min	Time
2.1	6.5	-222.1	4.6

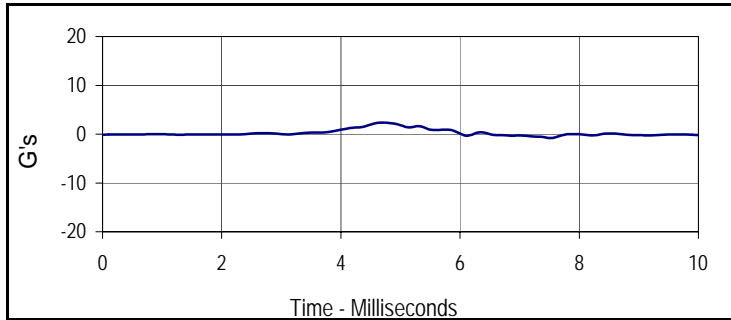

Curve Description			
Head Y			
Plot No.	Type	SAE Class	Units
003	FIL	1000	G's
Max	Time	Min	Time
2.4	4.7	-0.8	7.5

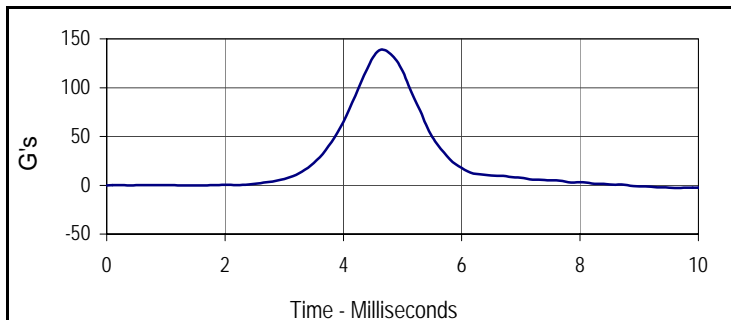

Curve Description			
Head Z			
Plot No.	Type	SAE Class	Units
004	FIL	1000	G's
Max	Time	Min	Time
138.5	4.7	-0.3	1.4

Test Program: Hybrid III 50th Percentile Male Neck Flexion Test

Test Date: 12/15/12



ATD Serial No.: 034

Test I.D.: M034NF038

Tested Parameter	Units	Specification	Result	Pass/Fail	
Neck Assembly Soak Time	Minutes	≥240	355	Pass	
Temperature During Soak	Max	20.6 to 22.2	21.8	Pass	
	Min		20.8	Pass	
Humidity During Soak	Max	10.0 to 70.0	32.1	Pass	
	Min		29.5	Pass	
Laboratory Temperature During Test	°C	20.6 to 22.2	21.2	Pass	
Laboratory Humidity During Test	%	10.0 to 70.0	29.9	Pass	
Pendulum Velocity	m/s	6.89 to 7.13	6.94	Pass	
Pendulum Deceleration	10 Msec.	G's	22.5 to 27.5	25.4	Pass
	20 Msec.	G's	17.6 to 22.6	22.4	Pass
	30 Msec.	G's	12.5 to 18.5	18.1	Pass
Peak Pendulum Decel. after 30 Msec.	G's	≤ 29.0	18.1	Pass	
Deceleration Decay, Time to Cross 5 G's	Msec.	34.0 to 42.0	36.9	Pass	
Maximum "D" Plane Rotation	Max	Degrees	64.0 to 78.0	77.9	Pass
	Time	Msec.	57.0 to 64.0	58.8	Pass
"D" Plane Rotation Decay, Time To Zero Crossing	Msec.	113.0 to 128.0	116.2	Pass	
Moment About Occ. Condyle	Max	Nm	84.1 to 108.5	93.2	Pass
	Time	Msec.	47.0 to 58.0	51.0	Pass
Positive Moment Decay, Time To Zero Crossing	Msec.	97.0 to 107.0	98.8	Pass	
<b>Overall Test Results</b>				<b>Pass</b>	

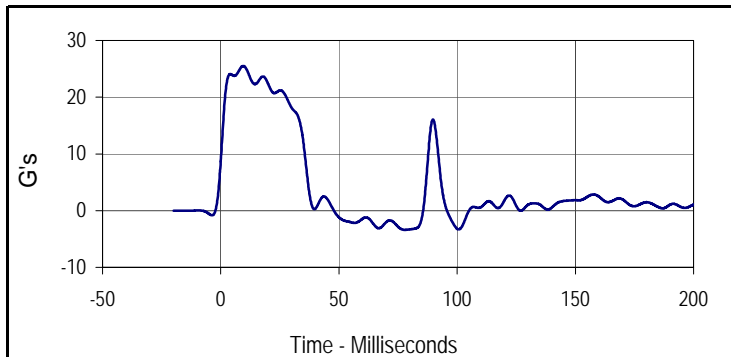

Curve Description			
Pendulum Deceleration			
Plot No.	Type	SAE Class	Units
001	FIL	60	G's
Max	Time	Min	Time
25.5	9.5	-3.4	77.9

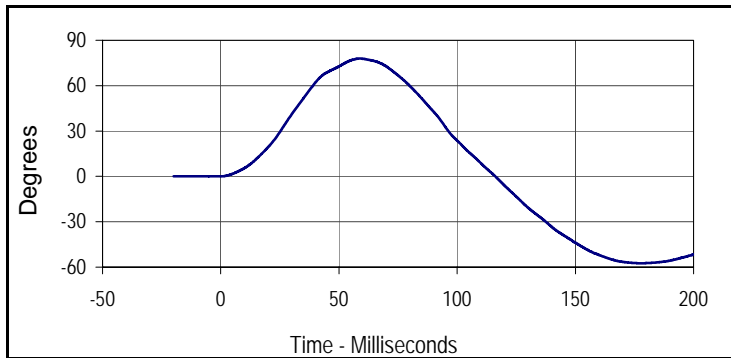

Curve Description			
"D" Plane Rotation			
Plot No.	Type	SAE Class	Units
002	FIL	60	Degrees
Max	Time	Min	Time
77.9	58.8	-57.4	177.7

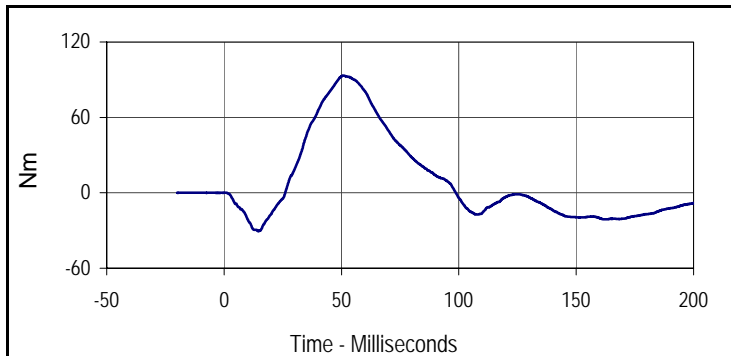

Curve Description			
Moment About Occipital Condyle			
Plot No.	Type	SAE Class	Units
003	FIL	600	Nm
Max	Time	Min	Time
93.2	51.0	-30.4	14.7

Test Program: Hybrid III 50th Percentile Male Neck Flexion Test

Test Date: 12/15/12



ATD Serial No.: 034

Test I.D.: M034NF038

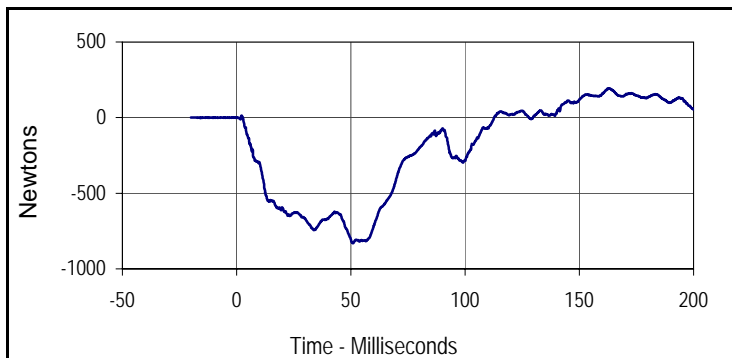

Curve Description			
Neck Force X			
Plot No.	Type	SAE Class	Units
004	FIL	1000	Newtons
Max	Time	Min	Time
193.5	162.9	-829.8	51.0

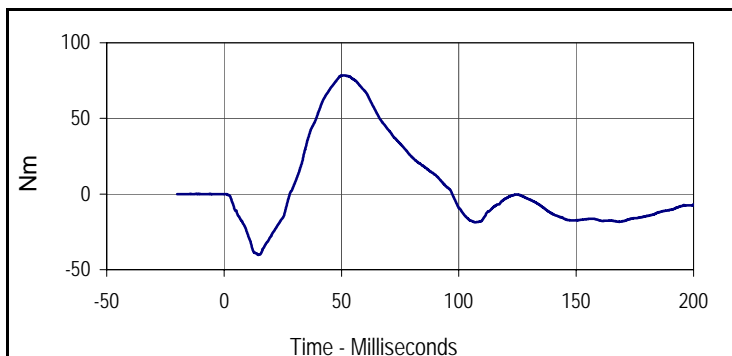

Curve Description			
Neck Moment Y			
Plot No.	Type	SAE Class	Units
005	FIL	600	Nm
Max	Time	Min	Time
78.5	51.1	-40.2	14.5

Test Program: Hybrid III 50th Percentile Male Neck Extension Test

Test Date: 12/15/12



ATD Serial No.: 034

Test I.D.: M034NE038

Tested Parameter	Units	Specification	Result	Pass/Fail	
Neck Assembly Soak Time	Minutes	≥240	390	Pass	
Temperature During Soak	Max	20.6 to 22.2	21.8	Pass	
	Min		20.8	Pass	
Humidity During Soak	Max	10.0 to 70.0	32.1	Pass	
	Min		29.5	Pass	
Laboratory Temperature During Test	°C	20.6 to 22.2	21.2	Pass	
Laboratory Humidity During Test	%	10.0 to 70.0	29.9	Pass	
Pendulum Velocity	m/s	5.94 to 6.19	6.06	Pass	
Pendulum Deceleration	10 Msec.	G's	17.2 to 21.2	19.4	Pass
	20 Msec.	G's	14.0 to 19.0	18.7	Pass
	30 Msec.	G's	11.0 to 16.0	15.5	Pass
Peak Pendulum Decel. after 30 Msec.	G's	≤ 22.0	15.5	Pass	
Deceleration Decay, Time to Cross 5 G's	Msec.	38.0 to 46.0	38.3	Pass	
Maximum "D" Plane Rotation	Max	Degrees	81.0 to 106.0	99.6	Pass
	Time	Msec.	72.0 to 82.0	75.2	Pass
"D" Plane Rotation Decay, Time To Zero Crossing	Msec.	147.0 to 174.0	153.6	Pass	
Moment About Occ. Condyle	Max	Nm	-52.9 to -79.9	-65.3	Pass
	Time	Msec.	65.0 to 79.0	68.6	Pass
Positive Moment Decay, Time To Zero Crossing	Msec.	120.0 to 148.0	138.2	Pass	
<b>Overall Test Results</b>				<b>Pass</b>	

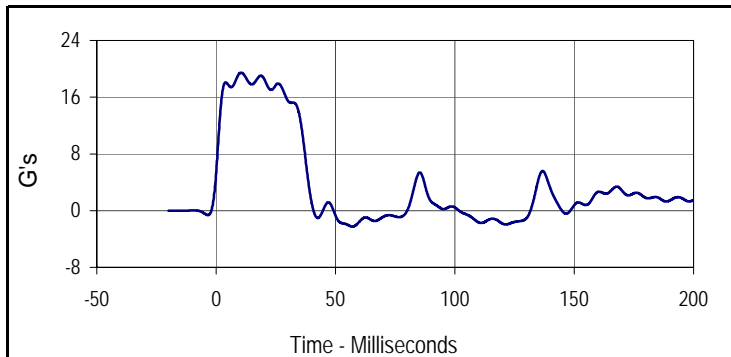

Curve Description			
Pendulum Deceleration			
Plot No.	Type	SAE Class	Units
001	FIL	60	G's
Max	Time	Min	Time
19.5	10.4	-2.3	57.1

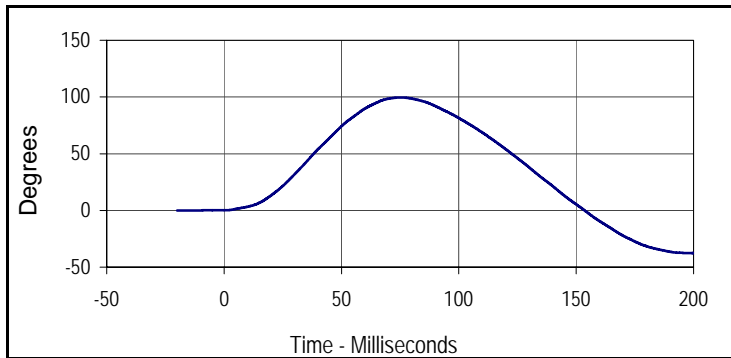

Curve Description			
"D" Plane Rotation			
Plot No.	Type	SAE Class	Units
002	FIL	60	Degrees
Max	Time	Min	Time
99.6	75.2	-37.6	200.0

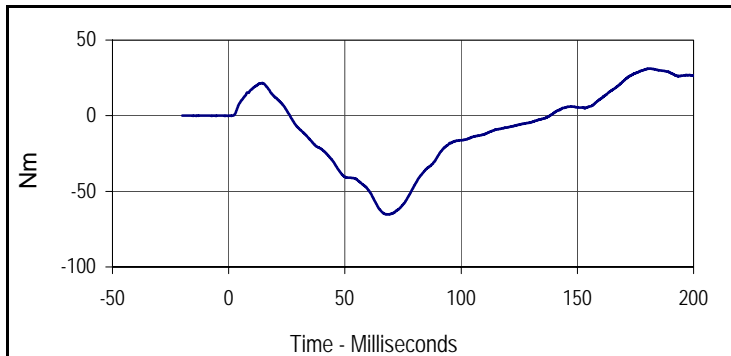

Curve Description			
Moment About Occipital Condyle			
Plot No.	Type	SAE Class	Units
003	FIL	600	Nm
Max	Time	Min	Time
31.1	181.5	-65.3	68.6

Test Program: Hybrid III 50th Percentile Male Neck Extension Test

Test Date: 12/15/12



ATD Serial No.: 034

Test I.D.: M034NE038

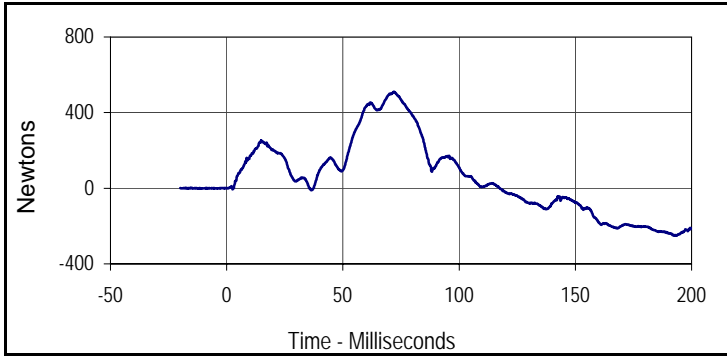

Curve Description			
Neck Force X			
Plot No.	Type	SAE Class	Units
004	FIL	1000	Newtons
Max	Time	Min	Time
510.2	72.0	-250.3	193.5

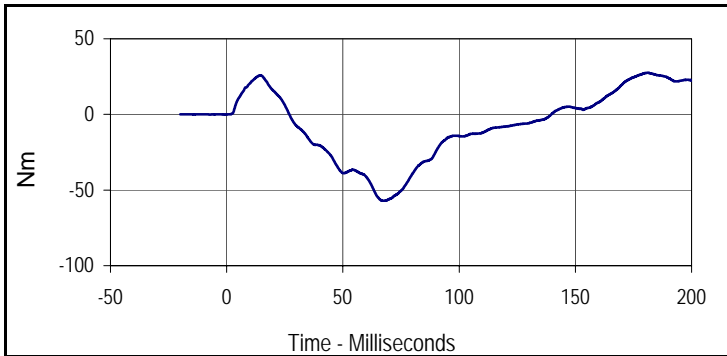

Curve Description			
Neck Moment Y			
Plot No.	Type	SAE Class	Units
005	FIL	600	Nm
Max	Time	Min	Time
27.5	181.0	-57.1	67.4

Test Program: Hybrid III 50th Percentile Male Thorax Impact Test

Test Date: 12/15/12



ATD Serial No.: 034

Test I.D.: M034CH038

Tested Parameter	Units	Specification	Result	Pass/Fail
Dummy Soak Time	Minutes	≥240	440	Pass
Temperature During Soak	Max	20.6 to 22.2	21.8	Pass
	Min		20.8	Pass
Humidity During Soak	Max	10.0 to 70.0	32.1	Pass
	Min		29.5	Pass
Laboratory Temperature During Test	°C	20.6 to 22.2	21.2	Pass
Laboratory Humidity During Test	%	10.0 to 70.0	29.9	Pass
Probe Velocity	m/s	6.58 to 6.82	6.65	Pass
Peak Probe Force	Newtons	5159 to 5893	5481	Pass
Peak Sternum Deflection	CM	6.35 to 7.26	6.76	Pass
Internal Hysteresis	%	69 to 85	69.5	Pass
Overall Test Results				Pass

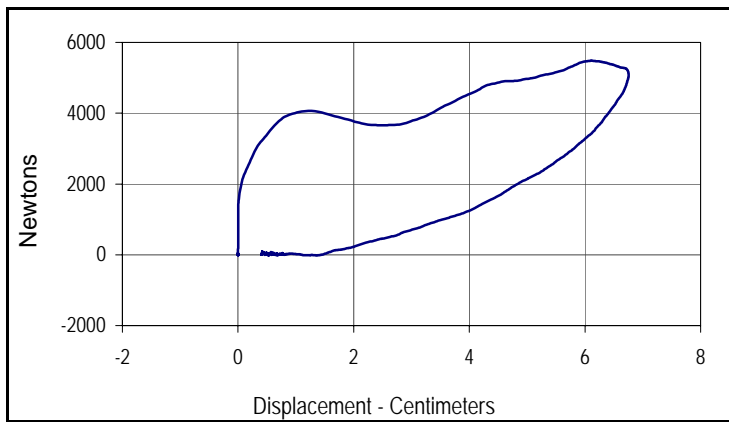

Curve Description			
Probe Force vs. Chest Deflection			
Plot No.	Type	SAE Class	Hysteresis
001	FIL	600	69.5
Peak Probe Force		Peak Chest Deflection	
5481		6.76	

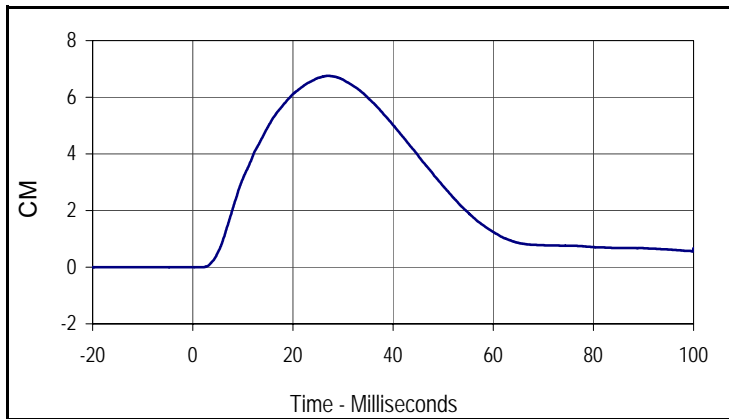

Curve Description			
Chest Deflection			
Plot No.	Type	SAE Class	Units
002	FIL	600	CM
Max	Time	Min	Time
6.8	27.2	0.0	-12.0

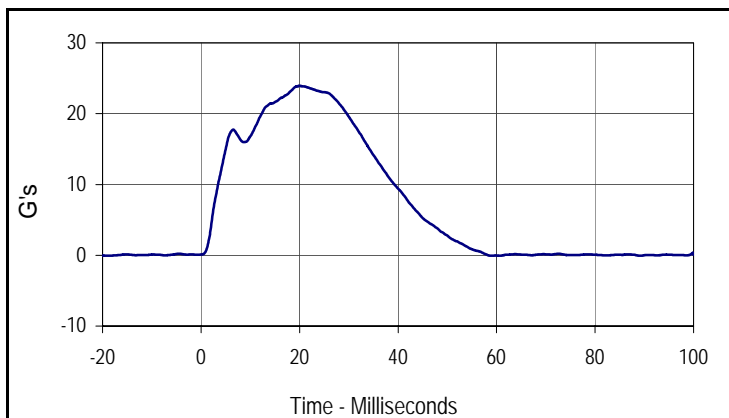

Curve Description			
Impactor Acceleration			
Plot No.	Type	SAE Class	Units
003	FIL	600	G's
Max	Time	Min	Time
23.9	20.0	-0.1	59.0

Test Program: Hybrid III 50th Percentile Male Knee Impact Test

Test Date: 12/15/12



ATD Serial No.: 034

Test I.D.: M034LK038, M034RK038

**Left Knee**

Tested Parameter	Units	Specification	Result	Pass/Fail
Knee Assembly Soak Time	Minutes	≥240	475	Pass
Temperature During Soak	Max	18.9 to 25.6	21.8	Pass
	Min		20.8	Pass
Humidity During Soak	Max	10.0 to 70.0	32.1	Pass
	Min		29.5	Pass
Laboratory Temperature During Test	°C	18.9 to 25.6	21.2	Pass
Laboratory Humidity During Test	%	10.0 to 70.0	30.0	Pass
Pendulum Velocity at T=0	m/sec	2.07 to 2.13	2.09	Pass
Peak Probe Force	Newtons	4715 to 5782	4845	Pass
<b>Overall Test Results</b>				<b>Pass</b>

**Right Knee**

Pendulum Velocity at T=0	m/sec	2.07 to 2.13	2.10	Pass
Peak Probe Force	Newtons	4715 to 5782	5099	Pass
<b>Overall Test Results</b>				<b>Pass</b>

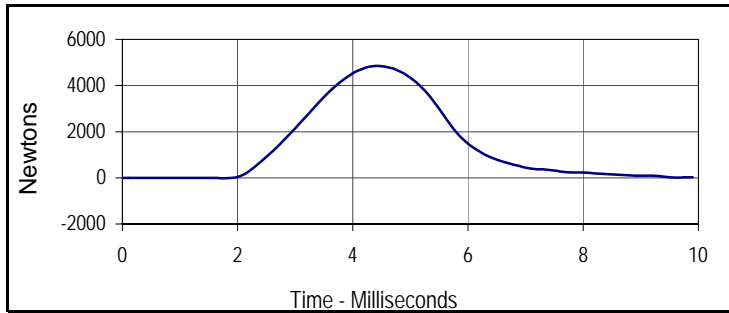

Curve Description			
Left Knee Probe Force			
Plot No.	Type	SAE Class	Units
001	FIL	600	Newtons
Max	Time	Min	Time
4844.6	4.4	-19.9	1.8

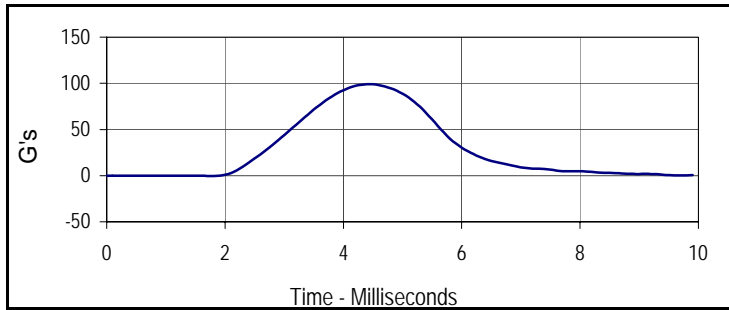

Curve Description			
Left Knee Acceleration			
Plot No.	Type	SAE Class	Units
002	FIL	600	G's
Max	Time	Min	Time
99.0	4.4	-0.4	1.8

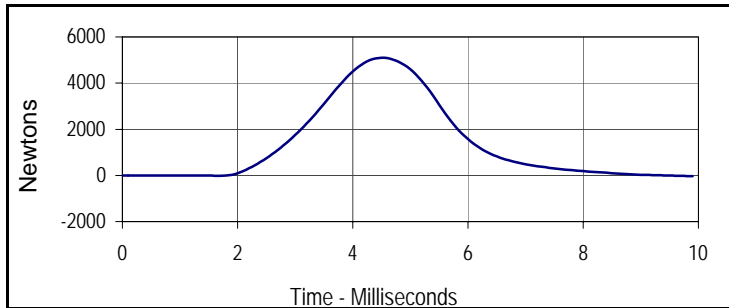

Curve Description			
Right Knee Probe Force			
Plot No.	Type	SAE Class	Units
003	FIL	600	Newtons
Max	Time	Min	Time
5098.7	4.5	-32.4	9.9

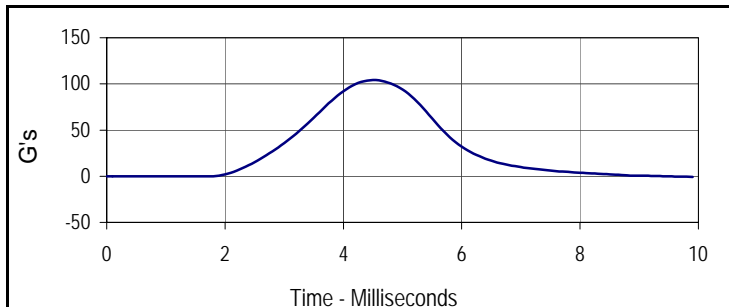

Curve Description			
Right Knee Acceleration			
Plot No.	Type	SAE Class	Units
004	FIL	600	G's
Max	Time	Min	Time
104.2	4.5	-0.7	9.9

Test Program: Hybrid III 50th Percentile Male Hip Joint-Femur Flexion Test

Test Date: 12/15/12



ATD Serial No.: 034

Test I.D.: M034LF038, M034RF038

**Left Hip Joint-Femur Results**

Tested Parameter	Units	Specification	Result	Pass/Fail
Hip Joint-Femur Assembly Soak Time	Minutes	≥240	525	Pass
Temperature During Soak	Max	18.9 to 25.6	21.8	Pass
	Min		20.8	Pass
Humidity During Soak	Max	10.0 to 70.0	32.1	Pass
	Min		29.5	Pass
Laboratory Temperature During Test	°C	18.9 to 25.6	21.2	Pass
Laboratory Humidity During Test	%	10.0 to 70.0	30.1	Pass
Rotation Rate	deg/sec	5 to 10	7.7	Pass
Femur Torque at 30°	Nm	≤ 95	93.8	Pass
Rotation at 203 Nm	Degrees	40.0 to 50.0	49.1	Pass
<b>Overall Test Results</b>				<b>Pass</b>

**Right Hip Joint-Femur Results**

Rotation Rate	deg/sec	5 to 10	7.9	Pass
Femur Torque at 30°	Nm	≤ 95	90.5	Pass
Rotation at 203 Nm	Degrees	40.0 to 50.0	49.9	Pass
<b>Overall Test Results</b>				<b>Pass</b>

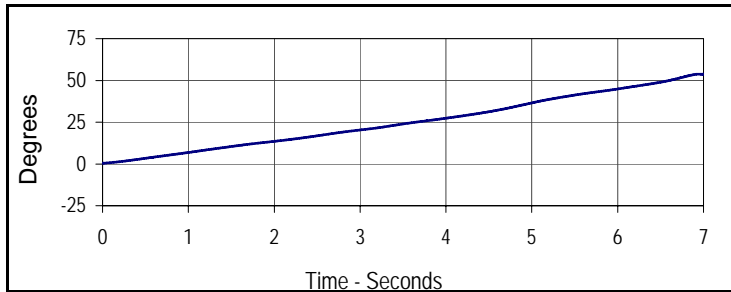

Curve Description			
Left Hip-Femur Rotation			
Plot No.	Type	SAE Class	Units
001	FIL	60	Degrees
Max	Time	Min	Time
53.9	7.0	0.4	0.0

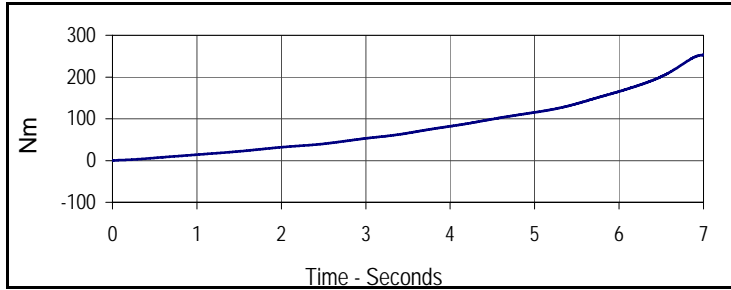

Curve Description			
Left Femur Torque			
Plot No.	Type	SAE Class	Units
002	FIL	600	Nm
Max	Time	Min	Time
254.0	7.0	0.4	0.0

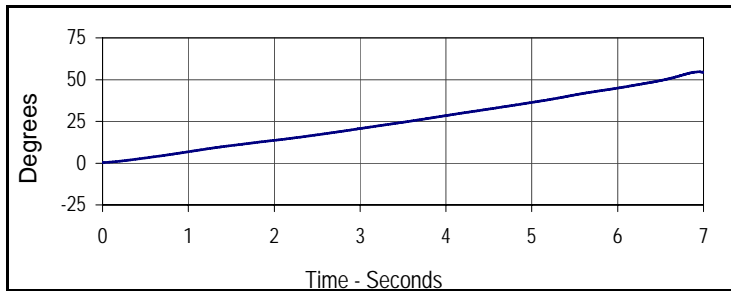

Curve Description			
Right Hip-Femur Rotation			
Plot No.	Type	SAE Class	Units
003	FIL	60	Degrees
Max	Time	Min	Time
54.6	6.9	0.3	0.0

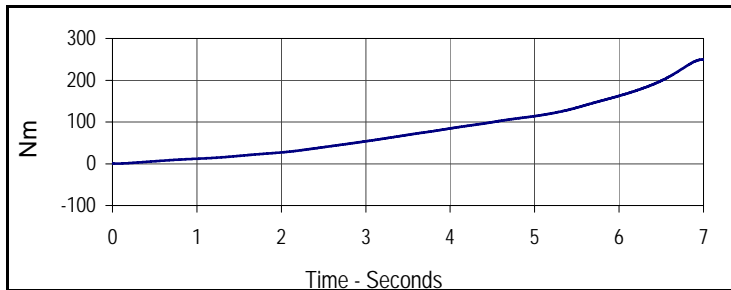

Curve Description			
Right Femur Torque			
Plot No.	Type	SAE Class	Units
004	FIL	600	Nm
Max	Time	Min	Time
249.6	7.0	0.1	0.0

Test Program: Hybrid III 5th Percentile Female Dummy Damage Checklist

Test Date: 12/17/12



ATD Serial No.: 635

Test I.D.: N/A

Dummy Item	Inspect for	Comments	Damaged	OK
Entire Dummy	Perform general cleaning			X
Outer Skin	Gashes, rips, cracks			X
Head	Ballast secure			X
	General appearance			X
Neck	Broken or cracked rubber			X
	Upper neck bracket firmly attached to the lower neck bracket			X
	Looseness at the condyle joint			X
	Nodding blocks cracked or out of position			X
Spine	Broken or cracks in rubber			X
Ribs	Broken or bent ribs			X
	Broken or bent rib supports			X
	Damping material separated or cracked			X
	Rubber bumpers in place			X
Chest Displacement Assembly	Bent shaft			X
	Slider arm riding in track			X
Transducer Leads	Torn cables			X
Accelerometer Mountings	Head mounting secure			X
	Chest mounting secure			X
Knees	Skin condition			X
	Insert (do not remove)			X
	Casting			X
Limbs	Normal movement and adjustment			X
Knee Sliders	Wires intact			X
	Rubber returned to "at rest" position			X
Pelvis	Broken			X
Other				X

Describe the repair on repair or replacement of parts:

---



---



---

Test Program: Hybrid III 5th Percentile Female External Measurements

Test Date: 12/17/12



ATD Serial No.: 635

Test I.D.: N/A

Tested Parameter	Units	Specification	Result	Pass/Fail
Laboratory Temperature	°C	20.6 to 22.2	21.25	Pass
Laboratory Relative Humidity	%	10 to 70	30.1	Pass
A - Total sitting height	mm	774.7 to 800.1	786	Pass
B - Shoulder pivot height	mm	431.8 to 457.2	450	Pass
C - H point height	mm	81.3 to 86.3	85	Pass
D - H point location from backline	mm	144.8 to 149.8	146	Pass
E - Shoulder pivot from backline	mm	68.6 to 83.8	77	Pass
F - Thigh clearance	mm	119.4 to 134.6	126	Pass
G - Back of elbow to wrist pivot	mm	243.9 to 259.1	250	Pass
H - Head back to backline	mm	40.7 to 45.7	44	Pass
I - Shoulder to elbow length	mm	276.8 to 297.2	285	Pass
J - Elbow rest height	mm	182.8 to 203.2	198	Pass
K - Buttock to knee length	mm	520.7 to 546.1	531	Pass
L - Popliteal length	mm	355.6 to 376.0	371	Pass
M - Knee pivot height	mm	393.7 to 419.1	402	Pass
N - Buttock popliteal length	mm	414.0 to 439.4	420	Pass
O - Chest depth without jacket	mm	175.3 to 190.5	186	Pass
P - Foot length	mm	218.5 to 233.7	221	Pass
R - Buttock to Knee Pivot Length	mm	457.2 to 482.6	473	Pass
S - Head Breadth	mm	137.1 to 147.3	144	Pass
T - Head Depth	mm	177.8 to 188.0	180	Pass
U - Hip Breadth	mm	299.7 to 314.9	302	Pass
V - Shoulder breadth	mm	350.5 to 365.7	359	Pass
W - Foot breadth	mm	78.8 to 94.0	90	Pass
X - Head circumference	mm	528.3 to 548.7	541	Pass
Y - Chest circumference (with chest jacket)	mm	850.8 to 881.3	864	Pass
Z - Waist circumference	mm	759.5 to 789.9	766	Pass
AA - Location for chest circumference	mm	299.7 to 309.9	300	Pass
BB - Location for waist circumference	mm	160.1 to 170.2	164	Pass
Overall Test Results				Pass

Test Program: Hybrid III 5th Percentile Female Head Drop Test

Test Date: 12/17/12



ATD Serial No.: 635

Test I.D.: F635HD036

Tested Parameter	Units	Specification	Result	Pass/Fail
Head Assembly Soak Time	Minutes	≥240	295	Pass
Temperature During Soak	Max	18.9 to 25.6	21.6	Pass
	Min		20.9	Pass
Humidity During Soak	Max	10.0 to 70.0	32.2	Pass
	Min		29.7	Pass
Laboratory Temperature During Test	°C	18.9 to 25.6	21.2	Pass
Laboratory Humidity During Test	%	10.0 to 70.0	30.1	Pass
Peak Resultant Acceleration	G's	250.0 to 300.0	270.1	Pass
Peak Lateral Acceleration	G's	≤15.0	5.9	Pass
Oscillations After Main Pulse	%	<10% of peak Res. Acceleration	1.6	Pass
Is Acceleration Unimodal?	Yes/No	Yes	Yes	Pass
<b>Overall Test Results</b>				<b>Pass</b>

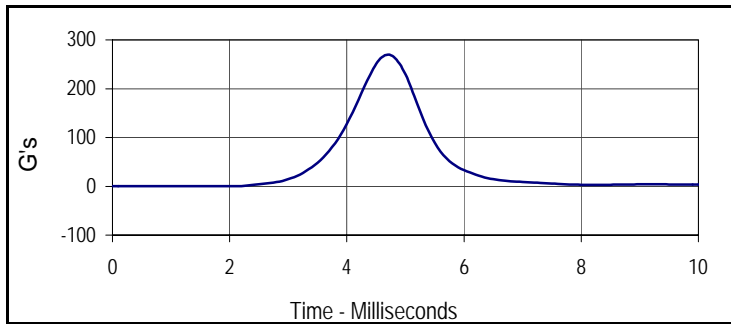

Curve Description			
Head Resultant			
Plot No.	Type	SAE Class	Units
001	RES	1000	G's
Max	Time	Min	Time
270.1	4.7	0.1	1.1

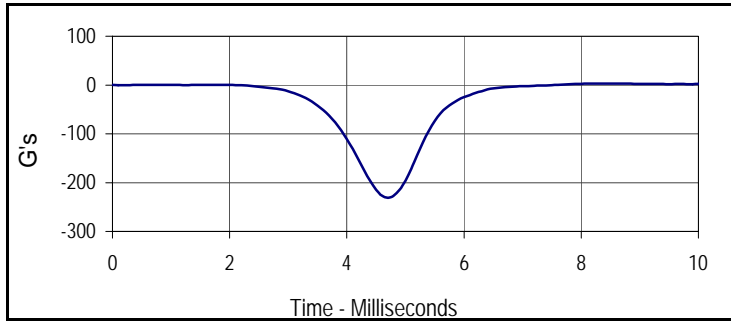

Curve Description			
Head X			
Plot No.	Type	SAE Class	Units
002	FIL	1000	G's
Max	Time	Min	Time
2.5	8.0	-231.0	4.7

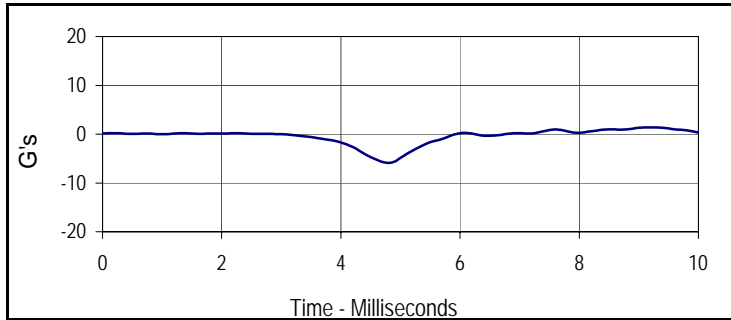

Curve Description			
Head Y			
Plot No.	Type	SAE Class	Units
003	FIL	1000	G's
Max	Time	Min	Time
1.0	7.6	-5.9	4.8

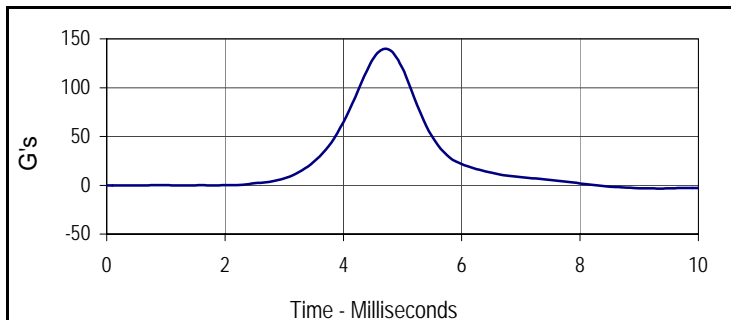

Curve Description			
Head Z			
Plot No.	Type	SAE Class	Units
004	FIL	1000	G's
Max	Time	Min	Time
139.9	4.7	-0.2	1.3

Test Program: Hybrid III 5th Percentile Female Neck Flexion Test

Test Date: 12/17/12



ATD Serial No.: 635

Test I.D.: F635NF036

Tested Parameter	Units	Specification	Result	Pass/Fail	
Neck Assembly Soak Time	Minutes	≥240	350	Pass	
Temperature During Soak	Max	20.6 to 22.2	21.6	Pass	
	Min		20.9	Pass	
Humidity During Soak	Max	10.0 to 70.0	32.2	Pass	
	Min		29.7	Pass	
Laboratory Temperature During Test	°C	20.6 to 22.2	21.2	Pass	
Laboratory Humidity During Test	%	10.0 to 70.0	30.0	Pass	
Pendulum Velocity	m/s	6.89 to 7.13	7.00	Pass	
Pendulum Deceleration	10 Msec.	m/s	2.1 to 2.5	2.4	Pass
	20 Msec.	m/s	4.0 to 5.0	4.8	Pass
	30 Msec.	m/s	5.8 to 7.0	6.8	Pass
"D" Plane Rotation	Max	Degrees	77.0 to 91.0	87.1	Pass
Peak Moment in Rotation	Max	Nm	69.0 to 83.0	73.9	Pass
Positive Moment Decay, Time To 10 Nm	Msec.	80.0 to 100.0	86.6	Pass	
Overall Test Results				Pass	

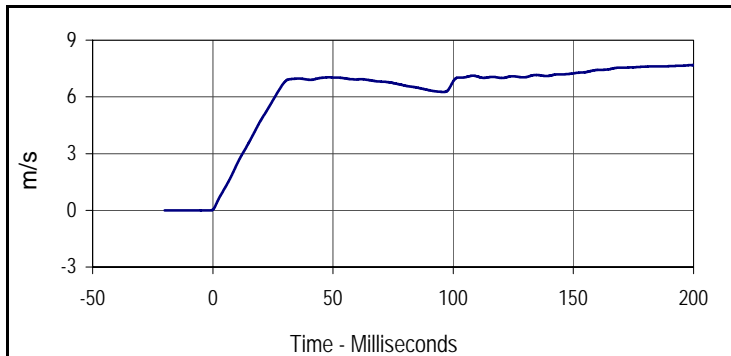

Curve Description			
Pendulum Velocity			
Plot No.	Type	SAE Class	Units
001	FIL	180	m/s
Max	Time	Min	Time
7.7	200.0	0.0	-0.9

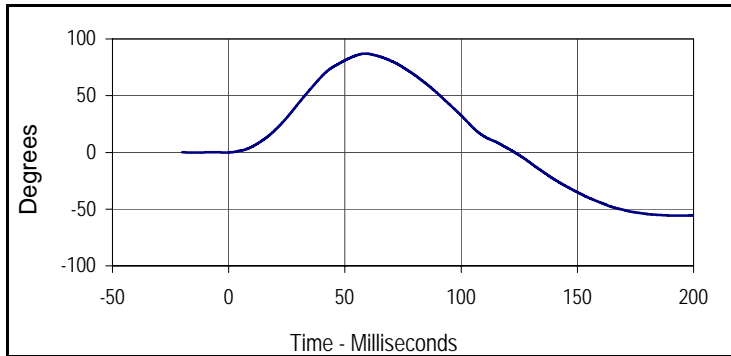

Curve Description			
"D" Plane Rotation			
Plot No.	Type	SAE Class	Units
002	FIL	60	Degrees
Max	Time	Min	Time
87.1	58.8	-55.7	192.8

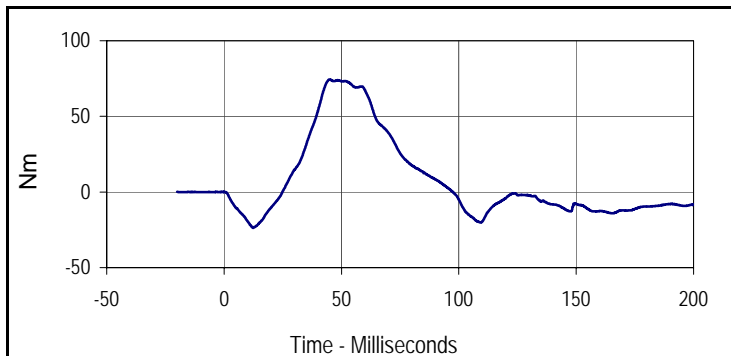

Curve Description			
Moment About Occipital Condyle			
Plot No.	Type	SAE Class	Units
003	FIL	600	Nm
Max	Time	Min	Time
74.4	44.9	-23.7	12.4

Test Program: Hybrid III 5th Percentile Female Neck Flexion Test

Test Date: 12/17/12



ATD Serial No.: 635

Test I.D.: F635NF036

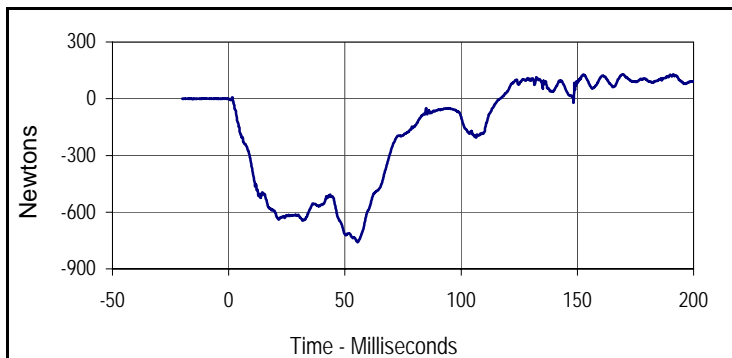

Curve Description			
Upper Neck Force X			
Plot No.	Type	SAE Class	Units
004	FIL	1000	Newtons
Max	Time	Min	Time
129.6	191.2	-758.8	55.4

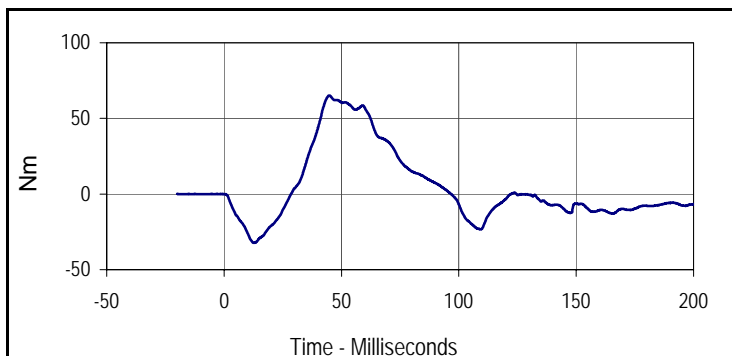

Curve Description			
Neck Moment Y			
Plot No.	Type	SAE Class	Units
005	FIL	600	Nm
Max	Time	Min	Time
65.1	44.8	-32.3	12.4

Test Program: Hybrid III 5th Percentile Female Neck Extension Test  
 ATD Serial No.: 635

Test Date: 12/17/12  
 Test I.D.: F635NE036



Tested Parameter	Units	Specification	Result	Pass/Fail	
Neck Assembly Soak Time	Minutes	≥240	385	Pass	
Temperature During Soak	Max	20.6 to 22.2	21.6	Pass	
	Min		20.9	Pass	
Humidity During Soak	Max	10.0 to 70.0	32.2	Pass	
	Min		29.7	Pass	
Laboratory Temperature During Test	°C	20.6 to 22.2	21.2	Pass	
Laboratory Humidity During Test	%	10.0 to 70.0	30.1	Pass	
Pendulum Velocity	m/s	5.95 to 6.19	6.00	Pass	
Pendulum Deceleration	10 Msec.	m/s	1.5 to 1.9	1.8	Pass
	20 Msec.	m/s	3.1 to 3.9	3.6	Pass
	30 Msec.	m/s	4.6 to 5.6	5.3	Pass
"D" Plane Rotation	Max	Degrees	99.0 to 114.0	107.4	Pass
Peak Moment in Rotation	Max	Nm	-53.0 to -65.0	-55.6	Pass
Positive Moment Decay, Time To -10 Nm	Msec.	94.0 to 114.0	100.0	Pass	
<b>Overall Test Results</b>				<b>Pass</b>	

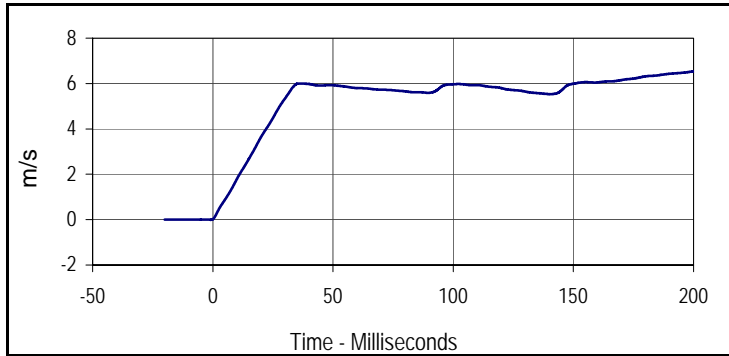

Curve Description			
Pendulum Velocity			
Plot No.	Type	SAE Class	Units
001	FIL	180	m/s
Max	Time	Min	Time
6.5	200.0	0.0	-0.9

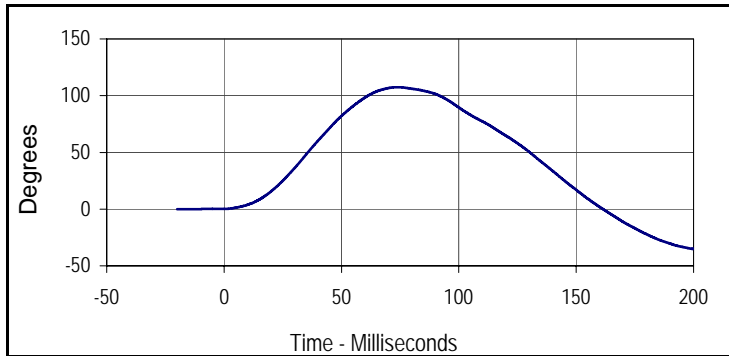

Curve Description			
"D" Plane Rotation			
Plot No.	Type	SAE Class	Units
002	FIL	60	Degrees
Max	Time	Min	Time
107.4	73.8	-35.2	200.0

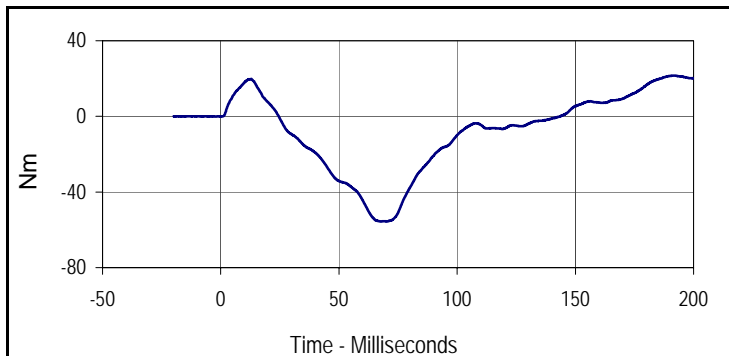

Curve Description			
Moment About Occipital Condyle			
Plot No.	Type	SAE Class	Units
003	FIL	600	Nm
Max	Time	Min	Time
21.6	191.1	-55.6	70.1

Test Program: Hybrid III 5th Percentile Female Neck Extension Test

Test Date: 12/17/12



ATD Serial No.: 635

Test I.D.: F635NE036

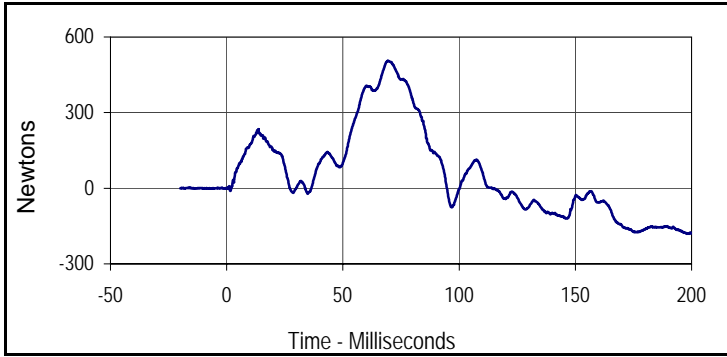

Curve Description			
Upper Neck Force X			
Plot No.	Type	SAE Class	Units
004	FIL	1000	Newtons
Max	Time	Min	Time
505.6	69.5	-181.1	198.4

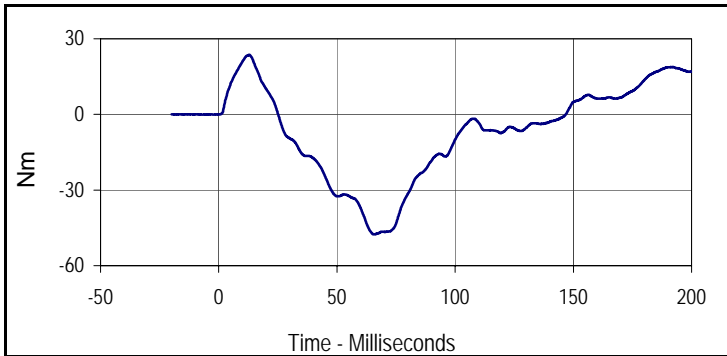

Curve Description			
Neck Moment Y			
Plot No.	Type	SAE Class	Units
005	FIL	600	Nm
Max	Time	Min	Time
23.7	12.9	-47.6	65.6

Test Program: Hybrid III 5th Percentile Female Thorax Impact Test

Test Date: 12/17/12



ATD Serial No.: 635

Test I.D.: F635CH036

Tested Parameter	Units	Specification	Result	Pass/Fail
Dummy Soak Time	Minutes	≥240	435	Pass
Temperature During Soak	Max	20.6 to 22.2	21.6	Pass
	Min		20.9	Pass
Humidity During Soak	Max	10.0 to 70.0	32.2	Pass
	Min		29.7	Pass
Laboratory Temperature During Test	°C	20.6 to 22.2	21.2	Pass
Laboratory Humidity During Test	%	10.0 to 70.0	30.1	Pass
Probe Velocity	m/s	6.59 to 6.83	6.67	Pass
Peak Chest Deflection	mm	50.0 to 58.0	55.4	Pass
Peak Force Between 50 and 58 MM	Newtons	3900 to 4400	3995	Pass
Peak Force Between 18 and 50 MM	Newtons	≤4600	4019	Pass
Internal Hysteresis	%	69 to 85	71.8	Pass
Overall Test Results				Pass

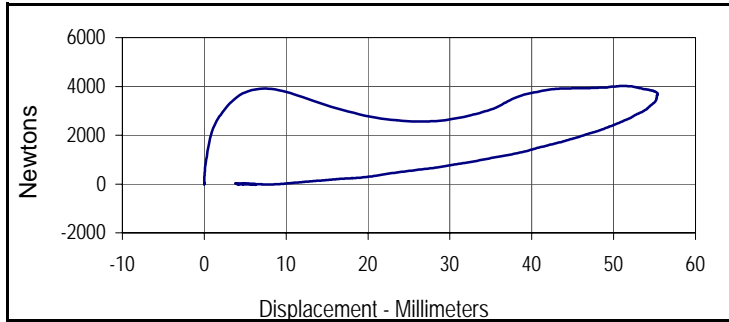

Curve Description			
Probe Force vs. Chest Deflection			
Plot No.	Type	SAE Class	Hysteresis
001	FIL	180	71.8
Peak Probe Force		Peak Chest Deflection	
4019.3		55.4	

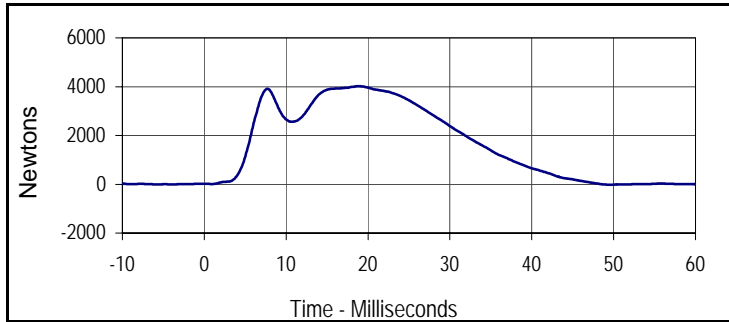

Curve Description			
Probe Force			
Plot No.	Type	SAE Class	Units
002	FIL	180	Newtons
Max	Time	Min	Time
4019.3	18.8	-28.6	66.0

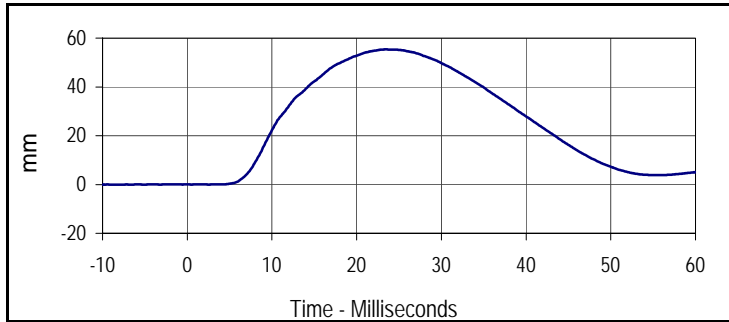

Curve Description			
Chest Deflection			
Plot No.	Type	SAE Class	Units
003	FIL	600	mm
Max	Time	Min	Time
55.4	23.4	0.0	-8.9

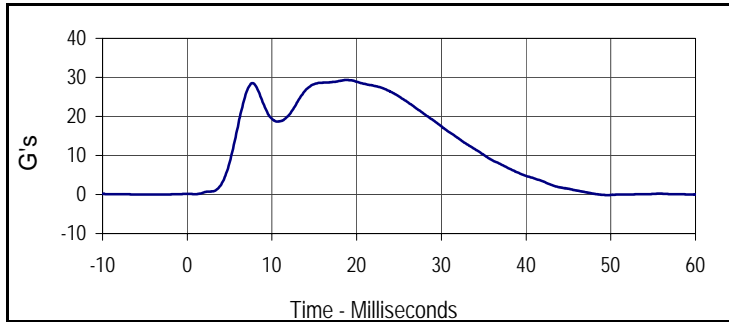

Curve Description			
Impactor Acceleration			
Plot No.	Type	SAE Class	Units
004	FIL	180	G's
Max	Time	Min	Time
29.3	18.8	-0.2	66.0

Test Program: Hybrid III 5th Percentile Female Knee Impact Test

Test Date: 12/17/12



ATD Serial No.: 635

Test I.D.: F635LK036, F635RK036

**Left Knee**

Tested Parameter	Units	Specification	Result	Pass/Fail
Knee Assembly Soak Time	Minutes	≥240	465	Pass
Temperature During Soak	Max	18.9 to 25.6	21.6	Pass
	Min		20.9	Pass
Humidity During Soak	Max	10.0 to 70.0	32.2	Pass
	Min		29.7	Pass
Laboratory Temperature During Test	°C	18.9 to 25.6	21.1	Pass
Laboratory Humidity During Test	%	10.0 to 70.0	30.1	Pass
Pendulum Velocity at T=0	m/sec	2.07 to 2.13	2.09	Pass
Peak Probe Force	Newtons	3450 to 4060	3810	Pass
<b>Overall Test Results</b>				<b>Pass</b>

**Right Knee**

Pendulum Velocity at T=0	m/sec	2.07 to 2.13	2.09	Pass
Peak Probe Force	Newtons	3450 to 4060	3782	Pass
<b>Overall Test Results</b>				<b>Pass</b>

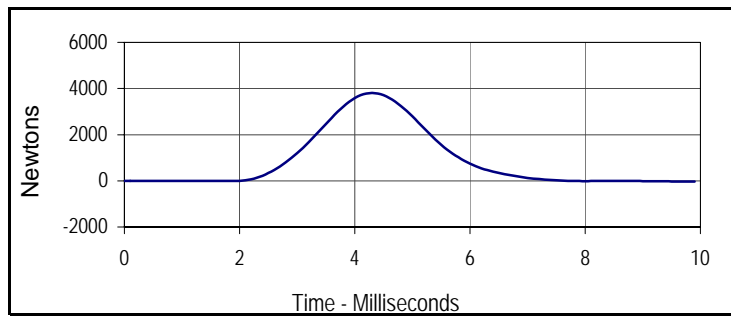

Curve Description			
Left Knee Probe Force			
Plot No.	Type	SAE Class	Units
001	FIL	600	Newtons
Max	Time	Min	Time
3809.8	4.3	-37.4	9.9

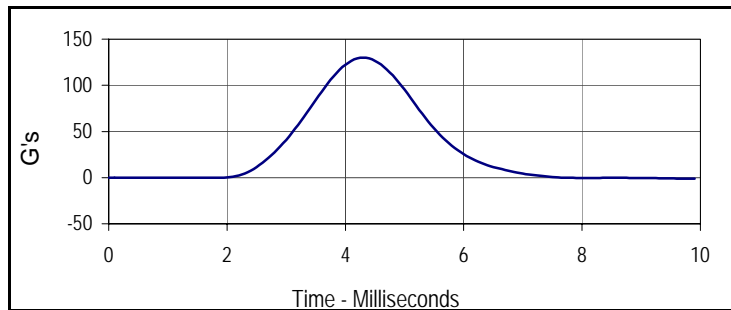

Curve Description			
Left Knee Acceleration			
Plot No.	Type	SAE Class	Units
002	FIL	600	G's
Max	Time	Min	Time
130.0	4.3	-1.3	9.9

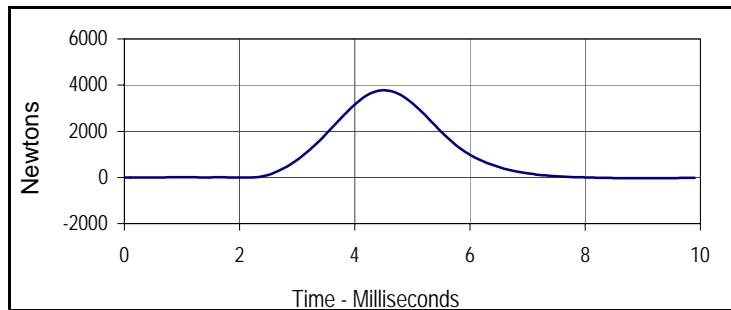

Curve Description			
Right Knee Probe Force			
Plot No.	Type	SAE Class	Units
003	FIL	600	Newtons
Max	Time	Min	Time
3782.3	4.5	-28.0	9.1

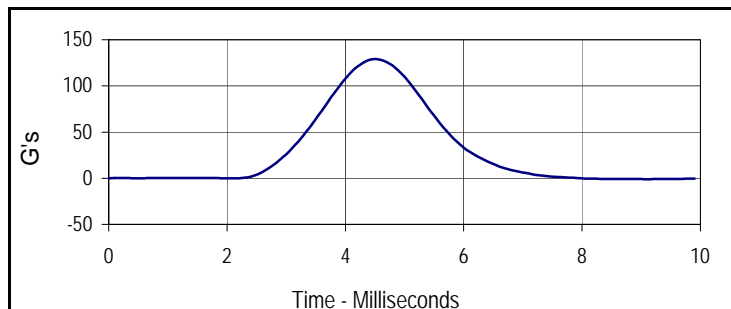

Curve Description			
Right Knee Acceleration			
Plot No.	Type	SAE Class	Units
004	FIL	600	G's
Max	Time	Min	Time
129.0	4.5	-1.0	9.1

Test Program: Hybrid III 5th Percentile Female Torso Flexion Test

Test Date: 12/17/12



ATD Serial No.: 635

Test I.D.: F635TF036

**Left Hip Joint-Femur Results**

Tested Parameter		Units	Specification	Result	Pass/Fail
Dummy Soak Time		Minutes	≥240	490	Pass
Temperature During Soak	Max	°C	18.9 to 25.6	21.6	Pass
	Min	°C		20.9	Pass
Humidity During Soak	Max	%	10.0 to 70.0	32.2	Pass
	Min	%		29.7	Pass
Laboratory Temperature During Test		°C	18.9 to 25.6	21.2	Pass
Laboratory Humidity During Test		%	10.0 to 70.0	30.2	Pass
Initial Reference Plane Angle		Degrees	≤ 20	1.2	Pass
Peak Force at 45° +/-0.5°		Newtons	320.0 to 390.0	350.5	Pass
Torso Rotation Rate		deg/sec	0.5 to 1.5	1.3	Pass
Final Reference Plane Angle		Degrees	+/-8	3.0	Pass
<b>Overall Test Results</b>					<b>Pass</b>