

**REPORT NUMBER: NCAP-MGA-2012-074**

**NEW CAR ASSESSMENT PROGRAM (NCAP)  
Frontal Barrier Impact Test**

**KIA MOTORS CORPORATION  
2012 KIA Rio LX 4-Dr Sedan  
NHTSA No.: MC0521**

**MGA RESEARCH CORPORATION  
5000 Warren Road  
Burlington, WI 53105**



**Test Date: March 13, 2012**

**Final Report Date: April 27, 2012**

**FINAL REPORT**

**U.S. DEPARTMENT OF TRANSPORTATION  
National Highway Traffic Safety Administration  
Office of Crashworthiness Standards  
Mail Code: NVS-111  
1200 New Jersey Ave, SE  
Room W43-410  
Washington, DC 20590**

This publication is distributed by the U.S. Department of Transportation, National Highway Traffic Safety Administration, in the interest of information exchange. The opinions, findings and conclusions expressed in this publication are those of the author(s) and not necessarily those of the Department of Transportation or the National Highway Traffic Safety Administration. The United States Government assumes no liability for its contents or use thereof.

If trade or manufacturers' names or products are mentioned, it is only because they are considered essential to the object of the publication and should not be construed as an endorsement. The United States Government does not endorse products or manufacturers.

Prepared by:   
Donna Janovicz, Project Manager

Approved by:   
Ben Fischer, Project Engineer

Approval Date: April 27, 2012

FINAL REPORT ACCEPTANCE BY OCWS:

\_\_\_\_\_  
Division Chief, New Car Assessment Program  
NHTSA, Office of Crashworthiness Standards

Date: \_\_\_\_\_

\_\_\_\_\_  
COTR, New Car Assessment Program  
NHTSA, Office of Crashworthiness Standards

Date: \_\_\_\_\_

### Technical Report Documentation Page

<b>1. Report No.</b> NCAP-MGA-2012-074	<b>2. Government Accession No.</b>	<b>3. Recipient's Catalog No.</b>																																																			
<b>4. Title and Subtitle</b> Final Report of New Car Assessment Program Frontal Impact Testing of 2012 KIA Rio LX 4-Dr Sedan, NHTSA No.: MC0521		<b>5. Report Date</b> April 27, 2012																																																			
		<b>6. Performing Organization Code</b> MGA																																																			
<b>7. Author(s)</b> Donna Janovicz, Project Manager Ben Fischer, Project Engineer		<b>8. Performing Organization Report No.</b> NCAP-MGA-2012-074																																																			
		<b>10. Work Unit No.</b>																																																			
<b>9. Performing Organization Name and Address</b> MGA Research Corporation 5000 Warren Road Burlington, WI 53105		<b>11. Contract or Grant No.</b> DTNH22-06-D-00028																																																			
		<b>13. Type of Report and Period Covered</b> Final Test Report March 13 to April 27, 2012																																																			
<b>12. Sponsoring Agency Name and Address</b> U.S. Department of Transportation National Highway Traffic Safety Administration Office of Crashworthiness Standards (NVS-111) 1200 New Jersey Ave, SE, Room W43-410 Washington, D.C. 20590		<b>14. Sponsoring Agency Code</b> NVS-111																																																			
		<b>15. Supplementary Notes</b>																																																			
<b>16. Abstract</b> A 56.3 km/h NCAP Frontal Impact Test was conducted on the 2012 KIA Rio LX 4-Dr Sedan in accordance with the specifications of the Office of Crashworthiness Standards Frontal NCAP Laboratory Test Procedure. This test was conducted to obtain data indicant of FMVSS 208, 212, 219 (partial), 301, and foot well intrusion performance. The test was conducted at MGA Research Corporation in Burlington, Wisconsin, on March 13, 2012.  The impact velocity was 56.1 km/h and the ambient temperature at the barrier face at the time of impact was 21.9°C. The target vehicle post-test maximum crush was 507 mm located at the vehicle's centerline. The test vehicle's performance was as follows:																																																					
<table border="1" style="width: 100%; border-collapse: collapse; background-color: #ffff00;"> <thead> <tr> <th rowspan="2">Measurement Description</th> <th rowspan="2">Units</th> <th colspan="2">Threshold</th> <th rowspan="2">Driver ATD</th> <th rowspan="2">Passenger ATD</th> </tr> <tr> <th>50<sup>th</sup></th> <th>5<sup>th</sup></th> </tr> </thead> <tbody> <tr> <td>Head Injury Criteria (HIC<sub>15</sub>)</td> <td>N/A</td> <td>700</td> <td>700</td> <td>318</td> <td>427</td> </tr> <tr> <td>Maximum Chest Compression</td> <td>mm</td> <td>63</td> <td>52</td> <td>24</td> <td>11</td> </tr> <tr> <td>Nij</td> <td>N/A</td> <td>1</td> <td>1</td> <td>0.31</td> <td>0.46</td> </tr> <tr> <td>Neck Tension</td> <td>N</td> <td>4170</td> <td>2620</td> <td>1824</td> <td>617</td> </tr> <tr> <td>Neck Compression</td> <td>N</td> <td>4000</td> <td>2520</td> <td>332</td> <td>439</td> </tr> <tr> <td>Left Femur Force</td> <td>N</td> <td>10008</td> <td>6805</td> <td>2545</td> <td>2493</td> </tr> <tr> <td>Right Femur Force</td> <td>N</td> <td>10008</td> <td>6805</td> <td>1456</td> <td>359</td> </tr> </tbody> </table>				Measurement Description	Units	Threshold		Driver ATD	Passenger ATD	50 <sup>th</sup>	5 <sup>th</sup>	Head Injury Criteria (HIC <sub>15</sub> )	N/A	700	700	318	427	Maximum Chest Compression	mm	63	52	24	11	Nij	N/A	1	1	0.31	0.46	Neck Tension	N	4170	2620	1824	617	Neck Compression	N	4000	2520	332	439	Left Femur Force	N	10008	6805	2545	2493	Right Femur Force	N	10008	6805	1456	359
Measurement Description	Units	Threshold				Driver ATD	Passenger ATD																																														
		50 <sup>th</sup>	5 <sup>th</sup>																																																		
Head Injury Criteria (HIC <sub>15</sub> )	N/A	700	700	318	427																																																
Maximum Chest Compression	mm	63	52	24	11																																																
Nij	N/A	1	1	0.31	0.46																																																
Neck Tension	N	4170	2620	1824	617																																																
Neck Compression	N	4000	2520	332	439																																																
Left Femur Force	N	10008	6805	2545	2493																																																
Right Femur Force	N	10008	6805	1456	359																																																
<b>17. Key Words</b>  35 mph Frontal Barrier Impact Test New Car Assessment Program (NCAP)		<b>18. Distribution Statement</b> Copies of this report are available from: National Highway Traffic Safety Administration Technical Information Services Division, NPO-411 1200 New Jersey Ave, SE, Room E12-100 Washington, DC 20590 Email: <a href="mailto:tis@nhtsa.dot.gov">tis@nhtsa.dot.gov</a> FAX: 202-493-2833																																																			
<b>19. Security Classification of Report</b> Unclassified	<b>20. Security Classification of Page</b> Unclassified	<b>21. No. of Pages</b> 163	<b>22. Price</b>																																																		

## TABLE OF CONTENTS

<u>Section</u>		<u>Page No.</u>
1	Purpose and Summary of Test	1
2	Occupant and Vehicle Information / Data Sheets	3

<u>Data Sheet No.</u>		<u>Page No.</u>
1	General Test and Vehicle Parameter Data	4
2	Seat Adjustment, Fuel System, and Steering Wheel Data	8
3	Dummy Longitudinal Clearance Dimensions	10
4	Dummy Lateral Clearance Dimensions	11
5	Seat Belt Positioning Data	12
6	High-Speed Camera Locations and Data	13
7	Vehicle Accelerometer Data	15
8	Photographic Reference Target Locations	16
9	Load Cell Locations on Fixed Barrier	17
10	Test Vehicle Summary of Results	18
11	Post-Test Observations	19
12	Vehicle Profile Measurements	20
13	Accident Investigation Division Data	22
14	Vehicle Intrusion Measurements	23
15	Summary of FMVSS 212, 219 (Partial), and 301 Data	26
16	FMVSS 301 Static Rollover Results	28
17	Dummy/Vehicle Temperature Stabilization Data	29

<u>Appendix</u>		
A	Photographs	A
B	Dummy Response Data Traces	B
C	Dummy Calibration and Performance Verification Data	C

## **SECTION 1 PURPOSE AND SUMMARY OF TEST**

### **PURPOSE**

This 56.3 km/h frontal barrier impact test is part of the Vehicle Barrier Impact Testing Program sponsored by the National Highway Traffic Safety Administration (NHTSA) under contract number DTNH22-06-D-00028. The purpose of this test was to obtain vehicle crashworthiness and occupant restraint system performance data for consumer information purposes.

The 56.3 km/h frontal barrier impact was conducted in accordance with the Office of Crashworthiness Standards Frontal NCAP Laboratory Test Procedure.

### **SUMMARY**

A load cell barrier was impacted by a 2012 KIA Rio LX 4-Dr Sedan at a velocity of 56.1 kph. The test was performed at MGA Research Corporation on March 13, 2012. Pre-test and post-test photographs of the vehicle and dummies can be found in Appendix A.

Two real-time cameras and fourteen (14) high-speed cameras were used to document the frontal barrier impact event. Camera locations and other pertinent camera information can be found in this report.

One Part 572E, 50<sup>th</sup> percentile male anthropomorphic test device (ATD), was placed in the driver seating position and one Part 572O 5<sup>th</sup> percentile female test device (ATD) was placed in the right-front passenger seating position according to dummy placement instructions specified in the Frontal NCAP Laboratory Test Procedure.

Both ATDs were fully instrumented with head, chest and pelvis tri-axial accelerometers, chest displacement potentiometers, upper neck transducers, right/left femur load cells, and lower leg instrumentation. Seat belt load cells were also installed on the driver's lap and shoulder belts and the passenger's lap and shoulder belts to measure dummy torso and pelvic section loading.

The driver (position 1) ATD (Serial No. 351) and the right-front passenger (position 2) ATD (Serial No. 138) were calibrated previous to this test. Certification details, along with instrumentation calibration data, are found in Appendix C of this report.

The 228 channels of data were recorded on an on-board data acquisition system. Appendix B contains the dummy head, chest displacement, neck, and femur response data traces.

There was 100 percent windshield retention and no intrusion into the protected zone of the windshield during the event. There was no Stoddard Solvent leakage after the event or during any phase of the static rollover.

The maximum static crush of the vehicle was 507 mm and both the driver and passenger side doors remained closed during the impact event and were operable after the impact.

The driver's visible contact points were as follows: The driver's head and chest contacted the airbag. The driver's head also contacted the headrest. The driver's knees contacted the knee bolster. The passenger's visible contact points were as follows: The passenger's head and chest contacted the airbag. The passenger's head also contacted the headrest. The passenger's knees contacted the glovebox.

The occupant data is summarized below:

ATD position	HIC <sub>15</sub>	Nij	Neck Tension (N)	Neck Comp. (N)	3ms Chest Clip (Gs)	Chest Disp. (mm)	Left Femur (N)	Right Femur (N)
Driver (50 <sup>th</sup> )	318	0.31	1824	332	48	24	2545	1456
Passenger (5 <sup>th</sup> )	427	0.46	617	439	47	11	2493	359

The test data can be found on the NHTSA website at [www.nhtsa.dot.gov](http://www.nhtsa.dot.gov).

**TEST NOTES**

Top of Engine X has no valid data after 39 ms.  
Load Cell 8-2 has no valid.

MGA does not endorse or certify products. The manufacturer's name appears solely for identification purposes.

**SECTION 2**  
**OCCUPANT AND VEHICLE INFORMATION / DATA SHEETS**

**DATA SHEET NO. 1  
GENERAL TEST AND VEHICLE PARAMETER DATA**

Test Vehicle: 2012 KIA Rio LX 4-Dr Sedan  
Test Program: NCAP Frontal Barrier Impact Test

NHTSA No.: MC0521  
Test Date: 03/13/2012

**TEST VEHICLE INFORMATION AND OPTIONS**

NHTSA No.	MC0521	Traction Control System (TCS)	Yes
Model Year	2012	Auto-Leveling System	No
Make	KIA	Automatic Door Locks (ADLs)	No
Model	Rio	Power Window Auto-Reverse	No
Body Style	Sedan	Other Optional Feature	N/A
VIN	KNADM4A35C6052289	Driver Front Airbag	Yes
Body Color	Bright Silver	Driver Curtain Airbag	Yes
Odometer (km/mi)	153 / 95	Driver Torso Airbag	No
Engine Displacement (L)	1.6	Driver Torso/Pelvis Airbag	Yes
Type/No. Cylinders	4	Driver Pelvis Airbag	No
Engine Placement	Lateral	Driver Knee Airbag	No
Transmission Type	Automatic	Pass. Curtain Airbag	Yes
Transmission Speeds	6	Pass. Front Airbag	Yes
Overdrive	Yes	Pass. Torso Airbag	No
Final Drive	Front	Pass. Torso/Pelvis Airbag	Yes
Roof Rack	No	Pass. Pelvis Airbag	No
Sunroof/T-Top	No	Pass. Knee Airbag	No
Running Boards	No	Driver Seat Belt Pretensioner	Yes
Tilt Steering Wheel	Yes	Pass. Seat Belt Pretensioner	Yes
Power Seats	No	Driver Load Limiter	Yes
Anti-Lock Brakes (ABS)	Yes	Pass. Load Limiter	Yes
All-Wheel Drive (AWD)	No	Other Safety Restraint	N/A
Does owner's manual provide instructions to turn off automatic door locks?			N/A

**DATA FROM CERTIFICATION LABEL**

Manufactured By	KIA MOTORS CORPORATION	GVWR (kg)	1660
Date of Manufacture	12/11	GAWR Front (kg)	920
Vehicle Type	Passenger Car	GAWR Rear (kg)	840

**VEHICLE SEATING AND WEIGHT CAPACITY DATA**

Measured Parameter	Front	Rear	Third	Total
Type of Seats	Bucket	Bench		
Designated Seating Capacity (DSC)	2	3		5
Capacity Weight (VCW) (kg)				420
Cargo Weight (RCLW) (kg)				80

**DATA SHEET NO. 1 (CONTINUED)**  
**GENERAL TEST AND VEHICLE PARAMETER DATA**

Test Vehicle: 2012 KIA Rio LX 4-Dr Sedan  
 Test Program: NCAP Frontal Barrier Impact Test

NHTSA No.: MC0521  
 Test Date: 03/13/2012

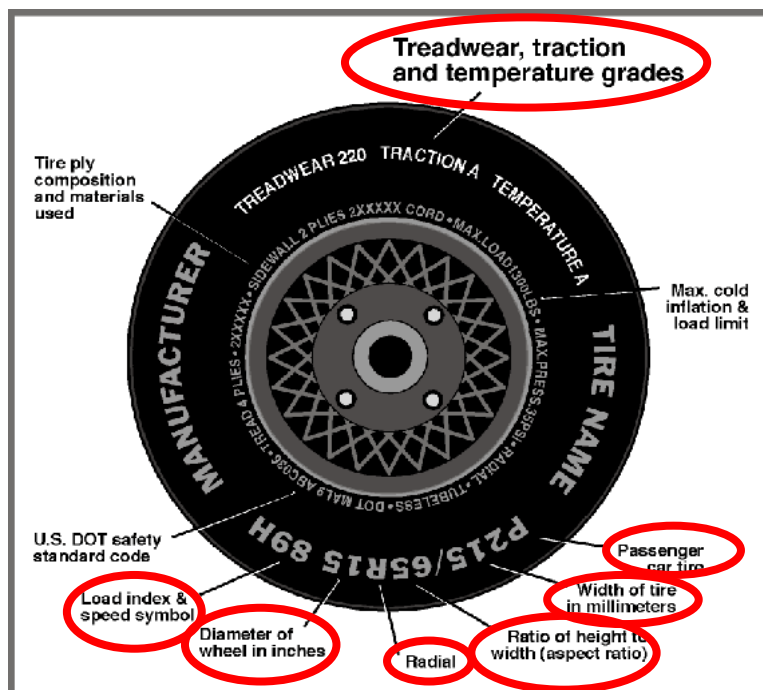

**TIRE PLACARD INFORMATION**

Measured Parameter	Front	Rear
Recommended Cold Tire Pressure (kPa)	220	220
Recommended Tire Size	P185/65R15	P185/65R15

**TIRE SIDEWALL INFORMATION**

Measured Parameter	Front	Rear
Max. Tire Pressure (kPa)	300	300
Tire Size on Vehicle	P185/65R15	P185/65R15
Tire Manufacturer	KUMHO	KUMHO
Tire Name	Solus KH25	Solus KH25
Tire Type	Passenger	Passenger
Tire Width	185	185
Aspect Ratio	65	65
Radial	Yes	Yes
Wheel Diameter	15	15
Load Index/Speed Symbol	86T	86T
Treadwear	480	480
Traction Grade	A	A
Temperature Grade	A	A
Tire Material	Rubber	Rubber

**DATA SHEET NO. 1 (CONTINUED)  
GENERAL TEST AND VEHICLE PARAMETER DATA**

Test Vehicle: 2012 KIA Rio LX 4-Dr Sedan  
Test Program: NCAP Frontal Barrier Impact Test

NHTSA No.: MC0521  
Test Date: 03/13/2012

**TEST VEHICLE WEIGHTS**

	Units	As Delivered (UVW)			As Tested (ATW)		
		Front	Rear	Total	Front	Rear	Total
Left	kg	363.3	231.4		396.9	314.8	
Right	kg	358.8	210.0		375.1	290.3	
Ratio	%	62.1	37.9		56.1	43.9	
Totals	kg	722.1	441.4	1163.5	772.0	605.1	1377.1

**TARGET TEST WEIGHT CALCULATION**

Measured Parameter	Units	Value
Total Delivered Weight (UVW)	kg	1163.5
Weight of 1 P572E ATD & 1 P572O ATD	kg	140.6
Rated Cargo/Luggage Weight (RCLW)	kg	80
Calculated Vehicle Target Weight (TVTW)	kg	1384.1

**TEST VEHICLE ATTITUDES AND CG**

	Units	LF	RF	LR	RR	CG (aft of front axle)
As Delivered	mm	642	658	670	665	975
As Tested	mm	640	648	621	631	1129
Post Test	mm	605	608	642	628	

**GENERAL TEST VEHICLE DATA**

Measurement Description	Units	Value
Total Vehicle Wheel Base	mm	2570
Total Vehicle Length at Left Side	mm	4244
Total Vehicle Length at Centerline	mm	4364
Total Vehicle Length at Right Side	mm	4424
Weight of Ballast in Cargo Area	kg	43.5
Weight of Vehicle Components Removed	kg	5.9
Amount of Stoddard Solvent in Fuel Tank	L	39.7

List of components removed: Right taillight, trunk carpet, tool kit, and tire inflator.

**DATA SHEET NO. 1 (CONTINUED)**  
**GENERAL TEST AND VEHICLE PARAMETER DATA**

Test Vehicle: 2012 KIA Rio LX 4-Dr Sedan  
 Test Program: NCAP Frontal Barrier Impact Test

NHTSA No.: MC0521  
 Test Date: 03/13/2012

**TARGET VEHICLE STRUCTURAL MEASUREMENT**

	Elements	Pre-Test (mm)
1	Total Length	4364
2	Total Width	1709
3	Bumper Top Height	515
4	Bumper Bottom Height	394
5	Longitudinal Member Top Height	501
6	Distance between Longitudinal Members	918
7	Longitudinal Member Width	62
8	Engine Top Height	760
9	Engine Bottom Height	171
10	Engine and Gearbox Width	808
11	Front Bumper-Engine Distance	269
12	Front Shock Absorber Fixing Height	833
13	Bonnet Leading Edge Height	795
14	Front Shock Absorber Fixing Width	1132
15	Front Bumper – Front Axle Distance	799
16	Front Axle – A-Pillar Distance	422
17	A-Pillar – B-Pillar Distance	1112
18	B-Pillar – Rear Axle Distance	1035
19	B-Pillar – C-Pillar Distance	623
20	Roof Sill Bottom Height	1232
21	Roof Sill Top Height	1398
22	Floor Sill Bottom Height	130
23	Floor Sill Top Height	322

**DATA SHEET NO. 2**  
**SEAT ADJUSTMENT, FUEL SYSTEM, AND STEERING WHEEL DATA**

Test Vehicle: 2012 KIA Rio LX 4-Dr Sedan  
 Test Program: NCAP Frontal Barrier Impact Test

NHTSA No.: MC0521  
 Test Date: 03/13/2012

**NOMINAL DESIGN RIDING POSITION**

The driver seat back is positioned as close as possible to the manufacturer's design angle. For the passenger seat back, seat back is adjusted following Appendix F, "Driver & Passenger Dummy Seating & Positioning Procedures" in the NCAP Test Procedure dated January 2010.

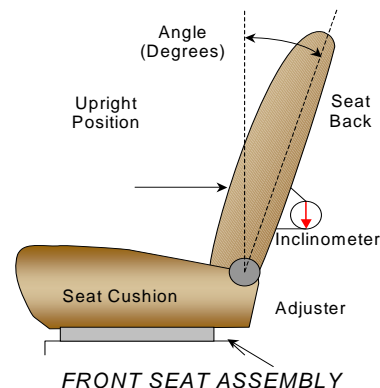

SEAT BACK ANGLE	Degrees
Driver Seat Back Angle	6.7° on headrest post
Passenger Seat Back Angle	6.6° on headrest post

**SEAT FORE/AFT POSITIONS**

The driver and passenger seat fore/aft positions are adjusted following Appendix F, "Driver & Passenger Dummy Seating & Positioning Procedures" in the NCAP Test Procedure dated January 2010.

	Total Fore/Aft Travel	Placed in Position #
Driver Seat	24 detents (1 <sup>st</sup> as 0)	10 <sup>th</sup> detent (forward most as 0)
Passenger Seat	24 detents (1 <sup>st</sup> as 0)	0 detent (forward most as 0)

**SEAT BELT UPPER ANCHORAGES**

The seat belt upper anchorages are positioning following the manufacturer's specified position as listed in Form 1.

	Total # of Positions	Placed in Position #
Driver Seat	4 (1 <sup>st</sup> as 1)	0 (uppermost as 0)
Passenger Seat	4 (1 <sup>st</sup> as 1)	0 (uppermost as 0)

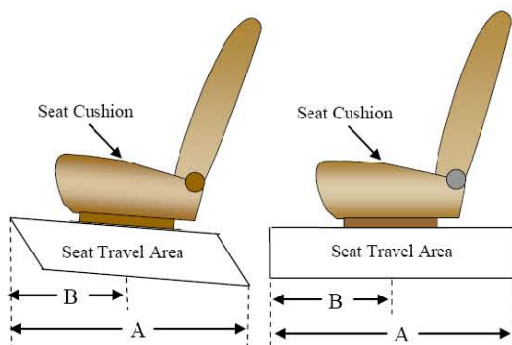

**DATA SHEET NO. 2 (CONTINUED)**  
**SEAT ADJUSTMENT, FUEL SYSTEM, AND STEERING WHEEL DATA**

Test Vehicle: 2012 KIA Rio LX 4-Dr Sedan  
 Test Program: NCAP Frontal Barrier Impact Test

NHTSA No.: MC0521  
 Test Date: 03/13/2012

**FUEL TANK CAPACITY DATA**

	Liters
Usable Capacity of "Standard Tank"	42.8
Usable Capacity of "Optional Tank"	
92-94% of Usable Capacity	39.4 to 40.1
Actual Amount of Solvent used	39.7
1/3 of Usable Capacity	14.3

**FUEL PUMP**

Describe the fuel pump type, its behavior, and the location of the fuel filler pipe.

The vehicle is equipped with an electric fuel pump. Fuel pump will operate when engine system is normally operating. The fuel pipe is on the left side.

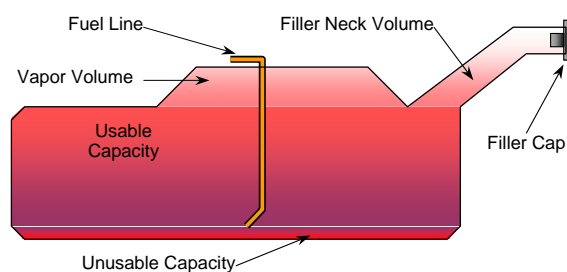

VEHICLE FUEL TANK ASSEMBLY

**STEERING COLUMN ADJUSTMENT**

Steering wheel and column adjustments are made so that the steering wheel hub is at the geometric center of the locus it describes when moved through its full range of motion. An aluminum plate is placed across the rim of the steering wheel, an inclinometer is placed on the plate and the angle is measured.

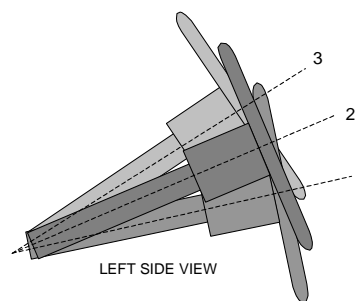

STEERING COLUMN ASSEMBLY

**STEERING COLUMN POSITION**

	Degrees	Fore/Aft Position (mm)
Lowermost – Position 1	64.7	
Geometric Center – Position 2	63.7	
Uppermost – Position 3	62.6	
Telescoping Steering Wheel Travel		
Test Position	63.7	

**DATA SHEET NO. 3  
DUMMY LONGITUDINAL CLEARANCE DIMENSIONS**

Test Vehicle: 2012 KIA Rio LX 4-Dr Sedan  
Test Program: NCAP Frontal Barrier Impact Test

NHTSA No.: MC0521  
Test Date: 03/13/2012

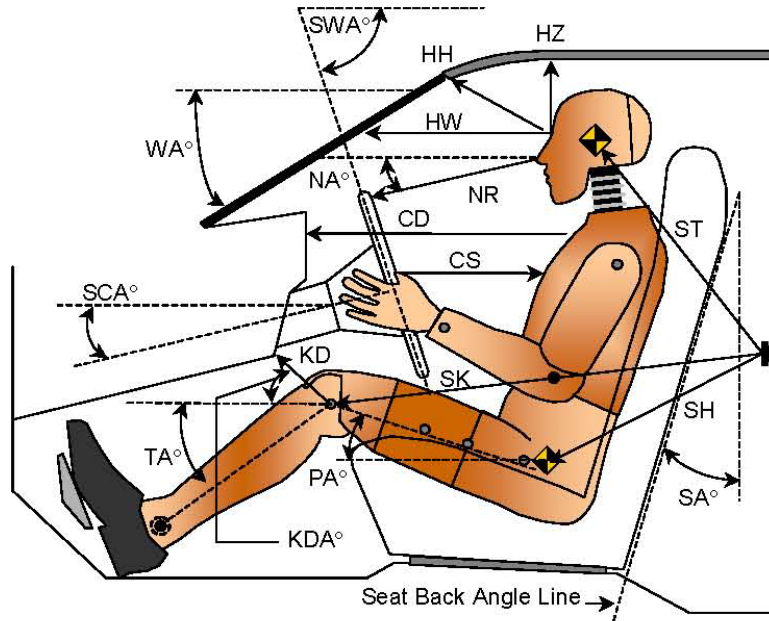

**LEFT SIDE VIEW**

Code	Measurement Description	Driver S/N 351		Passenger S/N 138	
		Length (mm)	Angle (°)	Length (mm)	Angle (°)
WA°	Windshield Angle		23.3		
SWA°	Steering Wheel Angle		63.7		
SCA°	Steering Column Angle		26.3		
SA°	Seat Back Angle (on headrest post)		6.7		6.6
HZ	Head to Roof (Z)	202	90	278	90
HH	Head to Header	425	16.0	395	27.8
HW	Head to Windshield	754	0	854	0
NR	Nose to Rim	444	12.9		
CD	Chest to Dash	564		428	
CS	Chest to Steering Hub	357	5.2		
RA	Rim to Abdomen	229	0		
KDL	Left Knee to Dash	182	18.3	126	31.1
KDR	Right Knee to Dash	159	19.6	156	29.4
PA°	Pelvic Angle		24.8		20.0
TA°	Tibia Angle		47.1		41.0
SK	Striker to Knee	576	102.1	668	107.2
ST	Striker to Head	414	5.0	346	37.4
SH	Striker to H-Point	296	138.7	391	131.2

**DATA SHEET NO. 4  
DUMMY LATERAL CLEARANCE DIMENSIONS**

Test Vehicle: 2012 KIA Rio LX 4-Dr Sedan  
 Test Program: NCAP Frontal Barrier Impact Test

NHTSA No.: MC0521  
 Test Date: 03/13/2012

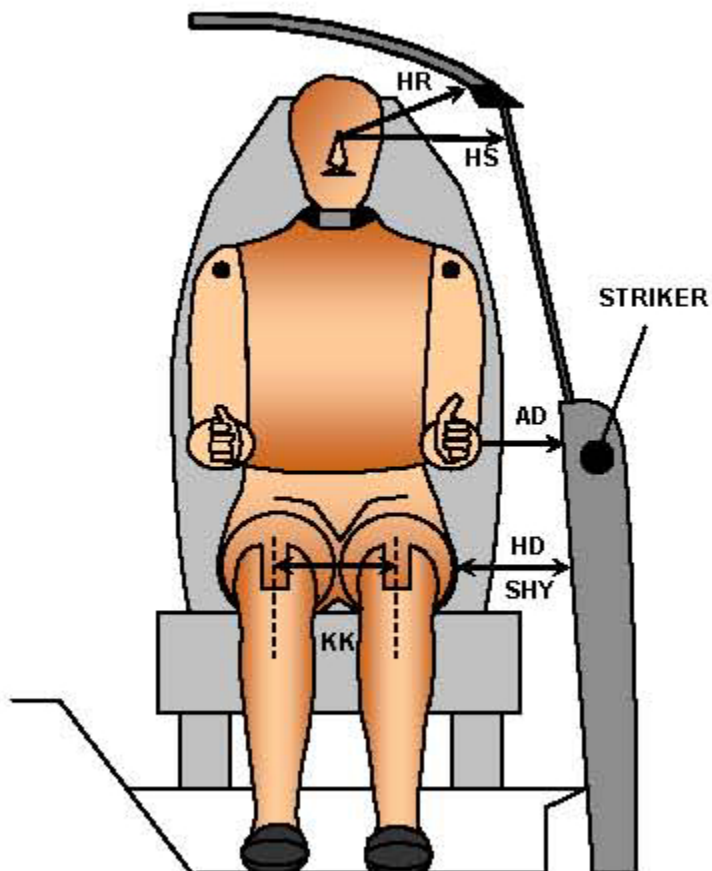

**FRONT VIEW OF DUMMY**

Code	Measurement Description	Driver S/N 351	Passenger S/N 138
		Length (mm)	
AD	Arm to Door	91	81
HD	H-Point to Door	137	182
HR	Head to Side Header	191	285
HS	Head to Side Window	306	404
KK	Knee to Knee	313	220
SHY	Striker to H-Point (Y Direction)	257	310
AA	Ankle to Ankle	346	175

**DATA SHEET NO. 5  
SEAT BELT POSITIONING DATA**

Test Vehicle: 2012 KIA Rio LX 4-Dr Sedan  
 Test Program: NCAP Frontal Barrier Impact Test

NHTSA No.: MC0521  
 Test Date: 03/13/2012

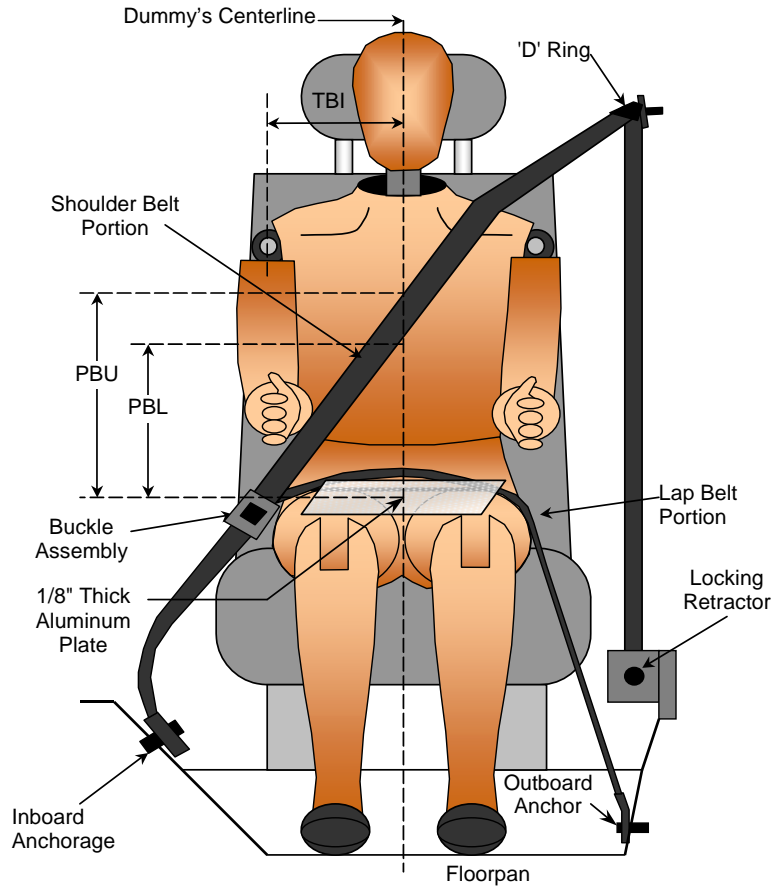

**FRONT VIEW OF DUMMY**

**SEAT BELT POSITIONING MEASUREMENTS**

Measurement Description	Units	Driver	Passenger
PBU - Top surface of reference to belt upper edge	mm	364	310
PBL - Top surface of reference to belt lower edge	mm	290	220

**BELT LENGTH DATA**

Measurement Description	Units	Driver	Passenger
Shoulder Belt Length as measured on ATD	mm	815	910
Lap Belt Length as measured on ATD	mm	635	630
Remainder of belt on reel	mm	2350	2260
Total Belt Length for Continuous Webbing Systems	mm	3800	3800

**DATA SHEET NO. 6  
HIGH-SPEED CAMERA LOCATIONS AND DATA**

Test Vehicle: 2012 KIA Rio LX 4-Dr Sedan  
Test Program: NCAP Frontal Barrier Impact Test

NHTSA No.: MC0521  
Test Date: 03/13/2012

**CAMERA POSITIONS FOR FRONTAL IMPACTS**

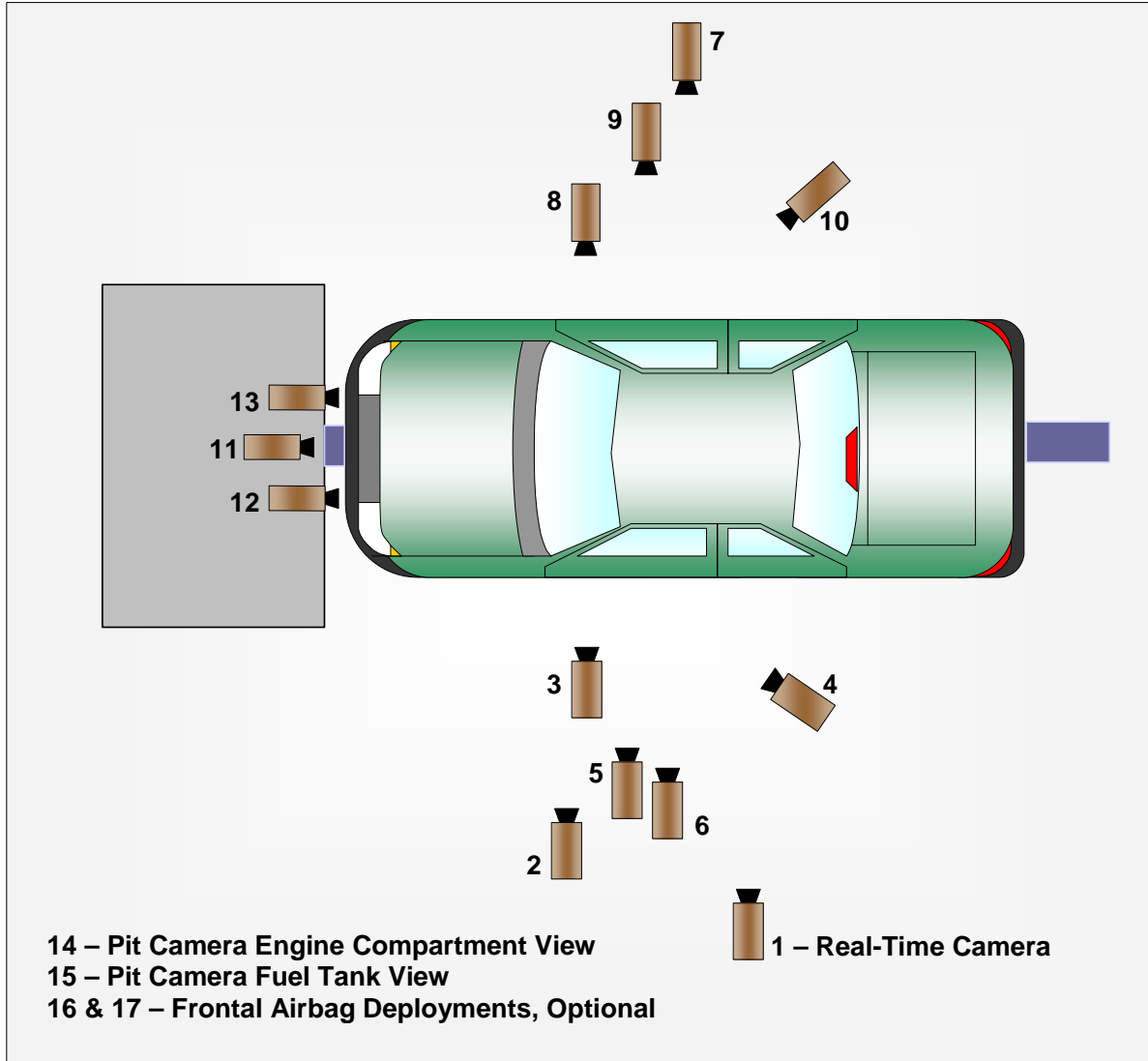

**DATA SHEET NO. 6 (CONTINUED)  
CAMERA LOCATIONS AND DATA**

Test Vehicle: 2012 KIA Rio LX 4-Dr Sedan  
Test Program: NCAP Frontal Barrier Impact Test

NHTSA No.: MC0521  
Test Date: 03/13/2012

**CAMERA LOCATIONS**

No.	Camera View	Coordinates (mm)			Lens (mm)	Speed (fps)
		X*	Y*	Z*		
1	Real-Time Left Overall					30
2	Driver Close-Up	1220	-6240	-1930	35	1000
3	Left Front Half	1070	-4780	-1090	24	1000
4	Left Angle	5810	-5190	-1950	50	1000
5	Steering Column - Top	540	-5200	-1240	24	1000
6	Steering Column - Bottom	520	-5160	-830	24	1000
7	Right Overall	1980	6080	-1110	20	1000
8	Passenger Close-Up	1490	6830	-1910	35	1000
9	Right Front Half	1170	4700	-1120	24	1000
10	Right Angle	5910	4810	-1910	50	1000
11	Windshield	-130	0	-2810	24	1000
12	Driver Windshield	250	-450	-2030	12.5	1000
13	Passenger Windshield	250	450	-2030	12.5	1000
14	Pit Front	1180	0	3150	24	1000
15	Pit Rear	3030	0	3150	24	1000
16	Onboard Driver Side (optional)					
17	Onboard Passenger Side (optional)					
18	Real-Time Pan View					30

\*COORDINATES:

- +X = forward of impact plane
- +Y = right of monorail centerline
- +Z = below ground level

Cameras 16 & 17 were not used for this test.

**DATA SHEET NO. 7  
VEHICLE ACCELEROMETER DATA**

Test Vehicle: 2012 KIA Rio LX 4-Dr Sedan  
 Test Program: NCAP Frontal Barrier Impact Test

NHTSA No.: MC0521  
 Test Date: 03/13/2012

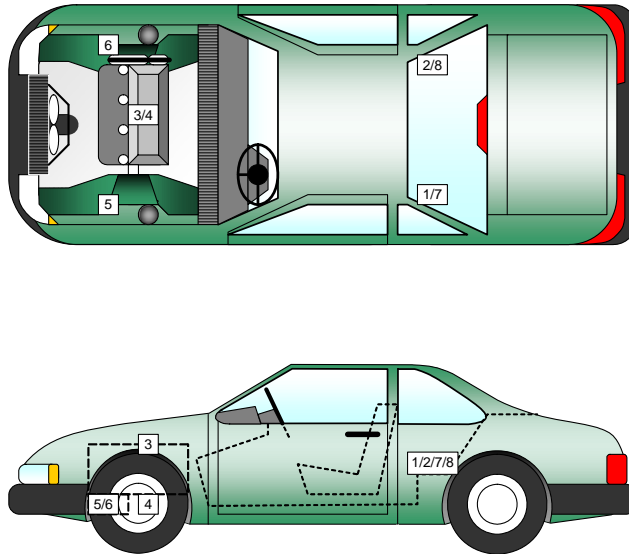

**VEHICLE ACCELEROMETER PRE-TEST LOCATIONS**

No.	Accelerometer Location	Measurements (mm)		
		X	Y	Z
1	Left Rear Accelerometer – X Direction	1776	-433	-211
2	Right Rear Accelerometer – X Direction	1776	433	-220
3	Engine Top X	3867	0	-739
4	Engine Bottom X	3710	0	-263
5	Left Brake Caliper X	3644	-678	-200
6	Right Brake Caliper X	3644	678	-203
7	Left Rear Accelerometer Redundant – X Direction			
8	Right Rear Accelerometer Redundant – X Direction			

Reference Points: X - Rear Surface of Vehicle (+ forward)  
 Y - Vehicle Centerline (+ to right)  
 Z - Ground Plane (+ down)

**DATA SHEET NO. 8**  
**PHOTOGRAPHIC REFERENCE TARGET LOCATIONS**

Test Vehicle: 2012 KIA Rio LX 4-Dr Sedan  
 Test Program: NCAP Frontal Barrier Impact Test

NHTSA No.: MC0521  
 Test Date: 03/13/2012

Item	Value (mm)
A	365
B	855
C	2250
D	670
E	1444
F	229
G	
H	902
I	1235
J	869
K	869
L	1391
M	902
N	1391
O	869
P	869
Q	1235

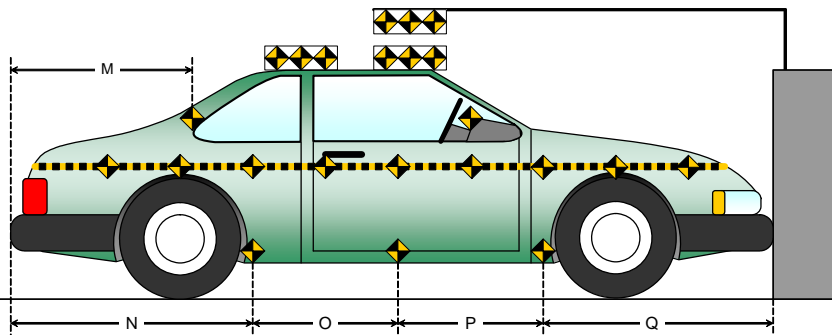
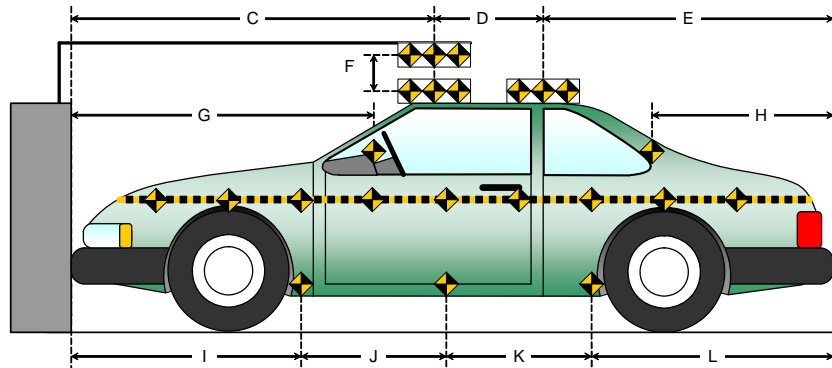
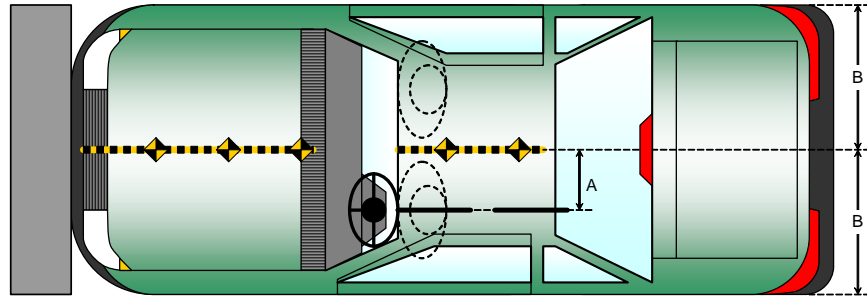

## DATA SHEET NO. 9 LOAD CELL LOCATIONS ON FIXED BARRIER

Test Vehicle: 2012 KIA Rio LX 4-Dr Sedan  
 Test Program: NCAP Frontal Barrier Impact Test

NHTSA No.: MC0521  
 Test Date: 03/13/2012

### Advanced Research Load Cell Barrier



1-1	1-2	1-3	1-4	1-5	1-6	1-7	1-8	1-9	1-10	1-11	1-12	1-13	1-14	1-15	1-16
2-1	2-2	2-3	2-4	2-5	2-6	2-7	2-8	2-9	2-10	2-11	2-12	2-13	2-14	2-15	2-16
3-1	3-2	3-3	3-4	3-5	3-6	3-7	3-8	3-9	3-10	3-11	3-12	3-13	3-14	3-15	3-16
4-1	4-2	4-3	4-4	4-5	4-6	4-7	4-8	4-9	4-10	4-11	4-12	4-13	4-14	4-15	4-16
5-1	5-2	5-3	5-4	5-5	5-6	5-7	5-8	5-9	5-10	5-11	5-12	5-13	5-14	5-15	5-16
6-1	6-2	6-3	6-4	6-5	6-6	6-7	6-8	6-9	6-10	6-11	6-12	6-13	6-14	6-15	6-16
7-1	7-2	7-3	7-4	7-5	7-6	7-7	7-8	7-9	7-10	7-11	7-12	7-13	7-14	7-15	7-16
8-1	8-2	8-3	8-4	8-5	8-6	8-7	8-8	8-9	8-10	8-11	8-12	8-13	8-14	8-15	8-16
9-1	9-2	9-3	9-4	9-5	9-6	9-7	9-8	9-9	9-10	9-11	9-12	9-13	9-14	9-15	9-16
10-1	10-2	10-3	10-4	10-5	10-6	10-7	10-8	10-9	10-10	10-11	10-12	10-13	10-14	10-15	10-16
11-1	11-2	11-3	11-4	11-5	11-6	11-7	11-8	11-9	11-10	11-11	11-12	11-13	11-14	11-15	11-16

Load Cells are 121 mm x 121 mm with a 7 mm gap in between each load cell.

**DATA SHEET NO. 10**  
**TEST VEHICLE SUMMARY OF RESULTS**

Test Vehicle: 2012 KIA Rio LX 4-Dr Sedan  
Test Program: NCAP Frontal Barrier Impact Test

NHTSA No.: MC0521  
Test Date: 03/13/2012

**INSTRUMENTATION**

Driver Dummy Data Channels	46
Passenger Dummy Data Channels	46
Vehicle Structure Accelerometers	8
Barrier Channels	128
Total	228

**CAMERA COVERAGE**

High-Speed Vehicle Onboard	0
High-Speed Offboard	14
Real-Time	2
Total	16

**DATA SHEET NO. 11  
POST-TEST OBSERVATIONS**

Test Vehicle: 2012 KIA Rio LX 4-Dr Sedan  
Test Program: NCAP Frontal Barrier Impact Test

NHTSA No.: MC0521  
Test Date: 03/13/2012

**TEST DUMMY INFORMATION AND CONTACT LOCATIONS**

Description	Driver	Passenger
Dummy Type / Serial No.	HIII 50% / 351	HIII 5% / 138
Head Contact	Airbag, Headrest	Airbag, Headrest
Upper Torso Contact	Airbag	Airbag
Lower Torso Contact	None	None
Left Knee Contact	Knee Bolster	Glovebox
Right Knee Contact	Knee Bolster	Glovebox

**DOOR OPENING AND SEAT TRACK INFORMATION**

Description	Driver	Passenger
Locked/Unlocked Doors	Doors were unlocked	Doors were unlocked
Front Door Opening	Door remained closed and latched; Door opened without tools	Door remained closed and latched; Door opened without tools
Rear Door Opening	Door remained closed and latched; Door opened without tools	Door remained closed and latched; Door opened without tools
Seat Track Shift (mm)	0	0
Seat Back Failure	None	None

**POST TEST STRUCTURAL OBSERVATIONS**

Critical Areas of Performance	Observations and Conclusions
Windshield Damage	Cracked
Window Damage	None
Other Notable Effects	None

**VEHICLE REBOUND FROM BARRIER**

Measured Parameter	Units	Value
Left Side	mm	1382
Center	mm	1394
Right Side	mm	1403
Average	mm	1393

**SUPPLEMENTAL RESTRAINT SYSTEM INFORMATION**

Restraint Type	Left Front (Driver) P1		Right Front (Passenger) P2	
	Mounted	Deployed	Mounted	Deployed
Frontal Airbag	Yes	Yes	Yes	Yes
Knee Airbag	No		No	
Curtain Side Airbag	Yes	No	Yes	No
Torso/Abdomen/Pelvis Side Airbag	Yes	Yes	Yes	Yes
Seat Belt Pretensioner	Yes	Yes	Yes	Yes
Seat Belt Load Limiter	Yes		Yes	

## DATA SHEET NO. 12 VEHICLE PROFILE MEASUREMENTS

Test Vehicle: 2012 KIA Rio LX 4-Dr Sedan  
 Test Program: NCAP Frontal Barrier Impact Test

NHTSA No.: MC0521  
 Test Date: 03/13/2012

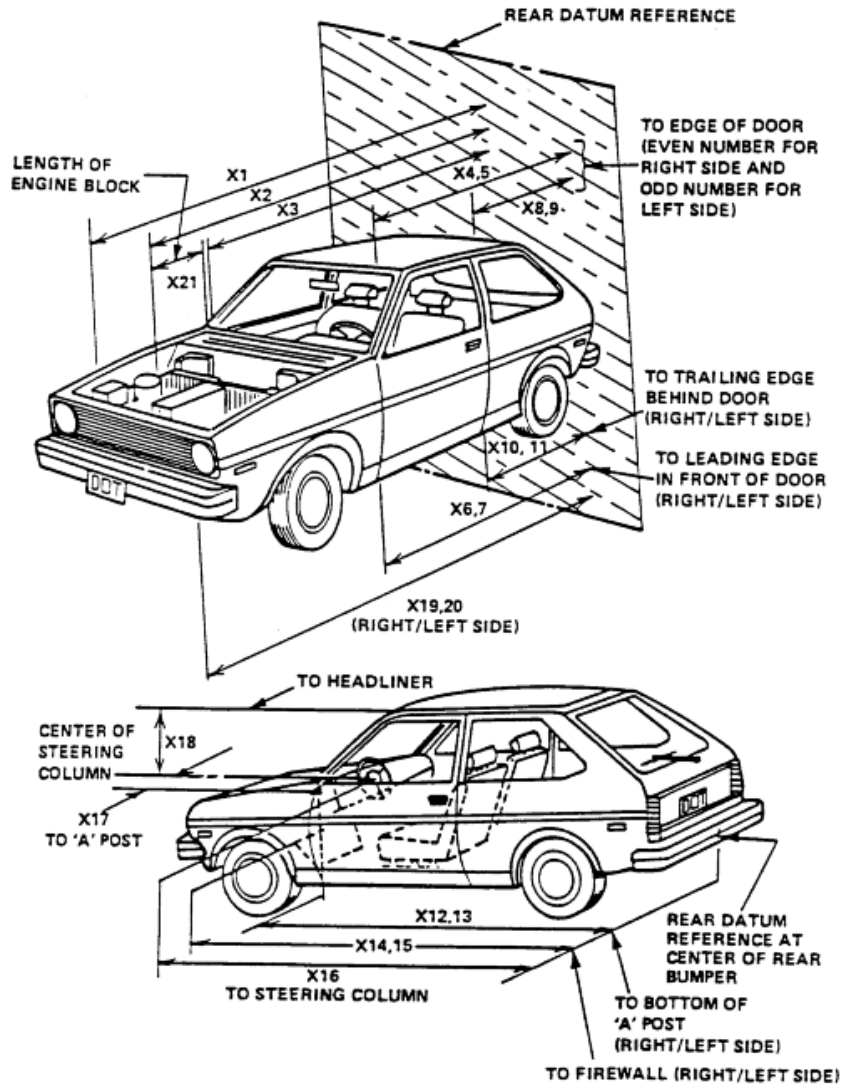

**DATA SHEET NO. 12 (CONTINUED)  
VEHICLE PROFILE MEASUREMENTS**

Test Vehicle: 2012 KIA Rio LX 4-Dr Sedan  
Test Program: NCAP Frontal Barrier Impact Test

NHTSA No.: MC0521  
Test Date: 03/13/2012

**RSOV (Rear Surface of Vehicle)**

No.	Measurement Description	Units	Pre-Test	Post-Test	Difference
1	Total Length of Vehicle at Centerline	mm	4364	3857	507
2	RSOV to Front of Engine	mm	3937	3730	207
3	RSOV to Firewall	mm	3488	3459	29
4	RSOV to Upper Leading Edge of Right Door	mm	3070	3068	2
5	RSOV to Upper Leading Edge of Left Door	mm	3070	3069	1
6	RSOV to Lower Leading Edge of Right Door	mm	3059	3052	7
7	RSOV to Lower Leading Edge of Left Door	mm	3059	3057	2
8	RSOV to Upper Trailing Edge of Right Door	mm	1985	1985	0
9	RSOV to Upper Trailing Edge of Left Door	mm	1983	1982	1
10	RSOV to Lower Trailing Edge of Right Door	mm	1996	1996	0
11	RSOV to Lower Trailing Edge of Left Door	mm	1997	1997	0
12	RSOV to Bottom of "A" Post of Right Side	mm	3060	3057	3
13	RSOV to Bottom of "A" Post of Left Side	mm	3065	3063	2
14	RSOV to Firewall, Right Side	mm	3476	3463	13
15	RSOV to Firewall, Left Side	mm	3495	3485	10
16	RSOV to Steering Column	mm	2592	2640	-48
17	Center of Steering Column to "A" Post	mm	385	405	-20
18	Center of Steering Column to Headliner	mm	405	447	-42
19	RSOV to Right Side of Front Bumper	mm	4244	3837	407
20	RSOV to Left Side of Front Bumper	mm	4244	3835	409
21	Length of Engine Block	mm	457	457	0
RD	RSOV to Right Side of Dash Panel	mm	2880	2877	3
CD	RSOV to Center of Dash Panel	mm	2871	2870	1
LD	RSOV to Left Side of Dash Panel	mm	2883	2882	1

**DATA SHEET NO. 13**  
**ACCIDENT INVESTIGATION DIVISION DATA**

Test Vehicle: 2012 KIA Rio LX 4-Dr Sedan  
Test Program: NCAP Frontal Barrier Impact Test

NHTSA No.: MC0521  
Test Date: 03/13/2012

**VEHICLE INFORMATION**

VIN: KNADM4A35C6052289 Wheelbase (mm): 2570  
Vehicle Size Category: Passenger Test Weight (kg): 1377.1

**ACCELEROMETER DATA**

Accelerometer Locations: As per measurements on Page 15  
Cal. Procedure/Interval: MGA procedure / 6 month  
Integration Algorithm: Trapezoidal Linearity: > 99%  
Impact Velocity (km/h): 56.1  
Velocity Change (km/h): 61.9  
Time of Separation (msec): 82.1

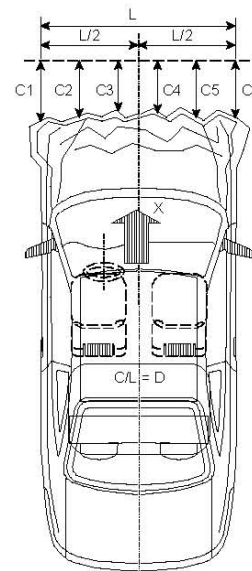

**CRUSH PROFILE**

Collision Deformation Classification: Frontal  
Midpoint of Damage: Centerline  
Damage Region Length (mm): 1104  
Impact Mode: Frontal

No.	Measurement Description	Units	Pre-Test	Post-Test	Difference
C1	Crush zone 1 at left side	mm	4244	3835	409
C2	Crush zone 2 at left side	mm	4311	3863	448
C3	Crush zone 3 at left side	mm	4330	3878	452
C4	Crush zone 4 at right side	mm	4330	3872	458
C5	Crush zone 5 at right side	mm	4311	3864	447
C6	Crush zone 6 at right side	mm	4244	3837	407
L	C1 TO C6	mm	1104	1102	2

**DATA SHEET NO. 14  
VEHICLE INTRUSION MEASUREMENTS**

Test Vehicle: 2012 KIA Rio LX 4-Dr Sedan  
 Test Program: NCAP Frontal Barrier Impact Test

NHTSA No.: MC0521  
 Test Date: 03/13/2012

**DOOR OPENING WIDTH**

Item	Description	Units	Pre-Test	Post-Test	Difference
A	Left Side Upper	mm	985	985	0
B	Left Side Lower	mm	927	927	0
D	Right Side Upper	mm	985	985	0
E	Right Side Lower	mm	927	927	0

**WHEELBASE MEASUREMENTS**

Item	Description	Units	Pre-Test	Post-Test	Difference
C	Left Side Wheelbase	mm	2570	2524	46
F	Right Side Wheelbase	mm	2570	2519	51

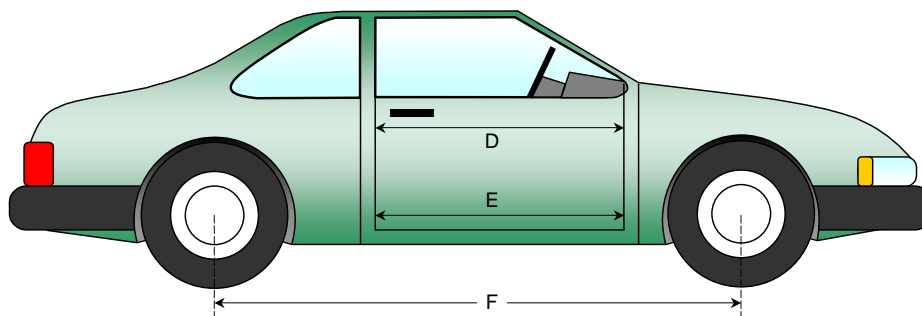
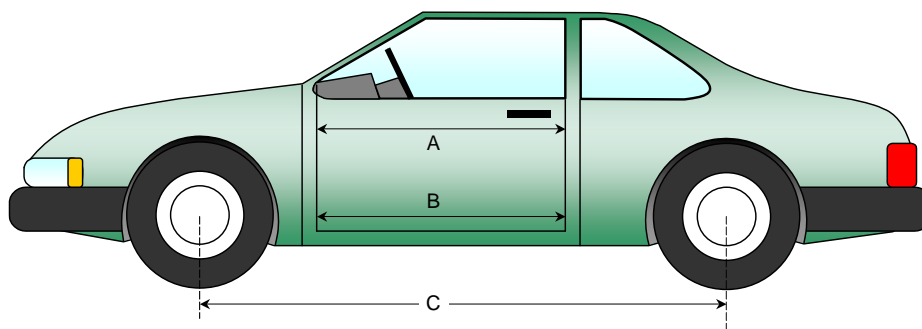

**DATA SHEET NO. 14 (CONTINUED)  
VEHICLE INTRUSION MEASUREMENTS**

Test Vehicle: 2012 KIA Rio LX 4-Dr Sedan  
 Test Program: NCAP Frontal Barrier Impact Test

NHTSA No.: MC0521  
 Test Date: 03/13/2012

**DRIVER COMPARTMENT INTRUSION**

Item	Description	Units	Pre-Test	Post-Test	Difference
AB	Door Opening (Inside window jam)	mm	865	865	0
CX	Left Knee Bolster to X	mm	301	312	-11
DX	Right Knee Bolster to X	mm	279	298	-19
EX	Brake Pedal to X	mm	544	453	91
FX	Foot Rest to X	mm	558	533	25
GX	Center of Steering Column Wheel Hub to X	mm	74	165	-91

X = Front of Seat Track (stationary)

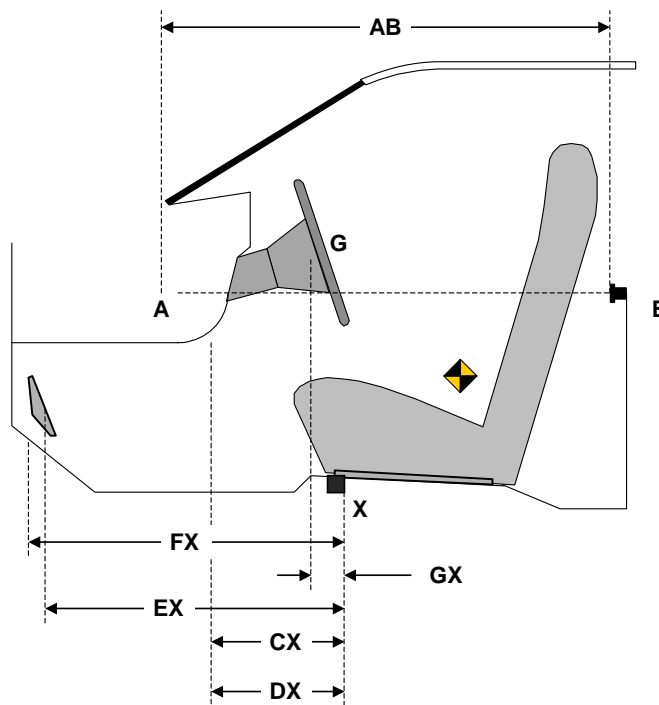

**DRIVER COMPARTMENT**

**DATA SHEET NO. 14 (CONTINUED)  
VEHICLE INTRUSION MEASUREMENTS**

Test Vehicle: 2012 KIA Rio LX 4-Dr Sedan  
Test Program: NCAP Frontal Barrier Impact Test

NHTSA No.: MC0521  
Test Date: 03/13/2012

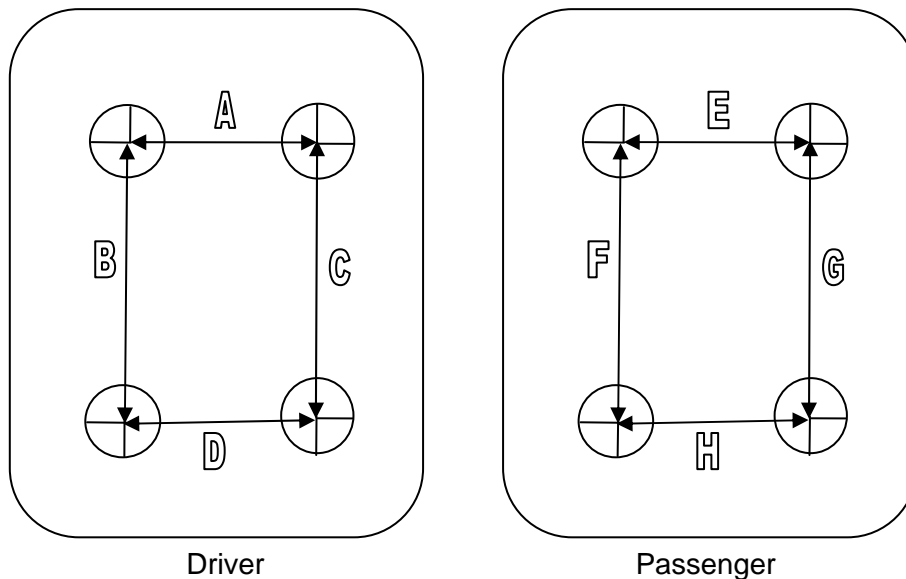

**TOP VIEW THROUGH FLOOR PAN**

**UNDERBODY FLOORBOARD DEFORMATION**

Measurement	Units	Pre-Test	Post-Test	Difference
A	mm	220	220	0
B	mm	220	220	0
C	mm	220	220	0
D	mm	220	220	0
E	mm	220	220	0
F	mm	220	220	0
G	mm	220	220	0
H	mm	220	220	0

**DATA SHEET NO. 15**  
**SUMMARY OF FMVSS 212, 219 (PARTIAL), AND 301 DATA**

Test Vehicle: 2012 KIA Rio LX 4-Dr Sedan  
 Test Program: NCAP Frontal Barrier Impact Test

NHTSA No.: MC0521  
 Test Date: 03/13/2012

**Windshield Mounting Details:**

Windshield glass is secured to the vehicle frame with a rubber trim and glue.

The standard requires that the post-test retention measurement be a minimum of 75 percent of the pretest total periphery measurement for vehicles not equipped with occupant passive restraints and 50 percent for each side of the windshield for vehicles, which are equipped with occupant passive restraints.

Temperature of windshield molding during test: 21.9°C

**WINDSHIELD PERIPHERY MEASUREMENTS**

Measurement	Pre-Test (mm)	Post-Test (mm)	% of Retention
Left Side	2058	2058	100
Right Side	2058	2058	100
Total	4116	4116	100

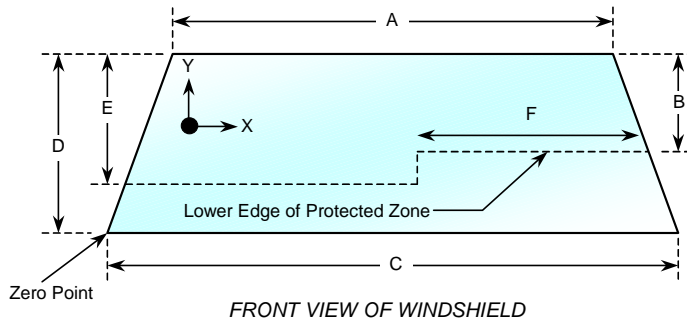

Item	Units	Value
A	mm	1164
B	mm	498
C	mm	1448
D	mm	752
E	mm	510
F	mm	506

**AREA OF PROTECTED ZONE FAILURES - NONE**

A. Provide coordinates of the area that the protected zone was penetrated more than 0.25 inches by a vehicle component other than one that is normally in contact with the windshield. **None**

X	Y

B. Provide coordinates of the area beneath the protected zone that the inner surface of the windshield was penetrated by a vehicle component. **None**

X	Y

**DATA SHEET NO. 15 (CONTINUED)**  
**SUMMARY OF FMVSS 212, 219 (PARTIAL), AND 301 DATA**

Test Vehicle: 2012 KIA Rio LX 4-Dr Sedan  
Test Program: NCAP Frontal Barrier Impact Test

NHTSA No.: MC0521  
Test Date: 03/13/2012

**FMVSS 301 FUEL SYSTEM INTEGRITY POST IMPACT DATA**

Test Time: 1:43 pm

Temperature: 21.9° C

- A. From impact until vehicle motion ceases: 0 oz.  
(Maximum Allowable = 1 ounce)
- B. For the 5 minute period after motion ceases: None  
(Maximum allowable = 5 ounces)
- C. For the following 25 minutes: None  
(Maximum allowable = 1 oz./minute)
- D. Spillage Details: None

**DATA SHEET NO. 16  
FMVSS 301 STATIC ROLLOVER RESULTS**

Test Vehicle: 2012 KIA Rio LX 4-Dr Sedan  
Test Program: NCAP Frontal Barrier Impact Test

NHTSA No.: MC0521  
Test Date: 03/13/2012

1. The specified fixture rollover rate for each 90° of rotation is 60 to 180 seconds.
2. The position hold time at each position is 300 seconds (minimum).
3. Details of Stoddard Solvent spillage: **None**

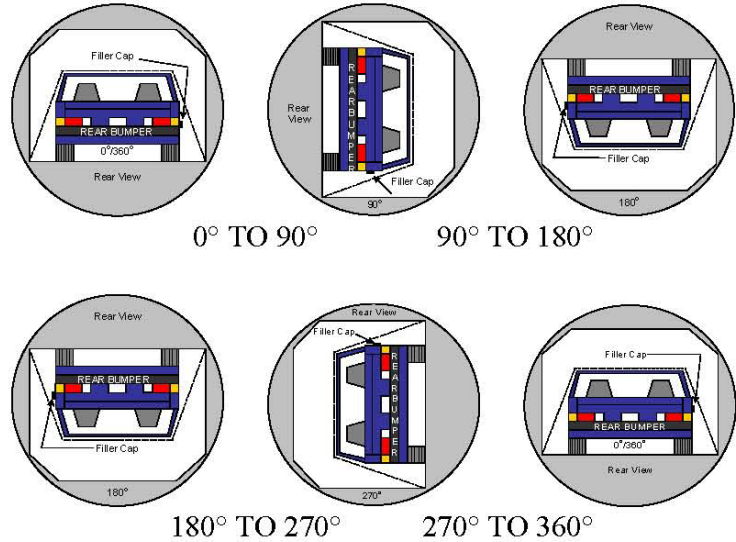

**SOLVENT COLLECTION TIME TABLE IN SECONDS**

Test Phase	Rotation Time	Hold Time	Total Time
0° to 90°	117	300	417
90° to 180°	117	300	417
180° to 270°	109	300	409
270° to 360°	115	300	415

**FMVSS 301 ROLLOVER SPILLAGE TABLE (units in ounces)**

Test Phase	First 5 Minutes	Sixth Minute	Seventh Minute	Eight Minute
0° to 90°	0	0	0	0
90° to 180°	0	0	0	0
180° to 270°	0	0	0	0
270° to 360°	0	0	0	0

**ROLLOVER SOLVENT SPILLAGE LOCATION TABLE**

Test Phase	Spillage Location
0° to 90°	
90° to 180°	
180° to 270°	
270° to 360°	

**DATA SHEET NO. 17  
DUMMY/VEHICLE TEMPERATURE STABILIZATION DATA**

Test Vehicle: 2012 KIA Rio LX 4-Dr Sedan  
 Test Program: NCAP Frontal Barrier Impact Test

NHTSA No.: MC0521  
 Test Date: 03/13/2012

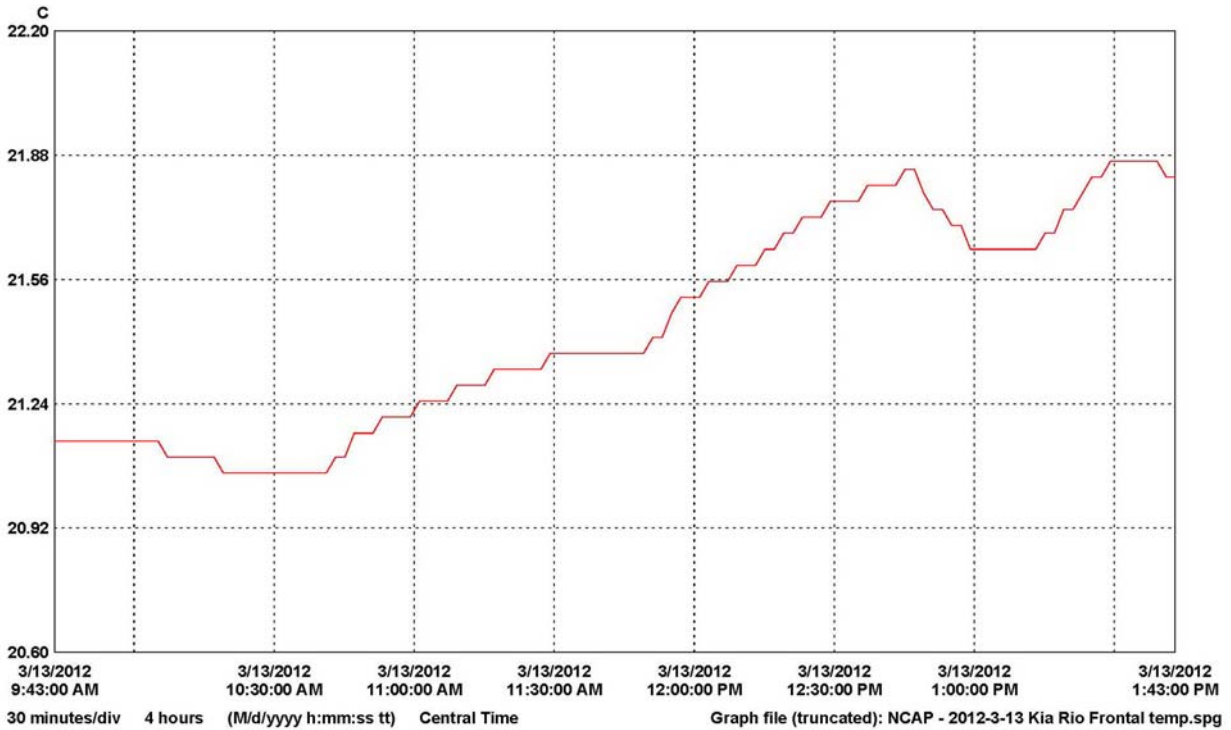

LN	Serial #	Description	CH	Value	Maximum	Average	Minimum	Units	CH description	Logger file
1	07082326	Prep 1	1		21.86	21.43	21.06	C	Temperature	07082326_Prep_1.spl

**APPENDIX A**  
**PHOTOGRAPHS**

## TABLE OF PHOTOGRAPHS

		<u>Page No.</u>
Photo No. 1.	Load Cell Location	A-1
Photo No. 2.	Load Cell Wall	A-1
Photo No. 3.	Manufacturer's Label	A-2
Photo No. 4.	Tire Placard	A-2
Photo No. 5.	2012 KIA Rio Frontal As Delivered	A-3
Photo No. 6.	Left Rear Three-Quarter View, As Received	A-3
Photo No. 7.	Pre-Test Front View of Test Vehicle	A-4
Photo No. 8.	Post-Test Front View of Test Vehicle	A-4
Photo No. 9.	Pre-Test Left View of Test Vehicle	A-5
Photo No. 10.	Post-Test Left View of Test Vehicle	A-5
Photo No. 11.	Pre-Test Right View of Test Vehicle	A-6
Photo No. 12.	Post-Test Right View of Test Vehicle	A-6
Photo No. 13.	Pre-Test Right Front Three-Quarter View	A-7
Photo No. 14.	Post-Test Right Front Three-Quarter View	A-7
Photo No. 15.	Pre-Test Left Rear Three-Quarter View	A-8
Photo No. 16.	Post-Test Left Rear Three-Quarter View	A-8
Photo No. 17.	Pre-Test Windshield View	A-9
Photo No. 18.	Post-Test Windshield View	A-9
Photo No. 19.	Pre-Test Engine Compartment View	A-10
Photo No. 20.	Post-Test Engine Compartment View	A-10
Photo No. 21.	Pre-Test Fuel Filler Cap View	A-11
Photo No. 22.	Post-Test Fuel Filler Cap View	A-11
Photo No. 23.	Pre-Test Front Underbody View	A-12
Photo No. 24.	Post-Test Front Underbody View	A-12
Photo No. 25.	Pre-Test Mid Front Underbody View	A-13
Photo No. 26.	Post-Test Mid Front Underbody View	A-13
Photo No. 27.	Pre-Test Mid Rear Underbody View	A-14
Photo No. 28.	Post-Test Mid Rear Underbody View	A-14

		<u>Page No.</u>
Photo No. 29.	Pre-Test Rear Underbody View	A-15
Photo No. 30.	Post-Test Rear Underbody View	A-15
Photo No. 31.	Pre-Test Dummy Cable Routing	A-16
Photo No. 32.	Post-Test Dummy Cable Routing	A-16
Photo No. 33.	Pre-Test Driver Dummy Front View	A-17
Photo No. 34.	Post-Test Driver Dummy Front View	A-17
Photo No. 35.	Pre-Test Driver Dummy Window View	A-18
Photo No. 36.	Post-Test Driver Dummy Window View	A-18
Photo No. 37.	Pre-Test Driver Dummy and Vehicle Interior (Door Open)	A-19
Photo No. 38.	Post-Test Driver Dummy and Vehicle Interior (Door Open)	A-19
Photo No. 39.	Pre-Test Driver's Seat Fore-Aft Markings	A-20
Photo No. 40.	Post-Test Driver's Seat Fore-Aft Markings	A-20
Photo No. 41.	Pre-Test Driver Dummy Feet	A-21
Photo No. 42.	Post-Test Driver Dummy Feet	A-21
Photo No. 43.	Pre-Test Driver's Side Knee Bolster (without dummy)	A-22
Photo No. 44.	Post-Test Driver's Side Knee Bolster (without dummy)	A-22
Photo No. 45.	Pre-Test Driver's Side Floorpan	A-23
Photo No. 46.	Post-Test Driver's Side Floorpan	A-23
Photo No. 47.	Post-Test Driver Dummy Face	A-24
Photo No. 48.	Post-Test Driver Dummy Contact with Airbag	A-24
Photo No. 49.	Post-Test Driver Dummy Contact with Headrest	A-25
Photo No. 50.	Post-Test Driver Dummy Contact with Knee Bolster	A-25
Photo No. 51.	Pre-Test View of the Steering Wheel	A-26
Photo No. 52.	Post-Test View of the Steering Wheel	A-26
Photo No. 53.	Pre-Test Passenger Dummy Front View	A-27
Photo No. 54.	Post-Test Passenger Dummy Front View	A-27
Photo No. 55.	Pre-Test Passenger Dummy Window View	A-28
Photo No. 56.	Post-Test Passenger Dummy Window View	A-28

		<u>Page No.</u>
Photo No. 57.	Pre-Test Passenger Dummy and Vehicle Interior (Door Open)	A-29
Photo No. 58.	Post-Test Passenger Dummy and Vehicle Interior (Door Open)	A-29
Photo No. 59.	Pre-Test Passenger's Seat Fore-Aft Markings	A-30
Photo No. 60.	Post-Test Passenger's Seat Fore-Aft Markings	A-30
Photo No. 61.	Pre-Test Passenger Dummy Feet	A-31
Photo No. 62.	Post-Test Passenger Dummy Feet	A-31
Photo No. 63.	Pre-Test Passenger's Side Knee Bolster (without dummy)	A-32
Photo No. 64.	Post-Test Passenger's Side Knee Bolster (without dummy)	A-32
Photo No. 65.	Pre-Test Passenger's Side Floorpan	A-33
Photo No. 66.	Post-Test Passenger's Side Floorpan	A-33
Photo No. 67.	Post-Test Passenger Dummy Contact with Airbag	A-34
Photo No. 68.	Post-Test Passenger Dummy Contact with Headrest	A-34
Photo No. 69.	Post-Test Passenger Dummy Contact with Glovebox	A-35
Photo No. 70.	Ballast Installed in Vehicle	A-35
Photo No. 71.	Post-Test Stoddard Solvent Spillage Location View	A-36
Photo No. 72.	Post-Test Speed Trap Read-Out	A-36
Photo No. 73.	Vehicle at 0 Degrees on Static Rollover Device	A-37
Photo No. 74.	Vehicle at 90 Degrees on Static Rollover Device	A-37
Photo No. 75.	Vehicle at 180 Degrees on Static Rollover Device	A-38
Photo No. 76.	Vehicle at 270 Degrees on Static Rollover Device	A-38
Photo No. 77.	Vehicle at 360 Degrees on Static Rollover Device	A-39
Photo No. 78.	2012 KIA Rio Frontal Impact Event	A-39
Photo No. 79.	Monroney Label	A-40

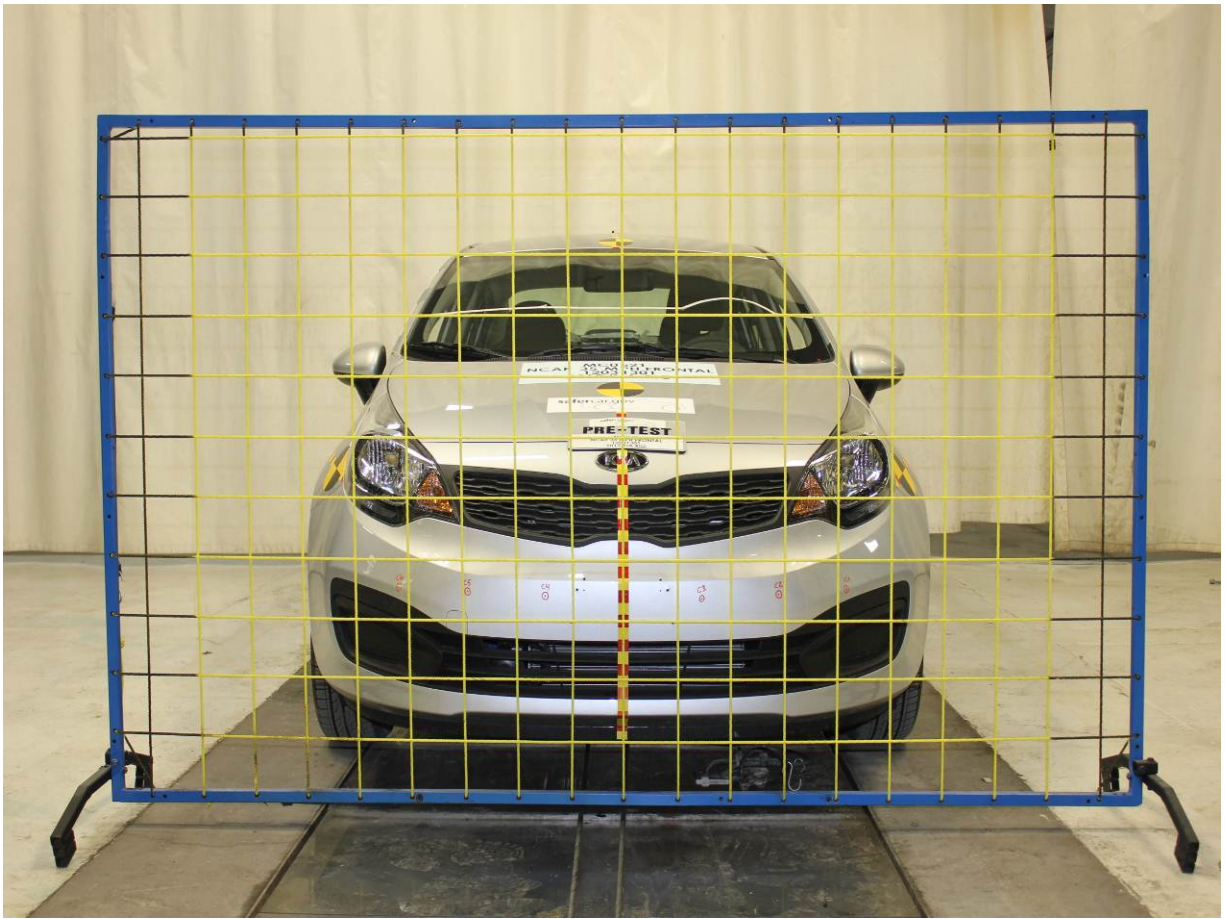

Load Cell Location

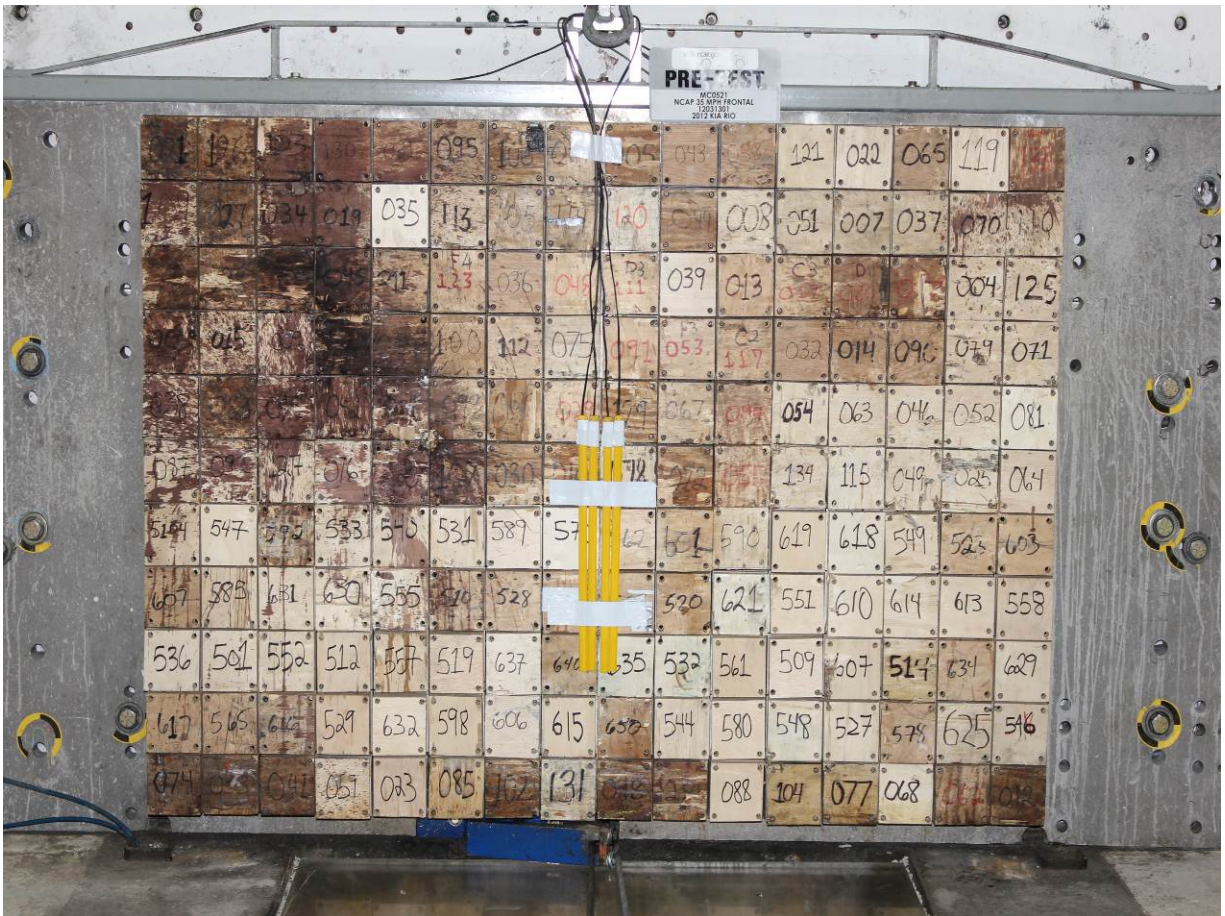

Load Cell Wall



Manufacturer's Label



Tire Placard



2012 KIA Rio Frontal As Delivered



Left Rear Three-Quarter View, As Received



Pre-Test Front View of Test Vehicle

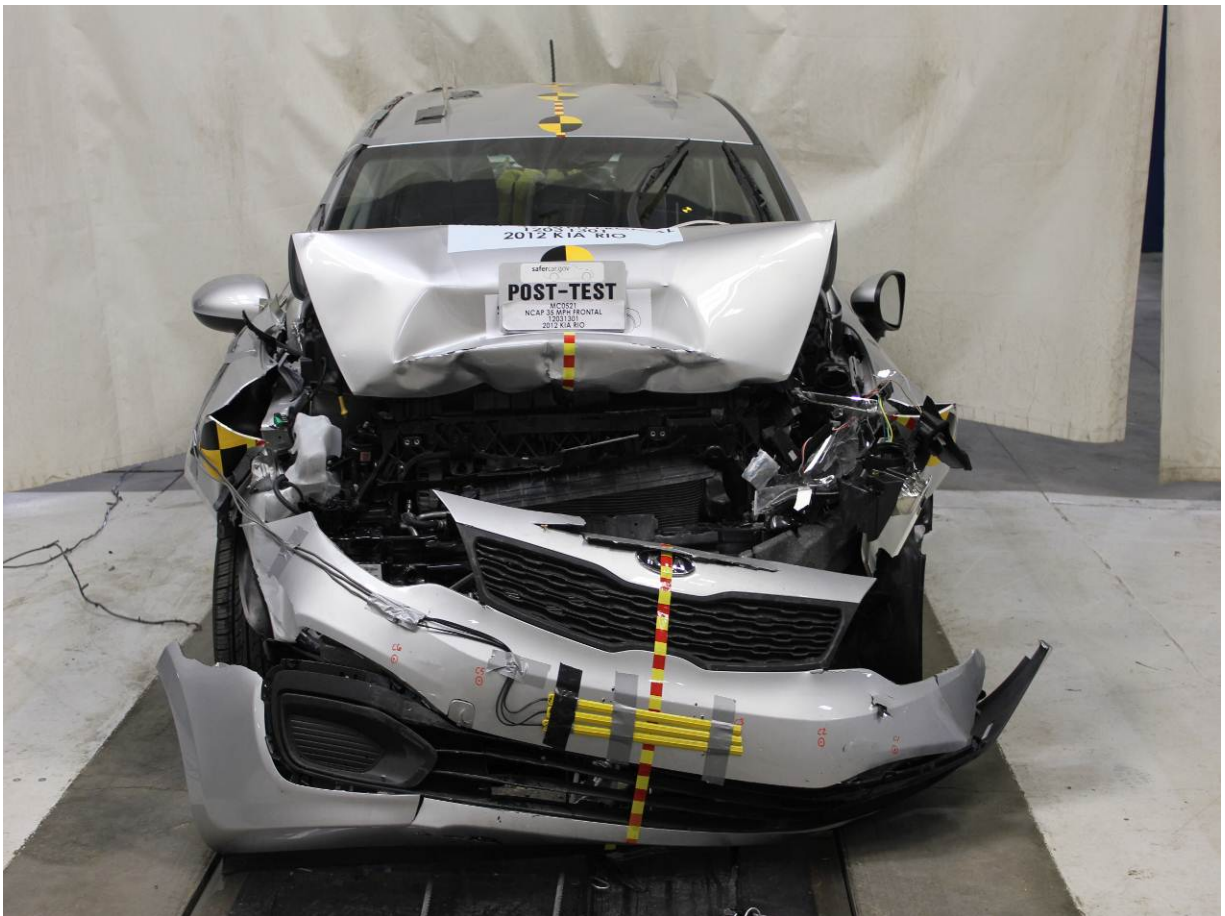

Post-Test Front View of Test Vehicle



Pre-Test Left View of Test Vehicle



Post-Test Left View of Test Vehicle



Pre-Test Right View of Test Vehicle

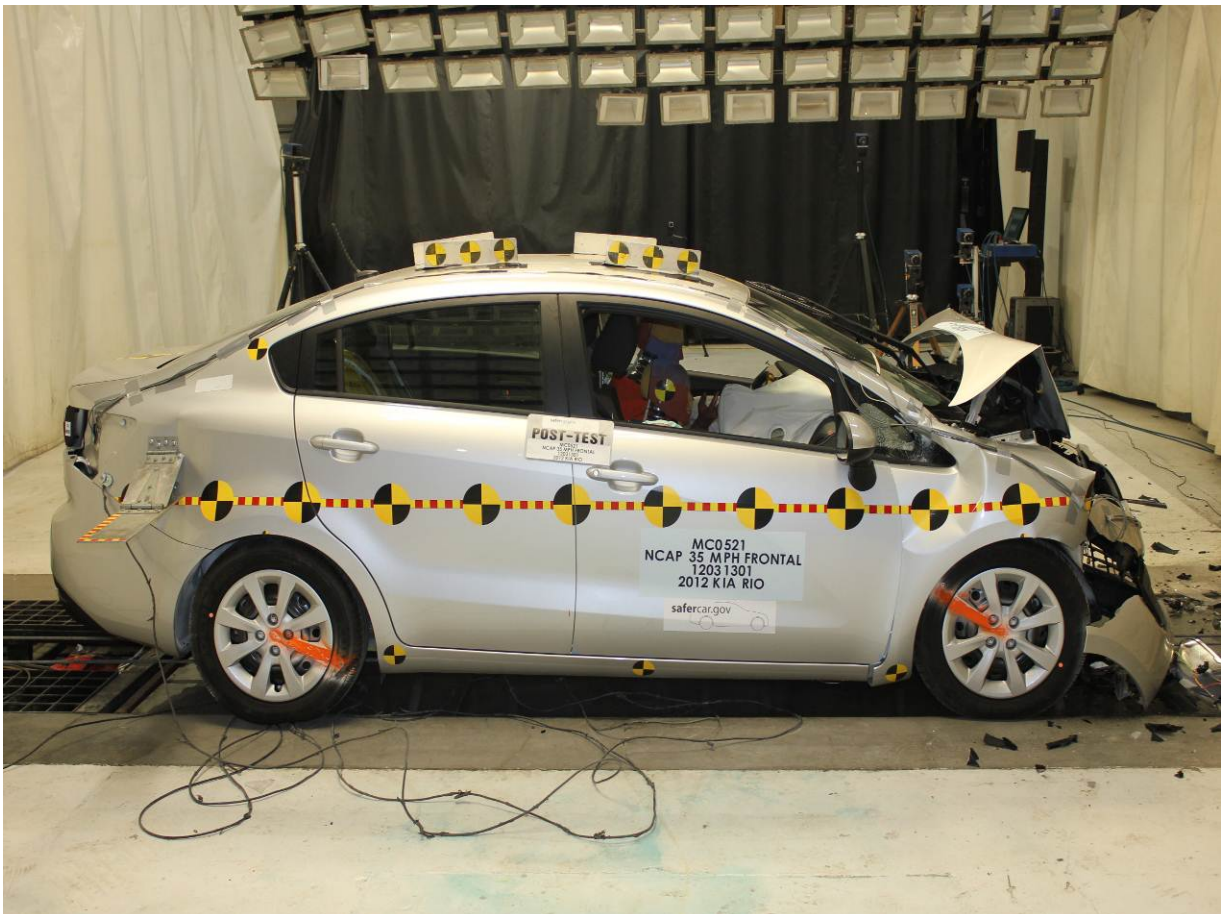

Post-Test Right View of Test Vehicle



Pre-Test Right Front Three-Quarter View



Post-Test Right Front Three-Quarter View



Pre-Test Left Rear Three-Quarter View



Post-Test Left Rear Three-Quarter View



Pre-Test Windshield View



Post-Test Windshield View



Pre-Test Engine Compartment View

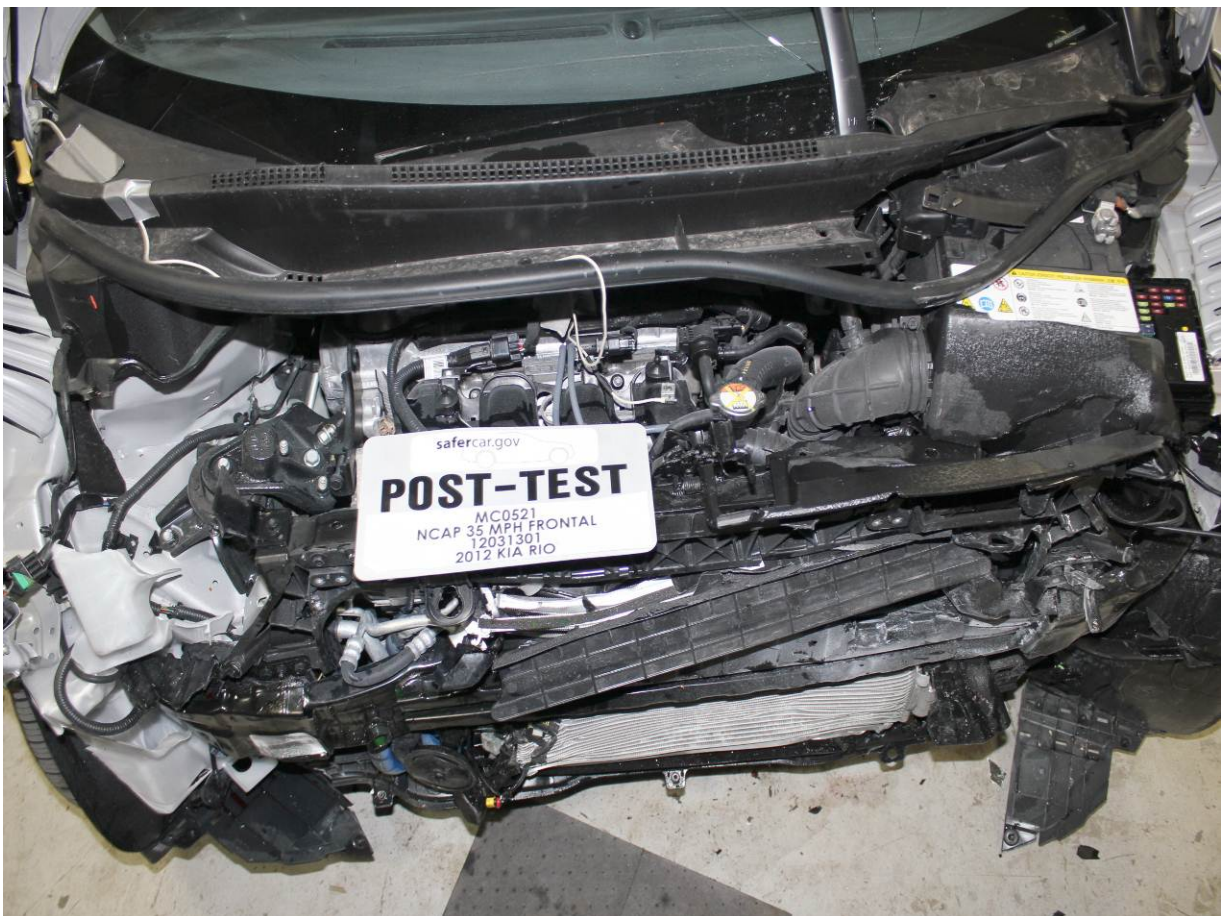

Post-Test Engine Compartment View



Pre-Test Fuel Filler Cap View



Post-Test Fuel Filler Cap View

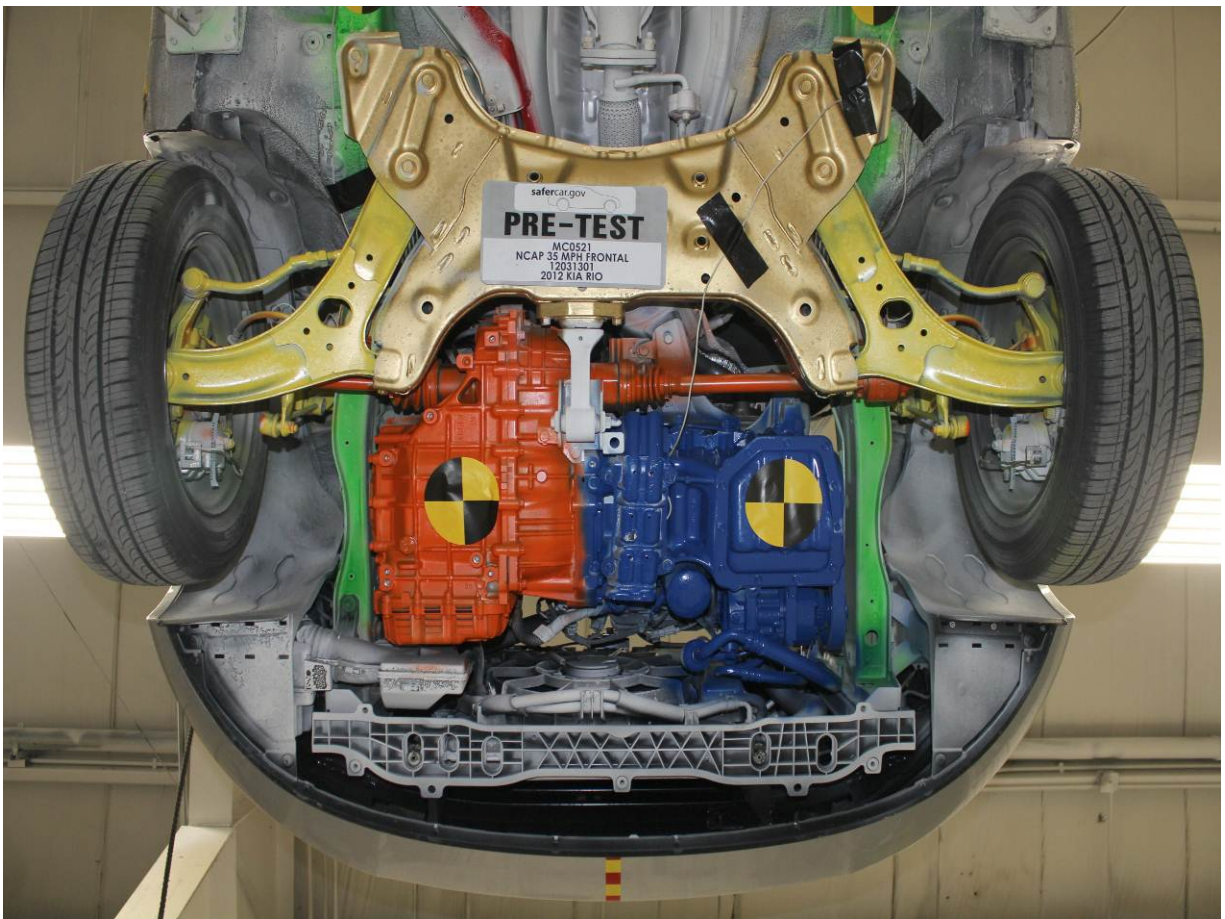

Pre-Test Front Underbody View

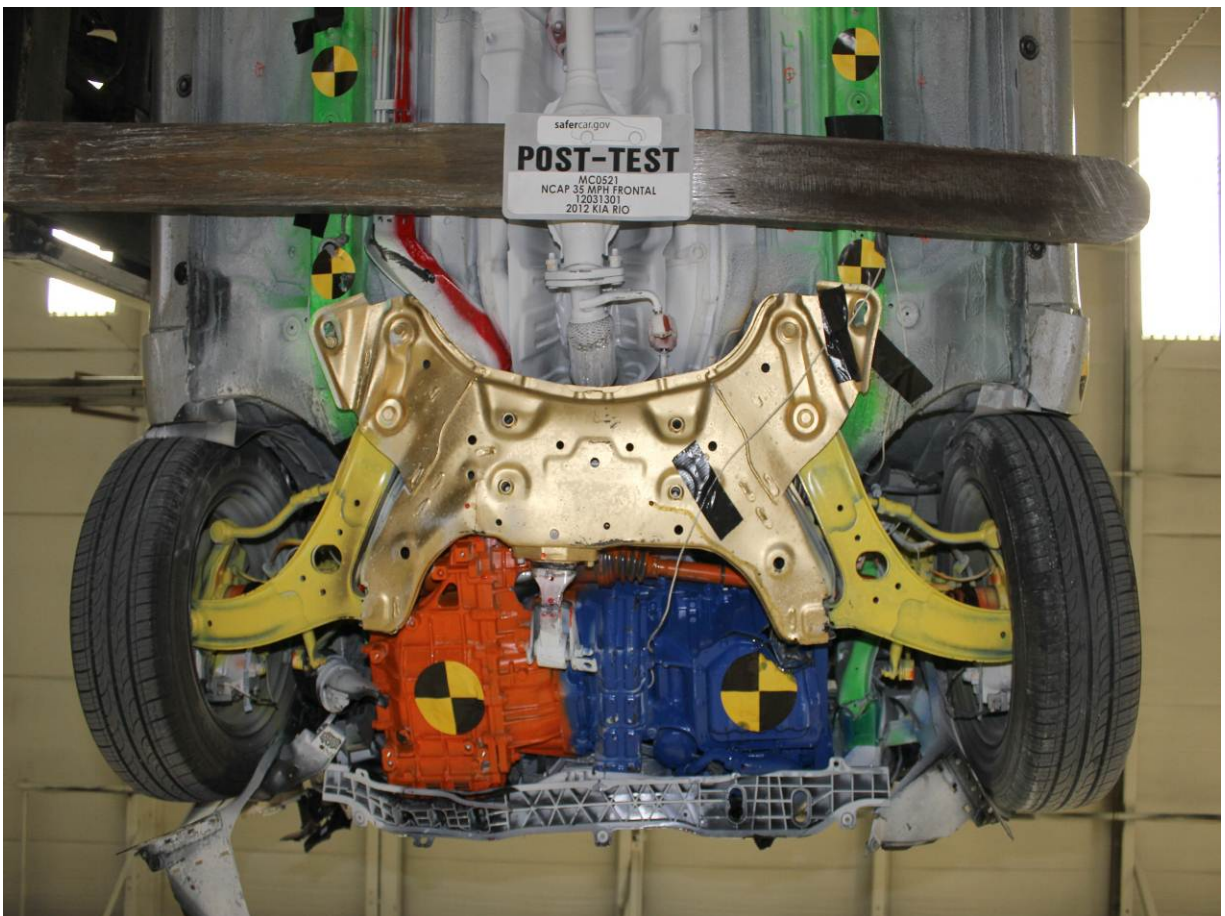

Post-Test Front Underbody View



Pre-Test Mid Front Underbody View

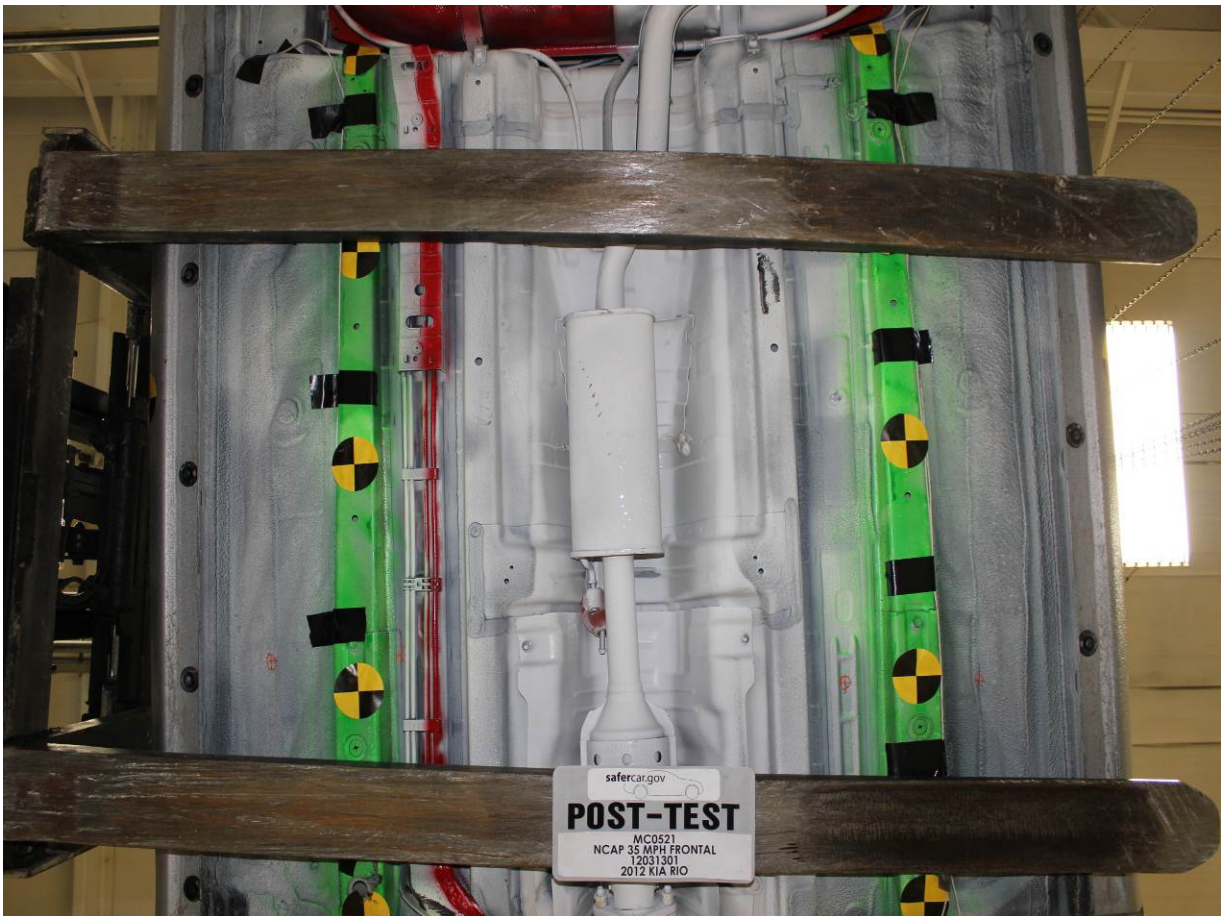

Post-Test Mid Front Underbody View

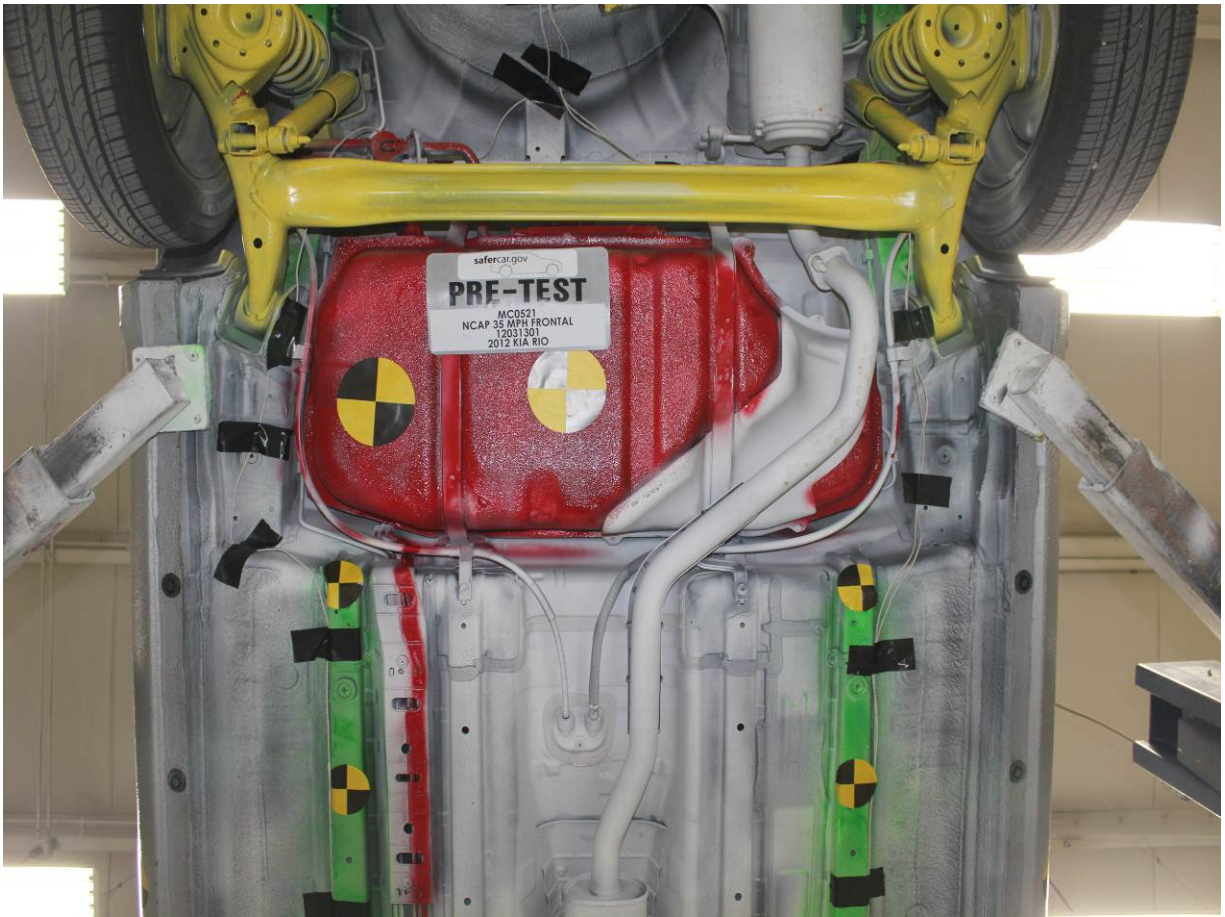

Pre-Test Mid Rear Underbody View

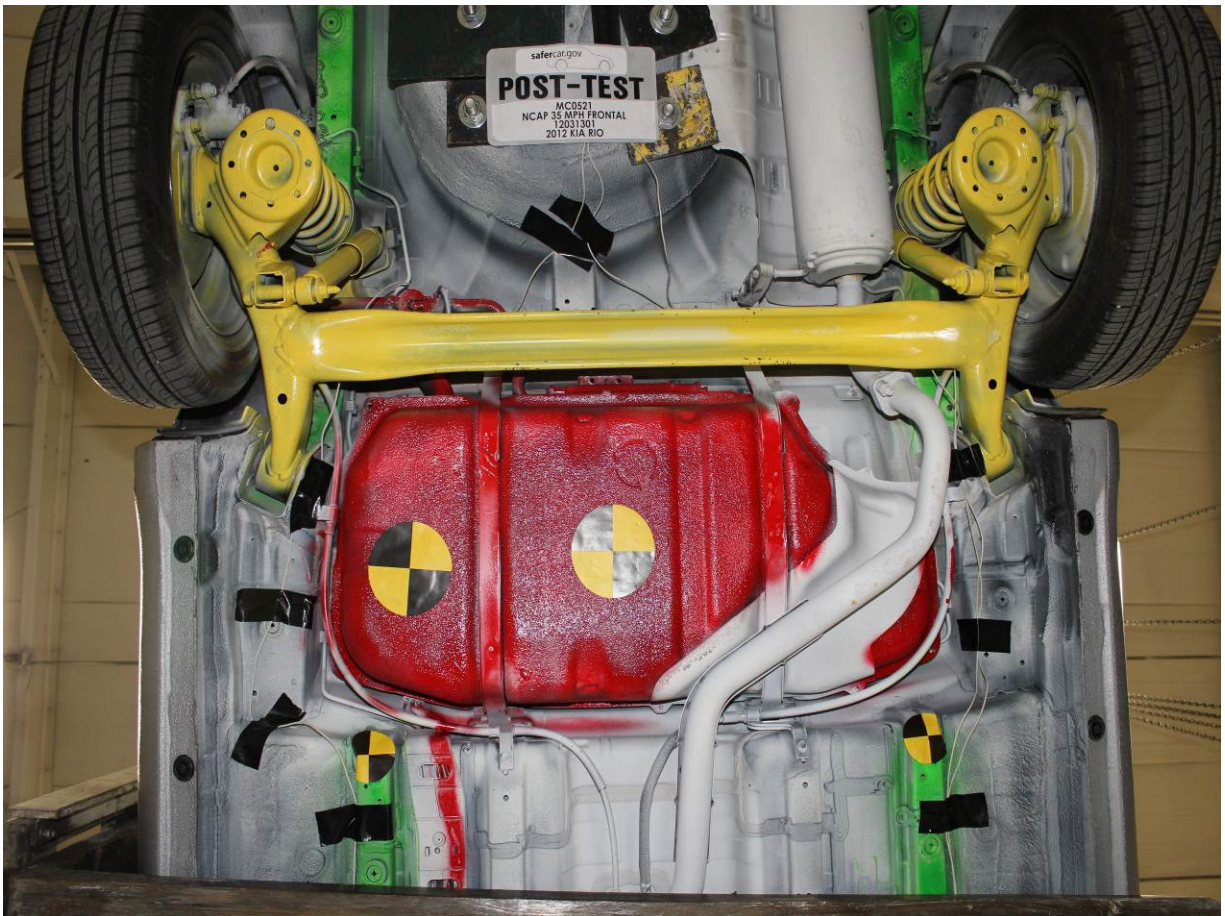

Post-Test Mid Rear Underbody View



Pre-Test Rear Underbody View



Post-Test Rear Underbody View



Pre-Test Dummy Cable Routing



Post-Test Dummy Cable Routing



Pre-Test Driver Dummy Front View



Post-Test Driver Dummy Front View



Pre-Test Driver Dummy Window View



Post-Test Driver Dummy Window View



Pre-Test Driver Dummy and Vehicle Interior (Door Open)



Post-Test Driver Dummy and Vehicle Interior (Door Open)



Pre-Test Driver's Seat Fore-Aft Markings



Post-Test Driver's Seat Fore-Aft Markings



Pre-Test Driver Dummy Feet



Post-Test Driver Dummy Feet



Pre-Test Driver's Side Knee Bolster (without dummy)



Post-Test Driver's Side Knee Bolster (without dummy)



Pre-Test Driver's Side Floorpan



Post-Test Driver's Side Floorpan



Post-Test Driver Dummy Face



Post-Test Driver Dummy Contact with Airbag



Post-Test Driver Dummy Contact with Headrest



Post-Test Driver Dummy Contact with Knee Bolster



Pre-Test View of the Steering Wheel



Post-Test View of the Steering Wheel



Pre-Test Passenger Dummy Front View



Post-Test Passenger Dummy Front View

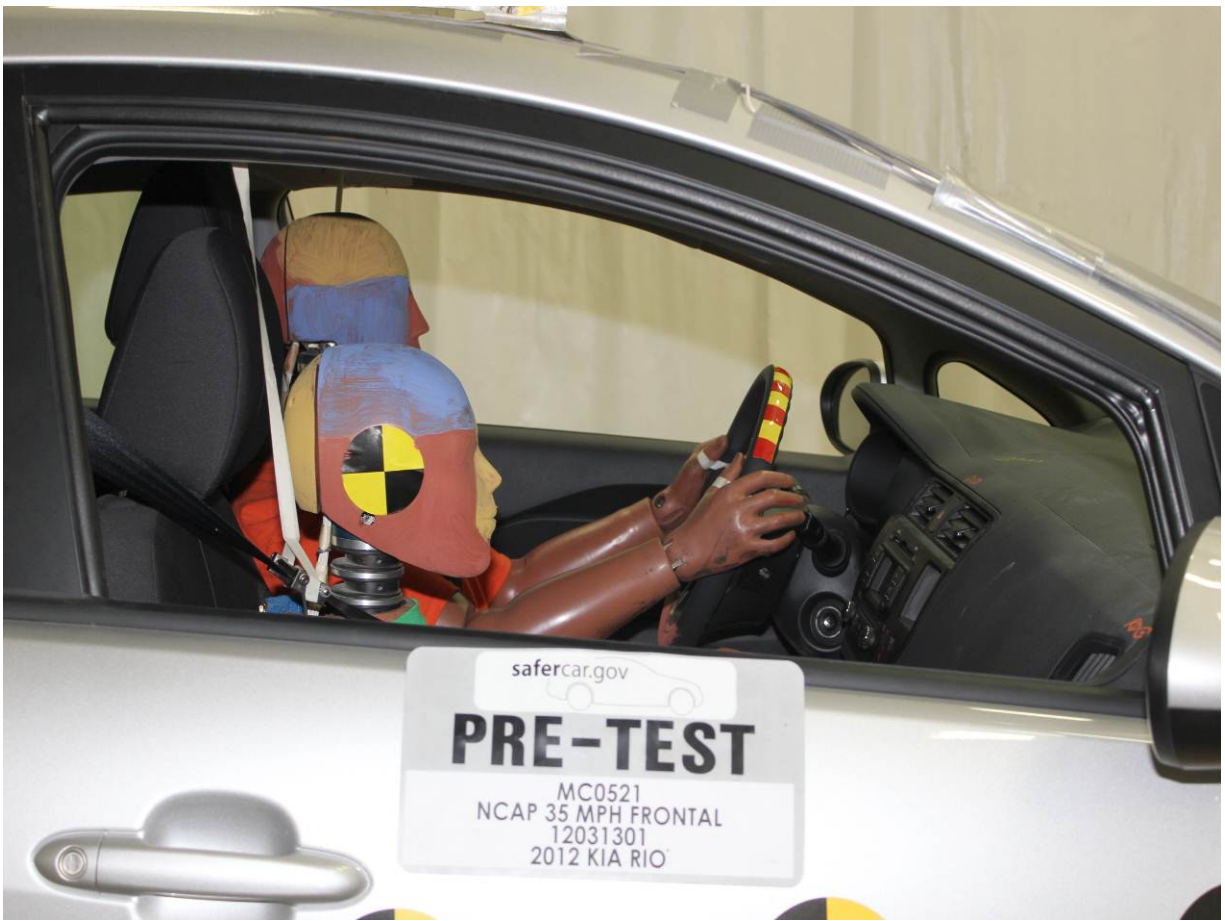

Pre-Test Passenger Dummy Window View



Post-Test Passenger Dummy Window View



Pre-Test Passenger Dummy and Vehicle Interior (Door Open)



Post-Test Passenger Dummy and Vehicle Interior (Door Open)



Pre-Test Passenger's Seat Fore-Aft Markings



Post-Test Passenger's Seat Fore-Aft Markings



Pre-Test Passenger Dummy Feet



Post-Test Passenger Dummy Feet



Pre-Test Passenger's Side Knee Bolster (without dummy)



Post-Test Passenger's Side Knee Bolster (without dummy)



Pre-Test Passenger's Side Floorpan



Post-Test Passenger's Side Floorpan



Post-Test Passenger Dummy Contact with Airbag

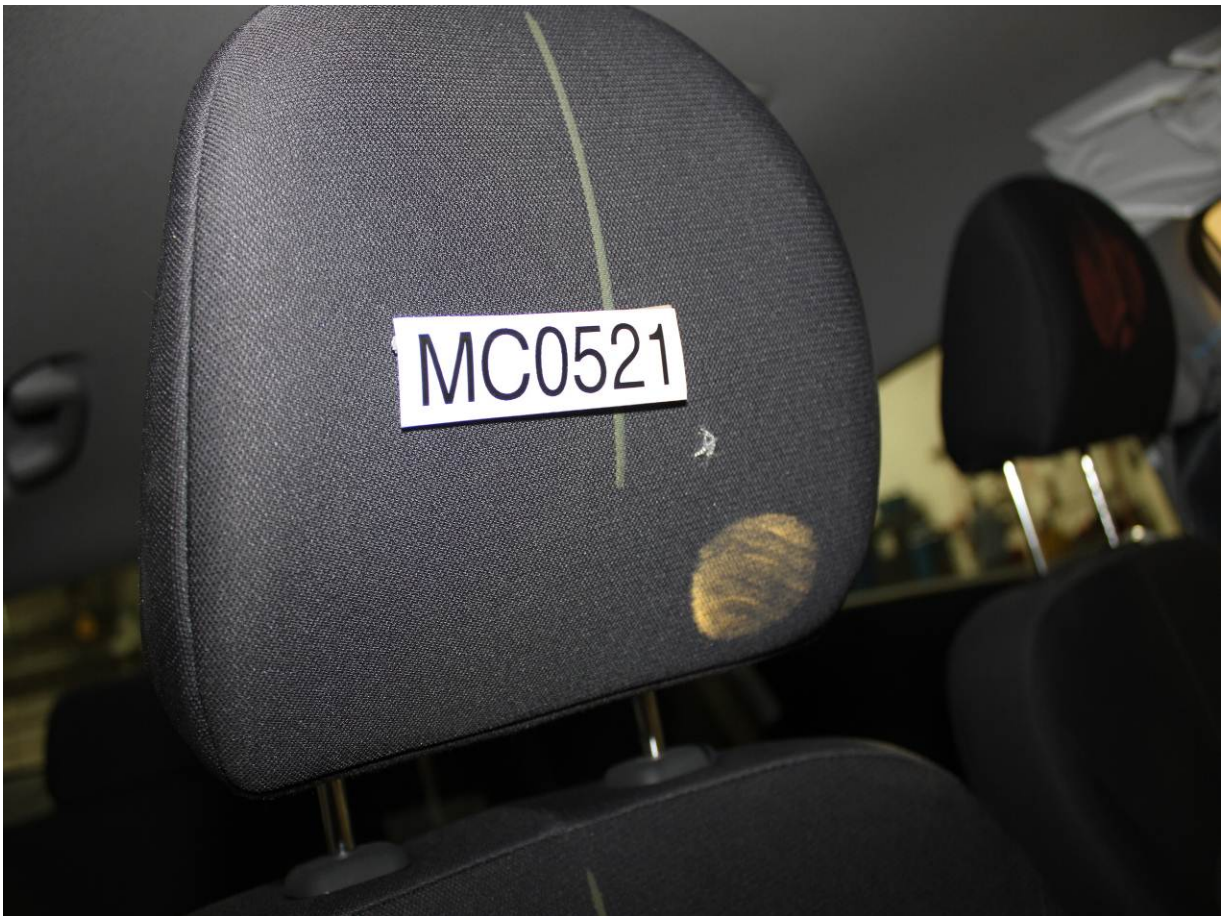

Post-Test Passenger Dummy Contact with Headrest



Post-Test Passenger Dummy Contact with Glovebox



Ballast Installed in Vehicle

PHOTOGRAPH NOT APPLICABLE

Post-Test Stoddard Solvent Spillage Location View



Post-Test Speed Trap Read-Out



Vehicle at 0 Degrees on Static Rollover Device



Vehicle at 90 Degrees on Static Rollover Device

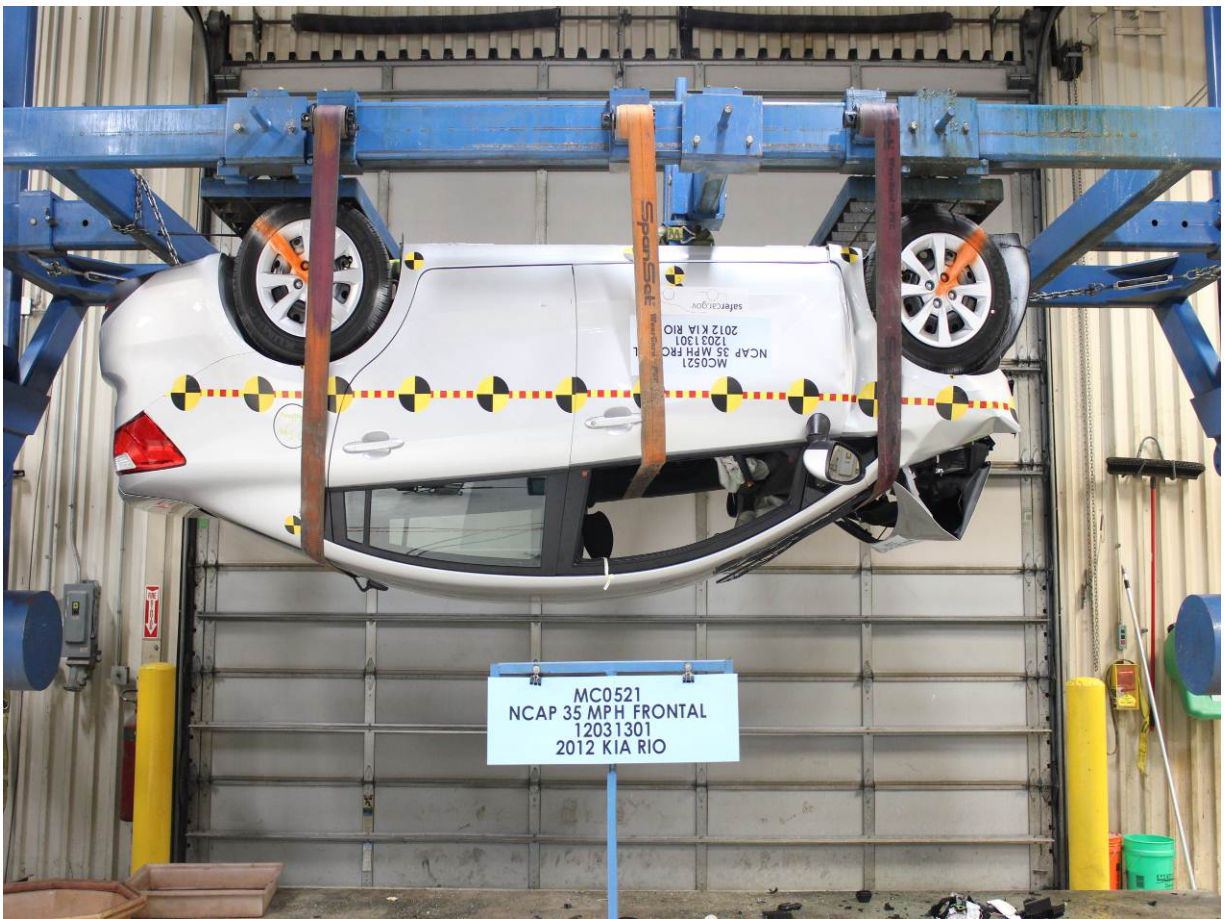

Vehicle at 180 Degrees on Static Rollover Device



Vehicle at 270 Degrees on Static Rollover Device



Vehicle at 360 Degrees on Static Rollover Device



2012 KIA Rio Frontal Impact Event

	2012 31422 KIA RIO LX	SOLD TO:	SHIP TO:
	MODEL YEAR MODEL MODEL DESCRIPTION	WI027	WI027
	BRIGHT SILVER/BLK	BOUCHER KIA	
	EXTERIOR / INTERIOR COLOR	8730 N. 91ST STREET	
KNADM4A35C8052289 G4FDBH51	MILWAUKEE WI 53224		
VEHICLE NUMBER ENGINE NUMBER			
TACOMA TRUCK			
PORT OF ORIGIN MODE OF TRANSPORTATION			
<b>STANDARD FEATURES</b>	<b>MANUFACTURER'S SUGGESTED RETAIL PRICE</b>	\$14,500.00	
<b>MECHANICAL</b> 1.6L Gas Direct Injection 4-cyl Engine 6-Speed Automatic Transmission Electric Power Steering 15" Steel Wheels with Wheel Covers	<b>ADDITIONAL INSTALLED EQUIPMENT:</b> (In addition to or in place of standard features) Carpeted Floor Mats \$95.00 Cargo Net \$50.00		
<b>SAFETY</b> Dual Front Advanced Airbags Front Seat-Mounted Side Airbags Full-Length Side Curtain Airbags 3-Point Seatbelts for All Seating Positions Lower Anchors and Tethers for Children (LATCH) Anti-Lock Brake System (ABS) Traction Control System (TCS) Electronic Stability Control (ESC) Vehicle Stability Management (VSM) Hill Assist Control (HAC)			
<b>INTERIOR</b> Air Conditioning AM/FM/CD/MP3 Audio System SIRIUS Satellite Radio w/ free 3-mo. subscription** USB & Auxiliary Input Jacks Multi-Adjustable Driver's Seat 60/40 Split Folding Rear Seats Tilt Steering Column Steering Wheel Mounted Audio Controls Trip Computer			
<b>EXTERIOR</b> Body Color Power Heated Outside Mirrors Body Color Door Handles Variable Intermittent Front Wipers			
<b>10 YEAR/100,000 MILE LIMITED POWERTRAIN WARRANTY</b> <b>5 YEAR/60,000 MILE</b> 5 Year/60,000 Mile Roadside Assistance **Ask dealer for details			
	<b>MSRP INCLUDING OPTIONS</b>	\$14,645.00	
	INLAND FREIGHT AND HANDLING	\$750.00	
	<b>TOTAL MANUFACTURER'S SUGGESTED RETAIL PRICE</b>	\$15,395.00	
Manufacturer's suggested retail price includes manufacturer's recommended pre-delivery service. License and title fees, state and local taxes and other dealer installed options and accessories are not included in the manufacturer's suggested retail price.			

TOTAL ADDITIONAL WEIGHT: 6.4



## EPA Fuel Economy Estimates

These estimates reflect new EPA methods beginning with 2008 models.

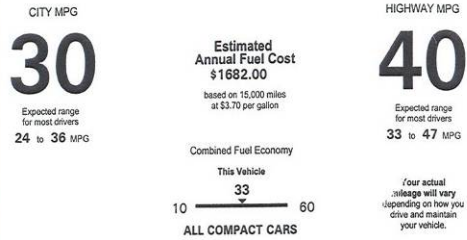

See the FREE Fuel Economy Guide at dealers or [www.fueleconomy.gov](http://www.fueleconomy.gov)

### GOVERNMENT SAFETY RATINGS

### PARTS CONTENT INFORMATION

This vehicle has not been rated by the government for frontal crash, side crash or rollover risk.

Source: National Highway Traffic Safety Administration (NHTSA).

FOR VEHICLES IN THIS CAR LINE U.S./CANADIAN PARTS CONTENT: 4%

MAJOR SOURCES OF FOREIGN PARTS:

KOREA: 90%

NOTE: PARTS CONTENT DOES NOT INCLUDE FINAL ASSEMBLY, DISTRIBUTION, OR OTHER NON-PARTS COSTS.

[www.safercar.gov](http://www.safercar.gov) or 1-888-327-4236

### Environmental Performance

Protect the environment, choose vehicles with higher scores:



Vehicle emissions are a primary contributor to global warming and smog. Scores are determined by the California Air Resources Board based on this vehicle's measured emissions. Please visit [www.DriveClean.ca.gov](http://www.DriveClean.ca.gov) for more information. AIR RESOURCES BOARD

FOR THIS VEHICLE FINAL ASSEMBLY POINT: KOREA

COUNTRY OF ORIGIN ENGINE: KOREA

TRANSMISSION: KOREA

Monroney Label

**APPENDIX B**  
**DUMMY RESPONSE DATA TRACES**

## TABLE OF DATA PLOTS

Page No.

### List of Data Plots Provided in the Test Report

Figure No. 1.	Driver Head X Acceleration vs. Time	B-1
Figure No. 2.	Driver Head Y Acceleration vs. Time	B-1
Figure No. 3.	Driver Head Z Acceleration vs. Time	B-1
Figure No. 4.	Driver Head Resultant Acceleration vs. Time	B-1
Figure No. 5.	Driver Chest Displacement vs. Time	B-2
Figure No. 6.	Driver Chest X Acceleration vs. Time	B-3
Figure No. 7.	Driver Chest Y Acceleration vs. Time	B-3
Figure No. 8.	Driver Chest Z Acceleration vs. Time	B-3
Figure No. 9.	Driver Chest Resultant Acceleration vs. Time	B-3
Figure No. 10.	Driver Neck Force X vs. Time	B-4
Figure No. 11.	Driver Neck Force Z vs. Time	B-4
Figure No. 12.	Driver Neck Moment Y vs. Time	B-4
Figure No. 13.	Driver Nij (NTF) vs. Time	B-5
Figure No. 14.	Driver Nij (NTE) vs. Time	B-5
Figure No. 15.	Driver Nij (NCF) vs. Time	B-5
Figure No. 16.	Driver Nij (NCE) vs. Time	B-5
Figure No. 17.	Driver Left Femur Force vs. Time	B-6
Figure No. 18.	Driver Right Femur Force vs. Time	B-6
Figure No. 19.	Passenger Head X Acceleration vs. Time	B-7
Figure No. 20.	Passenger Head Y Acceleration vs. Time	B-7
Figure No. 21.	Passenger Head Z Acceleration vs. Time	B-7
Figure No. 22.	Passenger Head Resultant Acceleration vs. Time	B-7
Figure No. 23.	Passenger Chest Displacement vs. Time	B-8
Figure No. 24.	Passenger Chest X Acceleration vs. Time	B-9
Figure No. 25.	Passenger Chest Y Acceleration vs. Time	B-9
Figure No. 26.	Passenger Chest Z Acceleration vs. Time	B-9
Figure No. 27.	Passenger Chest Resultant Z Acceleration vs. Time	B-9

	<u>Page No.</u>
Figure No. 28. Passenger Neck Force X vs. Time	B-10
Figure No. 29. Passenger Neck Force Z vs. Time	B-10
Figure No. 30. Passenger Neck Moment Y vs. Time	B-10
Figure No. 31. Passenger Nij (NTF) vs. Time	B-11
Figure No. 32. Passenger Nij (NTE) vs. Time	B-11
Figure No. 33. Passenger Nij (NCF) vs. Time	B-11
Figure No. 34. Passenger Nij (NCE) vs. Time	B-11
Figure No. 35. Passenger Left Femur Force vs. Time	B-12
Figure No. 36. Passenger Right Femur Force vs. Time	B-12

**The following additional dummy and vehicle response data can be found in the R&D section of the NHTSA website at [www.nhtsa.dot.gov](http://www.nhtsa.dot.gov)**

Driver Head X Redundant  
 Driver Head Y Redundant  
 Driver Head Z Redundant  
 Driver Upper Neck Force Y  
 Driver Upper Neck Moment X  
 Driver Upper Neck Moment Z  
 Driver Chest X Redundant  
 Driver Chest Y Redundant  
 Driver Chest Z Redundant  
 Driver Pelvis X  
 Driver Pelvis Y  
 Driver Pelvis Z  
 Driver Left Femur Redundant  
 Driver Right Femur Redundant  
 Driver Left Upper Tibia Moment X  
 Driver Left Upper Tibia Moment Y  
 Driver Left Upper Tibia Force Z  
 Driver Left Lower Tibia Moment X

Driver Left Lower Tibia Moment Y  
Driver Left Lower Tibia Force Z  
Driver Right Upper Tibia Moment X  
Driver Right Upper Tibia Moment Y  
Driver Right Upper Tibia Force Z  
Driver Right Lower Tibia Moment X  
Driver Right Lower Tibia Moment Y  
Driver Right Lower Tibia Force Z  
Driver Left Foot Fore Z  
Driver Left Foot Aft X  
Driver Left Foot Aft Z  
Driver Right Foot Fore Z  
Driver Right Foot Aft X  
Driver Right Foot Aft Z  
Driver Lap Belt Force  
Driver Shoulder Belt Force  
Passenger Head X Redundant  
Passenger Head Y Redundant  
Passenger Head Z Redundant  
Passenger Upper Neck Force Y  
Passenger Upper Neck Moment X  
Passenger Upper Neck Moment Z  
Passenger Chest X Redundant  
Passenger Chest Y Redundant  
Passenger Chest Z Redundant  
Passenger Pelvis X  
Passenger Pelvis Y  
Passenger Pelvis Z  
Passenger Left Femur Redundant  
Passenger Right Femur Redundant  
Passenger Left Upper Tibia Moment X

Passenger Left Upper Tibia Moment Y  
Passenger Left Upper Tibia Force Z  
Passenger Left Lower Tibia Moment X  
Passenger Left Lower Tibia Moment Y  
Passenger Left Lower Tibia Force Z  
Passenger Right Upper Tibia Moment X  
Passenger Right Upper Tibia Moment Y  
Passenger Right Upper Tibia Force Z  
Passenger Right Lower Tibia Moment X  
Passenger Right Lower Tibia Moment Y  
Passenger Right Lower Tibia Force Z  
Passenger Left Foot Fore Z  
Passenger Left Foot Aft X  
Passenger Left Foot Aft Z  
Passenger Right Foot Fore Z  
Passenger Right Foot Aft X  
Passenger Right Foot Aft Z  
Passenger Lap Belt Force  
Passenger Shoulder Belt Force  
Left Rear Seat Crossmember X  
Right Rear Seat Crossmember X  
Vehicle Engine Top X  
Vehicle Engine Bottom X  
Vehicle Left Brake Caliper X  
Vehicle Right Brake Caliper X  
Left Rear Seat Crossmember Xr  
Right Rear Seat Crossmember Xr  
Advanced Research Load Cell Barrier – 128 channels

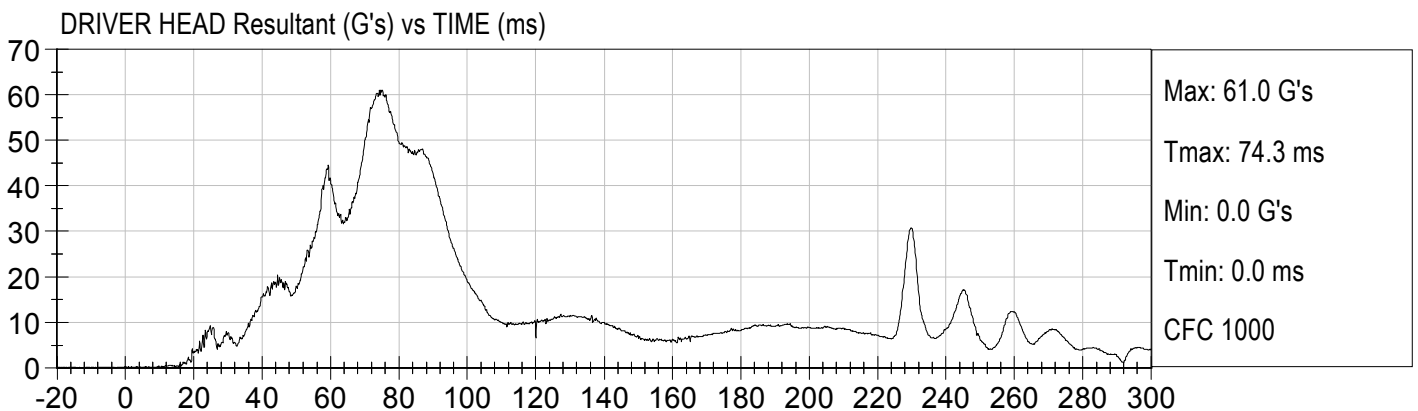
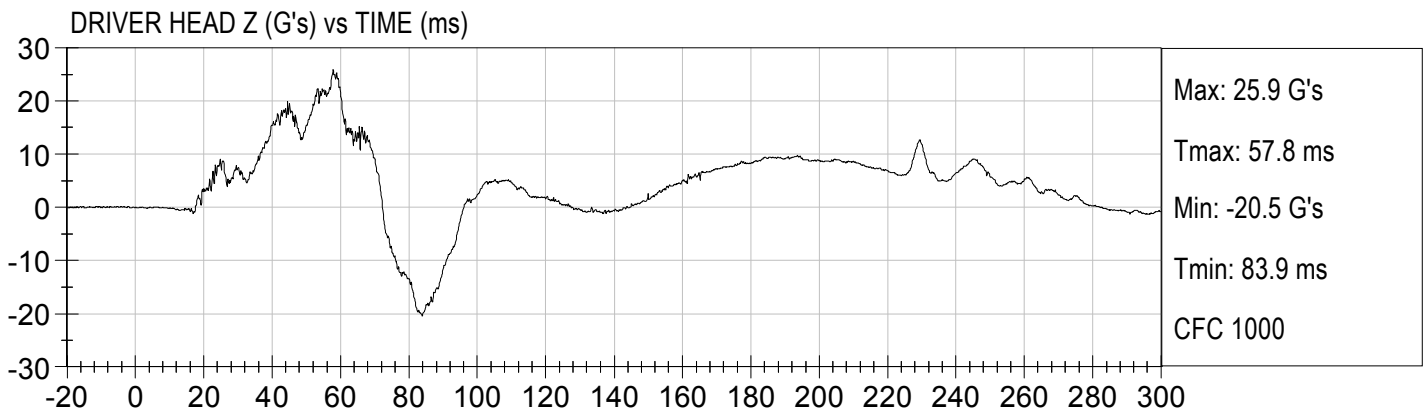
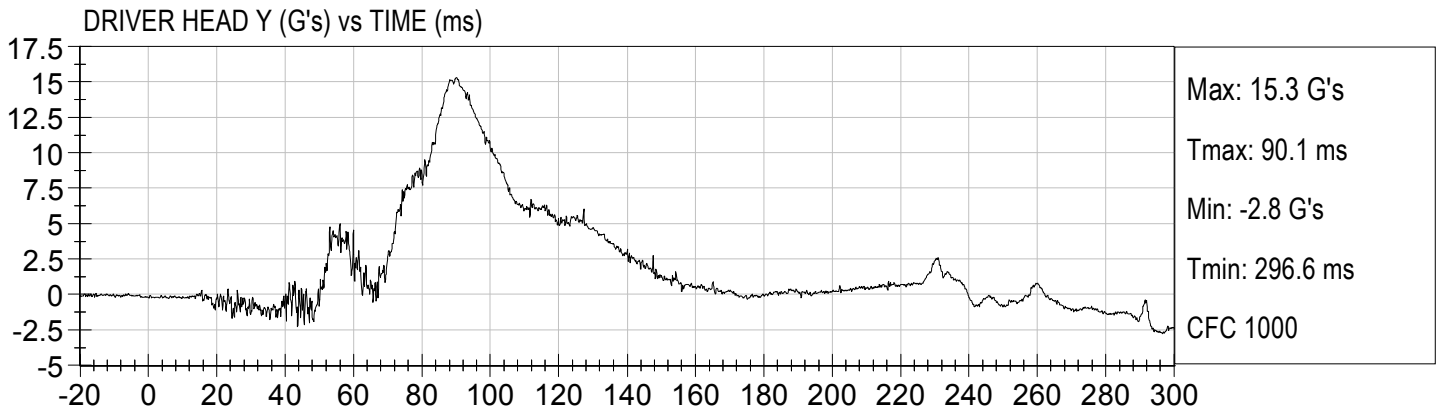
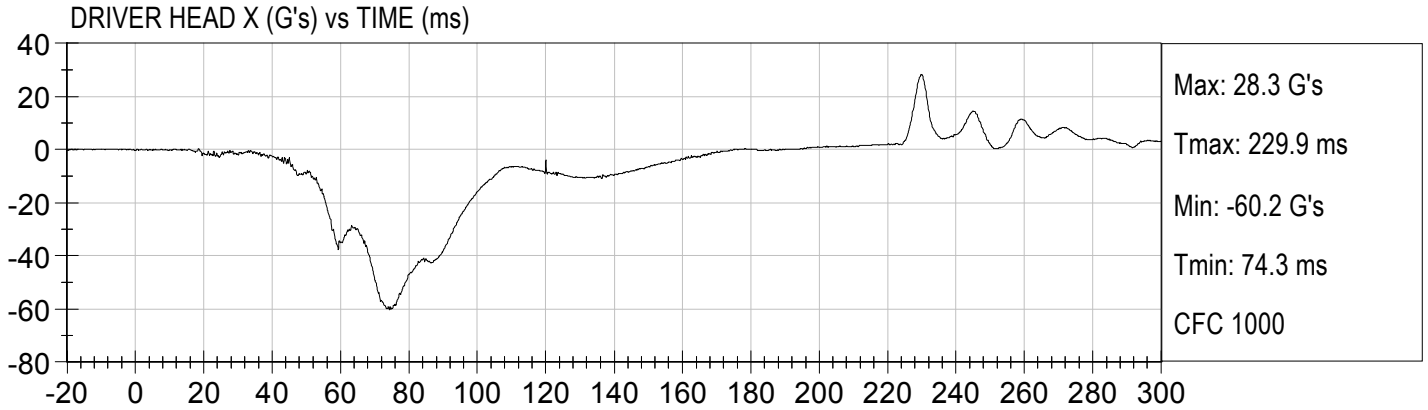

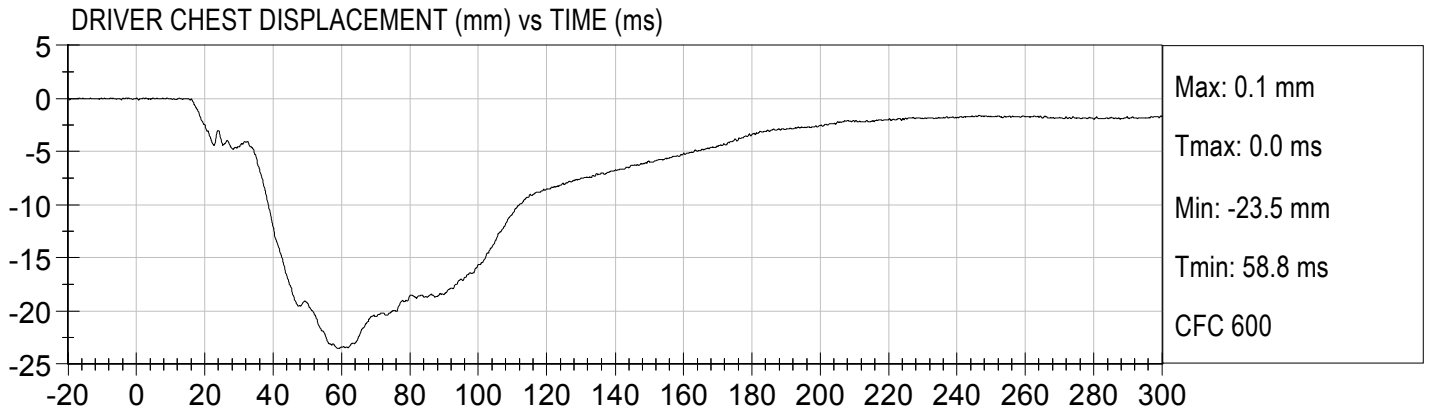

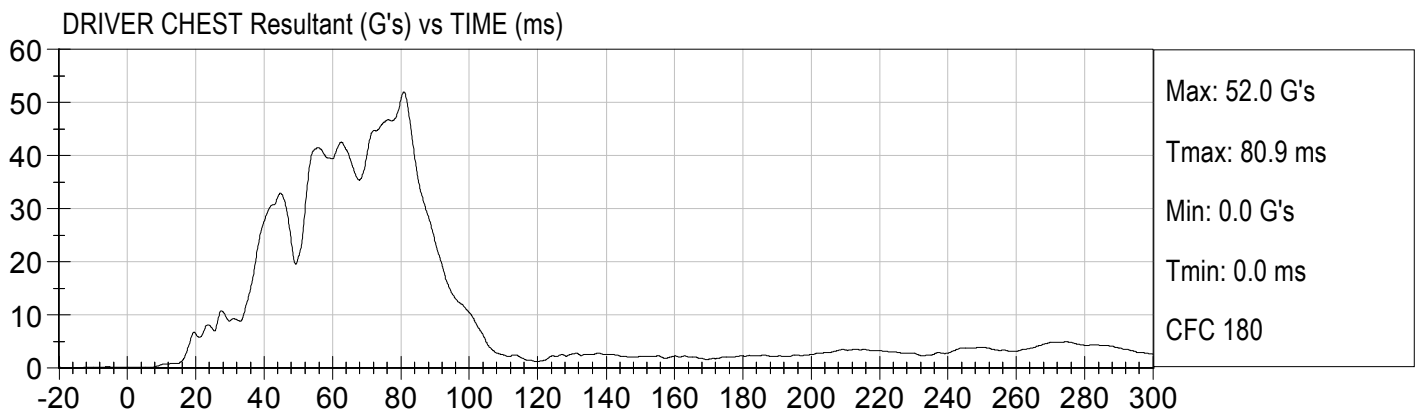
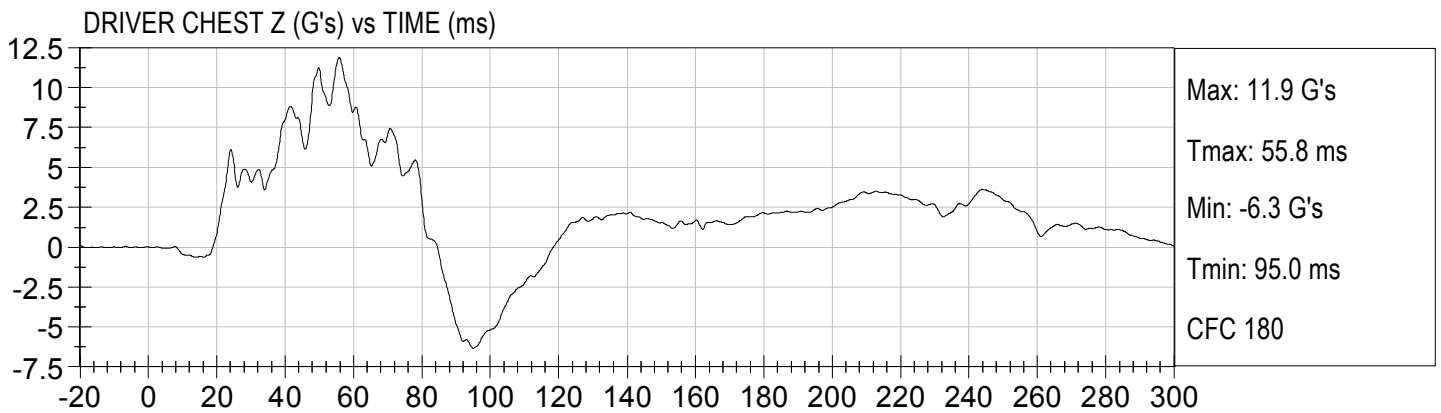
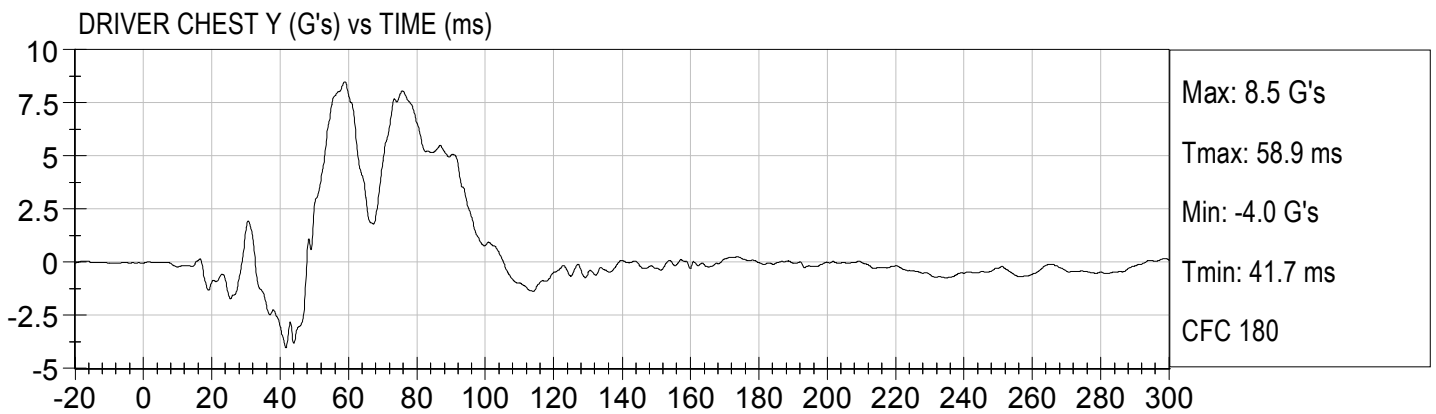
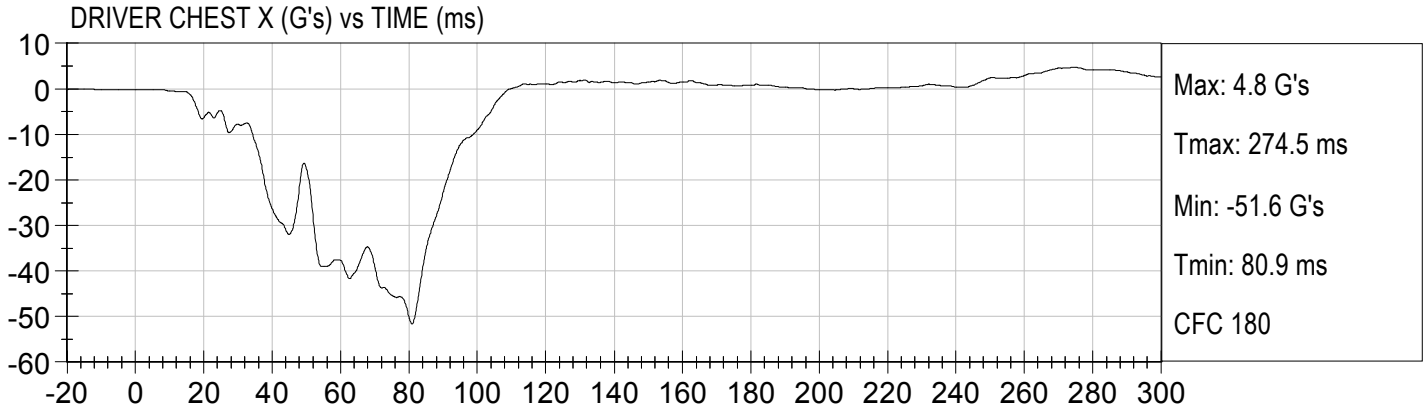

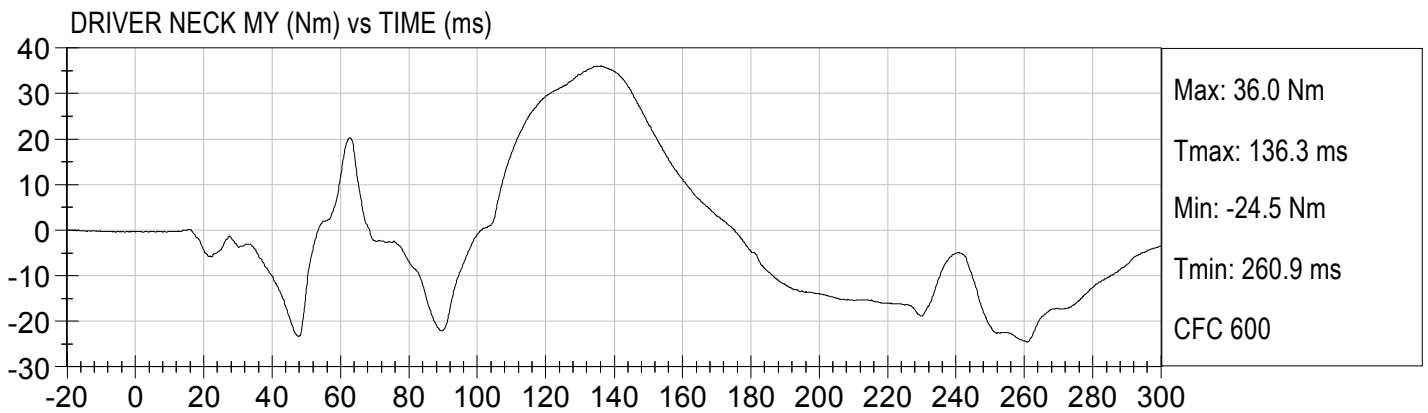
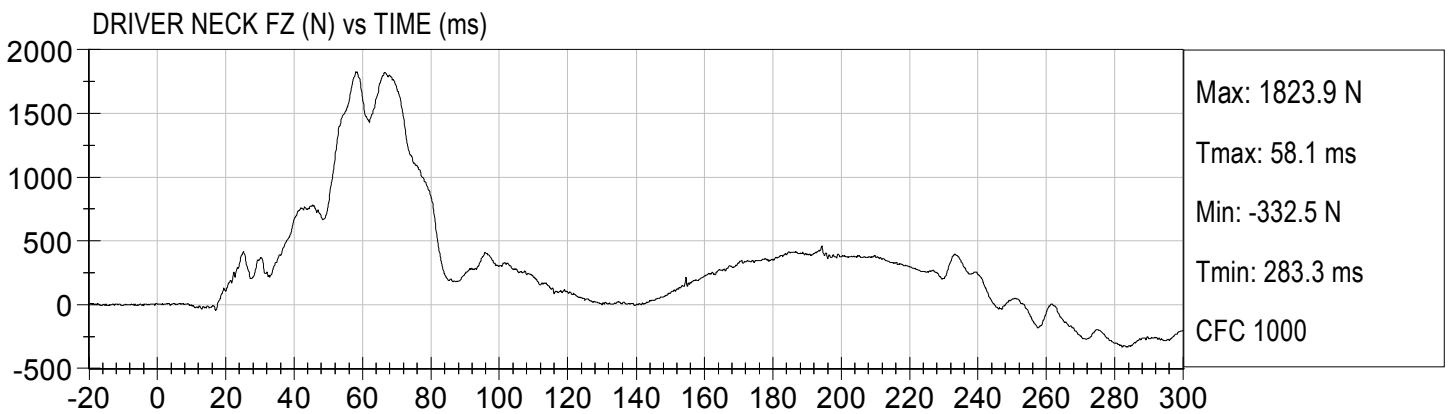
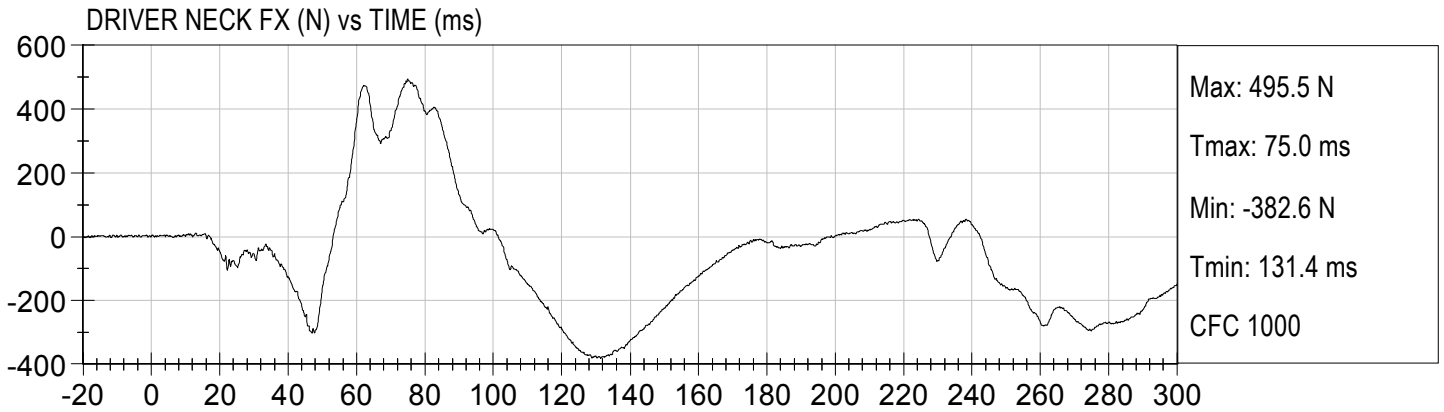

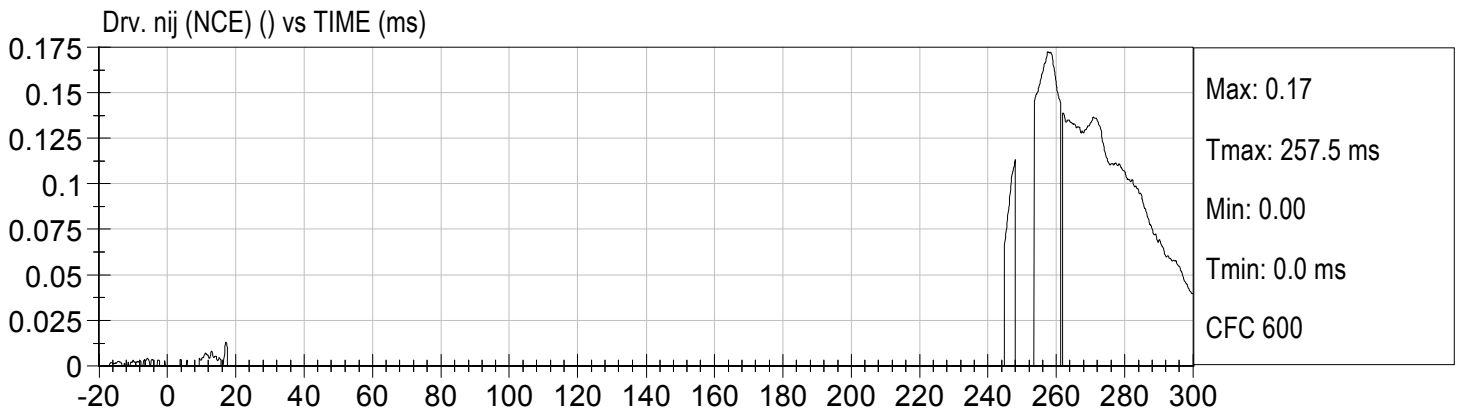
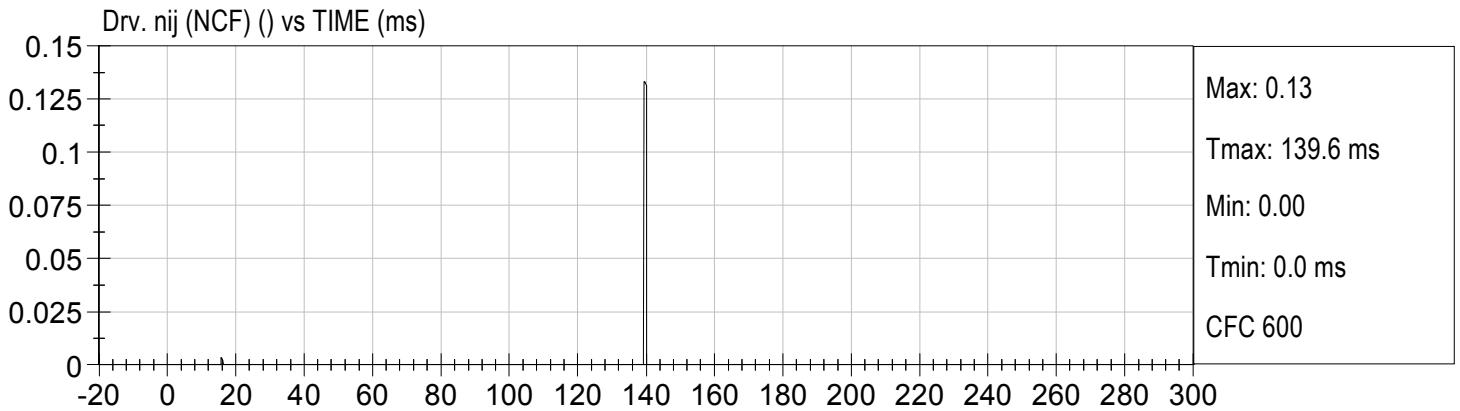
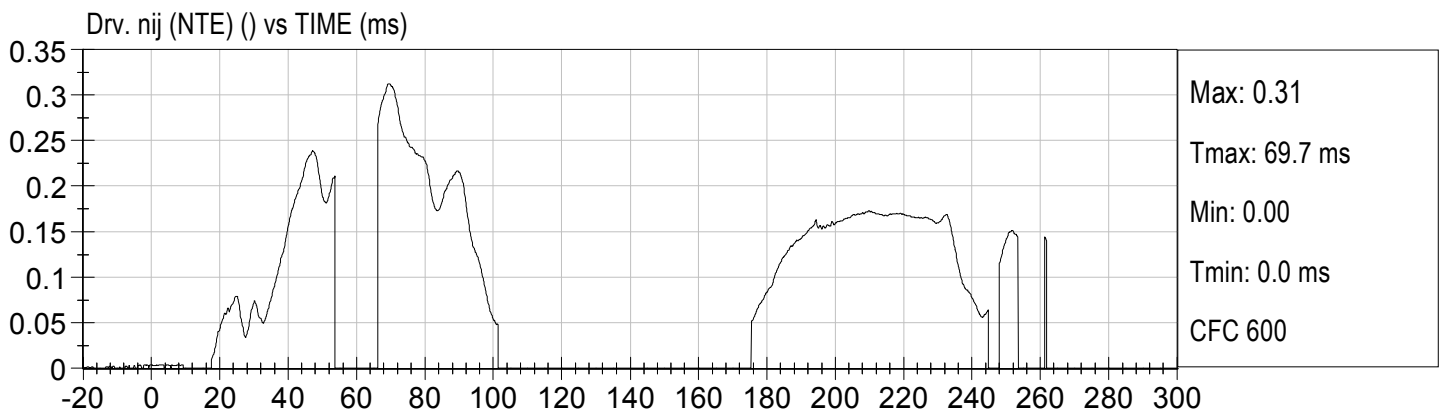
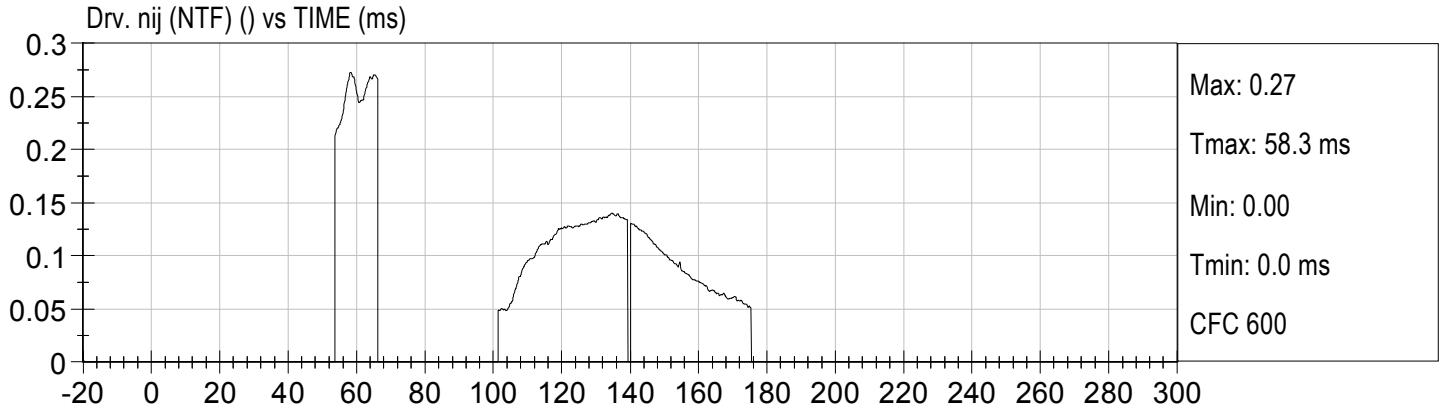

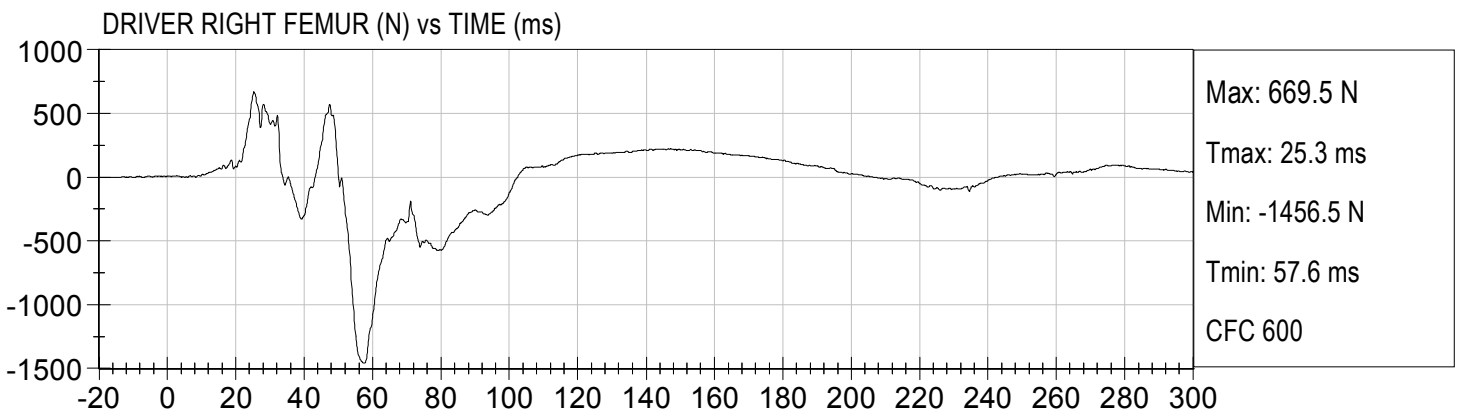
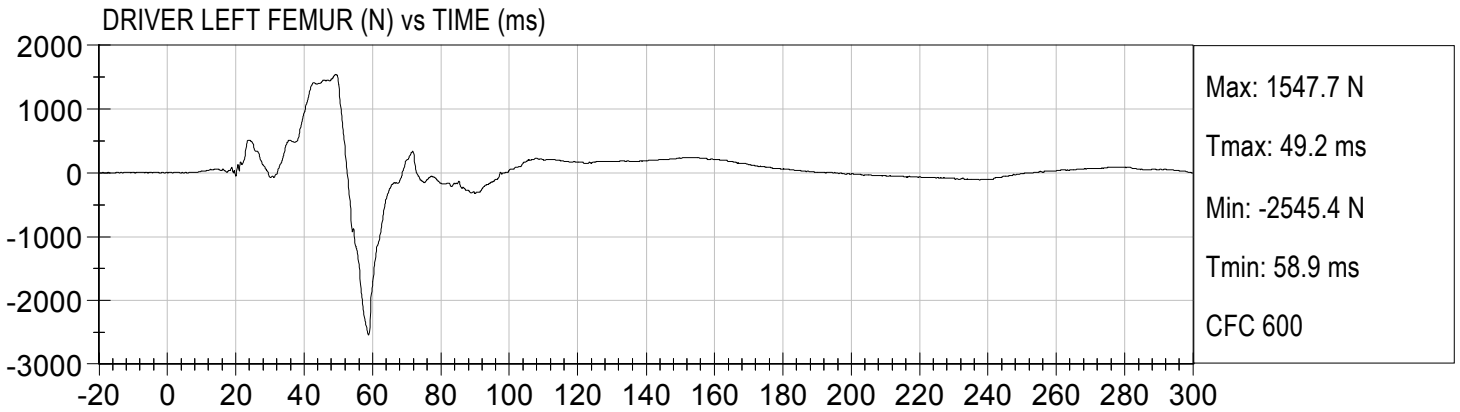

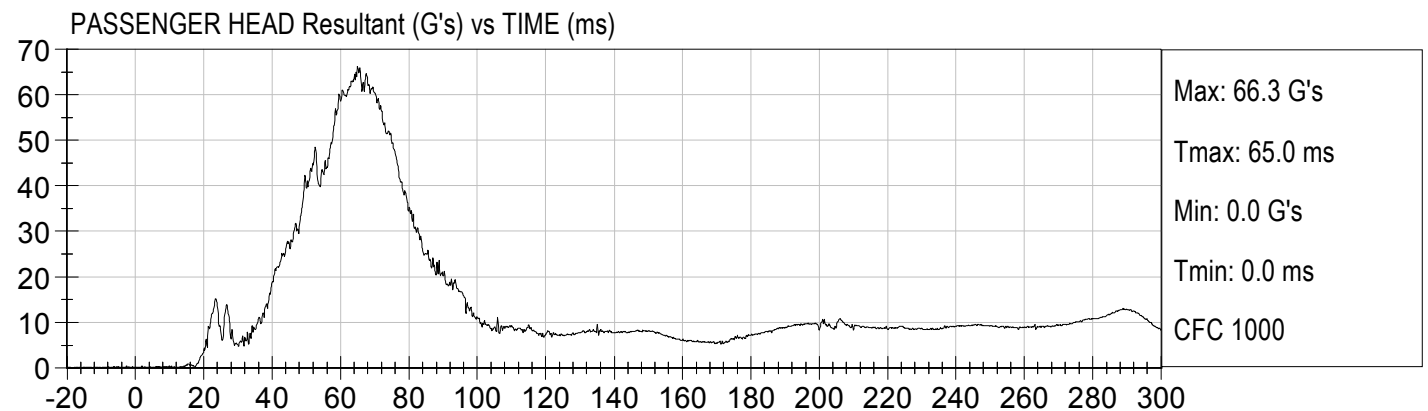
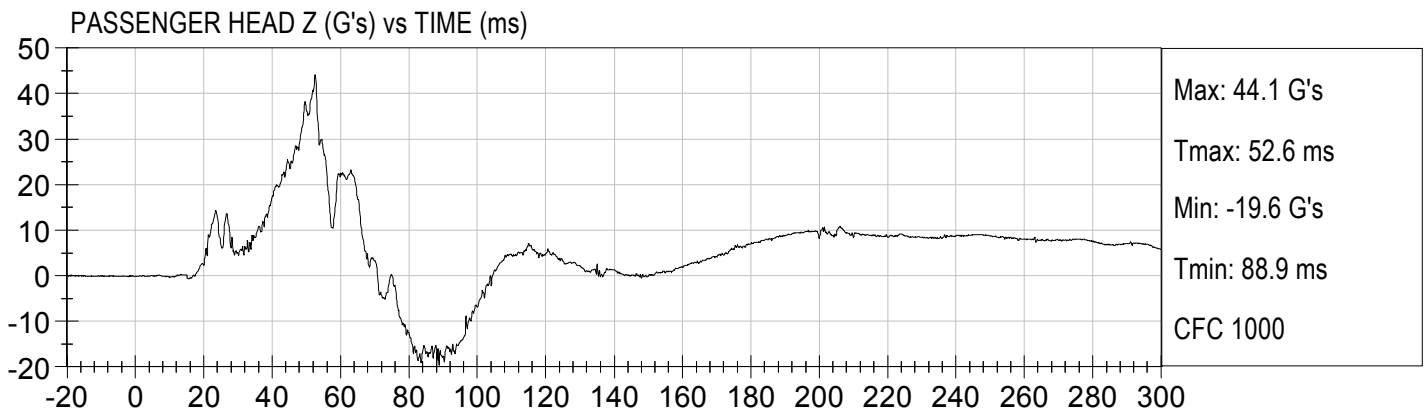
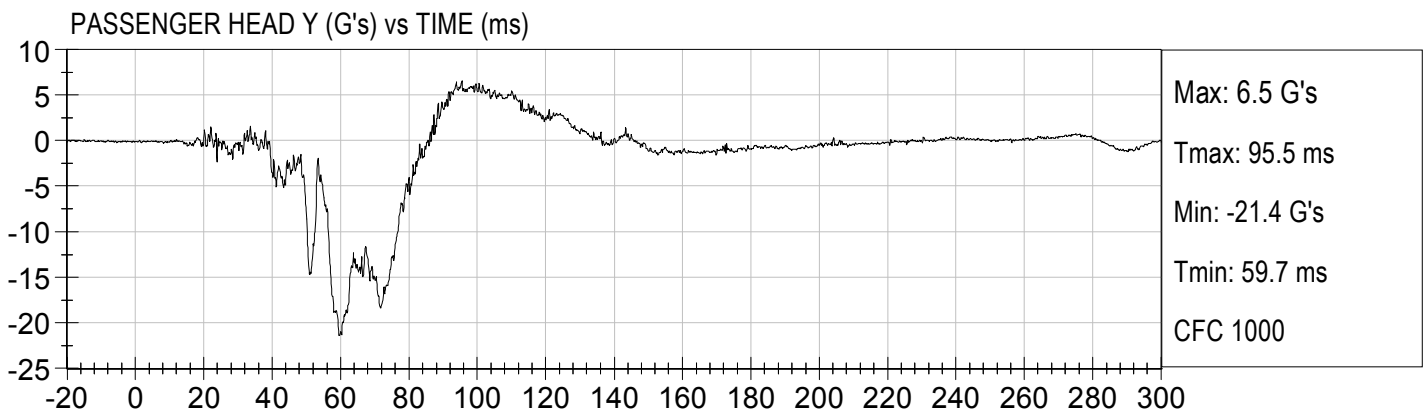
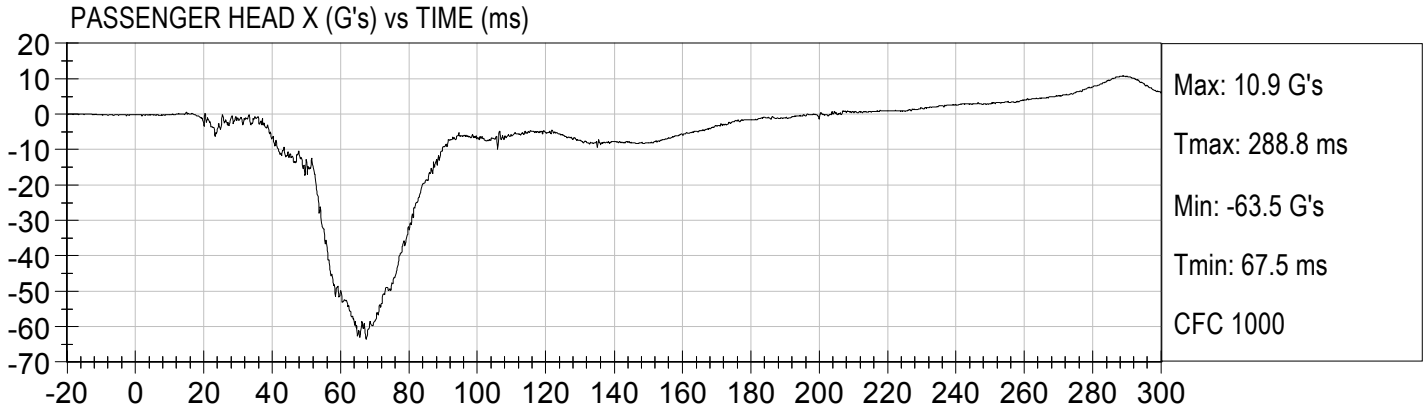

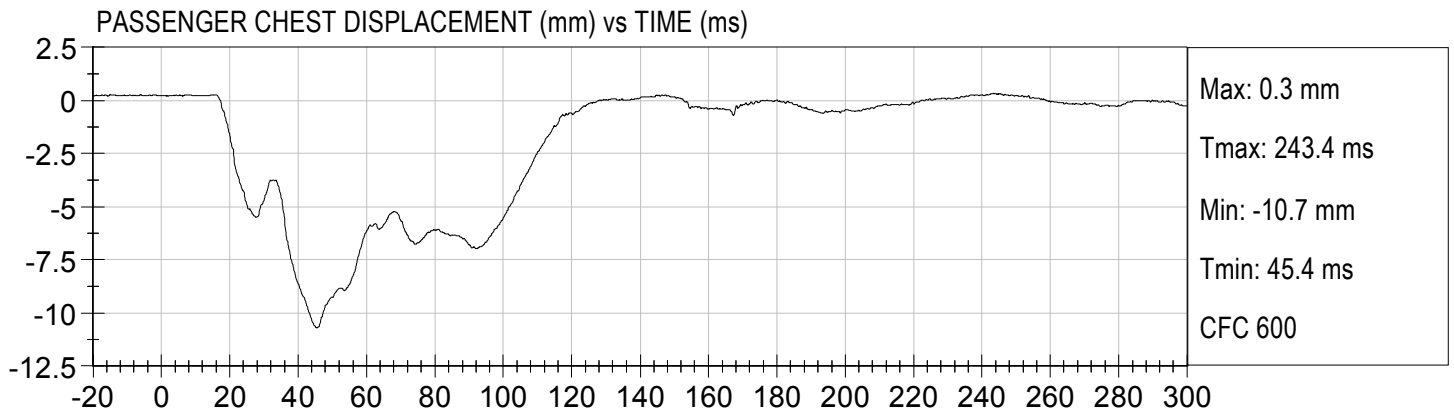

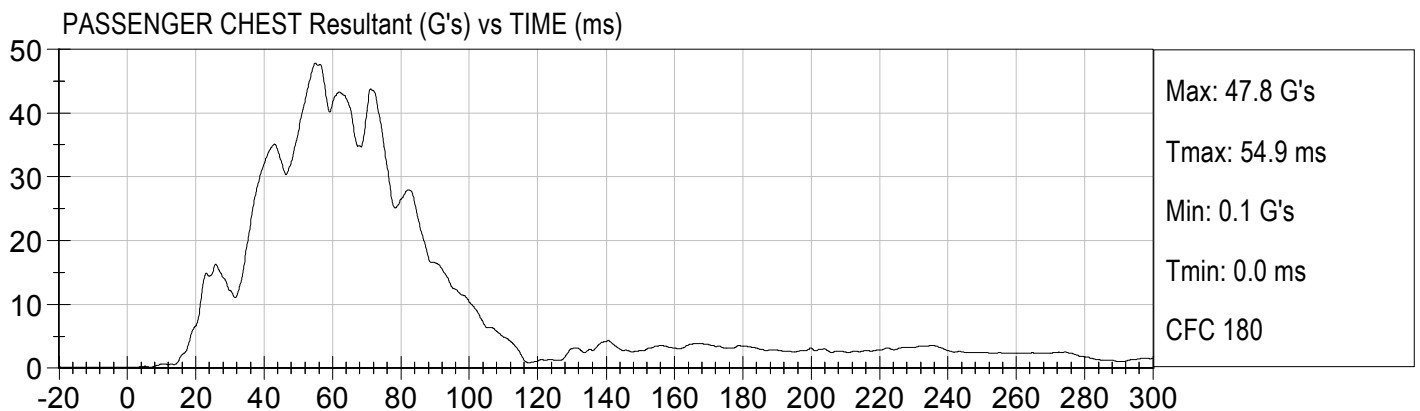
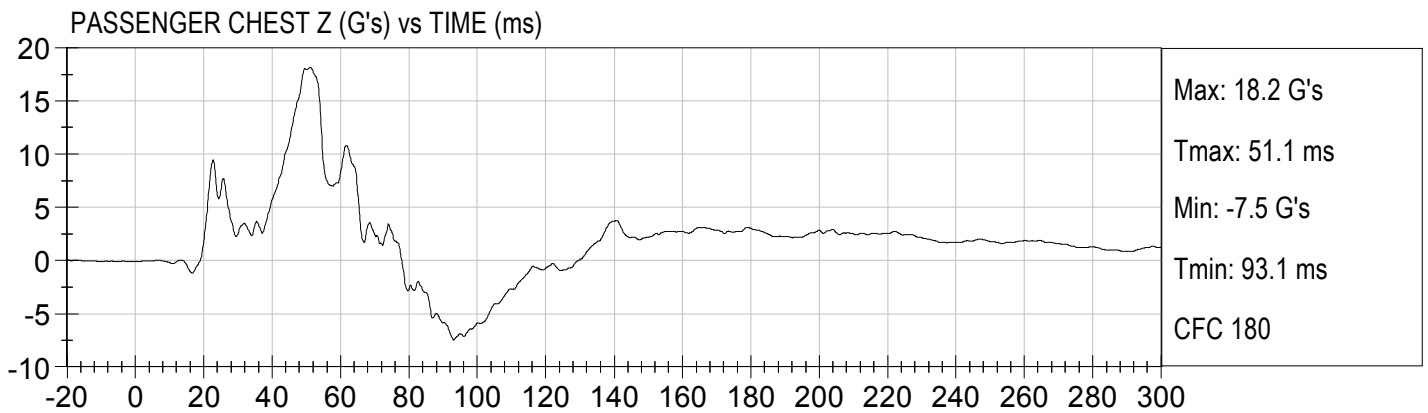
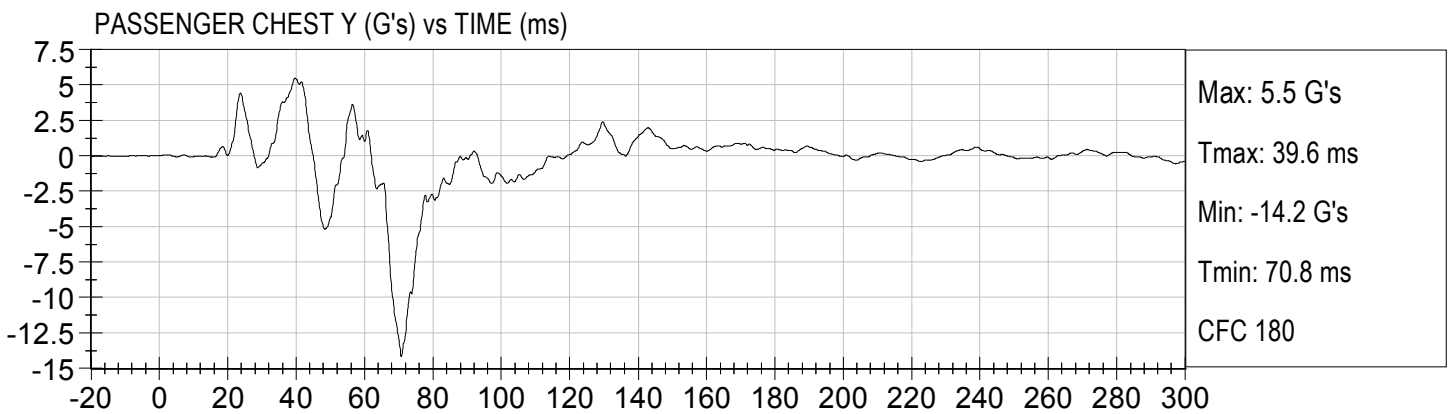
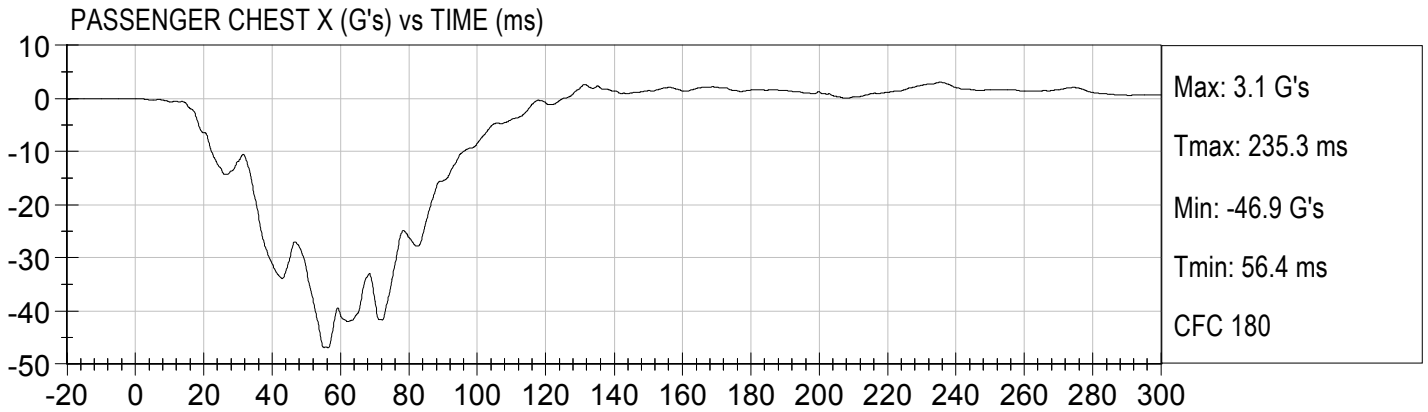

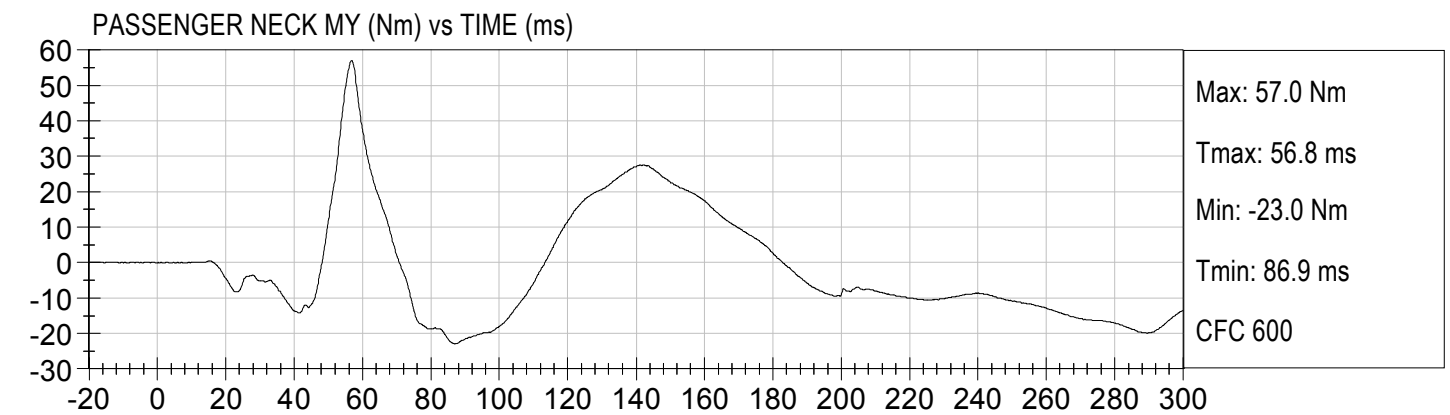
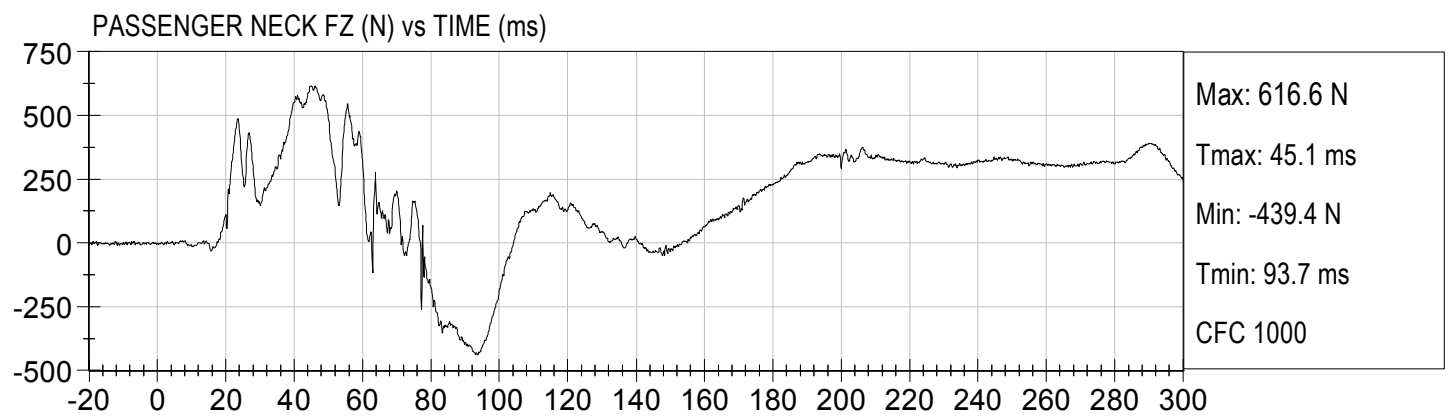
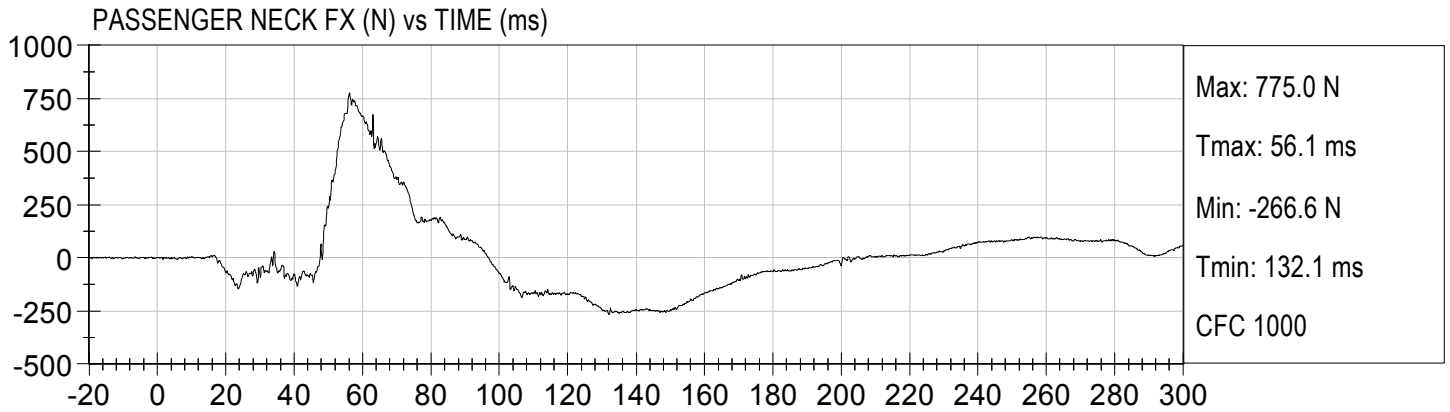

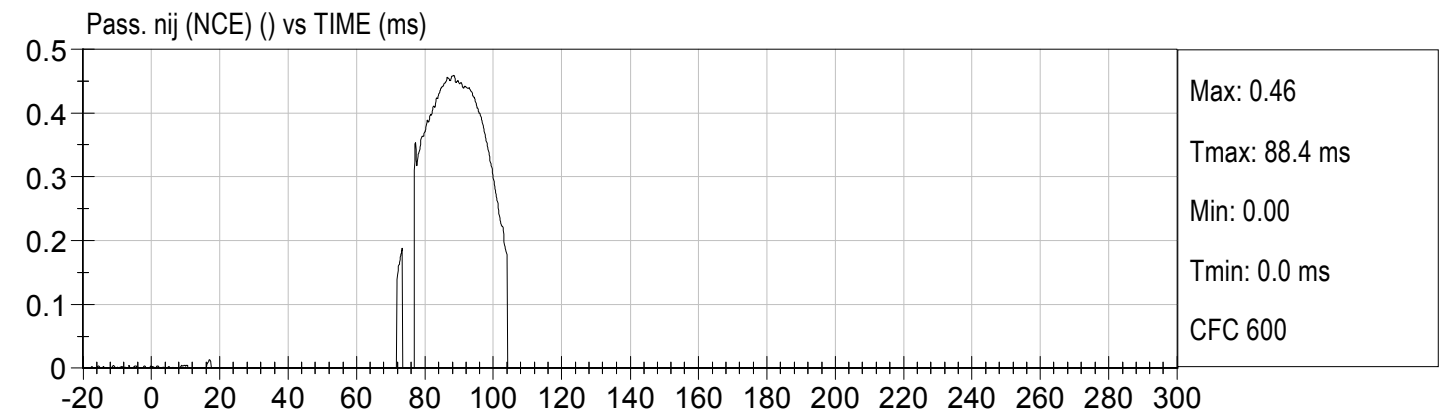
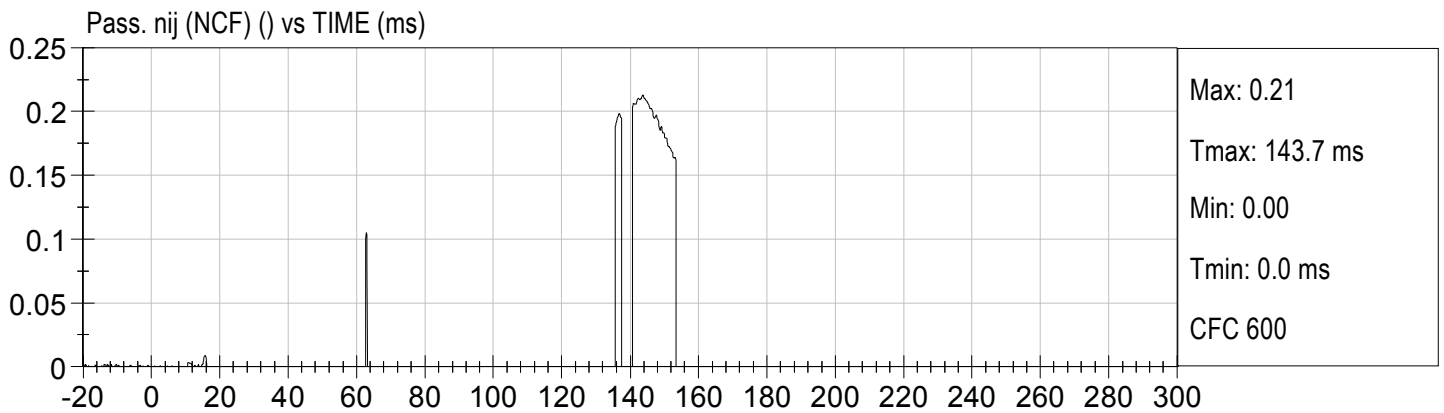
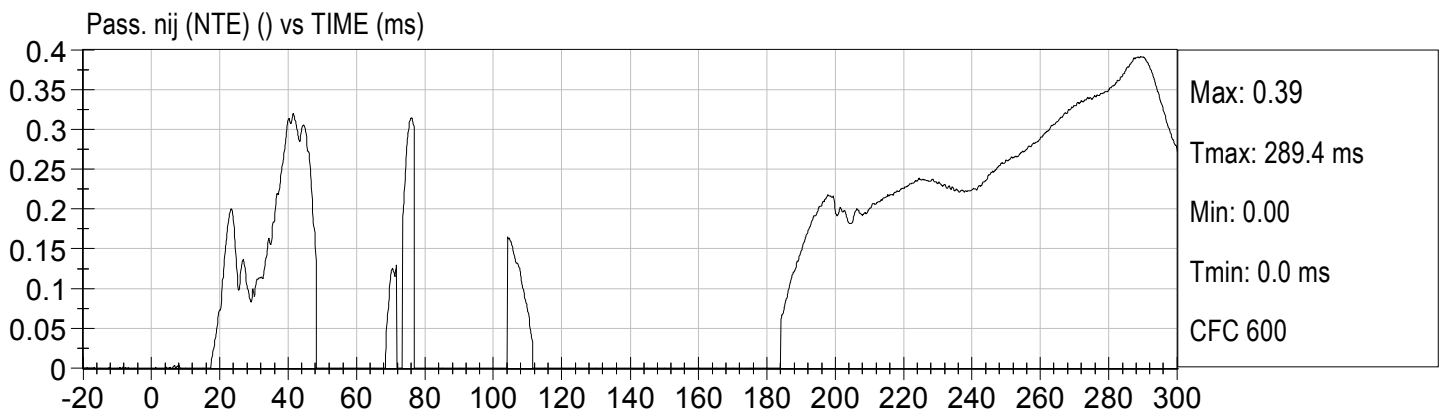
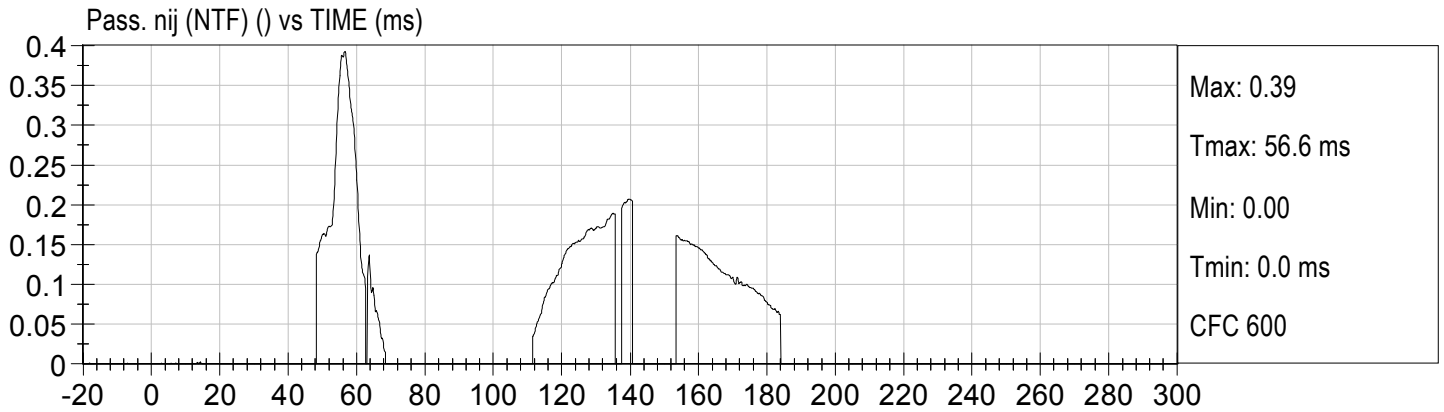

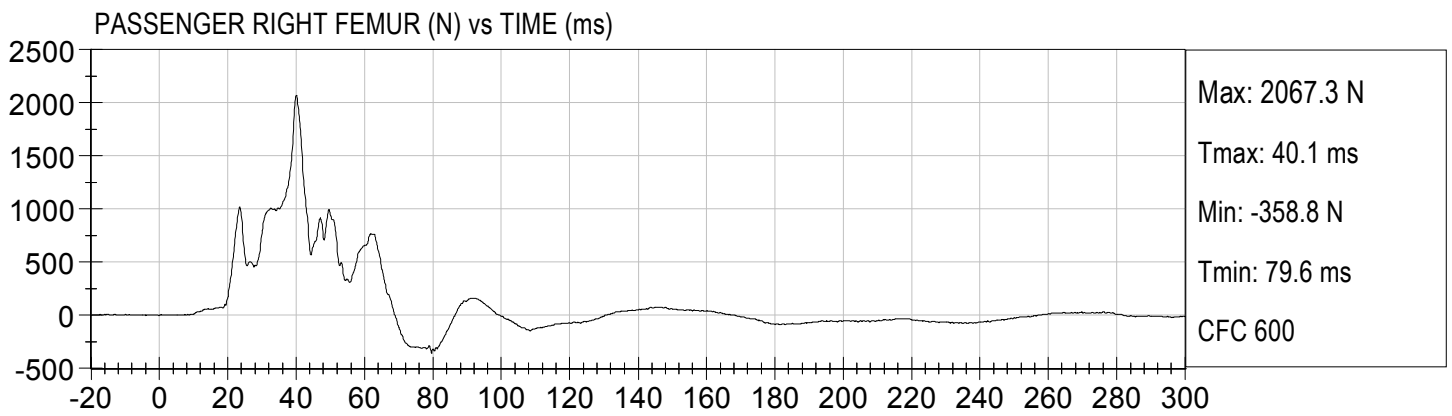
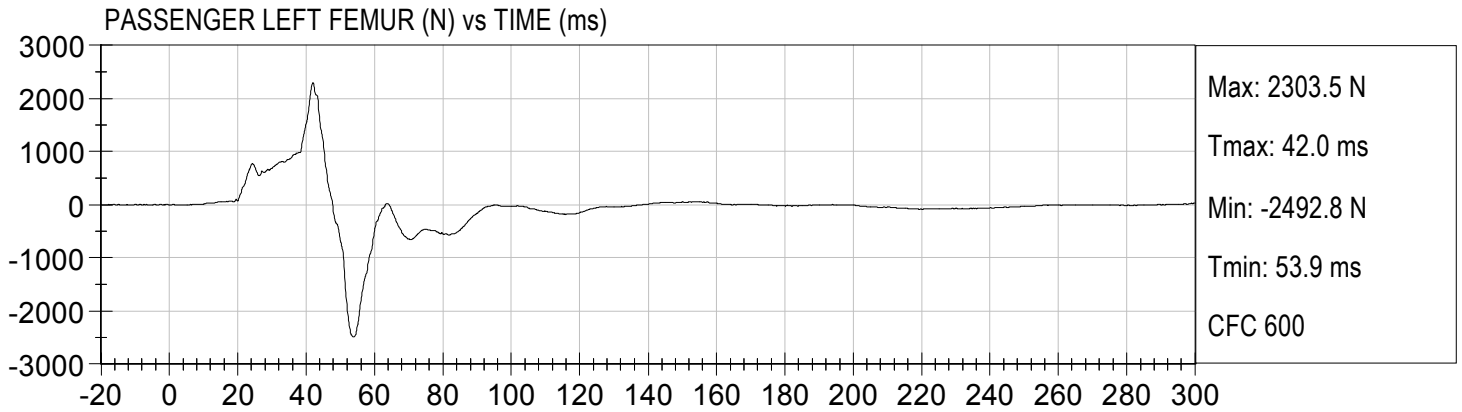

## **APPENDIX C**

### **DUMMY CALIBRATION AND PERFORMANCE VERIFICATION DATA**

**Hybrid III, 50th External Measurements  
SN: 351**

HYBRID III, PART 572, SUBPART E EXTERNAL DIMENSIONS				
DIMENSION	DESCRIPTION	DETAILS	ASSEMBLY DIMENSION (inches)	ACTUAL MEASUREMENT
A	TOTAL SITTING HEIGHT	Seat surface to highest point on top of the head.	34.6–35.0	34.8
B	SHOULDER PIVOT HEIGHT	Centerline of shoulder pivot bolt to the seat surface.	19.9-20.5	20.0
C	H-POINT HEIGHT	Reference	3.3-3.5	3.4
D	H-POINT LOCATION FROM BACKLINE	Reference	5.3-5.5	5.5
E	SHOULDER PIVOT FROM BACKLINE	Center of the shoulder clevis to the rear vertical surface of the fixture.	3.3-3.7	3.5
F	THIGH CLEARANCE	Measured at the highest point on the upper femur segment.	5.5-6.1	6.0
G	BACK OF ELBOW TO WRIST PIVOT	back of the elbow flesh to the wrist pivot in line with the elbow and wrist pivots	11.4-12.0	11.8
H	HEAD BACK TO BACKLINE	Back of Skull cap skin to seat rear vertical surface (Reference)	1.6-1.8	1.7
I	SHOULDER TO- ELBOW LENGTH	Measure from the highest point on top of the shoulder clevis to the lowest part of the flesh on the elbow in line with the elbow pivot bolt.	13.0-13.6	13.3
J	ELBOW REST HEIGHT	Measure from the flesh below the elbow pivot bolt to the seat surface.	7.5-8.3	7.8
K	BUTTOCK TO KNEE LENGTH	The forward most part of the knee flesh to the rear vertical surface of the fixture.	22.8-23.8	23.8
L	POPLITEAL HEIGHT	Seat surface to the plane of the horizontal plane of the bottom of the feet.	16.9-17.9	17.0
M	KNEE PIVOT HEIGHT	Centerline of knee pivot bolt to the horizontal plane of the bottom of the feet.	19.1-19.7	19.5
N	BUTTOCK POPLITEAL LENGTH	The rearmost surface of the lower leg to the same point on the rear surface of the buttocks used for dim. "K".	17.8-18.8	18.8

HYBRID III, SUBPART E EXTERIOR DIMENSIONS, continued

DIMENSION	DESCRIPTION	DETAILS		ACTUAL MEASUREMENT
O	CHEST DEPTH WITHOUT JACKET	Measured 16.9-17.1 in. above seat surface	8.4-9.0	8.5
P	FOOT LENGTH	Tip of toe to rear of heel	9.9-10.5	10.3
V	SHOULDER BREADTH	Outside edges of right and left shoulder clevises	16.3-17.2	16.5
W	FOOT BREADTH	The widest part of the foot	3.6-4.2	4.0
Y	CHEST CIRCUMFERENCE (WITH CHEST JACKET)	Measured 16.9-17.1 in. above seat surface	38.2-39.4	39.2
Z	WAIST CIRCUMFERENCE	Measured 8.9-9.1 in. above seat surface	32.9-34.1	33.7
AA	REFERENCE LOCATION FOR MEASUREMENT OF CHEST CIRCUMFERENCE	Reference	16.9-17.1	17.0
BB	REFERENCE LOCATION FOR MEASUREMENT OF WAIST CIRCUMFERENCE	Reference	8.9-9.1	9.0

**NOTE:** THE H-POINT IS LOCATED 1.83 INCHES FORWARD AND 2.57 INCHES DOWN FROM THE CENTER OF THE PELVIS ANGLE REFERENCE HOLE.

**MGA RESEARCH CORPORATION  
HEAD DROP TEST  
HYBRID III 50TH PERCENTILE MALE**

ATD Serial No: 351

Test ID: D12801

Tested Parameter	Units	Specification	Result	Pass/Fail
Laboratory Temperature	deg C	18.9 - 25.6	21.0	Pass
Laboratory Relative Humidity	%	10 to 70	34	Pass
Peak Resultant Acceleration	G's	225 - 275	250	Pass
Peak Lateral Acceleration	G's	<= +/- 15.0	1.9	Pass
Unimodal	N/A	Yes	Yes	Pass
Oscillations	N/A	within 10% of peak	Yes	Pass
Overall Test Results				Pass

*Jessica Hall*  
Laboratory Technician

3/2/12  
Test Date

*David Winkelbauer*  
Approved By



Test Desc: Head Drop  
Component ID: D12801

Test Date: 3/2/12  
Velocity: 0 ft/s, 0 m/s

RESULTANT HEAD ACCELERATION (G's) vs TIME (ms)

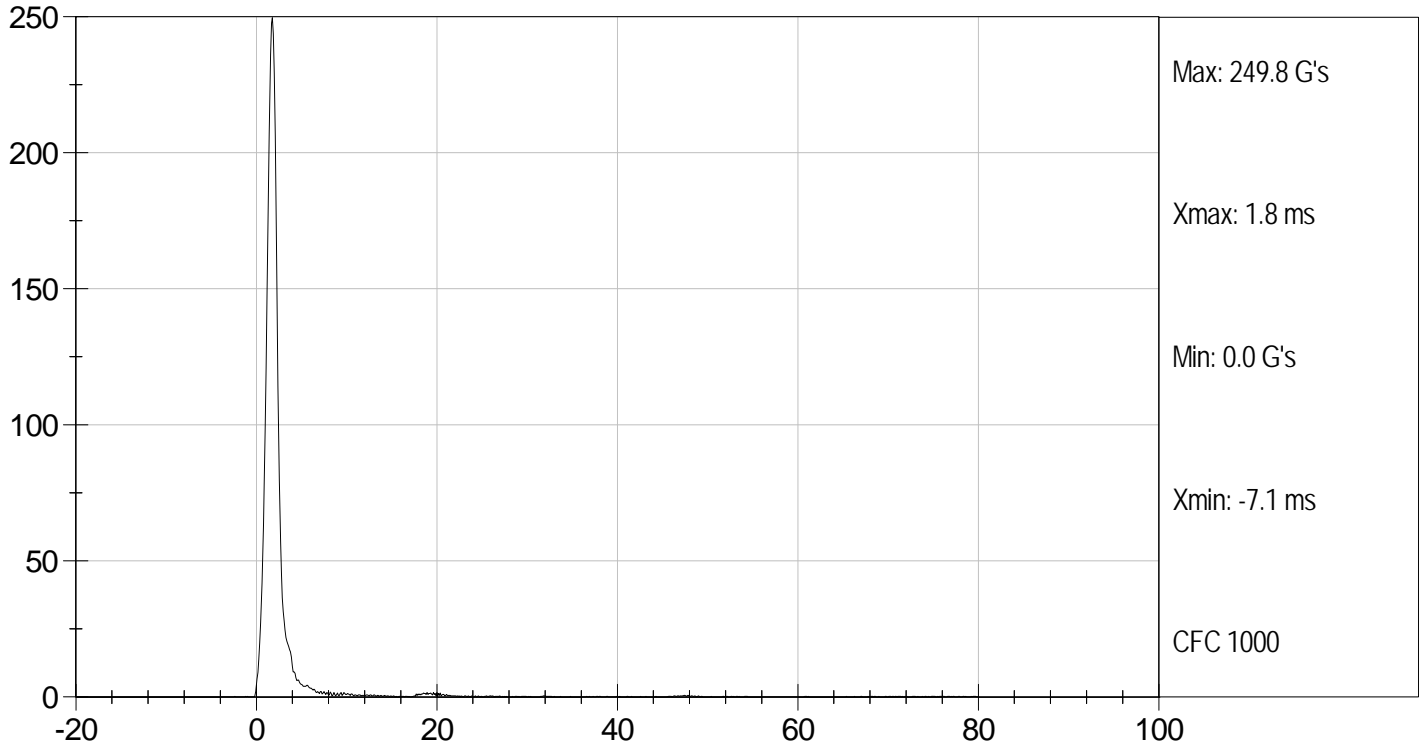

HEAD Y (G's) vs TIME (ms)

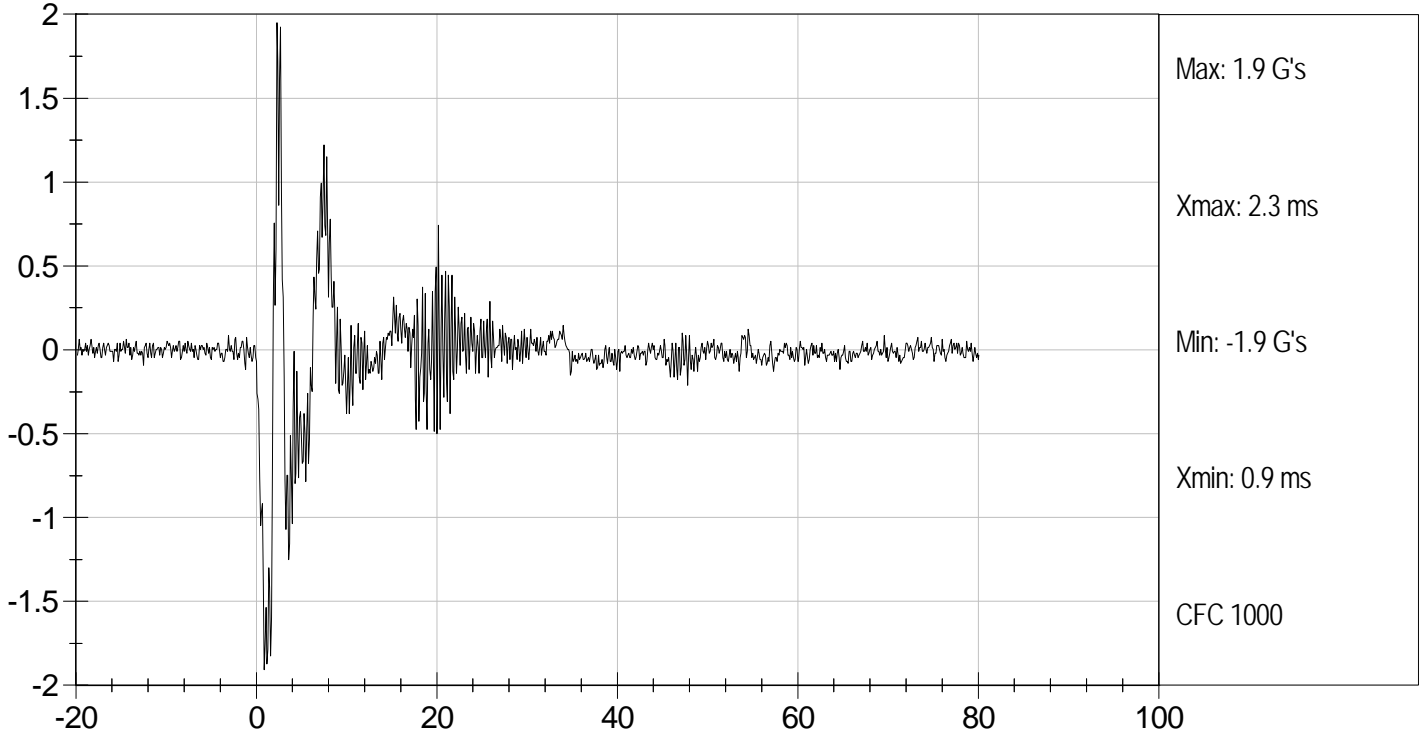

**MGA RESEARCH CORPORATION  
NECK FLEXION TEST  
HYBRID III 50TH PERCENTILE MALE**

ATD Serial No: 351

Test I.D.: D12802

Tested Parameter		Units	Specification	Result	Pass/Fail
Laboratory Temperature		deg C	20.6 to 22.2	21.2	Pass
Laboratory Relative Humidity		%	10 to 70	34	Pass
Pendulum Velocity		m/s	6.89 to 7.13	7.06	Pass
Pendulum Deceleration	10 ms	G's	22.50 to 27.50	25.59	Pass
	20 ms	G's	17.60 to 22.60	18.31	Pass
	30 ms	G's	12.50 to 18.50	15.32	Pass
Peak Pendulum Deceleration After 30 ms		G's	<= 29.0	15.2	Pass
Deceleration Decay Time to Cross 5 G's		ms	34.0 to 42.0	34.5	Pass
Maximum "D" Plane Rotation	Maximum	Degrees	64.0 to 78.0	68.0	Pass
	Time	ms	57.0 to 64.0	57.3	Pass
"D" Plane Rotation Decay Time To Zero Crossing		ms	113.0 to 128.0	113.5	Pass
Moment About Occipital Condyle	Maximum	N m	88.1 to 108.5	93.9	Pass
	Time	ms	47.0 to 58.0	47.6	Pass
Positive Moment Decay Time To Zero Crossing		ms	97.0 to 107.0	98.3	Pass
<b>Overall Test Results</b>					<b>Pass</b>

*Jessica Hall*  
Laboratory Technician

3/2/12  
Test Date

*David Winkelbauer*  
Approved By



Test Desc: Neck Flexion  
Component ID: D12802

Test Date: 3/2/12  
Velocity: 23.15 ft/s, 7.06 m/s

PENDULUM DECELERATION (g's) vs TIME (ms)

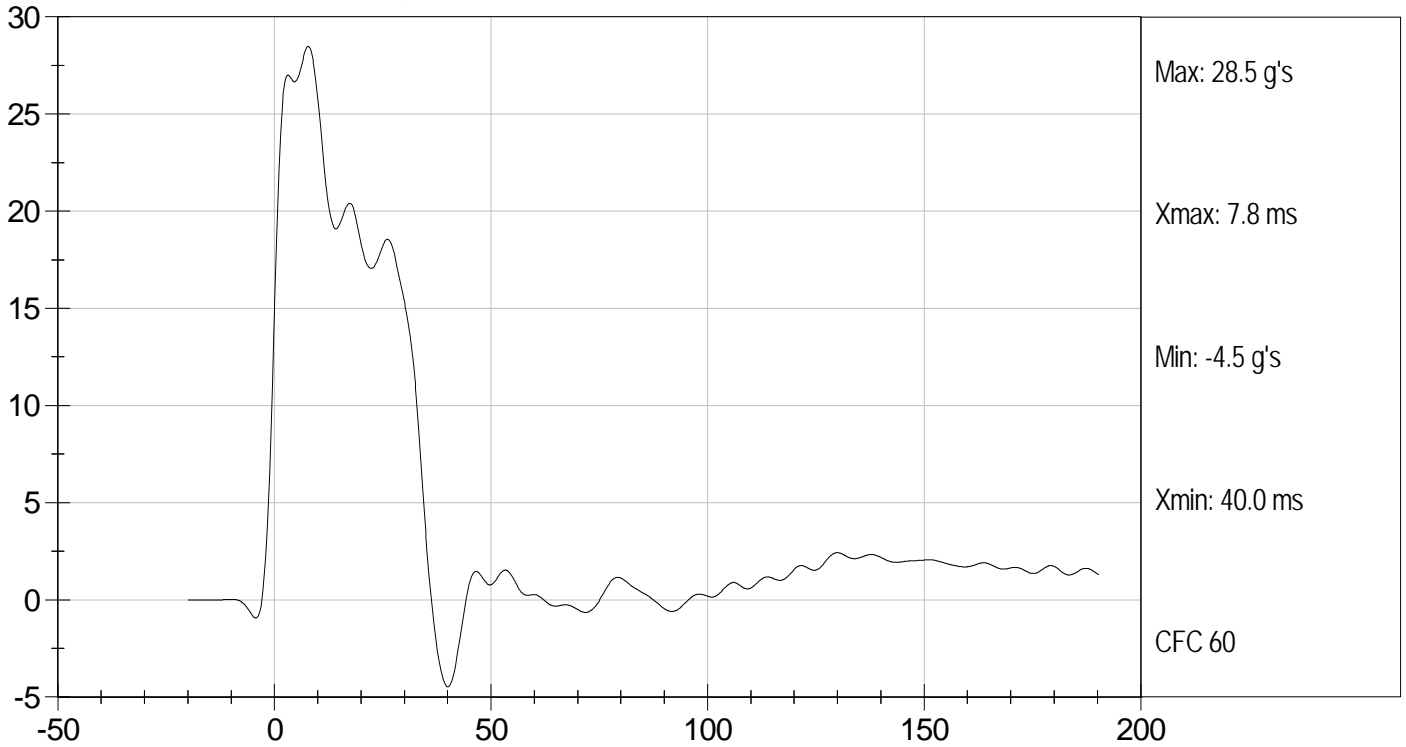

NECK ROTATION (DEG.) vs TIME (ms)

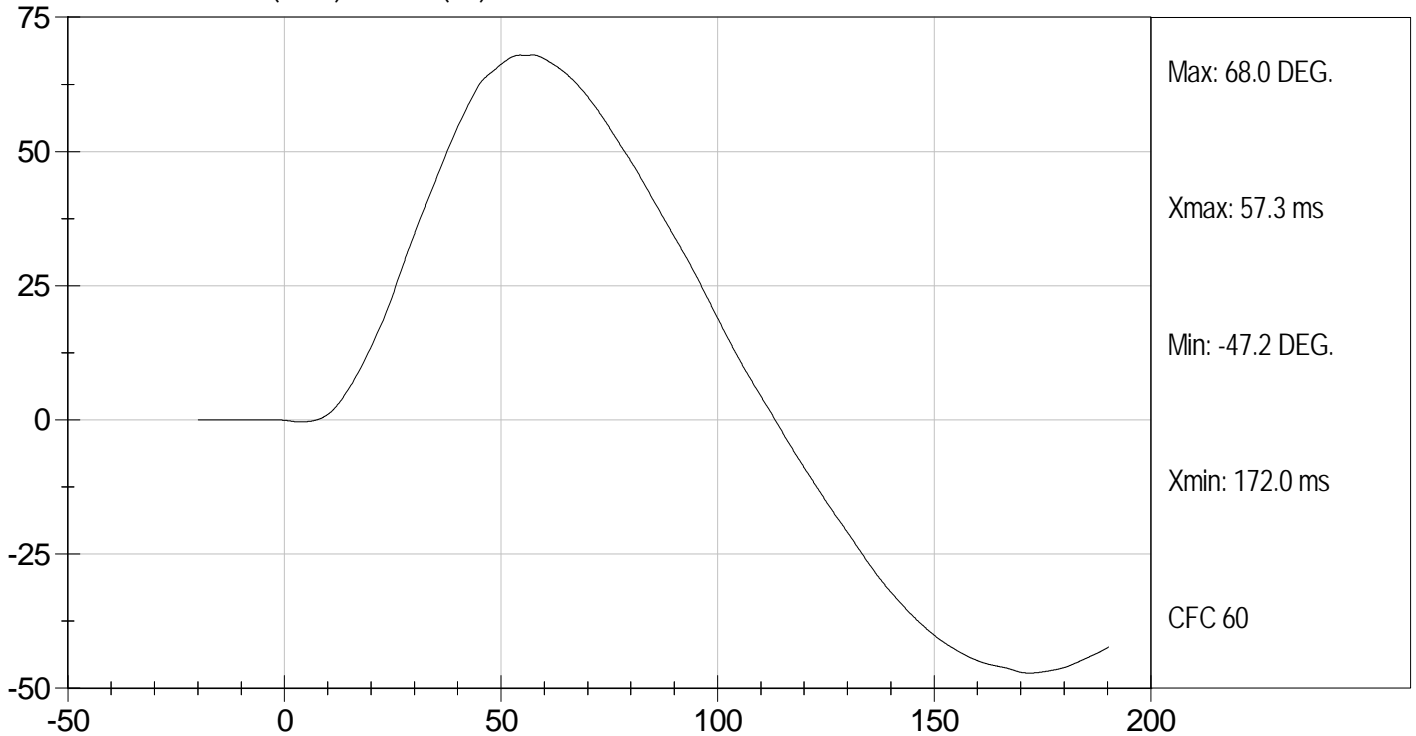



Test Desc: Neck Flexion  
Component ID: D12802

Test Date: 3/2/12  
Velocity: 23.15 ft/s, 7.06 m/s

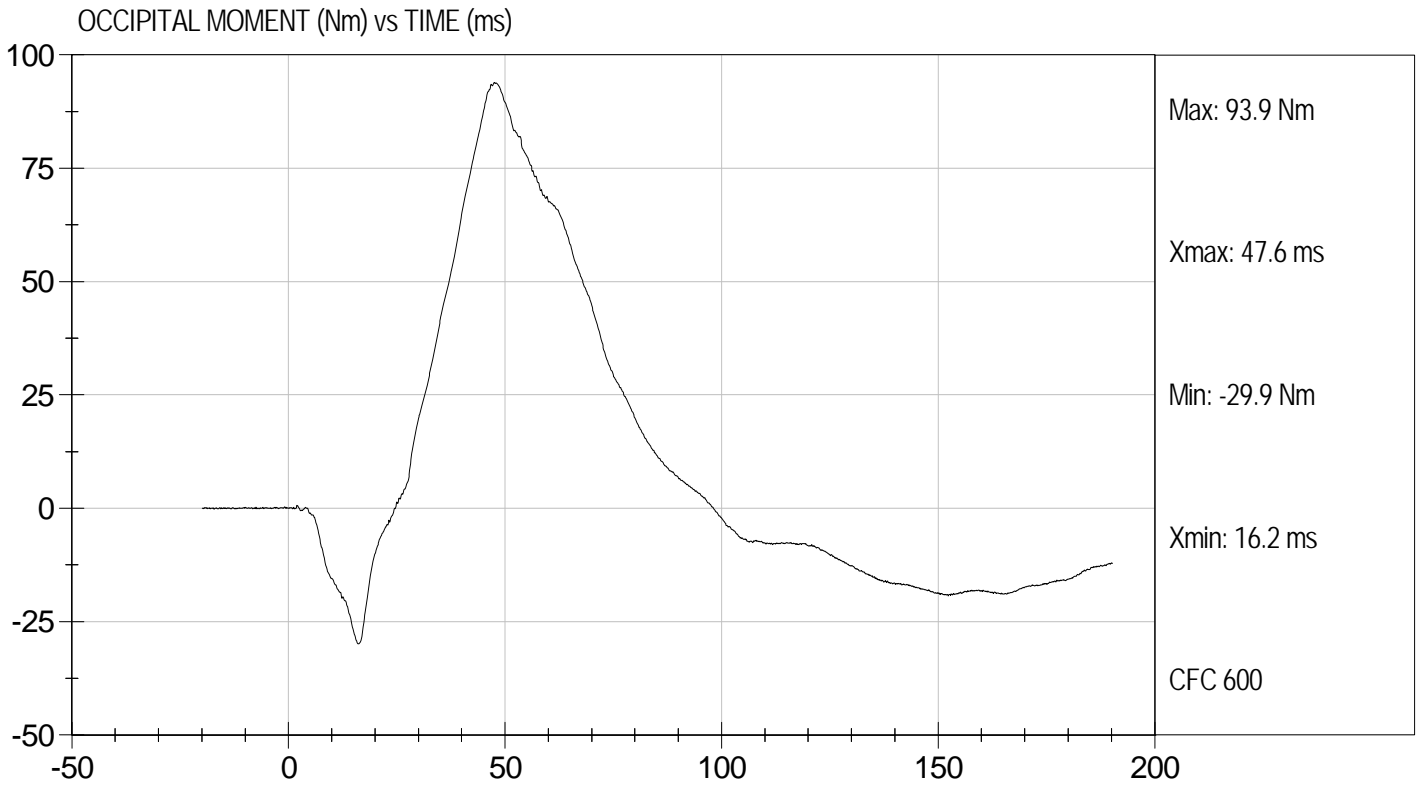

**MGA RESEARCH CORPORATION  
NECK EXTENSION TEST  
HYBRID III 50TH PERCENTILE MALE**

ATD Serial No: 351

Test I.D.: D12803

Tested Parameter		Units	Specification	Result	Pass/Fail
Laboratory Temperature		deg C	20.6 to 22.2	21.2	Pass
Laboratory Relative Humidity		%	10 to 70	34	Pass
Pendulum Velocity		m/s	5.95 to 6.19	6.12	Pass
Pendulum Deceleration	10 ms	G's	17.20 to 21.20	19.00	Pass
	20 ms	G's	14.00 to 19.00	15.15	Pass
	30 ms	G's	11.00 to 16.00	12.83	Pass
Peak Pendulum Deceleration After 30 ms		G's	<= 22.0	13.2	Pass
Deceleration Decay Time to Cross 5 G's		ms	38.0 to 46.0	38.3	Pass
Maximum "D" Plane Rotation	Maximum	Degrees	81.0 to 106.0	95.3	Pass
	Time	ms	72.0 to 82.0	76.0	Pass
"D" Plane Rotation Decay Time To Zero Crossing		ms	147.0 to 174.0	155.6	Pass
Moment About Occipital Condyle	Maximum	Nm	-52.9 to -79.9	-59.0	Pass
	Time	ms	65.0 to 79.0	70.5	Pass
Negative Moment Decay Time To Zero Crossing		ms	120.0 to 148.0	140.8	Pass
<b>Overall Test Results</b>					<b>Pass</b>

*Jessica Hall*  
Laboratory Technician

3/2/12  
Test Date

*David Winkelbauer*  
Approved By



Test Desc: Neck Extension  
Component ID: D12803

Test Date: 3/2/12  
Velocity: 20.08 ft/s, 6.12 m/s

PENDULUM DECELERATION (g's) vs TIME (ms)

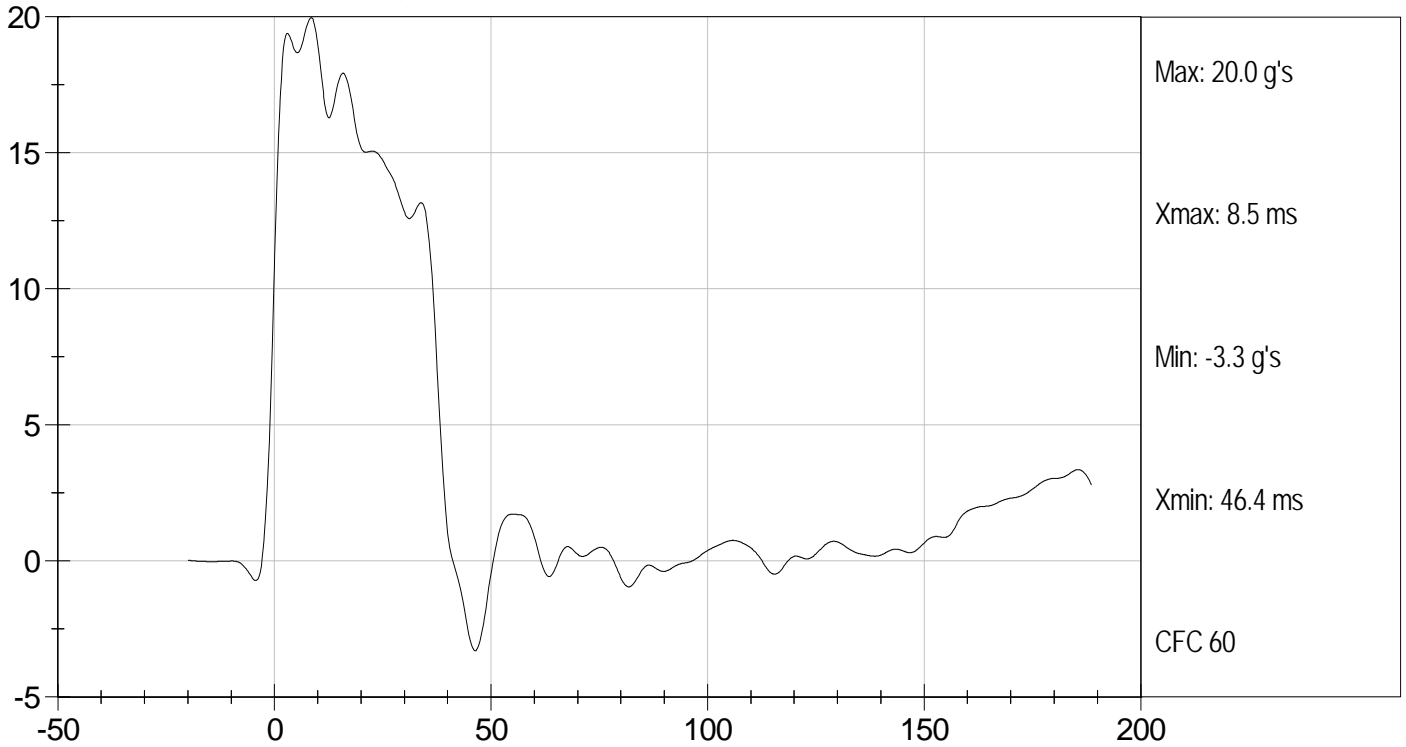

NECK ROTATION (DEG.) vs TIME (ms)

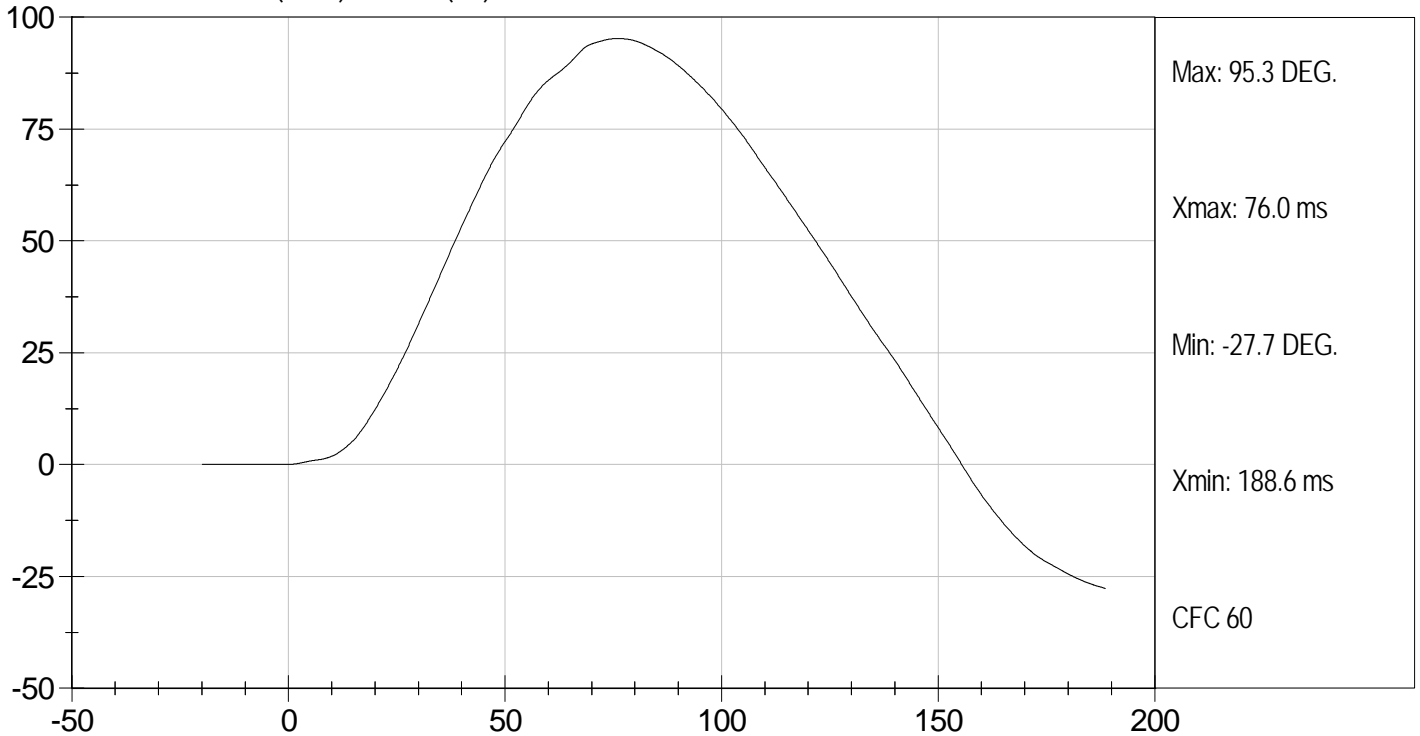



Test Desc: Neck Extension  
Component ID: D12803

Test Date: 3/2/12  
Velocity: 20.08 ft/s, 6.12 m/s

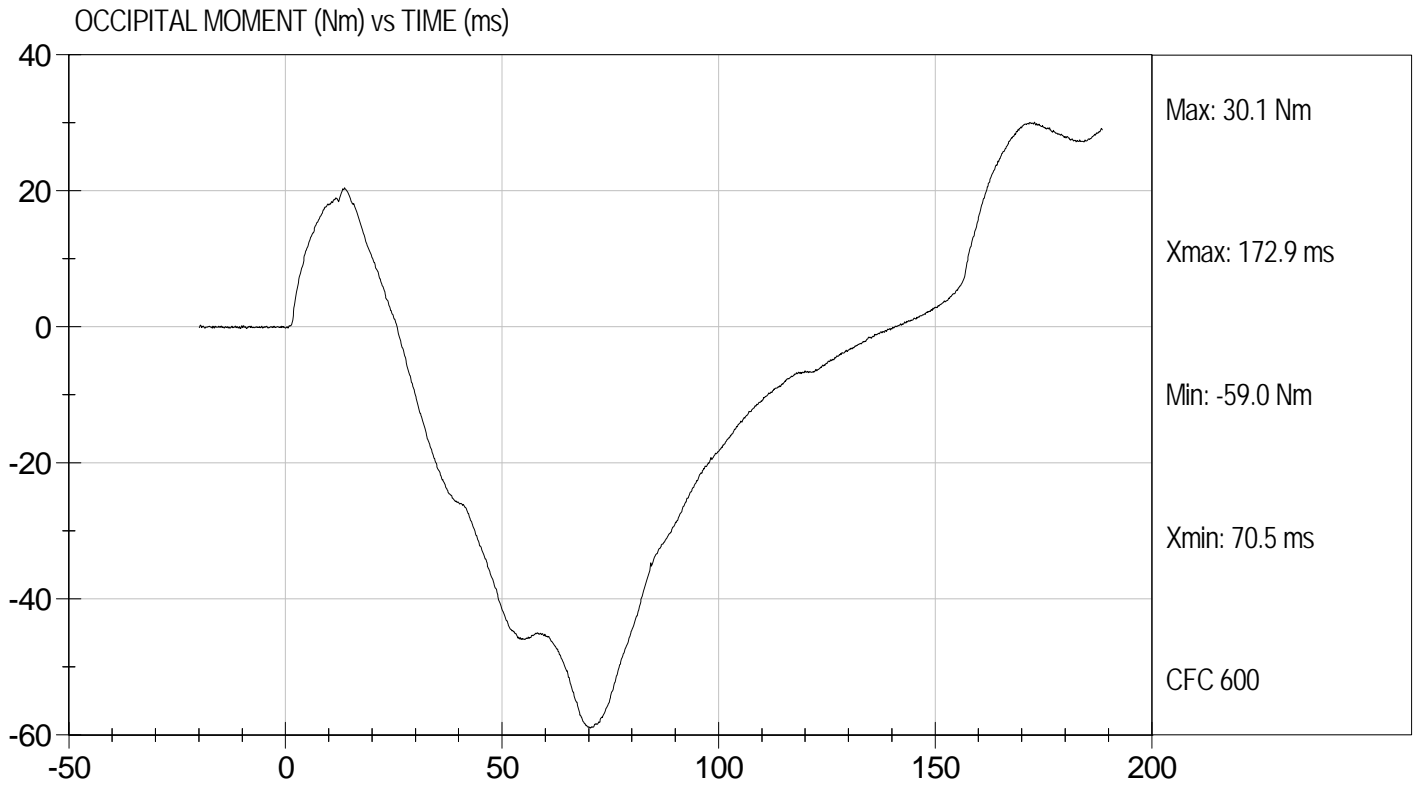

**MGA RESEARCH CORPORATION**  
**THORAX IMPACT**  
**HYBRID III 50TH PERCENTILE MALE**

ATD Serial No: 351

Test I.D.: D12804

Tested Parameter	Units	Specification	Result	Pass/Fail
Laboratory Temperature	deg C	20.6 to 22.2	22.0	Pass
Laboratory Relative Humidity	%	10 to 70	18	Pass
Probe Velocity	m/s	6.58 to 6.82	6.77	Pass
Peak Probe Force	N	5159 to 5893	5,208	Pass
Peak Sternum Displacement	cm	6.35 to 7.26	6.64	Pass
Internal Hysteresis	%	69 to 85	70	Pass
<b>Overall Test Results</b>				<b>Pass</b>

*Jessica Hall*  
 Laboratory Technician

3/5/12  
 Test Date

*David Winkelbauer*  
 Approved By



Test Desc: Thorax Impact  
Component ID: D12804

Test Date: 3/5/12  
Velocity: 22.22 ft/s, 6.77 m/s

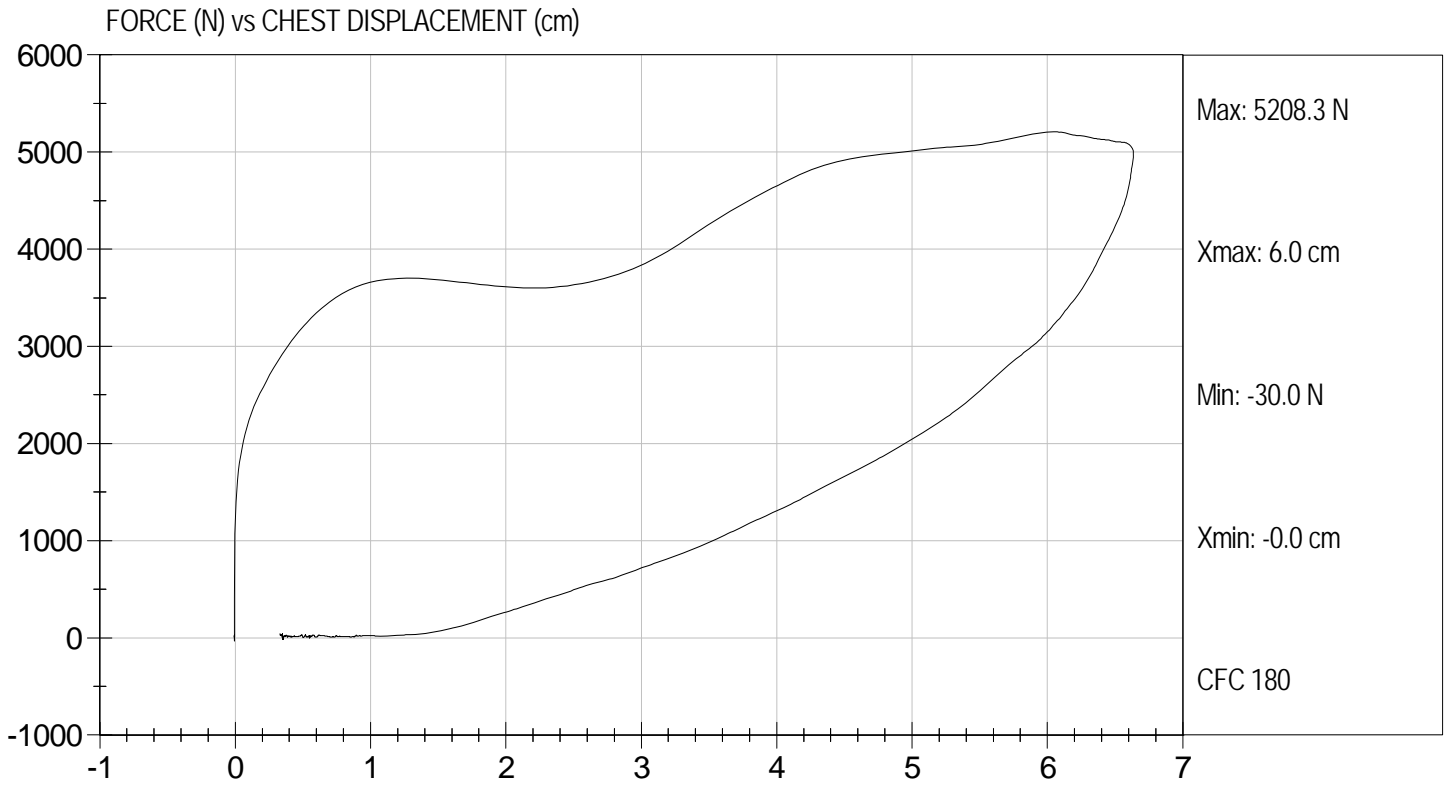

**MGA RESEARCH CORPORATION  
RIGHT KNEE IMPACT TEST  
HYBRID III 50TH PERCENTILE MALE**

ATD Serial No: 351

Test I.D.: D12805

Tested Parameter	Units	Specification	Result	Pass/Fail
Laboratory Temperature	deg C	18.9 to 25.5	21.7	Pass
Laboratory Relative Humidity	%	10 to 70	19	Pass
Probe Velocity	m/s	2.07 to 2.13	2.12	Pass
Peak Probe Force	Newtons	4715 to 5782	5,624	Pass
Overall Test Results				Pass

Jessica Hall  
Laboratory Technician

3/5/12  
Test Date

David Winkelbauer  
Approved By



Test Desc: Right Knee  
Component ID: D12805

Test Date: 3/5/12  
Velocity: 6.97 ft/s, 2.12 m/s

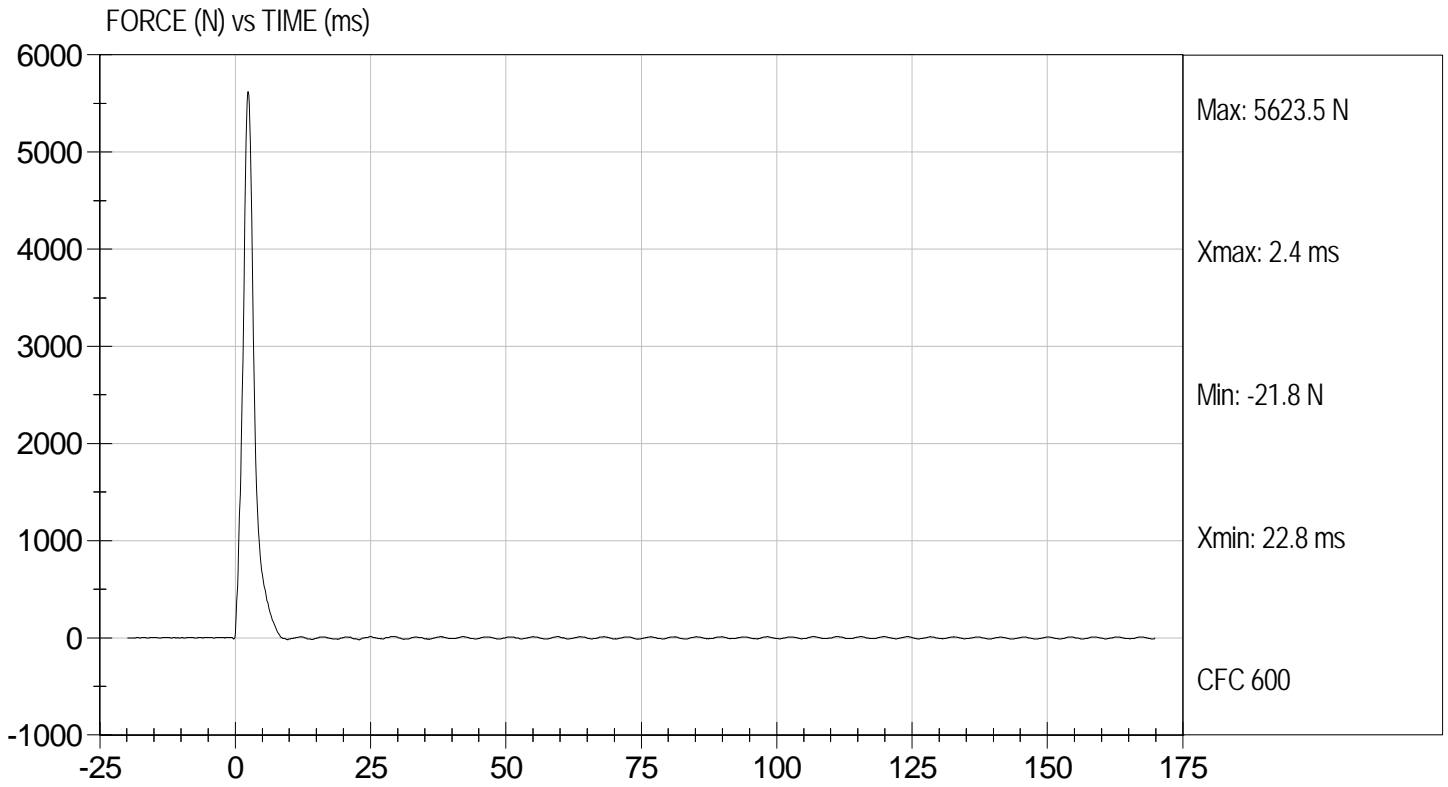

**MGA RESEARCH CORPORATION**  
**LEFT KNEE IMPACT TEST**  
**HYBRID III 50TH PERCENTILE MALE**

ATD Serial No: 351

Test I.D.: D12806

Tested Parameter	Units	Specification	Result	Pass/Fail
Laboratory Temperature	deg C	18.9 to 25.5	21.7	Pass
Laboratory Relative Humidity	%	10 to 70	19	Pass
Probe Velocity	m/s	2.07 to 2.13	2.12	Pass
Peak Probe Force	Newtons	4715 to 5782	5,500	Pass
Overall Test Results				Pass

  
 \_\_\_\_\_  
 Laboratory Technician

3/5/12  
 \_\_\_\_\_  
 Test Date

  
 \_\_\_\_\_  
 Approved By



Test Desc: Left Knee  
Component ID: D12806

Test Date: 3/5/12  
Velocity: 6.97 ft/s, 2.12 m/s

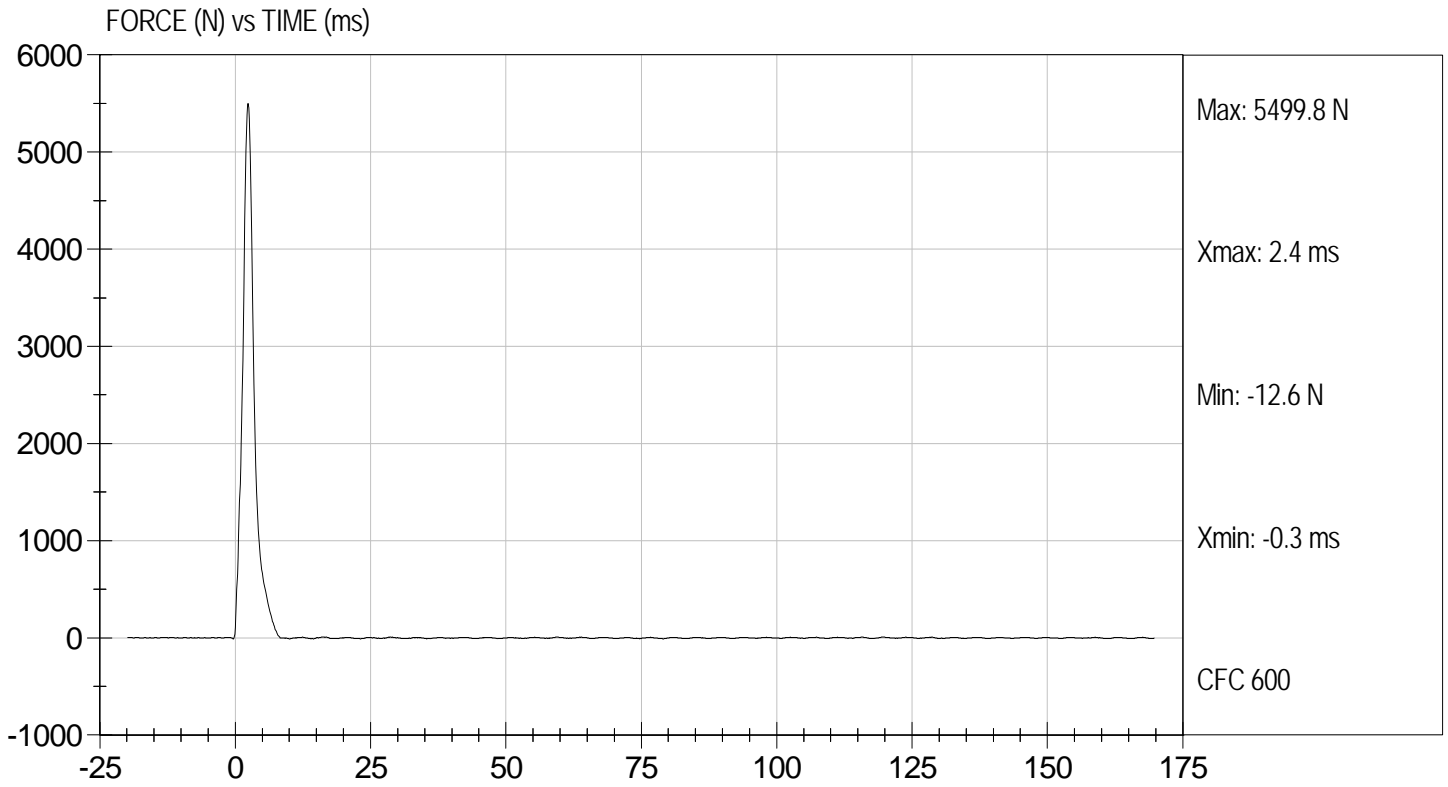

**MGA RESEARCH CORPORATION**  
**HIP-FEMUR FLEXION TEST**  
**HYBRID III 50TH PERCENTILE MALE**

**ATD Serial No:** 351

**Test I.D:** D12800

Tested Parameter	Units	Specification	Result		Pass/Fail
			Right	Left	
Laboratory Temperature	deg C	18.9 to 25.6	21.0	21.0	Pass
Laboratory Relative Humidity	%	10 to 70	34	34	Pass
Rotation Rate	deg/s	5.0 -10.0	6.3	6.3	Pass
30 Degrees	Nm	94.9 Nm Max	59.2	58.0	Pass
150 ft-lbf / 203.4 Nm	Deg	40.0 - 50.0 Degree Max Rotation	49.0	47.6	Pass
Overall Test Results					Pass

*Jessica Hall*  
 Laboratory Technician

3/2/12  
 Test Date

*David Winkelbauer*  
 Approved By



Test Desc: Hip Femur Flexion  
Component ID: D12809

Test Date: 3/2/12  
Velocity: 0 ft/s, 0.00 m/s

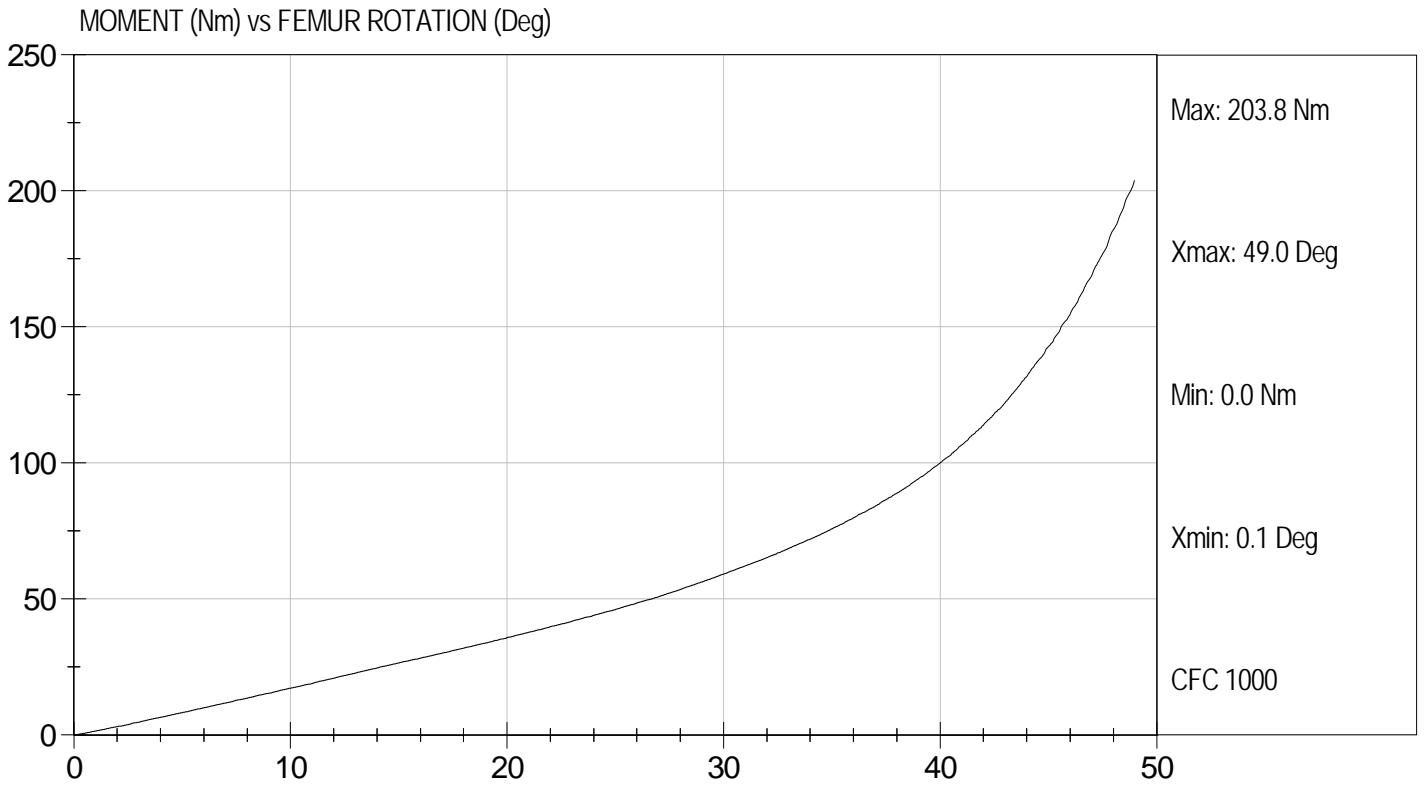



Test Desc: Hip Femur Flexion  
Component ID: D12800

Test Date: 3/2/12  
Velocity: 0 ft/s, 0.00 m/s

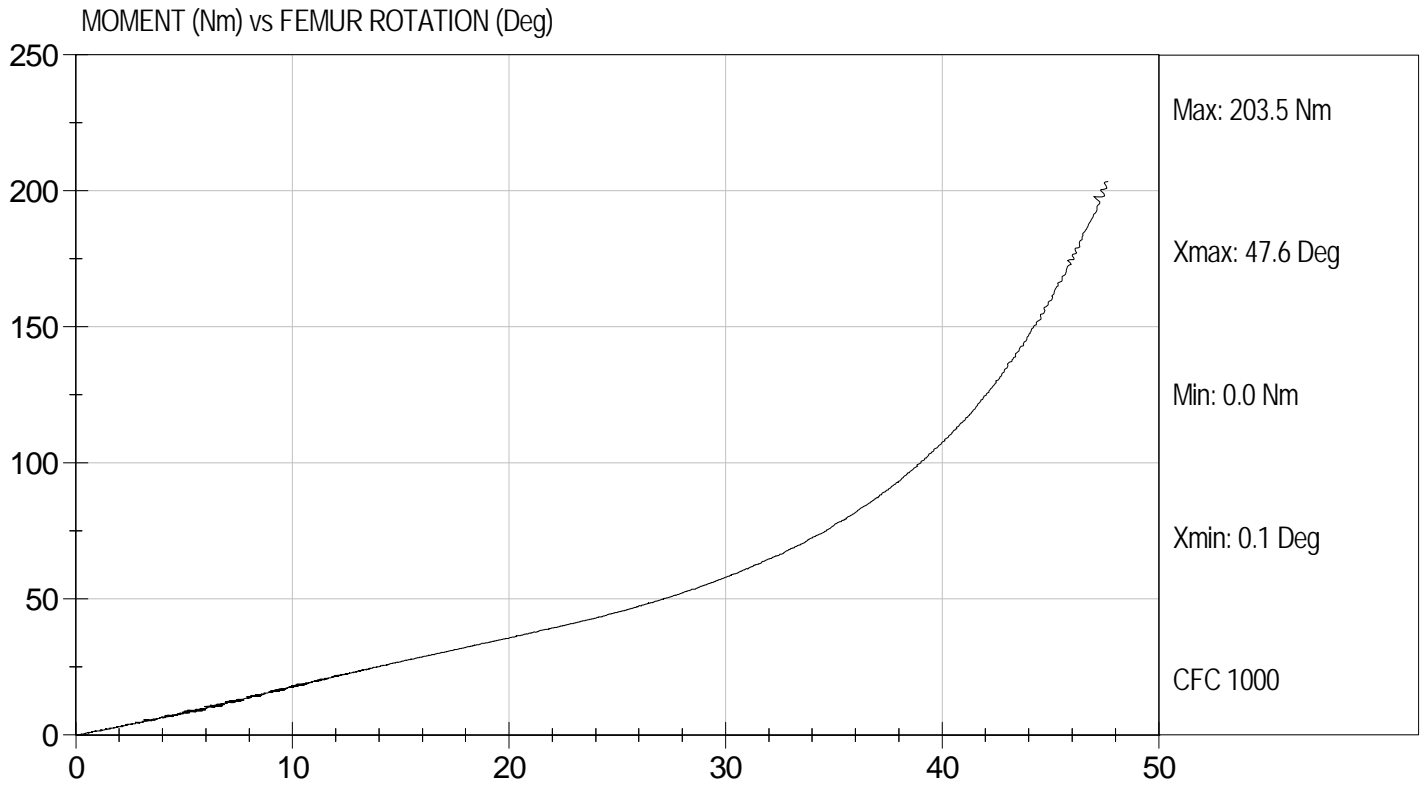

**MGA RESEARCH CORPORATION  
HEAD DROP TEST  
HYBRID III 50TH PERCENTILE MALE**

ATD Serial No: 351

Test ID: D121011

Tested Parameter	Units	Specification	Result	Pass/Fail
Laboratory Temperature	deg C	18.9 - 25.6	22.1	Pass
Laboratory Relative Humidity	%	10 to 70	31	Pass
Peak Resultant Acceleration	G's	225 - 275	249	Pass
Peak Lateral Acceleration	G's	<= +/- 15.0	-3.2	Pass
Unimodal	N/A	Yes	Yes	Pass
Oscillations	N/A	within 10% of peak	Yes	Pass
Overall Test Results				Pass

Jessica Gall  
Laboratory Technician

3/13/12  
Test Date

David Winkelbauer  
Approved By



Test Desc: Head Drop  
Component ID: D121011

Test Date: 3/13/12  
Velocity: 0 ft/s, 0 m/s

RESULTANT HEAD ACCELERATION (G's) vs TIME (ms)

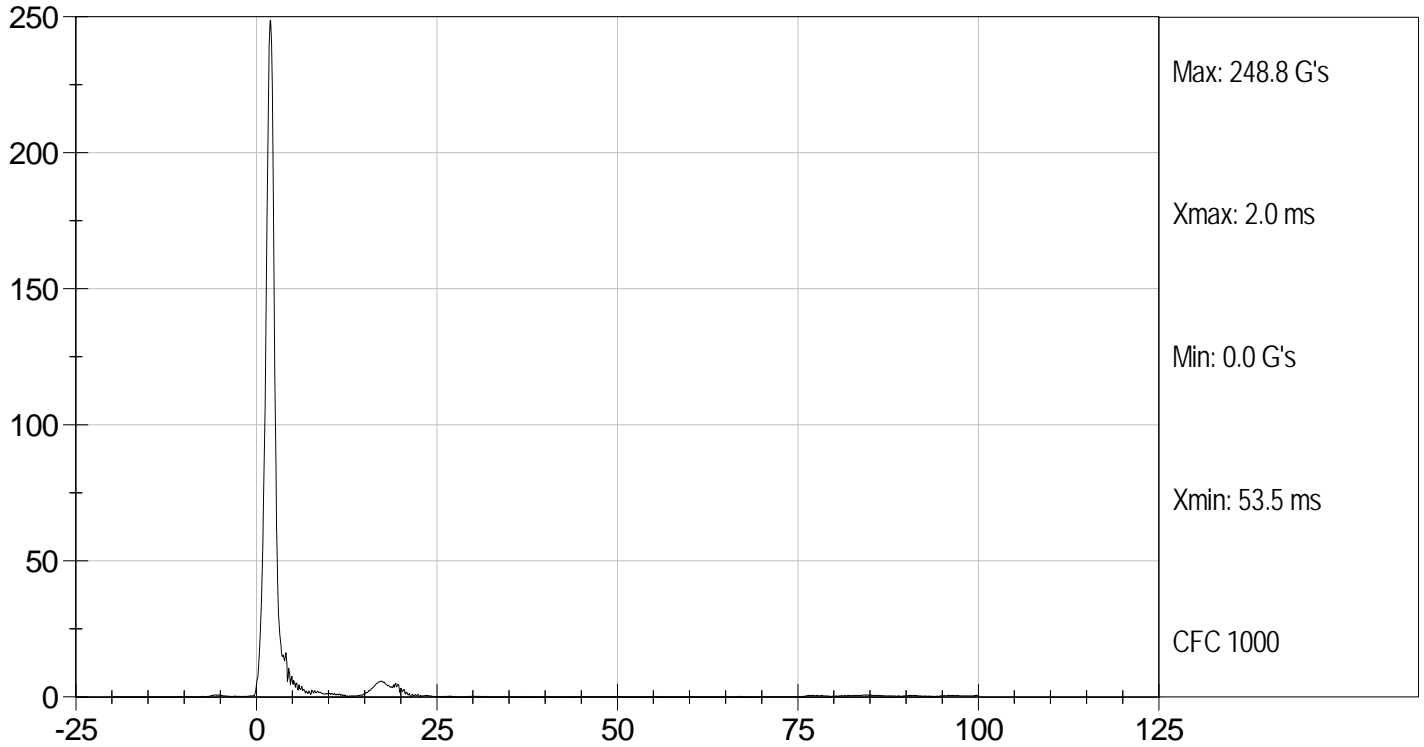

HEAD Y (G's) vs TIME (ms)

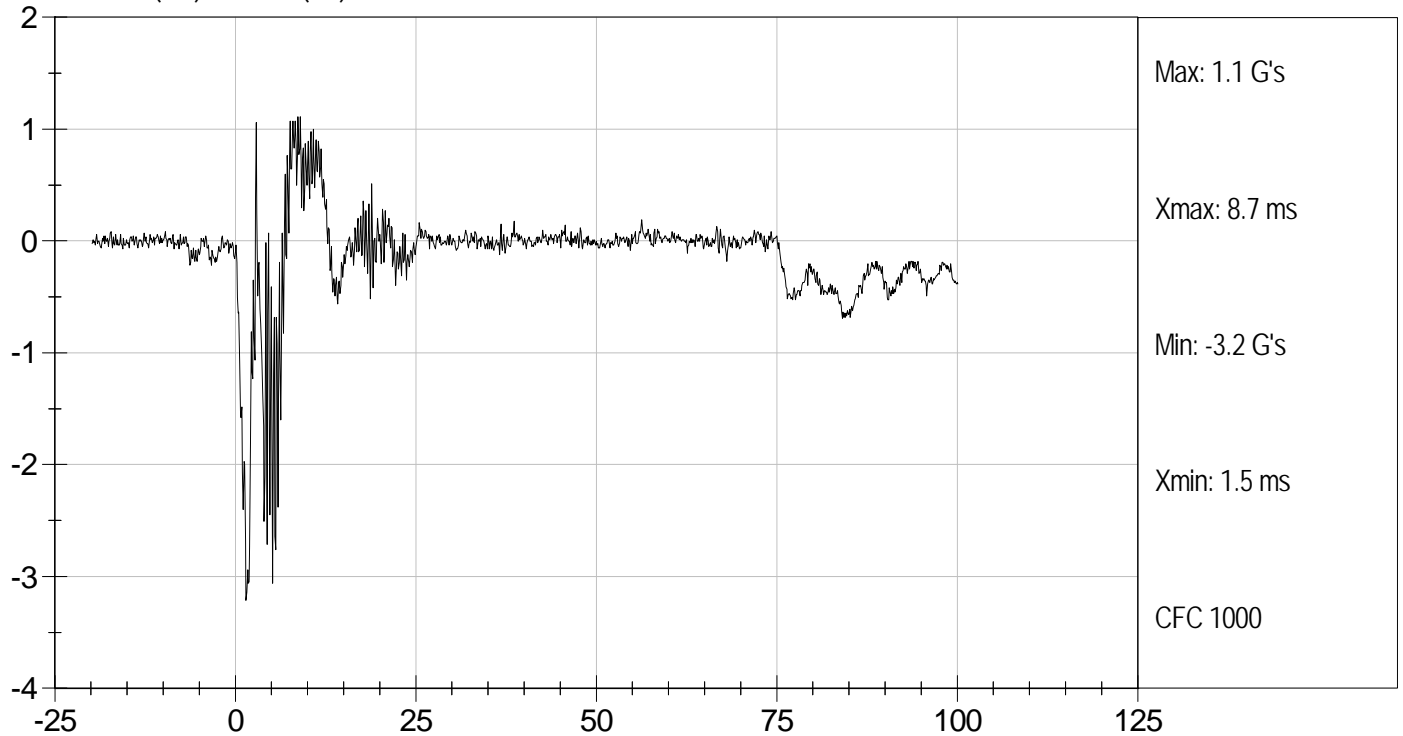

**MGA RESEARCH CORPORATION  
NECK FLEXION TEST  
HYBRID III 50TH PERCENTILE MALE**

ATD Serial No: 351

Test I.D.: D121012

Tested Parameter		Units	Specification	Result	Pass/Fail
Laboratory Temperature		deg C	20.6 to 22.2	21.9	Pass
Laboratory Relative Humidity		%	10 to 70	31	Pass
Pendulum Velocity		m/s	6.89 to 7.13	6.92	Pass
Pendulum Deceleration	10 ms	G's	22.50 to 27.50	22.57	Pass
	20 ms	G's	17.60 to 22.60	18.43	Pass
	30 ms	G's	12.50 to 18.50	12.84	Pass
Peak Pendulum Deceleration After 30 ms		G's	<= 29.0	13.2	Pass
Deceleration Decay Time to Cross 5 G's		ms	34.0 to 42.0	37.9	Pass
Maximum "D" Plane Rotation	Maximum	Degrees	64.0 to 78.0	71.0	Pass
	Time	ms	57.0 to 64.0	58.2	Pass
"D" Plane Rotation Decay Time To Zero Crossing		ms	113.0 to 128.0	113.4	Pass
Moment About Occipital Condyle	Maximum	N m	88.1 to 108.5	92.3	Pass
	Time	ms	47.0 to 58.0	51.7	Pass
Positive Moment Decay Time To Zero Crossing		ms	97.0 to 107.0	102.4	Pass
<b>Overall Test Results</b>					<b>Pass</b>

*Jessica Hall*  
Laboratory Technician

3/14/12  
Test Date

*David Winkelbauer*  
Approved By



Test Desc: Neck Flexion  
Component ID: D121012

Test Date: 3/14/12  
Velocity: 22.7 ft/s, 6.92 m/s

PENDULUM DECELERATION (g's) vs TIME (ms)

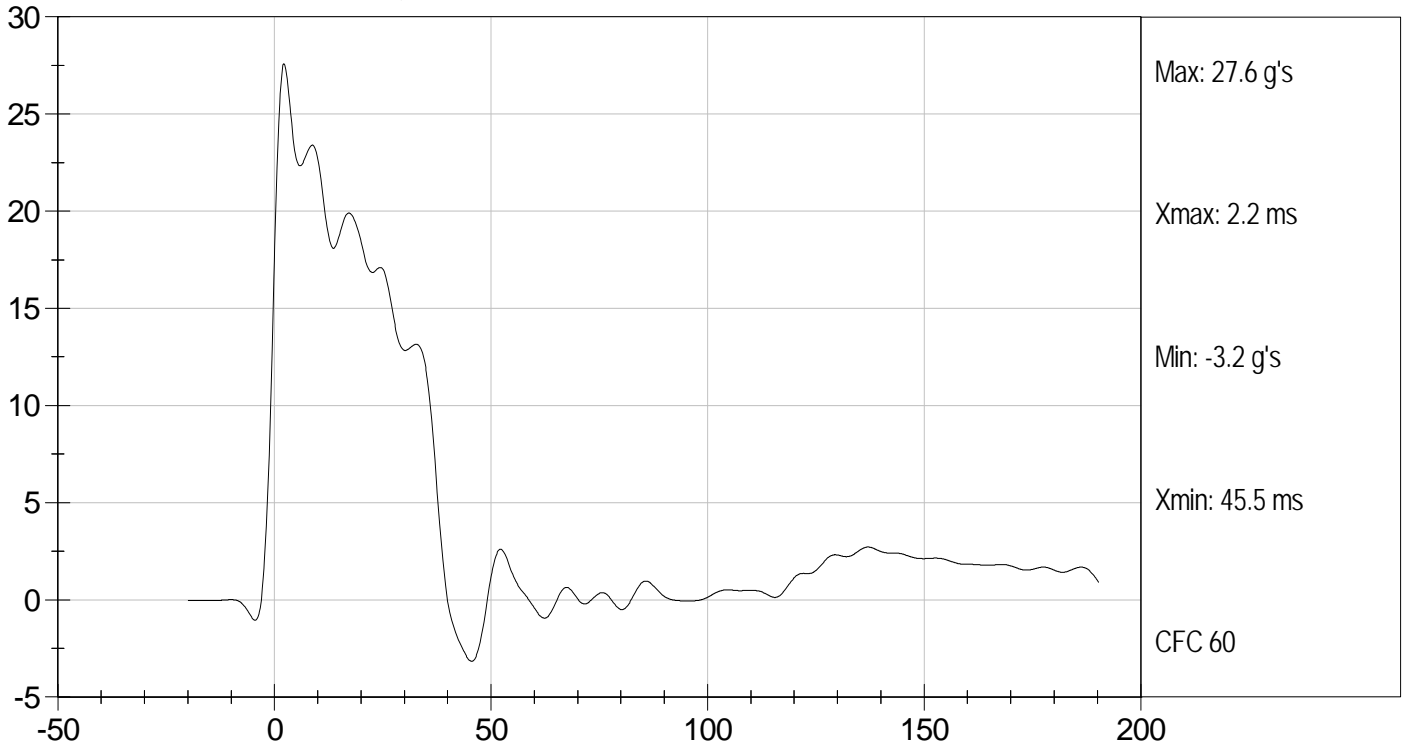

NECK ROTATION (DEG.) vs TIME (ms)

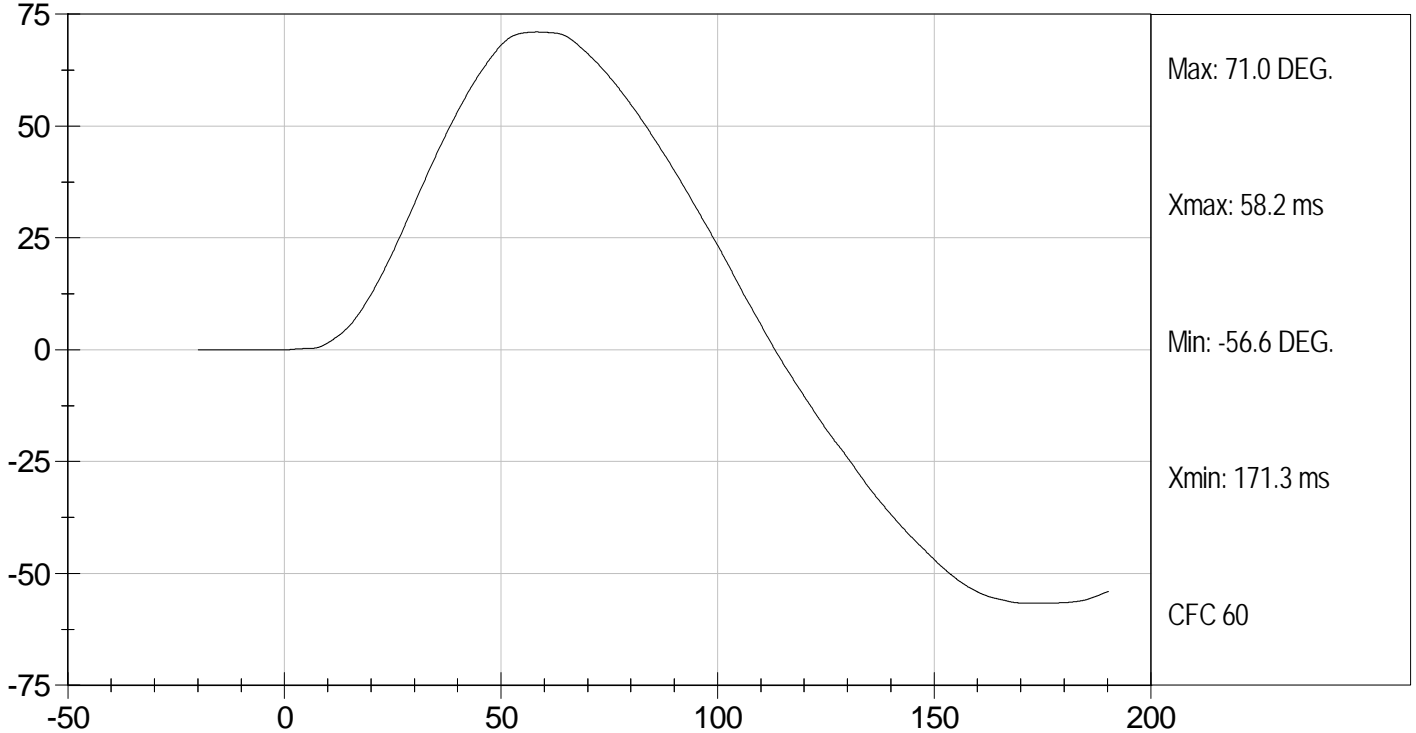



Test Desc: Neck Flexion  
Component ID: D121012

Test Date: 3/14/12  
Velocity: 22.7 ft/s, 6.92 m/s

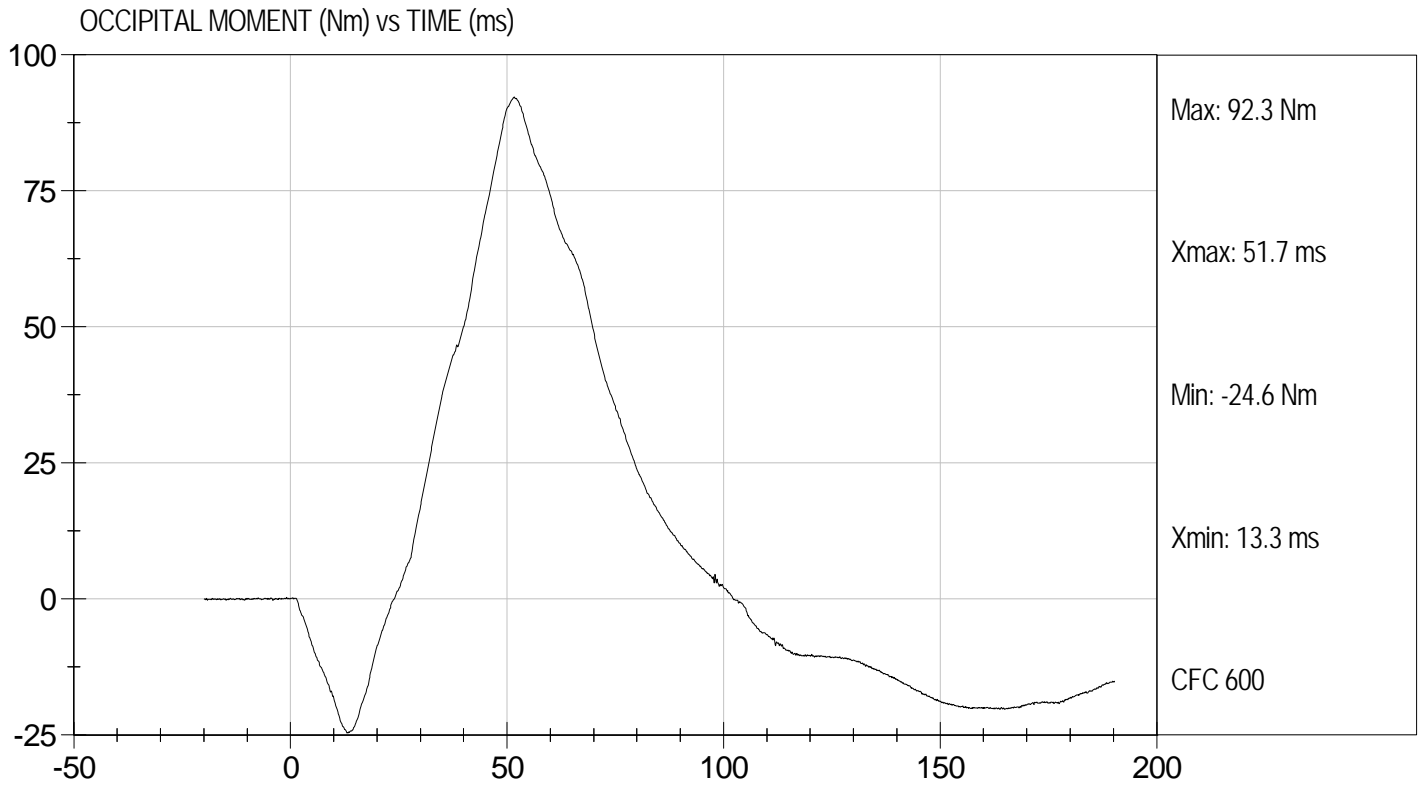

**MGA RESEARCH CORPORATION  
NECK EXTENSION TEST  
HYBRID III 50TH PERCENTILE MALE**

ATD Serial No: 351

Test I.D.: D121013

Tested Parameter		Units	Specification	Result	Pass/Fail
Laboratory Temperature		deg C	20.6 to 22.2	21.9	Pass
Laboratory Relative Humidity		%	10 to 70	31	Pass
Pendulum Velocity		m/s	5.95 to 6.19	6.05	Pass
Pendulum Deceleration	10 ms	G's	17.20 to 21.20	17.29	Pass
	20 ms	G's	14.00 to 19.00	15.35	Pass
	30 ms	G's	11.00 to 16.00	12.88	Pass
Peak Pendulum Deceleration After 30 ms		G's	<= 22.0	13.6	Pass
Deceleration Decay Time to Cross 5 G's		ms	38.0 to 46.0	38.8	Pass
Maximum "D" Plane Rotation	Maximum	Degrees	81.0 to 106.0	98.9	Pass
	Time	ms	72.0 to 82.0	78.2	Pass
"D" Plane Rotation Decay Time To Zero Crossing		ms	147.0 to 174.0	157.7	Pass
Moment About Occipital Condyle	Maximum	Nm	-52.9 to -79.9	-63.3	Pass
	Time	ms	65.0 to 79.0	72.9	Pass
Negative Moment Decay Time To Zero Crossing		ms	120.0 to 148.0	145.9	Pass
<b>Overall Test Results</b>					<b>Pass</b>

*Jessica Hall*  
Laboratory Technician

3/14/12  
Test Date

*David Winkelbauer*  
Approved By



PENDULUM DECELERATION (g's) vs TIME (ms)

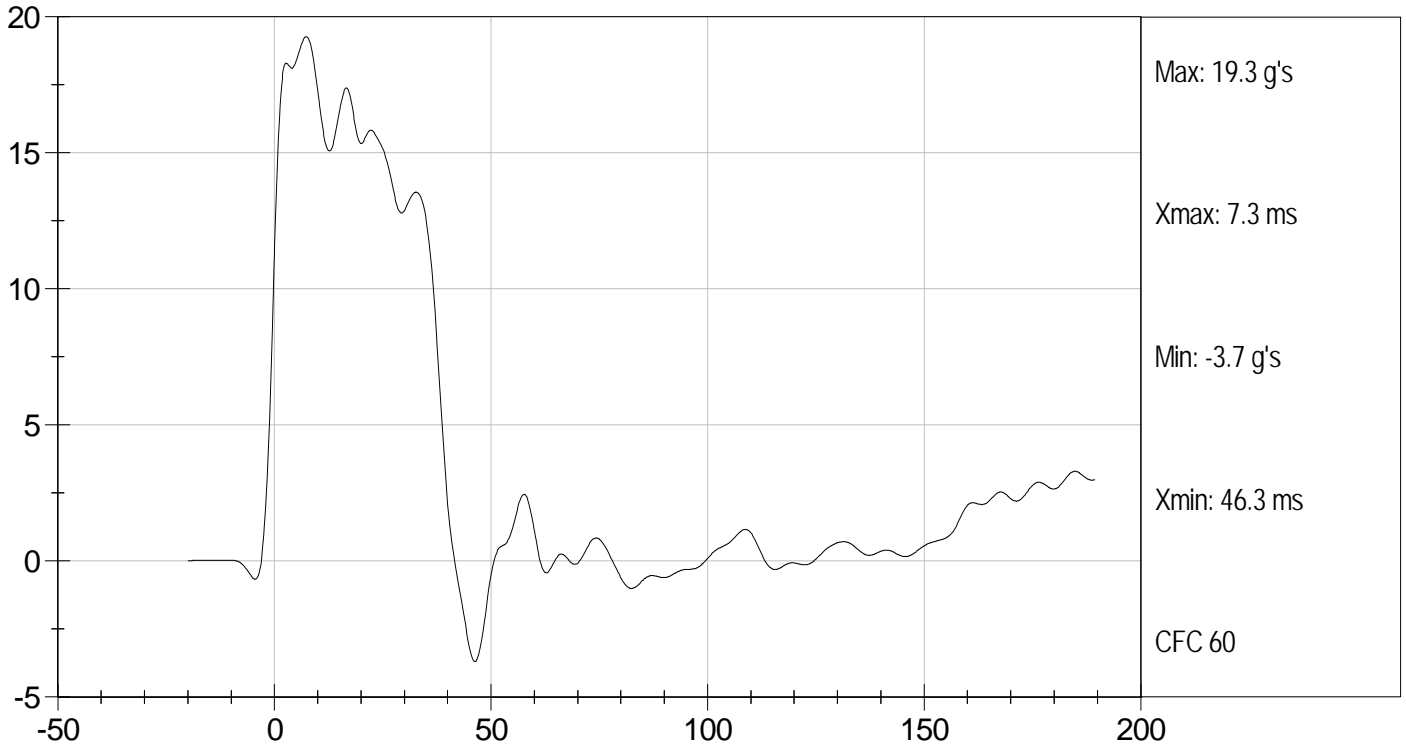

NECK ROTATION (DEG.) vs TIME (ms)

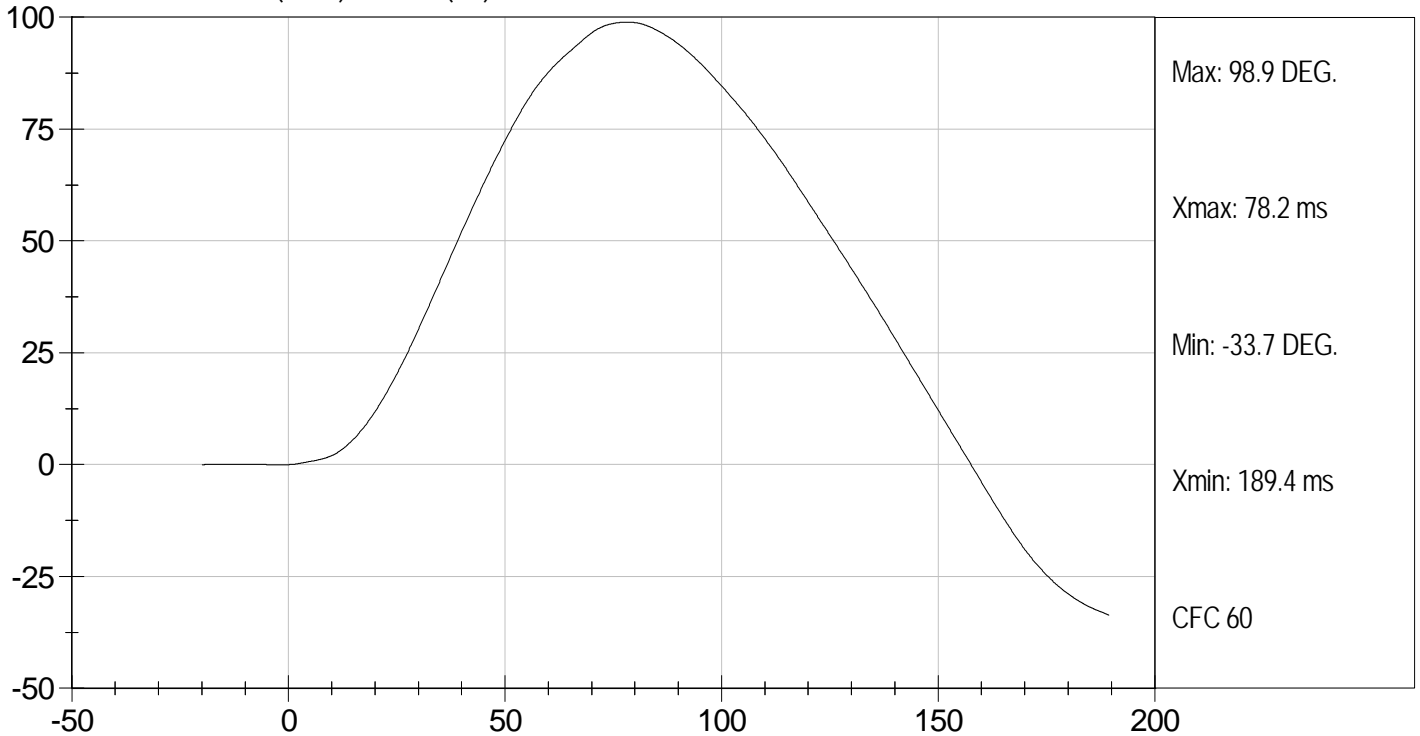



Test Desc: Neck Extension  
Component ID: D121013

Test Date: 3/14/12  
Velocity: 19.84 ft/s, 6.05 m/s

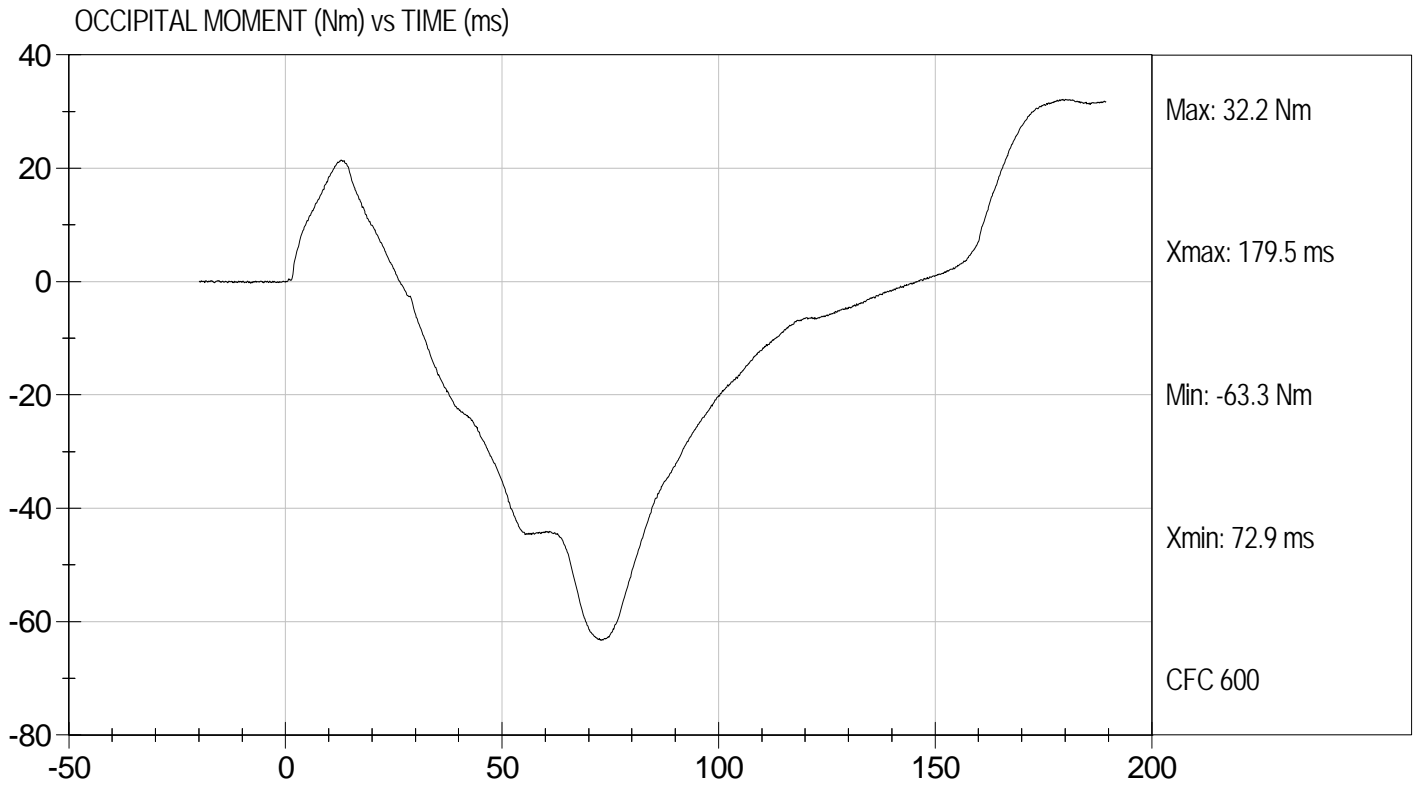

**MGA RESEARCH CORPORATION  
THORAX IMPACT  
HYBRID III 50TH PERCENTILE MALE**

ATD Serial No: 351

Test I.D: D121014

Tested Parameter	Units	Specification	Result	Pass/Fail
Laboratory Temperature	deg C	20.6 to 22.2	21.8	Pass
Laboratory Relative Humidity	%	10 to 70	32	Pass
Probe Velocity	m/s	6.58 to 6.82	6.77	Pass
Peak Probe Force	N	5159 to 5893	5,324	Pass
Peak Sternum Displacement	cm	6.35 to 7.26	6.48	Pass
Internal Hysteresis	%	69 to 85	69	Pass
<b>Overall Test Results</b>				<b>Pass</b>

Jessica Hall  
Laboratory Technician

3/14/12  
Test Date

David Winkelbauer  
Approved By



Test Desc: Thorax Impact  
Component ID: D121014

Test Date: 3/14/12  
Velocity: 22.22 ft/s, 6.77 m/s

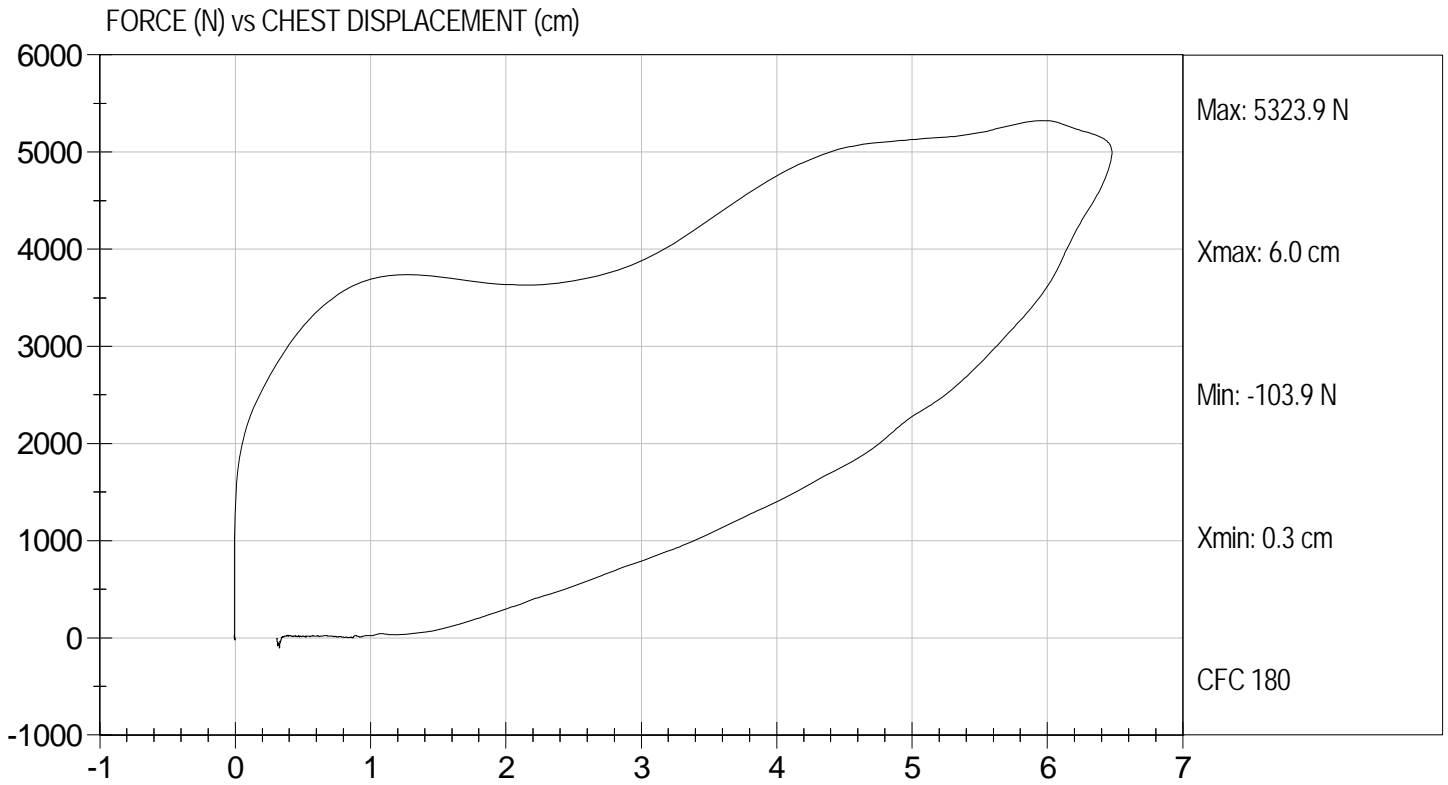

**MGA RESEARCH CORPORATION  
RIGHT KNEE IMPACT TEST  
HYBRID III 50TH PERCENTILE MALE**

ATD Serial No: 351

Test I.D.: D121015

Tested Parameter	Units	Specification	Result	Pass/Fail
Laboratory Temperature	deg C	18.9 to 25.5	22.0	Pass
Laboratory Relative Humidity	%	10 to 70	31	Pass
Probe Velocity	m/s	2.07 to 2.13	2.12	Pass
Peak Probe Force	Newtons	4715 to 5782	5,267	Pass
Overall Test Results				Pass

  
 \_\_\_\_\_  
 Laboratory Technician

3/13/12  
 \_\_\_\_\_  
 Test Date

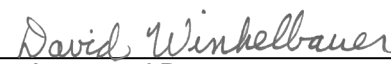
  
 \_\_\_\_\_  
 Approved By



Test Desc: Right Knee  
Component ID: D121015

Test Date: 3/13/12  
Velocity: 6.94 ft/s, 2.12 m/s

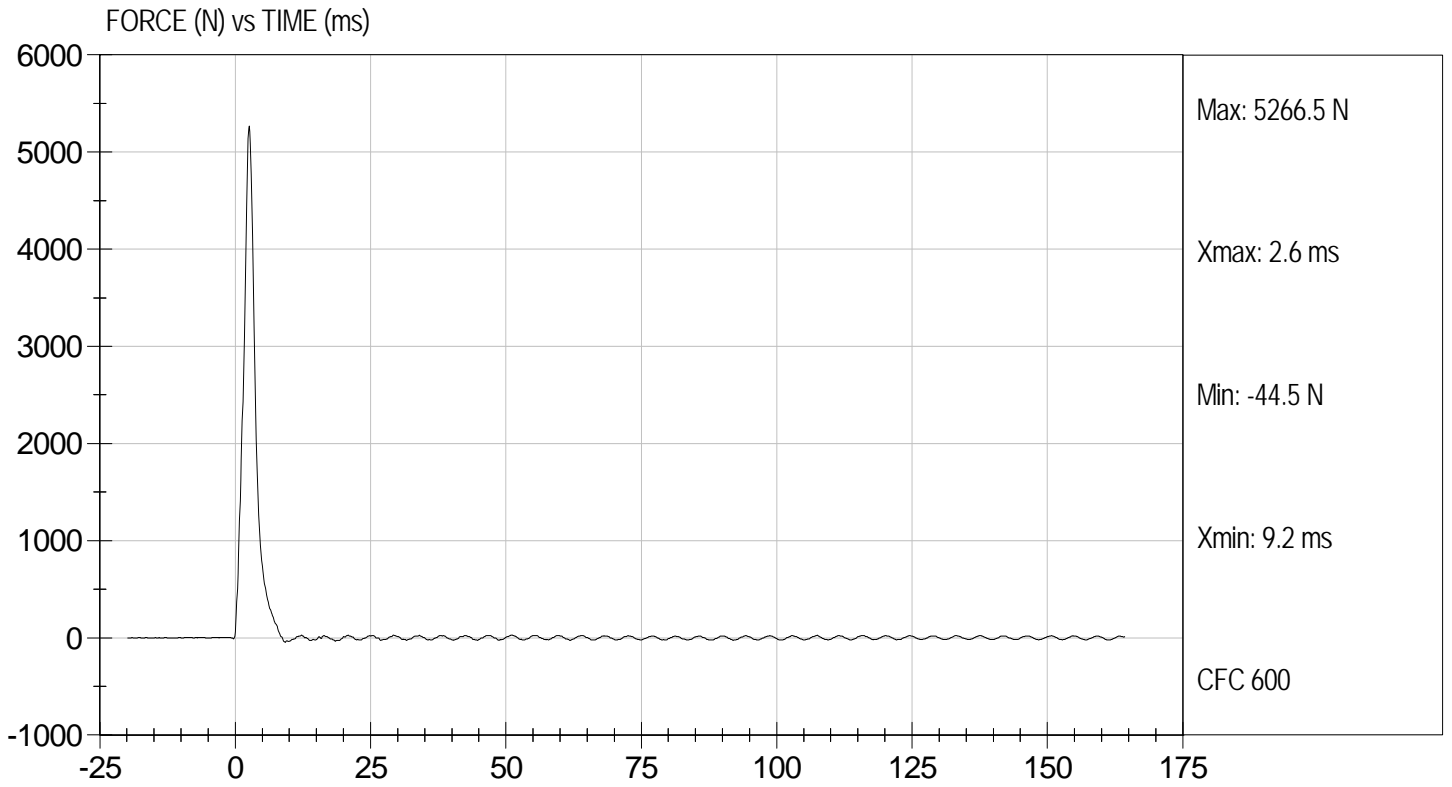

**MGA RESEARCH CORPORATION**  
**LEFT KNEE IMPACT TEST**  
**HYBRID III 50TH PERCENTILE MALE**

ATD Serial No: 351

Test I.D: D121016

Tested Parameter	Units	Specification	Result	Pass/Fail
Laboratory Temperature	deg C	18.9 to 25.5	22.0	Pass
Laboratory Relative Humidity	%	10 to 70	31	Pass
Probe Velocity	m/s	2.07 to 2.13	2.12	Pass
Peak Probe Force	Newtons	4715 to 5782	5,253	Pass
Overall Test Results				Pass

  
 \_\_\_\_\_  
 Laboratory Technician

3/13/12  
 \_\_\_\_\_  
 Test Date

  
 \_\_\_\_\_  
 Approved By



Test Desc: Left Knee  
Component ID: D121016

Test Date: 3/13/12  
Velocity: 6.97 ft/s, 2.12 m/s

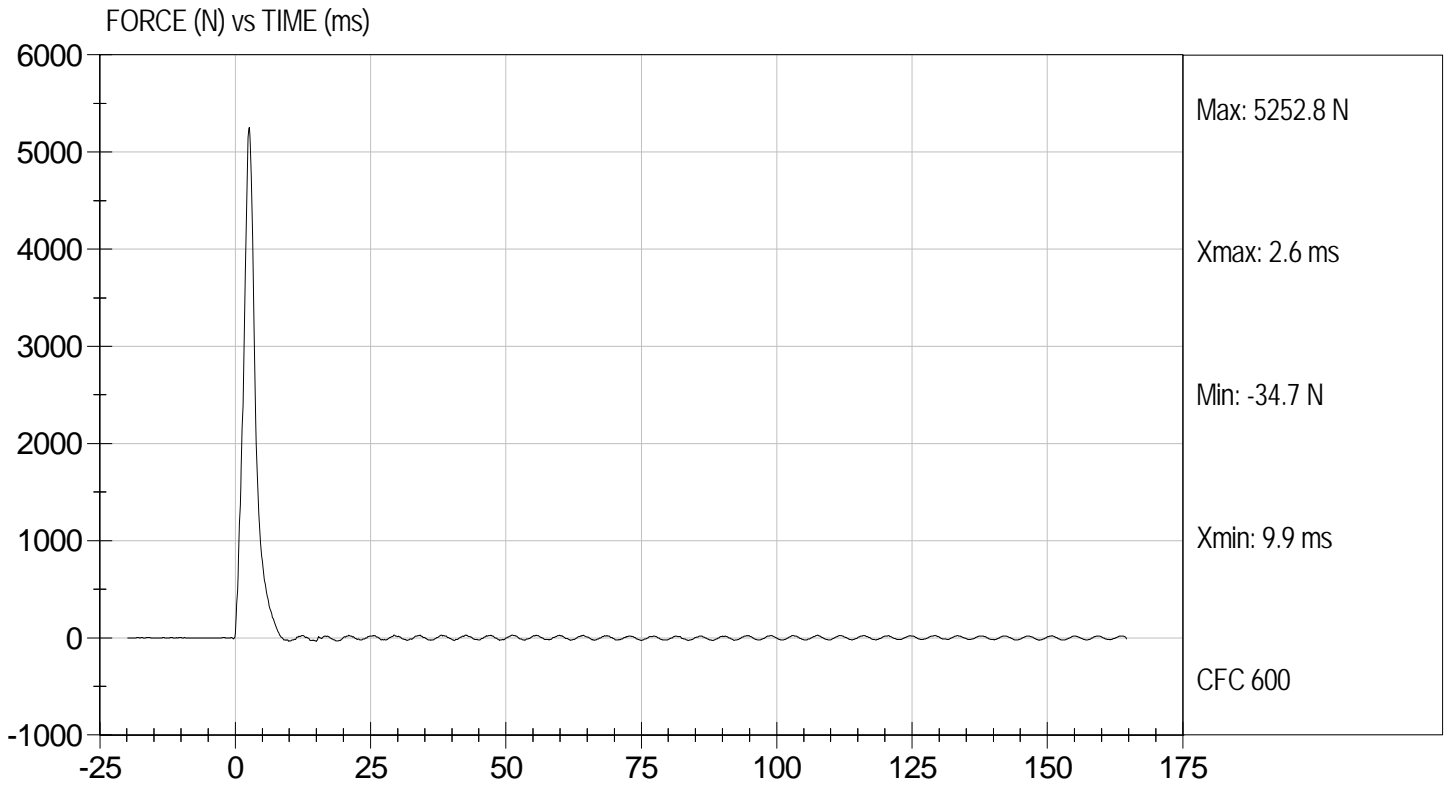

**MGA RESEARCH CORPORATION**  
**HIP-FEMUR FLEXION TEST**  
**HYBRID III 50TH PERCENTILE MALE**

ATD Serial No: 351

Test I.D: D121010

Tested Parameter	Units	Specification	Result		Pass/Fail
			Right	Left	
Laboratory Temperature	deg C	18.9 to 25.6	22.1	22.1	Pass
Laboratory Relative Humidity	%	10 to 70	31	31	Pass
Rotation Rate	deg/s	5.0 -10.0	6.4	6.3	Pass
30 Degrees	Nm	94.9 Nm Max	58.0	57.8	Pass
150 ft-lbf / 203.4 Nm	Deg	40.0 - 50.0 Degree Max Rotation	49.4	47.8	Pass
Overall Test Results					Pass

Jessica Hall  
 Laboratory Technician

3/13/12  
 Test Date

David Winkelbauer  
 Approved By



Test Desc: Hip Femur Flexion  
Component ID: D121019

Test Date: 3/13/12  
Velocity: 0 ft/s, 0.00 m/s

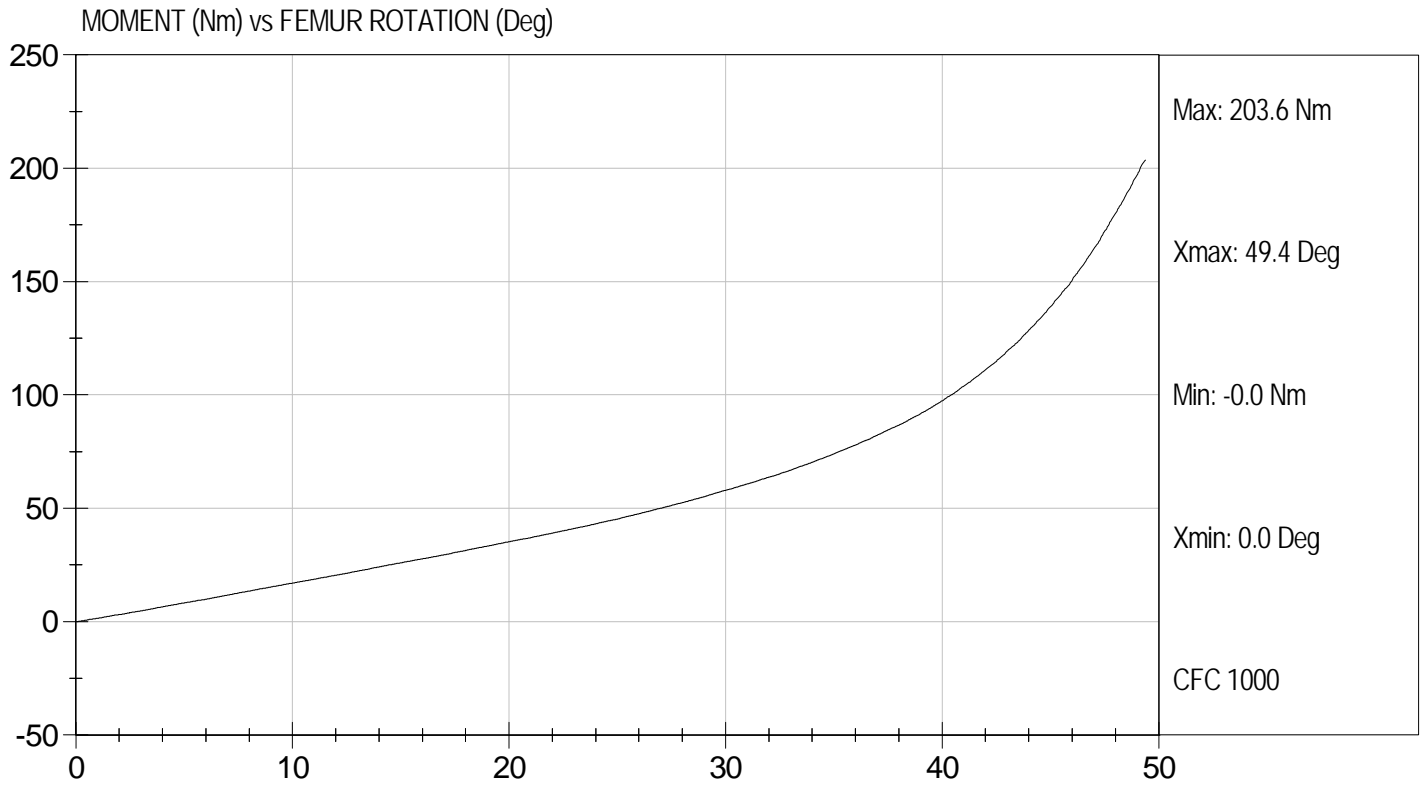



Test Desc: Hip Femur Flexion  
Component ID: D121010

Test Date: 3/13/12  
Velocity: 0 ft/s, 0.00 m/s

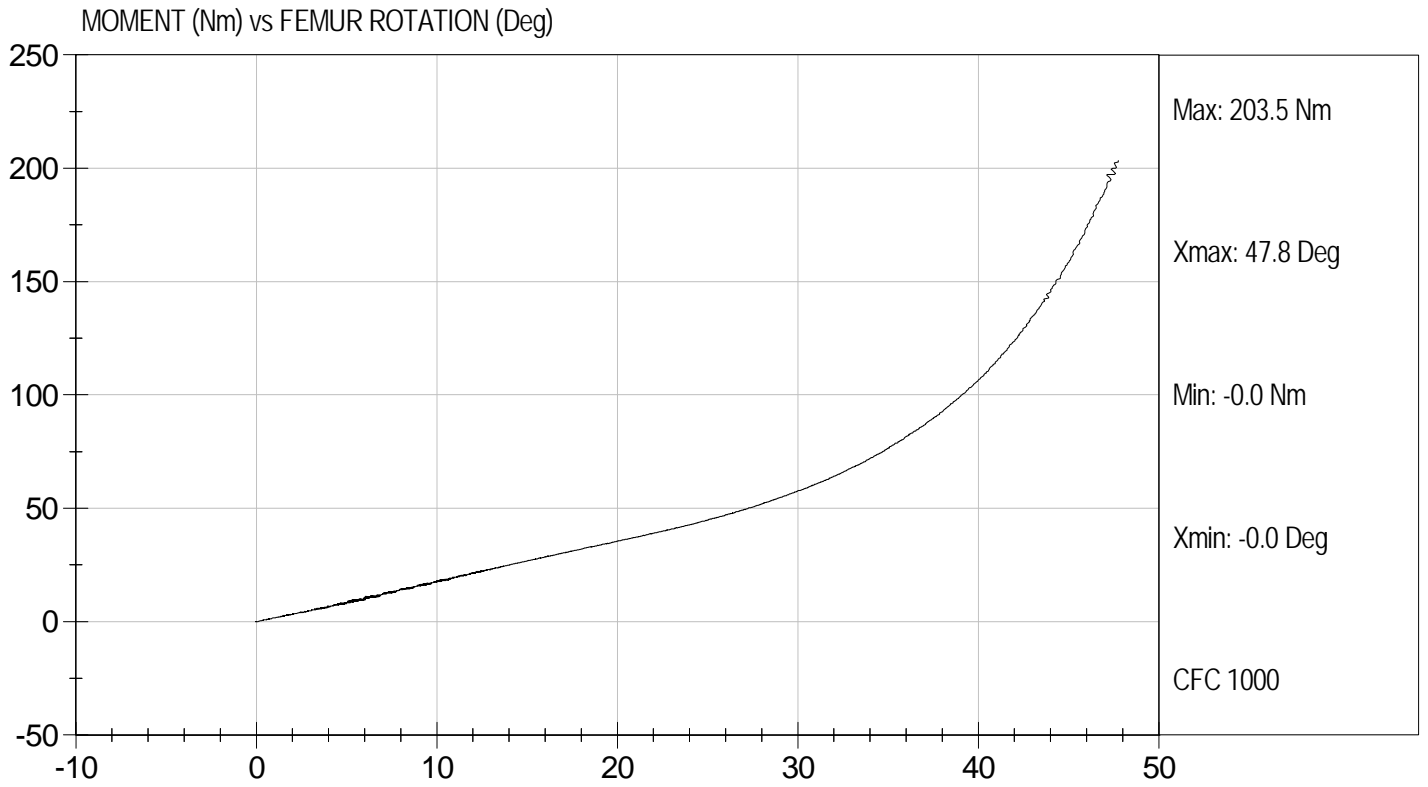

**Hybrid III, 5<sup>th</sup> External Measurements  
SN: 138**

HYBRID III, PART 572, SUBPART O EXTERNAL DIMENSIONS				
DIMENSION	DESCRIPTION	DETAILS	ASSEMBLY DIMENSION (mm)	ACTUAL MEASUREMENT
A	TOTAL SITTING HEIGHT	Seat surface to highest point on top of the head.	774.7-800.1	785.1
B	SHOULDER PIVOT HEIGHT	Centerline of shoulder pivot bolt to the seat surface.	431.8-457.2	456.8
C	H-POINT HEIGHT	Reference	81.3-86.3	84.0
D	H-POINT LOCATION FROM BACKLINE	Reference	144.8-149.8	146.2
E	SHOULDER PIVOT FROM BACKLINE	Center of the shoulder clevis to the rear vertical surface of the fixture.	68.6-83.8	78.0
F	THIGH CLEARANCE	Measured at the highest point on the upper femur segment.	119.4-134.6	127.5
G	BACK OF ELBOW TO WRIST PIVOT	back of the elbow flesh to the wrist pivot in line with the elbow and wrist pivots	243.9-259.1	249.6
H	HEAD BACK TO BACKLINE	Back of Skull cap skin to seat rear vertical surface (Reference)	43.2-48.2	45.0
I	SHOULDER TO- ELBOW LENGTH	Measure from the highest point on top of the shoulder clevis to the lowest part of the flesh on the elbow in line with the elbow pivot bolt.	276.8-297.2	280.2
J	ELBOW REST HEIGHT	Measure from the flesh below the elbow pivot bolt to the seat surface.	182.8-203.2	201.9
K	BUTTOCK TO KNEE LENGTH	The forward most part of the knee flesh to the rear vertical surface of the fixture.	520.7-546.1	526.7
L	POPLITEAL HEIGHT	Seat surface to the plane of the horizontal plane of the bottom of the feet.	355.6-376.0	362.3
M	KNEE PIVOT HEIGHT	Centerline of knee pivot bolt to the horizontal plane of the bottom of the feet.	393.7-419.1	398.0
N	BUTTOCK POPLITEAL LENGTH	The rearmost surface of the lower leg to the same point on the rear surface of the buttocks used for dim. "K".	414-439.4	430.5

HYBRID III, SUBPART O EXTERNAL DIMENSIONS, continued				
DIMENSION	DESCRIPTION	DETAILS	ASSEMBLY DIMENSION (mm)	ACTUAL MEASUREMENT
O	CHEST DEPTH WITHOUT JACKET	Measured 304.8 ± 5.1 mm above seat surface	175.3-190.5	184.6
P	FOOT LENGTH	Tip of toe to rear of heel	218.5-233.7	221.0
Q	STANDING HEIGHT	(THEORETICAL)	1501.1	N/A
R	BUTTOCK TO KNEE PIVOT LENGTH	The rear surface of the buttocks to the knee pivot bolt	457.2-482.6	472.6
S	HEAD BREADTH	The widest part of the head	137.1-147.3	141.9
T	HEAD DEPTH	Back of the head to the forehead	177.8-188.0	184.2
U	HIP BREADTH	The widest part of the hip	299.7-314.9	307.4
V	SHOULDER BREADTH	Outside edges of right and left shoulder clevises	350.5-365.7	360.5
W	FOOT BREADTH	The widest part of the foot	78.8-94.0	85.0
X	HEAD CIRCUMFERENCE	Measured at the point as in dim. "T"	528.3-548.7	546.2
Y	CHEST CIRCUMFERENCE (WITH CHEST JACKET)	Measured 345.4 ± 12.7 mm above seat surface	850.9-881.3	875.1
Z	WAIST CIRCUMFERENCE	Measured 165.1 ± 5.1 mm above seat surface	759.5-789.9	785.4
AA	REFERENCE LOCATION FOR MEASUREMENT OF CHEST CIRCUMFERENCE	Reference	332.7-358.1	345.4
BB	REFERENCE LOCATION FOR MEASUREMENT OF WAIST CIRCUMFERENCE	Reference	160.1-170.2	165.1

**MGA RESEARCH CORPORATION  
HEAD DROP TEST  
HYBRID III 5TH PERCENTILE**

ATD Serial No: 138

Test ID: D12541t

Tested Parameter	Units	Specification	Result	Pass/Fail
Laboratory Temperature	deg C	18.9 to 25.6	21.8	Pass
Laboratory Relative Humidity	%	10 to 70	23	Pass
Peak Resultant Acceleration	G's	250 to 300	268	Pass
Peak Lateral Acceleration	G's	+/- 15	3.9	Pass
Unimodal	N/A	Yes	Yes	Pass
Oscillations	N/A	within 10% of peak	Yes	Pass
Overall Test Results				Pass

Jessica Hall  
Laboratory Technician

2/16/12  
Test Date

David Winkelbauer  
Approved By



Test Desc: Head Drop  
Component ID: D12541t

Test Date: 2/16/12  
Velocity: 0 ft/s, 0 m/s

PEAK RESULTANT ACCELERATION (G's) vs TIME (ms)

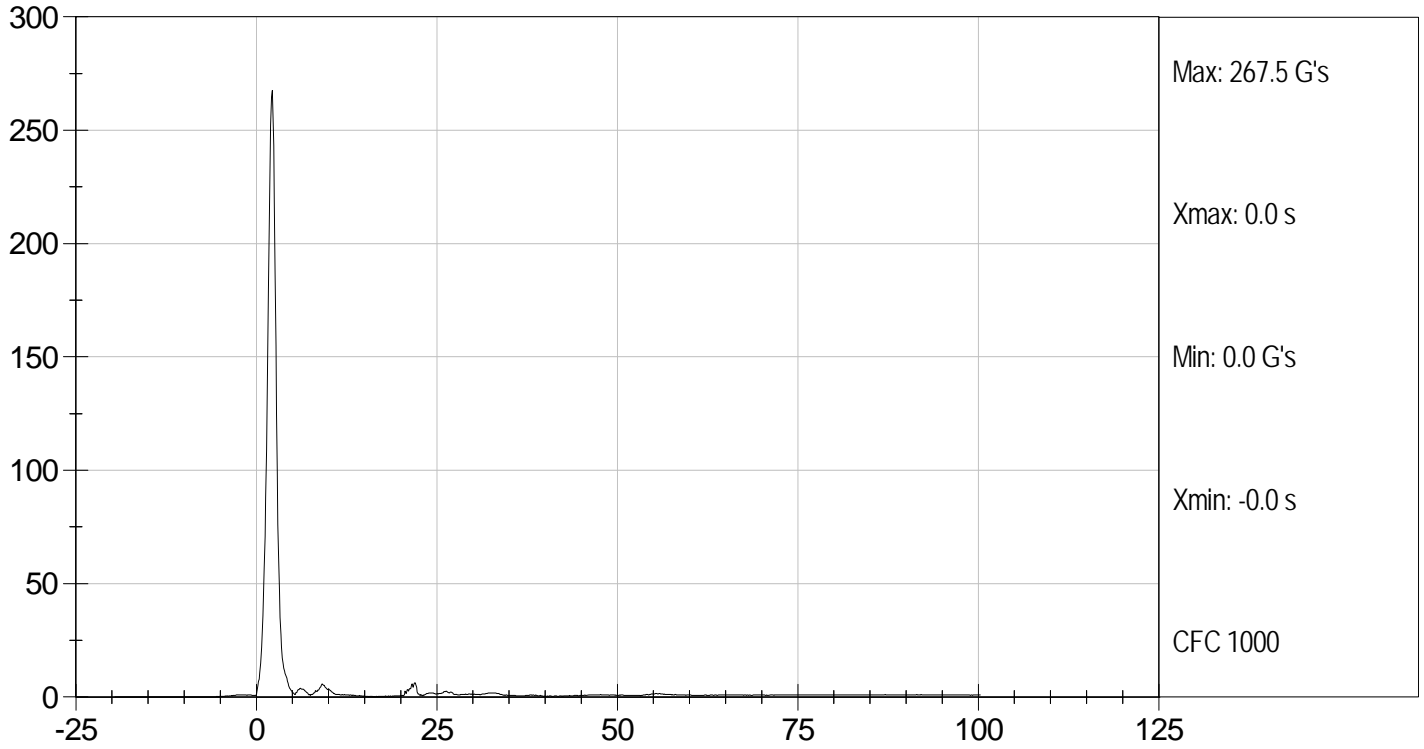

HEAD Y (G's) vs TIME (ms)

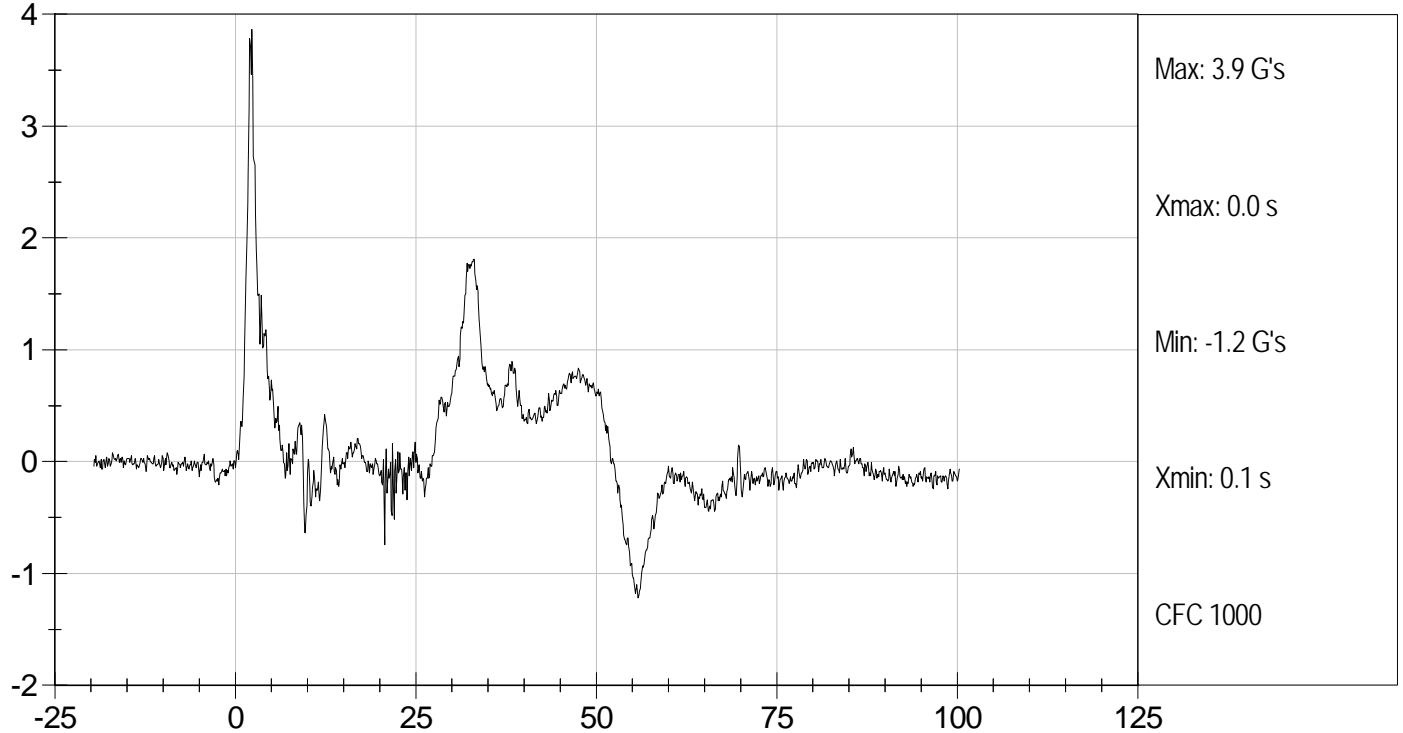

**MGA RESEARCH CORPORATION**  
**NECK FLEXION TEST**  
**HYBRID III 5TH PERCENTILE**

ATD Serial No: 138

Test I.D.: D12542

Tested Parameter		Units	Specification	Result	Pass/Fail
Laboratory Temperature		deg C	20.6 to 22.2	22.0	Pass
Laboratory Relative Humidity		%	10 to 70	25	Pass
Pendulum Speed		m/s	6.89 to 7.13	7.06	Pass
Pendulum Pulse	10 ms	m/s	2.1 to 2.5	2.5	Pass
	20 ms	m/s	4.0 to 5.0	4.7	Pass
	30 ms	m/s	5.8 to 7.0	6.4	Pass
D Plane Rotation	Max	deg	77 to 91	81	Pass
Occipital Condyle Moment within Deflection Corridor		Nm	69 to 83	77	Pass
Positive Moment Time Curve Decay to 10 Nm		ms	80 to 100	83	Pass
Overall Results					Pass

  
 Laboratory Technician

2/16/12  
 Test Date

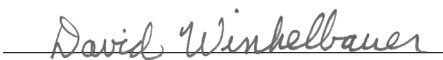
  
 Approved By



Test Desc: Neck Flexion  
Component ID: D12542

Test Date: 2/16/12  
Velocity: 23.15 ft/s, 7.06 m/s

PENDULUM VELOCITY (m/s) vs TIME (ms)

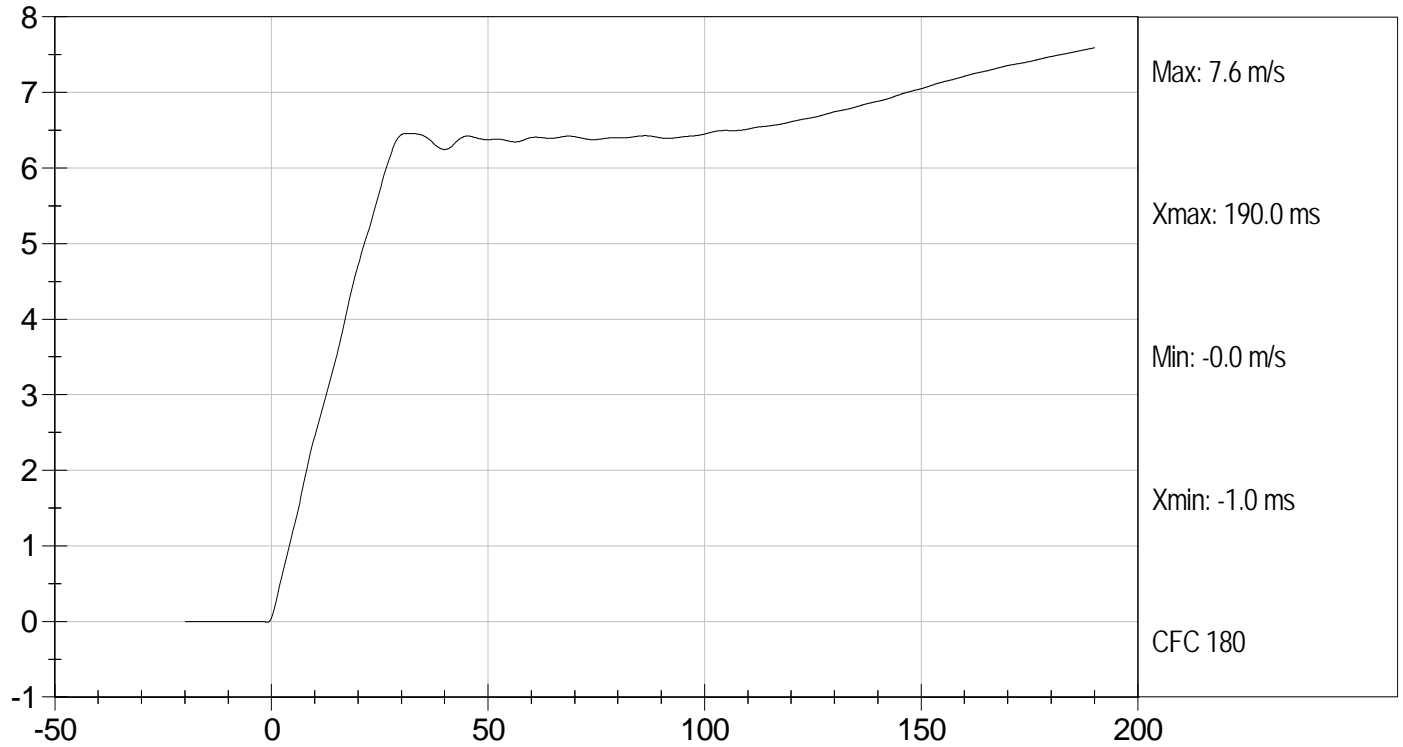

NECK ROTATION (DEG) vs TIME (ms)

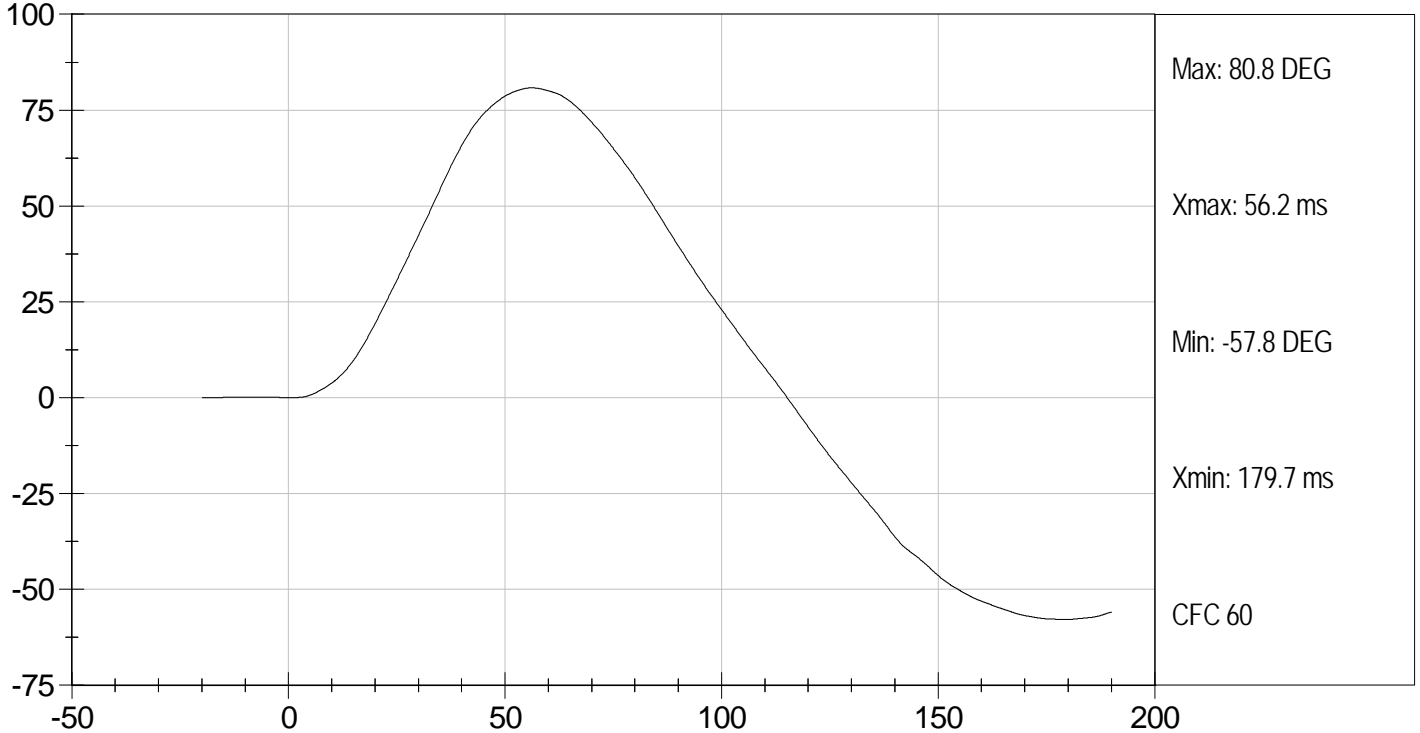



Test Desc: Neck Flexion  
Component ID: D12542

Test Date: 2/16/12  
Velocity: 23.15 ft/s, 7.06 m/s

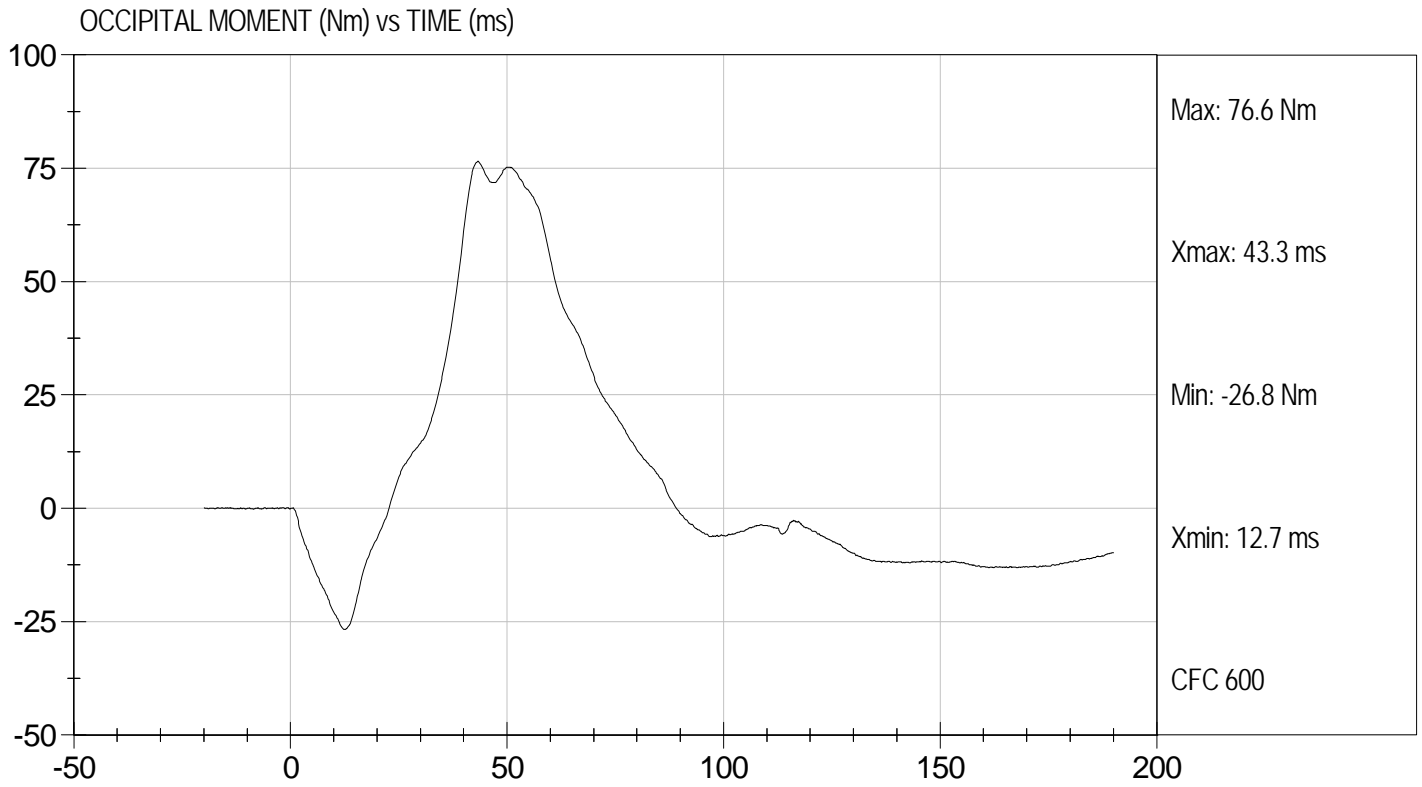

**MGA RESEARCH CORPORATION**  
**NECK EXTENSION TEST**  
**HYBRID III 5TH PERCENTILE**

ATD Serial No: 138

Test I.D.: D12543

Tested Parameter		Units	Specification	Result	Pass/Fail
Laboratory Temperature		deg C	20.6 to 22.2	21.9	Pass
Laboratory Relative Humidity		%	10 to 70	25	Pass
Pendulum Speed		m/s	5.95 to 6.19	6.13	Pass
Pendulum Pulse	10 ms	m/s	1.5 to 1.9	1.9	Pass
	20 ms	m/s	3.1 to 3.9	3.7	Pass
	30 ms	m/s	4.6 to 5.6	5.2	Pass
D Plane Rotation	Max	deg	99 to 114	107	Pass
Occipital Condyle Moment within Deflection Corridor		Nm	-65 to -53	-57	Pass
Negative Moment Time Curve Decay to -10 Nm		ms	94 to 114	101	Pass
<b>Overall Results</b>					<b>Pass</b>

  
 Laboratory Technician

2/16/12  
 Test Date

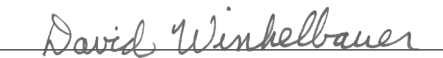
  
 Approved By



Test Desc: Neck Extension  
Component ID: D12543

Test Date: 2/16/12  
Velocity: 20.10 ft/s, 6.13 m/s

PENDULUM VELOCITY (m/s) vs TIME (ms)

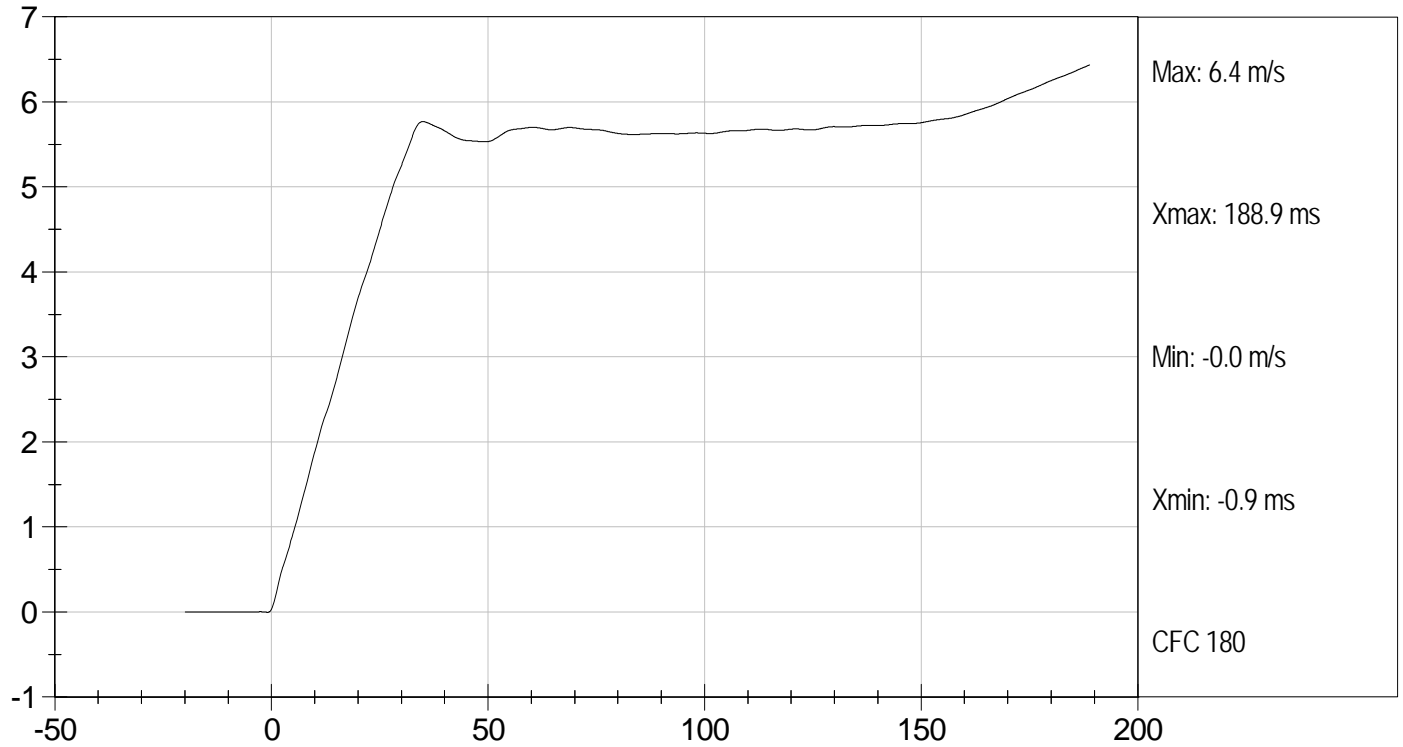

NECK ROTATION (DEG) vs TIME (ms)

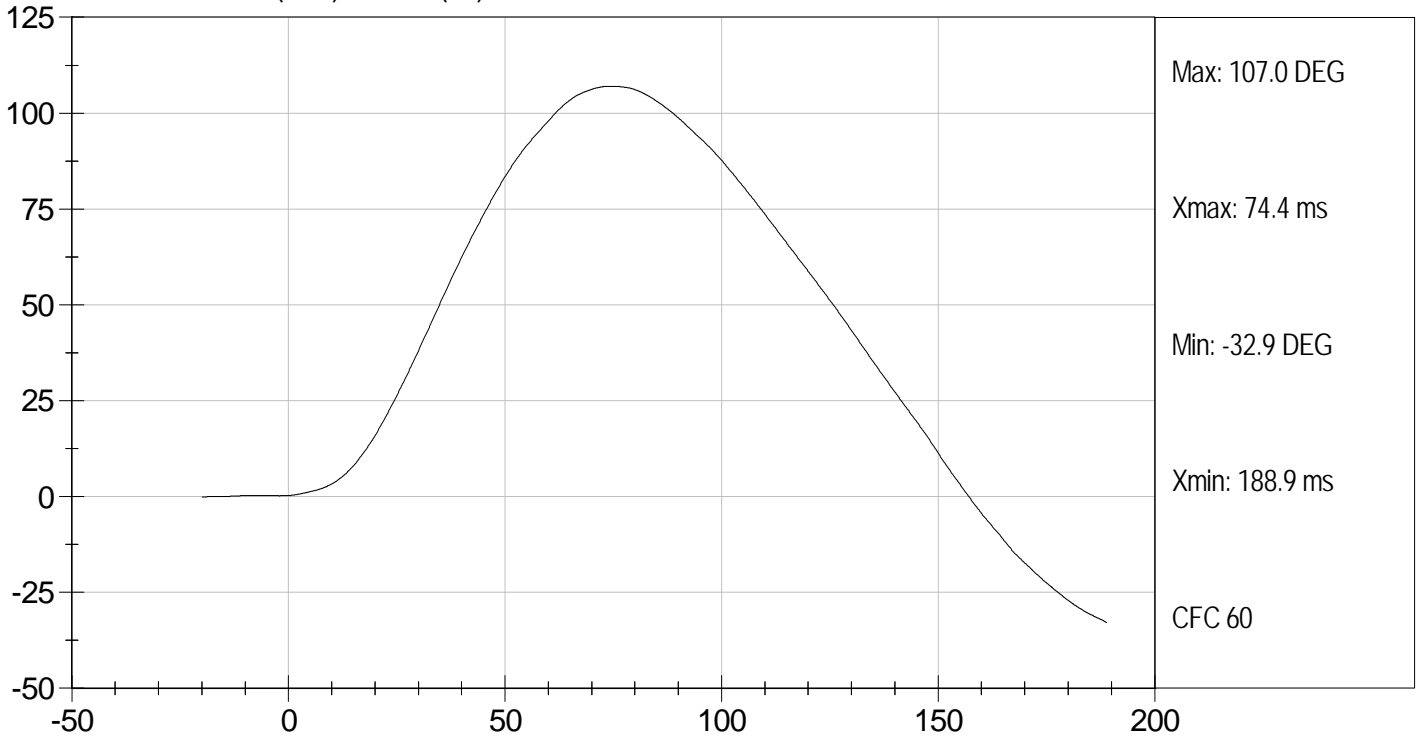



Test Desc: Neck Extension  
Component ID: D12543

Test Date: 2/16/12  
Velocity: 20.10 ft/s, 6.13 m/s

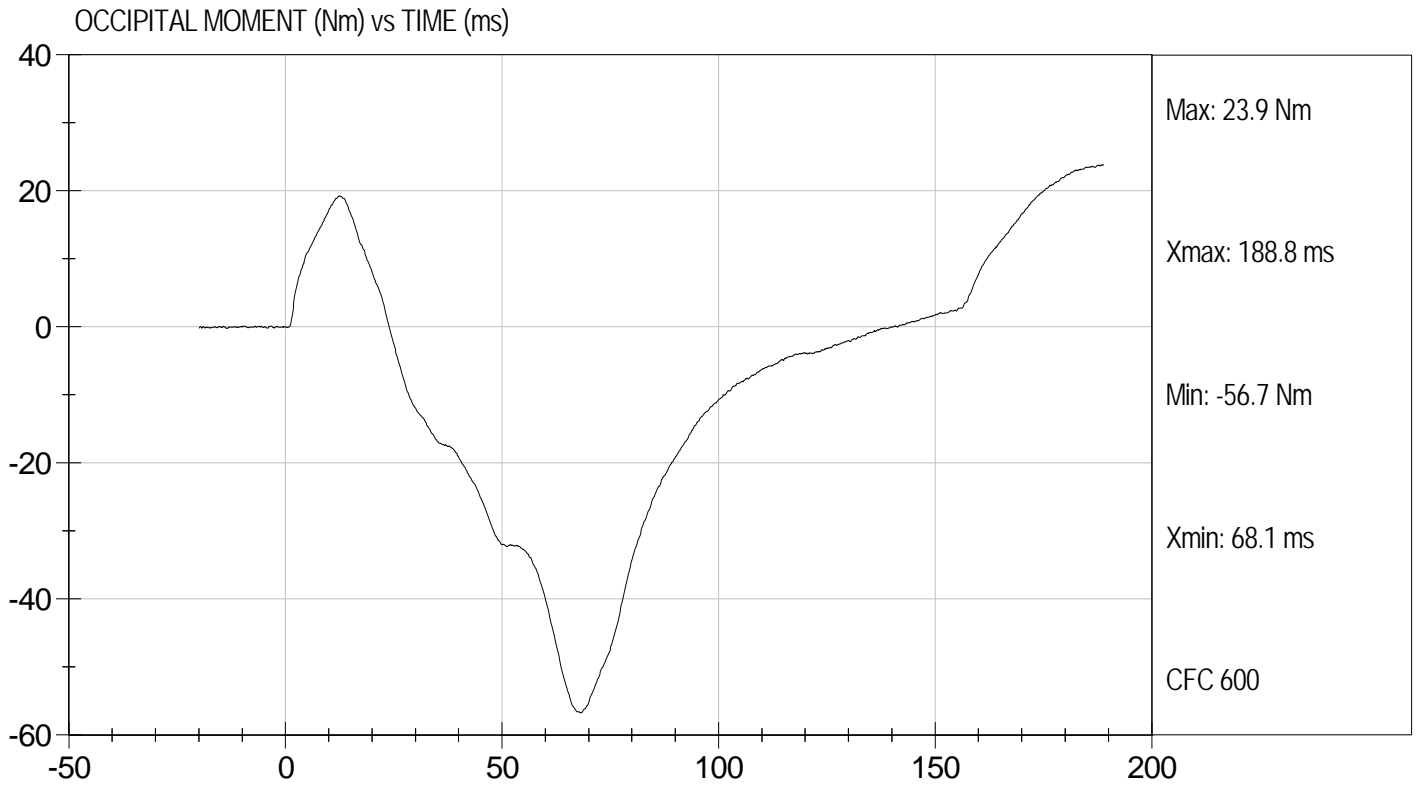

**MGA RESEARCH CORPORATION**  
**THORAX IMPACT**  
**HYBRID III 5TH PERCENTILE**

ATD Serial No: 138

Test I.D.: D12544

Tested Parameter	Units	Specification	Result	Pass/Fail
Temperature	deg C	20.6 to 22.2	21.5	Pass
Relative Humidity	%	10 to 70	21	Pass
Probe Speed	m/s	6.59 to 6.83	6.77	Pass
Peak Deflection	mm	50 to 58	53	Pass
Peak Resistive Force w/in Deflection Corridor	kN	3.9 to 4.4	4.20	Pass
Internal Hysteresis	%	69 to 85	71	Pass
Peak Force 18 mm - 50 mm	N	<= 4,600 N	4192	Pass
Overall Test Results				Pass

  
 Laboratory Technician

2/17/12  
 Test Date

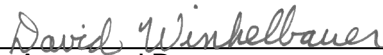
  
 Approved By



Test Desc: Thorax Impact  
Component ID: D12544

Test Date: 2/17/12  
Velocity: 22.22 ft/s, 6.77 m/s

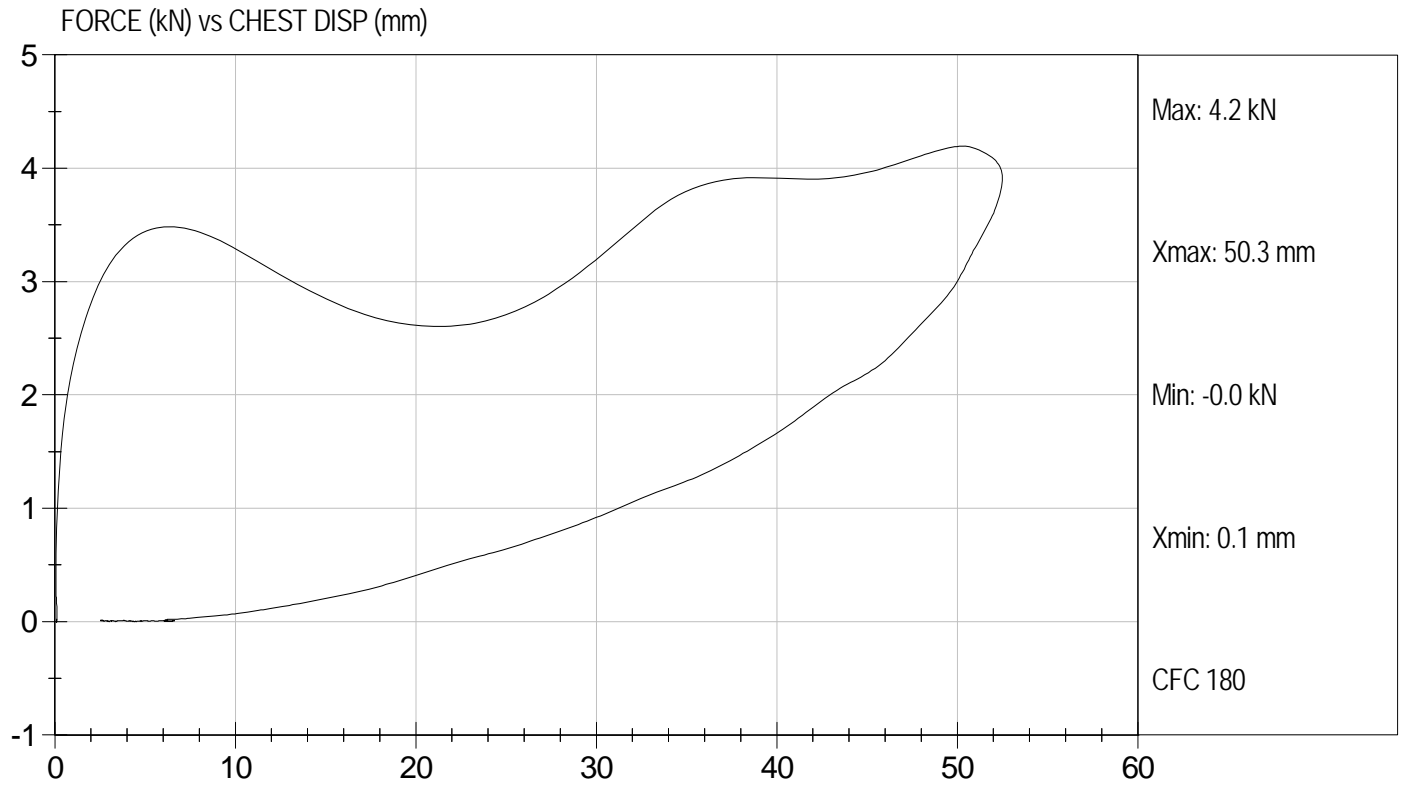

**MGA RESEARCH CORPORATION  
RIGHT KNEE IMPACT TEST  
HYBRID III 5TH PERCENTILE**

ATD Serial No: 138

Test I.D.: D12545

Tested Parameter	Units	Specification	Result	Pass/Fail
Laboratory Temperature	deg C	18.9 to 25.5	22.0	Pass
Laboratory Relative Humidity	%	10 to 70	24	Pass
Probe Speed	m/s	2.07 to 2.13	2.10	Pass
Maximum Force	kN	3.45 to 4.06	3.48	Pass
Overall Test Results				Pass

  
Laboratory Technician

2/16/12  
Test Date

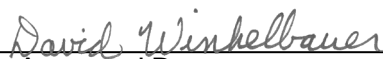
  
Approved By



Test Desc: Right Knee  
Component ID: D12545

Test Date: 2/16/12  
Velocity: 6.89 ft/s, 2.10 m/s

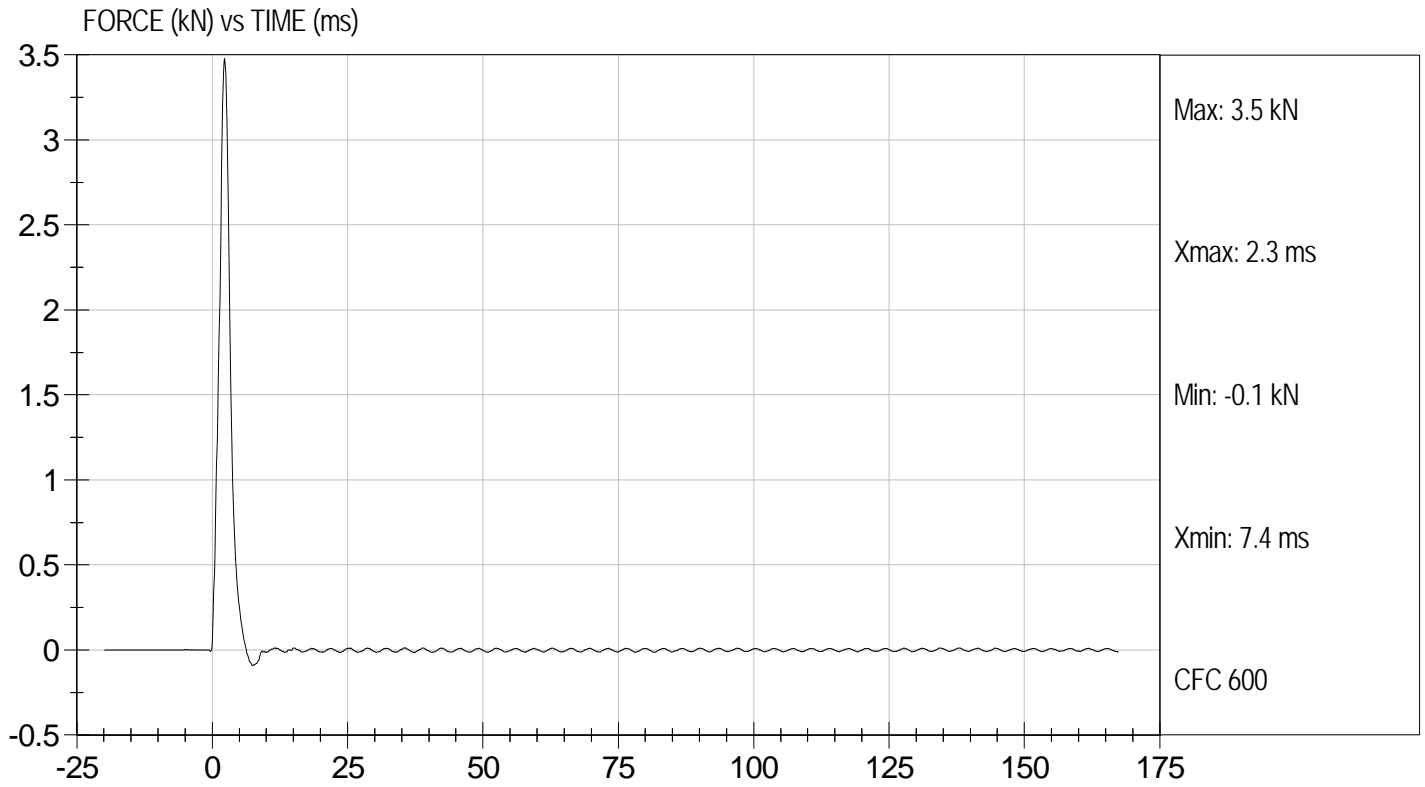

**MGA RESEARCH CORPORATION**  
**LEFT KNEE IMPACT TEST**  
**HYBRID III 5TH PERCENTILE**

ATD Serial No: 138

Test I.D: D12546

Tested Parameter	Units	Specification	Result	Pass/Fail
Laboratory Temperature	deg C	18.9 to 25.5	22.0	Pass
Laboratory Relative Humidity	%	10 to 70	24	Pass
Probe Speed	m/s	2.07 to 2.13	2.12	Pass
Maximum Force	kN	3.45 to 4.06	3.49	Pass
Overall Test Results				Pass

  
 \_\_\_\_\_  
 Laboratory Technician

2/16/12  
 \_\_\_\_\_  
 Test Date

  
 \_\_\_\_\_  
 Approved By



Test Desc: Left Knee  
Component ID: D12546

Test Date: 2/16/12  
Velocity: 6.97 ft/s, 2.12 m/s

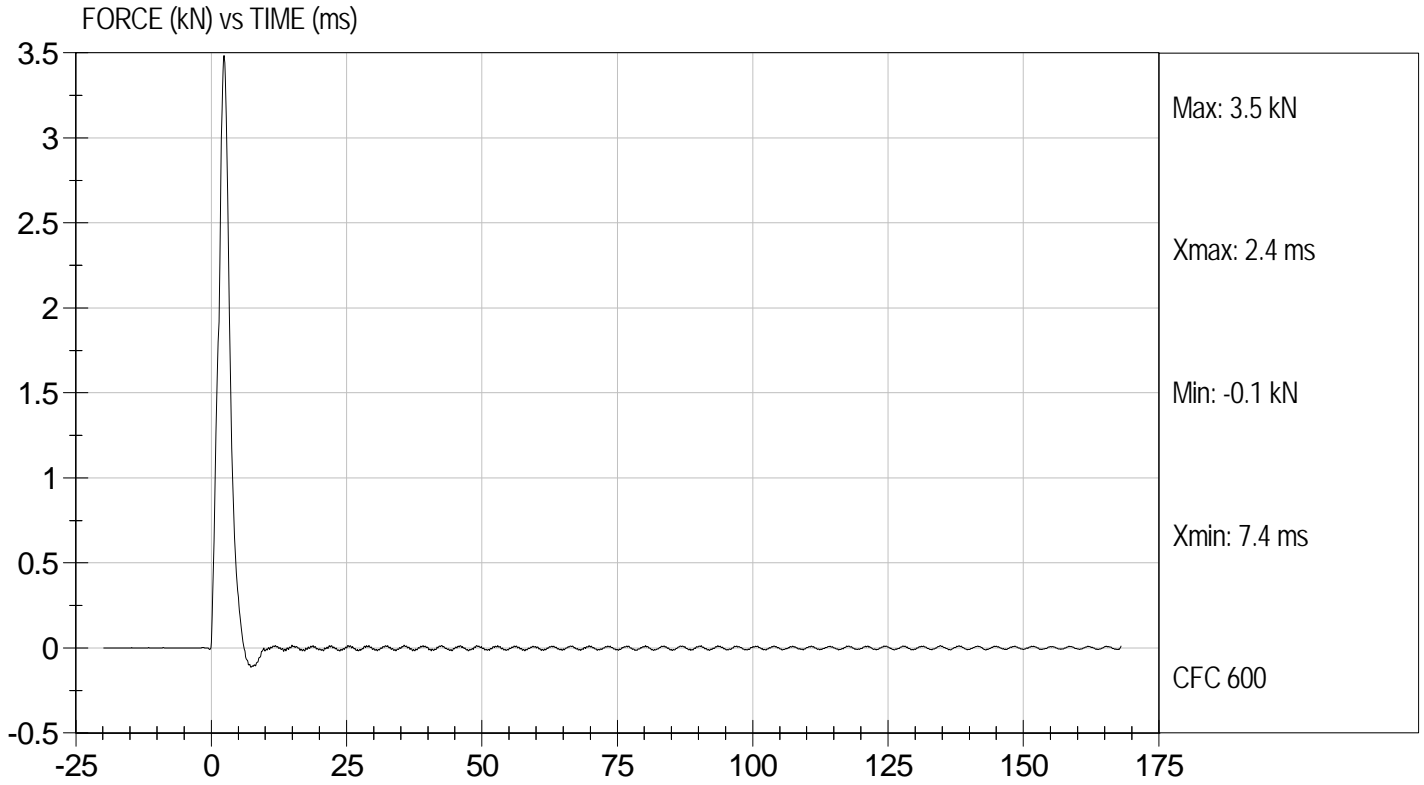

**MGA RESEARCH CORPORATION**  
**TORSO FLEXION TEST**  
**HYBRID III 5TH PERCENTILE**

ATD Serial No: 138

Test I.D.: D12547

Tested Parameter	Units	Specification	Result	Pass/Fail
Laboratory Temperature	deg C	18.9 to 25.6	22.0	Pass
Laboratory Relative Humidity	%	10 to 70	20	Pass
Initial Angle	deg	0 to 20	17	Pass
Return Angle	deg	+/- 8	5	Pass
Force at 45 deg	N	320 to 390	364	Pass
Upper Torso Deflection Rate	Deg/sec	0.5 to 1.5	1.0	Pass
Overall Result				Pass

  
 Laboratory Technician

2/16/12  
 Test Date

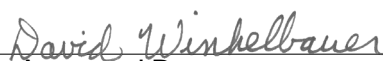
  
 Approved By

**MGA RESEARCH CORPORATION  
HEAD DROP TEST  
HYBRID III 5TH PERCENTILE**

ATD Serial No: 138

Test ID: D121001

Tested Parameter	Units	Specification	Result	Pass/Fail
Laboratory Temperature	deg C	18.9 to 25.6	22.0	Pass
Laboratory Relative Humidity	%	10 to 70	31	Pass
Peak Resultant Acceleration	G's	250 to 300	267	Pass
Peak Lateral Acceleration	G's	+/- 15	-2.9	Pass
Unimodal	N/A	Yes	Yes	Pass
Oscillations	N/A	within 10% of peak	Yes	Pass
Overall Test Results				Pass

Jessica Hall  
Laboratory Technician

3/13/12  
Test Date

David Winkelbauer  
Approved By



Test Desc: Head Drop  
Component ID: D121001

Test Date: 3/13/12  
Velocity: 0 ft/s, 0 m/s

RESULTANT HEAD ACCELERATION (G's) vs TIME (ms)

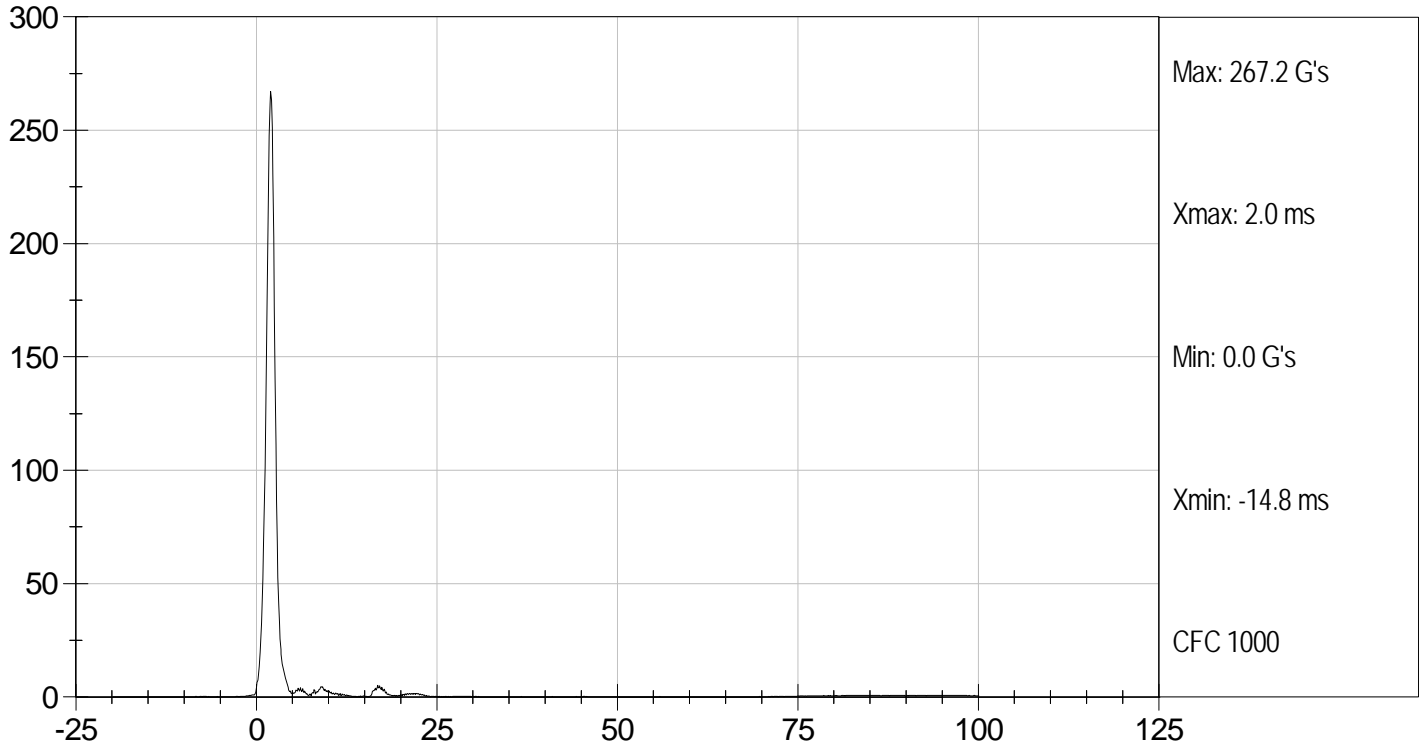

HEAD Y (G's) vs TIME (ms)

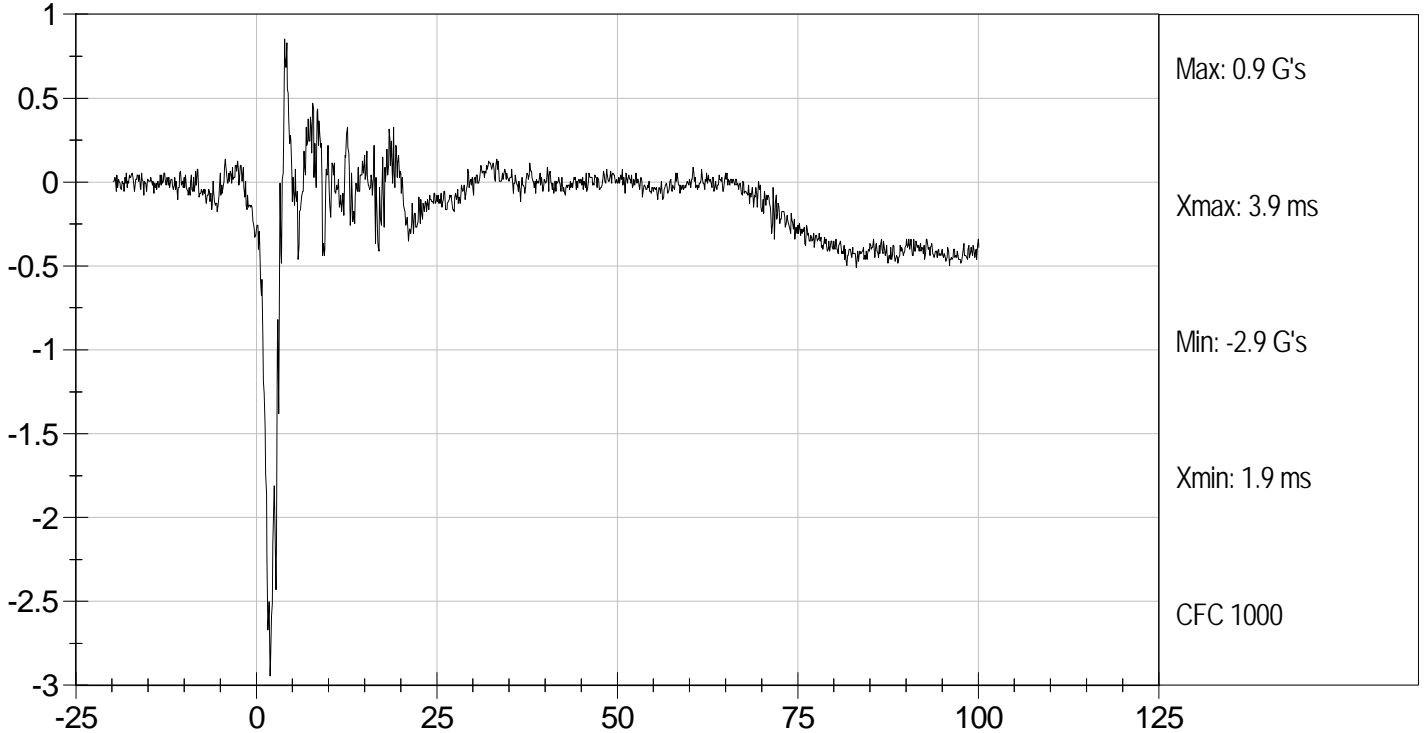

**MGA RESEARCH CORPORATION**  
**NECK FLEXION TEST**  
**HYBRID III 5TH PERCENTILE**

ATD Serial No: 138

Test I.D.: D121002

Tested Parameter		Units	Specification	Result	Pass/Fail
Laboratory Temperature		deg C	20.6 to 22.2	22.0	Pass
Laboratory Relative Humidity		%	10 to 70	32	Pass
Pendulum Speed		m/s	6.89 to 7.13	6.95	Pass
Pendulum Pulse	10 ms	m/s	2.1 to 2.5	2.4	Pass
	20 ms	m/s	4.0 to 5.0	4.8	Pass
	30 ms	m/s	5.8 to 7.0	6.5	Pass
D Plane Rotation	Max	deg	77 to 91	82	Pass
Occipital Condyle Moment within Deflection Corridor		Nm	69 to 83	73	Pass
Positive Moment Time Curve Decay to 10 Nm		ms	80 to 100	84	Pass
Overall Results					Pass

  
 Laboratory Technician

3/14/12  
 Test Date

  
 Approved By



Test Desc: Neck Flexion  
Component ID: D121002

Test Date: 3/14/12  
Velocity: 22.8 ft/s, 6.95 m/s

PENDULUM VELOCITY (m/s) vs TIME (ms)

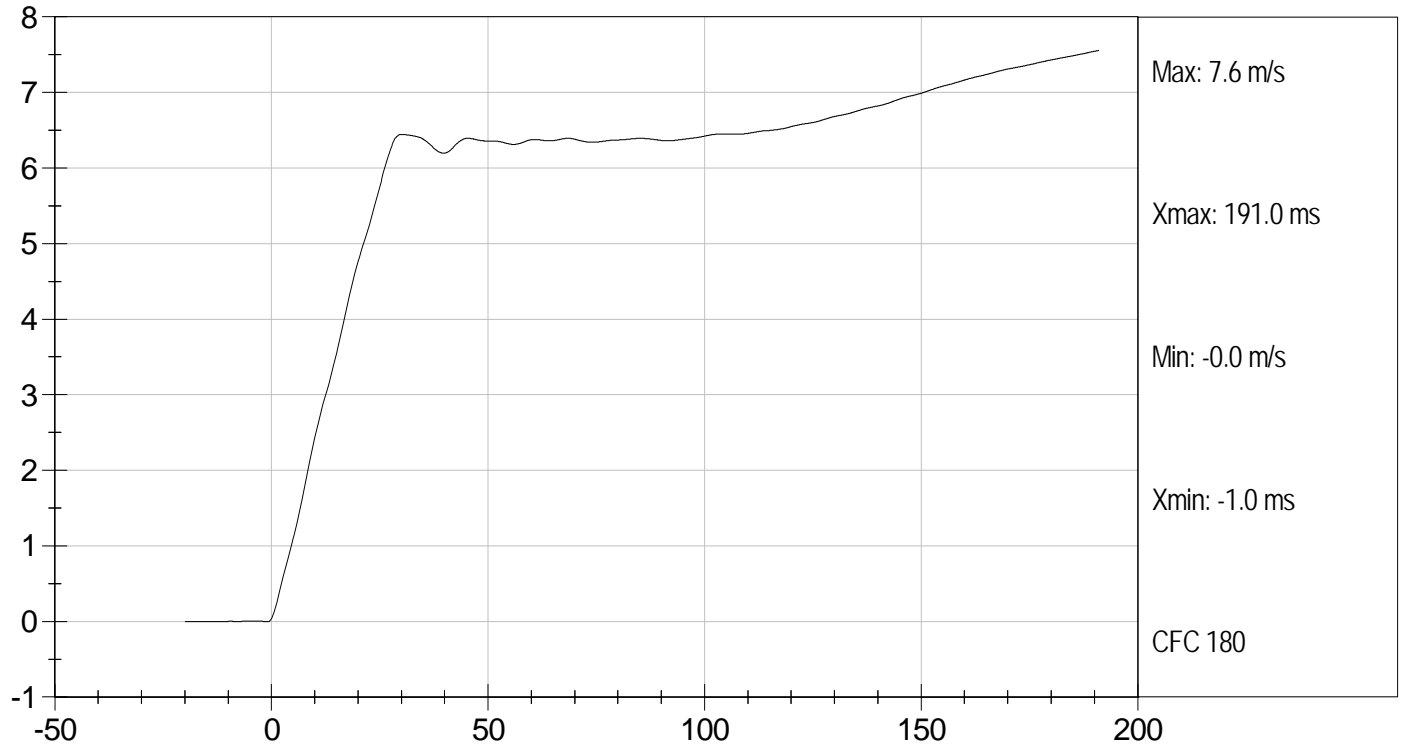

NECK ROTATION (DEG) vs TIME (ms)

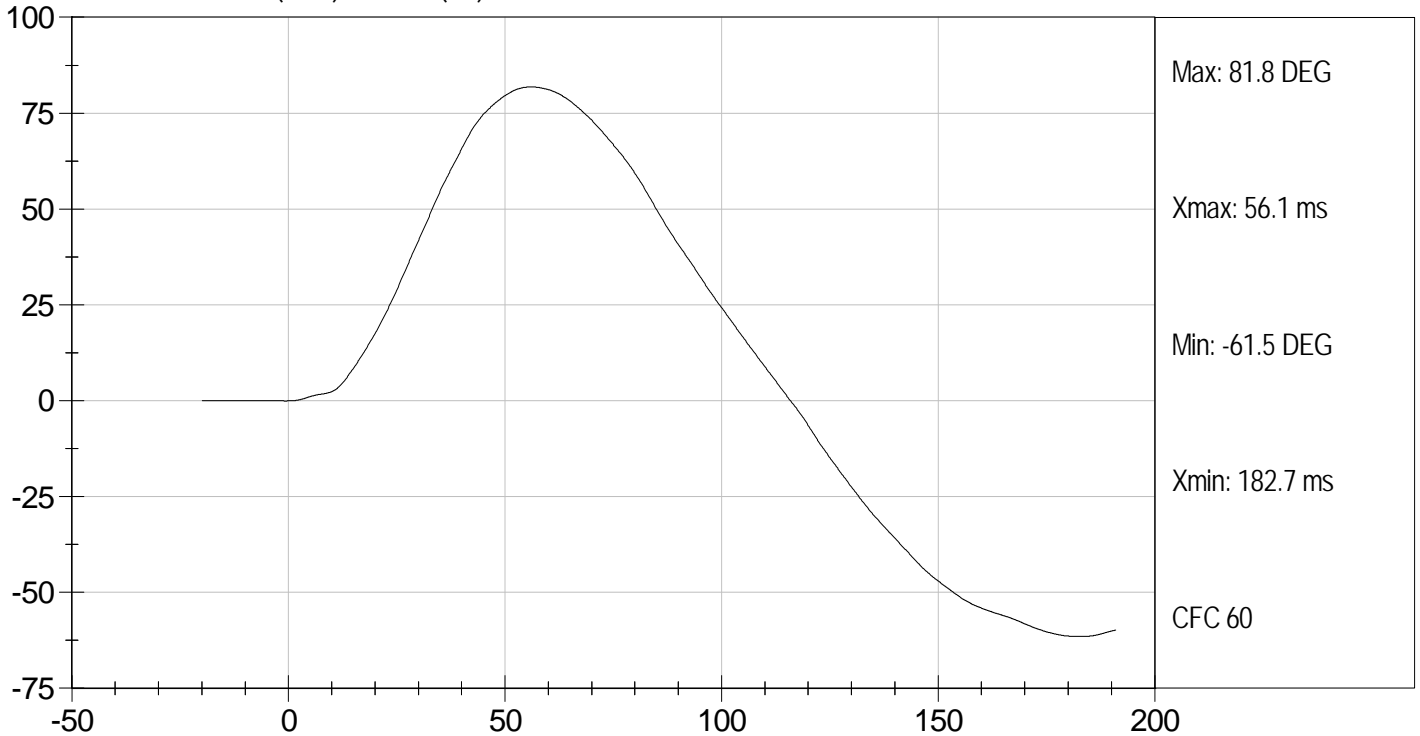



Test Desc: Neck Flexion  
Component ID: D121002

Test Date: 3/14/12  
Velocity: 22.8 ft/s, 6.95 m/s

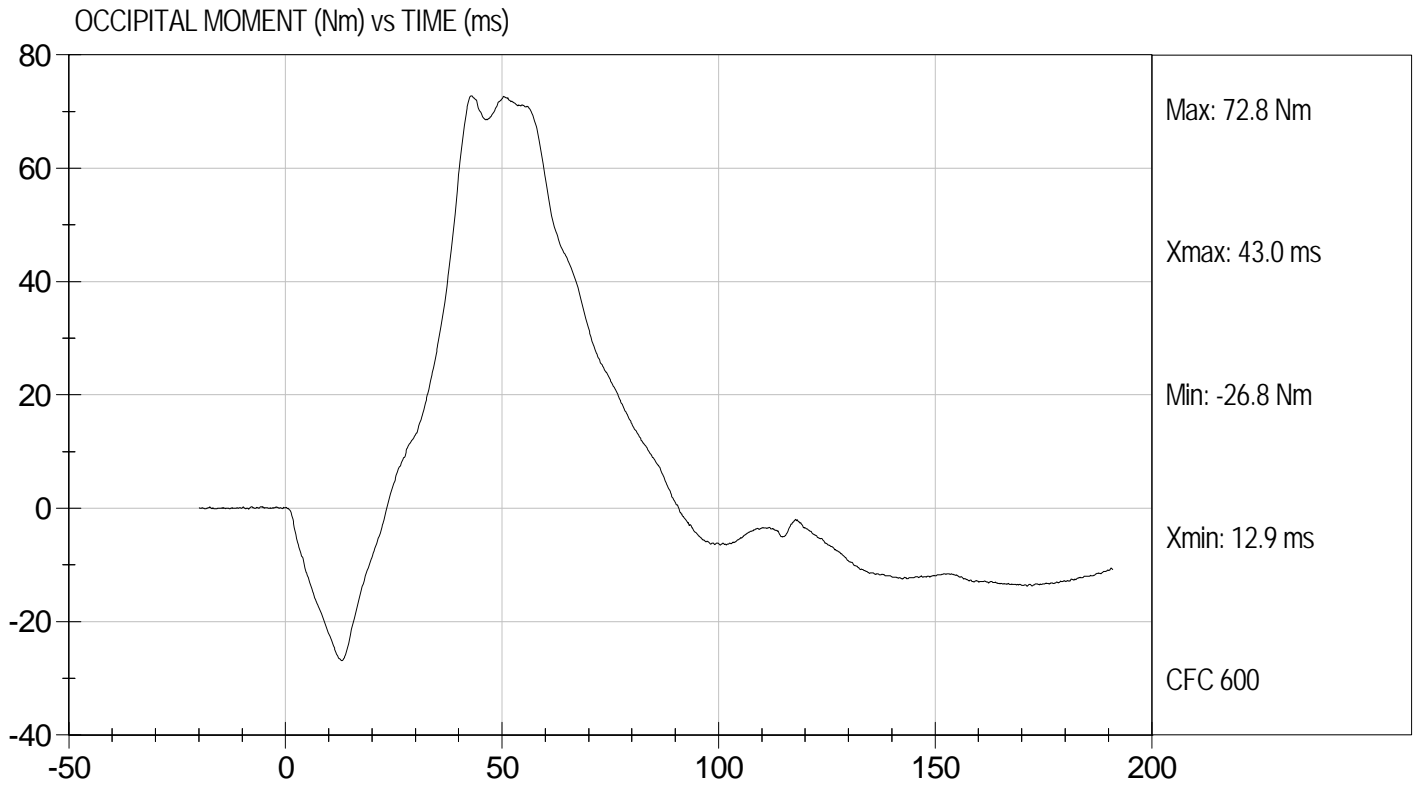

**MGA RESEARCH CORPORATION**  
**NECK EXTENSION TEST**  
**HYBRID III 5TH PERCENTILE**

ATD Serial No: 138

Test I.D.: D121003

Tested Parameter		Units	Specification	Result	Pass/Fail
Laboratory Temperature		deg C	20.6 to 22.2	22.0	Pass
Laboratory Relative Humidity		%	10 to 70	32	Pass
Pendulum Speed		m/s	5.95 to 6.19	6.05	Pass
Pendulum Pulse	10 ms	m/s	1.5 to 1.9	1.9	Pass
	20 ms	m/s	3.1 to 3.9	3.7	Pass
	30 ms	m/s	4.6 to 5.6	5.3	Pass
D Plane Rotation	Max	deg	99 to 114	107	Pass
Occipital Condyle Moment within Deflection Corridor		Nm	-65 to -53	-60	Pass
Negative Moment Time Curve Decay to -10 Nm		ms	94 to 114	101	Pass
<b>Overall Results</b>					<b>Pass</b>

  
 Laboratory Technician

3/14/12  
 Test Date

  
 Approved By



Test Desc: Neck Extension  
Component ID: D121003

Test Date: 3/14/12  
Velocity: 19.84 ft/s, 6.05 m/s

PENDULUM VELOCITY (m/s) vs TIME (ms)

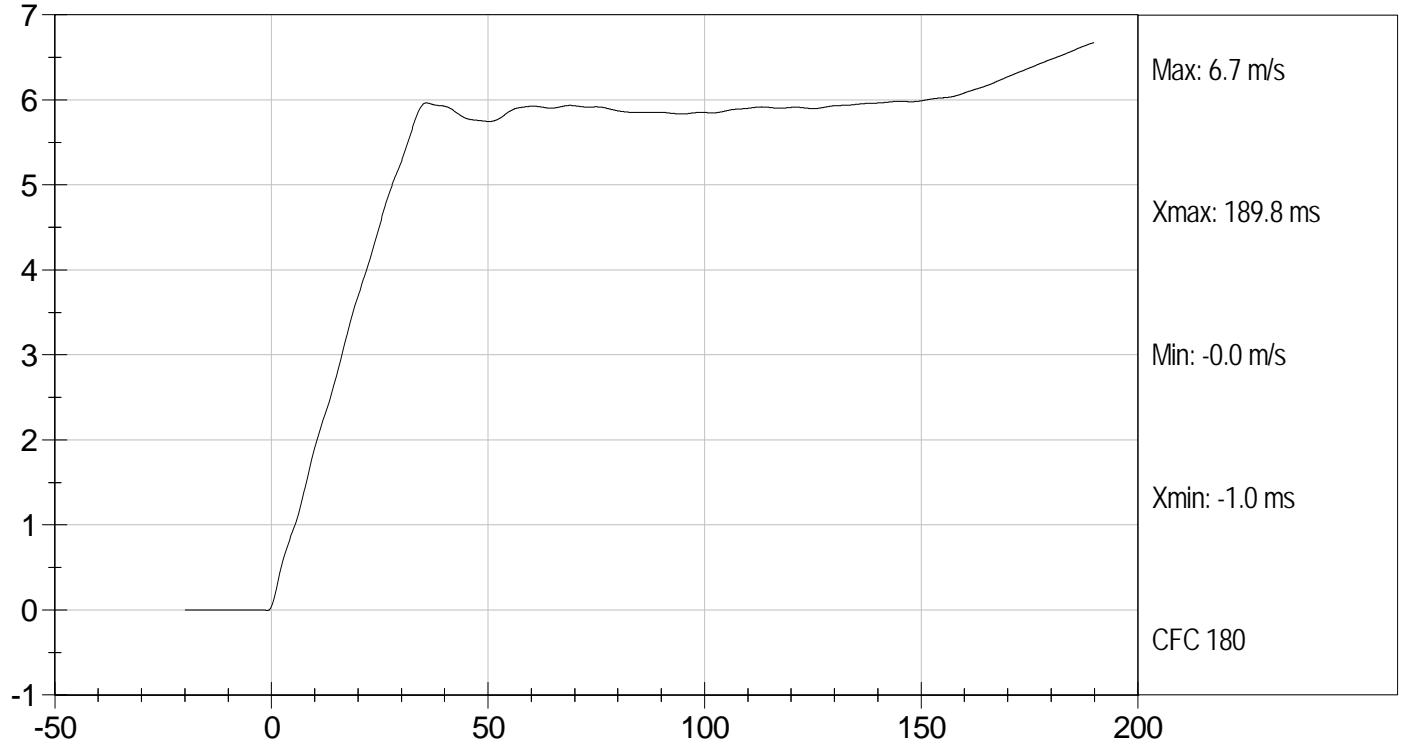

NECK ROTATION (DEG) vs TIME (ms)

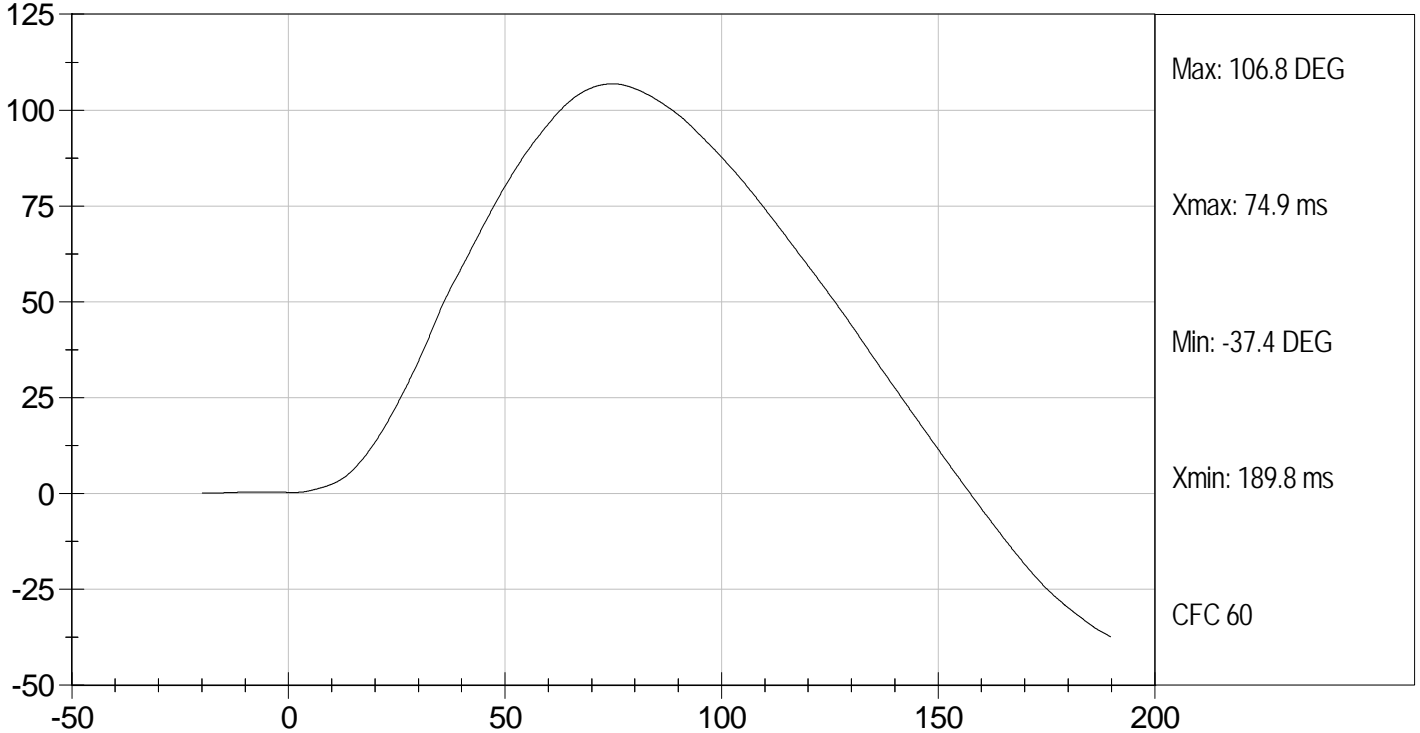



Test Desc: Neck Extension  
Component ID: D121003

Test Date: 3/14/12  
Velocity: 19.84 ft/s, 6.05 m/s

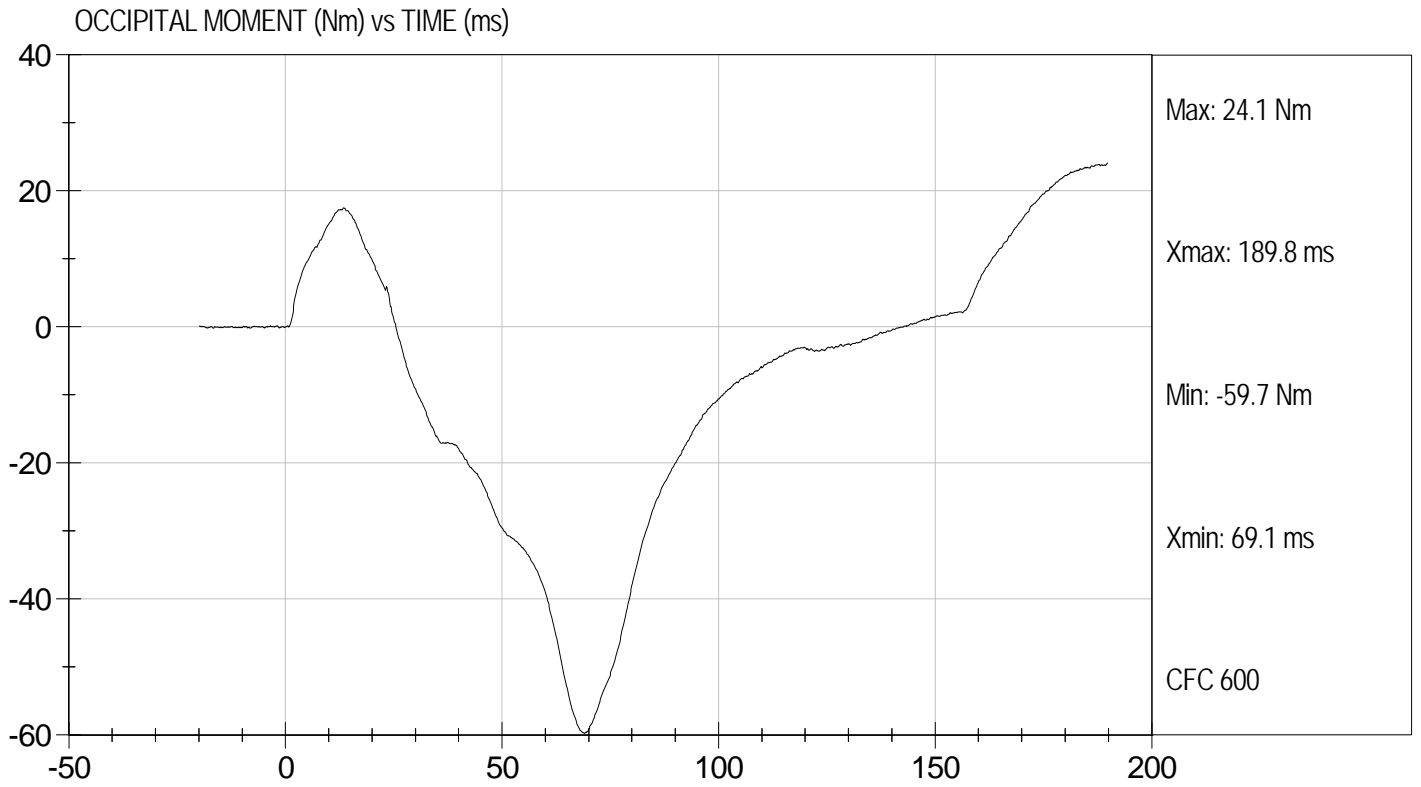

**MGA RESEARCH CORPORATION**  
**THORAX IMPACT**  
**HYBRID III 5TH PERCENTILE**

ATD Serial No: 138

Test I.D.: D121004

Tested Parameter	Units	Specification	Result	Pass/Fail
Temperature	deg C	20.6 to 22.2	22.0	Pass
Relative Humidity	%	10 to 70	33	Pass
Probe Speed	m/s	6.59 to 6.83	6.77	Pass
Peak Deflection	mm	50 to 58	55	Pass
Peak Resistive Force w/in Deflection Corridor	kN	3.9 to 4.4	4.08	Pass
Internal Hysteresis	%	69 to 85	69	Pass
Peak Force 18 mm - 50 mm	N	<= 4,600 N	3968	Pass
Overall Test Results				Pass

  
 Laboratory Technician

3/14/12  
 Test Date

  
 Approved By



Test Desc: Thorax Impact  
Component ID: D121004

Test Date: 3/14/12  
Velocity: 22.22 ft/s, 6.77 m/s

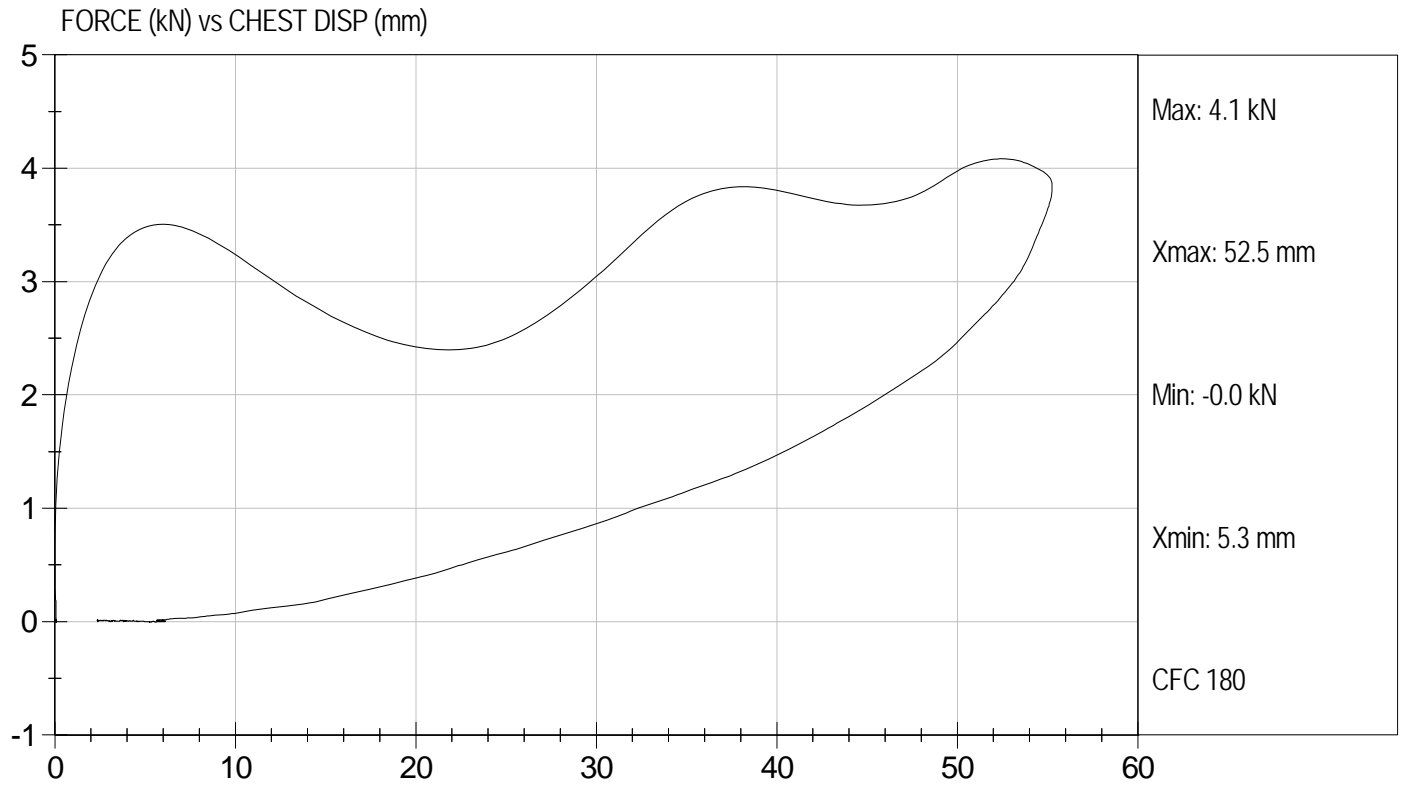

**MGA RESEARCH CORPORATION  
RIGHT KNEE IMPACT TEST  
HYBRID III 5TH PERCENTILE**

ATD Serial No: 138

Test I.D: D121005

Tested Parameter	Units	Specification	Result	Pass/Fail
Laboratory Temperature	deg C	18.9 to 25.5	22.0	Pass
Laboratory Relative Humidity	%	10 to 70	31	Pass
Probe Speed	m/s	2.07 to 2.13	2.12	Pass
Maximum Force	kN	3.45 to 4.06	3.60	Pass
Overall Test Results				Pass

*Jessica Hall*  
 \_\_\_\_\_  
 Laboratory Technician

3/13/12  
 \_\_\_\_\_  
 Test Date

*David Winkelbauer*  
 \_\_\_\_\_  
 Approved By



Test Desc: Right Knee  
Component ID: D121005

Test Date: 3/13/12  
Velocity: 6.97 ft/s, 2.12 m/s

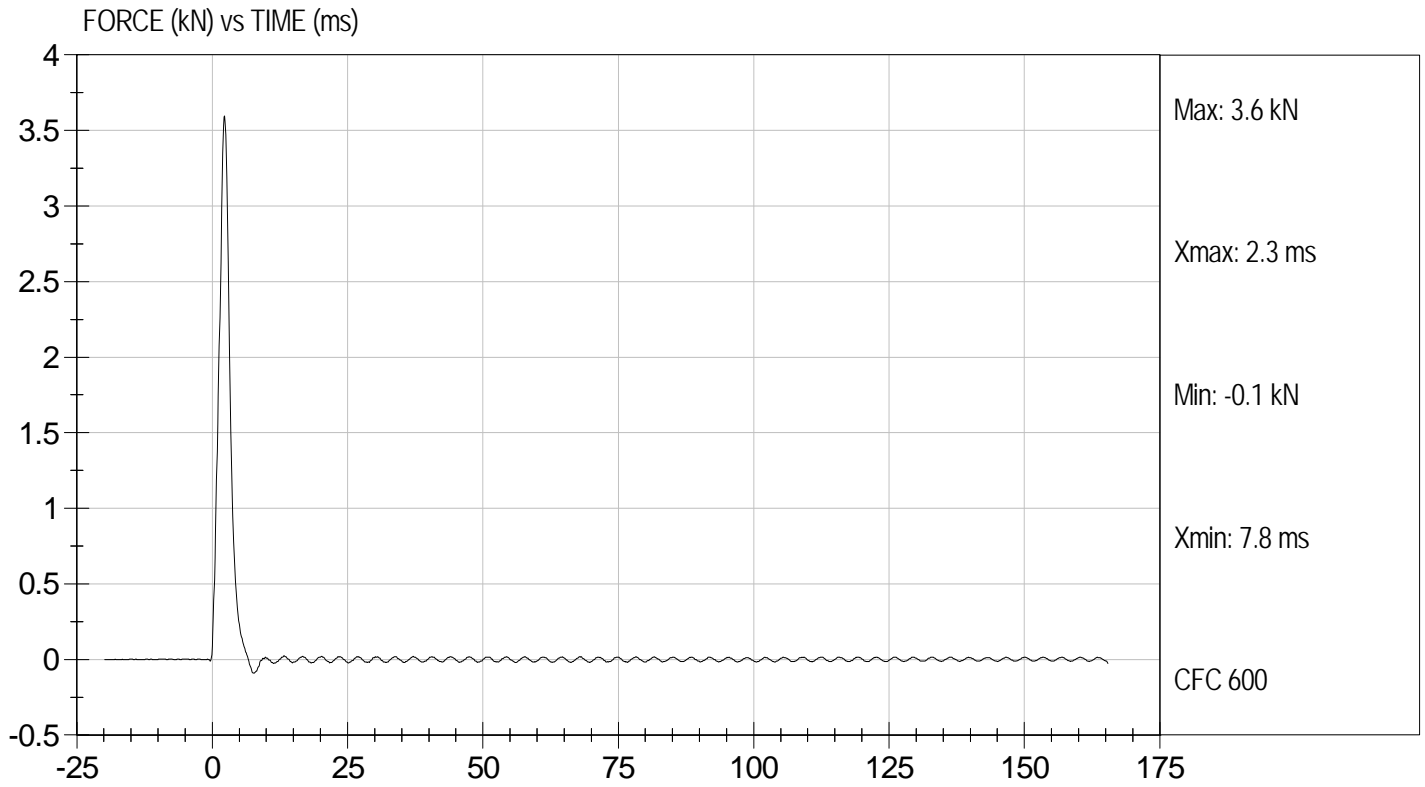

**MGA RESEARCH CORPORATION**  
**LEFT KNEE IMPACT TEST**  
**HYBRID III 5TH PERCENTILE**

ATD Serial No: 138

Test I.D: D121006

Tested Parameter	Units	Specification	Result	Pass/Fail
Laboratory Temperature	deg C	18.9 to 25.5	22.0	Pass
Laboratory Relative Humidity	%	10 to 70	31	Pass
Probe Speed	m/s	2.07 to 2.13	2.12	Pass
Maximum Force	kN	3.45 to 4.06	3.48	Pass
Overall Test Results				Pass

Jessica Hall  
 Laboratory Technician

3/13/12  
 Test Date

David Winkelbauer  
 Approved By



Test Desc: Left Knee  
Component ID: D121006

Test Date: 3/13/12  
Velocity: 6.97 ft/s, 2.12 m/s

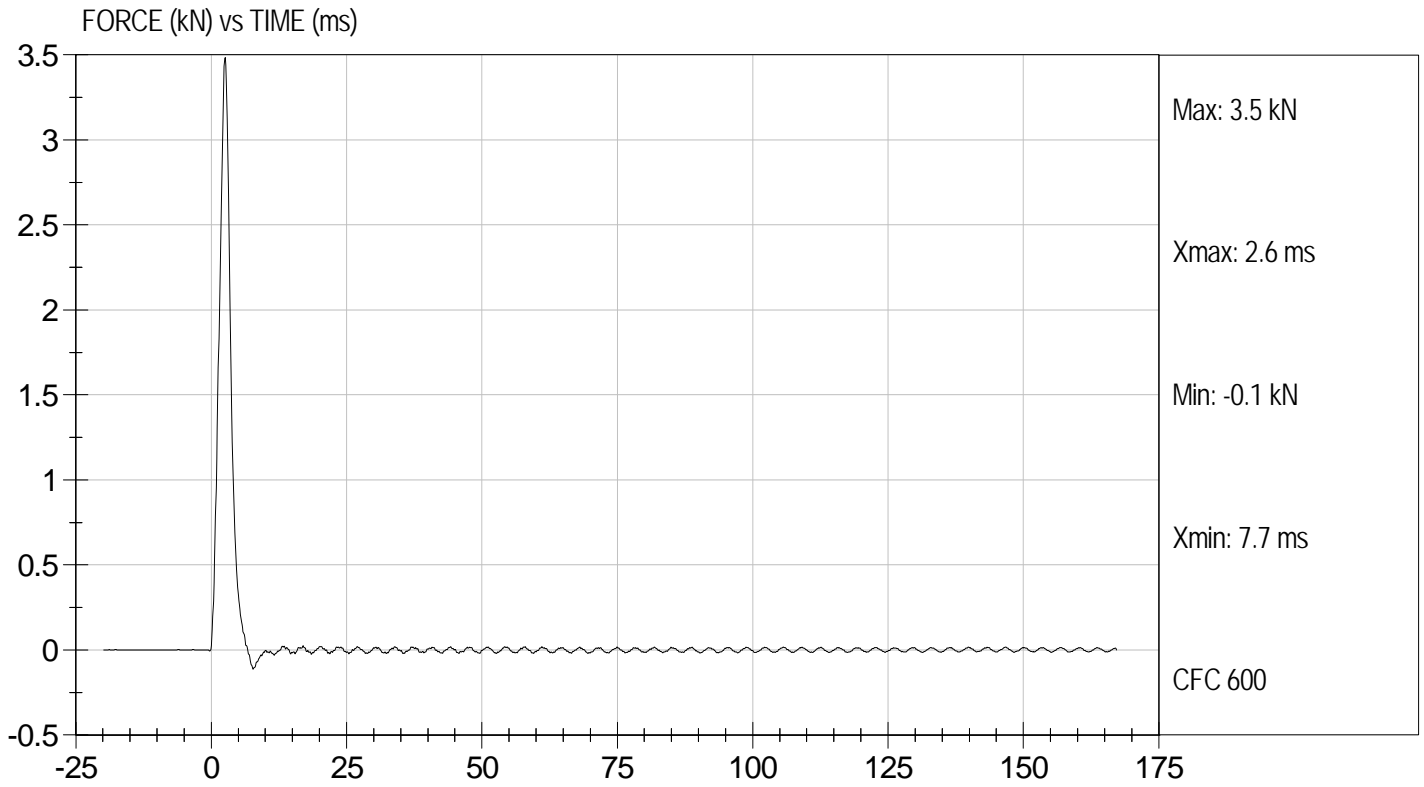

**MGA RESEARCH CORPORATION**  
**TORSO FLEXION TEST**  
**HYBRID III 5TH PERCENTILE**

ATD Serial No: 138

Test I.D.: D121007

Tested Parameter	Units	Specification	Result	Pass/Fail
Laboratory Temperature	deg C	18.9 to 25.6	21.8	Pass
Laboratory Relative Humidity	%	10 to 70	31	Pass
Initial Angle	deg	0 to 20	15	Pass
Return Angle	deg	+/- 8	6	Pass
Force at 45 deg	N	320 to 390	378	Pass
Upper Torso Deflection Rate	Deg/sec	0.5 to 1.5	1.0	Pass
Overall Result				Pass

  
 Laboratory Technician

3/13/12  
 Test Date

  
 Approved By