

REPORT NUMBER: R&D – CAL – 11 – 017

**MOVING BARRIER TO VEHICLE CRASH TEST IN SUPPORT OF NHTSA'S FRONTAL
OBLIQUE OFFSET PROGRAM
RESEARCH MOVING BARRIER INTO LEFT FRONT OF A**

**2011 BUICK LACROSSE
56 MPH, 15 DEGREE ANGLE, 35% OVERLAP**

**TEST DATE: SEPTEMBER 21st 2011
NHTSA NO: RB0179**

**PREPARED BY;
CALSPAN CORPORATION
4455 GENESEE, BUFFALO NY**



FINAL REPORT SUBMITTED:

FEBRUARY 9, 2012

**PREPARED FOR:
U.S. DEPARTMENT OF TRANSPORTATION
NATIONAL HIGHWAY TRAFFIC SAFETY ADMINISTRATION
VEHICLE SAFETY RESEARCH
1200 NEW JERSEY AVE, SE
ROOM W46-446
WASHINGTON, DC 20590**

This publication is distributed by the U.S. Department of Transportation, National Highway Traffic Safety Administration, in the interest of information exchange. The opinions, findings and conclusions expressed in this publication are those of the author(s) and not necessarily those of the Department of Transportation or the National Highway Traffic Safety Administration. The United States Government assumes no liability for its contents or use thereof. If trade or manufacturers' names or products are mentioned, it is only because they are considered essential to the object of the publication and should not be construed as an endorsement. The United States Government does not endorse products or manufacturers.

Prepared by: Vanessa Walsh Date: February 9, 2012
Vanessa Walsh, Test Engineer

Approved by: David Travale Date: February 9, 2012
David Travale, Program Manager

FINAL REPORT ACCEPTANCE BY OCWS:

Division Chief, New Car Assessment Program
NHTSA, Office of Crashworthiness Standards

Date: _____

COTR, New Car Assessment Program
NHTSA, Office of Crashworthiness Standards

Date: _____

Technical Report Document Page

1. Report No. NCAP-CAL-11-017	2. Government Accession No.	3. Recipient's Catalog No.																																																															
4. Title and Subtitle Report for Frontal Oblique Offset Program Testing of a 2011 Buick Lacrosse NHTSA No. RB0179		5. Report Date 9/2/2011																																																															
		6. Performing Organization Code CAL																																																															
7. Author(s) David J. Travale, Program Manager Vanessa Walsh, Test Engineer		8. Performing Organization Report No. TR2538																																																															
9. Performing Organization Name and Address Calspan Corporation 4455 Genesee Street Buffalo, NY 14225		10. Work Unit No.																																																															
		11. Contract or Grant No. DTNH22-10-D-00155																																																															
12. Sponsoring Agency Name and Address US Department of Transportation National Highway Traffic Safety Administration Office of Vehicle Safety Research 1200 New Jersey Ave SE Room W46-446 Washington, DC 20590		13. Type of Report and Period Covered Draft Report, 9/21/11 - 11/8/11																																																															
		14. Sponsoring Agency Code NPO-320																																																															
15. Supplementary Notes																																																																	
16. Abstract A test was conducted in accordance with Task Order 0001 of Contract DTNH22-10-D-00155. The Test consisted of a research moving deformable barrier (RMDB) traveling at a target speed of 90.12 kph into a stationary 2011 Buick Lacrosse four door sedan. The struck vehicle was positioned 15 degrees relative to the moving barrier, and impacted 35% of the left side of the vehicle. The test was conducted to obtain data indicant of FMVSS 208, 212, 219 (partial), 301, and foot well intrusion performance. The test was conducted at the Calspan Corporation's crash test facility in Buffalo, New York on 9/21/2011. The impact velocity of the vehicle was 90.46 km/h, and the ambient temperature at the barrier face at the time of impact was 25.5°C. The target vehicle post-test maximum crush was 435 mm of Vehicle. The test vehicle's performance is as follows:																																																																	
<table border="1" style="width: 100%; border-collapse: collapse;"> <thead> <tr> <th rowspan="2" style="width: 35%;">Measurement Description</th> <th colspan="3" style="width: 30%;">Driver ATD</th> <th colspan="3" style="width: 30%;">Pass. ATD</th> </tr> <tr> <th style="width: 10%;">Units</th> <th style="width: 10%;">Threshold</th> <th style="width: 10%;">Result</th> <th style="width: 10%;">Units</th> <th style="width: 10%;">Threshold</th> <th style="width: 10%;">Result</th> </tr> </thead> <tbody> <tr> <td>Head Injury Criteria (HIC₁₅)</td> <td>N/A</td> <td>700</td> <td style="background-color: yellow;">117.61</td> <td>N/A</td> <td>700</td> <td style="background-color: yellow;">436.13</td> </tr> <tr> <td>Maximum Chest Compression</td> <td>mm</td> <td>63</td> <td style="background-color: yellow;">46.24</td> <td>mm</td> <td>52</td> <td style="background-color: yellow;">32.76</td> </tr> <tr> <td>Nij</td> <td>N/A</td> <td>1</td> <td style="background-color: yellow;">1.14</td> <td>N/A</td> <td>1</td> <td style="background-color: yellow;">0.96</td> </tr> <tr> <td>Neck Tension</td> <td>N</td> <td>4,170</td> <td style="background-color: yellow;">7292.35</td> <td>N</td> <td>2,620</td> <td style="background-color: yellow;">2406.71</td> </tr> <tr> <td>Neck Compression</td> <td>N</td> <td>4,000</td> <td style="background-color: yellow;">-5820.7</td> <td>N</td> <td>2,520</td> <td style="background-color: yellow;">-217.61</td> </tr> <tr> <td>Left Femur Force</td> <td>N</td> <td>10,008</td> <td style="background-color: yellow;">-6985.16</td> <td>N</td> <td>6,805</td> <td style="background-color: yellow;">2214.47</td> </tr> <tr> <td>Right Femur Force</td> <td>N</td> <td>10,008</td> <td style="background-color: yellow;">-3579.10</td> <td>N</td> <td>6,805</td> <td style="background-color: yellow;">2379.18</td> </tr> </tbody> </table>				Measurement Description	Driver ATD			Pass. ATD			Units	Threshold	Result	Units	Threshold	Result	Head Injury Criteria (HIC ₁₅)	N/A	700	117.61	N/A	700	436.13	Maximum Chest Compression	mm	63	46.24	mm	52	32.76	Nij	N/A	1	1.14	N/A	1	0.96	Neck Tension	N	4,170	7292.35	N	2,620	2406.71	Neck Compression	N	4,000	-5820.7	N	2,520	-217.61	Left Femur Force	N	10,008	-6985.16	N	6,805	2214.47	Right Femur Force	N	10,008	-3579.10	N	6,805	2379.18
Measurement Description	Driver ATD				Pass. ATD																																																												
	Units	Threshold	Result	Units	Threshold	Result																																																											
Head Injury Criteria (HIC ₁₅)	N/A	700	117.61	N/A	700	436.13																																																											
Maximum Chest Compression	mm	63	46.24	mm	52	32.76																																																											
Nij	N/A	1	1.14	N/A	1	0.96																																																											
Neck Tension	N	4,170	7292.35	N	2,620	2406.71																																																											
Neck Compression	N	4,000	-5820.7	N	2,520	-217.61																																																											
Left Femur Force	N	10,008	-6985.16	N	6,805	2214.47																																																											
Right Femur Force	N	10,008	-3579.10	N	6,805	2379.18																																																											
17. Key Words THOR Small overlap Oblique offset		18. Distribution Statement Copies of this report are available from: National Highway Traffic Safety Adm. Technical Ref. Division, 1200 New Jersey Ave, SE Washington, D.C. 20590																																																															
19. Security Classif. (of this report) Unclassified	20. Security Classif. (of this page) Unclassified	21. No. of Pages 313	22. Price																																																														

TABLE OF CONTENTS

Test Vehicle:	2011 Buick Lacrosse	NHTSA No:	RB0179
Test Program:	R&D 56mph, 15° angle, 35% offset	Test Date	9/21/2011

Section	Page No.
1 Purpose of Test	1-1
2 Summary of Test	2-1
Crash Vehicle Summary	2-3
Preliminary Injury Summary: Driver Thor Male	2-4
Preliminary Injury Summary: Driver Thor Male Legs	2-6
Preliminary Injury Summary: HIII 5 th Female Rear Passenger	2-7
3 Data Sheets	3-1
Data	
Sheet No.	Page No.
1 General Test and Vehicle Parameter Data	3-2
2 Seat Adjustment, Fuel System, and Steering Wheel Data	3-6
3 Dummy Longitudinal Clearance Dimensions	3-9
4 Dummy Lateral Clearance Dimensions	3-11
5 Seat Belt Positioning Data	3-12
6 High-Speed Camera Locations and Data	3-13
7 Vehicle Instrumentation Locations	3-16
8 Photographic Reference Target Locations	3-19
9 Test Vehicle Summary of Results	3-22
10 Post-Test Observations	3-23
11 Vehicle Profile Measurements	3-24
12 Accident Investigation Division Data	3-26
13 Vehicle Intrusion Measurements	3-27
14 MDB Crush Measurements	3-45
15 Summary of FMVSS 212, 219 (Partial), and 301 Data	
Windshield Periphery Measurements	3-46
Fuel System Integrity Post Impact Data	3-47
16 FMVSS 301 Static Rollover Results	3-48
17 Dummy / Vehicle Temperature Stabilization	3-49
Appendix	
Appendix	Page No.
A Photographs	A-1
B Vehicle & Dummy Response Data Traces	B-1
C Part 572 E/O Dummy Calibration and Performance Verification Data Sheets	C-1
D Additional Measurements & Data Calculations	D-1
E Positioning Procedure for Rear Seat Part 572O 5 th Female ATD	E-1
F CMM Measurement Procedures	F-1

SECTION 1

PURPOSE

Test Vehicle:	<u>2011 Buick Lacrosse</u>	NHTSA No:	<u>RB0179</u>
Test Program:	<u>R&D 56mph, 15° angle, 35% offset</u>	Test Date	<u>9/21/2011</u>

This 90.12 km/h (56 mph) Moving Barrier into a vehicle test is part of Frontal Offset Program sponsored by the National Highway Traffic Safety Administration (NHTSA) under Contract No. DTNH22-10-D-00155. The purpose of this test was to obtain vehicle crashworthiness and occupant restraint system performance data for consumer information purposes.

This test was conducted in accordance with the instructions set forth by NHTSA for a 15° angle, 35% offset moving barrier to vehicle impact, outlined in Task Order (TO) DTNH22. Data was obtained indicant of Federal Motor Vehicle Safety Standard (FMVSS) 208-Occupant Crash Protection, FMVSS 212-Windshield Mounting, FMVSS 219 (partial)-Windshield Zone Intrusion, and FMVSS 301-Fuel System Integrity, in addition to the requirements of TO DTNH22.

SECTION 2

SUMMARY OF TEST

Test Vehicle:	<u>2011 Buick Lacrosse</u>	NHTSA No:	<u>RB0179</u>
Test Program:	<u>R&D 56mph, 15° angle, 35% offset</u>	Test Date	<u>9/21/2011</u>

A model year 2011 Buick Lacrosse was impacted on the left front corner by a Research Moving Deformable Barrier. This test vehicle was stationary and positioned at a target angle of 15° and at a target offset of 35% to the forward line of motion of the MDB. The MDB was towed down the test track in a full forward direction, without any crabbing, and the targeted impact velocity was 90.12 km/h (56 mph). The test vehicle mass was 1943.5 kg (4284.7 lbs), and the MDB mass was 2486.2 kg (5481 lbs). The test was conducted by Calspan Corporation on 9/21/11.

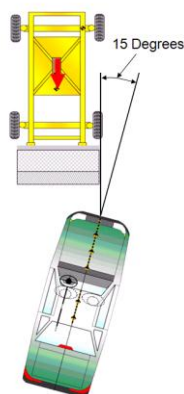

The test was documented by one (1) real time and fourteen (14) high-speed video cameras. Camera locations and other pertinent data are located in Data Sheet No. 06 of this report. Pre- and post-test photographs of the test vehicle, the MDB and the test setup were taken using a digital still camera. Photographic documentation of the test is presented in Appendix A of this report.

One 50% adult male THOR MK (Mod Kit) anthropomorphic test device (ATD) (Serial No.: 007) was seated in the left front (driver's) seating position and one Part 5720 5% adult female (HIII 5th) ATD (Serial No. 070) was seated in the left rear seating position. The THOR MK driver was positioned according to instructions specified in Laboratory Test Procedure for FMVSS No. 208, "Occupant Crash Protection", TP208 13, July 27, 2005. The HIII 5th% left rear seat occupant was positioned using a modified procedure of the Laboratory Test Procedure for FMVSS No. 214, "Side Impact Protection – Dynamic", TP214D-08, December 15, 2006. The exact procedure used is located in Appendix E.

Test Vehicle:	<u>2011 Buick Lacrosse</u>	NHTSA No:	<u>RB0179</u>
Test Program:	<u>R&D 56mph, 15° angle, 35% offset</u>	Test Date	<u>9/21/2011</u>

The driver was restrained with a 3-point seat belt, a dual stage frontal airbag, a curtain airbag, and a seat mounted torso airbag. The left rear passenger was restrained with a 3-point seat belt, and a curtain airbag.

One hundred and ninety eight (198) channels of data from the two ATD's, test vehicle and MDB were collected using Kayser-Threde and Slice data acquisition systems. Appendix B contains dummy data plots, as well as vehicle and MDB response data plots.

There was 86.8% total windshield retention, with 73.6% and 100% retention on the left and right sides respectively. There appeared to be no intrusion into the protected zone of the windshield during any portion of the impact test. The maximum static crush of the vehicle was 435 mm at C1 to the left of the vehicle's centerline. The maximum crush of the lower bumper beam was 483 mm at C2, to the left of vehicle's centerline. Full vehicle measurements are presented in Section 3 of this report.

All four vehicle doors remained closed and latched during the test. The left front door was jammed shut, but was able to be opened. The left rear, right front, and right rear doors all remained operational after the test.

Structure observations include the following:

- The A-Pillar and the door sill buckled, causing some separation at the top of the door from the vehicle.

- The hood also opened as a result of the crash.

The driver ATD's visible contact points are as follows:

- Head contacted the steering wheel airbag and curtain airbags.

- Torso contacted the steering wheel airbag.

- The knees contacted the knee bolster

The left rear passenger ATD's visible contact points are as follows:

- Head contacted the side curtain airbag and the interior of the C-Pillar

- Chin contacted the passenger's chest

CRASH VEHICLE SUMMARY

Test Vehicle: <u>2011 Buick Lacrosse</u>	NHTSA No: <u>RB0179</u>
Test Program: <u>R&D 56mph, 15° angle, 35% offset</u>	Test Date: <u>9/21/2011</u>

PRIMARY IMPACT DATA

Measured Parameter	Units	Value
MDB Velocity at Impact	km/h	90.3
MDB Test Weight	kg	2491
MDB Maximum Static Crush	mm	257.6
Vehicle Test Weight	kg	1943.5
Actual Vehicle Angle	°	15
Vehicle Maximum Static Crush	mm	435
Vertical Offset from Target Point	mm	11 (Up)
Lateral Offset from Target Point	mm	31 (Left)
Number of Data Channels		198
Number of Real-Time Cameras		1
Number of High-Speed Cameras		14

DUMMY CONTACTS

	Driver	Picture Ref.	Passenger	Picture Ref.
Dummy Type	50% Male, Thor 007	N/A	5% HIII Female, 070	N/A
Head Contact	Steering wheel airbag and curtain airbag	A-37 A-48	Side curtain airbag and the interior of the C-Pillar	A-49 A-52 A-58
Upper Torso Contact	Steering wheel airbag	-	None	-
Lower Torso Contact	None	A-46 A-47	None	-
Left Knee Contact	Knee bolster	A-45	None	A-59
Right Knee Contact	Knee bolster	A-44	None	A-59

Data Anomalies:

V2P1 NECK UPPER FZ	->	Questionable after 267 ms
V2P1 ABDOMEN LEFT RZ	->	Noise superimposed over data
V2P1 ABDOMEN RIGHT IRTRACC DX	->	Questionable after 83ms
V2P1 RIGHT ILIAC MY	->	Channel failed
V2P1 LEFT FEMUR FX	->	Questionable 49-59 ms -saturated
V2P1 LEFT FEMUR MY	->	Questionable 71-85 ms
V2P1 TIBIA LEFT UPPER FZ	->	Questionable after 15 ms
V2P1 FOOT LEFT x	->	Questionable magnitude
V2P1 TIBIA RIGHT LOWER MY	->	Questionable after 144 ms
V2P4 LOWER NECK MY	->	Data saturated between 102-106ms
V2P4 LOWER NECK MZ	->	Channel failed
V2P4 CHEST DISPLACEMENT	->	Questionable after 107ms
V2 RR PASSENGER LAP BELT	->	Questionable after 126 ms

PRELIMINARY INJURY SUMMARY: DRIVER THOR MALE

Test Vehicle: 2011 Buick Lacrosse NHTSA No: RB0179
 Test Program: R&D 56mph, 15° angle, 35% offset Test Date: 9/21/2011

Driver: THOR Male Injury Summary

	Nomenclature	Source	Max	Min
Head	Angular acceleration (rad/sec^2) – X	simon	969400.00	-490450.00
	Angular acceleration (rad/sec^2) – Y	simon	168370.00	-275410.00
	Angular acceleration (rad/sec^2) – Z	simon	439830.00	-590410.00
	Angular acceleration – resultant (rad/sec^2)	simon	978360.59	
	Angular velocity (rad/sec) – X	simon	173.82	-69.85
	Angular velocity (rad/sec) – Y	simon	79.46	-10.59
	Angular velocity (rad/sec) – Z	simon	76.21	-55.76
	Angular velocity – resultant (rad/sec)	simon	180.85	
	36 ms HIC	Compute	164.95	
	15 ms HIC	Compute	117.61	
	Skull fracture correlate	Simon	36.12	
	Cumulative strain (Tolerance = 0.05)	Simon	0.99	
	Cumulative strain (Tolerance = 0.10)	Simon	0.82	
	Cumulative strain (Tolerance = 0.15)	Simon	0.41	
	Head resultant CG acceleration, 3 ms clip (g's)	Compute	39.33	
Neck	UNLC Fx transferred to OC, neck system (N)	1000	284.82	-805.67
	UNLC Fz, neck system Tension (N)	1000	7292.35 ⁽¹⁾	
	UNLC Fz, neck system Compression (N)	1000		-5820.70 ⁽¹⁾
	UNLC My transferred to OC, neck system Flexion (N-m)	Thortest	46.28	
	UNLC My transferred to OC, neck system Extension (N-m)	Thortest		-63.74
	On head acting through total neck section, (N)Fx	Thortest	578.60	-2154.21
	On head acting through total neck section, (N)Fy	Thortest	373.80	-405.82
	On head acting through total neck section, (N)Fz	Thortest	7336.42 ⁽¹⁾	-5816.19 ⁽¹⁾
	On head acting through total neck section, (Nm)X	Thortest	17.17	-31.63
	On head acting through total neck section, (Nm)Y	Thortest	46.28	-63.74
	On head acting through total neck section, (Nm)Z	Thortest	11.28	-23.72
	On head acting through O.C. joint only (N) Fx	Thortest	466.45	-2079.24
	On head acting through O.C. joint only (N) Fz	Thortest	7295.20 ⁽¹⁾	-5821.93 ⁽¹⁾
	On head acting through O.C. joint only (Nm) My	Thortest	5.30	-52.54
	Chest	Upper Crux x-defl , Right (mm)	Thortest	0.05
Upper Crux y-defl , Right (mm)		Thortest	5.62	-11.62
Upper Crux z-defl , Right (mm)		Thortest	24.16	-15.27
Upper Crux “d” displacement , Right (mm)		Thortest	0.05	-33.62
Upper Crux x-defl , Left (mm)		Thortest	0.78	-14.68
Upper Crux y-defl , Left (mm)		Thortest	9.02	-5.36

PRELIMINARY INJURY SUMMARY: DRIVER THOR MALE

Test Vehicle: 2011 Buick Lacrosse NHTSA No: RB0179
 Test Program: R&D 56mph, 15° angle, 35% offset Test Date 9/21/2011

Driver: THOR Male Injury Summary (Continued)

	Nomenclature	Source	Max	Min
Chest (Cont)	Upper Crux z-defl , Left (mm)	Thortest	15.88	-10.28
	Upper Crux "d" displacement , Left (mm)	Thortest	1.26	-16.28
	Lower Crux x-defl , Right (mm)	Thortest	1.03	-46.35
	Lower Crux y-defl , Right (mm)	Thortest	2.57	-16.61
	Lower Crux z-defl , Right (mm)	Thortest	9.98	-4.09
	Lower Crux "d" displacement , Right (mm)	Thortest	1.52	-46.24
	Lower Crux x-defl , Left (mm)	Thortest	4.24	-14.40
	Lower Crux y-defl , Left (mm)	Thortest	1.87	-12.95
	Lower Crux z-defl , Left (mm)	Thortest	17.79	-4.05
	Lower Crux "d" displacement , Left (mm)	Thortest	3.11	-14.93
	Chest CG acceleration, 3 ms clip, (G's)	Compute	41.60	
Abdomen	Max upper string pot (mm)	Compute		
	Upper viscous criteria based on x-deflection	Compute		
	Lower right x-deflection (mm)	Thortest	244.79 ⁽²⁾	-51.63 ⁽²⁾
	Lower right y-deflection (mm)	Thortest	6.12	-13.42
	Lower right z-deflection (mm)	Thortest	18.85	-4.07
	Right viscous criterion based on x-deflection	Compute	62.70 ⁽²⁾	
	Lower left x-deflection (mm)	Thortest	0.13	-36.91
	Lower left y-deflection (mm)	Thortest	9.23	-1.38
	Lower left z-deflection (mm)	Thortest	17.17 ⁽³⁾	-2.07 ⁽³⁾
	Left viscous criterion based on x-deflection	Compute	0.35	
Pelvis	Pelvis cg resultant acceleration (G)	Compute	98.96	
Acetabulum	Right Fx force (N)	600	1594.55	-1031.14
	Right Fy force (N)	600	593.41	-2068.17
	Right Fz force (N)	600	1220.87	-1172.70
	Resultant of Fx, Fy, Fz (N)	Compute	2573.66	
	Left Fx force (N)	600	909.27	-4252.68
	Left Fy force (N)	600	1038.31	-694.26
	Left Fz force (N)	600	1977.081	-1230.60
	Resultant of Fx, Fy, Fz (N)	Compute	4363.92	
Femur	Right Fz force (N)	600	638.11	-3579.10
	Right Mx moment (Nm)	600	27.78	-306.53
	Right My moment (Nm)	600	96.22	-46.42
	Resultant of Mx and My only (not Mz) (Nm)	Compute	306.55	
	Left Fz force (N)	600	588.74	-6985.16

PRELIMINARY INJURY SUMMARY: DRIVER THOR MALE LEGS

Test Vehicle: 2011 Buick Lacrosse NHTSA No: RB0179
 Test Program: R&D 56mph, 15° angle, 35% offset Test Date 9/21/2011

Driver: THOR Male Injury Summary (Continued)

	Nomenclature	Source	Max	Min
Femur (Cont)	Left Mx moment (Nm)	600	19.70	-294.28
	Left My moment (Nm)	600	3.38 ⁽⁴⁾	-698.13 ⁽⁴⁾
	Resultant of Mx and My only (not Mz) (Nm)	Compute	698.99 ⁽⁴⁾	

Anomalies

- (1) Channel V2P1 NEKU Fz was questionable after 267 ms
- (2) Channel V2P1 ABDR Dx was questionable after 83ms
- (3) Channel V2P1 ABDL Rz had noise superimposed over the data
- (4) Channel V2P1 FMRL My was questionable between 71-85 ms

Driver: THOR Male LX/FLX Legs Injury Summary

	Metric	Source	Max	Min
Knee	Knee displacement (mm) R	180	1.81	-7.07
	Knee displacement (mm) L	180	1.72	-4.78
Tibia	Right upper axial force (N) Fz	600	102.22	-2650.90
	Right lower axial force (N) Fz	600	394.91	-3832.15
	Right upper bending moment (Nm) My	600	117.60	-50.86
	Right lower bending moment (Nm) My	600	36.89 ⁽⁵⁾	-51.08 ⁽⁵⁾
	Right upper tibia index	Compute	0.99	
	Right lower tibia index	Compute	1.10 ⁽⁵⁾	
	Left upper axial force (N) Fz	600	8755.00 ⁽⁶⁾	13643.82 ⁽⁶⁾
	Left lower axial force (N) Fz	600	221.01	-3008.11
	Left upper bending moment (Nm) My	600	37.91	-133.53
	Left lower bending moment (Nm) My	600	25.71	-71.57
	Left upper tibia index	Compute	1.39 ⁽⁶⁾	
	Left lower tibia index	Compute	0.55	
Ankle	Right Rotation about ankle X-axis, subtalar joint (deg)	180	18.24	-37.21
	Right Rotation about ankle Y-axis joint (deg)	180	10.00	-21.88
	Left Rotation about ankle X-axis, subtalar joint (deg)	180	21.95	-6.12
	Left Rotation about ankle Y-axis joint (deg)	180	26.73	-15.74

Anomalies

- (5) Channel V2P1 TBRL My was questionable after 144 ms
- (6) Channel V2P1 TBLU Fz was questionable after 15 ms

PRELIMINARY INJURY SUMMARY: REAR PASSENGER HIII 5TH FEMALE

Test Vehicle: 2011 Buick Lacrosse NHTSA No: RB0179
 Test Program: R&D 56mph, 15° angle, 35% offset Test Date: 9/21/2011

Rear Passenger: HIII 5th Female Injury Summary

	Nomenclature	Source	Max	Min
Head	Angular acceleration (rad/sec ²)X	simon	1267.00	-1316.60
	Angular acceleration (rad/sec ²)Y	simon	684.59	-198.78
	Angular acceleration (rad/sec ²)Z	simon	160.43	-967.93
	Angular acceleration – resultant (rad/sec ²)	simon	1402.42	
	Angular velocity (rad/sec)X	simon	15.64	-8.07
	Angular velocity (rad/sec)Y	simon	22.45	-0.14
	Angular velocity (rad/sec)Z	simon	0.00	-53.55
	Angular velocity – resultant (rad/sec)	simon	57.92	
	36 ms HIC	Compute	767.41	
	15 ms HIC	Compute	436.13	
	Skull fracture correlate	Simon	61.01	
	Cumulative strain (Tolerance = 0.05)	Simon	0.97	
	Cumulative strain (Tolerance = 0.10)	Simon	0.62	
	Cumulative strain (Tolerance = 0.15)	Simon	0.30	
Head resultant CG acceleration, 3 ms clip (g's)	Compute	64.04		
Neck	Upper Neck Tension (N) Fz	1000	2406.71	
	Upper Neck Compression (N) Fz	1000		-217.61
	Upper Neck NTF	Compute	0.76	
	Upper Neck NTE	Compute	0.96	
	Upper Neck NCF	Compute	0.10	
	Upper Neck NCE	Compute	0.04	
Chest	Chest Deflection (mm)	600	10.48 ⁽⁷⁾	-32.76 ⁽⁷⁾
	Upper Left Chest X (mm)	Compute	0.02	-24.43
	Upper Left Chest Y (mm)	Compute	11.17	-3.54
	Upper Right Chest X (mm)	Compute	0.07	-44.51
	Upper Right Chest Y (mm)	Compute	15.68	-1.72
	Lower Left Chest X (mm)	Compute	0.045	-14.61
	Lower Left Chest Y (mm)	Compute	13.25	-1.79
	Lower Right Chest X (mm)	Compute	0.03	-36.78
	Lower Right Chest Y (mm)	Compute	18.88	-0.58
	Chest CG acceleration, 3 ms clip, (G's)	Compute	52.39	
Femur	Right Fz force (N)	600	2379.18	-224.81
	Left Fz force (N)	600	2214.47	-101.58

Anomalies

(7) Channel V2P4 CHST D was questionable after 107ms

SECTION 3

DATA SHEETS

Test Vehicle:	<u>2011 Buick Lacrosse</u>	NHTSA No:	<u>RB0179</u>
Test Program:	<u>R&D 56mph, 15° angle, 35% offset</u>	Test Date	<u>9/21/2011</u>

<u>Data Sheet No.</u>		<u>Page No.</u>
1	General Test and Vehicle Parameter Data	3-2
2	Seat Adjustment, Fuel System, and Steering Wheel Data	3-6
3	Dummy Longitudinal Clearance Dimensions	3-9
4	Dummy Lateral Clearance Dimensions	3-11
5	Seat Belt Positioning Data	3-12
6	High-Speed Camera Locations and Data	3-13
7	Vehicle Instrumentation Locations	3-16
8	Photographic Reference Target Locations	3-19
9	Test Vehicle Summary of Results	3-22
10	Post-Test Observations	3-23
11	Vehicle Profile Measurements	3-24
12	Accident Investigation Division Data	3-26
13	Vehicle Intrusion Measurements	3-27
14	MDB Crush Measurements	3-45
15	Summary of FMVSS 212, 219 (Partial), and 301 Data	
	Windshield Periphery Measurements	3-46
	Fuel System Integrity Post Impact Data	3-47
16	FMVSS 301 Static Rollover Results	3-48
17	Dummy / Vehicle Temperature Stabilization	3-49

DATA SHEET NO. 1

GENERAL TEST AND VEHICLE PARAMETER DATA

Test Vehicle:	<u>2011 Buick Lacrosse</u>	NHTSA No:	<u>RB0179</u>
Test Program:	<u>R&D 56mph, 15° angle, 35% offset</u>	Test Date	<u>9/21/2011</u>

TEST VEHICLE INFORMATION

TEST VEHICLE OPTIONS

NHTSA No.	RB0179
Model Year	2011
Make	Buick
Model	Lacrosse CX
Body Style	Four Door Sedan
VIN	1G4GA5EC1BF243565
Body Color	White
Delivery Date	7/28/2011
Odometer Reading (km/mi)	91.7 km / 57 mi
Dealer	Mike Smith Buick
Transmission	6-Speed Automatic
Final Drive	Front Wheel Drive
Type/No. Cylinders	V4
Engine Displacement (L)	2.4
Engine Placement	Lateral
Roof Rack	No
Sunroof/T-Top	No
Tinted Glass	No
Traction Control	Yes
Power Brakes	Yes
Front Disc	Yes
Rear Disc	Yes
Other	--

Anti-Lock Brakes	Yes
All-Wheel Drive	No
Power Steering	Yes
Driver Front Airbag	Yes
Driver Curtain Airbag	Yes
Driver Head/Torso Airbag	No
Driver Torso Airbag	Yes
Driver Torso/Pelvis Airbag	No
Driver Pelvis Airbag	No
Driver Knee Airbag	No
Front Pass. Front Airbag	No
Front Pass. Curtain Airbag	Yes
Front Pass. Head/Torso Airbag	Yes
Front Pass. Torso Airbag	No
Front Pass. Torso/Pelvis Airbag	Yes
Front Pass. Knee Airbag	No
Pretensioners	Yes
Load Limiters	Yes
Tilt Steering	Yes
Automatic Door Locks	Yes
Power Windows	Yes
Power Seats	Yes
Air Conditioning	Yes

Does owner's manual provide instructions to turn off automatic door locks? -

DATA FROM CERTIFICATION LABEL

Manufactured By	General Motors LLC
Date of Manufacture	11/2010

GVWR (kg)	2158
GAWR Front (kg)	1102
GAWR Rear (kg)	1056

VEHICLE SEATING AND WEIGHT CAPACITY

Measured Parameter	Front	Rear	Third	Total
Type of Seats	Bucket	Bench	N/A	
Number of Occupants	2	3	-	5
Capacity Wt. (VCW) (kg)				420
Cargo Wt. (RCLW) (kg)				80

DATA SHEET NO. 1 (CONTINUED)

GENERAL TEST AND VEHICLE PARAMETER DATA

Test Vehicle: <u>2011 Buick Lacrosse</u>	NHTSA No: <u>RB0179</u>
Test Program: <u>R&D 56mph, 15° angle, 35% offset</u>	Test Date: <u>9/21/2011</u>

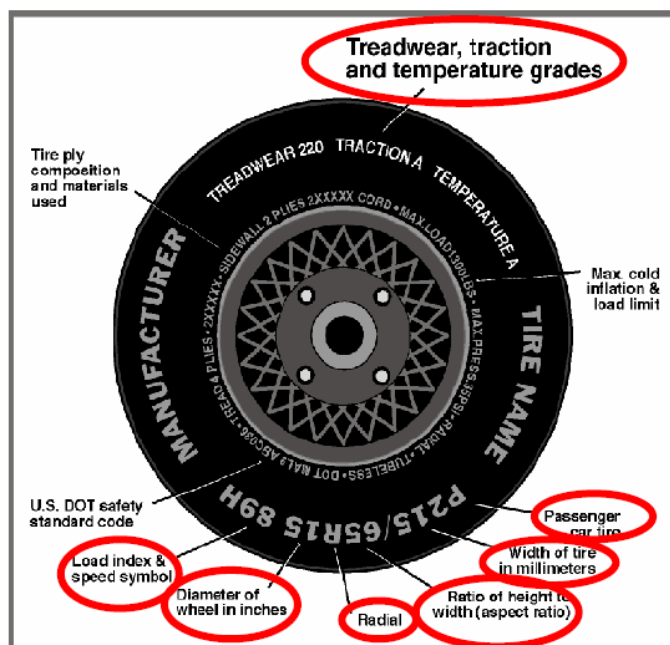

Measured Parameter	Front	Rear
Maximum Tire Pressure	300	300
Cold Pressure (kPa)	230	230
Recommended Tire Size	P245/50R17	P245/50R17
Tire Size on Vehicle	P245/50R17	P245/50R17
Tire Manufacturer	MICHELIN	MICHELIN
Tire Model	PRIMACY MXM4	PRIMACY MXM4
Treadwear	500	500
Traction	A	A
Temperature Grades	A	A
Tire Plies Sidewall	1 Polyester	1 Polyester
Tire Plies Body	1 Polyester, 1 Polyamide, 2 Steel	1 Polyester, 1 Polyamide, 2 Steel
Load Index/Speed Symbol	98H	98H
Tire Material	Rubber	Rubber
DOT Safety Code Right	B9LM001X3910	B9LM001X3910
DOT Safety Code Left	B9LM001X3910	B9LM001X3910

DATA SHEET NO. 1 (CONTINUED)

GENERAL TEST AND VEHICLE PARAMETER DATA

Test Vehicle: 2011 Buick Lacrosse NHTSA No: RB0179
 Test Program: R&D 56mph, 15° angle, 35% offset Test Date 9/21/2011

TEST VEHICLE WEIGHTS

	Units	As Delivered (UVW) (Axle)			As Tested (ATW) (Axle)		
		Front	Rear	Total	Front	Rear	Total
Left	kg	507	375		542	484.5	
Right	kg	491.5	344		495.5	421.5	
Ratio	%	58.1%	41.9%		53.4%	46.6%	
Totals	kg	998.5	719	1717.5	1037.5	906	1943.5

TARGET TEST WEIGHT CALCULATION

Measured Parameter	Units	Value
Total Delivered Weight (UVW)	kg	1717.5
Weight of 1 P572E ATD & 1 P572O ATD	kg	153.54
Rated Cargo/Luggage Weight (RCLW)	kg	80.0
Calculated Vehicle Target Weight (TVTW)	kg	1951.04

TEST VEHICLE ATTITUDES AND CG

	Units	LF	RF	LR	RR	CG (aft of front axle)
As Delivered	mm	751	753	754	758	1188.5
As Tested	mm	735	740	715	723	1323.5
Post Test	mm	-	-	-	-	

GENERAL TEST VEHICLE DATA

Measurement Description	Units	Value
Total Vehicle Wheel Base	mm	2,839
Total Vehicle Length at Left Side	mm	4,717
Total Vehicle Length at Centerline	mm	4,991
Total Vehicle Length at Right Side	mm	4,717
Weight of Ballast in Cargo Area	kg	11.4
Weight of Vehicle Components Removed	kg	0
Amount of Stoddard Solvent in Fuel Tank	L	64.7

LIST OF COMPONENTS REMOVED TO MEET TEST WEIGHT:

MASS OF BALLAST ADDED (kg) 11.4

DATA SHEET NO.1 (CONTINUED)

GENERAL TEST AND VEHICLE PARAMETER DATA

Test Vehicle: 2011 Buick Lacrosse NHTSA No: RB0179
Test Program: R&D 56mph, 15° angle, 35% offset Test Date 9/21/2011

TARGET VEHICLE STRUCTURAL MEASUREMENT

	Elements	Pre-Test (mm)
1	Total Length	4991
2	Total Width	1815
3	Bumper Top Height	-4
4	Bumper Bottom Height	175
5	Longitudinal Member Top Height	4
6	Distance Between Longitudinal Members	1072
7	Longitudinal Member Width	88
8	Engine Top Height	-303
9	Engine Bottom Height	365
10	Engine and Gearbox Width	575
11	Front Bumper-Engine Distance	463
12	Front Shock Absorber Fixing Height	-335
13	Bonnet Leading Edge Height	-263
14	Front Shock Absorber Fixing Width	1190
15	Front Bumper – Front Axle Distance	1026
16	Front Axle – A Pillar Distance	476
17	A- Pillar – B-Pillar Distance	1131
18	B-Pillar – Rear Axle Distance	1232
19	B-Pillar – C-Pillar Distance	1121
20	Roof Sill Bottom Height	-777
21	Roof Sill Top Height	-869
22	Floor Sill Bottom Height	331
23	Floor Sill Top Height	181

DATA SHEET NO. 2

SEAT ADJUSTMENT, FUEL SYSTEM, AND STEERING WHEEL

Test Vehicle: <u>2011 Buick Lacrosse</u>	NHTSA No: <u>RB0179</u>
Test Program: <u>R&D 56mph, 15° angle, 35% offset</u>	Test Date: <u>9/21/2011</u>

NOMINAL DESIGN RIDING POSITION

Inclinometer was zeroed on the door sill, then placed on the head rest post to measure the set angle, according to form 1.

	Deg.
Driver seat back angle:	-13.9
Passenger seat back angle:	N/A

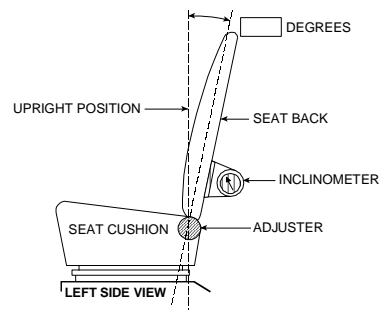

FRONT SEAT ASSEMBLY

SEAT FORE/AFT POSITIONS

Seat was set to full forward, full up and marked. Then moved to the full rear, full down position, and marked. Mid point was measured, and seat was set to full down, mid position, as per form 1.

	Total Fore/Aft Travel	Placed in Position #
Driver Seat	270	155
Passenger Seat	FIXED	FIXED

SEAT BELT UPPER ANCHORAGE

Belt anchorages were moved along the full range of motion, and marked on the B-pillar to their respective possible positions. Photographic evidence can be found in appendix A of this report.

	Total # of Positions	Placed in Position #
Driver Seat	5	0 (full up)
Passenger Seat	FIXED	FIXED

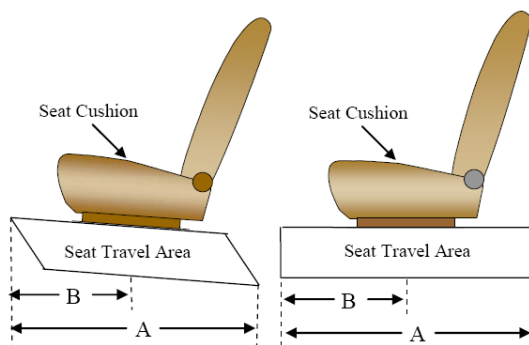

DATA SHEET NO. 2 (CONTINUED)

SEAT ADJUSTMENT, FUEL SYSTEM, AND STEERING WHEEL DATA

Test Vehicle: 2011 Buick Lacrosse NHTSA No: RB0179
 Test Program: R&D 56mph, 15° angle, 35% offset Test Date: 9/21/2011

SEAT BACK MEASUREMENT POINTS

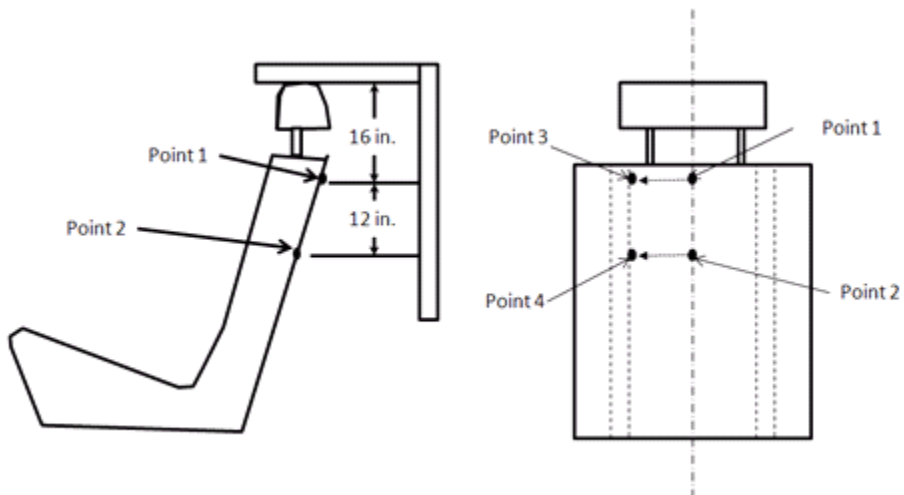

Reference point: Rear most center of the top of rear bumper beam
 +X – From the rear of the vehicle to the front of the vehicle
 +Y – From left side of the vehicle to the right side of the vehicle
 +Z – From the top of the vehicle to the bottom of the vehicle

	X	Y	Z
Point 3	2201.345	-538.76	-337.892
Point 4	2324.303	-568.613	-54.1592

*Please see Appendix F.1 for a detailed description of the CMM measurement procedure.

DATA SHEET NO. 2 (CONTINUED)

SEAT ADJUSTMENT, FUEL SYSTEM, AND STEERING WHEEL DATA

Test Vehicle: <u>2011 Buick Lacrosse</u>	NHTSA No: <u>RB0179</u>
Test Program: <u>R&D 56mph, 15° angle, 35% offset</u>	Test Date: <u>9/21/2011</u>

FUEL TANK CAPACITY

	Liters
Usable Capacity of "Standard Tank"	70.4
Usable Capacity of "Optional Tank"	
92%-94% of Usable Capacity	64.72
Actual Amount of Solvent Used	64.72
1/3 of Usable Capacity	23.467

FUEL PUMP

Electric fuel pump under the rear seat operates when ignition is placed in the on position. The fuel filler neck is located above the right rear wheel.

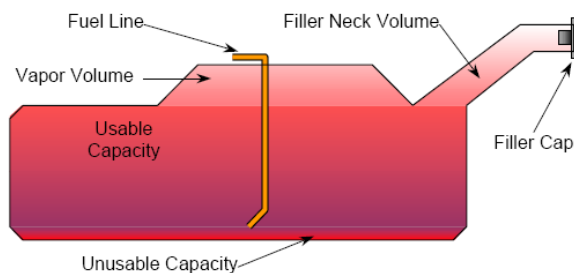

VEHICLE FUEL TANK ASSEMBLY

STEERING COLUMN ADJUSTMENT

A level line was drawn on the steering wheel and an inclinometer was used to determine the angle of adjustment. The steering column was then moved full in and full out. Positions were marked and the steering wheel was set to the geometric center of its possible movement.

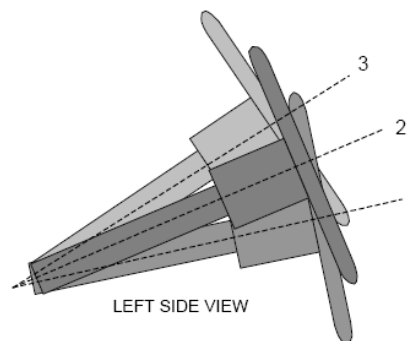

STEERING COLUMN ASSEMBLY

STEERING COLUMN POSITIONS

	Degrees	Fore/Aft Position (mm)
Lowermost position No. 1	70.2	
Geometric center position No. 2	68.2	
Uppermost position No. 3	66.2	
Telescoping Steering Wheel Travel		56
Test Position	68.2	28

DATA SHEET NO. 3

DUMMY LONGITUDINAL CLEARANCE DIMENSIONS

Test Vehicle: 2011 Buick Lacrosse NHTSA No: RB0179
 Test Program: R&D 56mph, 15° angle, 35% offset Test Date: 9/21/2011

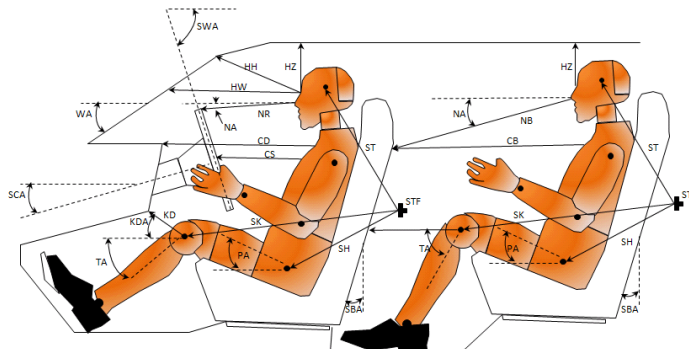

Code	Measurement Description	Driver		Left Rear Passenger	
		Length (mm)	Angle(°)	Length (mm)	Angle (°)
WA°	Windshield Angle		-25.4		
SWA°	Steering Wheel Angle		22		
SCA°	Steering Column Angle		-17.6		
SA°	Seat Back Angle (on headrest post)		14.6		18
HZ	Head to Roof (Z)	169	90	277	90
HH	Head to Header	430	15.9		
HW	Head to Windshield	795	0		
NR/NB	Nose to Rim/Seat Back	481	-13.9	558	-11.8
CD/CB	Chest to Dash/Seat Back	687		580	
CS	Chest to Steering Hub	413	-11.3		
RA	Rim to Abdomen	223	0		
KDL/KBL	Left Knee to Dash/Seat Back	183	26.9	296	29.2
KDR/KBR	Right Knee to Dash/Seat Back	181	26.3	276	26.5
PA°	Pelvic Angle		23.8		21.1
TA°	Tibia Angle		-45.3		-59.8
SK	Striker to Knee	575	-9.2	625	-21.7
ST	Striker to Head	556	83.2	325	64.5
SH	Striker to H-Point	225	-52.2	285	-56.5
HAX°	Head Angle X		0		
HAY°	Head Angle Y		4.8		
NAX°	Neck Angle X		-0.1		
NAY°	Neck Angle Y		1.6		
TAX°	T6 Angle X		15.4		
TAY°	T6 Angle Y		1.6		
LAX°	Lumbar Angle (X)		-1.5		
LAY°	Lumbar Angle (Y)		22.1		

DATA SHEET NO. 3 (CONTINUED)

DUMMY CMM MEASUREMENTS

Test Vehicle: 2011 Buick Lacrosse NHTSA No: RB0179
 Test Program: R&D 56mph, 15° angle, 35% offset Test Date: 9/21/2011

Description	Units	Driver			Left Rear Passenger		
		X	Y	Z	X	Y	Z
Striker (Driver/Passenger)	mm	2456.861	-785.759	-146.726	1405.065	-786.907	-259.071
Head CG	mm	2486.794	-459.268	-666.83	1508.107	-431.234	-556.904
Bridge of Nose	mm	2580.043	-374.652	-663.23	1595.332	-356.395	-553.334
Tip of Nose	mm	2576.585	-374.338	-609.772	1618.027	-355.828	-523.967
Shoulder Bolt	mm	2517.465	-567.327	-412.112	1500.315	-520.689	-317.179
Tip of Chin	mm	2570.311	-374.919	-534.454	1604.878	-357.33	-450.012
H-point	mm	2635.969	-569.846	31.8493	1588.706	-494.66	-18.3464
Left Knee	mm	3034.406	-547.483	-75.2536	2005.81	-484.121	-56.153
Right Knee	mm	3030.762	-285.244	-93.6752	2007.887	-323.931	-63.4306
Left Ankle	mm	3372.348	-544.381	177.0259	2185.738	-493.122	228.0682
Right Ankle	mm	3334.495	-263.865	194.4119	2174.271	-322.15	226.7841
Left Heel	mm	3376.649	-520.225	316.59	2107.993	-474.816	323.8424
Right Heel	mm	3362.104	-218.178	320.8047	2111.096	-306.739	324.9733
Driver's Outboard Seat Anchor Bolt	mm	2901.282	-593.568	210.373			
Outboard Head Restraint Post	mm	2240.024	-458.336	-446.094	1259.601	-441.521	-507.959
Top of Head Restraint*	mm	2283.69	-379.87	-750.373	1270.86	-353.357	-649.643
Center of Steering Wheel	mm	2986.172	-371.212	-346.074			

Reference point: Rear most center of the top of rear bumper beam
 +X – From the rear of the vehicle to the front of the vehicle
 +Y – From left side of the vehicle to the right side of the vehicle
 +Z – From the top of the vehicle to the bottom of the vehicle

DATA SHEET NO. 4

DUMMY LATERAL CLEARANCE DIMENSIONS

Test Vehicle:	2011 Buick Lacrosse	NHTSA No:	RB0179
Test Program:	R&D 56mph, 15° angle, 35% offset	Test Date	9/21/2011

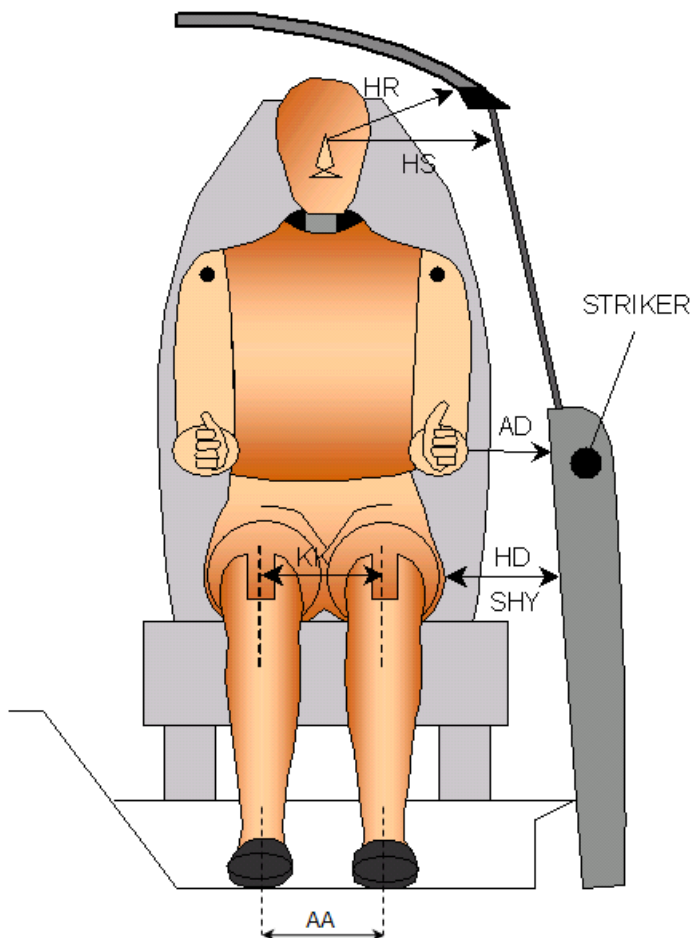

Code	Description	Units	Driver (P1)	Passenger (P4)
AD	Arm to Door	mm	142	98
HD	H-Point to Door	mm	137	181
HR	Head to Side Header	mm	200	265
HS	Head to Side Window	mm	360	375
KK	Knee to Knee	mm	270	170
SHY	Striker to H-Point (Y Direction)	mm	233	305
AA	Ankle to Ankle	mm	282	165

DATA SHEET NO. 5

SEAT BELT POSITIONING DATA

Test Vehicle: 2011 Buick Lacrosse	NHTSA No: RB0179
Test Program: R&D 56mph, 15° angle, 35% offset	Test Date: 9/21/2011

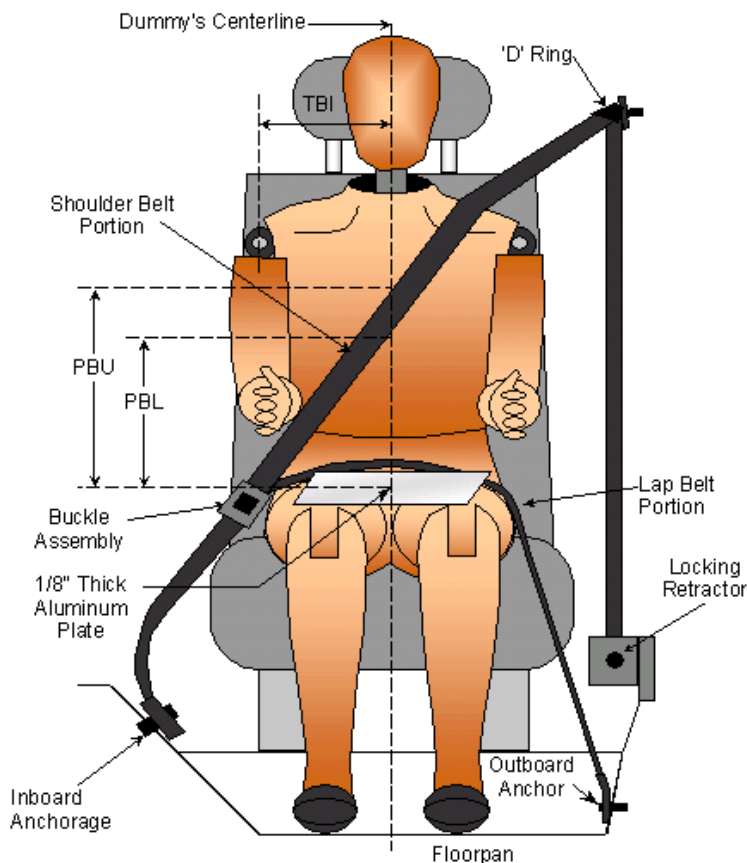

SEAT BELT POSITIONING MEASUREMENTS

Measurement Description	Units	Driver	Passenger
PBU — Top surface of aluminum plate to belt upper edge	mm	360	317
PBL — Top surface of aluminum plate to belt lower edge	mm	275	227

BELT LENGTH DATA

Measurement Description	Units	Driver	Passenger
Shoulder belt length as measured on ATD	mm	820	960
Lap Belt Length as measured on ATD	mm	525	560
Remainder of belt on reel	mm	1055	930
Total belt length for continuous webbing systems	mm	2400	2450

DATA SHEET NO. 6

HIGH-SPEED CAMERA LOCATIONS AND DATA

Test Vehicle: 2011 Buick Lacrosse NHTSA No: RB0179
 Test Program: R&D 56mph, 15° angle, 35% offset Test Date: 9/21/2011

Horizontal Location

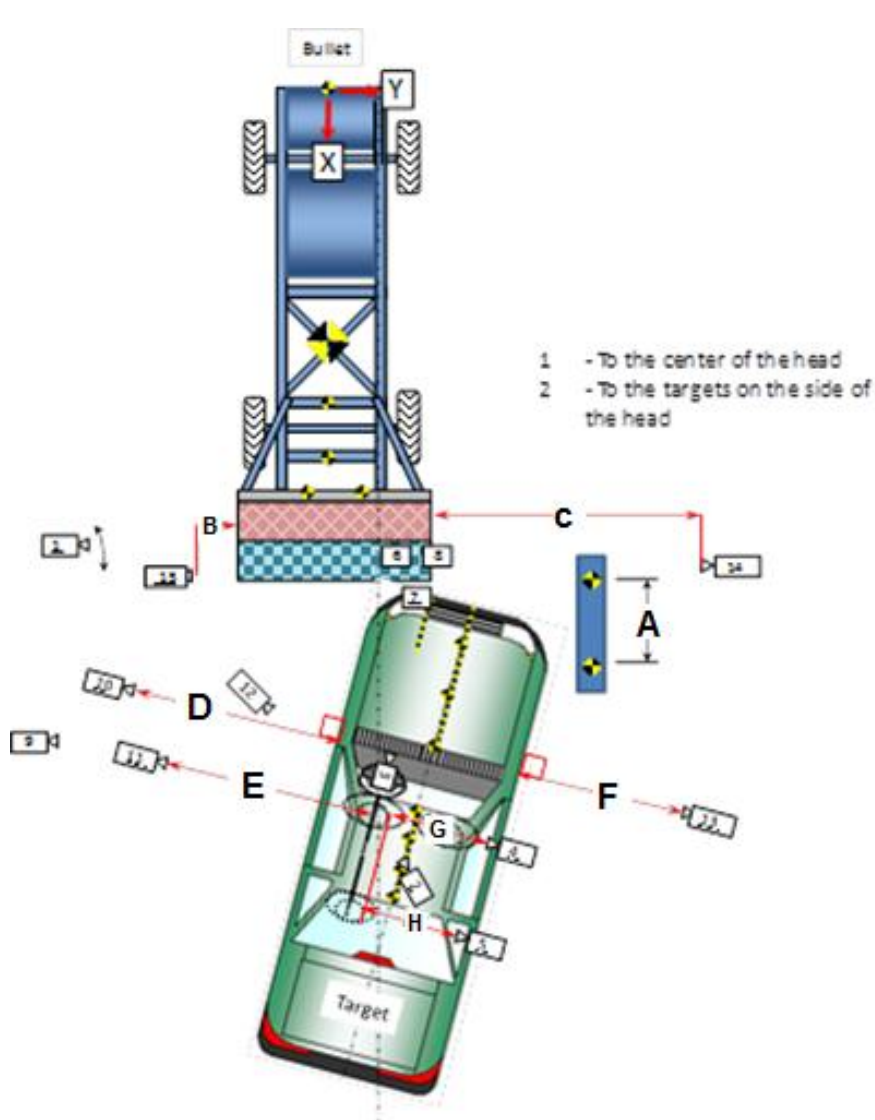

A	mm	915
B	mm	9060
C	mm	
D	mm	9285
E	mm	9882
F	mm	8333
G	mm	863
H	mm	817

DATA SHEET NO. 6 (CONTINUED)

HIGH-SPEED CAMERA LOCATIONS AND DATA

Test Vehicle: 2011 Buick Lacrosse NHTSA No: RB0179
 Test Program: R&D 56mph, 15° angle, 35% offset Test Date: 9/21/2011

Horizontal Location

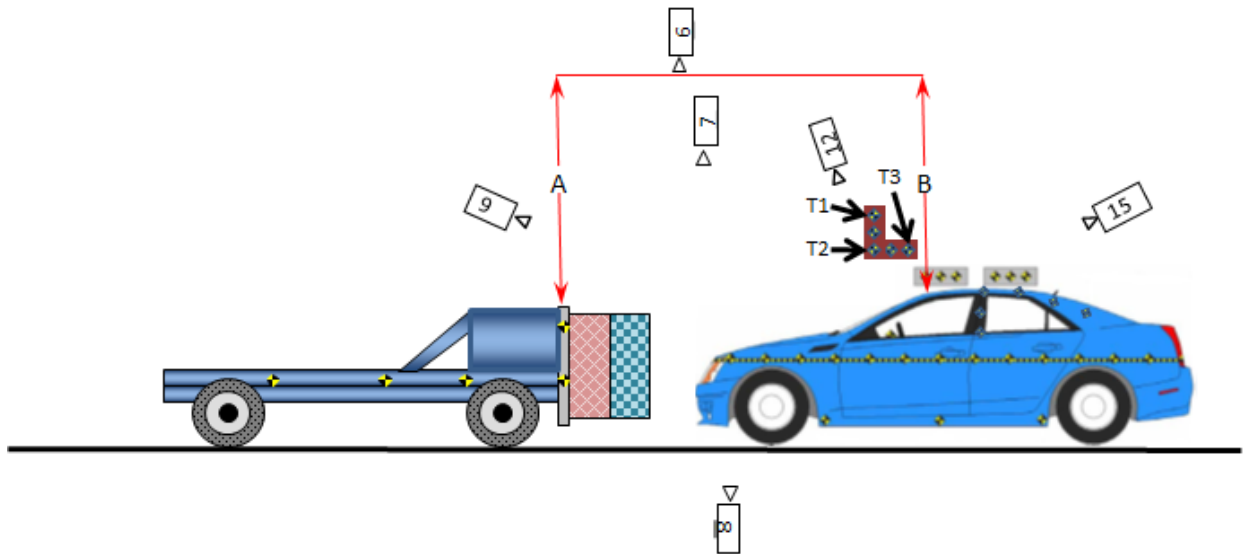

	Units	Value
A	mm	3958
B	mm	3584

DATA SHEET NO. 6 (CONTINUED)

HIGH-SPEED CAMERA LOCATIONS AND DATA

Test Vehicle: 2011 Buick Lacrosse NHTSA No: RB0179
 Test Program: R&D 56mph, 15° angle, 35% offset Test Date: 9/21/2011

CAMERA LOCATIONS

No.	Camera View	Location (mm)			Lens (mm)	Speed (fps)
		X	Y	Z		
1	Real-Time Left Side View					
2	Onboard Driver Over Shoulder	3165	855	1224	12.5	500
3	Onboard Driver Lower Leg	1630	520	270	6.5	500
4	Onboard Driver Perpendicular	2010	1334	970	12.5	500
5	Onboard Left Rear Passenger Perpendicular	2820	1160	890	12.5	500
6	Overall Top View	1835	865	5122	14	500
7	Zoomed Top View	0	1120	3805	28	1000
8	Pit Front					
9	Overall Left Side	-336	10130	2803	24	1000
10	Target Vehicle Left Side	1530	8620	1430	24	1000
11	Driver's Motion	1465	10003	1260	50	1000
12	Look Down Driver's Motion	2697	460	3640	24	1000
13	Target Vehicle Right Side	4220	10090	3040	28	1000
14	Bullet Vehicle Left Side					
15	Bullet Vehicle Right Side	3690	-9575	1530	28	1000
16	Above MDB	300	430	1740	13	1000

Reference point: center most rearward point of the MDB when in contact with the Target Vehicle):

- +X = from back of MDB to front of MDB
- +Y = right of monorail center
- +Z = up from ground

DATA SHEET NO. 7

VEHICLE INSTRUMENTATION LOCATIONS

Test Vehicle:	2011 Buick Lacrosse	NHTSA No:	RB0179
Test Program:	R&D 56mph, 15° angle, 35% offset	Test Date	9/21/2011



Accelerometer Location	Axes	Units	Location		
			X	Y	Z
Left Rear Sill	X,Y	mm	2068	-638	325
Right Rear Sill	X,Y	mm	2096	630	327
Vehicle CG	X, Y, Z	mm	3059	119	126
Driver Seat Track	X	mm	3274	-2	-318
Instrument Panel	X, Y, Z	mm	2458	-234	320
Behind Brake Pedal	X, Y, Z	mm	3703	-370	125

Reference point: Rear most center of the top of rear bumper beam
 +X – From the rear of the vehicle to the front of the vehicle
 +Y – From left side of the vehicle to the right side of the vehicle
 +Z – From the top of the vehicle to the bottom of the vehicle

DATA SHEET NO. 7 (CONTINUED)

VEHICLE INSTRUMENTATION DATA

Test Vehicle: 2011 Buick Lacrosse NHTSA No: RB0179
 Test Program: R&D 56mph, 15° angle, 35% offset Test Date: 9/21/2011

VEHICLE INSTRUMENTATION DATA

Loc.	Description	Axes	Units	Positive Direction		Negative Direction	
				Max	Time (ms)	Max	Time (ms)
1	Left Rear Cross Member	X	G	1.29	125.25	-33.85	48.20
		Y	G	26.58	42.35	-4.34	84.90
2	Right Rear Cross Member	X	G	2.15	134.60	-50.95	48.00
		Y	G	24.17	43.90	-4.74	84.75
3	Vehicle CG	X	G	1.38	140.25	-40.07	47.40
		Y	G	40.70	42.00	-16.36	74.10
		Z	G	23.02	39.95	-16.84	64.25
4	Instrument Panel	X	G	9.54	61.80	-71.04	45.55
5	Driver Seat Track	X	G	1.73	92.75	-39.33	41.50
		Y	G	34.33	43.30	-7.69	6.70
		Z	G	41.25	50.15	-26.84	11.60
6	Behind Brake Pedal	X	G	74.74	47.55	-122.83	41.50
		Y	G	40.58	39.45	-14.18	32.40
		Z	G	29.47	40.65	-17.26	55.35
7	Driver Shoulder Belt		N	3474.24	52.90	-52.49	265.85
8	Driver Lap Belt		N	4559.56	61.00	-117.85	92.50
9	Passenger Shoulder Belt		N	7489.70	70.90	-11.31	441.55
10	Passenger Lap Belt		N	11773.64	407.25	-0.97	-1.20

DATA SHEET NO. 7 (CONTINUED)

VEHICLE INSTRUMENTATION DATA

Test Vehicle: 2011 Buick Lacrosse NHTSA No: RB0179
 Test Program: R&D 56mph, 15° angle, 35% offset Test Date: 9/21/2011

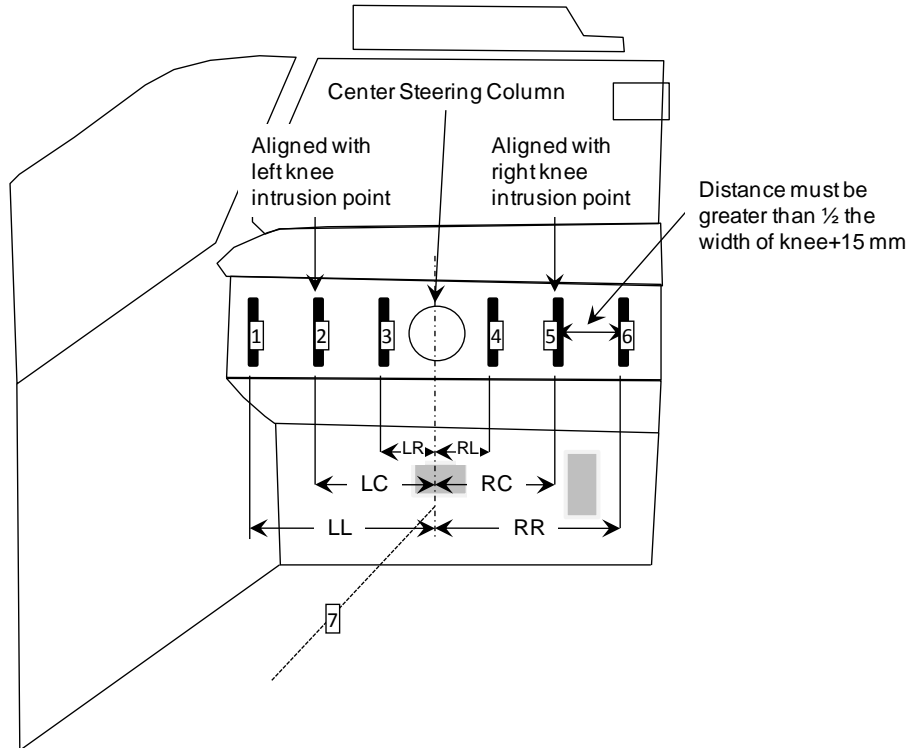

Location	Distance (mm)	Location	Distance (mm)
LL	200	RL	100
LC	150	RC	150
LR	100	RR	200

VEHICLE INSTRUMENTATION DATA

Loc.	Description		Positive Direction		Negative Direction	
			Max	Time (ms)	Max	Time (ms)
1	Left knee contact switch (LL) (ms)	*				49.3
2	Left knee contact switch (LC) (ms)	*				47.05
3	Left knee contact switch (LR) (ms)	*				47.85
4	Right knee contact switch (RL) (ms)	*				49.75
5	Right knee contact switch (RC) (ms)	*				52.35
6	Right knee contact switch (RR) (ms)	*				49.3
7	Toe pan string pot (mm)		0.117	-1.1	-47.887	60.3

* The measurement indicates the initial time the voltage changed

DATA SHEET NO. 8

VEHICLE PHOTOGRAPHIC REFERENCE TARGET LOCATIONS

Test Vehicle: 2011 Buick Lacrosse NHTSA No: RB0179
 Test Program: R&D 56mph, 15° angle, 35% offset Test Date: 9/21/2011

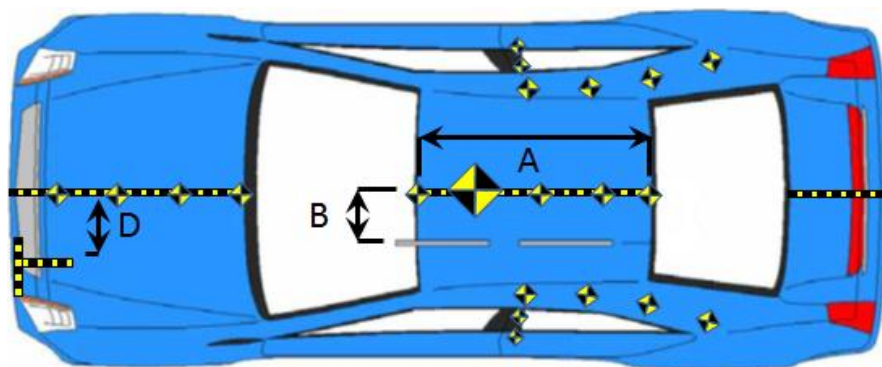

Item	Units	Value
A	mm	610
B	mm	303
C	mm	915
D	mm	272
E	mm	2594
F	mm	970
G	mm	971
H	mm	972
I	mm	974

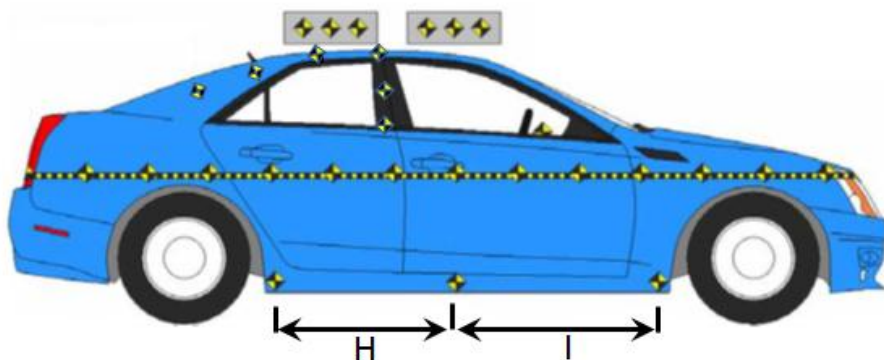
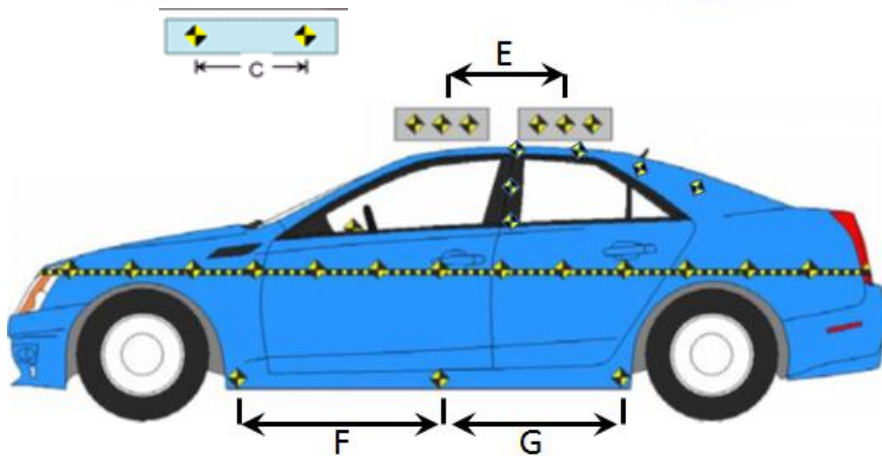

DATA SHEET NO. 8 (CONTINUED)

MDB PHOTOGRAPHIC REFERENCE TARGET LOCATIONS

Test Vehicle: 2011 Buick Lacrosse NHTSA No: RB0179
 Test Program: R&D 56mph, 15° angle, 35% offset Test Date: 9/21/2011

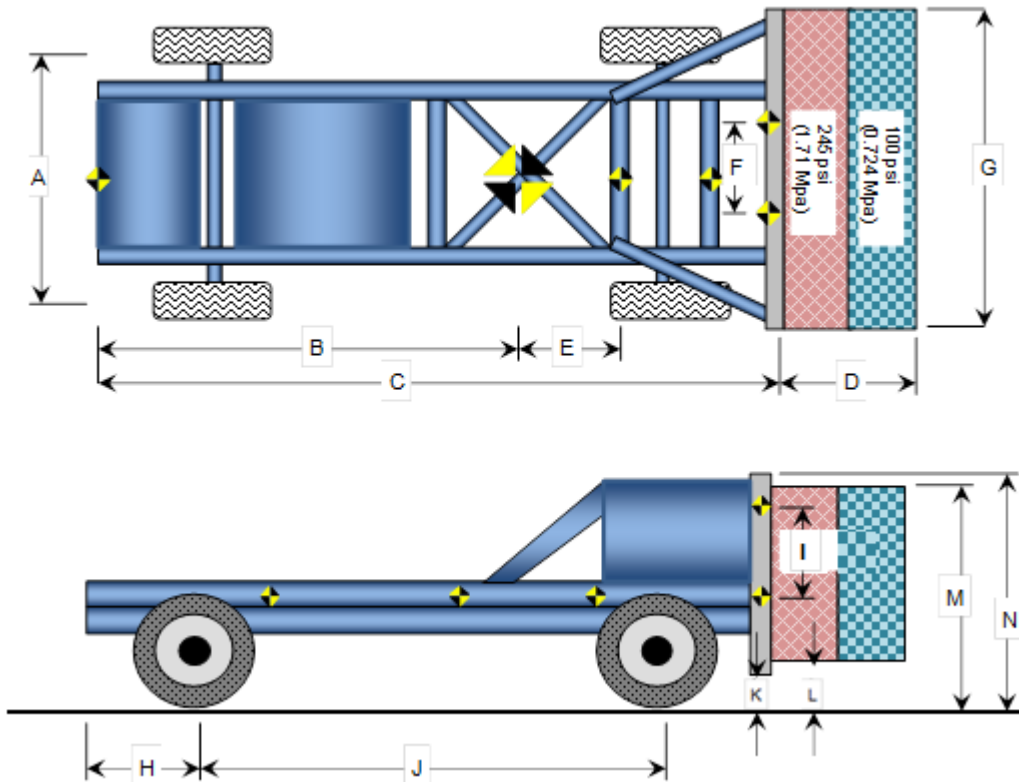

Item	Units	Value
A	mm	1550
B	mm	2215
C	mm	3940
D	mm	606
E	mm	1185
F	mm	1130
G	mm	2210
H	mm	795
I	mm	500
J	mm	2585
K	mm	90
L	mm	98
M	mm	1055
N	mm	1190

	Units	Front Axle	Rear Axle	Total
Left	kg	779.3	470.4	1249.7
Right	kg	749.3	487.2	1236.5
Ratio	%	61.5%	38.5%	100%
Total	kg	1528.6	957.6	2486.2
CG After of Front Axle	mm			1285.6

DATA SHEET NO. 8 (CONTINUED)

DUMMY PHOTOGRAPHIC REFERENCE TARGET LOCATIONS

Test Vehicle: 2011 Buick Lacrosse NHTSA No: RB0179
 Test Program: R&D 56mph, 15° angle, 35% offset Test Date: 9/21/2011

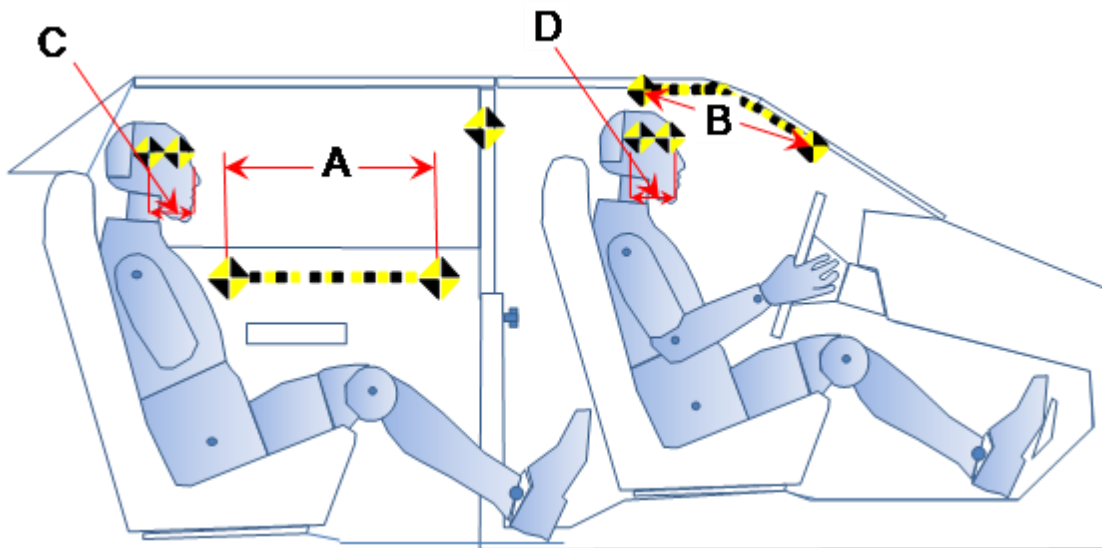

Item	Units	Value
A	mm	308
B	mm	305
C	mm	52
D	mm	52

DATA SHEET NO. 9

TEST VEHICLE SUMMARY OF RESULTS

Test Vehicle: 2011 Buick Lacrosse NHTSA No: RB0179
Test Program: R&D 56mph, 15° angle, 35% offset Test Date: 9/21/2011

INSTRUMENTATION

Driver Dummy Accelerometers	119
Passenger Dummy Accelerometers	34
Vehicle Structure Accelerometers	16
Total	169

CAMERA COVERAGE

High-Speed Vehicle Onboard	4
High-Speed Off board	10
Real-Time Panning	1
Total	15

DATA SHEET NO. 10

POST TEST OBSERVATIONS

Test Vehicle: 2011 Buick Lacrosse NHTSA No: RB0179
 Test Program: R&D 56mph, 15° angle, 35% offset Test Date: 9/21/2011

TEST DUMMY INFORMATION AND CONTACT

Description	Driver	Picture Ref.	Passenger	Picture Ref.
Dummy Type	THOR 50 th Male	N/A	HIII 5 th Female	N/A
Dummy Serial No.	0007	N/A	070	N/A
Lower Leg Type	THOR-FLX Lower Leg	N/A	HIII Lower Leg	N/A
Lower Leg Serial No.	LX0036/0037	N/A	-	N/A
Head Contact	Steering wheel airbag and side curtain airbag	A-37 A-48	Side curtain airbag and the interior of the C-Pillar	A-49 A-52 A-58
Upper Torso Contact	Steering wheel airbag		None	
Lower Torso Contact	None	A-46 A-47	None	
Left Knee Contact	Knee bolster	A-45	None	A-59
Right Knee Contact	Knee bolster	A-44	None	A-59

DOOR OPENING AND SEAT TRACK INFORMATION

Description	Driver	Passenger
Locked/Unlocked Doors	Unlocked	Unlocked
Front Door Opening	Closed	Closed / Operational
Rear Door Opening	Closed / Operational	Closed / Operational
Seat Track Shift (mm)	none	
Seat Back Failure	No failure	No failure
Glazing Damage	Windshield cracked	None

POST TEST STRUCTURAL OBSERVATIONS

Critical Areas of Performance	Observations and Conclusions	Picture Ref
Pillar Performance	A-Pillar and Door Sill buckled during impact	
Windshield Damage	Hinge caused a small hole in the lower left corner. Windshield cracked throughout.	A-21
Window Damage	-	A-36 / A-51
Other Notable Effects	None	

SUPPLEMENTAL RESTRAINT SYSTEM INFORMATION

Restraint Type	Driver (Occupant 1)		Passenger (Occupant 2)	
	Installed	Operated	Installed	Operated
Front Airbag	Yes	Yes	No	
Combination Head/Torso Airbag	Yes	Yes	No	
Curtain (or other Head) Airbag	Yes	Yes	Yes	Yes
Knee Airbag	No		No	
Seat Belt Pretensioner	Yes	Yes	No	
Seat Belt Load Limiter	Yes	Yes	No	

DATA SHEET NO. 11

VEHICLE PROFILE MEASUREMENTS

Test Vehicle:	<u>2011 Buick Lacrosse</u>	NHTSA No:	<u>RB0179</u>
Test Program:	<u>R&D 56mph, 15° angle, 35% offset</u>	Test Date	<u>9/21/2011</u>

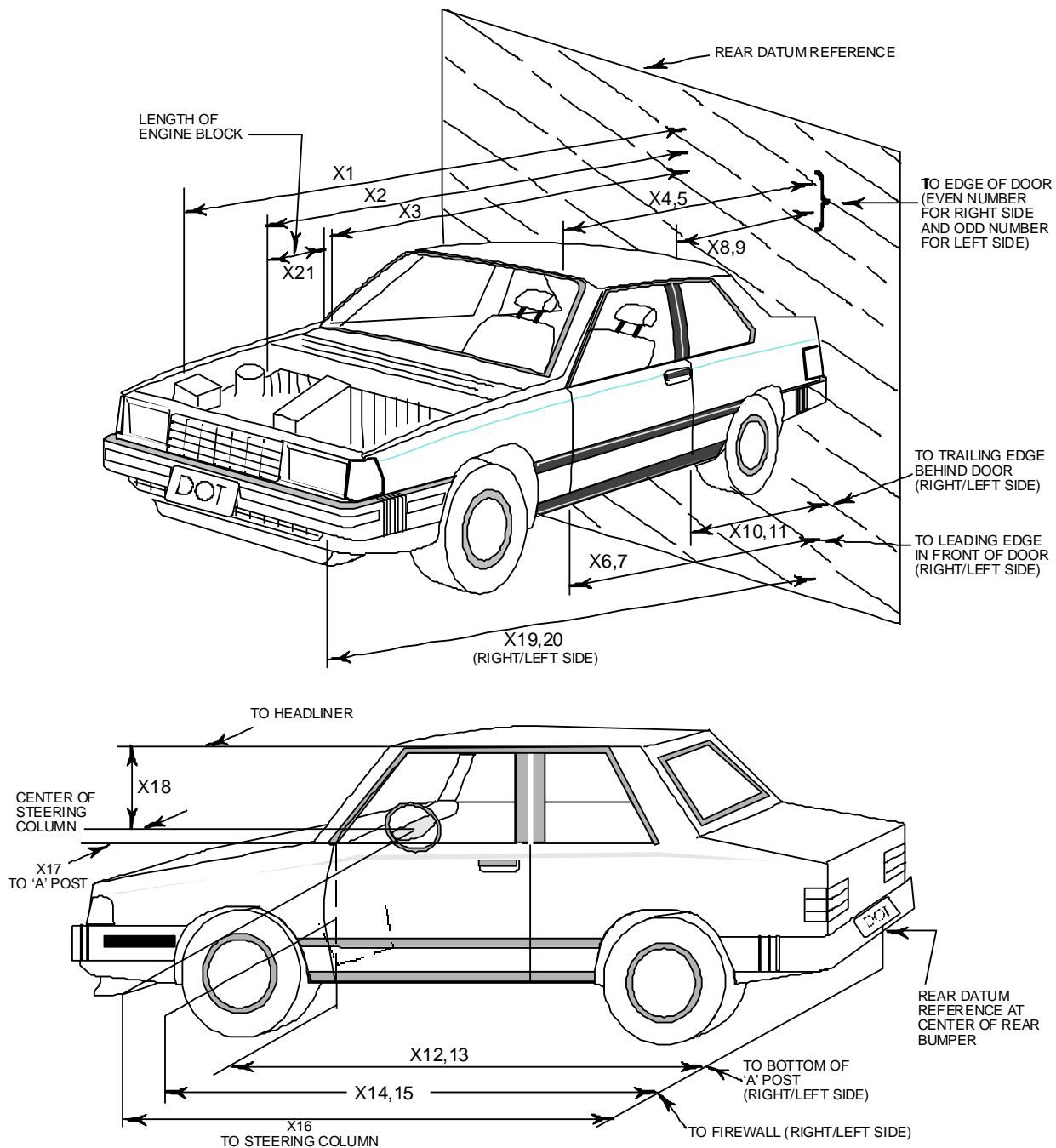

DATA SHEET NO. 11 (CONTINUED)

VEHICLE PROFILE MEASUREMENTS

Test Vehicle: 2011 Buick Lacrosse NHTSA No: RB0179
 Test Program: R&D 56mph, 15° angle, 35% offset Test Date: 9/21/2011

No.	Measurement Description	Pre-Test	Post-Test	Difference
1	Total Length of Vehicle at Centerline	4991	4765	226
2	Rear Surface of Vehicle (RSOV) to Front of Engine	4528	4241	287
3	RSOV to Firewall	3855	3744	111
4	RSOV to Upper Leading Edge of Right Door	3487	3491	-4
5	RSOV to Upper Leading Edge of Left Door	3489	3462	26
6	RSOV to Lower Leading Edge of Right Door	3483	3485	-2
7	RSOV to Lower Leading Edge of Left Door	3486	3458	28
8	RSOV to Upper Trailing Edge of Right Door	2358	2362	-4
9	RSOV to Upper Trailing Edge of Left Door	2357	2347	10
10	RSOV to Lower Trailing Edge of Right Door	2397	2400	-3
11	RSOV to Lower Trailing Edge of Left Door	2398	2377	21
12	RSOV to Bottom of "A" Post of Right Side	3575	3575	0
13	RSOV to Bottom of "A" Post of Left Side	3573	3549	24
14	RSOV to Firewall, Right Side	3938	3858	80
15	RSOV to Firewall, Left Side	3938	3769	169
16	RSOV to Steering Column	2984	2975	9
17	Center of Steering Column to "A" Post	269	241	29
18	Center of Steering Column to Headliner	430	413	17
19	RSOV to Right Side of Front Bumper	4834	4828	6
20	RSOV to Left Side of Front Bumper	4834	4402	432
21	Length of Engine Block	571	471	100
RD	RSOV to Right Side of Dash Panel	3130	3132	-2
CD	RSOV to Center of Dash Panel	3274	3243	31
LD	RSOV to Left Side of Dash Panel	3134	3092	42

All Dimensions in mm

DATA SHEET NO. 12

ACCIDENT INVESTIGATION DIVISION DATA

Test Vehicle: 2011 Buick Lacrosse NHTSA No: RB0179
 Test Program: R&D 56mph, 15° angle, 35% offset Test Date: 9/21/2011

VEHICLE INFORMATION

VIN: 1G4GAGA5EC1BF243565 Wheelbase: 2839
 Vehicle Size Category: Passenger Test Weight (kg): 1943.5

ACCELEROMETER DATA

Accelerometer Locations: Data Sheet No.7 Linearity: 99%
 Cal. Procedure/Interval: Calspan 6 Months
 Integration Algorithm: Trapezoidal
 Impact Velocity (km/h): 90.3
 Velocity Change (km/h): -
 Time of Separation (msec): 250 ms

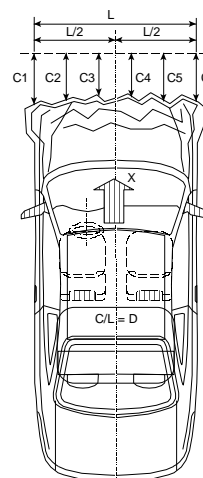

CRUSH PROFILE

Collision Deformation Classification : 11FYEW3
 Midpoint of Damage: C2
 Damage Region Length (mm): 1407
 Impact Mode: 35% offset, 15° Angle

CRUSH MEASUREMENTS: WITH BUMPER COVER

No.	Measurement Description	Units	Pre-Test	Post-Test	Difference
C1	Crush zone 1 at left side	mm	4749	4314	435
C2	Crush zone 2 at left side	mm	4892	4483	409
C3	Crush zone 3 at left side	mm	4965	4656	309
C4	Crush zone 4 at right side	mm	4965	4766	199
C5	Crush zone 5 at right side	mm	4893	4811	82
C6	Crush zone 6 at right side	mm	4751	4781	-30
L	C1 to C6	mm	1407	1240	167

CRUSH MEASUREMENTS: WITH BUMPER COVER REMOVED

No.	Measurement Description	Units	Pre-Test	Post-Test	Difference
C1	Crush zone 1 at left side	mm	4739	4343	396
C2	Crush zone 2 at left side	mm	4825	4342	483
C3	Crush zone 3 at left side	mm	4864	4491	373
C4	Crush zone 4 at right side	mm	4865	4638	227
C5	Crush zone 5 at right side	mm	4828	4753	75
C6	Crush zone 6 at right side	mm	4741	4819	-78
L	C1 to C6	mm	1251	1078	173

DATA SHEET NO. 13

VEHICLE INTRUSION MEASUREMENTS

Test Vehicle: 2011 Buick Lacrosse NHTSA No: RB0179
 Test Program: R&D 56mph, 15° angle, 35% offset Test Date: 9/21/2011

DOOR OPENING WIDTH

Item	Description	Units	Pre-Test	Post-Test	Difference
A	Left Side Upper	mm	968	925	-43
B	Left Side Lower	mm	880	860	-20
D	Right Side Upper	mm	968	967	-1
E	Right Side Lower	mm	888	888	0

WHEELBASE MEASUREMENTS

Item	Description	Units	Pre-Test	Post-Test	Difference
C	Left Side Wheelbase	mm	2838	2718	-120
F	Right Side Wheelbase	mm	2841	2784	-57

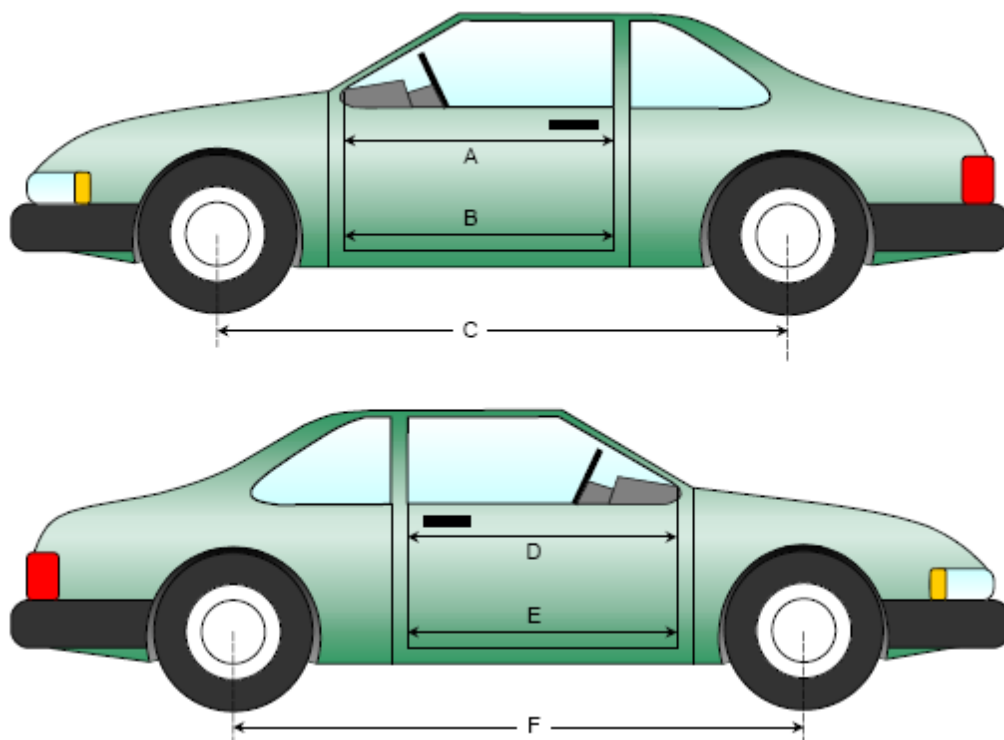

DATA SHEET NO.13 (CONTINUED)

VEHICLE INTRUSION MEASUREMENTS

Test Vehicle: 2011 Buick Lacrosse NHTSA No: RB0179
 Test Program: R&D 56mph, 15° angle, 35% offset Test Date: 9/21/2011

DRIVER COMPARTMENT INTRUSION

Item	Description	Units	Pre-Test	Post-Test	Difference
AB	Door Opening (Inside Window Jam)	mm	826	822	-3
CX	Left Knee Bolster to X	mm	262	190	-72
DX	Right Knee Bolster to X	mm	266	213	-53
EX	Brake Pedal to X	mm	579	483	-96
FX	Foot Rest to X	mm	694	567	-127
GX	Center of Steering Column Wheel Hub to X	mm	83	11	-72

X = Front of Seat Track (Stationary)

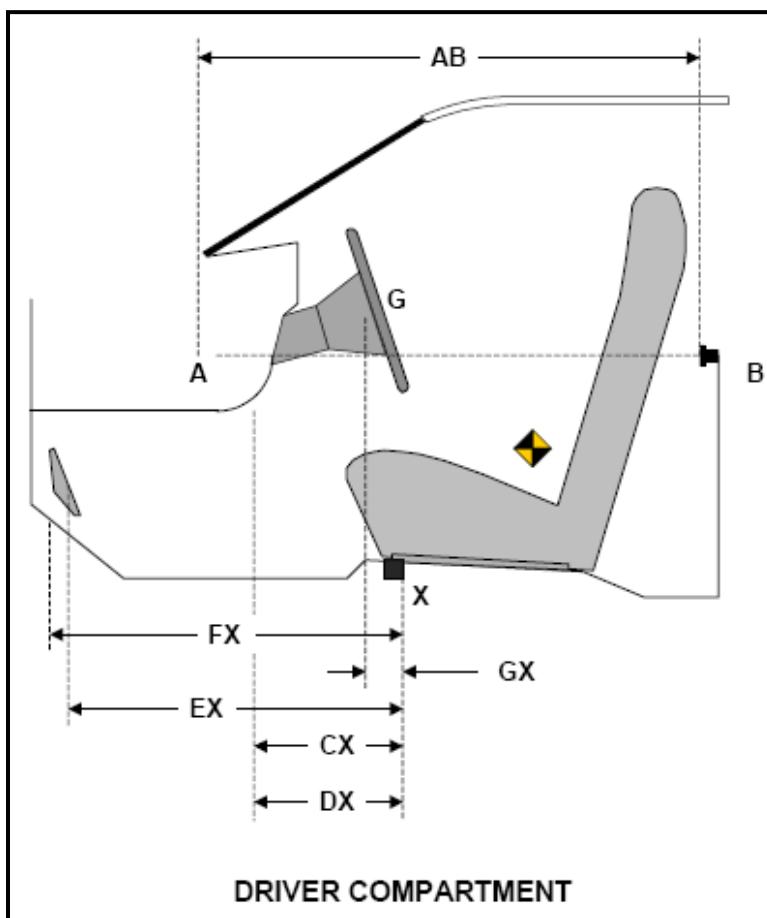

DATA SHEET NO.13 (CONTINUED)

VEHICLE INTRUSION MEASUREMENTS

Test Vehicle: 2011 Buick Lacrosse NHTSA No: RB0179
 Test Program: R&D 56mph, 15° angle, 35% offset Test Date: 9/21/2011

TOP VIEW THROUGH FLOOR PAN

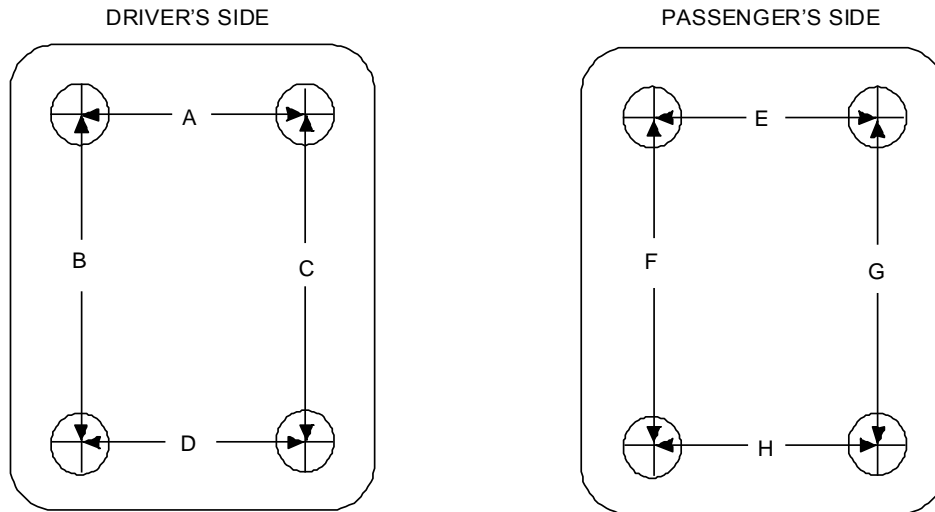

UNDERBODY FLOORBOARD DEFORMATION

Measurement	Pre-Test	Post-Test	Difference
A	422	419	4
B	291	291	0
C	263	265	-2
D	450	447	3
E	406	410	-4
F	377	378	-1
G	378	377	1
H	480	479	2

All units in millimeters

DATA SHEET NO.13 (CONTINUED)

VEHICLE INTRUSION MEASUREMENTS

Test Vehicle: 2011 Buick Lacrosse NHTSA No: RB0179
Test Program: R&D 56mph, 15° angle, 35% offset Test Date: 9/21/2011

DRIVER SIDE DOOR SILL INTRUSIONS

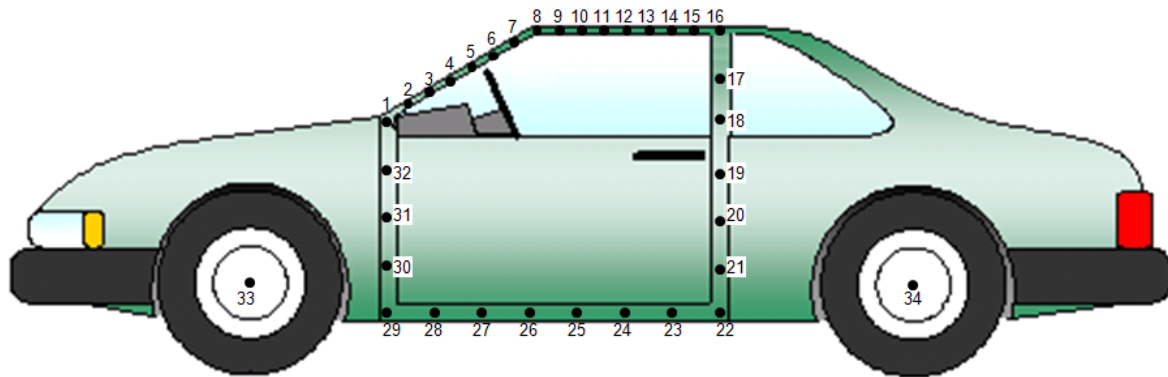

Left Side View

Reference point: Rear most center of the top of rear bumper beam

+X – From the rear of the vehicle to the front of the vehicle

+Y – From left side of the vehicle to the right side of the vehicle

+Z – From the top of the vehicle to the bottom of the vehicle

Note: See appendix F.2 for detailed procedure to measure required Door sill intrusion.

DATA SHEET NO.13 (CONTINUED)

VEHICLE INTRUSION MEASUREMENTS

Test Vehicle: 2011 Buick Lacrosse NHTSA No: RB0179
 Test Program: R&D 56mph, 15° angle, 35% offset Test Date: 9/21/2011

DRIVER SIDE DOOR SILL INTRUSIONS

Pt.	Pre-Test			Post-Test			Difference		
	X	Y	Z	X	Y	Z	X	Y	Z
1	3401.5	-738.8	-505.5	3386.7	-741.0	-497.7	-15	-2	8
2	3342.9	-724.3	-554.9	3338.9	-724.1	-553.0	-4	0	2
3	3275.0	-709.7	-588.6	3269.5	-715.3	-585.2	-6	-6	3
4	3209.1	-696.3	-620.5	3205.5	-703.7	-617.0	-4	-7	4
5	3140.6	-683.0	-654.2	3137.3	-688.5	-651.9	-3	-6	2
6	3073.4	-670.1	-686.1	3070.6	-674.2	-683.6	-3	-4	2
7	3002.1	-656.8	-714.1	3001.3	-659.6	-712.3	-1	-3	2
8	2933.0	-644.9	-734.4	2931.9	-645.6	-737.4	-1	-1	-3
9	2861.0	-635.0	-755.8	2861.9	-635.5	-756.3	1	0	-1
10	2788.4	-626.4	-769.7	2789.1	-628.7	-770.4	1	-2	-1
11	2714.2	-619.8	-780.5	2714.0	-622.1	-781.9	0	-2	-1
12	2638.5	-615.6	-792.8	2637.0	-617.4	-791.6	-2	-2	1
13	2559.4	-612.4	-798.5	2560.2	-614.4	-798.1	1	-2	0
14	2485.3	-610.8	-803.2	2485.1	-612.9	-801.9	0	-2	1
15	2407.5	-610.5	-799.3	2406.6	-612.9	-798.6	-1	-2	1
16	2335.5	-619.3	-785.9	2335.5	-621.7	-784.4	0	-2	1
17	2355.6	-702.9	-640.3	2355.1	-704.3	-638.5	-1	-1	2
18	2388.2	-761.3	-485.9	2386.9	-762.9	-484.1	-1	-2	2
19	2430.7	-799.9	-326.0	2431.1	-800.1	-323.0	0	0	3
20	2443.8	-823.2	-160.2	2441.5	-823.9	-158.0	-2	-1	2
21	2482.2	-820.5	10.0	2477.6	-820.0	12.2	-5	1	2
22	2519.5	-820.7	162.2	2516.9	-820.3	164.0	-3	0	2
23	2637.7	-824.5	185.6	2634.4	-823.9	187.9	-3	1	2
24	2758.0	-818.7	209.6	2754.6	-816.7	211.8	-3	2	2
25	2876.1	-819.5	214.4	2875.6	-817.8	216.8	0	2	2
26	2997.5	-825.3	218.2	2994.5	-824.0	219.8	-3	1	2
27	3114.3	-820.1	214.7	3112.0	-819.3	218.1	-2	1	3
28	3233.3	-818.1	214.3	3232.4	-818.4	218.3	-1	0	4
29	3341.1	-803.6	170.5	3330.3	-804.7	187.1	-11	-1	17
30	3419.2	-784.3	7.7	3388.9	-791.4	11.6	-30	-7	4
31	3421.3	-774.9	-173.7	3375.3	-775.6	-167.3	-46	-1	6
32	3401.6	-750.2	-359.5	3362.9	-755.6	-352.0	-39	-5	7

DATA SHEET NO.13 (CONTINUED)

VEHICLE INTRUSION MEASUREMENTS

Test Vehicle: 2011 Buick Lacrosse NHTSA No: RB0179
Test Program: R&D 56mph, 15° angle, 35% offset Test Date: 9/21/2011

PASSENGER SIDE DOOR SILL INTRUSIONS

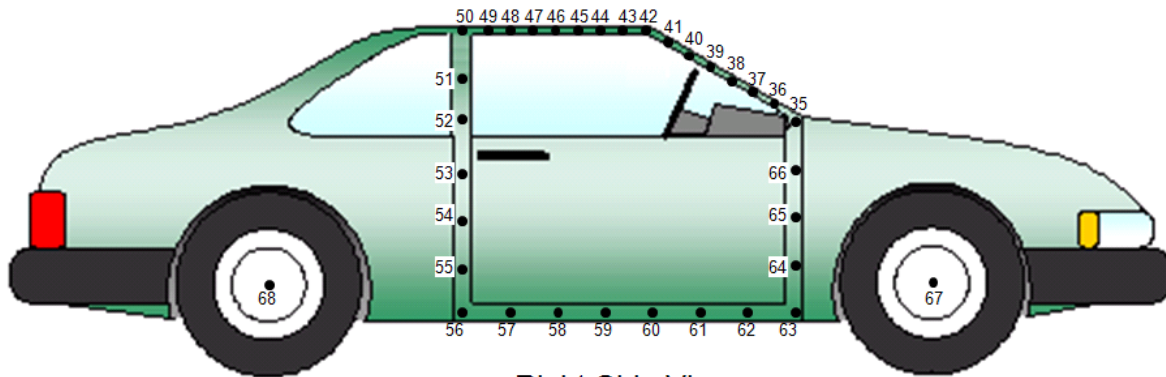

Right Side View

Reference point: Rear most center of the top of rear bumper beam

+X – From the rear of the vehicle to the front of the vehicle

+Y – From left side of the vehicle to the right side of the vehicle

+Z – From the top of the vehicle to the bottom of the vehicle

Note: See appendix F.2 for detailed procedure to measure required Door sill intrusion.

DATA SHEET NO.13 (CONTINUED)

VEHICLE INTRUSION MEASUREMENTS

Test Vehicle: 2011 Buick Lacrosse NHTSA No: RB0179
 Test Program: R&D 56mph, 15° angle, 35% offset Test Date: 9/21/2011

PASSENGER SIDE DOOR SILL INTRUSION

Pt.	Pre-Test			Post-Test			Difference		
	X	Y	Z	X	Y	Z	X	Y	Z
35	3402.2	739.5	-502.5	3403.2	743.2	-501.9	1	4	1
36	3343.4	726.9	-547.9	3344.4	729.6	-547.4	1	3	0
37	3275.3	713.7	-585.6	3275.9	714.9	-584.5	1	1	1
38	3211.1	700.7	-618.2	3212.2	701.3	-616.6	1	1	2
39	3141.8	686.8	-651.3	3143.5	687.3	-651.0	2	0	0
40	3070.9	672.8	-681.1	3073.0	672.8	-681.2	2	0	0
41	3001.4	660.1	-707.8	3003.3	659.4	-708.2	2	-1	0
42	2927.8	647.9	-733.6	2929.8	646.8	-733.2	2	-1	0
43	2855.3	638.1	-753.6	2857.2	636.8	-752.1	2	-1	2
44	2784.7	629.9	-768.5	2786.1	628.7	-767.9	1	-1	1
45	2710.1	623.6	-781.2	2711.5	622.5	-780.6	1	-1	1
46	2635.7	619.8	-791.8	2636.9	618.7	-790.3	1	-1	1
47	2558.7	616.5	-795.7	2559.8	615.7	-795.3	1	-1	0
48	2483.7	615.2	-800.5	2484.7	614.5	-799.5	1	-1	1
49	2408.9	614.6	-799.0	2409.6	614.0	-798.3	1	-1	1
50	2325.5	620.2	-788.9	2326.9	620.1	-787.5	1	0	1
51	2353.0	703.8	-645.6	2354.1	704.5	-644.2	1	1	1
52	2389.7	764.5	-487.0	2391.2	765.3	-487.1	1	1	0
53	2428.9	804.1	-325.2	2429.7	805.9	-325.8	1	2	-1
54	2439.7	828.4	-162.1	2445.0	830.4	-163.1	5	2	-1
55	2474.0	828.0	-9.4	2474.9	831.6	-8.5	1	4	1
56	2510.4	827.5	178.3	2511.6	831.9	175.5	1	4	-3
57	2631.9	828.5	180.2	2631.8	833.7	182.0	0	5	2
58	2747.3	821.8	212.0	2746.8	827.5	212.1	0	6	0
59	2868.1	824.4	218.8	2868.0	831.3	219.3	0	7	0
60	2984.6	825.6	219.8	2984.8	831.3	219.7	0	6	0
61	3104.8	822.9	219.6	3105.2	828.9	219.5	0	6	0
62	3223.3	823.5	220.2	3223.5	830.3	220.3	0	7	0
63	3346.4	801.3	167.9	3345.3	807.5	169.5	-1	6	2
64	3418.2	779.0	0.6	3418.7	785.3	1.7	0	6	1
65	3417.2	762.7	-164.8	3417.7	769.3	-165.5	1	7	-1
66	3399.6	746.8	-342.2	3400.6	751.3	-341.8	1	4	0

DATA SHEET NO.13 (CONTINUED)

VEHICLE INTRUSION MEASUREMENTS

Test Vehicle:	<u>2011 Buick Lacrosse</u>	NHTSA No:	<u>RB0179</u>
Test Program:	<u>R&D 56mph, 15° angle, 35% offset</u>	Test Date	<u>9/21/2011</u>

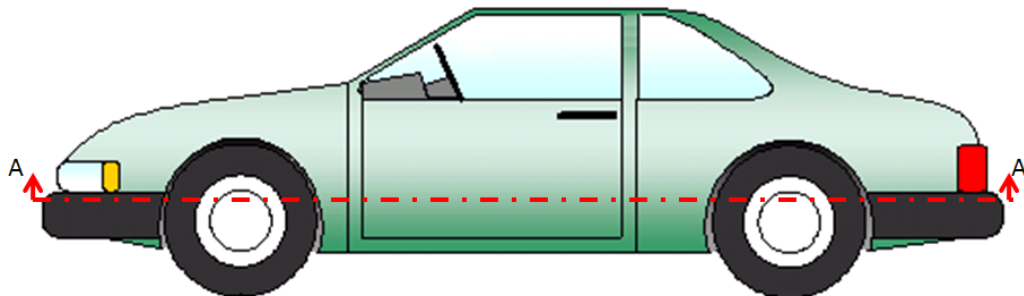

Reference point: Rear most center of the top of rear bumper beam
 +X – From the rear of the vehicle to the front of the vehicle
 +Y – From left side of the vehicle to the right side of the vehicle
 +Z – From the top of the vehicle to the bottom of the vehicle

**VEHICLE EXTERIOR CRUSH PROFILE
SECTION A-A**

Pt.	Pre-Test			Pt.	Post-Test		
	X	Y	Z		X	Y	Z
1	807.8	-913.7	-14.0	1	807.0	-914.8	-14.5
2	680.9	-879.3	-20.3	2	610.2	-863.5	-17.3
3	470.0	-823.9	-14.7	3	297.6	-779.4	-26.1
4	266.8	-767.8	-9.6	4	146.3	-647.9	-29.1
5	190.1	-714.6	-14.9	5	42.0	-326.2	-23.7
6	124.1	-607.7	-14.3	6	7.8	-82.5	-21.1
7	62.1	-420.8	-14.5	7	11.2	113.7	-30.2
8	12.8	-152.1	-7.8	8	70.1	456.7	-22.0
9	2.3	-2.7	-15.5	9	163.6	689.3	-13.1
10	20.7	210.0	-14.3	10	219.0	747.6	-10.2
11	74.4	472.2	-12.8	11	339.0	797.4	-4.0
12	140.6	645.8	-16.9	12	548.5	847.1	-1.1
13	202.7	731.8	-17.1	13	808.6	914.5	11.3
14	297.3	783.7	-17.7	14	1478.4	922.9	39.6
15	439.9	821.5	-17.4	15	1563.7	918.5	45.4
16	594.3	857.7	-18.5	16	1834.0	896.9	52.1
17	812.9	916.4	-15.6	17	2283.5	895.0	65.6
18	1456.1	926.0	-7.2	18	2547.7	897.1	77.3
19	1697.0	906.4	-12.2	19	2996.6	894.3	90.9
20	2158.6	902.4	-12.6	20	3383.0	895.5	102.9

Note:
 See appendix F.3 for a detailed procedure on how to measure vehicle exterior crush profile

DATA SHEET NO.13 (CONTINUED)

VEHICLE INTRUSION MEASUREMENTS

Test Vehicle: 2011 Buick Lacrosse NHTSA No: RB0179
 Test Program: R&D 56mph, 15° angle, 35% offset Test Date: 9/21/2011

**VEHICLE EXTERIOR CRUSH PROFILE
SECTION A-A (Continued)**

Pt.	Pre-Test			Pt.	Post-Test		
	X	Y	Z		X	Y	Z
21	2411.3	902.8	-13.0	21	3586.9	917.7	110.8
22	2891.0	901.4	-14.4	22	4447.9	817.3	123.2
23	3502.9	905.2	-16.7	23	4606.6	804.0	132.1
24	3655.3	921.5	-18.0	24	4821.6	713.1	135.7
25	4281.1	908.6	-20.9	25	4808.2	514.0	128.1
26	4419.3	869.2	-24.5	26	4770.8	400.3	127.0
27	4633.5	789.8	-22.5	27	4647.9	139.9	118.6
28	4704.9	735.9	-20.7	28	4543.9	78.9	115.3
29	4781.6	630.1	-19.6	29	4388.3	-129.0	105.4
30	4880.9	403.1	-21.7	30	4328.4	-242.9	98.9
31	4943.9	-1.5	-18.6	31	4286.7	-322.1	95.3
32	4901.1	-344.2	-18.0	32	4290.8	-400.7	94.5
33	4812.3	-576.2	-20.2	33	4283.1	-479.2	96.3
34	4734.7	-702.4	-16.6	34	4170.7	-489.4	93.2
35	4681.8	-758.9	-14.9	35	4111.7	-509.4	89.6
36	4627.0	-794.5	-14.9	36	4032.0	-479.6	89.3
37	4563.4	-821.6	-15.2	37	4012.4	-565.7	89.5
38	4386.1	-882.6	-17.6	38	4024.7	-649.5	85.0
39	4279.7	-908.8	-17.0	39	4162.4	-768.0	86.4
40	3651.9	-920.9	-15.0	40	4191.1	-842.0	84.2
41	3516.8	-906.3	-20.1	41	4139.2	-1004.3	81.8
42	2984.8	-901.0	-19.6	42	4066.4	-1009.1	88.7
43	2409.5	-903.8	-24.0	43	3522.2	-949.3	61.3
44	1718.6	-903.0	-14.2	44	3490.5	-970.7	53.0
45	1523.5	-920.0	-13.1	45	3451.8	-975.6	52.1
46	1460.2	-924.8	-12.0	46	3444.0	-925.4	52.6
47	807.8	-913.7	-14.0	47	3105.2	-921.6	40.3
				48	2674.1	-927.3	21.7
				49	2386.5	-929.5	10.2
				50	2380.1	-923.5	11.2
				51	1930.3	-928.5	-8.1
				52	1457.5	-958.6	-28.4
				53	807.0	-914.8	-14.5
				54	807.0	-914.8	-14.5
				55	610.2	-863.5	-17.3

Note:
See appendix F.3 for a detailed procedure on how to measure vehicle exterior crush profile

DATA SHEET NO.13 (CONTINUED)

VEHICLE INTRUSION MEASUREMENTS

Test Vehicle:	2011 Buick Lacrosse	NHTSA No:	RB0179
Test Program:	R&D 56mph, 15° angle, 35% offset	Test Date	9/21/2011

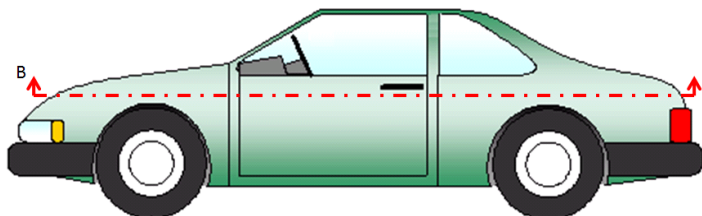

Reference point: Rear most center of the top of rear bumper beam
 +X – From the rear of the vehicle to the front of the vehicle
 +Y – From left side of the vehicle to the right side of the vehicle
 +Z – From the top of the vehicle to the bottom of the vehicle

VEHICLE EXTERIOR CRUSH PROFILE SECTION B-B

Pt.	Pre-Test			Pt.	Post-Test		
	X	Y	Z		X	Y	Z
1	1129.9	-922.3	-218.7	1	1127.8	-921.7	-219.4
2	1009.0	-913.0	-221.1	2	1006.2	-913.3	-219.9
3	707.6	-865.0	-211.5	3	708.1	-862.6	-227.6
4	409.6	-803.5	-210.1	4	412.6	-802.2	-233.5
5	275.5	-732.6	-204.6	5	303.2	-754.6	-237.2
6	211.9	-631.5	-211.4	6	248.6	-696.7	-235.4
7	145.5	-437.1	-212.3	7	170.4	-519.2	-236.4
8	126.7	-352.2	-217.3	8	129.6	-360.4	-232.3
9	132.3	-262.2	-211.3	9	136.9	-272.6	-232.2
10	127.7	3.2	-217.4	10	128.5	-0.1	-222.5
11	133.1	293.2	-217.0	11	132.6	253.3	-211.2
12	127.4	356.5	-218.0	12	126.7	348.4	-215.2
13	145.2	433.0	-215.0	13	240.6	693.2	-203.7
14	211.4	636.4	-202.3	14	346.7	784.0	-220.7
15	313.7	765.1	-213.7	15	459.9	820.6	-214.2
16	407.9	807.5	-217.0	16	701.5	868.5	-208.9
17	703.1	867.7	-211.8	17	1002.3	924.9	-199.1
18	1003.8	918.0	-217.1	18	1111.3	933.8	-196.4
19	1111.9	926.5	-220.0	19	1137.6	934.2	-186.8

Note:
See appendix F.3 for a detailed procedure on how to measure vehicle exterior crush profile

DATA SHEET NO.13 (CONTINUED)

VEHICLE INTRUSION MEASUREMENTS

Test Vehicle: 2011 Buick Lacrosse NHTSA No: RB0179
 Test Program: R&D 56mph, 15° angle, 35% offset Test Date: 9/21/2011

**VEHICLE EXTERIOR CRUSH PROFILE
SECTION B-B (Continued)**

Pt.	Pre-Test			Pt.	Post-Test		
	X	Y	Z		X	Y	Z
20	1135.6	928.6	-216.5	20	1268.7	934.4	-179.5
21	1303.8	922.0	-214.4	21	1414.0	919.8	-176.8
22	1608.8	907.6	-210.0	22	1610.8	910.7	-167.7
23	1913.1	908.3	-212.4	23	1914.9	910.1	-159.4
24	2214.8	907.5	-216.4	24	2218.7	909.0	-150.6
25	2521.7	907.3	-215.8	25	2445.8	910.1	-141.7
26	3131.5	900.8	-217.2	26	2846.0	912.9	-128.1
27	3435.3	893.3	-217.9	27	3384.2	901.8	-112.1
28	3735.5	898.3	-223.8	28	3766.3	937.4	-97.0
29	4041.3	893.9	-225.9	29	4178.3	929.2	-98.1
30	4131.8	879.6	-222.0	30	4213.8	924.9	-97.0
31	4163.3	874.2	-223.4	31	4365.4	854.7	-84.2
32	4344.4	832.7	-219.8	32	4514.9	820.9	-79.5
33	4511.5	775.4	-220.2	33	4376.8	752.8	-86.1
34	4577.3	735.6	-218.5	34	4611.0	686.5	-77.7
35	4631.4	671.4	-215.7	35	4637.6	602.1	-80.1
36	4729.4	506.1	-205.8	36	4618.8	560.2	-81.4
37	4768.4	415.8	-220.9	37	4645.0	484.5	-82.8
38	4849.3	145.8	-213.0	38	4620.0	427.6	-84.5
39	4859.1	-2.2	-223.3	39	4680.7	388.8	-84.5
40	4826.4	-243.1	-219.9	40	4671.2	343.1	-85.0
41	4772.4	-421.4	-219.0	41	4568.9	153.7	-90.9
42	4709.9	-549.5	-209.8	42	4423.2	-31.9	-103.2
43	4602.0	-705.2	-225.5	43	4271.1	-154.9	-110.1
44	4538.5	-759.8	-230.3	44	4277.8	-183.0	-107.8
45	4461.5	-794.9	-230.3	45	4239.7	-190.7	-110.2
46	4338.8	-834.8	-227.2	46	4250.1	-274.4	-110.1
47	4151.8	-880.5	-221.9	47	4308.8	-390.9	-105.0
48	3978.4	-905.6	-226.1	48	4240.1	-443.0	-115.5
49	3952.6	-904.5	-224.5	49	4160.6	-415.5	-115.6
50	3738.2	-899.1	-221.6	50	4082.0	-454.7	-121.5
51	3435.4	-893.4	-217.0	51	4025.1	-502.1	-122.8
52	3129.3	-899.8	-214.5	52	3990.8	-569.1	-130.6
53	2825.9	-903.6	-218.5	53	4051.1	-739.1	-127.9

Note:
See appendix F.3 for a detailed procedure on how to measure vehicle exterior crush profile

DATA SHEET NO.13 (CONTINUED)

VEHICLE INTRUSION MEASUREMENTS

Test Vehicle: 2011 Buick Lacrosse NHTSA No: RB0179
 Test Program: R&D 56mph, 15° angle, 35% offset Test Date: 9/21/2011

**VEHICLE EXTERIOR CRUSH PROFILE
SECTION B-B (Continued)**

Pt.	Pre-Test			Pt.	Post-Test		
	X	Y	Z		X	Y	Z
54	2523.6	-906.3	-218.5	54	4022.8	-926.7	-134.6
55	2218.6	-906.0	-216.7	55	3631.9	-914.3	-143.9
56	1915.5	-905.9	-208.6	56	3552.2	-847.0	-152.0
57	1611.0	-905.2	-208.6	57	3482.2	-931.1	-150.5
58	1304.9	-919.6	-217.9	58	3467.0	-948.2	-154.7
59	1150.4	-926.1	-220.6	59	3463.1	-919.3	-153.7
60	1129.9	-922.3	-218.7	60	3194.3	-925.1	-163.8
				61	2801.8	-931.8	-176.0
				62	2503.1	-936.0	-189.2
				63	2387.0	-933.8	-197.7
				64	2379.3	-929.4	-191.2
				65	2216.5	-931.2	-202.6
				66	1867.5	-934.2	-215.3
				67	1607.9	-936.0	-224.4
				68	1304.5	-952.4	-236.9
				69	1150.9	-958.9	-245.7
				70	1127.8	-921.7	-219.4

Note:
See appendix F.3 for a detailed procedure on how to measure vehicle exterior crush profile

DATA SHEET NO.13 (CONTINUED)

VEHICLE INTRUSION MEASUREMENTS

Test Vehicle: 2011 Buick Lacrosse NHTSA No: RB0179
Test Program: R&D 56mph, 15° angle, 35% offset Test Date: 9/21/2011

SECTION A-A

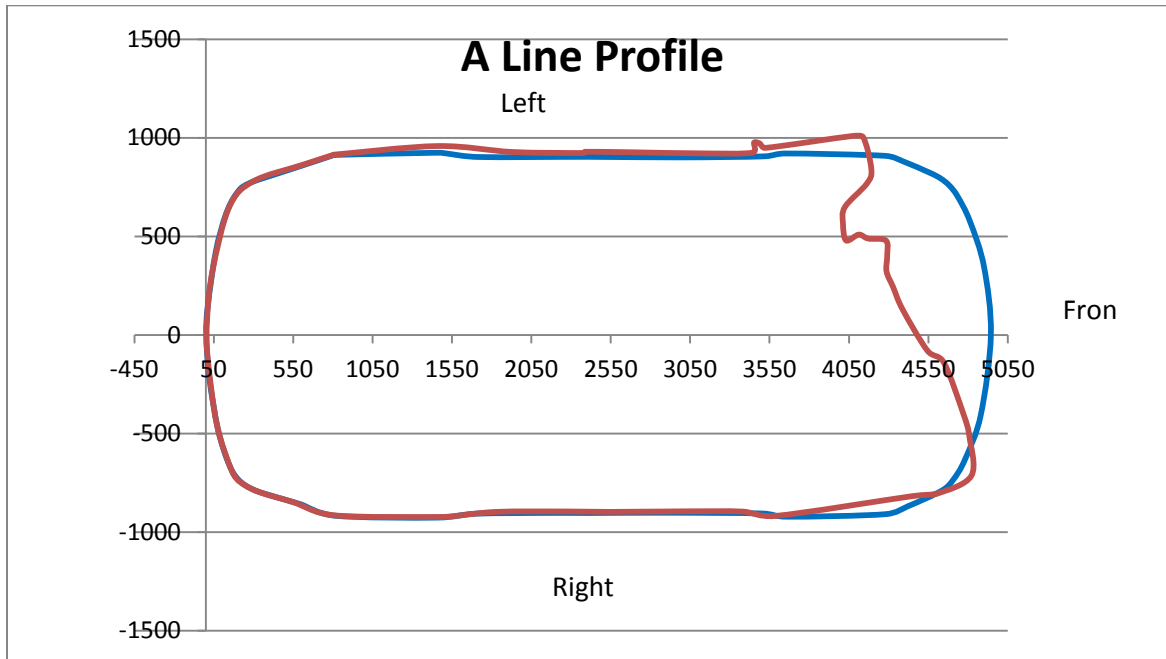

SECTION B-B

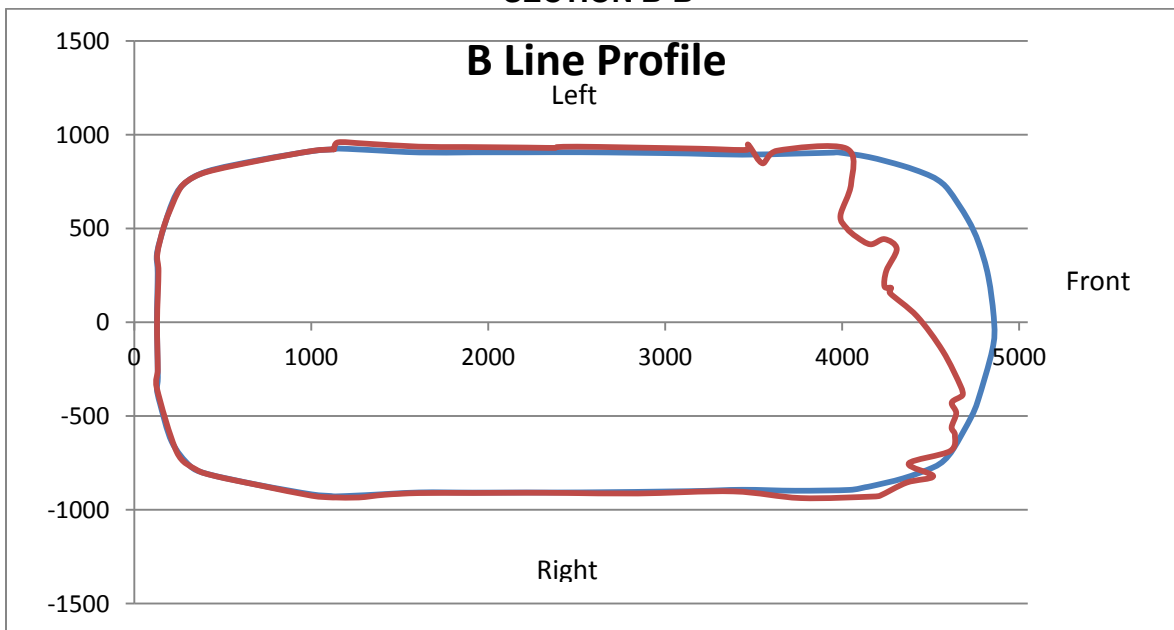

DATA SHEET NO.13 (CONTINUED)

VEHICLE INTRUSION MEASUREMENTS

Test Vehicle:	2011 Buick Lacrosse	NHTSA No:	RB0179
Test Program:	R&D 56mph, 15° angle, 35% offset	Test Date	9/21/2011

Left Profile of the Dash



Points	Pre-Test (mm)			Post-Test (mm)			Difference (mm)		
	X	Y	Z	X	Y	Z	X	Y	Z
LB3	3257.3	-494.1	-53.6	3243.0	-533.1	-33.3	-14.3	-39.0	20.2
LB2	3226.0	-495.9	-89.1	3211.2	-530.6	-74.9	-14.8	-34.7	14.2
LB1	3194.5	-496.9	-128.8	3183.5	-527.9	-114.2	-10.9	-31.0	14.6
DIPL	3163.4	-498.6	-172.5	3154.5	-527.2	-157.8	-8.9	-28.6	14.8
LT1	3137.7	-500.0	-215.0	3146.1	-529.8	-207.9	8.5	-29.8	7.1
LT2	3145.5	-498.7	-263.1	3140.4	-523.7	-254.7	-5.1	-25.0	8.4
LT3	3182.6	-498.0	-301.8	3170.9	-522.4	-299.4	-11.8	-24.5	2.3
LT4	3216.4	-498.6	-334.1	3200.3	-521.9	-337.5	-16.1	-23.4	-3.4
LT5	3229.7	-497.4	-386.7	3202.8	-519.1	-391.8	-26.9	-21.7	-5.2
LT6	3229.5	-498.7	-429.1	3199.5	-518.1	-436.8	-30.0	-19.4	-7.7

Reference point: Rear most center of the top of rear bumper beam
 +X – From the rear of the vehicle to the front of the vehicle
 +Y – From left side of the vehicle to the right side of the vehicle
 +Z – From the top of the vehicle to the bottom of the vehicle

Note:
 See Appendix F.4 for a detailed procedure on how to measure the required profile dash.

SHEET NO.13 (CONTINUED)

VEHICLE INTRUSION MEASUREMENTS

Test Vehicle:	<u>2011 Buick Lacrosse</u>	NHTSA No:	<u>RB0179</u>
Test Program:	<u>R&D 56mph, 15° angle, 35% offset</u>	Test Date	<u>9/21/2011</u>

Right Profile of the Dash



Points	Pre-Test (mm)			Post-Test (mm)			Difference (mm)		
	X	Y	Z	X	Y	Z	X	Y	Z
RB3	3258.2	-194.1	-43.3	3277.7	-231.8	-32.6	19.5	-37.7	10.7
RB2	3226.4	-194.2	-81.2	3242.8	-228.6	-68.7	16.4	-34.4	12.5
RB1	3195.1	-194.6	-121.8	3208.9	-225.6	-106.6	13.8	-31.0	15.2
DIPR	3167.0	-195.3	-162.1	3177.2	-224.2	-145.8	10.2	-28.9	16.3
RT1	3139.8	-194.3	-206.6	3160.9	-217.0	-202.0	21.1	-22.7	4.7
RT2	3144.9	-197.4	-255.0	3163.7	-218.5	-249.4	18.8	-21.1	5.6
RT3	3174.7	-195.8	-296.0	3188.2	-218.3	-293.6	13.5	-22.5	2.4
RT4	3209.0	-195.7	-331.2	3219.7	-219.6	-334.3	10.8	-23.9	-3.1
RT5	3227.9	-195.6	-378.0	3231.8	-216.8	-378.9	3.9	-21.2	-0.9
RT6	3215.5	-194.1	-415.9	3217.9	-213.0	-418.0	2.3	-18.9	-2.1

Reference point: Rear most center of the top of rear bumper beam
 +X – From the rear of the vehicle to the front of the vehicle
 +Y – From left side of the vehicle to the right side of the vehicle
 +Z – From the top of the vehicle to the bottom of the vehicle

Note:
 See Appendix F.4 for a detailed procedure on how to measure the required profile dash.

DATA SHEET NO.13 (CONTINUED)

VEHICLE INTRUSION MEASUREMENTS

Test Vehicle: 2011 Buick Lacrosse NHTSA No: RB0179
 Test Program: R&D 56mph, 15° angle, 35% offset Test Date: 9/21/2011

	Points	Pre-Test (mm)			Post-Test (mm)			Difference (mm)		
		X	Y	Z	X	Y	Z	X	Y	Z
Lower Bumper Beam	1	4738.8	-627.2	112.3	4343.1	-465.1	19.0	-396	162	-93
	2	4825.3	-385.5	114.2	4341.8	-269.1	23.8	-483	116	-90
	3	4863.4	-131.3	113.2	4490.6	-72.8	38.2	-373	58	-75
	4	4864.9	124.9	112.5	4637.5	135.9	62.2	-227	11	-50
	5	4828.3	380.2	110.9	4752.8	366.4	88.9	-75	-14	-22
	6	4741.1	623.6	112.1	4818.7	613.3	124.3	78	-10	12
Upper Bumper Beam	1	4737.8	-627.5	44.5	4340.7	-458.6	-47.6	-397	169	-92
	2	4825.0	-385.9	44.6	4345.7	-257.3	-43.8	-479	129	-88
	3	4863.6	-131.6	44.6	4486.4	-63.4	-28.4	-377	68	-73
	4	4864.8	125.2	43.7	4634.5	146.5	-3.0	-230	21	-47
	5	4827.8	380.8	43.9	4749.4	375.5	23.7	-78	-5	-20
	6	4739.8	623.6	43.5	4814.1	624.6	56.3	74	1	13
Upper Radiator Support	1	4604.4	-458.0	-210.0	4058.3	-262.7	-193.6	-546	195	16
	2	4629.2	-277.9	-210.9	4136.6	-81.0	-166.0	-493	197	45
	3	4635.8	-96.6	-210.9	4240.7	67.2	-188.2	-395	164	23
	4	4634.8	84.9	-210.6	4354.3	208.1	-183.6	-280	123	27
	5	4634.4	266.8	-209.3	4467.6	346.3	-143.3	-167	79	66
	6	4606.1	454.4	-207.9	4514.7	505.1	-98.5	-91	51	109

*Points unrecoverable, support beam was destroyed in crash

Reference point: Rear most center of the top of rear bumper beam

+X – From the rear of the vehicle to the front of the vehicle

+Y – From left side of the vehicle to the right side of the vehicle

+Z – From the top of the vehicle to the bottom of the vehicle

DATA SHEET NO.13 (CONTINUED)

VEHICLE INTRUSION MEASUREMENTS

Test Vehicle:	2011 Buick Lacrosse	NHTSA No:	RB0179
Test Program:	R&D 56mph, 15° angle, 35% offset	Test Date	9/21/2011

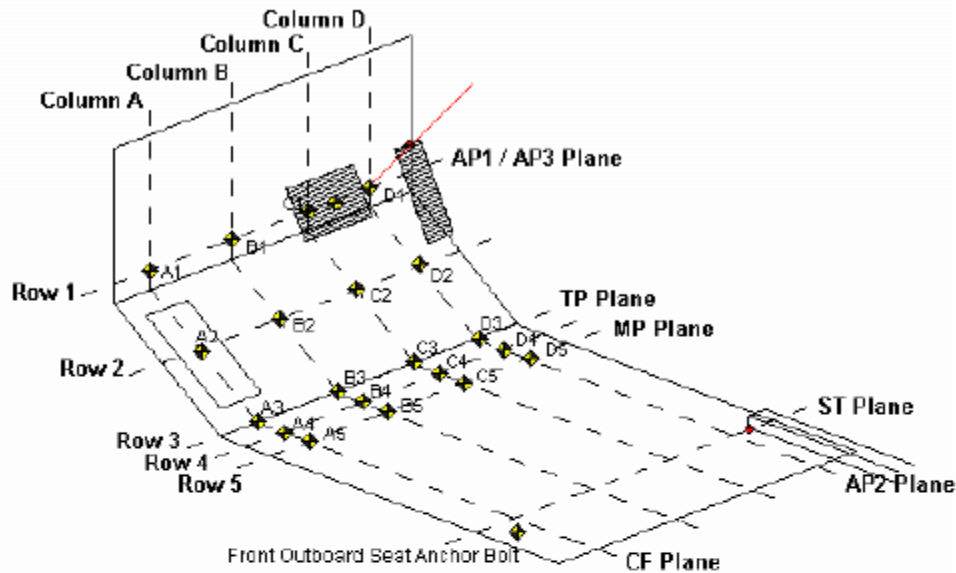

AP1: Y-Z Plane passing through D1

AP2: X-Z Plane passing through D1

AP3: X-Y plane passing through D1

MP: Y-Z plane, halfway between the ST plane and AP1 plane

CF Plane: X-Z plane passes through center of footrest.

BP Plane: X-Z plane passes through center of brake pedal

TP Plane: Y-Z plane, intersection of BP Plane and the intersection of the toe pan and floorboard

Column A: intersection of vehicle and CF plane

Column D: Intersection of vehicle and AP2 plane

Row 1: intersection of the vehicle and the AP3 Plane

Row 3: intersection of the vehicle and TP plane

Row 5: intersection of the vehicle and MP plane

Row 2: evenly spaced between row 1 and 3

Row 4: evenly spaced between row 3 and 5

DATA SHEET NO.13 (CONTINUED)

VEHICLE INTRUSION MEASUREMENTS

Test Vehicle: 2011 Buick Lacrosse NHTSA No: RB0179
 Test Program: R&D 56mph, 15° angle, 35% offset Test Date: 9/21/2011

Intrusion Location	Pre-Test (mm)			Post-Test (mm)			Difference (mm)		
	X	Y	Z	X	Y	Z	X	Y	Z
A1	3594.8	-568.0	168.0	3531.0	-538.9	160.4	-63.8	29.1	-7.6
B1	3671.1	-441.5	174.7	3572.1	-396.8	109.0	-98.9	44.7	-65.7
C1	3693.4	-301.1	173.0	3630.3	-280.5	160.1	-63.0	20.6	-12.8
D1	3676.3	-178.3	175.5	3616.7	-162.9	175.8	-59.5	15.4	0.3
A2	3567.0	-573.7	268.9	3530.9	-550.3	269.0	-36.1	23.3	0.1
B2	3560.7	-448.4	269.6	3537.3	-433.2	246.6	-23.4	15.1	-23.0
C2	3562.5	-315.9	272.2	3534.3	-302.8	292.6	-28.2	13.1	20.4
D2	3583.6	-185.9	276.0	3548.5	-175.8	274.1	-35.1	10.1	-1.9
A3	3474.1	-577.7	323.7	3471.4	-567.4	333.1	-2.7	10.2	9.4
B3	3467.2	-446.9	317.7	3459.6	-440.6	313.1	-7.6	6.3	-4.6
C3	3474.1	-320.1	327.9	3467.0	-312.0	355.4	-7.2	8.2	27.5
D3	3476.5	-187.4	332.7	3467.1	-183.4	358.4	-9.4	4.0	25.7
A4	3371.7	-581.4	333.5	3367.1	-574.4	344.9	-4.6	7.0	11.3
B4	3367.9	-452.1	323.0	3367.0	-444.6	333.6	-0.9	7.5	10.6
C4	3364.1	-325.1	324.1	3358.5	-317.6	347.6	-5.6	7.5	23.5
D4	3376.9	-200.8	343.4	3368.9	-188.2	366.8	-8.1	12.6	23.4
A5	3266.4	-588.3	329.8	3260.6	-582.2	339.8	-5.8	6.0	10.0
B5	3273.9	-455.4	320.8	3267.9	-446.4	336.6	-6.0	9.0	15.8
C5	3273.6	-330.2	325.9	3266.2	-321.5	345.7	-7.4	8.7	19.8
D5	3272.7	-197.4	342.0	3266.6	-191.0	364.9	-6.1	6.4	22.9
Brake Pedal	3480.0	-333.8	133.3	3447.7	-331.2	144.2	-32.4	2.5	10.9
IP Left	3163.4	-498.6	-172.5	3154.5	-527.2	-157.8	-8.9	-28.6	14.8
IP Right	3167.0	-195.3	-162.1	3177.2	-224.2	-145.8	10.2	-28.9	16.3
Steering Column	2984.3	-368.0	-342.9	2975.4	-364.4	-351.1	-8.8	3.5	-8.2
Front Outboard Bolt	2901.3	-593.6	210.4	2964.5	-580.6	262.6	63.2	13.0	52.3

Reference point: Rear most center of the top of rear bumper beam
 +X – From the rear of the vehicle to the front of the vehicle
 +Y – From left side of the vehicle to the right side of the vehicle
 +Z – From the top of the vehicle to the bottom of the vehicle

DATA SHEET NO.14

MDB CRUSH MEASUREMENTS

Test Vehicle: 2011 Buick Lacrosse NHTSA No: RB0179
 Test Program: R&D 56mph, 15° angle, 35% offset Test Date: 9/21/2011

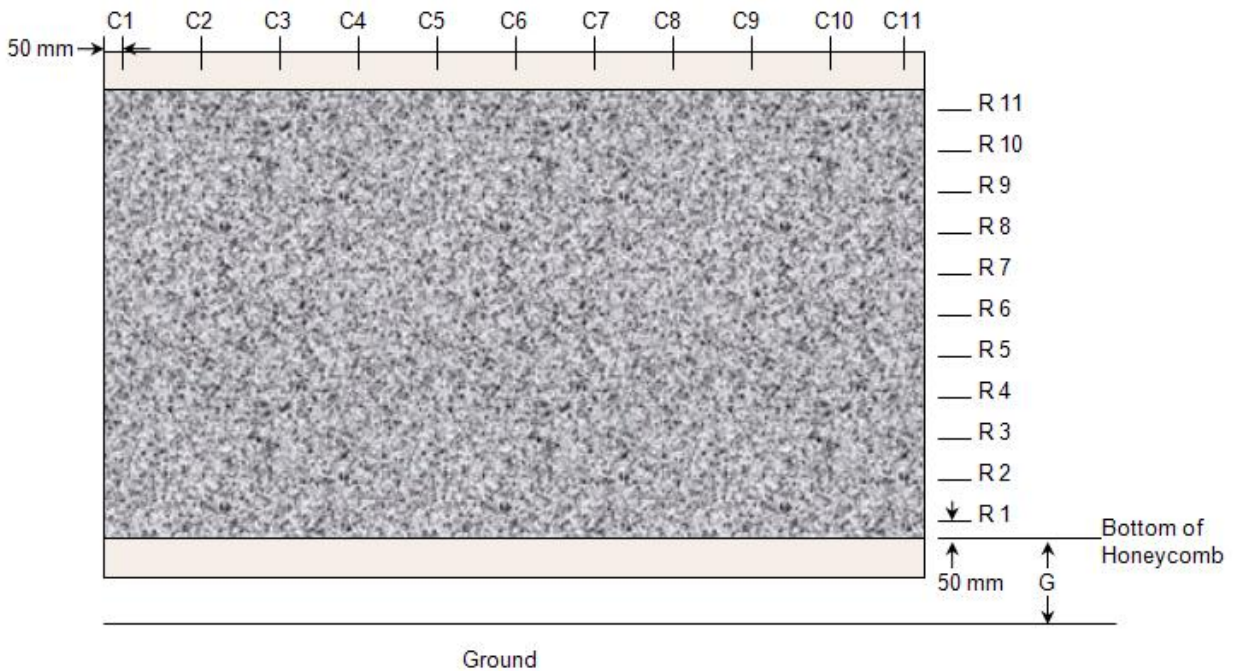

BARRIER X-CRUSH

		C1	C2	C3	C4	C5	C6	C7	C8	C9	C10	C11
		50 mm	260 mm	470 mm	680 mm	890 mm	1100 mm	1310 mm	1520 mm	1730 mm	1940 mm	2150 mm
R11	910mm	-3.3	-0.5	1.1	1.1	2.4	3.1	3.5	4.6	13.6	5.5	13.8
R10	824mm	-3.6	-3.0	-1.9	-1.3	-0.5	0.4	1.3	8.9	14.4	9.3	35.3
R9	738mm	-3.5	-3.4	-2.4	-1.8	-1.2	-0.1	5.5	42.4	31.7	21.2	61.7
R8	652mm	-3.7	-3.6	-2.8	-1.9	-1.5	-0.6	10.2	57.7	38.9	38.5	89.9
R7	566mm	-4.0	-3.6	-3.0	-2.3	-1.6	-0.8	4.4	30.5	45.3	86.7	122.4
R6	480mm	-4.2	-4.1	-3.2	-2.4	-1.7	-0.9	-0.2	25.1	97.0	144.5	171.8
R5	384mm	-4.3	-3.9	-3.1	-2.2	-1.8	-1.0	8.0	35.7	127.2	225.7	211.9
R4	308mm	-4.7	-4.2	-3.6	-2.6	-1.7	-1.2	23.9	49.4	107.5	257.6	227.4
R3	222mm	-5.1	-4.2	-3.5	-2.6	-1.9	-1.2	39.4	62.6	81.1	234.2	215.9
R2	136mm	-5.4	-4.2	-3.3	-2.1	-1.6	-0.9	49.0	72.6	56.8	233.7	242.2
R1	50mm	-5.1	-3.8	-2.4	-1.9	*	*	52.1	86.9	42.7	188.4	242.8

*Barrier was cut to clear rail and defined points were unmeasurable

DATA SHEET NO. 15

SUMMARY OF FMVSS 212, 219 (PARTIAL), AND 301 DATA

Test Vehicle: 2011 Buick Lacrosse NHTSA No: RB0179
 Test Program: R&D 56mph, 15° angle, 35% offset Test Date: 9/21/2011

Please provide windshield mounting details.

The standard requires that the post-test retention measurement be a minimum of 75% of the pre-test total periphery measurement for vehicles not equipped with occupant passive restraints and 50% for each side of the windshield for vehicles which are equipped with occupant passive restraints.

Temperature of windshield molding during test: 25.5°C

WINDSHIELD PERIPHERY MEASUREMENTS

Measurement	Pre-Test (mm)	Post-Test (mm)	% Retention
Left Side	2115	1556	73.6
Right Side	2115	2115	100
Total	4230	3671	86.8

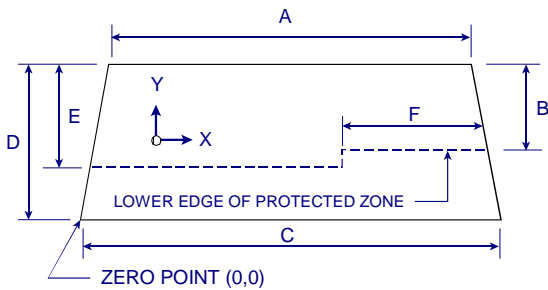

Item	Units	Value
A	mm	1210
B	mm	501
C	mm	1460
D	mm	780
E	mm	499
F	mm	490

AREAS OF PROTECTED ZONE FAILURES

A. Provide coordinates of the area that the protected zone was penetrated more than .25 inches by a vehicle component other than one that is normally in contact with the windshield.

X	Y

B. Provide coordinates of the area beneath the protected zone that the inner surface of the windshield was penetrated by a vehicle component.

- Area was opened up by the hood hinge assembly

X	Y
1410	0

DATA SHEET NO. 15 (CONTINUED)

SUMMARY OF FMVSS 212, 219 (PARTIAL), AND 301 DATA

Test Vehicle:	<u>2011 Buick Lacrosse</u>	NHTSA No:	<u>RB0179</u>
Test Program:	<u>R&D 56mph, 15° angle, 35% offset</u>	Test Date	<u>9/21/2011</u>

FMVSS 301 FUEL SYSTEM INTEGRITY POST IMPACT DATA

Temperature at Time of Impact: 22.2°C

Test Time: 5:00 PM

Stoddard Solvent Spillage Measurements

- | | | |
|----|---|---------------|
| A. | From impact until vehicle motion ceases:
(maximum allowable = 1 oz.) | <u>0</u> oz. |
| B. | For the 5-minute period after motion ceases:
(maximum allowable = 5 oz.) | <u>0</u> oz. |
| C. | For the following 25 minutes:
(maximum allowable = 1 oz./minute) | <u>0</u> oz.. |
| D. | Spillage: | <u>0</u> oz. |

DATA SHEET NO. 16

FMVSS 301 STATIC ROLLOVER RESULTS

Test Vehicle: 2011 Buick Lacrosse NHTSA No: RB0179
 Test Program: R&D 56mph, 15° angle, 35% offset Test Date: 9/21/2011

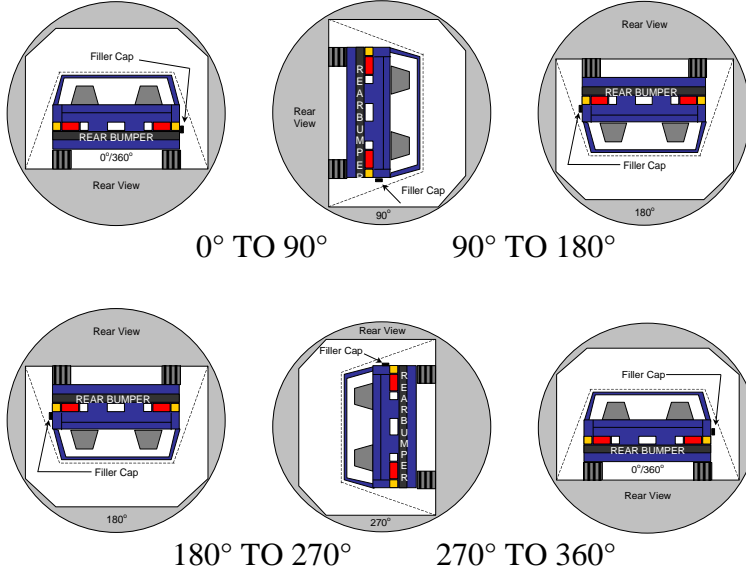

1. The specified fixture rollover rate for each 90° of rotation is 60 to 180 seconds.
2. The position hold time at each position is 300 seconds (minimum).
 - Details of Stoddard Solvent spillage: None

SOLVENT COLLECTION TIME TABLE IN SECONDS

Test Phase	Rotation Time	Hold Time	Total Time
0° to 90°	73	300	373
90° to 180°	61	300	361
180° to 270°	66	300	366
270° to 360°	66	300	366

FMVSS 301 SPILLAGE TABLE

Test Phase	First 5 Minutes	Sixth Minute	Seventh Minute	Eighth Minute
0° to 90°	0	0		
90° to 180°	0	0		
180° to 270°	0	0		
270° to 360°	0	0		

SOLVENT SPILLAGE LOCATION TABLE

Test Phase	Spillage Location
0° to 90°	
90° to 180°	
180° to 270°	
270° to 360°	

DATA SHEET NO. 17

DUMMY/VEHICLE TEMPERATURE STABILIZATION

Test Vehicle: 2011 Buick Lacrosse NHTSA No: RB0179
Test Program: R&D 56mph, 15° angle, 35% offset Test Date: 9/21/2011

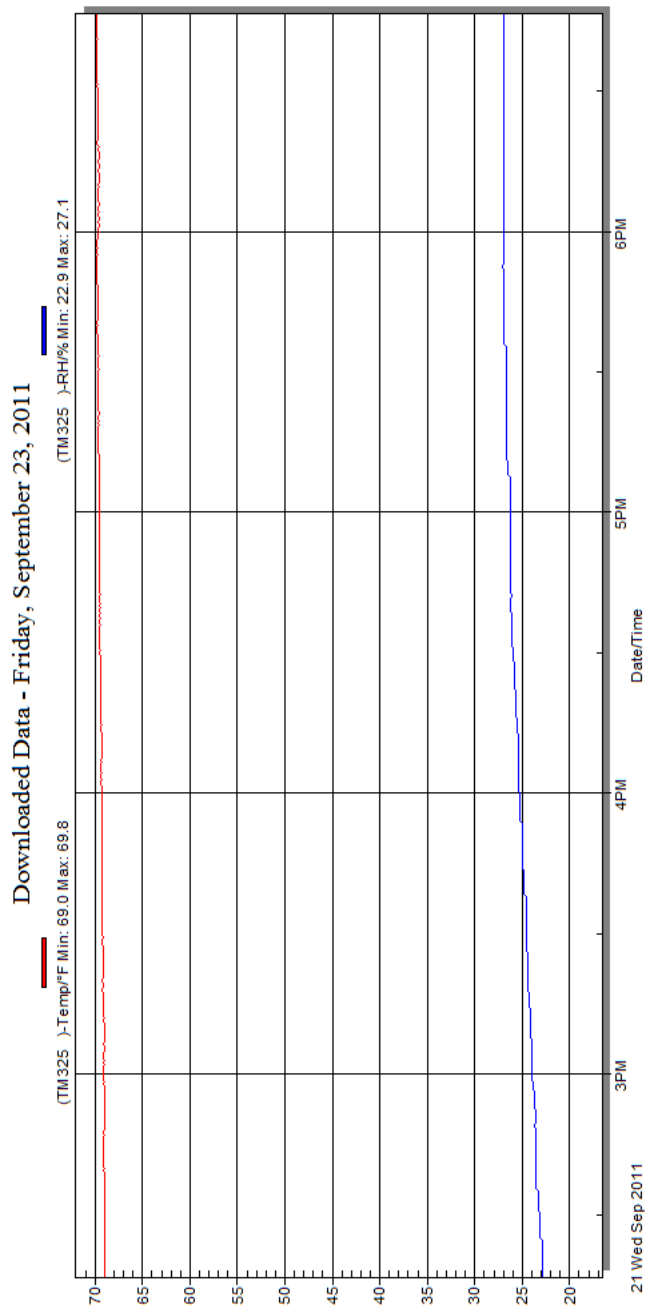

APPENDIX A
PHOTOGRAPHS

TABLE OF PHOTOGRAPHS		
No.		Page
1	As Delivered Right Front 3-4 View of Test Vehicle	A-7
2	As Delivered Left Rear 3-4 View of Test Vehicle	A-7
3	Test Vehicle Certification Label	A-8
4	Test Vehicle Tire Placard	A-8
5	Pre-Test Front View of Test Vehicle	A-9
6	Post-Test Front View of Test Vehicle	A-9
7	Pre-Test Left Front 3-4 View of Test Vehicle	A-10
8	Post-Test Left Front 3-4 View of Test Vehicle	A-10
9	Pre-Test Left Side View of Test Vehicle	A-11
10	Post-Test Left Side View of Test Vehicle	A-11
11	Pre-Test Left Rear 3-4 View of Test Vehicle	A-12
12	Post-Test Left Rear 3-4 View of Test Vehicle	A-12
13	Pre-Test Rear View of Test Vehicle	A-13
14	Post-Test Rear View of Test Vehicle	A-13
15	Pre-Test Right Side View of Test Vehicle	A-14
16	Post-Test Right Side View of Test Vehicle	A-14
17	Pre-Test Right Front 3-4 View of Test Vehicle	A-15
18	Post-Test Right Front 3-4 View of Test Vehicle	A-15
19	Pre-Test Overhead View of RMDB against target vehicle at ideal Impact Point	A-16
20	Pre-Test Left Side View of RMDB against target vehicle at ideal Impact Point	A-16
21	Pre-Test Right Side View of RMDB against target vehicle at ideal Impact Point	A-17
22	Pre-Test Close-up View of Impact Point	A-18
23	Post-Test Close-up View of Impact Point	A-18
24	Pre-Test Close-up View of Left Front Door Latch	A-19
25	Post-Test Close-up View of Left Front Door Latch	A-19
26	Pre-Test Close-up View of Left Rear Door Latch	A-20
27	Post-Test Close-up View of Left Rear Door Latch	A-20
28	Pre-Test Windshield View	A-21
29	Post-Test Windshield View	A-21

30	Pre-Test View of Driver Inner Door Panel	A-22
31	Post-Test View of Driver Inner Door Panel	A-22
32	Pre-Test View of Passenger Inner Door Panel	A-23
33	Post-Test View of Passenger Inner Door Panel	A-23
34	Pre-Test Frontal View of Driver Seat pan	A-24
35	Pre-Test Frontal View of Driver Seat back	A-24
36	Pre-Test Frontal View of Left Rear Seat pan	A-25
37	Pre-Test Frontal View of Left Rear Seat back	A-25
38	Pre-Test Overall View of Driver Knee Bolsters	A-26
39	Post-Test Overall View of Driver Knee Bolsters	A-26
40	Pre-Test Overall View of Driver Knee Bolsters with panel removed	A-27
41	Post-Test Overall View of Driver Knee Bolsters with panel removed	A-27
42	Pre-Test Left Side View of Driver Knee Bolsters	A-28
43	Post-Test Left Side View of Driver Knee Bolsters	A-28
44	Pre-Test Left Side View of Driver Knee Bolsters with panel removed	A-29
45	Post-Test Left Side View of Driver Knee Bolsters with panel removed	A-29
46	Pre-Test Right Side View of Driver Knee Bolsters	A-30
47	Post-Test Right Side View of Driver Knee Bolsters	A-30
48	Pre-Test Right Side View of Driver Knee Bolster with panel removed	A-31
49	Post-Test Right Side View of Driver Knee Bolster with panel removed	A-31
50	Pre-Test View of Driver Floor pan at Left sill level	A-32
51	Post-Test View of Driver Floor pan at Left sill level	A-32
52	Pre-Test View of Driver Floor pan at Mid seat level	A-33
53	Post-Test view of Driver Floor pan at Mid seat level	A-33
54	Pre-Test Driver Dummy Front Windshield View	A-34
55	Post-Test Driver Dummy Front Windshield View	A-34
56	Pre-Test Left Side View of Driver Dummy and Interior	A-35
57	Post-Test Left Side View of Driver Dummy and Interior	A-35
58	Pre-Test Left Side Driver Dummy Window View	A-36
59	Post-Test Left Side Driver Dummy Window View	A-36
60	Pre-Test Right Side View of Driver Dummy and Interior	A-37
61	Post-Test Right Side View of Driver Dummy and Interior	A-37

62	Pre-Test View of Driver Dummy Door Clearance	A-38
63	Post-Test View of Driver Dummy Door Clearance	A-38
64	Pre-Test Driver Seat Back Position markings	A-39
65	Pre-Test Driver Seat Back Position with Level or Inclinator	A-39
66	Pre-Test Driver Seat Fore Aft Markings	A-40
67	Post-Test Driver Seat Fore Aft Markings	A-40
68	Pre-Test Driver Adjustable D-ring	A-41
69	Pre-Test Overhead View of Driver Dummy Thighs in seat	A-41
70	Pre-Test View of Parking Brake	A-42
71	Pre-Test Driver Dummy Feet	A-43
72	Post-Test Driver Dummy Feet	A-43
73	Pre-Test View of Driver Dummy Right Knee and Bolster	A-44
74	Post-Test View of Driver Dummy Right Knee and Bolster	A-44
75	Pre-Test View of Driver Dummy Left Knee and Bolster	A-45
76	Post-Test View of Driver Dummy Left Knee and Bolster	A-45
77	Pre-Test View of Driver Dummy Abdomen	A-46
78	Post-Test View of Driver Dummy Abdomen	A-46
79	Pre-Test Left Side View of Steering Wheel set position	A-47
80	Post-Test Left Side View of Steering Wheel set position	A-47
81	Post-Test View of Driver Dummy Head Contact with Airbag	A-48
82	Post-Test View of Driver Dummy Head Contact with Vehicle Interior (a, b, c, etc)	A-48
83	Pre-Test Passenger Dummy Front Close-up View	A-49
84	Post-Test Passenger Dummy Front Close-up View	A-49
85	Pre-Test Left Side Passenger Dummy and Interior View	A-50
86	Post-Test Left Side Passenger Dummy and Interior View	A-50
87	Pre-Test Left Side Passenger Dummy Window View	A-51
88	Post-Test Left Side Passenger Dummy Window View	A-51
89	Pre-Test Right Side View of Passenger Dummy and Interior	A-52
90	Post-Test Right Side View of Passenger Dummy and Interior	A-52
91	Pre-Test View of Passenger Dummy Door Clearance	A-53
92	Post-Test View of Passenger Dummy Door Clearance	A-53

93	Pre-Test Passenger View Showing Head Level	A-54
94	Pre-Test Passenger Seat Fore-Aft Markings	A-54
95	Pre-Test Passenger Seat Back Angle	A-55
96	Pre-Test Overhead View of Passenger Dummy Thighs on seat	A-55
97	Pre-Test Passenger Adjustable D-ring	A-56
98	Pre-Test View of Passenger Dummy Feet	A-57
99	Post-Test View of Passenger Dummy Feet	A-57
100	Post-Test View of Passenger Dummy Head contact with Airbag	A-58
101	Post-Test View of Passenger Dummy Head contact with Interior (a,b,c)	A-58
102	Post-Test View of Passenger Dummy Knee Contact with Seatback	A-59
103	Pre-Test Ballast Locations	A-59
104	Post-Test Speed Trap Readout	A-60
105	Pre-Test View of Fuel Filler Cap	A-61
106	Post-Test View of Fuel Filler Cap	A-61
107	Pre-Test Engine Compartment View	A-62
108	Post-Test Engine Compartment View	A-62
109	Pre-Test View of Front Underbody (perpendicular to vehicle)	A-63
110	Post-Test View of Front Underbody (perpendicular to vehicle)	A-63
111	Pre-Test View of Overall Underbody (perpendicular to vehicle)	A-64
112	Post-Test View of Overall Underbody (perpendicular to vehicle)	A-64
113	Pre-Test View of Steering rack and or sway bar	A-65
114	Post-Test View of Steering rack and or sway bar	A-65
115	Pre-Test Close up of Bumper and Crush Initiators	A-66
116	Post-Test View of Front Sub-Frame Deformation	A-66
117	Pre-Test Frame Rail with tire removed	A-67
118	Post-Test Frame Rail with tire removed	A-67
119	Pre-Test View of Wheel Well with tire removed	A-68
120	Post-Test View of Wheel Well with tire removed	A-68
121	Post-Test View of Door Sill with door open	A-69
122	Post-Test View of Deformation of A pillar	A-69
123	Post-Test View of Deformation of B pillar	A-70
124	Post-Test View of Deformation of C pillar	A-70

125	Post-Test View of Wheel and or Tire Deformation	A-71
126	Post-Test View of Deformation of Rocker or Post	A-71
127	Post-Test View of Windshield Separation	A-72
128	Pre-Test Left Side View of RMDB	A-73
129	Post-Test Left Side View of RMDB	A-73
130	Pre-Test Right Side View of RMDB	A-74
131	Post-Test Right Side View of RMDB	A-74
132	Pre-Test Top View of RMDB	A-75
133	Post-Test Top View of RMDB	A-75
134	Pre-Test Front View of RMDB	A-76
135	Post-Test Front View of RMDB	A-76
136	Vehicle at 0 Degrees on Static Rollover Device	A-77
137	Vehicle at 90 Degrees on Static Rollover Device	A-77
138	Vehicle at 180 Degrees on Static Rollover Device	A-78
139	Vehicle at 270 Degrees on Static Rollover Device	A-78
140	Vehicle at 360 Degrees on Static Rollover Device	A-79



No. 001 As Delivered Right Front 3-4 View of Test Vehicle



No. 002 As Delivered Left Rear 3-4 View of Test Vehicle

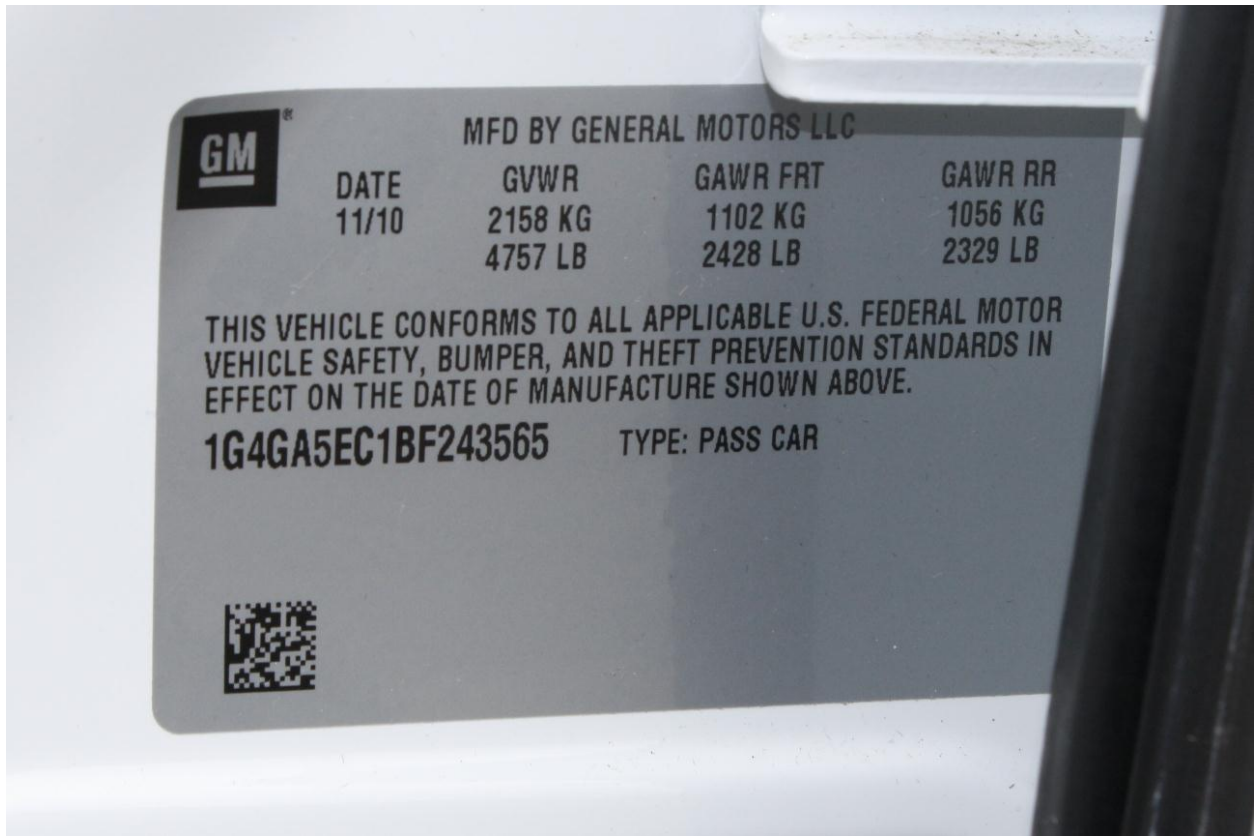

No. 003 Test Vehicle Certification Label

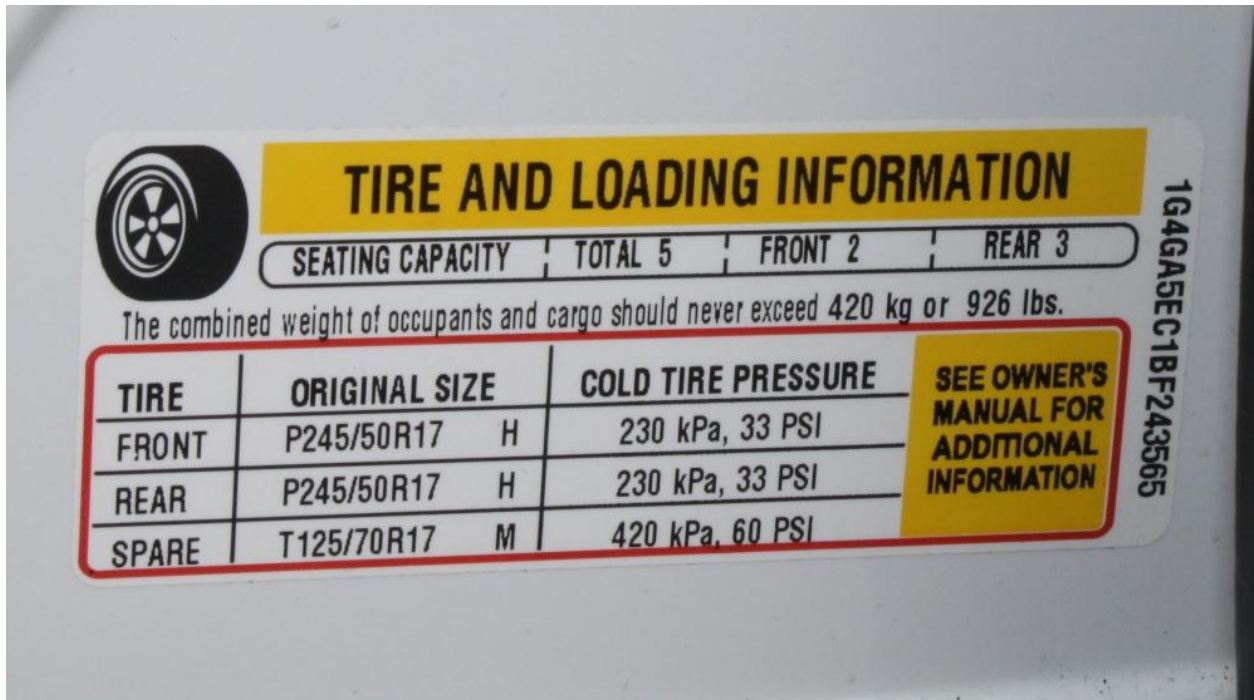

No. 004 Test Vehicle Tire Placard



No. 005 Pre-Test Front View of Test Vehicle



No. 006 Post-Test Front View of Test Vehicle



No. 007 Pre-Test Left Front 3-4 View of Test Vehicle



No. 008 Post-Test Left Front 3-4 View of Test Vehicle



No. 009 Pre-Test Left Side View of Test Vehicle



No. 010 Post-Test Left Side View of Test Vehicle



No. 011 Pre-Test Left Rear 3-4 View of Test Vehicle



No. 012 Post-Test Left Rear 3-4 View of Test Vehicle



No. 013 Pre-Test Rear View of Test Vehicle



No. 014 Post-Test Rear View of Test Vehicle

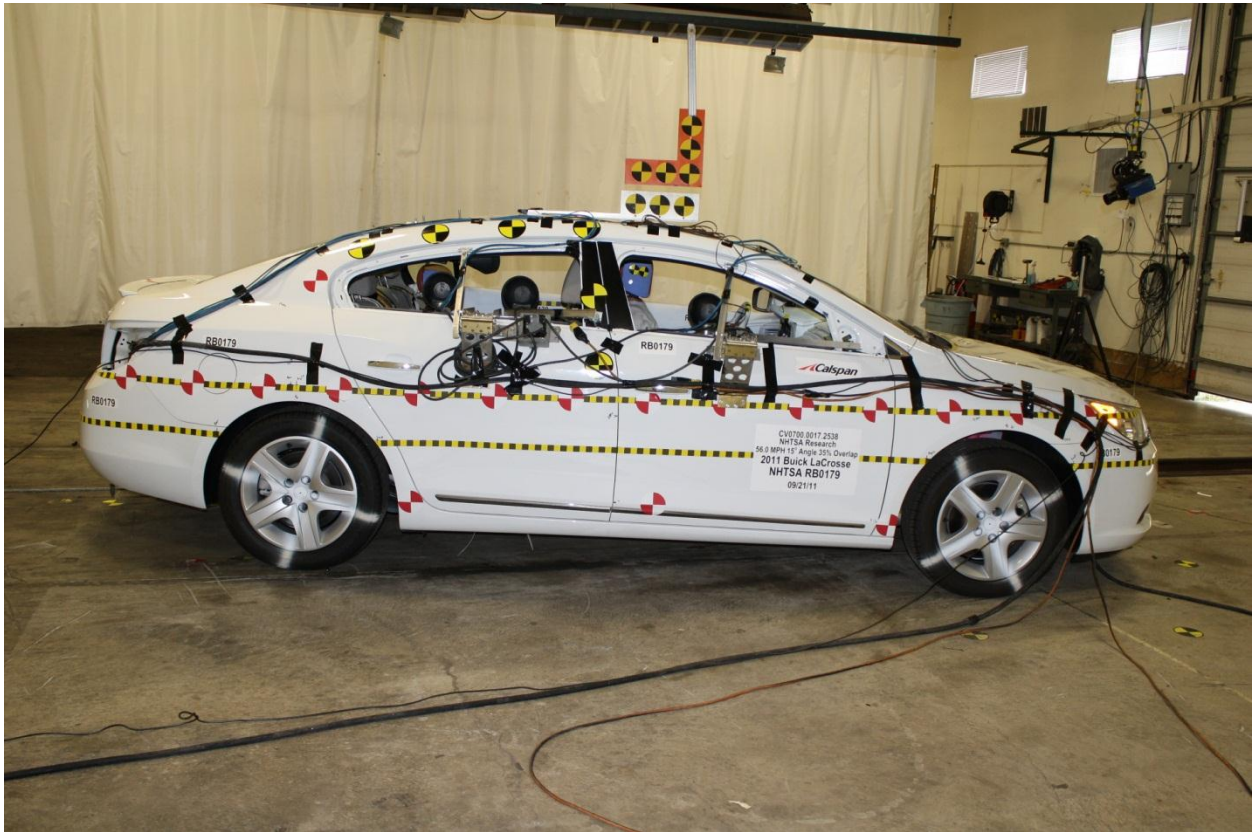

No. 015 Pre-Test Right Side View of Test Vehicle

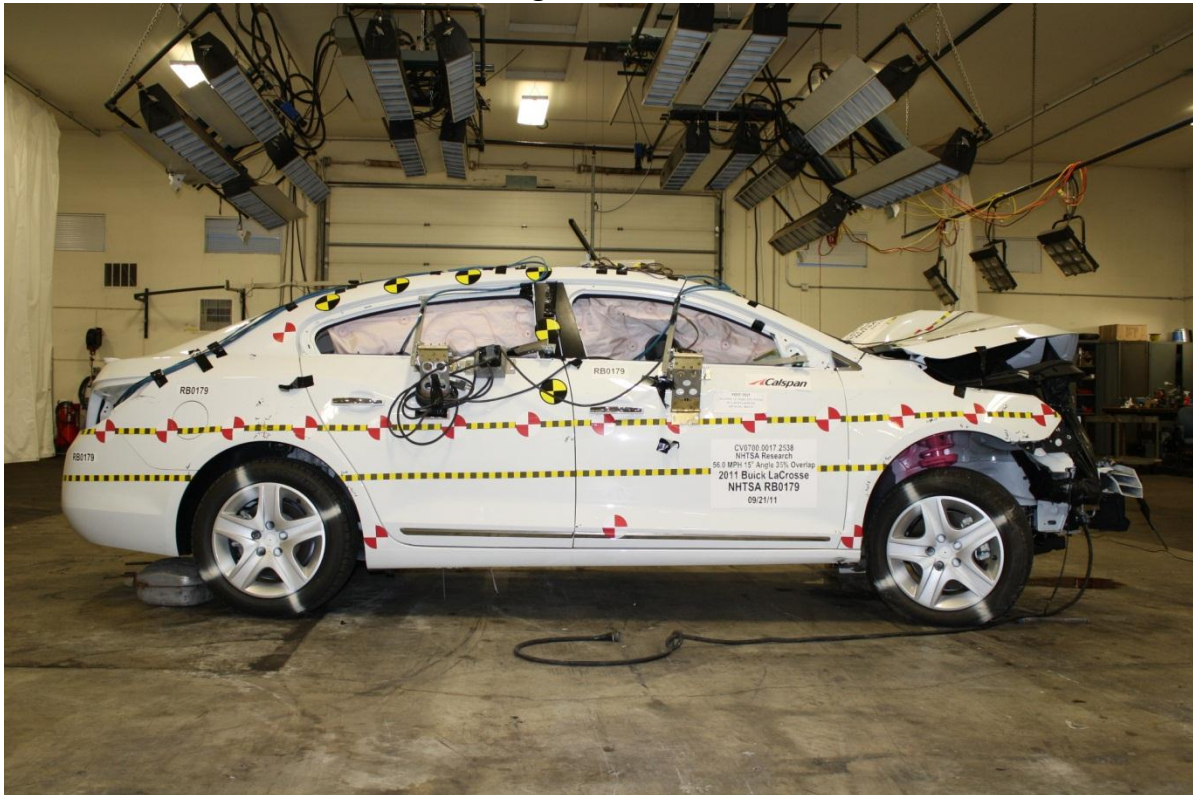

No. 016 Post-Test Right Side View of Test Vehicle



No. 017 Pre-Test Right Front 3-4 View of Test Vehicle



No. 018 Post-Test Right Front 3-4 View of Test Vehicle



No. 019 Pre-Test Overhead View of RMDB against target vehicle at ideal Impact Point



No. 020 Pre-Test Left Side View of RMDB against target vehicle at ideal Impact Point

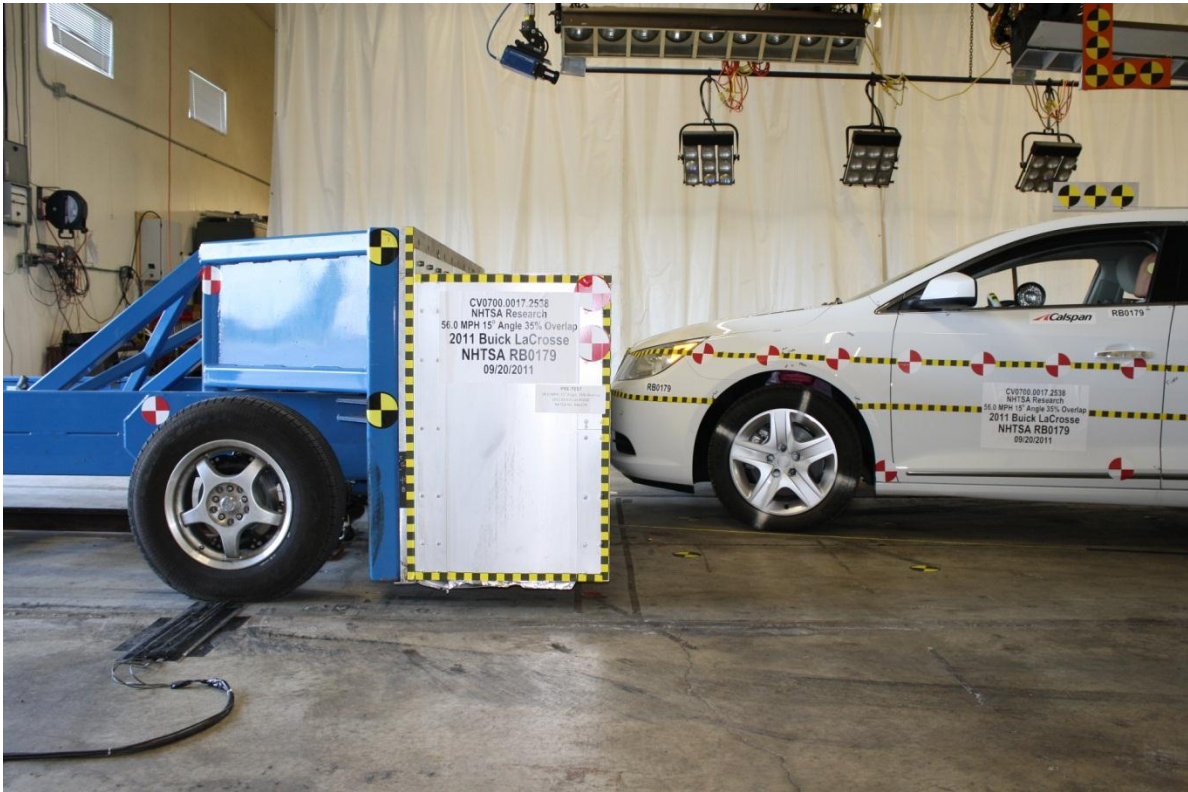

No. 021 Pre-Test Right Side View of RMDB against target vehicle at ideal Impact Point



No. 022 Pre-Test Close-up View of Impact Point

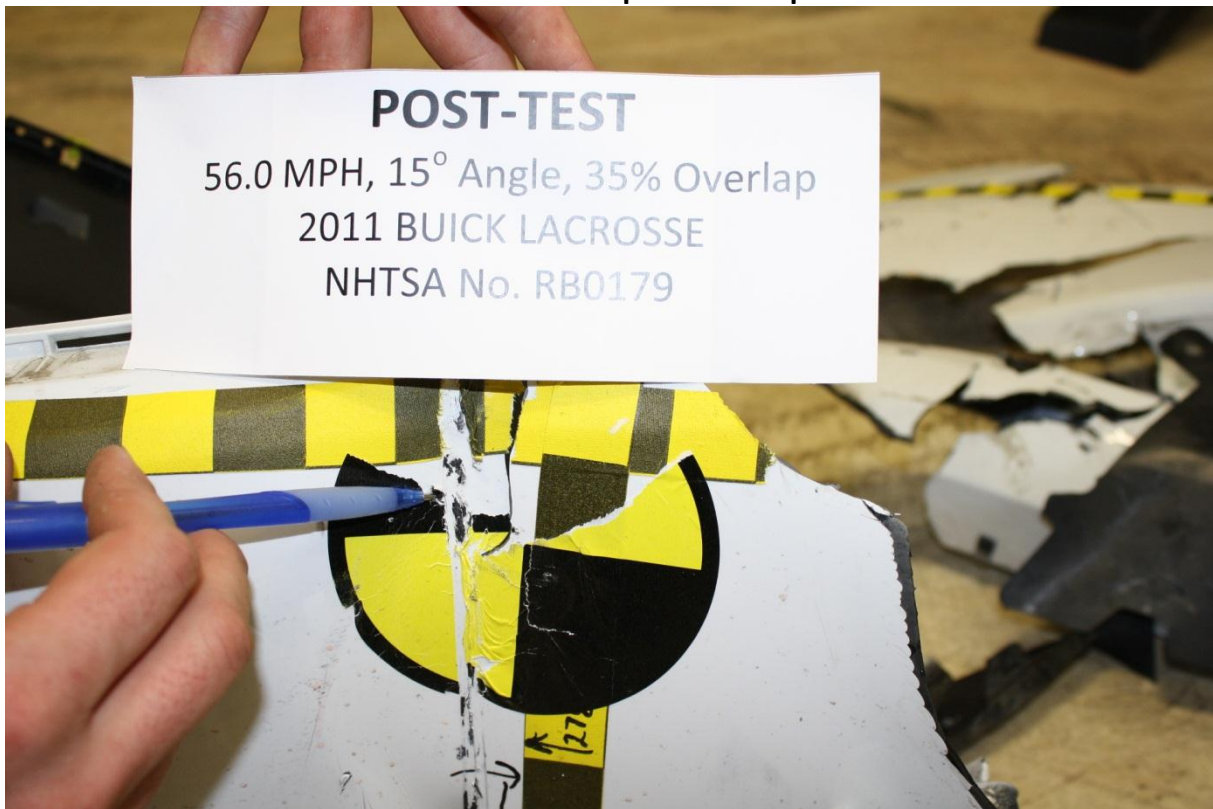

No. 023 Post-Test Close-up View of Impact Point



No. 024 Pre-Test Close-up View of Left Front Door Latch



No. 025 Post-Test Close-up View of Left Front Door Latch

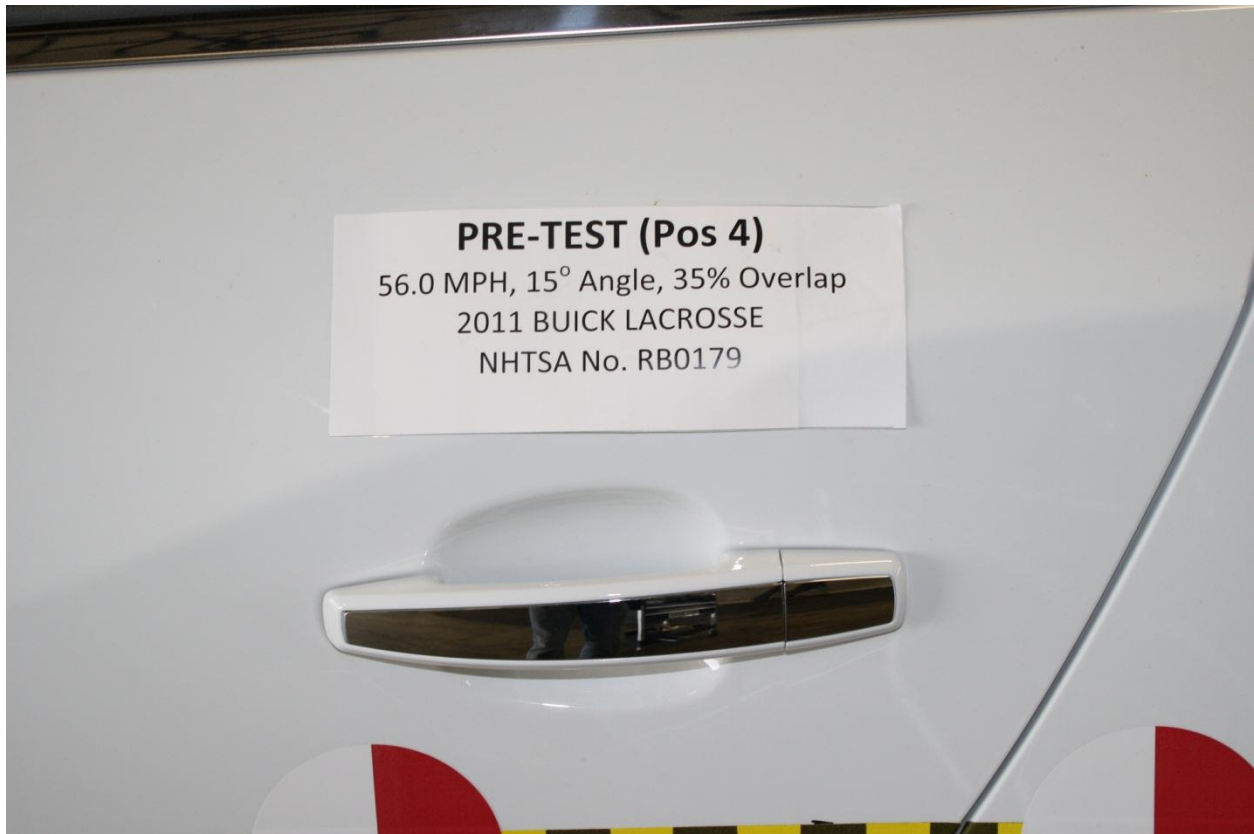

No. 026 Pre-Test Close-up View of Left Rear Door Latch

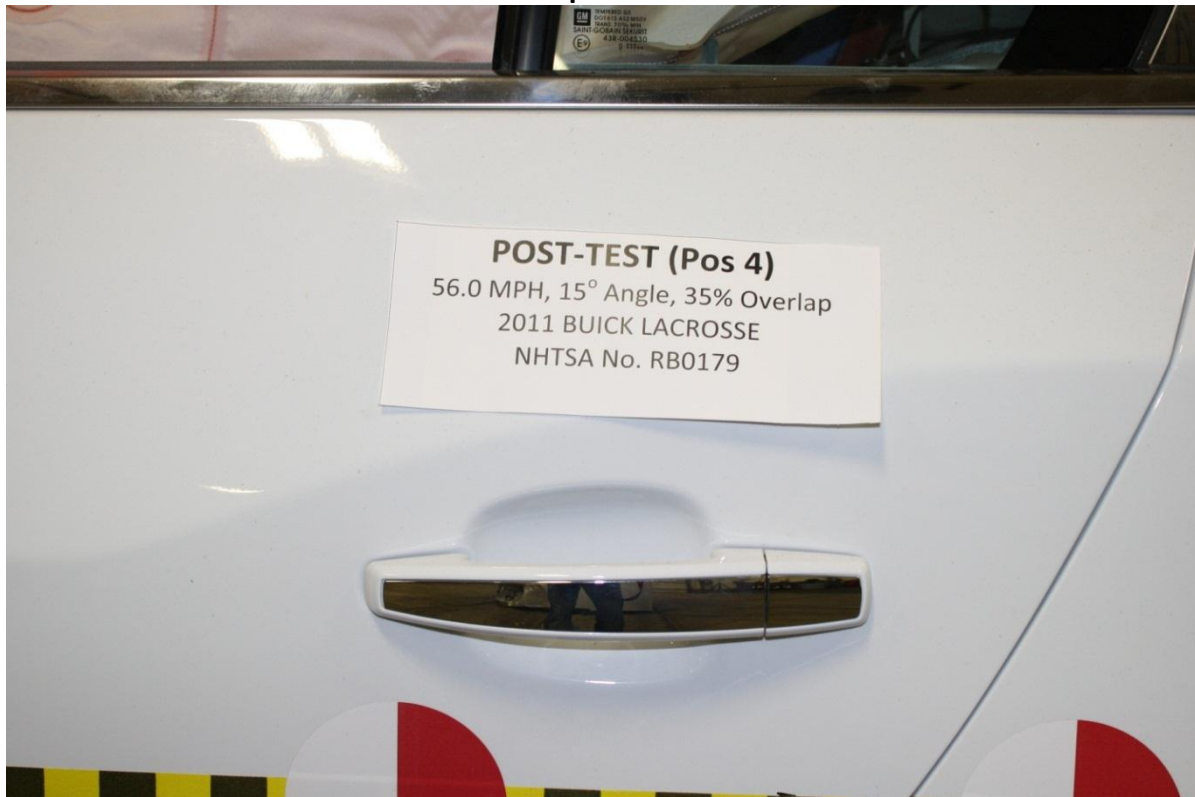

No. 027 Post-Test Close-up View of Left Rear Door Latch



No. 028 Pre-Test Windshield View

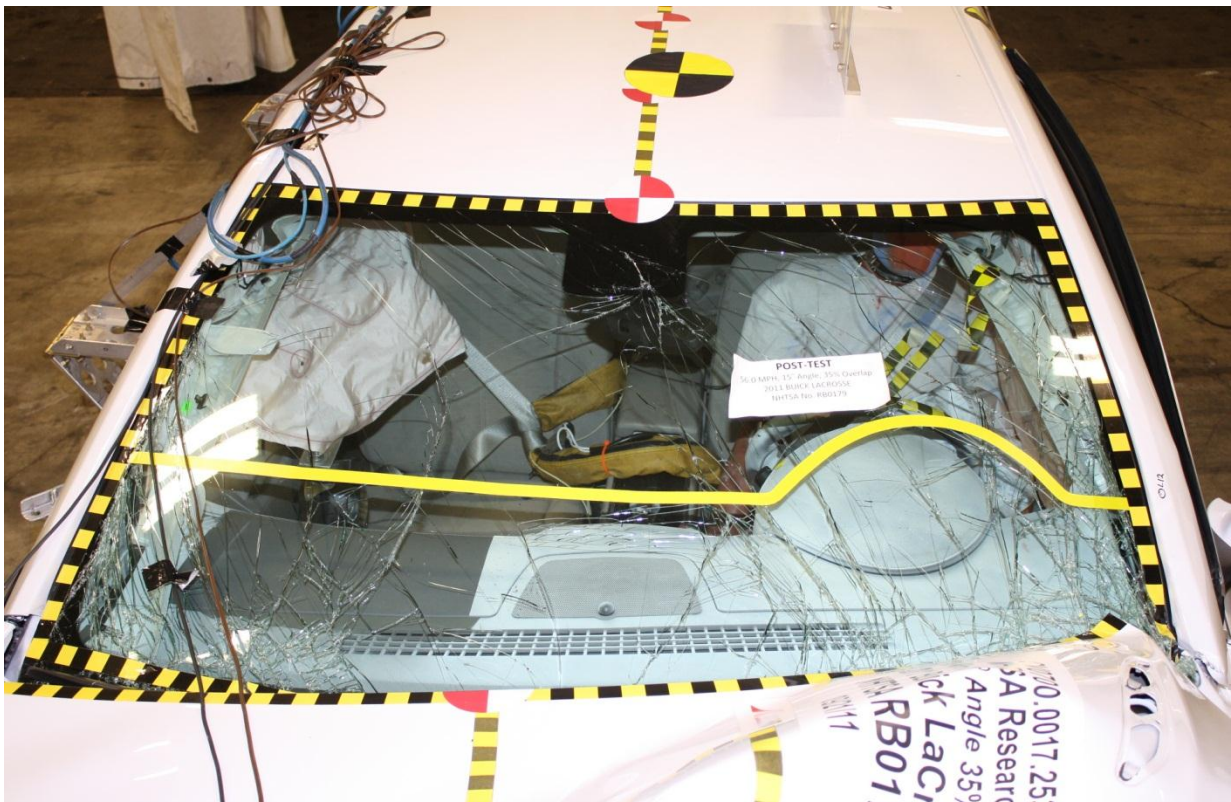

No. 029 Post-Test Windshield View



No. 030 Pre-Test View of Driver Inner Door Panel



No. 031 Post-Test View of Driver Inner Door Panel



No. 032 Pre-Test View of Passenger Inner Door Panel



No. 033 Post-Test View of Passenger Inner Door Panel



No. 034 Pre-Test Frontal View of Driver Seat pan



No. 035 Pre-Test Frontal View of Driver Seat back



No. 036 Pre-Test Frontal View of Left Rear Seat pan



No. 037 Pre-Test Frontal View of Left Rear Seat back

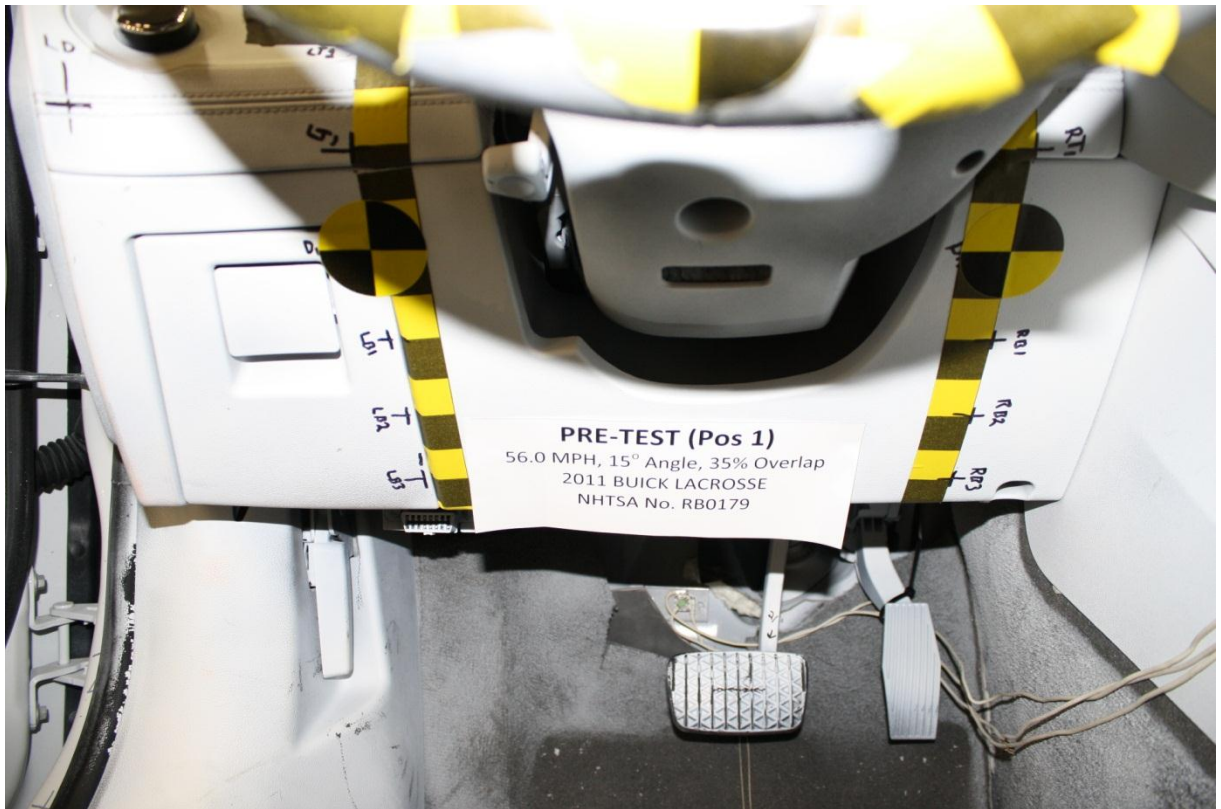

No. 038 Pre-Test Overall View of Driver Knee Bolsters

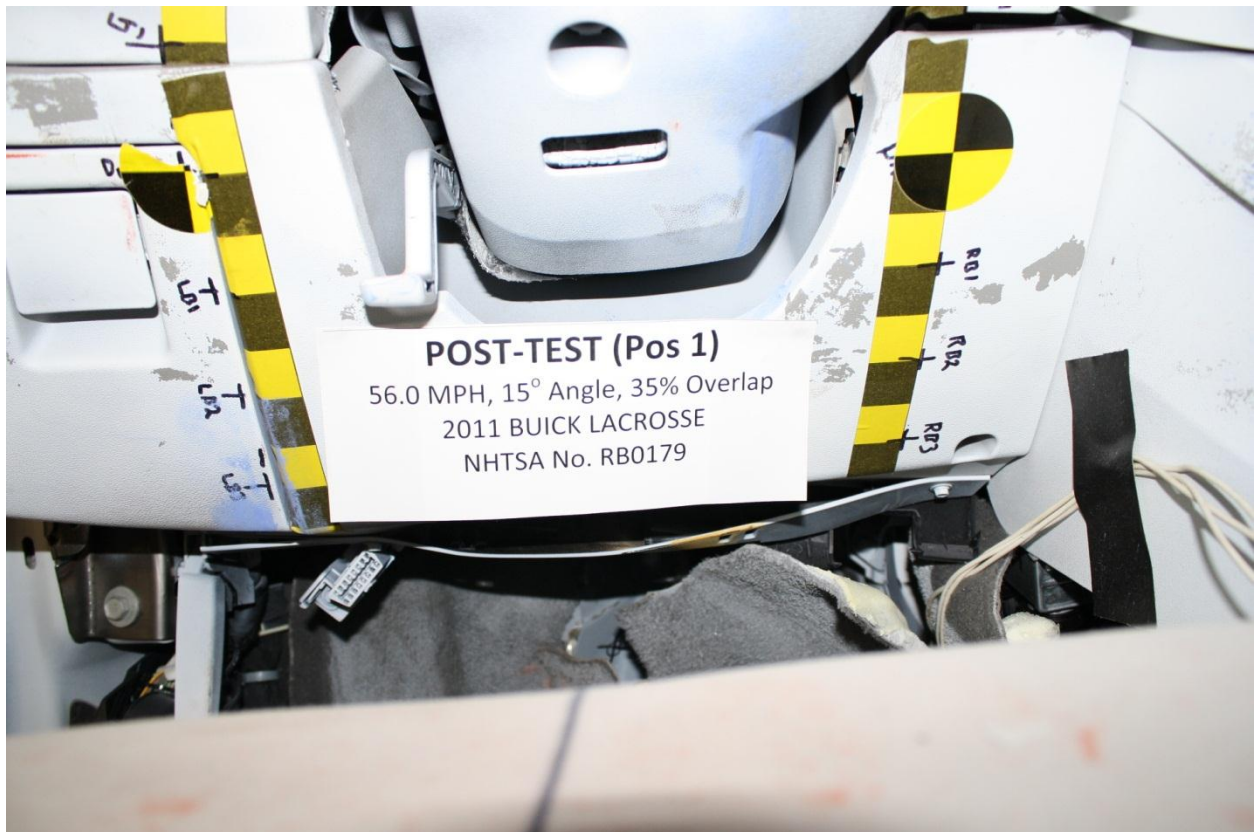

No. 039 Post-Test Overall View of Driver Knee Bolsters

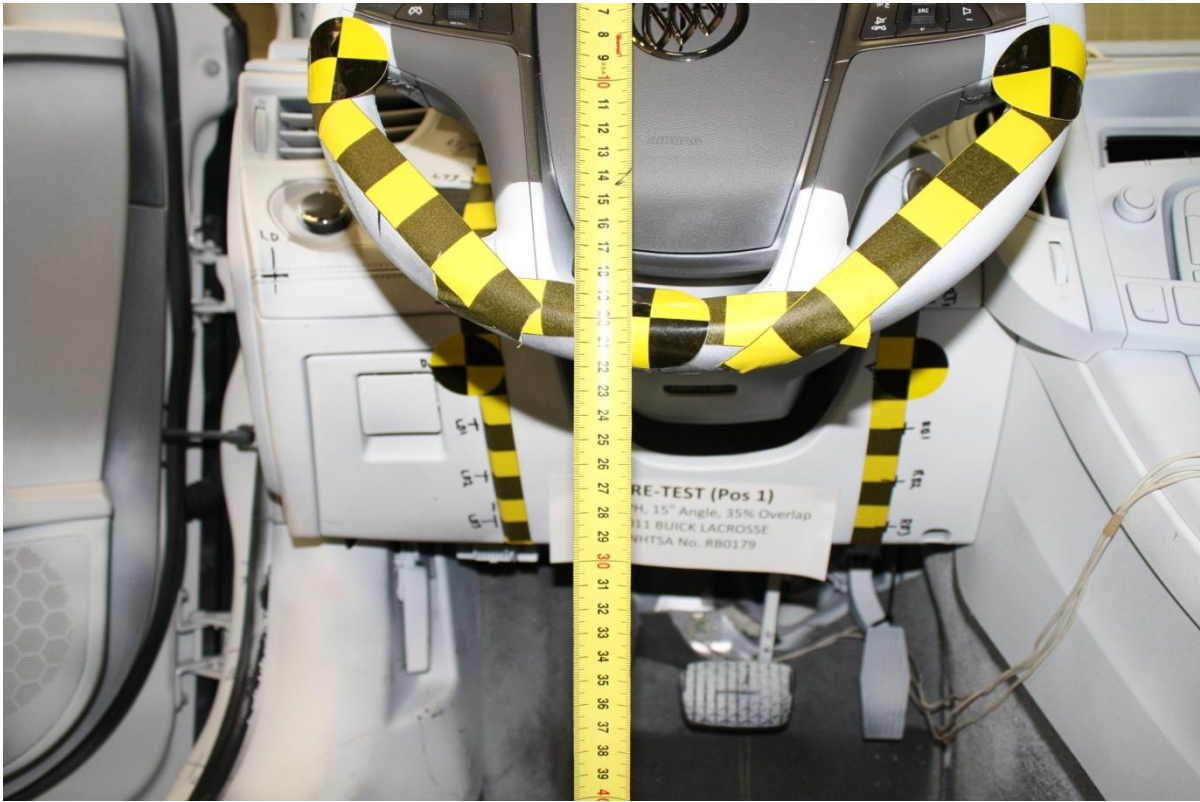

No. 040 Pre-Test Overall View of Driver Knee Bolsters with panel removed



No. 041 Post-Test Overall View of Driver Knee Bolsters with panel removed



No. 042 Pre-Test Left Side View of Driver Knee Bolsters



No. 043 Post-Test Left Side View of Driver Knee Bolsters



No. 044 Pre-Test Left Side View of Driver Knee Bolsters with panel removed



No. 045 Post-Test Left Side View of Driver Knee Bolsters with panel removed



No. 046 Pre-Test Right Side View of Driver Knee Bolsters



No. 047 Post-Test Right Side View of Driver Knee Bolsters

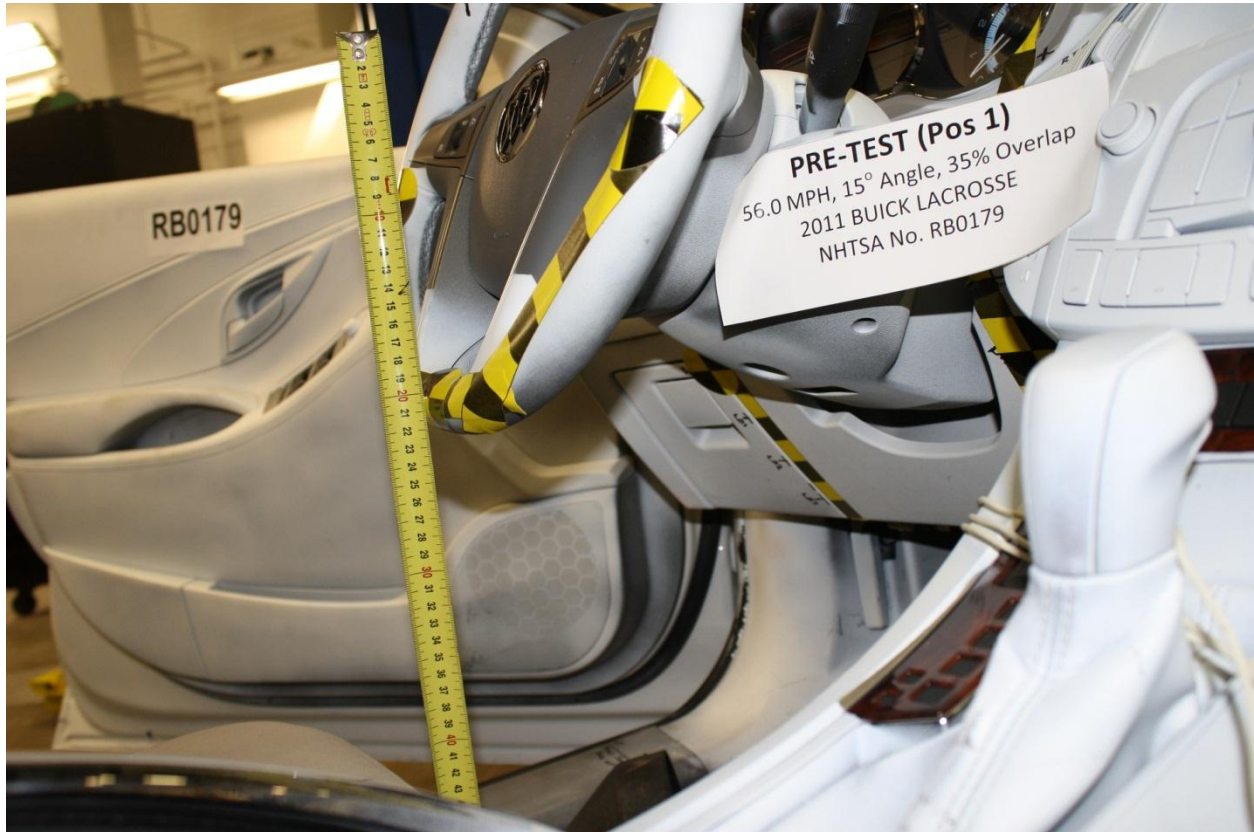

No. 048 Pre-Test Right Side View of Driver Knee Bolster with panel removed



No. 049 Post-test right side view of driver knee bolster with panel removed



No. 050 Pre-Test View of Driver Floor pan at Left sill level



No. 051 Post-Test View of Driver Floor pan at Left sill level

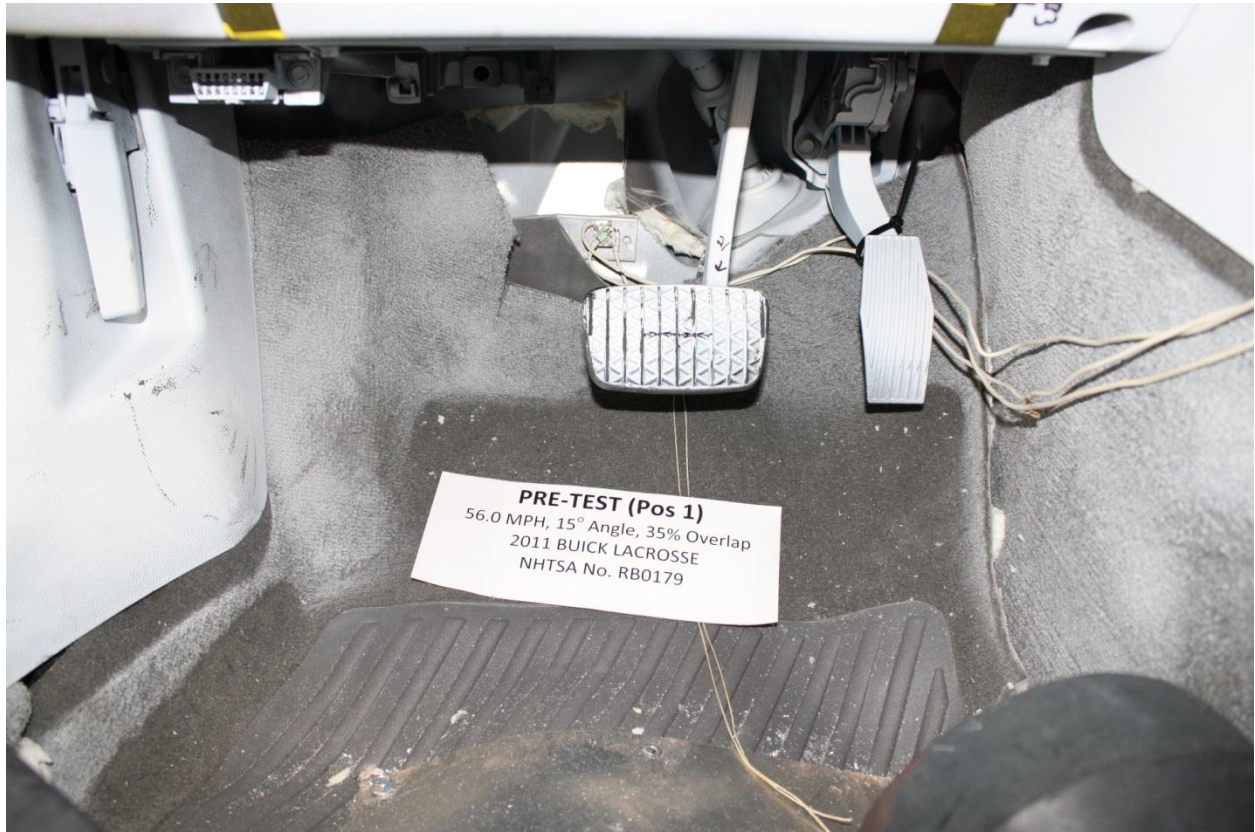

No. 052 Pre-Test View of Driver Floor pan at Mid seat level



No. 053 Post-Test view of Driver Floor pan at Mid seat level

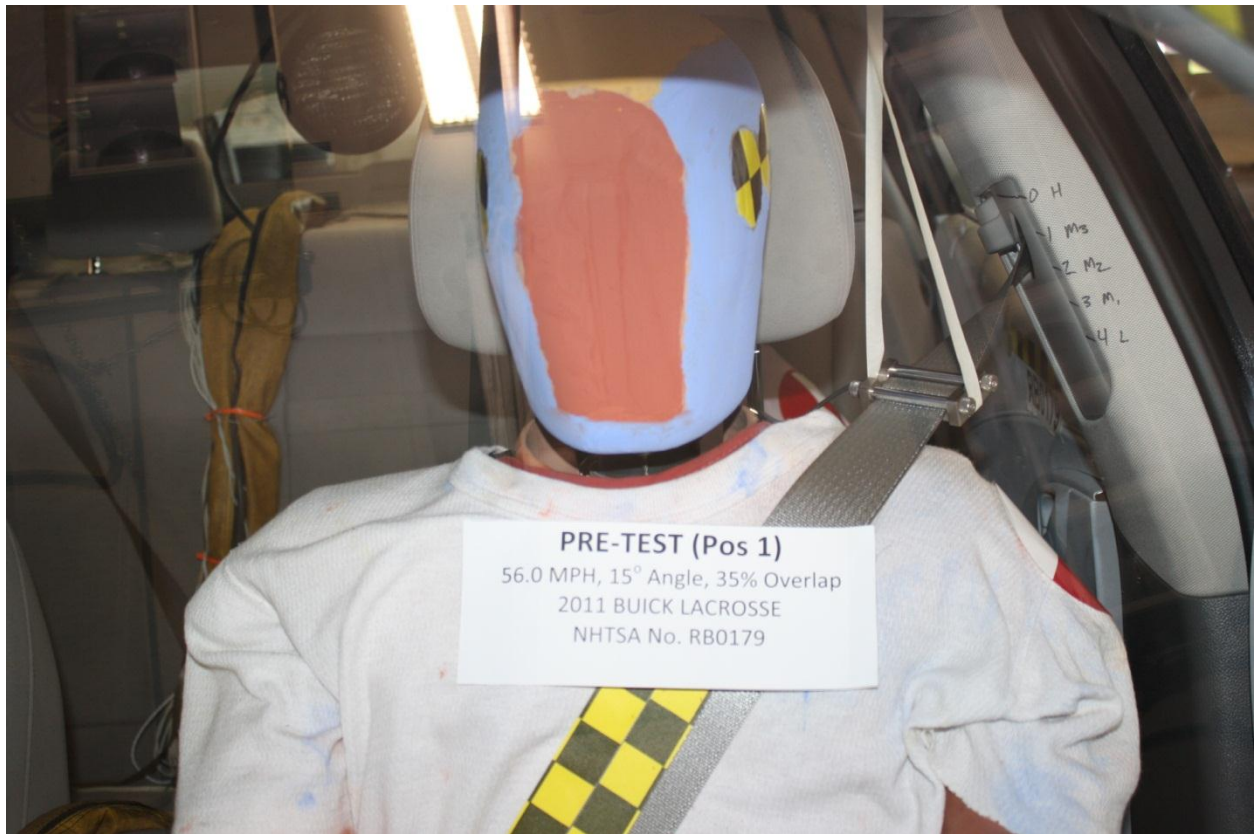

No. 054 Pre-Test Driver Dummy Front Windshield View

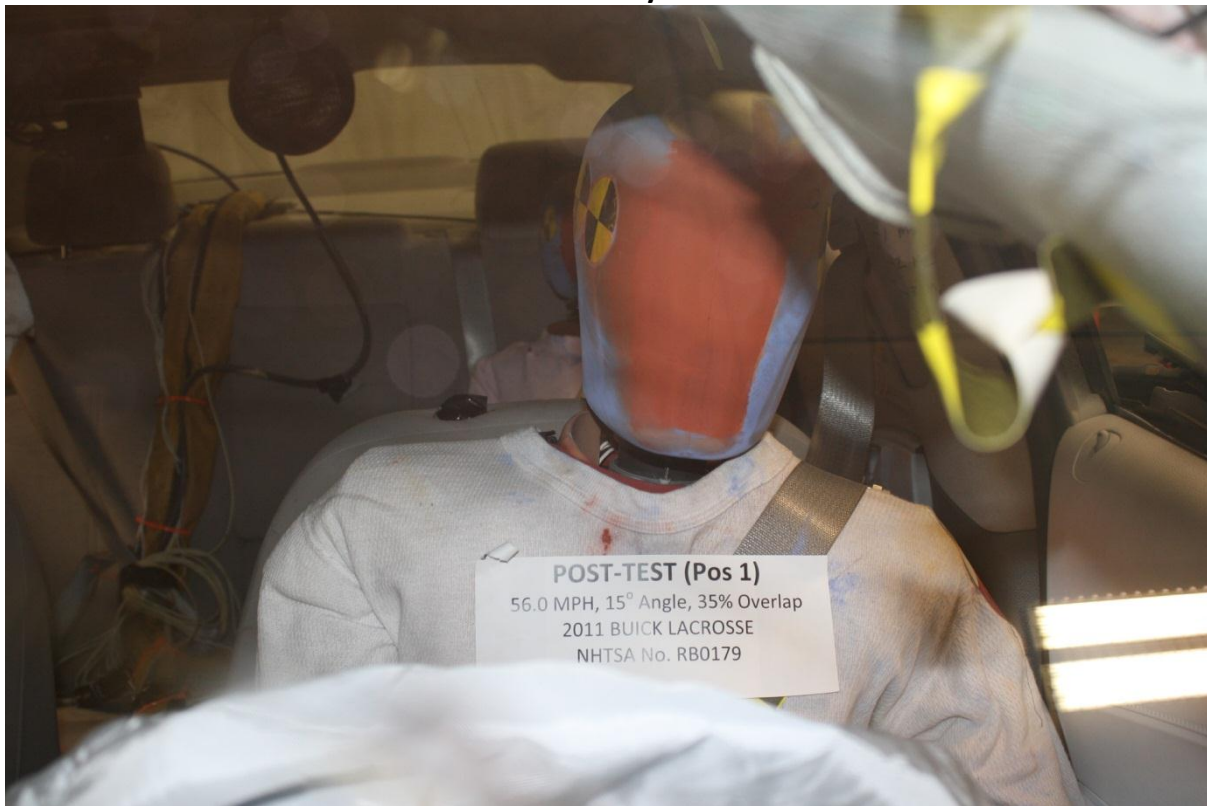

No. 055 Post-Test Driver Dummy Front Windshield View



No. 056 Pre-Test Left Side View of Driver Dummy and Interior



No. 057 Post-Test Left Side View of Driver Dummy and Interior



No. 058 Pre-Test Left Side Driver Dummy Window View



No. 059 Post-Test Left Side Driver Dummy Window View



No. 060 Pre-Test Right Side View of Driver Dummy and Interior



No. 061 Post-Test Right Side View of Driver Dummy and Interior



No. 062 Pre-Test View of Driver Dummy Door Clearance



No. 063 Post-Test View of Driver Dummy Door Clearance

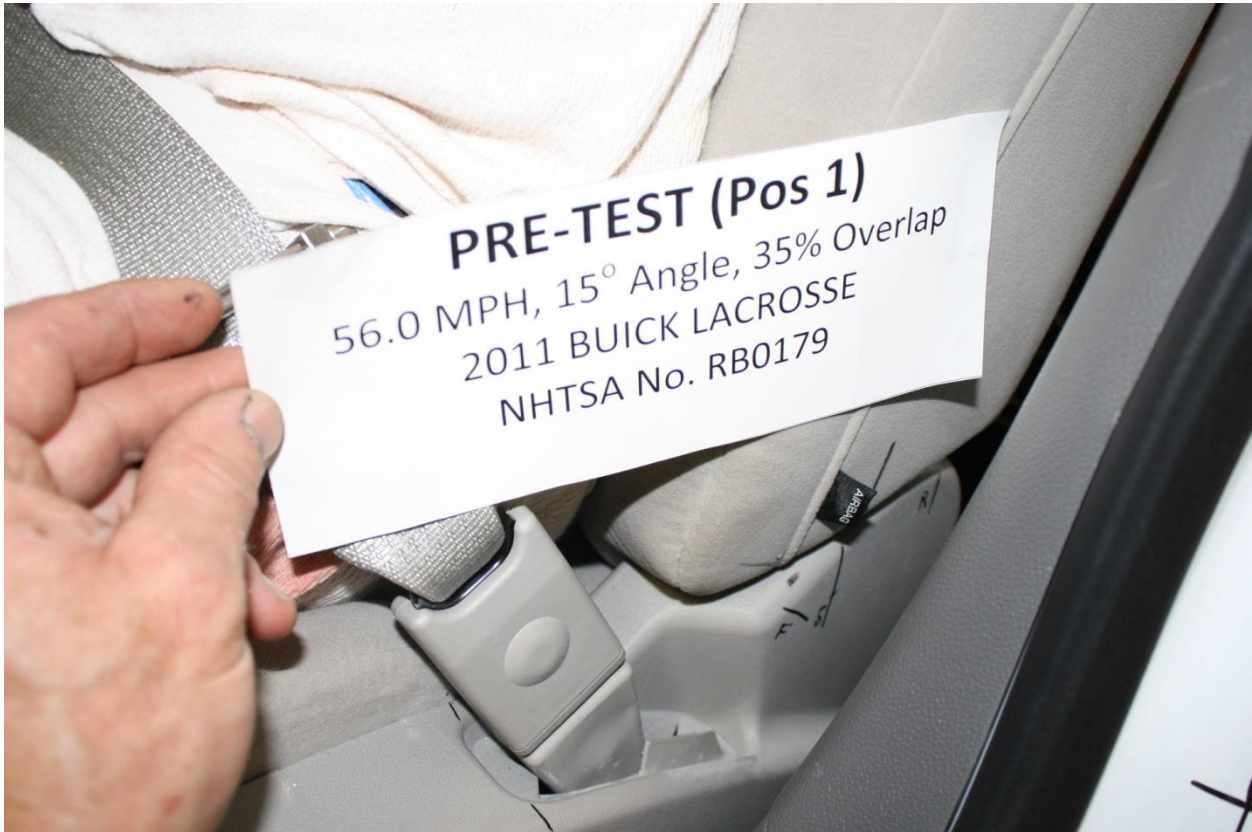

No. 064 Pre-Test Driver Seat Back Position markings



No. 065 Pre-Test Driver Seat Back Position with Level or Inclinator



No. 066 Pre-Test Driver Seat Fore Aft Markings



No. 067 Post-Test Driver Seat Fore Aft Markings

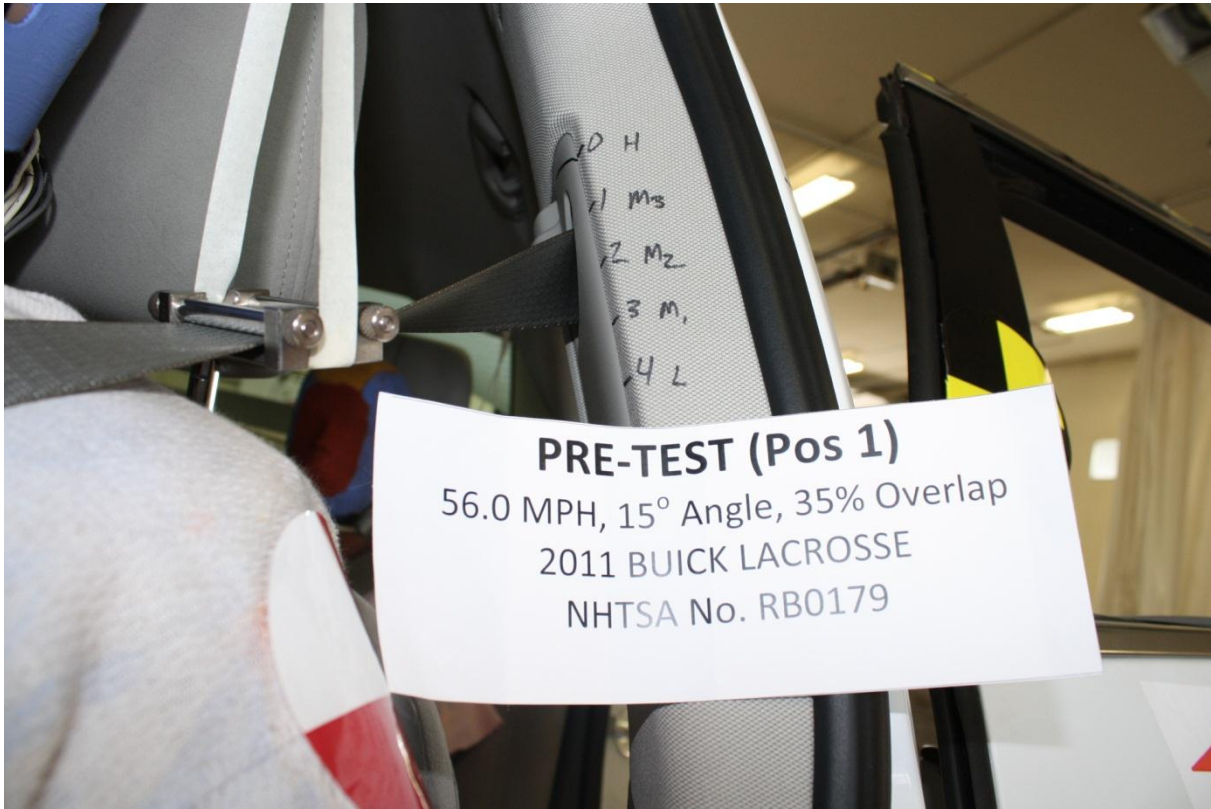

No. 068 Pre-Test Driver Adjustable D-ring

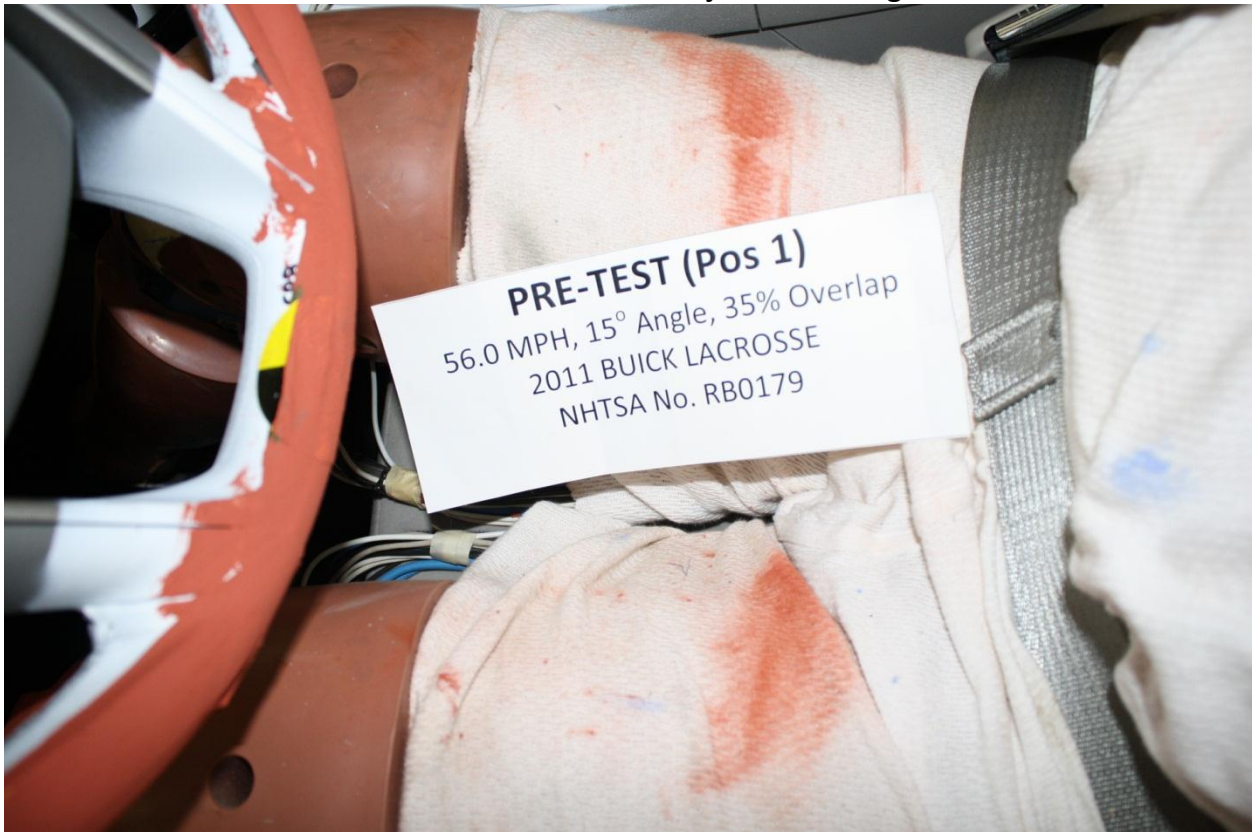

No. 069 Pre-Test Overhead View of Driver Dummy Thighs in seat

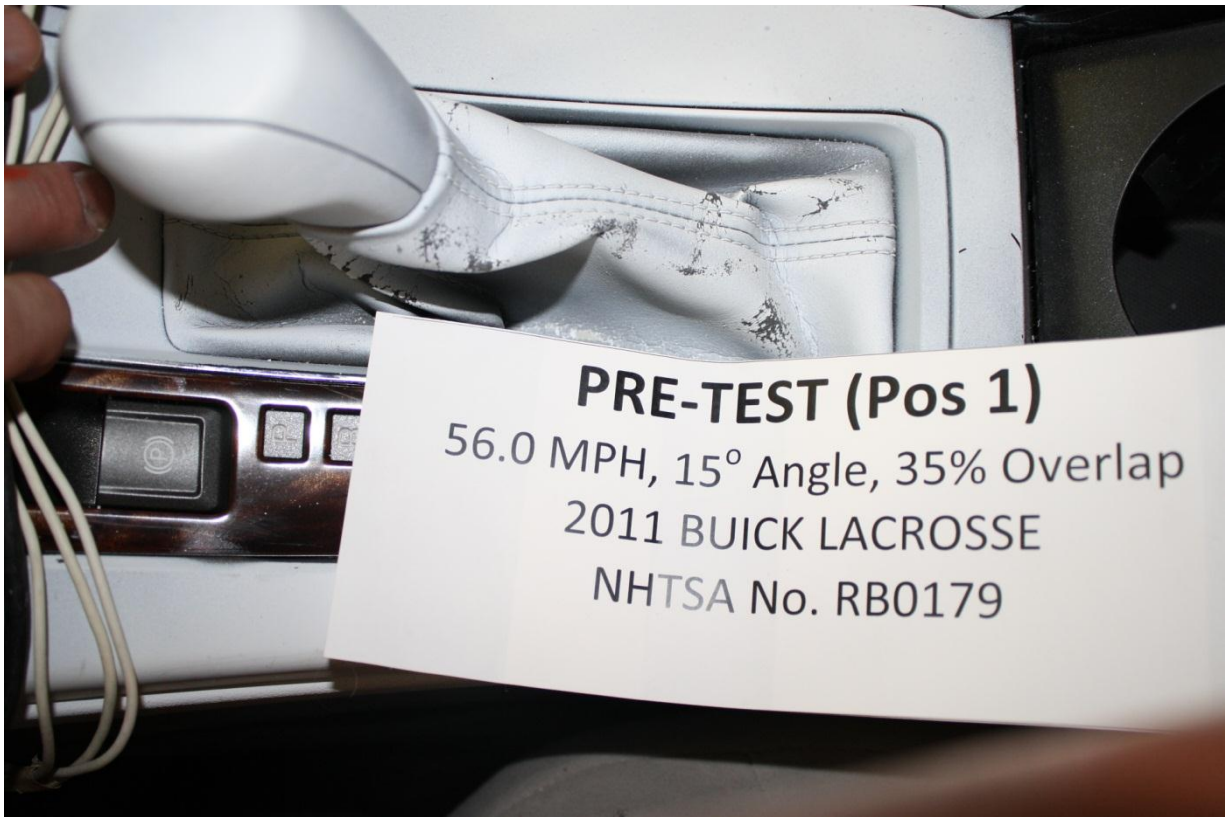

No. 070 Pre-Test View of Parking Brake



No. 071 Pre-Test Driver Dummy Feet



No. 072 Post-Test Driver Dummy Feet

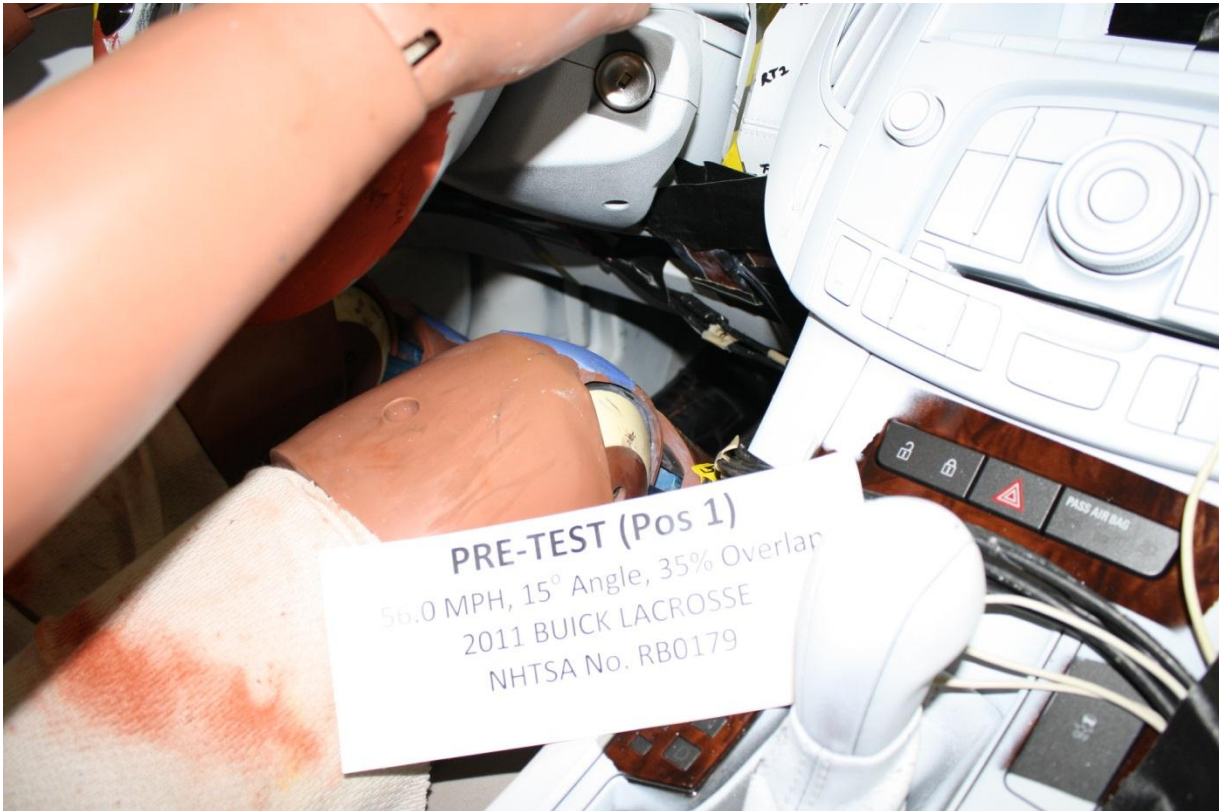

PRE-TEST (Pos 1)
56.0 MPH, 15° Angle, 35% Overlap
2011 BUICK LACROSSE
NHTSA No. RB0179

No. 073 Pre-Test View of Driver Dummy Right Knee and Bolster



POST-TEST (Pos 1)
56.0 MPH, 15° Angle, 35% Overlap
2011 BUICK LACROSSE
NHTSA No. RB0179

No. 074 Post-Test View of Driver Dummy Right Knee and Bolster



No. 075 Pre-Test View of Driver Dummy Left Knee and Bolster



No. 076 Post-Test View of Driver Dummy Left Knee and Bolster



No. 077 Pre-Test View of Driver Dummy Abdomen

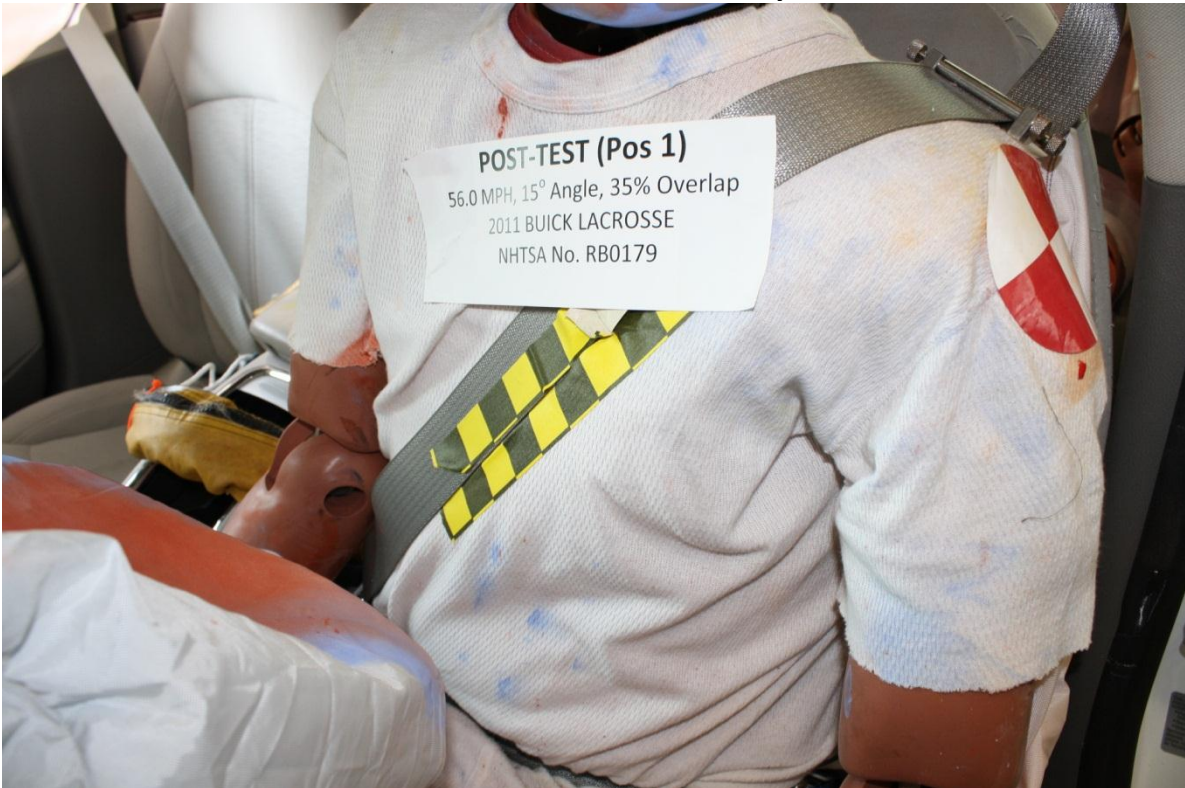

No. 078 Post-Test View of Driver Dummy Abdomen



PRE-TEST (Pos 1)
56.0 MPH, 15° Angle, 35% Overlap
2011 BUICK LACROSSE
NHTSA No. RB0179

No. 079 Pre-Test Left Side View of Steering Wheel set position

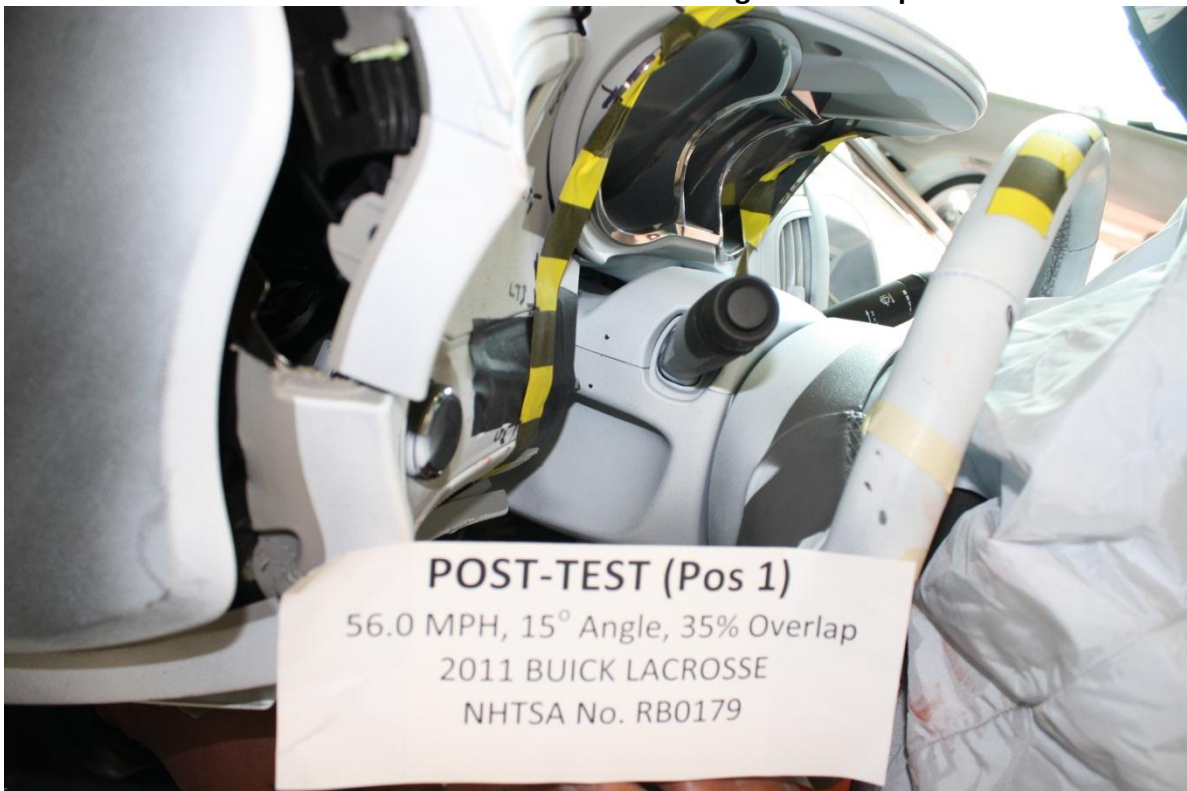

POST-TEST (Pos 1)
56.0 MPH, 15° Angle, 35% Overlap
2011 BUICK LACROSSE
NHTSA No. RB0179

No. 080 Post-Test Left Side View of Steering Wheel set position



No. 081 Post-Test View of Driver Dummy Head Contact with Airbag



No. 082 Post-Test View of Driver Dummy Head Contact with Vehicle Interior (a, b, c, etc)

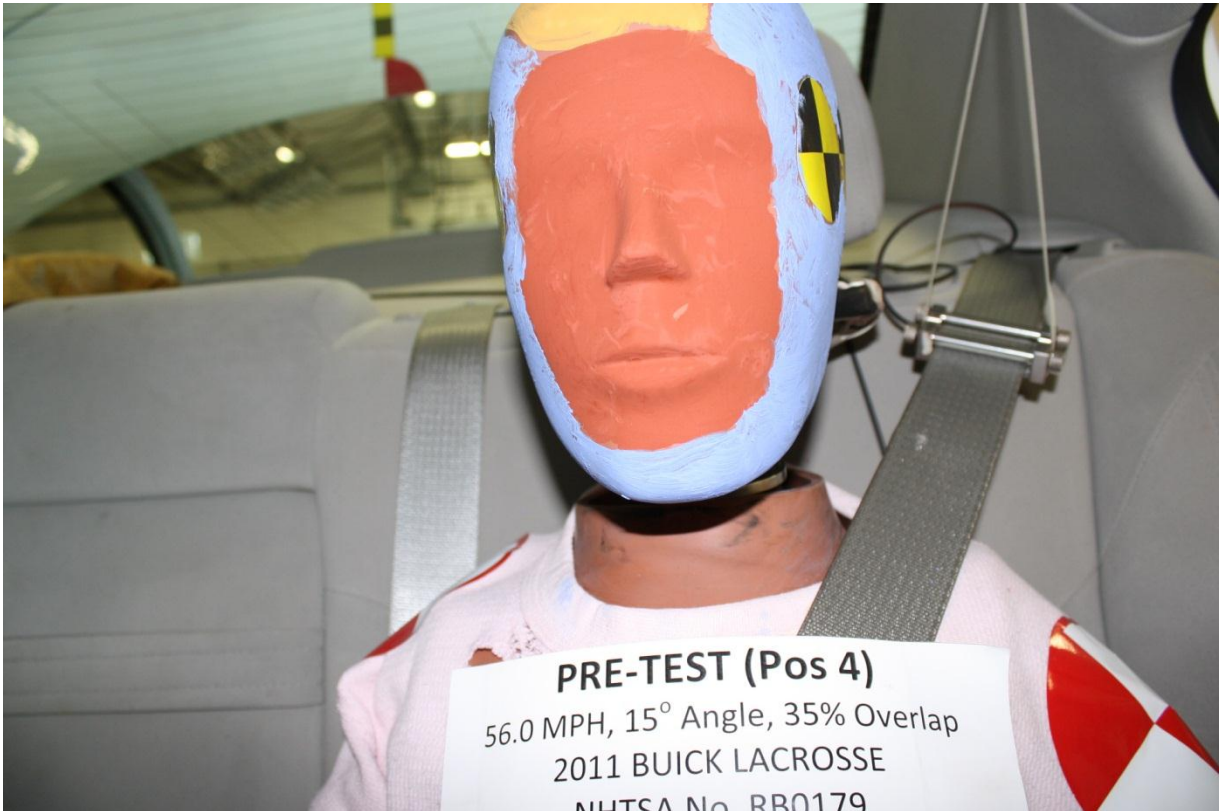

No. 083 Pre-Test Passenger Dummy Front Close-up View



No. 084 Post-Test Passenger Dummy Front Close-up View



No. 085 Pre-Test Left Side Passenger Dummy and Interior View



No. 086 Post-Test Left Side Passenger Dummy and Interior View



PRE-TEST (Pos 4)

56.0 MPH, 15° Angle, 35% Overlap
2011 BUICK LACROSSE
NHTSA No. RB0179



No. 087 Pre-Test Left Side Passenger Dummy Window View



POST-TEST (Pos 4)

56.0 MPH, 15° Angle, 35% Overlap
2011 BUICK LACROSSE
NHTSA No. RB0179



No. 088 Post-Test Left Side Passenger Dummy Window View



No. 089 Pre-Test Right Side View of Passenger Dummy and Interior



No. 090 Post-Test Right Side View of Passenger Dummy and Interior



PRE-TEST (Pos 4)
56.0 MPH, 15° Angle, 35% Overlap
2011 BUICK LACROSSE
NHTSA No. RB0179

No. 091 Pre-Test View of Passenger Dummy Door Clearance



POST-TEST (Pos 4)
56.0 MPH, 15° Angle, 35% Overlap
2011 BUICK LACROSSE
NHTSA No. RB0179

No. 092 Post-Test View of Passenger Dummy Door Clearance

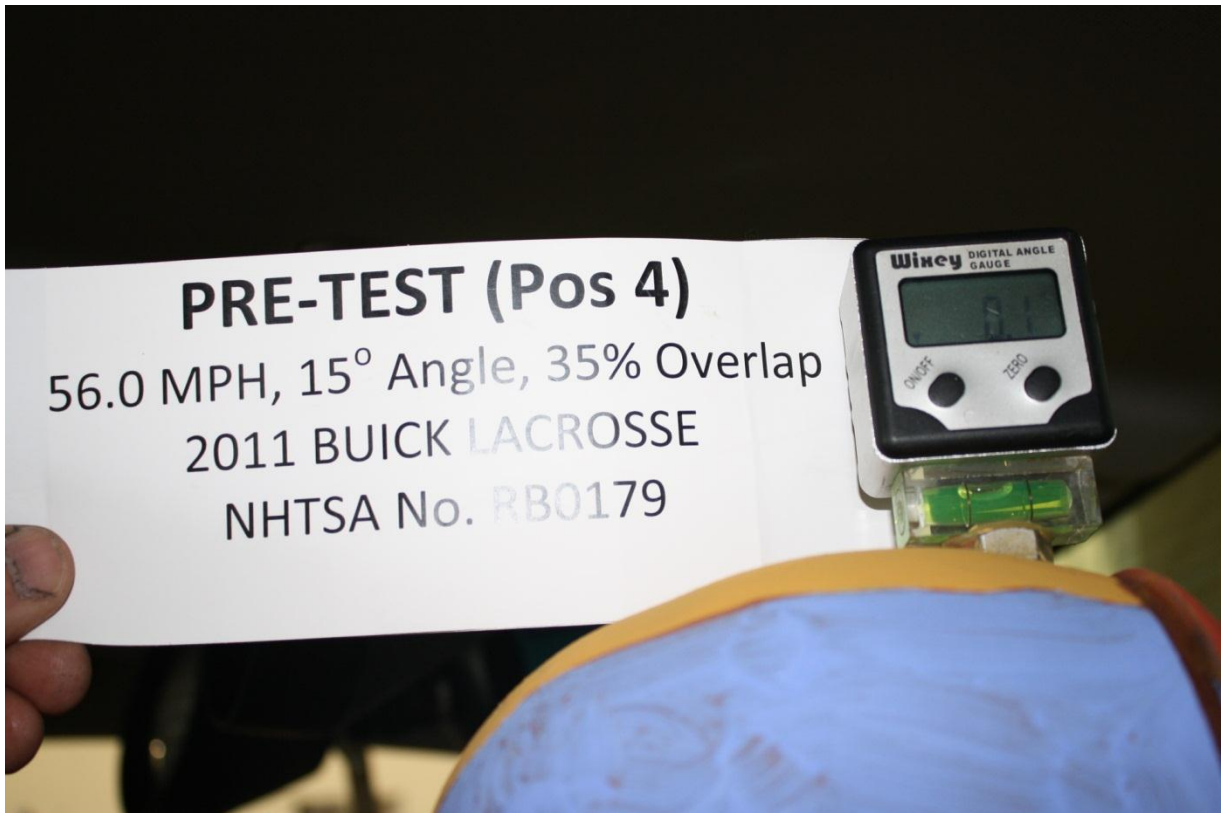

No. 093 Pre-Test Passenger View Showing Head Level



No. 094 Pre-Test Passenger Seat Fore-Aft Markings

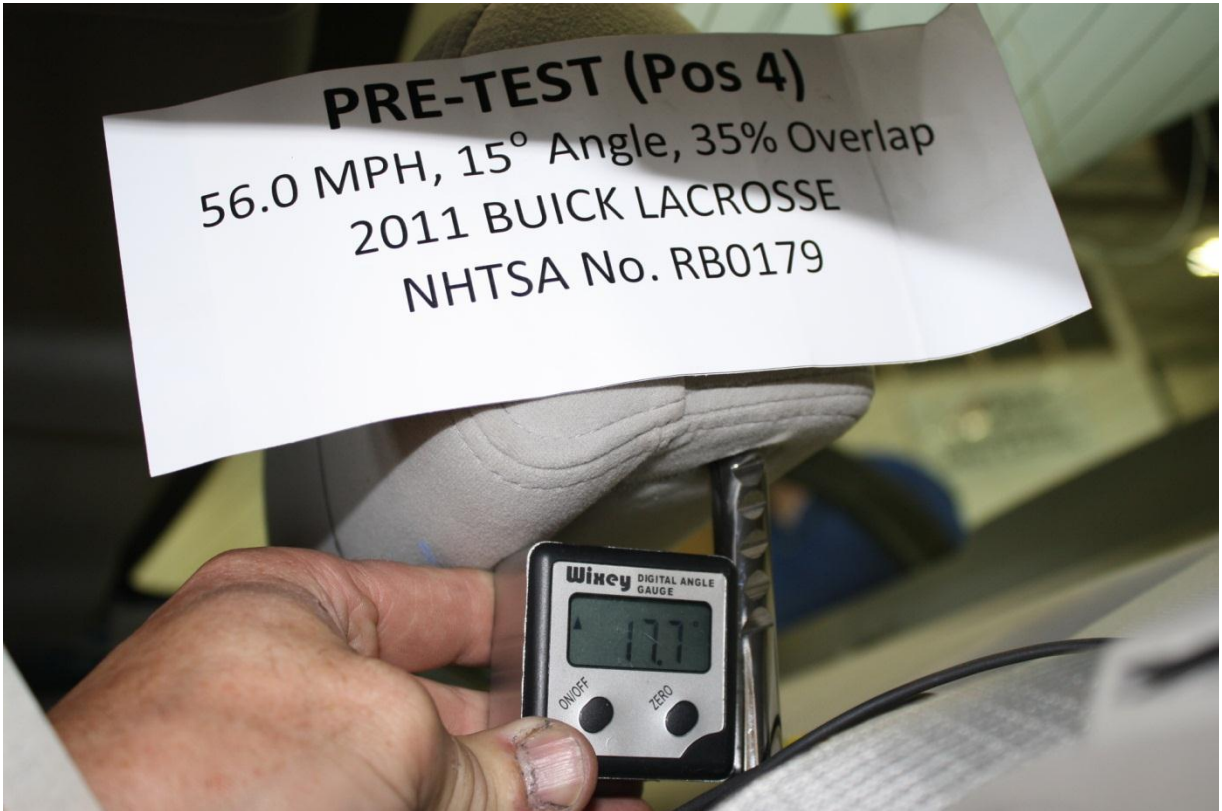

No. 095 Pre-Test Passenger Seat Back Angle



No. 096 Pre-Test Overhead View of Passenger Dummy Thighs on seat

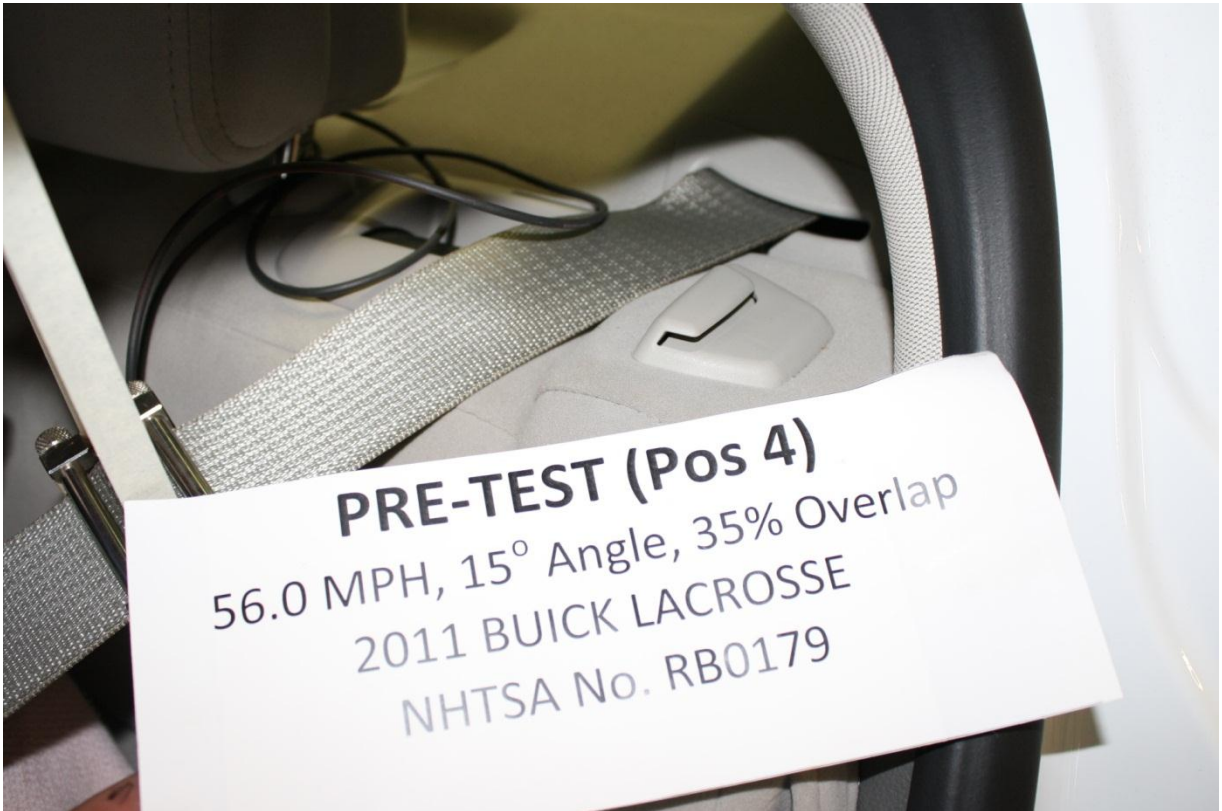

No. 097 Pre-Test Passenger Adjustable D-ring



No. 098 Pre-Test View of Passenger Dummy Feet



No. 099 Post-Test View of Passenger Dummy Feet

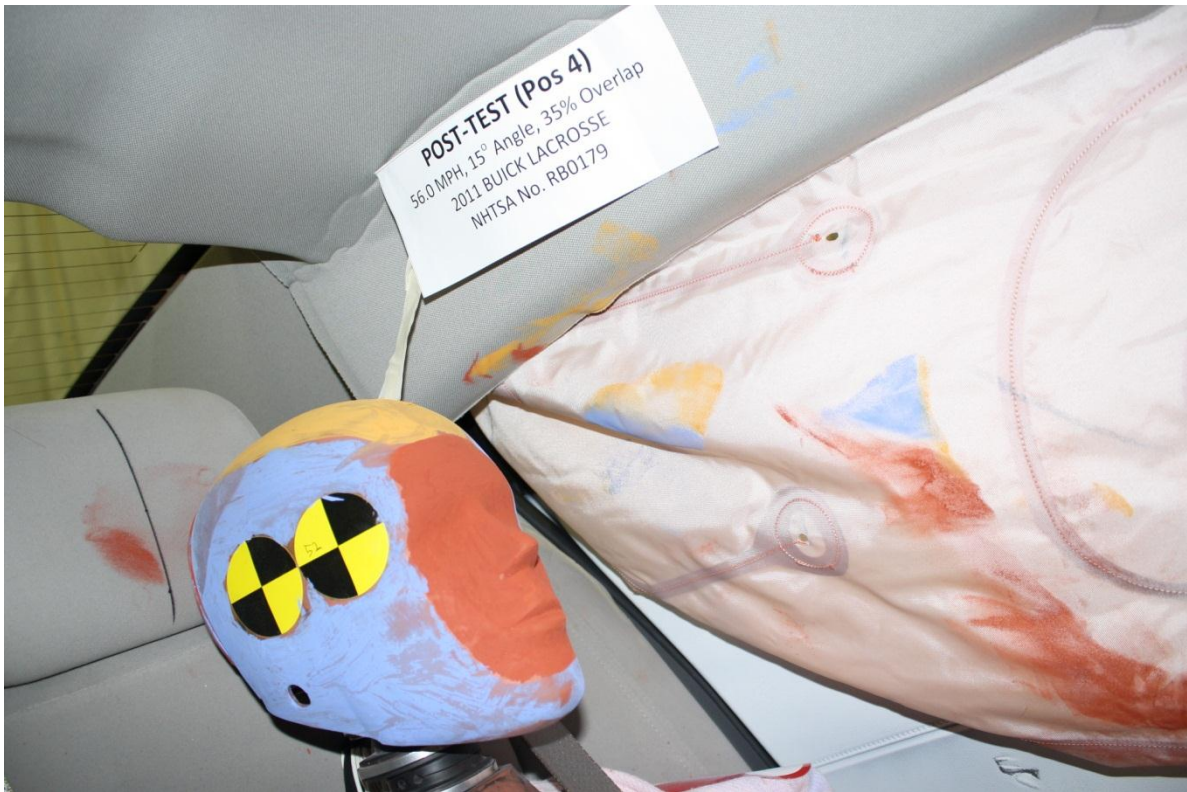

No. 100 Post-Test View of Passenger Dummy Head contact with Airbag

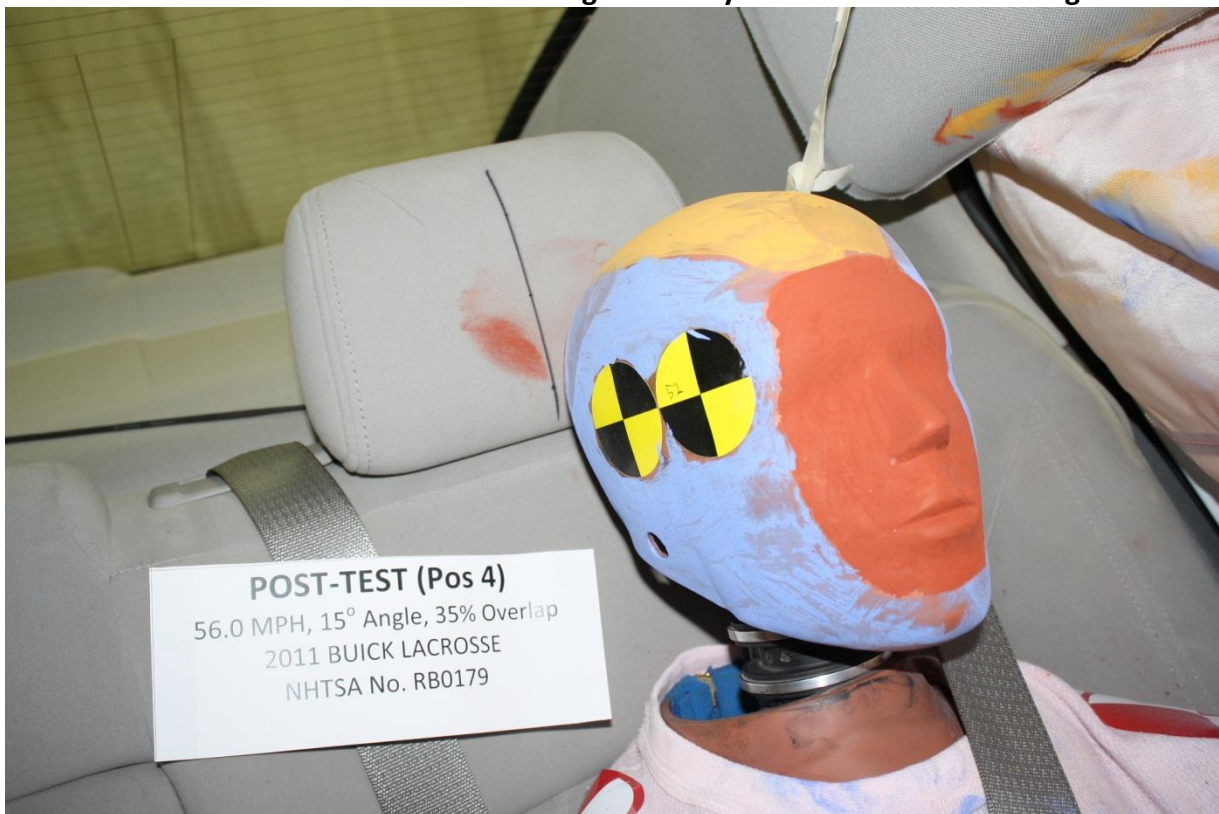

No. 101 Post-Test View of Passenger Dummy Head contact with Interior (a,b,c)



No. 102 Post-Test View of Passenger Dummy Knee Contact with Seatback

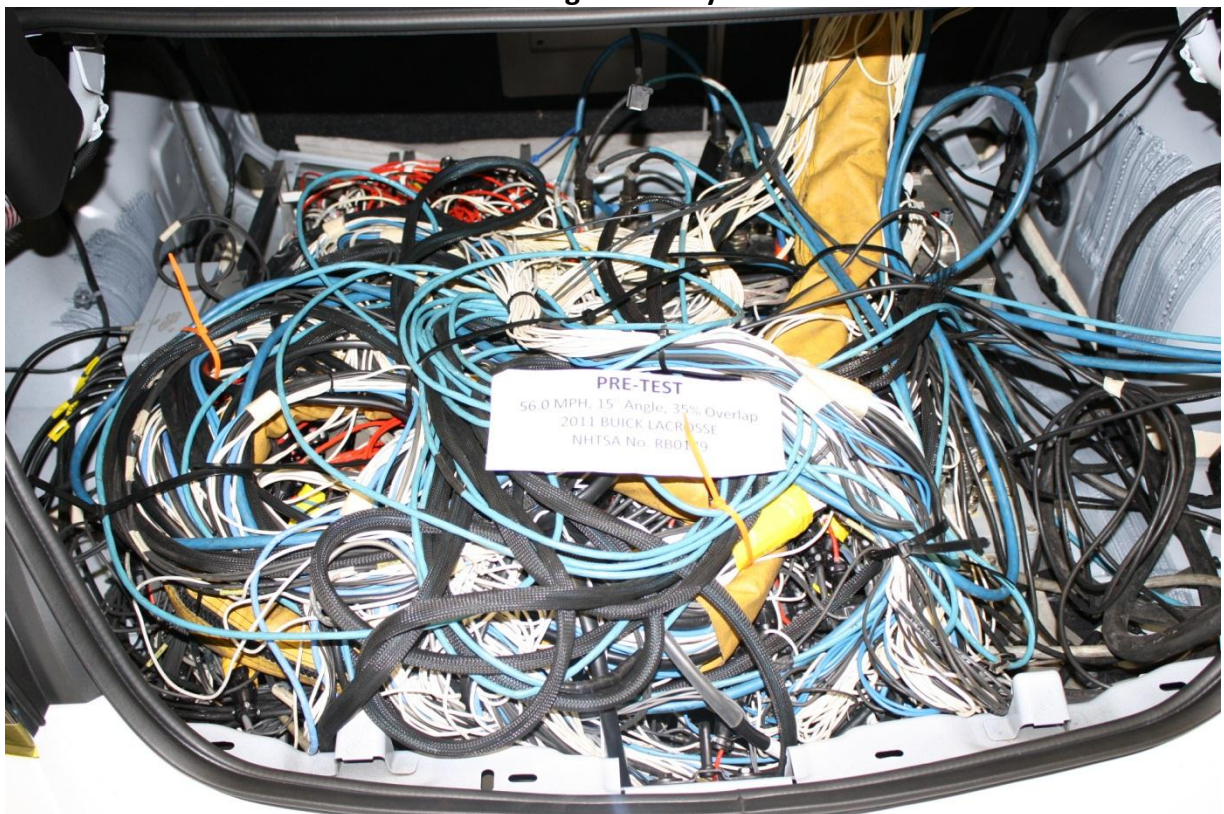

No. 103 Pre-Test Ballast Locations

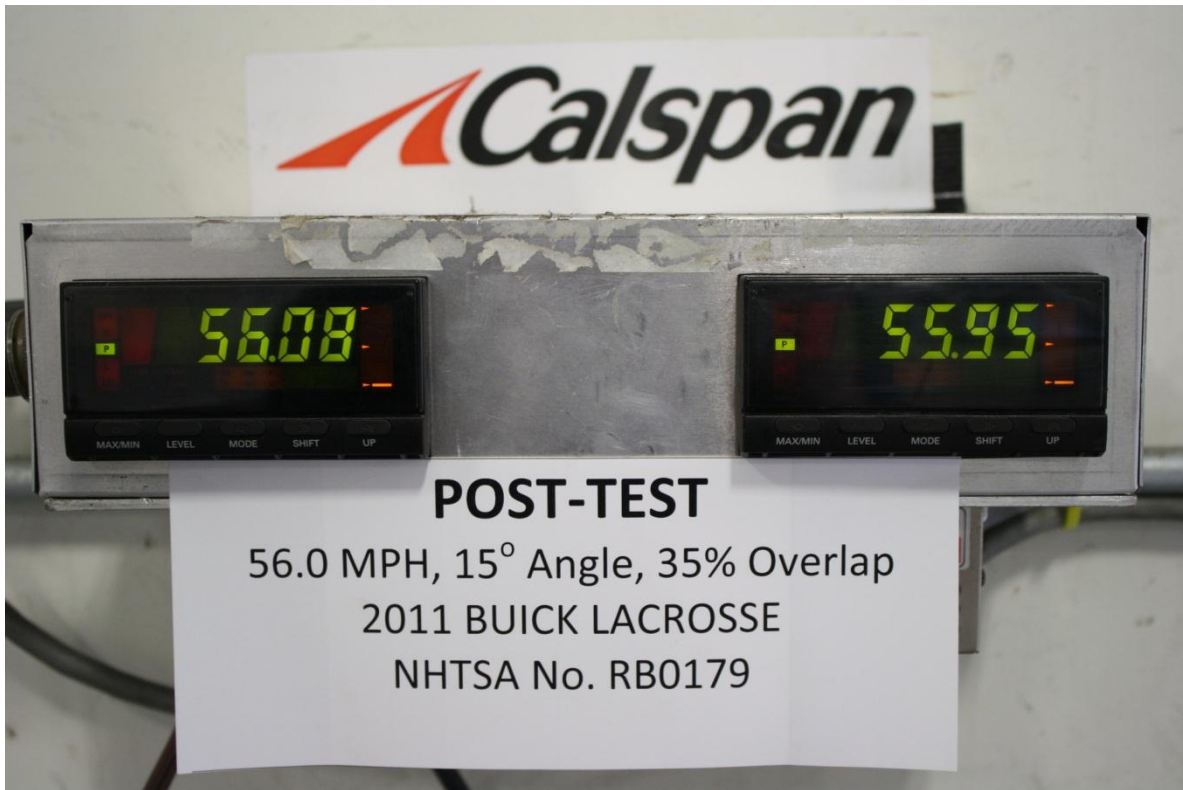

No. 104 Post-Test Speed Trap Readout



No. 105 Pre-Test View of Fuel Filler Cap



No. 106 Post-Test View of Fuel Filler Cap

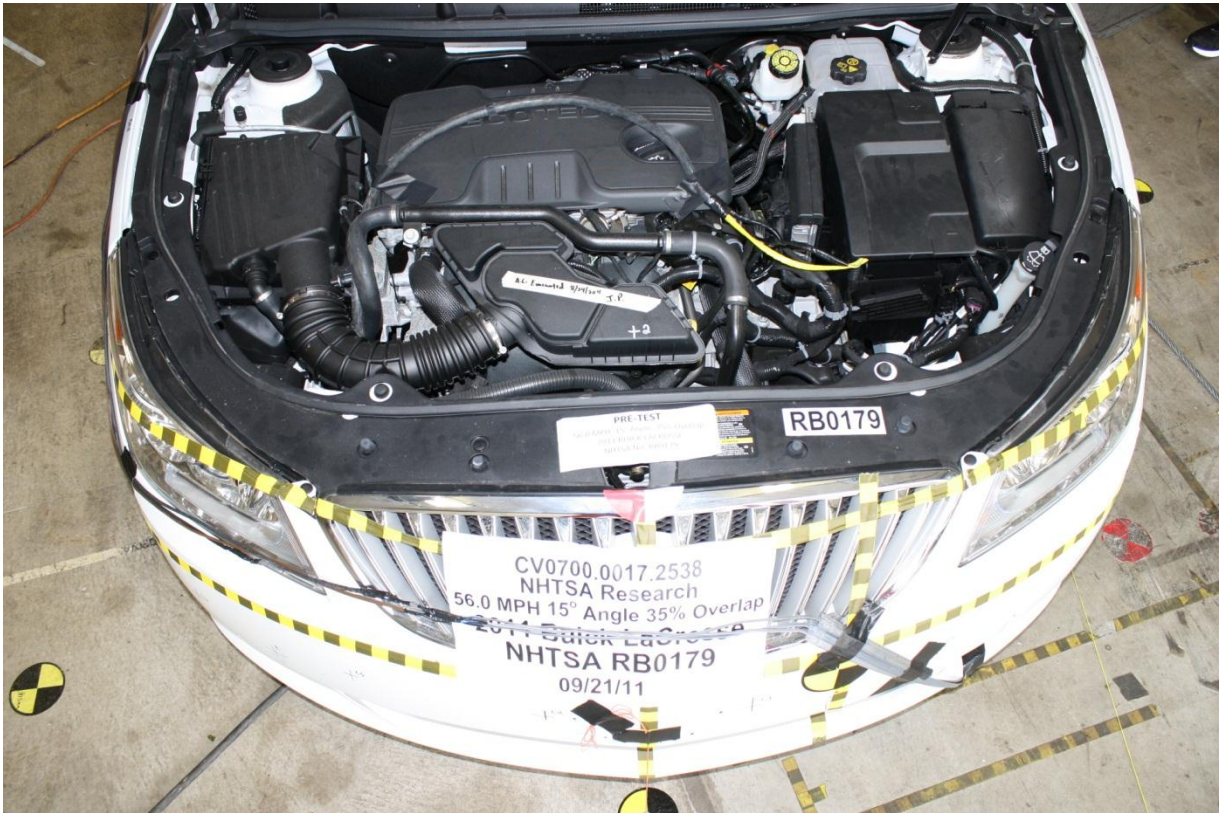

No. 107 Pre-Test Engine Compartment View



No. 108 Post-Test Engine Compartment View

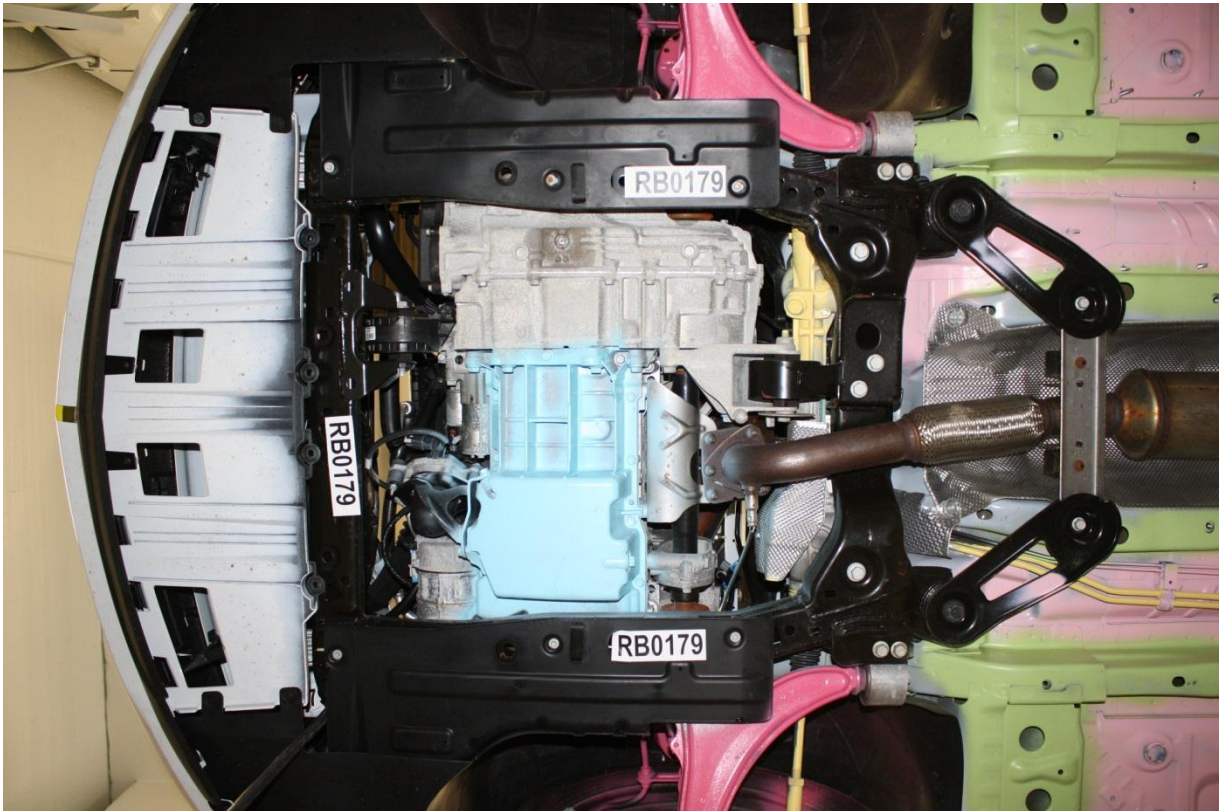

No. 109 Pre-Test View of Front Underbody (perpendicular to vehicle)



No. 110 Post-Test View of Front Underbody (perpendicular to vehicle)

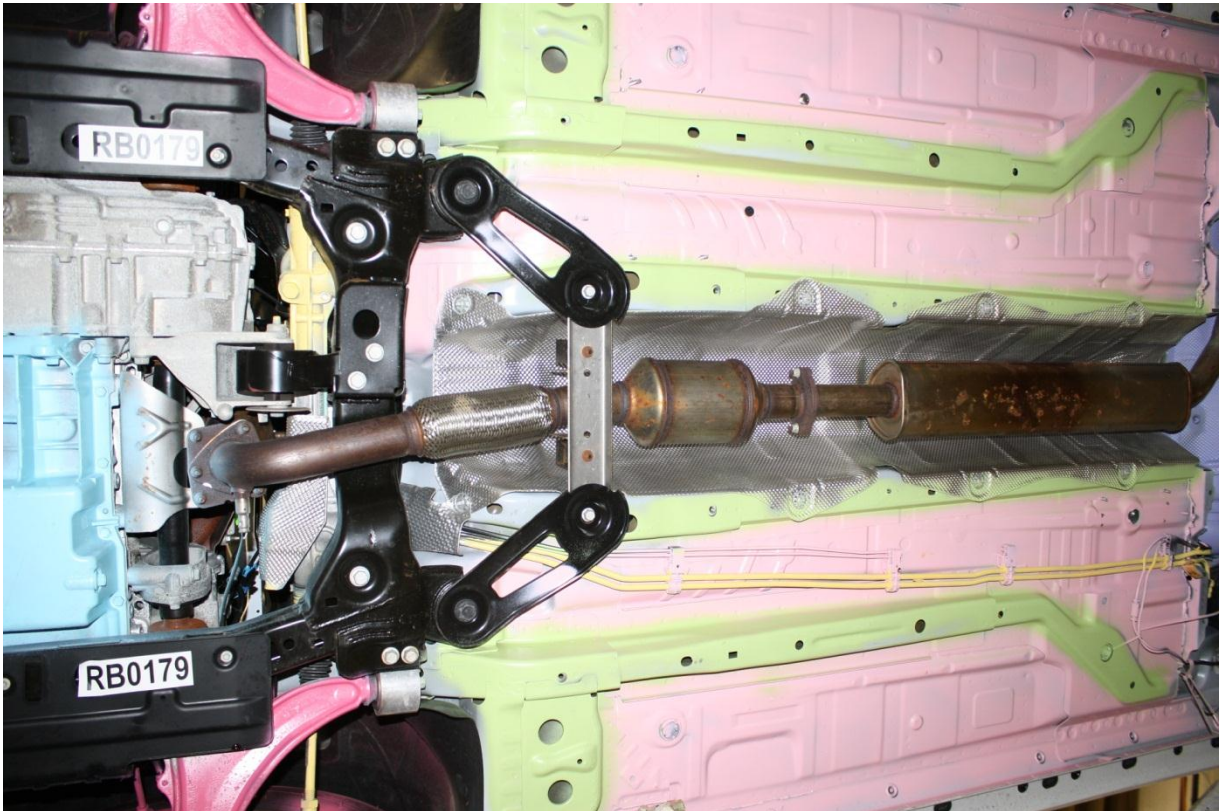

No. 111 Pre-Test View of Overall Underbody (perpendicular to vehicle)



No. 112 Post-Test View of Overall Underbody (perpendicular to vehicle)



No. 115 Pre-Test Close up of Bumper and Crush Initiators

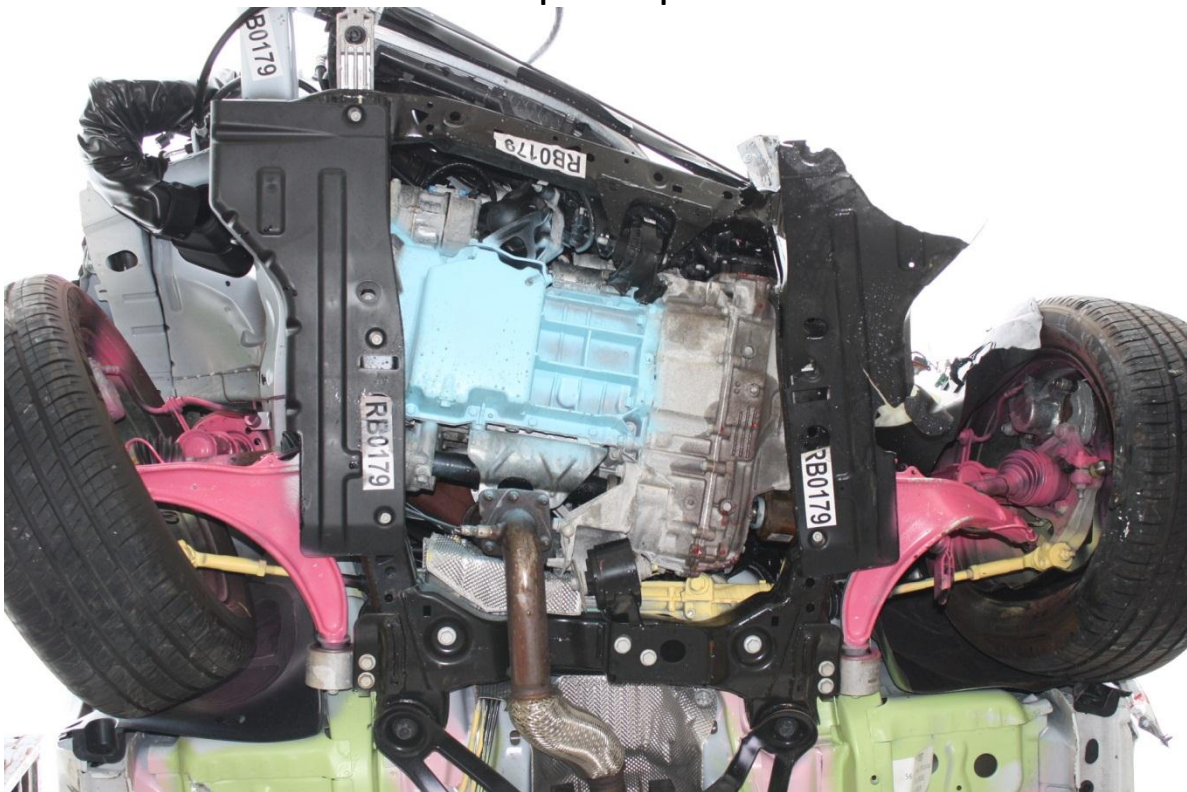

No. 116 Post-Test View of Front Sub-Frame Deformation

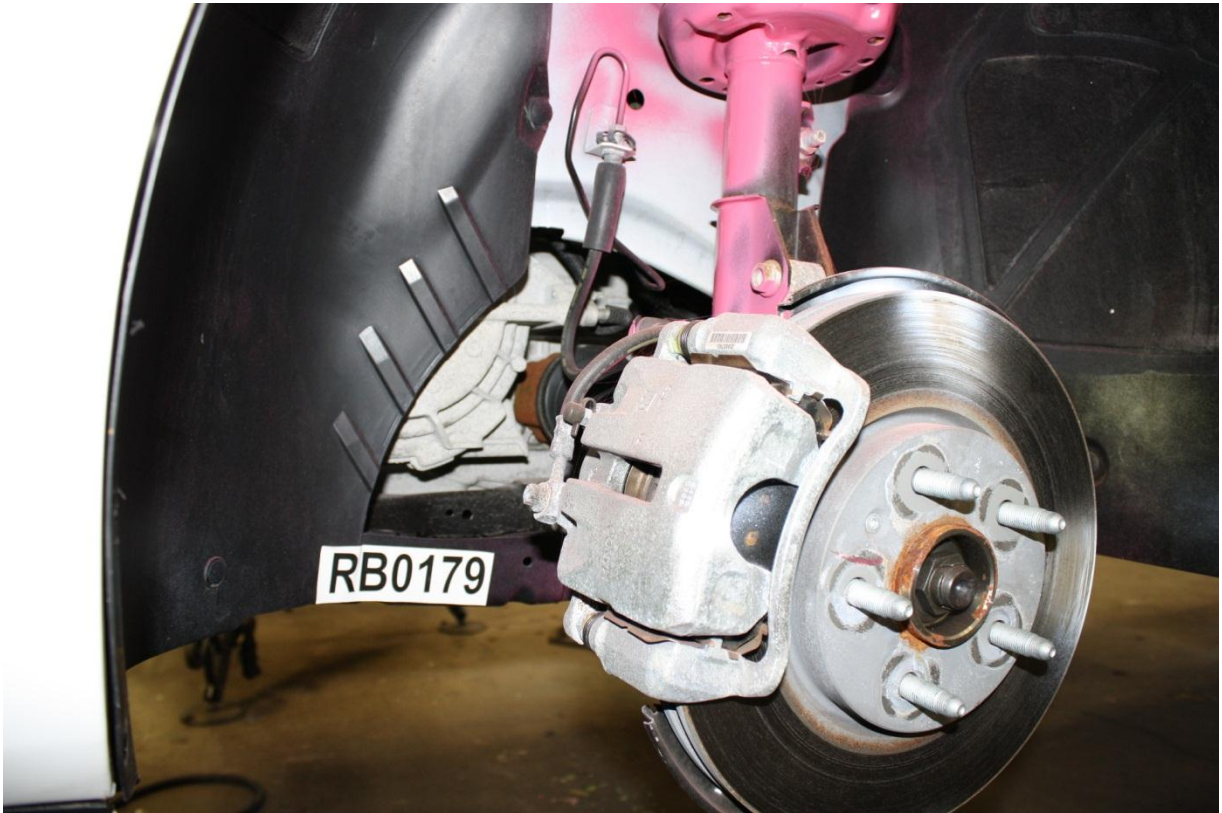

No. 117 Pre-Test Frame Rail with tire removed



No. 118 Post-Test Frame Rail with tire removed



No. 119 Pre-Test View of Wheel Well with tire removed



No. 120 Post-Test View of Wheel Well with tire removed

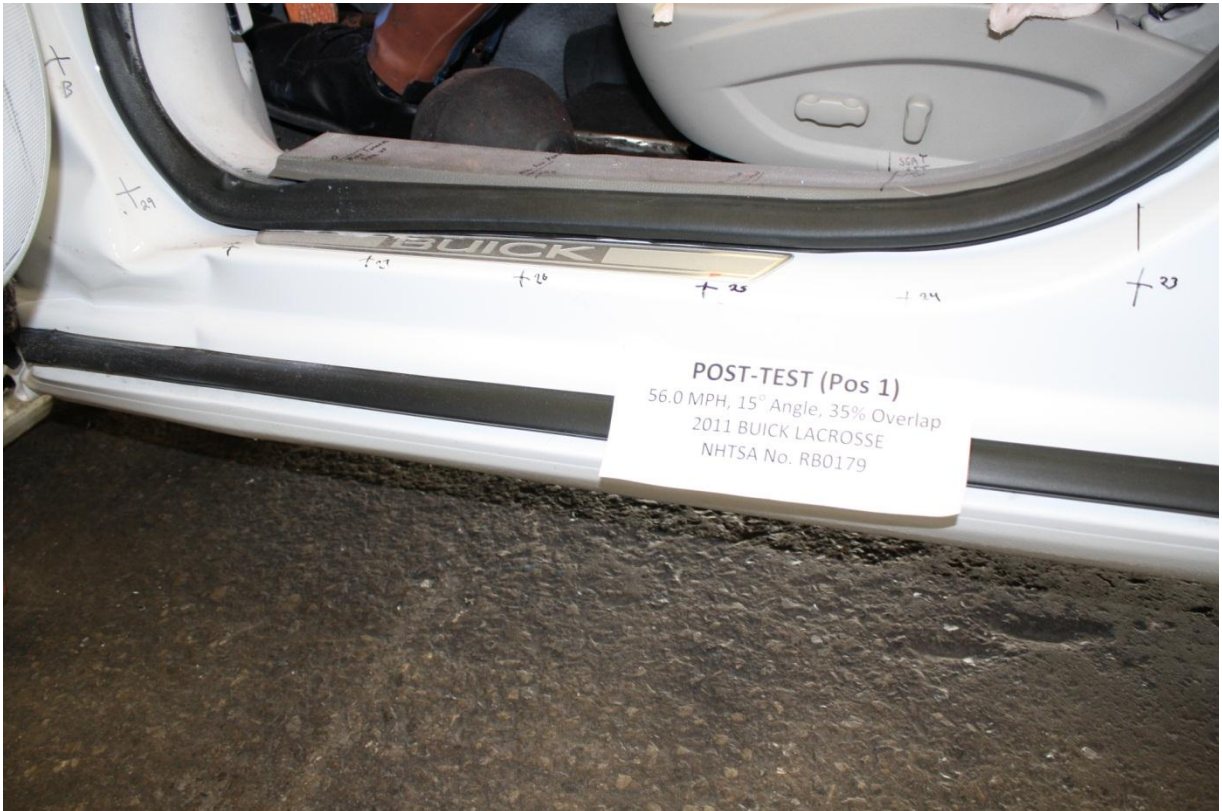

No. 121 Post-Test View of Door Sill with door open



No. 122 Post-Test View of Deformation of A pillar



No. 123 Post-Test View of Deformation of B pillar



No. 124 Post-Test View of Deformation of C pillar



No. 125 Post-Test View of Wheel and or Tire Deformation



No. 126 Post-Test View of Deformation of Rocker or Post

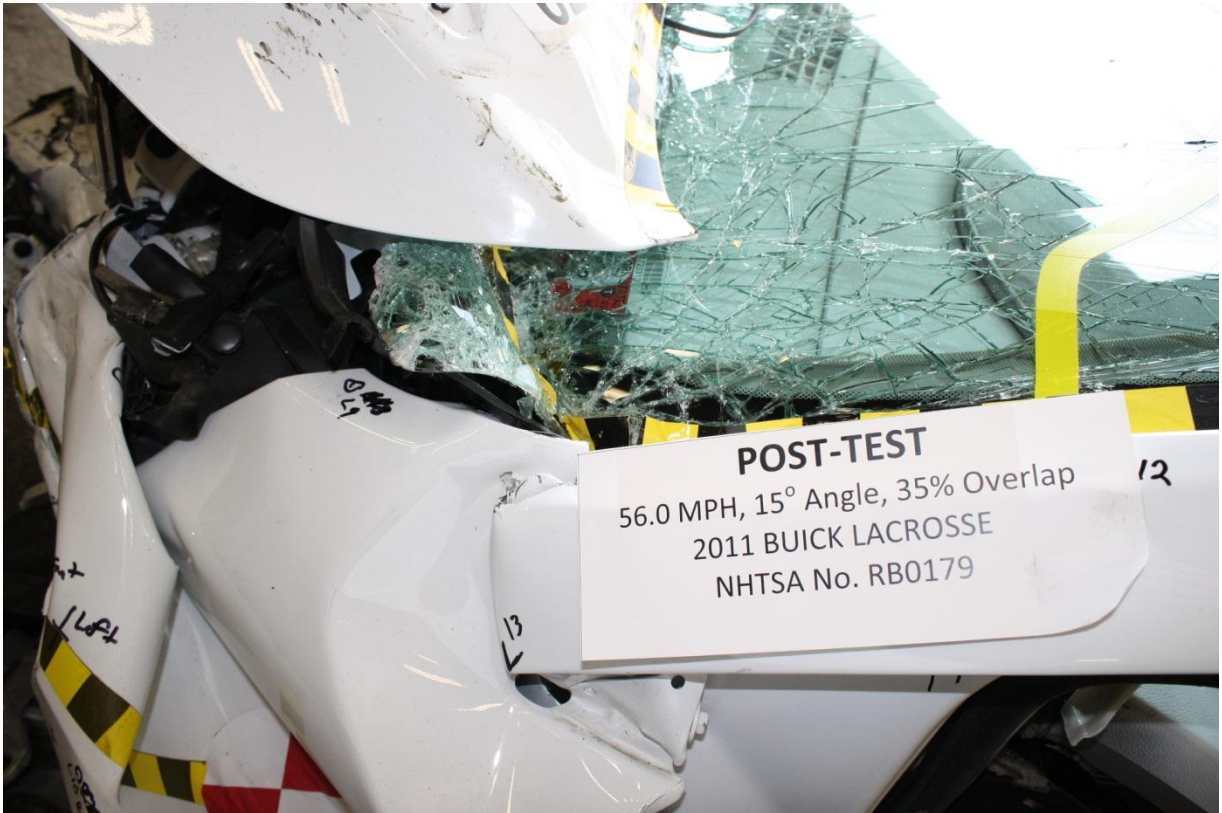

No. 127 Post-Test View of Windshield Separation



No. 128 Pre-Test Left Side View of RMVB



No. 129 Post-Test Left Side View of RMVB



No. 130 Pre-Test Right Side View of RMDB



No. 131 Post-Test Right Side View of RMDB



No. 132 Pre-Test Top View of RMDB



No. 133 Post-Test Top View of RMDB



No. 134 Pre-Test Front View of RMDB



No. 135 Post-Test Front View of RMDB



No. 136 Vehicle at 0 Degrees on Static Rollover Device

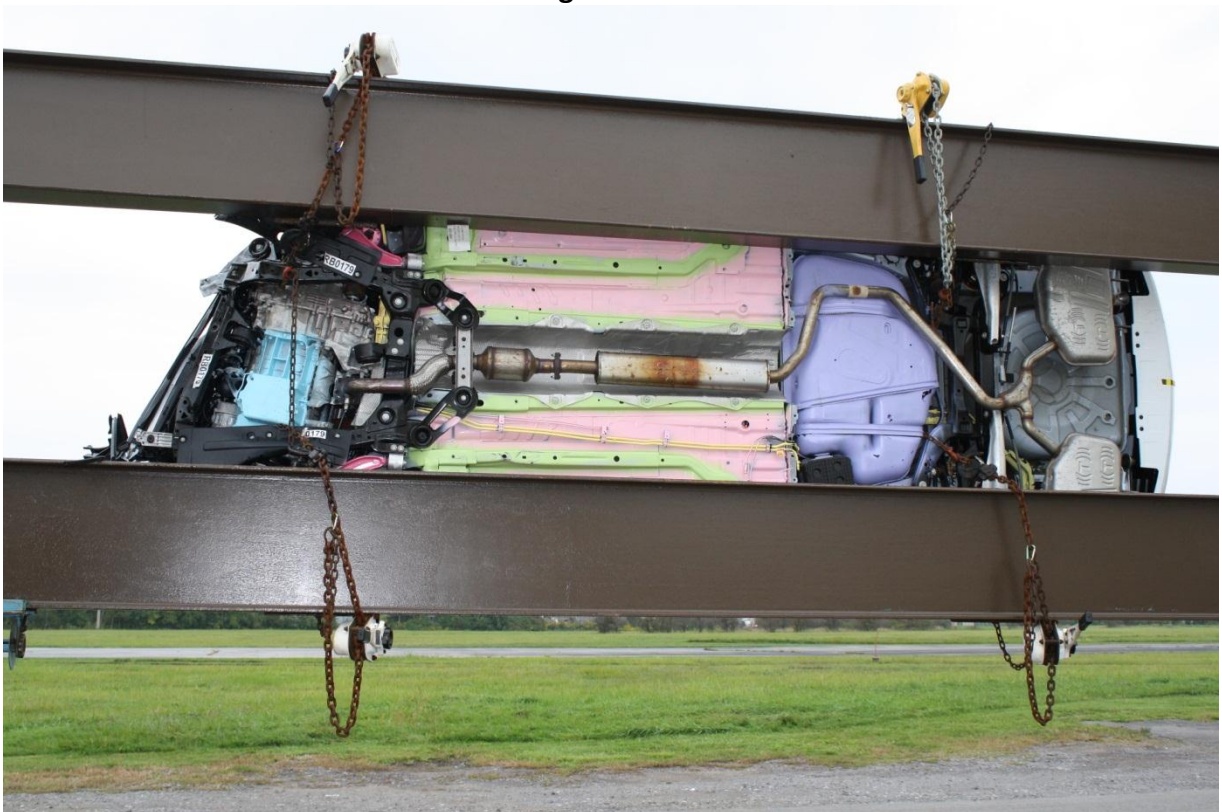

No. 137 Vehicle at 90 Degrees on Static Rollover Device



No. 138 Vehicle at 180 Degrees on Static Rollover Device



No. 139 Vehicle at 270 Degrees on Static Rollover Device



No. 140 Vehicle at 360 Degrees on Static Rollover Device

APPENDIX B
VEHICLE & DUMMY RESPONSE DATA TRACES

Table of Data Plots

No.	Description	Page
Plot 1	V2P1 HEAD CG X [G, CFC_1000]	B-8 top
Plot 2	V2P1 HEAD CG Y [G, CFC_1000]	B-8 bottom
Plot 3	V2P1 HEAD CG Z [G , CFC_1000]	B-9 top
Plot 4	V2P1 HEAD CG WX [DEG/S , CFC_1000]	B-9 bottom
Plot 5	V2P1 HEAD CG WY [DEG/S , CFC_1000]	B-10 top
Plot 6	V2P1 HEAD CG WZ [DEG/S , CFC_1000]	B-10 bottom
Plot 7	V2P1 NECK UPPER FX [N , CFC_1000]	B-11 top
Plot 8	V2P1 NECK UPPER FY [N , CFC_1000]	B-11 bottom
Plot 9	V2P1 NECK UPPER FZ [N , CFC_1000]	B-12 top
Plot 10	V2P1 NECK UPPER MX [N-M , CFC_600]	B-12 bottom
Plot 11	V2P1 NECK UPPER MY [N-M , CFC_600]	B-13 top
Plot 12	V2P1 NECK UPPER MZ [N-M , CFC_600]	B-13 bottom
Plot 13	V2P1 NECK LOWER FX [N , CFC_1000]	B-14 top
Plot 14	V2P1 NECK LOWER FY [N , CFC_1000]	B-14 bottom
Plot 15	V2P1 NECK LOWER FZ [N , CFC_1000]	B-15 top
Plot 16	V2P1 NECK LOWER MX [N-M , CFC_600]	B-15 bottom
Plot 17	V2P1 NECK LOWER MY [N-M , CFC_600]	B-16 top
Plot 18	V2P1 NECK LOWER MZ [N-M , CFC_600]	B-16 bottom
Plot 19	V2P1 NECK SPRING LOAD CELL - FRONT [N , CFC_1000]	B-17 top
Plot 20	V2P1 NECK SPRING LOAD CELL - REAR [N , CFC_1000]	B-17 bottom
Plot 21	V2P1 OC ANGLE RY [DEG , CFC_180]	B-18 top
Plot 22	V2P1 CLAVICLE - LEFT OUTER LC FX [N , CFC_1000]	B-18 bottom
Plot 23	V2P1 CLAVICLE - LEFT OUTER LC FZ [N , CFC_1000]	B-19 top
Plot 24	V2P1 CLAVICLE - LEFT INNER LC FX [N , CFC_1000]	B-19 bottom
Plot 25	V2P1 CLAVICLE - LEFT INNER LC FZ [N , CFC_1000]	B-20 top
Plot 26	V2P1 CLAVICLE - RIGHT OUTER LC FX [N , CFC_1000]	B-20 bottom
Plot 27	V2P1 CLAVICLE - RIGHT OUTER LC FZ [N , CFC_1000]	B-21 top
Plot 28	V2P1 CLAVICLE - RIGHT INNER LC FX [N , CFC_1000]	B-21 bottom
Plot 29	V2P1 CLAVICLE - RIGHT INNER LC FZ [N , CFC_1000]	B-22 top
Plot 30	V2P1 UL CHEST ISTRACC DX [V , CFC_600]	B-22 bottom
Plot 31	V2P1 UL CHEST RY [DEG , CFC_180]	B-23 top
Plot 32	V2P1 UL CHEST RZ [DEG , CFC_180]	B-23 bottom
Plot 33	V2P1 UR CHEST ISTRACC DX [V , CFC_600]	B-24 top
Plot 34	V2P1 UR CHEST RY [DEG , CFC_180]	B-24 bottom
Plot 35	V2P1 UR CHEST RZ [DEG , CFC_180]	B-25 top
Plot 36	V2P1 LL CHEST ISTRACC DX [V , CFC_600]	B-25 bottom
Plot 37	V2P1 LL CHEST RY [DEG , CFC_180]	B-26 top
Plot 38	V2P1 LL CHEST RZ [DEG , CFC_180]	B-26 bottom
Plot 39	V2P1 LR CHEST ISTRACC DX [V , CFC_600]	B-27 top
Plot 40	V2P1 LR CHEST RY [DEG , CFC_180]	B-27 bottom
Plot 41	V2P1 LR CHEST RZ [DEG , CFC_180]	B-28 top
Plot 42	V2P1 ABDOMEN LEFT ISTRACC DX [V , CFC_600]	B-28 bottom
Plot 43	V2P1 ABDOMEN LEFT RY [DEG , CFC_180]	B-29 top
Plot 44	V2P1 ABDOMEN LEFT RZ [DEG , CFC_180]	B-29 bottom
Plot 45	V2P1 ABDOMEN RIGHT ISTRACC DX [V , CFC_600]	B-30 top
Plot 46	V2P1 ABDOMEN RIGHT RY [DEG , CFC_180]	B-30 bottom

Plot 47	V2P1 ABDOMEN RIGHT RZ [DEG , CFC_180]	B-31 top
Plot 48	V2P1 T1 ACCEL AX [G , CFC_180]	B-31 bottom
Plot 49	V2P1 T1 ACCEL AY [G , CFC_180]	B-32 top
Plot 50	V2P1 T1 ACCEL AZ [G , CFC_180]	B-32 bottom
Plot 51	V2P1 T6 ACCEL AX [G , CFC_180]	B-33 top
Plot 52	V2P1 T6 ACCEL AY [G , CFC_180]	B-33 bottom
Plot 53	V2P1 T6 ACCEL AZ [G , CFC_180]	B-34 top
Plot 54	V2P1 T12 ACCEL AX [G , CFC_180]	B-34 bottom
Plot 55	V2P1 T12 ACCEL AY [G , CFC_180]	B-35 top
Plot 56	V2P1 T12 ACCEL AZ [G , CFC_180]	B-35 bottom
Plot 57	V2P1 SPINE LOWER FX [N , CFC_1000]	B-36 top
Plot 58	V2P1 SPINE LOWER FY [N , CFC_1000]	B-36 bottom
Plot 59	V2P1 SPINE LOWER FZ [N , CFC_1000]	B-37 top
Plot 60	V2P1 SPINE LOWER MX [N-M , CFC_1000]	B-37 bottom
Plot 61	V2P1 SPINE LOWER MY [N-M , CFC_1000]	B-38 top
Plot 62	V2P1 PELVIS CG AX [G , CFC_1000]	B-38 bottom
Plot 63	V2P1 PELVIS CG AY [G , CFC_1000]	B-39 top
Plot 64	V2P1 PELVIS CG AZ [G , CFC_1000]	B-39 bottom
Plot 65	V2P1 PELVIS ASIS LEFT Fx	B-40 top
Plot 66	V2P1 PELVIS ASIS LEFT Fy	B-40 bottom
Plot 67	V2P1 PELVIS ASIS LEFT Fz	B-41 top
Plot 68	V2P1 PELVIS ASIS RIGHT Fx	B-41 bottom
Plot 69	V2P1 PELVIS ASIS RIGHT Fy	B-42 top
Plot 70	V2P1 PELVIS ASIS RIGHT Fz	B-42 bottom
Plot 71	V2P1 LEFT ILIAC FX [N , CFC_1000]	B-43 top
Plot 72	V2P1 LEFT ILIAC MY [N-M , CFC_1000]	B-43 bottom
Plot 73	V2P1 RIGHT ILIAC FX [N , CFC_1000]	B-44 top
Plot 74	V2P1 RIGHT ILIAC MY [N-M , CFC_1000]	B-44 bottom
Plot 75	V2P1 LEFT FEMUR FX [N , CFC_600]	B-45 top
Plot 76	V2P1 LEFT FEMUR FY [N , CFC_600]	B-45 bottom
Plot 77	V2P1 LEFT FEMUR FZ [N , CFC_600]	B-46 top
Plot 78	V2P1 LEFT FEMUR MX [N-M , CFC_600]	B-46 bottom
Plot 79	V2P1 LEFT FEMUR MY [N-M , CFC_600]	B-47 top
Plot 80	V2P1 LEFT FEMUR MZ [N-M , CFC_600]	B-47 bottom
Plot 81	V2P1 KNEE LEFT DX [MM , CFC_180]	B-48 top
Plot 82	V2P1 TIBIA LEFT X [G , CFC_1000]	B-48 bottom
Plot 83	V2P1 TIBIA LEFT Y [G , CFC_1000]	B-49 top
Plot 84	V2P1 TIBIA LEFT UPPER FX [N , CFC_600]	B-49 bottom
Plot 85	V2P1 TIBIA LEFT UPPER FZ [N , CFC_600]	B-50 top
Plot 86	V2P1 TIBIA LEFT UPPER MX [N-M , CFC_600]	B-50 bottom
Plot 87	V2P1 TIBIA LEFT UPPER MY [N-M , CFC_600]	B-51 top
Plot 88	V2P1 TIBIA LEFT LOWER FX [N , CFC_600]	B-51 bottom
Plot 89	V2P1 TIBIA LEFT LOWER FY [N , CFC_600]	B-52 top
Plot 90	V2P1 TIBIA LEFT LOWER FZ [N , CFC_600]	B-52 bottom
Plot 91	V2P1 TIBIA LEFT LOWER MX [N-M , CFC_600]	B-53 top
Plot 92	V2P1 TIBIA LEFT LOWER MY [N-M , CFC_600]	B-53 bottom
Plot 93	V2P1 ANKLE LEFT POT X [DEG , CFC_180] [W/ OFFSET]	B-54 top
Plot 94	V2P1 ANKLE LEFT POT Y [DEG , CFC_180] [W/ OFFSET]	B-54 bottom

Plot 95	V2P1 ANKLE LEFT POT Z [DEG , CFC_180] [W/ OFFSET]	B-55 top
Plot 96	V2P1 FOOT LEFT X [G , CFC_1000]	B-55 bottom
Plot 97	V2P1 FOOT LEFT Y [G , CFC_1000]	B-56 top
Plot 98	V2P1 FOOT LEFT Z [G , CFC_1000]	B-56 bottom
Plot 99	V2P1 RIGHT FEMUR FX [N , CFC_600]	B-57 top
Plot 100	V2P1 RIGHT FEMUR FY [N , CFC_600]	B-57 bottom
Plot 101	V2P1 RIGHT FEMUR FZ [N , CFC_600]	B-58 top
Plot 102	V2P1 RIGHT FEMUR MX [N-M , CFC_600]	B-58 bottom
Plot 103	V2P1 RIGHT FEMUR MY [N-M , CFC_600]	B-59 top
Plot 104	V2P1 RIGHT FEMUR MZ [N-M , CFC_600]	B-59 bottom
Plot 105	V2P1 KNEE RIGHT DX [MM , CFC_180]	B-60 top
Plot 106	V2P1 TIBIA RIGHT X [G , CFC_1000]	B-60 bottom
Plot 107	V2P1 TIBIA RIGHT Y [G , CFC_1000]	B-61 top
Plot 108	V2P1 TIBIA RIGHT UPPER FX [N , CFC_600]	B-61 bottom
Plot 109	V2P1 TIBIA RIGHT UPPER FZ [N , CFC_600]	B-62 top
Plot 110	V2P1 TIBIA RIGHT UPPER MX [N-M , CFC_600]	B-62 bottom
Plot 111	V2P1 TIBIA RIGHT UPPER MY [N-M , CFC_600]	B-63 top
Plot 112	V2P1 TIBIA RIGHT LOWER FX [N , CFC_600]	B-63 bottom
Plot 113	V2P1 TIBIA RIGHT LOWER FY [N , CFC_600]	B-64 top
Plot 114	V2P1 TIBIA RIGHT LOWER FZ [N , CFC_600]	B-64 bottom
Plot 115	V2P1 TIBIA RIGHT LOWER MX [N-M , CFC_600]	B-65 top
Plot 116	V2P1 TIBIA RIGHT LOWER MY [N-M , CFC_600]	B-65 bottom
Plot 117	V2P1 ANKLE RIGHT POT X [DEG , CFC_180] [W/ OFFSET]	B-66 top
Plot 118	V2P1 ANKLE RIGHT POT Y [DEG , CFC_180] [W/ OFFSET]	B-66 bottom
Plot 119	V2P1 ANKLE RIGHT POT Z [DEG , CFC_180] [W/ OFFSET]	B-67 top
Plot 120	V2P1 FOOT RIGHT X [G , CFC_1000]	B-67 bottom
Plot 121	V2P1 FOOT RIGHT Y [G , CFC_1000]	B-68 top
Plot 122	V2P1 FOOT RIGHT Z [G , CFC_1000]	B-68 bottom
Plot 123	V2 DRIVER LAP BELT [N , CFC_60]	B-69 top
Plot 124	V2 DRIVER SHOULDER BELT [N , CFC_60]	B-69 bottom
Plot 125	V2P4 HEAD CG X [G , CFC_1000]	B-70 top
Plot 126	V2P4 HEAD CG Y [G , CFC_1000]	B-70 bottom
Plot 127	V2P4 HEAD CG Z [G , CFC_1000]	B-71 top
Plot 128	V2P4 HEAD 9 ARRAY X ARM Y [G , CFC_1000]	B-71 bottom
Plot 129	V2P4 HEAD 9 ARRAY X ARM Z [G , CFC_1000]	B-72 top
Plot 130	V2P4 HEAD 9 ARRAY Y ARM X [G , CFC_1000]	B-72 bottom
Plot 131	V2P4 HEAD 9 ARRAY Y ARM Z [G , CFC_1000]	B-73 top
Plot 132	V2P4 HEAD 9 ARRAY Z ARM X [G , CFC_1000]	B-73 bottom
Plot 133	V2P4 HEAD 9 ARRAY Z ARM Y [G , CFC_1000]	B-74 top
Plot 134	V2P4 HEAD 9 ARRAY CENTER X [G , CFC_1000]	B-74 bottom
Plot 135	V2P4 HEAD 9 ARRAY CENTER Y [G , CFC_1000]	B-75 top
Plot 136	V2P4 HEAD 9 ARRAY CENTER Z [G , CFC_1000]	B-75 bottom
Plot 137	V2P4 UPPER NECK FX [N , CFC_1000]	B-76 top
Plot 138	V2P4 UPPER NECK FY [N , CFC_1000]	B-76 bottom
Plot 139	V2P4 UPPER NECK FZ [N , CFC_1000]	B-77 top
Plot 140	V2P4 UPPER NECK MX [N-M , CFC_600]	B-77 bottom
Plot 141	V2P4 UPPER NECK MY [N-M , CFC_600]	B-78 top
Plot 142	V2P4 UPPER NECK MZ [N-M , CFC_600]	B-78 bottom

Plot 143	V2P4 LOWER NECK FX [N , CFC_1000]	B-79 top
Plot 144	V2P4 LOWER NECK FY [N , CFC_1000]	B-79 bottom
Plot 145	V2P4 LOWER NECK FZ [N , CFC_1000]	B-80 top
Plot 146	V2P4 LOWER NECK MX [N-M , CFC_600]	B-80 bottom
Plot 147	V2P4 LOWER NECK MY [N-M , CFC_600]	B-81 top
Plot 148	V2P4 LOWER NECK MZ [N-M , CFC_600]	B-81 bottom
Plot 149	V2P4 CHEST X [G , CFC_180]	B-82 top
Plot 150	V2P4 CHEST Y [G , CFC_180]	B-82 bottom
Plot 151	V2P4 CHEST Z [G , CFC_180]	B-83 top
Plot 152	V2P4 CHEST RED X [G , CFC_180]	B-83 bottom
Plot 153	V2P4 CHEST RED Y [G , CFC_180]	B-84 top
Plot 154	V2P4 CHEST RED Z [G , CFC_180]	B-84 bottom
Plot 155	V2P4 CHEST DISPLACEMENT [MM , CFC_600]	B-85 top
Plot 156	V2P4 8 STRING POD - UR TOP [MM , CFC_600]	B-85 bottom
Plot 157	V2P4 8 STRING POD - UR MID [MM , CFC_600]	B-86 top
Plot 158	V2P4 8 STRING POD - LR MID [MM , CFC_600]	B-86 bottom
Plot 159	V2P4 8 STRING POD - LR BOTTOM [MM , CFC_600]	B-87 top
Plot 160	V2P4 8 STRING POD - UL TOP [MM , CFC_600]	B-87 bottom
Plot 161	V2P4 8 STRING POD - UL MID [MM , CFC_600]	B-88 top
Plot 162	V2P4 8 STRING POD - LL MID [MM , CFC_600]	B-88 bottom
Plot 163	V2P4 8 STRING POD - LL BOTTOM [MM , CFC_600]	B-89 top
Plot 164	V2P4 PELVIC X [G , CFC_1000]	B-89 bottom
Plot 165	V2P4 PELVIC Y [G , CFC_1000]	B-90 top
Plot 166	V2P4 PELVIC Z [G , CFC_1000]	B-90 bottom
Plot 167	V2P4 LEFT FEMUR FZ [N , CFC_600]	B-91 top
Plot 168	V2P4 RIGHT FEMUR FZ [N , CFC_600]	B-91 bottom
Plot 169	V2 RR PASSENGER LAP BELT [N , CFC_60]	B-92 top
Plot 170	V2 RR PASSENGER SHOULDER BELT [N , CFC_60]	B-92 bottom
Plot 171	V2 LEFT REAR SILL X [G , CFC_60]	B-93 top
Plot 172	V2 LEFT REAR SILL Y [G , CFC_60]	B-93 bottom
Plot 173	V2 RIGHT REAR SILL X [G , CFC_60]	B-94 top
Plot 174	V2 RIGHT REAR SILL Y [G , CFC_60]	B-94 bottom
Plot 175	V2 VEHICLE CG X [G , CFC_60]	B-95 top
Plot 176	V2 VEHICLE CG Y [G , CFC_60]	B-95 bottom
Plot 177	V2 VEHICLE CG Z [G , CFC_60]	B-96 top
Plot 178	V2 INSTRUMENT PANEL X [G , CFC_60]	B-96 bottom
Plot 179	V2 DRIVER SEAT TRACK X [G , CFC_60]	B-97 top
Plot 180	V2 DRIVER SEAT TRACK Y [G , CFC_60]	B-97 bottom
Plot 181	V2 DRIVER SEAT TRACK Z [G , CFC_60]	B-98 top
Plot 182	V2 DRIVER FLOOR PAN X [G , CFC_60]	B-98 bottom
Plot 183	V2 DRIVER FLOOR PAN Y [G , CFC_60]	B-99 top
Plot 184	V2 DRIVER FLOOR PAN Z [G , CFC_60]	B-99 bottom
Plot 185	V2 DRIVER FLOOR PAN DS [MM , CFC_60]	B-100 top
Plot 186	V2 VEHICLE CG RX [G , CFC_60]	B-100 bottom
Plot 187	V2 VEHICLE CG RY [G , CFC_60]	B-101 top
Plot 188	V2 VEHICLE CG RZ [G , CFC_60]	B-101 bottom
Plot 189	V2 LEFT REAR SILL REDUNDANT X [G , CFC_60]	B-102 top
Plot 190	V2 LEFT REAR SILL REDUNDANT Y [G , CFC_60]	B-102 bottom

Plot 191	V2 DRIVER LEFT KNEE CS1	B-103 top
Plot 192	V2 DRIVER LEFT KNEE CS2	B-103 bottom
Plot 193	V2 DRIVER LEFT KNEE CS3	B-104 top
Plot 194	V2 DRIVER RIGHT KNEE CS4	B-104 bottom
Plot 195	V2 DRIVER RIGHT KNEE CS5	B-105 top
Plot 196	V2 DRIVER RIGHT KNEE CS6	B-105 bottom
Plot 197	V1 CG AX [G , CFC_60]	B-106 top
Plot 198	V1 CG AY [G , CFC_60]	B-106 bottom
Plot 199	V1 CG AZ [G , CFC_60]	B-107 top
Plot 200	V1 REAR C/L AX [G , CFC_60]	B-107 bottom
Plot 201	V1 REAR C/L AY [G , CFC_60]	B-108 top
Plot 202	V1 REAR C/L AZ [G , CFC_60]	B-108 bottom
Plot 203	V2P1 HEAD ANGULAR ACCELERATION X [SIMON]	B-109 top
Plot 204	V2P1 HEAD ANGULAR ACCELERATION Y [SIMON]	B-109 bottom
Plot 205	V2P1 HEAD ANGULAR ACCELERATION Z [SIMON]	B-110 top
Plot 206	V2P1 HEAD ANGULAR VELOCITY X [SIMON]	B-110 bottom
Plot 207	V2P1 HEAD ANGULAR VELOCITY Y [SIMON]	B-111 top
Plot 208	V2P1 HEAD ANGULAR VELOCITY Z [SIMON]	B-111 bottom
Plot 209	V2P1 CUMULATIVE STRAIN 0.05 [SIMON]	B-112 top
Plot 210	V2P1 CUMULATIVE STRAIN 0.10 [SIMON]	B-112 bottom
Plot 211	V2P1 CUMULATIVE STRAIN 0.15 [SIMON]	B-113 top
Plot 212	V2P1 NECK OCCIPITAL CONDYLE FX [THORTEST]	B-113 bottom
Plot 213	V2P1 NECK OCCIPITAL CONDYLE FZ [THORTEST]	B-114 top
Plot 214	V2P1 NECK OCCIPITAL CONDYLE MY [THORTEST]	B-114 bottom
Plot 215	V2P1 NECK UPPER FORCE X [THORTEST]	B-115 top
Plot 216	V2P1 NECK UPPER FORCE Y [THORTEST]	B-115 bottom
Plot 217	V2P1 NECK UPPER FORCE Z [THORTEST]	B-116 top
Plot 218	V2P1 NECK UPPER MOMENT X [THORTEST]	B-116 bottom
Plot 219	V2P1 NECK UPPER MOMENT Y [THORTEST]	B-117 top
Plot 220	V2P1 NECK UPPER MOMENT Z [THORTEST]	B-117 bottom
Plot 221	V2P1 CHEST LEFT UPPER X [CFC_180]	B-118 top
Plot 222	V2P1 CHEST LEFT UPPER Y [CFC_180]	B-118 bottom
Plot 223	V2P1 CHEST LEFT UPPER Z [CFC_180]	B-119 top
Plot 224	V2P1 CHEST LEFT UPPER D [CFC_180]	B-119 bottom
Plot 225	V2P1 CHEST RIGHT UPPER X [CFC_180]	B-120 top
Plot 226	V2P1 CHEST RIGHT UPPER Y [CFC_180]	B-120 bottom
Plot 227	V2P1 CHEST RIGHT UPPER Z [CFC_180]	B-121 top
Plot 228	V2P1 CHEST RIGHT UPPER D [CFC_180]	B-121 bottom
Plot 229	V2P1 CHEST LEFT LOWER X [CFC_180]	B-122 top
Plot 230	V2P1 CHEST LEFT LOWER Y [CFC_180]	B-122 bottom
Plot 231	V2P1 CHEST LEFT LOWER Z [CFC_180]	B-123 top
Plot 232	V2P1 CHEST LEFT LOWER D [CFC_180]	B-123 bottom
Plot 233	V2P1 CHEST RIGHT LOWER X [CFC_180]	B-124 top
Plot 234	V2P1 CHEST RIGHT LOWER Y [CFC_180]	B-124 bottom
Plot 235	V2P1 CHEST RIGHT LOWER Z [CFC_180]	B-125 top
Plot 236	V2P1 CHEST RIGHT LOWER D [CFC_180]	B-125 bottom
Plot 237	V2P1 ABDOMEN LEFT LOWER X [CFC_180]	B-126 top
Plot 238	V2P1 ABDOMEN LEFT LOWER Y [CFC_180]	B-126 bottom

Plot 239	V2P1 ABDOMEN LEFT LOWER Z [CFC_180]	B-127 top
Plot 240	V2P1 ABDOMEN RIGHT LOWER X [CFC_180]	B-127 bottom
Plot 241	V2P1 ABDOMEN RIGHT LOWER Y [CFC_180]	B-128 top
Plot 242	V2P1 ABDOMEN RIGHT LOWER Z [CFC_180]	B-128 bottom
Plot 243	V2P4 HEAD ANGULAR ACCELERATION X [SIMON]	B-129 top
Plot 244	V2P4 HEAD ANGULAR ACCELERATION Y [SIMON]	B-129 bottom
Plot 245	V2P4 HEAD ANGULAR ACCELERATION Z [SIMON]	B-130 top
Plot 246	V2P4 HEAD ANGULAR VELOCITY X [SIMON]	B-130 bottom
Plot 247	V2P4 HEAD ANGULAR VELOCITY Y [SIMON]	B-131 top
Plot 248	V2P4 HEAD ANGULAR VELOCITY Z [SIMON]	B-131 bottom
Plot 249	V2P4 CUMULATIVE STRAIN 0.05 [SIMON]	B-132 top
Plot 250	V2P4 CUMULATIVE STRAIN 0.10 [SIMON]	B-132 bottom
Plot 251	V2P4 CUMULATIVE STRAIN 0.15 [SIMON]	B-133 top
Plot 252	V2P4 CHEST LEFT UPPER X [COMPUTED, MM]	B-133 bottom
Plot 253	V2P4 CHEST LEFT UPPER Y [COMPUTED, MM]	B-134 top
Plot 254	V2P4 CHEST RIGHT UPPER X [COMPUTED, MM]	B-134 bottom
Plot 255	V2P4 CHEST RIGHT UPPER Y [COMPUTED, MM]	B-135 top
Plot 256	V2P4 CHEST LEFT LOWER X [COMPUTED, MM]	B-135 bottom
Plot 257	V2P4 CHEST LEFT LOWER Y [COMPUTED, MM]	B-136 top
Plot 258	V2P4 CHEST RIGHT LOWER X [COMPUTED, MM]	B-136 bottom
Plot 259	V2P4 CHEST RIGHT LOWER Y [COMPUTED, MM]	B-137 top

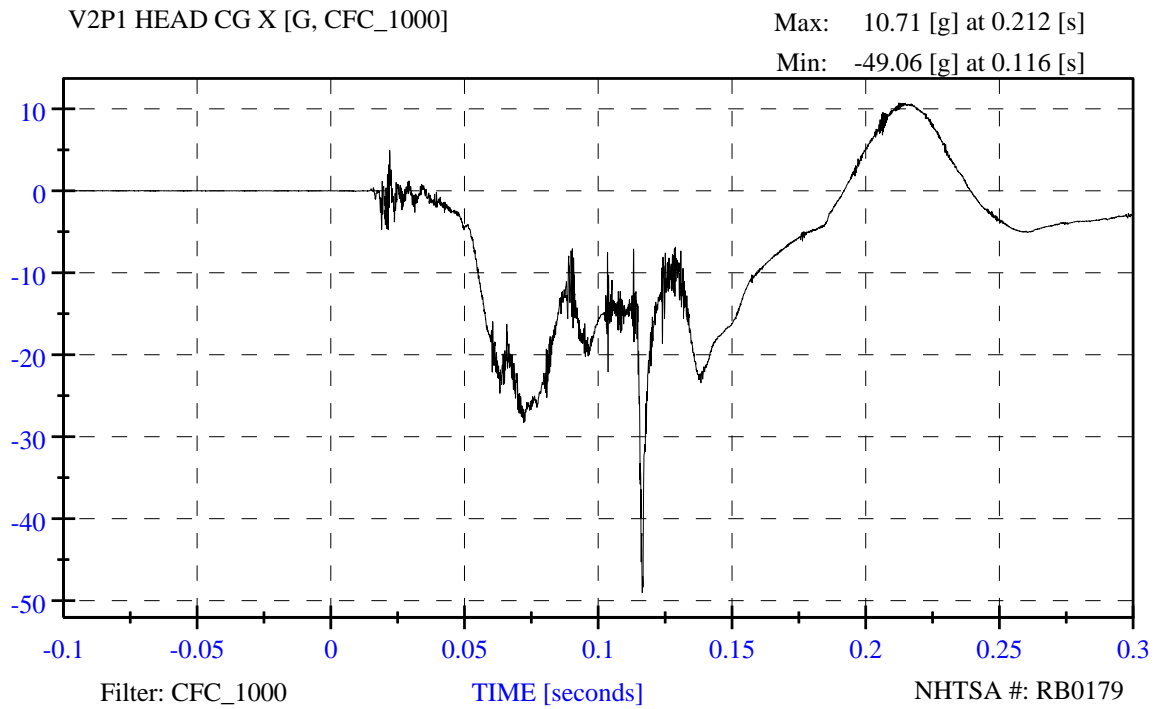

R&D 56 mph, 15deg angle, 35% overlap, 2011 Buick Lacrosse, RB0179

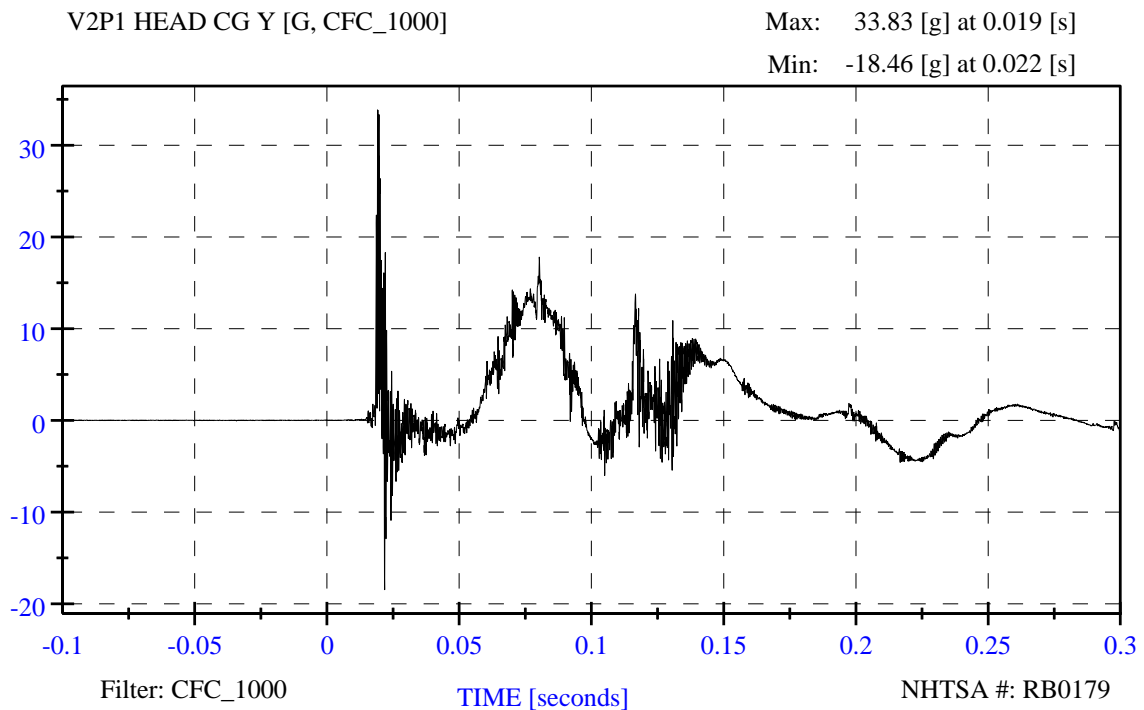

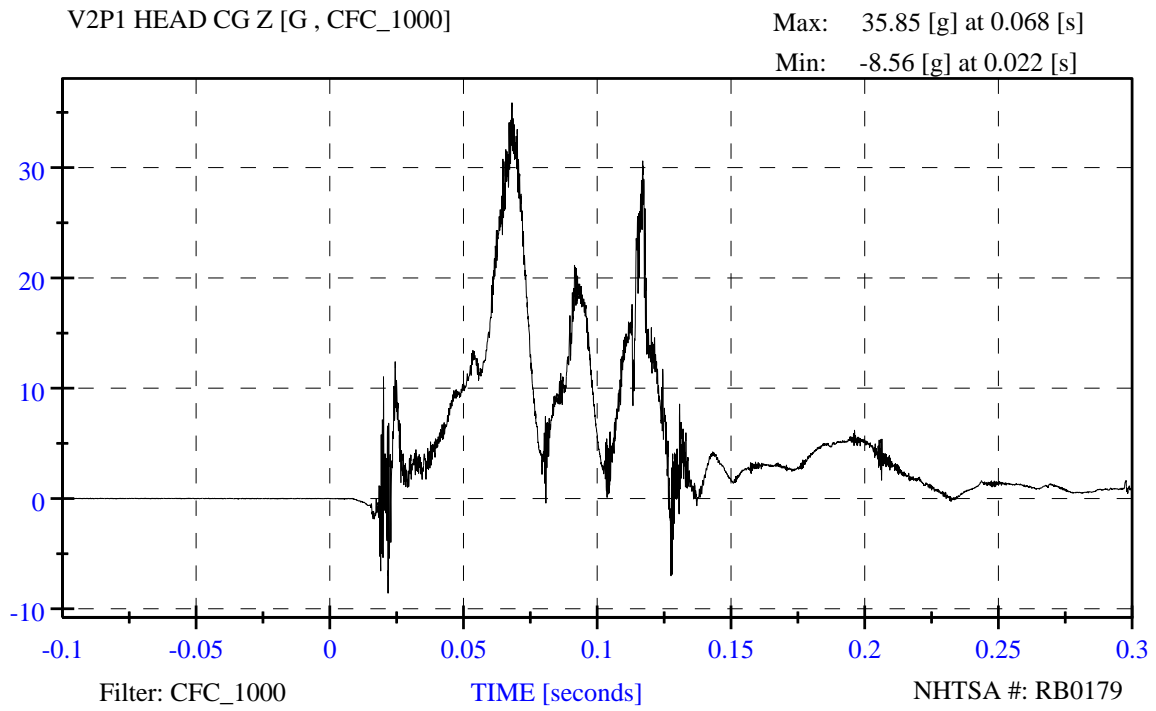

R&D 56 mph, 15deg angle, 35% overlap, 2011 Buick Lacrosse, RB0179

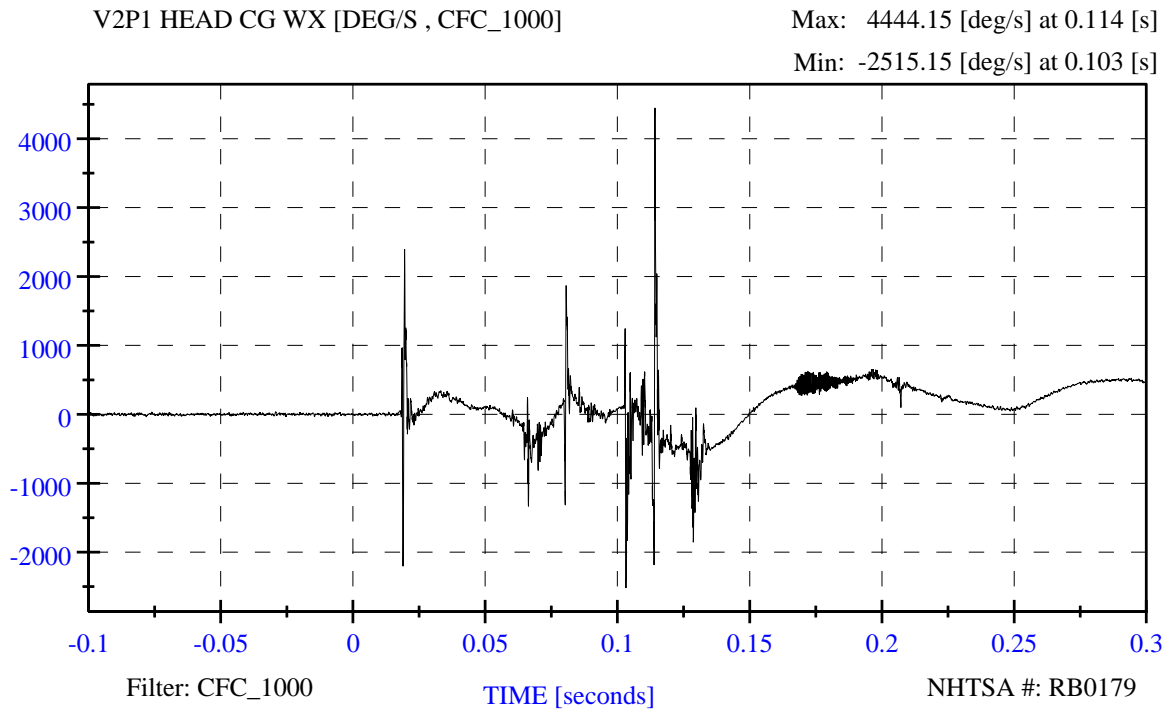

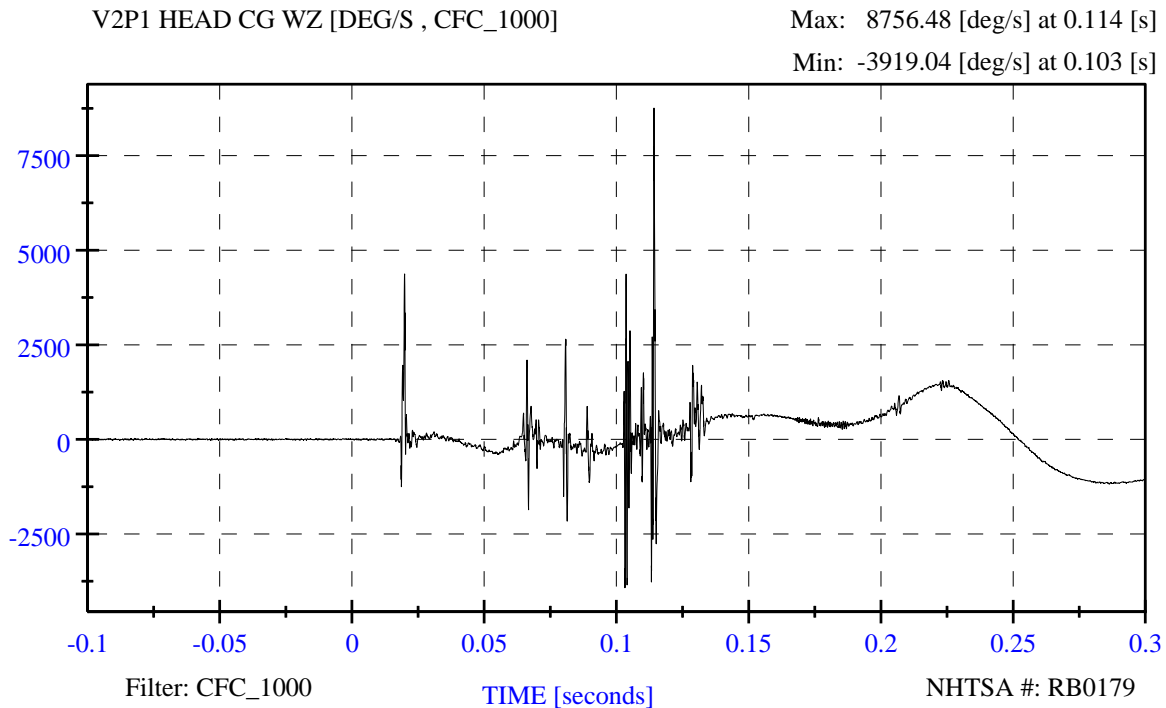
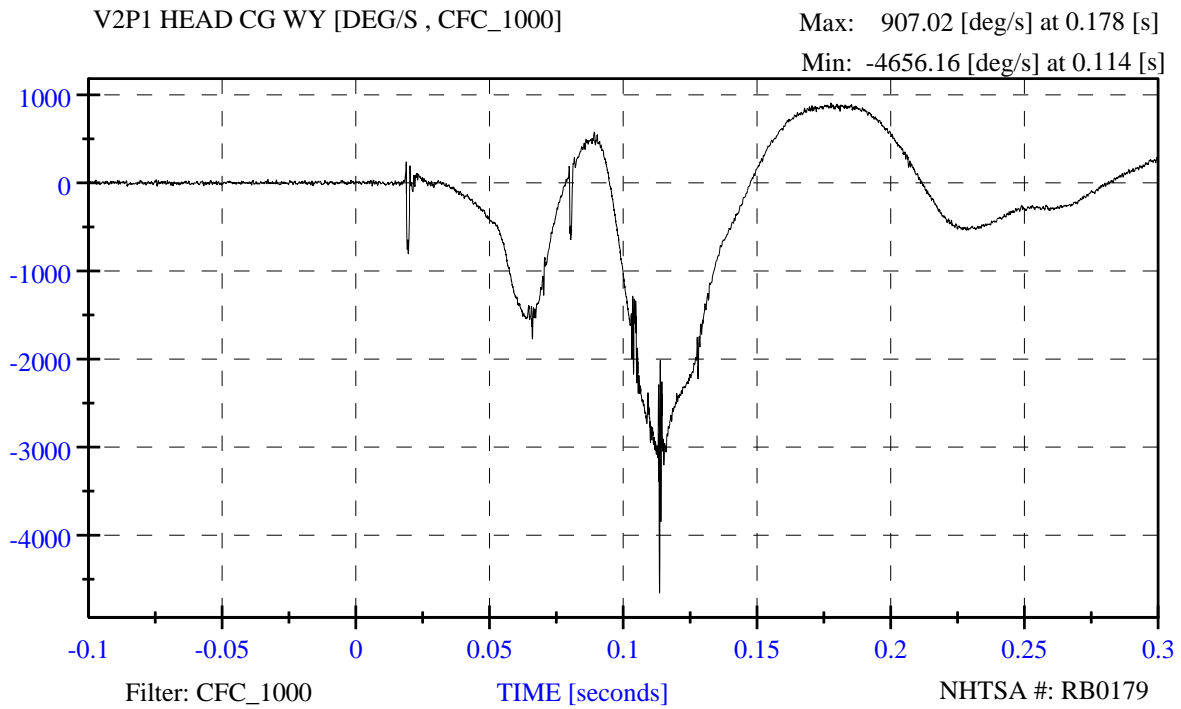

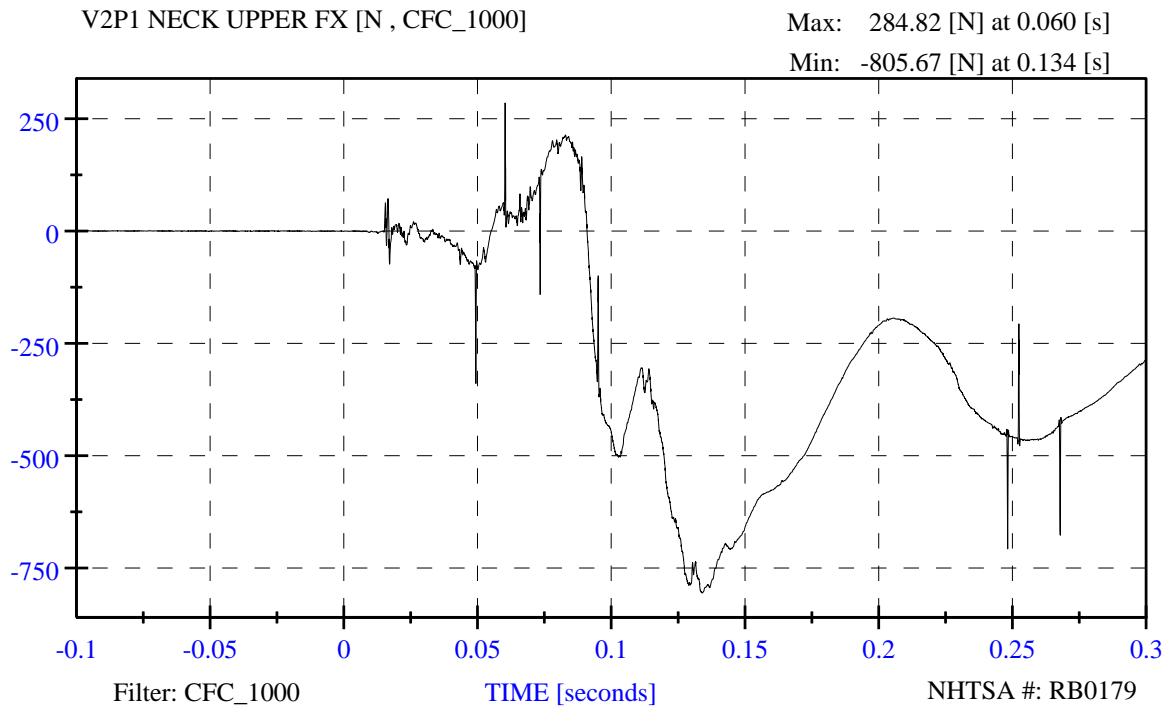

R&D 56 mph, 15deg angle, 35% overlap, 2011 Buick Lacrosse, RB0179

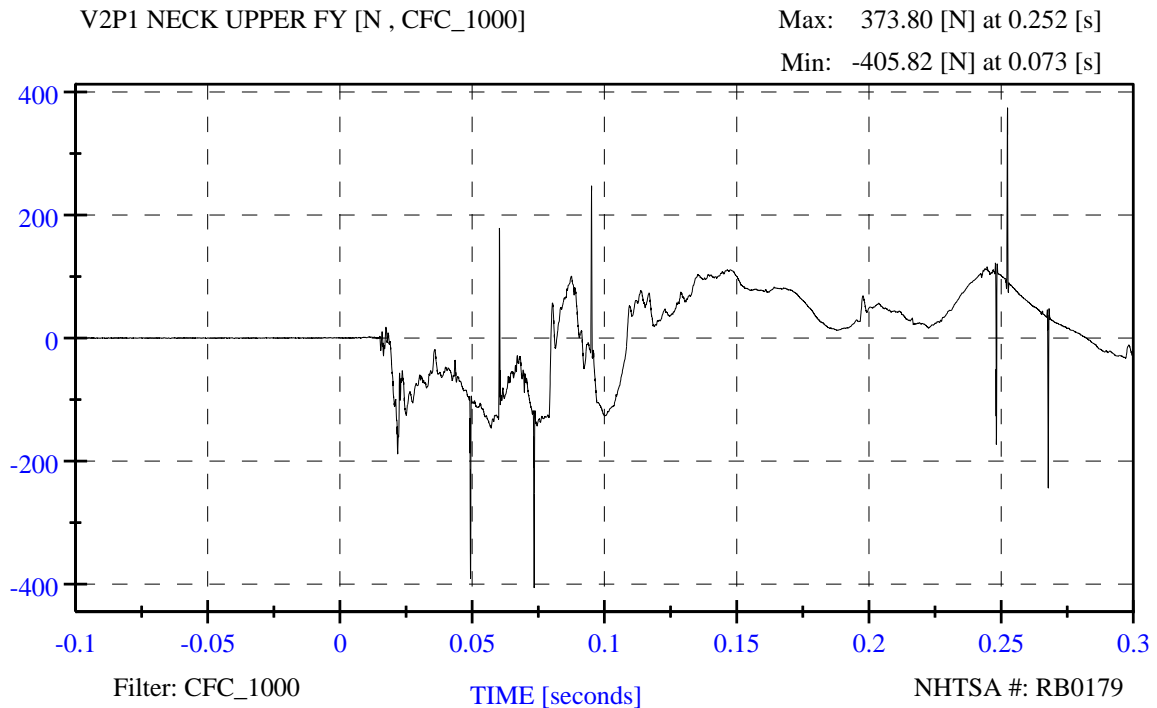

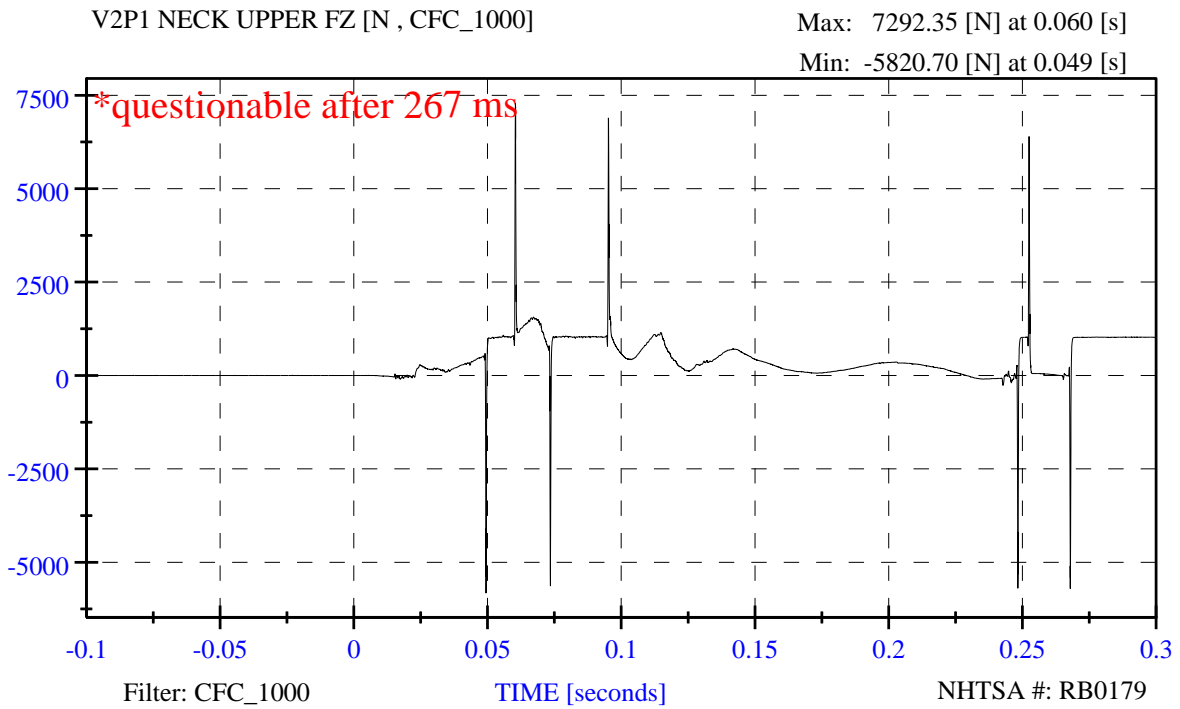

R&D 56 mph, 15deg angle, 35% overlap, 2011 Buick Lacrosse, RB0179

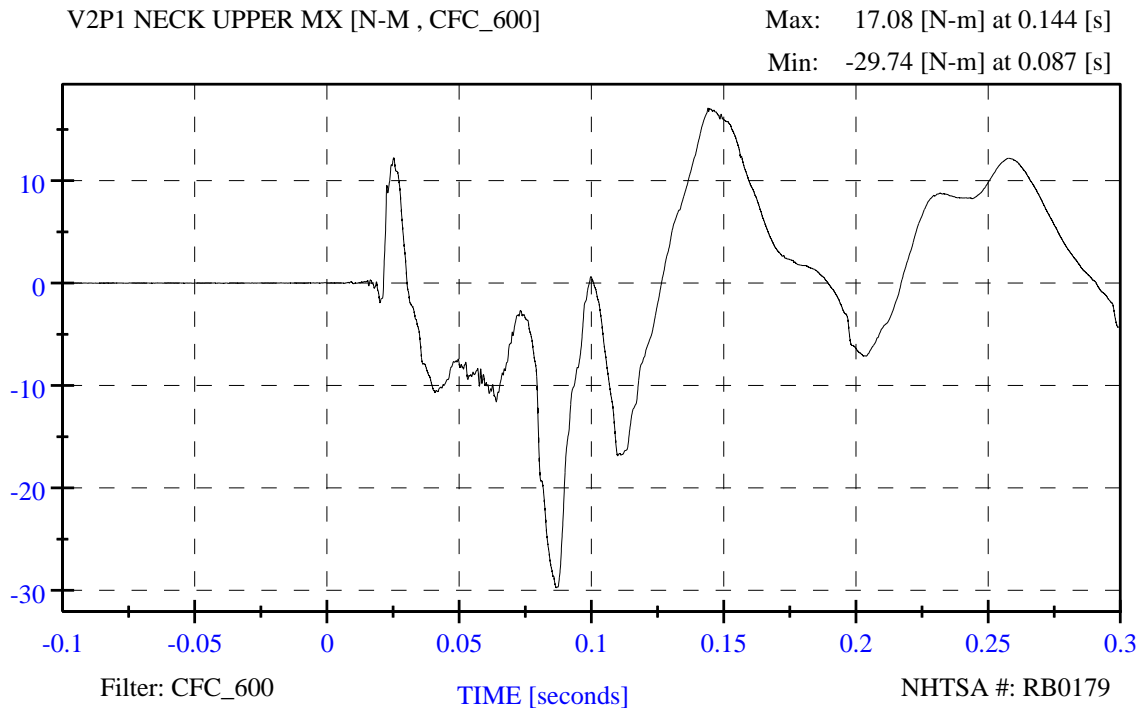

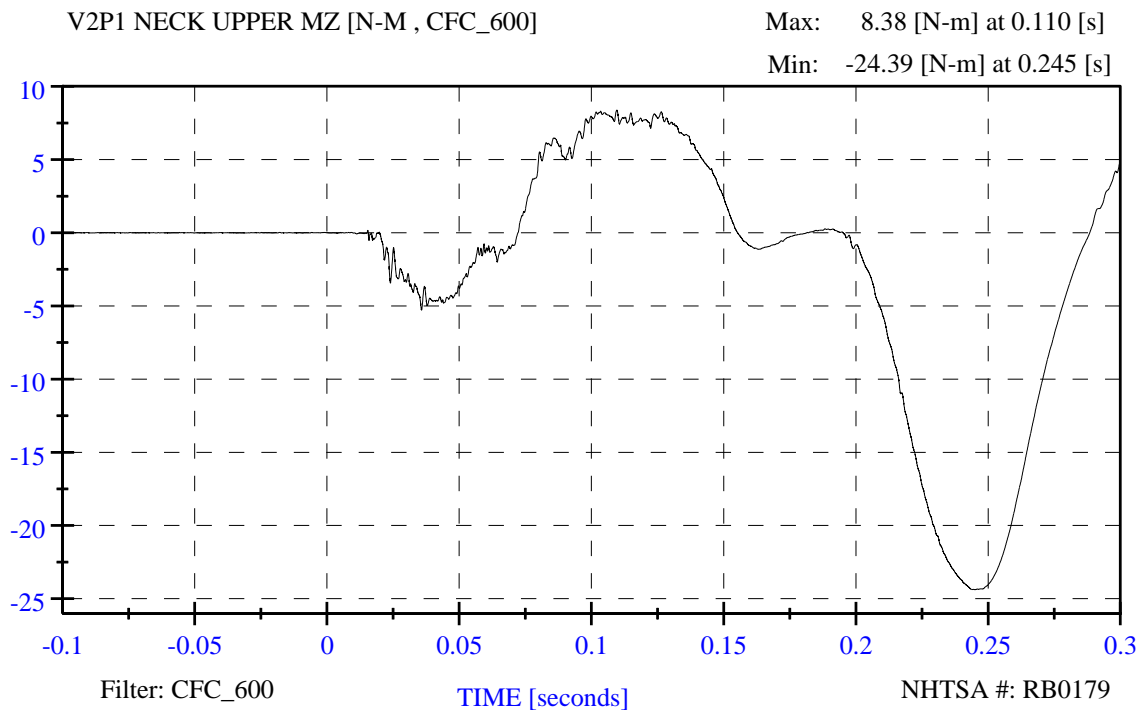
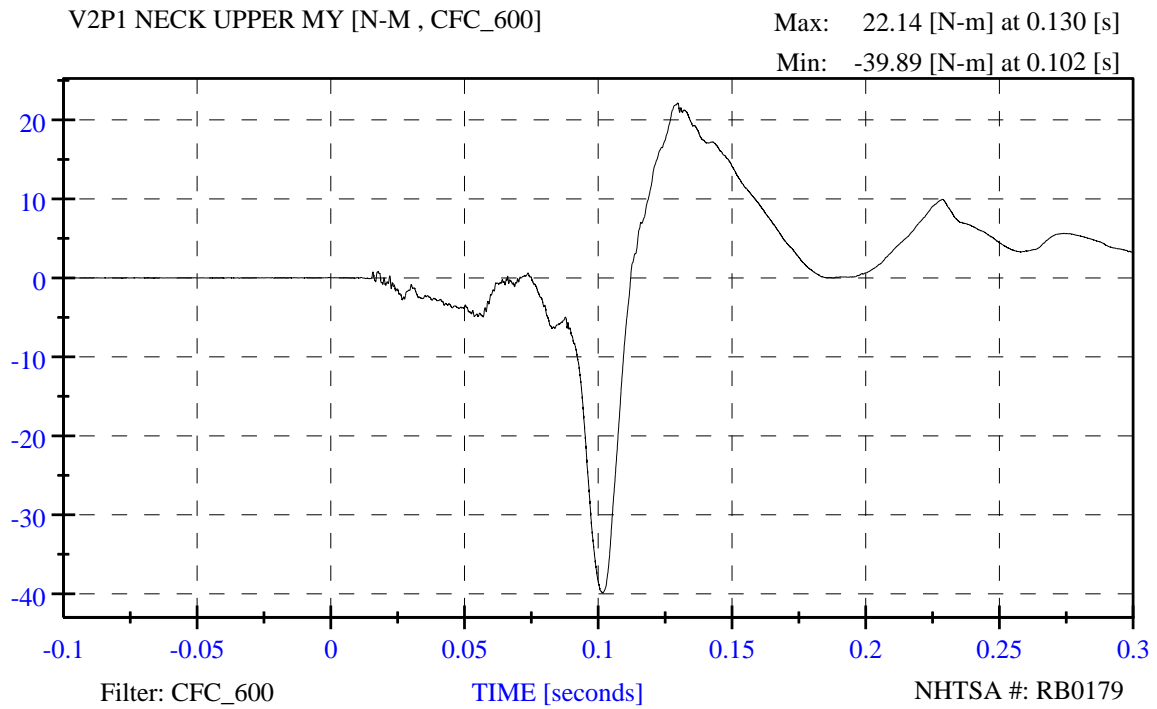

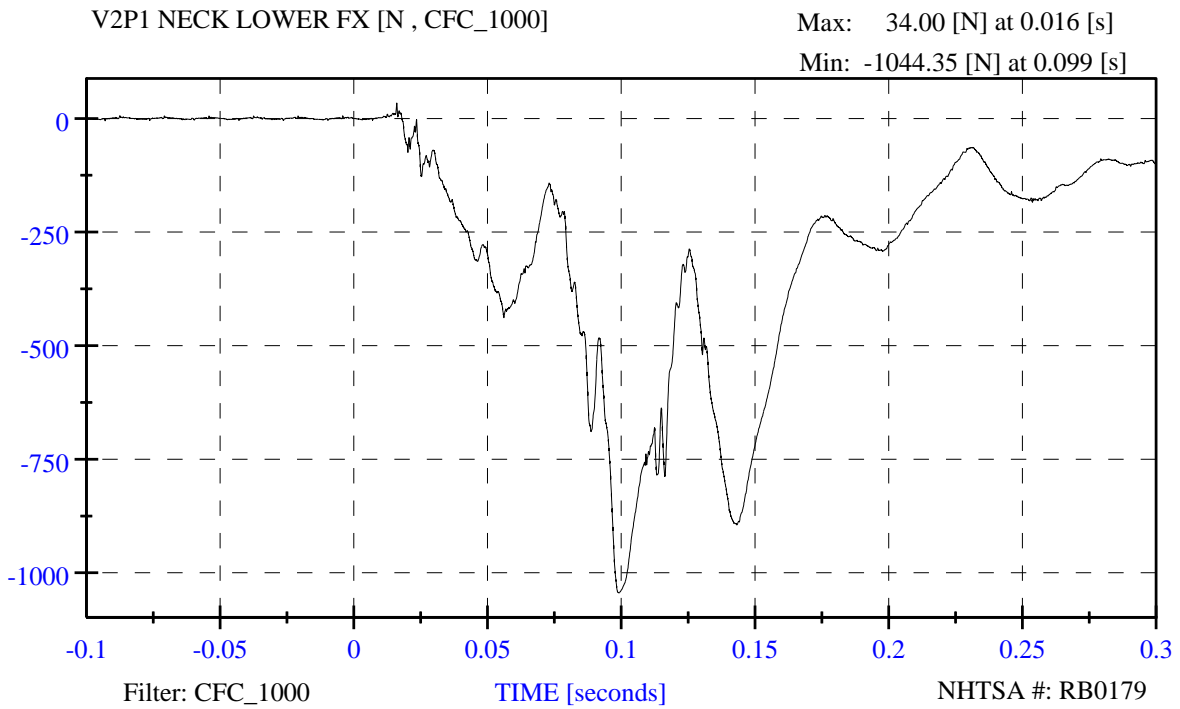

R&D 56 mph, 15deg angle, 35% overlap, 2011 Buick Lacrosse, RB0179

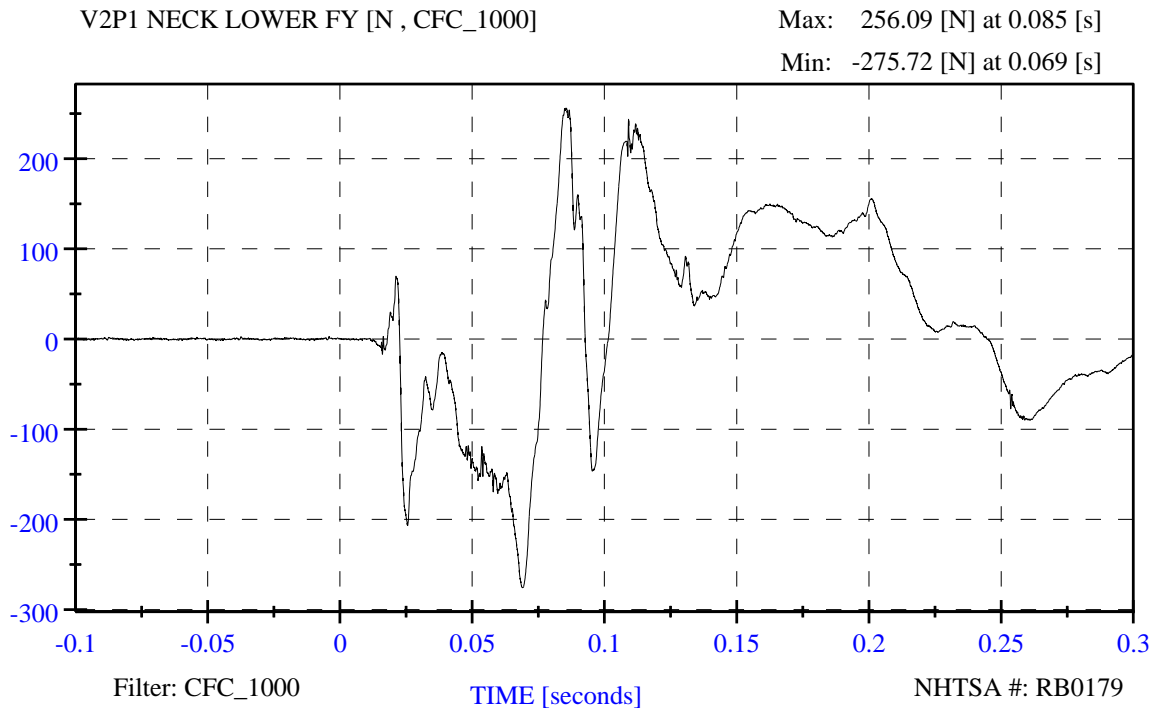

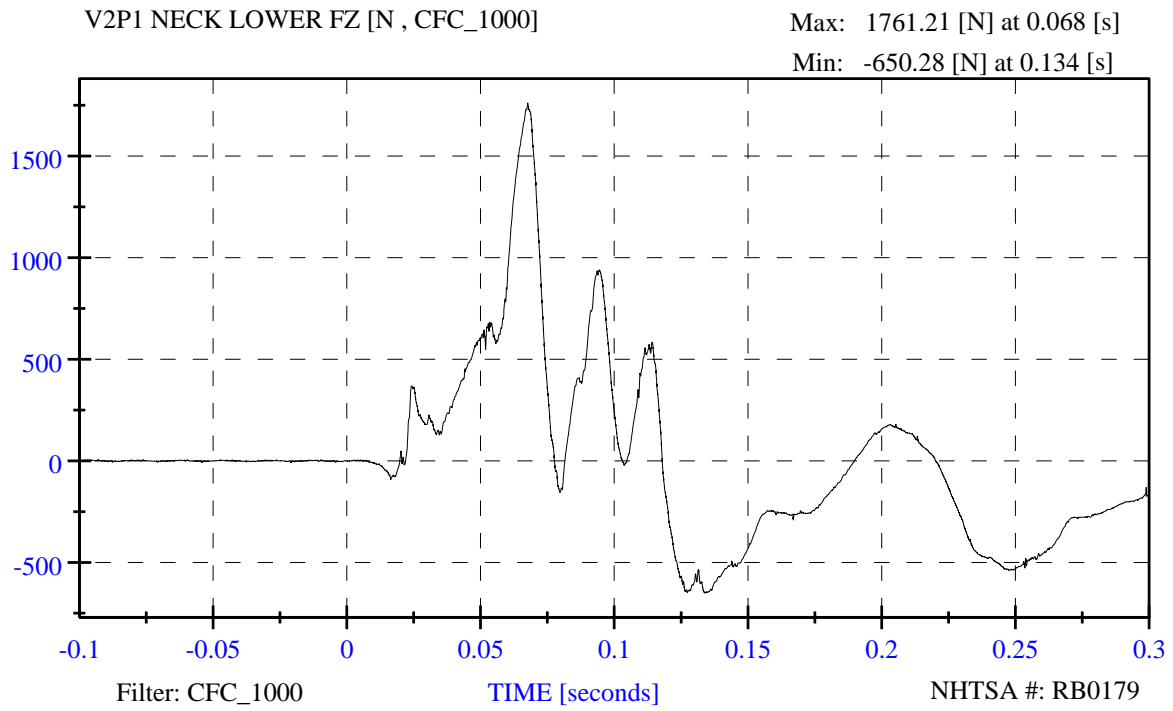

R&D 56 mph, 15deg angle, 35% overlap, 2011 Buick Lacrosse, RB0179

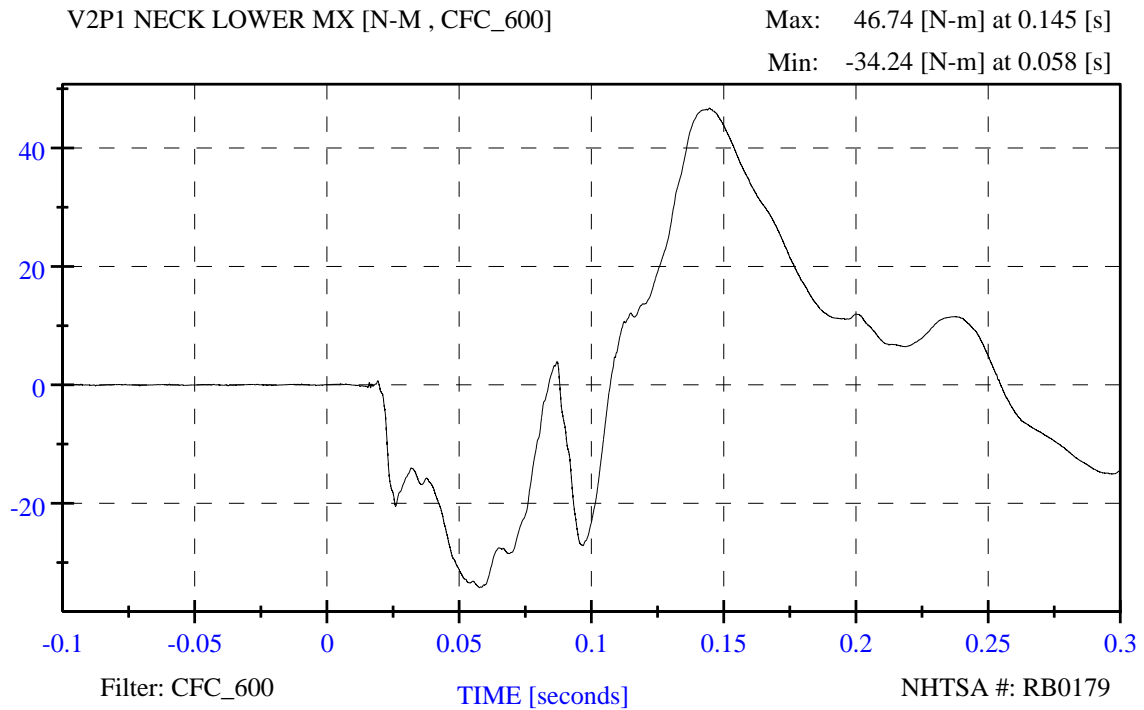

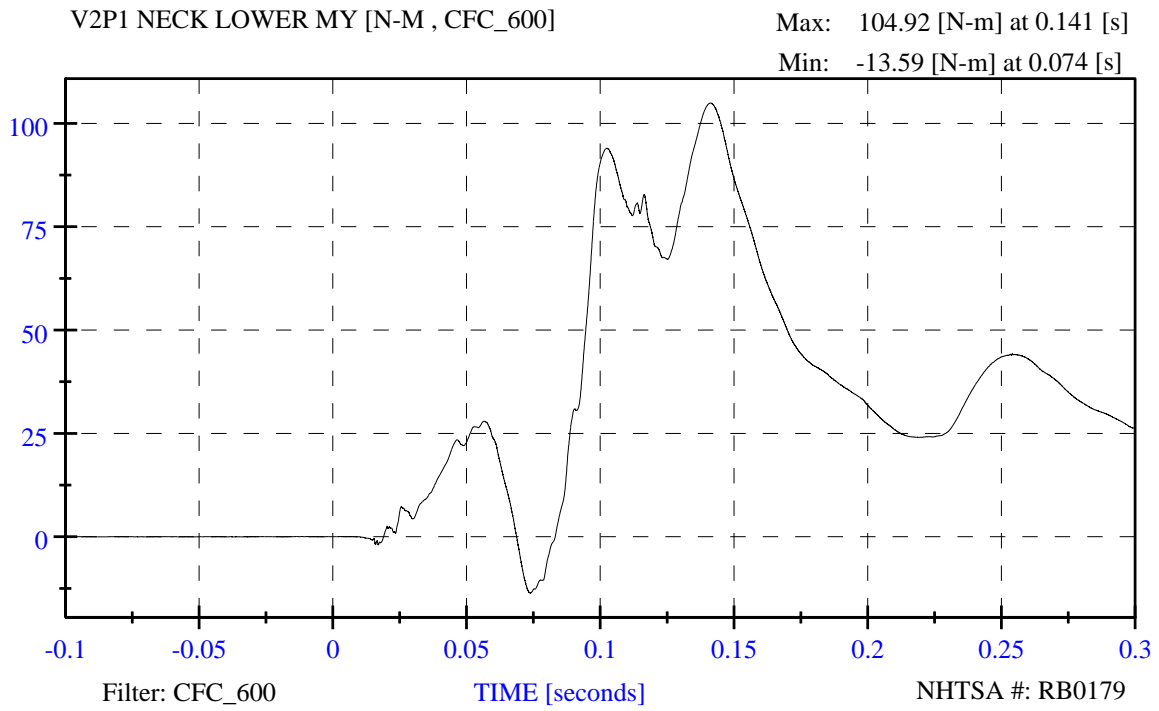

R&D 56 mph, 15deg angle, 35% overlap, 2011 Buick Lacrosse, RB0179

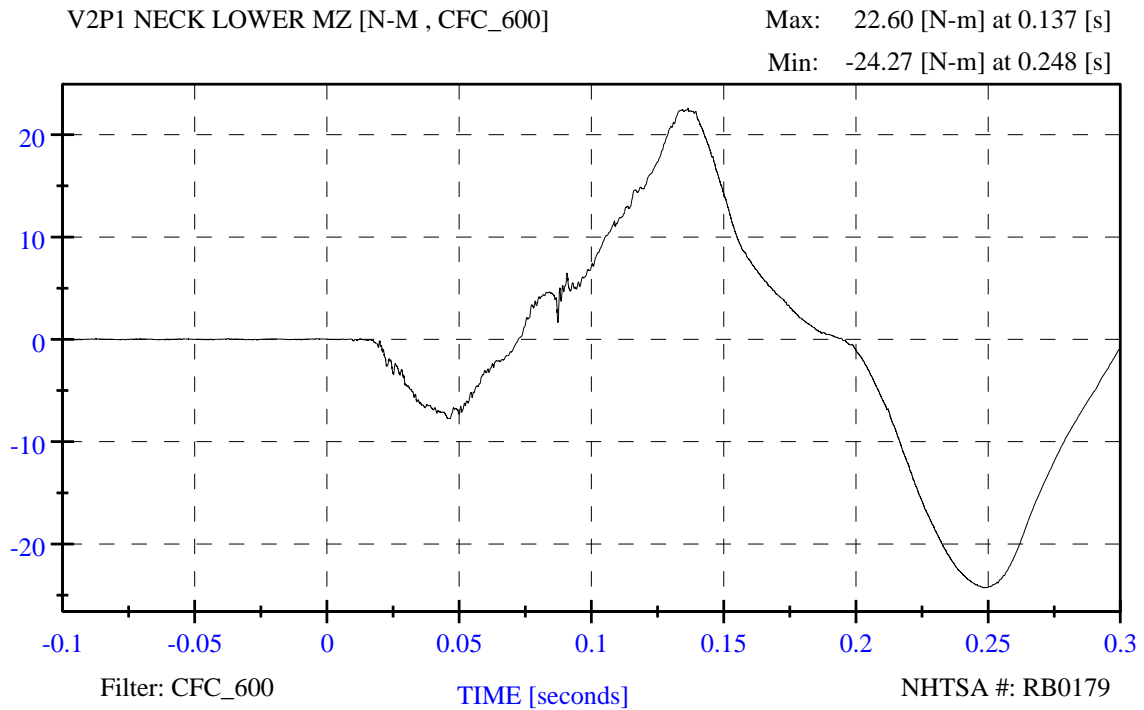

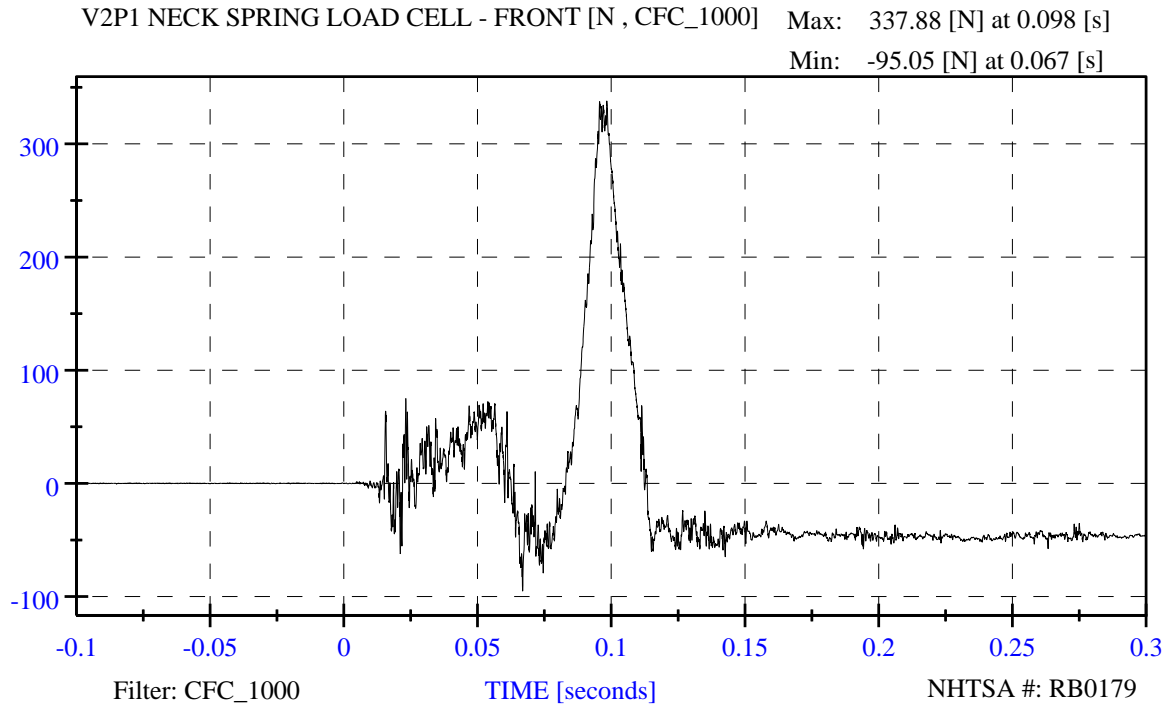

R&D 56 mph, 15deg angle, 35% overlap, 2011 Buick Lacrosse, RB0179

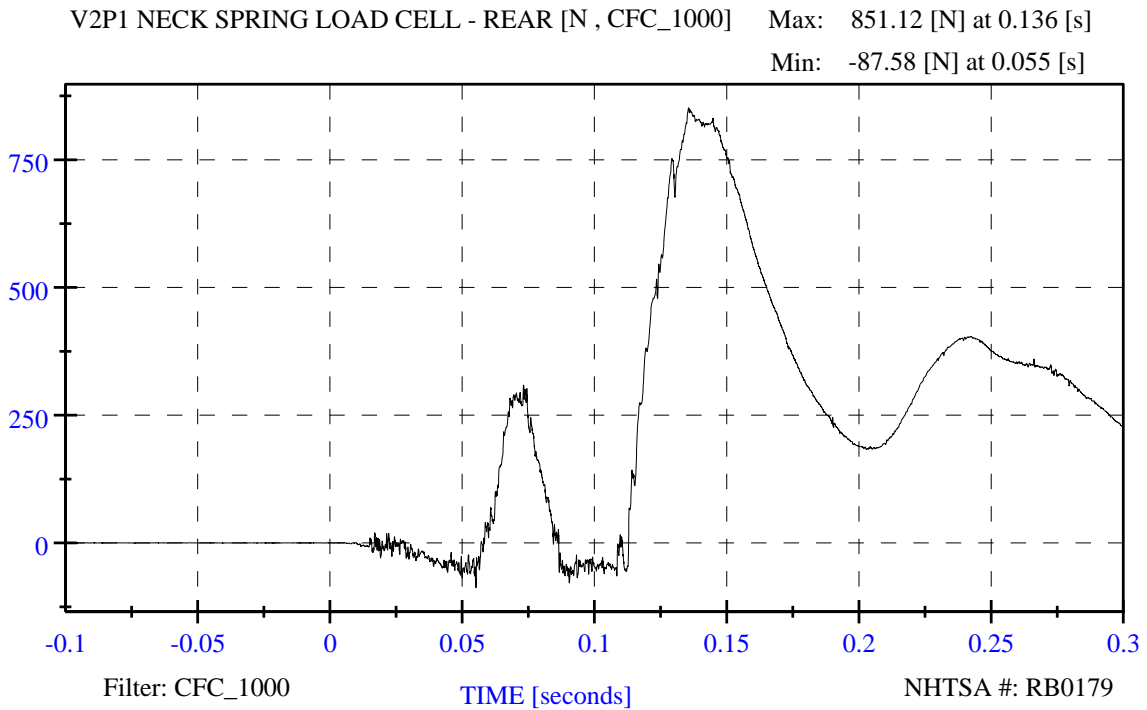

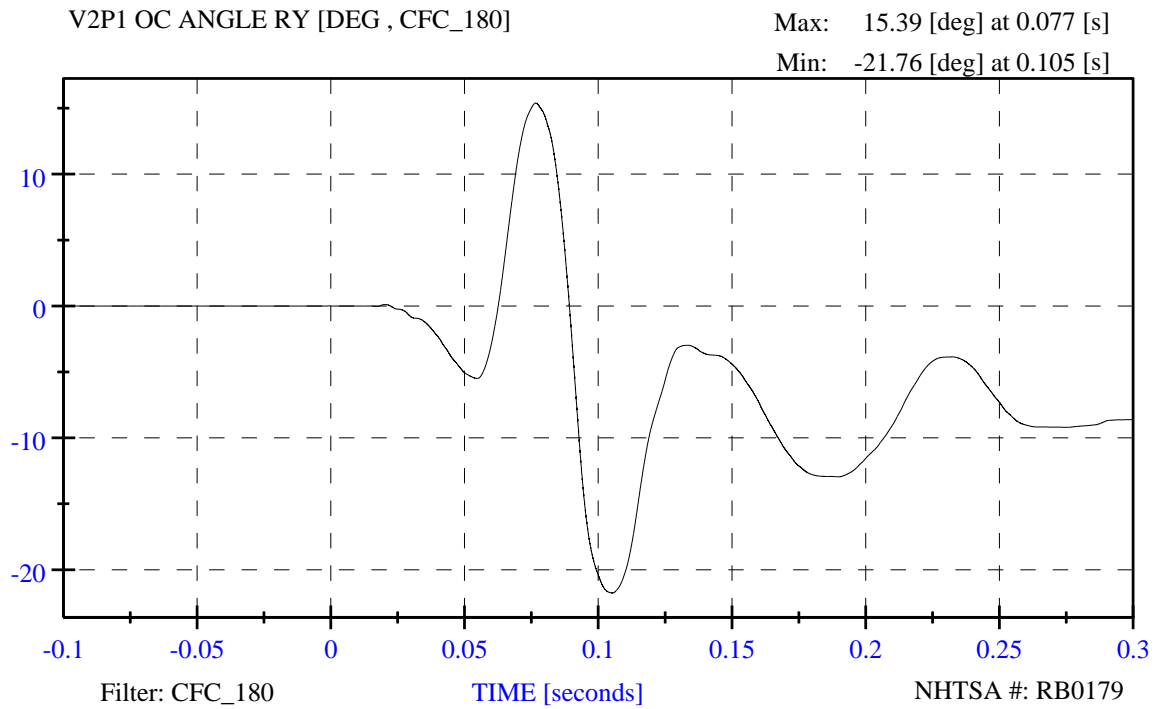

R&D 56 mph, 15deg angle, 35% overlap, 2011 Buick Lacrosse, RB0179

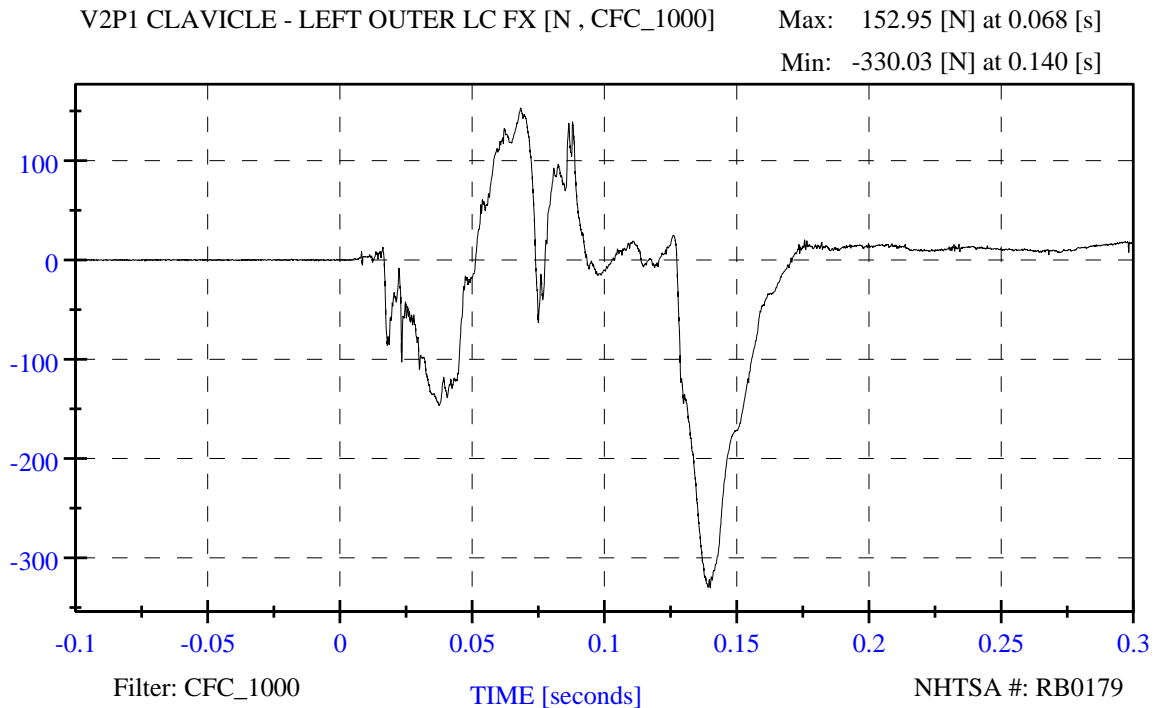

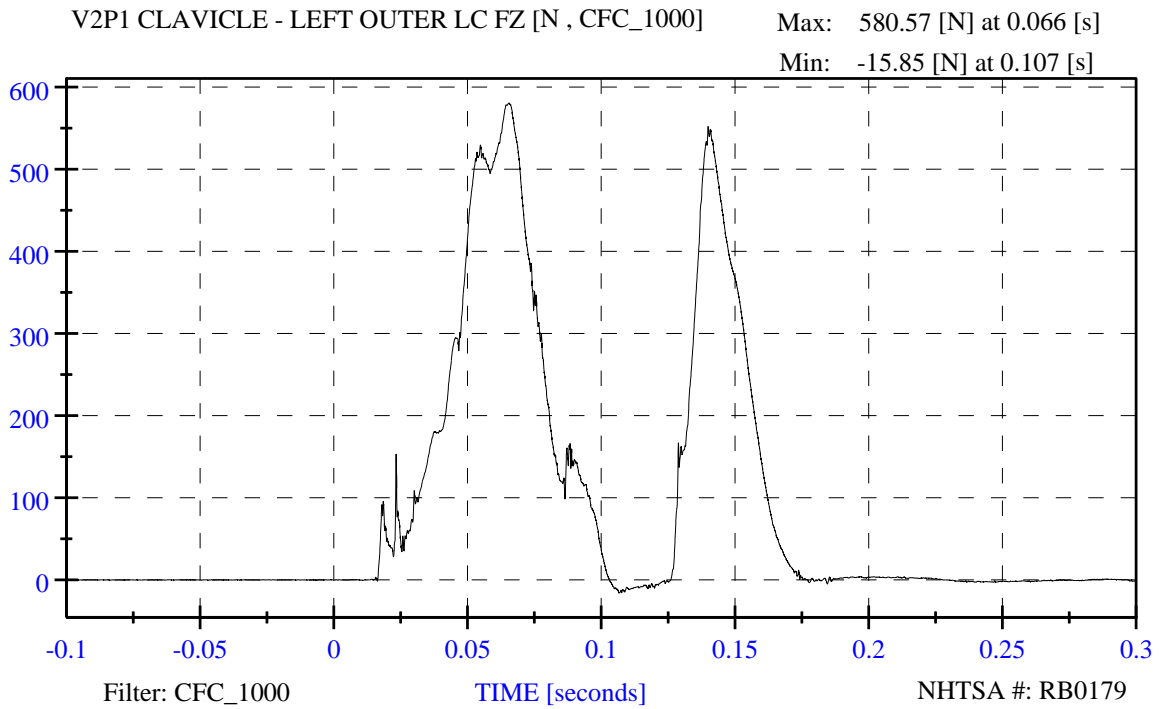

R&D 56 mph, 15deg angle, 35% overlap, 2011 Buick Lacrosse, RB0179

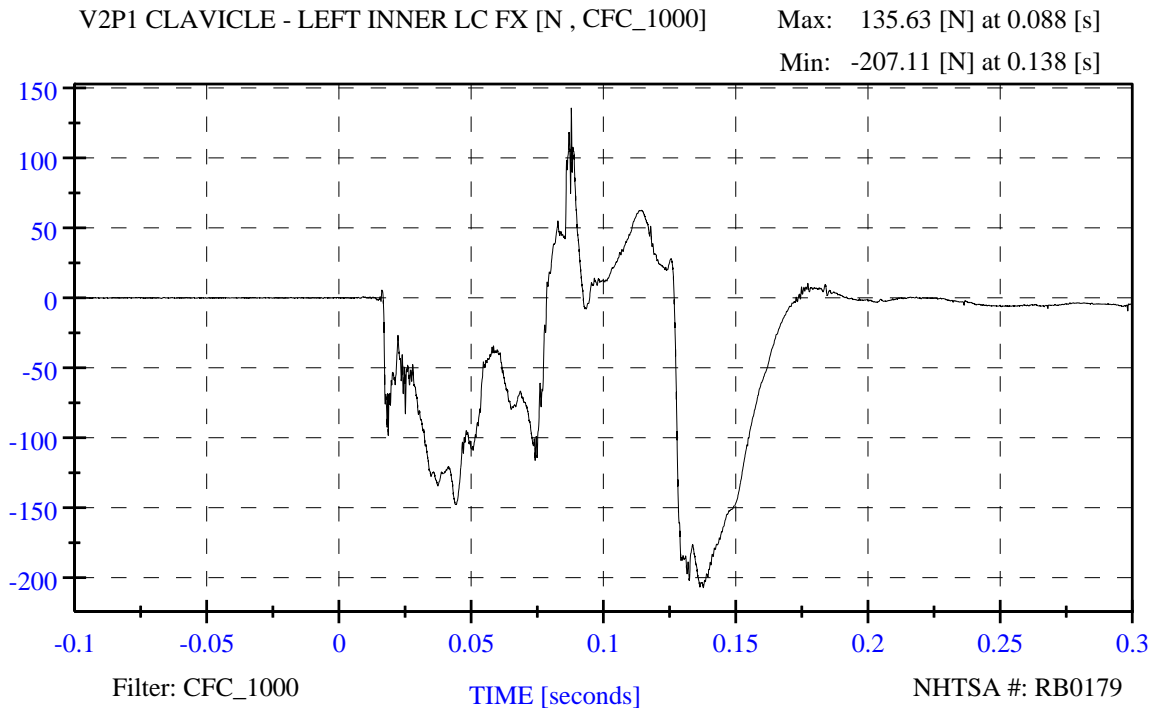

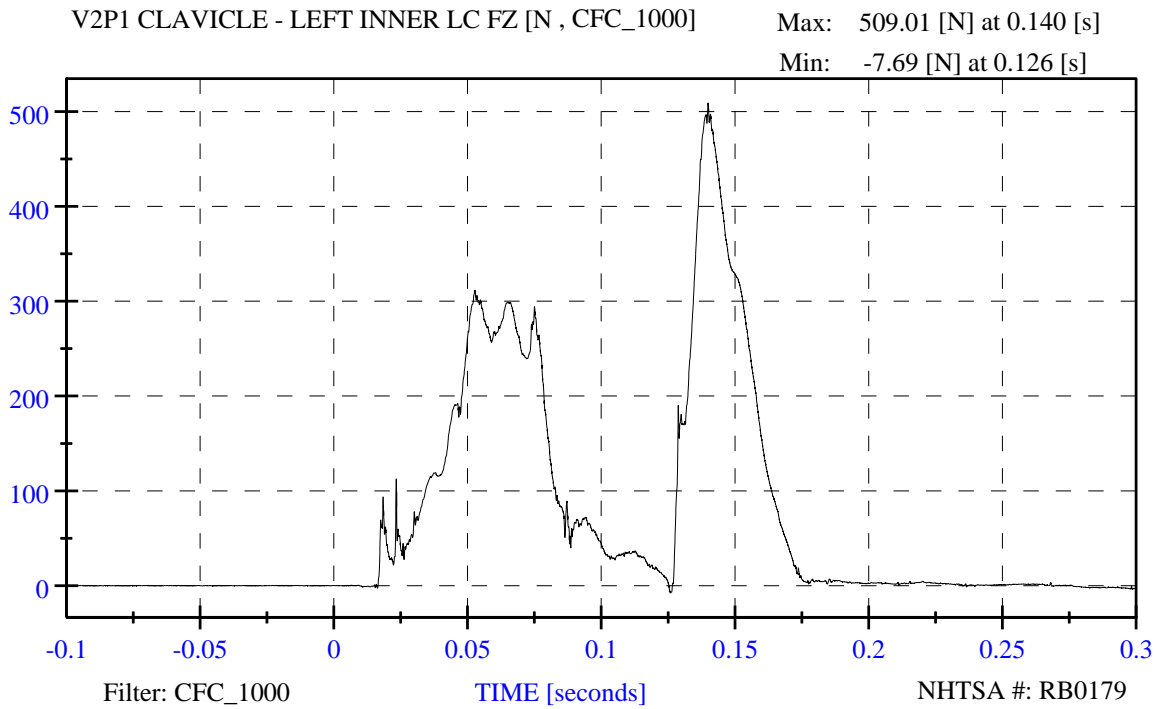

R&D 56 mph, 15deg angle, 35% overlap, 2011 Buick Lacrosse, RB0179

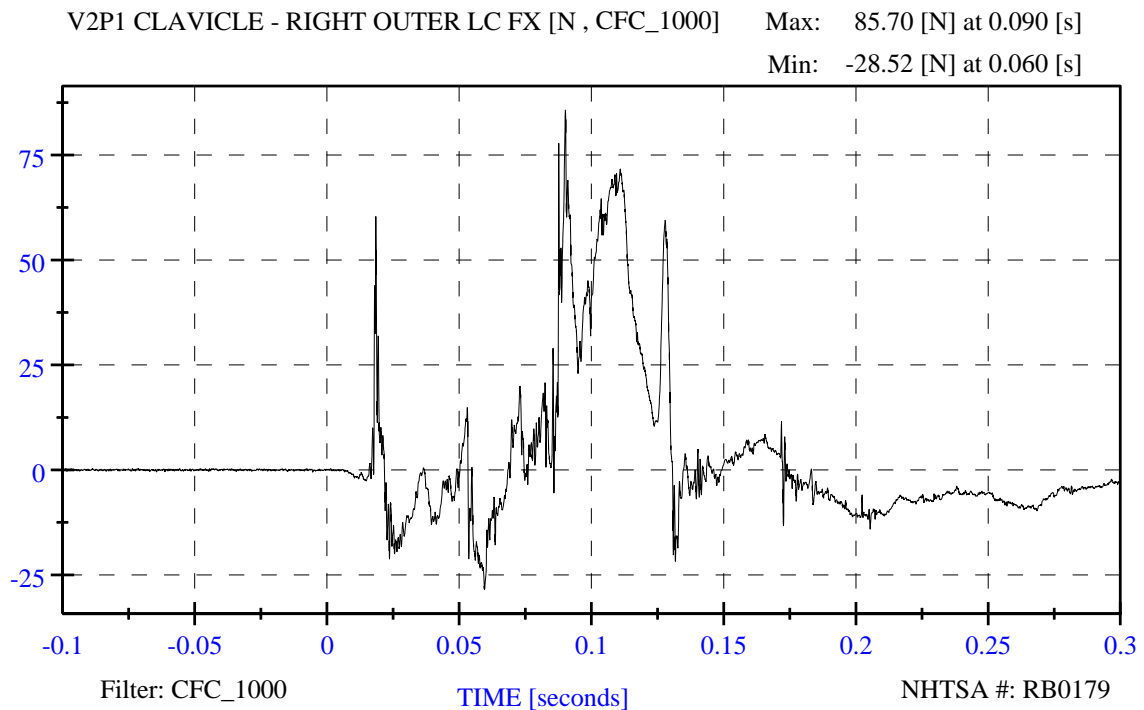

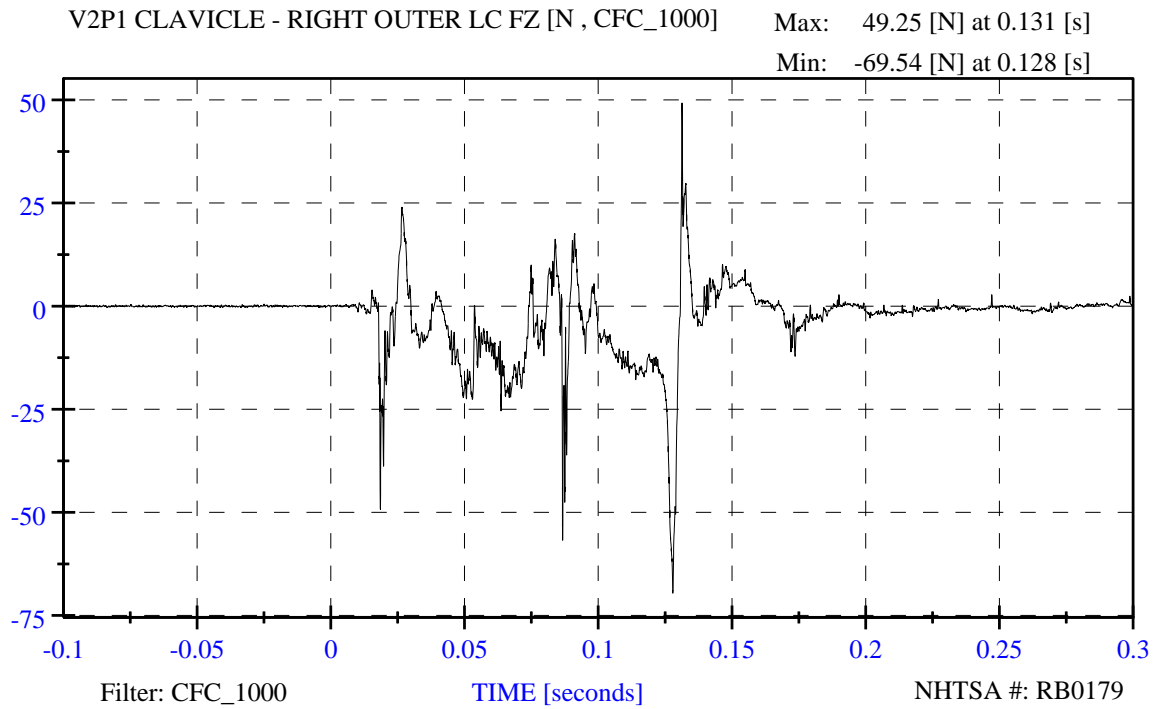

R&D 56 mph, 15deg angle, 35% overlap, 2011 Buick Lacrosse, RB0179

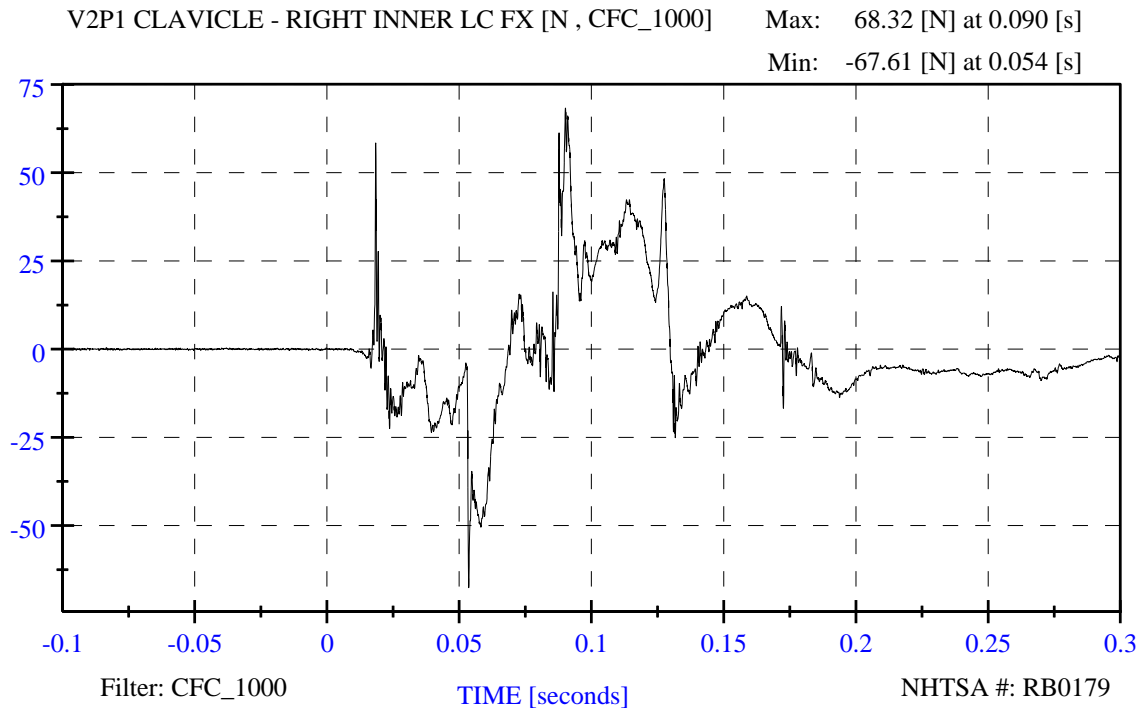

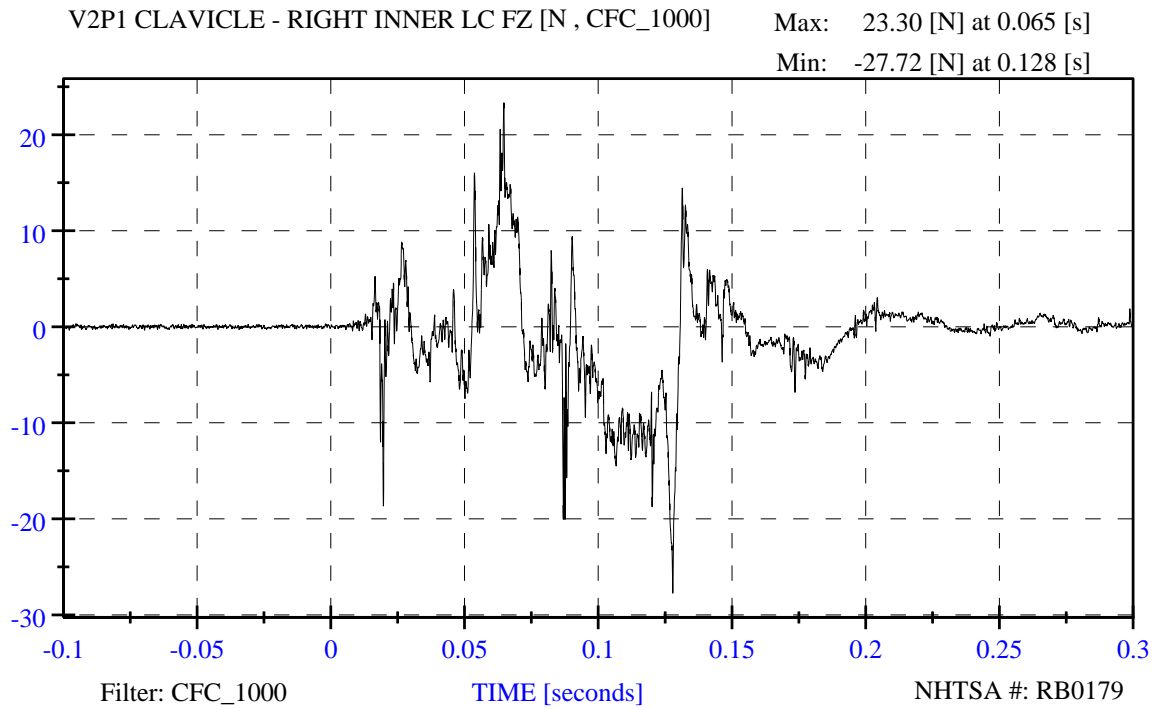

R&D 56 mph, 15deg angle, 35% overlap, 2011 Buick Lacrosse, RB0179

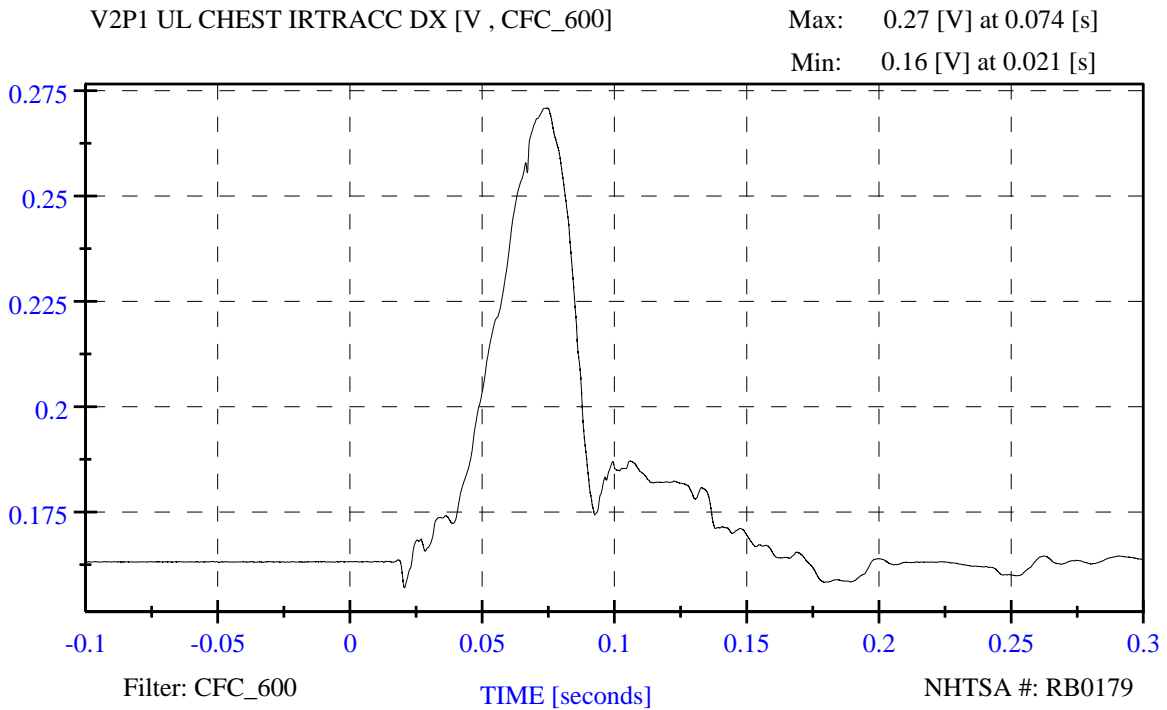

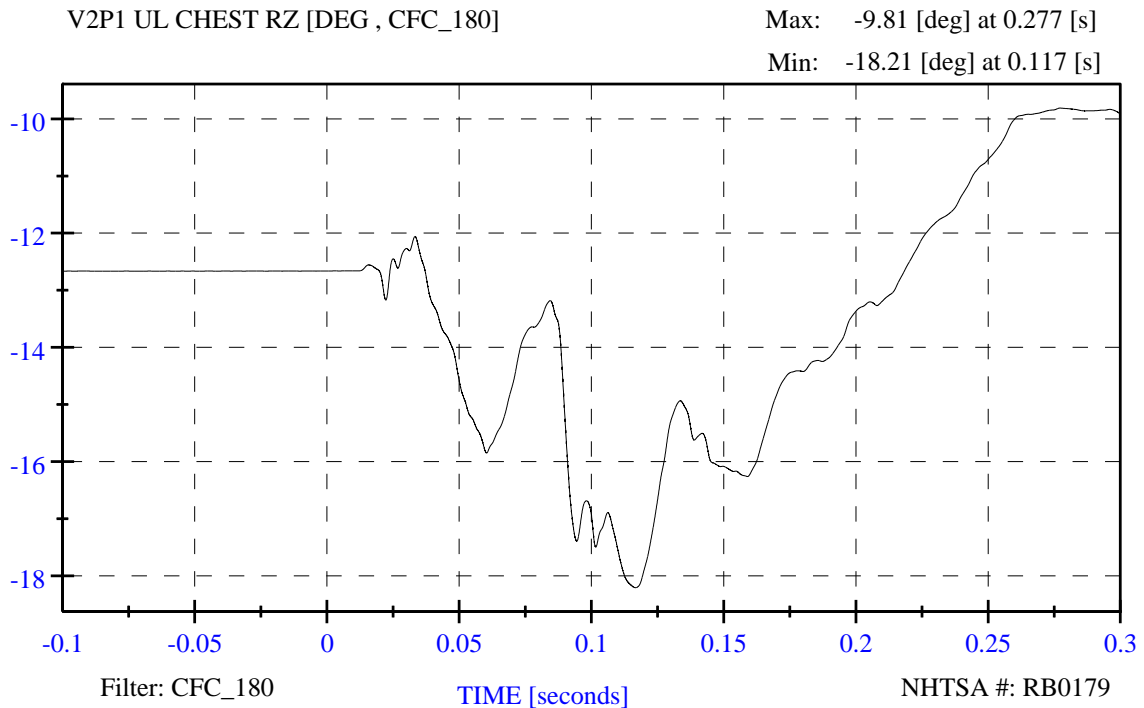
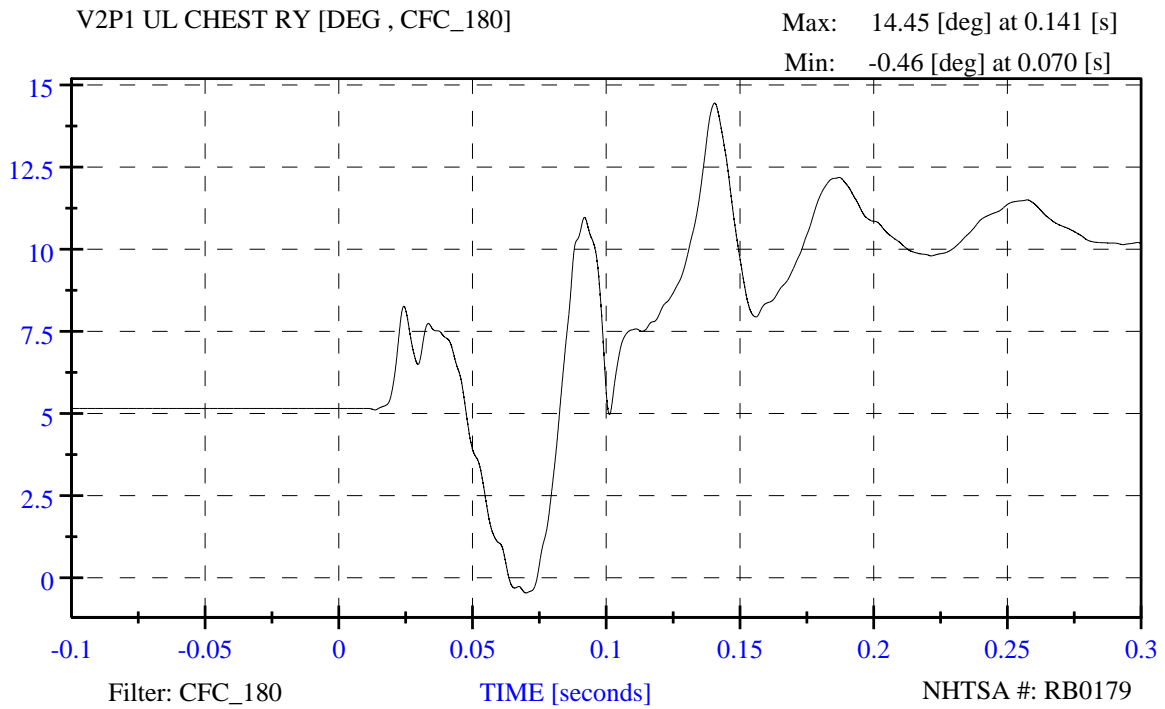

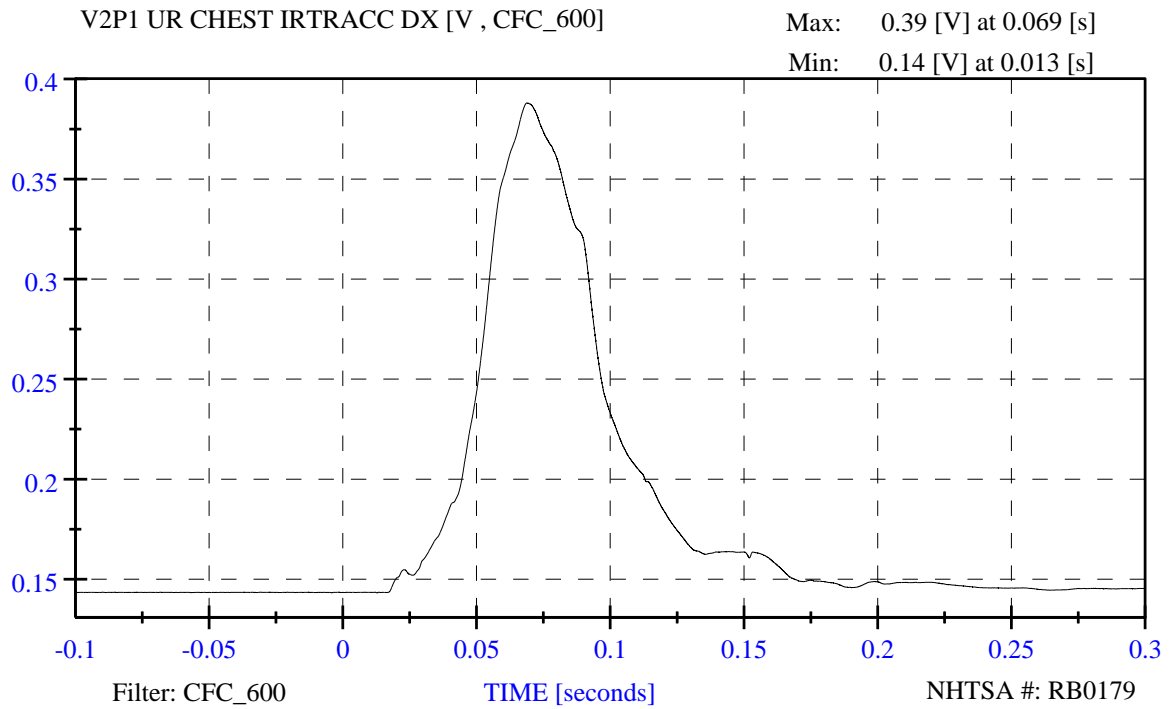

R&D 56 mph, 15deg angle, 35% overlap, 2011 Buick Lacrosse, RB0179

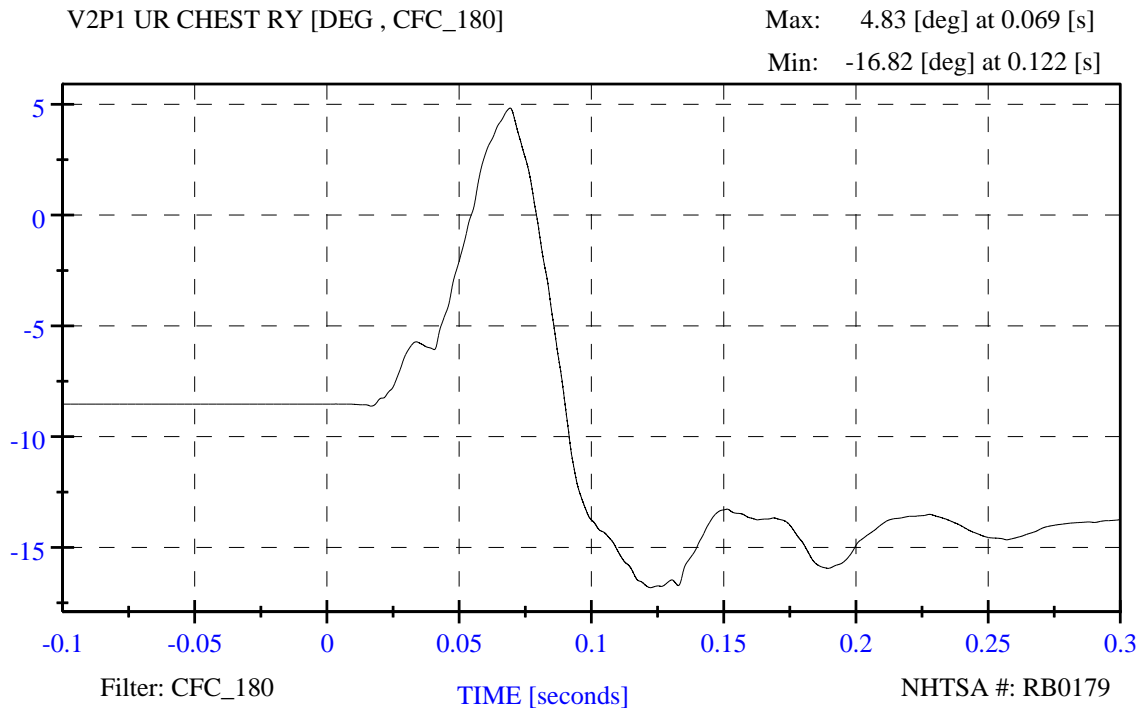

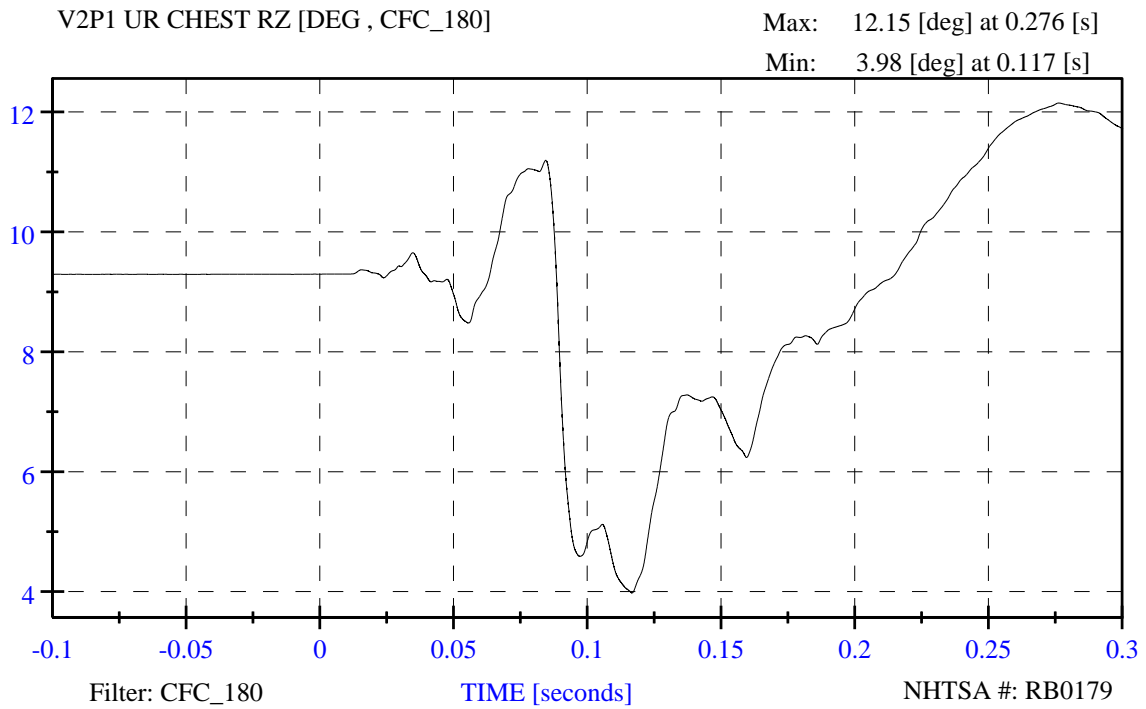

R&D 56 mph, 15deg angle, 35% overlap, 2011 Buick Lacrosse, RB0179

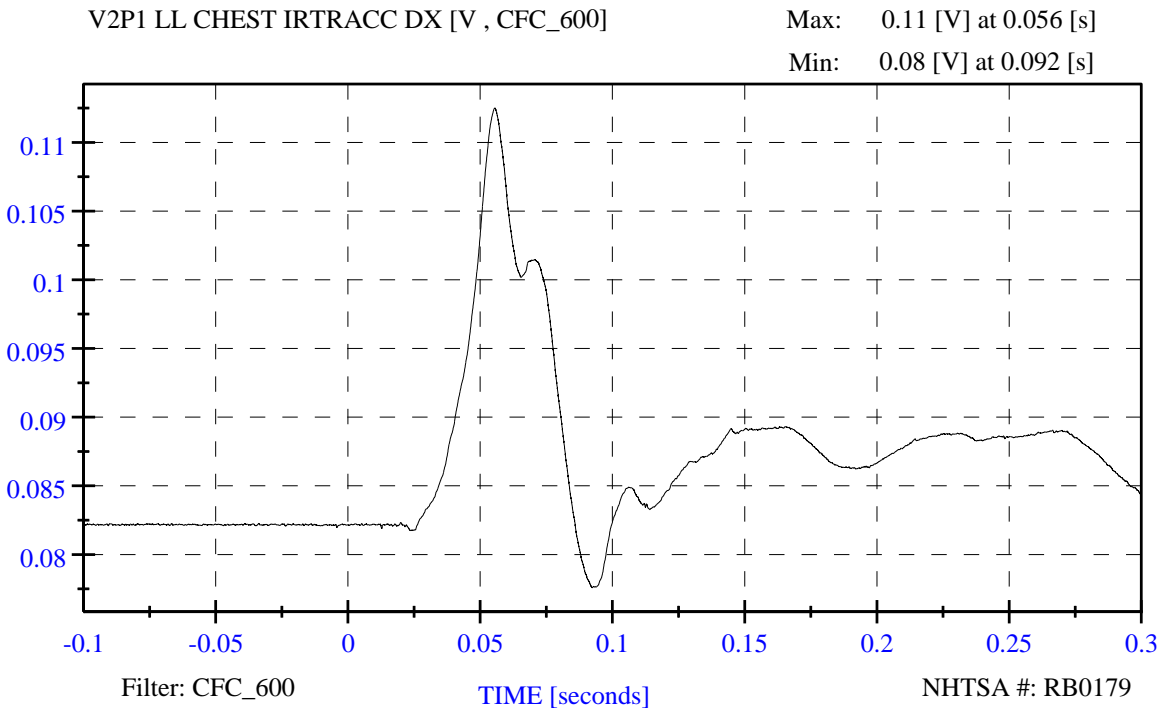

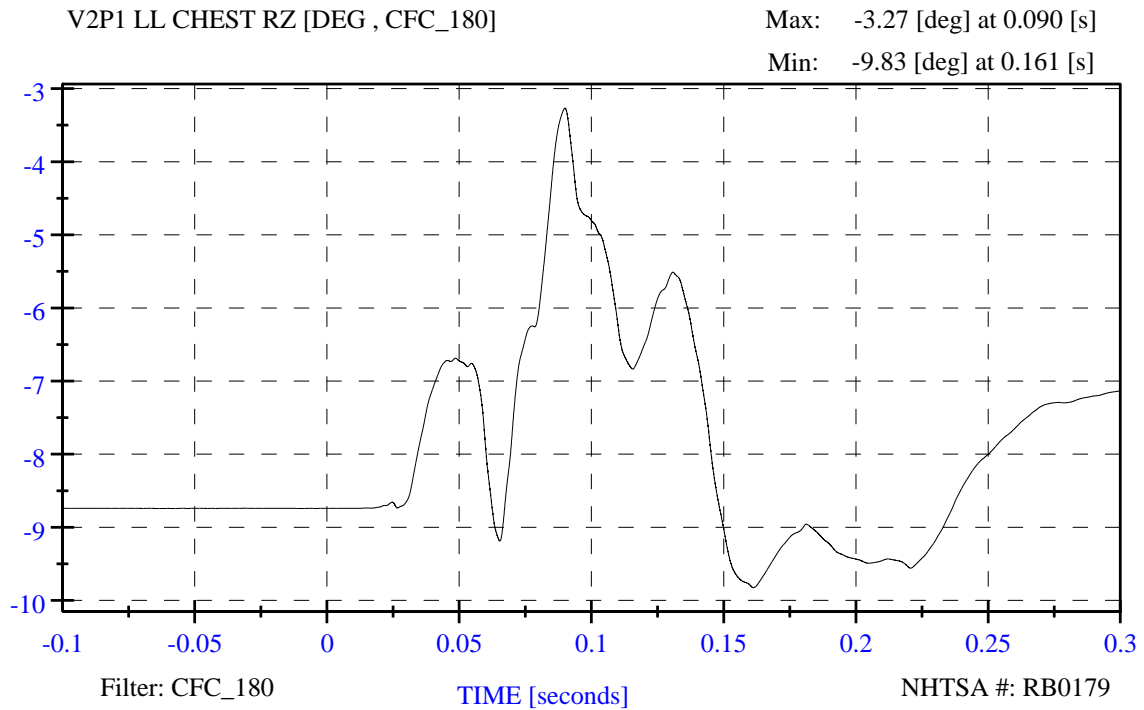
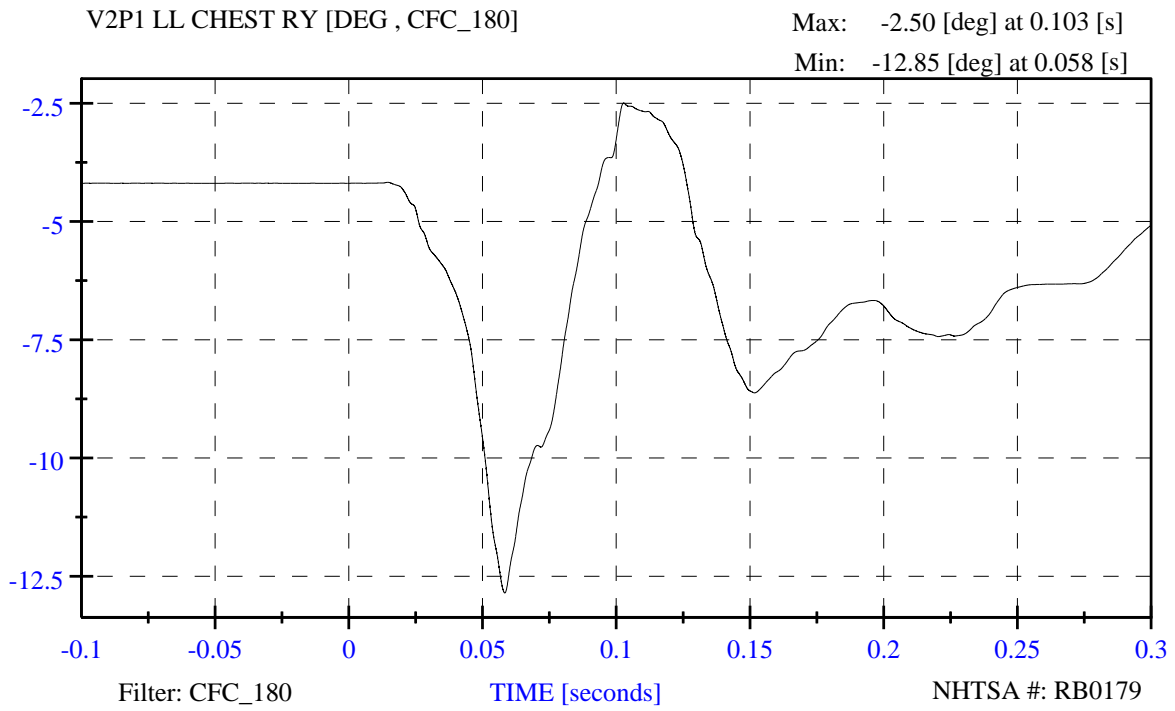

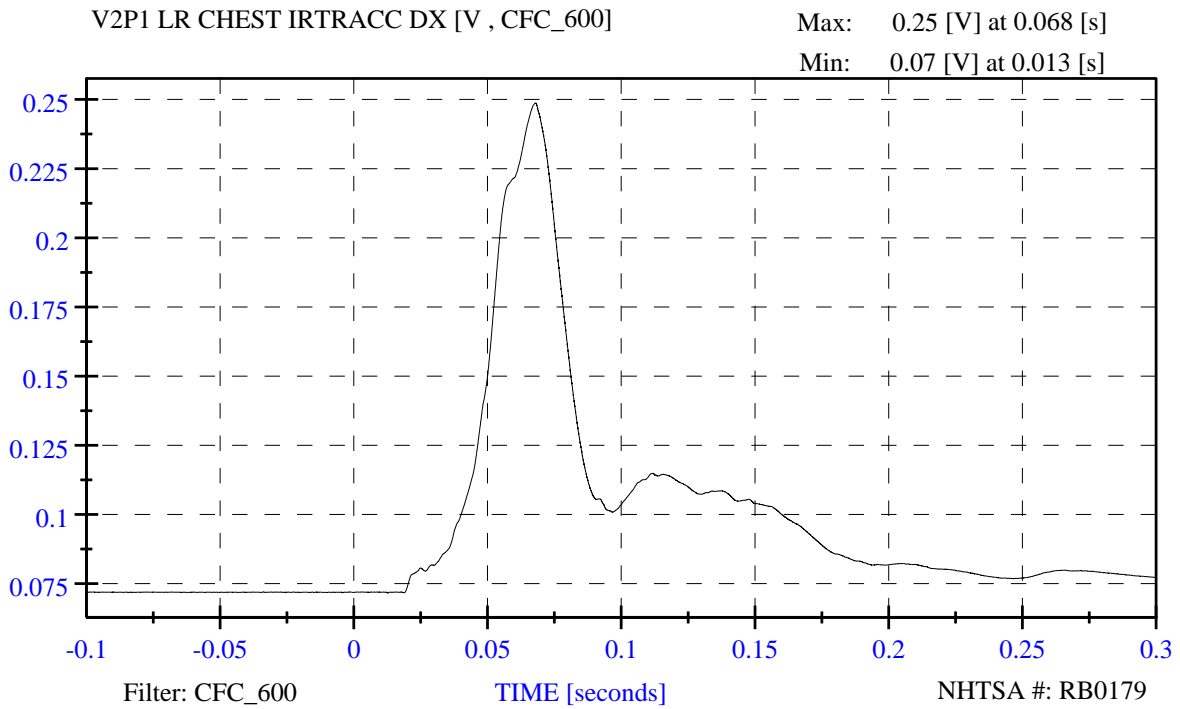

R&D 56 mph, 15deg angle, 35% overlap, 2011 Buick Lacrosse, RB0179

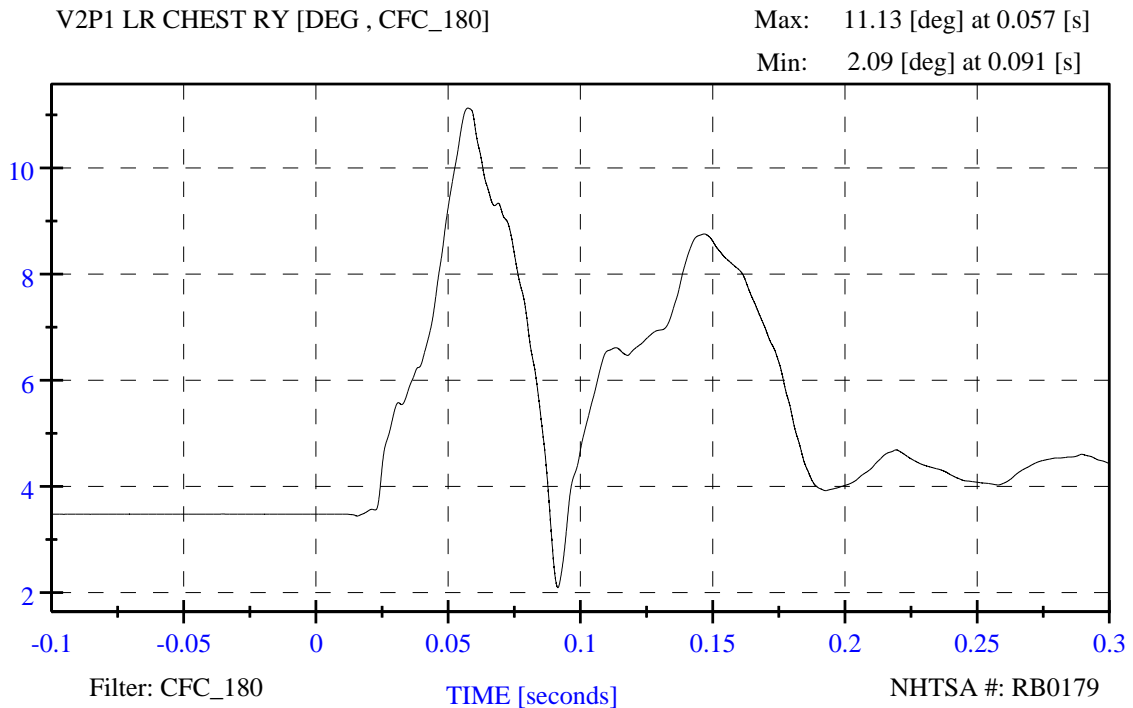

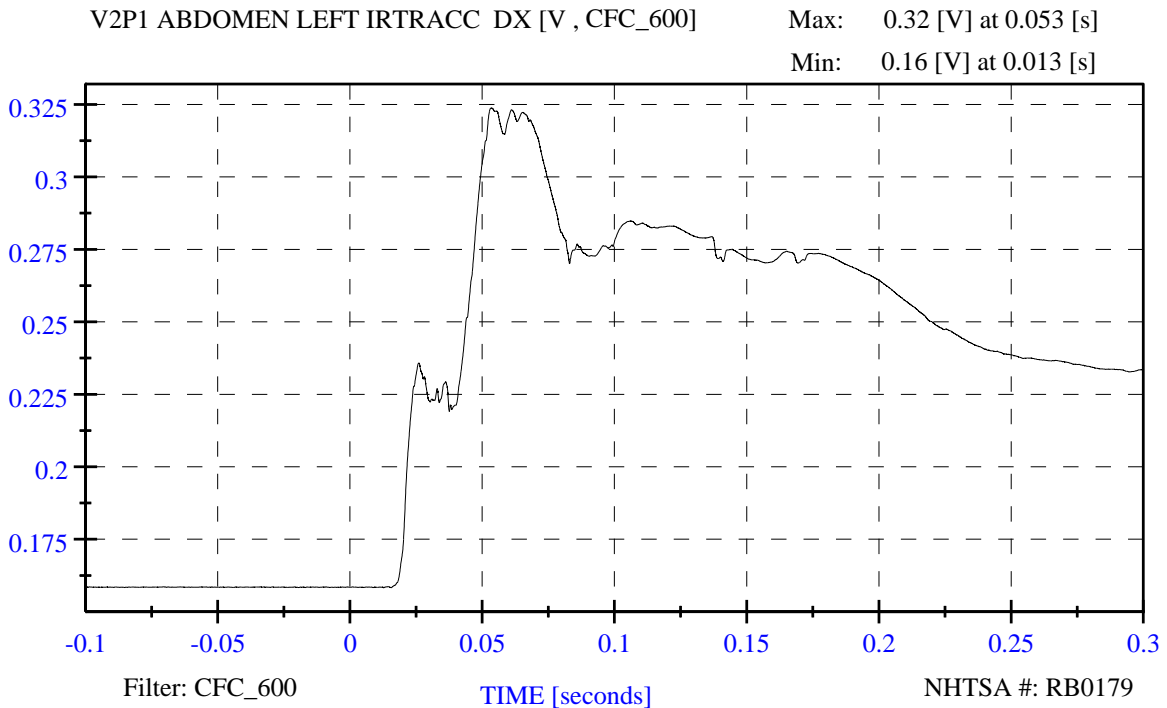
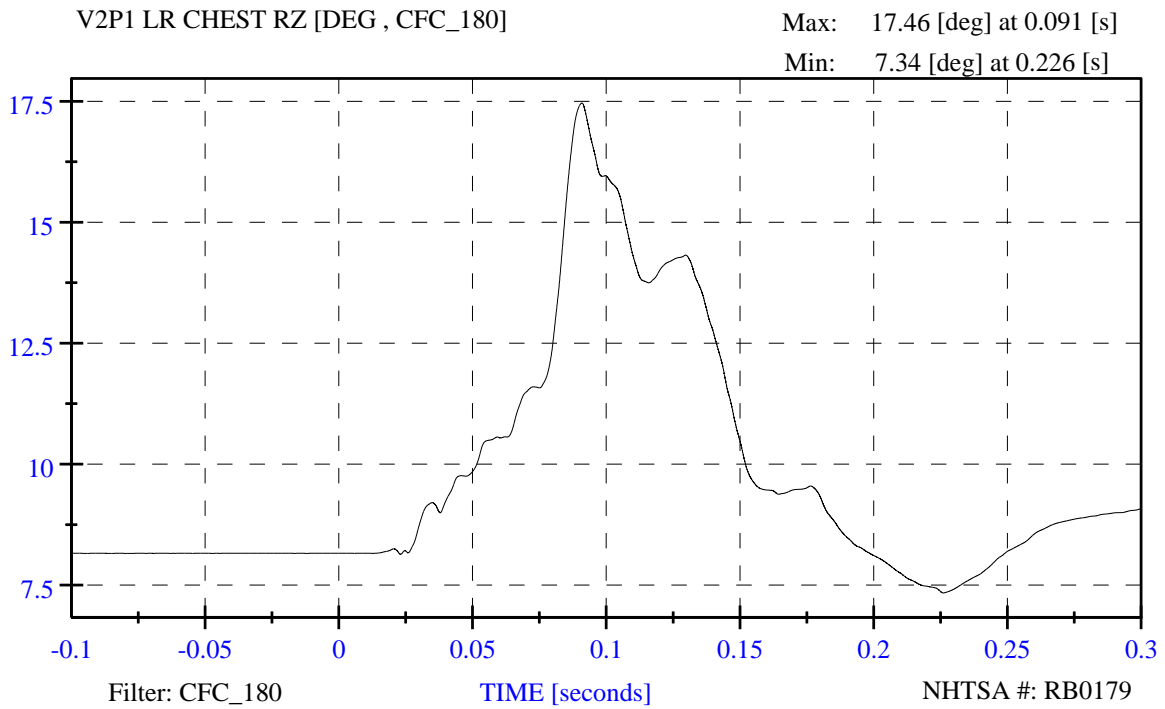

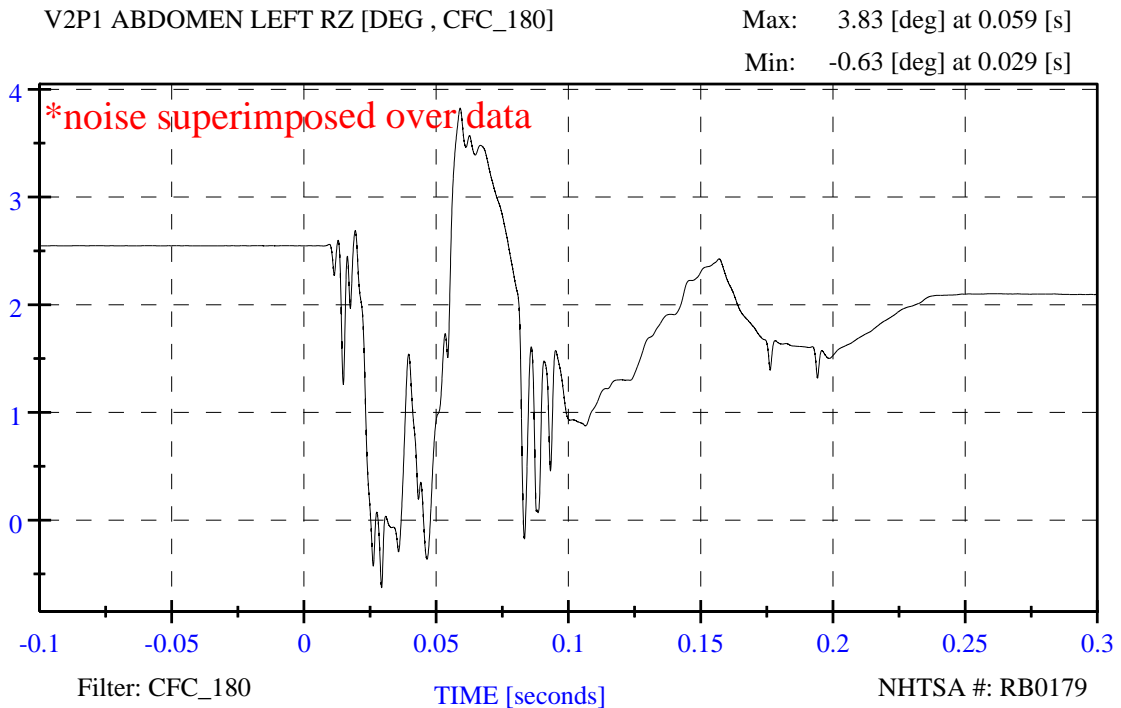
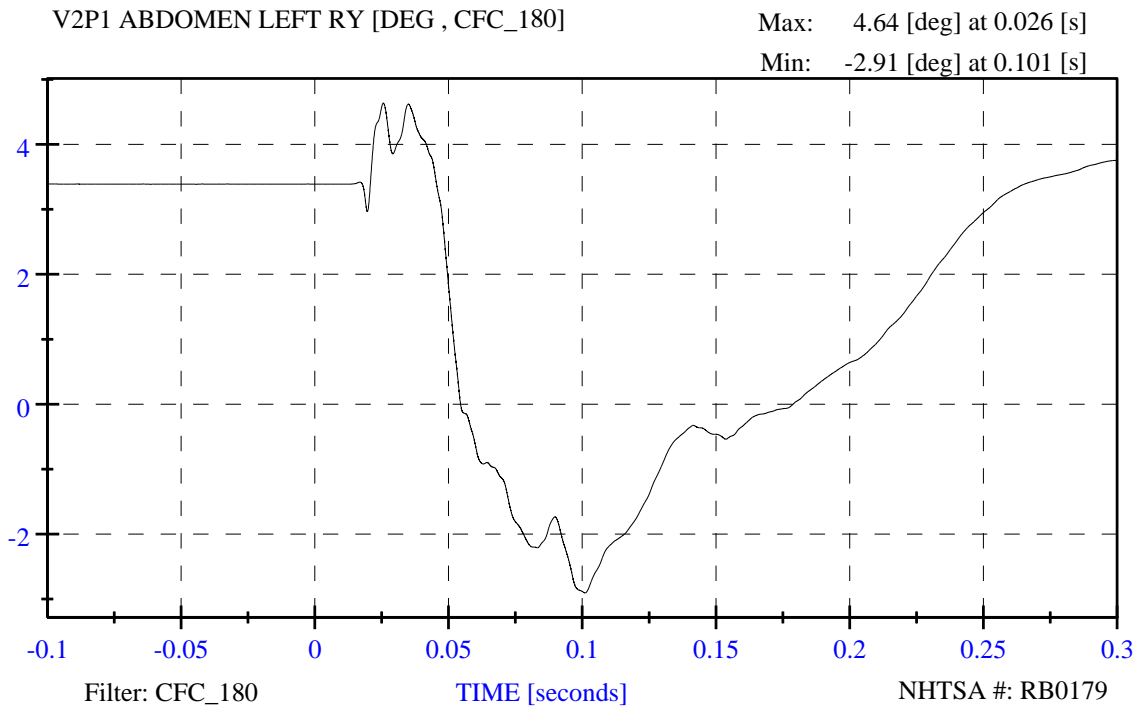

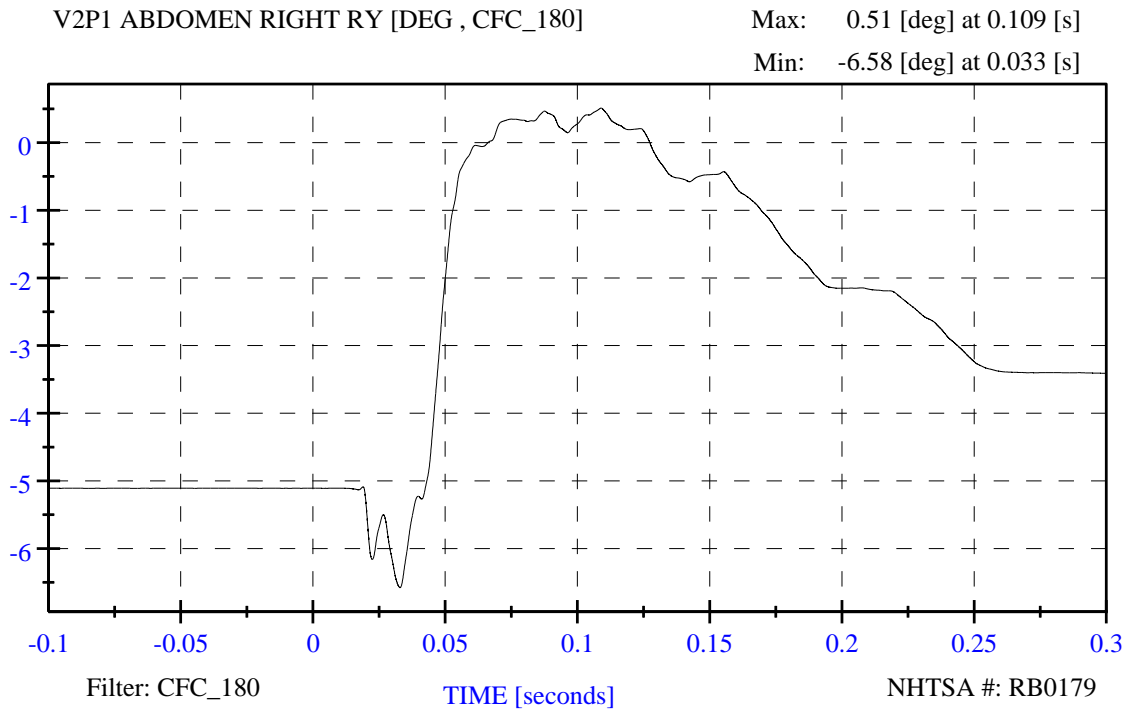
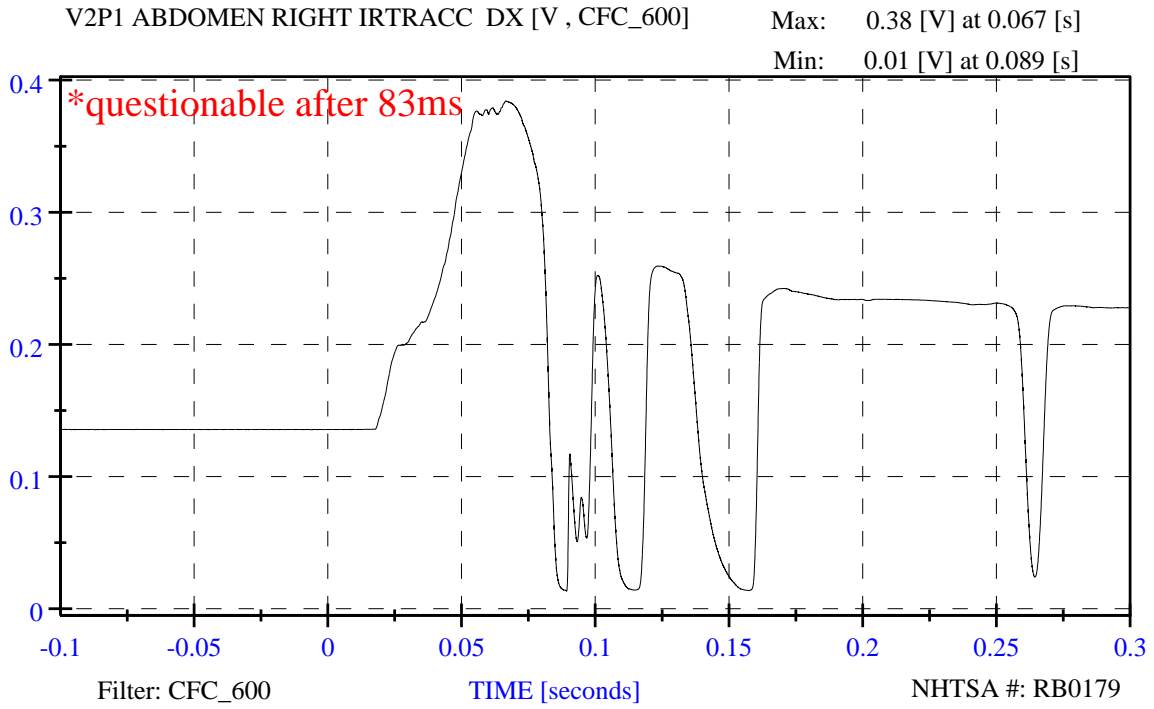

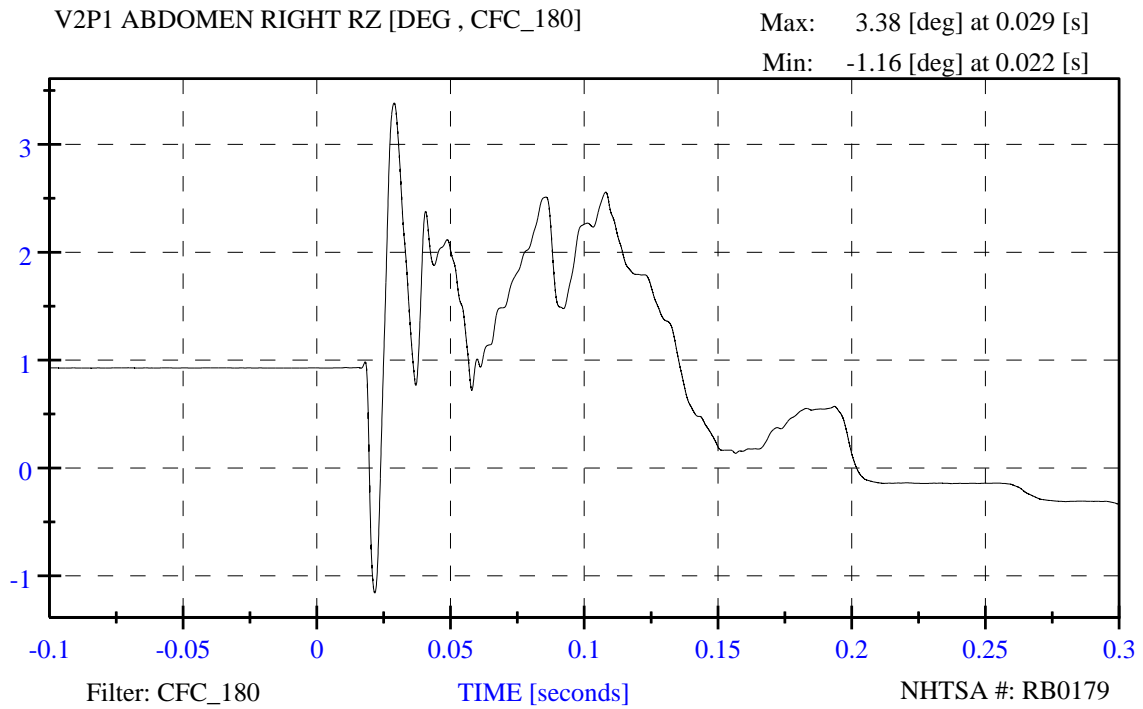

R&D 56 mph, 15deg angle, 35% overlap, 2011 Buick Lacrosse, RB0179

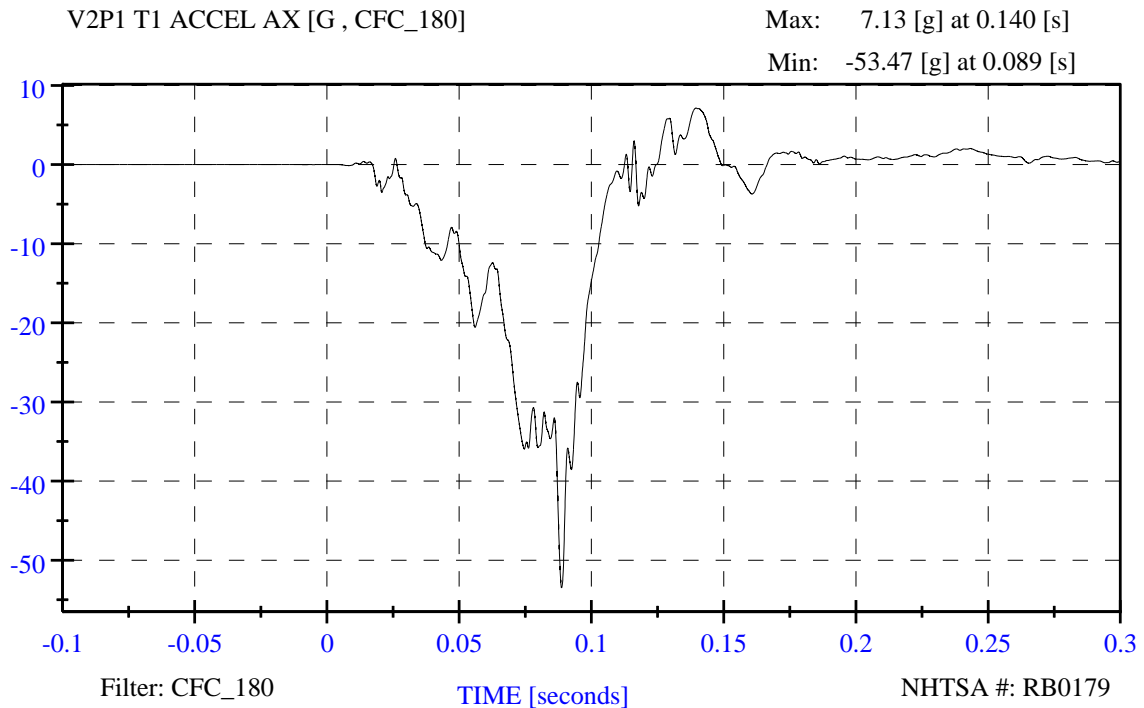

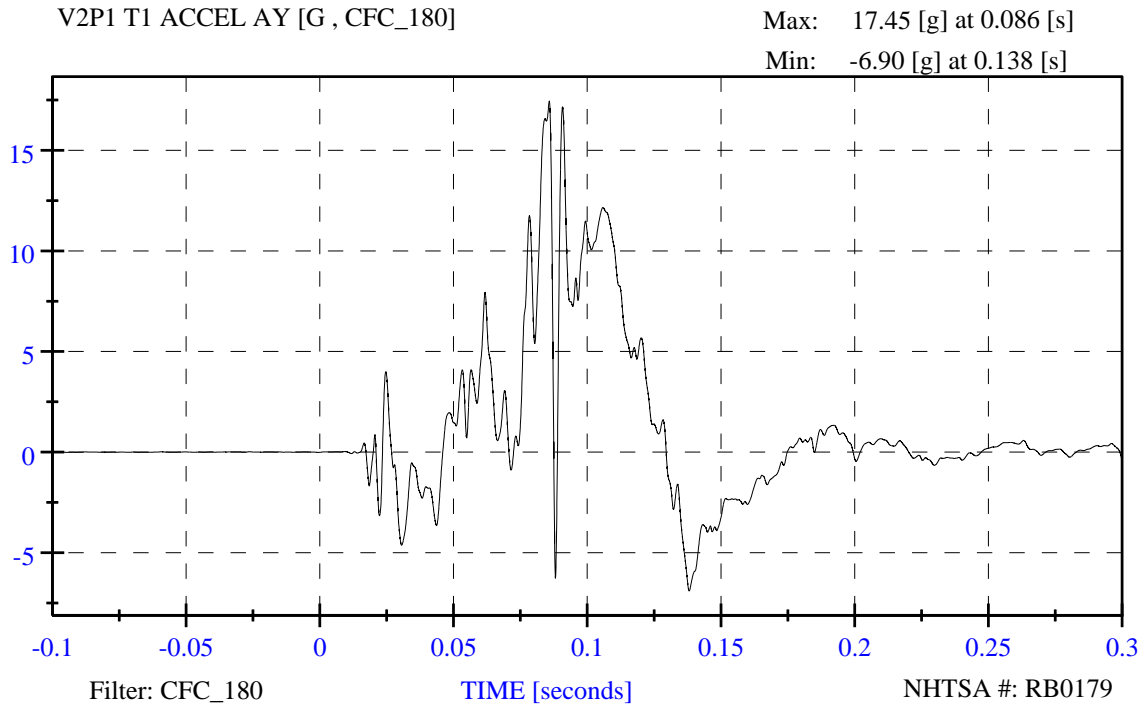

R&D 56 mph, 15deg angle, 35% overlap, 2011 Buick Lacrosse, RB0179

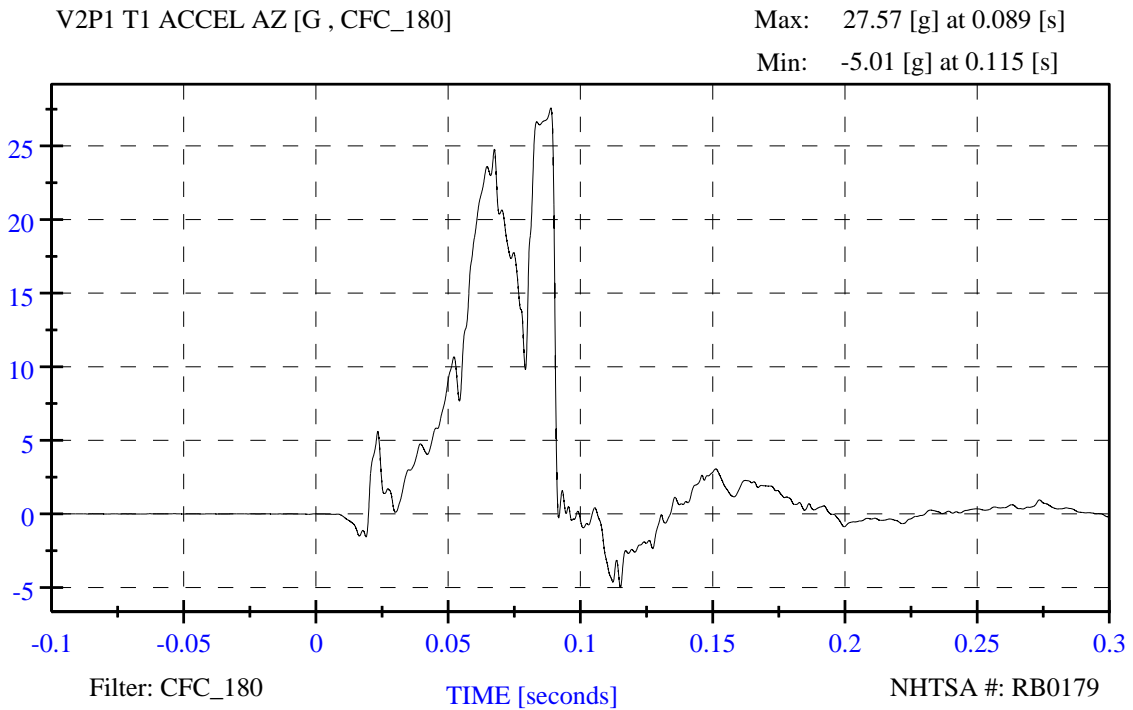

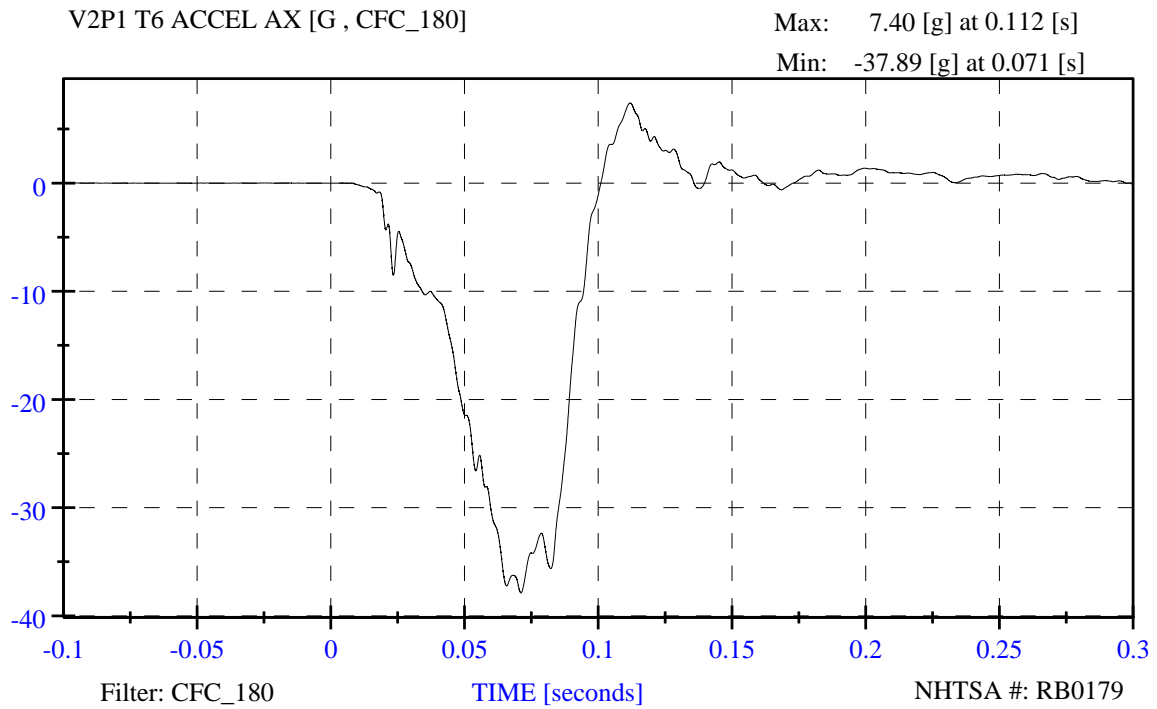

R&D 56 mph, 15deg angle, 35% overlap, 2011 Buick Lacrosse, RB0179

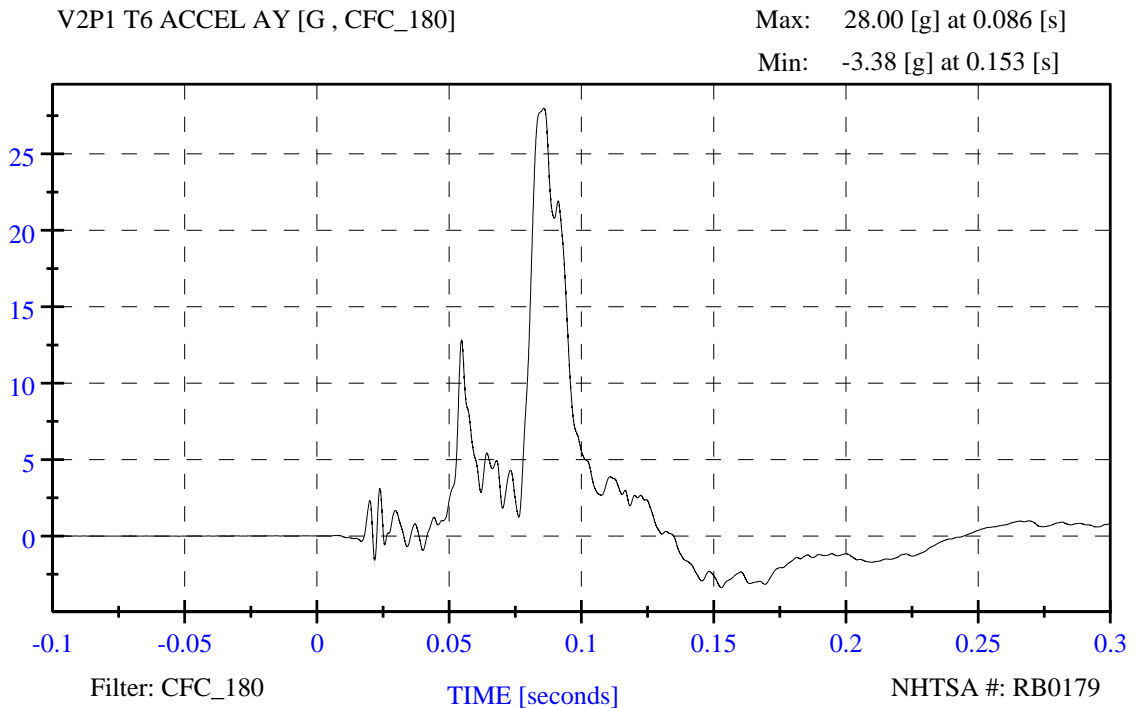

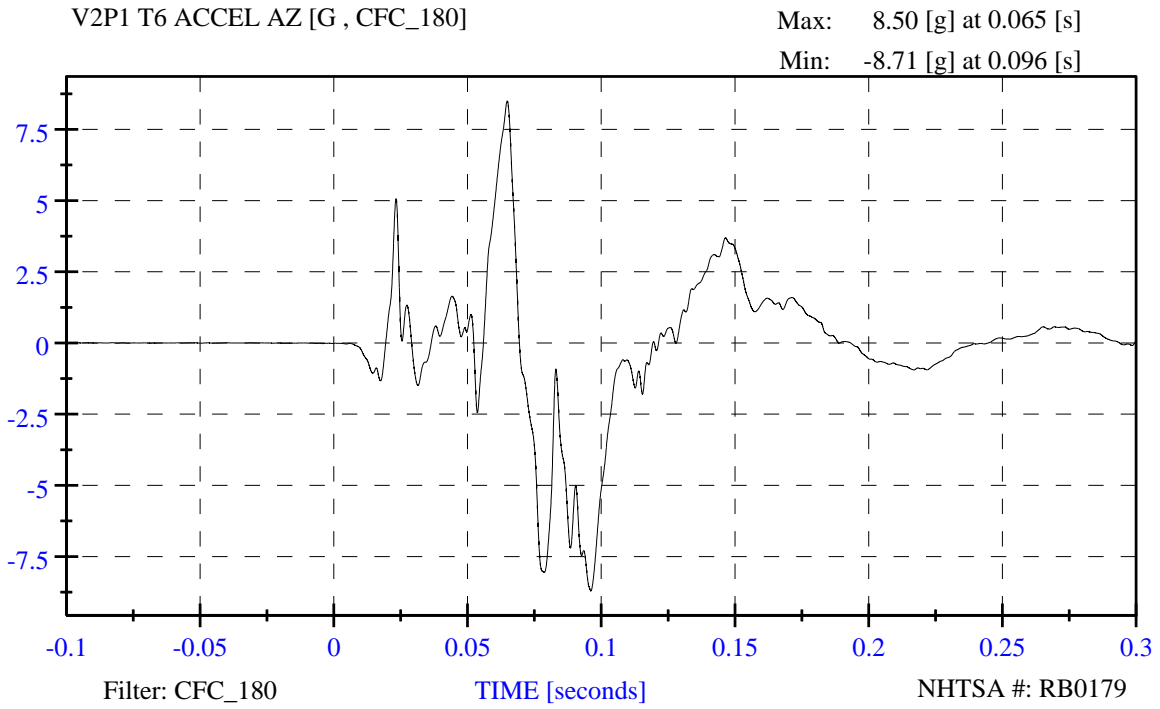

R&D 56 mph, 15deg angle, 35% overlap, 2011 Buick Lacrosse, RB0179

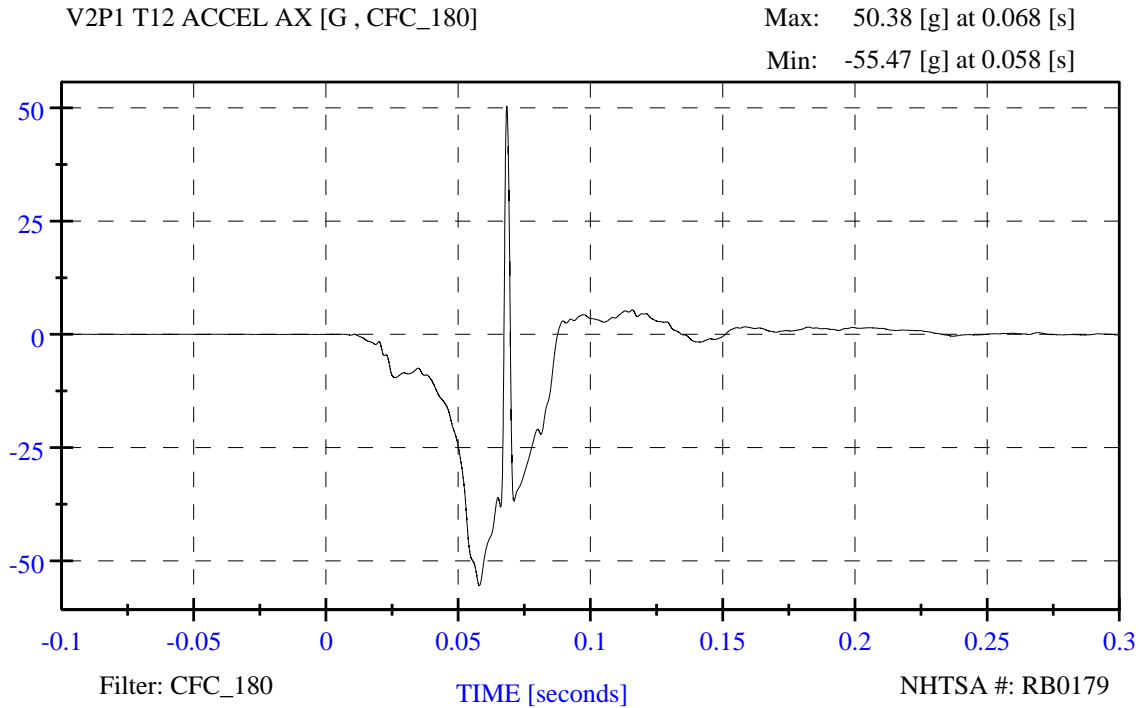

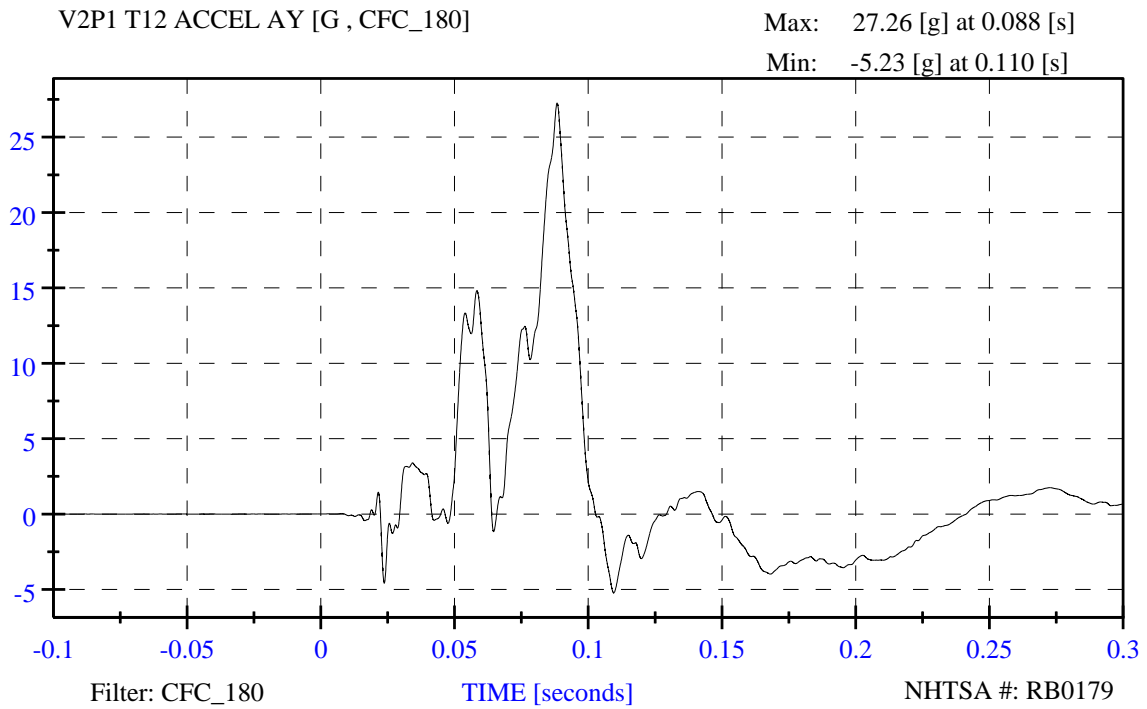

R&D 56 mph, 15deg angle, 35% overlap, 2011 Buick Lacrosse, RB0179

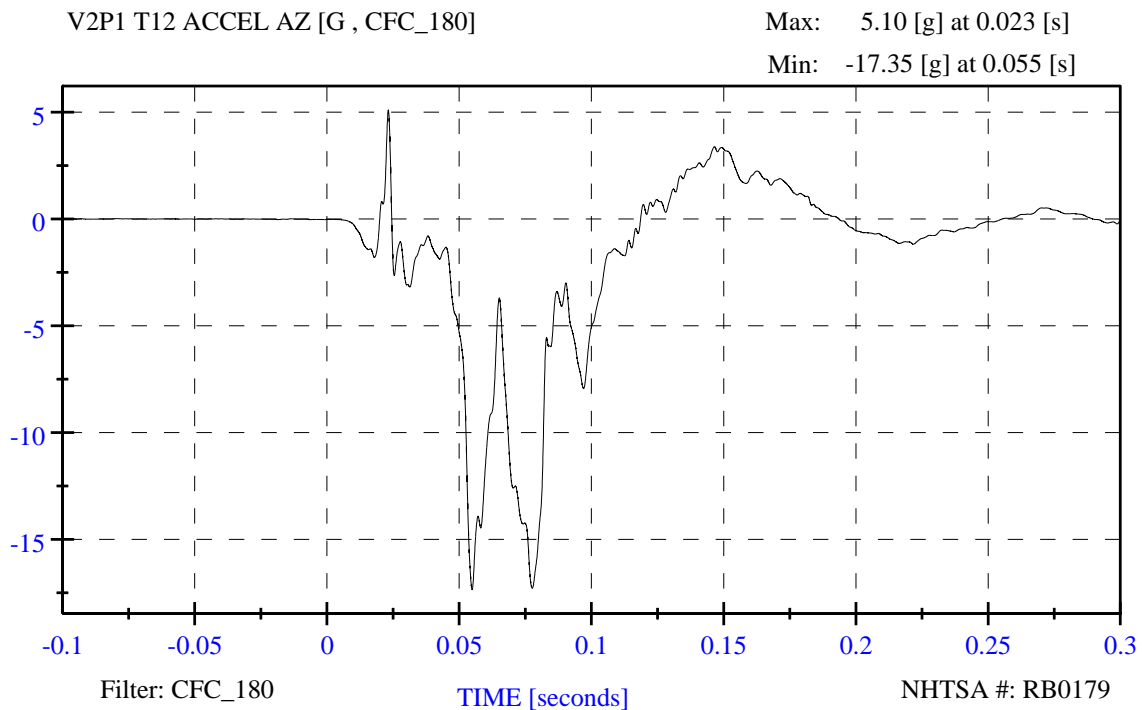

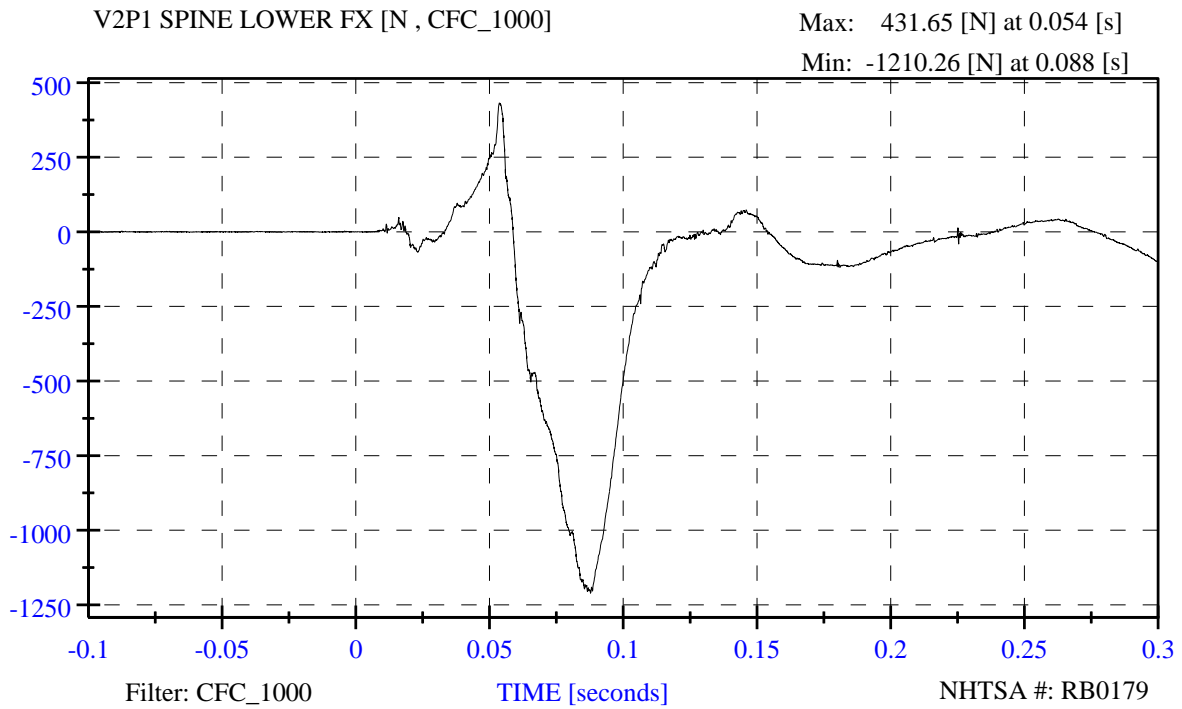

R&D 56 mph, 15deg angle, 35% overlap, 2011 Buick Lacrosse, RB0179

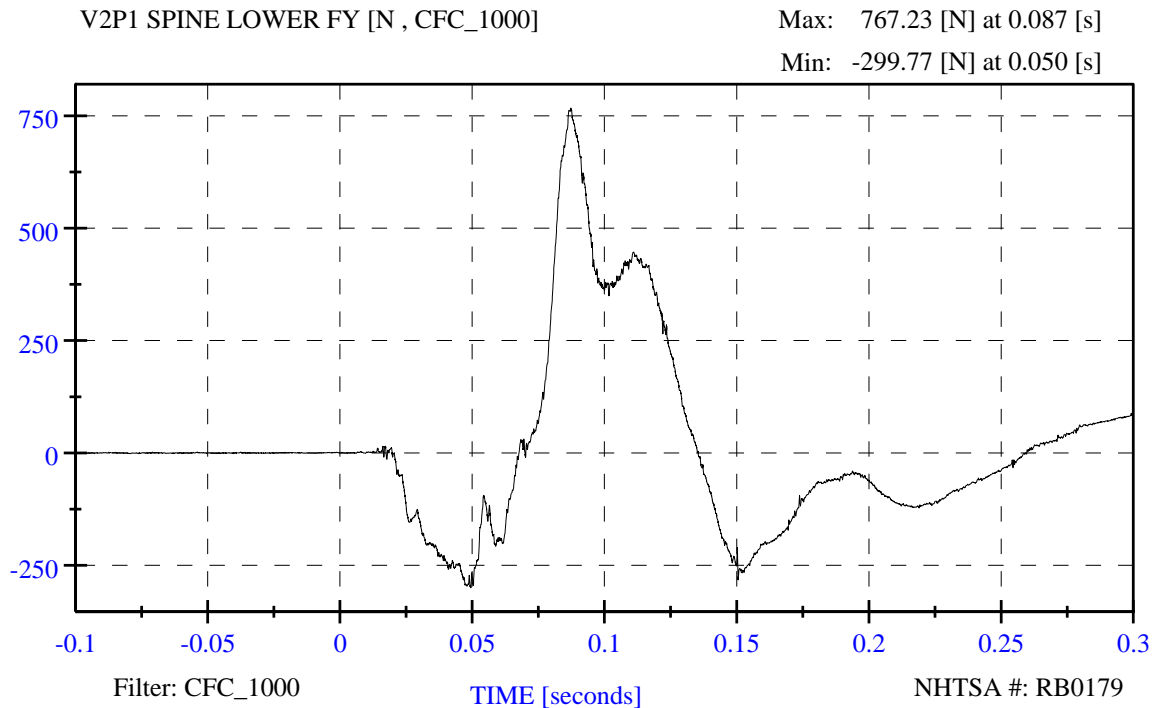

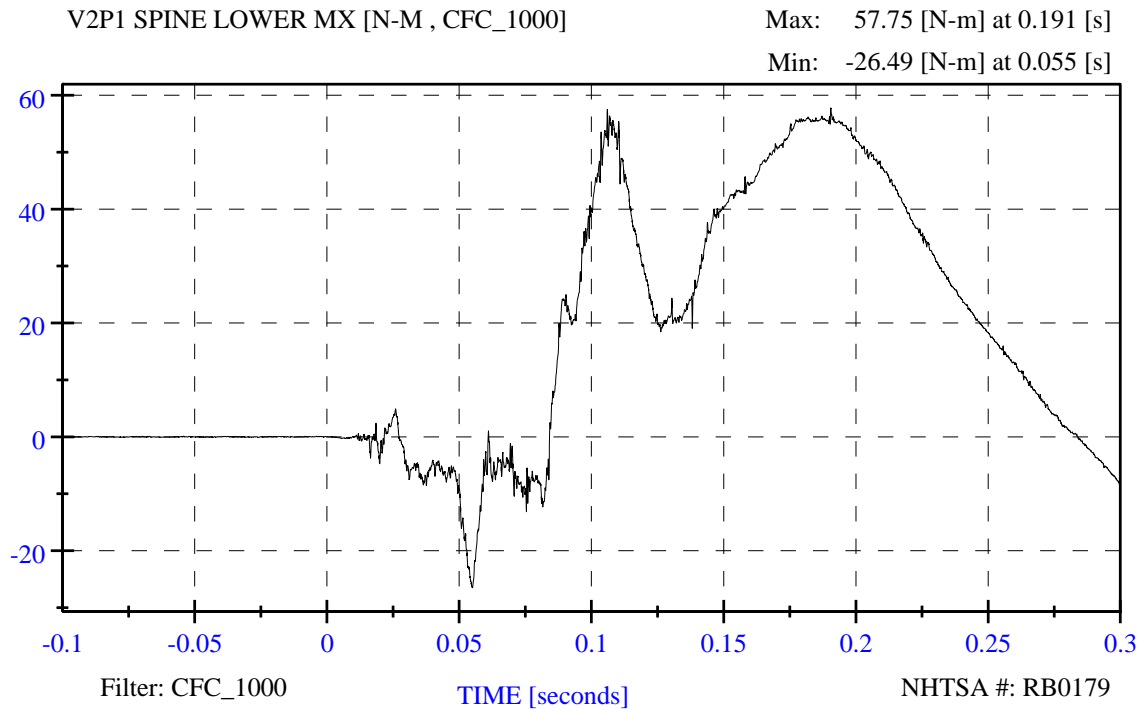
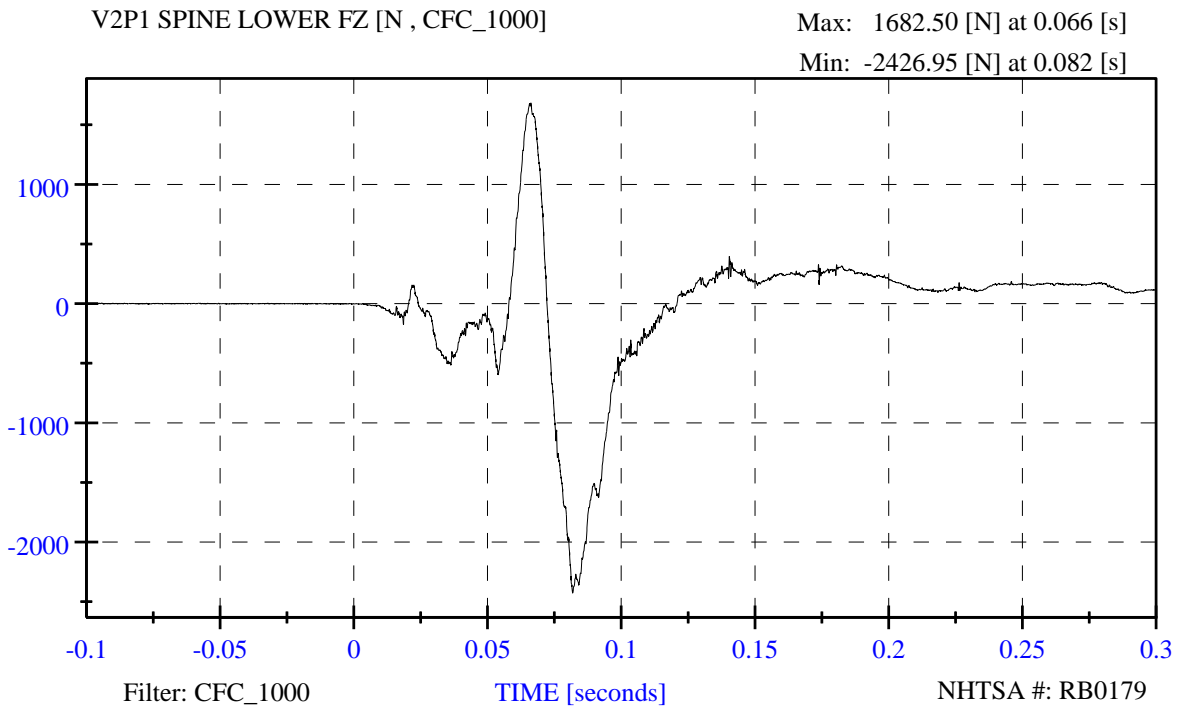

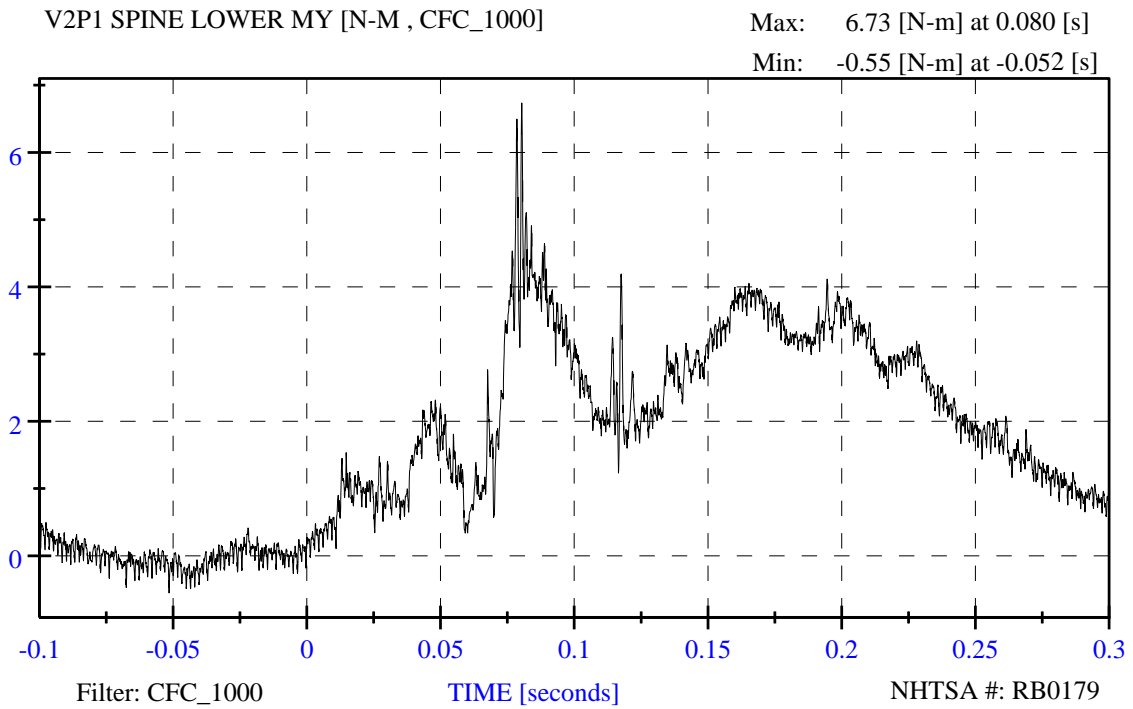

R&D 56 mph, 15deg angle, 35% overlap, 2011 Buick Lacrosse, RB0179

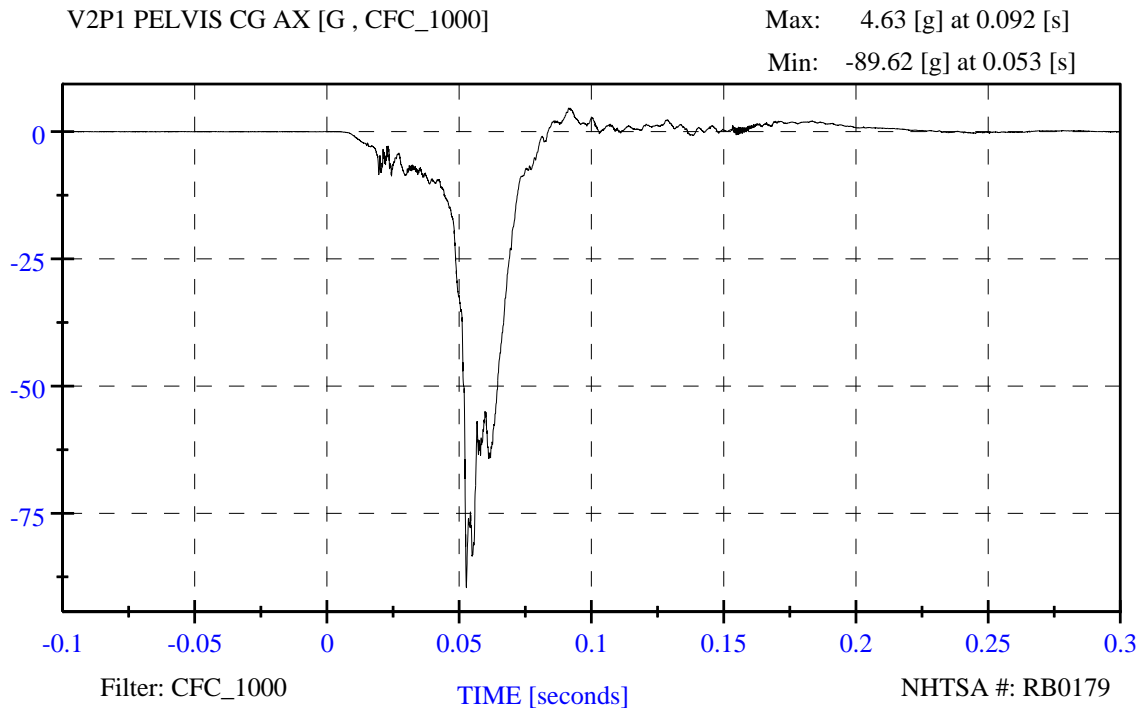

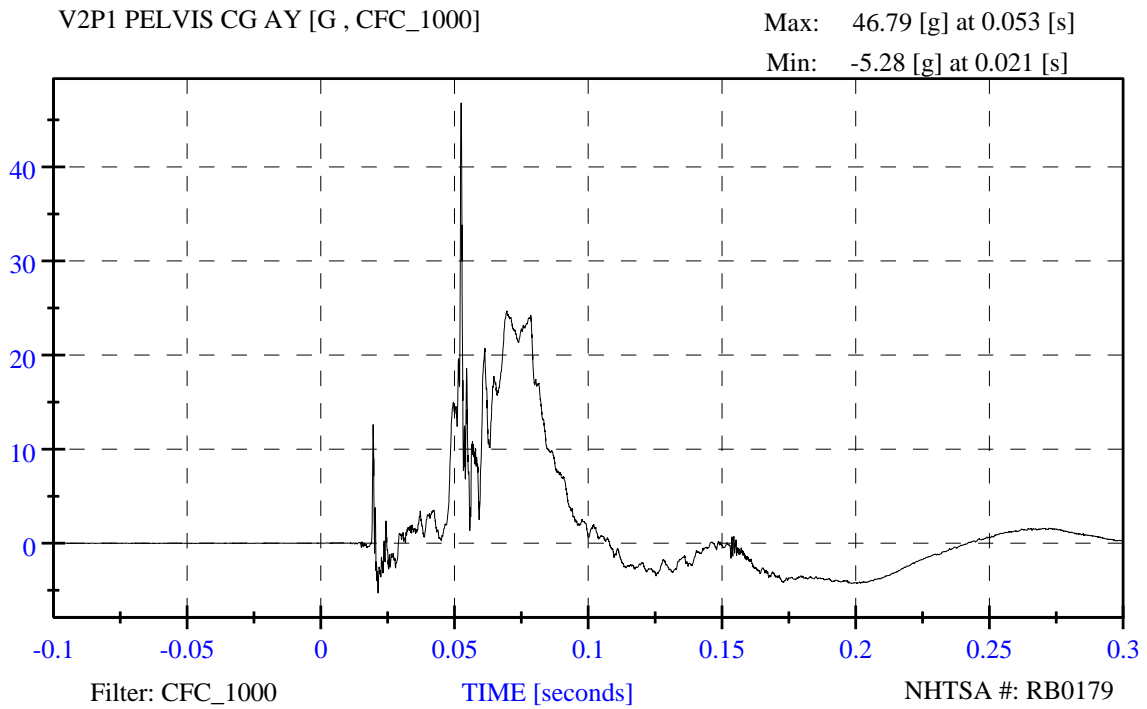

R&D 56 mph, 15deg angle, 35% overlap, 2011 Buick Lacrosse, RB0179

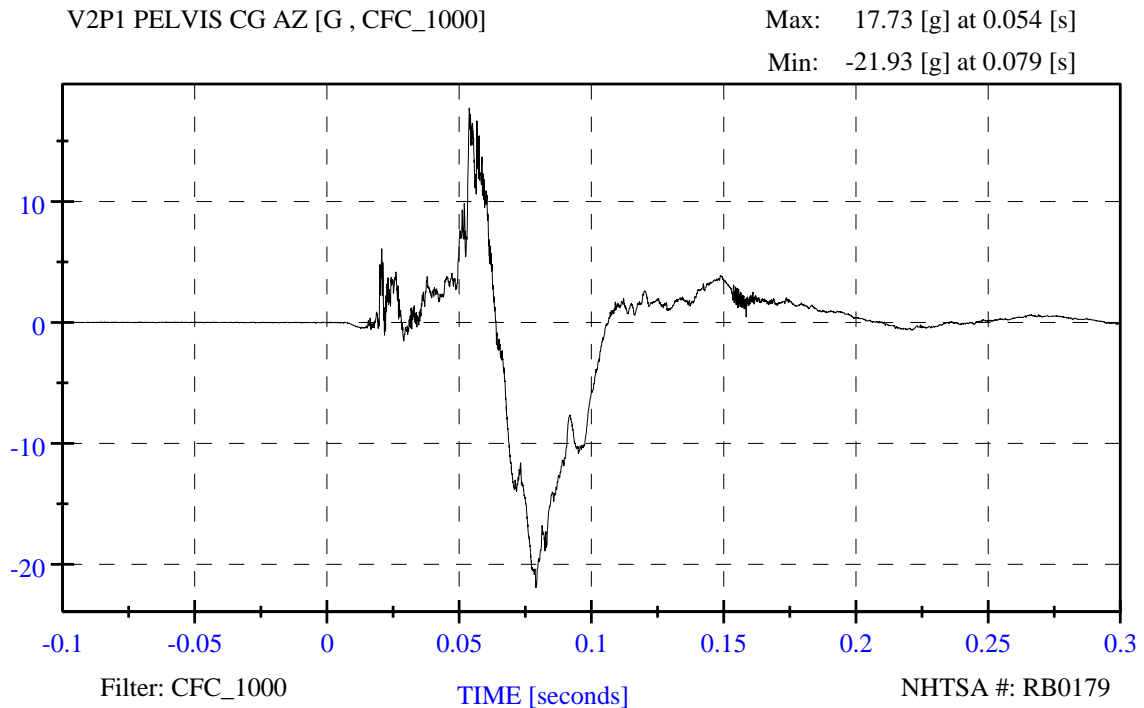

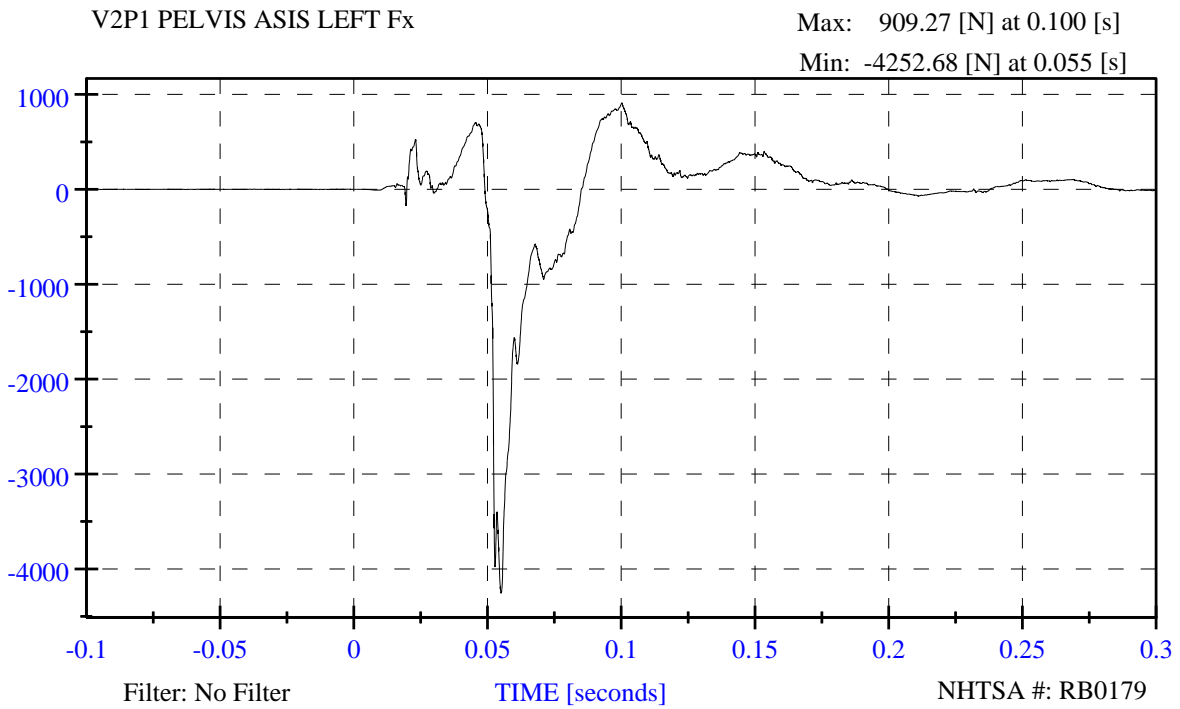

R&D 56 mph, 15deg angle, 35% overlap, 2011 Buick Lacrosse, RB0179

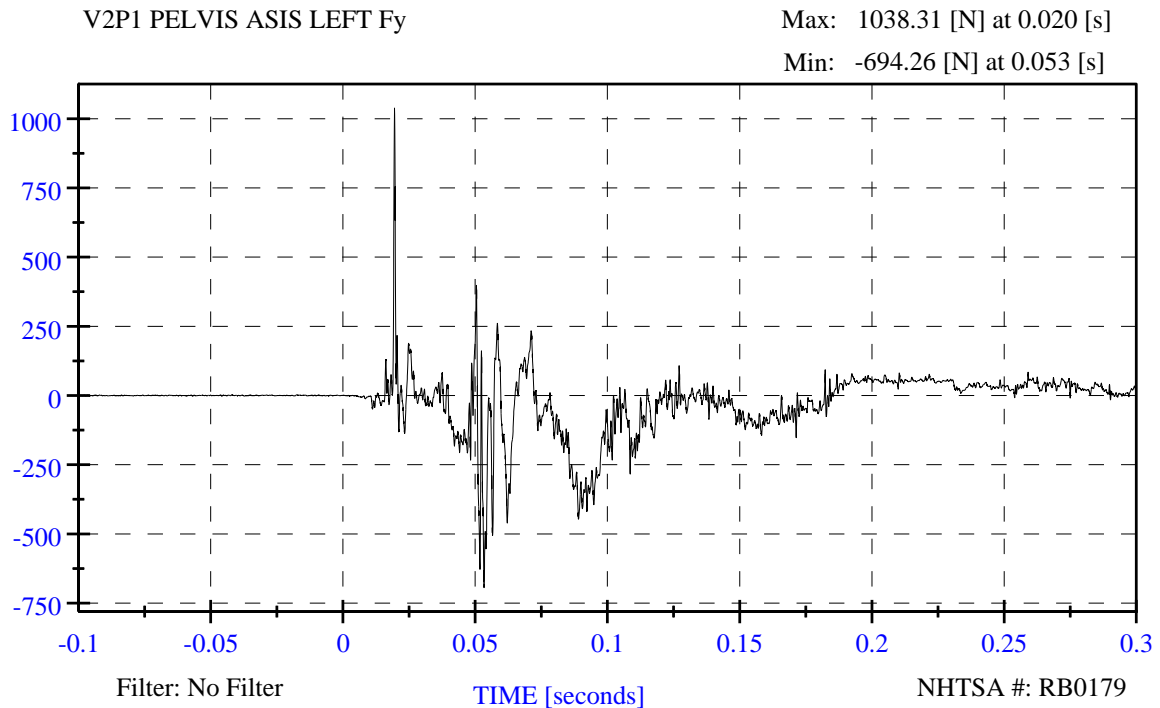

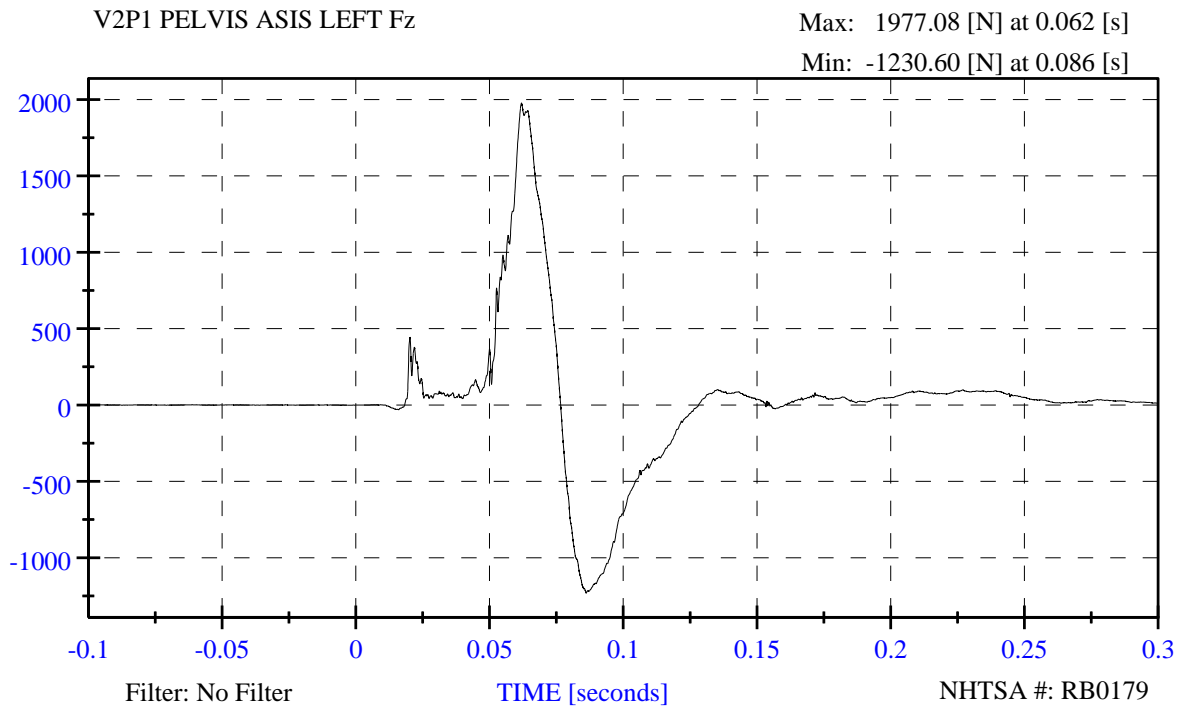

R&D 56 mph, 15deg angle, 35% overlap, 2011 Buick Lacrosse, RB0179

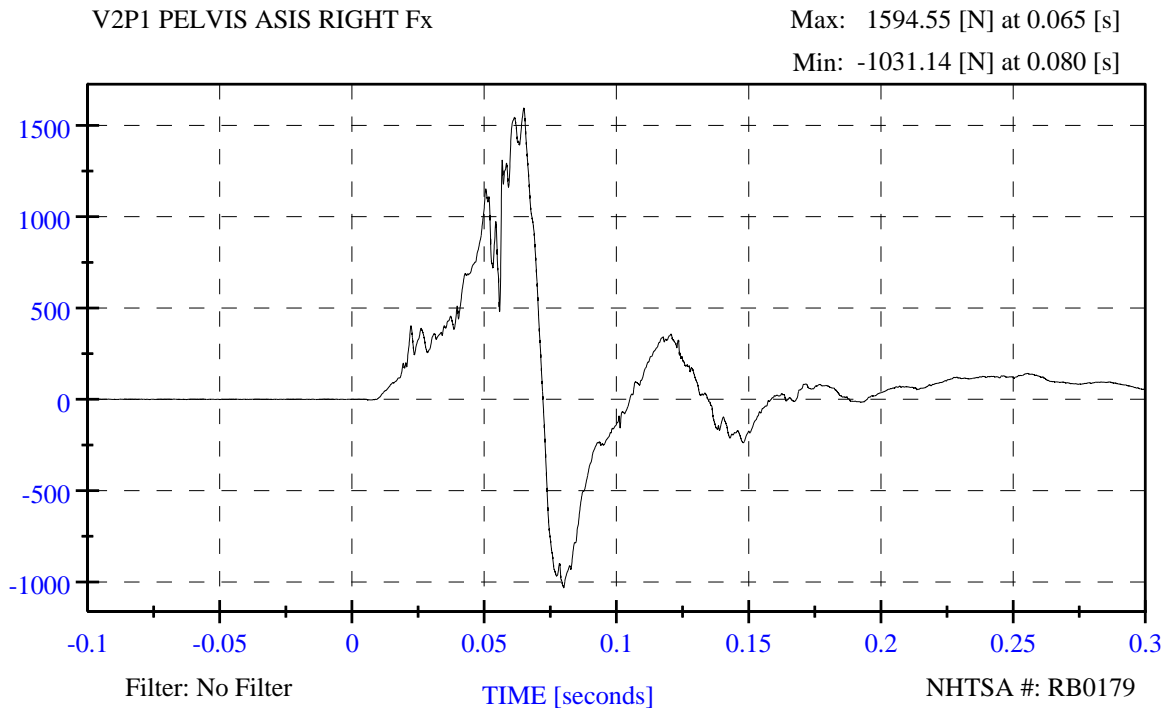

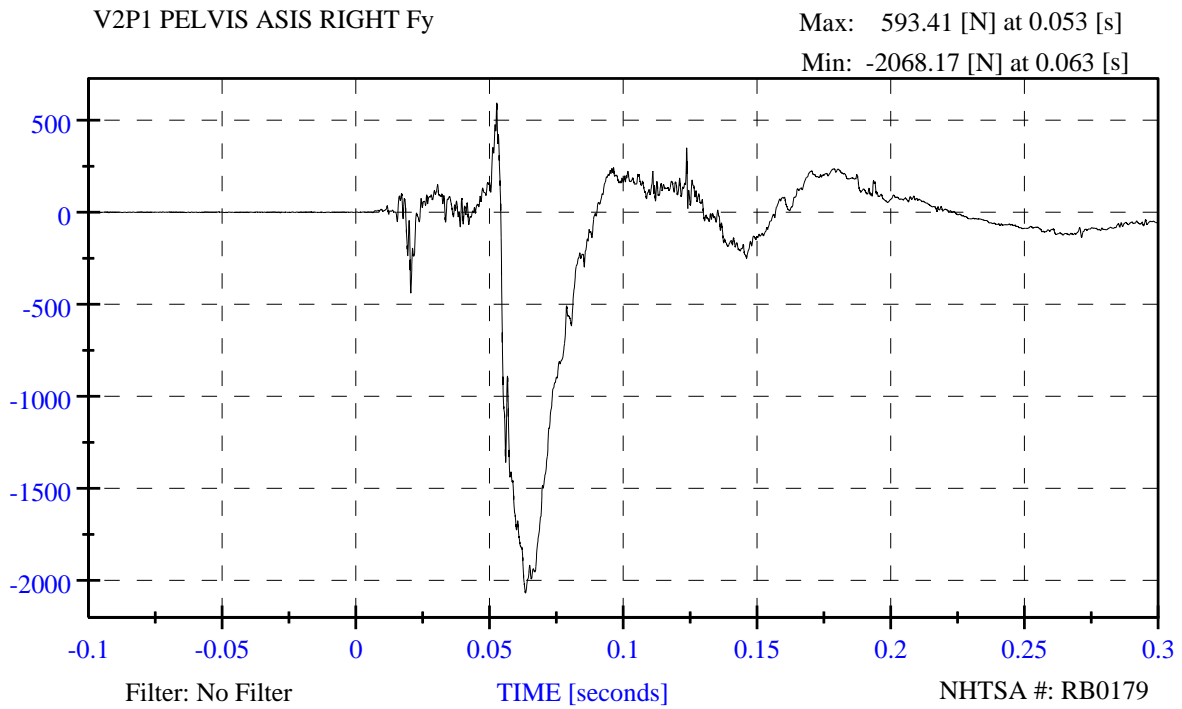

R&D 56 mph, 15deg angle, 35% overlap, 2011 Buick Lacrosse, RB0179

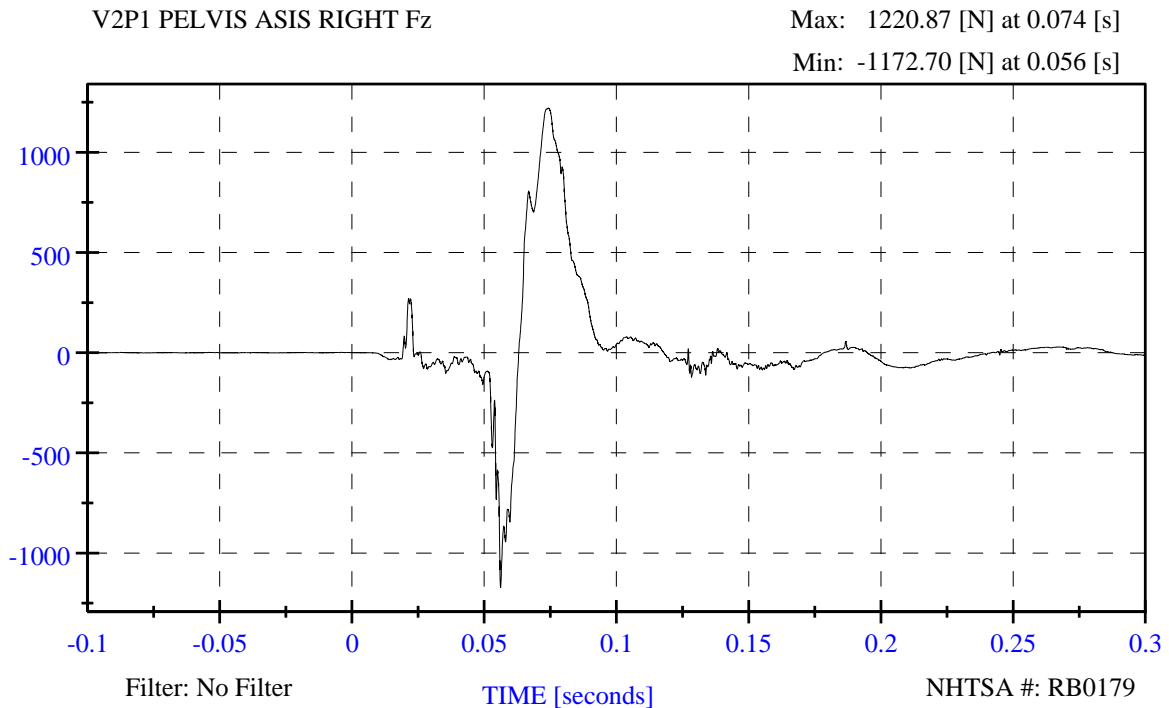

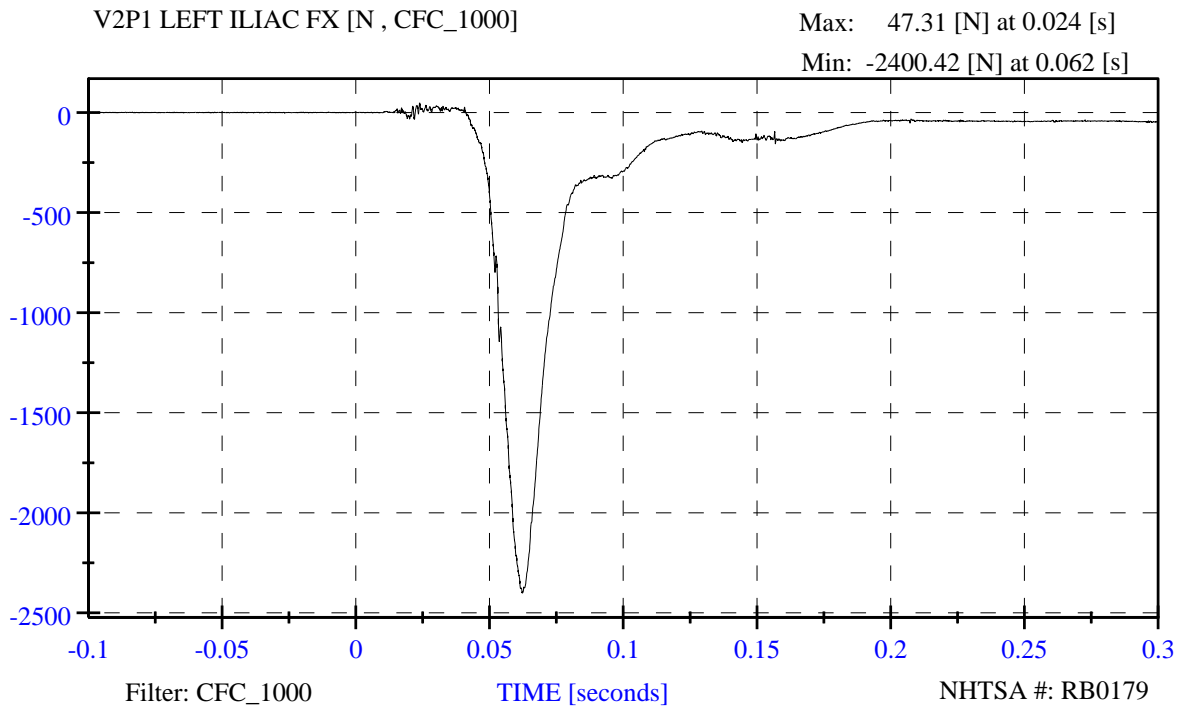

R&D 56 mph, 15deg angle, 35% overlap, 2011 Buick Lacrosse, RB0179

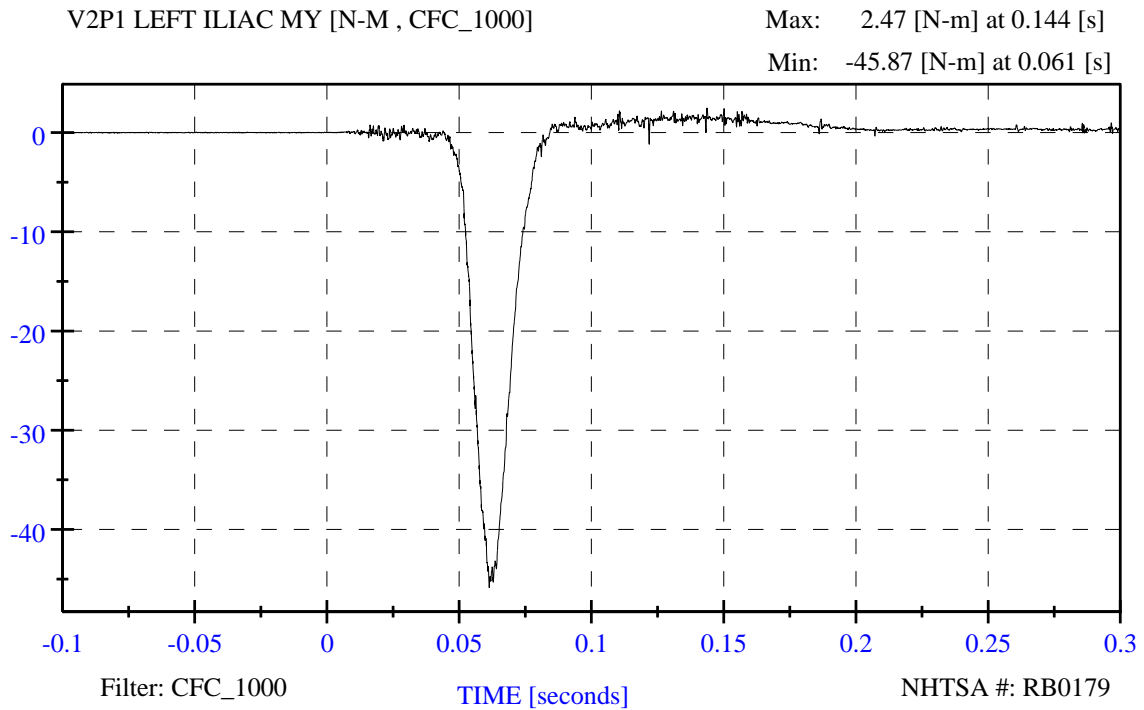

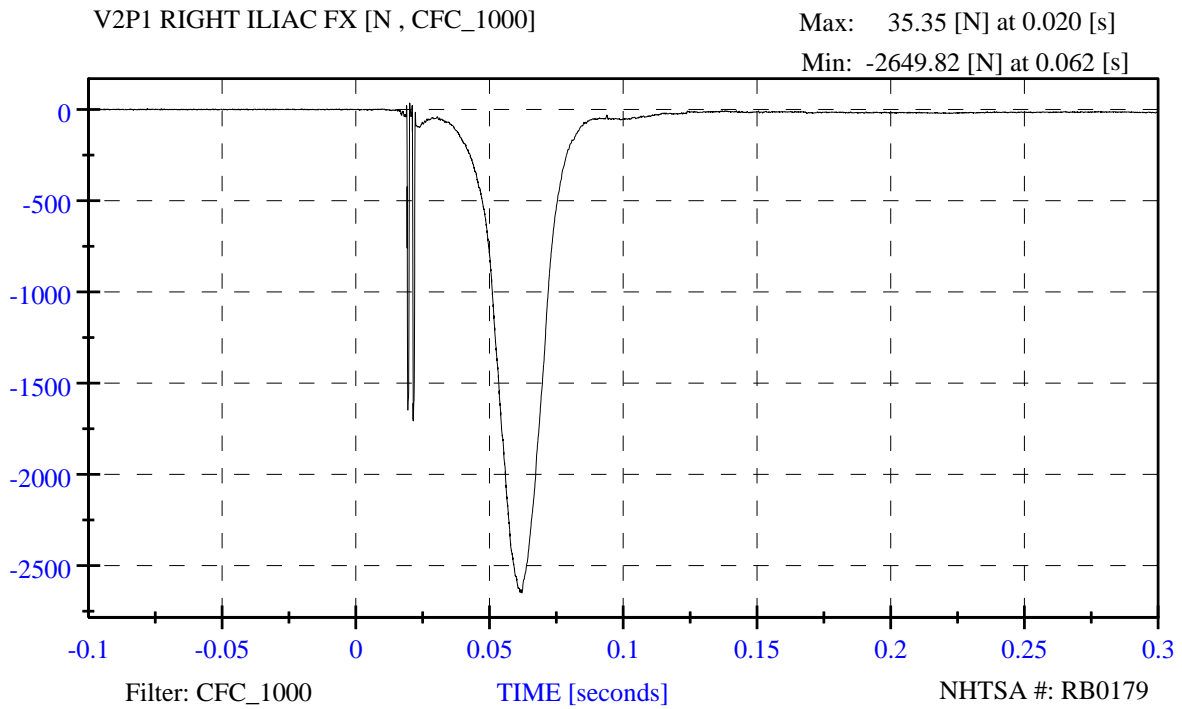

R&D 56 mph, 15deg angle, 35% overlap, 2011 Buick Lacrosse, RB0179

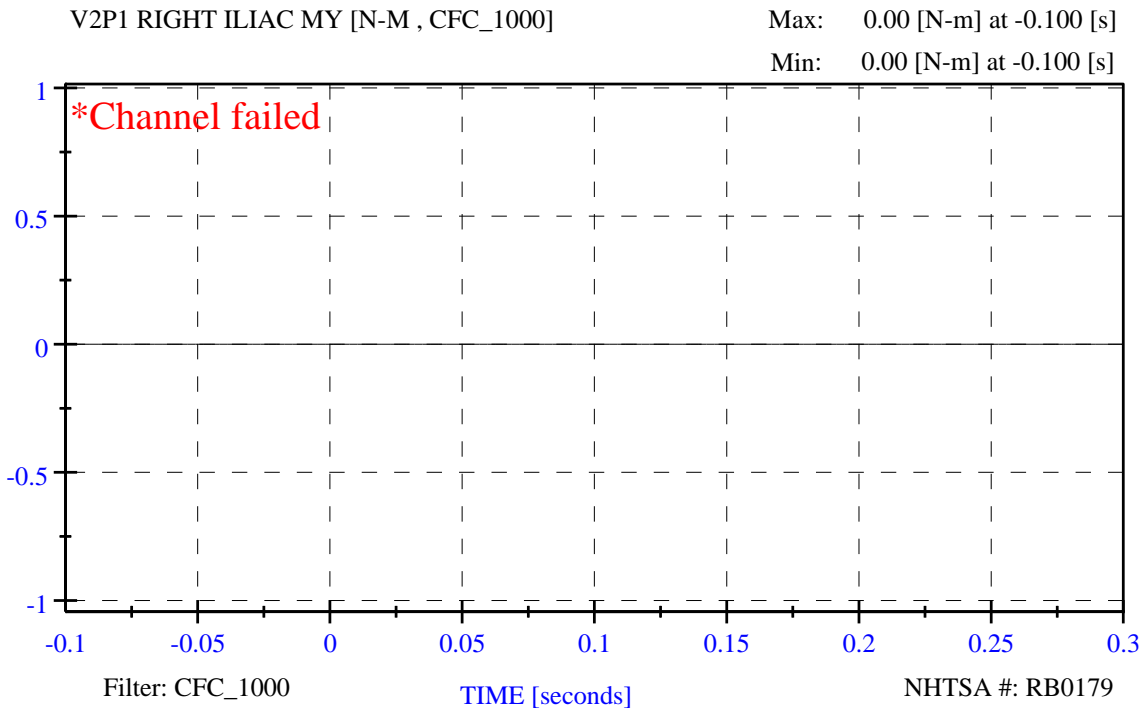

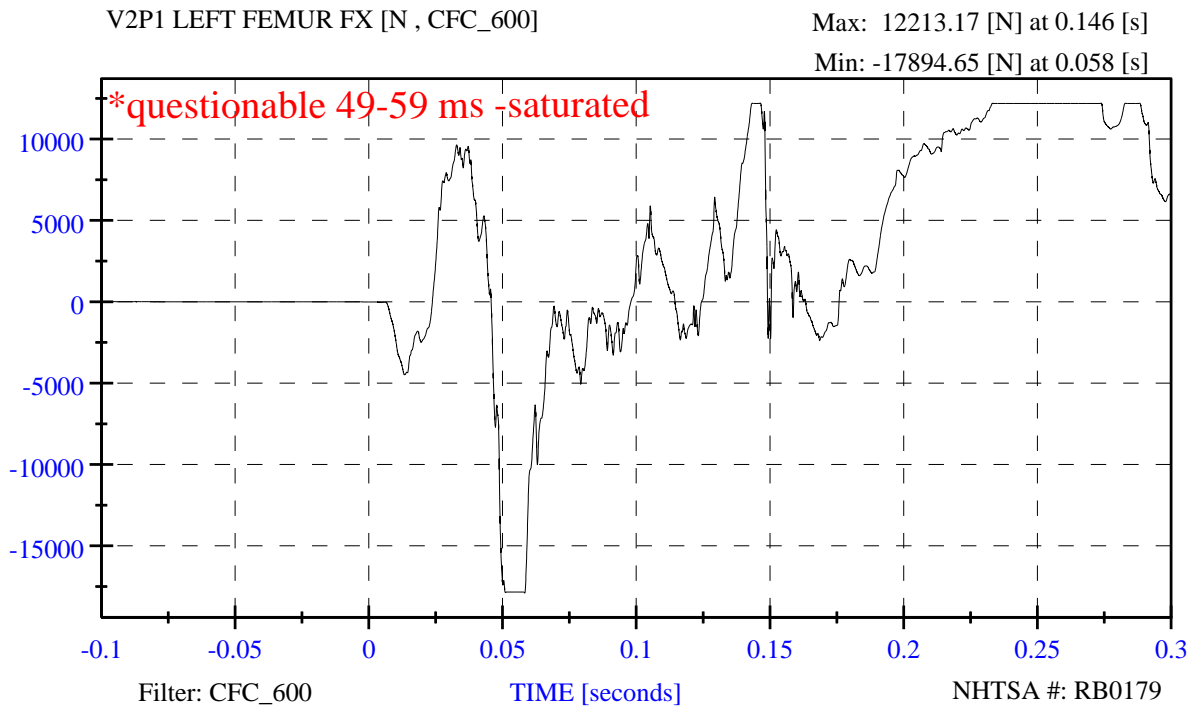

R&D 56 mph, 15deg angle, 35% overlap, 2011 Buick Lacrosse, RB0179

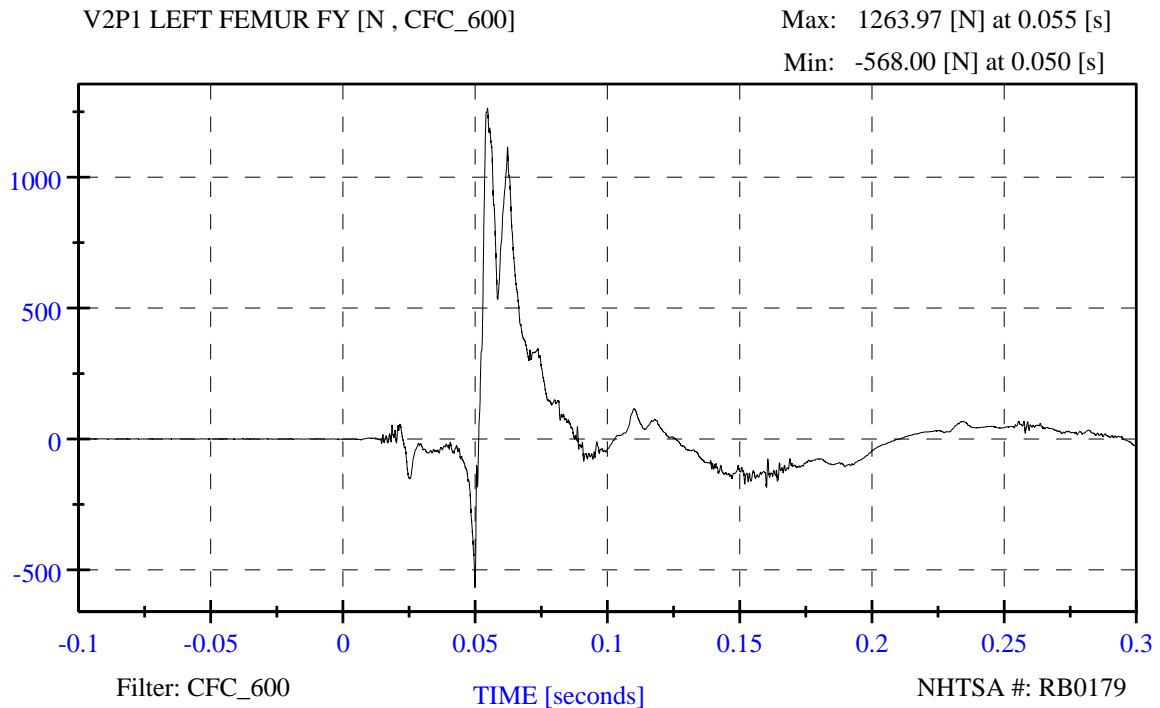

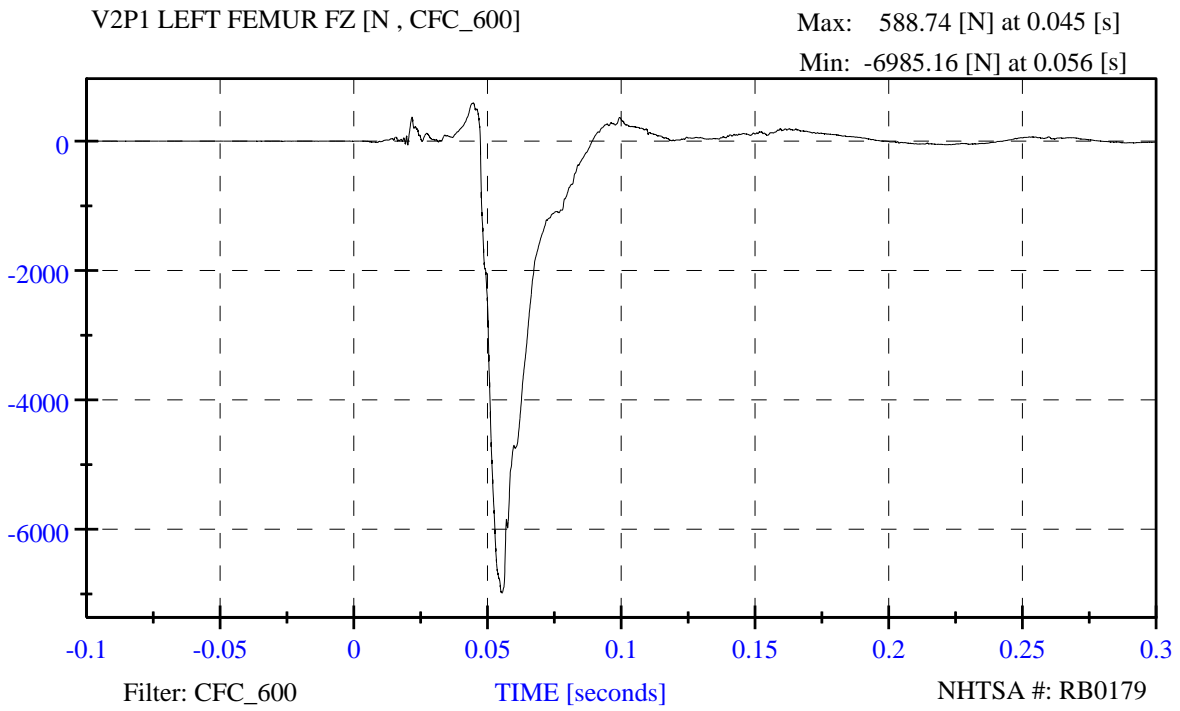

R&D 56 mph, 15deg angle, 35% overlap, 2011 Buick Lacrosse, RB0179

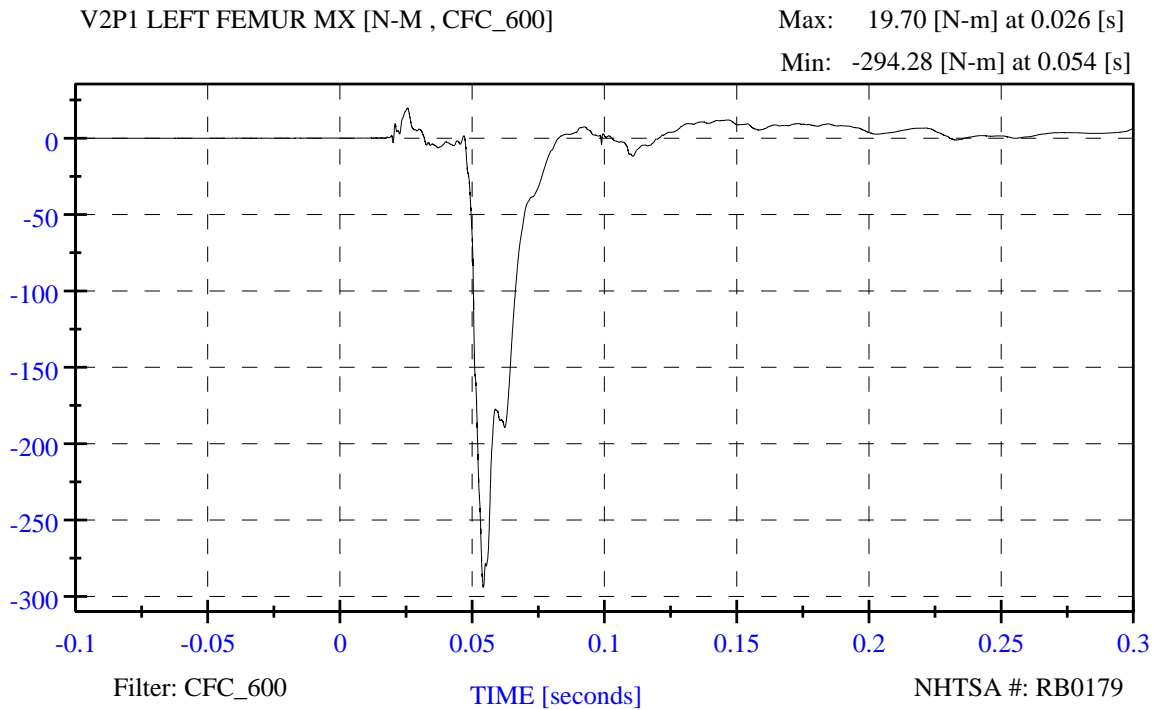

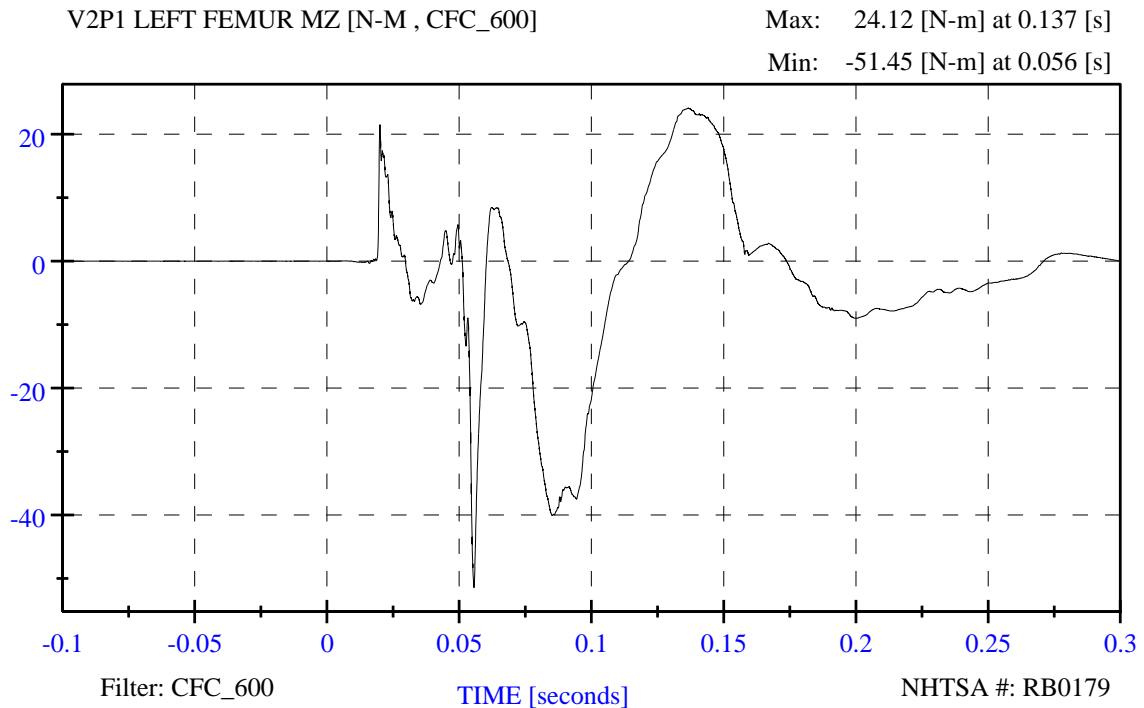
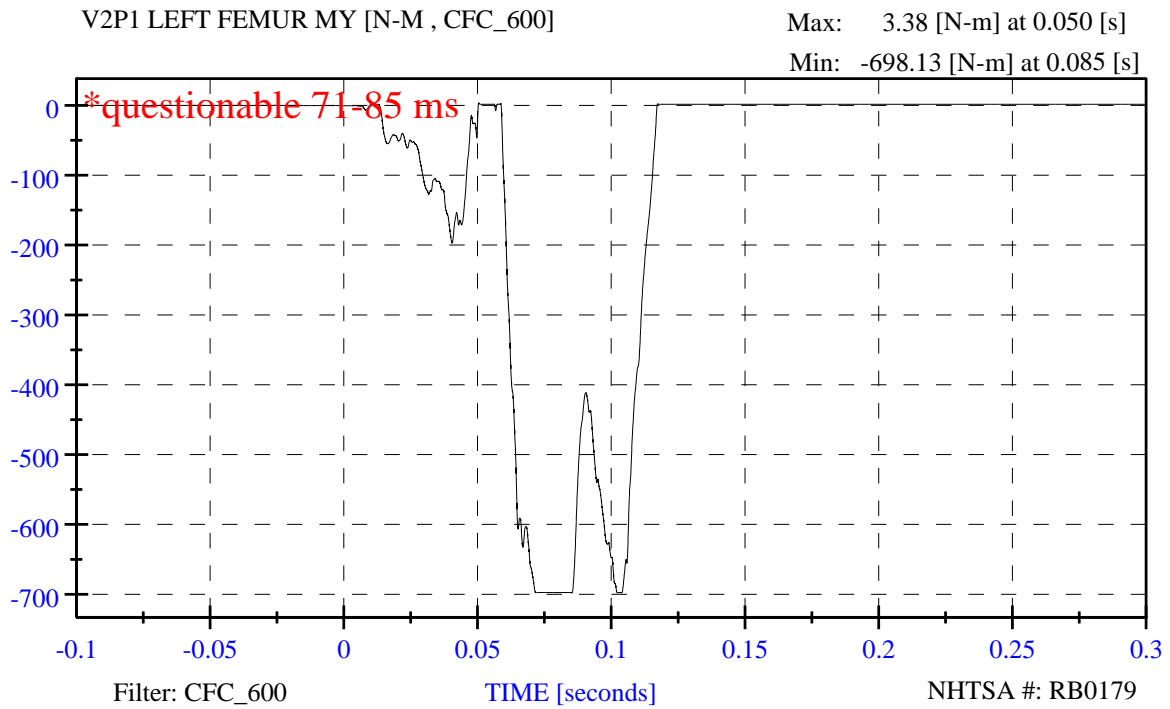

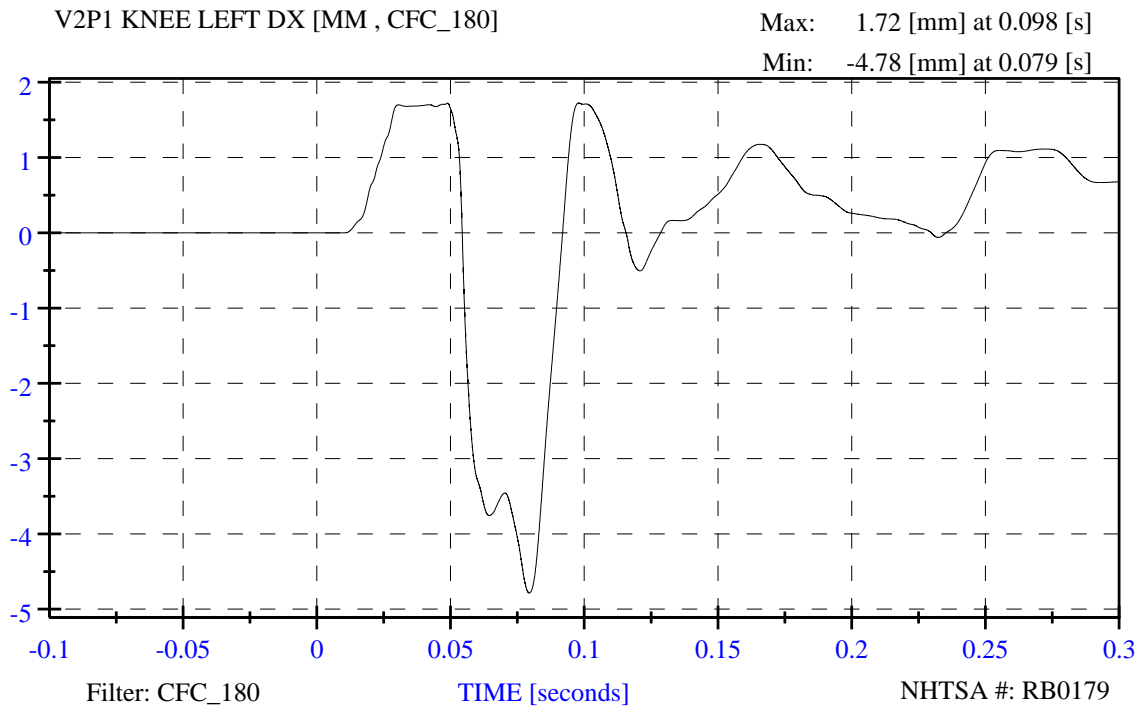

R&D 56 mph, 15deg angle, 35% overlap, 2011 Buick Lacrosse, RB0179

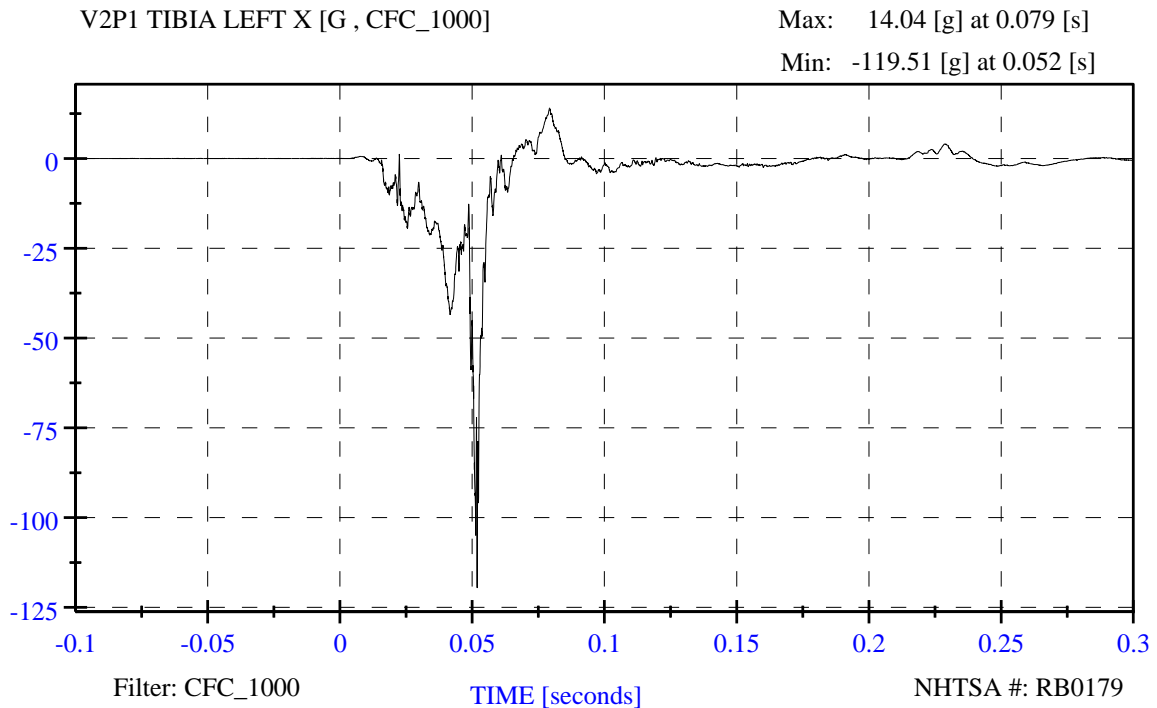

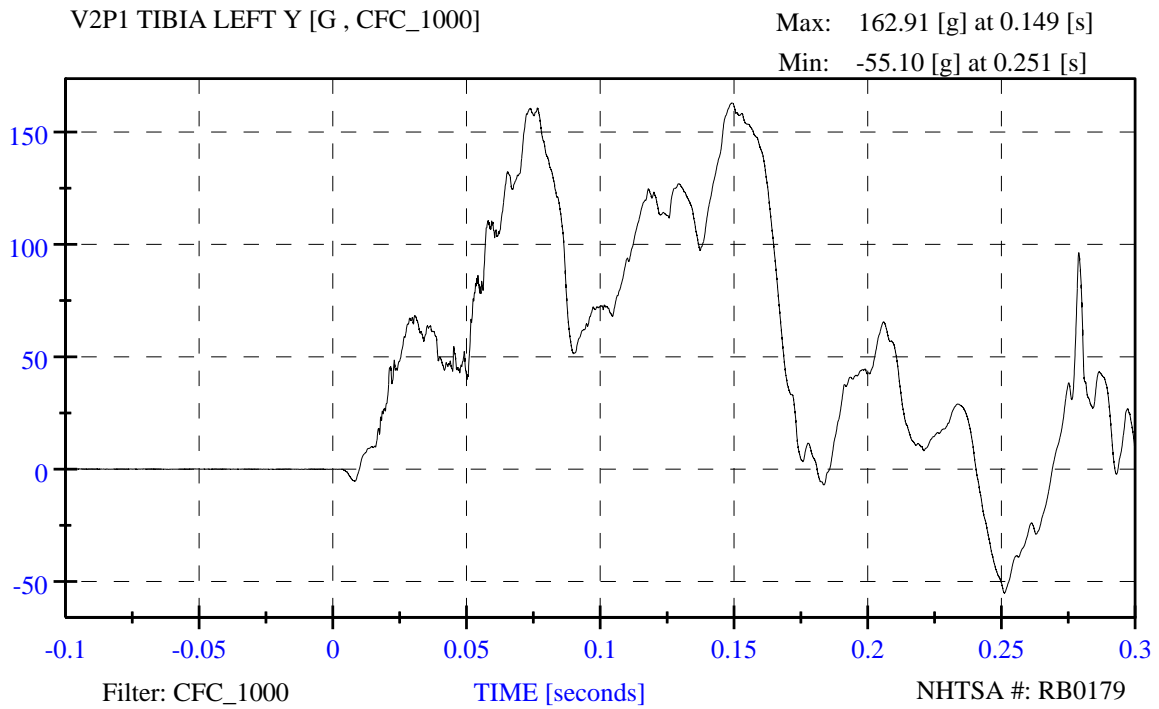

R&D 56 mph, 15deg angle, 35% overlap, 2011 Buick Lacrosse, RB0179

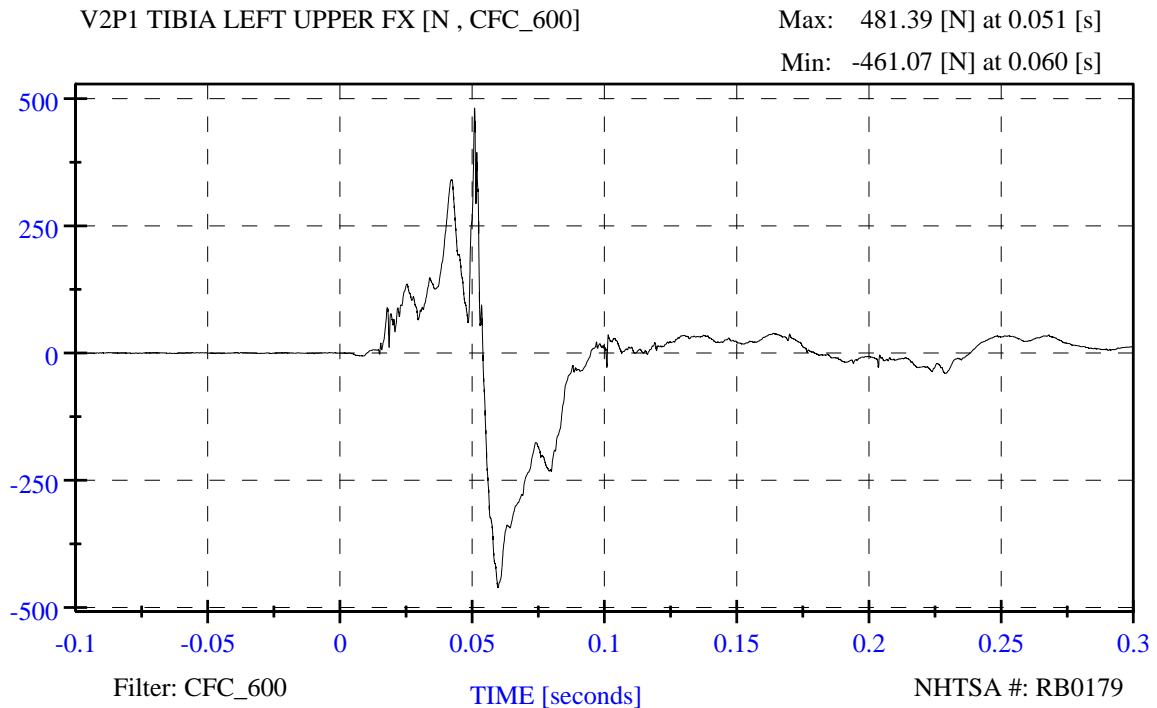

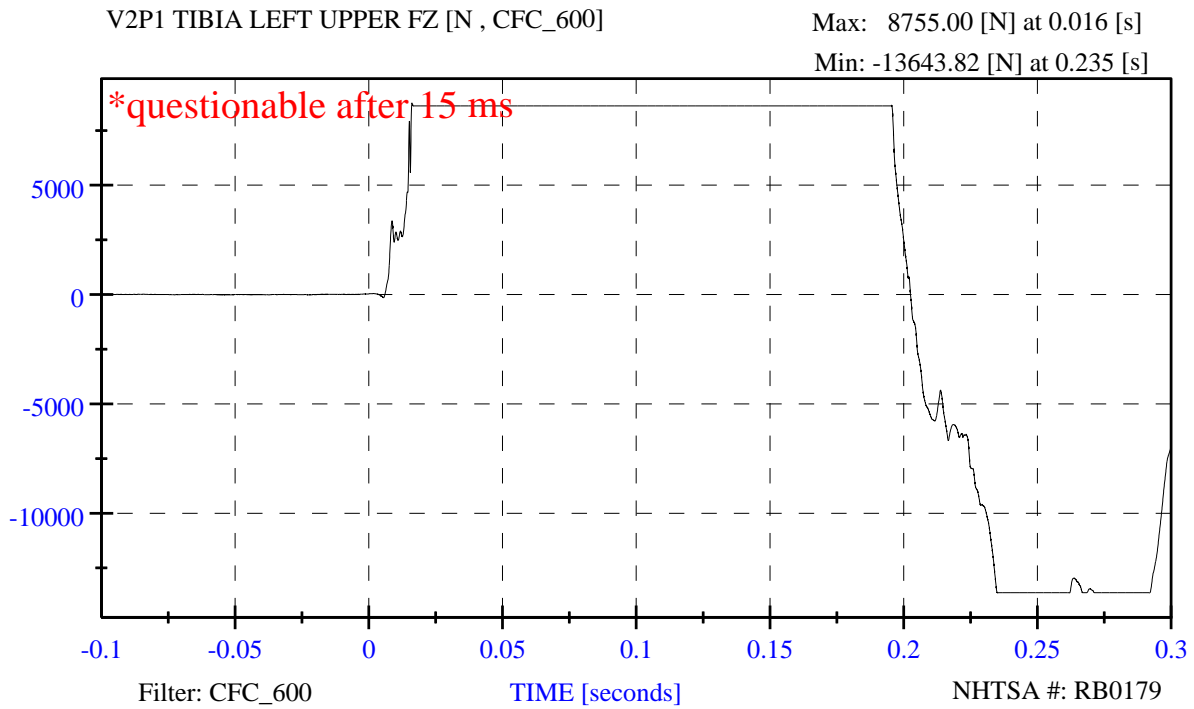

R&D 56 mph, 15deg angle, 35% overlap, 2011 Buick Lacrosse, RB0179

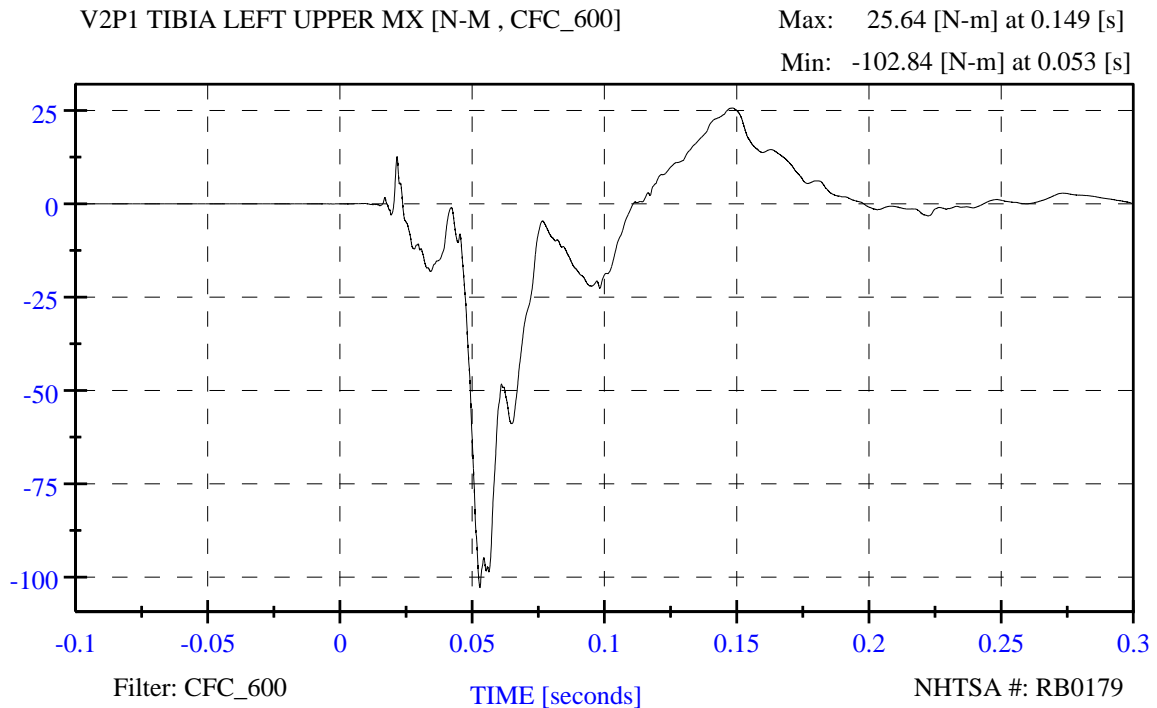

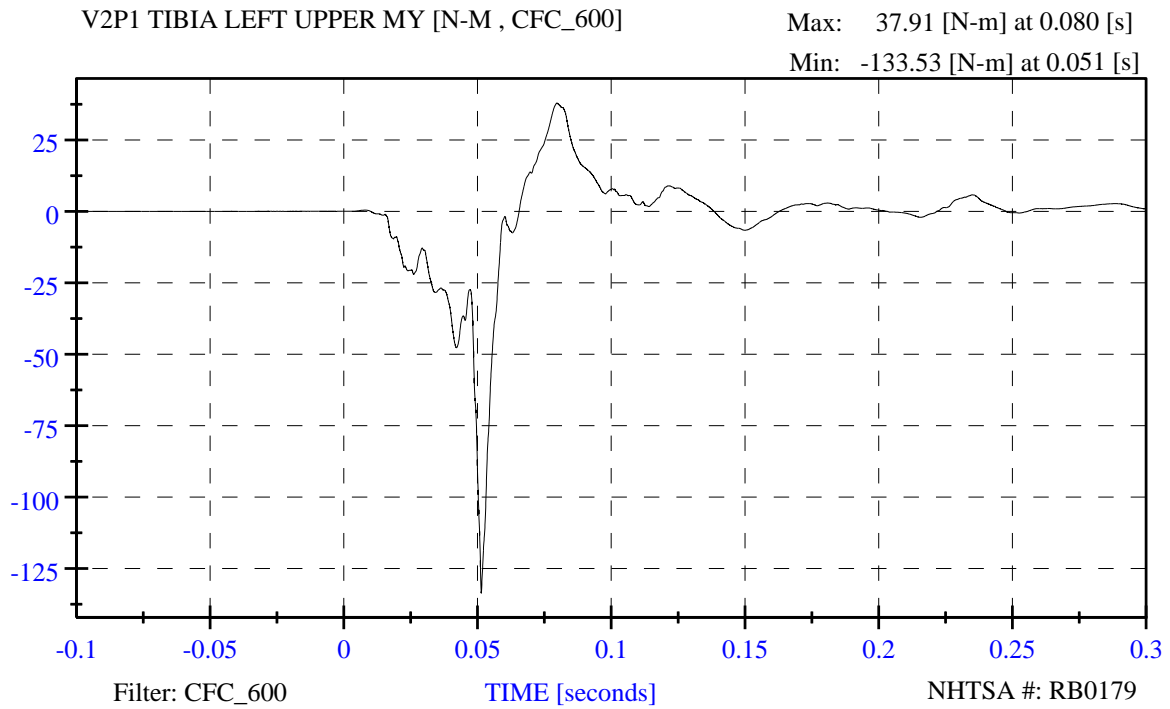

R&D 56 mph, 15deg angle, 35% overlap, 2011 Buick Lacrosse, RB0179

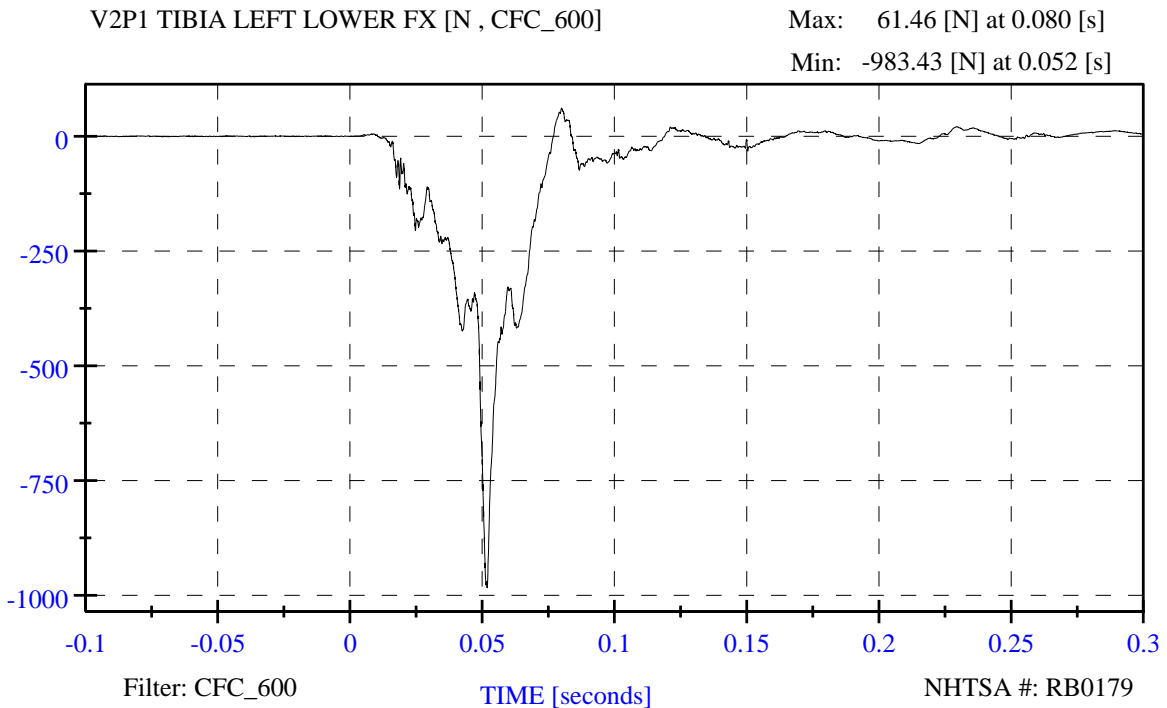

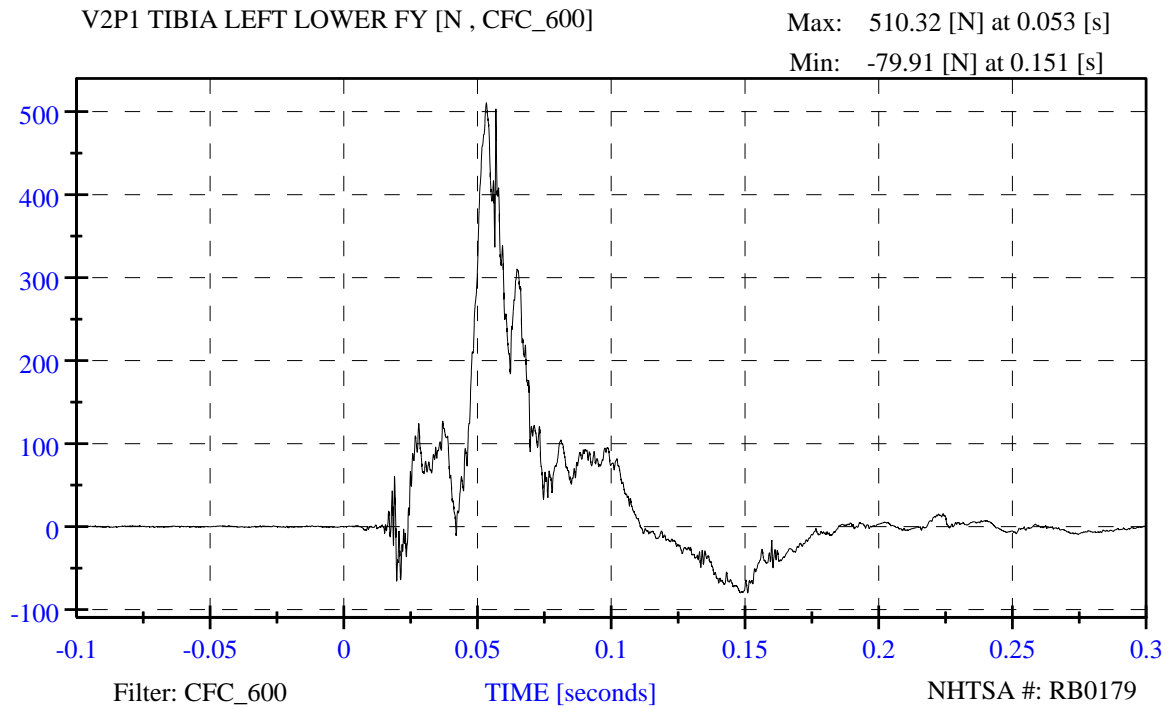

R&D 56 mph, 15deg angle, 35% overlap, 2011 Buick Lacrosse, RB0179

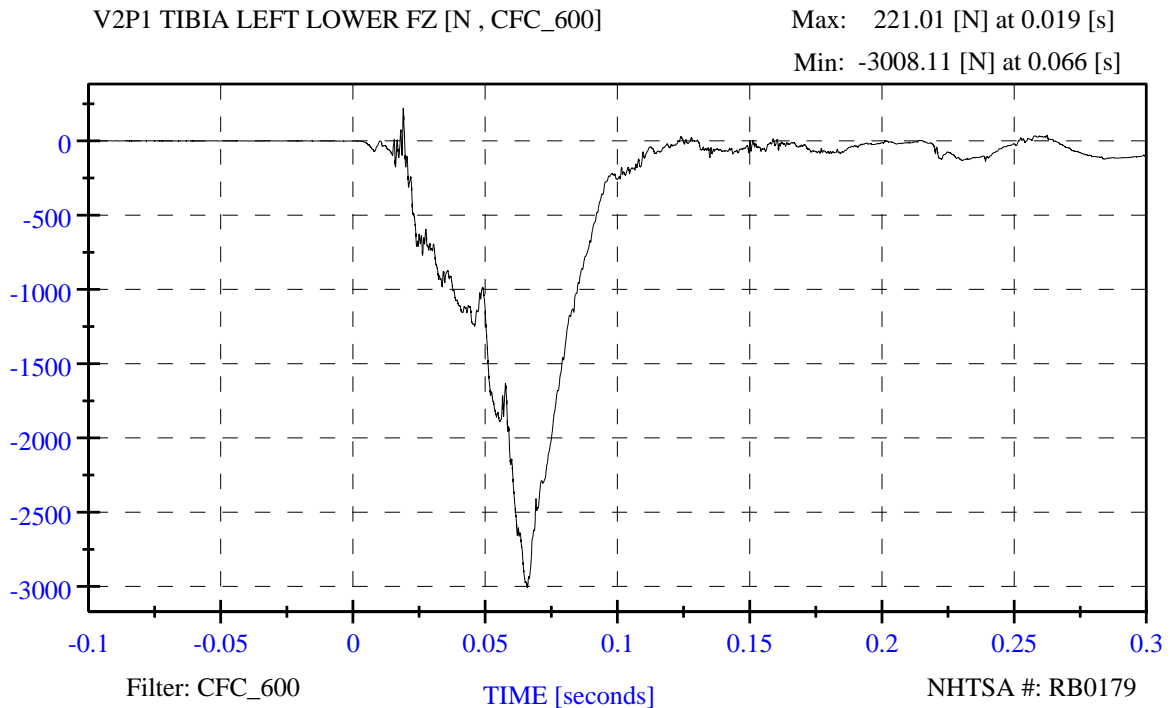

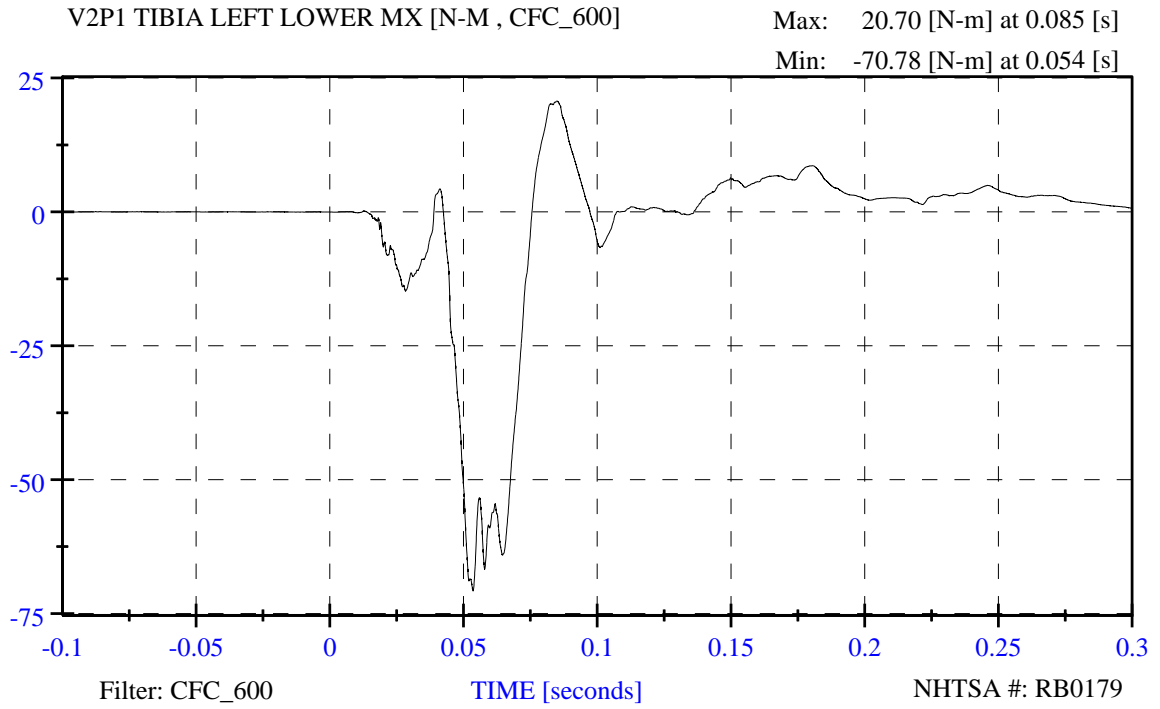

R&D 56 mph, 15deg angle, 35% overlap, 2011 Buick Lacrosse, RB0179

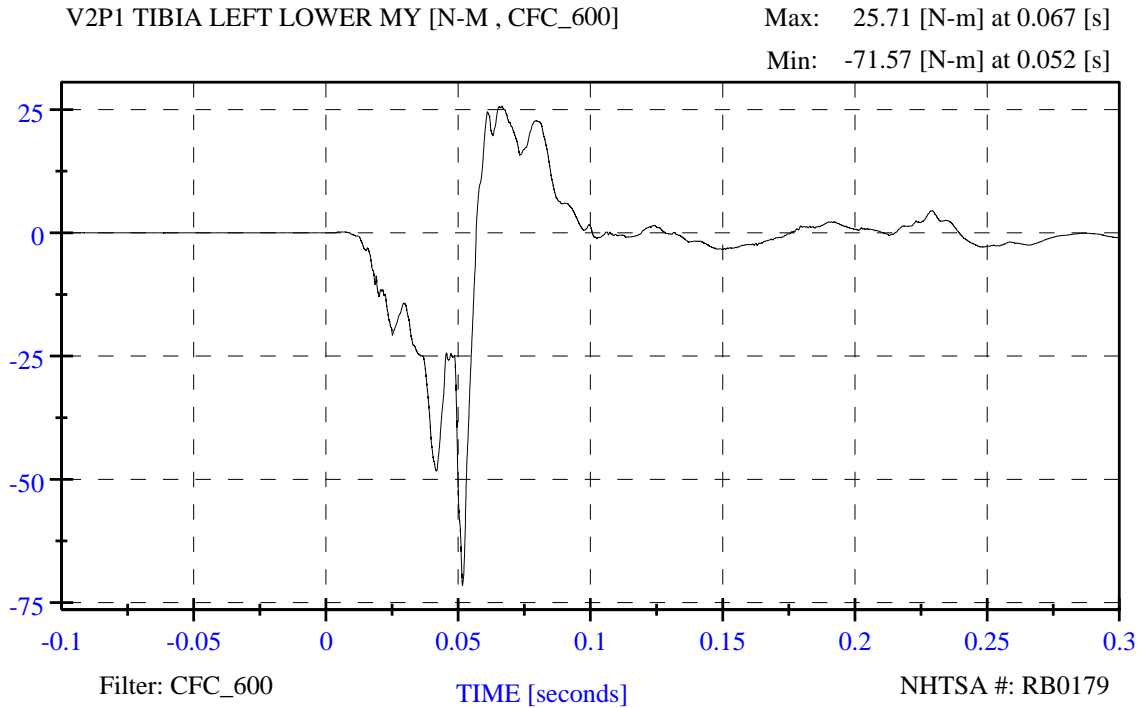

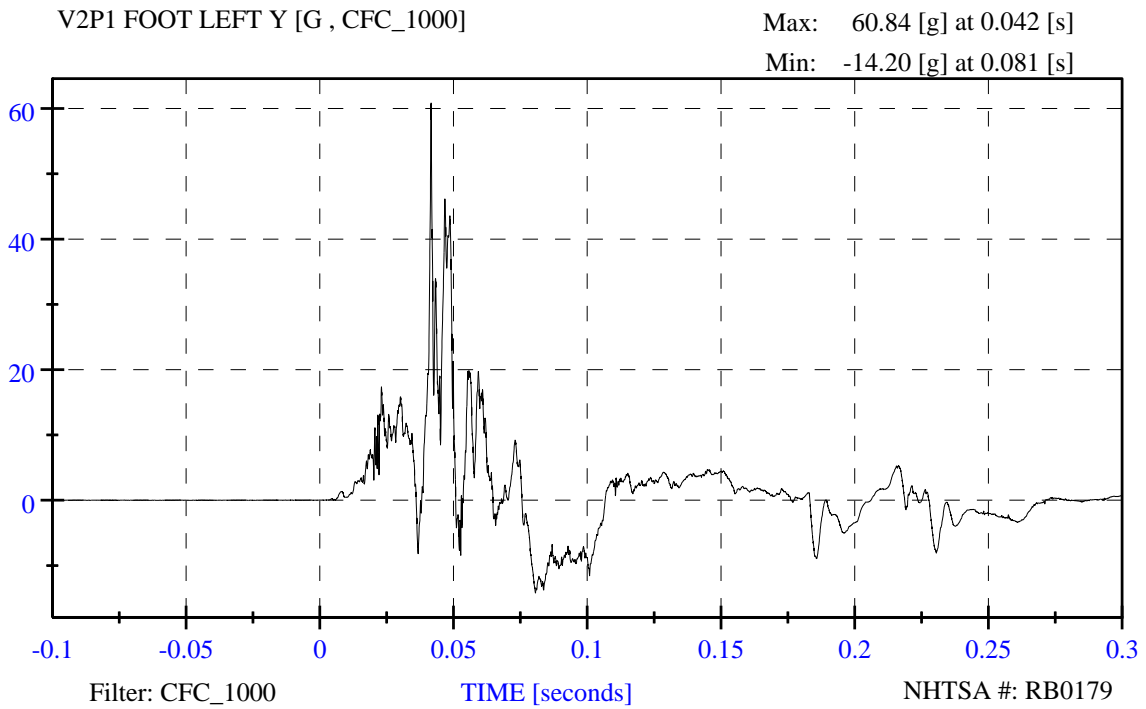

R&D 56 mph, 15deg angle, 35% overlap, 2011 Buick Lacrosse, RB0179

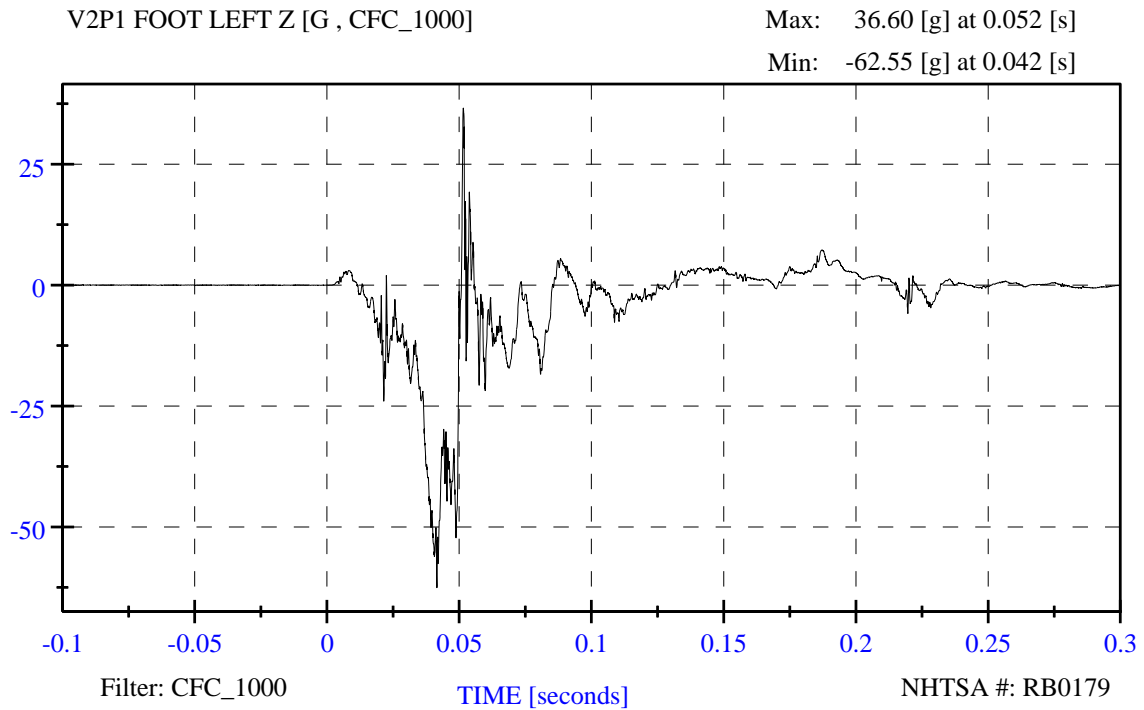

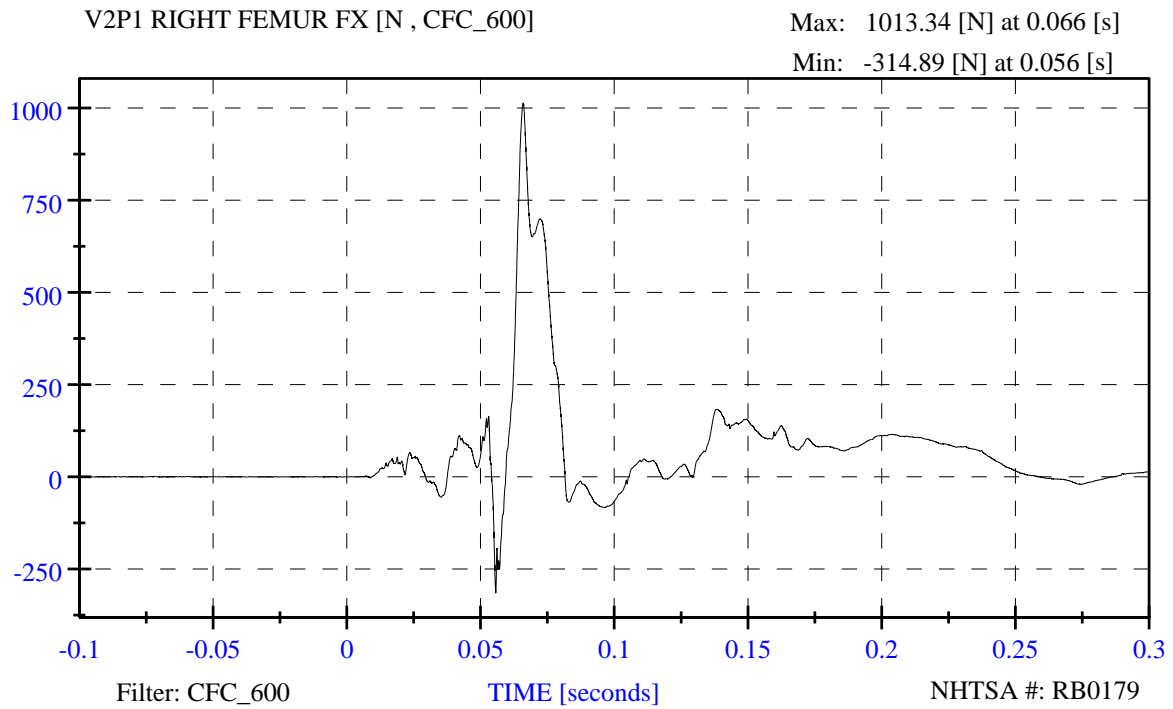

R&D 56 mph, 15deg angle, 35% overlap, 2011 Buick Lacrosse, RB0179

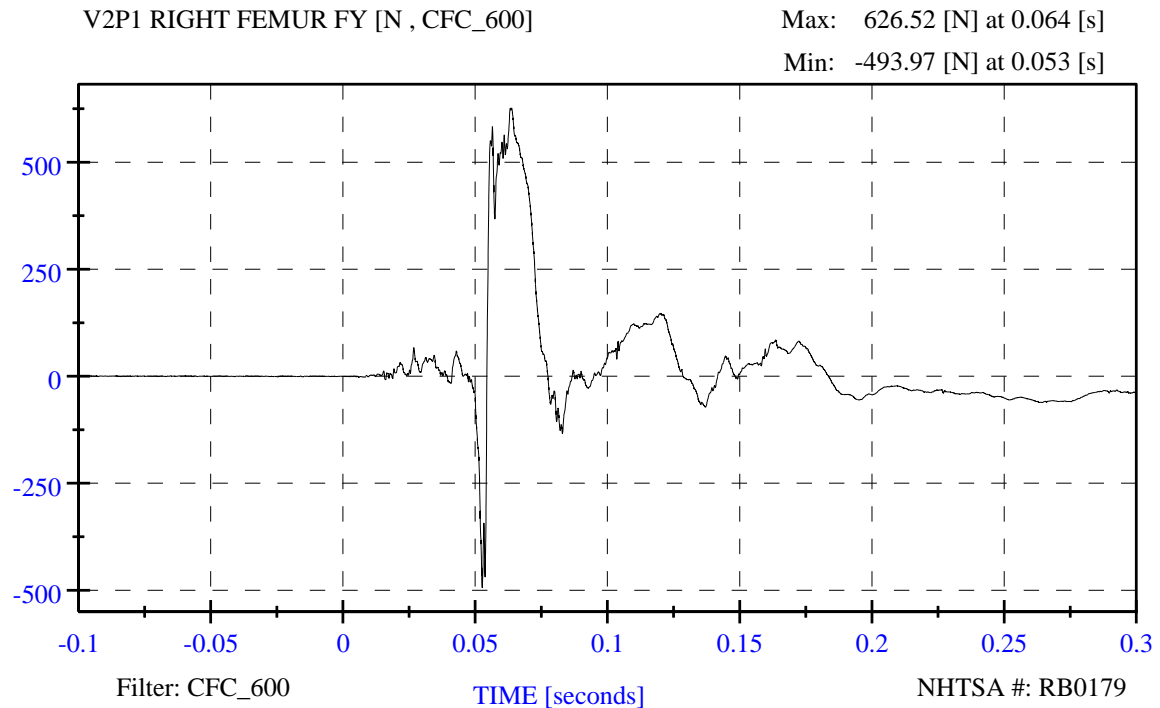

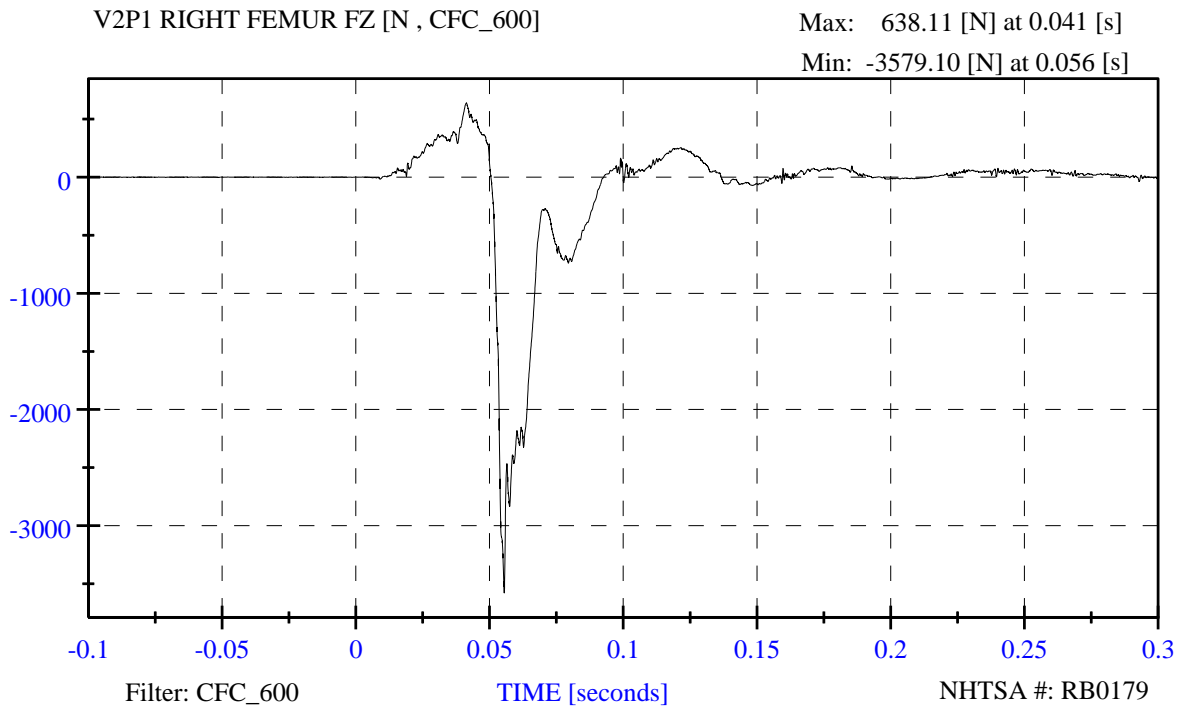

R&D 56 mph, 15deg angle, 35% overlap, 2011 Buick Lacrosse, RB0179

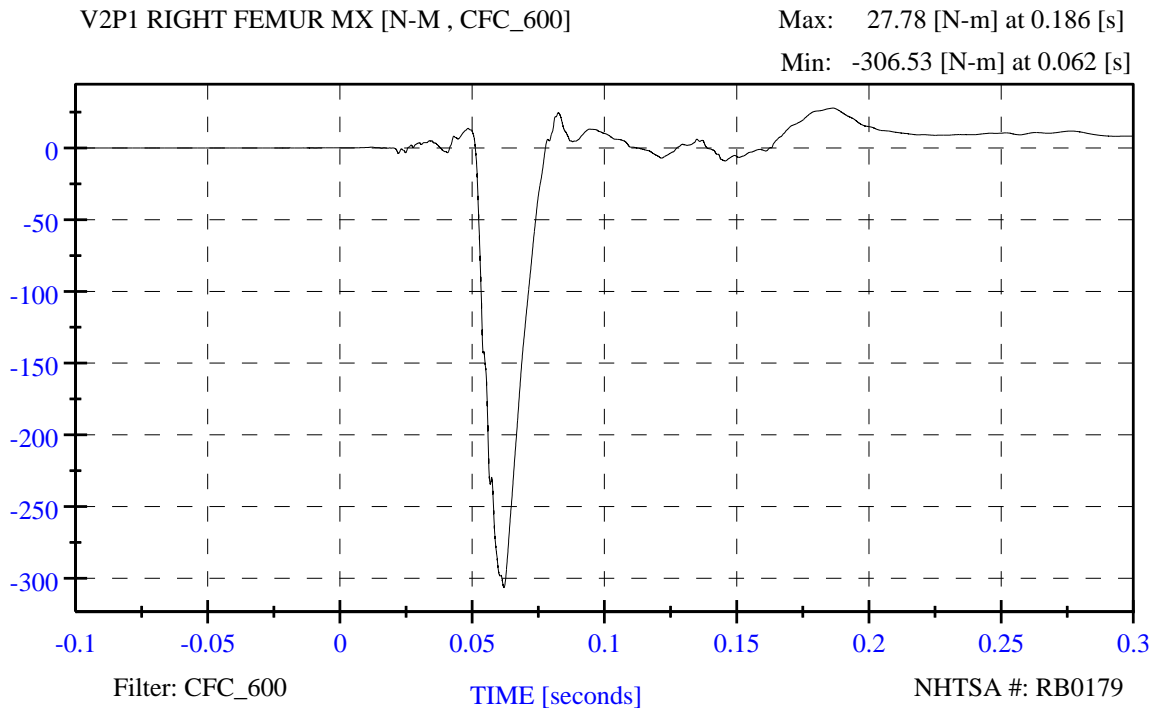

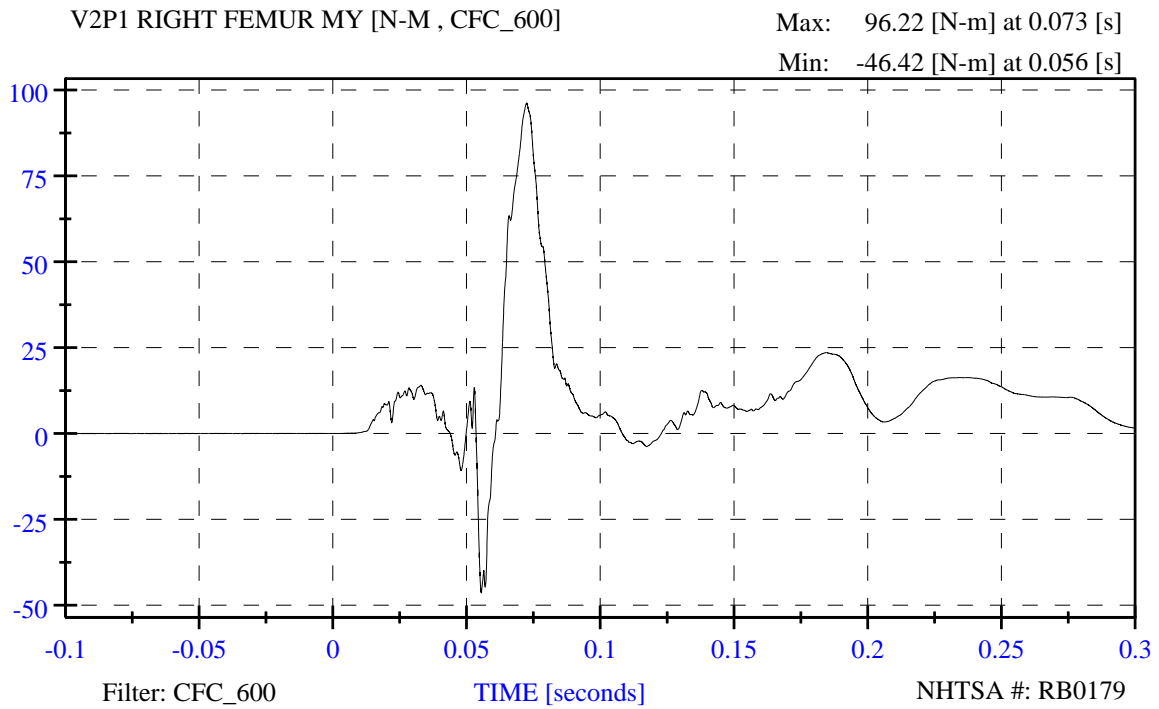

R&D 56 mph, 15deg angle, 35% overlap, 2011 Buick Lacrosse, RB0179

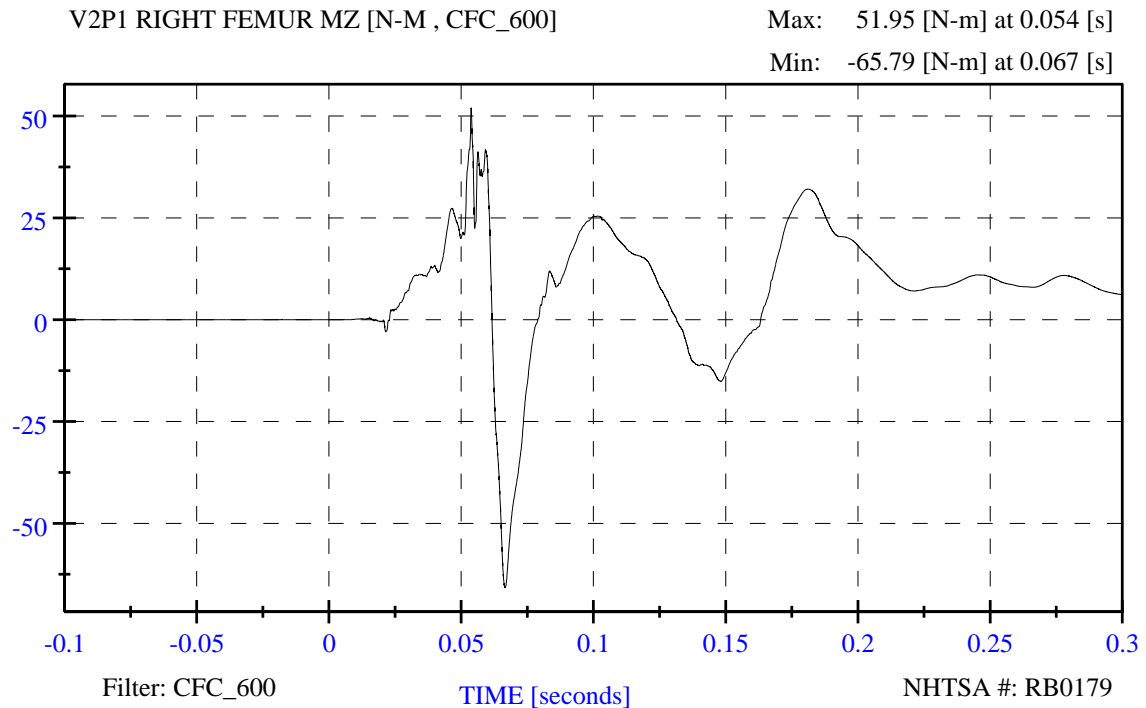

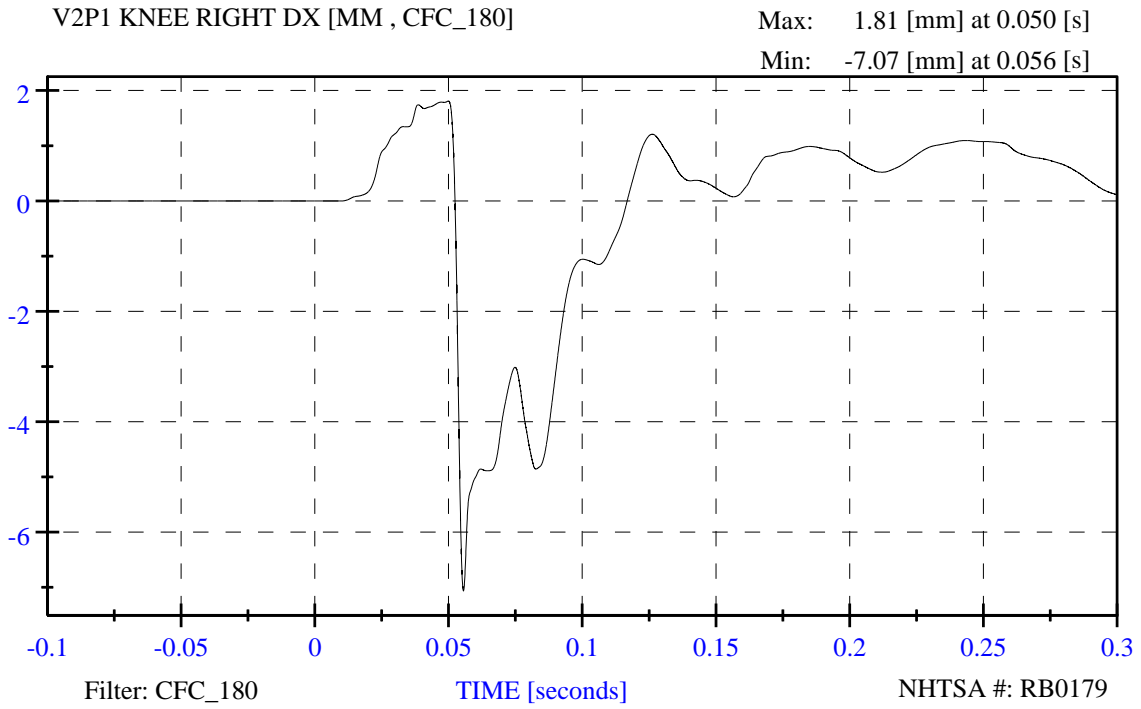

R&D 56 mph, 15deg angle, 35% overlap, 2011 Buick Lacrosse, RB0179

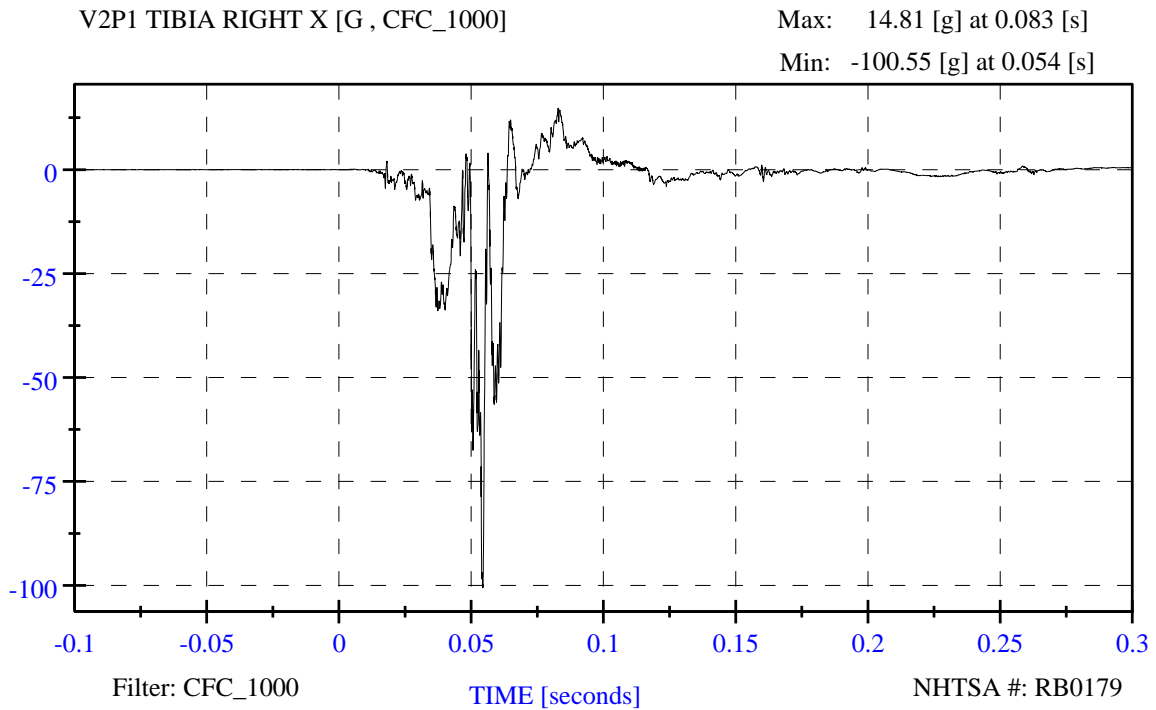

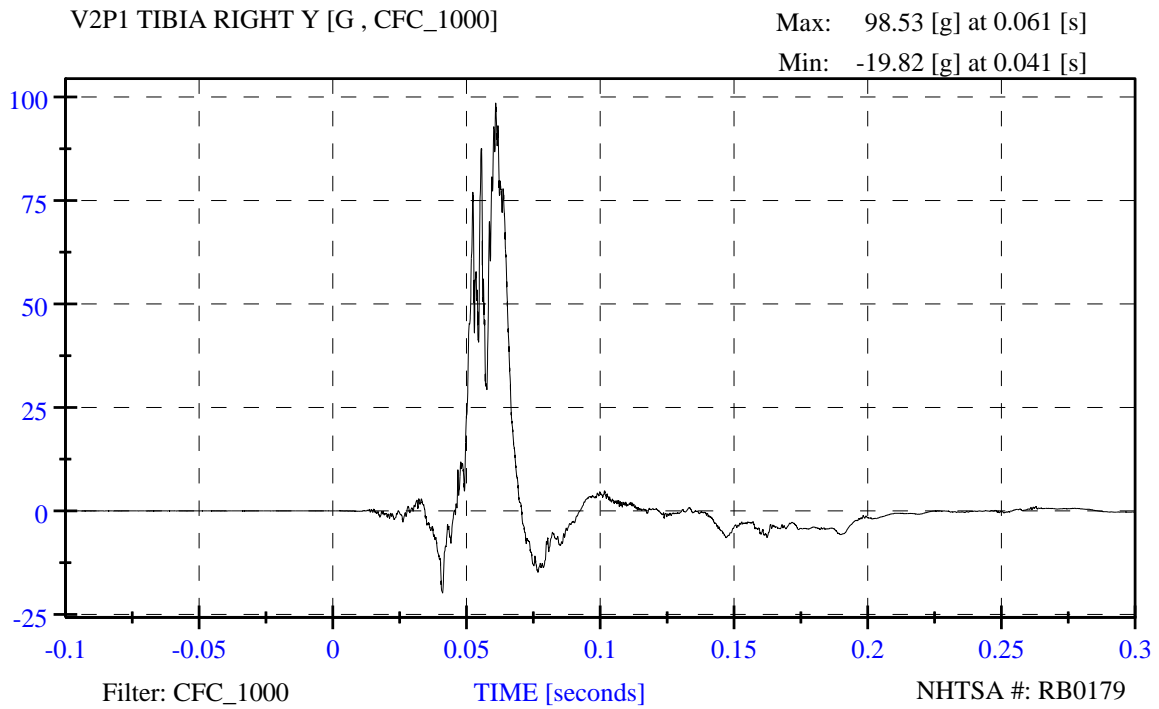

R&D 56 mph, 15deg angle, 35% overlap, 2011 Buick Lacrosse, RB0179

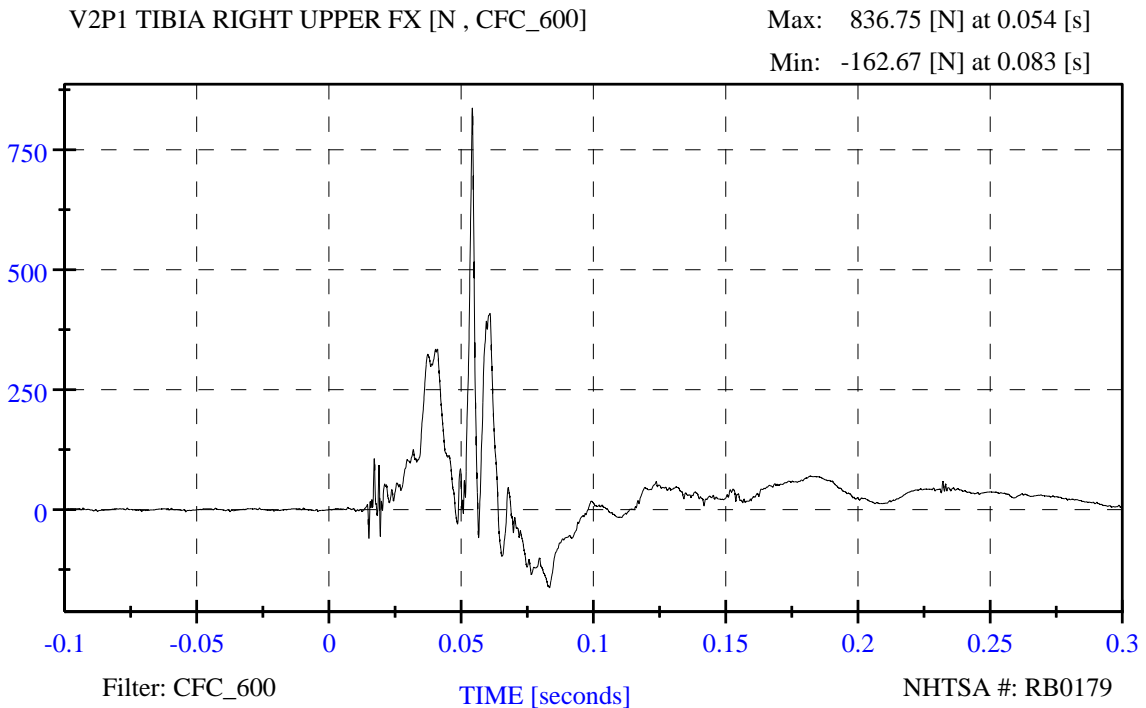

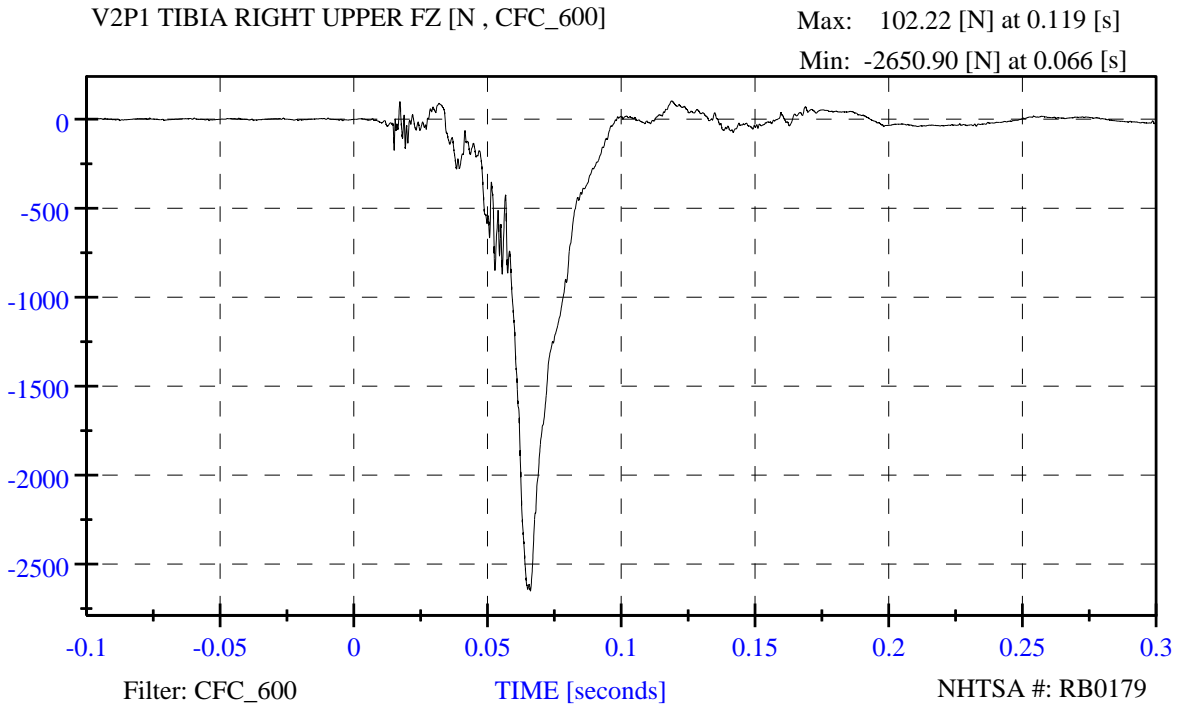

R&D 56 mph, 15deg angle, 35% overlap, 2011 Buick Lacrosse, RB0179

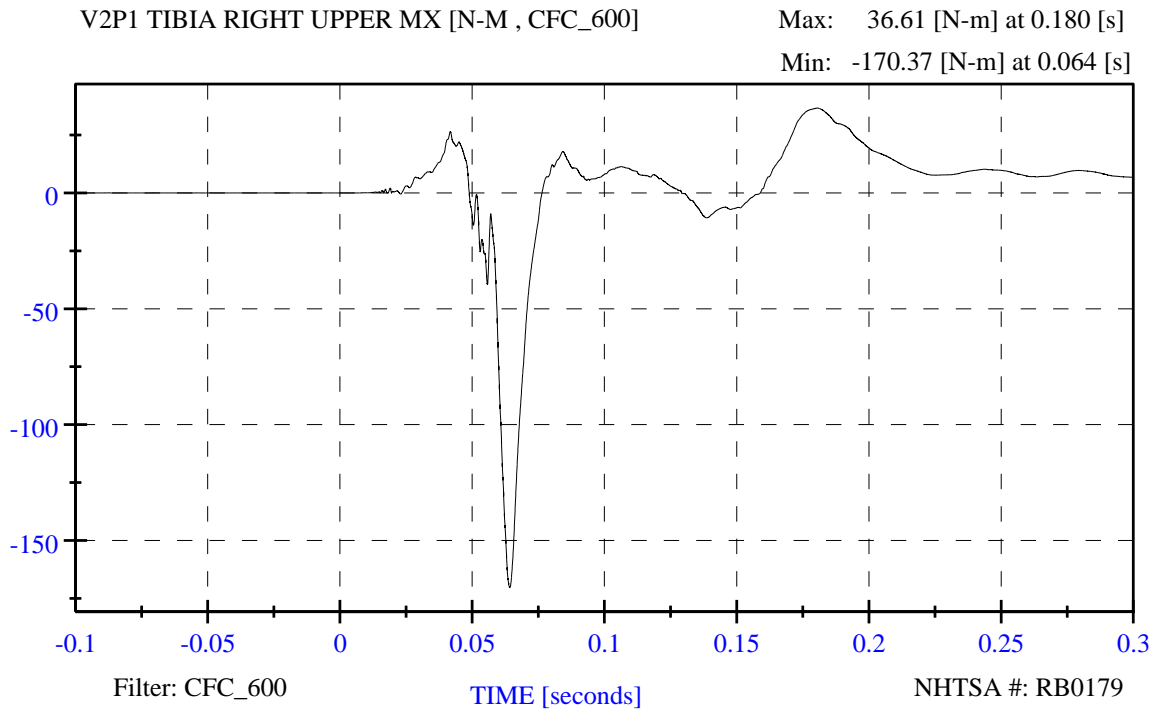

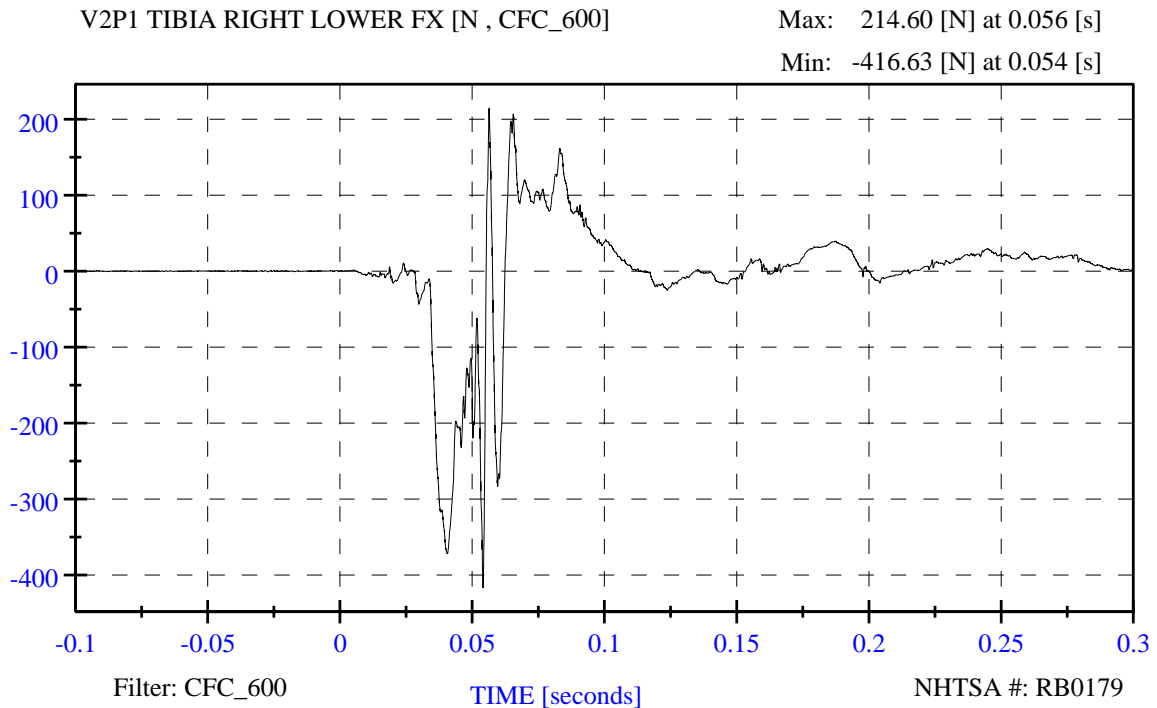
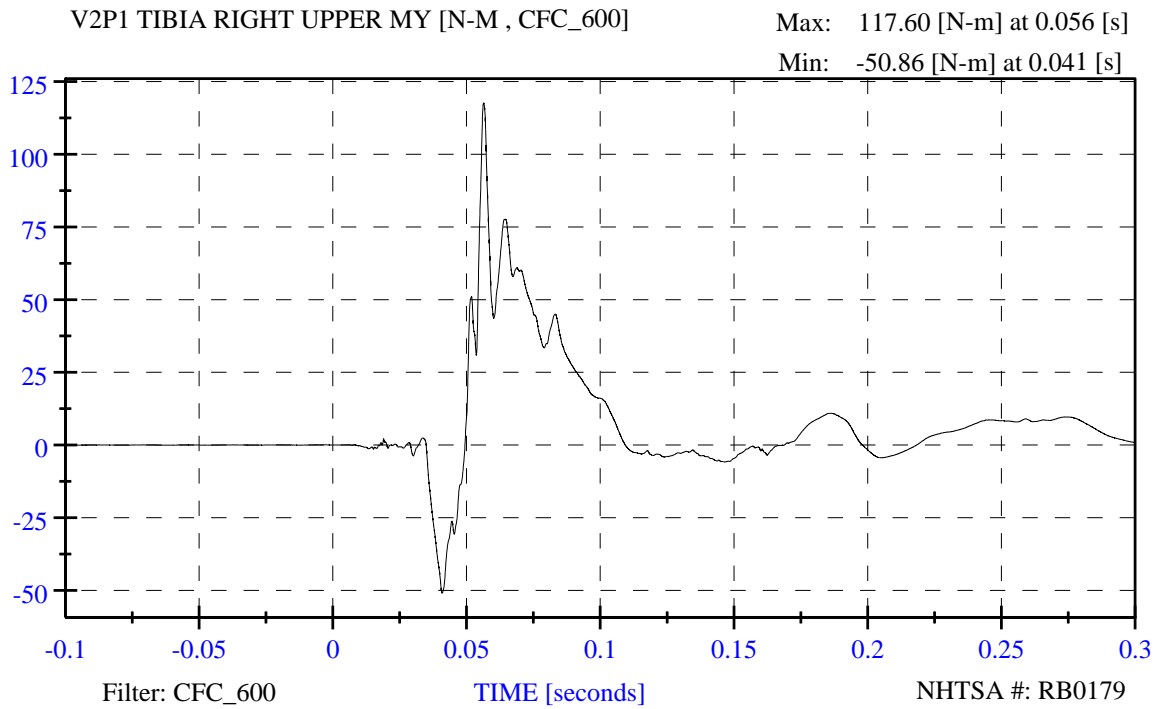

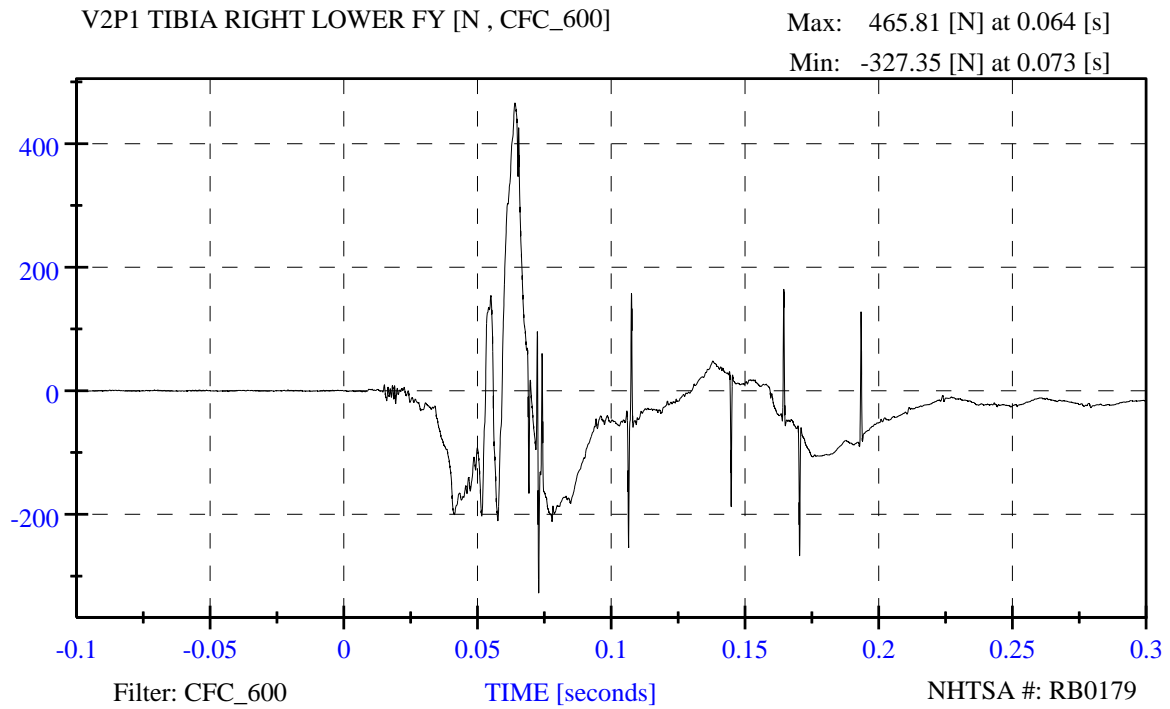

R&D 56 mph, 15deg angle, 35% overlap, 2011 Buick Lacrosse, RB0179

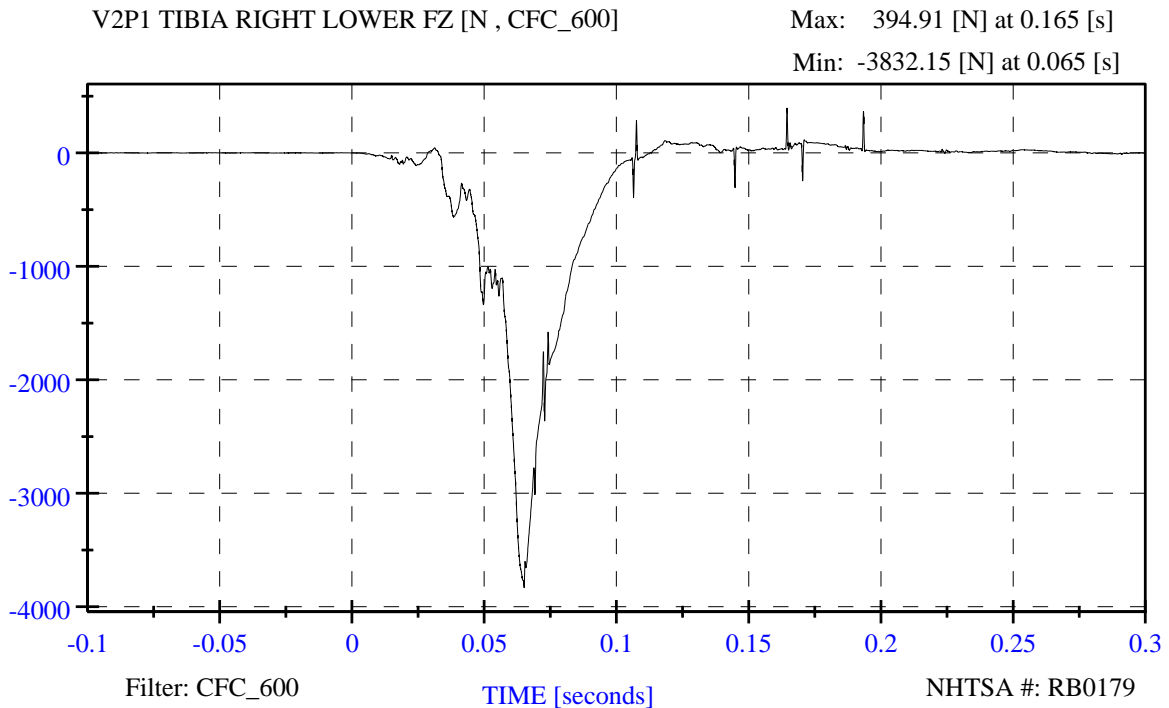

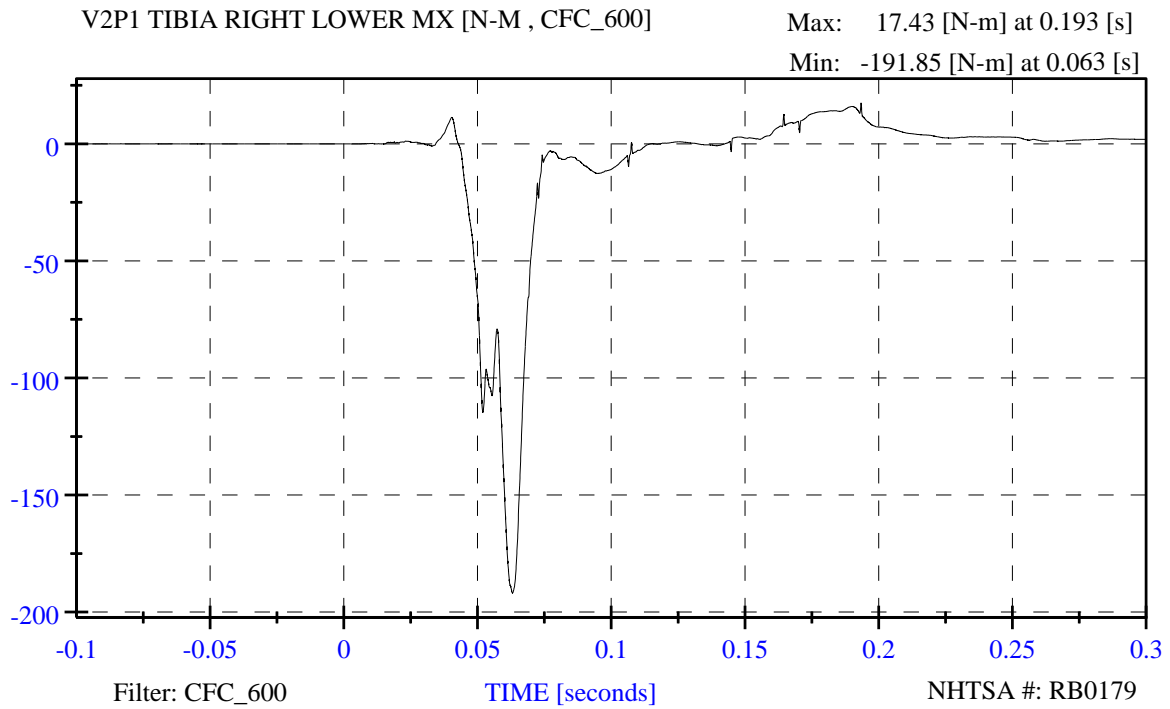

R&D 56 mph, 15deg angle, 35% overlap, 2011 Buick Lacrosse, RB0179

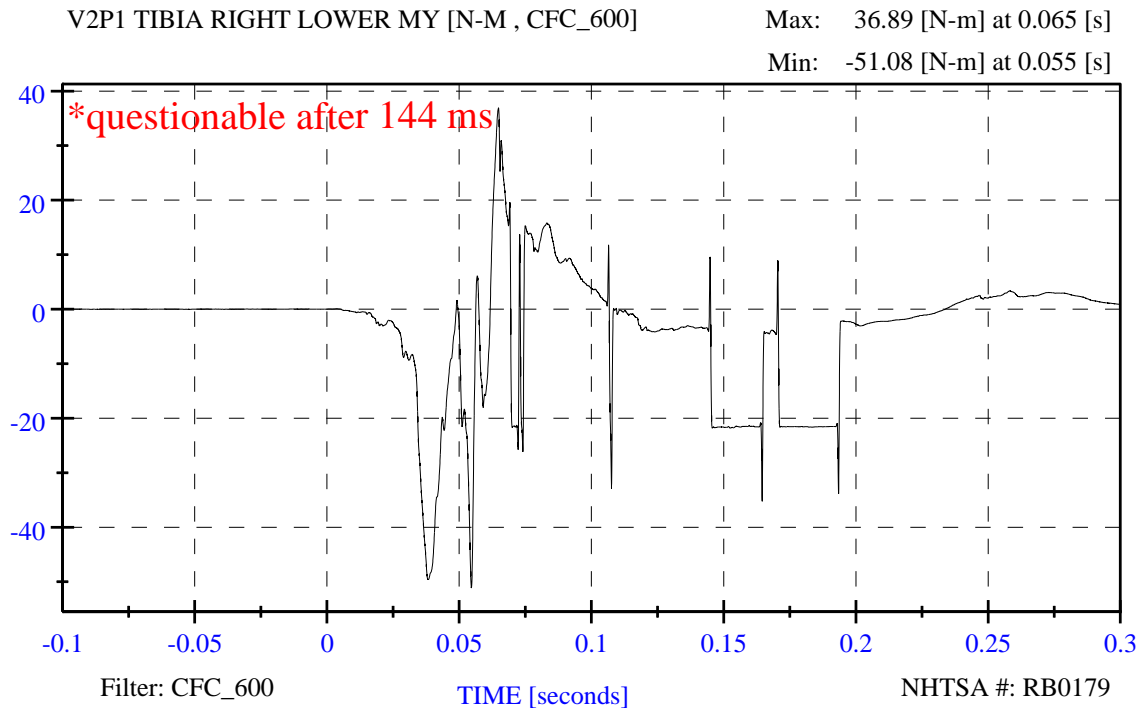

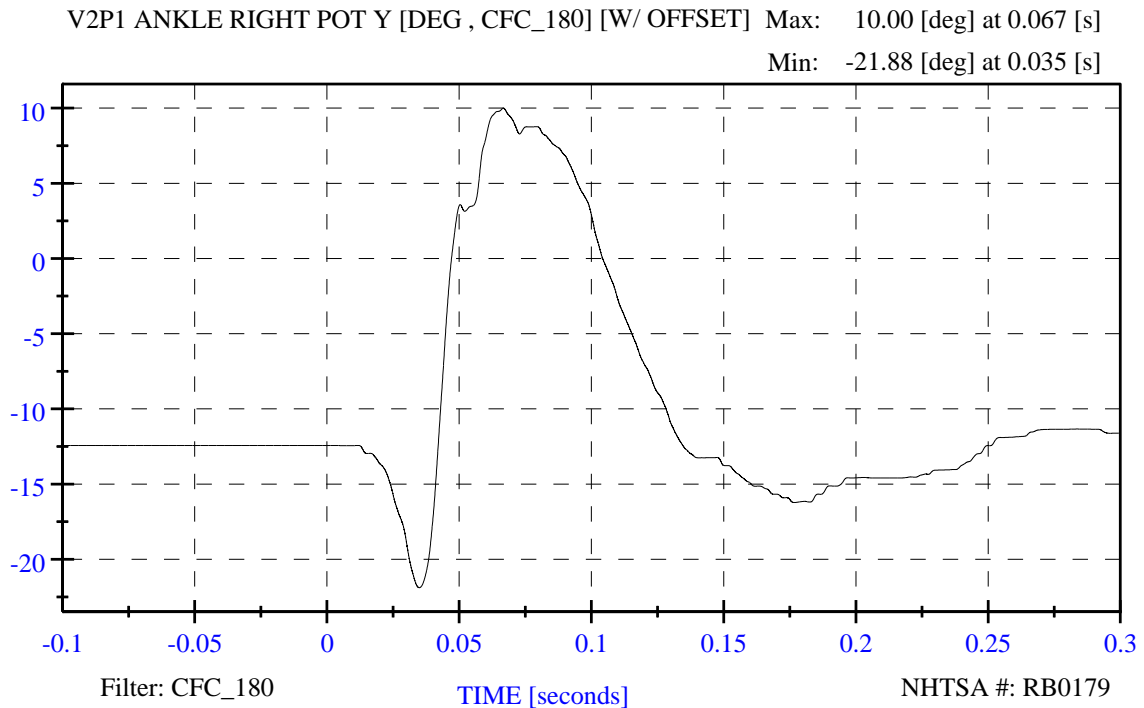
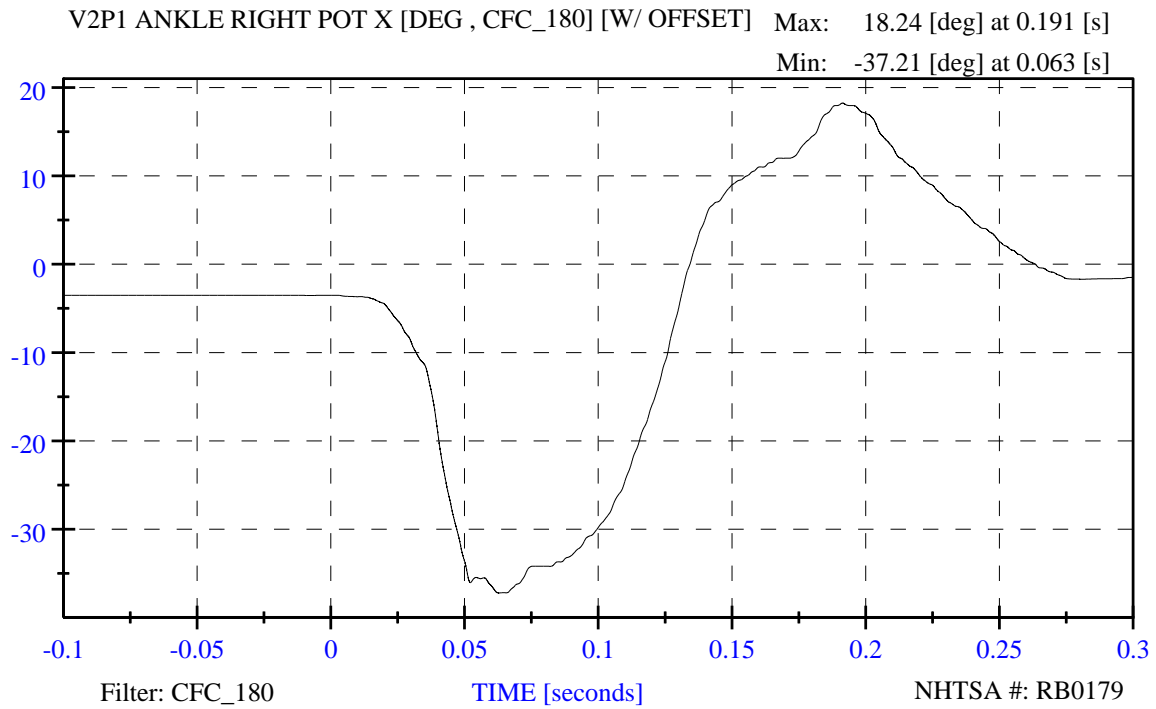

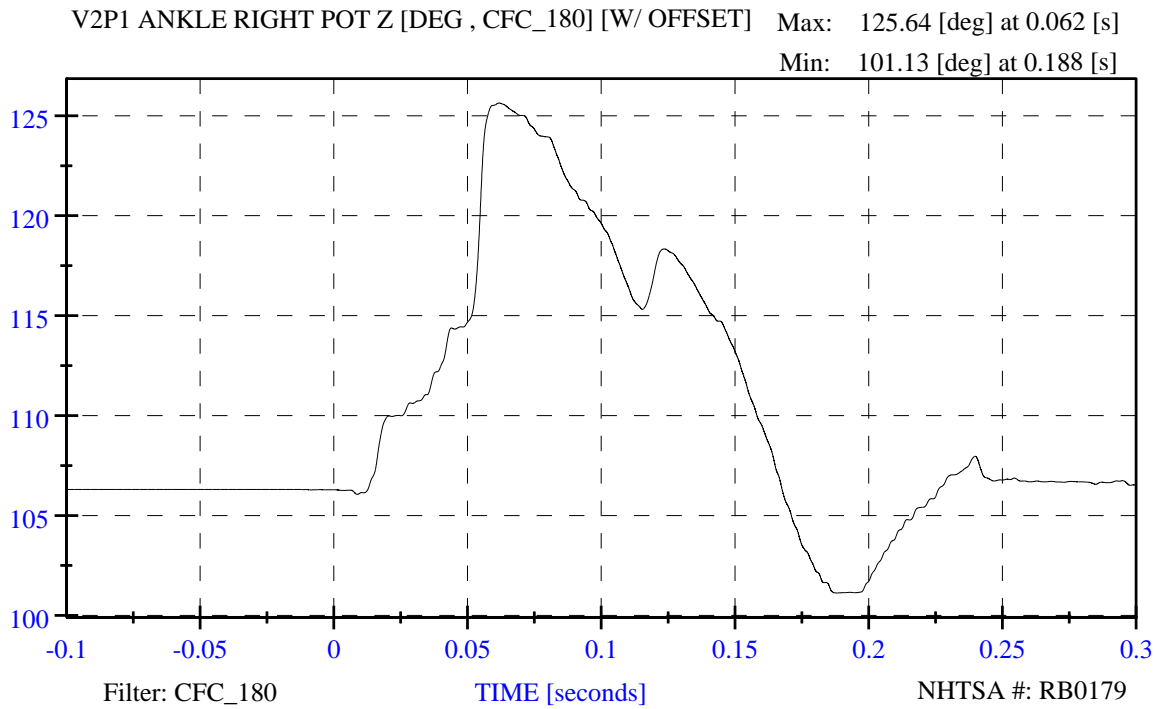

R&D 56 mph, 15deg angle, 35% overlap, 2011 Buick Lacrosse, RB0179

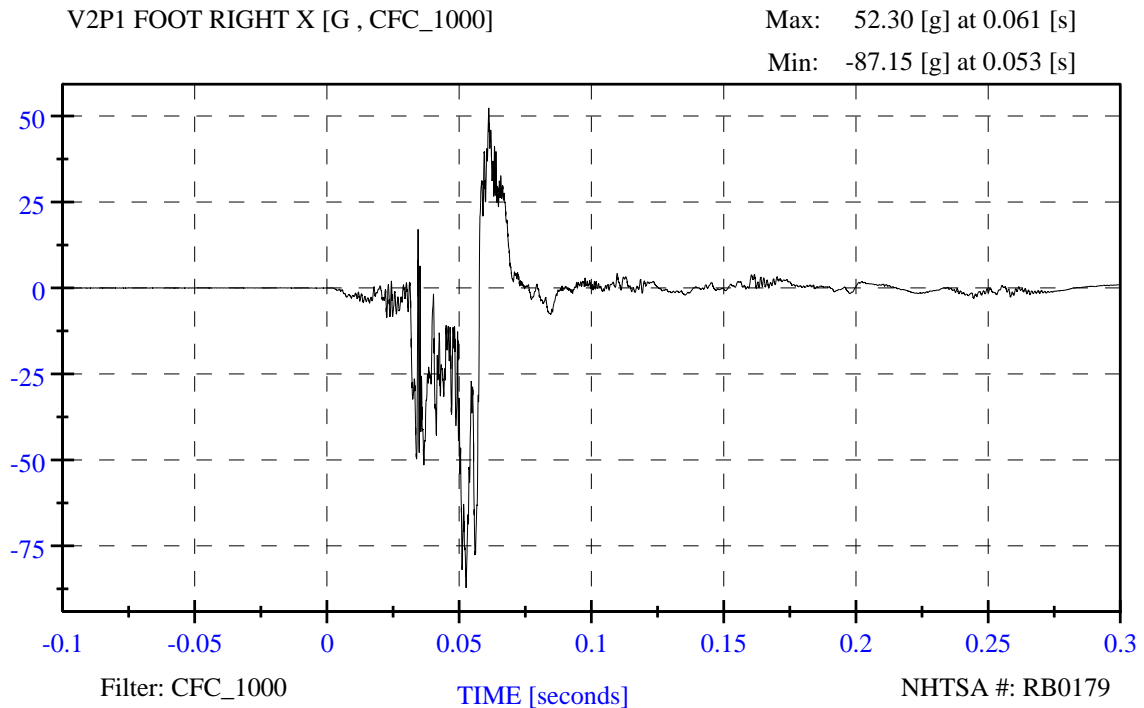

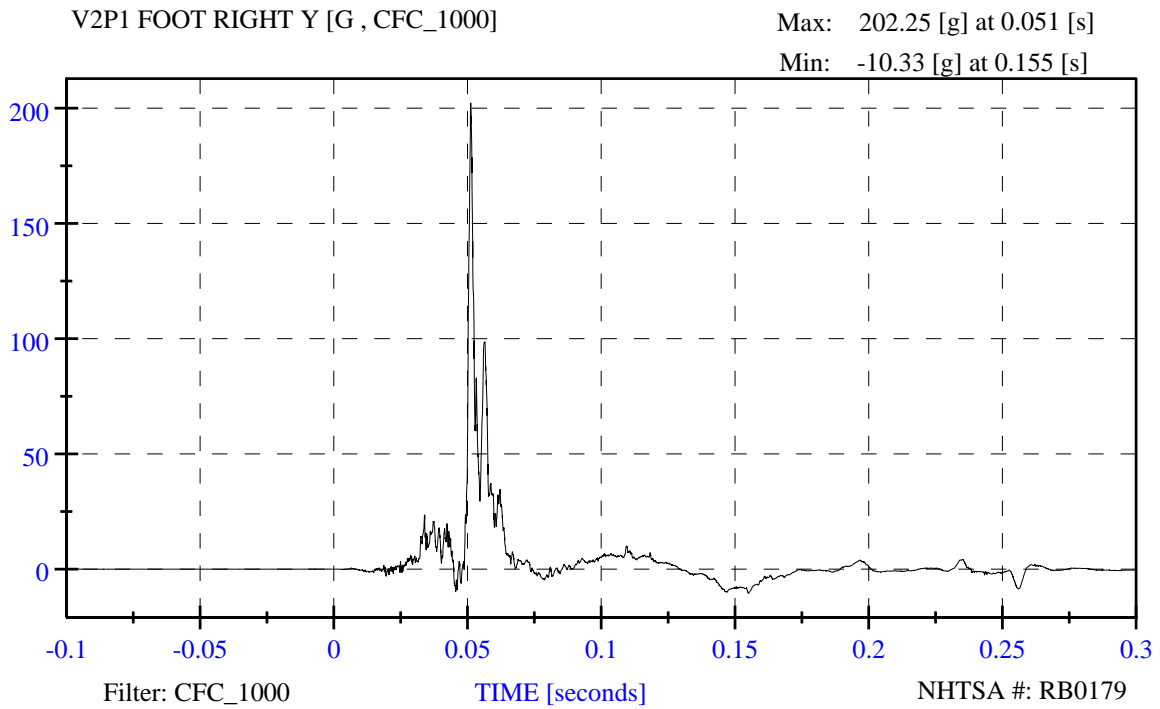

R&D 56 mph, 15deg angle, 35% overlap, 2011 Buick Lacrosse, RB0179

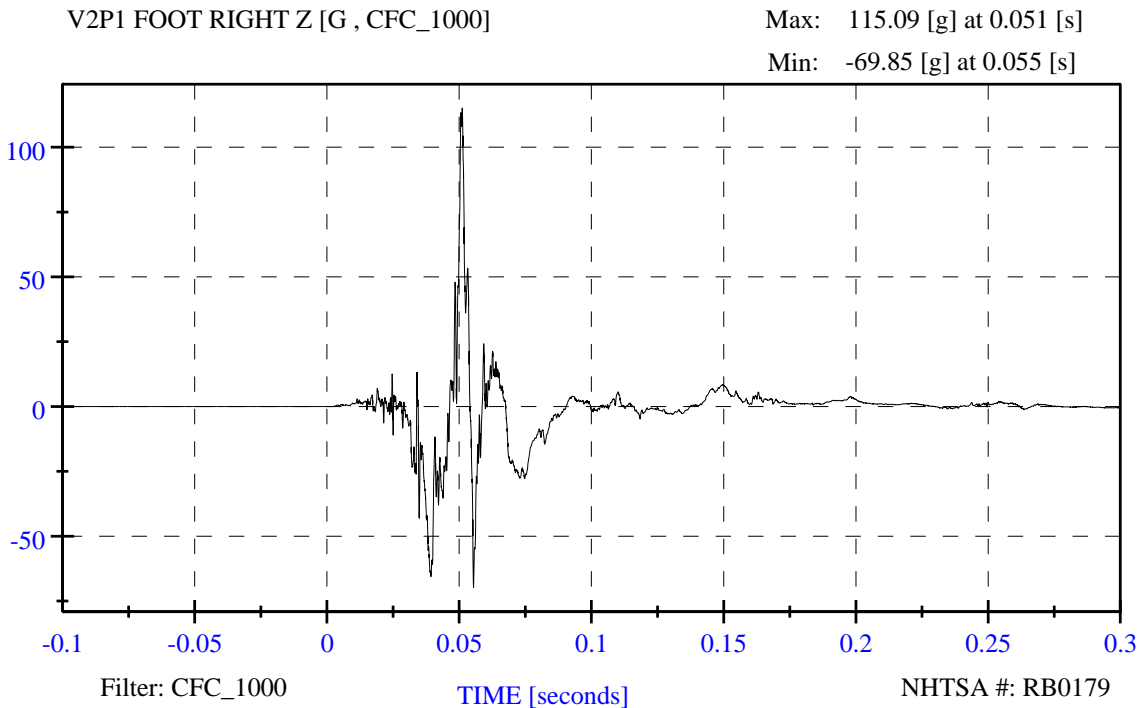

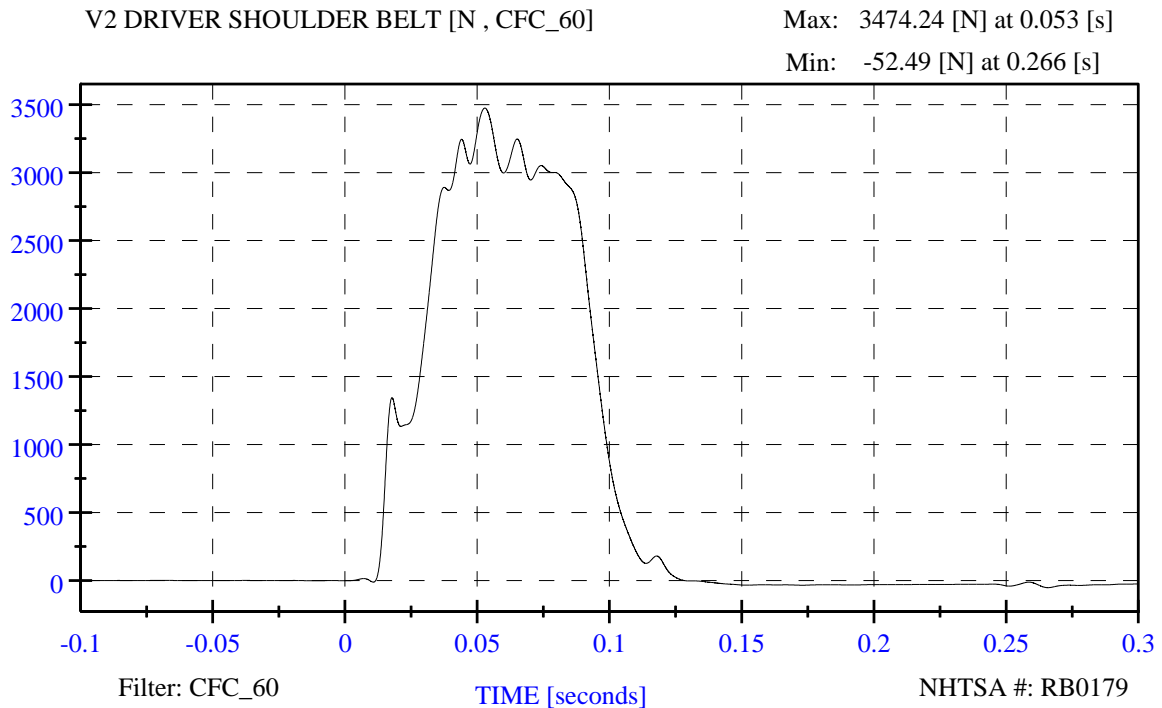
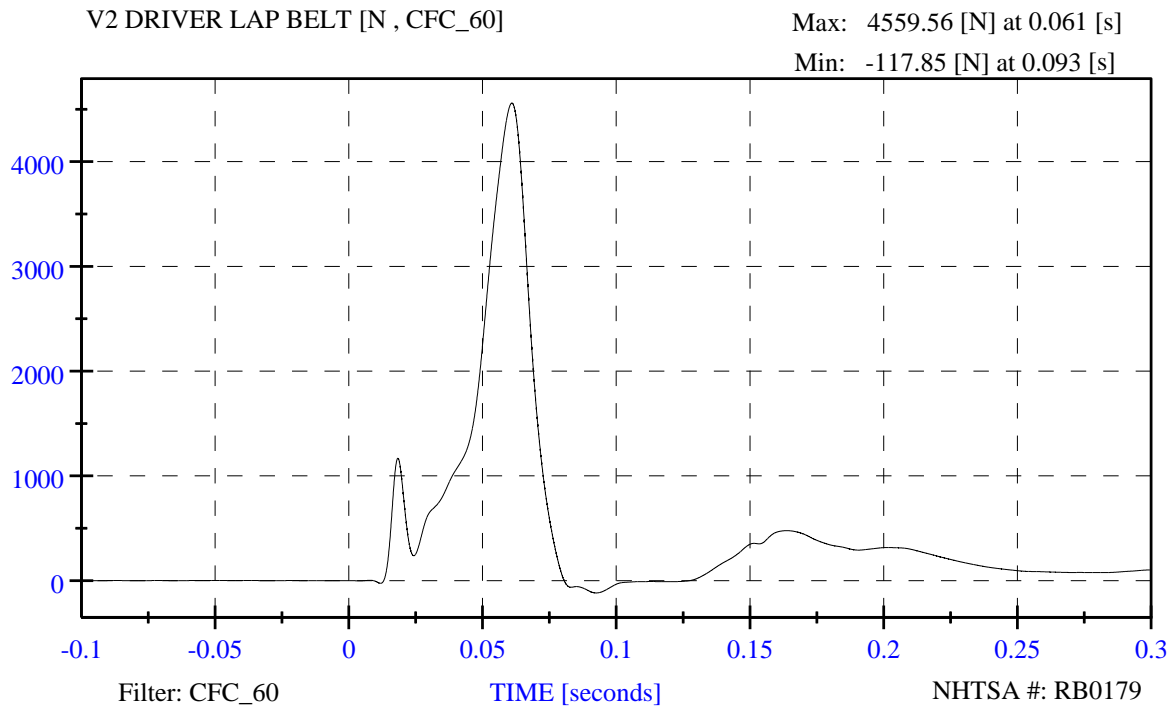

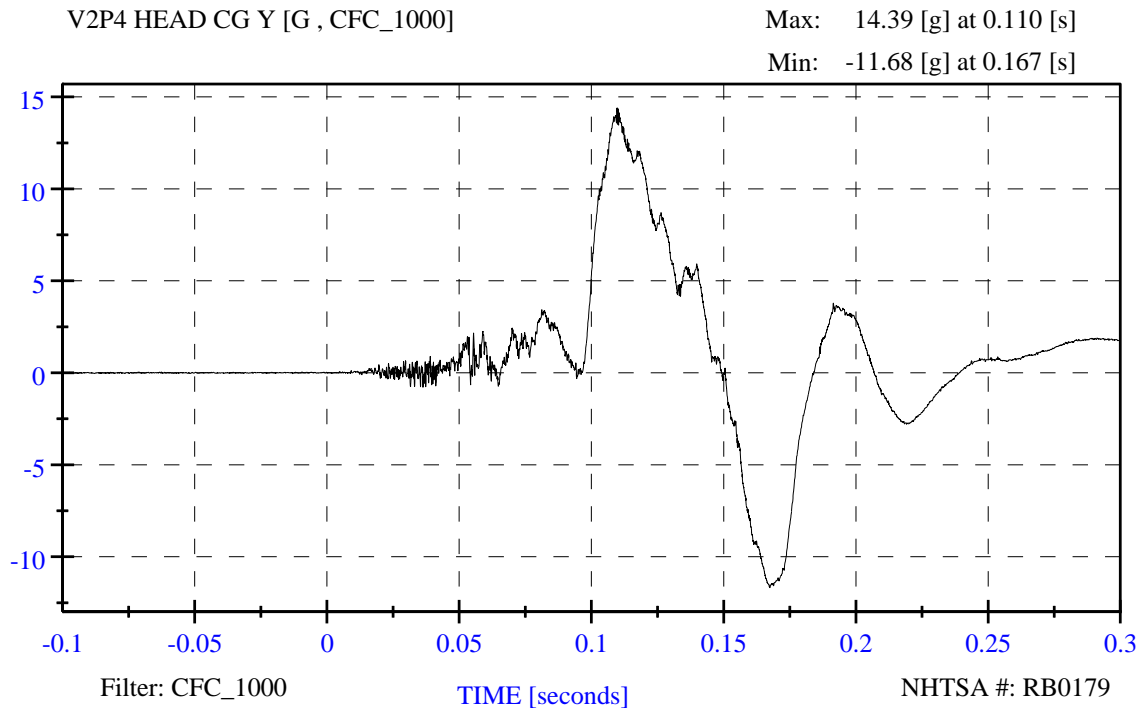
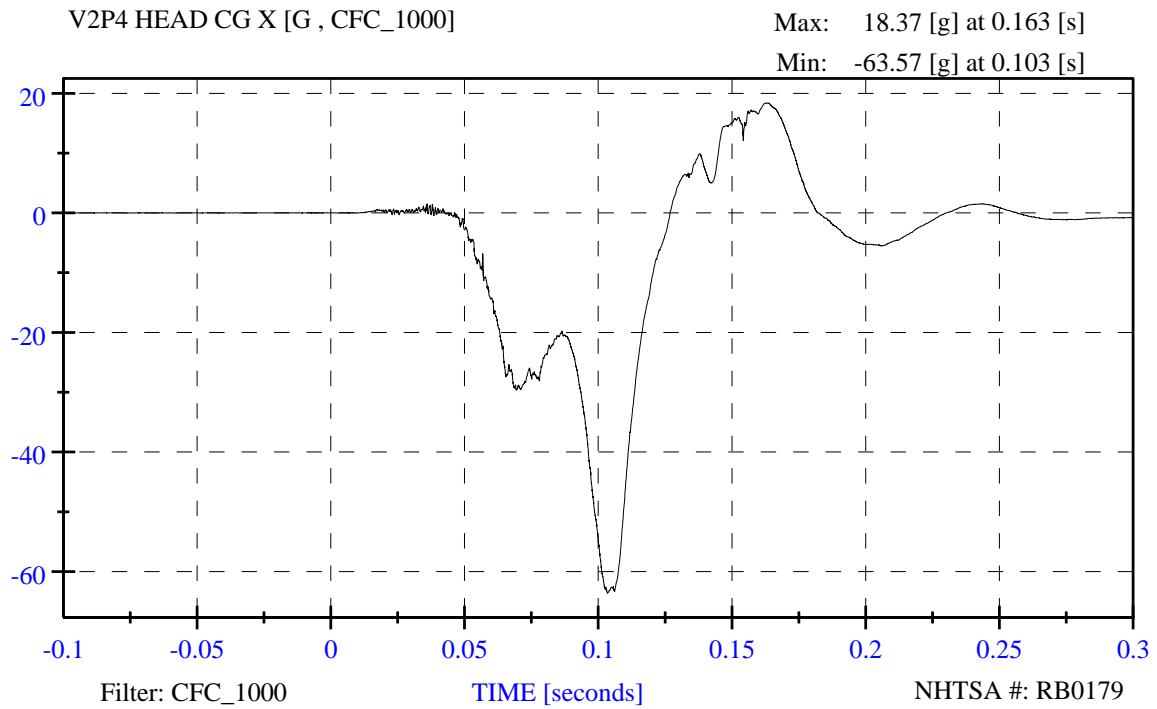

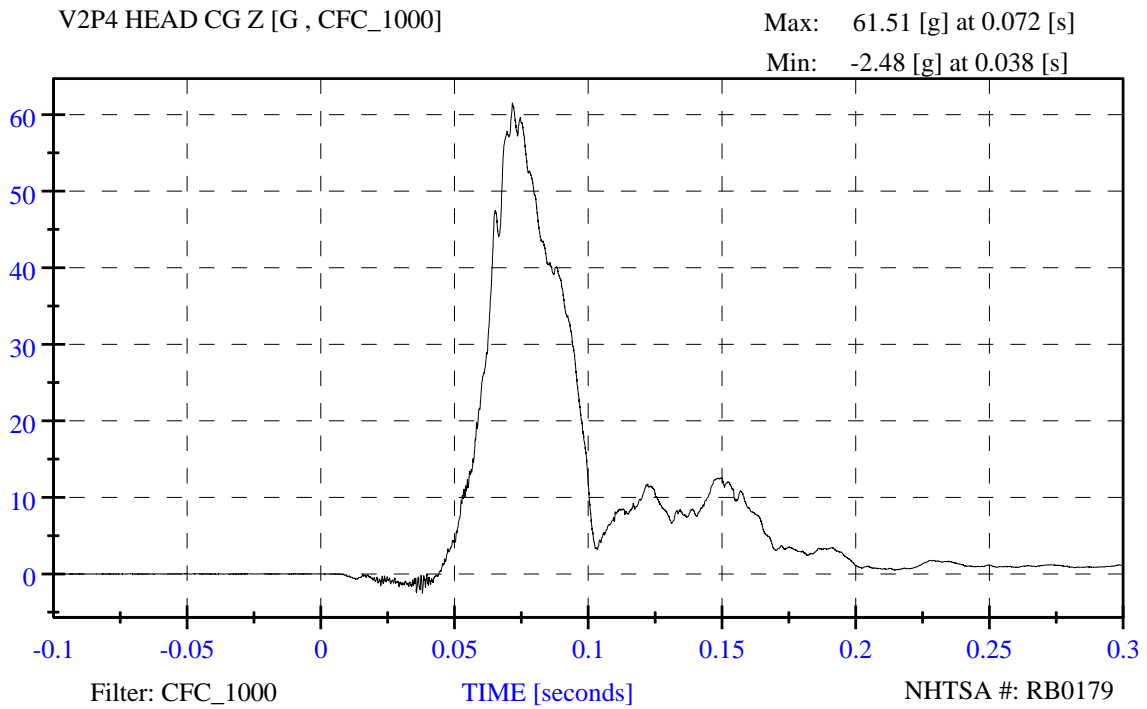

R&D 56 mph, 15deg angle, 35% overlap, 2011 Buick Lacrosse, RB0179

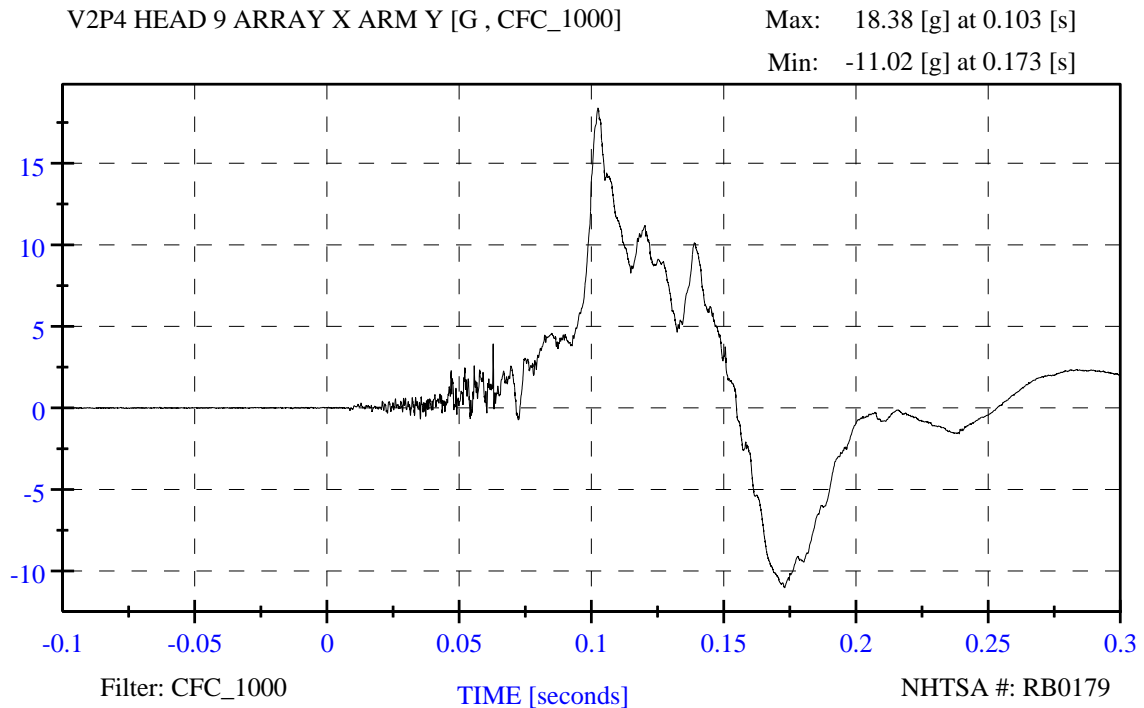

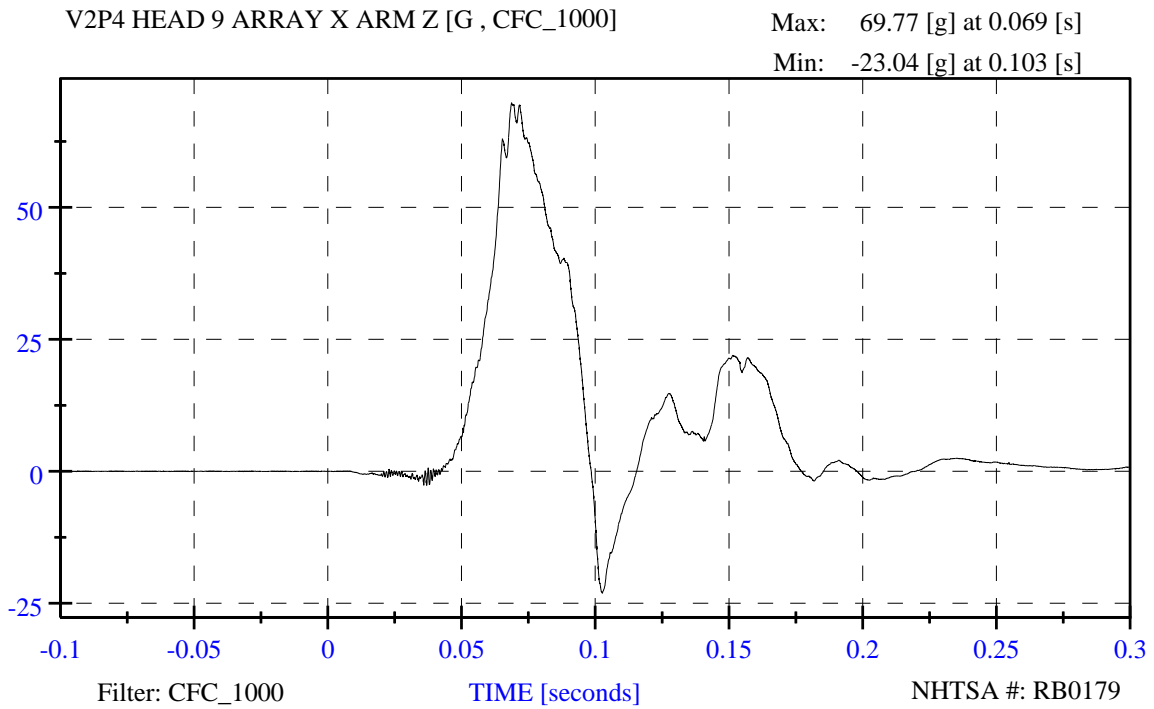

R&D 56 mph, 15deg angle, 35% overlap, 2011 Buick Lacrosse, RB0179

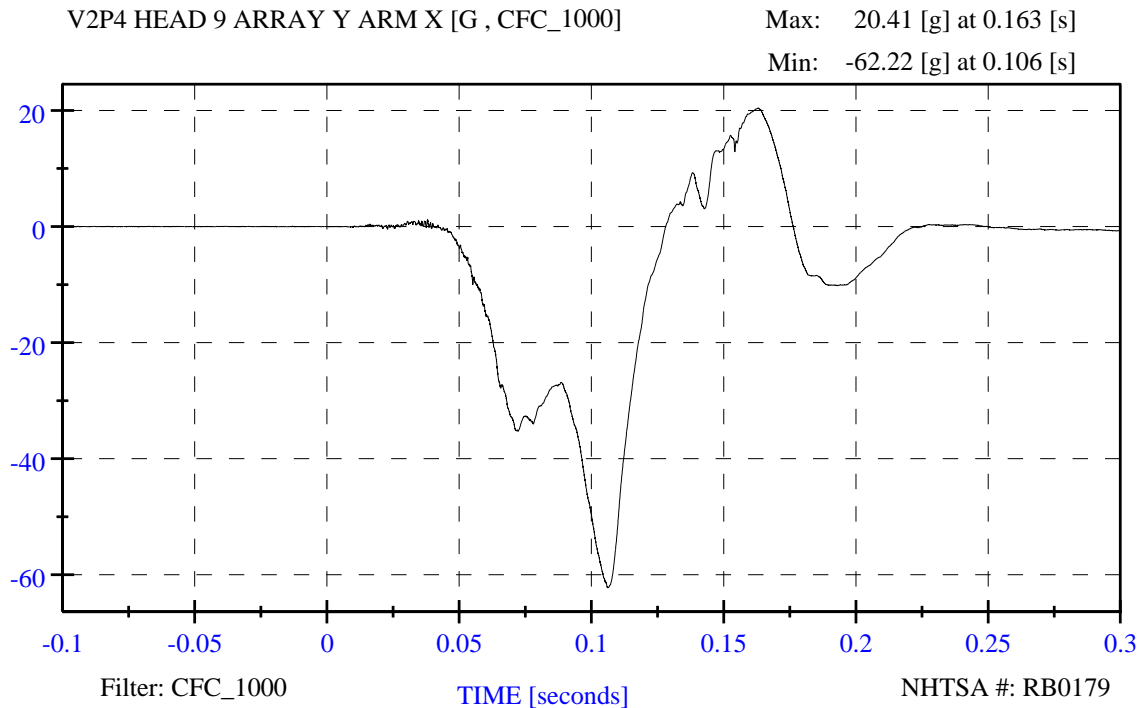

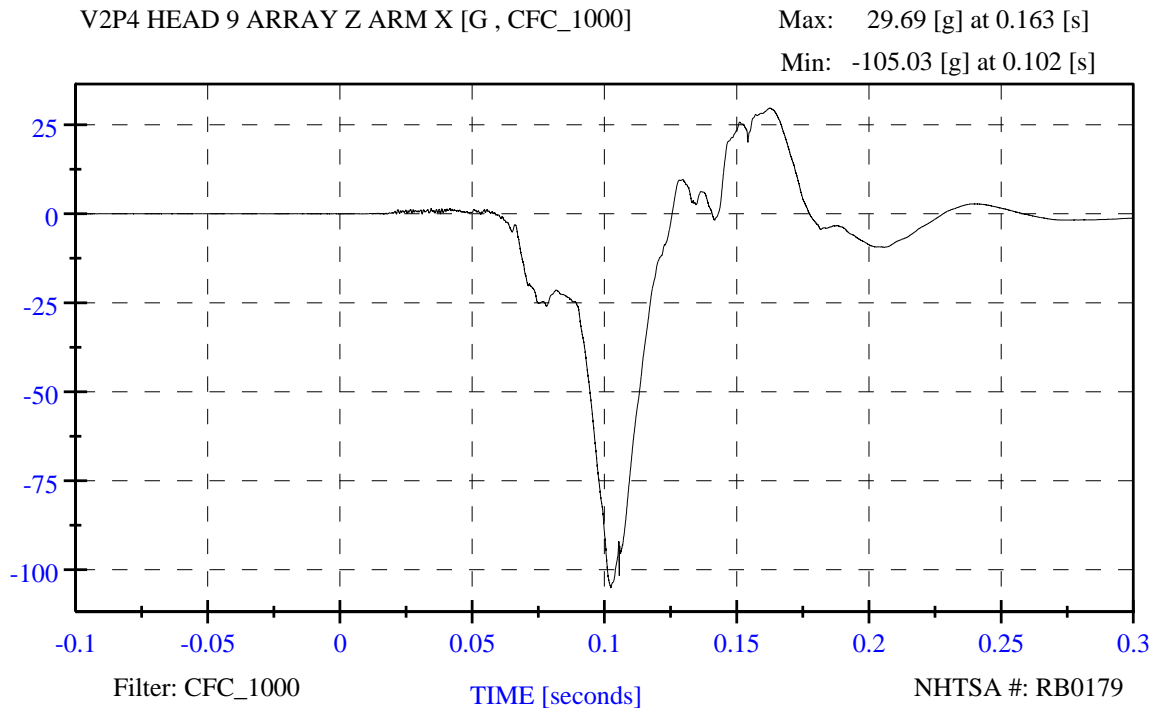
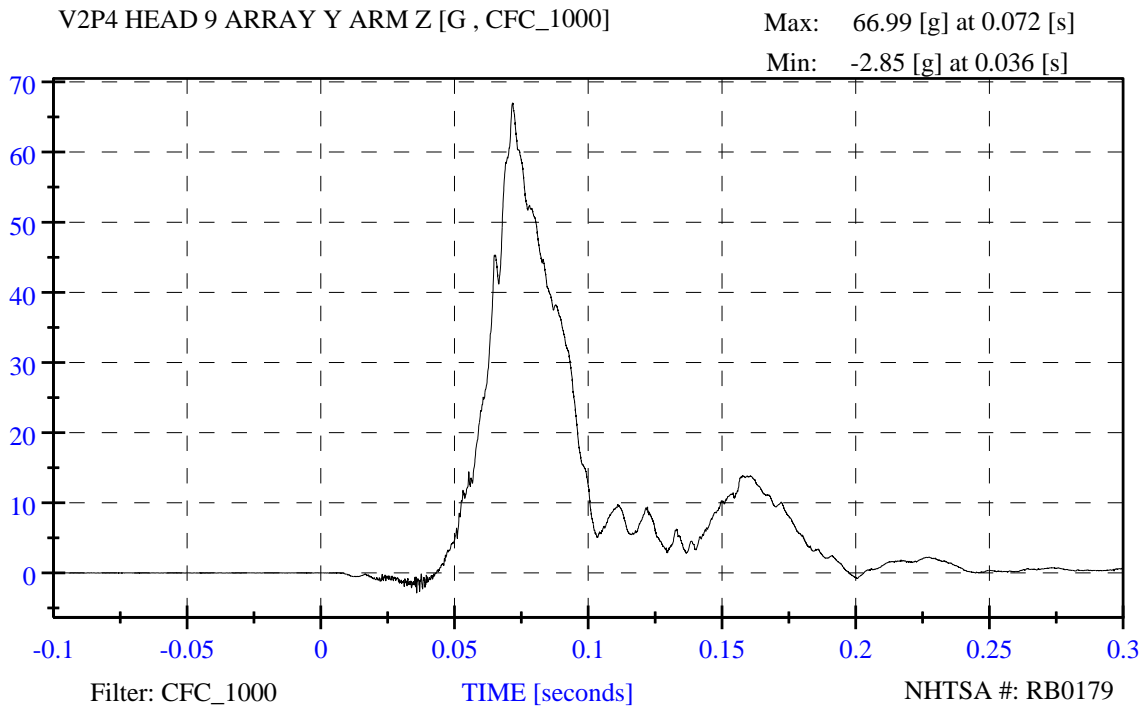

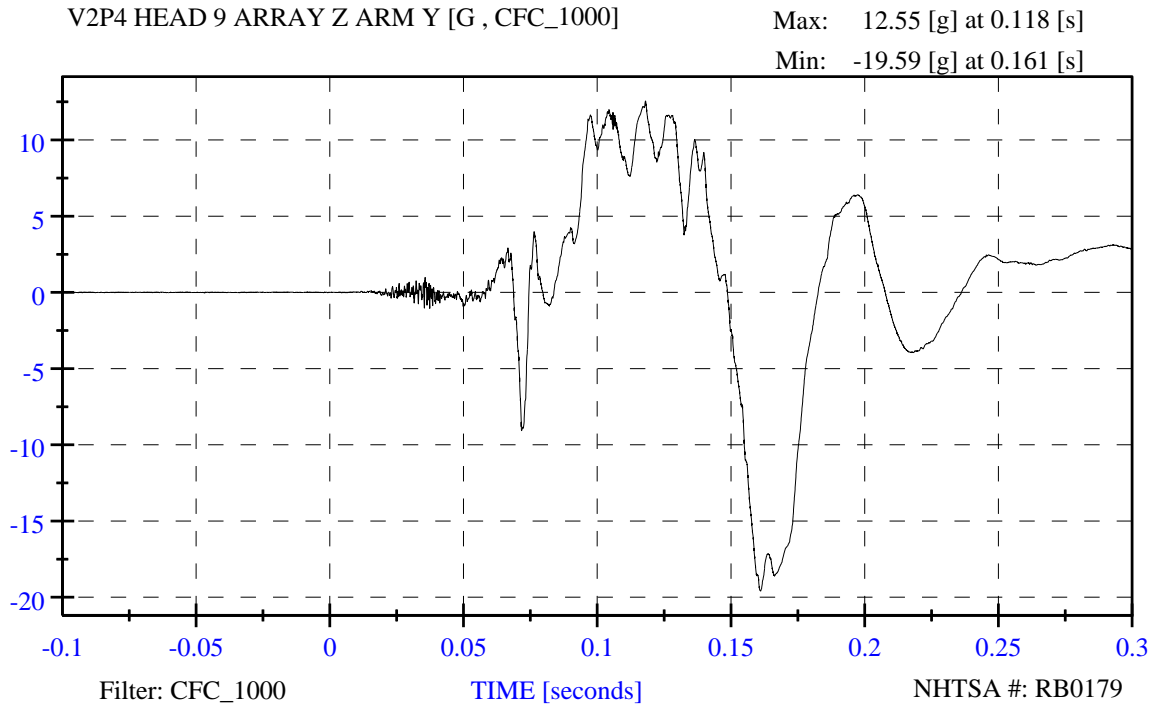

R&D 56 mph, 15deg angle, 35% overlap, 2011 Buick Lacrosse, RB0179

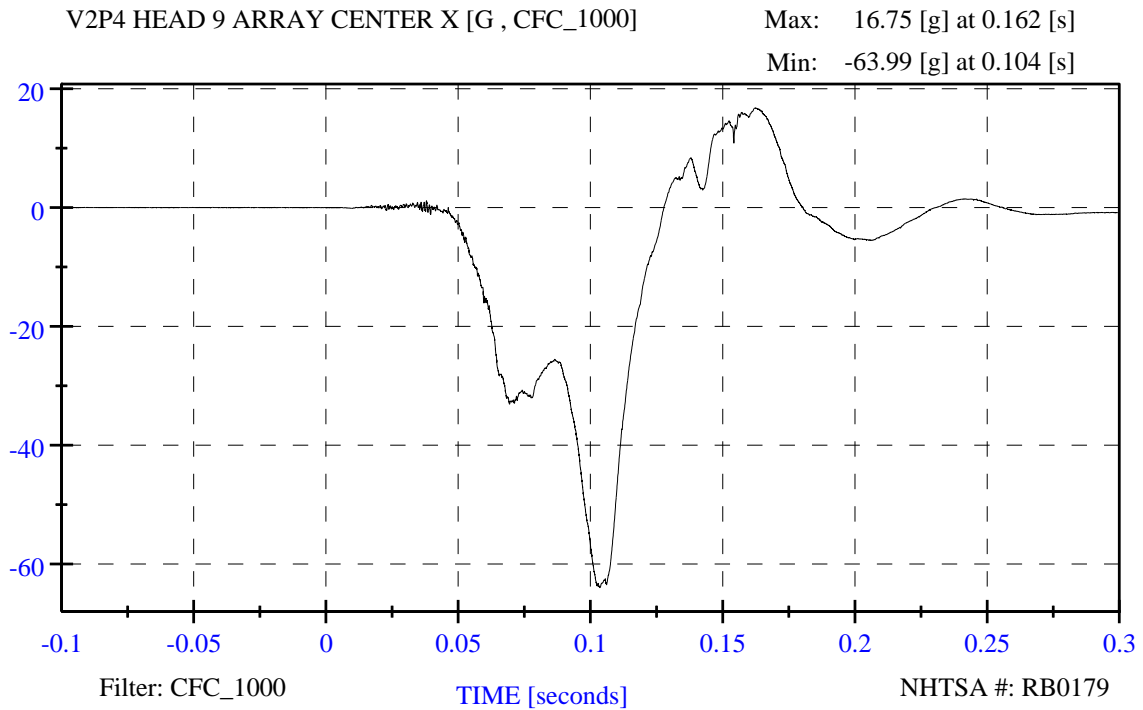

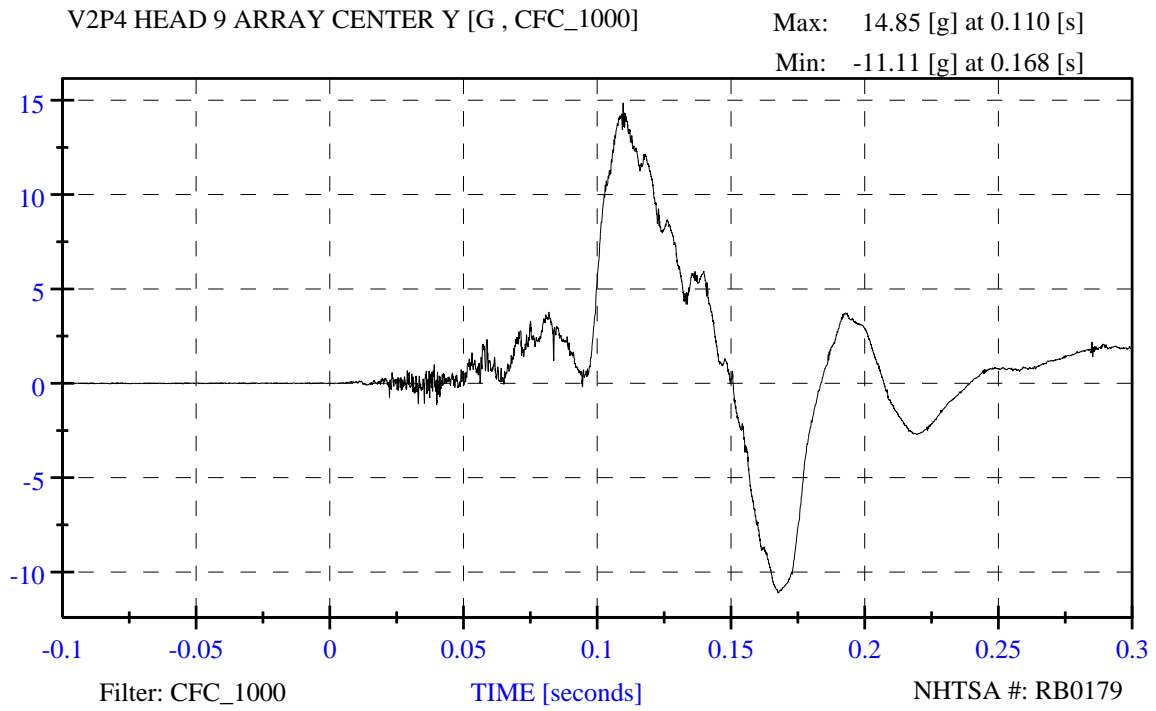

R&D 56 mph, 15deg angle, 35% overlap, 2011 Buick Lacrosse, RB0179

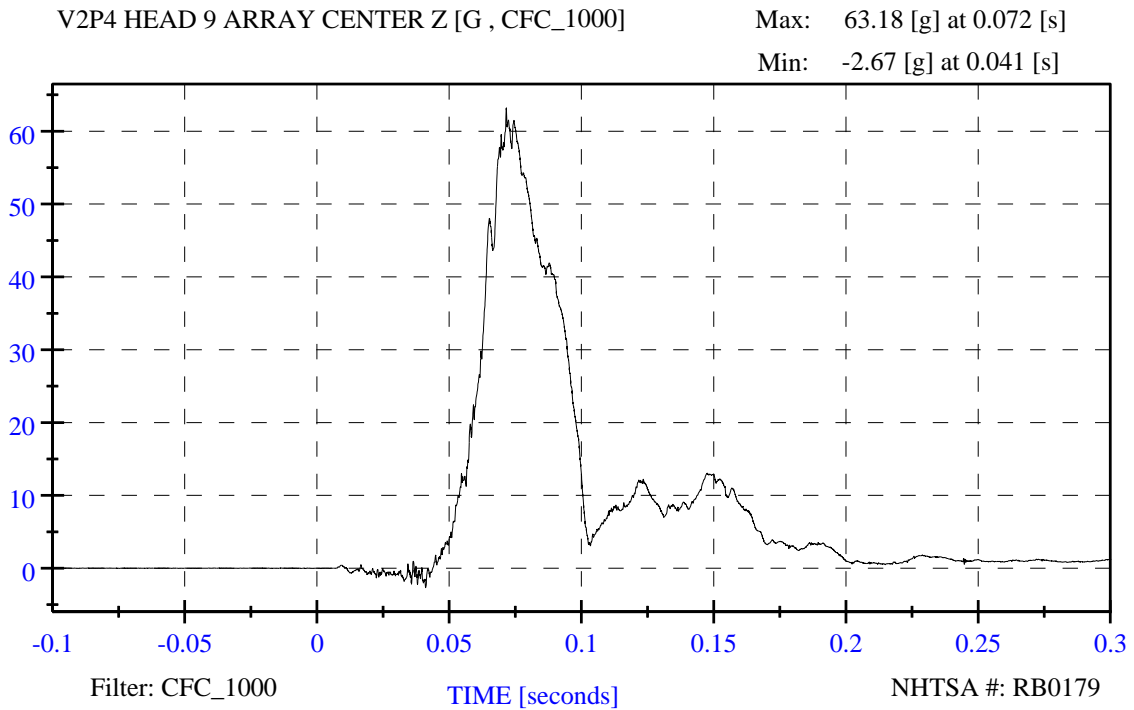

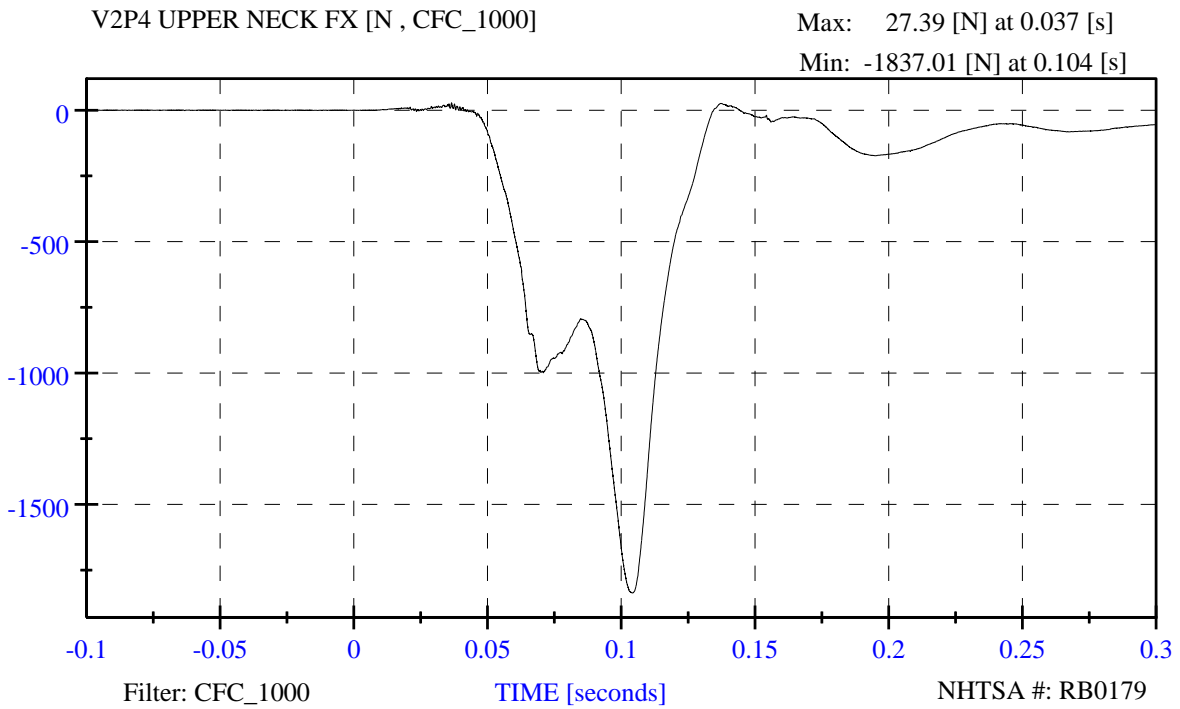

R&D 56 mph, 15deg angle, 35% overlap, 2011 Buick Lacrosse, RB0179

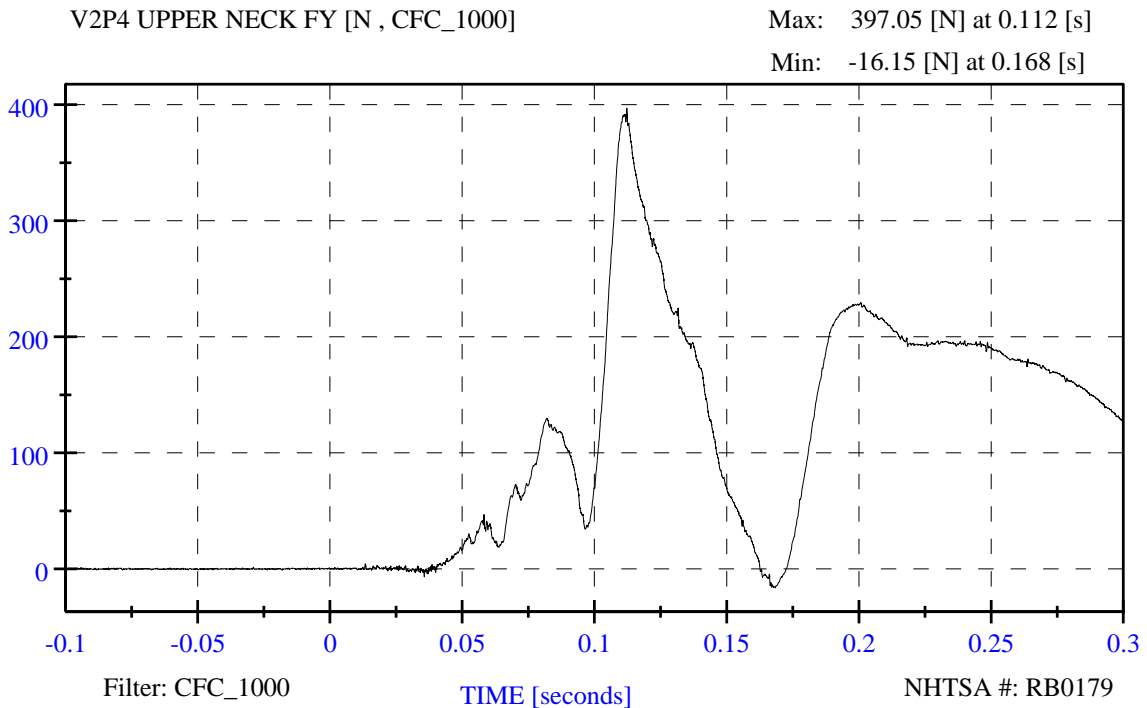

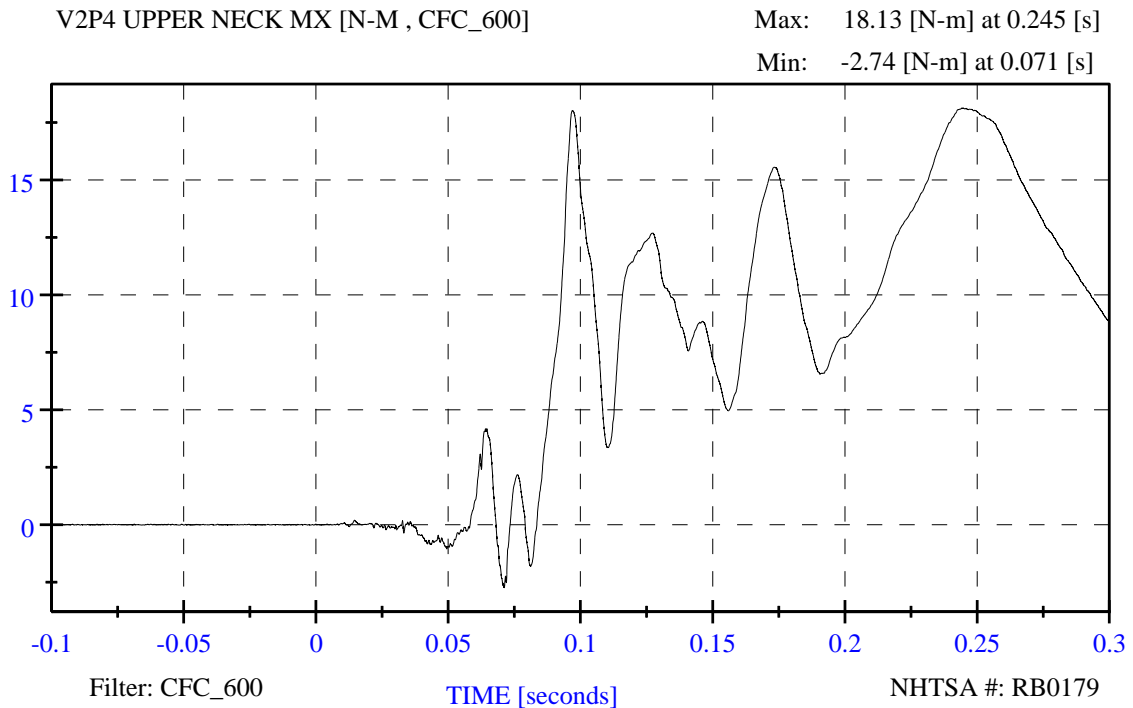
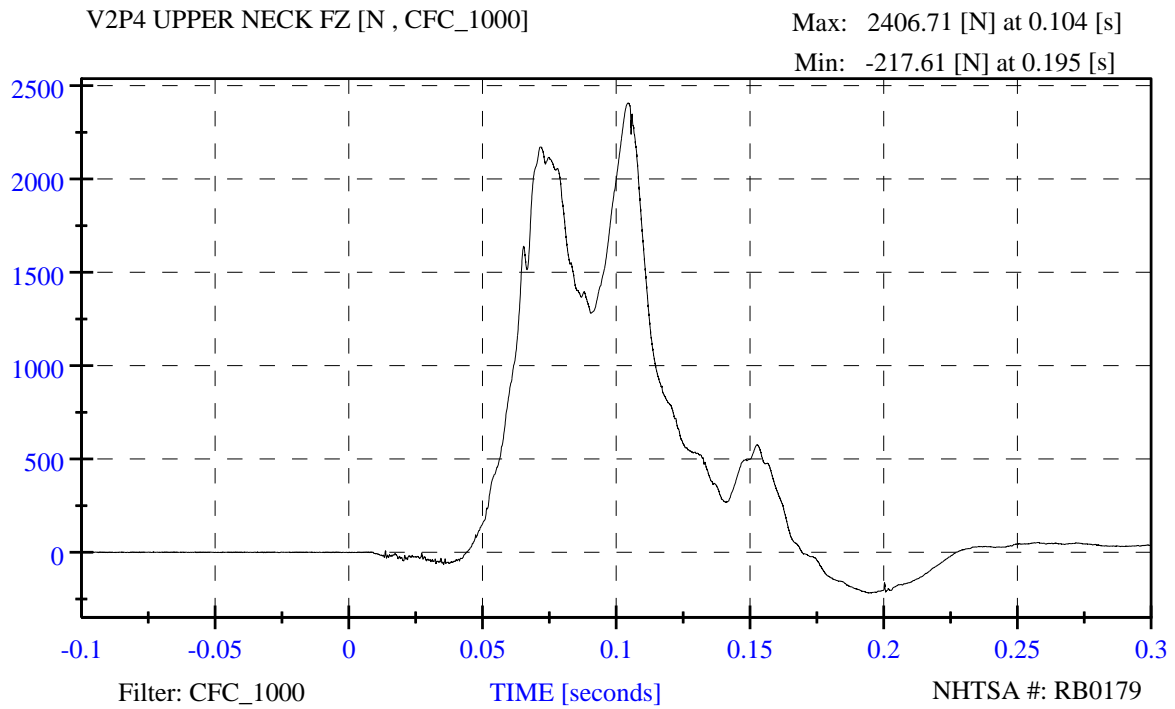

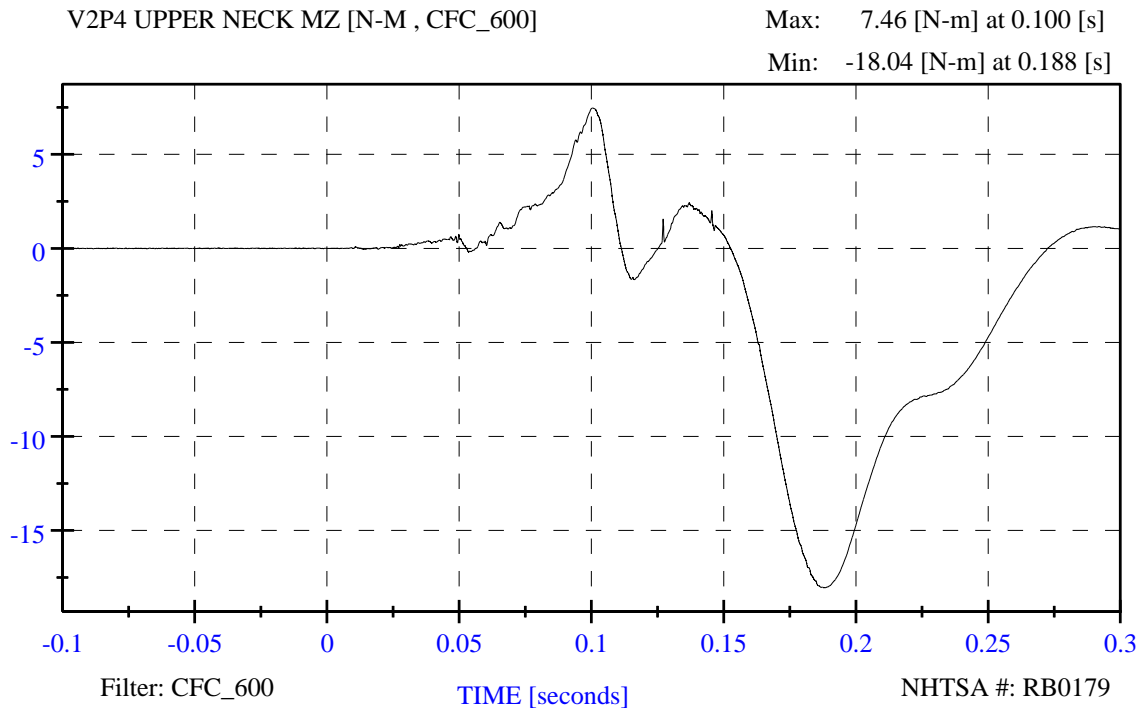
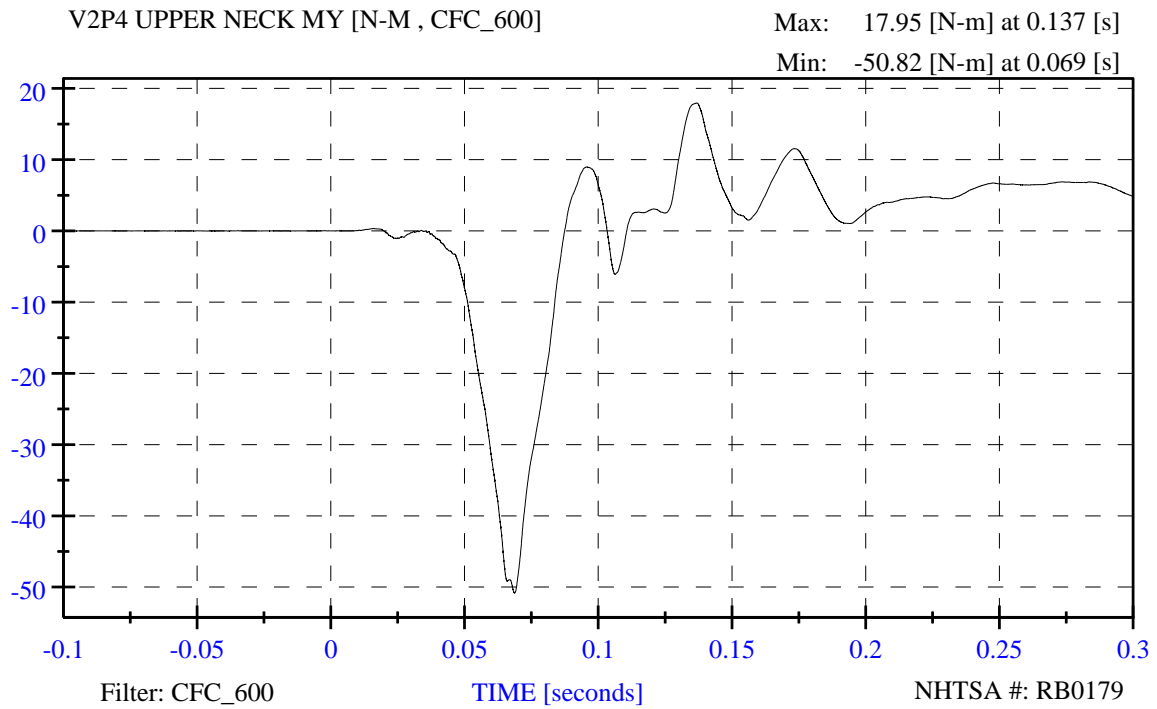

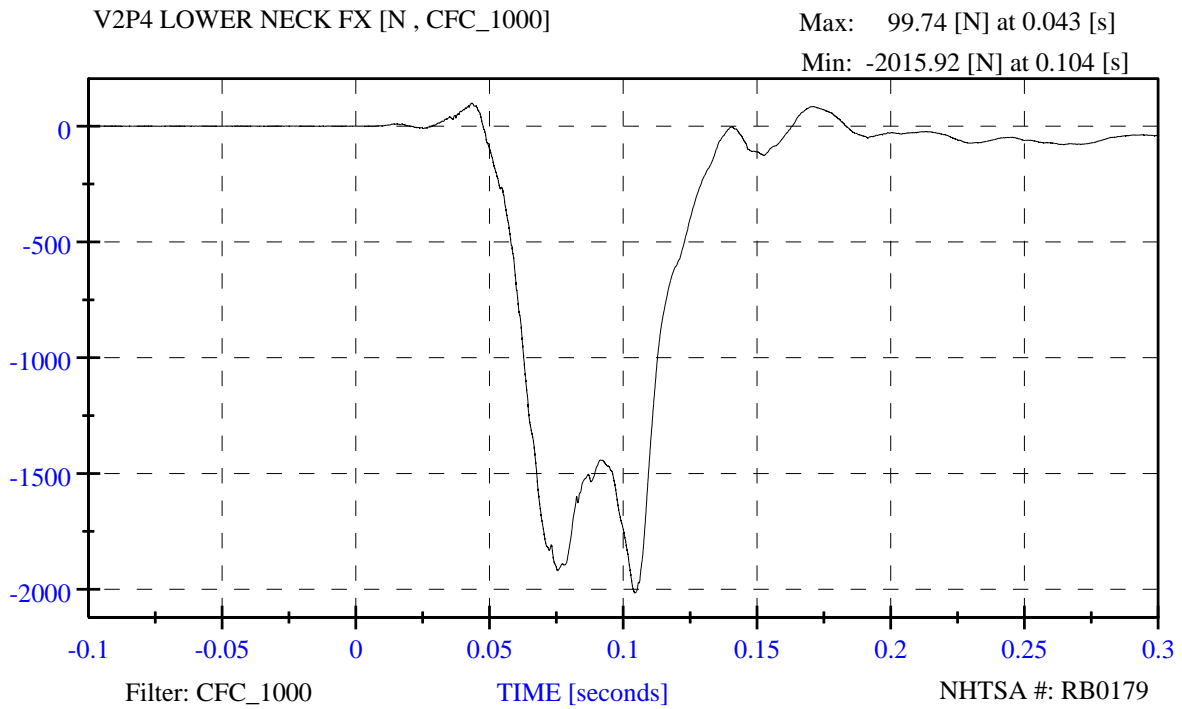

R&D 56 mph, 15deg angle, 35% overlap, 2011 Buick Lacrosse, RB0179

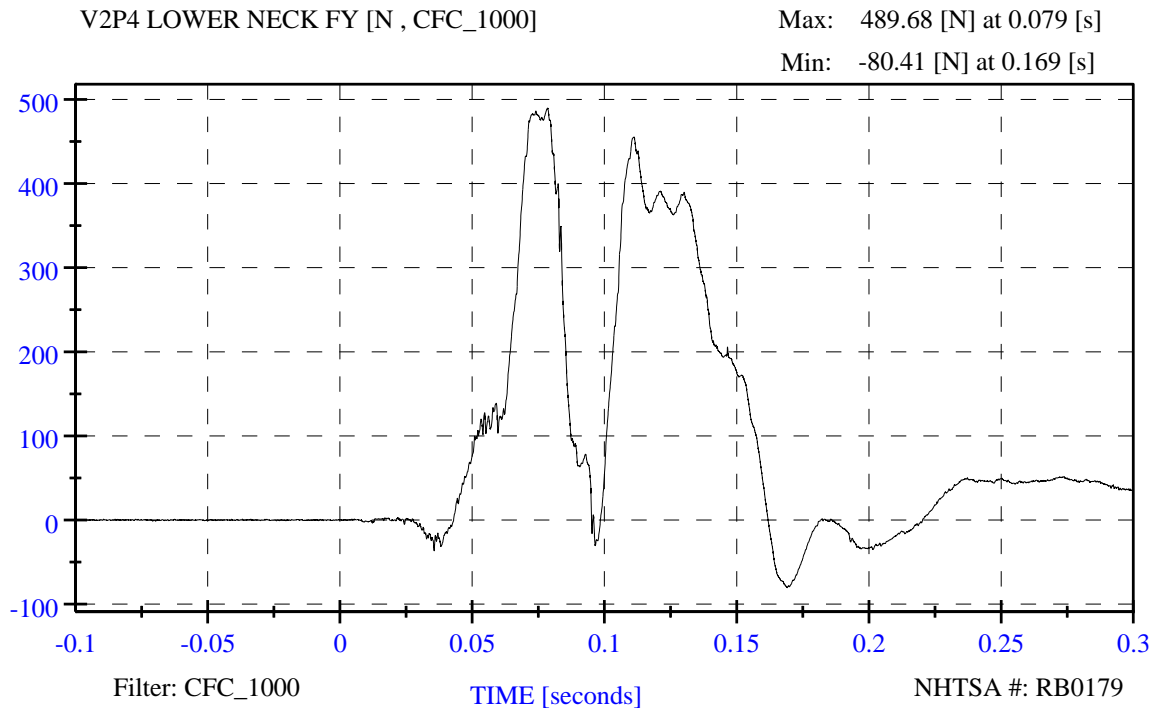

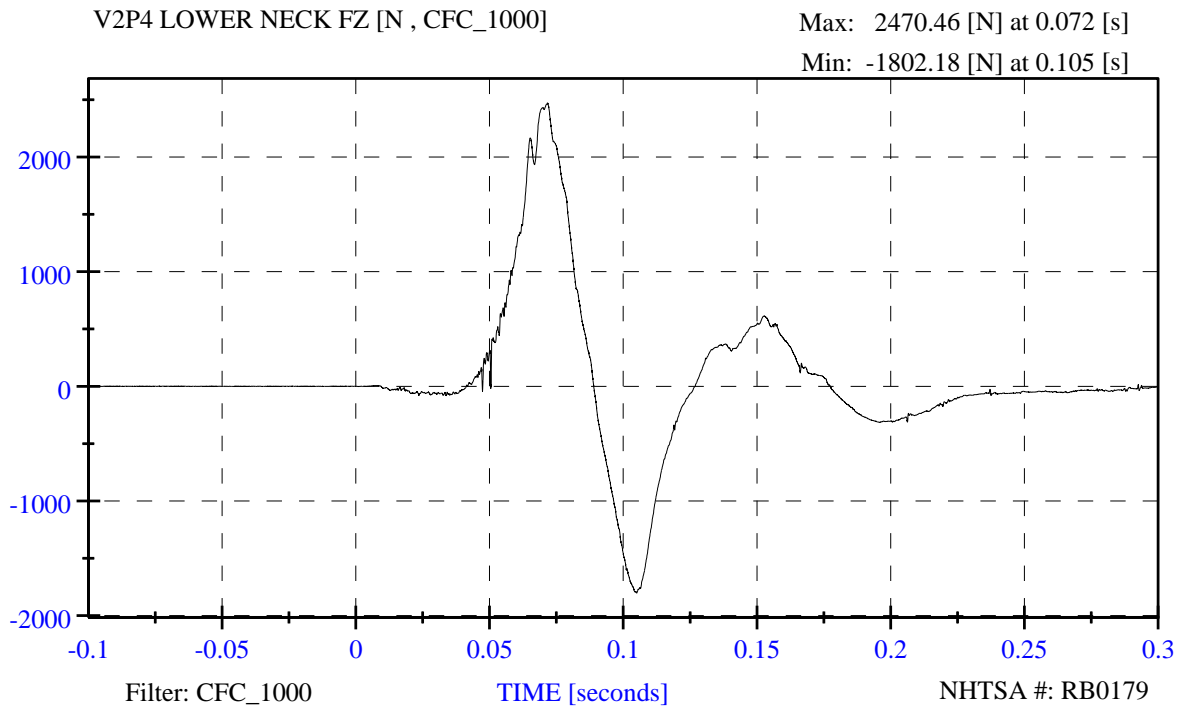

R&D 56 mph, 15deg angle, 35% overlap, 2011 Buick Lacrosse, RB0179

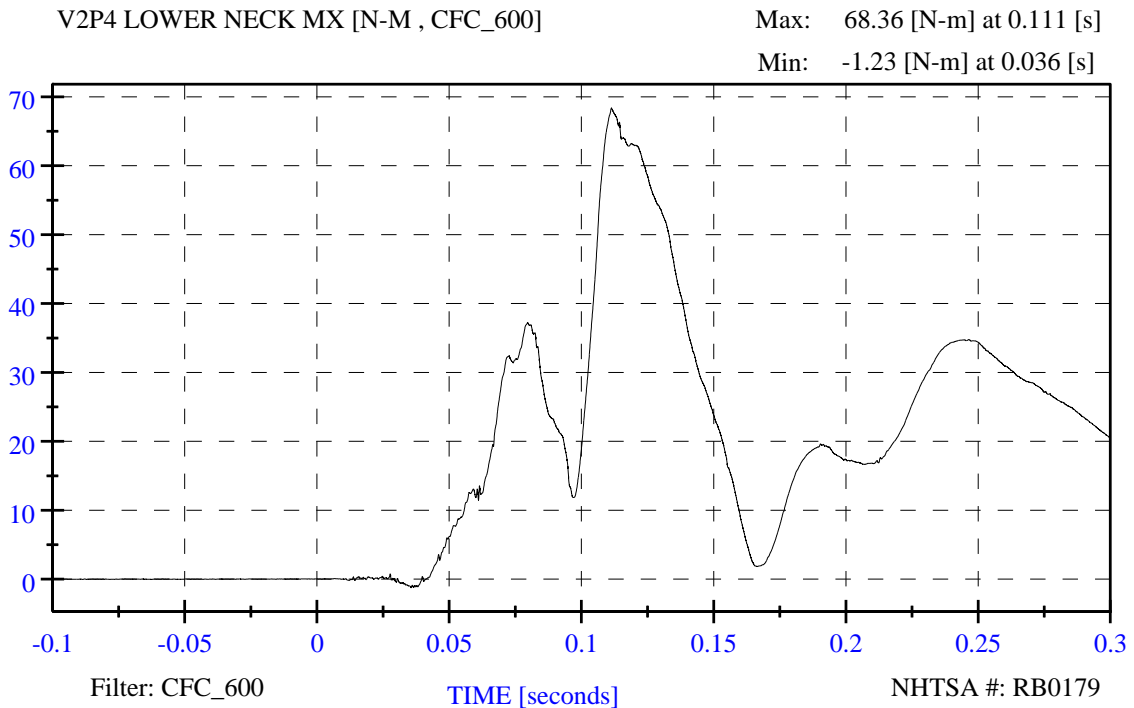

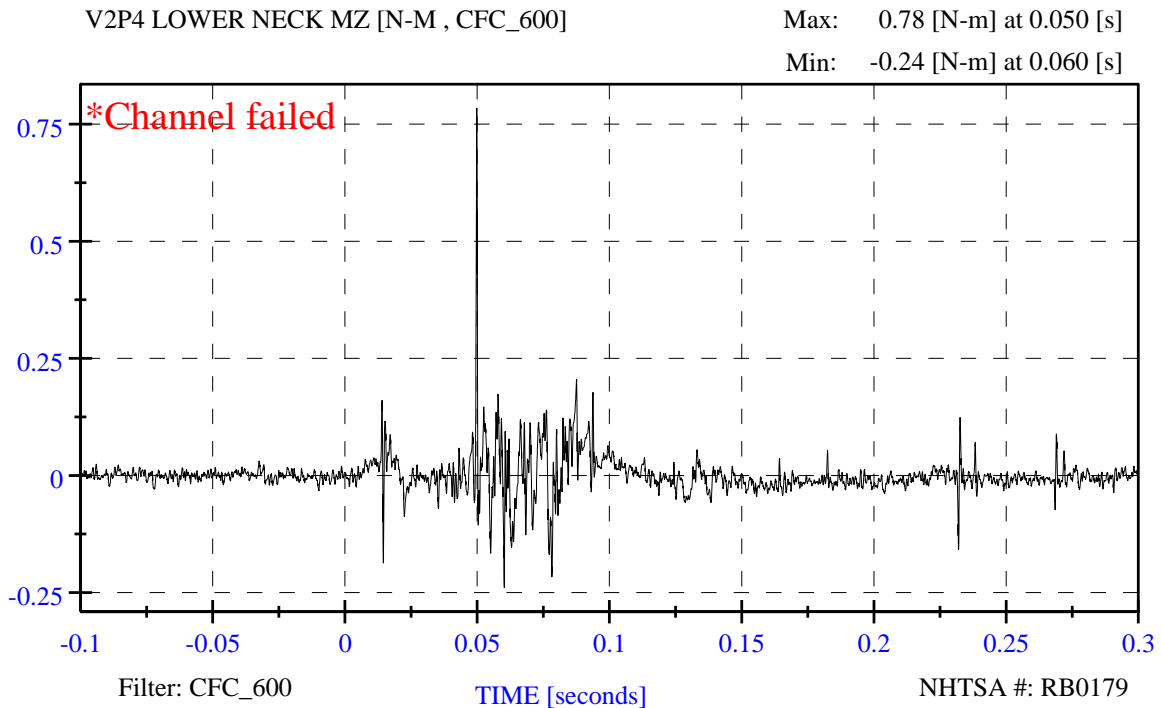
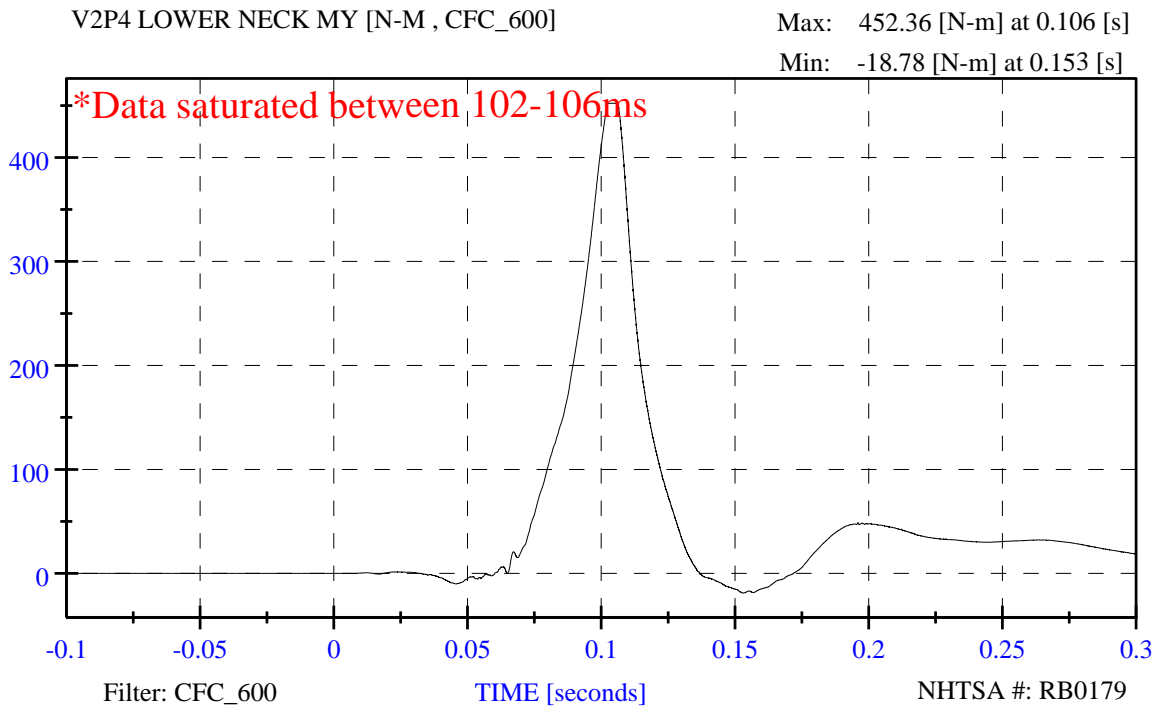

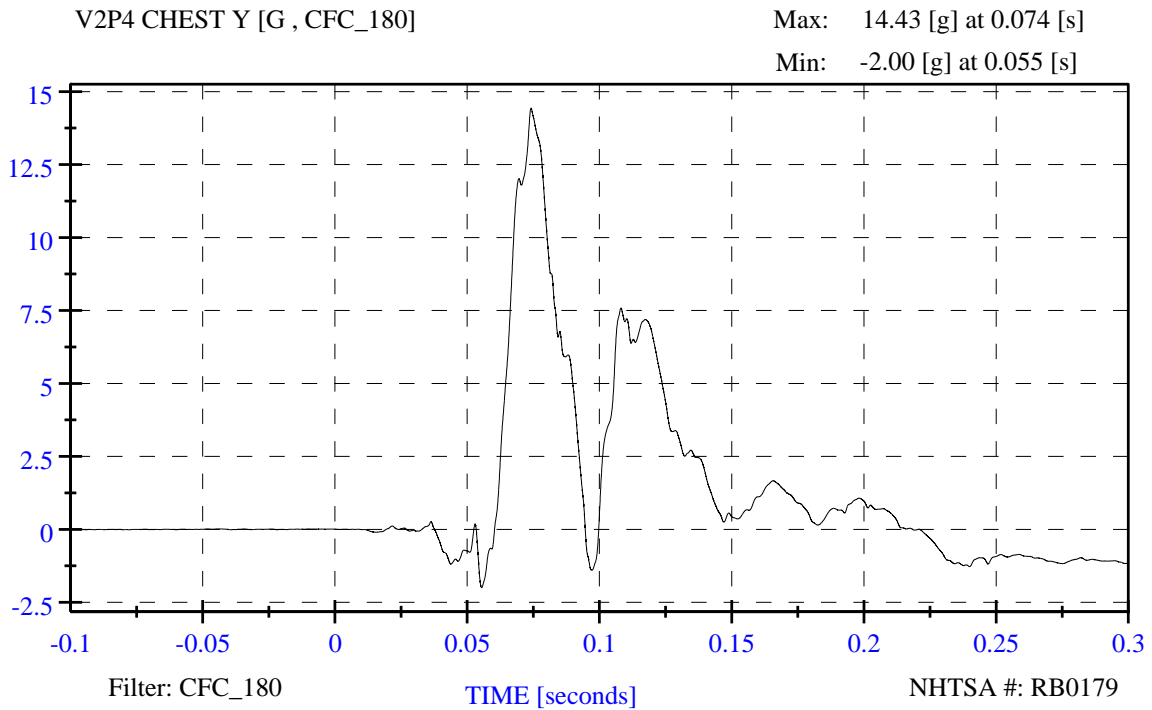
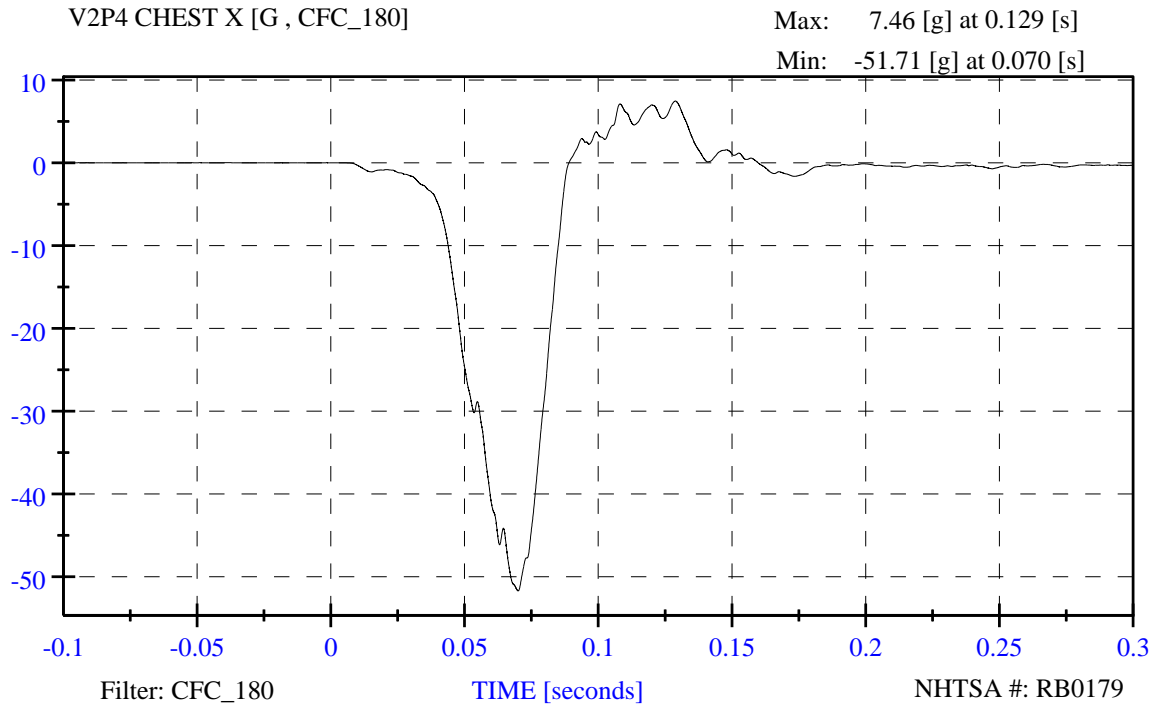

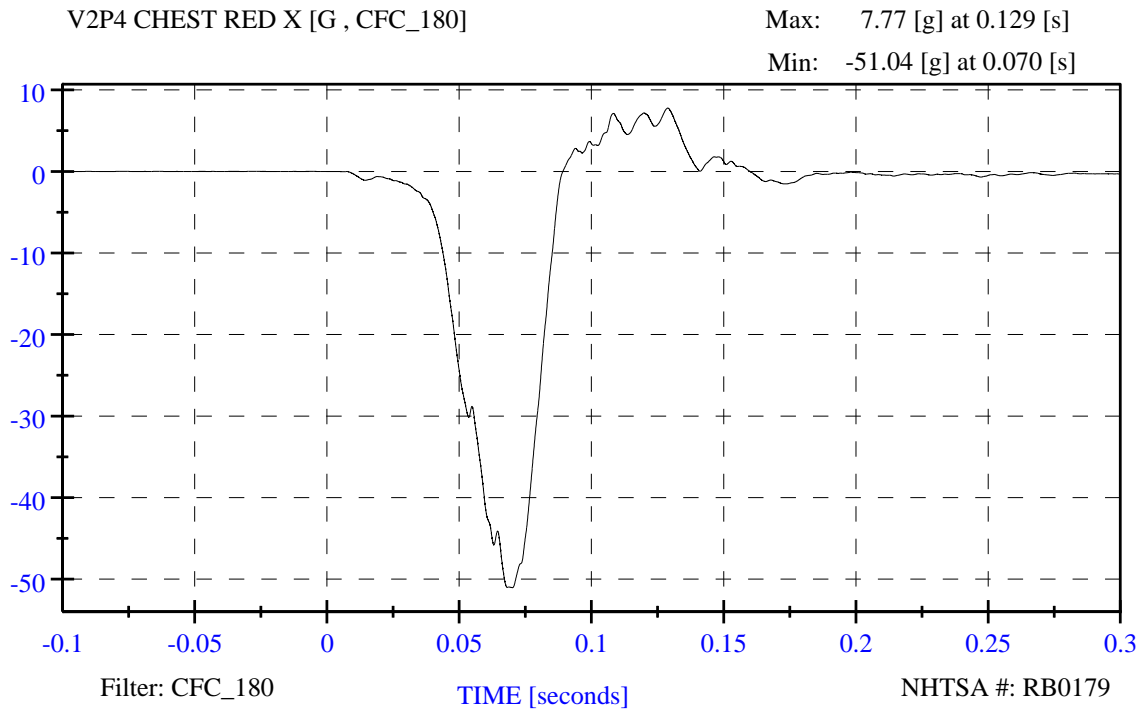
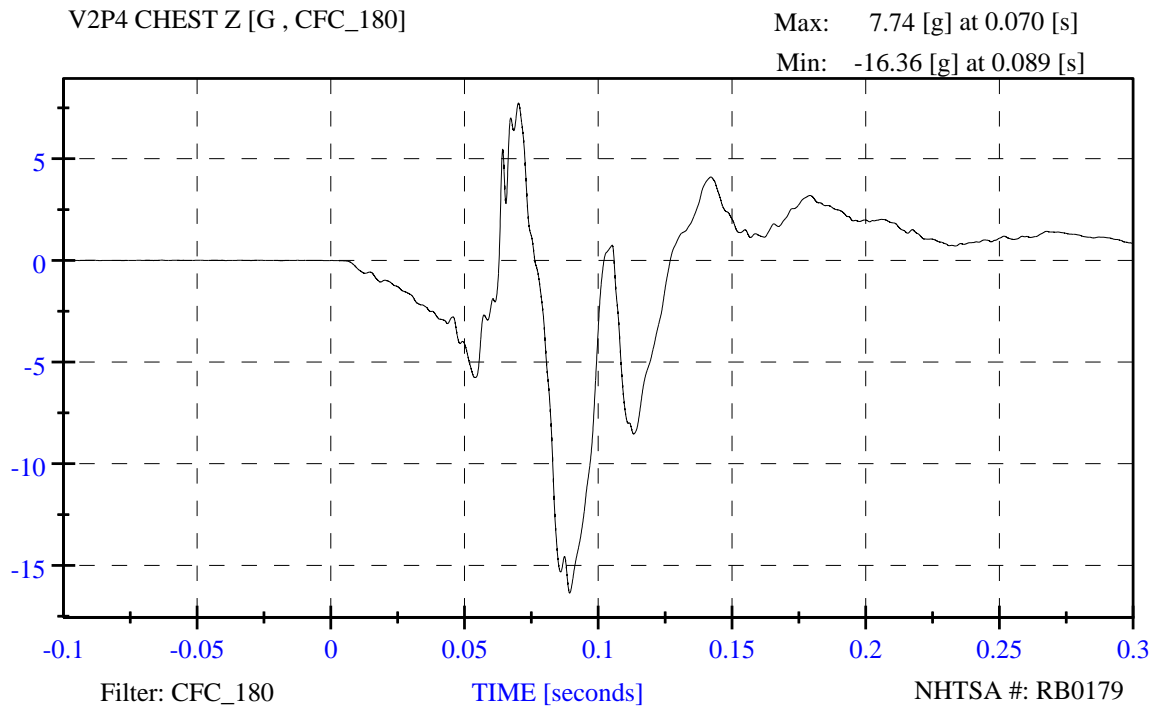

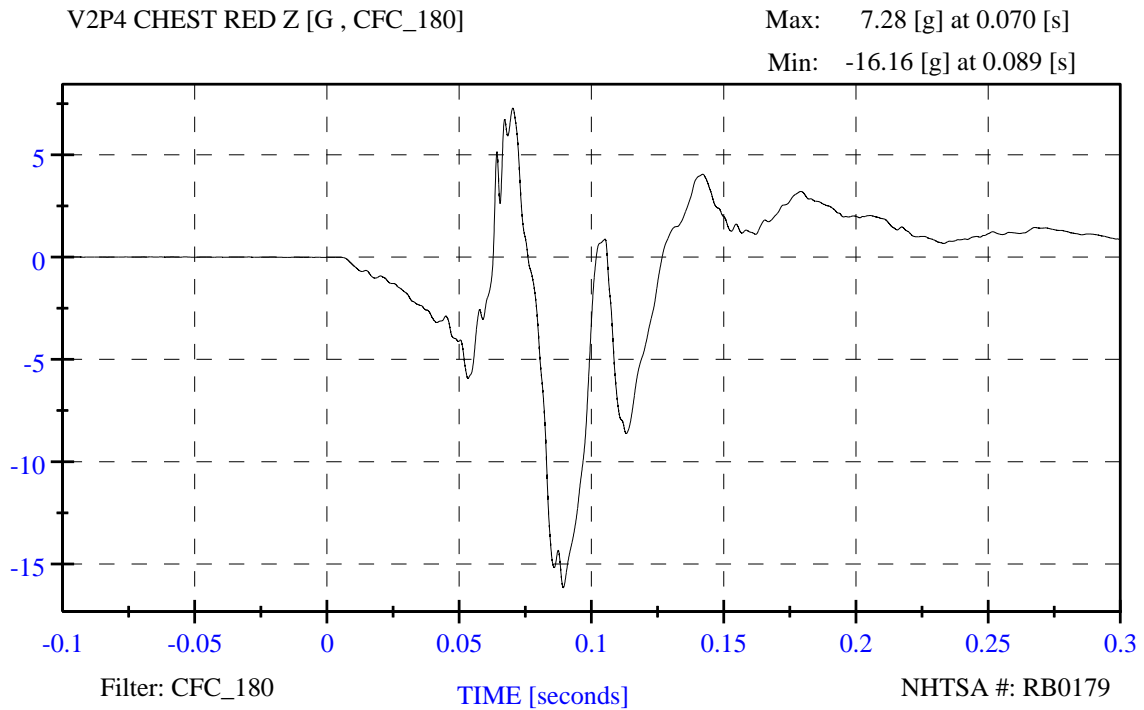
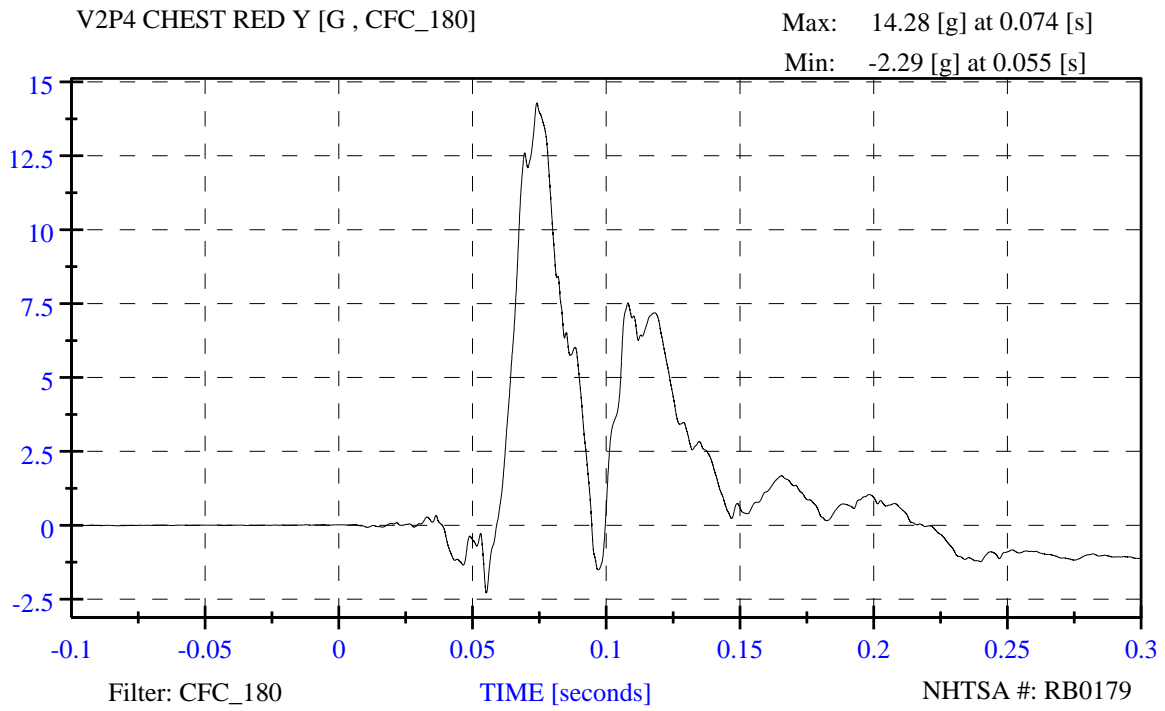

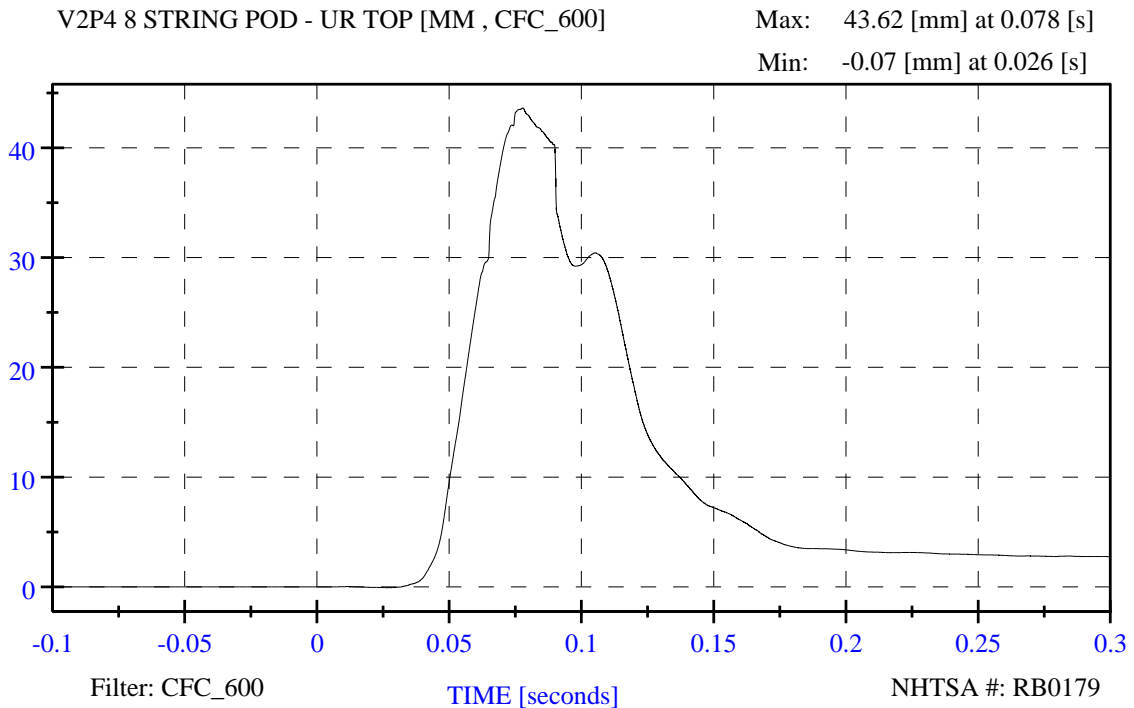
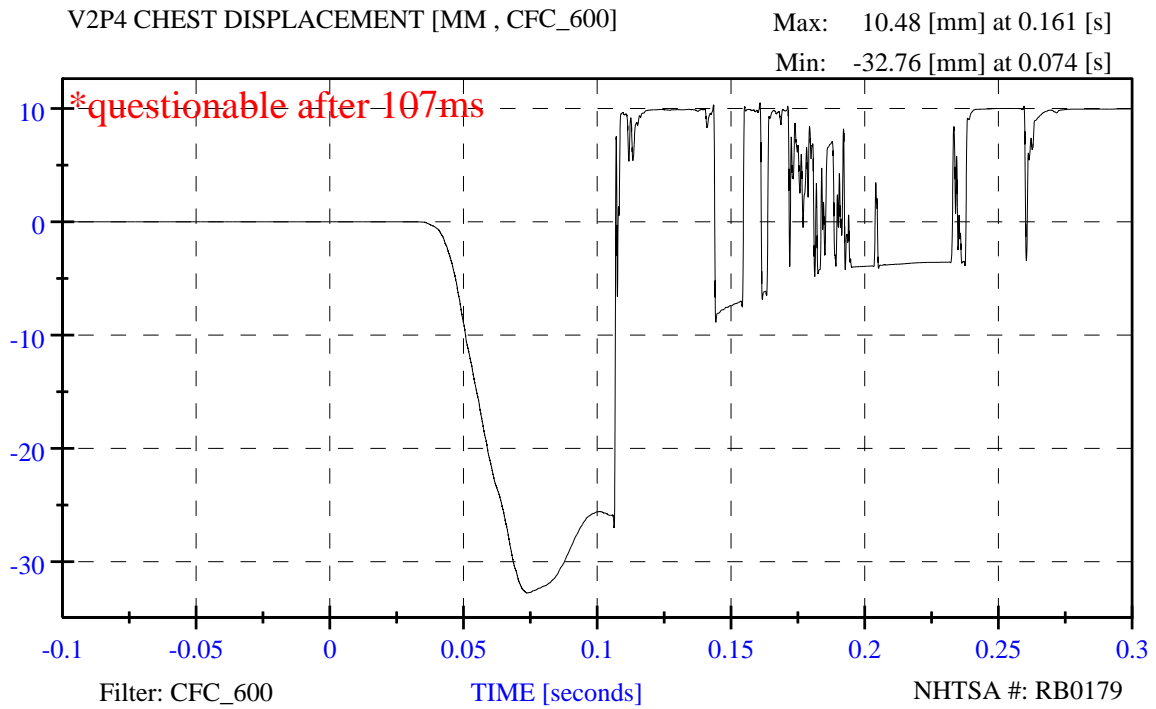

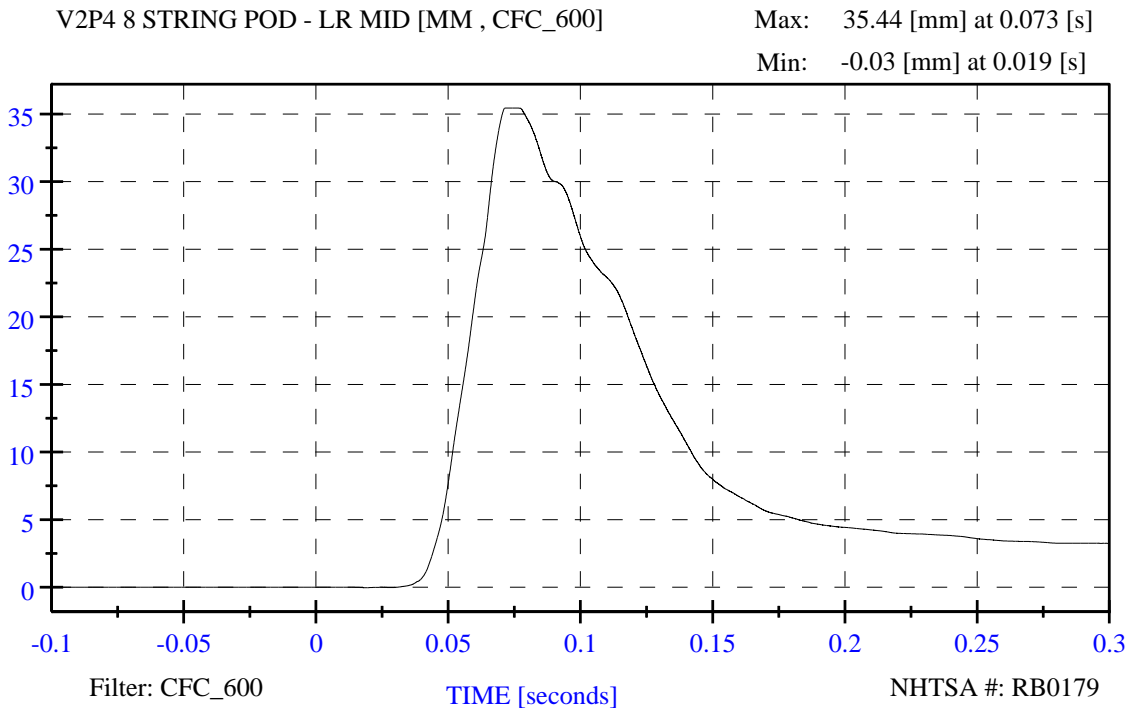
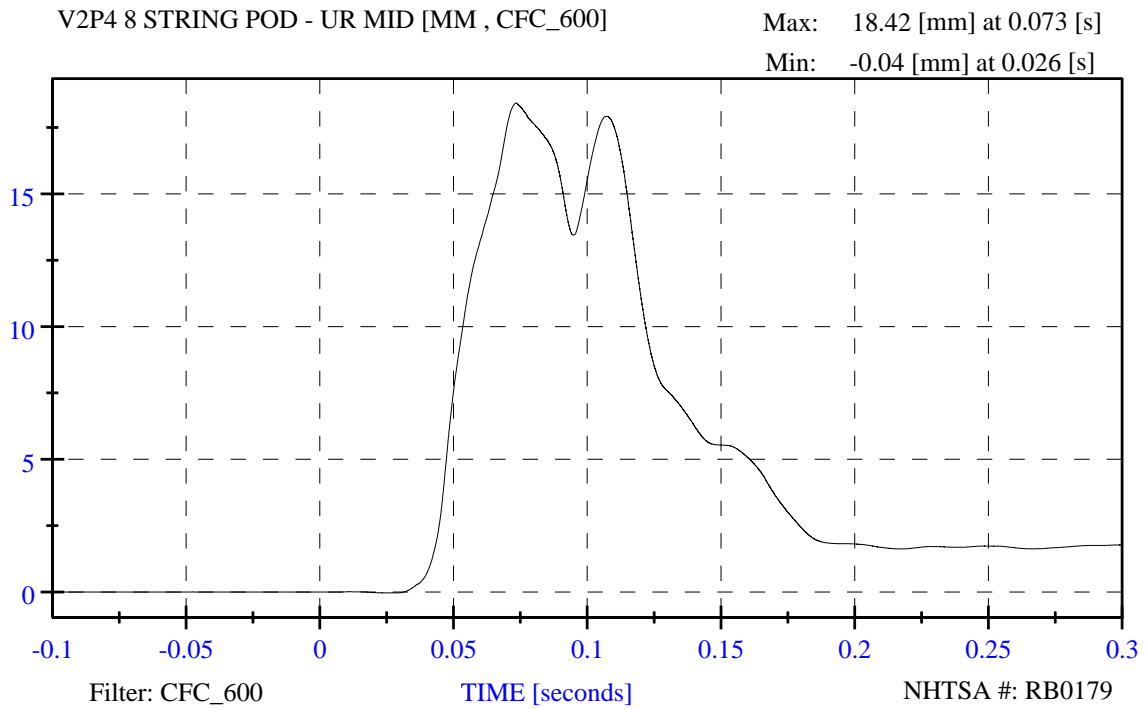

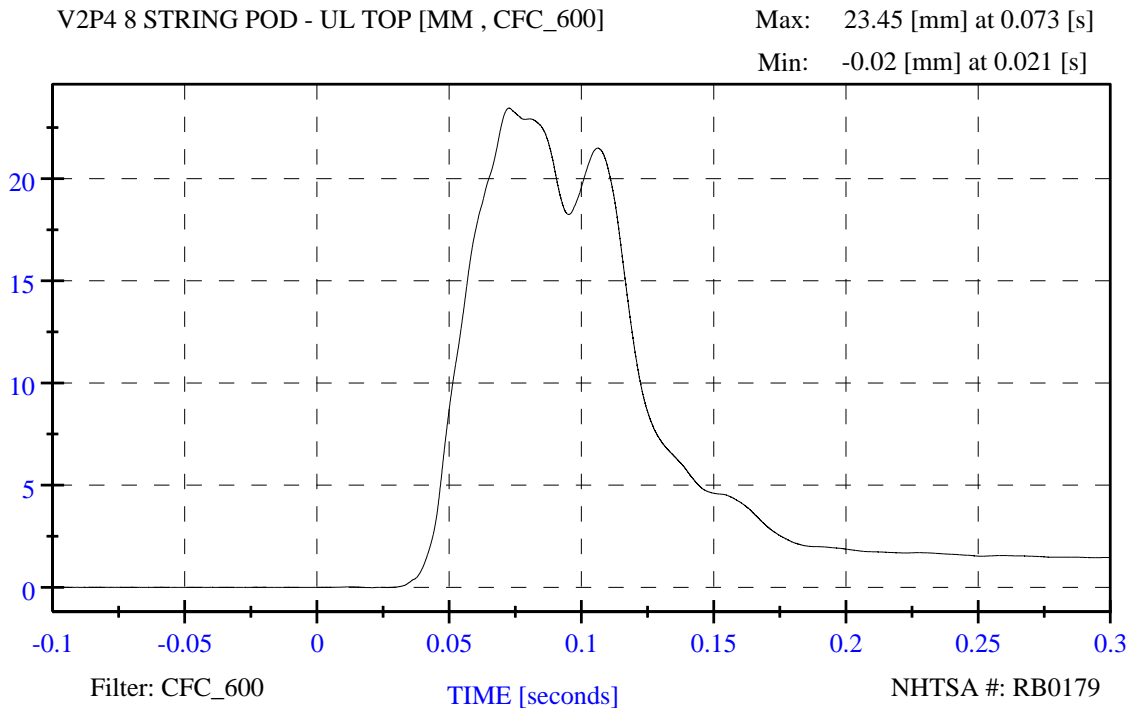
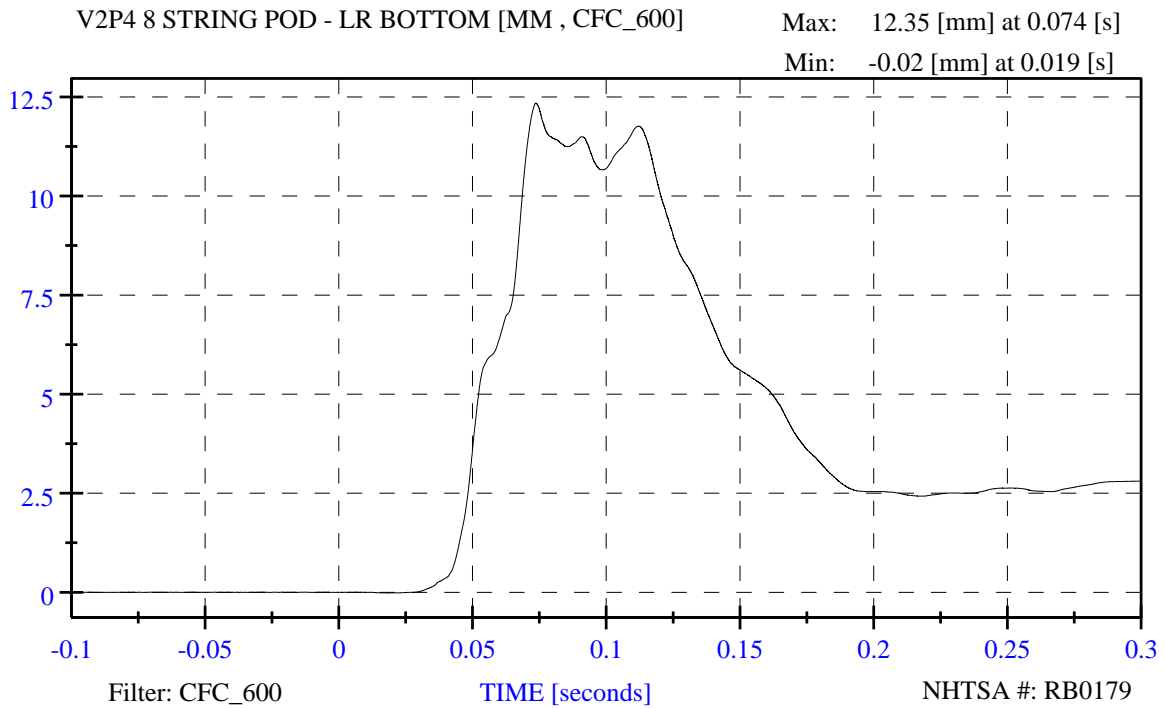

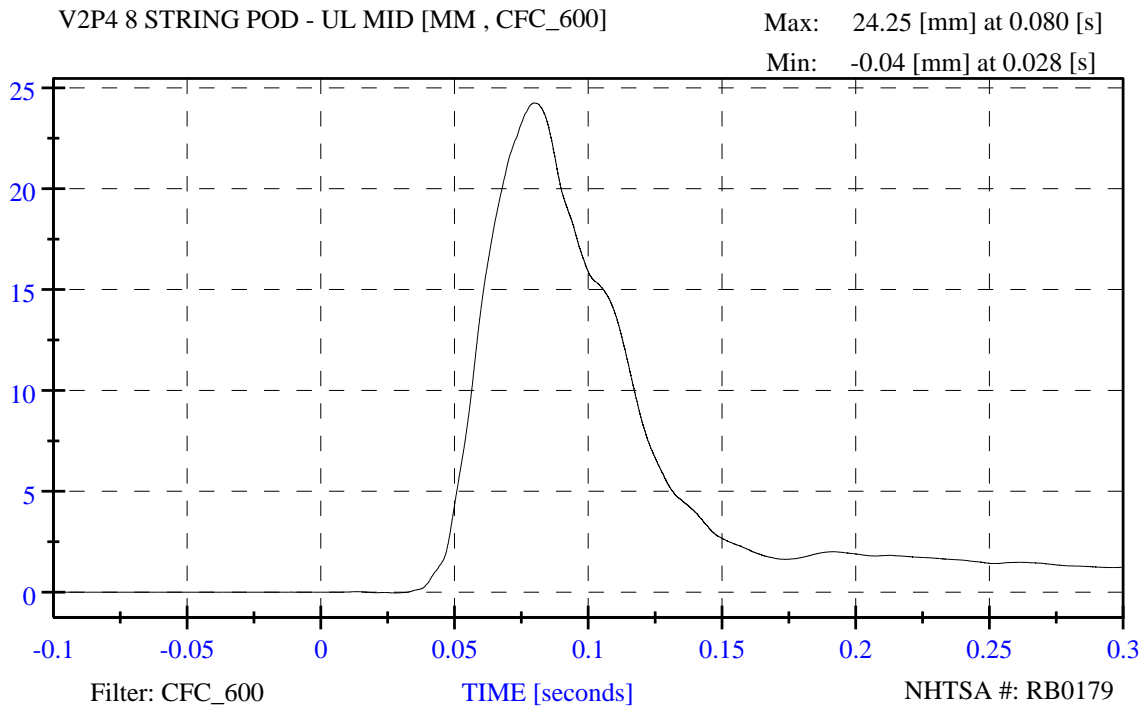

R&D 56 mph, 15deg angle, 35% overlap, 2011 Buick Lacrosse, RB0179

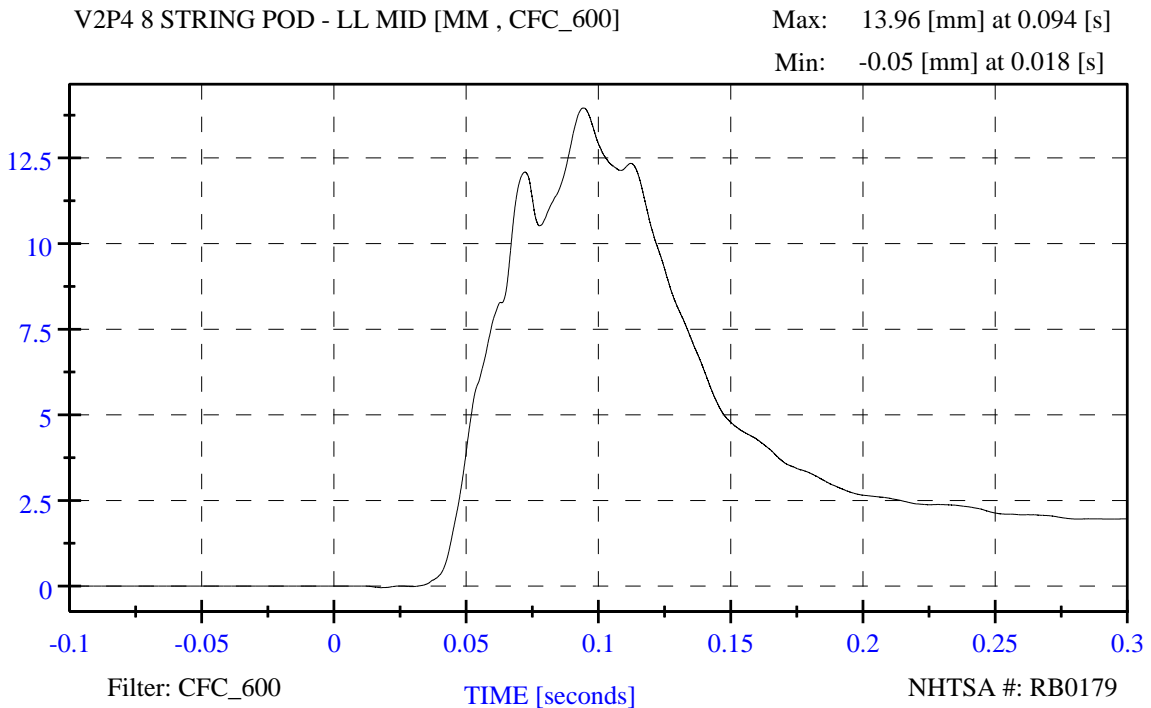

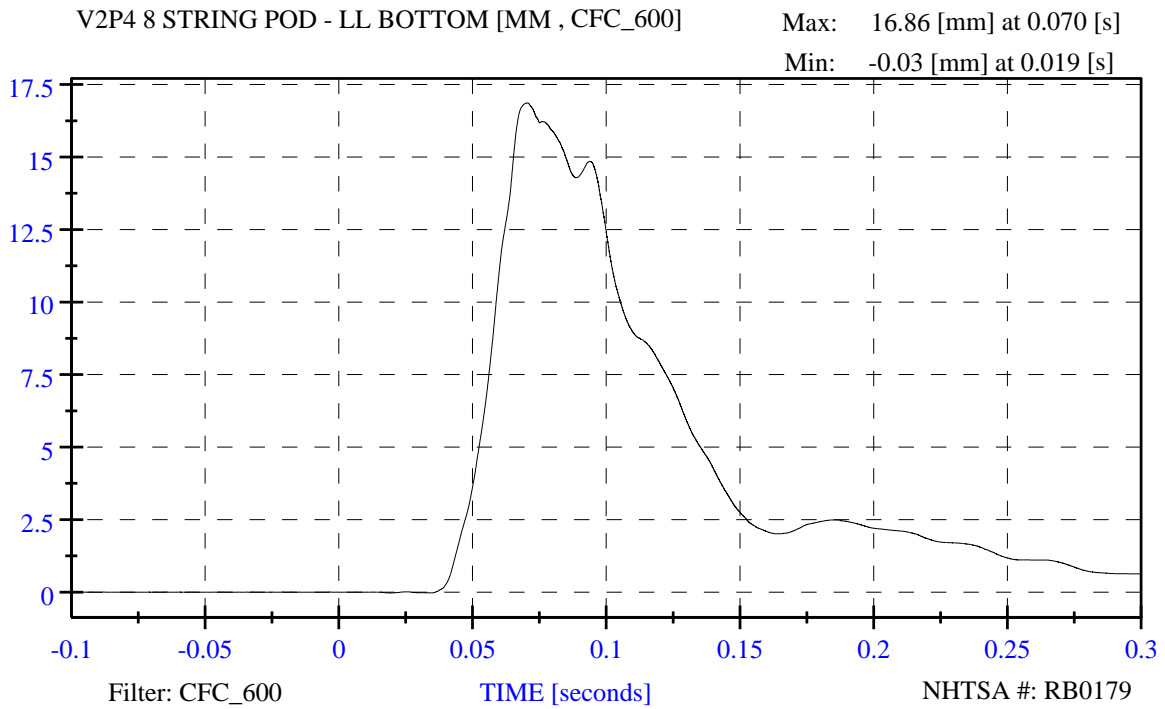

R&D 56 mph, 15deg angle, 35% overlap, 2011 Buick Lacrosse, RB0179

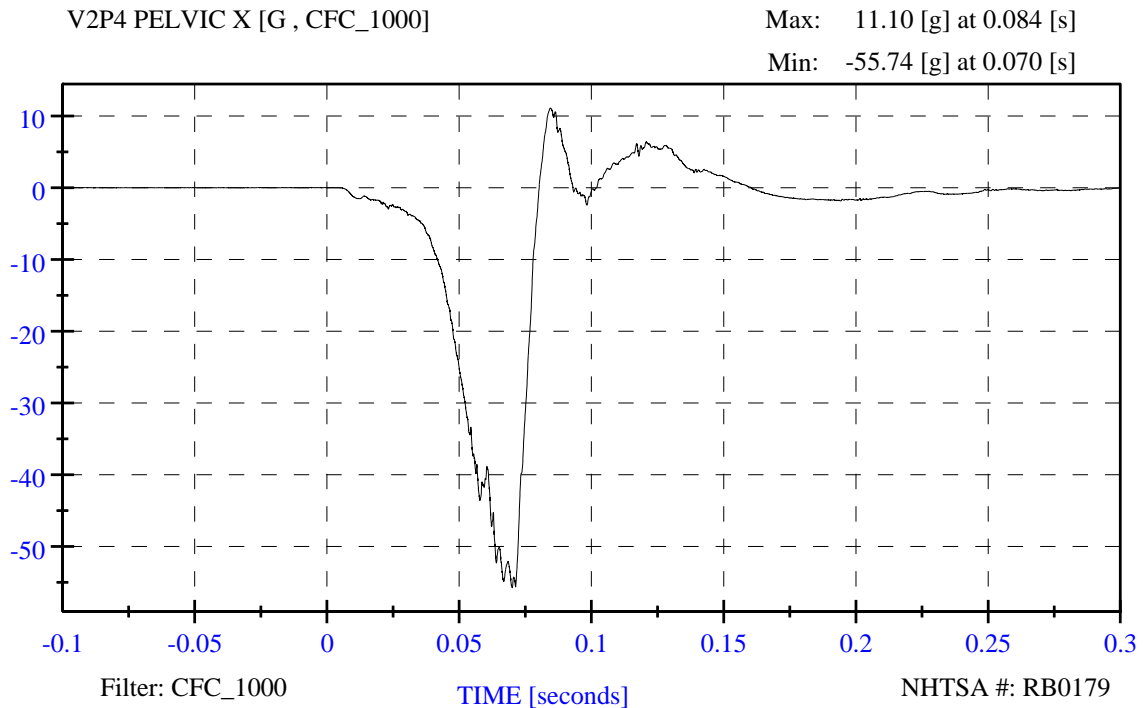

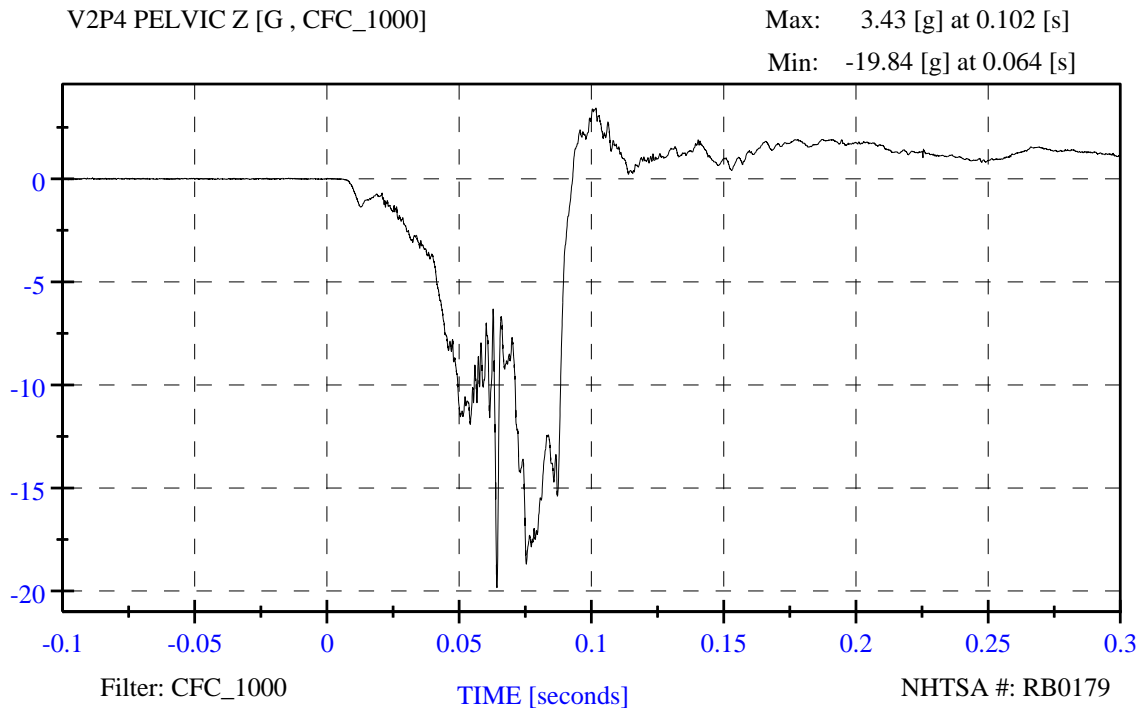
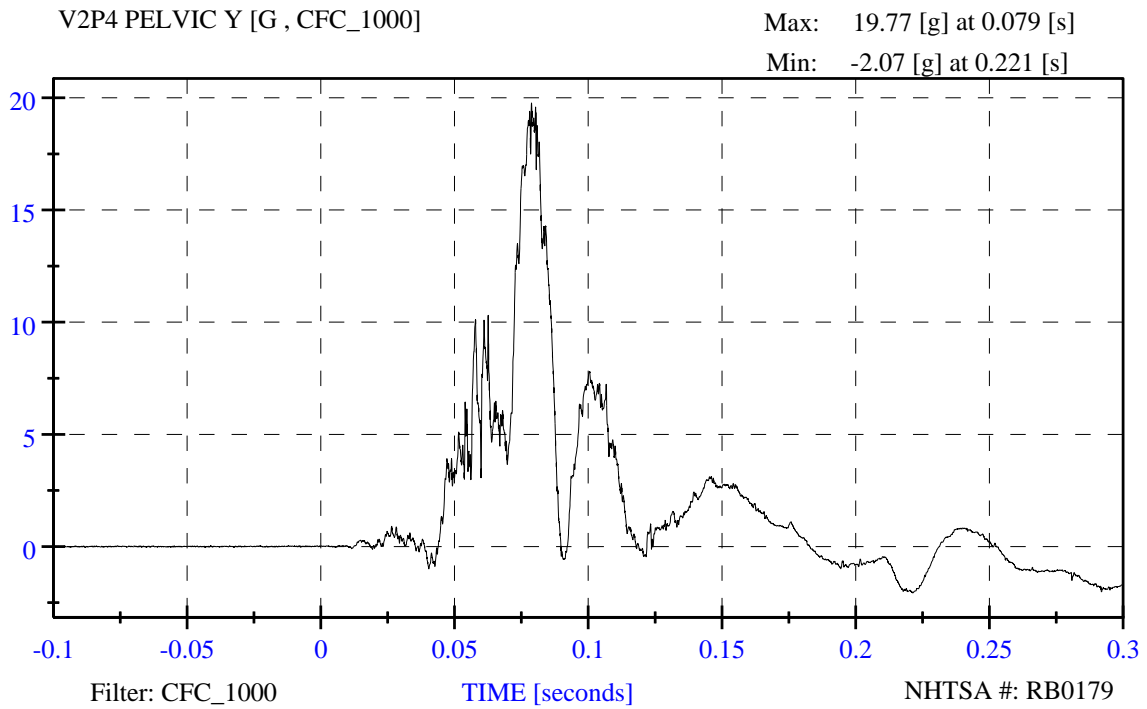

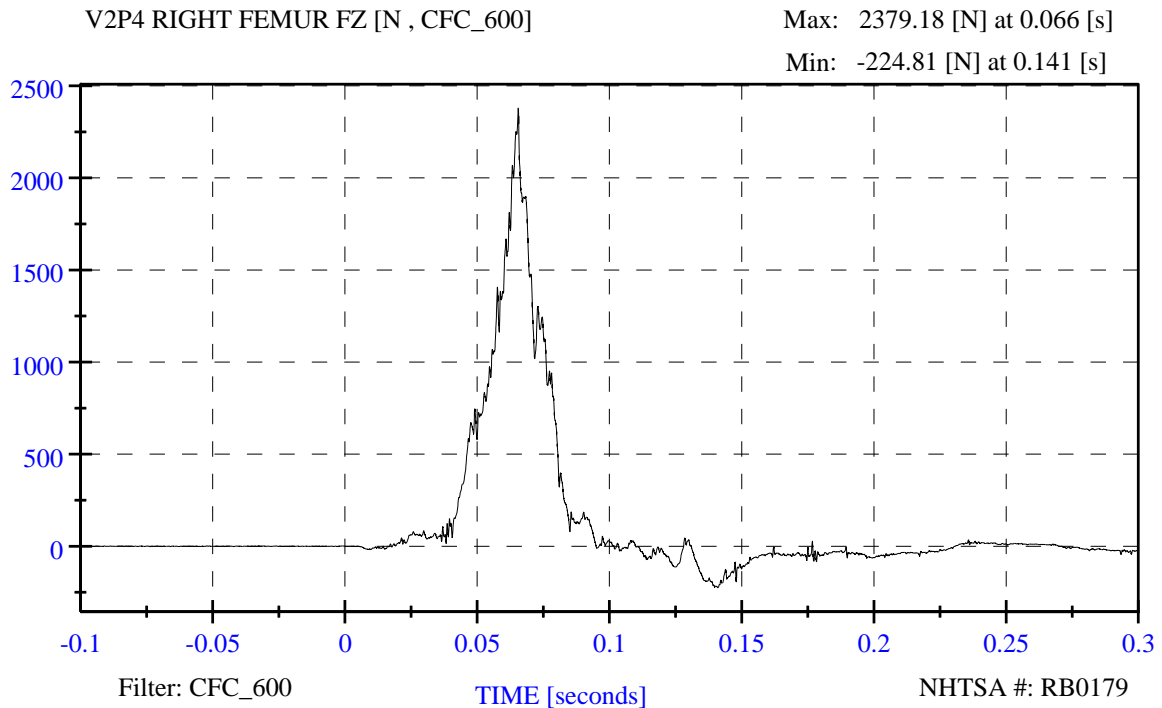
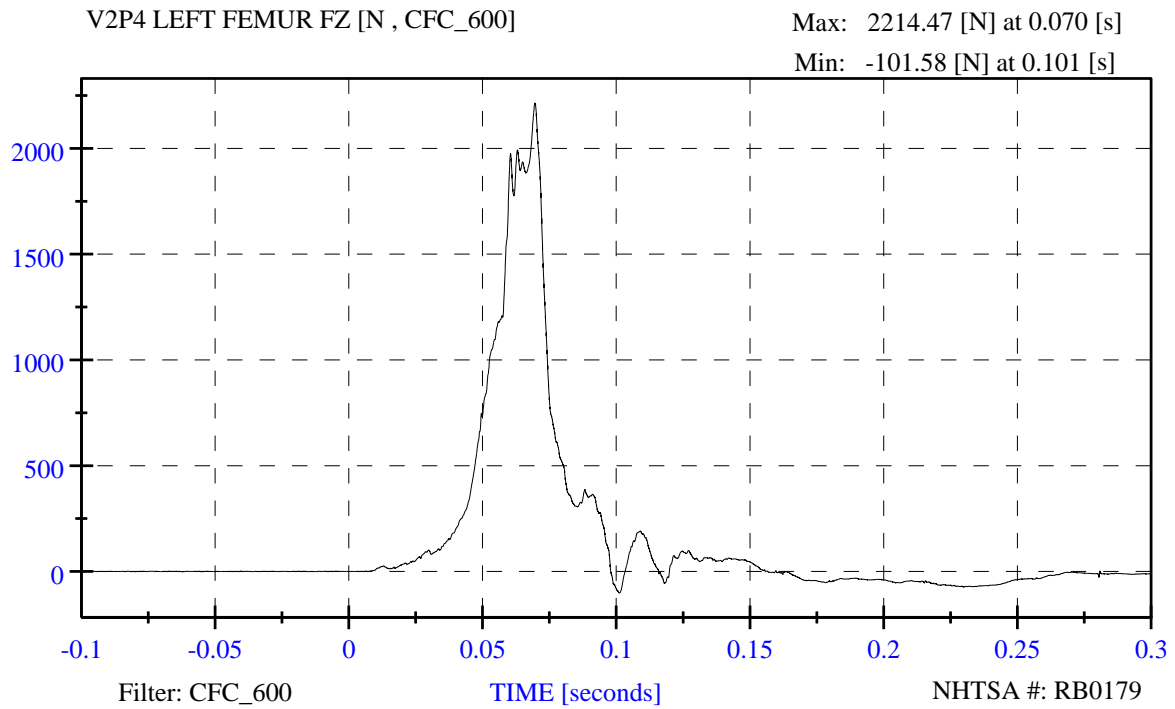

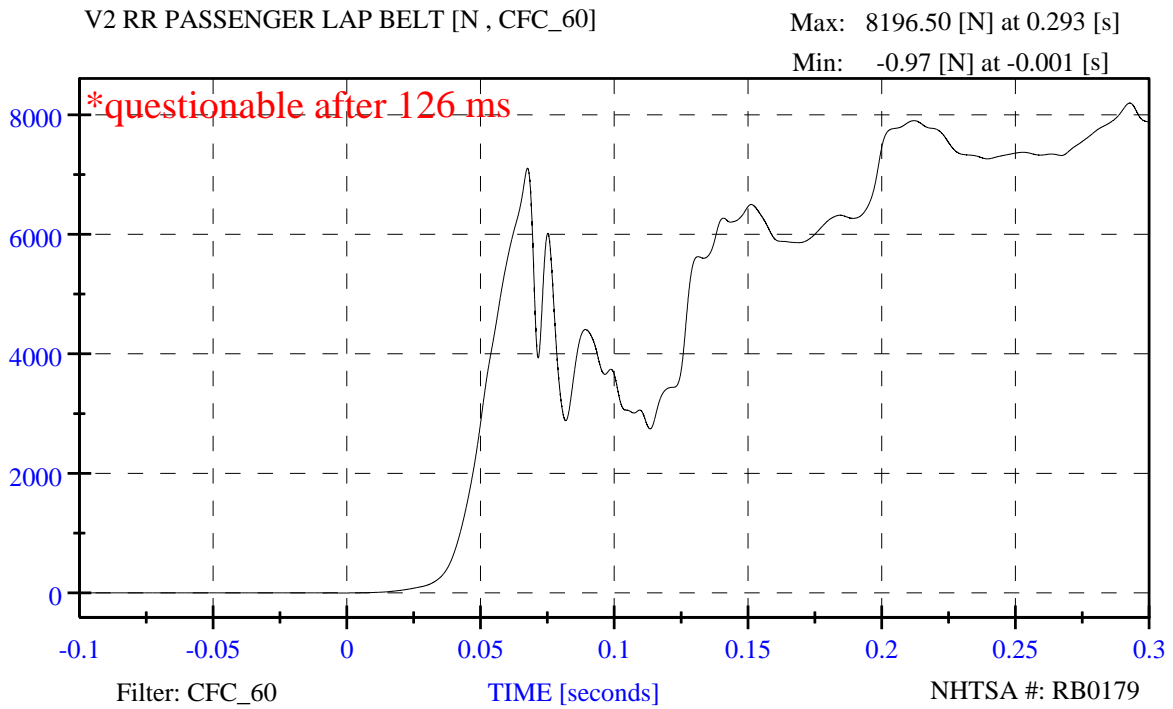

R&D 56 mph, 15deg angle, 35% overlap, 2011 Buick Lacrosse, RB0179

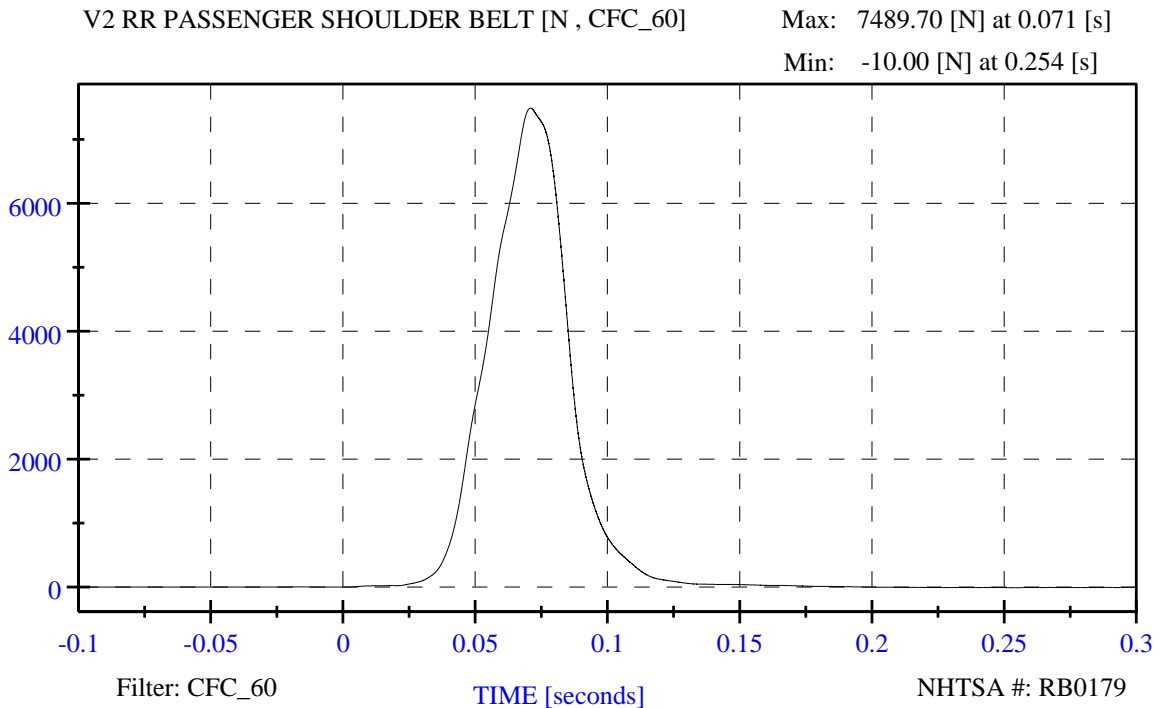

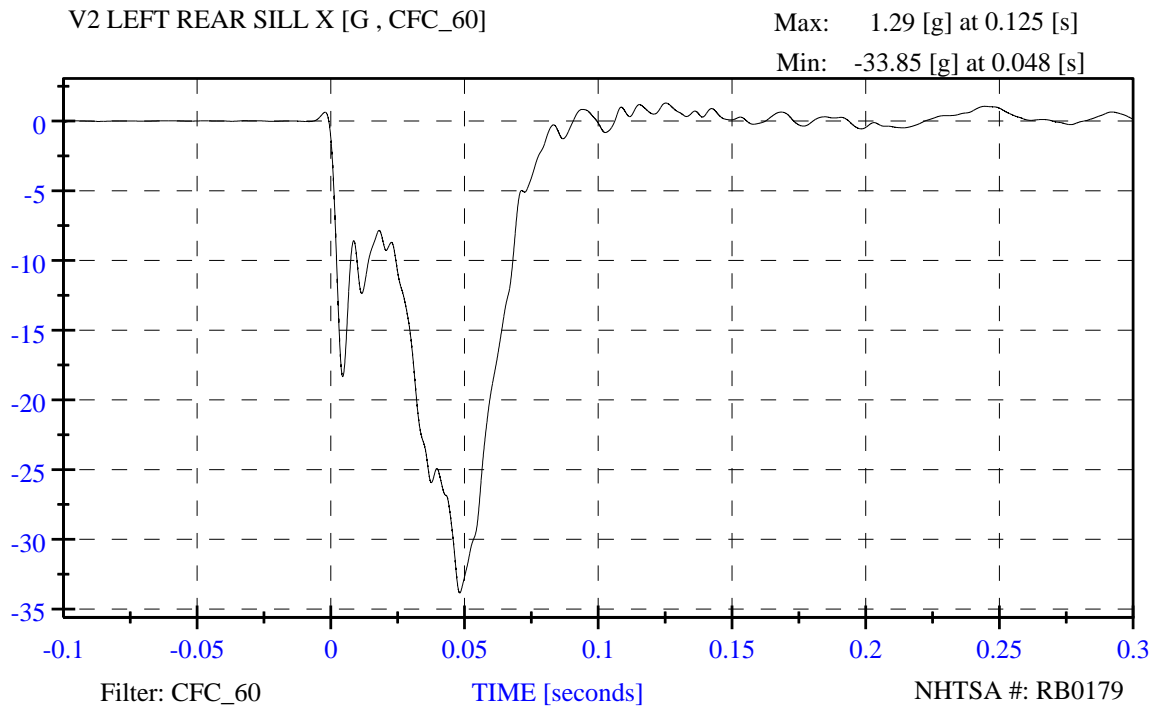

R&D 56 mph, 15deg angle, 35% overlap, 2011 Buick Lacrosse, RB0179

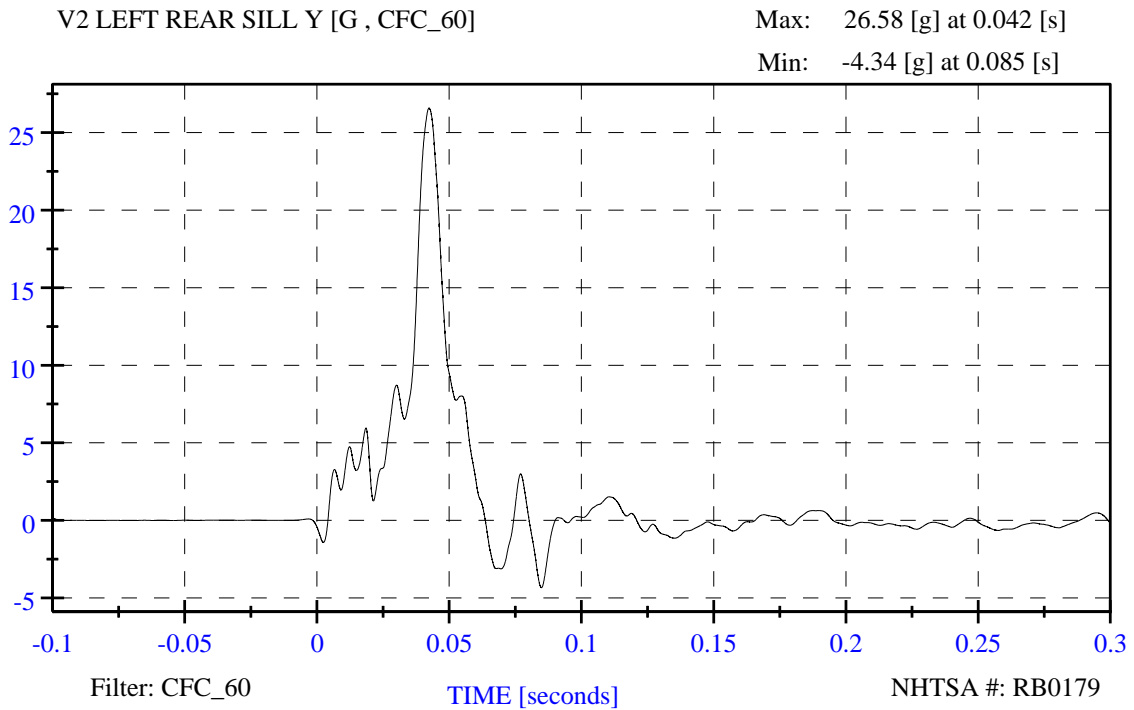

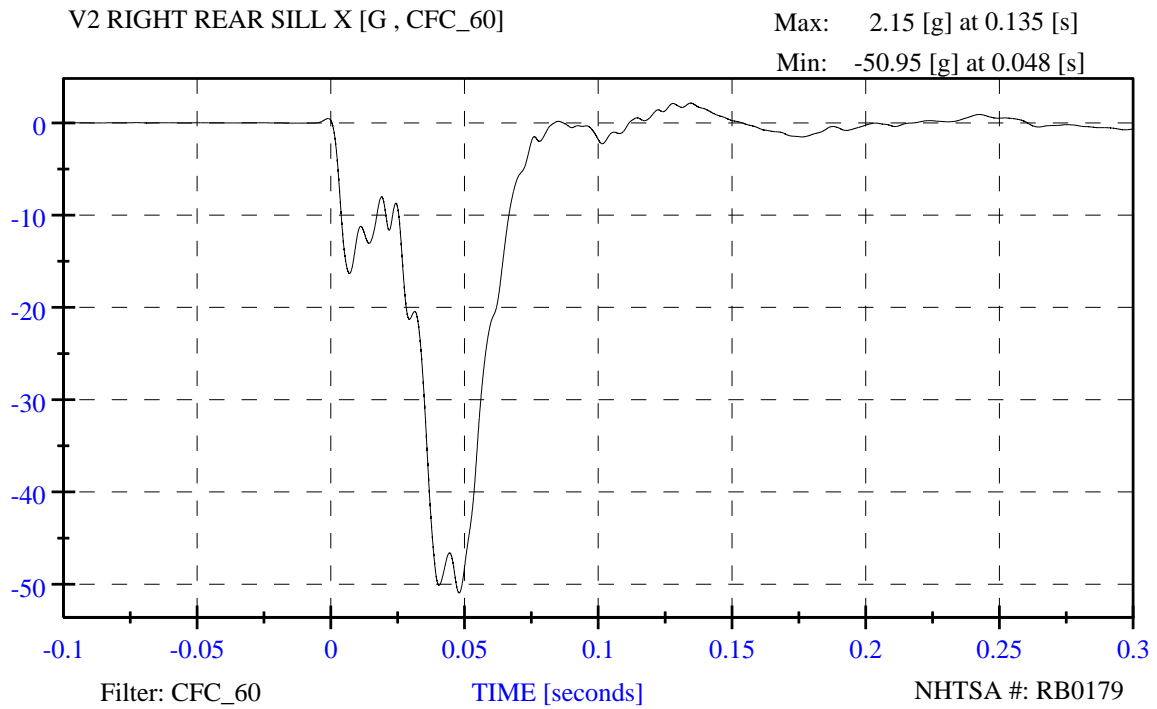

R&D 56 mph, 15deg angle, 35% overlap, 2011 Buick Lacrosse, RB0179

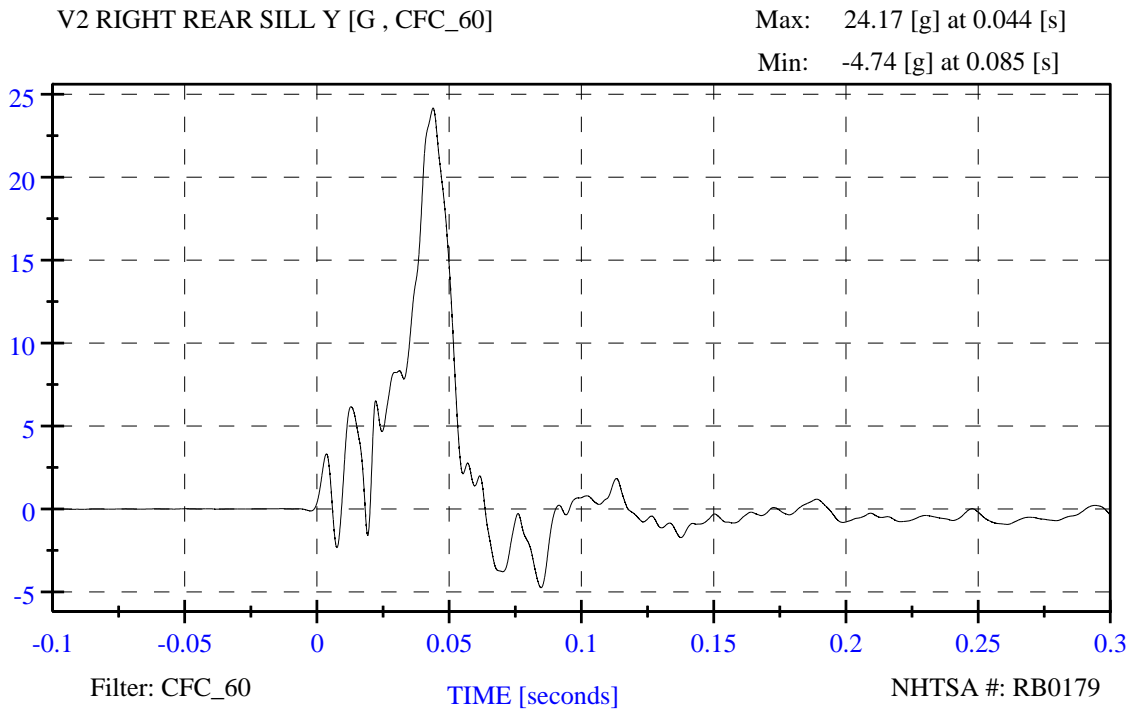

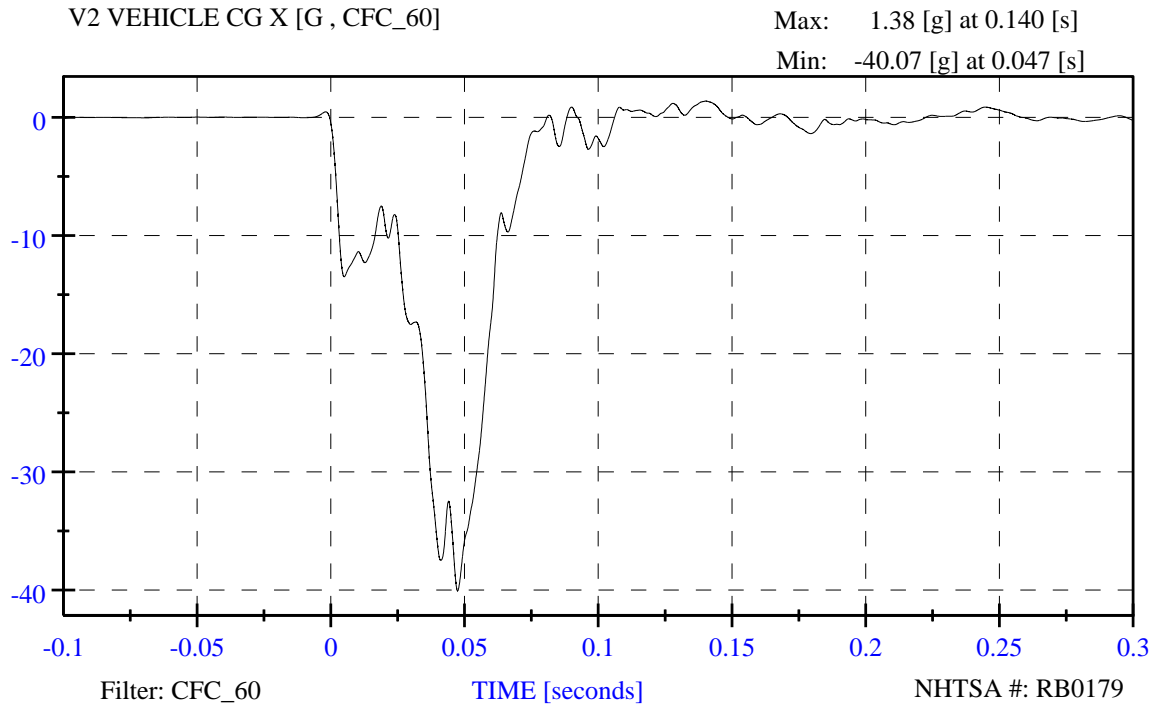

R&D 56 mph, 15deg angle, 35% overlap, 2011 Buick Lacrosse, RB0179

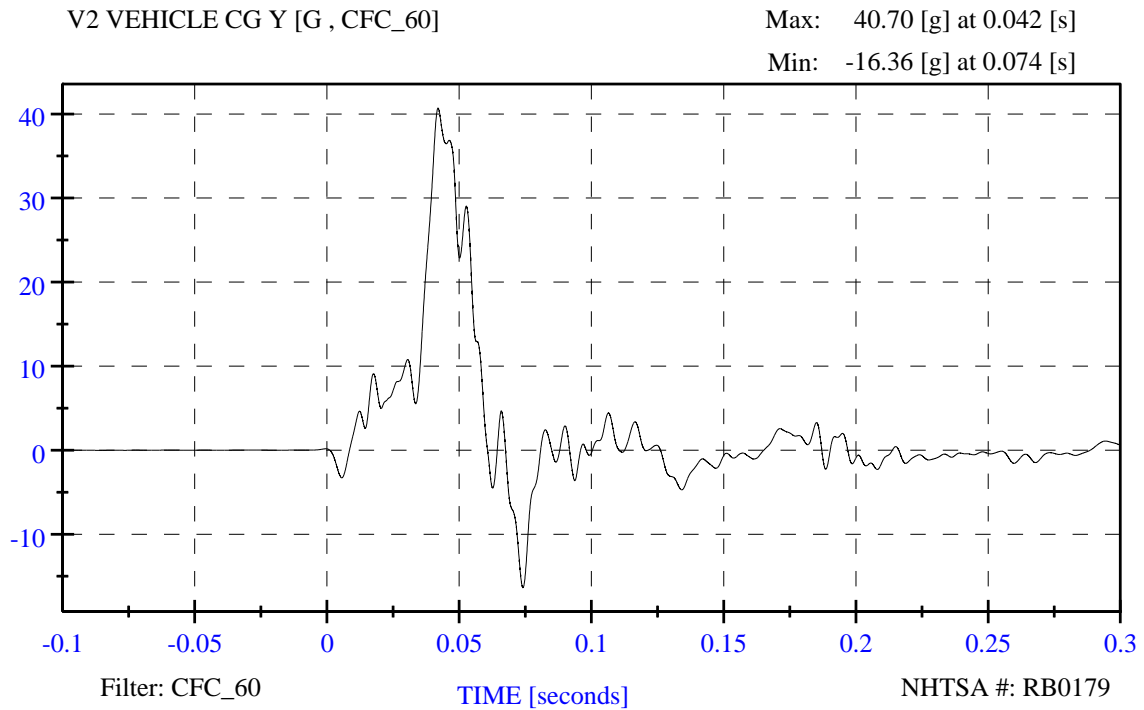

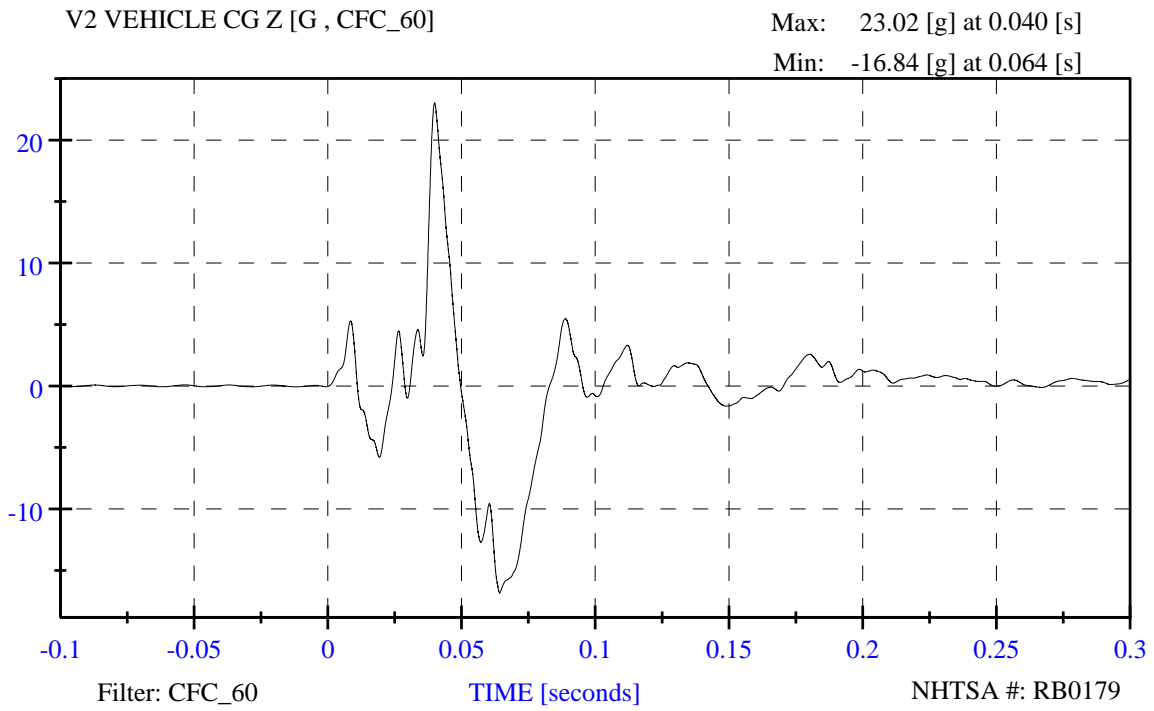

R&D 56 mph, 15deg angle, 35% overlap, 2011 Buick Lacrosse, RB0179

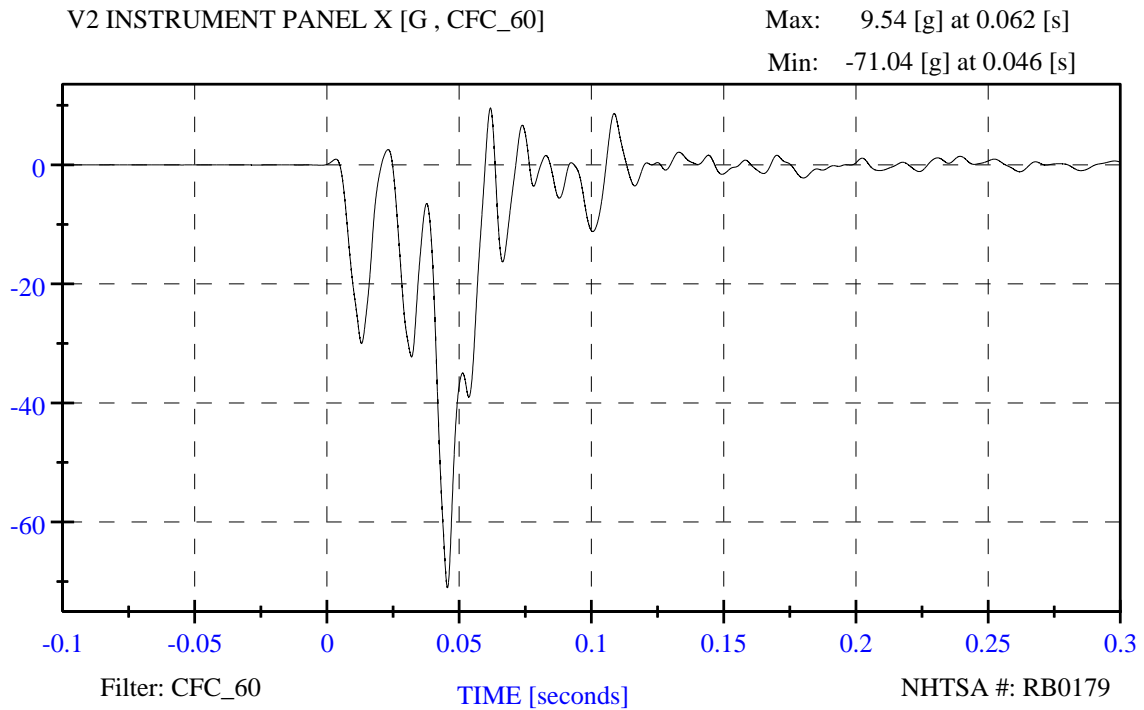

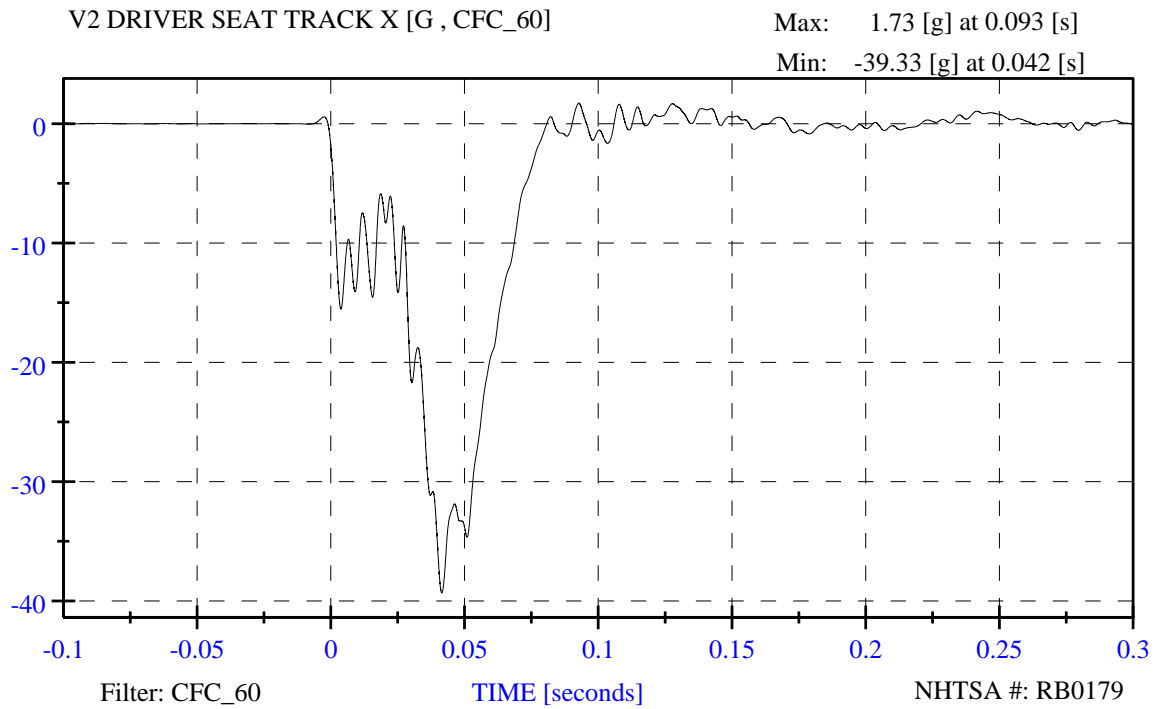

R&D 56 mph, 15deg angle, 35% overlap, 2011 Buick Lacrosse, RB0179

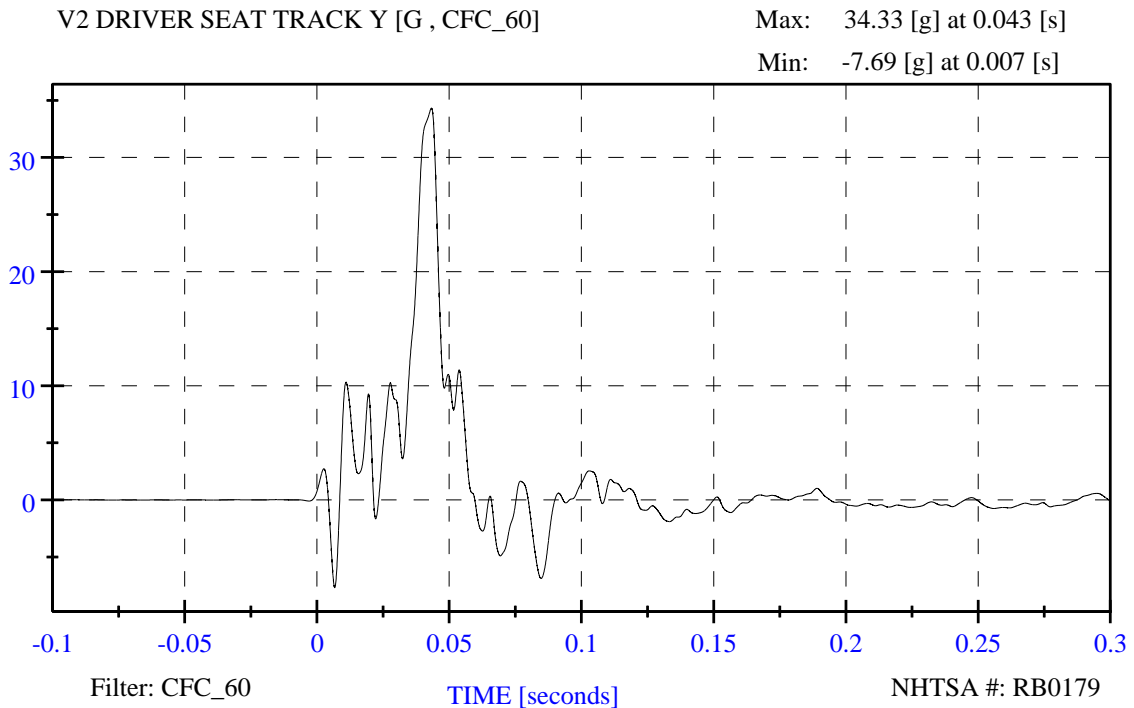

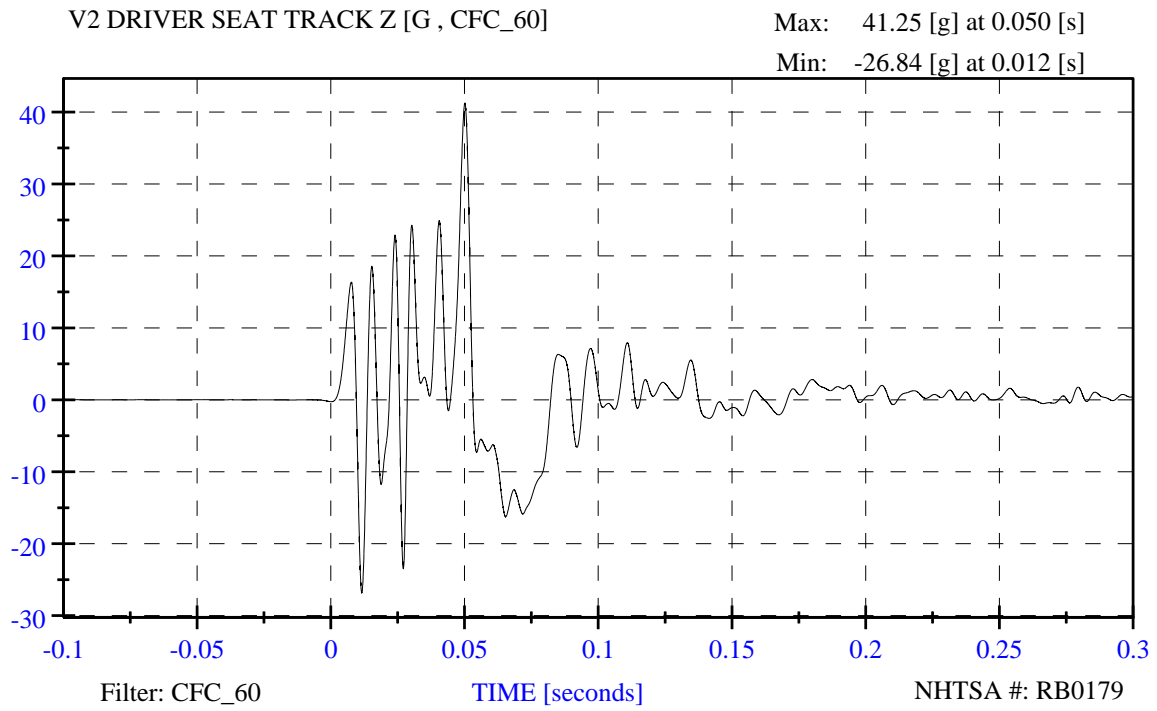

R&D 56 mph, 15deg angle, 35% overlap, 2011 Buick Lacrosse, RB0179

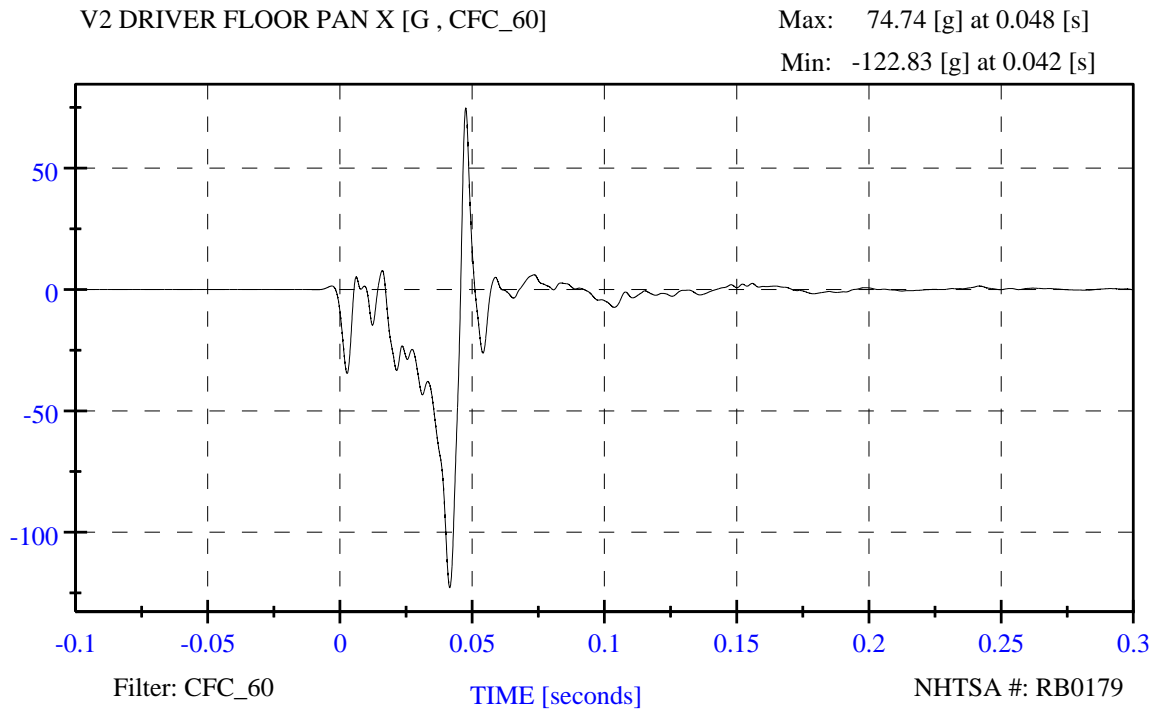

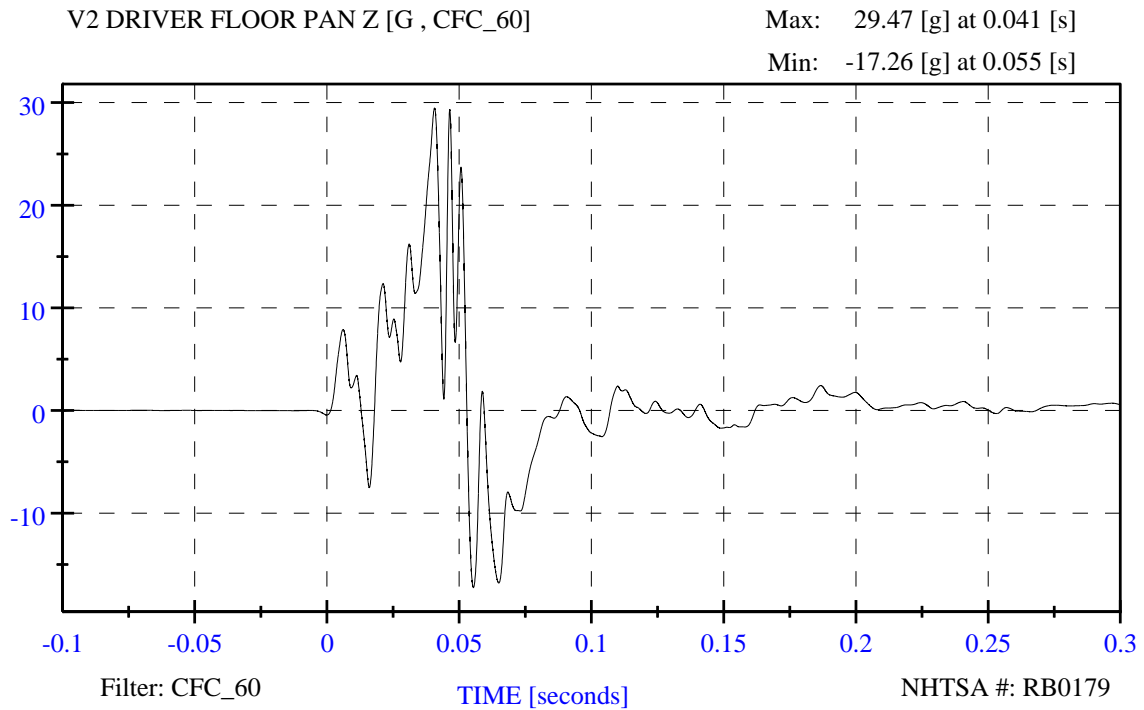
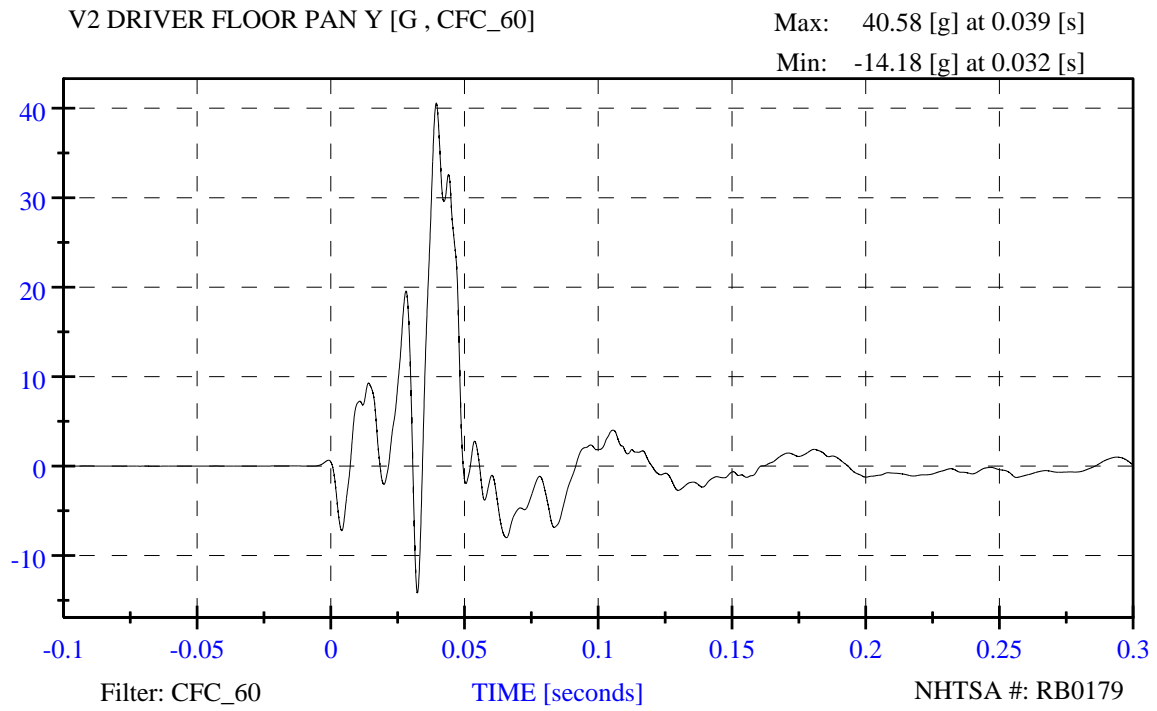

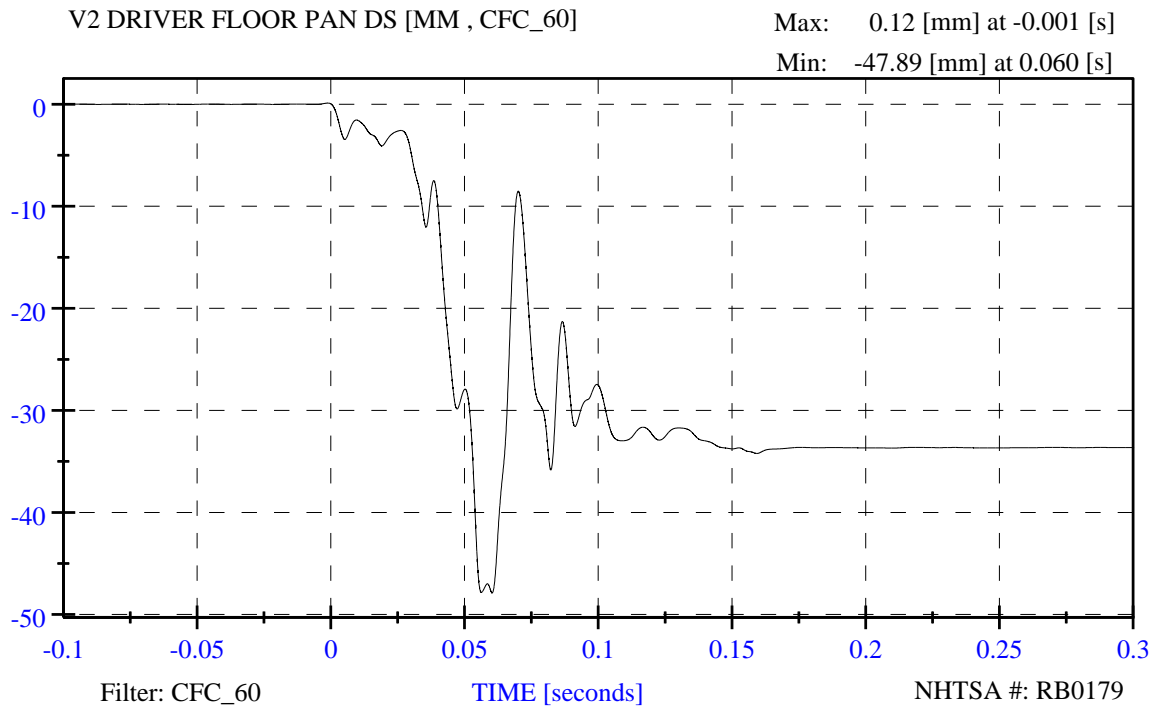

R&D 56 mph, 15deg angle, 35% overlap, 2011 Buick Lacrosse, RB0179

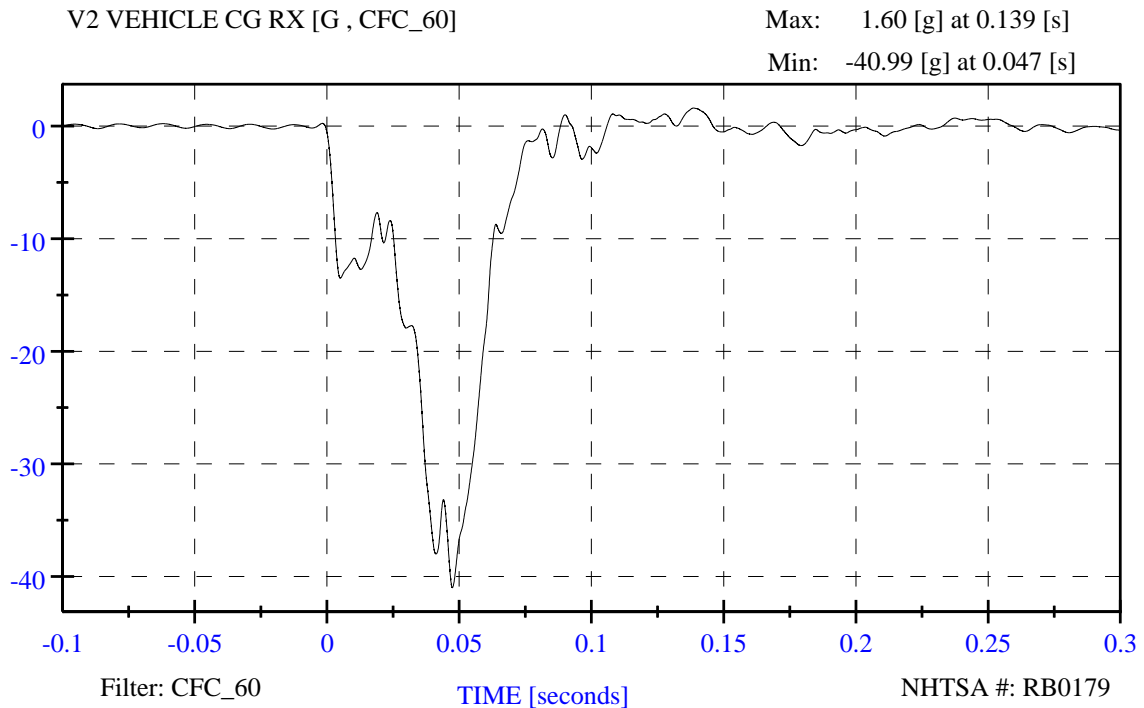

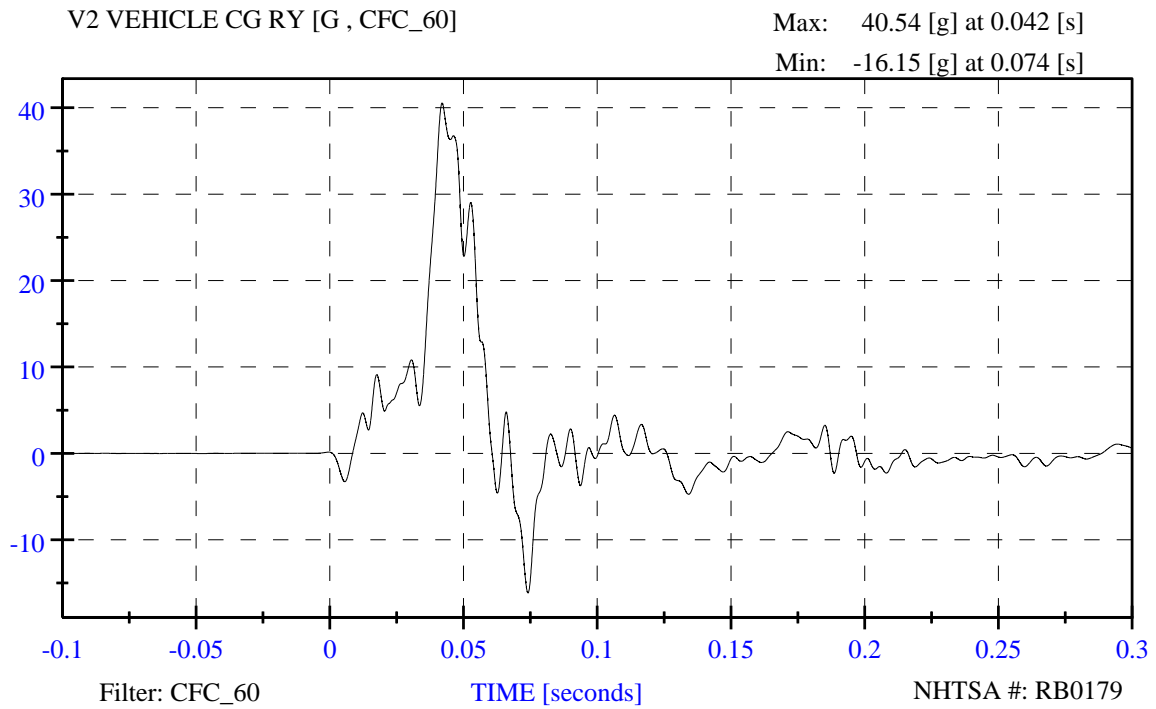

R&D 56 mph, 15deg angle, 35% overlap, 2011 Buick Lacrosse, RB0179

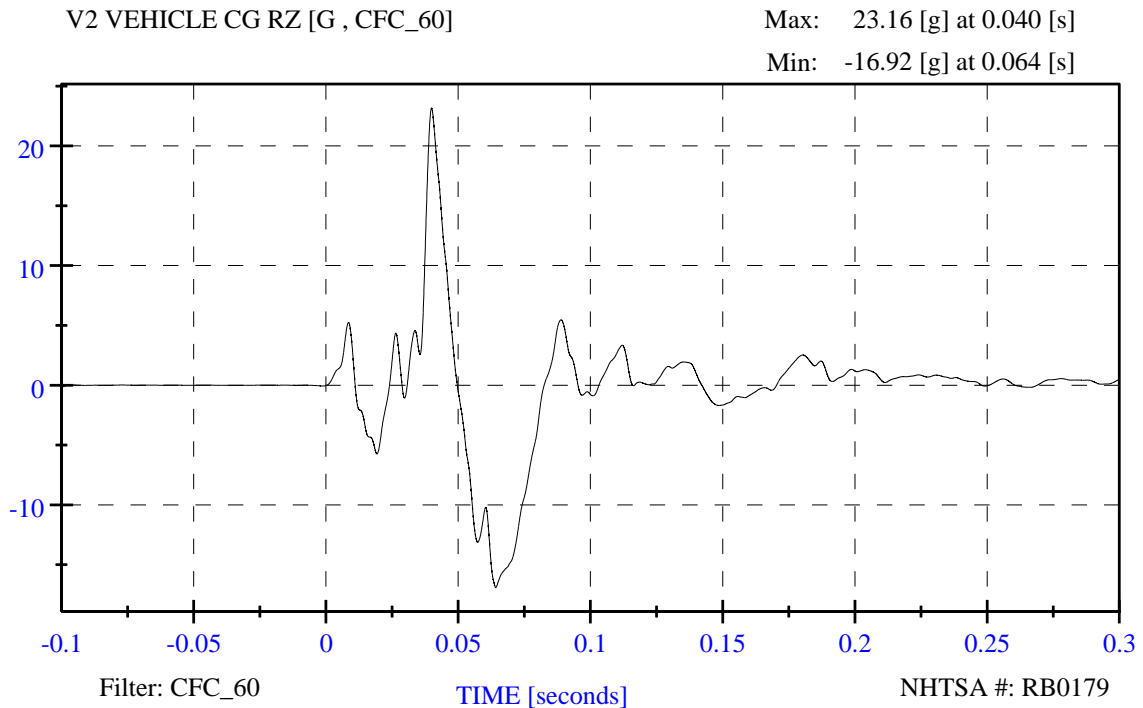

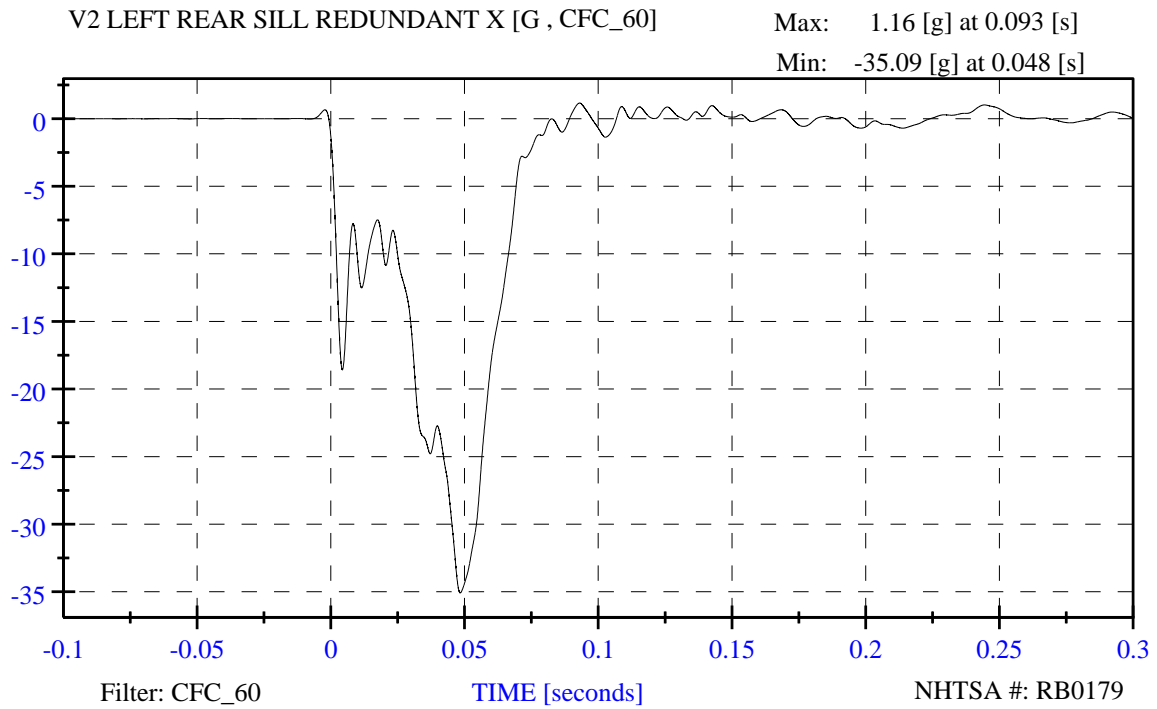

R&D 56 mph, 15deg angle, 35% overlap, 2011 Buick Lacrosse, RB0179

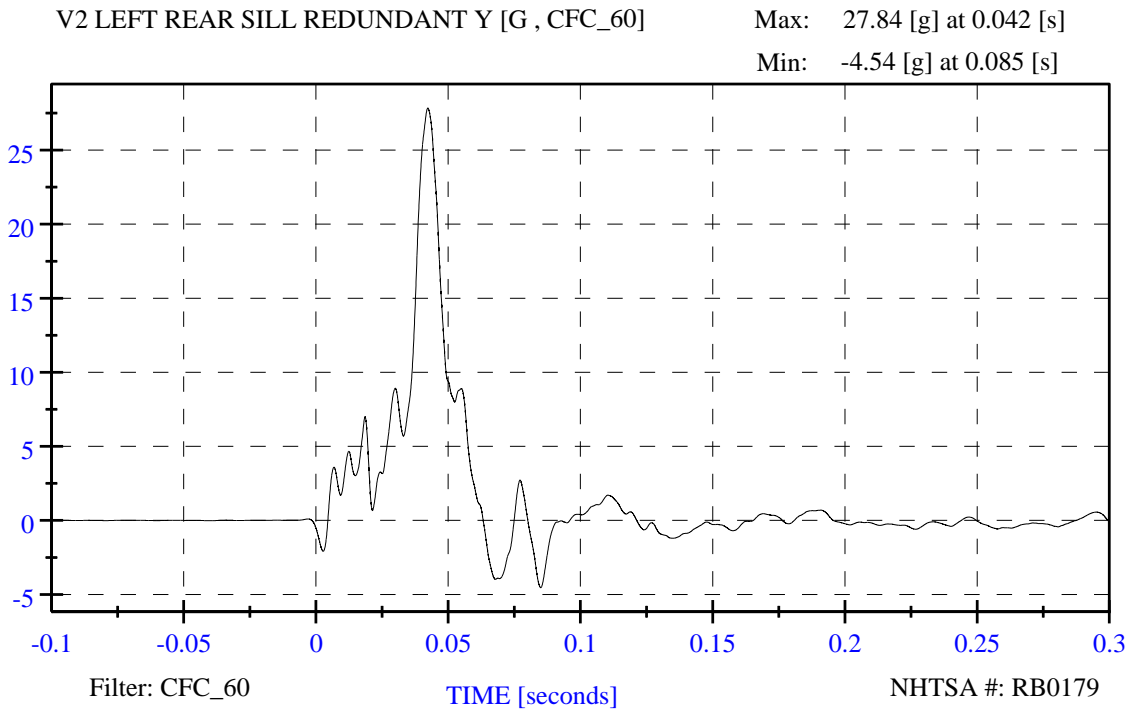

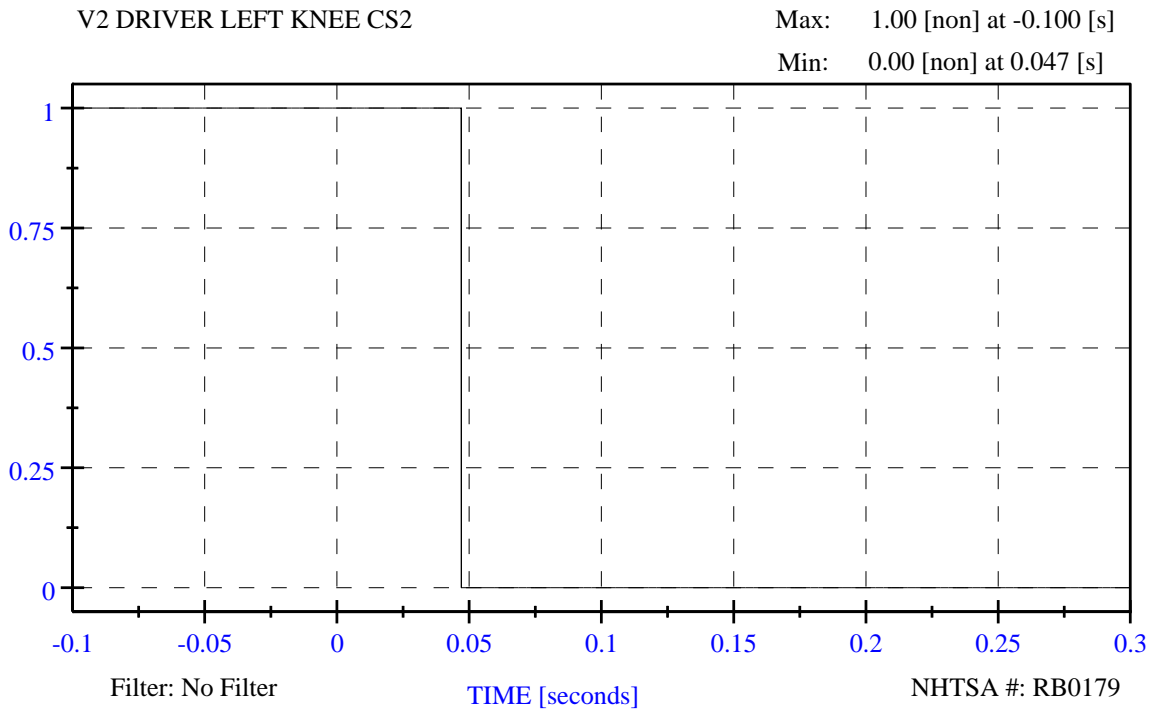
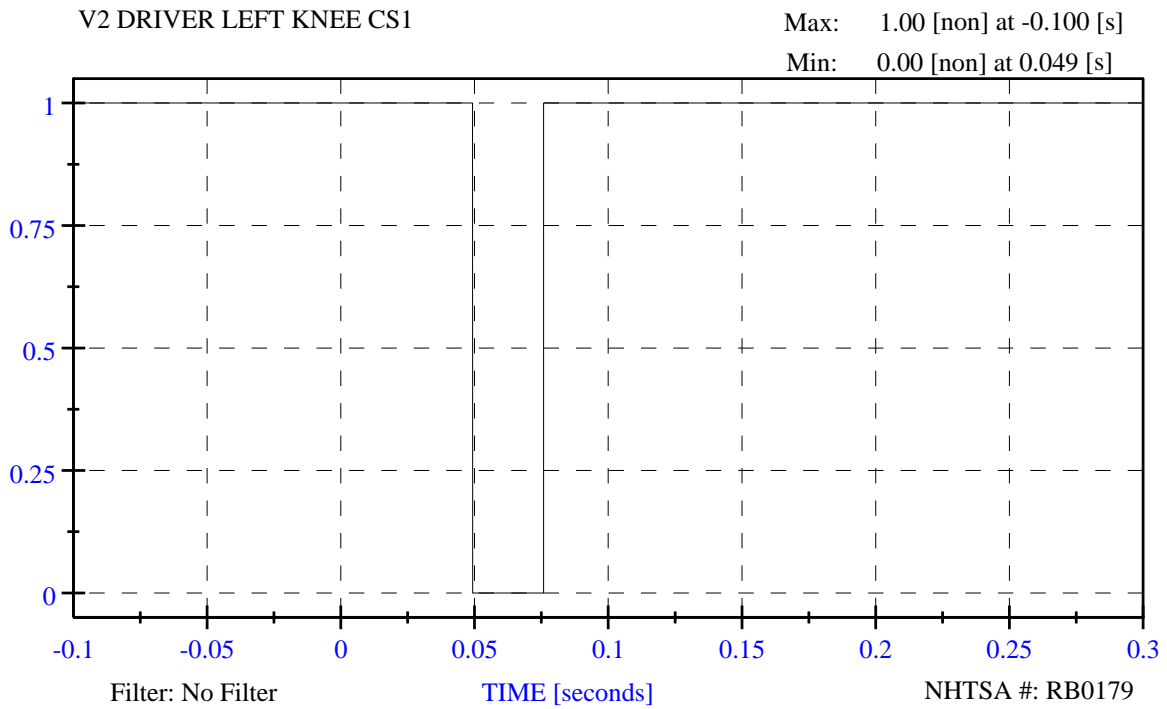

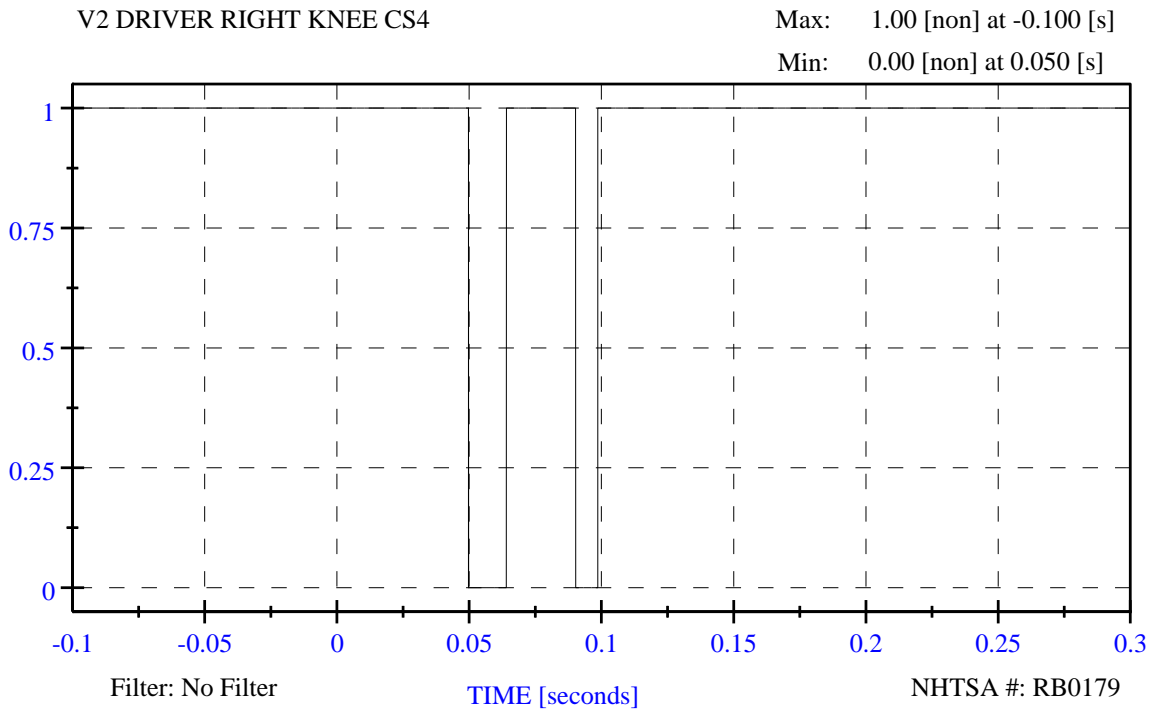
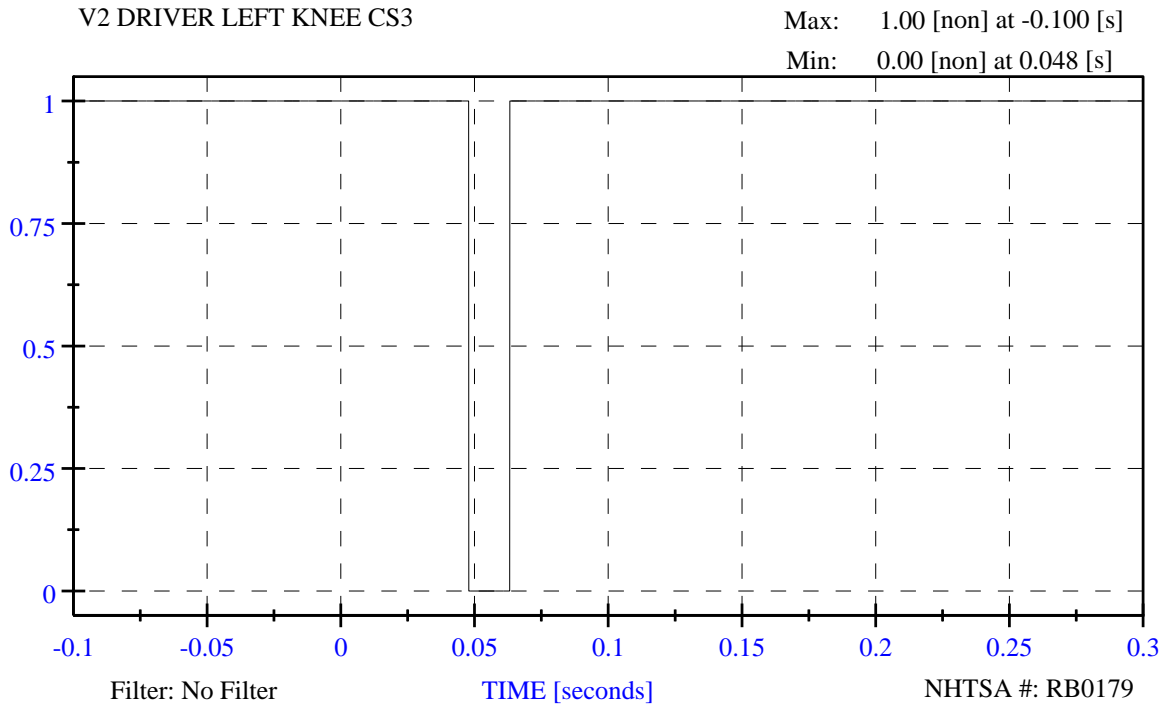

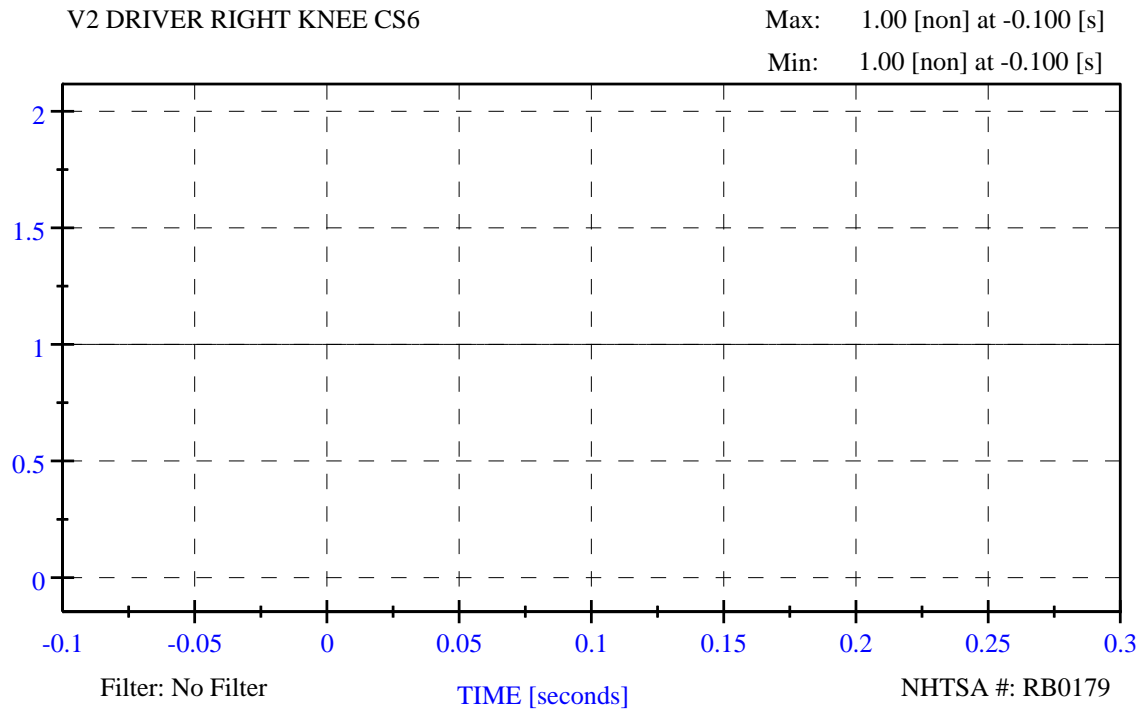
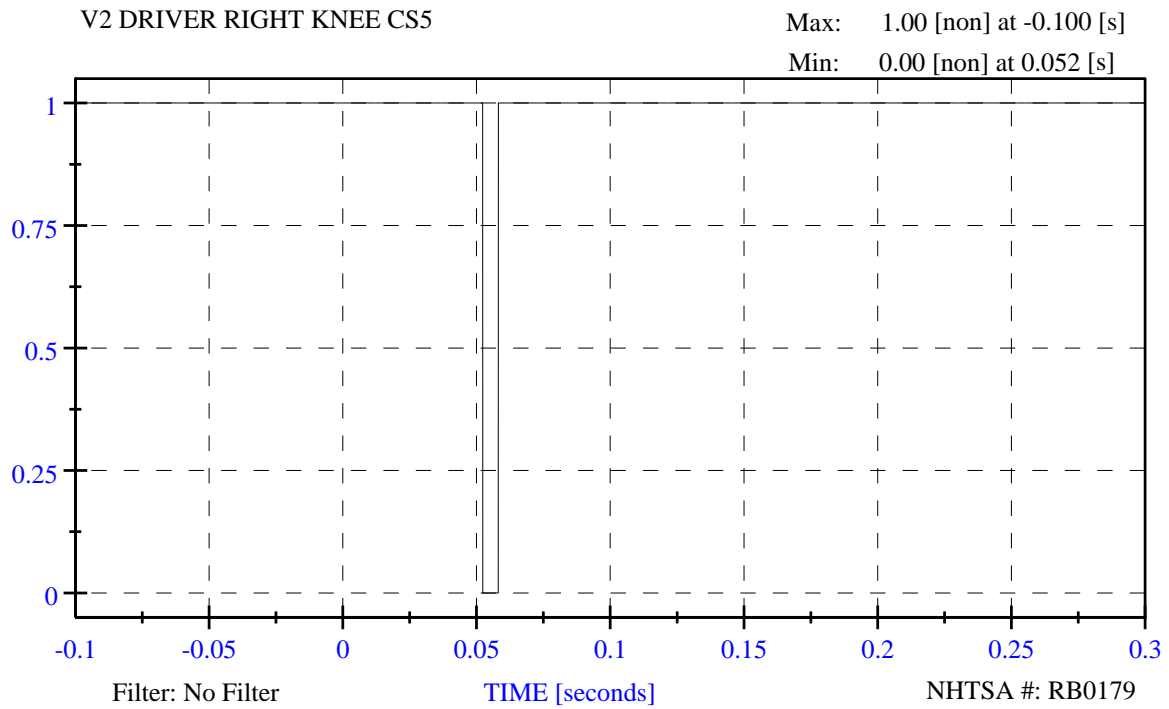

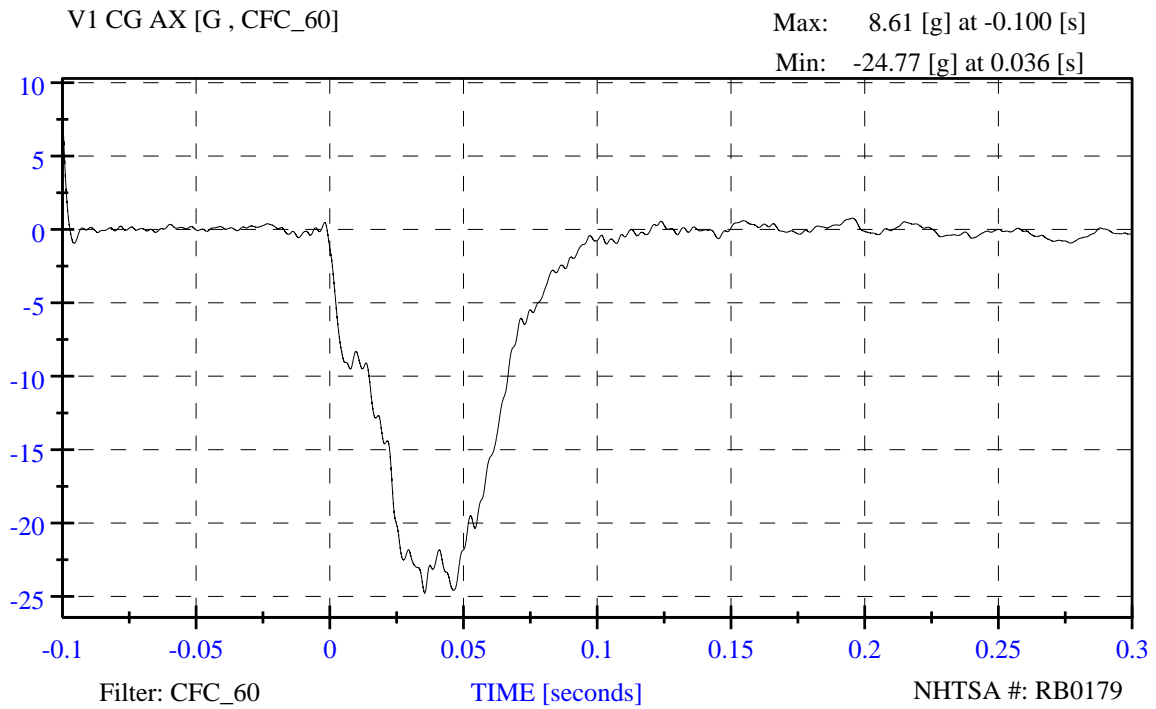

R&D 56 mph, 15deg angle, 35% overlap, 2011 Buick Lacrosse, RB0179

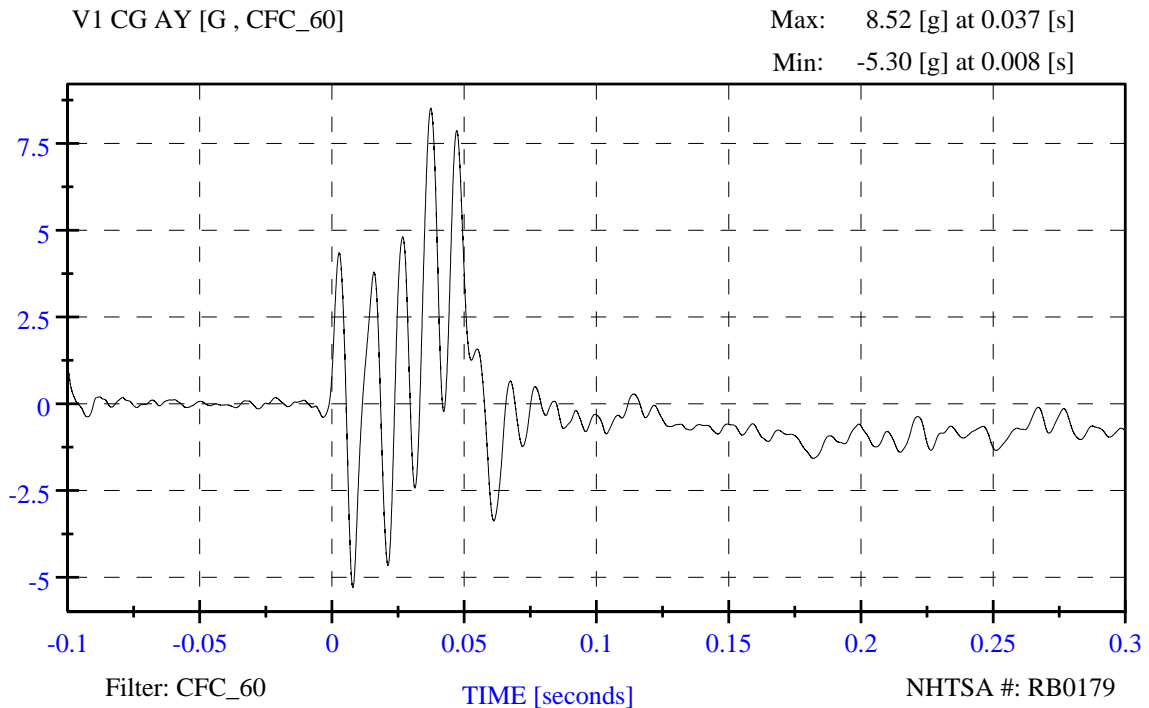

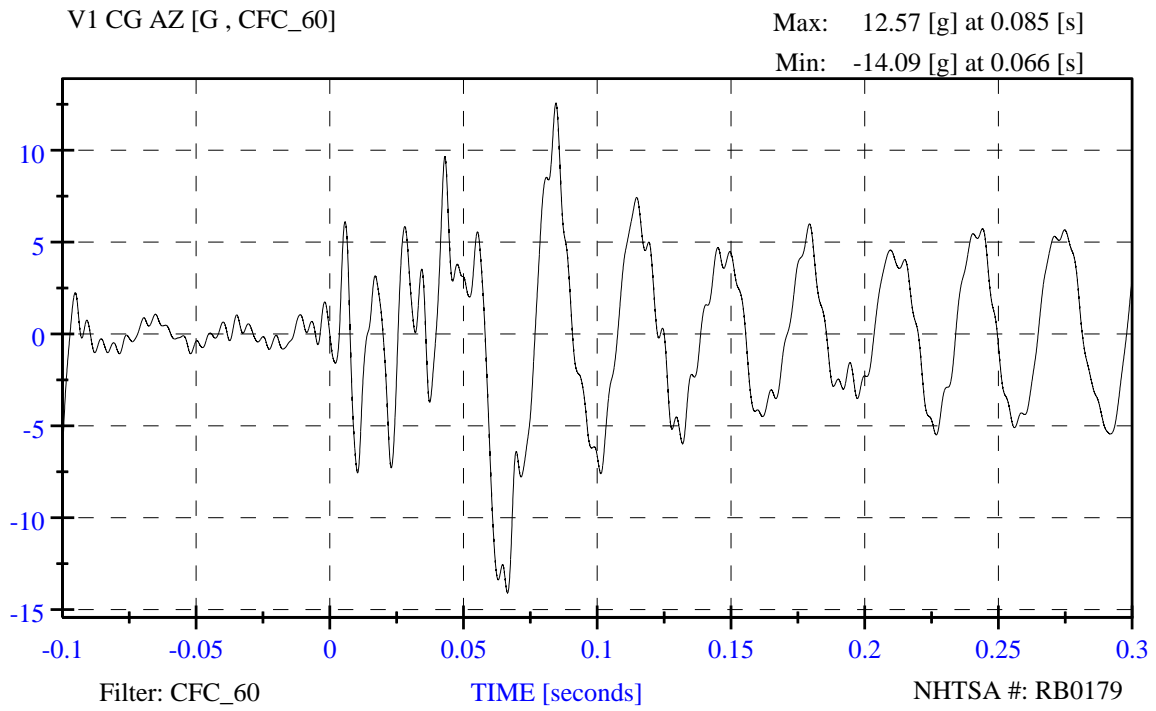

R&D 56 mph, 15deg angle, 35% overlap, 2011 Buick Lacrosse, RB0179

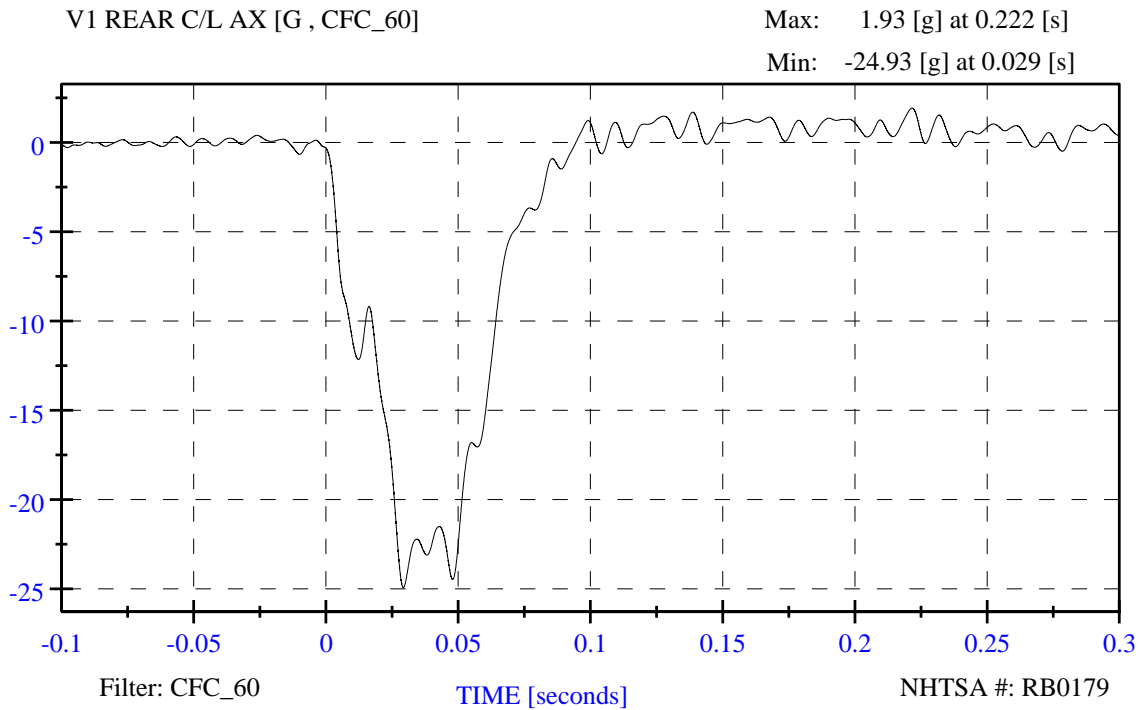

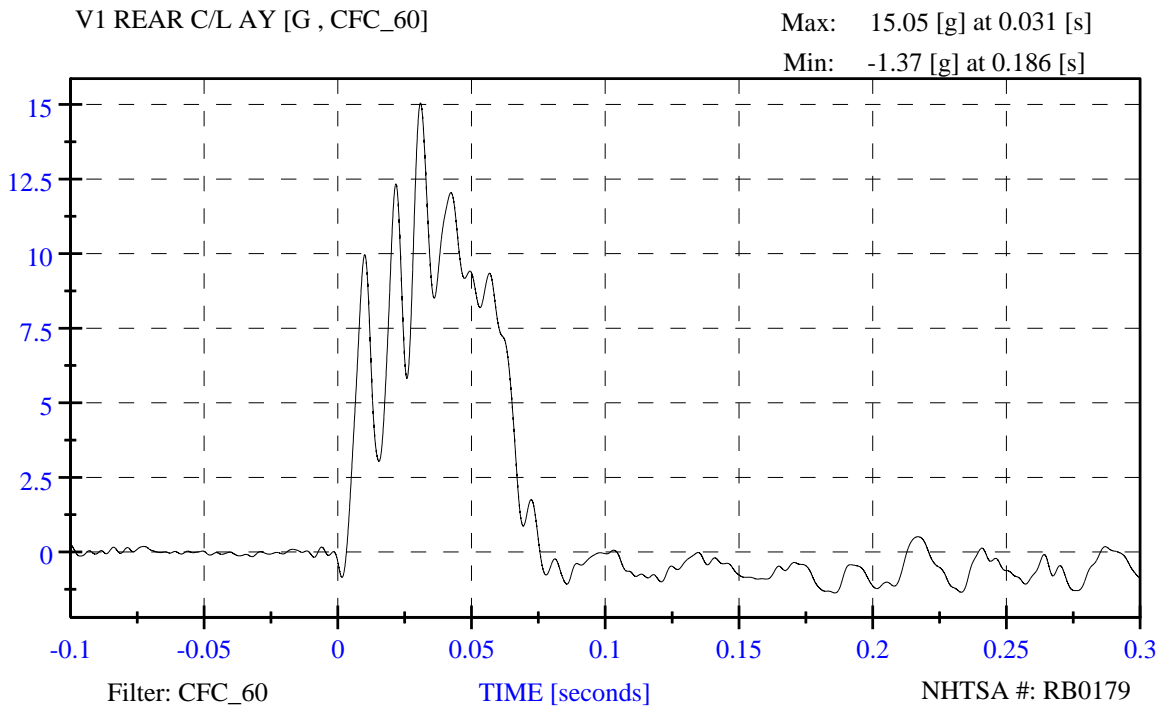

R&D 56 mph, 15deg angle, 35% overlap, 2011 Buick Lacrosse, RB0179

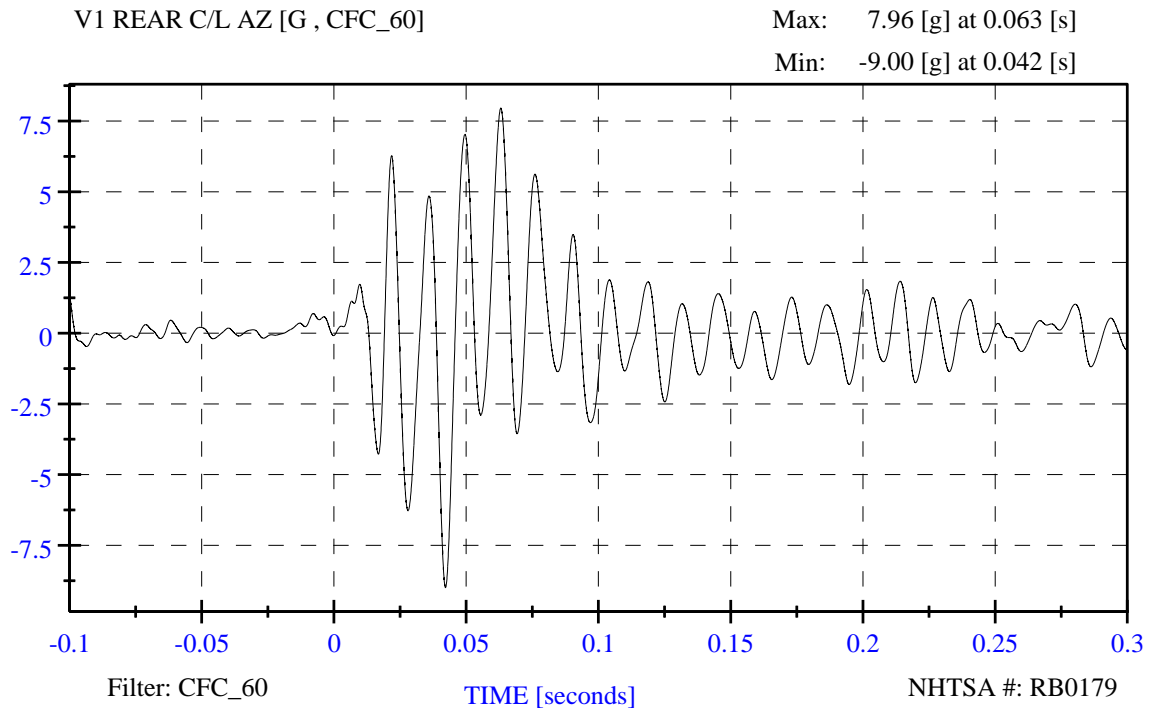

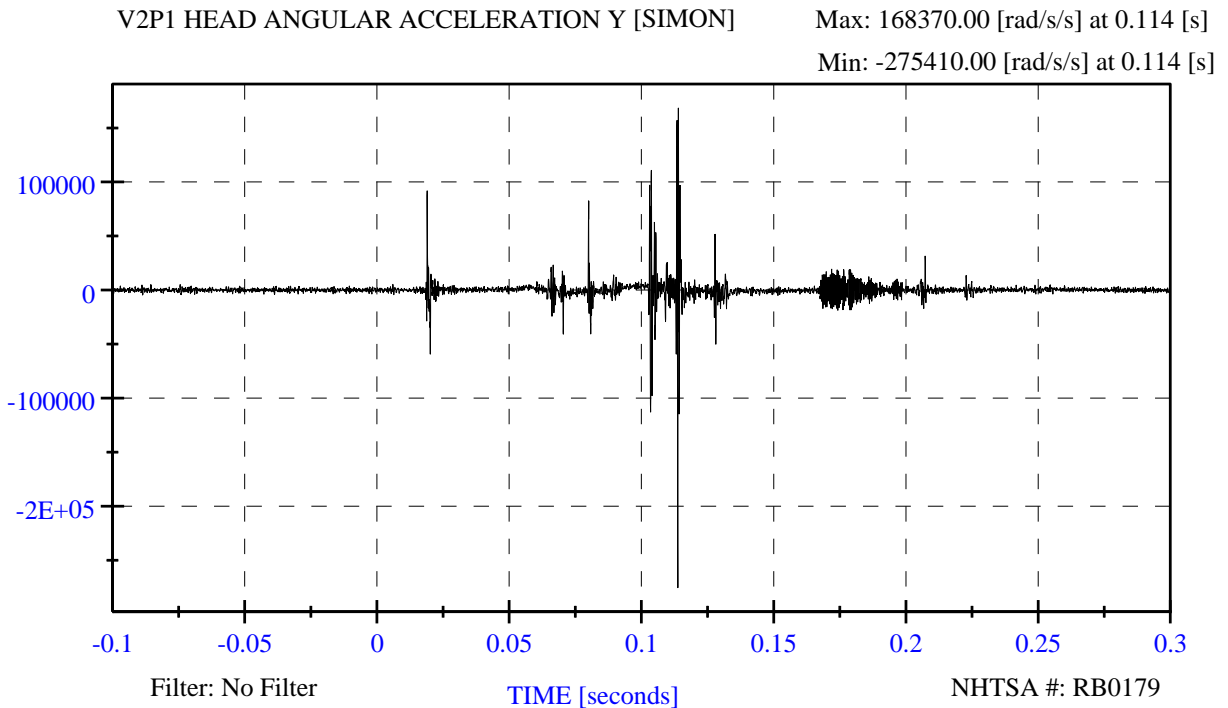
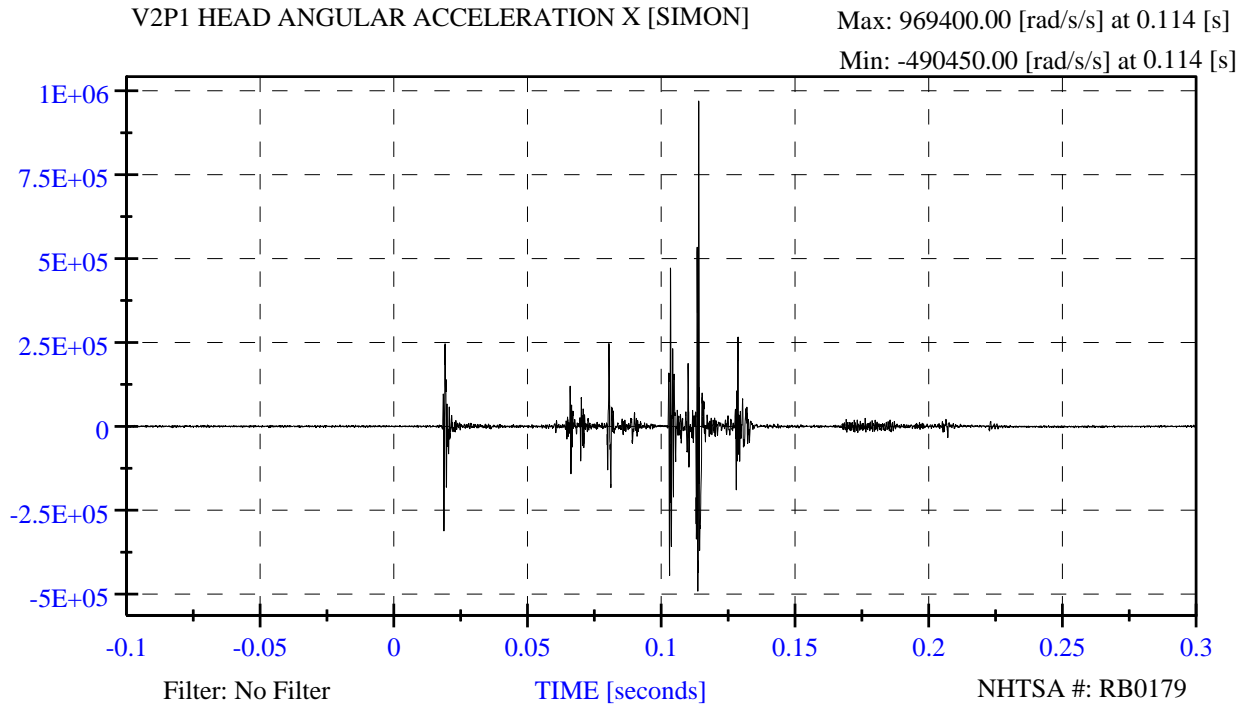

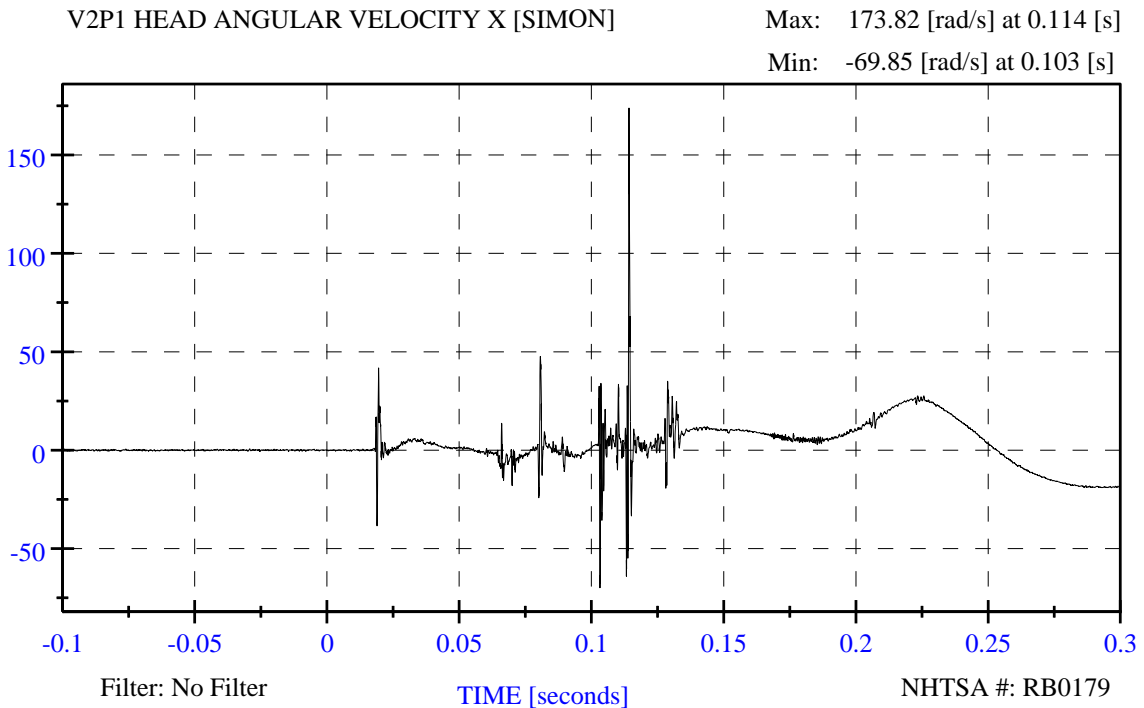
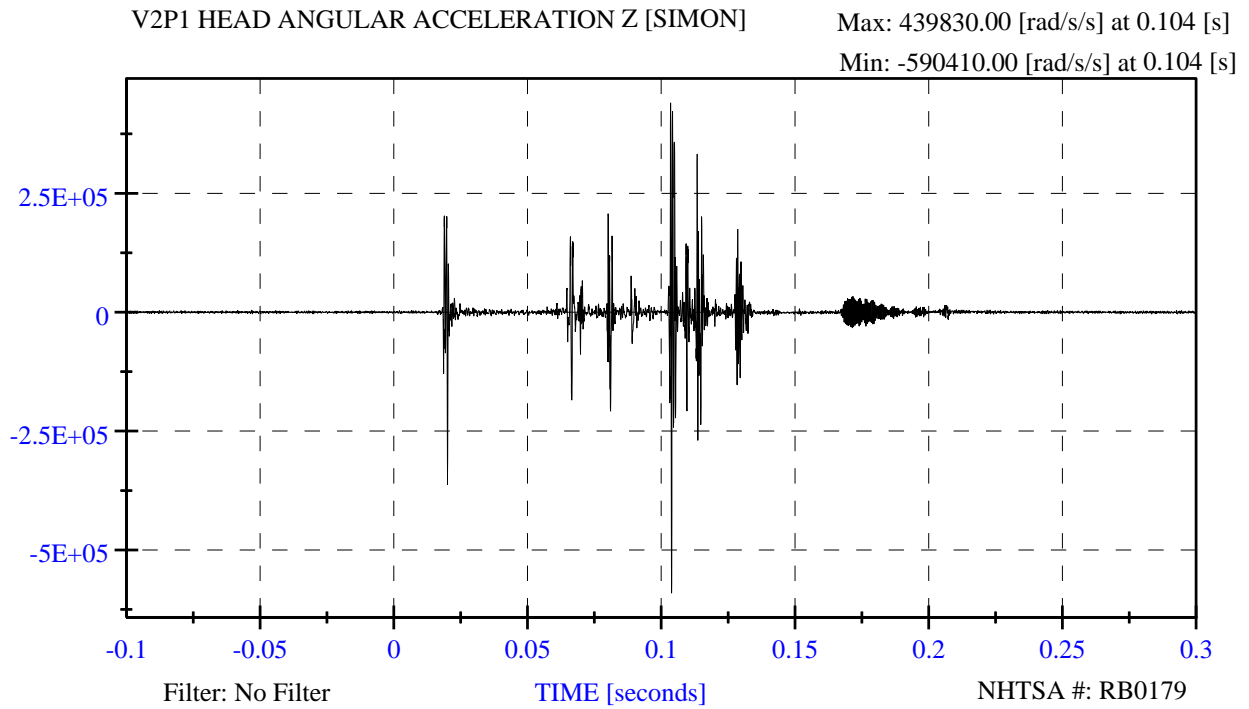

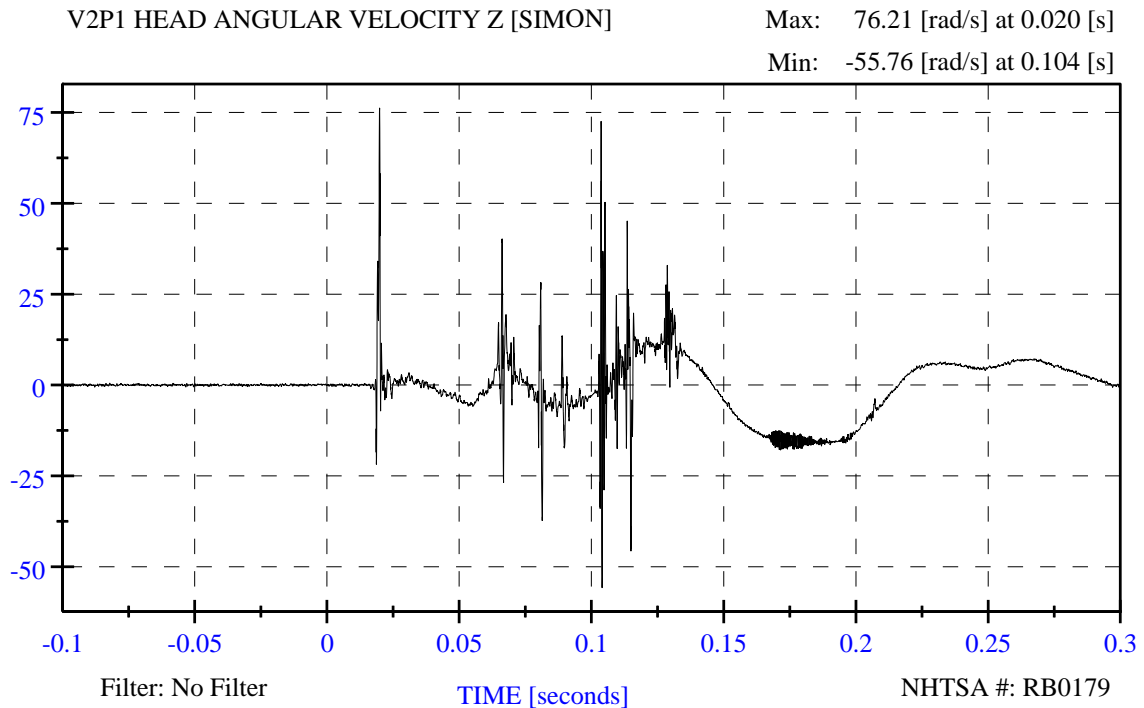
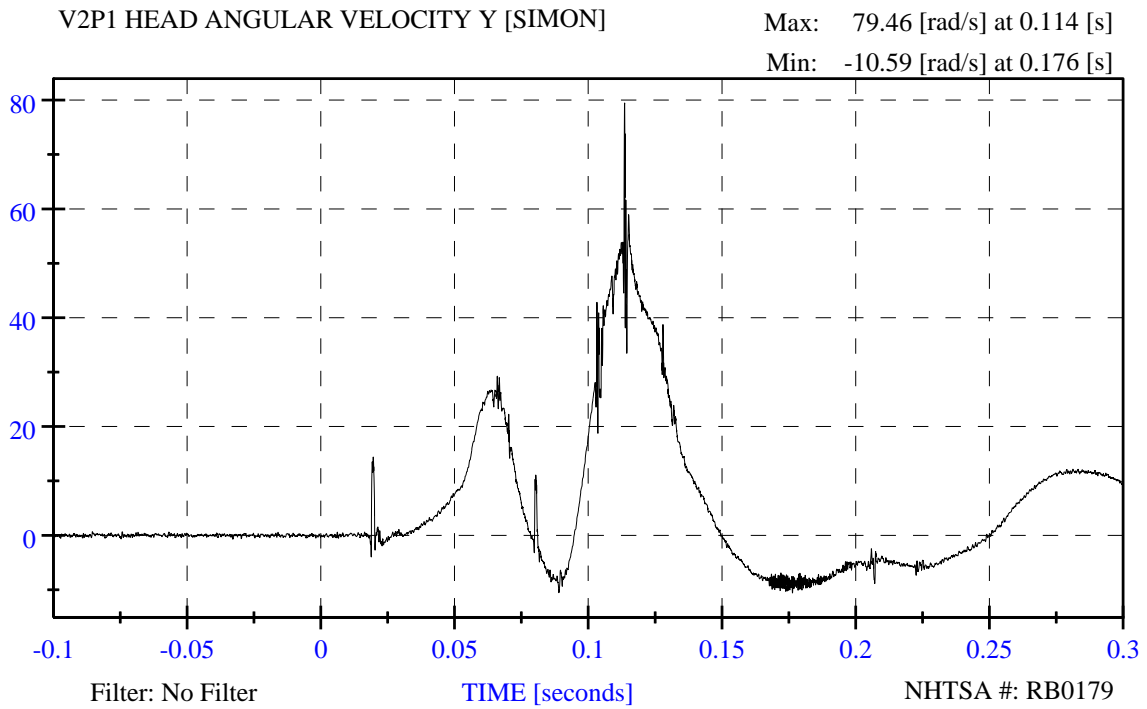

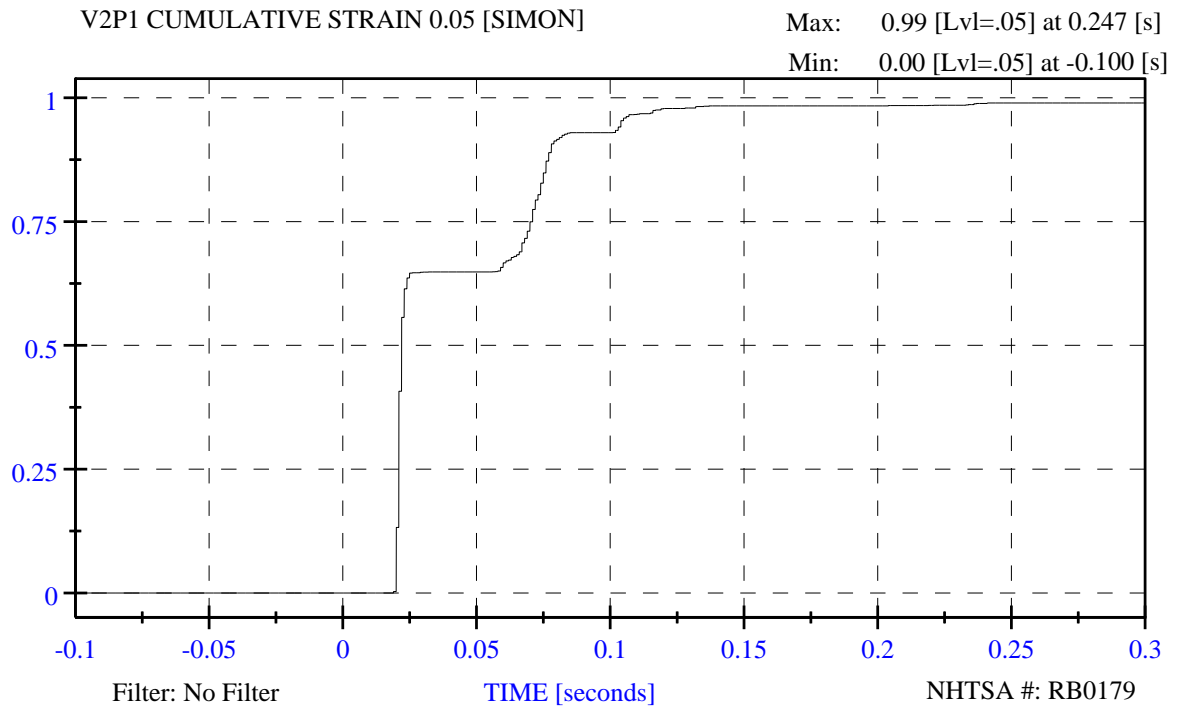

R&D 56 mph, 15deg angle, 35% overlap, 2011 Buick Lacrosse, RB0179

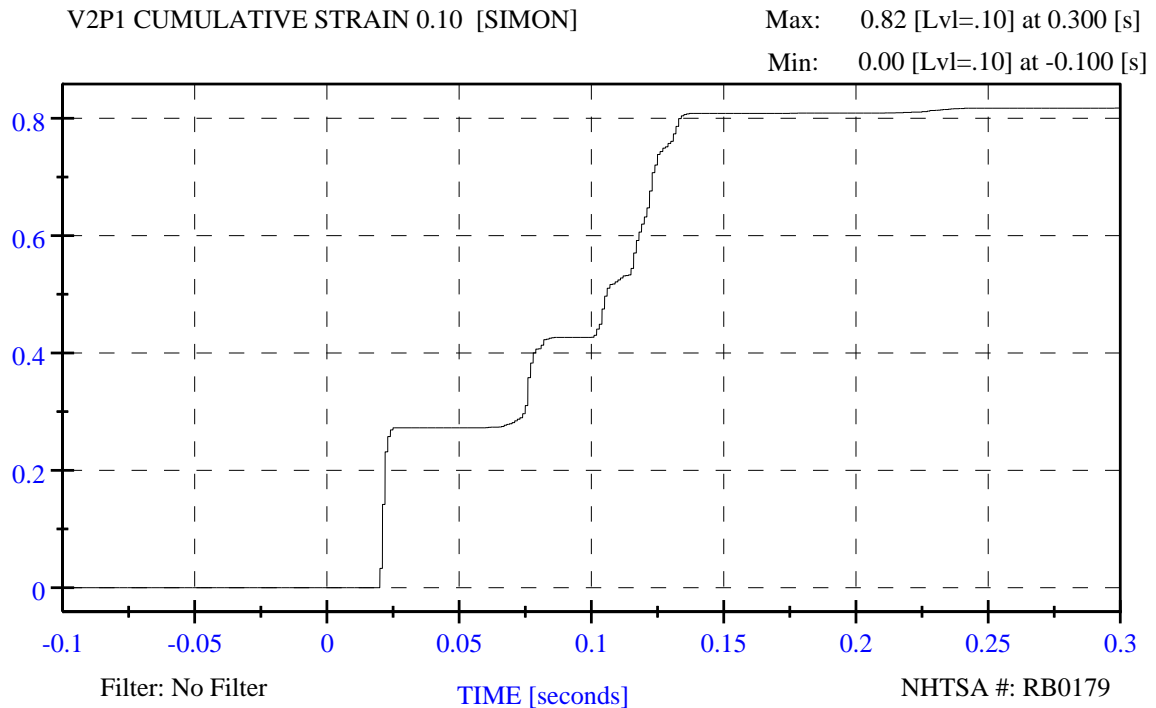

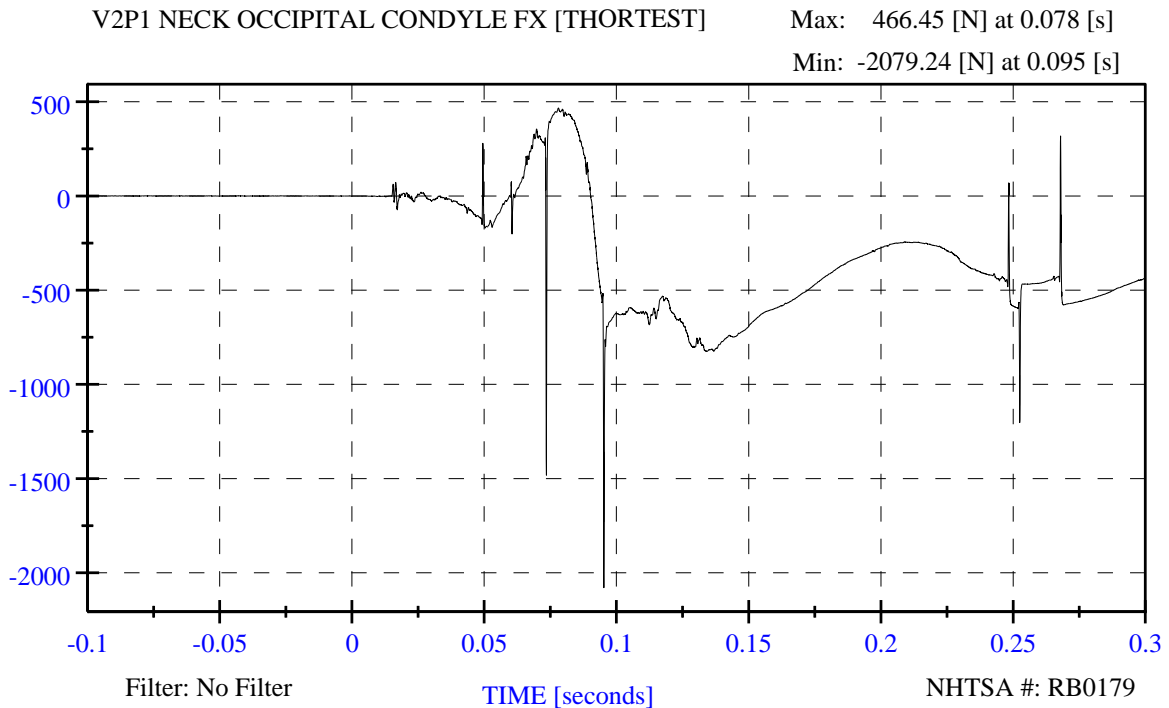
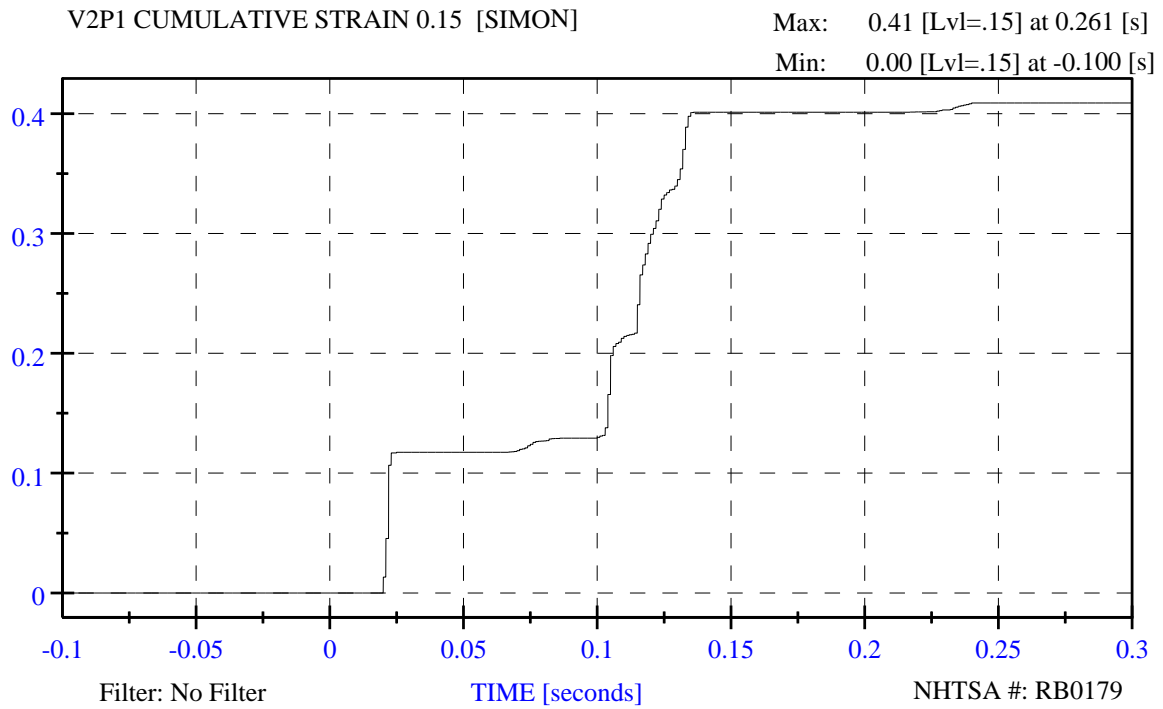

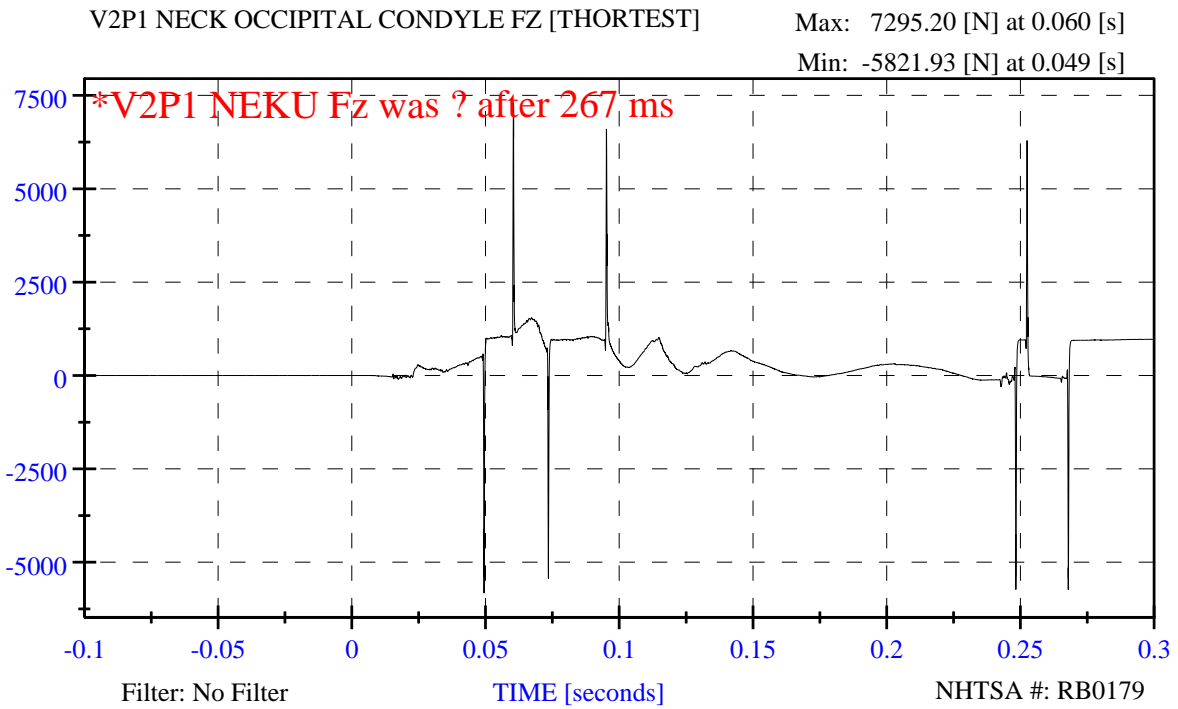

R&D 56 mph, 15deg angle, 35% overlap, 2011 Buick Lacrosse, RB0179

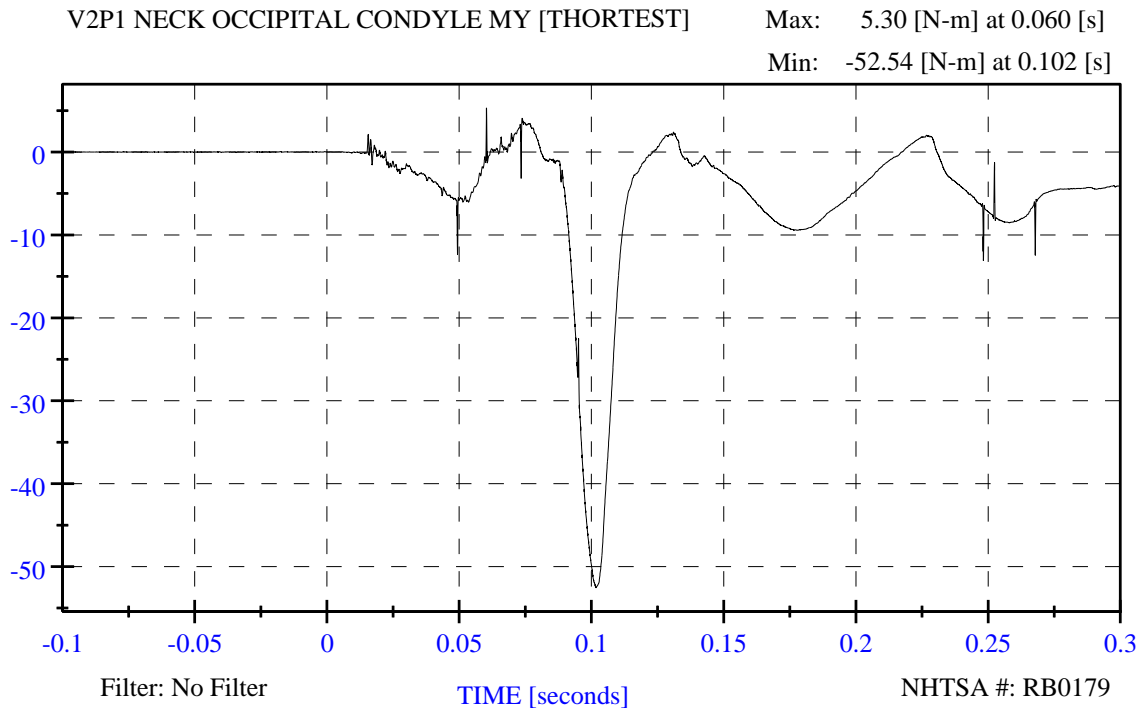

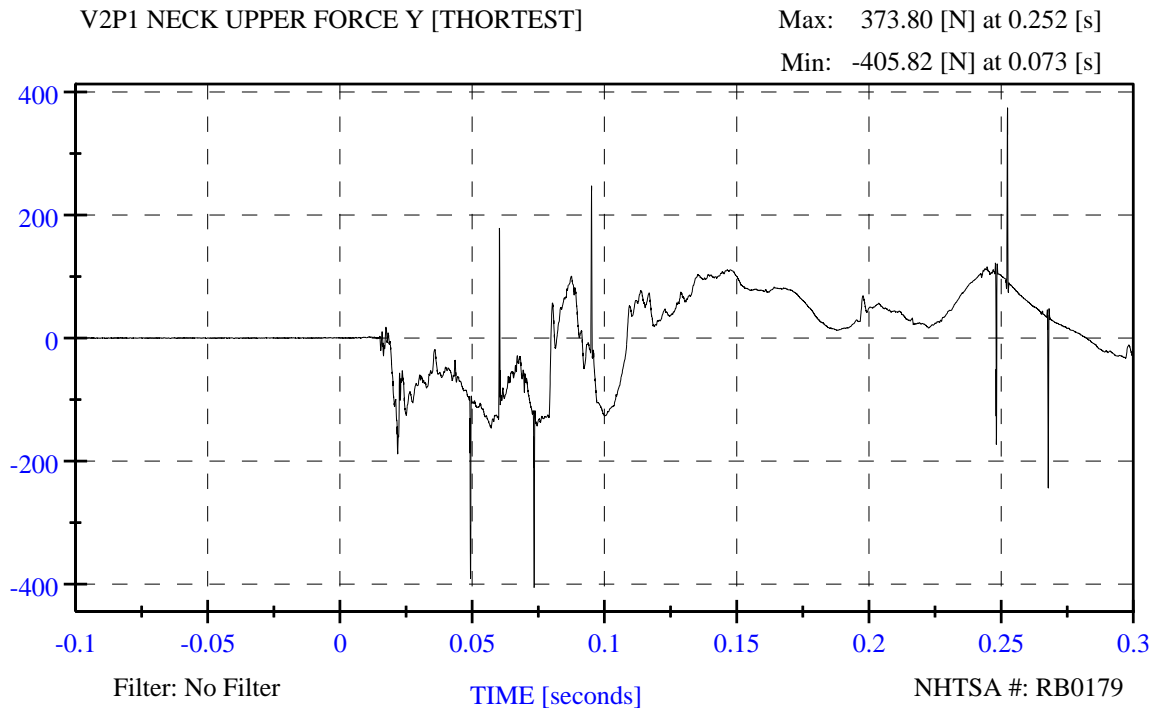
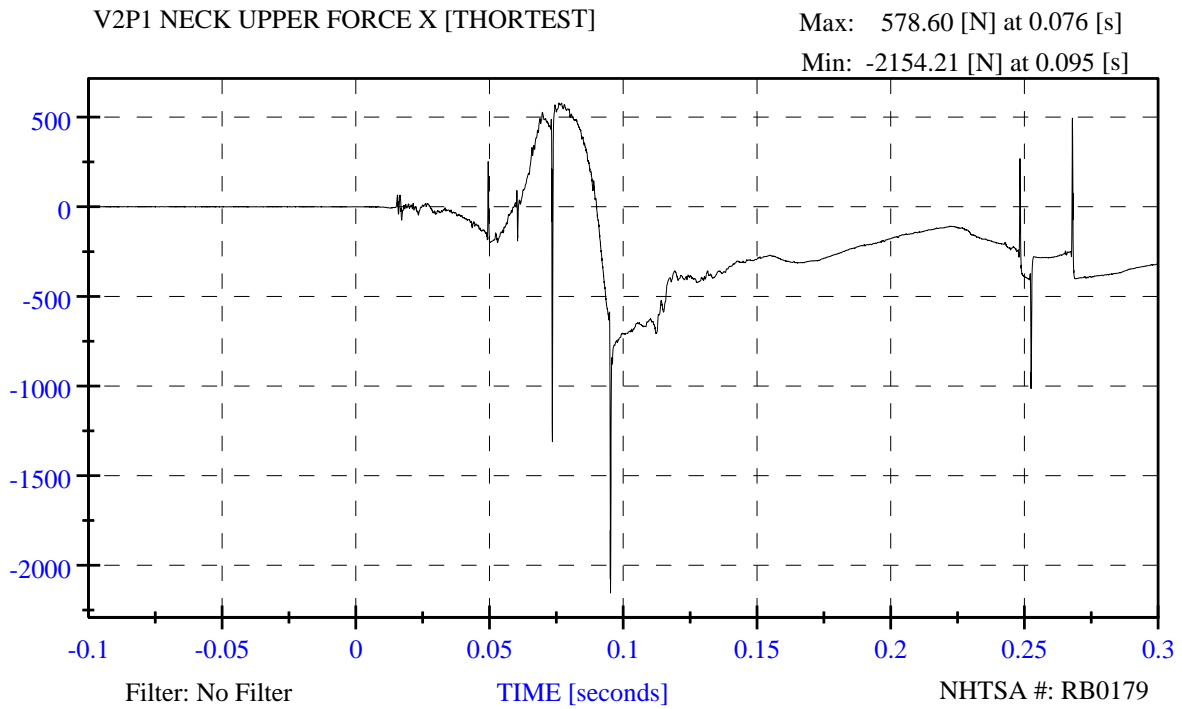

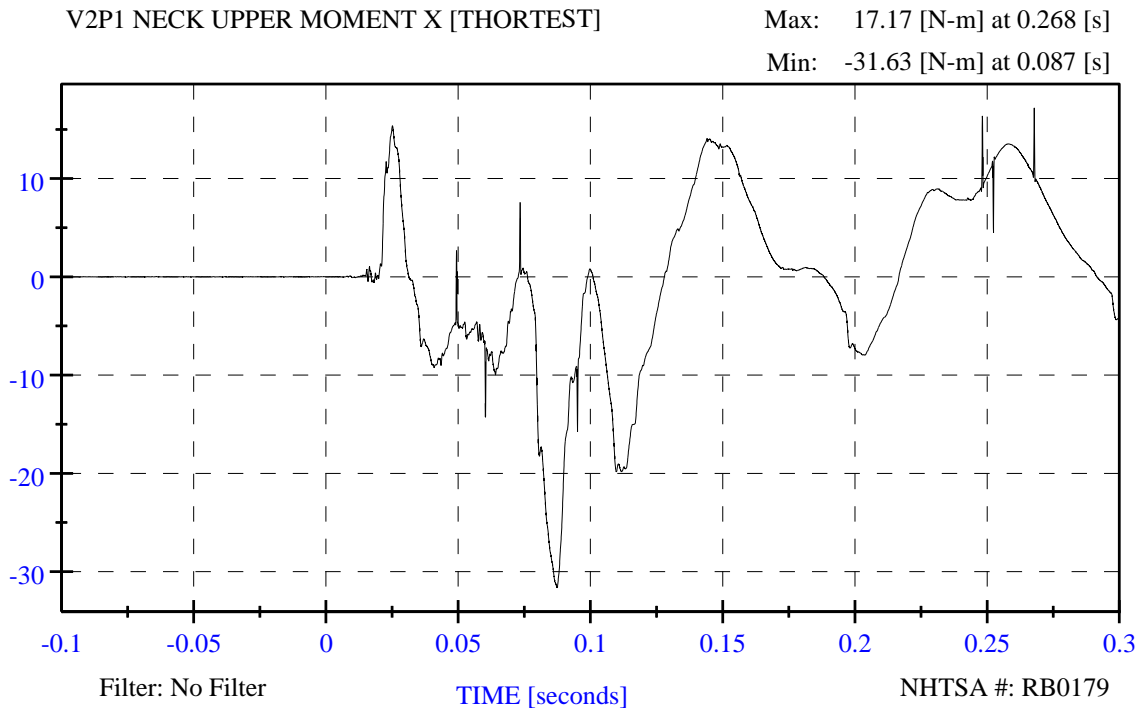
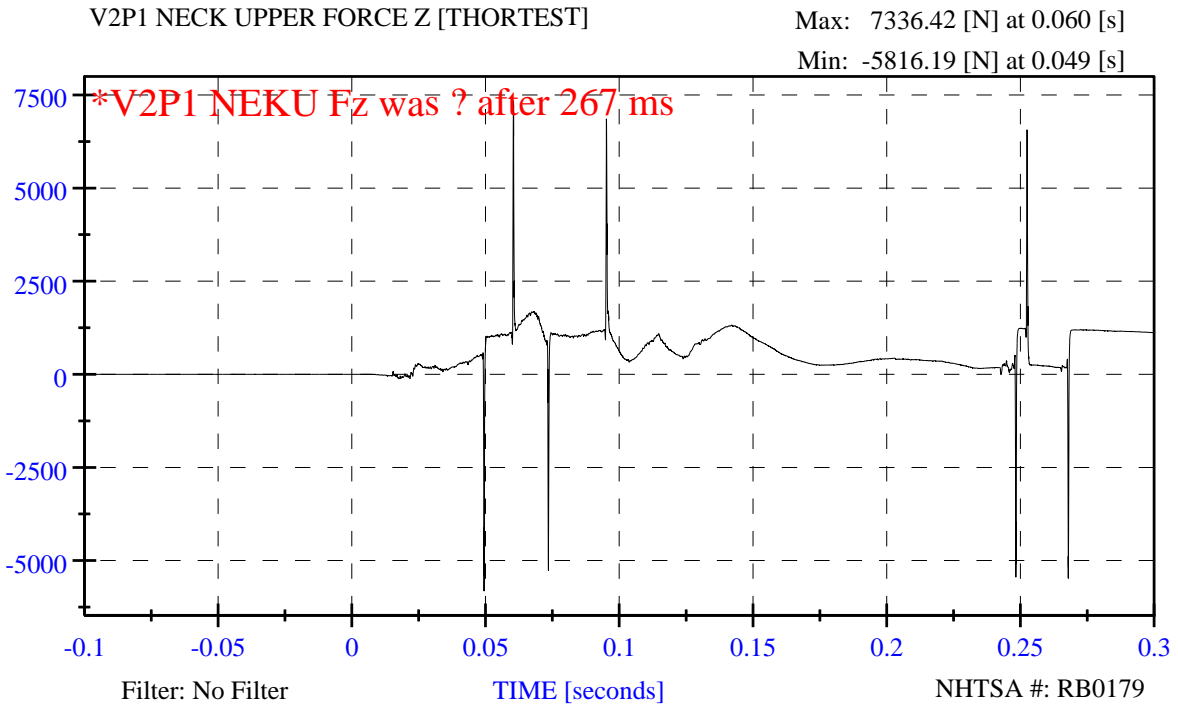

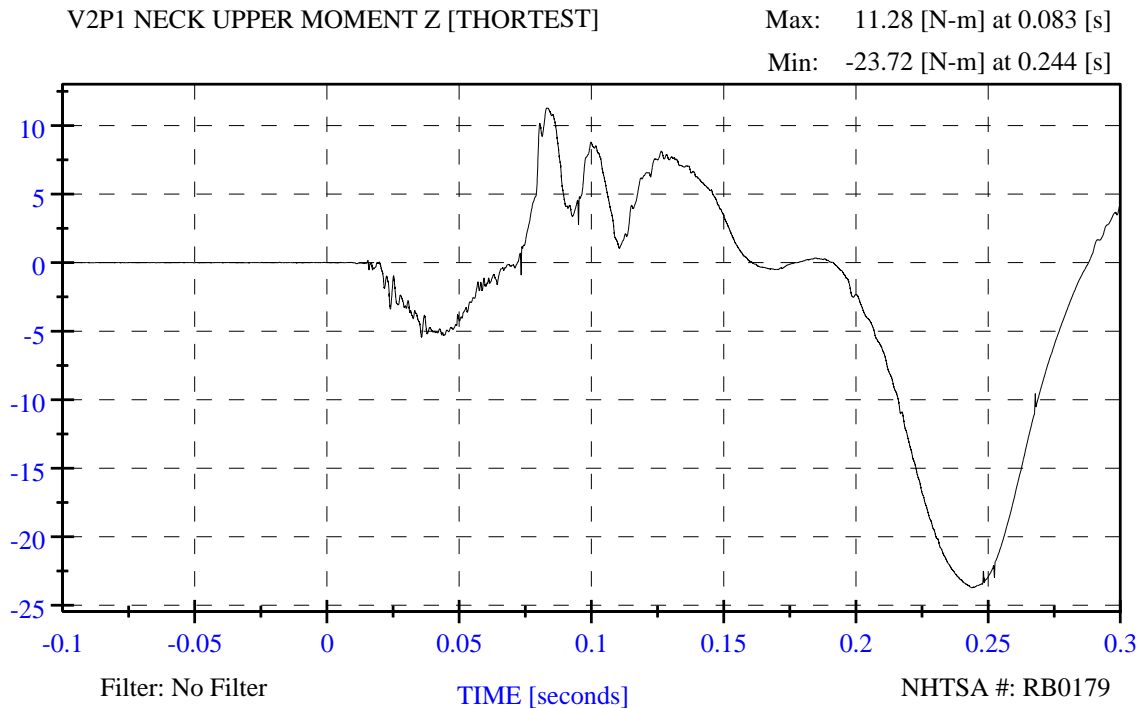
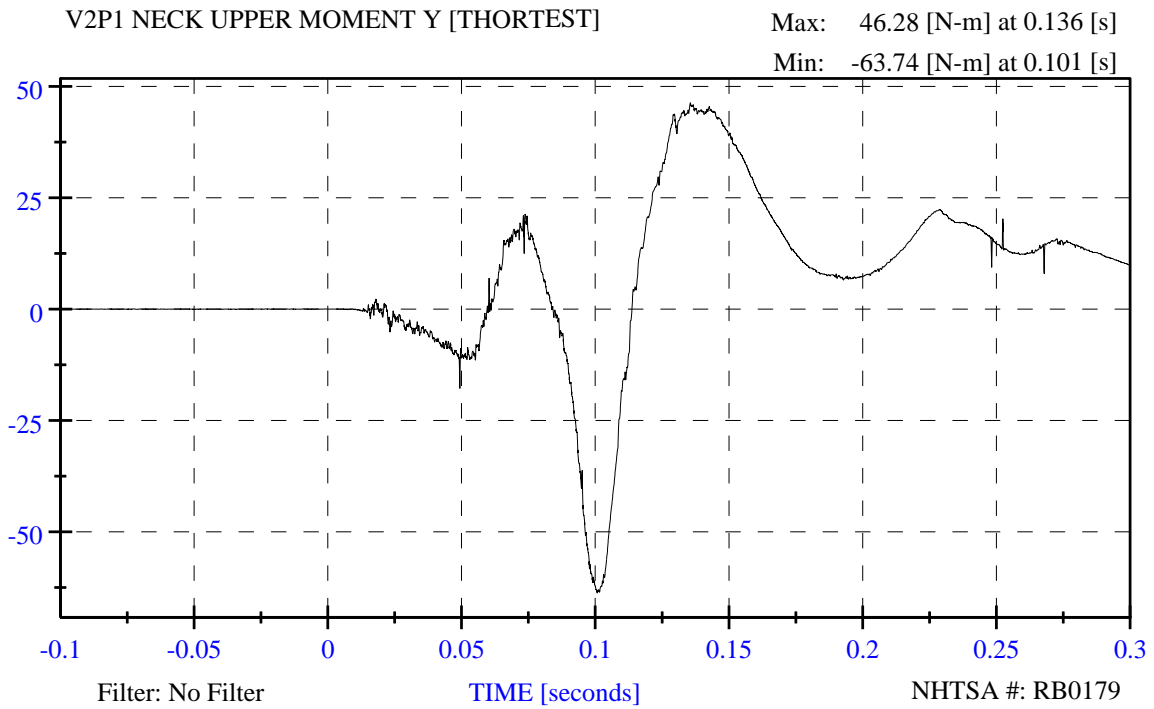

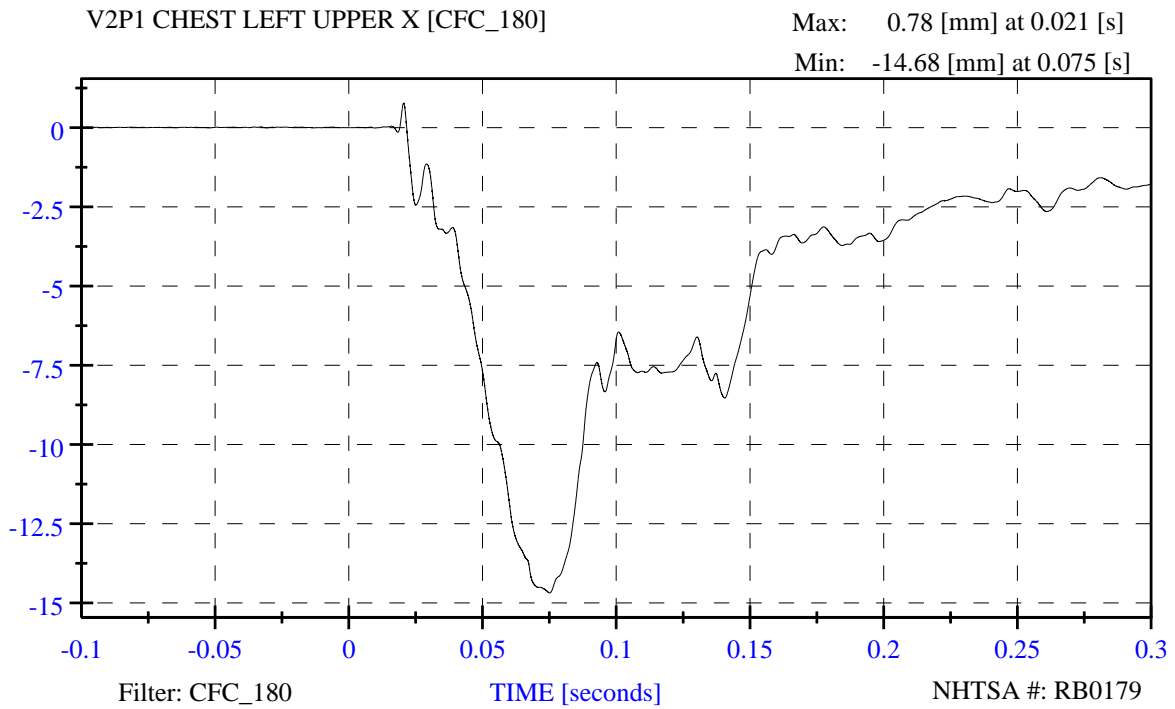

R&D 56 mph, 15deg angle, 35% overlap, 2011 Buick Lacrosse, RB0179

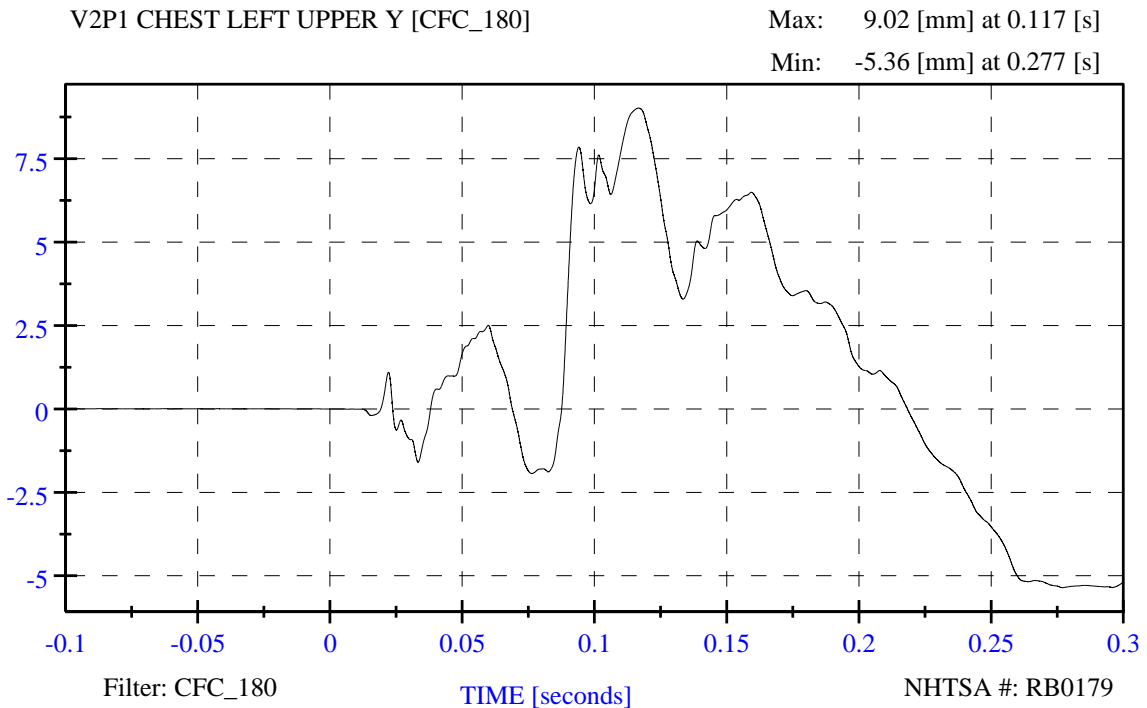

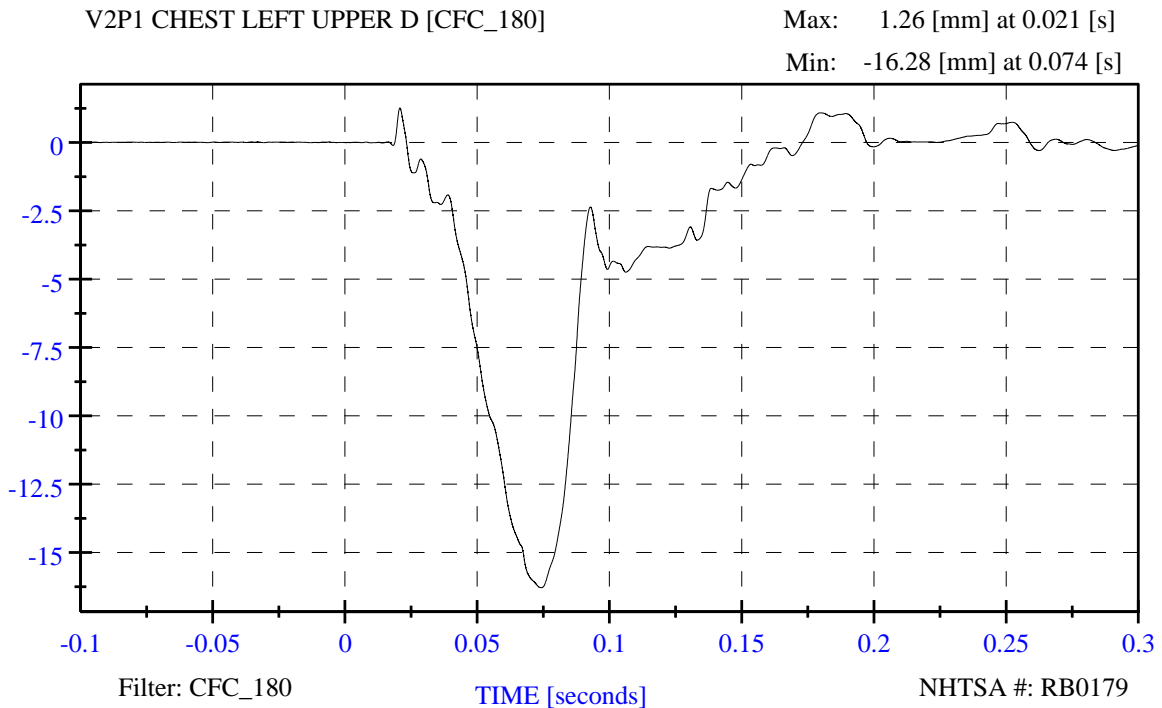
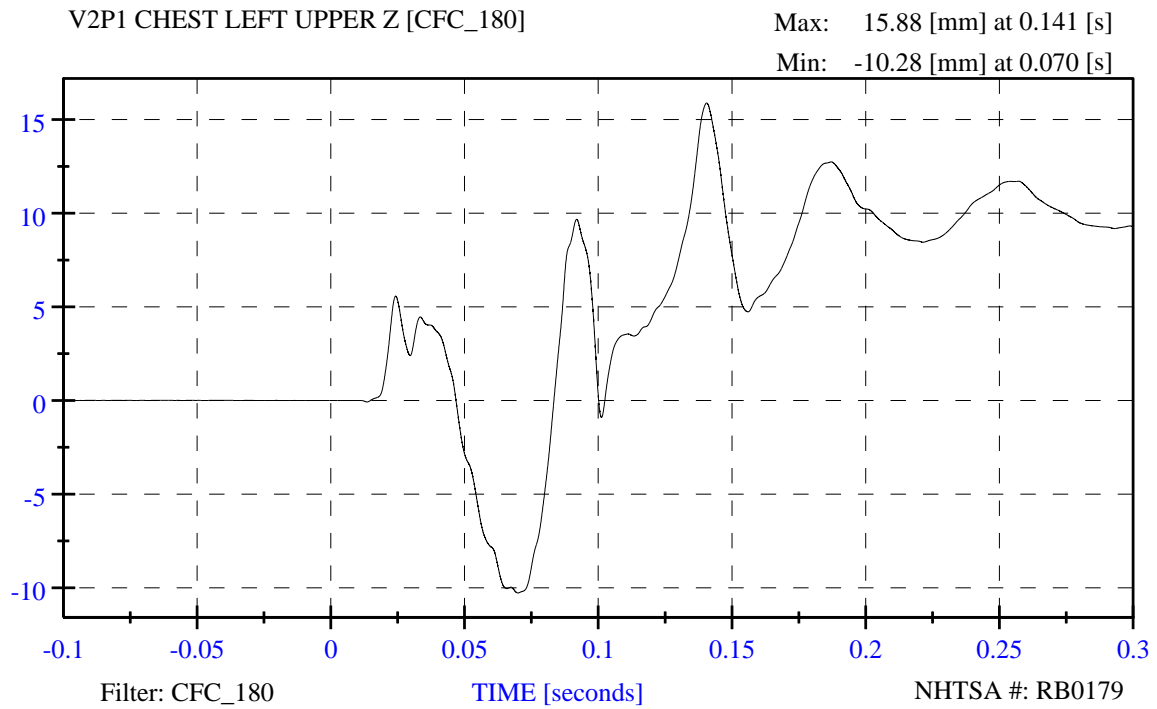

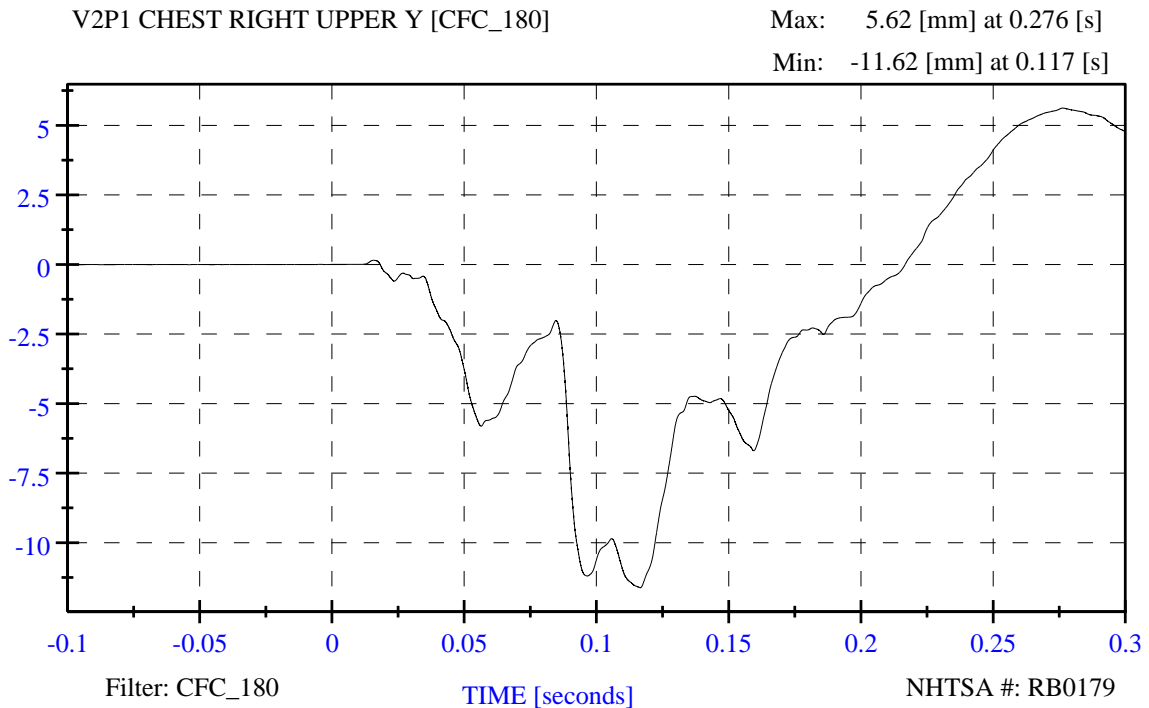
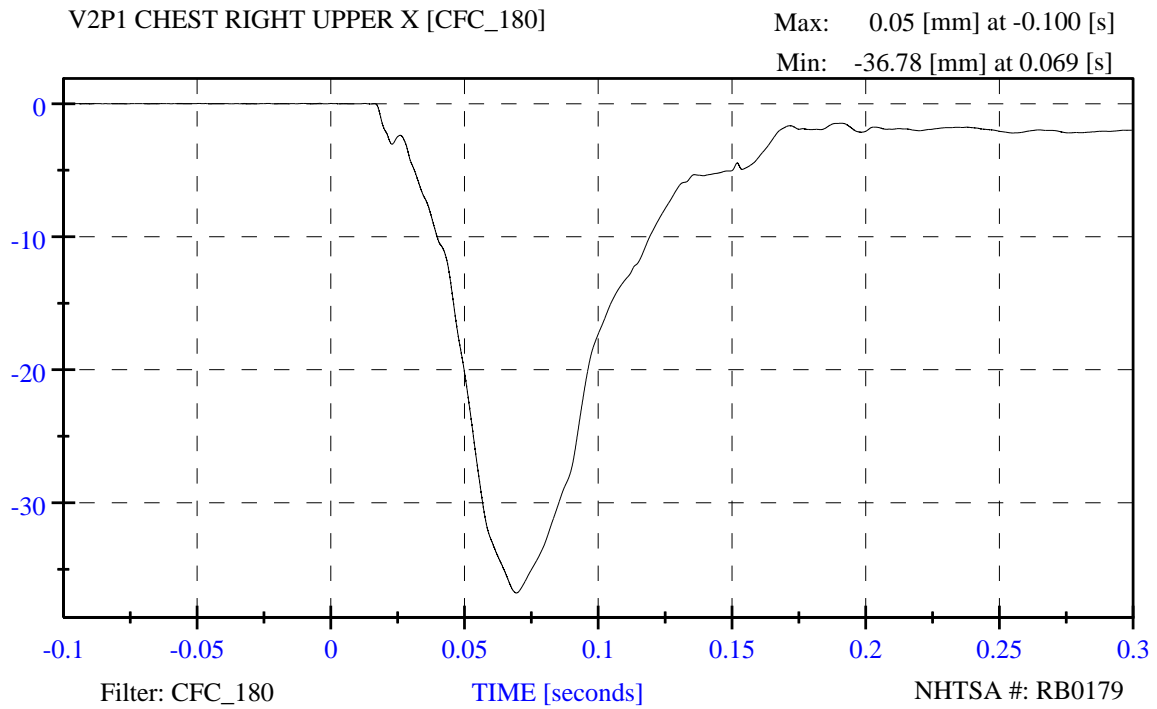

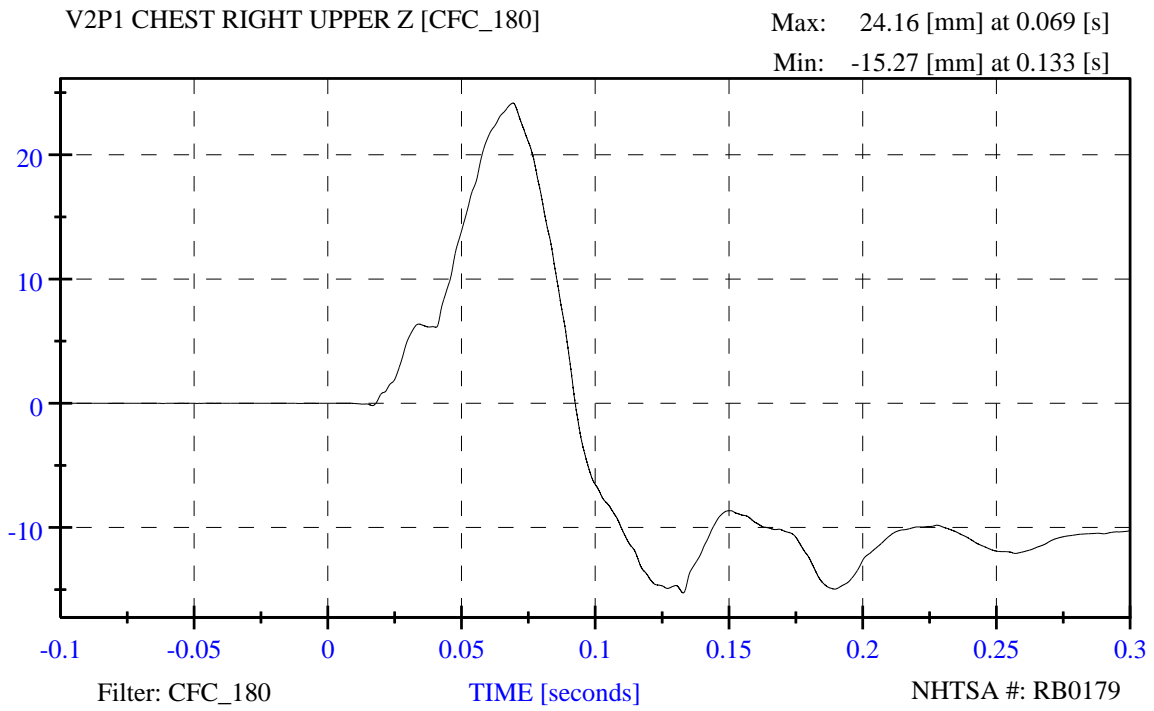

R&D 56 mph, 15deg angle, 35% overlap, 2011 Buick Lacrosse, RB0179

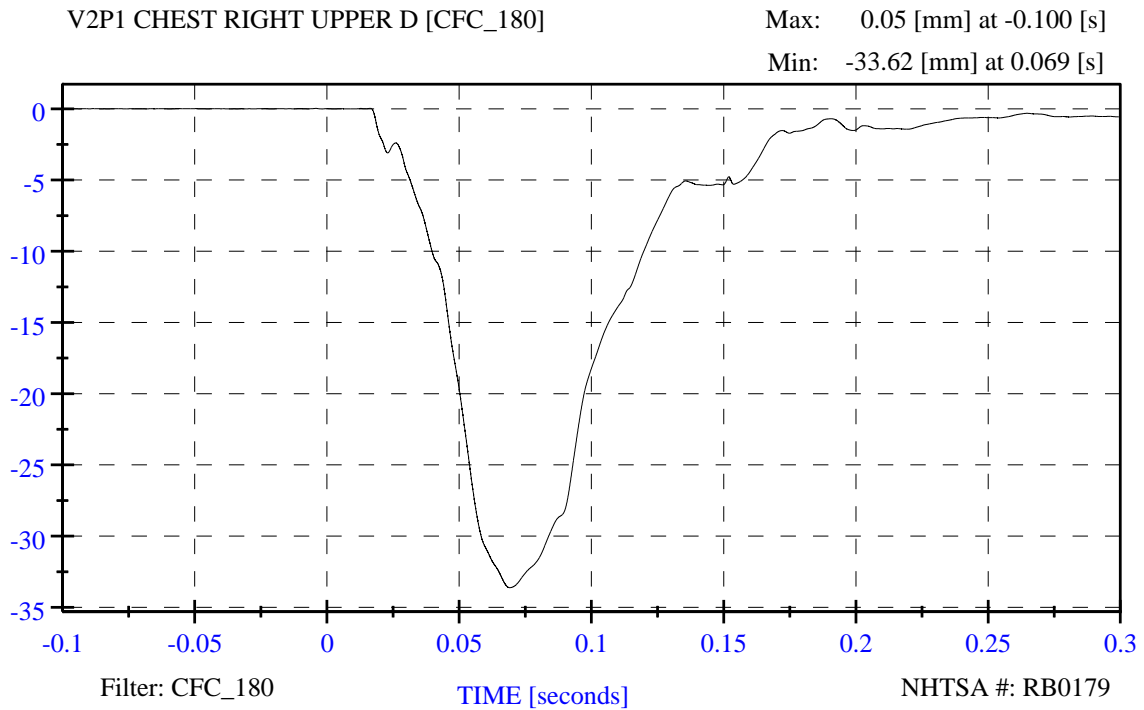

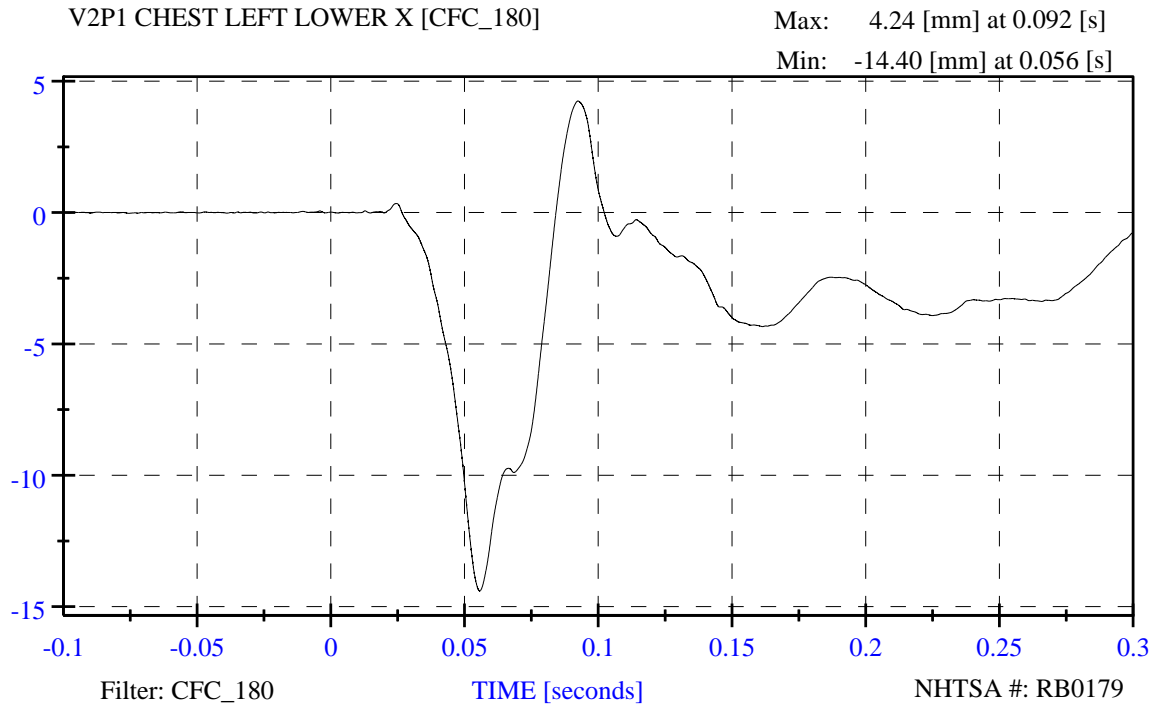

R&D 56 mph, 15deg angle, 35% overlap, 2011 Buick Lacrosse, RB0179

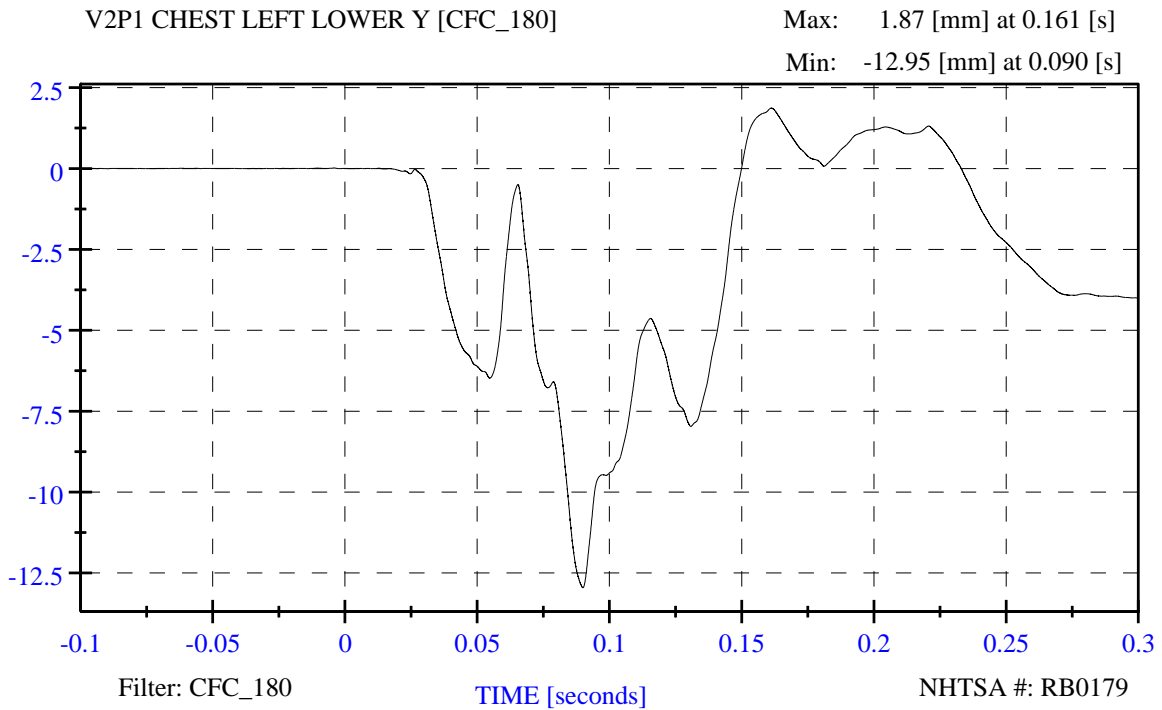

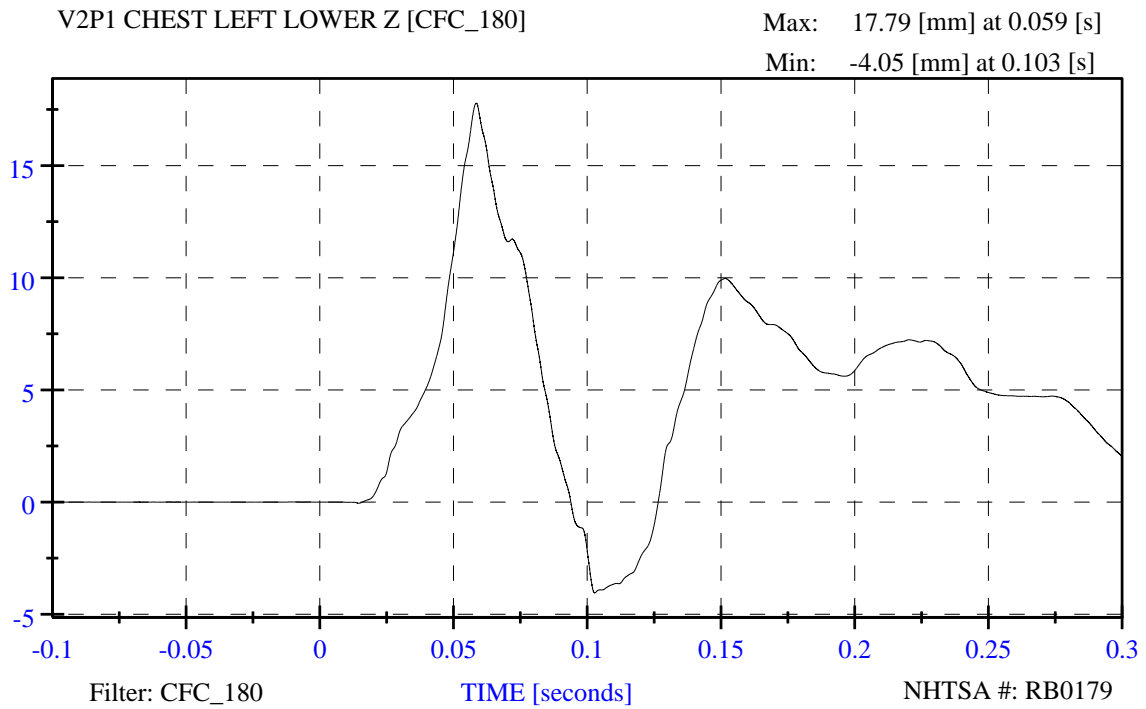

R&D 56 mph, 15deg angle, 35% overlap, 2011 Buick Lacrosse, RB0179

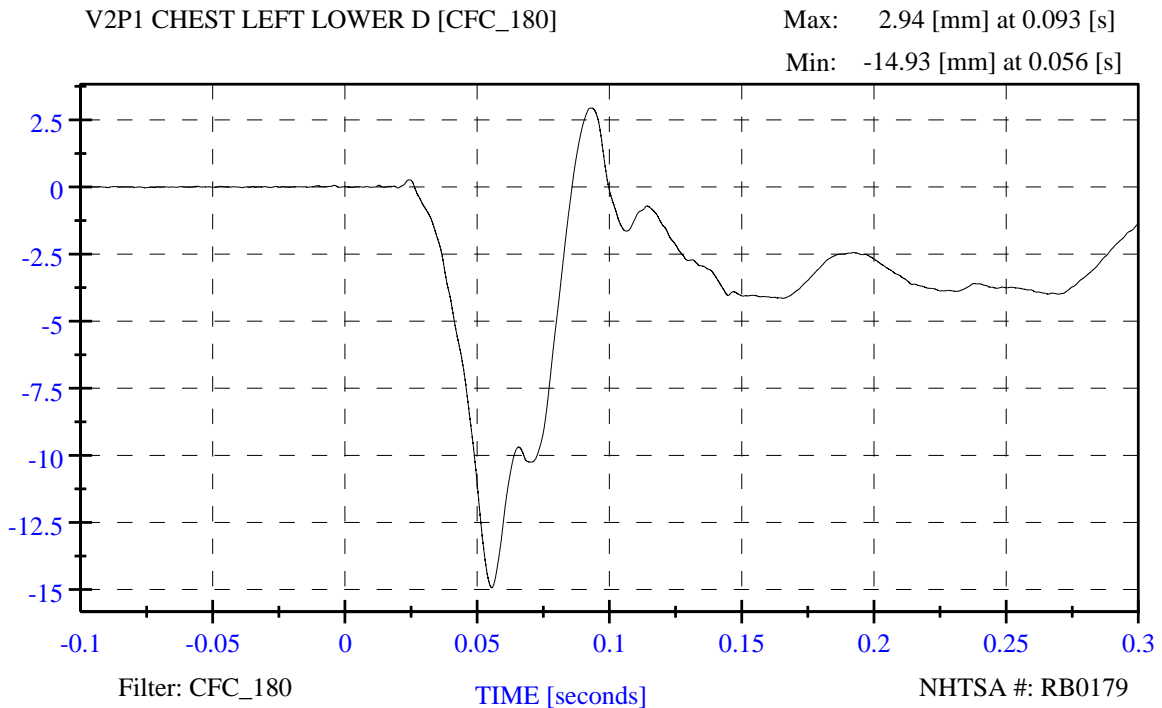

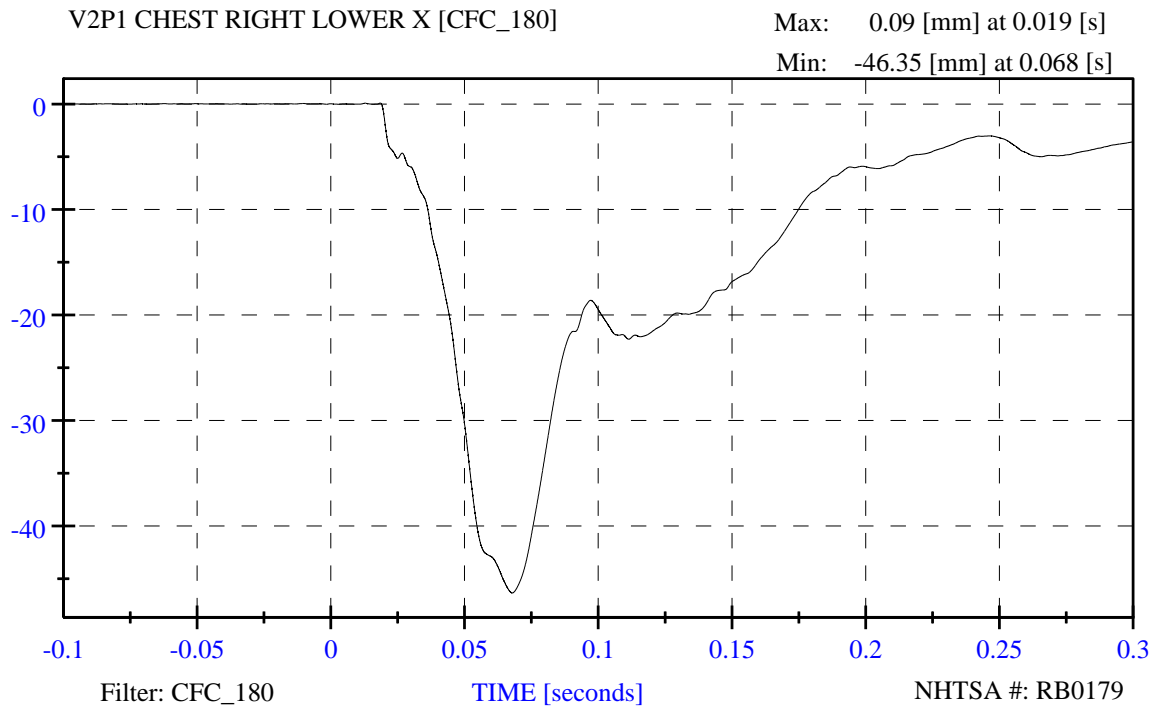

R&D 56 mph, 15deg angle, 35% overlap, 2011 Buick Lacrosse, RB0179

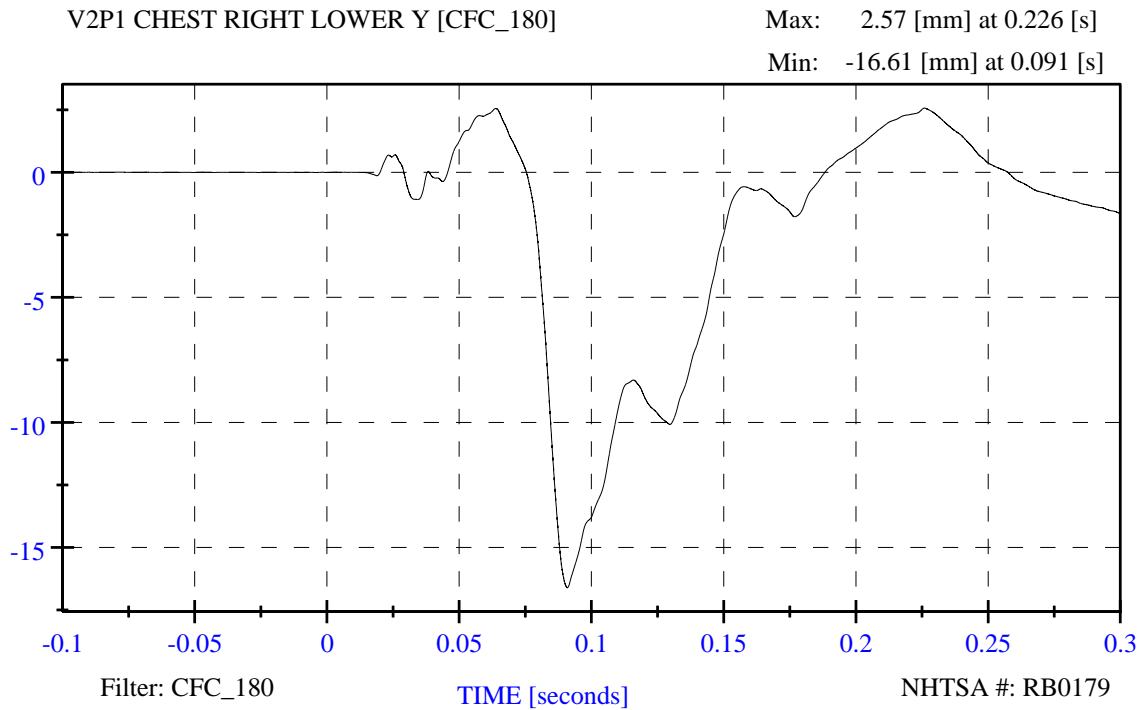

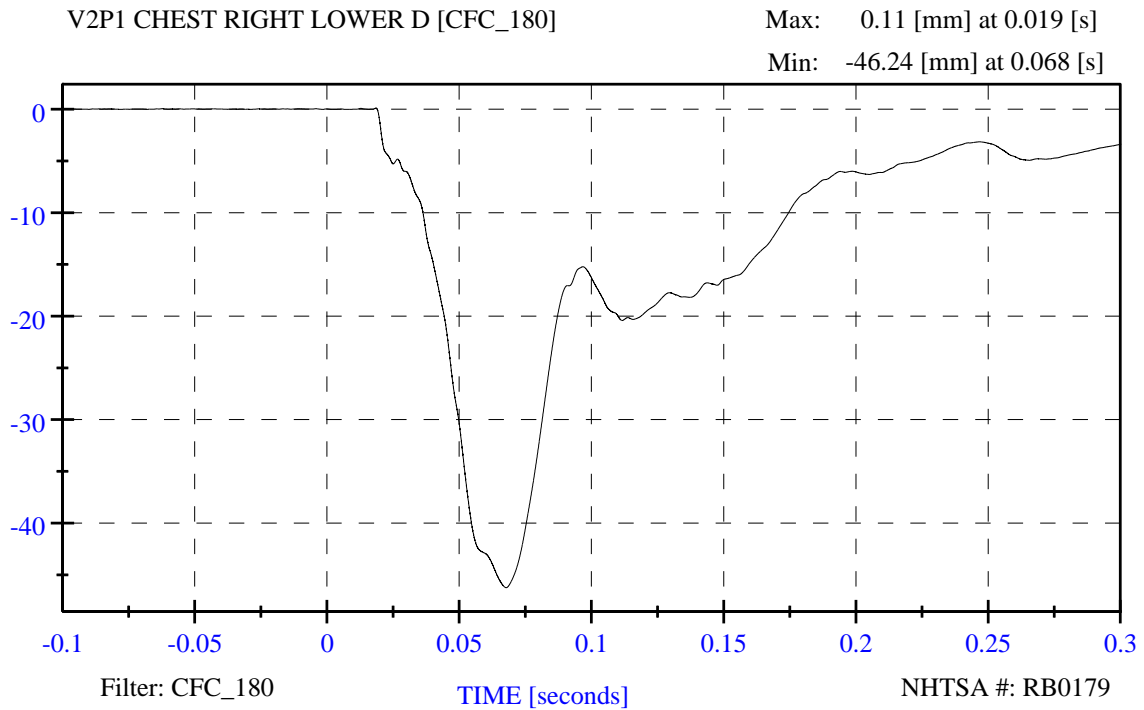
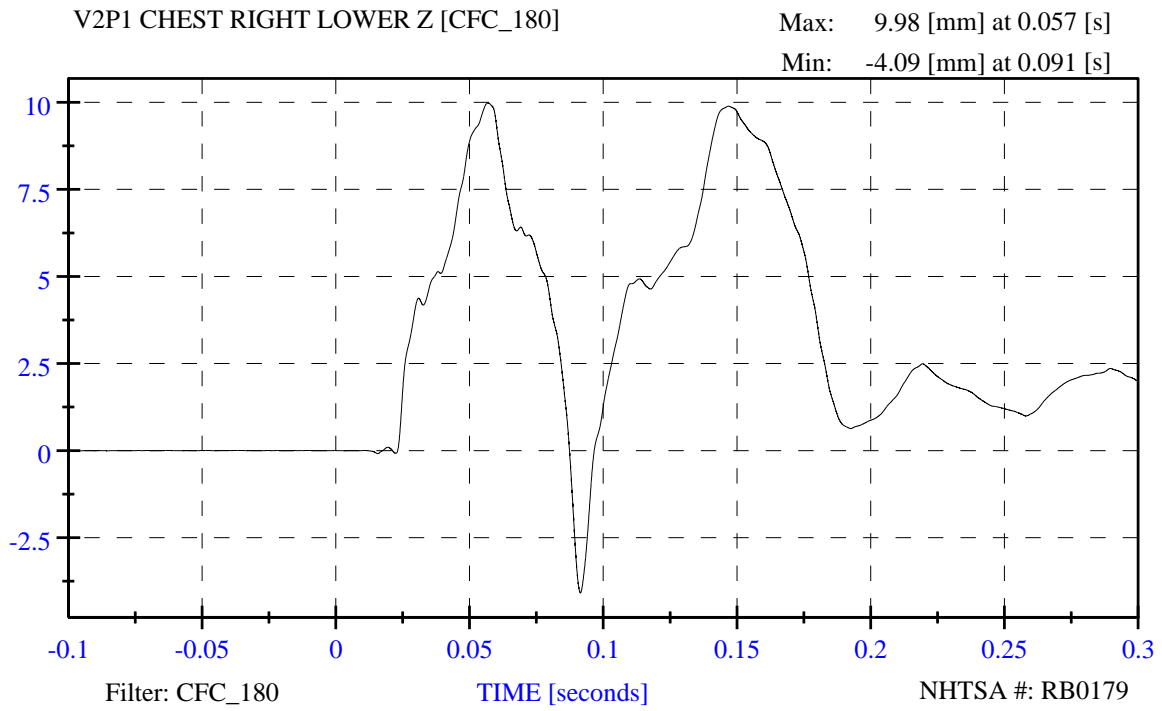

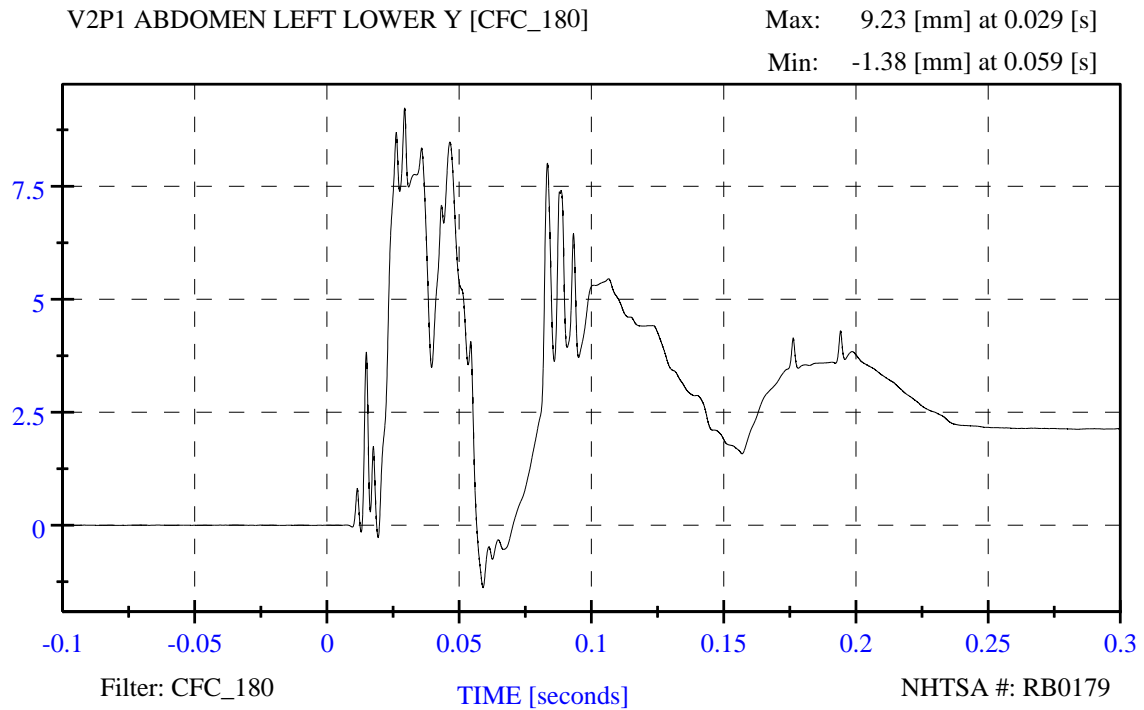
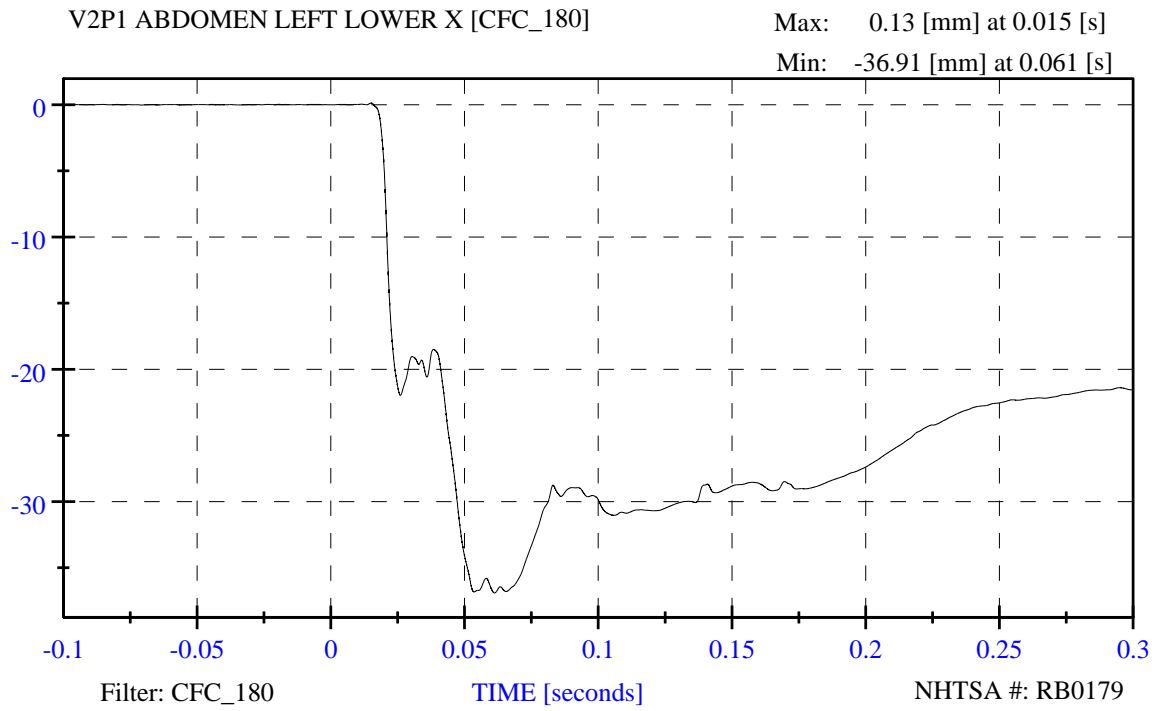

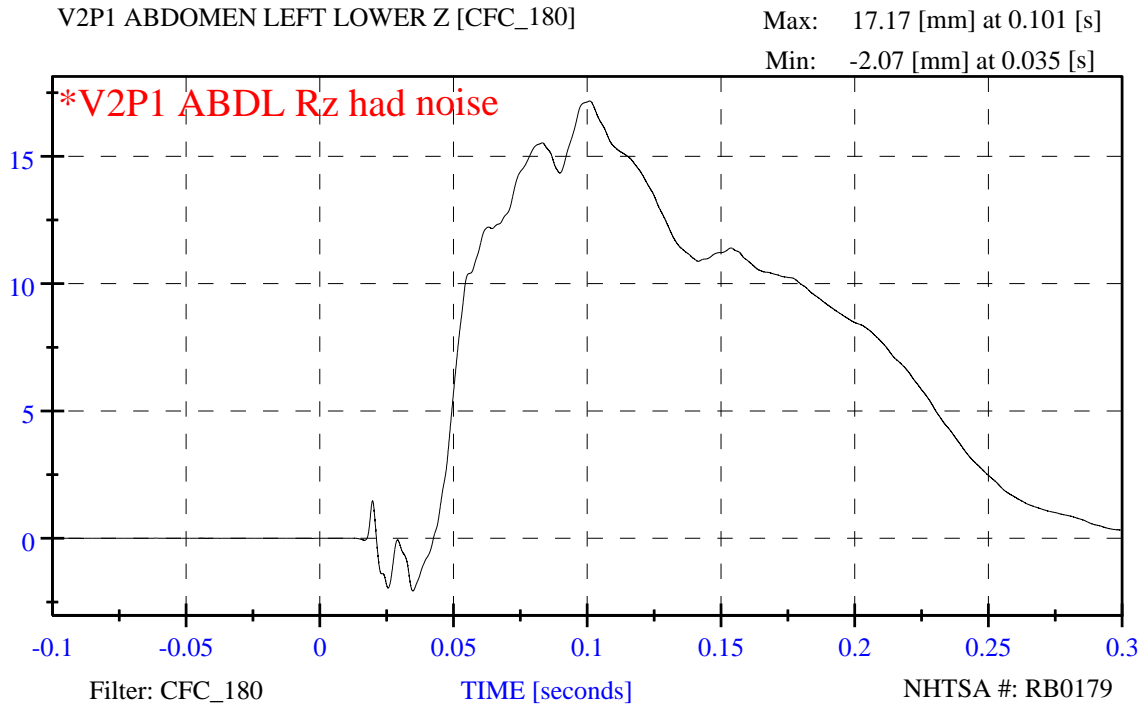

R&D 56 mph, 15deg angle, 35% overlap, 2011 Buick Lacrosse, RB0179

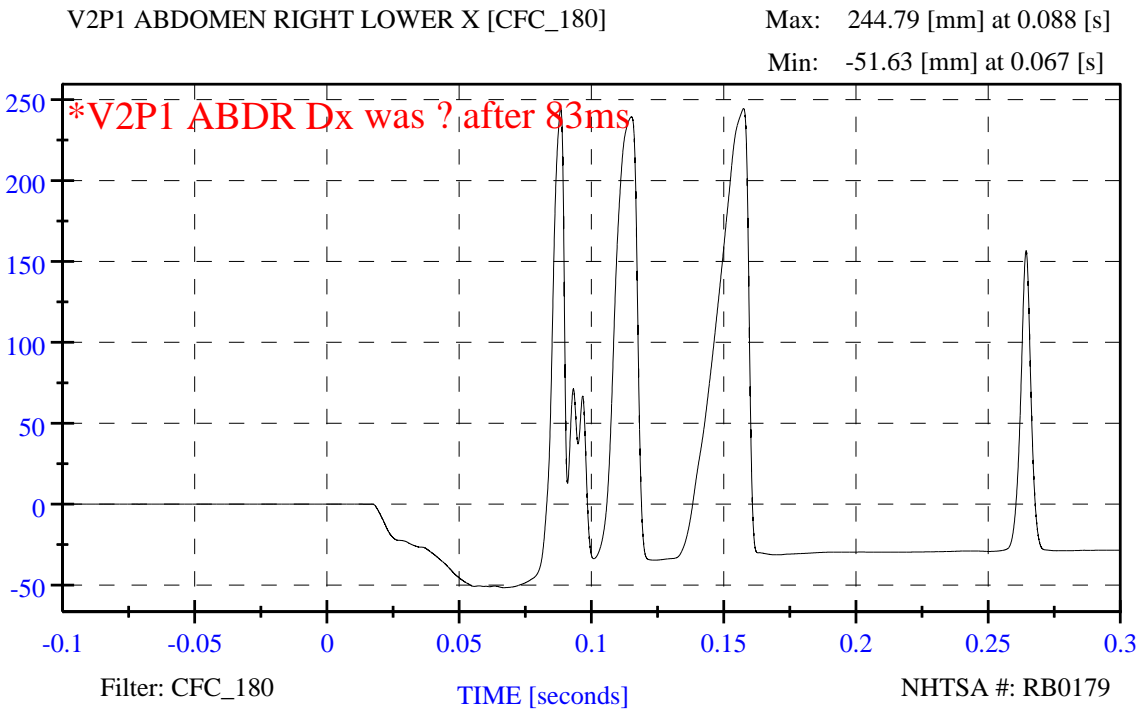

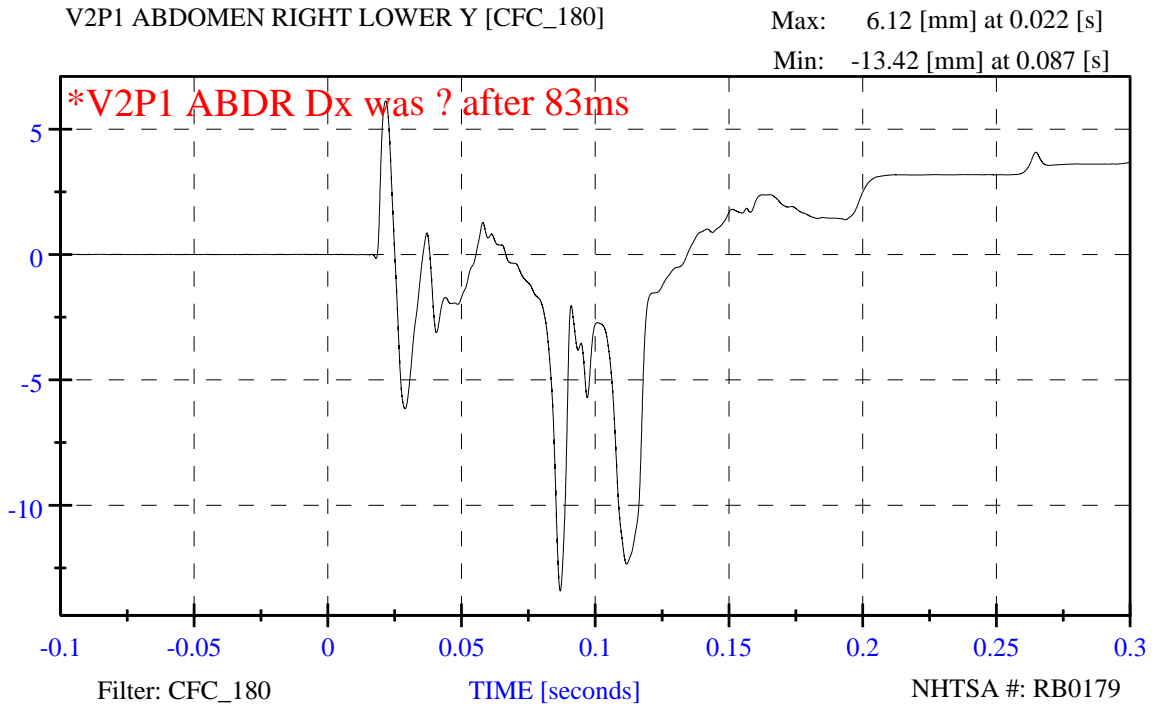

R&D 56 mph, 15deg angle, 35% overlap, 2011 Buick Lacrosse, RB0179

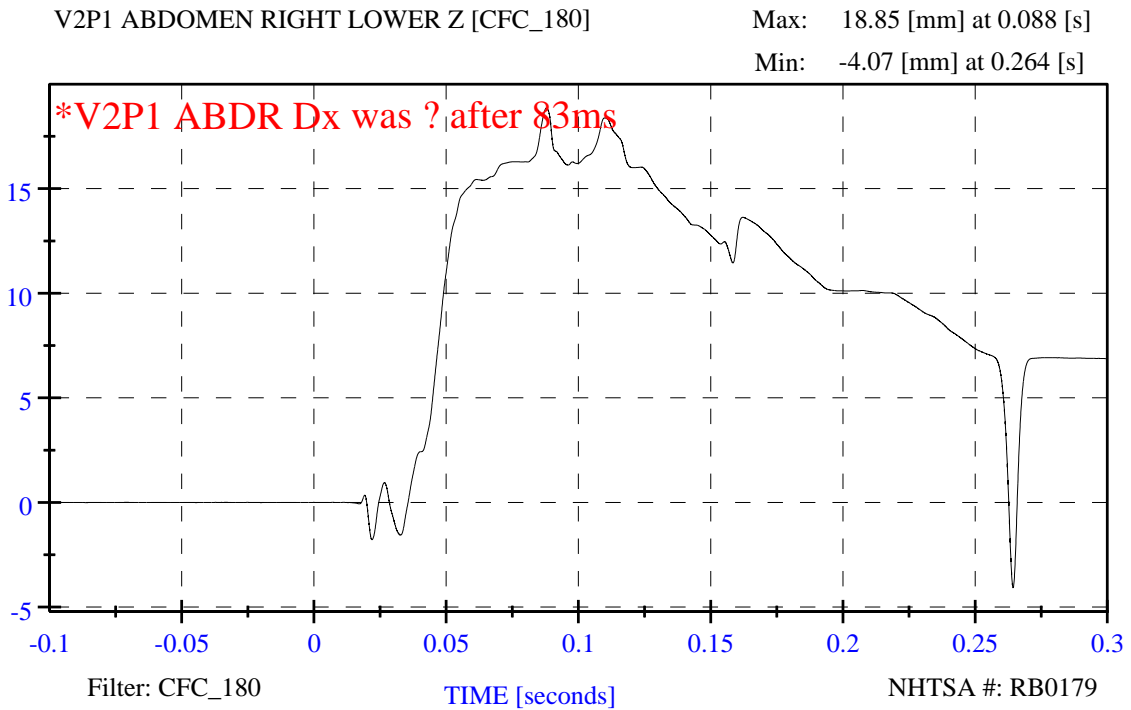

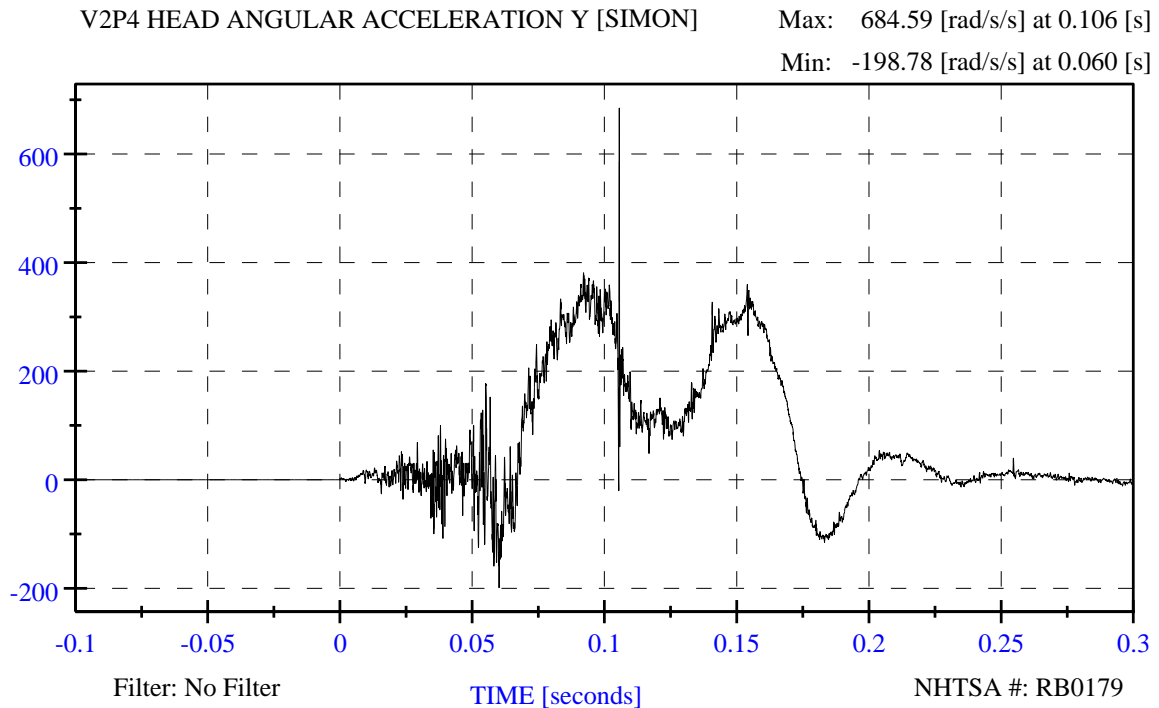
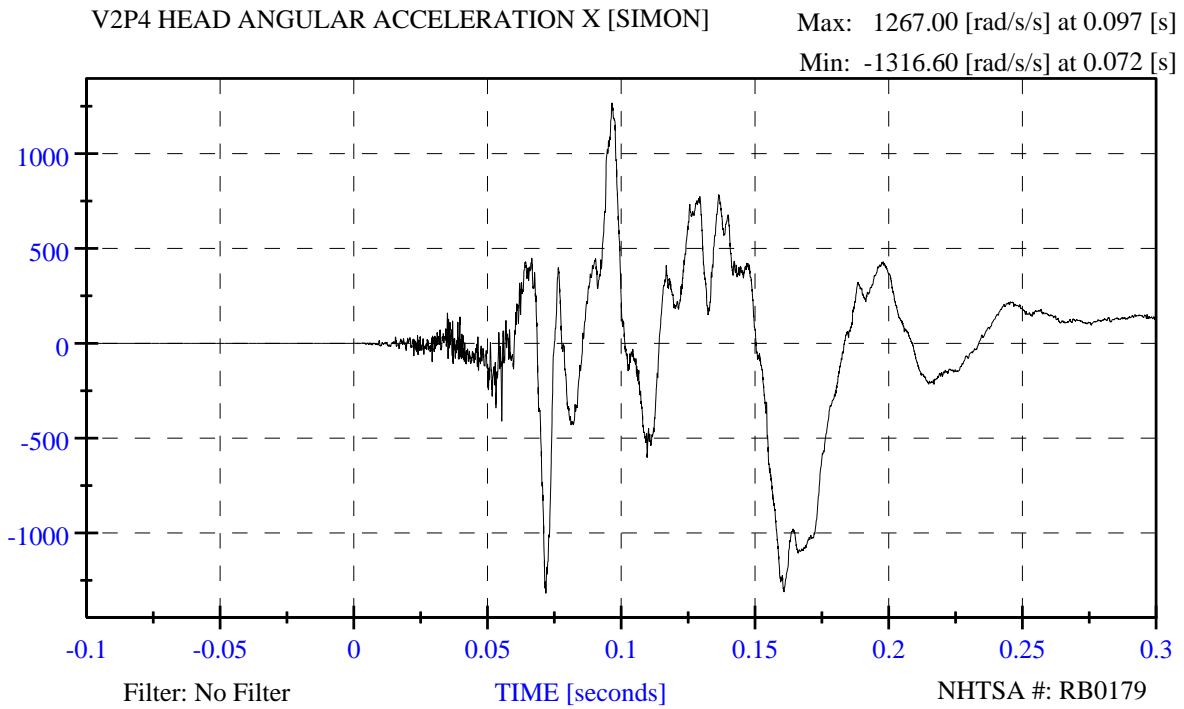

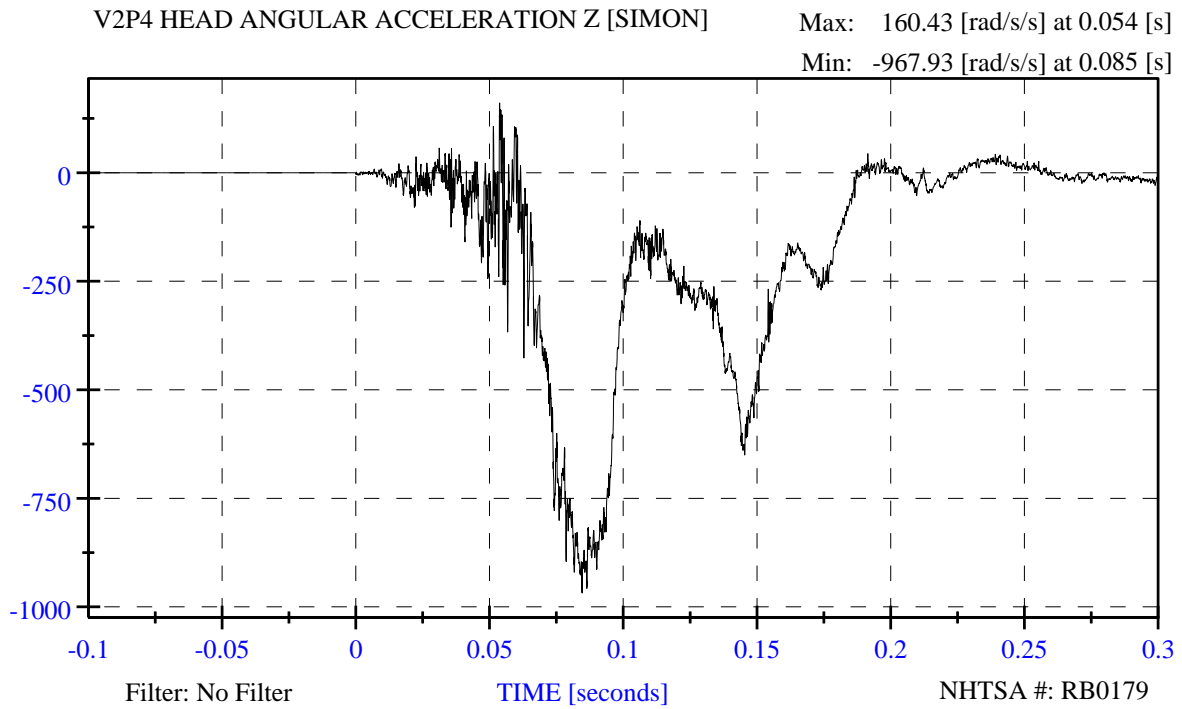

R&D 56 mph, 15deg angle, 35% overlap, 2011 Buick Lacrosse, RB0179

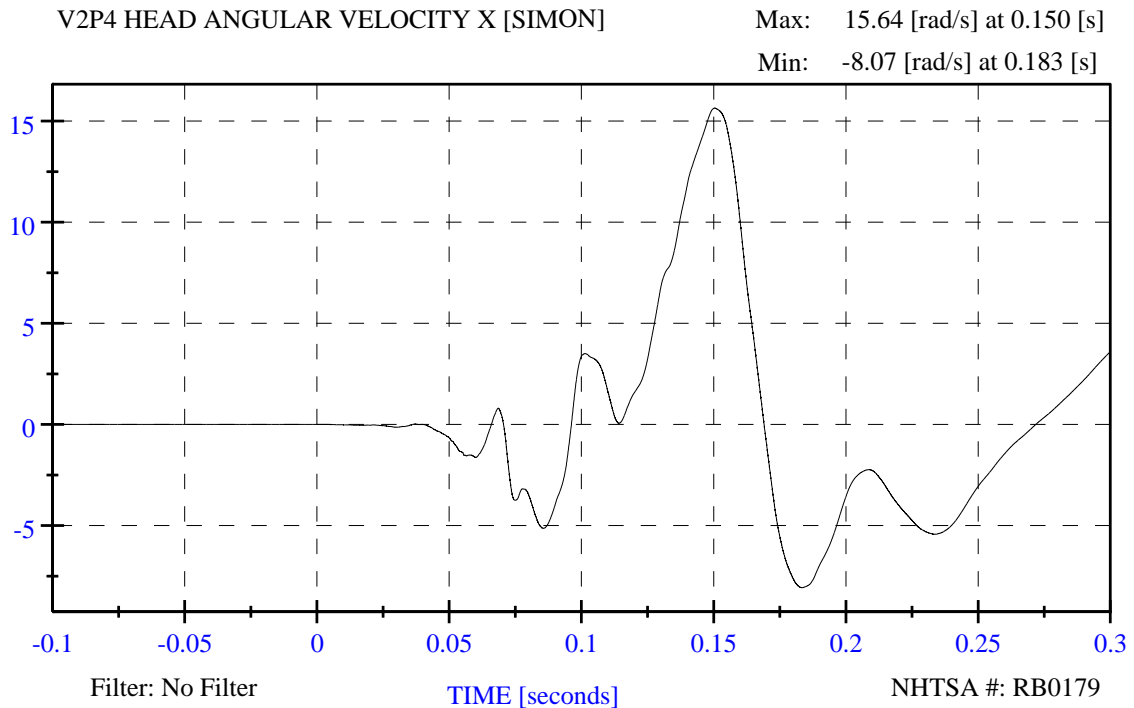

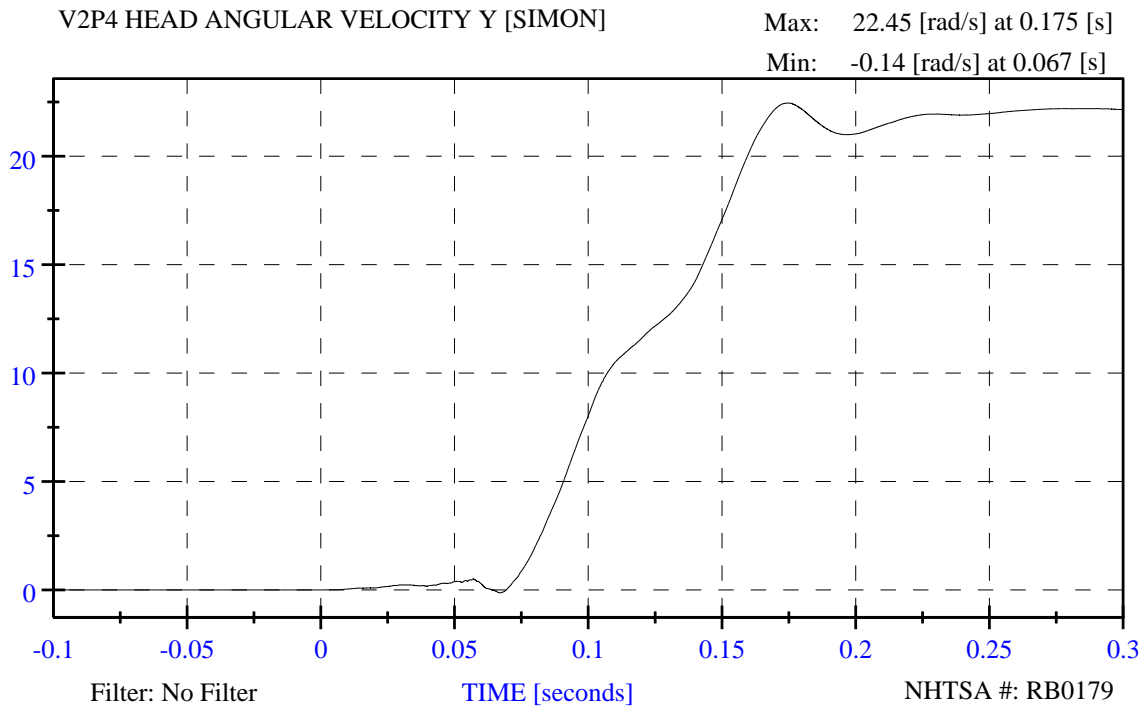

R&D 56 mph, 15deg angle, 35% overlap, 2011 Buick Lacrosse, RB0179

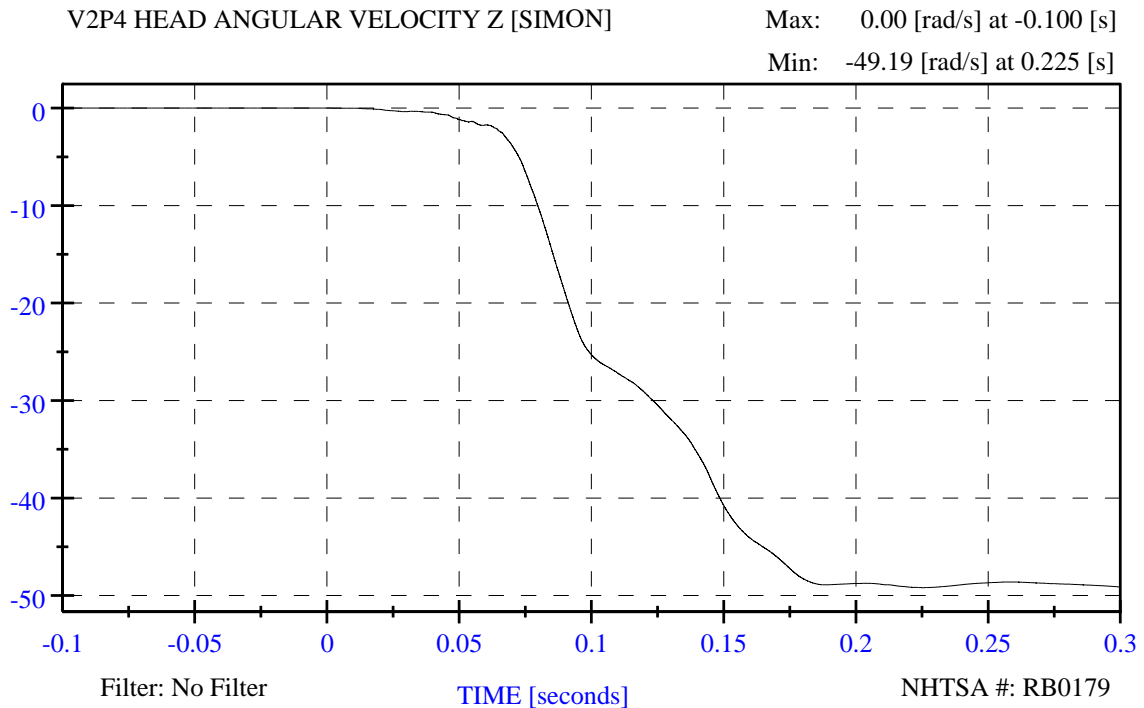

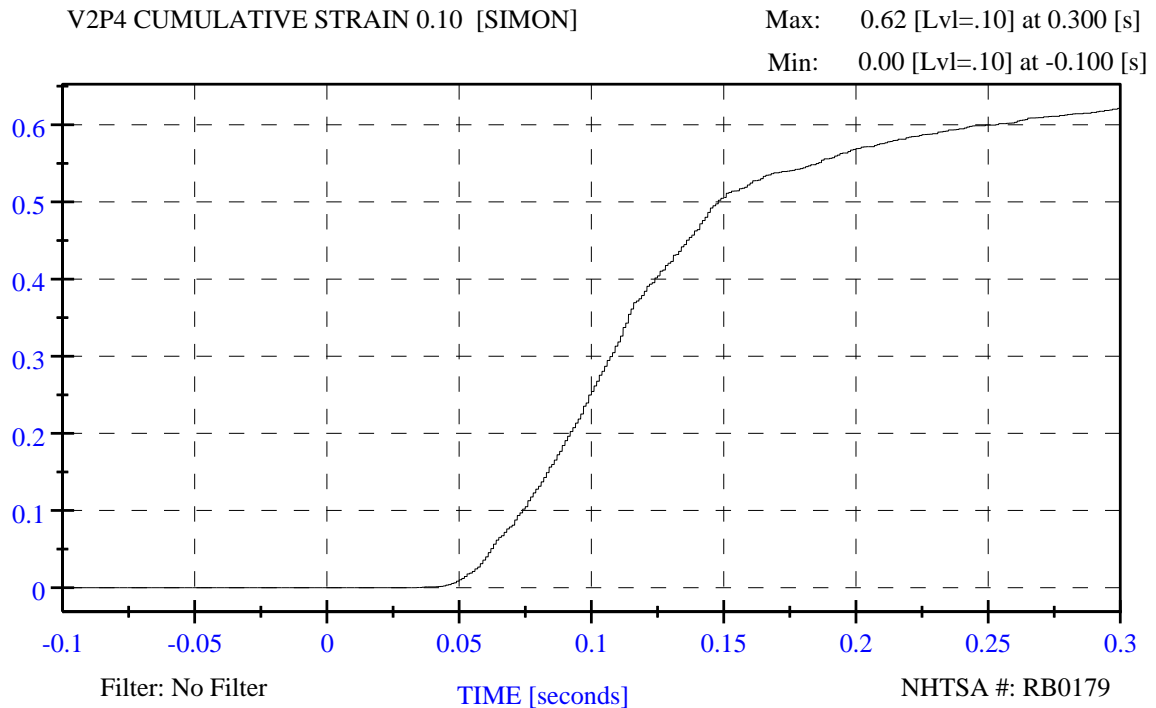
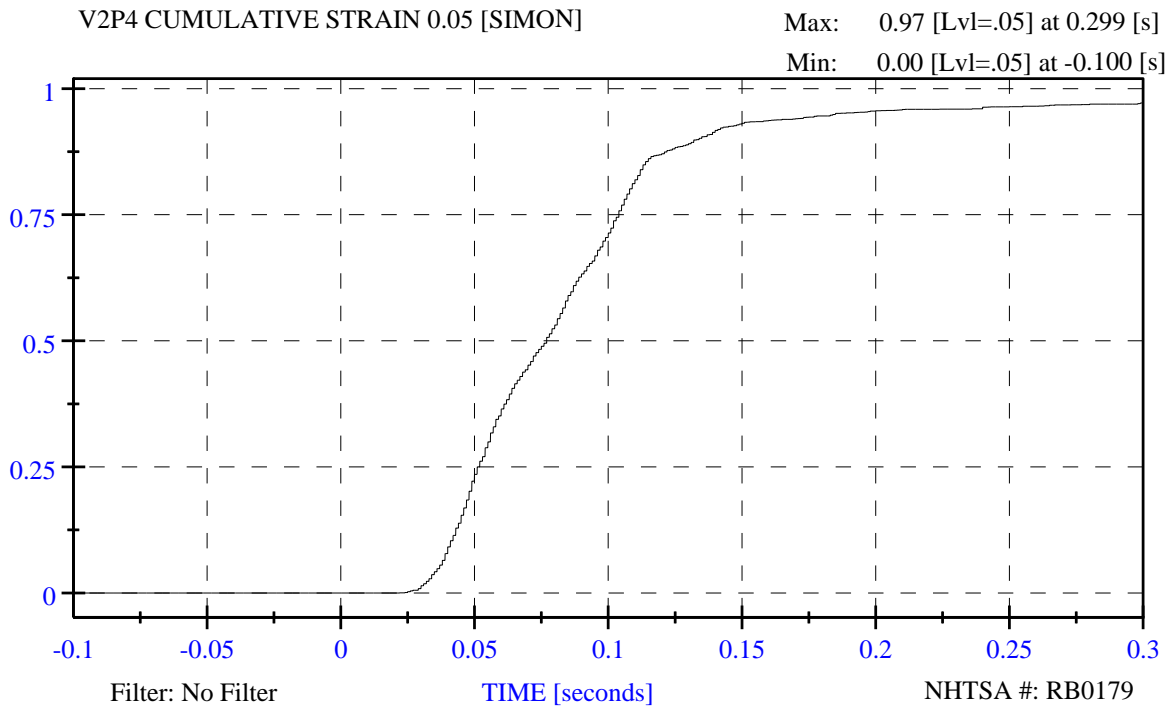

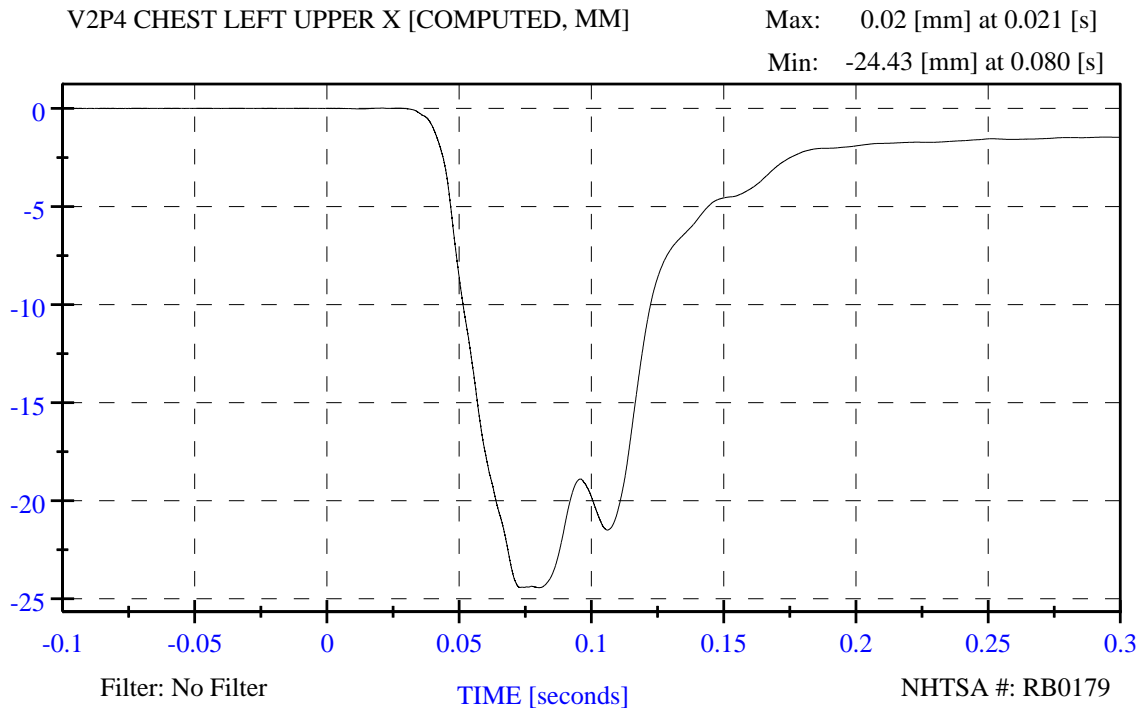
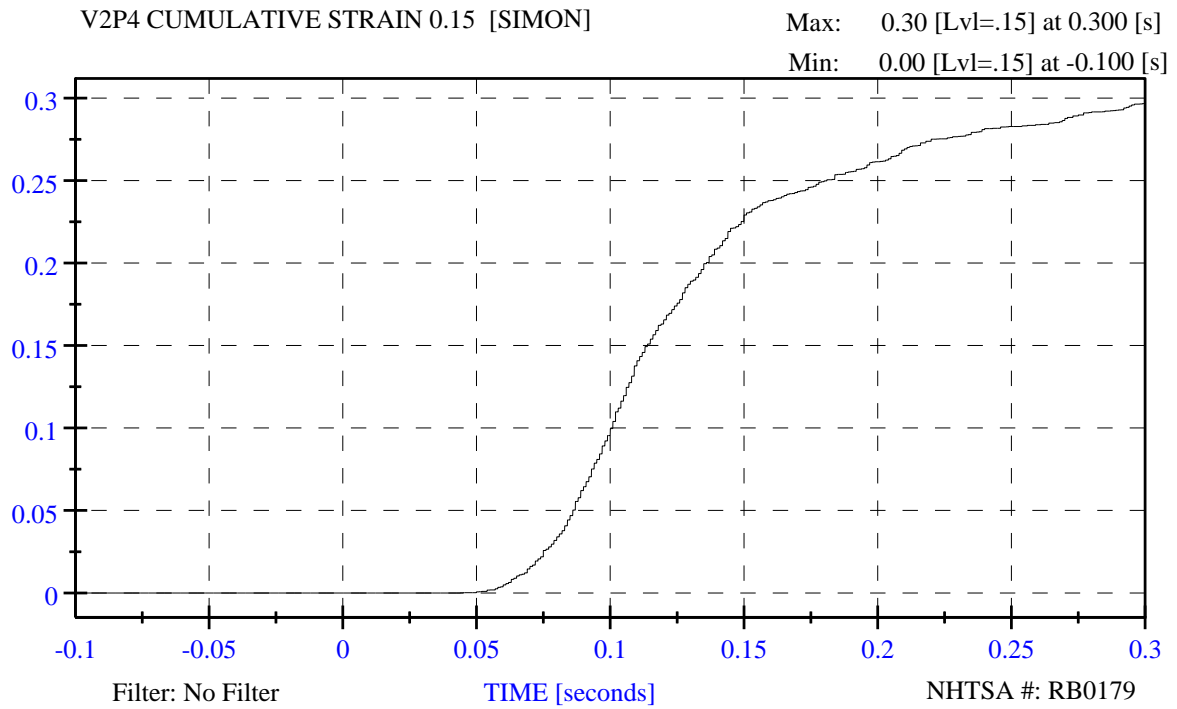

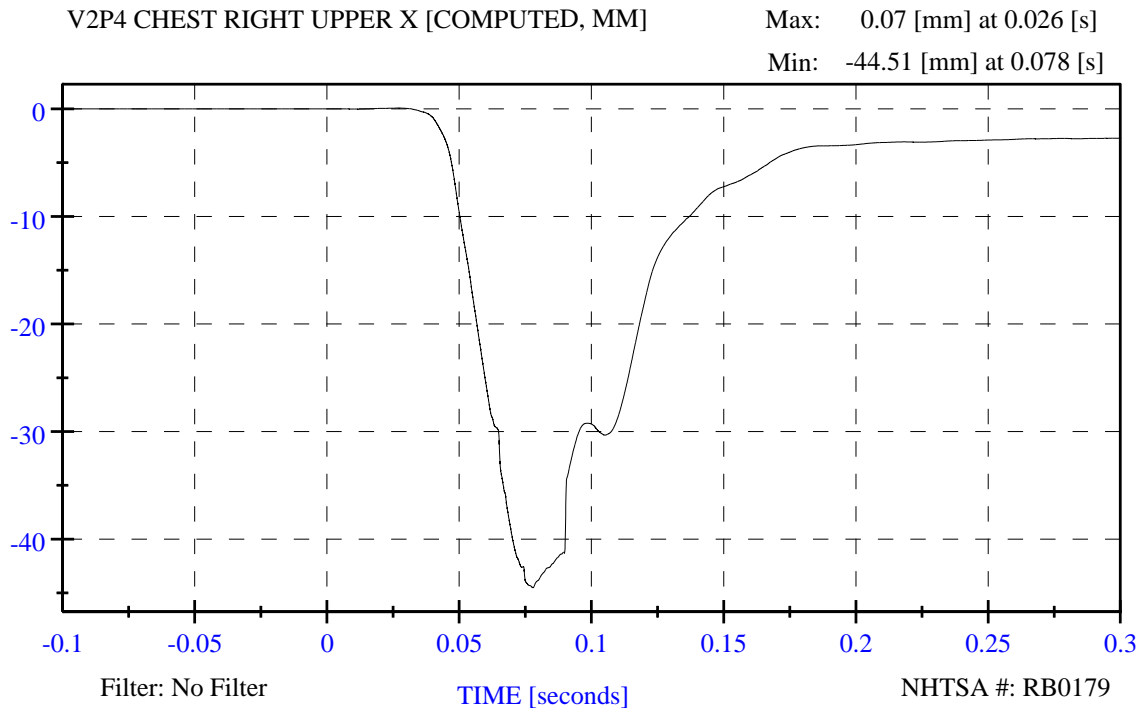
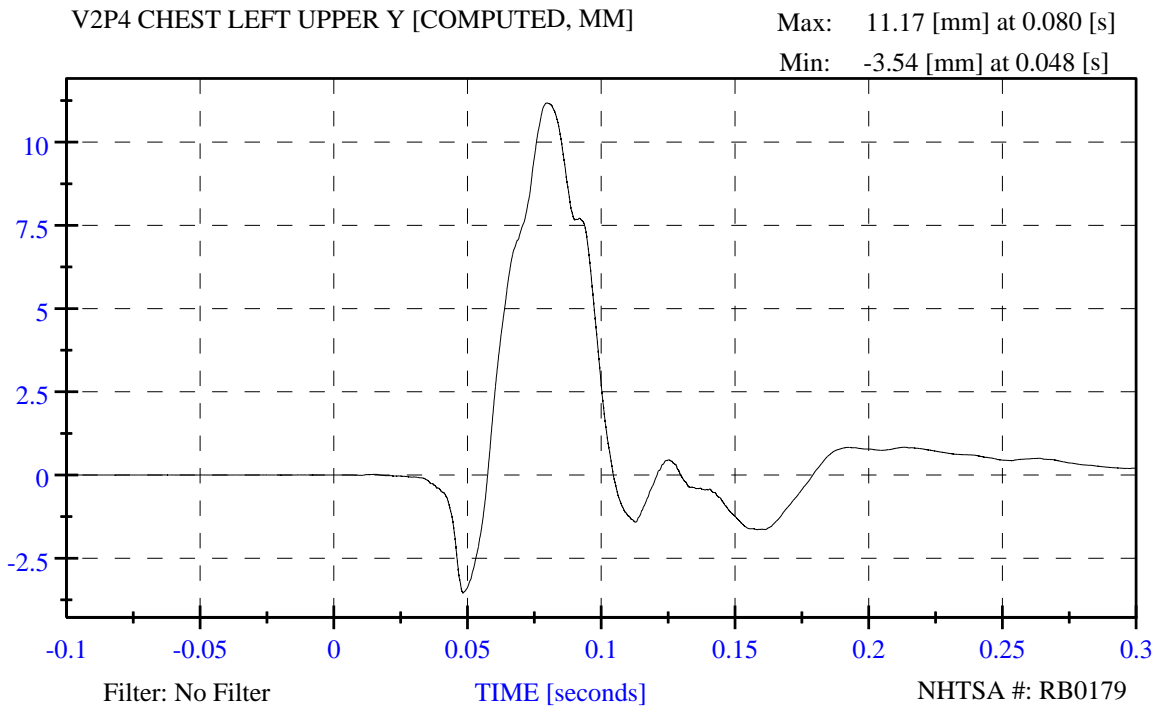

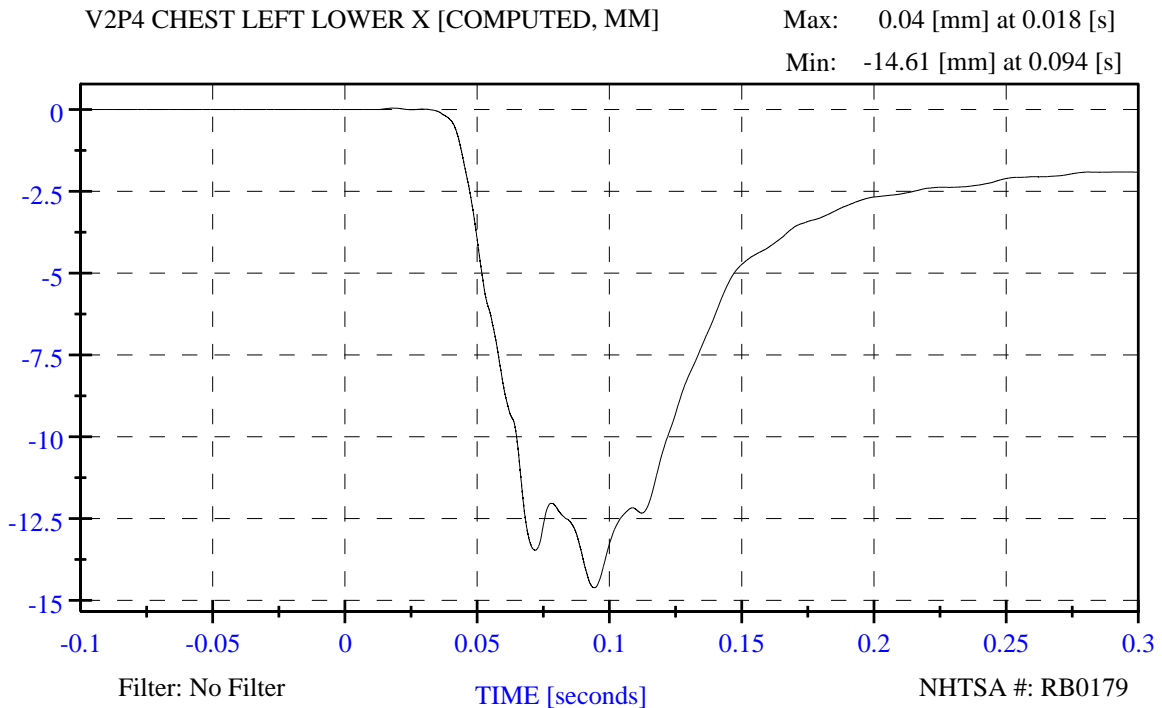
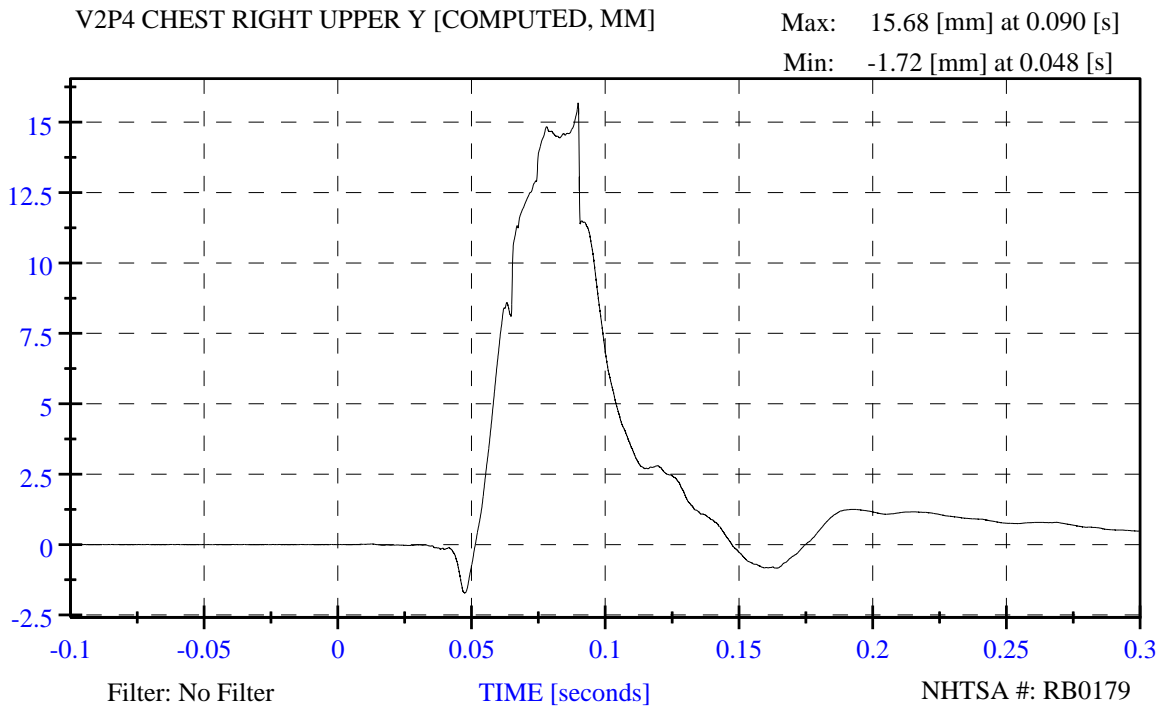

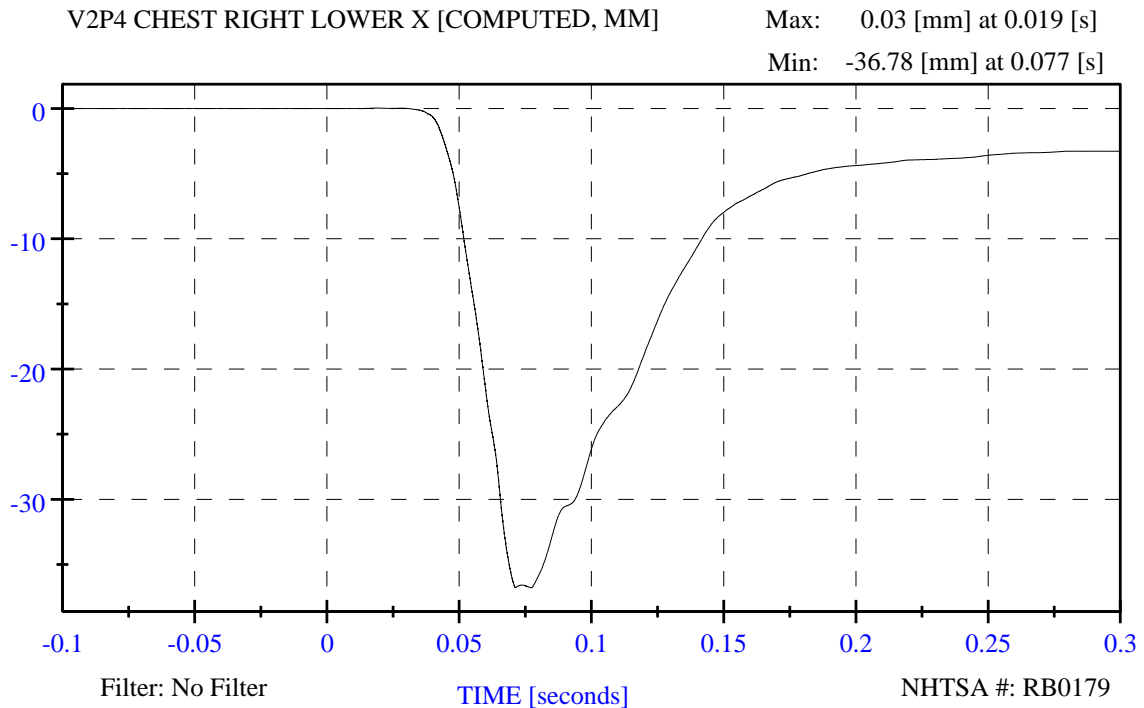
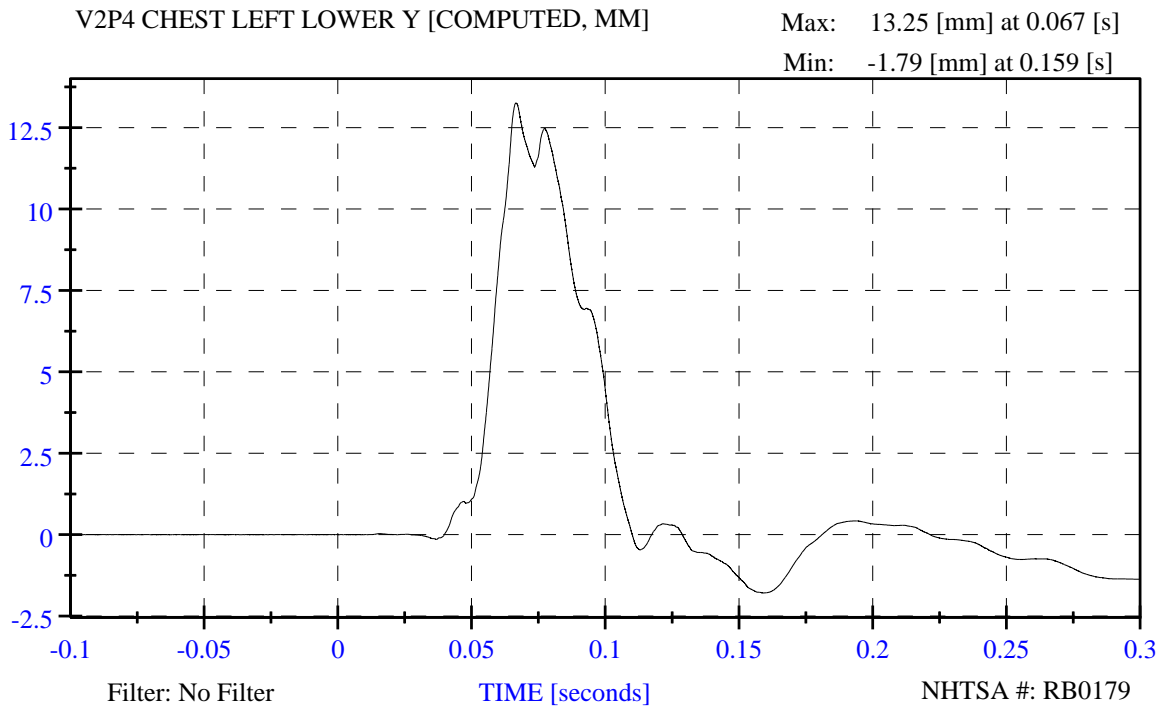

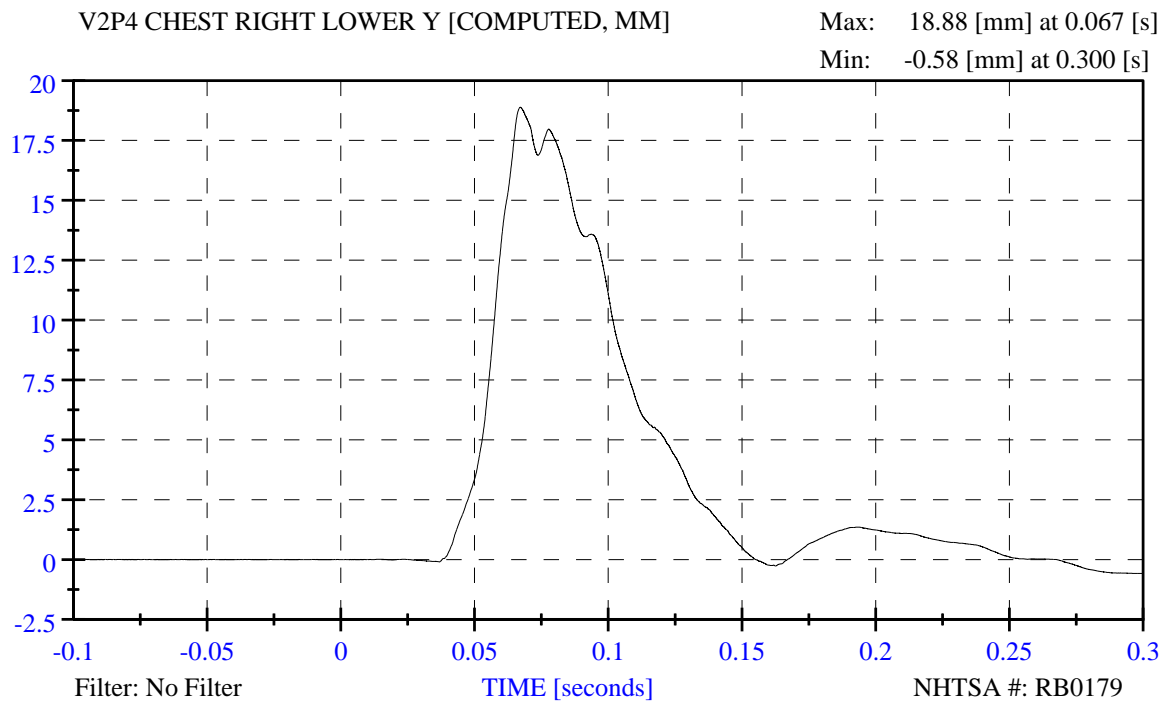

APPENDIX C

**PART 572 E/O DUMMY CALIBRATION
AND PERFORMANCE VERIFICATION DATA SHEETS**

TABLE OF CONTENT

No.		Page
Table1	Dummy Information	C-3
Table 2	THOR 6 File Set	C-3
Table 3	THOR Dummy Initial Set-Up Information	C-3
Table 4	THOR Pre-Test Inspection Checklist	C-4
Table 5	THOR Post-Test Inspection Checklist	C-9
	Dummy Calibration Plots	C-14

Table 1 – Dummy Information

TYPE	DESCRIPTION	SERIAL NUMBER
THOR Hybrid III	50 TH Male 5 th Female	0007 070

Table 2 – THOR6 Set File

LFTX	LFTY	LFTZ	RFTX	RFTY	RFTZ
Left Ankle X Rotation	Left Ankle Y Rotation	Left Ankle Z Rotation	Right Ankle X Rotation	Right Ankle X Rotation	Right Ankle X Rotation
3.98577	13.869	-34.481	0.30868	10.848	-58.84

Table 3 – THOR Dummy Initial SetUp Information

THOR – MK S/N: 0007									Sensitivi ty (JARI)	Sensitivi ty (GESAC)	Setup Angle (GESAC)
Sens or	Descripti on/Axis	MFG	Capa city	Unit 1	Unit 2	Ran ge	Directi on	CF C	V/Unit -1	V/Unit-1	Degrees
NKCRP	Upper Right Base										
Thorax CRUX	Upper Right Mid										
Thorax CRUX	Upper Right Elbow										
Thorax CRUX	Upper Left Base										
Thorax CRUX	Upper Left Mid										
Thorax CRUX	Upper Left Elbow										
Thorax CRUX	Lower Right Base										
Thorax CRUX	Lower Right Mid										
Thorax CRUX	Lower Right Elbow										
Thorax CRUX	Lower Left Base										
Thorax CRUX	Lower Left Mid										
Thorax CRUX	Lower left Elbow										
Thorax CRUX	Right Abdomen X										
DGSP	Right Abdomen Y										
DGSP	Right Abdomen Z										
DGSP	Left Abdomen X										
DGSP	Left Abdomen Y										
DGSP	Left Abdomen Z										
DGSP	Upper Right Base										

Table 4: Inspection Sheet
THOR Inspection Checklist

Date: August 25, 2011
NHTSA Representative: James Saunders
Witness(es):
Inspection type (circle one): PRE POST
Dummy S/N: 007
Dummy Description: THOR
Date of last Certification or Inspection: 8/25/2011
<u>Tests conducted since last full certification or inspection:</u> RB5137 Toyota Yaris – Test #16
<u>Known errors in data channels (no data, clipping, unexpected drops):</u> <ul style="list-style-type: none">• Sensor 3013• Amp connector ripped off, will repair
<u>Physical evidence of damage:</u>
<u>Anecdotal evidence of damage:</u>
<u>Equipment delivered to Borrower:</u>

HEAD	
<input checked="" type="radio"/> Y / <input type="radio"/> N	Rear head cap mounts securely to head
<input checked="" type="radio"/> Y / <input type="radio"/> N	Head skin fits securely over skull
Y / <input checked="" type="radio"/> N	Head skin shows no sign of tears or damage <ul style="list-style-type: none"> Gash on upper left side of the forehead
<input checked="" type="radio"/> Y / <input type="radio"/> N	Interior components of skull cavity (ballast, accelerometer mount, accelerometers) securely attached
Y / <input checked="" type="radio"/> N	Head securely mounted to OC joint <ul style="list-style-type: none"> OC Joint wobbles side to side, but OC pin is firmly attached
OTHER	
NECK	
<input checked="" type="radio"/> Y / <input type="radio"/> N	Neck cables slide freely through holes in neck plates
<input checked="" type="radio"/> Y / <input type="radio"/> N	Neck cables show no sign of fraying, broken strands, or kinking
Y / <input checked="" type="radio"/> N	No evidence of debonding between neck pucks and plates If N – indicate which interface (where plate/puck 1 attach to upper neck load cell): <ul style="list-style-type: none"> Debonding between pucks 4-5, on the rear of the neck
Y / <input checked="" type="radio"/> N	No evidence of debonding or permanent compression in neck soft stop assemblies <ul style="list-style-type: none"> Front puck is loose
<input checked="" type="radio"/> Y / <input type="radio"/> N	Neck securely attached to upper neck load cell
<input checked="" type="radio"/> Y / <input type="radio"/> N	Neck securely attached to lower neck load cell
<input checked="" type="radio"/> Y / <input type="radio"/> N	Neck pitch change joint mechanism mating teeth are engaged
OTHER	

SPINE	
<input checked="" type="radio"/> Y / <input type="radio"/> N	No evidence of debonding between thoracic spine flex joint and metal plates
<input checked="" type="radio"/> Y / <input type="radio"/> N	No evidence of debonding between lumbar spine flex joint and metal plates

Y / N	Lumbar spine pitch change joint mechanism mating teeth are engaged
OTHER	
SHOULDER	
Y <input checked="" type="radio"/> N	Urethane shoulder pads show no evidence of contact <ul style="list-style-type: none"> Left, right pads are scuffed
<input checked="" type="radio"/> / N	Clavicles securely attached to sternum and shoulder
Y <input checked="" type="radio"/> N	No evidence of debonding, tearing, or permanent compression of posterior soft stops <ul style="list-style-type: none"> Left Shoulder soft stop slightly debonding
OTHER	
THORAX	
Y <input checked="" type="radio"/> N	No evidence of contact at top, bottom, or interior faces of rib damping material <ul style="list-style-type: none"> Contact on interior of rib #4, both sides
<input checked="" type="radio"/> / N	No evidence of debonding between rib damping material and ribs
<input checked="" type="radio"/> / N	anterior arms securely attached to anterior ribs IR-Trace
<input checked="" type="radio"/> / N	posterior arms securely attached to double gimbals, spine IR-Trace
<input checked="" type="radio"/> / N	Urethane bib is securely attached to ribs with no sign of tearing or washer penetration
<input checked="" type="radio"/> / N	Ribs securely attached to posterior spine
Y <input checked="" type="radio"/> N	Rib stiffeners show no evidence of bending (no gaps between ribs and stiffeners) <ul style="list-style-type: none"> Right side rib #5 Left rib #4
OTHER	

ABDOMEN	
Y <input checked="" type="radio"/> N	No evidence of tearing, cuts, or broken stitches in upper abdomen bag and zipper <ul style="list-style-type: none"> Small tear in the top left corner
<input checked="" type="radio"/> / N	Upper abdomen insert securely attached to spine

Y / N	Upper abdomen insert shows no evidence of permanent set
Y / <input checked="" type="radio"/> N	No evidence of tearing, cuts, or broken stitches in lower abdomen bag and zipper <ul style="list-style-type: none"> • Broken stitches on the top right side
<input checked="" type="radio"/> Y / N	Lower abdomen insert securely attached to spine
<input checked="" type="radio"/> Y / N	Lower abdomen insert shows no evidence of permanent set
OTHER	
PELVIS	
<input checked="" type="radio"/> Y / N	Pelvis flesh fits securely over pelvis bones
<input checked="" type="radio"/> Y / N	H-point tool fits securely into hole on both sides of pelvis
OTHER	
FEMUR	
<input checked="" type="radio"/> Y / N	Acetabular load cells firmly attached
<input checked="" type="radio"/> Y / N	Femur load cells firmly attached
<input checked="" type="radio"/> Y / N	No evidence of deformation of knee slider bump stop
Y / <input checked="" type="radio"/> N	No cuts, tears, or scuffing of knee flesh <ul style="list-style-type: none"> • Both knees show cuts and scuffs, loose fitting • Left knee has gashes
OTHER	

LOWER EXTREMITY (LX)	
<input checked="" type="radio"/> Y / N	Rotational potentiometers in ankle securely attached
<input checked="" type="radio"/> Y / N	Achilles tendon provides resistance to dorsiflexion
<input checked="" type="radio"/> Y / N	No evidence of debonding, tearing, or permanent compression of ankle soft stops

OTHER	Using intermediate tibia "bone" from LX-104
JACKET	
<input checked="" type="radio"/> Y / N	Rib stiffeners show no sign of permanent deformation
<input checked="" type="radio"/> Y / N	No evidence of tears or holes in jacket fabric, velcro, or zippers
OTHER	

Table 5: THOR Post-Test Inspection

THOR Inspection Checklist

Date: September 22, 2011		
NHTSA Representative: James Saunders		
Witness(es):		
Inspection type (circle one):	PRE	POST
Dummy S/N: 007		
Dummy Description: THOR		
Date of last Certification or Inspection: 9/22/2011		
<u>Tests conducted since last full certification or inspection:</u>		
RB0179 Buick Lacrosse		
<u>Known errors in data channels (no data, clipping, unexpected drops):</u>		
<ul style="list-style-type: none">• 3005• 3010• 3015• 4001• 4029• 5020		
<u>Physical evidence of damage:</u>		
<u>Anecdotal evidence of damage:</u>		
<u>Equipment delivered to Borrower:</u>		

HEAD	
<input checked="" type="radio"/> Y / <input type="radio"/> N	Rear head cap mounts securely to head
<input checked="" type="radio"/> Y / <input type="radio"/> N	Head skin fits securely over skull
Y / <input checked="" type="radio"/> N	Head skin shows no sign of tears or damage <ul style="list-style-type: none"> Gouge left side of the forehead
<input checked="" type="radio"/> Y / <input type="radio"/> N	Interior components of skull cavity (ballast, accelerometer mount, accelerometers) securely attached
Y / <input checked="" type="radio"/> N	Head securely mounted to OC joint <ul style="list-style-type: none"> OC Joint wobbles, otherwise firmly attached
OTHER	
NECK	
<input checked="" type="radio"/> Y / <input type="radio"/> N	Neck cables slide freely through holes in neck plates
<input checked="" type="radio"/> Y / <input type="radio"/> N	Neck cables show no sign of fraying, broken strands, or kinking
Y / <input checked="" type="radio"/> N	No evidence of debonding between neck pucks and plates If N – indicate which interface (where plate/puck 1 attach to upper neck load cell): <ul style="list-style-type: none"> Debonding between pecks 4-5, rear surface
Y / <input checked="" type="radio"/> N	No evidence of debonding or permanent compression in neck soft stop assemblies <ul style="list-style-type: none"> Front soft stop debonding
<input checked="" type="radio"/> Y / <input type="radio"/> N	Neck securely attached to upper neck load cell
<input checked="" type="radio"/> Y / <input type="radio"/> N	Neck securely attached to lower neck load cell
<input checked="" type="radio"/> Y / <input type="radio"/> N	Neck pitch change joint mechanism mating teeth are engaged
OTHER	

SPINE	
<input checked="" type="radio"/> Y / <input type="radio"/> N	No evidence of debonding between thoracic spine flex joint and metal plates
<input checked="" type="radio"/> Y / <input type="radio"/> N	No evidence of debonding between lumbar spine flex joint and metal plates

Y / N	Lumbar spine pitch change joint mechanism mating teeth are engaged
OTHER	
SHOULDER	
Y <input checked="" type="radio"/> N	Urethane shoulder pads show no evidence of contact <ul style="list-style-type: none"> • Scuffing on both pads
<input checked="" type="radio"/> / N	Clavicles securely attached to sternum and shoulder
Y <input checked="" type="radio"/> N	No evidence of debonding, tearing, or permanent compression of posterior soft stops <ul style="list-style-type: none"> • Left Shoulder soft stop slightly debonding
OTHER	
THORAX	
Y <input checked="" type="radio"/> N	No evidence of contact at top, bottom, or interior faces of rib damping material <ul style="list-style-type: none"> • Contact on interior of rib #4, both sides
<input checked="" type="radio"/> / N	No evidence of debonding between rib damping material and ribs
<input checked="" type="radio"/> / N	CRUX anterior arms securely attached to anterior ribs
<input checked="" type="radio"/> / N	CRUX posterior arms securely attached to double gimbals, spine
<input checked="" type="radio"/> / N	Urethane bib is securely attached to ribs with no sign of tearing or washer penetration
<input checked="" type="radio"/> / N	Ribs securely attached to posterior spine
Y <input checked="" type="radio"/> N	Rib stiffeners show no evidence of bending (no gaps between ribs and stiffeners) <ul style="list-style-type: none"> • Right side rib #5 • Left rib #7
OTHER	

ABDOMEN	
Y <input checked="" type="radio"/> N	No evidence of tearing, cuts, or broken stitches in upper abdomen bag and zipper <ul style="list-style-type: none"> • Small tear in the top left corner
<input checked="" type="radio"/> / N	Upper abdomen insert securely attached to spine

Y / N	Upper abdomen insert shows no evidence of permanent set
Y / <input checked="" type="radio"/> N	No evidence of tearing, cuts, or broken stitches in lower abdomen bag and zipper <ul style="list-style-type: none"> • Broken stitches on the top right side
<input checked="" type="radio"/> Y / N	Lower abdomen insert securely attached to spine
<input checked="" type="radio"/> Y / N	Lower abdomen insert shows no evidence of permanent set
OTHER	
PELVIS	
<input checked="" type="radio"/> Y / N	Pelvis flesh fits securely over pelvis bones
<input checked="" type="radio"/> Y / N	H-point tool fits securely into hole on both sides of pelvis
OTHER	
FEMUR	
<input checked="" type="radio"/> Y / N	Acetabular load cells firmly attached
<input checked="" type="radio"/> Y / N	Femur load cells firmly attached
<input checked="" type="radio"/> Y / N	No evidence of deformation of knee slider bump stop
Y / <input checked="" type="radio"/> N	No cuts, tears, or scuffing of knee flesh <ul style="list-style-type: none"> • Both knees show cuts and scuffs, loose fitting
OTHER	

LOWER EXTREMITY (LX)	
<input checked="" type="radio"/> Y / N	Rotational potentiometers in ankle securely attached
<input checked="" type="radio"/> Y / N	Achilles tendon provides resistance to dorsiflexion
<input checked="" type="radio"/> Y / N	No evidence of debonding, tearing, or permanent compression of ankle soft stops

OTHER	Using intermediate tibia "bone" from LX-104
JACKET	
<input checked="" type="radio"/> Y / N	Rib stiffeners show no sign of permanent deformation
Y / <input checked="" type="radio"/> N	No evidence of tears or holes in jacket fabric, velcro, or zippers <ul style="list-style-type: none"> • Tearing of stitches around front collar
OTHER	

Dummy Calibration Plots

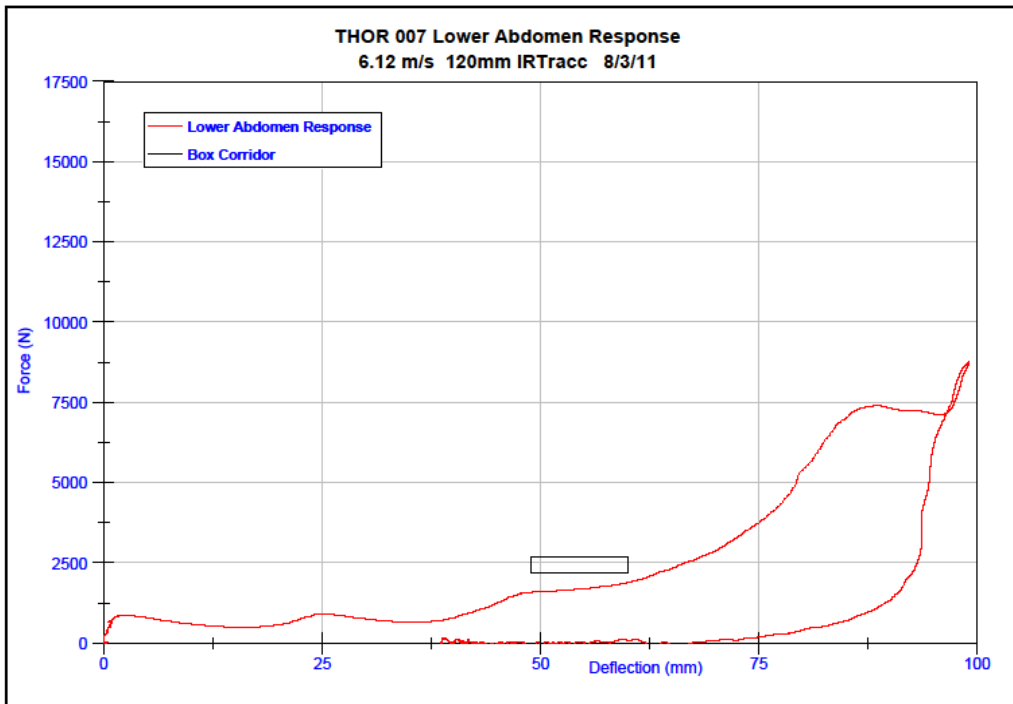
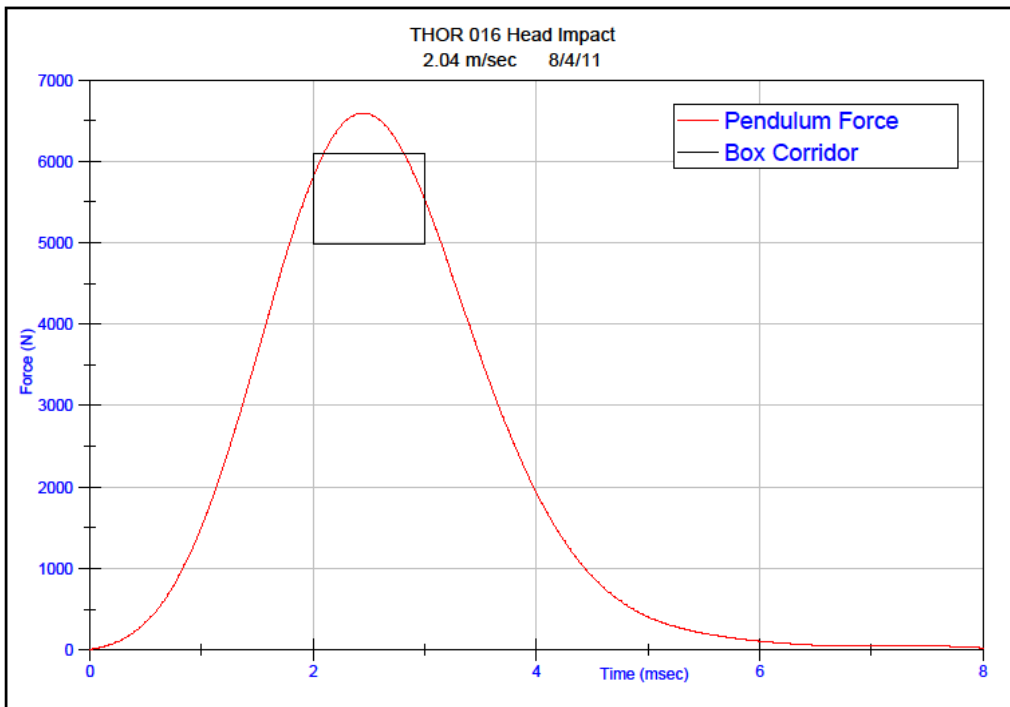

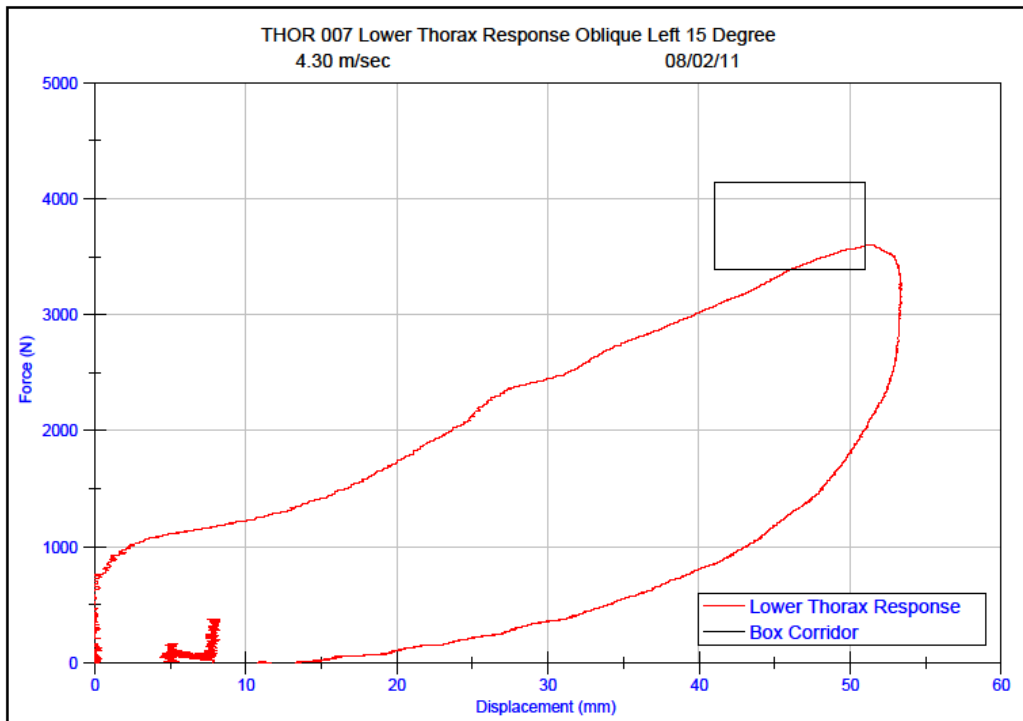
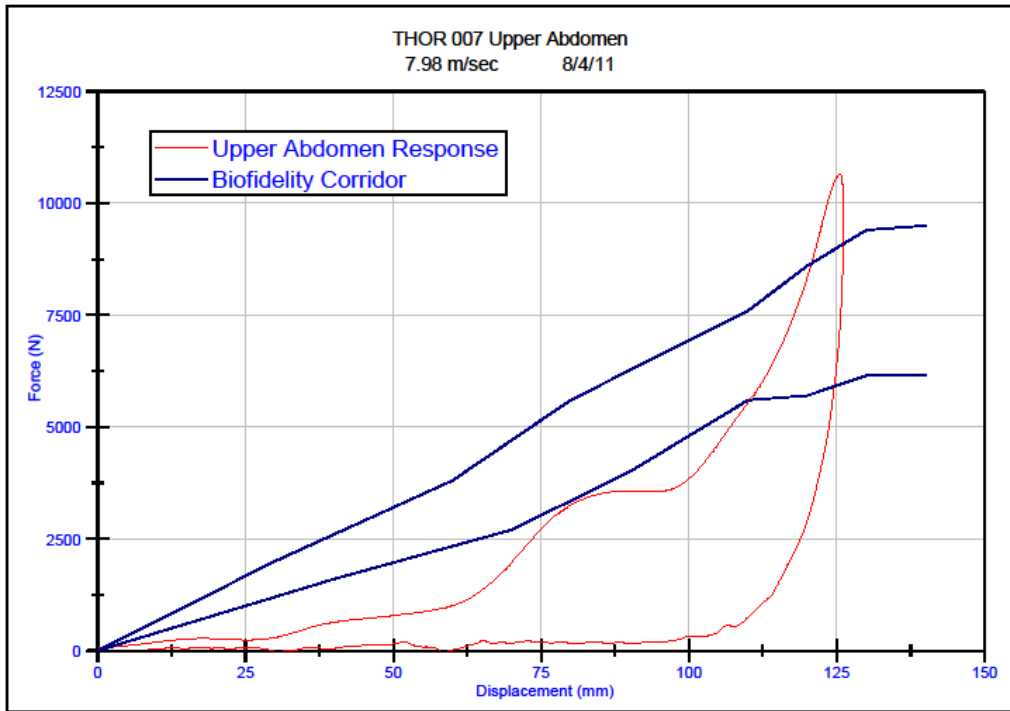

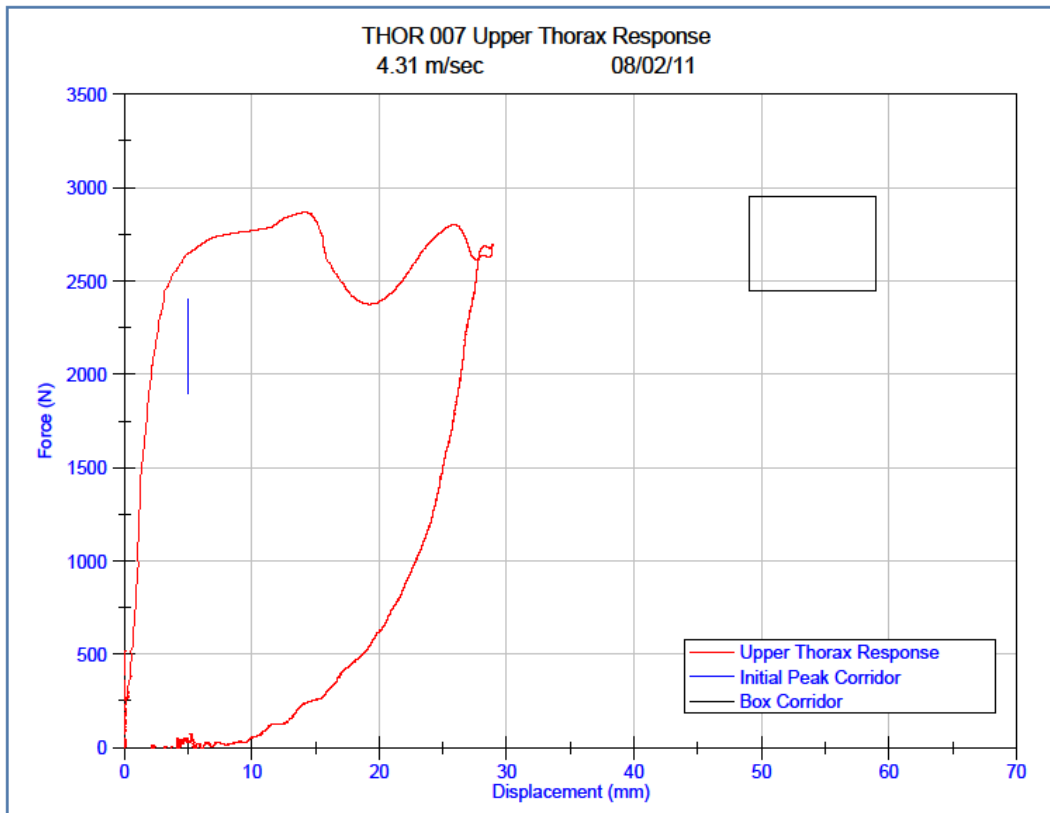
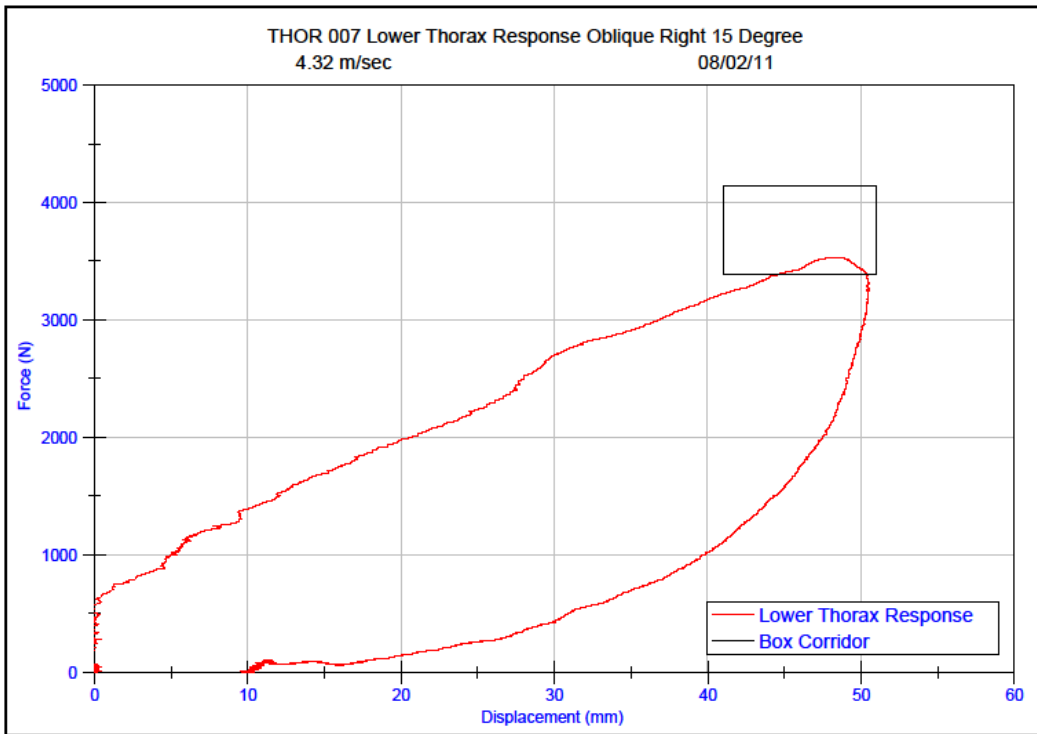

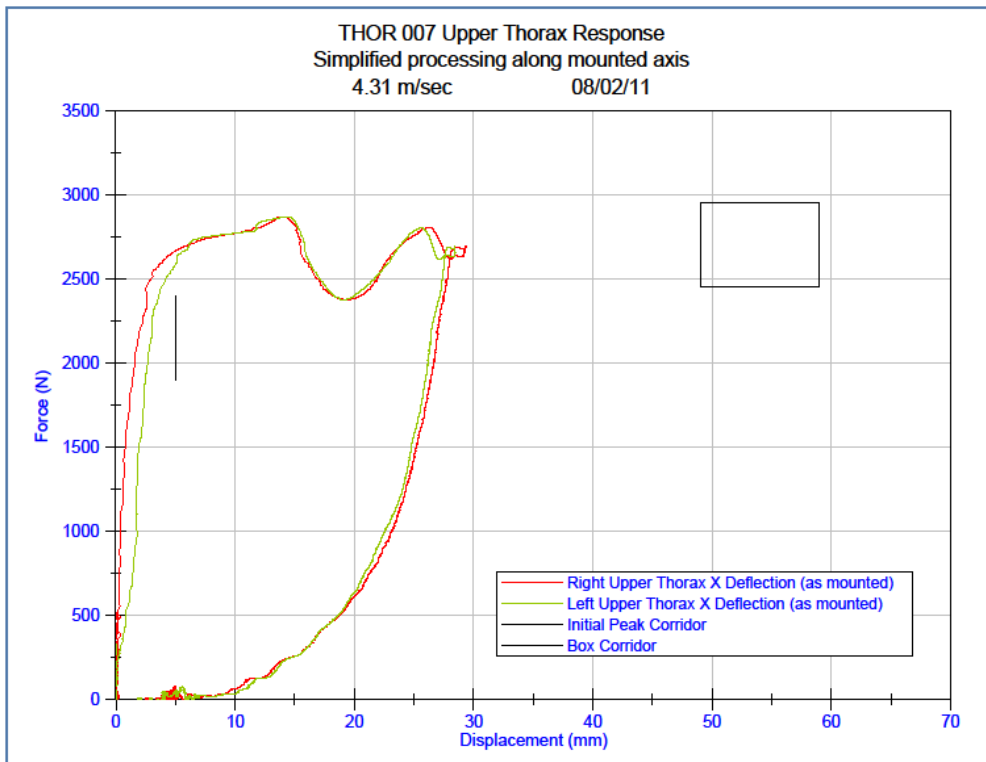

LEG S/N: LX036 / LX037

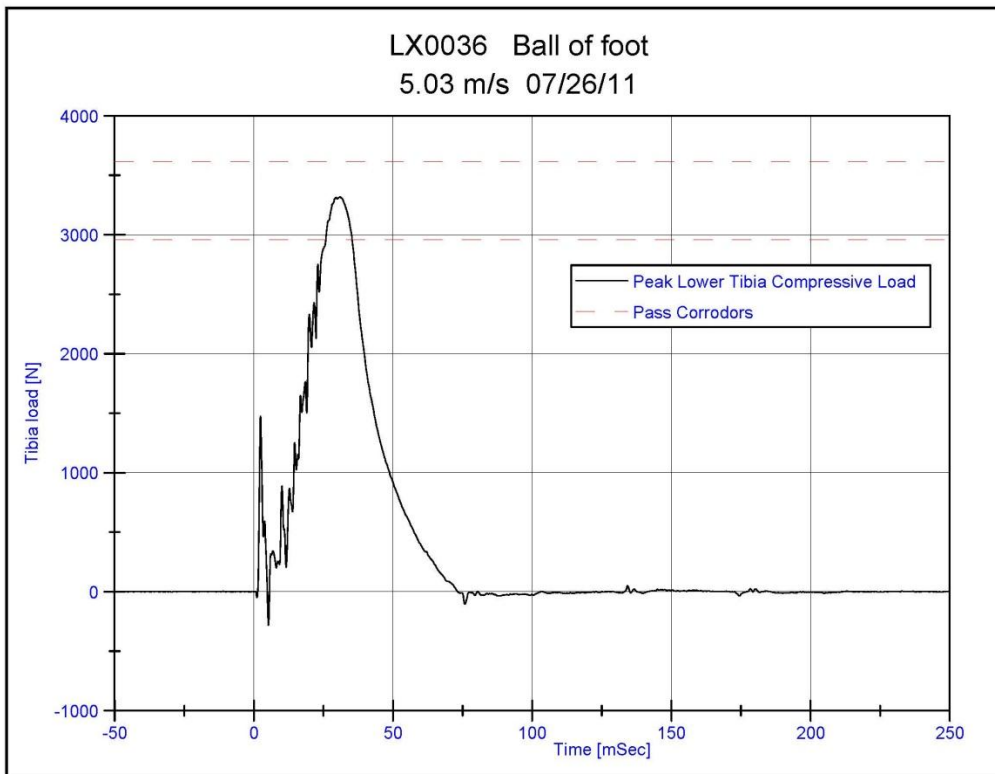

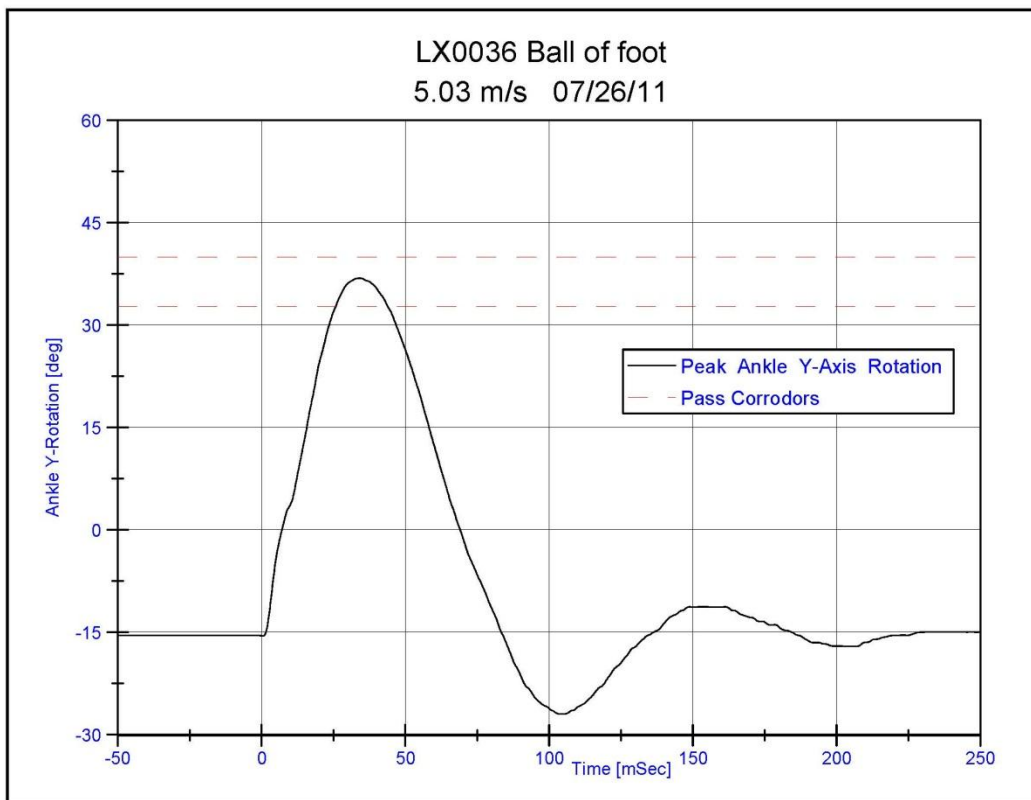
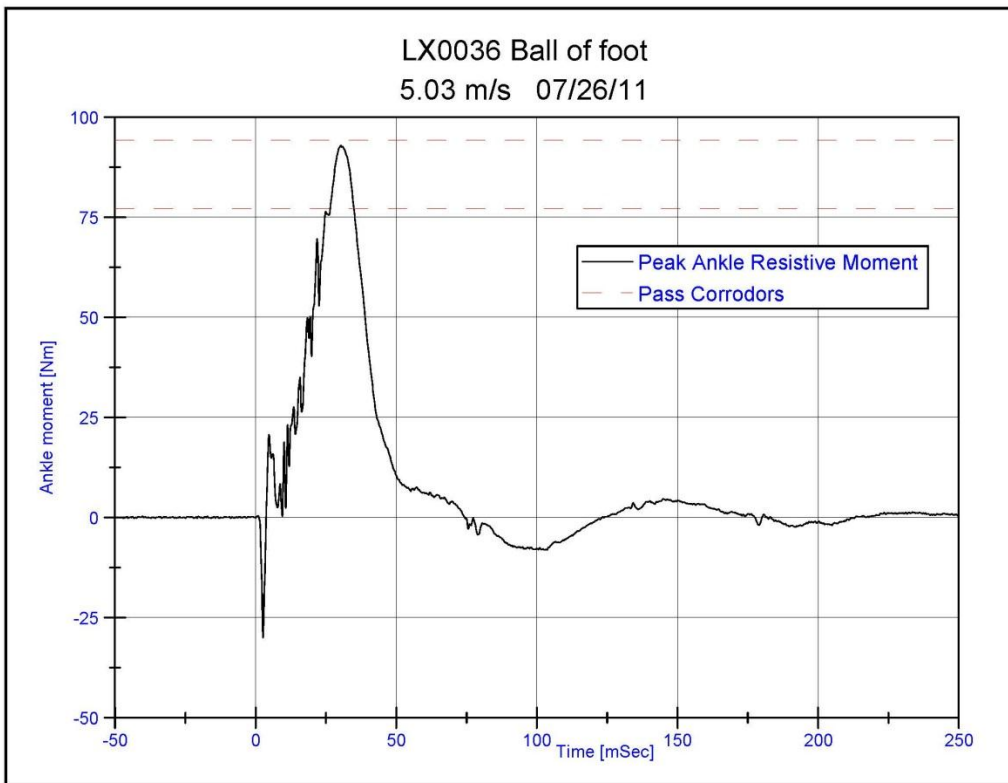

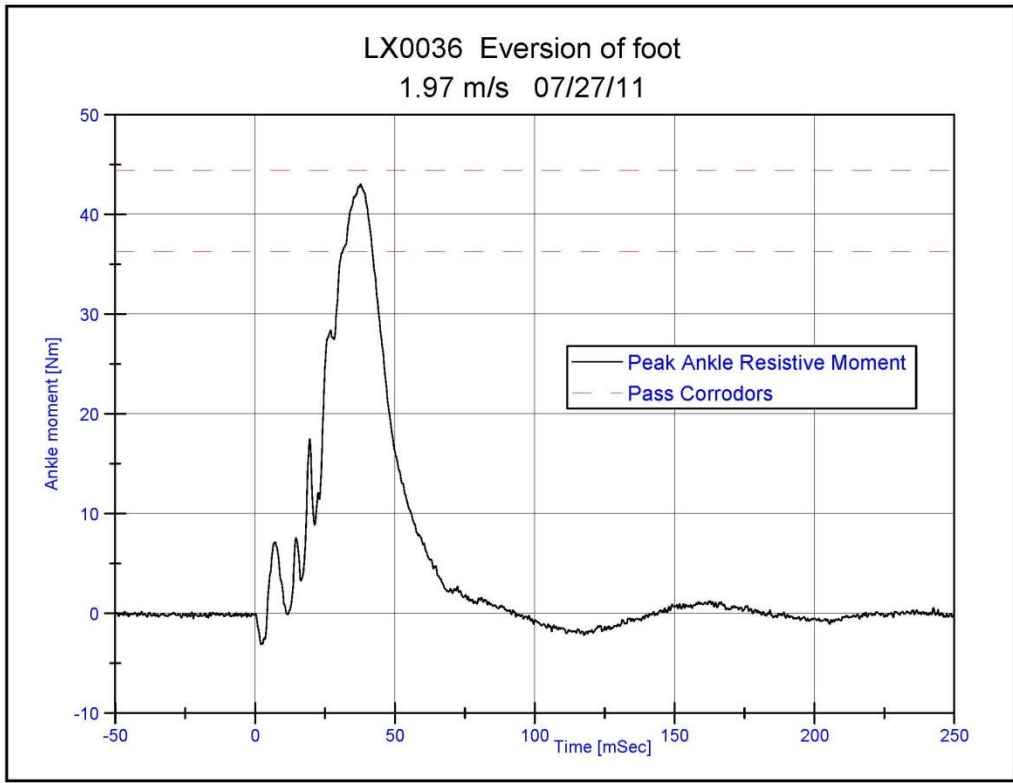
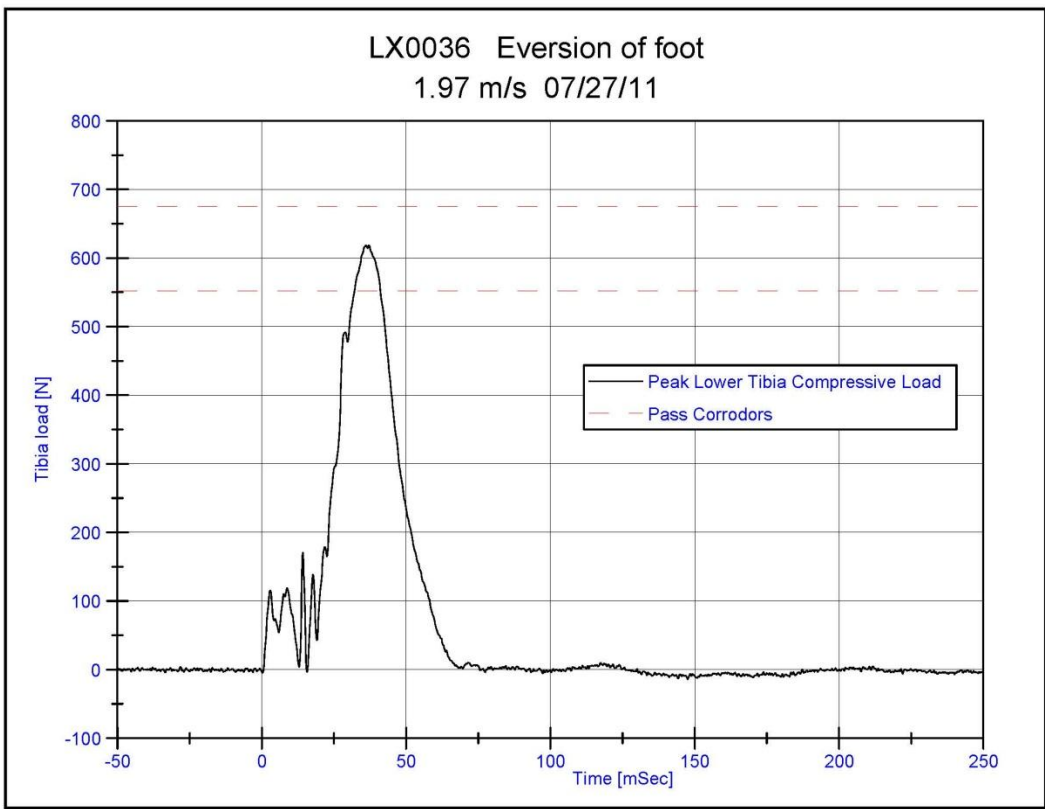

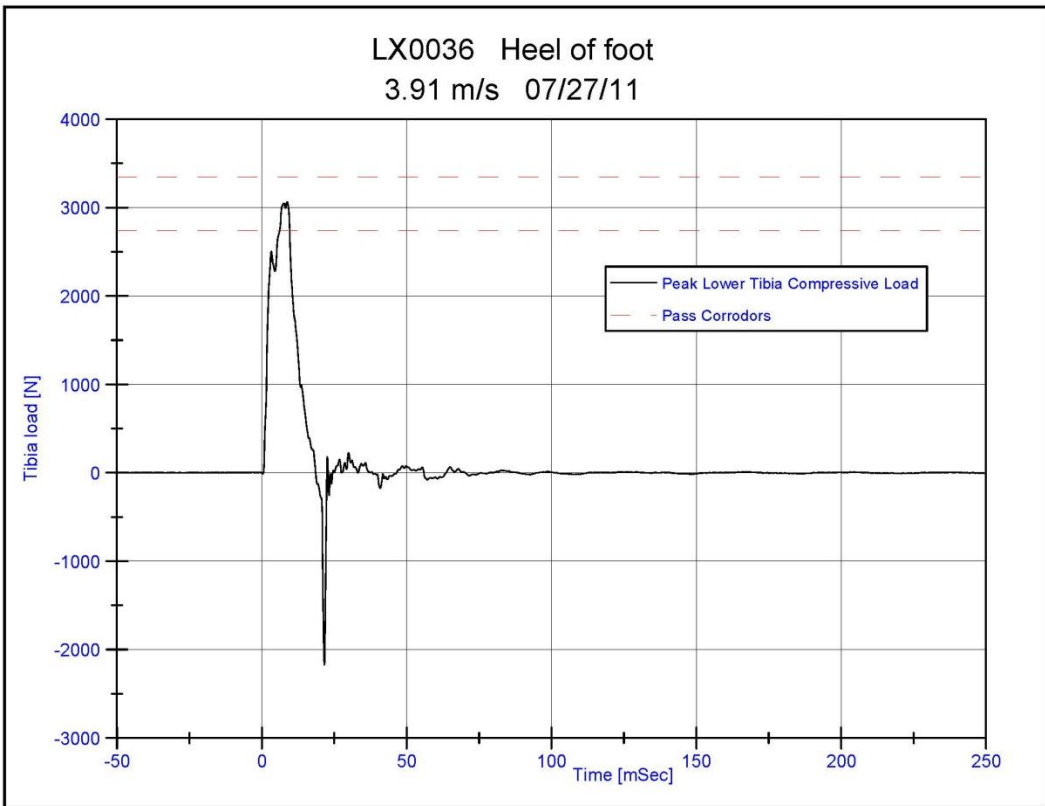
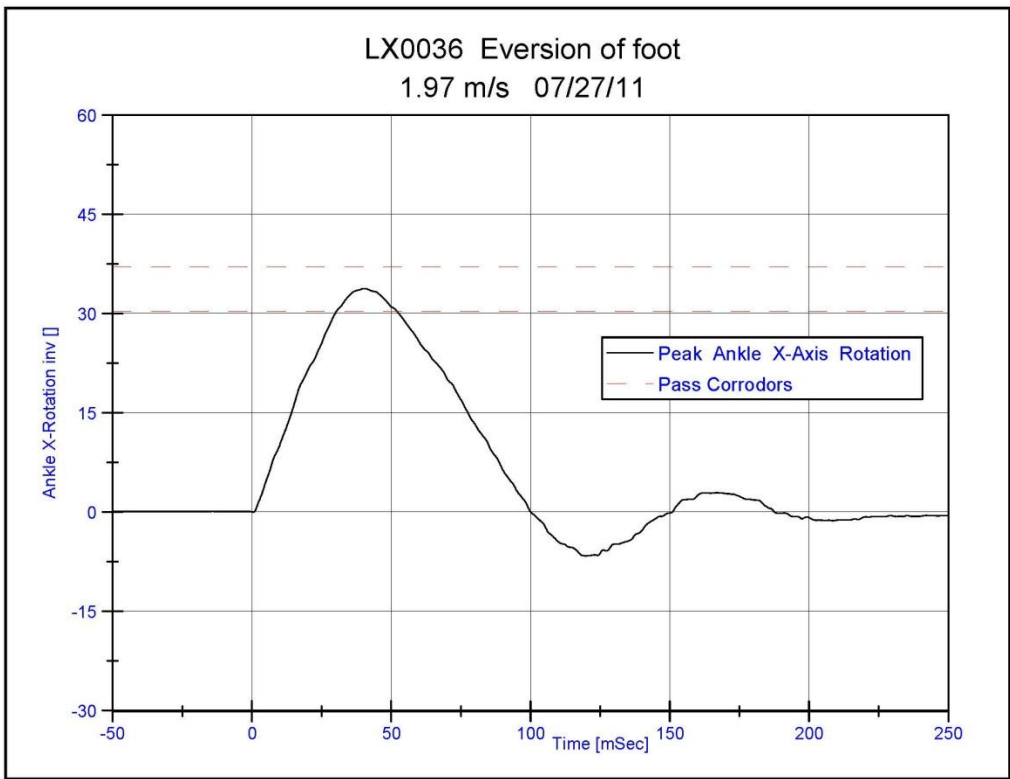

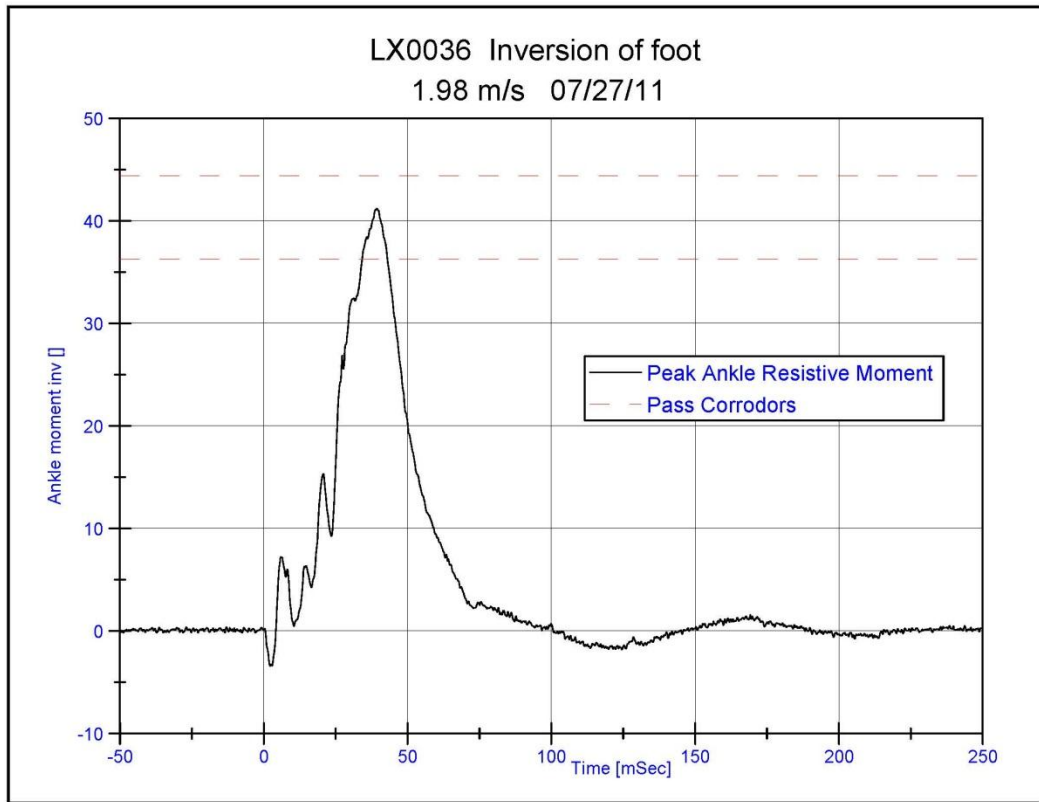
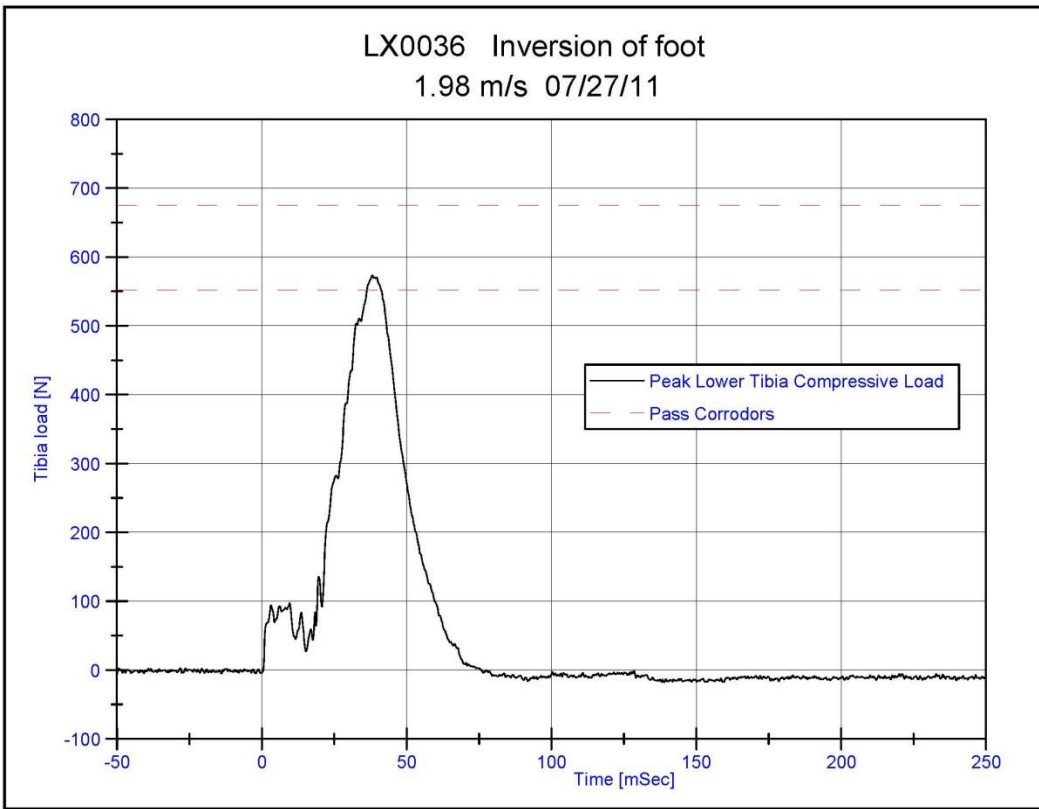

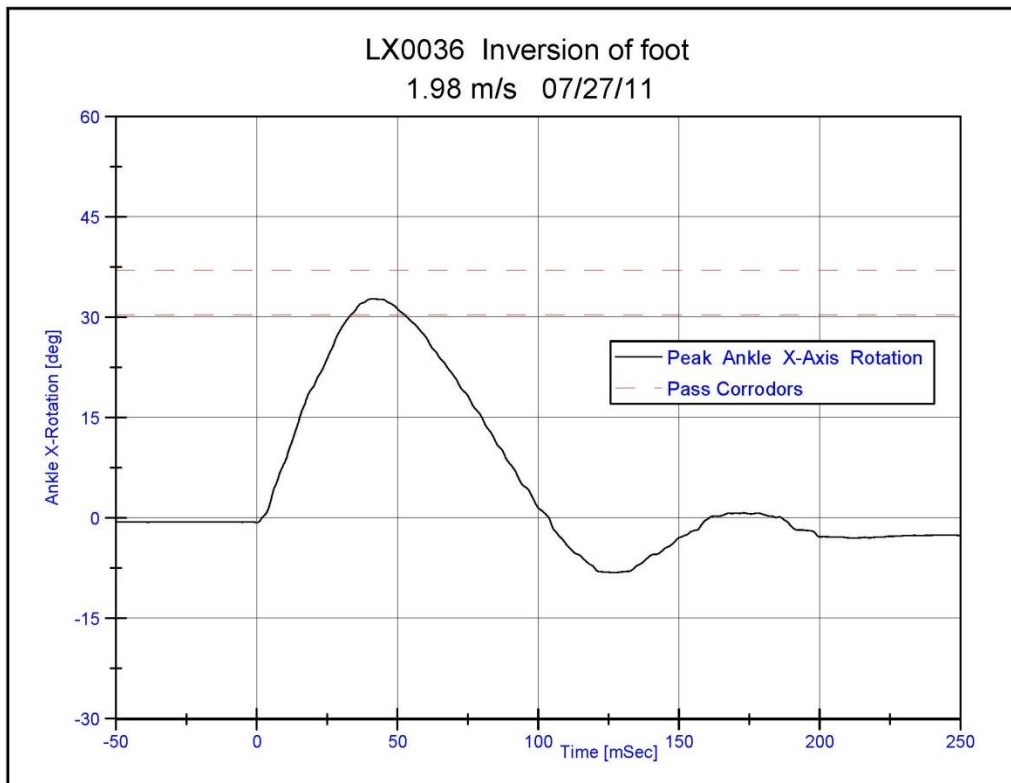

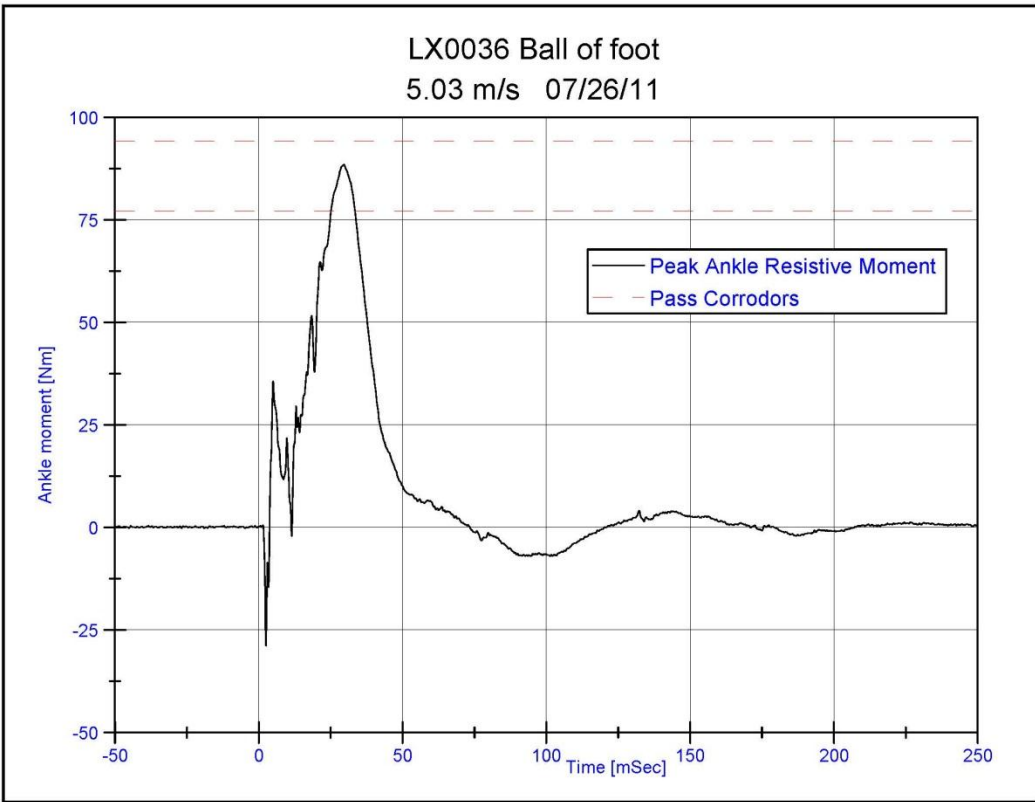
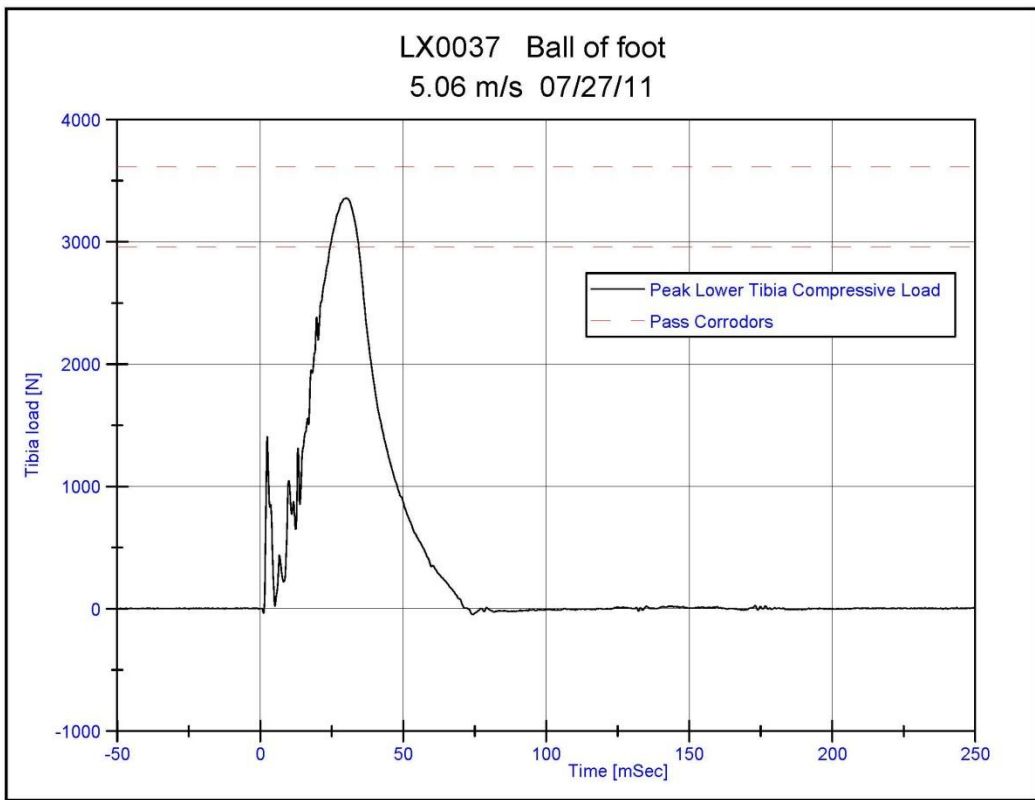

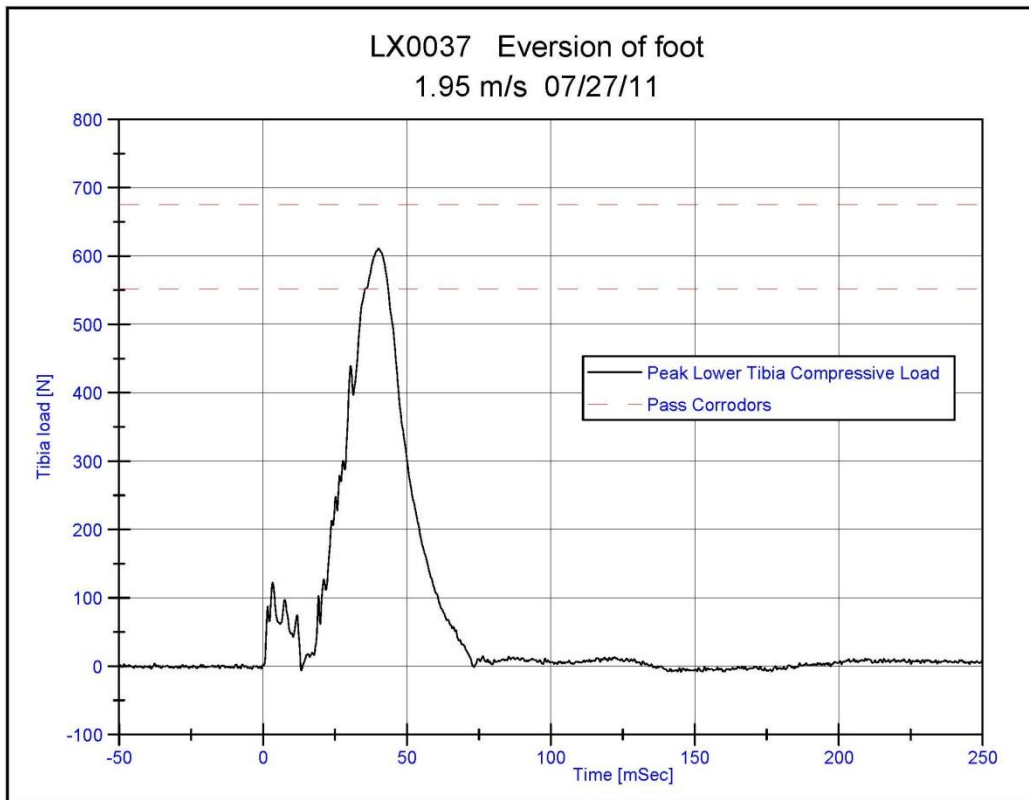
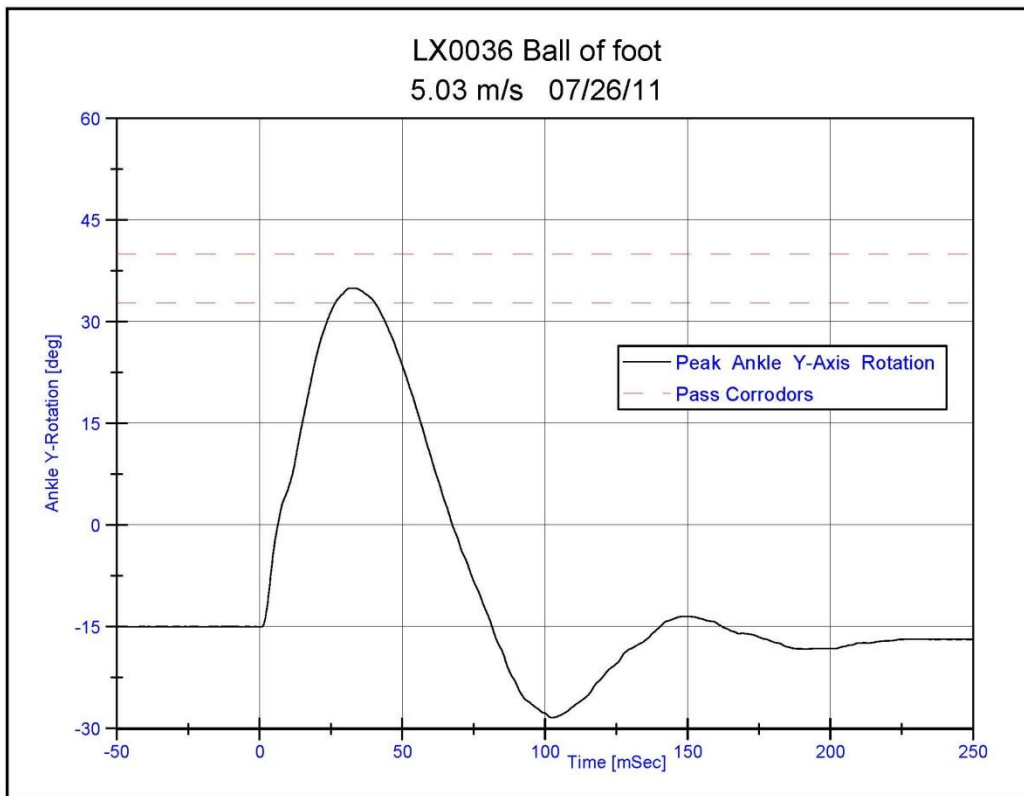

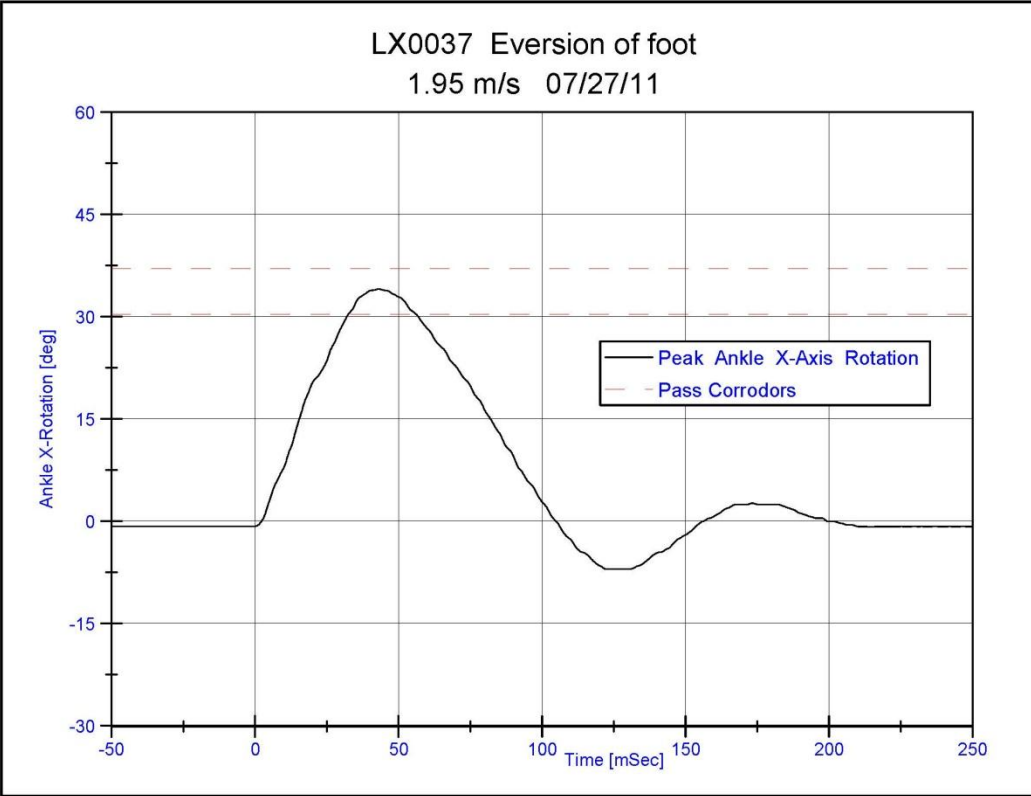
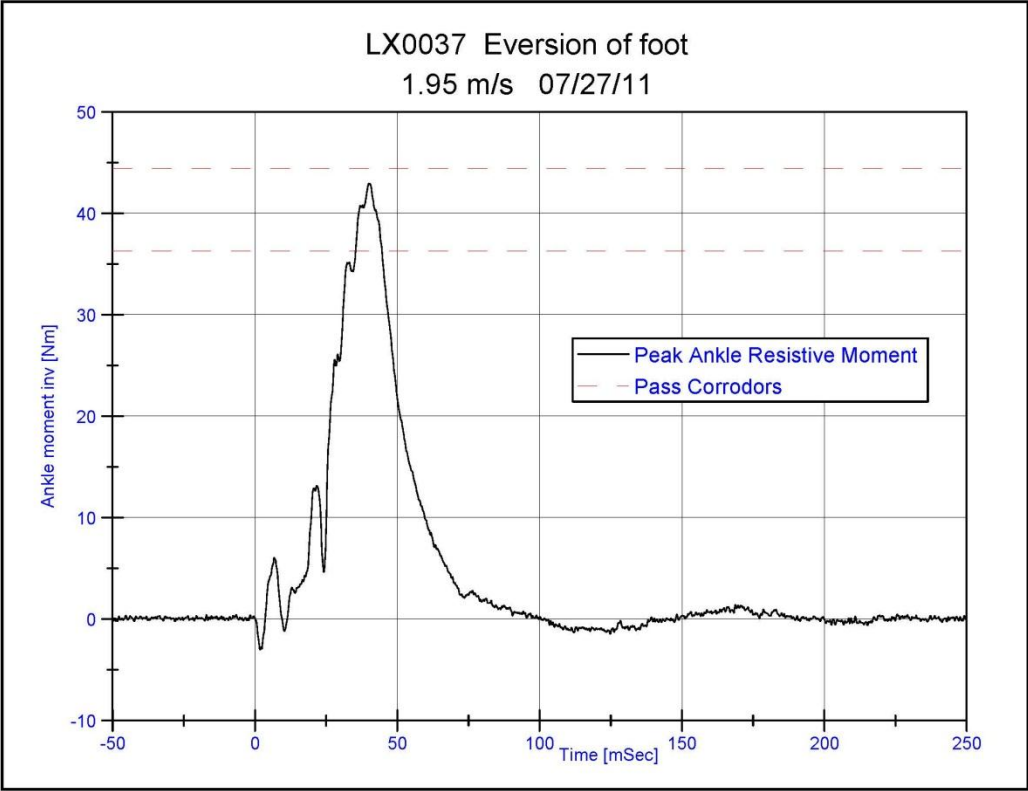

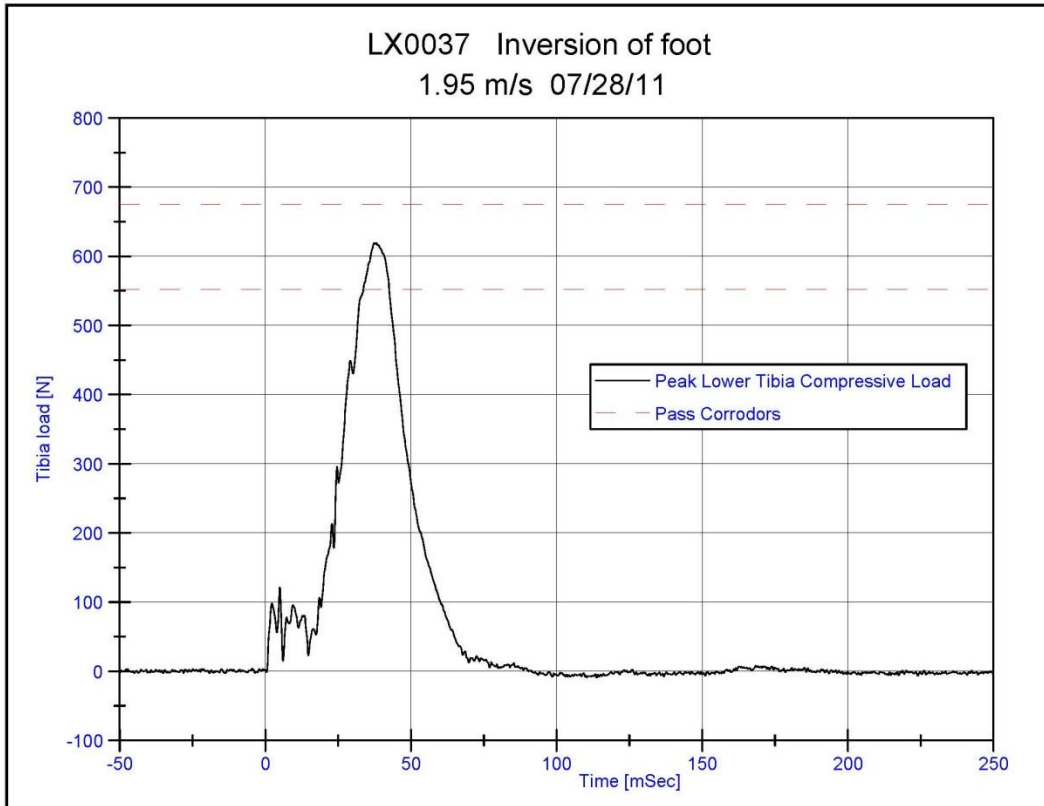
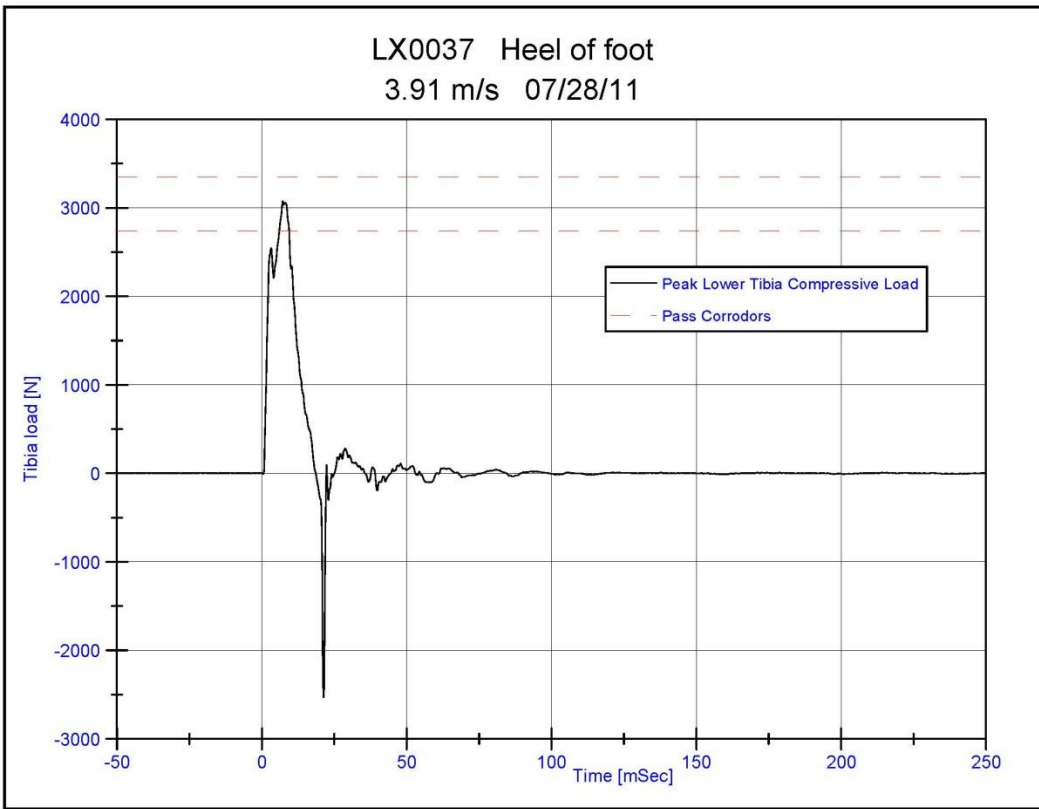

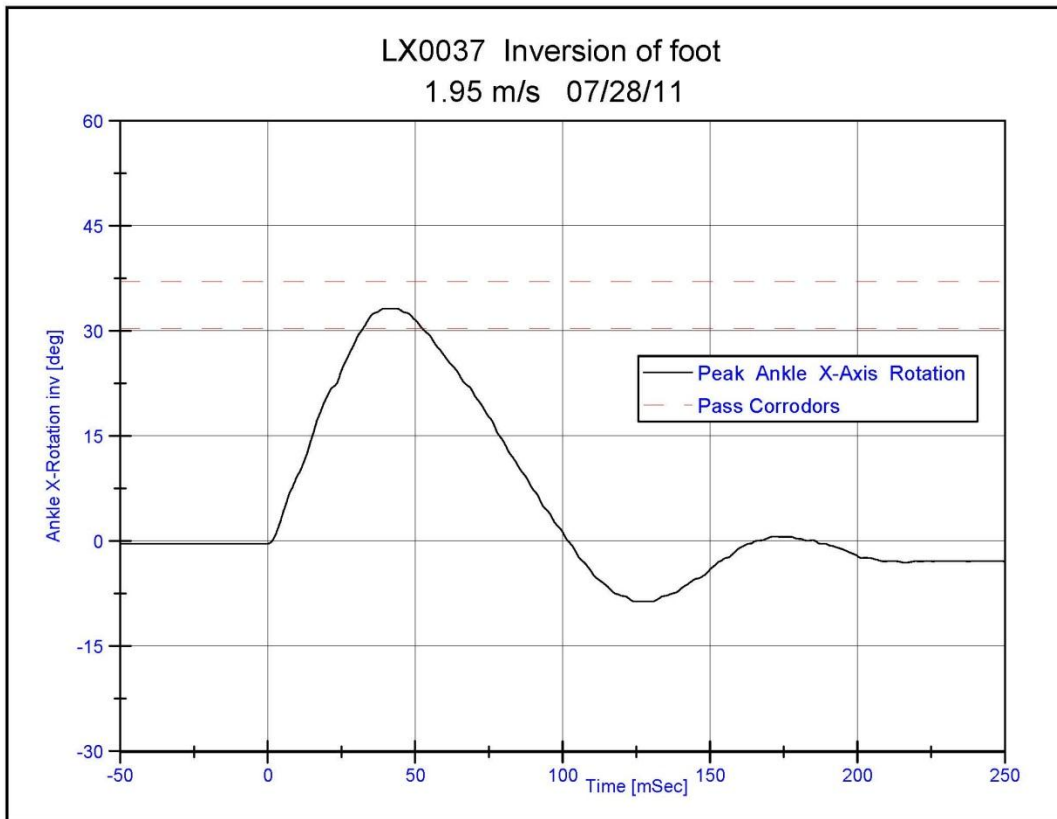
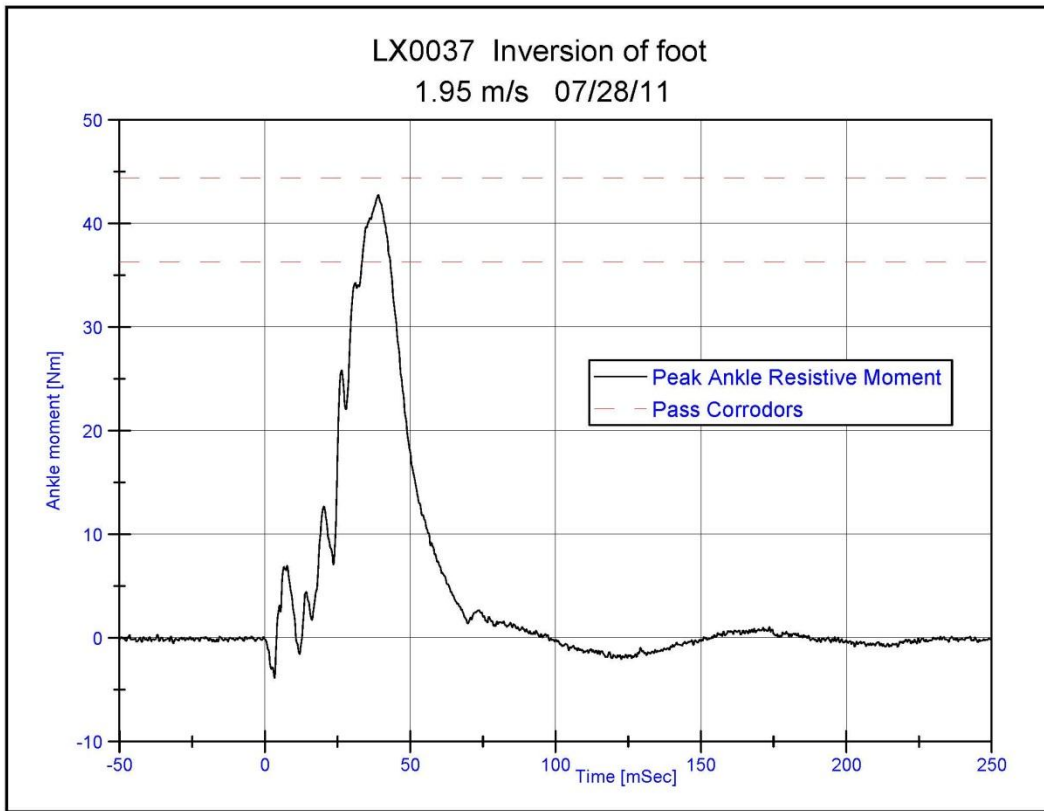

APPENDIX D

Additional Measurements & Data Calculations

ADDITIONAL TARGETS

Overhead Reference Targets:

AA (T1 to T2)	<u>236</u>	mm
BB (T2 to T3)	<u>234</u>	mm

Ground Reference Targets:

CC (T1 to T2)	<u>235</u>	mm
DD (T2 to T3)	<u>235</u>	mm

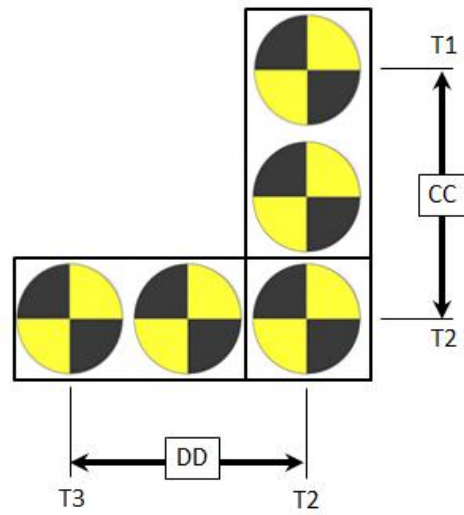
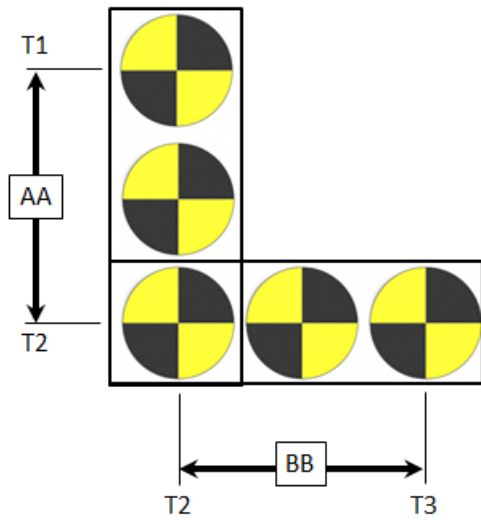

APPENDIX E

POSITIONING PROCEDURE FOR REAR SEAT PART 5720 5TH FEMALE ATD

The rear seat 5th female was positioned using a combination of the FMVSS 214D side impact and FMVSS 208 seating procedures.

The lateral seat centerline was determined by following the FMVSS 214D seating procedures for the rear seat. Once the Part 5720 5th female dummy was located on the lateral centerline, the dummy was positioned following FMVSS 208 as if it were in the front seating position. The legs would be positioned at the 120 degree angle and the pelvis would be pushed back against the seatback until the calves contacted the seat cushion. If the seatback was adjustable, the seatback would be raised to level the head. The 5th female dummy used in this test series had a lower neck transducer which prevented using the neck bracket as an adjustment to level the head.

APPENDIX F
CMM MEASUREMENT PROCEDURES

SECTION F.1

SEAT BACK MEASUREMENT PROCEDURE

The following procedure was used in obtaining the required seat back measurements, please see the below diagram for additional clarification:

1. Measure Points 3 and 4 on the using the following method after positioning the dummy and head restraint:
2. Place a level at the center of the head restraint and make sure it is level to the horizontal
3. Measure down 16 inches from the bottom of the level in the vertical direction
4. Project a line in the longitudinal direction until contact with seat and mark point 1 with a marker
5. Project another line in the longitudinal direction until contact with seat and mark point 2 with a marker
6. Push on the seat fabric at point 1 and determine if there is any structure. Do not push in the longitudinal direction more than an inch
7. If no structure found push on the seat cloth and move in the lateral direction toward the outboard of the seat until seat structure is found
8. Cut a slit in the seat fabric
9. Mark Point 3 at the begin on the structure and measure the point
10. Perform the same procedure to determine Point 4 using Point 2

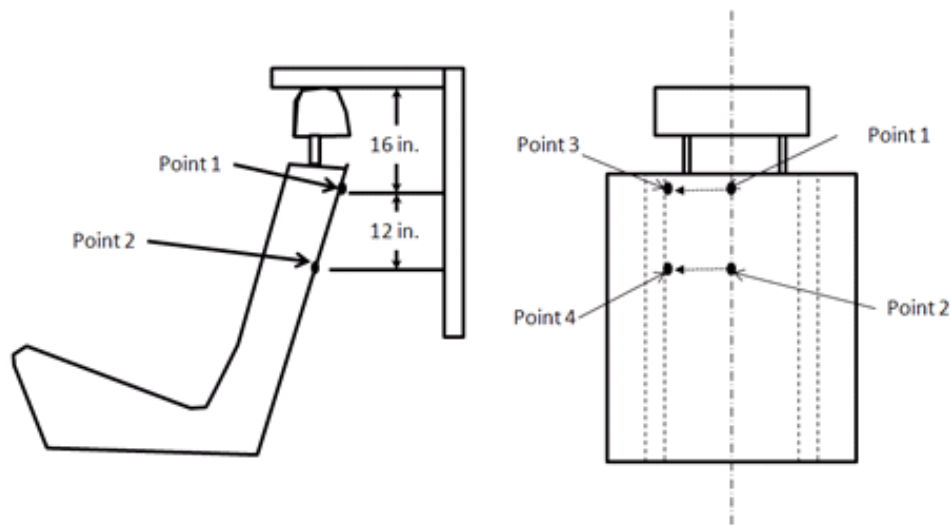

SECTION F.2

DOOR SILL INTRUSION MEASUREMENT PROCEDURE

The following procedure was conducted in order to obtain the required door sill intrusion measurements for this test. Please see the below picture for further clarifications:

1. Put steering wheel in center position. Create a horizontal plane (plane 1) that passes through the center of the steering wheel.
2. Point 1: Mark the sheet metal at the intersection of plane 1 and the outer edge of rubber part of the door sill running down the A-pillar.
3. Point 22: Mark the sheet metal at the intersection of plane 1 and the outer edge of rubber part of the door sill running down the B-pillar.
4. Mark 20 evenly spaced points between points 1 and 22 along the outer edge of the rubber door sill on the sheet metal. (A tape measure can be used to mark these points).
5. Mark 20 evenly spaced points between points 22 and 1 along the outer edge of the rubber door sill on the sheet metal. (A tape measure can be used to mark these points).
6. Measure points using CMM
7. Record in the appropriate data sheet and calculate the difference by subtracting the post-test minus the pre-test. A picture with the points labeled shall be included on the data sheet. All points shall be visible in the pictures.
8. Repeat on the passenger door.



SECTION F.3

VEHICLE EXTERIOR CRUSH PROFILE PROCEDURE

1. Expose the bumper beam and level the vehicle such that all attitudes are within 5 mm.
2. Cross section A-A is defined as a horizontal plane passing through the center of the front bumper beam at the centerline of the vehicle (Figure F.3.1). Record the height of this plane (d_1) and take enough points at this height to create an exterior cross-section of the vehicle.
3. Perform the same procedure for cross-section B-B. Cross section B-B is defined as a plane passing through the top the upper radiator support.
4. Post-test put the vehicle back to its original coordinate system (Figure F.3.2). Take enough points at the height of d_1 and d_2 to create a post-test cross-section A-A and B-B. There can be more points measured posttest than pre-test (Figure F.3.3). Record these points in the appropriate data sheet.

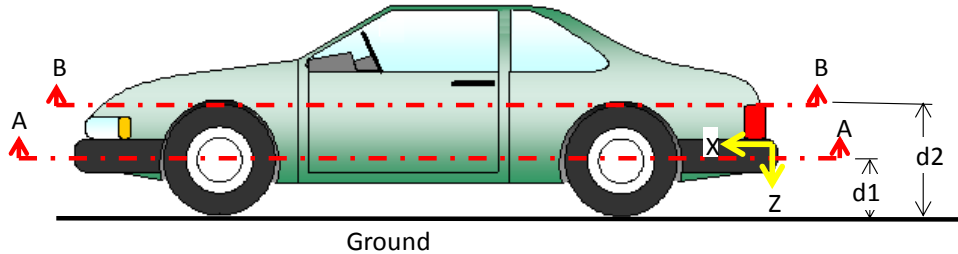

Figure F.3.1 - Pre-Test Cross-Sections

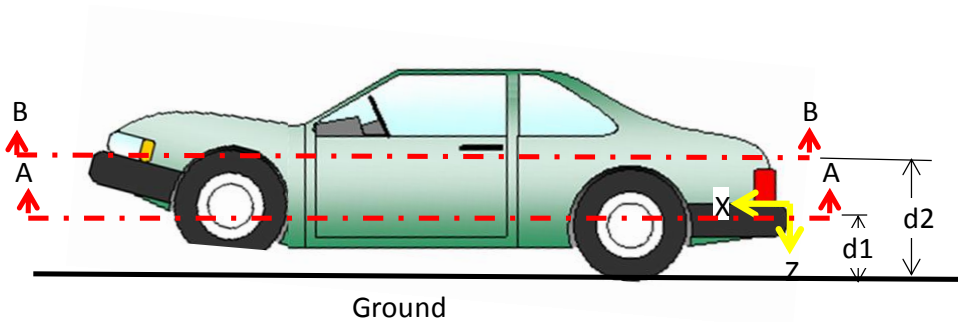

Figure F.3.2 - Post-Test Cross-Sections

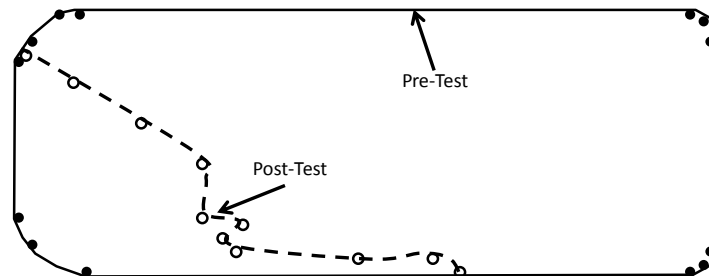

Figure F.3.3 - Plot of Cross-Section

SECTION F.4

DASH PROFILE MEASUREMENT PROCEDURE

The following procedure was used in order to obtain the dash profile measurements required for this test. Please see the diagram on the following page for further clarifications:

1. Left Plane: create a vertical plane that is parallel to the longitudinal axis of the vehicle and is located 150mm to the left of the center of the steering wheel (Figure 31).
2. Left Line: create a line on the IP/Knee Bolster at the intersection of the Left Plane and the IP/KneeBolster
3. L1: create a point on the dash that is located on the Left Line and is 450 mm above the floorboard (with floor mats removed). Note this is the Left IP point for the IP5 file and IP Left in DATA SHEET NO.13 (CONTINUED) - VEHICLE INTRUSION MEASUREMENTS.
4. Lt1: From L1 move up the Left Line 50 mm
5. Lt2: From Lt1 move up the Left Line 50 mm
6. Ltn: Mark points at 50 mm increments along Left Line until the window sill is reached.
7. Lb1: From L1 move down the Left Line 50 mm
8. Lb2: From Lb1 move down the Left Line 50 mm
9. Lbn: Mark points at 50 mm increments along Left Line until the bottom of the IP/Knee Bolster is reached.
10. Right Plane: create a vertical plane that is parallel to the longitudinal axis of the vehicle and is located 150mm to the right of the center of the steering wheel (Figure 31).
11. Right Line: create a line on the IP/Knee Bolster at the intersection of the Right Plane and the IP/KneeBolster
12. R1: create a point on the dash that is located on the Right Line and is 450 mm above the floorboard (with floor mats removed). Note this is the Right IP point for the IP5 file and IP Right in DATA SHEET NO.13 (CONTINUED) - VEHICLE INTRUSION MEASUREMENTS.
13. Rt1: From R1 move up the Right Line 50 mm
14. Rt2: From Rt1 move up the Right Line 50 mm
15. Rtn: Mark points at 50 mm increments along Right Line until the window sill is reached.
16. Rb1: From R1 move down the Right Line 50 mm
17. Rb2: From Rb1 move down the Right Line 50 mm
18. Rbn: Mark points at 50 mm increments along Right Line until the bottom of the IP/Knee Bolster is reached.

19. If dash panel or knee bolster loosens or breaks away in the crash, the post-test measurements are taken by pressing and holding the panel against the underlying structure. Record in the appropriate data sheet and calculate the difference by subtracting the post-test minus the pre-test. A picture with the points labeled shall be included on the data sheet. All points shall be visible in the picture.

