

**REPORT NUMBER: SNCAP-KAR-11-057**

**NEW CAR ASSESSMENT PROGRAM (NCAP)  
MOVING DEFORMABLE BARRIER SIDE IMPACT TEST**

**FORD MOTOR CO.  
2011 FORD F-150 XLT SUPERCREW 4-DOOR TRUCK**

**NHTSA No: MB0207**

**PREPARED BY:  
KARCO ENGINEERING, LLC.  
9270 HOLLY ROAD  
ADELANTO, CA 92301**



**FEBRUARY 11, 2011**

**FINAL REPORT**

**PREPARED FOR:  
U.S. DEPARTMENT OF TRANSPORTATION  
NATIONAL HIGHWAY TRAFFIC SAFETY ADMINISTRATION  
OFFICE OF CRASHWORTHINESS STANDARDS  
1200 NEW JERSEY AVE, SE  
ROOM W43-410  
WASHINGTON, D.C. 20590**



**TECHNICAL REPORT DOCUMENTATION PAGE**

<b>1. Report No.</b> SNCAP-KAR-11-057	<b>2. Government Accession No.</b>	<b>3. Recipient's Catalog No.</b>
<b>4. Title and Subtitle</b> Final Report of New Car Assessment Program Side Impact Testing of a 2011 Ford F-150 XLT SuperCrew 4-Door Truck NHTSA No. MB0207	<b>5. Report Date</b> February 25, 2011	
	<b>6. Performing Organization Code</b> KAR	
<b>7. Authors</b> Mr. Denver J. Schaffarzick, Project Engineer, KARCO Mr. Frank Richardson, Program Manager, KARCO	<b>8. Performing Organization Report No.</b> TR-P30003-24-NC	
	<b>10. Work Unit No.</b>	
<b>9. Performing Organization Name and Address</b> KARCO Engineering, LLC. 9270 Holly Rd. Adelanto, CA, 92301	<b>11. Contract or Grant No.</b> DTNH22-09-D-00122	
	<b>13. Type of Report and Period Covered</b> Final Report, February 2011	
<b>12. Sponsoring Agency Name and Address</b> U. S. Department of Transportation National Highway Traffic Safety Administration Office of Crashworthiness Standards 1200 New Jersey Ave., SE, Room W43-410 Washington, D.C. 20590	<b>14. Sponsoring Agency Code</b> NVS-111	
	<b>15. Supplementary Notes</b>	

**16. Abstract**

A 55/28 km/h 90 deg. Moving Deformable Barrier NCAP Side Impact Test was conducted on the subject 2011 Ford F-150 XLT SuperCrew 4-Door Truck in accordance with the specifications of the Office of Crash Worthiness Standards Test Procedure for the generation of consumer information on vehicle side crash protection. The test was conducted at KARCO Engineering, LLC in Adelanto, CA, on February 11, 2011.

The impact velocity of the Moving Deformable Barrier was 61.89 km/h and the outside ambient temperature at the struck (driver's) side of the vehicle was 17.8 deg. C. The target vehicle's maximum post-test static crush was 316 mm located at level 1. The test vehicle's occupant performance data is as follows:

Measurement Description	Driver ATD (ES-2re)		
	Units	Threshold	Result
Head Injury Criteria (HIC <sub>36</sub> )		1000	37.6
Maximum Thorax Rib Deflection	mm	44	6.5
Total Abdominal Force	N	2500	267
Pubic Symphysis Force	N	6000	943

Measurement Description	Passenger ATD (SID-IIs)		
	Units	Threshold	Result
Head Injury Criteria (HIC <sub>36</sub> )		1000	37.0
Lower Spine Resultant Acceleration	g	82	21
Total Pelvic Force (Sum of Acetubular and Iliac Forces)	N	5525	1361

The two doors on the struck side of the vehicle did not separate from the body at the hinges or latches, and the opposite doors did not open during the side impact event.

<b>17. Key Words</b> New Car Assessment Program (NCAP) Side Impact Moving Deformable Barrier (MDB) ES-2re SID-IIs		<b>18. Distribution Statement</b> Copies of this report are available from: National Highway Traffic Safety Admin. Technical Reference Division 1200 New Jersey Ave., SE Room W43-410 Washington, DC 20590	
<b>19. Security Classification of this report</b> UNCLASSIFIED	<b>20. Security Classification of this page</b> UNCLASSIFIED	<b>21. No. of Pages</b> 134	<b>22. Price</b>

## TABLE OF CONTENTS

<u>Section</u>		<u>Page</u>
1	Purpose and Summary of the Test	1
2	Occupant and Vehicle Information/Data Sheets	3
<u>Data Sheet</u>		<u>Page</u>
1	General Test and Vehicle Parameter Data	4
2	Seat Adjustment, Fuel Systems, and Steering Wheel Data	7
3	Dummy Longitudinal Clearance Dimensions	9
4	Dummy Lateral Clearance Dimensions	10
5	Camera Locations and Data	11
6	Vehicle Accelerometer Locations	12
7	MDB Accelerometer Locations	13
8	Test Vehicle Summary of Results	14
9	Moving Deformable Barrier (MDB) Summary of Results	15
10	Post-Test Observations	16
11	Vehicle Profile Measurements	17
12	Vehicle Exterior Crush Measurements	18
13	Vehicle Damage Profile Distances	21
14	Exterior Static Crush for Impactor Face	22
15	FMVSS No. 301 Fuel System Integrity Post-Impact Data	23
16	Dummy/Vehicle Temperature Stabilization	24
<u>Appendix</u>		<u>Page</u>
A	Photographs	A
B	Dummy Response Data	B
C	Dummy Calibration Data	C

**SECTION 1**  
**PURPOSE AND SUMMARY OF TEST**

**PURPOSE**

This moving deformable barrier side impact test is part of the MY 2011 New Car Assessment Program Side Impact Test Program, sponsored by the National Highway Traffic Safety Administration (NHTSA), under contract number DTNH22-09-D-00122. The purpose of this test is to generate comparative side impact performance in a 2011 Ford F-150 XLT SuperCrew 4-Door Truck. The side impact test was conducted in accordance with the Office of Crashworthiness Standard's Laboratory Test Procedure dated January 2010.

**SUMMARY**

A 2011 Ford F-150 XLT SuperCrew 4-Door Truck was impacted on the left (driver's) side by a Moving Deformable Barrier (MDB) which was moving forward in a 27° crabbed position to the tow road guidance system at a velocity of 61.89 km/h (38.46 mph). The target vehicle was stationary and was positioned at an angle of 63° to the line of forward motion. The side impact test was conducted by KARCO Engineering, LLC. in Adelanto, California, on February 11, 2011. Pre- and post-test photographs of the test vehicle, the MDB, and the dummies (ES-2re and SID-IIs) are included in Appendix A of this report.

Dummies were placed in the driver and left rear designated seating positions according to instructions specified in the OCWS Side Impact Laboratory Test Procedure, dated January 2010. The side impact event was documented by 11 cameras. Camera locations are included in Data Sheet No. 5 of this report.

The dummies were instrumented in the following manner:

DRIVER ATD (ES-2re)

Head Accelerometers

Thorax Rib 1 to Rib 3 Potentiometers

Abdomen Forward, Middle, and Rear Load Cells

Lower Spine Accelerometers

Pubic Load Cell

PASSENGER ATD (SID-IIs)

Head Accelerometers

Thorax Upper, Middle and Lower Rib Potentiometers

Abdomen Upper and Lower Rib Potentiometers  
 Lower Spine Accelerometers  
 Iliac Load Cell  
 Acetabulum Load Cell

Dummy injury values were recorded as follows:

Measurement Description	Units	Driver ATD (ES-2re)	
		Threshold	Result
Head Injury Criteria (HIC <sub>36</sub> )		1000	37.6
Maximum Thorax Rib Deflection	mm	44	6.5
Combined Abdominal Force	N	2500	267
Pubic Symphysis Force	N	6000	943

Measurement Description	Units	Passenger ATD (SID-IIs)	
		Threshold	Result
Head Injury Criteria (HIC <sub>36</sub> )		1000	37.0
Lower Spine (T12) Resultant Acceleration	g	82	21
Total Pelvic Force (sum of acetabular and iliac forces)	N	5525	1361

Supplemental restraint information is given below:

Restraint Type	Left Front (Driver)		Left Rear (Passenger)	
	Mounted	Deployed	Mounted	Deployed
Frontal Airbag	Yes	No	No	
Knee Airbag	No		No	
Side Airbag 1 (Torso/Pelvis)	Yes	Yes	No	
Side Airbag 2 (Curtain)	Yes	Yes	Yes	Yes
Seat Belt Pretensioner	Yes	Yes	No	
Seat Belt Load Limiter	Yes	Yes	No	
Other				

### GENERAL COMMENTS

Both the front and rear doors on the struck side of the vehicle remained closed and latched. There was no separation at the hinges or latches. Both doors on the non-struck side remained closed and latched. There were no ATD values that exceeded limits.

## SECTION 2

### OCCUPANT AND VEHICLE INFORMATION/DATA SHEETS

Test Vehicle: 2011 Ford F-150 XLT SuperCrew 4-Door Truck

NHTSA No. MB0207

Test Program: MDB Side Impact Test

Test Date: 2/11/11

### CONVERSION FACTORS

Quantity	Typical Application	Std Units	Metric Unit	Multiply By
Mass	Vehicle Weight	lb	kg	0.4536
Linear Velocity	Impact Velocity	miles/hr	km/hr	1.609344
Length or Distance	Measurements	in	mm	25.4
Volume	Fuel Systems	gal	liter	3.785
Volume	Small Fluids	oz	mL	29.573
Pressure	Tire Pressures	lbf/in <sup>2</sup>	kPa	7.0
Volume	Liquid	gal	liter	3.785
Temperature	General Use	°F	°C	$=(tf - 32)/1.8$
Force	Dynamic Forces	lbf	N	4.448
Moment	Torque	lbf/ft	Nm	1.355

**DATA SHEET NO. 1**

**GENERAL TEST AND VEHICLE PARAMETER DATA**

Test Vehicle: 2011 Ford F-150 XLT SuperCrew 4-Door Truck

NHTSA No. MB0207

Test Program: MDB Side Impact Test

Test Date: 2/11/11

**TEST VEHICLE INFORMATION AND OPTIONS**

NHTSA Number	MB0207
Model Year	2011
Make	Ford
Model	F-150 XLT SuperCrew
Body Style	4-Door Truck
VIN	1FTFW1CF3BFA43696
Body Color	Sterling Gray Metallic
Delivery Date	1/27/2011
Odometer Reading (km / mi)	27 / 17
Dealer	Galpin Ford
Transmission	6-Speed Automatic
Final Drive	Rear
Type / No. of Cylinders	V-8
Engine Displacement (L)	5.0
Engine Placement	Longitudinal
Roof Rack	No
Sunroof / T-Top	No
Tinted Glass	Yes
Traction Control	Yes
Power Brakes	Yes
Front Disc	Yes
Rear Disc	Yes

Anti-Lock Brakes	Yes
All Wheel Drive	No
Power Steering	Yes
Driver Front Airbag	Yes
Driver Curtain Airbag	Yes
Driver Head/Torso Airbag	No
Driver Torso Airbag	No
Driver Torso/Pelvis Airbag	Yes
Driver Pelvis Airbag	No
Driver Knee Airbag	No
Rear Pass. Curtain Airbag	Yes
Rear Pass. Head/Torso Airbag	No
Rear Pass. Torso Airbag	No
Rear Pass. Torso/Pelvis Airbag	No
Rear Pass. Pelvis Airbag	No
Pretensioners	Yes
Load Limiters	Yes
Automatic Door Locks	Yes
Bucket Seats	Yes
Tilt Steering	Yes
Other	
Other	

Does Owner's Manual provide instructions to turn off automatic door locks? Yes

**DATA FROM CERTIFICATION LABEL**

Manufactured By	Ford Motor Co.
Date of Manufacture	Dec-10

GVWR (kg)	3221
GAWR Front (kg)	1565
GAWR Rear (kg)	1746

**VEHICLE SEATING AND CAPACITY WEIGHT INFORMATION**

Measured Parameter	Front	Rear	Third	Total	
Designated Seating Capacity	3	3		6	
Capacity Weight (VCW) (kg)				785.0	A
DSC x 68.04 (kg)				408.2	B
Cargo Weight (RCLW) (kg)				136.0	A-B

**VEHICLE SEAT TYPE**

Seating Location	Type of Seat Pan				Type of Seat Back		
	Bucket	Bench	Split Bench	Contoured	Fixed	Adjustable	
						w/ Lever	w/ Knob
Front Seat	Yes					Yes	
Rear or Second Row Seat			Yes		Yes		
Third Row Seat							

**DATA SHEET NO. 1 ... (CONTINUED)**

**GENERAL TEST AND VEHICLE PARAMETER DATA**

Test Vehicle: 2011 Ford F-150 XLT SuperCrew 4-Door Truck

NHTSA No. MB0207

Test Program: MDB Side Impact Test

Test Date: 2/11/11

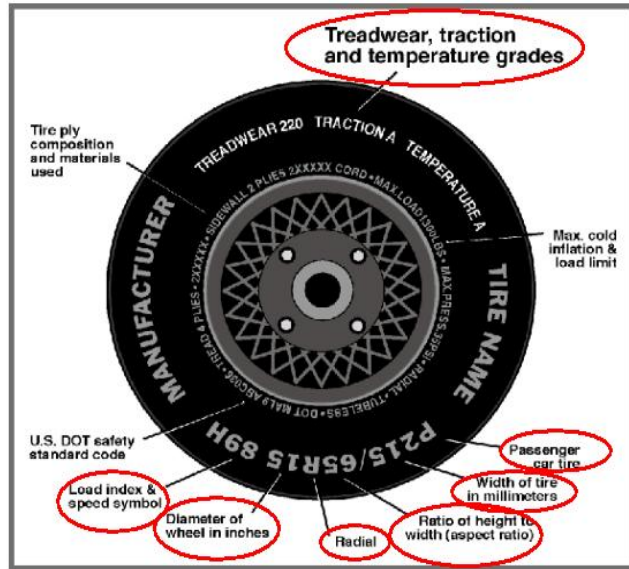

**VEHICLE TIRE INFORMATION**

Measured Parameter	Front	Rear
Max. Tire Pressure (kpa)	300	300
Cold Pressure (kpa)	240	240
Recommended Tire Size	P265/60R18	P265/60R18
Tire Size on Vehicle	P265/60R18	P265/60R18
Tire Model	LTX	LTX
Tire Manufacturer	Michelin	Michelin
Treadwear	420	420
Traction	A	A
Temperature Grades	B	B
Tire Plies Sidewall	2 Polyester	2 Polyester
Tire Plies Body	2 Polyester, 2 Steel, 1 Polyamide	2 Polyester, 2 Steel, 1 Polyamide
Load Index/Speed Symbol	109T	109T
Tire Material	Polyester, Steel, Polyamide	Polyester, Steel, Polyamide
DOT Safety Code Right	APC4 WV1X 4310	APC4 WV1X 4310
DOT Safety Code Left	APC4 WV1X 4311	APC4 WV1X 4311

**DATA SHEET NO. 1 ... (CONTINUED)**

**GENERAL TEST AND VEHICLE PARAMETER DATA**

Test Vehicle: 2011 Ford F-150 XLT SuperCrew 4-Door Truck

NHTSA No. MB0207

Test Program: MDB Side Impact Test

Test Date: 2/11/11

**TEST VEHICLE WEIGHTS**

	Units	As Delivered (UVW)			As Tested (ATW)			Fully Loaded		
		Front	Rear	Total	Front	Rear	Total	Front	Rear	Total
Left	kg	674.0	520.5		740.5	644.5		727.0	628.5	
Right	kg	664.5	553.0		651.5	630.5		664.5	649.5	
Ratio	%	55.5%	44.5%	100.0%	52.2%	47.8%	100.0%	52.1%	47.9%	100.0%
Total	kg	1338.5	1073.5	2412.0	1392.0	1275.0	2667.0	1391.5	1278.0	2669.5

**TARGET TEST WEIGHT CALCULATION**

Measured Parameter	Units	Value	
Total Delivered Weight (UVW)	kg	2412.0	A
Actual Weight of 2 P572 ATDs Used	kg	125.0	B
Rated Cargo/Luggage Wt (RCLW)	kg	136.0	C
Calculated Vehicle Target Wt (TVTW)	kg	2673.0	A+B+C

**TEST VEHICLE ATTITUDES**

Condition	Units	LF	RF	LR	RR	CG (Aft of Front Axle)
Fully Loaded	mm	909	915	947	936	1757
As Tested	mm	912	911	943	939	1754

**GENERAL TEST VEHICLE DATA**

Measurement Description	Units	Value
Total Vehicle Wheelbase	mm	3669
Total Vehicle Length at Left Side	mm	5055
Total Vehicle Length at Centerline	mm	5871
Total Vehicle Length at Right Side	mm	5062
Weight of Ballast in Cargo Area	kg	73.0
Weight of Vehicle Components Removed	kg	16.0
Amount of Stoddard Solvent in Fuel Tank	L	91.52

**Vehicle components removed to make Target Vehicle Test Weight:**

Non-struck side door panels (10.0 kg), Spare tire jack and tools (6.0 kg)

**TEST VEHICLE VERTICAL IMPACT LINE DATA**

Measurement Description	Units	Value
Target Impact Point Aft of Front Axle	mm	508
Actual Impact Point Aft of Front Axle	mm	499

## DATA SHEET NO. 2

### SEAT ADJUSTMENT, FUEL SYSTEMS, AND STEERING WHEEL DATA

Test Vehicle: 2011 Ford F-150 XLT SuperCrew 4-Door Truck  
 Test Program: MDB Side Impact Test

NHTSA No. MB0207  
 Test Date: 2/11/11

#### NOMINAL DESIGN RIDING POSITION

The driver's seat back is set to the manufacturer's designated seat back angle measured 330 mm up the seat back. The passenger's seat back is set to level the passenger ATD's head transverse instrumentation platform as close as possible. The passenger's seat back angles is measured at the headrest posts using a digital inclinometer.

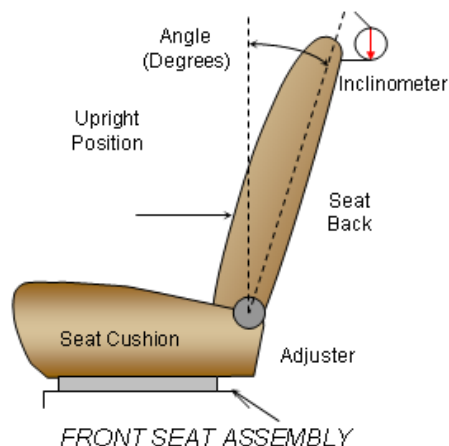

#### SEAT BACK ANGLES

	Degrees (°)
Driver w/Seated Dummy	18.0
Passenger w/Seated Dummy	3.3

#### SEAT FORE/AFT POSITION

Seat travel is measured from the forward most possible position to the rear most possible position with the seat set at mid angle and lowest height. The driver's seat is set to the middle of the fore-aft travel. The passenger's seat is fixed.

#### SEAT FORE/AFT POSITIONS

Seating Position	Total Fore/Aft Travel	Placed in Position
Driver Seat	246 mm	123 mm
Rear Seat	Fixed	Fixed

#### SEAT BELT UPPER ANCHORAGE

The seat belt upper anchorage is positioned to the manufacturer's design position, the driver for a 50<sup>th</sup> percentile adult male ATD, the left rear passenger for a 5<sup>th</sup> percentile adult female ATD. Position zero (0) is the uppermost position.

#### SEAT BELT UPPER ANCHORAGES

Seating Position	Total No. of Positions	Placed in Position
Driver Seat	4	1
Rear Seat	Fixed	Fixed

**DATA SHEET NO. 2 ... (CONTINUED)**

**SEAT ADJUSTMENT, FUEL SYSTEMS, AND STEERING WHEEL DATA**

Test Vehicle: 2011 Ford F-150 XLT SuperCrew 4-Door Truck

NHTSA No. MB0207

Test Program: MDB Side Impact Test

Test Date: 2/11/11

**FUEL TANK CAPACITY**

Description	Liters
Usable Capacity of "Standard Tank"	98.41
Usable Capacity of "Optional Tank"	136.26
Usable Capacity Used for FMVSS 301	98.41
Actual Amount of Stoddard Solvent Used	91.52

**FUEL PUMP**

The test vehicle is equipped with an electric fuel pump. The fuel pump will operate when the ignition is turned to the "ON" position. The fuel filler door is located on the left rear bed. The standard fuel tank occupies the area under the bed.

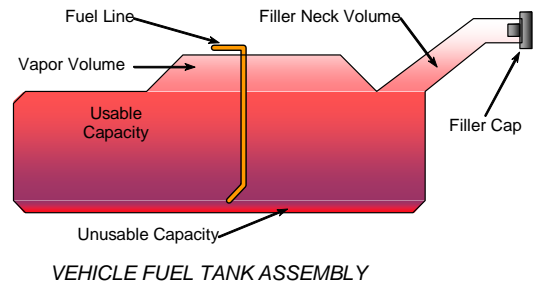

**STEERING COLUMN ADJUSTMENT**

Steering wheel and column adjustments are made so that the steering wheel hub is at the geometric center of the locus it describes when moved through its full range of motion. A digital inclinometer is used to measure a plate which is placed across the rim of the steering wheel for angular measurements. A tape measure is used with a reference mark on the steering column to measure telescoping travel.

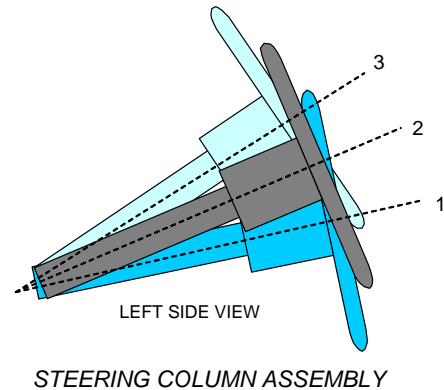

**STEERING COLUMN POSITIONING**

	Degrees	Fore-Aft Position (mm)
Lowermost Position, No. 1	20.0	Fixed
Geometric Center Position, No. 2	22.0	Fixed
Uppermost Position, No. 3	24.0	Fixed
Telescoping Steering Wheel Travel		Fixed
Test Position	22.0	Fixed

### DATA SHEET NO. 3

### DUMMY LONGITUDINAL CLEARANCE DIMENSIONS

Test Vehicle: 2011 Ford F-150 XLT SuperCrew 4-Door Truck

NHTSA No. MB0207

Test Program: MDB Side Impact Test

Test Date: 2/11/11

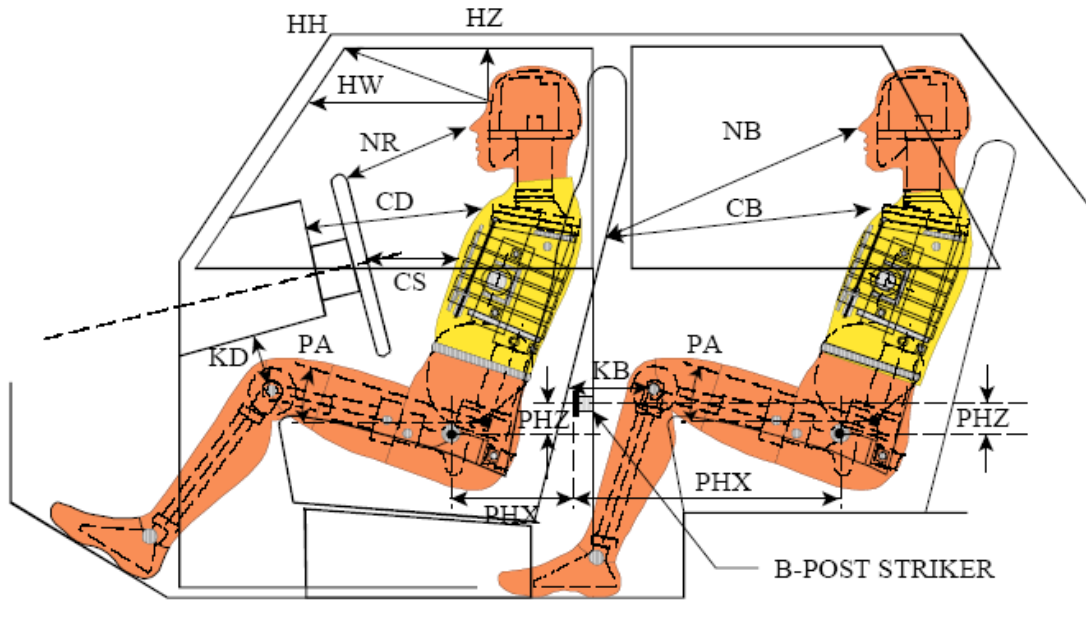

**LEFT SIDE VIEW**

NOTE: 2-DOOR VEHICLE SHOWN.  
REAR DUMMY PHX & PHZ  
MEASUREMENTS FOR A 4-DOOR  
VEHICLE WOULD USE THE C-POST  
STRIKER AS A REFERENCE POINT

### DUMMY LONGITUDINAL CLEARANCE DIMENSION INFORMATION

Driver Code	Pass. Code	Description	Driver		Passenger	
			Length (mm)	Angle (°)	Length (mm)	Angle (°)
HH		Head to Header	421	14.2		
HW		Head to Windshield	666	0.0		
HZ	HZ	Head to Roof	229	90.0	342	90.0
NR	NB	Nose to Rim/Seat Back	457	14.5	681	9.5
CD	CB	Chest to Dash/Seat Back	605	5.8	704	3.9
CS		Chest to Steering Wheel	389	13.6		
KDL	KBL	Left Knee to Dash/Seat Back	186	25.7	424	19.3
KDR	KBR	Right Knee to Dash/Seat Back	190	26.7	432	21.8
PA	PA	Pelvic Angle		12.6		20.8
PHX	PHX	H-Point to Striker (x-axis)	341	0.0	225	0.0
PHZ	PHZ	H-Point to Striker (z-axis)	50	90.0	47	90.0
SA	SA	Seat Back Angle		18.0		3.3

**DATA SHEET NO. 4**

**DUMMY LATERAL CLEARANCE DIMENSIONS**

Test Vehicle: 2011 Ford F-150 XLT SuperCrew 4-Door Truck

NHTSA No. MB0207

Test Program: MDB Side Impact Test

Test Date: 2/11/11

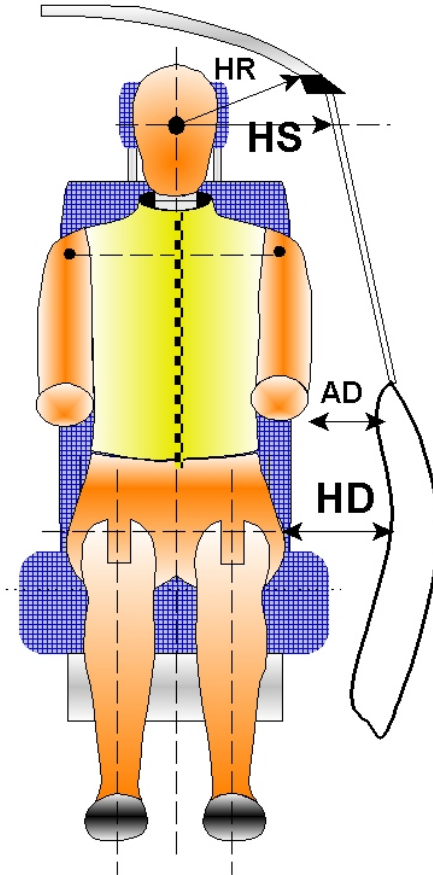

**DUMMY LATERAL CLEARANCE DIMENSION INFORMATION**

Code	Measurement Description	Units	Driver	Passenger
HR	Head to Side Header	mm	215	301
HS	Head to Side Window	mm	370	402
AD	Arm to Door	mm	127	178
HD	H-Point to Door	mm	167	215

**DATA SHEET NO. 5**  
**CAMERA LOCATIONS AND DATA**

Test Vehicle: 2011 Ford F-150 XLT SuperCrew 4-Door Truck

NHTSA No. MB0207

Test Program: MDB Side Impact Test

Test Date: 2/11/11

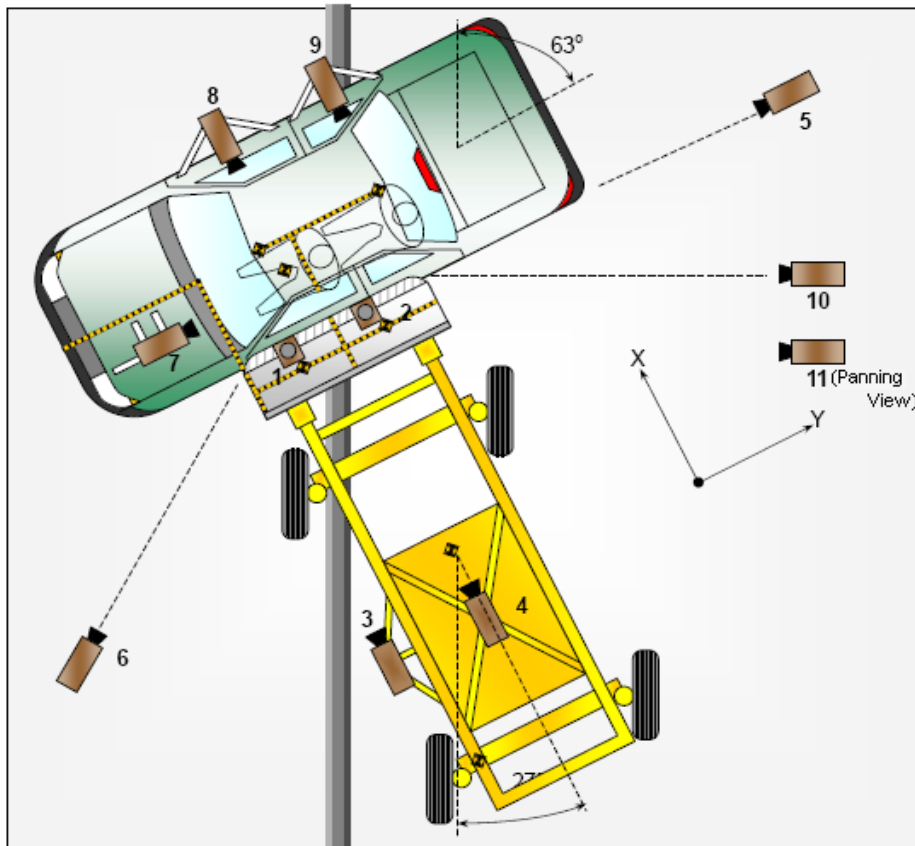

**CAMERA LOCATIONS AND DATA**

Camera No.	View	Coordinates (mm)			Angle (°)	Lens (mm)	Film Speed (fps)
		X*	Y*	Z*			
1	Overhead Overall	1220	2287	-5486	90	14	1000
2	Overhead Close-Up	609	2287	-5102	90	Zoom	1000
3	Left Impact Point (MDB)	-2134	0	-1143	7.5	25	1000
4	Side Overall (MDB)	-3912	838	-1829	11.9	12	1000
5	Rear	-64	2485	-1348	0	105	1000
6	Left Front	-2266	-3564	-1475	0	24	1000
7	Driver Front (On-Board)	589	-826	-814	8.5	35	1000
8	Driver Side (On-Board)	1764	901	-530	8.6	14	1000
9	Passenger Side (On-Board)	1758	1836	-548	13.5	14	1000
10	Real Time Overall					Zoom	30
11	Real Time Inrun					Zoom	30

Reference: Impact Point Projected to Ground  
 +X = To Front of MDB, +Y = To Right of MDB, +Z = Down  
 \*All measurements accurate to ±6 mm

**DATA SHEET NO. 6**

**VEHICLE ACCELEROMETER LOCATIONS**

Test Vehicle: 2011 Ford F-150 XLT SuperCrew 4-Door Truck

NHTSA No. MB0207

Test Program: MDB Side Impact Test

Test Date: 2/11/11

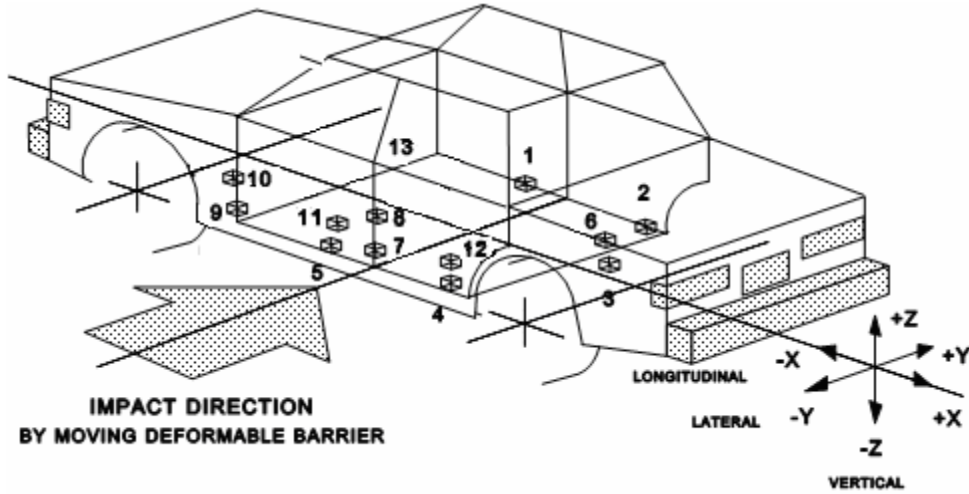

**VEHICLE ACCELEROMETER PRE-TEST LOCATIONS**

Loc. No.	Sensor Description	Coordinates (mm)		
		X	Y	Z
1	Right Sill at Front Seat	3398	808	-530
2	Right Sill at Rear Seat	2580	780	-535
3	Rear Floorpan Above Axle	1033	497	-792
4	Left Sill at Rear Door	2718	-495	-287
5	Left Sill at Front Door	3542	-495	-287
6	Right Rear Occupant Compartment	3004	555	-582
7	B-Pillar Lower	3020	-848	-772
8	B-Pillar Mid	3020	-848	-1016
9	A-Pillar Lower	4245	-898	-726
10	A-Pillar Mid	4245	-898	-935
11	Front Seat Track	3375	-659	-690
12	Rear Seat Structure			
13	Vehicle CG	2850	0	-582

Reference: X – Rear surface of vehicle (+ forward)  
 Y – Vehicle centerline (+ to right)  
 Z – Ground plane (+ down)

**DATA SHEET NO. 7**

**MDB ACCELEROMETER LOCATIONS**

Test Vehicle: 2011 Ford F-150 XLT SuperCrew 4-Door Truck

NHTSA No. MB0207

Test Program: MDB Side Impact Test

Test Date: 2/11/11

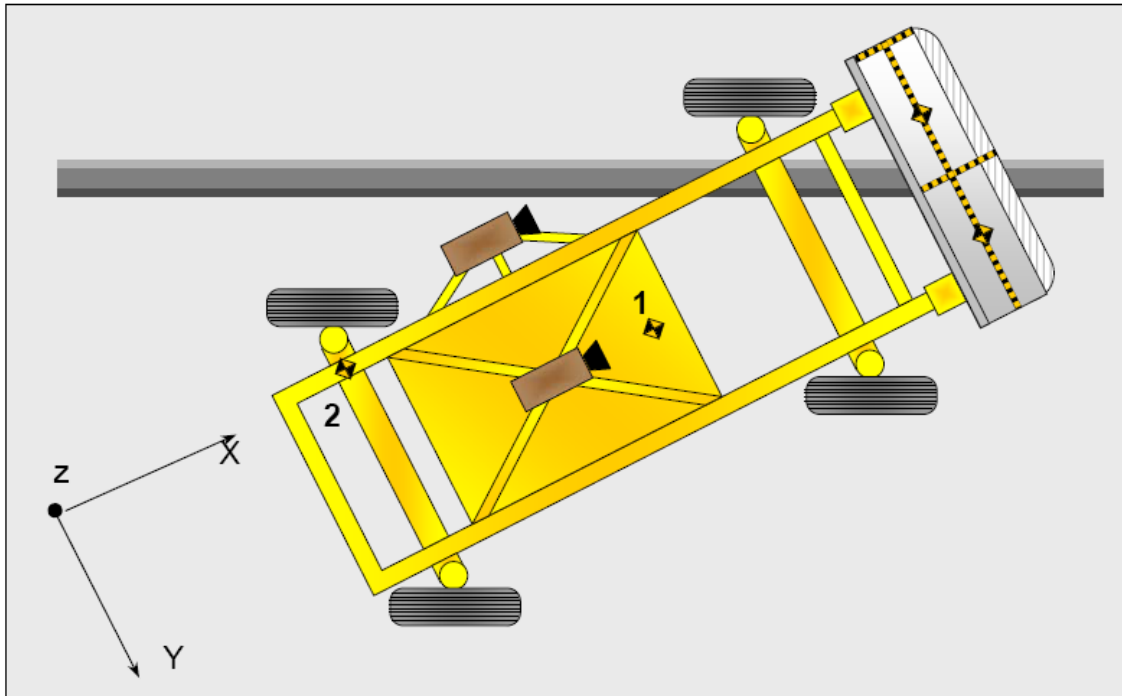

**MDB ACCELEROMETER LOCATIONS**

Loc. No.	Accelerometer Location	Measurement		
		X	Y	Z
1	MDB CG	-1195	0	-430
2	MDB Rear	-2642	-593	-608

Reference: X – Face of MDB (+ forward)  
 Y – MDB centerline (+ to right)  
 Z – Ground plane (+ down)

**DATA SHEET NO. 8**

**TEST VEHICLE SUMMARY OF RESULTS**

Test Vehicle: 2011 Ford F-150 XLT SuperCrew 4-Door Truck

NHTSA No. MB0207

Test Program: MDB Side Impact Test

Test Date: 2/11/11

**MAXIMUM EXTERIOR CRUSH**

Level	Description	Units	Maximum Crush	Above Ground
1	Sill Top Height	mm	77	446
2	Occupant H-Point Height	mm	188	882
3	Mid-Door Height	mm	280	840
4	Window Sill Height	mm	270	1170
5	Window Top Height	mm	318	1804
	Maximum Penetration	mm	318	

**INSTRUMENTATION**

Driver Dummy Channels	16
Passenger Dummy Channels	16
Airbag Timing Sensors	4
Vehicle Structure Accelerometers	21
MDB Accelerometers	5
Total No. of Contact Switches	8
Total	70

**CAMERA COVERAGE**

High-Speed Vehicle On-Board	3
High-Speed Vehicle Off-Board	4
High-Speed MDB On-Board	2
Real Time	2
Total	11

**DATA SHEET NO. 9**

**MOVING DEFORMABLE BARRIER (MDB) SUMMARY OF RESULTS**

Test Vehicle: 2011 Ford F-150 XLT SuperCrew 4-Door Truck

NHTSA No. MB0207

Test Program: MDB Side Impact Test

Test Date: 2/11/11

**MDB SPECIFICATIONS**

Measurement Description	Length (mm)
Overall Width of Framework Carriage	1251
Overall Length including Honeycomb Face	4023
Wheel Base of Framework Carriage	2595
CG location aft of Front Axle	1118

**MDB WEIGHTS**

	Units	Front Axle	Rear Axle	Total
Left	kg	402	298	
Right	kg	377	292	
Ratio	%	56.9%	43.1%	
Totals	kg	779	590	1368

**SPEED AND IMPACT DATA**

Measured Parameter	Units	Requirement	Value
Trap No. 1 Velocity (Primary)	km/h	61.1 to 62.7	61.89
Trap No. 2 Velocity (Redundant)	km/h	61.1 to 62.7	61.83
MDB CL to Target Vehicle CL	degrees	88.5-91.5	89.7

**MAXIMUM STATIC CRUSH OF HONEYCOMB FACE**

Vertical Location			From Centerline		Max. Crush (mm)
Row	Description	Height (mm)	Distance (mm)	Direction	
1	Center of Bumper	432	500	Right	244
2	Top of Bumper	533	800	Right	155
3	Mid Level	686	800	Left	141
4	Top of Stack	813	400	Right	165

**MDB INSTRUMENTATION AND CAMERAS**

Accelerometers	5
Contact Switches	2

**DATA SHEET NO. 10**  
**POST-TEST OBSERVATIONS**

Test Vehicle: 2011 Ford F-150 XLT SuperCrew 4-Door Truck

NHTSA No. MB0207

Test Program: MDB Side Impact Test

Test Date: 2/11/11

**TEST DUMMY INFORMATION AND CONTACT POINTS**

Description	Front Seat Dummy (ES-2re)	Rear Seat Dummy (SID-IIs)
Dummy Type/Serial No.	ES-2re, S/N: F035	SID-IIs, S/N: 307
Head Contact	Curtain Airbag, Side Header, Head Restraint	Curtain Airbag, Side Header, Head Restraint
Upper Torso Contact	Curtain Airbag, Torso/Pelvis Airbag	Door Panel
Lower Torso Contact	Torso/Pelvis Airbag	Door Panel
Left Knee Contact	Door Panel	Door Panel, Right Knee
Right Knee Contact	None	Left Knee

**POST-TEST DOOR OPENING AND SEAT TRACK INFORMATION**

Description	Front	Rear
Left Side Door Opening	Jammed shut	Jammed shut
Right Side Door Opening	Remained closed and operational	Remained closed and operational
Hatch and Other Doors	Remained closed and operational	Remained closed and operational
Seat Movement	None	None
Seatback Failure	No	No

**POST-TEST STRUCTURAL OBSERVATIONS**

Critical Areas of Performance	Observations and Conclusions	
Pillar Performance	No separation occurred	
Sill Separation	No separation occurred	
Windshield Damage	None	
Window Damage	None	None
Other Notable Effects	None	

**SUPPLEMENTAL RESTRAINT SYSTEM INFORMATION**

Restraint Type	Left Front (Driver) Occupant Location 1		Left Rear (Passenger) Occupant Location 4	
	Installed	Deployed	Installed	Deployed
Frontal Airbag	Yes	No	No	
Knee Airbag	No		No	
Side Airbag 1 (Torso/Pelvis)	Yes	Yes	No	
Side Airbag 2 (Curtain)	Yes	Yes	Yes	Yes
Seat Belt Pretensioner	Yes	Yes	No	
Seat Belt Load Limiter	Yes	Yes	No	
Other				

**MDB LEFT EDGE IMPACT POINT DATA**

Measured Parameter	Units	Requirement	Value
Horizontal Offset	mm	+/- 50	-9 (Left)
Vertical Offset	mm	+/- 20	+6 (Up)

**DATA SHEET NO. 11**  
**VEHICLE PROFILE MEASUREMENTS**

Test Vehicle: 2011 Ford F-150 XLT SuperCrew 4-Door Truck

NHTSA No. MB0207

Test Program: MDB Side Impact Test

Test Date: 2/11/11

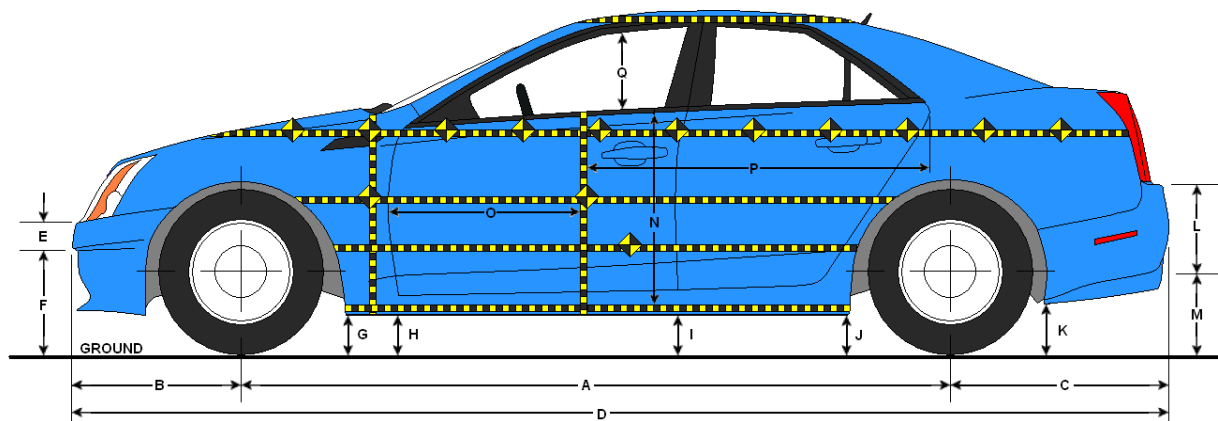

**LEFT SIDE VIEW**

**VEHICLE PRE AND POST-TEST MEASUREMENT INFORMATION**

Code	Dimension	Measurement (mm)		
		Pre	Post	Difference
A	Wheelbase	3669	3664	-5
B	Front Axle to FSOV	964	964	0
C	Rear Axle to RSOV	1237	1231	-6
D	Total Length at Centerline	5871	5859	-12
E	Front Bumper Thickness	239	240	1
F	Front Bumper Bottom to Ground	388	386	-2
G	Sill Height at Front Wheel Well	387	379	-8
H	Sill Height at Front Door Leading Edge	403	419	16
I	Sill Height at B-Pillar	415	423	8
J1	Sill Height at Rear Wheel Well	411	461	50
J2	Pinch Weld Height at Rear Wheel Well	401	442	41
K	Sill Height Aft of Rear Wheel Well	445	510	65
L	Rear Bumper Thickness	219	218	-1
M	Bottom of Rear Bumper to Ground	447	493	46
N	Sill Height to Window Bottom Sill	655	675	20
O	Front Door Leading Edge to Impact CL	737	729	-8
P	Rear Door Trailing Edge to Impact CL	1474	1416	-58
Q	Front Window Opening	535	578	43
R	Right Side Length	5062	5056	-6
S	Left Side Length	5055	5046	-9
T	Vehicle Width at B-Pillar	1987	1874	-113

All measurements in mm with tolerance of  $\pm 3$ mm

**DATA SHEET NO. 12**

**VEHICLE EXTERIOR CRUSH MEASUREMENTS**

Test Vehicle: 2011 Ford F-150 XLT SuperCrew 4-Door Truck

NHTSA No. MB0207

Test Program: MDB Side Impact Test

Test Date: 2/11/11

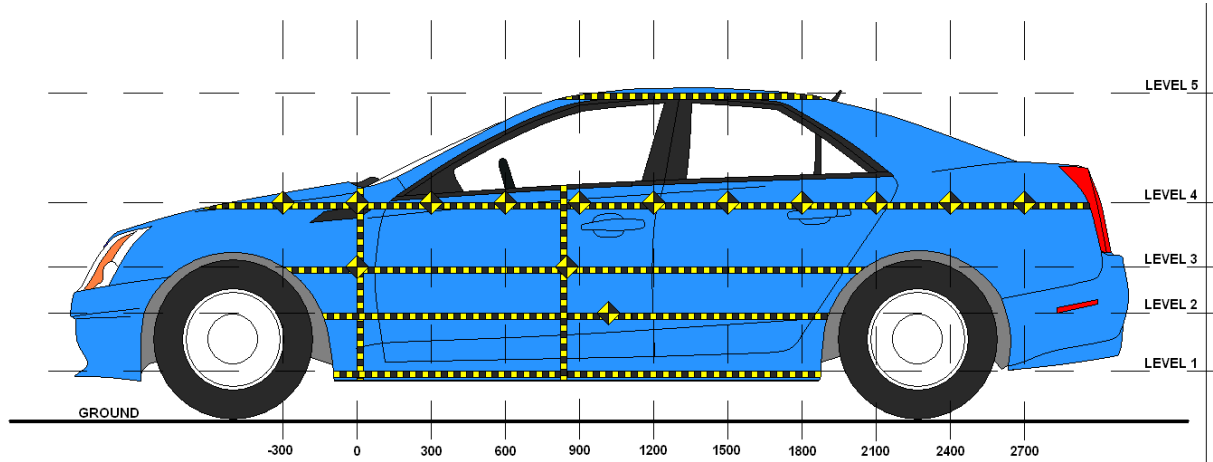

**LEFT SIDE VIEW**

Level	Description	Height Above Ground (mm)
1	Sill Top Height	446
2	Occupant H-Point Height	882
3	Mid-Door Height	840
4	Window Sill Height	1170
5	Window Top Height	1804

**DATA SHEET NO. 12 ... (CONTINUED)**

**VEHICLE EXTERIOR CRUSH MEASUREMENTS**

Test Vehicle: 2011 Ford F-150 XLT SuperCrew 4-Door Truck

NHTSA No. MB0207

Test Program: MDB Side Impact Test

Test Date: 2/11/11

	Pre-Test (mm)					Post-Test (mm)					Difference (mm)				
	1	2	3	4	5	1	2	3	4	5	1	2	3	4	5
-900															
-750															
-600															
-450															
-300		525		581			589		646			64		65	
-150		532	526	570			592	598	640			60	72	70	
0	563	544	545	562		712	617	626	617		149	73	81	55	
150	561	540	542	558		779	658	671	609		218	118	129	51	
300	556	534	536	553		794	706	723	609		238	172	187	56	
450	552	529	531	548		793	709	731	612		241	180	200	64	
600	549	525	527	543		788	719	740	611		239	194	213	68	
750	546	521	523	540	792	788	727	747	614	849	242	206	224	74	57
900	544	519	521	536	794	791	731	753	619	852	247	212	232	83	58
1050	543	517	519	532	796	796	743	763	628	858	253	226	244	96	62
1200	541	517	518	529	799	802	723	739	643	862	261	206	221	114	63
1350	540	517	518	529	800	808	713	733	660	863	268	196	215	131	63
1500	540	517	518	528	800	847	755	762	716	863	307	238	244	188	63
1650	540	516	517	527	800	856	786	797	687	865	316	270	280	160	65
1800	542	517	518	527	799	828	761	774	661	867	286	244	256	134	68
1950	543	518	519	527	799	738	739	746	635	868	195	221	227	108	69
2100	545	519	520	527	800	659	676	675	609	877	114	157	155	82	77
2250	547	521	522	528		583	599	592	576		36	78	70	48	
2400	557	531	533	540		579	562	564	576		22	31	31	36	
2550	554	531	532	537		574	560	561	572		20	29	29	35	
2700		521	517	536			548	544	569			27	27	33	
2850		505	507	536			529	530	566			24	23	30	

**MAXIMUM CRUSH DATA**

	Level 1	Level 2	Level 3	Level 4	Level 5
Maximum Crush (mm)	316	270	280	188	77
Distance from Impact (mm)	1650	1650	1650	1350	1950

**DATA SHEET NO. 12 ... (CONTINUED)**  
**VEHICLE EXTERIOR CRUSH MEASUREMENTS**

Test Vehicle: 2011 Ford F-150 XLT SuperCrew 4-Door Truck

NHTSA No. MB0207

Test Program: MDB Side Impact Test

Test Date: 2/11/11

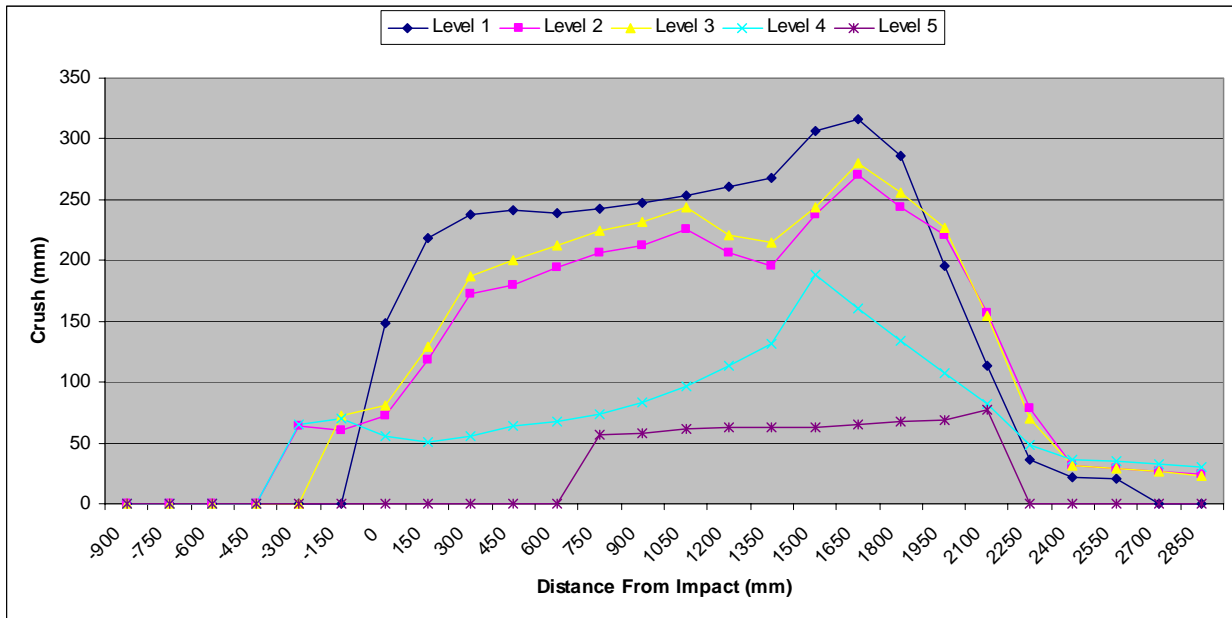

**DATA SHEET NO. 13**

**VEHICLE DAMAGE PROFILE DISTANCES**

Test Vehicle: 2011 Ford F-150 XLT SuperCrew 4-Door Truck

NHTSA No. MB0207

Test Program: MDB Side Impact Test

Test Date: 2/11/11

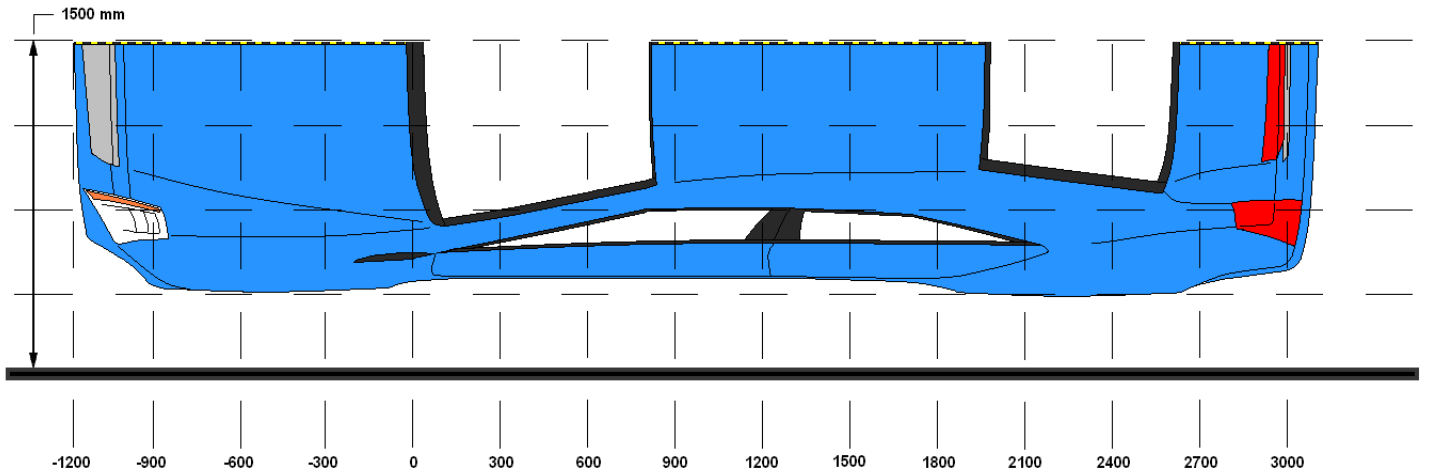

**TOP VIEW**

**DAMAGE PROFILE DISTANCES**

DPD	Distance From Impact Point in mm	Level	Pre-Test (mm)	Post-Test (mm)	Max. Static Crush (mm)
1	2850	4	536	566	30
2	2250	2	521	599	78
3	1650	1	540	856	316
4	1050	1	543	796	253
5	450	1	552	793	241
6	-150	3	526	598	72

**DATA SHEET NO. 14**

**EXTERIOR STATIC CRUSH FOR IMPACTOR FACE**

Test Vehicle: 2011 Ford F-150 XLT SuperCrew 4-Door Truck

NHTSA No. MB0207

Test Program: MDB Side Impact Test

Test Date: 2/11/11

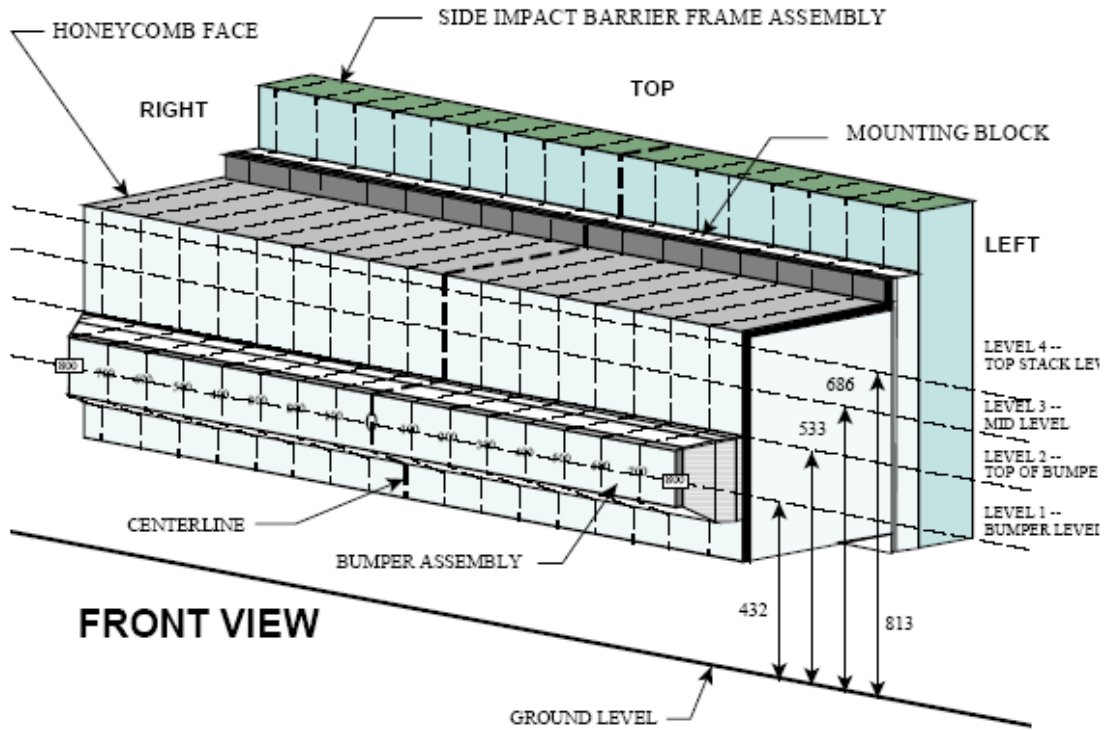

NOTE: Dimensions are shown in millimeters, mm

**DEFORMABLE BARRIER STATIC CRUSH**

Stack Level	Distance Right of Center								C/L	Distance Left of Center							
	800	700	600	500	400	300	200	100		100	200	300	400	500	600	700	800
1	172	149	150	244	141	139	138	136	136	135	155	128	124	127	120	121	128
2	155	155	141	97	97	95	104	114	119	123	129	129	132	127	127	122	110
3	110	85	88	105	126	115	93	85	82	75	74	78	73	76	81	87	141
4	133	106	105	134	165	138	109	95	84	83	78	80	88	107	119	130	161

All dimensions in millimeters.

**DATA SHEET NO. 15**

**FMVSS NO. 301 FUEL SYSTEM INTEGRITY POST-IMPACT DATA**

Test Vehicle: 2011 Ford F-150 XLT SuperCrew 4-Door Truck

NHTSA No. MB0207

Test Program: MDB Side Impact Test

Test Date: 2/11/11

**FMVSS 301 FUEL SYSTEM INTEGRITY POST IMPACT DATA**

Temperature at Time of Impact: 17.8° C

Test Time: 12:20 PM

- A. From impact until vehicle motion ceases: 0 oz.  
(Maximum allowable = 1 oz.)
- B. For the 5 minute period after motion ceases: 0 oz.  
(Maximum allowable = 5 oz.)
- C. For the following 25 minutes: 0 oz.  
(Maximum allowable = 1 oz./minute)
- D. Spillage Details: No spillage occurred

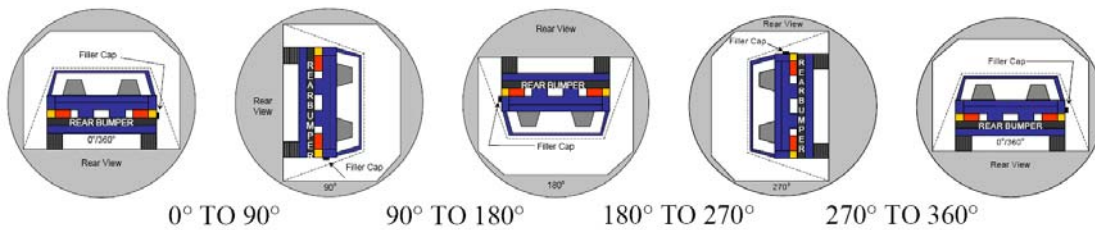

**SOLVENT COLLECTION TIME TABLE IN SECONDS**

Test Phase	Rotation Time	Hold Time	Total Time
0° To 90°	86	300	386
90° To 180°	81	300	381
180° To 270°	81	300	381
270° To 360°	79	300	379

**FMVSS 301 SPILLAGE TABLE**

Test Phase	First 5 Minutes	Sixth Minute	Seventh Minute	Eighth Minute
0° To 90°	0			
90° To 180°	0			
180° To 270°	0			
270° To 360°	0			

**SOLVENT SPILLAGE LOCATION TABLE**

Test Phase	Spillage Location
0° To 90°	None
90° To 180°	None
180° To 270°	None
270° To 360°	None

**DATA SHEET NO. 16**

**DUMMY / VEHICLE TEMPERATURE STABILIZATION**

Test Vehicle: 2011 Ford F-150 XLT SuperCrew 4-Door Truck

NHTSA No. MB0207

Test Program: MDB Side Impact Test

Test Date: 2/11/11

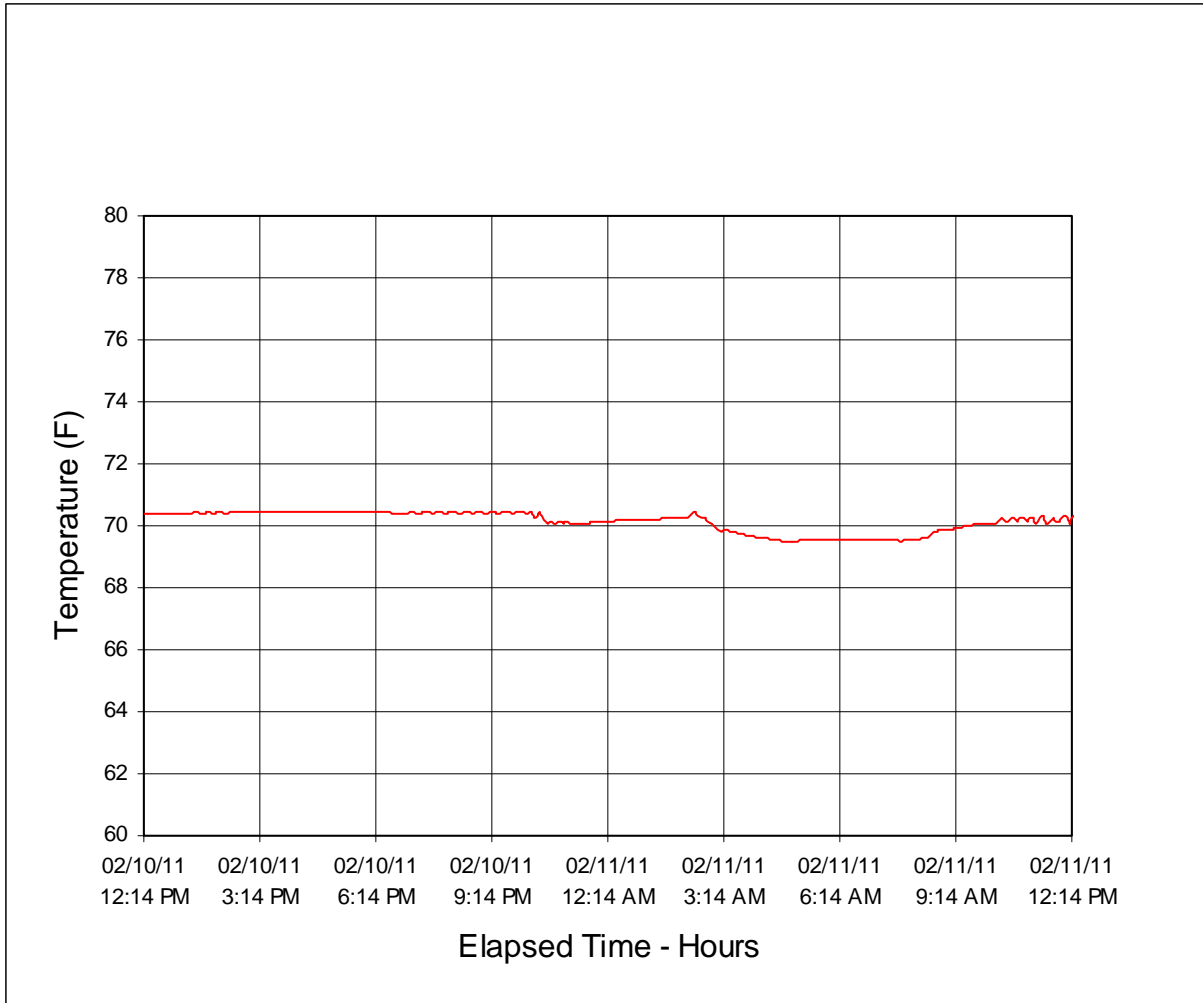

**APPENDIX A  
PHOTOGRAPHS**

## TABLE OF PHOTOGRAPHS

Figure		Page
1	As Delivered Right Front Three-Quarter View of Test Vehicle	A-1
2	As Delivered Left Rear Three-Quarter View of Test Vehicle	A-1
3	Pre-Test Frontal View of Test Vehicle	A-2
4	Post-Test Frontal View of Test Vehicle	A-2
5	Pre-Test Left Front Three-Quarter View of Test Vehicle	A-3
6	Post-Test Left Front Three-Quarter View of Test Vehicle	A-3
7	Pre-Test Left Side View of Test Vehicle	A-4
8	Post-Test Left Side View of Test Vehicle	A-4
9	Pre-Test Left Rear Three-Quarter View of Test Vehicle	A-5
10	Post-Test Left Rear Three-Quarter View of Impact Zone	A-5
11	Pre-Test Rear View of Test Vehicle	A-6
12	Post-Test Rear View of Test Vehicle	A-6
13	Pre-Test Right Side View of Test Vehicle	A-7
14	Post-Test Right Side View of Test Vehicle	A-7
15	Pre-Test Overhead View of Test Vehicle with MDB Positioned Against Side of Test Vehicle	A-8
16	Post-Test Overhead View of Test Vehicle and MDB	A-8
17	Pre-Test Left Side View of MDB Positioned Against Side of Test Vehicle	A-9
18	Pre-Test Right Side View of MDB Positioned Against Side of Test Vehicle	A-9
19	Pre-Test Close-Up View of Impact Point Target	A-10
20	Post-Test Close-Up View of Impact Point Target	A-10
21	Pre-Test Left Front Door Latch Close-Up	A-11
22	Post-Test Left Front Door Latch Close-Up	A-11
23	Pre-Test Left Rear Door Latch Close-Up	A-12
24	Post-Test Left Rear Door Latch Close-Up	A-12
25	Pre-Test Front Close-Up View of Driver Dummy	A-13
26	Post-Test Front Close-Up View of Driver Dummy	A-13
27	Pre-Test Left Side View of Driver Dummy Showing Belt, Chalking, and Contact Switches	A-14
28	Pre-Test Left Side View of Driver Dummy Shoulder and Door Top View	A-14
29	Post-Test Left Side View of Driver Dummy Shoulder and Door Top View	A-15
30	Pre-Test Frontal View of Driver Seat Back Prior to Dummy Positioning	A-15
31	Pre-Test Frontal View of Driver Dummy Head and Shoulders in Relation to Head Restraint	A-16
32	Pre-Test Frontal View of Driver Seat Pan Prior to Dummy Positioning	A-16
33	Pre-Test Overhead View of Driver Dummy Thighs on Seat Pan	A-17
34	Pre-Test Placement of Driver Dummy's Feet	A-17
35	Pre-Test View of Belt Anchorage for Driver Dummy	A-18

## TABLE OF PHOTOGRAPHS ... (CONTINUED)

Figure		Page
36	Pre-Test Left Side View of Steering Wheel	A-18
37	Pre-Test View of Parking Brake	A-19
38	Pre-Test Close-Up Left Side View of Driver Seat Track	A-19
39	Pre-Test Close-Up Left Side View of Driver Seat Back	A-20
40	Pre-Test Close-Up View of Driver Seat Back or Head Restraint	A-20
41	Pre-Test Driver Dummy and Door Clearance View	A-21
42	Post-Test Driver Dummy and Door Clearance View	A-21
43	Pre-Test Right Side View of Driver Dummy and Front Seat of Occupant Compartment	A-22
44	Post-Test Right Side View of Driver Dummy and Front Seat Occupant Compartment	A-22
45	Pre-Test Driver Inner Door Panel View	A-23
46	Post-Test Driver Inner Door Panel View Showing Driver Dummy Contact Locations	A-23
47	Post-Test Driver Dummy Close-Up Head Contact with Vehicle Interior View	A-24
48	Post-Test Driver Dummy Close-Up Head Contact with Side Airbag View	A-24
49	Post-Test Driver Dummy Close-Up Torso Contact with Vehicle Interior View	A-25
50	Post-Test Driver Dummy Close-Up Torso Contact with Side Airbag View	A-25
51	Post-Test Driver Dummy Close-Up Pelvis Contact with Vehicle Interior View	A-26
52	Post-Test Driver Dummy Close-Up Pelvis Contact with Side Airbag View	A-26
53	Pre-Test Left Side View of Rear Passenger Dummy Showing Belt, Chalking, and Contact Switches	A-27
54	Pre-Test Left Side View of Rear Passenger Dummy Shoulder and Door Top View	A-27
55	Post-Test Left Side View of Rear Passenger Dummy Shoulder and Door Top View	A-28
56	Pre-Test Frontal View of Rear Passenger Seat Back Prior to Dummy Positioning	A-28
57	Pre-Test Frontal View of Rear Passenger Dummy Head and Shoulders in Relation to Head Restraint	A-29
58	Pre-Test Overhead View of Rear Passenger Seat Pan Prior to Dummy Positioning	A-29
59	Pre-Test Overhead View of Rear Passenger Dummy Thighs on Seat Pan	A-30
60	Pre-Test View of Rear Passenger Dummy's Neck Showing Position of Adjustable Neck Bracket	A-30
61	Pre-Test View of Rear Passenger Dummy's Head Showing Dummy's Head is Level	A-31
62	Pre-Test Placement of Rear Passenger Dummy's Feet	A-31
63	Pre-Test View of Belt Anchorage for Rear Passenger Dummy	A-32
64	Pre-Test Close-Up Left Side View of Rear Passenger Seat Track	A-32
65	Pre-Test Close-Up Left Side View of Rear Passenger Seat Back	A-33
66	Pre-Test Close-Up View of Rear Passenger Seat Back or Head Restraint	A-33
67	Pre-Test Rear Passenger Dummy and Door Clearance View	A-34
68	Post-Test Rear Passenger Dummy and Door Clearance View	A-34
69	Pre-Test Right Side View of Rear Passenger Dummy and Rear Seat Occupant Compartment	A-35
70	Post-Test Right Side View of Rear Passenger Dummy and Rear Seat Occupant Compartment	A-35

## TABLE OF PHOTOGRAPHS ... (CONTINUED)

<u>Figure</u>		<u>Page</u>
71	Pre-Test Rear Passenger Inner Door Panel View	A-36
72	Post-Test Rear Passenger Inner Door Panel View Showing Dummy Contact Locations	A-36
73	Post-Test Rear Passenger Dummy Close-Up Head Contact with Vehicle Interior View	A-37
74	Post-Test Rear Passenger Dummy Close-Up Head Contact with Side Airbag View	A-37
75	Post-Test Rear Passenger Dummy Close-Up Torso Contact with Vehicle Interior View	A-38
76	Post-Test Rear Passenger Dummy Close-Up Torso Contact with Side Airbag View	A-38
77	Post-Test Rear Passenger Dummy Close-Up Pelvis Contact with Vehicle Interior View	A-39
78	Post-Test Rear Passenger Dummy Close-Up Pelvis Contact with Side Airbag View	A-39
79	Pre-Test View of Fuel Filler Cap or Fuel Filler Neck	A-40
80	Post-Test View of Fuel Filler Cap or Fuel Filler Neck	A-40
81	Pre-Test Front View of MDB Impactor Face	A-41
82	Post-Test Front View of MDB Impactor Face	A-41
83	Pre-Test Top View of MDB Impactor Face	A-42
84	Post-Test Top View of MDB Impactor Face	A-42
85	Pre-Test Left Side View of MDB Impactor Face	A-43
86	Post-Test Left Side View of MDB Impactor Face	A-43
87	Pre-Test Right Side View of MDB Impactor Face	A-44
88	Post-Test Right Side View of MDB Impactor Face	A-44
89	Close-Up View of Vehicle's Certification Label	A-45
90	Close-Up View of Vehicle's Tire Information Placard or Label	A-45
91	Pre-Test Ballast View	A-46
92	Post-Test Primary and Redundant Speed Trap Read-Out	A-46
93	FMVSS No. 301-305 Rollover 0 Degrees	A-47
94	FMVSS No. 301-305 Rollover 90 Degrees	A-47
95	FMVSS No. 301-305 Rollover 180 Degrees	A-48
96	FMVSS No. 301-305 Rollover 270 Degrees	A-48
97	FMVSS No. 301-305 Rollover 360 Degrees	A-49
98	Impact Event	A-49
99	Monroney Label	A-50
100	Driver Head Restraint Use and Adjustment Information from Vehicle Manual	A-50
101	Left Rear Passenger Head Restraint Use and Adjustment Information from Vehicle Manual	A-51



FIGURE 1. As-Delivered Right Front Three-Quarter View of Test Vehicle



FIGURE 2. As-Delivered Left Rear Three-Quarter View of Test Vehicle



FIGURE 3. Pre-Test Frontal View of Test Vehicle



FIGURE 4. Post-Test Frontal View of Test Vehicle



FIGURE 5. Pre-Test Left Front Three-Quarter View of the Test Vehicle



FIGURE 6. Post-Test Left Front Three-Quarter View of the Test Vehicle



FIGURE 7. Pre-Test Left Side View of Test Vehicle



FIGURE 8. Post-Test Left Side View of Test Vehicle



FIGURE 9. Pre-Test Left Rear Three-Quarter View of Test Vehicle



FIGURE 10. Post-Test Left Rear Three-Quarter View of Impact Zone



FIGURE 11. Pre-Test Rear View of Test Vehicle



FIGURE 12. Post-Test Rear View of Test Vehicle



FIGURE 13. Pre-Test Right Side View of Test Vehicle



FIGURE 14. Post-Test Right Side View of Test Vehicle



FIGURE 15. Pre-Test Overhead View of Test Vehicle with MDB Positioned Against Side of Test Vehicle



FIGURE 16. Post-Test Overhead View of Test Vehicle and MDB



FIGURE 17. Pre-Test Left Side View of MDB Positioned Against Side of Test Vehicle at Ideal Impact Point



FIGURE 18. Pre-Test Right Side View of MDB Positioned Against Side of Test Vehicle at Ideal Impact Point



FIGURE 19. Pre-Test Close-Up View of Impact Point Target



FIGURE 20. Post-Test Close-Up View of Impact Point Target  
Showing Impact Point Location



FIGURE 21. Pre-Test Left Front Door Latch Close-Up



FIGURE 22. Post-Test Left Front Door Latch Close-Up



FIGURE 23. Pre-Test Left Rear Door Latch Close-Up



FIGURE 24. Post-Test Left Rear Door Latch Close-Up



FIGURE 25. Pre-Test Front Close-Up View of Driver Dummy



FIGURE 26. Post-Test Front Close-Up View of Driver Dummy



FIGURE 27. Pre-Test Left Side View of Driver Dummy  
Showing Belt, Chalking, and Contact Switches



FIGURE 28. Pre-Test Left Side View of Driver Dummy Shoulder and Door Top View



FIGURE 29. Post-Test Left Side View of Driver Dummy Shoulder and Door Top View



FIGURE 30. Pre-Test Frontal View of Driver Seat Back Prior to Dummy Positioning



FIGURE 31. Pre-Test Frontal View of Driver Dummy Head and Shoulders in Relation to Head Restraint



FIGURE 32. Pre-Test Frontal View of Driver Seat Pan Prior to Dummy Positioning



FIGURE 33. Pre-Test Overhead View of Driver Dummy Thighs on Seat Pan



FIGURE 34. Pre-Test Placement of Driver Dummy's Feet



FIGURE 35. Pre-Test View of Belt Anchorage for Driver Dummy



FIGURE 36. Pre-Test Left Side View of Steering Wheel



FIGURE 37. Pre-Test View of Parking Brake



FIGURE 38. Pre-Test Close-Up Left Side View of Driver Seat Track



FIGURE 39. Pre-Test Close-Up Left Side View of Driver Seat Back



FIGURE 40. Pre-Test Close-Up View of Driver Seat Back or Head Restraint



FIGURE 41. Pre-Test Driver Dummy and Door Clearance View



FIGURE 42. Post-Test Driver Dummy and Door Clearance View



FIGURE 43. Pre-Test Right Side View of Driver Dummy and Front Seat Occupant Compartment



FIGURE 44. Post-Test Right Side View of Driver Dummy and Front Seat Occupant Compartment



FIGURE 45. Pre-Test Driver Inner Door Panel View



FIGURE 46. Post-Test Driver Dummy Inner Door Panel View  
Showing Driver Dummy Contact Locations



FIGURE 47. Post-Test Driver Dummy Close-Up Head Contact with Vehicle Interior View



FIGURE 48. Post-Test Driver Dummy Close-Up Head Contact with Side Airbag View



FIGURE 49. Post-Test Driver Dummy Close-Up Torso Contact with Vehicle Interior View



FIGURE 50. Post-Test Driver Dummy Close-Up Torso Contact with Side Airbag View



FIGURE 51. Post-Test Driver Dummy Close-Up Pelvis Contact with Vehicle Interior View



FIGURE 52. Post-Test Driver Dummy Close-Up Pelvis Contact with Side Airbag View



FIGURE 53. Pre-Test Left Side View of Rear Passenger Dummy Showing Belt, Chalking, and Contact Switches



FIGURE 54. Pre-Test Left Side View of Rear Passenger Dummy Shoulder and Door Top View



FIGURE 55. Post-Test Left Side View of Rear Passenger Dummy  
Shoulder and Door Top View



FIGURE 56. Pre-Test Frontal View of Rear Passenger Seat Back Prior to Dummy Positioning



FIGURE 57. Pre-Test Frontal View of Rear Passenger Dummy Head and Shoulders in Relation to Head Restraint



FIGURE 58. Pre-Test Overhead View of Rear Passenger Seat Pan Prior to Dummy Positioning



FIGURE 59. Pre-Test Overhead View of Rear Passenger Dummy Thighs on Seat Pan



FIGURE 60. Pre-Test View of Rear Passenger Dummy's Neck  
Showing Position of Adjustable Neck Bracket



FIGURE 61. Pre-Test View of Rear Passenger Dummy's Head  
Showing Dummy's Head is Level



FIGURE 62. Pre-Test Placement of Rear Passenger Dummy's Feet



FIGURE 63. Pre-Test View of Belt Anchorage for Rear Passenger Dummy



FIGURE 64. Pre-Test Close-Up Left Side View of Rear Passenger Seat Track



FIGURE 65. Pre-Test Close-Up Left Side View of Rear Passenger Seat Back



FIGURE 66. Pre-Test Close-Up View of Rear Passenger Seat Back or Head Restraint



FIGURE 67. Pre-Test Rear Passenger Dummy and Door Clearance View



FIGURE 68. Post-Test Rear Passenger Dummy and Door Clearance View



FIGURE 69. Pre-Test Right Side View of Rear Passenger Dummy and Rear Seat Occupant Compartment



FIGURE 70. Post-Test Right Side View of Rear Passenger Dummy and Rear Seat Occupant Compartment



FIGURE 71. Pre-Test Rear Passenger Inner Door Panel View



FIGURE 72. Post-Test Rear Passenger Inner Door Panel View  
Showing Rear Passenger Dummy Contact Locations



FIGURE 73. Post-Test Rear Passenger Dummy Close-Up  
Head Contact with Vehicle Interior View



FIGURE 74. Post-Test Rear Passenger Dummy Close-Up  
Head Contact with Side Airbag View



FIGURE 75. Post-Test Rear Passenger Dummy Close-Up  
Torso Contact with Vehicle Interior View

**Photograph Not Applicable**

**Vehicle Not Equipped With  
Rear Passenger Side Airbag**

FIGURE 76. Post-Test Rear Passenger Dummy Close-Up  
Torso Contact with Side Airbag View



FIGURE 77. Post-Test Rear Passenger Dummy Close-Up  
Pelvis Contact with Vehicle Interior View

Photograph Not Applicable

Vehicle Not Equipped With  
Rear Passenger Side Airbag

FIGURE 78. Post-Test Rear Passenger Dummy Close-Up  
Pelvis Contact with Side Airbag View



FIGURE 79. Pre-Test View of Fuel Filler Cap



FIGURE 80. Post-Test View of Fuel Filler Cap



FIGURE 81. Pre-Test Front View of MDB Impactor Face



FIGURE 82. Post-Test Front View of MDB Impactor Face



FIGURE 83. Pre-Test Top View of MDB Impactor Face



FIGURE 84. Post-Test Top View of MDB Impactor Face



FIGURE 85. Pre-Test Left Side View of MDB Impactor Face



FIGURE 86. Post-Test Left Side View of MDB Impactor Face



FIGURE 87. Pre-Test Right Side View of MDB Impactor Face



FIGURE 88. Post-Test Right Side View of MDB Impactor Face



FIGURE 89. Close-Up View of Vehicle's Certification Label



FIGURE 90. Close-Up View of Vehicle's Tire Information Placard

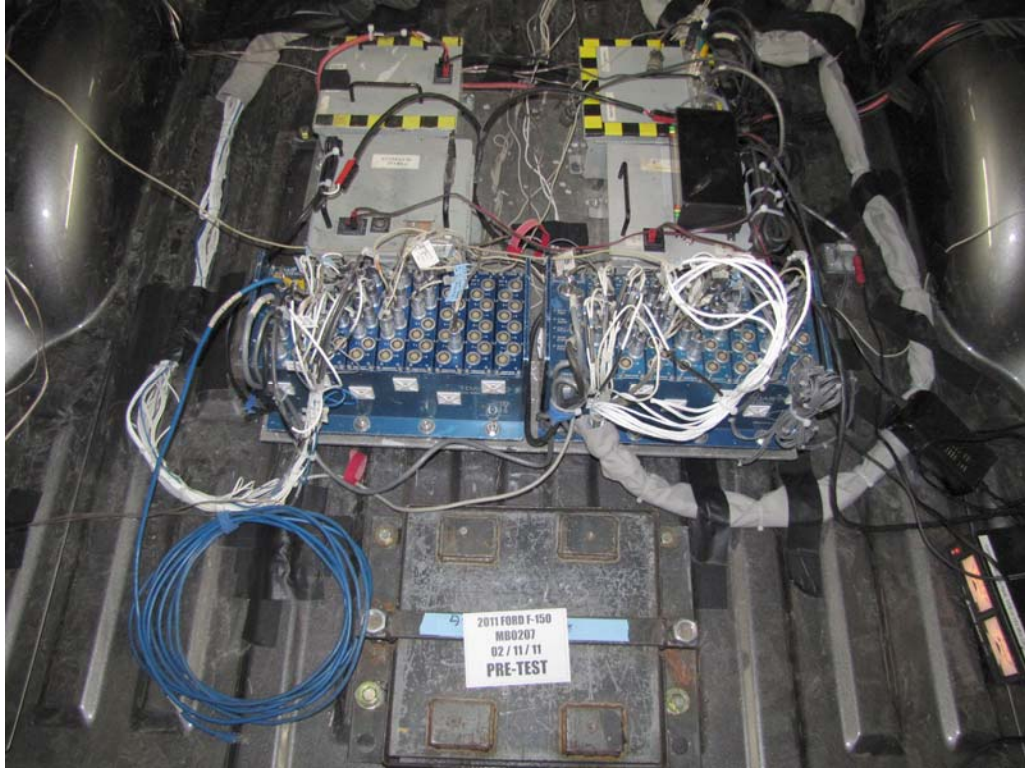

FIGURE 91. Pre-Test Ballast View

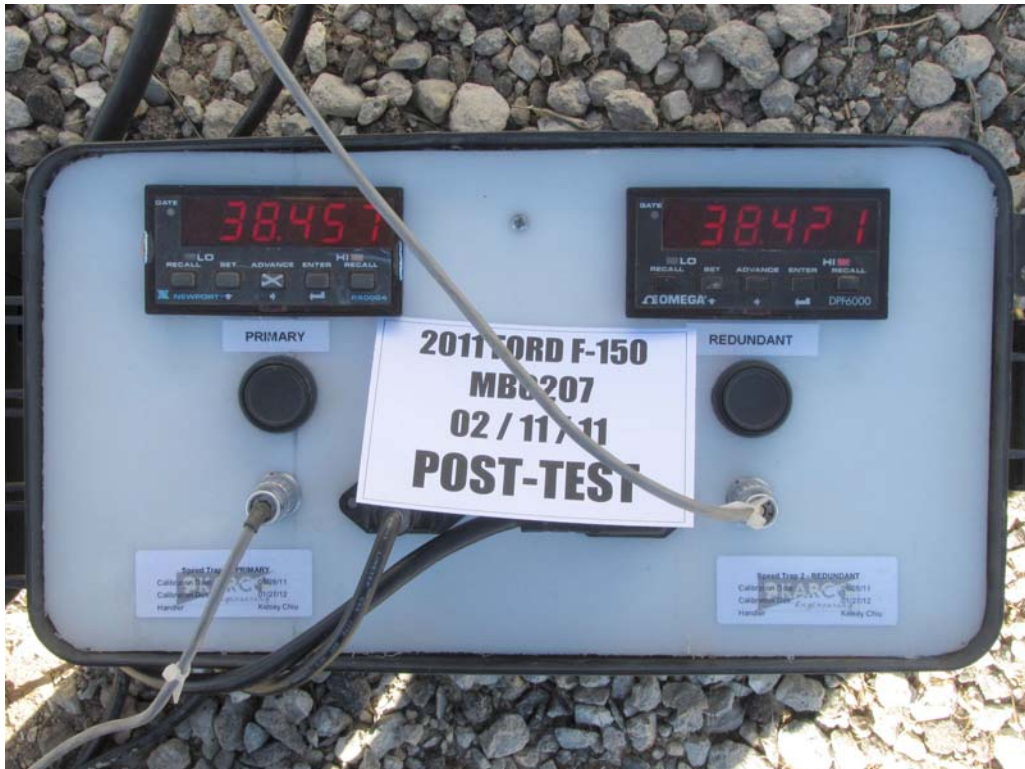

FIGURE 92. Post-Test Primary and Redundant Speed Trap Read-Out



FIGURE 93. FMVSS No. 301/305 Rollover 0 Degrees



FIGURE 94. FMVSS No. 301/305 Rollover 90 Degrees



FIGURE 95. FMVSS No. 301/305 Rollover 180 Degrees

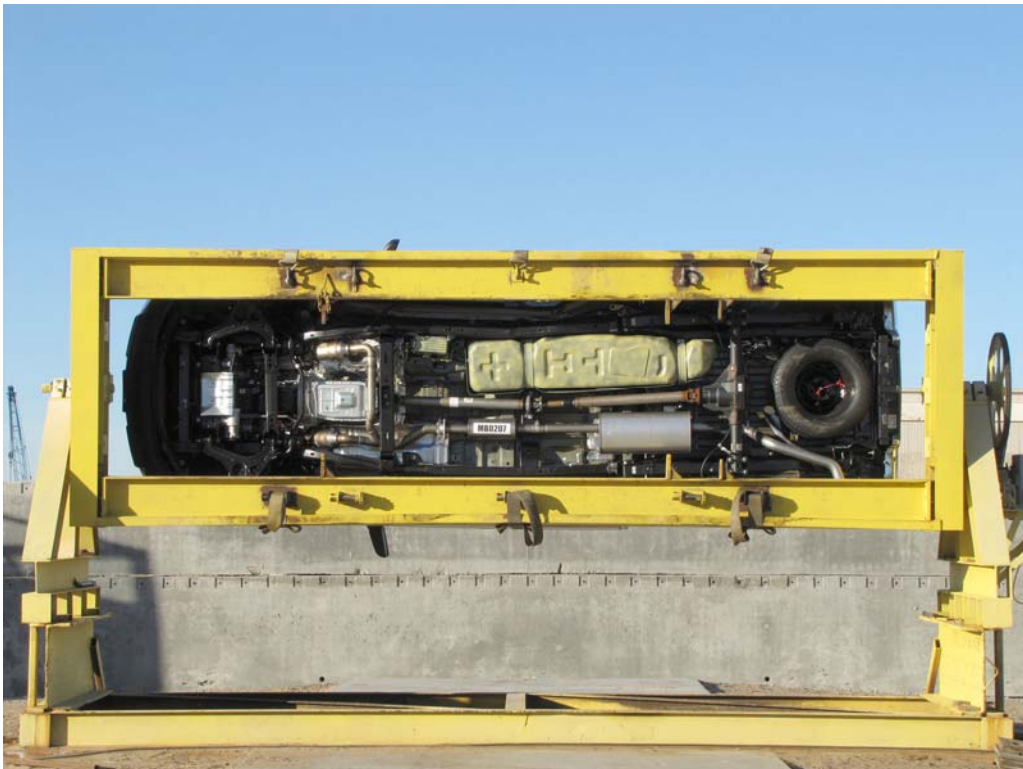

FIGURE 96. FMVSS No. 301/305 Rollover 270 Degrees



FIGURE 97. FMVSS No. 301/305 Rollover 360 Degrees



FIGURE 98. Impact Event

**Ford** **F-150** **BUILT TOUGH** 2011 F-150 4X2 SUPERCREW 148" WHEELBASE 5.0L V8 FVV ENGINE ELECTRONIC 6-SPD AUTO. EXTERIOR: STERLING GRAY METALLIC INTERIOR: GRAY CLOTH 402040 **BF A43696**

www.fordvehicles.com

**STANDARD EQUIPMENT INCLUDED AT NO EXTRA CHARGE**

**EXTERIOR**

- AUTOLAMP-AUTO ON/OFF HOLD MP
- LOCKING REMOVABLE TAILGATE
- W/ LIFT ASSIST
- PRETRAY GLASS, REAR
- SPARE TIRE & WHEEL LOCK
- FOG LAMPS

**INTERIOR**

- AIR CONDITIONING - MANUAL
- COLOR COORD. CARPET & MATS
- COVERED VISION MIRROR
- CRUISE CONTROL/TILT WHEEL
- DAY-NIGHT REAR VIEW MIRROR
- OUTSIDE TEMP/COMPASS DISPLAY

**FUNCTIONAL**

- AUXILIARY POWER POINT
- CARBON FIBER TIE DOWN HOOKS
- EASY FUEL CAPLESS FILLER
- FULL-SIZE COIL DOWN SYSTEM
- FULLY BOXED FRAME
- MAINT. FREE BATTERY W/SAVER
- OUTBOARD MOTO REAR HATCH
- POWER BACKUP/INTON STEERING
- POWER MIRROR/LOCKS/REARVIEW
- TIRE PRESSURE MONITORING SYS
- TRAILER BRAKE CONTROL

**SAFETY/SECURITY**

- 4-WHEEL DISC BRAKES W/ABS
- APWANCE TRAC W/
- ROLL STABILITY CONTROL
- ATIRAGS - FRONT SIDE SEAT
- REAR VIEW MOUNT STOP LAMP
- SAFETY CANOPY
- SECURELOCK ANTI THEFT ION

**WARRANTY**

- 1YR/50,000 POWERTRAIN
- 1YR/50,000 POWERTRAIN
- 5YR/60,000 ROADSIDE ASSIST

**PRICE INFORMATION**

STANDARD VEHICLE PRICE **\$31,810.00**

**OPTIONAL EQUIPMENT**

PREFERRED EQUIPMENT PKG. 507A

- 17" MACH ALUM W/PALNT ACCENTS
- AM/FM STEREO/CLOCK/SINGLE CD
- ALX SEERES
- 5.0L V8 FVV ENGINE
- 5.0L V8 FVV ENGINE
- 3.5L RATIO LIMITED SLIP ANLE
- 7100P GVWR PACKAGE
- SELECT SHIFT TRANSMISSION
- STANDARD FUEL TANK
- CALIFORNIA XLT VALUE PKG
- FRONT LICENSE PLATE BRACKET
- CALIFORNIA EMISSIONS SYSTEM
- TRAILER TOW PACKAGE
- XLT CONVENIENCE PACKAGE
- POWER ADJUSTABLE PEDALS
- POWER SIGNAL HEATED MIRRORS
- SYNC VOICE ACTIVATED SYSTEMS
- POWER 10-SPEAKER HEATED MIRRORS
- PHR DRIVER SEAT
- XLT PLUS PACKAGE
- POWER SLIDING REAR WINDOW
- REAR DEFROSTER/DEFOGGER
- REVERSE SENSING SYSTEM
- KEYLESS ENTRY KEY PAD
- SAT RADIO W/6 MOS SERVICE

TOTAL OPTIONS **3,390.00**

TOTAL VEHICLE & OPTIONS **35,200.00**

DESTINATION & DELIVERY **1,975.00**

TOTAL BEFORE DISCOUNTS **36,175.00**

XLT CONVENIENCE & TOW D **- 750.00**

TOTAL SAVINGS **- 750.00**

**EPA Fuel Economy Estimates**

**GASOLINE CITY MPG 15**

Expected range for most drivers 12 to 18 MPG

**Dual Fuel Vehicle\* Gasoline-Ethanol(E85)**

Estimated Annual Fuel Cost **\$2,646**

based on 15,000 miles at \$3.00 per gallon of gasoline

**Combined Gasoline Fuel Economy This Vehicle 17**

**GASOLINE HIGHWAY MPG 21**

Expected range for most drivers 17 to 25 MPG

Your actual mileage will vary depending on how you drive and maintain your vehicle.

**TOTAL MSRP \$35,425.00**

**GOVERNMENT SAFETY RATINGS**

Frontal Driver To Be Rated  
Crash Passenger To Be Rated

Star ratings based on the risk of injury in a frontal impact. Frontal ratings should ONLY be compared to other vehicles of similar size and weight.

Side Front seat To Be Rated  
Crash Rear seat To Be Rated

Star ratings based on the risk of injury in a side impact.

Rollover ★ ★ ★ ★

Star ratings based on the risk of rollover in a single vehicle crash. Star ratings range from 1 to 5 stars (★★★★), with 5 being the highest. Source: National Highway Traffic Safety Administration (NHTSA).

See the FREE Fuel Economy Guide at dealers or www.fueleconomy.gov

SOLD TO 71A 040 Gulfport Ford 13440 Lakeside Blvd North Hills CA 91343	ONE DEALER NO. RB27	71A 040	METHOD OF TRANSP. RAIL
SHIP TO FROM TRANSACTS	TWO	1FTFW1C38P A43696	ITEM # 71-2123 QV 2
SHIP THROUGH	FINAL ASSEMBLY POINT DEARBORN	This plate is affixed pursuant to the Federal Automotive Information Disclosure Act. It provides a means for identifying the vehicle's VIN, model, and other information.	

AM091 N 10 2X 120 006106 12 09 10

EXTENDED Ford Extended Service Plan is the only service contract backed by Ford and honored at all Ford and Lincoln Mercury

FIGURE 99. Monroney Label

**Seating and Safety Restraints**

**FRONT SEATS**

**WARNING:** Reclining the seatback can cause an occupant to lose control of the vehicle, resulting in severe personal injury in the event of a collision.

**WARNING:** Do not pile cargo higher than the seatbacks to reduce the risk of injury in a collision or sudden stop.

**WARNING:** Before returning the seatback to its original position, make sure that cargo or any objects are not trapped behind the seatback. After returning the seatback to its original position, pull on the seatback to ensure that it has fully latched. An unlatched seat may become dangerous in the event of a sudden stop or collision.

**Adjustable head restraints**

Your vehicle is equipped with front row outboard head restraints that are vertically adjustable.

**WARNING:** To minimize the risk of neck injury in the event of a crash, the driver and passenger occupants should not sit in or/operate the vehicle, until the head restraint is placed in its proper position. The driver should never adjust the head restraint while the vehicle is in motion.

The adjustable head restraints consist of:

- a trimmed energy absorbing foam and structure (1),
- two steel stems (2),
- a guide sleeve adjust/release button (3),
- and a guide sleeve unlock/remove button (4).

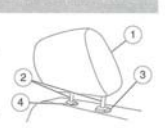

**Seating and Safety Restraints**

Properly adjust the head restraint so that the top of the head restraint is even with the top of your head and positioned as close as possible to the back of your head. For occupants of extremely tall stature, adjust the head restraint to its full up position.

**WARNING:** To minimize the risk of neck injury in the event of a crash, head restraints must be installed properly.

**Front seat**

- Lift the track release bar to move the seat forward or rearward. Make sure that the seat is latched into place.



**Seating and Safety Restraints**

To adjust the head restraint, do the following:

1. Adjust the seatback to an upright driving/riding position.
2. Raise the head restraint by pulling up on the head restraint.
3. Lower the head restraint by pressing and holding the guide sleeve adjust/release button (3) and pushing down on the head restraint.

Properly adjust the head restraint so that the top of the head restraint is even with the top of your head and positioned as close as possible to the back of your head. For occupants of extremely tall stature, adjust the head restraint to its full up position.

**WARNING:** The adjustable head restraint is a safety device. Whenever possible it should be installed and properly adjusted when the seat is occupied.

To remove the adjustable head restraint, do the following:

1. Pull up the head restraint until it reaches the highest adjustment position.
2. Simultaneously press and hold both the adjust/release button (3) and the unlock/remove button (4), then pull up on the head restraint.

To reinstall the adjustable head restraint, do the following:

1. Insert the two stems (2) into the guide sleeve collars.
2. Push the head restraint down until it locks.



FIGURE 100. Driver Head Restraint Use and Adjustment Information from Vehicle Manual

**Seating and Safety Restraints**

Properly adjust the head restraint so that the top of the head restraint is even with the top of your head and positioned as close as possible to the back of your head. For occupants of extremely tall stature, adjust the head restraint to its full up position.

**WARNING:** To minimize the risk of neck injury in the event of a crash, head restraints must be installed properly.

**Front seat**

- Lift the track release bar to move the seat forward or rearward. Make sure that the seat is retracted into place.



159

**Seating and Safety Restraints**

To adjust the head restraint, do the following:

- Adjust the seatback to an upright driving/riding position.
- Raise the head restraint by pulling up on the head restraint.
- Lower the head restraint by pressing and holding the guide sleeve adjust/release button (3) and pushing down on the head restraint.

Properly adjust the head restraint so that the top of the head restraint is even with the top of your head and positioned as close as possible to the back of your head. For occupants of extremely tall stature, adjust the head restraint to its full up position.

**WARNING:** The adjustable head restraint is a safety device. Whenever possible it should be installed and properly adjusted when the seat is occupied.

To remove the adjustable head restraint, do the following:

- Pull up the head restraint until it reaches the highest adjustment position.
- Simultaneously press and hold both the adjust/release button (3) and the unlock/remove button (4), then pull up on the head restraint.

To reinstall the adjustable head restraint, do the following:

- Insert the two stems (2) into the guide sleeve collars.
- Push the head restraint down until it locks.



158

FIGURE 101. Left Rear Passenger Head Restraint Use and Adjustment  
Information from Vehicle Manual

**APPENDIX B**  
**DUMMY RESPONSE DATA**

## TABLE OF DATA PLOTS

Plot		Page
1	Driver Head Acceleration (X) Primary vs. Time	B-1
2	Driver Head Acceleration (Y) Primary vs. Time	B-1
3	Driver Head Acceleration (Z) Primary vs. Time	B-1
4	Driver Head Resultant Acceleration Primary vs. Time	B-1
5	Driver Upper Thorax Rib Deflection (Y) vs. Time	B-2
6	Driver Middle Thorax Rib Deflection (Y) vs. Time	B-2
7	Driver Lower Thorax Rib Deflection (Y) vs. Time	B-2
8	Driver Thorax Rib Deflection Maximum vs. Time	B-2
9	Driver Anterior Abdominal Force (Y) vs. Time	B-3
10	Driver Middle Abdominal Force (Y) vs. Time	B-3
11	Driver Posterior Abdominal Force (Y) vs. Time	B-3
12	Driver Total Abdominal Force (Y) vs. Time	B-3
13	Driver Pubic Symphysis Force (Y) vs. Time	B-4
14	Passenger Head Acceleration (X) vs. Time Primary	B-5
15	Passenger Head Acceleration (Y) vs. Time Primary	B-5
16	Passenger Head Acceleration (Z) vs. Time Primary	B-5
17	Passenger Head Resultant Acceleration Primary vs. Time	B-5
18	Passenger Lower Spine T12 Acceleration (X) vs. Time	B-6
19	Passenger Lower Spine T12 Acceleration (Y) vs. Time	B-6
20	Passenger Lower Spine T12 Acceleration (Z) vs. Time	B-6
21	Passenger Lower Spine T12 Resultant Acceleration vs. Time	B-6
22	Passenger Iliac Force on Impact Side (Y) vs. Time	B-7
23	Passenger Acetabulum Force on Impact Side (Y) vs. Time	B-7
24	Passenger Total Pelvic Force on Impact Side (Y) vs. Time	B-7

**The following additional data for this test can be obtained from the Research and Development section of the NHTSA website. The website can be found at**

**[www.NHTSA.dot.gov](http://www.NHTSA.dot.gov).**

### **Driver & Passenger Dummy Instrumentation Data**

Driver Lower Spine T12 Acceleration (X)

Driver Lower Spine T12 Acceleration (Y)

Driver Lower Spine T12 Acceleration (Z)

Passenger Upper Thorax Rib Deflection (Y)

Passenger Middle Thorax Rib Deflection (Y)

Passenger Lower Thorax Rib Deflection (Y)  
Passenger Upper Abdomen Rib Deflection (Y)  
Passenger Lower Abdomen Rib Deflection (Y)  
Driver Head Acceleration Redundant (X)  
Driver Head Acceleration Redundant (Y)  
Driver Head Acceleration Redundant (Z)  
Driver Shoulder Contact Switch  
Driver Torso Contact Switch  
Driver Pelvis Contact Switch  
Passenger Head Acceleration Redundant (X)  
Passenger Head Acceleration Redundant (Y)  
Passenger Head Acceleration Redundant (Z)  
Passenger Shoulder Contact Switch  
Passenger Torso Contact Switch  
Passenger Pelvis Contact Switch

#### **Vehicle Instrumentation Data**

Driver Side Airbag Timing  
Driver Side Curtain Airbag Timing  
Passenger Side Airbag Timing (if applicable)  
Passenger Side Curtain Airbag Timing (if different from Driver)  
Right Side Sill at Front Seat Acceleration (X)  
Right Side Sill at Front Seat Acceleration (Y)  
Right Side Sill at Front Seat Acceleration (Z)  
Right Side Sill at Rear Seat Acceleration (X)  
Right Side Sill at Rear Seat Acceleration (Y)  
Right Side Sill at Rear Seat Acceleration (Z)  
Rear Floorpan Above Axle Acceleration (X)  
Rear Floorpan Above Axle Acceleration (Y)  
Rear Floorpan Above Axle Acceleration (Z)  
Left Side Sill at Front Seat Acceleration (Y)  
Left Side Sill at Rear Seat Acceleration (Y)  
Right Rear Occupant Compartment Acceleration (Y)  
Lower A-Post Acceleration (Y)  
Upper A-Post Acceleration (Y)  
Lower B-Post Acceleration (Y)  
Upper B-Post Acceleration (Y)

Front Seat Track Acceleration (Y)  
Rear Seat Track Acceleration (Y)  
Vehicle Center of Gravity Acceleration (X)  
Vehicle Center of Gravity Acceleration (Y)  
Vehicle Center of Gravity Acceleration (Z)

**MDB Instrumentation Data**

MDB Center of Gravity Acceleration (X)  
MDB Center of Gravity Acceleration (Y)  
MDB Center of Gravity Acceleration (Z)  
MDB Rear Acceleration (X)  
MDB Rear Acceleration (Y)  
Left MDB Contact Switch  
Right MDB Contact Switch

Test Vehicle: 2011 Ford F-150 XLT SuperCrew 4-Door Truck  
 Test Program: 61 km/h (38 mph) Side Impact NCAP 27° Moving Deformable Barrier Test

Test Date: 2/11/11  
 NHTSA No.: MB0207

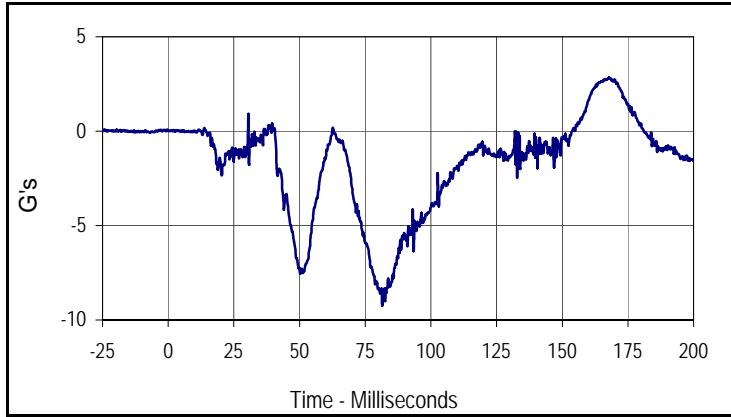

Curve Description			
Driver Head Acceleration X Primary			
CURNO	Type	SAE Class	Units
001	FIL	1000	G's
Max	Time	Min	Time
2.8	167.9	-9.2	81.5

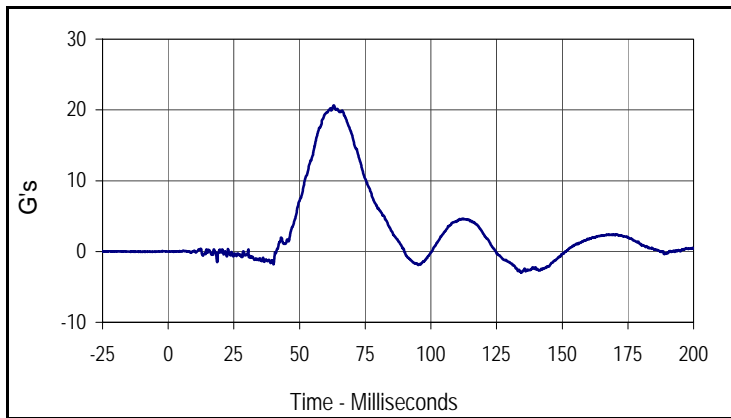

Curve Description			
Driver Head Acceleration Y Primary			
CURNO	Type	SAE Class	Units
002	FIL	1000	G's
Max	Time	Min	Time
20.6	63.1	-3.0	134.3

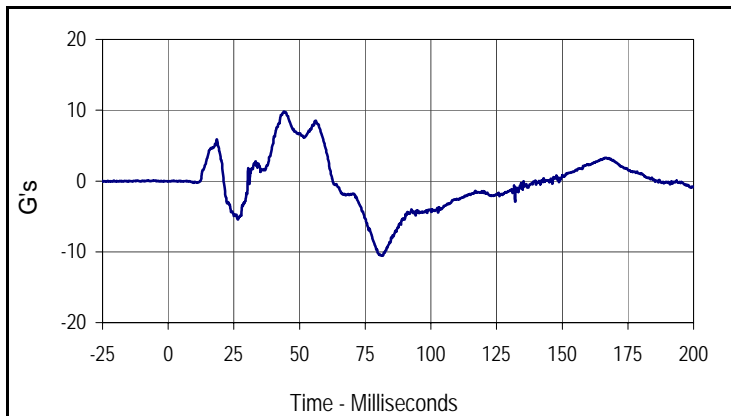

Curve Description			
Driver Head Acceleration Z Primary			
CURNO	Type	SAE Class	Units
003	FIL	1000	G's
Max	Time	Min	Time
9.9	44.1	-10.6	81.6

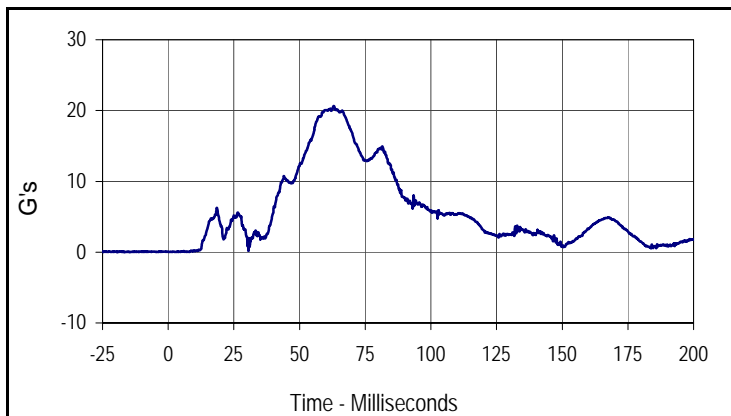

Curve Description			
Driver Head Resultant Acceleration Primary			
CURNO	Type	SAE Class	Units
001	RES	1000	G's
Max	Time	Min	Time
20.7	63.1	0.0	1.7

Test Vehicle: 2011 Ford F-150 XLT SuperCrew 4-Door Truck  
 Test Program: 61 km/h (38 mph) Side Impact NCAP 27° Moving Deformable Barrier Test

Test Date: 2/11/11  
 NHTSA No.: MB0207

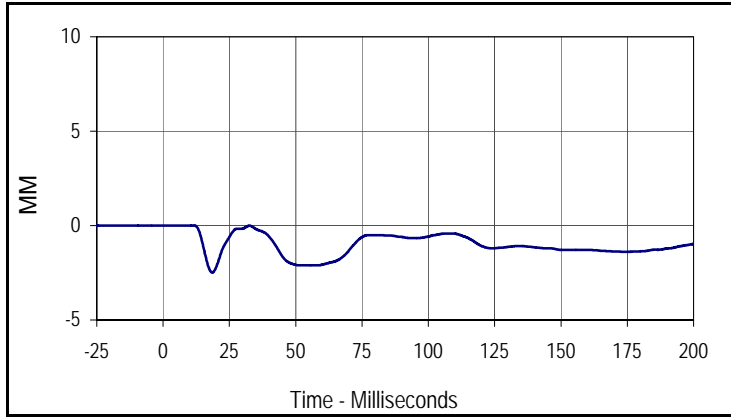

Curve Description			
Driver Upper Thorax Rib Deflection Y			
CURNO	Type	SAE Class	Units
007	FIL	180	MM
Max	Time	Min	Time
0.0	11.6	-2.5	18.5

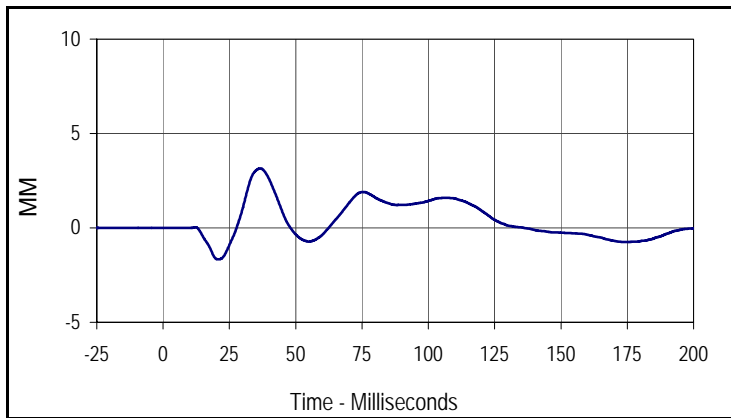

Curve Description			
Driver Middle Thorax Rib Deflection Y			
CURNO	Type	SAE Class	Units
008	FIL	180	MM
Max	Time	Min	Time
3.2	36.6	-1.7	20.8

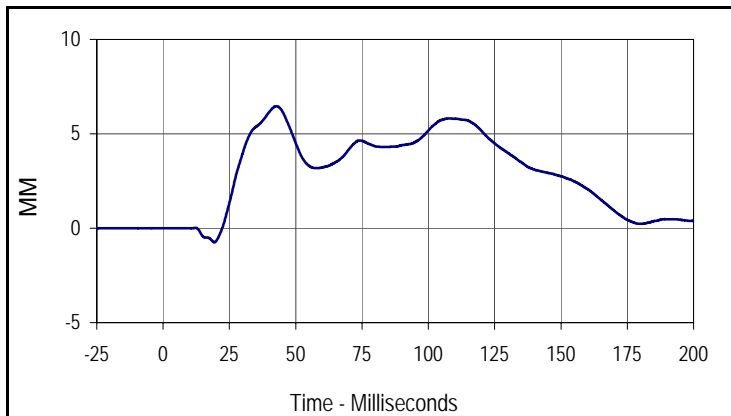

Curve Description			
Driver Lower Thorax Rib Deflection Y			
CURNO	Type	SAE Class	Units
009	FIL	180	MM
Max	Time	Min	Time
6.5	42.7	-0.7	19.3

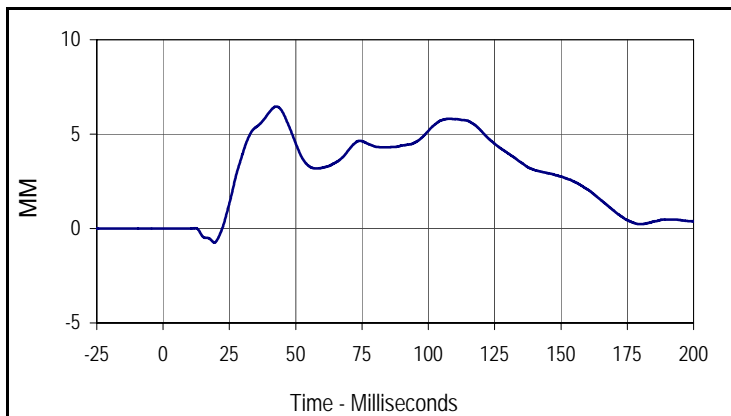

Curve Description			
Driver Thorax Rib Deflection Maximum			
CURNO	Type	SAE Class	Units
010	FIL	180	MM
Max	Time	Min	Time
6.5	42.7	-0.7	19.3

Test Vehicle: 2011 Ford F-150 XLT SuperCrew 4-Door Truck  
 Test Program: 61 km/h (38 mph) Side Impact NCAP 27° Moving Deformable Barrier Test

Test Date: 2/11/11  
 NHTSA No.: MB0207

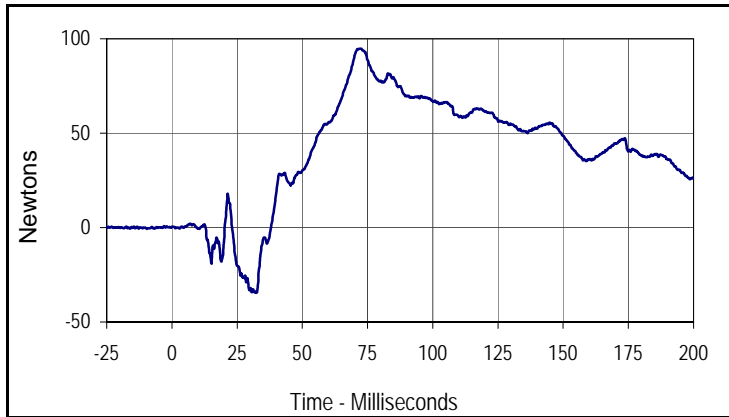

Curve Description			
Driver Anterior Abdominal Force Y			
CURNO	Type	SAE Class	Units
013	FIL	600	Newtons
Max	Time	Min	Time
94.8	72.0	-34.5	32.3

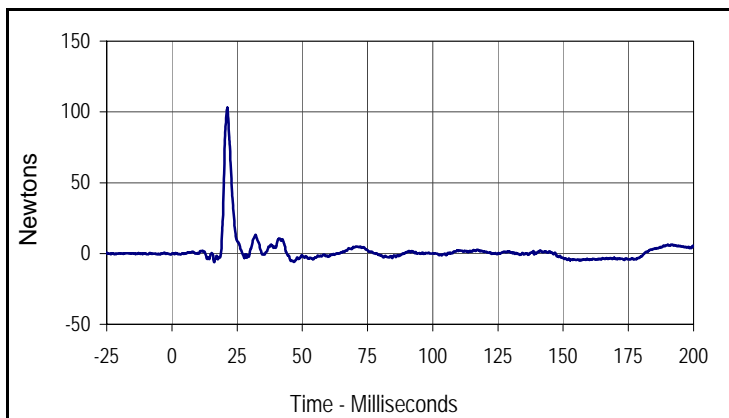

Curve Description			
Driver Middle Abdominal Force Y			
CURNO	Type	SAE Class	Units
014	FIL	600	Newtons
Max	Time	Min	Time
103.0	21.2	-6.1	16.2

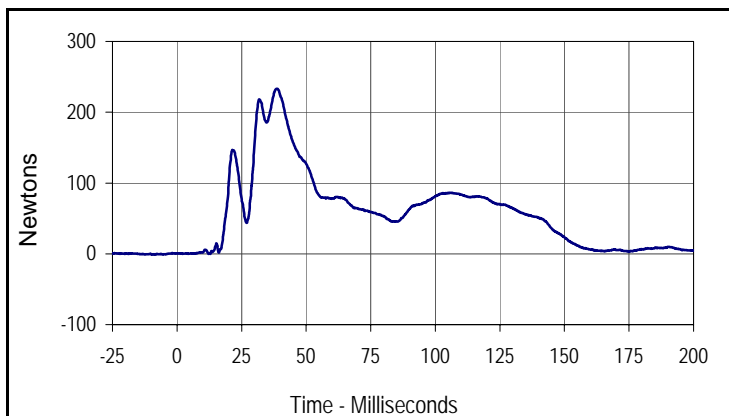

Curve Description			
Driver Posterior Abdominal Force Y			
CURNO	Type	SAE Class	Units
015	FIL	600	Newtons
Max	Time	Min	Time
233.3	38.6	0.0	2.2

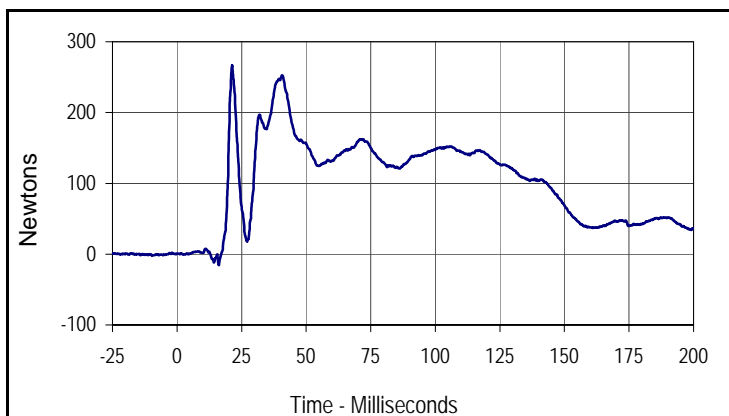

Curve Description			
Driver Total Abdominal Force			
CURNO	Type	SAE Class	Units
013	RES	600	Newtons
Max	Time	Min	Time
266.6	21.3	-15.4	16.2

Test Vehicle: 2011 Ford F-150 XLT SuperCrew 4-Door Truck

Test Date: 2/11/11

Test Program: 61 km/h (38 mph) Side Impact NCAP 27° Moving Deformable Barrier Test

NHTSA No.: MB0207

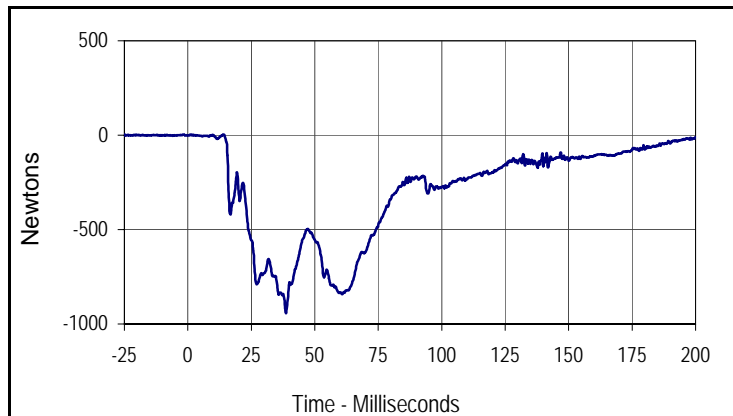

Curve Description			
Driver Pubic Symphysis Force Y			
CURNO	Type	SAE Class	Units
016	FIL	600	Newtons
Max	Time	Min	Time
3.6	1.0	-943.0	38.6

Test Vehicle: 2011 Ford F-150 XLT SuperCrew 4-Door Truck  
 Test Program: 61 km/h (38 mph) Side Impact NCAP 27° Moving Deformable Barrier Test

Test Date: 2/11/11  
 NHTSA No.: MB0207

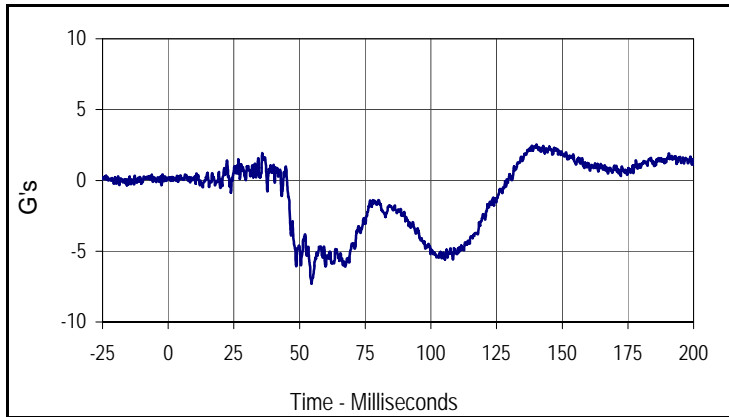

Curve Description			
Passenger Head Acceleration X Primary			
CURNO	Type	SAE Class	Units
021	FIL	1000	G's
Max	Time	Min	Time
2.5	140.2	-7.3	54.6

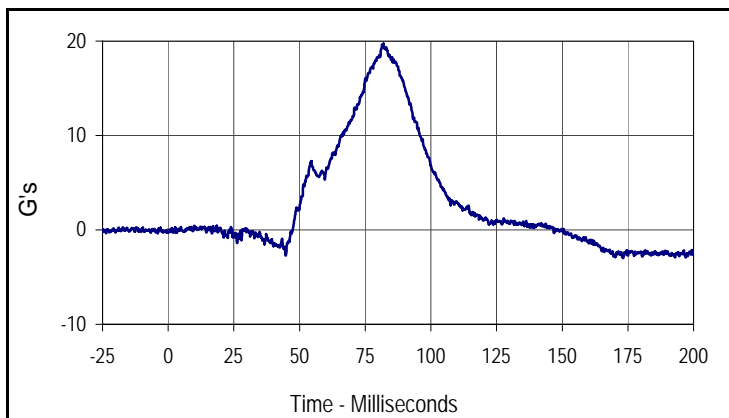

Curve Description			
Passenger Head Acceleration Y Primary			
CURNO	Type	SAE Class	Units
022	FIL	1000	G's
Max	Time	Min	Time
19.7	81.9	-3.0	173.1

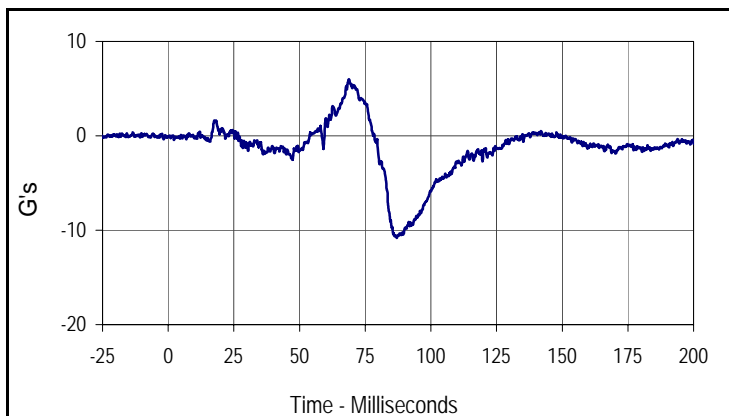

Curve Description			
Passenger Head Acceleration Z Primary			
CURNO	Type	SAE Class	Units
023	FIL	1000	G's
Max	Time	Min	Time
6.0	68.8	-10.8	87.1

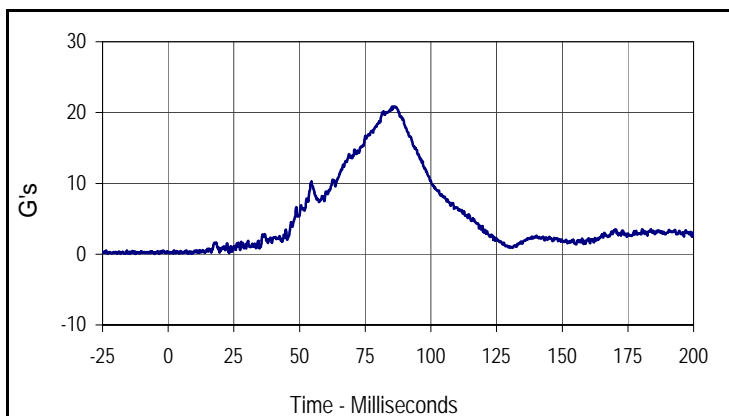

Curve Description			
Passenger Head Acceleration Resultant Primary			
CURNO	Type	SAE Class	Units
021	RES	1000	G's
Max	Time	Min	Time
20.9	85.8	0.1	9.1

Test Vehicle: 2011 Ford F-150 XLT SuperCrew 4-Door Truck  
 Test Program: 61 km/h (38 mph) Side Impact NCAP 27° Moving Deformable Barrier Test

Test Date: 2/11/11  
 NHTSA No.: MB0207

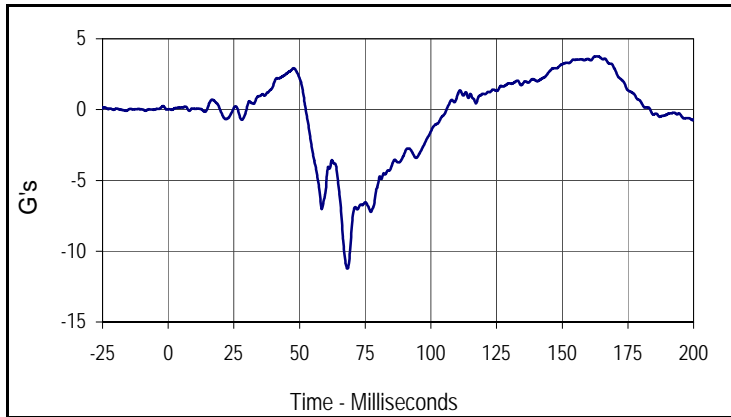

Curve Description			
Passenger Lower Spine T12 Acceleration X			
CURNO	Type	SAE Class	Units
037	FIL	180	G's
Max	Time	Min	Time
3.8	163.7	-11.2	68.2

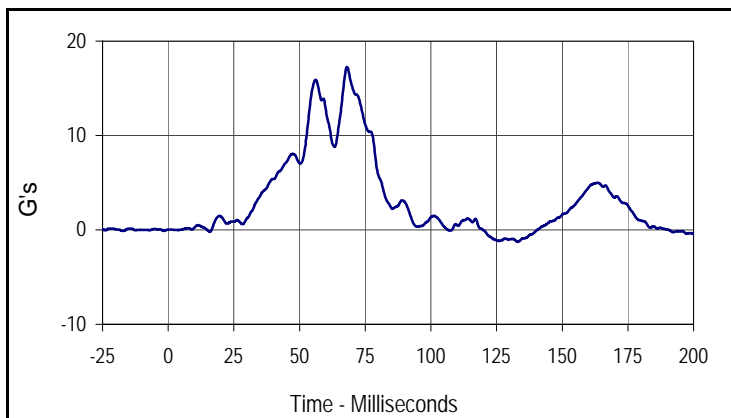

Curve Description			
Passenger Lower Spine T12 Acceleration Y			
CURNO	Type	SAE Class	Units
038	FIL	180	G's
Max	Time	Min	Time
17.3	68.0	-1.3	133.1

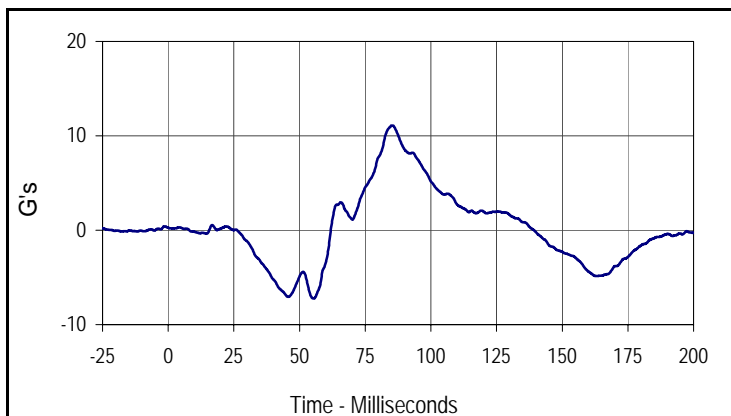

Curve Description			
Passenger Lower Spine T12 Acceleration Z			
CURNO	Type	SAE Class	Units
039	FIL	180	G's
Max	Time	Min	Time
11.1	85.4	-7.2	55.3

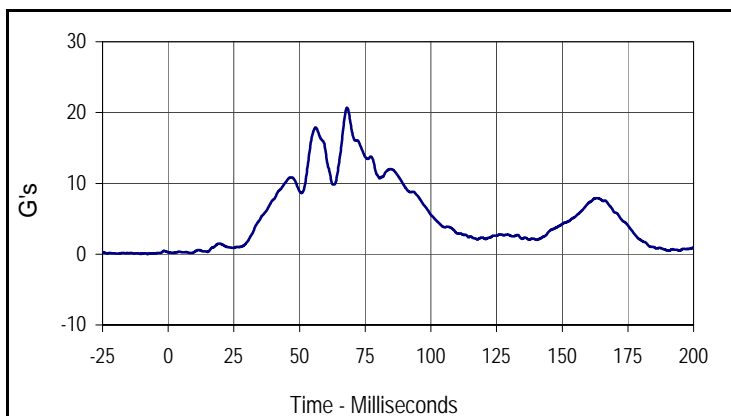

Curve Description			
Passenger Lower Spine T12 Acceleration Resultant			
CURNO	Type	SAE Class	Units
037	RES	180	G's
Max	Time	Min	Time
20.7	68.1	0.1	8.7

Test Vehicle: 2011 Ford F-150 XLT SuperCrew 4-Door Truck  
 Test Program: 61 km/h (38 mph) Side Impact NCAP 27° Moving Deformable Barrier Test

Test Date: 2/11/11  
 NHTSA No.: MB0207

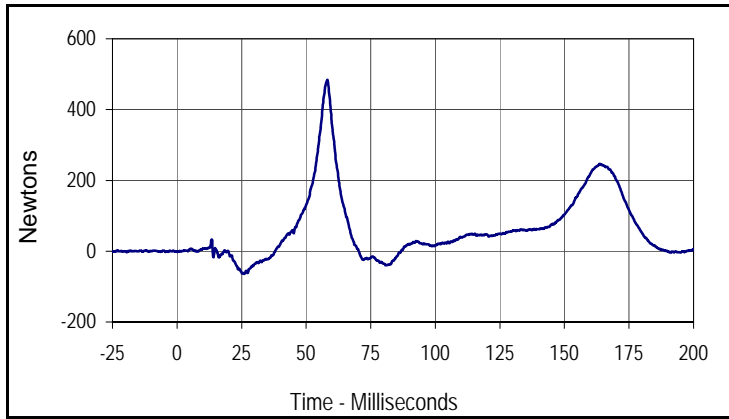

Curve Description			
Passenger Iliac Wing Force on Impact Side Y			
CURNO	Type	SAE Class	Units
043	FIL	600	Newtons
Max	Time	Min	Time
484.6	58.2	-64.0	26.1

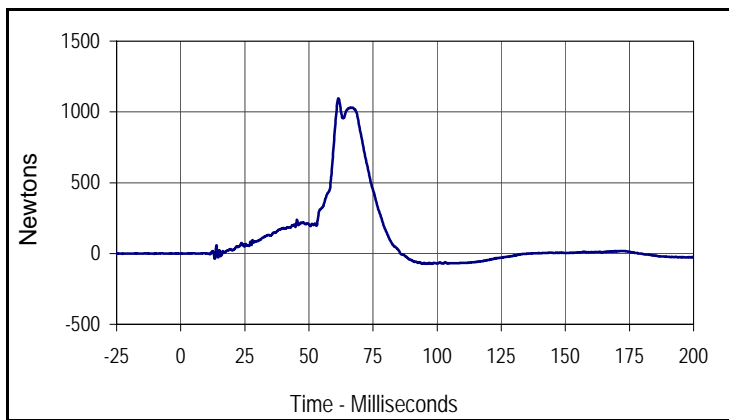

Curve Description			
Passenger Acetabulum Force on Impact Side Y			
CURNO	Type	SAE Class	Units
042	FIL	600	Newtons
Max	Time	Min	Time
1096.5	61.5	-72.6	95.5

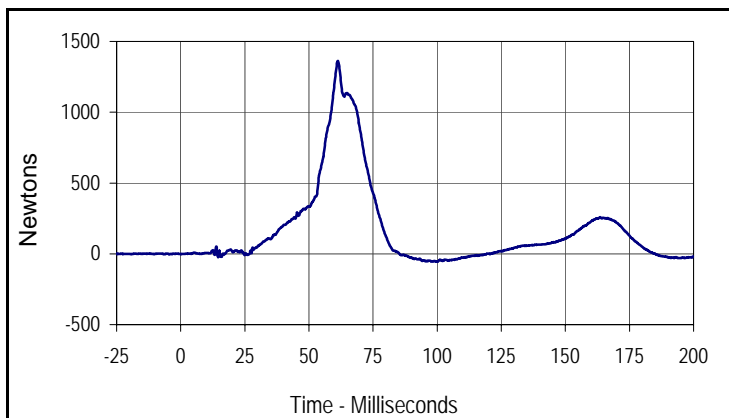

Curve Description			
Passenger Total Pelvic Force			
CURNO	Type	SAE Class	Units
042	SUM	600	Newtons
Max	Time	Min	Time
1361.4	61.3	-55.6	98.0

**APPENDIX C**  
**DUMMY CALIBRATION DATA**

**APPENDIX C**  
**PRE-TEST / ATD CONFIGURATION AND PERFORMANCE VERIFICATION DATA**

Test Program: ES2re Neck Calibration  
 ATD Serial No.: F035

Test Date: 2/2/11  
 Test I.D.: NBM02B



Tested Parameter	Units	Specification	Result	Pass/Fail	
Laboratory Temperature	°C	20.6 to 22.2	21.15	Pass	
Laboratory Relative Humidity	%	10 to 70	22.43	Pass	
Pendulum Velocity	m/s	3.30 to 3.50	3.40	Pass	
Pendulum Deceleration	1 msec	m/s	0.0 to -.050	-0.031	Pass
	3 msec	m/s	-.250 to -.375	-0.288	Pass
	14 msec	m/s	-3.20 to -3.70	-3.25	Pass
Headform Rotation	Max	Degrees	49.0 to 58.0	50.8	Pass
	Time	msec	54.0 to 66.0	57.3	Pass
Maximum Rotation To Time Zero Crossing	msec	53.0 to 88.0	60.7	Pass	
Overall Test Results				Pass	

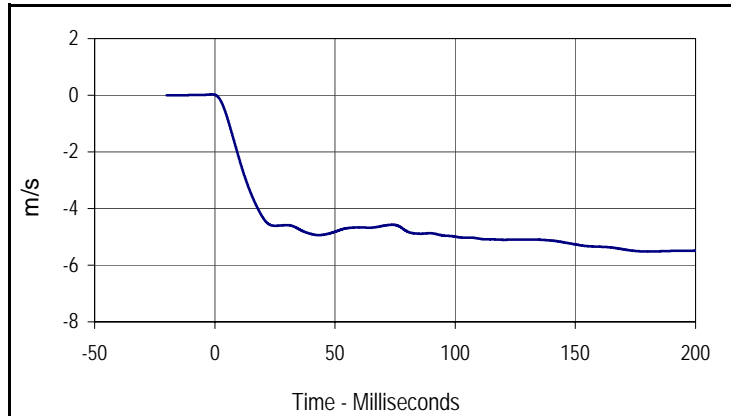

Curve Description			
Pendulum Velocity			
CURNO	Type	SAE Class	Units
001	FIL	60	m/s
Max	Time	Min	Time
0.0	-1.2	-5.5	180.2

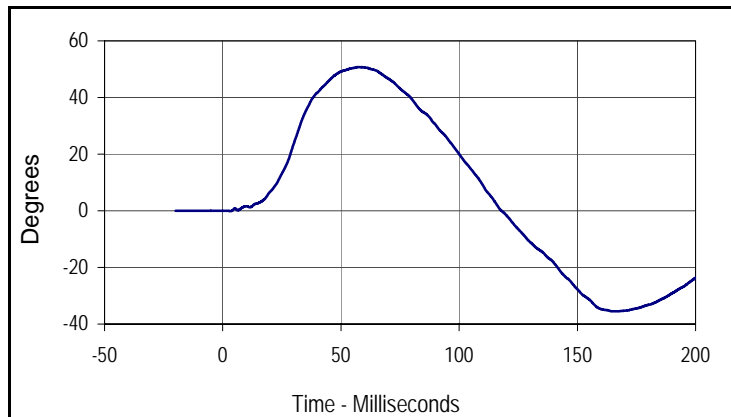

Curve Description			
Headform Rotation			
CURNO	Type	SAE Class	Units
002	FIL	180	Degrees
Max	Time	Min	Time
50.8	57.3	-35.5	164.8

Test Program: ES2re Shoulder Calibration  
 ATD Serial No.: F035

Test Date: 2/2/11  
 Test I.D.: SHM02B



Tested Parameter	Units	Specification	Result	Pass/Fail
Laboratory Temperature	°C	20.6 to 22.2	21.15	Pass
Laboratory Relative Humidity	%	10 to 70	22.43	Pass
Probe Velocity	m/s	4.20 to 4.40	4.22	Pass
Peak Impactor Acceleration	G's	7.5 to 10.5	9.55	Pass
Overall Test Results				Pass

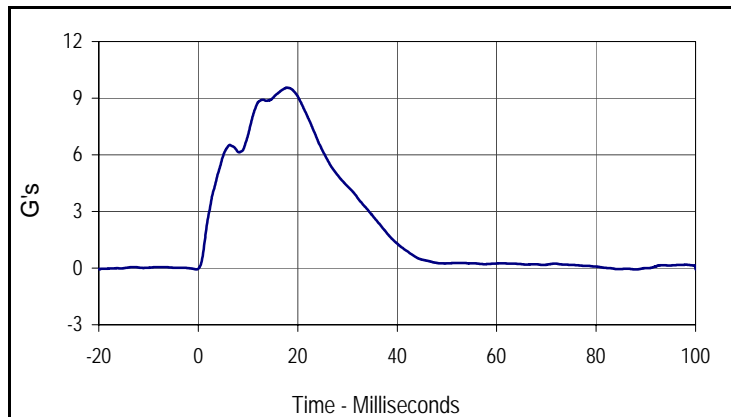

Curve Description			
<u>Impactor Acceleration</u>			
CURNO	Type	SAE Class	Units
001	FIL	180	G's
Max	Time	Min	Time
9.6	17.9	-0.1	88.0

Test Program: ES2re Rib Module Calibration  
 ATD Serial No.: F035 Rib #1

Test Date: 2/2/11  
 Test I.D.: RIB102B



Tested Parameter	Units	Specification	Result	Pass/Fail
Laboratory Temperature	°C	20.6 to 22.2	21.15	Pass
Laboratory Relative Humidity	%	10 to 70	22.34	Pass
Peak Rib Deflection at 459 MM Drop Height	MM	36 to 40	38.1	Pass
Peak Rib Deflection at 815 MM Drop Height	MM	46 to 51	48.1	Pass
Overall Test Results			Pass	Pass

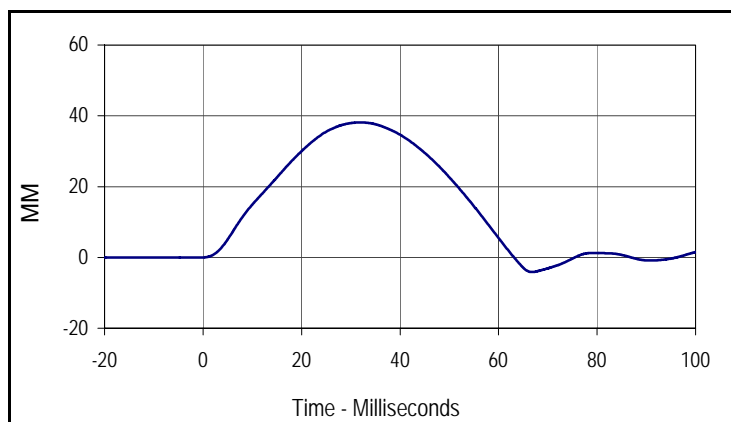

Curve Description			
Upper Rib Deflection (459 MM Drop Height)			
CURNO	Type	SAE Class	Units
001	FIL	180	MM
Max	Time	Min	Time
38.1	32.0	-4.1	66.8

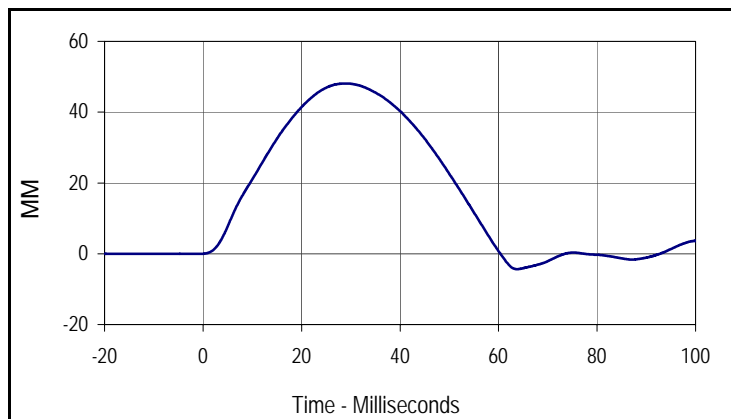

Curve Description			
Upper Rib Deflection (815 MM Drop Height)			
CURNO	Type	SAE Class	Units
001	FIL	180	MM
Max	Time	Min	Time
48.1	28.9	-4.3	63.7

Test Program: ES2re Rib Module Calibration  
 ATD Serial No.: F035 Rib #2

Test Date: 2/2/11  
 Test I.D.: RIB202B



Tested Parameter	Units	Specification	Result	Pass/Fail
Laboratory Temperature	°C	20.6 to 22.2	21.21	Pass
Laboratory Relative Humidity	%	10 to 70	22.29	Pass
Peak Rib Deflection at 459 MM Drop Height	MM	36 to 40	37.8	Pass
Peak Rib Deflection at 815 MM Drop Height	MM	46 to 51	47.6	Pass
Overall Test Results				Pass

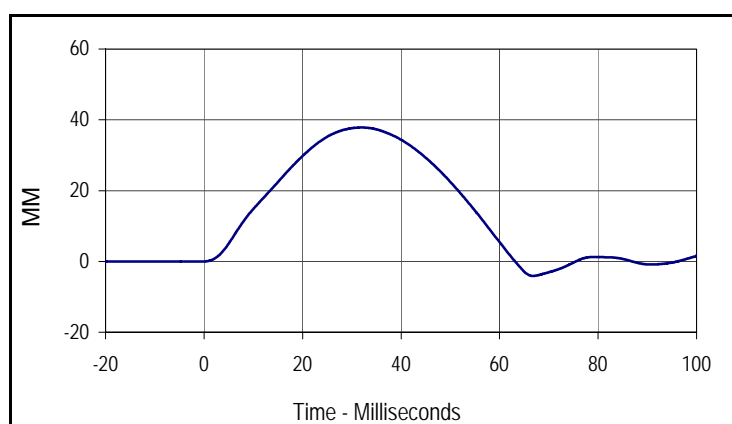

Curve Description			
Middle Rib Deflection (459 MM Drop Height)			
CURNO	Type	SAE Class	Units
001	FIL	180	MM
Max	Time	Min	Time
37.8	32.0	-4.1	66.8

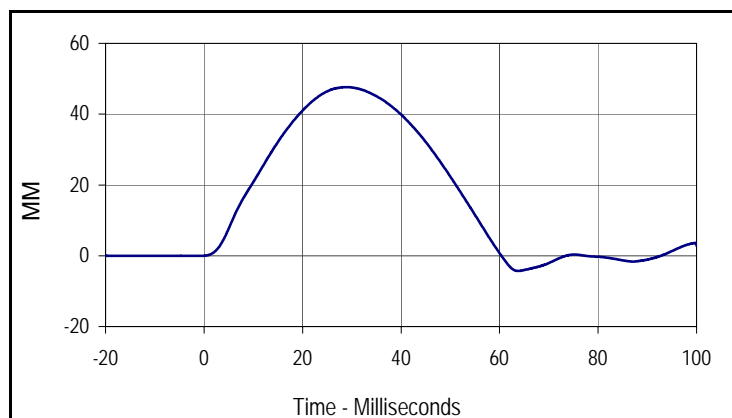

Curve Description			
Middle Rib Deflection (815 MM Drop Height)			
CURNO	Type	SAE Class	Units
001	FIL	180	MM
Max	Time	Min	Time
47.6	28.9	-4.3	63.7

Test Program: ES2re Rib Module Calibration  
 ATD Serial No.: F035 Rib #3

Test Date: 2/2/11  
 Test I.D.: RIB302B



Tested Parameter	Units	Specification	Result	Pass/Fail
Laboratory Temperature	°C	20.6 to 22.2	21.21	Pass
Laboratory Relative Humidity	%	10 to 70	22.34	Pass
Peak Rib Deflection at 459 MM Drop Height	MM	36 to 40	38.1	Pass
Peak Rib Deflection at 815 MM Drop Height	MM	46 to 51	48.2	Pass
Overall Test Results			Pass	Pass

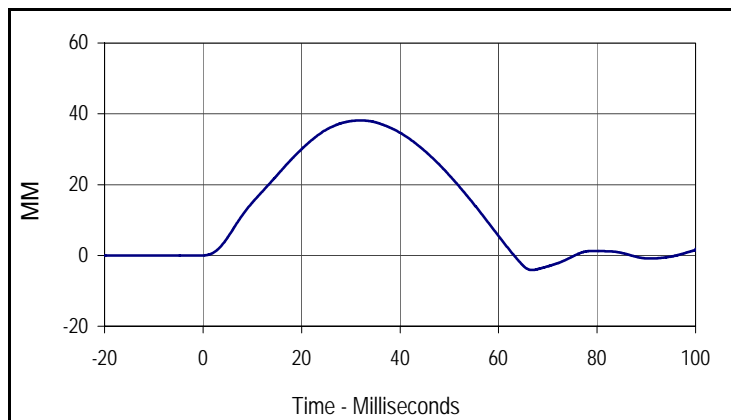

Curve Description			
Lower Rib Deflection (459 MM Drop Height)			
CURNO	Type	SAE Class	Units
001	FIL	180	MM
Max	Time	Min	Time
38.1	32.0	-4.1	66.8

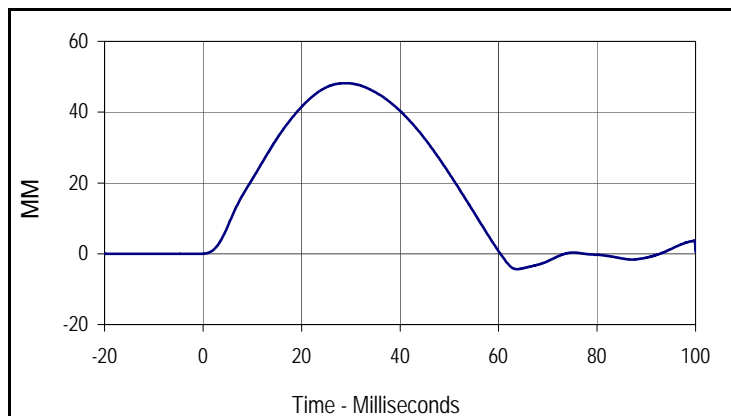

Curve Description			
Lower Rib Deflection (815 MM Drop Height)			
CURNO	Type	SAE Class	Units
001	FIL	180	MM
Max	Time	Min	Time
48.2	28.9	-4.4	63.7

Test Program: ES2re Thorax Calibration  
 ATD Serial No.: F035

Test Date: 2/2/11  
 Test I.D.: THM02B



Tested Parameter	Units	Specification	Result	Pass/Fail
Laboratory Temperature	°C	20.6 to 22.2	21.21	Pass
Laboratory Relative Humidity	%	10 to 70	22.24	Pass
Probe Velocity	m/s	5.40 to 5.60	5.44	Pass
Impactor Force	N	5100 to 6200	5351.8	Pass
	msec	> 6.0 msec	10.8	Pass
Upper Rib Deflection	MM	34 to 41	37.2	Pass
Middle Rib Deflection	MM	37 to 45	40.7	Pass
Lower Rib Deflection	MM	37 to 44	39.2	Pass
Overall Test Results				Pass

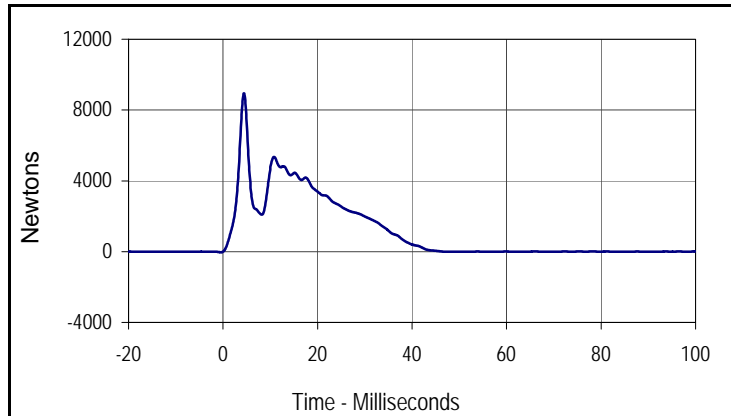

Curve Description			
Impactor Force			
CURNO	Type	SAE Class	Units
001	FIL	180	Newtons
Max	Time	Min	Time
8944.0	4.4	-36.1	-0.5

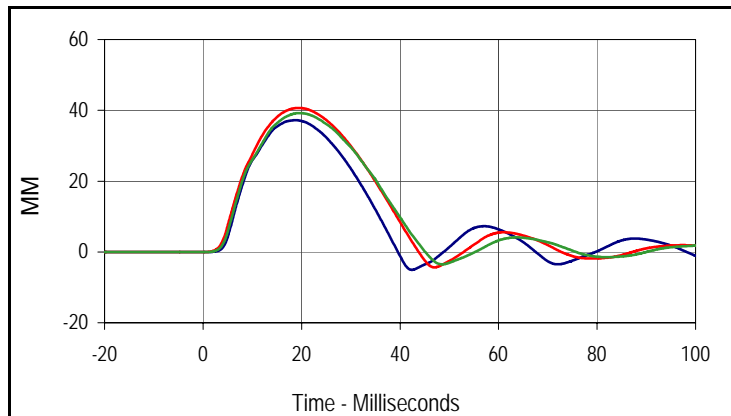

Curve Description			
Upper, Middle, Lower Rib Deflections			
CURNO(s)	Type	SAE Class	Units
002-003-004	FIL	180	MM
Max (Upper)	Time	Min (Upper)	Time
37.2	18.8	-5.1	42.4
Max (Middle)	Time	Min (Middle)	Time
40.7	19.5	-4.4	47.0
Max (Lower)	Time	Min (Lower)	Time
39.2	19.6	-3.5	48.6

Test Program: ES2re Abdomen Calibration  
 ATD Serial No.: F035

Test Date: 2/2/11  
 Test I.D.: ABDM02B



Tested Parameter	Units	Specification	Result	Pass/Fail
Laboratory Temperature	°C	20.6 to 22.2	21.21	Pass
Laboratory Relative Humidity	%	10 to 70	22.24	Pass
Probe Velocity	m/s	3.90 to 4.10	4.01	Pass
Impactor Force	N	4000 to 4800	4050.3	Pass
	msec	10.6 to 13.0	11.1	Pass
Abdominal Force	N	2200 to 2700	2286.6	Pass
	msec	10.0 to 12.3	11.1	Pass
Overall Test Results				Pass

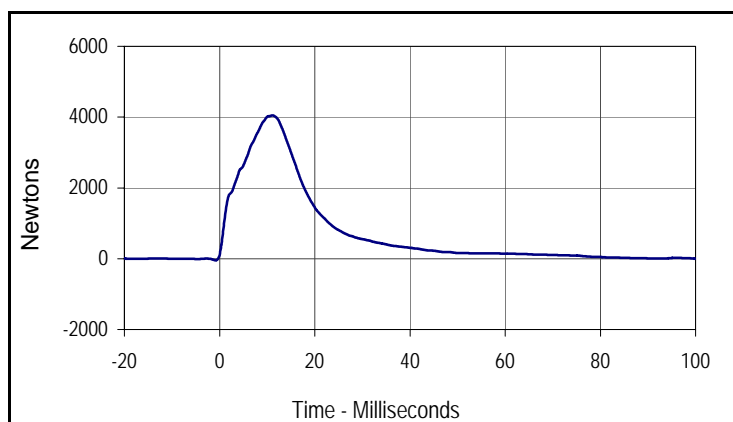

Curve Description			
Impactor Force			
CURNO	Type	SAE Class	Units
001	FIL	180	Newtons
Max	Time	Min	Time
4050.3	11.1	-43.6	-0.8

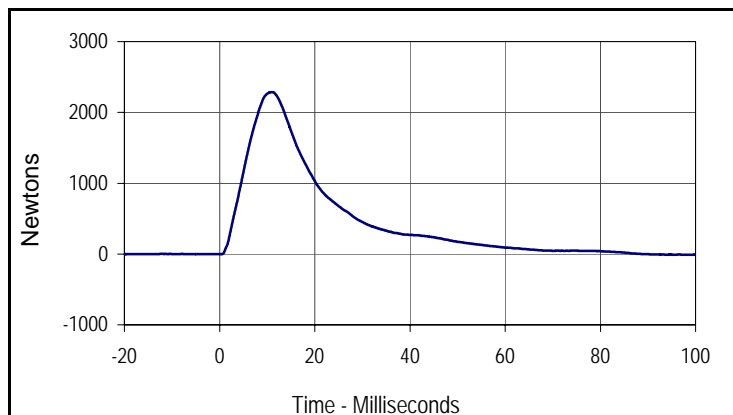

Curve Description			
Abdomen Sum Resultant			
CURNO	Type	SAE Class	Units
002	RES	600	Newtons
Max	Time	Min	Time
2286.6	11.1	-9.6	97.8

Test Program: ES2re Lumbar Spine Calibration  
 ATD Serial No.: F035

Test Date: 2/2/11  
 Test I.D.: SPM02B



Tested Parameter	Units	Specification	Result	Pass/Fail	
Laboratory Temperature	°C	20.6 to 22.2	21.21	Pass	
Laboratory Relative Humidity	%	10 to 70	22.20	Pass	
Pendulum Velocity	m/s	5.95 to 6.15	5.97	Pass	
Pendulum Deceleration	1 msec	m/s	0.0 to -.050	-0.029	Pass
	3.7 msec	m/s	-.240 to -.425	-0.380	Pass
	27 msec	m/s	-5.80 to -6.50	-5.96	Pass
	30 msec	m/s	< -6.50	-6.47	Pass
Headform Rotation	Max	Degrees	45.0 to 55.0	47.4	Pass
	Time	msec	39.0 to 53.0	42.6	Pass
Maximum Rotation To Time Zero Crossing	msec	37.0 to 57.0	41.5	Pass	
Overall Test Results				Pass	

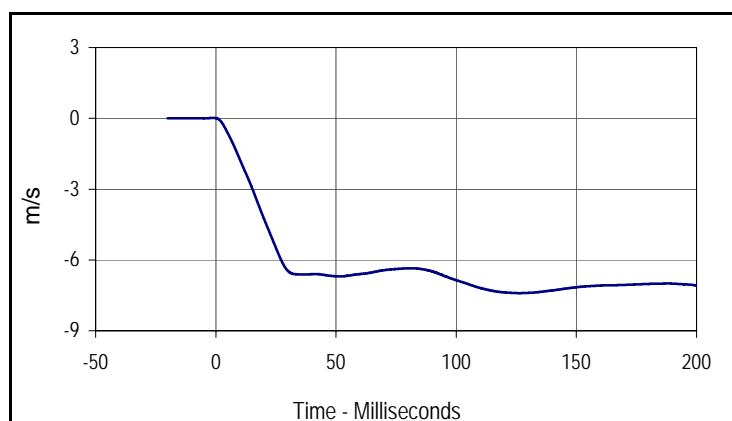

Curve Description			
CURNO	Type	SAE Class	Units
001	FIL	60	m/s
Max	Time	Min	Time
0.0	-1.0	-7.4	126.3

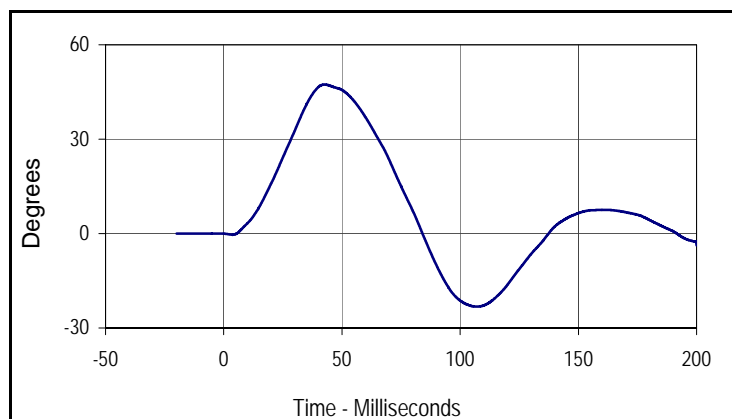

Curve Description			
Headform Rotation			
CURNO	Type	SAE Class	Units
002	FIL	180	Degrees
Max	Time	Min	Time
47.4	42.6	-23.2	107.0

Test Program: ES2re Pelvis Calibration  
 ATD Serial No.: F035

Test Date: 2/2/11  
 Test I.D.: PLM02B



Tested Parameter	Units	Specification	Result	Pass/Fail
Laboratory Temperature	°C	20.6 to 22.2	21.26	Pass
Laboratory Relative Humidity	%	10 to 70	22.19	Pass
Probe Velocity	m/s	4.20 to 4.40	4.28	Pass
Impactor Force	N	4700 to 5400	4709.1	Pass
	msec	11.8 to 16.1	14.4	Pass
Pubic Symphysis Load	N	-1230 to -1590	-1288.1	Pass
	msec	12.2 to 17.0	15.4	Pass
Overall Test Results				Pass

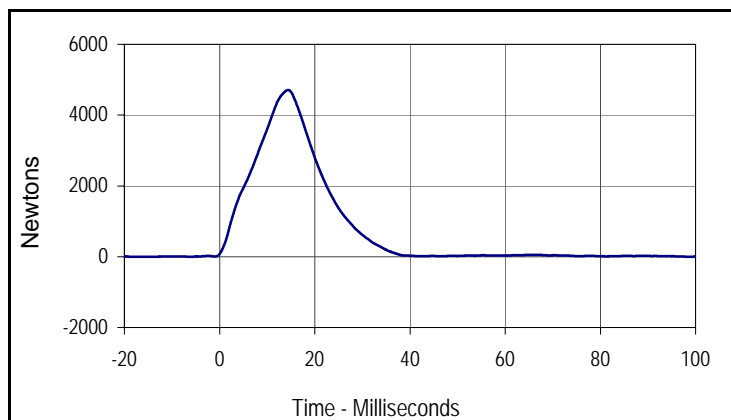

Curve Description			
Impactor Force			
CURNO	Type	SAE Class	Units
001	FIL	180	Newtons
Max	Time	Min	Time
4709.1	14.4	-3.3	-17.5

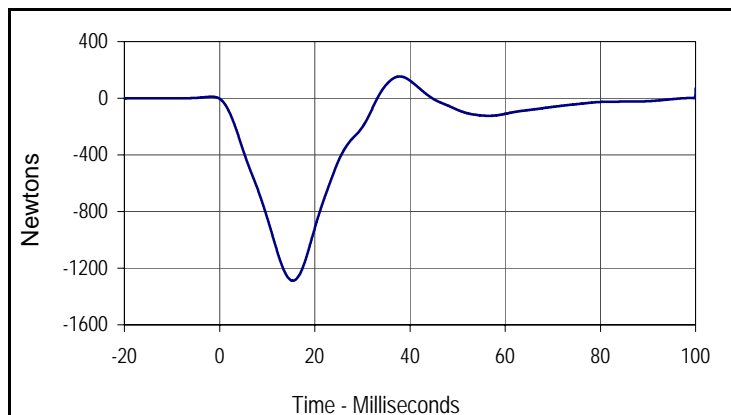

Curve Description			
Pubic FY			
CURNO	Type	SAE Class	Units
002	FIL	60	Newtons
Max	Time	Min	Time
154.0	37.9	-1288.1	15.4

Test Program: ES2re Lateral Head Drop Calibration  
 ATD Serial No.: F035

Test Date: 2/2/11  
 Test I.D.: HDM02B



Tested Parameter	Units	Specification	Result	Pass/Fail
Laboratory Temperature	°C	20.6 to 22.2	21.26	Pass
Laboratory Relative Humidity	%	10 to 70	22.24	Pass
Peak Resultant Acceleration	G's	125 to 155	143.3	Pass
Peak Longitudinal Acceleration	G's	≤15	1.4	Pass
Is Acceleration Unimodal?	Yes/No	Yes	Yes	Pass
Oscillations After Main Pulse	%	<15	5.1	Pass
<b>Overall Test Results</b>			<b>Pass</b>	

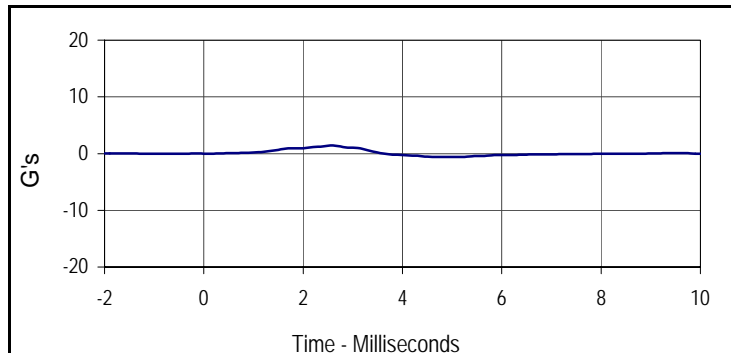

Curve Description			
Head X			
CURNO	Type	SAE Class	Units
001	FIL	1000	G's
Max	Time	Min	Time
1.4	2.6	-0.6	5.1

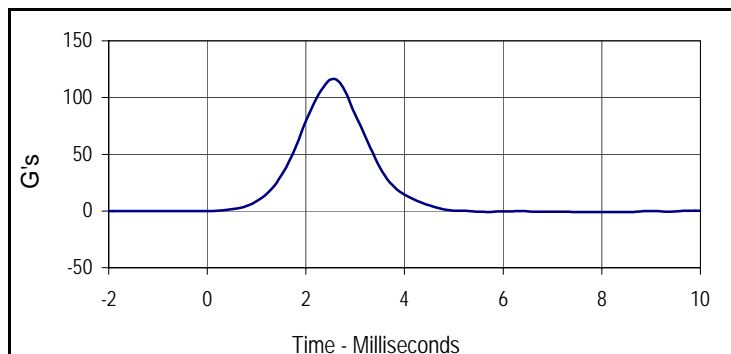

Curve Description			
Head Y			
CURNO	Type	SAE Class	Units
002	FIL	1000	G's
Max	Time	Min	Time
116.2	2.6	-1.0	7.7

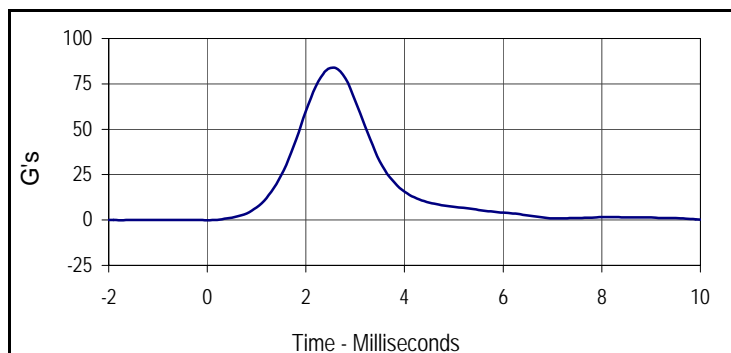

Curve Description			
Head Z			
CURNO	Type	SAE Class	Units
003	FIL	1000	G's
Max	Time	Min	Time
83.9	2.5	-0.1	-1.7

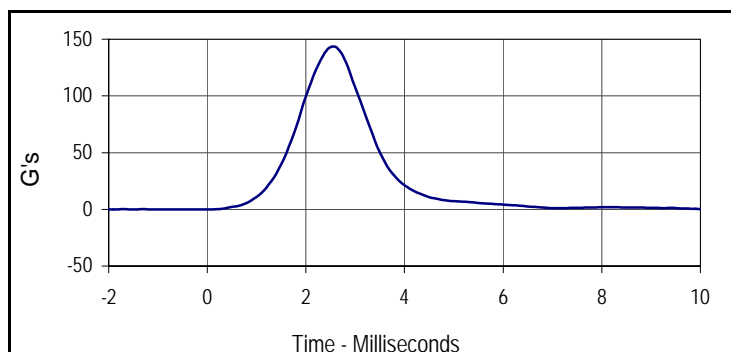

Curve Description			
Head Resultant			
CURNO	Type	SAE Class	Units
001	RES	1000	G's
Max	Time	Min	Time
143.3	2.6	0.0	-0.2

Test Program: SID IIs Lateral Head Drop Calibration  
 ATD Serial No.: 307

Test Date: 2/3/11  
 Test I.D.: HDF02B



Tested Parameter	Units	Specification	Result	Pass/Fail
Laboratory Temperature	°C	20.6 to 22.2	21.31	Pass
Laboratory Relative Humidity	%	10 to 70	22.10	Pass
Peak Resultant Acceleration	G's	115 to 137	128.4	Pass
Peak Longitudinal Acceleration	G's	≤15	3.3	Pass
Is Acceleration Unimodal?	Yes/No	Yes	Yes	Pass
Oscillations After Main Pulse	%	<15	10.3	Pass
<b>Overall Test Results</b>			<b>Pass</b>	

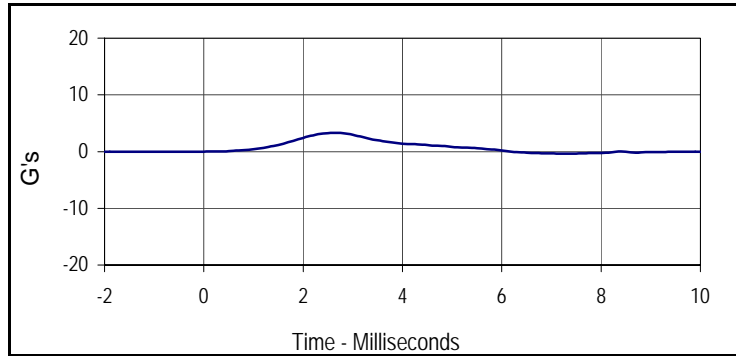

Curve Description			
Head X			
CURNO	Type	SAE Class	Units
001	FIL	1000	G's
Max	Time	Min	Time
3.3	2.6	-0.4	7.3

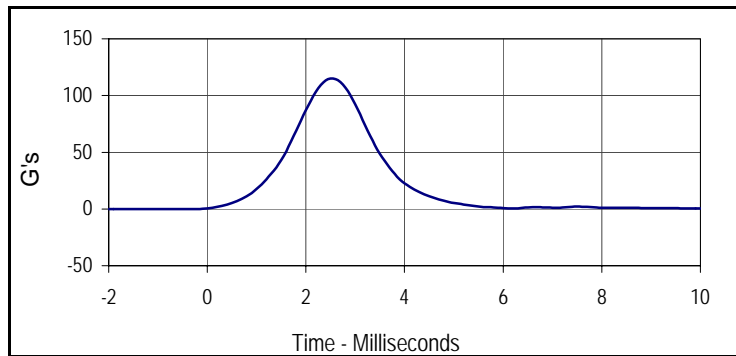

Curve Description			
Head Y			
CURNO	Type	SAE Class	Units
002	FIL	1000	G's
Max	Time	Min	Time
115.0	2.5	0.0	-0.2

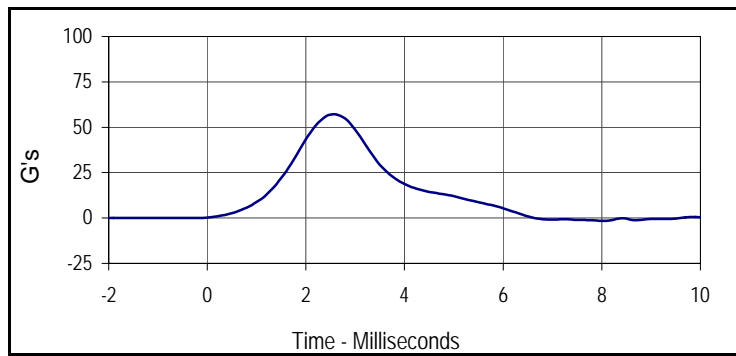

Curve Description			
Head Z			
CURNO	Type	SAE Class	Units
003	FIL	1000	G's
Max	Time	Min	Time
57.1	2.6	-1.5	8.0

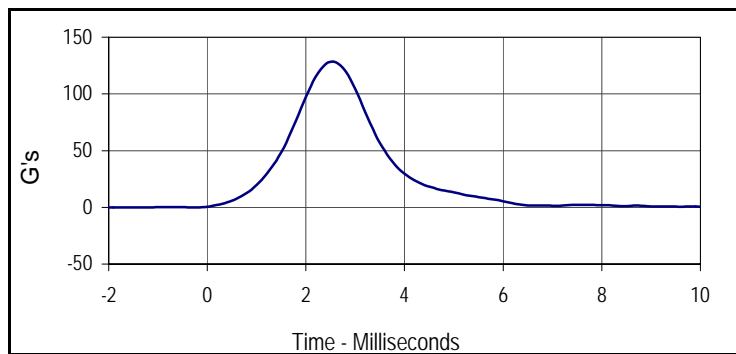

Curve Description			
Head Resultant			
CURNO	Type	SAE Class	Units
001	RES	1000	G's
Max	Time	Min	Time
128.4	2.5	0.0	-1.6

Test Program: SID IIs Neck Calibration  
 ATD Serial No.: 307

Test Date: 2/3/11  
 Test I.D.: NBF02B



Tested Parameter	Units	Specification	Result	Pass/Fail	
Laboratory Temperature	°C	20.6 to 22.2	21.31	Pass	
Laboratory Relative Humidity	%	10 to 70	21.96	Pass	
Pendulum Velocity	m/s	5.51 to 5.63	5.53	Pass	
Pendulum Deceleration	10 msec	m/s	-2.20 to -2.80	-2.35	Pass
	15 msec	m/s	-3.30 to -4.10	-3.53	Pass
	20 msec	m/s	-4.40 to -5.40	-4.62	Pass
	25 msec	m/s	-5.40 to -6.10	-5.41	Pass
	25-100 msec	m/s	-5.50 to -6.20	-5.99	Pass
Translation-Rotation	Max	Degrees	71.0 to 81.0	78.8	Pass
	Time	msec	50.0 to 70.0	67.6	Pass
Peak Occipital Condyle Moment	Nm	-36.0 to -44.0	-40.1	Pass	
Decaying Moment Time to Cross 0 Nm	msec	102.0 to 126.0	122.2	Pass	
<b>Overall Test Results</b>				<b>Pass</b>	

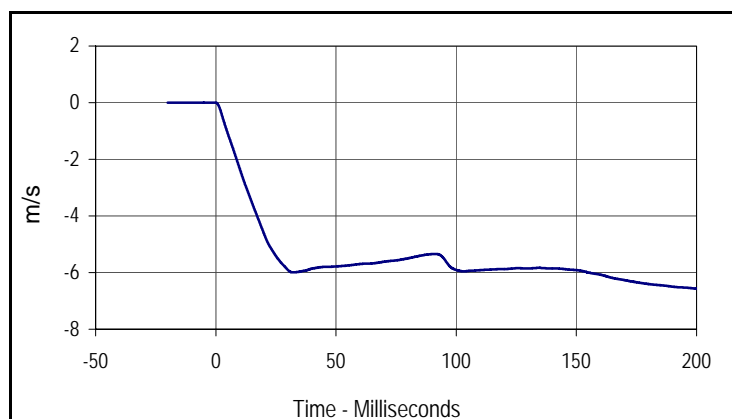

Curve Description			
Pendulum Velocity			
CURNO	Type	SAE Class	Units
001	FIL	180	m/s
Max	Time	Min	Time
0.0	-0.4	-6.6	200.0

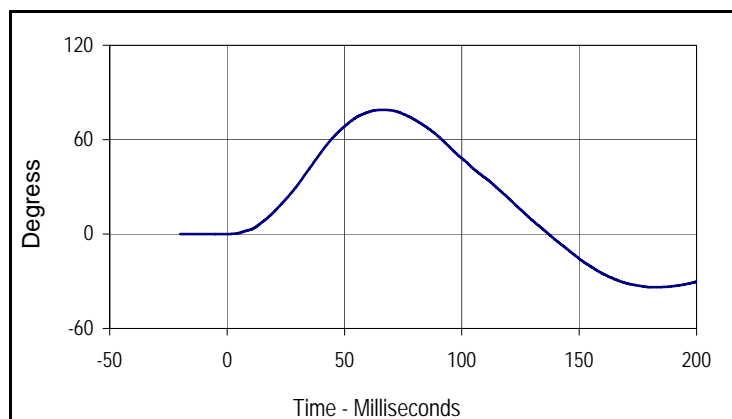

Curve Description			
Maximum Translation Rotation			
CURNO	Type	SAE Class	Units
002	FIL	60	Degree
Max	Time	Min	Time
78.8	67.6	-33.8	181.4

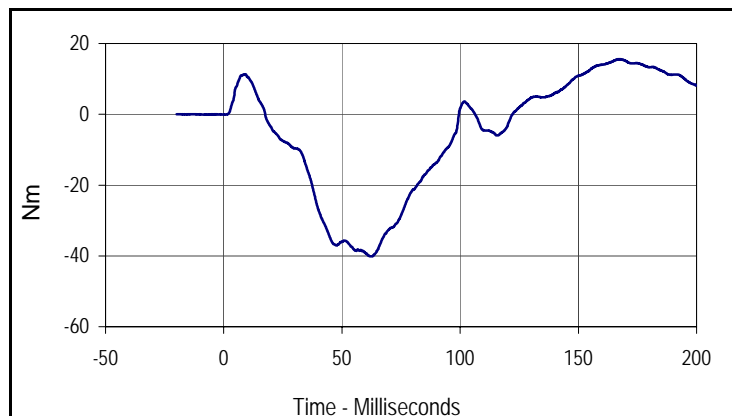

Curve Description			
Moment About Occipital Condyle			
CURNO	Type	SAE Class	Units
003	FIL	600	Nm
Max	Time	Min	Time
15.6	167.6	-40.1	62.0

Test Program: SID IIs Shoulder Calibration  
 ATD Serial No.: 307

Test Date: 2/3/11  
 Test I.D.: SHF02B



Tested Parameter	Units	Specification	Result	Pass/Fail
Laboratory Temperature	°C	20.6 to 22.2	21.31	Pass
Laboratory Relative Humidity	%	10 to 70	21.96	Pass
Pendulum Velocity	m/s	4.20 to 4.40	4.29	Pass
Shoulder Deflection	MM	28 to 37	30.0	Pass
Peak Upper Spine Y Acceleration	G's	17 to 22	18.5	Pass
Peak Impactor Acceleration	G's	13 to 18	14.7	Pass
Overall Test Results			Pass	

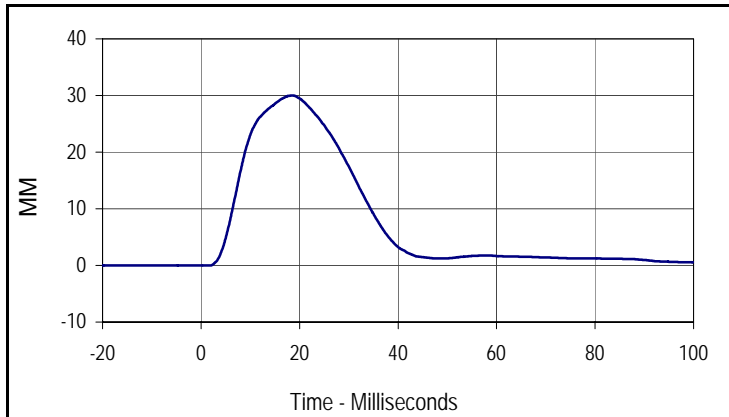

Curve Description			
Shoulder Acceleration			
CURNO	Type	SAE Class	Units
001	FIL	600	MM
Max	Time	Min	Time
30.0	18.6	0.0	0.3

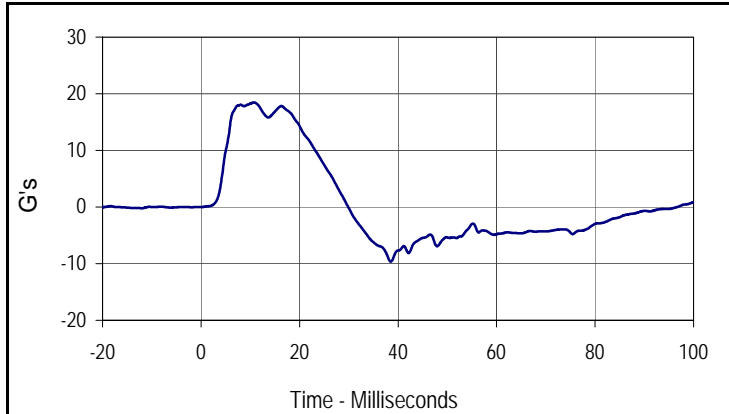

Curve Description			
Upper Spine Y Acceleration			
CURNO	Type	SAE Class	Units
002	FIL	180	G's
Max	Time	Min	Time
18.5	10.8	-9.6	38.5

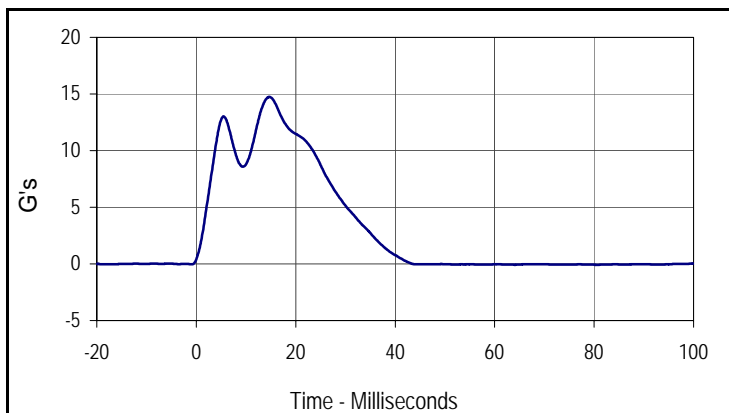

Curve Description			
Impactor Acceleration			
CURNO	Type	SAE Class	Units
003	FIL	180	G's
Max	Time	Min	Time
14.7	14.7	-0.1	80.6

Test Program: SID IIs Thorax with Arm Calibration  
 ATD Serial No.: 307

Test Date: 2/3/11  
 Test I.D.: THF02B



Tested Parameter	Units	Specification	Result	Pass/Fail
Laboratory Temperature	°C	20.6 to 22.2	21.31	Pass
Laboratory Relative Humidity	%	10 to 70	21.81	Pass
Pendulum Velocity	m/s	6.60 to 6.80	6.67	Pass
Shoulder Deflection	MM	31 to 40	35.3	Pass
Upper Thorax Rib Deflection	MM	25 to 32	27.0	Pass
Middle Thorax Rib Deflection	MM	30 to 36	32.0	Pass
Lower Thorax Rib Deflection	MM	32 to 38	34.2	Pass
Peak Upper Spine Y Acceleration	G's	34 to 43	38.4	Pass
Peak Lower Spine Y Acceleration	G's	29 to 37	32.6	Pass
Peak Impactor Acceleration After 5 msec.	G's	30 to 36	34.5	Pass
Overall Test Results				Pass

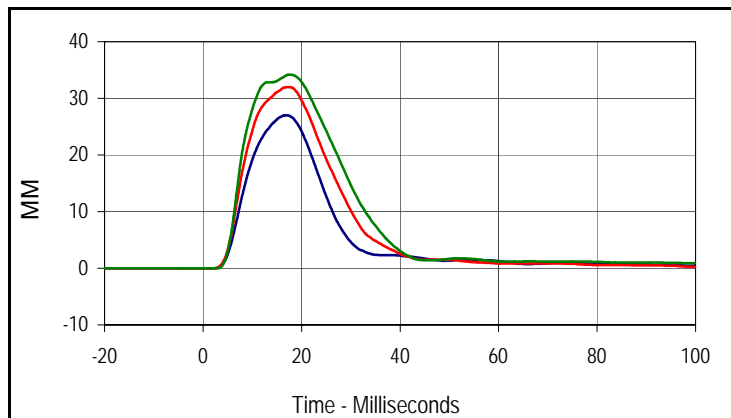

Curve Description			
<b>Upper Thorax Deflection</b>			
CURNO	Type	SAE Class	Units
001	FIL	600	MM
Max	Time	Min	Time
27.0	16.9	0.0	-6.1
<b>Middle Thorax Deflection</b>			
Max	Time	Min	Time
32.0	17.1	0.0	-6.7
<b>Lower Thorax Deflection</b>			
Max	Time	Min	Time
34.2	17.5	0.0	-12.8

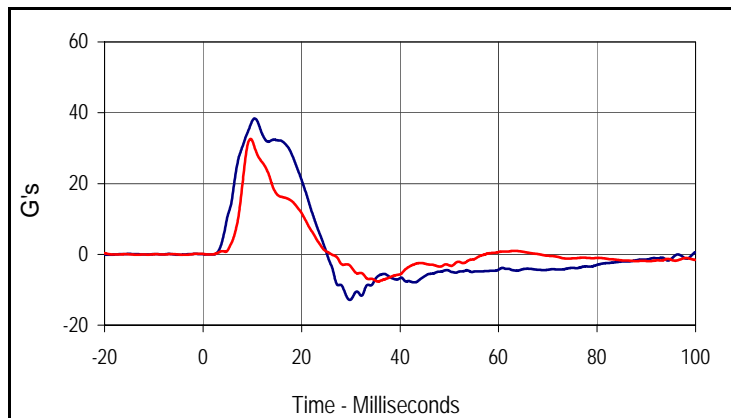

Curve Description			
<b>Upper Spine Y Acceleration</b>			
CURNO	Type	SAE Class	Units
004	FIL	180	G's
Max	Time	Min	Time
38.4	10.5	-12.9	29.8
<b>Lower Spine Y Acceleration</b>			
CURNO	Type	SAE Class	Units
005	FIL	180	G's
Max	Time	Min	Time
32.6	9.6	-7.7	35.5

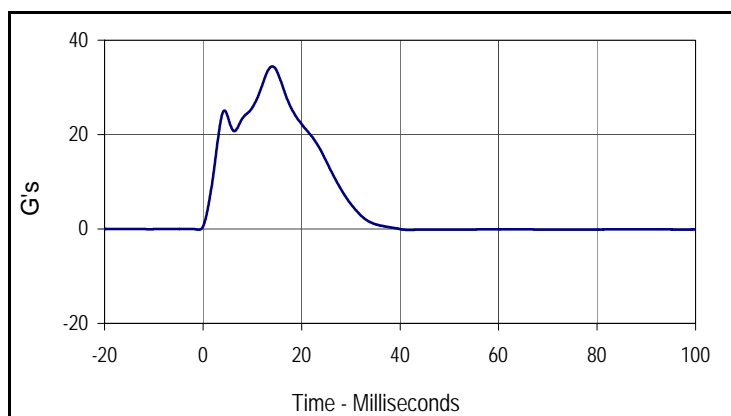

Curve Description			
<b>Impactor Acceleration</b>			
CURNO	Type	SAE Class	Units
006	FIL	180	G's
Max	Time	Min	Time
34.5	14.0	-0.2	41.6

Test Program: SID IIs Thorax w/o Arm Calibration  
 ATD Serial No.: 307

Test Date: 2/3/11  
 Test I.D.: TOA02B



Tested Parameter	Units	Specification	Result	Pass/Fail
Laboratory Temperature	°C	20.6 to 22.2	21.26	Pass
Laboratory Relative Humidity	%	10 to 70	21.72	Pass
Pendulum Velocity	m/s	4.20 to 4.40	4.31	Pass
Upper Thorax Rib Deflection	MM	32 to 40	38.3	Pass
Middle Thorax Rib Deflection	MM	39 to 45	41.3	Pass
Lower Thorax Rib Deflection	MM	35 to 43	41.9	Pass
Peak Upper Spine Y Acceleration	G's	13 to 17	15.0	Pass
Peak Lower Spine Y Acceleration	G's	7 to 11	10.1	Pass
Peak Impactor Acceleration	G's	14 to 18	16.6	Pass
Overall Test Results				Pass

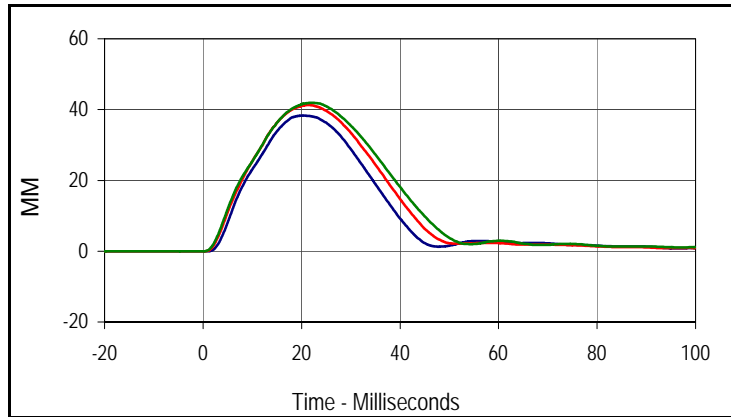

Curve Description			
<b>Upper Thorax Deflection</b>			
CURNO	Type	SAE Class	Units
001	FIL	600	MM
Max	Time	Min	Time
38.3	20.2	0.0	-16.8
<b>Middle Thorax Deflection</b>			
Max	Time	Min	Time
41.3	21.3	0.0	-17.6
<b>Lower Thorax Deflection</b>			
Max	Time	Min	Time
41.9	22.1	0.0	0.1

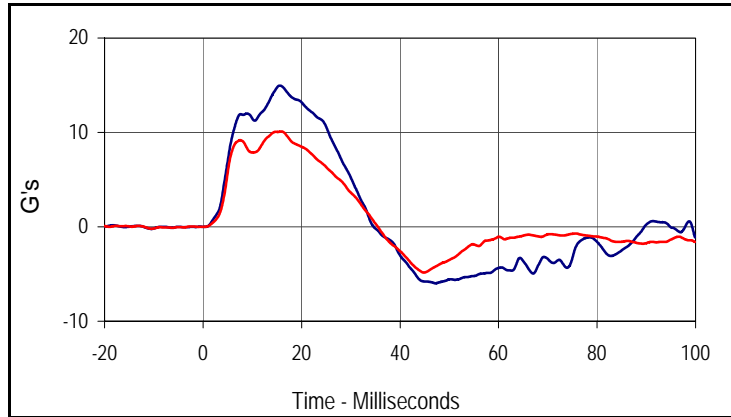

Curve Description			
<b>Upper Spine Y Acceleration</b>			
CURNO	Type	SAE Class	Units
004	FIL	180	G's
Max	Time	Min	Time
15.0	15.6	-6.0	47.2
<b>Lower Spine Y Acceleration</b>			
CURNO	Type	SAE Class	Units
005	FIL	180	G's
Max	Time	Min	Time
10.1	15.9	-4.8	44.9

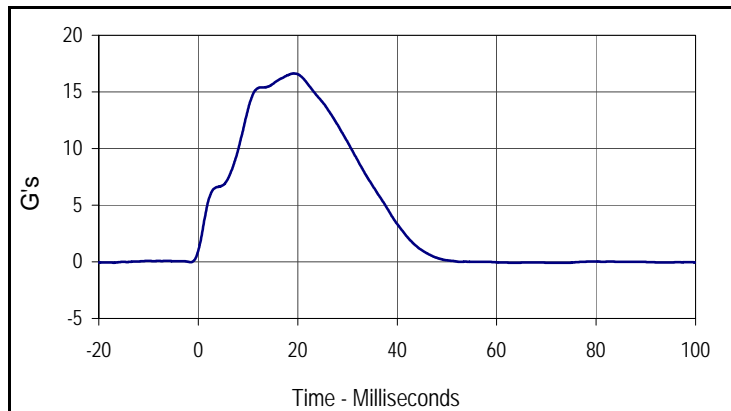

Curve Description			
<b>Impactor Acceleration</b>			
CURNO	Type	SAE Class	Units
006	FIL	180	G's
Max	Time	Min	Time
16.6	19.2	-0.1	74.1

Test Program: SID IIs Abdomen Calibration  
 ATD Serial No.: 307

Test Date: 2/3/11  
 Test I.D.: ABDF02B



Tested Parameter	Units	Specification	Result	Pass/Fail
Laboratory Temperature	°C	20.6 to 22.2	21.26	Pass
Laboratory Relative Humidity	%	10 to 70	21.77	Pass
Pendulum Velocity	m/s	4.20 to 4.40	4.36	Pass
Upper Abdominal Rib Deflection	MM	36 to 47	38.7	Pass
Lower Abdominal Rib Deflection	MM	33 to 44	36.9	Pass
Peak Lower Spine Y Acceleration	G's	9 to 14	13.4	Pass
Peak Impactor Acceleration	G's	12 to 16	14.3	Pass
Overall Test Results			Pass	

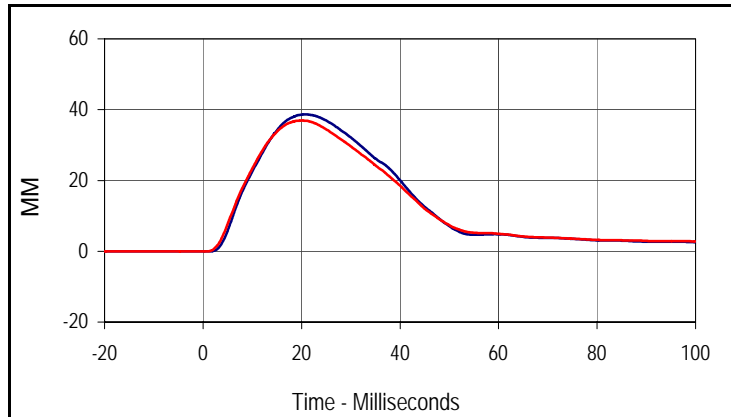

Curve Description			
Upper Abdominal Rib Deflection			
CURNO	Type	SAE Class	Units
001	FIL	600	MM
Max	Time	Min	Time
38.7	20.6	0.0	-5.6

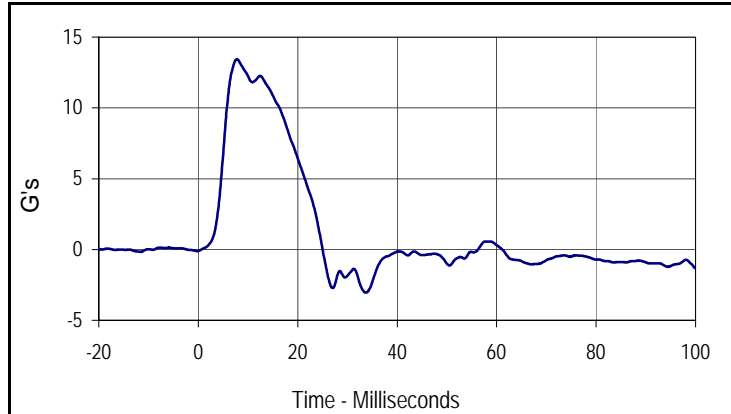

Curve Description			
Lower Abdominal Rib Deflection			
CURNO	Type	SAE Class	Units
002	FIL	600	MM
Max	Time	Min	Time
36.9	20.0	0.0	0.7

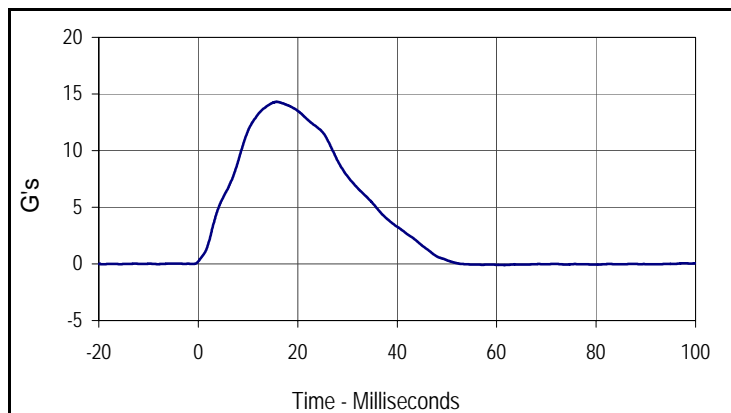

Curve Description			
Lower Spine Y Acceleration			
CURNO	Type	SAE Class	Units
003	FIL	180	G's
Max	Time	Min	Time
13.4	7.8	-3.0	33.7

Curve Description			
Impactor Acceleration			
CURNO	Type	SAE Class	Units
004	FIL	180	G's
Max	Time	Min	Time
14.3	15.8	-0.1	61.6

Test Program: SID IIs Pelvis Acetabulum Calibration  
 ATD Serial No.: 307

Test Date: 2/3/11  
 Test I.D.: ACET02B



Tested Parameter	Units	Specification	Result	Pass/Fail
Laboratory Temperature	°C	20.6 to 22.2	21.26	Pass
Laboratory Relative Humidity	%	10 to 70	21.86	Pass
Pendulum Velocity	m/s	6.60 to 6.80	6.61	Pass
Peak Acetabulum Force	Newtons	3600 to 4300	4086.8	Pass
Peak Pelvis Y Acceleration After 6 msec.	G's	34 to 42	36.4	Pass
Peak Impactor Acceleration	G's	38 to 47	41.3	Pass
Overall Test Results			Pass	

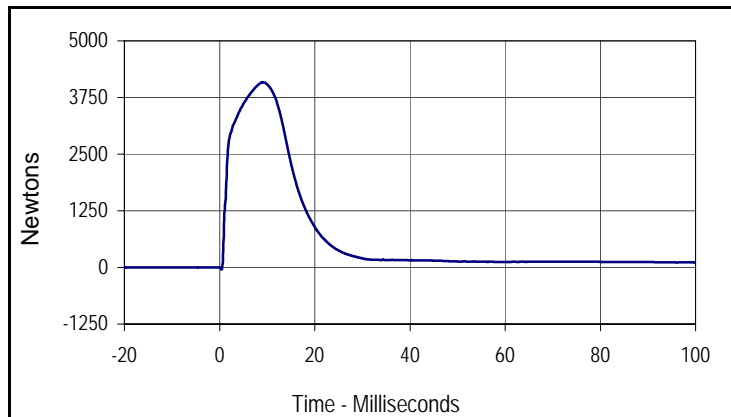

Curve Description			
Pelvis Acetabulum Force			
CURNO	Type	SAE Class	Units
001	FIL	600	Newtons
Max	Time	Min	Time
4086.8	9.0	-44.0	0.4

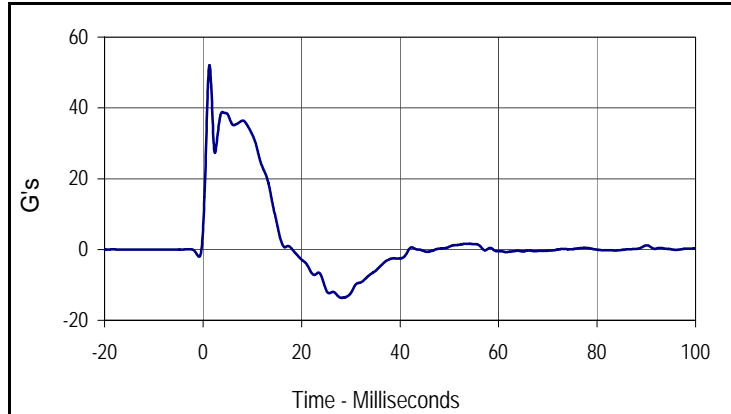

Curve Description			
Pelvis Y Acceleration			
CURNO	Type	SAE Class	Units
002	FIL	180	G's
Max	Time	Min	Time
52.0	1.3	-13.6	28.2

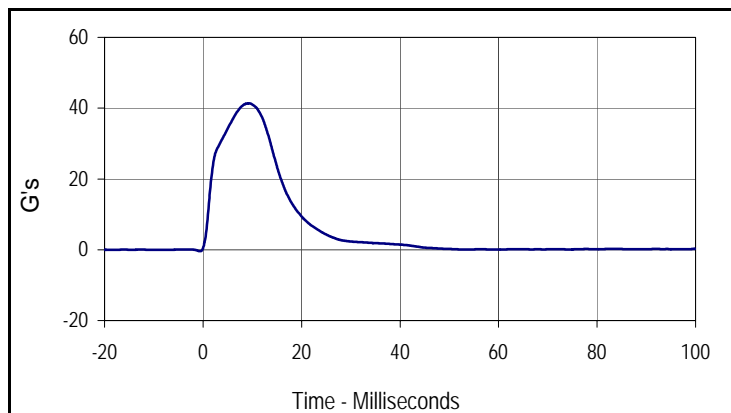

Curve Description			
Impactor Acceleration			
CURNO	Type	SAE Class	Units
003	FIL	180	G's
Max	Time	Min	Time
41.3	9.3	-0.4	-0.6

Test Program: SID IIs Pelvis Iliac Calibration  
 ATD Serial No.: 307

Test Date: 2/3/11  
 Test I.D.: PLF02B



Tested Parameter	Units	Specification	Result	Pass/Fail
Laboratory Temperature	°C	20.6 to 22.2	21.21	Pass
Laboratory Relative Humidity	%	10 to 70	21.82	Pass
Pendulum Velocity	m/s	4.2 to 4.4	4.31	Pass
Peak Iliac Force	Newtons	4100 to 5100	4220.0	Pass
Peak Pelvis Y Acceleration	G's	28 to 39	30.8	Pass
Peak Impactor Acceleration	G's	36 to 45	37.3	Pass
Overall Test Results			Pass	Pass

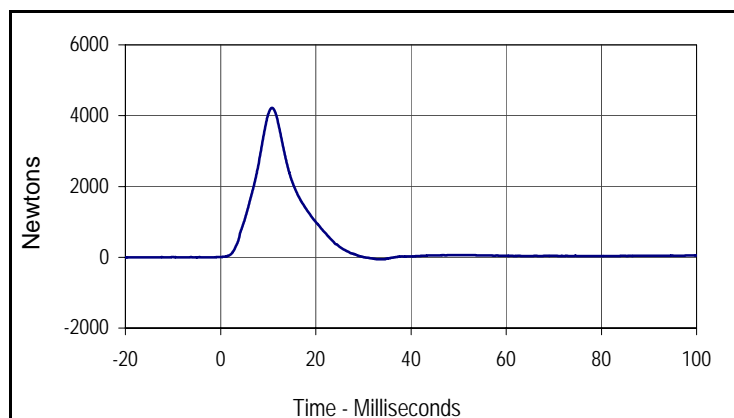

Curve Description			
Pelvis Iliac Force			
CURNO	Type	SAE Class	Units
001	FIL	600	Newtons
Max	Time	Min	Time
4220.0	10.8	-60.0	34.1

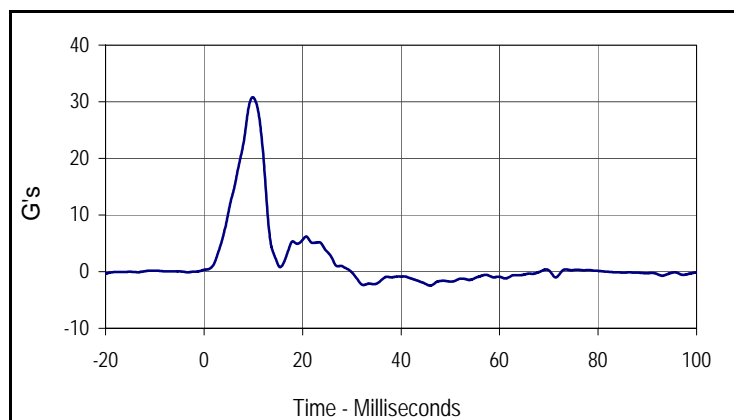

Curve Description			
Pelvis Y Acceleration			
CURNO	Type	SAE Class	Units
002	FIL	180	G's
Max	Time	Min	Time
30.8	9.9	-2.5	45.9

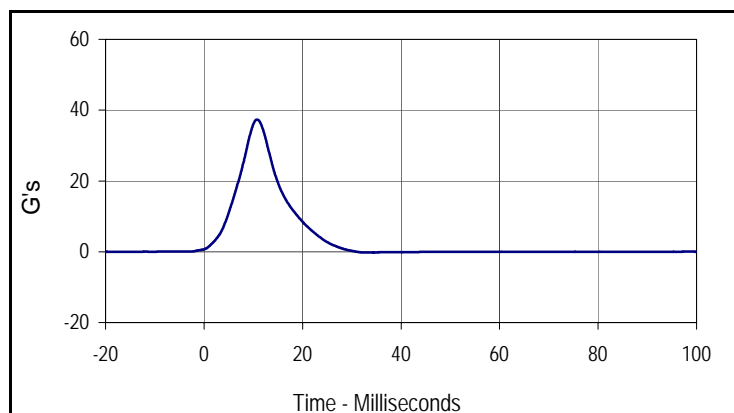

Curve Description			
Impactor Acceleration			
CURNO	Type	SAE Class	Units
003	FIL	180	G's
Max	Time	Min	Time
37.3	10.8	-0.2	32.6

**APPENDIX C**  
**POST-TEST / ATD CONFIGURATION AND PERFORMANCE VERIFICATION DATA**

Test Program: ES2re Neck Calibration  
 ATD Serial No.: F035

Test Date: 2/12/11  
 Test I.D.: NBM02C



Tested Parameter	Units	Specification	Result	Pass/Fail	
Laboratory Temperature	°C	20.6 to 22.2	21.32	Pass	
Laboratory Relative Humidity	%	10 to 70	22.58	Pass	
Pendulum Velocity	m/s	3.30 to 3.50	3.38	Pass	
Pendulum Deceleration	1 msec	m/s	0.0 to -.050	-0.032	Pass
	3 msec	m/s	-.250 to -.375	-0.250	Pass
	14 msec	m/s	-3.20 to -3.70	-3.20	Pass
Headform Rotation	Max	Degrees	49.0 to 58.0	50.2	Pass
	Time	msec	54.0 to 66.0	60.8	Pass
Maximum Rotation To Time Zero Crossing	msec	53.0 to 88.0	57.5	Pass	
Overall Test Results				Pass	

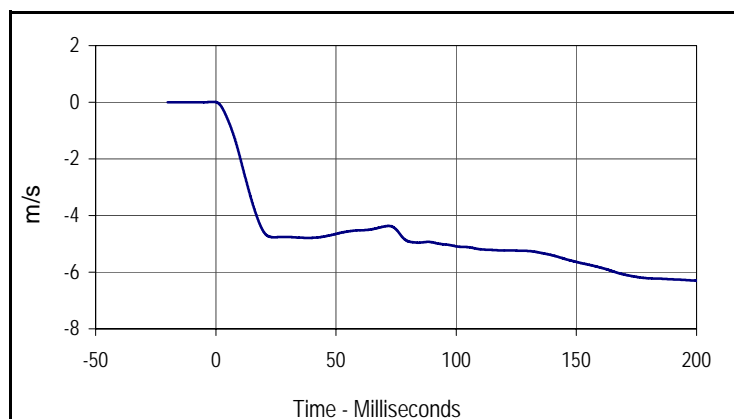

Curve Description			
CURNO	Type	SAE Class	Units
001	FIL	60	m/s
Max	Time	Min	Time
0.0	-1.1	-6.3	200.0

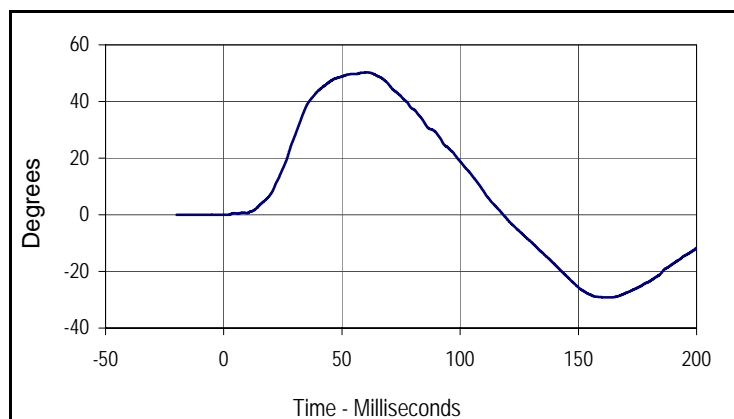

Curve Description			
Headform Rotation			
CURNO	Type	SAE Class	Units
002	FIL	180	Degrees
Max	Time	Min	Time
50.2	60.8	-29.2	162.5

Test Program: ES2re Shoulder Calibration  
 ATD Serial No.: F035

Test Date: 2/12/11  
 Test I.D.: SHM02C



Tested Parameter	Units	Specification	Result	Pass/Fail
Laboratory Temperature	°C	20.6 to 22.2	21.32	Pass
Laboratory Relative Humidity	%	10 to 70	22.58	Pass
Probe Velocity	m/s	4.20 to 4.40	4.23	Pass
Peak Impactor Acceleration	G's	7.5 to 10.5	9.81	Pass
Overall Test Results				Pass

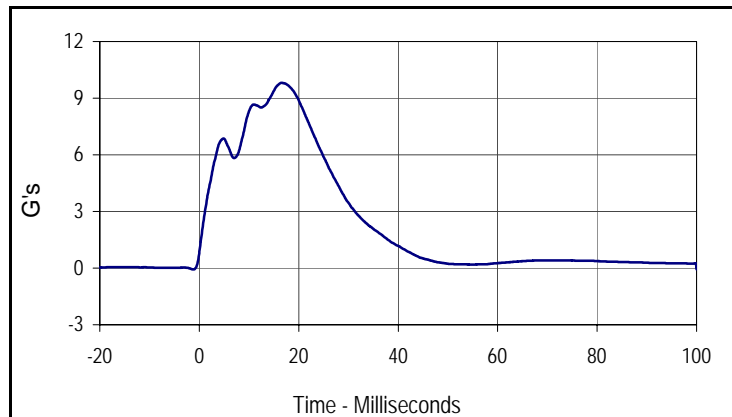

Curve Description			
<u>Impactor Acceleration</u>			
CURNO	Type	SAE Class	Units
001	FIL	180	G's
Max	Time	Min	Time
9.8	16.6	-0.1	-1.2

Test Program: ES2re Rib Module Calibration  
 ATD Serial No.: F035 Rib #1

Test Date: 2/12/11  
 Test I.D.: RIB102C



Tested Parameter	Units	Specification	Result	Pass/Fail
Laboratory Temperature	°C	20.6 to 22.2	21.32	Pass
Laboratory Relative Humidity	%	10 to 70	22.45	Pass
Peak Rib Deflection at 459 MM Drop Height	MM	36 to 40	38.3	Pass
Peak Rib Deflection at 815 MM Drop Height	MM	46 to 51	48.3	Pass
Overall Test Results			Pass	Pass

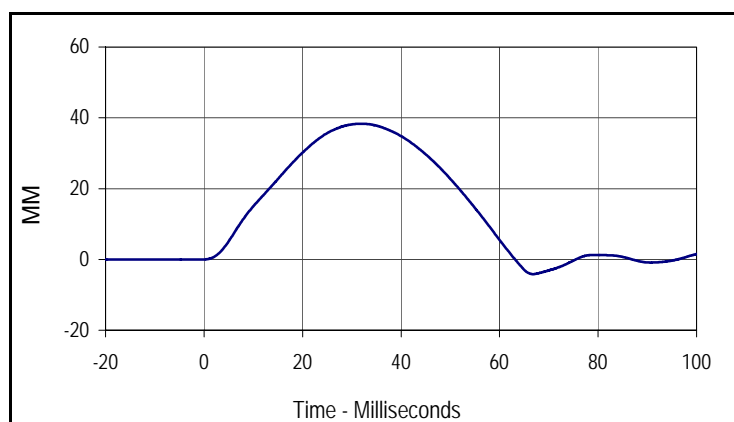

Curve Description			
Upper Rib Deflection (459 MM Drop Height)			
CURNO	Type	SAE Class	Units
001	FIL	180	MM
Max	Time	Min	Time
38.3	32.0	-4.2	66.8

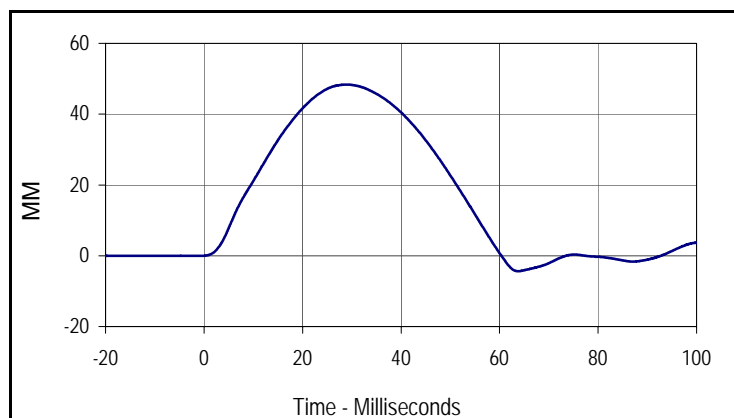

Curve Description			
Upper Rib Deflection (815 MM Drop Height)			
CURNO	Type	SAE Class	Units
001	FIL	180	MM
Max	Time	Min	Time
48.3	28.9	-4.4	63.7

Test Program: ES2re Rib Module Calibration  
 ATD Serial No.: F035 Rib #2

Test Date: 2/12/11  
 Test I.D.: RIB202C



Tested Parameter	Units	Specification	Result	Pass/Fail
Laboratory Temperature	°C	20.6 to 22.2	21.37	Pass
Laboratory Relative Humidity	%	10 to 70	22.41	Pass
Peak Rib Deflection at 459 MM Drop Height	MM	36 to 40	39.7	Pass
Peak Rib Deflection at 815 MM Drop Height	MM	46 to 51	49.0	Pass
Overall Test Results			Pass	Pass

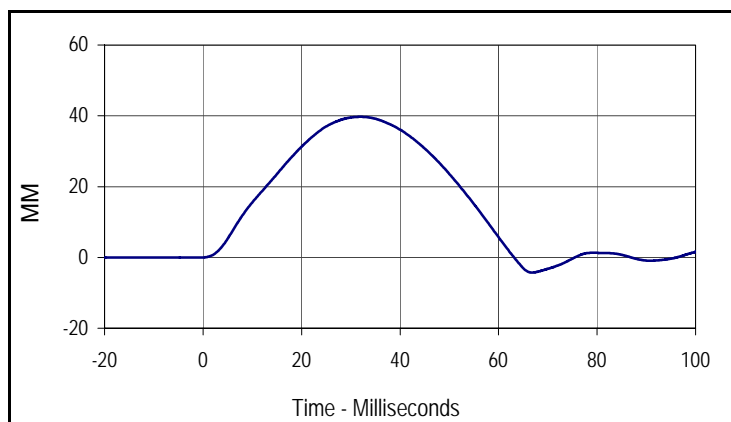

Curve Description			
Middle Rib Deflection (459 MM Drop Height)			
CURNO	Type	SAE Class	Units
001	FIL	180	MM
Max	Time	Min	Time
39.7	32.0	-4.3	66.8

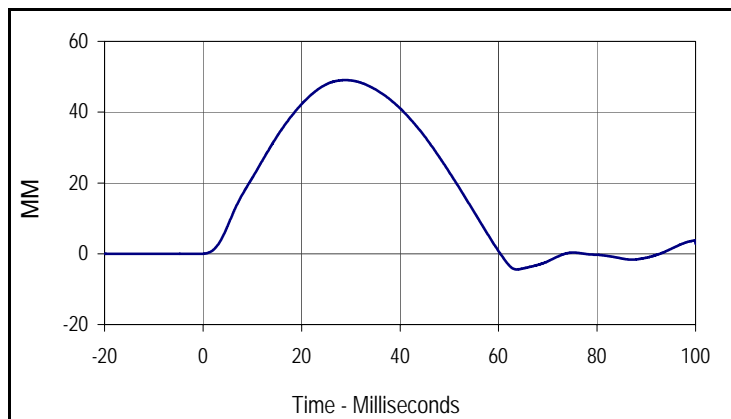

Curve Description			
Middle Rib Deflection (815 MM Drop Height)			
CURNO	Type	SAE Class	Units
001	FIL	180	MM
Max	Time	Min	Time
49.0	28.9	-4.4	63.7

Test Program: ES2re Rib Module Calibration  
 ATD Serial No.: F035 Rib #3

Test Date: 2/12/11  
 Test I.D.: RIB302C



Tested Parameter	Units	Specification	Result	Pass/Fail
Laboratory Temperature	°C	20.6 to 22.2	21.37	Pass
Laboratory Relative Humidity	%	10 to 70	22.43	Pass
Peak Rib Deflection at 459 MM Drop Height	MM	36 to 40	38.9	Pass
Peak Rib Deflection at 815 MM Drop Height	MM	46 to 51	50.1	Pass
Overall Test Results				Pass

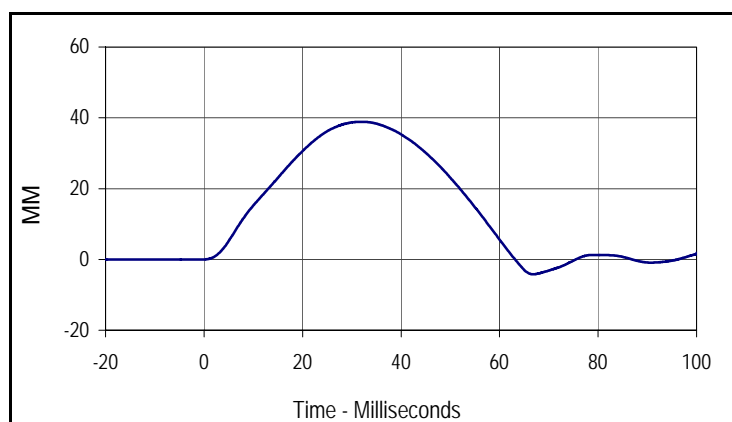

Curve Description			
Lower Rib Deflection (459 MM Drop Height)			
CURNO	Type	SAE Class	Units
001	FIL	180	MM
Max	Time	Min	Time
38.9	32.0	-4.2	66.8

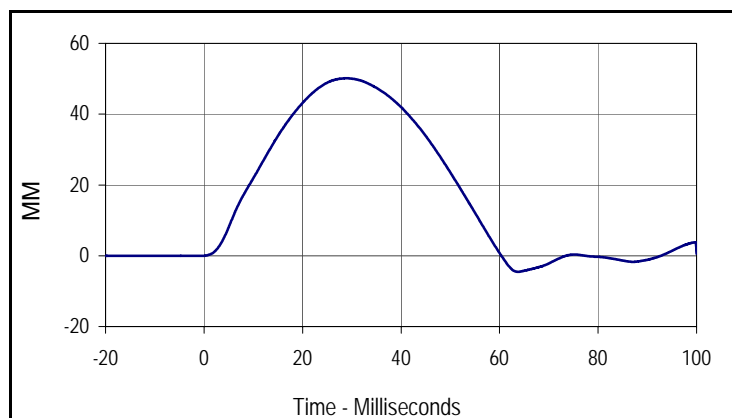

Curve Description			
Lower Rib Deflection (815 MM Drop Height)			
CURNO	Type	SAE Class	Units
001	FIL	180	MM
Max	Time	Min	Time
50.1	28.9	-4.5	63.7

Test Program: ES2re Thorax Calibration  
 ATD Serial No.: F035

Test Date: 2/12/11  
 Test I.D.: THM02C



Tested Parameter	Units	Specification	Result	Pass/Fail
Laboratory Temperature	°C	20.6 to 22.2	21.37	Pass
Laboratory Relative Humidity	%	10 to 70	22.29	Pass
Probe Velocity	m/s	5.40 to 5.60	5.45	Pass
Impactor Force	N	5100 to 6200	5476.5	Pass
	msec	> 6.0 msec	9.9	Pass
Upper Rib Deflection	MM	34 to 41	39.0	Pass
Middle Rib Deflection	MM	37 to 45	41.4	Pass
Lower Rib Deflection	MM	37 to 44	41.7	Pass
Overall Test Results				Pass

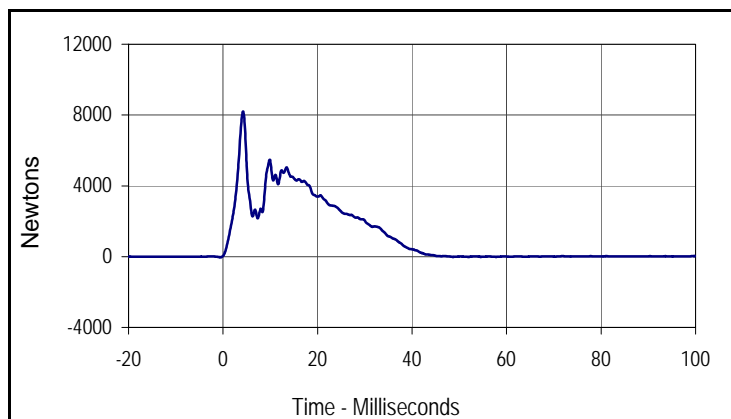

Curve Description			
Impactor Force			
CURNO	Type	SAE Class	Units
001	FIL	180	Newtons
Max	Time	Min	Time
8178.0	4.2	-33.6	-0.6

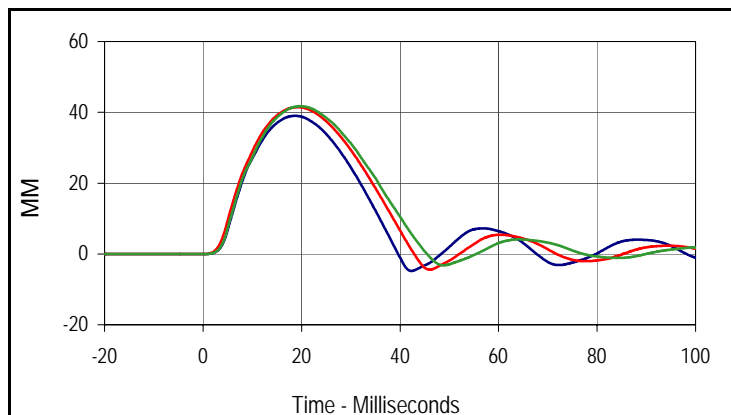

Curve Description			
Upper, Middle, Lower Rib Deflections			
CURNO(s)	Type	SAE Class	Units
002-003-004	FIL	180	MM
Max (Upper)	Time	Min (Upper)	Time
39.0	18.7	-4.8	42.3
Max (Middle)	Time	Min (Middle)	Time
41.4	19.3	-4.4	46.0
Max (Lower)	Time	Min (Lower)	Time
41.7	19.8	-3.2	48.8

Test Program: ES2re Abdomen Calibration  
 ATD Serial No.: F035

Test Date: 2/12/11  
 Test I.D.: ABDM02C



Tested Parameter	Units	Specification	Result	Pass/Fail
Laboratory Temperature	°C	20.6 to 22.2	21.37	Pass
Laboratory Relative Humidity	%	10 to 70	22.37	Pass
Probe Velocity	m/s	3.90 to 4.10	4.00	Pass
Impactor Force	N	4000 to 4800	4025.6	Pass
	msec	10.6 to 13.0	11.0	Pass
Abdominal Force	N	2200 to 2700	2255.3	Pass
	msec	10.0 to 12.3	10.7	Pass
Overall Test Results				Pass

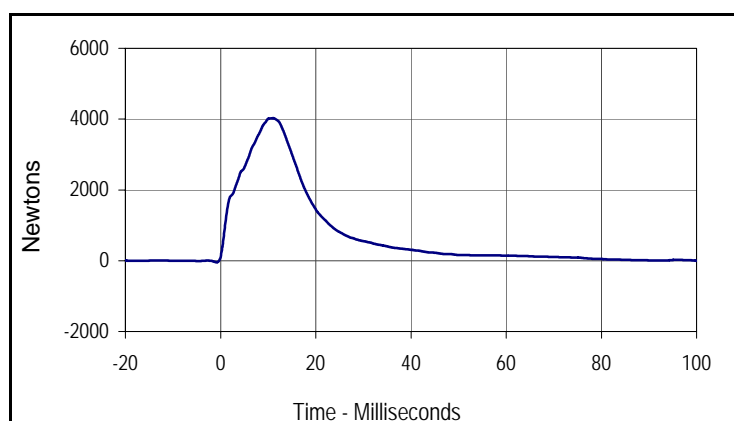

Curve Description			
Impactor Force			
CURNO	Type	SAE Class	Units
001	FIL	180	Newtons
Max	Time	Min	Time
4025.6	11.0	-43.6	-0.8

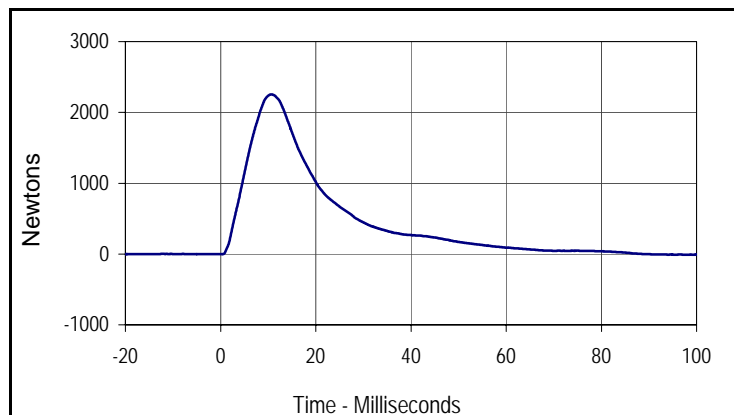

Curve Description			
Abdomen Sum Resultant			
CURNO	Type	SAE Class	Units
002	RES	600	Newtons
Max	Time	Min	Time
2255.3	10.7	-9.4	97.8

Test Program: ES2re Lumbar Spine Calibration  
 ATD Serial No.: F035

Test Date: 2/12/11  
 Test I.D.: SPM02C



Tested Parameter	Units	Specification	Result	Pass/Fail	
Laboratory Temperature	°C	20.6 to 22.2	21.37	Pass	
Laboratory Relative Humidity	%	10 to 70	22.29	Pass	
Pendulum Velocity	m/s	5.95 to 6.15	5.96	Pass	
Pendulum Deceleration	1 msec	m/s	0.0 to -.050	-0.031	Pass
	3.7 msec	m/s	-.240 to -.425	-0.417	Pass
	27 msec	m/s	-5.80 to -6.50	-5.97	Pass
	30 msec	m/s	< -6.50	-6.45	Pass
Headform Rotation	Max	Degrees	45.0 to 55.0	49.7	Pass
	Time	msec	39.0 to 53.0	43.3	Pass
Maximum Rotation To Time Zero Crossing	msec	37.0 to 57.0	40.7	Pass	
Overall Test Results				Pass	

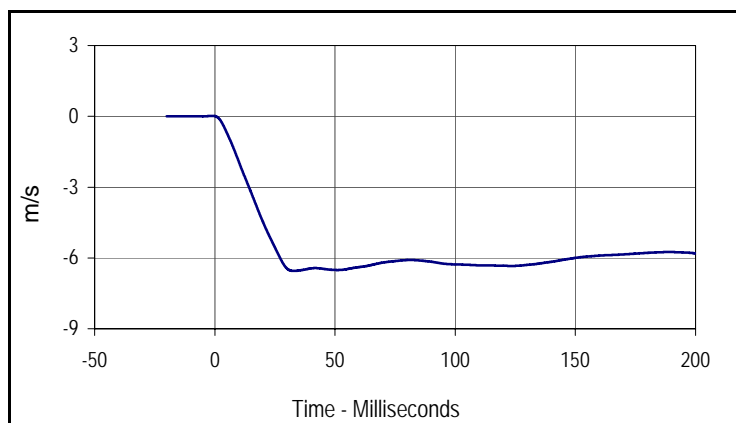

Curve Description			
CURNO	Type	SAE Class	Units
001	FIL	60	m/s
Max	Time	Min	Time
0.0	-1.0	-6.6	32.8

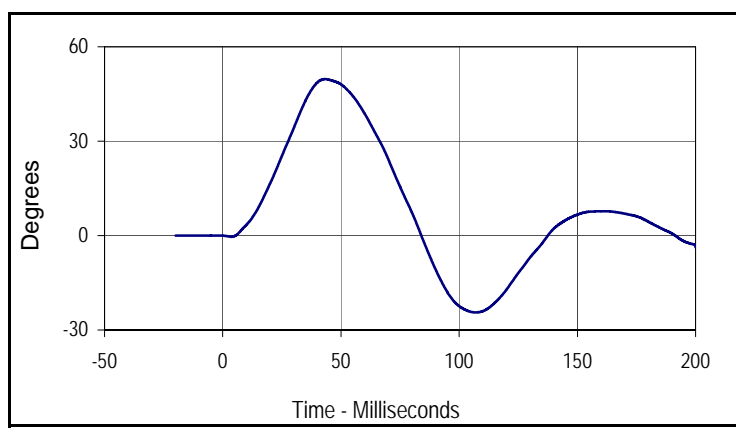

Curve Description			
Headform Rotation			
CURNO	Type	SAE Class	Units
002	FIL	180	Degrees
Max	Time	Min	Time
49.7	43.3	-24.4	107.0

Test Program: ES2re Pelvis Calibration  
 ATD Serial No.: F035

Test Date: 2/12/11  
 Test I.D.: PLM02C



Tested Parameter	Units	Specification	Result	Pass/Fail
Laboratory Temperature	°C	20.6 to 22.2	21.43	Pass
Laboratory Relative Humidity	%	10 to 70	22.22	Pass
Probe Velocity	m/s	4.20 to 4.40	4.29	Pass
Impactor Force	N	4700 to 5400	4745.3	Pass
	msec	11.8 to 16.1	13.4	Pass
Pubic Symphysis Load	N	-1230 to -1590	-1325.1	Pass
	msec	12.2 to 17.0	14.5	Pass
Overall Test Results				Pass

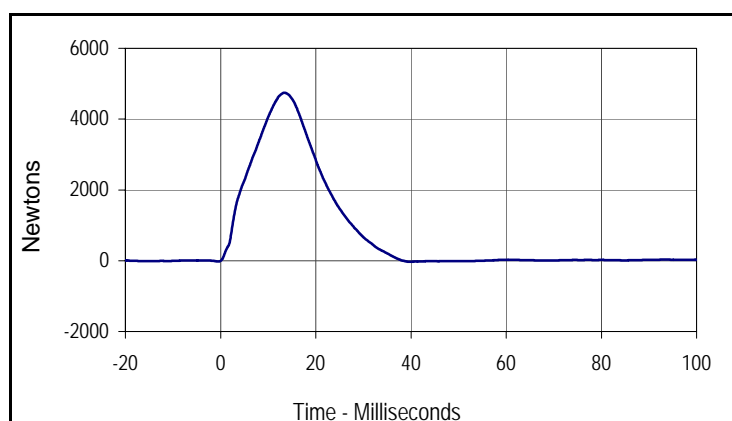

Curve Description			
Impactor Force			
CURNO	Type	SAE Class	Units
001	FIL	180	Newtons
Max	Time	Min	Time
4745.3	13.4	-28.6	40.2

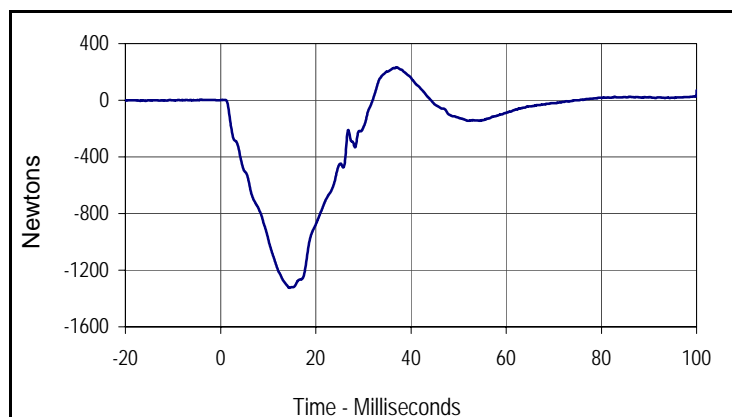

Curve Description			
Pubic FY			
CURNO	Type	SAE Class	Units
002	FIL	600	Newtons
Max	Time	Min	Time
232.0	37.1	-1325.1	14.5

Test Program: ES2re Lateral Head Drop Calibration  
 ATD Serial No.: F035

Test Date: 2/12/11  
 Test I.D.: HDM02C



Tested Parameter	Units	Specification	Result	Pass/Fail
Laboratory Temperature	°C	20.6 to 22.2	21.43	Pass
Laboratory Relative Humidity	%	10 to 70	22.28	Pass
Peak Resultant Acceleration	G's	125 to 155	145.2	Pass
Peak Longitudinal Acceleration	G's	≤15	0.6	Pass
Is Acceleration Unimodal?	Yes/No	Yes	Yes	Pass
Oscillations After Main Pulse	%	<15	5.1	Pass
<b>Overall Test Results</b>			<b>Pass</b>	

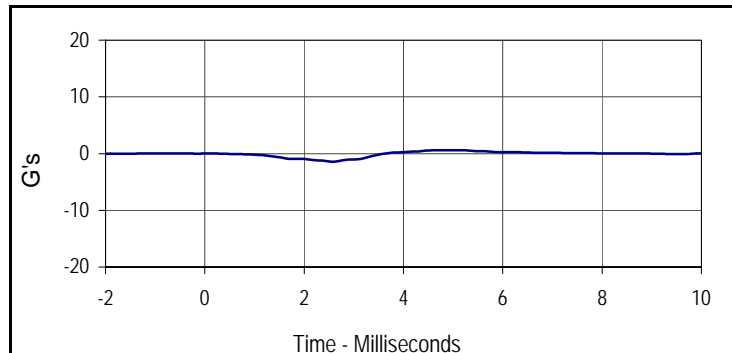

Curve Description			
Head X			
CURNO	Type	SAE Class	Units
001	FIL	1000	G's
Max	Time	Min	Time
0.6	5.1	-1.4	2.6

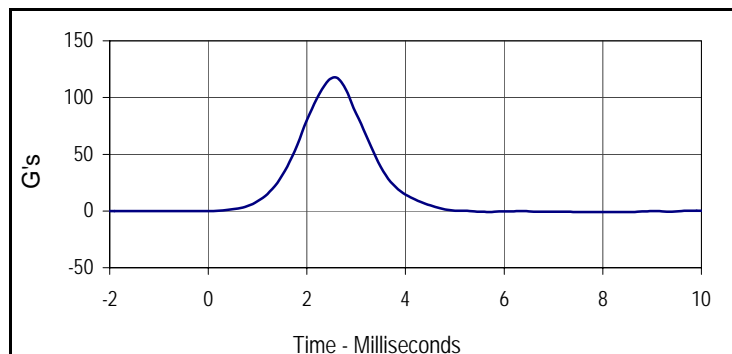

Curve Description			
Head Y			
CURNO	Type	SAE Class	Units
002	FIL	1000	G's
Max	Time	Min	Time
117.4	2.6	-1.0	7.7

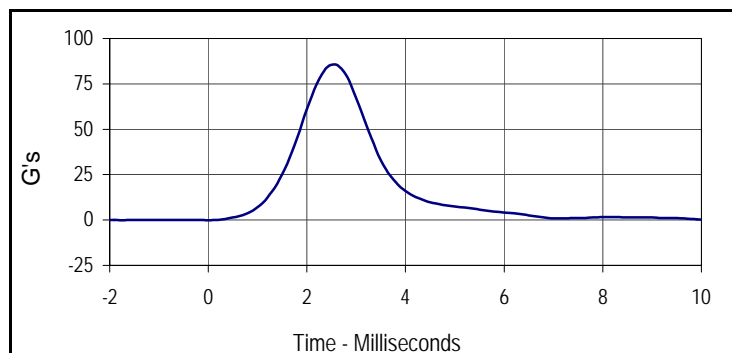

Curve Description			
Head Z			
CURNO	Type	SAE Class	Units
003	FIL	1000	G's
Max	Time	Min	Time
85.6	2.5	-0.1	-1.7

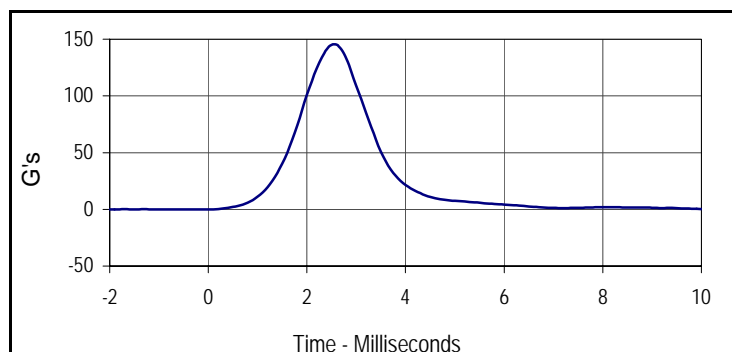

Curve Description			
Head Resultant			
CURNO	Type	SAE Class	Units
001	RES	1000	G's
Max	Time	Min	Time
145.2	2.6	0.0	-0.2

Test Program: SID IIs Lateral Head Drop Calibration  
 ATD Serial No.: 307

Test Date: 2/12/11  
 Test I.D.: HDF02C



Tested Parameter	Units	Specification	Result	Pass/Fail
Laboratory Temperature	°C	20.6 to 22.2	21.34	Pass
Laboratory Relative Humidity	%	10 to 70	22.02	Pass
Peak Resultant Acceleration	G's	115 to 137	131.0	Pass
Peak Longitudinal Acceleration	G's	≤15	2.2	Pass
Is Acceleration Unimodal?	Yes/No	Yes	Yes	Pass
Oscillations After Main Pulse	%	<15	13.2	Pass
<b>Overall Test Results</b>			<b>Pass</b>	

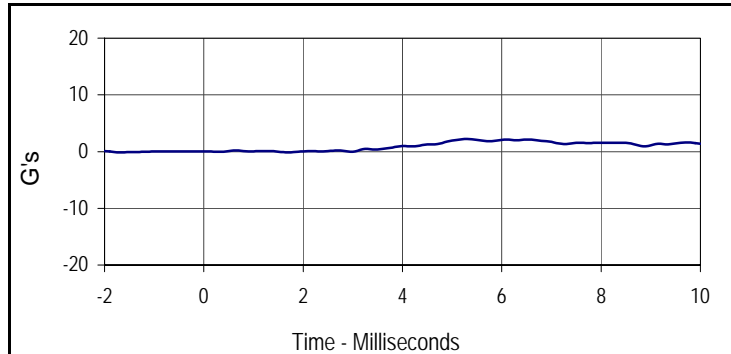

Curve Description			
Head X			
CURNO	Type	SAE Class	Units
001	FIL	1000	G's
Max	Time	Min	Time
2.2	5.3	-0.1	1.7

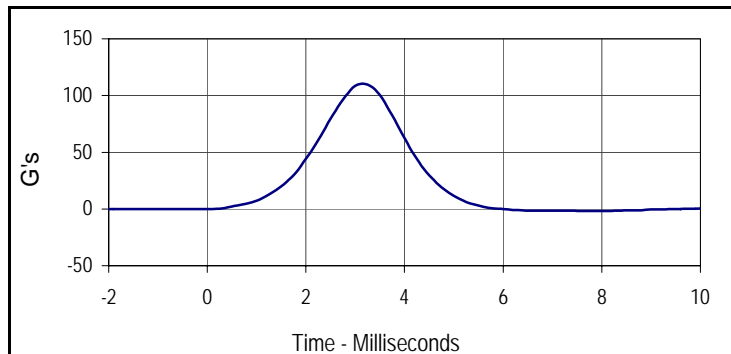

Curve Description			
Head Y			
CURNO	Type	SAE Class	Units
002	FIL	1000	G's
Max	Time	Min	Time
110.3	3.1	-1.8	7.7

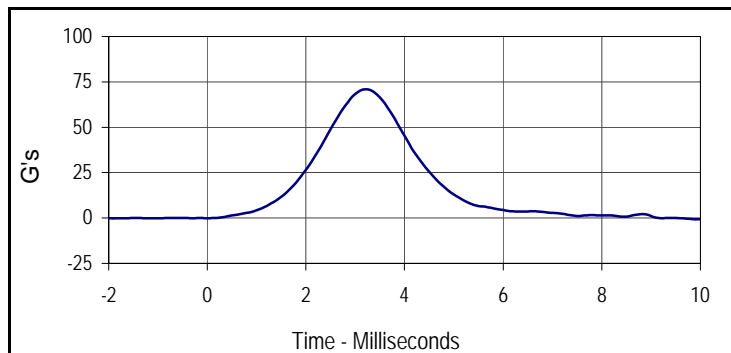

Curve Description			
Head Z			
CURNO	Type	SAE Class	Units
003	FIL	1000	G's
Max	Time	Min	Time
70.9	3.2	-0.7	10.0

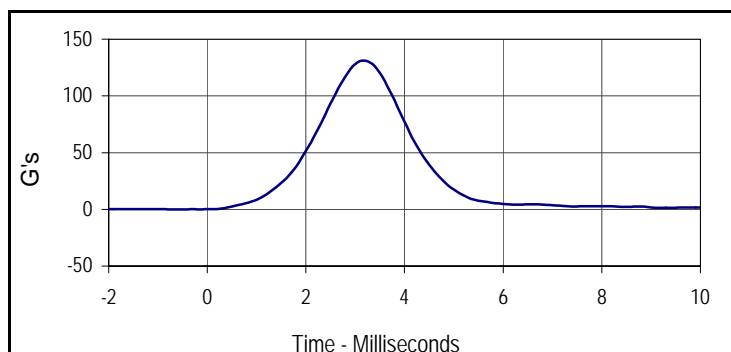

Curve Description			
Head Resultant			
CURNO	Type	SAE Class	Units
001	RES	1000	G's
Max	Time	Min	Time
131.0	3.2	0.0	-0.6

Test Program: SID IIs Neck Calibration  
 ATD Serial No.: 307

Test Date: 2/12/11  
 Test I.D.: NBF02C



Tested Parameter	Units	Specification	Result	Pass/Fail	
Laboratory Temperature	°C	20.6 to 22.2	21.32	Pass	
Laboratory Relative Humidity	%	10 to 70	22.01	Pass	
Pendulum Velocity	m/s	5.51 to 5.63	5.51	Pass	
Pendulum Deceleration	10 msec	m/s	-2.20 to -2.80	-2.37	Pass
	15 msec	m/s	-3.30 to -4.10	-3.58	Pass
	20 msec	m/s	-4.40 to -5.40	-4.69	Pass
	25 msec	m/s	-5.40 to -6.10	-5.50	Pass
	25-100 msec	m/s	-5.50 to -6.20	-6.09	Pass
Translation-Rotation	Max	Degrees	71.0 to 81.0	79.1	Pass
	Time	msec	50.0 to 70.0	64.2	Pass
Peak Occipital Condyle Moment	Nm	-36.0 to -44.0	-41.0	Pass	
Decaying Moment Time to Cross 0 Nm	msec	102.0 to 126.0	120.5	Pass	
<b>Overall Test Results</b>				<b>Pass</b>	

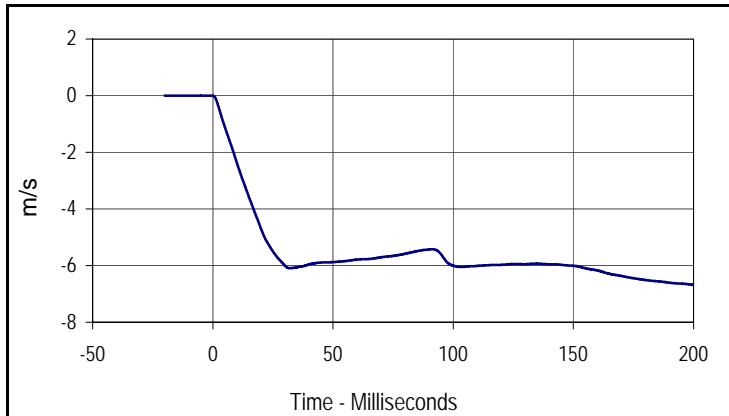

Curve Description			
Pendulum Velocity			
CURNO	Type	SAE Class	Units
001	FIL	180	m/s
Max	Time	Min	Time
0.0	-0.4	-6.7	200.0

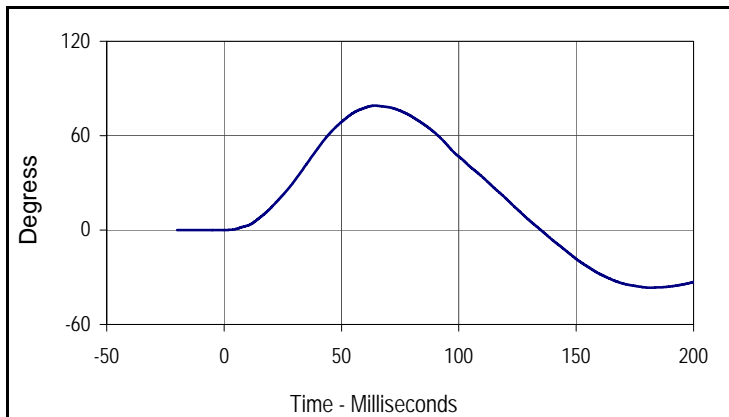

Curve Description			
Maximum Translation Rotation			
CURNO	Type	SAE Class	Units
002	FIL	60	Degree
Max	Time	Min	Time
79.1	64.2	-36.6	181.4

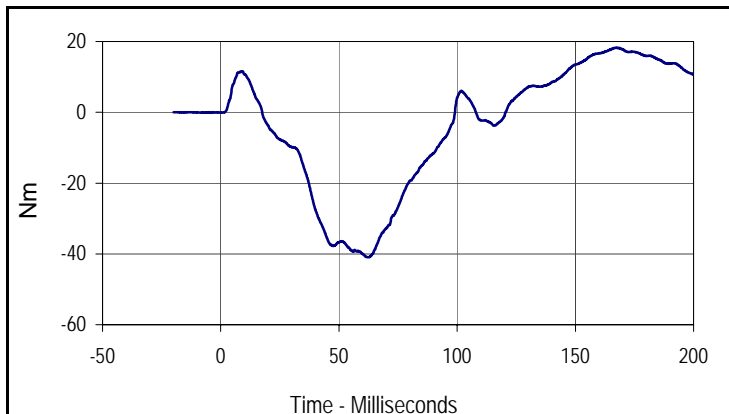

Curve Description			
Moment About Occipital Condyle			
CURNO	Type	SAE Class	Units
003	FIL	600	Nm
Max	Time	Min	Time
18.3	167.6	-41.0	62.0

Test Program: SID IIs Shoulder Calibration  
 ATD Serial No.: 307

Test Date: 2/12/11  
 Test I.D.: SHF02C



Tested Parameter	Units	Specification	Result	Pass/Fail
Laboratory Temperature	°C	20.6 to 22.2	21.33	Pass
Laboratory Relative Humidity	%	10 to 70	21.94	Pass
Pendulum Velocity	m/s	4.20 to 4.40	4.27	Pass
Shoulder Deflection	MM	28 to 37	29.8	Pass
Peak Upper Spine Y Acceleration	G's	17 to 22	18.1	Pass
Peak Impactor Acceleration	G's	13 to 18	14.1	Pass
Overall Test Results			Pass	Pass

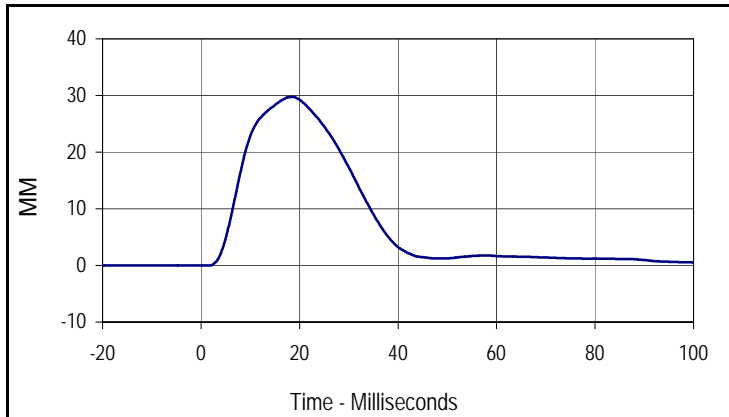

Curve Description			
Shoulder Acceleration			
CURNO	Type	SAE Class	Units
001	FIL	600	MM
Max	Time	Min	Time
29.8	18.6	0.0	0.3

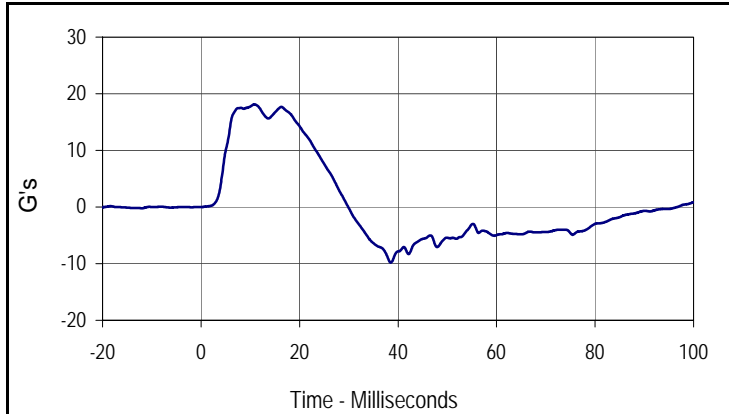

Curve Description			
Upper Spine Y Acceleration			
CURNO	Type	SAE Class	Units
002	FIL	180	G's
Max	Time	Min	Time
18.1	10.9	-9.8	38.5

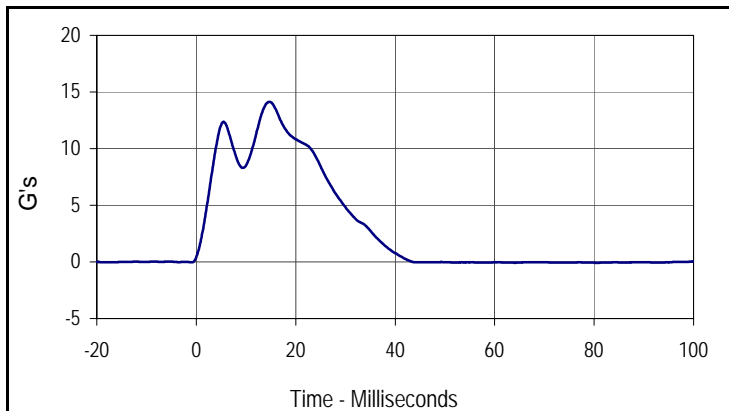

Curve Description			
Impactor Acceleration			
CURNO	Type	SAE Class	Units
003	FIL	180	G's
Max	Time	Min	Time
14.1	14.7	-0.1	80.6

Test Program: SID IIs Thorax with Arm Calibration  
 ATD Serial No.: 307

Test Date: 2/12/11  
 Test I.D.: THF02C



Tested Parameter	Units	Specification	Result	Pass/Fail
Laboratory Temperature	°C	20.6 to 22.2	21.34	Pass
Laboratory Relative Humidity	%	10 to 70	21.84	Pass
Pendulum Velocity	m/s	6.60 to 6.80	6.68	Pass
Shoulder Deflection	MM	31 to 40	36.1	Pass
Upper Thorax Rib Deflection	MM	25 to 32	28.1	Pass
Middle Thorax Rib Deflection	MM	30 to 36	32.6	Pass
Lower Thorax Rib Deflection	MM	32 to 38	34.9	Pass
Peak Upper Spine Y Acceleration	G's	34 to 43	40.9	Pass
Peak Lower Spine Y Acceleration	G's	29 to 37	30.6	Pass
Peak Impactor Acceleration After 5 msec.	G's	30 to 36	32.7	Pass
Overall Test Results			Pass	

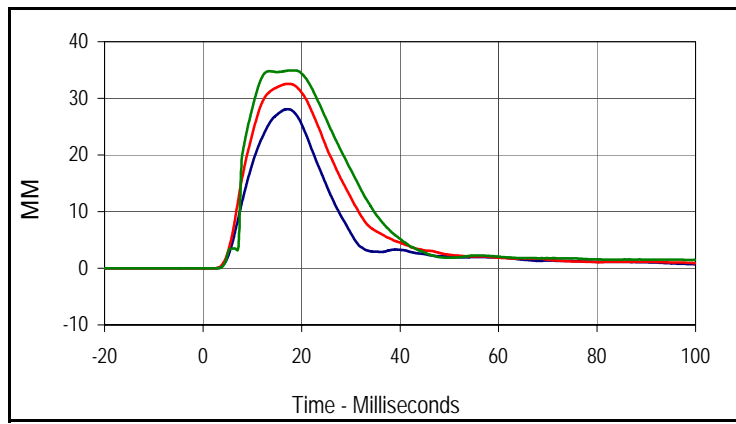

Curve Description			
<b>Upper Thorax Deflection</b>			
CURNO	Type	SAE Class	Units
001	FIL	600	MM
Max	Time	Min	Time
28.1	17.2	0.0	-12.8
<b>Middle Thorax Deflection</b>			
Max	Time	Min	Time
32.6	17.4	0.0	-3.0
<b>Lower Thorax Deflection</b>			
Max	Time	Min	Time
34.9	18.4	0.0	-17.7

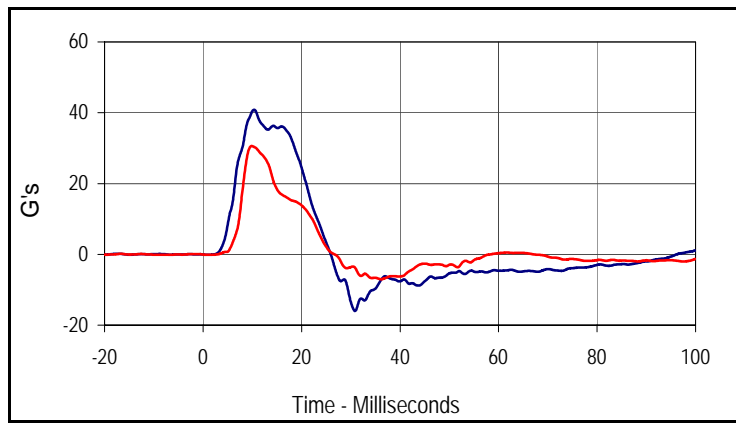

Curve Description			
<b>Upper Spine Y Acceleration</b>			
CURNO	Type	SAE Class	Units
004	FIL	180	G's
Max	Time	Min	Time
40.9	10.4	-16.0	30.8
<b>Lower Spine Y Acceleration</b>			
CURNO	Type	SAE Class	Units
005	FIL	180	G's
Max	Time	Min	Time
30.6	9.9	-7.0	36.2

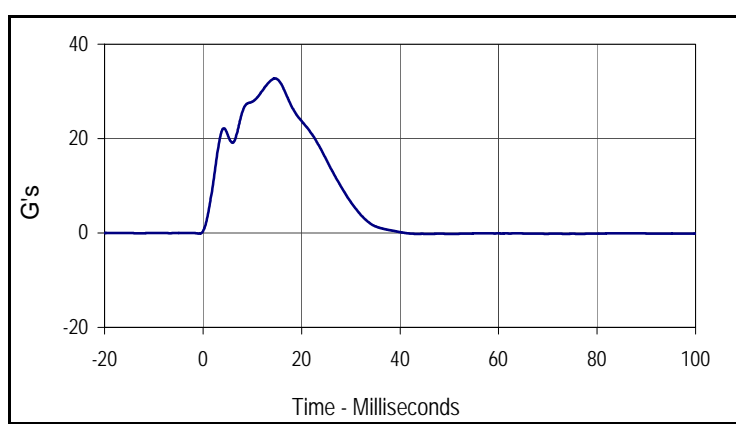

Curve Description			
<b>Impactor Acceleration</b>			
CURNO	Type	SAE Class	Units
006	FIL	180	G's
Max	Time	Min	Time
32.7	14.6	-0.2	50.4

Test Program: SID IIs Thorax w/o Arm Calibration  
 ATD Serial No.: 307

Test Date: 2/12/11  
 Test I.D.: TOA02C



Tested Parameter	Units	Specification	Result	Pass/Fail
Laboratory Temperature	°C	20.6 to 22.2	21.28	Pass
Laboratory Relative Humidity	%	10 to 70	21.76	Pass
Pendulum Velocity	m/s	4.20 to 4.40	4.29	Pass
Upper Thorax Rib Deflection	MM	32 to 40	37.2	Pass
Middle Thorax Rib Deflection	MM	39 to 45	41.1	Pass
Lower Thorax Rib Deflection	MM	35 to 43	41.4	Pass
Peak Upper Spine Y Acceleration	G's	13 to 17	14.9	Pass
Peak Lower Spine Y Acceleration	G's	7 to 11	10.0	Pass
Peak Impactor Acceleration	G's	14 to 18	15.8	Pass
Overall Test Results			Pass	

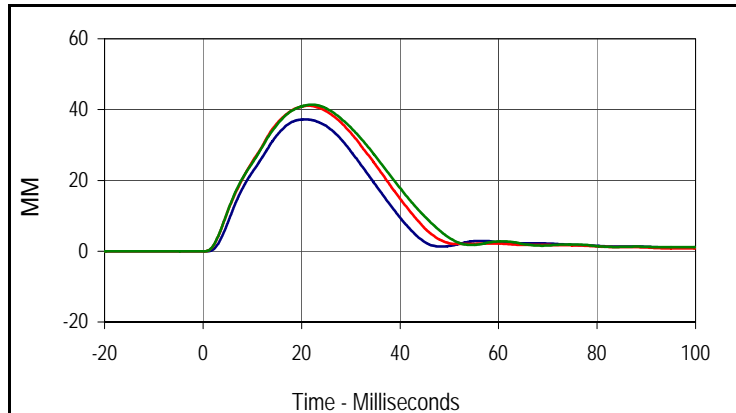

Curve Description			
<b>Upper Thorax Deflection</b>			
CURNO	Type	SAE Class	Units
001	FIL	600	MM
Max	Time	Min	Time
37.2	20.9	0.0	-2.5
<b>Middle Thorax Deflection</b>			
Max	Time	Min	Time
41.1	21.5	0.0	-9.7
<b>Lower Thorax Deflection</b>			
Max	Time	Min	Time
41.4	22.1	0.0	-2.1

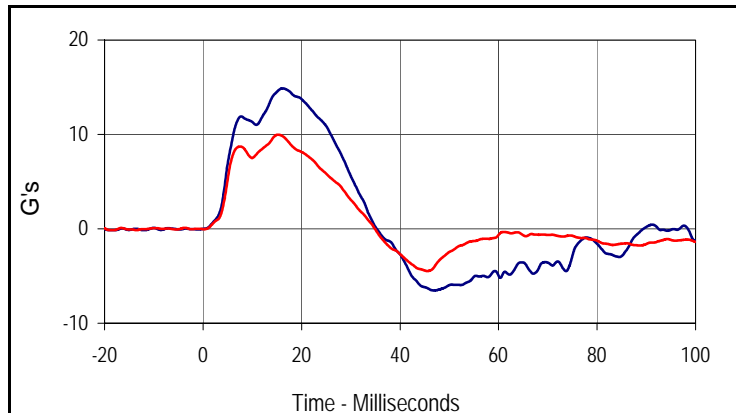

Curve Description			
<b>Upper Spine Y Acceleration</b>			
CURNO	Type	SAE Class	Units
004	FIL	180	G's
Max	Time	Min	Time
14.9	16.2	-6.5	46.9
<b>Lower Spine Y Acceleration</b>			
CURNO	Type	SAE Class	Units
005	FIL	180	G's
Max	Time	Min	Time
10.0	15.3	-4.5	45.5

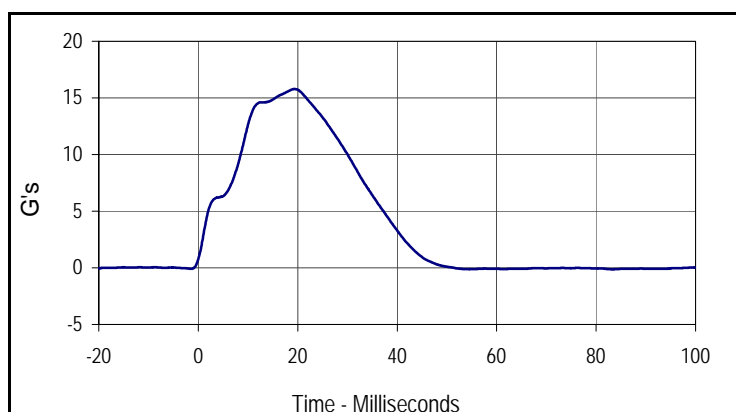

Curve Description			
<b>Impactor Acceleration</b>			
CURNO	Type	SAE Class	Units
006	FIL	180	G's
Max	Time	Min	Time
15.8	19.4	-0.1	83.2

Test Program: SID IIs Abdomen Calibration  
 ATD Serial No.: 307

Test Date: 2/12/11  
 Test I.D.: ABDF02C



Tested Parameter	Units	Specification	Result	Pass/Fail
Laboratory Temperature	°C	20.6 to 22.2	21.30	Pass
Laboratory Relative Humidity	%	10 to 70	21.82	Pass
Pendulum Velocity	m/s	4.20 to 4.40	4.33	Pass
Upper Abdominal Rib Deflection	MM	36 to 47	40.5	Pass
Lower Abdominal Rib Deflection	MM	33 to 44	38.1	Pass
Peak Lower Spine Y Acceleration	G's	9 to 14	13.7	Pass
Peak Impactor Acceleration	G's	12 to 16	14.9	Pass
Overall Test Results			Pass	Pass

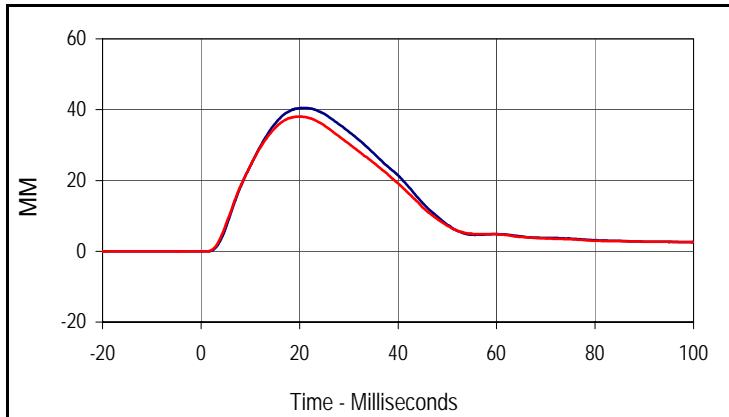

Curve Description			
Upper Abdominal Rib Deflection			
CURNO	Type	SAE Class	Units
001	FIL	600	MM
Max	Time	Min	Time
40.5	20.9	0.0	-16.3

Curve Description			
Lower Abdominal Rib Deflection			
CURNO	Type	SAE Class	Units
002	FIL	600	MM
Max	Time	Min	Time
38.1	20.0	0.0	-2.5

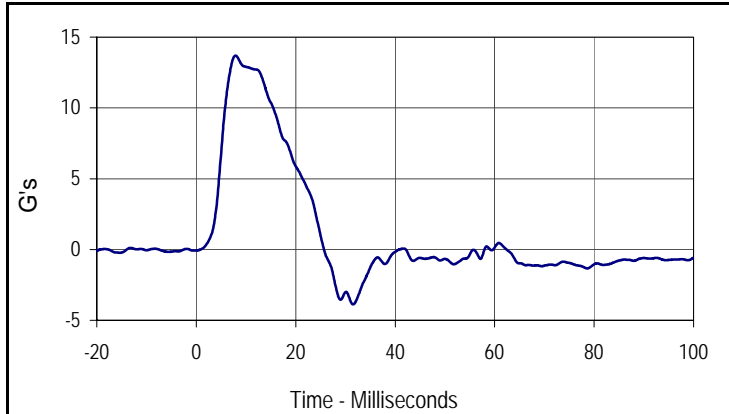

Curve Description			
Lower Spine Y Acceleration			
CURNO	Type	SAE Class	Units
003	FIL	180	G's
Max	Time	Min	Time
13.7	7.9	-3.9	31.5

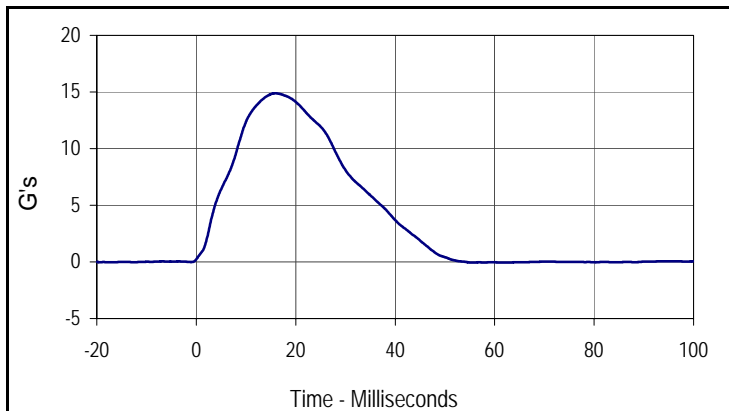

Curve Description			
Impactor Acceleration			
CURNO	Type	SAE Class	Units
004	FIL	180	G's
Max	Time	Min	Time
14.9	15.8	-0.1	55.4

Test Program: SID IIs Pelvis Acetabulum Calibration  
 ATD Serial No.: 307

Test Date: 2/12/11  
 Test I.D.: ACET02C



Tested Parameter	Units	Specification	Result	Pass/Fail
Laboratory Temperature	°C	20.6 to 22.2	21.31	Pass
Laboratory Relative Humidity	%	10 to 70	21.92	Pass
Pendulum Velocity	m/s	6.60 to 6.80	6.61	Pass
Peak Acetabulum Force	Newtons	3600 to 4300	4042.8	Pass
Peak Pelvis Y Acceleration After 6 msec.	G's	34 to 42	36.8	Pass
Peak Impactor Acceleration	G's	38 to 47	40.3	Pass
Overall Test Results			Pass	

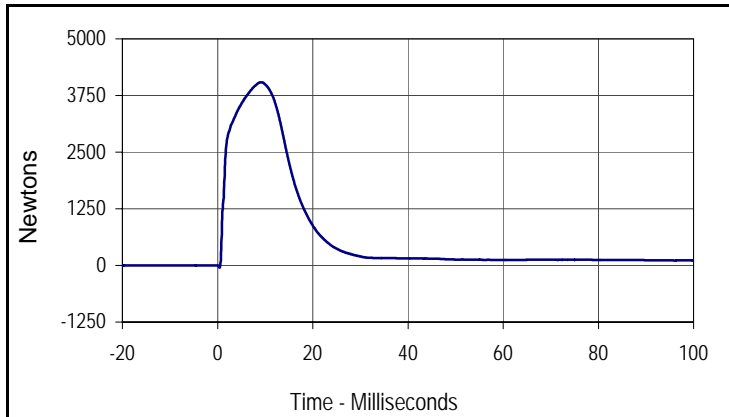

Curve Description			
Pelvis Acetabulum Force			
CURNO	Type	SAE Class	Units
001	FIL	600	Newtons
Max	Time	Min	Time
4042.8	9.0	-43.5	0.4

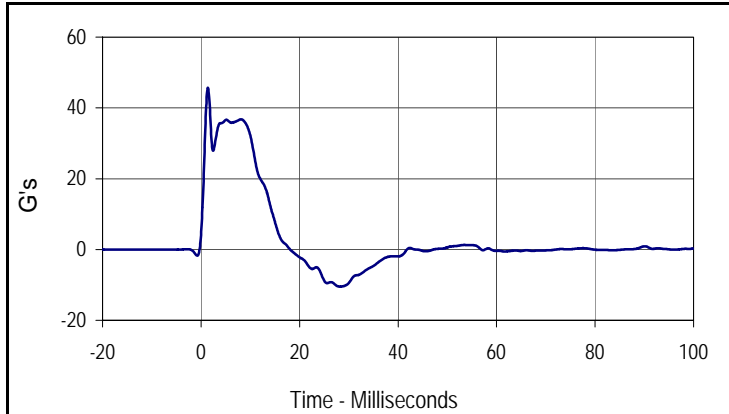

Curve Description			
Pelvis Y Acceleration			
CURNO	Type	SAE Class	Units
002	FIL	180	G's
Max	Time	Min	Time
45.7	1.4	-10.5	28.2

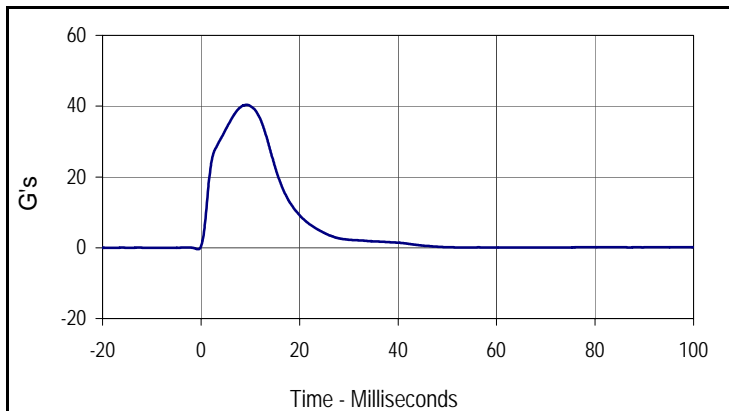

Curve Description			
Impactor Acceleration			
CURNO	Type	SAE Class	Units
003	FIL	180	G's
Max	Time	Min	Time
40.3	9.3	-0.4	-0.6

Test Program: SID IIs Pelvis Iliac Calibration  
 ATD Serial No.: 307

Test Date: 2/12/11  
 Test I.D.: PLF02C



Tested Parameter	Units	Specification	Result	Pass/Fail
Laboratory Temperature	°C	20.6 to 22.2	21.24	Pass
Laboratory Relative Humidity	%	10 to 70	21.89	Pass
Pendulum Velocity	m/s	4.2 to 4.4	4.29	Pass
Peak Iliac Force	Newtons	4100 to 5100	4301.8	Pass
Peak Pelvis Y Acceleration	G's	28 to 39	31.9	Pass
Peak Impactor Acceleration	G's	36 to 45	41.0	Pass
Overall Test Results			Pass	

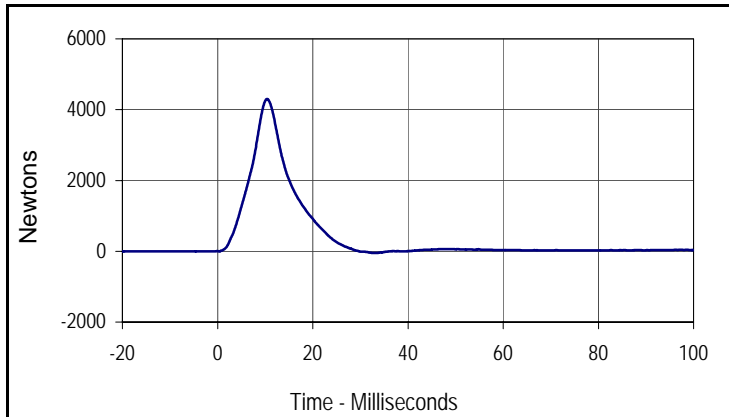

Curve Description			
Pelvis Iliac Force			
CURNO	Type	SAE Class	Units
001	FIL	600	Newtons
Max	Time	Min	Time
4301.8	10.4	-47.3	33.0

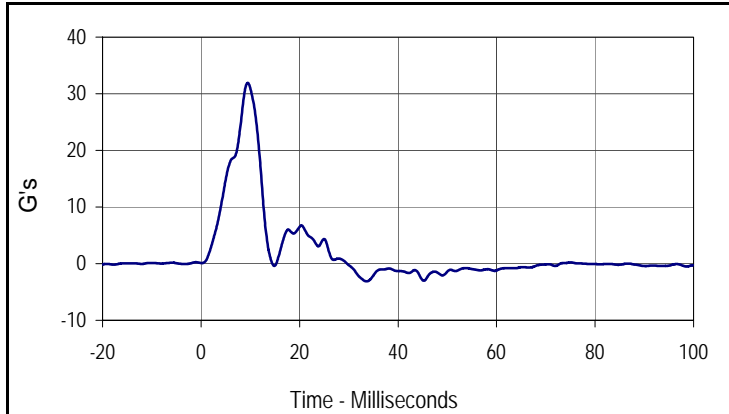

Curve Description			
Pelvis Y Acceleration			
CURNO	Type	SAE Class	Units
002	FIL	180	G's
Max	Time	Min	Time
31.9	9.5	-3.1	33.6

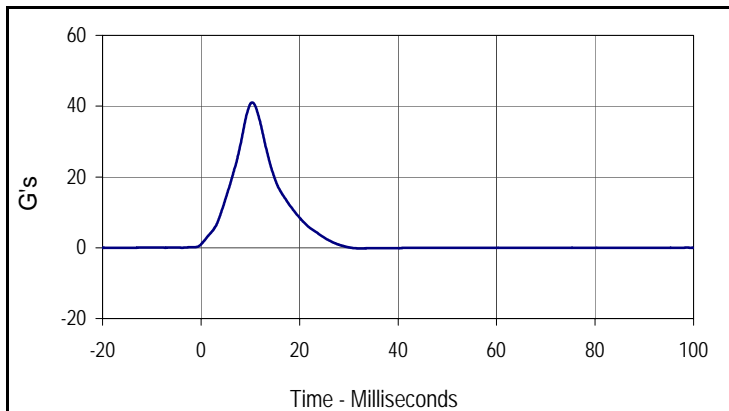

Curve Description			
Impactor Acceleration			
CURNO	Type	SAE Class	Units
003	FIL	180	G's
Max	Time	Min	Time
41.0	10.4	-0.2	32.3