

REPORT NUMBER: 208-MGA-2010-002

**VEHICLE SAFETY COMPLIANCE TESTING
FOR
FMVSS 208, OCCUPANT CRASH PROTECTION
FMVSS 212, WINDSHIELD MOUNTING
FMVSS 219, WINDSHIELD INTRUSION (PARTIAL)
FMVSS 301, FUEL SYSTEM INTEGRITY**

**MAZDA MOTOR CORPORATION
2010 MAZDA 6 PASSENGER CAR
NHTSA NO.: CA5400**

**PREPARED BY:
MGA RESEARCH CORPORATION
5000 WARREN ROAD
BURLINGTON, WI 53105**



TEST DATE: FEBRUARY 19, 2010

FINAL REPORT DATE: JUNE 19, 2012

FINAL REPORT

**PREPARED FOR:
U.S. DEPARTMENT OF TRANSPORTATION
NATIONAL HIGHWAY TRAFFIC SAFETY ADMINISTRATION
OFFICE OF ENFORCEMENT
OFFICE OF VEHICLE SAFETY COMPLIANCE
1200 NEW JERSEY AVENUE, S.E., NVS-220
WASHINGTON, D.C. 20590**

This final test report was prepared for the U.S. Department of Transportation, National Highway Traffic Safety Administration, in response to Contract Number DTNH22-08-D-00086.

This publication is distributed by the U.S. Department of Transportation, National Highway Traffic Safety Administration, in the interest of information exchange. The opinions, findings and conclusions expressed in this publication are those of the author(s) and not necessarily those of the Department of Transportation or the National Highway Traffic Safety Administration. The United States Government assumes no liability for its contents or use thereof. If trade or manufacturers' names or products are mentioned it is only because they are considered essential to the object of the publication and should not be construed as an endorsement. The United States Government does not endorse products or manufacturers.

Prepared by: Jeff Lewandowski Date: June 19, 2012
Jeff Lewandowski, Project Engineer

Reviewed by: David Winkelbauer Date: June 19, 2012
David Winkelbauer, Facility Director

FINAL REPORT ACCEPTED BY OVSC:

Accepted By: 

Acceptance Date: June 19, 2012

Technical Report Documentation Page

1. Report No. 208-MGA-2010-002		2. Government Accession No.		3. Recipient's Catalog No.	
4. Title and Subtitle Final Report of FMVSS 208 Compliance Testing of a 2010 Mazda 6 NHTSA No.: CA5400				5. Report Date June 19, 2012	
				6. Performing Organization Code MGA	
7. Author(s) Jeff Lewandowski, Project Engineer				8. Performing Organization Report No. 208-MGA-2010-002	
9. Performing Organization Name and Address MGA Research Corporation 5000 Warren Road Burlington, WI 53105				10. Work Unit No.	
				11. Contract or Grant No. DTNH22-08-D-00086	
12. Sponsoring Agency Name and Address U.S. Department of Transportation National Highway Traffic Safety Administration Office of Enforcement Office of Vehicle Safety Compliance 1200 New Jersey Avenue, S.E., NVS-220 Washington, D.C. 20590				13. Type of Report and Period Covered 2/19/10	
				14. Sponsoring Agency Code NVS-220	
15. Supplementary Notes					
16. Abstract Compliance tests were conducted on the subject 2010 Mazda 6 in accordance with the specifications of the Office of Vehicle Safety Compliance Test Procedure No. TP208-14 for the determination of FMVSS 208 compliance. Test failures identified were as follows: TEST FAILURES: None					
17. Key Words Frontal Impact 40 kmph Vehicle Safety Compliance Testing FMVSS 208, "Occupant Crash Protection" FMVSS 212, "Windshield Mounting" FMVSS 219, (partial), "Windshield Zone Intrusion" FMVSS 301, "Fuel System Integrity"				18. Distribution Statement Copies of this report are available from the following: U.S. Department of Transportation National Highway Traffic Safety Administration Technical Information Services (TIS), NPO-411 1200 New Jersey Avenue, S.E. (Room E12-100) Washington, DC 20590	
19. Security Classif. (of this report) Unclassified		20. Security Classif. (of this page) Unclassified		21. No. of Pages 151	22. Price

TABLE OF CONTENTS

<u>Section</u>		<u>Page No</u>
1	Purpose of Compliance Tests	1
2	Tests Performed	2
3	Injury Result Summary for FMVSS 208 Tests	4
4	Discussion of Tests (if applicable)	5
5	Test Data Sheets	6
 <u>Data Sheet</u>		
1	COTR Vehicle Work Order	7
2	Report of Vehicle Condition	12
3	Certification Label and Tire Placard Information	14
32	Vehicle Weight, Fuel Tank, and Attitude Data	15
33	Vehicle Accelerometer Locations and Measurements	18
34	Photographic Targets	21
35	Camera Locations	26
36	Dummy Positioning	28
37	Dummy Measurements	44
38	Crash Test	47
40	Accident Investigation Measurements	48
41	Windshield Mounting (FMVSS 212)	50
42	Windshield Zone Intrusion (FMVSS 219)	52
43	Fuel System Integrity (FMVSS 301)	54
 <u>Appendix</u>		
A	Crash Test Data	A-1
B	Crash Test Photographs	B-1
C	Instrumentation Calibration	C-1
D	Notice of Test Failure (If Applicable)	D-1

SECTION 1
PURPOSE OF COMPLIANCE TESTS

This Federal Motor Vehicle Safety Standard 208 compliance test is part of a program conducted for the National Highway Traffic Safety Administration (NHTSA) by MGA Research Corporation (MGA) under Contract No.: DTNH22-08-D-00086. The purpose of this test was to determine whether the subject vehicle, a 2010 Mazda 6, NHTSA No.: CA5400, meets certain performance requirements of FMVSS 208, "Occupant Crash Protection"; FMVSS 212, "Windshield Mounting"; FMVSS 219, "Windshield Zone Intrusion"; and FMVSS 301, "Fuel System Integrity". The compliance test was conducted in accordance with OVSC Laboratory Test Procedure No.: TP208-14 dated April 16, 2008.

SECTION 2
TESTS PERFORMED

Test Vehicle: 2010 Mazda 6
Test Program: FMVSS 208 Compliance

NHTSA No.: CA5400
Test Date: 2/19/10

The following checked items indicate the tests that were performed:

- | | | |
|-------------------------------------|-----|--|
| <input type="checkbox"/> | 1. | Rear seating position seat belts |
| <input type="checkbox"/> | 2. | Air bag labels (S4.5.1) |
| <input type="checkbox"/> | 3. | Readiness indicator (S4.5.2) |
| <input type="checkbox"/> | 4. | Passenger air bag manual cut-off device (S4.5.4) |
| <input type="checkbox"/> | 5. | Lap belt lockability (S7.1.1.5) |
| <input type="checkbox"/> | 6. | Seat belt warning system (S7.3) |
| <input type="checkbox"/> | 7. | Seat belt contact force (S7.4.3) |
| <input type="checkbox"/> | 8. | Seat belt latch plate access (S7.4.4) |
| <input type="checkbox"/> | 9. | Seat belt retraction (S7.4.5) |
| <input type="checkbox"/> | 10. | Seat belt guides and hardware (S7.4.6) |
| <input type="checkbox"/> | 11. | Air bag suppression telltale (S19.2.2) |
| <input type="checkbox"/> | 12. | Suppression tests with 12-month-old CRABI dummy (Part 572, Subpart R) |
| <input type="checkbox"/> | 13. | Suppression tests with Newborn infant (Part 572, Subpart K) |
| <input type="checkbox"/> | 14. | Suppression tests with 3-year-old dummy (Part 572, Subpart P) |
| <input type="checkbox"/> | 15. | Suppression tests with 6-year-old dummy (Part 572, Subpart N) |
| <input type="checkbox"/> | 16. | Test of Reactivation of the passenger air bag system with an unbelted 5 th percentile female dummy |
| <input type="checkbox"/> | 17. | Low risk deployment test with 12-month-old dummy (Part 572, Subpart R) |
| <input type="checkbox"/> | 18. | Low risk deployment test with 3-year-old dummy (Part 572, Subpart P) |
| <input type="checkbox"/> | 19. | Low risk deployment test with 6-year-old dummy (Part 572, Subpart N) |
| <input type="checkbox"/> | 20. | Low risk deployment test with 5 th female dummy (Part 572, Subpart O) |
| <input checked="" type="checkbox"/> | 21. | Impact Tests |
| | | <input type="checkbox"/> Frontal Oblique |
| | | <input type="checkbox"/> Belted 50 th male dummy driver and passenger (0 to 48 kmph) (S5.1.1(a)) |
| | | <input type="checkbox"/> Unbelted 50 th male dummy driver and passenger (0 to 48 kmph) (S5.1.2(a)(1)) |
| | | <input type="checkbox"/> Unbelted 50 th male dummy driver and passenger (32 to 40 kmph) (S5.1.2(a)(1) or S5.1.2(b)) |
| | | <input checked="" type="checkbox"/> Frontal 0° |
| | | <input type="checkbox"/> Belted 50 th male dummy driver (0 to 48 kmph) (S5.1.1.(b)(1) or S5.1.1(a)) |
| | | <input type="checkbox"/> Belted 50 th male dummy passenger (0 to 48 kmph) (S5.1.1.(b)(1) or S5.1.1(a)) |
| | | <input type="checkbox"/> Belted 5 th female dummy driver (0 to 48 kmph) (S16.1(a)) |
| | | <input type="checkbox"/> Belted 5 th female dummy passenger (0 to 48 kmph) (S16.1(a)) |
| | | <input type="checkbox"/> Belted 50 th male dummy driver and passenger (0 to 56 kmph) (S5.1.1.(b)(2)) |
| | | <input type="checkbox"/> Unbelted 50 th male dummy driver and passenger (0 to 48 kmph) (S5.1.2(a) (1)) |
| | | <input type="checkbox"/> Unbelted 50 th male dummy driver (32 to 40 kmph) (S5.1.2.(a)(2) or S5.1.2(b)) |
| | | <input type="checkbox"/> Unbelted 50 th male dummy passenger (32 to 40 kmph) (S5.1.2.(a)(2) or S5.1.2(b)) |
| | | <input checked="" type="checkbox"/> Unbelted 5 th female dummy driver (32 to 40 kmph) (S16.1(b)) |
| | | <input checked="" type="checkbox"/> Unbelted 5 th female dummy passenger (32 to 40 kmph) (S16.1(b)) |
| | | <input type="checkbox"/> 40% Offset 0° Belted 5 th female dummy driver and passenger (0 to 40 kmph) (S18.1) |
| <input type="checkbox"/> | 22. | FMVSS 204 Indicant Test |
| <input checked="" type="checkbox"/> | 23. | FMVSS 212 Test |
| <input checked="" type="checkbox"/> | 24. | FMVSS 219 Indicant Test |
| <input checked="" type="checkbox"/> | 25. | FMVSS 301 Frontal Test |

For the crash tests, the vehicle was instrumented with 8 accelerometers. The data from the vehicle and dummies were sampled at 10,000 samples per second and processed as specified in SAE J211/1 MAR95 and FMVSS 208, S4.13.

The dynamic tests were recorded using high-speed digital video.

The vehicle appears to meet the performance requirements to which it was tested.

SECTION 3

INJURY RESULT SUMMARY FOR FMVSS 208 TESTS

Test Vehicle: 2010 Mazda 6
 Test Program: FMVSS 208 Compliance

NHTSA No.: CA5400
 Test Date: 2/19/10

40 kmph Frontal Crash

Impact Angle:	Zero degrees			
Belted Dummies:		Yes	X	No

Speed Range:		0 to 40 kmph	X	32 to 40 kmph
		0 to 48 kmph		0 to 56 kmph

Test Speed (kmph):	39.8	Test Weight (kg):	1603.5
--------------------	------	-------------------	--------

Driver Dummy:	X	5 th female		50 th male
Passenger Dummy:	X	5 th female		50 th male

5th Percentile Female Frontal Crash Test

Vehicles certified to S16.1 (a) (1), S16.1 (a) (2), S16.1 (b), or S18.1

Injury Criteria	Max. Allowable Injury Assessment Values	Driver	Passenger
HIC15	700	25	* No Valid Data
N _{te}	1.0	0.4	0.2
N _{tf}	1.0	0.2	0.3
N _{ce}	1.0	0.0	0.2
N _{cf}	1.0	0.2	0.7
Neck Tension	2620 N	802	314
Neck Compression	2520 N	336	695
Chest g	60 g	42	34
Chest Displacement	52 mm	16	5
Left Femur	6805 N	2880	2963
Right Femur	6805 N	2520	3694

* There was no valid data collected on the X, Y, and Z passenger head accelerometers.

SECTION 4
DISCUSSION OF TESTS

Test Vehicle: 2010 Mazda 6
Test Program: FMVSS 208 Compliance

NHTSA No.: CA5400
Test Date: 2/19/10

At the request of the COTR, only a frontal crash test was performed on the 2010 Mazda 6.

There was no valid data on the Passenger Head X accelerometer.

There was no valid data on the Passenger Head Y accelerometer.

There was no valid data on the Passenger Head Z accelerometer.

The passenger HIC 15 was not calculated due to no valid data on the passenger head accelerometer channels. Data plots to 108 milliseconds are included for information only.

SECTION 5
TEST DATA SHEETS

Test Vehicle: 2010 Mazda 6
Test Program: FMVSS 208 Compliance

NHTSA No.: CA5400
Test Date: 2/19/10

DATA SHEET 1
COTR VEHICLE WORK ORDER

Test Vehicle: 2010 Mazda 6
Test Program: FMVSS 208 Compliance

NHTSA No.: CA5400
Test Date: 2/19/10

COTR Signature: Brian Smith

Test to be performed for this vehicle are checked below:

- | | |
|--------------------------|--|
| <input type="checkbox"/> | 1. Rear Seating Position Seat Belts |
| <input type="checkbox"/> | 2. Air Bag Labels (S4.5.1) |
| <input type="checkbox"/> | 3. Readiness Indicator (S4.5.2) |
| <input type="checkbox"/> | 4. Passenger Air Bag Manual Cut-off Device (S4.5.4) |
| <input type="checkbox"/> | 5. Lap Belt Lockability (S7.1.1.5) |
| <input type="checkbox"/> | 6. Seat Belt Warning System (S7.3) |
| <input type="checkbox"/> | 7. Seat Belt Contact Force (S7.4.3) |
| <input type="checkbox"/> | 8. Seat Belt Latch Plate Access (S7.4.4) |
| <input type="checkbox"/> | 9. Seat Belt Retraction (S7.4.5) |
| <input type="checkbox"/> | 10. Seat Belt Guides and Hardware (S7.4.6) |
| <input type="checkbox"/> | 11. Air bag suppression telltale (S19.2.2) |
| <input type="checkbox"/> | 12. Suppression tests with 12-month-old CRABI dummy (Part 572, Subpart R) using the following indicated child restraints (mid-height seat position): |

Section B – Rear Facing (unbelted and belted rear facing, unbelted forward facing)

<input type="checkbox"/>	Century Smart Fit 4543	<input type="checkbox"/>	Full Rearward	<input type="checkbox"/>	Mid Position	<input type="checkbox"/>	Full Forward
<input type="checkbox"/>	Cosco Arriva 22-049	<input type="checkbox"/>	Full Rearward	<input type="checkbox"/>	Mid Position	<input type="checkbox"/>	Full Forward
<input type="checkbox"/>	Evenflo Discovery Adjust Right 212	<input type="checkbox"/>	Full Rearward	<input type="checkbox"/>	Mid Position	<input type="checkbox"/>	Full Forward
<input type="checkbox"/>	Graco Infant 8457	<input type="checkbox"/>	Full Rearward	<input type="checkbox"/>	Mid Position	<input type="checkbox"/>	Full Forward
<input type="checkbox"/>	Graco Snugride 8645	<input type="checkbox"/>	Full Rearward	<input type="checkbox"/>	Mid Position	<input type="checkbox"/>	Full Forward
<input type="checkbox"/>	Peg Perego IMUN00US	<input type="checkbox"/>	Full Rearward	<input type="checkbox"/>	Mid Position	<input type="checkbox"/>	Full Forward

Section C – Convertible (unbelted and belted rear facing, unbelted and belted forward facing)

<input type="checkbox"/>	Britax Roundabout E9L02	<input type="checkbox"/>	Full Rearward	<input type="checkbox"/>	Mid Position	<input type="checkbox"/>	Full Forward
<input type="checkbox"/>	Cosco High Back Booster 22209	<input type="checkbox"/>	Full Rearward	<input type="checkbox"/>	Mid Position	<input type="checkbox"/>	Full Forward
<input type="checkbox"/>	Cosco Touriva 22-100	<input type="checkbox"/>	Full Rearward	<input type="checkbox"/>	Mid Position	<input type="checkbox"/>	Full Forward
<input type="checkbox"/>	Cosco Summit Deluxe 22260	<input type="checkbox"/>	Full Rearward	<input type="checkbox"/>	Mid Position	<input type="checkbox"/>	Full Forward
<input type="checkbox"/>	Evenflo Generations 352	<input type="checkbox"/>	Full Rearward	<input type="checkbox"/>	Mid Position	<input type="checkbox"/>	Full Forward
<input type="checkbox"/>	Evenflo Medallion 254	<input type="checkbox"/>	Full Rearward	<input type="checkbox"/>	Mid Position	<input type="checkbox"/>	Full Forward
<input type="checkbox"/>	Evenflo Tribute V 379	<input type="checkbox"/>	Full Rearward	<input type="checkbox"/>	Mid Position	<input type="checkbox"/>	Full Forward
<input type="checkbox"/>	Graco ComfortSport	<input type="checkbox"/>	Full Rearward	<input type="checkbox"/>	Mid Position	<input type="checkbox"/>	Full Forward
<input type="checkbox"/>	Graco Platinum Cargo	<input type="checkbox"/>	Full Rearward	<input type="checkbox"/>	Mid Position	<input type="checkbox"/>	Full Forward
<input type="checkbox"/>	Graco Safeseat Step 2	<input type="checkbox"/>	Full Rearward	<input type="checkbox"/>	Mid Position	<input type="checkbox"/>	Full Forward

- | | |
|--------------------------|--|
| <input type="checkbox"/> | 13. Suppression tests with newborn infant (Part 572, Subpart K) using the following indicated child restraints (mid-height seat position). |
|--------------------------|--|

Section A – Car Bed (Belted)

<input type="checkbox"/>	Angel Guard Angel Ride	<input type="checkbox"/>	Full Rearward	<input type="checkbox"/>	Mid Position	<input type="checkbox"/>	Full Forward
--------------------------	------------------------	--------------------------	---------------	--------------------------	--------------	--------------------------	--------------

- | | |
|--------------------------|--|
| <input type="checkbox"/> | 14. Suppression tests with 3-year-old dummy (Part 572, Subpart P) using the following indicated child restraints where a child restraint is required (mid-height seat position): |
|--------------------------|--|

Section C – Convertible (Belted forward-facing)

<input type="checkbox"/>	Britax Roundabout E9L02	<input type="checkbox"/>	Full Rearward	<input type="checkbox"/>	Mid Position	<input type="checkbox"/>	Full Forward
<input type="checkbox"/>	Cosco High Back Booster 22209	<input type="checkbox"/>	Full Rearward	<input type="checkbox"/>	Mid Position	<input type="checkbox"/>	Full Forward
<input type="checkbox"/>	Cosco Touriva 22-100	<input type="checkbox"/>	Full Rearward	<input type="checkbox"/>	Mid Position	<input type="checkbox"/>	Full Forward
<input type="checkbox"/>	Cosco Summit Deluxe 22260	<input type="checkbox"/>	Full Rearward	<input type="checkbox"/>	Mid Position	<input type="checkbox"/>	Full Forward
<input type="checkbox"/>	Evenflo Generations 352	<input type="checkbox"/>	Full Rearward	<input type="checkbox"/>	Mid Position	<input type="checkbox"/>	Full Forward
<input type="checkbox"/>	Evenflo Medallion 254	<input type="checkbox"/>	Full Rearward	<input type="checkbox"/>	Mid Position	<input type="checkbox"/>	Full Forward
<input type="checkbox"/>	Evenflo Tribute V 379	<input type="checkbox"/>	Full Rearward	<input type="checkbox"/>	Mid Position	<input type="checkbox"/>	Full Forward
<input type="checkbox"/>	Graco ComfortSport	<input type="checkbox"/>	Full Rearward	<input type="checkbox"/>	Mid Position	<input type="checkbox"/>	Full Forward
<input type="checkbox"/>	Graco Platinum Cargo	<input type="checkbox"/>	Full Rearward	<input type="checkbox"/>	Mid Position	<input type="checkbox"/>	Full Forward
<input type="checkbox"/>	Graco Safeseat Step 2	<input type="checkbox"/>	Full Rearward	<input type="checkbox"/>	Mid Position	<input type="checkbox"/>	Full Forward

Section D – Toddler/Belt Positioning Booster (Belted)

<input type="checkbox"/>	Britax Roadster 9004	<input type="checkbox"/>	Full Rearward	<input type="checkbox"/>	Mid Position	<input type="checkbox"/>	Full Forward
<input type="checkbox"/>	Cosco High Back Booster 22209	<input type="checkbox"/>	Full Rearward	<input type="checkbox"/>	Mid Position	<input type="checkbox"/>	Full Forward
<input type="checkbox"/>	Evenflo Right Fit 245	<input type="checkbox"/>	Full Rearward	<input type="checkbox"/>	Mid Position	<input type="checkbox"/>	Full Forward

15. Suppression tests with representative 3-year-old child using the following indicated child restraints where a child restraint is required (mid-height position). (Appendix H, Data Sheet 19H and 20H)

Section C – Convertible (Belted forward-facing)

<input type="checkbox"/>	Britax Roundabout E9L02	<input type="checkbox"/>	Full Rearward	<input type="checkbox"/>	Mid Position	<input type="checkbox"/>	Full Forward
<input type="checkbox"/>	Cosco High Back Booster 22209	<input type="checkbox"/>	Full Rearward	<input type="checkbox"/>	Mid Position	<input type="checkbox"/>	Full Forward
<input type="checkbox"/>	Cosco Touriva 22-100	<input type="checkbox"/>	Full Rearward	<input type="checkbox"/>	Mid Position	<input type="checkbox"/>	Full Forward
<input type="checkbox"/>	Cosco Summit Deluxe 22260	<input type="checkbox"/>	Full Rearward	<input type="checkbox"/>	Mid Position	<input type="checkbox"/>	Full Forward
<input type="checkbox"/>	Evenflo Generations 352	<input type="checkbox"/>	Full Rearward	<input type="checkbox"/>	Mid Position	<input type="checkbox"/>	Full Forward
<input type="checkbox"/>	Evenflo Medallion 254	<input type="checkbox"/>	Full Rearward	<input type="checkbox"/>	Mid Position	<input type="checkbox"/>	Full Forward
<input type="checkbox"/>	Evenflo Tribute V 379	<input type="checkbox"/>	Full Rearward	<input type="checkbox"/>	Mid Position	<input type="checkbox"/>	Full Forward
<input type="checkbox"/>	Graco ComfortSport	<input type="checkbox"/>	Full Rearward	<input type="checkbox"/>	Mid Position	<input type="checkbox"/>	Full Forward
<input type="checkbox"/>	Graco Platinum Cargo	<input type="checkbox"/>	Full Rearward	<input type="checkbox"/>	Mid Position	<input type="checkbox"/>	Full Forward
<input type="checkbox"/>	Graco Safeseat Step 2	<input type="checkbox"/>	Full Rearward	<input type="checkbox"/>	Mid Position	<input type="checkbox"/>	Full Forward

Section D – Toddler/Belt Positioning Booster (Belted)

<input type="checkbox"/>	Britax Roadster 9004	<input type="checkbox"/>	Full Rearward	<input type="checkbox"/>	Mid Position	<input type="checkbox"/>	Full Forward
<input type="checkbox"/>	Cosco High Back Booster 22209	<input type="checkbox"/>	Full Rearward	<input type="checkbox"/>	Mid Position	<input type="checkbox"/>	Full Forward
<input type="checkbox"/>	Evenflo Right Fit 245	<input type="checkbox"/>	Full Rearward	<input type="checkbox"/>	Mid Position	<input type="checkbox"/>	Full Forward

16. Suppression tests with 3-year-old dummy (Part 572, Subpart P) in the following positions (mid-height seat position):

<input type="checkbox"/>	Sitting on seat with back against seat back (S22.2.2.1)		
<input type="checkbox"/>	<input type="checkbox"/>	<input type="checkbox"/>	<input type="checkbox"/>
<input type="checkbox"/>	Full Rearward	Mid Position	Full Forward
<input type="checkbox"/>	Sitting on seat with back against reclined seat back (S22.2.2.2)		
<input type="checkbox"/>	<input type="checkbox"/>	<input type="checkbox"/>	<input type="checkbox"/>
<input type="checkbox"/>	Full Rearward	Mid Position	Full Forward
<input type="checkbox"/>	Sitting on seat with back not against seat back (S22.2.2.3)		
<input type="checkbox"/>	<input type="checkbox"/>	<input type="checkbox"/>	<input type="checkbox"/>
<input type="checkbox"/>	Full Rearward	Mid Position	Full Forward
<input type="checkbox"/>	Sitting on seat edge, spine vertical, hands by the child's side (S22.2.2.4)		
<input type="checkbox"/>	<input type="checkbox"/>	<input type="checkbox"/>	<input type="checkbox"/>
<input type="checkbox"/>	Full Rearward	Mid Position	Full Forward
<input type="checkbox"/>	Standing on seat, facing forward (S22.2.2.5)		
<input type="checkbox"/>	<input type="checkbox"/>	<input type="checkbox"/>	<input type="checkbox"/>
<input type="checkbox"/>	Full Rearward	Mid Position	Full Forward
<input type="checkbox"/>	Kneeling on seat facing forward (S22.2.2.6)		
<input type="checkbox"/>	<input type="checkbox"/>	<input type="checkbox"/>	<input type="checkbox"/>
<input type="checkbox"/>	Full Rearward	Mid Position	Full Forward
<input type="checkbox"/>	Kneeling on seat facing rearward (S22.2.2.7)		
<input type="checkbox"/>	<input type="checkbox"/>	<input type="checkbox"/>	<input type="checkbox"/>
<input type="checkbox"/>	Full Rearward	Mid Position	Full Forward
<input type="checkbox"/>	Lying on seat (S22.2.2.8)		
<input type="checkbox"/>	<input type="checkbox"/>	<input type="checkbox"/>	<input type="checkbox"/>
<input type="checkbox"/>	Full Rearward	Mid Position	Full Forward

17. Suppression tests with representative 3-year-old child in the following positions (mid-height seat position):

- Sitting on seat with back against seat back (S22.2.2.1)
 - Full Rearward Mid Position Full Forward
- Sitting on seat with back against reclined seat back (S22.2.2.2)
 - Full Rearward Mid Position Full Forward
- Sitting on seat with back not against seat back (S22.2.2.3)
 - Full Rearward Mid Position Full Forward
- Sitting on seat edge, spine vertical, hands by the child's side (S22.2.2.4)
 - Full Rearward Mid Position Full Forward
- Standing on seat, facing forward (S22.2.2.5)
 - Full Rearward Mid Position Full Forward
- Kneeling on seat facing forward (S22.2.2.6)
 - Full Rearward Mid Position Full Forward
- Kneeling on seat facing rearward (S22.2.2.7)
 - Full Rearward Mid Position Full Forward
- Lying on seat (S22.2.2.8)
 - Full Rearward Mid Position Full Forward

18. Suppression tests with 6-year-old dummy (Part 572, Subpart N) using the following indicated child restraints where a child restraint is required (mid-height seat position):

Section D

<input type="checkbox"/> Britax Roadster 9004	<input type="checkbox"/> Full Rearward	<input type="checkbox"/> Mid Position	<input type="checkbox"/> Full Forward
<input type="checkbox"/> Cosco High Back Booster 22209	<input type="checkbox"/> Full Rearward	<input type="checkbox"/> Mid Position	<input type="checkbox"/> Full Forward
<input type="checkbox"/> Cosco Summit Deluxe	<input type="checkbox"/> Full Rearward	<input type="checkbox"/> Mid Position	<input type="checkbox"/> Full Forward
<input type="checkbox"/> Evenflo Generations	<input type="checkbox"/> Full Rearward	<input type="checkbox"/> Mid Position	<input type="checkbox"/> Full Forward
<input type="checkbox"/> Evenflo Right Fit 245	<input type="checkbox"/> Full Rearward	<input type="checkbox"/> Mid Position	<input type="checkbox"/> Full Forward
<input type="checkbox"/> Graco Platinum Cargo	<input type="checkbox"/> Full Rearward	<input type="checkbox"/> Mid Position	<input type="checkbox"/> Full Forward

19. Suppression tests with representative 6-year-old child using the following indicated child restraints where a child restraint is required (mid-height seat position):

Section D

<input type="checkbox"/> Britax Roadster 9004	<input type="checkbox"/> Full Rearward	<input type="checkbox"/> Mid Position	<input type="checkbox"/> Full Forward
<input type="checkbox"/> Cosco High Back Booster 22209	<input type="checkbox"/> Full Rearward	<input type="checkbox"/> Mid Position	<input type="checkbox"/> Full Forward
<input type="checkbox"/> Cosco Summit Deluxe	<input type="checkbox"/> Full Rearward	<input type="checkbox"/> Mid Position	<input type="checkbox"/> Full Forward
<input type="checkbox"/> Evenflo Generations	<input type="checkbox"/> Full Rearward	<input type="checkbox"/> Mid Position	<input type="checkbox"/> Full Forward
<input type="checkbox"/> Evenflo Right Fit 245	<input type="checkbox"/> Full Rearward	<input type="checkbox"/> Mid Position	<input type="checkbox"/> Full Forward
<input type="checkbox"/> Graco Platinum Cargo	<input type="checkbox"/> Full Rearward	<input type="checkbox"/> Mid Position	<input type="checkbox"/> Full Forward

20. Suppression tests with 6-year-old dummy (Part 572, Subpart N) in the following positions (mid-height seat position):

- Sitting on seat with back against seat back (S22.2.2.1)
 - Full Rearward Mid Position Full Forward
- Sitting on seat with back against reclined seat back (S22.2.2.2)
 - Full Rearward Mid Position Full Forward
- Sitting on seat edge, spine vertical, hands by the child's side (S22.2.2.4)
 - Full Rearward Mid Position Full Forward
- Sitting back in the seat and leaning on the right front passenger door (S24.2.3)
 - Full Rearward Mid Position Full Forward

21. Suppression tests with representative 6-year-old child in the following positions (mid-height seat position):
- Sitting on seat with back against seat back (S22.2.2.1)
 - Full Rearward Mid Position Full Forward
 - Sitting on seat with back against reclined seat back (S22.2.2.2)
 - Full Rearward Mid Position Full Forward
 - Sitting on seat edge, spine vertical, hands by the child's side (S22.2.2.4)
 - Full Rearward Mid Position Full Forward
 - Sitting back in the seat and leaning on the right front passenger door (S24.2.3)
22. Test of Reactivation of the Passenger Air Bag System with an Unbelted 5th percentile female dummy (S20.3, 22.3, S24.3) (mid-height seat position). Perform this test after the following suppression tests:
23. Test of Reactivation of the Passenger Air Bag System with a representative 5th percentile female (S20.3, 22.3, S24.3) (mid-height seat position). Perform this test after the following suppression tests:
24. Low risk deployment test with 12-month-old dummy (Part 572, Subpart R) using the following indicated child restraints (full forward, mid-height seat position)(S20.4):
- Section B
- Century Smart Fit 4543
 - Cosco Arriva 22-049
 - Evenflo Discovery Adjust Right 212
 - Graco Infant 8457
 - Graco Snugride 8645
 - Peg Perego IMUN00US
- Section C
- Britax Roundabout E9L02
 - Cosco High Back Booster 22209
 - Cosco Touriva 22-100
 - Cosco Summit Deluxe 22260
 - Evenflo Generations 352
 - Evenflo Medallion 254
 - Evenflo Tribute V 379
 - Graco ComfortSport
 - Graco Platinum Cargo
 - Graco Safeseat Step 2
25. Low risk deployment test with 3-year-old dummy (Part 572, Subpart P) in the following positions:
- Position 1 (rearmost, lowest seat position)
 - Position 2 (mid-height seat position)
26. Low risk deployment test with 6-year-old dummy (Part 572, Subpart N) in the following positions:
- Position 1 (rearmost, lowest seat position)
 - Position 2 (mid-height seat position)
27. Low risk deployment test with 5th female dummy (Part 572, Subpart O) in the following positions:
- Position 1 (mid-height seat position)
 - Position 2 (mid-height seat position)

- | | |
|-------------------------------------|---|
| <input checked="" type="checkbox"/> | 28. Impact Tests |
| <input type="checkbox"/> | Frontal Oblique Impact Angle: Test Speed: |
| <input type="checkbox"/> | Belted 50 th male dummy driver and passenger (0 to 48 kmph) (S5.1.1(a)) |
| <input type="checkbox"/> | Unbelted 50 th male dummy driver and passenger (0 to 48 kmph) (S5.1.2(a)(1)) |
| <input type="checkbox"/> | Unbelted 50 th male dummy driver and passenger (32 to 40 kmph) (S5.1.2(a)(2) or S5.1.2(b)) |
| <input checked="" type="checkbox"/> | Frontal 0° - Test Speed: 39.8 kmph |
| <input type="checkbox"/> | Belted 50 th male dummy driver (0 to 48 kmph) (S5.1.1.(b)(1) or S5.1.1(a)) |
| <input type="checkbox"/> | Belted 50 th male dummy passenger (0 to 48 kmph) (S5.1.1.(b)(1) or S5.1.1(a)) |
| <input type="checkbox"/> | Belted 5 th female dummy driver (0 to 48 kmph) (S16.1(a)(1)) |
| <input type="checkbox"/> | Belted 5 th female dummy passenger (0 to 48 kmph) (S16.1(a)(1)) |
| <input type="checkbox"/> | Belted 5 th female dummy driver and passenger (0 to 56 kmph) (S16.1(a)(2)) |
| <input type="checkbox"/> | Belted 50 th male dummy driver and passenger (0 to 56 kmph) (S5.1.1.(b)(2)) |
| <input type="checkbox"/> | Unbelted 50 th male dummy driver and passenger (0 to 48 kmph) (S5.1.2(a) (1)) |
| <input type="checkbox"/> | Unbelted 50 th male dummy driver (32 to 40 kmph) (S5.1.2.(a)(2) or S5.1.2(b)) |
| <input type="checkbox"/> | Unbelted 50 th male dummy passenger (32 to 40 kmph) (S5.1.2.(a)(2) or S5.1.2(b)) |
| <input checked="" type="checkbox"/> | Unbelted 5 th female dummy driver (32 to 40 kmph) (S16.1(b)) |
| <input checked="" type="checkbox"/> | Unbelted 5 th female dummy passenger (32 to 40 kmph) (S16.1(b)) |
| <input type="checkbox"/> | 40% Offset 0° Belted 5 th female dummy driver and passenger (0 to 40 kmph) (S18.1) |
| | Test Speed: |
| <input type="checkbox"/> | 29. FMVSS 204 Indicant Test |
| <input checked="" type="checkbox"/> | 30. FMVSS 212 Test |
| <input checked="" type="checkbox"/> | 31. FMVSS 219 Indicant Test |
| <input checked="" type="checkbox"/> | 32. FMVSS 301 Frontal Test |

DATA SHEET 2
REPORT OF VEHICLE CONDITION

Test Vehicle: 2010 Mazda 6
Test Program: FMVSS 208 Compliance

NHTSA No.: CA5400
Test Date: 2/19/10

CONTRACT NO.: DTNH22-08-D-00086 Date: 3/4/10
FROM (Lab and rep name): MGA Research Corporation
TO: NHTSA, OVSC, NVS-220

PURPOSE: (X) Initial Receipt () Received via Transfer (X) Present vehicle condition

MODEL YEAR/MAKE/MODEL/BODY STYLE: 2010 Mazda 6 4 Door
MANUFACTURE DATE: 08/09
NHTSA NO. CA5400 GVWR: 1969 kg (4340 lbs)
BODY COLOR: Ebony Black GAWR (Fr): 1037 kg (2286 lbs)
VIN: 1YVHZ8BH4A5M04704 GAWR (Rr): 935 kg (2062 lbs)

ODOMETER READINGS: ARRIVAL (miles): 150 DATE: 1/12/10
COMPLETION (miles): 151 DATE: 2/19/10

PURCHASE PRICE: (\$) 18,000

DEALER'S NAME: Frank Boucher Mazda/VW/Kia – 9601 Washington Ave. Racine, WI 53408

- A. All options listed on window sticker are present on the test vehicle:
 Yes No
- B. Tires and wheel rims are new and the same as listed: Yes No
- C. There are no dents or other interior or exterior flaws: Yes No
- D. The vehicle has been properly prepared and is in running condition:
 Yes No
- E. Keyless remote is available and working: Yes No
- F. The glove box contains an owner's manual, warranty document, consumer information, and extra set of keys: Yes No
- G. Proper fuel filler cap is supplied on the test vehicle: Yes No
- H. Using permanent marker, identify vehicle with NHTSA number and FMVSS test type(s) on roof line above driver door or for school buses, place a placard with NHTSA number inside the windshield and to the exterior front and rear side of bus:
 Yes No
- I. Place vehicle in storage area: Yes No
- J. Inspect the vehicle's interior and exterior, including all windows, seats, doors, etc. to confirm that each system is complete and functional per the manufacturer's specifications. Any damage, misadjustment, or other unusual condition that could influence the test program or test results shall be recorded. Report any abnormal condition to the NHTSA COTR before beginning any test:
 Vehicle OK Conditions reported below in comment section

Identify the letter above to which any of the following comments apply.
Comments: _____

REPORT OF VEHICLE CONDITION AT THE COMPLETION OF TESTING

LIST OF FMVSS TESTS PERFORMED BY THIS LAB: FMVSS 208, 212, 219, 301

VEHICLE: 2010 Mazda 6

NHTSA NO.: CA5400

REMARKS:

Equipment that is no longer on the test vehicle as noted on previous page:

Spare tire, jack, right rear tail light, trunk carpet and trunk floor cover

Explanation for equipment removal:

Components removed for instrumentation installation and to meet target weight.

Test Vehicle Condition:

25 mph frontal impact damage- front suspension & structure damaged, hood & front quarter panels damaged, radiator damaged, air bags & pretensioners deployed, Stoddard in fuel system

RECORDED BY: Jeff Lewandowski

DATE: 3/4/2010

APPROVED BY: David Winkelbauer

DATE: 3/4/2010

#####

RELEASE OF TEST VEHICLE

The vehicle described above is released from MGA to be delivered to:

Date:

Time:

Odometer:

Lab Rep's Signature:

Title:

Carrier/Customer Rep:

Date:

DATA SHEET 3

CERTIFICATION LABEL AND TIRE PLACARD INFORMATION

Test Vehicle: 2010 Mazda 6
 Test Program: FMVSS 208 Compliance
 Test Technician: Daniel Sienko

NHTSA No.: CA5400
 Test Date: 2/19/10

Certification Label (Part 567)	
Manufacturer:	MAZDA MOTOR CORPORATION
Date of Manufacture:	08/09
VIN:	1YVHZ8BH4A5M04704
Vehicle Certified As (Pass. Car/MPV/Truck/Bus):	Passenger Car
Front Axle GVWR:	1037 kg (2286 lbs)
Rear Axle GVWR:	935 kg (2062 lbs)
Total GVWR:	1969 kg (4340 lbs)

Tire Placard for Motor Vehicles with GVWR of 10,000 lb or Less and Passenger Cars (571.110)	
Vehicle Capacity Weight:	385 kg (850 lbs)
Designated Seating Capacity Front:	2
Designated Seating Capacity Rear:	3
Total Designated Seating Capacity:	5
Recommended Cold Tire Inflation Pressure Front:	220 kpa (32 psi)
Recommended Cold Tire Inflation Pressure Rear:	220 kpa (32 psi)
Recommended Tire Size:	P205/65R16
Tire Size on Vehicle:	P205/65R16

Signature: 

Date: 2/19/10

DATA SHEET 32

VEHICLE WEIGHT, FUEL TANK, AND ATTITUDE DATA

Test Vehicle: 2010 Mazda 6
 Test Program: FMVSS 208 Compliance
 Test Technician: Daniel Sienko

NHTSA No.: CA5400
 Test Date: 2/19/10

IMPACT ANGLE:	Zero Degrees					
BELTED DUMMIES (YES/NO):	No					
TEST SPEED:	X	32 to 40 kmph		0 to 48 kmph		0 to 56 kmph
DRIVER DUMMY:	X		5 th female		50 th male	
PASSENGER DUMMY:	X		5 th female		50 th male	

- 1. Fill the transmission with transmission fluid to the satisfactory range.
- 2. Drain fuel from vehicle.
- 3. Run the engine until fuel remaining in the fuel delivery system is used and the engine stops.
- 4. Record the useable fuel tank capacity supplied by the COTR.
Useable Fuel Tank Capacity supplied by COTR: 70.0 liters (18.5 gallons)
- 5. Record the fuel tank capacity supplied in the owner's manual.
Useable Fuel Tank Capacity in owner's manual: 70.0 liters (18.5 gallons)
- 6. Using purple dyed Stoddard solvent having the physical and chemical properties of Type 1 solvent or cleaning fluid, Table 1, ASTM Standard D484-71, "Standard Specifications for Hydrocarbon Dry-cleaning Solvents," or gasoline, fill the fuel tank.
Amount Added: 70.0 liters (18.5 gallons)
- 7. Fill the coolant system to capacity.
- 8. Fill the engine with motor oil to the Max. mark on the dip stick.
- 9. Fill the brake reservoir with brake fluid to its normal level.
- 10. Fill the windshield washer reservoir to capacity.
- 11. Inflate the tires to the tire pressure on the tire placard. If no tire placard is available, inflate the tires to the recommended pressure in the owner's manual.

Tire placard pressure:	RF:	32 psi	LF:	32 psi	RR:	32 psi	LR:	32 psi
Owner's manual pressure:	RF:	32 psi	LF:	32 psi	RR:	32 psi	LR:	32 psi
Actual inflated pressure:	RF:	32 psi	LF:	32 psi	RR:	32 psi	LR:	32 psi

- 12. Record the vehicle weight at each wheel to determine the unloaded vehicle weight (UVW), (i.e. "as delivered" weight).

Right Front (kg):	435.5	Right Rear (kg):	300.3
Left Front (kg):	435.4	Left Rear (kg):	295.3
Total Front (kg):	870.9	Total Rear (kg):	595.6
% Total Weight:	59.4	% Total Weight:	40.6
UVW = TOTAL FRONT PLUS TOTAL REAR (KG):		1466.5	

- 13. UVW Test Vehicle Attitude: (All dimensions in millimeters)
- 13.1 Mark a point on the vehicle above the center of each wheel.
- 13.2 Place the vehicle on a level surface.
- 13.3 Measure perpendicular to the level surface to the 4 points marked on the body and record the measurements.

RF:	720	LF:	725	RR:	729	LR:	731
-----	-----	-----	-----	-----	-----	-----	-----

14. Calculate the Rated Cargo and Luggage Weight (RCLW): 45 kg
 14.1 Does the vehicle have the vehicle capacity weight (VCW) on the certification label or tire placard?

- Yes, go to 14.3
 No, go to 14.2

14.2 VCW = Gross Vehicle Weight - UVW
 VCW = _____ - _____ = _____

- 14.3 VCW = 385 kg (850 lbs)
 14.4 Does the certification or tire placard contain the Designated Seating Capacity (DSC)?

- Yes, go to 14.6
 No, go to 14.5 and skip 14.6

14.5 DSC = Total number of seat belt assemblies = 5

14.6 DSC = 5

14.7 RCLW = VCW - (68 kg x DSC) = 385 kg - (68 kg x 5) = 45 kg

- 14.8 Is the vehicle certified as a truck, MPV or bus (see the certification label on the door jamb)?
 Yes, if the calculated RCLW is greater than 136 kg, use 136 kg as the RCLW. (S8.1.1)
 No, use the RCLW calculated in 14.7

15. Fully Loaded Weight (100% fuel fill): 1609.8 kg

15.1 Place the appropriate test dummy in both front outboard seating positions.

Driver: 5th female 50th male
 Passenger: 5th female 50th male

15.2 Load the vehicle with the RCLW from 14.7 or 14.8 whichever is applicable.

15.3 Place the RCLW in the cargo area. Center the load over the longitudinal centerline of the vehicle. (S8.1.1 (d))

15.4 Record the vehicle weight at each wheel to determine the Fully Loaded Weight.

Right Front (kg):	455.4	Right Rear (kg):	350.6
Left Front (kg):	460.0	Left Rear (kg):	343.8
Total Front (kg):	915.4	Total Rear (kg):	694.4
% Total Weight:	56.9	% Total Weight:	43.1
% GVW	52.7	% GVW	47.5
(% GVW = Axle GVW divided by Vehicle GVW)			
Fully Loaded Weight = Total Front Plus Total Rear (kg):			1609.8

16. Fully Loaded Test Vehicle Attitude: (All dimensions in millimeters)

16.1 Place the vehicle on a level surface.

16.2 Measure perpendicular to the level surface to the 4 points marked on the body (see 13.1 above) and record the measurements.

RF: 720 LF: 725 RR: 729 LR: 731

17. Drain the fuel system

18. Using purple dyed Stoddard solvent having the physical and chemical properties of Type 1 solvent or cleaning fluid, Table 1, ASTM Standard D484-71, "Standard Specifications for Hydrocarbon Dry-cleaning Solvents," fill the fuel tank to 92 - 94 percent of useable capacity. Fuel tank capacity x .94 = 70.0 liters (18.5 gallons) x .94 = 65.8 liters (17.4 gallons)

Amount added: 65.1 liters (17.2 gallons) 93.0%

19. Crank the engine to fill the fuel delivery system with Stoddard solvent.

20. Calculate the test weight range.

20.1 Calculated Weight = UVW (see 12 above) + RCLW (see 14 above) + 2x(dummy weight)

1609.5 kg = 1466.5 kg + 45.0 kg + 98.0 kg

- 20.2 Test Weight Range = Calculated Weight (- 4.5 kg, - 9 kg.)
 Max. Test Weight = Calculated Test Weight - 4.5 kg = 1605.0 kg
 Min. Test Weight = Calculated Test Weight - 9 kg = 1600.5 kg
21. Remove the RCLW from the cargo area.
22. Drain transmission fluid, engine coolant, motor oil, and windshield washer fluid from the test vehicle so that Stoddard solvent leakage from the fuel system will be evident.
23. Vehicle Components Removed For Weight Reduction:
Spare tire, jack, trunk carpet, trunk floor cover and right rear tail light
24. Secure the equipment and ballast in the load carrying area and distribute it, as nearly as possible, to obtain the proportion of axle weight indicated by the gross axle weight ratings and center it over the longitudinal centerline of the vehicle.
25. If necessary, add ballast to achieve the actual test weight.

N/A

Weight of Ballast: 13.6 kg

26. Ballast, including test equipment, must be contained so that it will not shift during the impact event or interfere with data collection or interfere with high-speed film recordings or affect the structural integrity of the vehicle or do anything else to affect test results. Care must be taken to assure that any attachment hardware added to the vehicle is not in the vicinity of the fuel tank or lines.
27. Record the vehicle weight at each wheel to determine the actual test weight.

Right Front (kg):	456.8	Right Rear (kg):	345.2
Left Front (kg):	460.4	Left Rear (kg):	341.1
Total Front (kg):	917.2	Total Rear (kg):	686.3
% Total Weight:	57.2	% Total Weight:	42.8
% GVW	52.7	% GVW	47.5
(% GVW = Axle GVW divided by Vehicle GVW)			
TOTAL FRONT PLUS TOTAL REAR (kg):			1603.5

28. Is the test weight between the Max. Weight and the Min. Weight (See 20.2)?

Yes

No, explain why not.

29. Test Weight Vehicle Attitude: (all dimensions in millimeters)

- 29.1 Place the vehicle on a level surface

- 29.2 Measure perpendicular to the level surface to the 4 points marked on the body (see 13 above) and record the measurements.

RF:	715	LF:	719	RR:	722	LR:	713
-----	-----	-----	-----	-----	-----	-----	-----

30. Summary of test attitude

- 30.1 AS DELIVERED:

RF:	720	LF:	725	RR:	729	LR:	731
-----	-----	-----	-----	-----	-----	-----	-----

AS TESTED:

RF:	715	LF:	719	RR:	722	LR:	713
-----	-----	-----	-----	-----	-----	-----	-----

FULLY LOADED:

RF:	712	LF:	718	RR:	720	LR:	711
-----	-----	-----	-----	-----	-----	-----	-----

- 30.2 Is the "as tested" test attitude equal to or between the "fully loaded" and "as delivered" attitude?

Yes

No, explain why not.

REMARKS:

Signature: _____

Dan Simbor

Date: 2/19/10

I certify that I have read and performed each instruction.

DATA SHEET 33

VEHICLE ACCELEROMETER LOCATION AND MEASUREMENT

Test Vehicle: 2010 Mazda 6
 Test Program: FMVSS 208 Compliance
 Test Technician: Daniel Sienko

NHTSA No.: CA5400
 Test Date: 2/19/10

IMPACT ANGLE:	Zero Degrees			
BELTED DUMMIES (YES/NO):	No			
TEST SPEED:	X	32 to 40 kmph		0 to 56 kmph
DRIVER DUMMY:	X	5 th female		50 th male
PASSENGER DUMMY:	X	5 th female		50 th male

- 1. Find the location where the vertical plane parallel to the longitudinal centerline of the vehicle and through the center of the left front outboard seating position intersects the left rear seat cross member. Install an accelerometer at this intersection on the rear seat cross member to record x-direction accelerations. Record the location on the following chart.
- 2. Find the location where the vertical plane parallel to the longitudinal centerline of the vehicle and through the center of the right front outboard seating position intersects the right rear seat cross member. Install an accelerometer at this intersection on the rear seat cross member to record x-direction accelerations. Record the location on the following chart.
- 3. Find the location where a vertical plane through the longitudinal centerline of the vehicle and a vertical transverse plane through the center of the two wheels on opposite sides of the engine intersect at the top of the engine. Install an accelerometer at this intersection to record x-direction accelerations. Record the location on the following chart.
- 4. Find the location where a vertical plane through the longitudinal centerline of the vehicle and a vertical transverse plane through the center of the two wheels on opposite sides of the engine intersect the bottom of the engine. Install an accelerometer at this intersection to record x-direction accelerations. Record the location on the following chart.
- 5. Install an accelerometer on the right front brake caliper to record x-direction accelerations. Record the location on the following chart.
- 6. Find the location where a vertical plane through the longitudinal centerline of the vehicle intersects the top of the instrument panel. Install an accelerometer at this intersection to record x-direction accelerations. Record the location on the following chart.
- 7. Install an accelerometer on the left front brake caliper to record x-direction accelerations. Record the location on the following chart.
- 8. Find the location where a vertical plane through the longitudinal centerline of the vehicle intersects the floor of the trunk. Install an accelerometer on the trunk floor at this intersection to record z-direction accelerations. Record the location on the following chart.

REMARKS:

I certify that I have read and performed each instruction.

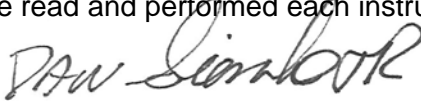
Signature: 

Date: 2/19/10

VEHICLE ACCELEROMETER LOCATION AND DATA SUMMARY

CENTERLINE OF FRONT WHEELS

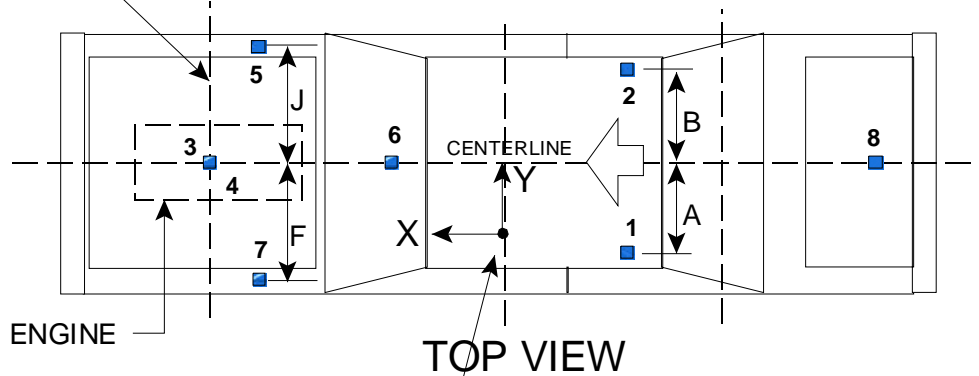

ACCELEROMETER COORDINATE SYSTEM (POSITIVE DIRECTION SHOWN)

REAR SEAT CUSHION ASSY. FRONT ATTACHMENT BRACKET SUPPORT

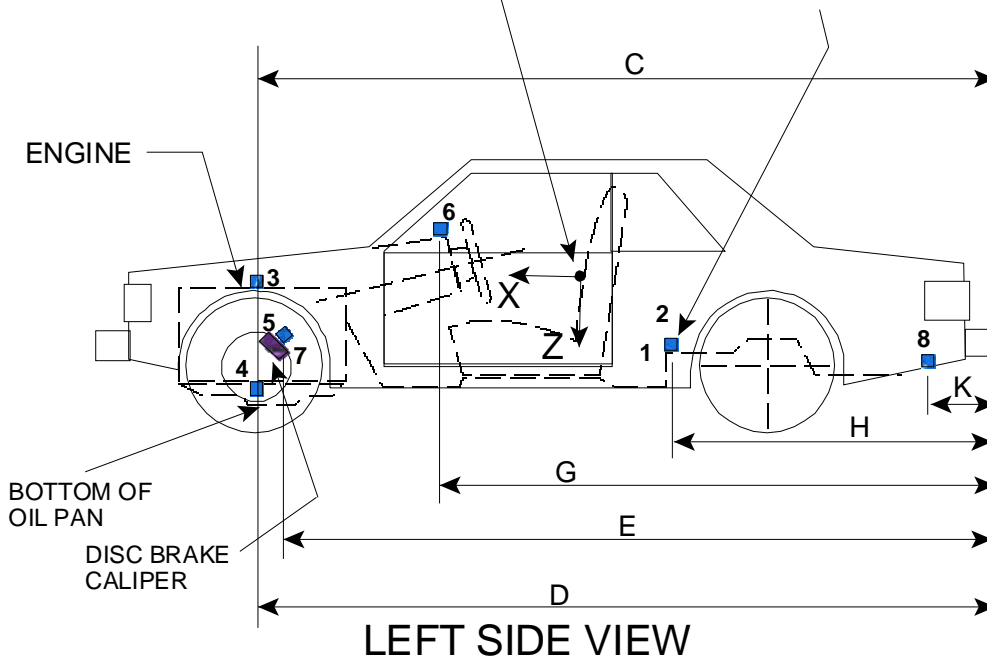

Dimensions Corresponding To The Letters "A" Through "K" (Excluding "I") Are Recorded In The Table On The Following Page.

Accelerometers Corresponding To The Numbers 1 Through 8 Are Specified On The Preceding Page.

VEHICLE ACCELEROMETER LOCATION AND MEASUREMENTS

<u>DIMENSION</u>	<u>LENGTH (mm)</u>
<u>PRETEST VALUES</u>	
<u>A</u> (LH Rear Seat Xmbr)	300
<u>B</u> (RH Rear Seat Xmbr)	300
<u>C</u> (Engine Top)	4130
<u>D</u> (Engine Bottom)	4035
<u>E</u> (Caliper)	Right Side: 3995 Left Side: 3995
<u>F</u> (Left Caliper)	730
<u>G</u> (IP)	3180
<u>H</u> (Seat)	1920
<u>J</u> (Right Caliper)	730
<u>K</u> (Trunk)	1090
<u>POST TEST VALUES</u>	
<u>A</u> (LH Rear Seat Xmbr)	300
<u>B</u> (RH Rear Seat Xmbr)	300
<u>C</u> (Engine Top)	3998
<u>D</u> (Engine Bottom)	3991
<u>E</u> (Caliper)	Right Side: 3989 Left Side: 3987
<u>F</u> (Left Caliper)	732
<u>G</u> (IP)	3180
<u>H</u> (Seat)	1920
<u>J</u> (Right Caliper)	736
<u>K</u> (Trunk)	1090

DATA SHEET 34
PHOTOGRAPHIC TARGETS

Test Vehicle: 2010 Mazda 6
 Test Program: FMVSS 208 Compliance
 Test Technician: Daniel Sienko

NHTSA No.: CA5400
 Test Date: 2/19/10

IMPACT ANGLE:	Zero Degrees				
BELTED DUMMIES (YES/NO):	No				
TEST SPEED:	X	32 to 40 kmph		0 to 48 kmph	
DRIVER DUMMY:	X		5 th female		50 th male
PASSENGER DUMMY:	X		5 th female		50 th male

- 1. **FMVSS 208 vehicle targeting requirements** (See Figures 28A and 28B)
- 1.1 Targets A1 and A2 are on flat rectangular panels.
- 1.2 Three circular targets at least 90 mm in diameter and with black and yellow quadrants are mounted at the front on the outboard sides of A1 and A2. The center of each circular target is 100 mm from the one next to it.
- Distance between targets (mm): 100 mm
- 1.3 Three circular targets at least 90 mm in diameter and with black and yellow quadrants are mounted at the back on the outboard sides of on A1 and A2. The center of each circular target is 100 mm from the one next to it.
- Distance between targets (mm): 100 mm
- 1.4 The distance between the first circular target at the front of A1 and A2 and the last circular target at the back of A1 and A2 is at least 915 mm.
- Distance between the first and last circular targets (mm): 915 mm
- 1.5 Firmly fix target A1 on the vehicle roof in the vertical longitudinal plane that is coincident with the midsagittal plane of the driver dummy.
- 1.6 Firmly fix target A2 on the vehicle roof in the vertical longitudinal plane that is coincident with the midsagittal plane of the passenger dummy.
- 1.7 Two circular targets (C1 and C2) at least 90 mm in diameter and with black and yellow quadrants are mounted on the outside of the driver door. The centers of each circular target are at least 610 mm apart.
- Distance between targets (mm): 610 mm
- 1.8 Two circular targets (C1 and C2) at least 90 mm in diameter and with black and yellow quadrants are mounted on the outside of the passenger door. The centers of each circular target are at least 610 mm apart.
- Distance between targets (mm): 610 mm
- 1.9 Place tape with squares having alternating colors on the top portion of the steering wheel.
- 1.10 Chalk the bottom portion of the steering wheel.
- 1.11 Is this an offset test?
- Yes, continue with this section**
- No, go to 2.**
- 1.12 Measure the width of the vehicle.
- Vehicle width (mm):
- 1.13 Find the centerline of the vehicle. ($\frac{1}{2}$ of the vehicle width)
- 1.14 Find the line parallel to the centerline of the vehicle and 0.1 x vehicle width from the centerline of the vehicle.

- 1.15 Apply 25 mm wide tape with alternating black and yellow squares parallel to and on each side of the line found in 1.14. The edge of each tape shall be 50 mm from the line found in 1.14. The tape shall extend from the bottom of the bumper to the front edge of the windshield. (Figure 28D)
2. **Barrier Targeting**
- 2.1 Fix two stationary targets D1 and D2 to the barrier as shown in the Figure 28A. One target is in the vertical longitudinal plane that is coincident with the midsagittal plane of the driver dummy. The other is in the vertical longitudinal plane that is coincident with the midsagittal plane of the passenger dummy.
- 2.2 Targets D1 and D2 are on a rectangular panel.
- 2.3 Three circular targets at least 90 mm in diameter and with black and yellow quadrants are mounted on the sides of the rectangular panel away from the longitudinal centerline of the vehicle. The center of each circular target is 100 mm from the one next to it.
- Distance between circular targets on D1 (mm): 100 mm
- Distance between circular targets on D2 (mm): 100 mm
3. **FMVSS 208 Dummy Targeting Requirements**
- 3.1 Place a circular target with black and yellow quadrants on both sides of the driver dummy head as close as possible to the center of gravity of the head in the x and z direction (relative to the measuring directions of the accelerometers).
- 3.2 Place a circular target with black and yellow quadrants on both sides of the passenger dummy head as close as possible to the center of gravity of the head in the x and z direction (relative to the measuring directions of the accelerometers).
- 3.3 Place a circular target with black and yellow quadrants on the outboard shoulder of the driver dummy. Place the target as high up on the arm as possible at the intersection of the arm and shoulder. The sleeve of the shirt on the dummy may be cut to make the target visible, but do not remove any material.
- 3.4 Place a circular target with black and yellow quadrants on the outboard shoulder of the passenger dummy. Place the target as high up on the arm as possible at the intersection of the arm and shoulder. The sleeve of the shirt on the dummy may be cut to make the target visible, but do not remove any material.
4. **FMVSS 204 Targeting Requirements**
- 4.1 Is an FMVSS 204 indicant test ordered on the "COTR Vehicle Work Order?"
- Yes, continue with this form.
- No, this form is complete.
- 4.2 Resection panel (Figure 28C)
- 4.2.1 The panel deviates no more than 6 mm from perfect flatness when suspended vertically.
- 4.2.2 The 8 targets on the panel are circular targets at least 90 mm in diameter and with black and yellow quadrants.
- 4.2.3 The center of each of the 4 outer targets are placed within 1 mm of the corners of a square measuring 914 mm on each side.
- 4.2.4 Locate another square with 228 mm sides and with the center of this square coincident with the center of the 914 mm square.
- 4.2.5 The center of the 4 inner targets are placed at the midpoints of each of the 228 mm sides.
- 4.3 Place a circular target at least 90 mm in diameter and with black and yellow quadrants on a material (cardboard, metal, etc.) that can be taped to the top of the steering column.
- 4.4 Tape the target from 4.3 to the top of the steering column in a manner that does not interfere with the movement of the steering column in a crash.

REMARKS:

Signature: Don Simbok

Date: 2/19/10

I certify that I have read and performed each instruction.

REFERENCE PHOTO TARGETS

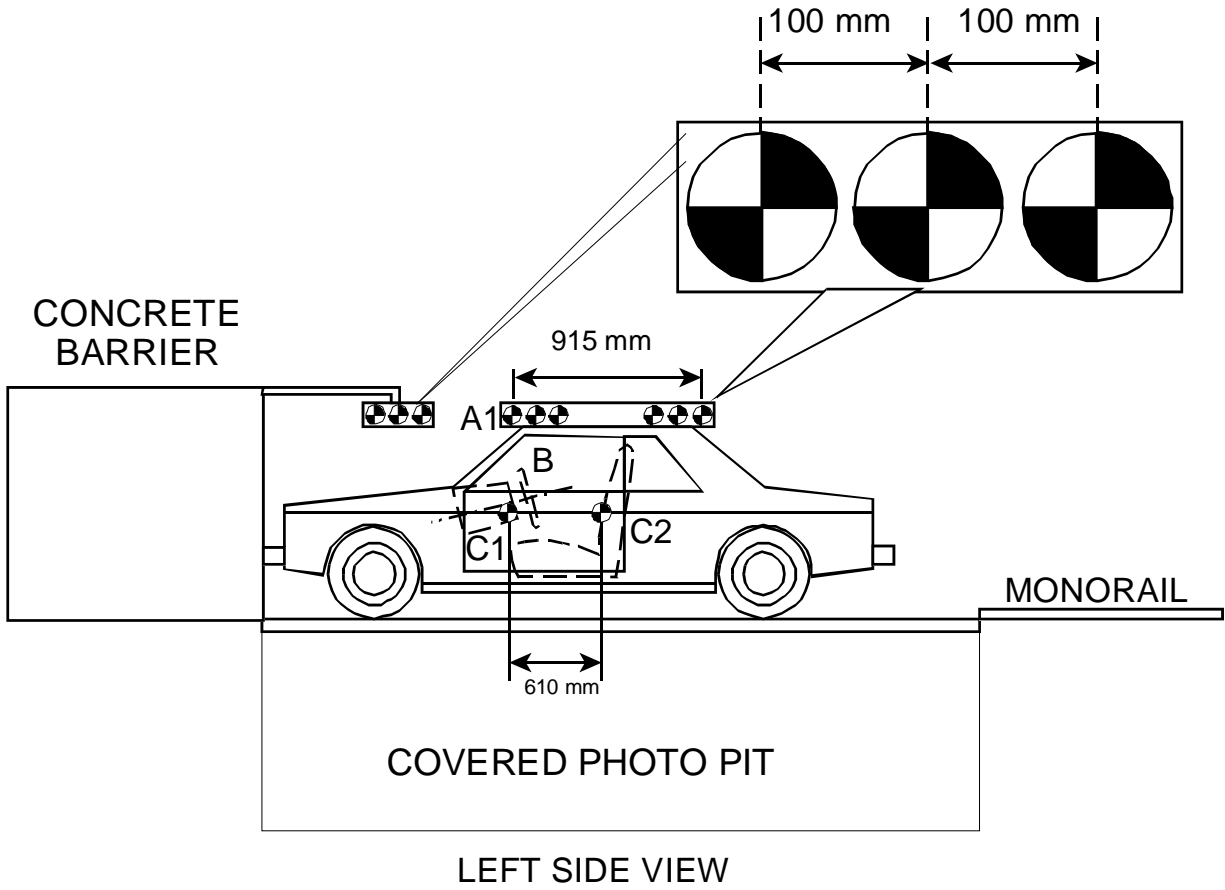

RESECTION PANEL TARGETING ALIGNMENT

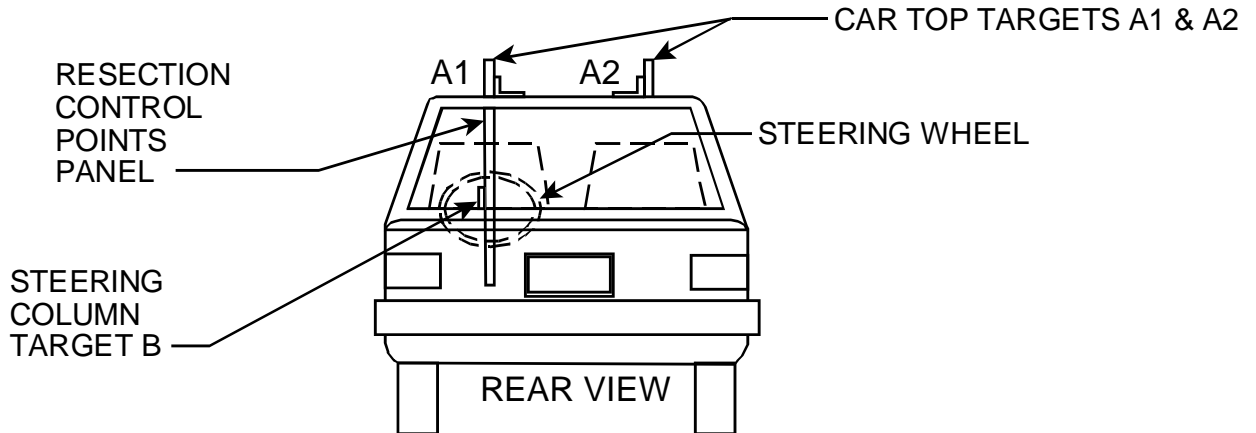

TEST RUN STEERING COLUMN CAMERA VIEW OF TYPICAL TIME ZERO VEHICLE POSITION

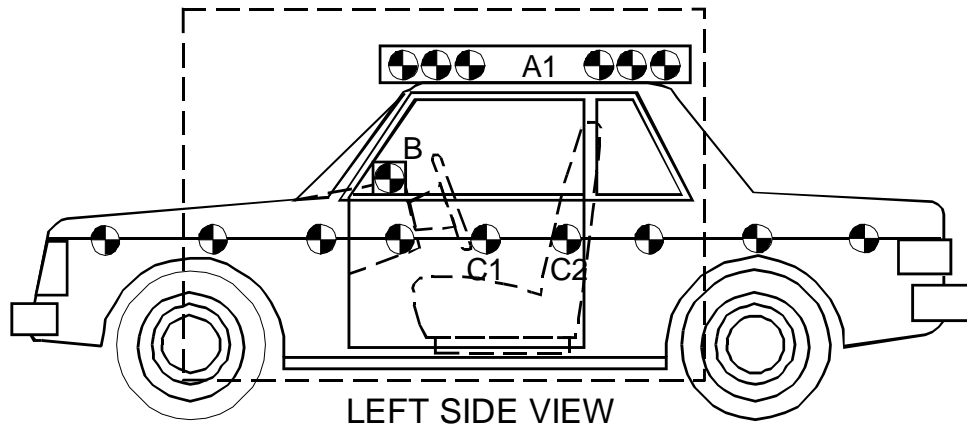

PRE-RUN STEERING COLUMN HIGH SPEED CAMERA VIEW

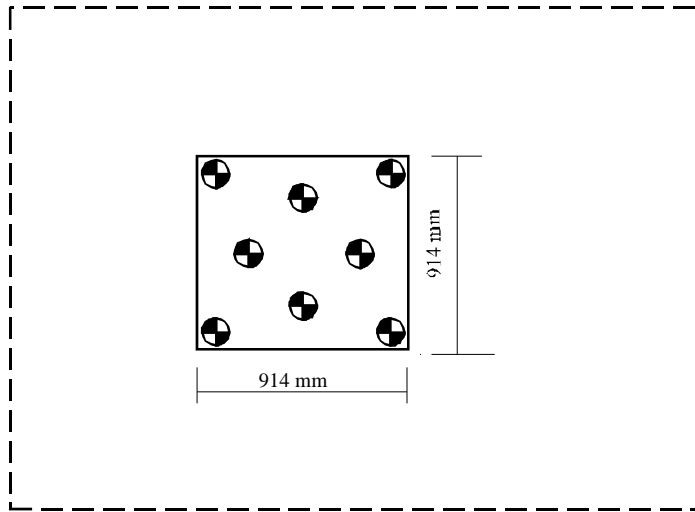

LEFT SIDE VIEW

DATA SHEET 35
CAMERA LOCATIONS

Test Vehicle: 2010 Mazda 6
Test Program: FMVSS 208 Compliance

NHTSA No.: CA5400
Test Date: 2/19/10
Time: 10:20 am

CAMERA NO.	VIEW	CAMERA POSITIONS (mm) *			LENS (mm)	SPEED (fps)
		X	Y	Z		
1	Real Time Left Side View				13	24
2	Left Side View (Barrier face to front seat backs)	1220	-5090	1160	24	1000
3	Left Side View (Driver)	1610	-5860	1530	35	1000
4	Left Side View (B-post aimed toward center of steering wheel)	5420	-4950	1880	50	1000
5	Left Side View (Steering Column)	950	-5300	1240	25	1000
6	Left Side View (Steering Column)	910	-5250	840	25	1000
7	Right Side View (Overall)	2130	6290	1120	20	1000
8	Right Side View (Passenger)	1560	5840	1560	35	1000
9	Right Side View (Angle)	5480	4910	1910	50	1000
10	Right Side View (Front door)	1200	5060	1180	24	1000
11	Front View Windshield	-260	0	2860	24	1000
12	Front View Driver	-30	-360	2270	16	1000
13	Front View Passenger	-30	360	2270	16	1000
14	Overhead Barrier Impact View	2330	0	4910	14	1000
15	Pit Camera Engine View	1160	0	-3150	24	1000
16	Pit Camera Fuel Tank View	3010	0	-3150	24	1000

*COORDINATES:

- +X - forward of impact plane
- +Y - right of monorail centerline
- +Z - above ground level

CAMERA POSITIONS FOR FMVSS 208

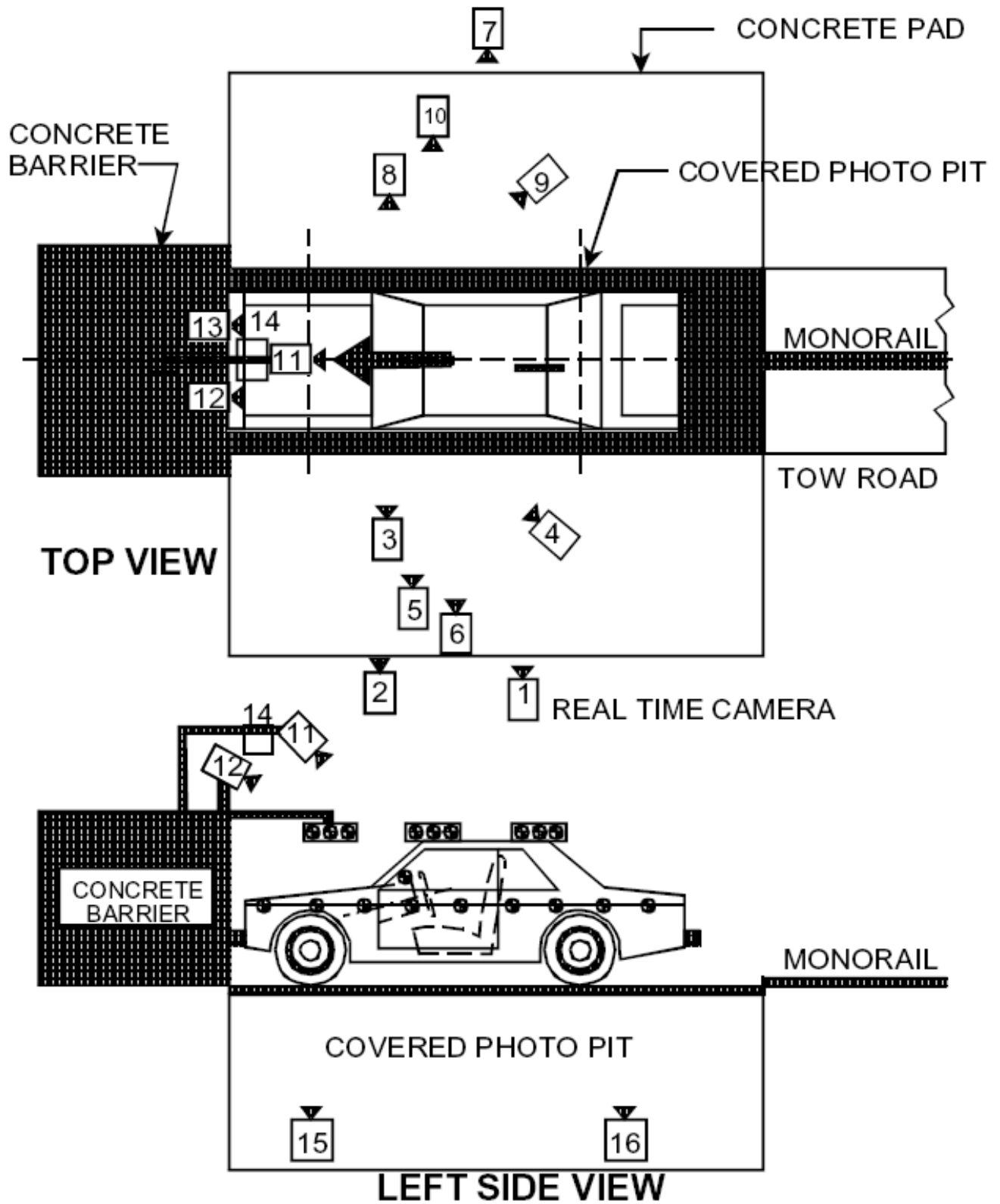

DATA SHEET 36 - APPENDIX G
DUMMY POSITIONING PROCEDURES
FOR 5th PERCENTILE FEMALE DRIVER TEST DUMMY
CONFORMING TO SUBPART O OF PART 572

Test Vehicle: 2010 Mazda 6
 Test Program: FMVSS 208 Compliance
 Test Technician: Jordan Haynes

NHTSA No.: CA5400
 Test Date: 2/19/10

IMPACT ANGLE:	Zero Degrees					
BELTED DUMMIES (YES/NO):	No					
TEST SPEED:	X	32 to 40 kmph		0 to 48 kmph		0 to 56 kmph
DRIVER DUMMY:		X		5 th female		50 th male
PASSENGER DUMMY:		X		5 th female		50 th male

Seating Procedure 5th Percentile Female Driver Dummy (Part 572, Subpart O) (S16.2-S16.3)

1. Seat Position

X 1.1 Position the seat's adjustable lumbar supports so that the lumbar supports are in the lowest, retracted or deflated adjustment positions. (S16.2.10.1, S20.1.9.1, S20.4.1, S22.1.7.1)

X N/A – No lumbar adjustment

X 1.2 Position any adjustable parts of the seat that provide additional support so that they are in the lowest or most open adjustment position. (S16.2.10.2, S20.1.9.2, S20.4.1, S22.1.7.1, S22.4.2.1, S22.4.3.1, S24.4.2.1, S26.2.3, S26.3.1)

X N/A – No additional support adjustment

X 1.3 Position an adjustable leg support system in its rearmost position. (8/27/04 interpretation to Toyota)

X N/A – No adjustable leg support system

X 1.4 **Mark** a point (seat cushion reference point) on the side of the seat cushion that is between 150 mm and 250 mm from the front edge of the seat cushion. (S16.3.1.12)

X 1.5 Draw a line (seat cushion reference line) through the seat cushion reference point. (S16.3.1.13)

X 1.6 Use only the controls that primarily move the seat in the fore-aft direction to move the seat cushion reference point to the rearmost position. (S16.2.10.3.1, S22.1.7.3)

X 1.7 If the seat cushion adjusts fore-aft, independent of the seat back, use only the controls that primarily move the seat cushion in the fore-aft direction to move the seat cushion reference point to the rearmost position. (S16.2.10.3.1, S20.1.9.3)

X N/A – No independent fore-aft seat cushion adjustment

X 1.8 Use any part of any control, other than the parts just used for fore-aft positioning, to determine the range of angles of the seat cushion reference line and to set the seat cushion reference line at the mid-angle. (S16.2.10.3.1)

Maximum angle Zero

Minimum angle Zero

Mid-angle Zero

- 1.9 If the seat and/or seat cushion height is adjustable, use any part of any control other than the parts which primarily move the seat or seat cushion fore-aft, to put the seat cushion reference point in its lowest position with the seat cushion reference line angle at the mid-angle found in 1.8. (S16.2.10.3.1)
 N/A – No seat height adjustment
- 1.10 Use only the controls that primarily move the seat in the fore-aft direction to verify the seat is in the rearmost position.
- 1.11 Use only the controls that primarily move the seat in the fore-aft direction to **mark** the fore-aft seat positions. **Mark** each position so that there is a visual indication when the seat is at a particular position. For manual seats, move the seat forward one detent at a time and **mark** each detent. For power seats, **mark** only the rearmost, middle, and foremost positions. Label three of the positions with the following: F for foremost, M for mid-position (if there is no mid-position, label the closest adjustment position to the rear of the mid-point), and R for rearmost.
- 1.12 Use only the controls that primarily move the seat in the fore-aft direction to place the seat in the rearmost position.
- 1.13 Use any part of any control, other than the parts which primarily move the seat or seat cushion fore-aft, to find and visually **mark** the maximum, minimum, and middle height of the seat cushion reference point with the seat cushion reference line at the mid-angle determined in 1.8. (S20.1.9.4, S22.1.2, S22.1.7.4, S22.3.1, S22.4.3.1, S24.1.2, S24.3.1, S24.4.3.1, S26.2.3, S26.3.1)
 N/A – No seat height adjustment. Go to 1.18
- 1.14 Use only the controls that primarily move the seat and/or seat cushion in the fore-aft direction to place the seat in the mid-fore-aft position.
- 1.15 Use any part of any control, other than the parts which primarily move the seat or seat cushion fore-aft, to find and visually **mark** the maximum, minimum, and middle height of the seat cushion reference point with the seat cushion reference line at the mid-angle determined in 1.8. (S20.1.9.4, S22.1.2, S22.1.7.4, S22.3.1, S24.1.2, S24.3.1)
- 1.16 Use only the control that change the seat in the fore-aft direction to place the seat in the foremost position. (S16.2.10.3.2)
- 1.17 Use any part of any control, other than the parts which primarily move the seat or seat cushion fore-aft, to find and visually **mark** the maximum, minimum, and middle height of the seat cushion reference point with the seat cushion reference line at the mid-angle determined in 1.8. (S16.2.10.3.3, S20.1.9.4, S22.1.2, S22.1.7.4, S22.3.1, S24.1.2, S24.3.1)
- 1.18. Is the seat a bucket seat?
 Yes, go to 1.19 and skip 1.20
 No, go to 1.20 and skip 1.19
- 1.19 Bucket seats:
Locate and **mark** for future reference the longitudinal centerline of the seat cushion. The intersection of the vertical longitudinal plane that passes through the SgRP and the seat cushion upper surface determines the longitudinal centerline of a bucket seat cushion. (S16.3.1.10 & S20.1.10)

1.20 Bench seats (complete ONLY the one that is applicable to the seat being marked):
Locate and **mark** for future reference the longitudinal line on the seat cushion that marks the intersection of the vertical longitudinal plane through the centerline of the steering wheel and the seat cushion upper surface.

2. Head Restraint Position

N/A Vehicle contains automatic head restraints.

N/A, there is no head restraint adjustment Go to 3

2.1 Adjust the head restraint to its lowest position. (S16.2.10.2, S20.1.9.6, S20.4.1, S22.1.7.6, S22.4.2.1, S22.4.3.1, S24.4.3.1, S26.2.3, S26.3.1)

2.2 All adjustments of the head restraint shall be used to position it full forward. For example, if it rotates, rotate it such that the head restraint extends as far forward as possible. **Mark** the foremost position. (S16.2.10.2 & S16.3.4.4 & S20.1.9.6, S20.4.1, S22.4.2.1, S22.4.3.1, S24.4.3.1, S26.2.3, S26.3.1)

2.3 Measure the vertical distance from the top most point of the head restraint to the bottom most point. Locate and **mark** a horizontal plane through the midpoint of this distance. (S16.3.4.3)

Vertical height of head restraint 230 mm

Mid-point height 115 mm

3. Is the **steering wheel** adjustable up and down and/or in and out?

Yes – go to 3.1

No – Go to 4

3.1. Find and **mark** for future reference each up and down position. Label three of the positions with the following: H for highest, M for mid-position (if there is no mid-position, label the next lowest adjustment position), and L for lowest.

N/A – steering wheel is not adjustable up and down

3.2. Find and **mark** for future references each in and out position. Label three of the positions with the following: F for foremost, M for mid-position (if there is no mid-position, label the next rearmost adjustment position), and R for rearmost.

N/A – steering wheel is not adjustable in and out.

3.3. Use the markings to position the steering controls in the mid-position or if applicable next lowest detent position. (S16.2.9)

4. Place the SCRP in the full rearward, mid-height position, and mid-seat cushion angle, determined in Item 1. (S16.3.2.1.1)

5. If the vehicle has an adjustable accelerator pedal, place it in the full forward position. (S16.3.2.2.1)

N/A accelerator pedal not adjustable

6. Fully recline the seat back. (S16.3.2.1.2)

N/A seat back not adjustable.

7. Place the dummy in the seat with the legs at an angle of 120 degrees to the thighs. The calves should not be touching the seat cushion. (S16.3.2.1.2)

8. Position the dummy in the seat such that the midsagittal plane is coincident with the longitudinal seat cushion markings as determined in Item 1.19 or 1.20. (S16.3.2.1.3 and S16.3.2.1.4)

9. Hold down the dummy's thighs and push rearward on the upper torso to maximize the pelvic angle. (S16.3.2.1.5)
10. Set the angle between the legs and the thighs to 120 degrees. (S16.3.2.1.6)
11. Set the transverse distance between the centers of the front of the knees at 160 to 170 mm. (6.3 to 6.7 inches) Center the knee separation with respect to the longitudinal seat cushion marking as determined in Item 1.19 or 1.20. (S16.3.2.1.6)
Record Knee Separation 165 mm
12. Push rearward on the dummy's knees until the pelvis contacts the seat back, or the backs of the calves contact the seat cushion, whichever occurs first. (S16.3.2.1.6)
 Pelvis contacted seat back.
 Calves contacted seat cushion.
13. Gently rock the upper torso ± 5 degrees (approximately 51 mm (2 inches)) side-to-side three time. (S16.3.2.1.7)
14. If needed, extend the legs until the feet do not contact the floor pan. The thighs should be resting on the seat cushion. (S16.3.2.1.8)
15. Position the right foot until the foot is in line with a longitudinal vertical plane passing through the center of the accelerator pedal. Maintain the leg and thigh in a vertical plane. (S16.3.2.1.8)
16. Rotate the left leg and thigh laterally to equalize the distance between each knee and the longitudinal seat cushion marking as determined in Item 1.19 or 1.20. (S16.3.2.1.8)
17. Attempt to return the seat to the foremost fore-aft position, mid-height, and seat cushion mid-angle as determined in Item 1. The foot may contact and depress the accelerator and/or change the angle of the foot with respect to the leg. (S16.3.2.1.8)
 Foremost position achieved. Proceed to step 22.
 Foremost not achieved because of foot interference. Proceed to step 19.
 Foremost not achieved because of steering wheel contact.
18. If either of the dummy's legs contact the steering wheel, move the steering wheel up the minimum amount required to avoid contact. If the steering wheel is not adjustable separate the knees the minimum required to avoid contact. (S16.3.2.1.8)
 N/A- there was no leg contact
 Steering wheel repositioned
 Knees separated
19. If the left foot interferes with the clutch or brake pedals, rotate the left foot about the leg to provide clearance. If this is not sufficient, rotate the thigh outboard at the hip the minimum amount required for clearance. (S16.3.2.1.8)
 N/A, No foot interference with pedals.
 Foot adjusted to provide clearance.
 Foot and Thigh adjusted to provide clearance.

_20. Continue to move the seat. Use seat controls to line up the seat markings determined during item 1 to set the foremost fore-aft position, mid-height position and the seat cushion mid-angle. If the dummy contacts the interior move the seat rearward until a maximum clearance of 5 mm (0.2 inches) is achieved or the seat is in the closest detent position that does not cause dummy contact. (S16.3.2.1.8)

_Foremost, mid-height position and the seat cushion mid-angle reached

_Dummy Contact. Clearance set at maximum of 5 mm

Measured Clearance _____

_Dummy Contact. Seat set at nearest detent position.

Seat position ____ detent positions rearward of foremost
(foremost is position zero)

_21. If the steering wheel was repositioned in step 18, return the steering wheel to the original position. If the steering wheel contacts the dummy before reaching the original position, position the wheel until a maximum clearance of 5 mm (.2 inches) is achieved, or the steering wheel is in the closest detent position that does not cause dummy contact. (S16.3.2.1.8)

_N/A Steering wheel was not repositioned.

_Original position achieved.

_Dummy Contact. Clearance set at maximum of 5 mm

Measured Clearance _____

_Dummy Contact. Steering wheel set at nearest detent position.

Steering wheel position ____ detent positions upward of original position.
(Original position is position zero)

_22. If the seat back is adjustable, rotate the seat back forward while holding the thighs in place. Continue rotating the seat back forward until the transverse instrument platform of the dummy head is level ± 0.5 degrees. If the head cannot be leveled using the seat back adjustment, or the seat back is not adjustable, use the lower neck bracket adjustment to level the head. If a level position cannot be achieved, minimize the angle. (S16.3.2.1.9)

_Head Level Achieved. (Check all that apply)

_Head leveled using the adjustable seat back

_Head leveled using the neck bracket.

Head Angle 0.0 degrees

_Head Level NOT Achieved. (Check all that apply)

_Head adjusted using the adjustable seat back

_Head adjusted using the neck bracket.

Head Angle _____ degrees

_23. Verify the pelvis is not interfering with the seat bight. (S16.3.2.1.9)

_No interference

_Pelvis moved forward the minimum amount so that it is not caught in the seat bight.

_24. Verify the dummy abdomen is properly installed. (S16.3.2.1.9)

_Abdomen still seated properly into dummy

_Abdomen was adjusted because it was not seated properly into dummy

25. Head Angle
 N/A, neither the pelvis nor the abdomen were adjusted.

25.1 Head still level (Go to 26)

25.2 Head level adjusted

Head Level Achieved. (Check all that apply)
 Head leveled using the adjustable seat back
 Head leveled using the neck bracket.
Head Angle _____ degrees
 Head Level NOT Achieved. (Check all that apply)
 Head level adjusted using the adjustable seat back
 Head level adjusted using the neck bracket.
Head Angle _____ degrees

26. If the dummy torso contacts the steering wheel while performing step 22, reposition the steering wheel in the following order to eliminate contact. (S16.3.2.1.9)
 N/A, No dummy torso contact with the steering wheel.

26.1 Adjust telescoping mechanism.

N/A No telescoping adjustment.
 Adjustment performed (fill in appropriate change)
Steering wheel moved _____ detent positions in the forward direction.
Steering wheel moved _____ mm in the forward direction.

26.2 Adjust tilt mechanism.

N/A No tilt adjustment.
 No adjustment performed.
 Adjustment performed. (circle one)
Steering wheel moved _____ detent positions Upward/Downward.
Steering wheel moved _____ degrees Upward/Downward

26.3 Adjust Seat in the aft direction.

No Adjustment performed.
 Seat moved aft _____ mm from original position.
 Seat moved aft _____ detent positions from the original position.

27. Measure and set the pelvic angle using the pelvic angle gage TE-2504. The pelvic angle should be 20.0 degrees \pm 2.5 degrees. If the pelvic angle cannot be set to the specified range because the head will not be level or because the dummy will have need major repositioning, adjust the pelvis as closely as possible to the angle range, but keep the head level. (S16.3.2.1.11)

Pelvic angle set to 20.0 degrees \pm 2.5 degrees.
 Pelvic angle of 20.0 degrees not achieved, the angular difference was minimized.
 Record the pelvic angle. 20.5 degrees

28. Check the dummy for contact with the interior after completing adjustments. (S16.3.2.1.12)

No contact.
 Dummy in contact with interior.
 Seat moved aft _____ mm from the previous position.
 Seat moved aft _____ detent positions from the previous position.

29. Check the dummy to see if additional interior clearance is obtained, allowing the seat to be moved forward. (S16.3.2.1.12)

N/A, Seat already at foremost position.

Clearance unchanged. No adjustments required.

Additional clearance available

Seat moved Forward ___ mm from the previous position.

Seat moved Forward ___ detent positions from the previous position.

30. Driver's foot positioning, right foot. Place the foot perpendicular to the leg and determine if the heel contacts the floor pan at any leg position. If the heel contacts the floor pan proceed to step 31 otherwise, proceed to step 32. (S16.3.2.2.1)

31. Perform the following steps until either all steps are completed, or the foot contacts the accelerator pedal. Step 31.6 shall be completed in all cases. (S16.3.2.2.1 (a))

31.1 With the rear of the heel contacting the floor pan, move the foot forward until pedal contact occurs or the foot is at the full forward position.

31.2 If the vehicle has an adjustable accelerator pedal, move the pedals rearward until pedal contact occurs or the pedals reach the full rearward position.

31.3 Extend the leg, allowing the heel to lose contact with the floor until the foot contacts the pedal. Do not raise the toe of the foot higher than the top of the accelerator pedal. If the foot does not contact the pedal, proceed to the next step. If pedal contact does occur, place a tapered foam block as shown in Figure G1 under the heel with the shallow part of the taper facing forward. (S16.3.2.2.3)

31.4 Angle the foot to achieve contact between the foot and the pedal. If the foot does not contact the pedal, return the foot to the perpendicular orientation. If pedal contact does occur, place a tapered foam block as shown in Figure G1 under the heel with the shallow part of the taper facing forward. (S16.3.2.2.3)

31.5 Align the centerline of the foot with the vertical-longitudinal plane passing through the center of the accelerator pedal. Place a tapered foam block as shown in Figure G1 under the heel with the shallow part of the taper facing forward. (S16.3.2.2.3)

31.6 Record foot position

Pedal Contact achieved. Contact occurred at step 31.1.

Heel contacts floor pan

Heel set _____ mm from floor pan.

Pedal Contact not achieved. Heel set _____ mm from the floor pan.

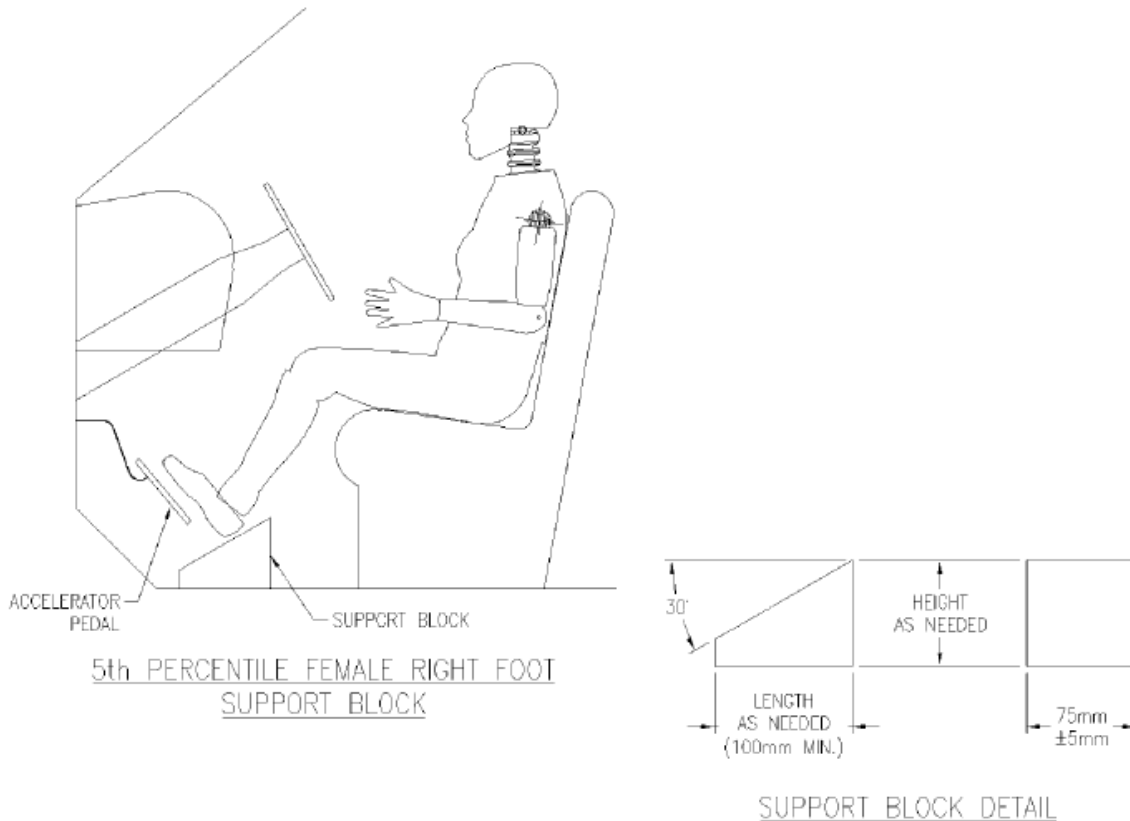

FIGURE G1

- __32. Perform the following steps until either all steps are completed, or the foot contacts the accelerator pedal. Step 32.5 shall be completed in all cases.
- __32.1 Extend the leg until the foot contacts the pedal. Do not raise the toe of the foot higher than the top of the accelerator pedal. If the foot does not contact the pedal, proceed to the next step. If pedal contact does occur, place a tapered foam block as shown in Figure G1 under the heel with the shallow part of the taper facing forward. (S16.3.2.2.1(b) & S16.3.2.2.3)
- __32.2 If the vehicle has an adjustable accelerator pedal, move the pedals rearward until pedal contact occurs or the pedals reach the full rearward position. If pedal contact does occur, place a tapered foam block as shown in Figure G1 under the heel with the shallow part of the taper facing forward. (S16.3.2.2.1(b) & S16.3.2.2.3)
 __N/A No pedal adjustment
- __32.3 Angle the foot to achieve contact between the foot and the pedal. If the foot does not contact the pedal, return the foot to the perpendicular orientation. If pedal contact does occur, place a tapered foam block as shown in Figure G1 under the heel with the shallow part of the taper facing forward. (S16.3.2.2.2 & S16.3.2.2.3)
- __32.4 Align the centerline of the foot in the same horizontal plane as the centerline of the accelerator pedal. Place a tapered foam block as shown in Figure G1 under the heel with the shallow part of the taper facing forward. (S16.3.2.2.3)
- __32.5 Record foot position
 __Pedal Contact achieved. Contact occurred at step _____.
 __Heel set _____ mm from floor pan.
 __Pedal Contact not achieved. Heel set _____ mm from the floor pan.

X 33. Driver's foot positioning, left foot.

X 33.1 Place the foot perpendicular to the leg and determine if the heel contacts the floor pan at any leg position. If the heel contacts the floor pan proceed to step 33.2, otherwise position the leg as perpendicular to the thigh as possible with the foot parallel to the floor pan. (S16.2.2.6)

X 33.2 Place the foot on the toe board with the heel resting on the floor pan as close to the intersection of the floor pan and the toe board as possible. Adjust the angle of the foot if necessary to contact the toe board. If the foot will not contact the toe board, set the foot perpendicular to the leg, and set the heel on the floor pan as far forward as possible. Avoid contact with the brake pedal, clutch pedal, wheel well projection, and footrest. To avoid this contact use the following three manipulations in the order listed, with each subsequent option incorporating the previous, until contact is avoided: rotate the foot about the lower leg (abduction/adduction), plantar flex the foot, rotate the leg outboard about the hip. Movement should be the minimum amount necessary. If it is not possible to avoid all foot contact, give priority to avoiding brake or clutch pedal contact. (S16.2.2.4 & S16.2.2.5 & S16.2.2.7)

No contact

Foot rotated about the leg (abduction/adduction)

Foot rotated about the leg, and foot plantar flexed

Foot rotated about the leg, foot plantar flexed, and the leg rotated about the hip.

X 33.3 Record foot position.

Heel does not contact floor pan.

Heel on floor pan and foot on toe board.

Heel on floor pan and foot not on toe board.

X 34. Driver arm/hand positioning.

X 34.1 Place the dummy's upper arms adjacent to the torso with the arm centerlines as close to a vertical longitudinal plane as possible. (S16.3.2.3.1)

X 34.2 Place the palms of the dummy in contact with the outer part of the steering wheel rim at its horizontal centerline with the thumbs over the steering wheel rim. (S16.3.2.3.2)

X 34.3 If it is not possible to position the thumbs inside the steering wheel rim at its horizontal centerline, then position them above and as close to the horizontal centerline of the steering wheel rim as possible. (S16.3.2.3.3)

X 34.4 Lightly tape the hands to the steering wheel rim so that if the hand of the test dummy is pushed upward by a force of not less than 9 N (2 lb) and not more than 22 N (5 lb), the tape releases the hand from the steering wheel rim. S16.3.2.3.4

X 35. Adjustable head restraints

N/A, there is no head restraint adjustment

35.1 If the head restraint has an automatic adjustment, leave it where the system positions the restraint after the dummy is placed in the seat. (S16.3.4.1) Go to 36.

35.2 Adjust each head restraint vertically so that the mid-horizontal plane determined in Item 2 is aligned with the center of gravity (CG) of the dummy head. (S16.3.4.3)

35.3 If the above position is not attainable, move the vertical center of the head restraint to the closest detent below the center of the head CG. (S16.3.4.3)

N/A midpoint position attained in previous step

Headrest set at nearest detent below the head CG

35.4 If the head restraint has a fore and aft adjustment, place the restraint in the foremost position or until contact with the head is made, whichever occurs first. (S16.3.4.4)

36. Driver and passenger manual belt adjustment (for tests conducted with a belted dummy). (S16.3.5)

N/A Dummies are unbelted for this test.

36.1 If an adjustable seat belt D-ring anchorage exists, place it in the manufacturer's design position for a 5th percentile adult female. (S16.3.5.1) **This information will be supplied by the COTR.**

Manufacturer's specified position _____

Actual Position _____

36.2 Place the Type 2 manual belt around the test dummy and fasten the latch. (S16.3.5.2)

36.3 Ensure that the dummy's head remains as level as possible. (S16.3.5.3)

36.4 Remove all slack from the lap belt. Pull the upper torso webbing out of the retractor and allow it to retract; repeat this operation four times. Apply a 9 N (2 lbf) to 18 N (4 lbf) tension load to the lap belt. If the belt system is equipped with a tension-relieving device, introduce the maximum amount of slack into the upper torso belt that is recommended by the manufacturer. If the belt system is not equipped with a tension-relieving device, allow the excess webbing in the shoulder belt to be retracted by the retractive force of the retractor. (S16.3.5.4)

I certify that I have read and performed each instruction.

Signature: Jordan Hayes Date: 2/19/10

DUMMY POSITIONING PROCEDURES
FOR 5th PERCENTILE FEMALE PASSENGER TEST DUMMY
CONFORMING TO SUBPART O OF PART 572

Test Vehicle: 2010 Mazda 6
 Test Program: FMVSS 208 Compliance
 Test Technician: Tim Bratz

NHTSA No.: CA5400
 Test Date: 2/19/10

IMPACT ANGLE:	Zero Degrees					
BELTED DUMMIES (YES/NO):	No					
TEST SPEED:	X	32 to 40 kmph		0 to 48 kmph		0 to 56 kmph
DRIVER DUMMY:	X		5 th female			50 th male
PASSENGER DUMMY:	X		5 th female			50 th male

(Check this item ONLY if it applies to this vehicle.)

 The passenger seat adjustments are controlled by the adjustments made to the driver's seat. Therefore, positioning of the passenger dummy is made simultaneously with the driver dummy. Adjustments made to the seat to position the driver will over ride any adjustments that would normally be made to position the passenger. (S16.2.10.3)

1. Seat Position

X 1.1 Position the seat's adjustable lumbar supports so that the lumbar supports are in the lowest, retracted or deflated adjustment positions. (S16.2.10.1, S20.1.9.1, S20.4.1, S22.1.7.1)

X N/A – No lumbar adjustment

X 1.2 Position any adjustable parts of the seat that provide additional support so that they are in the lowest or most open adjustment position. (S16.2.10.2, S20.1.9.2, S20.4.1, S22.1.7.1, S22.4.2.1, S22.4.3.1, S24.4.2.1, S26.2.3, S26.3.1)

X N/A – No additional support adjustment

X 1.3 Position an adjustable leg support system in its rearmost position. (8/27/04 interpretation to Toyota)

X N/A – No adjustable leg support system

X 1.4 **Mark** a point (seat cushion reference point) on the side of the seat cushion that is between 150 mm and 250 mm from the front edge of the seat cushion. (S16.3.1.12)

X 1.5 Draw a line (seat cushion reference line) through the seat cushion reference point. (S16.3.1.13)

X 1.6 Use only the controls that primarily move the seat in the fore-aft direction to move the seat cushion reference point to the rearmost position. (S16.2.10.3.1, S22.1.7.3)

X 1.7 If the seat cushion adjusts fore-aft, independent of the seat back, use only the controls that primarily move the seat cushion in the fore-aft direction to move the seat cushion reference point to the rearmost position. (S16.2.10.3.1, S20.1.9.3)

X N/A – No independent fore-aft seat cushion adjustment

- 1.8 Use any part of any control, other than the parts just used for fore-aft positioning, to determine the range of angles of the seat cushion reference line and to set the seat cushion reference line at the mid-angle. (S16.2.10.3.1)
Maximum angle Zero
Minimum angle Zero
Mid-angle Zero
- 1.9 If the seat and/or seat cushion height is adjustable, use any part of any control other than the parts which primarily move the seat or seat cushion fore-aft, to put the seat cushion reference point in its lowest position with the seat cushion reference line angle at the mid-angle found in 1.8. (S16.2.10.3.1)
 N/A – No seat height adjustment
- 1.10 Use only the controls that primarily move the seat in the fore-aft direction to verify the seat is in the rearmost position.
- 1.11 Use only the controls that primarily move the seat in the fore-aft direction to **mark** the fore-aft seat positions. **Mark** each position so that there is a visual indication when the seat is at a particular position. For manual seats, move the seat forward one detent at a time and **mark** each detent. For power seats, **mark** only the rearmost, middle, and foremost positions. Label three of the positions with the following: F for foremost, M for mid-position (if there is no mid-position, label the closest adjustment position to the rear of the mid-point), and R for rearmost.
- 1.12 Use only the controls that primarily move the seat in the fore-aft direction to place the seat in the rearmost position.
- 1.13 Use any part of any control, other than the parts which primarily move the seat or seat cushion fore-aft, to find and visually **mark** the maximum, minimum, and middle height of the seat cushion reference point with the seat cushion reference line at the mid-angle determined in 1.8. (S20.1.9.4, S22.1.2, S22.1.7.4, S22.3.1, S22.4.3.1, S24.1.2, S24.3.1, S24.4.3.1, S26.2.3, S26.3.1)
 N/A – No seat height adjustment. Go to 1.18
- 1.14 Use only the controls that primarily move the seat and/or seat cushion in the fore-aft direction to place the seat in the mid-fore-aft position.
- 1.15 Use any part of any control, other than the parts which primarily move the seat or seat cushion fore-aft, to find and visually **mark** the maximum, minimum, and middle height of the seat cushion reference point with the seat cushion reference line at the mid-angle determined in 1.8. (S20.1.9.4, S22.1.2, S22.1.7.4, S22.3.1, S24.1.2, S24.3.1)
- 1.16 Use only the controls that change the seat in the fore-aft direction to place the seat in the foremost position. (S16.2.10.3.2)
- 1.17 Use any part of any control, other than the parts which primarily move the seat or seat cushion fore-aft, to find and visually **mark** the maximum, minimum, and middle height of the seat cushion reference point with the seat cushion reference line at the mid-angle determined in 1.8. (S16.2.10.3.3, S20.1.9.4, S22.1.2, S22.1.7.4, S22.3.1, S24.1.2, S24.3.1)
- 1.18. Is the seat a bucket seat?
 Yes, go to 1.19 and skip 1.20
 No, go to 1.20 and skip 1.19

X 1.19 Bucket seats:

Locate and **mark** for future reference the longitudinal centerline of the seat cushion. The intersection of the vertical longitudinal plane that passes through the SgRP and the seat cushion upper surface determines the longitudinal centerline of a bucket seat cushion. (S16.3.1.10 & S20.1.10)

 1.20 Bench seats:

Locate and **mark** the longitudinal centerline of the passenger seat cushion. The longitudinal centerline is the same distance from the longitudinal centerline of the vehicle as the center of the steering wheel. (S20.2.1.4, S22.2.1.3, S24.2.3, S20.4.4, S22.2.2.1 (b), S22.2.2.3 (b), S22.2.2.4 (a), S22.2.2.5 (a), S22.2.2.6 (a), S22.2.2.7 (a), S24.2.3 (a))

Record the distance from the longitudinal centerline of the vehicle to the center of the steering wheel. _____

Record the distance from the longitudinal centerline of the vehicle to the longitudinal centerline of the seat cushion. (The vertical plane through this longitudinal centerline is Plane B for suppression.) _____

2. Head Restraint Position

 N/A Vehicle contains automatic head restraints.

 N/A, there is no head restraint adjustment Go to 3

X 2.1 Adjust the head restraint to its lowest position. (S16.2.10.2, S20.1.9.6, S20.4.1, S22.1.7.6, S22.4.2.1, S22.4.3.1, S24.4.3.1, S26.2.3, S26.3.1)

X 2.2 All adjustments of the head restraint shall be used to position it full forward. For example, if it rotates, rotate it such that the head restraint extends as far forward as possible. **Mark** the foremost position. (S16.2.10.2 & S16.3.4.4 & S20.1.9.6, S20.4.1, S22.4.2.1, S22.4.3.1, S24.4.3.1, S26.2.3, S26.3.1)

X 2.3 Measure the vertical distance from the top most point of the head restraint to the bottom most point. Locate and **mark** a horizontal plane through the midpoint of this distance. (S16.3.4.3)

Vertical height of head restraint 230 mm

Mid-point height 115 mm

X 3. Place the SCRIP in the full rearward, mid-height position, and mid-seat cushion angle. (S16.3.3.1.1)

X 4. Fully recline the seat back. (S16.3.3.1.2)

 N/A seat back not adjustable.

X 5. Place the dummy in the seat with the legs at an angle of 120 degrees to the thighs. The calves should not be touching the seat cushion. (S16.3.3.1.2)

X 6. Position the dummy in the seat such that the midsagittal plane is coincident with the longitudinal seat cushion marking that was determined in item 1.19 or 1.20. (S16.3.3.1.3 and S16.3.3.1.4)

X 7. Hold down the dummy's thighs and push rearward on the upper torso to maximize the pelvic angle. (S16.3.3.1.5)

X 8. Set the angle between the legs and the thighs to 120 degrees. (S16.3.3.1.6)

9. Set the transverse distance between the centers of the front of the knees at 160 to 170 mm. (6.3 to 6.7 inches). Center the knee separation with respect to the longitudinal seat cushion marking that was determined in item 1.19 or 1.20. (S16.3.3.1.6)
Record Knee Separation: 165 mm
10. Push rearward on the dummy's knees until the pelvis contacts the seat back, or the backs of the calves contact the seat cushion, whichever occurs first. (S16.3.3.1.6)
 Pelvis contacted seat back.
 Calves contacted seat cushion.
11. Gently rock the upper torso ± 5 degrees (approximately 51 mm (2 inches)) side-to-side three times. (S16.3.3.1.7)
12. If needed, extend the legs until the feet do not contact the floor pan. The thighs should be resting on the seat cushion. (S16.3.3.1.8)
13. Use seat controls to line up the seat markings determined during the completion of item 1 to set the foremost fore-aft position, mid-height position and the seat cushion mid-angle. If the dummy contacts the interior move the seat rearward until a maximum clearance of 5 mm (0.2 inches) is achieved or the seat is in the closest detent position that does not cause dummy contact. (S16.3.3.1.8)
 Foremost, mid-height position and the seat cushion mid-angle reached
 Dummy Contact. Clearance set at maximum of 5 mm
Measured Clearance _____
 Dummy Contact. Seat set at nearest detent position.
Seat position ___ detent positions rearward of foremost
(foremost is position zero)
14. If the seat back is adjustable, rotate the seat back forward while holding the thighs in place. Continue rotating the seat back forward until the transverse instrument platform of the dummy head is level ± 0.5 degrees. If head cannot be leveled using the seat back adjustment, or the seat back is not adjustable, use the lower neck bracket adjustment to level the head. If a level position cannot be achieved, adjust the head as closely as possible to the ± 0.5 degree range. (S16.3.3.1.9 and S16.3.3.1.10)
(Check All That Apply)
 Seat back not adjustable
 Seat back not independent of driver side seat back
 Head Level Achieved. (Check all that apply)
 Head leveled using the adjustable seat back
 Head leveled using the neck bracket.
Head Angle 0.0 degrees
 Head Level NOT Achieved. (Check all that apply)
 Head adjusted using the adjustable seat back
 Head adjusted using the neck bracket.
Head Angle _____ degrees
15. Verify the pelvis is not interfering with the seat bight. (S16.3.3.1.9)
 No interference
 Pelvis moved forward the minimum amount so that it is not caught in the seat bight.
16. Verify the dummy abdomen is properly installed. (S16.3.3.1.9)
 Abdomen still seated properly into dummy
 Abdomen was adjusted because it was not seated properly into dummy
17. Head Angle
 N/A, neither the pelvis nor the abdomen were adjusted.

17.1 Head still level (Go to 18)

17.2 Head level adjusted

Head Level Achieved. (Check all that apply)

Head leveled using the adjustable seat back

Head leveled using the neck bracket.

Head Angle _____ degrees

Head Level NOT Achieved. (Check all that apply)

Head adjusted using the adjustable seat back

Head adjusted using the neck bracket.

Head Angle _____ degrees

18. Measure and set the pelvic angle using the pelvic angle gage TE-2504. The pelvic angle should be 20.0 degrees \pm 2.5 degrees. If the pelvic angle cannot be set to the specified range because the head will not be level or because the dummy will have need major repositioning, adjust the pelvis as closely as possible to the angle range, but keep the head level.

Pelvic angle set to 20.0 degrees \pm 2.5 degrees.

Pelvic angle of 20.0 degrees not achieved, the angular difference was minimized.

Record the pelvic angle. 21.8 degrees

19. Check the dummy for contact with the interior after completing adjustments.

No contact.

Dummy in contact with interior.

Seat moved aft _____ mm from the previous position.

Seat moved aft _____ detent positions from the previous position.

20. Verify the transverse instrument platform of the dummy head is level \pm 0.5 degrees. Use the lower neck bracket adjustment to level the head. If a level position cannot be achieved, minimize the angle. (S16.3.3.1.9, S16.3.3.1.10, and S16.3.3.1.11)

Head Level Achieved

Head Angle 0.1 degrees

Head Level NOT Achieved.

Head Angle _____ degrees

21. Check the dummy to see if additional interior clearance is obtained, allowing the seat to be moved forward. (S16.3.3.1.12)

N/A Bench Seat

N/A Seat already at full forward position.

Clearance unchanged. No adjustments required.

Additional clearance available

Seat moved Forward _____ mm from the previous position.

Seat moved Forward _____ detent positions from the previous position.

Seat moved Forward, Full Forward position reached.

22. Passenger foot positioning. (Indicate final position achieved) (S16.3.3.2)

22.1 Place feet flat on the toe board; OR (S16.3.3.2.1)

22.2 If the feet cannot be placed flat on the toe board, set the feet perpendicular to the lower leg, and rest the heel as far forward on the floor pan as possible; OR (S16.3.3.2.2)

22.3 If the heels do not touch the floor pan, set the legs as perpendicular to the thighs as possible and set the feet parallel to the floor pan. (S16.3.3.2.2)

23. Passenger arm/hand positioning. (S16.3.3.3)

23.1 Place the dummy's upper arms adjacent to the torso with the arm centerlines as close to a vertical longitudinal plane as possible. (S16.3.3.3.1)

23.2 Place the palms of the dummy in contact with the outer part of the thighs. (S16.3.3.3.2)

23.3 Place the little fingers in contact with the seat cushion. (S16.3.3.3.3)

24. Adjustable head restraints (S16.3.4)
 N/A, there is no head restraint adjustment

24.1 If the head restraint has an automatic adjustment, leave it where the system positions the restraint after the dummy is placed in the seat. (S16.3.4.1) Go to 25.

24.2 Adjust each head restraint vertically so that the horizontal plane determined in Item 2 is aligned with the center of gravity (CG) of the dummy head. (S16.3.4.3)

24.3 If the above position is not attainable, move the vertical center of the head restraint to the closest detent below the center of the head CG. (S16.3.4.3)

N/A midpoint position attained in previous step
 Headrest set at nearest detent below the head CG

24.4 If the head restraint has a fore and aft adjustment, place the restraint in the foremost position or until contact with the head is made, whichever occurs first. (S16.3.4.4)

25. Manual belt adjustment (for tests conducted with a belted dummy) S16.3.5
 N/A, Unbelted test

25.1 If an adjustable seat belt D-ring anchorage exists, place it in the manufacturer's design position for a 5th percentile adult female. **This information will be supplied by the COTR.** (S16.3.5.1)

Manufacturer's specified position _____
Actual Position _____

25.2 Place the Type 2 manual belt around the test dummy and fasten the latch. (S16.3.5.2)

25.3 Ensure that the dummy's head remains as level as possible. (S16.3.5.3)

25.4 Remove all slack from the lap belt. Pull the upper torso webbing out of the retractor and allow it to retract; repeat this operation four times. Apply a 9 N (2 lbf) to 18 N (4 lbf) tension load to the lap belt. If the belt system is equipped with a tension-relieving device, introduce the maximum amount of slack into the upper torso belt that is recommended by the manufacturer. If the belt system is not equipped with a tension-relieving device, allow the excess webbing in the shoulder belt to be retracted by the retractive force of the retractor. (S16.3.5.4)

I certify that I have read and performed each instruction.

Signature:  Date: 2/19/10

DATA SHEET 37

DUMMY MEASUREMENTS

Test Vehicle: 2010 Mazda 6
 Test Program: FMVSS 208 Compliance
 Test Technician: Tim Bratz

NHTSA No.: CA5400
 Test Date: 2/19/10

DUMMY MEASUREMENTS FOR FRONT SEAT OCCUPANTS

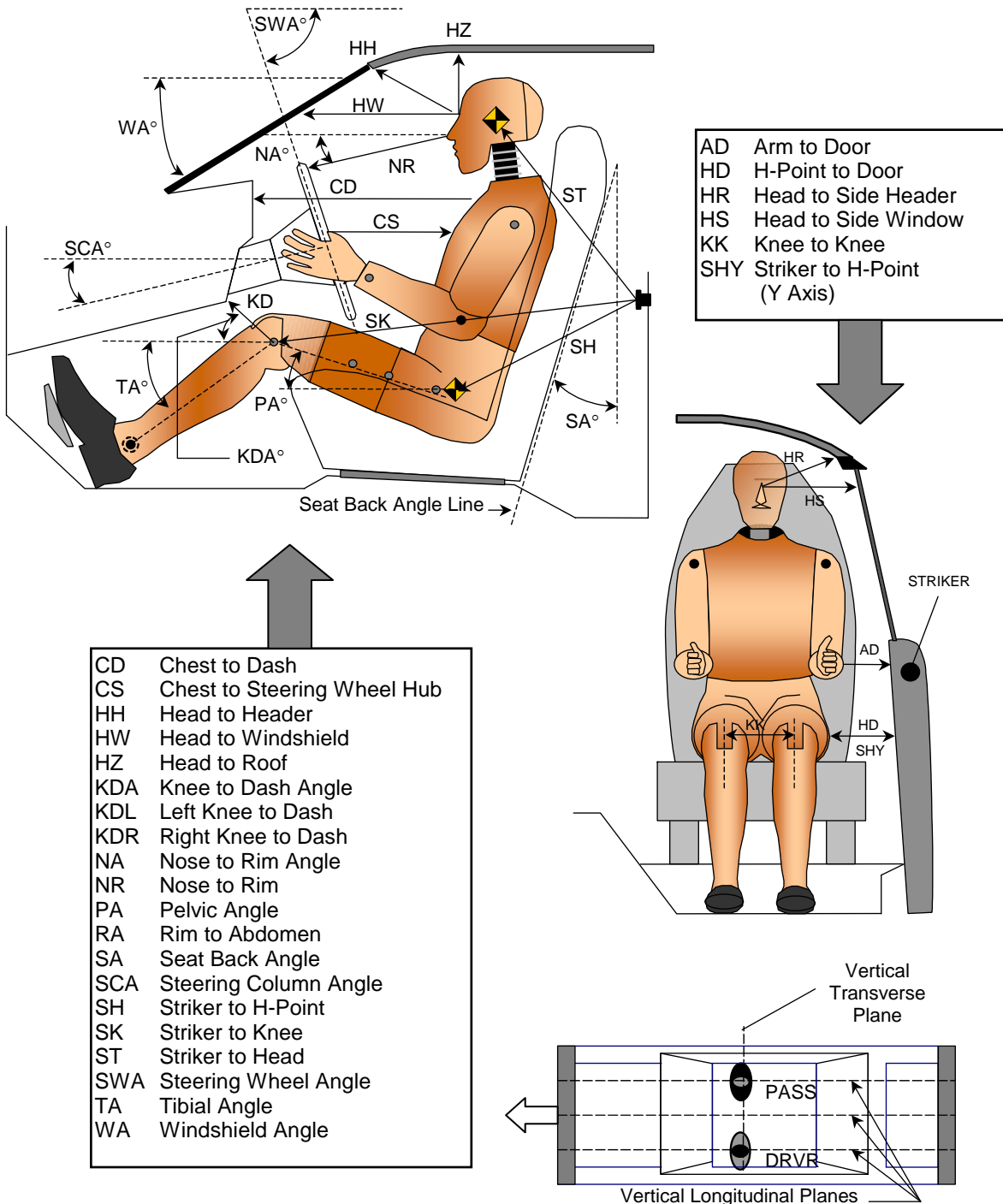

TEST DUMMY POSITION MEASUREMENTS

Code	Measurement Description	Driver SN 510		Passenger SN 511	
		Length (mm)	Angle (°)	Length (mm)	Angle (°)
WA	Windshield Angle		22.1		
SWA	Steering Wheel Angle		67.6		
SCA	Steering Column Angle		22.4		
SA	Seat Back Angle (On Headrest Post)		9.5		11.4
HZ	Head to Roof (Z)	169		187	
HH	Head to Header	244	54.3	261	51.1
HW	Head to Windshield	572	0.0	624	0.0
HR	Head to Side Header (Y)	217		230	
NR	Nose to Rim	257	5.4		
CD	Chest to Dash	410		435	
CS	Chest to Steering Hub	184	10.2		
RA	Rim to Abdomen	83	0.0		
KDL	Left Knee to Dash	102	27.4	88	
KDR	Right Knee to Dash	74		103	35.8
PA	Pelvic Angle		20.5		21.8
TA	Tibia Angle		47.7		45.4
KK	Knee to Knee (Y)	300		210	
SK	Striker to Knee	717	96.1	732	98.7
ST	Striker to Head	490	35.1	466	31.7
SH	Striker to H-Point	421	113.8	423	112.4
SHY	Striker to H-Point (Y)	321		316	
HS	Head to Side Window	362		373	
HD	H-Point to Door (Y)	179		189	
AD	Arm to Door (Y)	160		177	
AA	Ankle to Ankle	310		176	

SEAT BELT POSITIONING DATA

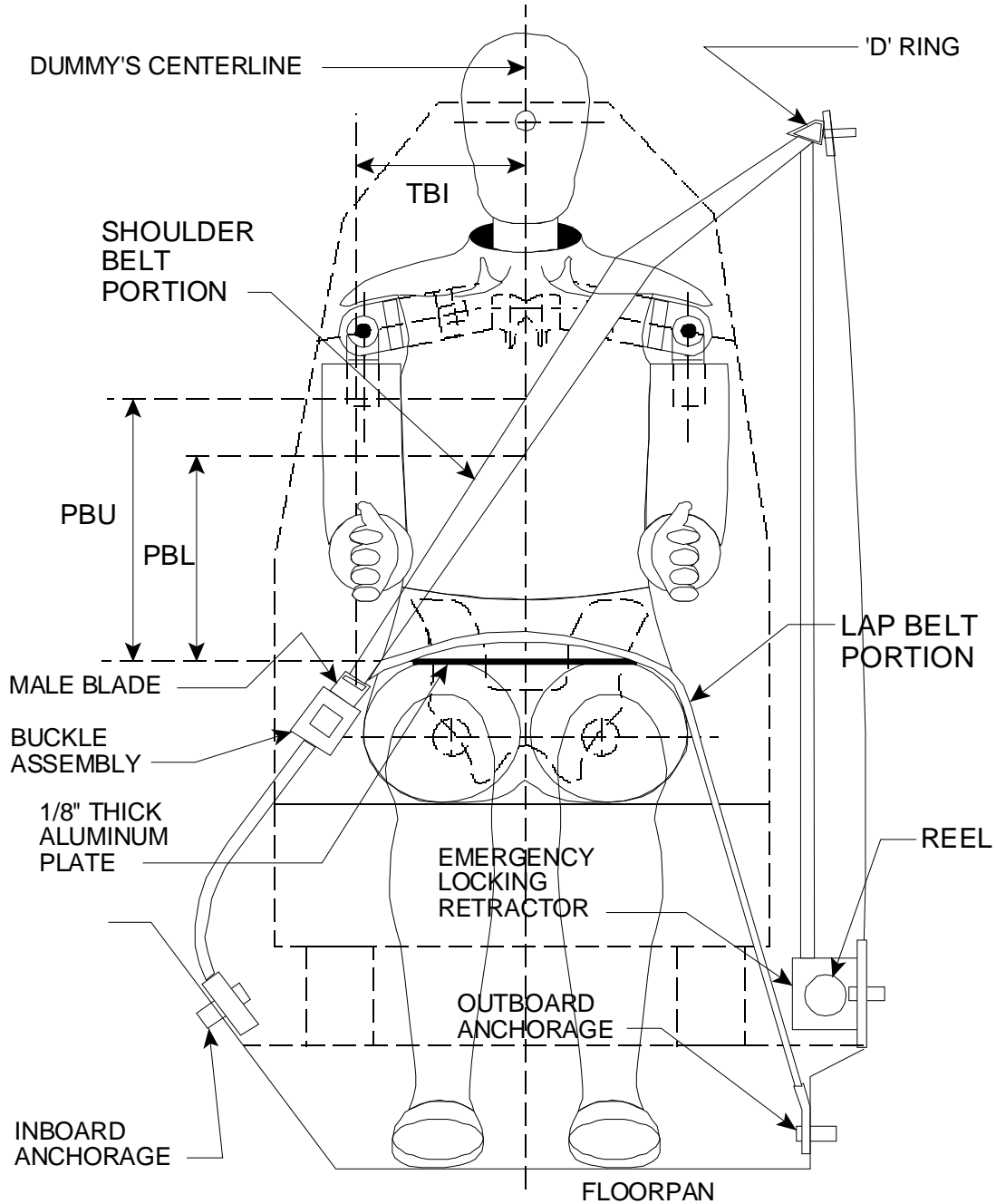

FRONT VIEW OF DUMMY

SEAT BELT POSITIONING MEASUREMENTS

Measurement Description	Units	Driver	Passenger
PBU - Top surface of reference to belt upper edge	mm	N/A	N/A
PBL - Top surface of reference to belt lower edge	mm	N/A	N/A

DATA SHEET 38

CRASH TEST

Test Vehicle: 2010 Mazda 6
 Test Program: FMVSS 208 Compliance
 Test Technician: Tim Bratz

NHTSA No.: CA5400
 Test Date: 2/19/10

IMPACT ANGLE:	Zero Degrees		
BELTED DUMMIES (YES/NO):	No		
TEST SPEED:	X 32 to 40 kmph	0 to 48 kmph	0 to 56 kmph
DRIVER DUMMY:	X	5 th female	50 th male
PASSENGER DUMMY:	X	5 th female	50 th male

- 1. Vehicle underbody painted.
- 2. The speed measuring devices are in place and functioning.
- 3. The speed measuring devices are 1.0 m from the barrier (spec. 1.5 m) and 30 cm from the barrier (spec. is 30 cm)
- 4. Convertible top is in the closed position.
 N/A, not a convertible
- 5. Instrumentation and wires are placed so motion of dummies during impact is not affected.
- 6. Tires inflated to pressure on tire placard or if it does not have a tire placard because it is not a passenger car, then inflated to the tire pressure specified in the owner information.
220 kpa front left tire 220 kpa specified on tire placard or in owner information
220 kpa front right tire 220 kpa specified on tire placard or in owner information
220 kpa rear left tire 220 kpa specified on tire placard or in owner information
220 kpa rear right tire 220 kpa specified on tire placard or in owner information
- 7. Time zero contacts on barrier in place.
- 8. Pre test zero and shunt calibration adjustments performed and recorded.
- 9. Dummy temperature meets requirements of section 12.2 of the test procedure.
- 10. Vehicle hood closed and latched.
- 11. Transmission placed in neutral.
- 12. Parking brake off.
- 13. Are the heads still level?
 Yes, go to 14
 No, Adjust dummy so that head is at the angle recorded in the Appendix F or G data sheets and then continue.
- 14. Ignition in the ON position.
- 15. Doors closed and latched but not locked.
- 16. Post test zero and shunt calibration checks performed and recorded.
- 17. Actual test speed 39.8 kmph
- 18. Vehicle rebound from the barrier 729 cm
- 19. Describe whether the doors open after the test and what method is used to open the doors.
 Left Front Door: Door remained closed and latched; Door opened without tools.
 Right Front Door: Door remained closed and latched; Door opened without tools.
 Left Rear Door: Door remained closed and latched; Door opened without tools.
 Right Rear Door: Door remained closed and latched; Door opened without tools.
- 20. Describe the contact points of the dummy with the interior of the vehicle.
 Driver Dummy: Head to Air Bag; Chest to Air Bag; Knees to Knee Bolster.
 Passenger Dummy: Head to Air Bag; Chest to Air Bag; Knees to Glove Box.

REMARKS:

Signature: 

Date: 2/19/10

I certify that I have read and performed each instruction.

DATA SHEET 40

ACCIDENT INVESTIGATION MEASUREMENTS

Test Vehicle: 2010 Mazda 6
 Test Program: FMVSS 208 Compliance
 Test Technician: Daniel Sienko

NHTSA No.: CA5400
 Test Date: 2/19/10

IMPACT ANGLE:	Zero Degrees					
BELTED DUMMIES (YES/NO):	No					
TEST SPEED:	X	32 to 40 kmph		0 to 48 kmph		0 to 56 kmph
DRIVER DUMMY:	X		5 th female			50 th male
PASSENGER DUMMY:	X		5 th female			50 th male

Vehicle Year/Make/Model/Body Style:	2010 Mazda 6 Passenger Car
VIN:	1YVHZ8BH4A5M04704
Wheelbase:	2785 mm
Build Date:	08/09
Vehicle Size Category:	3
Test Weight:	1603.5 kg
Front Overhang:	985 mm
Overall Width:	1840 mm
Overall Length Center:	4660 mm

Accelerometer Data	
Location:	As per measurements on Data Sheet 33
Linearity:	>99.9%

Integration Algorithm:	Trapezoidal
Vehicle Impact Speed:	39.8 kmph
Time of Separation:	122.8 ms
Velocity Change:	44.3 kmph

DATA SHEET 41
WINDSHIELD MOUNTING (FMVSS 212)

Test Vehicle: 2010 Mazda 6
 Test Program: FMVSS 208 Compliance
 Test Technician: Daniel Sienko

NHTSA No.: CA5400
 Test Date: 2/19/10

IMPACT ANGLE:	Zero Degrees					
BELTED DUMMIES (YES/NO):	No					
TEST SPEED:	<input checked="" type="checkbox"/>	32 to 40 kmph	<input type="checkbox"/>	0 to 48 kmph	<input type="checkbox"/>	0 to 56 kmph
DRIVER DUMMY:	<input checked="" type="checkbox"/>			5 th female	<input type="checkbox"/>	50 th male
PASSENGER DUMMY:	<input checked="" type="checkbox"/>			5 th female	<input type="checkbox"/>	50 th male

- 1. Pre-Crash
- 1.1 Describe from visual inspection how the windshield is mounted and describe any trim material.

Retained with glue
Rubber and plastic trim
- 1.2 Mark the longitudinal centerline of the windshield.
- 1.3 Measure pre-crash A, B, and C for the left side and record in the chart below.
- 1.4 Measure pre-crash C, D, and E for the right side and record in the chart below.
- 1.5 Measure from the edge of the retainer or molding to the edge of the windshield.
Dimension G (mm): 15 mm
- 2. Post Crash
- 2.1 Can a single thickness of copier type paper (as small a piece as necessary) slide between the windshield and the vehicle body?
 No - Pass. Skip to the table of measurements, complete it by repeating the pre-crash measurements in the post crash column, and calculate the retention percentage, which will be 100%.
 Yes, go to 2.2
- 2.2 Visibly mark the beginning and end of the portions of the periphery where the paper slides between the windshield and the vehicle body.
- 2.3 Measure and record post-crash A, B, C, D, E, and F such that the measurements do not include any of the parts of the windshield where the paper slides between the windshield and the vehicle body.
- 2.4 Calculate and record the percent retention for the right and left side of the windshield.
- 2.5 Is total right side percent retention less than 75%?
 Yes, Fail
 No, Pass
- 2.6 Is total left side percent retention less than 75%?
 Yes, Fail
 No, Pass

DATA SHEET 42
WINDSHIELD ZONE INTRUSION (FMVSS 219)

Test Vehicle: 2010 Mazda 6
 Test Program: FMVSS 208 Compliance
 Test Technician: Daniel Sienko

NHTSA No.: CA5400
 Test Date: 2/19/10

IMPACT ANGLE:	Zero Degrees		
BELTED DUMMIES (YES/NO):	No		
TEST SPEED:	X	32 to 40 kmph	0 to 48 kmph
DRIVER DUMMY:	X	5 th female	50 th male
PASSENGER DUMMY:	X	5 th female	50 th male

This standard specifies limits for the displacement of vehicle components into the windshield area during a frontal barrier impact test at any speed up to and including 48 kmph.

- 1. Place a 165 mm diameter rigid sphere, with a mass of 6.8 kg on the instrument panel so that it is simultaneously touching the instrument panel and the windshield. (571.219 S6.1(a))
- 2. Roll the sphere from one side of the windshield to the other while marking on the windshield where the sphere contacts the windshield. (571.219 S6.1(b))
- 3. From the outermost contactable points on the windshield draw a horizontal line to the edges of the windshield. (571.219 S6.1(b))
- 4. Draw a line on the inner surface of the windshield that is 13 mm below the line determined in items 2 and 3.
- 5. After the crash test, record any points where a part of the exterior of the vehicle has marked, penetrated, or broken the windshield.

Provide all dimensions necessary to reproduce the protected area.

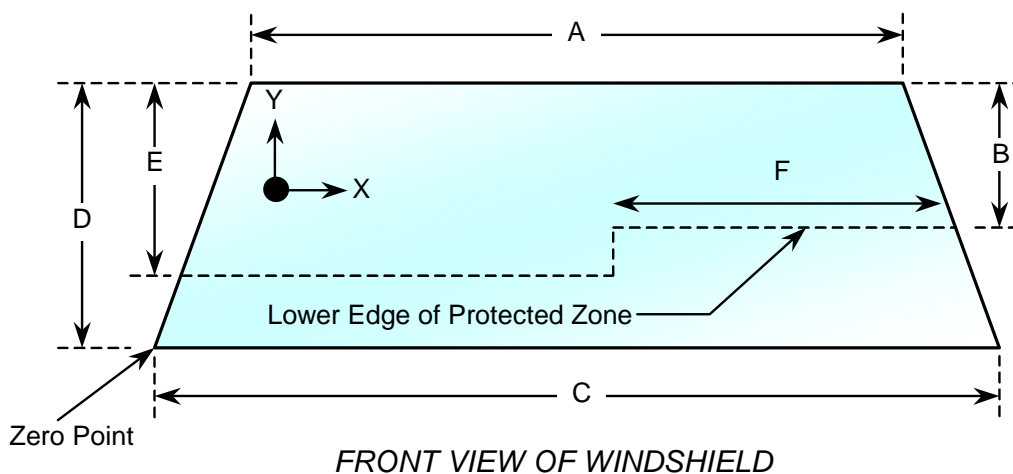

WINDSHIELD DIMENSIONS

Item	Units	Value
A	mm	1142
B	mm	495
C	mm	1391
D	mm	876
E	mm	575
F	mm	497

AREA OF PROTECTED ZONE FAILURES:

- B. Provide coordinates of the area that the protected zone was penetrated more than 0.25 inches by a vehicle component other than one which is normally in contact with the windshield.

X	Y
NONE	

- C. Provide coordinates of the area beneath the protected zone template that the inner surface of the windshield was penetrated by a vehicle component.

X	Y
NONE	

REMARKS:

I certify that I have read and performed each instruction.

Signature: *DAN SIMBOR*

Date: 2/19/10

DATA SHEET 43
FUEL SYSTEM INTEGRITY (FMVSS 301)

Test Vehicle: 2010 Mazda 6
Test Program: FMVSS 208 Compliance
Test Technician: Ben Fischer

NHTSA No.: CA5400
Test Date: 2/19/10

TYPE OF IMPACT:	25 mph Unbelted Flat Frontal
-----------------	------------------------------

Stoddard Solvent Spillage Measurements

- A. From impact until vehicle motion ceases: 0.0 grams
(Maximum Allowable = 28 grams)
- B. For the 5 minute period after motion ceases: 0.0 grams
(Maximum Allowable = 142 grams)
- C. For the following 25 minutes: 0.0 grams
(Maximum Allowable = 28 grams/minute)
- D. Spillage: NONE

REMARKS: NO SPILLAGE

FMVSS 301 STATIC ROLLOVER DATA

Test Vehicle: 2010 Mazda 6
 Test Program: FMVSS 208 Compliance

NHTSA No.: CA5400
 Test Date: 2/19/10

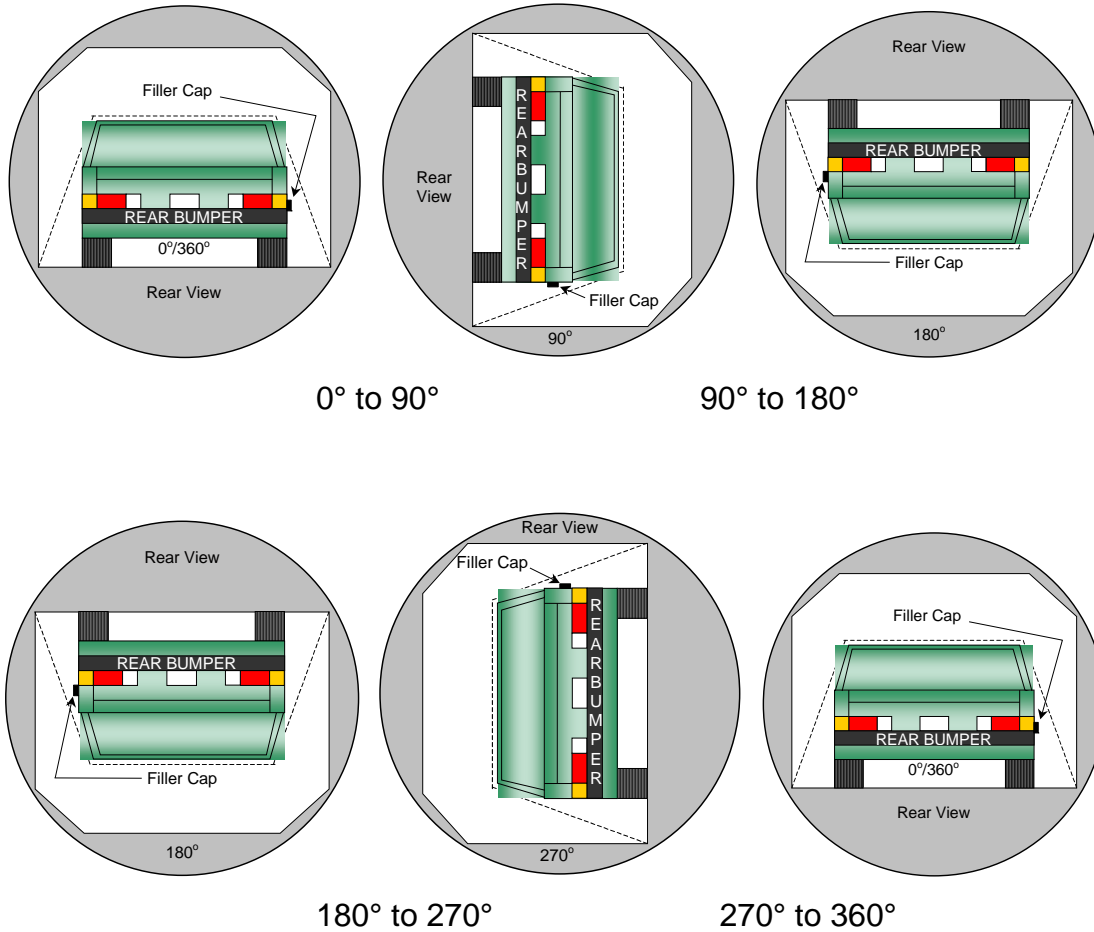

1. The specified fixture rollover rate for each 90° of rotation is 60 to 180 seconds.
2. The position hold time at each position is 300 seconds (minimum).
3. Details of Stoddard Solvent spillage locations: **None**

Test Phase	Rotation Time (sec.)	Hold Time (sec.)	Spillage (grams)
0° to 90°	119	300	0.0
90° to 180°	109	300	0.0
180° to 270°	117	300	0.0
270° to 360°	115	300	0.0

APPENDIX A
CRASH TEST DATA
TABLE OF DATA PLOTS

		<u>Page No.</u>
Figure No. 1.	Driver Head X Acceleration vs. Time	A-1
Figure No. 2.	Driver Head Y Acceleration vs. Time	A-1
Figure No. 3.	Driver Head Z Acceleration vs. Time	A-1
Figure No. 4.	Driver Head Resultant Acceleration vs. Time	A-1
Figure No. 5.	Driver Head X Velocity vs. Time	A-2
Figure No. 6.	Driver Head Y Velocity vs. Time	A-2
Figure No. 7.	Driver Head Z Velocity vs. Time	A-2
Figure No. 8.	Driver Neck Force X vs. Time	A-3
Figure No. 9.	Driver Neck Force Y vs. Time	A-3
Figure No. 10.	Driver Neck Force Z vs. Time	A-3
Figure No. 11.	Driver Neck Force Resultant vs. Time	A-3
Figure No. 12.	Driver Neck Moment X vs. Time	A-4
Figure No. 13.	Driver Neck Moment Y vs. Time	A-4
Figure No. 14.	Driver Neck Moment Z vs. Time	A-4
Figure No. 15.	Driver Neck Moment Resultant vs. Time	A-4
Figure No. 16.	Driver Chest X Acceleration vs. Time	A-5
Figure No. 17.	Driver Chest Y Acceleration vs. Time	A-5
Figure No. 18.	Driver Chest Z Acceleration vs. Time	A-5
Figure No. 19.	Driver Chest Resultant Acceleration vs. Time	A-5
Figure No. 20.	Driver Chest X Velocity vs. Time	A-6
Figure No. 21.	Driver Chest Y Velocity vs. Time	A-6
Figure No. 22.	Driver Chest Z Velocity vs. Time	A-6
Figure No. 23.	Driver Chest Displacement vs. Time	A-6
Figure No. 24.	Driver Left Femur Force vs. Time	A-7
Figure No. 25.	Driver Right Femur Force vs. Time	A-7

		<u>Page No.</u>
Figure No. 26.	Passenger Head X Acceleration vs. Time	A-8
Figure No. 27.	Passenger Head Y Acceleration vs. Time	A-8
Figure No. 28.	Passenger Head Z Acceleration vs. Time	A-8
Figure No. 29.	Passenger Head Resultant Acceleration vs. Time	A-8
Figure No. 30.	Passenger Head X Velocity vs. Time	A-9
Figure No. 31.	Passenger Head Y Velocity vs. Time	A-9
Figure No. 32.	Passenger Head Z Velocity vs. Time	A-9
Figure No. 33.	Passenger Neck Force X vs. Time	A-10
Figure No. 34.	Passenger Neck Force Y vs. Time	A-10
Figure No. 35.	Passenger Neck Force Z vs. Time	A-10
Figure No. 36.	Passenger Neck Force Resultant vs. Time	A-10
Figure No. 37.	Passenger Neck Moment X vs. Time	A-11
Figure No. 38.	Passenger Neck Moment Y vs. Time	A-11
Figure No. 39.	Passenger Neck Moment Z vs. Time	A-11
Figure No. 40.	Passenger Neck Moment Resultant vs. Time	A-11
Figure No. 41.	Passenger Chest X Acceleration vs. Time	A-12
Figure No. 42.	Passenger Chest Y Acceleration vs. Time	A-12
Figure No. 43.	Passenger Chest Z Acceleration vs. Time	A-12
Figure No. 44.	Passenger Chest Resultant Acceleration vs. Time	A-12
Figure No. 45.	Passenger Chest X Velocity vs. Time	A-13
Figure No. 46.	Passenger Chest Y Velocity vs. Time	A-13
Figure No. 47.	Passenger Chest Z Velocity vs. Time	A-13
Figure No. 48.	Passenger Chest Displacement vs. Time	A-13
Figure No. 49.	Passenger Left Femur Force vs. Time	A-14
Figure No. 50.	Passenger Right Femur Force vs. Time	A-14
Figure No. 51.	Driver Nij (N_{TF}) vs. Time	A-15
Figure No. 52.	Driver Nij (N_{TE}) vs. Time	A-15
Figure No. 53.	Driver Nij (N_{CF}) vs. Time	A-15

		<u>Page No.</u>
Figure No. 54.	Driver Nij (N_{CE}) vs. Time	A-15
Figure No. 55.	Passenger Nij (N_{TF}) vs. Time	A-16
Figure No. 56.	Passenger Nij (N_{TE}) vs. Time	A-16
Figure No. 57.	Passenger Nij (N_{CF}) vs. Time	A-16
Figure No. 58.	Passenger Nij (N_{CE}) vs. Time	A-16
Figure No. 59.	Driver Occipital Condyle Moment vs. Time	A-17
Figure No. 60.	Passenger Occipital Condyle Moment vs. Time	A-17
Figure No. 61.	Left Rear Seat Crossmember X Acceleration vs. Time	A-18
Figure No. 62.	Left Rear Seat Crossmember X Velocity vs. Time	A-18
Figure No. 63.	Right Rear Seat Crossmember X Acceleration vs. Time	A-18
Figure No. 64.	Right Rear Seat Crossmember X Velocity vs. Time	A-18
Figure No. 65.	Top of Engine X Acceleration vs. Time	A-19
Figure No. 66.	Top of Engine X Velocity vs. Time	A-19
Figure No. 67.	Bottom of Engine X Acceleration vs. Time	A-19
Figure No. 68.	Bottom of Engine X Velocity vs. Time	A-19
Figure No. 69.	Left Brake Caliper X Acceleration vs. Time	A-20
Figure No. 70.	Left Brake Caliper X Velocity vs. Time	A-20
Figure No. 71.	Right Brake Caliper X Acceleration vs. Time	A-20
Figure No. 72.	Right Brake Caliper X Velocity vs. Time	A-20
Figure No. 73.	Instrument Panel X Acceleration vs. Time	A-21
Figure No. 74.	Instrument Panel X Velocity vs. Time	A-21
Figure No. 75.	Trunk Z Acceleration vs. Time	A-21
Figure No. 76.	Trunk Z Velocity vs. Time	A-21

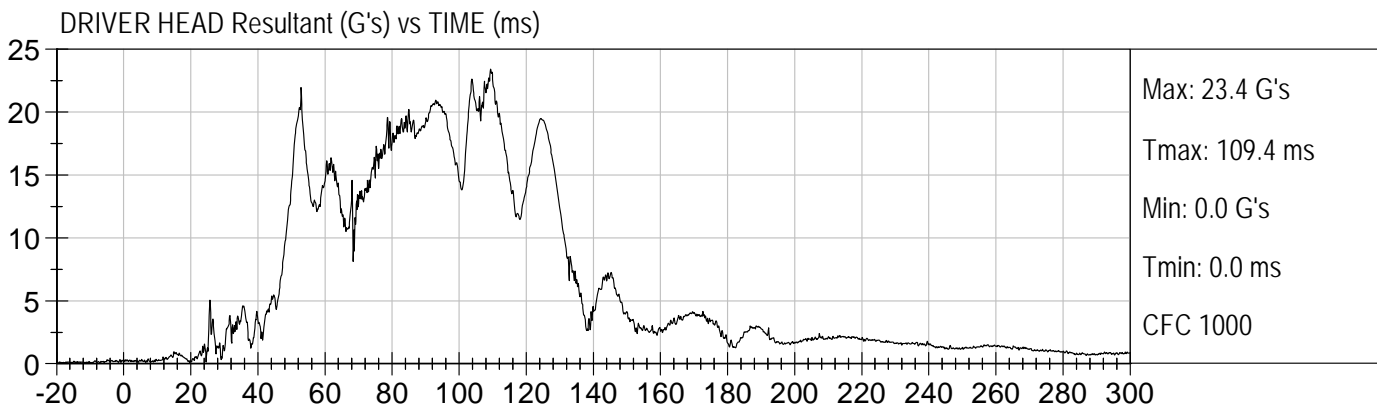
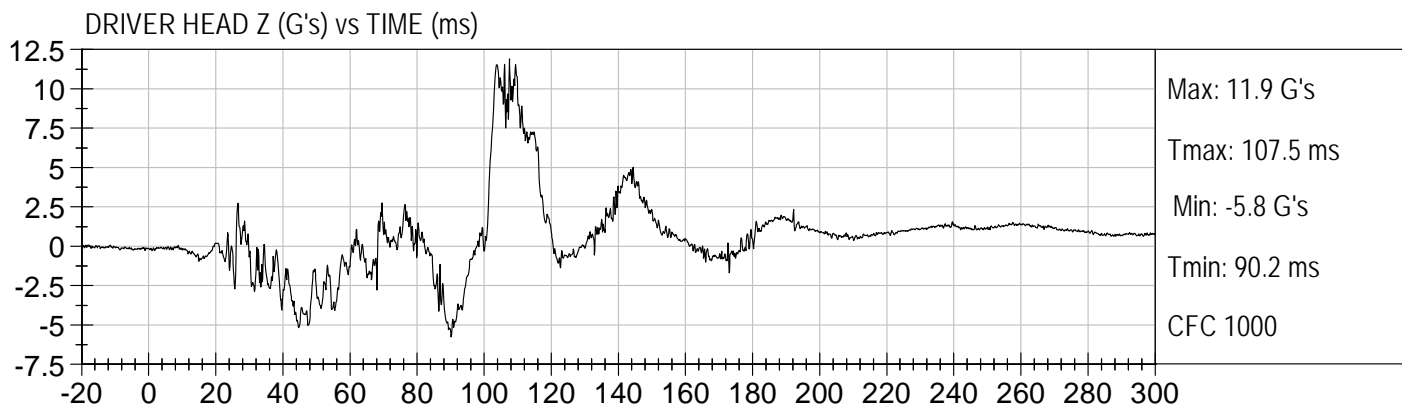
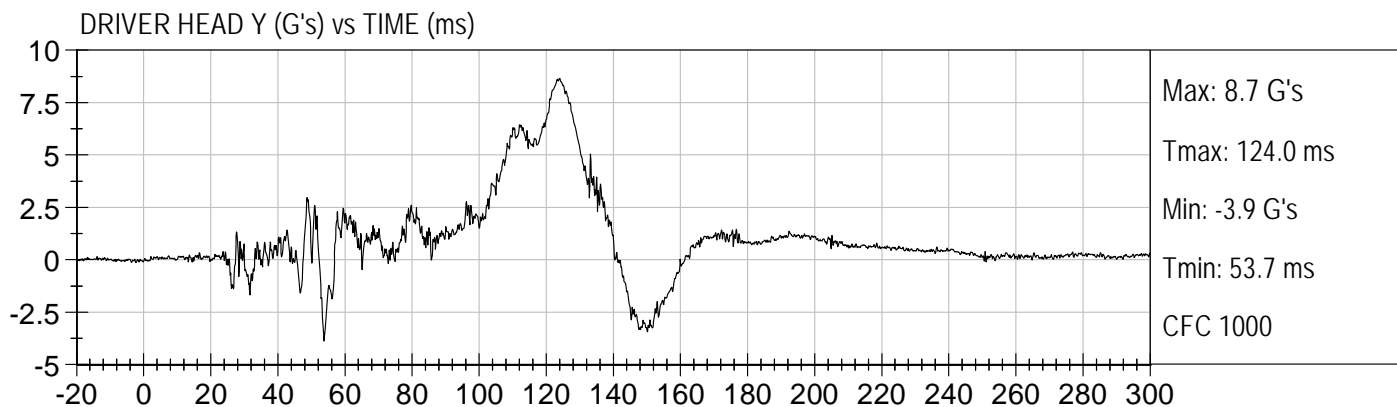
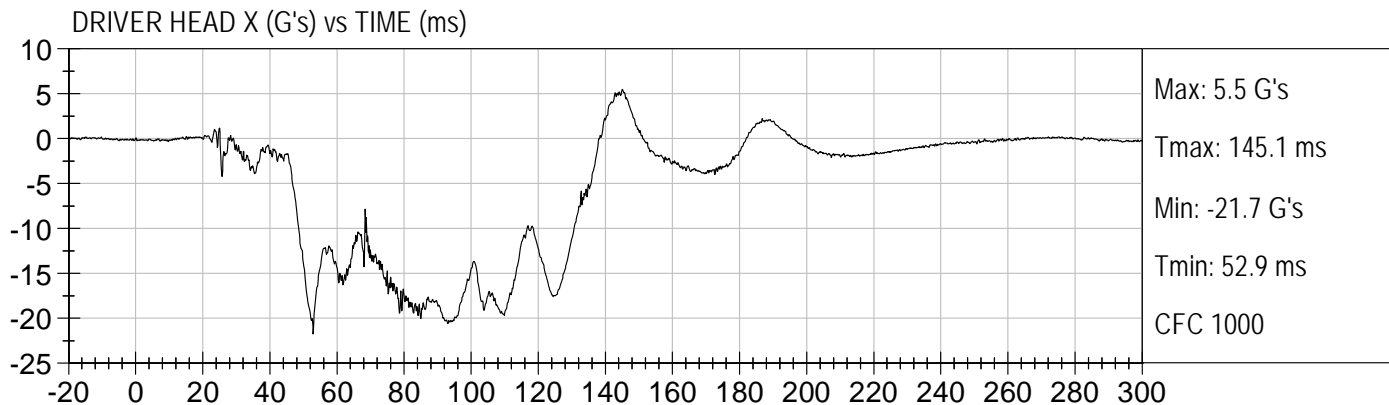

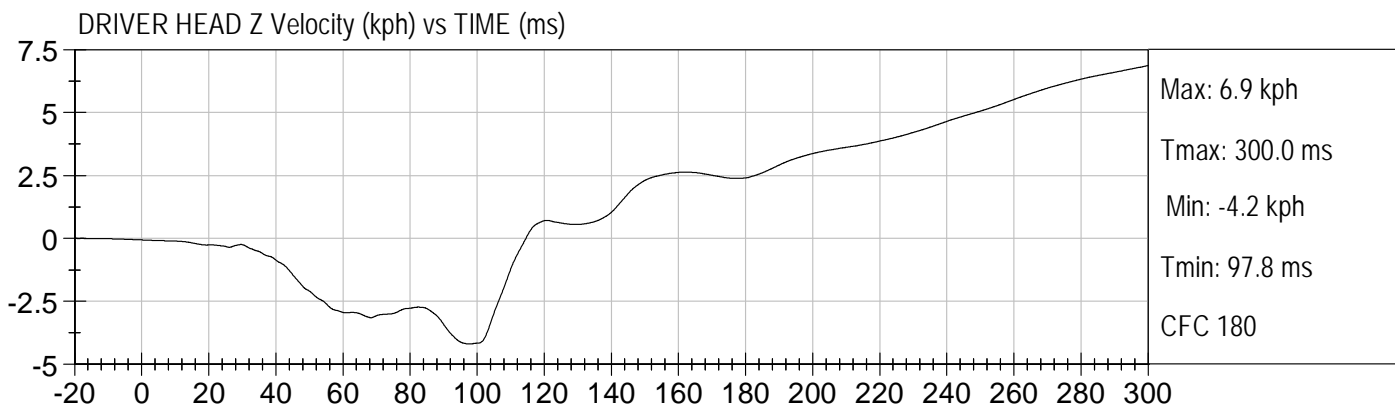
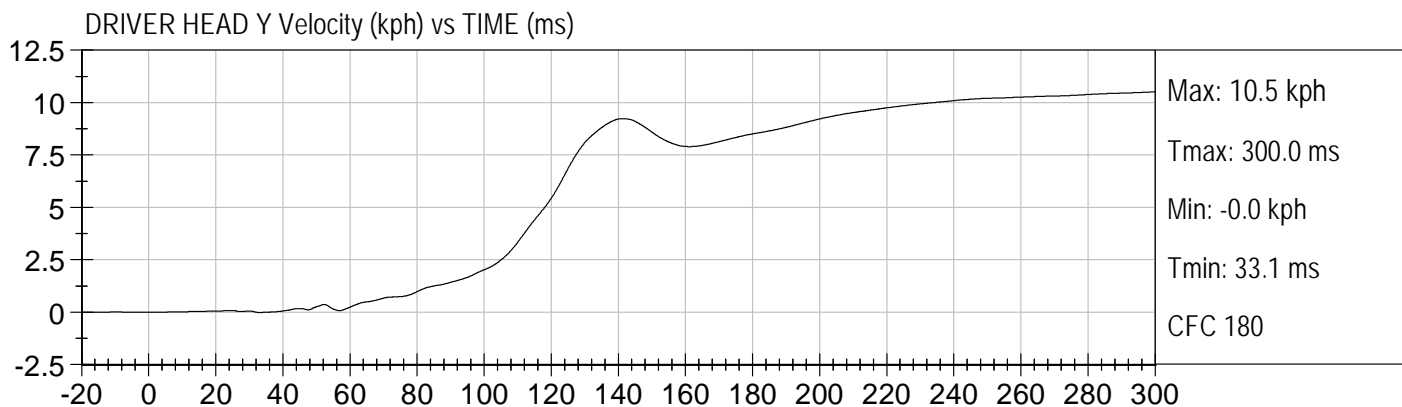
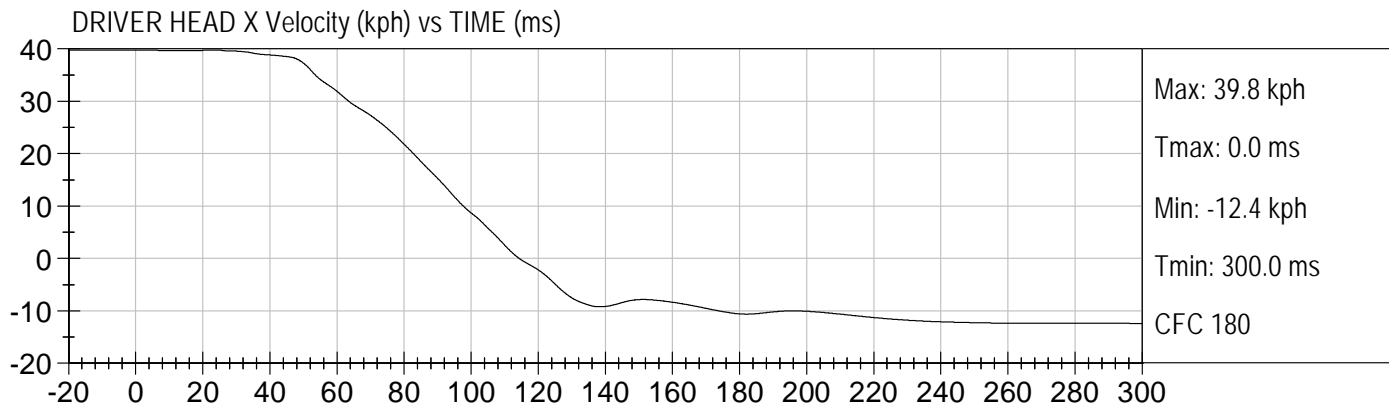

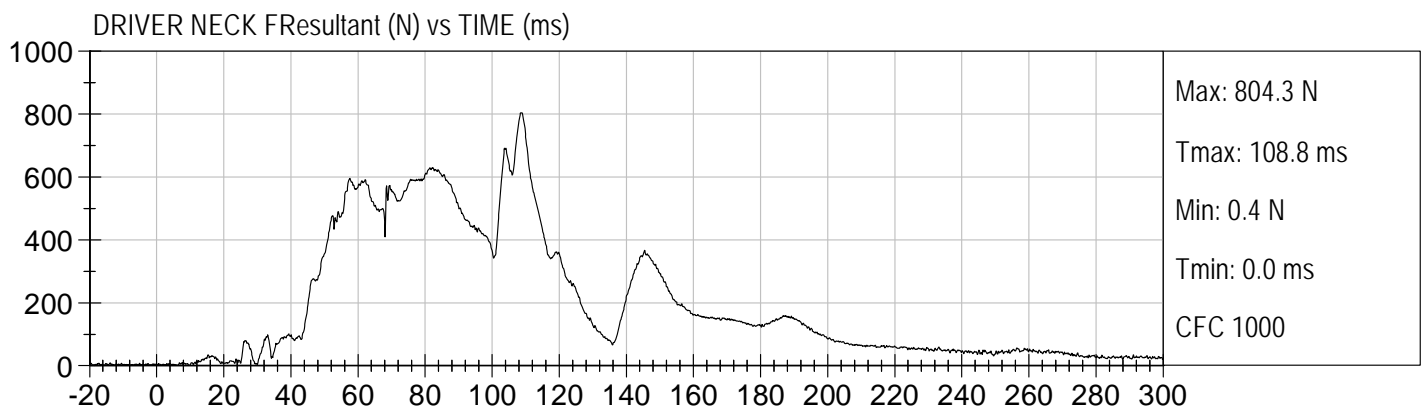
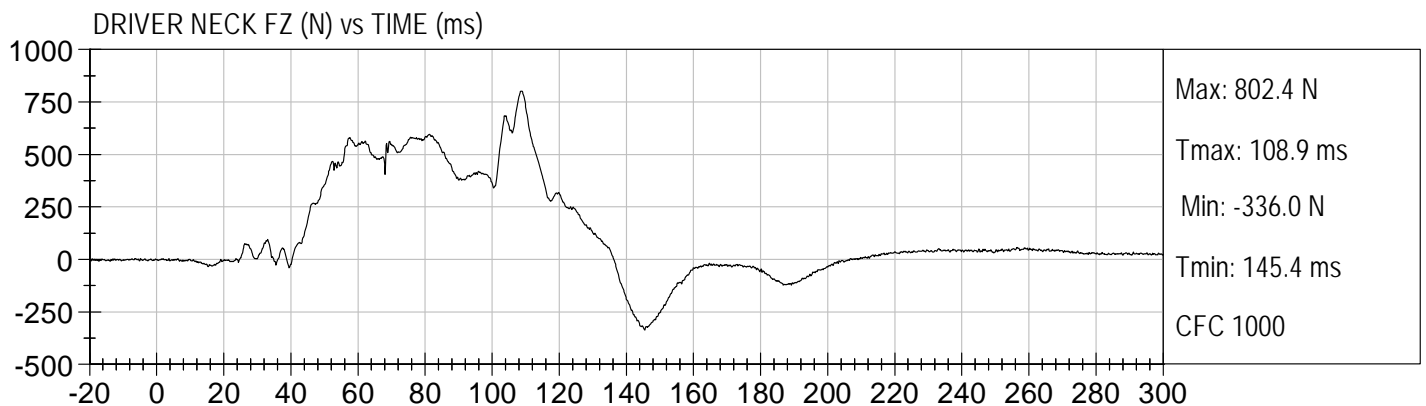
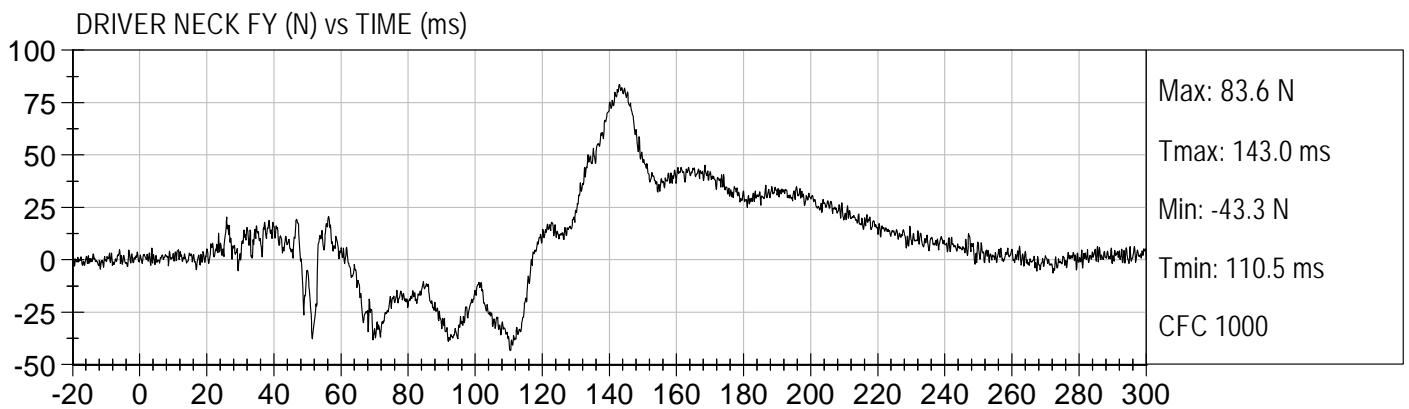
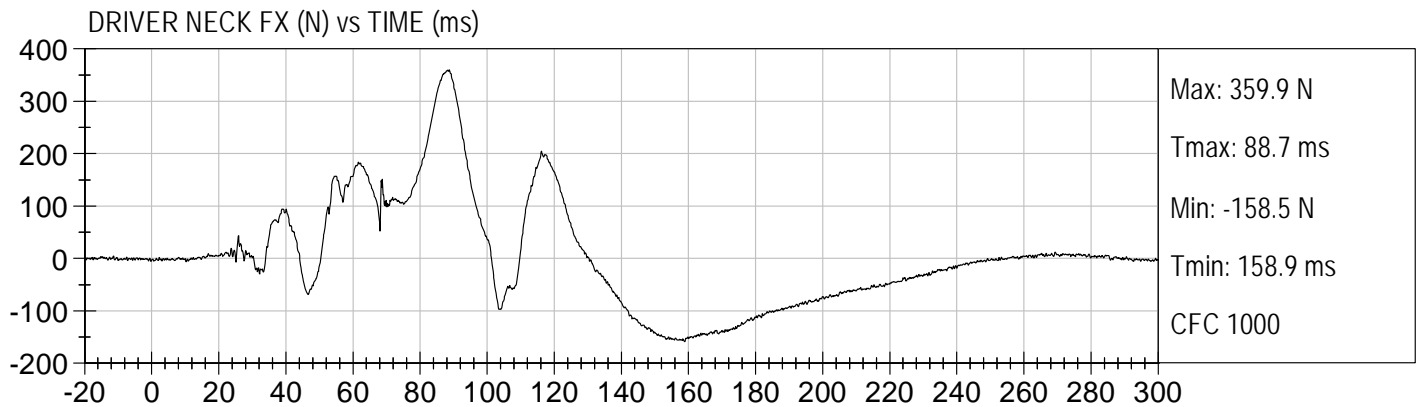

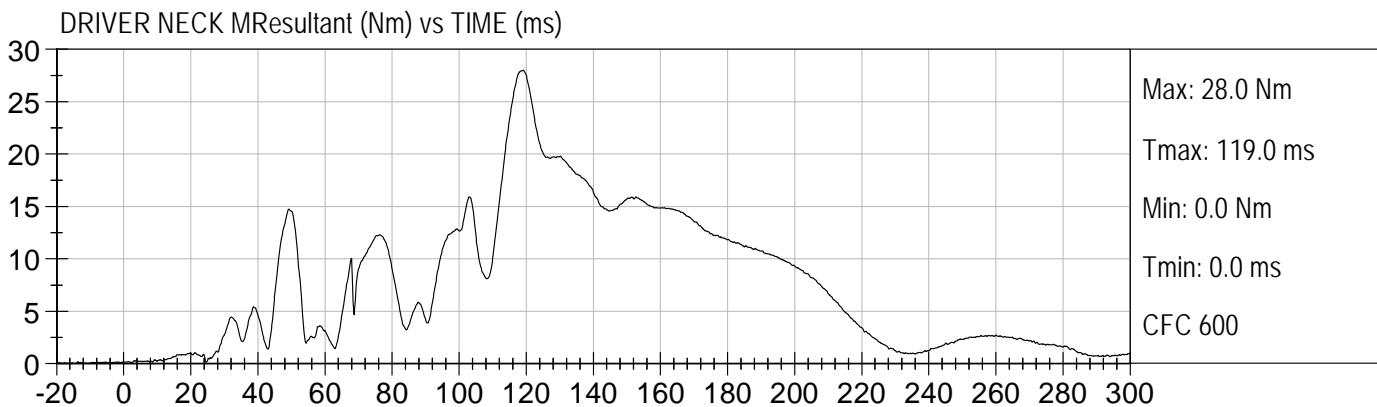
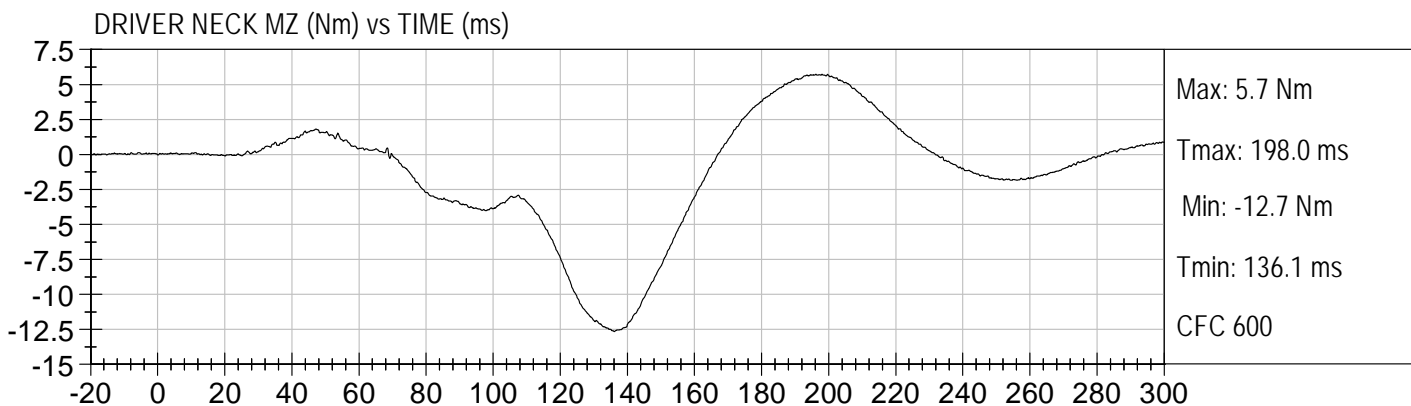
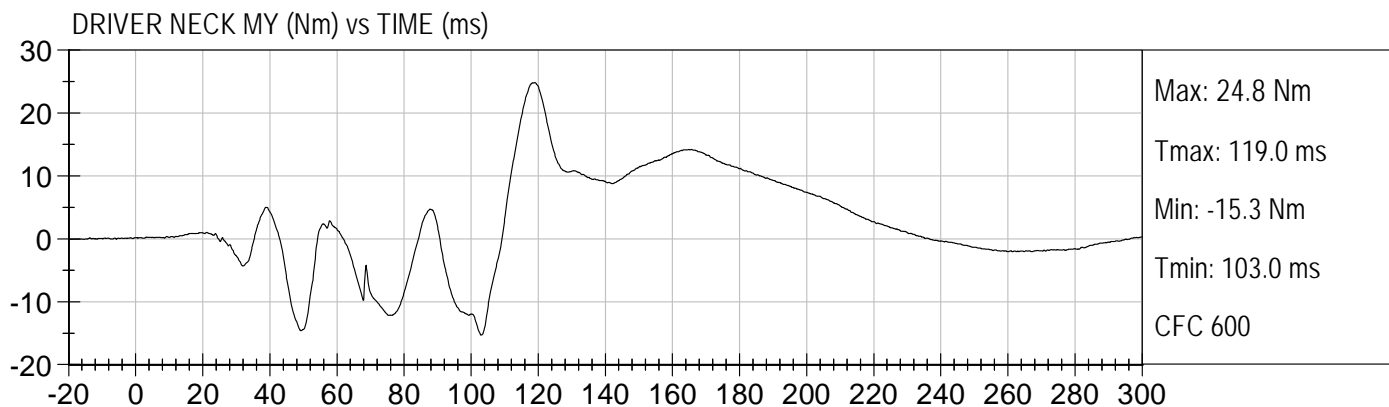
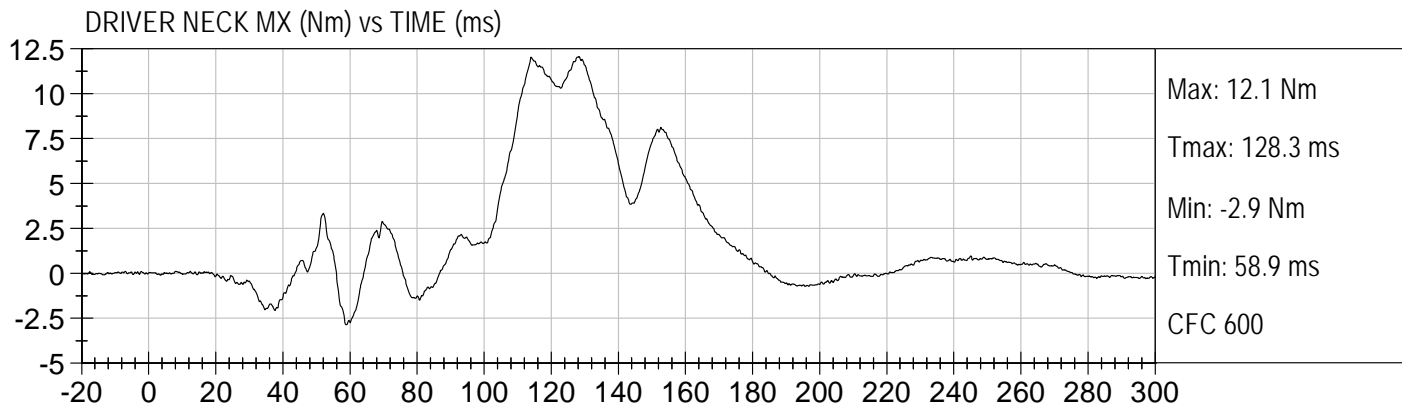

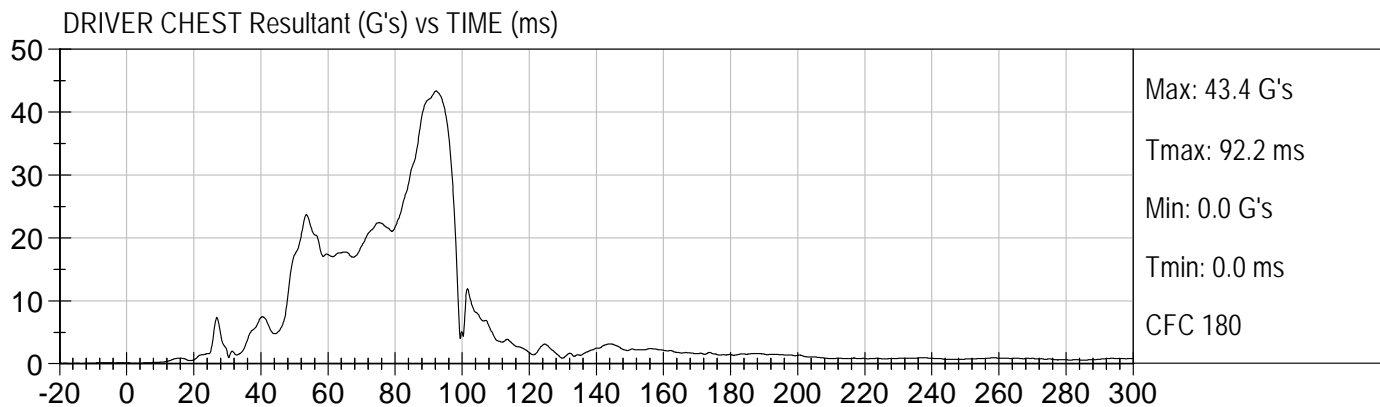
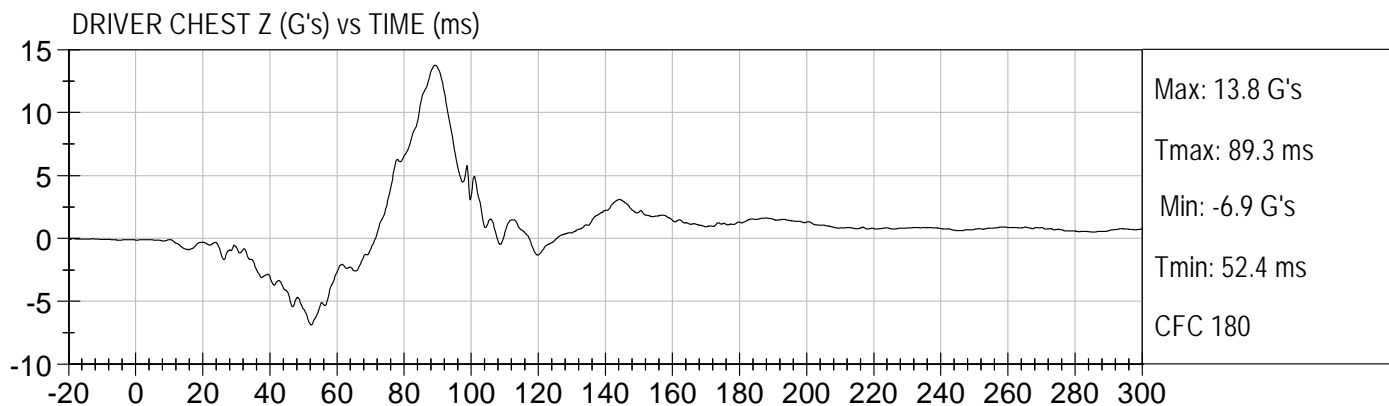
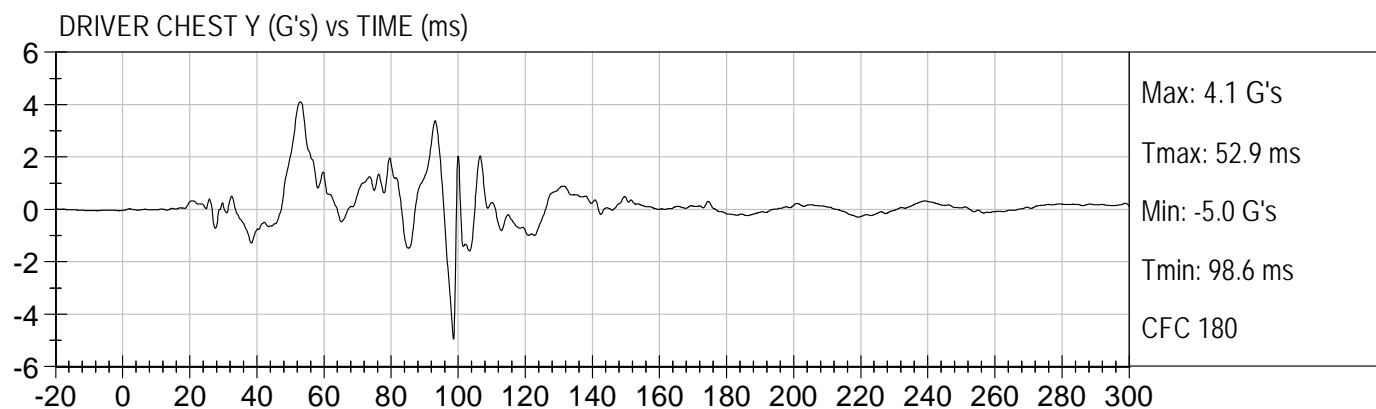
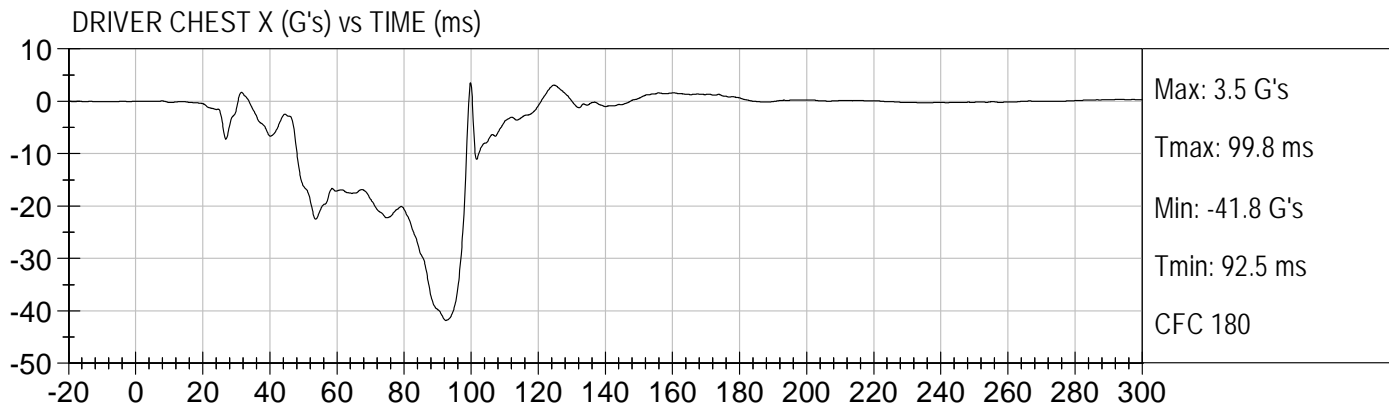

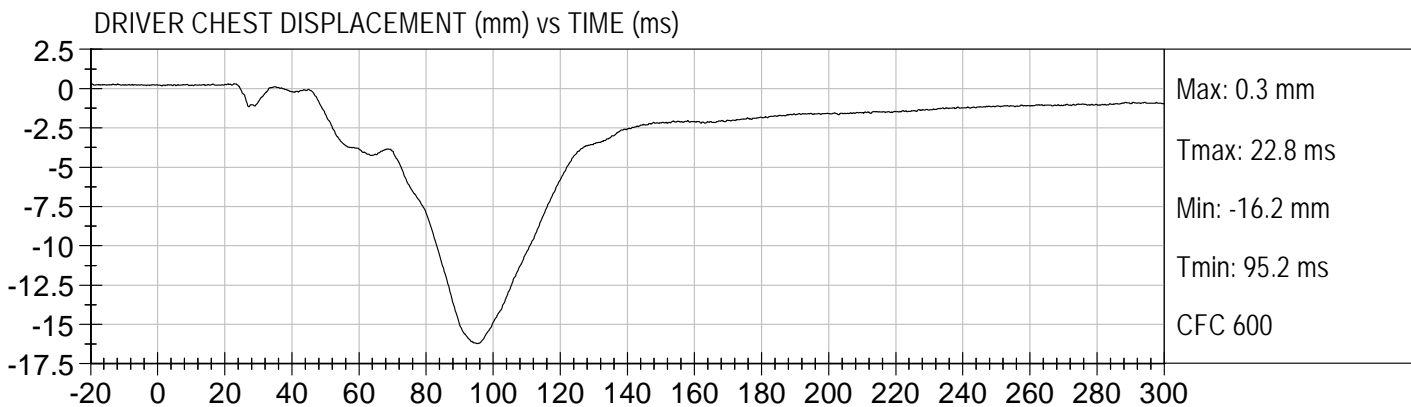
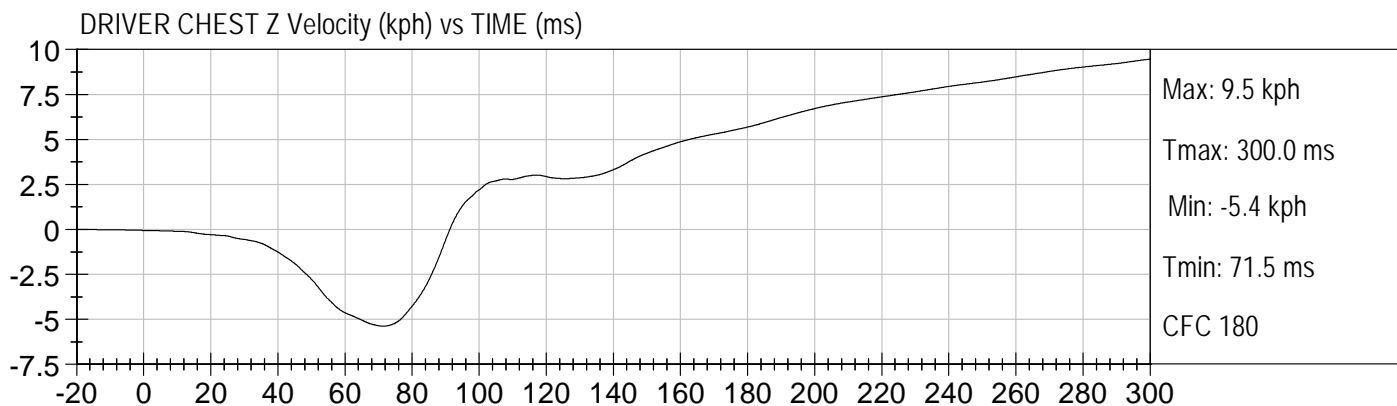
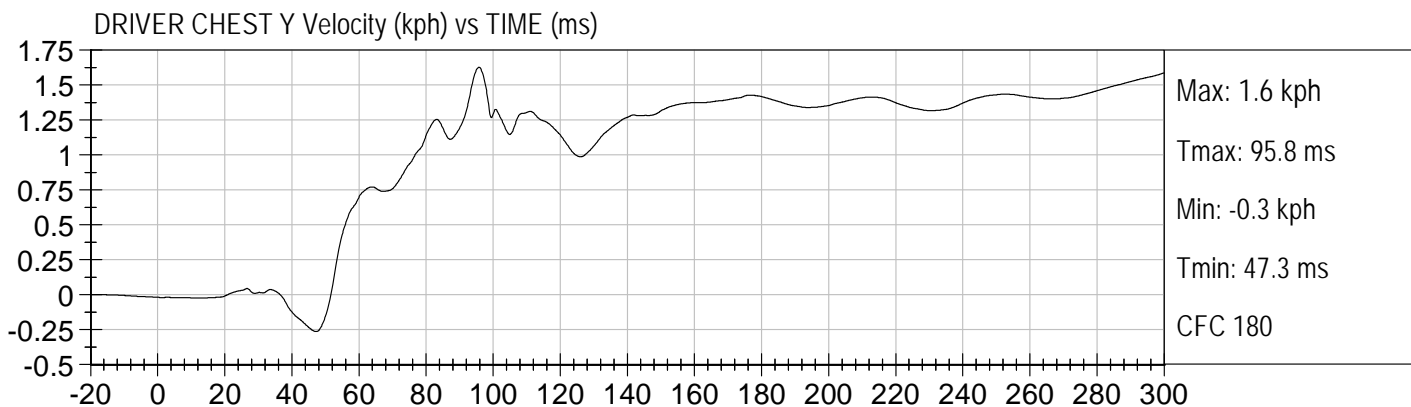
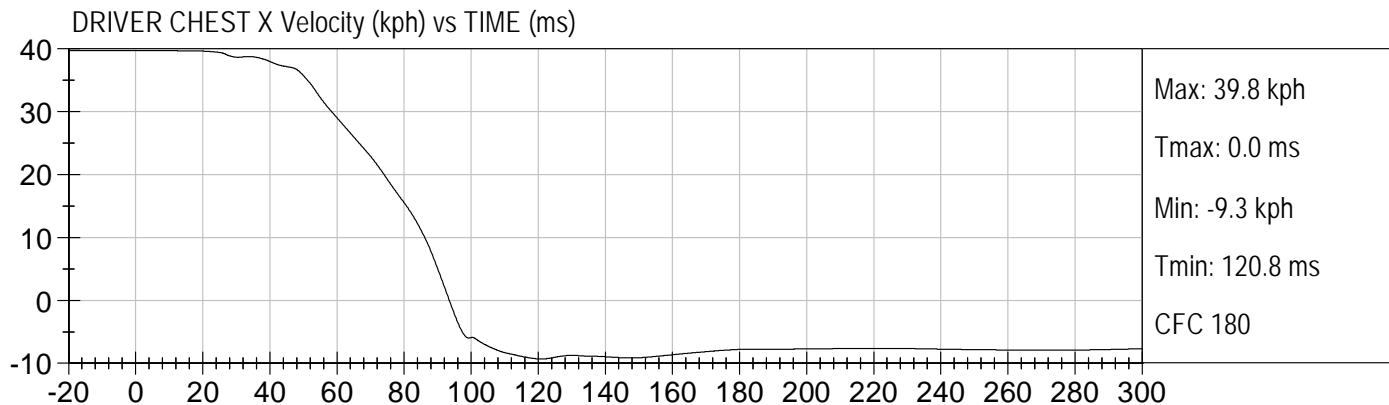



25 MPH FRONTAL UNBELTED 5THS
2010 MAZDA 6 (CA5400)

Test Date: 02/19/2010
Speed: 24.7 mph (39.8 km/h)

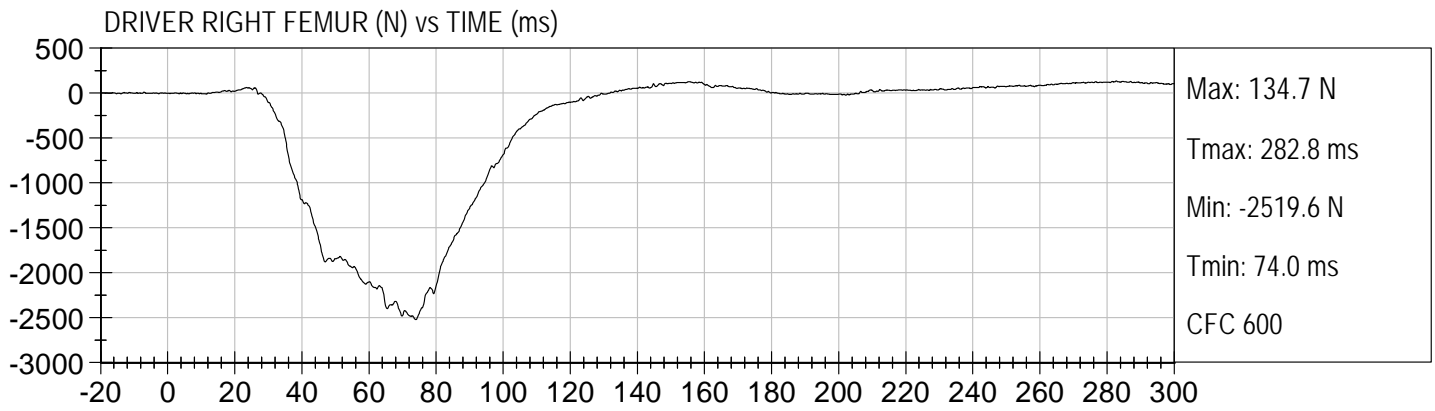
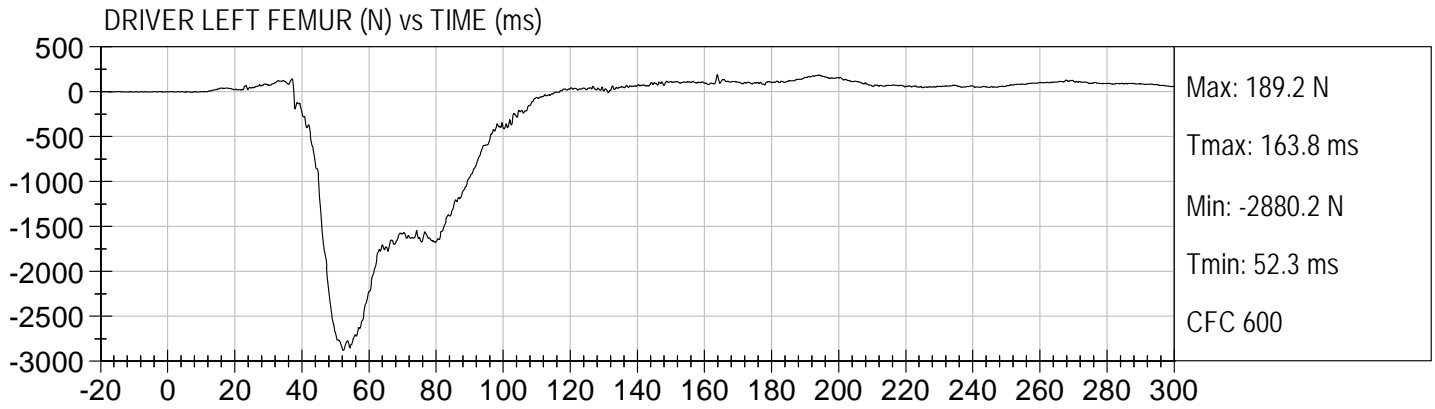

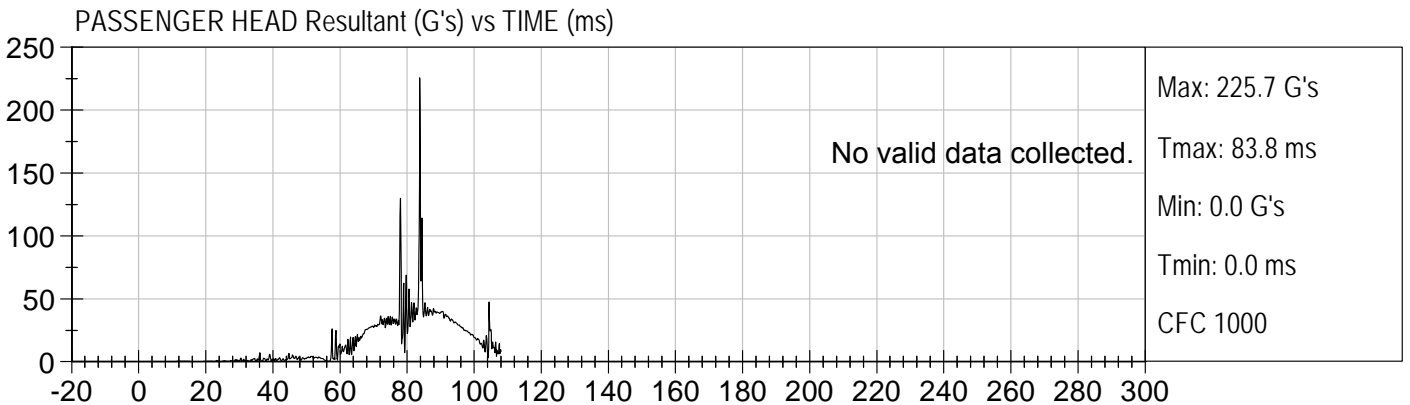
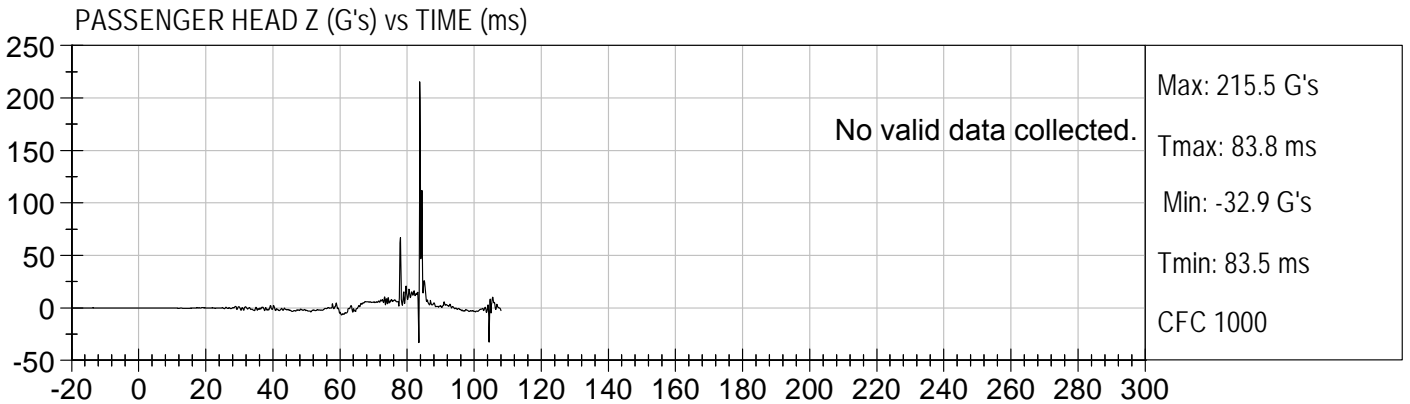
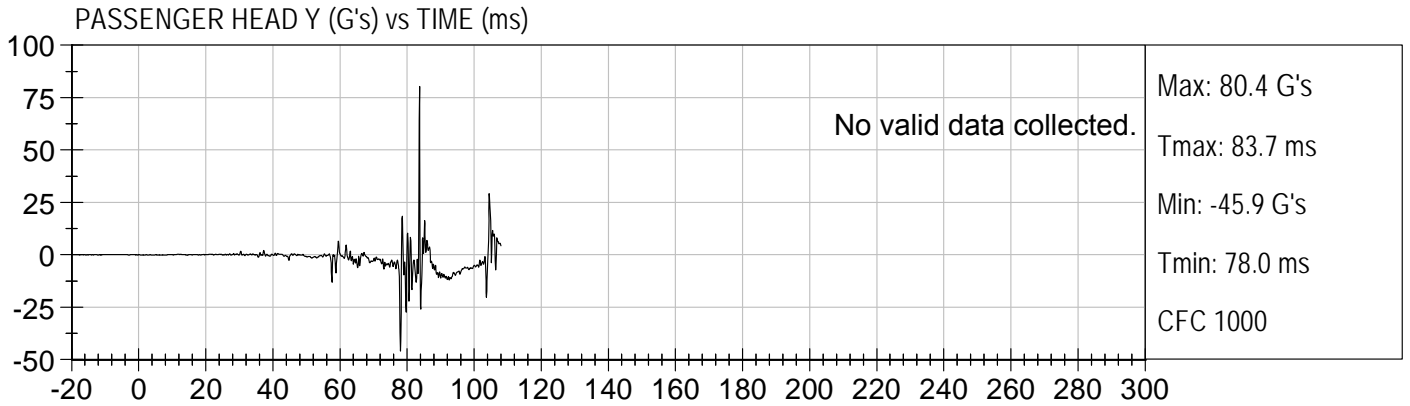
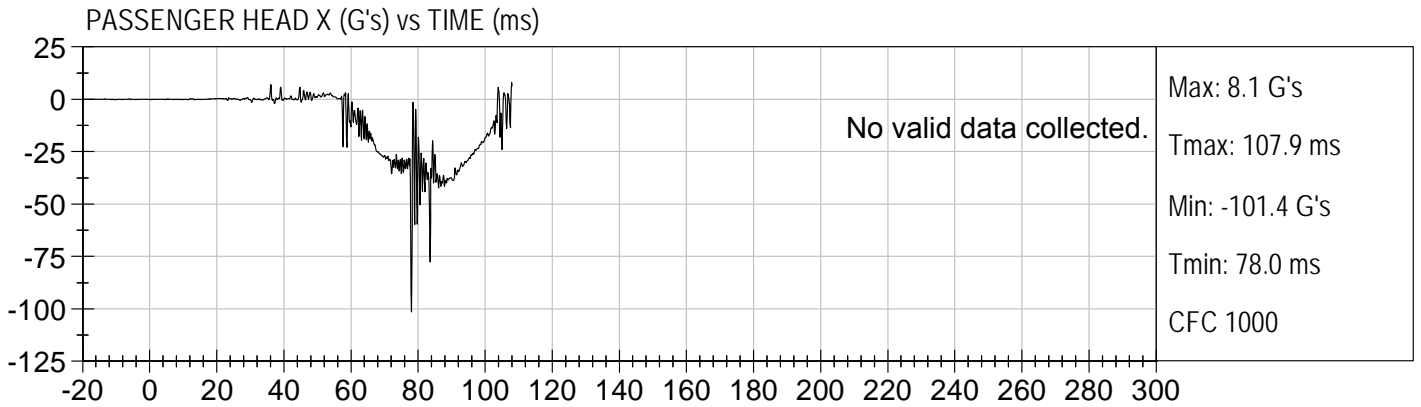

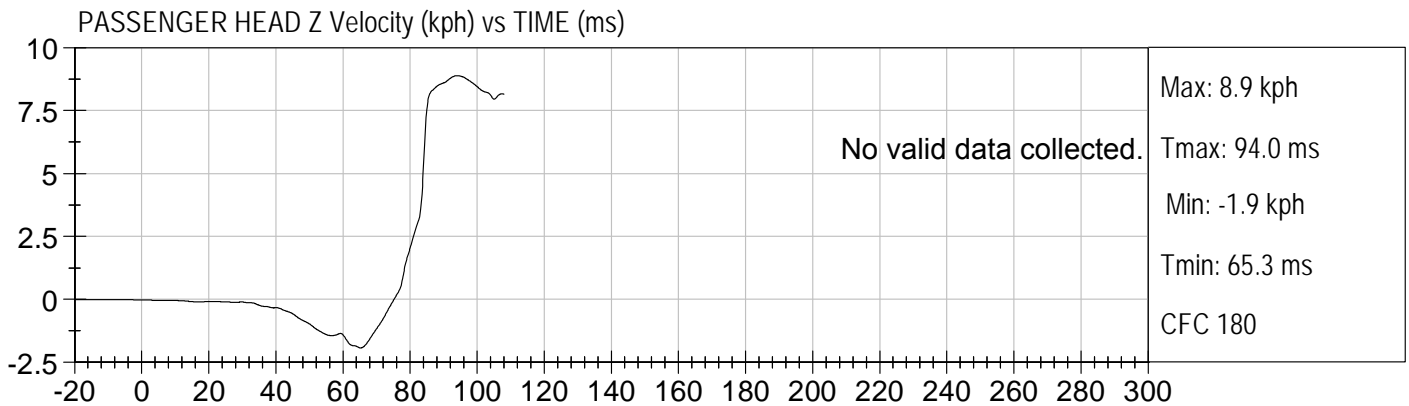
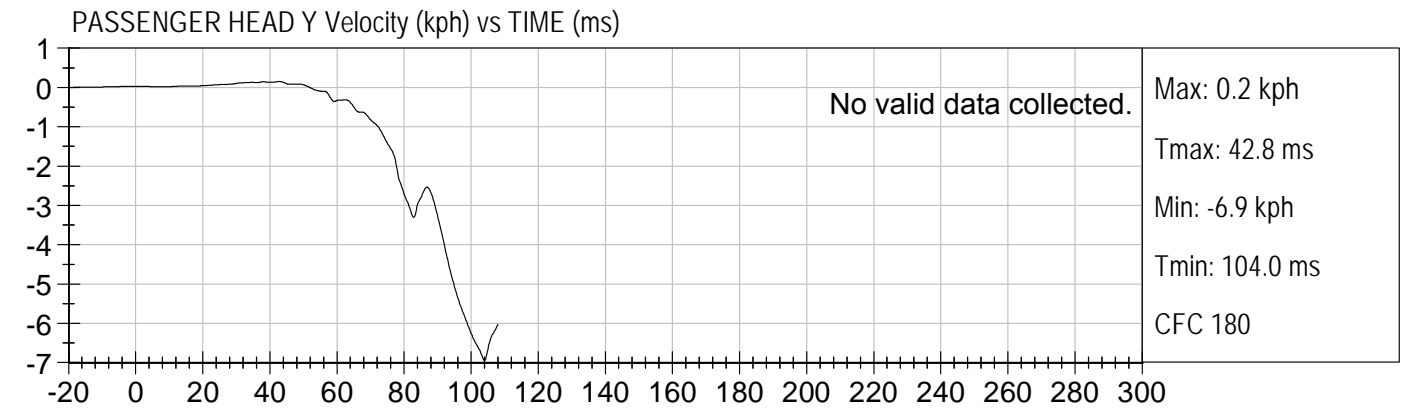
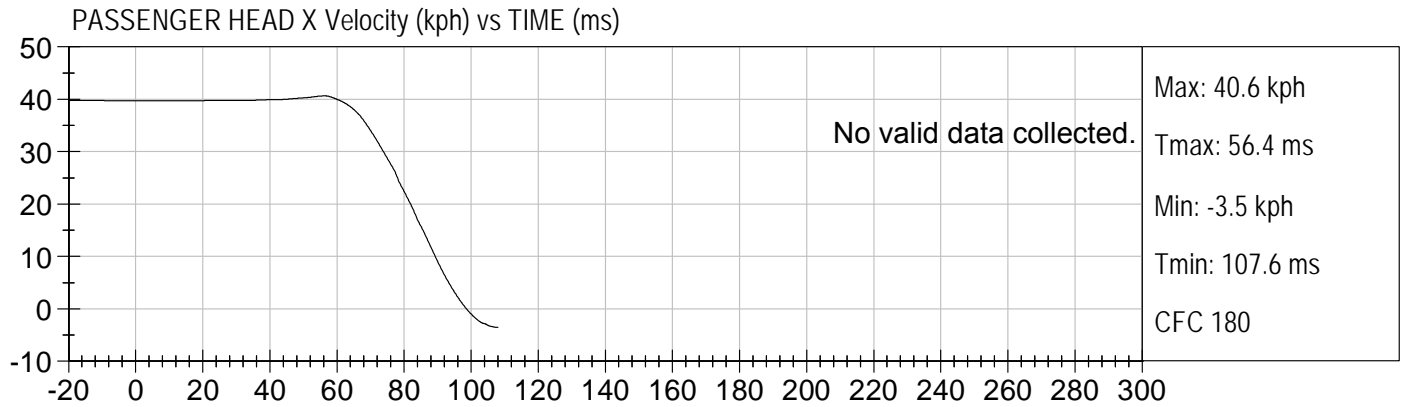

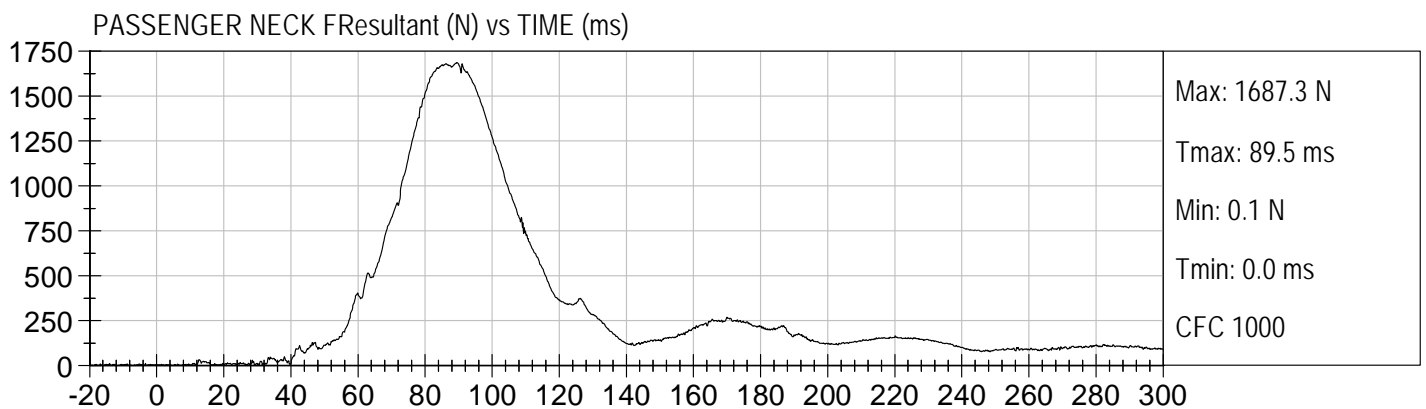
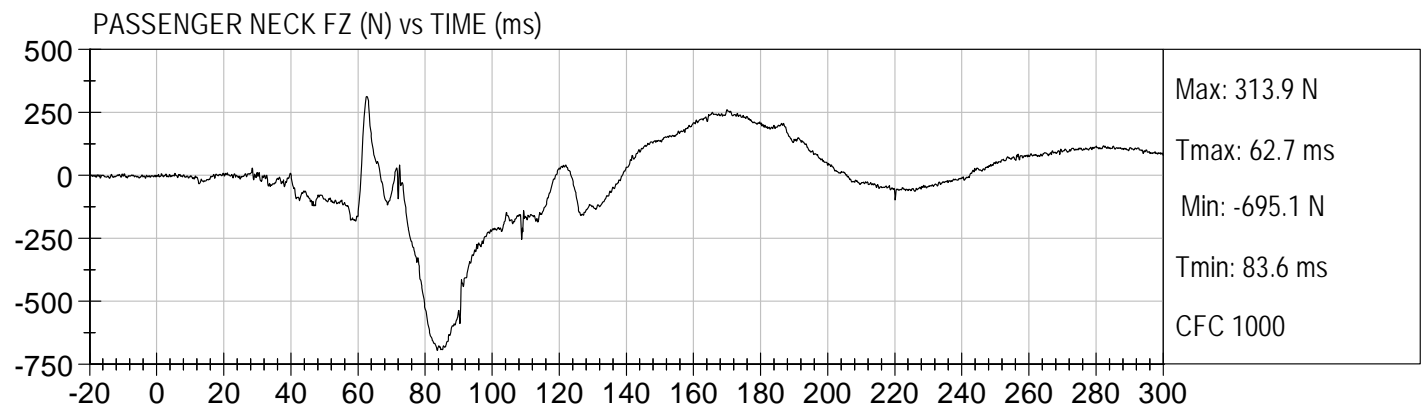
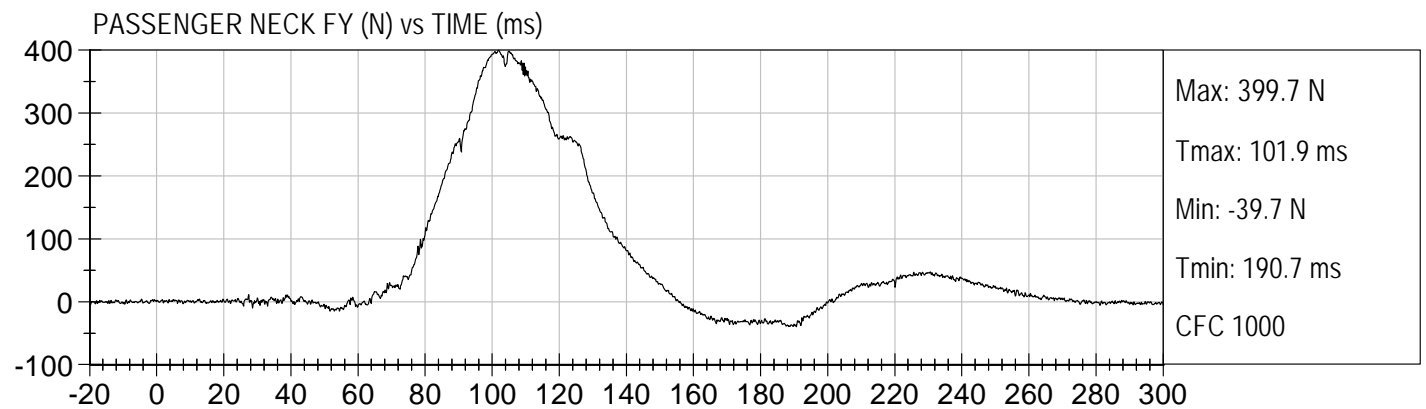
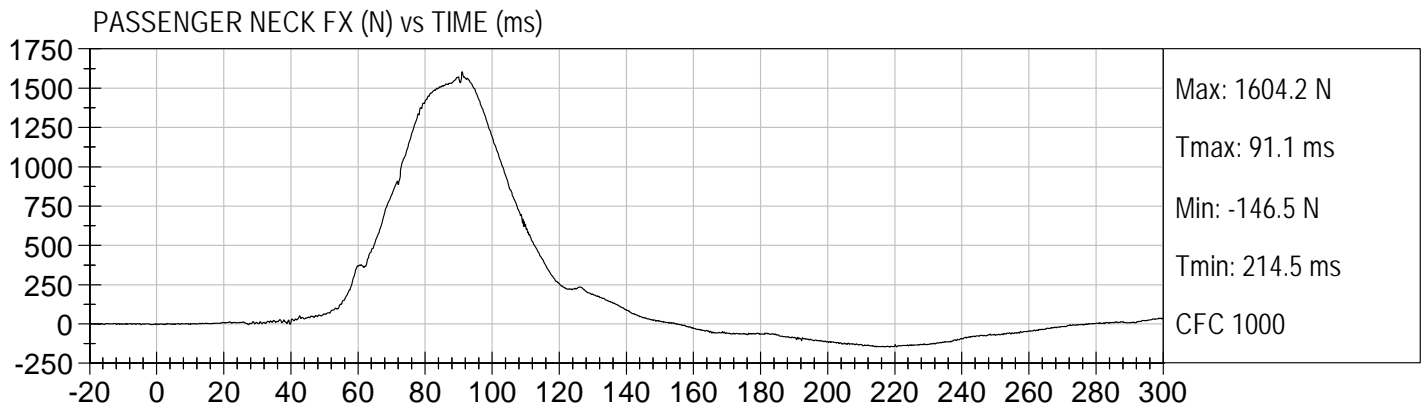

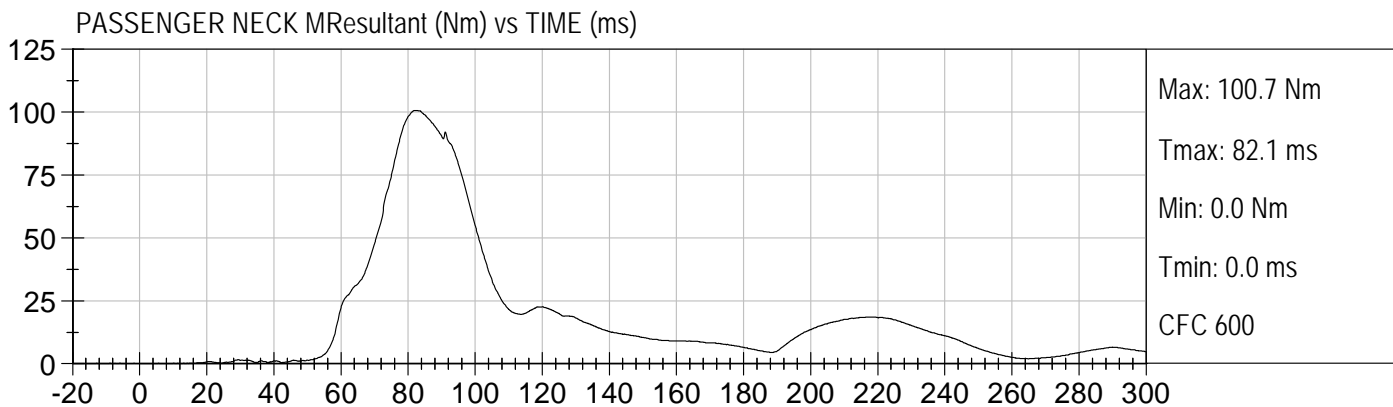
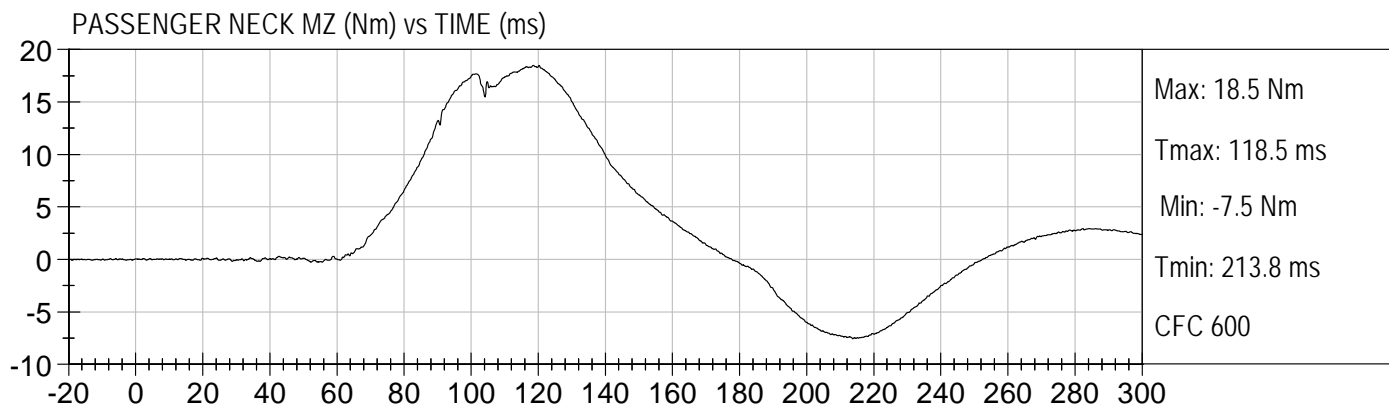
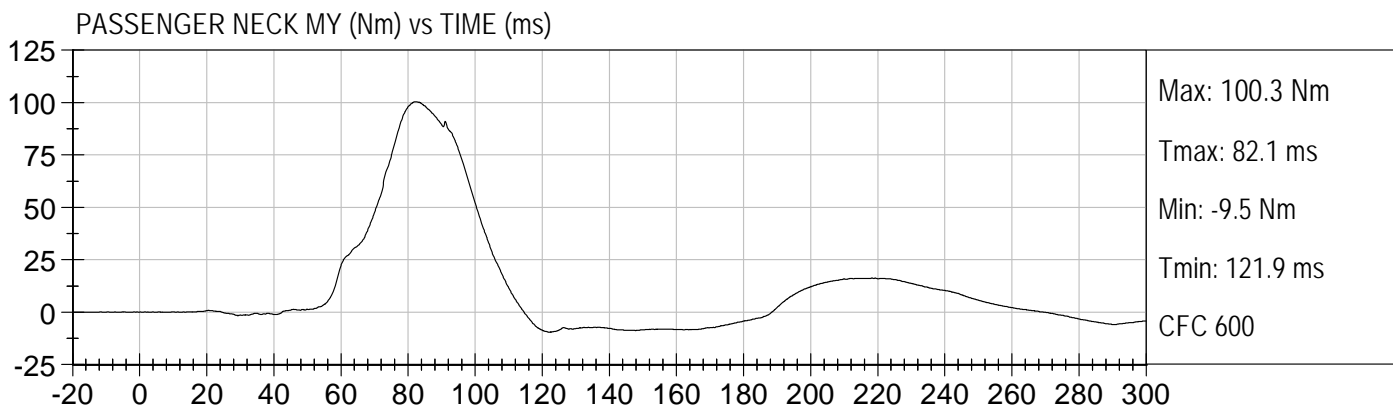
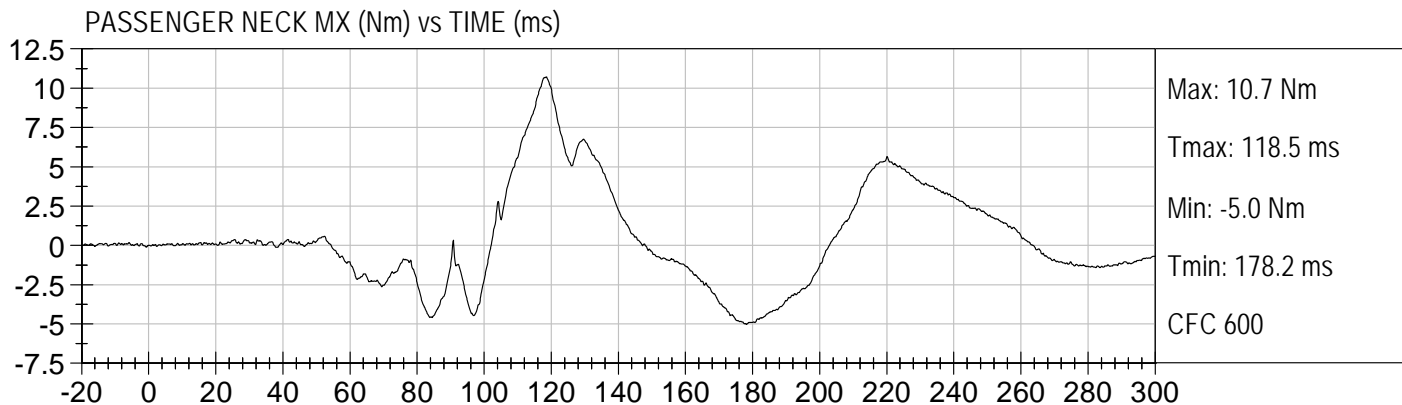

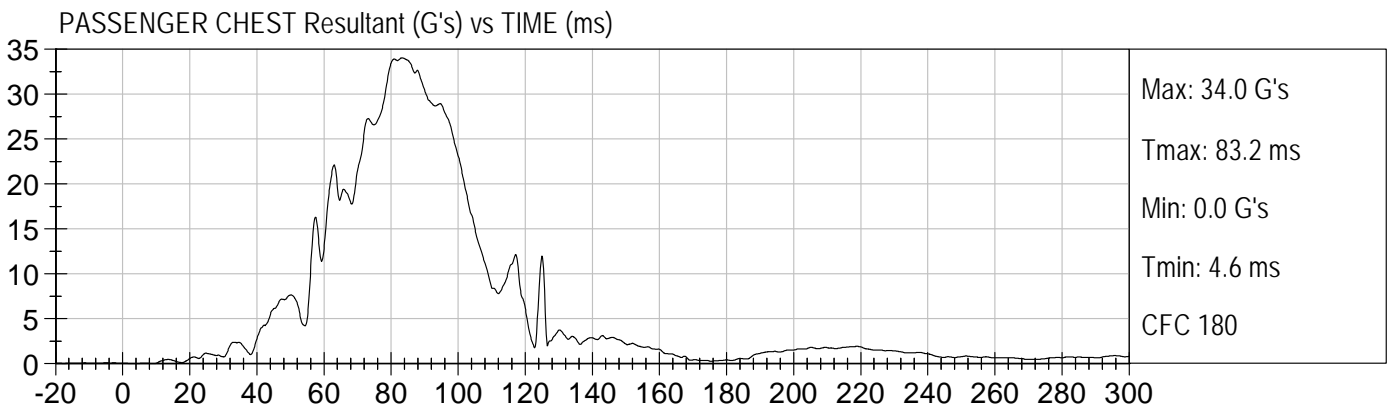
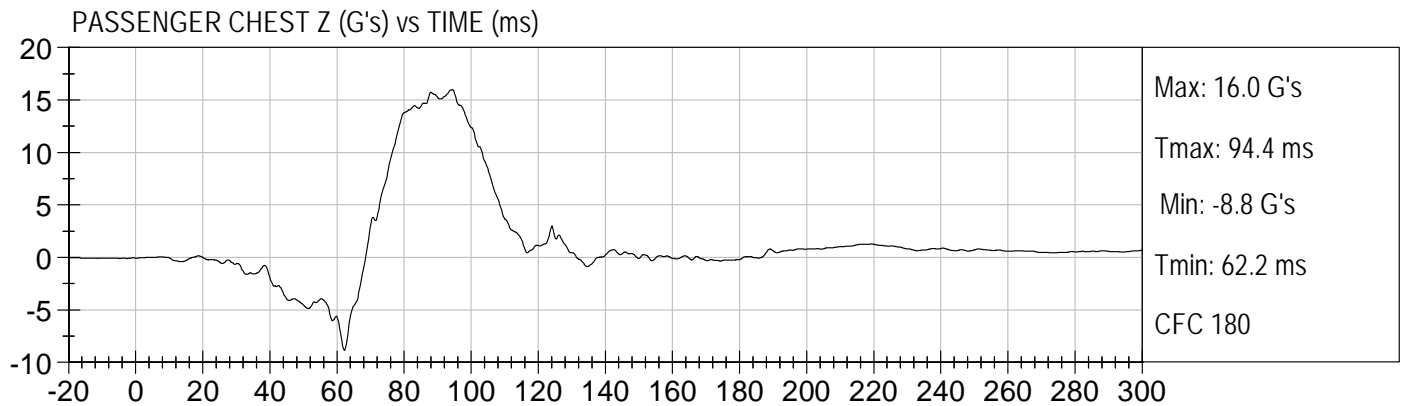
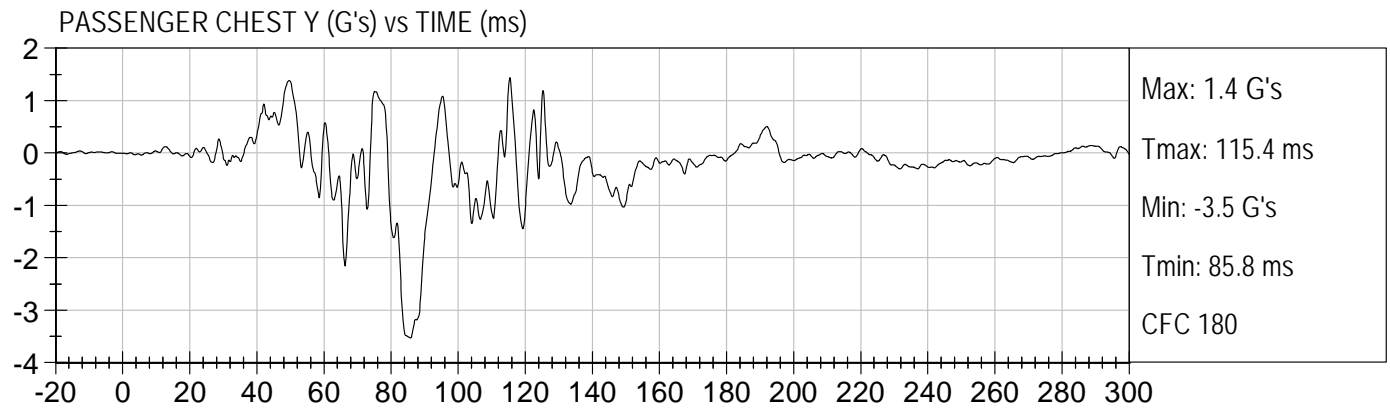
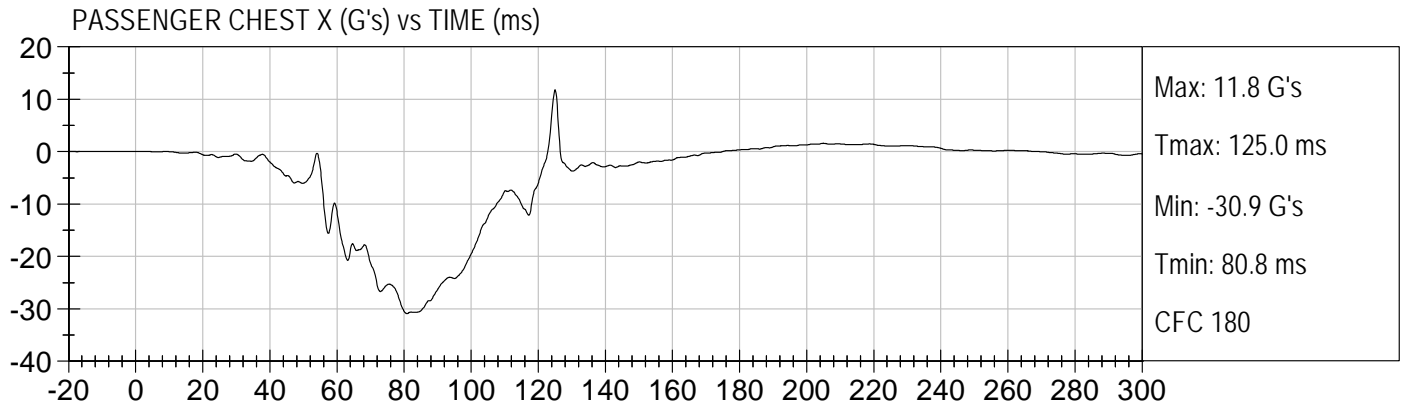

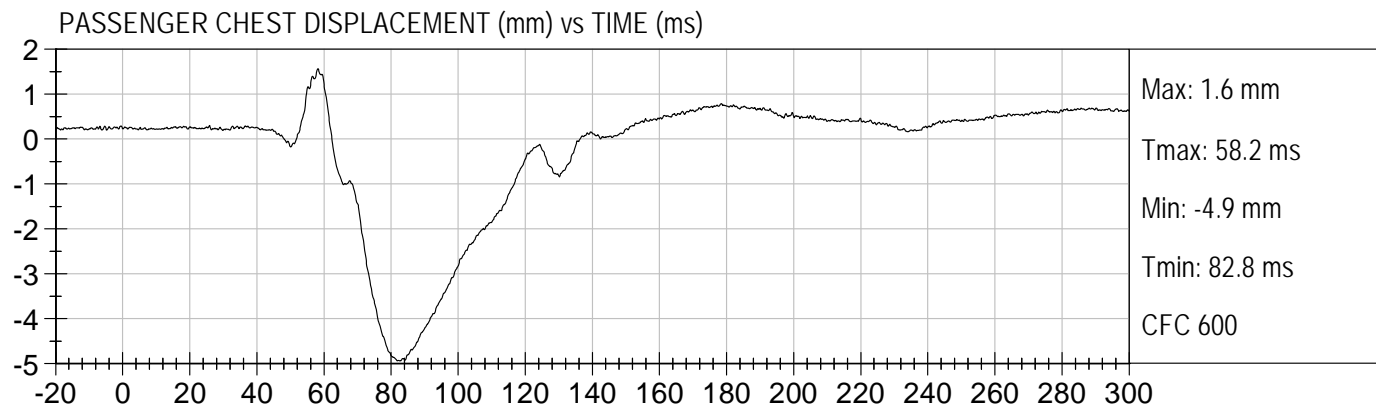
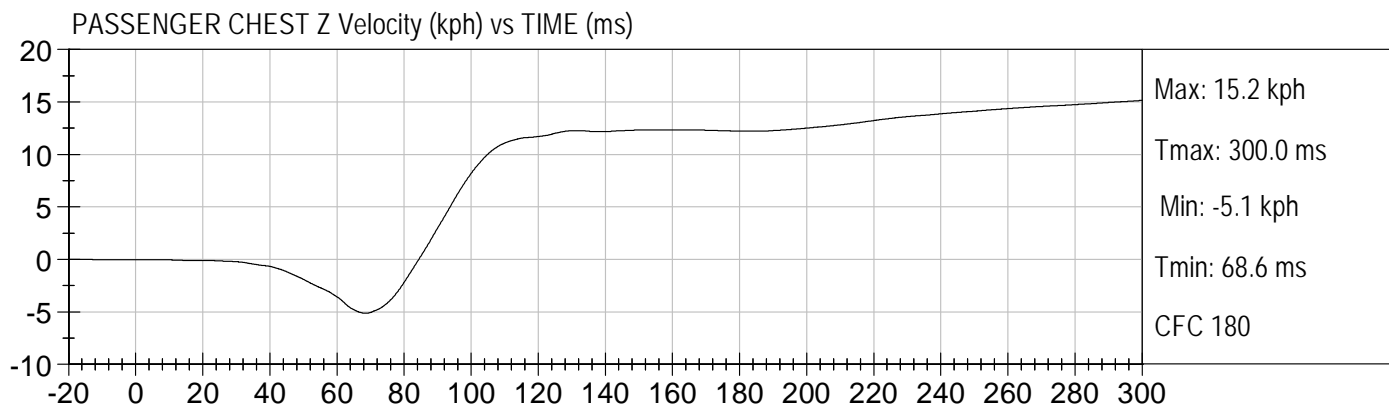
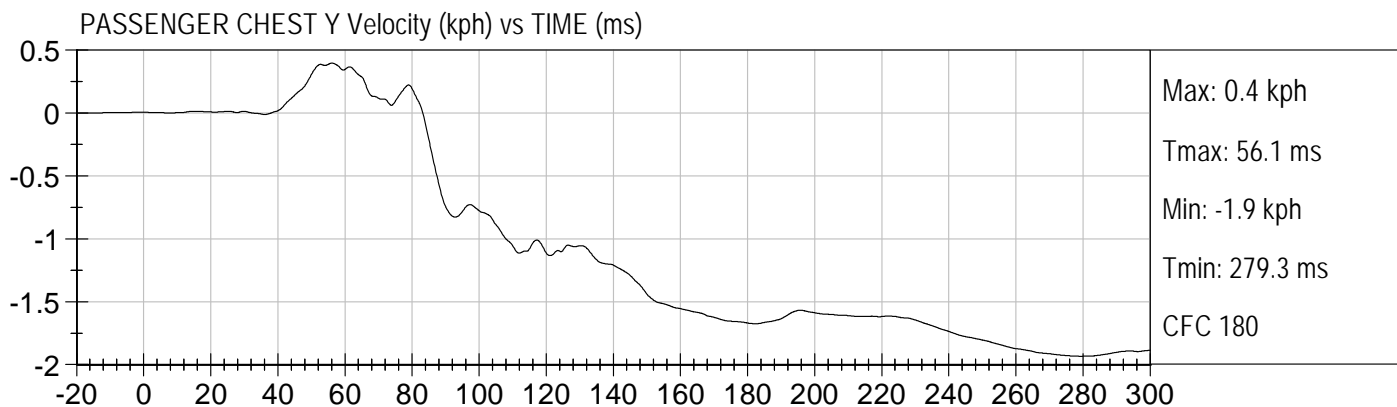
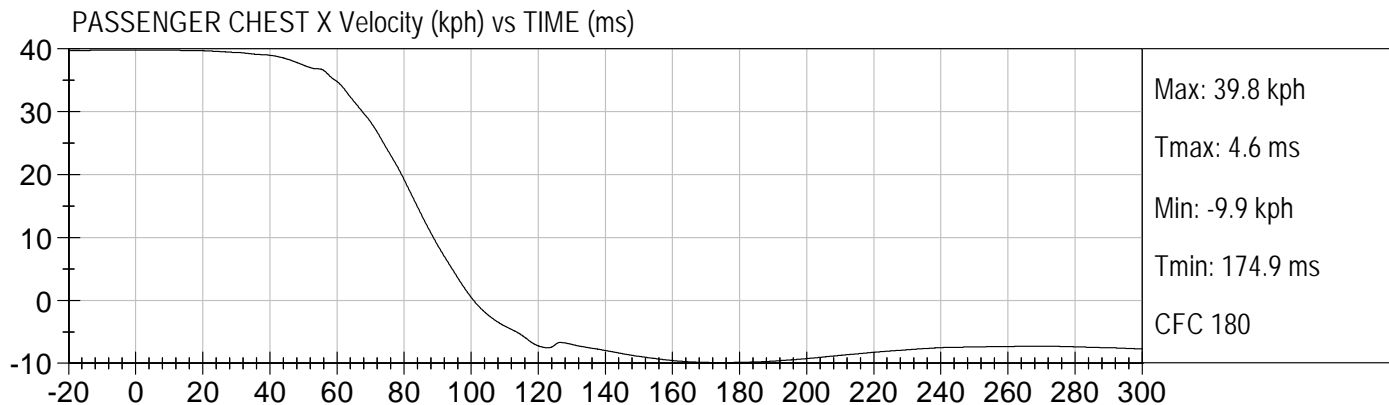

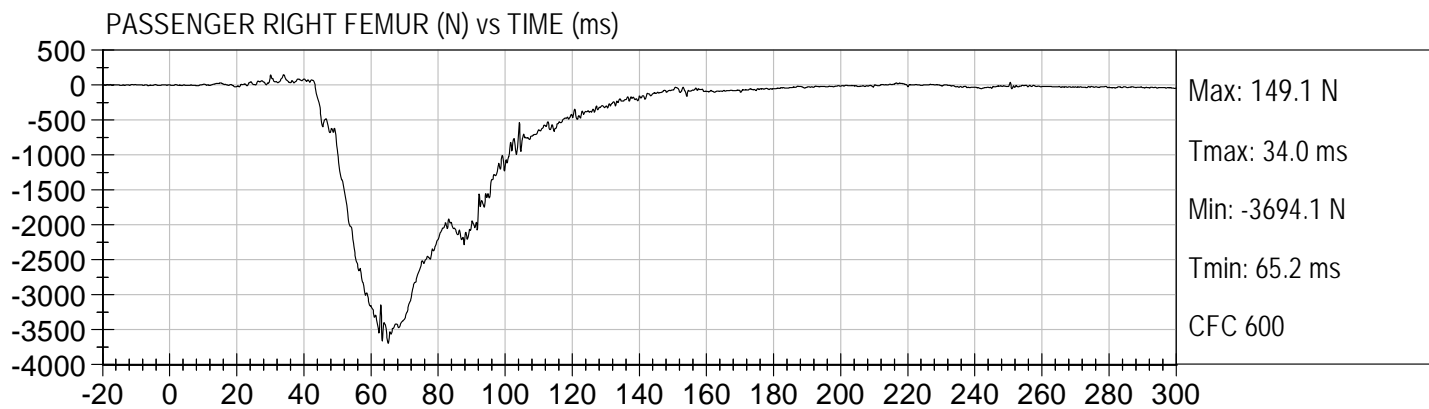
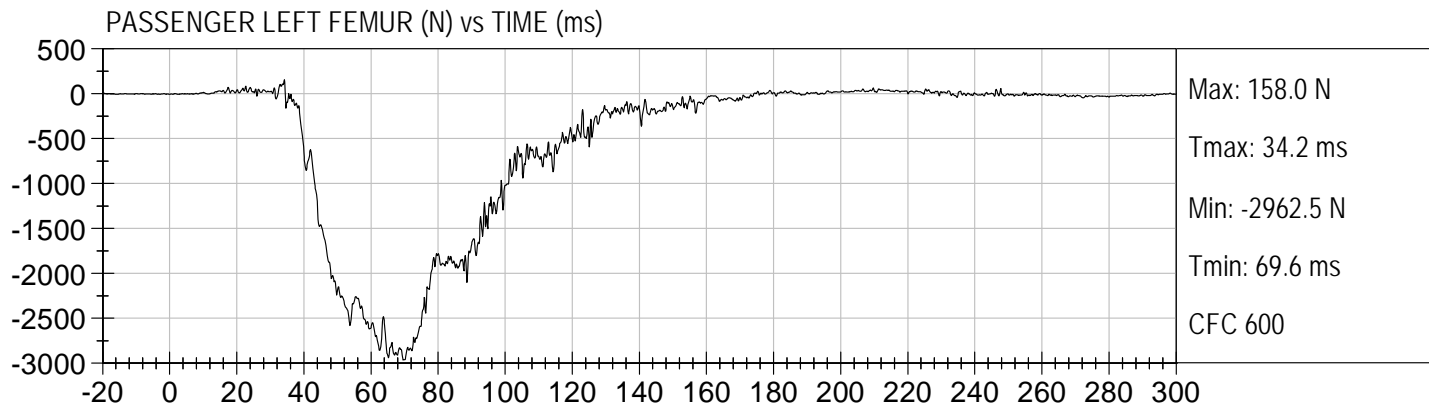

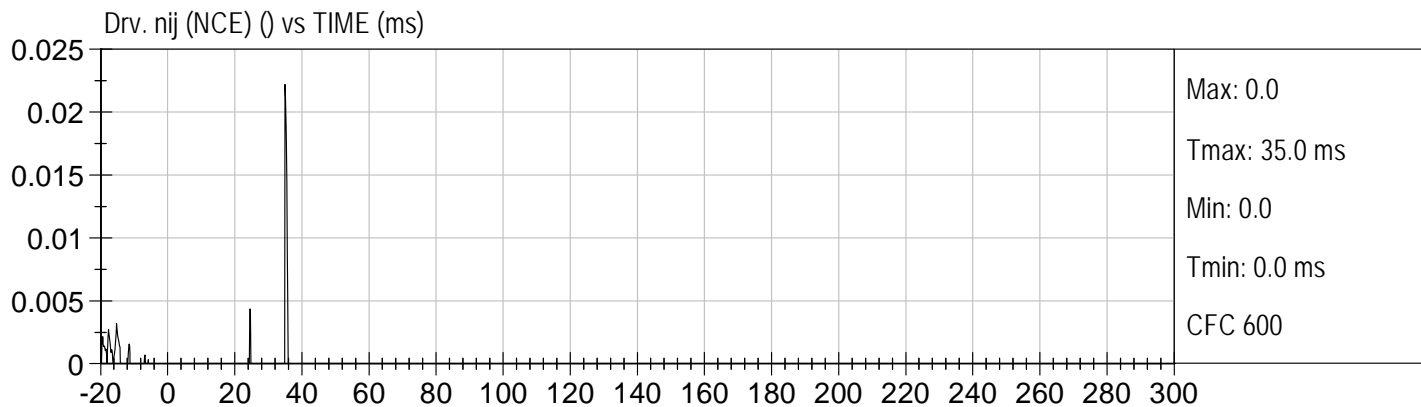
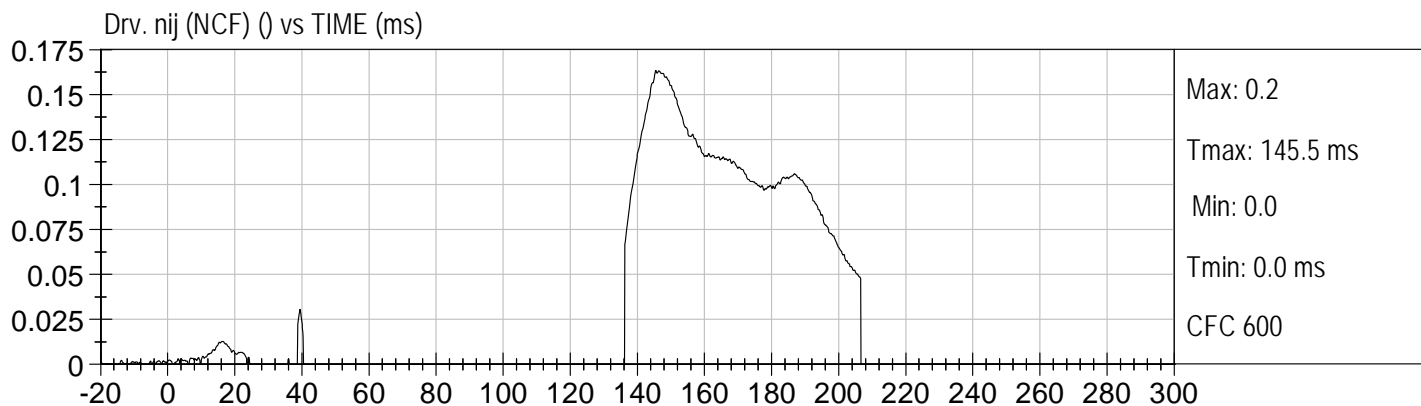
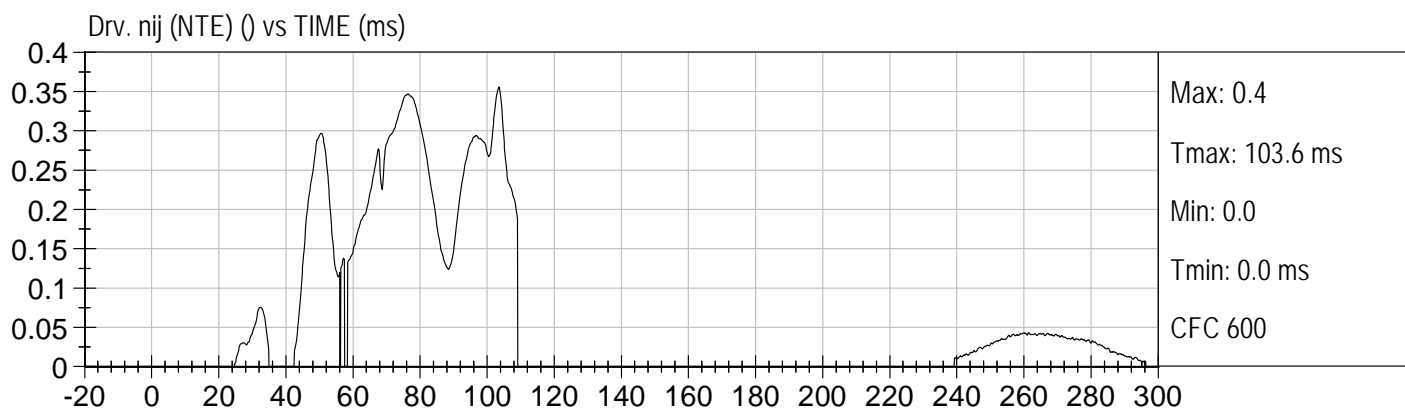
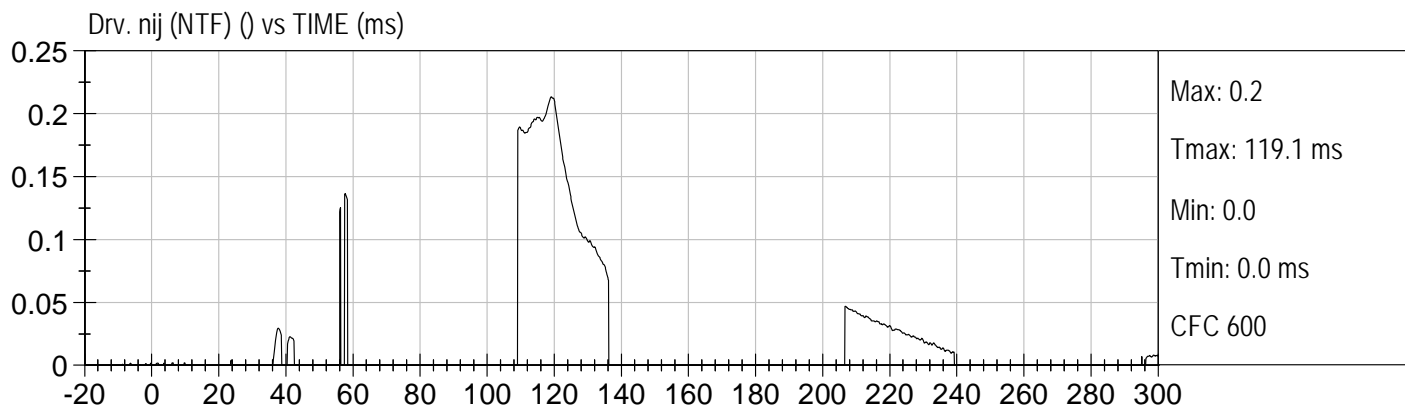

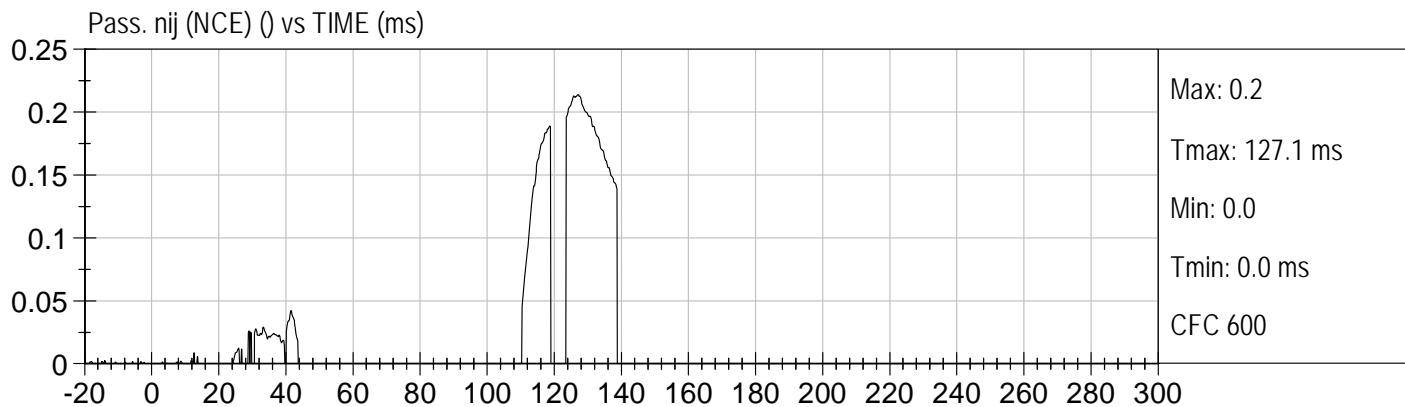
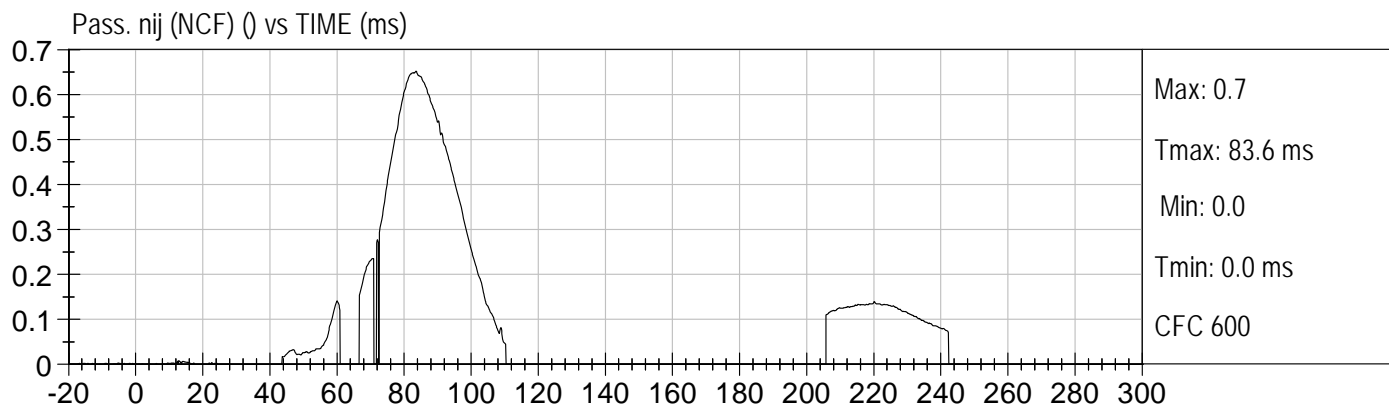
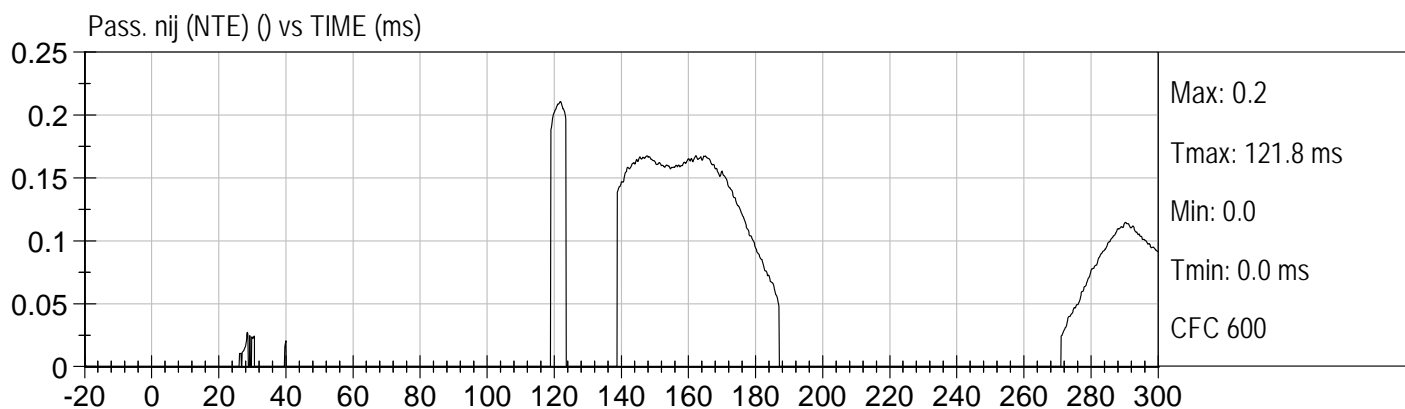
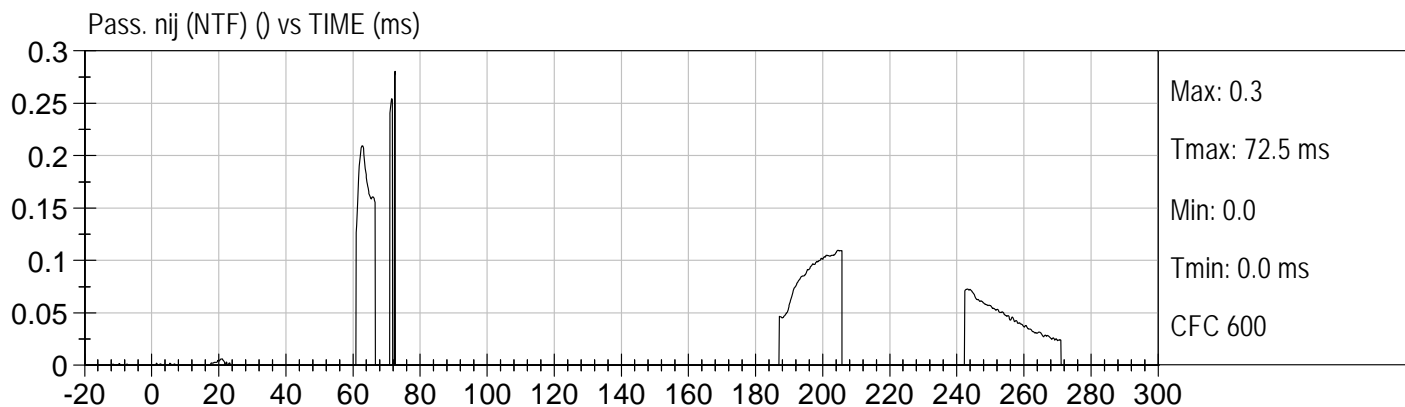

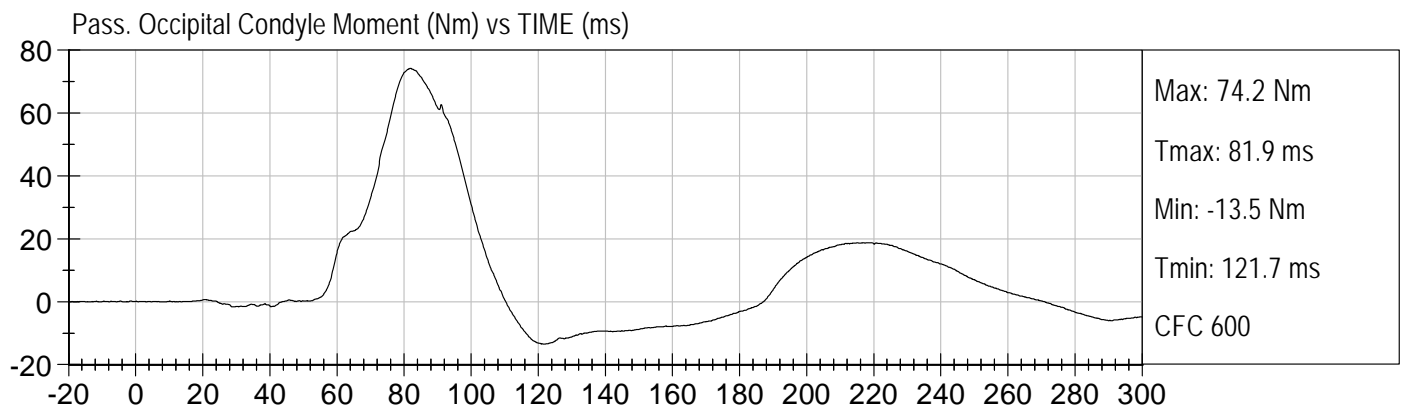
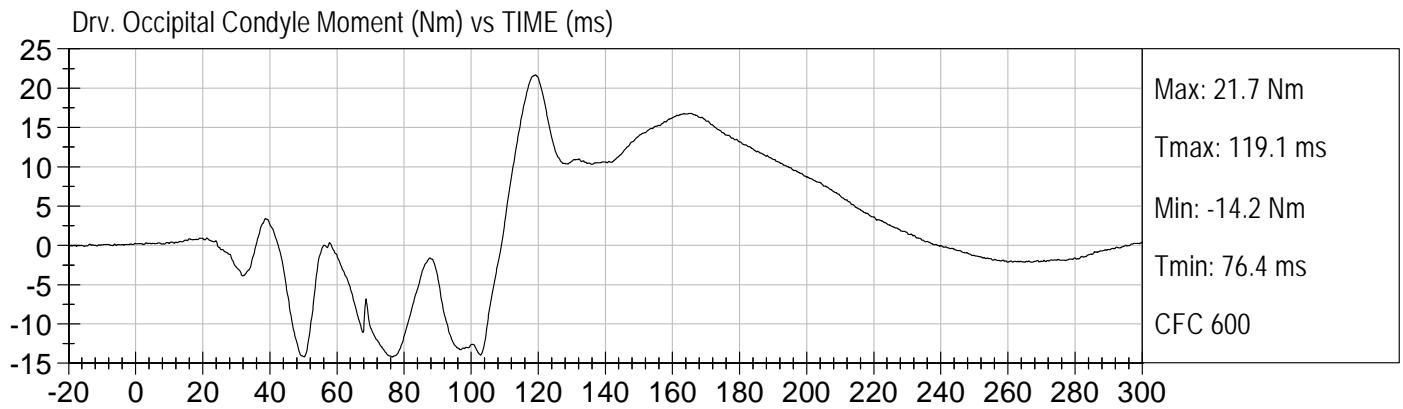

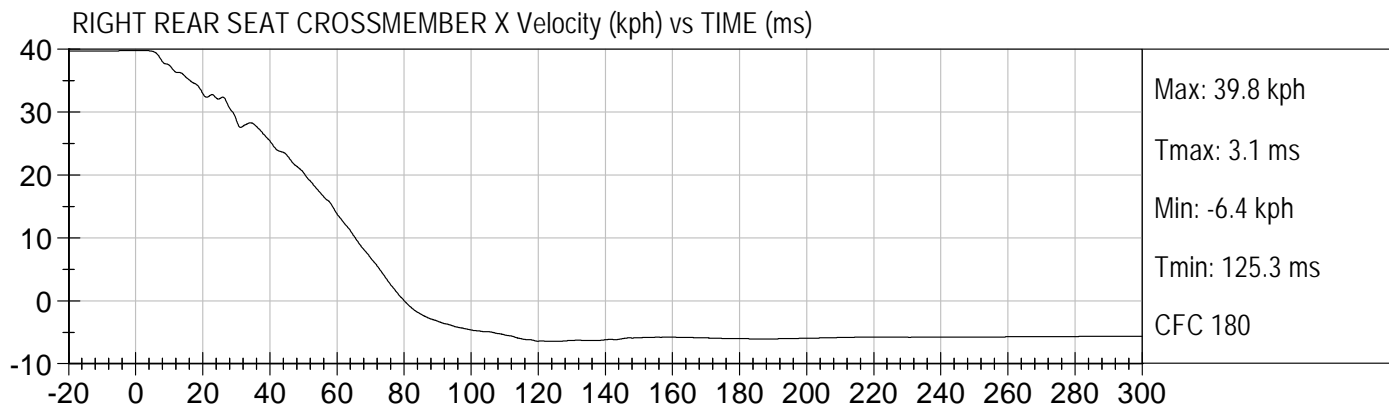
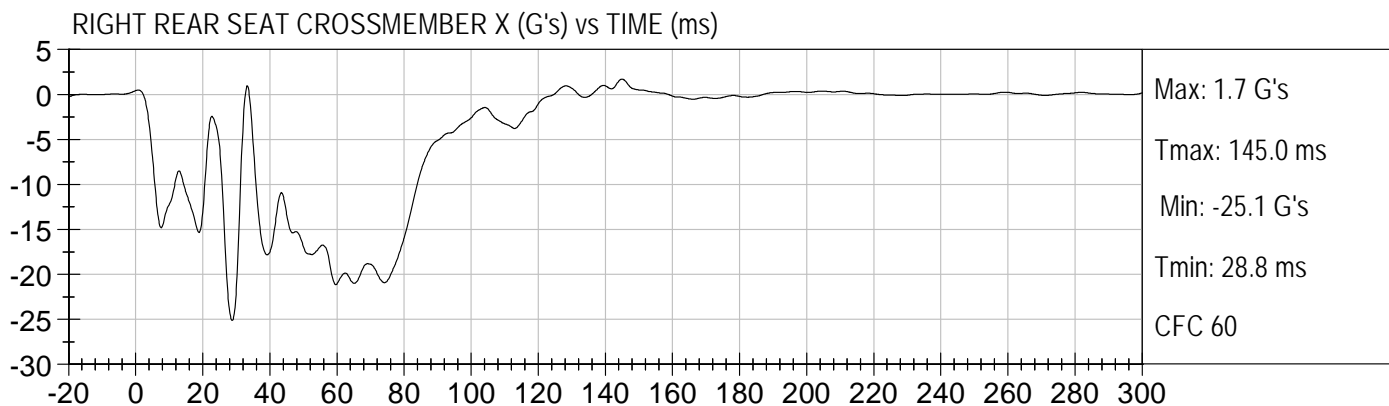
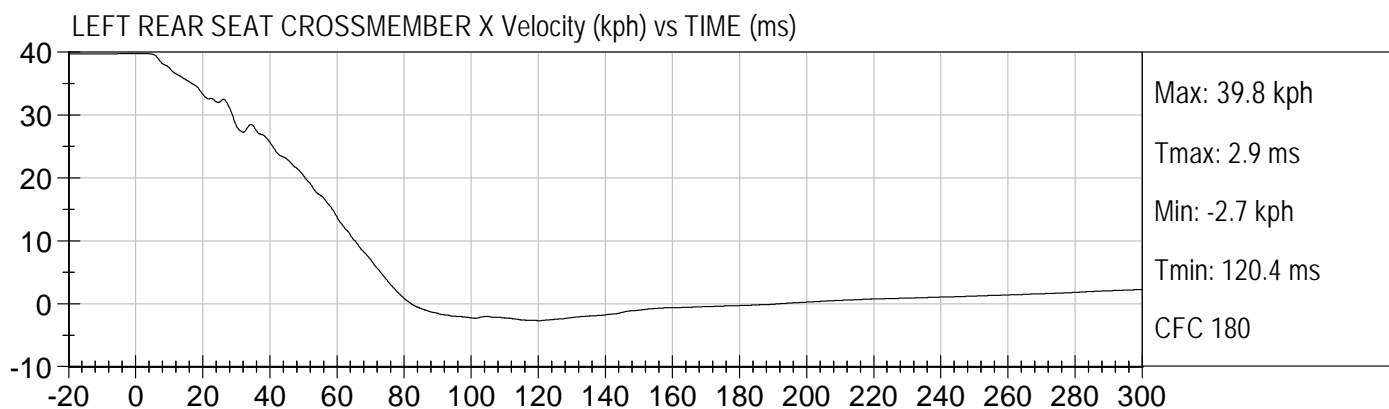
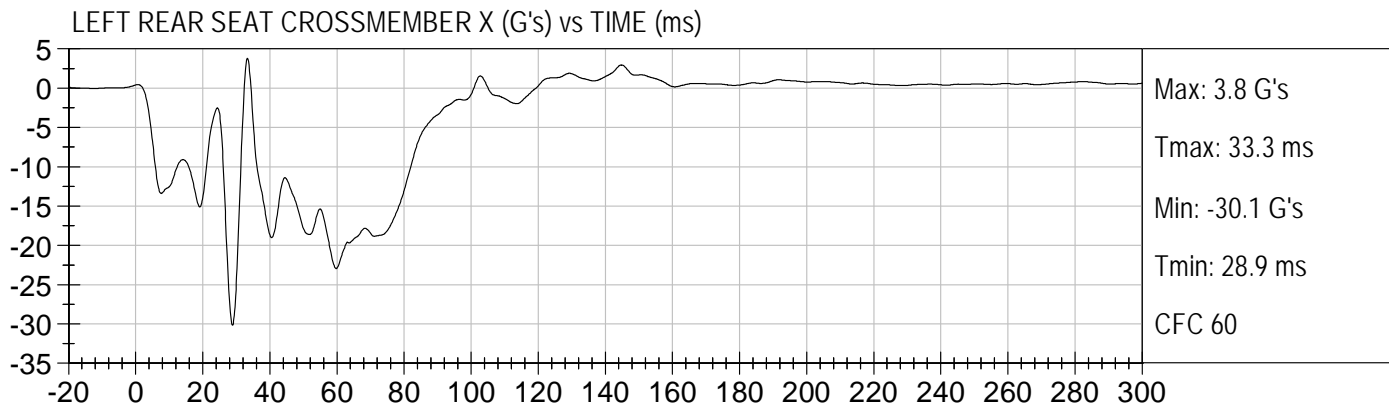

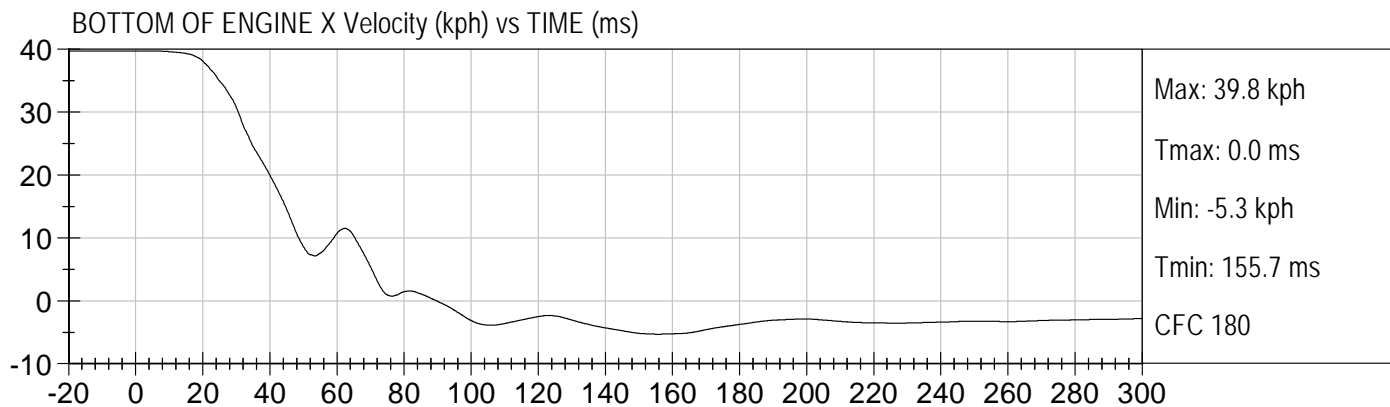
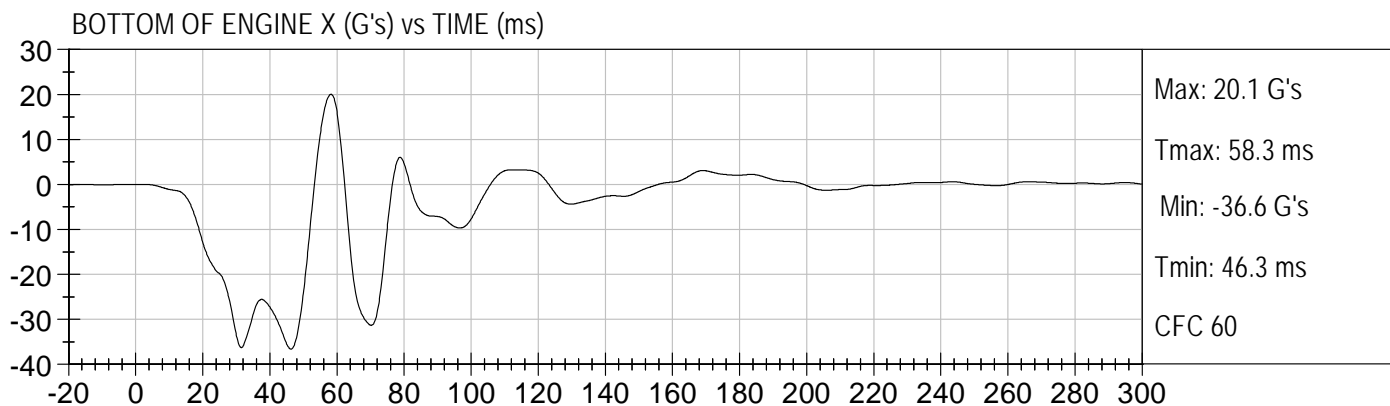
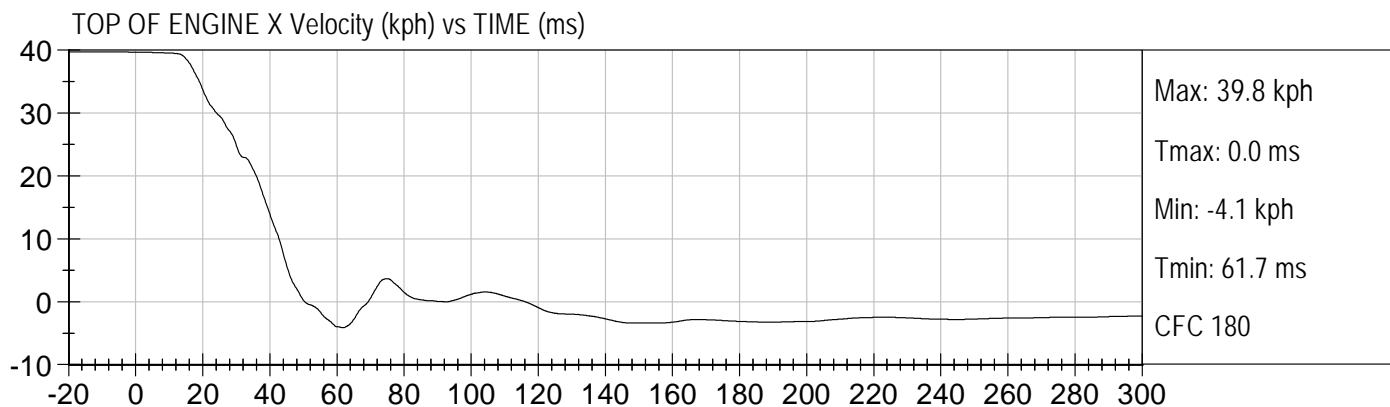
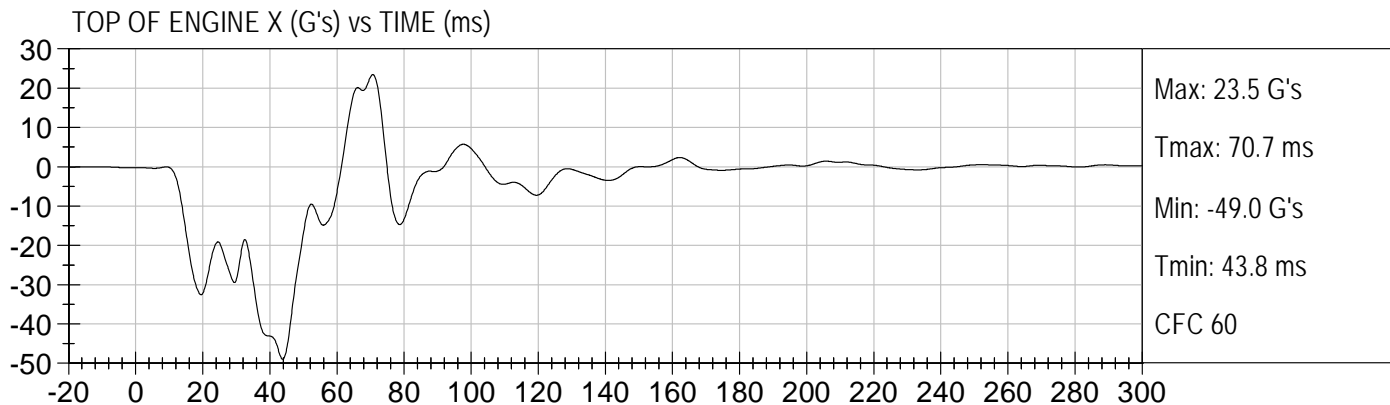

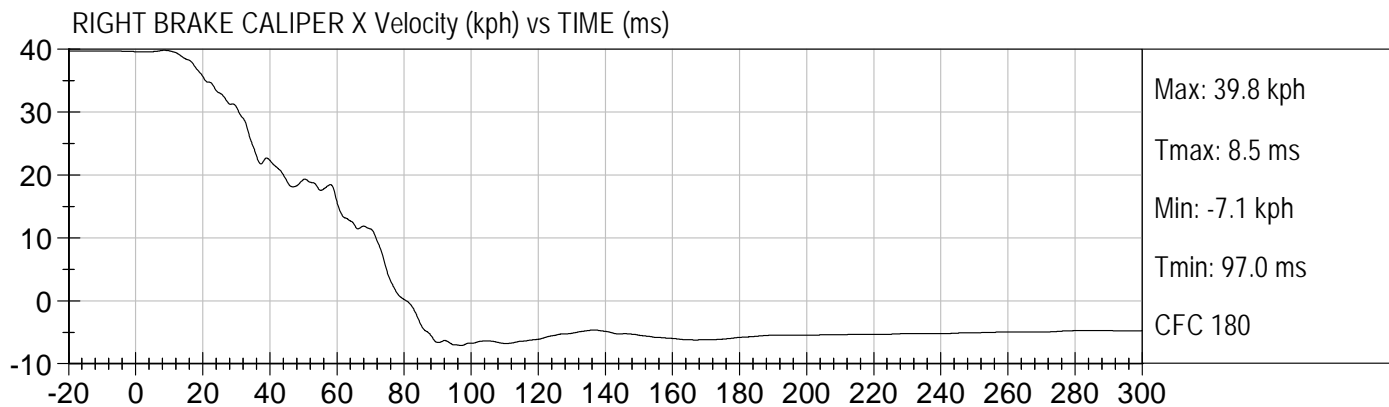
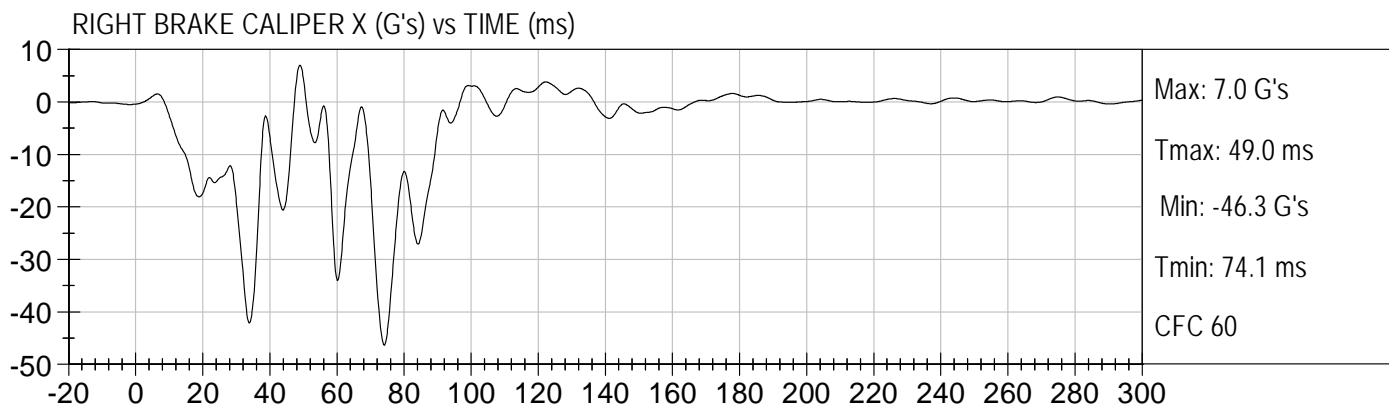
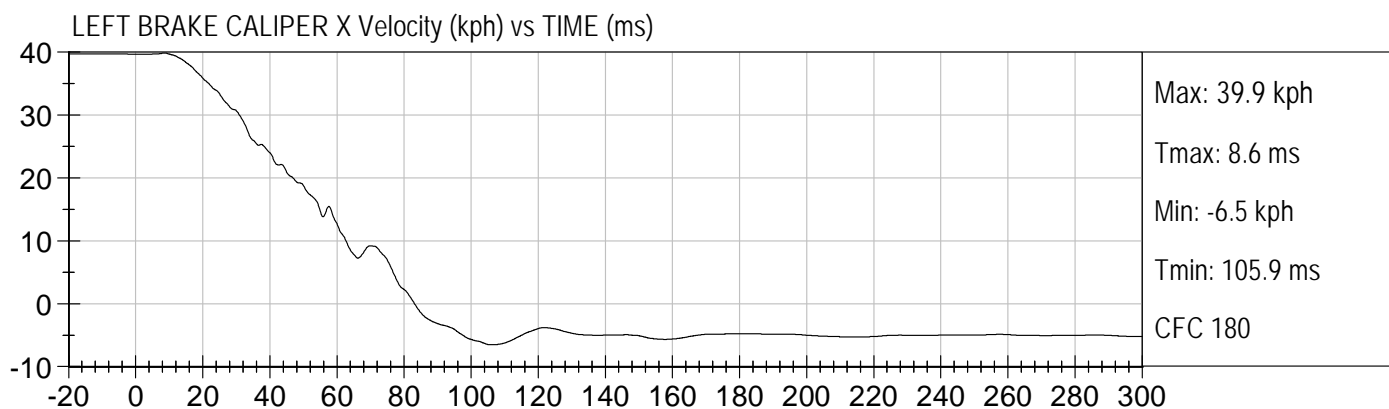
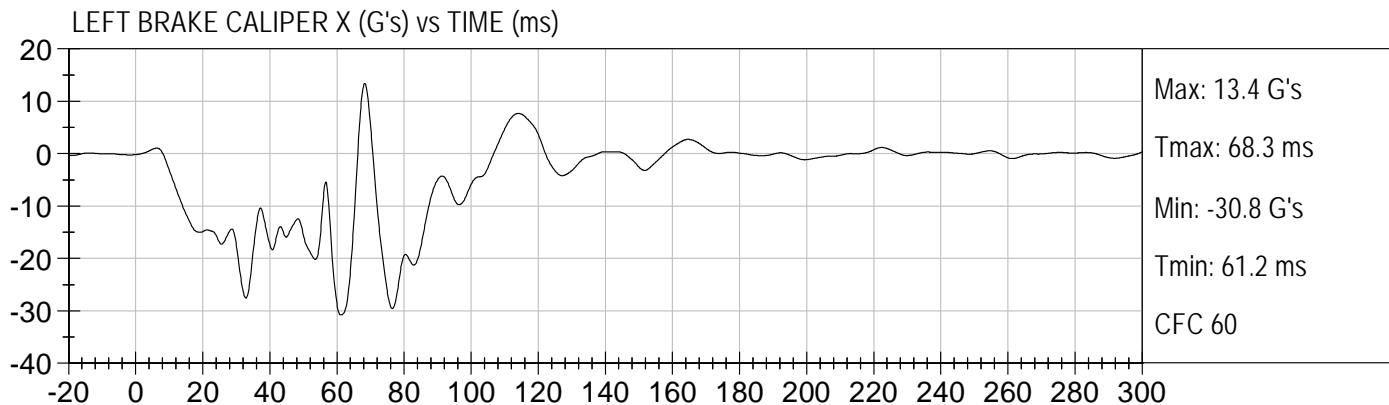

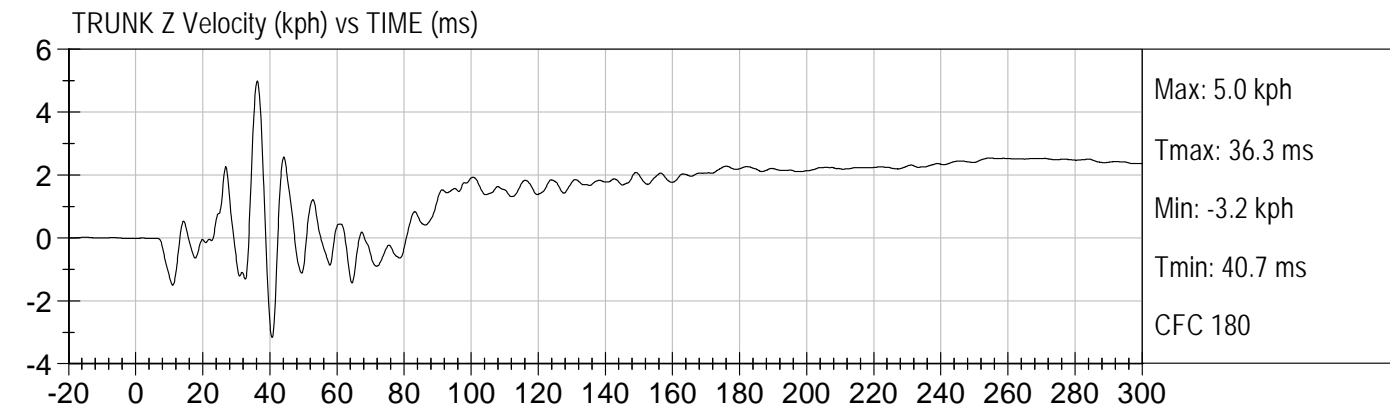
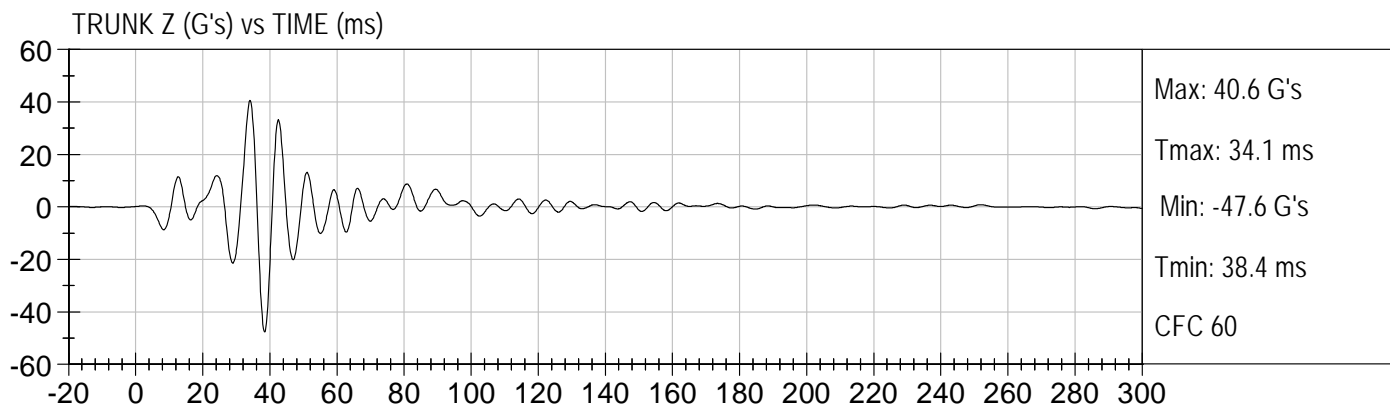
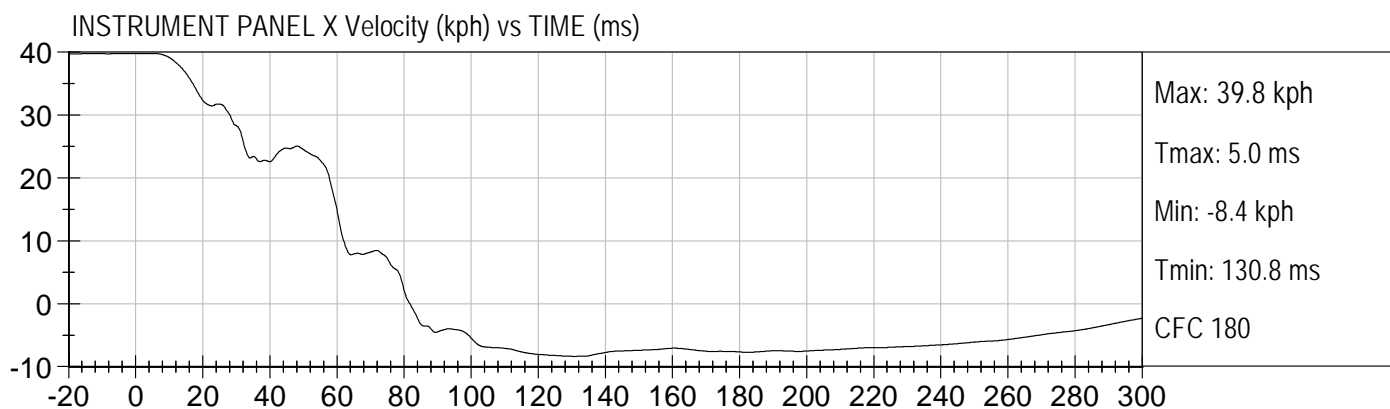
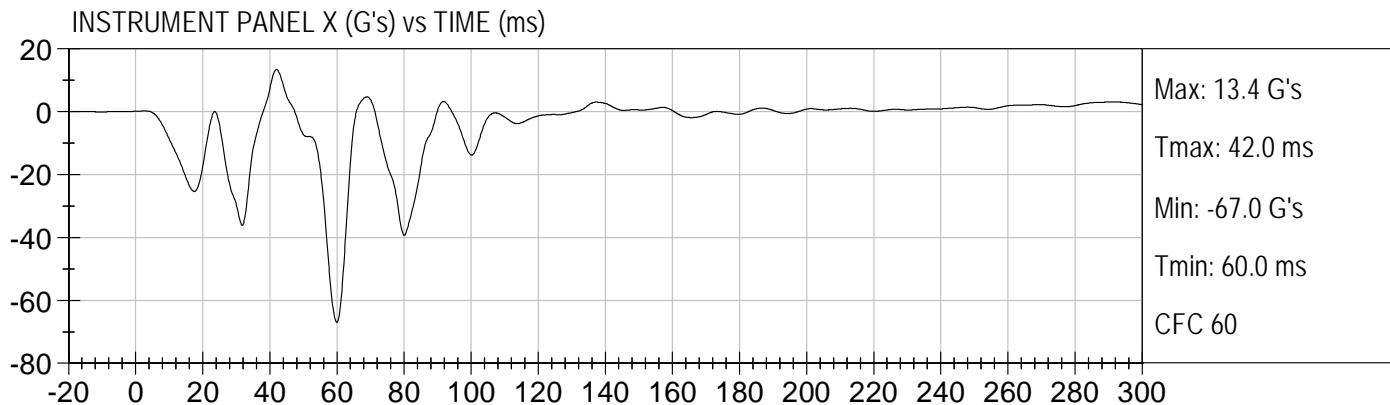

APPENDIX B
CRASH TEST PHOTOGRAPHS
TABLE OF PHOTOGRAPHS

	<u>Page No.</u>
Photo No. 1. Vehicle Certification Label	B-1
Photo No. 2. Tire Placard	B-2
Photo No. 3. Pre-Test Front View of Test Vehicle	B-3
Photo No. 4. Post-Test Front View of Test Vehicle	B-4
Photo No. 5. Pre-Test Left Side View of Test Vehicle	B-5
Photo No. 6. Post-Test Left Side View of Test Vehicle	B-6
Photo No. 7. Pre-Test Right Side View of Test Vehicle	B-7
Photo No. 8. Post-Test Right Side View of Test Vehicle	B-8
Photo No. 9. Pre-Test Left Front Three-Quarter View of Test Vehicle	B-9
Photo No. 10. Post-Test Left Front Three-Quarter View of Test Vehicle	B-10
Photo No. 11. Pre-Test Right Front Three-Quarter View of Test Vehicle	B-11
Photo No. 12. Post-Test Right Front Three-Quarter View of Test Vehicle	B-12
Photo No. 13. Pre-Test Right Rear Three-Quarter View of Test Vehicle	B-13
Photo No. 14. Post-Test Right Rear Three-Quarter View of Test Vehicle	B-14
Photo No. 15. Pre-Test Left Rear Three-Quarter View of Test Vehicle	B-15
Photo No. 16. Post-Test Left Rear Three-Quarter View of Test Vehicle	B-16
Photo No. 17. Pre-Test Rear View of Test Vehicle	B-17
Photo No. 18. Post-Test Rear View of Test Vehicle	B-18
Photo No. 19. Pre-Test Windshield View	B-19
Photo No. 20. Post-Test Windshield View	B-20
Photo No. 21. Pre-Test Engine Compartment View	B-21
Photo No. 22. Post-Test Engine Compartment View	B-22
Photo No. 23. Pre-Test Fuel Filler Cap View	B-23
Photo No. 24. Post-Test Fuel Filler Cap View	B-24

Page No.

Photo No. 25.	Pre-Test Front Underbody View	B-25
Photo No. 26.	Post-Test Front Underbody View	B-26
Photo No. 27.	Pre-Test Mid Underbody View	B-27
Photo No. 28.	Post-Test Mid Underbody View	B-28
Photo No. 29.	Pre-Test Rear Underbody View	B-29
Photo No. 30.	Post-Test Rear Underbody View	B-30
Photo No. 31.	Pre-Test Driver Dummy Front View (head position)	B-31
Photo No. 32.	Post-Test Driver Dummy Front View (head position)	B-32
Photo No. 33.	Pre-Test Driver Dummy Position Left Side View	B-33
Photo No. 34.	Post-Test Driver Dummy Position Left Side View	B-34
Photo No. 35.	Pre-Test Driver Dummy Position Left Side View (door open)	B-35
Photo No. 36.	Post-Test Driver Dummy Position Left Side View (door open)	B-36
Photo No. 37.	Pre-Test Driver Dummy Seat Position	B-37
Photo No. 38.	Post-Test Driver Dummy Seat Position	B-38
Photo No. 39.	Pre-Test Driver Dummy Feet Position	B-39
Photo No. 40.	Post-Test Driver Dummy Feet Position	B-40
Photo No. 41.	Pre-Test Driver Side Knee Bolster View	B-41
Photo No. 42.	Post-Test Driver Side Knee Bolster View	B-42
Photo No. 43.	Post-Test Driver Dummy Airbag Contact	B-43
Photo No. 44.	Post-Test Driver Dummy Knee Contact	B-44
Photo No. 45.	Pre-Test Passenger Dummy Front View (head position)	B-45
Photo No. 46.	Post-Test Passenger Dummy Front View (head position)	B-46
Photo No. 47.	Pre-Test Passenger Dummy Position Right Side View	B-47
Photo No. 48.	Post-Test Passenger Dummy Position Right Side View	B-48
Photo No. 49.	Pre-Test Passenger Dummy Position Right Side View (door open)	B-49
Photo No. 50.	Post-Test Passenger Dummy Position Right Side View (door open)	B-50
Photo No. 51.	Pre-Test Passenger Dummy Seat Position	B-51

	<u>Page No.</u>
Photo No. 52. Post-Test Passenger Dummy Seat Position	B-52
Photo No. 53. Pre-Test Passenger Dummy Feet Position	B-53
Photo No. 54. Post-Test Passenger Dummy Feet Position	B-54
Photo No. 55. Pre-Test Passenger Side Knee Bolster View	B-55
Photo No. 56. Post-Test Passenger Side Knee Bolster View	B-56
Photo No. 57. Post-Test Passenger Dummy Airbag Contact	B-57
Photo No. 58. Post-Test Passenger Dummy Knee Contact	B-58
Photo No. 59. Rollover 90 Degrees	B-59
Photo No. 60. Rollover 180 Degrees	B-60
Photo No. 61. Rollover 270 Degrees	B-61
Photo No. 62. Rollover 360 Degrees	B-62
Photo No. 63. Temperature Plot	B-63

MFD. BY AUTO ALLIANCE INTERNATIONAL, INC.
FOR MAZDA MOTOR CORPORATION
MADE IN U.S.A.

DATE: 08/09
GVWR: 4340LB/1969KG
FRONT GAWR: 2286LB/1037KG REAR GAWR: 2062LB/935KG

THIS VEHICLE CONFORMS TO ALL APPLICABLE FEDERAL MOTOR
VEHICLE SAFETY, BUMPER, AND THEFT PREVENTION STANDARDS
IN EFFECT ON THE DATE OF MANUFACTURE SHOWN ABOVE.

VIN: 1YVHZ8BH4A5M04704
TYPE: Passenger Car

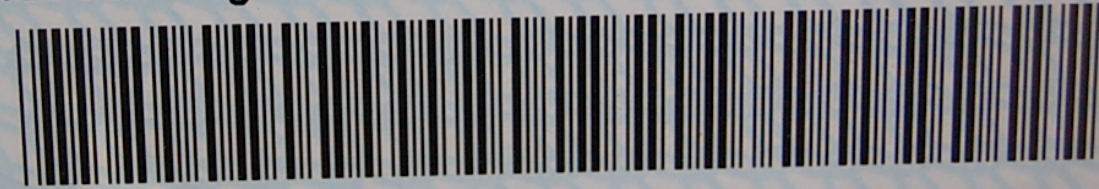

EXT PNT:	NN				RC:		DSO:
WB	BRK	INT TR	TP/PS	R	AXLE	TR	SPR
				ZFP			▽F85B-1520472-AB

B-1

Vehicle Certification Label



TIRE AND LOADING INFORMATION RENSEIGNEMENTS SUR LES PNEUS ET LE CHARGEMENT

SEATING CAPACITY | TOTAL 5 | FRONT 2 | REAR 3
NOMBRE DE PLACES | TOTAL 5 | AVANT 2 | ARRIERE 3

The combined weight of occupants and cargo should never exceed 385 kg or 850 lbs.*
Le poids total des occupants et du chargement ne doit jamais dépasser 385 kg ou 850 lb.*

TIRE PNEU	SIZE DIMENSIONS	COLD TIRE PRESSURE PRESSION DES PNEUS À FROID
FRONT AVANT	P205/65R16	220 kPa, 32 psi
REAR ARRIERE	P205/65R16	220 kPa, 32 psi
SPARE DE SECOURS	T115/70D16	420 kPa, 60 psi

SEE OWNER'S
MANUAL FOR
ADDITIONAL
INFORMATION
VOIR LE MANUEL
DE L'USAGER
POUR PLUS DE
RENSEIGNEMENTS

(GEA7A)

Tire Placard



Pre-Test Front View of Test Vehicle

B-4



Post-Test Front View of Test Vehicle

B-5



Pre-Test Left Side View of Test Vehicle

B-6



Post-Test Left Side View of Test Vehicle

B-7



Pre-Test Right Side View of Test Vehicle



Post-Test Right Side View of Test Vehicle



Pre-Test Left Front Three-Quarter View of Test Vehicle



Post-Test Left Front Three-Quarter View of Test Vehicle

B-11



Pre-Test Right Front Three-Quarter View of Test Vehicle



Post-Test Right Front Three-Quarter View of Test Vehicle



Pre-Test Right Rear Three-Quarter View of Test Vehicle



Post-Test Right Rear Three-Quarter View of Test Vehicle



Pre-Test Left Rear Three-Quarter View of Test Vehicle



Post-Test Left Rear Three-Quarter View of Test Vehicle



Pre-Test Rear View of Test Vehicle



Post-Test Rear View of Test Vehicle



Pre-Test Windshield View



Post-Test Windshield View

B-21



Pre-Test Engine Compartment View

B-22



Post-Test Engine Compartment View



Pre-Test Fuel Filler Cap View



Post-Test Fuel Filler Cap View

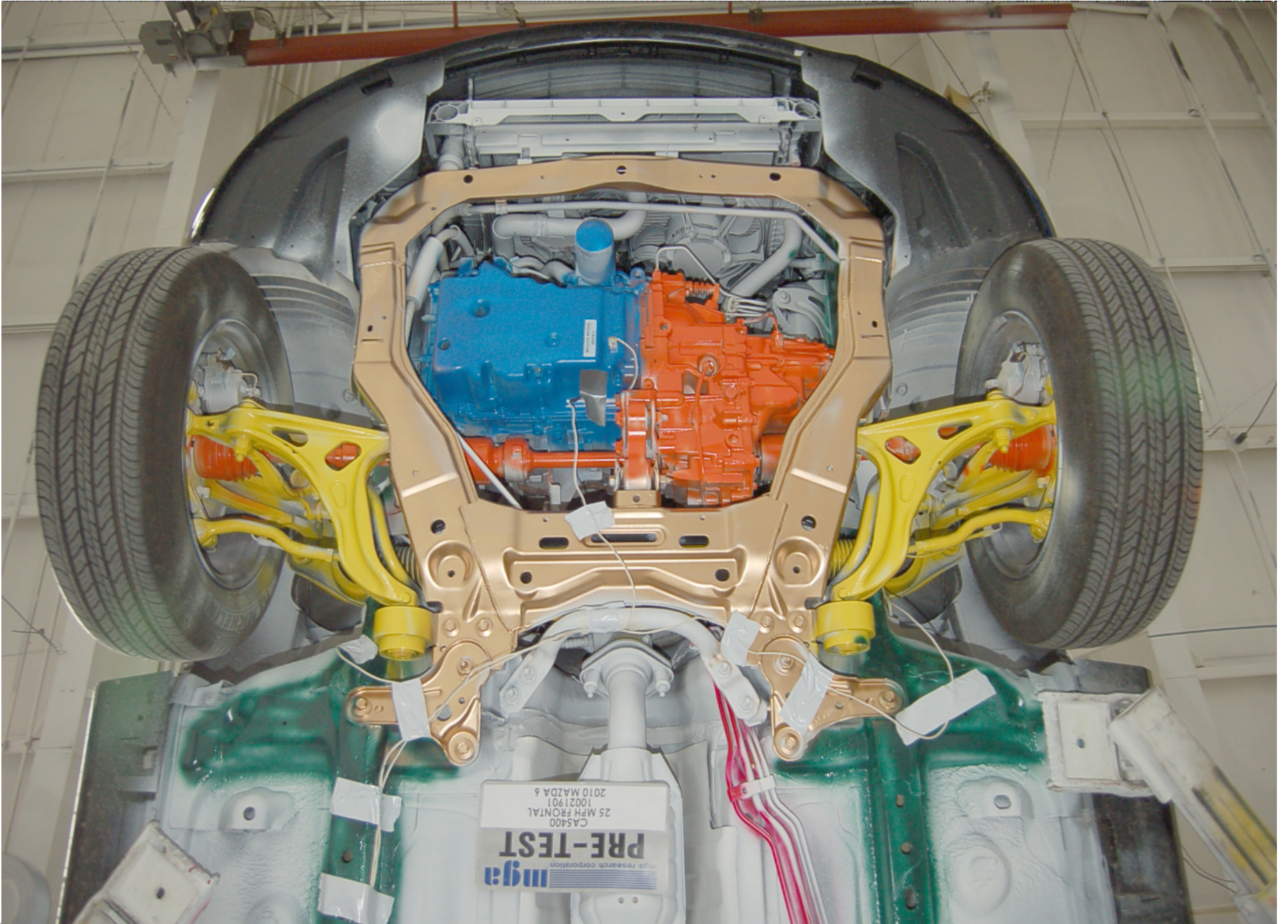

Pre-Test Front Underbody View

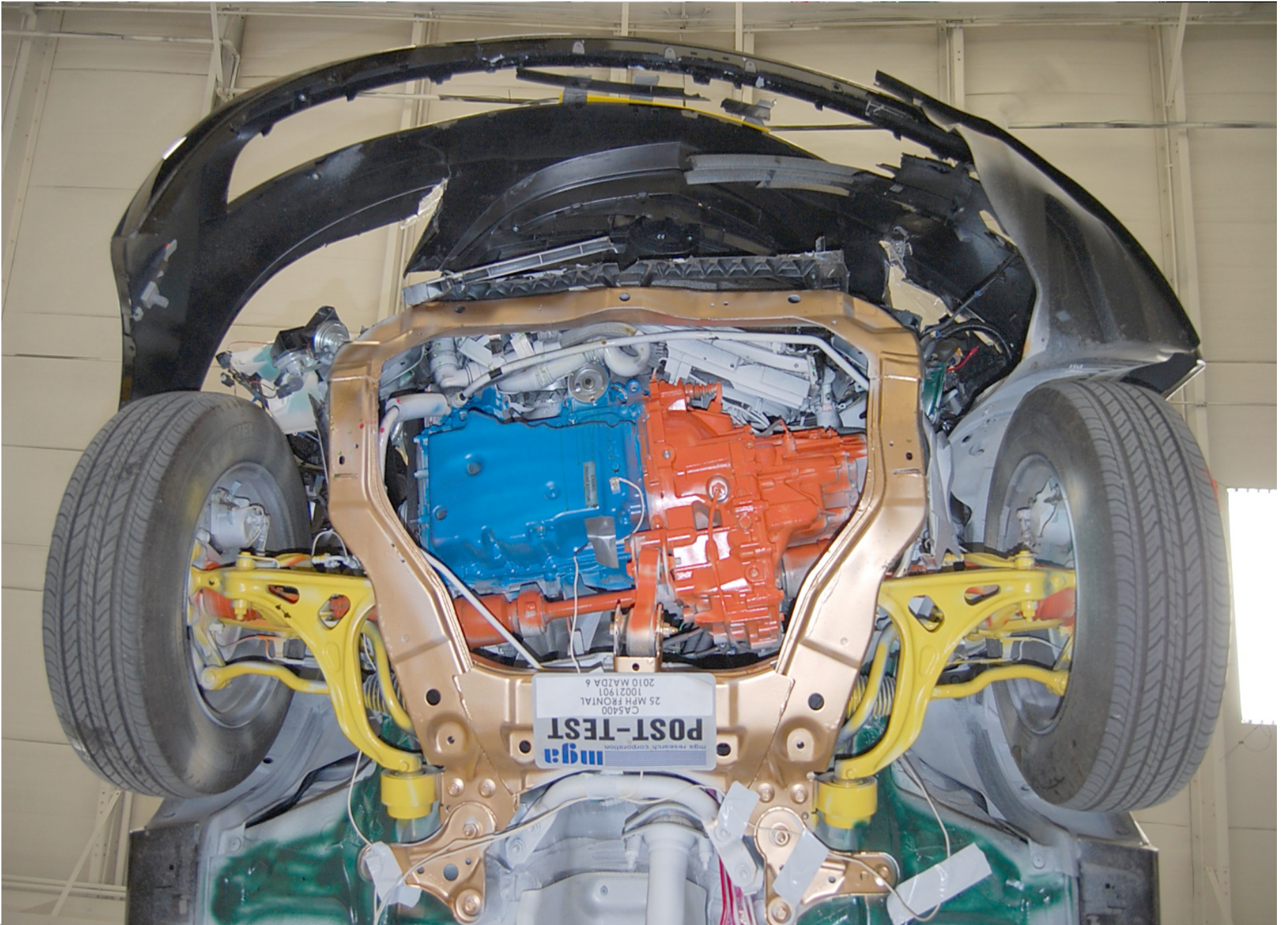

Post-Test Front Underbody View



B-27

Pre-Test Mid Underbody View



Post-Test Mid Underbody View

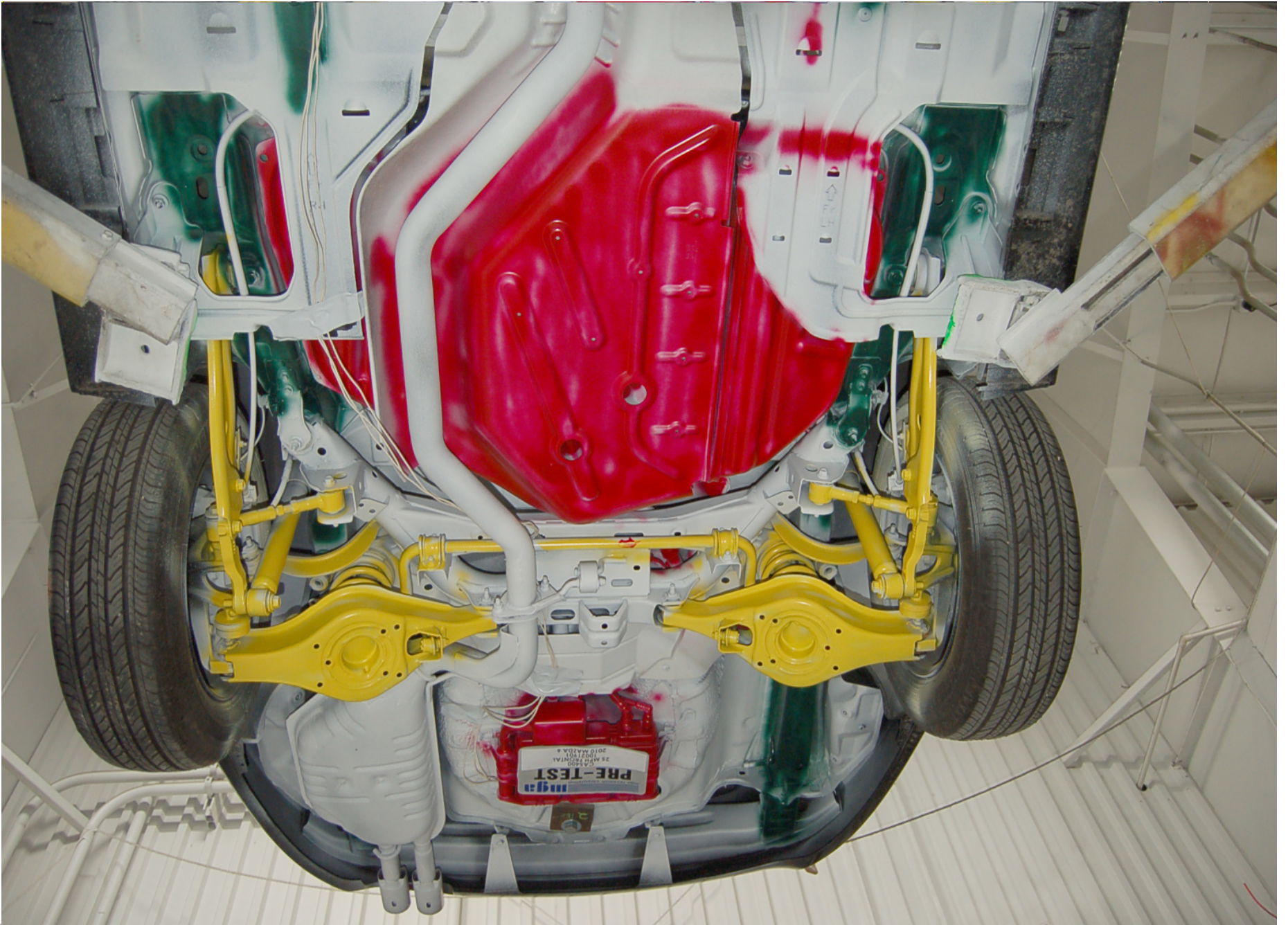

B-29

Pre-Test Rear Underbody View

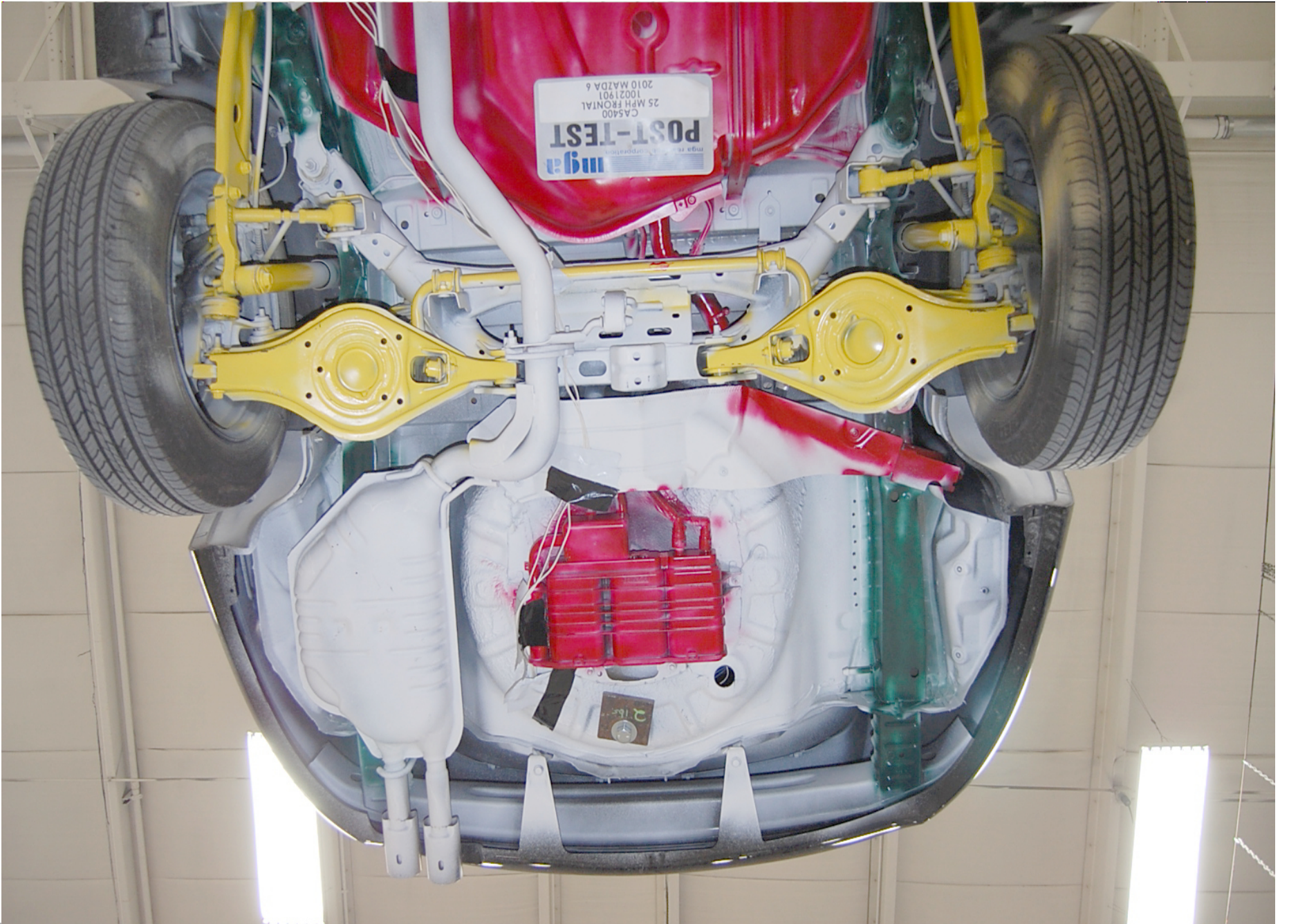

Post-Test Rear Underbody View

B-31



Pre-Test Driver Dummy Front View (head position)

B-32



Post-Test Driver Dummy Front View (head position)



Pre-Test Driver Dummy Position Left Side View



Post-Test Driver Dummy Position Left Side View



Pre-Test Driver Dummy Position Left Side View (door open)



Post-Test Driver Dummy Position Left Side View (door open)



Pre-Test Driver Dummy Seat Position



Post-Test Driver Dummy Seat Position



Pre-Test Driver Dummy Feet Position



Post-Test Driver Dummy Feet Position



Pre-Test Driver Side Knee Bolster View



Post-Test Driver Side Knee Bolster View

B-43

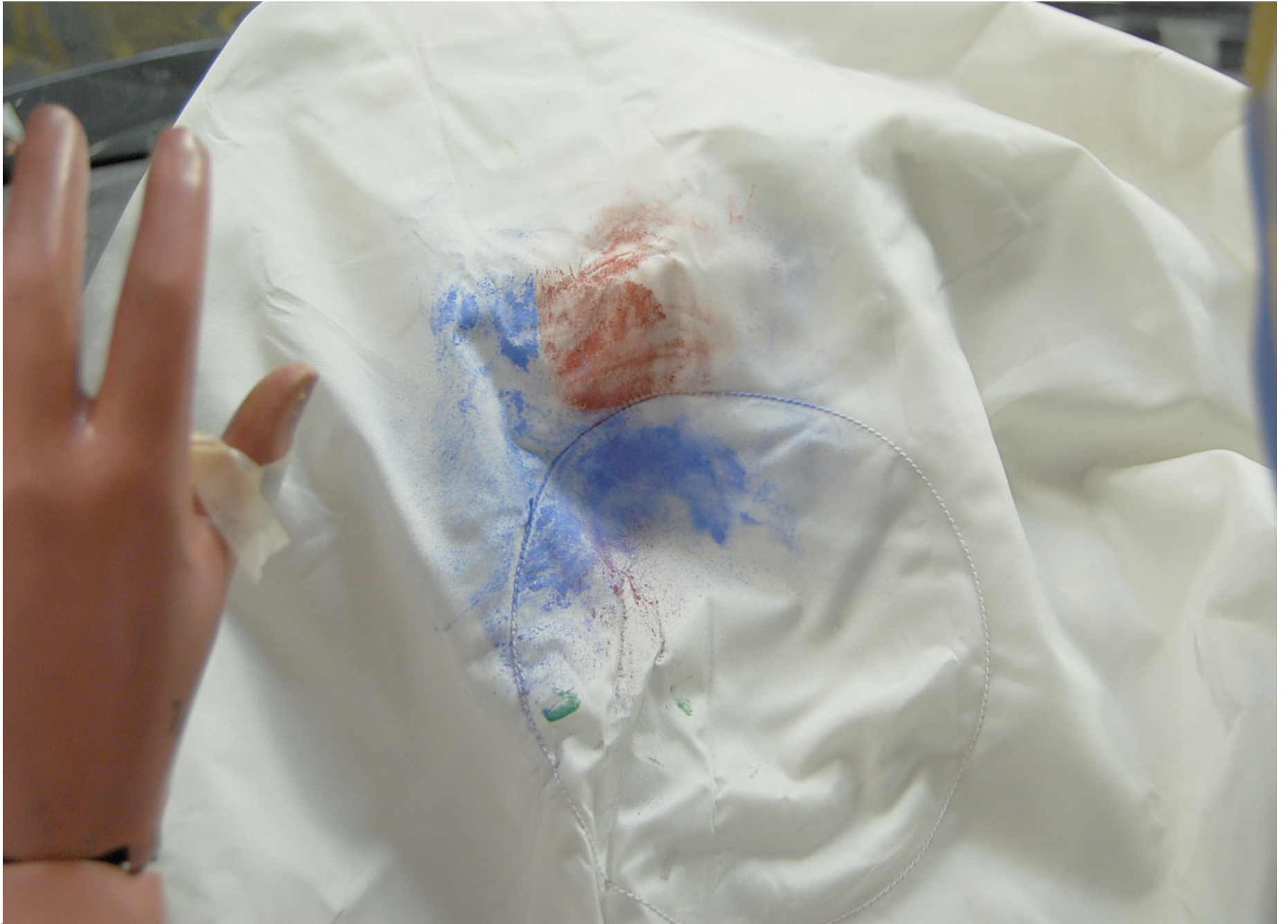

Post-Test Driver Dummy Airbag Contact



Post-Test Driver Dummy Knee Contact

B-45



Pre-Test Passenger Dummy Front View (head position)



Post-Test Passenger Dummy Front View (head position)



Pre-Test Passenger Dummy Position Right Side View



Post-Test Passenger Dummy Position Right Side View



Pre-Test Passenger Dummy Position Right Side View (door open)

B-50



Post-Test Passenger Dummy Position Right Side View (door open)



Pre-Test Passenger Dummy Seat Position



Post-Test Passenger Dummy Seat Position



Pre-Test Passenger Dummy Feet Position



Post-Test Passenger Dummy Feet Position

B-55



Pre-Test Passenger Side Knee Bolster View

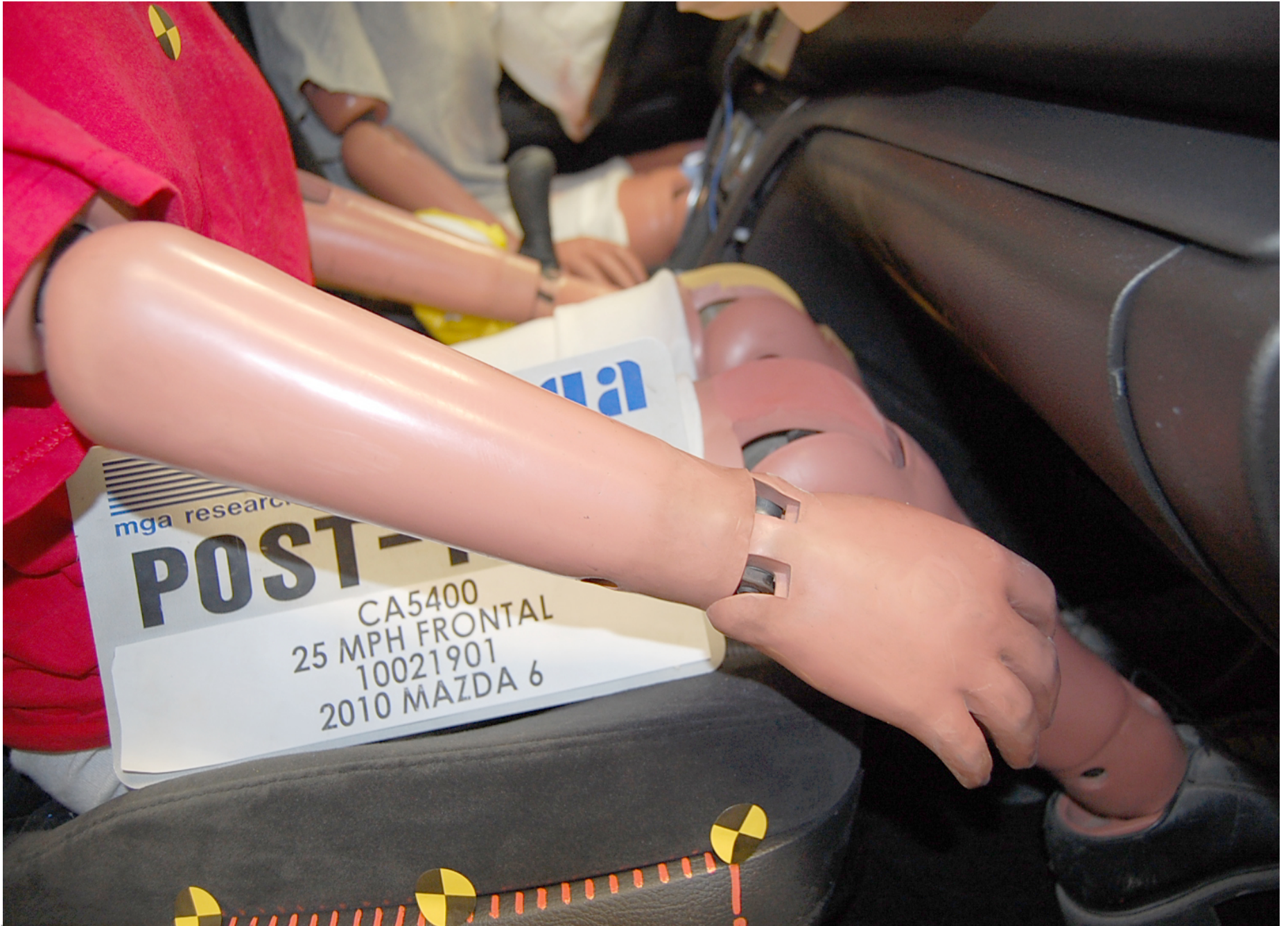

Post-Test Passenger Side Knee Bolster View

B-57



Post-Test Passenger Dummy Airbag Contact



Post-Test Passenger Dummy Knee Contact

B-59



Rollover 90 Degrees

B-60

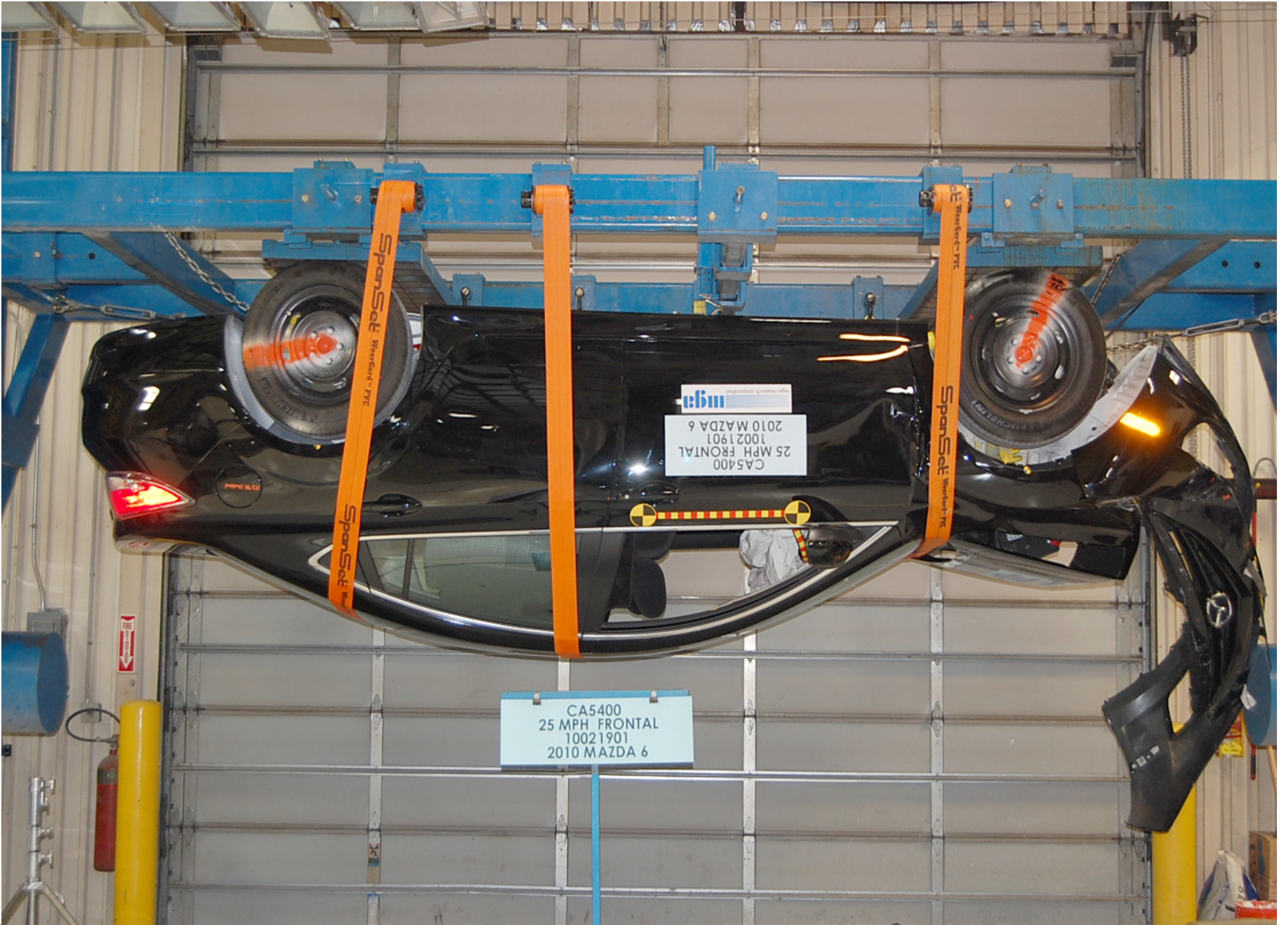

Rollover 180 Degrees

B-61



Rollover 270 Degrees

B-62



Rollover 360 Degrees

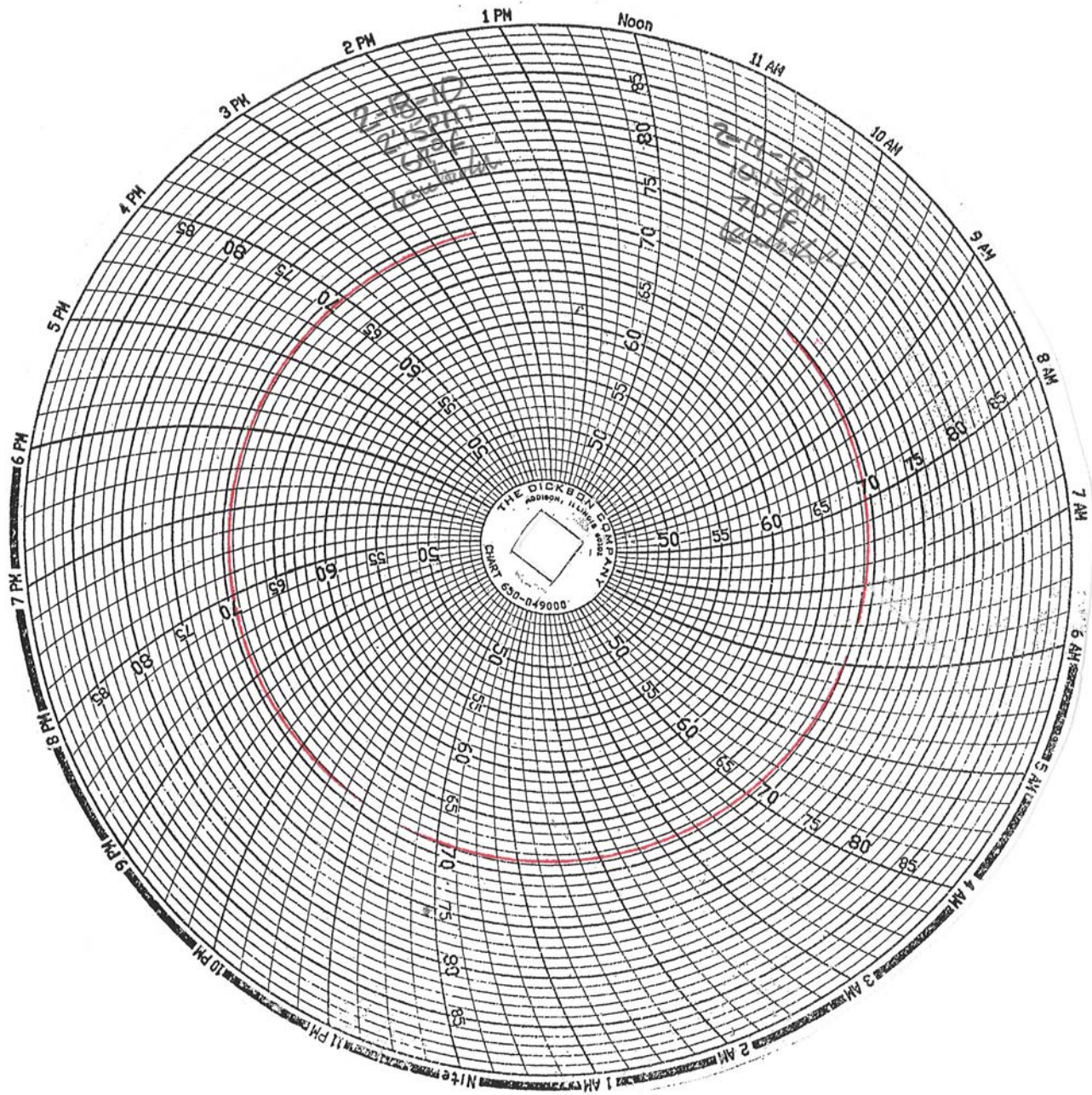

Temperature Plot

APPENDIX C

INSTRUMENTATION CALIBRATION

INSTRUMENTS FOR DRIVER DUMMY NO.: 510

	SERIAL NO.	MANUFACTURER	CALIBRATION DATE
Head X	P59657	Endevco	02/16/10
Head Y	P59658	Endevco	02/16/10
Head Z	P59659	Endevco	02/16/10
Neck Load Cell	1703	Denton	02/04/10
Chest X	P59665	Endevco	02/16/10
Chest Y	P59667	Endevco	02/16/10
Chest Z	P59669	Endevco	02/16/10
Chest Displacement	510	Servo	02/08/10
Left Femur Load Cell	979	Denton	10/29/09
Right Femur Load Cell	186	GSE	10/29/09

INSTRUMENTS FOR PASSENGER DUMMY NO.: 511

	SERIAL NO.	MANUFACTURER	CALIBRATION DATE
Head X	P52287	Endevco	02/16/10
Head Y	P59408	Endevco	02/12/10
Head Z	P59411	Endevco	02/12/10
Neck Load Cell	376	Denton	02/04/10
Chest X	P52231	Endevco	02/16/10
Chest Y	P59307	Endevco	02/16/10
Chest Z	P59399	Endevco	02/16/10
Chest Displacement	511	Servo	02/08/10
Left Femur Load Cell	959	GSE	01/08/10
Right Femur Load Cell	950	GSE	01/08/10

VEHICLE INSTRUMENTS

	SERIAL NO.	MANUFACTURER	CALIBRATION DATE
Left Rear Seat Crossmember X	F17-Y02	Entran	01/20/10
Right Rear Seat Crossmember X	ET21155	Entran	09/15/09
Top of Engine X	P47844	Endevco	11/23/09
Bottom of Engine X	A11-Z05	Entran	01/20/10
Left Brake Caliper X	A27-Z23	Entran	01/20/10
Right Brake Caliper X	D12-X20	Entran	10/18/09
Instrument Panel X	ET21195	Entran	09/15/09
Trunk Z	P47846	Endevco	11/23/09