

REPORT NUMBER: 208-MGA-2008-007

**VEHICLE SAFETY COMPLIANCE TESTING
FOR
FMVSS 208, OCCUPANT CRASH PROTECTION
FMVSS 212, WINDSHIELD MOUNTING
FMVSS 219, WINDSHIELD INTRUSION (PARTIAL)
FMVSS 301, FUEL SYSTEM INTEGRITY**

**CHRYSLER LLC
2008 DODGE CHARGER PASSENGER CAR
NHTSA NO.: C80301**

**PREPARED BY:
MGA RESEARCH CORPORATION
5000 WARREN ROAD
BURLINGTON, WI 53105**



TEST DATE: JUNE 11, 2008

FINAL REPORT DATE: JUNE 25, 2008

FINAL REPORT

**PREPARED FOR:
U.S. DEPARTMENT OF TRANSPORTATION
NATIONAL HIGHWAY TRAFFIC SAFETY ADMINISTRATION
OFFICE OF ENFORCEMENT
OFFICE OF VEHICLE SAFETY COMPLIANCE
1200 NEW JERSEY AVENUE, S.E., NVS-220
WASHINGTON, D.C. 20590**

This final test report was prepared for the U.S. Department of Transportation, National Highway Traffic Safety Administration, in response to Contract Number DTNH22-03-D-11002.

This publication is distributed by the U.S. Department of Transportation, National Highway Traffic Safety Administration, in the interest of information exchange. The opinions, findings and conclusions expressed in this publication are those of the author(s) and not necessarily those of the Department of Transportation or the National Highway Traffic Safety Administration. The United States Government assumes no liability for its contents or use thereof. If trade or manufacturers' names or products are mentioned it is only because they are considered essential to the object of the publication and should not be construed as an endorsement. The United States Government does not endorse products or manufacturers.

Prepared by: Jeff Lewandowski Date: June 25, 2008
Jeff Lewandowski, Project Engineer

Reviewed by: David Winkelbauer Date: June 25, 2008
David Winkelbauer, Facility Director

FINAL REPORT ACCEPTED BY OVSC:

Accepted By: Charles R. Case

Acceptance Date: June 25, 2008

Technical Report Documentation Page

1. Report No. 208-MGA-2008-007		2. Government Accession No.		3. Recipient's Catalog No.	
4. Title and Subtitle Final Report of FMVSS 208 Compliance Testing of a 2008 Dodge Charger NHTSA No.: C80301				5. Report Date June 25, 2008	
				6. Performing Organization Code MGA	
7. Author(s) Jeff Lewandowski, Project Engineer				8. Performing Organization Report No. 208-MGA-2008-007	
9. Performing Organization Name and Address MGA Research Corporation 5000 Warren Road Burlington, WI 53105				10. Work Unit No.	
				11. Contract or Grant No. DTNH22-03-D-11002	
12. Sponsoring Agency Name and Address U.S. Department of Transportation National Highway Traffic Safety Administration Office of Enforcement Office of Vehicle Safety Compliance 1200 New Jersey Avenue, S.E., NVS-220 Washington, D.C. 20590				13. Type of Report and Period Covered 6/11/08	
				14. Sponsoring Agency Code NVS-220	
15. Supplementary Notes					
16. Abstract Compliance tests were conducted on the subject 2008 Dodge Charger in accordance with the specifications of the Office of Vehicle Safety Compliance Test Procedure No. TP208-13 for the determination of FMVSS 208 compliance. Test failures identified were as follows: TEST FAILURES: None					
17. Key Words Frontal Impact 40 kmph Vehicle Safety Compliance Testing FMVSS 208, "Occupant Crash Protection" FMVSS 212, "Windshield Mounting" FMVSS 219, (partial), "Windshield Zone Intrusion" FMVSS 301, "Fuel System Integrity"				18. Distribution Statement Copies of this report are available from the following: U.S. Department of Transportation National Highway Traffic Safety Administration Technical Information Services (TIS), NPO-411 1200 New Jersey Avenue, S.E. (Room E12-100) Washington, DC 20590	
19. Security Classif. (of this report) Unclassified		20. Security Classif. (of this page) Unclassified		21. No. of Pages 168	22. Price

TABLE OF CONTENTS

<u>Section</u>		<u>Page No</u>
1	Purpose of Compliance Tests	1
2	Tests Performed	2
3	Injury Result Summary for FMVSS 208 Tests	4
4	Discussion of Test (if applicable)	5
5	Test Data Sheets	6
<u>Data Sheet</u>		
1	COTR Vehicle Work Order	7
2	Report of Vehicle Condition	11
3	Certification Label and Tire Placard Information	13
14	Marking of Reference Points for Various Test Positions & Points	14
32	Vehicle Weight, Fuel Tank, and Attitude Data	21
33	Vehicle Accelerometer Locations and Measurements	25
34	Photographic Targets	28
35	Camera Locations	34
36	Dummy Positioning	36
37	Dummy Measurements	48
38	Crash Test	51
40	Accident Investigation Measurements	53
41	Windshield Mounting (FMVSS 212)	55
42	Windshield Zone Intrusion (FMVSS 219)	57
43	Fuel System Integrity (FMVSS 301)	59
<u>Appendix</u>		
A	Crash Test Data	A-1
B	Crash Test Photographs	B-1
C	Instrumentation Calibration	C-1
D	Notice of Test Failure (If Applicable)	D-1

SECTION 1

PURPOSE OF COMPLIANCE TESTS

The tests performed are part of a program conducted for the National Highway Traffic Safety Administration (NHTSA) by MGA Research Corporation (MGA) under Contract No. DTNH22-03-D-11002. The purpose of this test was to determine whether the subject vehicle, a 2008 Dodge Charger, NHTSA No. C80301, meets certain performance requirements of FMVSS 208, "Occupant Crash Protection"; FMVSS 212, "Windshield Mounting"; FMVSS 219, "Windshield Zone Intrusion"; and FMVSS 301, "Fuel System Integrity". The compliance test was conducted in accordance with OVSC Laboratory Test Procedure No. TP208-13 dated July 27, 2005.

SECTION 2
TESTS PERFORMED

Test Vehicle: 2008 Dodge Charger
Test Program: FMVSS 208 Compliance

NHTSA No.: C80301
Test Dates: 6/11/08

The following checked items indicate the tests that were performed:

- | | | |
|-------------------------------------|-----|---|
| <input type="checkbox"/> | 1. | Rear outboard seating position seat belts (S4.1.1.2(b) & (S4.2.4)) |
| <input type="checkbox"/> | 2. | Air bag labels (S4.5.1) |
| <input type="checkbox"/> | 3. | Readiness indicator (S4.5.2) |
| <input type="checkbox"/> | 4. | Passenger air bag manual cut-off device (S4.5.4) |
| <input type="checkbox"/> | 5. | Lap belt lockability (S7.1.1.5) |
| <input type="checkbox"/> | 6. | Seat belt warning system (S7.3) |
| <input type="checkbox"/> | 7. | Seat belt contact force (S7.4.4) |
| <input type="checkbox"/> | 8. | Seat belt latch plate access (S7.4.4) |
| <input type="checkbox"/> | 9. | Seat belt retraction (S7.4.5) |
| <input type="checkbox"/> | 10. | Seat belt guides and hardware (S7.4.6) |
| <input type="checkbox"/> | 11. | Suppression tests with 12-month-old CRABI dummy (Part 572, Subpart R) |
| <input type="checkbox"/> | 12. | Suppression tests with newborn infant (Part 572, Subpart K) |
| <input type="checkbox"/> | 13. | Suppression tests with 3-year-old dummy (Part 572, Subpart P) |
| <input type="checkbox"/> | 14. | Suppression tests with 6-year-old dummy (Part 572, Subpart N) |
| <input type="checkbox"/> | 15. | Test of reactivation of the passenger air bag system with an unbelted 5 th percentile female dummy |
| <input type="checkbox"/> | 16. | Low risk deployment test with 12-month-old dummy (Part 572, Subpart R) |
| <input type="checkbox"/> | 17. | Low risk deployment test with 3-year-old dummy (Part 572, Subpart P) |
| <input type="checkbox"/> | 18. | Low risk deployment test with 6-year-old dummy (Part 572, Subpart N) |
| <input type="checkbox"/> | 19. | Low risk deployment test with 5 th female dummy (Part 572, Subpart O) |
| <input type="checkbox"/> | 20. | Impact Tests |
| <input type="checkbox"/> | | Frontal Oblique |
| <input type="checkbox"/> | | Belted 50 th male dummy driver and passenger (0 to 48 kmph) (S5.1.1(a)) |
| <input type="checkbox"/> | | Unbelted 50 th male dummy driver and passenger (0 to 48 kmph) (S5.1.2(a)(1)) |
| <input type="checkbox"/> | | Unbelted 50 th male dummy driver and passenger (32 to 40 kmph) (S5.1.2(a) (1) or S5.1.2(b)) |
| <input checked="" type="checkbox"/> | | Frontal 0° |
| <input type="checkbox"/> | | Belted 50 th male dummy driver (0 to 48 kmph) (S5.1.1.(b)(1) or S5.1.1(a)) |
| <input type="checkbox"/> | | Belted 50 th male dummy passenger (0 to 48 kmph) (S5.1.1.(b)(1) or S5.1.1(a)) |
| <input type="checkbox"/> | | Belted 5 th female dummy driver (0 to 48 kmph) (S16.1(a)) |
| <input type="checkbox"/> | | Belted 5 th female dummy passenger (0 to 48 kmph) (S16.1(a)) |
| <input type="checkbox"/> | | Belted 50 th male dummy driver and passenger (0 to 56 kmph) (S5.1.1.(b)(2)) |
| <input type="checkbox"/> | | Unbelted 50 th male dummy driver and passenger (0 to 48 kmph) (S5.1.2(a) (1)) |
| <input type="checkbox"/> | | Unbelted 50 th male dummy driver (32 to 40 kmph) (S5.1.2.(a)(2) or S5.1.2(b)) |

		Unbelted 50 th male dummy passenger (32 to 40 kmph) (S5.1.2.(a)(2) or S5.1.2(b))
	X	Unbelted 5 th female dummy driver (32 to 40 kmph) (S16.1(b))
	X	Unbelted 5 th female dummy passenger (32 to 40 kmph) (S16.1(b))
		40% Offset 0° Belted 5 th female dummy driver and passenger (0 to 40 kmph) (S18.1)
		21. Sled Test: unbelted 50 th male dummy driver and passenger (S13)
		22. FMVSS 204 Indicant Test
	X	23. FMVSS 212 Indicant Test
	X	24. FMVSS 219 Indicant Test
	X	25. FMVSS 301 Frontal Indicant Test

For the crash tests, the vehicle was instrumented with 8 accelerometers. The accelerometer data from the vehicle and dummies were sampled at 10,000 samples per second and processed as specified in SAE J211/1 MAR95 and FMVSS 208, S4.13.

The dynamic tests were recorded using high-speed film and high-speed digital video.

The vehicle appears to meet the performance requirements to which it was tested.

SECTION 3
INJURY RESULT SUMMARY FOR FMVSS 208 TESTS

Test Vehicle: 2008 Dodge Charger
 Test Program: FMVSS 208 Compliance

NHTSA No.: C80301
 Test Date: 6/11/08

40 kmph Frontal Crash

Impact Angle: Zero degrees

Belted Dummies: Yes No
 Speed Range: 0 to 40 kmph 32 to 40 kmph
 0 to 48 kmph 0 to 56 kmph

Test Speed: 39.9 kmph Test Weight: 1819.3 kg

Driver Dummy: 5th female 50th male
 Passenger Dummy: 5th female 50th male

5th Percentile Female Frontal Crash Test
Vehicles certified to S16.1(a), S16.1(b), or S18.1

Injury Criteria	Max. Allowable Injury Assessment Values	Driver	Passenger
HIC15	700	77	256
N _{te}	1.0	0.8	0.2
N _{tf}	1.0	0.1	0.4
N _{ce}	1.0	0.1	0.6
N _{cf}	1.0	0.1	0.3
Neck Tension	2620 N	1244	683
Neck Compression	2520 N	247	1518
Chest g	60 g	53	46
Chest Displacement	52 mm	19	4
Left Femur	6805 N	3091	4016
Right Femur	6805 N	3759	4682

SECTION 4
DISCUSSION OF TESTS

Test Vehicle: 2008 Dodge Charger
Test Program: FMVSS 208 Compliance

NHTSA No.: C80301
Test Dates: 6/11/08

SECTION 5
TEST DATA SHEETS

Test Vehicle: 2008 Dodge Charger
Test Program: FMVSS 208 Compliance

NHTSA No.: C80301
Test Dates: 6/11/08

DATA SHEET 1
COTR VEHICLE WORK ORDER

Test Vehicle: 2008 Dodge Charger
Test Program: FMVSS 208 Compliance

NHTSA No.: C80301
Test Dates: 6/11/08

COTR Signature: Charles R. Case

Test to be performed for this vehicle are checked below:

- | | | |
|--------------------------|-----|---|
| <input type="checkbox"/> | 1. | Rear Outboard Seating Position Seat Belts (S4.1.2(b)) & (S4.2.4) |
| <input type="checkbox"/> | 2. | Air Bag Labels (S4.5.1) |
| <input type="checkbox"/> | 3. | Readiness Indicator (S4.5.2) |
| <input type="checkbox"/> | 4. | Passenger Air Bag Manual Cut-off Device (S4.5.4) |
| <input type="checkbox"/> | 5. | Lap Belt Lockability (S7.1.1.5) |
| <input type="checkbox"/> | 6. | Seat Belt Warning System (S7.3) |
| <input type="checkbox"/> | 7. | Seat Belt Contact Force (S7.4.4) |
| <input type="checkbox"/> | 8. | Seat Belt Latch Plate Access (S7.4.4) |
| <input type="checkbox"/> | 9. | Seat Belt Retraction (S7.4.5) |
| <input type="checkbox"/> | 10. | Seat Belt Guides and Hardware (S7.4.6) |
| <input type="checkbox"/> | 11. | Suppression tests with 12-month-old CRABI dummy (Part 572, Subpart R) using the following indicated child restraints. |

Section B

<input type="checkbox"/>	Britax Handle with Care 191	<input type="checkbox"/>	Full Rearward	<input type="checkbox"/>	Mid Position	<input type="checkbox"/>	Full Forward
<input type="checkbox"/>	Century Assura 4553	<input type="checkbox"/>	Full Rearward	<input type="checkbox"/>	Mid Position	<input type="checkbox"/>	Full Forward
<input type="checkbox"/>	Century Avanta SE 41530	<input type="checkbox"/>	Full Rearward	<input type="checkbox"/>	Mid Position	<input type="checkbox"/>	Full Forward
<input type="checkbox"/>	Century Smart Fit 4543	<input type="checkbox"/>	Full Rearward	<input type="checkbox"/>	Mid Position	<input type="checkbox"/>	Full Forward
<input type="checkbox"/>	Cosco Arriva 02727	<input type="checkbox"/>	Full Rearward	<input type="checkbox"/>	Mid Position	<input type="checkbox"/>	Full Forward
<input type="checkbox"/>	Cosco Opus 35 02603	<input type="checkbox"/>	Full Rearward	<input type="checkbox"/>	Mid Position	<input type="checkbox"/>	Full Forward
<input type="checkbox"/>	Evenflo Discovery Adjust Right 212	<input type="checkbox"/>	Full Rearward	<input type="checkbox"/>	Mid Position	<input type="checkbox"/>	Full Forward
<input type="checkbox"/>	Evenflo First Choice 204	<input type="checkbox"/>	Full Rearward	<input type="checkbox"/>	Mid Position	<input type="checkbox"/>	Full Forward
<input type="checkbox"/>	Evenflo On My Way Position Right V 282	<input type="checkbox"/>	Full Rearward	<input type="checkbox"/>	Mid Position	<input type="checkbox"/>	Full Forward
<input type="checkbox"/>	Graco Infant 8457	<input type="checkbox"/>	Full Rearward	<input type="checkbox"/>	Mid Position	<input type="checkbox"/>	Full Forward

Section C

<input type="checkbox"/>	Britax Roundabout 161	<input type="checkbox"/>	Full Rearward	<input type="checkbox"/>	Mid Position	<input type="checkbox"/>	Full Forward
<input type="checkbox"/>	Century Encore 4612	<input type="checkbox"/>	Full Rearward	<input type="checkbox"/>	Mid Position	<input type="checkbox"/>	Full Forward
<input type="checkbox"/>	Century STE 1000 4416	<input type="checkbox"/>	Full Rearward	<input type="checkbox"/>	Mid Position	<input type="checkbox"/>	Full Forward
<input type="checkbox"/>	Cosco Olympian 02803	<input type="checkbox"/>	Full Rearward	<input type="checkbox"/>	Mid Position	<input type="checkbox"/>	Full Forward
<input type="checkbox"/>	Cosco Touriva 02519	<input type="checkbox"/>	Full Rearward	<input type="checkbox"/>	Mid Position	<input type="checkbox"/>	Full Forward
<input type="checkbox"/>	Evenflo Horizon V 425	<input type="checkbox"/>	Full Rearward	<input type="checkbox"/>	Mid Position	<input type="checkbox"/>	Full Forward
<input type="checkbox"/>	Evenflo Medallion 254	<input type="checkbox"/>	Full Rearward	<input type="checkbox"/>	Mid Position	<input type="checkbox"/>	Full Forward

- | | | |
|--------------------------|-----|---|
| <input type="checkbox"/> | 12. | Suppression tests with newborn infant (Part 572, Subpart K) using the following indicated child restraints. |
|--------------------------|-----|---|

Section A

- | | | | | | | | |
|--------------------------|-------------------------|---|---------------|--------------------------|--------------|--------------------------|--------------|
| <input type="checkbox"/> | Cosco Dream Ride 02-719 | <input type="checkbox"/> | Full Rearward | <input type="checkbox"/> | Mid Position | <input type="checkbox"/> | Full Forward |
| <input type="checkbox"/> | 13. | Suppression tests with 3-year-old dummy (Part 572, Subpart P) using the following indicated child restraints where a child restraint is required. | | | | | |

Section C

Britax Roundabout 161	Full Rearward	Mid Position	Full Forward
Century Encore 4612	Full Rearward	Mid Position	Full Forward
Century STE 1000 4416	Full Rearward	Mid Position	Full Forward
Cosco Olympian 02803	Full Rearward	Mid Position	Full Forward
Cosco Touriva 02519	Full Rearward	Mid Position	Full Forward
Evenflo Horizon V 425	Full Rearward	Mid Position	Full Forward
Evenflo Medallion 254	Full Rearward	Mid Position	Full Forward

Section D

Britax Roadster 9004	Full Rearward	Mid Position	Full Forward
Century Next Step 4920	Full Rearward	Mid Position	Full Forward
Cosco High Back Booster 02-442	Full Rearward	Mid Position	Full Forward
Evenflo Right Fit 245	Full Rearward	Mid Position	Full Forward

14. Suppression tests with representative 3-year-old child using the following indicated child restraints where a child restraint is required. (Appendix H, Data Sheet 16H and 17H)

Section C

Britax Roundabout 161	Full Rearward	Mid Position	Full Forward
Century Encore 4612	Full Rearward	Mid Position	Full Forward
Century STE 1000 4416	Full Rearward	Mid Position	Full Forward
Cosco Olympian 02803	Full Rearward	Mid Position	Full Forward
Cosco Touriva 02519	Full Rearward	Mid Position	Full Forward
Evenflo Horizon V 425	Full Rearward	Mid Position	Full Forward
Evenflo Medallion 254	Full Rearward	Mid Position	Full Forward

Section D

Britax Roadster 9004	Full Rearward	Mid Position	Full Forward
Century Next Step 4920	Full Rearward	Mid Position	Full Forward
Cosco High Back Booster 02-442	Full Rearward	Mid Position	Full Forward
Evenflo Right Fit 245	Full Rearward	Mid Position	Full Forward

15. Suppression tests with 3-year-old dummy (Part 572, Subpart P) in the following Forward, Middle, and Rearward seat track positions

- Sitting on seat with back against seat back (S22.2.2.1)
- Sitting on seat with back against reclined seat back (S22.2.2.2)
- Sitting on seat with back not against seat back (S22.2.2.3)
- Sitting on seat edge, spine vertical, hands by the child's side (S22.2.2.4)
- Standing on seat, facing forward (S22.2.2.5)
- Kneeling on seat facing forward (S22.2.2.6)
- Kneeling on seat facing rearward (S22.2.2.7)
- Lying on seat (S22.2.2.8)

16. Suppression tests with representative 3-year-old child in the following positions

- Sitting on seat with back against seat back (S22.2.2.1)
- Sitting on seat with back against reclined seat back (S22.2.2.2)
- Sitting on seat with back not against seat back (S22.2.2.3)
- Sitting on seat edge, spine vertical, hands by the child's side (S22.2.2.4)
- Standing on seat, facing forward (S22.2.2.5)
- Kneeling on seat facing forward (S22.2.2.6)
- Kneeling on seat facing rearward (S22.2.2.7)
- Lying on seat (S22.2.2.8)

17. Suppression tests with 6-year-old dummy (Part 572, Subpart N) using the following indicated child restraints where a child restraint is required.

Section D

	Britax Roadster 9004	Full Rearward	Mid Position	Full Forward
	Century Next Step 4920	Full Rearward	Mid Position	Full Forward
	Cosco High Back Booster 02-442	Full Rearward	Mid Position	Full Forward
	Evenflo Right Fit 245	Full Rearward	Mid Position	Full Forward

18. Suppression tests with representative 6-year-old child using the following indicated child restraints where a child restraint is required.

Section D

	Britax Roadster 9004	Full Rearward	Mid Position	Full Forward
	Century Next Step 4920	Full Rearward	Mid Position	Full Forward
	Cosco High Back Booster 02-442	Full Rearward	Mid Position	Full Forward
	Evenflo Right Fit 245	Full Rearward	Mid Position	Full Forward

19. Suppression tests with 6-year-old dummy (Part 572, Subpart N) in the following Forward, Middle, and Rearward seat track positions

- Sitting on seat with back against seat back (S22.2.2.1)
- Sitting on seat with back against reclined seat back (S22.2.2.2)
- Sitting on seat edge, spine vertical, hands by the child's side (S22.2.2.4)
- Sitting back in the seat and leaning on the right front passenger door (S24.2.3)

20. Suppression tests with representative 6-year-old child in the following positions

- Sitting on seat with back against seat back (S22.2.2.1)
- Sitting on seat with back against reclined seat back (S22.2.2.2)
- Sitting on seat edge, spine vertical, hands by the child's side (S22.2.2.4)
- Sitting back in the seat and leaning on the right front passenger door (S24.2.3)

21. Test of Reactivation of the Passenger Air Bag System with an Unbelted 5th percentile female dummy (S20.3, 22.3, S24.3). Perform this test after the following suppression tests: After each restraint.

22. Test of Reactivation of the passenger air bag system with a representative 5th percentile female (S20.3, 22.3, S24.3). Perform this test after the following suppression tests:

23. Low risk deployment test with 12-month-old dummy (Part 572, Subpart R) using the following indicated child restraints.

Section B

	Britax Handle with Care 191	Full Rearward	Mid Position	Full Forward
	Century Assura 4553	Full Rearward	Mid Position	Full Forward
	Century Avanta SE 41530	Full Rearward	Mid Position	Full Forward
	Century Smart Fit 4543	Full Rearward	Mid Position	Full Forward
	Cosco Arriva 02727	Full Rearward	Mid Position	Full Forward
	Cosco Opus 35 02603	Full Rearward	Mid Position	Full Forward
	Evenflo Discovery Adjust Right 212	Full Rearward	Mid Position	Full Forward
	Evenflo First Choice 204	Full Rearward	Mid Position	Full Forward
	Evenflo On My Way Position Right V 282	Full Rearward	Mid Position	Full Forward
	Graco Infant 8457	Full Rearward	Mid Position	Full Forward

Section C

	Britax Roundabout 161	Full Rearward	Mid Position	Full Forward
	Century Encore 4612	Full Rearward	Mid Position	Full Forward
	Century STE 1000 4416	Full Rearward	Mid Position	Full Forward
	Cosco Olympian 02803	Full Rearward	Mid Position	Full Forward
	Cosco Touriva 02519	Full Rearward	Mid Position	Full Forward
	Evenflo Horizon V 425	Full Rearward	Mid Position	Full Forward
	Evenflo Medallion 254	Full Rearward	Mid Position	Full Forward

- 24. Low risk deployment test with 3-year-old dummy (Part 572, Subpart P) in the following positions
 - Position 1
 - Position 2
- 25. Low risk deployment test with 6-year-old dummy (Part 572, Subpart N) in the following positions
 - Position 1
 - Position 2
- 26. Low risk deployment test with 5th percentile female dummy (Part 572, Subpart O) in the following positions
 - Position 1
 - Position 2
- 27. Impact Tests
 - Frontal Oblique - Test Speed:
 - Belted 50th male dummy driver and passenger (0 to 48 kmph) (S5.1.1(a))
 - Unbelted 50th male dummy driver and passenger (0 to 48 kmph) (S5.1.2(a)(1))
 - Unbelted 50th male dummy driver and passenger (32 to 40 kmph) (S5.1.2(a) (1) or S5.1.2(b))
 - Frontal 0° - Test Speed: 39.9 kmph
 - Belted 50th male dummy driver (0 to 48 kmph) (S5.1.1.(b)(1) or S5.1.1(a))
 - Belted 50th male dummy passenger (0 to 48 kmph) (S5.1.1.(b)(1) or S5.1.1(a))
 - Belted 5th female dummy driver (0 to 48 kmph) (S16.1(a))
 - Belted 5th female dummy passenger (0 to 48 kmph) (S16.1(a))
 - Belted 50th male dummy driver and passenger (0 to 56 kmph) (S5.1.1.(b)(2))
 - Unbelted 50th male dummy driver and passenger (0 to 48 kmph) (S5.1.2(a) (1))
 - Unbelted 50th male dummy driver (32 to 40 kmph) (S5.1.2.(a)(2) or S5.1.2(b))
 - Unbelted 50th male dummy passenger (32 to 40 kmph) (S5.1.2.(a)(2) or S5.1.2(b))
 - Unbelted 5th female dummy driver (32 to 40 kmph) (S16.1(b))
 - Unbelted 5th female dummy passenger (32 to 40 kmph) (S16.1(b))
 - 40% Offset 0° Belted 5th female dummy driver and passenger (0 to 40 kmph) (S18.1) - Test Speed:
- 28. Sled Test: Unbelted 50th male dummy driver and passenger (S13)
- 29. FMVSS 204 Indicant Test
- 30. FMVSS 212 Indicant Test
- 31. FMVSS 219 Indicant Test
- 32. FMVSS 301 Frontal Indicant Test

REPORT OF VEHICLE CONDITION AT THE COMPLETION OF TESTING

LIST OF FMVSS TESTS PERFORMED BY THIS LAB: FMVSS 208, 212, 219, 301

VEHICLE: 2008 Dodge Charger NHTSA NO. C80301

REMARKS:

Equipment that is no longer on the test vehicle as noted on previous page:

Spare tire, jack and tools, rear seat bottom, and trunk interior

Explanation for equipment removal:

Components removed for instrumentation installation and to meet target weight.

Test Vehicle Condition:

25 mph frontal impact damage- front suspension & structure damaged, hood & front quarter panels damaged, radiator damaged, air bags & pretensioners deployed, Stoddard in fuel system

RECORDED BY: Jeff Lewandowski DATE: 6/16/2008

APPROVED BY: David Winkelbauer DATE: 6/16/2008

#####

RELEASE OF TEST VEHICLE

The vehicle described above is released from MGA to be delivered to:

Date: Time: Odometer:

Lab Rep's Signature:

Title:

Carrier/Customer Rep:

Date:

DATA SHEET 3

CERTIFICATION LABEL AND TIRE PLACARD INFORMATION

Test Vehicle: 2008 Dodge Charger
 Test Program: FMVSS 208 Compliance
 Test Technician: Jamie Aide

NHTSA No.: C80301
 Test Date: 6/11/08

Certification Label	
Manufacturer:	Chrysler LLC
Date of Manufacture:	12/07
VIN:	2B3KA43R88H161597
Vehicle Certified As (Pass. Car/MPV/Truck/Bus):	Passenger Car
Front Axle GVWR:	1275 kg (2810 lbs)
Rear Axle GVWR:	1275 kg (2810 lbs)
Total GVWR:	2225 kg (4905 lbs)

Tire Placard	
Not applicable, vehicle is not a passenger car and does not have a tire placard.	Passenger Car
This is not a passenger car, but all or part of this information is still contained on a vehicle label and is reported here.	Passenger Car
Vehicle Capacity Weight:	392 kg (865 lbs)
Designated Seating Capacity Front:	2
Designated Seating Capacity Rear:	3
Total Designated Seating Capacity:	5
Recommended Cold Tire Inflation Pressure Front:	210 kpa (30 psi)
Recommended Cold Tire Inflation Pressure Rear:	210 kpa (30 psi)
Recommended Tire Size:	P215/65R17

Signature: 

Date: 6/11/08

DATA SHEET 14

MARKING OF REFERENCE POINTS FOR VARIOUS TEST POSITIONS AND POINTS

Test Vehicle: 2008 Dodge Charger
Test Program: FMVSS 208 Compliance
Test Technician: Tim Bratz

NHTSA No.: C80301
Test Date: 6/11/08

DATA SHEET 14.1

MARKING OF REFERENCE POINTS FOR 5th FEMALE

Driver Seat Passenger Seat

1. Seat Position

- 1.1 Position the seat's adjustable lumbar supports so that the lumbar supports are in the lowest, retracted or deflated adjustment positions. (S16.2.10.1, S20.1.9.1, S20.4.1, S22.1.7.1)
 N/A - No lumbar adjustment
- 1.2 Position any adjustable parts of the seat that provide additional support so that they are in the lowest or most open adjustment position. (S16.2.10.2, S20.1.9.2, S20.4.1, S22.1.7.1, S22.4.2.1, S22.4.3.1, S24.4.2.1, S26.2.3, S26.3.1)
 N/A - No additional support adjustment
- 1.3 Position an adjustable leg support system in its rearmost position. (8/27/04 interpretation to Toyota)
 N/A - No adjustable leg support system
- 1.4 **Mark** a point (seat cushion reference point) on the side of the seat cushion that is between 150 mm and 250 mm from the front edge of the seat cushion. (S16.3.1.12)
- 1.5 Draw a line (seat cushion reference line) through the seat cushion reference point. (S16.3.1.13)
- 1.6 Use only the controls that primarily move the seat in the fore-aft direction to move the seat cushion reference point to the rearmost position. (S16.2.10.3.1, S22.1.7.3)
- 1.7 If the seat cushion adjusts fore-aft, independent of the seat back, use only the controls that primarily move the seat cushion in the fore-aft direction to move the seat cushion reference point to the rearmost position. (S16.2.10.3.1, S20.1.9.3)
 N/A - No independent fore-aft seat cushion adjustment
- 1.8 Use any part of any control, other than the parts just used for fore-aft positioning, to determine the range of angles of the seat cushion reference line and to set the seat cushion reference line at the mid-angle. (S16.2.10.3.1)
Maximum angle 0°
Minimum angle 0°
Mid-angle 0°
- 1.9 If the seat and/or seat cushion height is adjustable, use any part of any control other than the parts which primarily move the seat or seat cushion fore-aft, to put the seat cushion reference point in its lowest position with the seat cushion reference line angle at the mid-angle found in 1.8. (S16.2.10.3.1)
 N/A - No seat height adjustment
- 1.10 Use only the controls that primarily move the seat in the fore-aft direction to verify the seat is in the rearmost position.

- 1.11 Use only the controls that primarily move the seat in the fore-aft direction to **mark** for future reference the fore-aft seat positions. **Mark** each position so that there is a visual indication when the seat is at a particular position. For manual seats, move the seat forward one detent at a time and **mark** each detent. For power seats, **mark** only the rearmost, middle, and foremost positions. Label three of the positions with the following: F for foremost, M for mid-position (if there is no mid-position, label the closest adjustment position to the rear of the mid-point), and R for rearmost.
- 1.12 Use only the controls that primarily move the seat in the fore-aft direction to place the seat in the rearmost position.
- 1.13 Use any part of any control, other than the parts which primarily move the seat or seat cushion fore-aft, to find and visually **mark** for future reference the maximum, minimum, and middle height of the seat cushion reference point with the seat cushion reference line at the mid-angle determined in 1.8. (S20.1.9.4, S22.1.2, S22.1.7.4, S22.3.1, S22.4.3.1, S24.1.2, S24.3.1, S24.4.3.1, S26.2.3, S26.3.1)
 N/A - No seat height adjustment. Go to 1.18
- 1.14 Use only the controls that primarily move the seat and/or seat cushion in the fore-aft direction to place the seat in the mid-fore-aft position.
- 1.15 Use any part of any control, other than the parts which primarily move the seat or seat cushion fore-aft, to find and visually **mark** for future reference the maximum, minimum, and middle height of the seat cushion reference point with the seat cushion reference line at the mid-angle determined in 1.8. (S20.1.9.4, S22.1.2, S22.1.7.4, S22.3.1, S24.1.2, S24.3.1)
- 1.16 Use only the control that change the seat in the fore-aft direction to place the seat in the foremost position. (S16.2.10.3.2)
- 1.17 Use any part of any control, other than the parts which primarily move the seat or seat cushion fore-aft, to find and visually **mark** for future reference the maximum, minimum, and middle height of the seat cushion reference point with the seat cushion reference line at the mid-angle determined in 1.8. (S16.2.10.3.3, S20.1.9.4, S22.1.2, S22.1.7.4, S22.3.1, S24.1.2, S24.3.1)
- 1.18. Visually **mark** for future reference the seat back angle at the manufacturer's nominal design riding position for a **50th percentile adult male** in the manner specified by the manufacturer for the rearmost, mid, and foremost seat positions. (S20.1.9.5, S22.1.7.5, S22.4.2.1, S22.4.3.1, S24.1.2, S24.4.2.1, S26.2.3, S26.3.1)
 N/A - No seat back angle adjustment
 Manufacturer's design seat back angle 14.0° On Seat Back Frame
- 1.19. Is the seat a bucket seat?
 Yes, go to 1.20 and skip 1.21
 No, go to 1.21 and skip 1.20
- 1.20 Bucket seats:
 Locate and **mark** for future reference the longitudinal centerline of the seat cushion. The intersection of the vertical longitudinal plane that passes through the SgRP and the seat cushion upper surface determines the longitudinal centerline of a bucket seat cushion. (S16.3.1.10 & S20.1.10)
- 1.21 Bench seats (complete ONLY the one that is applicable to the seat being marked):
 1.21.1 Driver Seat
 Locate and **mark** for future reference the longitudinal line on the seat cushion that marks the intersection of the vertical longitudinal plane through the centerline of the steering wheel and the seat cushion upper surface.

__1.21.2 Passenger Seat

Locate and **mark** for future reference the longitudinal centerline of the passenger seat cushion. The longitudinal centerline is the same distance from the longitudinal centerline of the vehicle as the center of the steering wheel. (S20.2.1.3, S22.2.1.3, S24.2.3, S20.4.4, S22.2.2.1(b), S22.2.2.3(b), S22.2.2.4(a), S22.2.2.5(a), S22.2.2.6(a), S22.2.2.7(a), S24.2.3(a))

Record the distance from the longitudinal centerline of the vehicle to the center of the steering wheel. _____

Record the distance from the longitudinal centerline of the vehicle to the longitudinal centerline of the seat cushion. (The vertical plane through this longitudinal centerline is Plane B for suppression.) _____

2. Head Restraint Position

__N/A Vehicle contains automatic head restraints.

__N/A, there is no head restraint adjustment

2.1 Adjust the head restraint to its lowest position. (S16.2.10.2, S20.1.9.6 S20.4.1, S22.1.7.6, S22.4.2.1, S22.4.3.1, S24.4.3.1, S26.2.3, S26.3.1)

2.2 All adjustments of the head restraint shall be used to position it full forward. For example, if it rotates, rotate it such that the head restraint extends as far forward as possible. **Mark** the foremost position. (S16.2.10.2 & S16.3.4.4 & S20.1.9.6, S20.4.1, S22.4.2.1, S22.4.3.1, S24.4.3.1, S26.2.3, S26.3.1)

2.3 Measure the vertical distance from the top most point of the head restraint to the bottom most point. Locate and **mark** a horizontal plane through the midpoint of this distance. (S16.3.4.3)

Vertical height of head restraint 200 mm

Mid-point height 100 mm

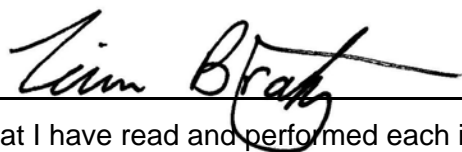

I certify that I have read and performed each instruction.

6/11/08

Date

DATA SHEET 14.1

MARKING OF REFERENCE POINTS FOR 5th FEMALE

Driver Seat Passenger Seat

1. Seat Position

- 1.1 Position the seat's adjustable lumbar supports so that the lumbar supports are in the lowest, retracted or deflated adjustment positions. (S16.2.10.1, S20.1.9.1, S20.4.1, S22.1.7.1)
 N/A - No lumbar adjustment
- 1.2 Position any adjustable parts of the seat that provide additional support so that they are in the lowest or most open adjustment position. (S16.2.10.2, S20.1.9.2, S20.4.1, S22.1.7.1, S22.4.2.1, S22.4.3.1, S24.4.2.1, S26.2.3, S26.3.1)
 N/A - No additional support adjustment
- 1.3 Position an adjustable leg support system in its rearmost position. (8/27/04 interpretation to Toyota)
 N/A - No adjustable leg support system
- 1.4 **Mark** a point (seat cushion reference point) on the side of the seat cushion that is between 150 mm and 250 mm from the front edge of the seat cushion. (S16.3.1.12)
- 1.5 Draw a line (seat cushion reference line) through the seat cushion reference point. (S16.3.1.13)
- 1.6 Use only the controls that primarily move the seat in the fore-aft direction to move the seat cushion reference point to the rearmost position. (S16.2.10.3.1, S22.1.7.3)
- 1.7 If the seat cushion adjusts fore-aft, independent of the seat back, use only the controls that primarily move the seat cushion in the fore-aft direction to move the seat cushion reference point to the rearmost position. (S16.2.10.3.1, S20.1.9.3)
 N/A - No independent fore-aft seat cushion adjustment
- 1.8 Use any part of any control, other than the parts just used for fore-aft positioning, to determine the range of angles of the seat cushion reference line and to set the seat cushion reference line at the mid-angle. (S16.2.10.3.1) NO ADJUSTMENT
Maximum angle Zero
Minimum angle Zero
Mid-angle Zero
- 1.9 If the seat and/or seat cushion height is adjustable, use any part of any control other than the parts which primarily move the seat or seat cushion fore-aft, to put the seat cushion reference point in its lowest position with the seat cushion reference line angle at the mid-angle found in 1.8. (S16.2.10.3.1)
 N/A - No seat height adjustment
- 1.10 Use only the controls that primarily move the seat in the fore-aft direction to verify the seat is in the rearmost position.
- 1.11 Use only the controls that primarily move the seat in the fore-aft direction to **mark** for future reference the fore-aft seat positions. **Mark** each position so that there is a visual indication when the seat is at a particular position. For manual seats, move the seat forward one detent at a time and **mark** each detent. For power seats, **mark** only the rearmost, middle, and foremost positions. Label three of the positions with the following: F for foremost, M for mid-position (if there is no mid-position, label the closest adjustment position to the rear of the mid-point), and R for rearmost.
- 1.12 Use only the controls that primarily move the seat in the fore-aft direction to place the seat in the rearmost position.

- 1.13 Use any part of any control, other than the parts which primarily move the seat or seat cushion fore-aft, to find and visually **mark** for future reference the maximum, minimum, and middle height of the seat cushion reference point with the seat cushion reference line at the mid-angle determined in 1.8. (S20.1.9.4, S22.1.2, S22.1.7.4, S22.3.1, S22.4.3.1, S24.1.2, S24.3.1, S24.4.3.1, S26.2.3, S26.3.1)
 N/A - No seat height adjustment. Go to 1.18
- 1.14 Use only the controls that primarily move the seat and/or seat cushion in the fore-aft direction to place the seat in the mid-fore-aft position.
- 1.15 Use any part of any control, other than the parts which primarily move the seat or seat cushion fore-aft, to find and visually **mark** for future reference the maximum, minimum, and middle height of the seat cushion reference point with the seat cushion reference line at the mid-angle determined in 1.8. (S20.1.9.4, S22.1.2, S22.1.7.4, S22.3.1, S24.1.2, S24.3.1)
- 1.16 Use only the control that change the seat in the fore-aft direction to place the seat in the foremost position. (S16.2.10.3.2)
- 1.17 Use any part of any control, other than the parts which primarily move the seat or seat cushion fore-aft, to find and visually **mark** for future reference the maximum, minimum, and middle height of the seat cushion reference point with the seat cushion reference line at the mid-angle determined in 1.8. (S16.2.10.3.3, S20.1.9.4, S22.1.2, S22.1.7.4, S22.3.1, S24.1.2, S24.3.1)
- 1.18. Visually **mark** for future reference the seat back angle at the manufacturer's nominal design riding position for a **50th percentile adult male** in the manner specified by the manufacturer for the rearmost, mid, and foremost seat positions. (S20.1.9.5, S22.1.7.5, S22.4.2.1, S22.4.3.1, S24.1.2, S24.4.2.1, S26.2.3, S26.3.1)
 N/A - No seat back angle adjustment
 Manufacturer's design seat back angle 14.0° On Seat Back Frame
- 1.19. Is the seat a bucket seat?
 Yes, go to 1.20 and skip 1.21
 No, go to 1.21 and skip 1.20
- 1.20 Bucket seats:
 Locate and **mark** for future reference the longitudinal centerline of the seat cushion. The intersection of the vertical longitudinal plane that passes through the SgRP and the seat cushion upper surface determines the longitudinal centerline of a bucket seat cushion. (S16.3.1.10 & S20.1.10)
- 1.21 Bench seats (complete ONLY the one that is applicable to the seat being marked):
- 1.21.1 Driver Seat
 Locate and **mark** for future reference the longitudinal line on the seat cushion that marks the intersection of the vertical longitudinal plane through the centerline of the steering wheel and the seat cushion upper surface.
- 1.21.2 Passenger Seat
 Locate and **mark** for future reference the longitudinal centerline of the passenger seat cushion. The longitudinal centerline is the same distance from the longitudinal centerline of the vehicle as the center of the steering wheel. (S20.2.1.3, S22.2.1.3, S24.2.3, S20.4.4, S22.2.2.1(b), S22.2.2.3(b), S22.2.2.4(a), S22.2.2.5(a), S22.2.2.6(a), S22.2.2.7(a), S24.2.3(a))
 Record the distance from the longitudinal centerline of the vehicle to the center of the steering wheel. _____
 Record the distance from the longitudinal centerline of the vehicle to the longitudinal centerline of the seat cushion. (The vertical plane through this longitudinal centerline is Plane B for suppression.) _____

2. Head Restraint Position

N/A Vehicle contains automatic head restraints.

N/A, there is no head restraint adjustment

2.1 Adjust the head restraint to its lowest position. (S16.2.10.2, S20.1.9.6 S20.4.1, S22.1.7.6, S22.4.2.1, S22.4.3.1, S24.4.3.1, S26.2.3, S26.3.1)

2.2 All adjustments of the head restraint shall be used to position it full forward. For example, if it rotates, rotate it such that the head restraint extends as far forward as possible. **Mark** the foremost position. (S16.2.10.2 & S16.3.4.4 & S20.1.9.6, S20.4.1, S22.4.2.1, S22.4.3.1, S24.4.3.1, S26.2.3, S26.3.1)

2.3 Measure the vertical distance from the top most point of the head restraint to the bottom most point. Locate and **mark** a horizontal plane through the midpoint of this distance. (S16.3.4.3)

Vertical height of head restraint 200 mm

Mid-point height 100 mm

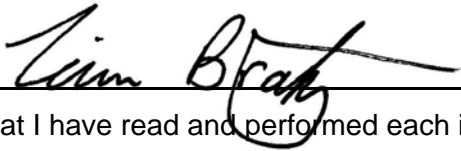

I certify that I have read and performed each instruction.

6/11/08

Date

DATA SHEET 14.3

MARKING OF REFERENCE POINTS FOR STEERING WHEEL

- X1. Is the steering wheel adjustable up and down and/or in and out?
X Yes - go to 2
___ No - this form is complete
- X2. Find and **mark** for future reference each up and down position. Label three of the positions with the following: H for Top of 4, M for mid-position (if there is no mid-position, label the next lowest adjustment position), and L for lowest.
___ N/A - steering wheel is not adjustable up and down
- X3. Find and **mark** for future references each in and out position. Label three of the positions with the following: F for foremost, M for mid-position (if there is no mid-position, label the next rearmost adjustment position), and R for rearmost.
___ N/A - steering wheel is not adjustable in and out.



I certify that I have read and performed each instruction.

6/11/08

Date

DATA SHEET 32

VEHICLE WEIGHT, FUEL TANK, AND ATTITUDE DATA

Test Vehicle: 2008 Dodge Charger
 Test Program: FMVSS 208 Compliance
 Test Technician: Jamie Aide

NHTSA No.: C80301
 Test Date: 6/11/08

IMPACT ANGLE:	Zero Degrees		
BELTED DUMMIES (YES/NO):	No		
TEST SPEED:	<input checked="" type="checkbox"/> 32 to 40 kmph	<input type="checkbox"/> 0 to 48 kmph	<input type="checkbox"/> 0 to 56 kmph
DRIVER DUMMY:	<input checked="" type="checkbox"/> 5 th female	<input type="checkbox"/> 50 th male	
PASSENGER DUMMY:	<input checked="" type="checkbox"/> 5 th female	<input type="checkbox"/> 50 th male	

- | | | |
|-------------------------------------|-----|---|
| <input checked="" type="checkbox"/> | 1. | Fill the transmission with transmission fluid to the satisfactory range. |
| <input checked="" type="checkbox"/> | 2. | Drain fuel from vehicle |
| <input checked="" type="checkbox"/> | 3. | Run the engine until fuel remaining in the fuel delivery system is used and the engine stops. |
| <input checked="" type="checkbox"/> | 4. | Record the useable fuel tank capacity supplied by the COTR |
| <input checked="" type="checkbox"/> | | Useable Fuel Tank Capacity supplied by COTR: 68.1 liters (18.0 gallons) |
| <input checked="" type="checkbox"/> | 5. | Record the fuel tank capacity supplied in the owner's manual. |
| <input checked="" type="checkbox"/> | | Useable Fuel Tank Capacity in owner's manual: 68.1 liters (18.0 gallons) |
| <input checked="" type="checkbox"/> | 6. | Using purple dyed Stoddard solvent having the physical and chemical properties of Type 1 solvent or cleaning fluid, Table 1, ASTM Standard D484-71, "Standard Specifications for Hydrocarbon Dry-cleaning Solvents," or gasoline, fill the fuel tank. |
| <input checked="" type="checkbox"/> | | Amount Added: 68.1 liters (18.0 gallons) |
| <input checked="" type="checkbox"/> | 7. | Fill the coolant system to capacity. |
| <input checked="" type="checkbox"/> | 8. | Fill the engine with motor oil to the Max. mark on the dip stick. |
| <input checked="" type="checkbox"/> | 9. | Fill the brake reservoir with brake fluid to its normal level. |
| <input checked="" type="checkbox"/> | 10. | Fill the windshield washer reservoir to capacity. |
| <input checked="" type="checkbox"/> | 11. | Inflate the tires to the tire pressure on the tire placard. If no tire placard is available, inflate the tires to the recommended pressure in the owner's manual. |

Tire placard pressure:	RF:	30 psi	LF:	30 psi	RR:	30 psi	LR:	30 psi
Owner's manual pressure:	RF:	30 psi	LF:	30 psi	RR:	30 psi	LR:	30 psi
Actual inflated pressure:	RF:	30 psi	LF:	30 psi	RR:	30 psi	LR:	30 psi

- | | | |
|-------------------------------------|-----|--|
| <input checked="" type="checkbox"/> | 12. | Record the vehicle weight at each wheel to determine the unloaded vehicle weight (UVW), i.e. "as delivered" weight). |
|-------------------------------------|-----|--|

Right Front (kg):	445.9	Right Rear (kg):	401.4
Left Front (kg):	438.6	Left Rear (kg):	391.5
Total Front (kg):	884.5	Total Rear (kg):	792.9
% Total Weight:	52.7	% Total Weight:	47.3
UVW = TOTAL FRONT PLUS TOTAL REAR (KG):	1677.4		

- | | | |
|-------------------------------------|------|---|
| <input checked="" type="checkbox"/> | 13. | UVW Test Vehicle Attitude: (All dimensions in millimeters) |
| <input checked="" type="checkbox"/> | 13.1 | Mark a point on the vehicle above the center of each wheel. |
| <input checked="" type="checkbox"/> | 13.2 | Place the vehicle on a level surface. |

- 13.3 Measure perpendicular to the level surface to the 4 points marked on the body and record the measurements

RF:	783	LF:	788	RR:	796	LR:	802
-----	-----	-----	-----	-----	-----	-----	-----

14. Calculate the Rated Cargo and Luggage Weight (RCLW): 52 kg
- 14.1 Does the vehicle have the vehicle capacity weight (VCW) on the certification label or tire placard?

- Yes, go to 14.3
- No, go to 14.2

- 14.2 VCW = Gross Vehicle Weight - UVW

$$VCW = \underline{\hspace{2cm}} - \underline{\hspace{2cm}} = \underline{\hspace{2cm}}$$

- 14.3 VCW = 392 kg (865 lbs)

- 14.4 Does the certification or tire placard contain the Designated Seating Capacity (DSC)?

- Yes, go to 14.6
- No, go to 14.5 and skip 14.6

- 14.5 DSC = Total number of seat belt assemblies =

- 14.6 DSC = 5

- 14.7 RCLW = VCW - (68 kg x DSC) = 392 kg - (68 kg x 5) = 52 kg

- 14.8 Is the vehicle certified as a truck, MPV or bus (see the certification label on the door jamb)?

Yes, if the calculated RCLW is greater than 136 kg, use 136 kg as the RCLW. (S8.1.1)

No, use the RCLW calculated in 14.7

15. Fully Loaded Weight (100% fuel fill): 1827.5 kg

- 15.1 Place the appropriate test dummy in both front outboard seating positions.

Driver: 5th female 50th male
 Passenger: 5th female 50th male

- 15.2 Load the vehicle with the RCLW from 14.7 or 14.8 whichever is applicable.

- 15.3 Place the RCLW in the cargo area. Center the load over the longitudinal centerline of the vehicle. (S8.1.1 (d))

- 15.4 Record the vehicle weight at each wheel to determine the Fully Loaded Weight.

Right Front (kg):	470.8	Right Rear (kg):	453.1
Left Front (kg):	461.8	Left Rear (kg):	441.8
Total Front (kg):	932.6	Total Rear (kg):	894.9
% Total Weight:	51.1	% Total Weight:	48.9
% GVW	57.3	% GVW	57.3
(% GVW = Axle GVW divided by Vehicle GVW)			
Fully Loaded Weight = Total Front Plus Total Rear (kg):			1827.5

16. Fully Loaded Test Vehicle Attitude: (All dimensions in millimeters)

- 16.1 Place the vehicle on a level surface.

- 16.2 Measure perpendicular to the level surface to the 4 points marked on the body (see 13.1 above) and record the measurements

RF:	772	LF:	778	RR:	778	LR:	786
-----	-----	-----	-----	-----	-----	-----	-----

17. Drain the fuel system
18. Using purple dyed Stoddard solvent having the physical and chemical properties of Type 1 solvent or cleaning fluid, Table 1, ASTM Standard D484-71, "Standard Specifications for Hydrocarbon Dry-cleaning Solvents," fill the fuel tank to 92 - 94 percent of useable capacity.

Fuel tank capacity x .94 = 68.1 liters (18.0 gallons) x .94 = 64.0 liters (16.9 gallons)

Amount added 63.2 liters (16.7 gallons) 92.8%

19. Crank the engine to fill the fuel delivery system with Stoddard solvent
20. Calculate the test weight range.
- 20.1 Calculated Weight = UVW (see 12 above) + RCLW (see 14 above) + 2x(dummy weight)

$$1827.4 \text{ kg} = 1677.4 \text{ kg} + 52.0 \text{ kg} + 98.0 \text{ kg}$$

- 20.2 Test Weight Range = Calculated Weight (- 4.5 kg, - 9 kg.)
 Max. Test Weight = Calculated Test Weight - 4.5 kg = 1822.9 kg
 Min. Test Weight = Calculated Test Weight - 9 kg = 1818.4 kg

21. Remove the RCLW from the cargo area.
22. Drain transmission fluid, engine coolant, motor oil, and windshield washer fluid from the test vehicle so that Stoddard solvent leakage from the fuel system will be evident.

23. Vehicle Components Removed For Weight Reduction:
Spare tire, jack and tools, rear seat bottom, and trunk interior

24. Secure the equipment and ballast in the load carrying area and distribute it, as nearly as possible, to obtain the proportion of axle weight indicated by the gross axle weight ratings and center it over the longitudinal centerline of the vehicle.

25. If necessary, add ballast to achieve the actual test weight.

N/A

Weight of Ballast: 25.4 kg

26. Ballast, including test equipment, must be contained so that it will not shift during the impact event or interfere with data collection or interfere with high-speed film recordings or affect the structural integrity of the vehicle or do anything else to affect test results. Care must be taken to assure that any attachment hardware added to the vehicle is not in the vicinity of the fuel tank or lines.

27. Record the vehicle weight at each wheel to determine the actual test weight.

Right Front (kg):	464.0	Right Rear (kg):	444.5
Left Front (kg):	469.9	Left Rear (kg):	440.9
Total Front (kg):	933.9	Total Rear (kg):	885.4
% Total Weight:	51.3	% Total Weight:	48.7
% GVW	57.3	% GVW	57.3
(% GVW = Axle GVW divided by Vehicle GVW)			
TOTAL FRONT PLUS TOTAL REAR (kg):			1819.3

28. Is the test weight between the Max. Weight and the Min. Weight (See 20.2)?
- Yes
- No, explain why not.
29. Test Weight Vehicle Attitude: (all dimensions in millimeters)
- 29.1 Place the vehicle on a level surface
- 29.2 Measure perpendicular to the level surface to the 4 points marked on the body (see 13 above) and record the measurements

RF:	772	LF:	778	RR:	796	LR:	786
-----	-----	-----	-----	-----	-----	-----	-----

30. Summary of test attitude
- 30.1 AS DELIVERED:

RF:	783	LF:	788	RR:	796	LR:	802
-----	-----	-----	-----	-----	-----	-----	-----

AS TESTED:

RF:	772	LF:	778	RR:	796	LR:	786
-----	-----	-----	-----	-----	-----	-----	-----

FULLY LOADED:

RF:	772	LF:	778	RR:	778	LR:	786
-----	-----	-----	-----	-----	-----	-----	-----

- 30.2 Is the "as tested" test attitude equal to or between the "fully loaded" and "as delivered" attitude?
- Yes
- No, explain why not.

REMARKS:

I certify that I have read and performed each instruction.

Signature: *Jamie Custer*

Date: 6/11/08

DATA SHEET 33

VEHICLE ACCELEROMETER LOCATION AND MEASUREMENTS

Test Vehicle: 2008 Dodge Charger
 Test Program: FMVSS 208 Compliance
 Test Technician: Jamie Aide

NHTSA No.: C80301
 Test Date: 6/11/08

IMPACT ANGLE:	Zero Degrees		
BELTED DUMMIES (YES/NO):	No		
TEST SPEED:	<u>X</u> 32 to 40 kmph	<u> </u> 0 to 48 kmph	<u> </u> 0 to 56 kmph
DRIVER DUMMY:	<u>X</u> 5 th female	<u> </u> 50 th male	
PASSENGER DUMMY:	<u>X</u> 5 th female	<u> </u> 50 th male	

1. Find the location where the vertical plane parallel to the longitudinal centerline of the vehicle and through the center of the left front outboard seating position intersects the left rear seat cross member. Install an accelerometer at this intersection on the rear seat cross member to record x-direction accelerations. Record the location on the following chart.
2. Find the location where the vertical plane parallel to the longitudinal centerline of the vehicle and through the center of the right front outboard seating position intersects the right rear seat cross member. Install an accelerometer at this intersection on the rear seat cross member to record x-direction accelerations. Record the location on the following chart.
3. Find the location where a vertical plane through the longitudinal centerline of the vehicle and a vertical transverse plane through the center of the two wheels on opposite sides of the engine intersect at the top of the engine. Install an accelerometer at this intersection to record x-direction accelerations. Record the location on the following chart.
4. Find the location where a vertical plane through the longitudinal centerline of the vehicle and a vertical transverse plane through the center of the two wheels on opposite sides of the engine intersect the bottom of the engine. Install an accelerometer at this intersection to record x-direction accelerations. Record the location on the following chart.
5. Install an accelerometer on the right front brake caliper to record x-direction accelerations. Record the location on the following chart.
6. Find the location where a vertical plane through the longitudinal centerline of the vehicle intersects the top of the instrument panel. Install an accelerometer at this intersection to record x-direction accelerations. Record the location on the following chart.
7. Install an accelerometer on the left front brake caliper to record x-direction accelerations. Record the location on the following chart.
8. Find the location where a vertical plane through the longitudinal centerline of the vehicle intersects the floor of the trunk. Install an accelerometer on the trunk floor at this intersection to record z-direction accelerations. Record the location on the following chart.

REMARKS:

I certify that I have read and performed each instruction.

Signature:  Date: 6/11/08

VEHICLE ACCELEROMETER LOCATION AND DATA SUMMARY

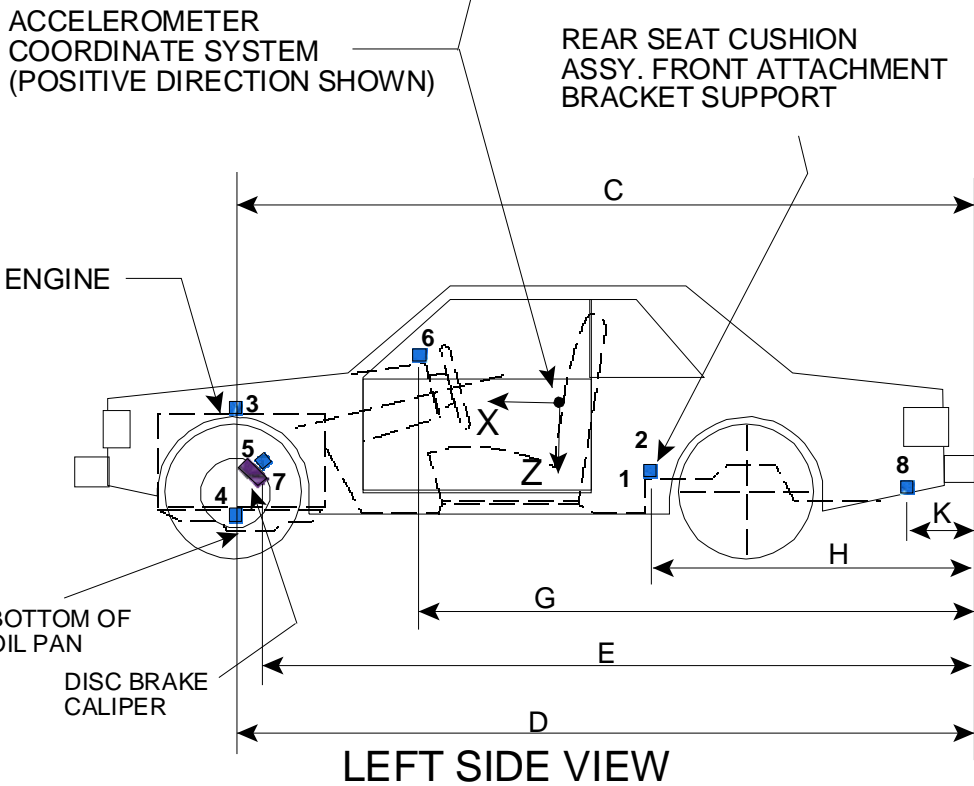
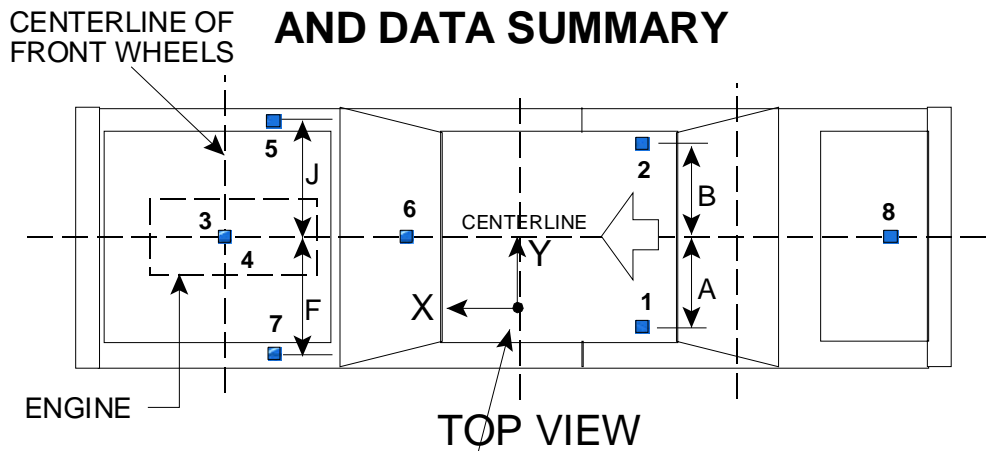

Dimensions Corresponding To The Letters "A" Through "K" (Excluding "I") Are Recorded In The Table On The Following Page.
Accelerometers Corresponding To The Numbers 1 Through 8 Are Specified On The Preceding Page.

DATA SHEET 33
VEHICLE ACCELEROMETER LOCATION AND MEASUREMENTS

<u>DIMENSION</u>	<u>LENGTH (mm)</u>	
PRETEST VALUES		
<u>A</u> (LH Rear Seat Xmbr)	379	
<u>B</u> (RH Rear Seat Xmbr)	405	
<u>C</u> (Engine Top)	4190	
<u>D</u> (Engine Bottom)	4353	
<u>E</u> (Caliper)	Right Side: 3967	Left Side: 3967
<u>F</u> (Left Caliper)	668	
<u>G</u> (IP)	3206	
<u>H</u> (Seat)	1954	
<u>J</u> (Right Caliper)	668	
<u>K</u> (Trunk)	845	
POST TEST VALUES		
<u>A</u> (LH Rear Seat Xmbr)	379	
<u>B</u> (RH Rear Seat Xmbr)	405	
<u>C</u> (Engine Top)	4122	
<u>D</u> (Engine Bottom)	4264	
<u>E</u> (Caliper)	Right Side: 3925	Left Side: 3933
<u>F</u> (Left Caliper)	672	
<u>G</u> (IP)	3201	
<u>H</u> (Seat)	1954	
<u>J</u> (Right Caliper)	665	
<u>K</u> (Trunk)	845	

DATA SHEET 34
PHOTOGRAPHIC TARGETS





Test Vehicle: 2008 Dodge Charger
 Test Program: FMVSS 208 Compliance
 Test Technician: Jamie Aide

NHTSA No.: C80301
 Test Date: 6/11/08

IMPACT ANGLE:	Zero Degrees		
BELTED DUMMIES (YES/NO):	No		
TEST SPEED:	<u>X</u> 32 to 40 kmph	<u> </u> 0 to 48 kmph	<u> </u> 0 to 56 kmph
DRIVER DUMMY:	<u>X</u> 5 th female	<u> </u> 50 th male	
PASSENGER DUMMY:	<u>X</u> 5 th female	<u> </u> 50 th male	

- 1. FMVSS 208 vehicle targeting requirements (See Figures 28A and 28B)
- 1.1 Targets A1 and A2 are on flat rectangular panels.
- 1.2 Three circular targets at least 90 mm in diameter and with black and yellow quadrants are mounted at the front on the outboard sides of A1 and A2. The center of each circular target is 100 mm from the one next to it.
 Distance between targets (mm): 100 mm
- 1.3 Three circular targets at least 90 mm in diameter and with black and yellow quadrants are mounted at the back on the outboard sides of on A1 and A2. The center of each circular target is 100 mm from the one next to it.
 Distance between targets (mm): 100 mm
- 1.4 The distance between the first circular target at the front of A1 and A2 and the last circular target at the back of A1 and A2 is at least 915 mm.
 Distance between the first and last circular targets (mm): 915 mm
- 1.5 Firmly fix target A1 on the vehicle roof in the vertical longitudinal plane that is coincident with the midsagittal plane of the driver dummy.
- 1.6 Firmly fix target A2 on the vehicle roof in the vertical longitudinal plane that is coincident with the midsagittal plane of the passenger dummy.
- 1.7 Two circular targets (C1 and C2) at least 90 mm in diameter and with black and yellow quadrants are mounted on the outside of the driver door. The centers of each circular target are at least 610 mm apart.
 Distance between targets (mm): 610 mm
- 1.8 Two circular targets (C1 and C2) at least 90 mm in diameter and with black and yellow quadrants are mounted on the outside of the passenger door. The centers of each circular target are at least 610 mm apart.
 Distance between targets (mm): 610 mm
- 1.9 Place tape with squares having alternating colors on the top portion of the steering wheel.
- 1.10 Chalk the bottom portion of the steering wheel
- 1.11 Is this an offset test?
 Yes, continue with this section
 No, go to 2.

- 1.12 Measure the width of the vehicle.
Vehicle width (mm):
- 1.13 Find the centerline of the vehicle. ($\frac{1}{2}$ of the vehicle width)
- 1.14 Find the line parallel to the centerline of the vehicle and 0.1 x vehicle width from the centerline of the vehicle.
- 1.15 Apply 25 mm wide tape with alternating black and yellow squares parallel to and on each side of the line found in 1.14. The edge of each tape shall be 50 mm from the line found in 1.14. The tape shall extend from the bottom of the bumper to the front edge of the windshield. (Figure 28D)
2. Barrier Targeting
- 2.1 Fix two stationary targets D1 and D2 to the barrier as shown in the Figure 28A. One target is in the vertical longitudinal plane that is coincident with the midsagittal plane of the driver dummy. The other is in the vertical longitudinal plane that is coincident with the midsagittal plane of the passenger dummy
- 2.2 Targets D1 and D2 are on a rectangular panel.
- 2.3 Three circular targets at least 90 mm in diameter and with black and yellow quadrants are mounted on the sides of the rectangular panel away from the longitudinal centerline of the vehicle. The center of each circular target is 100 mm from the one next to it.
- Distance between circular targets on D1 (mm): 100 mm
- Distance between circular targets on D2 (mm): 100 mm
3. FMVSS 208 Dummy Targeting Requirements
- 3.1 Place a circular target with black and yellow quadrants on both sides of the driver dummy head as close as possible to the center of gravity of the head in the x and z direction (relative to the measuring directions of the accelerometers).
- 3.2 Place a circular target with black and yellow quadrants on both sides of the passenger dummy head as close as possible to the center of gravity of the head in the x and z direction (relative to the measuring directions of the accelerometers).
- 3.3 Place a circular target with black and yellow quadrants on the outboard shoulder of the driver dummy. Place the target as high up on the arm as possible at the intersection of the arm and shoulder. The sleeve of the shirt on the dummy may be cut to make the target visible, but do not remove any material.
- 3.4 Place a circular target with black and yellow quadrants on the outboard shoulder of the passenger dummy. Place the target as high up on the arm as possible at the intersection of the arm and shoulder. The sleeve of the shirt on the dummy may be cut to make the target visible, but do not remove any material.
4. FMVSS 204 Targeting Requirements
- 4.1 Is an FMVSS 204 indicant test ordered on the "COTR Vehicle Work Order?"
- Yes, continue with this form.
- No, this form is complete.
- 4.2 Resection panel (Figure 28C)
- 4.2.1 The panel deviates no more than 6 mm from perfect flatness when suspended vertically
- 4.2.2 The 8 targets on the panel are circular targets at least 90 mm in diameter and with black and yellow quadrants.
- 4.2.3 The center of each of the 4 outer targets are placed within 1 mm of the corners of a square measuring 914 mm on each side.

-  4.2.4 Locate another square with 228 mm sides and with the center of this square coincident with the center of the 914 mm square.
-  4.2.5 The center of the 4 inner targets are placed at the midpoints of each of the 228 mm sides.
-  4.3 Place a circular target at least 90 mm in diameter and with black and yellow quadrants on a material (cardboard, metal, etc.) that can be taped to the top of the steering column.
-  4.4 Tape the target from 4.3 to the top of the steering column in a manner that does not interfere with the movement of the steering column in a crash

I certify that I have read and performed each instruction.

Signature: 

Date: 6/11/08

REFERENCE PHOTO TARGETS

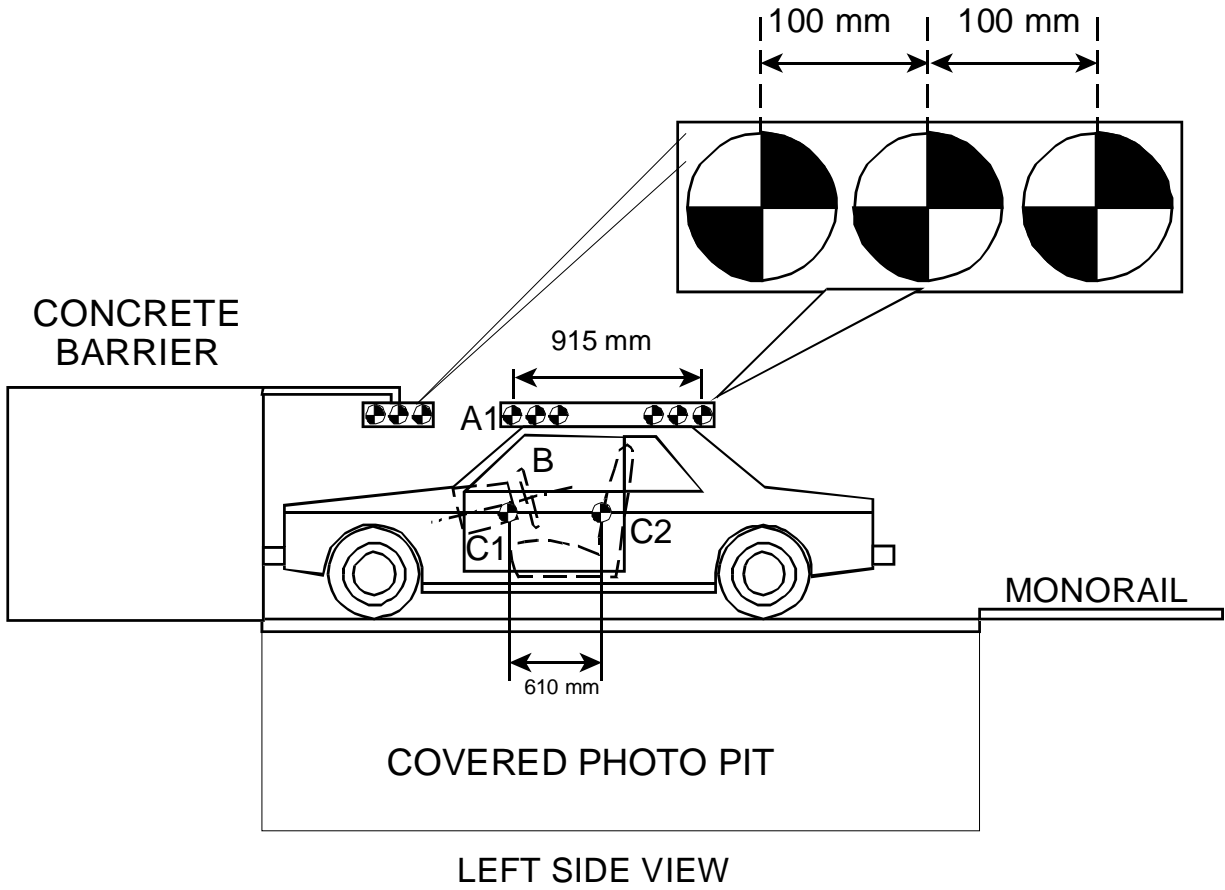

RESECTION PANEL TARGETING ALIGNMENT

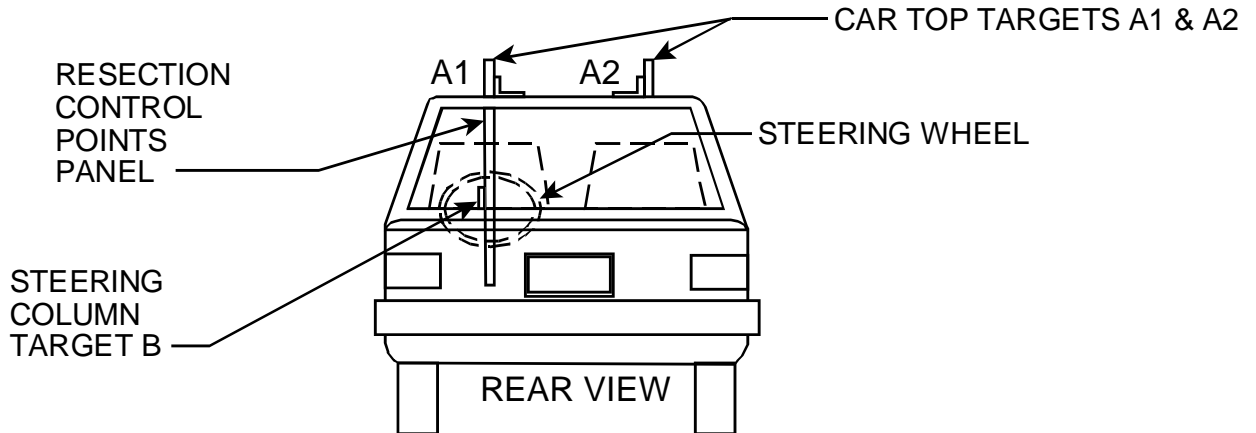

TEST RUN STEERING COLUMN CAMERA VIEW OF TYPICAL TIME ZERO VEHICLE POSITION

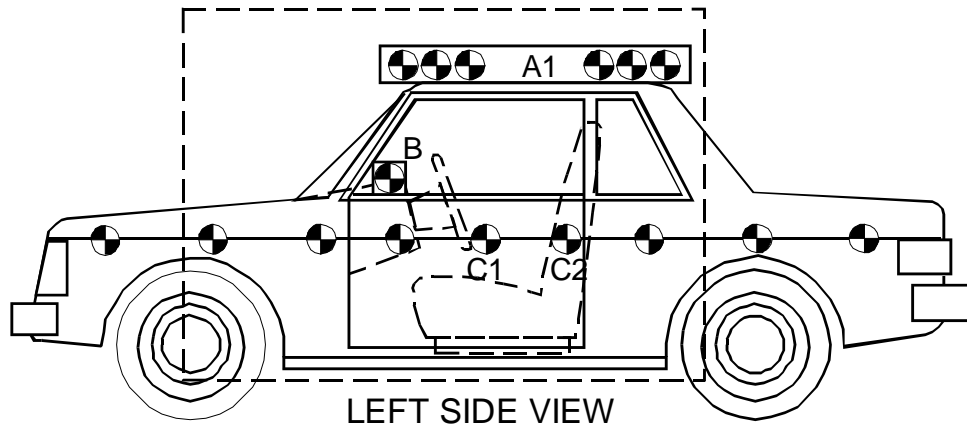

PRE-RUN STEERING COLUMN HIGH SPEED CAMERA VIEW

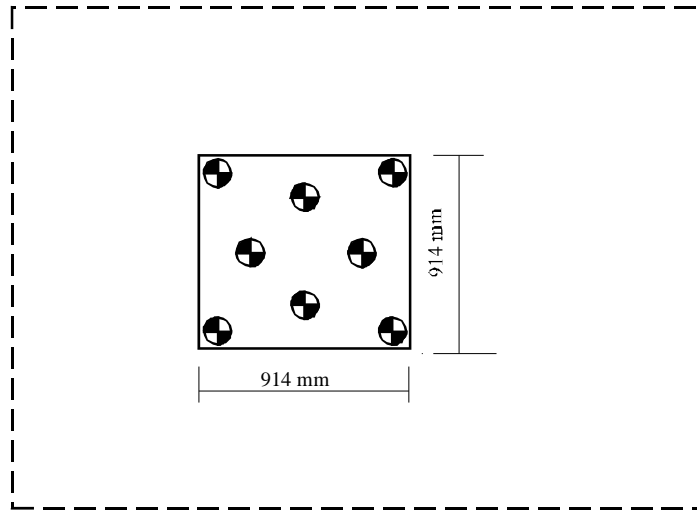

LEFT SIDE VIEW

DATA SHEET 35
CAMERA LOCATIONS

Test Vehicle: 2008 Dodge Charger
Test Program: FMVSS 208 Compliance

NHTSA No.: C80301
Test Date: 6/11/08
Time: 9:11 am

CAMERA NO.	VIEW	CAMERA POSITIONS (mm) *			LENS (mm)	SPEED (fps)
		X	Y	Z		
1	Real Time Left Side View				13	24
2	Left Side View (Barrier face to front seat backs)	960	-4790	1140	24	1000
3	Left Side View (Driver)	1600	-5990	1250	35	1000
4	Left Side View (B-post aimed toward center of steering wheel)	7510	-5740	1990	50	1000
5	Left Side View (Steering Column)	1320	-5290	1280	25	1000
6	Left Side View (Steering Column)	1280	-5300	920	25	1000
7	Right Side View (Overall)	2300	6145	1210	20	1000
8	Right Side View (Passenger)	1590	6124	1330	35	1000
9	Right Side View (Angle)	7160	5110	2060	50	1000
10	Right Side View (Front door)	1040	5320	1080	24	1000
11	Front View Windshield	-295	0	2830	12.5	1000
12	Front View Driver	-135	-395	2240	24	1000
13	Front View Passenger	-110	505	2240	24	1000
14	Overhead Barrier Impact View	1190	0	5050	14	1000
15	Pit Camera Engine View	1030	0	-3150	24	1000
16	Pit Camera Fuel Tank View	2835	0	-3150	24	1000

***COORDINATES:**

- +X - forward of impact plane
- +Y - right of monorail centerline
- +Z - above ground level

CAMERA POSITIONS FOR FMVSS 208

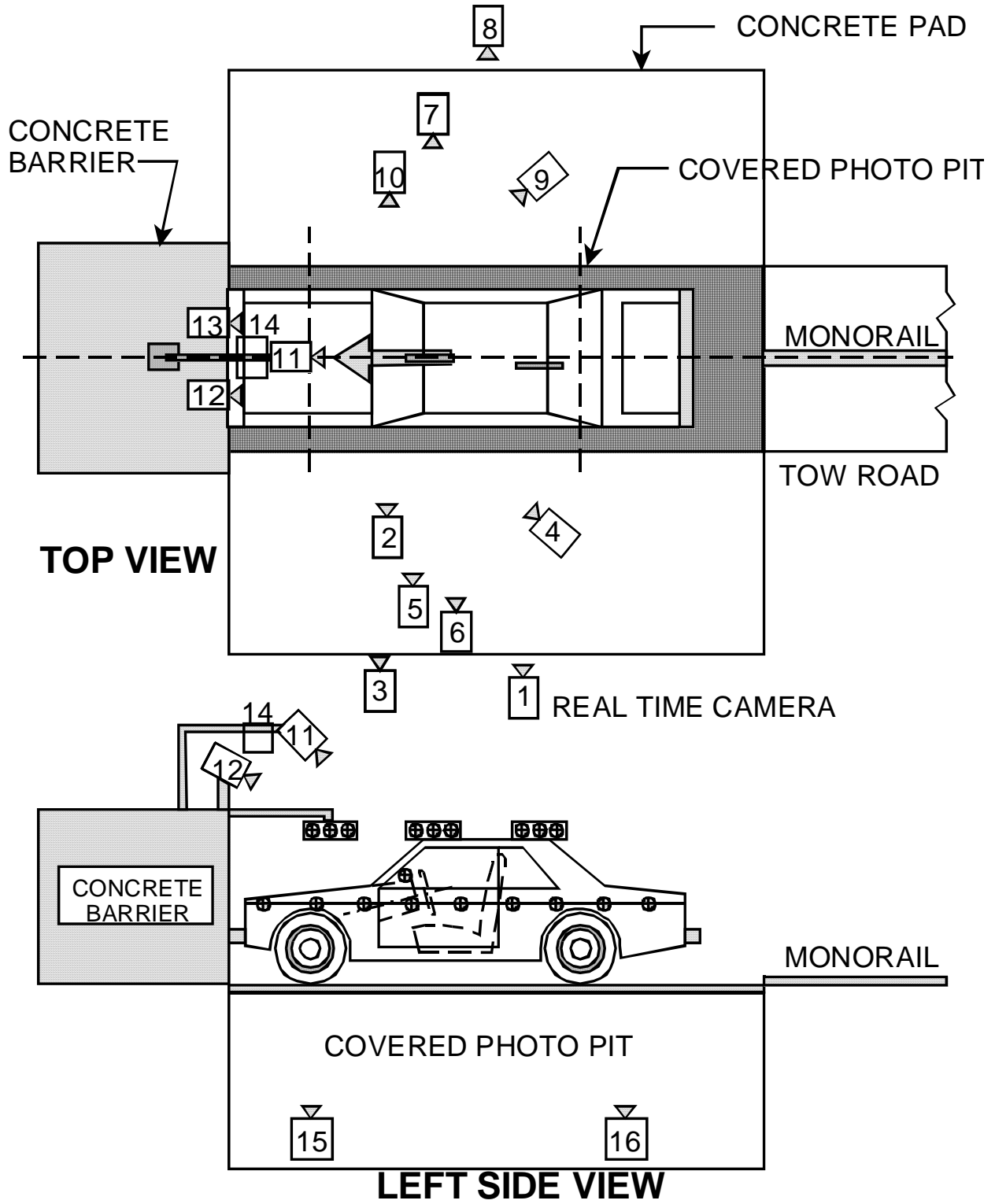

DATA SHEET 36
APPENDIX G
DUMMY POSITIONING PROCEDURES
FOR 5th% DRIVER TEST DUMMY CONFORMING TO SUBPART O OF PART 572

Test Vehicle: 2008 Dodge Charger
 Test Program: FMVSS 208 Compliance
 Test Technician: Tim Bratz

NHTSA No.: C80301
 Test Date: 6/11/08

IMPACT ANGLE:	Zero Degrees		
BELTED DUMMIES (YES/NO):	No		
TEST SPEED:	<input checked="" type="checkbox"/> 32 to 40 kmph	<input type="checkbox"/> 0 to 48 kmph	<input type="checkbox"/> 0 to 56 kmph
DRIVER DUMMY:	<input checked="" type="checkbox"/> 5 th female	<input type="checkbox"/> 50 th male	
PASSENGER DUMMY:	<input checked="" type="checkbox"/> 5 th female	<input type="checkbox"/> 50 th male	

- X 1. Using the markings made from data sheet 14.3 (If not done previously or steering repairs have been made, complete data sheet 14.3 at this time.) to position the steering controls in the mid-position or if applicable next lowest detent position. (S16.2.9)
- X 2. Place the SCRP in the full rearward, mid-height position, and mid-seat cushion angle, determined during the completion of Data Sheet 14.1. (S16.3.2.1.1)
- X 3. If the vehicle has an adjustable accelerator pedal, place it in the full forward position. (S16.3.2.2.1)
 N/A accelerator pedal not adjustable
- X 4. Fully recline the seat back. (S16.3.2.1.2)
 N/A seat back not adjustable.
- X 5. Place the dummy in the seat with the legs at an angle of 120 degrees to the thighs. The calves should not be touching the seat cushion. (S16.3.2.1.2)
- X 6. Position the dummy in the seat such that the midsagittal plane is coincident with the longitudinal seat cushion markings as determined in Data Sheet 14.1. (S16.3.2.1.3 and S16.3.2.1.4)
- X 7. Hold down the dummy's thighs and push rearward on the upper torso to maximize the pelvic angle. (S16.3.2.1.5)
- X 8. Set the angle between the legs and the thighs to 120 degrees. (S16.3.2.1.6)
- X 9. Set the transverse distance between the centers of the front of the knees at 160 to 170 mm. (6.3 to 6.7 inches) Center the knee separation with respect to the longitudinal seat cushion marking as determined Data Sheet 14.1. (S16.3.2.1.6)
 Record Knee Separation 168
- X 10. Push rearward on the dummy's knees until the pelvis contacts the seat back, or the backs of the calves contact the seat cushion, whichever occurs first. (S16.3.2.1.6)
 Pelvis contacted seat back.
 Calves contacted seat cushion.

11. Gently rock the upper torso ± 5 degrees (approximately 51 mm (2 inches)) side-to-side three time. (S16.3.2.1.7)
12. If needed, extend the legs until the feet do not contact the floor pan. The thighs should be resting on the seat cushion. (S16.3.2.1.8)
13. Position the right foot until the foot is in line with a longitudinal vertical plane passing through the center of the accelerator pedal. Maintain the leg and thigh in a vertical plane. (S16.3.2.1.8)
14. Rotate the left leg and thigh laterally to equalize the distance between each knee and the longitudinal seat cushion marking as determined in Data Sheet 14.1. (S16.3.2.1.8)
15. Attempt to return the seat to the foremost fore-aft position, mid-height, and seat cushion mid-angle as determined in Data Sheet 14.2. The foot may contact and depress the accelerator and/or change the angle of the foot with respect to the leg. (S16.3.2.1.8)
- Foremost position achieved. Proceed to step 20.
- Foremost not achieved because of foot interference. Proceed to step 17.
- Foremost not achieved because of steering wheel contact.
16. If either of the dummy's legs contact the steering wheel, move the steering wheel up the minimum amount required to avoid contact. If the steering wheel is not adjustable separate the knees the minimum required to avoid contact. (S16.3.2.1.8)
- N/A- there was no leg contact
- Steering wheel repositioned
- Knees separated
17. If the left foot interferes with the clutch or brake pedals, rotate the left foot about the leg to provide clearance. If this is not sufficient, rotate the thigh outboard at the hip the minimum amount required for clearance. (S16.3.2.1.8)
- N/A, No foot interference with pedals.
- Foot adjusted to provide clearance.
- Foot and Thigh adjusted to provide clearance.
18. Continue to move the seat. Use seat controls to line up the seat markings determined during the completion of Data Sheet 14.1 to set the foremost fore-aft position, mid-height position and the seat cushion mid-angle. If the dummy contacts the interior move the seat rearward until a maximum clearance of 5 mm (0.2 inches) is achieved or the seat is in the closest detent position that does not cause dummy contact. (S16.3.2.1.8)
- Foremost, mid-height position and the seat cushion mid-angle reached
- Dummy contact. Clearance set at maximum of 5mm
Measured Clearance _____
- Dummy Contact. Seat set at nearest detent position.
Seat position ____ detent positions rearward of foremost
(foremost is position zero)

19. If the steering wheel was repositioned in step 16, return the steering wheel to the original position. If the steering wheel contacts the dummy before reaching the original position, position the wheel until a maximum clearance of 5mm (.2 inches) is achieved, or the steering wheel is in the closest detent position that does not cause dummy contact. (S16.3.2.1.8)

N/A Steering wheel was not repositioned.

Original position achieved.

Dummy contact. Clearance set at maximum of 5mm

Measured Clearance _____

Dummy Contact. Steering wheel set at nearest detent position.

Steering wheel position detent positions upward of original position.

(Original position is position zero)

20. If the seat back is adjustable, rotate the seat back forward while holding the thighs in place. Continue rotating the seat back forward until the transverse instrument platform of the dummy head is level ± 0.5 degrees. If the head cannot be leveled using the seat back adjustment, or the seat back is not adjustable, use the lower neck bracket adjustment to level the head. If a level position cannot be achieved, minimize the angle. (S16.3.2.1.9)

Head Level Achieved. (Check all that apply)

Head leveled using the adjustable seat back

Head leveled using the neck bracket.

Head Angle 0.2 degrees

Head Level NOT Achieved. (Check all that apply)

Head adjusted using the adjustable seat back

Head adjusted using the neck bracket.

Head Angle _____ degrees

21. Verify the pelvis is not interfering with the seat bight. (S16.3.2.1.9)

No interference

Pelvis moved forward the minimum amount so that it is not caught in the seat bight.

22. Verify the dummy abdomen is properly installed. (S16.3.2.1.9)

Abdomen still seated properly into dummy

Abdomen was adjusted because it was not seated properly into dummy

23. Head Angle

N/A, neither the pelvis nor the abdomen were adjusted.

23.1 Head still level (Go to 24)

23.2 Head level adjusted

Head Level Achieved. (Check all that apply)

Head leveled using the adjustable seat back

Head leveled using the neck bracket.

Head Angle _____ degrees

Head Level NOT Achieved. (Check all that apply)

Head level adjusted using the adjustable seat back

Head level adjusted using the neck bracket.

Head Angle _____ degrees

24. If the dummy torso contacts the steering wheel while performing step 20, reposition the steering wheel in the following order to eliminate contact. (S16.3.2.1.9)
 N/A, No dummy torso contact with the steering wheel.

24.1 Adjust telescoping mechanism.

N/A No telescoping adjustment.

Adjustment performed (fill in appropriate change)

Steering wheel moved _____ detent positions in the forward direction.

Steering wheel moved _____ mm in the forward direction.

24.2 Adjust tilt mechanism.

N/A No tilt adjustment.

No adjustment performed.

Adjustment performed.

Steering wheel moved _____ detent positions Upward/Downward.
(circle one)

Steering wheel moved _____ degrees Upward/Downward

24.3 Adjust Seat in the aft direction.

No Adjustment performed.

Seat moved aft _____ mm from original position.

Seat moved aft _____ detent positions from the original position.

25. Measure and set the pelvic angle using the pelvic angle gage TE-2504. The pelvic angle should be 20.0 degrees \pm 2.5 degrees. If the pelvic angle cannot be set to the specified range because the head will not be level or because the dummy will have need major repositioning, adjust the pelvis as closely as possible to the angle range, but keep the head level. (S16.3.2.1.11)

Pelvic angle set to 20.0 degrees \pm 2.5 degrees.

Pelvic angle of 20.0 degrees not achieved, the angular difference was minimized.

Record the pelvic angle. _____ 21.5 _____ degrees

26. Check the dummy for contact with the interior after completing adjustments.
(S16.3.2.1.12)

No contact.

Dummy in contact with interior.

Seat moved aft _____ mm from the previous position.

Seat moved aft _____ detent positions from the previous position.

27. Check the dummy to see if additional interior clearance is obtained, allowing the seat to be moved forward. (S16.3.2.1.12)

N/A, Seat already at foremost position.

Clearance unchanged. No adjustments required.

Additional clearance available

Seat moved Forward _____ mm from the previous position.

Seat moved Forward _____ detent positions from the previous position.

28. Driver's foot positioning, right foot. Place the foot perpendicular to the leg and determine if the heel contacts the floor pan at any leg position. If the heel contacts the floor pan proceed to step 29 otherwise, proceed to step 30. (S16.3.2.2.1)

X 29. Perform the following steps until either all steps are completed, or the foot contacts the accelerator pedal. Step 29.6 shall be completed in all cases. (S16.3.2.2.1(a))

X 29.1 With the rear of the heel contacting the floor pan, move the foot forward until pedal contact occurs or the foot is at the full forward position.

 29.2 If the vehicle has an adjustable accelerator pedal, move the pedals rearward until pedal contact occurs or the pedals reach the full rearward position.

 29.3 Extend the leg, allowing the heel to lose contact with the floor until the foot contacts the pedal. Do not raise the toe of the foot higher than the top of the accelerator pedal. If the foot does not contact the pedal, proceed to the next step. If pedal contact does occur, place a tapered foam block as shown in Figure G1 under the heel with the shallow part of the taper facing forward. (S16.3.2.2.3)

 29.4 Angle the foot to achieve contact between the foot and the pedal. If the foot does not contact the pedal, return the foot to the perpendicular orientation. If pedal contact does occur, place a tapered foam block as shown in Figure G1 under the heel with the shallow part of the taper facing forward. (S16.3.2.2.3)

 29.5 Align the centerline of the foot with the vertical-longitudinal plane passing through the center of the accelerator pedal. Place a tapered foam block as shown in Figure G1 under the heel with the shallow part of the taper facing forward. (S16.3.2.2.3)

X 29.6 Record foot position

 Pedal Contact achieved. Contact occurred at step 29.1 .

 Heel contacts floor pan

 Heel set _____ mm from floor pan.

 Pedal Contact not achieved. Heel set _____ mm from the floor pan.

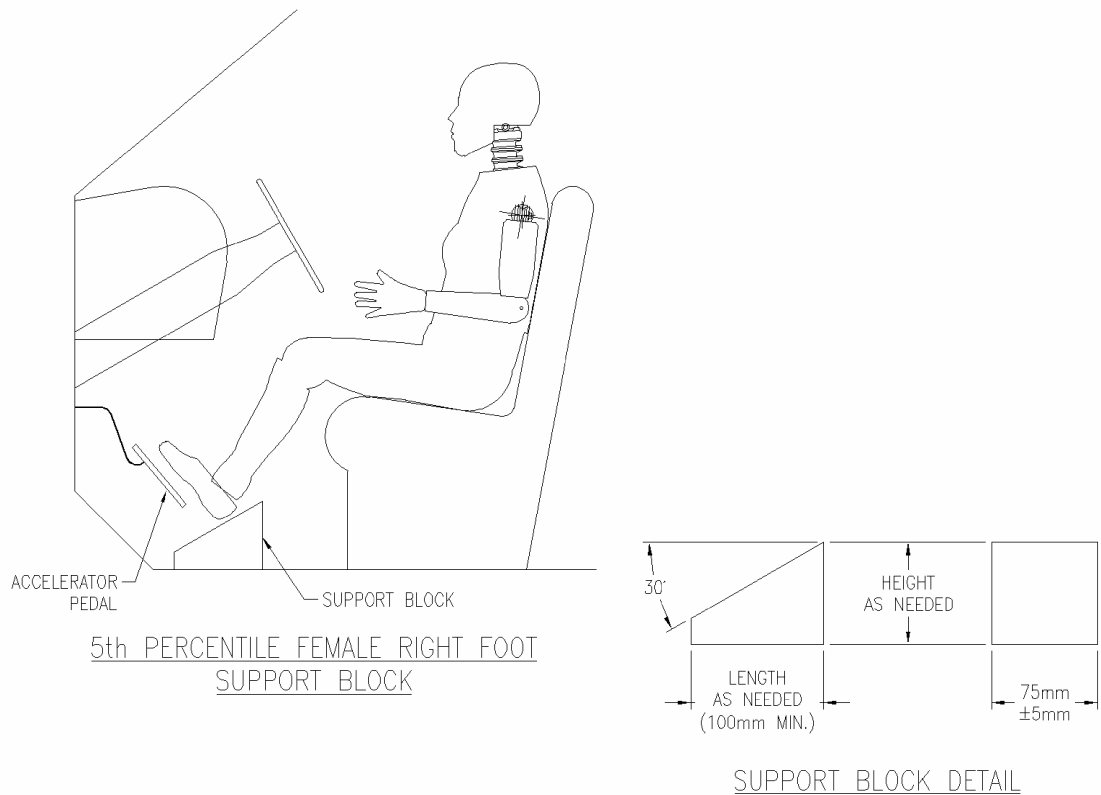

FIGURE G1

- __30. Perform the following steps until either all steps are completed, or the foot contacts the accelerator pedal. Step 30.5 shall be completed in all cases.
- __30.1 Extend the leg until the foot contacts the pedal. Do not raise the toe of the foot higher than the top of the accelerator pedal. If the foot does not contact the pedal, proceed to the next step. If pedal contact does occur, place a tapered foam block as shown in Figure G1 under the heel with the shallow part of the taper facing forward. (S16.3.2.2.1(b) & S16.3.2.2.3)
- __30.2 If the vehicle has an adjustable accelerator pedal, move the pedals rearward until pedal contact occurs or the pedals reach the full rearward position. If pedal contact does occur, place a tapered foam block as shown in Figure G1 under the heel with the shallow part of the taper facing forward. (S16.3.2.2.1(b) & S16.3.2.2.3)
- __N/A No pedal adjustment
- __30.3 Angle the foot to achieve contact between the foot and the pedal. If the foot does not contact the pedal, return the foot to the perpendicular orientation. If pedal contact does occur, place a tapered foam block as shown in Figure G1 under the heel with the shallow part of the taper facing forward. (S16.3.2.2.2 & S16.3.2.2.3)
- __30.4 Align the centerline of the foot in the same horizontal plane as the centerline of the accelerator pedal. Place a tapered foam block as shown in Figure G1 under the heel with the shallow part of the taper facing forward. (S16.3.2.2.3)

30.5 Record foot position

Pedal Contact achieved. Contact occurred at step _____.

Heel set _____ mm from floor pan.

Pedal Contact not achieved. Heel set _____ mm from the floor pan.

X31. Driver's foot positioning, left foot.

X31.1 Place the foot perpendicular to the leg and determine if the heel contacts the floor pan at any leg position. If the heel contacts the floor pan proceed to step 31.2, otherwise position the leg as perpendicular to the thigh as possible with the foot parallel to the floor pan. (S16.2.2.6)

X31.2 Place the foot on the toe board with the heel resting on the floor pan as close to the intersection of the floor pan and the toe board as possible. Adjust the angle of the foot if necessary to contact the toe board. If the foot will not contact the toe board, set the foot perpendicular to the leg, and set the heel on the floor pan as far forward as possible. Avoid contact with the brake pedal, clutch pedal, wheel well projection, and footrest. To avoid this contact use the following three manipulations in the order listed, with each subsequent option incorporating the previous, until contact is avoided: rotate the foot about the lower leg (abduction/adduction), plantar flex the foot, rotate the leg outboard about the hip. Movement should be the minimum amount necessary. If it is not possible to avoid all foot contact, give priority to avoiding brake or clutch pedal contact. (S16.2.2.4 & S16.2.2.5 & S16.2.2.7)

XNo contact

Foot rotated about the leg (abduction/adduction)

Foot rotated about the leg, and foot plantar flexed

Foot rotated about the leg, foot plantar flexed, and the leg rotated about the hip.

X31.3 Record foot position.

Heel does not contact floor pan.

Heel on floor pan and foot on toe board.

XHeel on floor pan and foot not on toe board.

X32. Driver arm/hand positioning.

X32.1 Place the dummy's upper arms adjacent to the torso with the arm centerlines as close to a vertical longitudinal plane as possible. (S16.3.2.3.1)

X32.2 Place the palms of the dummy in contact with the outer part of the steering wheel rim at its horizontal centerline with the thumbs over the steering wheel rim. (S16.3.2.3.2)

X32.3 If it is not possible to position the thumbs inside the steering wheel rim at its horizontal centerline, then position them above and as close to the horizontal centerline of the steering wheel rim as possible. (S16.3.2.3.3)

X32.4 Lightly tape the hands to the steering wheel rim so that if the hand of the test dummy is pushed upward by a force of not less than 9 N (2 lb) and not more than 22 N (5 lb), the tape releases the hand from the steering wheel rim. S16.3.2.3.4

X33. Adjustable head restraints

N/A, there is no head restraint adjustment

- 33.1 If the head restraint has an automatic adjustment, leave it where the system positions the restraint after the dummy is placed in the seat. (S16.3.4.1) Go to 34.
- 33.2 Adjust each head restraint vertically so that the mid-horizontal plane determined in Data Sheet 14.1 is aligned with the center of gravity (CG) of the dummy head. (S16.3.4.3)
- 33.3 If the above position is not attainable, move the vertical center of the head restraint to the closest detent below the center of the head CG. (S16.3.4.3)
 N/A midpoint position attained in previous step
 Headrest set at nearest detent below the head CG
- 33.4 If the head restraint has a fore and aft adjustment, place the restraint in the foremost position or until contact with the head is made, whichever occurs first. (S16.3.4.4)
34. Driver and passenger manual belt adjustment (for tests conducted with a belted dummy). (S16.3.5) UNBELTED TEST
- 34.1 If an adjustable seat belt D-ring anchorage exists, place it in the manufacturer's design position for a 5th percentile adult female. (S16.3.5.1) **This information will be supplied by the COTR.**
 Manufacturer's specified position _____
 Actual Position _____
- 34.2 Place the Type 2 manual belt around the test dummy and fasten the latch. (S16.3.5.2)
- 34.3 Ensure that the dummy's head remains as level as possible. (S16.3.5.3)
- 34.4 Remove all slack from the lap belt. Pull the upper torso webbing out of the retractor and allow it to retract; repeat this operation four times. Apply a 9 N (2 lbf) to 18 N (4 lbf) tension load to the lap belt. If the belt system is equipped with a tension-relieving device, introduce the maximum amount of slack into the upper torso belt that is recommended by the manufacturer. If the belt system is not equipped with a tension-relieving device, allow the excess webbing in the shoulder belt to be retracted by the retractive force of the retractor. (S16.3.5.4)

REMARKS:

I certify that I have read and performed each instruction.

Signature: Tim Brab Date: 6/11/08

APPENDIX G

DUMMY POSITIONING PROCEDURES FOR 5th% PASSENGER TEST DUMMY CONFORMING TO SUBPART O OF PART 572

Test Vehicle: 2008 Dodge Charger
 Test Program: FMVSS 208 Compliance
 Test Technician: Joe Fleck

NHTSA No.: C80301
 Test Date: 6/11/08

IMPACT ANGLE:	Zero Degrees		
BELTED DUMMIES (YES/NO):	No		
TEST SPEED:	<input checked="" type="checkbox"/> 32 to 40 kmph	<input type="checkbox"/> 0 to 48 kmph	<input type="checkbox"/> 0 to 56 kmph
DRIVER DUMMY:	<input checked="" type="checkbox"/> 5 th female		<input type="checkbox"/> 50 th male
PASSENGER DUMMY:	<input checked="" type="checkbox"/> 5 th female		<input type="checkbox"/> 50 th male

(Check this item ONLY if it applies to this vehicle.)

The passenger seat adjustments are controlled by the adjustments made to the driver's seat. Therefore, positioning of the passenger dummy is made simultaneously with the driver dummy. Adjustments made to the seat to position the driver will over ride any adjustments that would normally be made to position the passenger. (S16.2.10.3)

- 1. Place the SCRIP in the full rearward, mid-height position, and mid-seat cushion angle, determined during the completion of Data Sheet 14.1. (S16.3.3.1.1)
- 2. Fully recline the seat back. (S16.3.3.1.2)
 N/A seat back not adjustable.
- 3. Place the dummy in the seat with the legs at an angle of 120 degrees to the thighs. The calves should not be touching the seat cushion. (S16.3.3.1.2)
- 4. Position the dummy in the seat such that the midsagittal plane is coincident with the longitudinal seat cushion marking that was determined in Data Sheet 14.1. (S16.3.3.1.3 and S16.3.3.1.4)
- 5. Hold down the dummy's thighs and push rearward on the upper torso to maximize the pelvic angle. (S16.3.3.1.5)
- 6. Set the angle between the legs and the thighs to 120 degrees. (S16.3.3.1.6)
- 7. Set the transverse distance between the centers of the front of the knees at 160 to 170 mm. (6.3 to 6.7 inches). Center the knee separation with respect to the longitudinal seat cushion marking that was determined Data Sheet 14.1. (S16.3.3.1.6)
 Record Knee Separation 165
- 8. Push rearward on the dummy's knees until the pelvis contacts the seat back, or the backs of the calves contact the seat cushion, whichever occurs first. (S16.3.3.1.6)
 Pelvis contacted seat back.
 Calves contacted seat cushion.

15.2 Head level adjusted

Head Level Achieved. (Check all that apply)

Head leveled using the adjustable seat back

Head leveled using the neck bracket.

Head Angle _____ degrees

Head Level NOT Achieved. (Check all that apply)

Head adjusted using the adjustable seat back

Head adjusted using the neck bracket.

Head Angle _____ degrees

X 16. Measure and set the pelvic angle using the pelvic angle gage TE-2504. The pelvic angle should be 20.0 degrees \pm 2.5 degrees. If the pelvic angle cannot be set to the specified range because the head will not be level or because the dummy will have need major repositioning, adjust the pelvis as closely as possible to the angle range, but keep the head level.

X Pelvic angle set to 20.0 degrees \pm 2.5 degrees.

Pelvic angle of 20.0 degrees not achieved, the angular difference was minimized.

X Record the pelvic angle. 21.8 degrees

X 17. Check the dummy for contact with the interior after completing adjustments.

X No contact.

Dummy in contact with interior.

Seat moved aft _____ mm from the previous position.

Seat moved aft _____ detent positions from the previous position.

X 18. Verify the transverse instrument platform of the dummy head is level +/- 0.5 degrees. Use the lower neck bracket adjustment to level the head. If a level position cannot be achieved, minimize the angle. (S16.3.3.1.9, S16.3.3.1.10, and S16.3.3.1.11)

X Head Level Achieved

Head Angle 0.2 degrees

Head Level NOT Achieved.

Head Angle _____ degrees

X 19. Check the dummy to see if additional interior clearance is obtained, allowing the seat to be moved forward. (S16.3.3.1.12)

N/A Bench Seat

X N/A Seat already at full forward position.

Clearance unchanged. No adjustments required.

Additional clearance available

Seat moved Forward _____ mm from the previous position.

Seat moved Forward _____ detent positions from the previous position.

Seat moved Forward, Full Forward position reached.

X 20. Passenger foot positioning. (Indicate final position achieved) (S16.3.3.2)

20.1 Place feet flat on the toe board; OR (S16.3.3.2.1)

X 20.2 If the feet cannot be placed flat on the toe board, set the feet perpendicular to the lower leg, and rest the heel as far forward on the floor pan as possible; OR (S16.3.3.2.2)

20.3 If the heels do not touch the floor pan, set the legs as perpendicular to the thighs as possible and set the feet parallel to the floor pan. (S16.3.3.2.2)

X 21. Passenger arm/hand positioning. (S16.3.3.3)

X 21.1 Place the dummy's upper arms adjacent to the torso with the arm centerlines as close to a vertical longitudinal plane as possible. (S16.3.3.3.1)

X 21.2 Place the palms of the dummy in contact with the outer part of the thighs (S16.3.3.3.2)

X 21.3 Place the little fingers in contact with the seat cushion. (S16.3.3.3.3)

X 22. Adjustable head restraints (S16.3.4)

 N/A, there is no head restraint adjustment

 22.1 If the head restraint has an automatic adjustment, leave it where the system positions the restraint after the dummy is placed in the seat. (S16.3.4.1) Go to 23.

 22.2 Adjust each head restraint vertically so that the horizontal plane determined in Data Sheet 14.1 is aligned with the center of gravity (CG) of the dummy head. (S16.3.4.3)

 22.3 If the above position is not attainable, move the vertical center of the head restraint to the closest detent below the center of the head CG. (S16.3.4.3)

 N/A midpoint position attained in previous step

 Headrest set at nearest detent below the head CG

 22.4 If the head restraint has a fore and aft adjustment, place the restraint in the foremost position or until contact with the head is made, whichever occurs first. (S16.3.4.4)

X 23. Manual belt adjustment (for tests conducted with a belted dummy) S16.3.5

X N/A UNBELTED TEST

 23.1 If an adjustable seat belt D-ring anchorage exists, place it in the manufacturer's design position for a 5th percentile adult female. **This information will be supplied by the COTR.** (S16.3.5.1)

Manufacturer's specified position _____

Actual Position _____

 23.2 Place the Type 2 manual belt around the test dummy and fasten the latch. (S16.3.5.2)

 23.3 Ensure that the dummy's head remains as level as possible. (S16.3.5.3)

 23.4 Remove all slack from the lap belt. Pull the upper torso webbing out of the retractor and allow it to retract; repeat this operation four times. Apply a 9 N (2 lbf) to 18 N (4 lbf) tension load to the lap belt. If the belt system is equipped with a tension-relieving device, introduce the maximum amount of slack into the upper torso belt that is recommended by the manufacturer. If the belt system is not equipped with a tension-relieving device, allow the excess webbing in the shoulder belt to be retracted by the retractive force of the retractor. (S16.3.5.4)

REMARKS:

I certify that I have read and performed each instruction.

Signature: Joe Flack

Date: 6/11/08

DATA SHEET 37

DUMMY MEASUREMENTS

Test Vehicle: 2008 Dodge Charger
 Test Program: FMVSS 208 Compliance
 Test Technician: Joe Fleck

NHTSA No.: C80301
 Test Date: 6/11/08

DUMMY MEASUREMENTS FOR FRONT SEAT OCCUPANTS

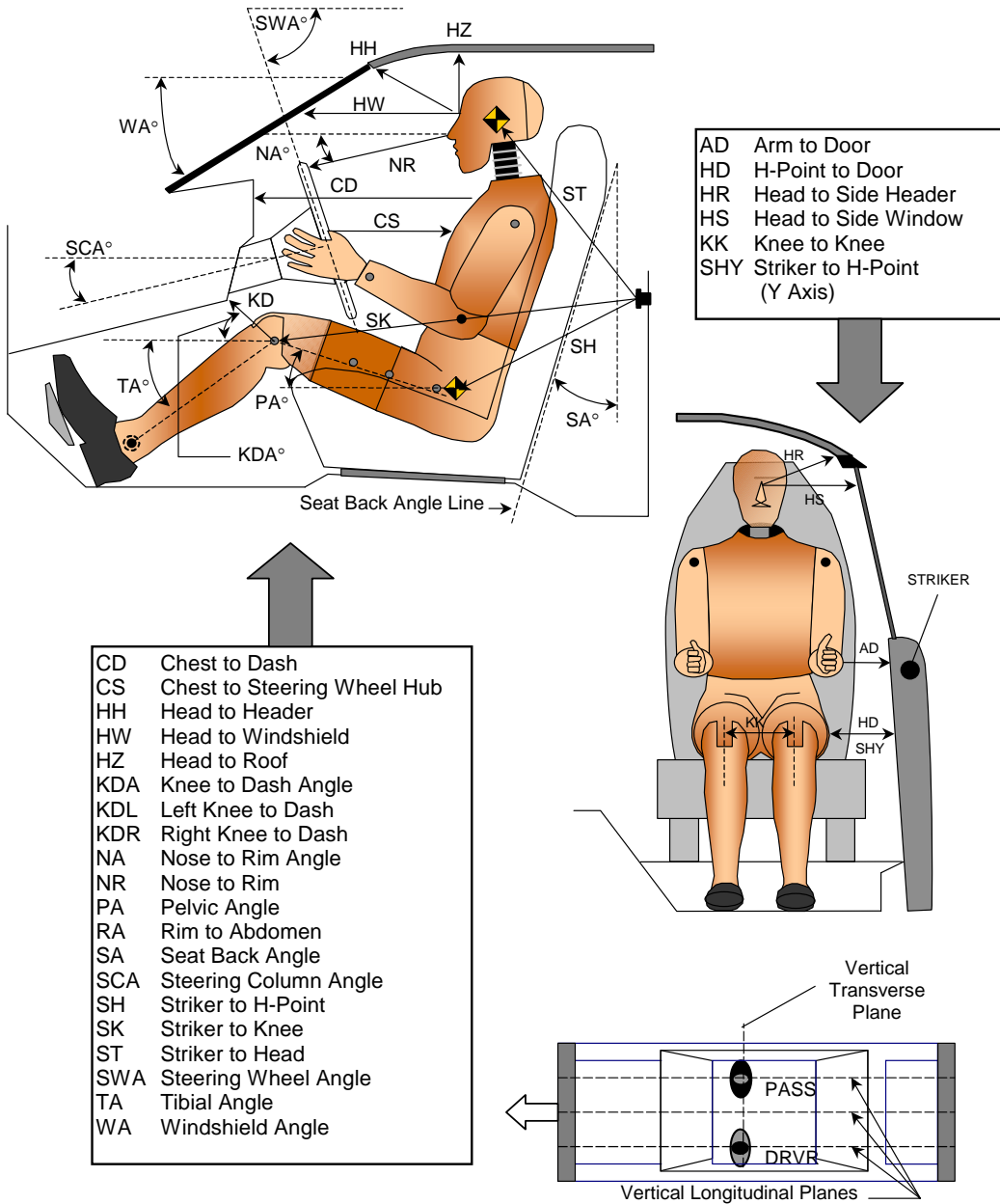

DATA SHEET 37
DUMMY MEASUREMENTS

Test Vehicle: 2008 Dodge Charger
 Test Program: FMVSS 208 Compliance
 Test Technician: Joe Fleck

NHTSA No.: C80301
 Test Date: 6/11/08

TEST DUMMY POSITION MEASUREMENTS

Code	Measurement Description	Driver SN 511		Passenger SN 516	
		Length (mm)	Angle (°)	Length (mm)	Angle (°)
WA	Windshield Angle		30.1		
SWA	Steering Wheel Angle		69.0		
SCA	Steering Column Angle		21.2		
SA	Seat Back Angle (On Headrest Post)		3.5		3.2
HZ	Head to Roof (Z)	236		235	
HH	Head to Header	441	27.1	438	26.3
HW	Head to Windshield	742	0.0	734	0.0
HR	Head to Side Header (Y)	224		228	
NR	Nose to Rim	236	2.3		
CD	Chest to Dash	438		386	
CS	Chest to Steering Hub	197	5.2		
RA	Rim to Abdomen	82	0.0		
KDL	Left Knee to Dash	103	32.2	85	
KDR	Right Knee to Dash	90		98	30.5
PA	Pelvic Angle		21.5		21.8
TA	Tibia Angle		49.4		49.7
KK	Knee to Knee (Y)	255		220	
SK	Striker to Knee	658	96.0	663	96.5
ST	Striker to Head	484	26.2	490	29.2
SH	Striker to H-Point	321	108.3	332	111.2
SHY	Striker to H-Point (Y)	320		340	
HS	Head to Side Window	366		358	
HD	H-Point to Door (Y)	253		280	
AD	Arm to Door (Y)	201		212	
AA	Ankle to Ankle	244		184	

SEAT BELT POSITIONING DATA

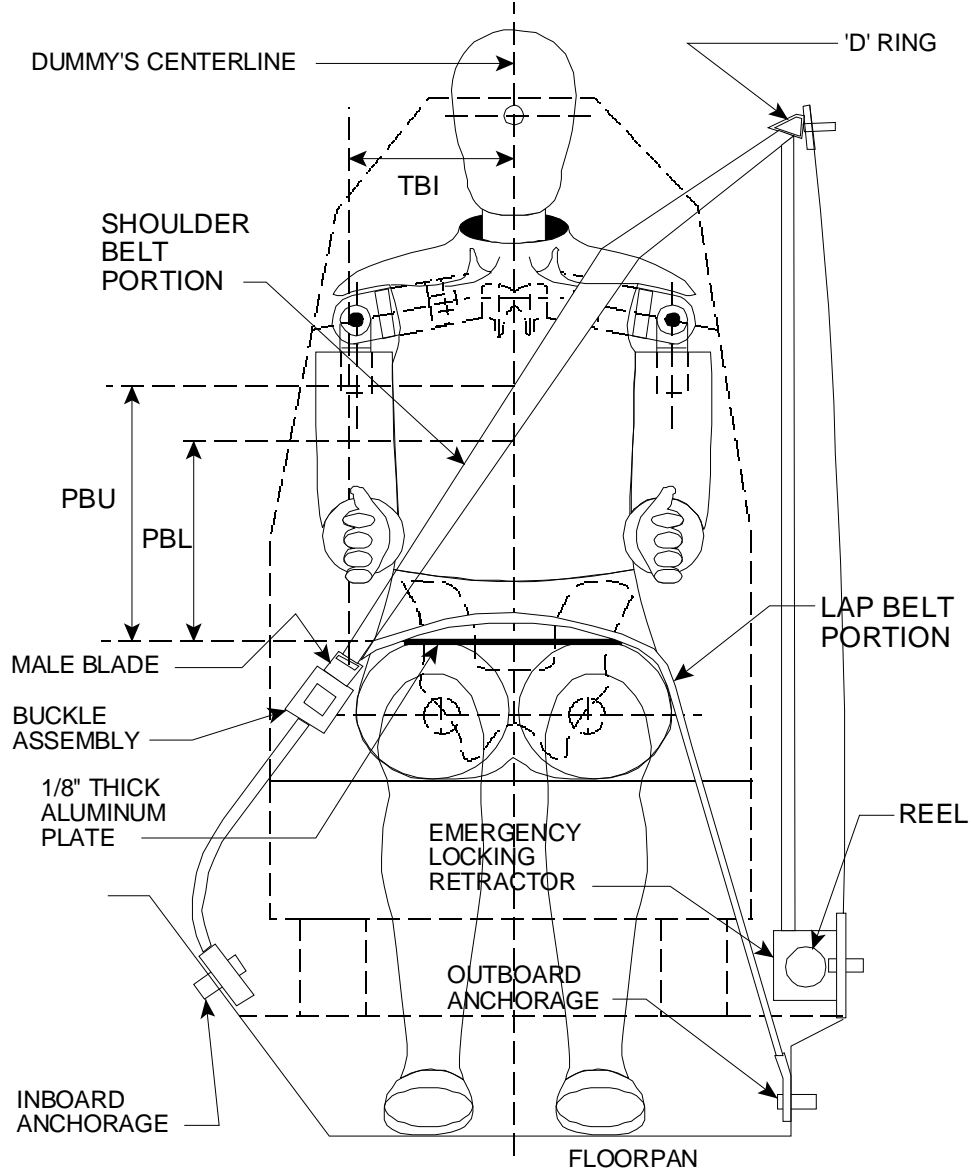

FRONT VIEW OF DUMMY

SEAT BELT POSITIONING MEASUREMENTS

Measurement Description	Units	Driver	Passenger
PBU - Top surface of reference to belt upper edge	mm	N/A	N/A
PBL - Top surface of reference to belt lower edge	mm	N/A	N/A

DATA SHEET 38

CRASH TEST

Test Vehicle: 2008 Dodge Charger
 Test Program: FMVSS 208 Compliance
 Test Technician: Joe Fleck

NHTSA No.: C80301
 Test Date: 6/11/08

IMPACT ANGLE:	Zero Degrees		
BELTED DUMMIES (YES/NO):	No		
TEST SPEED:	<u>X</u> 32 to 40 kmph	<u> </u> 0 to 48 kmph	<u> </u> 0 to 56 kmph
DRIVER DUMMY:	<u>X</u> 5 th female	<u> </u> 50 th male	
PASSENGER DUMMY:	<u>X</u> 5 th female	<u> </u> 50 th male	

- 1. Vehicle underbody painted
- 2. The speed measuring devices are in place and functioning.
- 3. The speed measuring devices are 1.0 m from the barrier (spec. 1.5m) and 30 cm from the barrier (spec. is 30 cm)
- 4. Convertible top is in the closed position.
- N/A, not a convertible
- 5. Instrumentation and wires are placed so the motion of the dummies during impact is not affected.
- 6. Tires inflated to pressure on tire placard or if it does not have a tire placard because it is not a passenger car, then inflated to the tire pressure specified in the owner information.

210 kpa front left tire 210 kpa specified on tire placard or in owner information
210 kpa front right tire 210 kpa specified on tire placard or in owner information
210 kpa rear left tire 210 kpa specified on tire placard or in owner information
210 kpa rear right tire 210 kpa specified on tire placard or in owner information

- 7. Time zero contacts on barrier in place.
- 8. Pre test zero and shunt calibration adjustments performed and recorded
- 9. Dummy temperature meets requirements of section 12.2 of the test procedure.
- 10. Vehicle hood closed and latched
- 11. Transmission placed in neutral
- 12. Parking brake off
- 13. Ignition in the ON position
- 14. Doors closed and latched but not locked
- 15. Posttest zero and shunt calibration checks performed and recorded
- 16. Actual test speed 39.9 kmph
- 17. Vehicle rebound from the barrier 456 cm
- 18. Describe whether the doors open after the test and what method is used to open the doors.
 - Left Front Door: Door remained closed and latched; Door opened without tools
 - Right Front Door: Door remained closed and latched; Door opened without tools
 - Left Rear Door: Door remained closed and latched; Door opened without tools
 - Right Rear Door: Door remained closed and latched; Door opened without tools

19. Describe the contact points of the dummy with the interior of the vehicle.
- Driver Dummy: Head to Air Bag, Visor, and Headrest; Chest to Air Bag; Knees to Knee Bolster
 - Passenger Dummy: Head to Air Bag, Visor, Header, Windshield, and Headrest; Chest to Air Bag; Knees to Glove Box

REMARKS:

I certify that I have read and performed each instruction.

Signature: Joe Fleck

Date: 6/11/08

DATA SHEET NO. 40

ACCIDENT INVESTIGATION MEASUREMENTS

Test Vehicle: 2008 Dodge Charger
 Test Program: FMVSS 208 Compliance
 Test Technician: Jamie Aide

NHTSA No.: C80301
 Test Date: 6/11/08

IMPACT ANGLE:	Zero Degrees		
BELTED DUMMIES (YES/NO):	No		
TEST SPEED:	<input checked="" type="checkbox"/> 32 to 40 kmph	<input type="checkbox"/> 0 to 48 kmph	<input type="checkbox"/> 0 to 56 kmph
DRIVER DUMMY:	<input checked="" type="checkbox"/> 5 th female	<input type="checkbox"/> 50 th male	
PASSENGER DUMMY:	<input checked="" type="checkbox"/> 5 th female	<input type="checkbox"/> 50 th male	

Vehicle Year/Make/Model/Body Style:	2008 Dodge Charger Passenger Car
VIN:	2B3KA43R88H161597
Wheelbase:	3048 mm
Build Date:	12/07
Vehicle Size Category:	5
Test Weight:	1819.3 kg
Front Overhang:	945 mm
Overall Width:	1876 mm
Overall Length Center:	5045 mm

Accelerometer Data	
Location:	As per measurements on Data Sheet 33
Linearity:	>99.9%

Integration Algorithm:	Trapezoidal
Vehicle Impact Speed:	39.9 kmph
Time of Separation:	116.2 ms
Velocity Change:	47.1 kmph

CRUSH PROFILE

Collision Deformation Classification: 12FDEW6
 Midpoint of Damage: Vehicle Longitudinal Centerline
 Damage Region Length (mm): 1430
 Impact Mode: Frontal Barrier

No.	Measurement Description	Units	Pre-Test	Post-Test	Difference
C1	Crush zone 1 at left side	mm	4871	4823	48
C2	Crush zone 2 at left side	mm	4947	4900	47
C3	Crush zone 3 at left side	mm	5005	4941	64
C4	Crush zone 4 at right side	mm	5007	4935	72
C5	Crush zone 5 at right side	mm	4945	4848	97
C6	Crush zone 6 at right side	mm	4868	4743	125

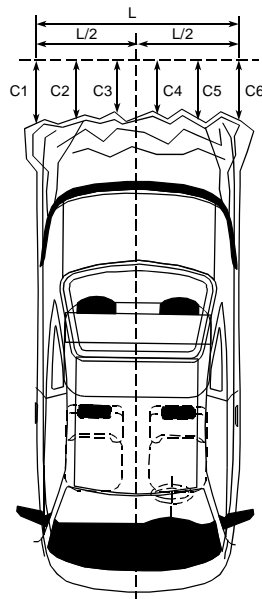

REMARKS:

I certify that I have read and performed each instruction.

Signature: *Juan Carlos*

Date: 6/11/08

DATA SHEET 41
WINDSHIELD MOUNTING (FMVSS 212)

Test Vehicle: 2008 Dodge Charger
 Test Program: FMVSS 208 Compliance
 Test Technician: Jamie Aide

NHTSA No.: C80301
 Test Date: 6/11/08

IMPACT ANGLE:	Zero Degrees		
BELTED DUMMIES (YES/NO):	No		
TEST SPEED:	<u>X</u> 32 to 40 kmph	<u> </u> 0 to 48 kmph	<u> </u> 0 to 56 kmph
DRIVER DUMMY:	<u>X</u> 5 th female	<u> </u> 50 th male	
PASSENGER DUMMY:	<u>X</u> 5 th female	<u> </u> 50 th male	

1. Pre-Crash
- 1.1 Describe from visual inspection how the windshield is mounted and describe any trim material.
- Retained with glue
Plastic trim
- 1.2 Mark the longitudinal centerline of the windshield
- 1.3 Measure pre-crash A, B, and C for the left side and record in the chart below.
- 1.4 Measure pre-crash C, D, and E for the right side and record in the chart below.
- 1.5 Measure from the edge of the retainer or molding to the edge of the windshield.
- Dimension G (mm): 15 mm
2. Post Crash
- 2.1 Can a single thickness of copier type paper (as small a piece as necessary) slide between the windshield and the vehicle body?
- No - Pass. Skip to the table of measurements, complete it by repeating the pre-crash measurements in the post crash column, and calculate the retention percentage, which will be 100%.
- Yes, go to 2.2
- 2.2 Visibly mark the beginning and end of the portions of the periphery where the paper slides between the windshield and the vehicle body.
- 2.3 Measure and record post-crash A, B, C, D, E, and F such that the measurements do not include any of the parts of the windshield where the paper slides between the windshield and the vehicle body.
- 2.4 Calculate and record the percent retention for the right and left side of the windshield.
- 2.5 Is total right side percent retention less than 75%?
- Yes, Fail
- No, Pass
- 2.6 Is total left side percent retention less than 75%?
- Yes, Fail
- No, Pass

WINDSHIELD RETENTION MEASUREMENTS

	Dimension	Pre-Crash (mm)	Post-Crash (mm)	Percent Retention (Post-Test ÷ Pre-Crash)
Left Side	A	653	653	100%
	B	725	725	100%
	C	825	825	100%
	Total	2203	2203	100%
Right Side	D	653	653	100%
	E	725	725	100%
	F	825	825	100%
	Total	2203	2203	100%

Indicate area of mounting failure. NONE

FRONT VIEW OF WINDSHIELD

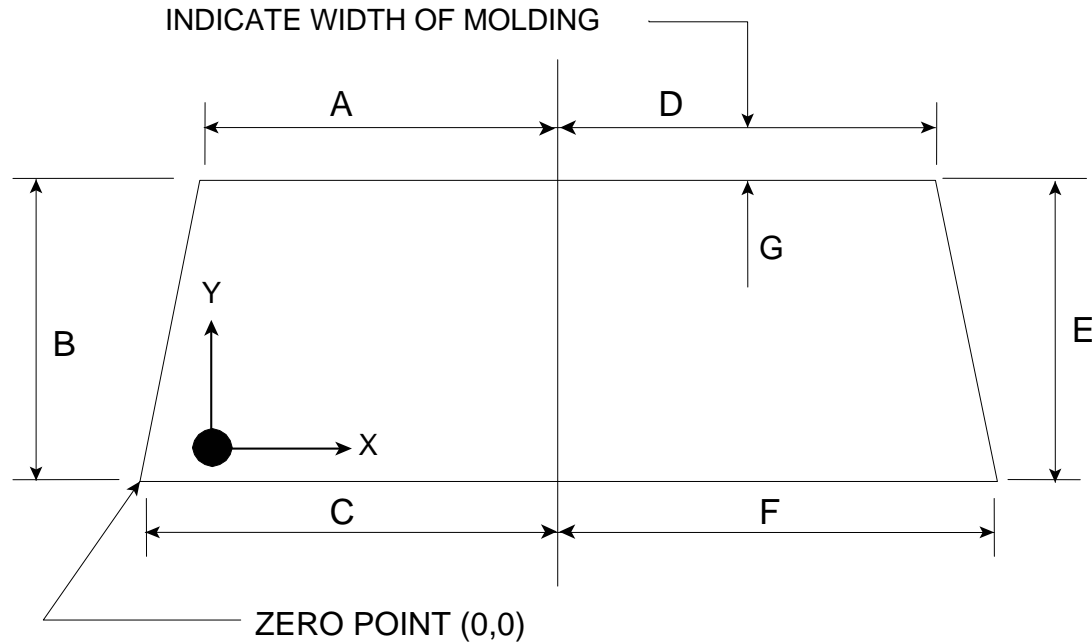

REMARKS:

I certify that I have read and performed each instruction.

Signature: *Jamie Costa*

Date: 6/11/08

DATA SHEET 42
WINDSHIELD ZONE INTRUSION (FMVSS 219)

Test Vehicle: 2008 Dodge Charger
 Test Program: FMVSS 208 Compliance
 Test Technician: Jamie Aide

NHTSA No.: C80301
 Test Date: 6/11/08

IMPACT ANGLE:	Zero Degrees		
BELTED DUMMIES (YES/NO):	No		
TEST SPEED:	<input checked="" type="checkbox"/> 32 to 40 kmph	<input type="checkbox"/> 0 to 48 kmph	<input type="checkbox"/> 0 to 56 kmph
DRIVER DUMMY:	<input checked="" type="checkbox"/> 5 th female	<input type="checkbox"/> 50 th male	
PASSENGER DUMMY:	<input checked="" type="checkbox"/> 5 th female	<input type="checkbox"/> 50 th male	

- 1. Place a 165 mm diameter rigid sphere, with a mass of 6.8 kg on the instrument panel so that it is simultaneously touching the instrument panel and the windshield. (571.219 S6.1(a))
- 2. Roll the sphere from one side of the windshield to the other while marking on the windshield where the sphere contacts the windshield. (571.219 S6.1(b))
- 3. From the outermost contactable points on the windshield draw a horizontal line to the edges of the windshield. (571.219 S6.1(b))
- 4. Draw a line on the inner surface of the windshield that is 13 mm below the line determined in items 2 and 3
- 5. After the crash test, record any points where a part of the exterior of the vehicle has marked, penetrated, or broken the windshield.

Provide all dimensions necessary to reproduce the protected area.

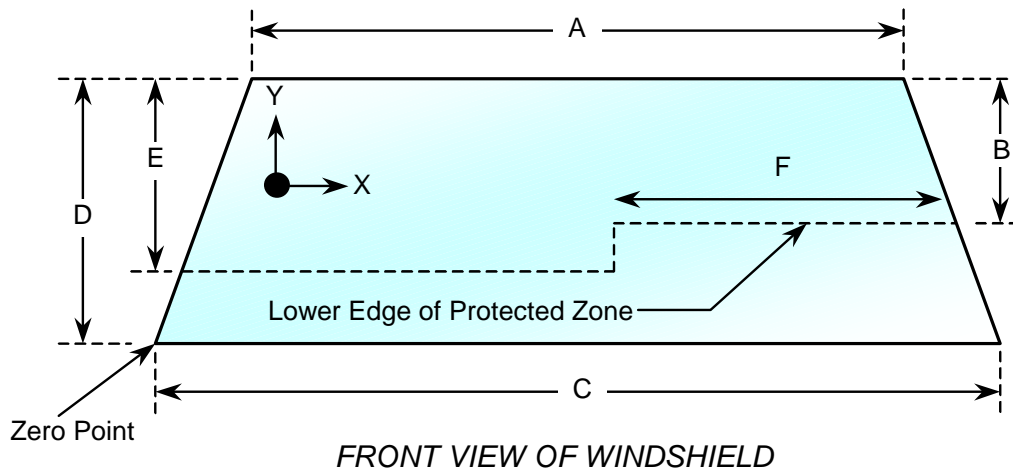

WINDSHIELD DIMENSIONS

Item	Units	Value
A	mm	1306
B	mm	418
C	mm	1650
D	mm	725
E	mm	420
F	mm	474

AREA OF PROTECTED ZONE FAILURES:

- B. Provide coordinates of the area that the protected zone was penetrated more than 0.25 inches by a vehicle component other than one which is normally in contact with the windshield.

X	Y
NONE	

- C. Provide coordinates of the area beneath the protected zone template that the inner surface of the windshield was penetrated by a vehicle component.

X	Y
NONE	

REMARKS:

I certify that I have read and performed each instruction.

Signature: _____ *Jamie Costa*

Date: 6/11/08

DATA SHEET 43

FUEL SYSTEM INTEGRITY (FMVSS 301)

Test Vehicle: 2008 Dodge Charger
Test Program: FMVSS 208 Compliance
Test Technician: Daniel Sienko

NHTSA No.: C80301
Test Date: 6/11/08

TYPE OF IMPACT:	25 mph Unbelted Flat Frontal
-----------------	------------------------------

Stoddard Solvent Spillage Measurements

- A. From impact until vehicle motion ceases: 0.0 grams
(Maximum Allowable = 28 grams)
- B. For the 5 minute period after motion ceases: 0.0 grams
(Maximum Allowable = 142 grams)
- C. For the following 25 minutes: 0.0 grams
(Maximum Allowable = 28 grams/minute)
- D. Spillage: NONE

REMARKS: NO SPILLAGE

DATA SHEET NO. 43
FMVSS 301 STATIC ROLLOVER DATA

Test Vehicle: 2008 Dodge Charger
 Test Program: FMVSS 208 Compliance

NHTSA No.: C80301
 Test Date: 6/11/08

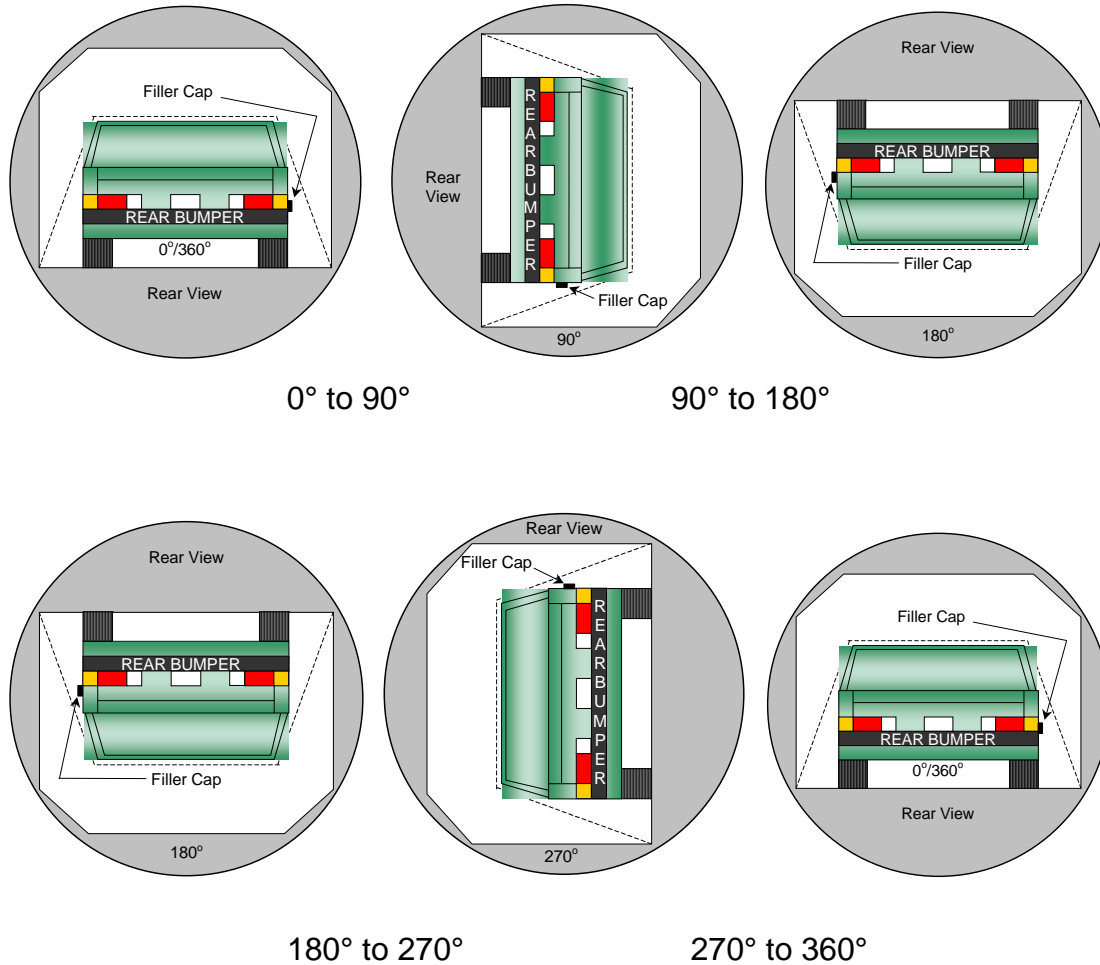

1. The specified fixture rollover rate for each 90° of rotation is 60 to 180 seconds.
2. The position hold time at each position is 300 seconds (minimum).
3. Details of Stoddard Solvent spillage locations: **None**

Test Phase	Rotation Time (sec.)	Hold Time (sec.)	Spillage (grams)
0° to 90°	117	300	0.0
90° to 180°	119	300	0.0
180° to 270°	116	300	0.0
270° to 360°	117	300	0.0

APPENDIX A
CRASH TEST DATA

TABLE OF DATA PLOTS

		<u>Page No.</u>
Figure No. 1.	Driver Head X Acceleration vs. Time	A-1
Figure No. 2.	Driver Head Y Acceleration vs. Time	A-1
Figure No. 3.	Driver Head Z Acceleration vs. Time	A-1
Figure No. 4.	Driver Head Resultant Acceleration vs. Time	A-1
Figure No. 5.	Driver Head X Velocity vs. Time	A-2
Figure No. 6.	Driver Head Y Velocity vs. Time	A-2
Figure No. 7.	Driver Head Z Velocity vs. Time	A-2
Figure No. 8.	Driver Neck Force X vs. Time	A-3
Figure No. 9.	Driver Neck Force Y vs. Time	A-3
Figure No. 10.	Driver Neck Force Z vs. Time	A-3
Figure No. 11.	Driver Neck Force Resultant vs. Time	A-3
Figure No. 12.	Driver Neck Moment X vs. Time	A-4
Figure No. 13.	Driver Neck Moment Y vs. Time	A-4
Figure No. 14.	Driver Neck Moment Z vs. Time	A-4
Figure No. 15.	Driver Neck Moment Resultant vs. Time	A-4
Figure No. 16.	Driver Chest X Acceleration vs. Time	A-5
Figure No. 17.	Driver Chest Y Acceleration vs. Time	A-5
Figure No. 18.	Driver Chest Z Acceleration vs. Time	A-5
Figure No. 19.	Driver Chest Resultant Acceleration vs. Time	A-5
Figure No. 20.	Driver Chest X Velocity vs. Time	A-6
Figure No. 21.	Driver Chest Y Velocity vs. Time	A-6
Figure No. 22.	Driver Chest Z Velocity vs. Time	A-6
Figure No. 23.	Driver Chest Displacement vs. Time	A-6
Figure No. 24.	Driver Left Femur Force vs. Time	A-7
Figure No. 25.	Driver Right Femur Force vs. Time	A-7
Figure No. 26.	Passenger Head X Acceleration vs. Time	A-8
Figure No. 27.	Passenger Head Y Acceleration vs. Time	A-8
Figure No. 28.	Passenger Head Z Acceleration vs. Time	A-8
Figure No. 29.	Passenger Head Resultant Acceleration vs. Time	A-8

		<u>Page No.</u>
Figure No. 30.	Passenger Head X Velocity vs. Time	A-9
Figure No. 31.	Passenger Head Y Velocity vs. Time	A-9
Figure No. 32.	Passenger Head Z Velocity vs. Time	A-9
Figure No. 33.	Passenger Neck Force X vs. Time	A-10
Figure No. 34.	Passenger Neck Force Y vs. Time	A-10
Figure No. 35.	Passenger Neck Force Z vs. Time	A-10
Figure No. 36.	Passenger Neck Force Resultant vs. Time	A-10
Figure No. 37.	Passenger Neck Moment X vs. Time	A-11
Figure No. 38.	Passenger Neck Moment Y vs. Time	A-11
Figure No. 39.	Passenger Neck Moment Z vs. Time	A-11
Figure No. 40.	Passenger Neck Moment Resultant vs. Time	A-11
Figure No. 41.	Passenger Chest X Acceleration vs. Time	A-12
Figure No. 42.	Passenger Chest Y Acceleration vs. Time	A-12
Figure No. 43.	Passenger Chest Z Acceleration vs. Time	A-12
Figure No. 44.	Passenger Chest Resultant Acceleration vs. Time	A-12
Figure No. 45.	Passenger Chest X Velocity vs. Time	A-13
Figure No. 46.	Passenger Chest Y Velocity vs. Time	A-13
Figure No. 47.	Passenger Chest Z Velocity vs. Time	A-13
Figure No. 48.	Passenger Chest Displacement vs. Time	A-13
Figure No. 49.	Passenger Left Femur Force vs. Time	A-14
Figure No. 50.	Passenger Right Femur Force vs. Time	A-14
Figure No. 51.	Driver Nij (N_{TF}) vs. Time	A-15
Figure No. 52.	Driver Nij (N_{TE}) vs. Time	A-15
Figure No. 53.	Driver Nij (N_{CF}) vs. Time	A-15
Figure No. 54.	Driver Nij (N_{CE}) vs. Time	A-15
Figure No. 55.	Passenger Nij (N_{TF}) vs. Time	A-16
Figure No. 56.	Passenger Nij (N_{TE}) vs. Time	A-16
Figure No. 57.	Passenger Nij (N_{CF}) vs. Time	A-16
Figure No. 58.	Passenger Nij (N_{CE}) vs. Time	A-16
Figure No. 59.	Driver Occipital Condyle Moment vs. Time	A-17

		<u>Page No.</u>
Figure No. 60.	Passenger Occipital Condyle Moment vs. Time	A-17
Figure No. 61.	Left Rear Seat Crossmember X Acceleration vs. Time	A-18
Figure No. 62.	Left Rear Seat Crossmember X Velocity vs. Time	A-18
Figure No. 63.	Right Rear Seat Crossmember X Acceleration vs. Time	A-18
Figure No. 64.	Right Rear Seat Crossmember X Velocity vs. Time	A-18
Figure No. 65.	Top of Engine X Acceleration vs. Time	A-19
Figure No. 66.	Top of Engine X Velocity vs. Time	A-19
Figure No. 67.	Bottom of Engine X Acceleration vs. Time	A-19
Figure No. 68.	Bottom of Engine X Velocity vs. Time	A-19
Figure No. 69.	Left Brake Caliper X Acceleration vs. Time	A-20
Figure No. 70.	Left Brake Caliper X Velocity vs. Time	A-20
Figure No. 71.	Right Brake Caliper X Acceleration vs. Time	A-20
Figure No. 72.	Right Brake Caliper X Velocity vs. Time	A-20
Figure No. 73.	Instrument Panel X Acceleration vs. Time	A-21
Figure No. 74.	Instrument Panel X Velocity vs. Time	A-21
Figure No. 75.	Trunk Z Acceleration vs. Time	A-21
Figure No. 76.	Trunk Z Velocity vs. Time	A-21
Figure No. 77.	Barrier Force – Upper Left vs. Time	A-22
Figure No. 78.	Barrier Force – Upper Center vs. Time	A-22
Figure No. 79.	Barrier Force – Upper Right vs. Time	A-22
Figure No. 80.	Barrier Force – Lower Left vs. Time	A-23
Figure No. 81.	Barrier Force – Lower Center vs. Time	A-23
Figure No. 82.	Barrier Force – Lower Right vs. Time	A-23
Figure No. 83.	Barrier Force – Sum Left vs. Time	A-24
Figure No. 84.	Barrier Force – Sum Center vs. Time	A-24
Figure No. 85.	Barrier Force – Sum Right vs. Time	A-24
Figure No. 86.	Barrier Force – Sum All vs. Time	A-24

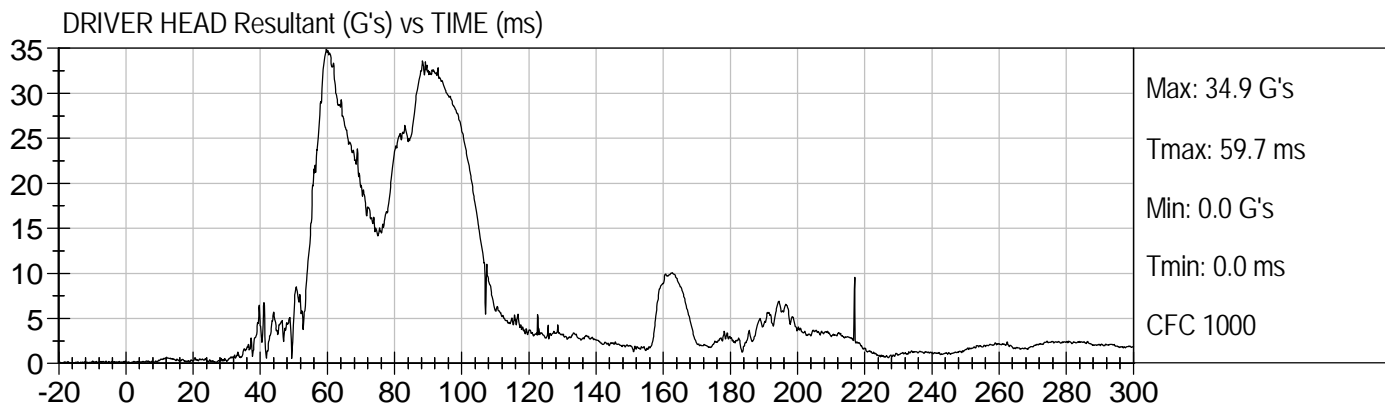
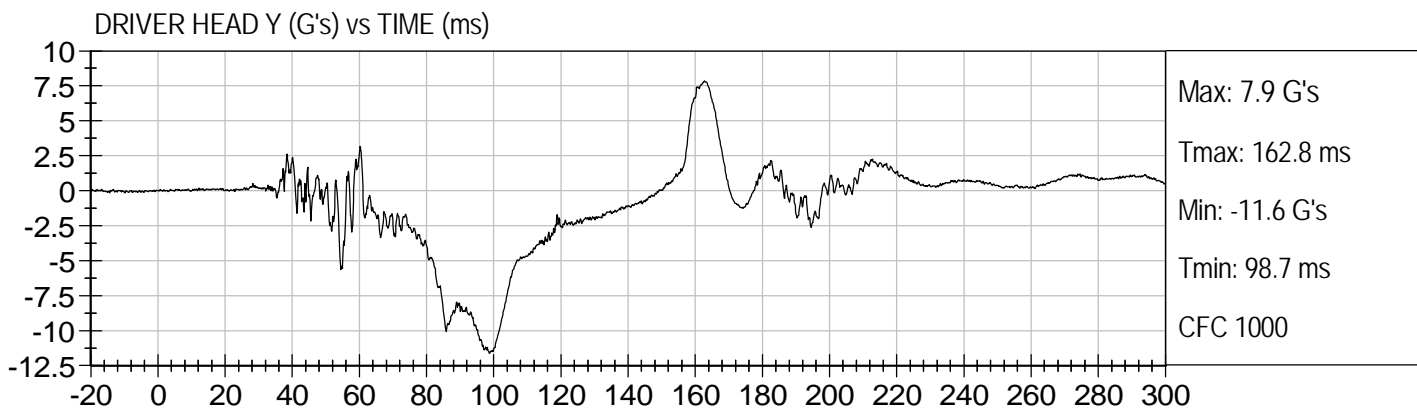
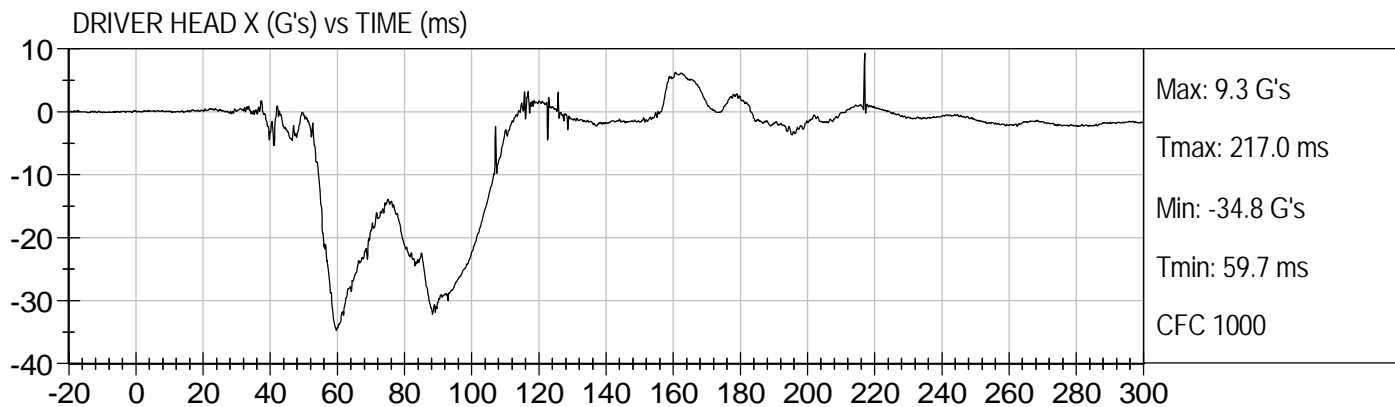

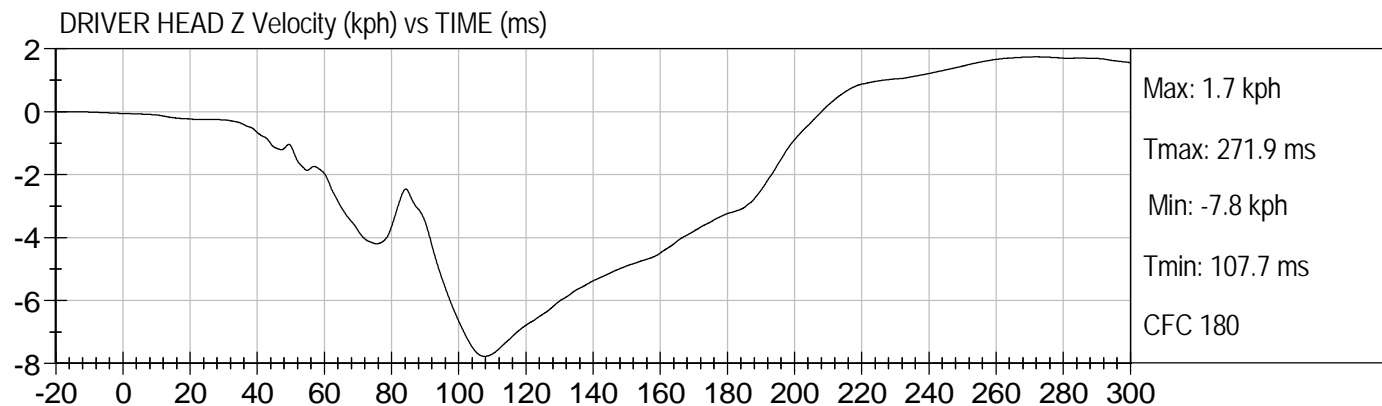
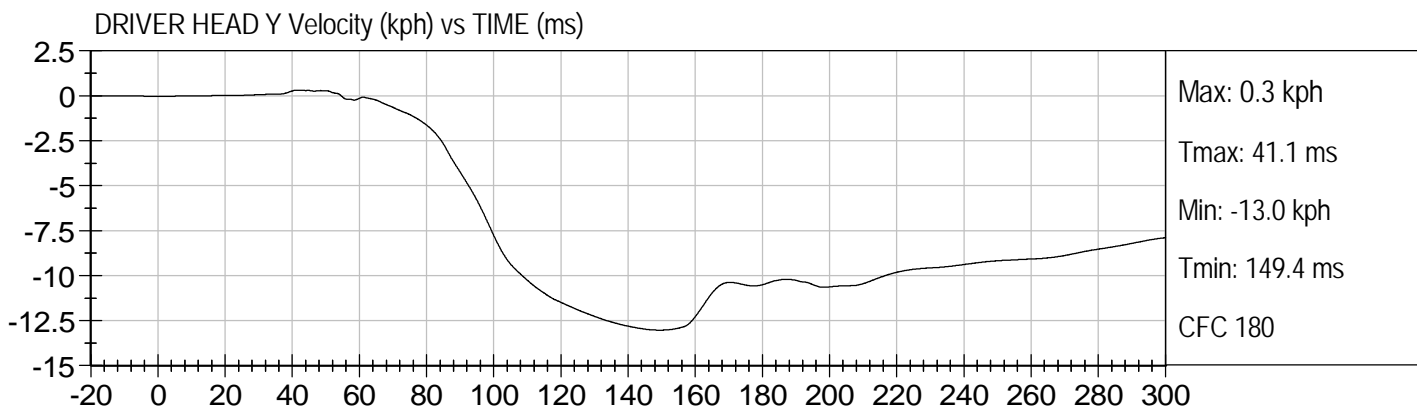
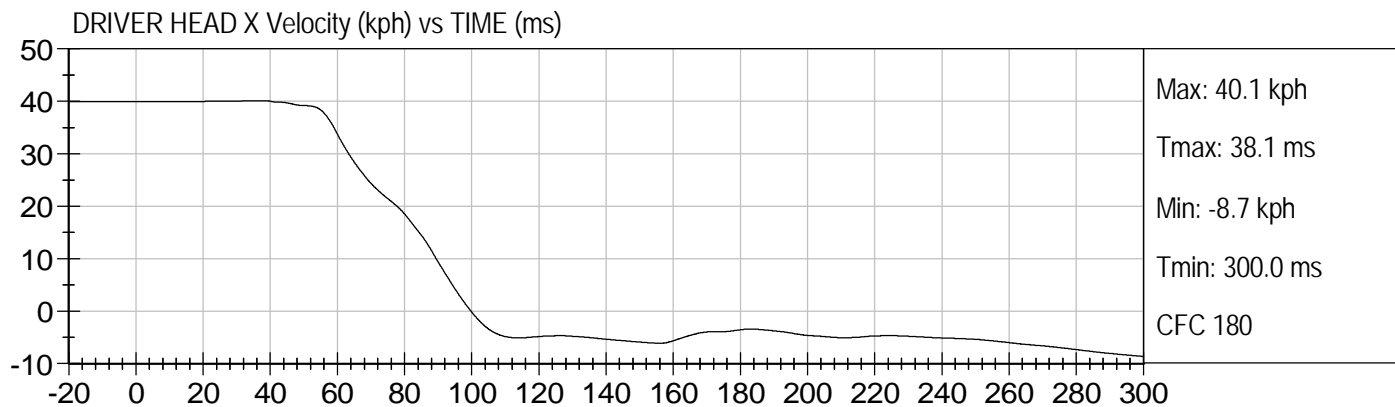

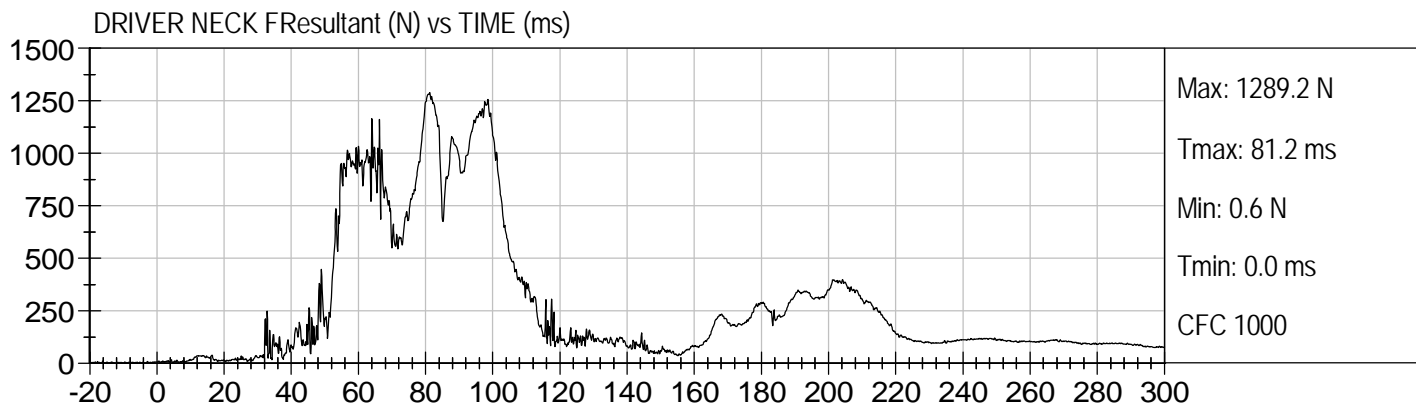
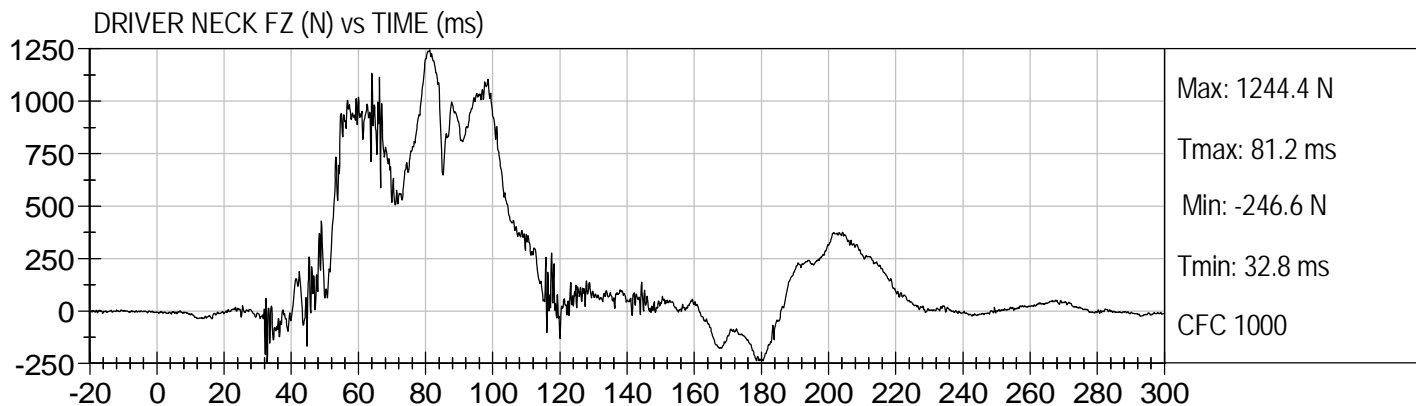
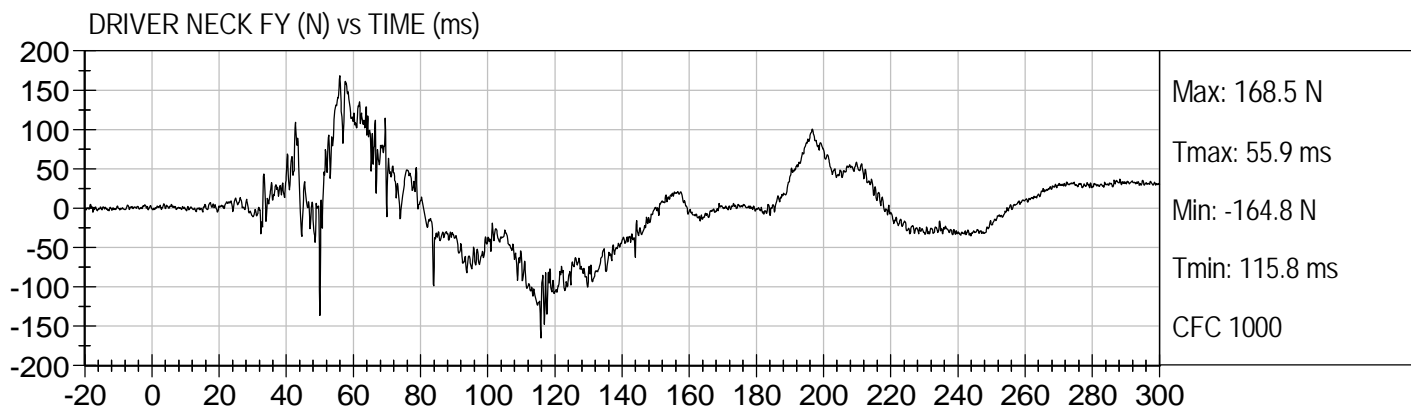
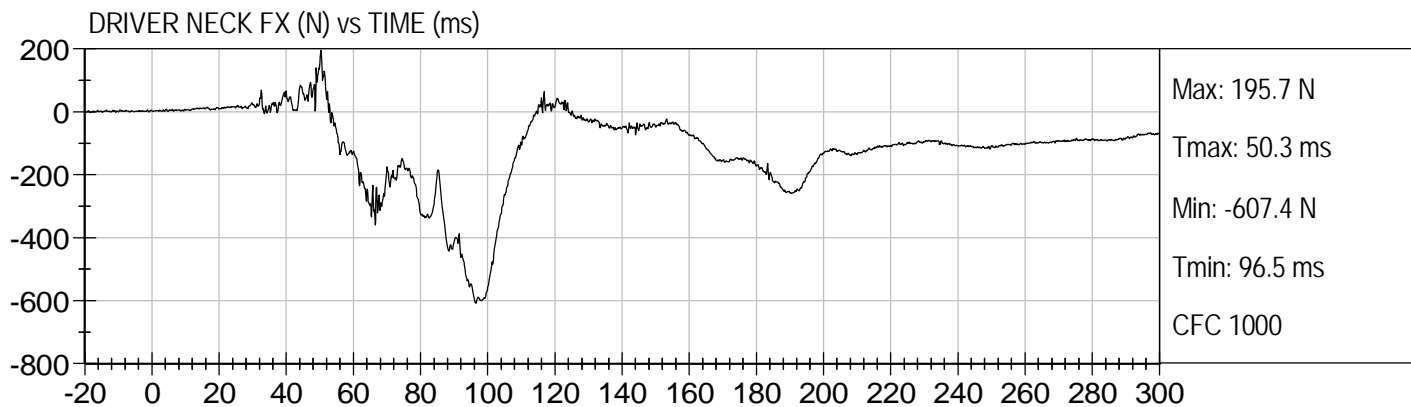

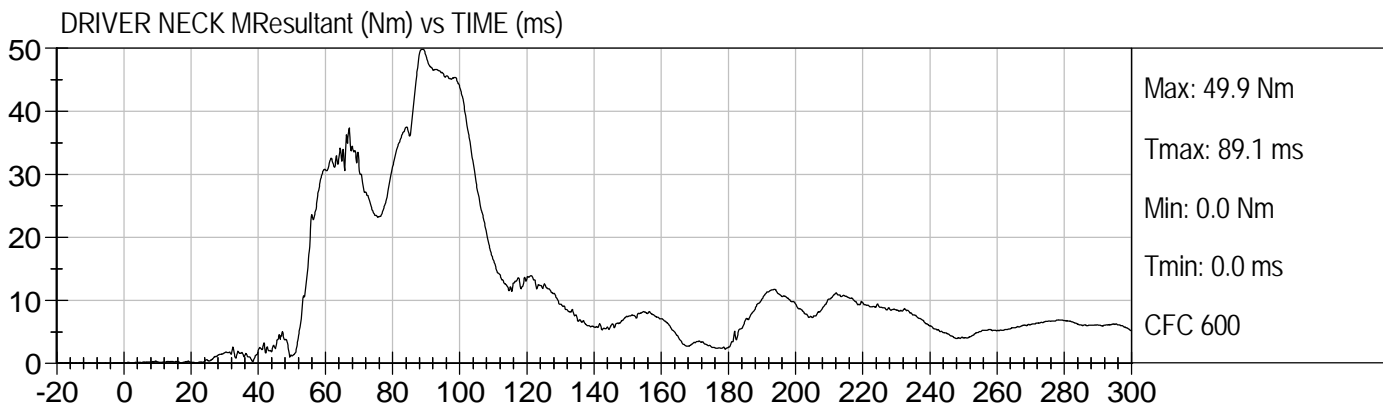
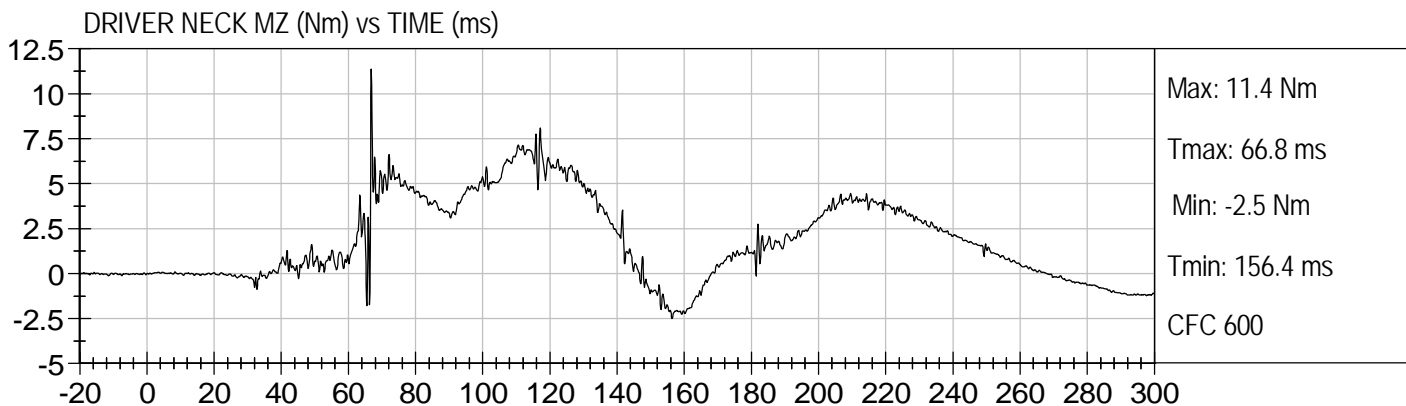
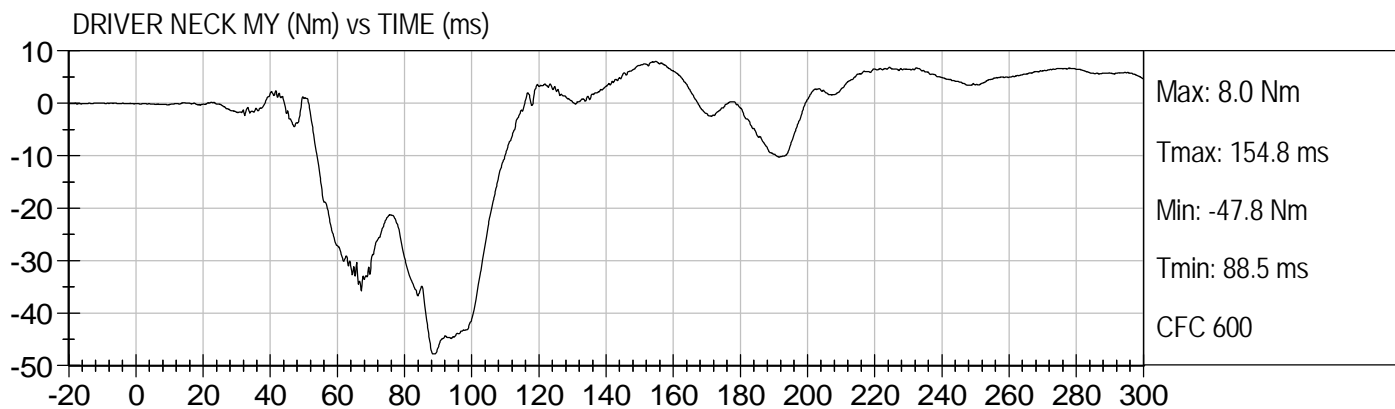
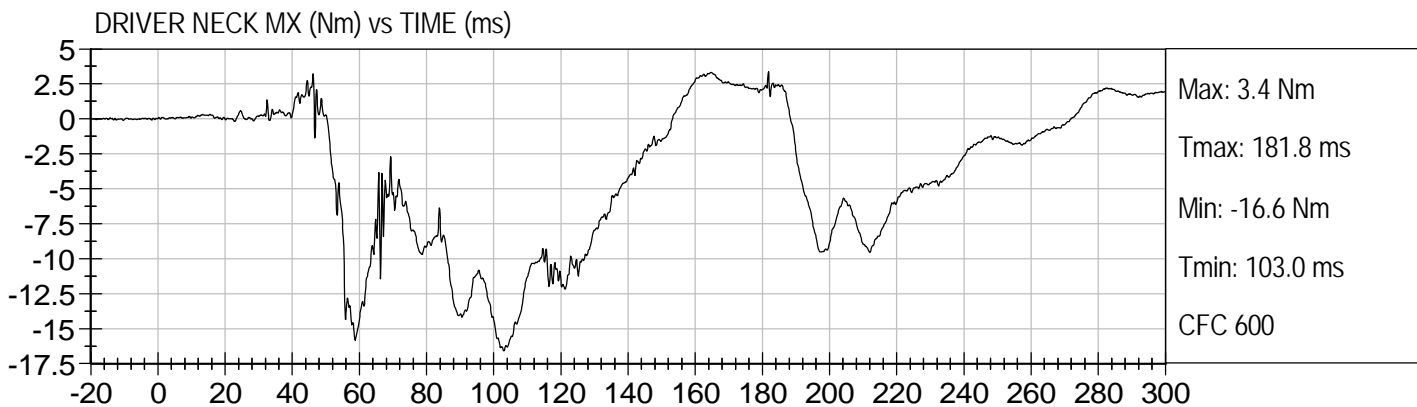

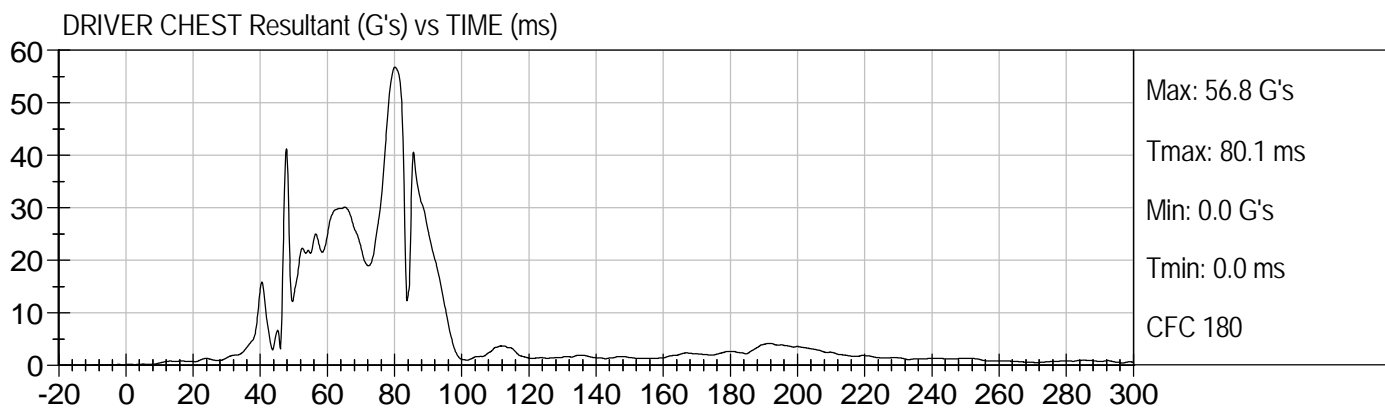
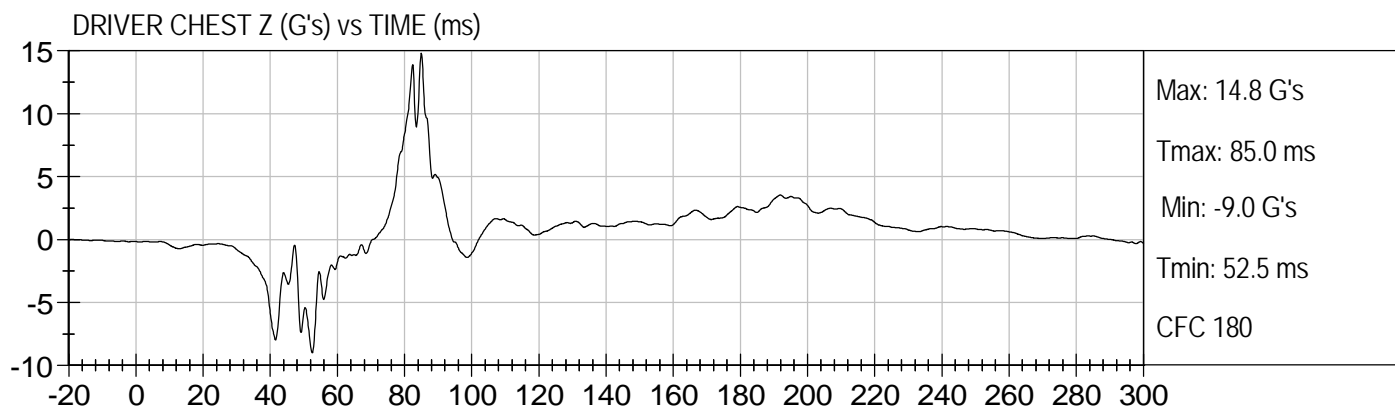
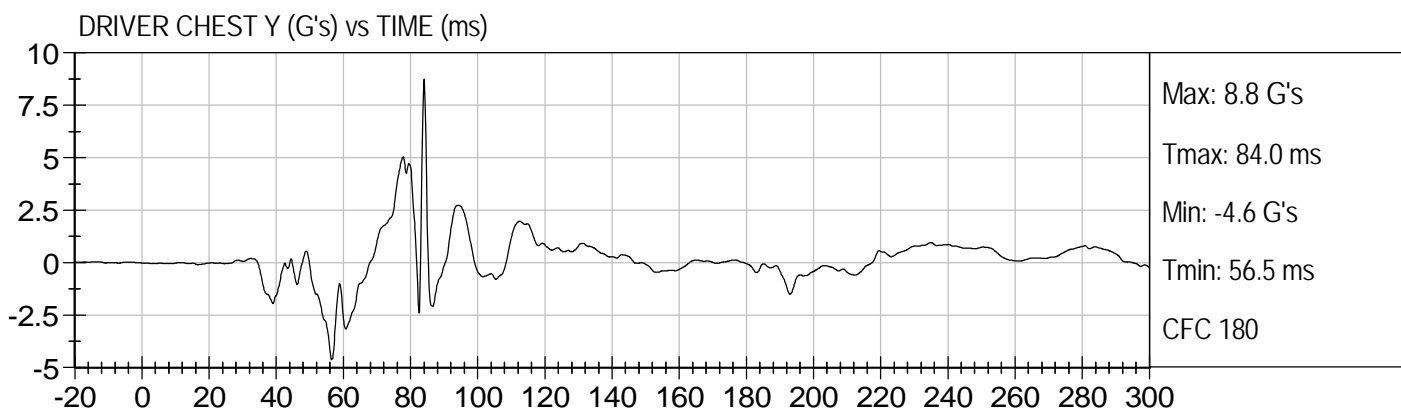
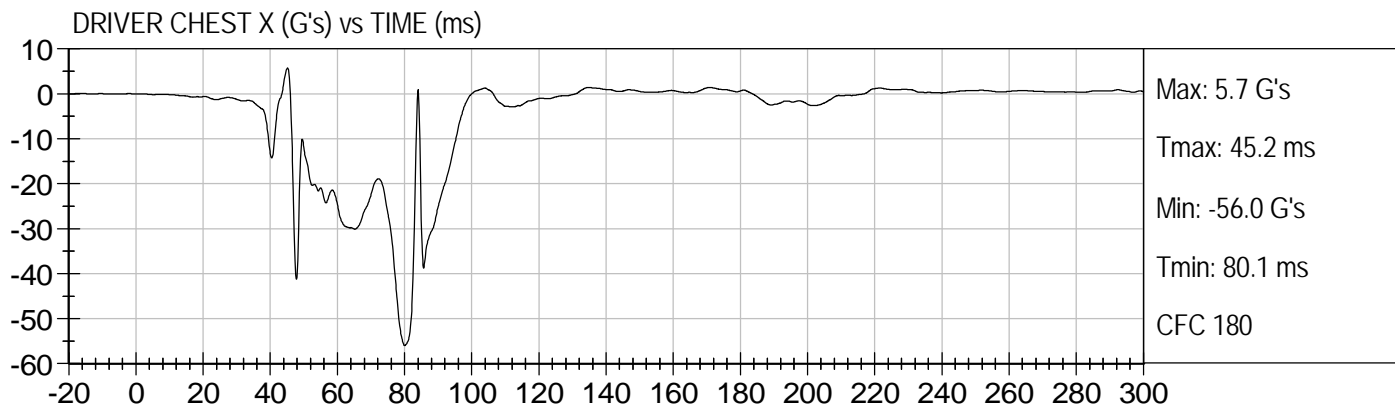

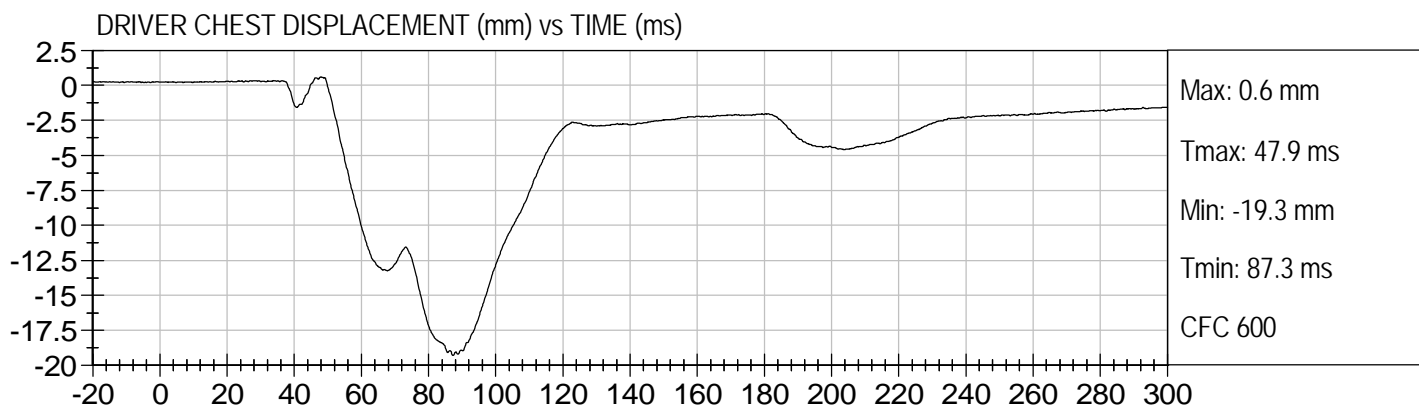
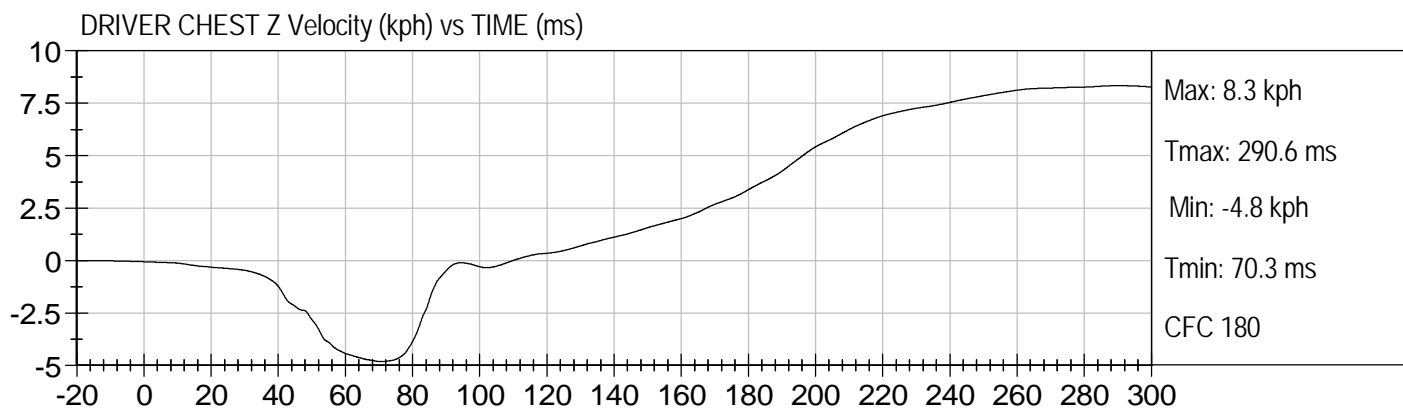
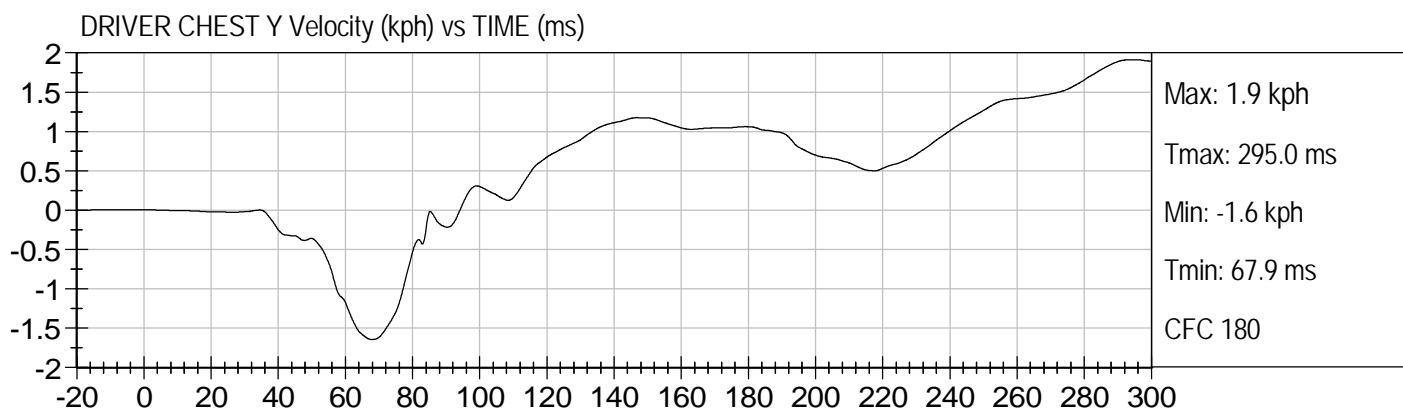
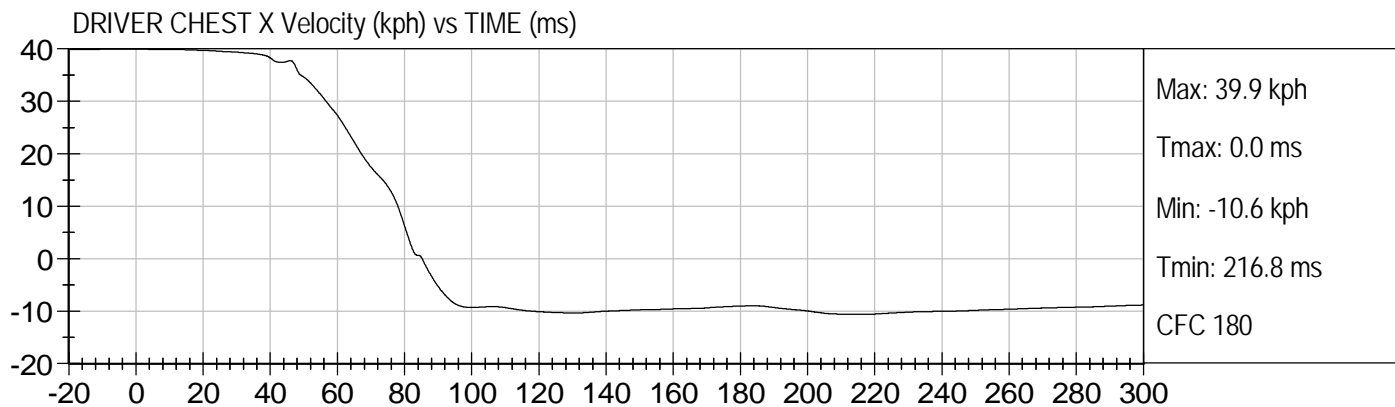

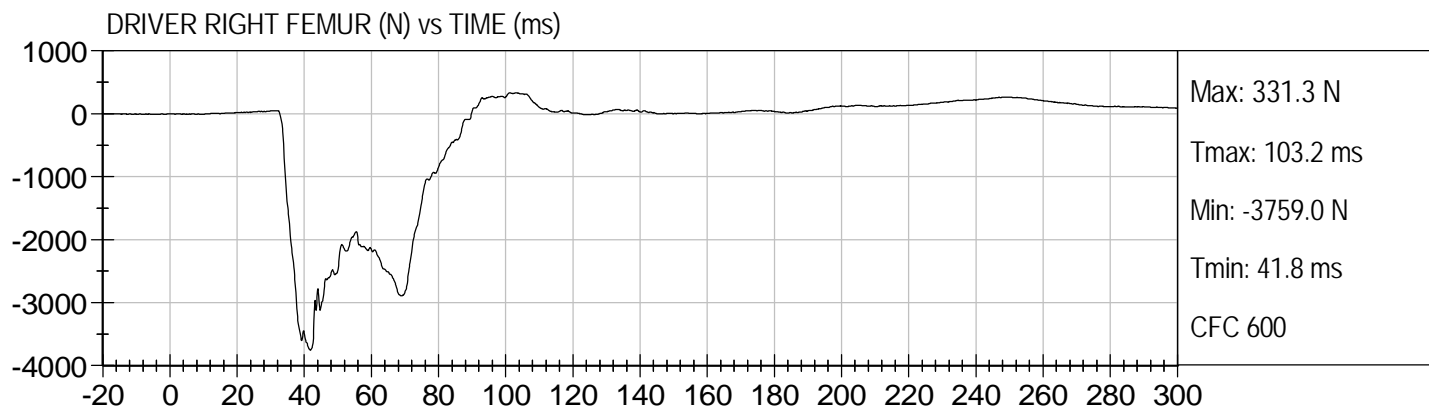
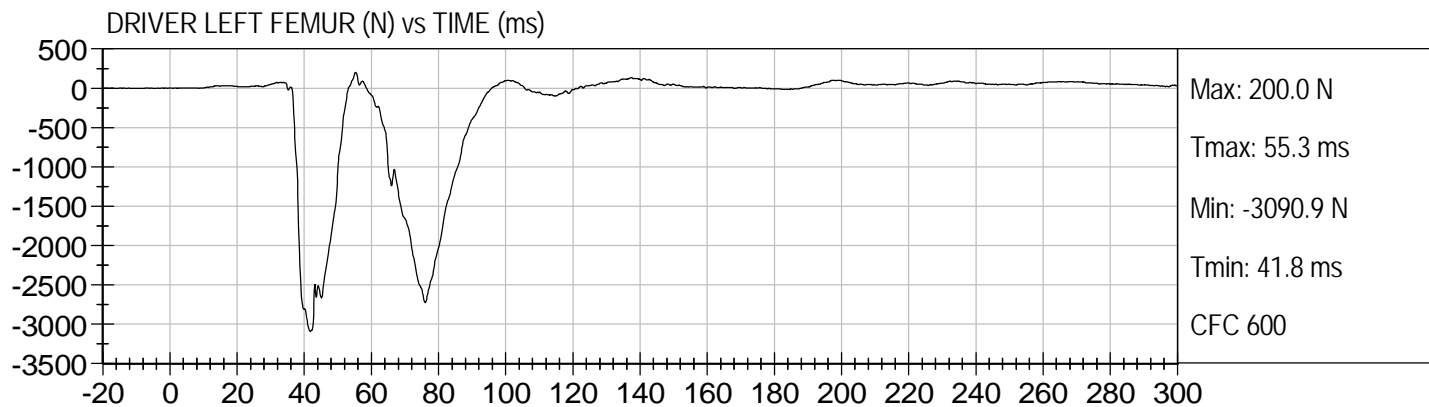



PASSENGER HEAD X (G's) vs TIME (ms)

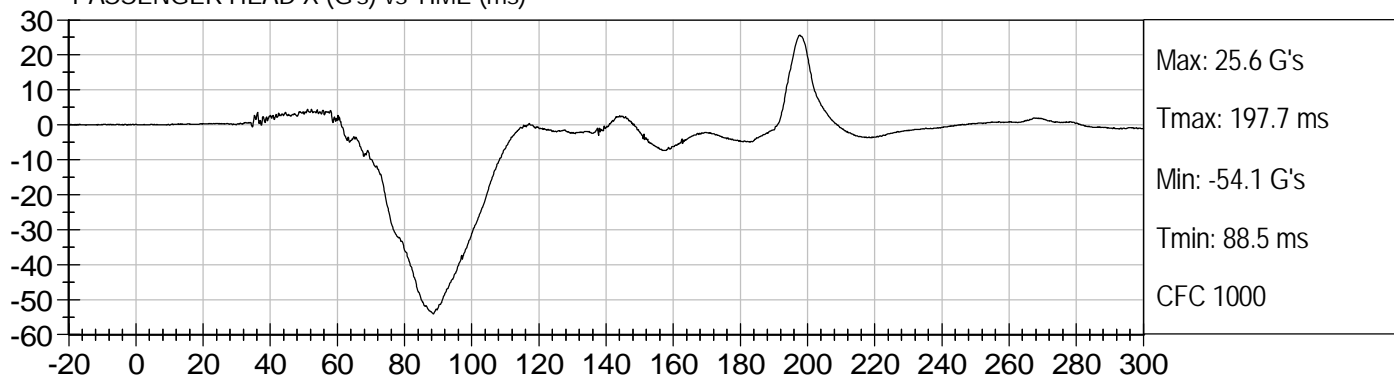

PASSENGER HEAD Y (G's) vs TIME (ms)

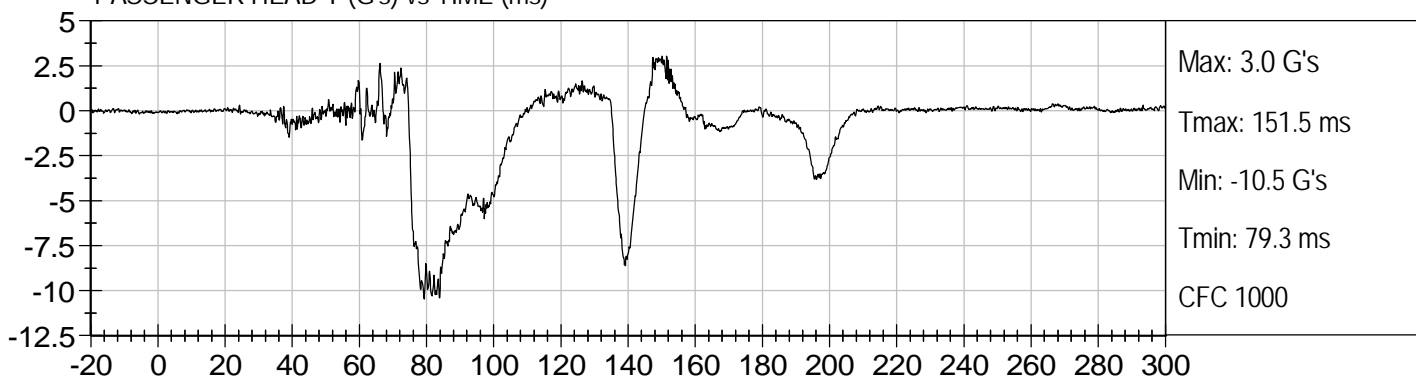

PASSENGER HEAD Z (G's) vs TIME (ms)

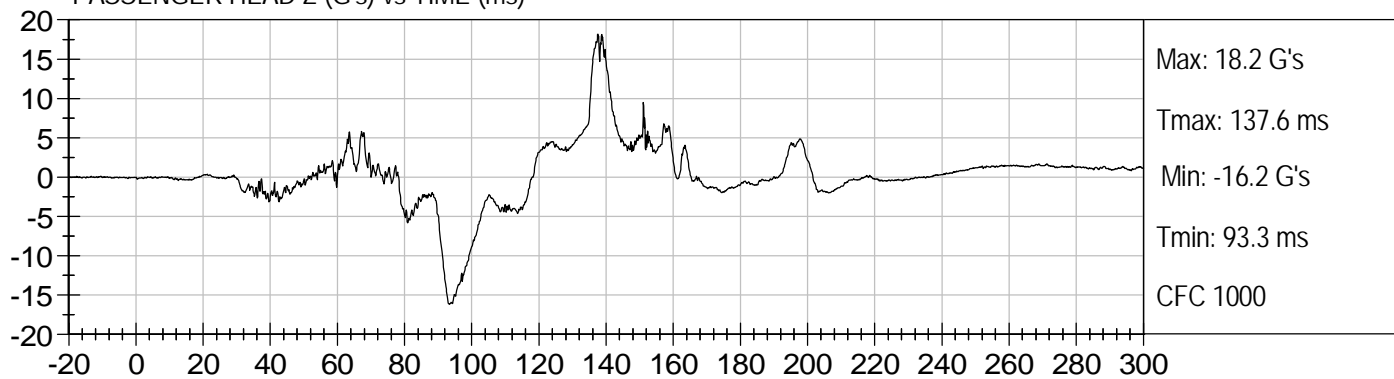

PASSENGER HEAD Resultant (G's) vs TIME (ms)

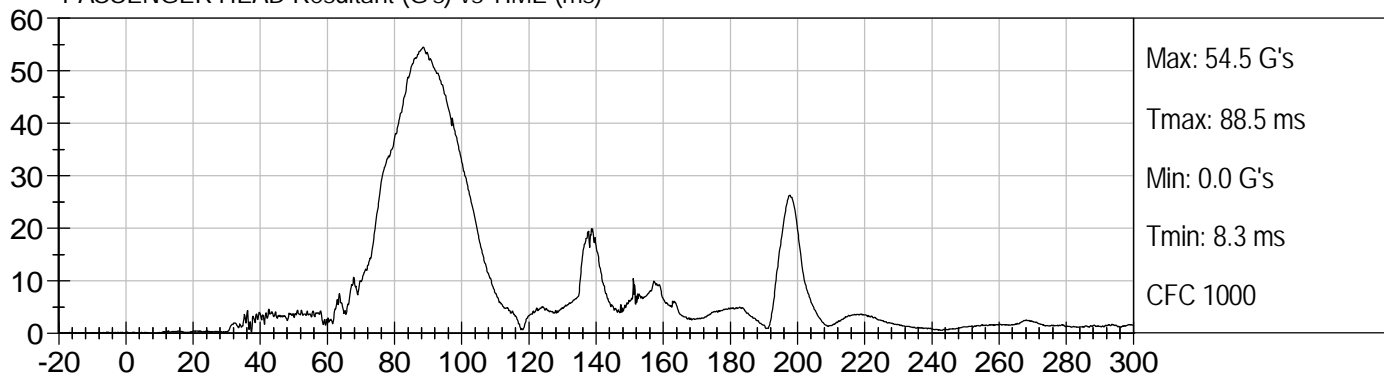

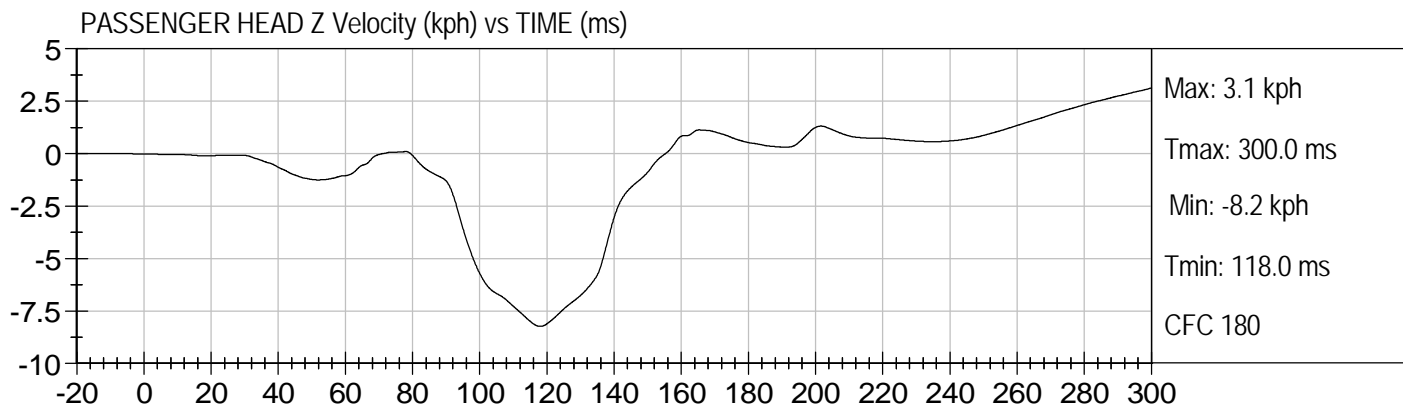
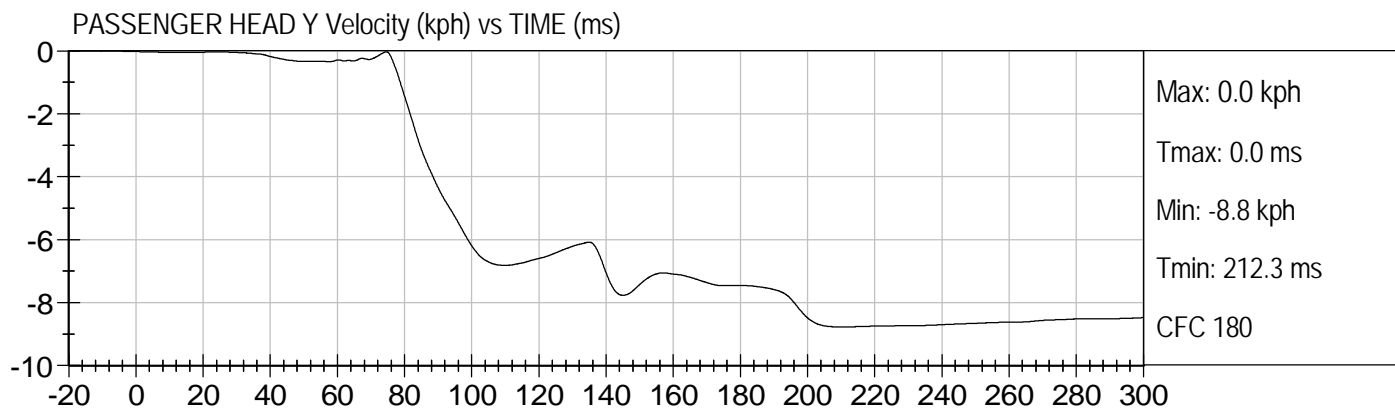
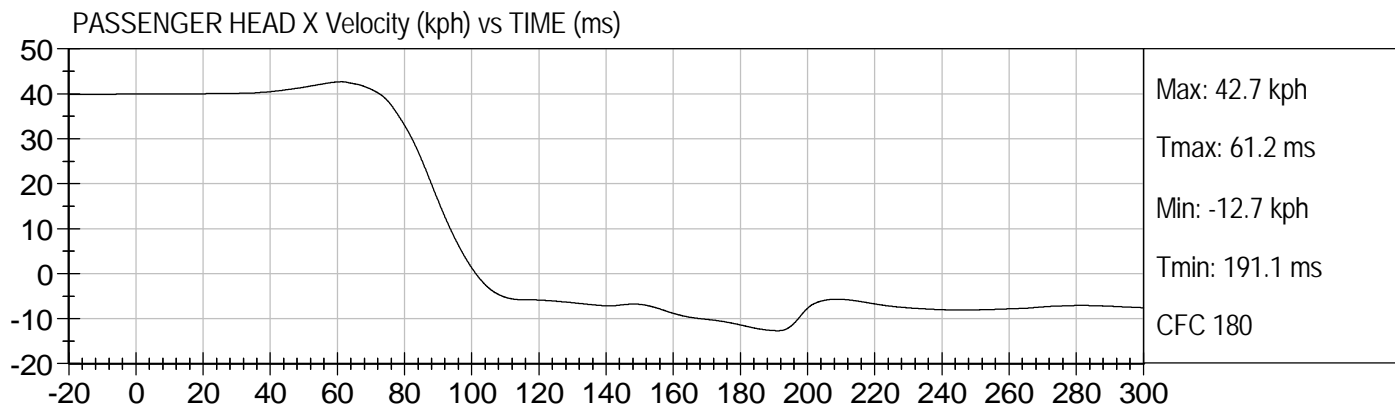

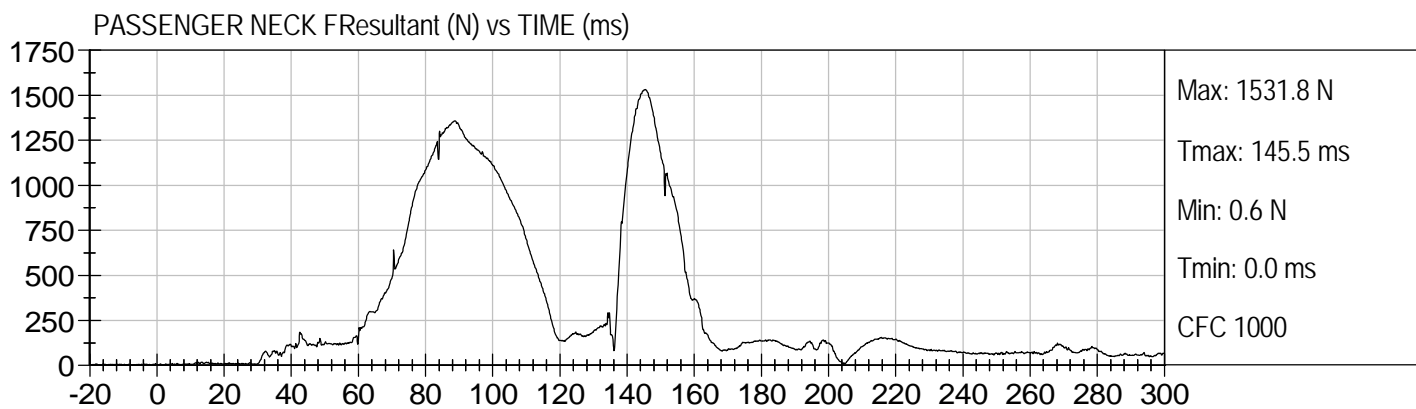
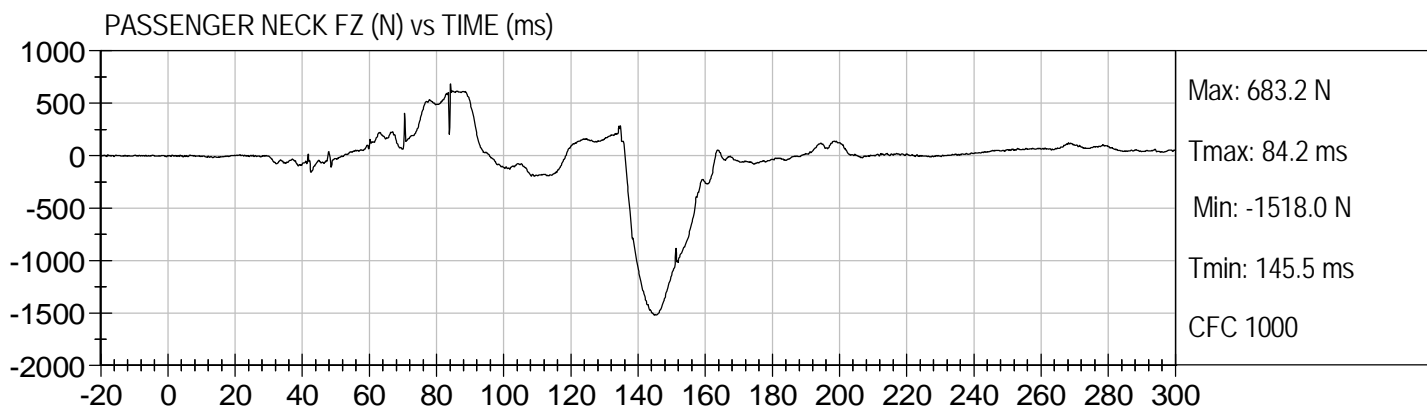
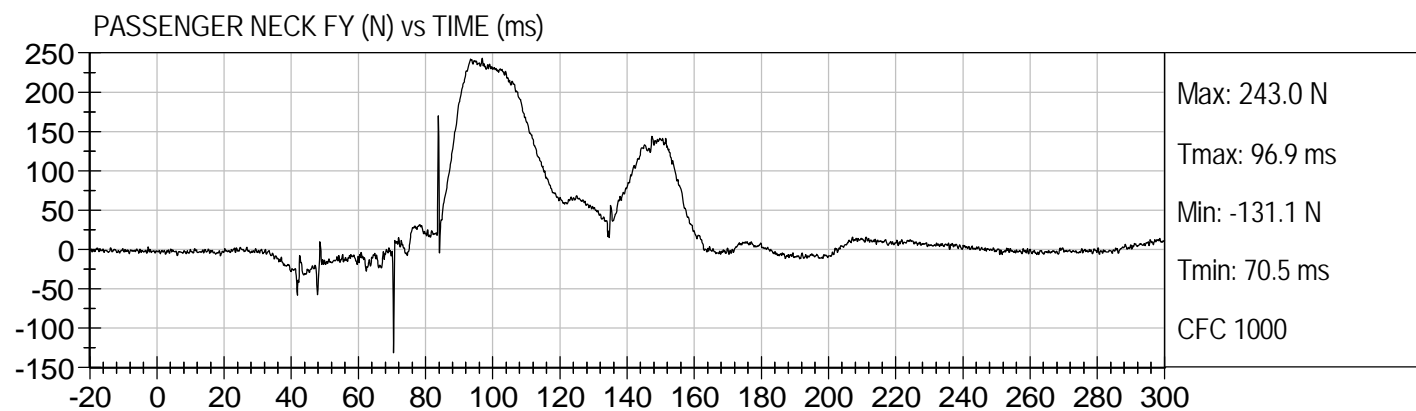
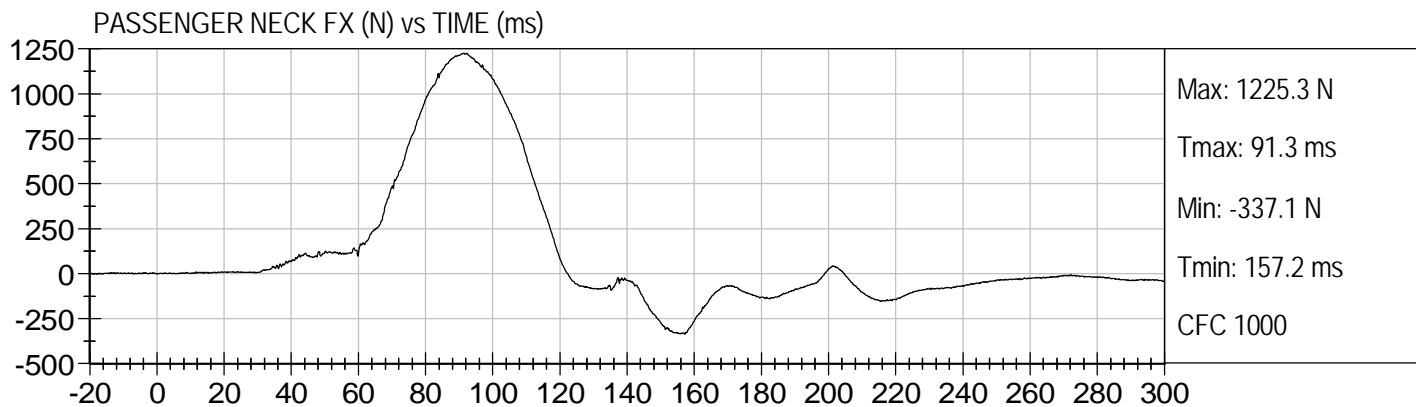

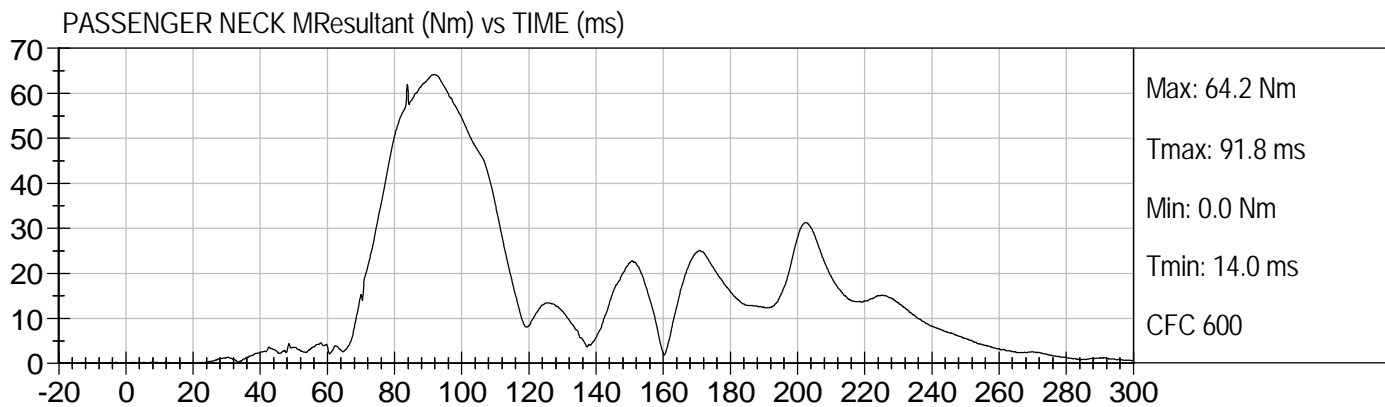
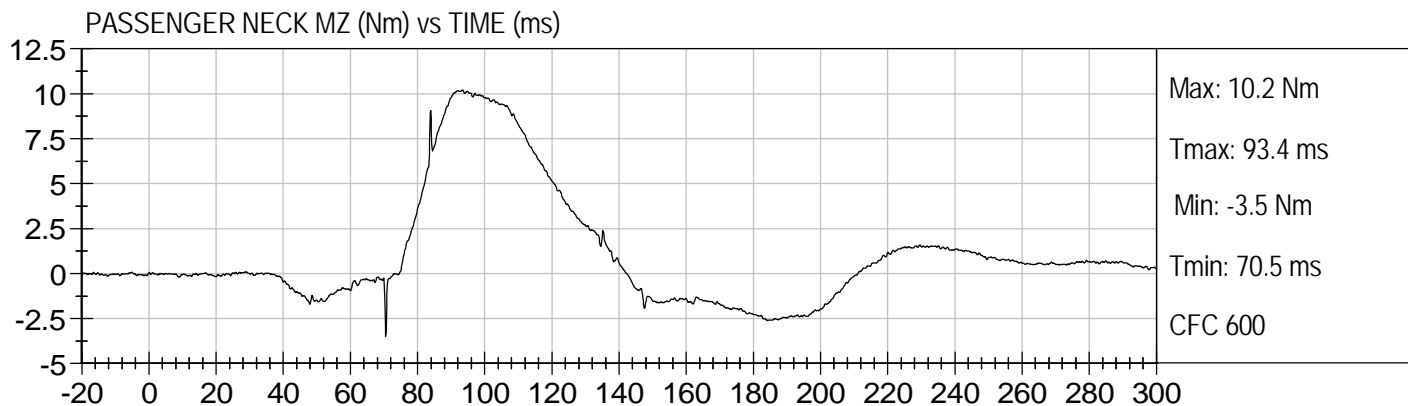
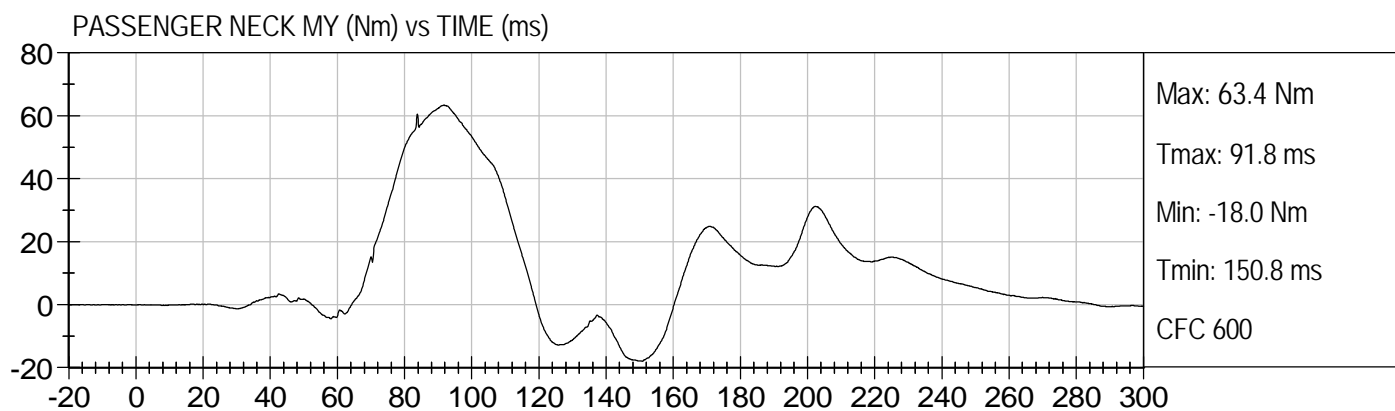
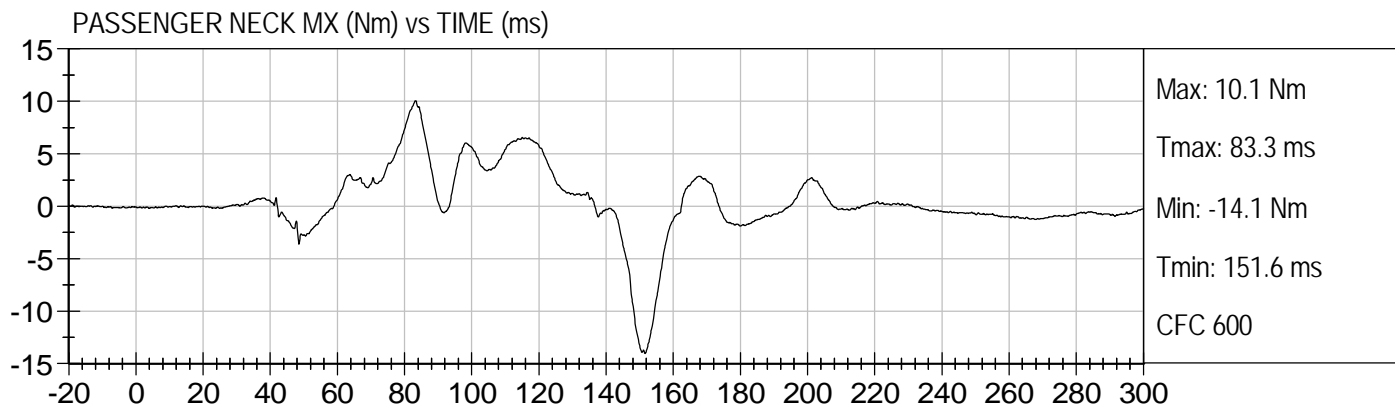

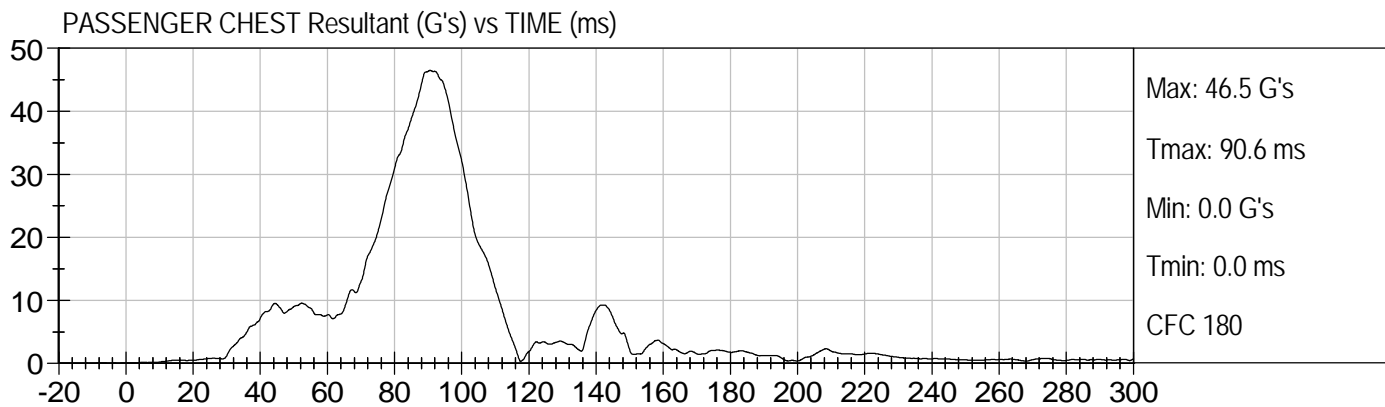
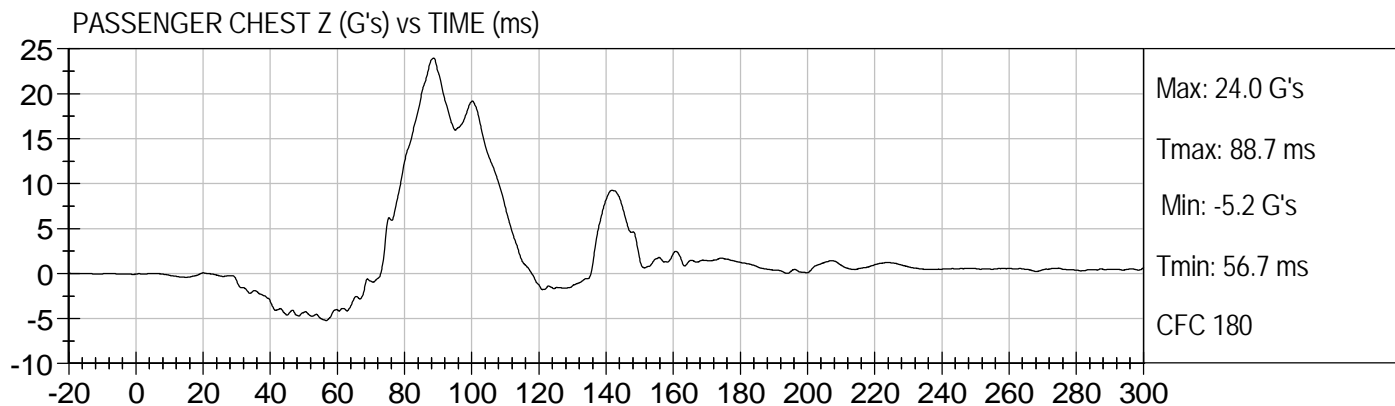
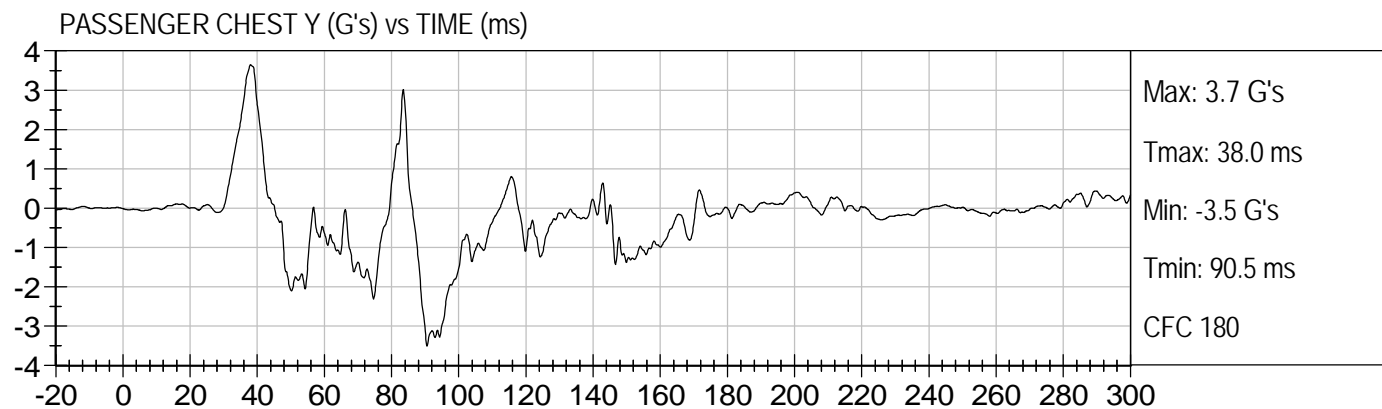
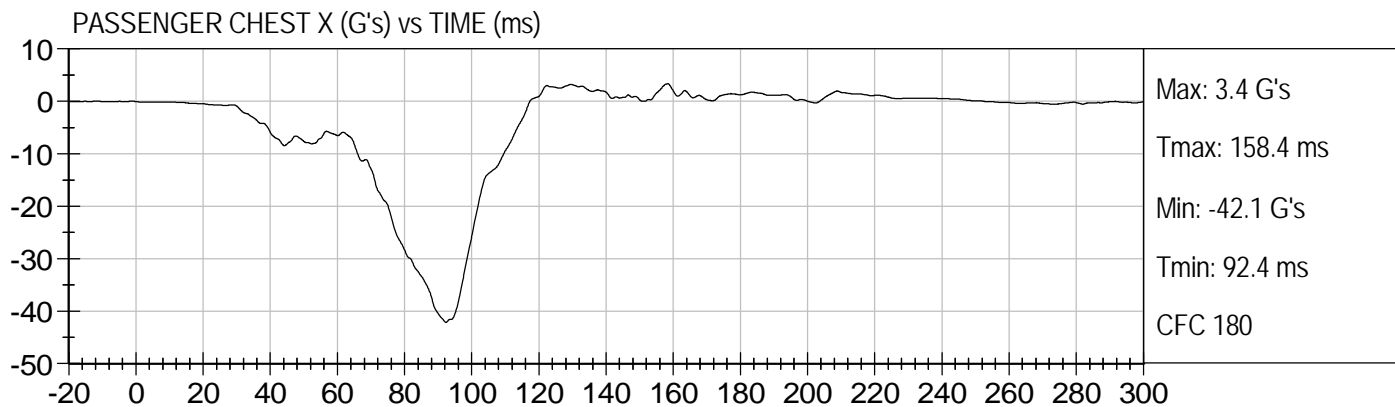

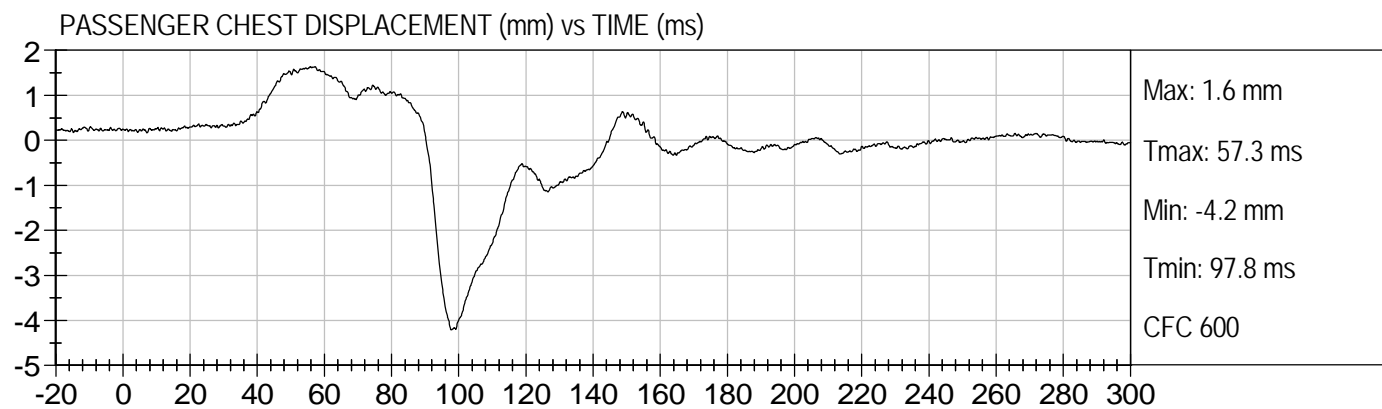
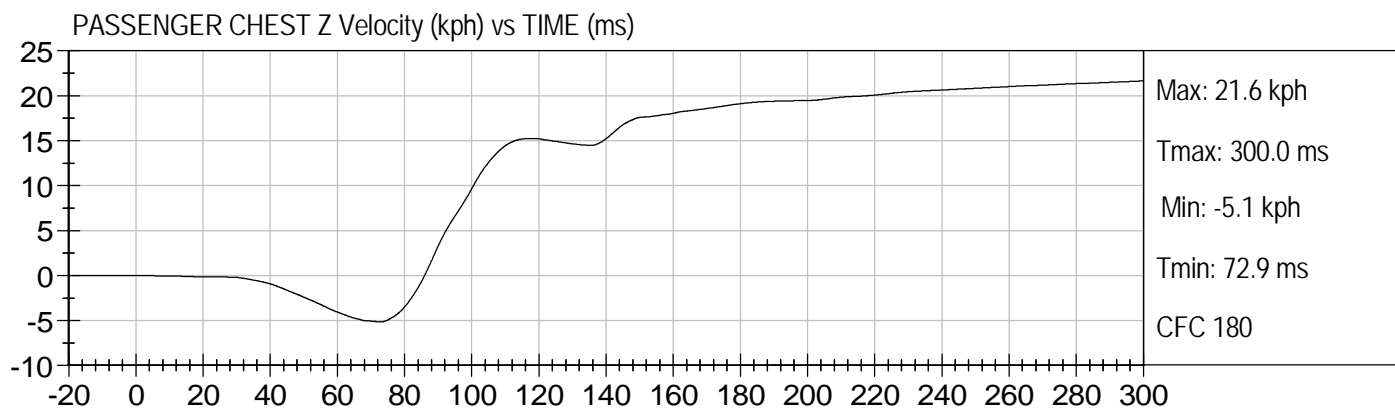
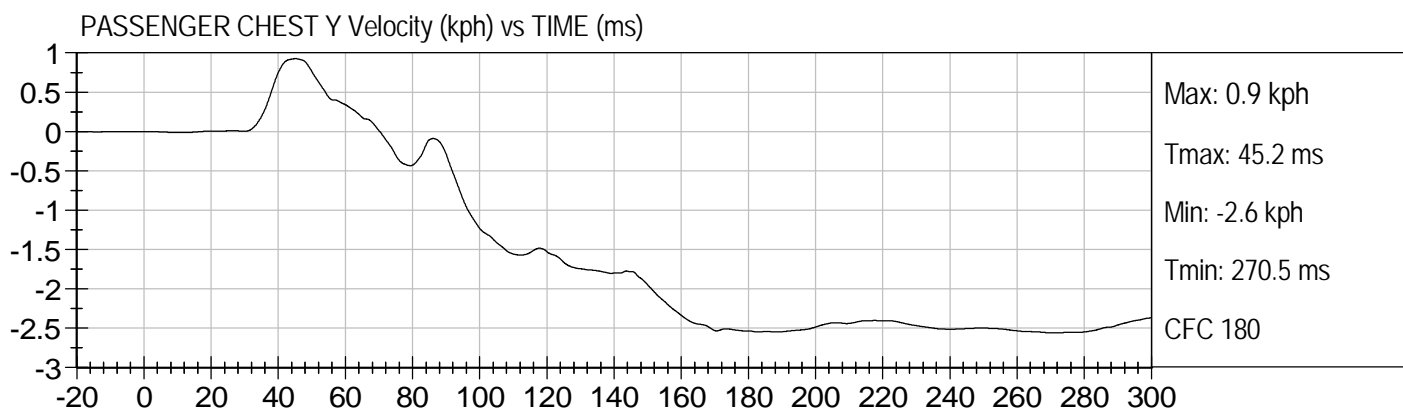
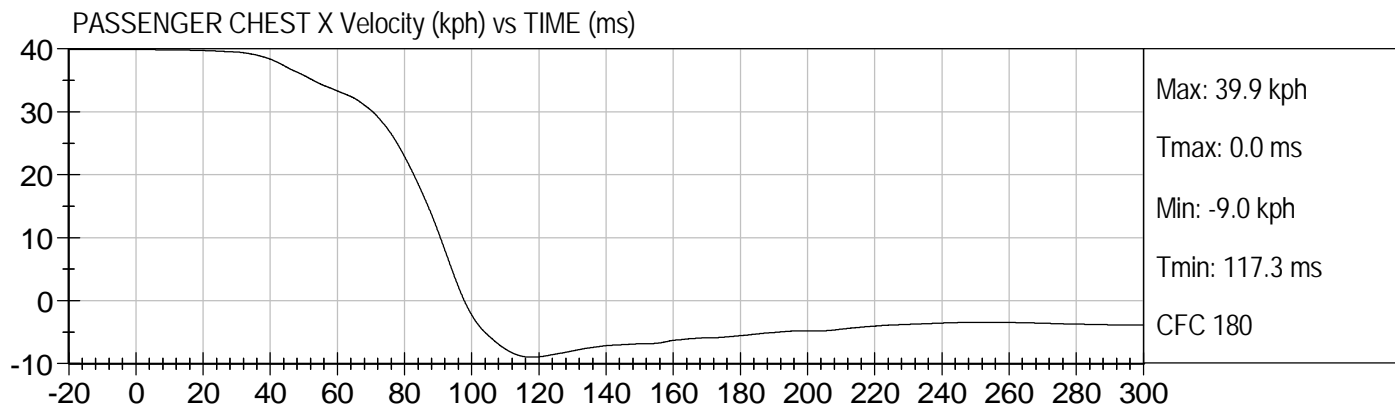

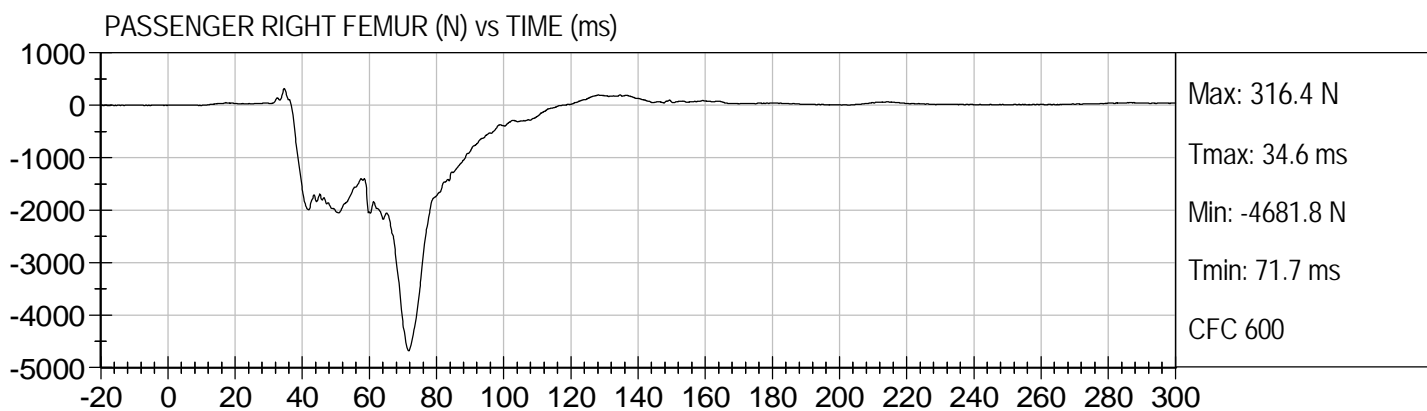
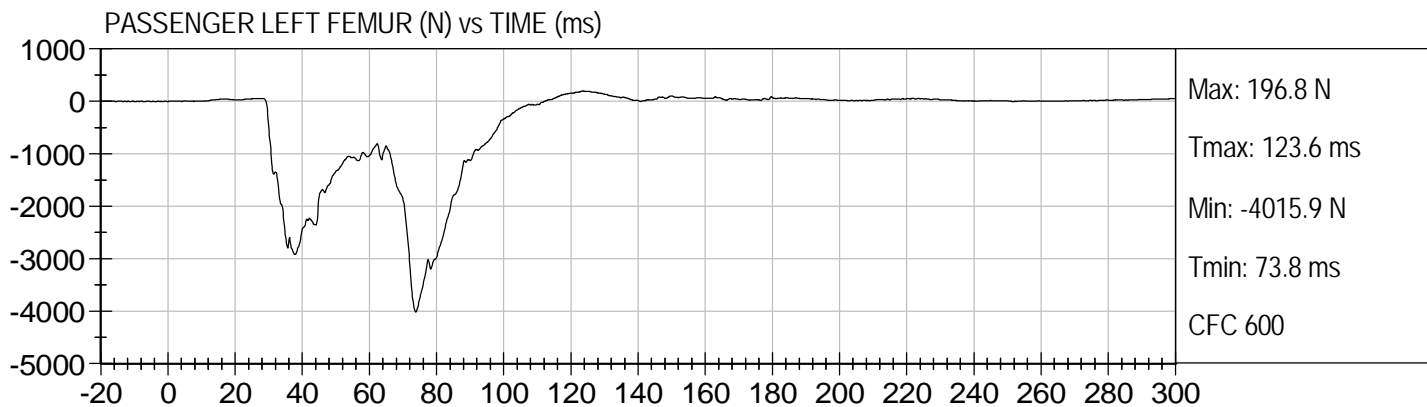

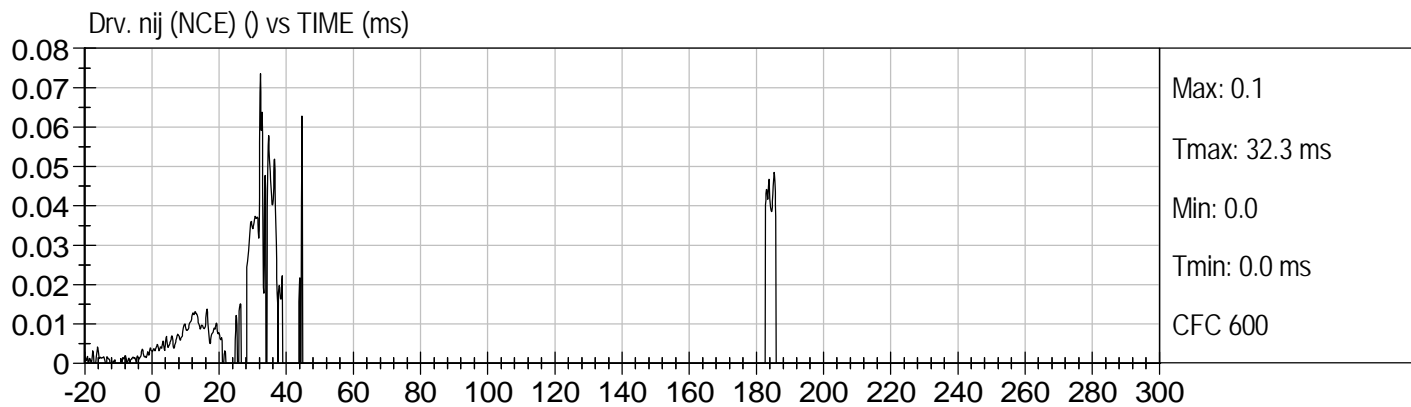
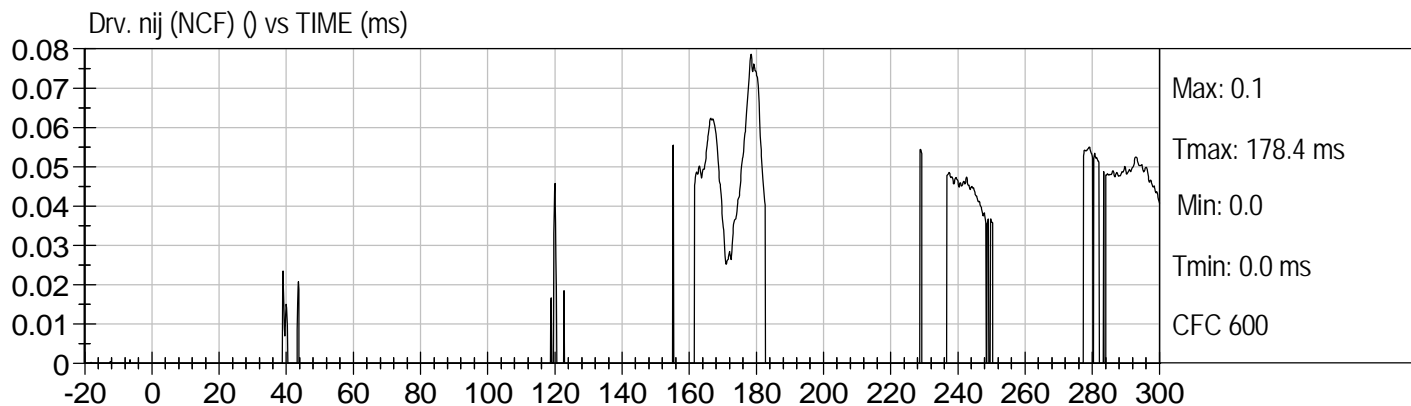
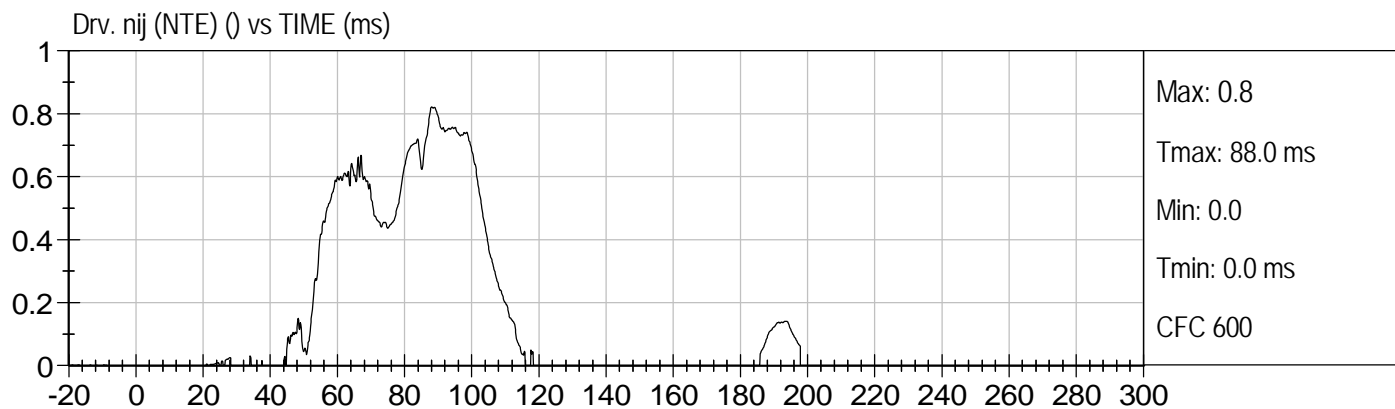
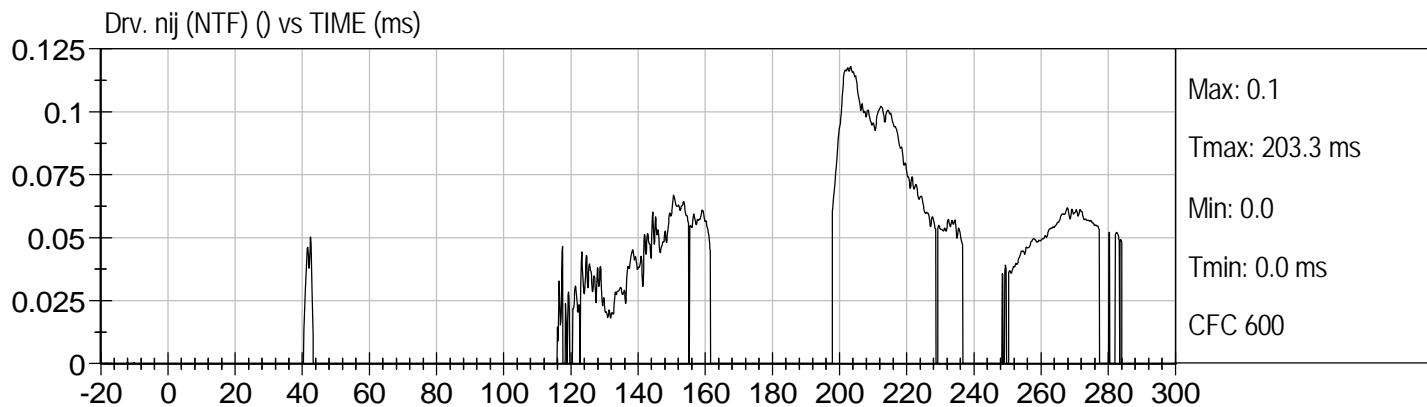



Pass. nij (NTF) () vs TIME (ms)

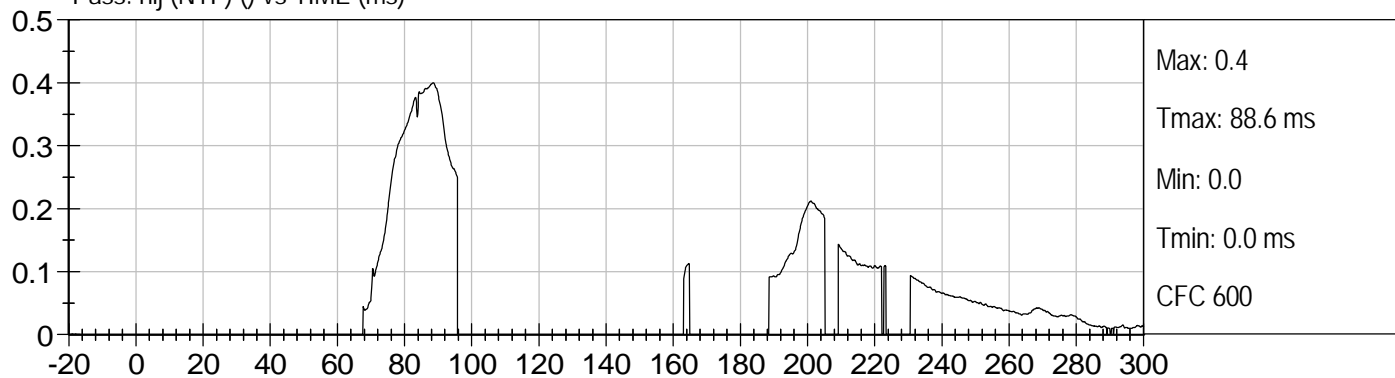

Pass. nij (NTE) () vs TIME (ms)

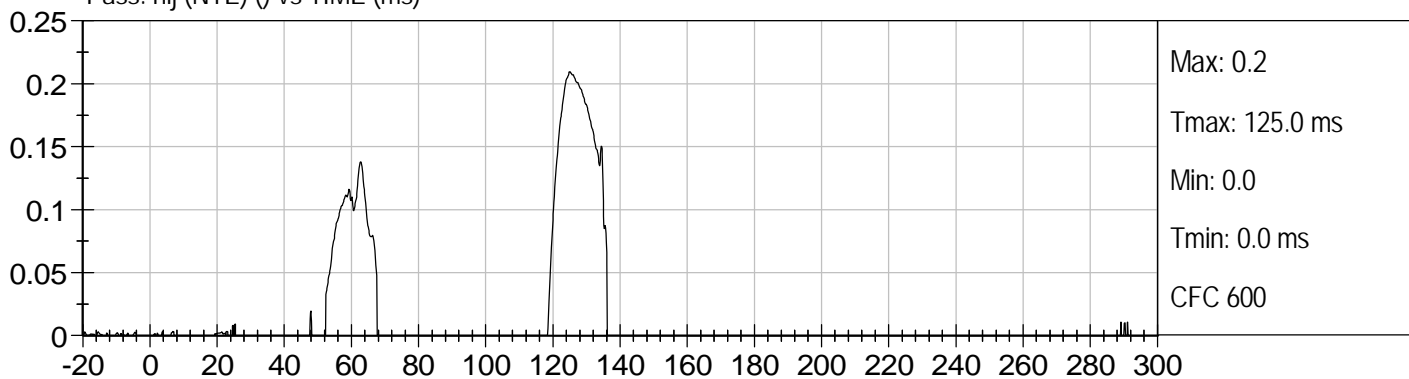

Pass. nij (NCF) () vs TIME (ms)

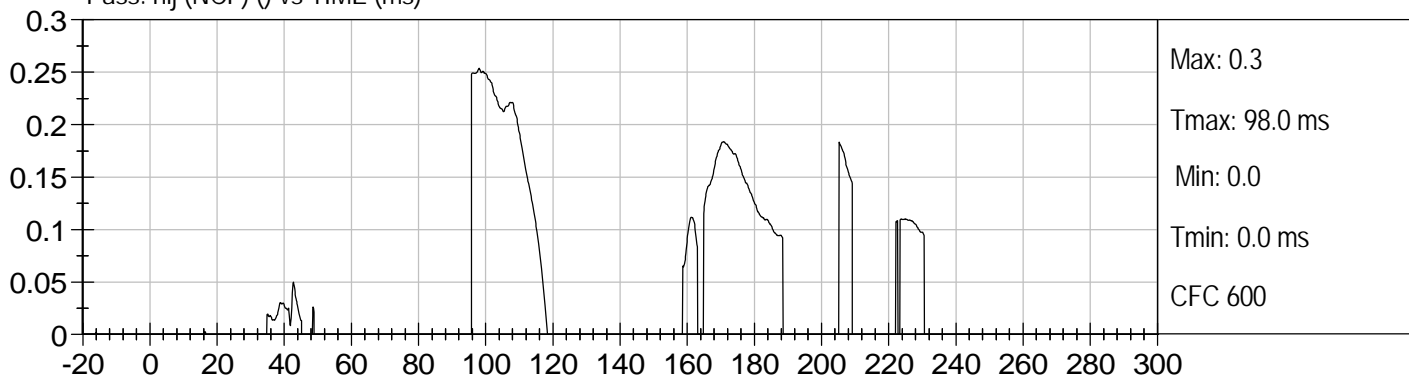

Pass. nij (NCE) () vs TIME (ms)

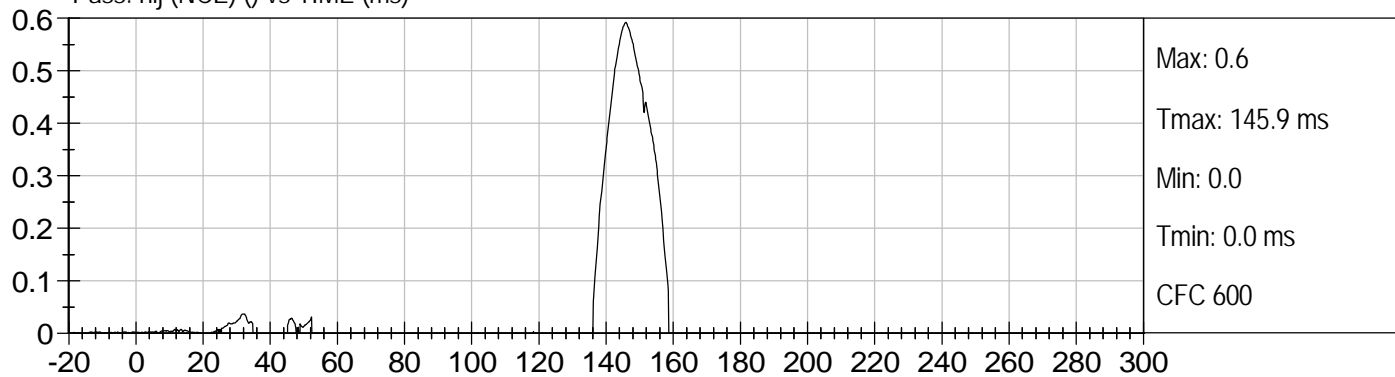

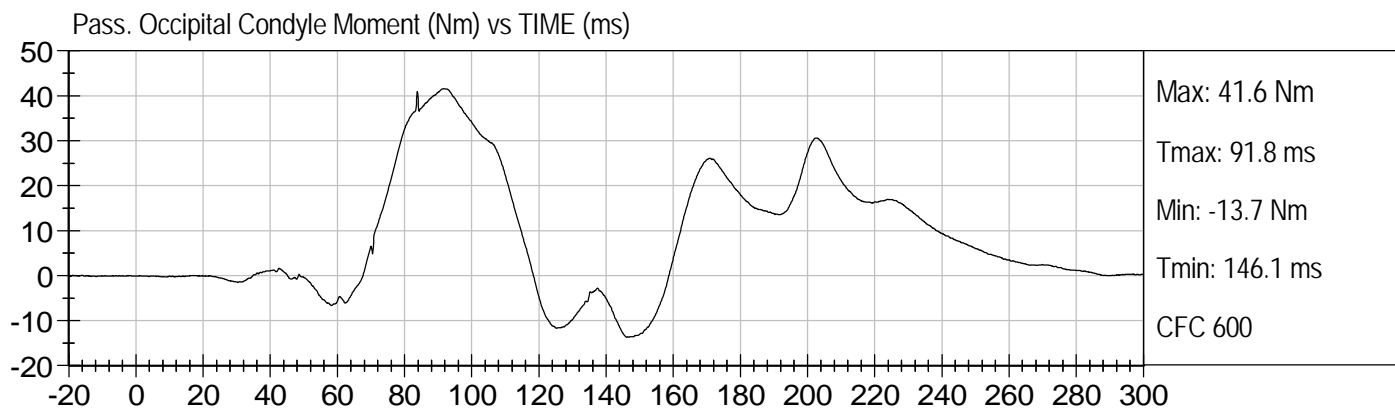
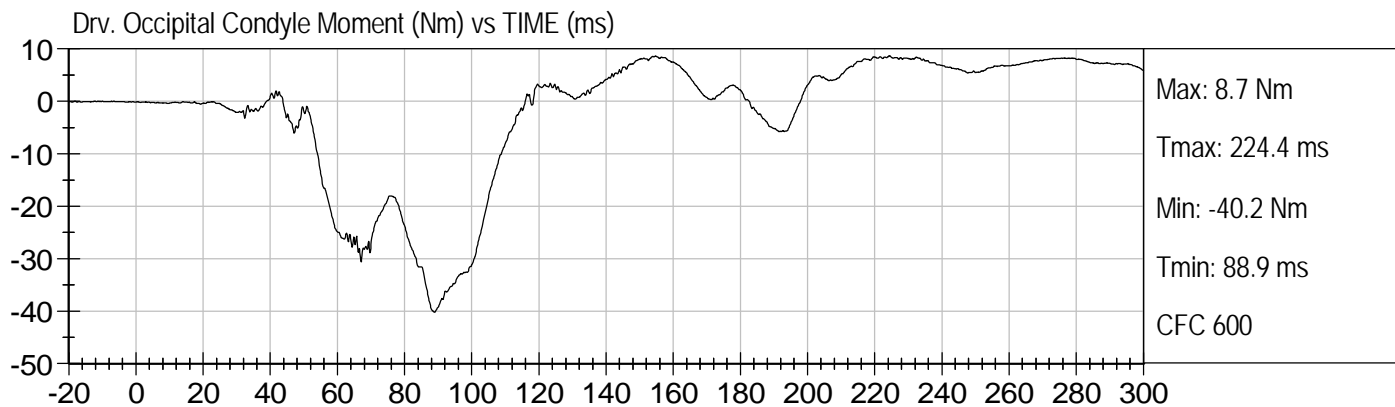

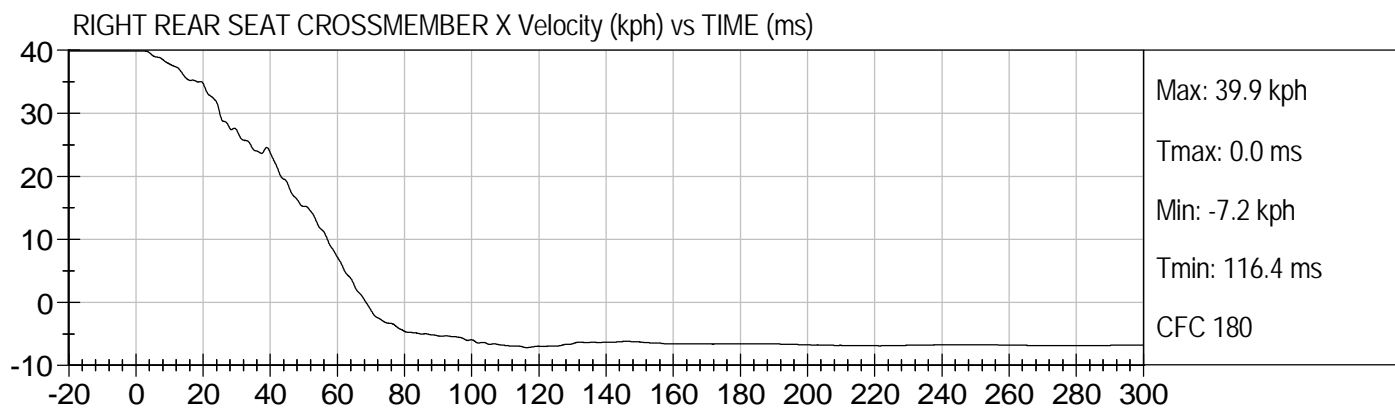
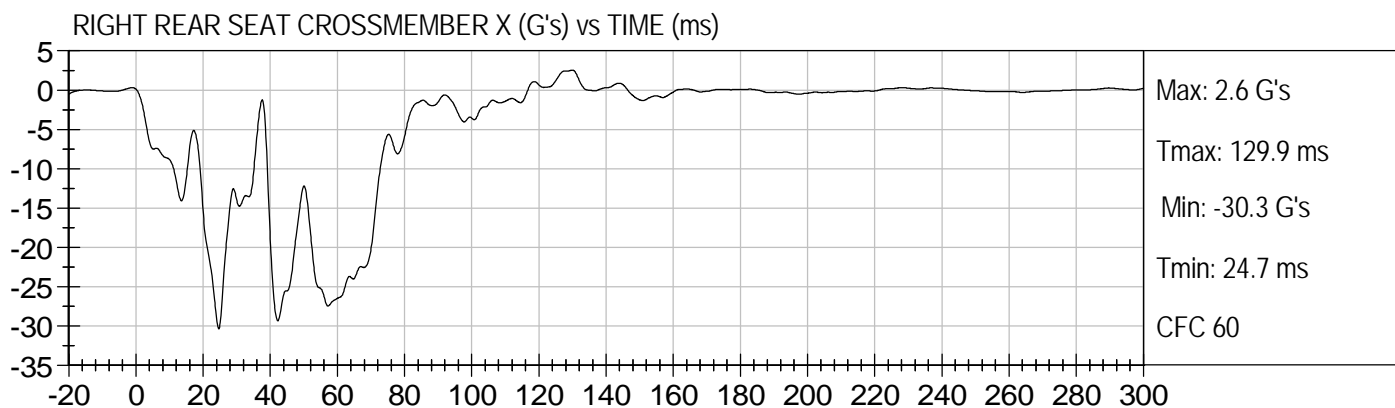
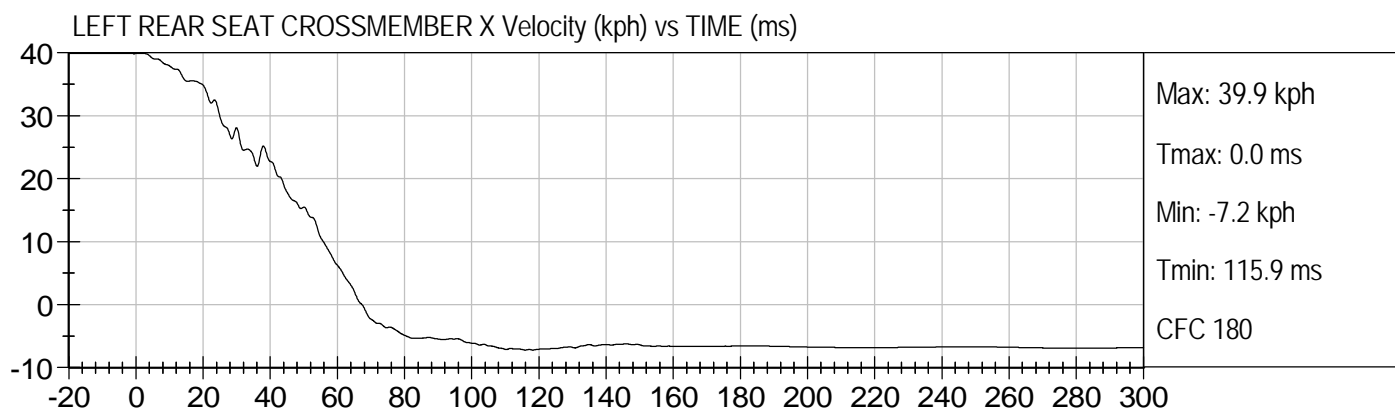
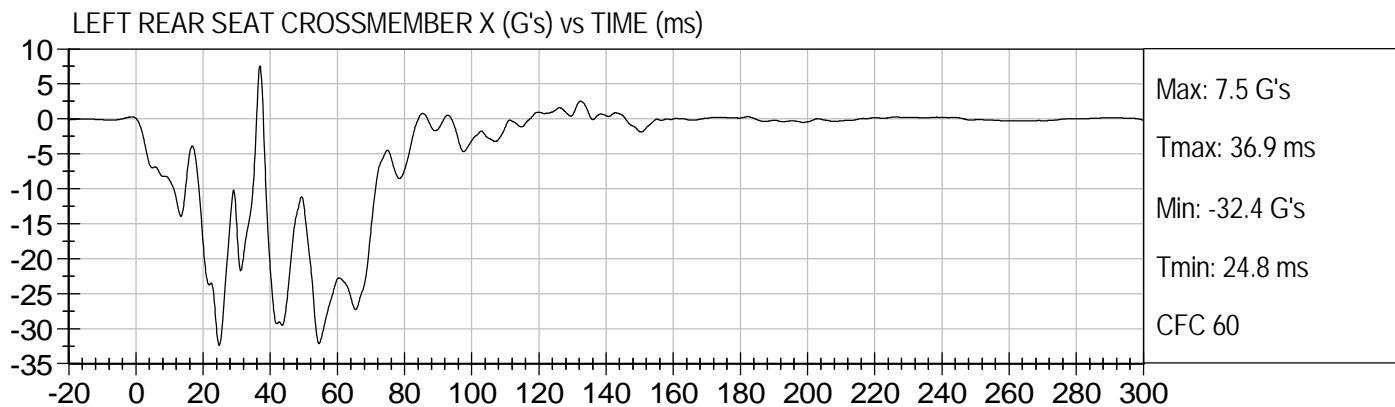

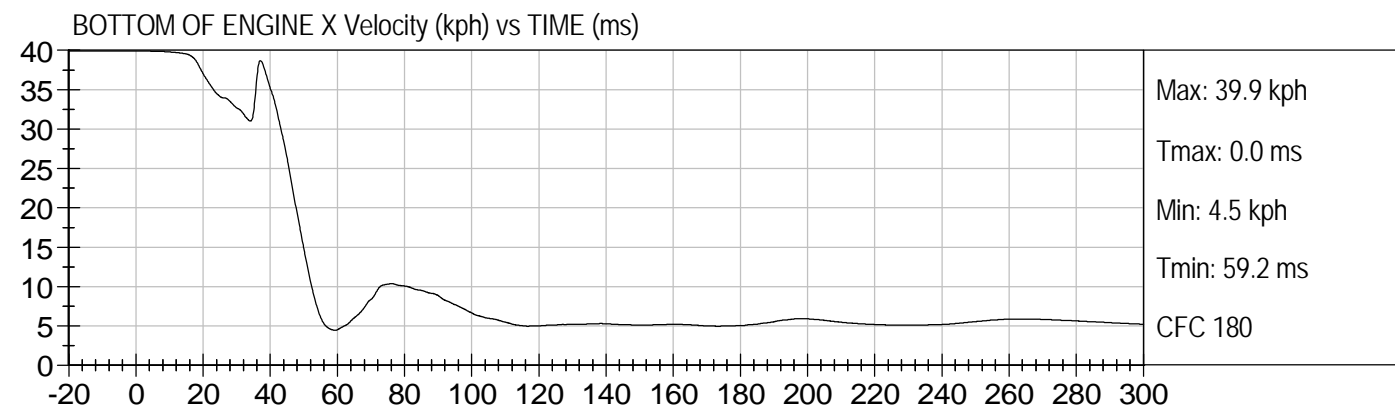
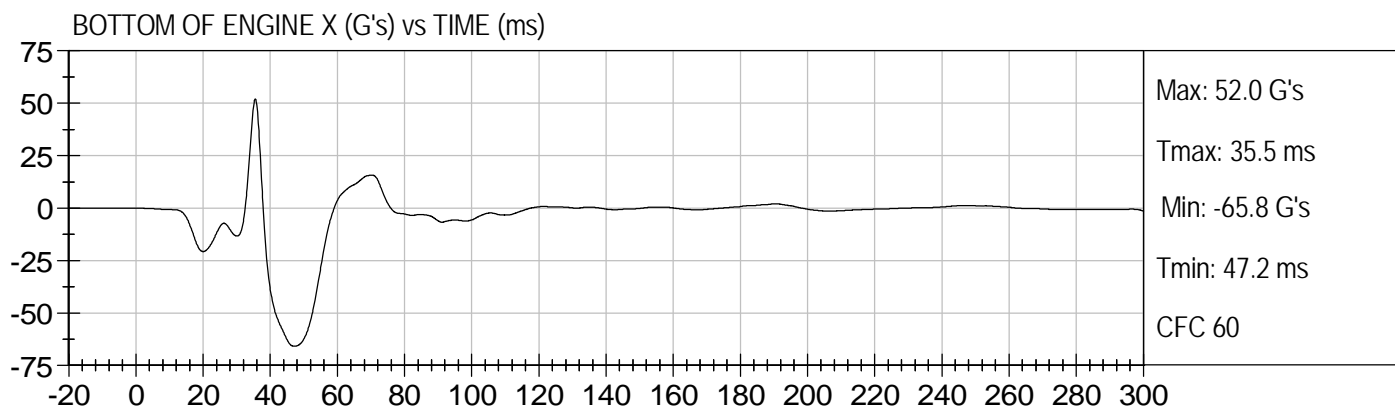
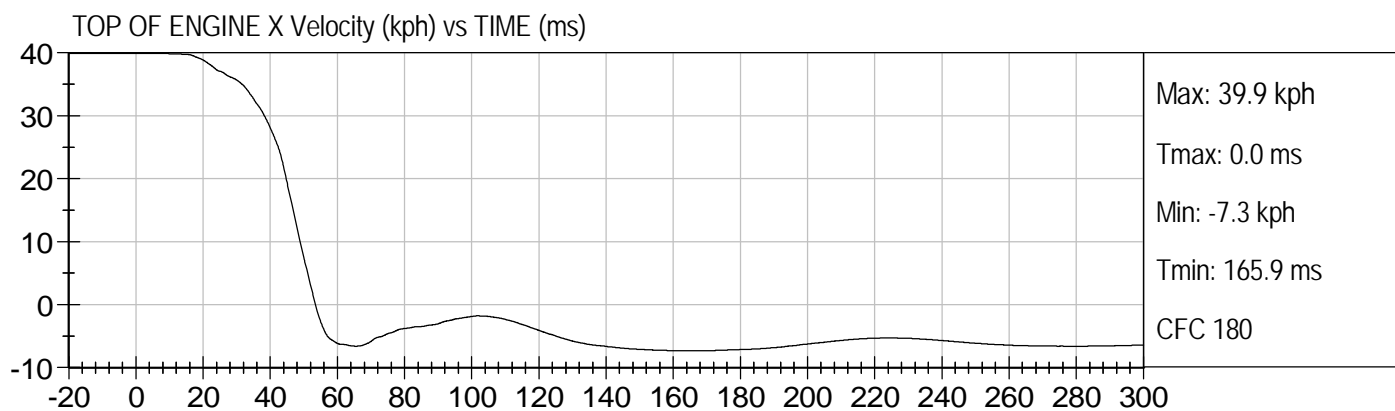
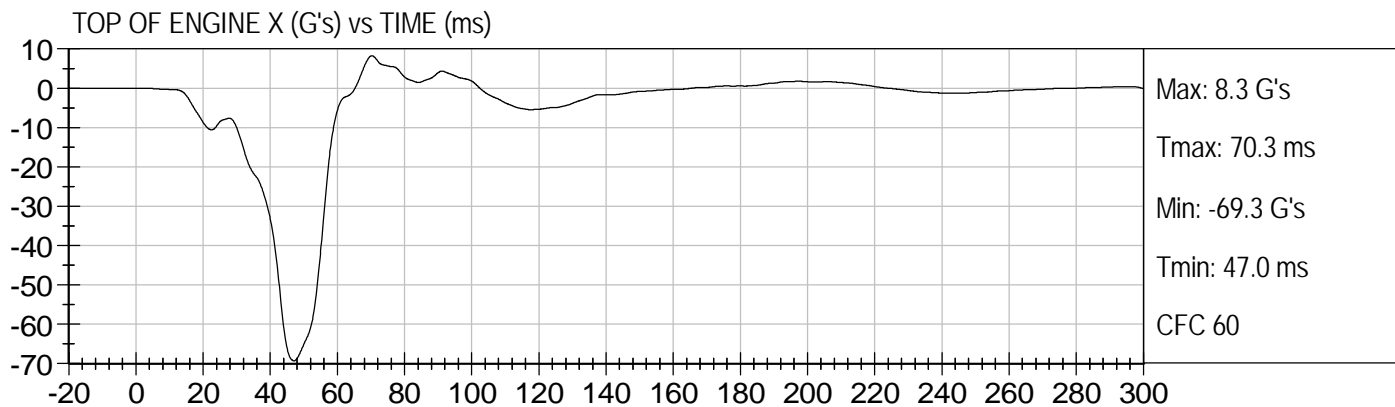

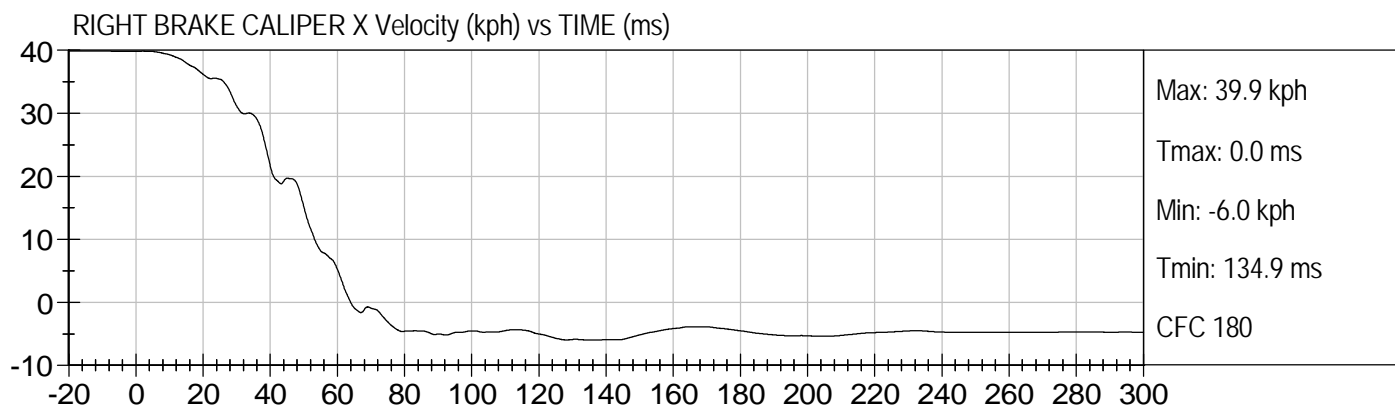
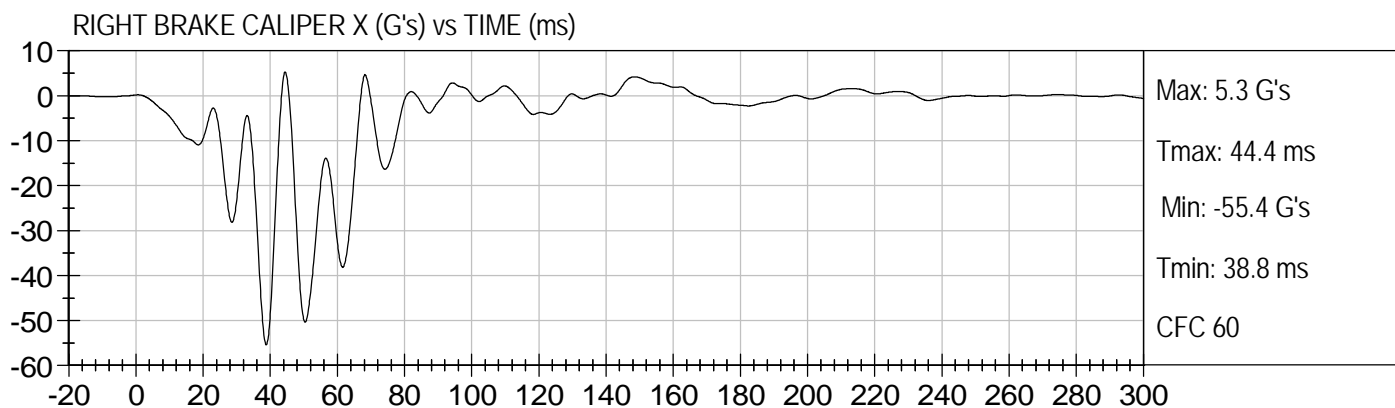
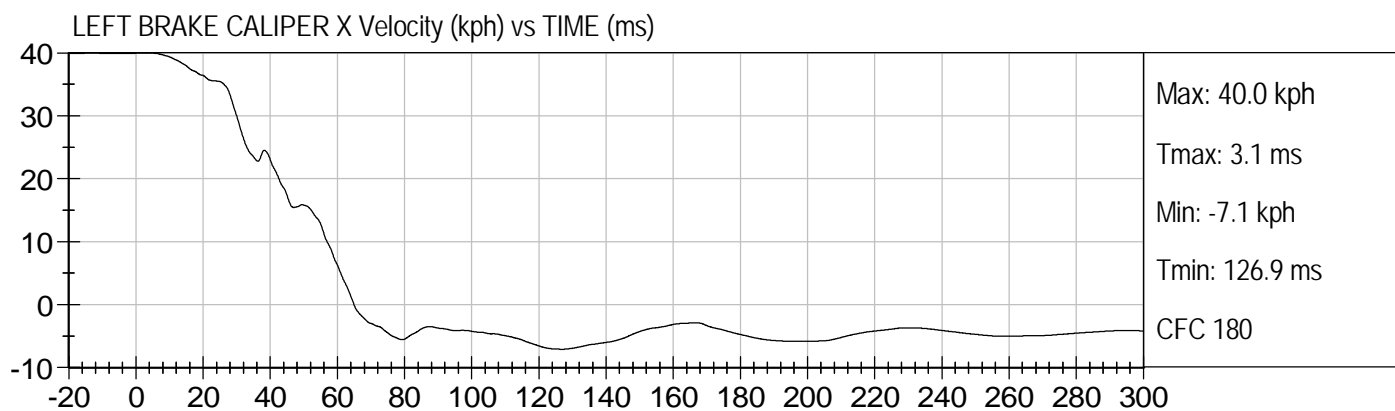
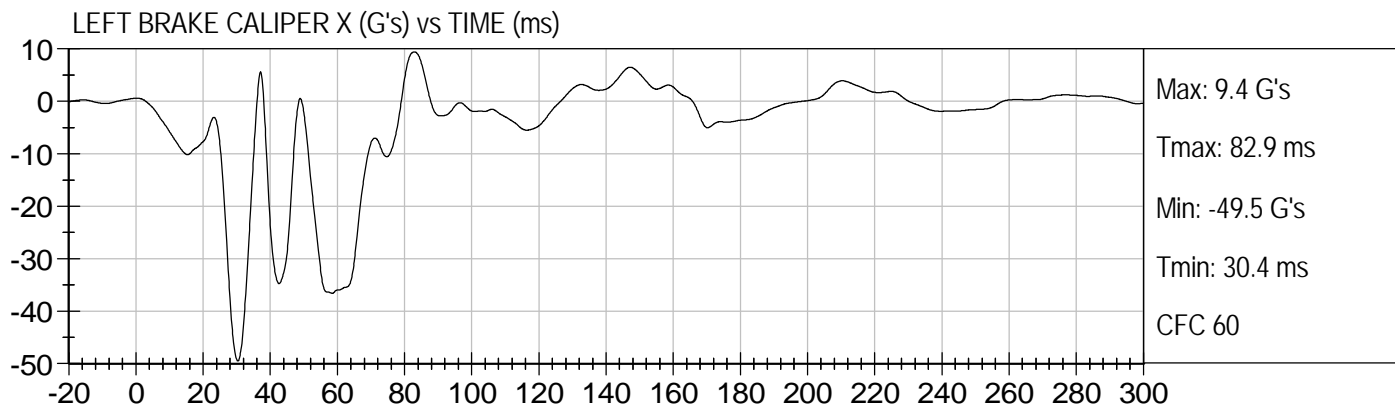

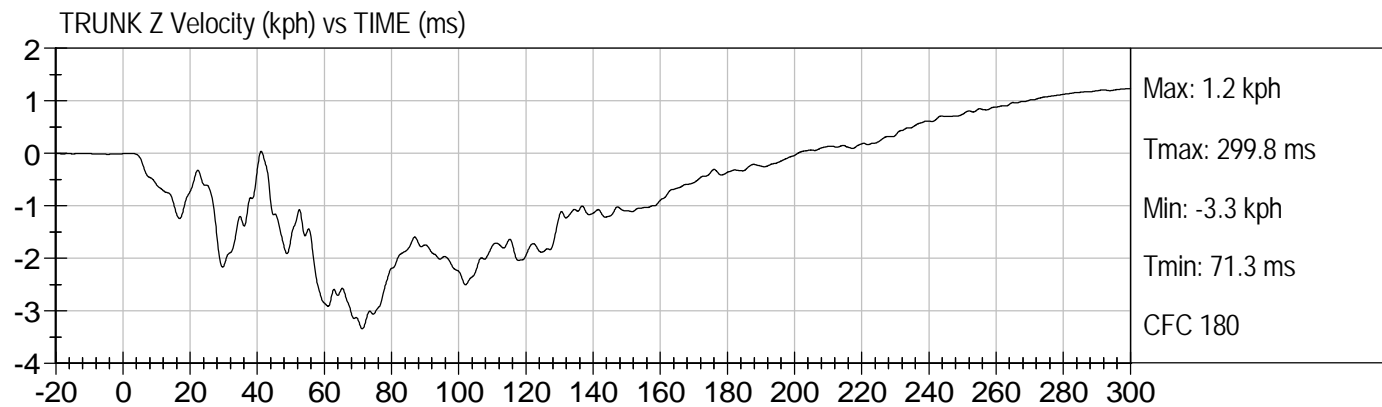
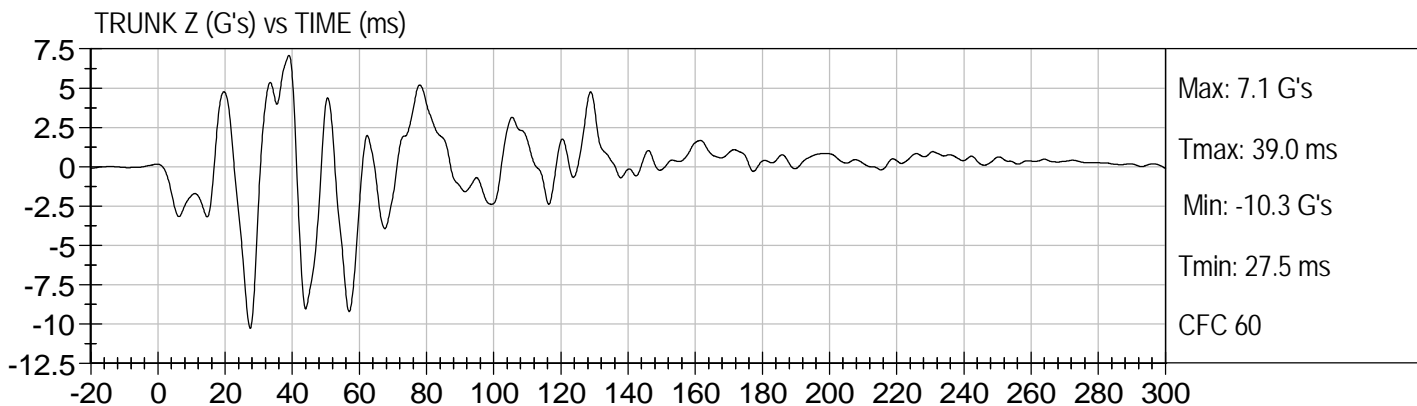
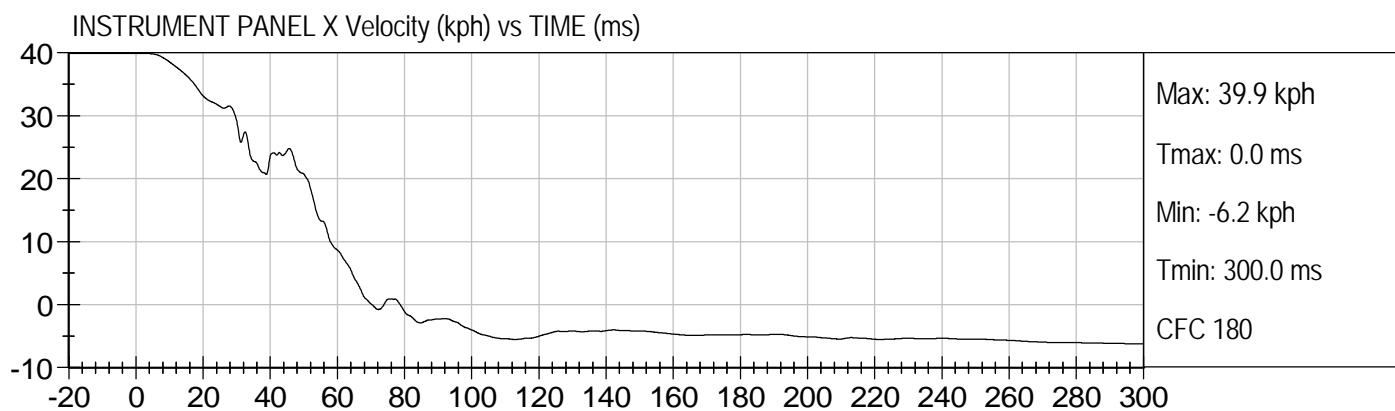
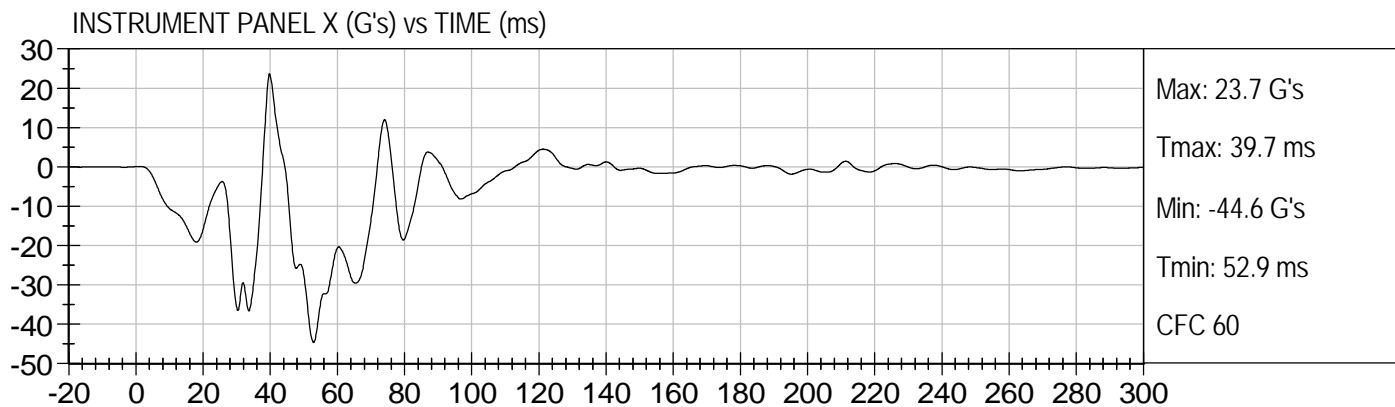

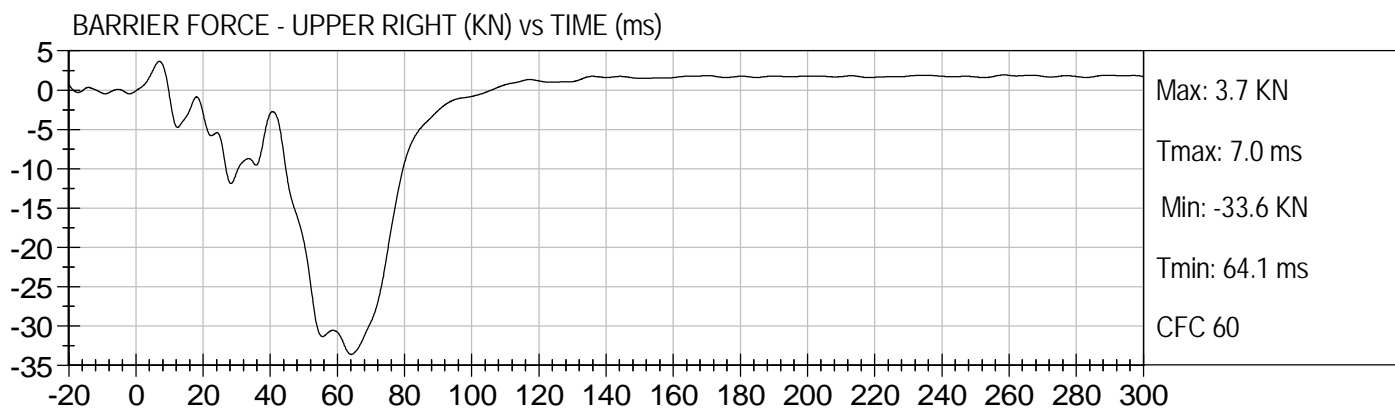
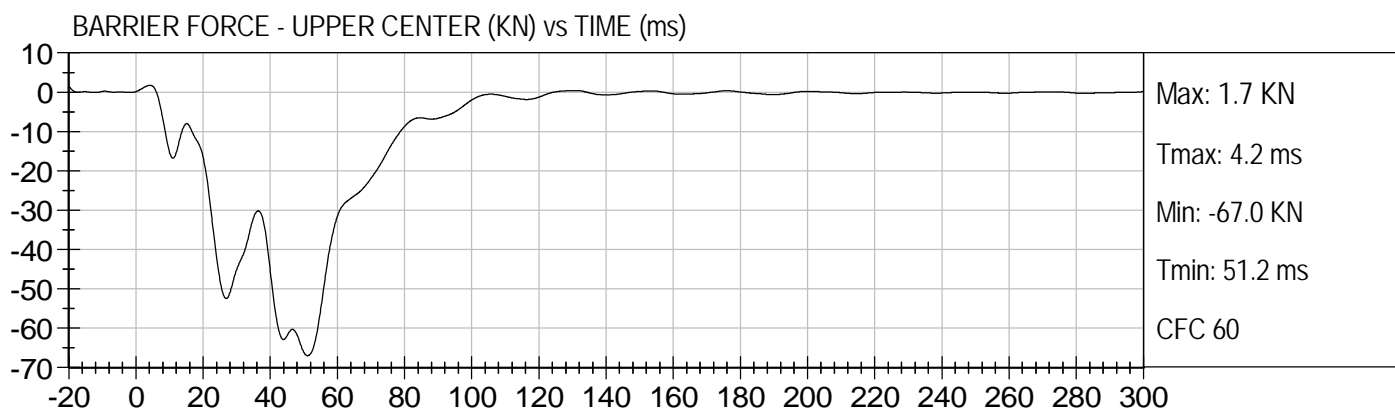
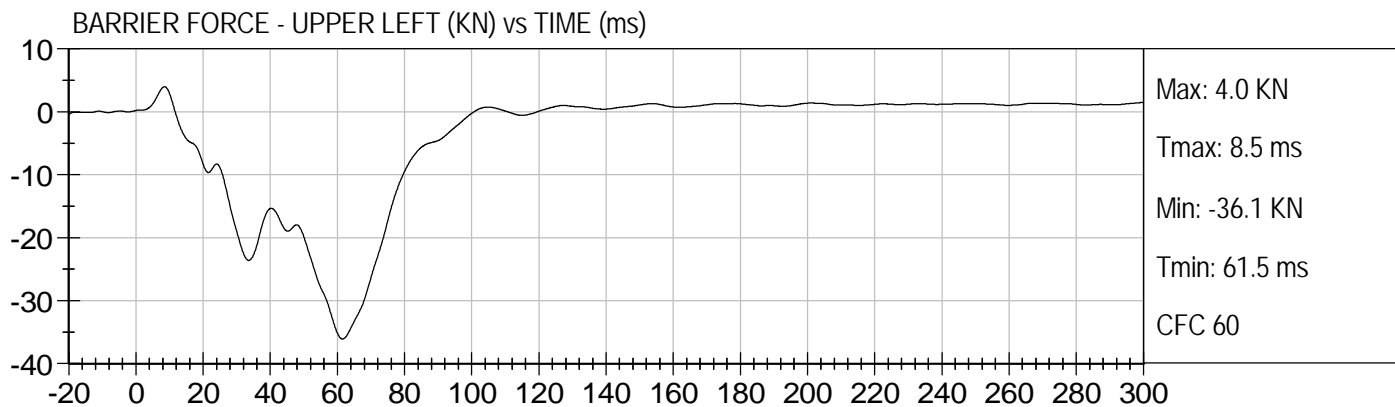

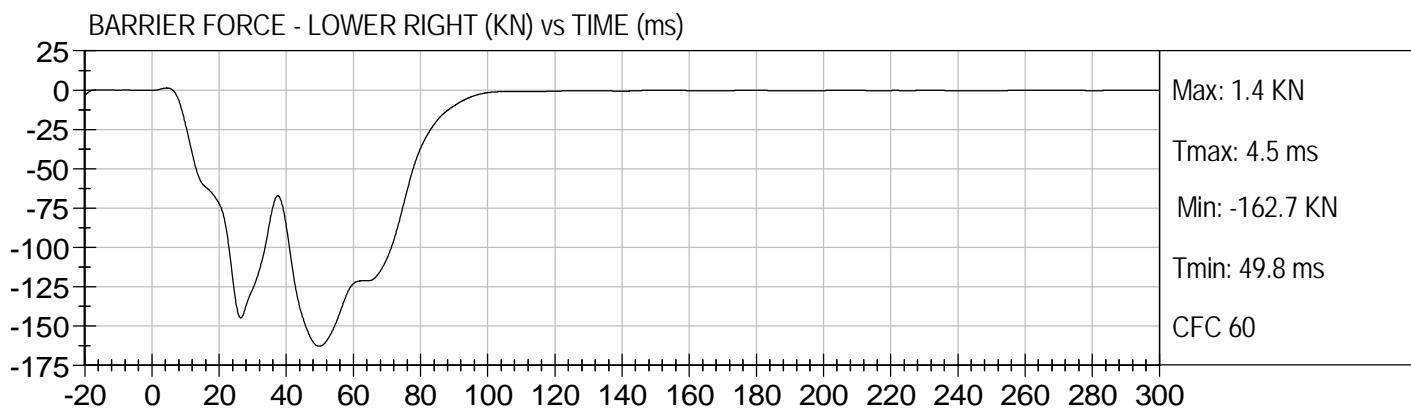
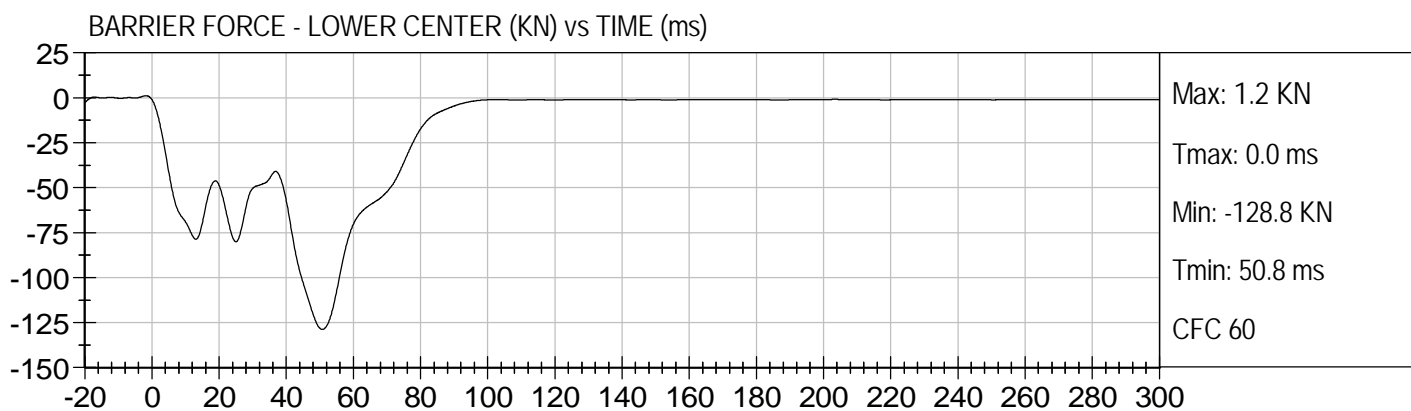
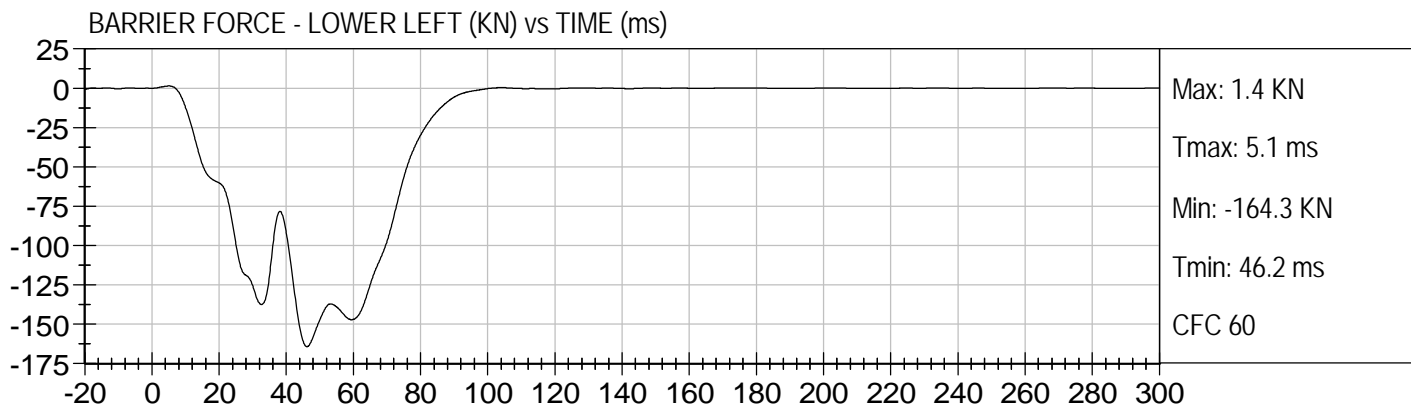

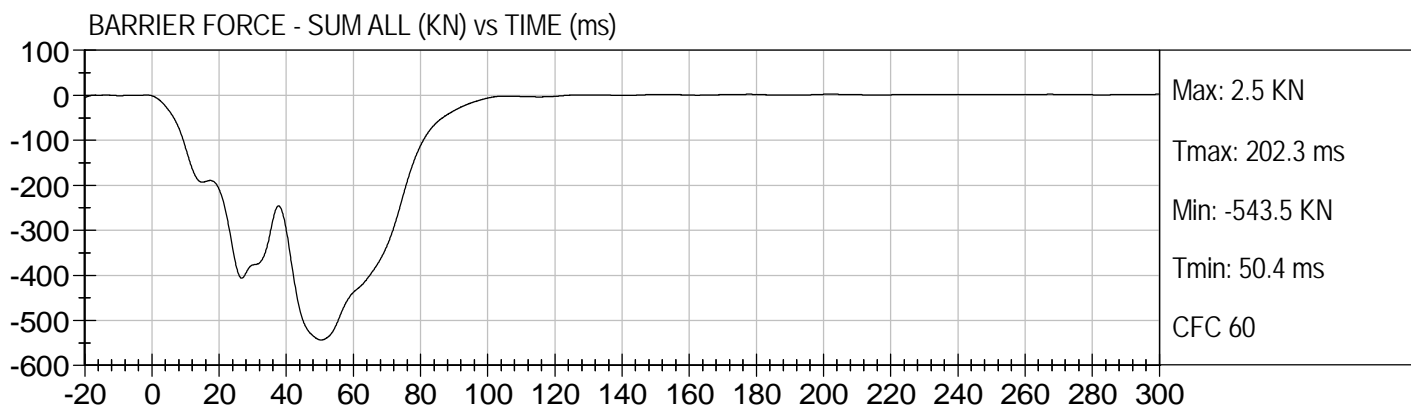
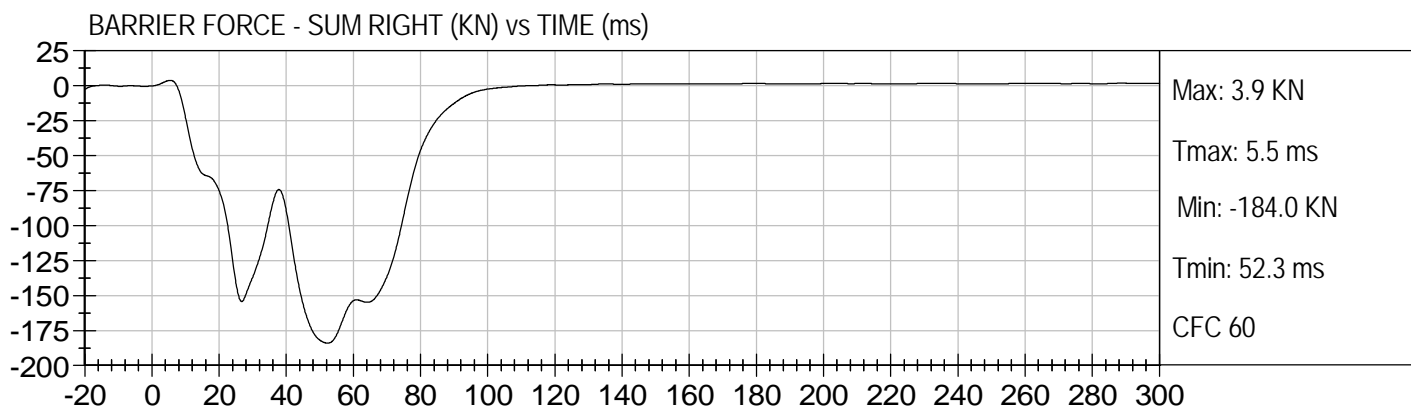
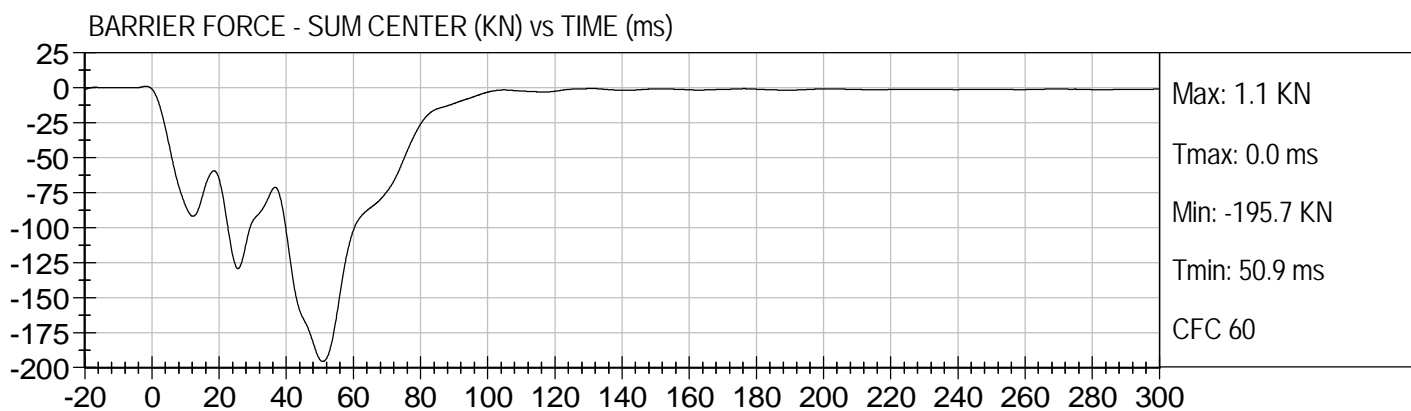
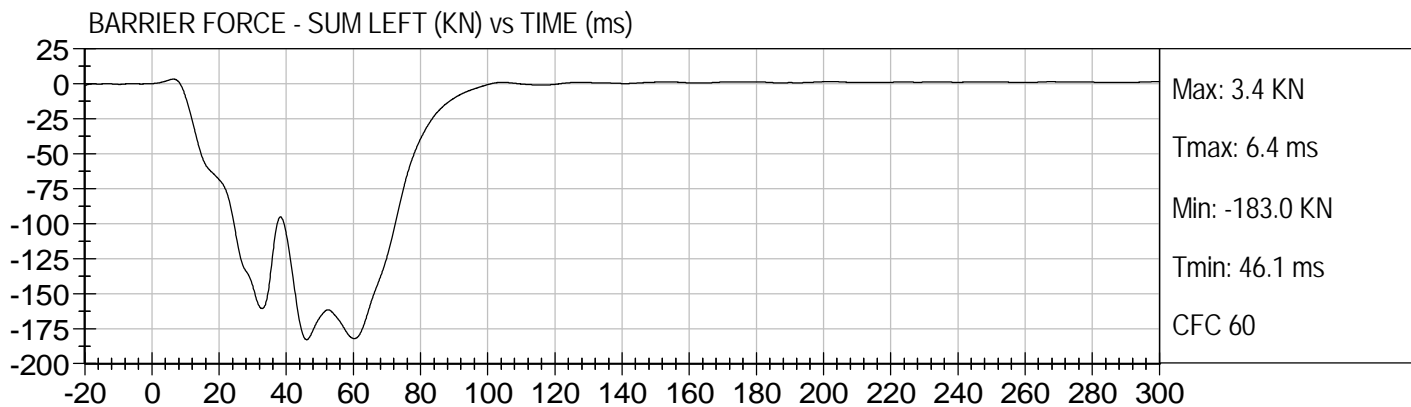

APPENDIX B
CRASH TEST PHOTOGRAPHS

TABLE OF PHOTOGRAPHS

	<u>Page No.</u>
Photo No. 1. Vehicle Certification Label	B-1
Photo No. 2. Tire Placard	B-2
Photo No. 3. Pre-Test Front View of Test Vehicle	B-3
Photo No. 4. Post-Test Front View of Test Vehicle	B-4
Photo No. 5. Pre-Test Left Side View of Test Vehicle	B-5
Photo No. 6. Post-Test Left Side View of Test Vehicle	B-6
Photo No. 7. Pre-Test Right Side View of Test Vehicle	B-7
Photo No. 8. Post-Test Right Side View of Test Vehicle	B-8
Photo No. 9. Pre-Test Right Front Three-Quarter View of Test Vehicle	B-9
Photo No. 10. Post-Test Right Front Three-Quarter View of Test Vehicle	B-10
Photo No. 11. Pre-Test Left Front Three-Quarter View of Test Vehicle	B-11
Photo No. 12. Post-Test Left Front Three-Quarter View of Test Vehicle	B-12
Photo No. 13. Pre-Test Right Rear Three-Quarter View of Test Vehicle	B-13
Photo No. 14. Post-Test Right Rear Three-Quarter View of Test Vehicle	B-14
Photo No. 15. Pre-Test Left Rear Three-Quarter View of Test Vehicle	B-15
Photo No. 16. Post-Test Left Rear Three-Quarter View of Test Vehicle	B-16
Photo No. 17. Pre-Test Rear View of Test Vehicle	B-17
Photo No. 18. Post-Test Rear View of Test Vehicle	B-18
Photo No. 19. Pre-Test Windshield View	B-19
Photo No. 20. Post-Test Windshield View	B-20
Photo No. 21. Pre-Test Engine Compartment View	B-21
Photo No. 22. Post-Test Engine Compartment View	B-22
Photo No. 23. Pre-Test Fuel Filler Cap View	B-23
Photo No. 24. Post-Test Fuel Filler Cap View	B-24
Photo No. 25. Pre-Test Front Underbody View	B-25

	<u>Page No.</u>
Photo No. 26. Post-Test Front Underbody View	B-26
Photo No. 27. Pre-Test Mid Underbody View	B-27
Photo No. 28. Post-Test Mid Underbody View	B-28
Photo No. 29. Pre-Test Fuel Tank View	B-29
Photo No. 30. Post-Test Fuel Tank View	B-30
Photo No. 31. Pre-Test Rear Underbody View	B-31
Photo No. 32. Post-Test Rear Underbody View	B-32
Photo No. 33. Pre-Test Driver Dummy Front View (head position)	B-33
Photo No. 34. Post-Test Driver Dummy Front View (head position)	B-34
Photo No. 35. Pre-Test Driver Dummy Position Left Side View	B-35
Photo No. 36. Post-Test Driver Dummy Position Left Side View	B-36
Photo No. 37. Pre-Test Driver Dummy Position Left Side View (Door Open)	B-37
Photo No. 38. Post-Test Driver Dummy Position Left Side View (Door Open)	B-38
Photo No. 39. Pre-Test Driver Dummy Seat Position	B-39
Photo No. 40. Post-Test Driver Dummy Seat Position	B-40
Photo No. 41. Pre-Test Driver Dummy Feet Position	B-41
Photo No. 42. Post-Test Driver Dummy Feet Position	B-42
Photo No. 43. Pre-Test Driver Side Knee Bolster View	B-43
Photo No. 44. Post-Test Driver Side Knee Bolster View	B-44
Photo No. 45. Post-Test Driver Dummy Airbag Contact	B-45
Photo No. 46. Post-Test Driver Dummy Head Contact (visor and header)	B-46
Photo No. 47. Post-Test Driver Dummy Knee Contact (left side)	B-47
Photo No. 48. Post-Test Driver Dummy Knee Contact (right side)	B-48
Photo No. 49. Pre-Test Passenger Dummy Front View (head position)	B-49
Photo No. 50. Post-Test Passenger Dummy Front View (head position)	B-50
Photo No. 51. Pre-Test Passenger Dummy Position Right Side View	B-51
Photo No. 52. Post-Test Passenger Dummy Position Right Side View	B-52

	<u>Page No.</u>
Photo No. 53. Pre-Test Passenger Dummy Position Right Side View (Door Open)	B-53
Photo No. 54. Post-Test Passenger Dummy Position Right Side View (Door Open)	B-54
Photo No. 55. Pre-Test Passenger Dummy Seat Position	B-55
Photo No. 56. Post-Test Passenger Dummy Seat Position	B-56
Photo No. 57. Pre-Test Passenger Dummy Feet Position	B-57
Photo No. 58. Post-Test Passenger Dummy Feet Position	B-58
Photo No. 59. Pre-Test Passenger Side Knee Bolster View	B-59
Photo No. 60. Post-Test Passenger Side Knee Bolster View	B-60
Photo No. 61. Post-Test Passenger Dummy Head Contact (visor, header & windshield)	B-61
Photo No. 62. Post-Test Passenger Dummy Head Contact (headrest)	B-62
Photo No. 63. Post-Test Passenger Dummy Knee Contact	B-63
Photo No. 64. Post-Test Passenger Dummy Airbag Contact	B-64
Photo No. 65. Rollover 90 Degrees	B-65
Photo No. 66. Rollover 180 Degrees	B-66
Photo No. 67. Rollover 270 Degrees	B-67
Photo No. 68. Rollover 360 Degrees	B-68
Photo No. 69. Temperature Plot	B-69
Photo No. 70. Vehicle in Relation to The Load Cell Grid	B-70

MFD BY CHRYSLER LLC

DATE OF MFR: 12-07

GWR 2225 KG
04905 LB

GWR 1275 KG
FRONT 2810 LB

GWR 1275 KG
REAR 2810 LB

THIS VEHICLE CONFORMS TO ALL APPLICABLE U.S.A. FEDERAL MOTOR VEHICLE SAFETY, BUMPER AND THEFT PREVENTION STANDARDS IN EFFECT ON THE DATE OF MANUFACTURE SHOWN ABOVE.

VIN: 2B3KA43R88H161597

TYPE: PASSENGER CAR



MDH: 121303 970AA PNT: PXR VEHICLE MADE IN CANADA TRM: E7DU 4648104

B-1.

Vehicle Certification Label

B-2.



TIRE AND LOADING INFORMATION

SEATING CAPACITY – TOTAL **5** FRONT **2** REAR **3**

THE COMBINED WEIGHT OF OCCUPANTS AND CARGO SHOULD NEVER EXCEED
392 KG OR 865 LB

TIRE	FRONT	REAR	SPARE
ORIGINAL TIRE SIZE	P215/65R17	P215/65R17	T135/90D17
COLD TIRE INFLATION PRESSURE	210 kPa / 30 PSI	210 kPa / 30 PSI	420 kPa / 60 PSI

SEE OWNERS MANUAL FOR ADDITIONAL INFORMATION  8H161597

Tire Placard

B-3.



Pre-Test Front View of Test Vehicle

B-4.



Post-Test Front View of Test Vehicle

B-5.



Pre-Test Left Side View of Test Vehicle

B-6.



Post-Test Left Side View of Test Vehicle

B-7.



Pre-Test Right Side View of Test Vehicle

B-8.



Post-Test Right Side View of Test Vehicle



B-9.

Pre-Test Right Front Three-Quarter View of Test Vehicle

B-10.



Post-Test Right Front Three-Quarter View of Test Vehicle

B-11.



Pre-Test Left Front Three-Quarter View of Test Vehicle



Post-Test Left Front Three-Quarter View of Test Vehicle

B-13.



Pre-Test Right Rear Three-Quarter View of Test Vehicle

B-14.



Post-Test Right Rear Three-Quarter View of Test Vehicle



B-15.

Pre-Test Left Rear Three-Quarter View of Test Vehicle



B-16.

Post-Test Left Rear Three-Quarter View of Test Vehicle

B-17.



Pre-Test Rear View of Test Vehicle

B-18.



Post-Test Rear View of Test Vehicle

B-19.



Pre-Test Windshield View

B-20.



Post-Test Windshield View

B-21.



Pre-Test Engine Compartment View

B-22.



Post-Test Engine Compartment View

B-23.



Pre-Test Fuel Filler Cap View

B-24.



Post-Test Fuel Filler Cap View

B-25.

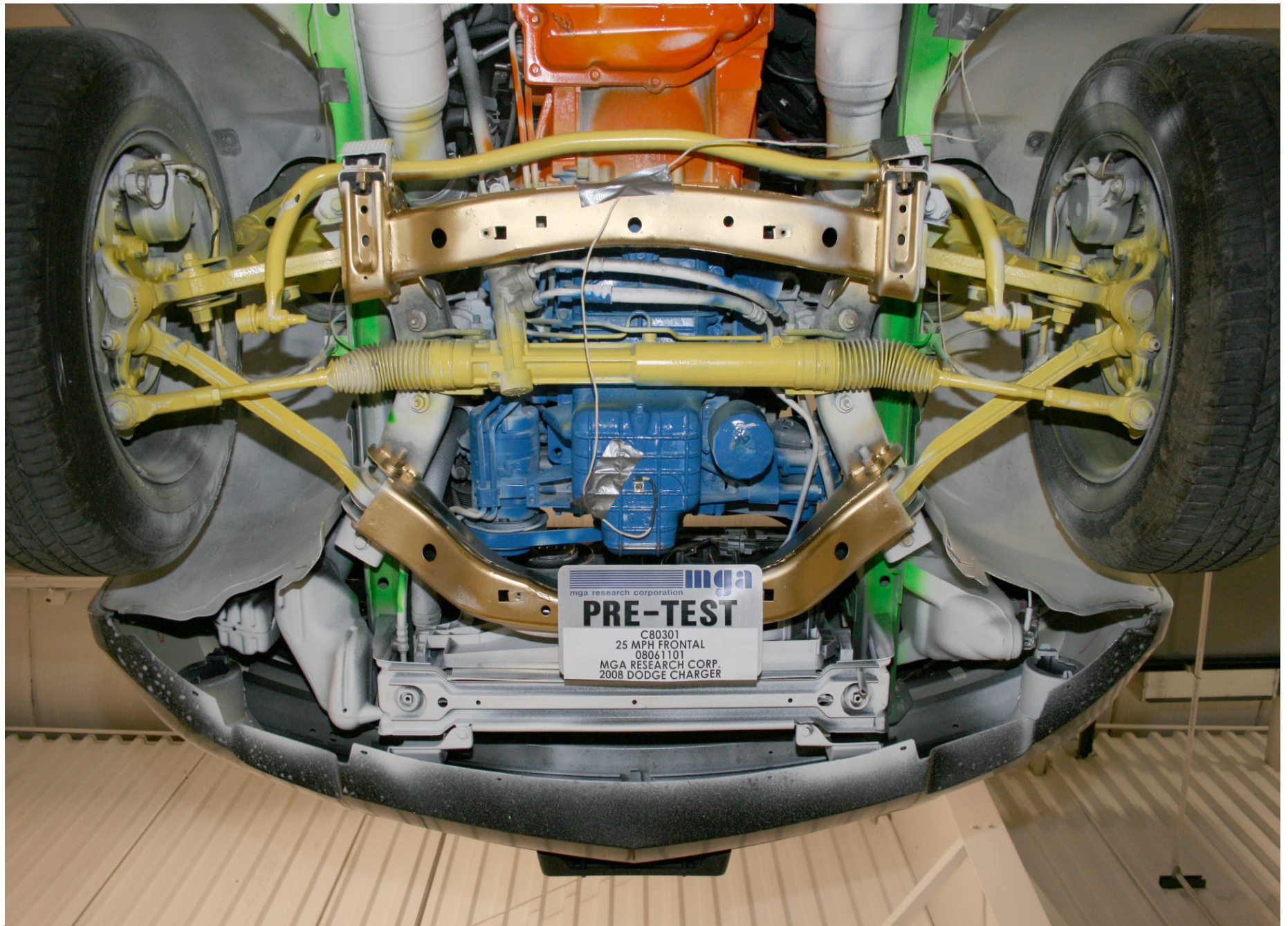

Pre-Test Front Underbody View

B-26.

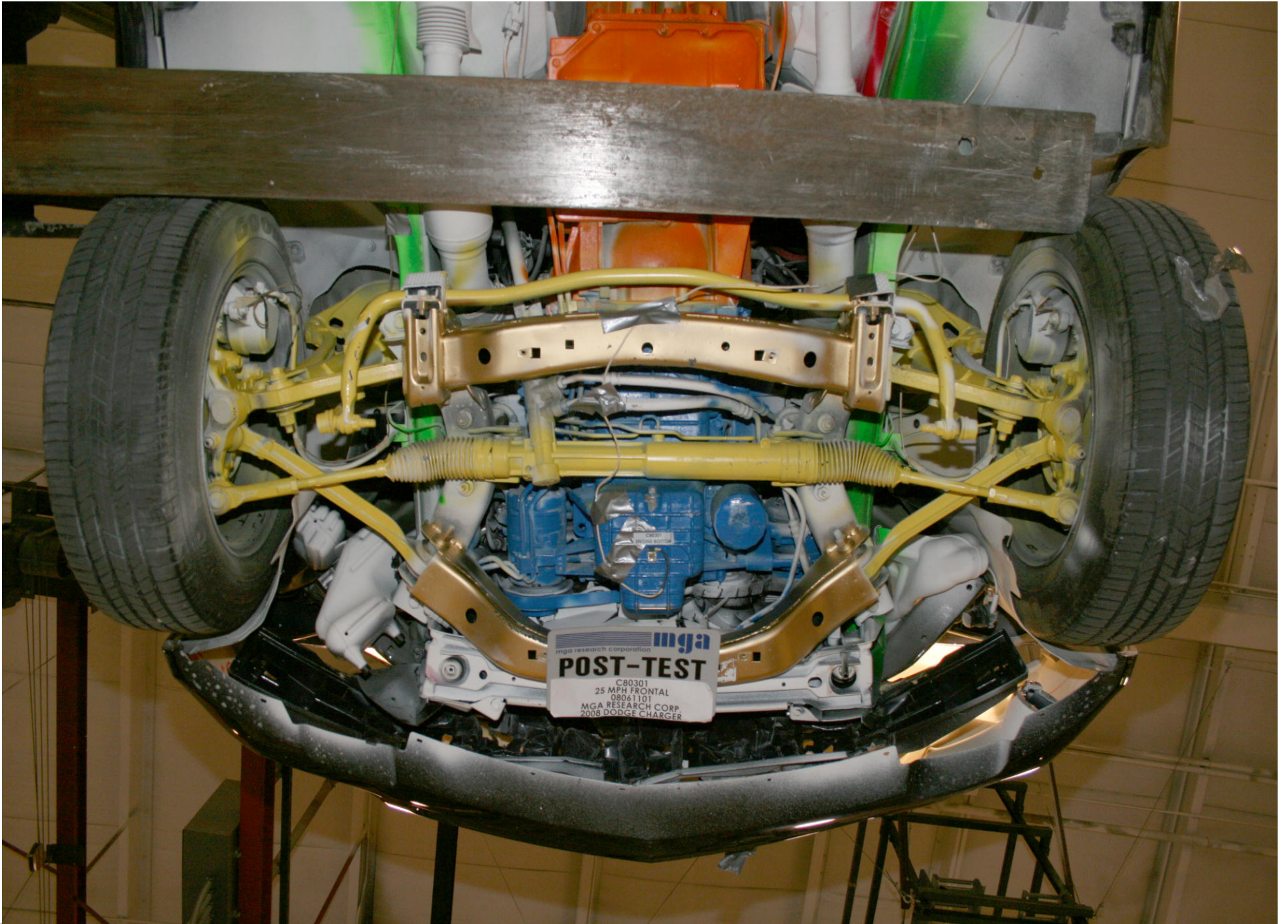

Post-Test Front Underbody View

B-27.



Pre-Test Mid Underbody View

B-28.



Post-Test Mid Underbody View



Pre-Test Fuel Tank View

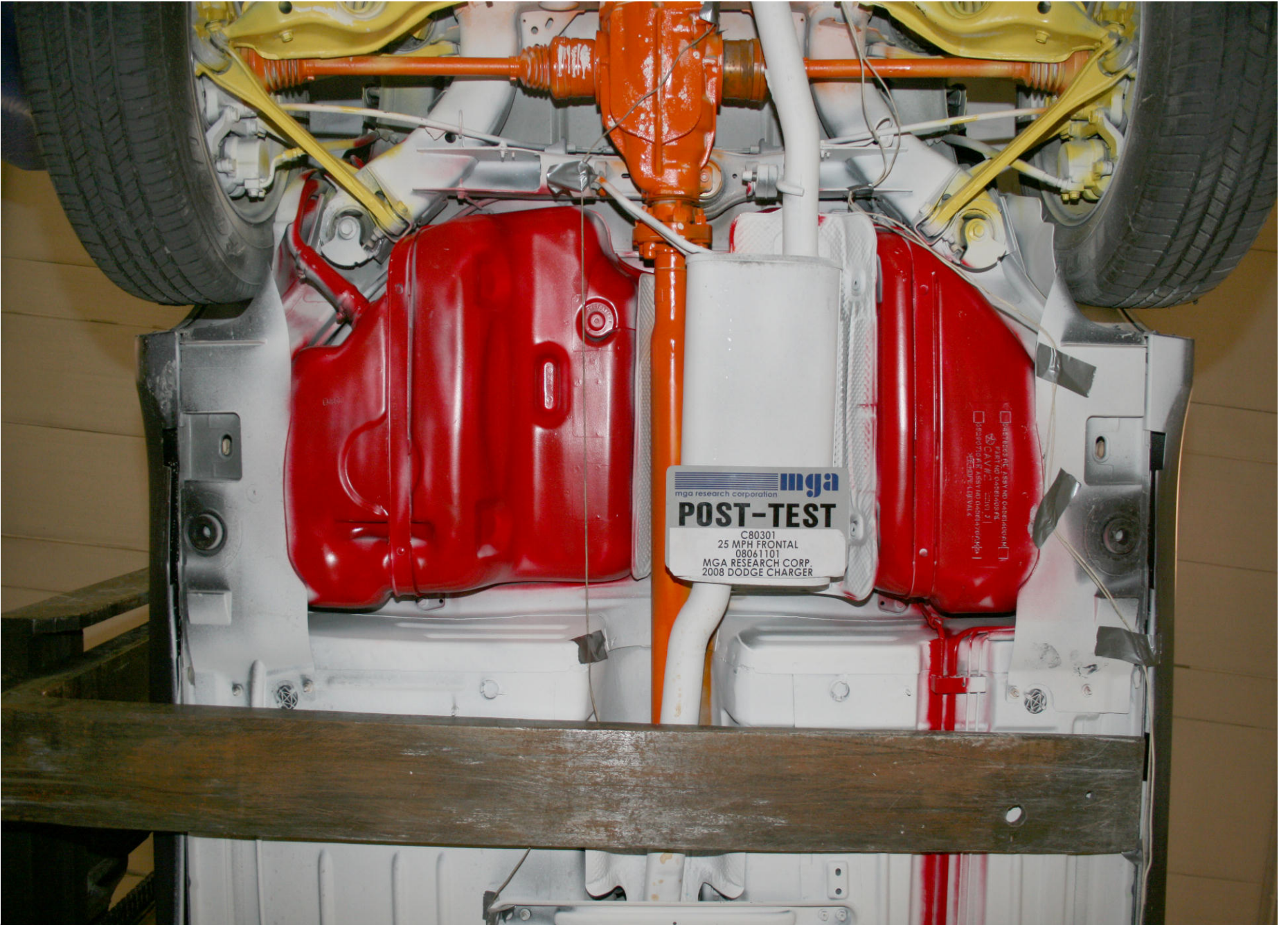

B-30.

Post-Test Fuel Tank View

B-31.

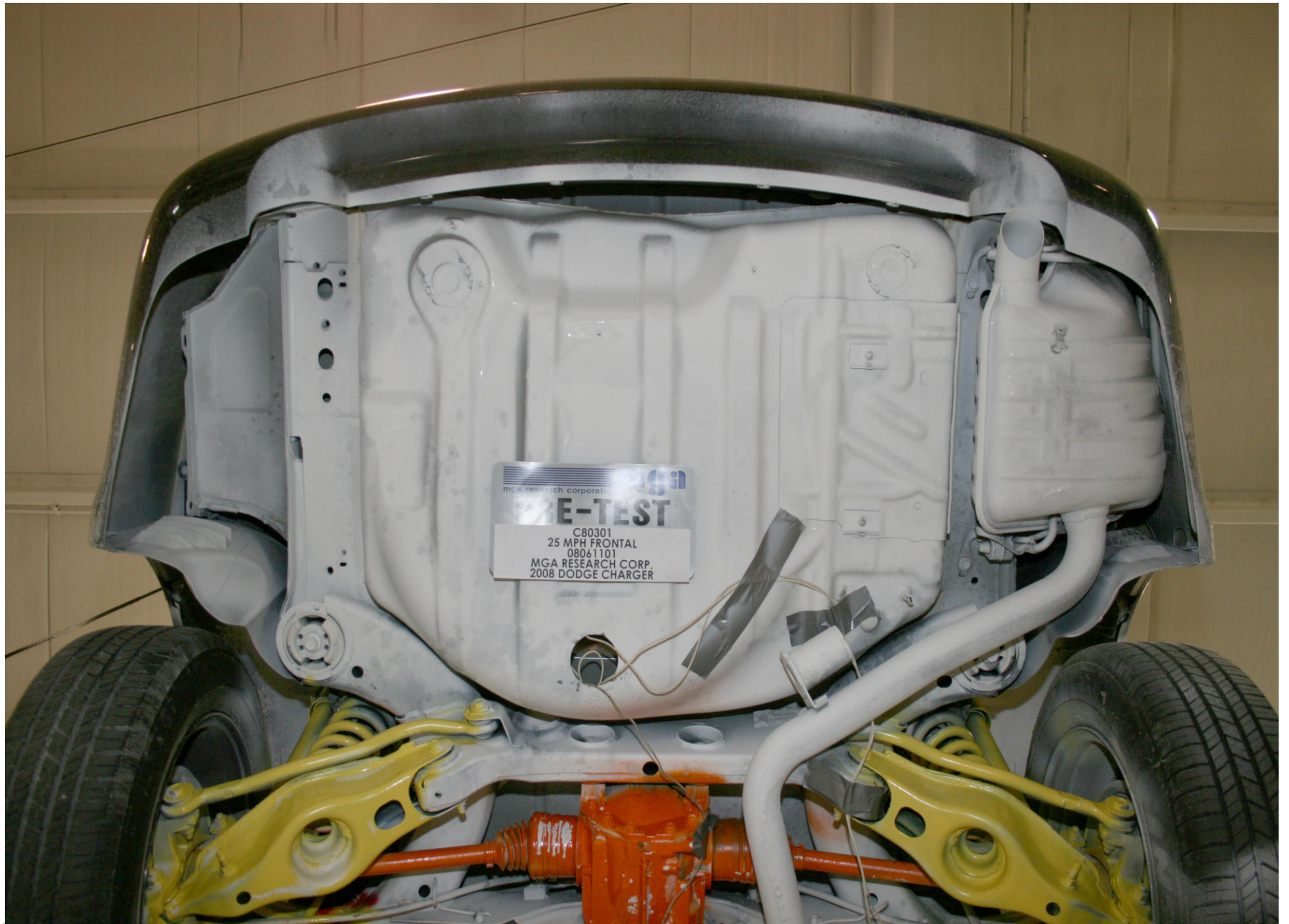

Pre-Test Rear Underbody View

B-32.



Post-Test Rear Underbody View

B-33.



Pre-Test Driver Dummy Front View (head position)

B-34.



Post-Test Driver Dummy Front View (head position)

B-35.



Pre-Test Driver Dummy Position Left Side View

B-36.



Post-Test Driver Dummy Position Left Side View

B-37.



Pre-Test Driver Dummy Position Left Side View (Door Open)

B-38.



Post-Test Driver Dummy Position Left Side View (Door Open)

B-39.



Pre-Test Driver Dummy Seat Position

B-40.



Post-Test Driver Dummy Seat Position

B-41.



Pre-Test Driver Dummy Feet Position

B-42.



Post-Test Driver Dummy Feet Position

B-43.



Pre-Test Driver Side Knee Bolster View

B-44.



Post-Test Driver Side Knee Bolster View

B-45.



Post-Test Driver Dummy Airbag Contact

B-46.



Post-Test Driver Dummy Head Contact (visor and header)

B-47.



Post-Test Driver Dummy Knee Contact (left side)

B-48.



Post-Test Driver Dummy Knee Contact (right side)



Pre-Test Passenger Dummy Front View (head position)

B-50.



Post-Test Passenger Dummy Front View (head position)

B-51.



Pre-Test Passenger Dummy Position Right Side View

B-52.



Post-Test Passenger Dummy Position Right Side View

B-53.



Pre-Test Passenger Dummy Position Right Side View (Door Open)

B-54.



Post-Test Passenger Dummy Position Right Side View (Door Open)

B-55.



Pre-Test Passenger Dummy Seat Position

B-56.



Post-Test Passenger Dummy Seat Position

B-57.



Pre-Test Passenger Dummy Feet Position



Post-Test Passenger Dummy Feet Position

B-59.



Pre-Test Passenger Side Knee Bolster View

B-60.



Post-Test Passenger Side Knee Bolster View

B-61.



Post-Test Passenger Dummy Head Contact (visor, header & windshield)

B-62.



Post-Test Passenger Dummy Head Contact (headrest)

B-63.



Post-Test Passenger Dummy Knee Contact

B-64.



Post-Test Passenger Dummy Airbag Contact

B-65.

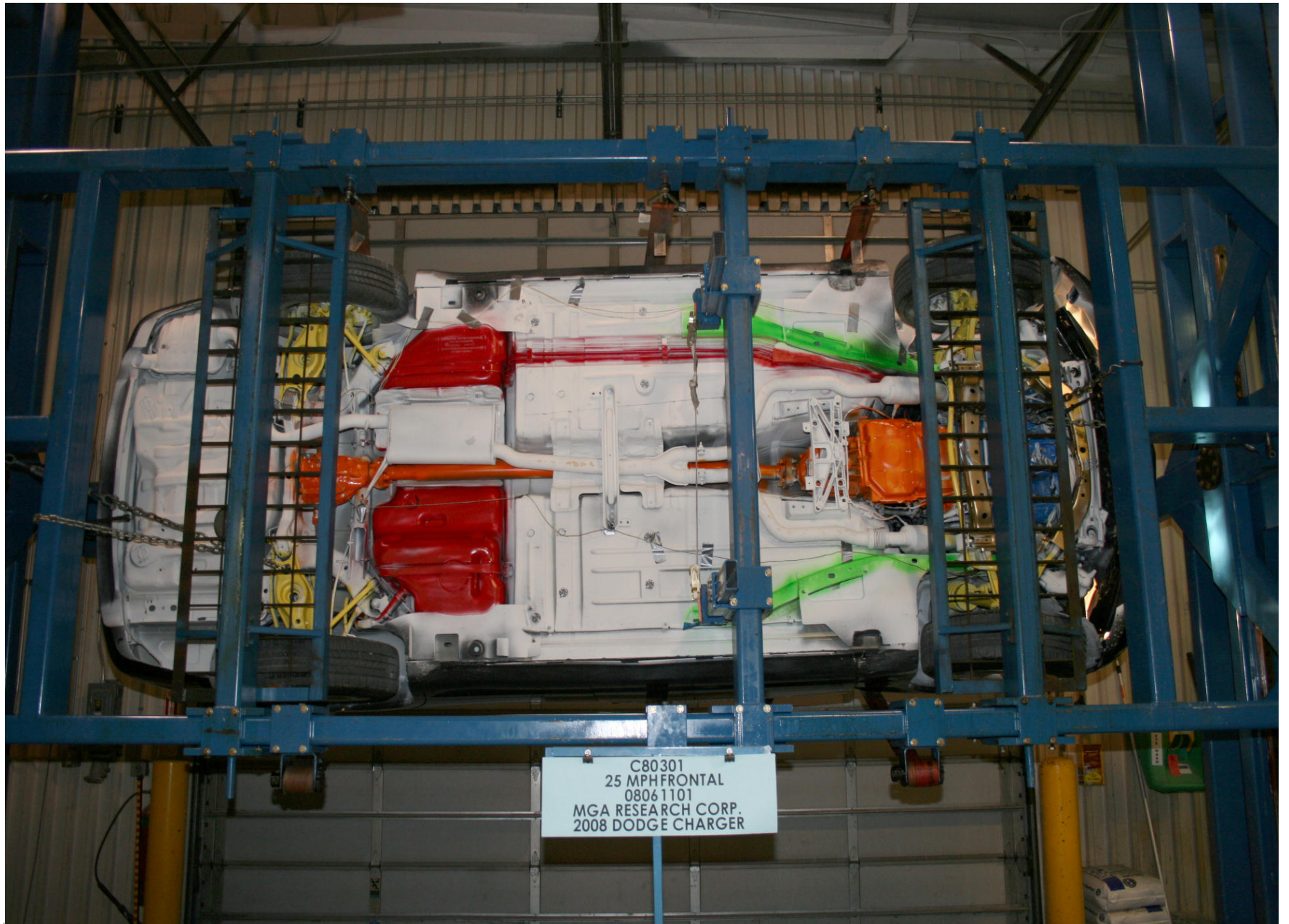

Rollover 90 Degrees

B-66.



Rollover 180 Degrees

B-67.



Rollover 270 Degrees

B-68.



Rollover 360 Degrees

B-69.

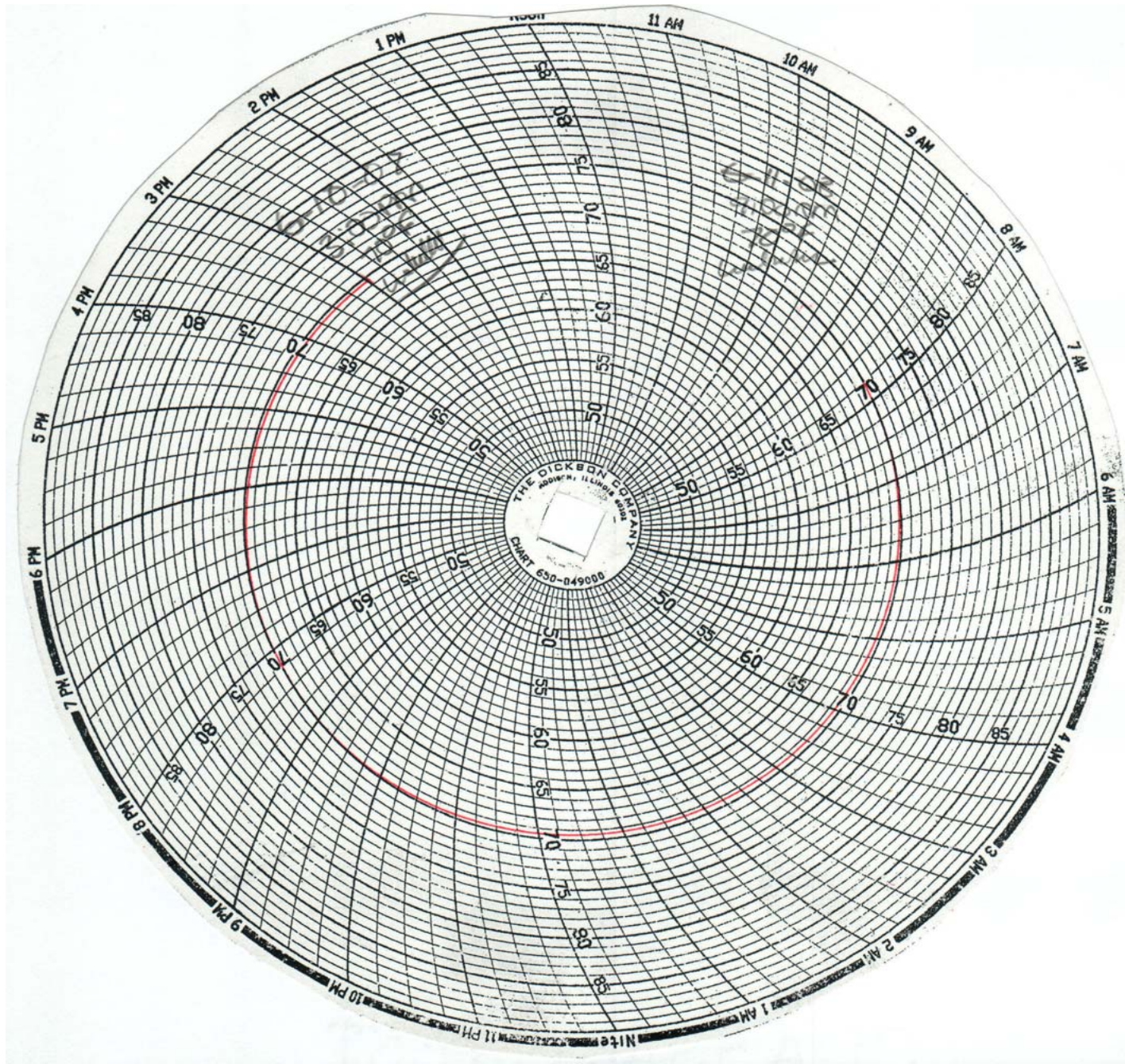

Temperature Plot

B-70.

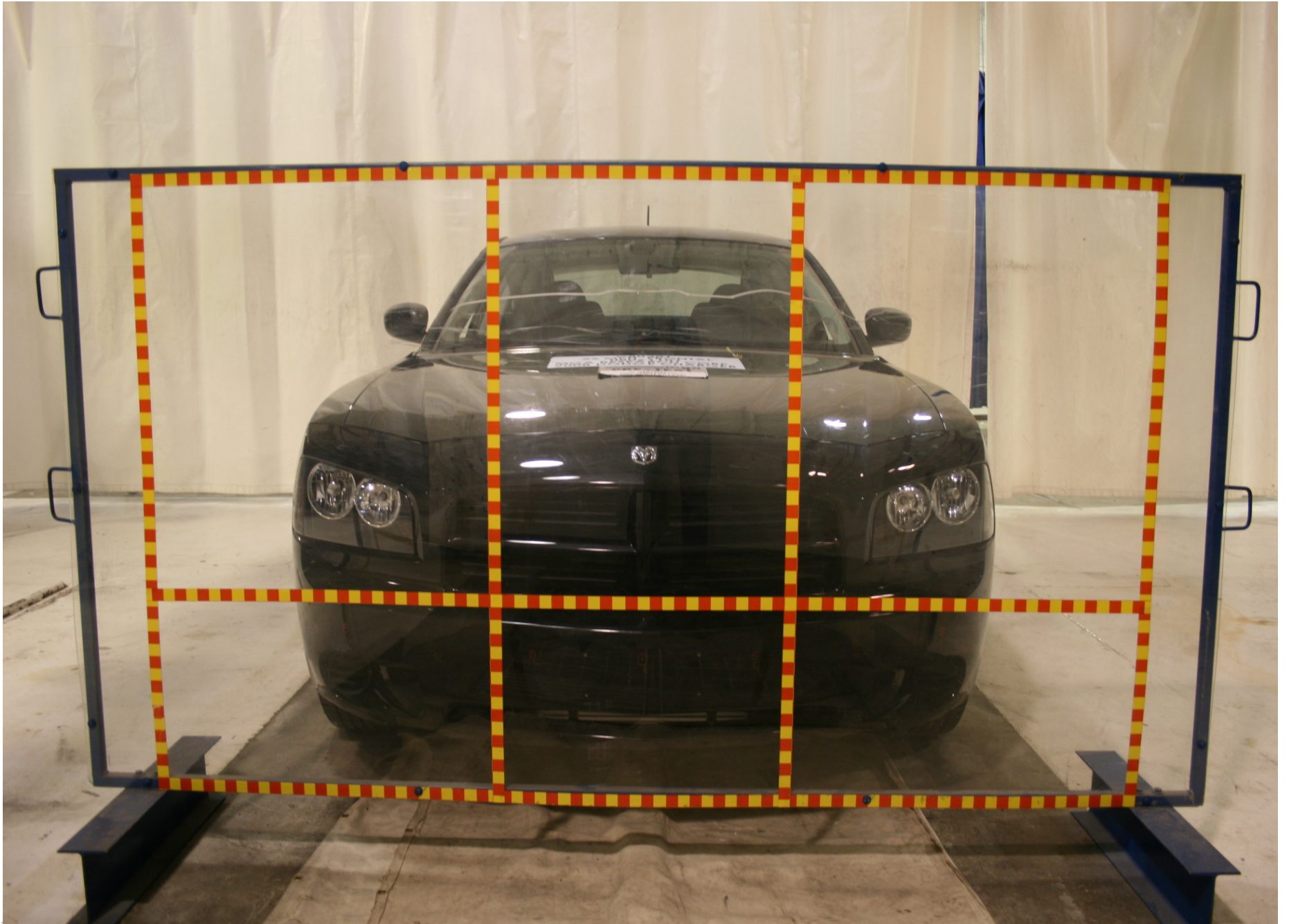

Vehicle in Relation to The Load Cell Grid

APPENDIX C
INSTRUMENTATION CALIBRATION

INSTRUMENTS FOR DRIVER DUMMY NO. 511

	SERIAL NO.	MANUFACTURER	CALIBRATION DATE
Head X	ET21246	Entran	02/21/08
Head Y	ET21255	Entran	02/21/08
Head Z	ET21245	Entran	02/12/08
Neck Load Cell	1748	Denton	05/22/08
Chest X	ET21217	Entran	02/21/08
Chest Y	ET21196	Entran	02/21/08
Chest Z	ET21259	Entran	02/21/08
Chest Displacement	511	Servo	02/04/08
Left Femur Load Cell	83	Denton	04/15/08
Right Femur Load Cell	84	Denton	04/15/08

INSTRUMENTS FOR PASSENGER DUMMY NO. 516

	SERIAL NO.	MANUFACTURER	CALIBRATION DATE
Head X	G04-Z09	Entran	03/13/08
Head Y	G04-Z26	Entran	03/13/08
Head Z	J14-J20	Entran	03/13/08
Neck Load Cell	1703	Denton	12/20/07
Chest X	G16-Z03	Entran	03/13/08
Chest Y	A28-H02	Entran	03/13/08
Chest Z	J03-J09	Entran	03/13/08
Chest Displacement	516	Servo	02/04/08
Left Femur Load Cell	995	Denton	05/01/08
Right Femur Load Cell	991	Denton	05/01/08

VEHICLE INSTRUMENTS

	SERIAL NO.	MANUFACTURER	CALIBRATION DATE
Left Rear Seat Crossmember X	P47819	Endevco	02/22/08
Right Rear Seat Crossmember X	P47820	Endevco	02/22/08
Top of Engine X	P47826	Endevco	02/22/08
Bottom of Engine X	P24154	Endevco	02/06/08
Left Brake Caliper X	J12471	Endevco	03/07/08
Right Brake Caliper X	A008123	Entran	05/23/08
Instrument Panel X	P48173	Endevco	02/22/08
Trunk Z	P48182	Endevco	03/07/08