

REPORT NUMBER: 208-MGA-2008-013

**VEHICLE SAFETY COMPLIANCE TESTING
FOR
FMVSS 208, OCCUPANT CRASH PROTECTION
FMVSS 212, WINDSHIELD MOUNTING
FMVSS 219, WINDSHIELD INTRUSION (PARTIAL)
FMVSS 301, FUEL SYSTEM INTEGRITY**

**FORD MOTOR CO.
2008 FORD EDGE MPV
NHTSA NO.: C80202**

**PREPARED BY:
MGA RESEARCH CORPORATION
5000 WARREN ROAD
BURLINGTON, WI 53105**



TEST DATES: MAY 15, 2008 – JULY 10, 2008

FINAL REPORT DATE: NOVEMBER 7, 2008

FINAL REPORT

**PREPARED FOR:
U.S. DEPARTMENT OF TRANSPORTATION
NATIONAL HIGHWAY TRAFFIC SAFETY ADMINISTRATION
OFFICE OF ENFORCEMENT
OFFICE OF VEHICLE SAFETY COMPLIANCE
1200 NEW JERSEY AVENUE, S.E., NVS-220
WASHINGTON, D.C. 20590**

This final test report was prepared for the U.S. Department of Transportation, National Highway Traffic Safety Administration, in response to Contract Number DTNH22-03-D-11002.

This publication is distributed by the U.S. Department of Transportation, National Highway Traffic Safety Administration, in the interest of information exchange. The opinions, findings and conclusions expressed in this publication are those of the author(s) and not necessarily those of the Department of Transportation or the National Highway Traffic Safety Administration. The United States Government assumes no liability for its contents or use thereof. If trade or manufacturers' names or products are mentioned it is only because they are considered essential to the object of the publication and should not be construed as an endorsement. The United States Government does not endorse products or manufacturers.

Prepared by: Jeff Lewandowski Date: November 7, 2008
Jeff Lewandowski, Project Engineer

Reviewed by: David Winkelbauer Date: November 7, 2008
David Winkelbauer, Facility Director

FINAL REPORT ACCEPTED BY OVSC:

Accepted By: Charles R. Case

Acceptance Date: November 7, 2008

Technical Report Documentation Page

1. Report No. 208-MGA-2008-013		2. Government Accession No.		3. Recipient's Catalog No.	
4. Title and Subtitle Final Report of FMVSS 208 Compliance Testing of a 2008 Ford Edge NHTSA No.: C80202				5. Report Date November 7, 2008	
				6. Performing Organization Code MGA	
7. Author(s) Jeff Lewandowski, Project Engineer				8. Performing Organization Report No. 208-MGA-2008-013	
9. Performing Organization Name and Address MGA Research Corporation 5000 Warren Road Burlington, WI 53105				10. Work Unit No.	
				11. Contract or Grant No. DTNH22-03-D-11002	
12. Sponsoring Agency Name and Address U.S. Department of Transportation National Highway Traffic Safety Administration Office of Enforcement Office of Vehicle Safety Compliance 1200 New Jersey Avenue, S.E., NVS-220 Washington, D.C. 20590				13. Type of Report and Period Covered 5/15/08 – 7/10/08	
				14. Sponsoring Agency Code NVS-220	
15. Supplementary Notes					
16. Abstract Compliance tests were conducted on the subject 2008 Ford Edge in accordance with the specifications of the Office of Vehicle Safety Compliance Test Procedure No. TP208-13 for the determination of FMVSS 208 compliance. Test failures identified were as follows: TEST FAILURES: None					
17. Key Words Frontal Impact 40 kmph Vehicle Safety Compliance Testing FMVSS 208, "Occupant Crash Protection" FMVSS 212, "Windshield Mounting" FMVSS 219, (partial), "Windshield Zone Intrusion" FMVSS 301, "Fuel System Integrity"				18. Distribution Statement Copies of this report are available from the following: U.S. Department of Transportation National Highway Traffic Safety Administration Technical Information Services (TIS), NPO-411 1200 New Jersey Avenue, S.E. (Room E12-100) Washington, DC 20590	
19. Security Classif. (of this report) Unclassified		20. Security Classif. (of this page) Unclassified		21. No. of Pages 335	22. Price

TABLE OF CONTENTS

<u>Section</u>		<u>Page No</u>
1	Purpose of Compliance Tests	1
2	Tests Performed	2
3	Injury Result Summary	4
4	Discussion of Test (if applicable)	6
5	Test Data Sheets	7
<u>Data Sheet</u>		
1	COTR Vehicle Work Order	8
2	Report of Vehicle Condition	12
3	Certification Label and Tire Placard Information	14
4	Rear Outboard Seating Position Seat Belts	15
5	Air Bag Labels	16
6	FMVSS 208 Readiness Indicator	28
7	Passenger Air Bag Manual Cut-Off Device	29
8	Lap Belt Lockability	32
9	FMVSS Seat Belt Warning System Check	44
10	Belt Contact Force	46
11	Latch Plate Access	56
12	Seat Belt Retraction	60
13	Seat Belt Guides and Hardware	64
14	Marking of Reference Points for Various Test Positions & Points	74
16	Air Bag Suppression Telltale	82
17	Suppression Test Using 12-Month CRABI Dummy	83
18	Suppression Test Using Newborn Infant Dummy	90
19	Suppression Test Using 3-YO Dummy and Booster Seats	91
20	Suppression Test Using 3-YO Dummy and Fwd Facing Restraints	93
21	Suppression Test Using an Unbelted 3-YO Dummy	96
22	Suppression Test Using 6-YO Dummy and Booster Seats	97
23	Suppression Test Using an Unbelted 6-YO Dummy	100
29	Summary of Low Risk Deployment Using an Unbelted 5 th % Dummy Position 1	101
30	Summary of Low Risk Deployment Using an Unbelted 5 th % Dummy Position 2	102
32	Vehicle Weight, Fuel Tank, and Attitude Data	103
33	Vehicle Accelerometer Locations and Measurements	107
34	Photographic Targets	110

<u>Data Sheet</u>		<u>Page No</u>
35	Camera Locations	116
36	Dummy Positioning	118
37	Dummy Measurements	130
38	Crash Test	133
40	Accident Investigation Measurements	135
41	Windshield Mounting (FMVSS 212)	137
42	Windshield Zone Intrusion (FMVSS 219)	139
43	Fuel System Integrity (FMVSS 301)	141

Appendix

A	Crash Test Data	A-1
B	Low Risk Test Data	B-1
C	Crash Test Photographs	C-1
D	Low Risk Photographs	D-1
E	Suppression Photographs	E-1
F	Instrumentation Calibration	F-1
G	Notice of Test Failure (If Applicable)	G-1

SECTION 1

PURPOSE OF COMPLIANCE TESTS

The tests performed are part of a program conducted for the National Highway Traffic Safety Administration (NHTSA) by MGA Research Corporation (MGA) under Contract No. DTNH22-03-D-11002. The purpose of this test was to determine whether the subject vehicle, a 2008 Ford Edge, NHTSA No. C80202, meets certain performance requirements of FMVSS 208, "Occupant Crash Protection"; FMVSS 212, "Windshield Mounting"; FMVSS 219, "Windshield Zone Intrusion"; and FMVSS 301, "Fuel System Integrity". The compliance test was conducted in accordance with OVSC Laboratory Test Procedure No. TP208-13 dated July 27, 2005.

SECTION 2
TESTS PERFORMED

Test Vehicle: 2008 Ford Edge
Test Program: FMVSS 208 Compliance

NHTSA No.: C80202
Test Dates: 5/15/08 – 7/10/08

The following checked items indicate the tests that were performed:

- | | | |
|-------------------------------------|-----|---|
| <input checked="" type="checkbox"/> | 1. | Rear outboard seating position seat belts (S4.1.1.2(b) & (S4.2.4)) |
| <input checked="" type="checkbox"/> | 2. | Air bag labels (S4.5.1) |
| <input checked="" type="checkbox"/> | 3. | Readiness indicator (S4.5.2) |
| <input checked="" type="checkbox"/> | 4. | Passenger air bag manual cut-off device (S4.5.4) |
| <input checked="" type="checkbox"/> | 5. | Lap belt lockability (S7.1.1.5) |
| <input checked="" type="checkbox"/> | 6. | Seat belt warning system (S7.3) |
| <input checked="" type="checkbox"/> | 7. | Seat belt contact force (S7.4.4) |
| <input checked="" type="checkbox"/> | 8. | Seat belt latch plate access (S7.4.4) |
| <input checked="" type="checkbox"/> | 9. | Seat belt retraction (S7.4.5) |
| <input checked="" type="checkbox"/> | 10. | Seat belt guides and hardware (S7.4.6) |
| <input checked="" type="checkbox"/> | 11. | Suppression tests with 12-month-old CRABI dummy (Part 572, Subpart R) |
| <input checked="" type="checkbox"/> | 12. | Suppression tests with newborn infant (Part 572, Subpart K) |
| <input checked="" type="checkbox"/> | 13. | Suppression tests with 3-year-old dummy (Part 572, Subpart P) |
| <input checked="" type="checkbox"/> | 14. | Suppression tests with 6-year-old dummy (Part 572, Subpart N) |
| <input checked="" type="checkbox"/> | 15. | Test of reactivation of the passenger air bag system with an unbelted 5 th percentile female dummy |
| <input type="checkbox"/> | 16. | Low risk deployment test with 12-month-old dummy (Part 572, Subpart R) |
| <input type="checkbox"/> | 17. | Low risk deployment test with 3-year-old dummy (Part 572, Subpart P) |
| <input type="checkbox"/> | 18. | Low risk deployment test with 6-year-old dummy (Part 572, Subpart N) |
| <input checked="" type="checkbox"/> | 19. | Low risk deployment test with 5 th female dummy (Part 572, Subpart O) |
| <input checked="" type="checkbox"/> | 20. | Impact Tests |
| <input type="checkbox"/> | | Frontal Oblique |
| <input type="checkbox"/> | | Belted 50 th male dummy driver and passenger (0 to 48 kmph) (S5.1.1(a)) |
| <input type="checkbox"/> | | Unbelted 50 th male dummy driver and passenger (0 to 48 kmph) (S5.1.2(a)(1)) |
| <input type="checkbox"/> | | Unbelted 50 th male dummy driver and passenger (32 to 40 kmph) (S5.1.2(a) (1) or S5.1.2(b)) |
| <input checked="" type="checkbox"/> | | Frontal 0° |
| <input type="checkbox"/> | | Belted 50 th male dummy driver (0 to 48 kmph) (S5.1.1.(b)(1) or S5.1.1(a)) |
| <input type="checkbox"/> | | Belted 50 th male dummy passenger (0 to 48 kmph) (S5.1.1.(b)(1) or S5.1.1(a)) |
| <input type="checkbox"/> | | Belted 5 th female dummy driver (0 to 48 kmph) (S16.1(a)) |
| <input type="checkbox"/> | | Belted 5 th female dummy passenger (0 to 48 kmph) (S16.1(a)) |
| <input type="checkbox"/> | | Belted 50 th male dummy driver and passenger (0 to 56 kmph) (S5.1.1.(b)(2)) |
| <input type="checkbox"/> | | Unbelted 50 th male dummy driver and passenger (0 to 48 kmph) (S5.1.2(a) (1)) |
| <input type="checkbox"/> | | Unbelted 50 th male dummy driver (32 to 40 kmph) (S5.1.2.(a)(2) or S5.1.2(b)) |
| <input type="checkbox"/> | | Unbelted 50 th male dummy passenger (32 to 40 kmph) (S5.1.2.(a)(2) or S5.1.2(b)) |

	X	Unbelted 5 th female dummy driver (32 to 40 kmph) (S16.1(b))
	X	Unbelted 5 th female dummy passenger (32 to 40 kmph) (S16.1(b))
		40% Offset 0° Belted 5 th female dummy driver and passenger (0 to 40 kmph) (S18.1)
		21. Sled Test: Unbelted 50 th male dummy driver and passenger (S13)
		22. FMVSS 204 Indicant Test
	X	23. FMVSS 212 Indicant Test
	X	24. FMVSS 219 Indicant Test
	X	25. FMVSS 301 Frontal Indicant Test

For the crash tests, the vehicle was instrumented with 8 accelerometers. The accelerometer data from the vehicle and dummies were sampled at 10,000 samples per second and processed as specified in SAE J211/1 MAR95 and FMVSS 208, S4.13.

The dynamic tests were recorded using high-speed digital video.

The vehicle appears to meet all of the performance requirements to which it was tested.

SECTION 3

INJURY RESULT SUMMARY FOR FMVSS 208 TESTS

Test Vehicle: 2008 Ford Edge
 Test Program: FMVSS 208 Compliance

NHTSA No.: C80202
 Test Date: 6/5/08

5th Percentile Female Low Risk Deployments

5th Percentile Female SN 507 Position 1 (Chin On Module) 6/5/08

Injury Criteria	Max. Allowable Injury Assessment Values	Measured Value
HIC15	700	34
Peak Nij (Nte)	1.0	0.3
Time (ms)	NA	47.0
Peak Nij (Ntf)	1.0	0.3
Time (ms)	NA	30.2
Peak Nij (Nce)	1.0	0.2
Time (ms)	NA	175.8
Peak Nij (Ncf)	1.0	0.1
Time (ms)	NA	220.9
Neck Tension	2070 N	557
Neck Compression	2520 N	222
Chest g	60 g	10
Chest Displacement	52 mm	6
Left Femur	6805 N	105
Right Femur	6805 N	97

Second stage fire time of 150 ms; Injuries calculated on 0 ms to 275 ms

5th Percentile Female SN 507 Position 2 (Chin On Rim) 6/5/08

Injury Criteria	Max. Allowable Injury Assessment Values	Measured Value
HIC15	700	17
Peak Nij (Nte)	1.0	0.4
Time (ms)	NA	31.1
Peak Nij (Ntf)	1.0	0.3
Time (ms)	NA	71.5
Peak Nij (Nce)	1.0	0.1
Time (ms)	NA	161.0
Peak Nij (Ncf)	1.0	0.2
Time (ms)	NA	55.4
Neck Tension	2070 N	772
Neck Compression	2520 N	174
Chest g	60 g	13
Chest Displacement	52 mm	19
Left Femur	6805 N	26
Right Femur	6805 N	22

Second stage fire time of 150 ms; Injuries calculated on 0 ms to 275 ms

SECTION 3
INJURY RESULT SUMMARY FOR FMVSS 208 TESTS

Test Vehicle: 2008 Ford Edge
 Test Program: FMVSS 208 Compliance

NHTSA No.: C80202
 Test Date: 7/10/08

40 kmph Frontal Crash

Impact Angle: Zero degrees

Belted Dummies: Yes No
 Speed Range: 0 to 40 kmph 32 to 40 kmph
 0 to 48 kmph 0 to 56 kmph

Test Speed: 39.9 kmph Test Weight: 2023.6 kg

Driver Dummy: 5th female 50th male
 Passenger Dummy: 5th female 50th male

5th Percentile Female Frontal Crash Test
Vehicles certified to S16.1(a), S16.1(b), or S18.1

Injury Criteria	Max. Allowable Injury Assessment Values	Driver	Passenger
HIC15	700	50	125
N _{te}	1.0	0.3	0.2
N _{tf}	1.0	0.3	0.2
N _{ce}	1.0	0.1	0.2
N _{cf}	1.0	0.2	0.6
Neck Tension	2620 N	812	324
Neck Compression	2520 N	230	790
Chest g	60 g	37	39
Chest Displacement	52 mm	22	2
Left Femur	6805 N	3517	4580
Right Femur	6805 N	3863	3961

SECTION 4
DISCUSSION OF TESTS

Test Vehicle: 2008 Ford Edge
Test Program: FMVSS 208 Compliance

NHTSA No.: C80202
Test Dates: 5/15/08 – 7/10/08

A blanket and visor were not used in the suppression testing because they did not affect the sensing system used on the vehicle.

Due to a software error there was no high speed video for the 5th female driver position 2, low risk deployment test conducted on 6-5-08.

SECTION 5
TEST DATA SHEETS

Test Vehicle: 2008 Ford Edge
Test Program: FMVSS 208 Compliance

NHTSA No.: C80202
Test Dates: 5/15/08 – 7/10/08

DATA SHEET 1
COTR VEHICLE WORK ORDER

Test Vehicle: 2008 Ford Edge
 Test Program: FMVSS 208 Compliance
 COTR Signature: Charles R. Case

NHTSA No.: C80202
 Test Dates: 5/15/08 – 7/10/08

Test to be performed for this vehicle are checked below:

- | | |
|-------------------------------------|---|
| <input checked="" type="checkbox"/> | 1. Rear Outboard Seating Position Seat Belts (S4.1.2(b)) & (S4.2.4) |
| <input checked="" type="checkbox"/> | 2. Air Bag Labels (S4.5.1) |
| <input checked="" type="checkbox"/> | 3. Readiness Indicator (S4.5.2) |
| <input checked="" type="checkbox"/> | 4. Passenger Air Bag Manual Cut-off Device (S4.5.4) |
| <input checked="" type="checkbox"/> | 5. Lap Belt Lockability (S7.1.1.5) |
| <input checked="" type="checkbox"/> | 6. Seat Belt Warning System (S7.3) |
| <input checked="" type="checkbox"/> | 7. Seat Belt Contact Force (S7.4.4) |
| <input checked="" type="checkbox"/> | 8. Seat Belt Latch Plate Access (S7.4.4) |
| <input checked="" type="checkbox"/> | 9. Seat Belt Retraction (S7.4.5) |
| <input checked="" type="checkbox"/> | 10. Seat Belt Guides and Hardware (S7.4.6) |
| <input checked="" type="checkbox"/> | 11. Suppression tests with 12-month-old CRABI dummy (Part 572, Subpart R) using the following indicated child restraints. |

Section B

<input checked="" type="checkbox"/>	Britax Handle with Care 191	<input checked="" type="checkbox"/>	Full Rearward	<input checked="" type="checkbox"/>	Mid Position	<input checked="" type="checkbox"/>	Full Forward
	Century Assura 4553		Full Rearward		Mid Position		Full Forward
	Century Avanta SE 41530		Full Rearward		Mid Position		Full Forward
	Century Smart Fit 4543		Full Rearward		Mid Position		Full Forward
	Cosco Arriva 02727		Full Rearward		Mid Position		Full Forward
	Cosco Opus 35 02603		Full Rearward		Mid Position		Full Forward
	Evenflo Discovery Adjust Right 212		Full Rearward		Mid Position		Full Forward
<input checked="" type="checkbox"/>	Evenflo First Choice 204	<input checked="" type="checkbox"/>	Full Rearward	<input checked="" type="checkbox"/>	Mid Position	<input checked="" type="checkbox"/>	Full Forward
	Evenflo On My Way Position Right V 282		Full Rearward		Mid Position		Full Forward
<input checked="" type="checkbox"/>	Graco Infant 8457	<input checked="" type="checkbox"/>	Full Rearward	<input checked="" type="checkbox"/>	Mid Position	<input checked="" type="checkbox"/>	Full Forward

Section C

<input checked="" type="checkbox"/>	Britax Roundabout 161	<input checked="" type="checkbox"/>	Full Rearward	<input checked="" type="checkbox"/>	Mid Position	<input checked="" type="checkbox"/>	Full Forward
<input checked="" type="checkbox"/>	Century Encore 4612	<input checked="" type="checkbox"/>	Full Rearward	<input checked="" type="checkbox"/>	Mid Position	<input checked="" type="checkbox"/>	Full Forward
	Century STE 1000 4416		Full Rearward		Mid Position		Full Forward
	Cosco Olympian 02803		Full Rearward		Mid Position		Full Forward
	Cosco Touriva 02519		Full Rearward		Mid Position		Full Forward
	Evenflo Horizon V 425		Full Rearward		Mid Position		Full Forward
<input checked="" type="checkbox"/>	Evenflo Medallion 254	<input checked="" type="checkbox"/>	Full Rearward	<input checked="" type="checkbox"/>	Mid Position	<input checked="" type="checkbox"/>	Full Forward

- | | |
|-------------------------------------|---|
| <input checked="" type="checkbox"/> | 12. Suppression tests with newborn infant (Part 572, Subpart K) using the following indicated child restraints. |
|-------------------------------------|---|

Section A

- | | | | | | | | |
|-------------------------------------|---|-------------------------------------|---------------|-------------------------------------|--------------|-------------------------------------|--------------|
| <input checked="" type="checkbox"/> | Cosco Dream Ride 02-719 | <input checked="" type="checkbox"/> | Full Rearward | <input checked="" type="checkbox"/> | Mid Position | <input checked="" type="checkbox"/> | Full Forward |
| <input checked="" type="checkbox"/> | 13. Suppression tests with 3-year-old dummy (Part 572, Subpart P) using the following indicated child restraints where a child restraint is required. | | | | | | |

Section C

X	Britax Roundabout 161	X	Full Rearward	X	Mid Position	X	Full Forward
X	Century Encore 4612	X	Full Rearward	X	Mid Position	X	Full Forward
	Century STE 1000 4416		Full Rearward		Mid Position		Full Forward
	Cosco Olympian 02803		Full Rearward		Mid Position		Full Forward
	Cosco Touriva 02519		Full Rearward		Mid Position		Full Forward
	Evenflo Horizon V 425		Full Rearward		Mid Position		Full Forward
X	Evenflo Medallion 254	X	Full Rearward	X	Mid Position	X	Full Forward

Section D

	Britax Roadster 9004		Full Rearward		Mid Position		Full Forward
X	Century Next Step 4920	X	Full Rearward	X	Mid Position	X	Full Forward
X	Cosco High Back Booster 02-442	X	Full Rearward	X	Mid Position	X	Full Forward
	Evenflo Right Fit 245		Full Rearward		Mid Position		Full Forward

14. Suppression tests with representative 3-year-old child using the following indicated child restraints where a child restraint is required. (Appendix H, Data Sheet 16H and 17H)

Section C

	Britax Roundabout 161		Full Rearward		Mid Position		Full Forward
	Century Encore 4612		Full Rearward		Mid Position		Full Forward
	Century STE 1000 4416		Full Rearward		Mid Position		Full Forward
	Cosco Olympian 02803		Full Rearward		Mid Position		Full Forward
	Cosco Touriva 02519		Full Rearward		Mid Position		Full Forward
	Evenflo Horizon V 425		Full Rearward		Mid Position		Full Forward
	Evenflo Medallion 254		Full Rearward		Mid Position		Full Forward

Section D

	Britax Roadster 9004		Full Rearward		Mid Position		Full Forward
	Century Next Step 4920		Full Rearward		Mid Position		Full Forward
	Cosco High Back Booster 02-442		Full Rearward		Mid Position		Full Forward
	Evenflo Right Fit 245		Full Rearward		Mid Position		Full Forward

X 15. Suppression tests with 3-year-old dummy (Part 572, Subpart P) in the following Forward, Middle, and Rearward seat track positions

X	Sitting on seat with back against seat back (S22.2.2.1)
X	Sitting on seat with back against reclined seat back (S22.2.2.2)
X	Sitting on seat with back not against seat back (S22.2.2.3)
X	Sitting on seat edge, spine vertical, hands by the child's side (S22.2.2.4)
X	Standing on seat, facing forward (S22.2.2.5)
X	Kneeling on seat facing forward (S22.2.2.6)
X	Kneeling on seat facing rearward (S22.2.2.7)
X	Lying on seat (S22.2.2.8)

16. Suppression tests with representative 3-year-old child in the following positions

	Sitting on seat with back against seat back (S22.2.2.1)
	Sitting on seat with back against reclined seat back (S22.2.2.2)
	Sitting on seat with back not against seat back (S22.2.2.3)
	Sitting on seat edge, spine vertical, hands by the child's side (S22.2.2.4)
	Standing on seat, facing forward (S22.2.2.5)
	Kneeling on seat facing forward (S22.2.2.6)
	Kneeling on seat facing rearward (S22.2.2.7)
	Lying on seat (S22.2.2.8)

X 17. Suppression tests with 6-year-old dummy (Part 572, Subpart N) using the following indicated child restraints where a child restraint is required.

Section D

	Britax Roadster 9004		Full Rearward		Mid Position		Full Forward
X	Century Next Step 4920	X	Full Rearward	X	Mid Position	X	Full Forward
X	Cosco High Back Booster 02-442	X	Full Rearward	X	Mid Position	X	Full Forward
X	Evenflo Right Fit 245	X	Full Rearward	X	Mid Position	X	Full Forward

18. Suppression tests with representative 6-year-old child using the following indicated child restraints where a child restraint is required.

Section D

	Britax Roadster 9004		Full Rearward		Mid Position		Full Forward
	Century Next Step 4920		Full Rearward		Mid Position		Full Forward
	Cosco High Back Booster 02-442		Full Rearward		Mid Position		Full Forward
	Evenflo Right Fit 245		Full Rearward		Mid Position		Full Forward

X 19. Suppression tests with 6-year-old dummy (Part 572, Subpart N) in the following Forward, Middle, and Rearward seat track positions

X	Sitting on seat with back against seat back (S22.2.2.1)
X	Sitting on seat with back against reclined seat back (S22.2.2.2)
X	Sitting on seat edge, spine vertical, hands by the child's side (S22.2.2.4)
X	Sitting back in the seat and leaning on the right front passenger door (S24.2.3)

20. Suppression tests with representative 6-year-old child in the following positions

	Sitting on seat with back against seat back (S22.2.2.1)
	Sitting on seat with back against reclined seat back (S22.2.2.2)
	Sitting on seat edge, spine vertical, hands by the child's side (S22.2.2.4)
	Sitting back in the seat and leaning on the right front passenger door (S24.2.3)

X 21. Test of Reactivation of the Passenger Air Bag System with an Unbelted 5th percentile female dummy (S20.3, 22.3, S24.3). Perform this test after the following suppression tests: After each restraint.

22. Test of Reactivation of the passenger air bag system with a representative 5th percentile female (S20.3, 22.3, S24.3). Perform this test after the following suppression tests:

23. Low risk deployment test with 12-month-old dummy (Part 572, Subpart R) using the following indicated child restraints.

Section B

	Britax Handle with Care 191		Full Rearward		Mid Position		Full Forward
	Century Assura 4553		Full Rearward		Mid Position		Full Forward
	Century Avanta SE 41530		Full Rearward		Mid Position		Full Forward
	Century Smart Fit 4543		Full Rearward		Mid Position		Full Forward
	Cosco Arriva 02727		Full Rearward		Mid Position		Full Forward
	Cosco Opus 35 02603		Full Rearward		Mid Position		Full Forward
	Evenflo Discovery Adjust Right 212		Full Rearward		Mid Position		Full Forward
	Evenflo First Choice 204		Full Rearward		Mid Position		Full Forward
	Evenflo On My Way Position Right V 282		Full Rearward		Mid Position		Full Forward
	Graco Infant 8457		Full Rearward		Mid Position		Full Forward

Section C

	Britax Roundabout 161		Full Rearward		Mid Position		Full Forward
	Century Encore 4612		Full Rearward		Mid Position		Full Forward
	Century STE 1000 4416		Full Rearward		Mid Position		Full Forward
	Cosco Olympian 02803		Full Rearward		Mid Position		Full Forward
	Cosco Touriva 02519		Full Rearward		Mid Position		Full Forward
	Evenflo Horizon V 425		Full Rearward		Mid Position		Full Forward
	Evenflo Medallion 254		Full Rearward		Mid Position		Full Forward

- | | | |
|-------------------------------------|-------------------------------------|--|
| <input type="checkbox"/> | 24. | Low risk deployment test with 3-year-old dummy (Part 572, Subpart P) in the following positions |
| | <input type="checkbox"/> | Position 1 |
| | <input type="checkbox"/> | Position 2 |
| <input type="checkbox"/> | 25. | Low risk deployment test with 6-year-old dummy (Part 572, Subpart N) in the following positions |
| | <input type="checkbox"/> | Position 1 |
| | <input type="checkbox"/> | Position 2 |
| <input checked="" type="checkbox"/> | 26. | Low risk deployment test with 5 th percentile female dummy (Part 572, Subpart O) in the following positions |
| | <input checked="" type="checkbox"/> | Position 1 |
| | <input checked="" type="checkbox"/> | Position 2 |
| <input checked="" type="checkbox"/> | 27. | Impact Tests |
| | <input type="checkbox"/> | Frontal Oblique - Test Speed: |
| | <input type="checkbox"/> | Belted 50 th male dummy driver and passenger (0 to 48 kmph) (S5.1.1(a)) |
| | <input type="checkbox"/> | Unbelted 50 th male dummy driver and passenger (0 to 48 kmph) (S5.1.2(a)(1)) |
| | <input type="checkbox"/> | Unbelted 50 th male dummy driver and passenger (32 to 40 kmph) (S5.1.2(a) (1) or S5.1.2(b)) |
| | <input checked="" type="checkbox"/> | Frontal 0° - Test Speed: 39.9 kmph |
| | <input type="checkbox"/> | Belted 50 th male dummy driver (0 to 48 kmph) (S5.1.1.(b)(1) or S5.1.1(a)) |
| | <input type="checkbox"/> | Belted 50 th male dummy passenger (0 to 48 kmph) (S5.1.1.(b)(1) or S5.1.1(a)) |
| | <input type="checkbox"/> | Belted 5 th female dummy driver (0 to 48 kmph) (S16.1(a)) |
| | <input type="checkbox"/> | Belted 5 th female dummy passenger (0 to 48 kmph) (S16.1(a)) |
| | <input type="checkbox"/> | Belted 50 th male dummy driver and passenger (0 to 56 kmph) (S5.1.1.(b)(2)) |
| | <input type="checkbox"/> | Unbelted 50 th male dummy driver and passenger (0 to 48 kmph) (S5.1.2(a) (1)) |
| | <input type="checkbox"/> | Unbelted 50 th male dummy driver (32 to 40 kmph) (S5.1.2.(a)(2) or S5.1.2(b)) |
| | <input type="checkbox"/> | Unbelted 50 th male dummy passenger (32 to 40 kmph) (S5.1.2.(a)(2) or S5.1.2(b)) |
| | <input checked="" type="checkbox"/> | Unbelted 5 th female dummy driver (32 to 40 kmph) (S16.1(b)) |
| | <input checked="" type="checkbox"/> | Unbelted 5 th female dummy passenger (32 to 40 kmph) (S16.1(b)) |
| | <input type="checkbox"/> | 40% Offset 0° Belted 5 th female dummy driver and passenger (0 to 40 kmph) (S18.1) - Test Speed: |
| <input type="checkbox"/> | 28. | Sled Test: Unbelted 50 th male dummy driver and passenger (S13) |
| <input type="checkbox"/> | 29. | FMVSS 204 Indicant Test |
| <input checked="" type="checkbox"/> | 30. | FMVSS 212 Indicant Test |
| <input checked="" type="checkbox"/> | 31. | FMVSS 219 Indicant Test |
| <input checked="" type="checkbox"/> | 32. | FMVSS 301 Frontal Indicant Test |

REPORT OF VEHICLE CONDITION AT THE COMPLETION OF TESTING

LIST OF FMVSS TESTS PERFORMED BY THIS LAB: FMVSS 208, 212, 219, 301

VEHICLE: 2008 Ford Edge

NHTSA NO.: C80202

REMARKS:

Equipment that is no longer on the test vehicle as noted on previous page:

Spare tools, trunk area carpet and right rear tail light

Explanation for equipment removal:

Components removed for instrumentation installation and to meet target weight.

Test Vehicle Condition:

25 mph frontal impact damage- front suspension & structure damaged, hood & front quarter panels damaged, radiator damaged, air bags & pretensioners deployed, Stoddard in fuel system

RECORDED BY: Jeff Lewandowski

DATE: 7/17/2008

APPROVED BY: David Winkelbauer

DATE: 7/17/2008

#####

RELEASE OF TEST VEHICLE

The vehicle described above is released from MGA to be delivered to:

Date:

Time:

Odometer:

Lab Rep's Signature:

Title:

Carrier/Customer Rep:

Date:

DATA SHEET 3

CERTIFICATION LABEL AND TIRE PLACARD INFORMATION

Test Vehicle: 2008 Ford Edge
 Test Program: FMVSS 208 Compliance
 Test Technician: Jamie Aide

NHTSA No.: C80202
 Test Date: 7/10/08

Certification Label	
Manufacturer:	Ford Motor Co.
Date of Manufacture:	12/07
VIN:	2FMDK36C88BA38516
Vehicle Certified As (Pass. Car/MPV/Truck/Bus):	MPV
Front Axle GVWR:	1288 kg (2840 lbs)
Rear Axle GVWR:	1148 kg (2530 lbs)
Total GVWR:	2422 kg (5340 lbs)

Tire Placard	
Not applicable, vehicle is not a passenger car and does not have a tire placard.	YES (MPV)
This is not a passenger car, but all or part of this information is still contained on a vehicle label and is reported here.	YES (MPV)
Vehicle Capacity Weight:	412 kg (909 lbs)
Designated Seating Capacity Front:	2
Designated Seating Capacity Rear:	3
Total Designated Seating Capacity:	5
Recommended Cold Tire Inflation Pressure Front:	240 kpa (35 psi)
Recommended Cold Tire Inflation Pressure Rear:	240 kpa (35 psi)
Recommended Tire Size:	P235/65R17

Signature: 

Date: 7/10/08

DATA SHEET 4

REAR OUTBOARD SEATING POSITION SEAT BELTS

Test Vehicle: 2008 Ford Edge
Test Program: FMVSS 208 Compliance
Test Technician: Wayne Dahlke

NHTSA No.: C80202
Test Date: 5/15/08

	Yes	No
Do all rear outboard seating positions have Type 2 seat belts?	X	

If NO, describe the seat belt installed, the seat location, and any other information about the seat that would explain why a Type 2 seat belt was not installed.

REMARKS:

Signature: Wayne Dahlke

Date: 5/15/08

DATA SHEET 5
AIR BAG LABELS (S4.5.1)

Test Vehicle: 2008 Ford Edge
 Test Program: FMVSS 208 Compliance
 Test Technician: Wayne Dahlke

NHTSA No.: C80202
 Test Date: 5/15/08

1. Air bag maintenance label and owner's manual instructions: (S4.5.1(a))
- 1.1 Does the manufacturer recommend periodic maintenance or replacement of the air bag?
 Yes, go to 1.2
 No - go to 2
- 1.2 Does the vehicle have a label specifying air bag maintenance or replacement?
 Yes - Pass
 No - Fail
- 1.3 Does the label contain one of the following?
 Yes - Pass
 No - Fail
 Check applicable schedule:
 ___ Schedule on label specifies month and year (Record date _____)
 ___ Schedule on label specified vehicle mileage (Record mileage _____)
 ___ Schedule on label specifies interval measured from date on certification label (Record interval _____)
- 1.4 Is the label permanently affixed within the passenger compartment such that it cannot be removed without destroying or defacing the label or the sunvisor? (3/19/01 legal interpretation to Todd Mitchell)
 Yes - Pass
 No - Fail
- 1.5 Is the label lettered in English?
 Yes - Pass
 No - Fail
- 1.6 Is the label in block capitals and numerals?
 Yes - Pass
 No - Fail
- 1.7 Are the letters and numerals at least 3/32 inches high?
 Yes - Pass
 No - Fail
- 1.8 Does the owner's manual set forth the recommended schedule for maintenance or replacement?
2. Does the owner's manual: (S4.5.1(f))
- 2.1 Include a description of the vehicle's air bag system in an easily understandable format?
 Yes - Pass
 No - Fail
- 2.2 Include a statement that the vehicle is equipped with an air bag and a lap/shoulder belt at the front outboard seating position?
 Yes - Pass
 No - Fail

- 2.3 Include a statement that the air bag is a supplemental restraint at the front outboard seating position?
 Yes - Pass
 No - Fail
- 2.4 Emphasize that all occupants, including the driver, should always wear their seat belts whether or not an air bag is also provided at their seating positions to minimize the risk of severe injury or death in the event of a crash?
 Yes - Pass
 No - Fail
- 2.5 Provide any necessary precautions regarding the proper positioning of occupants, including children, at seating positions equipped with air bags to ensure maximum safety protection for those occupants?
 Yes - Pass
 No - Fail
- 2.6 Explain that no objects should be placed over or near the air bag on the steering wheel or on the instrument panel, because any such objects could cause harm if the vehicle is in a crash severe enough to cause the air bag to inflate?
 Yes - Pass
 No - Fail
- 2.7 Is the vehicle certified to meet the requirements of S14.5, S15, S17, S19, S21, S23, and S25? (Obtain answer from COTR) (S4.5.1(f)(2))
 Yes - (Go to 2.7.1)
 No - (Go to 3.)
- 2.7.1 Explain the proper functioning of the advanced air bag system? (S4.5.1(f)(2))
 Yes - Pass
 No - Fail
- 2.7.2 Provide a summary of the actions that may affect the proper functioning of the system? (S4.5.1(f)(2))
 Yes - Pass
 No - Fail
- 2.7.3 Present and explain the main components of the advanced passenger air bag system? (S4.5.1(f)(2)(i))
 Yes - Pass
 No - Fail
- 2.7.4 Explain how the components function together as part of the advanced passenger air bag system? (S4.5.1(f)(2)(ii))
 Yes - Pass
 No - Fail
- 2.7.5 Contain the basic requirements for proper operation, including an explanation of the actions that may affect the proper functioning of the system? (S4.5.1(f)(2)(iii))
 Yes - Pass
 No - Fail
- 2.7.6 Is the vehicle certified to the requirements of S19.2, S21.2, or 23.2 (automatic suppression)?
 Yes, continue with 2.7.6
 No, go to 2.7.7
- 2.7.6.1 Contain a complete description of the passenger air bag suppression system installed in the vehicle, including a discussion of any suppression zone? (S4.5.1(f)(2)(iv))
 Yes - Pass
 No - Fail

- 2.7.6.2 Discuss the telltale light, specifying its location in the vehicle and explaining when the light is illuminated?
- Yes - Pass
 No - Fail
- 2.7.7 Explain the interaction of the advanced passenger air bag system with other vehicle components, such as seat belts, seats or other components? (S4.5.1(f)(2)(v))
- Yes - Pass
 No - Fail
- 2.7.8 Summarize the expected outcomes when child restraint systems, children and small teenagers or adults are both properly and improperly positioned in the passenger seat, including cautionary advice against improper placement of child restraint systems? (S4.5.1(f)(2)(vi))
- Yes - Pass
 No - Fail
- 2.7.9 Provide information on how to contact the vehicle manufacturer concerning modifications for persons with disabilities that may affect the advanced air bag system? (S4.5.1(f)(2)(vii))
- Yes - Pass
 No - Fail
3. Sun Visor Air Bag Warning Label (S4.5.1(b)) Check only one of the following:
- The vehicle is not certified to meet the requirements of S19, S21, and S23 (Obtain answer from COTR) (S4.5.1(b)(1)) Go to 3.1 and skip 3.2
- The vehicle is certified to meet the requirements of S19, S21, and S23 on 9/1/03 or later. (Obtain answer from COTR) (S4.5.1(b)(3)) Go to 3.2 and skip 3.1
- 3.1 Vehicles not certified to meet the requirements of S19, S21, and S23.
- 3.1.1 Is the label permanently affixed (including permanent marking on the visor material or molding into the visor material) to either side of the sun visor at each front outboard seating position such that it cannot be removed without destroying or defacing the label or sun visor? (S4.5.1(b)(1)) (3/19/01 legal interpretation to Todd Mitchell)
- Driver Side, Yes - Pass
 Driver Side, No - Fail
 Passenger Side, Yes - Pass
 Passenger Side, No - Fail



3.1.2

Does the label conform in content to the label shown in either Figure 6A or 6B (Figure 6b is for vehicles with passenger air bag on-off switches), as appropriate, at each front outboard seating position? (S4.5.1(b)(1)) (Vehicles without back seats may omit the statement: "The back seat is the safest place for children." (S4.5.1(b)(1)(iv))



Figure 6a. Sun Visor Label Visible When Visor is in Down Position.



Figure 6b. Sun Visor Label Visible When Visor is in Down Position.

- Driver Side, Yes - Pass
- Driver Side, No - Fail
- Passenger Side, Yes - Pass
- Passenger Side, No - Fail



3.1.3

Is the label heading area yellow with the word "WARNING" and the alert symbol in black? (S4.5.1(b)(1)(i))

- Driver Side, Yes - Pass
- Driver Side, No - Fail
- Passenger Side, Yes - Pass
- Passenger Side, No - Fail



3.1.4

Is the message area white with black text? (S4.5.1(b)(1)(ii))

- Driver Side, Yes - Pass
- Driver Side, No - Fail
- Passenger Side, Yes - Pass
- Passenger Side, No - Fail



3.1.5

Is the message area at least 30 cm²? (S4.5.1(b)(1)(ii))

The message area consists of the total label area minus the yellow heading area and the pictogram. The pictogram is enclosed on the left side and bottom by the edge of the label and on the top by line that borders the yellow heading area. The right side of the pictogram is defined by a vertical line midway between the rightmost edge of the pictogram and the left most edge of the text, including any bullets. (See 5/6/03 interpretation to Gerald Plante on behalf of Subaru)

Driver Side: Length_____, Width_____

Passenger Side: Length_____, Width_____

Actual message area _____ cm²

Driver Side, Yes - Pass



Driver Side, No - Fail



Passenger Side, Yes - Pass



Passenger Side, No - Fail



3.1.6

Is the pictogram black with a red circle and slash on a white background?
(S4.5.1(b)(2)(iii))

Driver Side, Yes - Pass



Driver Side, No - Fail



Passenger Side, Yes - Pass



Passenger Side, No - Fail



3.1.7

Is the pictogram at least 30 mm in diameter? (S4.5.1(b)(2)(iii))

Actual diameter _____mm



Driver Side, Yes - Pass



Driver Side, No - Fail



Passenger Side, Yes - Pass



Passenger Side, No - Fail



3.2

Vehicles certified to meet the requirements of S19, S21, and S23 on 9/1/03 and later.
(S4.5.1(b)(3))

3.2.1

Is the label permanently affixed (including permanent marking on the visor material or molding into the visor material) to either side of the sun visor at each front outboard seating position such that it cannot be removed without destroying or defacing the label or the sun visor? (S4.5.1(b)(3)) (3/19/01 legal interpretation to Todd Mitchell)



Driver Side, Yes - Pass



Driver Side, No - Fail



Passenger Side, Yes - Pass



Passenger Side, No - Fail

- 3.2.2 Does the label conform in content to the label shown in Figure 11 at each front outboard seating position? (S4.5.1(b)(2)) (Vehicles without back seats may omit the statement: "The back seat is the safest place for children." (S4.5.1(b)(3)(iv)) Vehicles without back seats or the back seat is too small to accommodate a rear-facing child restraint may omit the statement "Never put a rear-facing child seat in the front."(S4.5.1(b)(3)(v))



Figure 11. Sun Visor Label Visible when Visor is in Down Position.

- Driver Side, Yes - Pass
- Driver Side, No - Fail
- Passenger Side, Yes - Pass
- Passenger Side, No - Fail
- 3.2.3 Is the label heading area yellow with the word "WARNING" and the alert symbol in black? (S4.5.1(b)(3)(i))
- Driver Side, Yes - Pass
- Driver Side, No - Fail
- Passenger Side, Yes - Pass
- Passenger Side, No - Fail
- 3.2.4 Is the message area white with black text? (S4.5.1(b)(3)(ii))
- Driver Side, Yes - Pass
- Driver Side, No - Fail
- Passenger Side, Yes - Pass
- Passenger Side, No - Fail

- 3.2.5 Is the message area at least 30 cm²? (S4.5.1(b)(3)(ii)) The message area consists of the total label area minus the yellow heading area and the pictogram. The pictogram is enclosed on the left side and bottom by the edge of the label. The top edge of the pictogram area is defined by a horizontal line midway between the uppermost edge of the pictogram and the lowermost edge of the text. The right side of the pictogram is defined by a vertical line midway between the rightmost edge of the pictogram and the left most edge of the text, including any bullets. (See 5/6/03 interpretation to Gerald Plante on behalf of Subaru)
- Driver Side: Length 8.7 cm, Width 3.6 cm
 Passenger Side: Length 8.7 cm, Width 3.6 cm
 Actual message area 31.3 cm²
- Driver Side, Yes - Pass
 Driver Side, No - Fail
 Passenger Side, Yes - Pass
 Passenger Side, No - Fail
- 3.2.6 Is the pictogram black on a white background? (S4.5.1(b)(3)(iii))
- Driver Side, Yes - Pass
 Driver Side, No - Fail
 Passenger Side, Yes - Pass
 Passenger Side, No - Fail
- 3.2.7 Is the pictogram at least 30 mm (1.2 inches) in length? (S4.5.1(b)(3)(iii))
- Driver Side: Length 32 mm
 Passenger Side: Length 32 mm
- Driver Side, Yes - Pass
 Driver Side, No - Fail
 Passenger Side, Yes - Pass
 Passenger Side, No - Fail
- 3.3 Is the same side of the sun visor that contains the air bag warning label free of other information with the exception of the air bag maintenance label and/or the rollover-warning label? (S4.5.1(b)(5)(i))
- Driver Side, Yes - Pass
 Driver Side, No - Fail
 Passenger Side, Yes - Pass
 Passenger Side, No - Fail
- 3.4 Is the sun visor free of other information about air bags or the need to wear seat belts with the exception of the air bag alert label and/or the rollover-warning label? (S4.5.1(b)(5)(ii))
- Driver Side, Yes - Pass
 Driver Side, No - Fail
 Passenger Side, Yes - Pass
 Passenger Side, No - Fail

- 3.5 Does the driver side visor contain a rollover-warning label on the same side of the visor as the air bag warning label?
 ___ Yes, go to 3.5.1
 No, **go to 4** (skipping 3.5.1 through 3.5.3)
- 3.5.1 Are both the rollover-warning label and the air bag warning label surrounded by a continuous solid-lined border?
 ___ Yes, go to 3.5.2 and skip 3.5.3
 ___ No, go to 3.5.3 and skip 3.5.2
- 3.5.2 Is the shortest distance from the border of the rollover label to the border of the air bag warning label at least 1 cm? (575.105 (d)(1)(iv)(B))
 ___ actual distance
- 3.5.3 Is the shortest distance from any of the lettering or graphics on the rollover-warning label to any of the lettering or graphics of the air bag warning label at least 3 cm? (575.105 (d)(1)(iv)(A))
 ___ actual distance
 ___ Yes-Pass ___ No-FAIL
4. Air Bag Alert Label (S4.5.1(c) (A "Rollover Warning Label" or "Rollover Alert Label" may be on the same side of the driver's sun visor as the "Air Bag Alert Label." 575.105(d))
- 4.1 Is the sun visor warning label visible when the sun visor is in the stowed position?
 If yes for driver and passenger, go to 5.
 Driver Side, Yes
 Driver Side, No
 Passenger Side, Yes
 Passenger Side, No
- 4.2 Is the air bag alert label permanently affixed (including permanent marking on the visor material or molding into the visor material) to the sun visor at each front outboard seating position such that it cannot be removed without destroying or defacing the label or the sun visor? (S4.5.1(c)) (3/19/01 legal interpretation to Todd Mitchell)
 Driver Side, Yes - Pass
 Driver Side, No - Fail
 Passenger Side, Yes - Pass (Visible when the sun visor is in the stowed position)
 Passenger Side, No - Fail
- 4.3 Is the air bag alert label visible when the visor is in the stowed position? (S4.5.1(c))
 Driver Side, Yes - Pass
 Driver Side, No - Fail
 Passenger Side, Yes - Pass
 Passenger Side, No - Fail



4.4 Does the label conform in content to the label shown in Figure 6C? (S4.5.1(c))

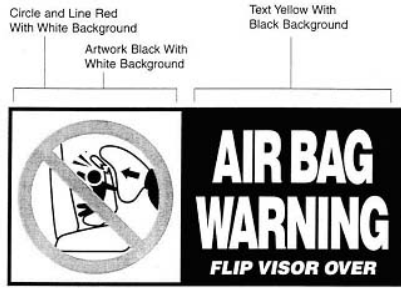

Figure 6c. Sun Visor Label Visible When Visor is in Up Position.

- Driver Side, Yes - Pass
- Driver Side, No - Fail
- Passenger Side, Yes - Pass
- Passenger Side, No - Fail



4.5 Is the message area black with yellow text? (S4.5.1(c)(1))

- Driver Side, Yes - Pass
- Driver Side, No - Fail
- Passenger Side, Yes - Pass
- Passenger Side, No - Fail



4.6 Is the message area at least 20 cm²? (S4.5.1(c)(1)) The message area consists of the black part of the label.

Driver Side: Length _____, Width _____

Passenger Side: Length _____, Width _____

Actual message area _____ cm²

- Driver Side, Yes - Pass
- Driver Side, No - Fail
- Passenger Side, Yes - Pass
- Passenger Side, No - Fail



4.7 Is the pictogram black with a red circle and slash on a white background? (S4.5.1(c)(2))

- Driver Side, Yes - Pass
- Driver Side, No - Fail
- Passenger Side, Yes - Pass
- Passenger Side, No - Fail



4.8 Is the pictogram at least 20 mm in diameter? (S4.5.1(c)(2))

Driver Side Diameter _____

Passenger Side Diameter _____

- Driver Side, Yes - Pass
- Driver Side, No - Fail
- Passenger Side, Yes - Pass
- Passenger Side, No - Fail

- 5. Label on the Dashboard
- 5.1 Is the vehicle certified to meet the requirements of S19, S21, and S23? (Obtain answer from COTR) (S4.5.1(e)(3))
 - Yes, go to 5.1.1 and skip 5.2
 - No, go to 5.2, skipping 5.1.1 through 5.1.6
- 5.1.1 Does the vehicle have a label on the dash or steering wheel hub? (S4.5.1(e)(3))
 - Yes - Pass
 - No - Fail
- 5.1.2 Is the label clearly visible from all front seating positions? (S4.5.1(e)(3))
 - Yes - Pass
 - No - Fail
- 5.1.3 Does the label conform in content to the label shown in Figure 12? (S4.5.1(e)(3))
 Vehicles without back seats may omit the statement: "The back seat is the safest place for children." Vehicles without back seats or too small to accommodate a rear-facing child restraint consistent with S4.5.4.1 as determined in DATA SHEET 7 may omit the statement "Never put a rear-facing child seat in the front." (S4.5.1(e)(3)(iii))
 - Yes - Pass
 - No - Fail

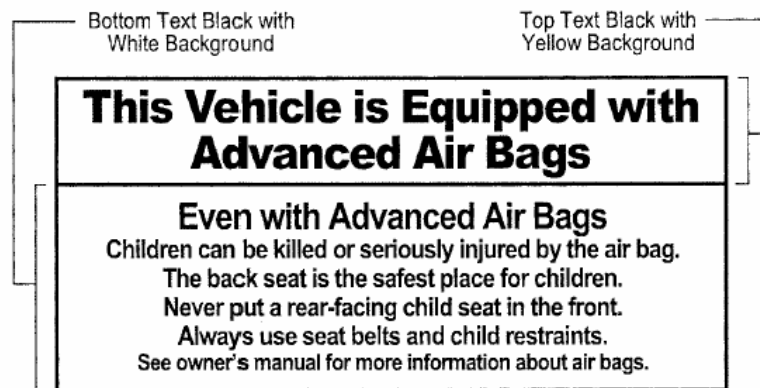

Figure 12. Removable Label on Dash.

- 5.1.4 Is the heading area yellow with black text? (S4.5.1(e)(3)(i))
 - Yes - Pass
 - No - Fail
- 5.1.5 Is the message white with black text? (S4.5.1(e)(3)(ii))
 - Yes - Pass
 - No - Fail

5.1.6 Is the message area at least 30 cm²? (S4.5.1(e)(3)(ii)) The message area consists of the total label area minus the yellow heading area. (See 5/6/03 interpretation to Gerald Plante on behalf of Subaru)
 Length 13.3 cm, Width 3.4 cm
 Actual message area 45.2 cm²

- Yes - Pass
- No - Fail

5.2 Does the vehicle have a label on the dash or steering wheel hub? (S4.5.1(e)(1))

- Yes - Pass
- No - Fail

5.2.1 Is the label clearly visible from all front seating positions? (S4.5.1(e)(1))

- Yes - Pass
- No - Fail

5.2.2 Does the label conform in content to the label shown in Figure 7? (S4.5.1(e)(1)(iii))
 Vehicles without back seats may omit the statement: "The back seat is the safest place for children." (S4.5.1(e)(1)(iii))

- Yes - Pass
- No - Fail

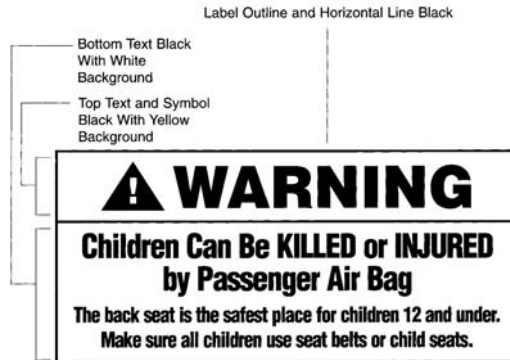

Figure 7. Removable Label on Dash.

5.2.3 Is the heading area yellow with the word "WARNING" and the alert symbol in black? (S4.5.1(e)(1)(i))

- Yes - Pass
- No - Fail

5.2.4 Is the message white with black text? (S4.5.1(e)(1)(ii))

- Yes - Pass
- No - Fail

5.2.5 Is the message area at least 30 cm²? (S4.5.1(e)(1)(ii)) The message area consists of the total label area minus the yellow heading area. (See 5/6/03 interpretation to Gerald Plante on behalf of Subaru)

Length _____, Width _____
 Actual message area _____ cm²

- Yes - Pass
- No - Fail

REMARKS:

I certify that I have read and performed each instruction.

Signature: Wayne Zahle

Date: 5/15/08

DATA SHEET 6

FMVSS 208 READINESS INDICATOR (S4.5.2)

Test Vehicle: 2008 Ford Edge
Test Program: FMVSS 208 Compliance
Test Technician: Wayne Dahlke

NHTSA No.: C80202
Test Date: 5/15/08

An occupant restraint system that deploys in the event of a crash shall have a monitoring system with a readiness indicator. A totally mechanical system is exempt from this requirement. (11/8/94 legal interpretation to Lawrence F. Hennegerger on behalf of Breed)

- 1. Is the system totally mechanical? If Yes, this data sheet is complete.
 - Yes
 - No
- 2. Describe the location of the readiness indicator: *Center Right of Cluster*
- 3. Is the readiness indicator clearly visible to the driver?
 - Yes - Pass
 - No - Fail
- 4. Is a list of the elements in the occupant restraint system, being monitored by the readiness indicator, provided on a label or in the owner's manual?
 - Yes - Pass
 - No - Fail
- 5. Does the vehicle have an on-off switch for the passenger air bag?
 - If Yes, go to 6
 - If No, this form is complete.
- 6. Is the air bag readiness indicator off when the passenger air bag switch is in the off position?
 - Yes - Pass
 - No - Fail

REMARKS:

I certify that I have read and performed each instruction.

Signature: Wayne Dahlke

Date: 5/15/08

DATA SHEET 7

PASSENGER AIR BAG MANUAL CUT-OFF DEVICE (S4.5.4)

Test Vehicle: 2008 Ford Edge
Test Program: FMVSS 208 Compliance
Test Technician: Wayne Dahlke

NHTSA No.: C80202
Test Date: 5/15/08

- 1. Is the vehicle equipped with an on-off switch that deactivates the air bag installed at the right front outboard seating position?
2. Does the vehicle have any forward-facing rear designated seating positions?
3. Verification there is room for a child restraint in the rear seat behind the driver's seat.
3.1 Using all the controls that affect the fore-aft movement of the seat, move the seat to the rearmost position.
3.2 Using all the controls that affect the fore-aft movement of the seat, move the seat to the foremost position.
3.3 Move the seat to the middle of the foremost and rearmost positions.
3.4 If the driver's seat height is adjustable, use all the controls that affect height to put it in the lowest position while maintaining the middle fore-aft position.
3.5 Position the driver's seat adjustable lumbar supports so that the lumbar support is in its lowest, retracted or deflated adjustment position.
3.6 The driver's seat back angle, if adjustable, is set at the manufacturer's nominal design riding position for a 50th percentile adult male in the manner specified by the manufacturer.
3.7 Is the driver seat a bucket seat?
3.7.1 Bucket seats:
3.7.1.1 Locate and mark a vertical Plane B through the longitudinal centerline of the driver's seat cushion.

- 3.7.1.2 Locate the longitudinal horizontal line in plane B that is tangent to the highest point of the rear seat cushion behind the driver's seat. Measure along this line from the front of the seat back of the rear seat to the rear of the seat back of the driver's seat.
 _____ mm distance
 less than 720 mm - Pass
 more than 720 mm - FAIL
 Go to 4
- 3.2 Bench seats (including split bench seats):
- 3.7.2.1 Locate and mark a vertical Plane B through the center of the steering wheel parallel to the vehicle longitudinal centerline. (S4.5.4.1(b)(2))
- 3.7.2.2 Locate the longitudinal horizontal line in plane B that is tangent to the highest point of the rear seat cushion. Measure along this line from the front of the seat back of the rear seat to the rear of the seat back of the front seat.
 _____ mm distance
 less than 720 mm - Pass
 more than 720 mm - FAIL
 Go to 4
4. Does the device turn the air bag on and off using the vehicle's ignition key? (S4.5.4.2)
 Yes - Pass
 No - Fail
5. Is the on-off device separate from the ignition switch? (S4.5.4.2)
 Yes - Pass
 No - Fail
6. Is there a telltale light that comes on when the passenger air bag is turned off? (S4.5.4.2)
 Yes - Pass
 No - Fail
7. Telltale light (S4.5.4.3)
- 7.1 Is the light yellow? S4.5.4.3(a)
 Yes - Pass
 No - Fail
- 7.2 Are the words "PASSENGER AIR BAG OFF" or "PASS AIR BAG OFF" (S4.5.4.3(b))
- 7.2.1 on the telltale?
 Yes - Pass, go to 7.3
 No - go to 7.2.2
- 7.2.2 Within 25 mm of the telltale?
 Measurement from the edge of the telltale light (mm):
 Yes - Pass
 No - Fail

- 7.3 Does the telltale remain illuminated while the air bag is turned off? (S4.5.4.3c) (Leave the air bag off for 5 minutes.)
 Yes - Pass
 No - Fail
- 7.4 Is the telltale illuminated while the air bag is turned on? (S4.5.4.3(d))
 Yes - Fail
 No - Pass
- 7.5 Is the telltale combined with the air bag readiness indicator? (S4.5.4.3(e))
 Yes - Fail
 No - Pass
8. Owner's Manual
- 8.1 Does the owner's manual contain complete instructions on the operation of the on-off switch? (S4.5.4.4(a))
 Yes - Pass
 No - Fail
- 8.2 Does the owner's manual contain a statement that the on-off switch should only be used when a member of one of the following risk groups is occupying the right front passenger seating position? (S4.5.4.4(b))
- there is no back seat
 - Infants: the rear seat is too small to accommodate a child restraint
 - there is a medical condition that must be monitored constantly
 - Children: there is no back seat
 - aged: space is not always available in the rear seat
 - 1 to 12: there is a medical condition that must be monitored constantly
 - Medical: medical risk causes special risk for passenger
 - condition: greater risk for harm than with the air bag on
- Yes - Pass
 No - Fail
- 8.3 Does the owner's manual contain a warning about the safety consequences of using the on-off switch at other times?
 Yes - Pass
 No - Fail

REMARKS:

I certify that I have read and performed each instruction.

Signature: Wayne Gahl

Date: 5/15/08

DATA SHEET 8

LAP BELT LOCKABILITY

**Passenger cars, trucks, buses, and multipurpose passenger
Vehicles with a GVWR of 10,000 pounds or less. (S7.1.1.5)**

Test Vehicle: 2008 Ford Edge
 Test Program: FMVSS 208 Compliance
 Test Technician: Wayne Dahlke

NHTSA No.: C80202
 Test Date: 5/16/08

Complete one of these forms for **each** designated seating position that can be adjusted to forward-facing or that is a forward-facing seat, other than the driver's seat (S7.1.1.5(a), **and** that has seat belt retractors that are not solely automatic locking retractors. (S7.1.1.5(c))

DESIGNATED SEATING POSITION:	Front Passenger
------------------------------	-----------------

- | | | |
|-------------------------------------|-----|--|
| <input type="checkbox"/> | | N/A - no retractor is at this position |
| <input type="checkbox"/> | | N/A - the retractor is an automatic locking retractor ONLY |
| <input checked="" type="checkbox"/> | 1. | Record test fore-aft seat position: 9 th notch from full forward (S7.1.1.5(c)(1)) (Any position is acceptable) |
| <input checked="" type="checkbox"/> | 2. | Does the lap belt portion of the seat belt in the forward-facing seat or seat that can be adjusted to forward-facing consist of a locking device that does NOT have to be attached by the vehicle user to the seat belt webbing, retractor, or any other part of the vehicle. (S7.1.1.5 (a)) |
| | | <input checked="" type="checkbox"/> Yes - Pass |
| | | <input type="checkbox"/> No - Fail |
| <input checked="" type="checkbox"/> | 3. | Does the lap belt portion of the seat belt in the forward-facing seat or seat that can be adjusted to forward-facing consist of a locking device that does NOT require inverting, twisting or deforming of the belt webbing. (S7.1.1.5 (a)) |
| | | <input checked="" type="checkbox"/> Yes - Pass |
| | | <input type="checkbox"/> No - Fail |
| <input checked="" type="checkbox"/> | 4. | Place any adjustable seat belt anchorage in the lowest adjustment position. |
| | | <input type="checkbox"/> N/A The anchorage is not adjustable. |
| <input checked="" type="checkbox"/> | 5. | Buckle the seat belt. (S7.1.1.5(c)(1)) |
| <input checked="" type="checkbox"/> | 6. | Locate a reference point A on the seat belt buckle. (S7.1.1.5(c)(2)) |
| <input checked="" type="checkbox"/> | 7. | Locate a reference point B on the attachment hardware or retractor assembly at the other end of the lap belt or lap belt portion of the seat belt assembly. (S7.1.1.5(c)(2)) |
| <input checked="" type="checkbox"/> | 8. | Does the vehicle user need to take some action to activate the locking feature on the lap belt portion of the seat belt in any forward-facing seat or seat that can be adjusted to forward-facing? |
| | | <input checked="" type="checkbox"/> Yes, go to 8.1 |
| | | <input type="checkbox"/> No, go to 9. |
| <input checked="" type="checkbox"/> | 8.1 | Does the vehicle owner's manual include a description in words and/or diagrams describing how to activate the locking feature so that the seat belt assembly can tightly secure a child restraint system and how to deactivate the locking feature to remove the child restraint system. (S7.1.1.5(b)) |
| | | <input checked="" type="checkbox"/> Yes - Pass |
| | | <input type="checkbox"/> No - Fail |

9. Adjust the lap belt or lap belt portion of the seat belt assembly according to any procedures recommended in the vehicle owner's manual to activate any locking feature so that the webbing between points A and B is at the maximum length allowed by the belt system. (S7.1.1.5(c)(2) & S7.1.1.5(c)(1))
10. Measure and record the distance between points A and B along the longitudinal centerline of the webbing for the lap belt or lap belt portion of the seat belt assembly. (S7.1.1.5(c)(2))
- Measured distance between A and B (inches): 64 ½ inches
11. Readjust the belt system so that the webbing between points A and B is at 1/2 the maximum length of the webbing. (S7.1.1.5(c)(3))
12. To the lap belt or lap belt portion of the seat belt assembly, apply a preload of 10 pounds using the webbing tension pull device in Figure 5. Apply the load in a vertical plane parallel to the longitudinal axis of the vehicle and passing through the seating reference point of the designated seating position. Apply the preload in a horizontal direction toward the front of the vehicle with a force application angle of not less than 5 degrees nor more than 15 degrees above the horizontal. (S7.1.1.5(c)(4))
- Measured force application angle (Spec. 5-15 degrees): 10°
13. Measure the length between points A and B along the longitudinal centerline of the webbing while the preload is being applied. (S7.1.1.5(c)(4))
- Measured distance between A and B (inches): 37 inches
14. Increase the load to 50 pounds at a rate of no more than 50 pounds per second. Attain the load in not more than 5 seconds. (If webbing sensitive emergency locking retractors are installed as part of the lap belt or lap belt portion of the seat belt assembly, apply the load at a rate less than the threshold value for lock-up specified by the manufacturer.) Maintain the load for at least 5 seconds. Measure and record the distance between points A and B along the longitudinal centerline of the webbing. (S7.1.1.5(c)(5))
- Record onset rate (lb/sec) (spec. 10 to 50 lb/sec) (S7.1.1.5(c)(5)): 15 lbs./sec
- Measured distance between A and B (inches) (S7.1.1.5(c)(6)): 37 ¼ inches
15. Let the seat belt webbing retract to its minimum length with the seat belt still buckled
16. To the lap belt or lap belt portion of the seat belt assembly, apply a preload of 10 pounds using the webbing tension pull device in Figure 5. Apply the load in a vertical plane parallel to the longitudinal axis of the vehicle and passing through the seating reference point of the designated seating position. Apply the preload in a horizontal direction toward the front of the vehicle with a force application angle of not less than 5 degrees nor more than 15 degrees above the horizontal. (S7.1.1.5(c)(4))
- Measured force application angle 10° spec. 5 - 15 degrees)
17. Measure the length between points A and B along the longitudinal centerline of the webbing while the preload is being applied. (S7.1.1.5(c)(4))
- Measured distance between A and B 15 inches

18. Increase the load to 50 pounds at a rate of no more than 50 pounds per second. Attain the load in not more than 5 seconds. (If webbing sensitive emergency locking retractors are installed as part of the lap belt or lap belt portion of the seat belt assembly, apply the load at a rate less than the threshold value for lock-up specified by the manufacturer.) Maintain the load for at least 5 seconds. Measure and record the distance between points A and B along the longitudinal centerline of the webbing. (S7.1.1.5(c)(5))
Record onset rate 15 lb/sec (spec. 10 to 50 lb/sec) (S7.1.1.5(c)(5))
Measured distance between A and B 15 3/4 inches (S7.1.1.5(c)(6))
19. Subtract the measurement in 13 from the measurement in 14 and the measurement in 17 from the measurement in 18. Is the difference 2 inches or less for both?
(S7.1.1.5(c)(7))
 14-13 = 37 1/4 - 37 = 1/4 inch
 18-17 = 15 3/4 - 15 = 3/4 inch
 Yes - Pass
 No - Fail
20. Subtract the measurement in 14 from the measurement in 10 and the measurement in 18 from the measurement in 10. Is the difference 3 inches or more for both?
(S7.1.1.5(c)(8))
 10-14 = 64 1/2 - 37 1/4 = 27 1/4 inches
 10-18 = 64 1/2 - 15 3/4 = 48 3/4 inches
 Yes - Pass
 No - Fail

REMARKS:

I certify that I have read and performed each instruction.

Signature: Wayne Gable

Date: 5/16/08

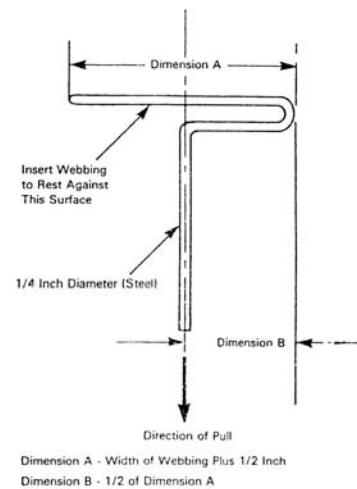

Figure 5. - Webbing Tension Pull Device

DATA SHEET 8

LAP BELT LOCKABILITY

Passenger cars, trucks, buses, and multipurpose passenger
Vehicles with a GVWR of 10,000 pounds or less. (S7.1.1.5)

Test Vehicle: 2008 Ford Edge
Test Program: FMVSS 208 Compliance
Test Technician: Wayne Dahlke

NHTSA No.: C80202
Test Date: 5/16/08

Complete one of these forms for **each** designated seating position that can be adjusted to forward-facing or that is a forward-facing seat, other than the driver's seat (S7.1.1.5(a), **and** that has seat belt retractors that are not solely automatic locking retractors. (S7.1.1.5(c))

DESIGNATED SEATING POSITION: **Left Rear Passenger**

- N/A - no retractor is at this position
- N/A - the retractor is an automatic locking retractor ONLY
- 1. Record test fore-aft seat position: *FIXED*
(S7.1.1.5(c)(1)) (Any position is acceptable)
- 2. Does the lap belt portion of the seat belt in the forward-facing seat or seat that can be adjusted to forward-facing consist of a locking device that does NOT have to be attached by the vehicle user to the seat belt webbing, retractor, or any other part of the vehicle. (S7.1.1.5 (a))
 - Yes - Pass
 - No - Fail
- 3. Does the lap belt portion of the seat belt in the forward-facing seat or seat that can be adjusted to forward-facing consist of a locking device that does NOT require inverting, twisting or deforming of the belt webbing. (S7.1.1.5 (a))
 - Yes - Pass
 - No - Fail
- 4. Place any adjustable seat belt anchorage in the lowest adjustment position.
 - N/A The anchorage is not adjustable.
- 5. Buckle the seat belt. (S7.1.1.5(c)(1))
- 6. Locate a reference point A on the seat belt buckle. (S7.1.1.5(c)(2))
- 7. Locate a reference point B on the attachment hardware or retractor assembly at the other end of the lap belt or lap belt portion of the seat belt assembly. (S7.1.1.5(c)(2))
- 8. Does the vehicle user need to take some action to activate the locking feature on the lap belt portion of the seat belt in any forward-facing seat or seat that can be adjusted to forward-facing?
 - Yes, go to 8.1
 - No, go to 9.
- 8.1 Does the vehicle owner's manual include a description in words and/or diagrams describing how to activate the locking feature so that the seat belt assembly can tightly secure a child restraint system and how to deactivate the locking feature to remove the child restraint system. (S7.1.1.5(b))
 - Yes - Pass
 - No - Fail

9. Adjust the lap belt or lap belt portion of the seat belt assembly according to any procedures recommended in the vehicle owner's manual to activate any locking feature so that the webbing between points A and B is at the maximum length allowed by the belt system. (S7.1.1.5(c)(2) & S7.1.1.5(c)(1))
10. Measure and record the distance between points A and B along the longitudinal centerline of the webbing for the lap belt or lap belt portion of the seat belt assembly. (S7.1.1.5(c)(2))
Measured distance between A and B (inches): 70 ¼ inches
11. Readjust the belt system so that the webbing between points A and B is at 1/2 the maximum length of the webbing. (S7.1.1.5(c)(3))
12. To the lap belt or lap belt portion of the seat belt assembly, apply a preload of 10 pounds using the webbing tension pull device in Figure 5. Apply the load in a vertical plane parallel to the longitudinal axis of the vehicle and passing through the seating reference point of the designated seating position. Apply the preload in a horizontal direction toward the front of the vehicle with a force application angle of not less than 5 degrees nor more than 15 degrees above the horizontal. (S7.1.1.5(c)(4))
Measured force application angle (Spec. 5-15 degrees): 10°
13. Measure the length between points A and B along the longitudinal centerline of the webbing while the preload is being applied. (S7.1.1.5(c)(4))
Measured distance between A and B (inches): 37 ¾ inches
14. Increase the load to 50 pounds at a rate of no more than 50 pounds per second. Attain the load in not more than 5 seconds. (If webbing sensitive emergency locking retractors are installed as part of the lap belt or lap belt portion of the seat belt assembly, apply the load at a rate less than the threshold value for lock-up specified by the manufacturer.) Maintain the load for at least 5 seconds. Measure and record the distance between points A and B along the longitudinal centerline of the webbing. (S7.1.1.5(c)(5))
Record onset rate (lb/sec) (spec. 10 to 50 lb/sec) (S7.1.1.5(c)(5)): 15 lbs/sec
Measured distance between A and B (inches) (S7.1.1.5(c)(6)): 38 ¼ inches
15. Let the seat belt webbing retract to its minimum length with the seat belt still buckled
16. To the lap belt or lap belt portion of the seat belt assembly, apply a preload of 10 pounds using the webbing tension pull device in Figure 5. Apply the load in a vertical plane parallel to the longitudinal axis of the vehicle and passing through the seating reference point of the designated seating position. Apply the preload in a horizontal direction toward the front of the vehicle with a force application angle of not less than 5 degrees nor more than 15 degrees above the horizontal. (S7.1.1.5(c)(4))
Measured force application angle 10 (spec. 5 - 15 degrees)
17. Measure the length between points A and B along the longitudinal centerline of the webbing while the preload is being applied. (S7.1.1.5(c)(4))
Measured distance between A and B 23 inches
18. Increase the load to 50 pounds at a rate of no more than 50 pounds per second. Attain the load in not more than 5 seconds. (If webbing sensitive emergency locking retractors are installed as part of the lap belt or lap belt portion of the seat belt assembly, apply the load at a rate less than the threshold value for lock-up specified by the manufacturer.) Maintain the load for at least 5 seconds. Measure and record the distance between points A and B along the longitudinal centerline of the webbing. (S7.1.1.5(c)(5))
Record onset rate 15 lbs/sec (spec. 10 to 50 lb/sec) (S7.1.1.5(c)(5))
Measured distance between A and B 24 inches (S7.1.1.5(c)(6))

19. Subtract the measurement in 13 from the measurement in 14 and the measurement in 17 from the measurement in 18. Is the difference 2 inches or less for both? (S7.1.1.5(c)(7))
- 14-13 = $38 \frac{1}{4} - 37 \frac{3}{4} = \frac{1}{2}$ inch
- 18-17 = $24 - 23 = 1$ inch
- Yes – Pass
- No – Fail
20. Subtract the measurement in 14 from the measurement in 10 and the measurement in 18 from the measurement in 10. Is the difference 3 inches or more for both? (S7.1.1.5(c)(8))
- 10-14 = $70 \frac{1}{4} - 38 \frac{1}{4} = 32$ inches
- 10-18 = $70 \frac{1}{4} - 24 = 46 \frac{1}{4}$ inches
- Yes - Pass
- No - Fail

REMARKS:

I certify that I have read and performed each instruction.

Signature: Wayne Zalk

Date: 5/16/08

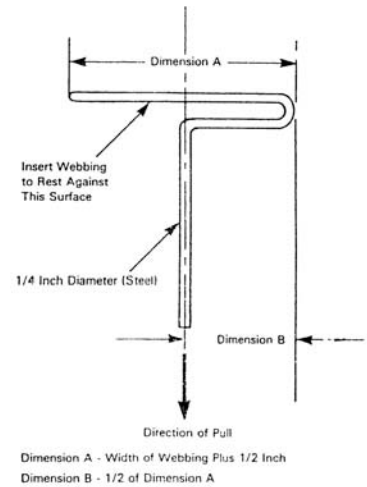

Figure 5. - Webbing Tension Pull Device

DATA SHEET 8

LAP BELT LOCKABILITY

**Passenger cars, trucks, buses, and multipurpose passenger
Vehicles with a GVWR of 10,000 pounds or less. (S7.1.1.5)**

Test Vehicle: 2008 Ford Edge
 Test Program: FMVSS 208 Compliance
 Test Technician: Wayne Dahlke

NHTSA No.: C80202
 Test Date: 5/16/08

Complete one of these forms for **each** designated seating position that can be adjusted to forward-facing or that is a forward-facing seat, other than the driver's seat (S7.1.1.5(a), **and** that has seat belt retractors that are not solely automatic locking retractors. (S7.1.1.5(c))

DESIGNATED SEATING POSITION:	Center Rear Passenger
------------------------------	-----------------------

- | | | |
|-------------------------------------|-----|--|
| <input type="checkbox"/> | | N/A - no retractor is at this position |
| <input type="checkbox"/> | | N/A - the retractor is an automatic locking retractor ONLY |
| <input checked="" type="checkbox"/> | 1. | Record test fore-aft seat position: <i>FIXED</i>
(S7.1.1.5(c)(1)) (Any position is acceptable) |
| <input checked="" type="checkbox"/> | 2. | Does the lap belt portion of the seat belt in the forward-facing seat or seat that can be adjusted to forward-facing consist of a locking device that does NOT have to be attached by the vehicle user to the seat belt webbing, retractor, or any other part of the vehicle. (S7.1.1.5 (a)) |
| | | <input checked="" type="checkbox"/> Yes - Pass |
| | | <input type="checkbox"/> No - Fail |
| <input checked="" type="checkbox"/> | 3. | Does the lap belt portion of the seat belt in the forward-facing seat or seat that can be adjusted to forward-facing consist of a locking device that does NOT require inverting, twisting or deforming of the belt webbing. (S7.1.1.5 (a)) |
| | | <input checked="" type="checkbox"/> Yes - Pass |
| | | <input type="checkbox"/> No - Fail |
| <input checked="" type="checkbox"/> | 4. | Place any adjustable seat belt anchorage in the lowest adjustment position. |
| | | <input checked="" type="checkbox"/> N/A The anchorage is not adjustable. |
| <input checked="" type="checkbox"/> | 5. | Buckle the seat belt. (S7.1.1.5(c)(1)) |
| <input checked="" type="checkbox"/> | 6. | Locate a reference point A on the seat belt buckle. (S7.1.1.5(c)(2)) |
| <input checked="" type="checkbox"/> | 7. | Locate a reference point B on the attachment hardware or retractor assembly at the other end of the lap belt or lap belt portion of the seat belt assembly. (S7.1.1.5(c)(2)) |
| <input checked="" type="checkbox"/> | 8. | Does the vehicle user need to take some action to activate the locking feature on the lap belt portion of the seat belt in any forward-facing seat or seat that can be adjusted to forward-facing? |
| | | <input checked="" type="checkbox"/> Yes, go to 8.1 |
| | | <input type="checkbox"/> No, go to 9 |
| <input checked="" type="checkbox"/> | 8.1 | Does the vehicle owner's manual include a description in words and/or diagrams describing how to activate the locking feature so that the seat belt assembly can tightly secure a child restraint system and how to deactivate the locking feature to remove the child restraint system. (S7.1.1.5(b)) |
| | | <input checked="" type="checkbox"/> Yes - Pass |
| | | <input type="checkbox"/> No - Fail |

9. Adjust the lap belt or lap belt portion of the seat belt assembly according to any procedures recommended in the vehicle owner's manual to activate any locking feature so that the webbing between points A and B is at the maximum length allowed by the belt system. (S7.1.1.5(c)(2) & S7.1.1.5(c)(1))
10. Measure and record the distance between points A and B along the longitudinal centerline of the webbing for the lap belt or lap belt portion of the seat belt assembly. (S7.1.1.5(c)(2))
Measured distance between A and B (inches): 72 ¼ inches
11. Readjust the belt system so that the webbing between points A and B is at 1/2 the maximum length of the webbing. (S7.1.1.5(c)(3))
12. To the lap belt or lap belt portion of the seat belt assembly, apply a preload of 10 pounds using the webbing tension pull device in Figure 5. Apply the load in a vertical plane parallel to the longitudinal axis of the vehicle and passing through the seating reference point of the designated seating position. Apply the preload in a horizontal direction toward the front of the vehicle with a force application angle of not less than 5 degrees nor more than 15 degrees above the horizontal. (S7.1.1.5(c)(4))
Measured force application angle (Spec. 5-15 degrees): 10°
13. Measure the length between points A and B along the longitudinal centerline of the webbing while the preload is being applied. (S7.1.1.5(c)(4))
Measured distance between A and B (inches): 40 ½ inches
14. Increase the load to 50 pounds at a rate of no more than 50 pounds per second. Attain the load in not more than 5 seconds. (If webbing sensitive emergency locking retractors are installed as part of the lap belt or lap belt portion of the seat belt assembly, apply the load at a rate less than the threshold value for lock-up specified by the manufacturer.) Maintain the load for at least 5 seconds. Measure and record the distance between points A and B along the longitudinal centerline of the webbing. (S7.1.1.5(c)(5))
Record onset rate (lb/sec) (spec. 10 to 50 lb/sec) (S7.1.1.5(c)(5)): 15 lbs/sec
Measured distance between A and B (inches) (S7.1.1.5(c)(6)): 41 inches
15. Let the seat belt webbing retract to its minimum length with the seat belt still buckled
16. To the lap belt or lap belt portion of the seat belt assembly, apply a preload of 10 pounds using the webbing tension pull device in Figure 5. Apply the load in a vertical plane parallel to the longitudinal axis of the vehicle and passing through the seating reference point of the designated seating position. Apply the preload in a horizontal direction toward the front of the vehicle with a force application angle of not less than 5 degrees nor more than 15 degrees above the horizontal. (S7.1.1.5(c)(4))
Measured force application angle 10° (spec. 5 - 15 degrees)
17. Measure the length between points A and B along the longitudinal centerline of the webbing while the preload is being applied. (S7.1.1.5(c)(4))
Measured distance between A and B 12 inches

18. Increase the load to 50 pounds at a rate of no more than 50 pounds per second. Attain the load in not more than 5 seconds. (If webbing sensitive emergency locking retractors are installed as part of the lap belt or lap belt portion of the seat belt assembly, apply the load at a rate less than the threshold value for lock-up specified by the manufacturer.) Maintain the load for at least 5 seconds. Measure and record the distance between points A and B along the longitudinal centerline of the webbing. (S7.1.1.5(c)(5))
Record onset rate 15 lb/sec (spec. 10 to 50 lb/sec) (S7.1.1.5(c)(5))
Measured distance between A and B 12 1/2 inches (S7.1.1.5(c)(6))
19. Subtract the measurement in 13 from the measurement in 14 and the measurement in 17 from the measurement in 18. Is the difference 2 inches or less for both? (S7.1.1.5(c)(7))
14-13 = 41 - 40 1/2 = 1/2 inch
18-17 = 12 1/2 - 12 = 1/2 inch
- Yes - Pass
 No - Fail
20. Subtract the measurement in 14 from the measurement in 10 and the measurement in 18 from the measurement in 10. Is the difference 3 inches or more for both? (S7.1.1.5(c)(8))
10-14 = 72 1/4 - 41 = 31 1/4 inches
10-18 = 72 1/4 - 12 1/2 = 59 3/4 inches
- Yes - Pass
 No - Fail

REMARKS:

I certify that I have read and performed each instruction.

Signature: Wayne Gahl

Date: 5/16/08

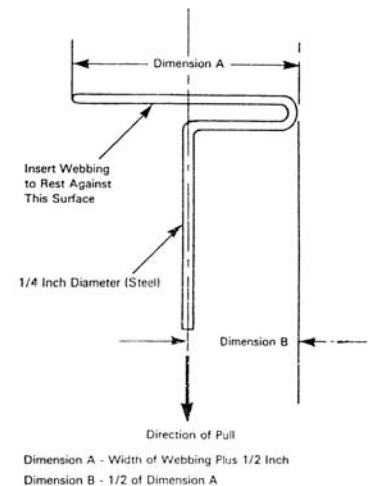

Figure 5. - Webbing Tension Pull Device

DATA SHEET 8

LAP BELT LOCKABILITY

**Passenger cars, trucks, buses, and multipurpose passenger
Vehicles with a GVWR of 10,000 pounds or less. (S7.1.1.5)**

Test Vehicle: 2008 Ford Edge
 Test Program: FMVSS 208 Compliance
 Test Technician: Wayne Dahlke

NHTSA No.: C80202
 Test Date: 5/16/08

Complete one of these forms for **each** designated seating position that can be adjusted to forward-facing or that is a forward-facing seat, other than the driver's seat (S7.1.1.5(a), **and** that has seat belt retractors that are not solely automatic locking retractors. (S7.1.1.5(c))

DESIGNATED SEATING POSITION:	Right Rear Passenger
------------------------------	----------------------

- | | |
|---|--|
| | N/A - no retractor is at this position |
| | N/A - the retractor is an automatic locking retractor ONLY |
| X | 1. Record test fore-aft seat position: <i>FIXED</i>
(S7.1.1.5(c)(1)) (Any position is acceptable) |
| X | 2. Does the lap belt portion of the seat belt in the forward-facing seat or seat that can be adjusted to forward-facing consist of a locking device that does NOT have to be attached by the vehicle user to the seat belt webbing, retractor, or any other part of the vehicle. (S7.1.1.5 (a)) |
| X | Yes - Pass |
| | No - Fail |
| X | 3. Does the lap belt portion of the seat belt in the forward-facing seat or seat that can be adjusted to forward-facing consist of a locking device that does NOT require inverting, twisting or deforming of the belt webbing. (S7.1.1.5 (a)) |
| X | Yes - Pass |
| | No - Fail |
| X | 4. Place any adjustable seat belt anchorage in the lowest adjustment position. |
| X | N/A The anchorage is not adjustable. |
| X | 5. Buckle the seat belt. (S7.1.1.5(c)(1)) |
| X | 6. Locate a reference point A on the seat belt buckle. (S7.1.1.5(c)(2)) |
| X | 7. Locate a reference point B on the attachment hardware or retractor assembly at the other end of the lap belt or lap belt portion of the seat belt assembly. (S7.1.1.5(c)(2)) |
| X | 8. Does the vehicle user need to take some action to activate the locking feature on the lap belt portion of the seat belt in any forward-facing seat or seat that can be adjusted to forward-facing? |
| X | Yes, go to 8.1 |
| | No, go to 9. |
| X | 8.1 Does the vehicle owner's manual include a description in words and/or diagrams describing how to activate the locking feature so that the seat belt assembly can tightly secure a child restraint system and how to deactivate the locking feature to remove the child restraint system. (S7.1.1.5(b)) |
| X | Yes - Pass |
| | No - Fail |

9. Adjust the lap belt or lap belt portion of the seat belt assembly according to any procedures recommended in the vehicle owner's manual to activate any locking feature so that the webbing between points A and B is at the maximum length allowed by the belt system. (S7.1.1.5(c)(2) & S7.1.1.5(c)(1))
10. Measure and record the distance between points A and B along the longitudinal centerline of the webbing for the lap belt or lap belt portion of the seat belt assembly. (S7.1.1.5(c)(2))
Measured distance between A and B (inches): 70 ½ inches
11. Readjust the belt system so that the webbing between points A and B is at 1/2 the maximum length of the webbing. (S7.1.1.5(c)(3))
12. To the lap belt or lap belt portion of the seat belt assembly, apply a preload of 10 pounds using the webbing tension pull device in Figure 5. Apply the load in a vertical plane parallel to the longitudinal axis of the vehicle and passing through the seating reference point of the designated seating position. Apply the preload in a horizontal direction toward the front of the vehicle with a force application angle of not less than 5 degrees nor more than 15 degrees above the horizontal. (S7.1.1.5(c)(4))
Measured force application angle (Spec. 5-15 degrees): 10°
13. Measure the length between points A and B along the longitudinal centerline of the webbing while the preload is being applied. (S7.1.1.5(c)(4))
Measured distance between A and B (inches): 46 inches
14. Increase the load to 50 pounds at a rate of no more than 50 pounds per second. Attain the load in not more than 5 seconds. (If webbing sensitive emergency locking retractors are installed as part of the lap belt or lap belt portion of the seat belt assembly, apply the load at a rate less than the threshold value for lock-up specified by the manufacturer.) Maintain the load for at least 5 seconds. Measure and record the distance between points A and B along the longitudinal centerline of the webbing. (S7.1.1.5(c)(5))
Record onset rate (lb/sec) (spec. 10 to 50 lb/sec) (S7.1.1.5(c)(5)): 15 lbs/sec
Measured distance between A and B (inches) (S7.1.1.5(c)(6)): 46 ½ inches
15. Let the seat belt webbing retract to its minimum length with the seat belt still buckled
16. To the lap belt or lap belt portion of the seat belt assembly, apply a preload of 10 pounds using the webbing tension pull device in Figure 5. Apply the load in a vertical plane parallel to the longitudinal axis of the vehicle and passing through the seating reference point of the designated seating position. Apply the preload in a horizontal direction toward the front of the vehicle with a force application angle of not less than 5 degrees nor more than 15 degrees above the horizontal. (S7.1.1.5(c)(4))
Measured force application angle 10 (spec. 5 - 15 degrees)
17. Measure the length between points A and B along the longitudinal centerline of the webbing while the preload is being applied. (S7.1.1.5(c)(4))
Measured distance between A and B 24 ¾ inches

18. Increase the load to 50 pounds at a rate of no more than 50 pounds per second. Attain the load in not more than 5 seconds. (If webbing sensitive emergency locking retractors are installed as part of the lap belt or lap belt portion of the seat belt assembly, apply the load at a rate less than the threshold value for lock-up specified by the manufacturer.) Maintain the load for at least 5 seconds. Measure and record the distance between points A and B along the longitudinal centerline of the webbing. (S7.1.1.5(c)(5))
Record onset rate 15 lbs/sec (spec. 10 to 50 lb/sec) (S7.1.1.5(c)(5))
Measured distance between A and B 25 1/2 inches (S7.1.1.5(c)(6))
19. Subtract the measurement in 13 from the measurement in 14 and the measurement in 17 from the measurement in 18. Is the difference 2 inches or less for both?
(S7.1.1.5(c)(7))
14-13 = 46 1/2 - 46 = 1/2 inch
18-17 = 25 1/2 - 24 3/4 = 3/4 inch
- Yes - Pass
 No - Fail
20. Subtract the measurement in 14 from the measurement in 10 and the measurement in 18 from the measurement in 10. Is the difference 3 inches or more for both?
(S7.1.1.5(c)(8))
10-14 = 70 1/2 - 46 1/2 = 24 inches
10-18 = 70 1/2 - 25 1/2 = 45 inches
- Yes - Pass
 No - Fail

REMARKS:

I certify that I have read and performed each instruction.

Signature: Wayne J. Hill

Date: 5/16/08

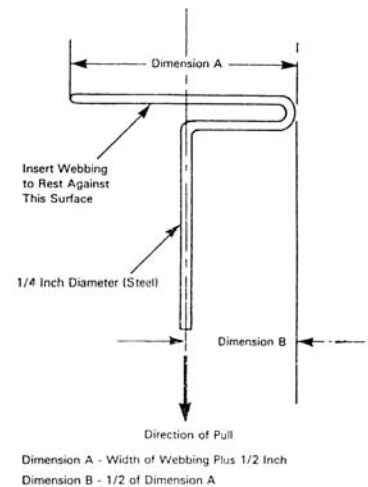

Figure 5. - Webbing Tension Pull Device

DATA SHEET 9

FMVSS 208 SEAT BELT WARNING SYSTEM CHECK (S7.3)

Test Vehicle: 2008 Ford Edge
 Test Program: FMVSS 208 Compliance
 Test Technician: Wayne Dahlke

NHTSA No.: C80202
 Test Date: 5/16/08

- | | | |
|-------------------------------------|-----|---|
| <input checked="" type="checkbox"/> | 1. | The occupant is in the driver's seat. |
| <input checked="" type="checkbox"/> | 2. | The seat belt is in the stowed position. |
| <input checked="" type="checkbox"/> | 3. | The key is in the "on" or "start" position. |
| <input checked="" type="checkbox"/> | 4. | The time duration of the audible signal beginning with key "on" or "start" is
Seconds: 6 |
| <input checked="" type="checkbox"/> | 5. | The occupant is in the driver's seat. |
| <input checked="" type="checkbox"/> | 6. | The seat belt is in the stowed position. |
| <input checked="" type="checkbox"/> | 7. | The key is in the "on" or "start" position. |
| <input checked="" type="checkbox"/> | 8. | The time duration of the warning light beginning with key "on" or "start" is
Seconds: 64 |
| <input checked="" type="checkbox"/> | 9. | The occupant is in the driver's seat. |
| <input checked="" type="checkbox"/> | 10. | The seat belt is in the latched position and with at least 4 inches of belt webbing extended. |
| <input checked="" type="checkbox"/> | 11. | The key is in the "on" or "start" position. |
| <input checked="" type="checkbox"/> | 12. | The time duration of the warning light beginning with key "on" or "start" is
Seconds: 0 |
| <input checked="" type="checkbox"/> | 13. | Complete the following table with the data from 4, 8, and 12 to determine which option is used. |

		Warning light	Warning light specification	Audible signal	Audible signal specification*
S7.3 (a)(1)	Belt stowed & key on or start	Item 8: 64	60 seconds minimum	Item 4: 6	4 to 8 seconds
S7.3 (a)(2)	Belt latched & key on or start	Item 12: 0	4 to 8 seconds		
	Belt stowed & key on or start	Item 8: 64	4 to 8 seconds	Item 4: 6	4 to 8 seconds

* 49 USCS @ 30124 does NOT allow an audible signal to operate for more than 8 seconds. A voluntary audible signal after the 4 to 8 second required signal may be provided. It must be differentiated from the required signal (5/25/2001 legal interpretation to Longacre and Associates).

14. The seat belt warning system meets the requirements of (manufacturers may comply with either section)
- S7.3 (a)(1)
 - S7.3 (a)(2)
 - FAIL - does not meet the requirements of either option
15. Note wording of visual warning: (S7.3(a)(1) and S7.3(a)(2))
- Fasten seat belts
 - Fasten belts
 - Symbol 101 - 
 - FAIL - does not use any of the above wording or symbol

REMARKS:

I certify that I have read and performed each instruction.

Signature: Wayne Zuhl

Date: 5/16/08

DATA SHEET 10
BELT CONTACT FORCE (S7.4.3)

Test Vehicle: 2008 Ford Edge
 Test Program: FMVSS 208 Compliance
 Test Technician: Wayne Dahlke

NHTSA No.: C80202
 Test Date: 5/16/08

Test all Type 2 seat belts other than those in walk-in van-type vehicles and those at front outboard designated seating positions in passenger cars. Complete a form for each applicable seat belt.

DESIGNATED SEATING POSITION:	Left Front Driver
------------------------------	-------------------

- | | | |
|-------------------------------------|----|---|
| <input checked="" type="checkbox"/> | 1. | Does the vehicle incorporate a webbing tension-relieving device?
<input type="checkbox"/> Yes, this form is complete
<input checked="" type="checkbox"/> No, continue with this check sheet |
| <input checked="" type="checkbox"/> | 2. | Position the seat's adjustable lumbar supports so that the lumbar support is in its lowest, retracted or deflated adjustment position. (S8.1.3)
<input checked="" type="checkbox"/> N/A, no lumbar adjustment |
| <input checked="" type="checkbox"/> | 3. | Position any adjustable parts of the seat that provide additional support so that they are in the lowest or most open adjustment position. (S16.2.10.2)
<input checked="" type="checkbox"/> N/A, no additional support adjustment |
| <input checked="" type="checkbox"/> | 4. | Is the fore-aft position of the seat adjustable?
<input type="checkbox"/> No- go to 5
<input checked="" type="checkbox"/> Yes - Put the seat in the mid fore-aft and full down height position determined in Data Sheet 14.2 |
| <input checked="" type="checkbox"/> | 5. | Is the seat back angle adjustable?
<input type="checkbox"/> No- go to 6
<input checked="" type="checkbox"/> Yes-Use the seat back angle determined in Data Sheet 14.2 |
| <input checked="" type="checkbox"/> | 6. | Position the test dummies according to dummy position placement instructions in Appendix F. Complete the Appendix F check sheets, but include them in the test report ONLY if there is a test failure. |
| <input checked="" type="checkbox"/> | 7. | Fasten the seat belt latch. |
| <input checked="" type="checkbox"/> | 8. | Pull either 12 inches of belt webbing or the maximum available amount of belt webbing, whichever is less, from the retractor and then release it, allowing the belt webbing to return to the dummy's chest. |
| <input checked="" type="checkbox"/> | 9. | Locate the point where the centerline of the upper torso belt webbing crosses the midsagittal line on the dummy's chest. At that point pull the belt webbing out 3 inches from the dummy's chest and release until it is within one inch from the dummy's chest. (S10.8) Using a force measuring gage with a full scale range of no more than 1.5 pounds, measure the contact force perpendicular to the dummy's chest exerted by the belt webbing. |
| <input checked="" type="checkbox"/> | | Contact Force (lb):
<input checked="" type="checkbox"/> 0.0 to 0.7 pounds - Pass <u>0.4 lbs.</u>
<input type="checkbox"/> Greater than 0.7 pounds - Fail |

REMARKS:

I certify that I have read and performed each instruction.

Signature: Wayne Jahlh

Date: 5/16/08

DATA SHEET 10
BELT CONTACT FORCE (S7.4.3)

Test Vehicle: 2008 Ford Edge
 Test Program: FMVSS 208 Compliance
 Test Technician: Wayne Dahlke

NHTSA No.: C80202
 Test Date: 5/16/08

Test all Type 2 seat belts other than those in walk-in van-type vehicles and those at front outboard designated seating positions in passenger cars. Complete a form for each applicable seat belt.

DESIGNATED SEATING POSITION:	Right Front Passenger
------------------------------	-----------------------

- | | | |
|-------------------------------------|----|---|
| <input checked="" type="checkbox"/> | 1. | Does the vehicle incorporate a webbing tension-relieving device?
<input type="checkbox"/> Yes, this form is complete
<input checked="" type="checkbox"/> No, continue with this check sheet |
| <input checked="" type="checkbox"/> | 2. | Position the seat's adjustable lumbar supports so that the lumbar support is in its lowest, retracted or deflated adjustment position. (S8.1.3)
<input checked="" type="checkbox"/> N/A, no lumbar adjustment |
| <input checked="" type="checkbox"/> | 3. | Position any adjustable parts of the seat that provide additional support so that they are in the lowest or most open adjustment position. (S16.2.10.2)
<input checked="" type="checkbox"/> N/A, no additional support adjustment |
| <input checked="" type="checkbox"/> | 4. | Is the fore-aft position of the seat adjustable?
<input type="checkbox"/> No- go to 5
<input checked="" type="checkbox"/> Yes - Put the seat in the mid fore-aft and full down height position determined in Data Sheet 14.2 |
| <input checked="" type="checkbox"/> | 5. | Is the seat back angle adjustable?
<input type="checkbox"/> No- go to 6
<input checked="" type="checkbox"/> Yes-Use the seat back angle determined in Data Sheet 14.2 |
| <input checked="" type="checkbox"/> | 6. | Position the test dummies according to dummy position placement instructions in Appendix F. Complete the Appendix F check sheets, but include them in the test report ONLY if there is a test failure. |
| <input checked="" type="checkbox"/> | 7. | Fasten the seat belt latch. |
| <input checked="" type="checkbox"/> | 8. | Pull either 12 inches of belt webbing or the maximum available amount of belt webbing, whichever is less, from the retractor and then release it, allowing the belt webbing to return to the dummy's chest. |
| <input checked="" type="checkbox"/> | 9. | Locate the point where the centerline of the upper torso belt webbing crosses the midsagittal line on the dummy's chest. At that point pull the belt webbing out 3 inches from the dummy's chest and release until it is within one inch from the dummy's chest. (S10.8) Using a force measuring gage with a full scale range of no more than 1.5 pounds, measure the contact force perpendicular to the dummy's chest exerted by the belt webbing. |
| <input checked="" type="checkbox"/> | | Contact Force (lb):
<input checked="" type="checkbox"/> 0.0 to 0.7 pounds - Pass <u>0.4 lbs.</u>
<input type="checkbox"/> Greater than 0.7 pounds - Fail |

REMARKS:

I certify that I have read and performed each instruction.

Signature: Wayne Zuhl

Date: 5/16/08

DATA SHEET 10
BELT CONTACT FORCE (S7.4.3)

Test Vehicle: 2008 Ford Edge
 Test Program: FMVSS 208 Compliance
 Test Technician: Wayne Dahlke

NHTSA No.: C80202
 Test Date: 5/16/08

Test all Type 2 seat belts other than those in walk-in van-type vehicles and those at front outboard designated seating positions in passenger cars. Complete a form for each applicable seat belt.

DESIGNATED SEATING POSITION:	Left Rear Passenger
------------------------------	---------------------

- | | | | |
|-------------------------------------|--|----|--|
| <input checked="" type="checkbox"/> | | 1. | Does the vehicle incorporate a webbing tension-relieving device? |
| | | | <input type="checkbox"/> Yes, this form is complete |
| | | | <input checked="" type="checkbox"/> No, continue with this check sheet |
- | | | | |
|-------------------------------------|--|----|---|
| <input checked="" type="checkbox"/> | | 2. | Position the seat's adjustable lumbar supports so that the lumbar support is in its lowest, retracted or deflated adjustment position. (S8.1.3) |
| | | | <input checked="" type="checkbox"/> N/A, no lumbar adjustment |
- | | | | |
|-------------------------------------|--|----|---|
| <input checked="" type="checkbox"/> | | 3. | Position any adjustable parts of the seat that provide additional support so that they are in the lowest or most open adjustment position. (S16.2.10.2) |
| | | | <input checked="" type="checkbox"/> N/A, no additional support adjustment |
- | | | | |
|-------------------------------------|--|----|---|
| <input checked="" type="checkbox"/> | | 4. | Is the fore-aft position of the seat adjustable? |
| | | | <input checked="" type="checkbox"/> No- go to 5 |
| | | | <input type="checkbox"/> Yes - Put the seat in the mid fore-aft and full down height position determined in Data Sheet 14.2 |
- | | | | |
|-------------------------------------|--|----|---|
| <input checked="" type="checkbox"/> | | 5. | Is the seat back angle adjustable? |
| | | | <input type="checkbox"/> No- go to 6 |
| | | | <input checked="" type="checkbox"/> Yes-Use the seat back angle determined in Data Sheet 14.2 |
- | | | | |
|-------------------------------------|--|----|---|
| <input checked="" type="checkbox"/> | | 6. | Position the test dummies according to dummy position placement instructions in Appendix F. Complete the Appendix F check sheets, but include them in the test report ONLY if there is a test failure. |
|-------------------------------------|--|----|---|
- | | | | |
|-------------------------------------|--|----|-----------------------------|
| <input checked="" type="checkbox"/> | | 7. | Fasten the seat belt latch. |
|-------------------------------------|--|----|-----------------------------|
- | | | | |
|-------------------------------------|--|----|---|
| <input checked="" type="checkbox"/> | | 8. | Pull either 12 inches of belt webbing or the maximum available amount of belt webbing, whichever is less, from the retractor and then release it, allowing the belt webbing to return to the dummy's chest. |
|-------------------------------------|--|----|---|
- | | | | |
|-------------------------------------|--|----|---|
| <input checked="" type="checkbox"/> | | 9. | Locate the point where the centerline of the upper torso belt webbing crosses the midsagittal line on the dummy's chest. At that point pull the belt webbing out 3 inches from the dummy's chest and release until it is within one inch from the dummy's chest. (S10.8) Using a force measuring gage with a full scale range of no more than 1.5 pounds, measure the contact force perpendicular to the dummy's chest exerted by the belt webbing. |
| | | | Contact Force (lb): |
| | | | <input checked="" type="checkbox"/> 0.0 to 0.7 pounds - Pass <u>0.5 lbs.</u> |
| | | | <input type="checkbox"/> Greater than 0.7 pounds - Fail |

REMARKS:

I certify that I have read and performed each instruction.

Signature: Wayne Zuhl

Date: 5/16/08

DATA SHEET 10
BELT CONTACT FORCE (S7.4.3)

Test Vehicle: 2008 Ford Edge
 Test Program: FMVSS 208 Compliance
 Test Technician: Wayne Dahlke

NHTSA No.: C80202
 Test Date: 5/16/08

Test all Type 2 seat belts other than those in walk-in van-type vehicles and those at front outboard designated seating positions in passenger cars. Complete a form for each applicable seat belt.

DESIGNATED SEATING POSITION:	Center Rear Passenger
------------------------------	-----------------------

- | | | |
|-------------------------------------|----|---|
| <input checked="" type="checkbox"/> | 1. | Does the vehicle incorporate a webbing tension-relieving device? |
| | | <input type="checkbox"/> Yes, this form is complete |
| | | <input checked="" type="checkbox"/> No, continue with this check sheet |
| <input checked="" type="checkbox"/> | 2. | Position the seat's adjustable lumbar supports so that the lumbar support is in its lowest, retracted or deflated adjustment position. (S8.1.3) |
| | | <input checked="" type="checkbox"/> N/A, no lumbar adjustment |
| <input checked="" type="checkbox"/> | 3. | Position any adjustable parts of the seat that provide additional support so that they are in the lowest or most open adjustment position. (S16.2.10.2) |
| | | <input checked="" type="checkbox"/> N/A, no additional support adjustment |
| <input checked="" type="checkbox"/> | 4. | Is the fore-aft position of the seat adjustable? |
| | | <input checked="" type="checkbox"/> No- go to 5 |
| | | <input type="checkbox"/> Yes - Put the seat in the mid fore-aft and full down height position determined in Data Sheet 14.2 |
| <input checked="" type="checkbox"/> | 5. | Is the seat back angle adjustable? |
| | | <input type="checkbox"/> No- go to 6 |
| | | <input checked="" type="checkbox"/> Yes-Use the seat back angle determined in Data Sheet 14.2 |
| <input checked="" type="checkbox"/> | 6. | Position the test dummies according to dummy position placement instructions in Appendix F. Complete the Appendix F check sheets, but include them in the test report ONLY if there is a test failure. |
| <input checked="" type="checkbox"/> | 7. | Fasten the seat belt latch. |
| <input checked="" type="checkbox"/> | 8. | Pull either 12 inches of belt webbing or the maximum available amount of belt webbing, whichever is less, from the retractor and then release it, allowing the belt webbing to return to the dummy's chest. |
| <input checked="" type="checkbox"/> | 9. | Locate the point where the centerline of the upper torso belt webbing crosses the midsagittal line on the dummy's chest. At that point pull the belt webbing out 3 inches from the dummy's chest and release until it is within one inch from the dummy's chest. (S10.8) Using a force measuring gage with a full scale range of no more than 1.5 pounds, measure the contact force perpendicular to the dummy's chest exerted by the belt webbing. |
| <input checked="" type="checkbox"/> | | Contact Force (lb): |
| | | <input checked="" type="checkbox"/> 0.0 to 0.7 pounds - Pass <u>0.4 lbs.</u> |
| | | <input type="checkbox"/> Greater than 0.7 pounds - Fail |

REMARKS:

I certify that I have read and performed each instruction.

Signature: Wayne Jahlh

Date: 5/16/08

DATA SHEET 10
BELT CONTACT FORCE (S7.4.3)

Test Vehicle: 2008 Ford Edge
 Test Program: FMVSS 208 Compliance
 Test Technician: Wayne Dahlke

NHTSA No.: C80202
 Test Date: 5/16/08

Test all Type 2 seat belts other than those in walk-in van-type vehicles and those at front outboard designated seating positions in passenger cars. Complete a form for each applicable seat belt.

DESIGNATED SEATING POSITION:	Right Rear Passenger
------------------------------	----------------------

- | | | |
|-------------------------------------|----|---|
| <input checked="" type="checkbox"/> | 1. | Does the vehicle incorporate a webbing tension-relieving device?
<input type="checkbox"/> Yes, this form is complete
<input checked="" type="checkbox"/> No, continue with this check sheet |
| <input checked="" type="checkbox"/> | 2. | Position the seat's adjustable lumbar supports so that the lumbar support is in its lowest, retracted or deflated adjustment position. (S8.1.3)
<input checked="" type="checkbox"/> N/A, no lumbar adjustment |
| <input checked="" type="checkbox"/> | 3. | Position any adjustable parts of the seat that provide additional support so that they are in the lowest or most open adjustment position. (S16.2.10.2)
<input checked="" type="checkbox"/> N/A, no additional support adjustment |
| <input checked="" type="checkbox"/> | 4. | Is the fore-aft position of the seat adjustable?
<input checked="" type="checkbox"/> No- go to 5
<input type="checkbox"/> Yes – Put the seat in the mid fore-aft and full down height position determined in Data Sheet 14.2 |
| <input checked="" type="checkbox"/> | 5. | Is the seat back angle adjustable?
<input type="checkbox"/> No- go to 6
<input checked="" type="checkbox"/> Yes-Use the seat back angle determined in Data Sheet 14.2 |
| <input checked="" type="checkbox"/> | 6. | Position the test dummies according to dummy position placement instructions in Appendix F. Complete the Appendix F check sheets, but include them in the test report ONLY if there is a test failure. |
| <input checked="" type="checkbox"/> | 7. | Fasten the seat belt latch. |
| <input checked="" type="checkbox"/> | 8. | Pull either 12 inches of belt webbing or the maximum available amount of belt webbing, whichever is less, from the retractor and then release it, allowing the belt webbing to return to the dummy's chest. |
| <input checked="" type="checkbox"/> | 9. | Locate the point where the centerline of the upper torso belt webbing crosses the midsagittal line on the dummy's chest. At that point pull the belt webbing out 3 inches from the dummy's chest and release until it is within one inch from the dummy's chest. (S10.8) Using a force measuring gage with a full scale range of no more than 1.5 pounds, measure the contact force perpendicular to the dummy's chest exerted by the belt webbing. |
| <input checked="" type="checkbox"/> | | Contact Force (lb):
<input checked="" type="checkbox"/> 0.0 to 0.7 pounds – Pass <u>0.5 lbs.</u>
<input type="checkbox"/> Greater than 0.7 pounds - Fail |

REMARKS:

I certify that I have read and performed each instruction.

Signature: Wayne Jahlh

Date: 5/16/08

DATA SHEET 11
LATCH PLATE ACCESS (S7.4.4)

Test Vehicle: 2008 Ford Edge
 Test Program: FMVSS 208 Compliance
 Test Technician: Wayne Dahlke

NHTSA No.: C80202
 Test Date: 5/16/08

Test all front outboard seat belts **other than those in** walk-in van-type vehicles and those at front outboard designated seating positions in **passenger cars**. Complete a form for each applicable seat belt.

DESIGNATED SEATING POSITION:	Left Front Driver
------------------------------	-------------------

- | | | | |
|-------------------------------------|-------------------------------------|-----|--|
| <input checked="" type="checkbox"/> | | 1. | Put the seat in the forwardmost fore-aft and full down height position determined in Data Sheet 14.2. (S10.7) |
| <input checked="" type="checkbox"/> | | 2. | Put the seat back angle in the position determined in Data Sheet 14.2. |
| <input checked="" type="checkbox"/> | | 3. | Position the test dummy using the procedures in Appendix F. (Some modifications to the positioning procedure may need to be made because the seat is in its forward most position. Note on the Appendix F positioning check sheet any deviations necessary to position the Part 572, Subpart E dummy.) Complete the Appendix F check sheets, but include them in the test report ONLY if there is a test failure. |
| <input checked="" type="checkbox"/> | | 4. | Position the adjustable seat belt anchorage in the manufacturer's nominal design position for a 50 th percentile adult male occupant. |
| <input checked="" type="checkbox"/> | | 5. | Attach the inboard reach string to the base of the head following the instructions on Figure 3. |
| <input checked="" type="checkbox"/> | | 6. | Attach the outboard reach string to the torso sheath following the instructions on Figure 3. |
| <input checked="" type="checkbox"/> | | 7. | Place the latch plate in the stowed position. |
| <input checked="" type="checkbox"/> | | 8. | Extend inboard reach string in front of the dummy and then backward and outboard to the latch plate to generate an arc of the reach envelope of the test dummy's arms. Is the latch plate within the reach envelope? |
| | <input checked="" type="checkbox"/> | | Yes - Pass |
| | <input type="checkbox"/> | | No |
| <input checked="" type="checkbox"/> | | 9. | Extend outboard reach string in front of the dummy and then backward and outboard to the latch plate to generate arcs of the reach envelope of the test dummy's arms. Is the latch plate within the reach envelope? |
| | <input checked="" type="checkbox"/> | | Yes - Pass |
| | <input type="checkbox"/> | | No |
| <input checked="" type="checkbox"/> | | 10. | Is the latch plate within the inboard (item 10) or outboard (item 11) reach envelope? |
| | <input checked="" type="checkbox"/> | | Yes - Pass |
| | <input type="checkbox"/> | | No - Fail |
| <input checked="" type="checkbox"/> | | 11. | Using the clearance test block, specified in Figure 4, is there sufficient clearance between the vehicle seat and the side of vehicle interior to allow the test block to move unhindered to the latch plate or buckle? |
| | <input checked="" type="checkbox"/> | | Yes - Pass |
| | <input type="checkbox"/> | | No - Fail |

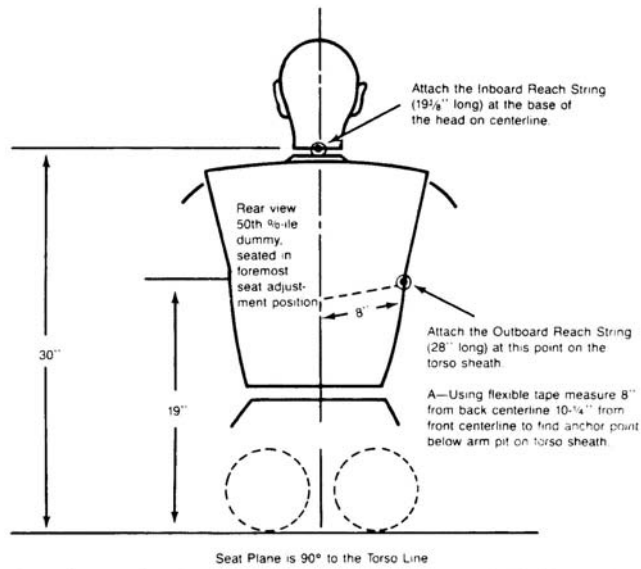

Figure 3. Location of Anchoring Points for Latchplate Reach Limiting Chains or Strings to Test for Latchplate Accessibility Using Subpart E Test Device

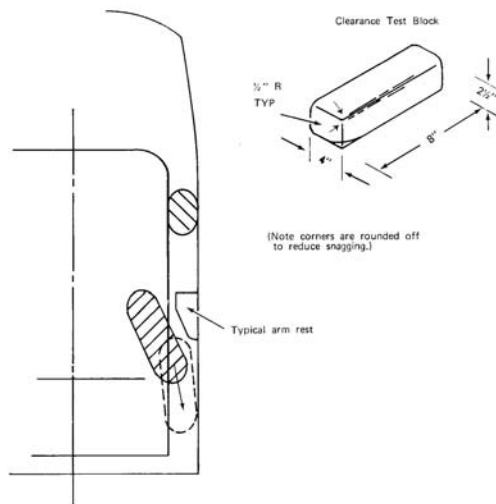

Figure 4—USE OF CLEARANCE TEST BLOCK TO DETERMINE HAND/ARM ACCESS

REMARKS:

I certify that I have read and performed each instruction.

Signature: Wayne Zahle

Date: 5/16/08

DATA SHEET 11
LATCH PLATE ACCESS (S7.4.4)

Test Vehicle: 2008 Ford Edge
 Test Program: FMVSS 208 Compliance
 Test Technician: Wayne Dahlke

NHTSA No.: C80202
 Test Date: 5/16/08

Test all front outboard seat belts **other than those in** walk-in van-type vehicles and those at front outboard designated seating positions in **passenger cars**. Complete a form for each applicable seat belt.

DESIGNATED SEATING POSITION:	Right Front Passenger
------------------------------	-----------------------

- | | | | |
|-------------------------------------|-------------------------------------|-----|--|
| <input checked="" type="checkbox"/> | | 1. | Put the seat in the forwardmost fore-aft and full down height position determined in Data Sheet 14.2. (S10.7) |
| <input checked="" type="checkbox"/> | | 2. | Put the seat back angle in the position determined in Data Sheet 14.2. |
| <input checked="" type="checkbox"/> | | 3. | Position the test dummy using the procedures in Appendix F. (Some modifications to the positioning procedure may need to be made because the seat is in its forward most position. Note on the Appendix F positioning check sheet any deviations necessary to position the Part 572, Subpart E dummy.) Complete the Appendix F check sheets, but include them in the test report ONLY if there is a test failure. |
| <input checked="" type="checkbox"/> | | 4. | Position the adjustable seat belt anchorage in the manufacturer's nominal design position for a 50 th percentile adult male occupant. |
| <input checked="" type="checkbox"/> | | 5. | Attach the inboard reach string to the base of the head following the instructions on Figure 3. |
| <input checked="" type="checkbox"/> | | 6. | Attach the outboard reach string to the torso sheath following the instructions on Figure 3. |
| <input checked="" type="checkbox"/> | | 7. | Place the latch plate in the stowed position. |
| <input checked="" type="checkbox"/> | | 8. | Extend inboard reach string in front of the dummy and then backward and outboard to the latch plate to generate an arc of the reach envelope of the test dummy's arms. Is the latch plate within the reach envelope? |
| | <input checked="" type="checkbox"/> | | Yes - Pass |
| | <input type="checkbox"/> | | No |
| <input checked="" type="checkbox"/> | | 9. | Extend outboard reach string in front of the dummy and then backward and outboard to the latch plate to generate arcs of the reach envelope of the test dummy's arms. Is the latch plate within the reach envelope? |
| | <input checked="" type="checkbox"/> | | Yes - Pass |
| | <input type="checkbox"/> | | No |
| <input checked="" type="checkbox"/> | | 10. | Is the latch plate within the inboard (item 10) or outboard (item 11) reach envelope? |
| | <input checked="" type="checkbox"/> | | Yes - Pass |
| | <input type="checkbox"/> | | No - Fail |
| <input checked="" type="checkbox"/> | | 11. | Using the clearance test block, specified in Figure 4, is there sufficient clearance between the vehicle seat and the side of vehicle interior to allow the test block to move unhindered to the latch plate or buckle? |
| | <input checked="" type="checkbox"/> | | Yes - Pass |
| | <input type="checkbox"/> | | No - Fail |

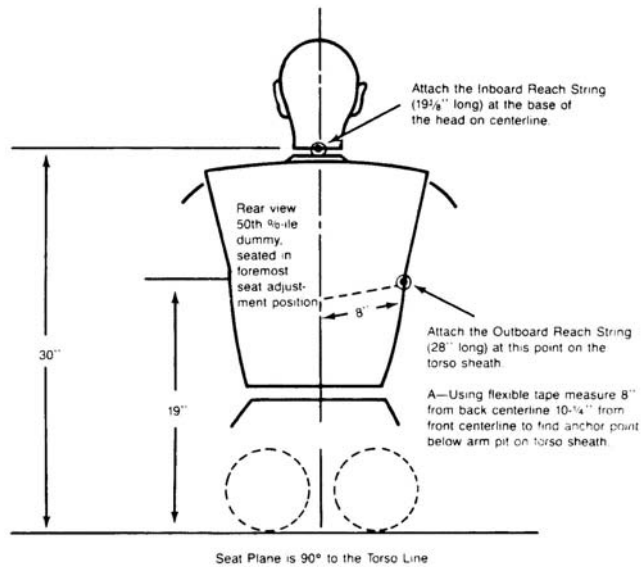

Figure 3. Location of Anchoring Points for Latchplate Reach Limiting Chains or Strings to Test for Latchplate Accessibility Using Subpart E Test Device

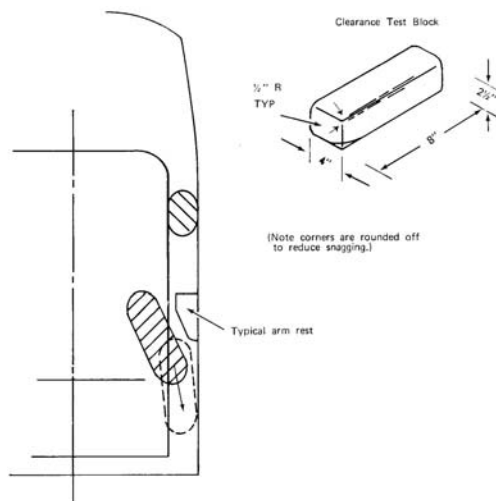

Figure 4—USE OF CLEARANCE TEST BLOCK TO DETERMINE HAND/ARM ACCESS

REMARKS:

I certify that I have read and performed each instruction.

Signature: Wayne Zahl

Date: 5/16/08

DATA SHEET 12

SEAT BELT RETRACTION (S7.4.5)

Test Vehicle: 2008 Ford Edge
 Test Program: FMVSS 208 Compliance
 Test Technician: Wayne Dahlke

NHTSA No.: C80202
 Test Date: 5/16/08

Test all front outboard seat belts except those in walk-in van-type vehicles and those at front outboard designated seating positions in passenger cars. Complete a form for each applicable seat belt.

DESIGNATED SEATING POSITION: **Left Front Driver**

- | | | | |
|-------------------------------------|--|----|---|
| <input checked="" type="checkbox"/> | | 1. | Is the vehicle a passenger car or walk-in van-type vehicle? |
| | | | <input type="checkbox"/> Yes, this form is complete |
| | | | <input checked="" type="checkbox"/> No |

- | | | | |
|-------------------------------------|--|----|--|
| <input checked="" type="checkbox"/> | | 2. | Put the seat in the mid fore-aft and full down height position determined in Data Sheet 14.2. (S8.1.2) |
|-------------------------------------|--|----|--|

- | | | | |
|-------------------------------------|--|----|--|
| <input checked="" type="checkbox"/> | | 3. | Put the seat back angle in the position determined in Data Sheet 14.2. (8.1.3) |
|-------------------------------------|--|----|--|

- | | | | |
|-------------------------------------|--|----|--|
| <input checked="" type="checkbox"/> | | 4. | Position the Part 572 Subpart E test dummy according to dummy position placement instructions in Appendix F. Complete the Appendix F check sheets, but include them in the test report ONLY if there is a test failure. |
|-------------------------------------|--|----|--|

- | | | | |
|-------------------------------------|--|----|--|
| <input checked="" type="checkbox"/> | | 5. | Fasten the seat belt around the dummy. |
|-------------------------------------|--|----|--|

- | | | | |
|-------------------------------------|--|----|---|
| <input checked="" type="checkbox"/> | | 6. | Remove all slack from the lap belt portion. (S10.9) |
|-------------------------------------|--|----|---|

- | | | | |
|--|--|--|--|
| | | | <input type="checkbox"/> N/A, the seat does not have a fore-aft adjustment |
|--|--|--|--|

- | | | | |
|-------------------------------------|--|----|--|
| <input checked="" type="checkbox"/> | | 7. | Pull the upper torso webbing out of the retractor and allow it to retract; repeat this four times. (S10.9) |
|-------------------------------------|--|----|--|

- | | | | |
|-------------------------------------|--|----|--|
| <input checked="" type="checkbox"/> | | 8. | Apply a 2 to 4 pound tension load to the lap belt. (S10.9) |
|-------------------------------------|--|----|--|

- | | | | |
|-------------------------------------|--|--|-------------------------------------|
| <input checked="" type="checkbox"/> | | | Pound load applied: <u>3</u> |
|-------------------------------------|--|--|-------------------------------------|

- | | | | |
|-------------------------------------|--|----|--|
| <input checked="" type="checkbox"/> | | 9. | Is the belt system equipped with a tension relieving device? |
| | | | <input type="checkbox"/> Yes, continue |
| | | | <input checked="" type="checkbox"/> No, go to 12 |

- | | | | |
|--|--|-----|---|
| | | 10. | Introduce the maximum amount of slack into the upper torso belt that is recommended by the vehicle manufacturer in the vehicle owner's manual. (S10.9). |
|--|--|-----|---|

- | | | | |
|--|--|-----|--|
| | | 11. | Check the statement that applies to this test vehicle: |
|--|--|-----|--|

- | | | | |
|--|--|------|---|
| | | 11.1 | The torso and lap belt webbing of the seat belt system automatically retracts to a stowed position when the adjacent vehicle door is in an open position and the seat belt latch plate is released. |
| | | | <input type="checkbox"/> Yes - Pass go to 12 |
| | | | <input type="checkbox"/> No - go to 11.2 |

- | | | | |
|--|--|------|---|
| | | 11.2 | The torso and lap belt webbing of the seat belt system automatically retracts when the seat belt latch plate is released. |
| | | | <input type="checkbox"/> Yes - Pass go to 12 |
| | | | <input type="checkbox"/> No - go to 11.3 |

- | | | | |
|--|--|------|-------------------------------|
| | | 11.3 | Neither 11.1 nor 11.2 apply. |
| | | | <input type="checkbox"/> Fail |

12. With the webbing and hardware in the stowed position are the webbing and hardware prevented from being pinched when the door is closed?
- Yes - Pass
 No - Fail
13. If this test vehicle has an open body (without doors) and has a belt system with a tension-relieving device, does the belt system fully retract when the tension-relieving device is deactivated?
- N/A - Not an open body vehicle
 Yes - Pass
 No - Fail

REMARKS:

I certify that I have read and performed each instruction.

Signature: Wayne Jahlh

Date: 5/16/08

DATA SHEET 12

SEAT BELT RETRACTION (S7.4.5)

Test Vehicle: 2008 Ford Edge
Test Program: FMVSS 208 Compliance
Test Technician: Wayne Dahlke

NHTSA No.: C80202
Test Date: 5/16/08

Test all front outboard seat belts except those in walk-in van-type vehicles and those at front outboard designated seating positions in passenger cars. Complete a form for each applicable seat belt.

DESIGNATED SEATING POSITION: Right Front Passenger

- 1. Is the vehicle a passenger car or walk-in van-type vehicle?
2. Put the seat in the mid fore-aft and full down height position determined in Data Sheet 14.2. (S8.1.2)
3. Put the seat back angle in the position determined in Data Sheet 14.2. (8.1.3)
4. Position the Part 572 Subpart E test dummy according to dummy position placement instructions in Appendix F. Complete the Appendix F check sheets, but include them in the test report ONLY if there is a test failure.
5. Fasten the seat belt around the dummy.
6. Remove all slack from the lap belt portion. (S10.9)
7. Pull the upper torso webbing out of the retractor and allow it to retract; repeat this four times. (S10.9)
8. Apply a 2 to 4 pound tension load to the lap belt. (S10.9)
9. Is the belt system equipped with a tension relieving device?
10. Introduce the maximum amount of slack into the upper torso belt that is recommended by the vehicle manufacturer in the vehicle owner's manual. (S10.9)
11. Check the statement that applies to this test vehicle:
11.1 The torso and lap belt webbing of the seat belt system automatically retracts to a stowed position when the adjacent vehicle door is in an open position and the seat belt latch plate is released.
11.2 The torso and lap belt webbing of the seat belt system automatically retracts when the seat belt latch plate is released.
11.3 Neither 11.1 nor 11.2 apply.

12. With the webbing and hardware in the stowed position are the webbing and hardware prevented from being pinched when the door is closed?
- Yes - Pass
 No - Fail
13. If this test vehicle has an open body (without doors) and has a belt system with a tension-relieving device, does the belt system fully retract when the tension-relieving device is deactivated?
- N/A - Not an open body vehicle
 Yes - Pass
 No - Fail

REMARKS:

I certify that I have read and performed each instruction.

Signature: Wayne Gahl

Date: 5/16/08

DATA SHEET 13

SEAT BELT GUIDES AND HARDWARE (S7.4.6)

Test Vehicle: 2008 Ford Edge
Test Program: FMVSS 208 Compliance
Test Technician: Wayne Dahlke

NHTSA No.: C80202
Test Date: 5/16/08

Test seat belts except those in walk-in van-type vehicles and those at front outboard designated seating positions in passenger cars. Complete a form for each applicable seat belt.

DESIGNATED SEATING POSITION: **Left Front Driver**

- 1. Is the seat cushion movable so that the seat back serves a function other than seating? (S7.4.6.1 (b))
 - Yes, this form is complete
 - No, go to 2
- 2. Is the seat removable? (S7.4.6.1(b))
 - Yes, this form is complete
 - No, go to 3
- 3. Is the seat movable so that the space formerly occupied by the seat can be used for a secondary function? (S7.4.6.1(b))
 - Yes, this form is complete
 - No, go to 4
- 4. Is the webbing designed to pass through the seat cushion or between the seat cushion and seat back? (S7.4.6.1(a))
 - Yes, go to 5
 - No, this form is complete
- 5. Does one of the following three parts, the seat belt latch plate, the buckle, or the seat belt webbing, stay on top of or above the seat cushion under normal conditions (i.e., conditions other than when belt hardware is intentionally pushed behind the seat by a vehicle occupant)? (S7.4.6.1(a))
 - Yes - Pass
 - No - Fail
 - Identify the part(s) on top or above the seat.
 - Seat belt latch plate
 - Buckle
 - Seat belt webbing
- 6. Are the remaining two seat belt parts accessible under normal conditions?
 - Yes - Pass
 - No - Fail
- 7. The buckle and latch plate do not pass through the guides or conduits provided and fall behind the seat when the belt is completely retracted or, if the belt is nonretractable, the belt is unlatched. (S7.4.6.2)
 - Yes - Pass
 - No - Fail

8. The buckle and latch plate do not pass through the guides or conduits provided and fall behind the seat when the seat is moved to any position to which it is designed to be adjusted. (S7.4.6.2)
- Yes - Pass
 No - Fail
9. The buckle and latch plate do not pass through the guides or conduits provided and fall behind the seat back, if foldable, is folded forward as far as possible and then moved backward into position. (S7.4.6.2)
- Yes - Pass
 No - Fail
10. Is the inboard receptacle end of the seat belt assembly, installed in the front outboard designated seating position, accessible with the center armrest in any position to which it can be adjusted (without moving the armrest)? (S7.4.6.2)
- Yes - Pass
 No - Fail
 N/A - Rear seat

REMARKS:

I certify that I have read and performed each instruction.

Signature: Wesley Stahl

Date: 5/16/08

DATA SHEET 13

SEAT BELT GUIDES AND HARDWARE (S7.4.6)

Test Vehicle: 2008 Ford Edge
Test Program: FMVSS 208 Compliance
Test Technician: Wayne Dahlke

NHTSA No.: C80202
Test Date: 5/16/08

Test seat belts except those in walk-in van-type vehicles and those at front outboard designated seating positions in passenger cars. Complete a form for each applicable seat belt.

DESIGNATED SEATING POSITION: Right Front Passenger

- 1. Is the seat cushion movable so that the seat back serves a function other than seating? (S7.4.6.1 (b))
2. Is the seat removable? (S7.4.6.1(b))
3. Is the seat movable so that the space formerly occupied by the seat can be used for a secondary function? (S7.4.6.1(b))
4. Is the webbing designed to pass through the seat cushion or between the seat cushion and seat back? (S7.4.6.1(a))
5. Does one of the following three parts, the seat belt latch plate, the buckle, or the seat belt webbing, stay on top of or above the seat cushion under normal conditions...
6. Are the remaining two seat belt parts accessible under normal conditions?
7. The buckle and latch plate do not pass through the guides or conduits provided and fall behind the seat when the belt is completely retracted or, if the belt is nonretractable, the belt is unlatched. (S7.4.6.2)

8. The buckle and latch plate do not pass through the guides or conduits provided and fall behind the seat when the seat is moved to any position to which it is designed to be adjusted. (S7.4.6.2)
- Yes - Pass
 No - Fail
9. The buckle and latch plate do not pass through the guides or conduits provided and fall behind the seat back, if foldable, is folded forward as far as possible and then moved backward into position. (S7.4.6.2)
- Yes - Pass
 No - Fail
10. Is the inboard receptacle end of the seat belt assembly, installed in the front outboard designated seating position, accessible with the center armrest in any position to which it can be adjusted (without moving the armrest)? (S7.4.6.2)
- Yes - Pass
 No - Fail
 N/A - Rear seat

REMARKS:

I certify that I have read and performed each instruction.

Signature: Wayne Gahl

Date: 5/16/08

DATA SHEET 13

SEAT BELT GUIDES AND HARDWARE (S7.4.6)

Test Vehicle: 2008 Ford Edge
Test Program: FMVSS 208 Compliance
Test Technician: Wayne Dahlke

NHTSA No.: C80202
Test Date: 5/16/08

Test seat belts except those in walk-in van-type vehicles and those at front outboard designated seating positions in passenger cars. Complete a form for each applicable seat belt.

DESIGNATED SEATING POSITION: **Left Rear Passenger**

- 1. Is the seat cushion movable so that the seat back serves a function other than seating? (S7.4.6.1 (b))
 - Yes, this form is complete
 - No, go to 2
- 2. Is the seat removable? (S7.4.6.1(b))
 - Yes, this form is complete
 - No, go to 3
- 3. Is the seat movable so that the space formerly occupied by the seat can be used for a secondary function? (S7.4.6.1(b))
 - Yes, this form is complete
 - No, go to 4
- 4. Is the webbing designed to pass through the seat cushion or between the seat cushion and seat back? (S7.4.6.1(a))
 - Yes, go to 5
 - No, this form is complete
- 5. Does one of the following three parts, the seat belt latch plate, the buckle, or the seat belt webbing, stay on top of or above the seat cushion under normal conditions (i.e., conditions other than when belt hardware is intentionally pushed behind the seat by a vehicle occupant)? (S7.4.6.1(a))
 - Yes - Pass
 - No - Fail

Identify the part(s) on top or above the seat.

 - Seat belt latch plate
 - Buckle
 - Seat belt webbing
- 6. Are the remaining two seat belt parts accessible under normal conditions?
 - Yes - Pass
 - No - Fail
- 7. The buckle and latch plate do not pass through the guides or conduits provided and fall behind the seat when the belt is completely retracted or, if the belt is nonretractable, the belt is unlatched. (S7.4.6.2)
 - Yes - Pass
 - No - Fail

8. The buckle and latch plate do not pass through the guides or conduits provided and fall behind the seat when the seat is moved to any position to which it is designed to be adjusted. (S7.4.6.2)
- Yes - Pass
 No - Fail
9. The buckle and latch plate do not pass through the guides or conduits provided and fall behind the seat back, if foldable, is folded forward as far as possible and then moved backward into position. (S7.4.6.2)
- Yes - Pass
 No - Fail
10. Is the inboard receptacle end of the seat belt assembly, installed in the front outboard designated seating position, accessible with the center armrest in any position to which it can be adjusted (without moving the armrest)? (S7.4.6.2)
- Yes - Pass
 No - Fail
 N/A - Rear seat

REMARKS:

I certify that I have read and performed each instruction.

Signature: Wayne J. Hill

Date: 5/16/08

DATA SHEET 13

SEAT BELT GUIDES AND HARDWARE (S7.4.6)

Test Vehicle: 2008 Ford Edge
Test Program: FMVSS 208 Compliance
Test Technician: Wayne Dahlke

NHTSA No.: C80202
Test Date: 5/16/08

Test seat belts except those in walk-in van-type vehicles and those at front outboard designated seating positions in passenger cars. Complete a form for each applicable seat belt.

DESIGNATED SEATING POSITION: **Center Rear Passenger**

- 1. Is the seat cushion movable so that the seat back serves a function other than seating? (S7.4.6.1 (b))
 - Yes, this form is complete
 - No, go to 2
- 2. Is the seat removable? (S7.4.6.1(b))
 - Yes, this form is complete
 - No, go to 3
- 3. Is the seat movable so that the space formerly occupied by the seat can be used for a secondary function? (S7.4.6.1(b))
 - Yes, this form is complete
 - No, go to 4
- 4. Is the webbing designed to pass through the seat cushion or between the seat cushion and seat back? (S7.4.6.1(a))
 - Yes, go to 5
 - No, this form is complete
- 5. Does one of the following three parts, the seat belt latch plate, the buckle, or the seat belt webbing, stay on top of or above the seat cushion under normal conditions (i.e., conditions other than when belt hardware is intentionally pushed behind the seat by a vehicle occupant)? (S7.4.6.1(a))
 - Yes - Pass
 - No - Fail

Identify the part(s) on top or above the seat.

 - Seat belt latch plate
 - Buckle
 - Seat belt webbing
- 6. Are the remaining two seat belt parts accessible under normal conditions?
 - Yes - Pass
 - No - Fail
- 7. The buckle and latch plate do not pass through the guides or conduits provided and fall behind the seat when the belt is completely retracted or, if the belt is nonretractable, the belt is unlatched. (S7.4.6.2)
 - Yes - Pass
 - No - Fail

8. The buckle and latch plate do not pass through the guides or conduits provided and fall behind the seat when the seat is moved to any position to which it is designed to be adjusted. (S7.4.6.2)
- Yes - Pass
 No - Fail
9. The buckle and latch plate do not pass through the guides or conduits provided and fall behind the seat back, if foldable, is folded forward as far as possible and then moved backward into position. (S7.4.6.2)
- Yes - Pass
 No - Fail
10. Is the inboard receptacle end of the seat belt assembly, installed in the front outboard designated seating position, accessible with the center armrest in any position to which it can be adjusted (without moving the armrest)? (S7.4.6.2)
- Yes - Pass
 No - Fail
 N/A - Rear seat

REMARKS:

I certify that I have read and performed each instruction.

Signature: Wayne Gahl

Date: 5/16/08

DATA SHEET 13

SEAT BELT GUIDES AND HARDWARE (S7.4.6)

Test Vehicle: 2008 Ford Edge
Test Program: FMVSS 208 Compliance
Test Technician: Wayne Dahlke

NHTSA No.: C80202
Test Date: 5/16/08

Test seat belts except those in walk-in van-type vehicles and those at front outboard designated seating positions in passenger cars. Complete a form for each applicable seat belt.

DESIGNATED SEATING POSITION: **Right Rear Passenger**

- 1. Is the seat cushion movable so that the seat back serves a function other than seating? (S7.4.6.1 (b))
 - Yes, this form is complete
 - No, go to 2
- 2. Is the seat removable? (S7.4.6.1(b))
 - Yes, this form is complete
 - No, go to 3
- 3. Is the seat movable so that the space formerly occupied by the seat can be used for a secondary function? (S7.4.6.1(b))
 - Yes, this form is complete
 - No, go to 4
- 4. Is the webbing designed to pass through the seat cushion or between the seat cushion and seat back? (S7.4.6.1(a))
 - Yes, go to 5
 - No, this form is complete
- 5. Does one of the following three parts, the seat belt latch plate, the buckle, or the seat belt webbing, stay on top of or above the seat cushion under normal conditions (i.e., conditions other than when belt hardware is intentionally pushed behind the seat by a vehicle occupant)? (S7.4.6.1(a))
 - Yes - Pass
 - No - Fail

Identify the part(s) on top or above the seat.

 - Seat belt latch plate
 - Buckle
 - Seat belt webbing
- 6. Are the remaining two seat belt parts accessible under normal conditions?
 - Yes - Pass
 - No - Fail
- 7. The buckle and latch plate do not pass through the guides or conduits provided and fall behind the seat when the belt is completely retracted or, if the belt is nonretractable, the belt is unlatched. (S7.4.6.2)
 - Yes - Pass
 - No - Fail

8. The buckle and latch plate do not pass through the guides or conduits provided and fall behind the seat when the seat is moved to any position to which it is designed to be adjusted. (S7.4.6.2)
- Yes - Pass
 No - Fail
9. The buckle and latch plate do not pass through the guides or conduits provided and fall behind the seat back, if foldable, is folded forward as far as possible and then moved backward into position. (S7.4.6.2)
- Yes - Pass
 No - Fail
10. Is the inboard receptacle end of the seat belt assembly, installed in the front outboard designated seating position, accessible with the center armrest in any position to which it can be adjusted (without moving the armrest)? (S7.4.6.2)
- Yes - Pass
 No - Fail
 N/A - Rear seat

REMARKS:

I certify that I have read and performed each instruction.

Signature: Wayne Gahl

Date: 5/16/08

DATA SHEET 14

MARKING OF REFERENCE POINTS FOR VARIOUS TEST POSITIONS AND POINTS

Test Vehicle: 2008 Ford Edge
Test Program: FMVSS 208 Compliance
Test Technician: Tim Bratz

NHTSA No.: C80202
Test Date: 7/10/08

DATA SHEET 14.1

MARKING OF REFERENCE POINTS FOR 5th FEMALE

Driver Seat Passenger Seat

1. Seat Position

- 1.1 Position the seat's adjustable lumbar supports so that the lumbar supports are in the lowest, retracted or deflated adjustment positions. (S16.2.10.1, S20.1.9.1, S20.4.1, S22.1.7.1)
 N/A - No lumbar adjustment
- 1.2 Position any adjustable parts of the seat that provide additional support so that they are in the lowest or most open adjustment position. (S16.2.10.2, S20.1.9.2, S20.4.1, S22.1.7.1, S22.4.2.1, S22.4.3.1, S24.4.2.1, S26.2.3, S26.3.1)
 N/A - No additional support adjustment
- 1.3 Position an adjustable leg support system in its rearmost position. (8/27/04 interpretation to Toyota)
 N/A - No adjustable leg support system
- 1.4 **Mark** a point (seat cushion reference point) on the side of the seat cushion that is between 150 mm and 250 mm from the front edge of the seat cushion. (S16.3.1.12)
- 1.5 Draw a line (seat cushion reference line) through the seat cushion reference point. (S16.3.1.13)
- 1.6 Use only the controls that primarily move the seat in the fore-aft direction to move the seat cushion reference point to the rearmost position. (S16.2.10.3.1, S22.1.7.3)
- 1.7 If the seat cushion adjusts fore-aft, independent of the seat back, use only the controls that primarily move the seat cushion in the fore-aft direction to move the seat cushion reference point to the rearmost position. (S16.2.10.3.1, S20.1.9.3)
 N/A - No independent fore-aft seat cushion adjustment
- 1.8 Use any part of any control, other than the parts just used for fore-aft positioning, to determine the range of angles of the seat cushion reference line and to set the seat cushion reference line at the mid-angle. (S16.2.10.3.1)
Maximum angle 6.0°
Minimum angle 0.0°
Mid-angle 3.0°
- 1.9 If the seat and/or seat cushion height is adjustable, use any part of any control other than the parts which primarily move the seat or seat cushion fore-aft, to put the seat cushion reference point in its lowest position with the seat cushion reference line angle at the mid-angle found in 1.8. (S16.2.10.3.1)
 N/A - No seat height adjustment
- 1.10 Use only the controls that primarily move the seat in the fore-aft direction to verify the seat is in the rearmost position.

- 1.11 Use only the controls that primarily move the seat in the fore-aft direction to **mark** for future reference the fore-aft seat positions. **Mark** each position so that there is a visual indication when the seat is at a particular position. For manual seats, move the seat forward one detent at a time and **mark** each detent. For power seats, **mark** only the rearmost, middle, and foremost positions. Label three of the positions with the following: F for foremost, M for mid-position (if there is no mid-position, label the closest adjustment position to the rear of the mid-point), and R for rearmost.
- 1.12 Use only the controls that primarily move the seat in the fore-aft direction to place the seat in the rearmost position.
- 1.13 Use any part of any control, other than the parts which primarily move the seat or seat cushion fore-aft, to find and visually **mark** for future reference the maximum, minimum, and middle height of the seat cushion reference point with the seat cushion reference line at the mid-angle determined in 1.8. (S20.1.9.4, S22.1.2, S22.1.7.4, S22.3.1, S22.4.3.1, S24.1.2, S24.3.1, S24.4.3.1, S26.2.3, S26.3.1)
 N/A - No seat height adjustment. Go to 1.18
- 1.14 Use only the controls that primarily move the seat and/or seat cushion in the fore-aft direction to place the seat in the mid-fore-aft position.
- 1.15 Use any part of any control, other than the parts which primarily move the seat or seat cushion fore-aft, to find and visually **mark** for future reference the maximum, minimum, and middle height of the seat cushion reference point with the seat cushion reference line at the mid-angle determined in 1.8. (S20.1.9.4, S22.1.2, S22.1.7.4, S22.3.1, S24.1.2, S24.3.1)
- 1.16 Use only the control that change the seat in the fore-aft direction to place the seat in the foremost position. (S16.2.10.3.2)
- 1.17 Use any part of any control, other than the parts which primarily move the seat or seat cushion fore-aft, to find and visually **mark** for future reference the maximum, minimum, and middle height of the seat cushion reference point with the seat cushion reference line at the mid-angle determined in 1.8. (S16.2.10.3.3, S20.1.9.4, S22.1.2, S22.1.7.4, S22.3.1, S24.1.2, S24.3.1)
- 1.18. Visually **mark** for future reference the seat back angle at the manufacturer's nominal design riding position for a **50th percentile adult male** in the manner specified by the manufacturer for the rearmost, mid, and foremost seat positions. (S20.1.9.5, S22.1.7.5, S22.4.2.1, S22.4.3.1, S24.1.2, S24.4.2.1, S26.2.3, S26.3.1)
 N/A - No seat back angle adjustment
 Manufacturer's design seat back angle 21.0° (7.4° on Head Rest Post)
- 1.19. Is the seat a bucket seat?
 Yes, go to 1.20 and skip 1.21
 No, go to 1.21 and skip 1.20
- 1.20 Bucket seats:
 Locate and **mark** for future reference the longitudinal centerline of the seat cushion. The intersection of the vertical longitudinal plane that passes through the SgRP and the seat cushion upper surface determines the longitudinal centerline of a bucket seat cushion. (S16.3.1.10 & S20.1.10)
- 1.21 Bench seats (complete ONLY the one that is applicable to the seat being marked):
 1.21.1 Driver Seat
 Locate and **mark** for future reference the longitudinal line on the seat cushion that marks the intersection of the vertical longitudinal plane through the centerline of the steering wheel and the seat cushion upper surface.

__1.21.2 Passenger Seat

Locate and **mark** for future reference the longitudinal centerline of the passenger seat cushion. The longitudinal centerline is the same distance from the longitudinal centerline of the vehicle as the center of the steering wheel. (S20.2.1.3, S22.2.1.3, S24.2.3, S20.4.4, S22.2.2.1(b), S22.2.2.3(b), S22.2.2.4(a), S22.2.2.5(a), S22.2.2.6(a), S22.2.2.7(a), S24.2.3(a))

Record the distance from the longitudinal centerline of the vehicle to the center of the steering wheel. _____

Record the distance from the longitudinal centerline of the vehicle to the longitudinal centerline of the seat cushion. (The vertical plane through this longitudinal centerline is Plane B for suppression.) _____

2. Head Restraint Position

__N/A Vehicle contains automatic head restraints.

__N/A, there is no head restraint adjustment

2.1 Adjust the head restraint to its lowest position. (S16.2.10.2, S20.1.9.6, S20.4.1, S22.1.7.6, S22.4.2.1, S22.4.3.1, S24.4.3.1, S26.2.3, S26.3.1)

2.2 All adjustments of the head restraint shall be used to position it full forward. For example, if it rotates, rotate it such that the head restraint extends as far forward as possible. **Mark** the foremost position. (S16.2.10.2 & S16.3.4.4 & S20.1.9.6, S20.4.1, S22.4.2.1, S22.4.3.1, S24.4.3.1, S26.2.3, S26.3.1)

2.3 Measure the vertical distance from the top most point of the head restraint to the bottom most point. Locate and **mark** a horizontal plane through the midpoint of this distance. (S16.3.4.3)

Vertical height of head restraint 240 mm

Mid-point height 120 mm

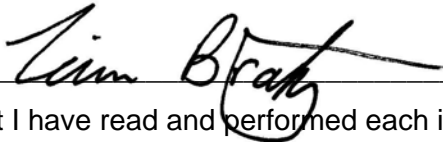

I certify that I have read and performed each instruction.

7/10/08

Date

DATA SHEET 14.1

MARKING OF REFERENCE POINTS FOR 5th FEMALE

Driver Seat Passenger Seat

1. Seat Position

- 1.1 Position the seat's adjustable lumbar supports so that the lumbar supports are in the lowest, retracted or deflated adjustment positions. (S16.2.10.1, S20.1.9.1, S20.4.1, S22.1.7.1)
 N/A - No lumbar adjustment
- 1.2 Position any adjustable parts of the seat that provide additional support so that they are in the lowest or most open adjustment position. (S16.2.10.2, S20.1.9.2, S20.4.1, S22.1.7.1, S22.4.2.1, S22.4.3.1, S24.4.2.1, S26.2.3, S26.3.1)
 N/A - No additional support adjustment
- 1.3 Position an adjustable leg support system in its rearmost position. (8/27/04 interpretation to Toyota)
 N/A - No adjustable leg support system
- 1.4 **Mark** a point (seat cushion reference point) on the side of the seat cushion that is between 150 mm and 250 mm from the front edge of the seat cushion. (S16.3.1.12)
- 1.5 Draw a line (seat cushion reference line) through the seat cushion reference point. (S16.3.1.13)
- 1.6 Use only the controls that primarily move the seat in the fore-aft direction to move the seat cushion reference point to the rearmost position. (S16.2.10.3.1, S22.1.7.3)
- 1.7 If the seat cushion adjusts fore-aft, independent of the seat back, use only the controls that primarily move the seat cushion in the fore-aft direction to move the seat cushion reference point to the rearmost position. (S16.2.10.3.1, S20.1.9.3)
 N/A - No independent fore-aft seat cushion adjustment
- 1.8 Use any part of any control, other than the parts just used for fore-aft positioning, to determine the range of angles of the seat cushion reference line and to set the seat cushion reference line at the mid-angle. (S16.2.10.3.1)
Maximum angle Zero
Minimum angle Zero
Mid-angle Zero
- 1.9 If the seat and/or seat cushion height is adjustable, use any part of any control other than the parts which primarily move the seat or seat cushion fore-aft, to put the seat cushion reference point in its lowest position with the seat cushion reference line angle at the mid-angle found in 1.8. (S16.2.10.3.1)
 N/A - No seat height adjustment
- 1.10 Use only the controls that primarily move the seat in the fore-aft direction to verify the seat is in the rearmost position.
- 1.11 Use only the controls that primarily move the seat in the fore-aft direction to **mark** for future reference the fore-aft seat positions. **Mark** each position so that there is a visual indication when the seat is at a particular position. For manual seats, move the seat forward one detent at a time and **mark** each detent. For power seats, **mark** only the rearmost, middle, and foremost positions. Label three of the positions with the following: F for foremost, M for mid-position (if there is no mid-position, label the closest adjustment position to the rear of the mid-point), and R for rearmost.
- 1.12 Use only the controls that primarily move the seat in the fore-aft direction to place the seat in the rearmost position.

- 1.13 Use any part of any control, other than the parts which primarily move the seat or seat cushion fore-aft, to find and visually **mark** for future reference the maximum, minimum, and middle height of the seat cushion reference point with the seat cushion reference line at the mid-angle determined in 1.8. (S20.1.9.4, S22.1.2, S22.1.7.4, S22.3.1, S22.4.3.1, S24.1.2, S24.3.1, S24.4.3.1, S26.2.3, S26.3.1)
 N/A - No seat height adjustment. Go to 1.18
- 1.14 Use only the controls that primarily move the seat and/or seat cushion in the fore-aft direction to place the seat in the mid-fore-aft position.
- 1.15 Use any part of any control, other than the parts which primarily move the seat or seat cushion fore-aft, to find and visually **mark** for future reference the maximum, minimum, and middle height of the seat cushion reference point with the seat cushion reference line at the mid-angle determined in 1.8. (S20.1.9.4, S22.1.2, S22.1.7.4, S22.3.1, S24.1.2, S24.3.1)
- 1.16 Use only the control that change the seat in the fore-aft direction to place the seat in the foremost position. (S16.2.10.3.2)
- 1.17 Use any part of any control, other than the parts which primarily move the seat or seat cushion fore-aft, to find and visually **mark** for future reference the maximum, minimum, and middle height of the seat cushion reference point with the seat cushion reference line at the mid-angle determined in 1.8. (S16.2.10.3.3, S20.1.9.4, S22.1.2, S22.1.7.4, S22.3.1, S24.1.2, S24.3.1)
- 1.18 Visually **mark** for future reference the seat back angle at the manufacturer's nominal design riding position for a **50th percentile adult male** in the manner specified by the manufacturer for the rearmost, mid, and foremost seat positions. (S20.1.9.5, S22.1.7.5, S22.4.2.1, S22.4.3.1, S24.1.2, S24.4.2.1, S26.2.3, S26.3.1)
 N/A - No seat back angle adjustment
 Manufacturer's design seat back angle 21.0° (7.4° on Head Rest Post)
- 1.19 Is the seat a bucket seat?
 Yes, go to 1.20 and skip 1.21
 No, go to 1.21 and skip 1.20
- 1.20 Bucket seats:
 Locate and **mark** for future reference the longitudinal centerline of the seat cushion. The intersection of the vertical longitudinal plane that passes through the SgRP and the seat cushion upper surface determines the longitudinal centerline of a bucket seat cushion. (S16.3.1.10 & S20.1.10)
- 1.21 Bench seats (complete ONLY the one that is applicable to the seat being marked):
- 1.21.1 Driver Seat
 Locate and **mark** for future reference the longitudinal line on the seat cushion that marks the intersection of the vertical longitudinal plane through the centerline of the steering wheel and the seat cushion upper surface.
- 1.21.2 Passenger Seat
 Locate and **mark** for future reference the longitudinal centerline of the passenger seat cushion. The longitudinal centerline is the same distance from the longitudinal centerline of the vehicle as the center of the steering wheel. (S20.2.1.3, S22.2.1.3, S24.2.3, S20.4.4, S22.2.2.1(b), S22.2.2.3(b), S22.2.2.4(a), S22.2.2.5(a), S22.2.2.6(a), S22.2.2.7(a), S24.2.3(a))
 Record the distance from the longitudinal centerline of the vehicle to the center of the steering wheel. _____
 Record the distance from the longitudinal centerline of the vehicle to the longitudinal centerline of the seat cushion. (The vertical plane through this longitudinal centerline is Plane B for suppression.) _____

2. Head Restraint Position

N/A Vehicle contains automatic head restraints.

N/A, there is no head restraint adjustment

2.1 Adjust the head restraint to its lowest position. (S16.2.10.2, S20.1.9.6 S20.4.1, S22.1.7.6, S22.4.2.1, S22.4.3.1, S24.4.3.1, S26.2.3, S26.3.1)

2.2 All adjustments of the head restraint shall be used to position it full forward. For example, if it rotates, rotate it such that the head restraint extends as far forward as possible. **Mark** the foremost position. (S16.2.10.2 & S16.3.4.4 & S20.1.9.6, S20.4.1, S22.4.2.1, S22.4.3.1, S24.4.3.1, S26.2.3, S26.3.1)

2.3 Measure the vertical distance from the top most point of the head restraint to the bottom most point. Locate and **mark** a horizontal plane through the midpoint of this distance. (S16.3.4.3)

Vertical height of head restraint 240 mm

Mid-point height 120 mm



I certify that I have read and performed each instruction.

7/10/08

Date

DATA SHEET 14.3

MARKING OF REFERENCE POINTS FOR STEERING WHEEL

- X1. Is the steering wheel adjustable up and down and/or in and out?
X Yes - go to 2
___ No - this form is complete
- X2. Find and **mark** for future reference each up and down position. Label three of the positions with the following: H for highest, M for mid-position (if there is no mid-position, label the next lowest adjustment position), and L for lowest.
___ N/A - steering wheel is not adjustable up and down
- X3. Find and **mark** for future references each in and out position. Label three of the positions with the following: F for foremost, M for mid-position (if there is no mid-position, label the next rearmost adjustment position), and R for rearmost.
___ N/A - steering wheel is not adjustable in and out.



_____ I certify that I have read and performed each instruction.

7/10/08

_____ Date

DATA SHEET 14.4

MARKING OF REFERENCE POINTS FOR DRIVER LOW RISK DEPLOYMENT

Position 1 Position 2

1. Position the steering wheel so the front wheels are in the straight-ahead position. (S26.2.1)
2. Position any adjustable parts of the steering controls to the mid-position as determined in Data Sheet 14.3 above. If a mid-position adjustment is not achievable, position the controls to the next lowest detent position. (S26.2.1)
3. Locate and **mark** the point that is defined by the intersection of the steering wheel cover and a line between the volumetric center of the smallest volume that can encompass the folded undeployed air bag and the volumetric center of the static fully inflated air bag. The vertical plane parallel to the vehicle longitudinal centerline through this point is referred to as "Plane E." (Check determination method below.) (S26.2.2)
Measurements with respect to measurement reference points:

The longitudinal centerline of the air bag was used.

Point determined using manufacturer's information supplied by the COTR .
(Include manufacturer's information in the test report.)
OR

Point determined by test lab personnel and approved by the COTR.
(Include supporting documentation in the test report.)

4. Locate the highest point of the air bag module cover. The horizontal plane through this point is referred to as "Plane F." (Check determination method below.) (S26.2.6)
Measurements with respect to measurement reference points:

The top of the air bag module cover was used.

Point determined using manufacturer's information supplied by the COTR .
(Include manufacturer's information in the test report.)
OR

Point determined by test lab personnel and approved by the COTR.
(Include manufacturer's information in the test report.)

Brian Roach

I certify that I have read and performed each instruction.

6/5/08

Date

DATA SHEET 16

AIR BAG SUPPRESSION TELLTALE (S19.2.2)

Test Vehicle: 2008 Ford Edge
Test Program: FMVSS 208 Compliance
Test Technician: Wayne Dahlke

NHTSA No.: C80202
Test Date: 5/22/08

- X 1. Is the vehicle certified to any suppression performance standards of FMVSS 208?
X 2. Does telltale emit yellow light when the air bag is suppressed? (S19.2.2(a))
X 3. Are the words "PASSENGER AIR BAG OFF" or "PASS AIR BAG OFF" (S19.2.2(b))
X 3.1 on the telltale? (S19.2.2(b))
3.2 Within 25 mm of the telltale? (S19.2.2(b)) 3 mm from the edge of the telltale light
X 4. Is the telltale separate from the air bag readiness indicator? (S19.2.2(c))
X 5. Is the telltale within the interior of the vehicle? (S19.2.2(d))
X 6. Is the telltale forward of and above the design H-point of both the driver's and the front outboard passenger's seat when the seats are in their forwardmost seating positions? (S19.2.2(d))
X 7. Is the telltale away from surfaces that can be used for temporary or permanent storage of objects that could obscure the telltale from either the driver's or front outboard passenger's view? (S19.2.2(d))
X 8. Is the telltale located so that it is not obscured from the driver or front outboard passenger by a rear-facing child restraint in Appendix A installed in the front outboard passenger seat? (S19.2.2(d))
X 9. Is the telltale visible or recognizable during the night? (S19.2.2(e))
X 10. Is the telltale visible or recognizable during the day? (S19.2.2(e))
X 11. If there is a visibility adjustment, do all the adjustment levels make the telltale visible and recognizable? (S19.2.2(g))
X 12. Does the telltale remain illuminated while the air bag is suppressed? (S19.2.2(h)) (Leave the air bag suppressed for 5 minutes.)
X 13. Is the telltale off while the air bag is activated? (S19.2.2(h)) (Leave the air bag activated for 5 minutes.)

Wayne Dahlke

5/22/08

I certify that I have read and performed each instruction.

Date

DATA SHEET 17 SUMMARY

Suppression Test Using 12-month-old CRABI Dummy (Part 572, Subpart R)
Section B Rear Facing CRS

NHTSA NO.:	C80202	TEST DATE:	5/22/08
LABORATORY:	MGA	TECHNICIANS:	WD
DUMMY TYPE:	12 Month Old	DUMMY SERIAL NO.:	062

CHILD RESTRAINT NAME:	Britax
CHILD RESTRAINT MODEL:	Handle With Care 191
DATE OF MANUFACTURE:	5-26-2000

Base: __On __Off N/A-Constraint does not have a removable base

Manufacturer's design seat back angle: 21°
 Tested seat back angle: 21°
 Manufacturer's specified anchorage position: 1st down from full up
 Tested anchorage position: 1st down from full up

A blanket and visor were not used in the suppression testing because they did not affect the weight sensing system used on the vehicle.

Test Summary

Seat Belt	Seat Slide	Cinch Load (N)	Result
Belted Rear Facing	Forward	133	Suppressed
	Middle	131	Suppressed
	Rearward	131	Suppressed
Unbelted Rear Facing	Forward	N/A	Suppressed
	Middle	N/A	Suppressed
	Rearward	N/A	Suppressed
Unbelted Forward Facing	Forward	N/A	Suppressed
	Middle	N/A	Suppressed
	Rearward	N/A	Suppressed

Successful Unbelted 5th percentile Female Dummy Reactivation was performed with the seat in the Middle position. (SN506)

DATA SHEET 17 SUMMARY

Suppression Test Using 12-month-old CRABI Dummy (Part 572, Subpart R)
Section B Rear Facing CRS

NHTSA NO.:	C80202	TEST DATE:	5/22/08
LABORATORY:	MGA	TECHNICIANS:	WD
DUMMY TYPE:	12 Month Old	DUMMY SERIAL NO.:	062

CHILD RESTRAINT NAME:	Evenflo
CHILD RESTRAINT MODEL:	First Choice 204
DATE OF MANUFACTURE:	6-20-2000

Base: On Off N/A-Constraint does not have a removable base

Manufacturer's design seat back angle: 21°
 Tested seat back angle: 21°
 Manufacturer's specified anchorage position: 1st down from full up
 Tested anchorage position: 1st down from full up

A blanket and visor were not used in the suppression testing because they did not affect the weight sensing system used on the vehicle.

Test Summary

Seat Belt	Seat Slide	Cinch Load (N)	Result
Belted Rear Facing	Forward 5 *	130	Suppressed
	Middle	128	Suppressed
	Rearward	127	Suppressed
Unbelted Rear Facing	Forward 10 *	N/A	Suppressed
	Middle	N/A	Suppressed
	Rearward	N/A	Suppressed
Unbelted Forward Facing	Forward 5 *	N/A	Suppressed
	Middle	N/A	Suppressed
	Rearward	N/A	Suppressed

Successful Unbelted 5th percentile Female Dummy Reactivation was performed with the seat in the Rearward position. (SN506)

* The CRS would not fit in this Forward Seat Slide position. If there is a number in the Seat Slide column, it indicates the fore-aft position with respect to the foremost position. (1 = Full Forward; 29 = Full Rearward; 29 notches total Seat Slide travel)

DATA SHEET 17 SUMMARY

Suppression Test Using 12-month-old CRABI Dummy (Part 572, Subpart R)
Section B Rear Facing CRS

NHTSA NO.:	C80202	TEST DATE:	5/22/08
LABORATORY:	MGA	TECHNICIANS:	WD
DUMMY TYPE:	12 Month Old	DUMMY SERIAL NO.:	062

CHILD RESTRAINT NAME:	Graco
CHILD RESTRAINT MODEL:	Infant 8457
DATE OF MANUFACTURE:	8-31-2000

Base: On Off N/A-Constraint does not have a removable base

Manufacturer's design seat back angle: 21°
 Tested seat back angle: 21°
 Manufacturer's specified anchorage position: 1st down from full up
 Tested anchorage position: 1st down from full up

A blanket and visor were not used in the suppression testing because they did not affect the weight sensing system used on the vehicle.

Test Summary

Seat Belt	Seat Slide	Cinch Load (N)	Result
Belted Rear Facing	Forward 5 *	131	Suppressed
	Middle	130	Suppressed
	Rearward	127	Suppressed
Unbelted Rear Facing	Forward 6 *	N/A	Suppressed
	Middle	N/A	Suppressed
	Rearward	N/A	Suppressed
Unbelted Forward Facing	Forward 6 *	N/A	Suppressed
	Middle	N/A	Suppressed
	Rearward	N/A	Suppressed

* The CRS would not fit in this Forward Seat Slide position. If there is a number in the Seat Slide column, it indicates the fore-aft position with respect to the foremost position. (1 = Full Forward; 29 = Full Rearward; 29 notches total Seat Slide travel)

DATA SHEET 17 SUMMARY

Suppression Test Using 12-month-old CRABI Dummy (Part 572, Subpart R)
Section B Rear Facing CRS

NHTSA NO.:	C80202	TEST DATE:	5/15/08
LABORATORY:	MGA	TECHNICIANS:	WD
DUMMY TYPE:	12 Month Old	DUMMY SERIAL NO.:	062

CHILD RESTRAINT NAME:	Graco
CHILD RESTRAINT MODEL:	Infant 8457
DATE OF MANUFACTURE:	8-31-2000

Base: On Off N/A-Constraint does not have a removable base

Manufacturer's design seat back angle: 21°
 Tested seat back angle: 21°
 Manufacturer's specified anchorage position: 1st down from full up
 Tested anchorage position: 1st down from full up

A blanket and visor were not used in the suppression testing because they did not affect the weight sensing system used on the vehicle.

Test Summary

Seat Belt	Seat Slide	Cinch Load (N)	Result
Belted Rear Facing	Forward 9 *	128	Suppressed
	Middle	127	Suppressed
	Rearward	127	Suppressed
Unbelted Rear Facing	Forward 10 *	N/A	Suppressed
	Middle	N/A	Suppressed
	Rearward	N/A	Suppressed
Unbelted Forward Facing	Forward 3 *	N/A	Suppressed
	Middle	N/A	Suppressed
	Rearward	N/A	Suppressed

Successful Unbelted 5th percentile Female Dummy Reactivation was performed with the seat in the Middle position. (SN506)

* The CRS would not fit in this Forward Seat Slide position. If there is a number in the Seat Slide column, it indicates the fore-aft position with respect to the foremost position. (1 = Full Forward; 29 = Full Rearward; 29 notches total Seat Slide travel)

DATA SHEET 17 SUMMARY

Suppression Test Using 12-month-old CRABI Dummy (Part 572, Subpart R)
Section C Forward Facing Convertible CRS

NHTSA NO.:	C80202	TEST DATE:	5/23/08
LABORATORY:	MGA	TECHNICIANS:	WD
DUMMY TYPE:	12 Month Old	DUMMY SERIAL NO.:	062

CHILD RESTRAINT NAME:	Britax
CHILD RESTRAINT MODEL:	Roundabout 161
DATE OF MANUFACTURE:	7-21-2000

Base: On Off N/A-Constraint does not have a removable base

Manufacturer's design seat back angle: 21°
 Tested seat back angle: 21°
 Manufacturer's specified anchorage position: 1st down from full up
 Tested anchorage position: 1st down from full up

A blanket was not used in the suppression testing because it did not affect the weight sensing system used on the vehicle.

Test Summary

Seat Belt	Seat Slide	Cinch Load (N)	Result
Belted Forward Facing	Forward	133	Suppressed
	Middle	132	Suppressed
	Rearward	130	Suppressed
Unbelted Forward Facing	Forward	N/A	Suppressed
	Middle	N/A	Suppressed
	Rearward	N/A	Suppressed
Belted Rear Facing	Forward	130	Suppressed
	Middle	128	Suppressed
	Rearward	127	Suppressed
Unbelted Rear Facing	Forward	N/A	Suppressed
	Middle	N/A	Suppressed
	Rearward	N/A	Suppressed

Successful Unbelted 5th percentile Female Dummy Reactivation was performed with the seat in the Forward position. (SN506)

DATA SHEET 17 SUMMARY

Suppression Test Using 12-month-old CRABI Dummy (Part 572, Subpart R)
Section C Forward Facing Convertible CRS

NHTSA NO.:	C80202	TEST DATE:	5/23/08
LABORATORY:	MGA	TECHNICIANS:	WD
DUMMY TYPE:	12 Month Old	DUMMY SERIAL NO.:	062

CHILD RESTRAINT NAME:	Century
CHILD RESTRAINT MODEL:	Encore 4612
DATE OF MANUFACTURE:	8-16-2000

Base: On Off N/A-Constraint does not have a removable base

Manufacturer's design seat back angle: 21°
 Tested seat back angle: 21°
 Manufacturer's specified anchorage position: 1st down from full up
 Tested anchorage position: 1st down from full up

A blanket was not used in the suppression testing because it did not affect the weight sensing system used on the vehicle.

Test Summary

Seat Belt	Seat Slide	Cinch Load (N)	Result
Belted Forward Facing	Forward	133	Suppressed
	Middle	131	Suppressed
	Rearward	129	Suppressed
Unbelted Forward Facing	Forward	N/A	Suppressed
	Middle	N/A	Suppressed
	Rearward	N/A	Suppressed
Belted Rear Facing	Forward	131	Suppressed
	Middle	133	Suppressed
	Rearward	129	Suppressed
Unbelted Rear Facing	Forward	N/A	Suppressed
	Middle	N/A	Suppressed
	Rearward	N/A	Suppressed

Successful Unbelted 5th percentile Female Dummy Reactivation was performed with the seat in the Middle position. (SN506)

DATA SHEET 17 SUMMARY

Suppression Test Using 12-month-old CRABI Dummy (Part 572, Subpart R)
Section C Forward Facing Convertible CRS

NHTSA NO.:	C80202	TEST DATE:	5/23/08
LABORATORY:	MGA	TECHNICIANS:	WD
DUMMY TYPE:	12 Month Old	DUMMY SERIAL NO.:	062

CHILD RESTRAINT NAME:	Evenflo
CHILD RESTRAINT MODEL:	Medallion 254
DATE OF MANUFACTURE:	6-1-2000

Base: On Off N/A-Constraint does not have a removable base

Manufacturer's design seat back angle: 21°
 Tested seat back angle: 21°
 Manufacturer's specified anchorage position: 1st down from full up
 Tested anchorage position: 1st down from full up

A blanket was not used in the suppression testing because it did not affect the weight sensing system used on the vehicle.

Test Summary

Seat Belt	Seat Slide	Cinch Load (N)	Result
Belted Forward Facing	Forward	131	Suppressed
	Middle	132	Suppressed
	Rearward	129	Suppressed
Unbelted Forward Facing	Forward	N/A	Suppressed
	Middle	N/A	Suppressed
	Rearward	N/A	Suppressed
Belted Rear Facing	Forward	133	Suppressed
	Middle	128	Suppressed
	Rearward	127	Suppressed
Unbelted Rear Facing	Forward 5 *	N/A	Suppressed
	Middle	N/A	Suppressed
	Rearward	N/A	Suppressed

Successful Unbelted 5th percentile Female Dummy Reactivation was performed with the seat in the Rearward position. (SN506)

* The CRS would not fit in this Forward Seat Slide position. If there is a number in the Seat Slide column, it indicates the fore-aft position with respect to the foremost position. (1 = Full Forward; 29 = Full Rearward; 29 notches total Seat Slide travel)

DATA SHEET 18 SUMMARY

Suppression Test Using Newborn Infant Dummy (Part 572, Subpart K) Section A Car Bed

NHTSA NO.:	C80202	TEST DATE:	5/22/08
LABORATORY:	MGA	TECHNICIANS:	WD
DUMMY TYPE:	Newborn Infant	DUMMY SERIAL NO.:	003

CAR BED NAME:	Cosco
CAR BED MODEL:	Dream Ride 02-719
DATE OF MANUFACTURE:	6-16-2000

Base: On Off N/A-Constraint does not have a removable base
 (A car bed with a removable base shall be treated as two separate models, i.e. this form and test procedure will be completed with the base on and then repeated on a new form with the base off.

Manufacturer's design seat back angle: 21°
 Tested seat back angle: 21°
 Manufacturer's specified anchorage position: 1st down from full up
 Tested anchorage position: 1st down from full up

A blanket and visor were not used in the suppression testing because they did not affect the weight sensing system used on the vehicle.

Test Summary

Seat Belt	Seat Slide	Result
Belted	Forward	Suppressed
	Middle	Suppressed
	Rearward	Suppressed

Successful Unbelted 5th percentile Female Dummy Reactivation was performed with the seat in the Forward position. (SN506)

DATA SHEET 19 SUMMARY

Suppression Test Using 3 Year Old Dummy And Booster Seats (Part 572, Subpart P)
Section D Forward Facing Belt Positioning Booster

NHTSA NO.:	C80202	TEST DATE:	5/27/08
LABORATORY:	MGA	TECHNICIANS:	WD
DUMMY TYPE:	3 Year Old	DUMMY SERIAL NO.:	032

BOOSTER SEAT NAME:	Century
BOOSTER SEAT MODEL:	Next Step 4920
DATE OF MANUFACTURE:	8-16-2000

Manufacturer's design seat back angle: 21°
 Tested seat back angle: 21°
 Manufacturer's specified anchorage position: 1st down from full up
 Tested anchorage position: 1st down from full up

Test Summary

Seat Belt	Seat Slide	Cinch Load (N)	Result
Belted Forward Facing Without Harness	Forward	9	Suppressed
	Middle	14	Suppressed
	Rearward	12	Suppressed
Belted Forward Facing Cinched With Harness	Forward	132	Suppressed
	Middle	128	Suppressed
	Rearward	127	Suppressed

Successful Unbelted 5th percentile Female Dummy Reactivation was performed with the seat in the Forward position. (SN506)

DATA SHEET 19 SUMMARY

Suppression Test Using 3 Year Old Dummy And Booster Seats (Part 572, Subpart P)
Section D Forward Facing Toddler Belt Positioning Booster Seat

NHTSA NO.:	C80202	TEST DATE:	5/27/08
LABORATORY:	MGA	TECHNICIANS:	WD
DUMMY TYPE:	3 Year Old	DUMMY SERIAL NO.:	032

BOOSTER SEAT NAME:	Cosco
BOOSTER SEAT MODEL:	High Back Booster 02-442
DATE OF MANUFACTURE:	4-28-2000

Manufacturer's design seat back angle: 21°
 Tested seat back angle: 21°
 Manufacturer's specified anchorage position: 1st down from full up
 Tested anchorage position: 1st down from full up

Test Summary

Seat Belt	Seat Slide	Cinch Load (N)	Result
Belted Forward Facing Without Harness	Forward	10	Suppressed
	Middle	12	Suppressed
	Rearward	18	Suppressed
Belted Forward Facing Cinched With Harness	Forward	129	Suppressed
	Middle	129	Suppressed
	Rearward	127	Suppressed

Successful Unbelted 5th percentile Female Dummy Reactivation was performed with the seat in the Rearward position. (SN506)

DATA SHEET 20 SUMMARY

Suppression Test Using 3 Year Old Dummy And Convertible Restraints (Part 572, Subpart P)
Section C Forward Facing Convertible CRS

NHTSA NO.:	C80202	TEST DATE:	5/23/08
LABORATORY:	MGA	TECHNICIANS:	WD
DUMMY TYPE:	3 Year Old	DUMMY SERIAL NO.:	032

CHILD RESTRAINT NAME:	Britax
CHILD RESTRAINT MODEL:	Roundabout 161
DATE OF MANUFACTURE:	7-21-2000

Manufacturer's design seat back angle: 21°
 Tested seat back angle: 21°
 Manufacturer's specified anchorage position: 1st down from full up
 Tested anchorage position: 1st down from full up

Test Summary

Seat Belt	Seat Slide	Cinch Load (N)	Result
Belted	Forward	132	Suppressed
	Middle	130	Suppressed
	Rearward	130	Suppressed

Successful Unbelted 5th percentile Female Dummy Reactivation was performed with the seat in the Middle position. (SN506)

DATA SHEET 20 SUMMARY

Suppression Test Using 3 Year Old Dummy And Convertible Restraints (Part 572, Subpart P)
Section C Forward Facing Convertible CRS

NHTSA NO.:	C80202	TEST DATE:	5/23/08
LABORATORY:	MGA	TECHNICIANS:	WD
DUMMY TYPE:	3 Year Old	DUMMY SERIAL NO.:	032

CHILD RESTRAINT NAME:	Century
CHILD RESTRAINT MODEL:	Encore 4612
DATE OF MANUFACTURE:	8-16-2000

Manufacturer's design seat back angle: 21°
 Tested seat back angle: 21°
 Manufacturer's specified anchorage position: 1st down from full up
 Tested anchorage position: 1st down from full up

Test Summary

Seat Belt	Seat Slide	Cinch Load (N)	Result
Belted	Forward	133	Suppressed
	Middle	130	Suppressed
	Rearward	130	Suppressed

Successful Unbelted 5th percentile Female Dummy Reactivation was performed with the seat in the Forward position. (SN506)

DATA SHEET 20 SUMMARY

Suppression Test Using 3 Year Old Dummy And Convertible Restraints (Part 572, Subpart P)
Section C Forward Facing Convertible CRS

NHTSA NO.:	C80202	TEST DATE:	5/23/08
LABORATORY:	MGA	TECHNICIANS:	WD
DUMMY TYPE:	3 Year Old	DUMMY SERIAL NO.:	032

CHILD RESTRAINT NAME:	Evenflo
CHILD RESTRAINT MODEL:	Medallion 254
DATE OF MANUFACTURE:	6-1-2000

Manufacturer's design seat back angle: 21°
 Tested seat back angle: 21°
 Manufacturer's specified anchorage position: 1st down from full up
 Tested anchorage position: 1st down from full up

Test Summary

Seat Belt	Seat Slide	Cinch Load (N)	Result
Belted	Forward	133	Suppressed
	Middle	129	Suppressed
	Rearward	127	Suppressed

Successful Unbelted 5th percentile Female Dummy Reactivation was performed with the seat in the Rearward position. (SN506)

DATA SHEET 21 SUMMARY

Suppression Test Using An Unbelted 3 Year Old Dummy (Part 572, Subpart P)
No CRS

NHTSA NO.:	C80202	TEST DATE:	5/27/08
LABORATORY:	MGA	TECHNICIANS:	WD
DUMMY TYPE:	3 Year Old	DUMMY SERIAL NO.:	032

Test Summary

Position	Seat Slide	Seat Back Angle **	Result
Position 1 Sitting on seat with back against seat back	Forward	6.4° on HRP (21°)	Suppressed
	Middle	6.4° on HRP (21°)	Suppressed
	Rearward	6.4° on HRP (21°)	Suppressed
Position 2 Sitting on seat with back against reclined seat back	Forward	31.2° on HRP (45.8°)	Suppressed
	Middle	31.2° on HRP (45.8°)	Suppressed
	Rearward	31.2° on HRP (45.8°)	Suppressed
Position 3 Sitting on seat with back not against seat back	Forward	6.4° on HRP (21°)	Suppressed
	Middle	6.4° on HRP (21°)	Suppressed
	Rearward	6.4° on HRP (21°)	Suppressed
Position 4 Sitting on seat edge, spine vertical, hands at dummy's sides	Forward	6.4° on HRP (21°)	Suppressed
	Middle	6.4° on HRP (21°)	Suppressed
	Rearward	6.4° on HRP (21°)	Suppressed
Position 5 Standing on seat, facing forward	Forward	6.4° on HRP (21°)	Suppressed
	Middle	6.4° on HRP (21°)	Suppressed
	Rearward	6.4° on HRP (21°)	Suppressed
Position 6 Kneeling on seat, facing forward	Forward	6.4° on HRP (21°)	Suppressed
	Middle	6.4° on HRP (21°)	Suppressed
	Rearward	6.4° on HRP (21°)	Suppressed
Position 7 Kneeling on seat, facing rearward	Forward	6.4° on HRP (21°)	Suppressed
	Middle	6.4° on HRP (21°)	Suppressed
	Rearward	6.4° on HRP (21°)	Suppressed
Position 8 Lying on seat. (Three designated seating positions only)	Forward	N/A	N/A
	Middle	N/A	N/A
	Rearward	N/A	N/A

Successful Unbelted 5th percentile Female Dummy Reactivation was performed with the seat in the Forward position. (SN506)

** The manufacturer's seat back angle of 21° equated to 6.4° on the Head Rest Post

DATA SHEET 22 SUMMARY

Suppression Test Using 6 Year Old Dummy And Booster Seats (Part 572, Subpart N)
Section D Forward Facing Toddler Belt Positioning Booster Seat

NHTSA NO.:	C80202	TEST DATE:	5/27/08
LABORATORY:	MGA	TECHNICIANS:	WD
DUMMY TYPE:	6 Year Old	DUMMY SERIAL NO.:	153

BOOSTER SEAT NAME:	Century
BOOSTER SEAT MODEL:	Next Step 4920
DATE OF MANUFACTURE:	8-16-2000

Manufacturer's design seat back angle: 21°
 Tested seat back angle: 21°
 Manufacturer's specified anchorage position: 1st down from full up
 Tested anchorage position: 1st down from full up

Test Summary

Seat Belt	Seat Slide	Belt Load (N)	Result
Belted	Forward	18	Suppressed
	Middle	15	Suppressed
	Rearward	11	Suppressed

Successful Unbelted 5th percentile Female Dummy Reactivation was performed with the seat in the Middle position. (SN506)

DATA SHEET 22 SUMMARY

Suppression Test Using 6 Year Old Dummy And Booster Seats (Part 572, Subpart N)
Section D Forward Facing Toddler Belt Positioning Booster Seat

NHTSA NO.:	C80202	TEST DATE:	5/27/08
LABORATORY:	MGA	TECHNICIANS:	WD
DUMMY TYPE:	6 Year Old	DUMMY SERIAL NO.:	153

BOOSTER SEAT NAME:	Cosco
BOOSTER SEAT MODEL:	High Back Booster 02-442
DATE OF MANUFACTURE:	4-28-2000

Manufacturer's design seat back angle: 21°
Tested seat back angle: 21°
Manufacturer's specified anchorage position: 1st down from full up
Tested anchorage position: 1st down from full up

Test Summary

Seat Belt	Seat Slide	Belt Load (N)	Result
Belted	Forward	14	Suppressed
	Middle	17	Suppressed
	Rearward	12	Suppressed

Successful Unbelted 5th percentile Female Dummy Reactivation was performed with the seat in the Rearward position. (SN506)

DATA SHEET 22 SUMMARY

Suppression Test Using 6-Year-Old Dummy And Booster Seats (Part 572, Subpart N)
Section D Forward Facing Toddler Belt Positioning Booster Seat

NHTSA NO.:	C80202	TEST DATE:	5/27/08
LABORATORY:	MGA	TECHNICIANS:	WD
DUMMY TYPE:	6 Year Old	DUMMY SERIAL NO.:	153

BOOSTER SEAT NAME:	Evenflo
BOOSTER SEAT MODEL:	Right Fit 245
DATE OF MANUFACTURE:	6-26-2000

Manufacturer's design seat back angle: 21°
 Tested seat back angle: 21°
 Manufacturer's specified anchorage position: 1st down from full up
 Tested anchorage position: 1st down from full up

Test Summary

Seat Belt	Seat Slide	Belt Load (N)	Result
Belted	Forward	18	Suppressed
	Middle	12	Suppressed
	Rearward	9	Suppressed

Successful Unbelted 5th percentile Female Dummy Reactivation was performed with the seat in the Forward position. (SN506)

DATA SHEET 23 SUMMARY

Suppression Test Using An Unbelted 6-Year-Old Dummy (Part 572, Subpart N)
No CRS

NHTSA NO.:	C80202	TEST DATE:	5/27/08
LABORATORY:	MGA	TECHNICIANS:	WD
DUMMY TYPE:	6 Year Old	DUMMY SERIAL NO.:	155

Test Summary

Position	Seat Slide	Seat Back Angle **	Result
Position 1 Sitting on seat with back against seat back	Forward 9 *	6.4° on HRP (21°)	Suppressed
	Middle	6.4° on HRP (21°)	Suppressed
	Rearward	6.4° on HRP (21°)	Suppressed
Position 2 Sitting on seat with back against reclined seat back	Forward	31.2° off HRP (45.8°)	Suppressed
	Middle	31.2° off HRP (45.8°)	Suppressed
	Rearward	31.2° off HRP (45.8°)	Suppressed
Position 3 Sitting on seat edge, spine vertical, hands at dummy's sides	Forward	6.4° on HRP (21°)	Suppressed
	Middle	6.4° on HRP (21°)	Suppressed
	Rearward	6.4° on HRP (21°)	Suppressed
Position 4 Sitting on seat with back against seat back then leaning on the door	Forward	6.4° on HRP (21°)	Suppressed
	Middle	6.4° on HRP (21°)	Suppressed
	Rearward	6.4° on HRP (21°)	Suppressed

Successful Unbelted 5th percentile Female Dummy Reactivation was performed with the seat in the Middle position. (SN506)

* The CRS would not fit in this Forward Seat Slide position. If there is a number in the Seat Slide column, it indicates the fore-aft position with respect to the foremost position. (1 = Full Forward; 29 = Full Rearward; 29 notches total Seat Slide travel)

** The manufacturer's seat back angle of 21° equated to 6.4° on the Head Rest Post

DATA SHEET 29 SUMMARY

Low Risk Deployment Tests Using an Unbelted 5th Percentile Female
Dummy (Part 572, Subpart O) (S26) Position 1 - Chin On Module (S26.2)

NHTSA NO.:	C80202	TEST DATE:	6/5/08
LABORATORY:	MGA	TECHNICIANS:	WD/AP
DUMMY TYPE:	5 th Percentile Female	DUMMY SERIAL NO.:	507

Manufacturer's design seat back angle: 21°
 Tested seat back angle: 21°
 Tested seat position: Full Aft

 Tested steering wheel angle: 29.7°
 Thorax cavity angle: 35.5°
 Bottom of chin height: 0 mm

Air Bag Deployment Timing

Stage No.	Firing time (ms)	Recorded firing time (ms)
1	0.0	0.3
2	150.0	150.3

5th Percentile Female SN 507 Position 1 (Chin On Module) 6/5/08

Injury Criteria	Max. Allowable Injury Assessment Values	Measured Value
HIC15	700	34
Peak Nij (Nte)	1.0	0.3
Time (ms)	NA	47.0
Peak Nij (Ntf)	1.0	0.3
Time (ms)	NA	30.2
Peak Nij (Nce)	1.0	0.2
Time (ms)	NA	175.8
Peak Nij (Ncf)	1.0	0.1
Time (ms)	NA	220.9
Neck Tension	2070 N	557
Neck Compression	2520 N	222
Chest g	60 g	10
Chest Displacement	52 mm	6
Left Femur	6805 N	105
Right Femur	6805 N	97

Calculated on data recorded for 125 ms after the initiation of the final stage of air bag deployment
 designed to deploy in any full frontal rigid barrier crash up to 26 km/h. (S4.11(d))
 Second stage fire time of 150 ms; Injuries calculated on 0 ms to 275 ms

The original equipment parts were used for this deployment.

DATA SHEET 30 SUMMARY

Low Risk Deployment Tests Using an Unbelted 5th Percentile Female Dummy (Part 572, Subpart O) (S26) Position 2 - Chin On Rim (S26.3)

NHTSA NO.:	C80202	TEST DATE:	6/5/08
LABORATORY:	MGA	TECHNICIANS:	WD/AP
DUMMY TYPE:	5 th Percentile Female	DUMMY SERIAL NO.:	507

Manufacturer's design seat back angle: 21°
 Tested seat back angle: 21°
 Tested seat position: Full Aft

Tested steering wheel angle: 29.7°
 Thorax cavity angle: 35.7°
 Chin Point height: 0 mm - At Steering Wheel Target
 Note: The chin on rim steering wheel target is 10 mm below the highest point on the steering wheel

Air Bag Deployment Timing

Stage No.	Firing time (ms)	Recorded firing time (ms)
1	0.0	0.3
2	150.0	150.3

5th Percentile Female SN 507 Position 2 (Chin On Rim) 6/5/08

Injury Criteria	Max. Allowable Injury Assessment Values	Measured Value
HIC15	700	17
Peak Nij (Nte)	1.0	0.4
Time (ms)	NA	31.1
Peak Nij (Ntf)	1.0	0.3
Time (ms)	NA	71.5
Peak Nij (Nce)	1.0	0.1
Time (ms)	NA	161.0
Peak Nij (Ncf)	1.0	0.2
Time (ms)	NA	55.4
Neck Tension	2070 N	772
Neck Compression	2520 N	174
Chest g	60 g	13
Chest Displacement	52 mm	19
Left Femur	6805 N	26
Right Femur	6805 N	22

Calculated on data recorded for 125ms after the initiation of the final stage of air bag deployment designed to deploy in any full frontal rigid barrier crash up to 26 km/h. (S4.11(d))
 Second stage fire time of 150 ms; Injuries calculated on 0 ms to 275 ms

The steering column and airbag were replaced for this deployment.

DATA SHEET 32

VEHICLE WEIGHT, FUEL TANK, AND ATTITUDE DATA

Test Vehicle: 2008 Ford Edge
 Test Program: FMVSS 208 Compliance
 Test Technician: Jamie Aide

NHTSA No.: C80202
 Test Date: 7/10/08

IMPACT ANGLE:	Zero Degrees		
BELTED DUMMIES (YES/NO):	No		
TEST SPEED:	<input checked="" type="checkbox"/> 32 to 40 kmph	<input type="checkbox"/> 0 to 48 kmph	<input type="checkbox"/> 0 to 56 kmph
DRIVER DUMMY:	<input checked="" type="checkbox"/> 5 th female	<input type="checkbox"/> 50 th male	
PASSENGER DUMMY:	<input checked="" type="checkbox"/> 5 th female	<input type="checkbox"/> 50 th male	

- 1. Fill the transmission with transmission fluid to the satisfactory range.
- 2. Drain fuel from vehicle
- 3. Run the engine until fuel remaining in the fuel delivery system is used and the engine stops.
- 4. Record the useable fuel tank capacity supplied by the COTR
- Useable Fuel Tank Capacity supplied by COTR: 71.9 liters (19.0 gallons)
- 5. Record the fuel tank capacity supplied in the owner's manual.
- Useable Fuel Tank Capacity in owner's manual: 71.9 liters (19.0 gallons)
- 6. Using purple dyed Stoddard solvent having the physical and chemical properties of Type 1 solvent or cleaning fluid, Table 1, ASTM Standard D484-71, "Standard Specifications for Hydrocarbon Dry-cleaning Solvents," or gasoline, fill the fuel tank.
- Amount Added: 71.9 liters (19.0 gallons)
- 7. Fill the coolant system to capacity.
- 8. Fill the engine with motor oil to the Max. mark on the dip stick.
- 9. Fill the brake reservoir with brake fluid to its normal level.
- 10. Fill the windshield washer reservoir to capacity.
- 11. Inflate the tires to the tire pressure on the tire placard. If no tire placard is available, inflate the tires to the recommended pressure in the owner's manual.

Tire placard pressure:	RF:	35 psi	LF:	35 psi	RR:	35 psi	LR:	35 psi
Owner's manual pressure:	RF:	35 psi	LF:	35 psi	RR:	35 psi	LR:	35 psi
Actual inflated pressure:	RF:	35 psi	LF:	35 psi	RR:	35 psi	LR:	35 psi

- 12. Record the vehicle weight at each wheel to determine the unloaded vehicle weight (UVW), i.e. "as delivered" weight).

Right Front (kg):	549.8	Right Rear (kg):	374.2
Left Front (kg):	552.0	Left Rear (kg):	384.7
Total Front (kg):	1101.8	Total Rear (kg):	758.9
% Total Weight:	59.2	% Total Weight:	40.8
UVW = TOTAL FRONT PLUS TOTAL REAR (KG):	1860.7		

- 13. UVW Test Vehicle Attitude: (All dimensions in millimeters)
- 13.1 Mark a point on the vehicle above the center of each wheel.
- 13.2 Place the vehicle on a level surface.

- 13.3 Measure perpendicular to the level surface to the 4 points marked on the body and record the measurements

RF:	840	LF:	838	RR:	842	LR:	842
-----	-----	-----	-----	-----	-----	-----	-----

14. Calculate the Rated Cargo and Luggage Weight (RCLW): 72 kg
- 14.1 Does the vehicle have the vehicle capacity weight (VCW) on the certification label or tire placard?

- Yes, go to 14.3
- No, go to 14.2

- 14.2 VCW = Gross Vehicle Weight - UVW

$$VCW = \underline{\hspace{2cm}} - \underline{\hspace{2cm}} = \underline{\hspace{2cm}}$$

- 14.3 VCW = 412 kg (909 lbs)

- 14.4 Does the certification or tire placard contain the Designated Seating Capacity (DSC)?

- Yes, go to 14.6
- No, go to 14.5 and skip 14.6

- 14.5 DSC = Total number of seat belt assemblies = _____

- 14.6 DSC = 5

- 14.7 RCLW = VCW - (68 kg x DSC) = 412 kg - (68 kg x 5) = 72 kg

- 14.8 Is the vehicle certified as a truck, MPV or bus (see the certification label on the door jamb)?

- Yes, if the calculated RCLW is greater than 136 kg, use 136 kg as the RCLW. (S8.1.1)
- No, use the RCLW calculated in 14.7

15. Fully Loaded Weight (100% fuel fill): 2030.7 kg

- 15.1 Place the appropriate test dummy in both front outboard seating positions.

Driver: 5th female ___ 50th male
 Passenger: 5th female ___ 50th male

- 15.2 Load the vehicle with the RCLW from 14.7 or 14.8 whichever is applicable.

- 15.3 Place the RCLW in the cargo area. Center the load over the longitudinal centerline of the vehicle. (S8.1.1 (d))

- 15.4 Record the vehicle weight at each wheel to determine the Fully Loaded Weight.

Right Front (kg):	579.2	Right Rear (kg):	430.9
Left Front (kg):	580.6	Left Rear (kg):	440.0
Total Front (kg):	1159.8	Total Rear (kg):	870.9
% Total Weight:	57.1	% Total Weight:	42.9
% GVW	53.2	% GVW	47.4
(% GVW = Axle GVW divided by Vehicle GVW)			
Fully Loaded Weight = Total Front Plus Total Rear (kg):			2030.7

16. Fully Loaded Test Vehicle Attitude: (All dimensions in millimeters)

- 16.1 Place the vehicle on a level surface.

- 16.2 Measure perpendicular to the level surface to the 4 points marked on the body (see 13.1 above) and record the measurements

RF:	832	LF:	830	RR:	827	LR:	826
-----	-----	-----	-----	-----	-----	-----	-----

17. Drain the fuel system
18. Using purple dyed Stoddard solvent having the physical and chemical properties of Type 1 solvent or cleaning fluid, Table 1, ASTM Standard D484-71, "Standard Specifications for Hydrocarbon Dry-cleaning Solvents," fill the fuel tank to 92 - 94 percent of useable capacity.

Fuel tank capacity x .94 = 71.9 liters (19.0 gallons) x .94 = 67.6 liters (17.9 gallons)

Amount added 66.6 liters (17.6 gallons) 92.6%

19. Crank the engine to fill the fuel delivery system with Stoddard solvent
20. Calculate the test weight range.
- 20.1 Calculated Weight = UVW (see 12 above) + RCLW (see 14 above) + 2x(dummy weight)

$$\underline{2030.7 \text{ kg} = 1860.7 \text{ kg} + 72.0 \text{ kg} + 98.0 \text{ kg}}$$

- 20.2 Test Weight Range = Calculated Weight (- 4.5 kg, - 9 kg.)
 Max. Test Weight = Calculated Test Weight - 4.5 kg = 2026.2 kg
 Min. Test Weight = Calculated Test Weight - 9 kg = 2021.7 kg

21. Remove the RCLW from the cargo area.
22. Drain transmission fluid, engine coolant, motor oil, and windshield washer fluid from the test vehicle so that Stoddard solvent leakage from the fuel system will be evident.

23. Vehicle Components Removed For Weight Reduction:
Spare tools, trunk area carpet and right rear tail light

24. Secure the equipment and ballast in the load carrying area and distribute it, as nearly as possible, to obtain the proportion of axle weight indicated by the gross axle weight ratings and center it over the longitudinal centerline of the vehicle.

25. If necessary, add ballast to achieve the actual test weight.

N/A

Weight of Ballast: 72.1 kg

26. Ballast, including test equipment, must be contained so that it will not shift during the impact event or interfere with data collection or interfere with high-speed film recordings or affect the structural integrity of the vehicle or do anything else to affect test results. Care must be taken to assure that any attachment hardware added to the vehicle is not in the vicinity of the fuel tank or lines.

27. Record the vehicle weight at each wheel to determine the actual test weight.

Right Front (kg):	573.4	Right Rear (kg):	430.5
Left Front (kg):	582.0	Left Rear (kg):	437.7
Total Front (kg):	1155.4	Total Rear (kg):	868.2
% Total Weight:	57.1	% Total Weight:	42.9
% GVW	53.2	% GVW	47.4
(% GVW = Axle GVW divided by Vehicle GVW)			
TOTAL FRONT PLUS TOTAL REAR (kg):			2023.6

28. Is the test weight between the Max. Weight and the Min. Weight (See 20.2)?
- Yes
- No, explain why not.
29. Test Weight Vehicle Attitude: (all dimensions in millimeters)
- 29.1 Place the vehicle on a level surface
- 29.2 Measure perpendicular to the level surface to the 4 points marked on the body (see 13 above) and record the measurements

RF:	833	LF:	831	RR:	829	LR:	826
-----	-----	-----	-----	-----	-----	-----	-----

30. Summary of test attitude
- 30.1 AS DELIVERED:

RF:	840	LF:	838	RR:	842	LR:	842
-----	-----	-----	-----	-----	-----	-----	-----

AS TESTED:

RF:	833	LF:	831	RR:	829	LR:	826
-----	-----	-----	-----	-----	-----	-----	-----

FULLY LOADED:

RF:	832	LF:	830	RR:	827	LR:	826
-----	-----	-----	-----	-----	-----	-----	-----

- 30.2 Is the "as tested" test attitude equal to or between the "fully loaded" and "as delivered" attitude?
- Yes
- No, explain why not.

REMARKS:

I certify that I have read and performed each instruction.

Signature:

Jamie C. Costello

Date: 7/10/08

DATA SHEET 33

VEHICLE ACCELEROMETER LOCATION AND MEASUREMENT

Test Vehicle: 2008 Ford Edge
 Test Program: FMVSS 208 Compliance
 Test Technician: Chris Novak

NHTSA No.: C80202
 Test Date: 7/10/08

IMPACT ANGLE:	Zero Degrees		
BELTED DUMMIES (YES/NO):	No		
TEST SPEED:	<u>X</u> 32 to 40 kmph	<u> </u> 0 to 48 kmph	<u> </u> 0 to 56 kmph
DRIVER DUMMY:	<u>X</u> 5 th female	<u> </u> 50 th male	
PASSENGER DUMMY:	<u>X</u> 5 th female	<u> </u> 50 th male	

- 1. Find the location where the vertical plane parallel to the longitudinal centerline of the vehicle and through the center of the left front outboard seating position intersects the left rear seat cross member. Install an accelerometer at this intersection on the rear seat cross member to record x-direction accelerations. Record the location on the following chart.
- 2. Find the location where the vertical plane parallel to the longitudinal centerline of the vehicle and through the center of the right front outboard seating position intersects the right rear seat cross member. Install an accelerometer at this intersection on the rear seat cross member to record x-direction accelerations. Record the location on the following chart.
- 3. Find the location where a vertical plane through the longitudinal centerline of the vehicle and a vertical transverse plane through the center of the two wheels on opposite sides of the engine intersect at the top of the engine. Install an accelerometer at this intersection to record x-direction accelerations. Record the location on the following chart.
- 4. Find the location where a vertical plane through the longitudinal centerline of the vehicle and a vertical transverse plane through the center of the two wheels on opposite sides of the engine intersect the bottom of the engine. Install an accelerometer at this intersection to record x-direction accelerations. Record the location on the following chart.
- 5. Install an accelerometer on the right front brake caliper to record x-direction accelerations. Record the location on the following chart.
- 6. Find the location where a vertical plane through the longitudinal centerline of the vehicle intersects the top of the instrument panel. Install an accelerometer at this intersection to record x-direction accelerations. Record the location on the following chart.
- 7. Install an accelerometer on the left front brake caliper to record x-direction accelerations. Record the location on the following chart.
- 8. Find the location where a vertical plane through the longitudinal centerline of the vehicle intersects the floor of the trunk. Install an accelerometer on the trunk floor at this intersection to record z-direction accelerations. Record the location on the following chart.

REMARKS:

I certify that I have read and performed each instruction.

Signature: 

Date: 7/10/08

VEHICLE ACCELEROMETER LOCATION AND DATA SUMMARY

CENTERLINE OF FRONT WHEELS

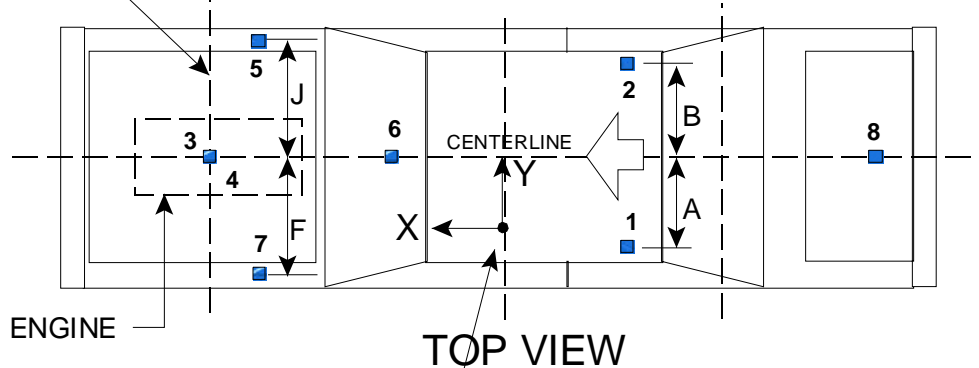

ACCELEROMETER COORDINATE SYSTEM (POSITIVE DIRECTION SHOWN)

REAR SEAT CUSHION ASSY. FRONT ATTACHMENT BRACKET SUPPORT

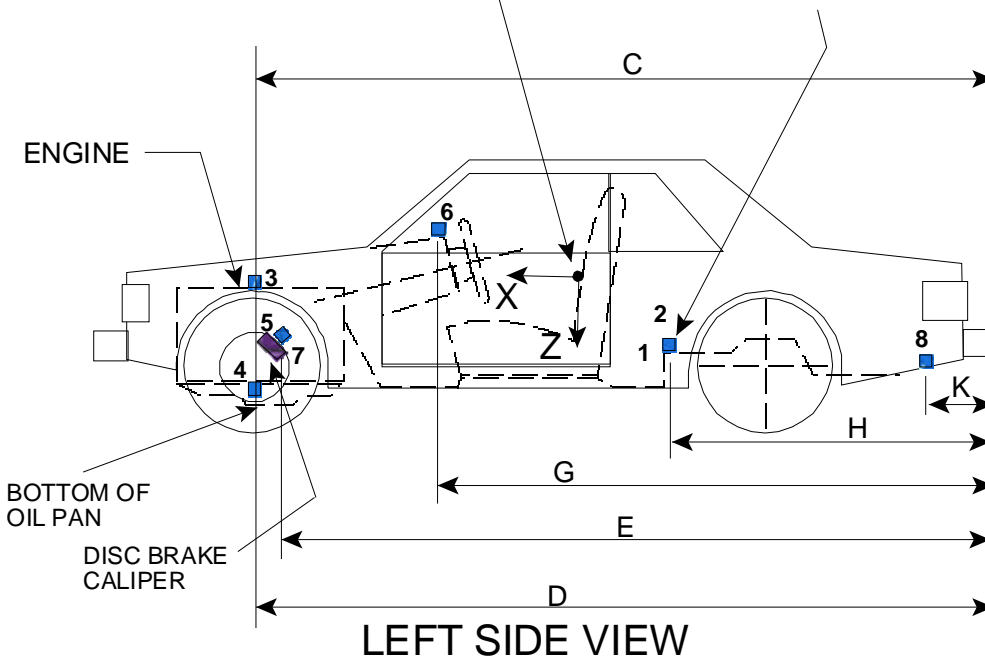

Dimensions Corresponding To The Letters "A" Through "K" (Excluding "I") Are Recorded In The Table On The Following Page.
Accelerometers Corresponding To The Numbers 1 Through 8 Are Specified On The Preceding Page.

DATA SHEET 33
VEHICLE ACCELEROMETER LOCATION AND MEASUREMENTS

<u>DIMENSION</u>	<u>LENGTH (mm)</u>	
PRETEST VALUES		
<u>A</u> (LH Rear Seat Xmbr)	367	
<u>B</u> (RH Rear Seat Xmbr)	367	
<u>C</u> (Engine Top)	3860	
<u>D</u> (Engine Bottom)	4038	
<u>E</u> (Caliper)	Right Side: 3871	Left Side: 3871
<u>F</u> (Left Caliper)	760	
<u>G</u> (IP)	2928	
<u>H</u> (Seat)	1820	
<u>J</u> (Right Caliper)	760	
<u>K</u> (Trunk)	239	
POST TEST VALUES		
<u>A</u> (LH Rear Seat Xmbr)	367	
<u>B</u> (RH Rear Seat Xmbr)	367	
<u>C</u> (Engine Top)	3819	
<u>D</u> (Engine Bottom)	4009	
<u>E</u> (Caliper)	Right Side: 3864	Right Side: 3867
<u>F</u> (Left Caliper)	732	
<u>G</u> (IP)	2917	
<u>H</u> (Seat)	1820	
<u>J</u> (Right Caliper)	732	
<u>K</u> (Trunk)	239	

DATA SHEET 34
PHOTOGRAPHIC TARGETS





Test Vehicle: 2008 Ford Edge
 Test Program: FMVSS 208 Compliance
 Test Technician: Jamie Aide

NHTSA No.: C80202
 Test Date: 7/10/08

IMPACT ANGLE:	Zero Degrees		
BELTED DUMMIES (YES/NO):	No		
TEST SPEED:	<u>X</u> 32 to 40 kmph	<u> </u> 0 to 48 kmph	<u> </u> 0 to 56 kmph
DRIVER DUMMY:	<u>X</u> 5 th female	<u> </u> 50 th male	
PASSENGER DUMMY:	<u>X</u> 5 th female	<u> </u> 50 th male	

- 1. FMVSS 208 vehicle targeting requirements (See Figures 28A and 28B)
- 1.1 Targets A1 and A2 are on flat rectangular panels.
- 1.2 Three circular targets at least 90 mm in diameter and with black and yellow quadrants are mounted at the front on the outboard sides of A1 and A2. The center of each circular target is 100 mm from the one next to it.
 Distance between targets (mm): 100 mm
- 1.3 Three circular targets at least 90 mm in diameter and with black and yellow quadrants are mounted at the back on the outboard sides of on A1 and A2. The center of each circular target is 100 mm from the one next to it.
 Distance between targets (mm): 100 mm
- 1.4 The distance between the first circular target at the front of A1 and A2 and the last circular target at the back of A1 and A2 is at least 915 mm.
 Distance between the first and last circular targets (mm): 915 mm
- 1.5 Firmly fix target A1 on the vehicle roof in the vertical longitudinal plane that is coincident with the midsagittal plane of the driver dummy.
- 1.6 Firmly fix target A2 on the vehicle roof in the vertical longitudinal plane that is coincident with the midsagittal plane of the passenger dummy.
- 1.7 Two circular targets (C1 and C2) at least 90 mm in diameter and with black and yellow quadrants are mounted on the outside of the driver door. The centers of each circular target are at least 610 mm apart.
 Distance between targets (mm): 610 mm
- 1.8 Two circular targets (C1 and C2) at least 90 mm in diameter and with black and yellow quadrants are mounted on the outside of the passenger door. The centers of each circular target are at least 610 mm apart.
 Distance between targets (mm): 610 mm
- 1.9 Place tape with squares having alternating colors on the top portion of the steering wheel.
- 1.10 Chalk the bottom portion of the steering wheel
- 1.11 Is this an offset test?
 Yes, continue with this section
 No, go to 2.

- 1.12 Measure the width of the vehicle.
Vehicle width (mm):
- 1.13 Find the centerline of the vehicle. ($\frac{1}{2}$ of the vehicle width)
- 1.14 Find the line parallel to the centerline of the vehicle and 0.1 x vehicle width from the centerline of the vehicle.
- 1.15 Apply 25 mm wide tape with alternating black and yellow squares parallel to and on each side of the line found in 1.14. The edge of each tape shall be 50 mm from the line found in 1.14. The tape shall extend from the bottom of the bumper to the front edge of the windshield. (Figure 28D)
2. Barrier Targeting
- 2.1 Fix two stationary targets D1 and D2 to the barrier as shown in the Figure 28A. One target is in the vertical longitudinal plane that is coincident with the midsagittal plane of the driver dummy. The other is in the vertical longitudinal plane that is coincident with the midsagittal plane of the passenger dummy
- 2.2 Targets D1 and D2 are on a rectangular panel.
- 2.3 Three circular targets at least 90 mm in diameter and with black and yellow quadrants are mounted on the sides of the rectangular panel away from the longitudinal centerline of the vehicle. The center of each circular target is 100 mm from the one next to it.
- Distance between circular targets on D1 (mm): 100 mm
- Distance between circular targets on D2 (mm): 100 mm
3. FMVSS 208 Dummy Targeting Requirements
- 3.1 Place a circular target with black and yellow quadrants on both sides of the driver dummy head as close as possible to the center of gravity of the head in the x and z direction (relative to the measuring directions of the accelerometers).
- 3.2 Place a circular target with black and yellow quadrants on both sides of the passenger dummy head as close as possible to the center of gravity of the head in the x and z direction (relative to the measuring directions of the accelerometers).
- 3.3 Place a circular target with black and yellow quadrants on the outboard shoulder of the driver dummy. Place the target as high up on the arm as possible at the intersection of the arm and shoulder. The sleeve of the shirt on the dummy may be cut to make the target visible, but do not remove any material.
- 3.4 Place a circular target with black and yellow quadrants on the outboard shoulder of the passenger dummy. Place the target as high up on the arm as possible at the intersection of the arm and shoulder. The sleeve of the shirt on the dummy may be cut to make the target visible, but do not remove any material.
4. FMVSS 204 Targeting Requirements
- 4.1 Is an FMVSS 204 indicant test ordered on the "COTR Vehicle Work Order?"
- Yes, continue with this form.
- No, this form is complete.
- 4.2 Resection panel (Figure 28C)
- 4.2.1 The panel deviates no more than 6 mm from perfect flatness when suspended vertically
- 4.2.2 The 8 targets on the panel are circular targets at least 90 mm in diameter and with black and yellow quadrants.
- 4.2.3 The center of each of the 4 outer targets are placed within 1 mm of the corners of a square measuring 914 mm on each side.

-  4.2.4 Locate another square with 228 mm sides and with the center of this square coincident with the center of the 914 mm square.
-  4.2.5 The center of the 4 inner targets are placed at the midpoints of each of the 228 mm sides.
-  4.3 Place a circular target at least 90 mm in diameter and with black and yellow quadrants on a material (cardboard, metal, etc.) that can be taped to the top of the steering column.
-  4.4 Tape the target from 4.3 to the top of the steering column in a manner that does not interfere with the movement of the steering column in a crash

REMARKS:

I certify that I have read and performed each instruction.

Signature: 

Date: 7/10/08

REFERENCE PHOTO TARGETS

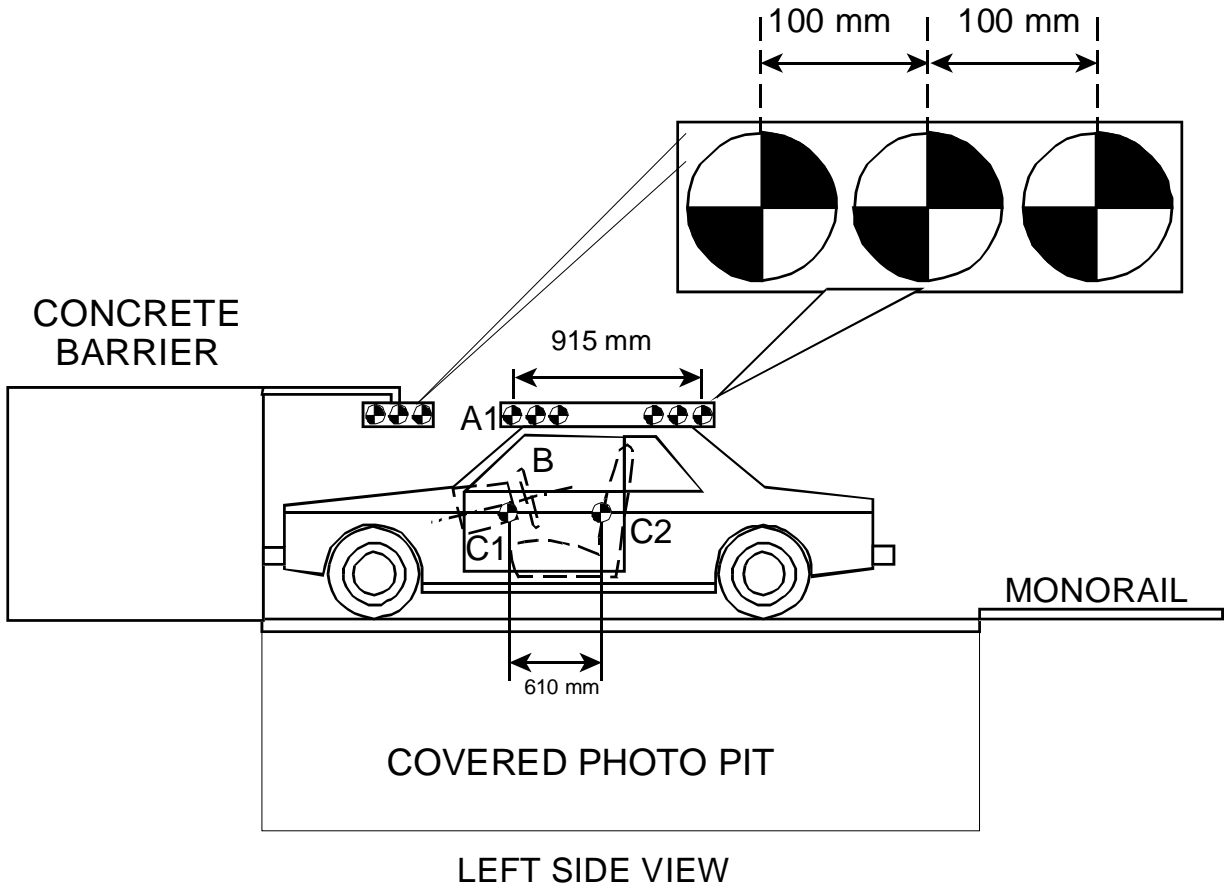

RESECTION PANEL TARGETING ALIGNMENT

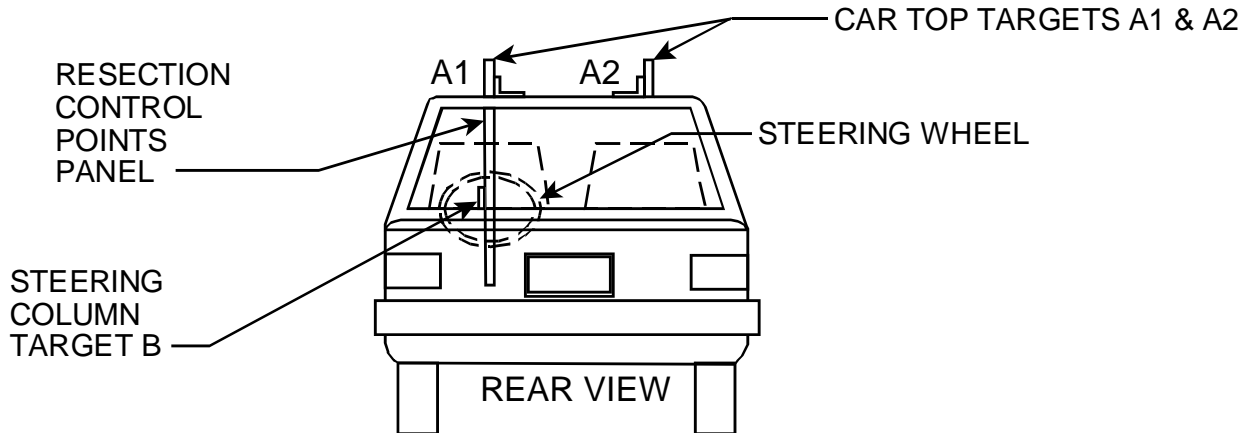

TEST RUN STEERING COLUMN CAMERA VIEW OF TYPICAL TIME ZERO VEHICLE POSITION

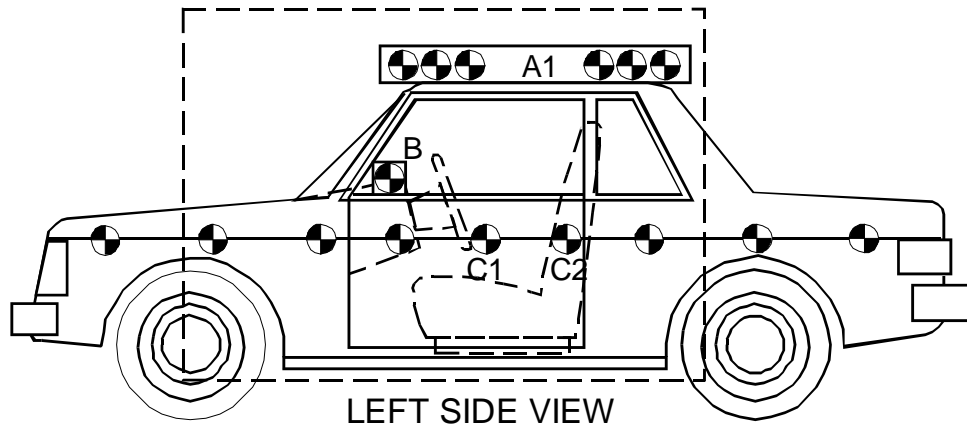

PRE-RUN STEERING COLUMN HIGH SPEED CAMERA VIEW

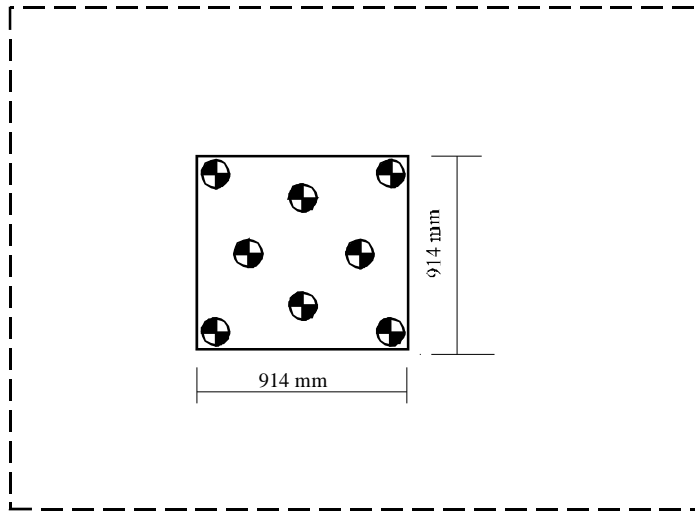

LEFT SIDE VIEW

DATA SHEET 35
CAMERA LOCATIONS

Test Vehicle: 2008 Ford Edge
Test Program: FMVSS 208 Compliance

NHTSA No.: C80202
Test Date: 7/10/08
Time: 9:45 am

CAMERA NO.	VIEW	CAMERA POSITIONS (mm) *			LENS (mm)	SPEED (fps)
		X	Y	Z		
1	Real Time Left Side View				13	24
2	Left Side View (Barrier face to front seat backs)	1175	-4915	1195	24	1000
3	Left Side View (Driver)	1420	-5880	1270	35	1000
4	Left Side View (B-post aimed toward center of steering wheel)	6325	-4805	2015	50	1000
5	Left Side View (Steering Column)	770	-5585	1235	25	1000
6	Left Side View (Steering Column)	755	-5590	870	25	1000
7	Right Side View (Overall)	1960	6075	1200	24	1000
8	Right Side View (Passenger)	1520	5425	1345	35	1000
9	Right Side View (Angle)	6335	4955	2035	50	1000
10	Right Side View (Front door)	1260	5125	1245	24	1000
11	Front View Windshield	-305	0	2830	12.5	1000
12	Front View Driver	-135	-395	2240	24	1000
13	Front View Passenger	-110	505	2240	24	1000
14	Overhead Barrier Impact View	1190	0	5050	14	1000
15	Pit Camera Engine View	1690	0	-3150	24	1000
16	Pit Camera Fuel Tank View	3415	0	-3150	24	1000

*COORDINATES:

- +X - forward of impact plane
- +Y - right of monorail centerline
- +Z - above ground level

CAMERA POSITIONS FOR FMVSS 208

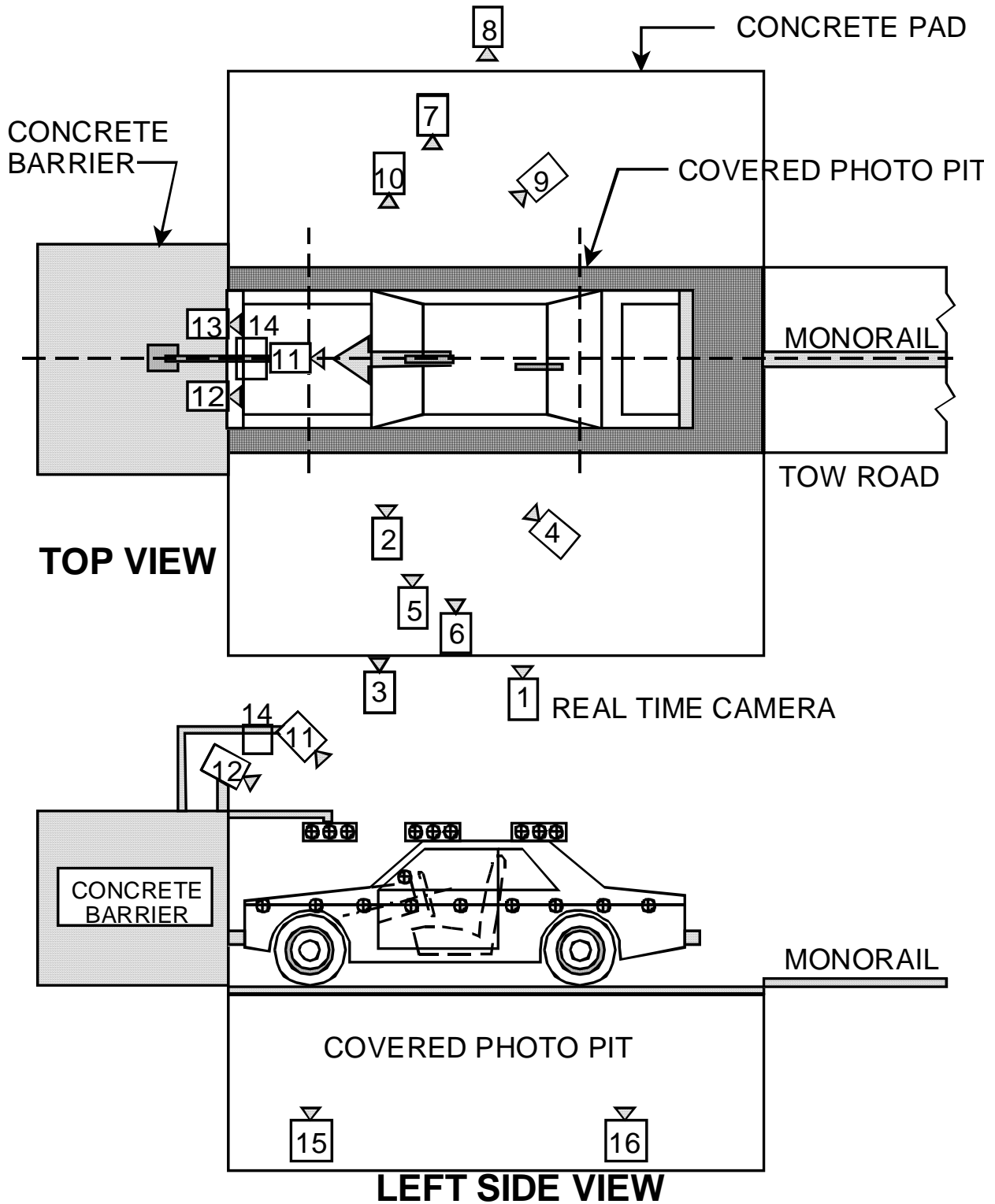

DATA SHEET 36
APPENDIX G
DUMMY POSITIONING PROCEDURES
FOR 5th% DRIVER TEST DUMMY CONFORMING TO SUBPART O OF PART 572

Test Vehicle: 2008 Ford Edge
 Test Program: FMVSS 208 Compliance
 Test Technician: Tim Bratz

NHTSA No.: C80202
 Test Date: 7/10/08

IMPACT ANGLE:	Zero Degrees		
BELTED DUMMIES (YES/NO):	No		
TEST SPEED:	<input checked="" type="checkbox"/> 32 to 40 kmph	<input type="checkbox"/> 0 to 48 kmph	<input type="checkbox"/> 0 to 56 kmph
DRIVER DUMMY:	<input checked="" type="checkbox"/> 5 th female	<input type="checkbox"/> 50 th male	
PASSENGER DUMMY:	<input checked="" type="checkbox"/> 5 th female	<input type="checkbox"/> 50 th male	

- X 1. Using the markings made from data sheet 14.3 (If not done previously or steering repairs have been made, complete data sheet 14.3 at this time.) to position the steering controls in the mid-position or if applicable next lowest detent position. (S16.2.9)
- X 2. Place the SCRP in the full rearward, mid-height position, and mid-seat cushion angle, determined during the completion of Data Sheet 14.1. (S16.3.2.1.1)
- X 3. If the vehicle has an adjustable accelerator pedal, place it in the full forward position. (S16.3.2.2.1)
 N/A accelerator pedal not adjustable
- X 4. Fully recline the seat back. (S16.3.2.1.2)
 N/A seat back not adjustable.
- X 5. Place the dummy in the seat with the legs at an angle of 120 degrees to the thighs. The calves should not be touching the seat cushion. (S16.3.2.1.2)
- X 6. Position the dummy in the seat such that the midsagittal plane is coincident with the longitudinal seat cushion markings as determined in Data Sheet 14.1. (S16.3.2.1.3 and S16.3.2.1.4)
- X 7. Hold down the dummy's thighs and push rearward on the upper torso to maximize the pelvic angle. (S16.3.2.1.5)
- X 8. Set the angle between the legs and the thighs to 120 degrees. (S16.3.2.1.6)
- X 9. Set the transverse distance between the centers of the front of the knees at 160 to 170 mm. (6.3 to 6.7 inches) Center the knee separation with respect to the longitudinal seat cushion marking as determined Data Sheet 14.1. (S16.3.2.1.6)
 Record Knee Separation 168
- X 10. Push rearward on the dummy's knees until the pelvis contacts the seat back, or the backs of the calves contact the seat cushion, whichever occurs first. (S16.3.2.1.6)
 Pelvis contacted seat back.
 Calves contacted seat cushion.

19. If the steering wheel was repositioned in step 16, return the steering wheel to the original position. If the steering wheel contacts the dummy before reaching the original position, position the wheel until a maximum clearance of 5mm (.2 inches) is achieved, or the steering wheel is in the closest detent position that does not cause dummy contact. (S16.3.2.1.8)
- N/A Steering wheel was not repositioned.
- Original position achieved.
- Dummy contact. Clearance set at maximum of 5mm
Measured Clearance _____
- Dummy Contact. Steering wheel set at nearest detent position.
Steering wheel position detent positions upward of original position.
(Original position is position zero)
20. If the seat back is adjustable, rotate the seat back forward while holding the thighs in place. Continue rotating the seat back forward until the transverse instrument platform of the dummy head is level ± 0.5 degrees. If the head cannot be leveled using the seat back adjustment, or the seat back is not adjustable, use the lower neck bracket adjustment to level the head. If a level position cannot be achieved, minimize the angle. (S16.3.2.1.9)
- Head Level Achieved. (Check all that apply)
- Head leveled using the adjustable seat back
- Head leveled using the neck bracket.
Head Angle 0.3 degrees
- Head Level NOT Achieved. (Check all that apply)
- Head adjusted using the adjustable seat back
- Head adjusted using the neck bracket.
Head Angle _____ degrees
21. Verify the pelvis is not interfering with the seat bight. (S16.3.2.1.9)
- No interference
- Pelvis moved forward the minimum amount so that it is not caught in the seat bight.
22. Verify the dummy abdomen is properly installed. (S16.3.2.1.9)
- Abdomen still seated properly into dummy
- Abdomen was adjusted because it was not seated properly into dummy
23. Head Angle
- N/A, neither the pelvis nor the abdomen were adjusted.
- 23.1 Head still level (Go to 24)
- 23.2 Head level adjusted
- Head Level Achieved. (Check all that apply)
- Head leveled using the adjustable seat back
- Head leveled using the neck bracket.
Head Angle _____ degrees
- Head Level NOT Achieved. (Check all that apply)
- Head level adjusted using the adjustable seat back
- Head level adjusted using the neck bracket.
Head Angle _____ degrees
24. If the dummy torso contacts the steering wheel while performing step 20, reposition the steering wheel in the following order to eliminate contact. (S16.3.2.1.9)
- N/A, No dummy torso contact with the steering wheel.

X 24.1 Adjust telescoping mechanism.

N/A No telescoping adjustment.

Adjustment performed (fill in appropriate change)

Steering wheel moved _____ detent positions in the forward direction.

Steering wheel moved _____ mm in the forward direction.

X 24.2 Adjust tilt mechanism.

N/A No tilt adjustment.

X No adjustment performed.

Adjustment performed.

Steering wheel moved _____ detent positions Upward/Downward.
(circle one)

Steering wheel moved _____ degrees Upward/Downward

X 24.3 Adjust Seat in the aft direction.

X No Adjustment performed.

Seat moved aft _____ mm from original position.

Seat moved aft _____ detent positions from the original position.

X 25. Measure and set the pelvic angle using the pelvic angle gage TE-2504. The pelvic angle should be 20.0 degrees \pm 2.5 degrees. If the pelvic angle cannot be set to the specified range because the head will not be level or because the dummy will have need major repositioning, adjust the pelvis as closely as possible to the angle range, but keep the head level. (S16.3.2.1.11)

X Pelvic angle set to 20.0 degrees \pm 2.5 degrees.

Pelvic angle of 20.0 degrees not achieved, the angular difference was minimized.

X Record the pelvic angle. 22.2 degrees

X 26. Check the dummy for contact with the interior after completing adjustments.

(S16.3.2.1.12)

X No contact.

Dummy in contact with interior.

Seat moved aft _____ mm from the previous position.

Seat moved aft _____ detent positions from the previous position.

X 27. Check the dummy to see if additional interior clearance is obtained, allowing the seat to be moved forward. (S16.3.2.1.12)

X N/A, Seat already at foremost position.

Clearance unchanged. No adjustments required.

Additional clearance available

Seat moved Forward _____ mm from the previous position.

Seat moved Forward _____ detent positions from the previous position.

X 28. Driver's foot positioning, right foot. Place the foot perpendicular to the leg and determine if the heel contacts the floor pan at any leg position. If the heel contacts the floor pan proceed to step 29 otherwise, proceed to step 30. (S16.3.2.2.1)

X 29. Perform the following steps until either all steps are completed, or the foot contacts the accelerator pedal. Step 29.6 shall be completed in all cases. (S16.3.2.2.1(a))

X 29.1 With the rear of the heel contacting the floor pan, move the foot forward until pedal contact occurs or the foot is at the full forward position.

- ___29.2 If the vehicle has an adjustable accelerator pedal, move the pedals rearward until pedal contact occurs or the pedals reach the full rearward position.
- ___29.3 Extend the leg, allowing the heel to lose contact with the floor until the foot contacts the pedal. Do not raise the toe of the foot higher than the top of the accelerator pedal. If the foot does not contact the pedal, proceed to the next step. If pedal contact does occur, place a tapered foam block as shown in Figure G1 under the heel with the shallow part of the taper facing forward. (S16.3.2.2.3)
- ___29.4 Angle the foot to achieve contact between the foot and the pedal. If the foot does not contact the pedal, return the foot to the perpendicular orientation. If pedal contact does occur, place a tapered foam block as shown in Figure G1 under the heel with the shallow part of the taper facing forward. (S16.3.2.2.3)
- ___29.5 Align the centerline of the foot with the vertical-longitudinal plane passing through the center of the accelerator pedal. Place a tapered foam block as shown in Figure G1 under the heel with the shallow part of the taper facing forward. (S16.3.2.2.3)

X29.6 Record foot position

X Pedal Contact achieved. Contact occurred at step 29.1.

X Heel contacts floor pan

___ Heel set _____ mm from floor pan.

___ Pedal Contact not achieved. Heel set _____ mm from the floor pan.

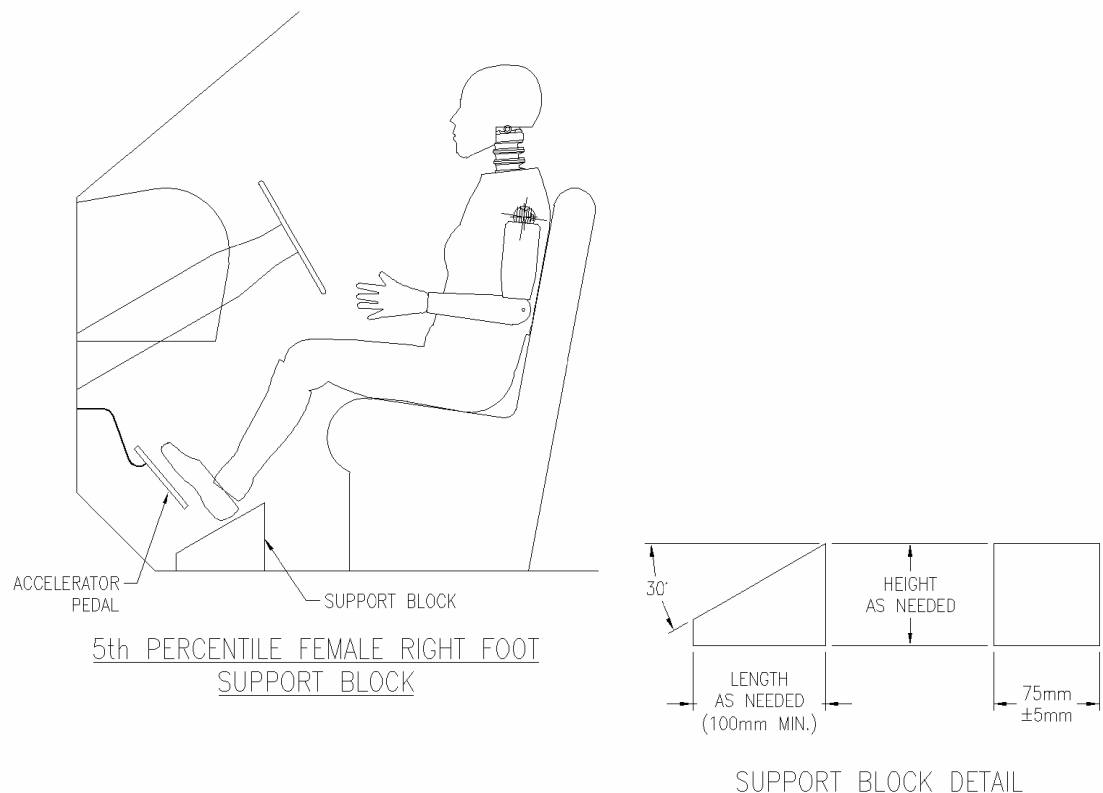

FIGURE G1

30. Perform the following steps until either all steps are completed, or the foot contacts the accelerator pedal. Step 30.5 shall be completed in all cases.
- 30.1 Extend the leg until the foot contacts the pedal. Do not raise the toe of the foot higher than the top of the accelerator pedal. If the foot does not contact the pedal, proceed to the next step. If pedal contact does occur, place a tapered foam block as shown in Figure G1 under the heel with the shallow part of the taper facing forward. (S16.3.2.2.1(b) & S16.3.2.2.3)
- 30.2 If the vehicle has an adjustable accelerator pedal, move the pedals rearward until pedal contact occurs or the pedals reach the full rearward position. If pedal contact does occur, place a tapered foam block as shown in Figure G1 under the heel with the shallow part of the taper facing forward. (S16.3.2.2.1(b) & S16.3.2.2.3)
 N/A No pedal adjustment
- 30.3 Angle the foot to achieve contact between the foot and the pedal. If the foot does not contact the pedal, return the foot to the perpendicular orientation. If pedal contact does occur, place a tapered foam block as shown in Figure G1 under the heel with the shallow part of the taper facing forward. (S16.3.2.2.2 & S16.3.2.2.3)
- 30.4 Align the centerline of the foot in the same horizontal plane as the centerline of the accelerator pedal. Place a tapered foam block as shown in Figure G1 under the heel with the shallow part of the taper facing forward. (S16.3.2.2.3)
- 30.5 Record foot position
 Pedal Contact achieved. Contact occurred at step _____.
 Heel set _____ mm from floor pan.
 Pedal Contact not achieved. Heel set _____ mm from the floor pan.

X 31. Driver's foot positioning, left foot.

X 31.1 Place the foot perpendicular to the leg and determine if the heel contacts the floor pan at any leg position. If the heel contacts the floor pan proceed to step 31.2, otherwise position the leg as perpendicular to the thigh as possible with the foot parallel to the floor pan. (S16.2.2.6)

X 31.2 Place the foot on the toe board with the heel resting on the floor pan as close to the intersection of the floor pan and the toe board as possible. Adjust the angle of the foot if necessary to contact the toe board. If the foot will not contact the toe board, set the foot perpendicular to the leg, and set the heel on the floor pan as far forward as possible. Avoid contact with the brake pedal, clutch pedal, wheel well projection, and footrest. To avoid this contact use the following three manipulations in the order listed, with each subsequent option incorporating the previous, until contact is avoided: rotate the foot about the lower leg (abduction/adduction), plantar flex the foot, rotate the leg outboard about the hip. Movement should be the minimum amount necessary. If it is not possible to avoid all foot contact, give priority to avoiding brake or clutch pedal contact. (S16.2.2.4 & S16.2.2.5 & S16.2.2.7)

- No contact
 Foot rotated about the leg (abduction/adduction)
 Foot rotated about the leg, and foot plantar flexed
 Foot rotated about the leg, foot plantar flexed, and the leg rotated about the hip.

31.3 Record foot position.

Heel does not contact floor pan.

Heel on floor pan and foot on toe board.

Heel on floor pan and foot not on toe board.

32. Driver arm/hand positioning.

32.1 Place the dummy's upper arms adjacent to the torso with the arm centerlines as close to a vertical longitudinal plane as possible. (S16.3.2.3.1)

32.2 Place the palms of the dummy in contact with the outer part of the steering wheel rim at its horizontal centerline with the thumbs over the steering wheel rim. (S16.3.2.3.2)

32.3 If it is not possible to position the thumbs inside the steering wheel rim at its horizontal centerline, then position them above and as close to the horizontal centerline of the steering wheel rim as possible. (S16.3.2.3.3)

32.4 Lightly tape the hands to the steering wheel rim so that if the hand of the test dummy is pushed upward by a force of not less than 9 N (2 lb) and not more than 22 N (5 lb), the tape releases the hand from the steering wheel rim. S16.3.2.3.4

33. Adjustable head restraints

N/A, there is no head restraint adjustment

33.1 If the head restraint has an automatic adjustment, leave it where the system positions the restraint after the dummy is placed in the seat. (S16.3.4.1) Go to 34.

33.2 Adjust each head restraint vertically so that the mid-horizontal plane determined in Data Sheet 14.1 is aligned with the center of gravity (CG) of the dummy head. (S16.3.4.3)

33.3 If the above position is not attainable, move the vertical center of the head restraint to the closest detent below the center of the head CG. (S16.3.4.3)

N/A midpoint position attained in previous step

Headrest set at nearest detent below the head CG

33.4 If the head restraint has a fore and aft adjustment, place the restraint in the foremost position or until contact with the head is made, whichever occurs first. (S16.3.4.4)

34. Driver and passenger manual belt adjustment (for tests conducted with a belted dummy). (S16.3.5) UNBELTED TEST

34.1 If an adjustable seat belt D-ring anchorage exists, place it in the manufacturer's design position for a 5th percentile adult female. (S16.3.5.1) **This information will be supplied by the COTR.**

Manufacturer's specified position _____

Actual Position _____

34.2 Place the Type 2 manual belt around the test dummy and fasten the latch. (S16.3.5.2)

34.3 Ensure that the dummy's head remains as level as possible. (S16.3.5.3)

__34.4 Remove all slack from the lap belt. Pull the upper torso webbing out of the retractor and allow it to retract; repeat this operation four times. Apply a 9 N (2 lbf) to 18 N (4 lbf) tension load to the lap belt. If the belt system is equipped with a tension-relieving device, introduce the maximum amount of slack into the upper torso belt that is recommended by the manufacturer. If the belt system is not equipped with a tension-relieving device, allow the excess webbing in the shoulder belt to be retracted by the retractive force of the retractor. (S16.3.5.4)

REMARKS:

I certify that I have read and performed each instruction.

Signature:  Date: 7/10/08

APPENDIX G

**DUMMY POSITIONING PROCEDURES
FOR 5th% PASSENGER TEST DUMMY CONFORMING TO SUBPART O OF PART 572**

Test Vehicle: 2008 Ford Edge
 Test Program: FMVSS 208 Compliance
 Test Technician: Jordan Haynes

NHTSA No.: C80202
 Test Date: 7/10/08

IMPACT ANGLE:	Zero Degrees		
BELTED DUMMIES (YES/NO):	No		
TEST SPEED:	<input checked="" type="checkbox"/> 32 to 40 kmph	<input type="checkbox"/> 0 to 48 kmph	<input type="checkbox"/> 0 to 56 kmph
DRIVER DUMMY:	<input checked="" type="checkbox"/> 5 th female	<input type="checkbox"/> 50 th male	
PASSENGER DUMMY:	<input checked="" type="checkbox"/> 5 th female	<input type="checkbox"/> 50 th male	

(Check this item ONLY if it applies to this vehicle.)

The passenger seat adjustments are controlled by the adjustments made to the driver's seat. Therefore, positioning of the passenger dummy is made simultaneously with the driver dummy. Adjustments made to the seat to position the driver will over ride any adjustments that would normally be made to position the passenger. (S16.2.10.3)

- 1. Place the SCRP in the full rearward, mid-height position, and mid-seat cushion angle, determined during the completion of Data Sheet 14.1. (S16.3.3.1.1)
- 2. Fully recline the seat back. (S16.3.3.1.2)
 N/A seat back not adjustable.
- 3. Place the dummy in the seat with the legs at an angle of 120 degrees to the thighs. The calves should not be touching the seat cushion. (S16.3.3.1.2)
- 4. Position the dummy in the seat such that the midsagittal plane is coincident with the longitudinal seat cushion marking that was determined in Data Sheet 14.1. (S16.3.3.1.3 and S16.3.3.1.4)
- 5. Hold down the dummy's thighs and push rearward on the upper torso to maximize the pelvic angle. (S16.3.3.1.5)
- 6. Set the angle between the legs and the thighs to 120 degrees. (S16.3.3.1.6)
- 7. Set the transverse distance between the centers of the front of the knees at 160 to 170 mm. (6.3 to 6.7 inches). Center the knee separation with respect to the longitudinal seat cushion marking that was determined Data Sheet 14.1. (S16.3.3.1.6)
 Record Knee Separation 170
- 8. Push rearward on the dummy's knees until the pelvis contacts the seat back, or the backs of the calves contact the seat cushion, whichever occurs first. (S16.3.3.1.6)
 Pelvis contacted seat back.
 Calves contacted seat cushion.
- 9. Gently rock the upper torso ± 5 degrees (approximately 51 mm (2 inches)) side-to-side three times. (S16.3.3.1.7)

10. If needed, extend the legs until the feet do not contact the floor pan. The thighs should be resting on the seat cushion. (S16.3.3.1.8)
11. Use seat controls to line up the seat markings determined during the completion of Data Sheet 14.1 to set the foremost fore-aft position, mid-height position and the seat cushion mid-angle. If the dummy contacts the interior move the seat rearward until a maximum clearance of 5 mm (0.2 inches) is achieved or the seat is in the closest detent position that does not cause dummy contact. (S16.3.3.1.8)
- Foremost, mid-height position and the seat cushion mid-angle reached
- Dummy contact. Clearance set at maximum of 5mm
Measured Clearance _____
- Dummy Contact. Seat set at nearest detent position.
Seat position ___ detent positions rearward of foremost
(foremost is position zero)
12. If the seat back is adjustable, rotate the seat back forward while holding the thighs in place. Continue rotating the seat back forward until the transverse instrument platform of the dummy head is level ± 0.5 degrees. If head cannot be leveled using the seat back adjustment, or the seat back is not adjustable, use the lower neck bracket adjustment to level the head. If a level position cannot be achieved, adjust the head as closely as possible to the ± 0.5 degree range. (S16.3.3.1.9 and S16.3.3.1.10)
- (Check All That Apply)
- Seat back not adjustable
- Seat back not independent of driver side seat back
- Head Level Achieved. (Check all that apply)
- Head leveled using the adjustable seat back
- Head leveled using the neck bracket.
Head Angle 0.0 degrees
- Head Level NOT Achieved. (Check all that apply)
- Head adjusted using the adjustable seat back
- Head adjusted using the neck bracket.
Head Angle _____ degrees
13. Verify the pelvis is not interfering with the seat bight. (S16.3.3.1.9)
- No interference
- Pelvis moved forward the minimum amount so that it is not caught in the seat bight.
14. Verify the dummy abdomen is properly installed. (S16.3.3.1.9)
- Abdomen still seated properly into dummy
- Abdomen was adjusted because it was not seated properly into dummy
15. Head Angle
- N/A, neither the pelvis nor the abdomen were adjusted.
- 15.1 Head still level (Go to 16)

15.2 Head level adjusted

Head Level Achieved. (Check all that apply)

Head leveled using the adjustable seat back

Head leveled using the neck bracket.

Head Angle _____ degrees

Head Level NOT Achieved. (Check all that apply)

Head adjusted using the adjustable seat back

Head adjusted using the neck bracket.

Head Angle _____ degrees

X 16. Measure and set the pelvic angle using the pelvic angle gage TE-2504. The pelvic angle should be 20.0 degrees \pm 2.5 degrees. If the pelvic angle cannot be set to the specified range because the head will not be level or because the dummy will have need major repositioning, adjust the pelvis as closely as possible to the angle range, but keep the head level.

X Pelvic angle set to 20.0 degrees \pm 2.5 degrees.

Pelvic angle of 20.0 degrees not achieved, the angular difference was minimized.

X Record the pelvic angle. 21.2 degrees

X 17. Check the dummy for contact with the interior after completing adjustments.

X No contact.

Dummy in contact with interior.

Seat moved aft _____ mm from the previous position.

Seat moved aft _____ detent positions from the previous position.

X 18. Verify the transverse instrument platform of the dummy head is level \pm 0.5 degrees. Use the lower neck bracket adjustment to level the head. If a level position cannot be achieved, minimize the angle. (S16.3.3.1.9, S16.3.3.1.10, and S16.3.3.1.11)

X Head Level Achieved

Head Angle 0.0 degrees

Head Level NOT Achieved.

Head Angle _____ degrees

X 19. Check the dummy to see if additional interior clearance is obtained, allowing the seat to be moved forward. (S16.3.3.1.12)

N/A Bench Seat

X N/A Seat already at full forward position.

Clearance unchanged. No adjustments required.

Additional clearance available

Seat moved Forward _____ mm from the previous position.

Seat moved Forward _____ detent positions from the previous position.

Seat moved Forward, Full Forward position reached.

X 20. Passenger foot positioning. (Indicate final position achieved) (S16.3.3.2)

20.1 Place feet flat on the toe board; OR (S16.3.3.2.1)

X 20.2 If the feet cannot be placed flat on the toe board, set the feet perpendicular to the lower leg, and rest the heel as far forward on the floor pan as possible; OR (S16.3.3.2.2)

20.3 If the heels do not touch the floor pan, set the legs as perpendicular to the thighs as possible and set the feet parallel to the floor pan. (S16.3.3.2.2)

X 21. Passenger arm/hand positioning. (S16.3.3.3)

21.1 Place the dummy's upper arms adjacent to the torso with the arm centerlines as close to a vertical longitudinal plane as possible. (S16.3.3.3.1)

21.2 Place the palms of the dummy in contact with the outer part of the thighs (S16.3.3.3.2)

21.3 Place the little fingers in contact with the seat cushion. (S16.3.3.3.3)

22. Adjustable head restraints (S16.3.4)

N/A, there is no head restraint adjustment

22.1 If the head restraint has an automatic adjustment, leave it where the system positions the restraint after the dummy is placed in the seat. (S16.3.4.1) Go to 23.

22.2 Adjust each head restraint vertically so that the horizontal plane determined in Data Sheet 14.1 is aligned with the center of gravity (CG) of the dummy head. (S16.3.4.3)

22.3 If the above position is not attainable, move the vertical center of the head restraint to the closest detent below the center of the head CG. (S16.3.4.3)

N/A midpoint position attained in previous step

Headrest set at nearest detent below the head CG

22.4 If the head restraint has a fore and aft adjustment, place the restraint in the foremost position or until contact with the head is made, whichever occurs first. (S16.3.4.4)

23. Manual belt adjustment (for tests conducted with a belted dummy) S16.3.5

N/A, Unbelted test

23.1 If an adjustable seat belt D-ring anchorage exists, place it in the manufacturer's design position for a 5th percentile adult female. (S16.3.5.1) **This information will be supplied by the COTR.**

Manufacturer's specified position _____

Actual Position _____

23.2 Place the Type 2 manual belt around the test dummy and fasten the latch. (S16.3.5.2)

23.3 Ensure that the dummy's head remains as level as possible. (S16.3.5.3)

23.4 Remove all slack from the lap belt. Pull the upper torso webbing out of the retractor and allow it to retract; repeat this operation four times. Apply a 9 N (2 lbf) to 18 N (4 lbf) tension load to the lap belt. If the belt system is equipped with a tension-relieving device, introduce the maximum amount of slack into the upper torso belt that is recommended by the manufacturer. If the belt system is not equipped with a tension-relieving device, allow the excess webbing in the shoulder belt to be retracted by the retractive force of the retractor. (S16.3.5.4)

REMARKS:

I certify that I have read and performed each instruction.

Signature:

Jordan Haynes

Date:

7/10/08

DATA SHEET 37

DUMMY MEASUREMENTS

Test Vehicle: 2008 Ford Edge
 Test Program: FMVSS 208 Compliance
 Test Technician: Joe Fleck

NHTSA No.: C80202
 Test Date: 7/10/08

DUMMY MEASUREMENTS FOR FRONT SEAT OCCUPANTS

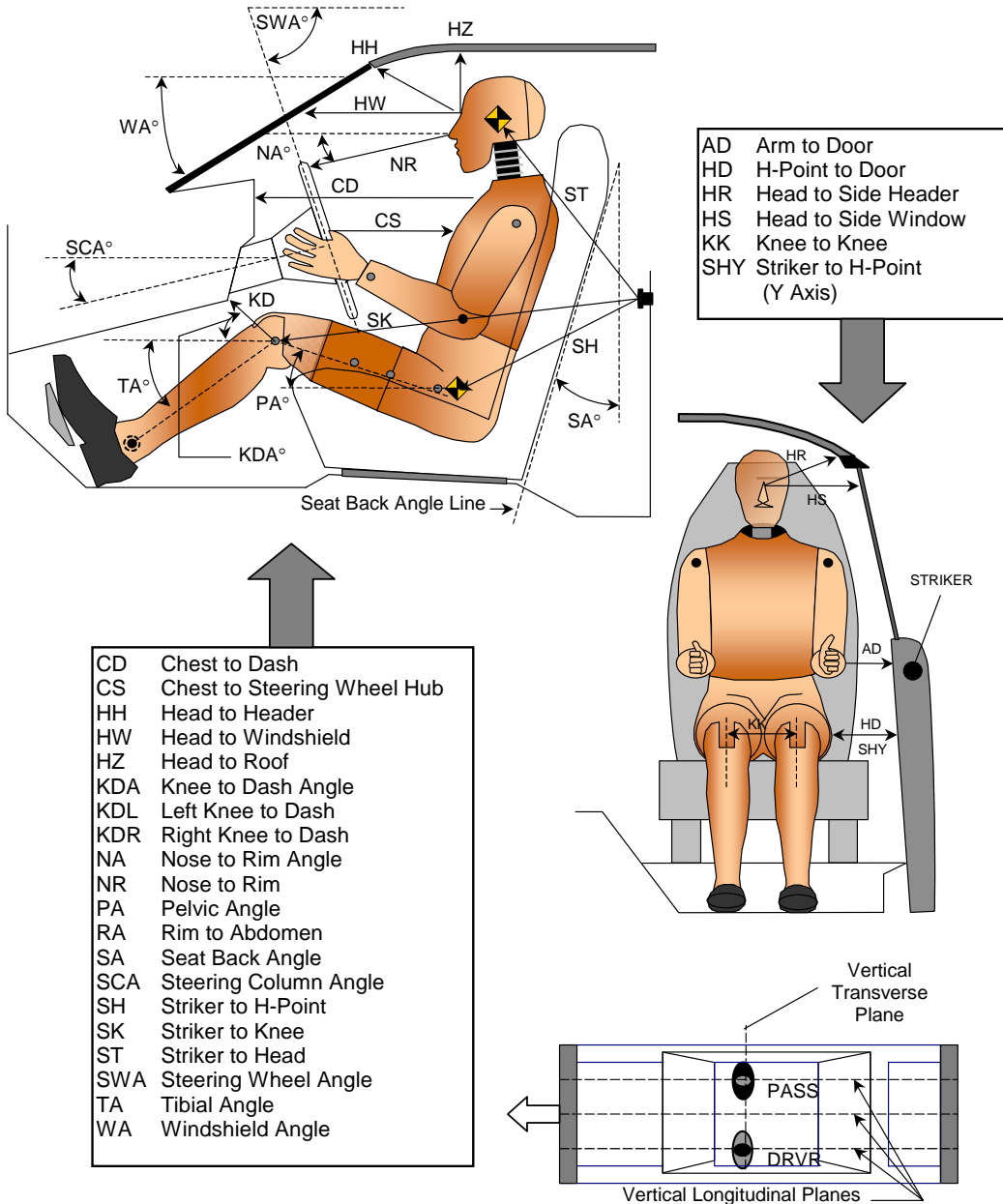

DATA SHEET 37
DUMMY MEASUREMENTS

Test Vehicle: 2008 Ford Edge
 Test Program: FMVSS 208 Compliance
 Test Technician: Joe Fleck

NHTSA No.: C80202
 Test Date: 7/10/08

TEST DUMMY POSITION MEASUREMENTS

Code	Measurement Description	Driver SN 124		Passenger SN 125	
		Length (mm)	Angle (°)	Length (mm)	Angle (°)
WA	Windshield Angle		25.6		
SWA	Steering Wheel Angle		60.4		
SCA	Steering Column Angle		29.7		
SA	Seat Back Angle (On Head Rest Post)		1.9		1.7
HZ	Head to Roof (Z)	198		211	
HH	Head to Header	283	43.7	291	48.0
HW	Head to Windshield	686	0.0	701	0.0
HR	Head to Side Header (Y)	273		273	
NR	Nose to Rim	279	4.6		
CD	Chest to Dash	527		366	
CS	Chest to Steering Hub	224	12.9		
RA	Rim to Abdomen	74	0.0		
KDL	Left Knee to Dash	95	33.7	100	
KDR	Right Knee to Dash	92		104	29.7
PA	Pelvic Angle		22.2		21.2
TA	Tibia Angle		66.0		53.3
KK	Knee to Knee (Y)	270		210	
SK	Striker to Knee	712	96.4	725	98.5
ST	Striker to Head	510	30.3	504	33.2
SH	Striker to H-Point	403	108.4	430	114.7
SHY	Striker to H-Point (Y)	335		325	
HS	Head to Side Window	396		403	
HD	H-Point to Door (Y)	169		173	
AD	Arm to Door (Y)	166		88	
AA	Ankle to Ankle	276		190	

SEAT BELT POSITIONING DATA

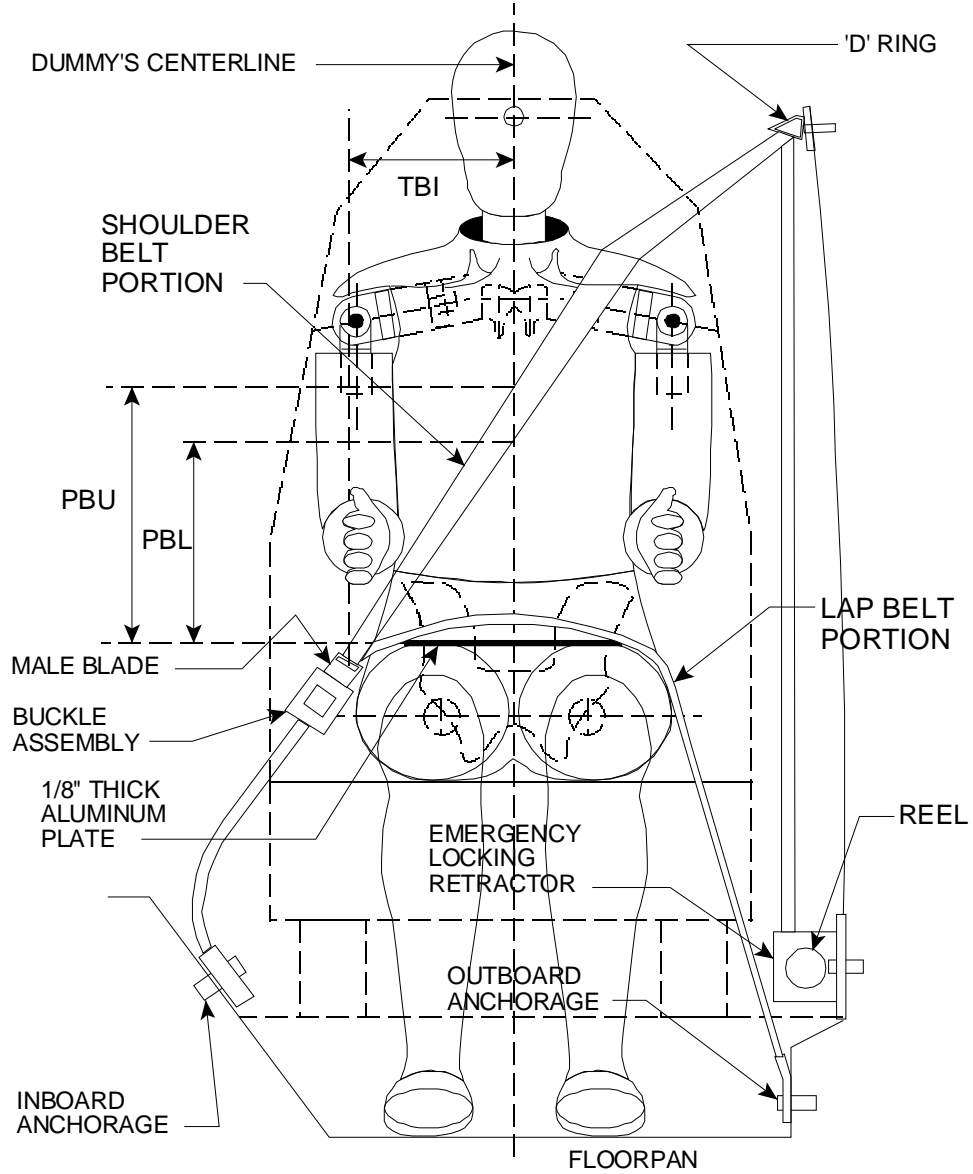

FRONT VIEW OF DUMMY

SEAT BELT POSITIONING MEASUREMENTS

Measurement Description	Units	Driver	Passenger
PBU - Top surface of reference to belt upper edge	mm	N/A	N/A
PBL - Top surface of reference to belt lower edge	mm	N/A	N/A

DATA SHEET 38

CRASH TEST

Test Vehicle: 2008 Ford Edge
 Test Program: FMVSS 208 Compliance
 Test Technician: Jordan Haynes

NHTSA No.: C80202
 Test Date: 7/10/08

IMPACT ANGLE:	Zero Degrees		
BELTED DUMMIES (YES/NO):	No		
TEST SPEED:	<u>X</u> 32 to 40 kmph	<u> </u> 0 to 48 kmph	<u> </u> 0 to 56 kmph
DRIVER DUMMY:	<u>X</u> 5 th female	<u> </u> 50 th male	
PASSENGER DUMMY:	<u>X</u> 5 th female	<u> </u> 50 th male	

- 1. Vehicle underbody painted
- 2. The speed measuring devices are in place and functioning.
- 3. The speed measuring devices are 1.0 m from the barrier (spec. 1.5m) and 30 cm from the barrier (spec. is 30 cm)
- 4. Convertible top is in the closed position.
- N/A, not a convertible
- 5. Instrumentation and wires are placed so the motion of the dummies during impact is not affected.
- 6. Tires inflated to pressure on tire placard or if it does not have a tire placard because it is not a passenger car, then inflated to the tire pressure specified in the owner information.

240 kpa front left tire 240 kpa specified on tire placard or in owner information
240 kpa front right tire 240 kpa specified on tire placard or in owner information
240 kpa rear left tire 240 kpa specified on tire placard or in owner information
240 kpa rear right tire 240 kpa specified on tire placard or in owner information

- 7. Time zero contacts on barrier in place.
- 8. Pre test zero and shunt calibration adjustments performed and recorded
- 9. Dummy temperature meets requirements of section 12.2 of the test procedure.
- 10. Vehicle hood closed and latched
- 11. Transmission placed in neutral
- 12. Parking brake off
- 13. Ignition in the ON position
- 14. Doors closed and latched but not locked
- 15. Posttest zero and shunt calibration checks performed and recorded
- 16. Actual test speed 39.9 kmph
- 17. Vehicle rebound from the barrier 493 cm
- 18. Describe whether the doors open after the test and what method is used to open the doors.
 - Left Front Door: Door remained closed and latched; Door opened without tools
 - Right Front Door: Door remained closed and latched; Door opened without tools
 - Left Rear Door: Door remained closed and latched; Door opened without tools
 - Right Rear Door: Door remained closed and latched; Door opened without tools

19. Describe the contact points of the dummy with the interior of the vehicle.
- Driver Dummy: Head to Air Bag and Headrest; Chest to Air Bag; Knees to Bolster
 - Passenger Dummy: Head to Air Bag and Headrest; Chest to Air Bag; Knees to Glove Box

REMARKS:

I certify that I have read and performed each instruction.

Signature: *Jordan Haynes* Date: 7/10/08

DATA SHEET NO. 40

ACCIDENT INVESTIGATION MEASUREMENTS

Test Vehicle: 2008 Ford Edge
 Test Program: FMVSS 208 Compliance
 Test Technician: Jamie Aide

NHTSA No.: C80202
 Test Date: 7/10/08

IMPACT ANGLE:	Zero Degrees		
BELTED DUMMIES (YES/NO):	No		
TEST SPEED:	<input checked="" type="checkbox"/> 32 to 40 kmph	<input type="checkbox"/> 0 to 48 kmph	<input type="checkbox"/> 0 to 56 kmph
DRIVER DUMMY:	<input checked="" type="checkbox"/> 5 th female	<input type="checkbox"/> 50 th male	
PASSENGER DUMMY:	<input checked="" type="checkbox"/> 5 th female	<input type="checkbox"/> 50 th male	

Vehicle Year/Make/Model/Body Style:	2008 Ford Edge MPV
VIN:	2FMDK36C88BA38516
Wheelbase:	2820 mm
Build Date:	12/07
Vehicle Size Category:	4
Test Weight:	2023.6 kg
Front Overhang:	961 mm
Overall Width:	1889 mm
Overall Length Center:	4699 mm

Accelerometer Data	
Location:	As per measurements on Data Sheet 33
Linearity:	>99.9%

Integration Algorithm:	Trapezoidal
Vehicle Impact Speed:	39.9 kmph
Time of Separation:	115.8 ms
Velocity Change:	44.5 kmph

CRUSH PROFILE

Collision Deformation Classification: 12FDEW6
 Midpoint of Damage: Vehicle Longitudinal Centerline
 Damage Region Length (mm): 1200
 Impact Mode: Frontal Barrier

No.	Measurement Description	Units	Pre-Test	Post-Test	Difference
C1	Crush zone 1 at left side	mm	4561	4345	216
C2	Crush zone 2 at left side	mm	4636	4358	278
C3	Crush zone 3 at left side	mm	4669	4380	289
C4	Crush zone 4 at right side	mm	4669	4382	287
C5	Crush zone 5 at right side	mm	4636	4370	266
C6	Crush zone 6 at right side	mm	4561	4355	206

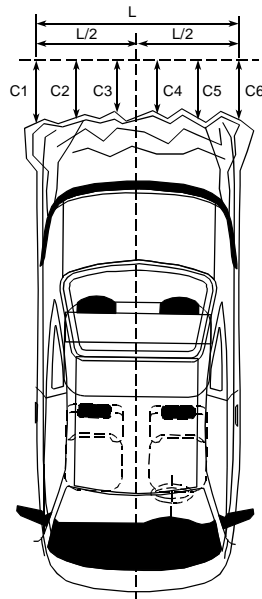

REMARKS:

I certify that I have read and performed each instruction.

Signature: *Jamie Costa*

Date: 7/10/08

DATA SHEET 41

WINDSHIELD MOUNTING (FMVSS 212)

Test Vehicle: 2008 Ford Edge
 Test Program: FMVSS 208 Compliance
 Test Technician: Jamie Aide

NHTSA No.: C80202
 Test Date: 7/10/08

IMPACT ANGLE:	Zero Degrees		
BELTED DUMMIES (YES/NO):	No		
TEST SPEED:	<u>X</u> 32 to 40 kmph	<u> </u> 0 to 48 kmph	<u> </u> 0 to 56 kmph
DRIVER DUMMY:	<u>X</u> 5 th female	<u> </u> 50 th male	
PASSENGER DUMMY:	<u>X</u> 5 th female	<u> </u> 50 th male	

- 1. Pre-Crash
 - 1.1 Describe from visual inspection how the windshield is mounted and describe any trim material.

Retained with glue
Plastic trim
 - 1.2 Mark the longitudinal centerline of the windshield
 - 1.3 Measure pre-crash A, B, and C for the left side and record in the chart below.
 - 1.4 Measure pre-crash C, D, and E for the right side and record in the chart below.
 - 1.5 Measure from the edge of the retainer or molding to the edge of the windshield.
Dimension G (mm): 17 mm
- 2. Post Crash
 - 2.1 Can a single thickness of copier type paper (as small a piece as necessary) slide between the windshield and the vehicle body?
 - No - Pass. Skip to the table of measurements, complete it by repeating the pre-crash measurements in the post crash column, and calculate the retention percentage, which will be 100%.
 - Yes, go to 2.2
 - 2.2 Visibly mark the beginning and end of the portions of the periphery where the paper slides between the windshield and the vehicle body.
 - 2.3 Measure and record post-crash A, B, C, D, E, and F such that the measurements do not include any of the parts of the windshield where the paper slides between the windshield and the vehicle body.
 - 2.4 Calculate and record the percent retention for the right and left side of the windshield.
 - 2.5 Is total right side percent retention less than 75%?
 - Yes, Fail
 - No, Pass
 - 2.6 Is total left side percent retention less than 75%?
 - Yes, Fail
 - No, Pass

DATA SHEET 42
WINDSHIELD ZONE INTRUSION (FMVSS 219)

Test Vehicle: 2008 Ford Edge
 Test Program: FMVSS 208 Compliance
 Test Technician: Jamie Aide

NHTSA No.: C80202
 Test Date: 7/10/08

IMPACT ANGLE:	Zero Degrees		
BELTED DUMMIES (YES/NO):	No		
TEST SPEED:	<input checked="" type="checkbox"/> 32 to 40 kmph	<input type="checkbox"/> 0 to 48 kmph	<input type="checkbox"/> 0 to 56 kmph
DRIVER DUMMY:	<input checked="" type="checkbox"/> 5 th female	<input type="checkbox"/> 50 th male	
PASSENGER DUMMY:	<input checked="" type="checkbox"/> 5 th female	<input type="checkbox"/> 50 th male	

- 1. Place a 165 mm diameter rigid sphere, with a mass of 6.8 kg on the instrument panel so that it is simultaneously touching the instrument panel and the windshield. (571.219 S6.1(a))
- 2. Roll the sphere from one side of the windshield to the other while marking on the windshield where the sphere contacts the windshield. (571.219 S6.1(b))
- 3. From the outermost contactable points on the windshield draw a horizontal line to the edges of the windshield. (571.219 S6.1(b))
- 4. Draw a line on the inner surface of the windshield that is 13 mm below the line determined in items 2 and 3
- 5. After the crash test, record any points where a part of the exterior of the vehicle has marked, penetrated, or broken the windshield.

Provide all dimensions necessary to reproduce the protected area.

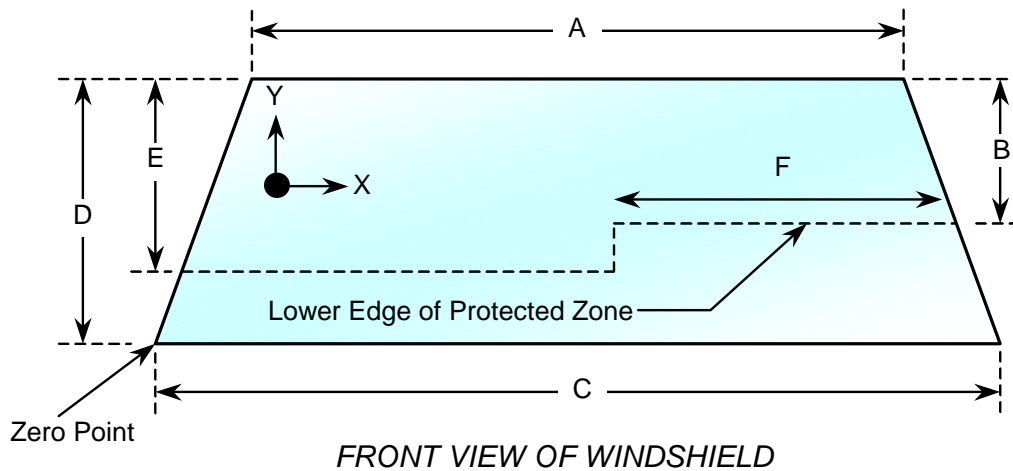

DATA SHEET 43

FUEL SYSTEM INTEGRITY (FMVSS 301)

Test Vehicle: 2008 Ford Edge
Test Program: FMVSS 208 Compliance
Test Technician: Tim Bratz

NHTSA No.: C80202
Test Date: 7/10/08

TYPE OF IMPACT:	25 mph Unbelted Flat Frontal
-----------------	------------------------------

Stoddard Solvent Spillage Measurements

- A. From impact until vehicle motion ceases: 0.0 grams
(Maximum Allowable = 28 grams)
- B. For the 5 minute period after motion ceases: 0.0 grams
(Maximum Allowable = 142 grams)
- C. For the following 25 minutes: 0.0 grams
(Maximum Allowable = 28 grams/minute)
- D. Spillage: NONE

REMARKS: NO SPILLAGE

DATA SHEET NO. 43
FMVSS 301 STATIC ROLLOVER DATA

Test Vehicle: 2008 Ford Edge
 Test Program: FMVSS 208 Compliance

NHTSA No.: C80202
 Test Date: 7/10/08

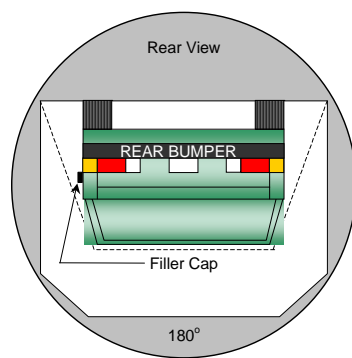
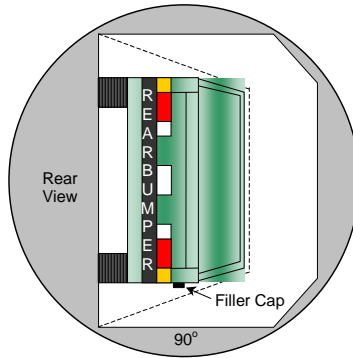
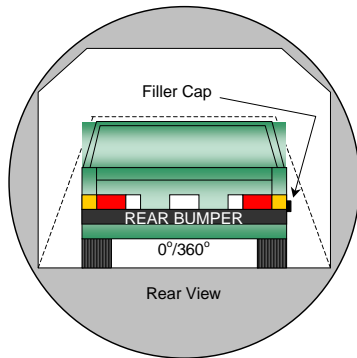

0° to 90°

90° to 180°

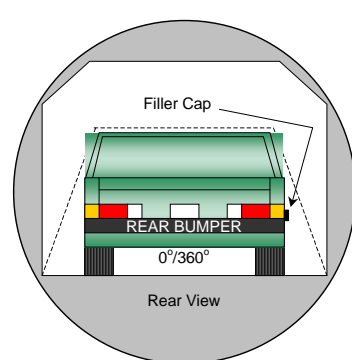
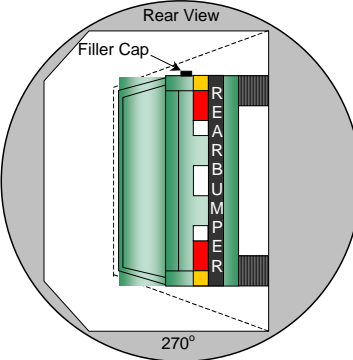
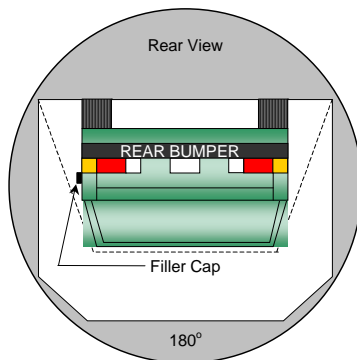

180° to 270°

270° to 360°

1. The specified fixture rollover rate for each 90° of rotation is 60 to 180 seconds.
2. The position hold time at each position is 300 seconds (minimum).
3. Details of Stoddard Solvent spillage locations: **None**

Test Phase	Rotation Time (sec.)	Hold Time (sec.)	Spillage (grams)
0° to 90°	124	300	0.0
90° to 180°	117	300	0.0
180° to 270°	111	300	0.0
270° to 360°	115	300	0.0

APPENDIX A
CRASH TEST DATA

TABLE OF DATA PLOTS

		<u>Page No.</u>
Figure No. 1.	Driver Head X Acceleration vs. Time	A-1
Figure No. 2.	Driver Head Y Acceleration vs. Time	A-1
Figure No. 3.	Driver Head Z Acceleration vs. Time	A-1
Figure No. 4.	Driver Head Resultant Acceleration vs. Time	A-1
Figure No. 5.	Driver Head X Velocity vs. Time	A-2
Figure No. 6.	Driver Head Y Velocity vs. Time	A-2
Figure No. 7.	Driver Head Z Velocity vs. Time	A-2
Figure No. 8.	Driver Neck Force X vs. Time	A-3
Figure No. 9.	Driver Neck Force Y vs. Time	A-3
Figure No. 10.	Driver Neck Force Z vs. Time	A-3
Figure No. 11.	Driver Neck Force Resultant vs. Time	A-3
Figure No. 12.	Driver Neck Moment X vs. Time	A-4
Figure No. 13.	Driver Neck Moment Y vs. Time	A-4
Figure No. 14.	Driver Neck Moment Z vs. Time	A-4
Figure No. 15.	Driver Neck Moment Resultant vs. Time	A-4
Figure No. 16.	Driver Chest X Acceleration vs. Time	A-5
Figure No. 17.	Driver Chest Y Acceleration vs. Time	A-5
Figure No. 18.	Driver Chest Z Acceleration vs. Time	A-5
Figure No. 19.	Driver Chest Resultant Acceleration vs. Time	A-5
Figure No. 20.	Driver Chest X Velocity vs. Time	A-6
Figure No. 21.	Driver Chest Y Velocity vs. Time	A-6
Figure No. 22.	Driver Chest Z Velocity vs. Time	A-6
Figure No. 23.	Driver Chest Displacement vs. Time	A-6
Figure No. 24.	Driver Left Femur Force vs. Time	A-7
Figure No. 25.	Driver Right Femur Force vs. Time	A-7
Figure No. 26.	Passenger Head X Acceleration vs. Time	A-8
Figure No. 27.	Passenger Head Y Acceleration vs. Time	A-8
Figure No. 28.	Passenger Head Z Acceleration vs. Time	A-8
Figure No. 29.	Passenger Head Resultant Acceleration vs. Time	A-8

		<u>Page No.</u>
Figure No. 30.	Passenger Head X Velocity vs. Time	A-9
Figure No. 31.	Passenger Head Y Velocity vs. Time	A-9
Figure No. 32.	Passenger Head Z Velocity vs. Time	A-9
Figure No. 33.	Passenger Neck Force X vs. Time	A-10
Figure No. 34.	Passenger Neck Force Y vs. Time	A-10
Figure No. 35.	Passenger Neck Force Z vs. Time	A-10
Figure No. 36.	Passenger Neck Force Resultant vs. Time	A-10
Figure No. 37.	Passenger Neck Moment X vs. Time	A-11
Figure No. 38.	Passenger Neck Moment Y vs. Time	A-11
Figure No. 39.	Passenger Neck Moment Z vs. Time	A-11
Figure No. 40.	Passenger Neck Moment Resultant vs. Time	A-11
Figure No. 41.	Passenger Chest X Acceleration vs. Time	A-12
Figure No. 42.	Passenger Chest Y Acceleration vs. Time	A-12
Figure No. 43.	Passenger Chest Z Acceleration vs. Time	A-12
Figure No. 44.	Passenger Chest Resultant Acceleration vs. Time	A-12
Figure No. 45.	Passenger Chest X Velocity vs. Time	A-13
Figure No. 46.	Passenger Chest Y Velocity vs. Time	A-13
Figure No. 47.	Passenger Chest Z Velocity vs. Time	A-13
Figure No. 48.	Passenger Chest Displacement vs. Time	A-13
Figure No. 49.	Passenger Left Femur Force vs. Time	A-14
Figure No. 50.	Passenger Right Femur Force vs. Time	A-14
Figure No. 51.	Driver Nij (N_{TF}) vs. Time	A-15
Figure No. 52.	Driver Nij (N_{TE}) vs. Time	A-15
Figure No. 53.	Driver Nij (N_{CF}) vs. Time	A-15
Figure No. 54.	Driver Nij (N_{CE}) vs. Time	A-15
Figure No. 55.	Passenger Nij (N_{TF}) vs. Time	A-16
Figure No. 56.	Passenger Nij (N_{TE}) vs. Time	A-16
Figure No. 57.	Passenger Nij (N_{CF}) vs. Time	A-16
Figure No. 58.	Passenger Nij (N_{CE}) vs. Time	A-16
Figure No. 59.	Driver Occipital Condyle Moment vs. Time	A-17

		<u>Page No.</u>
Figure No. 60.	Passenger Occipital Condyle Moment vs. Time	A-17
Figure No. 61.	Left Rear Seat Crossmember X Acceleration vs. Time	A-18
Figure No. 62.	Left Rear Seat Crossmember X Velocity vs. Time	A-18
Figure No. 63.	Right Rear Seat Crossmember X Acceleration vs. Time	A-18
Figure No. 64.	Right Rear Seat Crossmember X Velocity vs. Time	A-18
Figure No. 65.	Top of Engine X Acceleration vs. Time	A-19
Figure No. 66.	Top of Engine X Velocity vs. Time	A-19
Figure No. 67.	Bottom of Engine X Acceleration vs. Time	A-19
Figure No. 68.	Bottom of Engine X Velocity vs. Time	A-19
Figure No. 69.	Left Brake Caliper X Acceleration vs. Time	A-20
Figure No. 70.	Left Brake Caliper X Velocity vs. Time	A-20
Figure No. 71.	Right Brake Caliper X Acceleration vs. Time	A-20
Figure No. 72.	Right Brake Caliper X Velocity vs. Time	A-20
Figure No. 73.	Instrument Panel X Acceleration vs. Time	A-21
Figure No. 74.	Instrument Panel X Velocity vs. Time	A-21
Figure No. 75.	Trunk Z Acceleration vs. Time	A-21
Figure No. 76.	Trunk Z Velocity vs. Time	A-21
Figure No. 77.	Barrier Force – Upper Left vs. Time	A-22
Figure No. 78.	Barrier Force – Upper Center vs. Time	A-22
Figure No. 79.	Barrier Force – Upper Right vs. Time	A-22
Figure No. 80.	Barrier Force – Lower Left vs. Time	A-23
Figure No. 81.	Barrier Force – Lower Center vs. Time	A-23
Figure No. 82.	Barrier Force – Lower Right vs. Time	A-23
Figure No. 83.	Barrier Force – Sum Left vs. Time	A-24
Figure No. 84.	Barrier Force – Sum Center vs. Time	A-24
Figure No. 85.	Barrier Force – Sum Right vs. Time	A-24
Figure No. 86.	Barrier Force – Sum All vs. Time	A-24

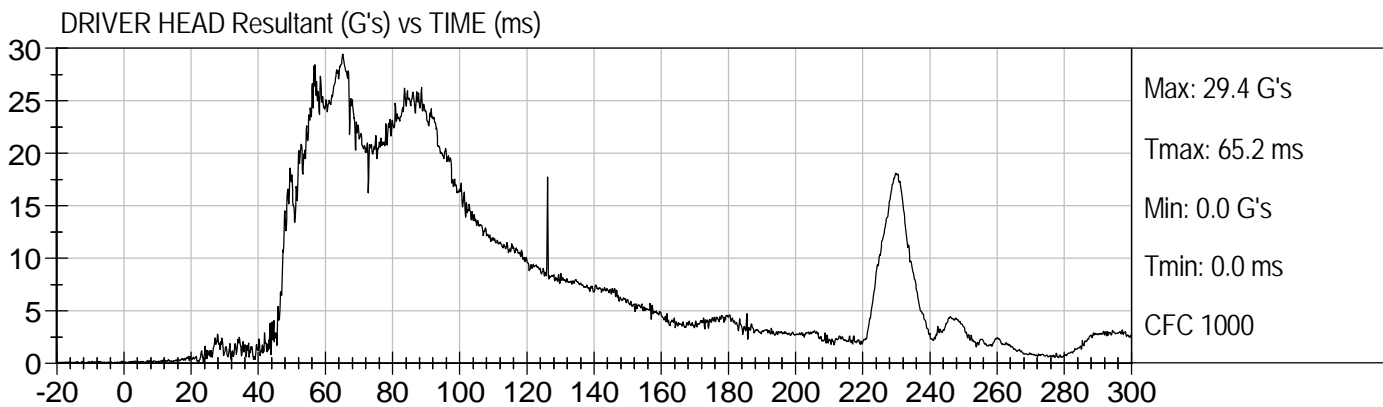
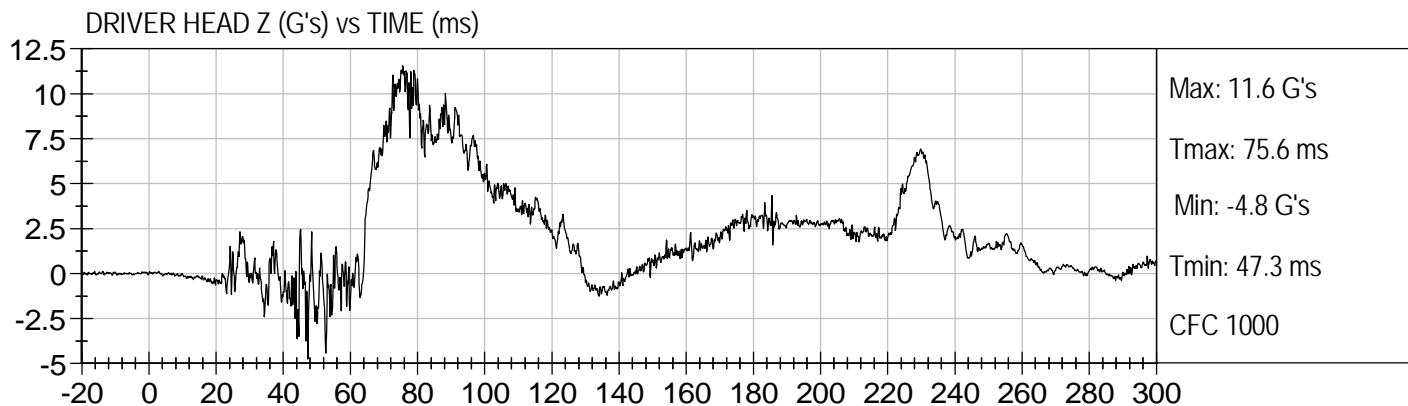
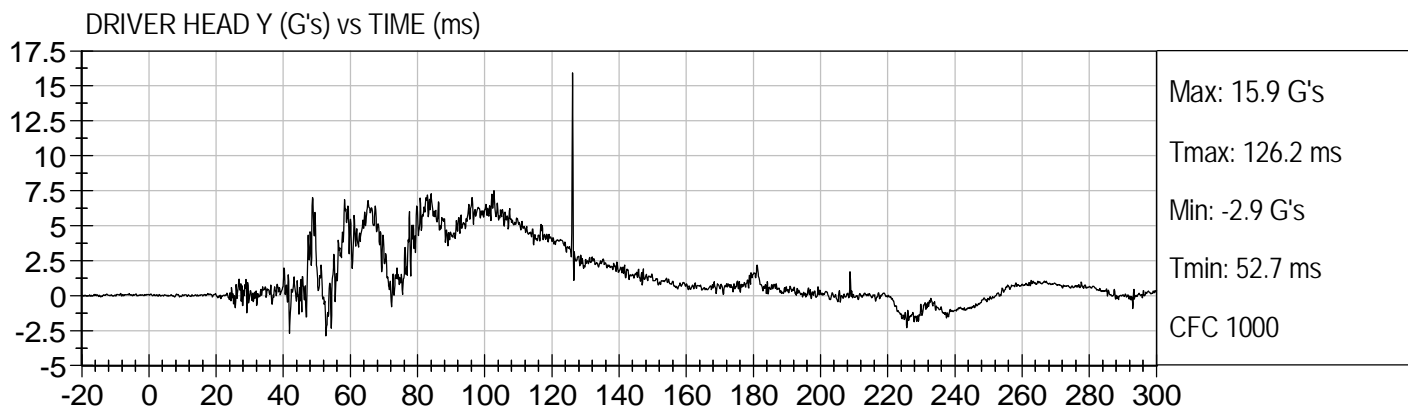
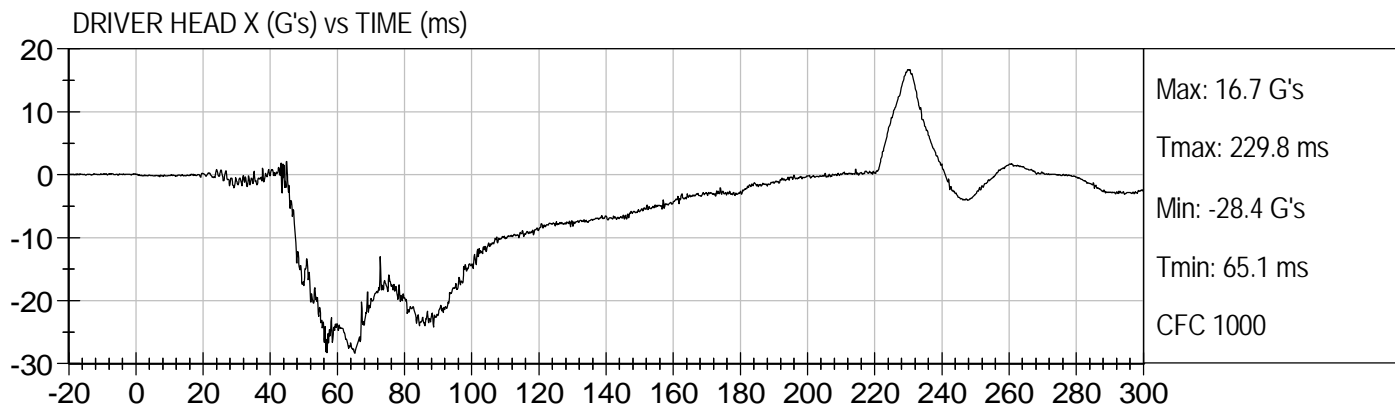

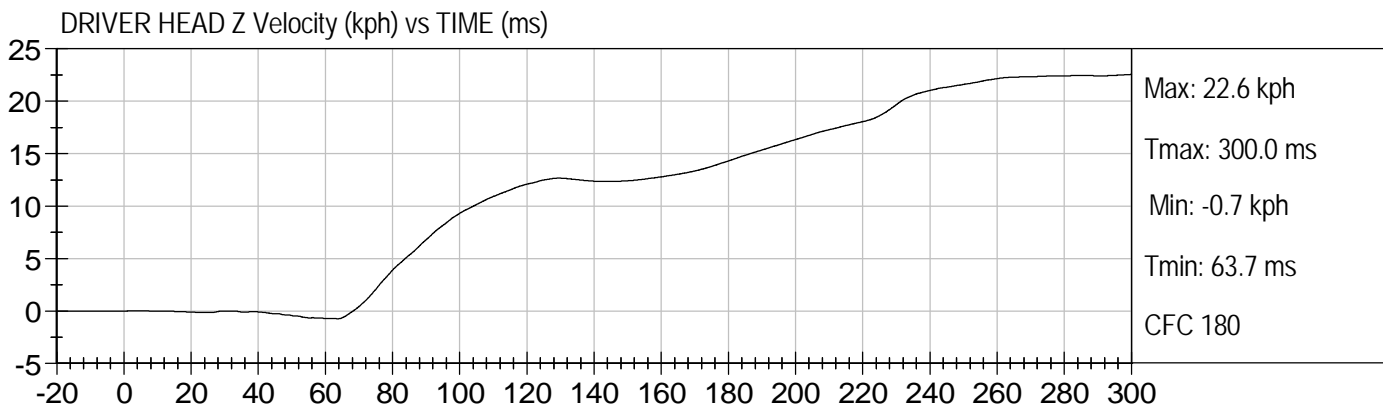
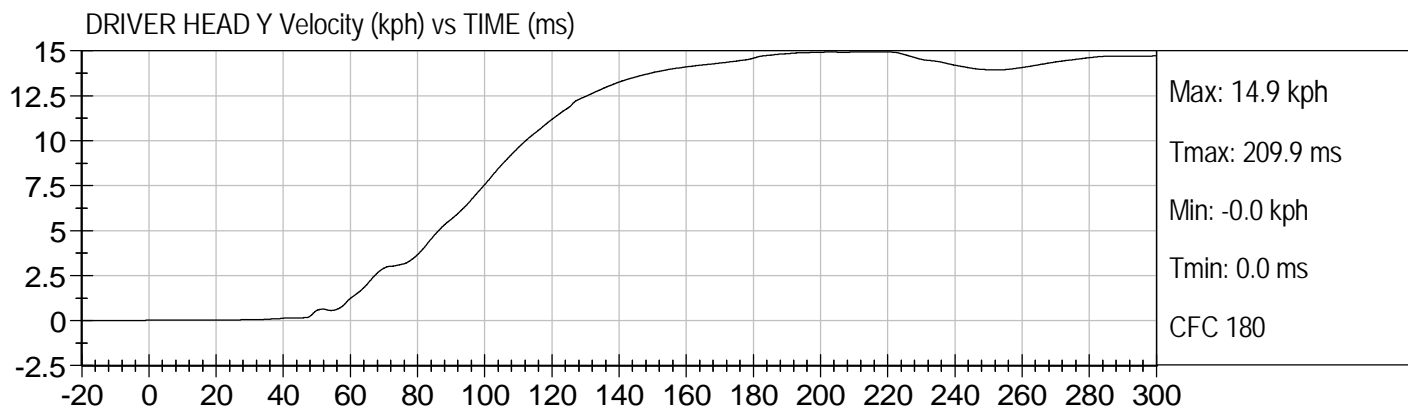
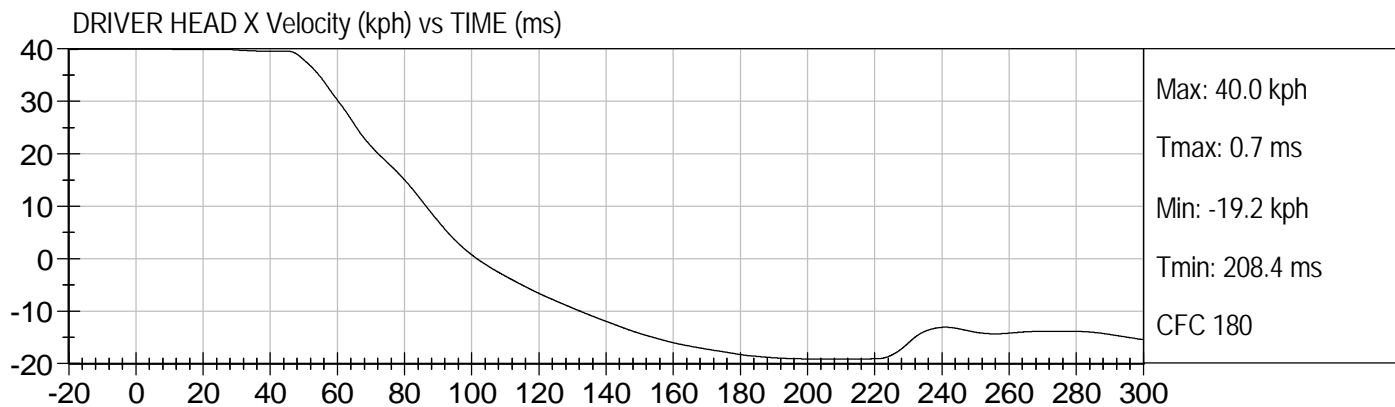

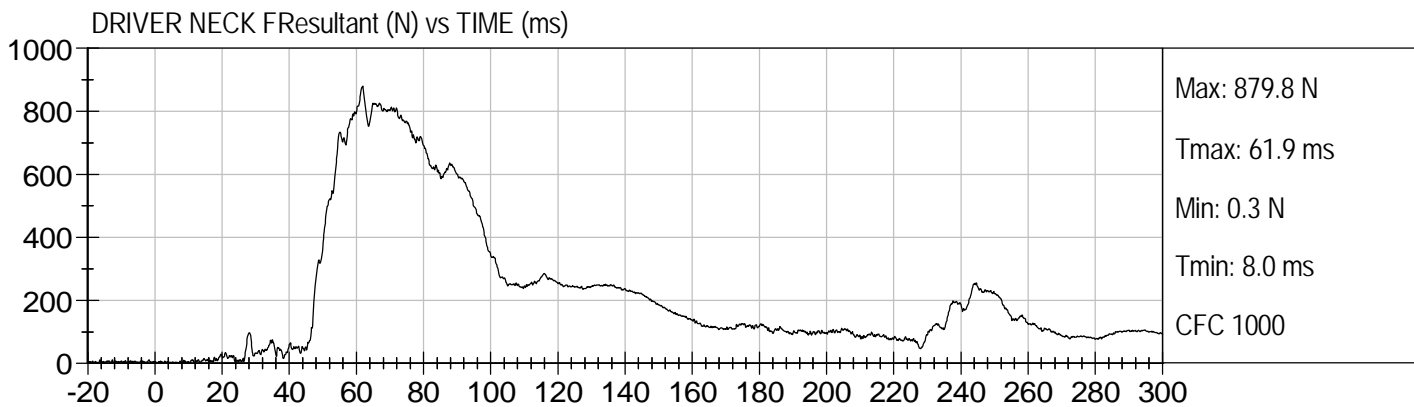
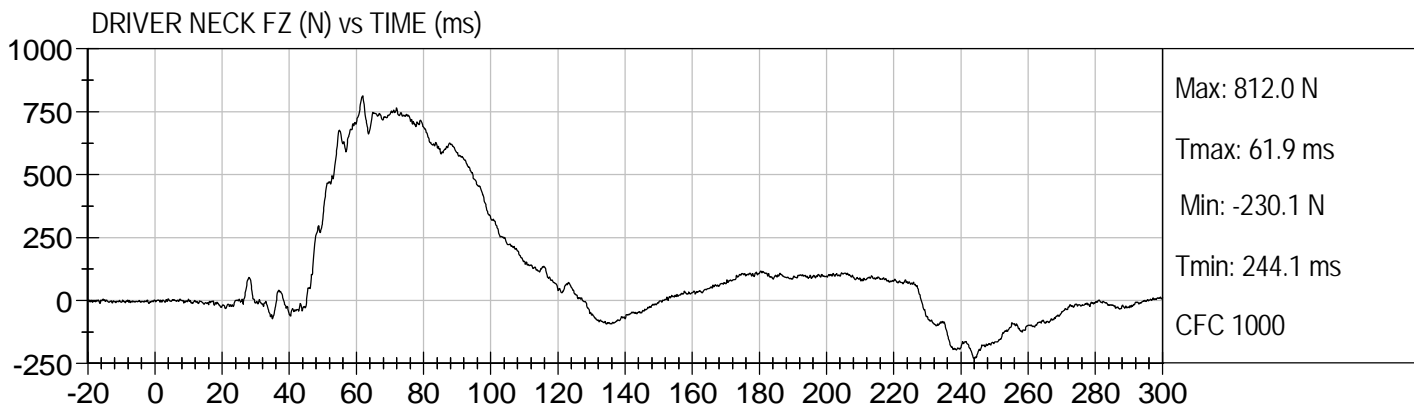
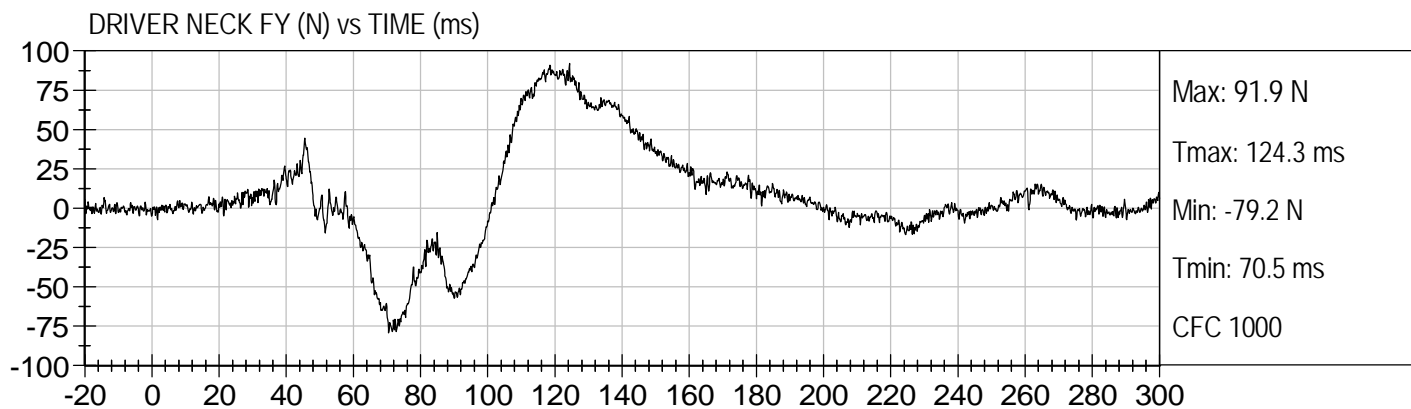
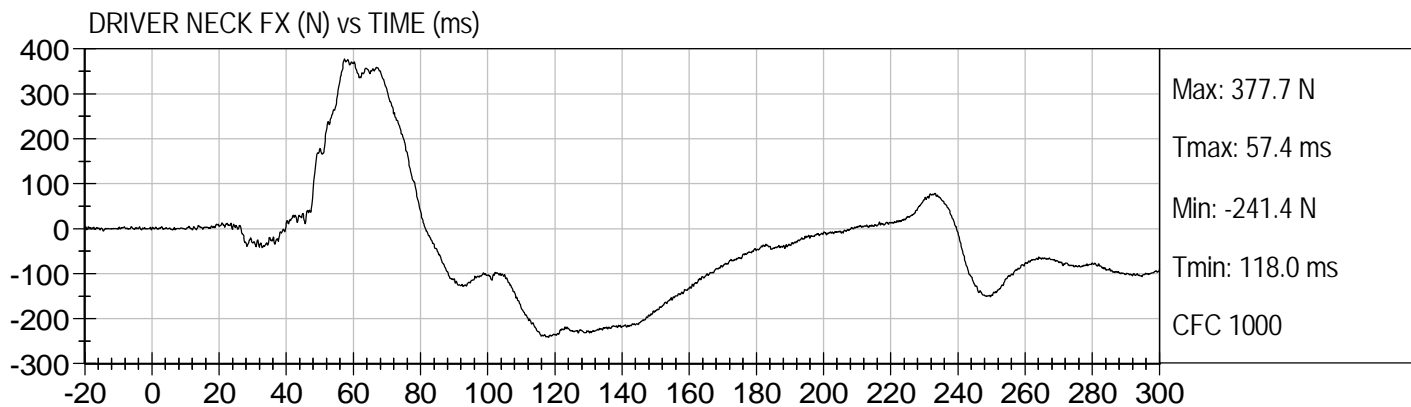

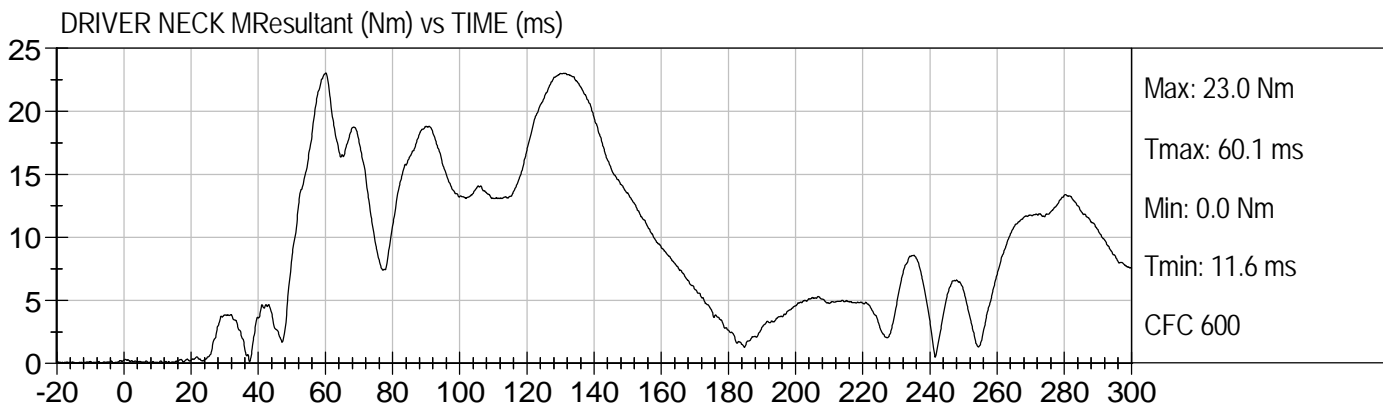
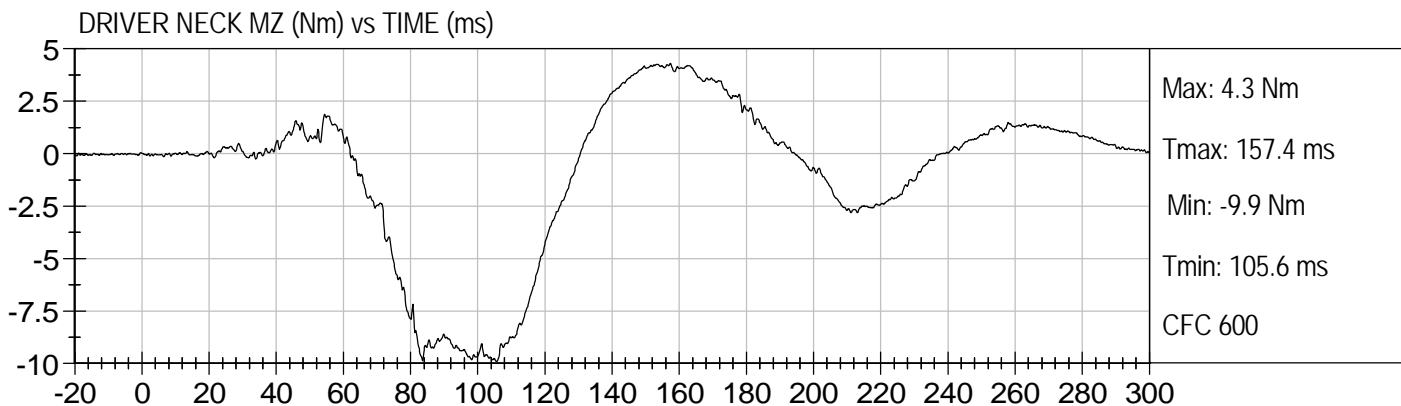
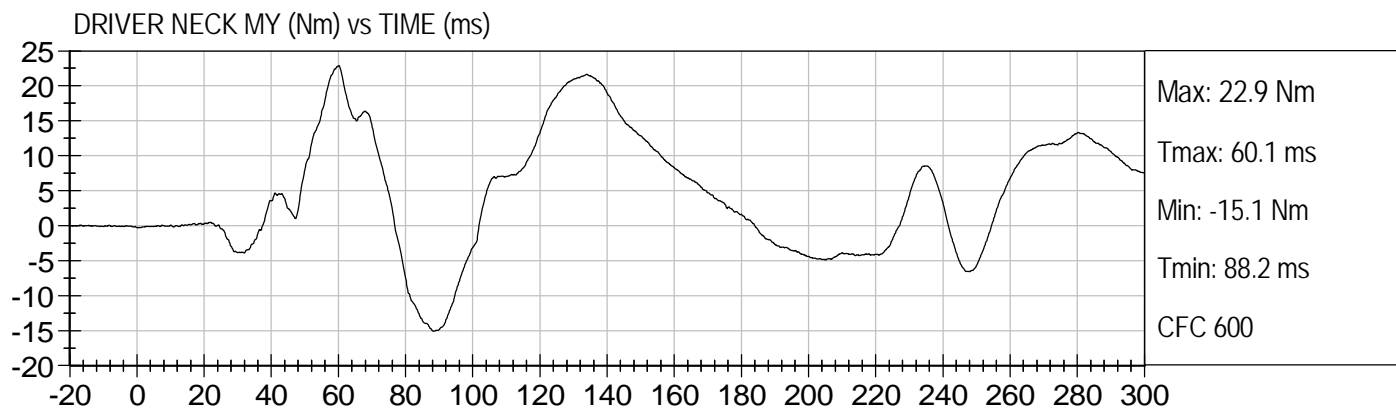
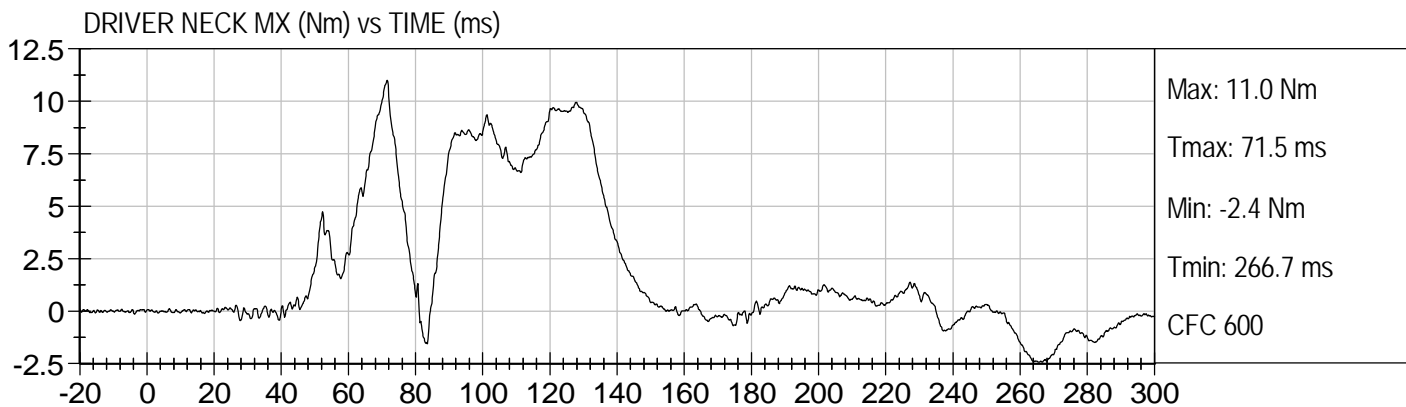

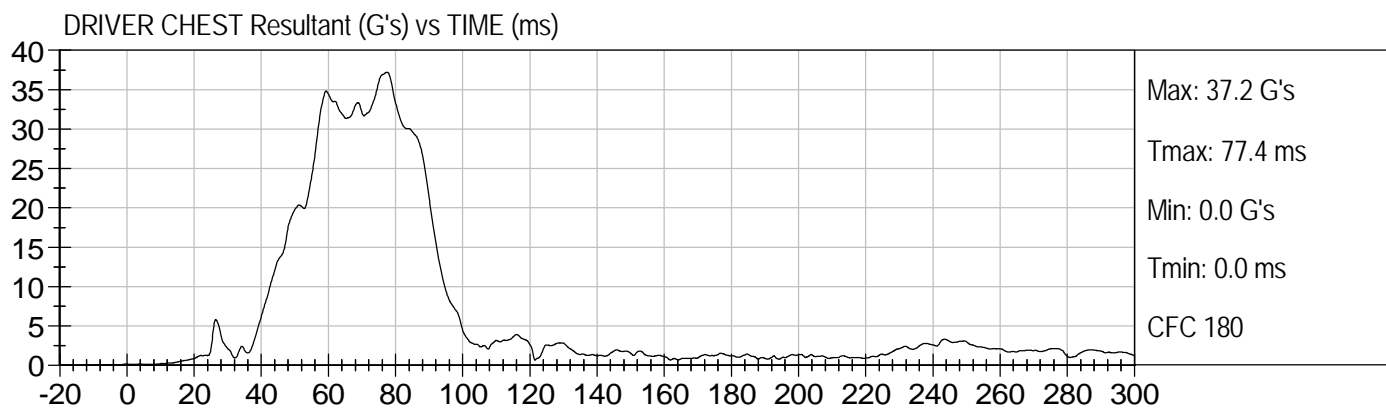
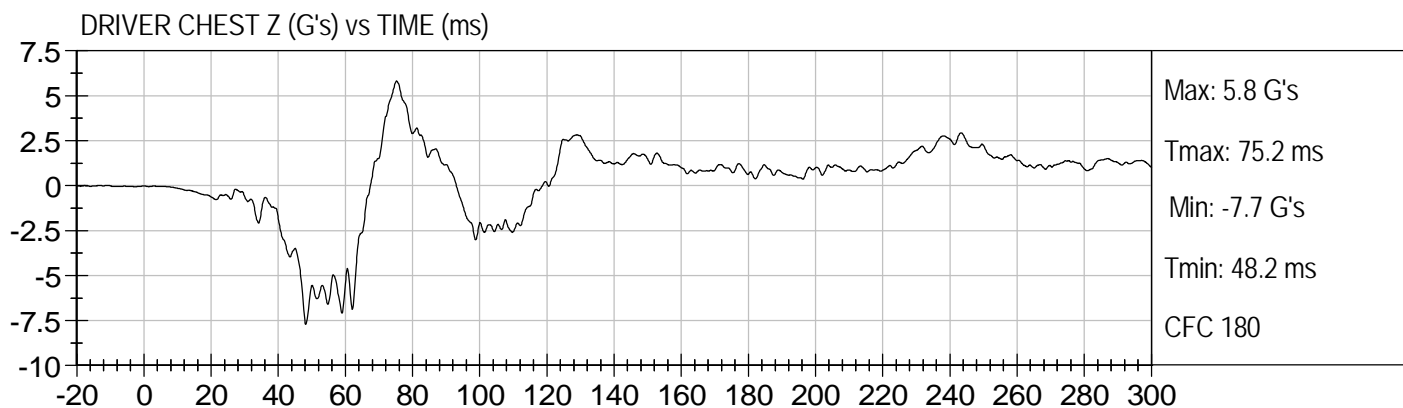
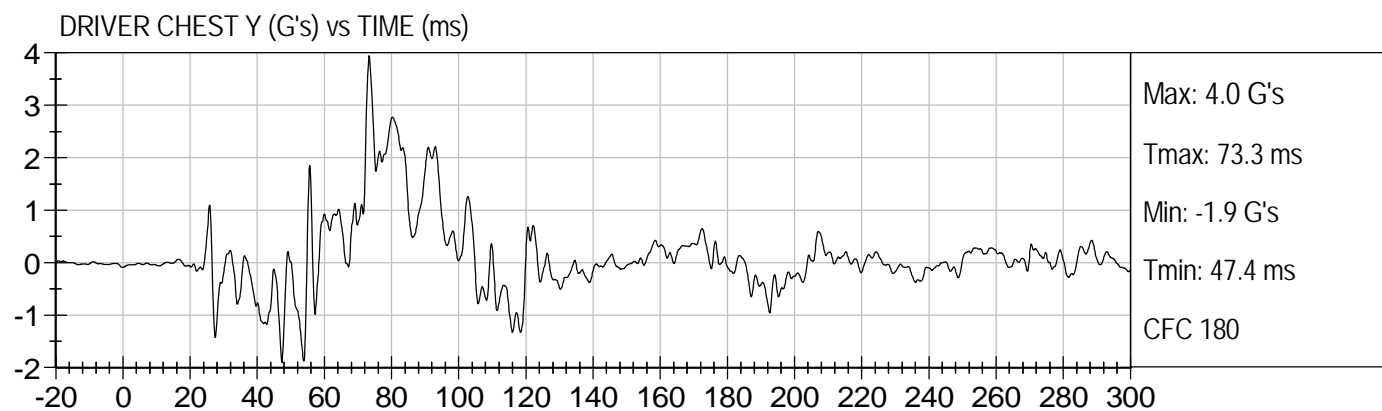
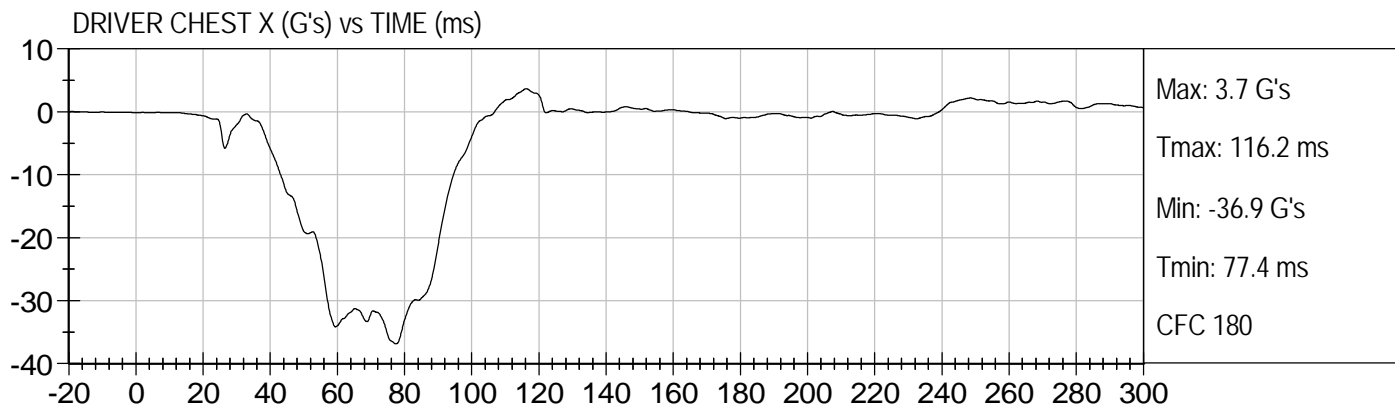

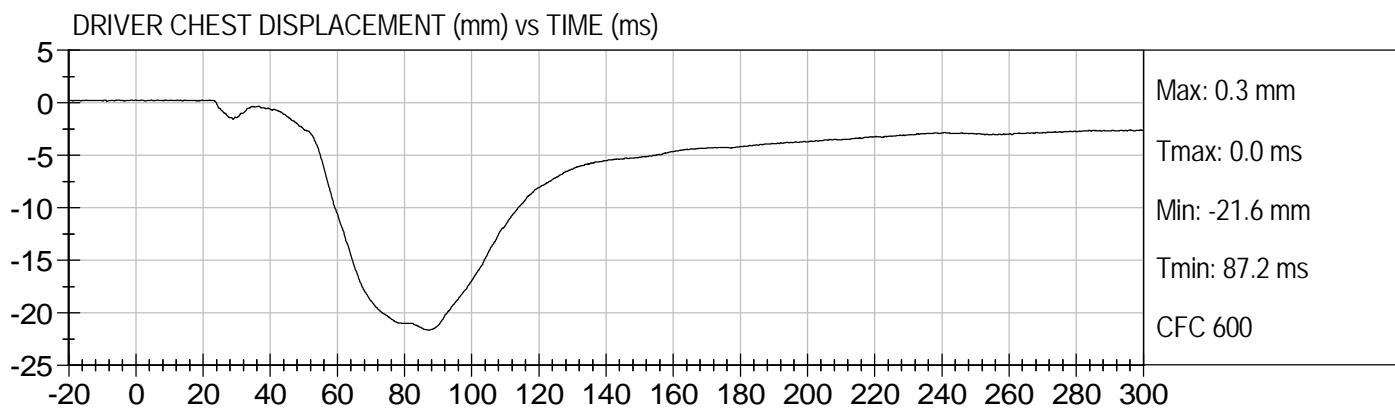
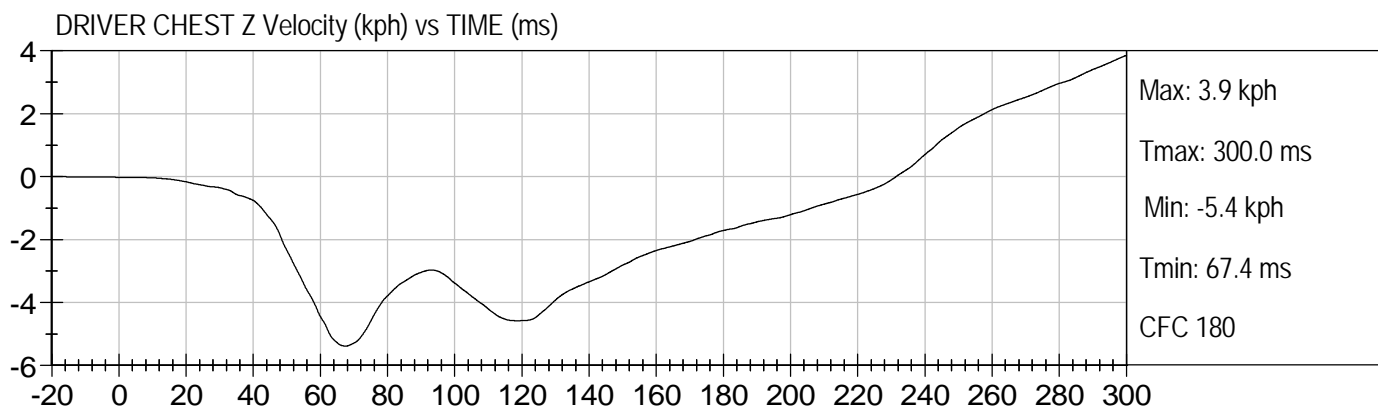
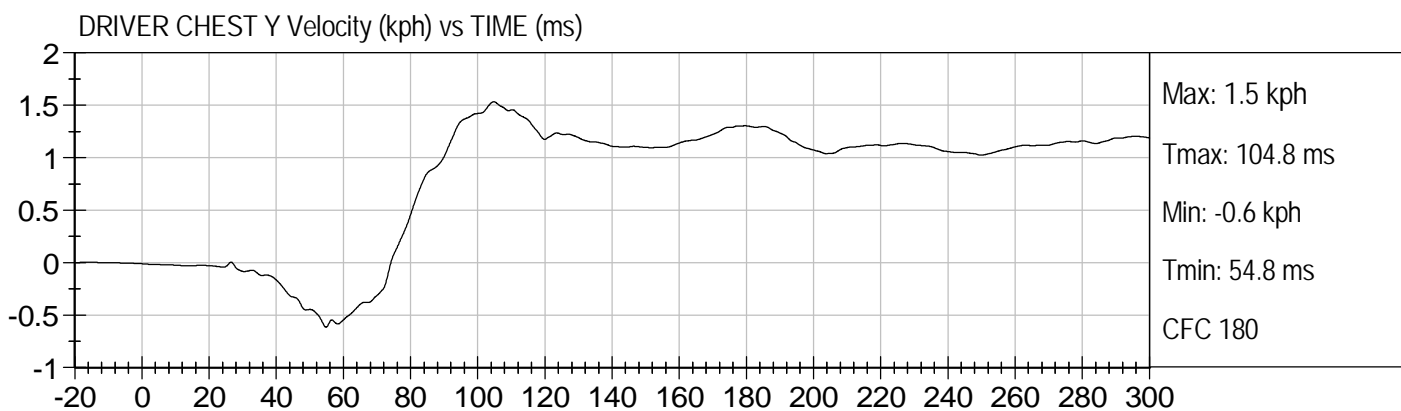
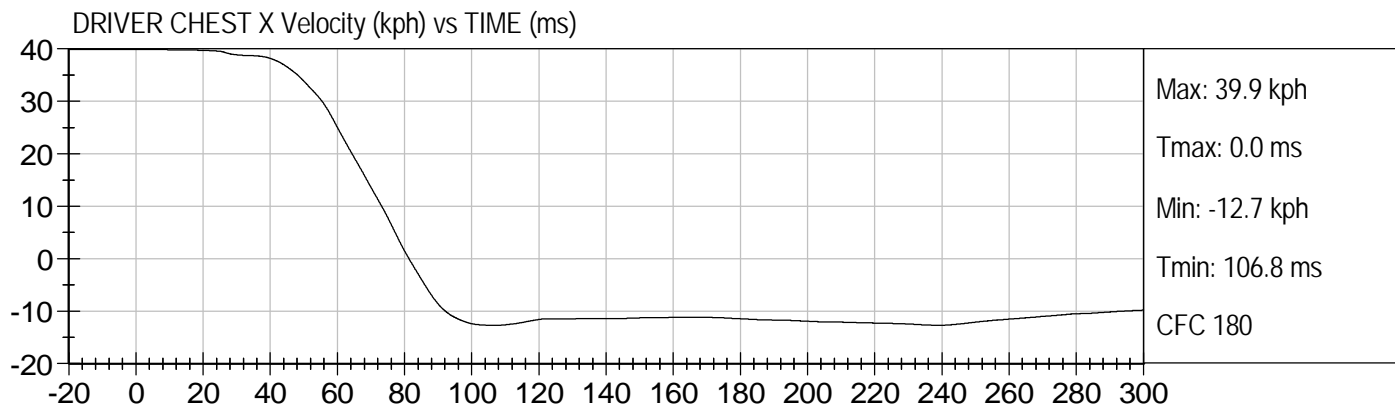



25 MPH FRONTAL UNBELTED
2008 FORD EDGE (C80202)

Test Date: 07/10/2008
Speed: 24.8 mph (39.9 km/h)

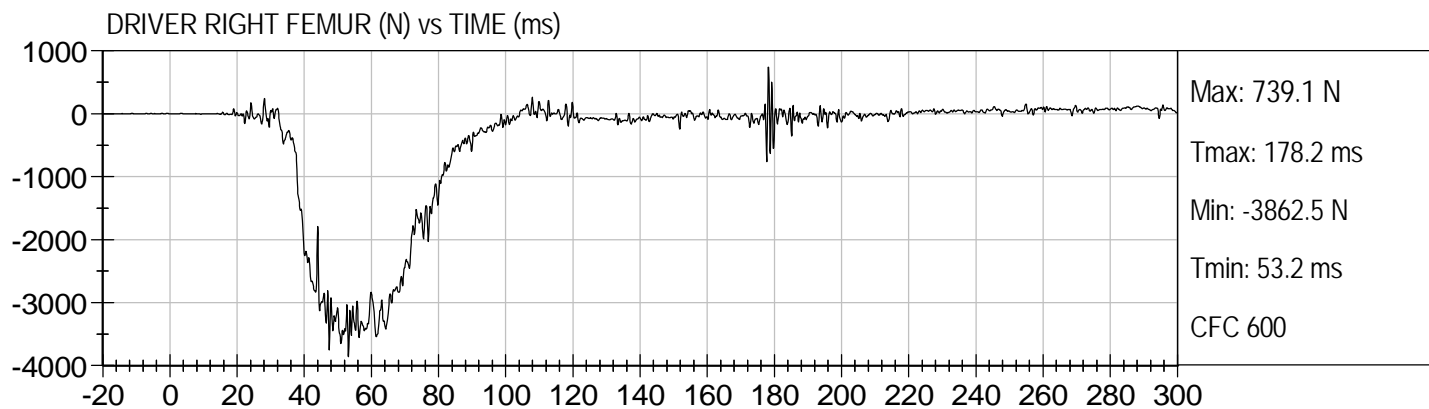
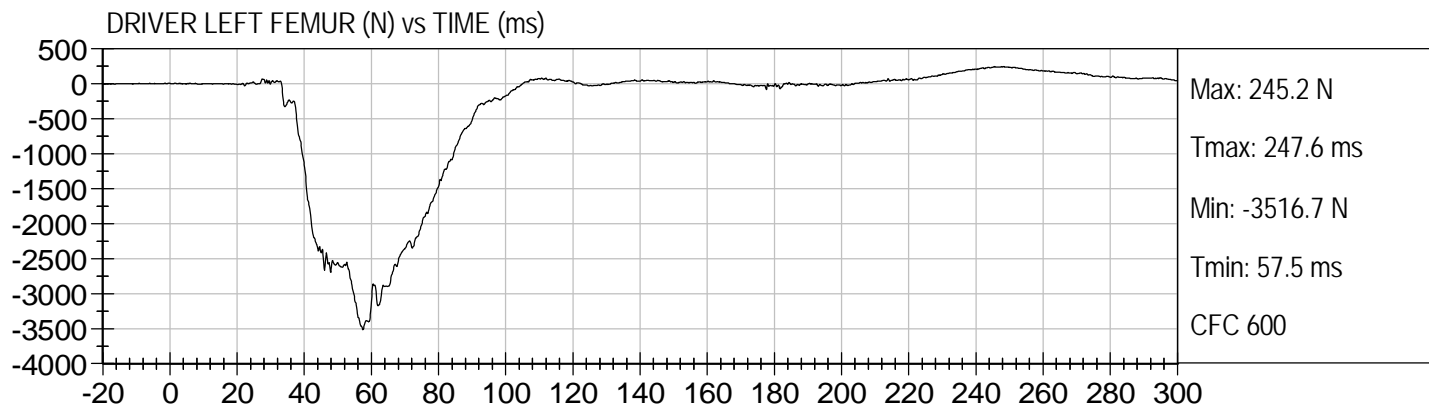

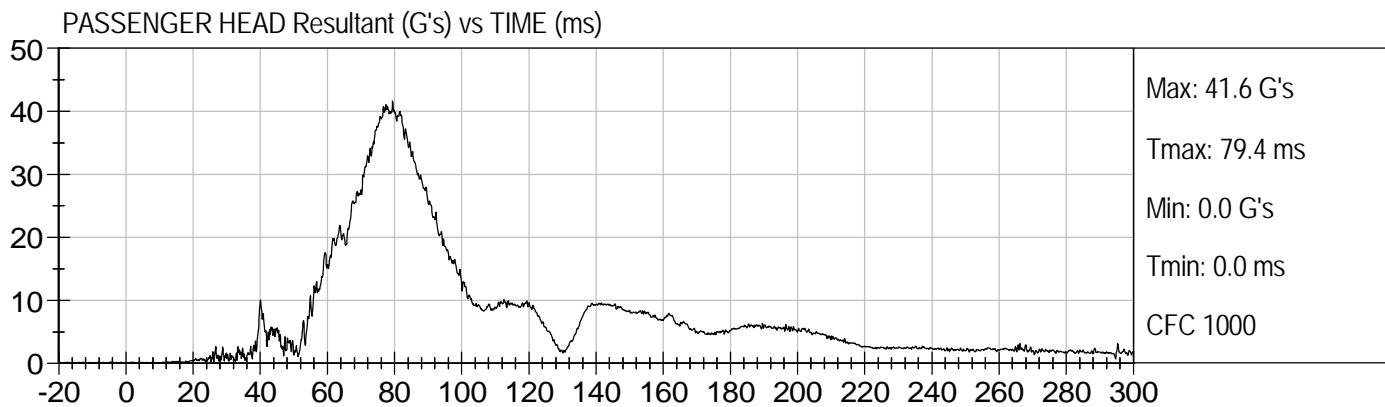
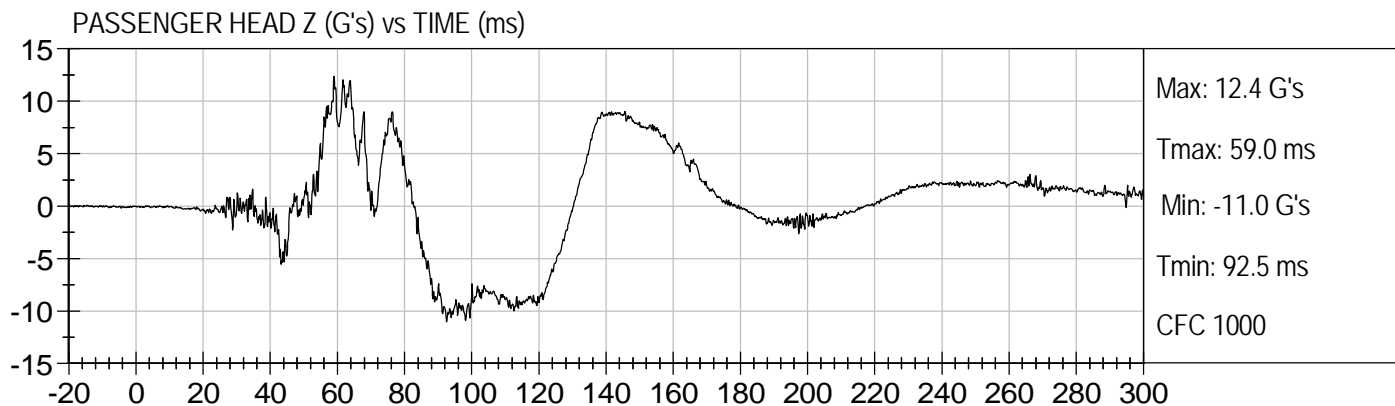
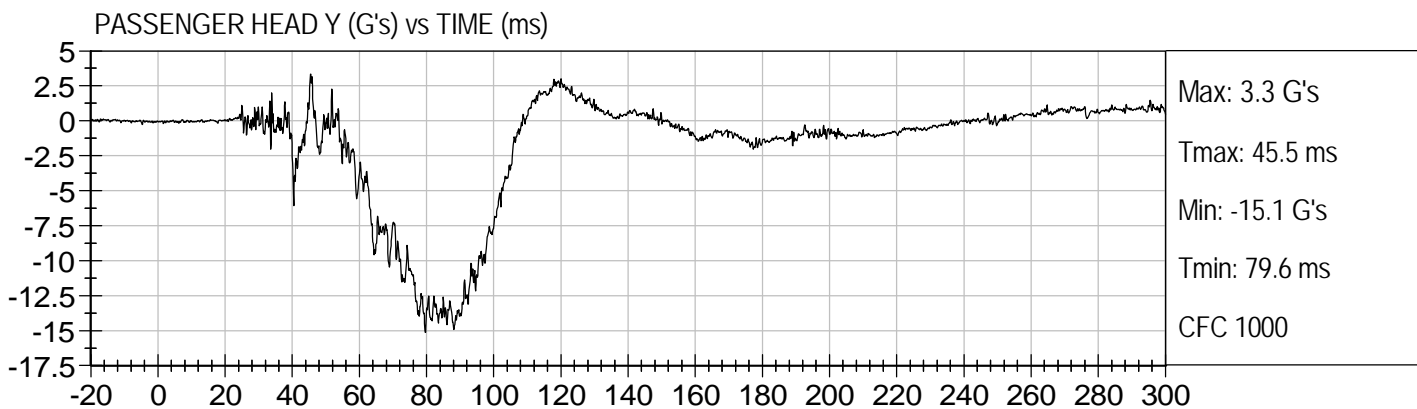
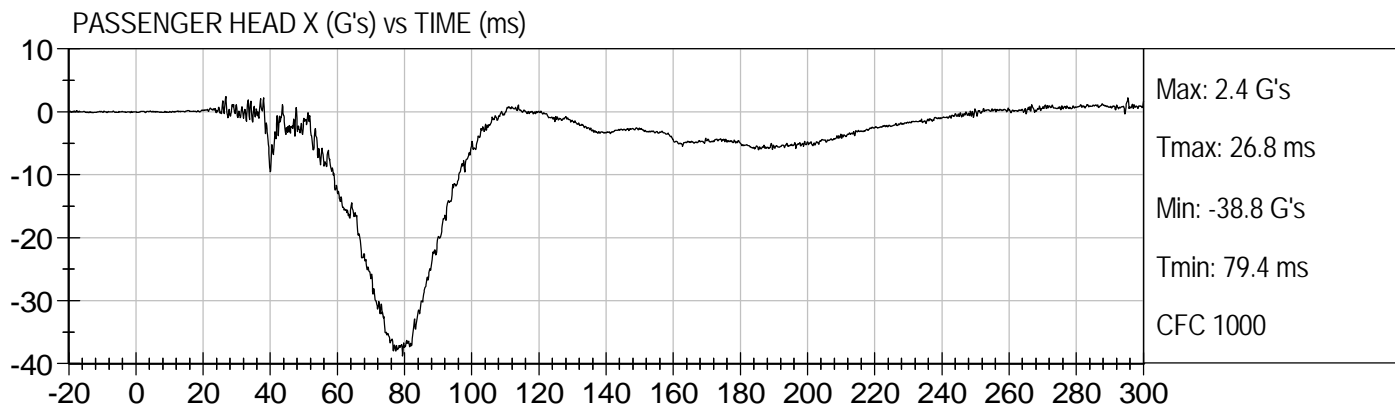

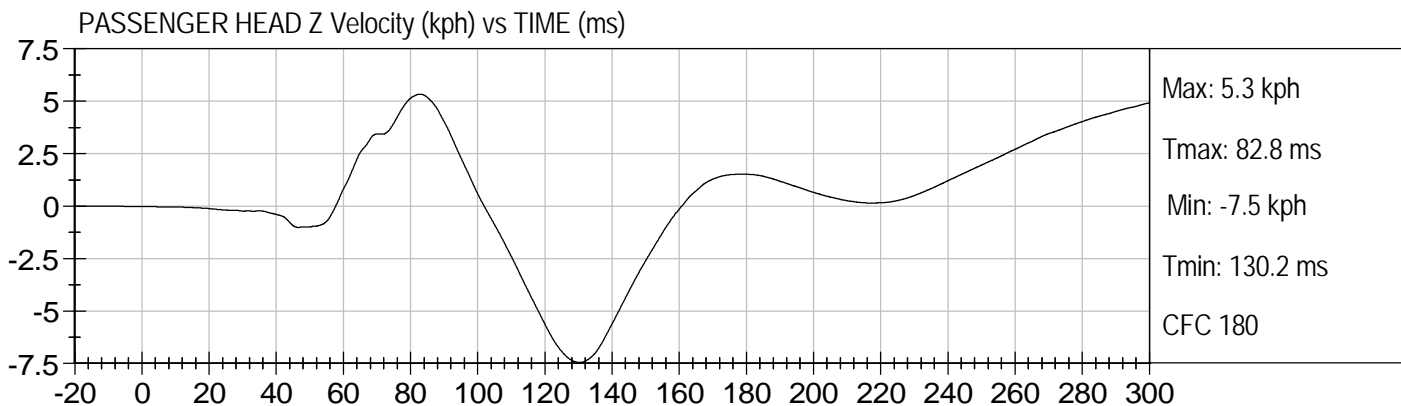
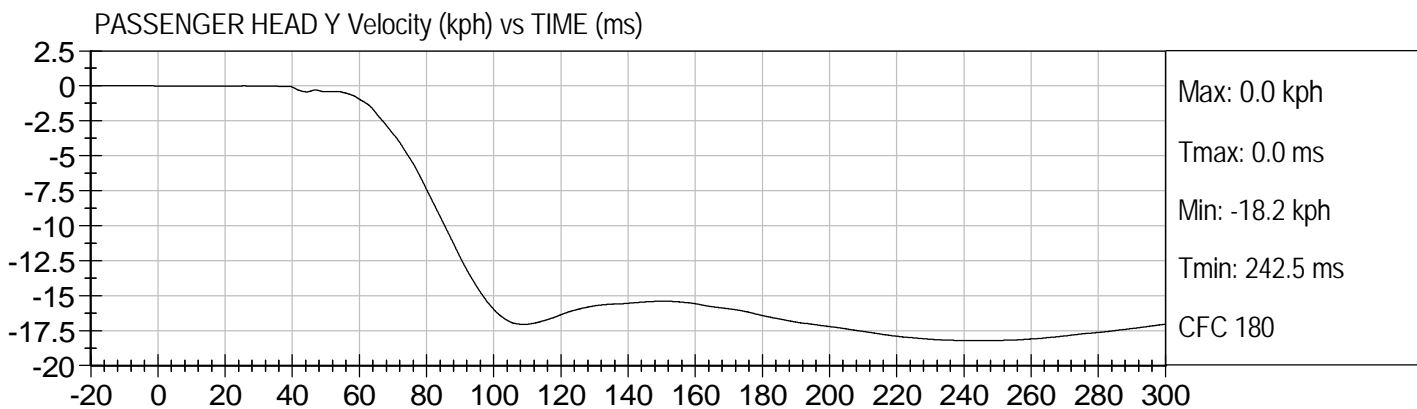
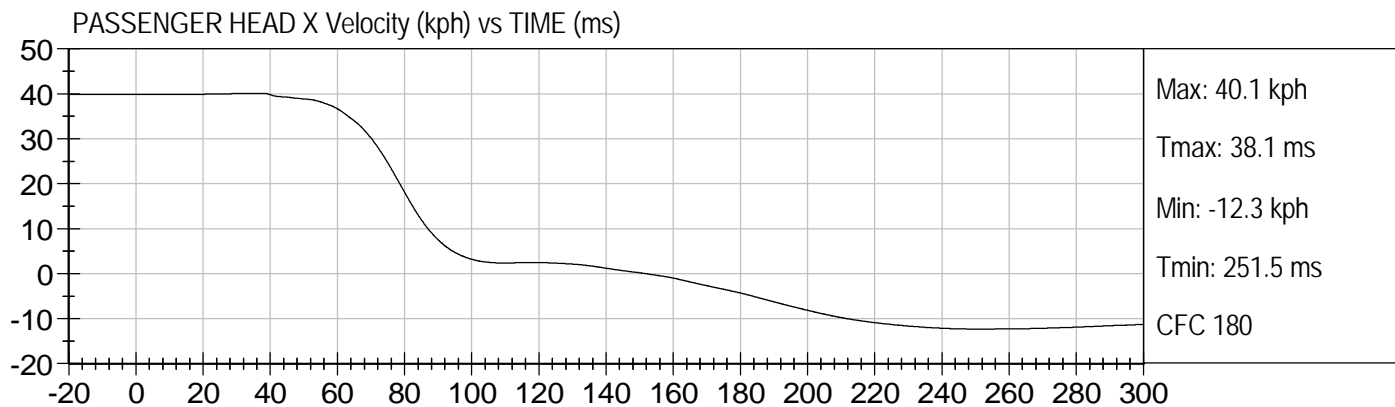

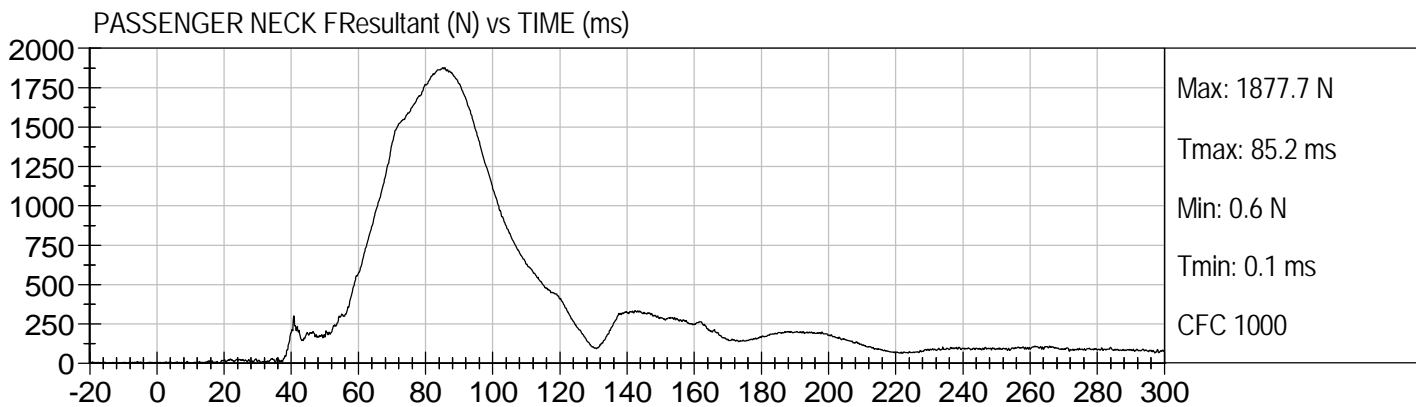
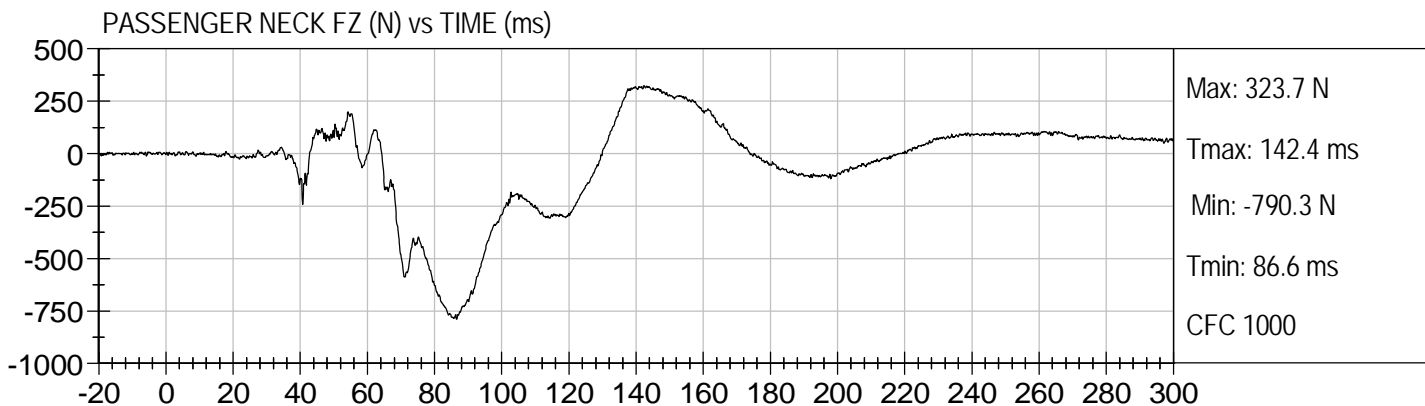
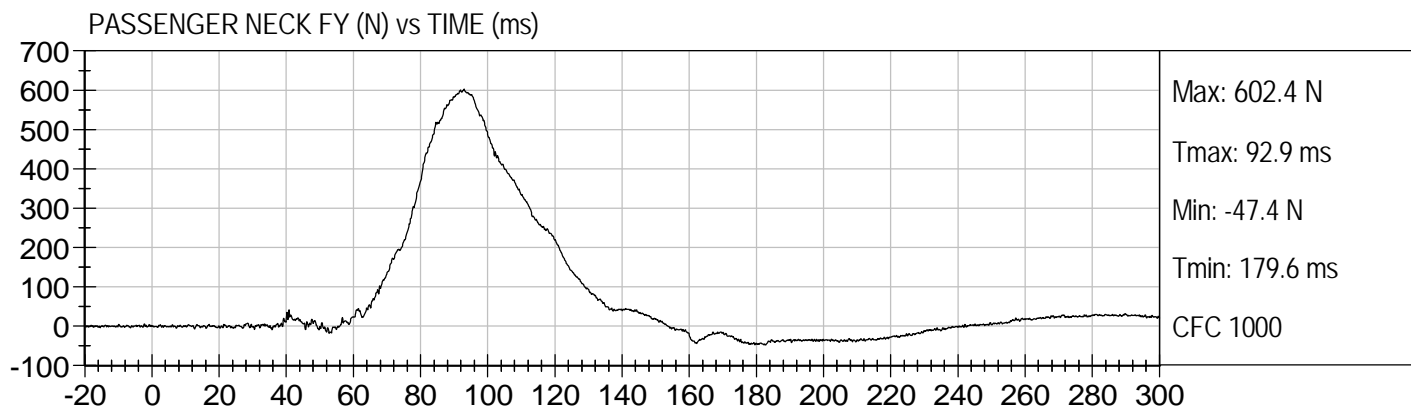
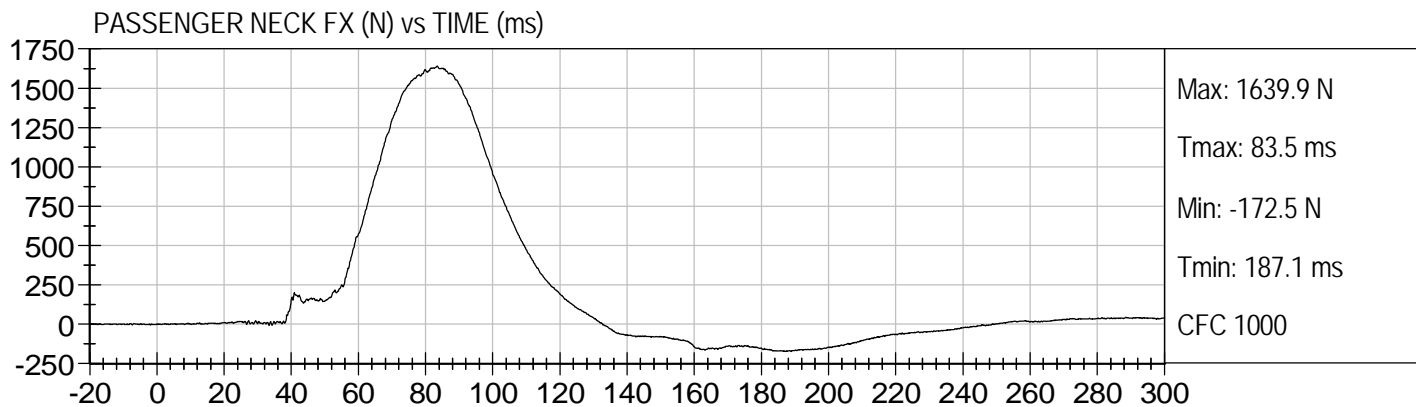

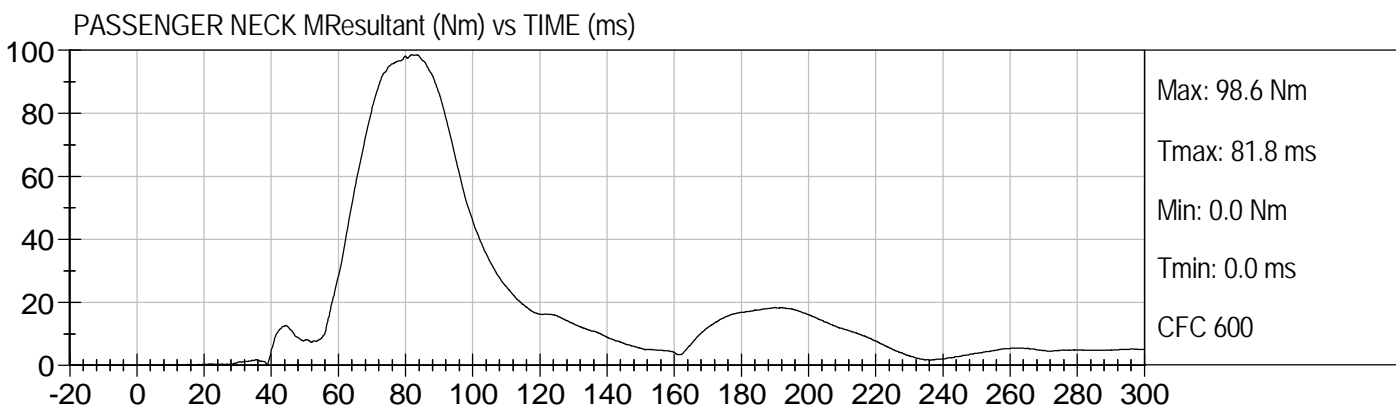
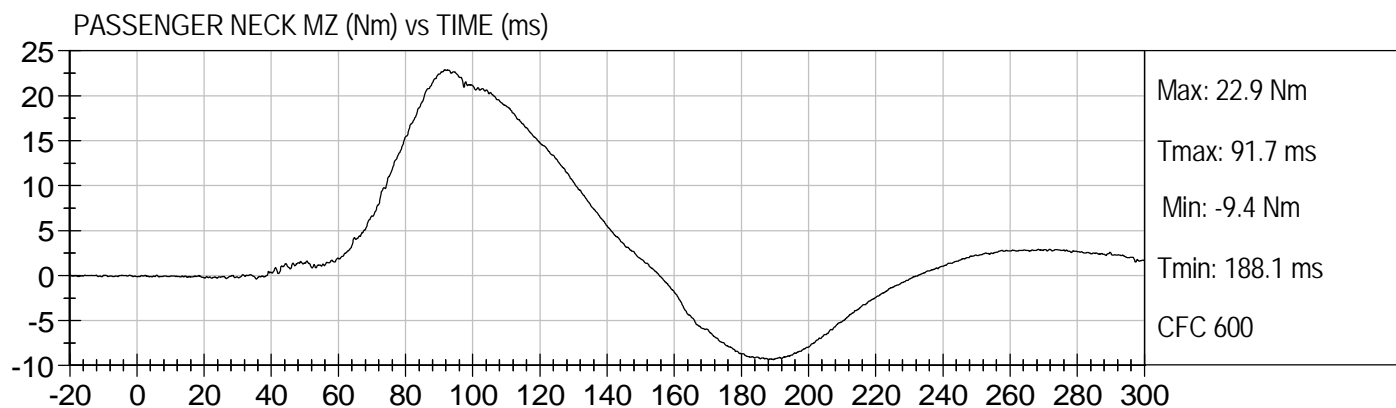
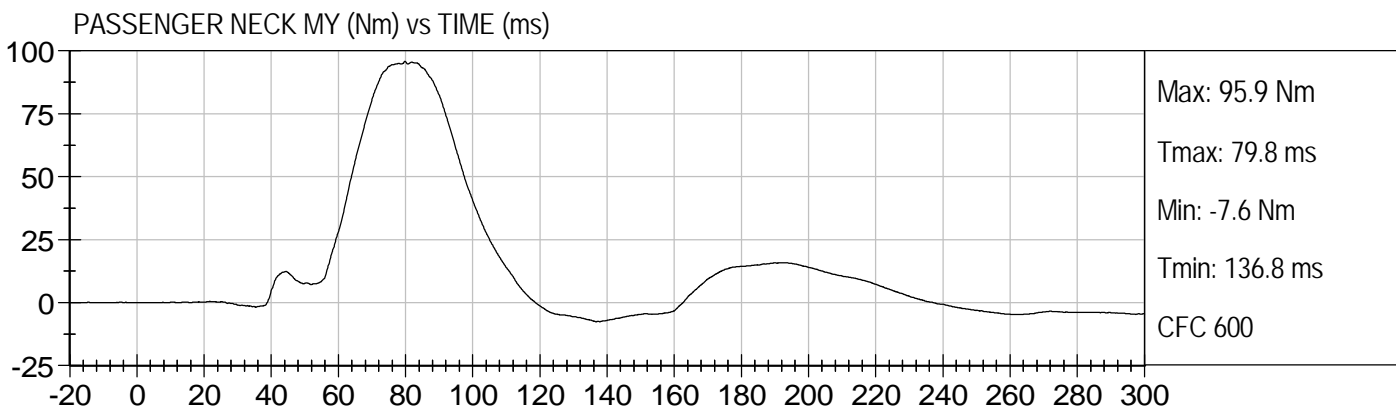
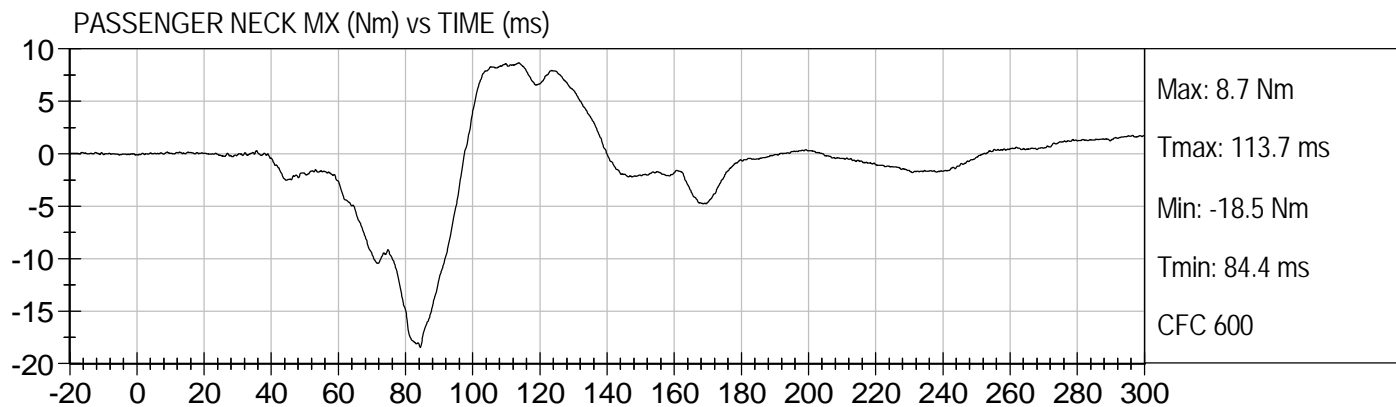

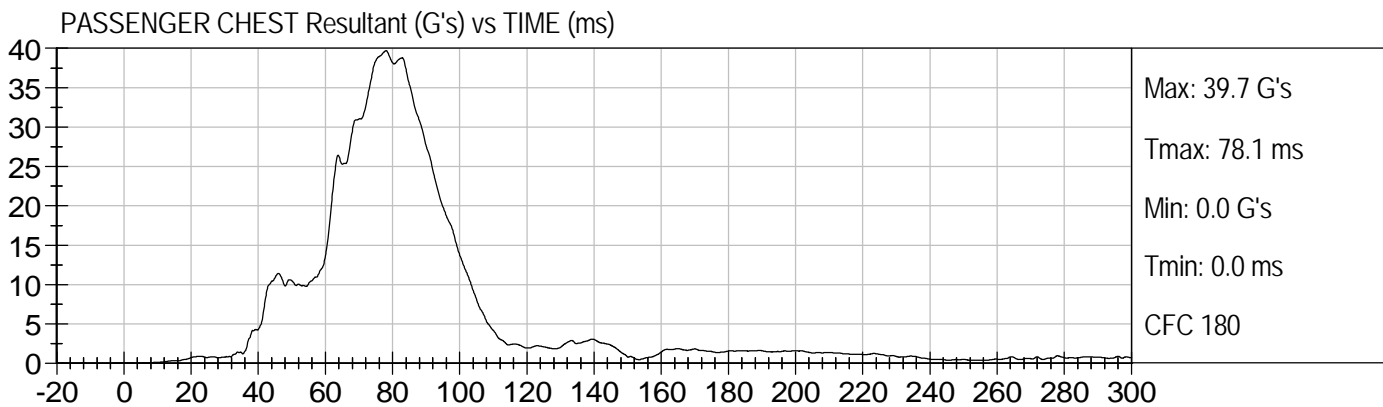
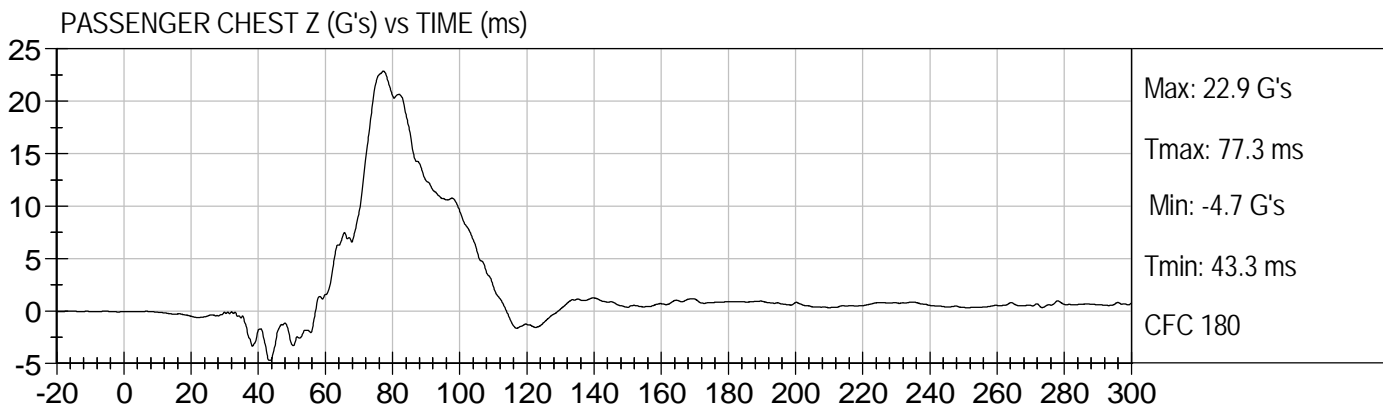
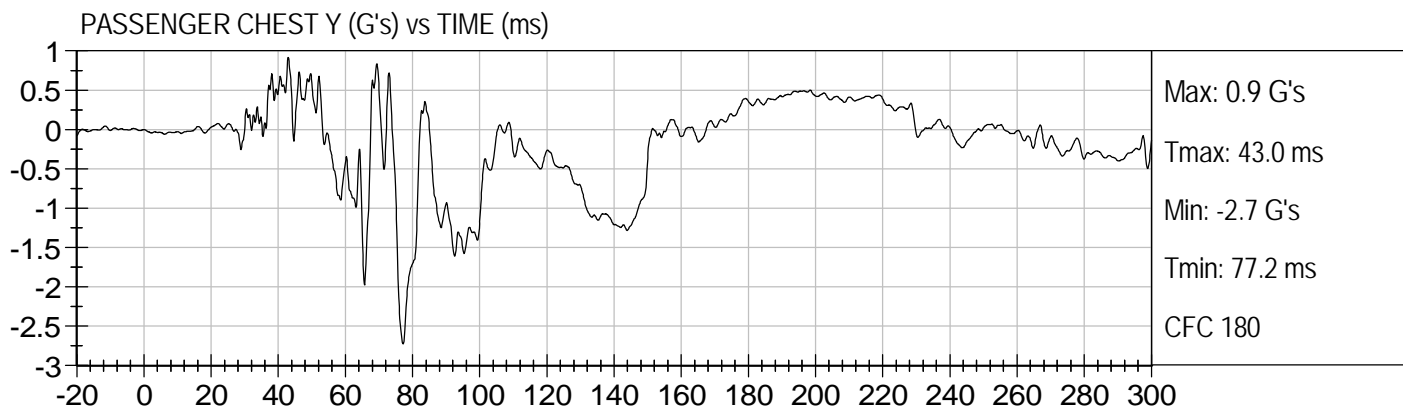
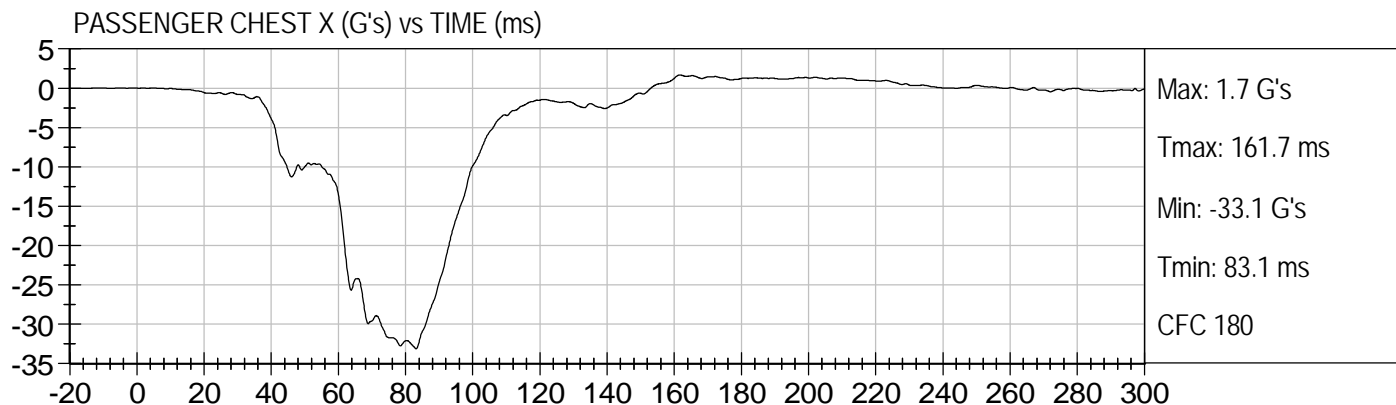

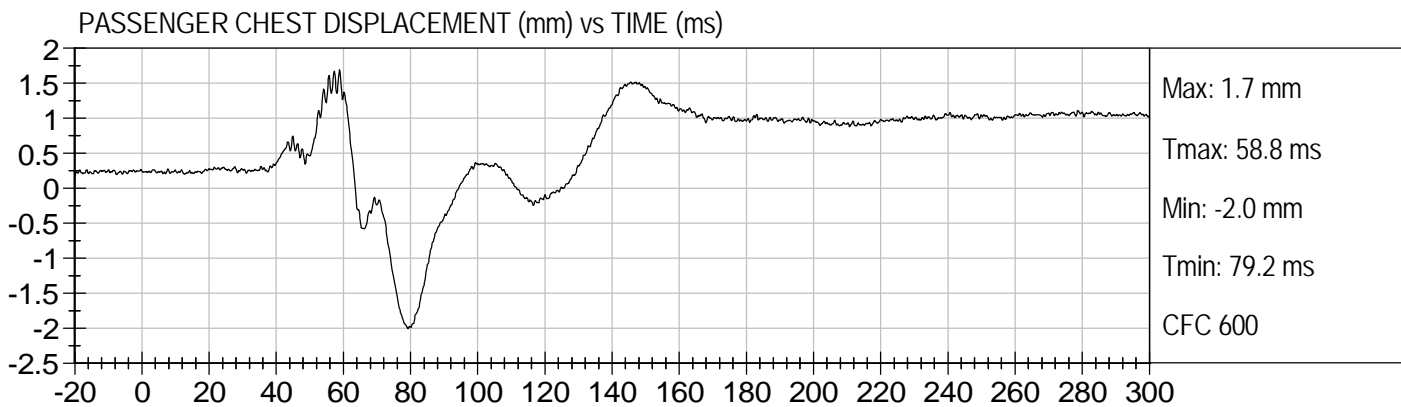
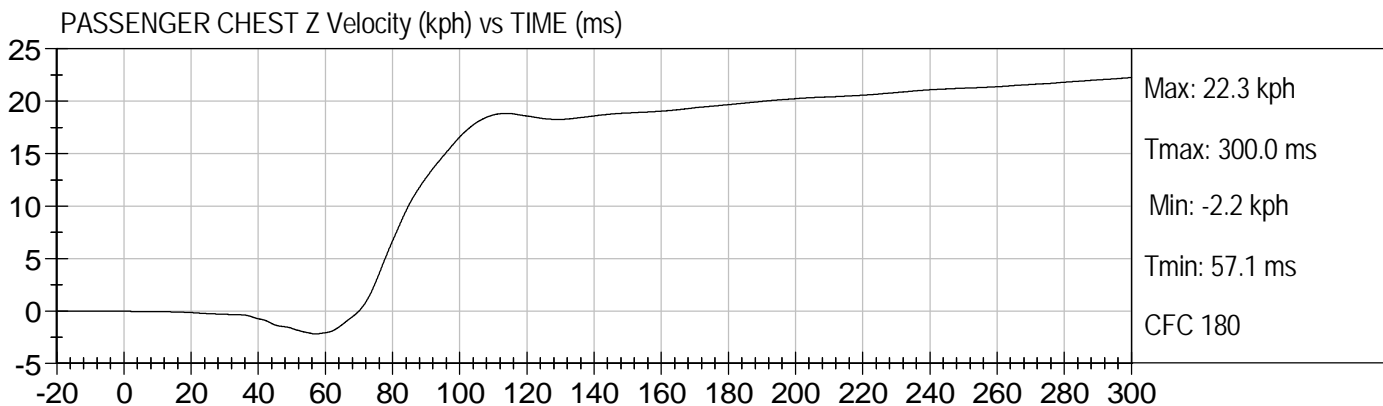
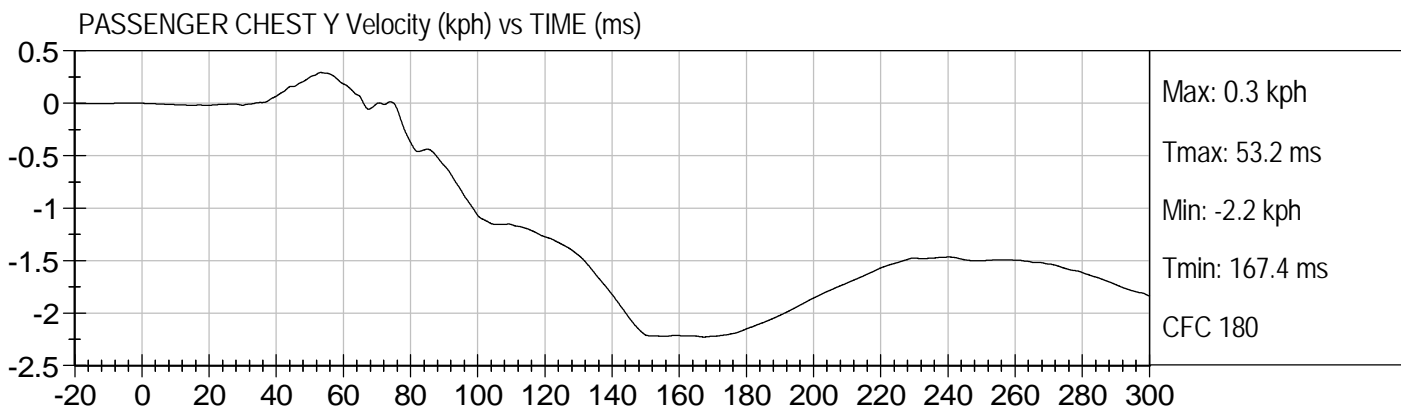
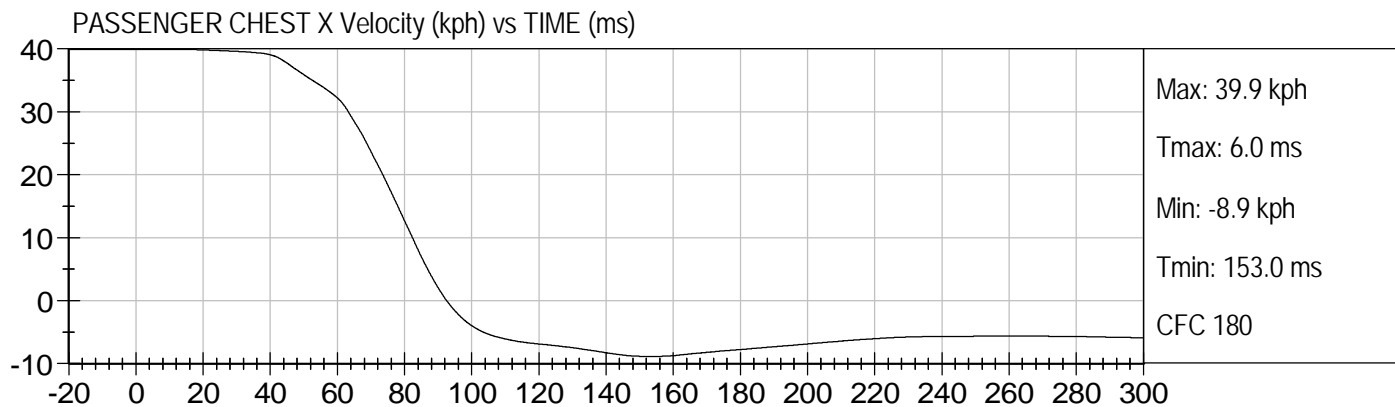



25 MPH FRONTAL UNBELTED
2008 FORD EDGE (C80202)

Test Date: 07/10/2008
Speed: 24.8 mph (39.9 km/h)

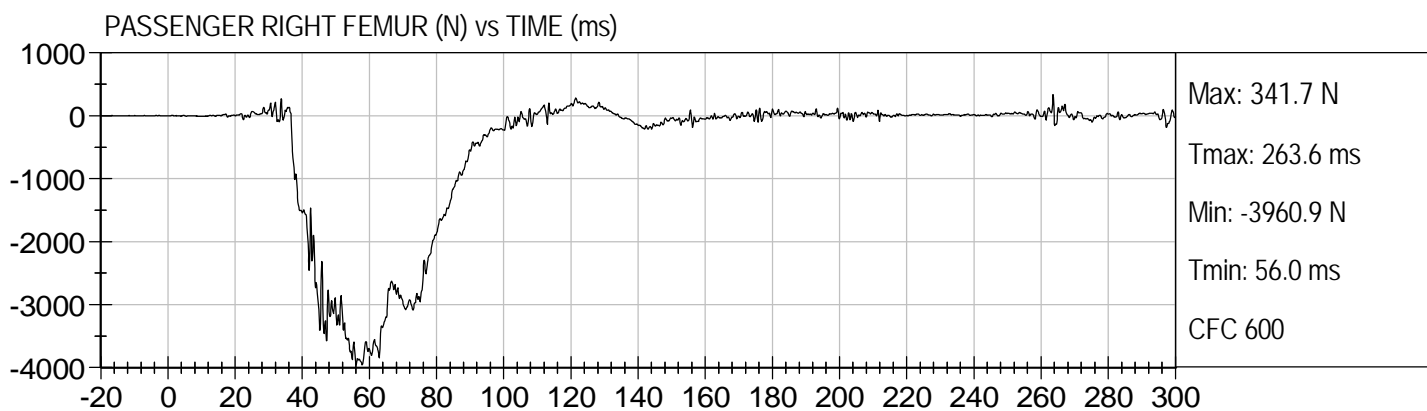
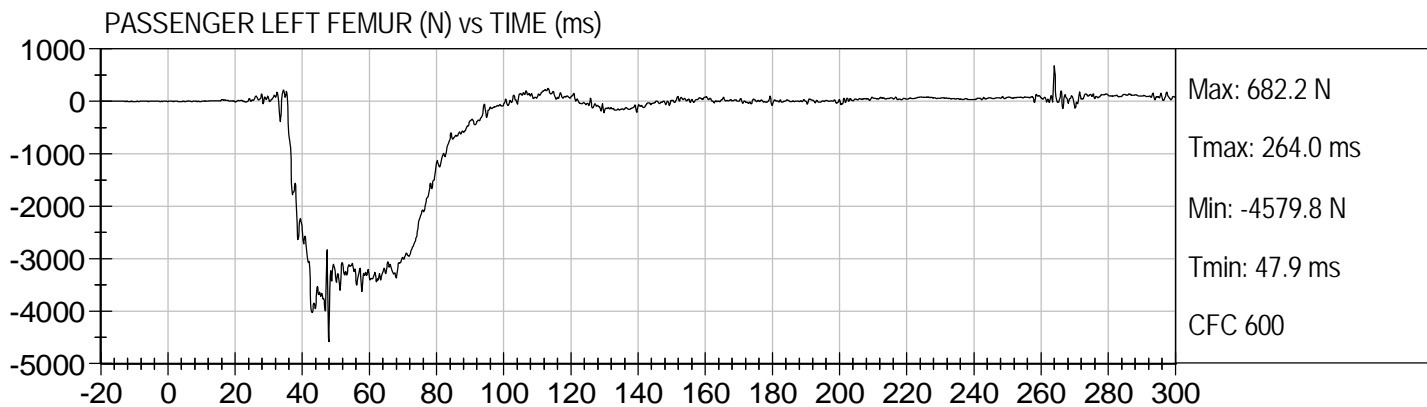

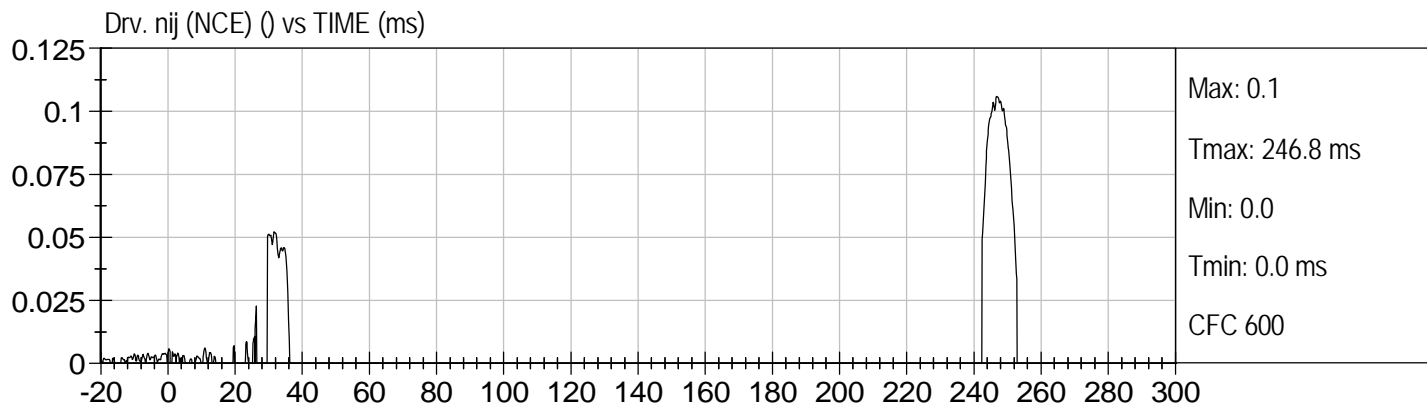
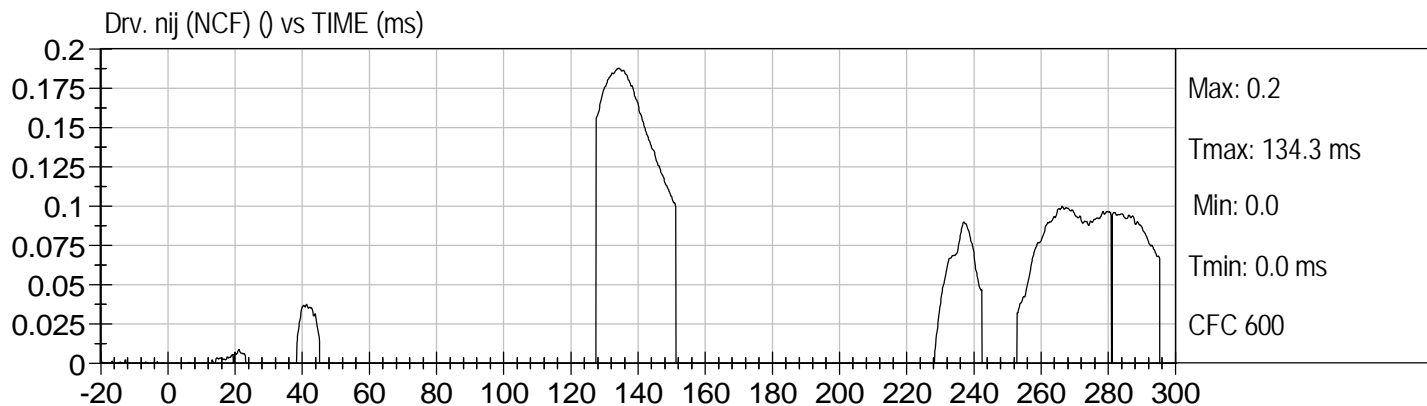
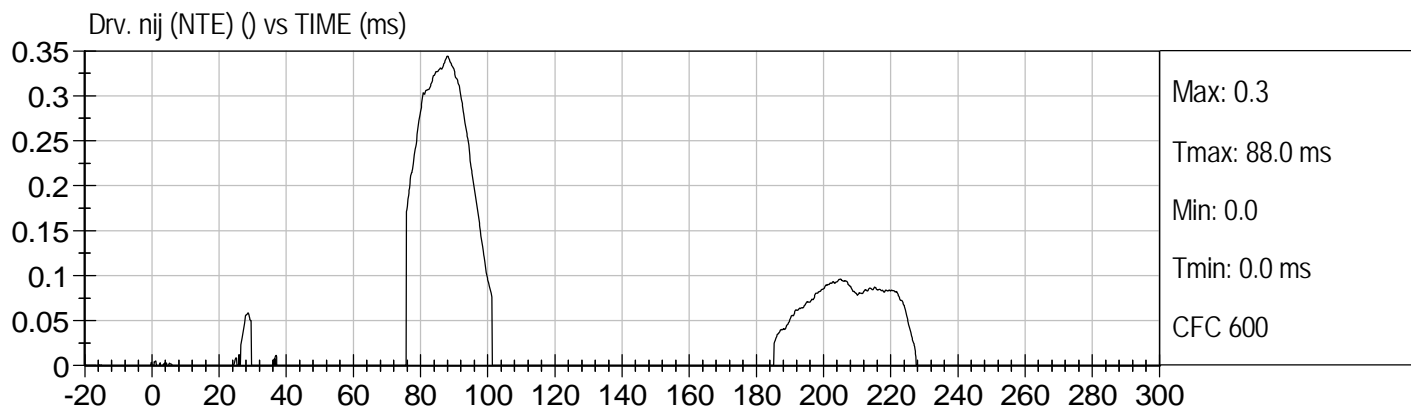
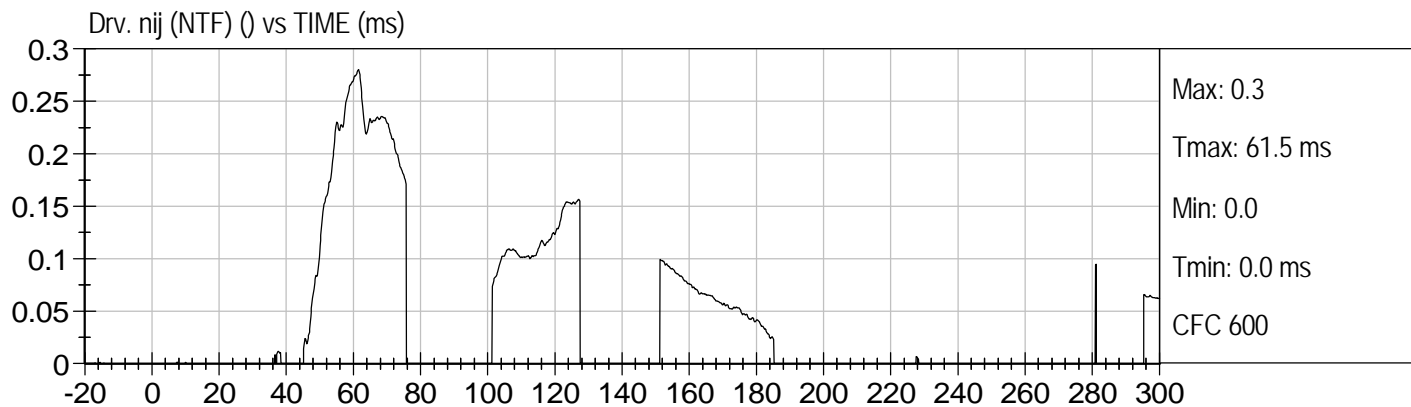



Pass. nij (NTF) () vs TIME (ms)

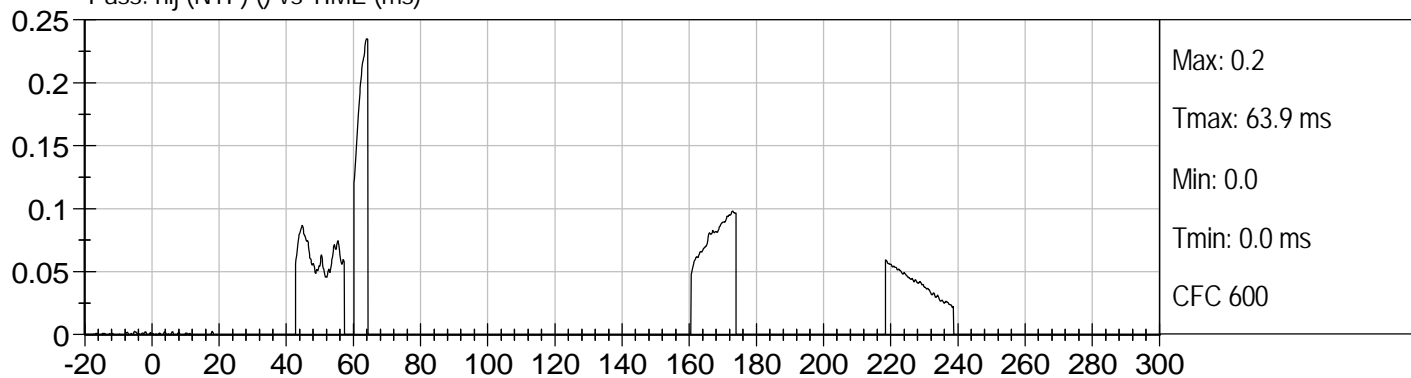

Pass. nij (NTE) () vs TIME (ms)

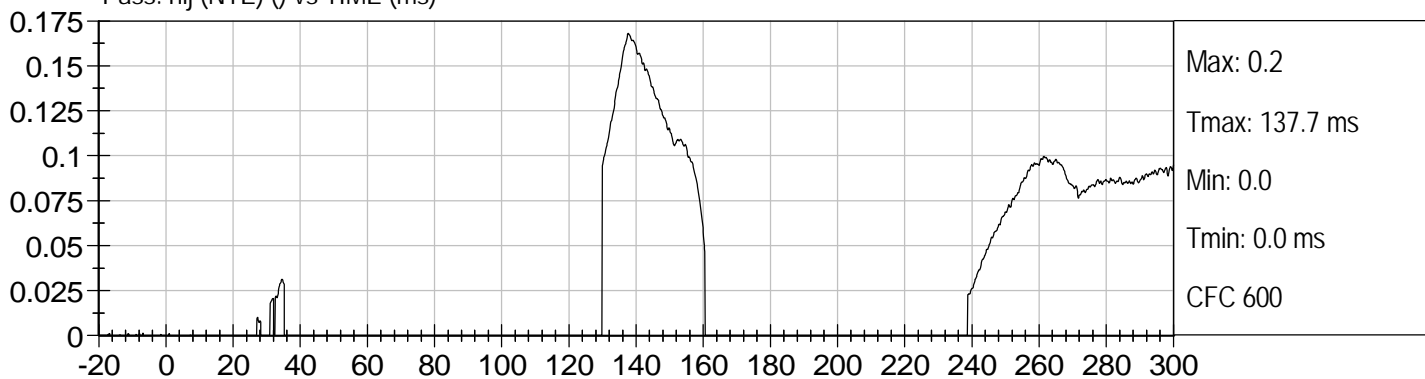

Pass. nij (NCF) () vs TIME (ms)

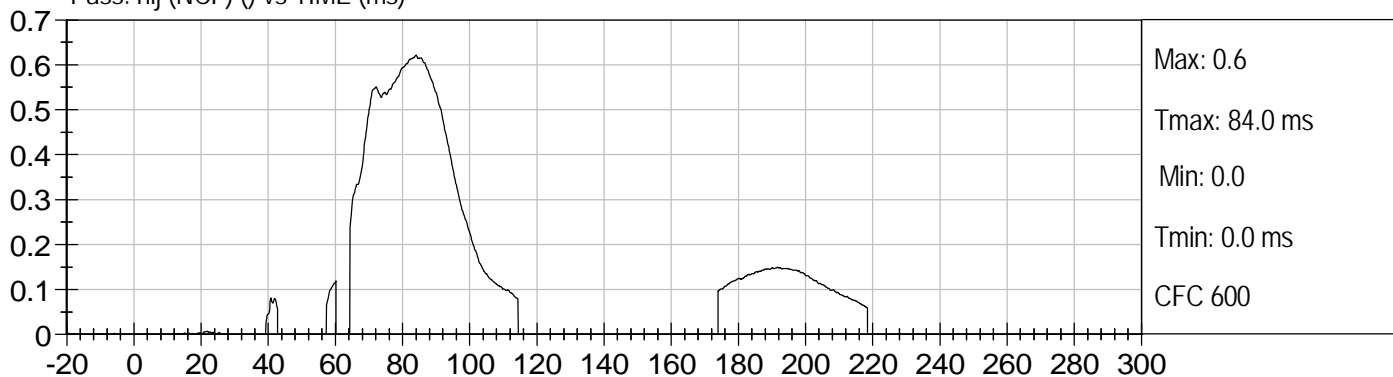

Pass. nij (NCE) () vs TIME (ms)

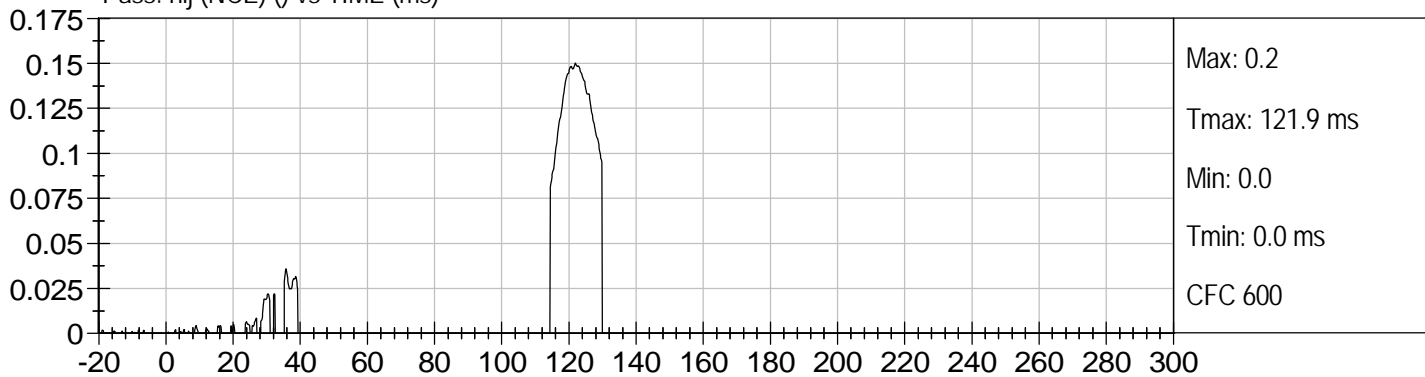

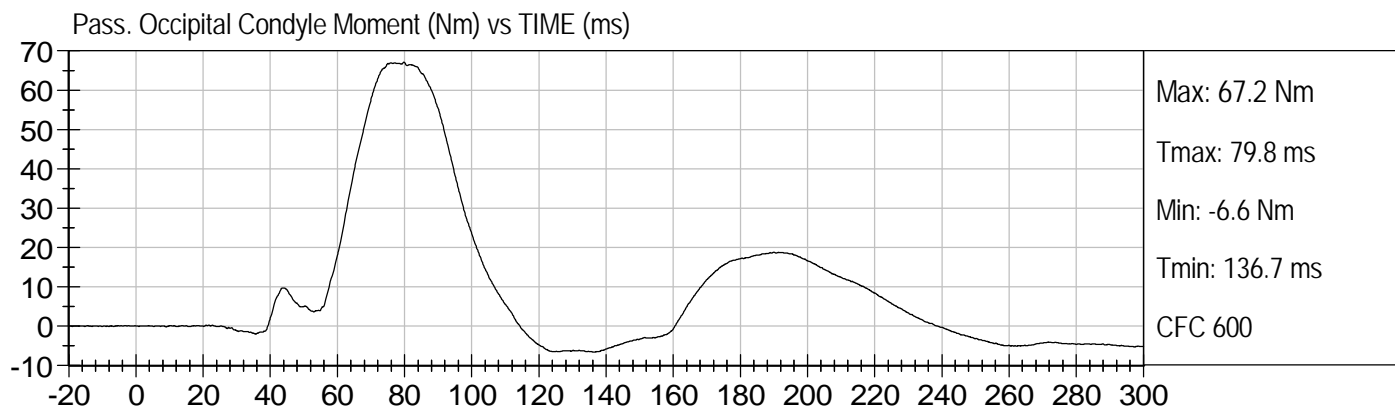
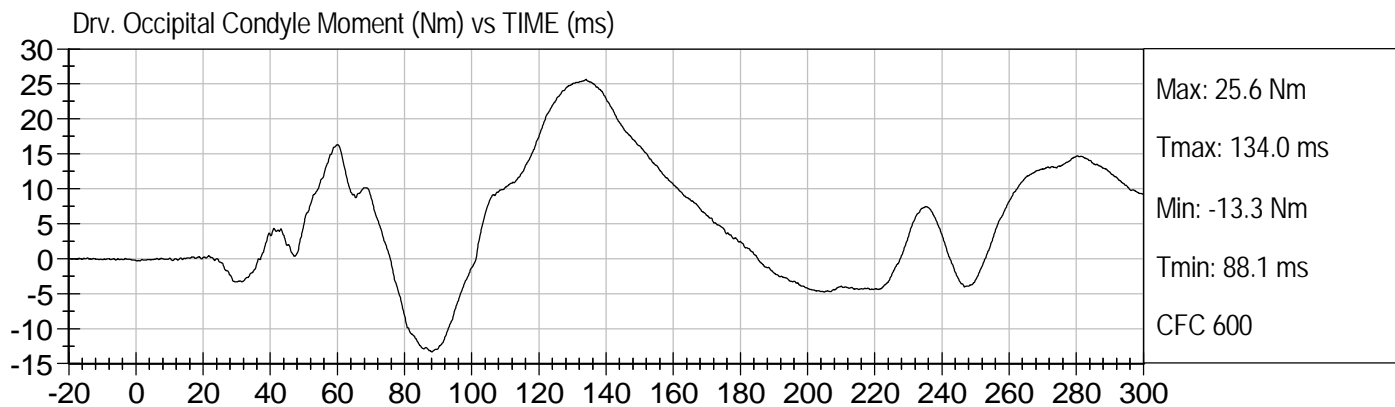

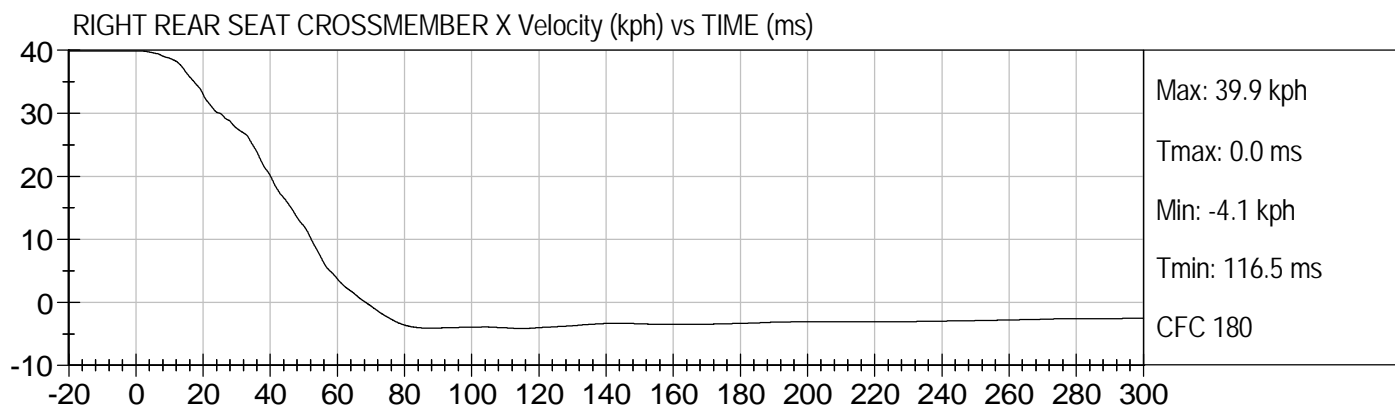
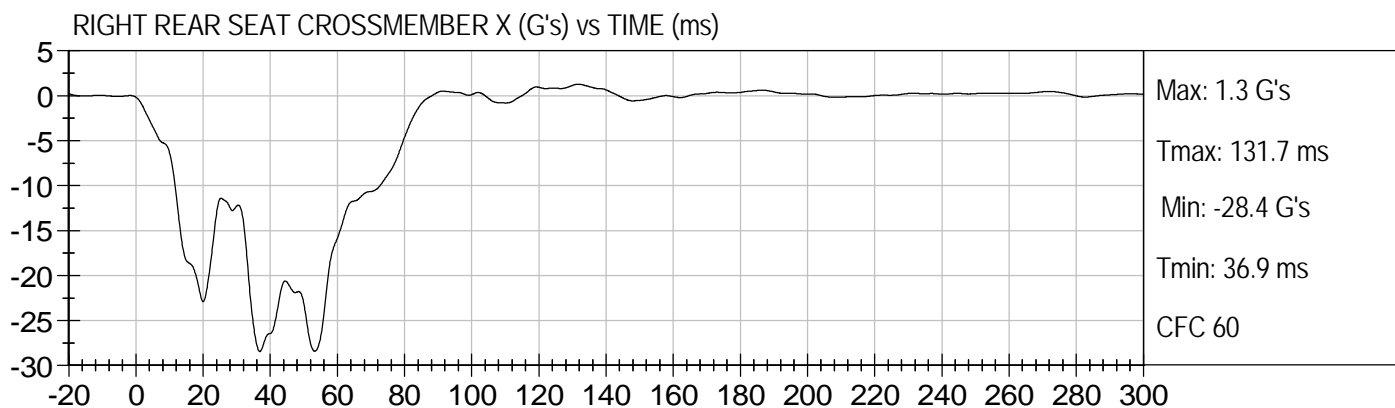
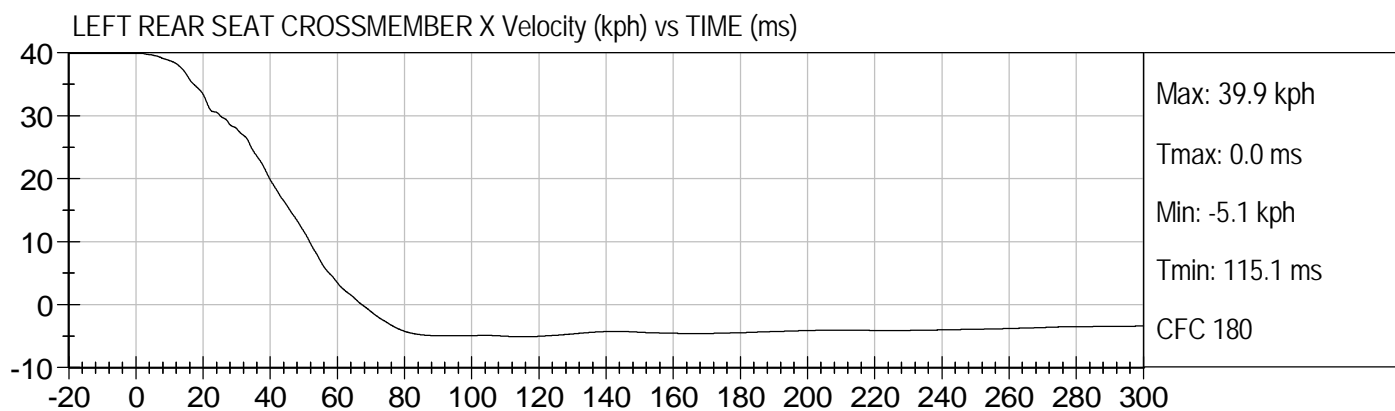
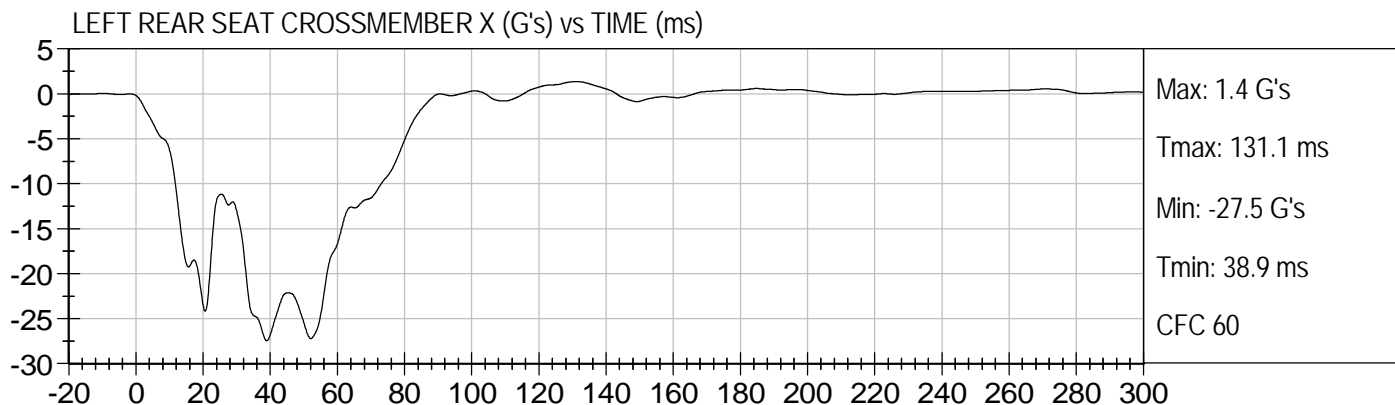

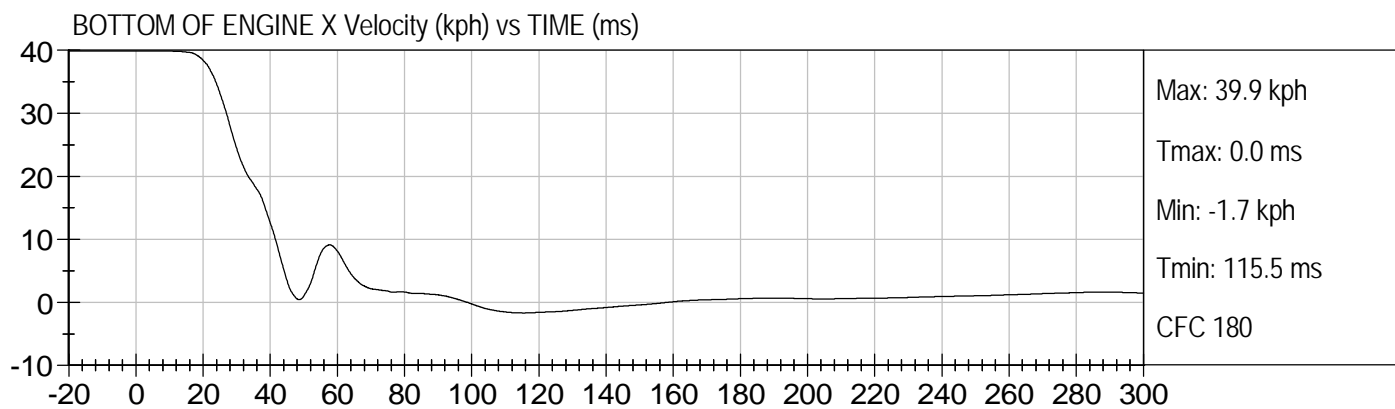
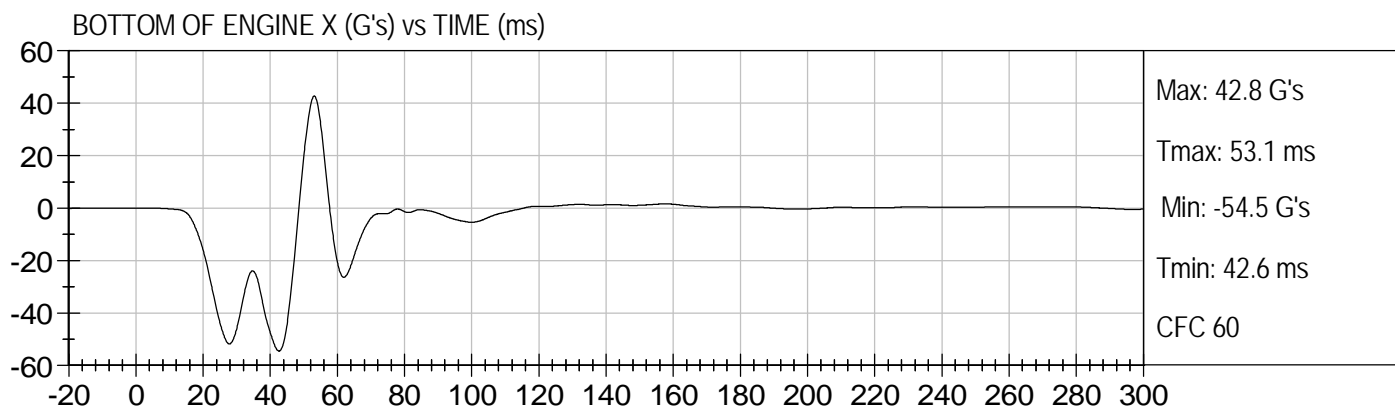
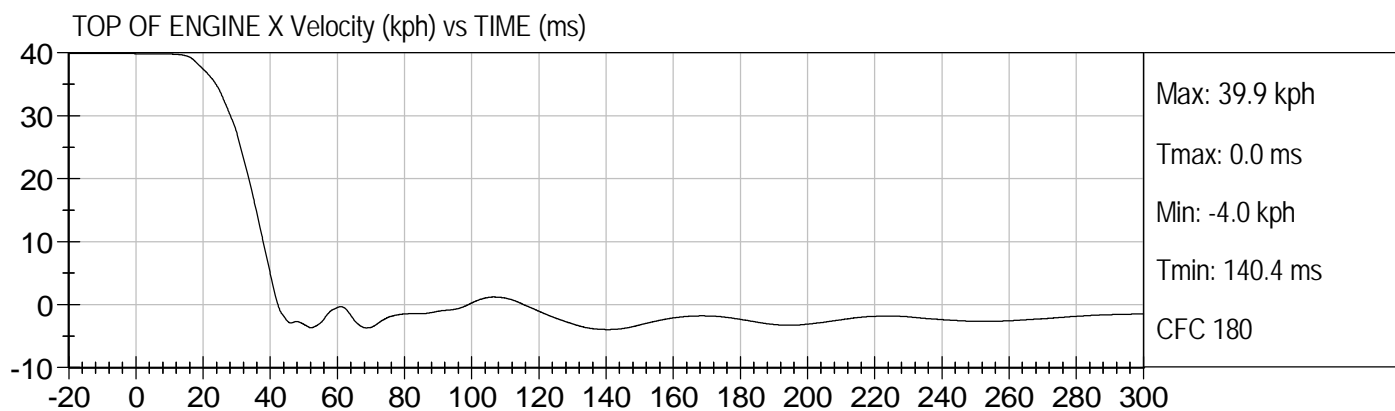
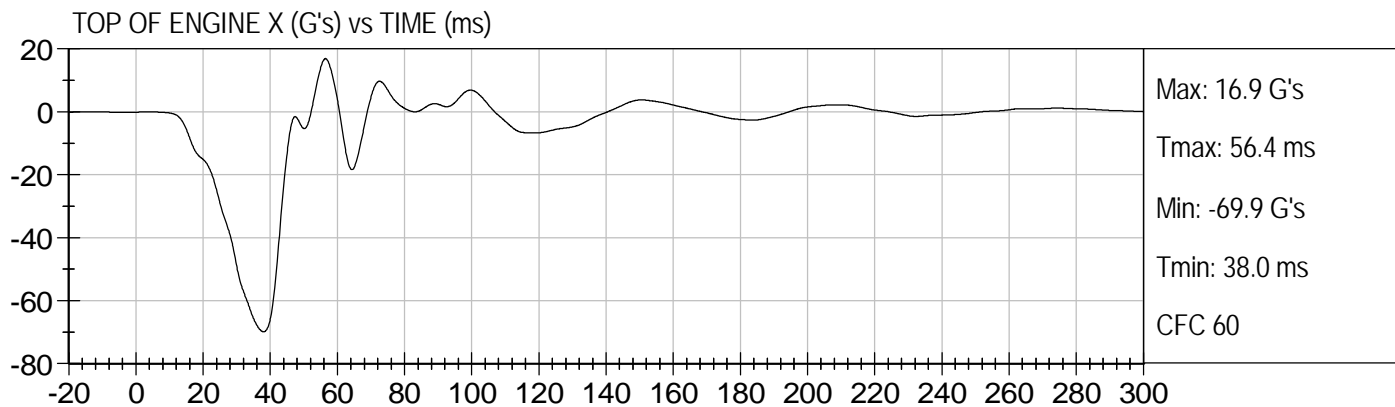

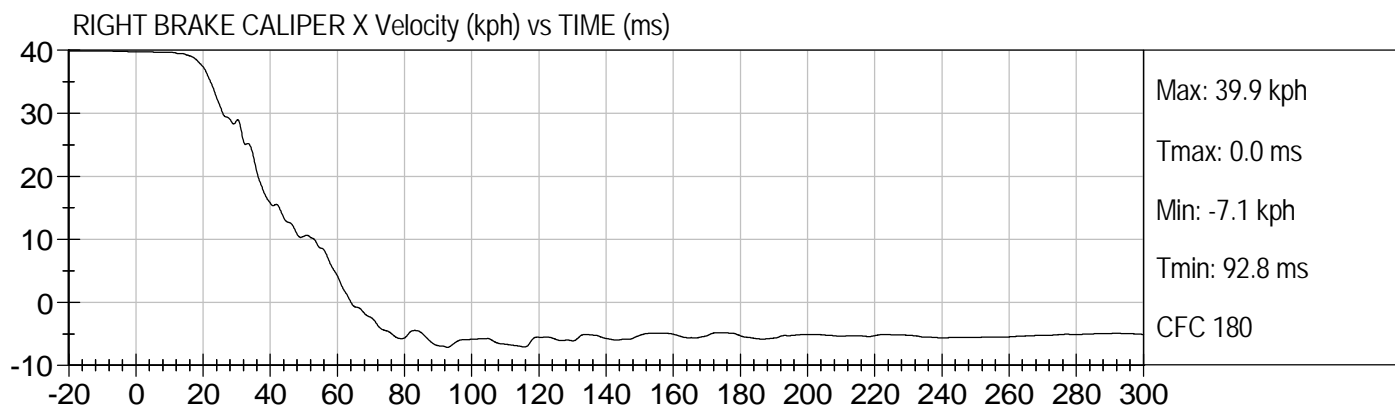
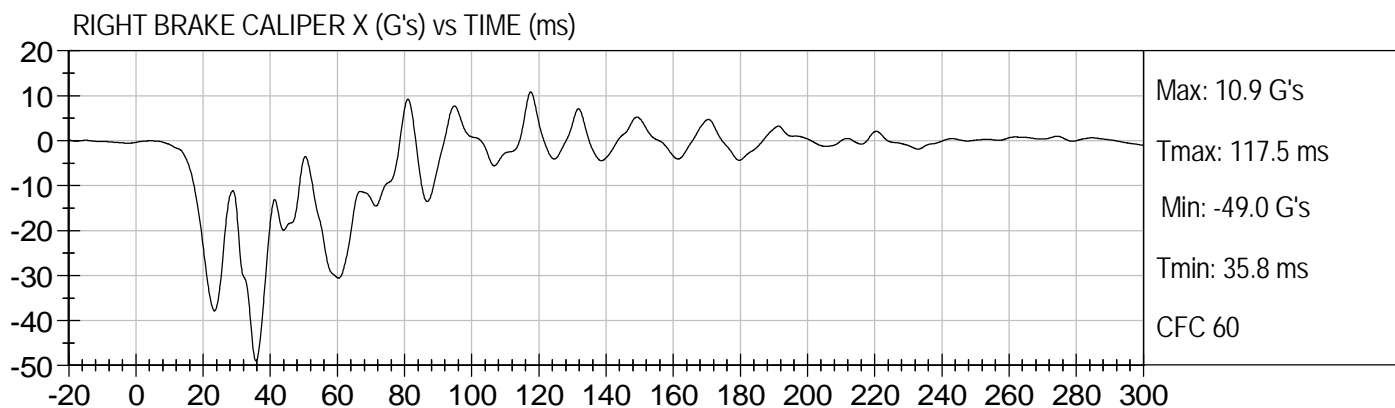
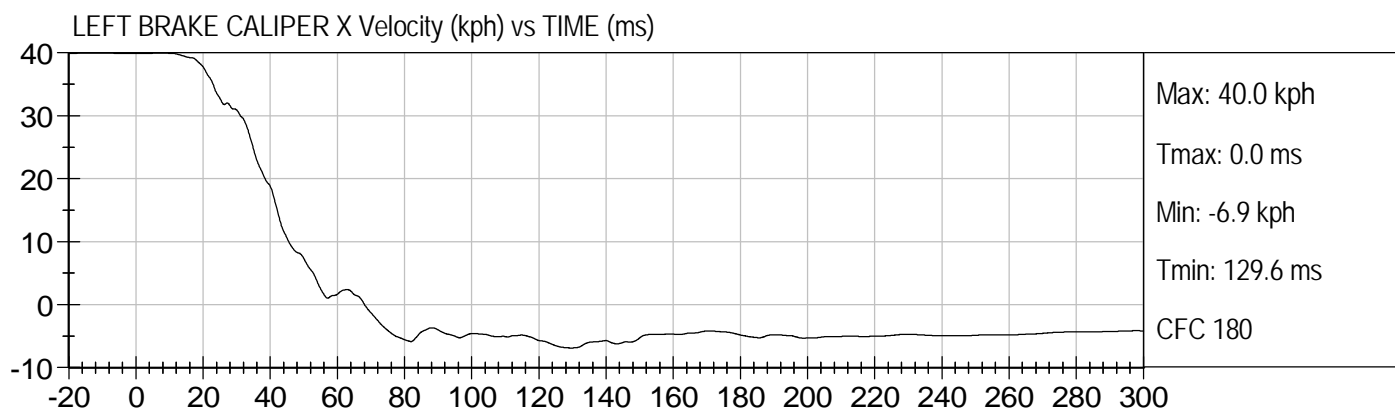
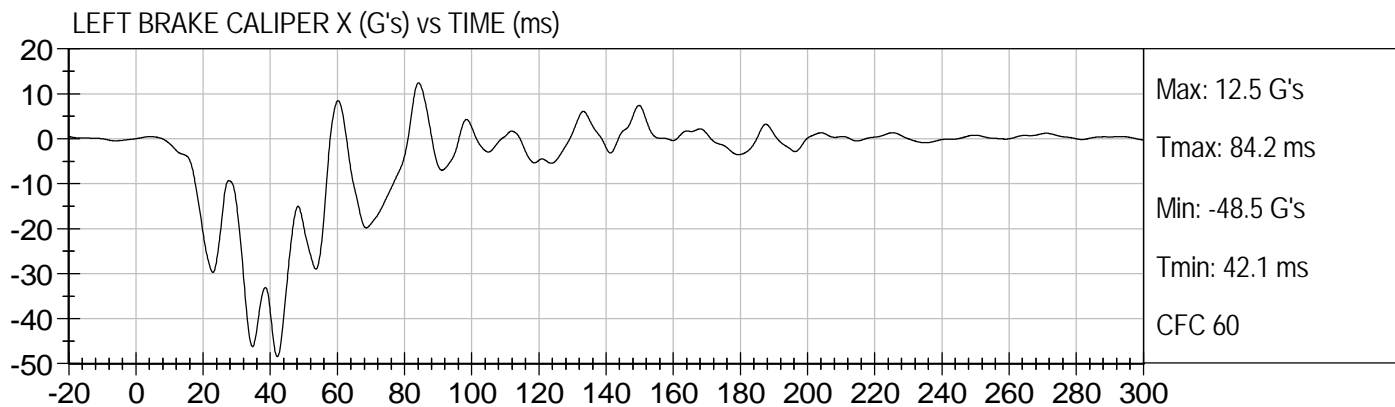

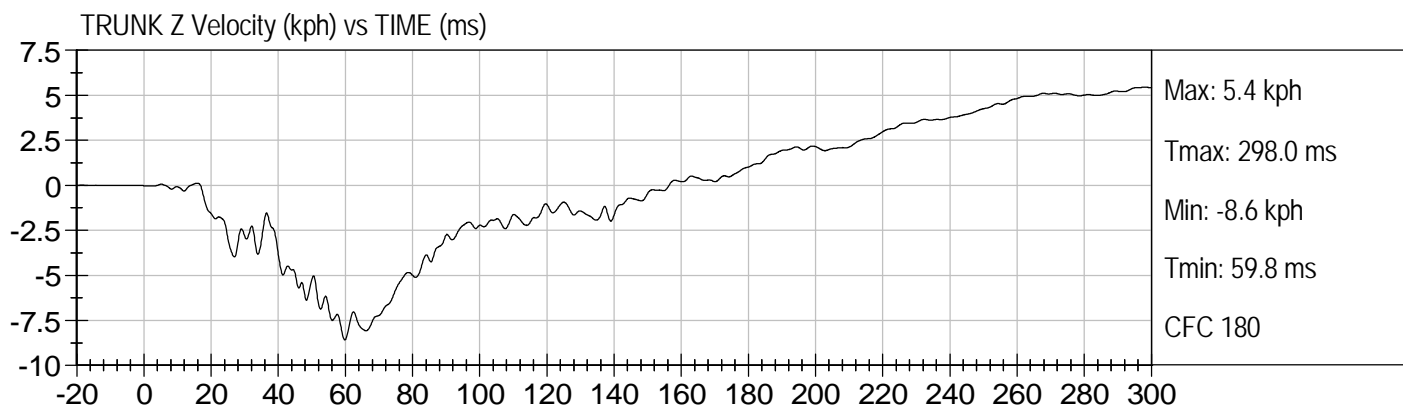
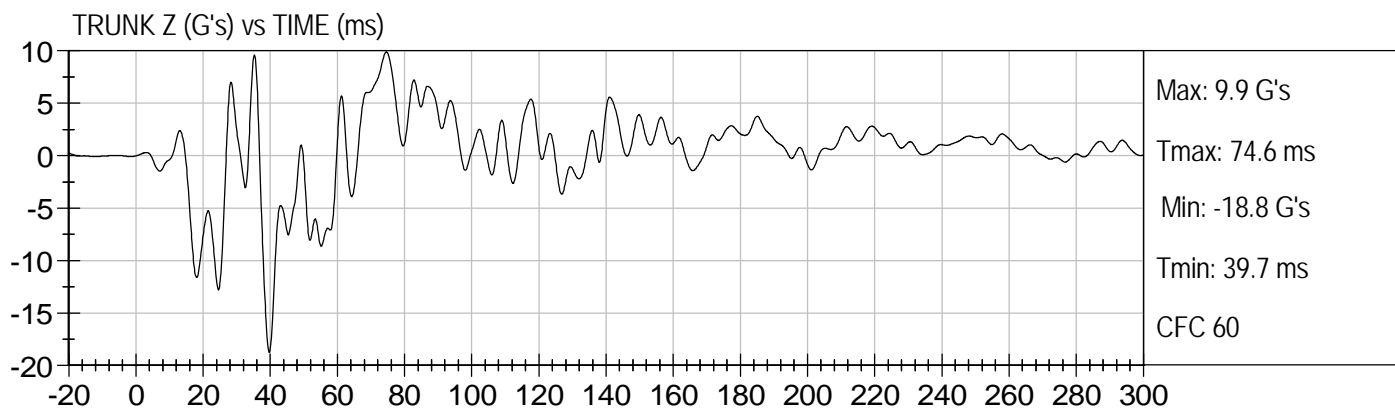
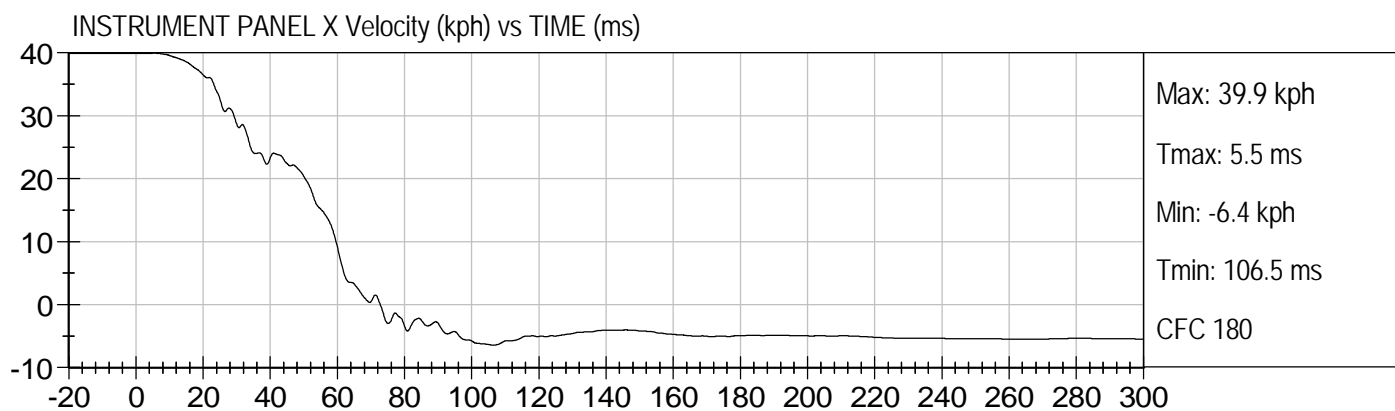
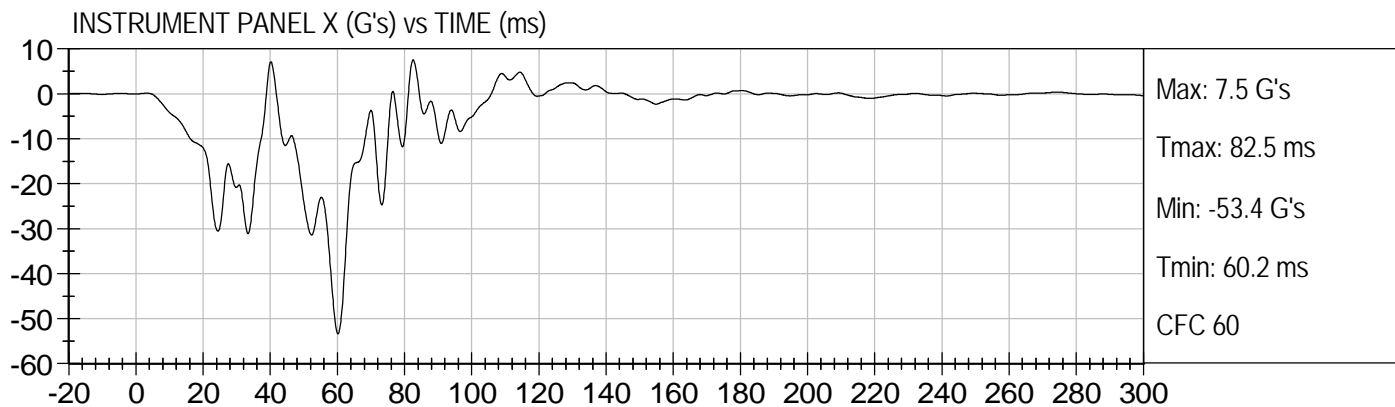

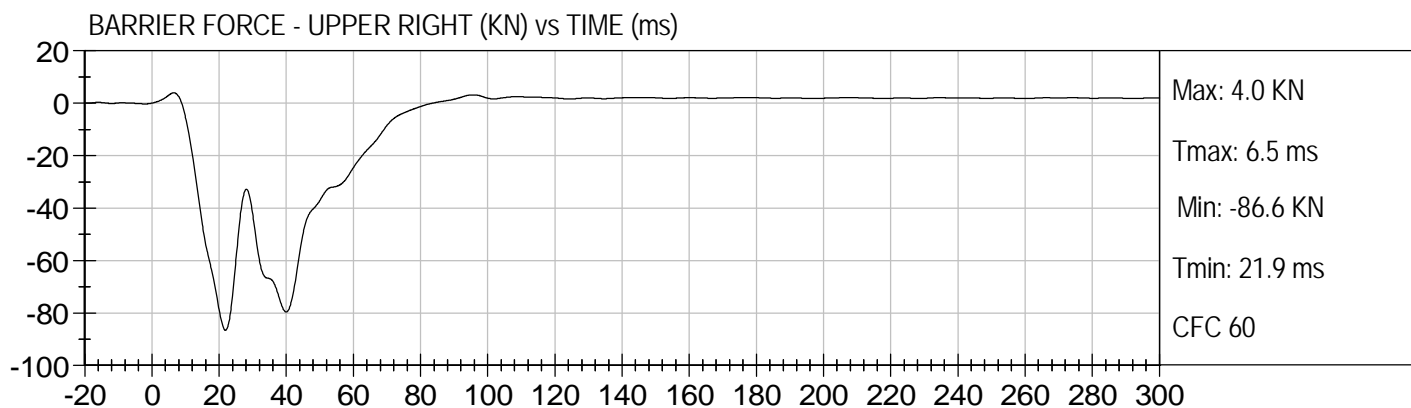
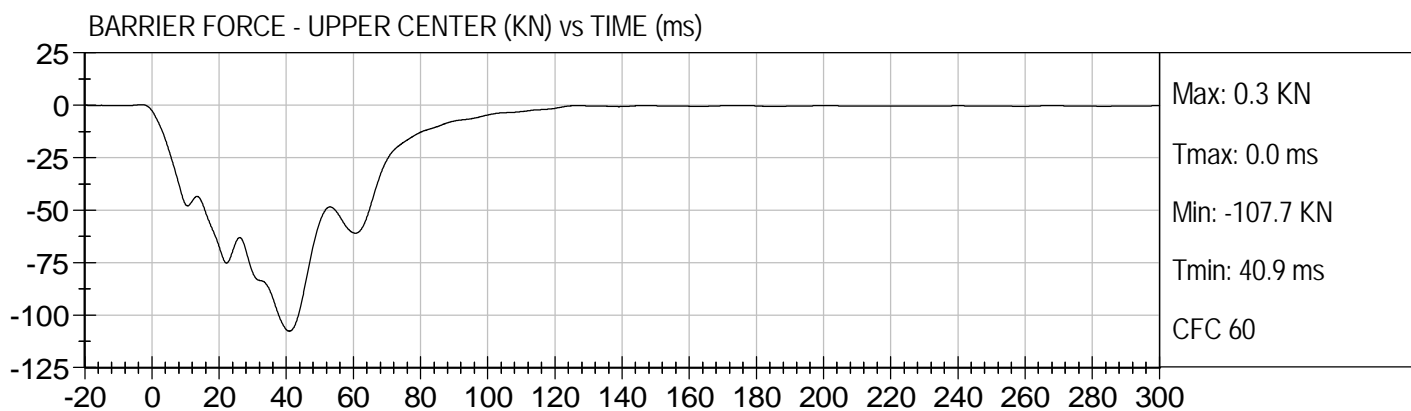
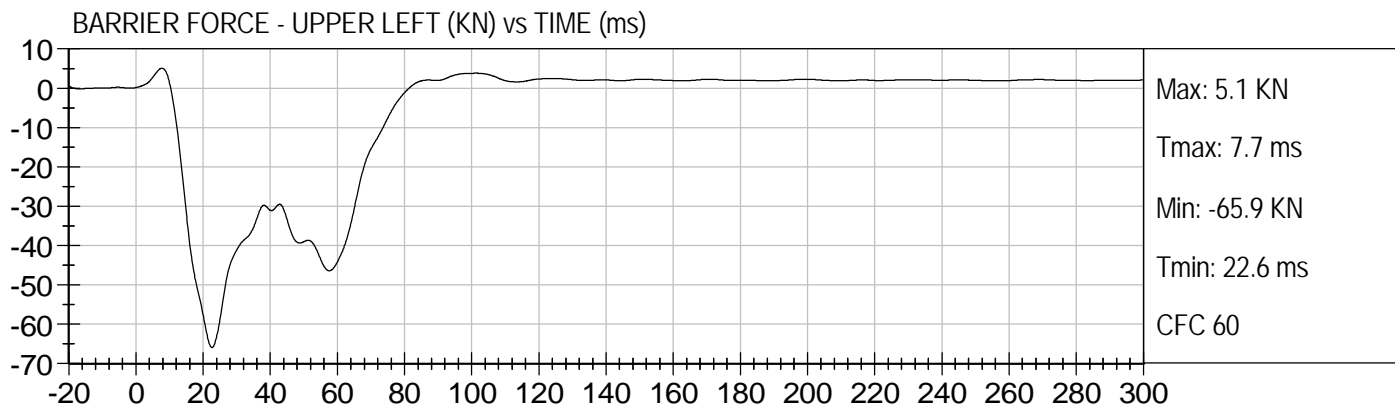

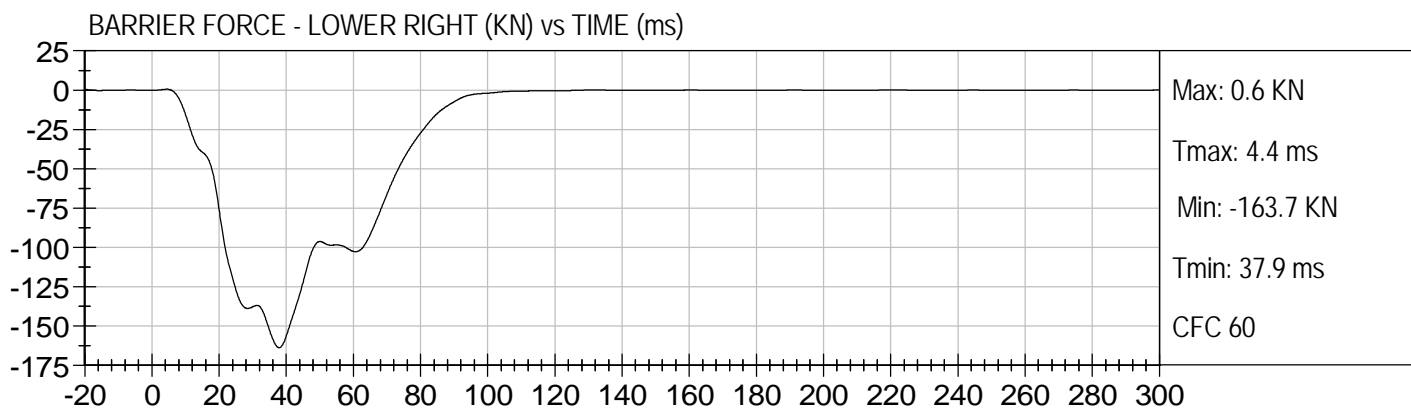
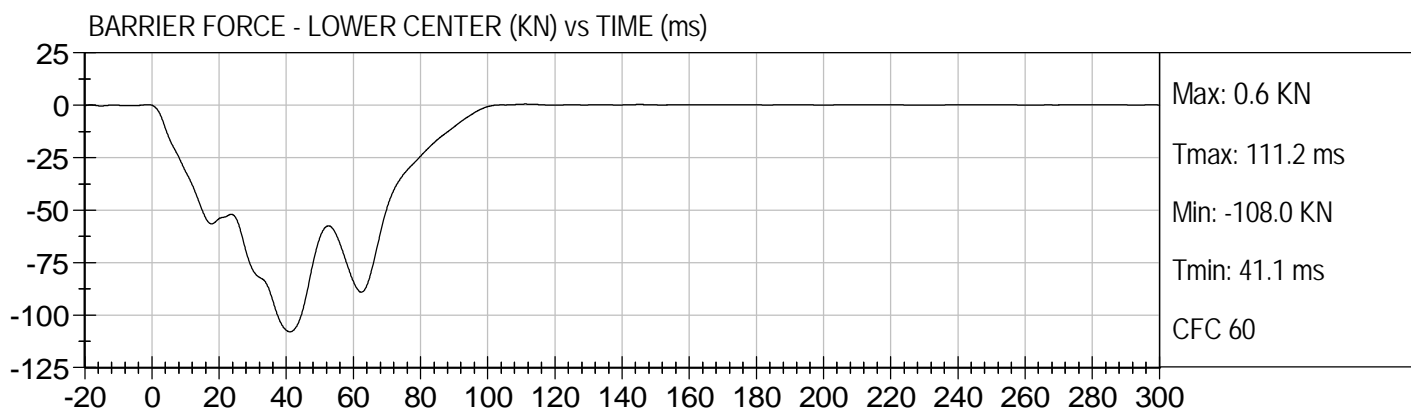
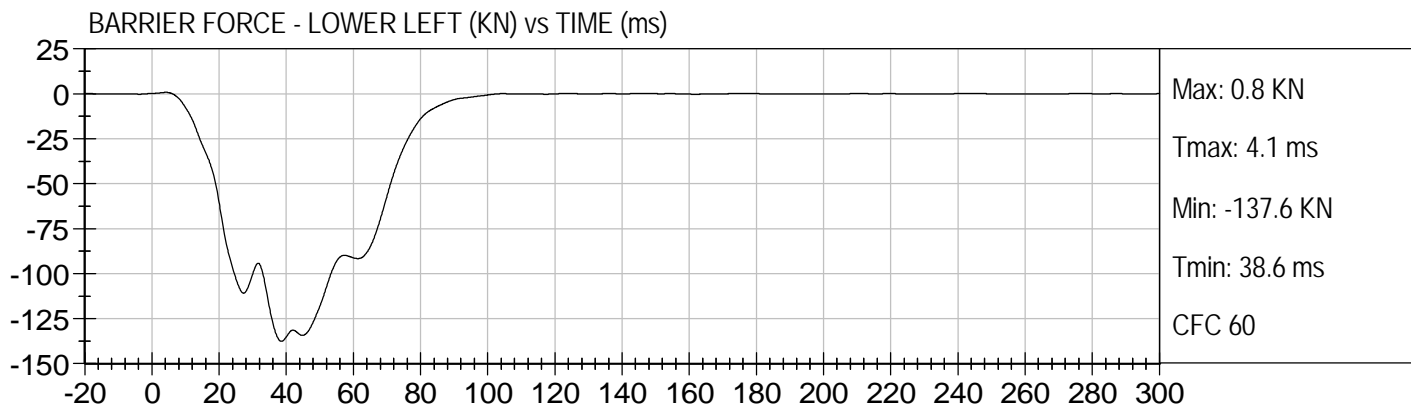

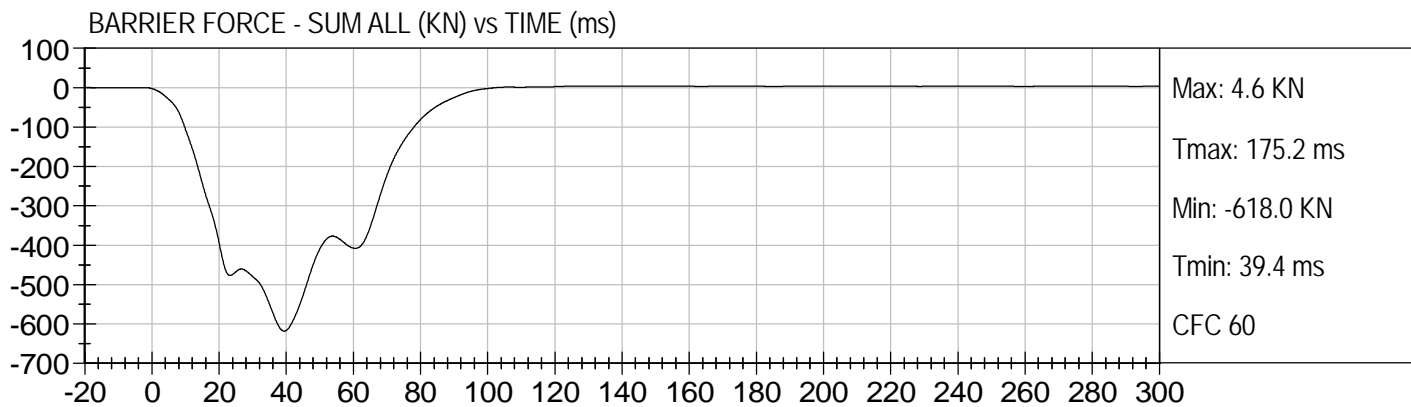
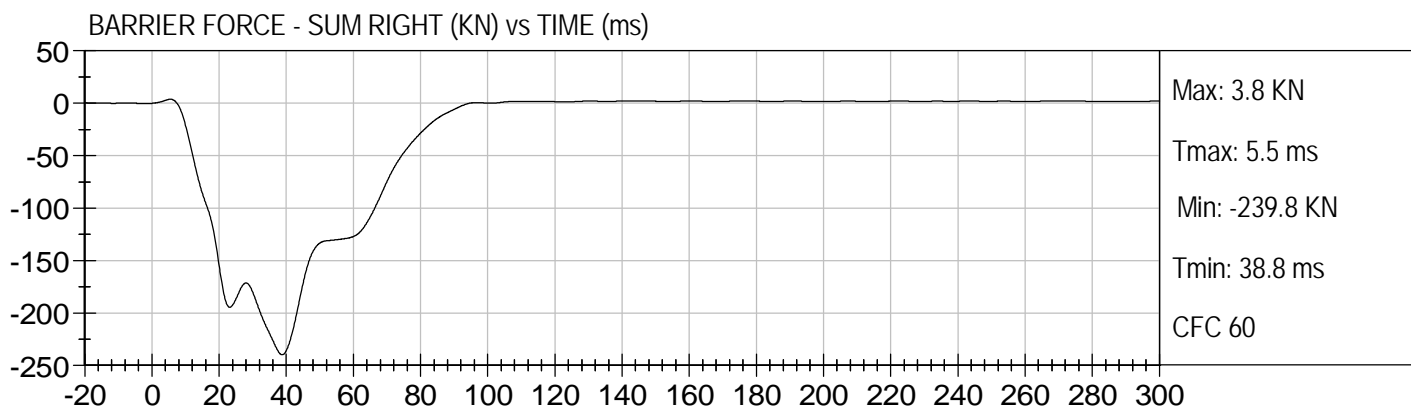
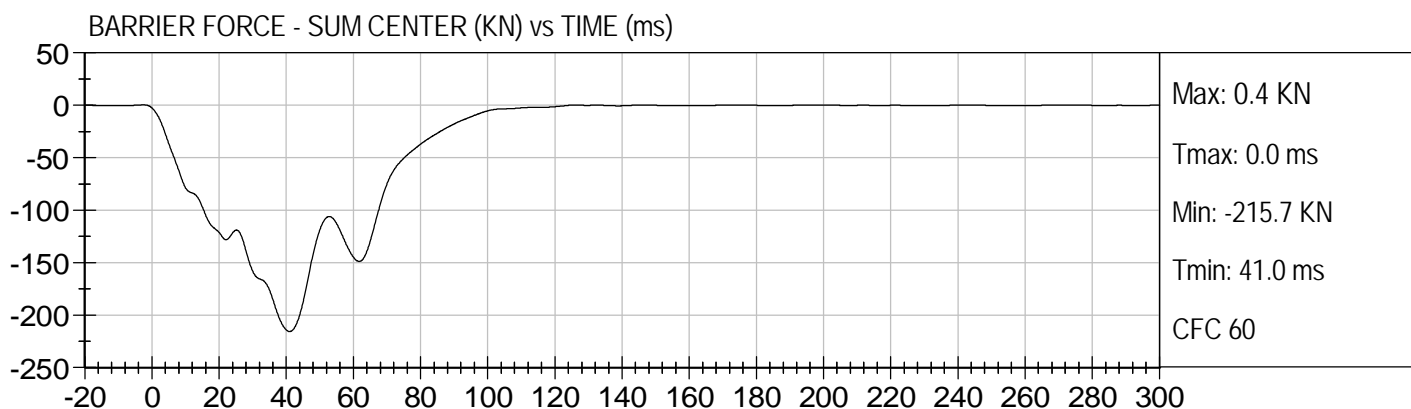
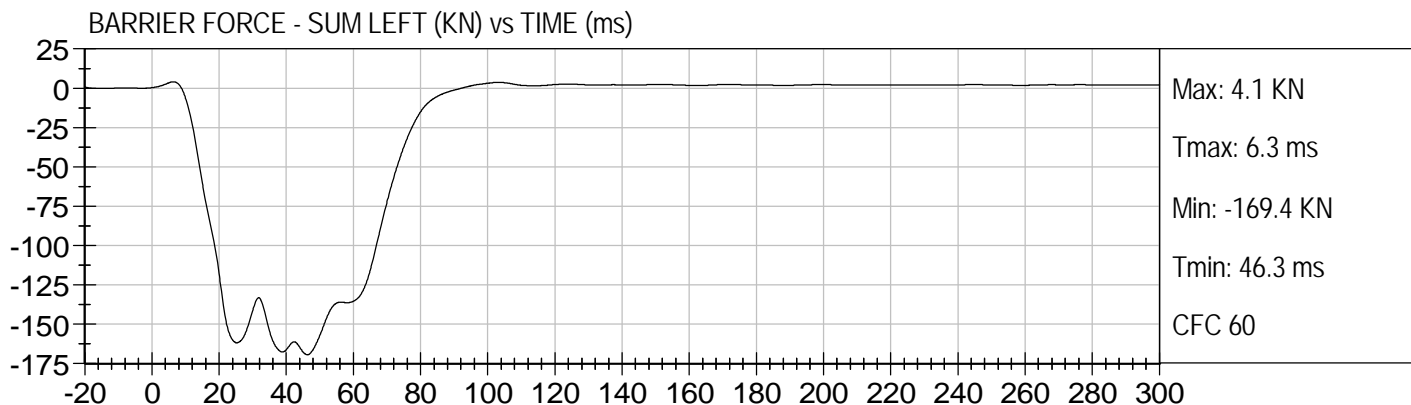

APPENDIX B
LOW RISK TEST DATA

TABLE OF DATA PLOTS

	<u>Page No.</u>	
Figure No. 1.	5 th Fem. P1 Driver Head X Acceleration vs. Time	B-1
Figure No. 2.	5 th Fem. P1 Driver Head Y Acceleration vs. Time	B-1
Figure No. 3.	5 th Fem. P1 Driver Head Z Acceleration vs. Time	B-1
Figure No. 4.	5 th Fem. P1 Driver Head Resultant Acceleration vs. Time	B-1
Figure No. 5.	5 th Fem. P1 Driver Head X Velocity vs. Time	B-2
Figure No. 6.	5 th Fem. P1 Driver Head Y Velocity vs. Time	B-2
Figure No. 7.	5 th Fem. P1 Driver Head Z Velocity vs. Time	B-2
Figure No. 8.	5 th Fem. P1 Driver Neck Force X vs. Time	B-3
Figure No. 9.	5 th Fem. P1 Driver Neck Force Y vs. Time	B-3
Figure No. 10.	5 th Fem. P1 Driver Neck Force Z vs. Time	B-3
Figure No. 11.	5 th Fem. P1 Driver Neck Force Resultant vs. Time	B-3
Figure No. 12.	5 th Fem. P1 Driver Neck Moment X vs. Time	B-4
Figure No. 13.	5 th Fem. P1 Driver Neck Moment Y vs. Time	B-4
Figure No. 14.	5 th Fem. P1 Driver Neck Moment Z vs. Time	B-4
Figure No. 15.	5 th Fem. P1 Driver Occipital Condyle Moment vs. Time	B-4
Figure No. 16.	5 th Fem. P1 Driver Chest X Acceleration vs. Time	B-5
Figure No. 17.	5 th Fem. P1 Driver Chest Y Acceleration vs. Time	B-5
Figure No. 18.	5 th Fem. P1 Driver Chest Z Acceleration vs. Time	B-5
Figure No. 19.	5 th Fem. P1 Driver Chest Resultant Acceleration vs. Time	B-5
Figure No. 20.	5 th Fem. P1 Driver Chest X Velocity vs. Time	B-6
Figure No. 21.	5 th Fem. P1 Driver Chest Y Velocity vs. Time	B-6
Figure No. 22.	5 th Fem. P1 Driver Chest Z Velocity vs. Time	B-6
Figure No. 23.	5 th Fem. P1 Driver Chest Displacement vs. Time	B-6
Figure No. 24.	5 th Fem. P1 Driver Left Femur Force vs. Time	B-7
Figure No. 25.	5 th Fem. P1 Driver Right Femur Force vs. Time	B-7
Figure No. 26.	Fire Voltage #1 vs. Time	B-8
Figure No. 27.	Fire Current #1 vs. Time	B-8
Figure No. 28.	Fire Voltage #2 vs. Time	B-8
Figure No. 29.	Fire Current #2 vs. Time	B-8

Figure No. 30.	5 th Fem. P1 Driver Nij (N_{TF}) vs. Time	B-9
Figure No. 31.	5 th Fem. P1 Driver Nij (N_{TE}) vs. Time	B-9
Figure No. 32.	5 th Fem. P1 Driver Nij (N_{CF}) vs. Time	B-9
Figure No. 33.	5 th Fem. P1 Driver Nij (N_{CE}) vs. Time	B-9
Figure No. 34.	5 th Fem. P2 Driver Head X Acceleration vs. Time	B-10
Figure No. 35.	5 th Fem. P2 Driver Head Y Acceleration vs. Time	B-10
Figure No. 36.	5 th Fem. P2 Driver Head Z Acceleration vs. Time	B-10
Figure No. 37.	5 th Fem. P2 Driver Head Resultant Acceleration vs. Time	B-10
Figure No. 38.	5 th Fem. P2 Driver Head X Velocity vs. Time	B-11
Figure No. 39.	5 th Fem. P2 Driver Head Y Velocity vs. Time	B-11
Figure No. 40.	5 th Fem. P2 Driver Head Z Velocity vs. Time	B-11
Figure No. 41.	5 th Fem. P2 Driver Neck Force X vs. Time	B-12
Figure No. 42.	5 th Fem. P2 Driver Neck Force Y vs. Time	B-12
Figure No. 43.	5 th Fem. P2 Driver Neck Force Z vs. Time	B-12
Figure No. 44.	5 th Fem. P2 Driver Neck Force Resultant vs. Time	B-12
Figure No. 45.	5 th Fem. P2 Driver Neck Moment X vs. Time	B-13
Figure No. 46.	5 th Fem. P2 Driver Neck Moment Y vs. Time	B-13
Figure No. 47.	5 th Fem. P2 Driver Neck Moment Z vs. Time	B-13
Figure No. 48.	5 th Fem. P2 Driver Occipital Condyle Moment vs. Time	B-13
Figure No. 49.	5 th Fem. P2 Driver Chest X Acceleration vs. Time	B-14
Figure No. 50.	5 th Fem. P2 Driver Chest Y Acceleration vs. Time	B-14
Figure No. 51.	5 th Fem. P2 Driver Chest Z Acceleration vs. Time	B-14
Figure No. 52.	5 th Fem. P2 Driver Chest Resultant Acceleration vs. Time	B-14
Figure No. 53.	5 th Fem. P2 Driver Chest X Velocity vs. Time	B-15
Figure No. 54.	5 th Fem. P2 Driver Chest Y Velocity vs. Time	B-15
Figure No. 55.	5 th Fem. P2 Driver Chest Z Velocity vs. Time	B-15
Figure No. 56.	5 th Fem. P2 Driver Chest Displacement vs. Time	B-15
Figure No. 57.	5 th Fem. P2 Driver Left Femur Force vs. Time	B-16
Figure No. 58.	5 th Fem. P2 Driver Right Femur Force vs. Time	B-16
Figure No. 59.	Fire Voltage #1 vs. Time	B-17

Page No.

Figure No. 60.	Fire Current #1 vs. Time	B-17
Figure No. 61.	Fire Voltage #2 vs. Time	B-17
Figure No. 62.	Fire Current #2 vs. Time	B-17
Figure No. 63.	5 th Fem. P2 Driver Nij (N_{TF}) vs. Time	B-18
Figure No. 64.	5 th Fem. P2 Driver Nij (N_{TE}) vs. Time	B-18
Figure No. 65.	5 th Fem. P2 Driver Nij (N_{CF}) vs. Time	B-18
Figure No. 66.	5 th Fem. P2 Driver Nij (N_{CE}) vs. Time	B-18



Injury Values Calculated between 0ms and 275ms

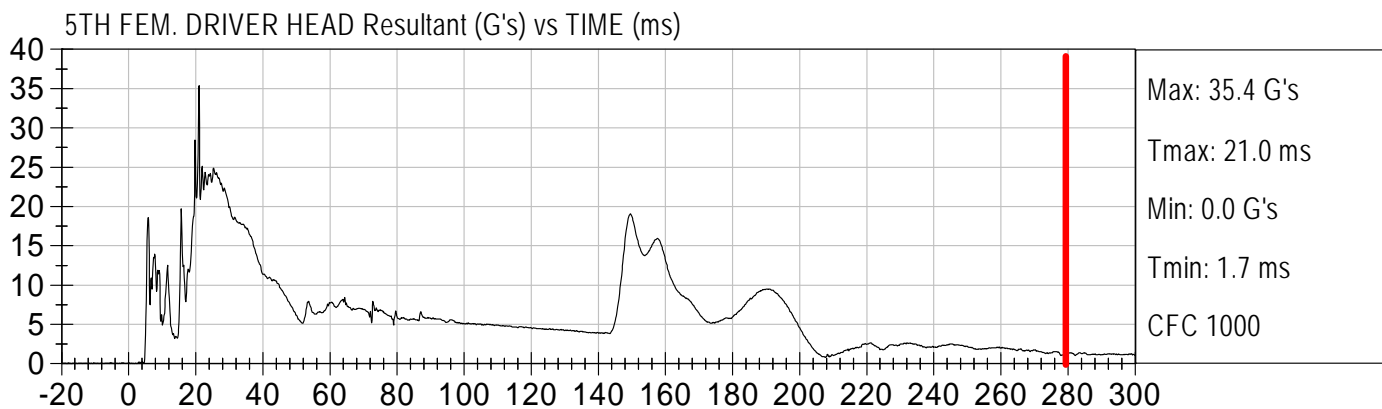
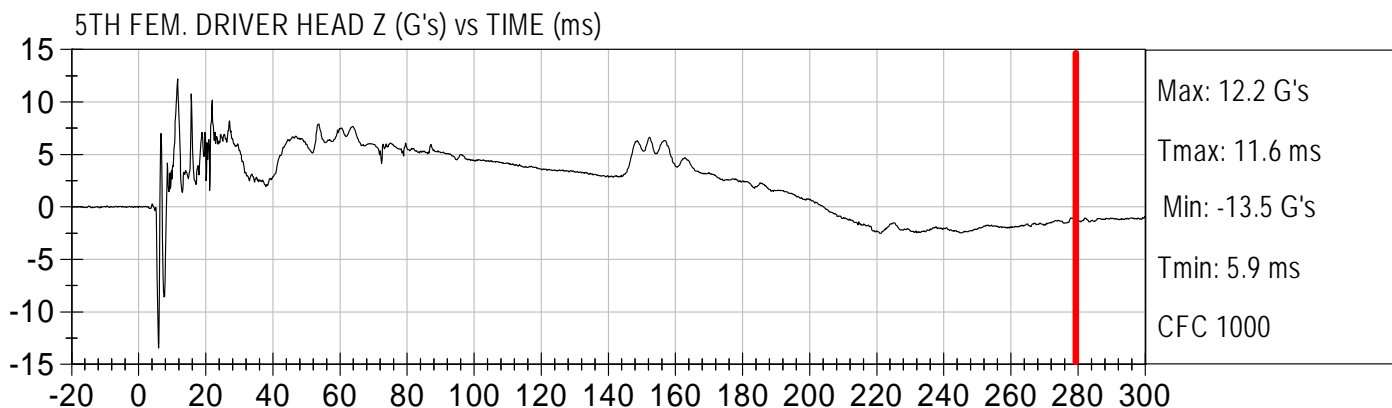
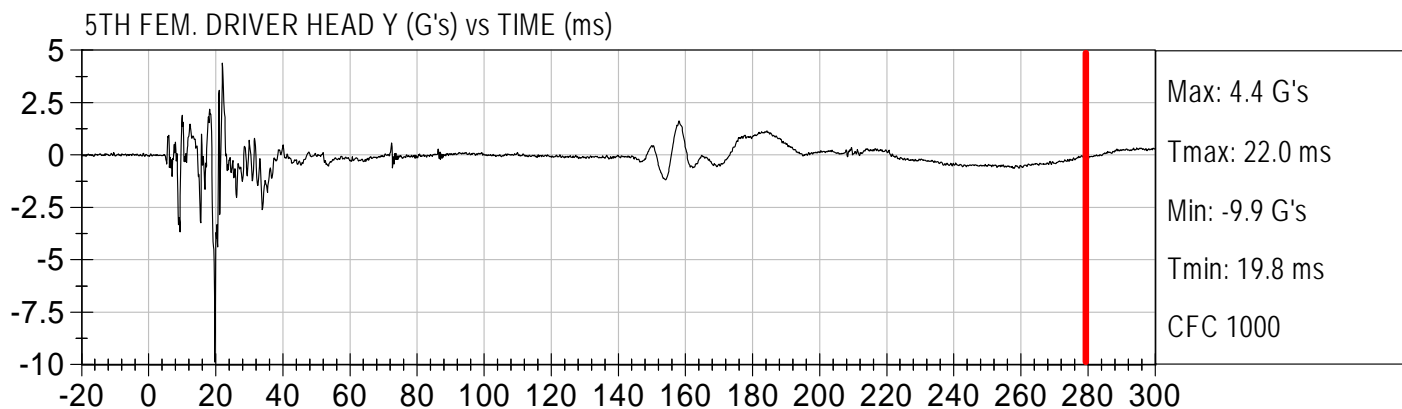
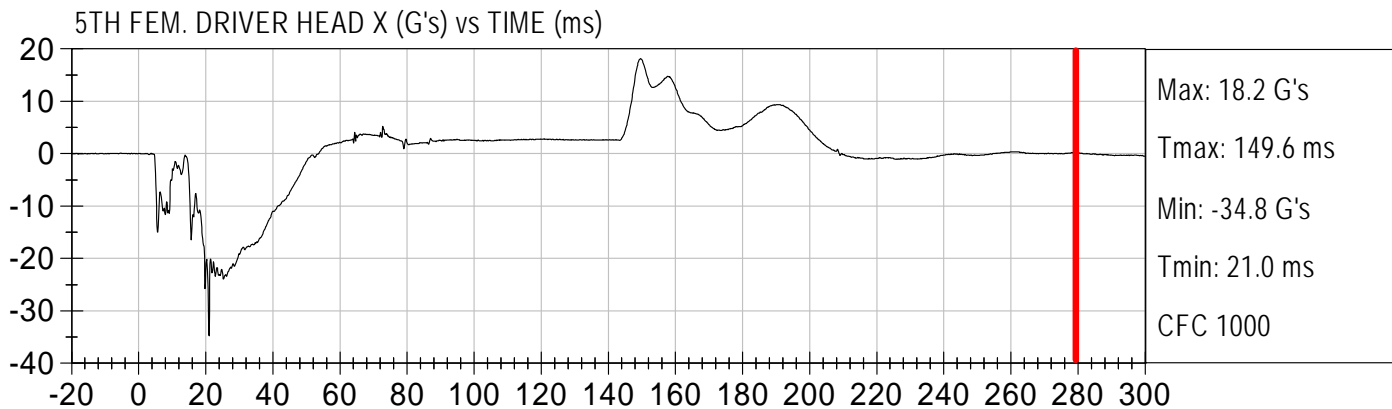



Injury Values Calculated between 0ms and 275ms

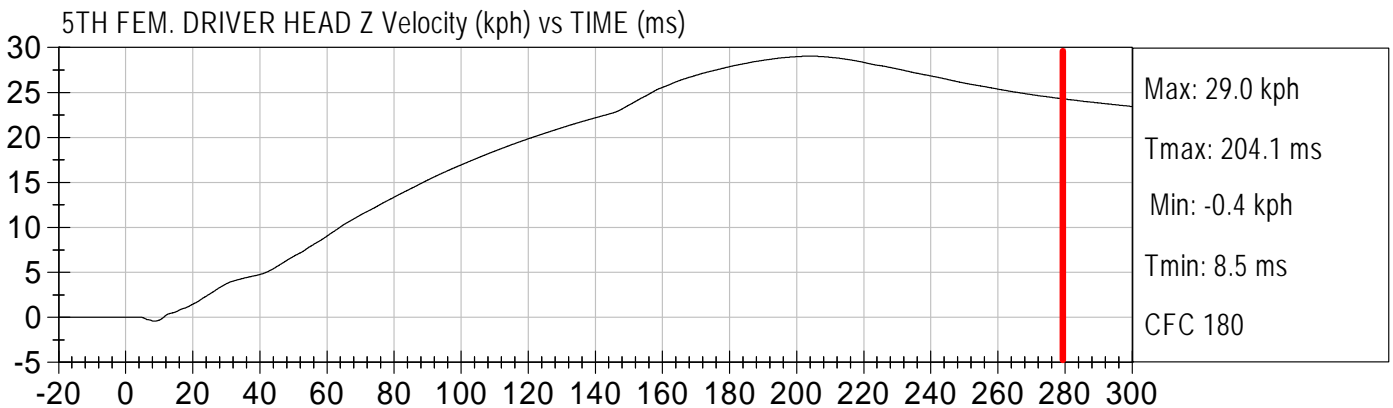
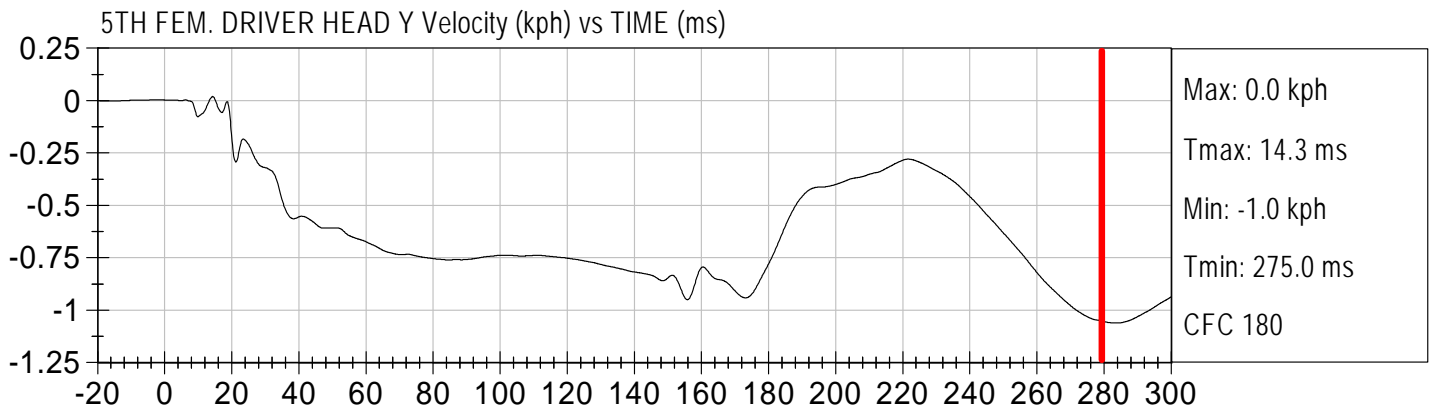
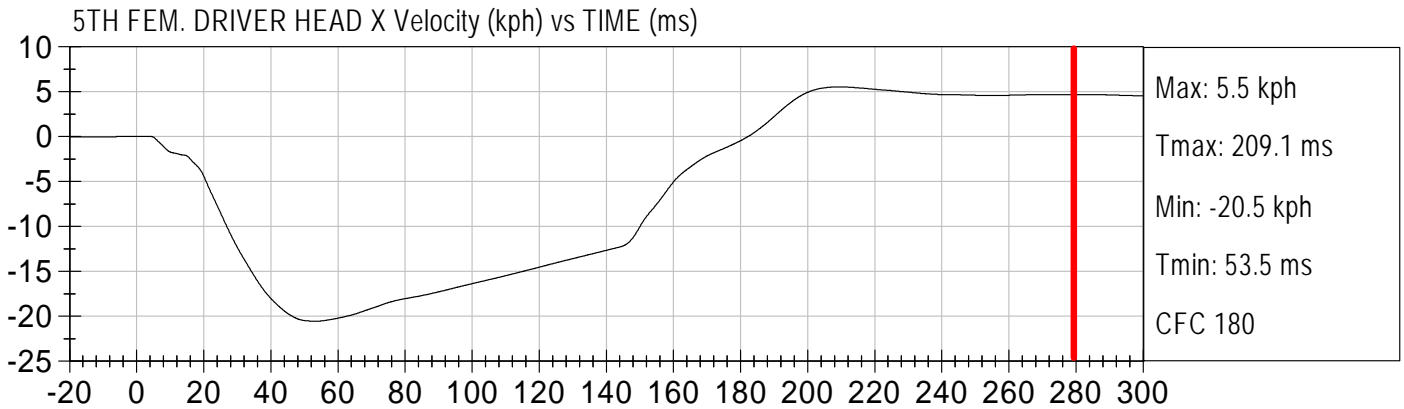



Injury Values Calculated between 0ms and 275ms

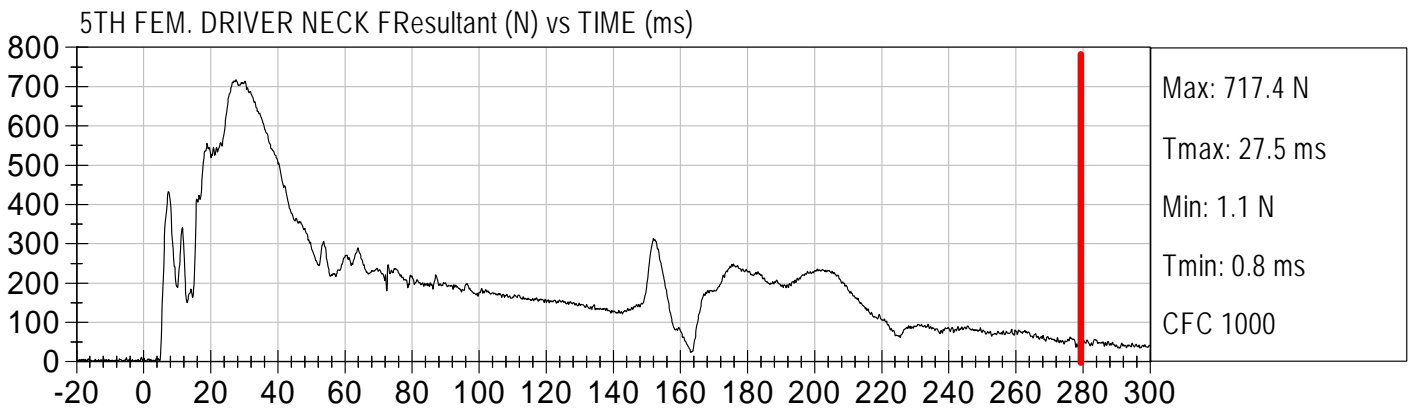
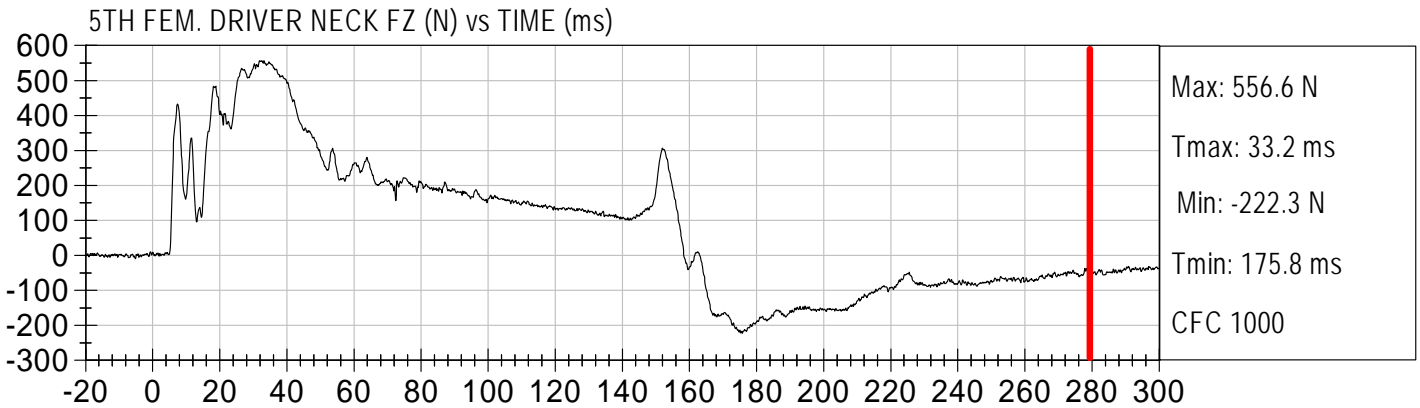
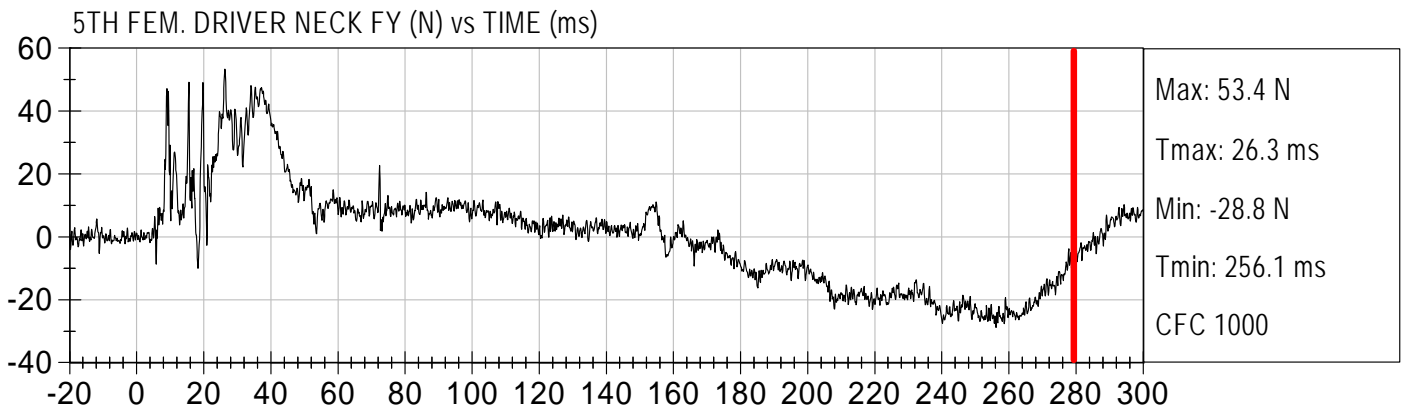
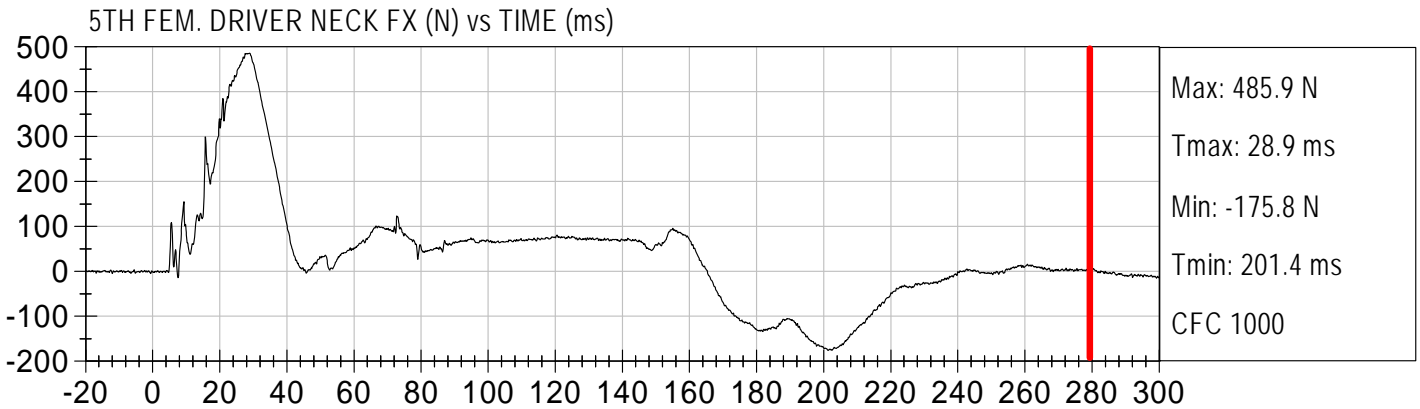



Injury Values Calculated between 0ms and 275ms

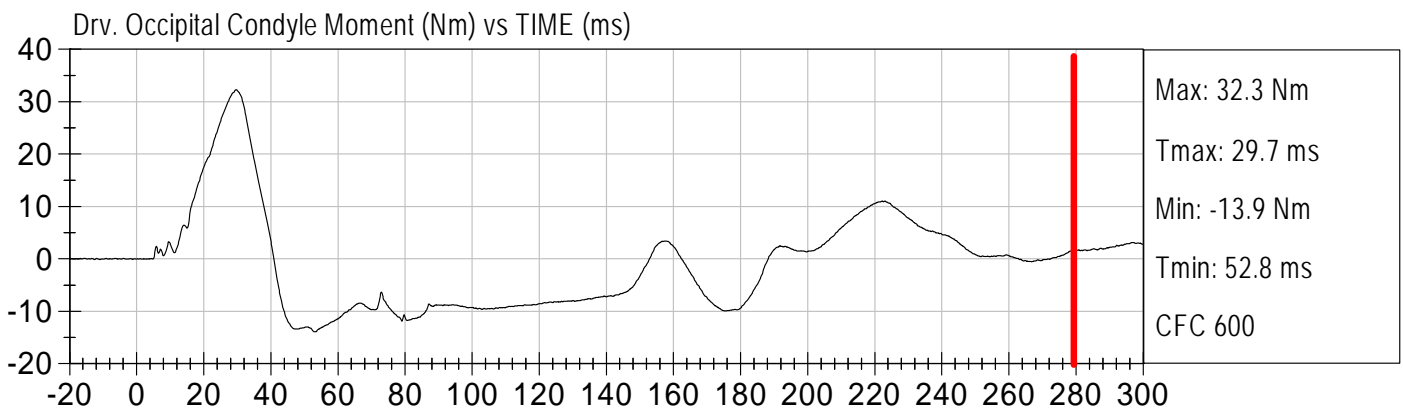
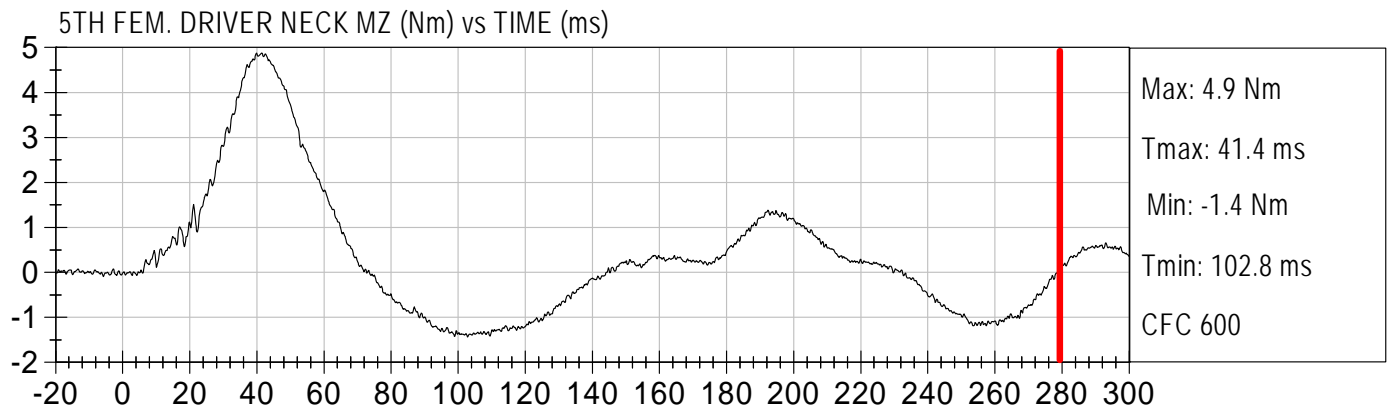
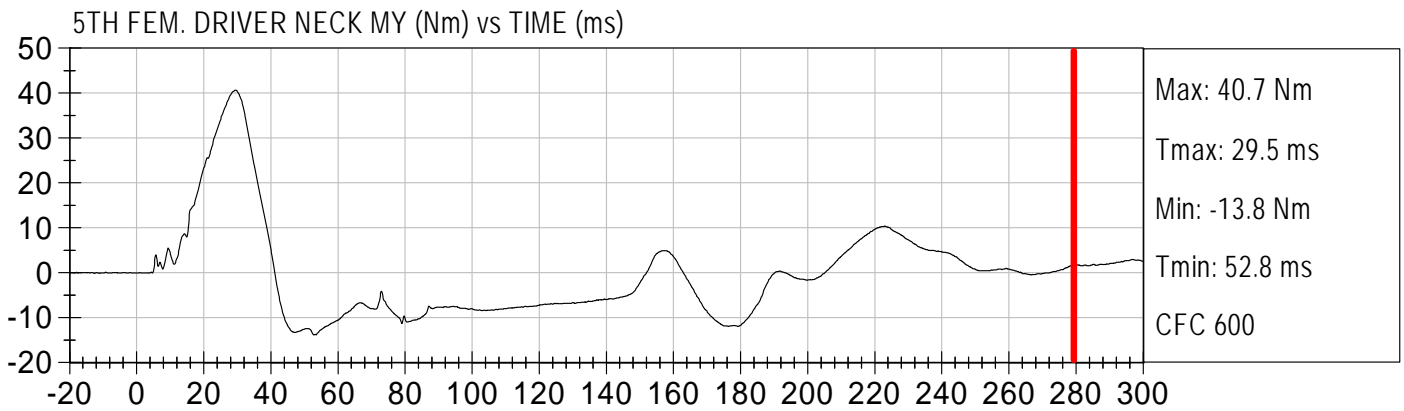
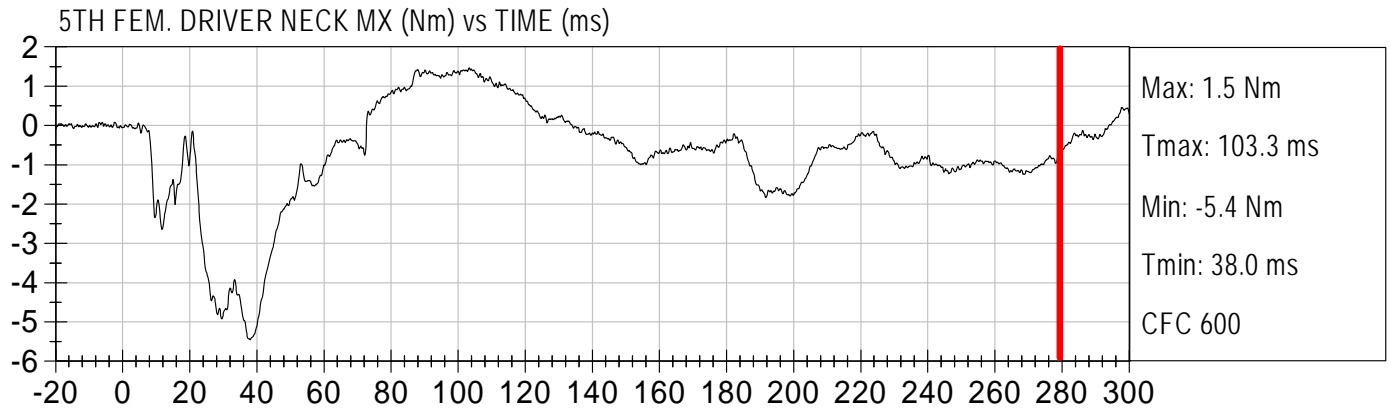



Injury Values Calculated between 0ms and 275ms

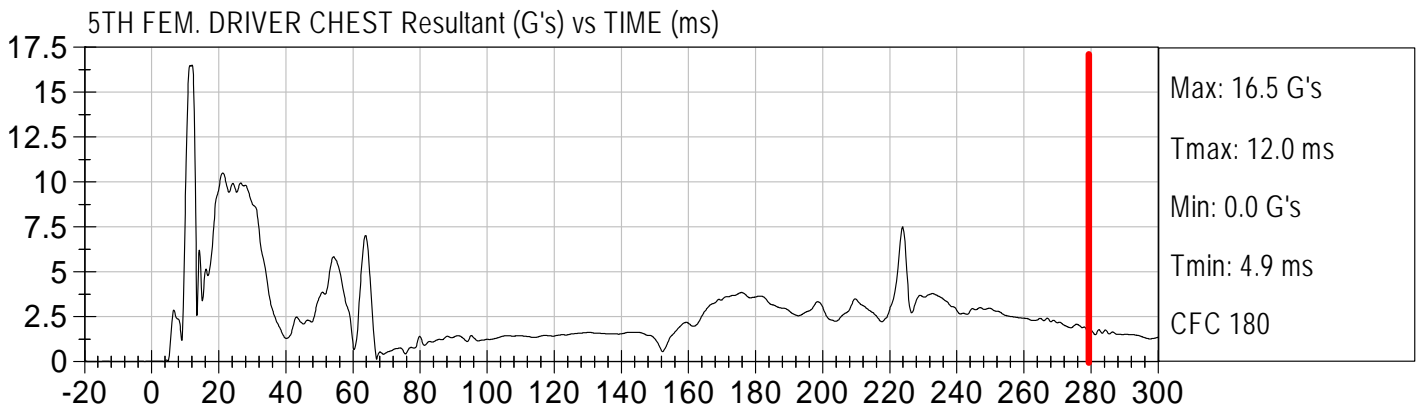
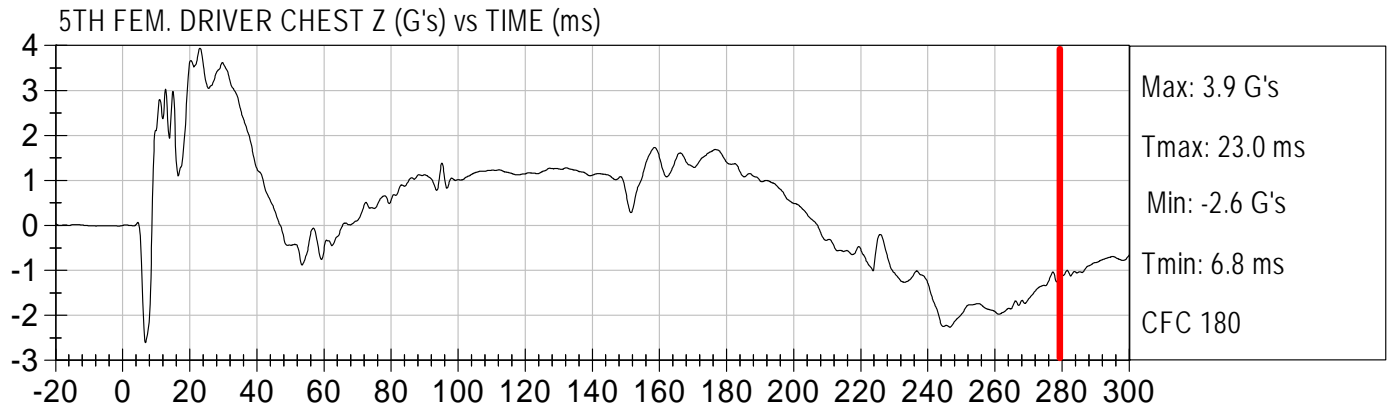
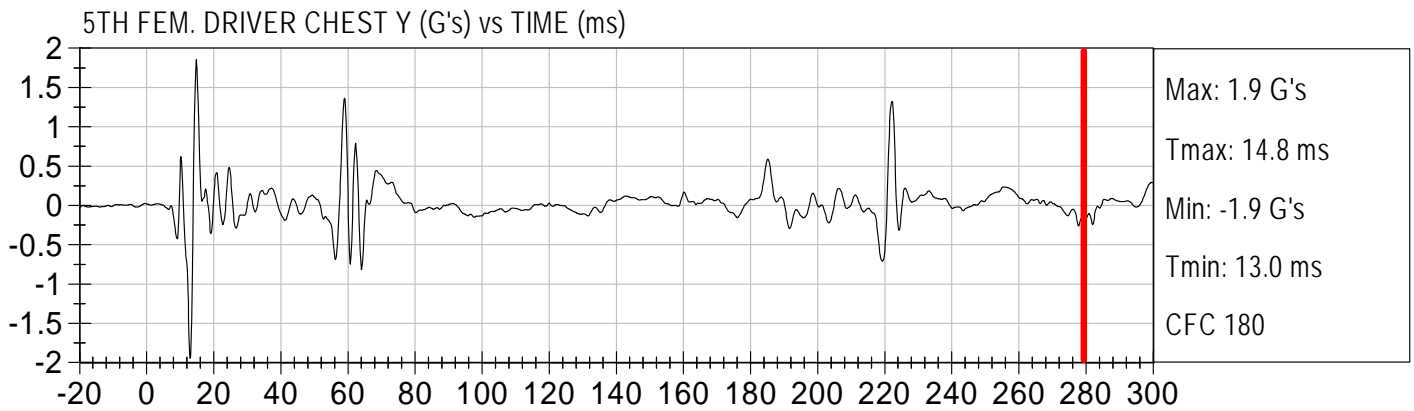
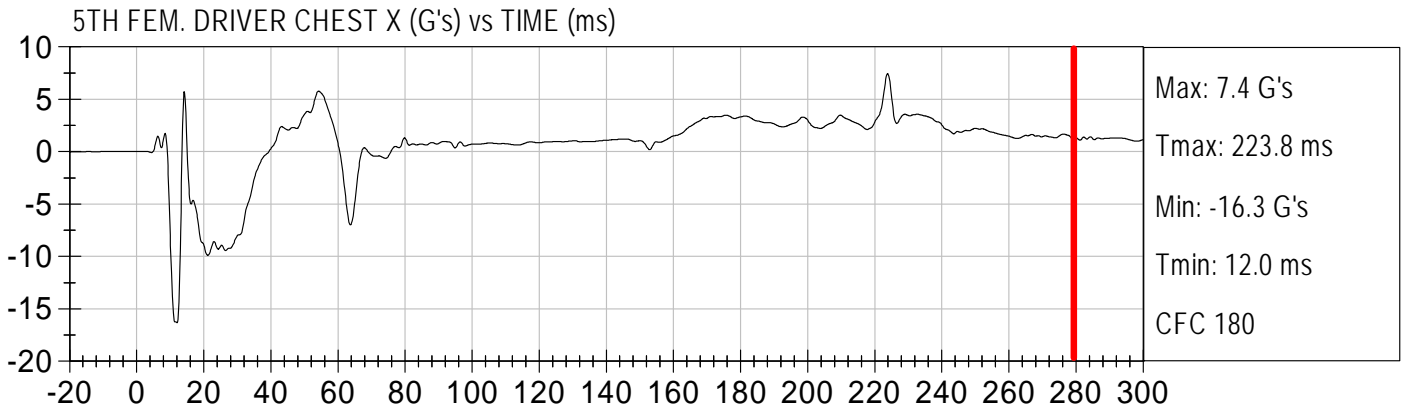



Injury Values Calculated between 0ms and 275ms

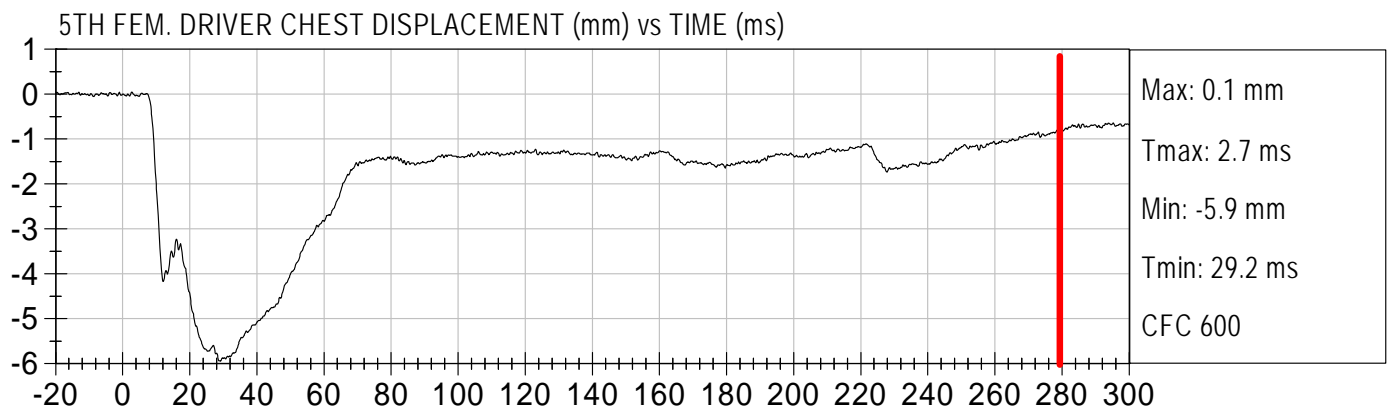
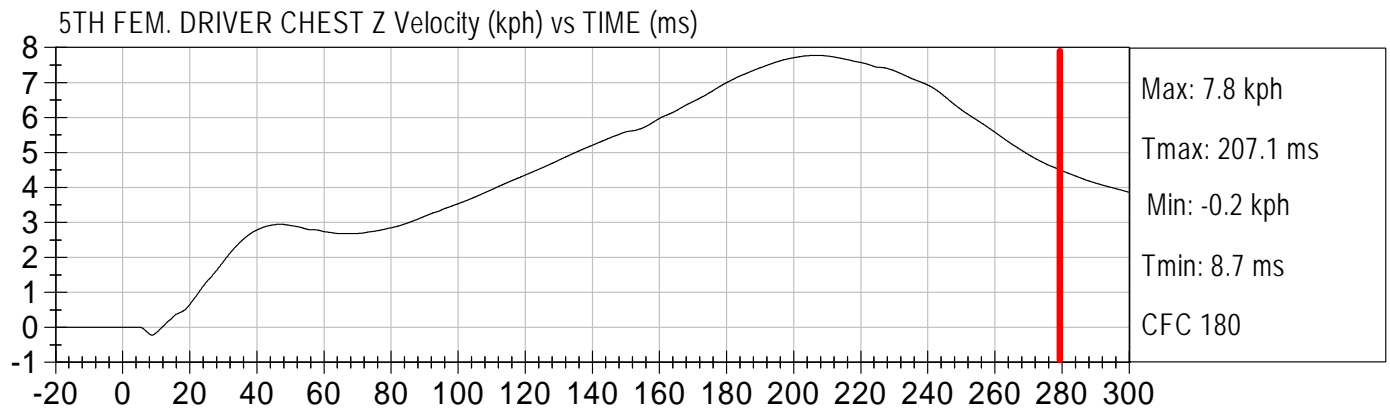
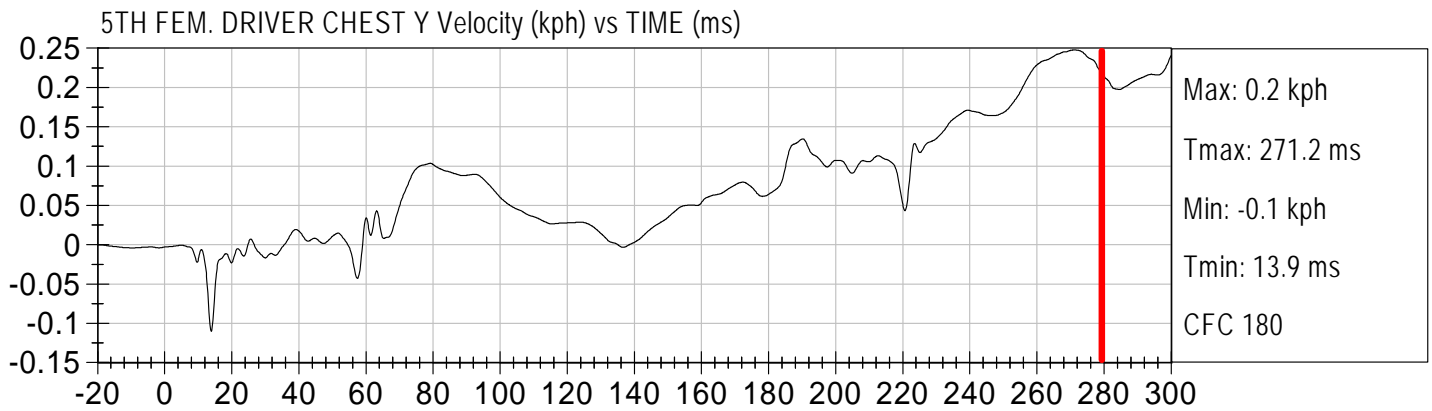
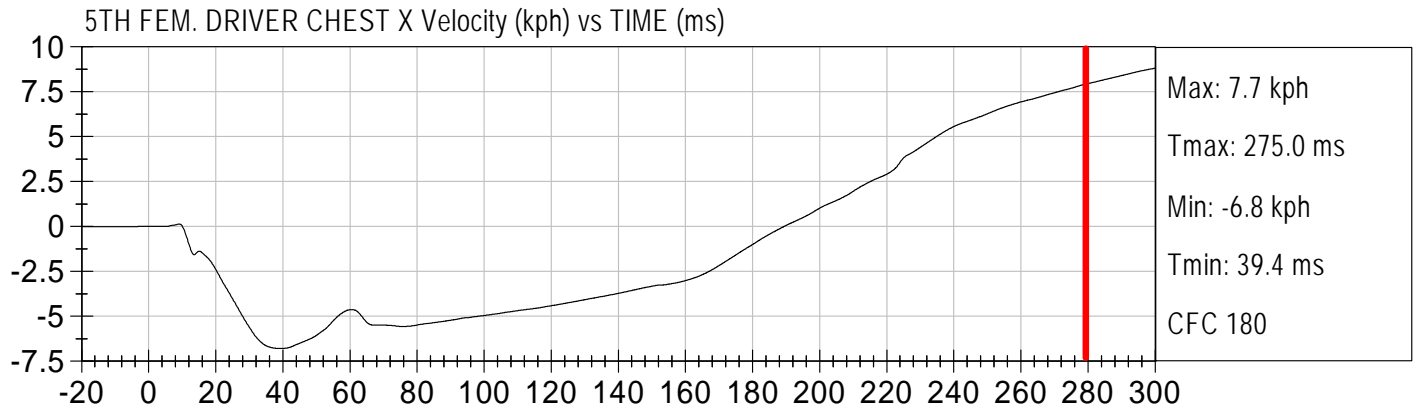



Injury Values Calculated between 0ms and 275ms

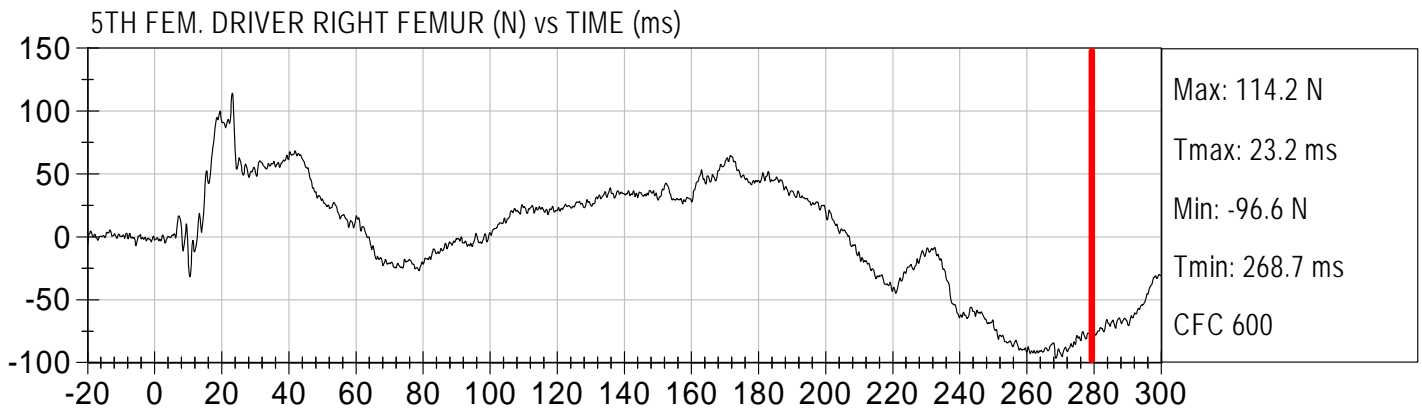
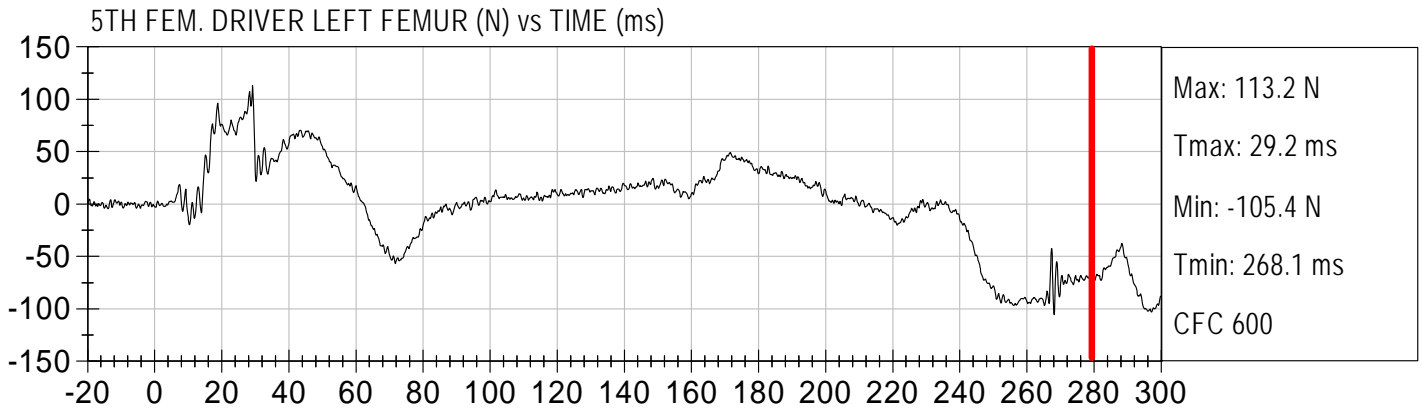



Injury Values Calculated between 0ms and 275ms

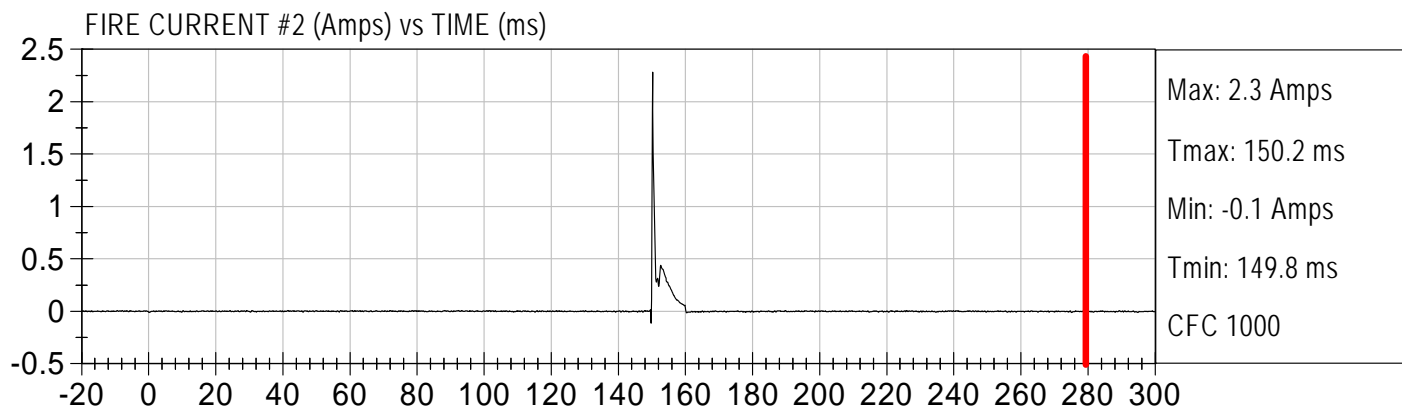
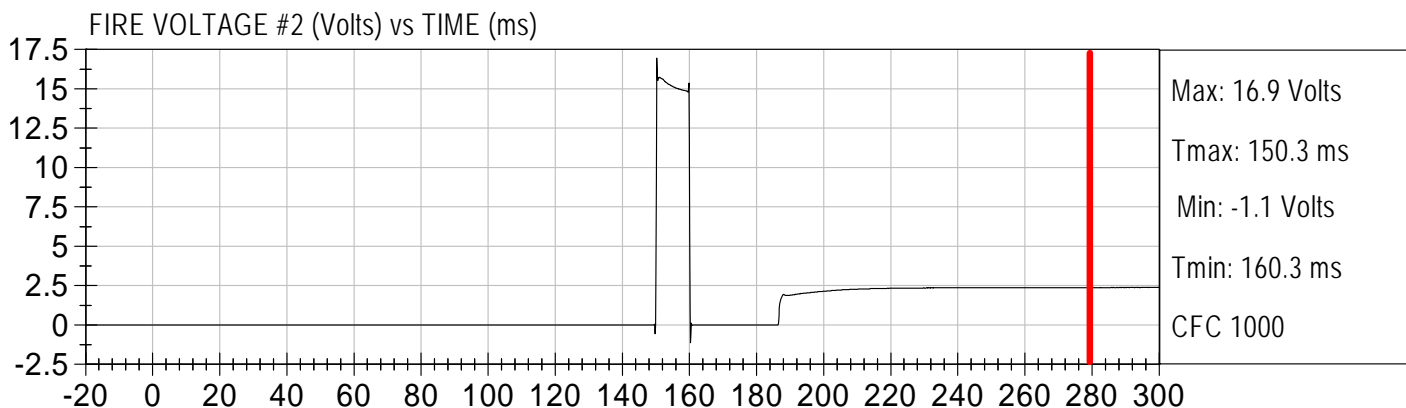
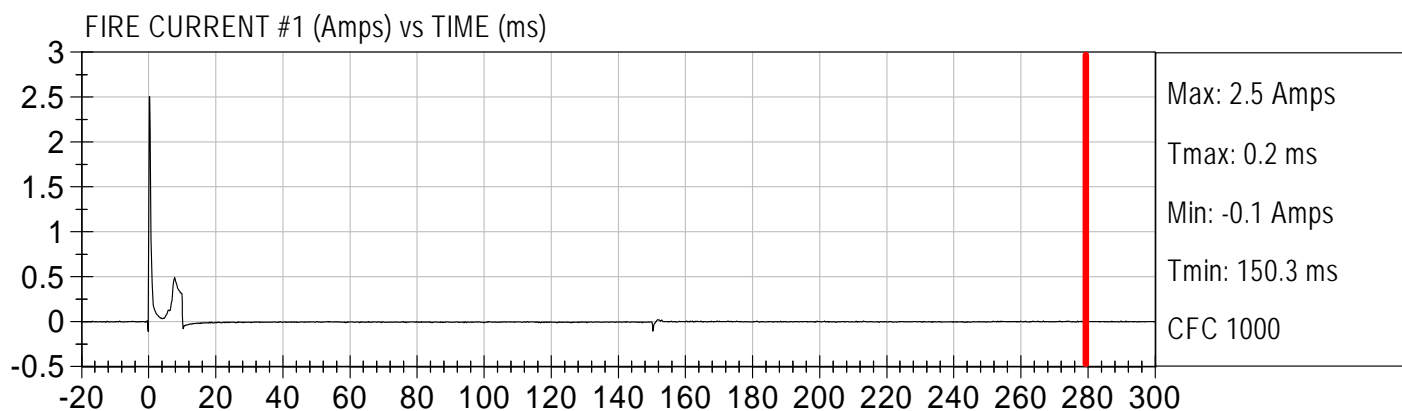
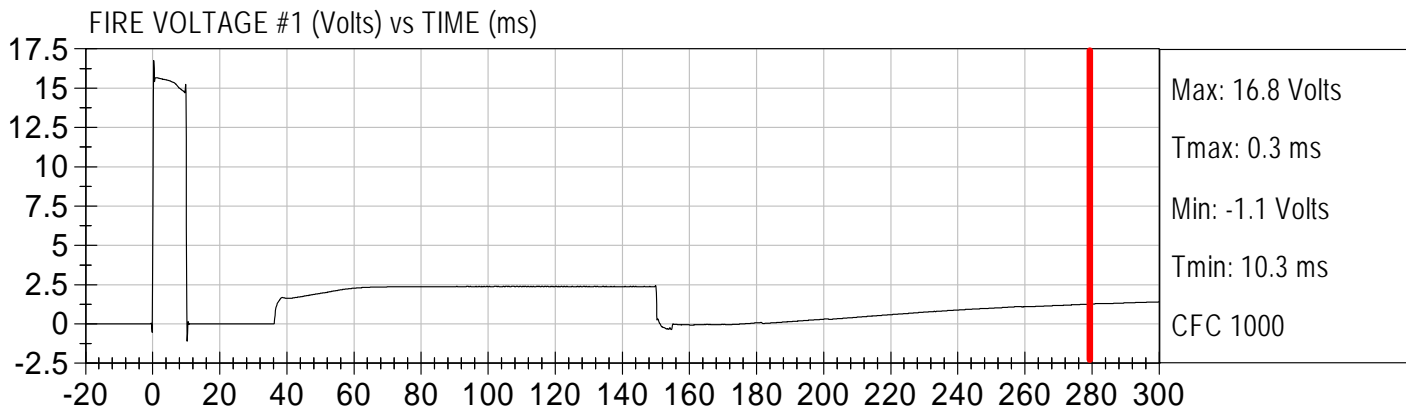



Drv. nij (NTF) () vs TIME SPECIAL CHS (ms)

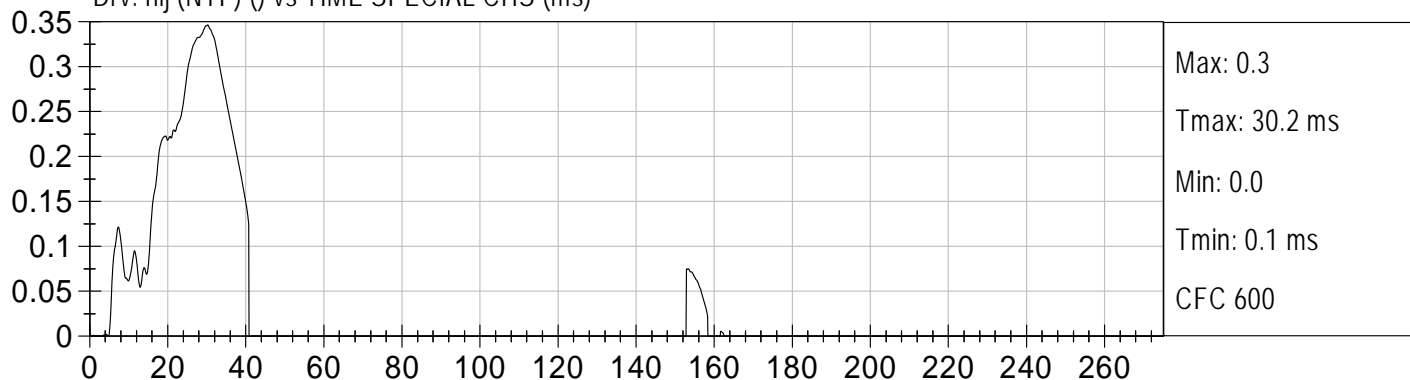

Drv. nij (NTE) () vs TIME SPECIAL CHS (ms)

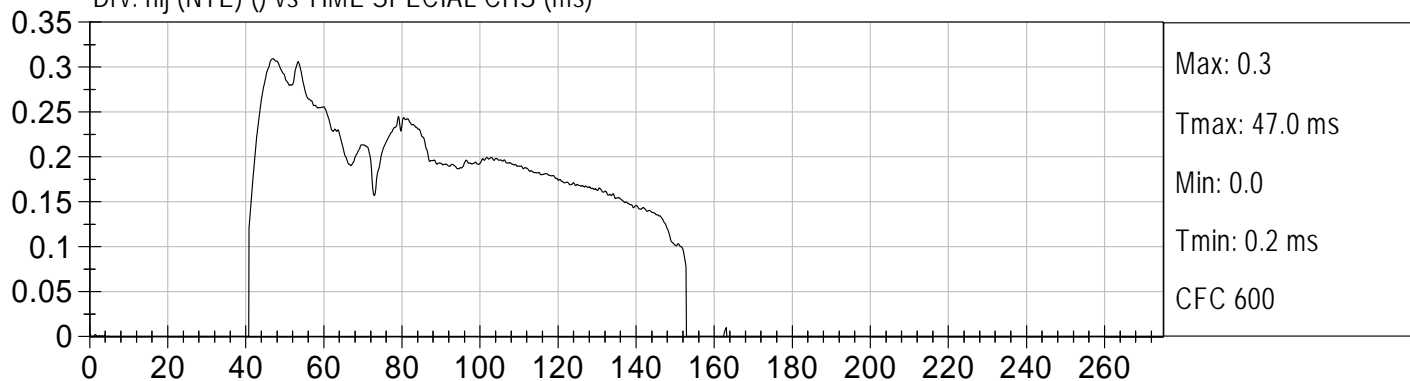

Drv. nij (NCF) () vs TIME SPECIAL CHS (ms)

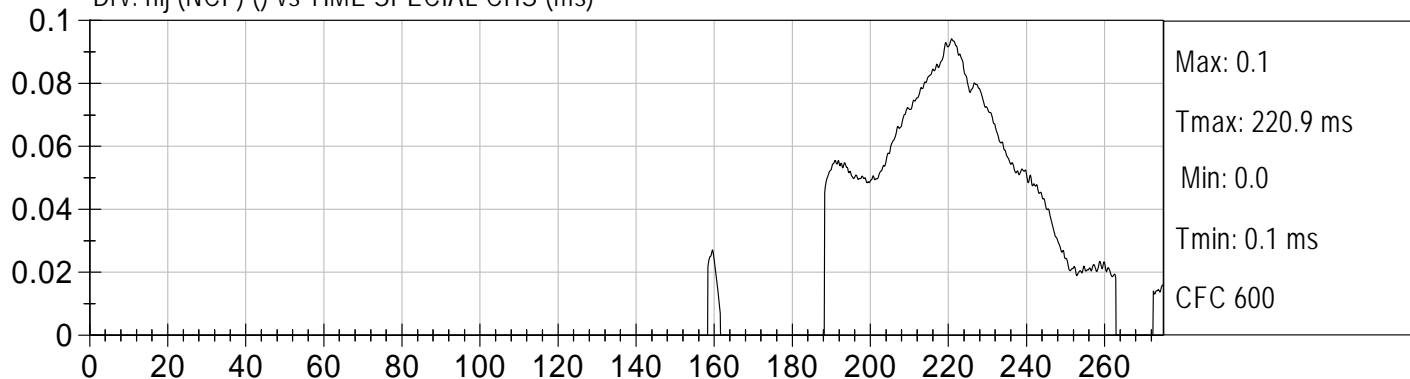

Drv. nij (NCE) () vs TIME SPECIAL CHS (ms)

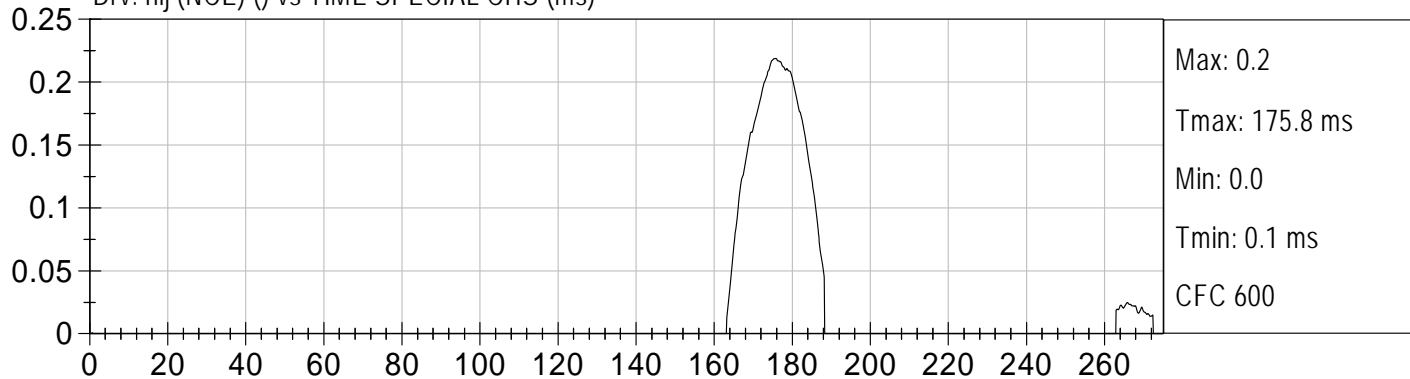



Injury Values Calculated between 0ms and 275ms

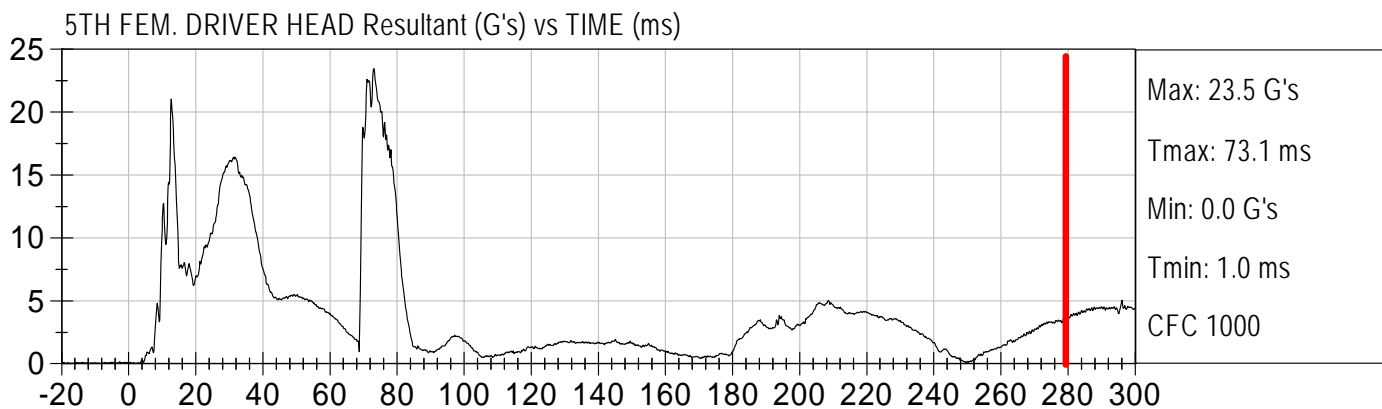
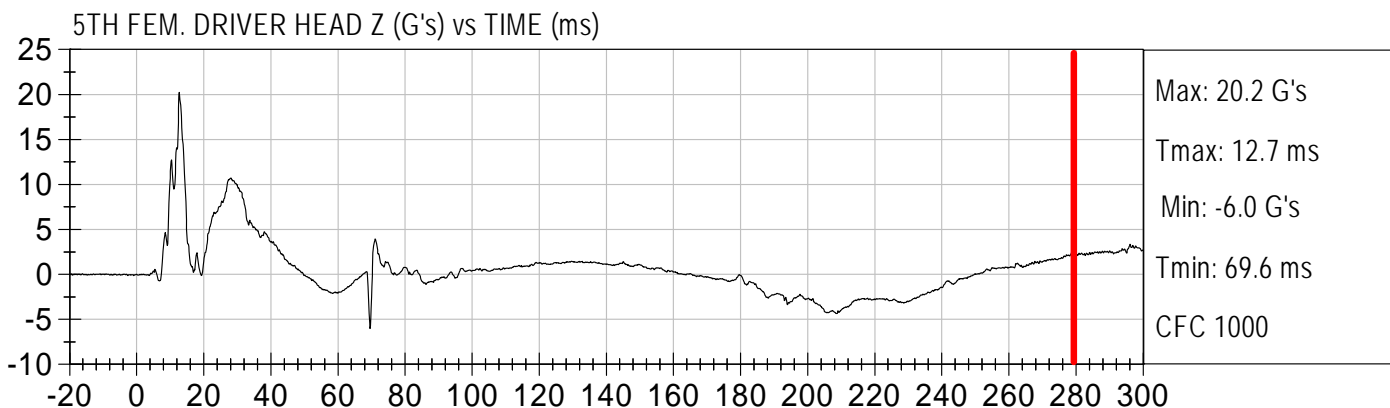
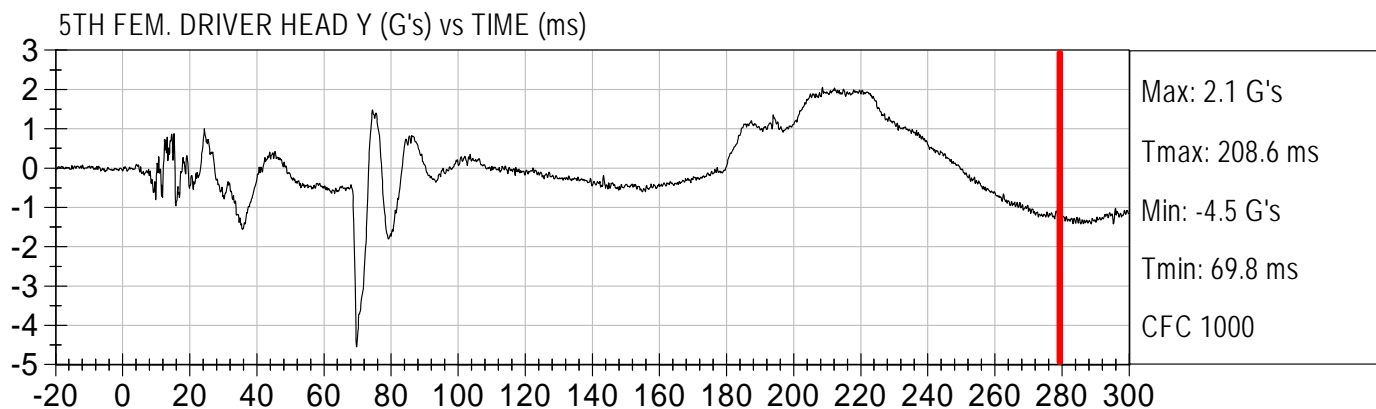
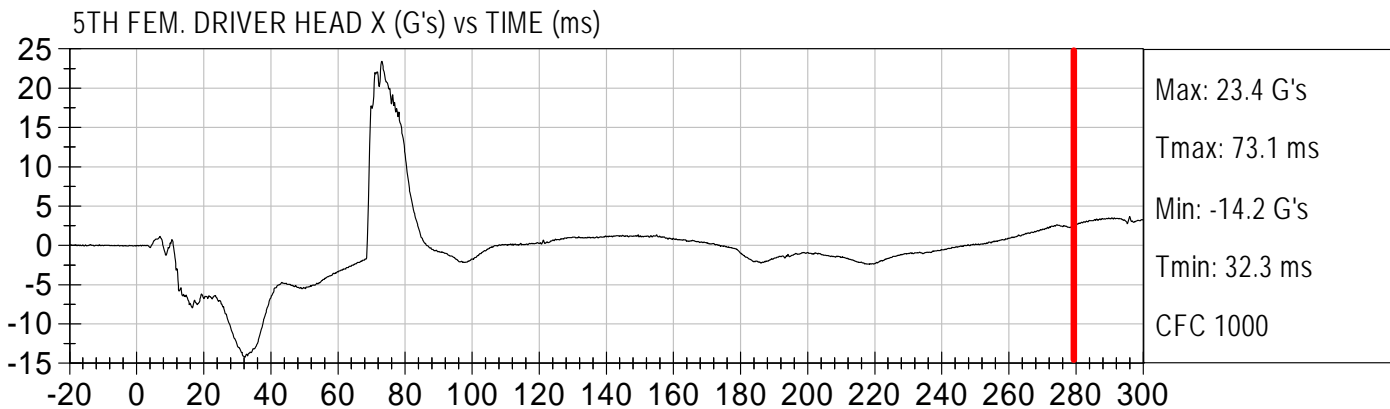



Injury Values Calculated between 0ms and 275ms

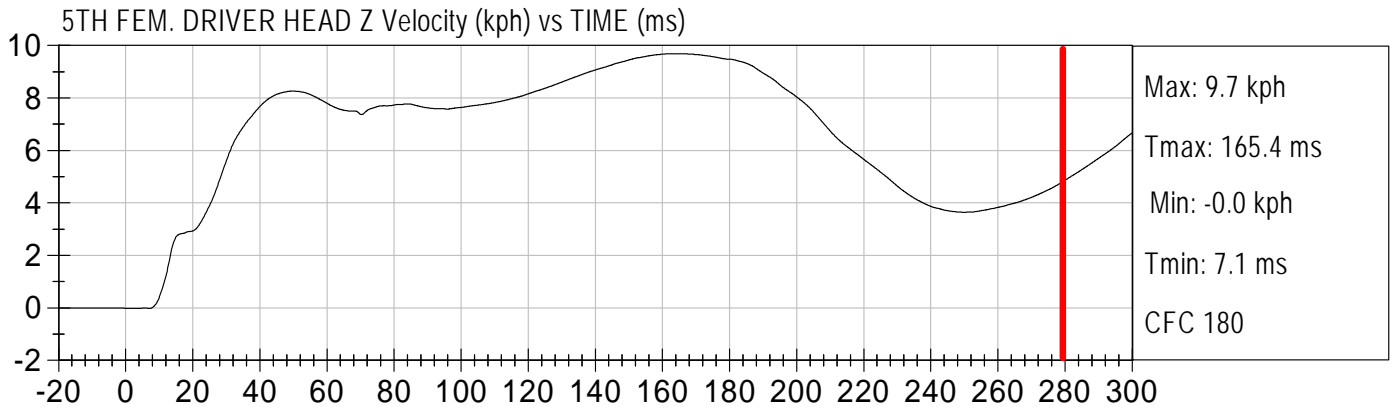
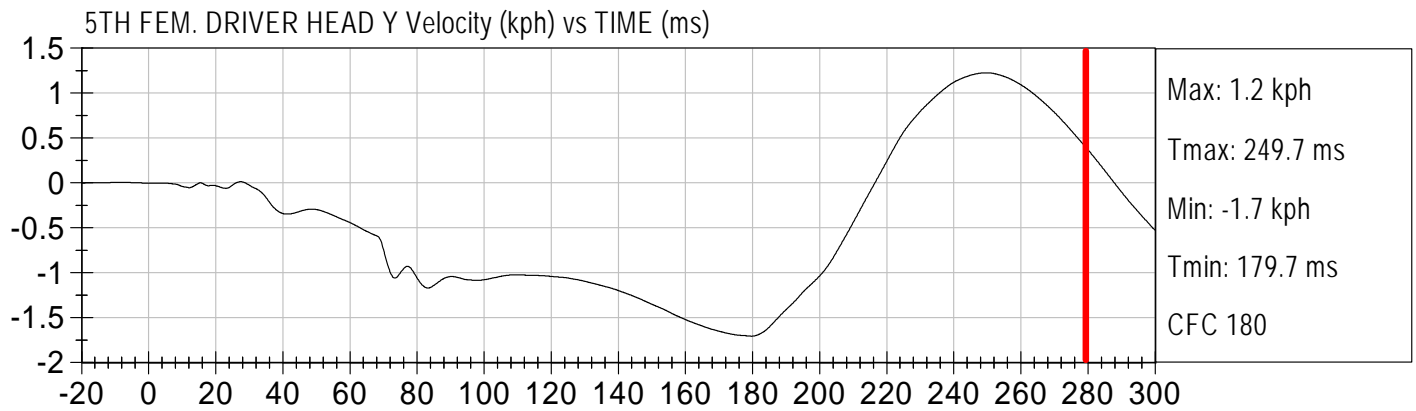
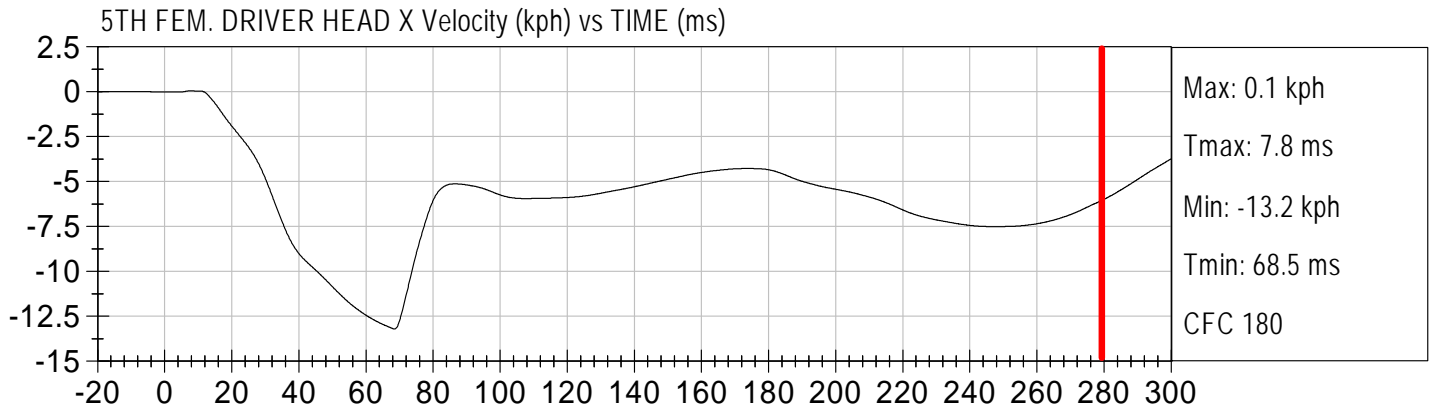



Injury Values Calculated between 0ms and 275ms

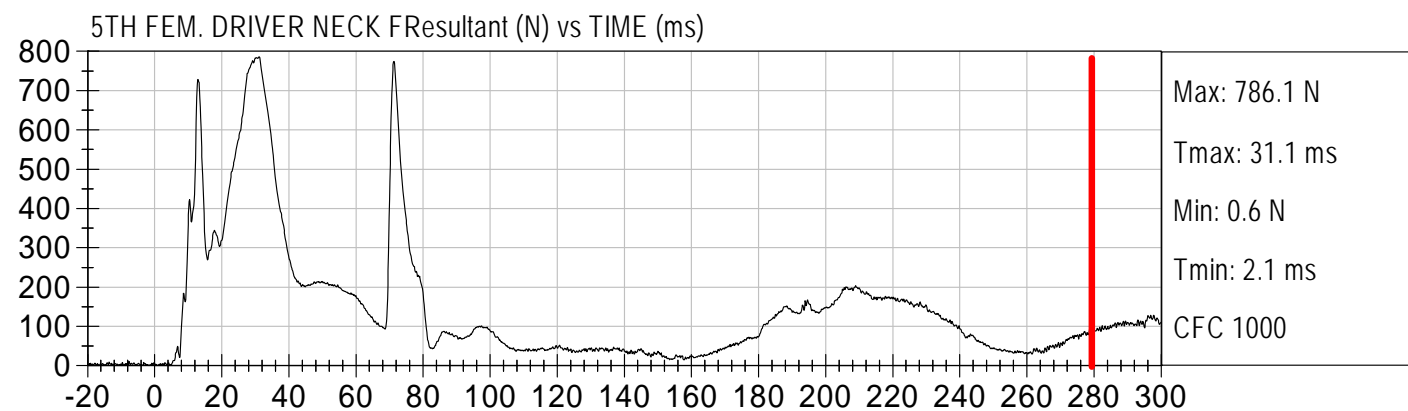
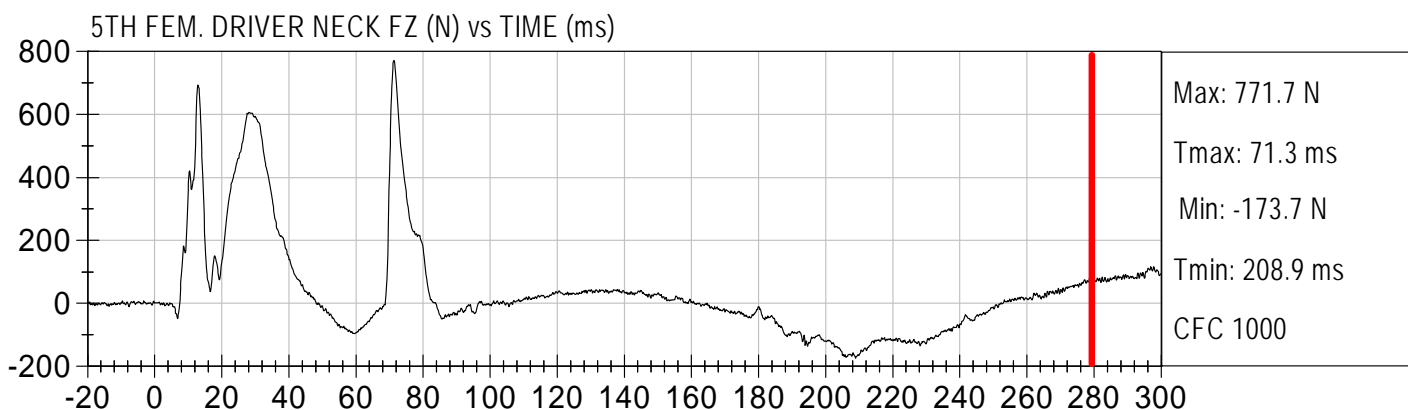
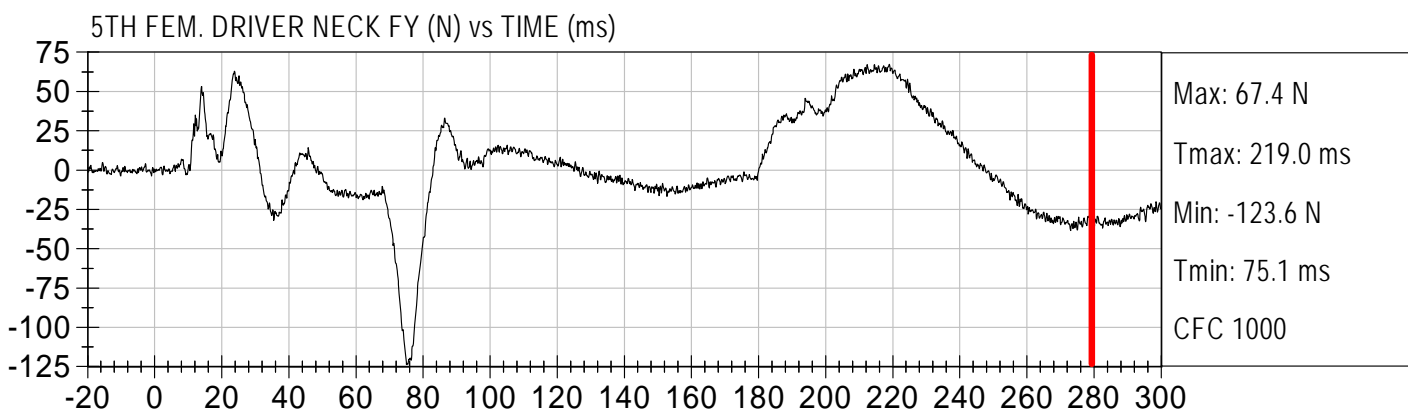
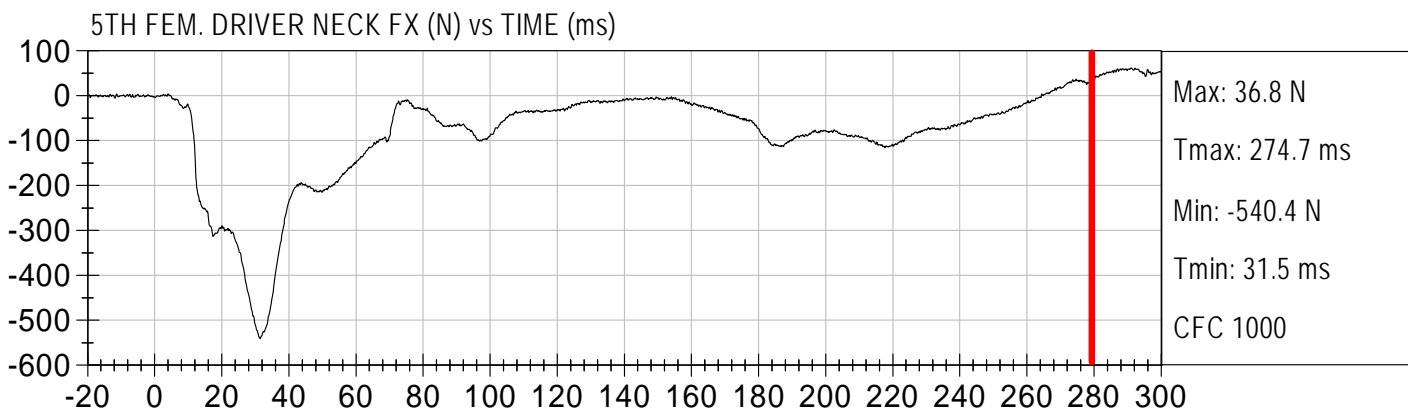



Injury Values Calculated between 0ms and 275ms

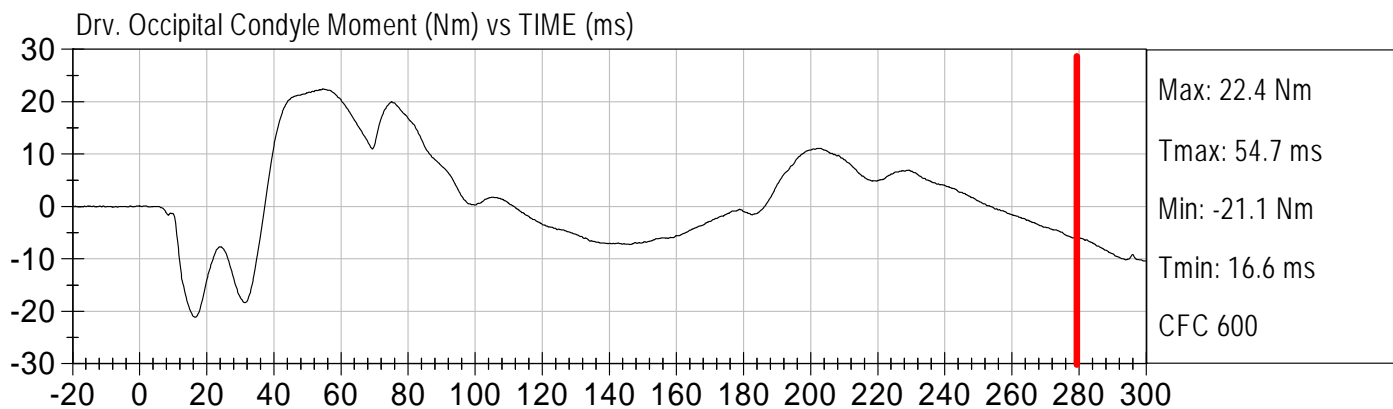
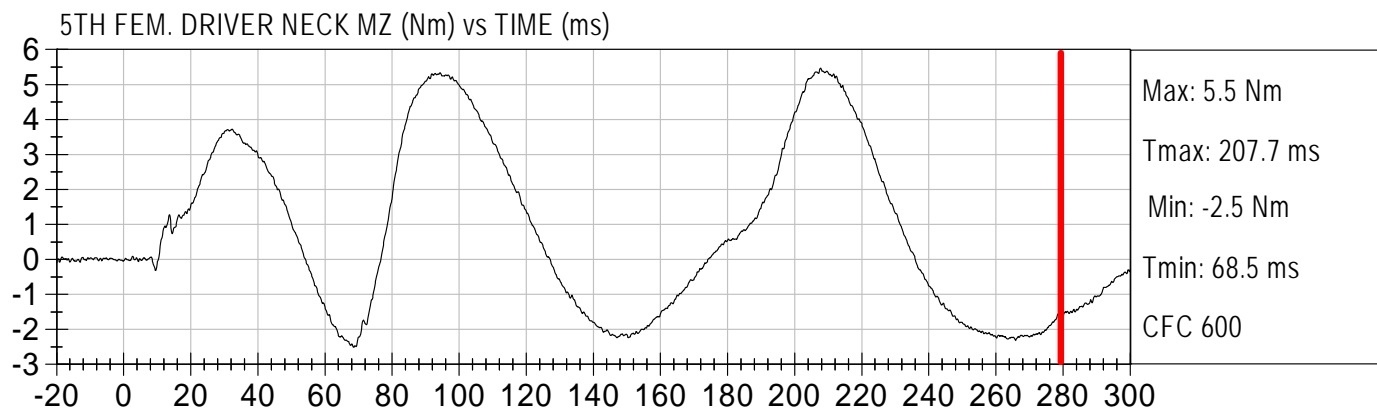
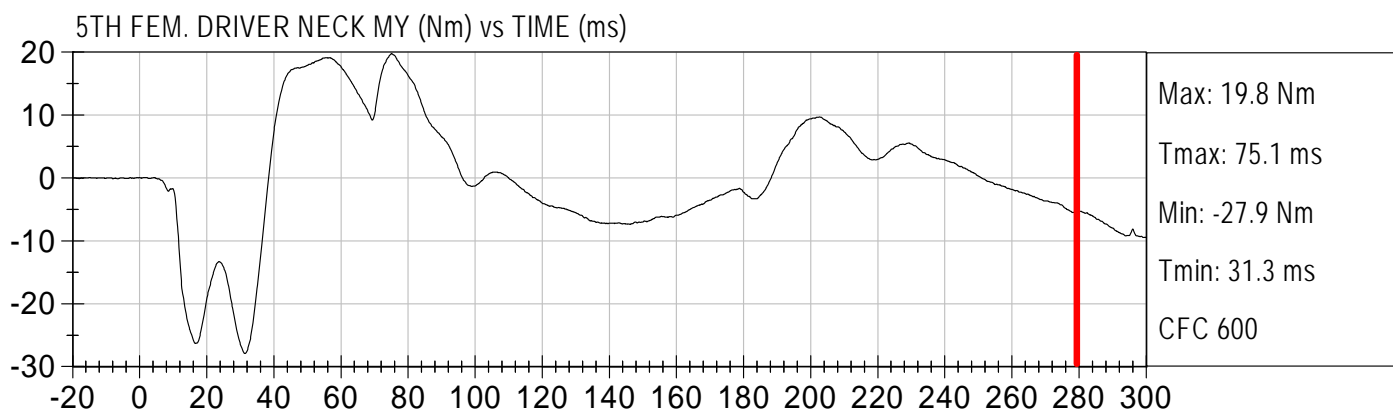
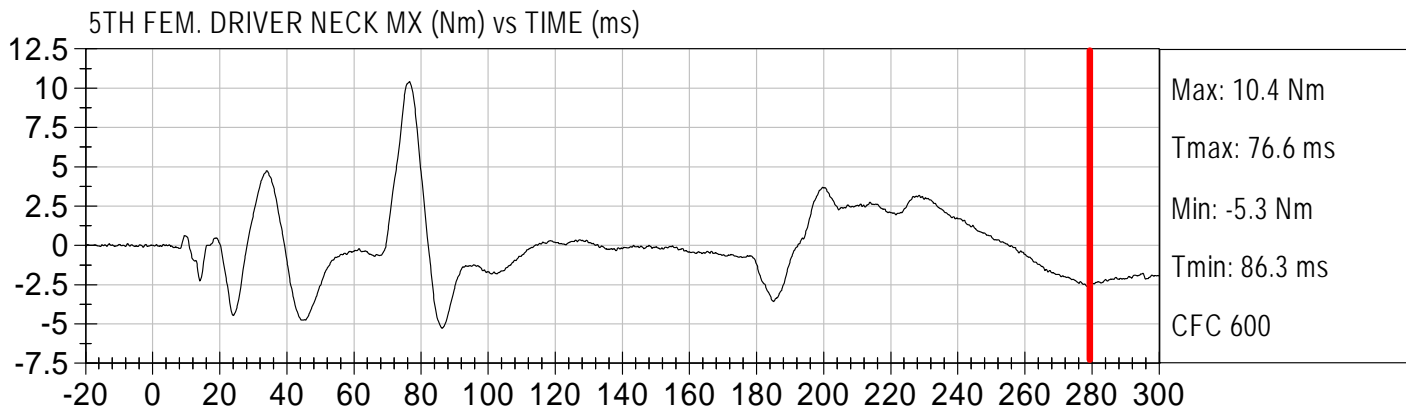



Injury Values Calculated between 0ms and 275ms

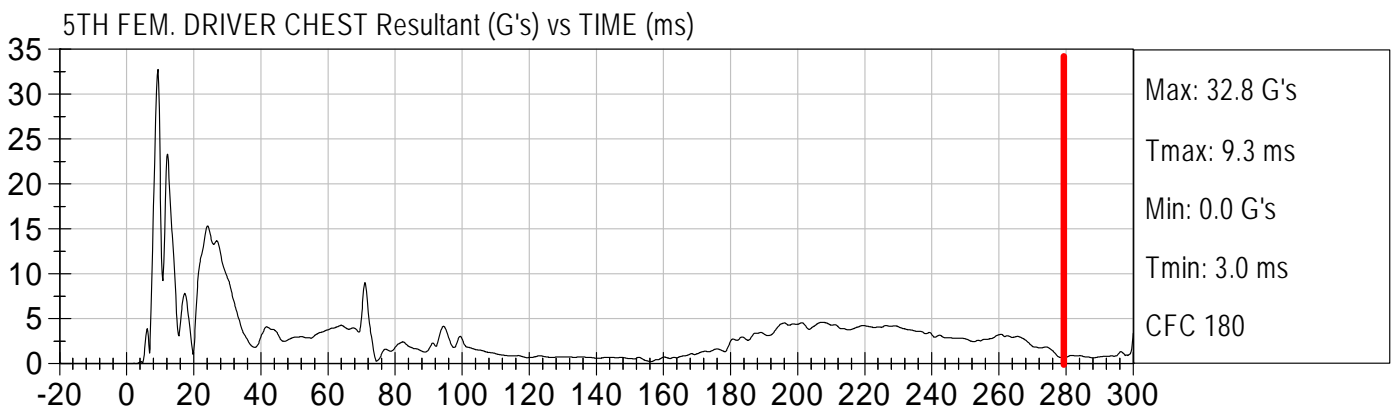
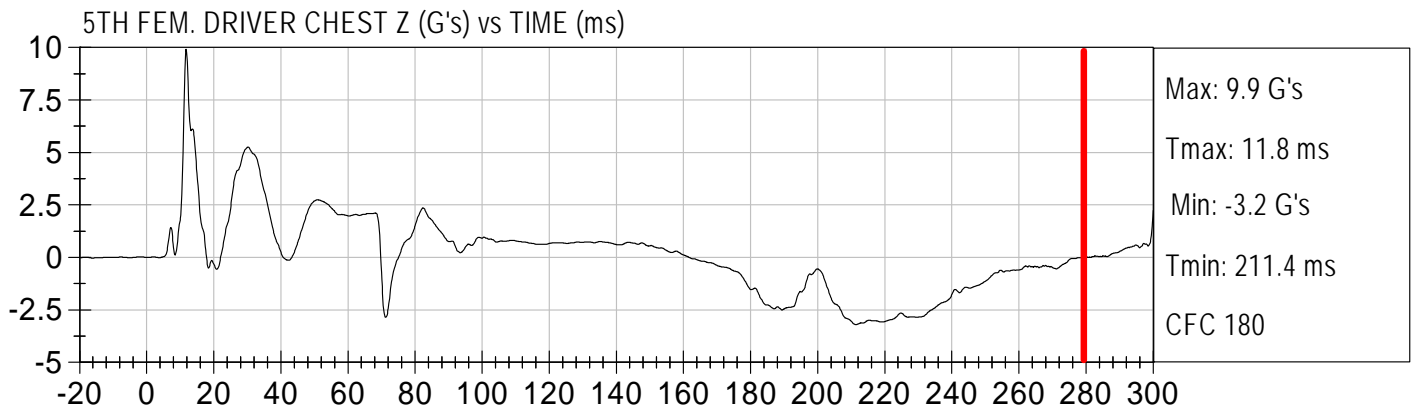
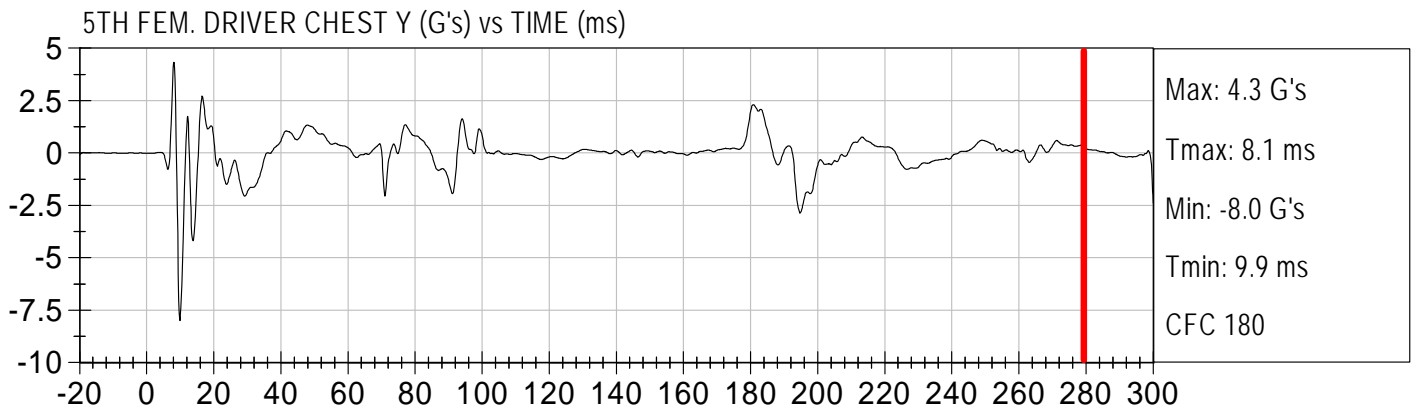
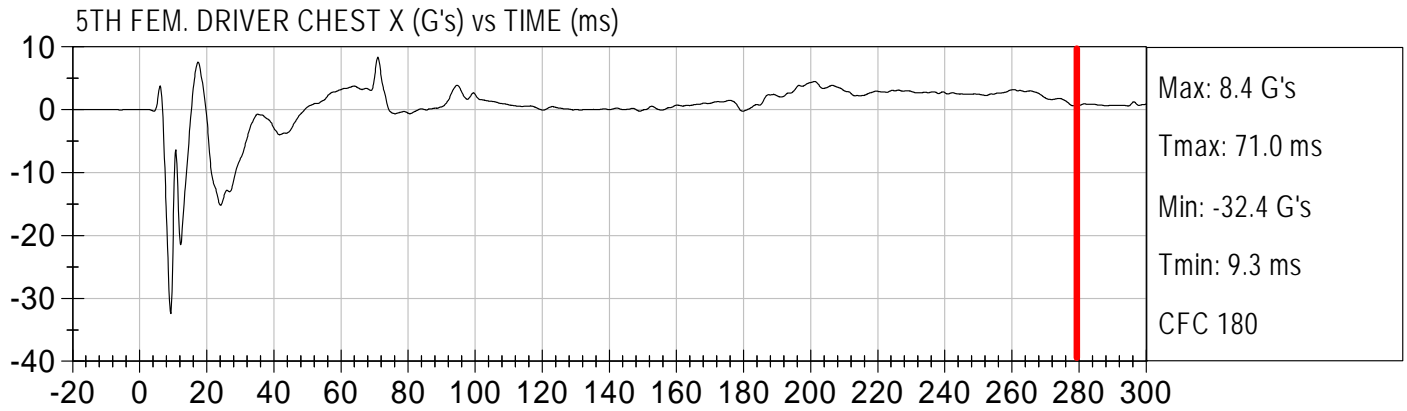



Injury Values Calculated between 0ms and 275ms

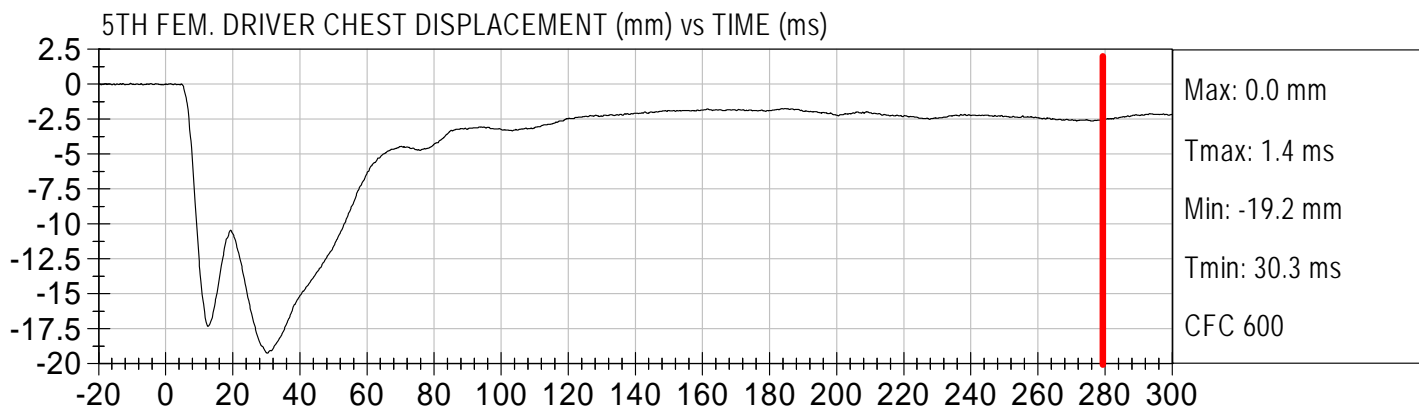
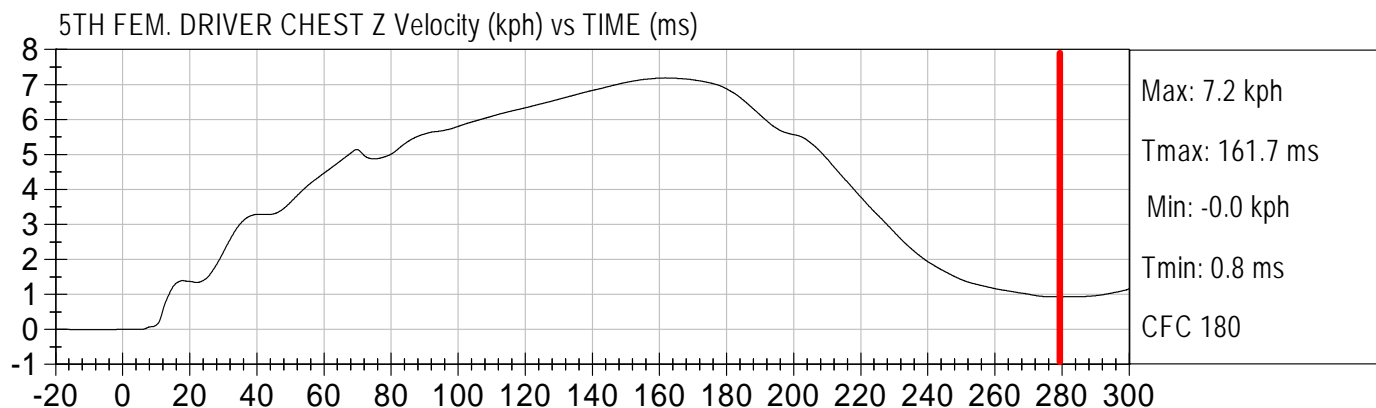
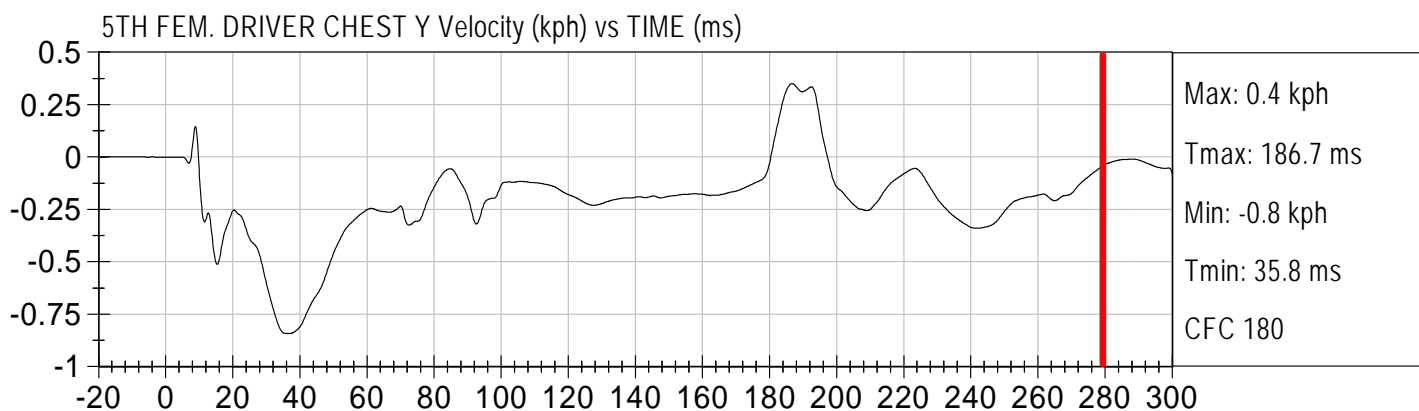
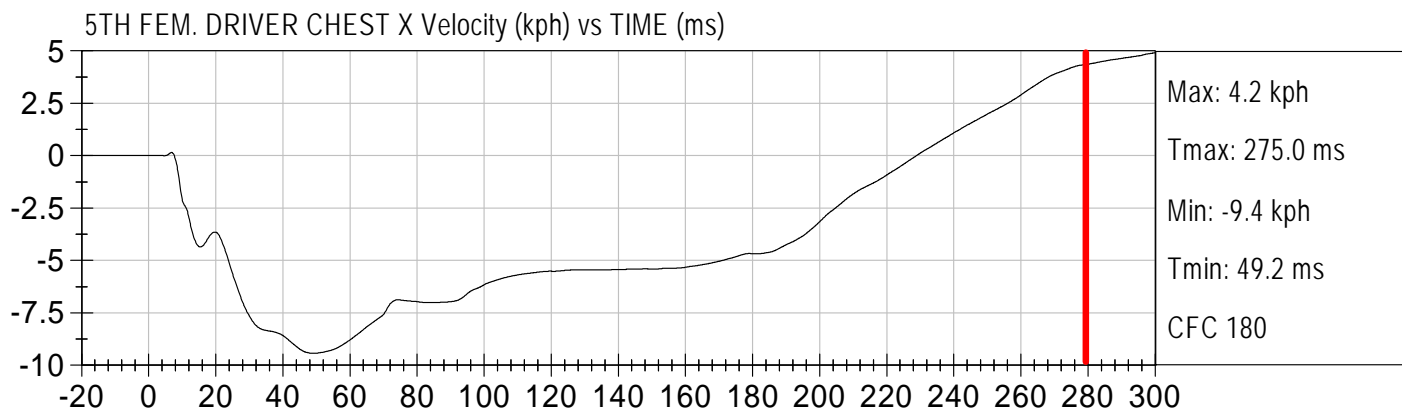



Injury Values Calculated between 0ms and 275ms

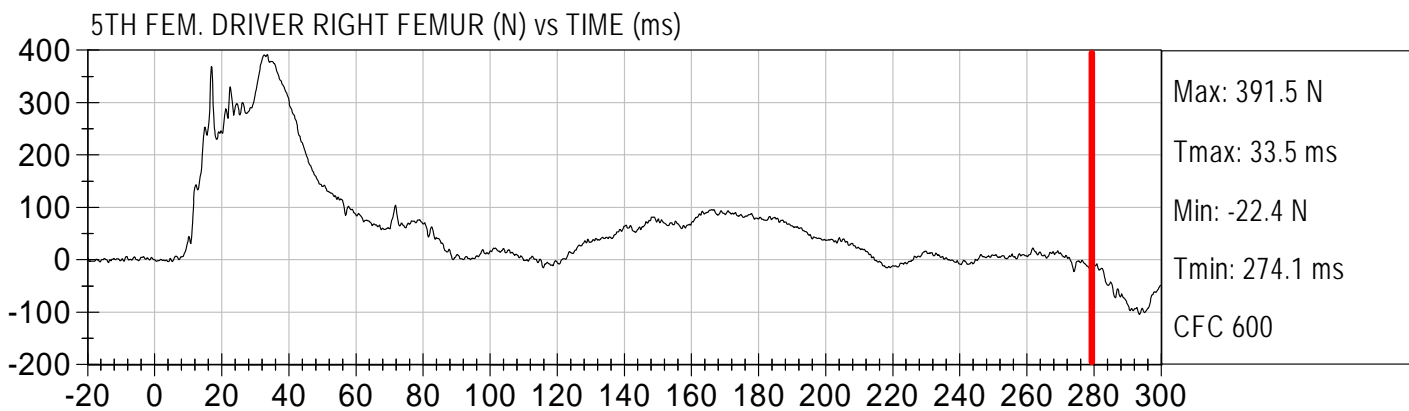
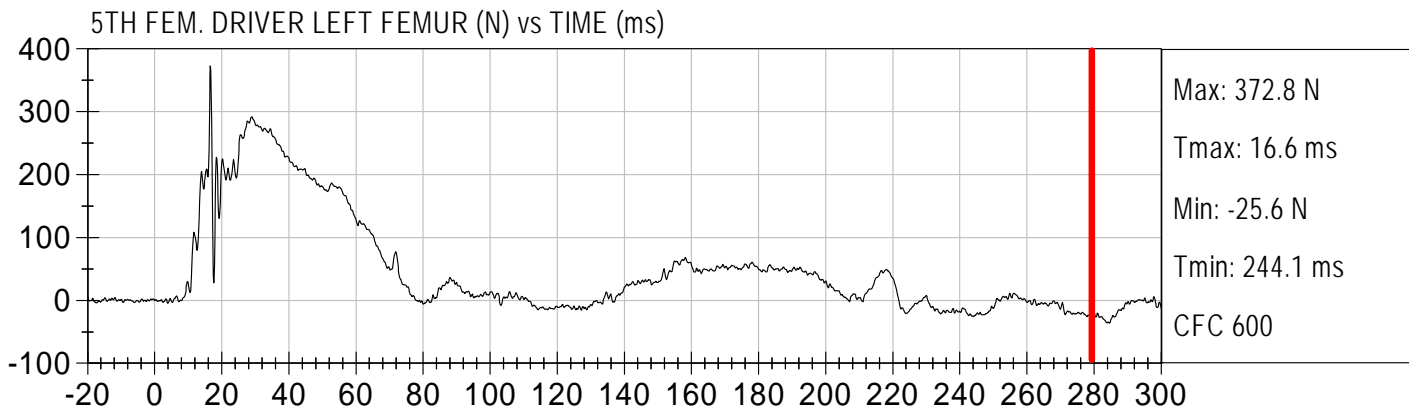



Injury Values Calculated between 0ms and 275ms

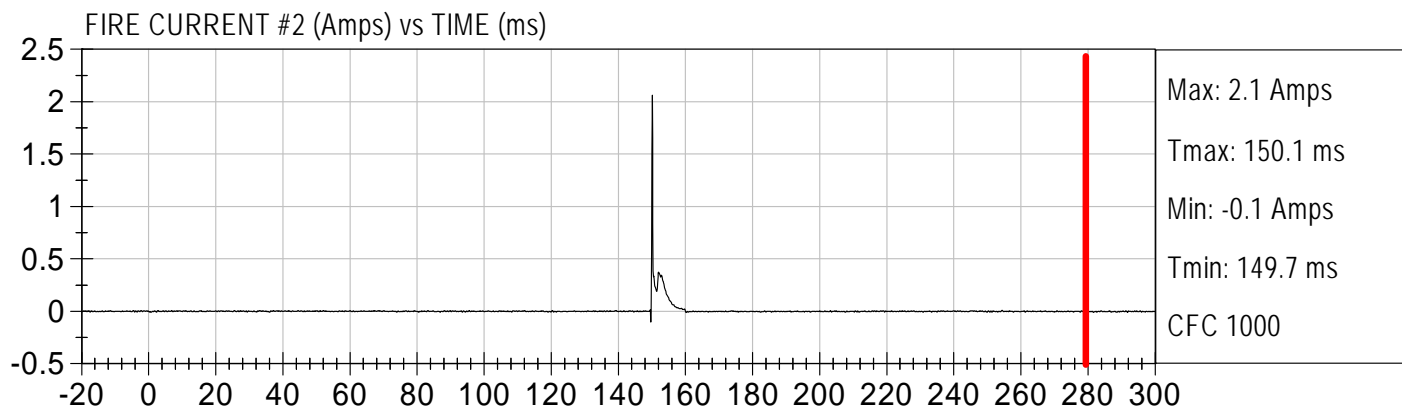
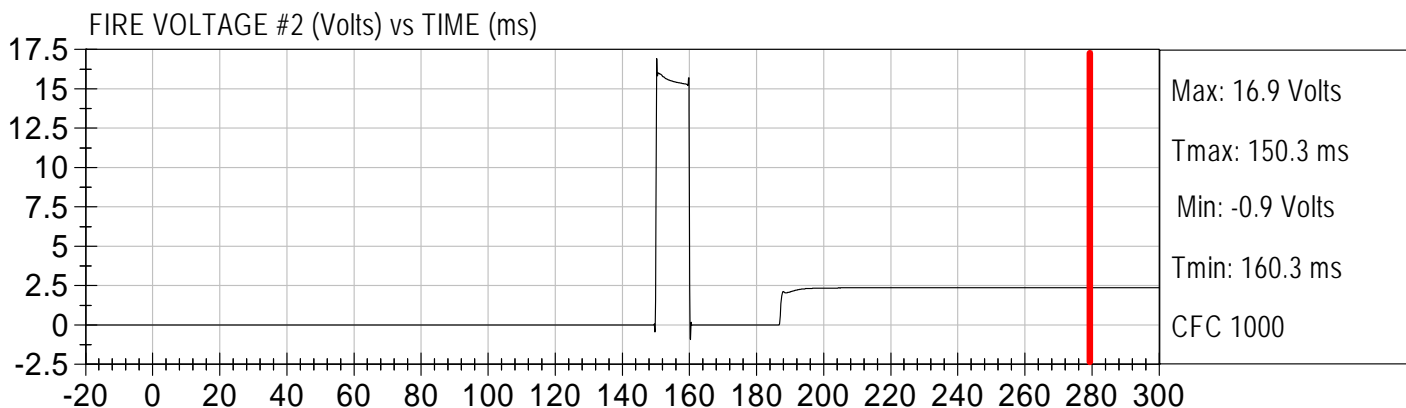
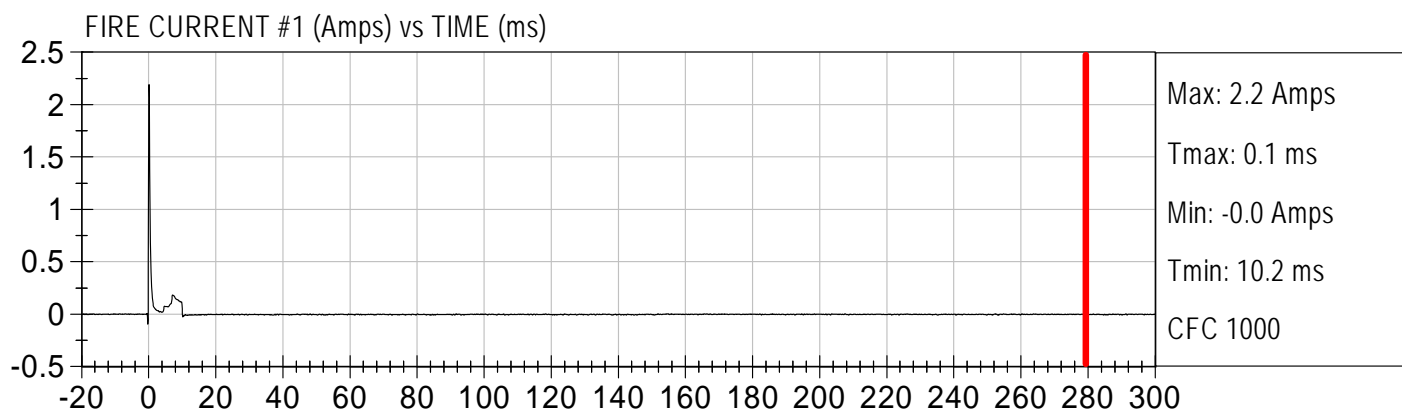
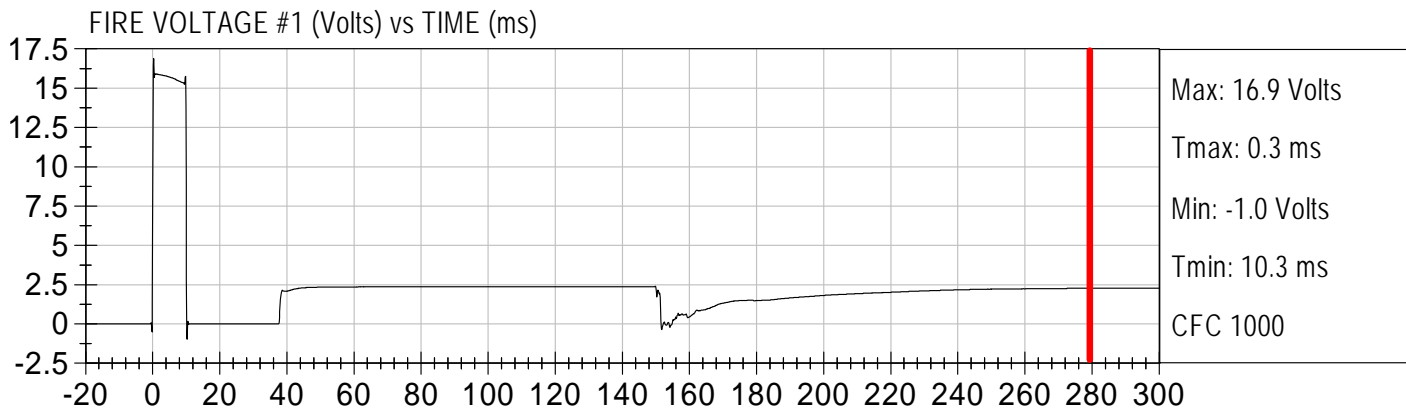

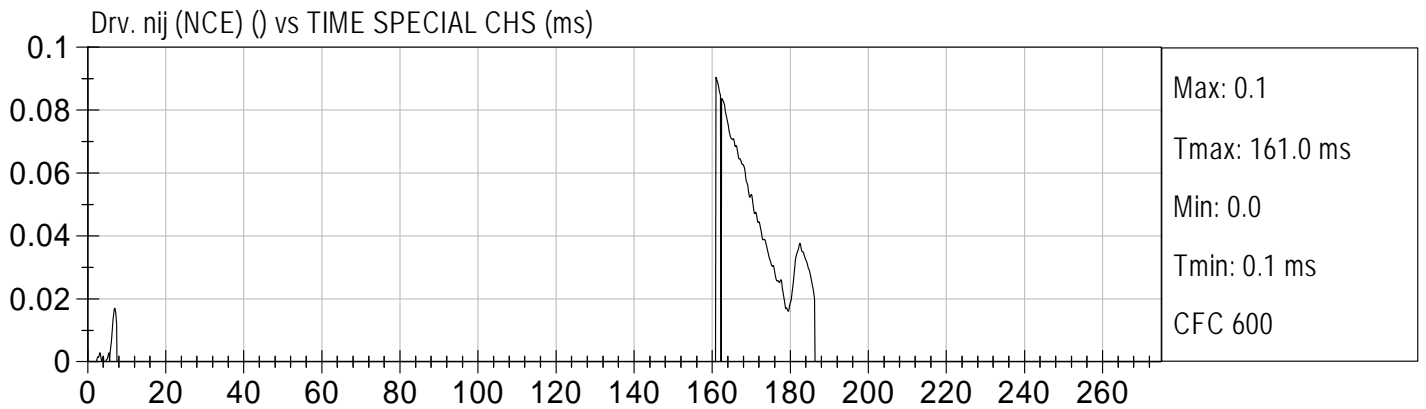
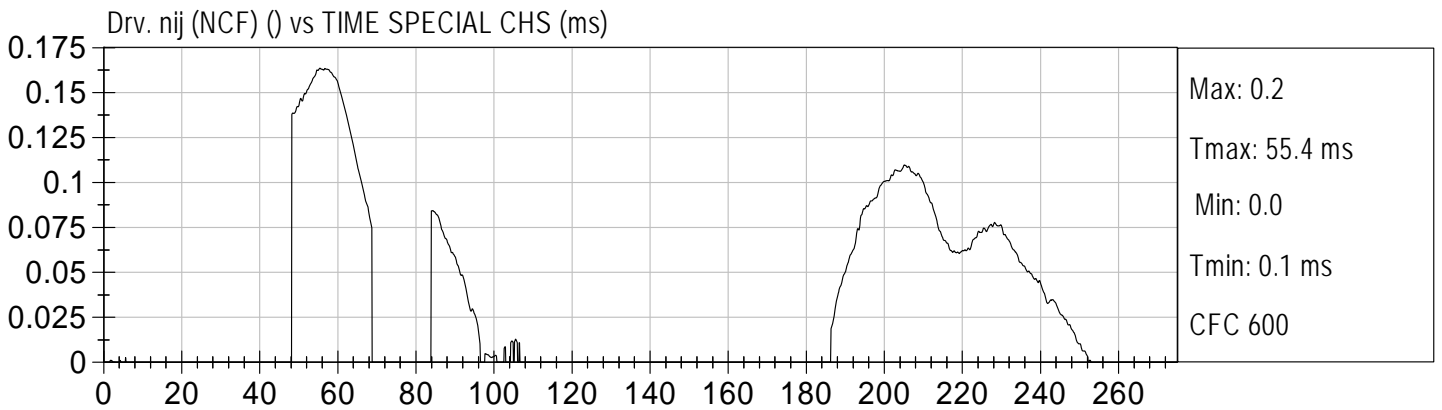
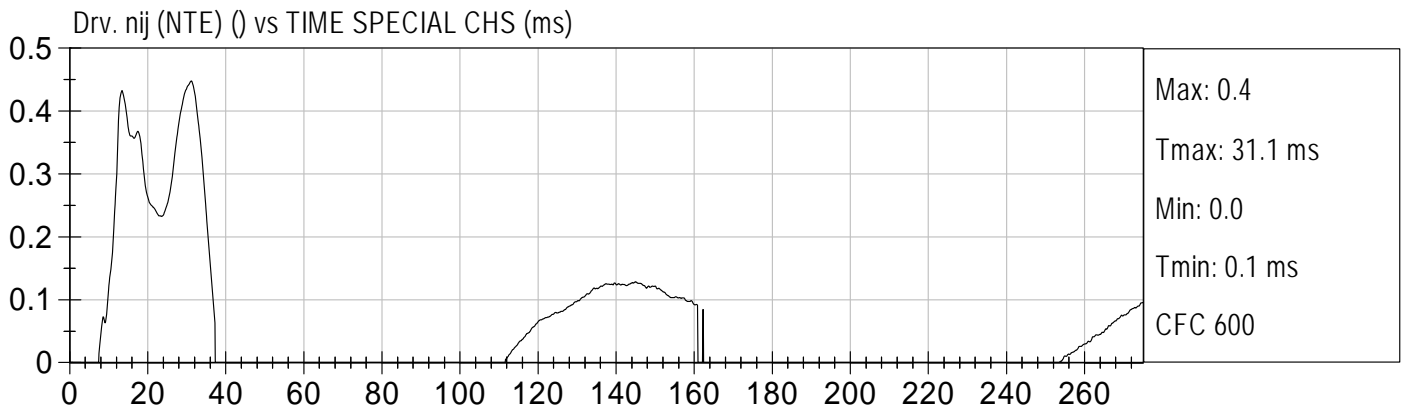
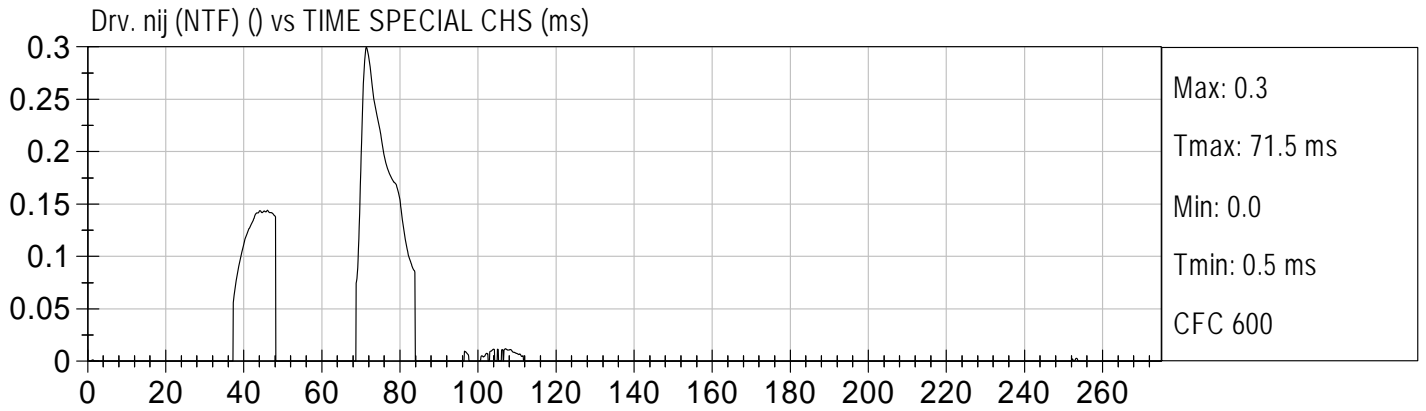

APPENDIX C
CRASH TEST PHOTOGRAPHS

TABLE OF PHOTOGRAPHS

		<u>Page No.</u>
Photo No. 1.	Vehicle Certification Label	C-1
Photo No. 2.	Tire Placard	C-2
Photo No. 3.	Pre-Test Front View of Test Vehicle	C-3
Photo No. 4.	Post-Test Front View of Test Vehicle	C-4
Photo No. 5.	Pre-Test Left Side View of Test Vehicle	C-5
Photo No. 6.	Post-Test Left Side View of Test Vehicle	C-6
Photo No. 7.	Pre-Test Right Side View of Test Vehicle	C-7
Photo No. 8.	Post-Test Right Side View of Test Vehicle	C-8
Photo No. 9.	Pre-Test Right Front Three-Quarter View of Test Vehicle	C-9
Photo No. 10.	Post-Test Right Front Three-Quarter View of Test Vehicle	C-10
Photo No. 11.	Pre-Test Left Front Three-Quarter View of Test Vehicle	C-11
Photo No. 12.	Post-Test Left Front Three-Quarter View of Test Vehicle	C-12
Photo No. 13.	Pre-Test Right Rear Three-Quarter View of Test Vehicle	C-13
Photo No. 14.	Post-Test Right Rear Three-Quarter View of Test Vehicle	C-14
Photo No. 15.	Pre-Test Left Rear Three-Quarter View of Test Vehicle	C-15
Photo No. 16.	Post-Test Left Rear Three-Quarter View of Test Vehicle	C-16
Photo No. 17.	Pre-Test Rear View of Test Vehicle	C-17
Photo No. 18.	Post-Test Rear View of Test Vehicle	C-18
Photo No. 19.	Pre-Test Windshield View	C-19
Photo No. 20.	Post-Test Windshield View	C-20
Photo No. 21.	Pre-Test Engine Compartment View	C-21
Photo No. 22.	Post-Test Engine Compartment View	C-22
Photo No. 23.	Pre-Test Fuel Filler Cap View	C-23
Photo No. 24.	Post-Test Fuel Filler Cap View	C-24
Photo No. 25.	Pre-Test Front Underbody View	C-25

	<u>Page No.</u>
Photo No. 26. Post-Test Front Underbody View	C-26
Photo No. 27. Pre-Test Mid Underbody View	C-27
Photo No. 28. Post-Test Mid Underbody View	C-28
Photo No. 29. Pre-Test Rear Underbody View	C-29
Photo No. 30. Post-Test Rear Underbody View	C-30
Photo No. 31. Pre-Test Driver Dummy Front View (head position)	C-31
Photo No. 32. Post-Test Driver Dummy Front View (head position)	C-32
Photo No. 33. Pre-Test Driver Dummy Position Left Side View	C-33
Photo No. 34. Post-Test Driver Dummy Position Left Side View	C-34
Photo No. 35. Pre-Test Driver Dummy Position Left Side View (door open)	C-35
Photo No. 36. Post-Test Driver Dummy Position Left Side View (door open)	C-36
Photo No. 37. Pre-Test Driver Dummy Seat Position	C-37
Photo No. 38. Post-Test Driver Dummy Seat Position	C-38
Photo No. 39. Pre-Test Driver Dummy Feet Position	C-39
Photo No. 40. Post-Test Driver Dummy Feet Position	C-40
Photo No. 41. Pre-Test Driver Side Knee Bolster View	C-41
Photo No. 42. Post-Test Driver Side Knee Bolster View	C-42
Photo No. 43. Post-Test Driver Dummy Airbag Contact	C-43
Photo No. 44. Post-Test Driver Dummy Head Contact (headrest)	C-44
Photo No. 45. Post-Test Driver Dummy Head Contract (header and visor)	C-45
Photo No. 46. Post-Test Driver Dummy Knee Contact	C-46
Photo No. 47. Pre-Test Passenger Dummy Front View (head position)	C-47
Photo No. 48. Post-Test Passenger Dummy Front View (head position)	C-48
Photo No. 49. Pre-Test Passenger Dummy Position Right Side View (door open)	C-49
Photo No. 50. Post-Test Passenger Dummy Position Right Side View (door open)	C-50
Photo No. 51. Pre-Test Passenger Dummy Seat Position	C-51
Photo No. 52. Post-Test Passenger Dummy Seat Position	C-52

	<u>Page No.</u>
Photo No. 53. Pre-Test Passenger Dummy Feet Position	C-53
Photo No. 54. Post-Test Passenger Dummy Feet Position	C-54
Photo No. 55. Pre-Test Passenger Side Knee Bolster View	C-55
Photo No. 56. Post-Test Passenger Side Knee Bolster View	C-56
Photo No. 57. Post-Test Passenger Dummy Airbag Contact	C-57
Photo No. 58. Post-Test Passenger Dummy Head Contact View (headrest)	C-58
Photo No. 59. Post-Test Passenger Dummy Knee Contact	C-59
Photo No. 60. Rollover 90 Degrees	C-60
Photo No. 61. Rollover 180 Degrees	C-61
Photo No. 62. Rollover 270 Degrees	C-62
Photo No. 63. Rollover 360 Degrees	C-63
Photo No. 64. Temperature Plot	C-64
Photo No. 65. Vehicle in Relation to The Load Cell Grid	C-65

C-1.

MFD. BY FORD MOTOR CO.

DATE: 12/07	GVWR: 5340LB/ 2422KG
FRONT GAWR: 2840LB	REAR GAWR: 2530LB
1288KG	WITH 1148KG
P235/65R17	TIRES P235/65R17
17x7.5J	RIMS 17x7.5J
AT 240 kPa/ 35 PSI COLD	AT 240 kPa/ 35 PSI COLD

THIS VEHICLE CONFORMS TO ALL APPLICABLE FEDERAL MOTOR VEHICLE SAFETY AND THEFT PREVENTION STANDARDS IN EFFECT ON THE DATE OF MANUFACTURE SHOWN ABOVE.

VIN: 2FMDK36C88BA38516

TYPE: MPV

F0155
T0507



EXT PNT: 1S	RC: 41	DSO:
WB INT TR TP/PS R AXLE TR SPR 8Q11F		
111 1H Z 3E J AAAA WOA		
UTC	5U5A-1520472-BA	

Vehicle Certification Label

TIRE AND LOADING INFORMATION

SEATING CAPACITY TOTAL : 5 FRONT: 2 REAR: 3

The combined weight of occupants and cargo should never exceed : 412 kg or 909 lbs.

TIRE	SIZE	COLD TIRE PRESSURE	SEE OWNERS MANUAL FOR ADDITIONAL INFORMATION
FRONT	P235/65R17	240 KPA, 35 PSI	
REAR	P235/65R17	240 KPA, 35 PSI	
SPARE	T165/80D17	415 KPA, 60 PSI	

2FMDK36C88BA38516

5U5A-1532-AA (TLU)

Tire Placard

C-3.



Pre-Test Front View of Test Vehicle

C-4.



Post-Test Front View of Test Vehicle

C-5.



Pre-Test Left Side View of Test Vehicle

C-6.



Post-Test Left Side View of Test Vehicle

C-7.



Pre-Test Right Side View of Test Vehicle



Post-Test Right Side View of Test Vehicle



Pre-Test Right Front Three-Quarter View of Test Vehicle

C-10.



Post-Test Right Front Three-Quarter View of Test Vehicle



Pre-Test Left Front Three-Quarter View of Test Vehicle



Post-Test Left Front Three-Quarter View of Test Vehicle



Pre-Test Right Rear Three-Quarter View of Test Vehicle

C-14.



Post-Test Right Rear Three-Quarter View of Test Vehicle

C-15.



Pre-Test Left Rear Three-Quarter View of Test Vehicle



C-16.

Post-Test Left Rear Three-Quarter View of Test Vehicle

C-17.



Pre-Test Rear View of Test Vehicle



Post-Test Rear View of Test Vehicle



Pre-Test Windshield View

C-20.



Post-Test Windshield View

C-21.



Pre-Test Engine Compartment View

C-22.



Post-Test Engine Compartment View



Pre-Test Fuel Filler Cap View

C-24.



Post-Test Fuel Filler Cap View

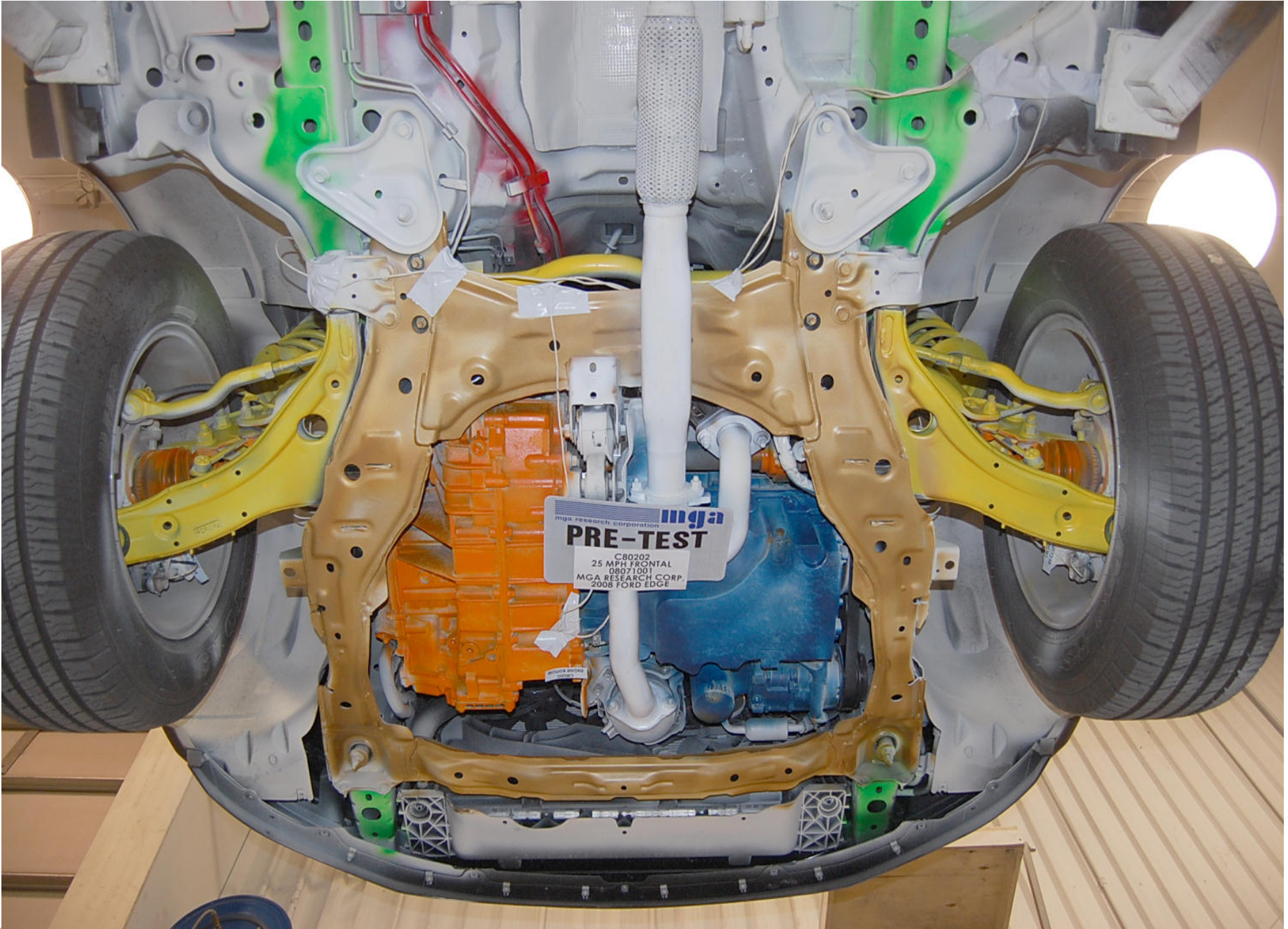

C-25.

Pre-Test Front Underbody View

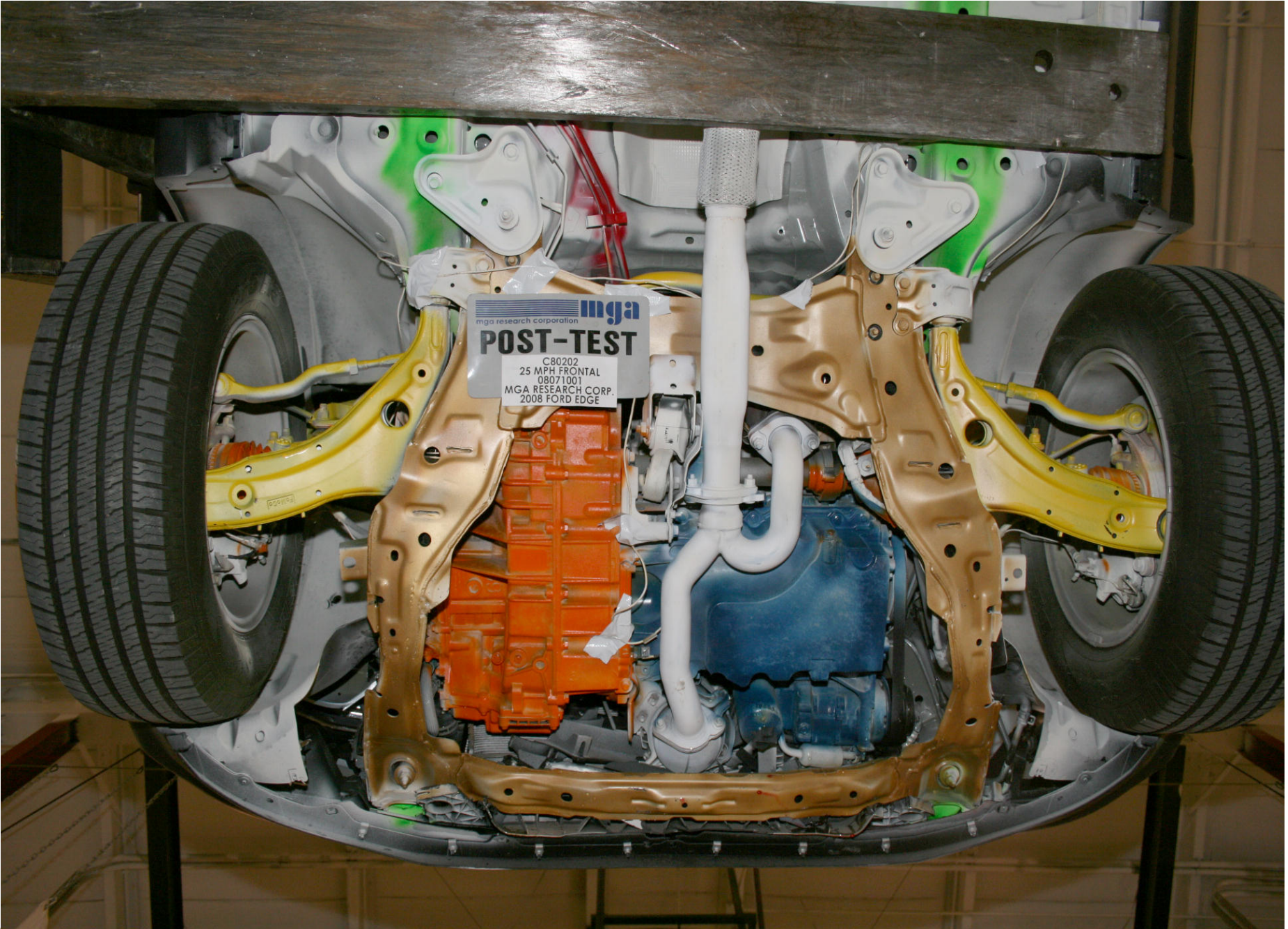

Post-Test Front Underbody View



C-27.

Pre-Test Mid Underbody View



C-28.

Post-Test Mid Underbody View



C-29.

Pre-Test Rear Underbody View

C-30.

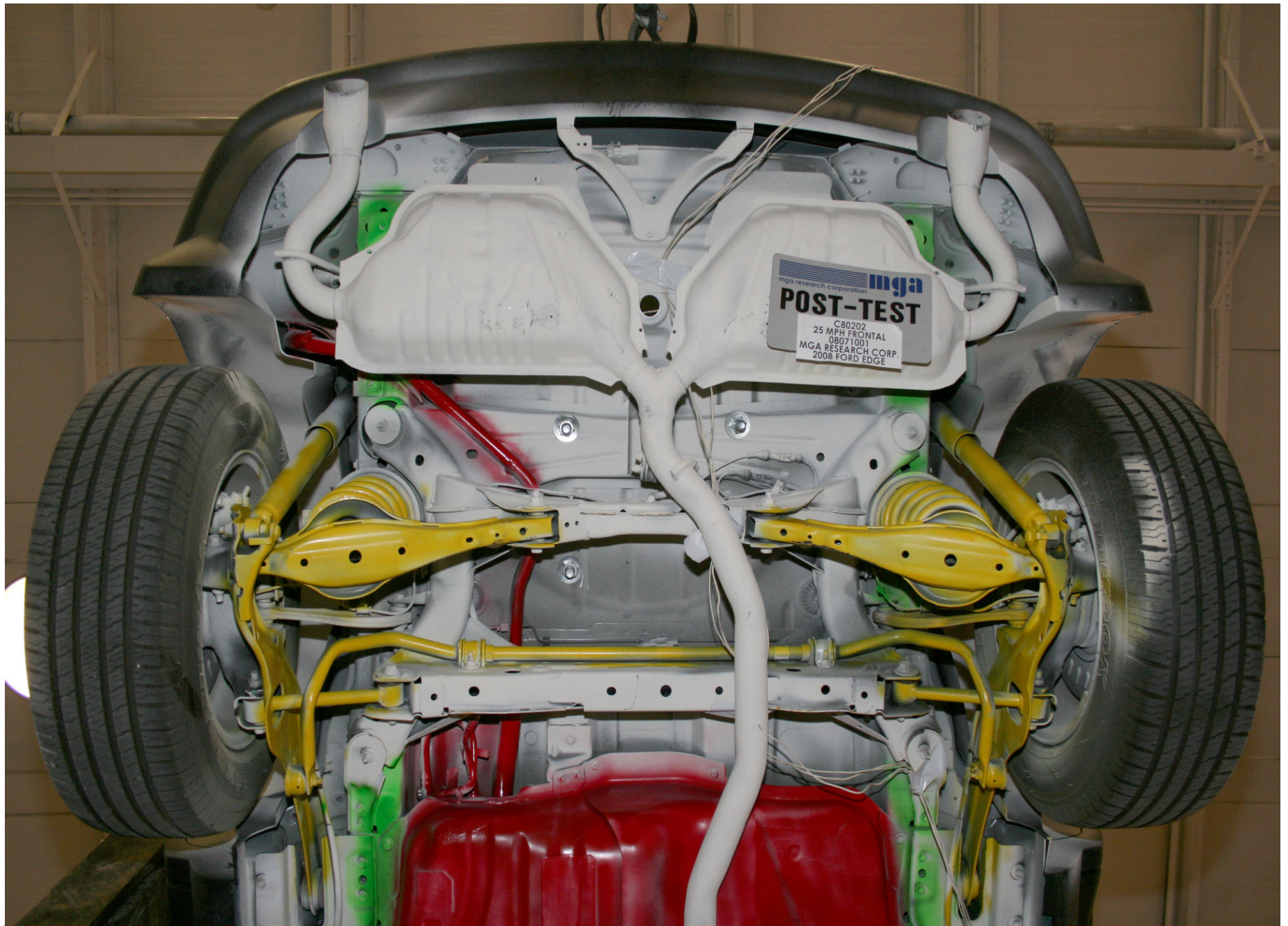

Post-Test Rear Underbody View

C-31.



Pre-Test Driver Dummy Front View (head position)

C-32.



Post-Test Driver Dummy Front View (head position)



Pre-Test Driver Dummy Position Left Side View

C-34.



Post-Test Driver Dummy Position Left Side View



Pre-Test Driver Dummy Position Left Side View (door open)



Post-Test Driver Dummy Position Left Side View (door open)

C-37.

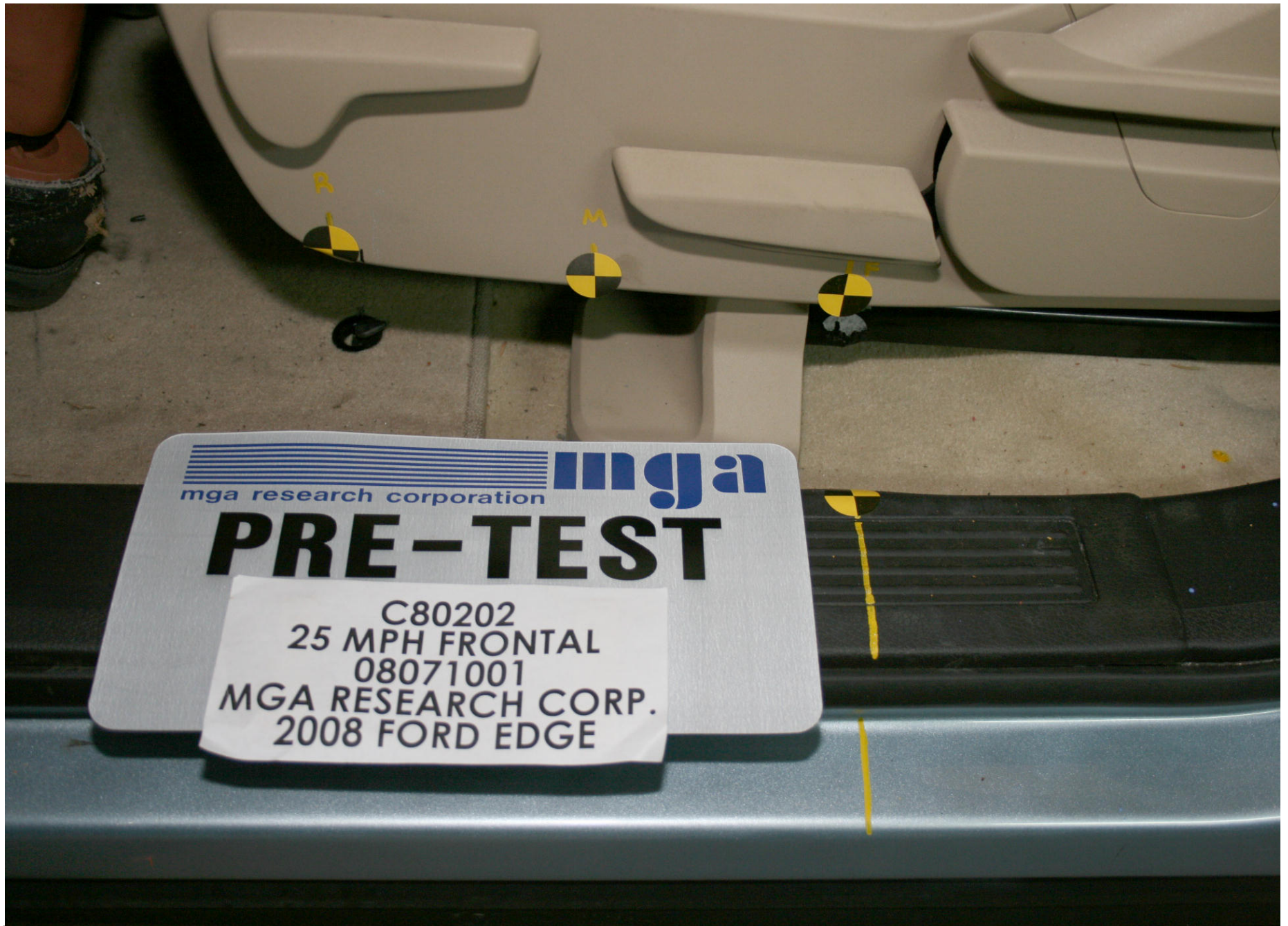

Pre-Test Driver Dummy Seat Position



Post-Test Driver Dummy Seat Position



Pre-Test Driver Dummy Feet Position



Post-Test Driver Dummy Feet Position

C-41.



Pre-Test Driver Side Knee Bolster View



Post-Test Driver Side Knee Bolster View

C-43.



Post-Test Driver Dummy Airbag Contact

C-44.



Post-Test Driver Dummy Head Contact (headrest)

C-45.



Post-Test Driver Dummy Head Contact (header and visor)

C-46.



Post-Test Driver Dummy Knee Contact

C-47.



Pre-Test Passenger Dummy Front View (head position)

C-48.



Post-Test Passenger Dummy Front View (head position)



Pre-Test Passenger Dummy Position Right Side View (door open)

C-50.



Post-Test Passenger Dummy Position Right Side View (door open)

C-51.



Pre-Test Passenger Dummy Seat Position

C-52.



Post-Test Passenger Dummy Seat Position



Pre-Test Passenger Dummy Feet Position



Post-Test Passenger Dummy Feet Position



Pre-Test Passenger Side Knee Bolster View



Post-Test Passenger Side Knee Bolster View



C-57.

Post-Test Passenger Dummy Airbag Contact

C-58.



Post-Test Passenger Dummy Head Contact View (headrest)

C-59.



Post-Test Passenger Dummy Knee Contact

C-60.



Rollover 90 Degrees



C-61.

Rollover 180 Degrees

C-62.



Rollover 270 Degrees

C-63.



Rollover 360 Degrees

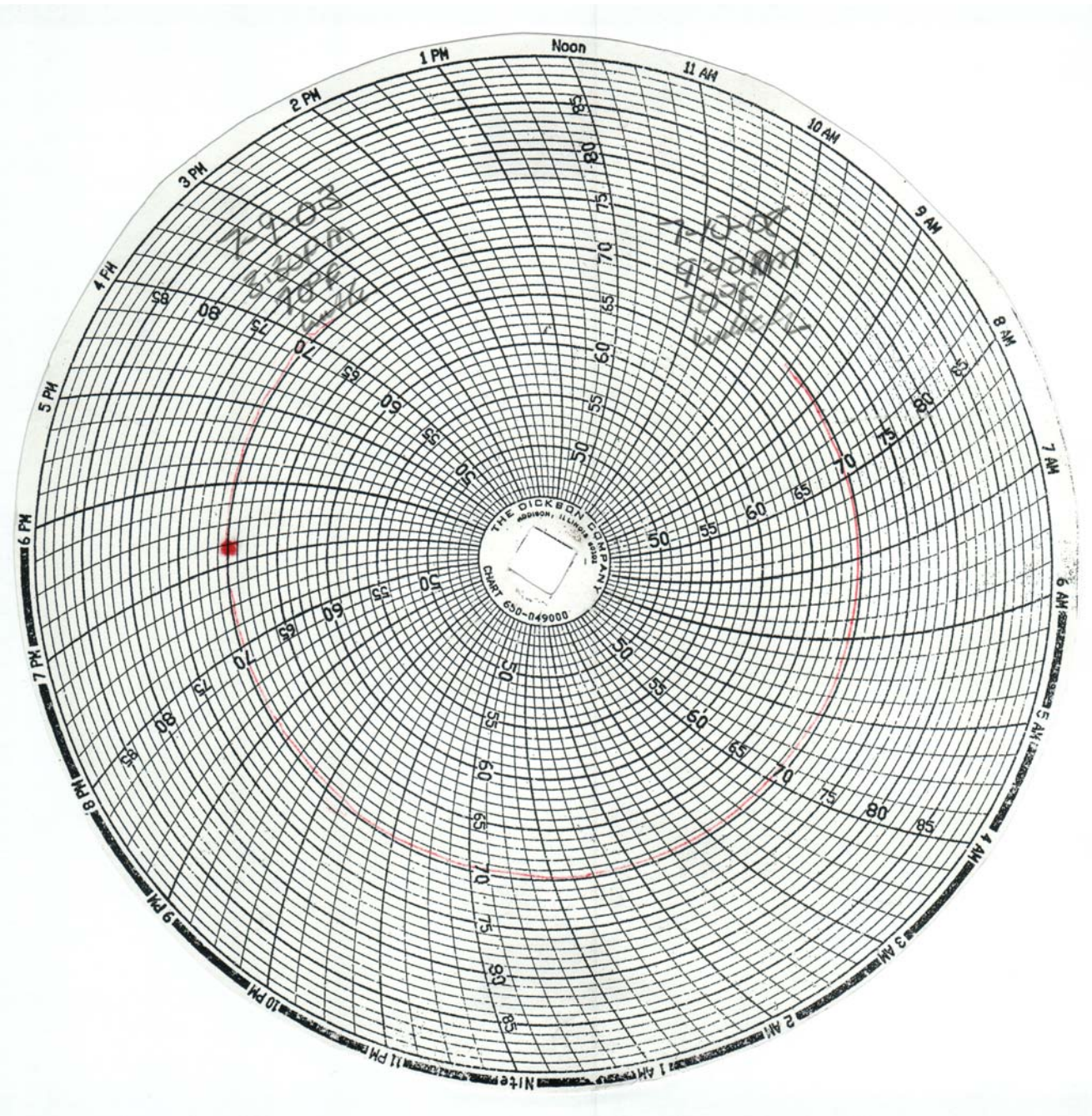

Temperature Plot

C-65.



Vehicle in Relation to The Load Cell Grid

APPENDIX D
LOW RISK PHOTOGRAPHS

TABLE OF PHOTOGRAPHS

		<u>Page No.</u>
Photo No. 1.	Pre-Test 5 th Fem. P1 Driver Dummy Left Side View	D-1
Photo No. 2.	Post-Test 5 th Fem. P1 Driver Dummy Left Side View	D-2
Photo No. 3.	Pre-Test 5 th Fem. P1 Driver Dummy Right Side View	D-3
Photo No. 4.	Post-Test 5 th Fem. P1 Driver Dummy Right Side View	D-4
Photo No. 5.	Post-Test 5 th Fem. P1 Driver Dummy Airbag Left Side View	D-5
Photo No. 6.	Post-Test 5 th Fem. P1 Driver Dummy Airbag Right Side View	D-6
Photo No. 7.	Post-Test 5 th Fem. P1 Driver Dummy Head Contact (headrest)	D-7
Photo No. 8.	Pre-Test 5 th Fem. P2 Driver Dummy Left Side View	D-8
Photo No. 9.	Post-Test 5 th Fem. P2 Driver Dummy Left Side View	D-9
Photo No. 10.	Pre-Test 5 th Fem. P2 Driver Dummy Right Side View	D-10
Photo No. 11.	Post-Test 5 th Fem. P2 Driver Dummy Right Side View	D-11
Photo No. 12.	Post-Test 5 th Fem. P2 Driver Dummy Airbag Left Side View	D-12
Photo No. 13.	Post-Test 5 th Fem. P2 Driver Dummy Airbag Right Side View	D-13
Photo No. 14.	Post-Test 5 th Fem. P2 Driver Dummy Head Contact (header and visor)	D-14

D-1.



Pre-Test 5th Fem. P1 Driver Dummy Left Side View

D-2.



Post-Test 5th Fem. P1 Driver Dummy Left Side View

D-3.



Pre-Test 5th Fem. P1 Driver Dummy Right Side View

D-4.



Post-Test 5th Fem. P1 Driver Dummy Right Side View

D-5.



Post-Test 5th Fem. P1 Driver Dummy Airbag Left Side View

D-6.



Post-Test 5th Fem. P1 Driver Dummy Airbag Right Side View

D-7.



Post-Test 5th Fem. P1 Driver Dummy Head Contact (headrest)

D-8.



Pre-Test 5th Fem. P2 Driver Dummy Left Side View

D-9.



Post-Test 5th Fem. P2 Driver Dummy Left Side View



Pre-Test 5th Fem. P2 Driver Dummy Right Side View

D-11.



Post-Test 5th Fem. P2 Driver Dummy Right Side View

D-12.



Post-Test 5th Fem. P2 Driver Dummy Airbag Left Side View

D-13.



Post-Test 5th Fem. P2 Driver Dummy Airbag Right Side View

D-14.



Post-Test 5th Fem. P2 Driver Dummy Head Contact (header and visor)

APPENDIX E
SUPPRESSION PHOTOGRAPHS

TABLE OF PHOTOGRAPHS

		<u>Page #</u>
Photo No. 1.	Cosco Dream Ride Car Bed Belted, Forward Seat Track	E-1
Photo No. 2.	Cosco Dream Ride Car Bed Belted, Middle Seat Track	E-1
Photo No. 3.	Cosco Dream Ride Car Bed Belted, Rearward Seat Track	E-1
Photo No. 4.	Unbelted 5 th Percentile Female Reactivation, Forward Seat Track	E-1
Photo No. 5.	Britax Handle With Care 191 Belted, Forward Seat Track	E-2
Photo No. 6.	Britax Handle With Care 191 Belted, Middle Seat Track	E-2
Photo No. 7.	Britax Handle With Care 191 Belted, Rearward Seat Track	E-2
Photo No. 8.	Britax Handle With Care 191 Unbelted, Forward Seat Track	E-2
Photo No. 9.	Britax Handle With Care 191 Unbelted, Middle Seat Track	E-3
Photo No. 10.	Britax Handle With Care 191 Unbelted, Rearward Seat Track	E-3
Photo No. 11.	Britax Handle With Care 191 Forward Facing Unbelted, Forward Seat Track	E-3
Photo No. 12.	Britax Handle With Care 191 Forward Facing Unbelted, Middle Seat Track	E-3
Photo No. 13.	Britax Handle With Care 191 Forward Facing Unbelted, Rearward Seat Track	E-4
Photo No. 14.	Unbelted 5 th Percentile Female Reactivation, Middle Seat Track	E-4
Photo No. 15.	Evenflo First Choice 204 Belted, Forward Seat Track	E-5
Photo No. 16.	Evenflo First Choice 204 Belted, Middle Seat Track	E-5
Photo No. 17.	Evenflo First Choice 204 Belted, Rearward Seat Track	E-5
Photo No. 18.	Evenflo First Choice 204 Unbelted, Forward Seat Track	E-5
Photo No. 19.	Evenflo First Choice 204 Unbelted, Middle Seat Track	E-6
Photo No. 20.	Evenflo First Choice 204 Unbelted, Rearward Seat Track	E-6
Photo No. 21.	Evenflo First Choice 204 Forward Facing Unbelted, Forward Seat Track	E-6
Photo No. 22.	Evenflo First Choice 204 Forward Facing Unbelted, Middle Seat Track	E-6
Photo No. 23.	Evenflo First Choice 204 Forward Facing Unbelted, Rearward Seat Track	E-7
Photo No. 24.	Unbelted 5 th Percentile Female Reactivation, Rearward Seat Track	E-7
Photo No. 25.	Graco Infant W/ Base Belted, Forward Seat Track	E-8
Photo No. 26.	Graco Infant W/ Base Belted, Middle Seat Track	E-8
Photo No. 27.	Graco Infant W/ Base Belted, Rearward Seat Track	E-8
Photo No. 28.	Graco Infant W/ Base Unbelted, Forward Seat Track	E-8
Photo No. 29.	Graco Infant W/ Base Unbelted, Middle Seat Track	E-9
Photo No. 30.	Graco Infant W/ Base Unbelted, Rearward Seat Track	E-9
Photo No. 31.	Graco Infant W/ Base Forward Facing Unbelted, Forward Seat Track	E-9
Photo No. 32.	Graco Infant W/ Base Forward Facing Unbelted, Middle Seat Track	E-9
Photo No. 33.	Graco Infant W/ Base Forward Facing Unbelted, Rearward Seat Track	E-10

	<u>Page #</u>
Photo No. 34. Graco Infant W/O Base Belted, Forward Seat Track	E-10
Photo No. 35. Graco Infant W/O Base Belted, Middle Seat Track	E-10
Photo No. 36. Graco Infant W/O Base Belted, Rearward Seat Track	E-10
Photo No. 37. Graco Infant W/O Base Unbelted, Forward Seat Track	E-11
Photo No. 38. Graco Infant W/O Base Unbelted, Middle Seat Track	E-11
Photo No. 39. Graco Infant W/O Base Unbelted, Rearward Seat Track	E-11
Photo No. 40. Graco Infant W/O Base Forward Facing Unbelted, Forward Seat Track	E-11
Photo No. 41. Graco Infant W/O Base Forward Facing Unbelted, Middle Seat Track	E-12
Photo No. 42. Graco Infant W/O Base Forward Facing Unbelted, Rearward Seat Track	E-12
Photo No. 43. Unbelted 5 th Percentile Female Reactivation, Middle Seat Track	E-12
Photo No. 44. Britax Roundabout 161 Forward Facing Belted, Forward Seat Track	E-13
Photo No. 45. Britax Roundabout 161 Forward Facing Belted, Middle Seat Track	E-13
Photo No. 46. Britax Roundabout 161 Forward Facing Belted, Rearward Seat Track	E-13
Photo No. 47. Britax Roundabout 161 Forward Facing Unbelted, Forward Seat Track	E-13
Photo No. 48. Britax Roundabout 161 Forward Facing Unbelted, Middle Seat Track	E-14
Photo No. 49. Britax Roundabout 161 Forward Facing Unbelted, Rearward Seat Track	E-14
Photo No. 50. Britax Roundabout 161 Rear Facing Belted, Forward Seat Track	E-14
Photo No. 51. Britax Roundabout 161 Rear Facing Belted, Middle Seat Track	E-14
Photo No. 52. Britax Roundabout 161 Rear Facing Belted, Rearward Seat Track	E-15
Photo No. 53. Britax Roundabout 161 Rear Facing Unbelted, Forward Seat Track	E-15
Photo No. 54. Britax Roundabout 161 Rear Facing Unbelted, Middle Seat Track	E-15
Photo No. 55. Britax Roundabout 161 Rear Facing Unbelted, Rearward Seat Track	E-15
Photo No. 56. Unbelted 5 th Percentile Female Reactivation, Forward Seat Track	E-16
Photo No. 57. Century Encore Forward Facing Belted, Forward Seat Track	E-17
Photo No. 58. Century Encore Forward Facing Belted, Middle Seat Track	E-17
Photo No. 59. Century Encore Forward Facing Belted, Rearward Seat Track	E-17
Photo No. 60. Century Encore Forward Facing Unbelted, Forward Seat Track	E-17
Photo No. 61. Century Encore Forward Facing Unbelted, Middle Seat Track	E-18
Photo No. 62. Century Encore Forward Facing Unbelted, Rearward Seat Track	E-18
Photo No. 63. Century Encore Rear Facing Belted, Forward Seat Track	E-18
Photo No. 64. Century Encore Rear Facing Belted, Middle Seat Track	E-18
Photo No. 65. Century Encore Rear Facing Belted, Rearward Seat Track	E-19
Photo No. 66. Century Encore Rear Facing Unbelted, Forward Seat Track	E-19
Photo No. 67. Century Encore Rear Facing Unbelted, Middle Seat Track	E-19
Photo No. 68. Century Encore Rear Facing Unbelted, Rearward Seat Track	E-19

	<u>Page #</u>
Photo No. 69. Unbelted 5 th Percentile Female Reactivation, Middle Seat Track	E-20
Photo No. 70. Evenflo Medallion 254 Forward Facing Belted, Forward Seat Track	E-21
Photo No. 71. Evenflo Medallion 254 Forward Facing Belted, Middle Seat Track	E-21
Photo No. 72. Evenflo Medallion 254 Forward Facing Belted, Rearward Seat Track	E-21
Photo No. 73. Evenflo Medallion 254 Forward Facing Unbelted, Forward Seat Track	E-21
Photo No. 74. Evenflo Medallion 254 Forward Facing Unbelted, Middle Seat Track	E-22
Photo No. 75. Evenflo Medallion 254 Forward Facing Unbelted, Rearward Seat Track	E-22
Photo No. 76. Evenflo Medallion 254 Rear Facing Belted, Forward Seat Track	E-22
Photo No. 77. Evenflo Medallion 254 Rear Facing Belted, Middle Seat Track	E-22
Photo No. 78. Evenflo Medallion 254 Rear Facing Belted, Rearward Seat Track	E-23
Photo No. 79. Evenflo Medallion 254 Rear Facing Unbelted, Forward Seat Track	E-23
Photo No. 80. Evenflo Medallion 254 Rear Facing Unbelted, Middle Seat Track	E-23
Photo No. 81. Evenflo Medallion 254 Rear Facing Unbelted, Rearward Seat Track	E-23
Photo No. 82. Unbelted 5 th Percentile Female Reactivation, Rearward Seat Track	E-24
Photo No. 83. 3-Year-Old Forward Facing Britax Roundabout Belted, Forward Seat Track	E-25
Photo No. 84. 3-Year-Old Forward Facing Britax Roundabout Belted, Middle Seat Track	E-25
Photo No. 85. 3-Year-Old Forward Facing Britax Roundabout Belted, Rearward Seat Track	E-25
Photo No. 86. Unbelted 5 th Percentile Female Reactivation, Middle Seat Track	E-25
Photo No. 87. 3-Year-Old Forward Facing Century Encore Belted, Forward Seat Track	E-26
Photo No. 88. 3-Year-Old Forward Facing Century Encore Belted, Middle Seat Track	E-26
Photo No. 89. 3-Year-Old Forward Facing Century Encore Belted, Rearward Seat Track	E-26
Photo No. 90. Unbelted 5 th Percentile Female Reactivation, Forward Seat Track	E-26
Photo No. 91. 3-Year-Old Forward Facing Evenflo Medallion Belted, Forward Seat Track	E-27
Photo No. 92. 3-Year-Old Forward Facing Evenflo Medallion Belted, Middle Seat Track	E-27
Photo No. 93. 3-Year-Old Forward Facing Evenflo Medallion Belted, Rearward Seat Track	E-27
Photo No. 94. Unbelted 5 th Percentile Female Reactivation, Rearward Seat Track	E-27
Photo No. 95. 3-Year-Old Century Next Step Belted, Forward Seat Track	E-28
Photo No. 96. 3-Year-Old Century Next Step Belted, Middle Seat Track	E-28
Photo No. 97. 3-Year-Old Century Next Step Belted, Rearward Seat Track	E-28
Photo No. 98. 3-Year-Old Century Next Step Cinched With Harness, Forward Seat Track	E-28
Photo No. 99. 3-Year-Old Century Next Step Cinched With Harness, Middle Seat Track	E-29
Photo No. 100. 3-Year-Old Century Next Step Cinched With Harness, Rearward Seat Track	E-29
Photo No. 101. Unbelted 5 th Percentile Female Reactivation, Forward Seat Track	E-29
Photo No. 102. 3-Year-Old Cosco High Back Booster Belted, Forward Seat Track	E-30
Photo No. 103. 3-Year-Old Cosco High Back Booster Belted, Middle Seat Track	E-30

	<u>Page #</u>
Photo No. 104. 3-Year-Old Cosco High Back Booster Belted, Rearward Seat Track	E-30
Photo No. 105. 3-Year-Old Cosco High Back Booster Cinched With Harness, Forward Seat Track	E-30
Photo No. 106. 3-Year-Old Cosco High Back Booster Cinched With Harness, Middle Seat Track	E-31
Photo No. 107. 3-Year-Old Cosco High Back Booster Cinched With Harness, Rearward Seat Track	E-31
Photo No. 108. Unbelted 5 th Percentile Female Reactivation, Rearward Seat Track	E-31
Photo No. 109. 6-Year-Old Century Next Step Belted, Forward Seat Track	E-32
Photo No. 110. 6-Year-Old Century Next Step Belted, Middle Seat Track	E-32
Photo No. 111. 6-Year-Old Century Next Step Belted, Rearward Seat Track	E-32
Photo No. 112. Unbelted 5 th Percentile Female Reactivation, Middle Seat Track	E-32
Photo No. 113. 6-Year-Old Cosco High Back Booster Belted, Forward Seat Track	E-33
Photo No. 114. 6-Year-Old Cosco High Back Booster Belted, Middle Seat Track	E-33
Photo No. 115. 6-Year-Old Cosco High Back Booster Belted, Rearward Seat Track	E-33
Photo No. 116. Unbelted 5 th Percentile Female Reactivation, Rearward Seat Track	E-33
Photo No. 117. 6-Year-Old Evenflo Right Fit Belted, Forward Seat Track	E-34
Photo No. 118. 6-Year-Old Evenflo Right Fit Belted, Middle Seat Track	E-34
Photo No. 119. 6-Year-Old Evenflo Right Fit Belted, Rearward Seat Track	E-34
Photo No. 120. Unbelted 5 th Percentile Female Reactivation, Forward Seat Track	E-34
Photo No. 121. 3-Year-Old Unbelted, Forward Seat Track, Position 1	E-35
Photo No. 122. 3-Year-Old Unbelted, Forward Seat Track, Position 2	E-35
Photo No. 123. 3-Year-Old Unbelted, Forward Seat Track, Position 3	E-35
Photo No. 124. 3-Year-Old Unbelted, Forward Seat Track, Position 4	E-35
Photo No. 125. 3-Year-Old Unbelted, Forward Seat Track, Position 5	E-36
Photo No. 126. 3-Year-Old Unbelted, Forward Seat Track, Position 6	E-36
Photo No. 127. 3-Year-Old Unbelted, Forward Seat Track, Position 7	E-36
Photo No. 128. 3-Year-Old Unbelted, Middle Seat Track, Position 1	E-36
Photo No. 129. 3-Year-Old Unbelted, Middle Seat Track, Position 2	E-37
Photo No. 130. 3-Year-Old Unbelted, Middle Seat Track, Position 3	E-37
Photo No. 131. 3-Year-Old Unbelted, Middle Seat Track, Position 4	E-37
Photo No. 132. 3-Year-Old Unbelted, Middle Seat Track, Position 5	E-37
Photo No. 133. 3-Year-Old Unbelted, Middle Seat Track, Position 6	E-38
Photo No. 134. 3-Year-Old Unbelted, Middle Seat Track, Position 7	E-38
Photo No. 135. 3-Year-Old Unbelted, Rearward Seat Track, Position 1	E-38
Photo No. 136. 3-Year-Old Unbelted, Rearward Seat Track, Position 2	E-38
Photo No. 137. 3-Year-Old Unbelted, Rearward Seat Track, Position 3	E-39
Photo No. 138. 3-Year-Old Unbelted, Rearward Seat Track, Position 4	E-39

	<u>Page #</u>
Photo No. 139. 3-Year-Old Unbelted, Rearward Seat Track, Position 5	E-39
Photo No. 140. 3-Year-Old Unbelted, Rearward Seat Track, Position 6	E-39
Photo No. 141. 3-Year-Old Unbelted, Rearward Seat Track, Position 7	E-40
Photo No. 142. Unbelted 5 th Percentile Female Reactivation, Forward Seat Track	E-40
Photo No. 143. 6-Year-Old Unbelted, Forward Seat Track, Position 1	E-41
Photo No. 144. 6-Year-Old Unbelted, Forward Seat Track, Position 2	E-41
Photo No. 145. 6-Year-Old Unbelted, Forward Seat Track, Position 3	E-41
Photo No. 146. 6-Year-Old Unbelted, Forward Seat Track, Position 4	E-41
Photo No. 147. 6-Year-Old Unbelted, Middle Seat Track, Position 1	E-42
Photo No. 148. 6-Year-Old Unbelted, Middle Seat Track, Position 2	E-42
Photo No. 149. 6-Year-Old Unbelted, Middle Seat Track, Position 3	E-42
Photo No. 150. 6-Year-Old Unbelted, Middle Seat Track, Position 4	E-42
Photo No. 151. 6-Year-Old Unbelted, Rearward Seat Track, Position 1	E-43
Photo No. 152. 6-Year-Old Unbelted, Rearward Seat Track, Position 2	E-43
Photo No. 153. 6-Year-Old Unbelted, Rearward Seat Track, Position 3	E-43
Photo No. 154. 6-Year-Old Unbelted, Rearward Seat Track, Position 4	E-43
Photo No. 155. Unbelted 5 th Percentile Female Reactivation, Middle Seat Track	E-44



Cosco Dream Ride Car Bed Belted, Forward Seat Track



Cosco Dream Ride Car Bed Belted, Middle Seat Track



Cosco Dream Ride Car Bed Belted, Rearward Seat Track



Unbelted 5th Percentile Female Reactivation,
Forward Seat Track

DOT/NHTSA 208 Suppression Test - 2008 Ford Edge (C80202)

12 Month

Section B

Rear Facing CRS



Britax Handle With Care 191 Belted, Forward Seat Track



Britax Handle With Care 191 Belted, Middle Seat Track



Britax Handle With Care 191 Belted, Rearward Seat Track



Britax Handle With Care 191 Unbelted, Forward Seat Track

E-3



Britax Handle With Care 191 Unbelted, Middle Seat Track



Britax Handle With Care 191 Unbelted, Rearward Seat Track



Britax Handle With Care 191 Forward Facing Unbelted,
Forward Seat Track



Britax Handle With Care 191 Forward Facing Unbelted,
Middle Seat Track



Britax Handle With Care 191 Forward Facing Unbelted,
Rearward Seat Track



Unbelted 5th Percentile Female Reactivation,
Middle Seat Track



Evenflo First Choice 204 Belted, Forward Seat Track



Evenflo First Choice 204 Belted, Middle Seat Track



Evenflo First Choice 204 Belted, Rearward Seat Track



Evenflo First Choice 204 Unbelted, Forward Seat Track



Evenflo First Choice 204 Unbelted, Middle Seat Track



Evenflo First Choice 204 Unbelted, Rearward Seat Track



Evenflo First Choice 204 Forward Facing Unbelted,
Forward Seat Track



Evenflo First Choice 204 Forward Facing Unbelted,
Middle Seat Track



Evenflo First Choice 204 Forward Facing Unbelted,
Rearward Seat Track



Unbelted 5th Percentile Female Reactivation,
Rearward Seat Track



Graco Infant W/ Base Belted, Forward Seat Track



Graco Infant W/ Base Belted, Middle Seat Track



Graco Infant W/ Base Belted, Rearward Seat Track



Graco Infant W/ Base Unbelted, Forward Seat Track



Graco Infant W/ Base Unbelted, Middle Seat Track



Graco Infant W/ Base Unbelted, Rearward Seat Track



Graco Infant W/ Base Forward Facing Unbelted,
Forward Seat Track



Graco Infant W/ Base Forward Facing Unbelted,
Middle Seat Track

E-10



Graco Infant W/ Base Forward Facing Unbelted,
Rearward Seat Track



Graco Infant W/O Base Belted, Forward Seat Track



Graco Infant W/O Base Belted, Middle Seat Track



Graco Infant W/O Base Belted, Rearward Seat Track



Graco Infant W/O Base Unbelted, Forward Seat Track



Graco Infant W/O Base Unbelted, Middle Seat Track



Graco Infant W/O Base Unbelted, Rearward Seat Track



Graco Infant W/O Base Forward Facing Unbelted,
Forward Seat Track



Graco Infant W/O Base Forward Facing Unbelted,
Middle Seat Track



Graco Infant W/O Base Forward Facing Unbelted,
Rearward Seat Track



Unbelted 5th Percentile Female Reactivation,
Middle Seat Track



Britax Roundabout 161 Forward Facing Belted,
Forward Seat Track



Britax Roundabout 161 Forward Facing Belted,
Middle Seat Track



Britax Roundabout 161 Forward Facing Belted,
Rearward Seat Track



Britax Roundabout 161 Forward Facing Unbelted,
Forward Seat Track



Britax Roundabout 161 Forward Facing Unbelted,
Middle Seat Track



Britax Roundabout 161 Forward Facing Unbelted,
Rearward Seat Track



Britax Roundabout 161 Rear Facing Belted,
Forward Seat Track



Britax Roundabout 161 Rear Facing Belted,
Middle Seat Track



Britax Roundabout 161 Rear Facing Belted,
Rearward Seat Track



Britax Roundabout 161 Rear Facing Unbelted,
Forward Seat Track



Britax Roundabout 161 Rear Facing Unbelted,
Middle Seat Track



Britax Roundabout 161 Rear Facing Unbelted,
Rearward Seat Track



Unbelted 5th Percentile Female Reactivation,
Forward Seat Track



Century Encore Forward Facing Belted, Forward Seat Track



Century Encore Forward Facing Belted, Middle Seat Track



Century Encore Forward Facing Belted, Rearward Seat Track



Century Encore Forward Facing Unbelted, Forward Seat Track



Century Encore Forward Facing Unbelted, Middle Seat Track



Century Encore Forward Facing Unbelted, Rearward Seat Track



Century Encore Rear Facing Belted, Forward Seat Track



Century Encore Rear Facing Belted, Middle Seat Track



Century Encore Rear Facing Belted, Rearward Seat Track



Century Encore Rear Facing Unbelted, Forward Seat Track



Century Encore Rear Facing Unbelted, Middle Seat Track



Century Encore Rear Facing Unbelted, Rearward Seat Track

DOT/NHTSA 208 Suppression Test - 2008 Ford Edge (C80202)
12 Month Section C

Forward Facing Convertible CRS



Unbelted 5th Percentile Female Reactivation,
Middle Seat Track



Evenflo Medallion 254 Forward Facing Belted,
Forward Seat Track



Evenflo Medallion 254 Forward Facing Belted,
Middle Seat Track



Evenflo Medallion 254 Forward Facing Belted,
Rearward Seat Track



Evenflo Medallion 254 Forward Facing Unbelted,
Forward Seat Track



Evenflo Medallion 254 Forward Facing Unbelted,
Middle Seat Track



Evenflo Medallion 254 Forward Facing Unbelted,
Rearward Seat Track



Evenflo Medallion 254 Rear Facing Belted,
Forward Seat Track



Evenflo Medallion 254 Rear Facing Belted,
Middle Seat Track



Evenflo Medallion 254 Rear Facing Belted,
Rearward Seat Track



Evenflo Medallion 254 Rear Facing Unbelted,
Forward Seat Track



Evenflo Medallion 254 Rear Facing Unbelted,
Middle Seat Track



Evenflo Medallion 254 Rear Facing Unbelted,
Rearward Seat Track



Unbelted 5th Percentile Female Reactivation,
Rearward Seat Track



3-Year-Old Forward Facing Britax Roundabout Belted,
Forward Seat Track



3-Year-Old Forward Facing Britax Roundabout Belted,
Middle Seat Track



3-Year-Old Forward Facing Britax Roundabout Belted,
Rearward Seat Track



Unbelted 5th Percentile Female Reactivation,
Middle Seat Track



3-Year-Old Forward Facing Century Encore Belted,
Forward Seat Track



3-Year-Old Forward Facing Century Encore Belted,
Middle Seat Track



3-Year-Old Forward Facing Century Encore Belted,
Rearward Seat Track



Unbelted 5th Percentile Female Reactivation,
Forward Seat Track



3-Year-Old Forward Facing Evenflo Medallion Belted,
Forward Seat Track



3-Year-Old Forward Facing Evenflo Medallion Belted,
Middle Seat Track



3-Year-Old Forward Facing Evenflo Medallion Belted,
Rearward Seat Track



Unbelted 5th Percentile Female Reactivation,
Rearward Seat Track

DOT/NHTSA 208 Suppression Test - 2008 Ford Edge (C80202)

3 Year Old

Section D

Forward Facing Toddler

Belt Positioning Booster Seat



3-Year-Old Century Next Step Belted, Forward Seat Track



3-Year-Old Century Next Step Belted, Middle Seat Track



3-Year-Old Century Next Step Belted, Rearward Seat Track



3-Year-Old Century Next Step Cinched With Harness,
Forward Seat Track

DOT/NHTSA 208 Suppression Test - 2008 Ford Edge (C80202)

3 Year Old

Section D

Forward Facing Toddler

Belt Positioning Booster Seat



3-Year-Old Century Next Step Cinched With Harness,
Middle Seat Track



3-Year-Old Century Next Step Cinched With Harness,
Rearward Seat Track



Unbelted 5th Percentile Female Reactivation,
Forward Seat Track

DOT/NHTSA 208 Suppression Test - 2008 Ford Edge (C80202)

3 Year Old

Section D

Forward Facing Toddler

Belt Positioning Booster Seat



3-Year-Old Cosco High Back Booster Belted,
Forward Seat Track



3-Year-Old Cosco High Back Booster Belted,
Middle Seat Track



3-Year-Old Cosco High Back Booster Belted,
Rearward Seat Track



3-Year-Old Cosco High Back Booster Cinched With Harness,
Forward Seat Track

DOT/NHTSA 208 Suppression Test - 2008 Ford Edge (C80202)

3 Year Old

Section D

Forward Facing Toddler

Belt Positioning Booster Seat



3-Year-Old Cosco High Back Booster Cinched With Harness,
Middle Seat Track



3-Year-Old Cosco High Back Booster Cinched With Harness,
Rearward Seat Track



Unbelted 5th Percentile Female Reactivation,
Rearward Seat Track

DOT/NHTSA 208 Suppression Test - 2008 Ford Edge (C80202)

6 Year Old

Section D

Forward Facing Toddler

Belt Positioning Booster Seat



6-Year-Old Century Next Step Belted, Forward Seat Track



6-Year-Old Century Next Step Belted, Middle Seat Track



6-Year-Old Century Next Step Belted, Rearward Seat Track



Unbelted 5th Percentile Female Reactivation, Middle Seat Track

DOT/NHTSA 208 Suppression Test - 2008 Ford Edge (C80202)

6 Year Old

Section D

Forward Facing Toddler

Belt Positioning Booster Seat



6-Year-Old Cosco High Back Booster Belted, Forward Seat Track



6-Year-Old Cosco High Back Booster Belted, Middle Seat Track



6-Year-Old Cosco High Back Booster Belted, Rearward Seat Track



Unbelted 5th Percentile Female Reactivation, Rearward Seat Track

DOT/NHTSA 208 Suppression Test - 2008 Ford Edge (C80202)

6 Year Old

Section D

Forward Facing Toddler

Belt Positioning Booster Seat



6-Year-Old Evenflo Right Fit Belted, Forward Seat Track



6-Year-Old Evenflo Right Fit Belted, Middle Seat Track



6-Year-Old Evenflo Right Fit Belted, Rearward Seat Track



Unbelted 5th Percentile Female Reactivation, Forward Seat Track

DOT/NHTSA 208 Suppression Test - 2008 Ford Edge (C80202)

3 Year Old

No CRS



3-Year-Old Unbelted, Forward Seat Track, Position 1



3-Year-Old Unbelted, Forward Seat Track, Position 2



3-Year-Old Unbelted, Forward Seat Track, Position 3



3-Year-Old Unbelted, Forward Seat Track, Position 4

DOT/NHTSA 208 Suppression Test - 2008 Ford Edge (C80202)
3 Year Old No CRS



3-Year-Old Unbelted, Forward Seat Track, Position 5



3-Year-Old Unbelted, Forward Seat Track, Position 6



3-Year-Old Unbelted, Forward Seat Track, Position 7



3-Year-Old Unbelted, Middle Seat Track, Position 1

DOT/NHTSA 208 Suppression Test - 2008 Ford Edge (C80202)
3 Year Old No CRS

E-37



3-Year-Old Unbelted, Middle Seat Track, Position 2



3-Year-Old Unbelted, Middle Seat Track, Position 3



3-Year-Old Unbelted, Middle Seat Track, Position 4



3-Year-Old Unbelted, Middle Seat Track, Position 5

DOT/NHTSA 208 Suppression Test - 2008 Ford Edge (C80202)
3 Year Old No CRS

E-38



3-Year-Old Unbelted, Middle Seat Track, Position 6



3-Year-Old Unbelted, Middle Seat Track, Position 7



3-Year-Old Unbelted, Rearward Seat Track, Position 1



3-Year-Old Unbelted, Rearward Seat Track, Position 2

DOT/NHTSA 208 Suppression Test - 2008 Ford Edge (C80202)

3 Year Old

No CRS



3-Year-Old Unbelted, Rearward Seat Track, Position 3



3-Year-Old Unbelted, Rearward Seat Track, Position 4



3-Year-Old Unbelted, Rearward Seat Track, Position 5



3-Year-Old Unbelted, Rearward Seat Track, Position 6

DOT/NHTSA 208 Suppression Test - 2008 Ford Edge (C80202)
3 Year Old No CRS



3-Year-Old Unbelted, Rearward Seat Track, Position 7



Unbelted 5th Percentile Female Reactivation,
Forward Seat Track

DOT/NHTSA 208 Suppression Test - 2008 Ford Edge (C80202)
6 Year Old No CRS



6-Year-Old Unbelted, Forward Seat Track, Position 1



6-Year-Old Unbelted, Forward Seat Track, Position 2



6-Year-Old Unbelted, Forward Seat Track, Position 3



6-Year-Old Unbelted, Forward Seat Track, Position 4

DOT/NHTSA 208 Suppression Test - 2008 Ford Edge (C80202)

6 Year Old

No CRS



6-Year-Old Unbelted, Middle Seat Track, Position 1



6-Year-Old Unbelted, Middle Seat Track, Position 2

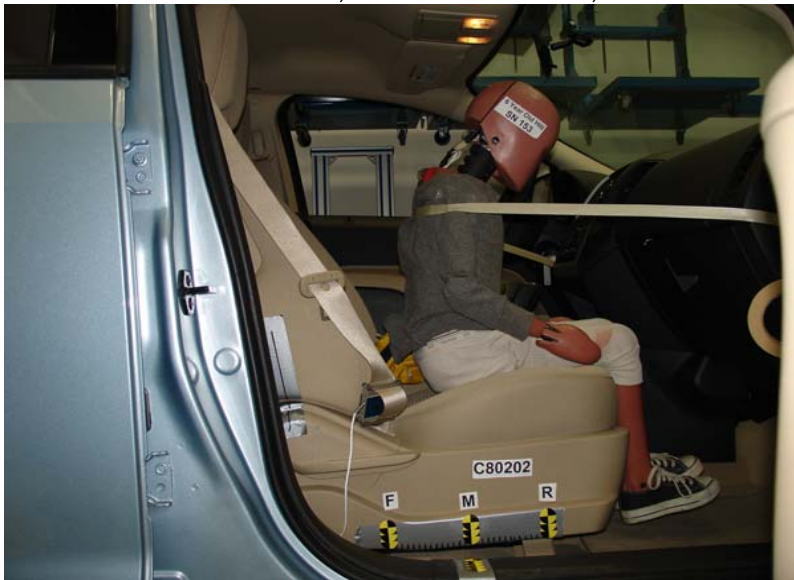

6-Year-Old Unbelted, Middle Seat Track, Position 3



6-Year-Old Unbelted, Middle Seat Track, Position 4

DOT/NHTSA 208 Suppression Test - 2008 Ford Edge (C80202)

6 Year Old

No CRS



6-Year-Old Unbelted, Rearward Seat Track, Position 1



6-Year-Old Unbelted, Rearward Seat Track, Position 2



6-Year-Old Unbelted, Rearward Seat Track, Position 3

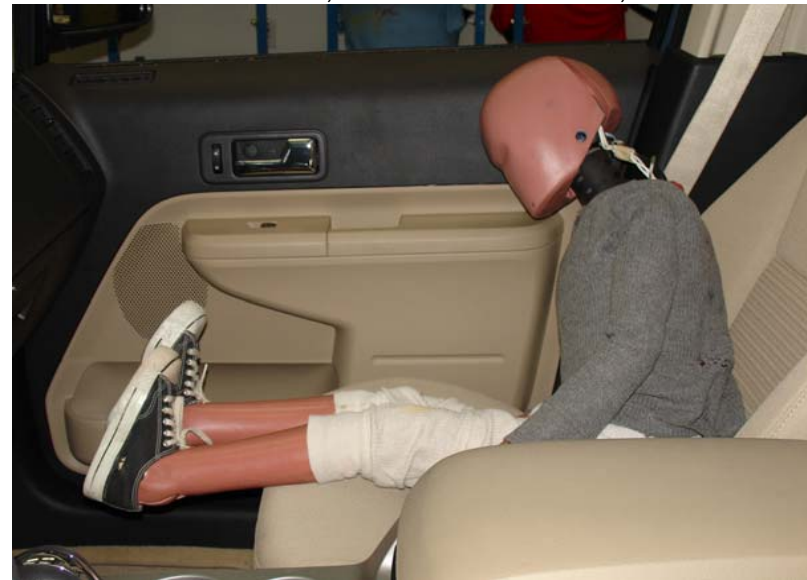

6-Year-Old Unbelted, Rearward Seat Track, Position 4

DOT/NHTSA 208 Suppression Test - 2008 Ford Edge (C80202)
6 Year Old No CRS

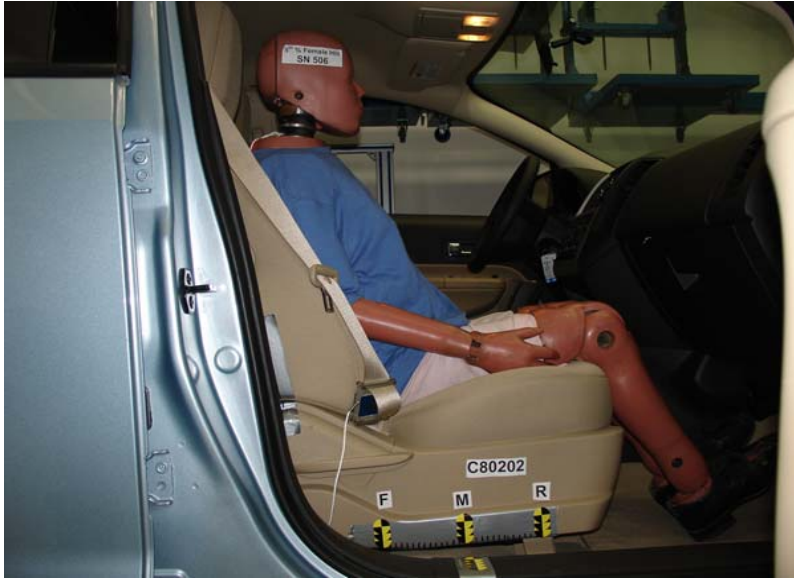

Unbelted 5th Percentile Female Reactivation,
Middle Seat Track

APPENDIX F
INSTRUMENTATION CALIBRATION

INSTRUMENTS FOR DRIVER DUMMY NO. 124

	SERIAL NO.	MANUFACTURER	CALIBRATION DATE
Head X	P52176	Endevco	02/19/08
Head Y	P52175	Endevco	02/19/08
Head Z	P52177	Endevco	02/19/08
Neck Load Cell	376	Denton	06/25/08
Chest X	P22805	Endevco	02/19/08
Chest Y	P52148	Endevco	02/19/08
Chest Z	P52147	Endevco	02/19/08
Chest Displacement	124	Servo	02/12/08
Left Femur Load Cell	1359	Denton	02/04/08
Right Femur Load Cell	1360	Denton	02/04/08

INSTRUMENTS FOR PASSENGER DUMMY NO. 125

	SERIAL NO.	MANUFACTURER	CALIBRATION DATE
Head X	P49490	Endevco	02/19/08
Head Y	P49487	Endevco	02/19/08
Head Z	P49225	Endevco	02/19/08
Neck Load Cell	606	Denton	01/30/08
Chest X	P48386	Endevco	02/19/08
Chest Y	P48388	Endevco	02/19/08
Chest Z	P48387	Endevco	02/19/08
Chest Displacement	125	Servo	02/12/08
Left Femur Load Cell	1362	Denton	04/15/08
Right Femur Load Cell	1361	Denton	04/15/08

INSTRUMENTS FOR LOW RISK 5TH FEMALE DUMMY NO. 507 (P1 & P2)

	SERIAL NO.	MANUFACTURER	CALIBRATION DATE
Head X	P47091	Endevco	01/24/08
Head Y	P47118	Endevco	01/24/08
Head Z	P47304	Endevco	01/24/08
Neck Load Cell	253	Denton	03/28/08
Chest X	P47083	Endevco	01/24/08
Chest Y	P47085	Endevco	01/24/08
Chest Z	P47092	Endevco	01/24/08
Chest Displacement	507	Servo	02/04/08
Left Femur Load Cell	992	Denton	04/15/08
Right Femur Load Cell	988	Denton	04/15/08

VEHICLE INSTRUMENTS

	SERIAL NO.	MANUFACTURER	CALIBRATION DATE
Left Rear Seat Crossmember X	G29-X12	Entran	06/09/08
Right Rear Seat Crossmember X	G29-X58	Entran	06/09/08
Top of Engine X	G06-X10	Entran	05/23/08
Bottom of Engine X	P24154	Endevco	02/06/08
Left Brake Caliper X	P27001	Endevco	04/11/08
Right Brake Caliper X	P28960	Endevco	04/28/08
Instrument Panel X	B05-J04	Entran	02/19/08
Trunk Z	F29-X18	Entran	03/07/08