

**REPORT NUMBER: NCAPSIDE-MGA-2008-015**

**NEW CAR ASSESSMENT PROGRAM  
SIDE IMPACT TEST**

**CHRYSLER LLC  
2009 DODGE JOURNEY SE  
NHTSA NUMBER: M90301**

**PREPARED BY:  
MGA RESEARCH CORPORATION  
5000 WARREN ROAD  
BURLINGTON, WI 53105**



**Test Date: March 26, 2008**

**Report Date: April 14, 2008**

**FINAL REPORT**

**PREPARED FOR:  
U.S. DEPARTMENT OF TRANSPORTATION  
NATIONAL HIGHWAY TRAFFIC SAFETY ADMINISTRATION  
RULEMAKING  
OFFICE OF CRASHWORTHINESS STANDARDS  
1200 NEW JERSEY AVENUE, SE, ROOM W43-410  
WASHINGTON, D.C. 20590**

This final test report was prepared for the U.S. Department of Transportation, National Highway Traffic Safety Administration, in response to Contract Number DTNH22-03-D-12005.

This publication is distributed by the U.S. Department of Transportation, National Highway Traffic Safety Administration, in the interest of information exchange. The opinions, findings and conclusions expressed in this publication are those of the author(s) and not necessarily those of the Department of Transportation or the National Highway Traffic Safety Administration. The United States Government assumes no liability for its contents or use thereof. If trade or manufacturers' names or products are mentioned it is only because they are considered essential to the object of the publication and should not be construed as an endorsement. The United States Government does not endorse products or manufacturers.

Prepared by:  Date: 4/14/08  
Ben Fischer, Project Engineer

Reviewed by:  Date: 4/14/08  
David Winkelbauer, Facility Director

**Technical Report Documentation Page**

1. Report No. NCAPSIDE-MGA-2008-015		2. Government Accession No.		3. Recipient's Catalog No.	
4. Title and Subtitle Final Report of New Car Assessment Program Side Impact Testing of 2009 Dodge Journey SE NHTSA No.: M90301				5. Report Date April 14, 2008	
				6. Performing Organization Code MGA	
7. Author(s) Ben Fischer, Project Engineer				8. Performing Organization Report No. NCAPSIDE-MGA-2008-015	
9. Performing Organization Name and Address MGA Research Corporation 5000 Warren Road Burlington, WI 53105				10. Work Unit No.	
				11. Contract or Grant No. DTNH22-03-D-12005	
12. Sponsoring Agency Name and Address U.S. Department of Transportation National Highway Traffic Safety Administration Rulemaking, Office of Crashworthiness Standards 1200 New Jersey Ave, SE, Room W43-410, NVS-111 Washington, D.C. 20590				13. Type of Report and Period Covered: Final Report 3/26/2008 to 4/14/2008	
				14. Sponsoring Agency Code NVS-111	
15. Supplementary Notes					
16. Abstract A 55/28 km/h 90° Moving Deformable Barrier NCAP side impact was conducted on the subject 2009 Dodge Journey SE to obtain new car assessment and research data indicant of FMVSS No. 214D performance. The test was conducted at MGA Research Corporation, in Burlington, Wisconsin, on March 26, 2008. The impact velocity of the Moving Deformable Barrier (MDB) was 62.4 km/h, and the ambient temperature at the struck side (drivers) of the vehicle was 21°C. The target vehicle's maximum post test static crush was 181 mm at level 3. The test vehicle's occupant performance is as follows:					
		<u>DRIVER</u>		<u>PASS.</u>	
Left Upper Rib (LUR) Accel., g		20.2		33.0	
Left Lower Rib (LLR) Accel., g		23.5		33.6	
Lower Spine (T <sub>12</sub> ) Accel., g		24.9		40.1	
Thoracic Trauma Index (TTI)		24		37	
Pelvis (PEV) Accel., g		36.2		42.2	
HIC		116		109	
The driver door became unlatched. The left rear door on the struck side of the vehicle did not separate from the body at the hinges or latches and the opposite doors did not open during the side impact event.					
17. Key Words New Car Assessment Program (NCAP) Side Impact Side Impact Hybrid III Dummy (SID/HIII) Occupant Side Impact Protection				18. Distribution Statement Copies of this report are available from: National Highway Traffic Safety Adm. Technical Ref. Division, 1200 New Jersey Ave, SE Washington, D.C. 20590	
19. Security Classif. (of this report) Unclassified		20. Security Classif. (of this page) Unclassified		21. No. of Pages 138	
				22. Price	

Form DOT F1700.7 (8-72)

## TABLE OF CONTENTS

<u>Section</u>		<u>Page No.</u>
1	Purpose and Test Procedure	1
2	Summary of NCAP Side Impact Test	2
<u>Data Sheet No.</u>		<u>Page No.</u>
1	General Test and Vehicle Parameter Data	4
2	Test Vehicle Tire Information	6
3	Test Vehicle Information	7
4	Moving Deformable Barrier (MDB) Summary of Results	9
5	Post Test Observations	10
6	Vehicle Pre-Test and Post Test Measurements	11
7	SID/HIII Longitudinal Clearance Dimensions	12
8	SID/HIII Lateral Clearance Dimensions	13
9	Vehicle Side Measurements	14
10	Vehicle Exterior Crush Profiles	15
11	Vehicle Damage Profile Distances	17
12	Deformable Barrier Honeycomb Face Static Crush	18
13	Vehicle Accelerometer Locations	19
14	MDB Accelerometer Locations	20
15	Vehicle Structural Measurements	21
16	High Speed Camera Locations and Data	22
17	Summary of FMVSS 301 Data	23
<u>Appendix</u>		
A	Photographs	A
B	SID/HIII Response Data Traces	B
C	Dummy Calibration Data	C

**SECTION 1**  
**PURPOSE AND TEST PROCEDURE**

**PURPOSE**

This side impact test was conducted as part of the FY' 2008 test program sponsored by the National Highway Traffic Safety Administration (NHTSA), under Contract No. DTNH22-03-D-12005. The purpose of this test was to evaluate side impact protection in a 2009 Dodge Journey SE manufactured by Chrysler LLC.

**TEST PROCEDURE**

The side impact test was conducted in accordance with the Laboratory Test Procedure for New Car Assessment Program Side Impact Testing dated November 2002 and the corresponding MGA Research Corporation Test Procedure MGA-NHTSA5. The procedures for receiving, inspection, testing, and reporting of test results are described in the test procedures and are not repeated in this report.

MGA does not endorse or certify products. The manufacturer's name appears solely for identification purposes.

## SECTION 2

### SUMMARY OF NCAP SIDE IMPACT TEST

A model year 2009 Dodge Journey SE was impacted on the left (driver's) side by a Moving Deformable Barrier (MDB) which was moving forward in a 27° crabbed position to the tow road guidance system at a velocity of 62.4 km/h. The specified impact velocity range is from 61.1 to 62.7 km/h. The test (target) vehicle was stationary and positioned 63° to the line of forward motion. The weight of the vehicle as tested was 1928.7 kg and the test weight of the MDB was 1360.8 kg. The test was conducted at MGA Research Corporation in Burlington, Wisconsin, on March 26, 2008.

One (1) real-time motion picture camera and nine (9) high-speed motion picture cameras were used to document the impact event. The pre-test and post-test conditions were recorded by one (1) real-time motion picture camera. Camera locations and pertinent camera information are documented in the data sheets. Pre- and post-test photographs of the vehicle and Side Impact Dummies (SID/HIIIs) can be found in Appendix A. Two 50th percentile adult male SID/HIIIs were placed in the driver and left rear passenger designated seating positions according to instructions specified in the Laboratory Test Procedure for New Car Assessment Program Side Impact Testing dated November 2002. Each SID/HIII was instrumented in the following locations:

- Left Upper Rib (LUR) uni-axial accelerometer (Y-axis primary and redundant)
- Left Lower Rib (LLR) uni-axial accelerometer (Y-axis primary and redundant)
- Lower Thoracic Spine (T12) uni-axial accelerometer (Y-axis primary and redundant)
- Pelvic (PEV) section uni-axial accelerometer (Y-axis primary and redundant)
- Head Center of Gravity (CG) tri-axial accelerometers (X, Y and Z axes primary and redundant)
- Upper Neck load cell (Fx, Fy, Fz, Mx, My, Mz)

The test vehicle was instrumented with twenty-one (21) structural accelerometers and the MDB was instrumented with five (5) accelerometers and two (2) contact switches on the bumper to compare left side to right side bumper impact timing. All data channels were recorded with a fully self contained on-board DTS TDAS Pro Data Acquisition System. The data was digitally sampled at 10,000 samples per second and processed per Appendix V of the Test Procedure.

#### **2.2 GENERAL COMMENTS**

The test vehicle sustained a maximum static crush of 181 mm at level 3, 750 mm rearward of the vertical impact point. The driver and passenger SID/HIIIs, Serial Nos. 904 and 271 respectively, were calibrated just prior to this test.

Appendix A contains the still photograph prints. Appendix B contains the SID/HIII response data traces. Appendix C contains the dummy calibration data.

The occupant data is summarized below:

ATD position	HIC	T <sup>1</sup>	T <sup>2</sup>	TTI (G's)	Peak Pelvis (G's)
Driver	116	53.1	86.3	24	36.2
Passenger	109	44.9	80.9	37	42.2

#### SUPPLEMENTAL RESTRAINT SYSTEM INFORMATION

Restraint Information	Left Front (Driver)		Left Rear (Passenger)	
	Installed	Deployed	Installed	Deployed
Front Airbag	Yes	No	No	
Side Torso Airbag	Yes	Yes	No	
Curtain Airbag	Yes	Yes	Yes	Yes

The test data can be found on the NHTSA website at [www.nhtsa.dot.gov](http://www.nhtsa.dot.gov).

#### TEST NOTES

There was no valid data collected for:

- Left Mid B-Post Y
- Vehicle CG X, Y, Z after 130 msec.
- MDB CG X after 120 msec.
- MDB CG Z after 30 msec.
- MDB Rear X, Y after 115 msec.

**DATA SHEET NO. 1**

**GENERAL TEST AND VEHICLE PARAMETER DATA**

Test Vehicle: 2009 Dodge Journey SE  
 Test Program: NCAP Side Impact

NHTSA No. M90301  
 Test Date: 3/26/2008

**TEST VEHICLE INFORMATION**

Make	Dodge
Model	Journey
Body Style	MPV
NHTSA No.	M90301
VIN	3D4GG47B69T134717
Color	Stone White Clearcoat
Delivery Date	3/04/2008
Odometer Reading (mile)	118
Dealer	Boucher Fleet Group
Transmission	Automatic
Final Drive	Front
Number of Cylinders	4
Engine Displacement (L)	2.4
Engine Placement	Lateral
Automatic Door Locks (ADL)	Yes
Owner's Manual Details Instructions on Disabling ADLs	No

**TEST VEHICLE OPTIONS**

Driver Front Airbag	Yes
Driver Side Curtain Airbag	Yes
Driver Side Torso Airbag	Yes
Rear Passenger Side Curtain Airbag	Yes
Rear Passenger Side Torso Airbag	No
Power Steering	Yes
Power Door Locks	Yes
Tilt Wheel	Yes
Anti-lock Brakes	Yes
Traction Control	Yes
All Wheel Drive	No
Power Seats	No
Pretensioners	Yes
Load Limiters	Yes
Bucket Seats	Yes

**DATA FROM CERTIFICATION LABEL**

Manufactured By	Chrysler LLC
Date of Manufacture	1-08

GVWR (kg)	2271
GAWR Front (kg)	1248
GAWR Rear (kg)	1316

Measured Parameter	Front	Rear	Third	Total
Type of Seats	Bucket	Bench		
Number Of Occupants	2	3		5
Capacity Wt. (VCW) (kg)				408
Cargo Wt. (RCLW) (kg)				68

**DATA SHEET NO. 1 (continued)**

**GENERAL TEST AND VEHICLE PARAMETER DATA**

Test Vehicle: 2009 Dodge Journey SE  
 Test Program: NCAP Side Impact

NHTSA No. M90301  
 Test Date: 3/26/2008

**TEST VEHICLE WEIGHTS**

	Units	As Delivered (UVW) (Axle)			As Tested (ATW) (Axle)		
		Front	Rear	Total	Front	Rear	Total
Left	kg	498.5	373.8		550.2	477.2	
Right	kg	463.1	370.6		464.0	437.3	
Ratio	%	56.4	43.6		52.6	47.4	
Totals	kg	961.6	744.4	1706.0	1014.2	914.5	1928.7

**TARGET TEST WEIGHT CALCULATION**

Measured Parameter	Units	Value
Total Delivered Weight (UVW)	kg	1706.0
Weight of 2 P572M ATDs	kg	161.5
Rated Cargo/Luggage Weight (RCLW)	kg	68
Calculated Vehicle Target Weight (TVTW)	kg	1935.5

\* Actual As Tested Weight (ATW) will be TVTW -5/-10 kg

Weight of Ballast in Spare Tire Well: 49 kg

**TEST VEHICLE ATTITUDES AND CG**

	Units	LF	RF	LR	RR	CG (aft of front axle)
As Delivered	mm	810	810	810	813	1261
As Tested	mm	798	806	781	788	1371
Fully Loaded	mm	794	804	772	783	

**TEST VEHICLE VERTICAL IMPACT LINE DATA**

Measurement Description	Units	Value
Test Vehicle Wheel Base	mm	2891
Target Impact Point Aft of Front Axle	mm	506
Actual Impact Point Aft of Front Axle	mm	511



**DATA SHEET NO. 3**  
**TEST VEHICLE INFORMATION**

Test Vehicle: 2009 Dodge Journey SE  
Test Program: NCAP Side Impact

NHTSA No. M90301  
Test Date: 3/26/2008

**NORMAL DESIGN RIDING POSITION**

The driver and passenger seat back is positioned to the manufacturer's designated angle. The procedure is as follows: Set the driver's seat back angle at 19.4 degrees (measured from upright position). Set the left rear passenger's seat back angle at 21.0 degrees (measured from upright position).

Driver seat back angle: 9.7 degrees from headrest post

Passenger seat back angle: 20.3 degrees from upright position

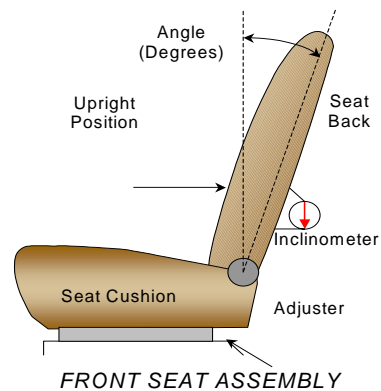

**SEAT FORE/AFT POSITIONS**

	Total Fore/Aft Travel	Placed in position #
Driver Seat	312 mm	156 mm
Rear Seat	120 mm	60 mm

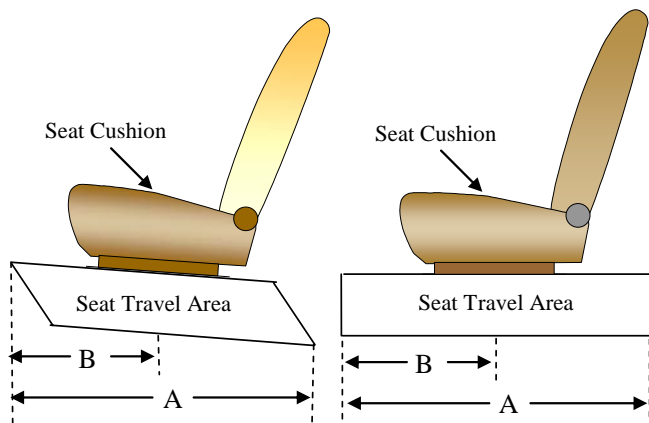

## DATA SHEET NO. 3 (CONTINUED)

### TEST VEHICLE INFORMATION

Test Vehicle: 2009 Dodge Journey SE  
 Test Program: NCAP Side Impact

NHTSA No. M90301  
 Test Date: 3/26/2008

### FUEL TANK CAPACITY

	Liters
Usable Capacity of "Standard Tank"	75.7
Usable Capacity of "Optional" Tank	
92-94% of Usable Capacity	69.6 to 71.2
Actual Amount of Solvent used	70.4
1/3 of Usable Capacity	25.2

The test vehicle is equipped with an electric fuel pump. The fuel pump runs during normal vehicle operation. The pump must see a minimal engine speed of 400 rpm in order to activate. (The pump will prime for 2 seconds at key on also). Pump will turn off if airbag deployment signal is detected.

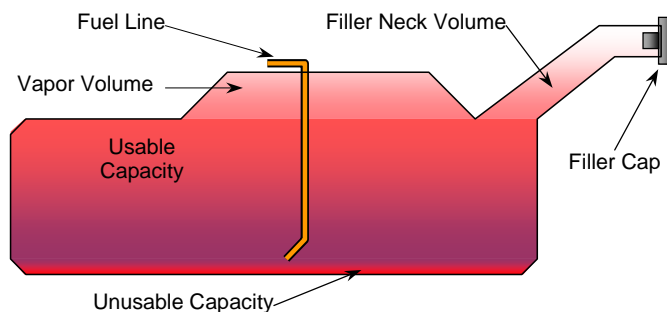

VEHICLE FUEL TANK ASSEMBLY

### STEERING COLUMN ADJUSTMENT

Steering wheel and column adjustments are made so that the steering wheel hub is at the geometric center of the locus it describes when moved through its full range of motion. An aluminum plate is placed across the rim of the steering wheel, an inclinometer is placed on the plate and the angle is measured.

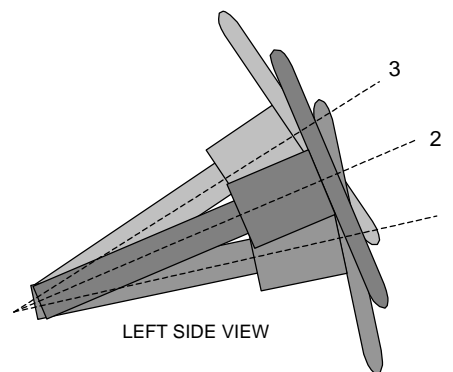

STEERING COLUMN ASSEMBLY

### STEERING COLUMN POSITION

	Fore/Aft (mm)	Degrees
Lowermost position No. 1	0	64.0
Geometric center position No. 2	22 mm	67.2
Uppermost position No. 3	44 mm	70.5

## DATA SHEET NO. 4

### MOVING DEFORMABLE BARRIER (MDB) SUMMARY OF RESULTS

Test Vehicle: 2009 Dodge Journey SE  
Test Program: NCAP Side Impact

NHTSA No. M90301  
Test Date: 3/26/2008

#### MDB SPECIFICATIONS

Measurement Description	Length (mm)
Overall Width of Framework Carriage	1252
Overall Length Including Honeycomb Face	4115
Wheel base of Framework Carriage	2588
C.G. Location aft of Front Axle	1101

#### MDB WEIGHTS

	Units	Front Axle	Rear Axle	Total
Left	kg	473.5	219.5	
Right	kg	308.3	359.5	
Ratio	%	57.5	42.5	
Totals	kg	781.8	579.0	1360.8

#### SPEED AND IMPACT ANGLE DATA

Measured Parameter	Units	Requirement	Value
Trap No. 1 Velocity (Primary)	km/h	61.1 to 62.7	62.4
Trap No. 2 Velocity (Redundant)	km/h	61.1 to 62.7	62.6
MDB CL to Target Vehicle CL	degrees	88.5 to 91.5	89.8

#### POST TEST OBSERVATIONS MDB LEFT EDGE IMPACT POINT DATA

Measured Parameter	Units	Requirement	Value
Horizontal Offset	mm	+/- 50	5 rearward
Vertical Offset	mm	+/-20	2 up

**DATA SHEET NO. 5**

**POST TEST OBSERVATIONS**

Test Vehicle: 2009 Dodge Journey SE  
 Test Program: NCAP Side Impact

NHTSA No. M90301  
 Test Date: 3/26/2008

**TEST DUMMY INFORMATION AND CONTACT POINTS**

Description	Front Seat SID/HIII	Rear Seat SID/HIII
Dummy Type / Serial No.	SID HIII / 904	SID HIII / 271
Head Contact	Curtain Airbag, Headrest	Curtain Airbag, Headrest
Upper Torso Contact	Side Airbag	Door Panel
Lower Torso Contact	Door Panel	Door Panel
Left Knee Contact	Door Panel	Door Panel
Right Knee Contact	Left Knee	Left Knee

**POST TEST DOOR OPENING AND SEAT TRACK INFORMATION**

Description	Front	Rear
Locked/Unlocked Doors	Struck side doors were locked	Struck side doors were locked
Left Side Door Opening	Door became unlatched, but the opening was less than 6 inches.	Door remained closed and latched
Right Side Door Opening	Door remained closed and latched; Door opened without tools	Door remained closed and latched; Door opened without tools
Seat Movement	0	0
Seat Back Failure	None	None

**POST TEST STRUCTURAL OBSERVATIONS**

Critical Areas of Performance	Observations and Conclusions
Pillar Performance	No Separation
Sill Separation	None
Windshield Damage	None
Window Damage	Left Rear Window Broke
Other Notable Effects	None

**SUPPLEMENTAL RESTRAINT SYSTEM INFORMATION**

Restraint Information	Left Front (Driver)		Left Rear (Passenger)	
	Installed	Deployed	Installed	Deployed
Front Airbag	Yes	No	No	
Side Torso Airbag	Yes	Yes	No	
Curtain Airbag	Yes	Yes	Yes	Yes

## DATA SHEET NO. 6

### VEHICLE PRE-TEST AND POST-TEST MEASUREMENTS

Test Vehicle: 2009 Dodge Journey SE  
 Test Program: NCAP Side Impact

NHTSA No. M90301  
 Test Date: 3/26/2008

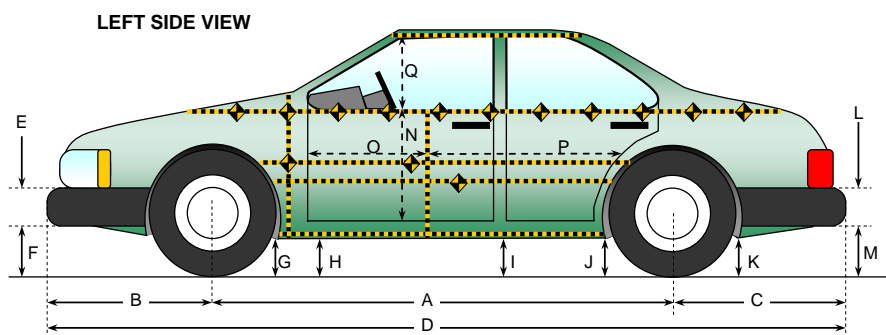

All Measurements in mm

Code	Measurement Description	Pre-Test	Post-Test	Difference
A	Wheelbase	2891	2893	2
B	Front Axle to FSOV	993	993	0
C	Rear Axle to RSOV	982	982	0
D	Total Length at Centerline	4866	4868	2
E	Front Bumper Thickness	140	140	0
F	Front Bumper Bottom to Ground	264	261	-3
G	Sill Height at Front Wheel Well	217	216	-1
H	Sill Height at Front Door Leading Edge	215	215	0
I	Sill Height at "B" Pillar	224	224	0
J1	Sill Height at Rear Wheel Well	234	235	1
J2	Pinch Weld Height at Rear Wheel Well	232	230	-2
K	Sill Height Aft of Rear Wheel Well	255	255	0
L	Rear Bumper Thickness	221	221	0
M	Rear Bumper Bottom to Ground	317	317	0
N	Sill Height to Window Bottom Sill	801	745	-56
O	Front Door Leading Edge to Impact CL	818	747	-71
P	Rear Door Trailing Edge to Impact CL	1345	1241	-104
Q	Front Window Opening	425	423	-2
R	Right Side Length	3852	3860	8
S	Left Side Length	3852	3845	-7
T	Vehicle Width at "B" Post	1833	1784	-49

**DATA SHEET NO. 7**  
**SID/HIII LONGITUDINAL CLEARANCE DIMENSIONS**

Test Vehicle: 2009 Dodge Journey SE  
 Test Program: NCAP Side Impact

NHTSA No. M90301  
 Test Date: 3/26/2008

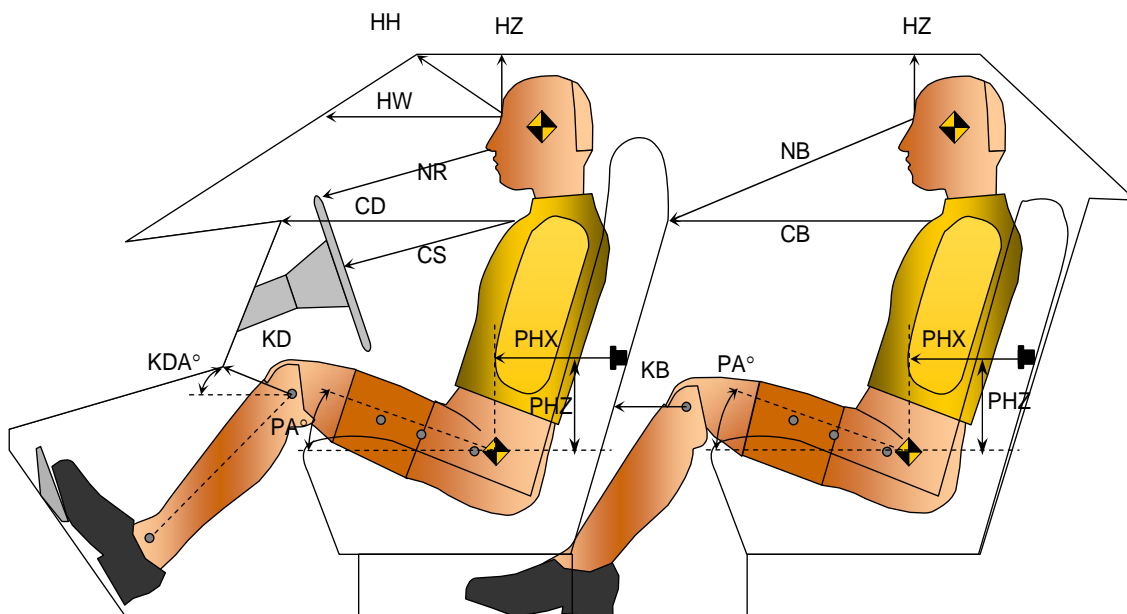

Driver Code	Pass. Code	Measurement Description	Driver S/N 904		Passenger S/N 271	
			Length(mm)	Angle(°)	Length(mm)	Angle(°)
HH		Head to Header	441			
HW		Head to Windshield	771			
HZ	HZ	Head to Roof	225		188	
NR	NB	Nose to Rim/Nose to Seatback	426		508	
CD	CB	Chest to Dash or Seatback	557		436	
CS		Chest to Steering Wheel	329			
KDL	KBL	Left Knee to Dash or Seatback	165	23.5	145	29.9
KDR	KBR	Right Knee to Dash or Seatback	154	26.2	137	20.8
PA	PA	Pelvic Angle		24.3		23.1
PHX	PHX	H-Point to Striker (X-Axis)	206		365	
PHZ	PHZ	H-Point to Striker (Z-Axis)	160		209	

**DATA SHEET NO. 8**  
**SID/HIII LATERAL CLEARANCE DIMENSIONS**

Test Vehicle: 2009 Dodge Journey SE  
 Test Program: NCAP Side Impact

NHTSA No. M90301  
 Test Date: 3/26/2008

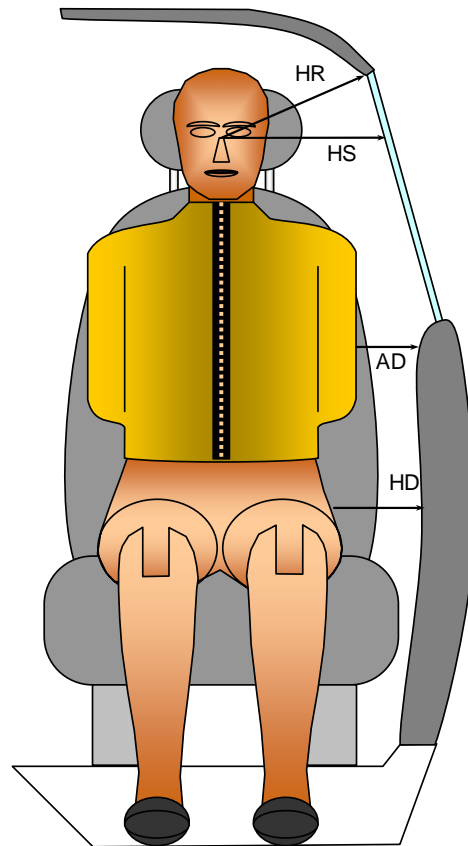

*FRONT VIEW OF DUMMY*

Code	Measurement Description	Units	Driver S/N 904	Passenger S/N 271
HR	Head to Side Header	mm	223	182
HS	Head to Side Window	mm	359	306
AD	Arm to Door	mm	54	51
HD	H-Point to Door	mm	161	142

**DATA SHEET NO. 9**  
**VEHICLE SIDE MEASUREMENTS**

Test Vehicle: 2009 Dodge Journey SE  
Test Program: NCAP Side Impact

NHTSA No. M90301  
Test Date: 3/26/2008

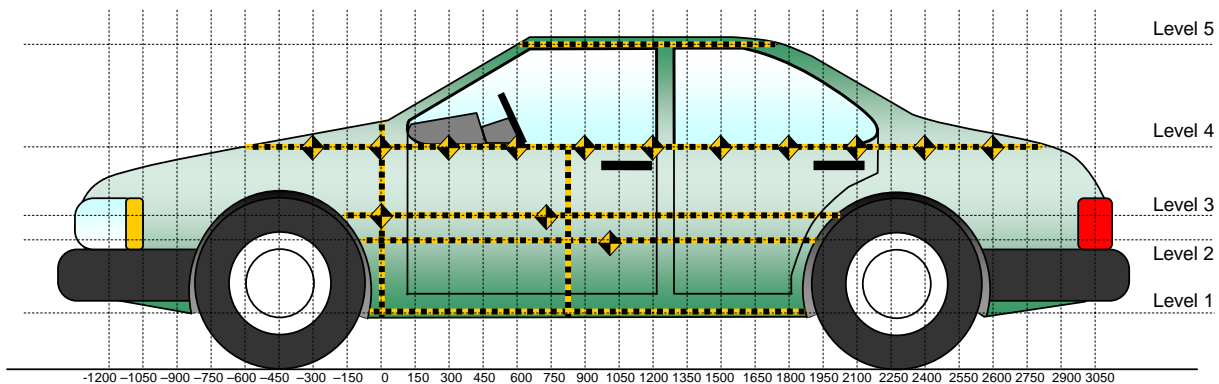

All Measurements Shown in mm

**LEFT SIDE VIEW**

Measurements are taken with vehicle in the as tested condition.  
Measurements along the vertical 800 mm.  
All measurements below in mm.

Level	Measurement Description	Maximum Exterior Static Crush	Distance From Impact	Height Above Ground
5	Window	17	1350	1576
4	Window Sill	68	1200	1045
3	Mid Door	181	750	725
2	Occupant H-Point	164	300	584
1	Sill Top	97	1650	348
	Maximum Penetration	181		

**DATA SHEET NO. 10**  
**VEHICLE EXTERIOR CRUSH PROFILES**

Test Vehicle: 2009 Dodge Journey SE  
Test Program: NCAP Side Impact

NHTSA No. M90301  
Test Date: 3/26/2008

	Pre-Test					Post-Test					Difference				
	1	2	3	4	5	1	2	3	4	5	1	2	3	4	5
-1050				310					314					4	
-900				288					295					7	
-750				273					287					14	
-600				266					275					9	
-450				260					270					10	
-300				251					273					22	
-150			167	247				192	275				25	28	
0	206	192	189	241		218	214	216	270		12	22	27	29	
150	220	200	187	240		282	336	325	260		62	136	138	20	
300	217	198	185	242		297	362	335	256		80	164	150	14	
450	215	197	183	241		296	348	350	245		81	151	167	4	
600	214	198	182	240		293	334	359	235		79	136	177	-5	
750	212	197	181	240	440	288	328	362	225	446	76	131	181	-15	6
900	211	197	182	239	444	289	352	350	218	451	78	155	168	-21	7
1050	212	197	182	237	442	281	305	320	212	456	69	108	138	-25	14
1200	214	202	186	241	445	306	344	338	309	461	92	142	152	68	16
1350	217	205	190	243	448	307	347	368	310	465	90	142	178	67	17
1500	219	210	194	246	450	313	346	369	293	466	94	136	175	47	16
1650	223	215	199	250	453	320	347	363	279	468	97	132	164	29	15
1800	227	220	205	256	458	288	352	347	266	472	61	132	142	10	14
1950	195	187	210	264	464	178	276	317	255	470	-17	89	107	-9	6
2100			175	270	469			235	253	480			60	-17	11
2250				278	476				296	483				18	7
2400				285	483				299	489				14	6
2550				295	491				302	496				7	5
2700				305	504				311	507				6	3
2850				314					316					2	
3000				325					326					1	

Reference plane is parallel to test vehicle longitudinal centerline.

Given dimensions = Reference plane to car body

**DATA SHEET NO. 10... (continued)**  
**VEHICLE EXTERIOR CRUSH PROFILES**

Test Vehicle: 2009 Dodge Journey SE  
Test Program: NCAP Side Impact

NHTSA No. M90301  
Test Date: 3/26/2008

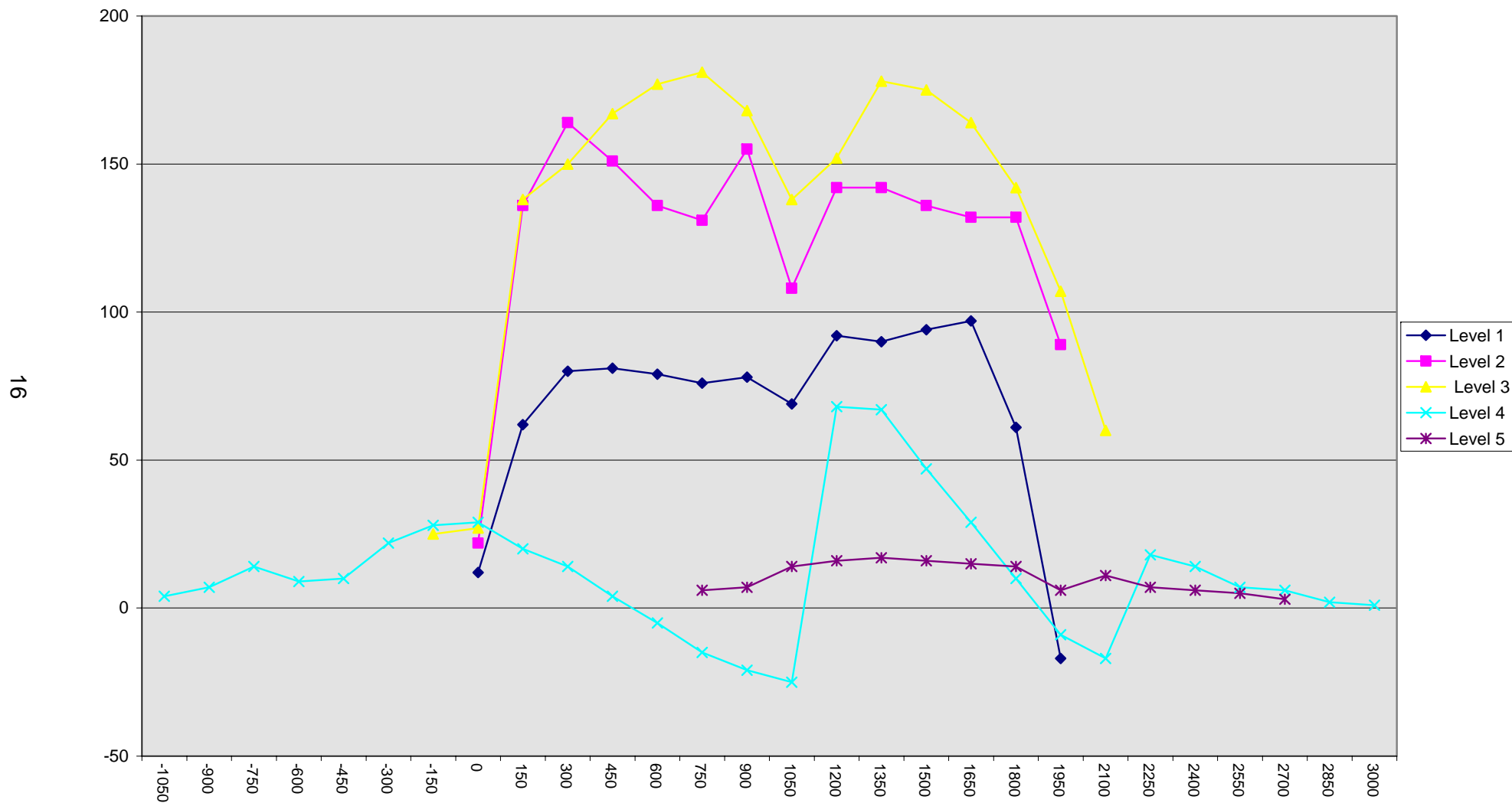

**DATA SHEET NO. 11**  
**VEHICLE DAMAGE PROFILE DISTANCES**

Test Vehicle: 2009 Dodge Journey SE  
 Test Program: NCAP Side Impact

NHTSA No. M90301  
 Test Date: 3/26/2008

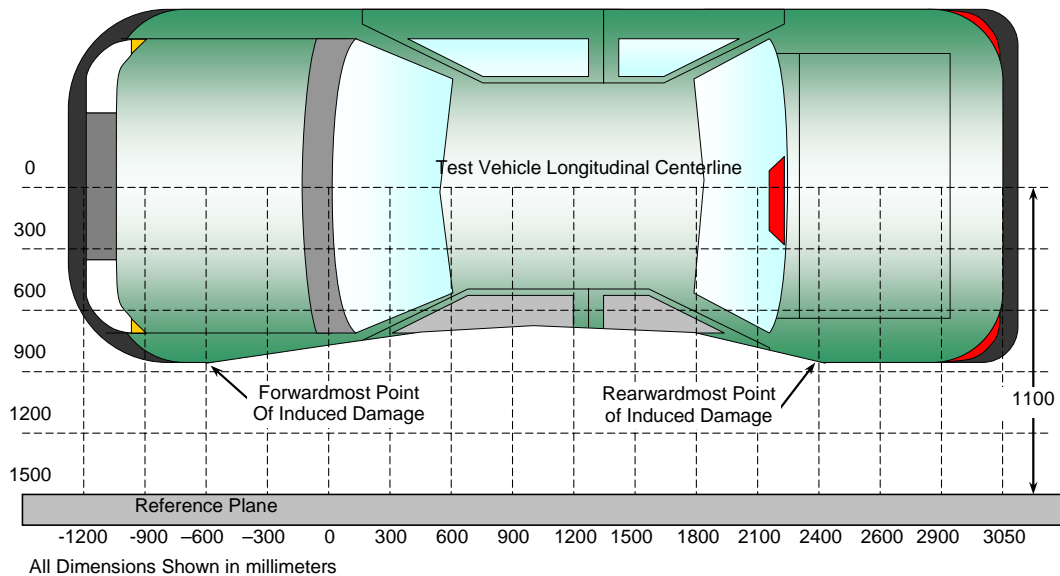

**TOP VIEW**

**DAMAGE PROFILE DISTANCES**

DPD	Distance from Impact Point in mm	Level	Pre-Test (mm)	Post-Test (mm)	Max Static Crush (mm)
1	3000	4	325	326	1
2	2200	4	274	294	20
3	1390	2	244	387	143
4	570	3	240	362	122
5	-235	4	249	274	25
6	-1050	4	310	314	4

Reference plane is parallel to test vehicle longitudinal centerline.  
 Given dimensions = Reference plane to car body.

## DATA SHEET NO. 12

### DEFORMABLE BARRIER HONEYCOMB FACE STATIC CRUSH

Test Vehicle: 2009 Dodge Journey SE  
 Test Program: NCAP Side Impact

NHTSA No. M90301  
 Test Date: 3/26/2008

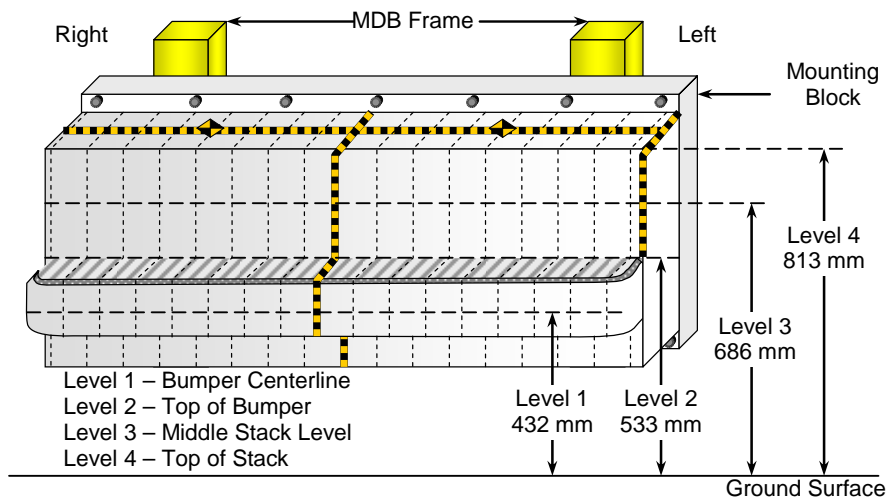

### DEFORMABLE BARRIER STATIC CRUSH

Stack Level	Distance Right of Center								C <sub>L</sub>	Distance Left of Center							
	800	700	600	500	400	300	200	100		100	200	300	400	500	600	700	800
1	230	227	223	225	224	222	222	222	224	224	224	223	223	223	224	227	225
2	129	125	124	124	122	115	111	110	106	118	125	126	126	126	126	126	127
3	115	96	81	77	78	89	121	130	98	68	60	62	59	79	96	110	124
4	103	94	84	75	87	111	150	136	116	78	81	87	95	108	121	128	143

All Dimensions in mm

**DATA SHEET NO. 13**  
**VEHICLE ACCELEROMETER LOCATIONS**

Test Vehicle: 2009 Dodge Journey SE  
 Test Program: NCAP Side Impact

NHTSA No. M90301  
 Test Date: 3/26/2008

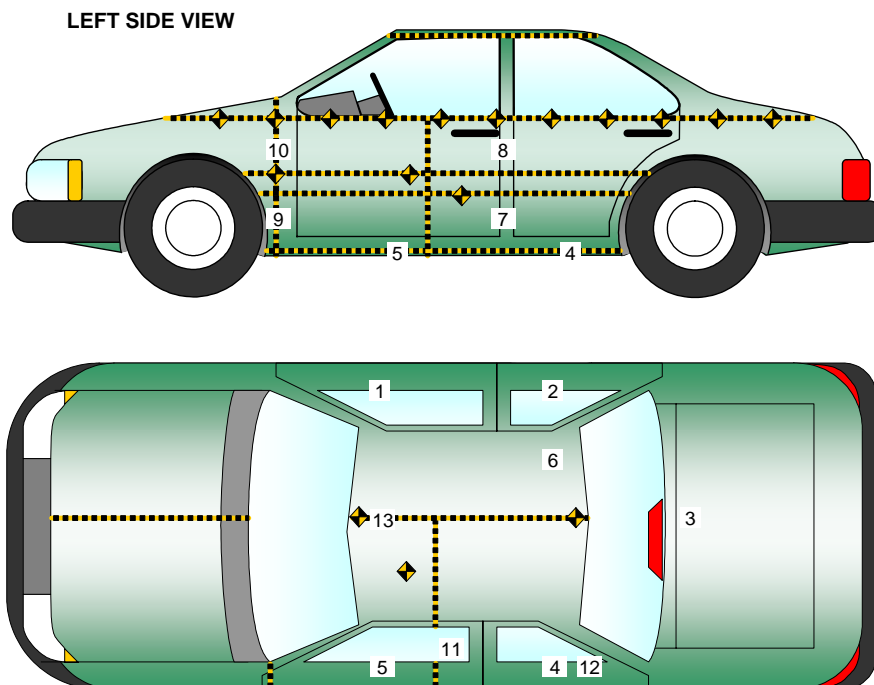

Loc. No.	Accelerometer Location	Measurements (mm)		
		X	Y	Z
1	Right Sill at Front Seat	2470	710	-290
2	Right Sill at Rear Seat	1503	723	-365
3	Rear Floorpan Above Axle	1041	0	-670
4	Left Sill at Rear Door	1507	-723	-281
5	Left Sill at Front Door	2527	-710	-275
6	Rear Occupant Compartment	1906	-427	-403
7	Left Lower B-Post	2204	-740	-627
8	Left Middle B-Post	2220	-736	-865
9	Left Lower A-Post	3313	-662	-569
10	Left Middle A-Post	3307	-818	-903
11	Front Seat Track	2425	-581	-501
12	Rear Seat Track or Structure	1490	-492	-552
13	Vehicle CG	2589	0	-435

Reference Points X - Test Vehicle Rear Bumper (+ forward)  
 Y - Test Vehicle Centerline (+ to right)  
 Z - Ground Plane (+ down)

**DATA SHEET NO. 14**  
**MDB ACCELEROMETER LOCATIONS**

Test Vehicle: 2009 Dodge Journey SE  
 Test Program: NCAP Side Impact

NHTSA No. M90301  
 Test Date: 3/26/2008

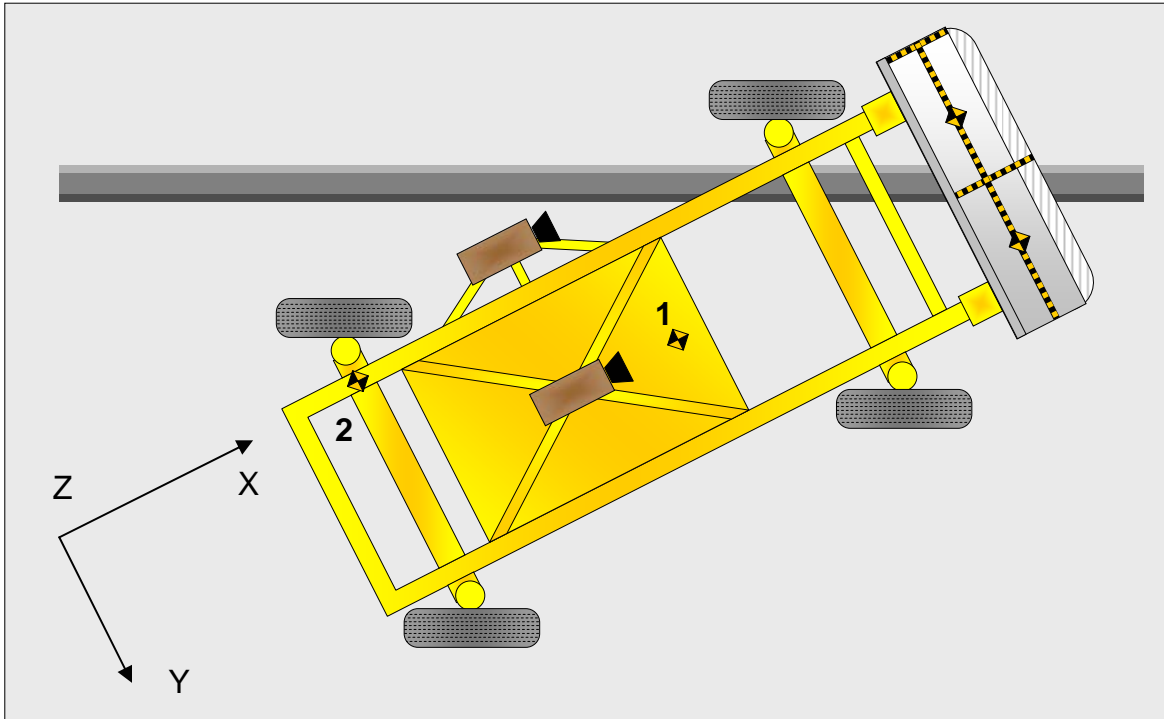

Loc. No.	Accelerometer Location	Measurements (mm)		
		X	Y	Z
1	MDB CG	-1092	0	-483
2	MDB Rear	-2591	-625	-622

Reference Points    X - MDB Front Axle (+ forward)  
                           Y - MDB Centerline (+ to right)  
                           Z - Ground Plane (+ down)

**DATA SHEET NO. 15**  
**VEHICLE STRUCTURAL MEASUREMENTS**

Test Vehicle: 2009 Dodge Journey SE  
 Test Program: NCAP Side Impact

NHTSA No. M90301  
 Test Date: 3/26/2008

	Elements	Pre-Test (mm)
1	Total Length	4866
2	Total Width	1833
3	Bumper Top Height	616
4	Bumper Bottom Height	483
5	Longitudinal Member Top Height	650
6	Distance between Longitudinal Members	1045
7	Longitudinal Member Width	62
8	Engine Top Height	873
9	Engine Bottom Height	253
10	Engine and gearbox width	672
11	Front bumper-engine distance	521
12	Front shock absorber fixing height	962
13	Bonnet leading edge height	884
14	Front shock absorber fixing width	1134
15	Front bumper – front axle distance	993
16	Front axle – a pillar distance	523
17	A-pillar – B-pillar distance	1092
18	B-Pillar – rear axle distance	1282
19	B-pillar – C-pillar distance	1080
20	Roof sill bottom height	1596
21	Roof sill top height	1649
22	Floor sill bottom height	272
23	Floor sill top height	362

**DATA SHEET NO. 16**  
**HIGH SPEED CAMERA LOCATIONS AND DATA**

Test Vehicle: 2009 Dodge Journey SE  
 Test Program: NCAP Side Impact

NHTSA No. M90301  
 Test Date: 3/26/2008

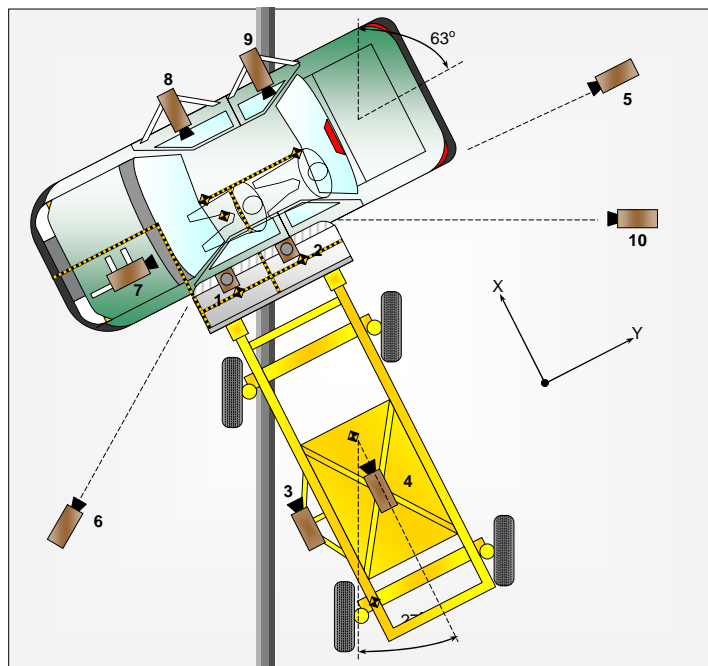

No.	Camera View	Location (mm)			Lens (mm)	Film Speed (fps)
		X	Y	Z		
1	Overhead Close-up	100	0	5050	50	1000
2	Overhead Overall	-340	0	5050	14	1000
3	MDB Onboard, Impact Point Close-up				50	1000
4	MDB Onboard, Centerline of Impact				16	1000
5	Right Side, Ground Level, Overall	155	4980	1205	24	1000
6	Left Side, Ground Level, Overall	1155	-5070	1245	24	1000
7	Vehicle Onboard Front SID/HIII, Front				12.5	1000
8	Vehicle Onboard Front SID/HIII, Side				8	1000
9	Vehicle Onboard Rear SID/HIII, Side				8	1000
10	Real Time Coverage				13	24

Reference Points X - Impact Line  
 Y - MDB Left Edge Impact Point  
 Z - Ground Plane

**DATA SHEET NO. 17**  
**SUMMARY OF FMVSS 301 DATA**

Test Vehicle: 2009 Dodge Journey SE  
 Test Program: NCAP Side Impact

NHTSA No. M90301  
 Test Date: 3/26/2008

**FMVSS 301 FUEL SYSTEM INTEGRITY POST IMPACT DATA**

Temperature at Time of Impact: 21° C      Test Time: 10:24 am

Stoddard Solvent Spillage Measurements

- A. From impact until vehicle motion ceases: 0 oz.  
 (Maximum Allowable = 1 ounce)
- B. For the 5 minute period after motion ceases: None  
 (Maximum allowable = 5 ounces)
- C. For the following 25 minutes: None  
 (Maximum allowable = 1 oz./minute)
- D. Spillage Details: None

**FMVSS 301 STATIC ROLLOVER DATA**

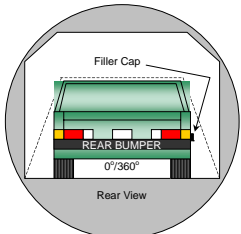
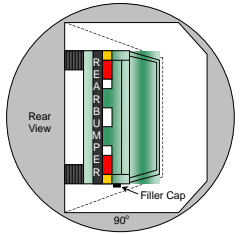
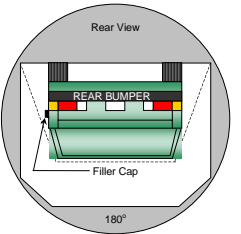
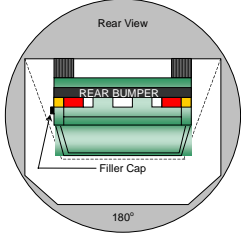
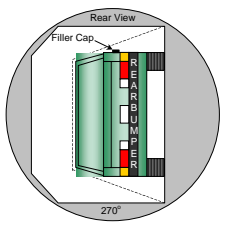
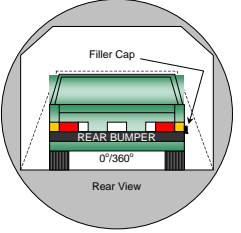
			<p>1. The specified fixture rollover rate for each 90° of rotation is 60 to 180 seconds.</p> <p>2. The position hold time at each position is 300 seconds (minimum).</p> <p>3. Details of Stoddard Solvent spillage locations:  <b>None</b></p>
0° to 90°	90° to 180°		
			
180° to 270°	270° to 360°		

Test Phase	Rotation Time (sec.)	Hold Time (sec.)	Spillage Collection Time (min)	Spillage (oz.)
0° to 90°	118	300	First 5	0
90° to 180°	116	300	First 5	0
180° to 270°	107	300	First 5	0
270° to 360°	123	300	First 5	0

**APPENDIX A**  
**PHOTOGRAPHS**

## TABLE OF PHOTOGRAPHS

		<u>Page No.</u>
Photo No. 1.	Left Front $\frac{3}{4}$ View, As Received	A-1
Photo No. 2.	Right Rear $\frac{3}{4}$ View, As Received	A-1
Photo No. 3.	Manufacturer's Label	A-2
Photo No. 4.	Tire Placard	A-2
Photo No. 5.	Pre-Test Front View	A-3
Photo No. 6.	Post-Test Front View	A-3
Photo No. 7.	Pre-Test Left Front $\frac{3}{4}$ View	A-4
Photo No. 8.	Post-Test Left Front $\frac{3}{4}$ View	A-4
Photo No. 9.	Pre-Test Left Side View	A-5
Photo No. 10.	Post-Test Left Side View	A-5
Photo No. 11.	Pre-Test Left Rear $\frac{3}{4}$ View	A-6
Photo No. 12.	Post-Test Left Rear $\frac{3}{4}$ View	A-6
Photo No. 13.	Pre-Test Rear View	A-7
Photo No. 14.	Post-Test Rear View	A-7
Photo No. 15.	Pre-Test Right Rear $\frac{3}{4}$ View	A-8
Photo No. 16.	Post-Test Right Rear $\frac{3}{4}$ View	A-8
Photo No. 17.	Pre-Test Right Side View	A-9
Photo No. 18.	Post-Test Right Side View	A-9
Photo No. 19.	Pre-Test Right Front $\frac{3}{4}$ View	A-10
Photo No. 20.	Post-Test Right Front $\frac{3}{4}$ View	A-10
Photo No. 21.	Pre-Test Left Impact Point	A-11
Photo No. 22.	Post-Test Left Impact Point	A-11
Photo No. 23.	Pre-Test Front $\frac{3}{4}$ View of Left Side Doors	A-12
Photo No. 24.	Post-Test Front $\frac{3}{4}$ View of Left Side Doors	A-12
Photo No. 25.	Pre-Test Rear $\frac{3}{4}$ View of Left Side Doors	A-13
Photo No. 26.	Post-Test Rear $\frac{3}{4}$ View of Left Side Doors	A-13
Photo No. 27.	Pre-Test Overhead View	A-14
Photo No. 28.	Post-Test Overhead View	A-14
Photo No. 29.	Pre-Test Overhead Close-up View	A-15
Photo No. 30.	Post-Test Overhead Close-up View	A-15
Photo No. 31.	Pre-Test Driver Dummy (Door Open)	A-16
Photo No. 32.	Pre-Test Driver Dummy Clearance From Door	A-17

	<u>Page No.</u>
Photo No. 33. Post-Test Driver Dummy Clearance From Door	A-17
Photo No. 34. Pre-Test Driver Dummy (Through Window)	A-18
Photo No. 35. Post-Test Driver Dummy (Through Window)	A-18
Photo No. 36. Pre-Test Driver Dummy Right Side View	A-19
Photo No. 37. Post-Test Driver Dummy Right Side View	A-19
Photo No. 38. Pre-Test Passenger Dummy Clearance From Door	A-20
Photo No. 39. Post-Test Passenger Dummy Clearance From Door	A-20
Photo No. 40. Pre-Test Passenger Dummy (Through Window)	A-21
Photo No. 41. Post-Test Passenger Dummy (Through Window)	A-21
Photo No. 42. Pre-Test Passenger Dummy Right Side View	A-22
Photo No. 43. Post-Test Passenger Dummy Right Side View	A-22
Photo No. 44. Pre-Test Front View of Deformable Barrier	A-23
Photo No. 45. Post-Test Front View of Deformable Barrier	A-23
Photo No. 46. Pre-Test Top View of Deformable Barrier	A-24
Photo No. 47. Post-Test Top View of Deformable Barrier	A-24
Photo No. 48. Pre-Test Right Side View of Deformable Barrier	A-25
Photo No. 49. Post-Test Right Side View of Deformable Barrier	A-25
Photo No. 50. Pre-Test Left Side View of Deformable Barrier	A-26
Photo No. 51. Post-Test Left Side View of Deformable Barrier	A-26
Photo No. 52. Vehicle on Rollover Device (90 Degrees)	A-27
Photo No. 53. Vehicle on Rollover Device (180 Degrees)	A-27
Photo No. 54. Vehicle on Rollover Device (270 Degrees)	A-28
Photo No. 55. Vehicle on Rollover Device (360 Degrees)	A-28
Photo No. 56. Vehicle Impact	A-29
Photo No. 57. Post-Test Driver Dummy Head Contact	A-30
Photo No. 58. Post-Test Driver Dummy Torso Contact	A-30
Photo No. 59. Post-Test Driver Dummy Torso Contact (SAB)	A-31
Photo No. 60. Post-Test Driver Dummy Contact	A-31
Photo No. 61. Post-Test Passenger Dummy Head Contact	A-32
Photo No. 62. Post-Test Passenger Dummy Torso Contact	A-32
Photo No. 63. Post-Test Passenger Dummy Contact	A-33



Left Front ¾ View, As Received



Right Rear ¾ View, As Received



Manufacturer's Label



Tire Placard



Pre-Test Front View



Post-Test Front View



Pre-Test Left Front  $\frac{3}{4}$  View



Post-Test Left Front  $\frac{3}{4}$  View



Pre-Test Left Side View



Post-Test Left Side View



Pre-Test Left Rear 3/4 View



Post-Test Left Rear 3/4 View



Pre-Test Rear View



Post-Test Rear View



Pre-Test Right Rear  $\frac{3}{4}$  View



Post-Test Right Rear  $\frac{3}{4}$  View



Pre-Test Right Side View



Post-Test Right Side View



Pre-Test Right Front 3/4 View



Post-Test Right Front 3/4 View



Pre-Test Left Impact Point



Post-Test Left Impact Point



Pre-Test Front 3/4 View of Left Side Doors



Post-Test Front 3/4 View of Left Side Doors



Pre-Test Rear 3/4 View of Left Side Doors



Post-Test Rear 3/4 View of Left Side Doors



Pre-Test Overhead View



Post-Test Overhead View



Pre-Test Overhead Close-up View



Post-Test Overhead Close-up View



Pre-Test Driver Dummy (Door Open)



Pre-Test Driver Dummy Clearance From Door



Post-Test Driver Dummy Clearance From Door



Pre-Test Driver Dummy (Through Window)



Post-Test Driver Dummy (Through Window)



Pre-Test Driver Dummy Right Side View



Post-Test Driver Dummy Right Side View



Pre-Test Passenger Dummy Clearance From Door



Post-Test Passenger Dummy Clearance From Door



Pre-Test Passenger Dummy (Through Window)



Post-Test Passenger Dummy (Through Window)



Pre-Test Passenger Dummy Right Side View



Post-Test Passenger Dummy Right Side View



Pre-Test Front View of Deformable Barrier



Post-Test Front View of Deformable Barrier

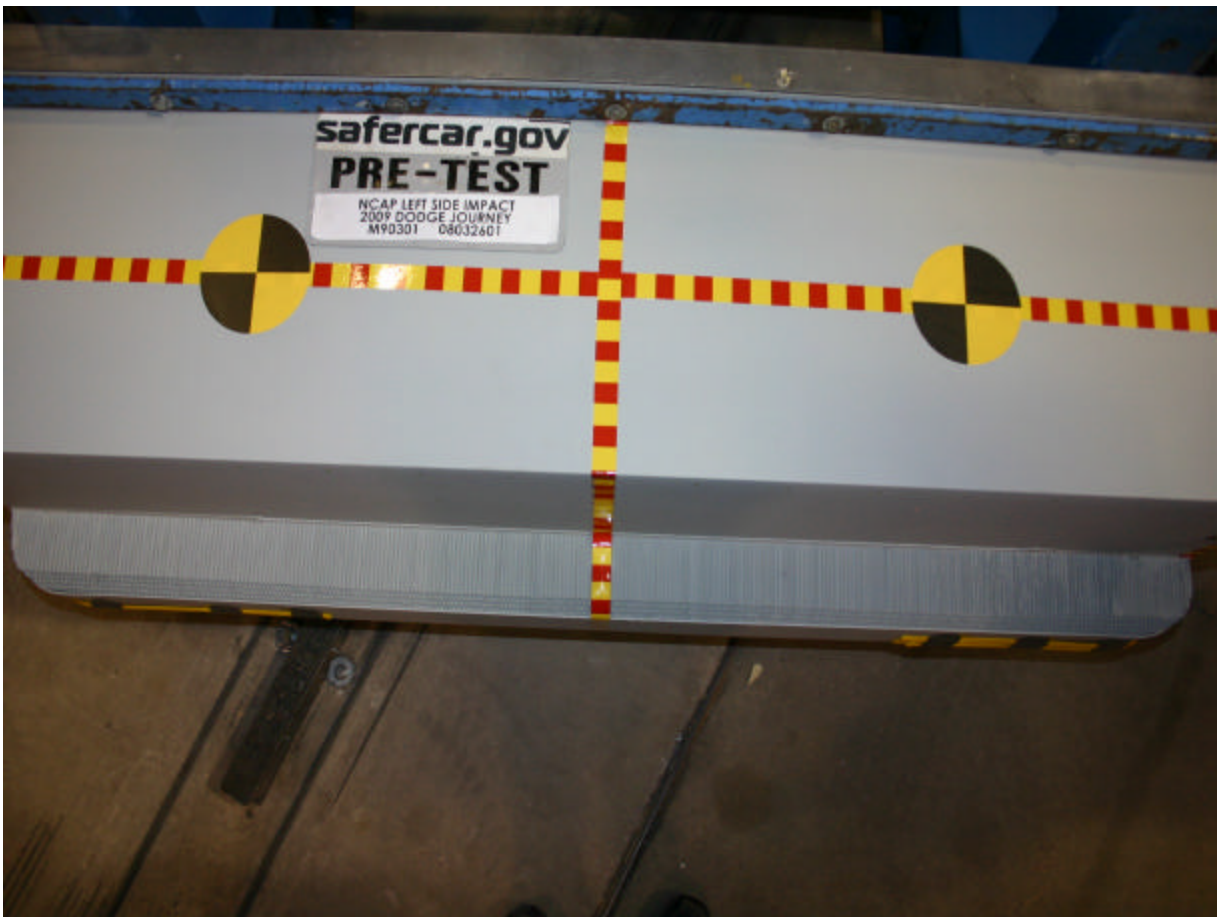

Pre-Test Top View of Deformable Barrier



Post-Test Top View of Deformable Barrier



Pre-Test Right Side View of Deformable Barrier



Post-Test Right Side View of Deformable Barrier



Pre-Test Left Side View of Deformable Barrier



Post-Test Left Side View of Deformable Barrier



Vehicle on Rollover Device (90 Degrees)



Vehicle on Rollover Device (180 Degrees)



Vehicle on Rollover Device (270 Degrees)



Vehicle on Rollover Device (360 Degrees)



Vehicle Impact



Post-Test Driver Dummy Head Contact



Post-Test Driver Dummy Torso Contact



Post-Test Driver Dummy Torso Contact (SAB)



Post-Test Driver Dummy Contact



Post-Test Passenger Dummy Head Contact



Post-Test Passenger Dummy Torso Contact



Post-Test Passenger Dummy Contact

**APPENDIX B**  
**SID/HIII RESPONSE DATA TRACES**

## TABLE OF DATA PLOTS

Page No.

### List of Data Plots Provided in the Test Report

Figure No. 1.	Driver Upper Rib Y Acceleration vs. Time	B-1
Figure No. 2.	Driver Upper Rib Y Velocity vs. Time	B-1
Figure No. 3.	Driver Lower Rib Y Acceleration vs. Time	B-1
Figure No. 4.	Driver Lower Rib Y Velocity vs. Time	B-1
Figure No. 5.	Driver Lower Spine Y Acceleration vs. Time	B-2
Figure No. 6.	Driver Lower Spine Y Velocity vs. Time	B-2
Figure No. 7.	Driver Pelvis Y Acceleration vs. Time	B-2
Figure No. 8.	Driver Pelvis Y Velocity vs. Time	B-2
Figure No. 9.	Passenger Upper Rib Y Acceleration vs. Time	B-3
Figure No. 10.	Passenger Upper Rib Y Velocity vs. Time	B-3
Figure No. 11.	Passenger Lower Rib Y Acceleration vs. Time	B-3
Figure No. 12.	Passenger Lower Rib Y Velocity vs. Time	B-3
Figure No. 13.	Passenger Lower Spine Y Acceleration vs. Time	B-4
Figure No. 14.	Passenger Lower Spine Y Velocity vs. Time	B-4
Figure No. 15.	Passenger Pelvis Y Acceleration vs. Time	B-4
Figure No. 16.	Passenger Pelvis Y Velocity vs. Time	B-4

**The following dummy and vehicle response data can be found in the R&D section of the NHTSA website at [www.nhtsa.dot.gov](http://www.nhtsa.dot.gov)**

Driver Head X Primary

Driver Head Y Primary

Driver Head Z Primary

Driver Head X Redundant

Driver Head Y Redundant

Driver Head Z Redundant

Driver Upper Neck Force X

Driver Upper Neck Force Y

Driver Upper Neck Force Z

Driver Upper Neck Moment X

Driver Upper Neck Moment Y  
Driver Upper Neck Moment Z  
Driver Upper Rib Redundant Y  
Driver Lower Rib Redundant Y  
Driver Lower Spine Redundant Y  
Driver Pelvis Redundant Y  
Driver Thorax Contact  
Driver Pelvis Contact  
Passenger Head X Primary  
Passenger Head Y Primary  
Passenger Head Z Primary  
Passenger Head X Redundant  
Passenger Head Y Redundant  
Passenger Head Z Redundant  
Passenger Upper Neck Force X  
Passenger Upper Neck Force Y  
Passenger Upper Neck Force Z  
Passenger Upper Neck Moment X  
Passenger Upper Neck Moment Y  
Passenger Upper Neck Moment Z  
Passenger Upper Rib Redundant Y  
Passenger Lower Rib Redundant Y  
Passenger Lower Spine Redundant Y  
Passenger Pelvis Redundant Y  
Passenger Thorax Contact  
Passenger Pelvis Contact  
Vehicle Right Sill at Front Seat X  
Vehicle Right Sill at Front Seat Y  
Vehicle Right Sill at Front Seat Z  
Vehicle Right Sill at Rear Seat X  
Vehicle Right Sill at Rear Seat Y  
Vehicle Right Sill at Rear Seat Z

Vehicle Rear Floor Above Axle X  
Vehicle Rear Floor Above Axle Y  
Vehicle Rear Floor Above Axle Z  
Vehicle Left Sill at Rear Door Y  
Vehicle Left Sill at Front Door Y  
Vehicle Right Rear Occupant Compartment  
Vehicle B-Post Lower Y  
Vehicle B-Post Middle Y  
Vehicle A-Post Lower Y  
Vehicle A-Post Middle Y  
Vehicle Left Front Seat Track  
Vehicle Rear Seat Track  
Vehicle CG X  
Vehicle CG Y  
Vehicle CG Z  
MDB CG X  
MDB CG Y  
MDB CG Z  
MDB Rear X  
MDB Rear Y  
MDB Left Bumper Contact  
MDB Right Bumper Contact

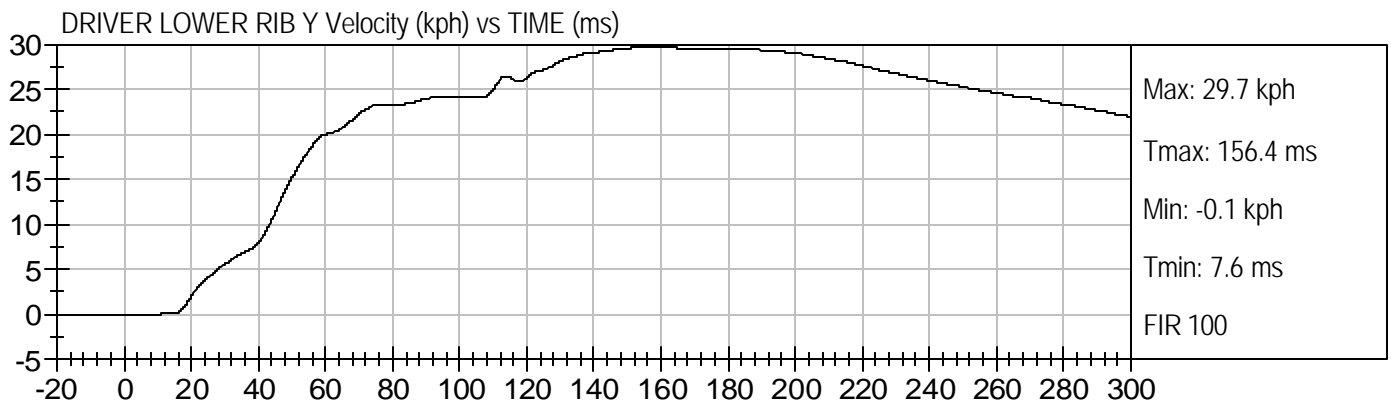
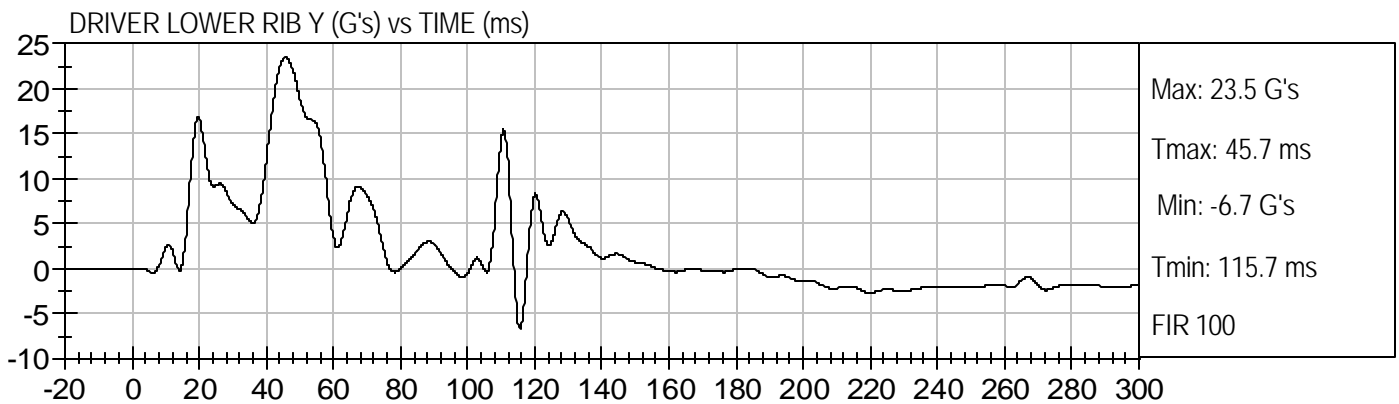
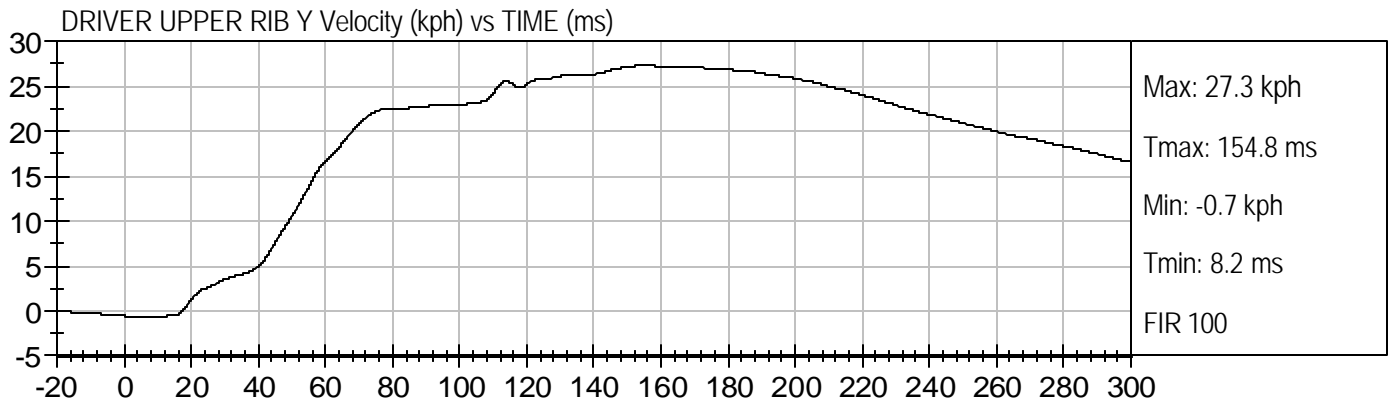
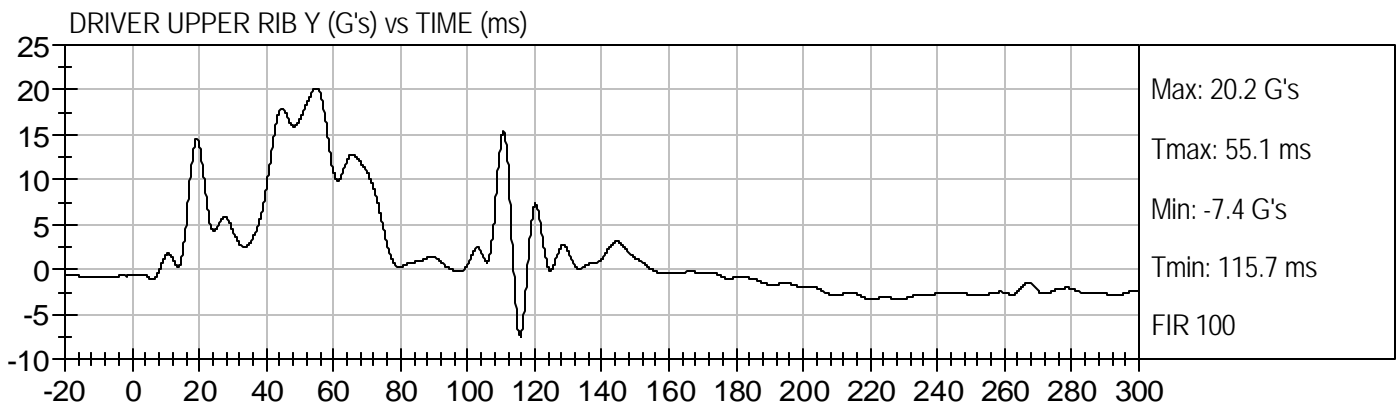

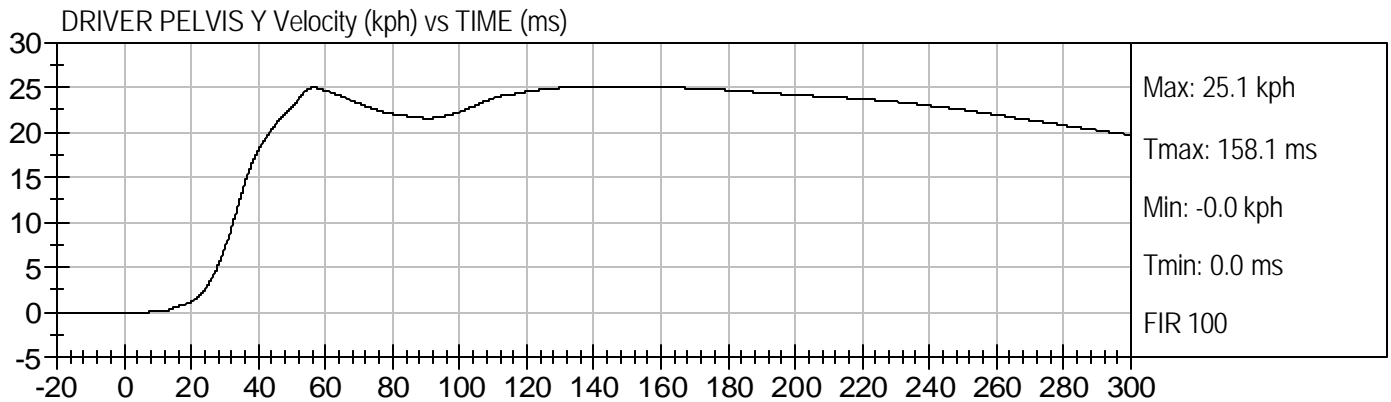
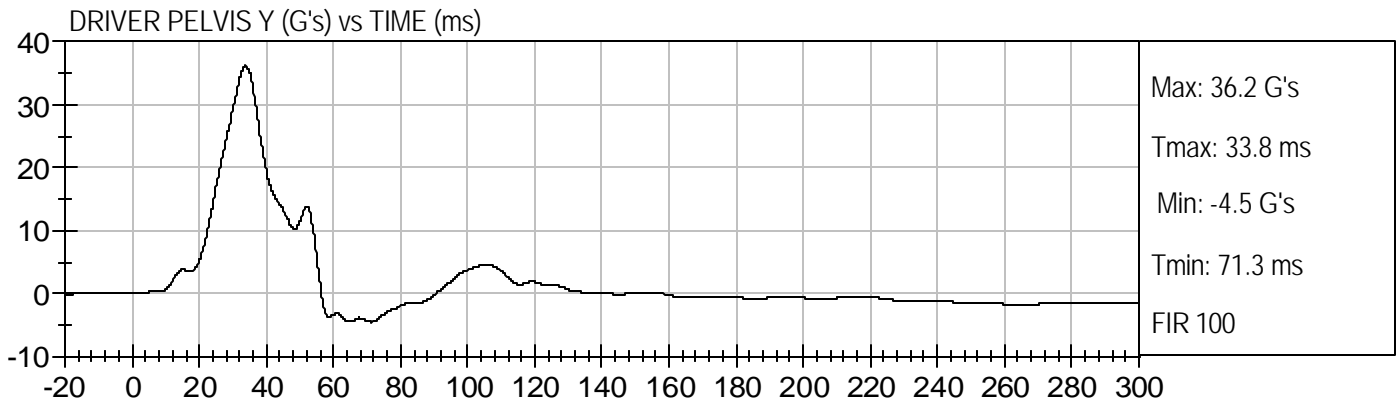
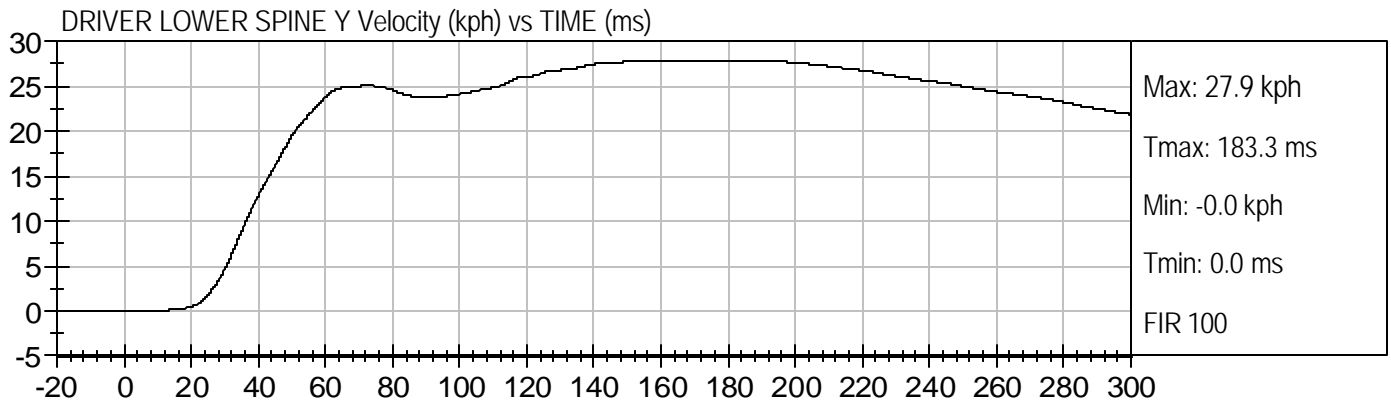
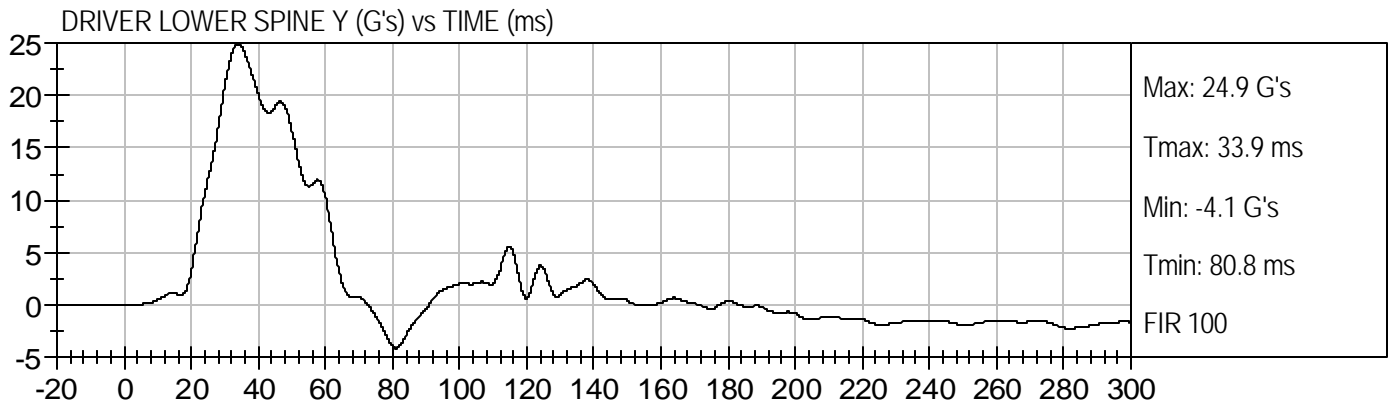

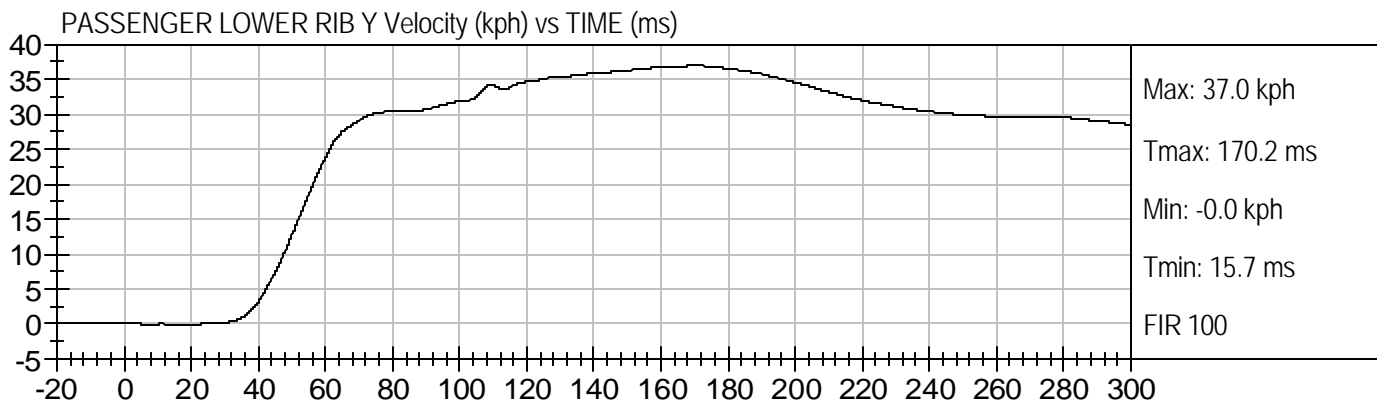
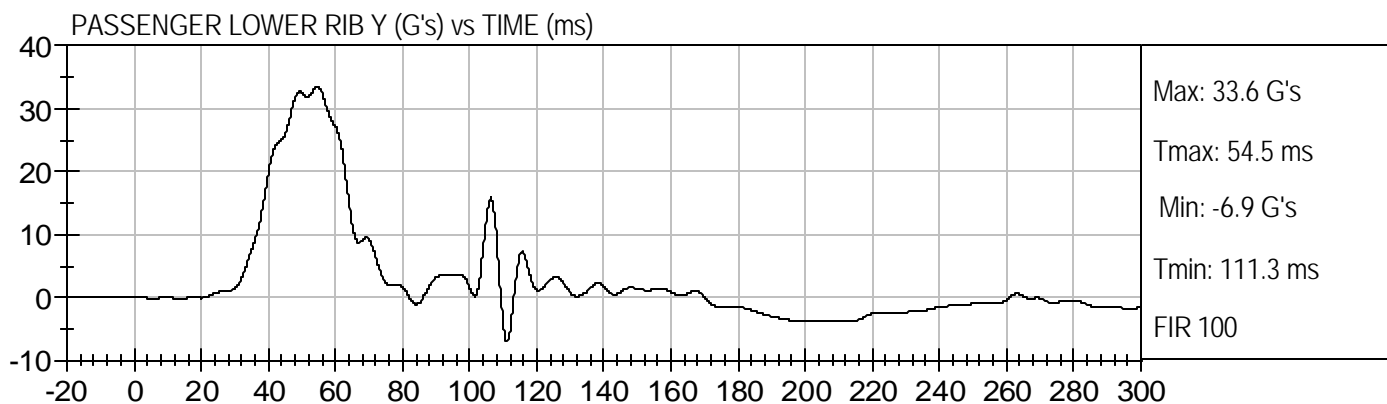
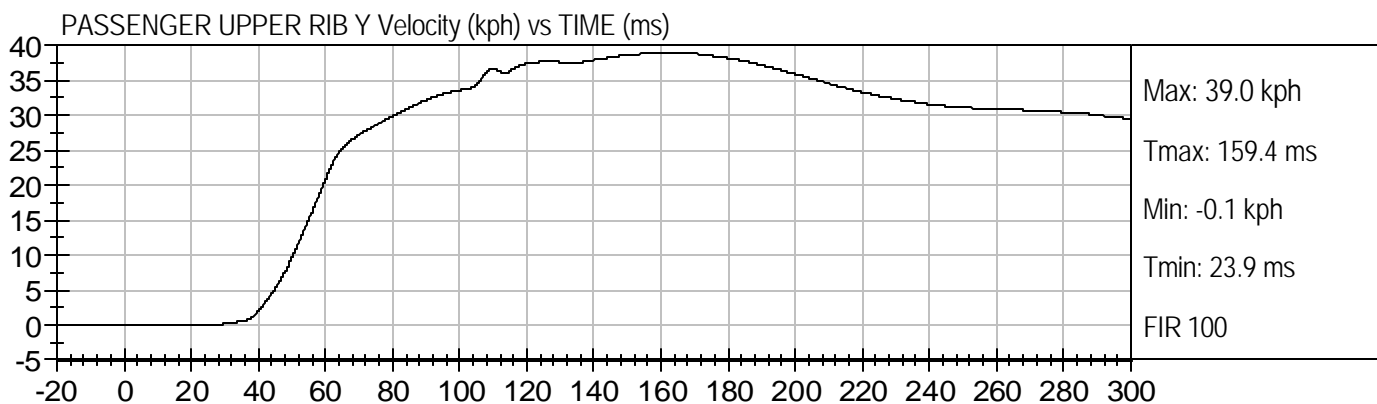
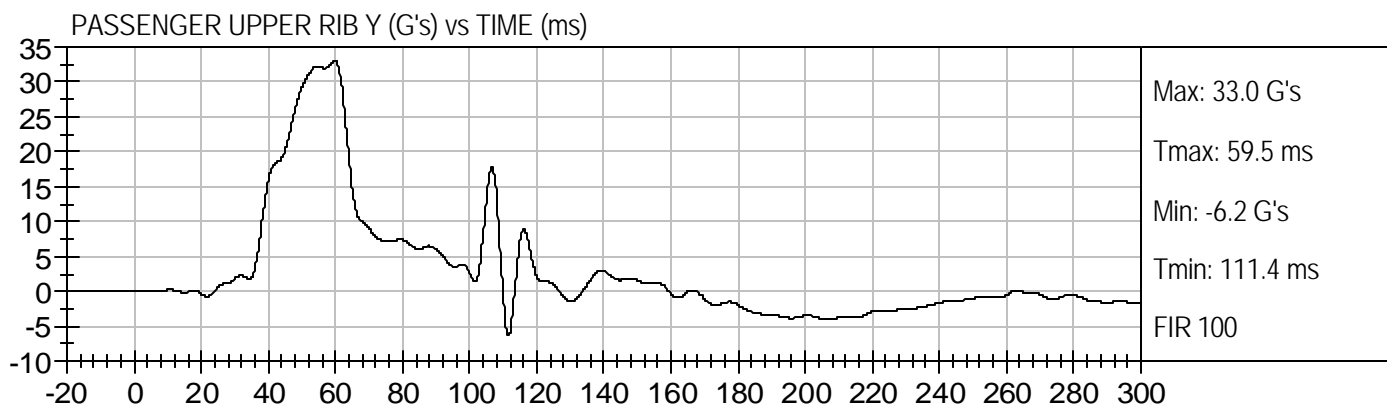

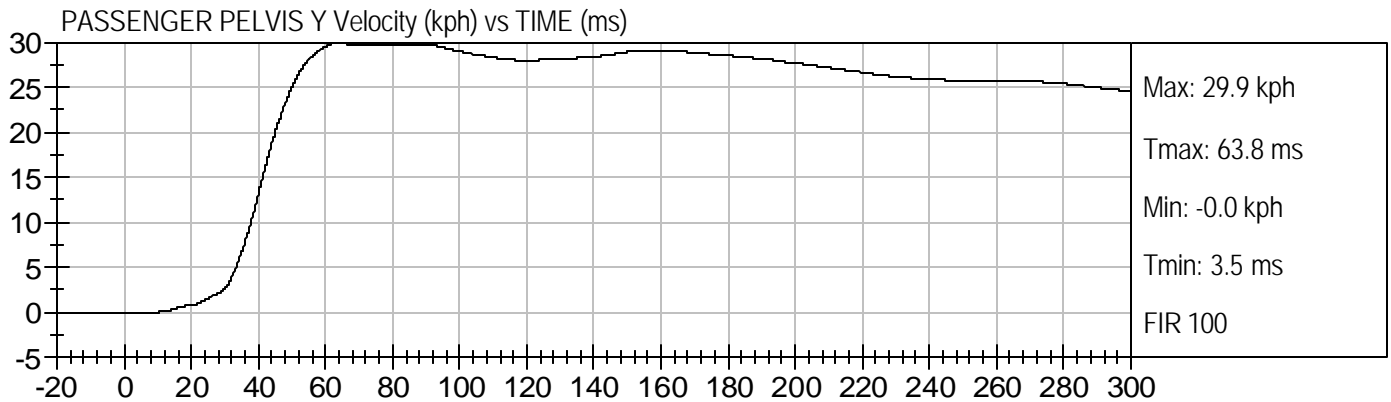
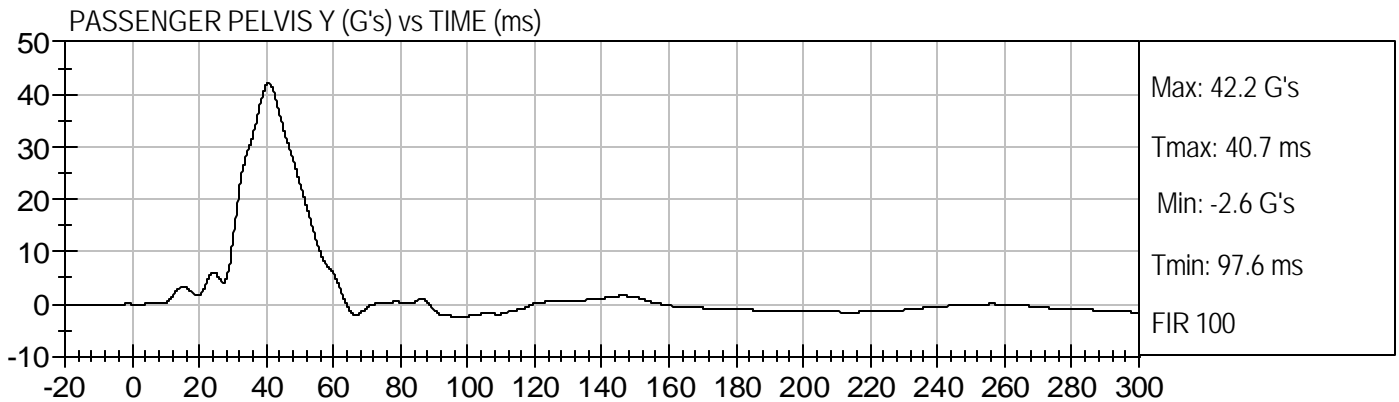
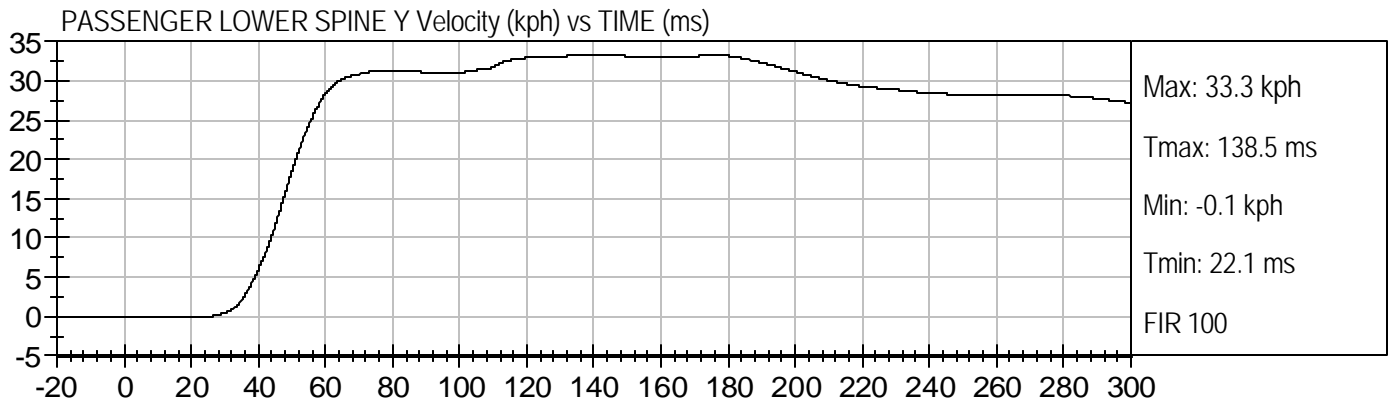
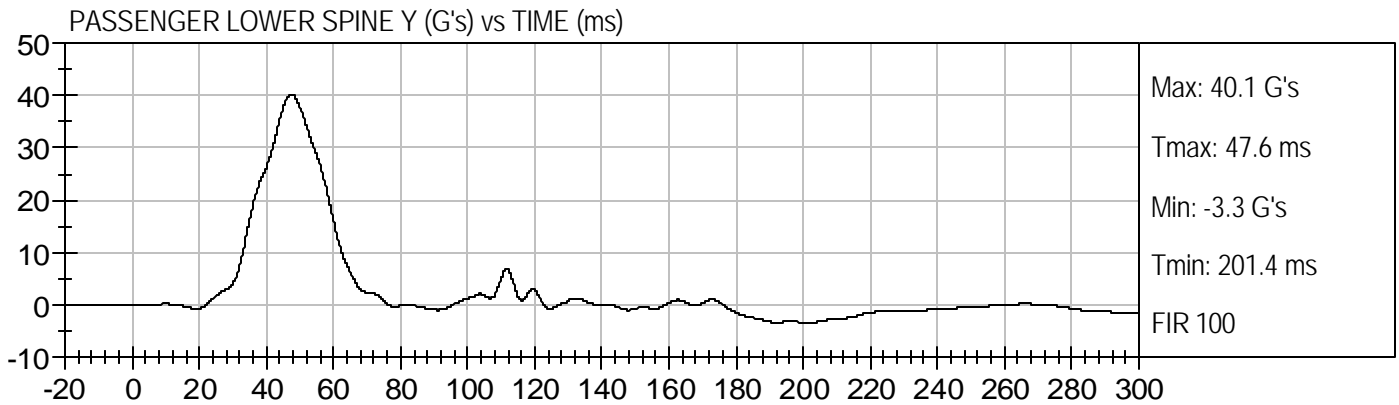

**APPENDIX C**  
**DUMMY CALIBRATION DATA**

CERTIFICATION DATA

Dummy Serial Number: 904

## Calibration Test Results Summary

Dummy Serial Number: 904

### Pre-Test Calibration

External Dimensions:	The dummy passed all external dimension requirements.
Head Drop Test:	The head passed all drop test requirements.
Neck Pendulum Test:	The neck passed all pendulum test requirements.
Thorax Impact Test:	The thorax passed all impact test requirements.
Pelvic Impact Test:	The pelvis passed all impact test requirements.
Abdominal Compression Test:	The abdomen passed all compression test requirements.
Lumbar Flexion Test:	The lumbar passed all flexion test requirements.

**SID/HIII Calibration Data Sheet**  
**Side Impact Dummy**  
**External Measurements**

ATD Serial No: 904

Test I.D: D0875

Tested Parameter	Units	Specification	Result	Pass/Fail
SH - Seated Height	mm	889 - 909	906	Pass
RH - Rib Height	mm	501 - 521	508	Pass
HP - Hip Pivot Height	mm	99 ref.	99	Pass
RD - Rib from Back Line	mm	229 - 241	240	Pass
KV - Knee Pivot to Back Line	mm	511 - 526	523	Pass
SW - Knee Pivot to Floor	mm	490 - 505	496	Pass
HW - Hip Width	mm	356 - 391	360	Pass
Overall Test Results				Pass

Jessica Hall  
 Laboratory Technician

3/12/2008  
 Test Date

David Winkelbauer  
 Approved By

**SID/HIII Calibration Data Sheet**  
**Side Impact Dummy**  
**Head Drop Calibration (Lateral)**

ATD Serial No: 904

Test I.D.: D08751

Tested Parameter	Units	Specification	Result	Pass/Fail
Laboratory Temperature	deg C	18.9 to 25.5	21.2	Pass
Laboratory Relative Humidity	%	10 to 70	22	Pass
Peak Resultant Acceleration	G's	120 to 150	124	Pass
Is Resultant Curve Unimodal?	N/A	15% of peak	Yes	Pass
Peak Longitudnal Acceleration	G's	+/- 15	-10.4	Pass
Overall Test Results				Pass

Jessica Hall  
 Laboratory Technician

3/12/08  
 Test Date

David Winkelbauer  
 Approved By



Test Description: Head Drop

Test Date: 3/12/08

Component: D08751

Speed: 0 ft/s, 0 m/s

Peak Resultant Acceleration (G's) Vs Time (msec)

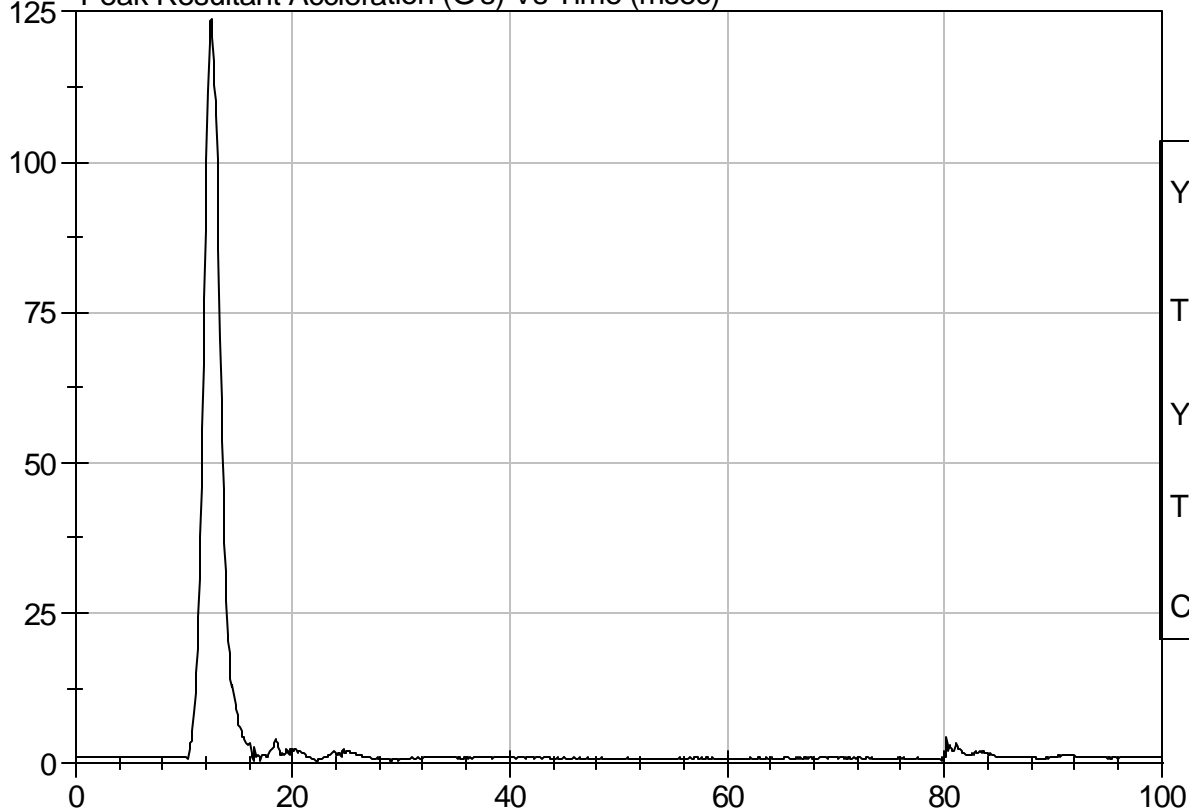

YMax: 123.7 G

Tmax: 12.5 ms

YMin: 0.3 G

Tmin: 17.0 ms

CFC 1000

Peak Longitudnal Acceleration (G's) Vs Time (msec)

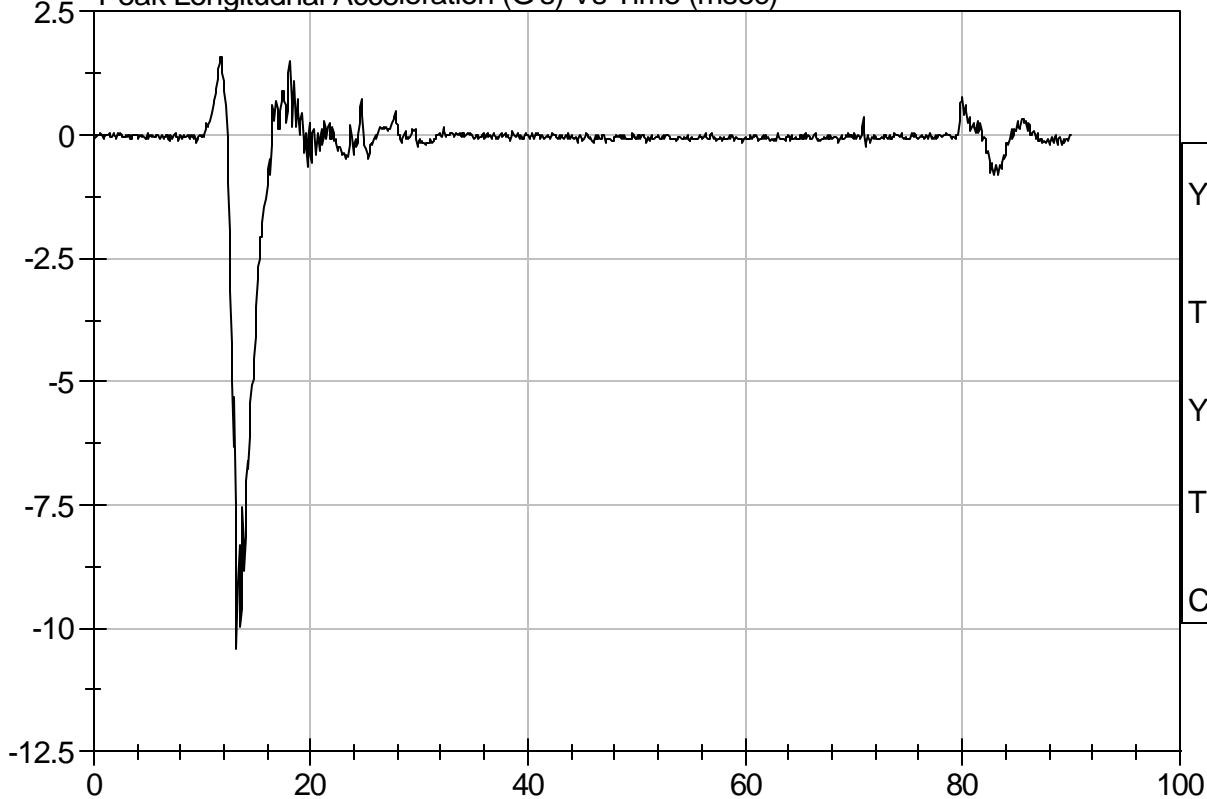

YMax: 1.6 G

Tmax: 11.8 ms

YMin: -10.4 G

Tmin: 13.2 ms

CFC 1000

**SID/HIII Calibration Data Sheet**  
**Side Impact Dummy**  
**Thorax Impact Test**

ATD Serial No: 904

Test I.D.: D08752

Tested Parameter	Units	Specification	Result	Pass/Fail
Laboratory Temperature	deg C	18.9 - 25.5	20.7	Pass
Laboratory Relative Humidity	%	10 to 70	22	Pass
Probe Velocity	m/s	4.22 - 4.31	4.23	Pass
Upper Rib	G's	37 - 46	41	Pass
Lower Rib	G's	37 - 46	38	Pass
Lower Spine	G's	15 - 22	21	Pass
Overall Test Results				Pass

Jessica Hall  
 Laboratory Technician

3/12/08  
 Test Date

David Winkelbauer  
 Approved By



Test Desc: Thorax Impact  
Component ID: D08752

Test Date: 3/12/08  
Speed: 13.89 ft/sec, 4.23 m/sec

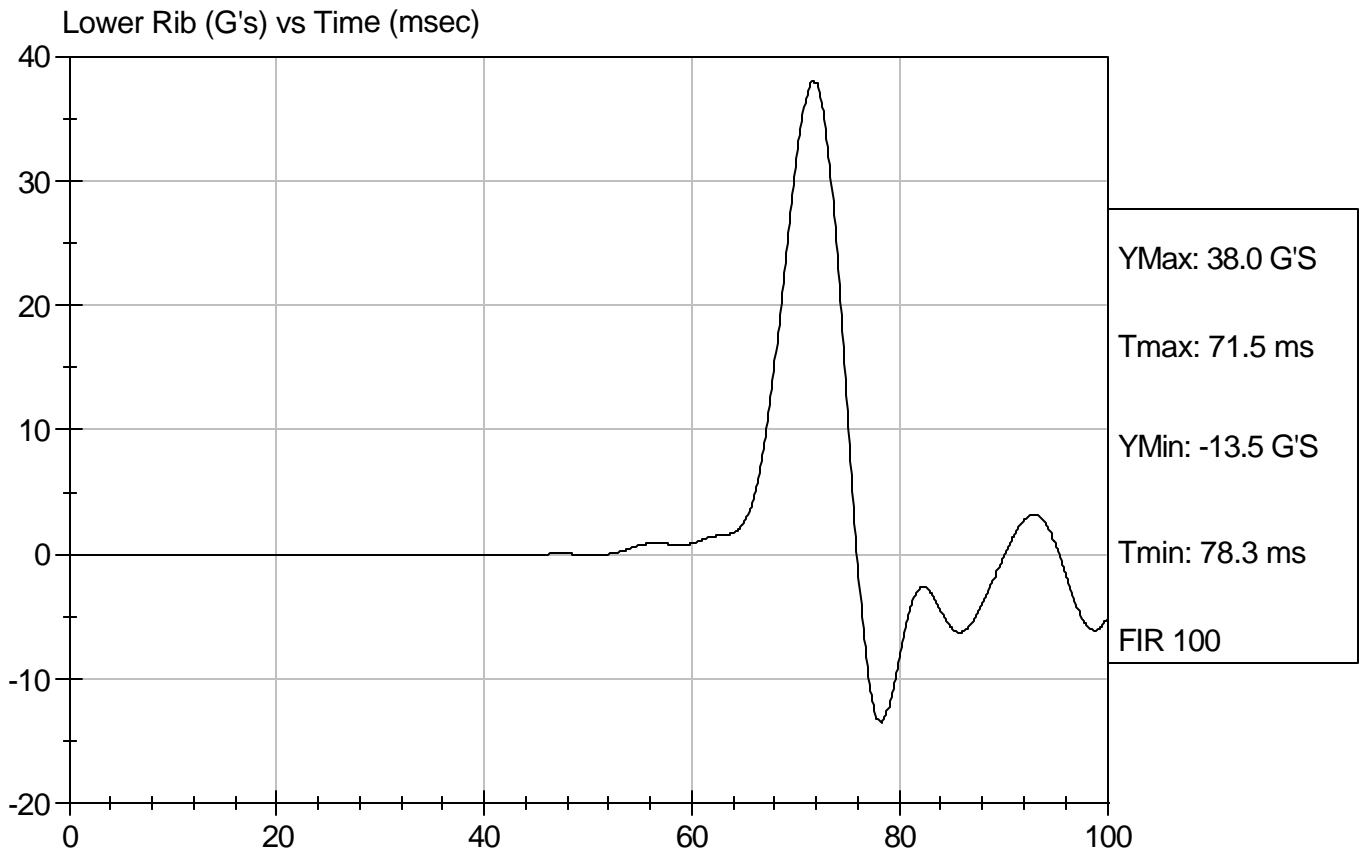
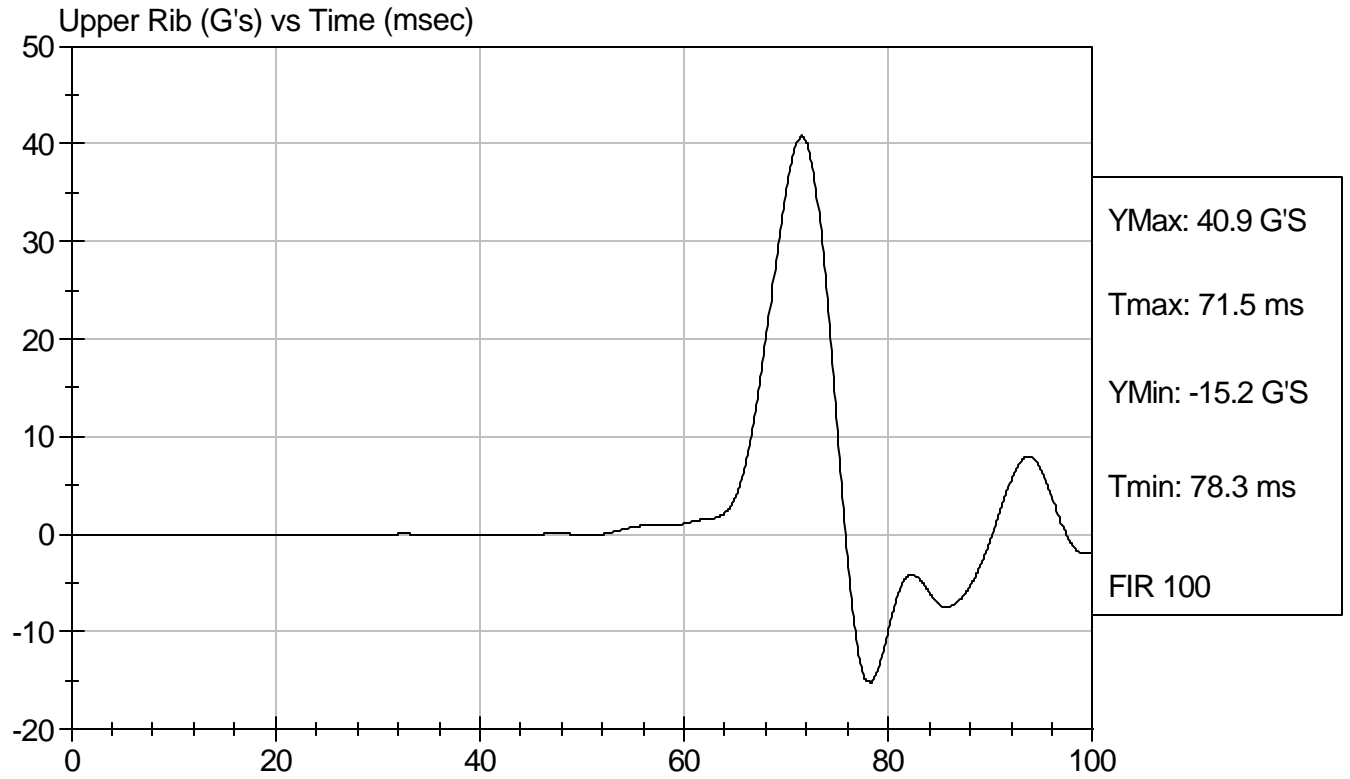

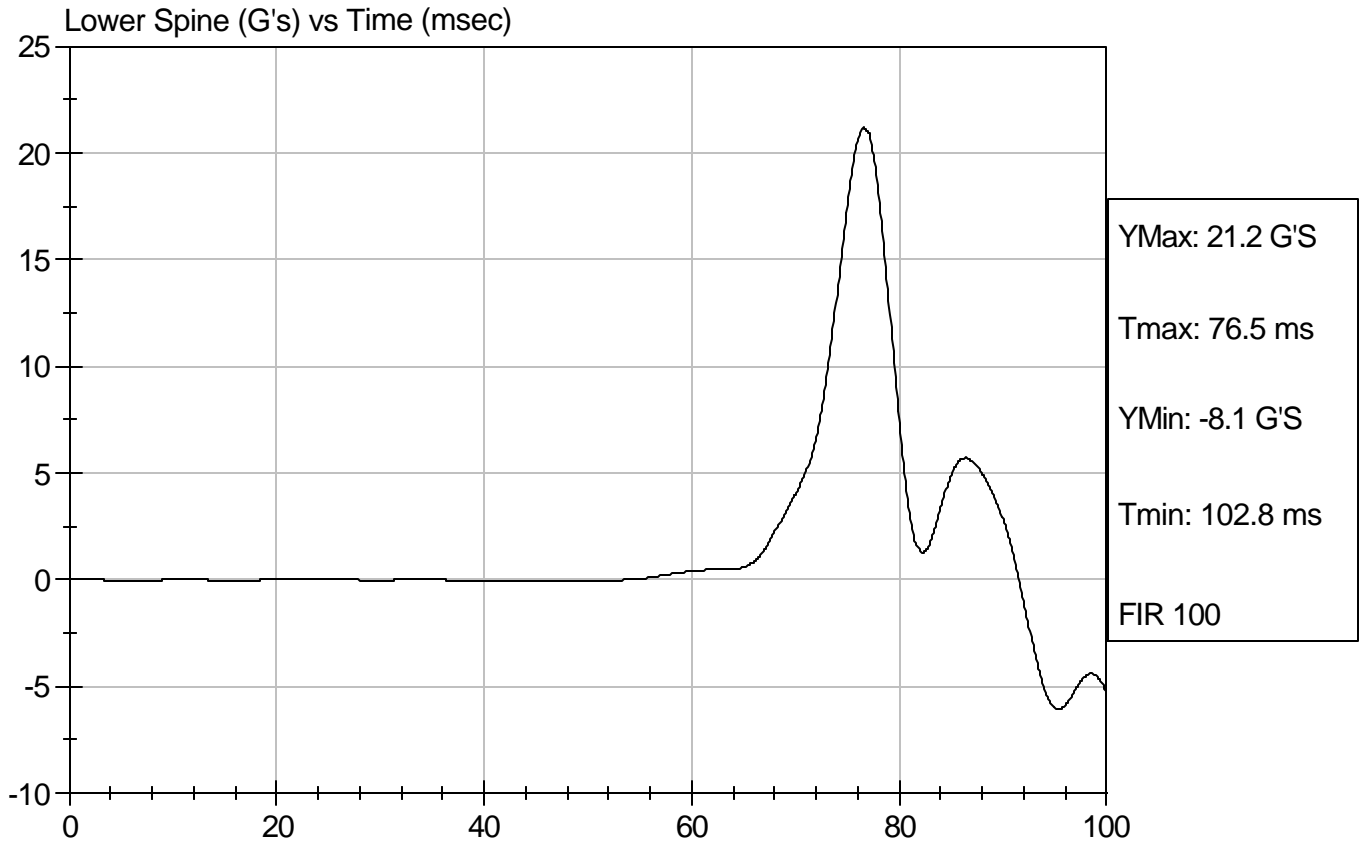

**SID/HIII Calibration Data Sheet**  
**Side Impact Dummy**  
**Pelvis Impact Test**

ATD Serial No: 904

Test I.D.: D08753

Tested Parameter	Units	Specification	Result	Pass/Fail
Laboratory Temperature	deg C	18.9 to 25.5	20.7	Pass
Laboratory Relative Humidity	%	10 to 70	22	Pass
Probe Velocity	m/s	4.27 - 4.33	4.30	Pass
Pelvis Acceleration	G's	40 - 60	44	Pass
Overall Test Results				Pass

Jessica Hall  
Laboratory Technician

3/12/08  
Test Date

David Winkelbauer  
Approved By



Test Desc: Pelvis Impact  
Component ID: D08753

Test Date: 3/12/08  
Speed: 14.12 ft/sec, 4.30 m/sec

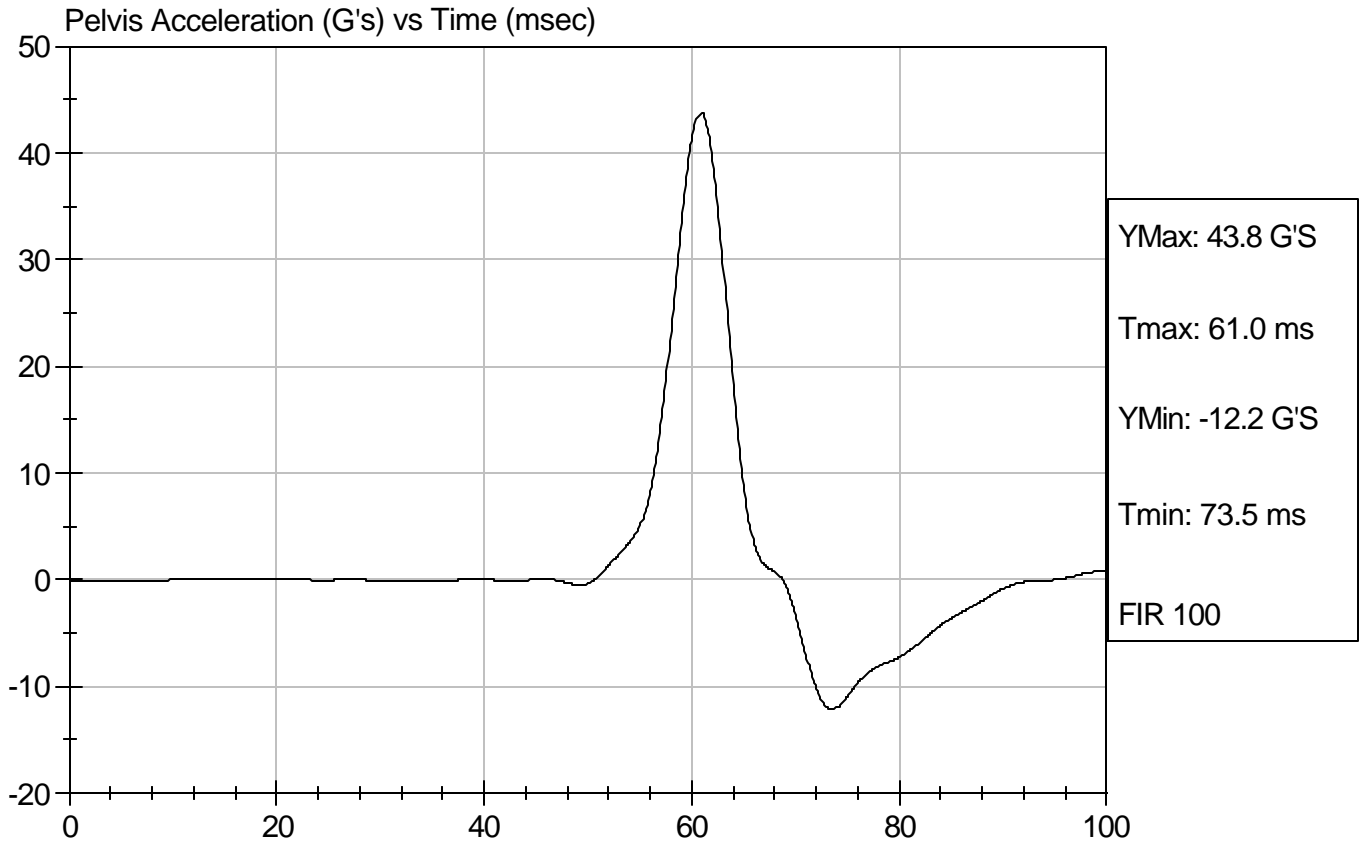

**SID/HIII Calibration Data Sheet**  
**Side Impact Dummy**  
**Abdominal Compression Calibration (Pre-Load = 10 lbs)**

ATD Serial No: 904

Test I.D.: D08754

Tested Parameter	Units	Specification	Result	Pass/Fail
Laboratory Temperature	deg C	18.9 - 25.5	20.2	Pass
Laboratory Relative Humidity	%	10 to 70	23	Pass
Force At 12.7 mm	N	104 -162	137	Pass
Force At 19 mm	N	163 - 222	190	Pass
Force At 25.4 mm	N	222 - 280	257	Pass
Force At 33 mm	N	325 - 391	343	Pass
Overall Test Results				Pass

Jessica Hall  
 Laboratory Technician

3/12/08  
 Test Date

David Winkelbauer  
 Approved By



Test Description: Abdomen Compression

Test Date: 3/12/08

Component: D08754

Speed: 0 ft/sec, 0 m/sec

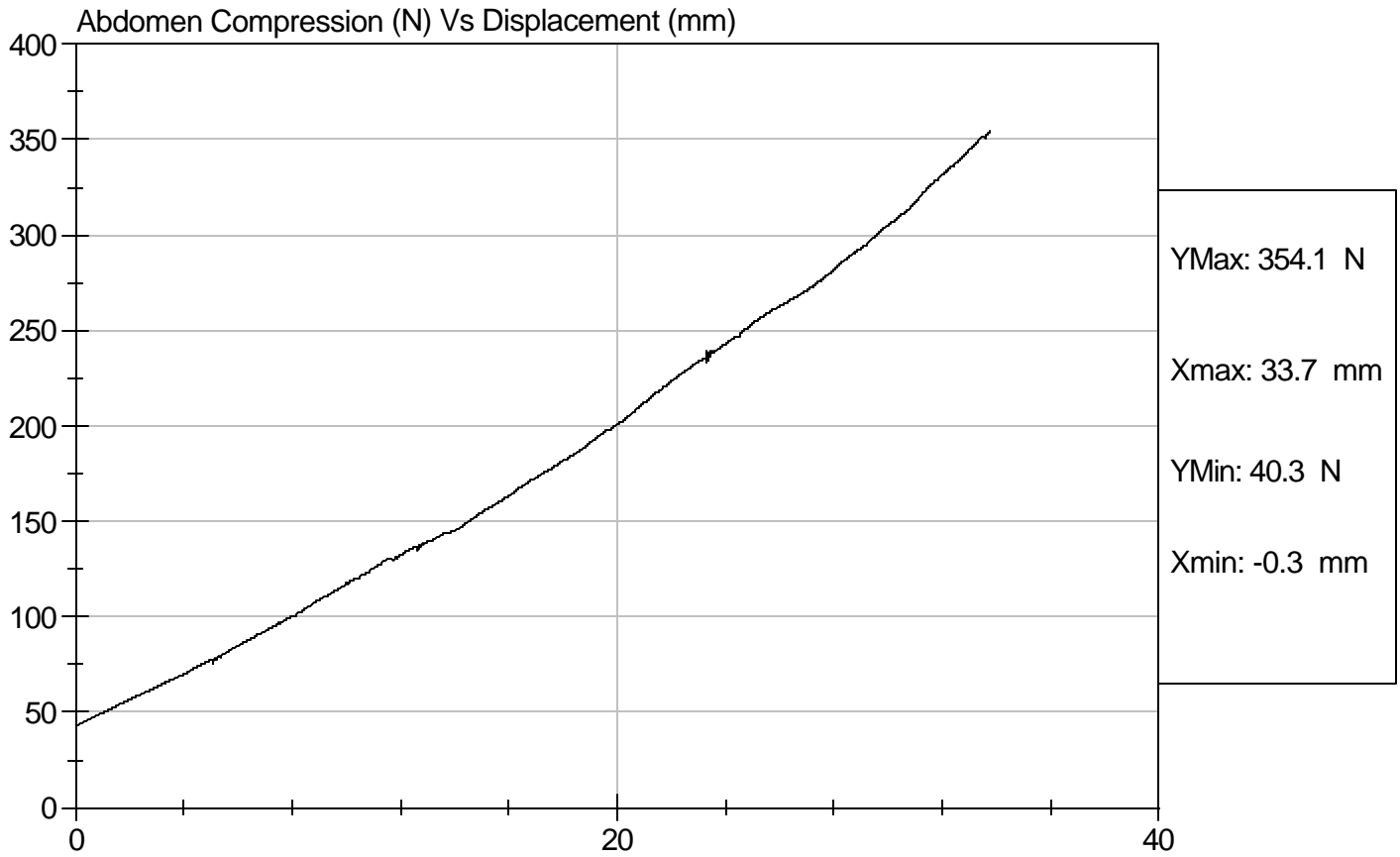

**SID/HIII Calibration Data Sheet**  
**Side Impact Dummy**  
**Lumbar Flexion Calibration**

ATD Serial No: 904

Test I.D.: D08755

Tested Parameter	Units	Specification	Result	Pass/Fail
Laboratory Temperature	deg C	18.9 - 25.5	20.2	Pass
Laboratory Relative Humidity	%	10 to 70	23	Pass
Force At 0 deg	N	0 - 26.7	0	Pass
Force At 20 deg	N	97.9 - 151.2	139.9	Pass
Force At 30 deg	N	151.2 - 204.6	188.6	Pass
Force At 40 deg	N	204.6 - 258.0	244.6	Pass
Return Angle	Deg	12 Maximum	6	Pass
Overall Test Results				Pass

Jessica Hall  
 Laboratory Technician

3/12/08  
 Test Date

David Winkelbauer  
 Approved By



Test Description: Lumbar Flexion

Test Date: 3/12/08

Component: D08755

Speed: 0 ft/sec, 0 m/sec

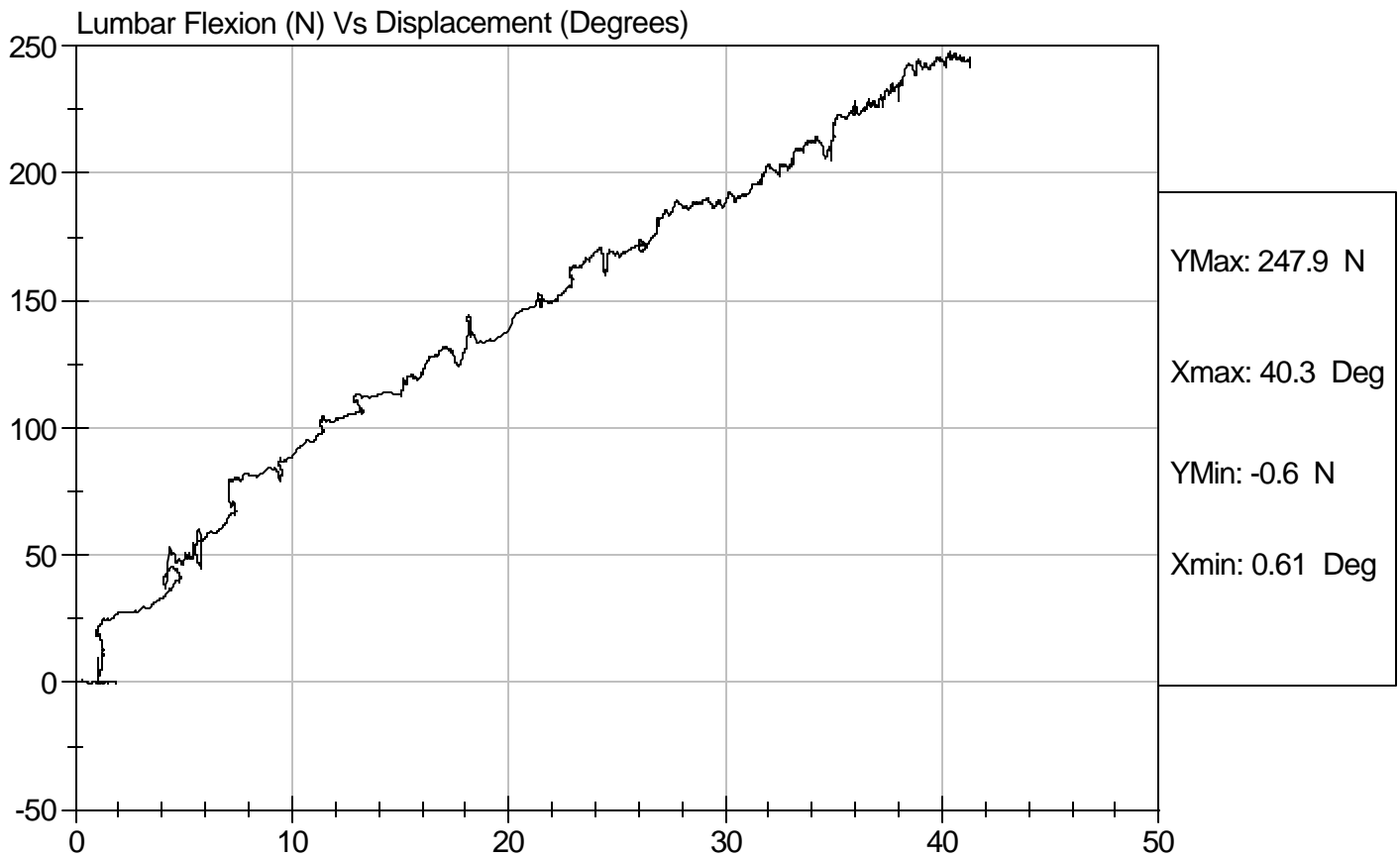

**SID/HIII Calibration Data Sheet**  
**Side Impact Dummy**  
**Neck Pendulum Test**

ATD Serial No: 904

Test I.D.: D08759

Tested Parameter		Units	Specification	Result	Pass/Fail
Laboratory Temperature		deg C	20.6 to 22.2	21.4	Pass
Laboratory Relative Humidity		%	10 to 70	22	Pass
Impact Velocity		m/s	6.89 to 7.13	7.06	Pass
Pendulum Deceleration	10 msec	m/s	1.96 to 2.55	2.43	Pass
	20 msec	m/s	4.12 to 5.10	4.67	Pass
	30 msec	m/s	5.73 to 7.01	6.37	Pass
	40 to 70 msec	m/s	6.27 to 7.64	6.68	Pass
Midsaggital Plane Max Rotation		deg	66 to 82	74	Pass
Head Rotation Peak to Zero - Decay Time		msec	58 to 67	59	Pass
Max. Mx at Occipital Condyles		Nm	73 to 88	76	Pass
Mx Peak To Zero - Decay Time		msec	49 to 64	60	Pass
Mx Peak to Max. Head Rotation		msec	2 to 16	13	Pass

Jessica Hall  
 Laboratory Technician

3/12/08  
 Test Date

David Winkelbauer  
 Approved By



Test Desc: Neck Bending  
Component ID: D08759

Test Date: 3/12/08  
Speed: 23.15 ft/sec, 7.06 m/sec

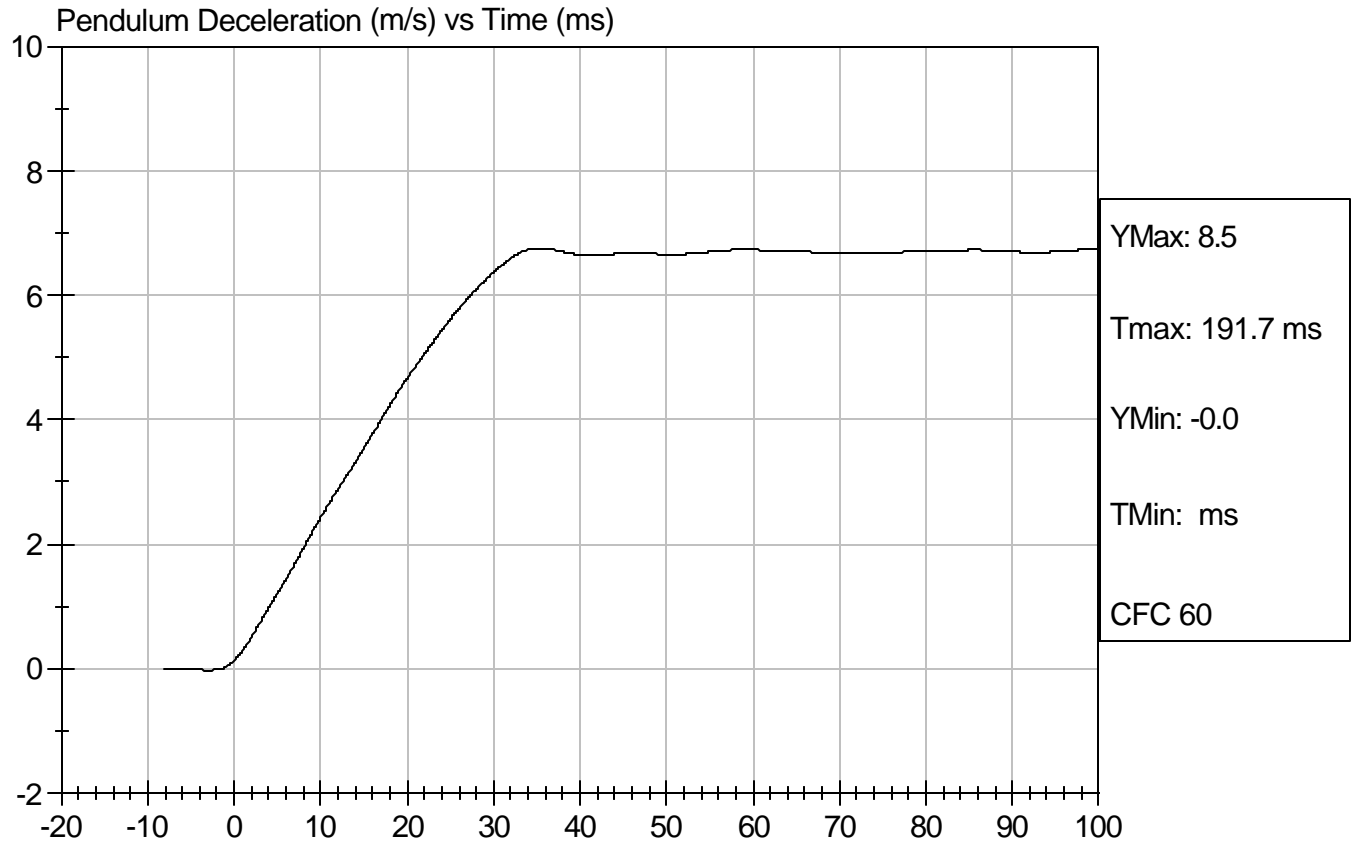



Test Desc: Neck Bending  
Component ID: D08759

Test Date: 3/12/08  
Speed: 23.15 ft/sec, 7.06 m/sec

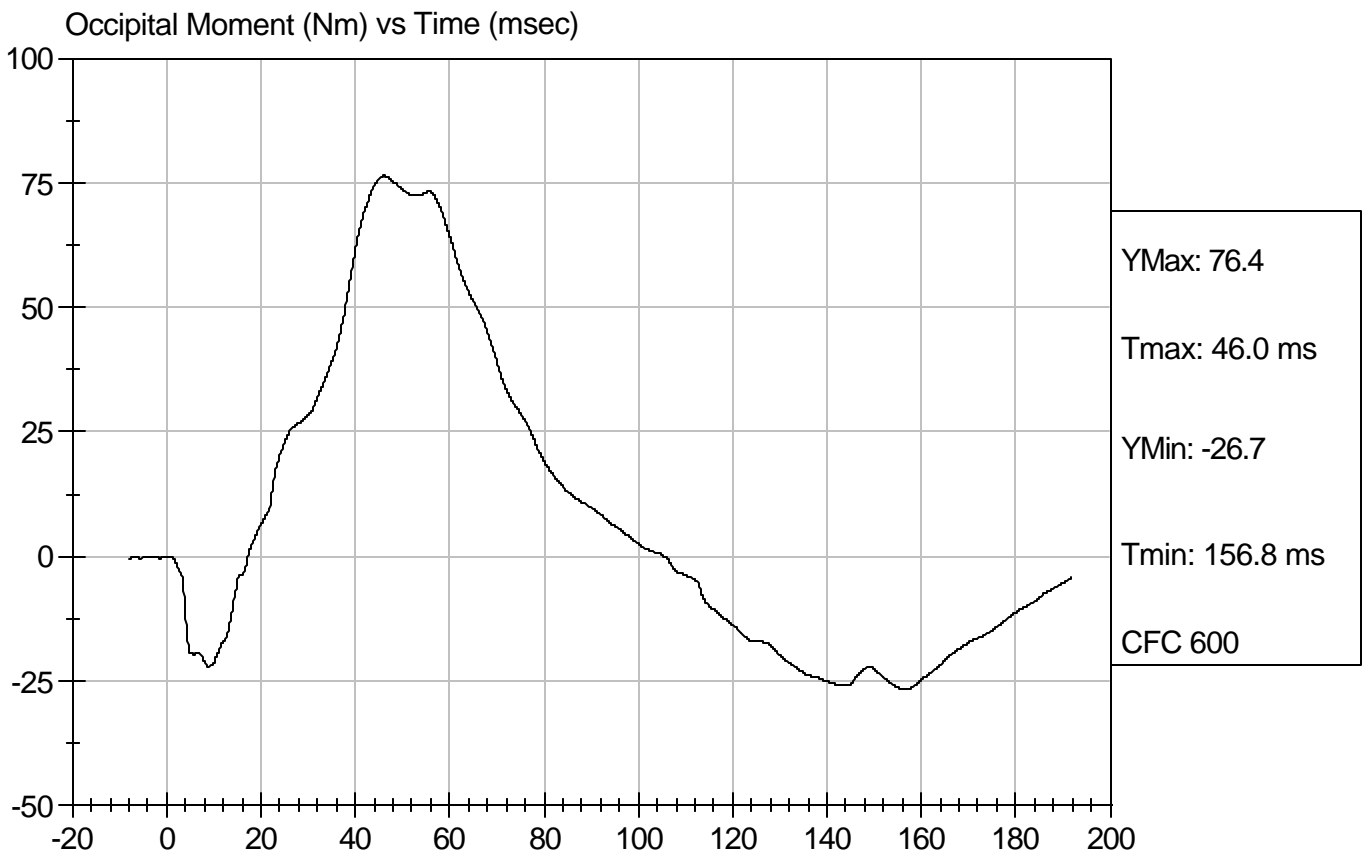
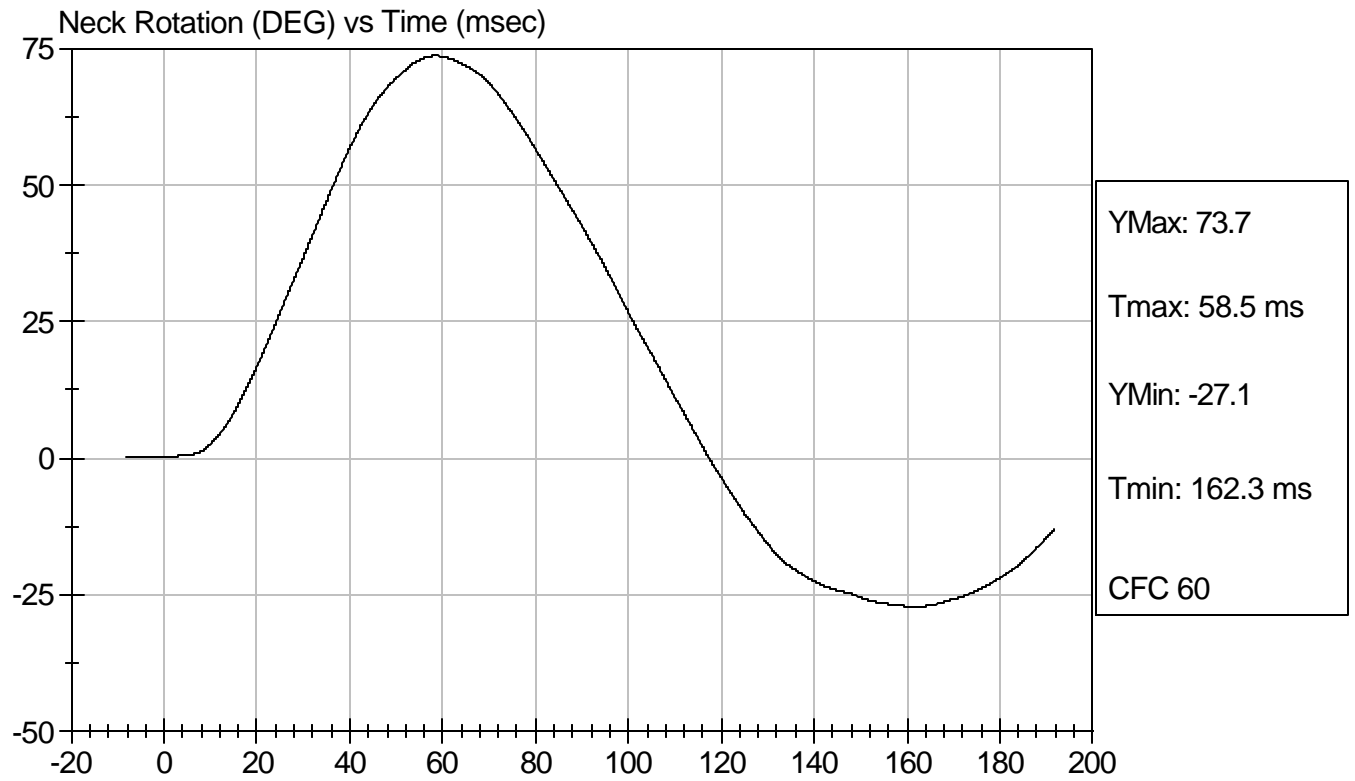

## Calibration Test Results Summary

Dummy Serial Number: 904

### Post-Test Calibration

External Dimensions:	The dummy passed all external dimension requirements.
Head Drop Test:	The head passed all drop test requirements.
Neck Pendulum Test:	The neck passed all pendulum test requirements.
Thorax Impact Test:	The thorax passed all impact test requirements.
Pelvic Impact Test:	The pelvis passed all impact test requirements.
Abdominal Compression Test:	The abdomen passed all compression test requirements.
Lumbar Flexion Test:	The lumbar passed all flexion test requirements.

**SID/HIII Calibration Data Sheet**  
**Side Impact Dummy**  
**Head Drop Calibration (Lateral)**

ATD Serial No: 904

Test I.D.: D08921

Tested Parameter	Units	Specification	Result	Pass/Fail
Laboratory Temperature	deg C	18.9 to 25.5	20.7	Pass
Laboratory Relative Humidity	%	10 to 70	25	Pass
Peak Resultant Acceleration	G's	120 to 150	139	Pass
Is Resultant Curve Unimodal?	N/A	15% of peak	Yes	Pass
Peak Longitudnal Acceleration	G's	+/- 15	-10.3	Pass
Overall Test Results				Pass

Jessica Hall  
 Laboratory Technician

3/28/08  
 Test Date

David Winkelbauer  
 Approved By



Test Description: Head Drop

Test Date: 3/28/08

Component: D08921

Speed: 0 ft/s, 0 m/s

Peak Resultant Acceleration (G's) Vs Time (msec)

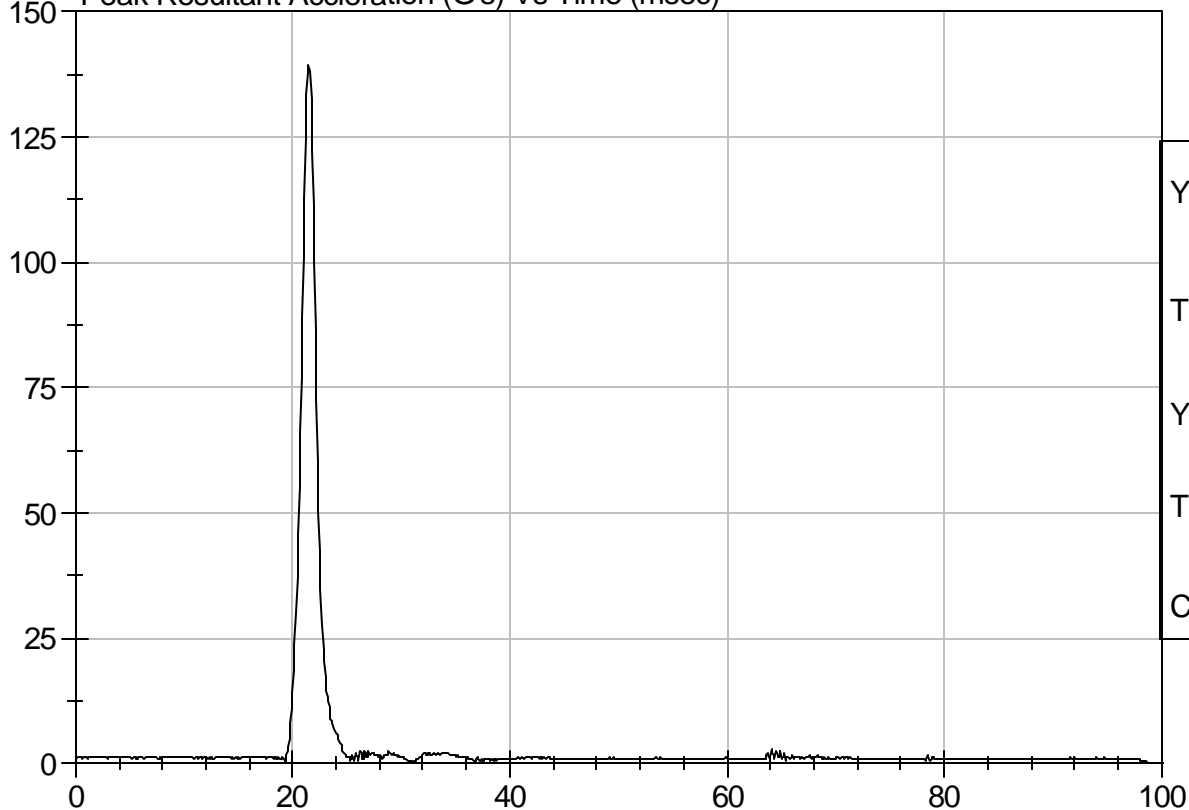

YMax: 139.4 G

Tmax: 21.5 ms

YMin: 0.0 G

Tmin: 98.7 ms

CFC 1000

Peak Longitudnal Acceleration (G's) Vs Time (msec)

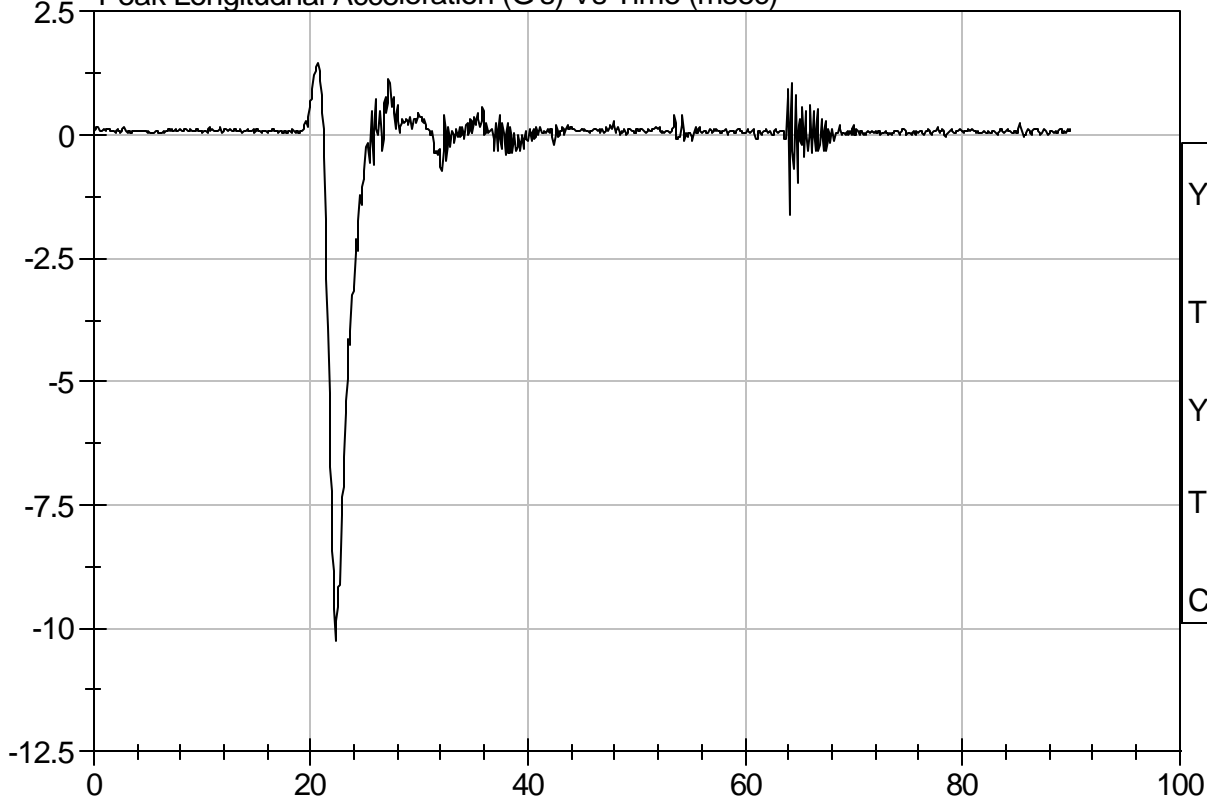

YMax: 1.5 G

Tmax: 20.7 ms

YMin: -10.3 G

Tmin: 22.3 ms

CFC 1000

**SID/HIII Calibration Data Sheet**  
**Side Impact Dummy**  
**Thorax Impact Test**

ATD Serial No: 904

Test I.D.: D08922

Tested Parameter	Units	Specification	Result	Pass/Fail
Laboratory Temperature	deg C	18.9 - 25.5	21.5	Pass
Laboratory Relative Humidity	%	10 to 70	21	Pass
Probe Velocity	m/s	4.22 - 4.31	4.23	Pass
Upper Rib	G's	37 - 46	41	Pass
Lower Rib	G's	37 - 46	39	Pass
Lower Spine	G's	15 - 22	22	Pass
Overall Test Results				Pass

Jessica Hall  
 Laboratory Technician

3/26/08  
 Test Date

David Winkelbauer  
 Approved By



Test Desc: Thorax Impact  
Component ID: D08922

Test Date: 3/26/08  
Speed: 13.88 ft/sec, 4.23 m/sec

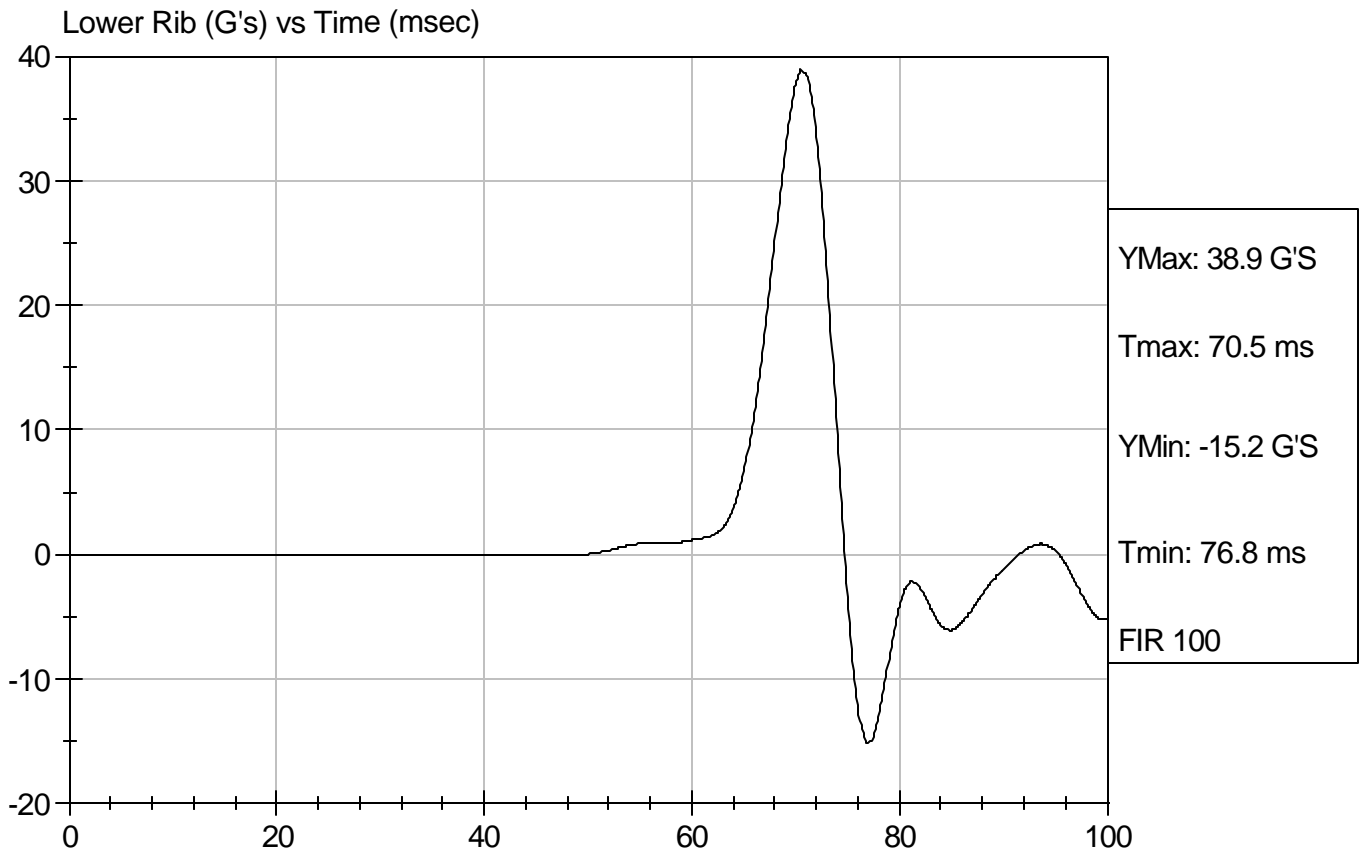
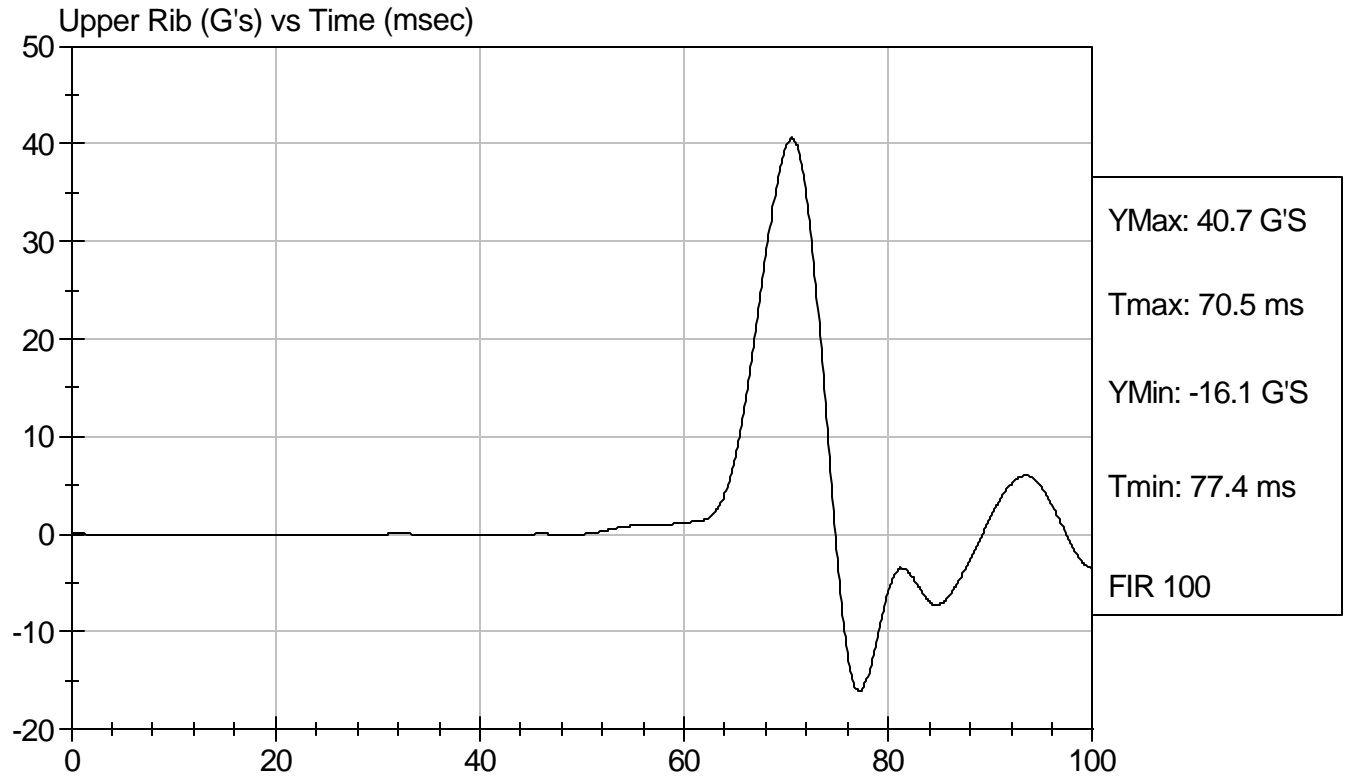



Test Desc: Thorax Impact  
Component ID: D08922

Test Date: 3/26/08  
Speed: 13.88 ft/sec, 4.23 m/sec

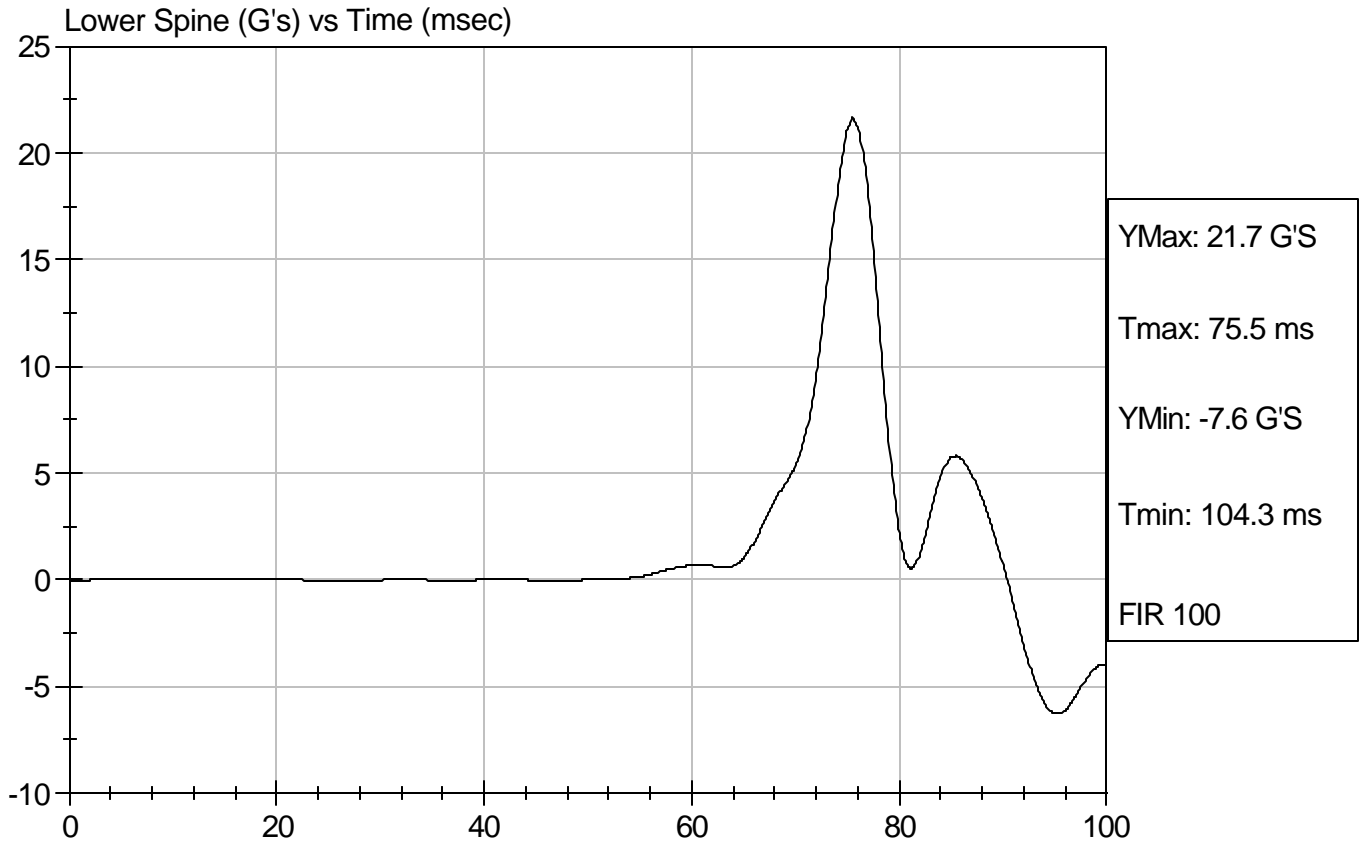

**SID/HIII Calibration Data Sheet**  
**Side Impact Dummy**  
**Pelvis Impact Test**

ATD Serial No: 904

Test I.D.: D08923

Tested Parameter	Units	Specification	Result	Pass/Fail
Laboratory Temperature	deg C	18.9 to 25.5	21.5	Pass
Laboratory Relative Humidity	%	10 to 70	21	Pass
Probe Velocity	m/s	4.27 - 4.33	4.30	Pass
Pelvis Acceleration	G's	40 - 60	40	Pass
Overall Test Results				Pass

Jessica Hall  
 Laboratory Technician

3/26/08  
 Test Date

David Winkelbauer  
 Approved By



Test Desc: Pelvis Impact  
Component ID: D08923

Test Date: 3/26/08  
Speed: 14.124 ft/sec, 4.30 m/sec

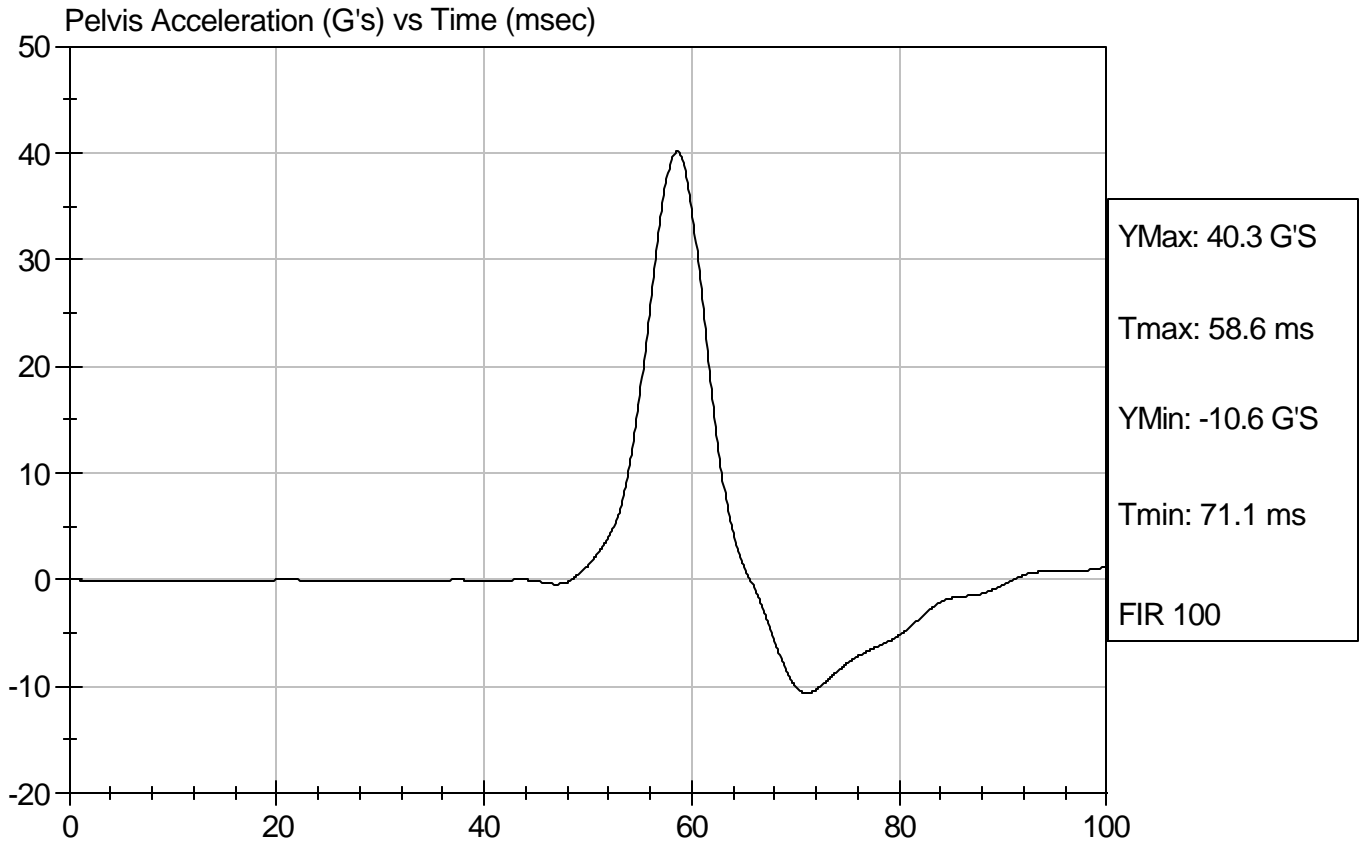

**SID/HIII Calibration Data Sheet**  
**Side Impact Dummy**  
**Abdominal Compression Calibration (Pre-Load = 10 lbs)**

ATD Serial No: 904

Test I.D.: D08924

Tested Parameter	Units	Specification	Result	Pass/Fail
Laboratory Temperature	deg C	18.9 - 25.5	20.7	Pass
Laboratory Relative Humidity	%	10 to 70	25	Pass
Force At 12.7 mm	N	104 - 162	137	Pass
Force At 19 mm	N	163 - 222	191	Pass
Force At 25.4 mm	N	222 - 280	258	Pass
Force At 33 mm	N	325 - 391	352	Pass
Overall Test Results				Pass

Jessica Hall  
 Laboratory Technician

3/27/08  
 Test Date

David Winkelbauer  
 Approved By



Test Description: Abdomen Compression

Test Date: 3/27/08

Component: D08924

Speed: 0 ft/sec, 0 m/sec

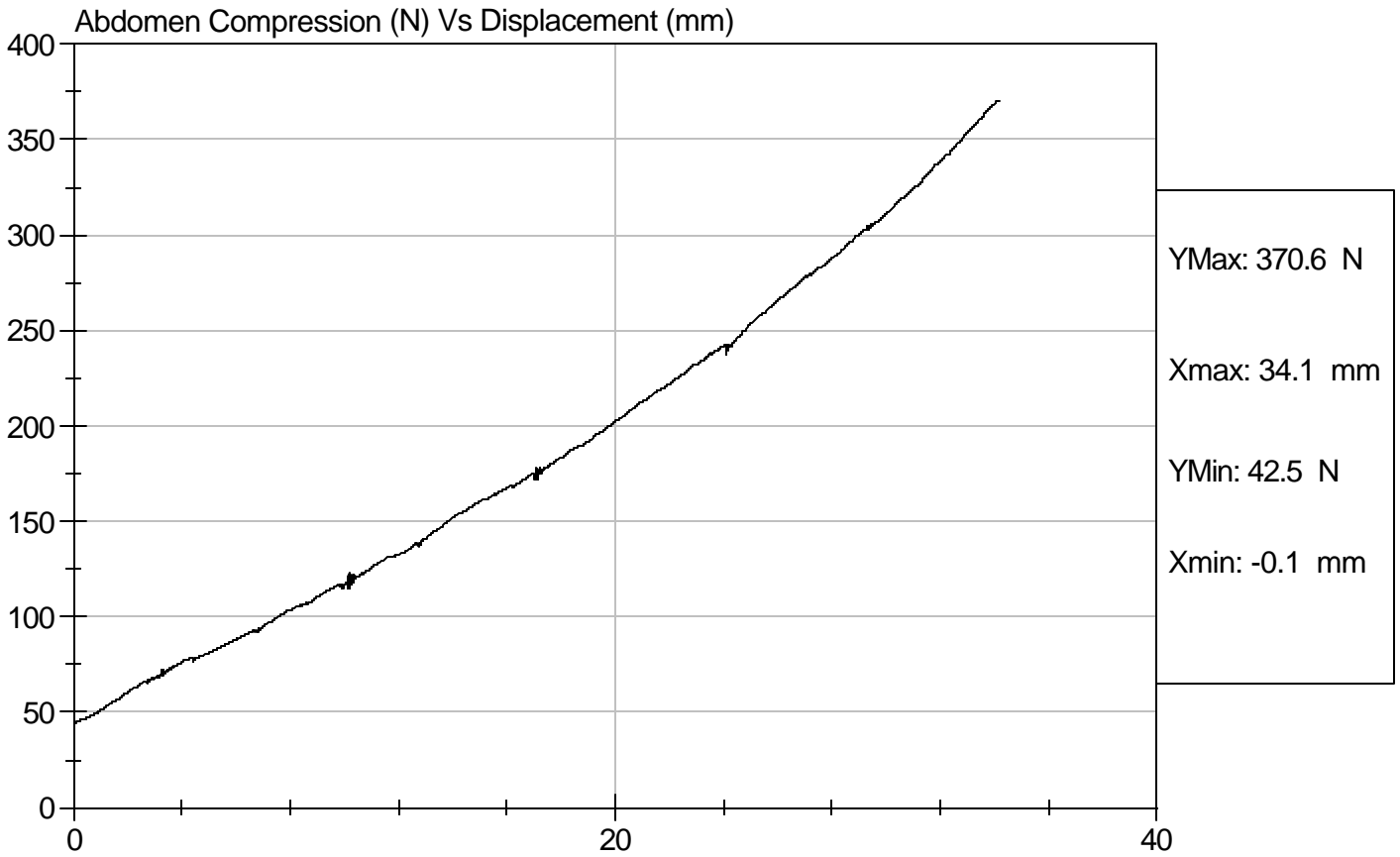

**SID/HIII Calibration Data Sheet**  
**Side Impact Dummy**  
**Lumbar Flexion Calibration**

ATD Serial No: 904

Test I.D.: D08925

Tested Parameter	Units	Specification	Result	Pass/Fail
Laboratory Temperature	deg C	18.9 - 25.5	20.7	Pass
Laboratory Relative Humidity	%	10 to 70	25	Pass
Force At 0 deg	N	0 - 26.7	0	Pass
Force At 20 deg	N	97.9 - 151.2	110.2	Pass
Force At 30 deg	N	151.2 - 204.6	165.3	Pass
Force At 40 deg	N	204.6 - 258.0	233.2	Pass
Return Angle	Deg	12 Maximum	8	Pass
Overall Test Results				Pass

Jessica Hall  
 Laboratory Technician

3/27/08  
 Test Date

David Winkelbauer  
 Approved By



Test Description: Lumbar Flexion

Test Date: 3/27/08

Component: D08925

Speed: 0 ft/sec, 0 m/sec

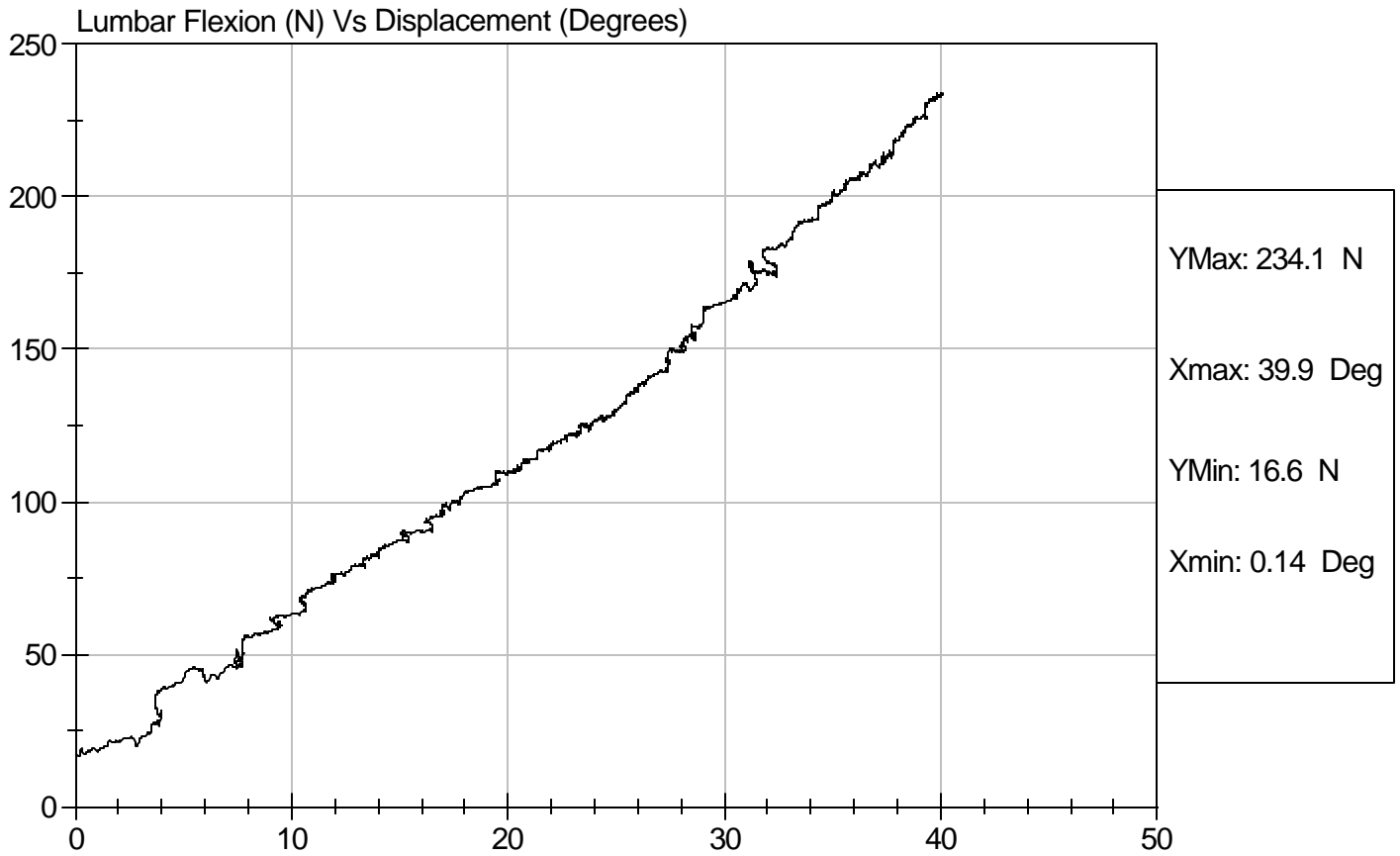

**Calibration Data Sheet  
Side Impact Dummy  
Neck Pendulum Test**

ATD Serial No: 904

Test I.D.: D08929

Tested Parameter	Units	Specification	Result	Pass/Fail	
Laboratory Temperature	deg C	20.6 to 22.2	20.6	Pass	
Laboratory Relative Humidity	%	10 to 70	25	Pass	
Impact Velocity	m/s	6.89 to 7.13	7.06	Pass	
Pendulum Deceleration	10 msec	m/s	1.96 to 2.55	2.16	Pass
	20 msec	m/s	4.12 to 5.10	4.22	Pass
	30 msec	m/s	5.73 to 7.01	5.92	Pass
	40 to 70 msec	m/s	6.27 to 7.64	6.73	Pass
Midsaggital Plane Max Rotation	deg	66 to 82	71	Pass	
Head Rotation Peak to Zero - Decay Time	msec	58 to 67	60	Pass	
Max. Mx at Occipital Condyles	Nm	73 to 88	78	Pass	
Mx Peak To Zero - Decay Time	msec	49 to 64	59	Pass	
Mx Peak to Max. Head Rotation	msec	2 to 16	10	Pass	

Jessica Hall  
Laboratory Technician

3/27/08  
Test Date

David Winkelbauer  
Approved By

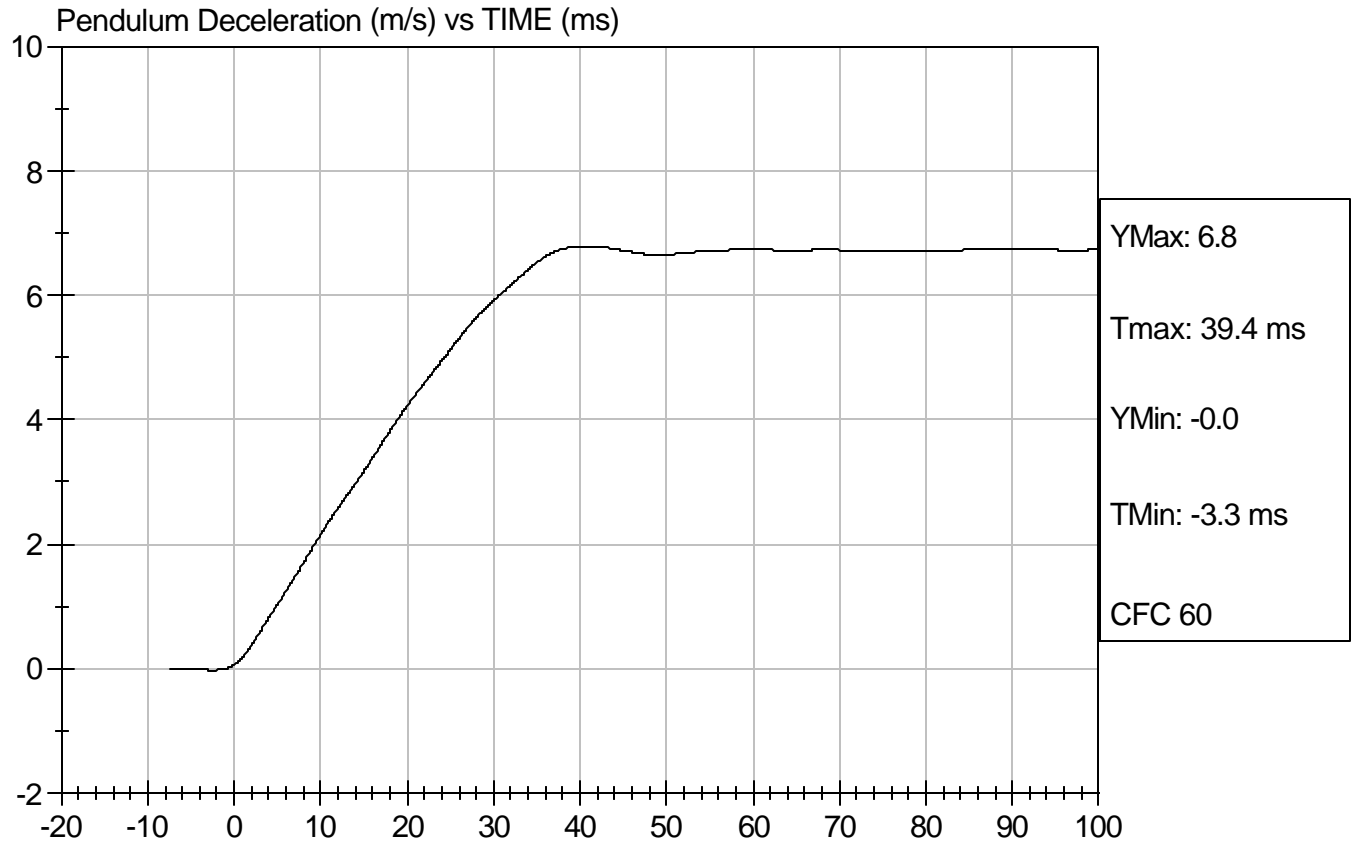



Test Desc: Neck Bending  
Component ID: D08929

Test Date: 3/27/08  
Speed: 23.15 ft/sec, 7.06 m/sec

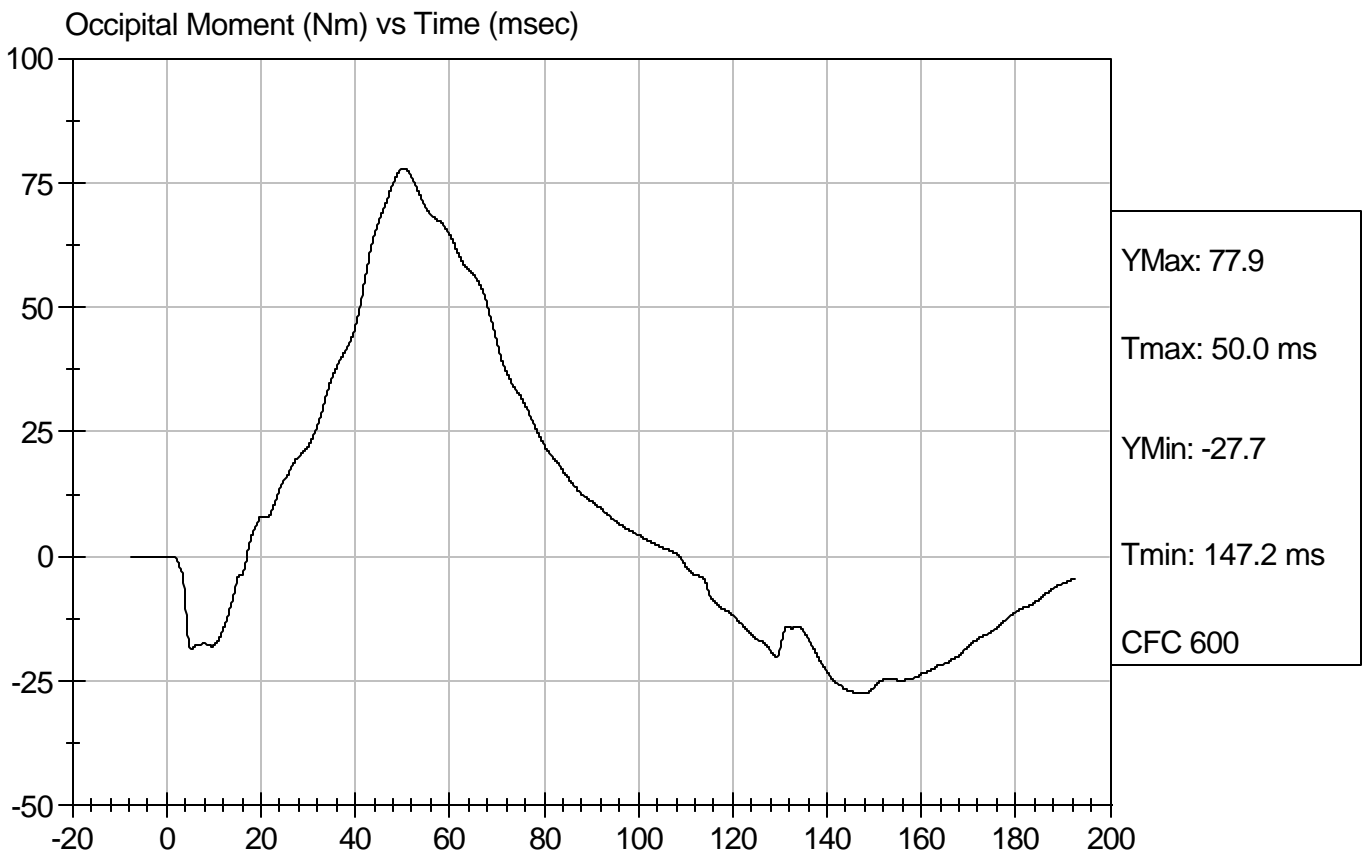
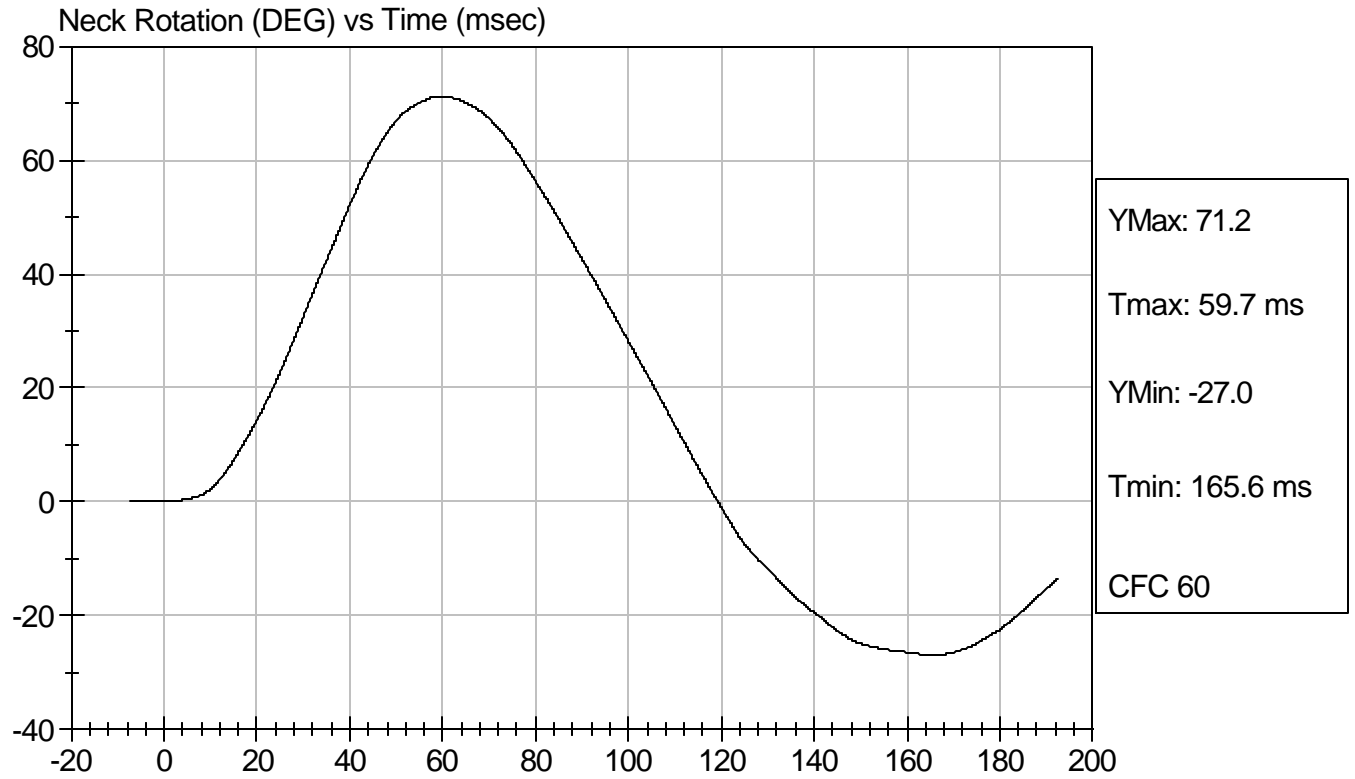

**SID/HIII Calibration Data Sheet**  
**Side Impact Dummy**  
**Inspection Checklist**

**ATD Serial No:** 904

Test Part	Items Checked	Result
Skin	Visual inspection	Pass
Head	Visual, ballast, accelerometer mount	Pass
Neck	Visual	Pass
Spine Box	Visual, ballast, accelerometer mount	Pass
Rib Cage	Visual, measure	Pass
Sternum	Visual	Pass
Lumbar Spine	Visual	Pass
Abdomen	Visual	Pass
Pelvis	Visual, palpate, accelerometer mount	Pass
Upper Legs	Visual	Pass
Knees	Visual	Pass
Lower Legs	Visual, range of motion	Pass
Ankles	Visual, range of motion	Pass
Feet	Visual, range of motion	Pass
Joints	1 to 2 g range	Pass
Other		Pass

*Jessica Hall*  
 Laboratory Technician  
*David Winkelbauer*  
 Approved By

3/27/2008  
 Test Date

CERTIFICATION DATA

Dummy Serial Number: 271

## Calibration Test Results Summary

Dummy Serial Number: 271

### Pre-Test Calibration

External Dimensions:	The dummy passed all external dimension requirements.
Head Drop Test:	The head passed all drop test requirements.
Neck Pendulum Test:	The neck passed all pendulum test requirements.
Thorax Impact Test:	The thorax passed all impact test requirements.
Pelvic Impact Test:	The pelvis passed all impact test requirements.
Abdominal Compression Test:	The abdomen passed all compression test requirements.
Lumbar Flexion Test:	The lumbar passed all flexion test requirements.

**SID/HIII Calibration Data Sheet**  
**Side Impact Dummy**  
**External Measurements**

ATD Serial No: 271

Test I.D.: D0874

Tested Parameter	Units	Specification	Result	Pass/Fail
SH - Seated Height	mm	889 - 909	905	Pass
RH - Rib Height	mm	501 - 521	502	Pass
HP - Hip Pivot Height	mm	99 ref.	99	Pass
RD - Rib from Back Line	mm	229 - 241	239	Pass
KV - Knee Pivot to Back Line	mm	511 - 526	526	Pass
SW - Knee Pivot to Floor	mm	490 - 505	497	Pass
HW - Hip Width	mm	356 - 391	371	Pass
Overall Test Results				Pass

Jessica Gall  
 Laboratory Technician

3/12/2008  
 Test Date

David Winkelbauer  
 Approved By

**SID/HIII Calibration Data Sheet**  
**Side Impact Dummy**  
**Head Drop Calibration (Lateral)**

ATD Serial No: 271

Test I.D.: D08741

Tested Parameter	Units	Specification	Result	Pass/Fail
Laboratory Temperature	deg C	18.9 to 25.5	21.2	Pass
Laboratory Relative Humidity	%	10 to 70	22	Pass
Peak Resultant Acceleration	G's	120 to 150	143	Pass
Is Resultant Curve Unimodal?	N/A	15% of peak	Yes	Pass
Peak Longitudnal Acceleration	G's	+/- 15	8.4	Pass
Overall Test Results				Pass

Jessica Hall  
 Laboratory Technician

3/12/08  
 Test Date

David Winkelbauer  
 Approved By



Test Description: Head Drop

Test Date: 3/12/08

Component: D08741

Speed: 0 ft/s, 0 m/s

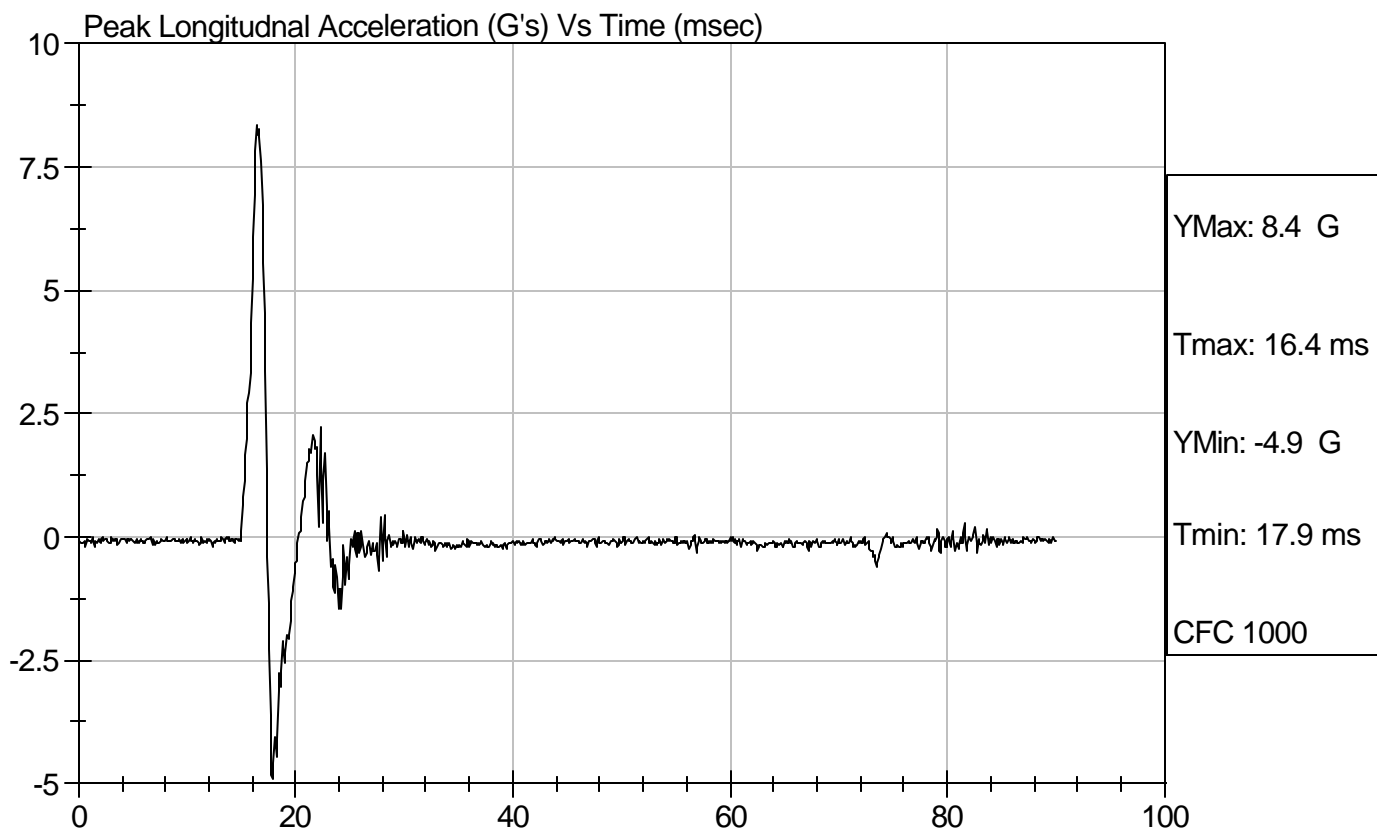
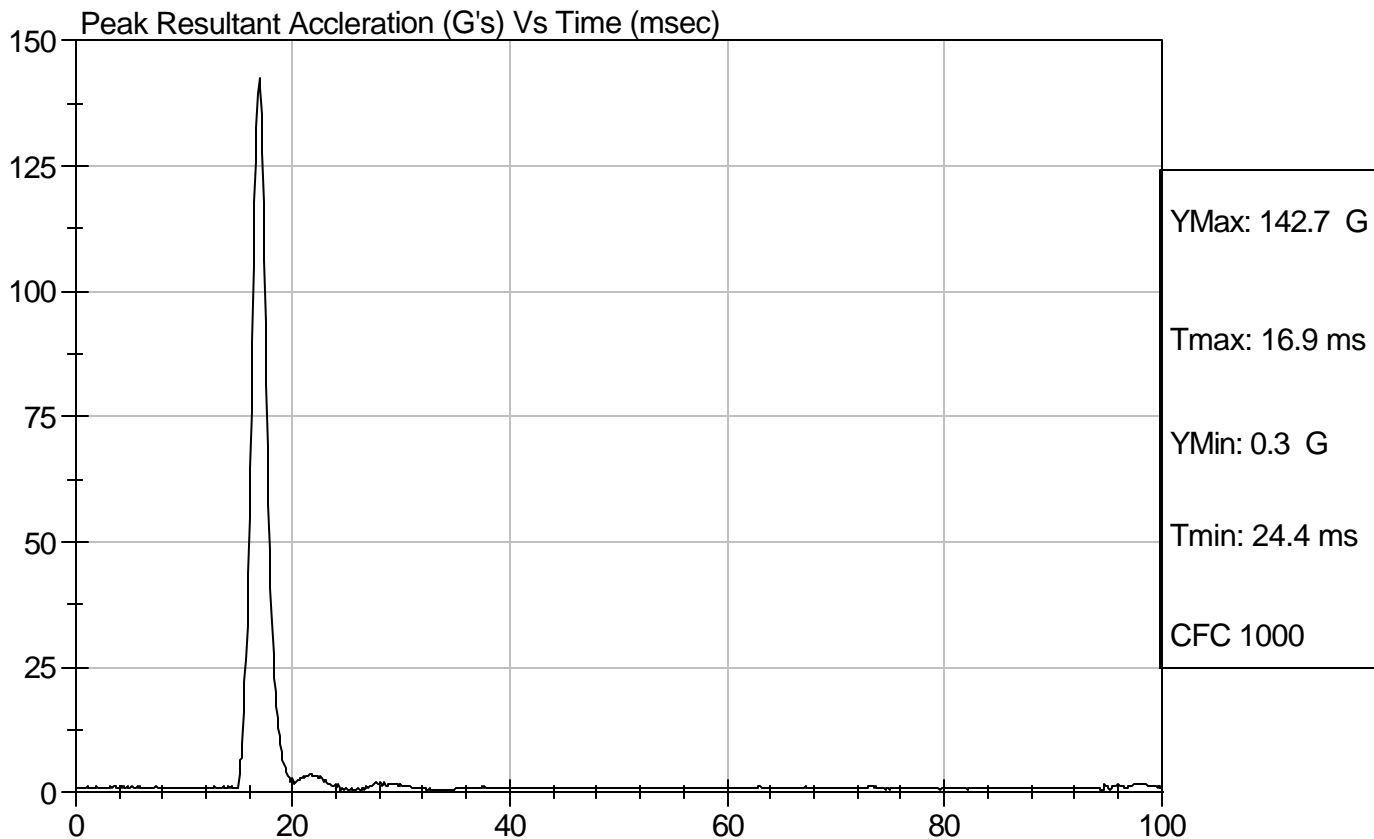

**SID/HIII Calibration Data Sheet**  
**Side Impact Dummy**  
**Thorax Impact Test**

ATD Serial No: 271

Test I.D.: D08742

Tested Parameter	Units	Specification	Result	Pass/Fail
Laboratory Temperature	deg C	18.9 - 25.5	20.7	Pass
Laboratory Relative Humidity	%	10 to 70	22	Pass
Probe Velocity	m/s	4.22 - 4.31	4.23	Pass
Upper Rib	G's	37 - 46	44	Pass
Lower Rib	G's	37 - 46	43	Pass
Lower Spine	G's	15 - 22	21	Pass
Overall Test Results				Pass

Jessica Hall  
 Laboratory Technician

3/12/08  
 Test Date

David Winkelbauer  
 Approved By



Test Desc: Thorax Impact  
Component ID: D08742

Test Date: 3/12/08  
Speed: 13.89 ft/sec, 4.23 m/sec

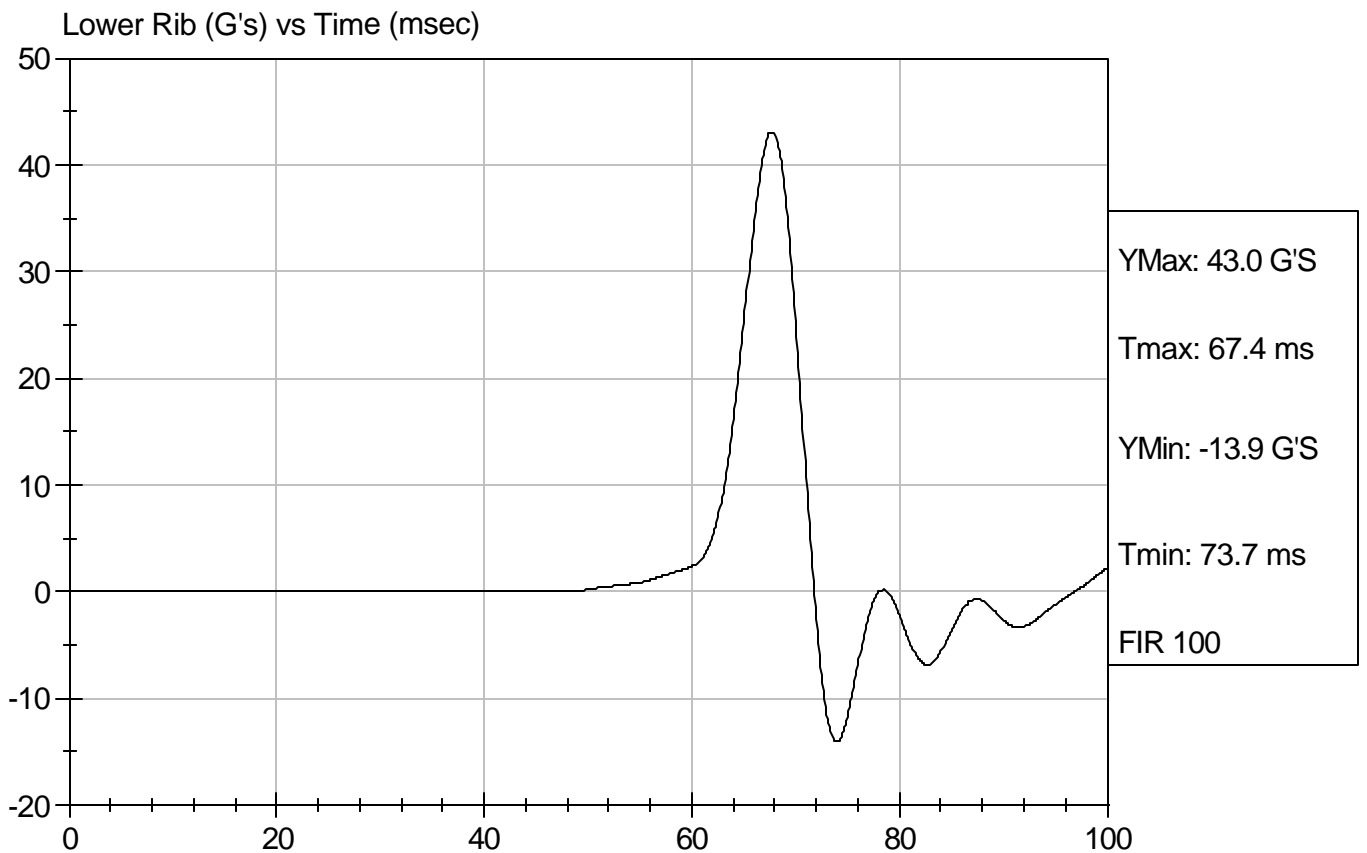
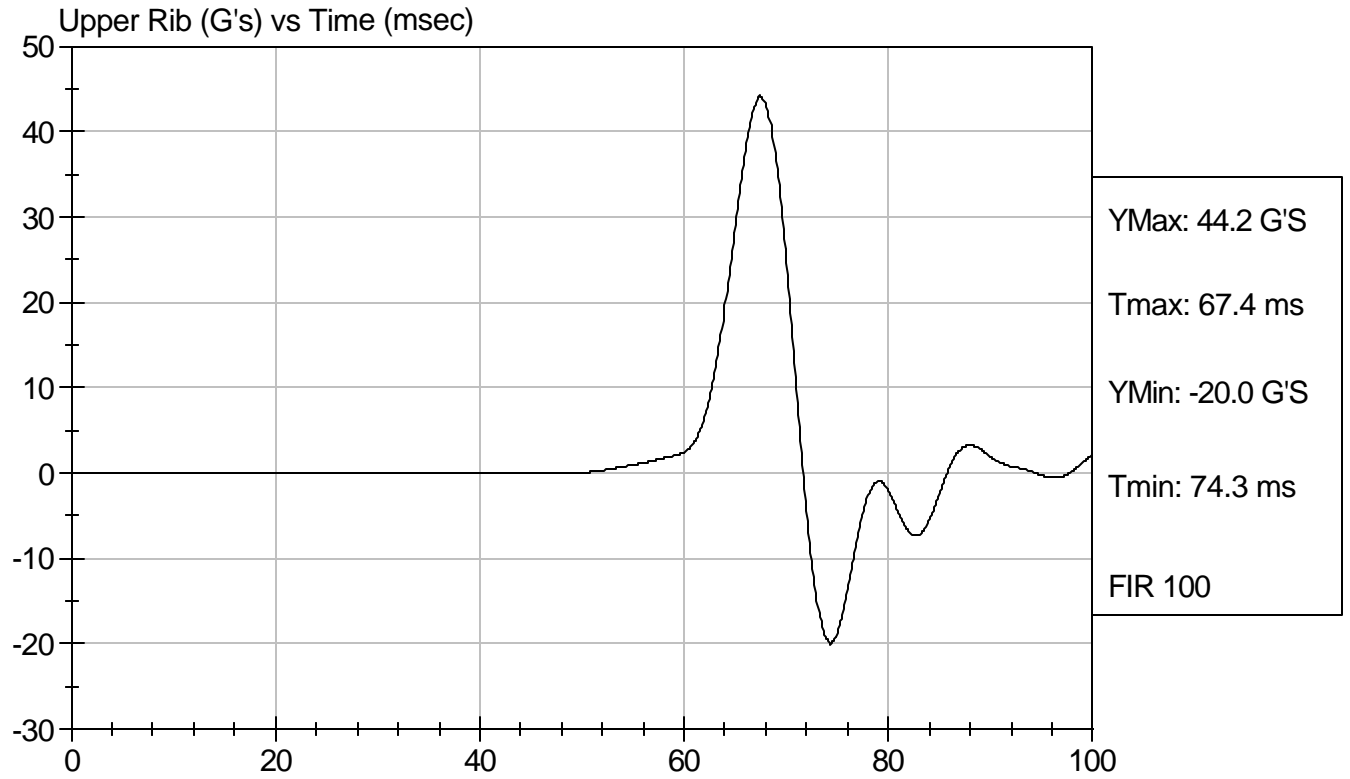



Test Desc: Thorax Impact  
Component ID: D08742

Test Date: 3/12/08  
Speed: 13.89 ft/sec, 4.23 m/sec

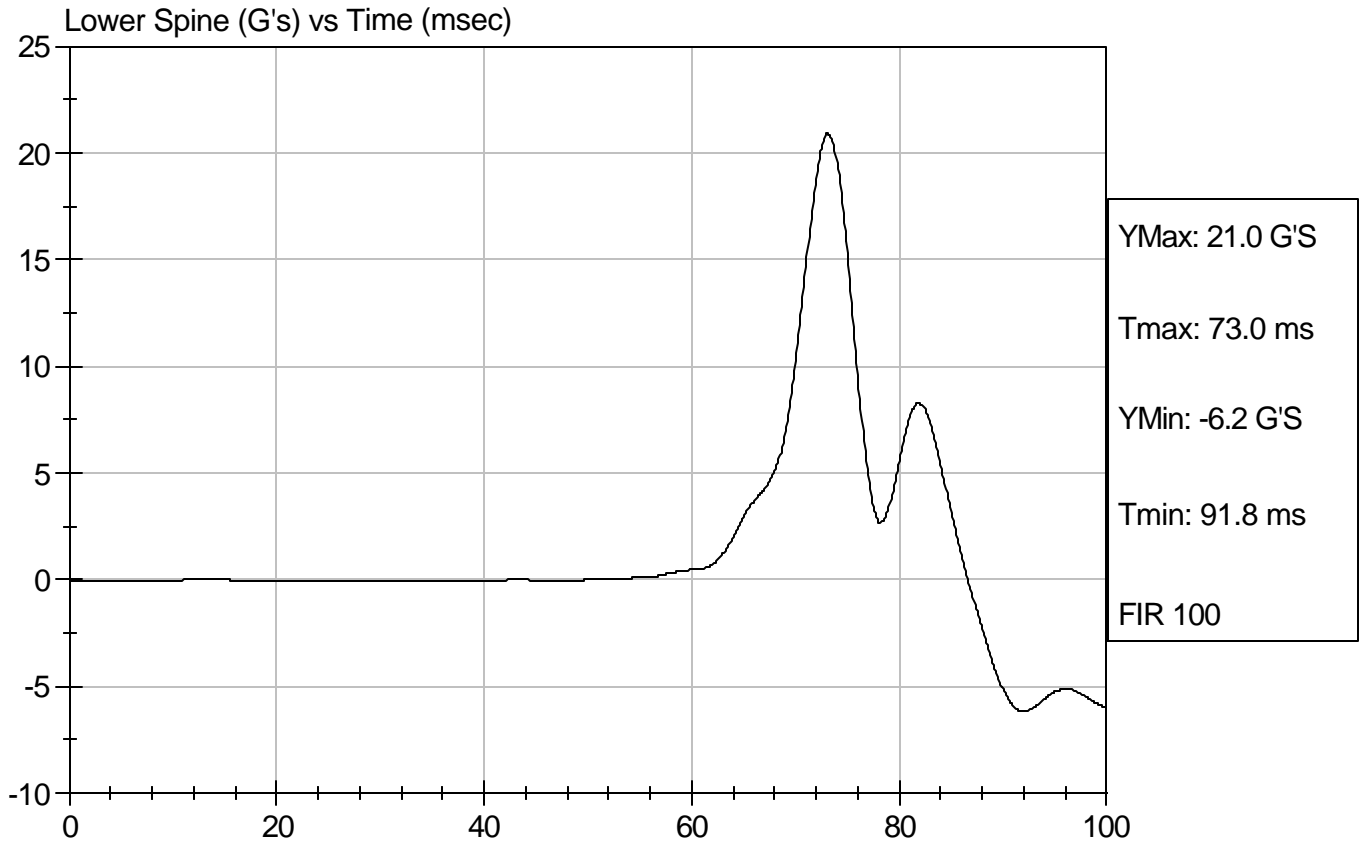

**SID/HIII Calibration Data Sheet**  
**Side Impact Dummy**  
**Pelvis Impact Test**

ATD Serial No: 271

Test I.D.: D08743

Tested Parameter	Units	Specification	Result	Pass/Fail
Laboratory Temperature	deg C	18.9 to 25.5	20.7	Pass
Laboratory Relative Humidity	%	10 to 70	22	Pass
Probe Velocity	m/s	4.27 - 4.33	4.30	Pass
Pelvis Acceleration	G's	40 - 60	41	Pass
Overall Test Results				Pass

Jessica Hall  
Laboratory Technician

3/12/08  
Test Date

David Winkelbauer  
Approved By



Test Desc: Pelvis Impact  
Component ID: D08743

Test Date: 3/12/08  
Speed: 14.12 ft/sec, 4.30 m/sec

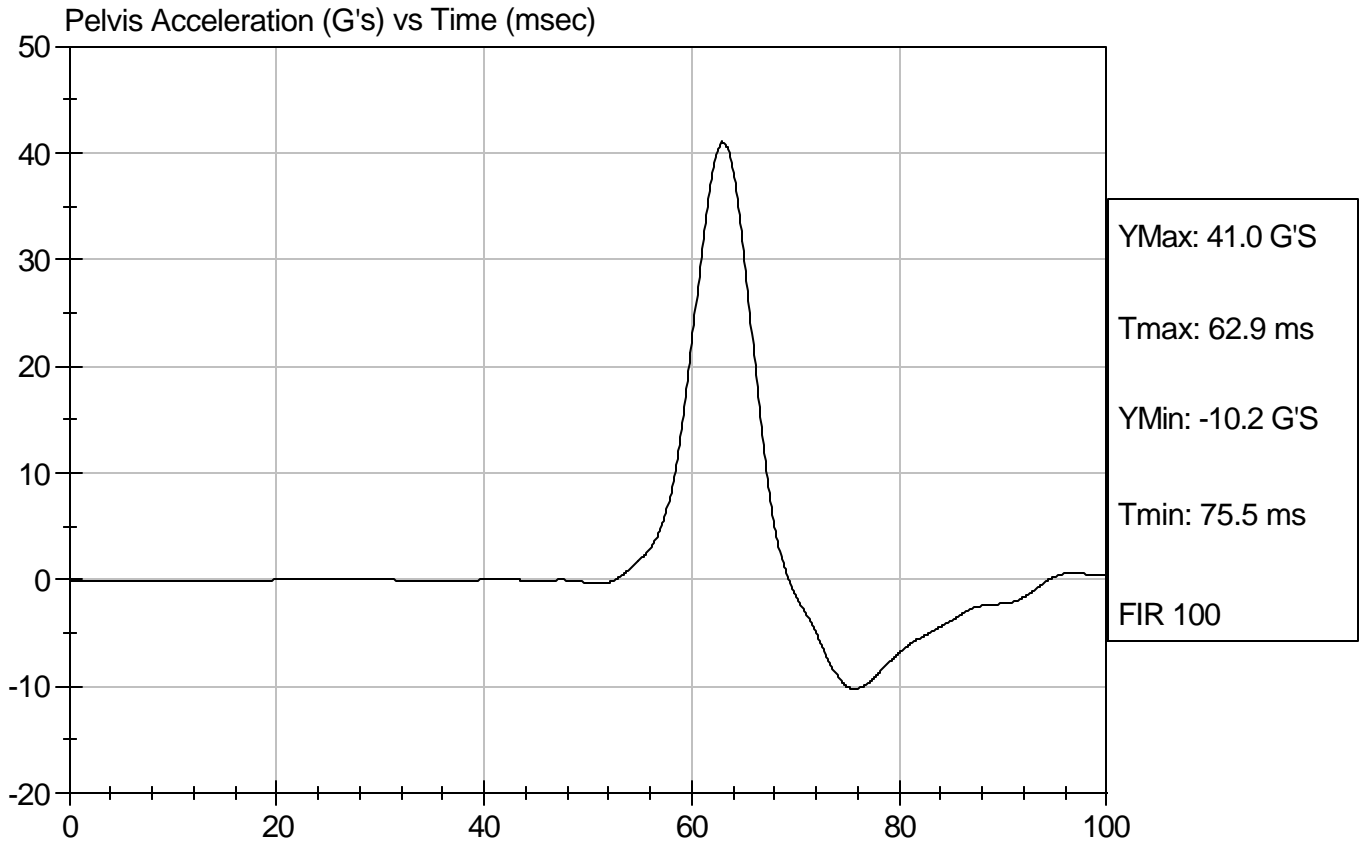

**SID/HIII Calibration Data Sheet**  
**Side Impact Dummy**  
**Abdominal Compression Calibration (Pre-Load = 10 lbs)**

ATD Serial No: 271

Test I.D.: D08744

Tested Parameter	Units	Specification	Result	Pass/Fail
Laboratory Temperature	deg C	18.9 - 25.5	20.2	Pass
Laboratory Relative Humidity	%	10 to 70	23	Pass
Force At 12.7 mm	N	104 -162	140	Pass
Force At 19 mm	N	163 - 222	191	Pass
Force At 25.4 mm	N	222 - 280	265	Pass
Force At 33 mm	N	325 - 391	368	Pass
Overall Test Results				Pass

Jessica Hall  
 Laboratory Technician

3/12/08  
 Test Date

David Winkelbauer  
 Approved By



Test Description: Abdomen Compression

Test Date: 3/12/08

Component: D08744

Speed: 0 ft/sec, 0 m/sec

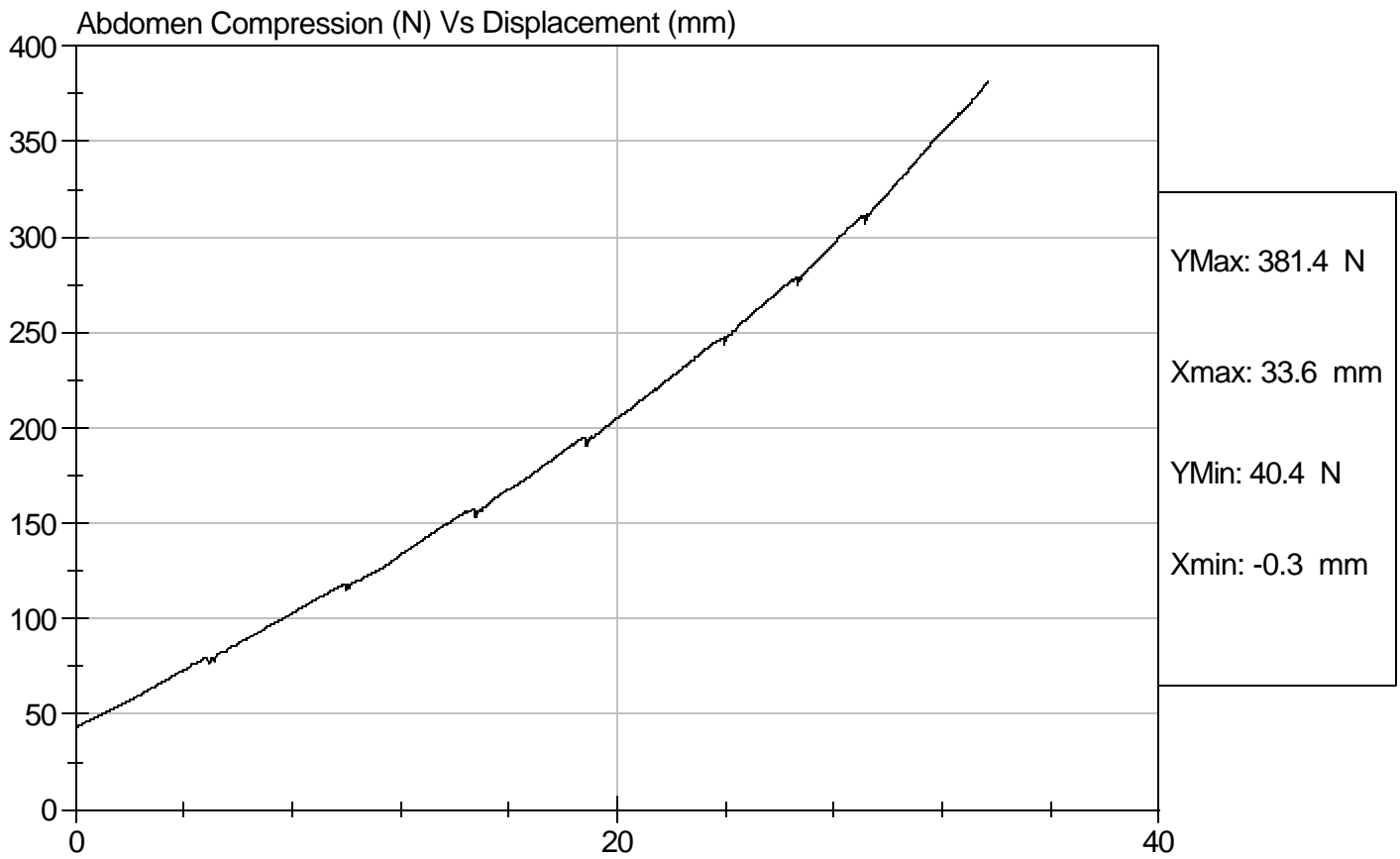

**SID/HIII Calibration Data Sheet**  
**Side Impact Dummy**  
**Lumbar Flexion Calibration**

ATD Serial No: 271

Test I.D.: D08745

Tested Parameter	Units	Specification	Result	Pass/Fail
Laboratory Temperature	deg C	18.9 - 25.5	20.2	Pass
Laboratory Relative Humidity	%	10 to 70	23	Pass
Force At 0 deg	N	0 - 26.7	0	Pass
Force At 20 deg	N	97.9 - 151.2	137.2	Pass
Force At 30 deg	N	151.2 - 204.6	173.4	Pass
Force At 40 deg	N	204.6 - 258.0	232.4	Pass
Return Angle	Deg	12 Maximum	4	Pass
Overall Test Results				Pass

Jessica Hall  
 Laboratory Technician

3/12/08  
 Test Date

David Winkelbauer  
 Approved By



Test Description: Lumbar Flexion

Test Date: 3/12/08

Component: D08745

Speed: 0 ft/sec, 0 m/sec

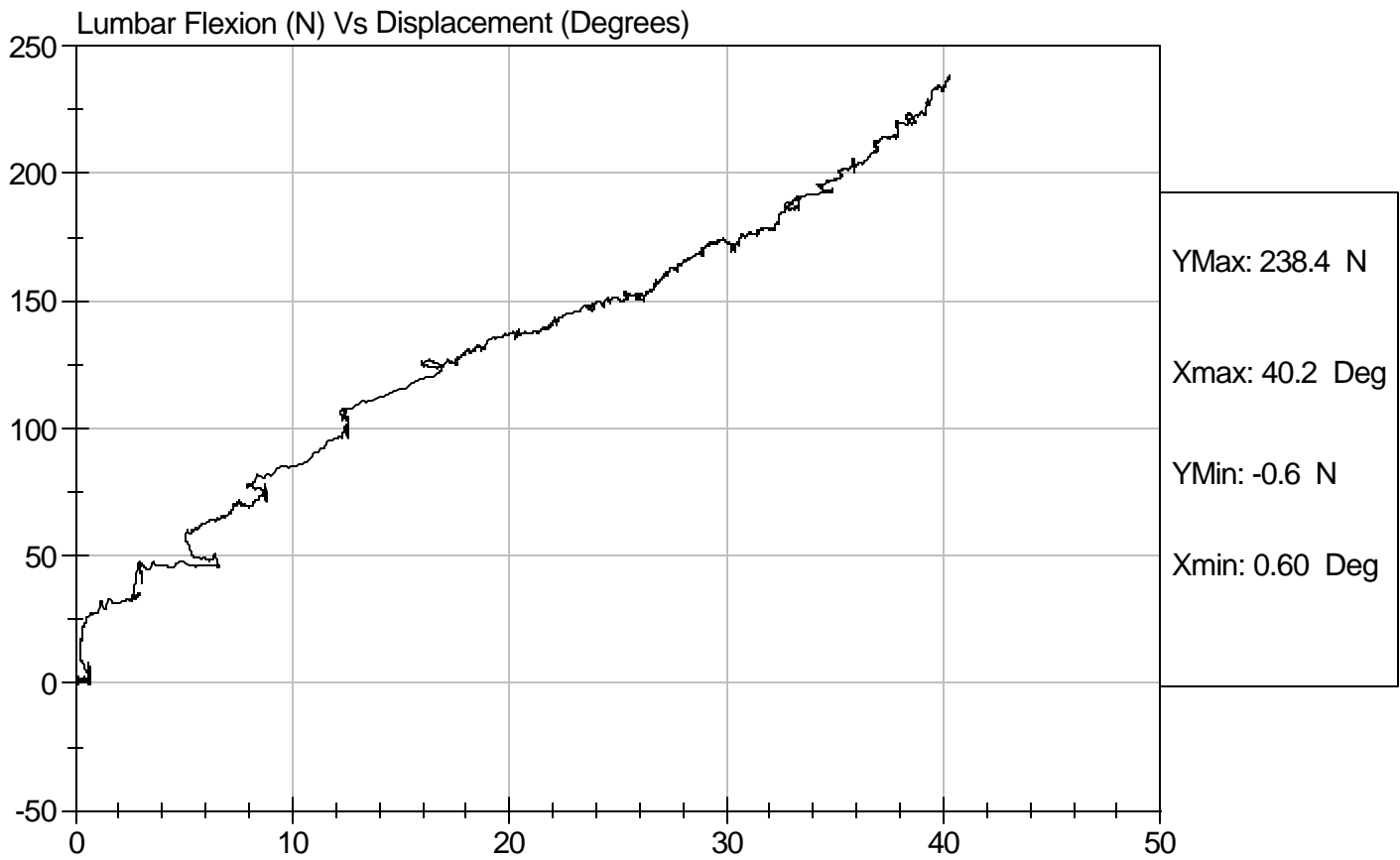

**SID/HIII Calibration Data Sheet**

**Side Impact Dummy  
Neck Pendulum Test**

**ATD Serial No:** 271

**Test I.D.:** D08749

Tested Parameter		Units	Specification	Result	Pass/Fail
Laboratory Temperature		deg C	20.6 to 22.2	21.0	Pass
Laboratory Relative Humidity		%	10 to 70	22	Pass
Impact Velocity		m/s	6.89 to 7.13	7.07	Pass
Pendulum Deceleration	10 msec	m/s	1.96 to 2.55	2.20	Pass
	20 msec	m/s	4.12 to 5.10	4.31	Pass
	30 msec	m/s	5.73 to 7.01	6.10	Pass
	40 to 70 msec	m/s	6.27 to 7.64	6.71	Pass
Midsaggital Plane Max Rotation		deg	66 to 82	73	Pass
Head Rotation Peak to Zero - Decay Time		msec	58 to 67	60	Pass
Max. Mx at Occipital Condyles		Nm	73 to 88	77	Pass
Mx Peak To Zero - Decay Time		msec	49 to 64	59	Pass
Mx Peak to Max. Head Rotation		msec	2 to 16	11	Pass

Jessica Hall  
Laboratory Technician

3/12/08  
Test Date

David Winkelbauer  
Approved By

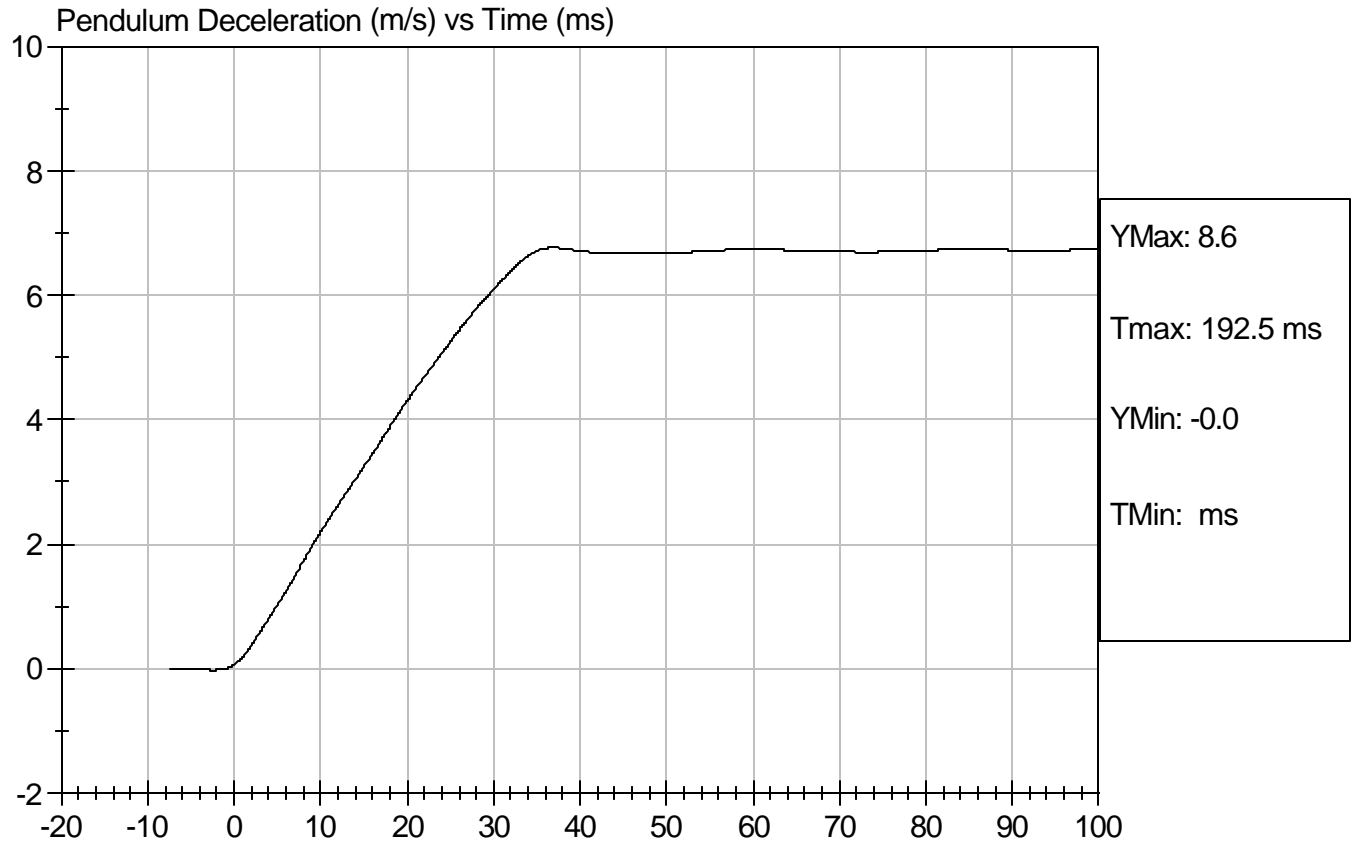



Test Desc: Neck Bending  
Component ID: D08749

Test Date: 3/12/08  
Speed: 23.20 ft/sec, 7.07 m/sec

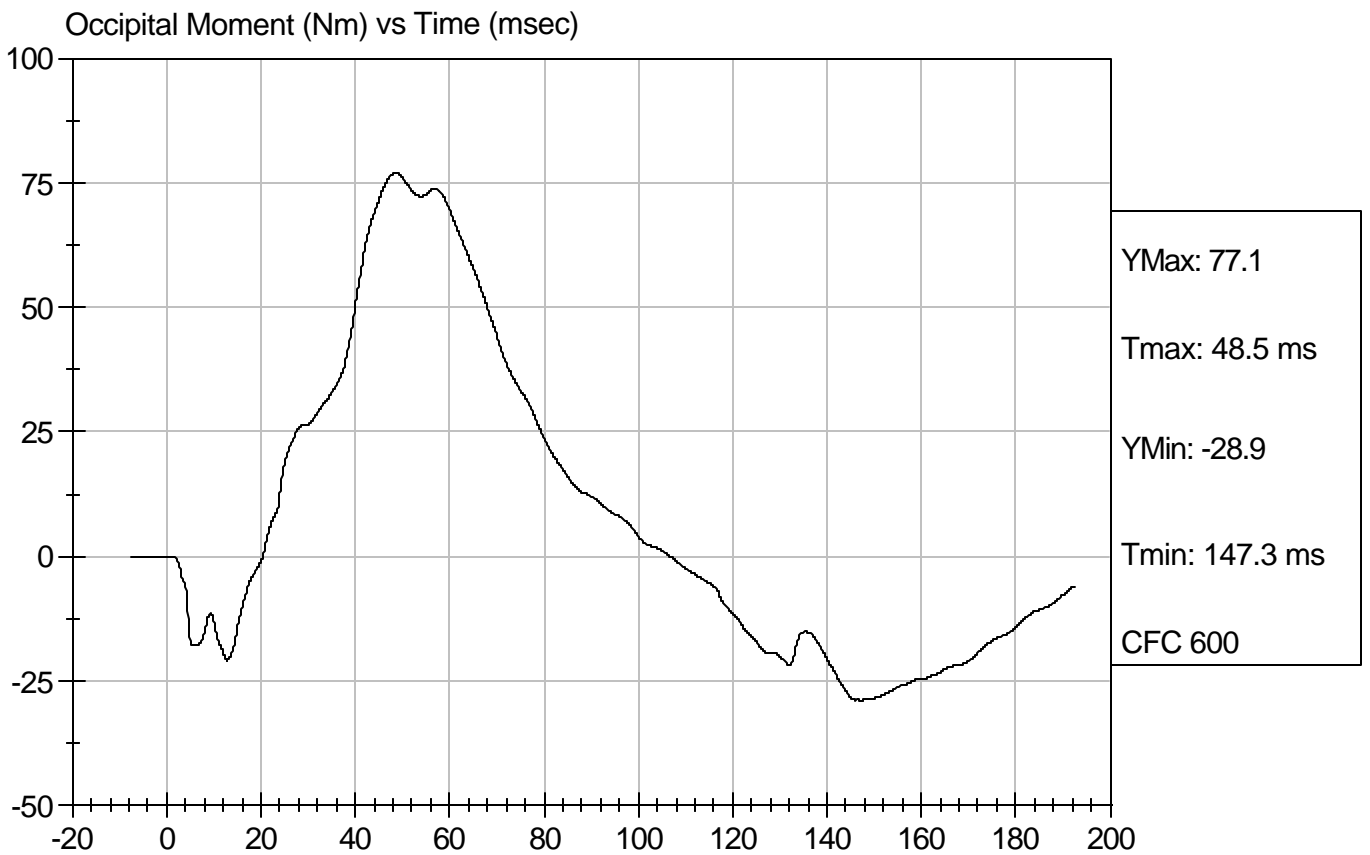
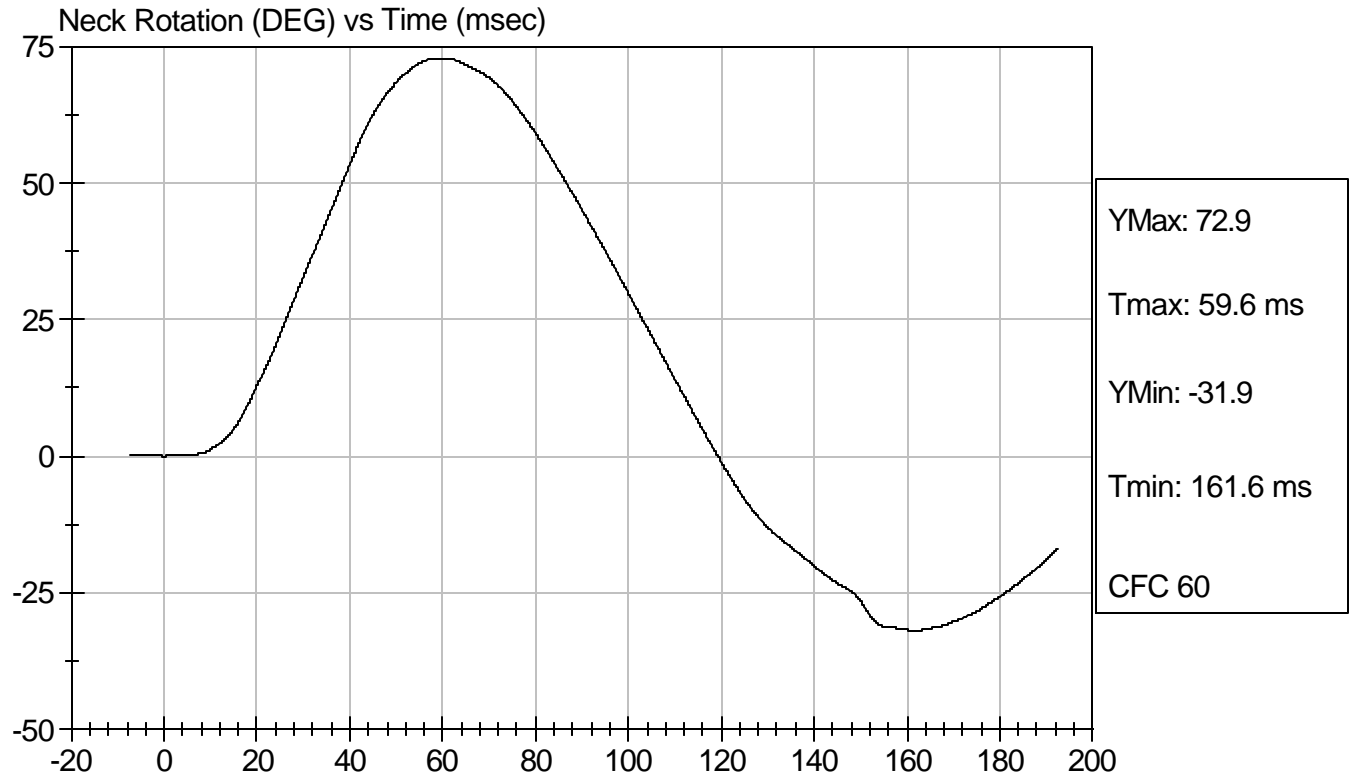

## Calibration Test Results Summary

Dummy Serial Number: 271

### Post-Test Calibration

External Dimensions:	The dummy passed all external dimension requirements.
Head Drop Test:	The head passed all drop test requirements.
Neck Pendulum Test:	The neck passed all pendulum test requirements.
Thorax Impact Test:	The thorax passed all impact test requirements.
Pelvic Impact Test:	The pelvis passed all impact test requirements.
Abdominal Compression Test:	The abdomen passed all compression test requirements.
Lumbar Flexion Test:	The lumbar passed all flexion test requirements.

**SID/HIII Calibration Data Sheet**  
**Side Impact Dummy**  
**Head Drop Calibration (Lateral)**

ATD Serial No: 271

Test I.D.: D08911

Tested Parameter	Units	Specification	Result	Pass/Fail
Laboratory Temperature	deg C	18.9 to 25.5	20.7	Pass
Laboratory Relative Humidity	%	10 to 70	25	Pass
Peak Resultant Acceleration	G's	120 to 150	143	Pass
Is Resultant Curve Unimodal?	N/A	15% of peak	Yes	Pass
Peak Longitudnal Acceleration	G's	+/- 15	-8.3	Pass
Overall Test Results				Pass

Jessica Hall  
 Laboratory Technician

3/27/08  
 Test Date

David Winkelbauer  
 Approved By



Test Description: Head Drop

Test Date: 3/27/08

Component: D08911

Speed: 0 ft/s, 0 m/s

Peak Resultant Acceleration (G's) Vs Time (msec)

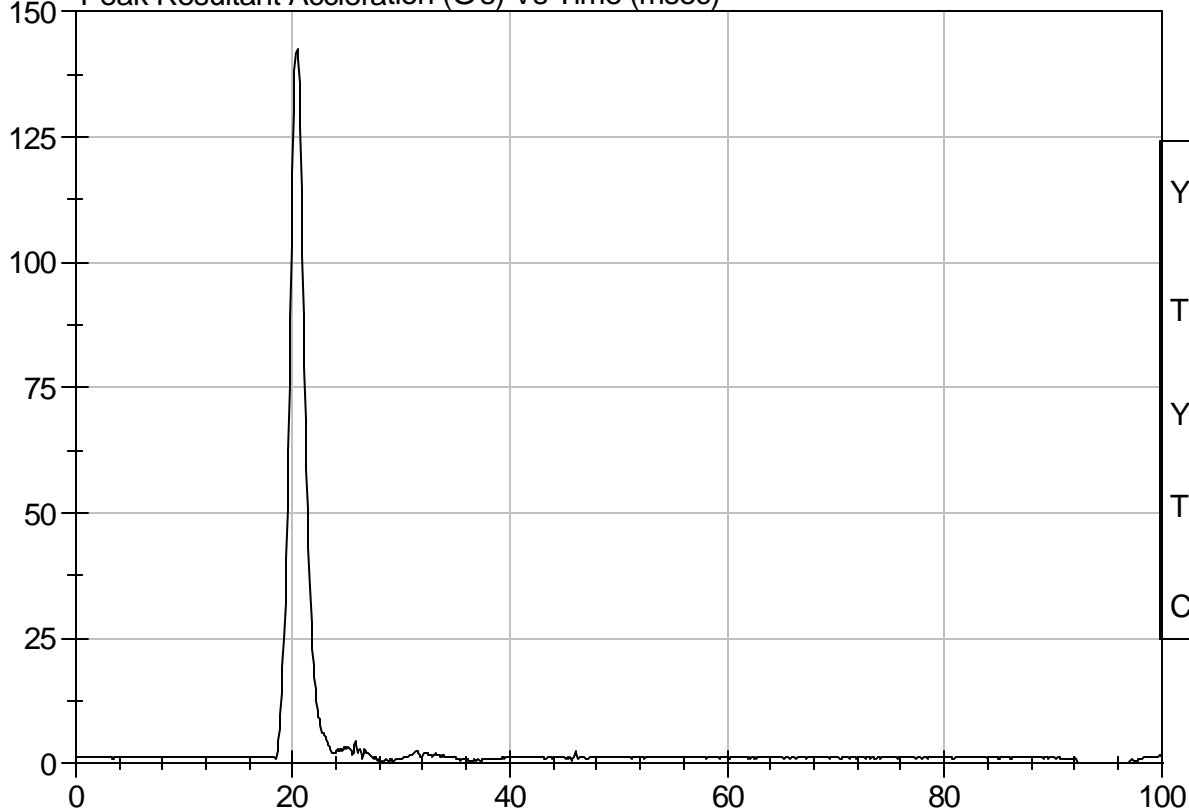

Peak Longitudnal Acceleration (G's) Vs Time (msec)

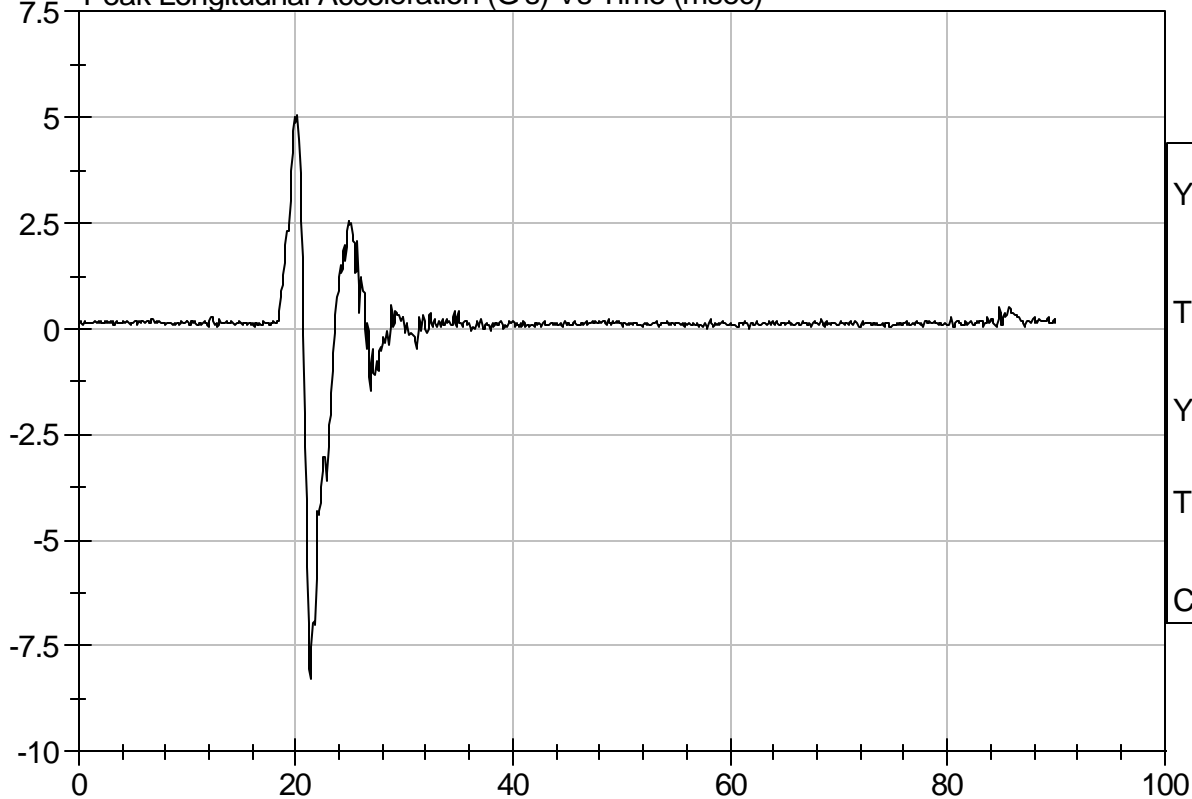

**SID/HIII Calibration Data Sheet**  
**Side Impact Dummy**  
**Thorax Impact Test**

ATD Serial No: 271

Test I.D.: D08912

Tested Parameter	Units	Specification	Result	Pass/Fail
Laboratory Temperature	deg C	18.9 - 25.5	21.5	Pass
Laboratory Relative Humidity	%	10 to 70	21	Pass
Probe Velocity	m/s	4.22 - 4.31	4.23	Pass
Upper Rib	G's	37 - 46	43	Pass
Lower Rib	G's	37 - 46	42	Pass
Lower Spine	G's	15 - 22	21	Pass
Overall Test Results				Pass

Jessica Hall  
 Laboratory Technician

3/26/08  
 Test Date

David Winkelbauer  
 Approved By



Test Desc: Pelvis Impact  
Component ID: D08912

Test Date: 3/26/08  
Speed: 13.88 ft/sec, 4.23 m/sec

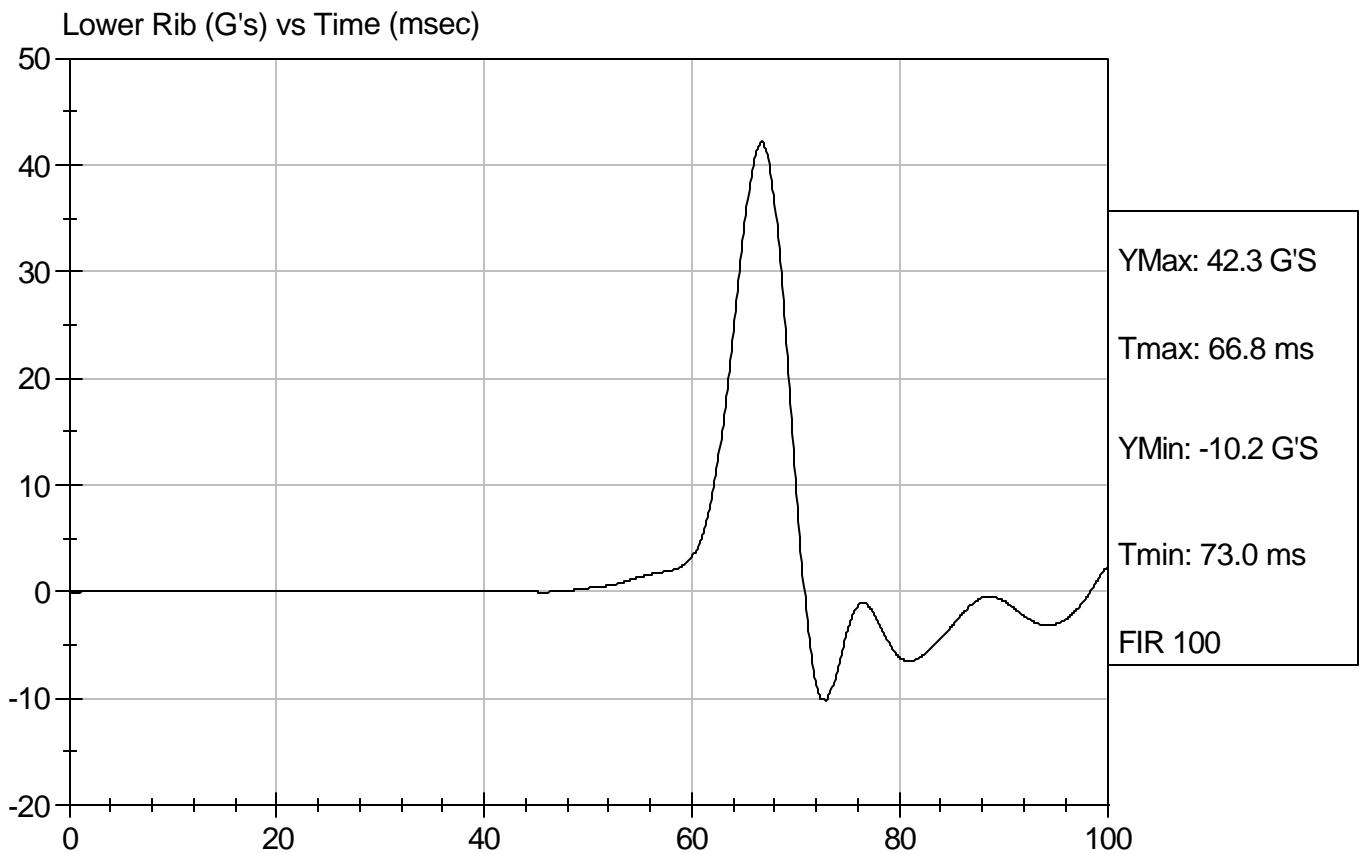
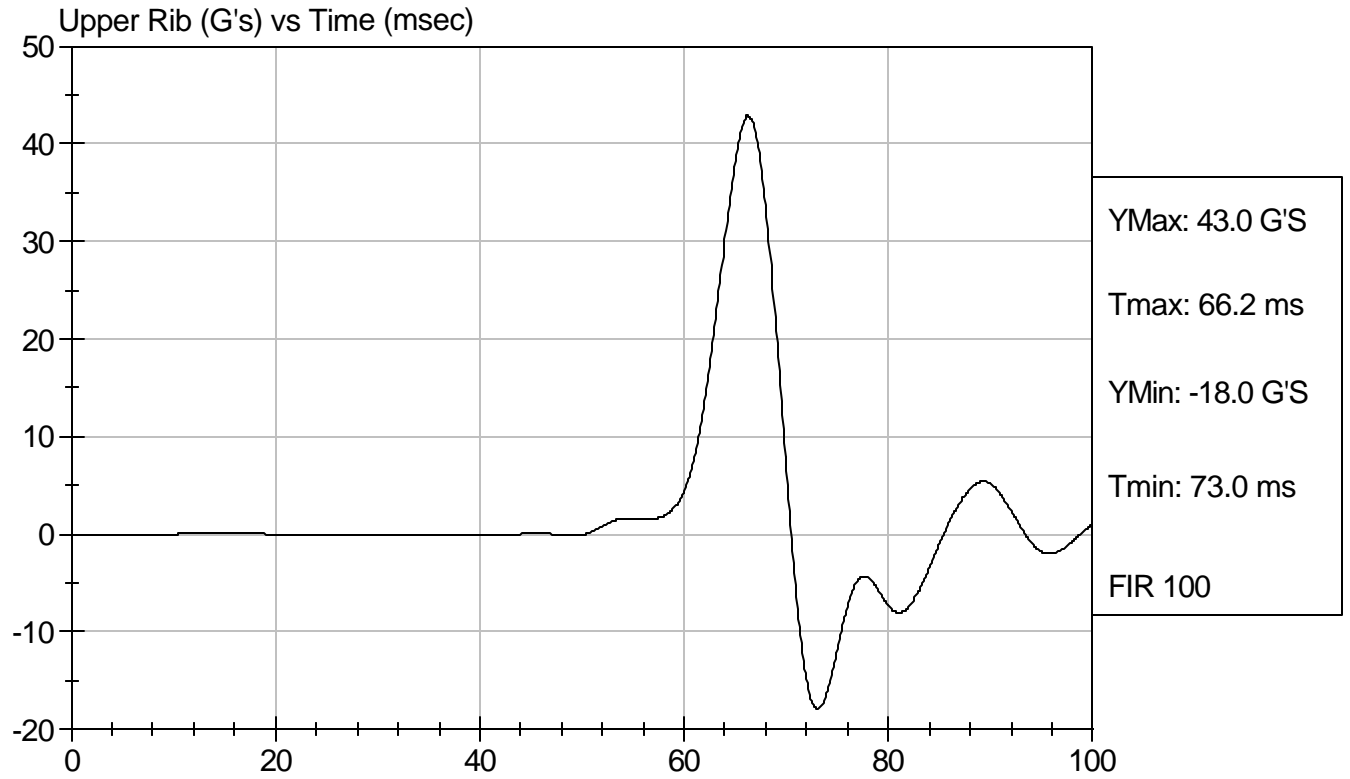



Test Desc: Pelvis Impact  
Component ID: D08912

Test Date: 3/26/08  
Speed: 13.88 ft/sec, 4.23 m/sec

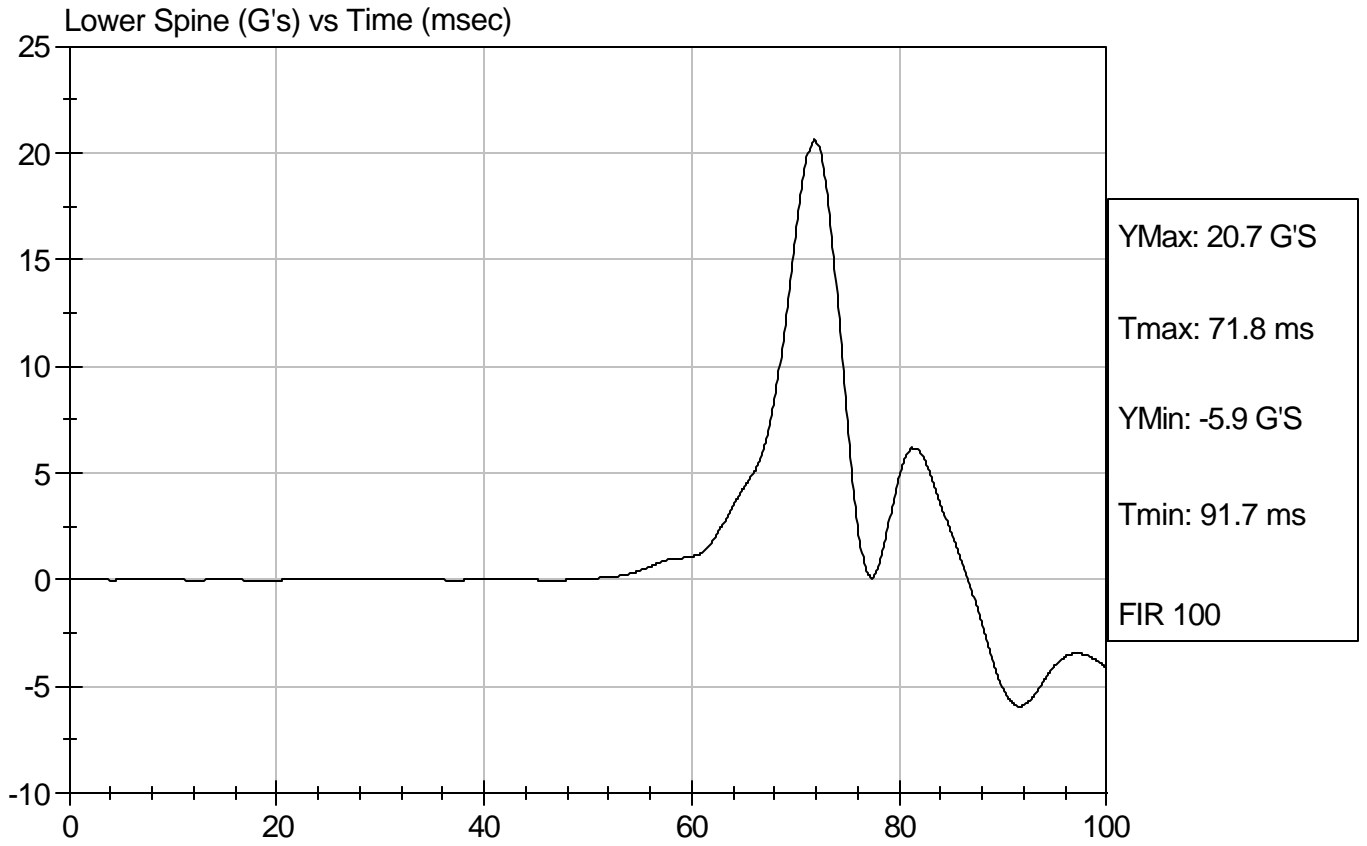

**SID/HIII Calibration Data Sheet**  
**Side Impact Dummy**  
**Pelvis Impact Test**

ATD Serial No: 271

Test I.D.: D08913

Tested Parameter	Units	Specification	Result	Pass/Fail
Laboratory Temperature	deg C	18.9 to 25.5	21.5	Pass
Laboratory Relative Humidity	%	10 to 70	21	Pass
Probe Velocity	m/s	4.27 - 4.33	4.27	Pass
Pelvis Acceleration	G's	40 - 60	41	Pass
Overall Test Results				Pass

Jessica Hall  
Laboratory Technician

3/26/08  
Test Date

David Winkelbauer  
Approved By



Test Desc: Pelvis Impact  
Component ID: D08913

Test Date: 3/26/08  
Speed: 14.01 ft/sec, 4.27 m/sec

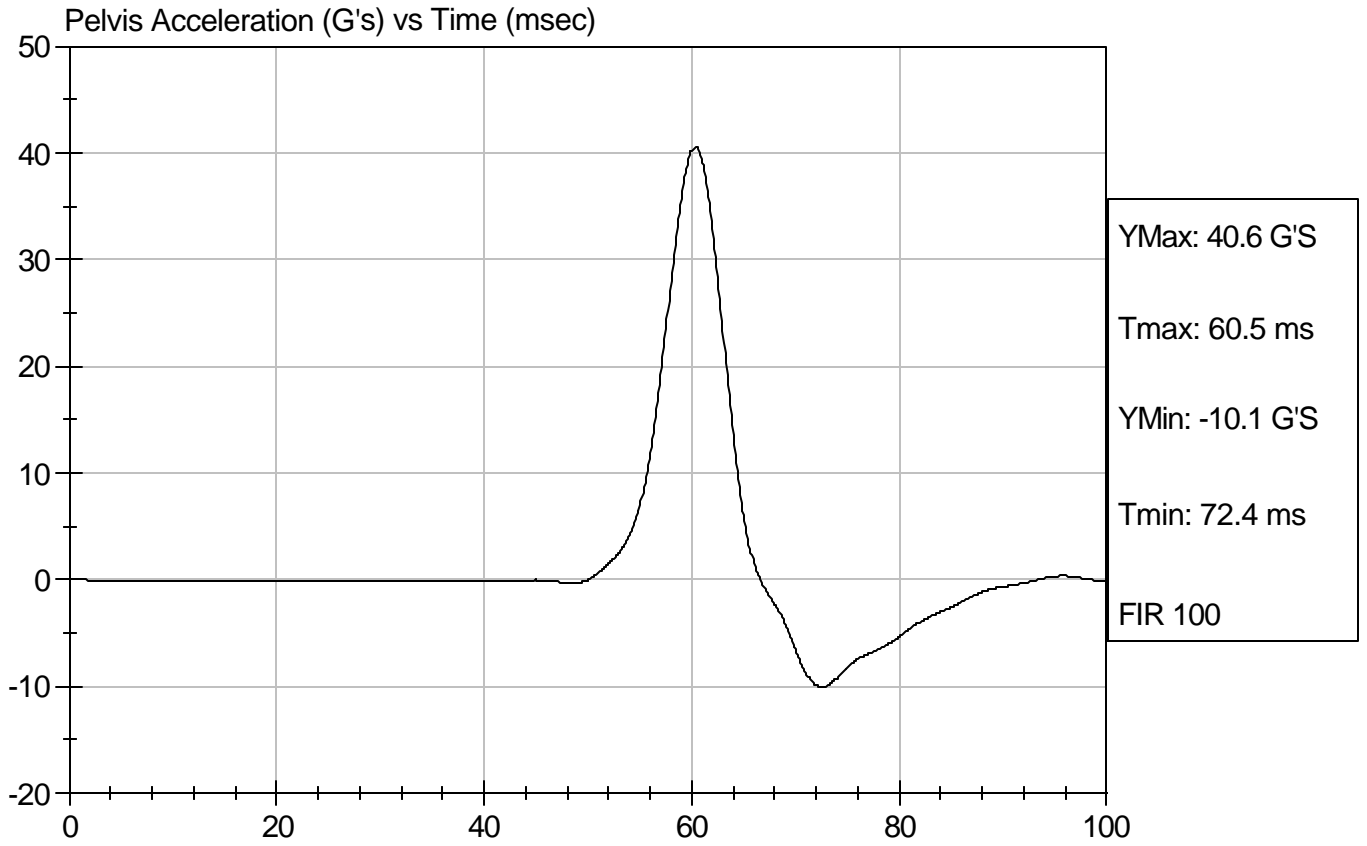

**SID/HIII Calibration Data Sheet**  
**Side Impact Dummy**  
**Abdominal Compression Calibration (Pre-Load = 10 lbs)**

ATD Serial No: 271

Test I.D.: D08914

Tested Parameter	Units	Specification	Result	Pass/Fail
Laboratory Temperature	deg C	18.9 - 25.5	20.7	Pass
Laboratory Relative Humidity	%	10 to 70	25	Pass
Force At 12.7 mm	N	104 -162	143	Pass
Force At 19 mm	N	163 - 222	200	Pass
Force At 25.4 mm	N	222 - 280	279	Pass
Force At 33 mm	N	325 - 391	378	Pass
Overall Test Results				Pass

Jessica Hall  
 Laboratory Technician

3/27/08  
 Test Date

David Winkelbauer  
 Approved By



Test Description: Abdomen Compression

Test Date: 3/27/08

Component: D08914

Speed: 0 ft/sec, 0 m/sec

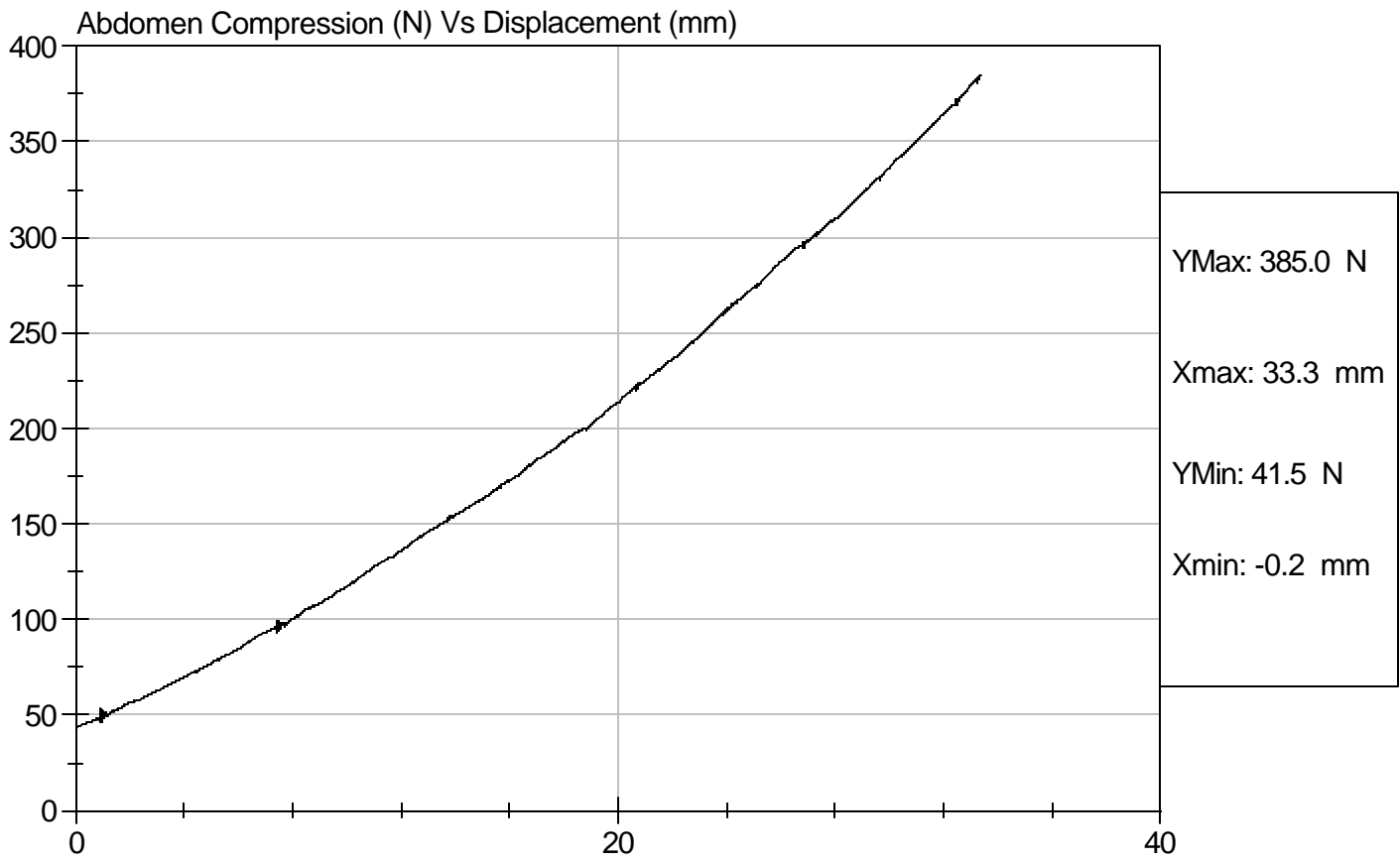

**SID/HIII Calibration Data Sheet**  
**Side Impact Dummy**  
**Lumbar Flexion Calibration**

ATD Serial No: 271

Test I.D.: D08915

Tested Parameter	Units	Specification	Result	Pass/Fail
Laboratory Temperature	deg C	18.9 - 25.5	20.7	Pass
Laboratory Relative Humidity	%	10 to 70	25	Pass
Force At 0 deg	N	0 - 26.7	0	Pass
Force At 20 deg	N	97.9 - 151.2	113.3	Pass
Force At 30 deg	N	151.2 - 204.6	163.2	Pass
Force At 40 deg	N	204.6 - 258.0	217.3	Pass
Return Angle	Deg	12 Maximum	6	Pass
Overall Test Results				Pass

Jessica Hall  
 Laboratory Technician

3/27/08  
 Test Date

David Winkelbauer  
 Approved By



Test Description: Lumbar Flexion

Test Date: 3/27/08

Component: D08915

Speed: 0 ft/sec, 0 m/sec

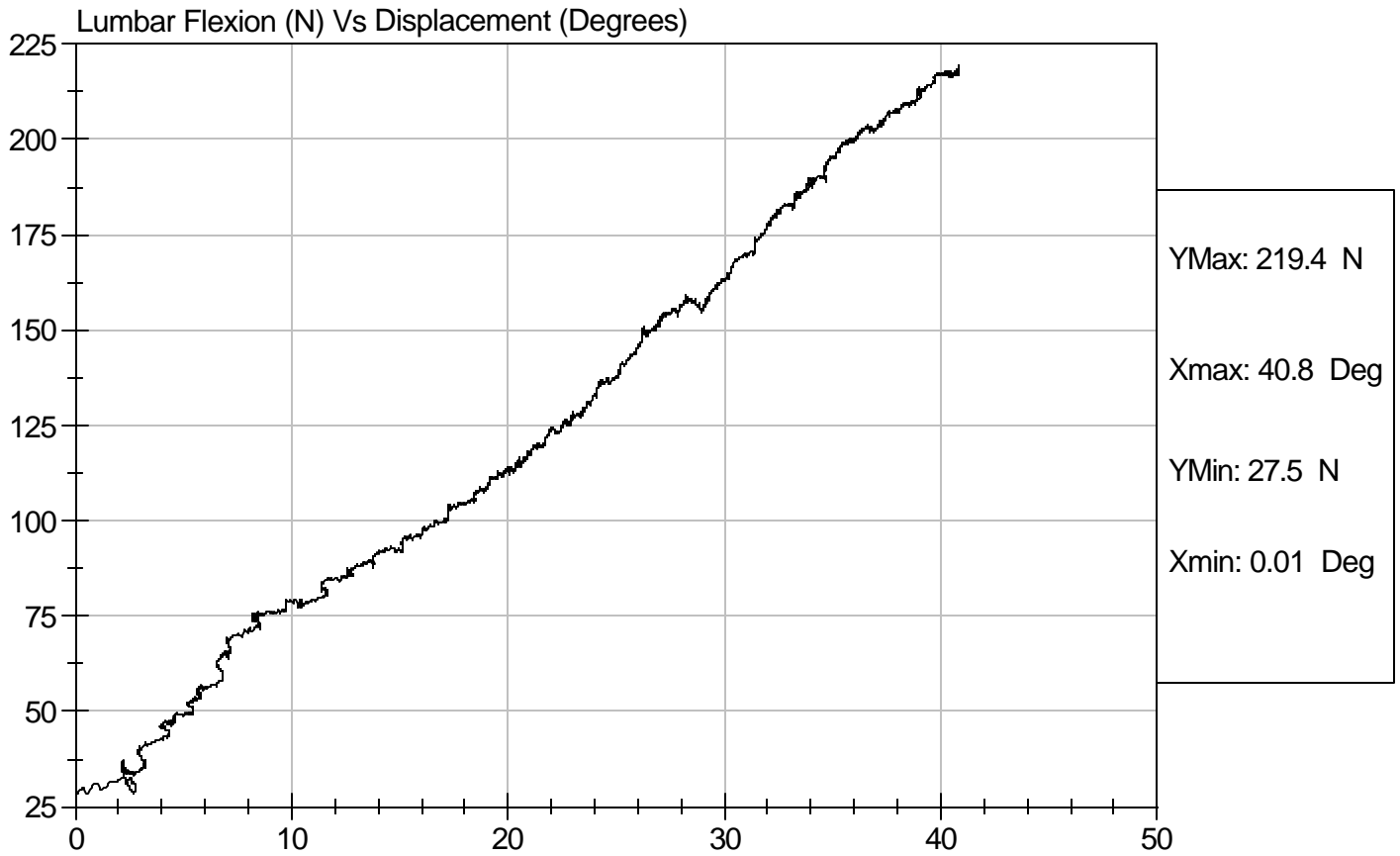

**SID/HIII Calibration Data Sheet**  
**Side Impact Dummy**  
**Neck Pendulum Test**

ATD Serial No: 271

Test I.D.: D08919

Tested Parameter		Units	Specification	Result	Pass/Fail
Laboratory Temperature		deg C	20.6 to 22.2	20.6	Pass
Laboratory Relative Humidity		%	10 to 70	25	Pass
Impact Velocity		m/s	6.89 to 7.13	7.06	Pass
Pendulum Deceleration	10 msec	m/s	1.96 to 2.55	2.54	Pass
	20 msec	m/s	4.12 to 5.10	4.91	Pass
	30 msec	m/s	5.73 to 7.01	6.66	Pass
	40 to 70 msec	m/s	6.27 to 7.64	6.70	Pass
Midsaggital Plane Max Rotation		deg	66 to 82	73	Pass
Head Rotation Peak to Zero - Decay Time		msec	58 to 67	59	Pass
Max. Mx at Occipital Condyles		Nm	73 to 88	76	Pass
Mx Peak To Zero - Decay Time		msec	49 to 64	50	Pass
Mx Peak to Max. Head Rotation		msec	2 to 16	4	Pass

Jessica Hall  
Laboratory Technician

3/27/08  
Test Date

David Winkelbauer  
Approved By



Test Desc: Neck Bending  
Component ID: D08919

Test Date: 3/27/08  
Speed: 23.15 ft/sec, 7.06 m/sec

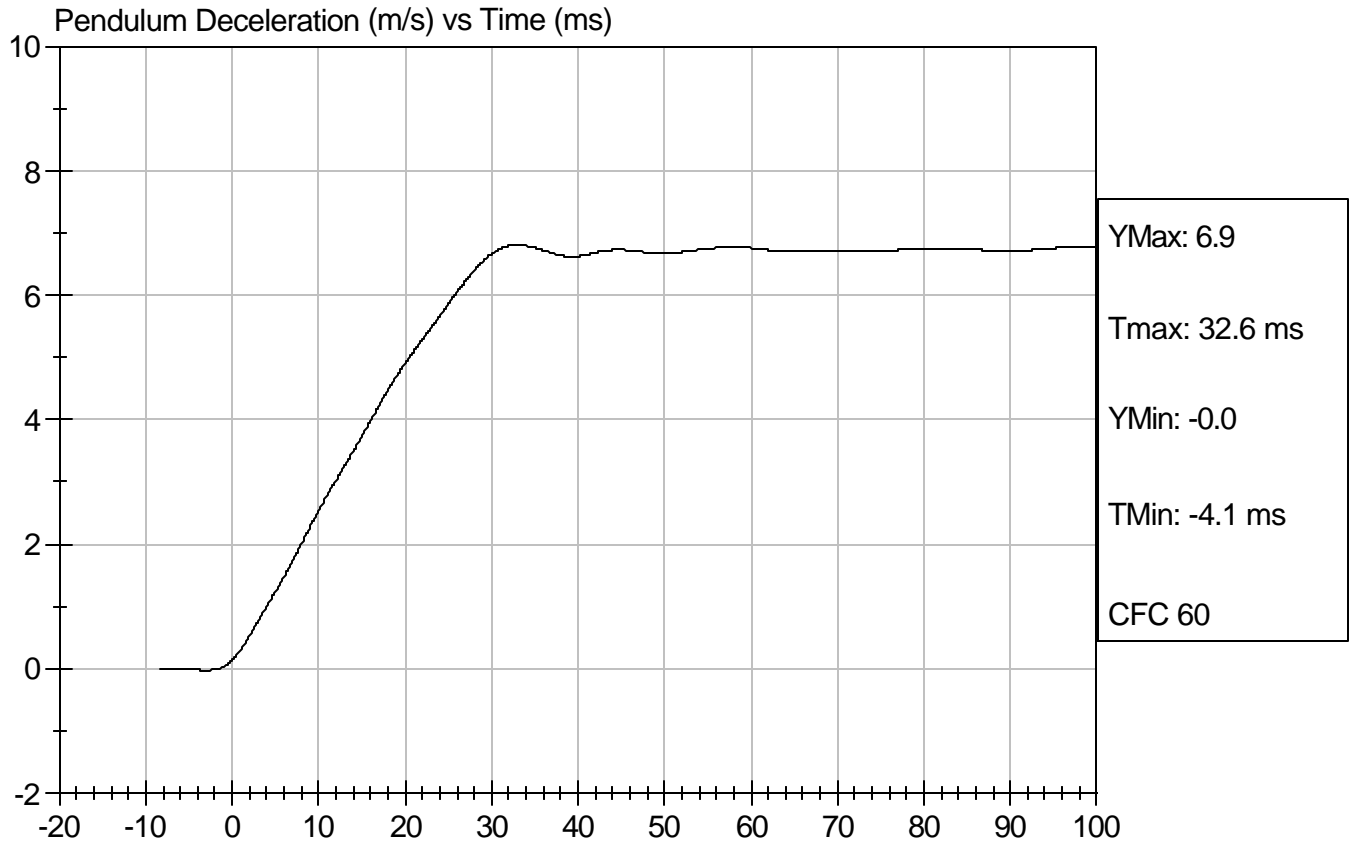



Test Desc: Neck Bending  
Component ID: D08919

Test Date: 3/27/08  
Speed: 23.15 ft/sec, 7.06 m/sec

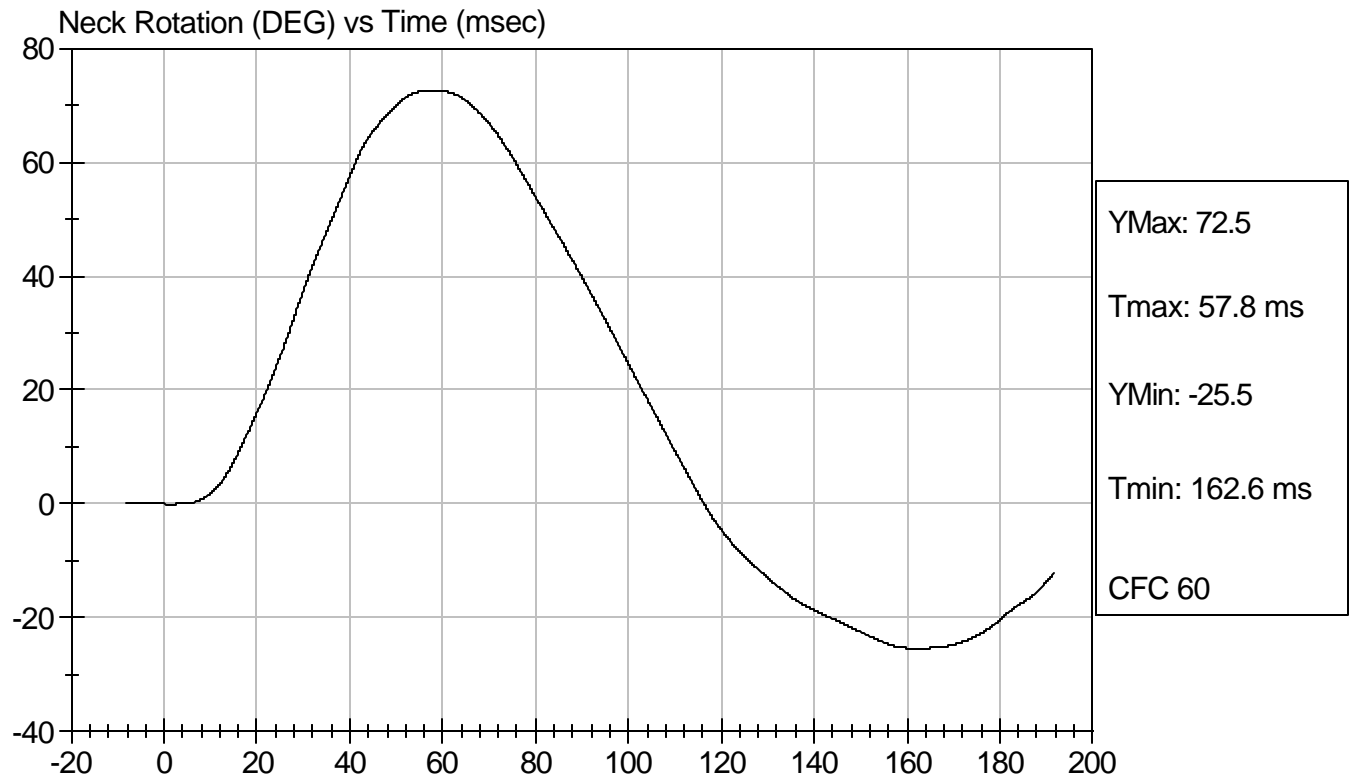

**SID/HIII Calibration Data Sheet**  
**Side Impact Dummy**  
**Inspection Checklist**

**ATD Serial No:** 271

Test Part	Items Checked	Result
Skin	Visual inspection	Pass
Head	Visual, ballast, accelerometer mount	Pass
Neck	Visual	Pass
Spine Box	Visual, ballast, accelerometer mount	Pass
Rib Cage	Visual, measure	Pass
Sternum	Visual	Pass
Lumbar Spine	Visual	Pass
Abdomen	Visual	Pass
Pelvis	Visual, palpate, accelerometer mount	Pass
Upper Legs	Visual	Pass
Knees	Visual	Pass
Lower Legs	Visual, range of motion	Pass
Ankles	Visual, range of motion	Pass
Feet	Visual, range of motion	Pass
Joints	1 to 2 g range	Pass
Other		Pass

*Jessica Hall*  
 Laboratory Technician  
*David Winkelbauer*  
 Approved By

3/27/2008  
 Test Date