

REPORT NUMBER TR-P28001-16-NC

**NEW CAR ASSESMENT PROGRAM
FRONTAL BARRIER IMPACT TEST**

**TOYOTA MOTOR MANUFACTURING, INDIANA, INC.
2008 TOYOTA SEQUOIA SR5
5-DOOR MPV**

NHTSA NUMBER: M85115

**Prepared By:
KARCO ENGINEERING, LLC
9270 HOLLY ROAD
ADELANTO, CALIFORNIA 92301**



JANUARY 22, 2008

FINAL REPORT

**PREPARED FOR:
U.S. DEPARTMENT OF TRANSPORTATION
NATIONAL HIGHWAY TRAFFIC SAFETY ADMINISTRATION
OFFICE OF CRASHWORTHINESS STANDARDS
RULEMAKING
MAIL CODE: NVS-111
1200 NEW JERSEY AVE SE, ROOM W43-410
WASHINGTON, D.C. 20590**

This final test report was prepared for the U.S. Department of Transportation, National Highway Traffic Safety Administration, in response to Contract Number DTNH22-06-D-00027.

This publication is distributed by the U.S. Department of Transportation, National Highway Traffic Safety Administration, in the interest of information exchange. The opinions, findings and conclusions expressed in this publication are those of the author(s) and not necessarily those of the Department of Transportation or the National Highway Traffic Safety Administration. The United States Government assumes no liability for its contents or use thereof. If trade or manufacturers' names or products are mentioned it is only because they are considered essential to the object of the publication and should not be construed as an endorsement. The United States Government does not endorse products or manufacturers.

Prepared by:  Date: January 22, 2008
Mr. Pablo Vega, Test Engineer
KARCO Engineering, LLC

Reviewed by:  Date: January 22, 2008
Mr. Michael L. Dunlap, Director of Operations
KARCO Engineering, LLC

Approved by:  Date: January 22, 2008
Mr. Frank D. Richardson, Program Manager
KARCO Engineering, LLC

FINAL REPORT ACCEPTED BY:

Manager, New Car Assessment Program

Date of Acceptance

COTR, NCAP Frontal Impact Program

Date of Acceptance

Technical Report Documentation Page

1. Report No. TR-P28001-16-NC	2. Government Accession No.	3. Recipients Catalog No.		
4. Title and Subtitle Final Report of New Car Assessment Program Testing of a 2008 Toyota Sequoia SR5 5-Door MPV NHTSA No. M85115	5. Report Date January 22, 2008		6. Performing Organization Code KAR	
	8. Performing Organization Report No. TR-P28001-16-NC			
7. Authors Mr. Pablo Vega, Project Engineer, KARCO Mr. Frank Richardson, Program Manager, KARCO	10. Work Unit No.			
	11. Contract or Grant No. DTNH22-06-D-00027			
9. Performing Organization Name and Address Karco Engineering, LLC 9270 Holly Rd. Adelanto, CA, 92301	13. Type of Report and Period Covered Final Test Report			
	14. Sponsoring Agency Code DOT/NHTSA/NRM/OCS			
12. Sponsoring Agency Name and Address U. S. Department of Transportation National Highway Traffic Safety Administration Rulemaking Office of Crashworthiness Standards Mail Code NVS-111 1200 New Jersey Ave., SE, Room W43-410 Washington, D.C 20590				
15. Supplementary Notes				
16. Abstract A 35 mph (56.3 km/h) frontal barrier impact test was conducted on the subject 2008 Toyota Sequoia SR5 5-Door MPV at KARCO Engineering, LLC, in Adelanto, CA, on January 22, 2008. This test was conducted to obtain data indicant of FMVSS 208, 212, 219 (partial), 301, and footwell intrusion performance. The impact velocity was 56.35 km/h. The ambient temperature at the barrier at the time of the crash was 10.6 degrees Celsius. The vehicle's maximum post static crush was 428 mm at the vehicle's centerline. The test vehicle was equipped with a 3-point continuous belt system and a second generation airbag at both front outboard positions. With respect to FMVSS 208 'Occupant Crash Protection', the occupant injury criteria summary is as follows:				
Measurement Description	Units	Threshold	Driver ATD	Passenger ATD
Head Injury Criteria (HIC)	N/A	1000	430.3	452.3
Max. Chest Accel. (3 msec. Chest Clip)	G's	60	44.4	45.2
Left Femur Force	Newtons	10008	-3769.1	-2175.3
Right Femur Force	Newtons	10008	-3933.3	-2347.0
17. Key Words 56.3 km/h NCAP Frontal Impact Test New Car Assesment Program (NCAP) 2008 Toyota Sequoia SR5 5-Door MPV NHTSA No. M85115			18. Distribution Statement Copies of this report are available from: National Highway Traffic Safety Admin. NHTSA Technical Reference Division 1200 New Jersey Ave., SE, Room W43-410 Washington, DC 20590	
19. Security Classification of this report UNCLASSIFIED	20. Security Classification of this page UNCLASSIFIED		21. No. of Pages 200	22. Price

Form DOT F1700.7 (8-72)

TR-P28001-16-NC

TABLE OF CONTENTS

Section	Description	Page
1	Purpose and Summary of Test M85115	1
2	Occupant and Vehicle Information/Data Sheets	3

Data Sheet	Description	Page
1	Crash Test Summary	4
2	General Test and Vehicle Parameter Data	5
3	Post-Test Impact Data	8
4	Test Vehicle Information	9
5	Dummy Positioning in Vehicle	11
6	Seat Belt Positioning Data	13
7	Vehicle Accelerometer Location	14
8	Seat Belt Assessment Test Data	15
9	Summary of FMVSS 212 Data	16
10	Windshield Zone Intrusion FMVSS 219 Data (Partial)	17
11	FMVSS 301 Fuel System Integrity Post-Impact Data	18
12	FMVSS 301 Static Rollover Data	19
13	Vehicle Measurements	21
14	Camera Locations	24
15	Photographic Reference Target Locations	25
16	Vehicle Intrusion Measurements	26
17	Fixed Barrier Load Cell Locations	31
18	Accident Investigation Division Data	32
19	Dummy/Vehicle Temperature Stabilization	33

Appendix	Description	Appendix
A	Photographs	A
B	Data Plots	B
C	Dummy Calibration Data	C

SECTION 1
PURPOSE AND SUMMARY OF TEST M85115

1.1 PURPOSE

This 35 mph (56.3 km/h) frontal barrier impact test is part of the New Car Assessment Program (NCAP) sponsored by the National Highway Traffic Safety Administration (NHTSA) under Contract No. DTNH22-06-D-00027. The purpose of this test was to obtain vehicle crashworthiness and occupant restraint system performance data for an impact speed in excess of the current 30 mph (48.3 km/h) requirements.

The 35 mph (56.3 km/h) frontal barrier impact test was conducted in accordance with the Office of Crashworthiness Standards (OCS) New Car Assessment Program (NCAP) Laboratory Indicant Test Procedure, dated July 2005. Data was obtained indicant of FMVSS 208 "Occupant Crash Protection", FMVSS 212, "Windshield Retention", FMVSS 219, "Windshield Zone Intrusion (Partial)", and FMVSS 301 "Fuel System Integrity", performance. Procedures for receiving, inspection, testing and reporting of test results are described in the test procedures and are not repeated in this report.

1.2 SUMMARY

A load cell barrier consisting of 36 load cells was impacted by a 2008 Toyota Sequoia SR5 5-Door MPV at a velocity of 56.35 km/h. The test was performed at KARCO Engineering, LLC on January 22, 2008

Three (3) real-time and fourteen (14) high-speed cameras were used to document the frontal barrier impact event. Camera locations and other pertinent camera information can be found in Data Sheet number 14 (page number 24) of this report.

Two Part 572E, 50th percentile male anthropomorphic test devices (ATDs), were placed in the driver and right-front passenger seating positions according to dummy placement instructions specified in the Laboratory Indicant Test Procedure.

Both ATDs were fully instrumented with head (primary and redundant), chest (primary and redundant) and pelvis triaxial accelerometers, chest displacement potentiometers, six-axis upper neck transducers, right/left femur load cells, and lower leg instrumentation. Seat belt load cells were placed on the driver's and passenger's lap and shoulder belts to measure dummy torso and pelvic section loading. Shoulder belt spool-off was measured for the driver and passenger dummies. The driver (position 1) ATD (Serial No.035) and the right-front passenger (position 2) ATD (Serial No. 034) were calibrated prior to this test.

One hundred and thirty-two (132) channels of data were recorded using a TDAS data acquisition system. Appendix A contains Pre and Post-Test Photographs, Appendix B contains the Dummy Response data traces, and Appendix C contains the Dummy Calibration data.

There was 100% windshield retention and no intrusion into the protected zone of the windshield during impact. There was no Stoddard solvent leakage after the event, or during any phase of the static rollover.

The maximum static crush of the vehicle was 428 mm at the vehicle's centerline. Both the driver and passenger side doors remained closed and latched during the impact event, and were operable after the impact.

The driver's visible contact points were as follows: The driver ATD's head, chest, and abdomen contacted the airbag. The head also contacted the headrest. Both knees contacted the bolster.

The passenger's visible contact points were as follows: The passenger ATD's head, chest, and abdomen contacted the airbag. Both knees contacted the glovebox.

Occupant injury data is contained in table below.

OCCUPANT DATA SUMMARY

ATD Position	HIC 36	3 msec Chest Clip	Chest Defl. (mm)	Left Femur (N)	Right Femur (N)
Driver	430.3	44.4	-27.7	-3769.1	-3933.3
Passenger	452.3	45.2	-29.8	-2175.3	-2347.0

Additional data plots for this test are available in the research and development section of the NHTSA website. The website can be found at: www.NHTSA.Dot.Gov

SECTION 2

OCCUPANT AND VEHICLE INFORMATION/DATA SHEETS

Test Vehicle: 2008 Toyota Sequoia SR5 5-Door MPV NHTSA No.: M85115
Test Program: NHTSA 35mph NCAP Test Date: 01/22/08

CONVERSION FACTORS USED IN THIS REPORT*

Quantity	Typical Application	Std Units	Metric Unit	Multiply By
Mass	Vehicle Weight	lb	kg	0.4536
Linear Velocity	Impact Velocity	miles/hr	km/hr	1.609
Length or Distance	Measurements	in	mm	25.4
Volume	Fuel Systems	gal	liter	3.785
Volume	Small Fluids	oz	mL	29.573
Pressure	Tire Pressures	lbf/in ²	kPa	7.0
Volume	Liquid	gal	liter	3.785
Temperature	General Use	°F	°C	$=(tf - 32)/1.8$
Force	Dynamic Forces	lbf	N	4.448
Moment	Torque	lbf/ft	Nm	1.355

* Based on the Recommended Practice in SAE J916, May 85

**DATA SHEET NO. 1
CRASH TEST SUMMARY**

Test Vehicle: 2008 Toyota Sequoia SR5 5-Door MPV
 Test Program: NHTSA 35mph NCAP

NHTSA No.: M85115
 Test Date: 01/22/08

PRIMARY IMPACT DATA

Measured Parameter	Units	Value
Velocity at Impact	km/h	56.35
Test Weight	kg	2816
Impact Angle	degrees	0
Average Rebound	mm	1480
Maximum Static Crush	mm	428

DOOR OPENING AND SEAT TRACK INFORMATION

Description	Driver	Passenger
Front Door Opening	Remained closed and latched, opened without tools	Remained closed and latched, opened without tools
Rear Door Opening	Remained closed and latched, opened without tools	Remained closed and latched, opened without tools
Seat Track Shift (mm)	None	None
Seatback Failure	No	No

TEST DUMMY INFORMATION

Description	Driver	Passenger
Dummy Type/Serial No.	50% Male Hybrid III No.035	50% Male Hybrid III No. 034
Head Contact	Airbag, headrest	Airbag
Chest Contact	Airbag	Airbag
Abdomen Contact	Airbag	Airbag
Left Knee Contact	Bolster	Glovebox
Right Knee Contact	Bolster	Glovebox

MOVIE COVERAGE

Cameras	Standard	Additional
High Speed	14	0
Real Time	1	2
Total	15	2

DATA CHANNELS

Driver ATD Sensors	40
Passenger ATD Sensors	40
Belt Assessment Sensors	8
Vehicle Structure Acclerometers	8
Rigid Barrier Load Cells	36
Total	132

DATA SHEET NO. 2

GENERAL TEST AND VEHICLE PARAMETER DATA

Test Vehicle: 2008 Toyota Sequoia SR5 5-Door MPV NHTSA No.: M85115
 Test Program: NHTSA 35mph NCAP Test Date: 01/22/08

TEST VEHICLE INFORMATION AND OPTIONS

NHTSA No.	M85115
Make	Toyota
Model	Sequoia SR5
Body Style	5-Door MPV
VIN No.	5TDBY64A68S002738
Color	Blue
Delivery Date	01/08/08
Odometer (Miles)	83.0
Dealer	Valley Hi Toyota
Transmission	6-Speed Automatic
Final Drive	4WD
Type/No. of Cylinders	V8
Engine Displ. (L)	5.7
Engine Placement	Longitudinal
Roof Rack	No
Sunroof/T-top	No
Tinted Glass	No
Traction Control	Yes
Power Brakes	Yes
Front Disc	Yes
Rear Disc	Yes

Anti-Lock Brakes	Yes
All Wheel Drive	Yes
Power Steering	Yes
Driver Front Airbag	Yes
Driver Side Torso Airbag	Yes
Driver Side Head Airbag	No
Driver Curtain Airbag	Yes
Pass. Airbag	Yes
Pass. Side Airbag	Yes
Pass. Head Airbag	No
Pass. Curtain Airbag	Yes
Pre-Tensioners	Yes
Load Limiters	Yes
Bucket Seats	Yes
Air Conditioning	Yes
AM/FM CD	Yes
Tilt Steering	Yes
Automatic Door Locks	No
Power Windows	Yes
Power Seats	Driver Only
Other	n/a

Does the Owner's Manual provide instructions to turn off automatic door locks? No

DATA FROM CERTIFICATION TABLE

Manufactured By	Toyota Motor Manufacturing, Indiana, Inc.
Date of Manufacture	Dec-07

GVWR (kg)	3310
GAWR Front (kg)	1810
GAWR Rear (kg)	1940

VEHICLE SEATING CAPACITY AND WEIGHT INFORMATION

Measured Parameter	Front	Rear	Third	Total
Type of Seats	Bucket	Bench	Bench	
Number of Occupants	2	3	3	8
Capacity Weight (VCW) (kg)				549
Cargo Weight (RCLW) (kg)				5

DATA SHEET NO. 2...(CONTINUED)

GENERAL TEST AND VEHICLE PARAMETER DATA

Test Vehicle: 2008 Toyota Sequoia SR5 5-Door MPV

NHTSA No.: M85115

Test Program: NHTSA 35mph NCAP

Test Date: 01/22/08

Collect year, make, model, VIN, items circled in red, and tire manufacturer and tire name.

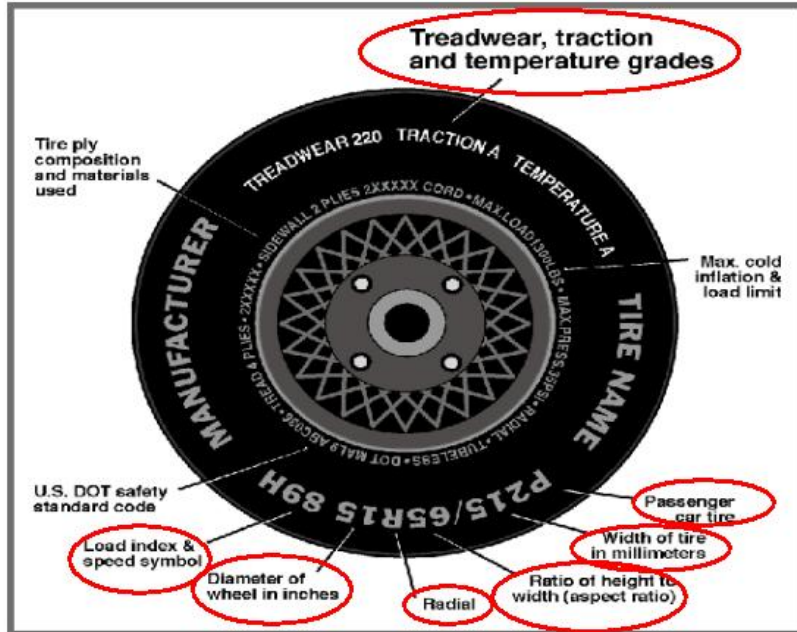

TIRE INFORMATION

Measured Parameter	Front	Rear
Max. Tire Pressure (kPa)	308	308
Cold Tire Pressure (kPa)	230	230
Recommended Tire Size	P275/65R18	P275/65R18
Tire Size on Vehicle	P275/65R18	P275/65R18
Tire Manufacturer	Michelin	Michelin
Treadwear	420	420
Traction	A	A
Temperature Grades	B	B
Tire Plies - Sidewall	2 Polyester	2 Polyester
Tire Plies - Body	2 Polyester + 1 Polyamide + 2 Steel	2 Polyester + 1 Polyamide + 2 Steel
Load Index/Speed Symbol	97V	97V
Tire Material	Polyester, Polyamide, Steel	Polyester, Polyamide, Steel
DOT Safety Code Right	M3B9 UJXX 4807	M3B9 UJXX 4807
DOT Safety Code Left	M3B9 UJXX 4807	M3B9 UJXX 4807

DATA SHEET NO. 2...(CONTINUED)

GENERAL TEST AND VEHICLE PARAMETER DATA

Test Vehicle: 2008 Toyota Sequoia SR5 5-Door MPV NHTSA No.: M85115
 Test Program: NHTSA 35mph NCAP Test Date: 01/22/08

TEST VEHICLE WEIGHTS

	Units	As Delivered Weights (UVW)			As Tested Weights (ATW)		
		Front Axle	Rear Axle	Total	Front Axle	Rear Axle	Total
Left	kg	709	671	1380	767	695	1462
Right	kg	663	624	1287	714	640	1354
Ratio	%	51.4	48.6	100.0	52.6	47.4	100.0
Totals	kg	1372	1295	2667	1481	1335	2816

TARGET TEST WEIGHT CALCULATION

Measured Parameter	Units	Value
Total Delivered Weight (UVW)	kg	2667
Weight of 2 P572 ATD's	kg	152
Rated Cargo/Luggage Weight (RCLW)	kg	5
Calculated Target Vehicle Test Weight (TVT _W)	kg	2824

TEST VEHICLE ATTITUDE AND CG

	Units	LF	RF	LR	RR	CG Aft of Front Axle
As Delivered	mm	914	920	943	944	1507
As Tested	mm	905	910	947	945	1469

Vehicle Wheel Base (mm) 3100
 Weight of Ballast Secured in Cargo Area (kg) 0
 Weight of Items Removed (kg) 204
 Vehicle Components Removed: Spare Tire, Rear Bumper, Trunk lid, Third Row Seat

*Ballast weight does not include cameras, instrumentation or brake abort system.

FUEL SYSTEM DATA

Fuel System Capacity from Owner's Manual (L) 99.92
 Actual Test Volume with Entire Fuel System Filled (L) 92.92
 Test Fluid Type Stoddard Solvent
 Kinematic Viscosity as per ASTM Standard D484-71 Red
 Is Vehicle Fuel Pump Electric or Mechanical? Electrical
 If electric, does pump operate with the ignition switch "ON" & engine "OFF"? Yes
 Fuel System Particulars Electric fuel pump. Activated when electrical system is activated.
Fuel pump will run for 3 seconds when ignition is in "on" position.

DATA SHEET NO. 3
POST-TEST IMPACT DATA

Test Vehicle: 2008 Toyota Sequoia SR5 5-Door MPV
 Test Program: NHTSA 35mph NCAP

NHTSA No.: M85115
 Test Date: 01/22/08

SPEED TRAP DATA

Measured Parameter	Units	Requirement	Value
Trap No. 1 Velocity	km/h	55.1 to 57.12	56.35
Trap No. 2 Velocity	km/h	55.1 to 57.12	56.27

VEHICLE STATIC CRUSH

Measured Parameter	Units	Pre-Test	Post-Test	Difference
Left Side	mm	5046	4742	304
Center	mm	5196	4768	428
Right Side	mm	5046	4767	279

VEHICLE REBOUND FROM BARRIER

Measured Parameter	Units	Value
Left Side	mm	1425
Center	mm	1440
Right Side	mm	1480
Average	mm	1448

DATA SHEET NO. 4

TEST VEHICLE INFORMATION

Test Vehicle: 2008 Toyota Sequoia SR5 5-Door MPV
 Test Program: NHTSA 35mph NCAP

NHTSA No.: M85115
 Test Date: 01/22/08

NOMINAL DESIGN RIDING POSITION

The driver and passenger seat backs are positioned to the manufacturer’s designated angle. The procedure is as follows: Seat back angle was measured at the headrest, using a digital inclinometer.

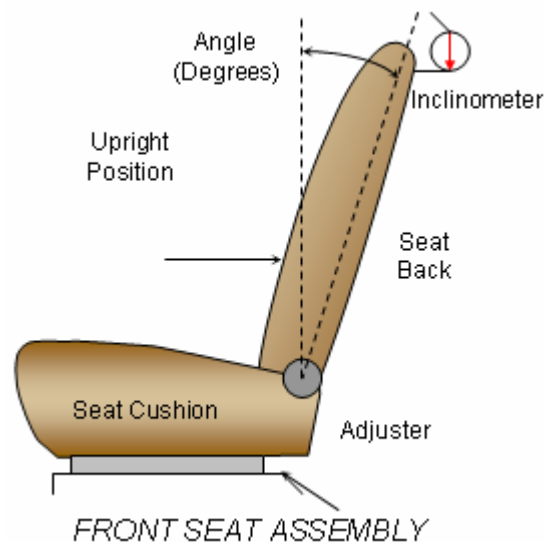

SEAT BACK ANGLES

Position	Degrees
Driver w/ Seated Dummy	3.0 @ Headrest
Passenger w/ Seated Dummy	1.4 @ Headrest

SEAT FORE/AFT POSITIONS

The total seat travel was measured from forward most position to rearmost position. The seat was set at the longitudinal mid position. There were vertical adjustments on the driver seat that was equipped with the vehicle. There were no adjustments on the passenger seat. The driver seat was placed in the lowermost position.

SEAT FORE/AFT POSITIONING

Position	Total Fore/Aft Travel	Placed in Position
Driver Seat	270 mm	135 mm
Passenger Seat	270 mm	135 mm

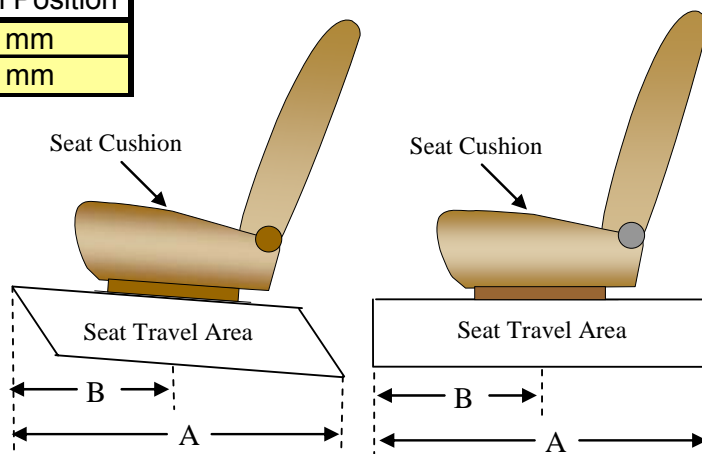

SEAT BELT ANCHORAGE

Position number one (1) is the uppermost position.

SEAT BELT ANCHORAGE POSITIONING

	Total Number of Positions	Placed in Position
Driver Seat	4	2
Passenger Seat	4	2

DATA SHEET NO. 4...(CONTINUED)

TEST VEHICLE INFORMATION

Test Vehicle: 2008 Toyota Sequoia SR5 5-Door MPV

NHTSA No.: M85115

Test Program: NHTSA 35mph NCAP

Test Date: 01/22/08

FUEL TANK CAPACITY

	Liters
Usable Capacity of Standard Tank	99.92
Usable Capacity of Optional Tank	
Usable Capacity Used for FMVSS 301	91.98 to 93.87
Actual Amount of Solvent Used	92.92

The test vehicle is equipped with an electric fuel pump. The fuel pump will operate for approximately two (2) seconds with the ignition in the "ON" position, after which the fuel pump automatically shuts off. The fuel filler door is located on the left rear fender. The standard fuel tank occupies the area under the rear passenger seat.

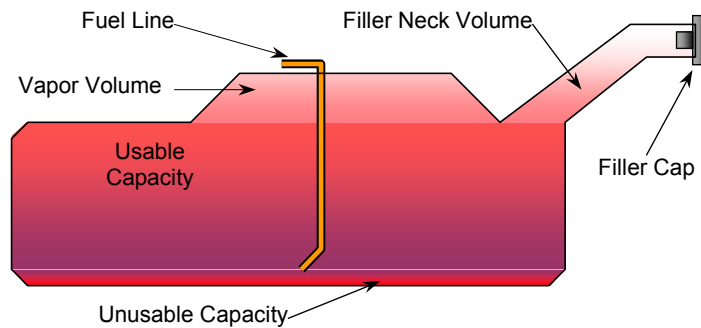

VEHICLE FUEL TANK ASSEMBLY

STEERING COLUMN ADJUSTMENT

Steering wheel and column adjustments are made so that the steering wheel hub is at the geometric center of the locus it describes when moved through its full range of motion. An aluminum plate is placed across the rim of the steering wheel, an inclinometer is placed on the plate and the angle is measured.

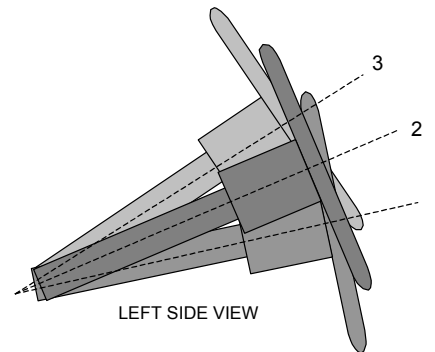

STEERING COLUMN ASSEMBLY

STEERING COLUMN POSITIONS

	Degrees	Fore/Aft Position
Lowermost - Position No. 1	24.0	130
Geometric Center - Position No. 2	30.6	150
Uppermost - Position No. 3	27.3	170

DATA SHEET NO. 5

DUMMY POSITIONING IN VEHICLE

Test Vehicle: 2008 Toyota Sequoia SR5 5-Door MPV

NHTSA No.: M85115

Test Program: NHTSA 35mph NCAP

Test Date: 01/22/08

TEST DUMMY POSITION MEASUREMENTS

Code	Measurement Description	Driver		Passenger	
		Length (mm)	Angle (°)	Length (mm)	Angle (°)
WA	Windsheild angle		30.3		
SWA	Steering wheel angle		30.6		
SCA	Steering column angle		59.4		
SA	Seat Back angle		3.0 @ Headrest		1.4 @ Headrest
HZ	Head to roof (Z)	241	90.0	235	90.0
HH	Head to header	440		425	
HW	Head to windshield	698		683	
HR	Head to side header (Y)	270		240	
NR	Nost to rim	400	15.1		
CD	Chest to dash	538		550	
CS	Chest to steering hub	315			
RA	Rim to abdomen	187			
KDL	Left knee to dash	115	25.9	76	
KDR	Right knee to dash	108		95	29.8
PA	Pelvic angle		24.2		23.7
TA	Tibia Angle		50.3		57.5
KK	Knee to knee	335		275	
SK	Striker to outboard knee	708	3.1	730	5.8
ST	Striker to head	543	82.5	520	83.9
SH	Striker to H-Point	296	0.0	313	0.0
SHY	Striker to H-Point (Y)	261		310	
HS	Head to side window	305		325	
HD	H-Point to door	138		142	
AD	Arm to door	134		141	

DATA SHEET NO. 5...(CONTINUED)

DUMMY POSITIONING IN VEHICLE

Test Vehicle: 2008 Toyota Sequoia SR5 5-Door MPV

NHTSA No.: M85115

Test Program: NHTSA 35mph NCAP

Test Date: 01/22/08

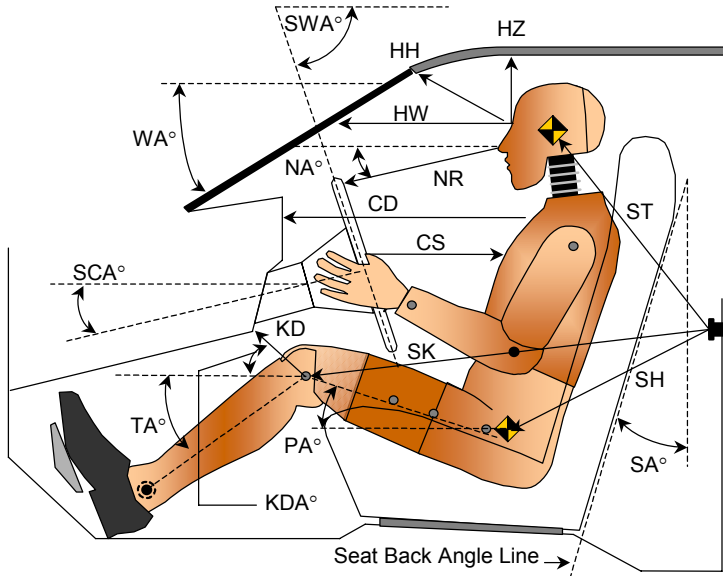

- | | |
|-----|--------------------------------|
| AD | Arm to Door |
| HD | H-Point to Door |
| HR | Head to Side Header |
| HS | Head to Side Window |
| KK | Knee to Knee |
| SHY | Striker to H-Point
(Y Axis) |

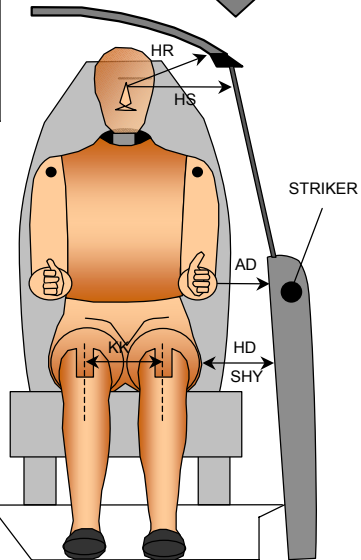

- | | |
|-----|-----------------------------|
| CD | Chest to Dash |
| CS | Chest to Steering Wheel Hub |
| HH | Head to Header |
| HW | Head to Windshield |
| HZ | Head to Roof |
| KDA | Knee to Dash Angle |
| KDL | Left Knee to Dash |
| KDR | Right Knee to Dash |
| NA | Nose to Rim Angle |
| NR | Nose to Rim |
| PA | Pelvic Angle |
| RA | Rim to Abdomen |
| SA | Seat Back Angle |
| SCA | Steering Column Angle |
| SH | Striker to H-Point |
| SK | Striker to Knee |
| ST | Striker to Head |
| SWA | Steering Wheel Angle |
| TA | Tibial Angle |
| WA | Windshield Angle |

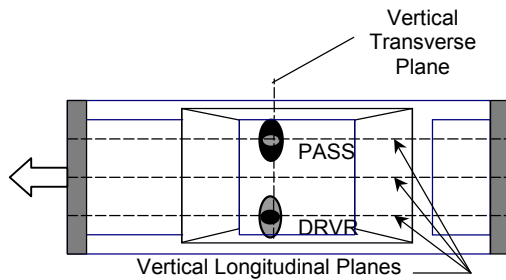

DATA SHEET NO. 6

SEAT BELT POSITIONING DATA

Test Vehicle: 2008 Toyota Sequoia SR5 5-Door MPV

NHTSA No.: M85115

Test Program: NHTSA 35mph NCAP

Test Date: 01/22/08

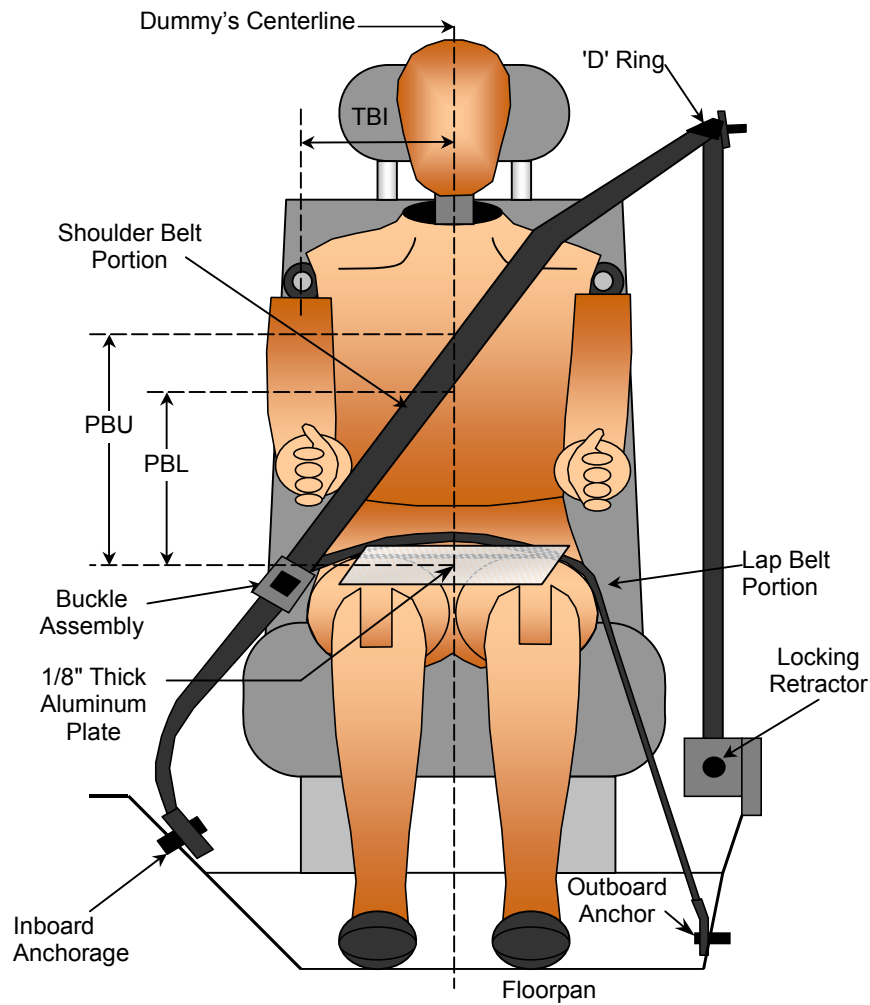

SEAT BELT POSITIONING MEASUREMENTS

Measured Parameter	Units	Driver	Passenger
TBI - Dummy C/L to Lap/Shoulder Belt Intersect	mm	225	290
PBU - Top Surface of Reference to Belt Upper Edge	mm	345	275
PBL - Top Surface of Reference to Belt Lower Edge	mm	275	205
Lap Belt Tension	Newtons	10	10
Shoulder Belt Tension	N/A	Retractor	Retractor

DATA SHEET NO. 7**VEHICLE ACCELEROMETER LOCATIONS**Test Vehicle: 2008 Toyota Sequoia SR5 5-Door MPVNHTSA No.: M85115Test Program: NHTSA 35mph NCAPTest Date: 01/22/08**VEHICLE ACCELEROMETER PRE-TEST LOCATIONS**

No.	Accelerometer Location	Measurement (mm)		
		X	Y	Z
1	Left Rear X-Member	1891	-741	597
2	Right Rear X-Member	1891	741	597
3	Engine Top			
4	Engine Bottom	4033	0	279
5	Left Brake Caliper	4145	-780	435
6	Right Brake Caliper	4145	780	435
7	Instrument Panel			
8	Left Rear X-Member (Z-Axis)	1891	741	597
9	Right Rear X-Member (Z-Axis)	1891	741	597

Reference Planes: X=From Rear Surface of Vehicle, Y=Vehicle Centerline, Z=Ground Plane

1.) Instrument Panel no longer used by NHTSA.

2.) Channel failed, no data.

DATA SHEET NO. 8**SEAT BELT ASSESSMENT TEST DATA**

Test Vehicle: 2008 Toyota Sequoia SR5 5-Door MPV NHTSA No.: M85115
 Test Program: NHTSA 35mph NCAP Test Date: 01/22/08

SEAT BELT POSITIONING MEASUREMENTS

Measurement Description	Units	Driver	Passenger
Retractor Reel to D-Ring	mm	827	802
Shoulder Belt Length as Measured on ATD	mm	952	978
Lap Belt Length as Measured on ATD	mm	808	950
Remainder of Belt on Reel	mm	825	681
Total Belt Length for Continuous Webbing Systems	mm	3412	3411

SHOULDER BELT SPOOL-OFF DATA

Measurement Description	Units	Driver	Passenger
As determined mechanically	mm	N/A	152
As determined electronically	mm	309.9	202.1

BELT STRETCH DATA

Measurement Description	Units	Driver	Passenger
Electronically between belt load cell and D-Ring	mm/cm	*	*
Mechanically	mm/cm		

*Not used with shoulder belt pre-tensioner systems

DATA SHEET NO. 9

SUMMARY OF FMVSS 212 DATA

Test Vehicle: 2008 Toyota Sequoia SR5 5-Door MPV NHTSA No.: M85115
 Test Program: NHTSA 35mph NCAP Test Date: 01/22/08

Windshield Mounting Details: Windshield glass is secured to the vehicle frame with rubber cement type adhesive. plastic molding covers the windshield periphery.

The standard requires that the post-test retention measurement be a minimum of 75 percent of the pretest total periphery measurement for vehicles not equipped with occupant passive restraints and 50 percent for each side of the windshield for vehicles that are equipped with occupant passive restraints.

Temperature of windshield molding during test: 10.6 °C

WINDSHIELD PERIPHERY MEASUREMENTS

Measurement	Pre-Test (mm)	Post-Test (mm)	% of Retention
Left Side	2353	2353	100.0
Right Side	2353	2353	100.0
Total	4706	4706	100.0

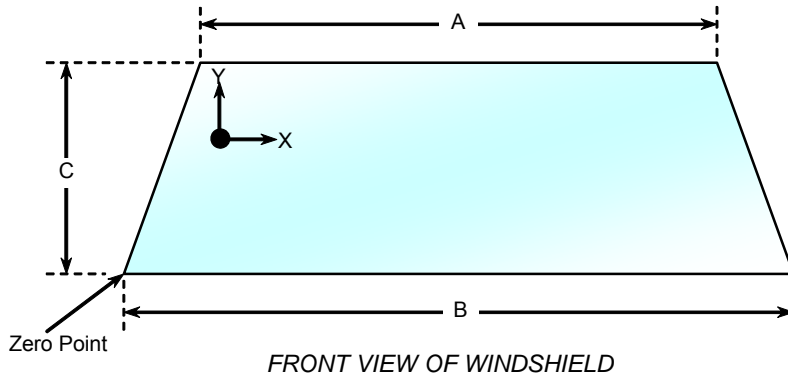

WINDSHIELD DIMENSIONS

Item	Units	Segment Length	Molding Width
A	mm	1410	N/A
B	mm	1675	10
C-Left	mm	810	10
C-Right	mm	810	10

DATA SHEET NO. 10

WINDSHIELD ZONE INTRUSION FMVSS 219 DATA (PARTIAL)

Test Vehicle: 2008 Toyota Sequoia SR5 5-Door MPV
 Test Program: NHTSA 35mph NCAP

NHTSA No.: M85115
 Test Date: 01/22/08

WINDSHIELD AND PROTECTED ZONE

Item	Units	Value
A	mm	1410
B	mm	410
C	mm	1675
D	mm	810
E	mm	496
F	mm	620

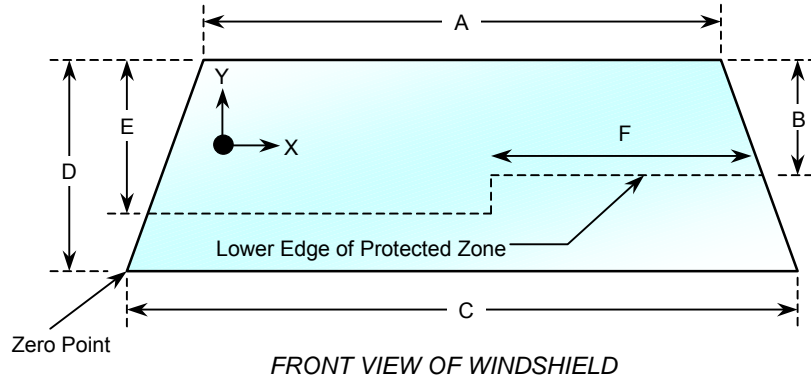

AREA OF PROTECTED ZONE FAILURES

A. Provide coordinates of the area that the protected zone was penetrated more than 0.25 in. by a vehicle component other than one that is normally in contact with the windshield.

X	Y

B. Provide coordinates of the area beneath the protected zone that the inner surface of the windshield was penetrated by a vehicle component.

X	Y

DATA SHEET NO. 11

FMVSS 301 FUEL SYSTEM INTEGRITY POST-IMPACT DATA

Test Vehicle: 2008 Toyota Sequoia SR5 5-Door MPV NHTSA No.: M85115
Test Program: NHTSA 35mph NCAP Test Date: 01/22/08

Test Time: 11:42 AM Temperature: 10.6 ° C

STODDARD SOLVENT SPILLAGE MEASUREMENTS

- A. From impact until vehicle motion ceases: 0
(Maximum allowable = 1 ounce)
- B. For the 5 minute period after motion ceases: 0
(Maximum allowable = 5 ounces)
- C. For the following 25 minutes: 0
(Maximum allowable = 1 oz/minute)
- D. Spillage Details: No leakage occurred

DATA SHEET NO. 12

FMVSS 301 STATIC ROLLOVER DATA

Test Vehicle: 2008 Toyota Sequoia SR5 5-Door MPV

NHTSA No.: M85115

Test Program: NHTSA 35mph NCAP

Test Date: 01/22/08

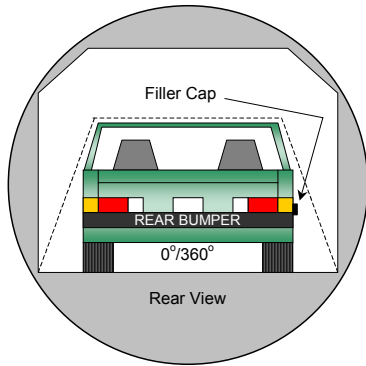

0° to 90°

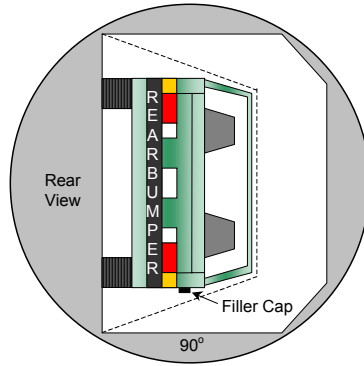

90° to 180°

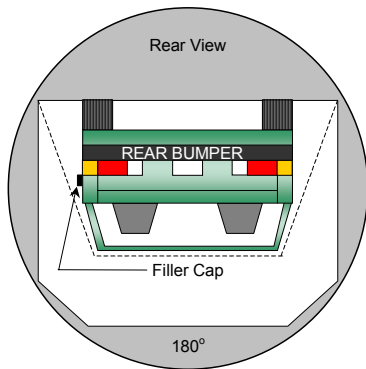
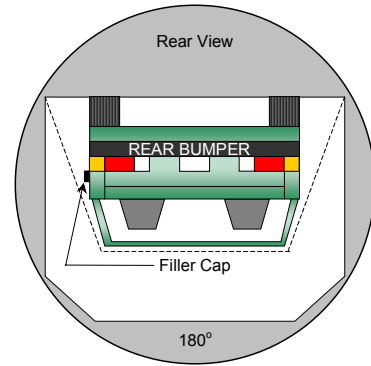

180° to 270°

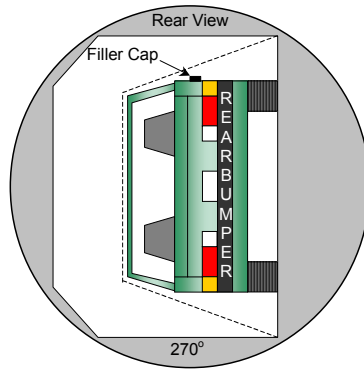

270° to 360°

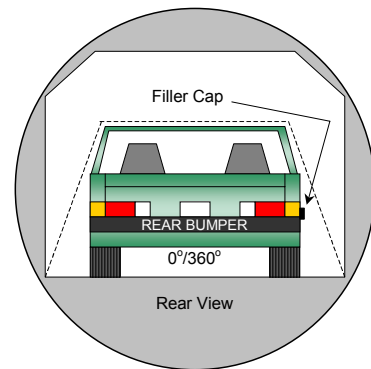

1. The specified fixture rollover rate for each 90° of rotation is 60 to 120 seconds.
2. The position hold time at each position is 300 seconds (minimum).
3. No solvent leakage occurred during rollover.

DATA SHEET NO. 12...(CONTINUED)
FMVSS 301 STATIC ROLLOVER DATA

Test Vehicle: 2008 Toyota Sequoia SR5 5-Door MPV NHTSA No.: M85115
 Test Program: NHTSA 35mph NCAP Test Date: 01/22/08

SOLVENT COLLECTION TIME TABLE IN SECONDS

Test Phase	Rotation Time	Hold Time	Total Time
0° to 90°	83	303	386
90° to 180°	84	306	390
180° to 270°	88	302	390
270° to 360°	84	305	389

FMVSS 301 SPILLAGE TABLE REQUIREMENT

First 5 Minutes	5.0
Sixth Minute	1.0
Seventh Minute	1.0
Eighth Minute	1.0

ACTUAL TEST VEHICLE SOLVENT SPILLAGE TABLE (OZ)

Test Phase	First 5 Minutes	Sixth Minute	Seventh Minute	Eighth Minute
0° to 90°	0	0	0	0
90° to 180°	0	0	0	0
180° to 270°	0	0	0	0
270° to 360°	0	0	0	0

SOLVENT SPILLAGE LOCATION TABLE

Test Phase	Spillage Location
0° to 90°	None
90° to 180°	None
180° to 270°	None
270° to 360°	None

DATA SHEET NO. 13
VEHICLE MEASUREMENTS

Test Vehicle: 2008 Toyota Sequoia SR5 5-Door MPV

NHTSA No.: M85115

Test Program: NHTSA 35mph NCAP

Test Date: 01/22/08

VEHICLE MEASUREMENT TABLE

No.	Measurement Description	Units	Pre-Test	Post-Test	Difference
1	Length of test vehicle at centerline	mm	5196	4768	-428
2	RSOV to front of engine	mm	4516	4446	-70
3	RSOV to firewall centerline	mm	3986	4035	49
4	RSOV to upper leading edge of right door	mm	3743	3844	101
5	RSOV to upper leading edge of left door	mm	3758	3850	92
6	RSOV to lower leading edge of right door	mm	3650	3739	89
7	RSOV to lower leading edge of left door	mm	3663	3741	78
8	RSOV to upper trailing edge of right door	mm	2583	2680	97
9	RSOV to upper trailing edge of left door	mm	2596	2690	94
10	RSOV to lower trailing edge of right door	mm	2563	2641	78
11	RSOV to lower trailing edge of left door	mm	2573	2646	73
12	RSOV to bottom of right A-pillar	mm	3706	3786	80
13	RSOV to bottom of left A-pillar	mm	3726	3783	57
14	RSOV to firewall on right side	mm	3976	4025	49
15	RSOV to firewall on left side	mm	3981	3976	-5
16	RSOV to steering column hub	mm	3325	3416	91
17	Center of steering column to left A-pillar, Y	mm	415	380	-35
18	Center of steering column to headlining, Z	mm	435	490	55
19	RSOV to right side of front bumper	mm	5046	4767	-279
20	RSOV to left side of front bumper	mm	5046	4742	-304
21	Length of engine block	mm	590	590	0
RD	RSOV to right side of dash panel	mm	3501	3608	107
CD	RSOV to center of dash panel	mm	3460	3525	65
LD	RSOV to left side of dash panel	mm	3486	3602	116

DATA SHEET NO. 13...(CONTINUED)

VEHICLE STRUCTURAL MEASUREMENTS

Test Vehicle: 2008 Toyota Sequoia SR5 5-Door MPV

NHTSA No.: M85115

Test Program: NHTSA 35mph NCAP

Test Date: 01/22/08

VEHICLE STRUCTURAL MEASUREMENT TABLE

No.	Measurement Description	Units	Pre-Test	Post-Test	Difference
1	Total length	mm	5196	4768	-428
2	Total width	mm	2025	2030	5
3	Front bumper top height	mm	785	876	91
4	Front bumper bottom height	mm	366	370	4
5	Longitudinal member top height	mm	495	631	136
6	Longitudinal member bottom height	mm	347	531	184
7	Distance between longitudinal members	mm	780	760	-20
8	Longitudinal member width	mm	65	70	5
9	Engine top height	mm	1105	1152	47
10	Engine bottom height	mm	316	324	8
11	Engine and gearbox width	mm	740	740	0
12	Front bumper-engine distance	mm	680	434	-246
13	Front shock absorber height	mm	785	840	55
14	Front hood leading edge height	mm	1130	1195	65
15	Distance between front shock absorbers	mm	1310	1310	0
16	Front bumper-front axle distance	mm	885	550	-335
17	Front axle to A-pillar distance	mm	526	510	-16
18	A Pillar to B Pillar distance	mm	1170	1158	-12
19	B Pillar to rear axle distance	mm	1410	1490	80
20	B Pillar to C Pillar distance	mm	1125	1125	0
21	Roof sill bottom height	mm	1712	1735	23
22	Roof sill top height	mm	1827	1830	3
23	Floor sill bottom height	mm	500	560	60
24	Floor sill top height	mm	545	504	-41

DATA SHEET NO. 13...(CONTINUED)

VEHICLE MEASUREMENTS

Test Vehicle: 2008 Toyota Sequoia SR5 5-Door MPV

NHTSA No.: M85115

Test Program: NHTSA 35mph NCAP

Test Date: 01/22/08

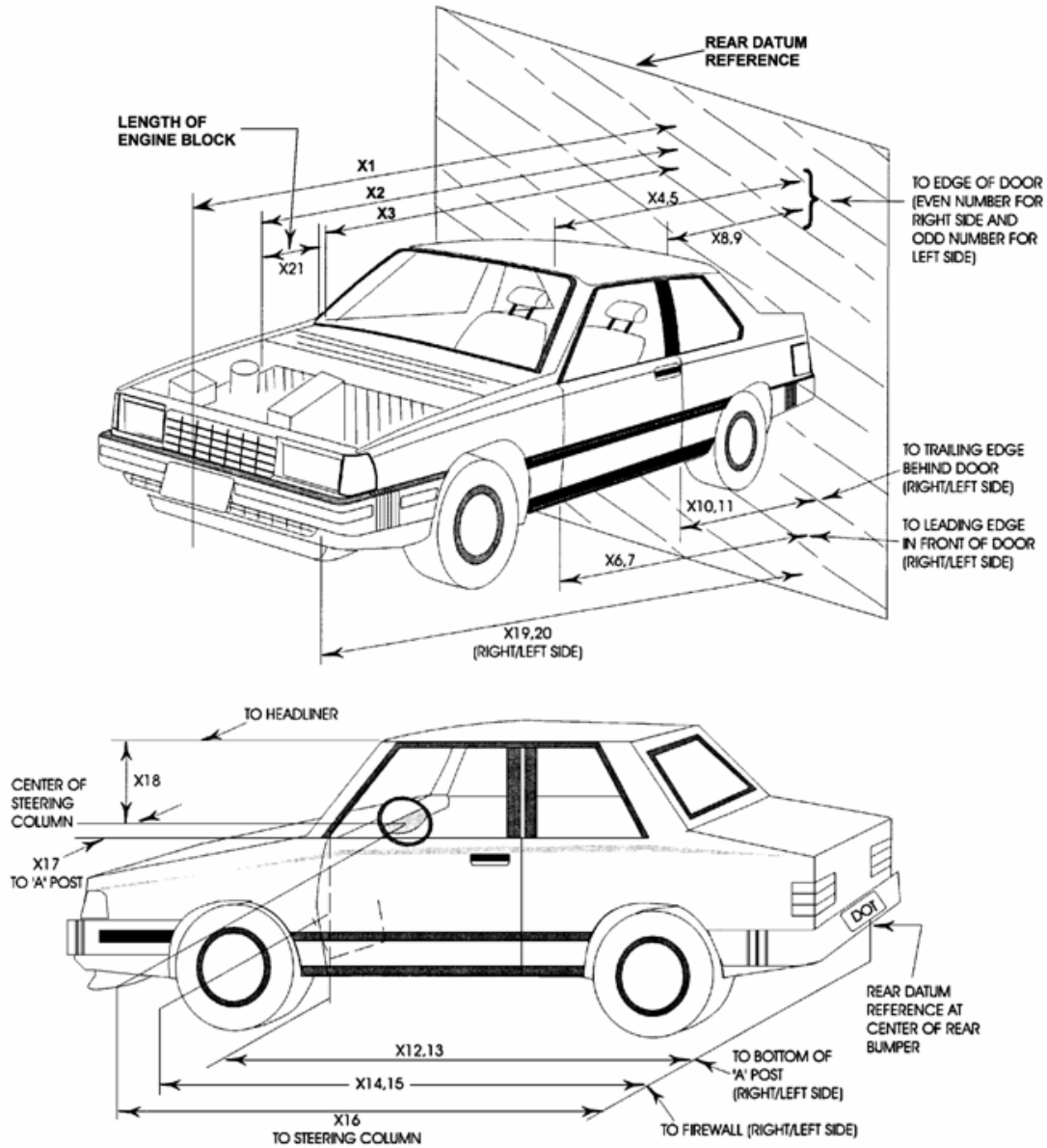

DATA SHEET NO. 14
CAMERA LOCATIONS

Test Vehicle: 2008 Toyota Sequoia SR5 5-Door MPV
Test Program: NHTSA 35mph NCAP

NHTSA No.: M85115
Test Date: 01/22/08

VEHICLE CAMERA MEASUREMENT TABLE

No.	Camera View	Location			Angle (deg)	Film Plane to Head	Lens (mm)	Speed (fps)
		X	Y	Z				
1	Real Time Camera (Panning)	-11412	-8150	-1484	0			30
2	Overall Left Side	-2446	8216.9	-1084	0	8105	20	1000
3	Closeup Left Side	-1653	5954	-1293	0	7844	50	1000
4	Driver and Interior View	-6696	-5987	-1071	-17	15570	ZOOM	1000
5	Steering Column (Bottom)	-1972	-8184	-2879	-13	9453	35	1000
6	Steering Column (Top)	-1966	-8141	-3258	-13	9549	35	1000
7	Overall Right Side	-2667	-8077	-1117	0	7409	20	1000
8	Closeup Right Side	-1737	-7084	-1193	0	7079	50	1000
9	Passenger and Interior View	-5136	9516	-2460	-10	10211	ZOOM	1000
10	Right Side View	-1582	7995	-1713	-6	7134	ZOOM	1000
11	Windshield View	-354	0	-5749	-90		24	1000
12	Driver Front View	363	-543	-2548	-34		25	1000
13	Passenger Front View	381	445	-2548	-34		25	1000
14	Pit View of Engine	-756	0	1495	90		12	1000
15	Pit View of Fuel Tank	-3398	0	1495	90		8	1000
16	Driver Side Dummy On-Board	-114	-12.7	-70	-2	869	12	1000
17	Passenger Side Dummy On-Board	-117	13	-71	-2	871	12	1000
18	Real Time Driver	-1926	-8089	-1704	-1	8539		30
19	Real Time Passenger	-1433	8047	-1704	-1	8361		30

All measurements are made relative to the point of impact.

DATA SHEET NO. 15

PHOTOGRAPHIC REFERENCE TARGET LOCATIONS

Test Vehicle: 2008 Toyota Sequoia SR5 5-Door MPV

NHTSA No.: M85115

Test Program: NHTSA 35mph NCAP

Test Date: 01/22/08

All Dimensions in Millimeters (mm)	
Item	Value
A	470
B	1012.5
C	2120
D	615
E	2520
F	155
G	1740
H	1590
I	1465
J	992.5
K	992.5
L	1730
M	1615
N	1730
O	992.5
P	992.5
Q	1465

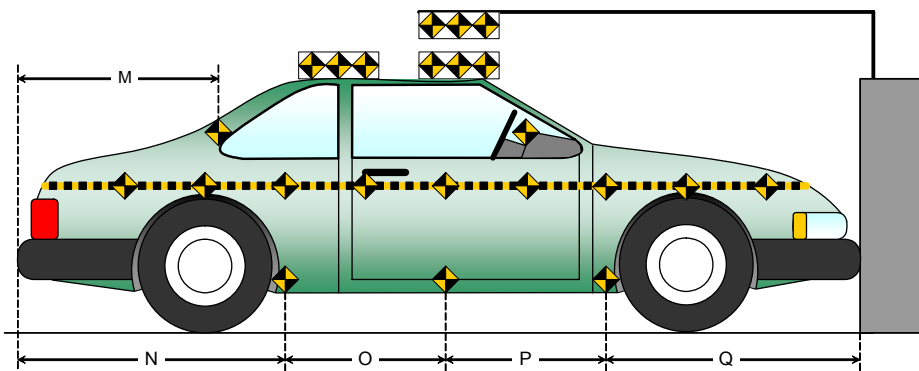
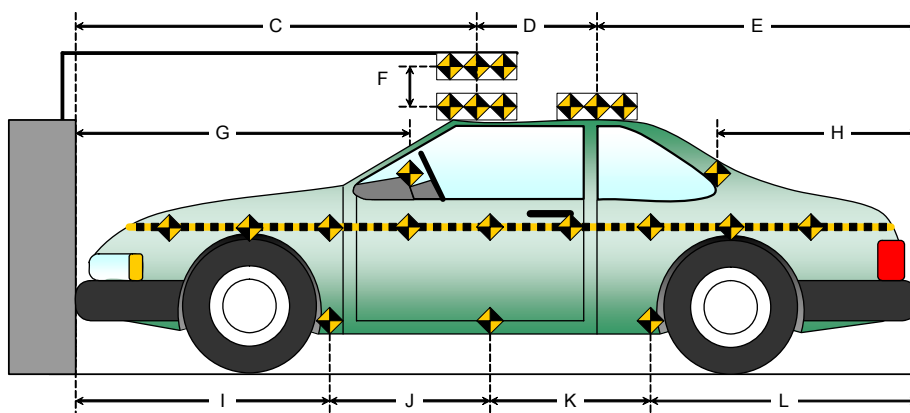
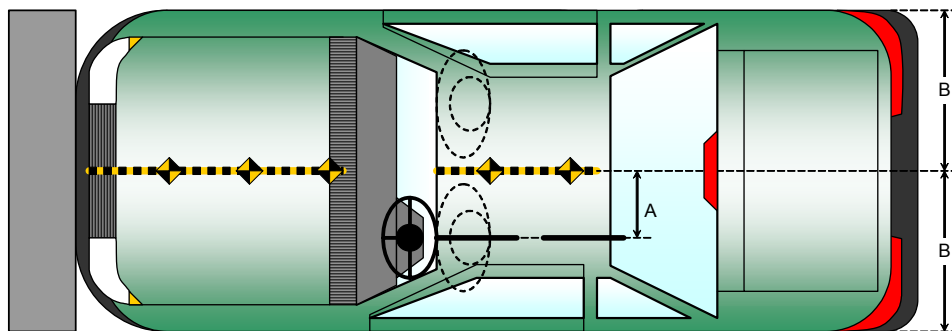

DATA SHEET NO. 16

VEHICLE INTRUSION MEASUREMENTS

Test Vehicle: 2008 Toyota Sequoia SR5 5-Door MPV

NHTSA No.: M85115

Test Program: NHTSA 35mph NCAP

Test Date: 01/22/08

DOOR OPENING WIDTH TABLE

Item	Description	Units	Pre-Test	Post-Test	Difference
1L	Left Side	mm	1071	1072	-1
2L	Left Side (Diagonally)	mm	1576	1571	5
3L	Left Side (Diagonally)	mm	1181	1191	-10
1R	Right Side	mm	1071	1076	-5
2R	Right Side (Diagonally)	mm	1581	1580	1
3R	Right Side (Diagonally)	mm	1211	1229	-18

WHEELBASE MEASUREMENT TABLE

Item	Description	Units	Pre-Test	Post-Test	Difference
C	Left Side Wheelbase	mm	3100	3070	30
F	Right Side Wheelbase	mm	3100	3070	30

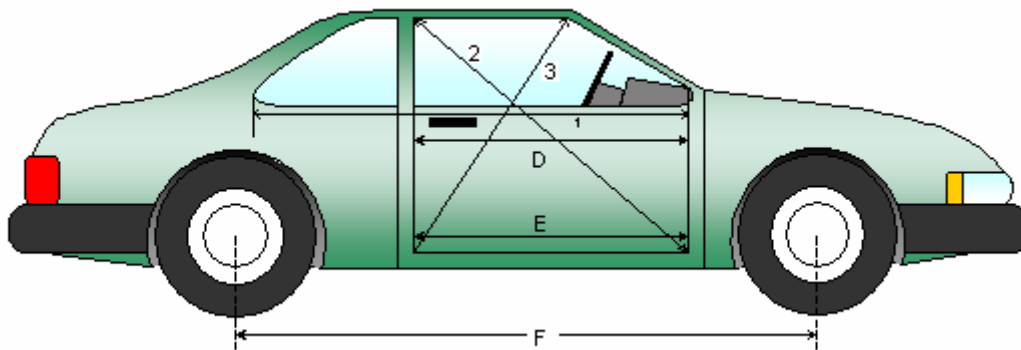
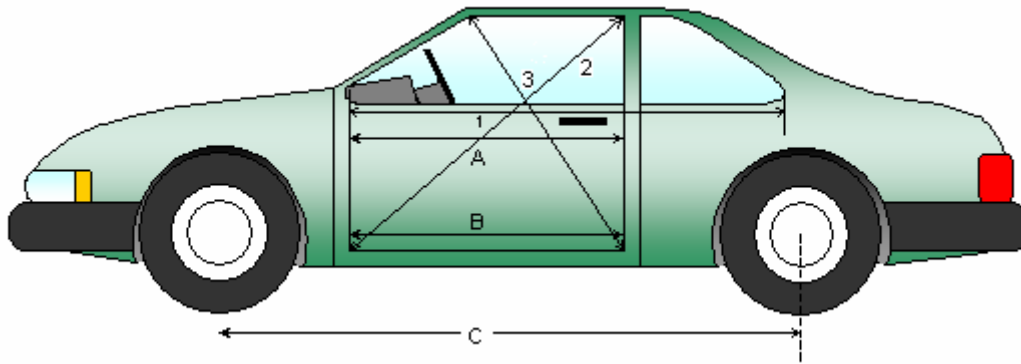

DATA SHEET NO. 16...(CONTINUED)
VEHICLE INTRUSION MEASUREMENTS

Test Vehicle: 2008 Toyota Sequoia SR5 5-Door MPV
 Test Program: NHTSA 35mph NCAP

NHTSA No.: M85115
 Test Date: 01/22/08

DRIVER COMPARTMENT INTRUSION TABLE

Item	Description	Units	Pre-Test	Post-Test	Difference
AB	Door Opening (Inside Window Jam)	mm	1071	1072	-1
CX	Left Knee Bolster to X	mm	265	300	-35
DX	Right Knee Bolster to X	mm	255	310	-55
EX	Brake Pedal to X	mm	561	530	31
FX	Foot Rest to X	mm	541	571	-30
GX	Center of Steering Wheel Hub to X	mm	85	145	-60

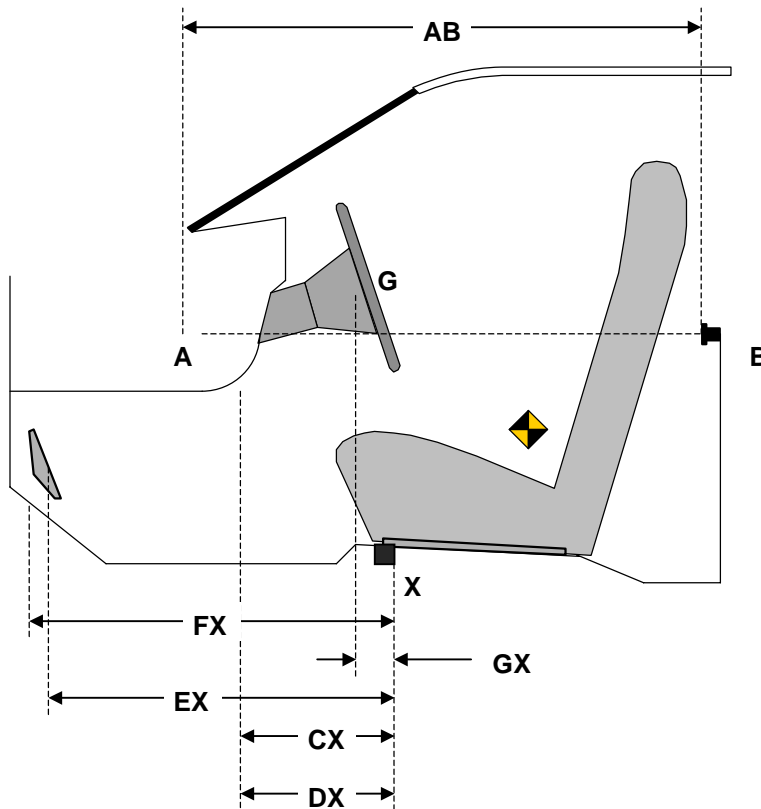

DATA SHEET NO. 16...(CONTINUED)
VEHICLE INTRUSION MEASUREMENTS

Test Vehicle: 2008 Toyota Sequoia SR5 5-Door MPV
 Test Program: NHTSA 35mph NCAP

NHTSA No.: M85115
 Test Date: 01/22/08

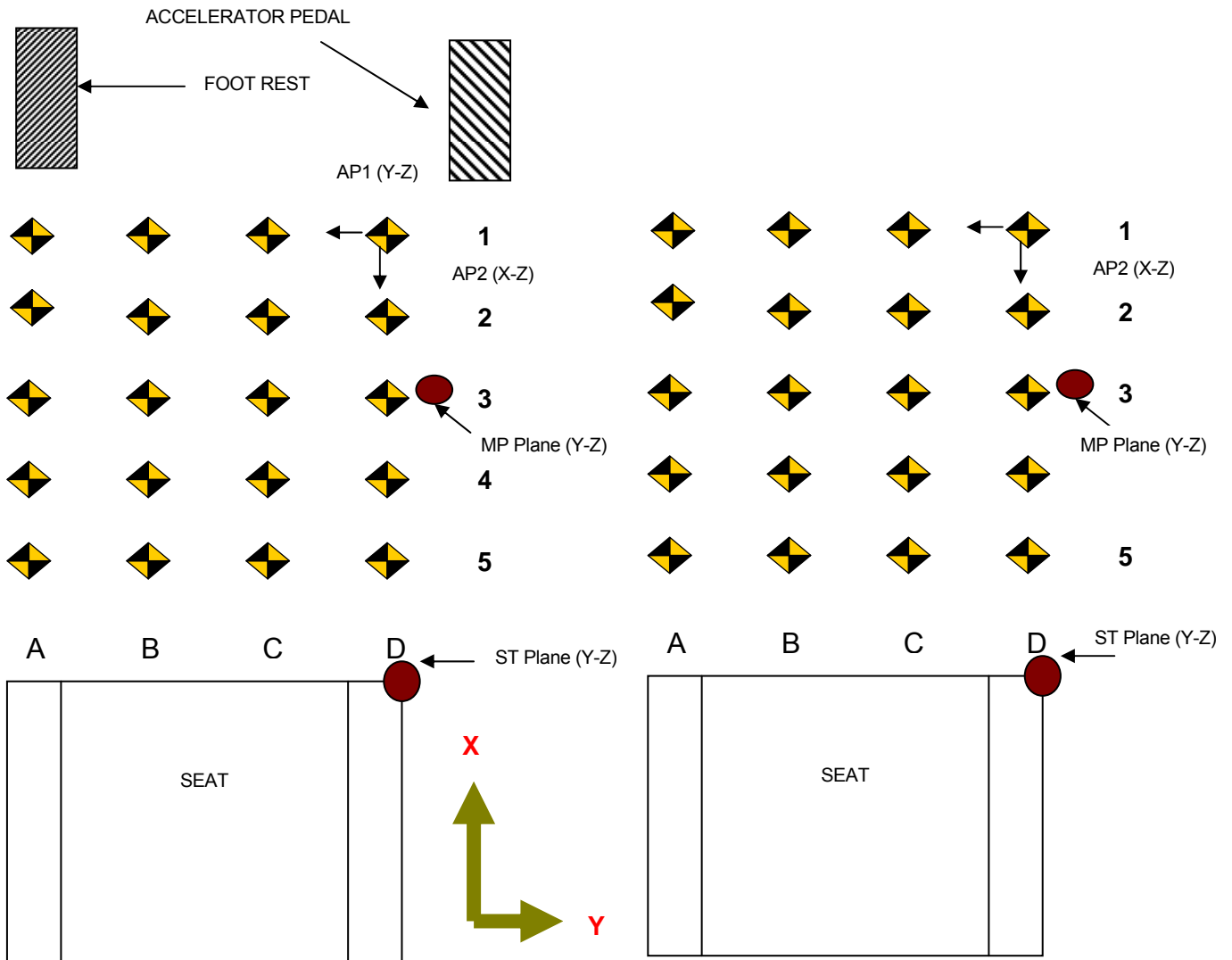

- AP1: Y-Z Plane passing through D1
- AP2: X-Z Plane passing through D1
- AP3: X-Y plane passing through D1
- MP: Y-Z plane, halfway between the ST plane and AP1 plane
- CF Plane: X-Z plane passes through center of footrest.
- BP Plane: X-Z plane passes through center of brake pedal
- TP Plane: Y-Z plane, intersection of BP Plane and the intersection of the toe pan and floorboard
- Column A: intersection of vehicle and CF plane
- Column D: Intersection of vehicle and AP2 plane
- Row 1: intersection of the vehicle and the AP3 Plane
- Row 3: intersection of the vehicle and TP plane
- Row 5: intersection of the vehicle and MP plane
- Row 2: evenly spaced between row 1 and 3
- Row 4: evenly spaced between row 3 and 5

DATA SHEET NO. 16...(CONTINUED)
VEHICLE INTRUSION MEASUREMENTS

Test Vehicle: 2008 Toyota Sequoia SR5 5-Door MPV

NHTSA No.: M85115

Test Program: NHTSA 35mph NCAP

Test Date: 01/22/08

All measurements in mm

DRIVER FLOORPAN X-AXIS

	Pre-Test				Post-Test				Difference			
	A	B	C	D	A	B	C	D	A	B	C	D
1	649	686	707	661	662	690	700	615	-13	-4	7	46
2	602	635	620	612	604	640	622	599	-2	-5	-2	13
3	542	526	519	507	530	530	529	519	12	-4	-10	-12
4	404	404	399	388	402	407	412	411	2	-3	-13	-23
5	282	278	275	266	280	285	287	287	2	-7	-12	-21

DRIVER FLOORPAN Y-AXIS

	Pre-Test				Post-Test				Difference			
	A	B	C	D	A	B	C	D	A	B	C	D
1	8	134	255	417	-24	104	213	370	32	30	42	47
2	8	136	255	423	-23	104	223	384	31	32	32	39
3	9	135	252	422	-21	103	221	388	30	32	31	34
4	6	133	252	419	-20	107	227	395	26	26	25	24
5	1	129	249	415	-16	114	231	399	17	15	18	16

DRIVER FLOORPAN Z-AXIS

	Pre-Test				Post-Test				Difference			
	A	B	C	D	A	B	C	D	A	B	C	D
1	-96	-56	-33	-66	-71	-38	-13	-64	-25	-18	-20	-2
2	-7	19	13	15	10	40	38	22	-17	-21	-25	-7
3	78	58	57	56	88	75	77	66	-10	-17	-20	-10
4	71	79	72	61	71	81	82	74	0	-2	-10	-13
5	65	64	62	56	63	68	67	63	2	-4	-5	-7

DATA SHEET NO. 16...(CONTINUED)

VEHICLE INTRUSION MEASUREMENTS

Test Vehicle: 2008 Toyota Sequoia SR5 5-Door MPV

NHTSA No.: M85115

Test Program: NHTSA 35mph NCAP

Test Date: 01/22/08

All measurements in mm

PASSENGER FLOORPAN X-AXIS

	Pre-Test				Post-Test				Difference			
	A	B	C	D	A	B	C	D	A	B	C	D
1	705	744	718	647	608	659	698	651	97	85	20	-4
2	663	665	655	550	561	584	642	607	102	81	13	-5
3	435	555	547	421	525	527	538	548	35	28	9	2
4	296	430	426	283	407	409	415	420	28	21	11	1
5	296	294	289	283	267	273	279	282	29	21	10	1

DRIVER FLOORPAN Y-AXIS

	Pre-Test				Post-Test				Difference			
	A	B	C	D	A	B	C	D	A	B	C	D
1	-370	-252	-91	29	-411	-316	-156	-20	41	64	65	49
2	-368	-252	-84	34	-406	-290	-137	-13	38	38	53	47
3	-372	-253	-89	34	-408	-292	-130	-14	36	39	41	48
4	-381	-260	-97	31	-412	-294	-130	-4	31	34	33	35
5	-396	-274	-105	21	-417	-296	-129	-5	21	22	24	26

PASSENGER FLOORPAN Z-AXIS

	Pre-Test				Post-Test				Difference			
	A	B	C	D	A	B	C	D	A	B	C	D
1	-82	-39	-56	-88	-124	-77	-65	-80	42	38	9	-8
2	-1	14	12	-10	-44	-16	10	-5	43	30	2	-5
3	53	55	55	77	13	32	52	78	40	23	3	-1
4	67	66	82	70	36	44	63	64	31	22	19	6
5	60	58	63	66	31	37	53	63	29	21	10	3

DATA SHEET NO. 17

FIXED BARRIER LOAD CELL LOCATIONS

Test Vehicle: 2008 Toyota Sequoia SR5 5-Door MPV
 Test Program: NHTSA 35mph NCAP

NHTSA No.: M85115
 Test Date: 01/22/08

36 Load Cell Rigid Barrier (NHTSA Standard)
 Load Cell Locations on Fixed Barrier

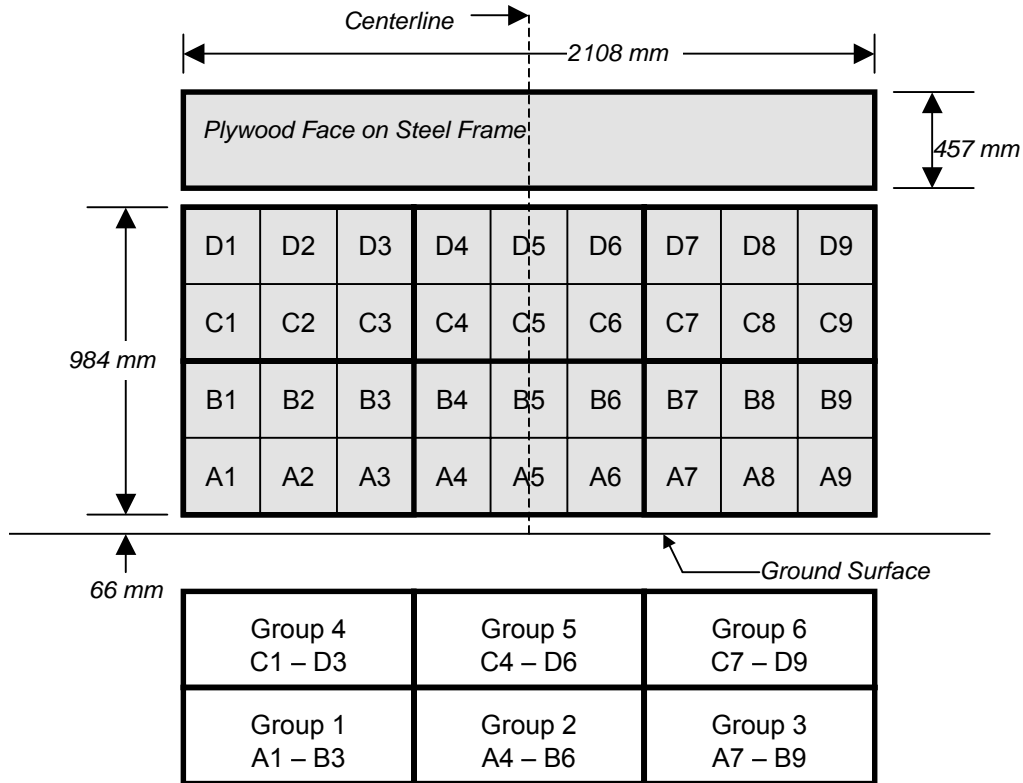

6 Groups of 6 Load Cells Each

DATA SHEET NO. 18

ACCIDENT INVESTIGATION DIVISION DATA

Test Vehicle: 2008 Toyota Sequoia SR5 5-Door MPV NHTSA No.: M85115
 Test Program: NHTSA 35mph NCAP Test Date: 01/22/08

VEHICLE INFORMATION

VIN: 5TDBY64A68S002738 Wheelbase (mm): 3100
 Vehicle Size Category: 5-Door MPV Test Weight (kg): 2816

ACCELEROMETER DATA

Accelerometer Location: Left rear cross member
 Cal. Procedure/Interval: 6 months/drop test
 Integration Algorithm: NHTSA Standard Linearity: Good
 Impact Velocity (km/h): 56.35
 Velocity Change (km/h): 64.7 Time of Separation (msec): 61.8

CRUSH PROFILE

Collision Deformation Classification: 12FDEW6 Midpoint of Damage: Vehicle Centerline
 Damage Region Length: 1743 Impact Mode: Full frontal

No.	Measurement Description	Units	Pre-Test	Post-Test	Difference
C1	Crush zone 1 at left side of vehicle	mm	150	454	-304
C2	Crush zone 2 on left side of vehicle	mm	16	411	-395
C3	Crush zone 3 on left side of vehicle	mm	0	419	-419
C4	Crush zone 4 on right side of vehicle	mm	0	427	-427
C5	Crush zone 5 on right side of vehicle	mm	16	432	-416
C6	Crush zone 6 at right side of vehicle	mm	150	429	-279

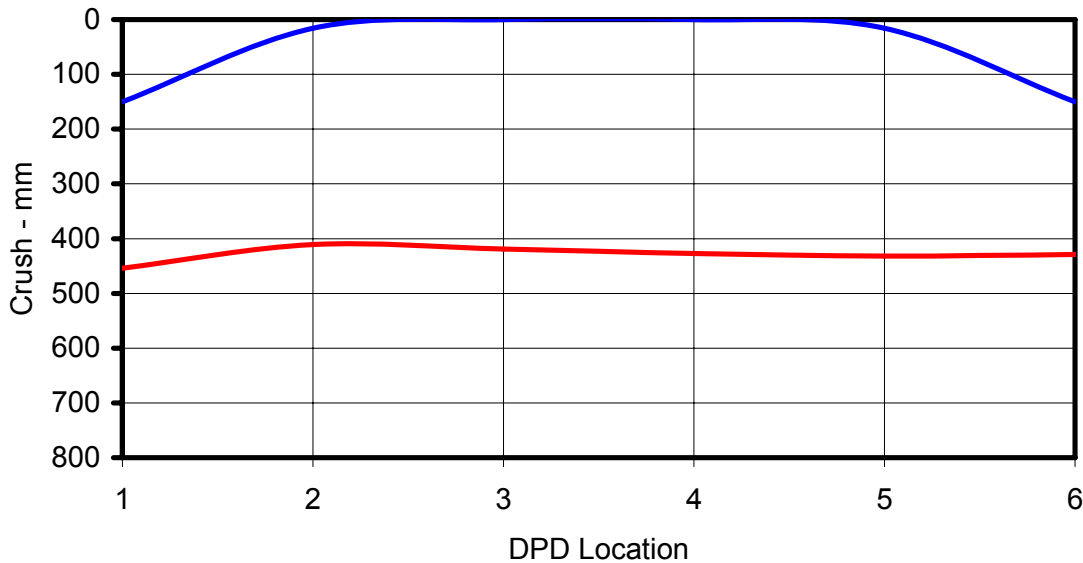

DATA SHEET NO. 19

DUMMY/VEHICLE TEMPERATURE STABILIZATION

Test Vehicle: 2008 Toyota Sequoia SR5 5-Door MPV

NHTSA No.: M85115

Test Program: NHTSA 35mph NCAP

Test Date: 01/22/08

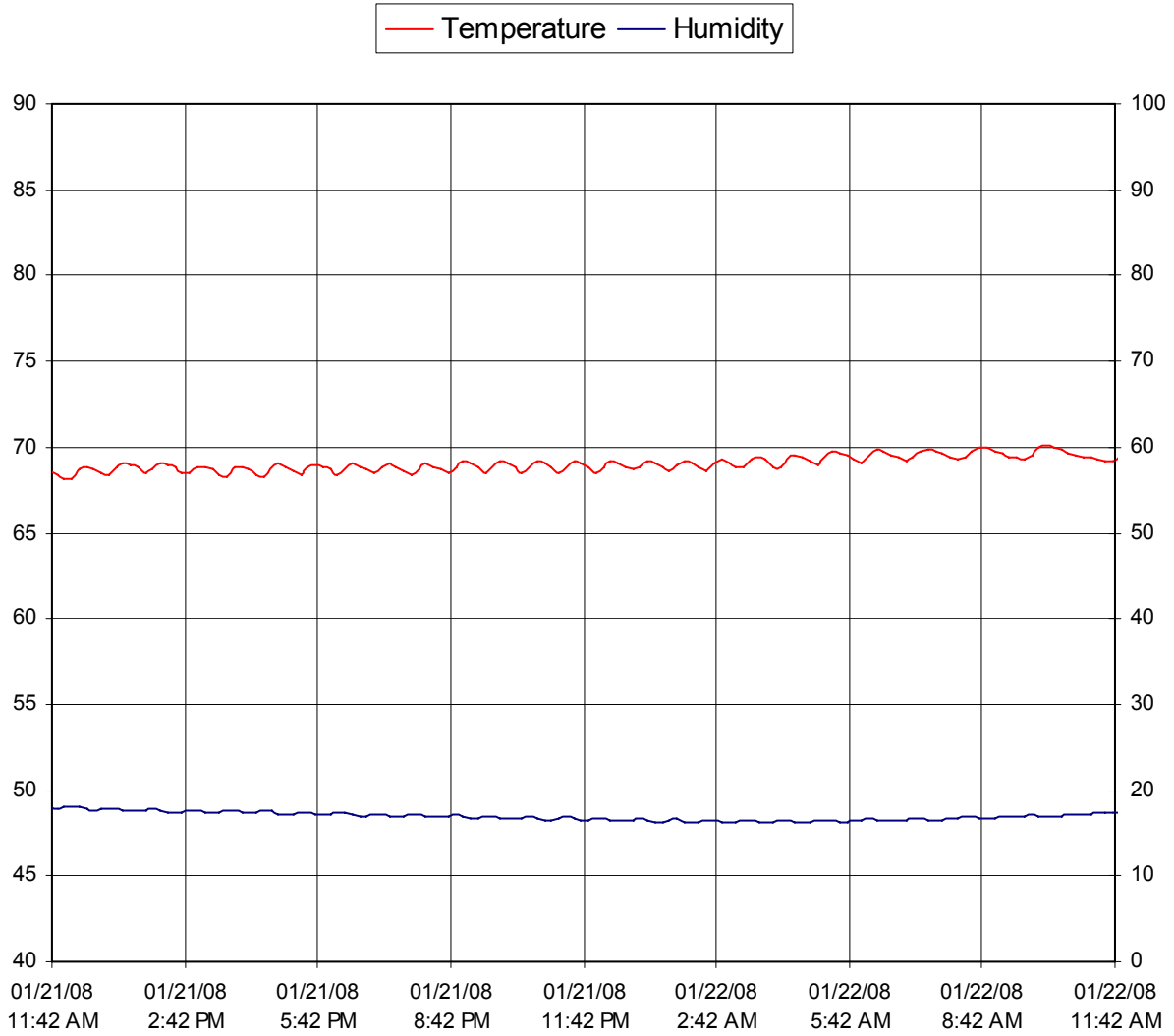

APPENDIX A
PHOTOGRAPHS

LIST OF PHOTOGRAPHS

Figure		Page
A-1	Load Cell Location	A-1
A-2	Manufacturer's Label	A-2
A-3	Tire Placard	A-3
A-4	Right Front $\frac{3}{4}$ View, As Received	A-4
A-5	Left Rear $\frac{3}{4}$ View, As Received	A-5
A-6	Pre-Test Front View	A-6
A-7	Post-Test Front View	A-7
A-8	Pre-Test Left Side View	A-8
A-9	Post-Test Left Side View	A-9
A-10	Pre-Test Right Side View	A-10
A-11	Post-Test Right Side View	A-11
A-12	Pre-Test Right Front $\frac{3}{4}$ View	A-12
A-13	Post-Test Right Front $\frac{3}{4}$ View	A-13
A-14	Pre-Test Left Rear $\frac{3}{4}$ View	A-14
A-15	Post-Test Left Rear $\frac{3}{4}$ View	A-15
A-16	Post-Test Left Side $\frac{3}{4}$ View of Doors After Impact	A-16
A-17	Post-Test Right Side $\frac{3}{4}$ View of Doors After Impact	A-17
A-18	Pre-Test Windshield	A-18
A-19	Post-Test Windshield	A-19
A-20	Pre-Test Engine Compartment	A-20
A-21	Post-Test Engine Compartment (Vehicle Moved)	A-21
A-22	Pre-Test Fuel Cap	A-22
A-23	Post-Test Fuel Cap	A-23
A-24	Pre-Test Front Underbody	A-24
A-25	Post-Test Front Underbody	A-25
A-26	Pre-Test Mid Underbody	A-26
A-27	Post-Test Mid Underbody	A-27
A-28	Pre-Test Rear Underbody	A-28
A-29	Post-Test Rear Underbody	A-29
A-30	Pre-Test Driver Dummy Front View (Head Position)	A-30
A-31	Post-Test Driver Dummy Front View (Head Position)	A-31
A-32	Pre-Test Driver Dummy (Through Window)	A-32
A-33	Post-Test Driver Dummy (Through Window)	A-33
A-34	Pre-Test Driver Dummy (Door Open)	A-34
A-35	Post-Test Driver Dummy (Door Open)	A-35

LIST OF PHOTOGRAPHS...(CONTINUED)

<u>Figure</u>		<u>Page</u>
A-36	Pre-Test Driver Dummy Feet	A-36
A-37	Post-Test Driver Dummy Feet	A-37
A-38	Pre-Test Driver Side Knee Bolster	A-38
A-39	Post-Test Driver Side Knee Bolster	A-39
A-40	Pre-Test Driver Side Floor Pan	A-40
A-41	Post-Test Driver Side Floor Pan	A-41
A-42	Post-Test Driver Dummy Head	A-42
A-43	Post-Test Driver Dummy Airbag Contact	A-43
A-44	Pre-Test Passenger Dummy Front View (Head Position)	A-44
A-45	Post-Test Passenger Dummy Front View (Head Position)	A-45
A-46	Pre-Test Passenger Dummy Front (Through Window)	A-46
A-47	Post-Test Passenger Dummy Front (Through Window)	A-47
A-48	Pre-Test Passenger Dummy (Door Open)	A-48
A-49	Post-Test Passenger Dummy (Door Open)	A-49
A-50	Pre-Test Passenger Dummy Feet	A-50
A-51	Post-Test Passenger Dummy Feet	A-51
A-52	Pre-Test Passenger Side Glove Box	A-52
A-53	Post-Test Passenger Side Glove Box	A-53
A-54	Pre-Test Passenger Side Floor Pan	A-54
A-55	Post-Test Passenger Side Floor Pan	A-55
A-56	Post-Test Passenger Dummy Head	A-56
A-57	Post-Test Passenger Dummy Airbag Contact	A-57
A-58	Vehicle on Rollover Device (0°)	A-58
A-59	Vehicle on Rollover Device (90°)	A-59
A-60	Vehicle on Rollover Device (180°)	A-60
A-61	Vehicle on Rollover Device (270°)	A-61
A-62	Vehicle Impact	A-62



Figure A-1: Load Cell Location

This Space Intentionally Left Blank

MFD. BY: TOYOTA MOTOR MANUFACTURING, INDIANA, INC.

12/07

GVWR: 3310KG (7300LB)

GAWR: FRT. 1810KG (4000LB) WITH P275/65R18 TIRES,
18X8J RIMS, AT 230KPA (33PSI) COLD.

RR. 1940KG (4280LB) WITH P275/65R18 TIRES,
18X8J RIMS, AT 230KPA (33PSI) COLD.

THIS VEHICLE CONFORMS TO ALL APPLICABLE FEDERAL MOTOR
VEHICLE SAFETY AND THEFT PREVENTION STANDARDS IN EFFECT ON
THE DATE OF MANUFACTURE SHOWN ABOVE.

5TDBY64A68S002738 MPV



C/TR: 1F9/FB13

USK65L-GKTSKA

A/TM: A01A/AB60F

MADE IN U.S.A.

338

A

Figure A-2: Manufacturer's Label



TIRE AND LOADING INFORMATION

RENSEIGNEMENTS RELATIFS AUX PNEUS ET À LA CHARGE DU VÉHICULE

SEATING CAPACITY NOMBRE DE PLACES	TOTAL TOTAL: 8	FRONT AVANT: 2	REAR ARRIÈRE: 6
--------------------------------------	-------------------	-------------------	--------------------

The combined weight of occupants and cargo should never exceed 545kg or 1210lbs.
La charge du véhicule (occupants et bagages) ne doit jamais dépasser 545kg ou 1210lb.

TIRE PNEUS	ORIGINAL TIRE SIZE DIMENSIONS DES PNEUS D'ORIGINE	COLD TIRE INFLATION PRESSURE PRESSION DE GONFLAGE À FROID	SEE OWNER'S MANUAL FOR ADDITIONAL INFORMATION CONSULTER LE GUIDE DU PROPRIÉTAIRE POUR DE PLUS AMPLES RENSEIGNEMENTS
FRONT AVANT	P275/65R18	230 kPa, 33 PSI	
REAR ARRIÈRE	P275/65R18	230 kPa, 33 PSI	
SPARE SECOURS	P255/70R18	SEE ABOVE / VOIR CI-DESSUS	



Figure A-3: Tire Placard



Figure A-4: Right Front $\frac{3}{4}$ View, As Received



A-5

TR-P28001-16-NC

Figure A-5: Left Rear 3/4 View, as Received



Figure A-6: Pre-Test Front View



Figure A-7: Post-Test Front View (Vehicle Moved)



A-8

TR-P28001-16-NC

Figure A-8: Pre-Test Left Side View



A-9

TR-P28001-16-NC

Figure A-9: Post-Test Left Side View



Figure A-10: Pre-Test Right Side View



Figure A-11: Post-Test Right Side View



Figure A-12: Pre-Test Right Front 3/4 View



Figure A-13: Post-Test Right Front 3/4 View (Vehicle Moved)



Figure A-14: Pre-Test Left Rear ¾ View



Figure A-15: Post-Test Left Rear ¾ View



Figure A-16: Post-Test Left Side 3/4 View of Doors After Impact



Figure A-17: Post-Test Right Side ¾ View of Doors After Impact



Figure A-19: Post-Test Windshield



Figure A-20: Pre-Test Engine Compartment



Figure A-21: Post-Test Engine Compartment (Vehicle Moved)



2008 Toyota Sequoia SR5
M85115
STODDARD SOLVENT ADDED
24.55 GALLONS
(92.92 LITERS)

Figure A-22: Pre-Test Fuel Cap



2008 Toyota Sequoia SR5
M85115
STODDARD SOLVENT ADDED
24.55 GALLONS
(92.92 LITERS)

Figure A-23: Post-Test Fuel Cap

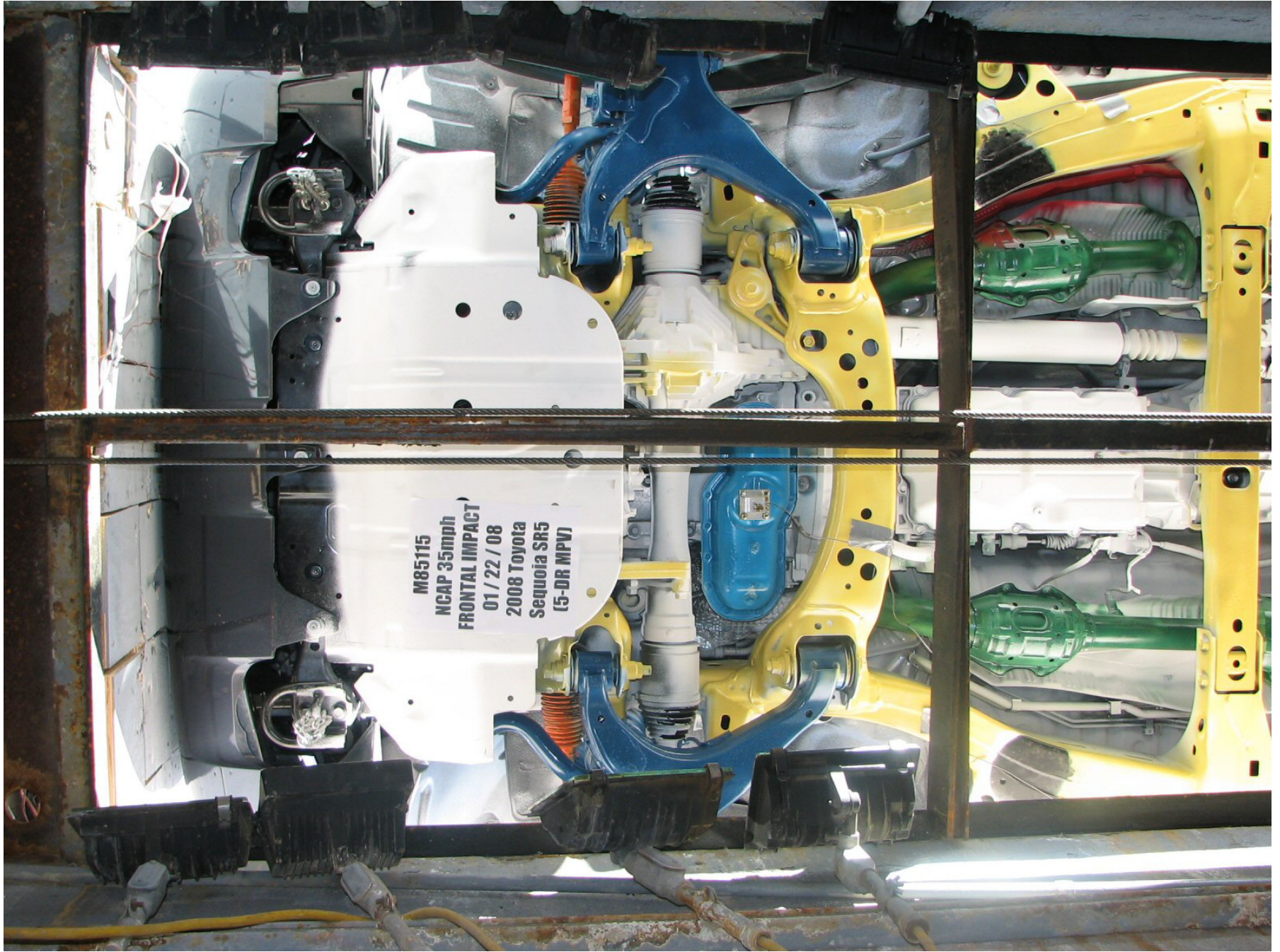

Figure A-24: Pre-Test Front Underbody

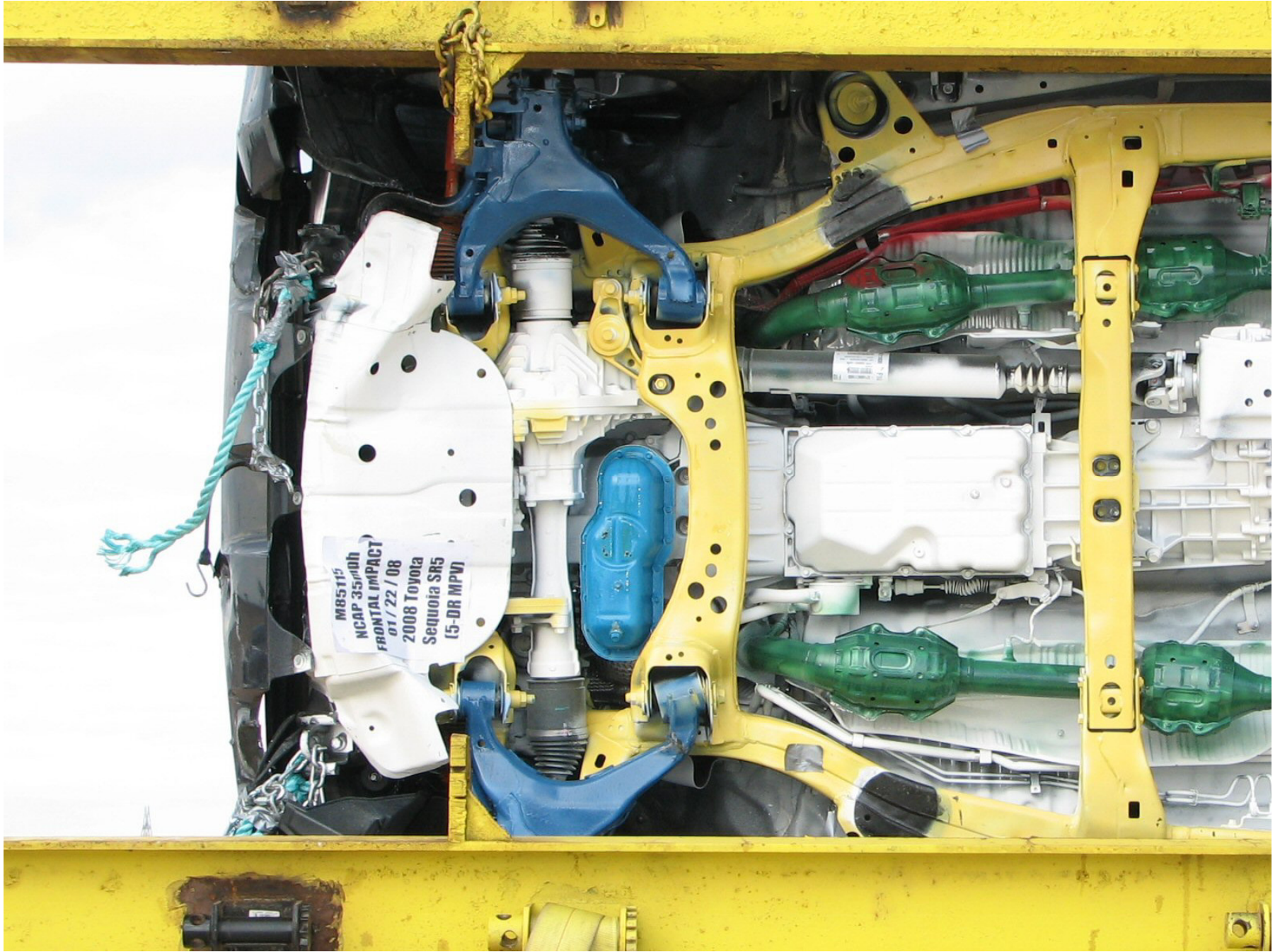

Figure A-25: Post-Test Front Underbody

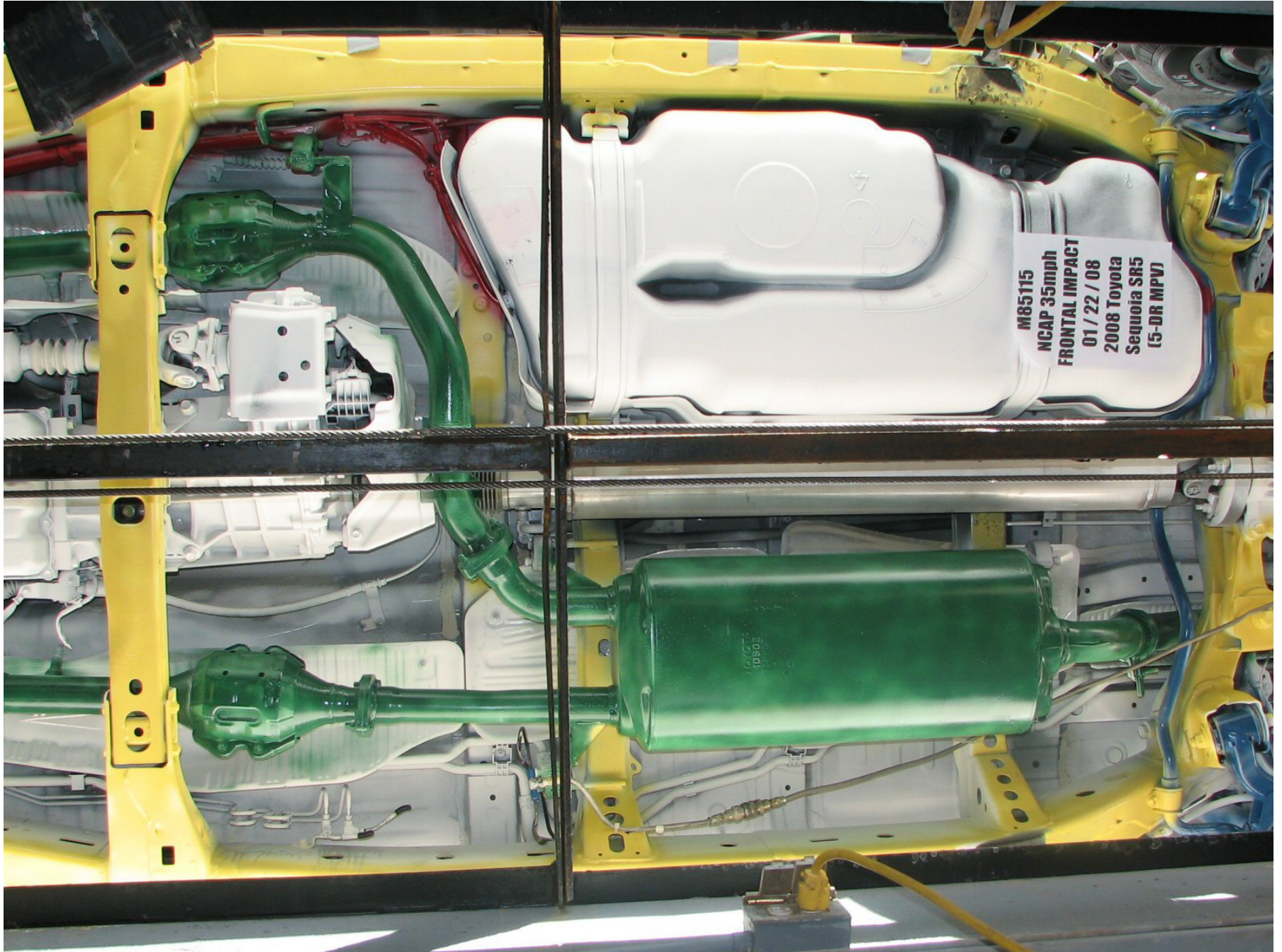
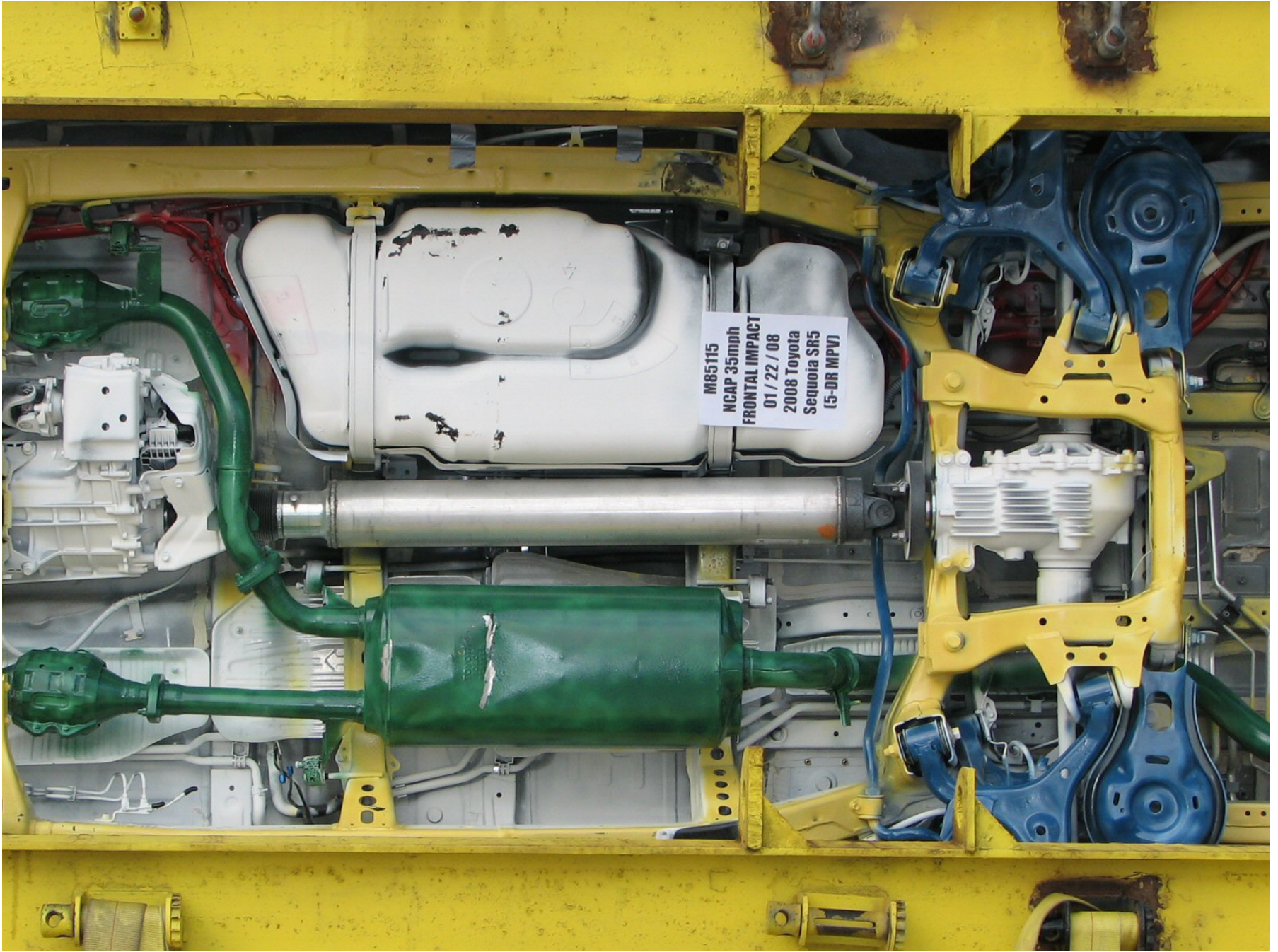

Figure A-26: Pre-Test Mid Underbody



M85115
NCAP 35mph
FRONTAL IMPACT
01 / 22 / 08
2008 Toyota
Sequoia SR5
(5-DR MPV)

Figure A-27: Post-Test Mid Underbody

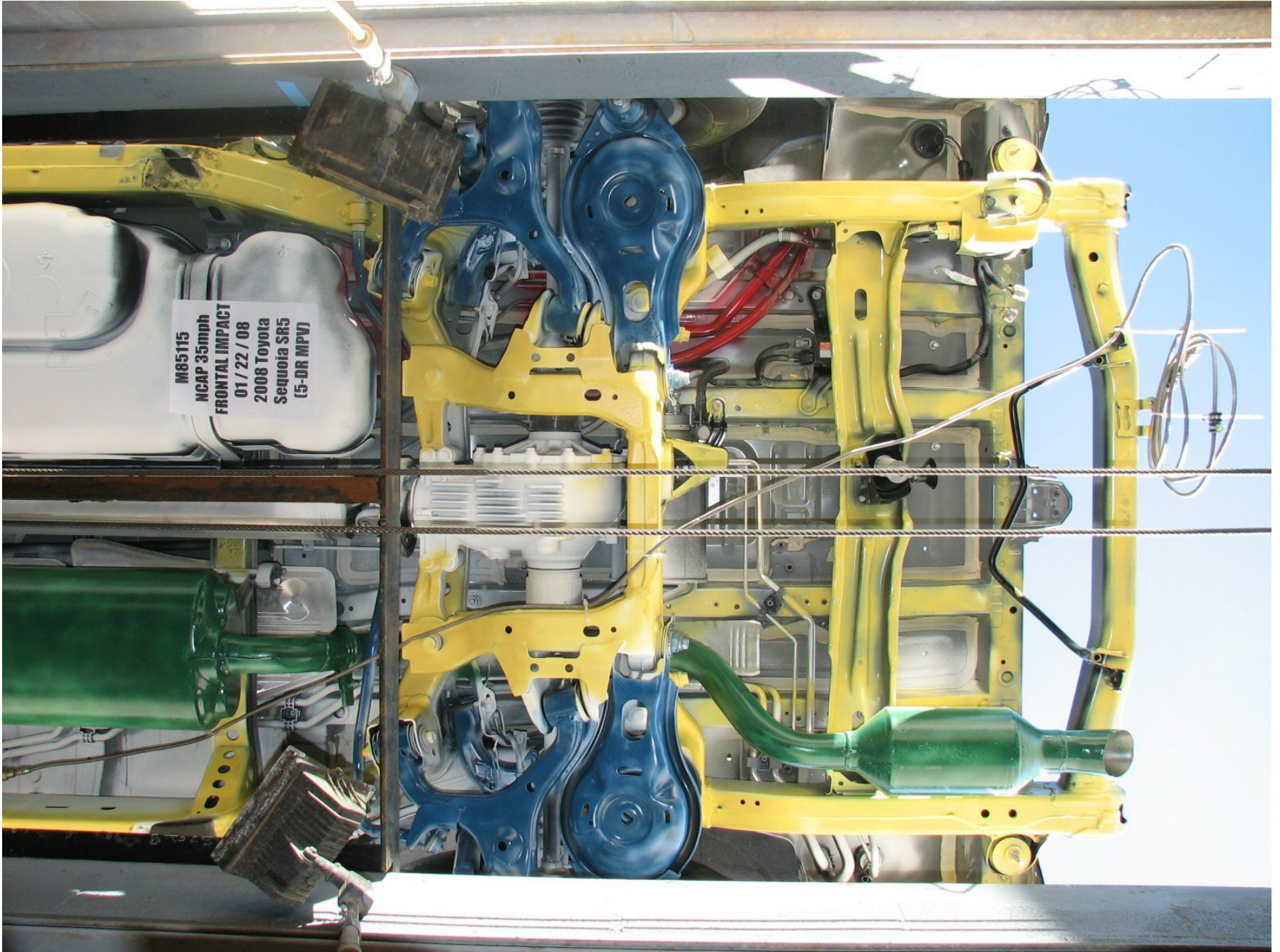

Figure A-28: Pre-Test Rear Underbody

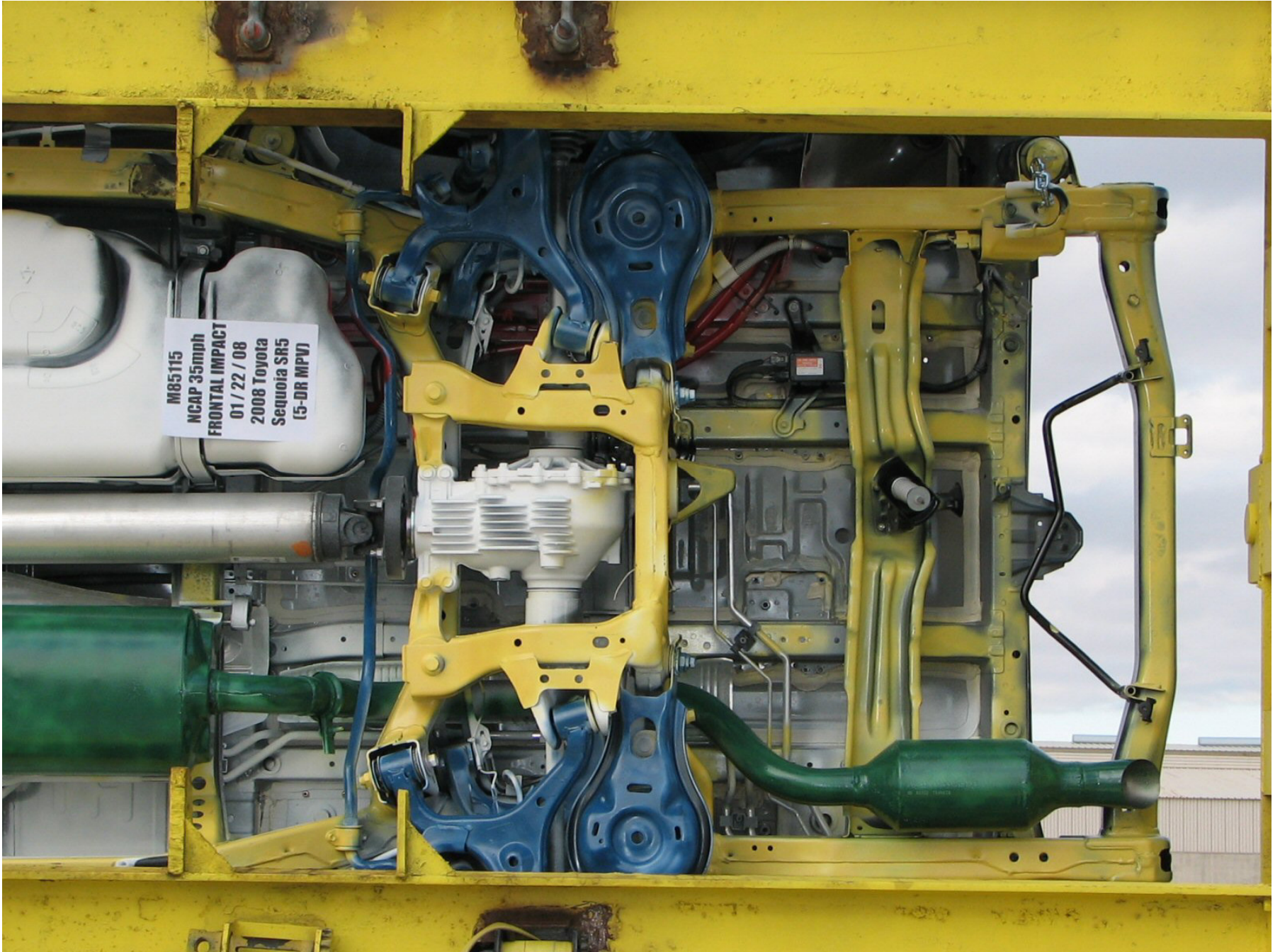

Figure A-29: Post-Test Rear Underbody



Figure A-30: Pre-Test Driver Dummy Front View (Head Position)



Figure A-31: Post-Test Driver Dummy Front View (Head Position)



Figure A-32: Pre-Test Driver Dummy (Through Window)



A-33

TR-P28001-16-NC

Figure A-33: Post-Test Driver Dummy (Through Window)



Figure A-34: Pre-Test Driver Dummy (Door Open)



Figure A-35: Post-Test Driver Dummy (Door Open)



Figure A-36: Pre-Test Driver Dummy Feet



Figure A-37: Post-Test Driver Dummy Feet



Figure A-38: Pre-Test Driver Side Knee Bolster



Figure A-39: Post-Test Driver Side Knee Bolster



Figure A-40: Pre-Test Driver Side Floor Pan



Figure A-41: Post-Test Driver Side Floor Pan



Figure A-42: Post-Test Driver Dummy Head

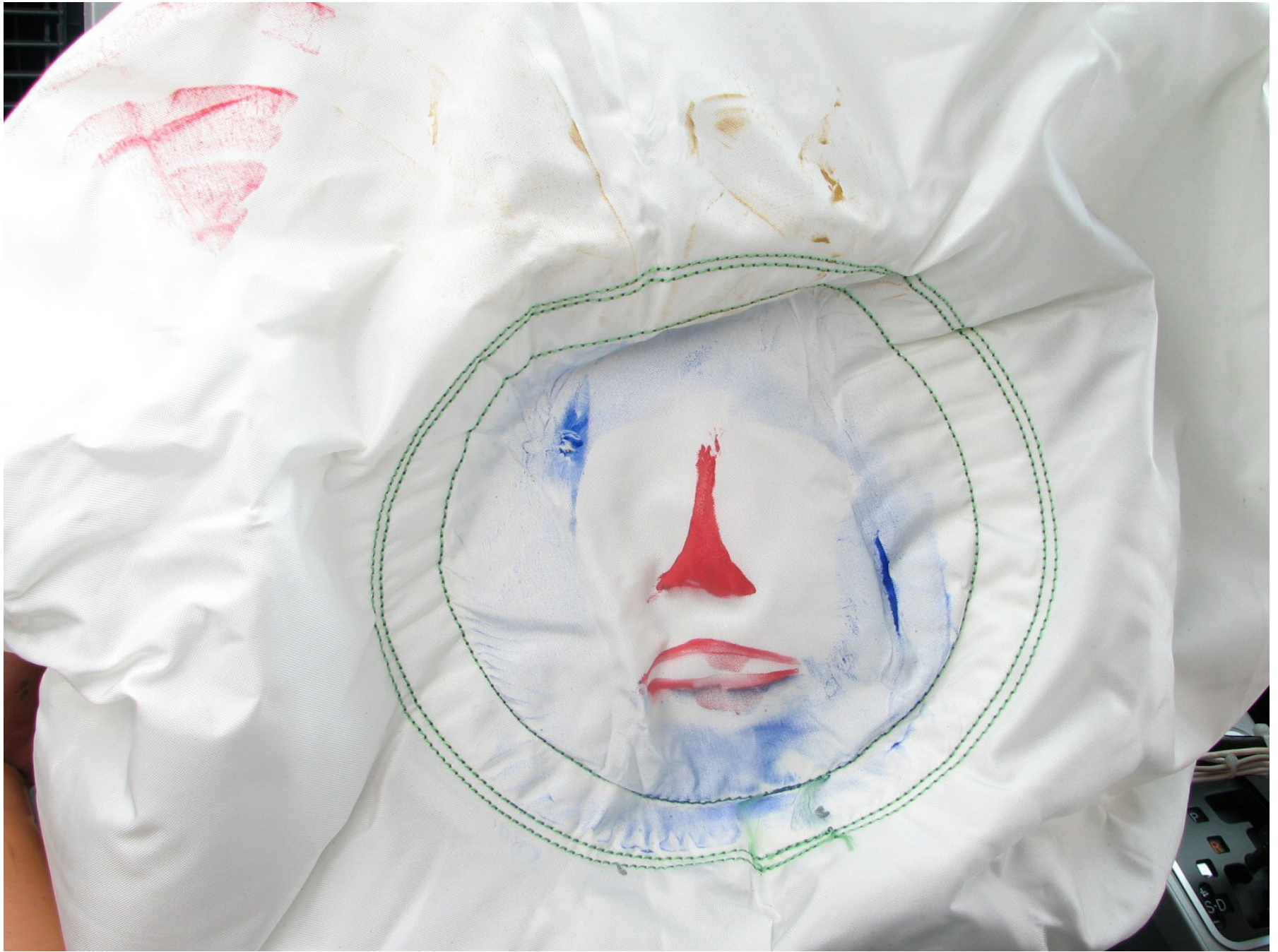

Figure A-43: Post-Test Driver Dummy Airbag Contact



Figure A-44: Pre-Test Passenger Dummy Front View (Head Position)



Figure A-45: Post-Test Passenger Dummy Front View (Head Position)



Figure A-46: Pre-Test Passenger Dummy (Through Window)



Figure A-47: Post-Test Passenger Dummy (Through Window)



Figure A-48: Pre-Test Passenger Dummy (Door Open)



Figure A-49: Post-Test Passenger Dummy (Door Open)



Figure A-50: Pre-Test Passenger Dummy Feet



Figure A-51: Post-Test Passenger Dummy Feet



Figure A-52: Pre-Test Passenger Side Glove Box



Figure A-53: Post-Test Passenger Side Glove Box



Figure A-54: Pre-Test Passenger Side Floor Pan



Figure A-55: Post-Test Passenger Side Floor Pan



Figure A-56: Post-Test Passenger Dummy Head



Figure A-57: Post-Test Passenger Dummy Airbag Contact



A-58

TR-P28001-16-NC

Figure A-58: Vehicle on Rollover Device (0°)



Figure A-59: Vehicle on Rollover Device (90°)



Figure A-60: Vehicle on Rollover Device (180°)

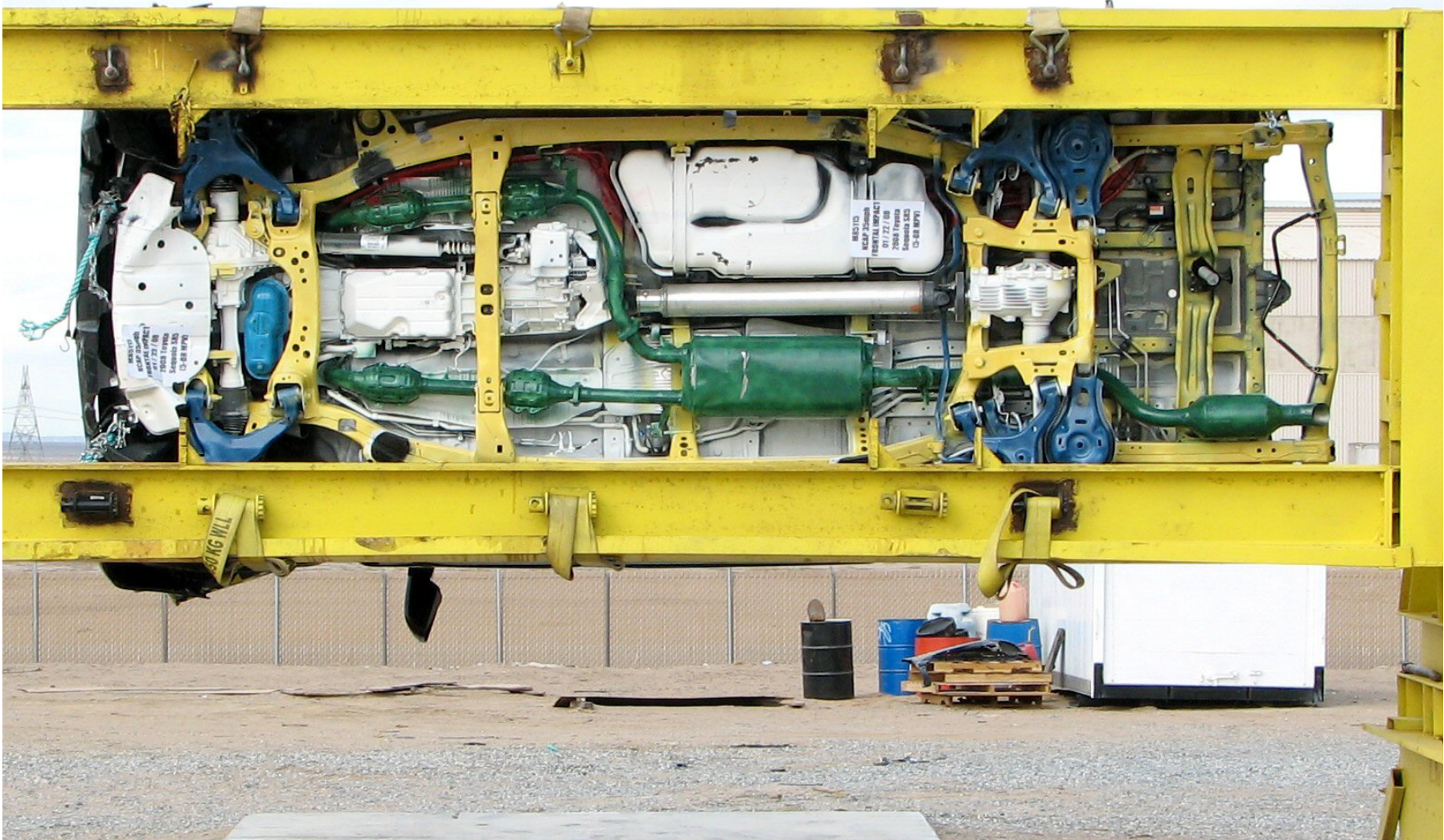

Figure A-61: Vehicle on Rollover Device (270°)



Figure A-62: Vehicle Impact

APPENDIX B
DATA PLOTS

LIST OF DATA PLOTS

Data Plot	Page	
B-1	Driver Head Primary X	B-1
	Driver Head Primary Y	B-1
	Driver Head Primary Z	B-1
	Driver Head Resultant Primary	B-1
B-2	Driver Chest Primary X	B-2
	Driver Chest Primary Y	B-2
	Driver Chest Primary Z	B-2
	Driver Chest Resultant Primary	B-2
B-3	Driver Left Femur Force Z	B-3
	Driver Right Femur Force Z	B-3
B-4	Passenger Head Primary X	B-4
	Passenger Head Primary Y	B-4
	Passenger Head Primary Z	B-4
	Passenger Head Resultant Primary	B-4
B-5	Passenger Chest Primary X	B-5
	Passenger Chest Primary Y	B-5
	Passenger Chest Primary Z	B-5
	Passenger Chest Resultant Primary	B-5
B-6	Passenger Left Femur Force Z	B-6
	Passenger Right Femur Force Z	B-6

LIST OF DATA PLOTS...(CONTINUED)

The following additional data plots for this test can be obtained from the research and development section of the NHTSA website. The website can be found at www.NHTSA.dot.gov.

Driver Head Primary X Velocity
Driver Head Primary X Displacement
Driver Head Redundant X
Driver Head Redundant Y
Driver Head Redundant Z
Driver Head Resultant Redundant
Driver Head Redundant X Velocity
Driver Head Redundant X Displacement
Driver Upper Neck Force X
Driver Upper Neck Force Y
Driver Upper Neck Force Z
Driver Upper Neck Force Resultant
Driver Upper Neck Moment X
Driver Upper Neck Moment Y
Driver Upper Neck Moment Z
Driver Upper Neck Moment Resultant
Driver Chest Primary X Velocity
Driver Chest Primary X Displacement
Driver Chest Redundant X
Driver Chest Redundant Y
Driver Chest Redundant Z
Driver Chest Resultant Redundant
Driver Chest Redundant X Velocity
Driver Chest Redundant X Displacement
Driver Chest Displacement
Driver Pelvis X
Driver Pelvis Y
Driver Pelvis Z
Driver Pelvis Resultant
Driver Pelvis X Velocity
Driver Pelvis X Displacement
Driver Left Upper Tibia Moment X
Driver Left Upper Tibia Moment Y
Driver Right Upper Tibia Moment X

LIST OF DATA PLOTS...(CONTINUED)

Driver Right Upper Tibia Moment Y
Driver Left Lower Tibia Moment X
Driver Left Lower Tibia Moment Y
Driver Left Lower Tibia Force Z
Driver Right Lower Tibia Moment X
Driver Right Lower Tibia Moment Y
Driver Right Lower Tibia Force Z
Driver Left Foot Aft X
Driver Left Foot Aft Z
Driver Left Foot Fore Z
Driver Right Foot Aft X
Driver Right Foot Aft Z
Driver Right Foot Fore Z
Driver Lap Belt Force
Driver Shoulder Belt Force
Driver Shoulder Belt Pullout
Driver Shoulder Belt Elongation
Passenger Head Primary X Velocity
Passenger Head Primary X Displacement
Passenger Head Redundant X
Passenger Head Redundant Y
Passenger Head Redundant Z
Passenger Head Resultant Redundant
Passenger Head Redundant X Velocity
Passenger Head Redundant X Displacement
Passenger Upper Neck Force X
Passenger Upper Neck Force Y
Passenger Upper Neck Force Z
Passenger Upper Neck Force Resultant
Passenger Upper Neck Moment X
Passenger Upper Neck Moment Y
Passenger Upper Neck Moment Z
Passenger Upper Neck Moment Resultant
Passenger Chest Primary X Velocity
Passenger Chest Primary X Displacement
Passenger Chest Redundant X

LIST OF DATA PLOTS...(CONTINUED)

Passenger Chest Redundant Y
Passenger Chest Redundant Z
Passenger Chest Resultant Redundant
Passenger Chest Redundant X Velocity
Passenger Chest Redundant X Displacement
Passenger Chest Displacement
Passenger Pelvis X
Passenger Pelvis Y
Passenger Pelvis Z
Passenger Pelvis Resultant
Passenger Pelvis X Velocity
Passenger Pelvis X Displacement
Passenger Left Femur Force
Passenger Right Femur Force
Passenger Left Upper Tibia Moment X
Passenger Left Upper Tibia Moment Y
Passenger Right Upper Tibia Moment X
Passenger Right Upper Tibia Moment Y
Passenger Left Lower Tibia Moment X
Passenger Left Lower Tibia Moment Y
Passenger Left Lower Tibia Force Z
Passenger Right Lower Tibia Moment X
Passenger Right Lower Tibia Moment Y
Passenger Right Lower Tibia Force Z
Passenger Left Foot Aft X
Passenger Left Foot Aft Z
Passenger Left Foot Fore Z
Passenger Right Foot Aft X
Passenger Right Foot Aft Z
Passenger Right Foot Fore Z
Passenger Lap Belt Force
Passenger Shoulder Belt Force
Passenger Shoulder Belt Pullout
Passenger Shoulder Belt Elongation
Vehicle Left Rear X
Vehicle Left Rear X Velocity

LIST OF DATA PLOTS...(CONTINUED)

Vehicle Left Rear X Displacement
Vehicle Right Rear X
Vehicle Right Rear X Velocity
Vehicle Right Rear X Displacement
Vehicle Engine Top
Vehicle Engine Top Velocity
Vehicle Engine Top Displacement
Vehicle Engine Bottom
Vehicle Engine Bottom Velocity
Vehicle Engine Bottom Displacement
Vehicle Left Brake Caliper
Vehicle Left Brake Caliper Velocity
Vehicle Left Brake Caliper Displacement
Vehicle Right Brake Caliper
Vehicle Right Brake Caliper Velocity
Vehicle Right Brake Caliper Displacement
Vehicle Instrument Panel
Vehicle Instrument Panel Velocity
Vehicle Instrument Panel Displacement
Vehicle Left Rear Z
Vehicle Left Rear Z Velocity
Vehicle Left Rear Z Displacement
Vehicle Right Rear Z
Vehicle Right Rear Z Velocity
Vehicle Right Rear Z Displacement

Test Vehicle: 2008 Toyota Sequoia SR5 5-Door MPV
 Test Program: NHTSA 35mph NCAP

Test Date: 1/22/08
 NHTSA No.: M85115

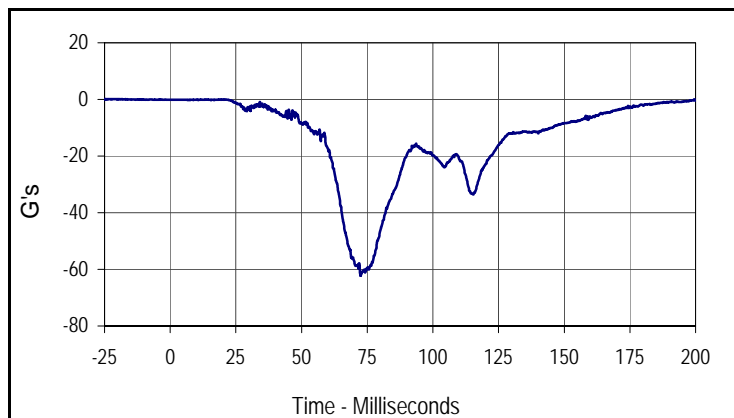

Curve Description			
Driver Head Primary X			
CURNO	Type	SAE Class	Units
001	FIL	1000	G's
Max	Time	Min	Time
0.0	21.1	-62.2	72.4

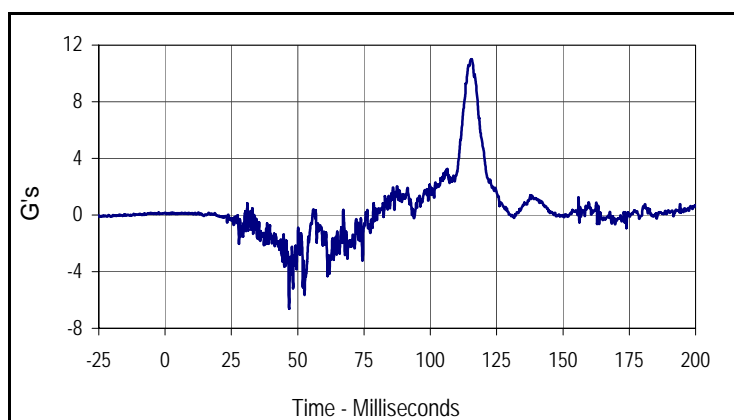

Curve Description			
Driver Head Primary Y			
CURNO	Type	SAE Class	Units
002	FIL	1000	G's
Max	Time	Min	Time
11.0	115.6	-6.6	46.8

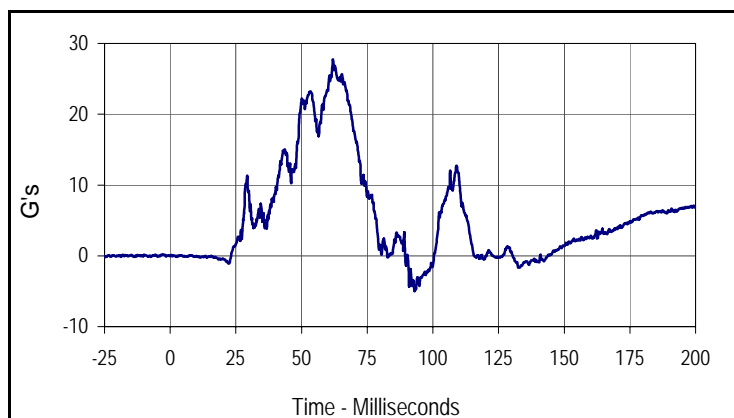

Curve Description			
Driver Head Primary Z			
CURNO	Type	SAE Class	Units
003	FIL	1000	G's
Max	Time	Min	Time
27.7	61.9	-5.0	93.0

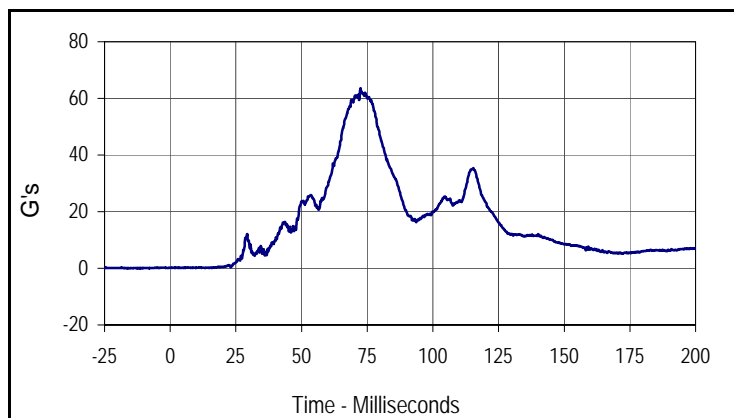

Curve Description			
Driver Head Resultant Primary			
CURNO	Type	SAE Class	Units
001	RES	1000	G's
Max	Time	Min	Time
63.5	72.4	0.1	13.5

Test Vehicle: 2008 Toyota Sequoia SR5 5-Door MPV
 Test Program: NHTSA 35mph NCAP

Test Date: 1/22/08
 NHTSA No.: M85115

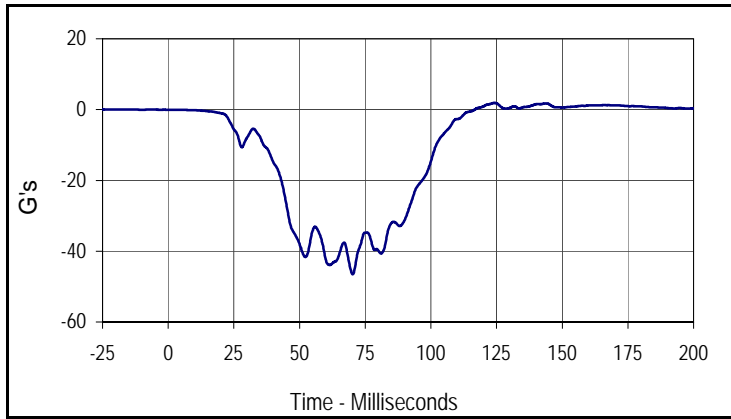

Curve Description			
Driver Chest Primary X			
CURNO	Type	SAE Class	Units
004	FIL	180	G's
Max	Time	Min	Time
1.9	124.1	-46.5	70.2

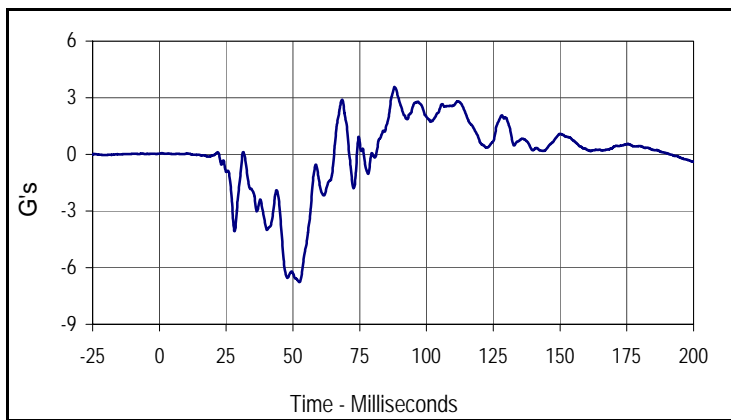

Curve Description			
Driver Chest Primary Y			
CURNO	Type	SAE Class	Units
005	FIL	180	G's
Max	Time	Min	Time
3.6	88.0	-6.8	52.4

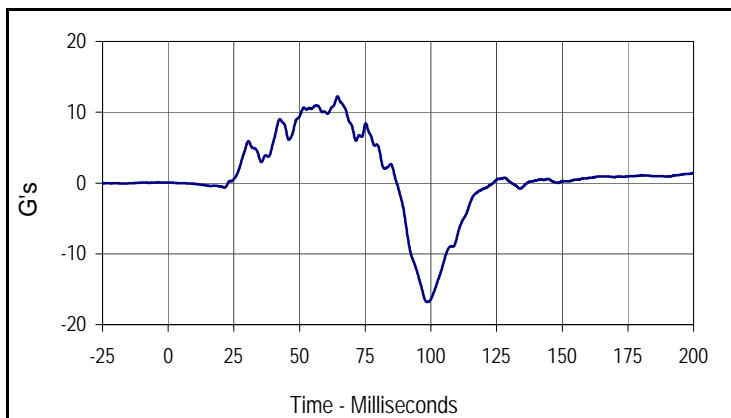

Curve Description			
Driver Chest Primary Z			
CURNO	Type	SAE Class	Units
006	FIL	180	G's
Max	Time	Min	Time
12.2	64.5	-16.8	98.6

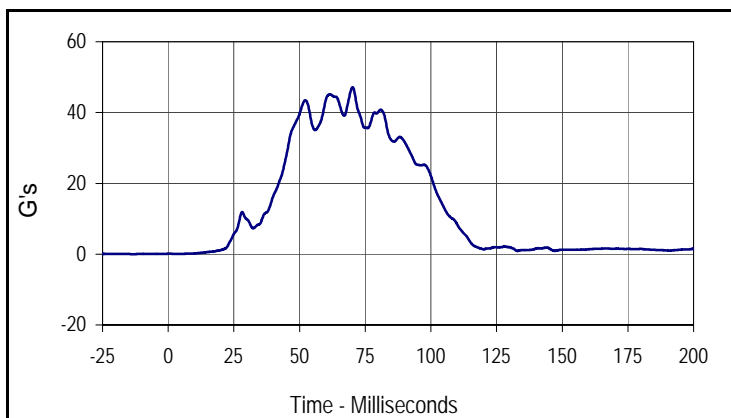

Curve Description			
Driver Chest Resultant Primary			
CURNO	Type	SAE Class	Units
004	RES	180	G's
Max	Time	Min	Time
47.2	70.2	0.1	2.8

Test Vehicle: 2008 Toyota Sequoia SR5 5-Door MPV
 Test Program: NHTSA 35mph NCAP

Test Date: 1/22/08
 NHTSA No.: M85115

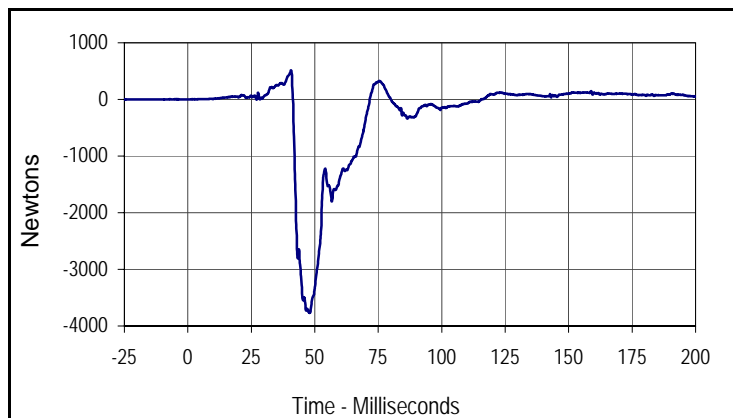

Curve Description			
Driver Left Femur Force Z			
CURNO	Type	SAE Class	Units
007	FIL	600	Newtons
Max	Time	Min	Time
516.0	40.7	-3769.1	48.0

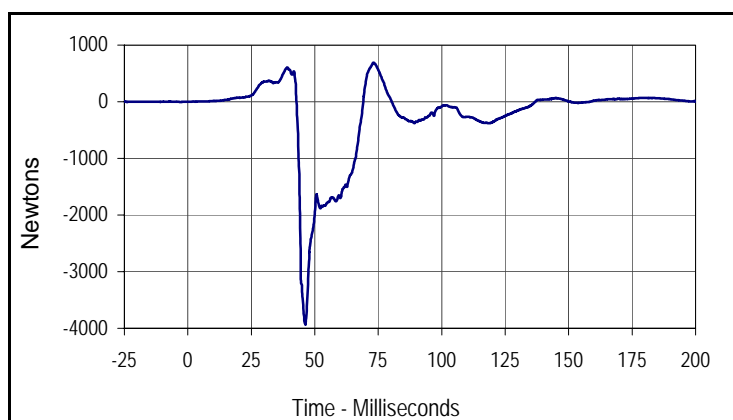

Curve Description			
Driver Right Femur Force Z			
CURNO	Type	SAE Class	Units
008	FIL	600	Newtons
Max	Time	Min	Time
689.8	73.1	-3933.3	46.3

Test Vehicle: 2008 Toyota Sequoia SR5 5-Door MPV
 Test Program: NHTSA 35mph NCAP

Test Date: 1/22/08
 NHTSA No.: M85115

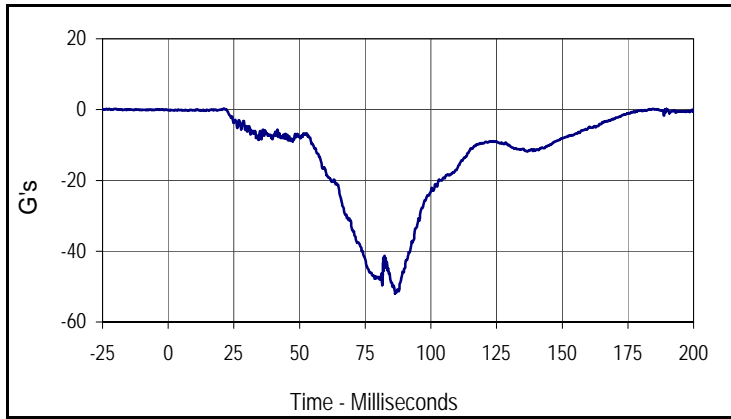

Curve Description			
Passenger Head Primary X			
CURNO	Type	SAE Class	Units
009	FIL	1000	G's
Max	Time	Min	Time
0.3	21.2	-51.9	86.4

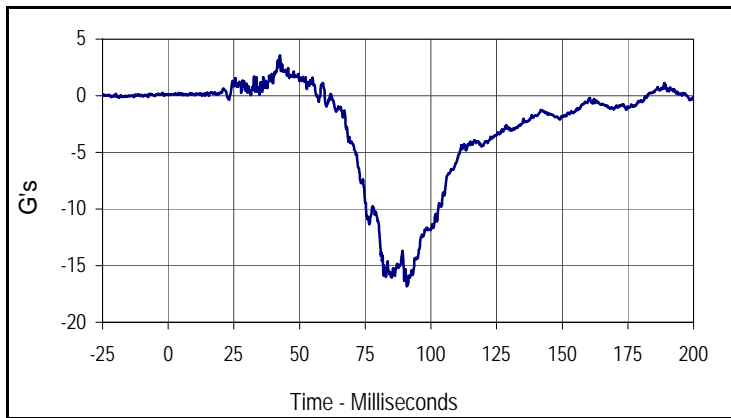

Curve Description			
Passenger Head Primary Y			
CURNO	Type	SAE Class	Units
010	FIL	1000	G's
Max	Time	Min	Time
3.6	42.6	-16.8	90.8

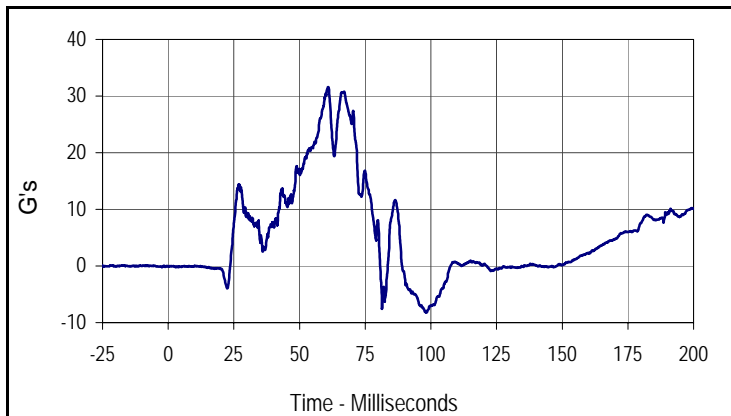

Curve Description			
Passenger Head Primary Z			
CURNO	Type	SAE Class	Units
011	FIL	1000	G's
Max	Time	Min	Time
31.6	60.9	-8.2	98.3

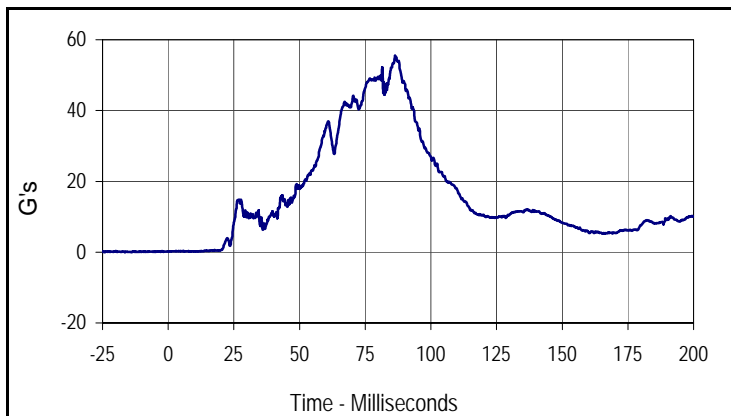

Curve Description			
Passenger Head Resultant Primary			
CURNO	Type	SAE Class	Units
009	RES	1000	G's
Max	Time	Min	Time
55.5	86.4	0.2	10.8

Test Vehicle: 2008 Toyota Sequoia SR5 5-Door MPV
 Test Program: NHTSA 35mph NCAP

Test Date: 1/22/08
 NHTSA No.: M85115

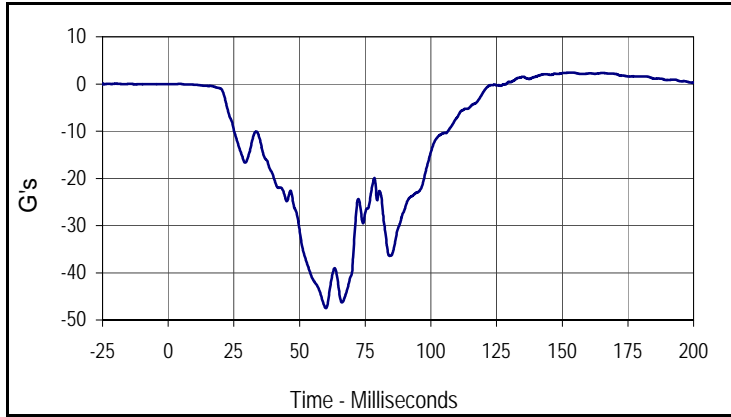

Curve Description			
Passenger Chest Primary X			
CURNO	Type	SAE Class	Units
012	FIL	180	G's
Max	Time	Min	Time
2.4	153.2	-47.5	60.1

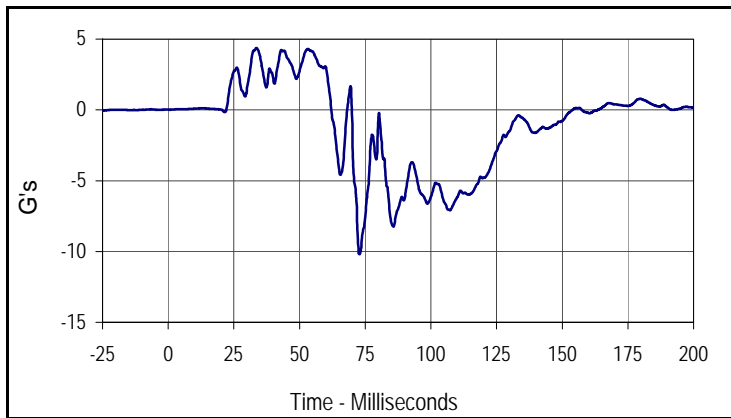

Curve Description			
Passenger Chest Primary Y			
CURNO	Type	SAE Class	Units
013	FIL	180	G's
Max	Time	Min	Time
4.4	33.6	-10.2	72.8

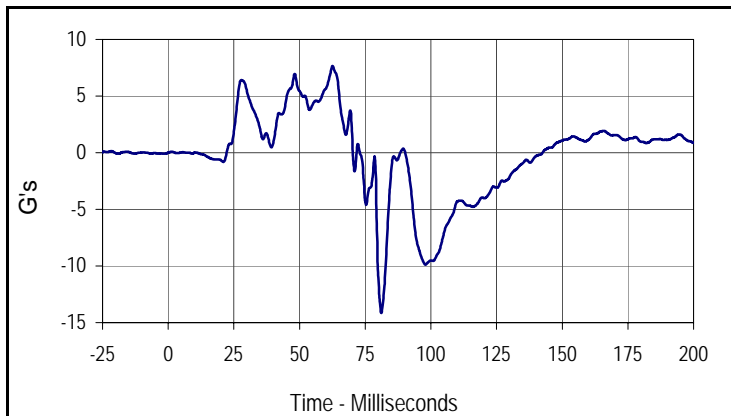

Curve Description			
Passenger Chest Primary Z			
CURNO	Type	SAE Class	Units
014	FIL	180	G's
Max	Time	Min	Time
7.7	62.6	-14.1	81.1

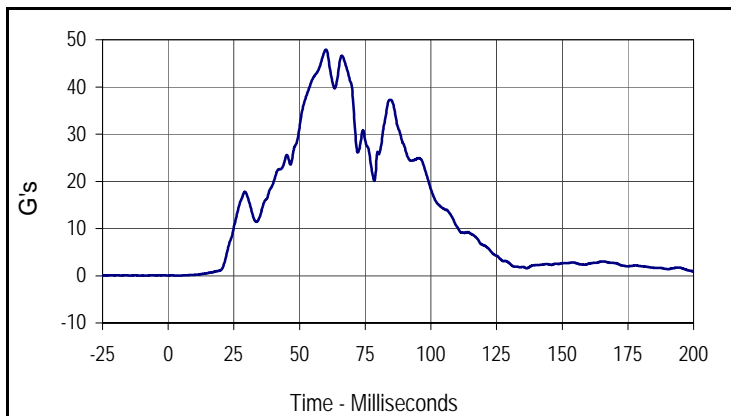

Curve Description			
Passenger Chest Resultant Primary			
CURNO	Type	SAE Class	Units
012	RES	180	G's
Max	Time	Min	Time
47.9	60.1	0.0	0.0

Test Vehicle: 2008 Toyota Sequoia SR5 5-Door MPV
 Test Program: NHTSA 35mph NCAP

Test Date: 1/22/08
 NHTSA No.: M85115

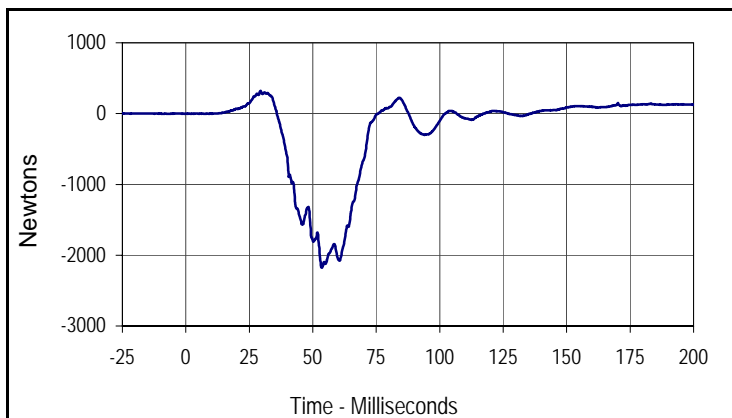

Curve Description			
Passenger Left Femur Force Z			
CURNO	Type	SAE Class	Units
015	FIL	600	Newtons
Max	Time	Min	Time
319.8	29.4	-2175.3	53.5

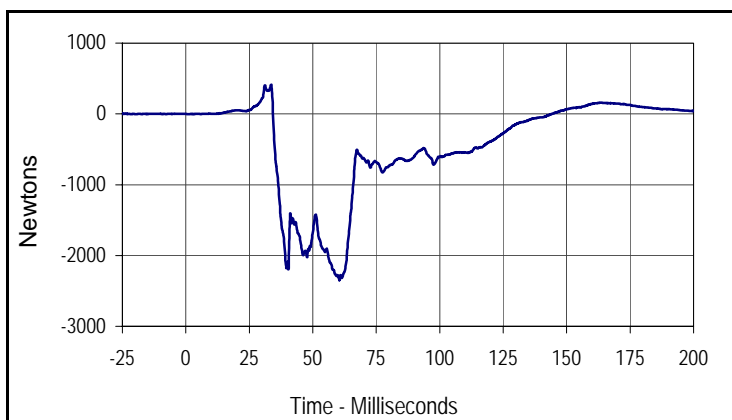

Curve Description			
Passenger Right Femur Force Z			
CURNO	Type	SAE Class	Units
016	FIL	600	Newtons
Max	Time	Min	Time
413.4	33.6	-2347.0	60.5

APPENDIX C
DUMMY CALIBRATION DATA

Test Program: Hybrid III 50th Percentile Male Head Drop Test

Test Date: 1/15/08

ATD Serial No.: 035

Test I.D.: HD12A



Tested Parameter	Units	Specification	Result	Pass/Fail
Laboratory Temperature	°C	18.9 to 25.6	21.1	Pass
Laboratory Relative Humidity	%	10 to 70	30	Pass
Peak Resultant Acceleration	G's	225.0 to 275.0	229.5	Pass
Peak Lateral Acceleration	G's	≤15.0	4.0	Pass
Is Acceleration Unimodal?	Yes/No	Yes	Yes	Pass
Overall Test Results			Pass	

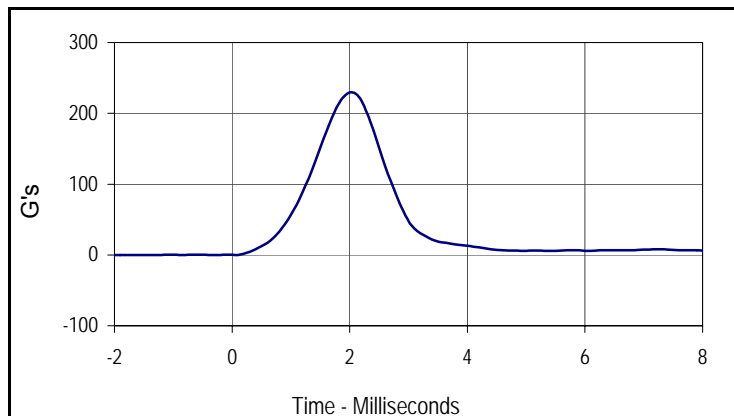

Curve Description			
Head Resultant			
CURNO	Type	SAE Class	Units
001	RES	1000	G's
Max	Time	Min	Time
229.5	2.0	0.0	-1.3

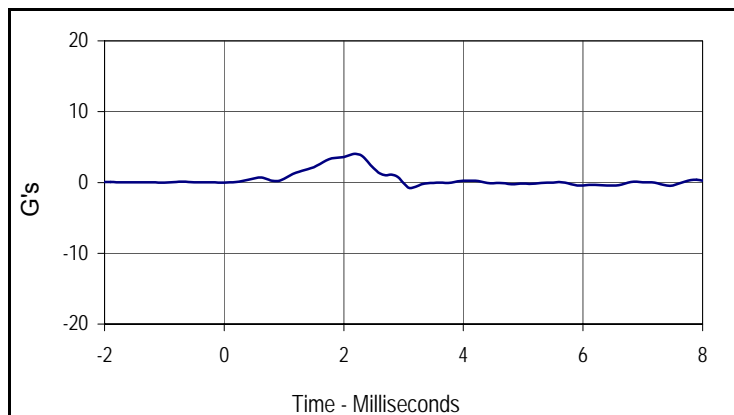

Curve Description			
Head Y			
CURNO	Type	SAE Class	Units
002	FIL	1000	G's
Max	Time	Min	Time
4.0	2.2	-0.8	3.1

Test Program: Hybrid III 50th Percentile Male Thorax Impact Test

Test Date: 1/15/08

ATD Serial No.: 035

Test I.D.: CH12A



Tested Parameter	Units	Specification	Result	Pass/Fail
Laboratory Temperature	°C	20.6 to 22.2	21.1	Pass
Laboratory Relative Humidity	%	10 to 70	30	Pass
Probe Velocity	m/s	6.58 to 6.82	6.68	Pass
Peak Probe Force	Newtons	5159 to 5893	5503	Pass
Peak Sternum Deflection	CM	6.35 to 7.26	6.75	Pass
Internal Hysteresis	%	69 to 85	72.9	Pass
Overall Test Results				Pass

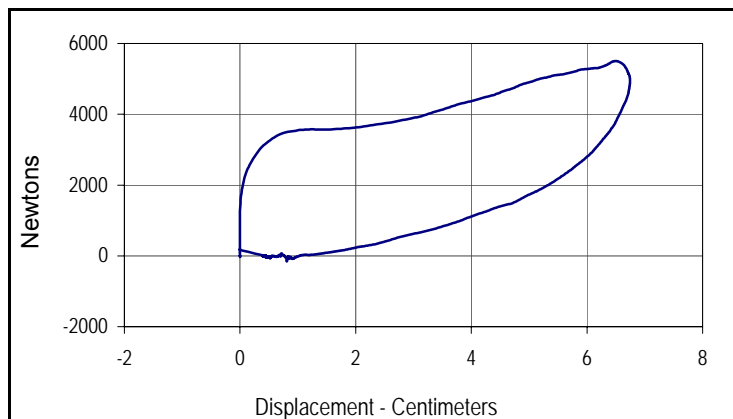

Curve Description			
Probe Force vs. Chest Deflection			
CURNO	Type	SAE Class	Hysteresis
001	FIL	180	72.9
Peak Probe Force		Peak Chest Deflection	
5503		6.75	

Test Program: Hybrid III 50th Percentile Male Neck Flexion Test

Test Date: 1/15/08

ATD Serial No.: 035

Test I.D.: NF12A



Tested Parameter	Units	Specification	Result	Pass/Fail	
Laboratory Temperature	°C	20.6 to 22.2	21.1	Pass	
Laboratory Relative Humidity	%	10 to 70	30	Pass	
Pendulum Velocity	m/s	6.89 to 7.13	7.04	Pass	
Pendulum Deceleration	10 Msec.	G's	22.5 to 27.5	23.8	Pass
	20 Msec.	G's	17.6 to 22.6	20.8	Pass
	30 Msec.	G's	12.5 to 18.5	16.9	Pass
Peak Pendulum Decel. after 30 Msec.	G's	≤ 29.0	16.9	Pass	
Deceleration Decay, Time to Cross 5 G's	Msec.	34.0 to 42.0	38.1	Pass	
Maximum "D" Plane Rotation	Max	Degrees	64.0 to 78.0	75.8	Pass
	Time	Msec.	57.0 to 64.0	61.1	Pass
"D" Plane Rotation Decay, Time To Zero Crossing	Msec.	113.0 to 128.0	121.6	Pass	
Moment About Occ. Condyle	Max	Nm	84.1 to 108.5	87.2	Pass
	Time	Msec.	47.0 to 58.0	56.3	Pass
Positive Moment Decay, Time To Zero Crossing	Msec.	97.0 to 107.0	102.4	Pass	
Overall Test Results				Pass	

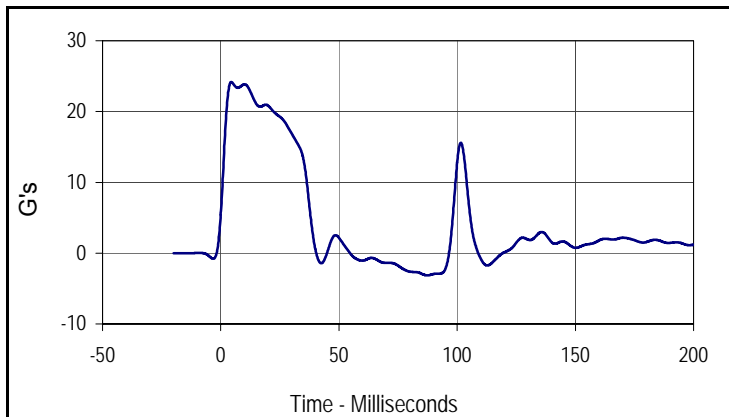

Curve Description			
Pendulum Deceleration			
CURNO	Type	SAE Class	Units
001	FIL	60	G's
Max	Time	Min	Time
24.2	4.5	-3.1	87.3

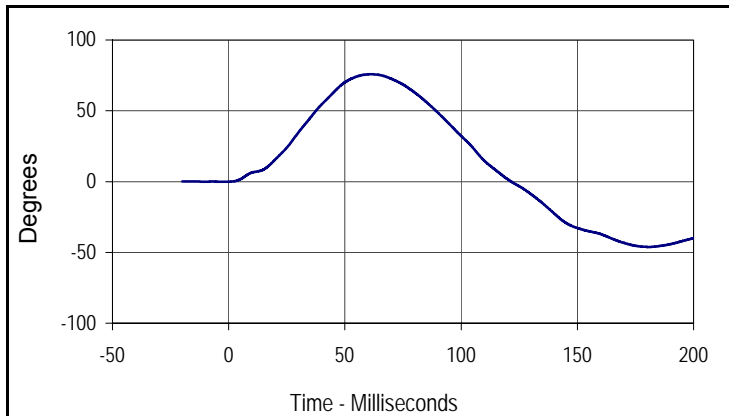

Curve Description			
"D" Plane Rotation			
CURNO	Type	SAE Class	Units
003	FIL	60	Degrees
Max	Time	Min	Time
75.8	61.1	-46.1	180.8

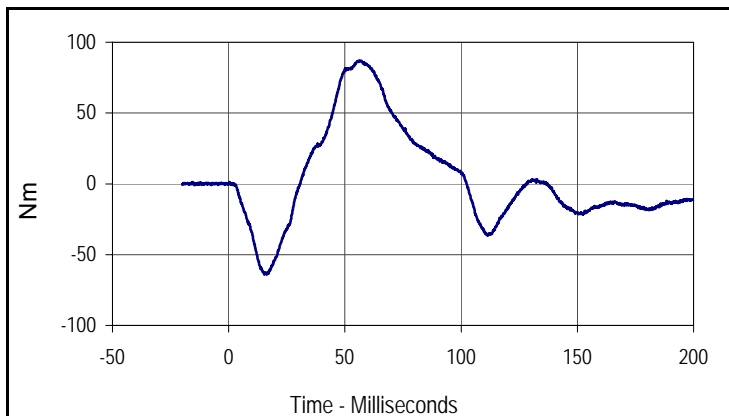

Curve Description			
Moment About Occipital Condyle			
CURNO	Type	SAE Class	Units
004	FIL	600	Nm
Max	Time	Min	Time
87.2	56.3	-64.0	16.4



Tested Parameter	Units	Specification	Result	Pass/Fail	
Laboratory Temperature	°C	20.6 to 22.2	21.1	Pass	
Laboratory Relative Humidity	%	10 to 70	30	Pass	
Pendulum Velocity	m/s	5.94 to 6.19	6.16	Pass	
Pendulum Deceleration	10 Msec.	G's	17.2 to 21.2	17.4	Pass
	20 Msec.	G's	14.0 to 19.0	17.4	Pass
	30 Msec.	G's	11.0 to 16.0	15.7	Pass
Peak Pendulum Decel. after 30 Msec.	G's	≤ 22.0	15.7	Pass	
Deceleration Decay, Time to Cross 5 G's	Msec.	38.0 to 46.0	38.1	Pass	
Maximum "D" Plane Rotation	Max	Degrees	81.0 to 106.0	97.0	Pass
	Time	Msec.	72.0 to 82.0	81.0	Pass
"D" Plane Rotation Decay, Time To Zero Crossing	Msec.	147.0 to 174.0	168.5	Pass	
Moment About Occ. Condyle	Max	Nm	-52.9 to- 79.9	-75.8	Pass
	Time	Msec.	65.0 to 79.0	67.0	Pass
Positive Moment Decay, Time To Zero Crossing	Msec.	120.0 to 148.0	146.2	Pass	
Overall Test Results				Pass	

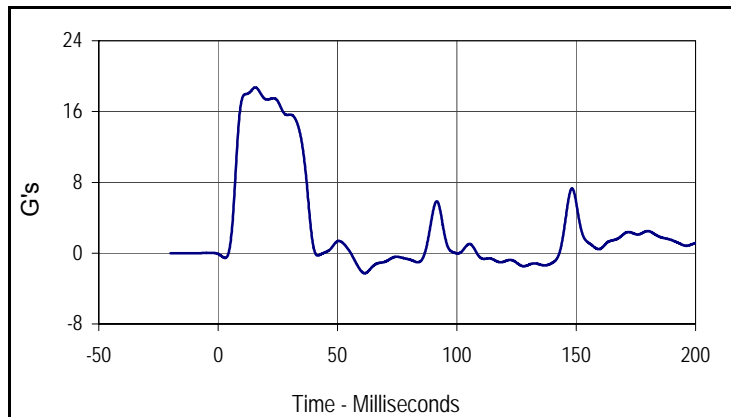

Curve Description			
Pendulum Deceleration			
CURNO	Type	SAE Class	Units
001	FIL	60	G's
Max	Time	Min	Time
18.7	15.6	-2.3	61.4

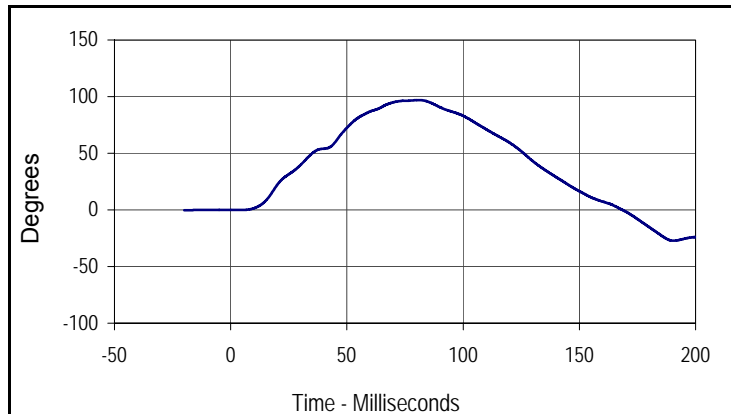

Curve Description			
"D" Plane Rotation			
CURNO	Type	SAE Class	Units
003	FIL	60	Degrees
Max	Time	Min	Time
97.0	81.0	-27.2	190.5

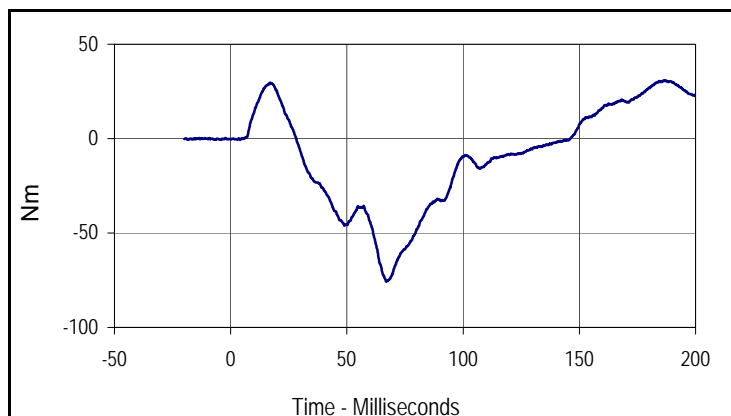

Curve Description			
Moment About Occipital Condyle			
CURNO	Type	SAE Class	Units
004	FIL	600	Nm
Max	Time	Min	Time
30.8	186.9	-75.8	67.0

Test Program: Hybrid III 50th Percentile Male Knee Impact Test

Test Date: 1/15/08

ATD Serial No.: 035

Test I.D.: LK12A , RK12A



Left Knee

Tested Parameter	Units	Specification	Result	Pass/Fail
Laboratory Temperature	°C	18.9 to 25.6	21.1	Pass
Laboratory Relative Humidity	%	10 to 70	30	Pass
Pendulum Velocity at T=0	m/sec	2.07 to 2.13	2.08	Pass
Peak Probe Force	Newtons	4715 to 5782	5074	Pass
Overall Test Results				Pass

Right Knee

Pendulum Velocity at T=0	m/sec	2.07 to 2.13	2.12	Pass
Peak Probe Force	Newtons	4715 to 5782	5569	Pass
Overall Test Results				Pass

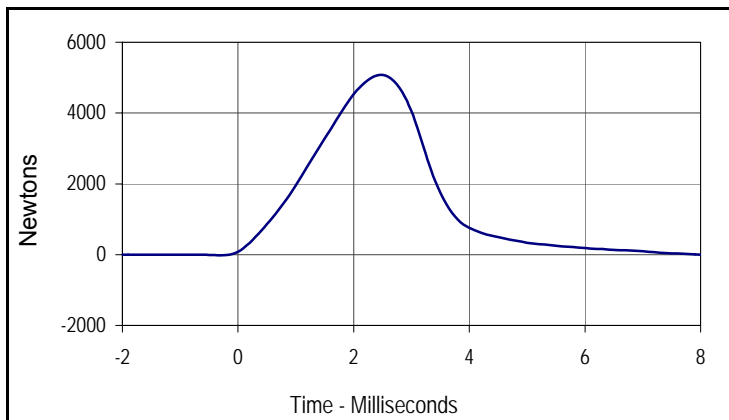

Curve Description			
Left Knee Probe Force			
CURNO	Type	SAE Class	Units
001	FIL	600	Newtons
Max	Time	Min	Time
5073.6	2.5	-25.6	9.7

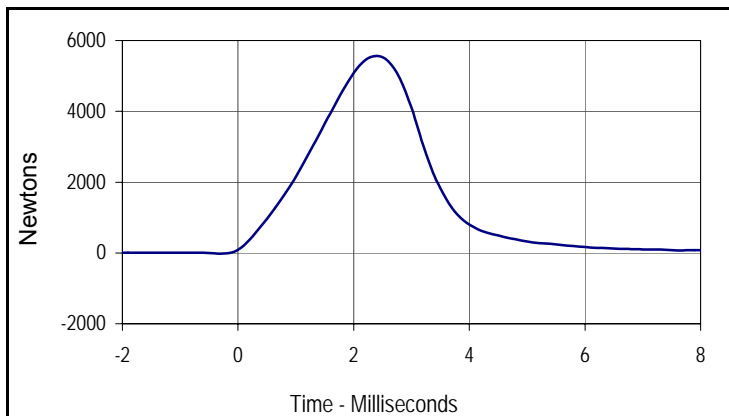

Curve Description			
Right Knee Probe Force			
CURNO	Type	SAE Class	Units
002	FIL	600	Newtons
Max	Time	Min	Time
5568.7	2.4	-16.3	-0.3

Test Program: Hybrid III 50th Percentile Male External Measurements

Test Date: 1/14/08

ATD Serial No.: 035

Test I.D.: N/A



Tested Parameter	Units	Specification	Result	Pass/Fail
Laboratory Temperature	°C	20.6 to 22.2	21.1	Pass
Laboratory Relative Humidity	%	10 to 70	30	Pass
A - Total sitting height	mm	879 to 889	886	Pass
B - Shoulder pivot height	mm	505 to 521	510	Pass
C - "H" point height	mm	84 to 89	86	Pass
D - "H" point from seat back	mm	135 to 140	137	Pass
E - Shoulder pivot from back	mm	84 to 94	89	Pass
F - Thigh clearance	mm	140 to 155	150	Pass
G - Elbow back to wrist pivot	mm	290 to 305	301	Pass
H - Skull cap to back line	mm	41 to 46	44	Pass
I - Shoulder to elbow length	mm	330 to 345	339	Pass
J - Elbow rest height	mm	190 to 211	205	Pass
K - Buttock to knee length	mm	579 to 604	591	Pass
L - Popliteal length	mm	429 to 455	446	Pass
M - Knee pivot height	mm	485 to 500	498	Pass
N - Buttock popliteal length	mm	452 to 477	474	Pass
O - Chest depth	mm	213 to 229	220	Pass
P - Foot length	mm	251 to 267	260	Pass
V - Shoulder breadth	mm	422 to 437	431	Pass
W - Foot breadth	mm	91 to 107	100	Pass
Y - Chest circumference	mm	970 to 1001	989	Pass
Z - Waist circumference	mm	836 to 866	851	Pass
AA - Location for chest circumference	mm	429 to 434	430	Pass
BB - Location for waist circumference	mm	226 to 231	227	Pass
Overall Test Results				Pass

Test Program: Hybrid III 50th Percentile Male Head Drop Test

Test Date: 1/15/08

ATD Serial No.: 034

Test I.D.: HD12B



Tested Parameter	Units	Specification	Result	Pass/Fail
Laboratory Temperature	°C	18.9 to 25.6	21.1	Pass
Laboratory Relative Humidity	%	10 to 70	30	Pass
Peak Resultant Acceleration	G's	225.0 to 275.0	267.2	Pass
Peak Lateral Acceleration	G's	≤15.0	7.6	Pass
Is Acceleration Unimodal?	Yes/No	Yes	Yes	Pass
Overall Test Results			Pass	

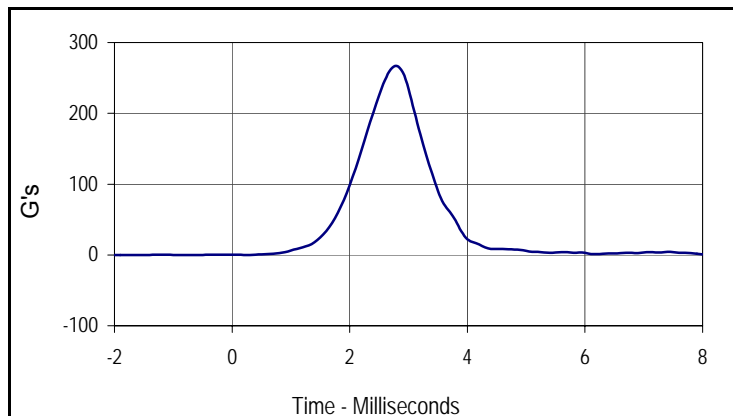

Curve Description			
Head Resultant			
CURNO	Type	SAE Class	Units
001	RES	1000	G's
Max	Time	Min	Time
267.2	2.8	0.0	-1.9

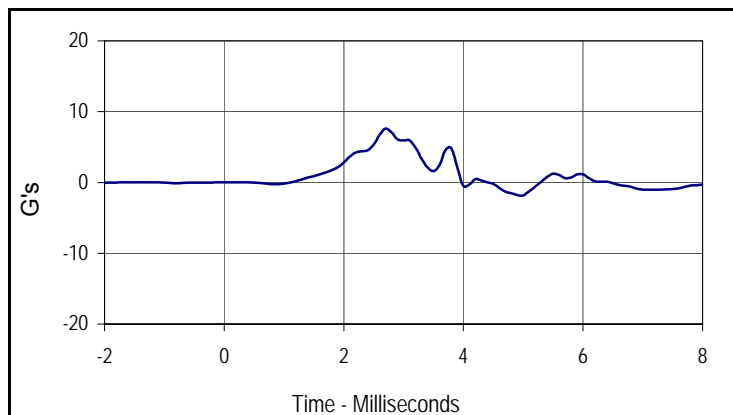

Curve Description			
Head Y			
CURNO	Type	SAE Class	Units
002	FIL	1000	G's
Max	Time	Min	Time
7.6	2.7	-1.8	5.0

Test Program: Hybrid III 50th Percentile Male Thorax Impact Test

Test Date: 1/16/08

ATD Serial No.: 034

Test I.D.: CH12B



Tested Parameter	Units	Specification	Result	Pass/Fail
Laboratory Temperature	°C	20.6 to 22.2	21.1	Pass
Laboratory Relative Humidity	%	10 to 70	30	Pass
Probe Velocity	m/s	6.58 to 6.82	6.63	Pass
Peak Probe Force	Newtons	5159 to 5893	5565	Pass
Peak Sternum Deflection	CM	6.35 to 7.26	7.14	Pass
Internal Hysteresis	%	69 to 85	73.0	Pass
Overall Test Results				Pass

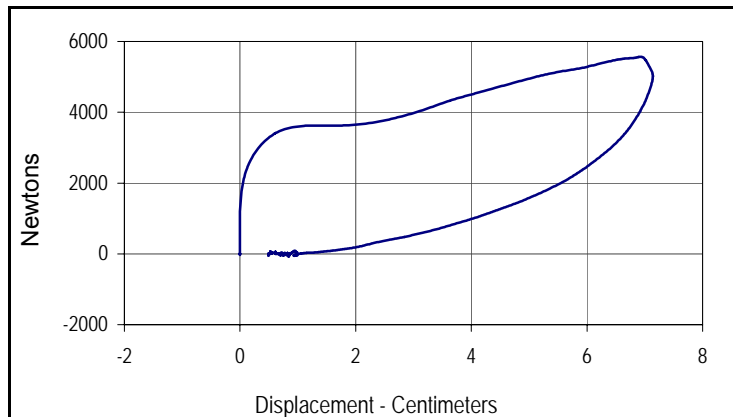

Curve Description			
Probe Force vs. Chest Deflection			
CURNO	Type	SAE Class	Hysteresis
001	FIL	180	73.0
Peak Probe Force		Peak Chest Deflection	
5565		7.14	

Test Program: Hybrid III 50th Percentile Male Neck Flexion Test

Test Date: 1/16/08

ATD Serial No.: 034

Test I.D.: NF12B



Tested Parameter	Units	Specification	Result	Pass/Fail	
Laboratory Temperature	°C	20.6 to 22.2	21.1	Pass	
Laboratory Relative Humidity	%	10 to 70	30	Pass	
Pendulum Velocity	m/s	6.89 to 7.13	7.04	Pass	
Pendulum Deceleration	10 Msec.	G's	22.5 to 27.5	22.6	Pass
	20 Msec.	G's	17.6 to 22.6	21.7	Pass
	30 Msec.	G's	12.5 to 18.5	16.5	Pass
Peak Pendulum Decel. after 30 Msec.	G's	≤ 29.0	16.5	Pass	
Deceleration Decay, Time to Cross 5 G's	Msec.	34.0 to 42.0	41.9	Pass	
Maximum "D" Plane Rotation	Max	Degrees	64.0 to 78.0	73.3	Pass
	Time	Msec.	57.0 to 64.0	62.7	Pass
"D" Plane Rotation Decay, Time To Zero Crossing	Msec.	113.0 to 128.0	115.4	Pass	
Moment About Occ. Condyle	Max	Nm	84.1 to 108.5	95.9	Pass
	Time	Msec.	47.0 to 58.0	52.1	Pass
Positive Moment Decay, Time To Zero Crossing	Msec.	97.0 to 107.0	97.0	Pass	
Overall Test Results				Pass	

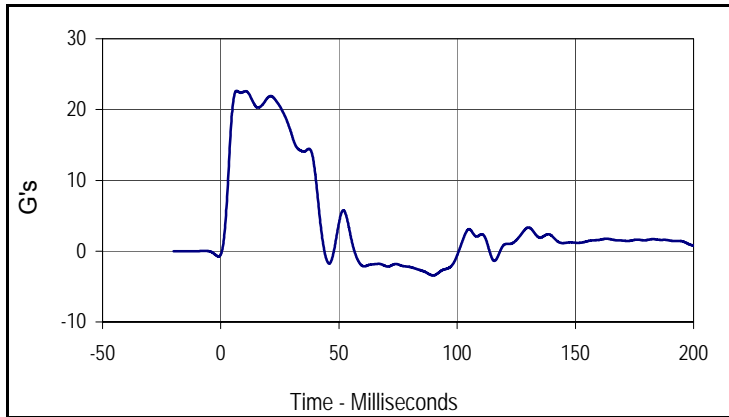

Curve Description			
Pendulum Deceleration			
CURNO	Type	SAE Class	Units
001	FIL	60	G's
Max	Time	Min	Time
22.6	6.7	-3.4	89.8

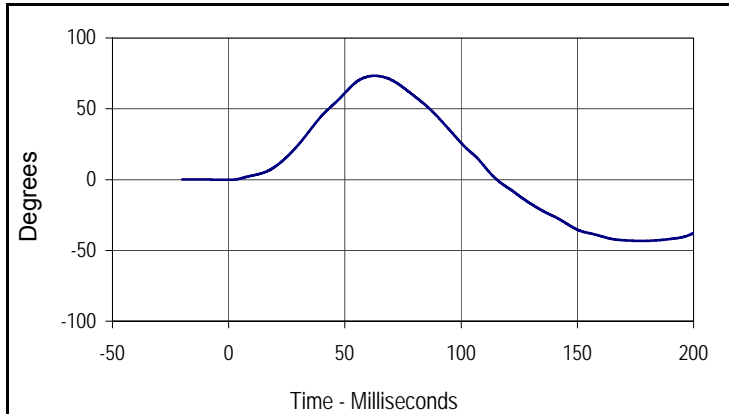

Curve Description			
"D" Plane Rotation			
CURNO	Type	SAE Class	Units
003	FIL	60	Degrees
Max	Time	Min	Time
73.3	62.7	-43.3	178.6

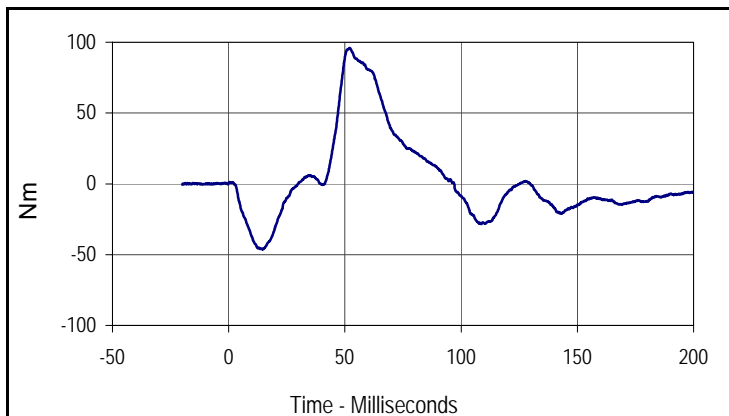

Curve Description			
Moment About Occipital Condyle			
CURNO	Type	SAE Class	Units
004	FIL	600	Nm
Max	Time	Min	Time
95.9	52.1	-46.2	14.7



Tested Parameter	Units	Specification	Result	Pass/Fail	
Laboratory Temperature	°C	20.6 to 22.2	21.1	Pass	
Laboratory Relative Humidity	%	10 to 70	30	Pass	
Pendulum Velocity	m/s	5.94 to 6.19	6.16	Pass	
Pendulum Deceleration	10 Msec.	G's	17.2 to 21.2	17.9	Pass
	20 Msec.	G's	14.0 to 19.0	17.8	Pass
	30 Msec.	G's	11.0 to 16.0	15.1	Pass
Peak Pendulum Decel. after 30 Msec.	G's	≤ 22.0	15.1	Pass	
Deceleration Decay, Time to Cross 5 G's	Msec.	38.0 to 46.0	38.3	Pass	
Maximum "D" Plane Rotation	Max	Degrees	81.0 to 106.0	102.0	Pass
	Time	Msec.	72.0 to 82.0	81.0	Pass
"D" Plane Rotation Decay, Time To Zero Crossing	Msec.	147.0 to 174.0	168.5	Pass	
Moment About Occ. Condyle	Max	Nm	-52.9 to- 79.9	-77.5	Pass
	Time	Msec.	65.0 to 79.0	67.0	Pass
Positive Moment Decay, Time To Zero Crossing	Msec.	120.0 to 148.0	146.2	Pass	
Overall Test Results				Pass	

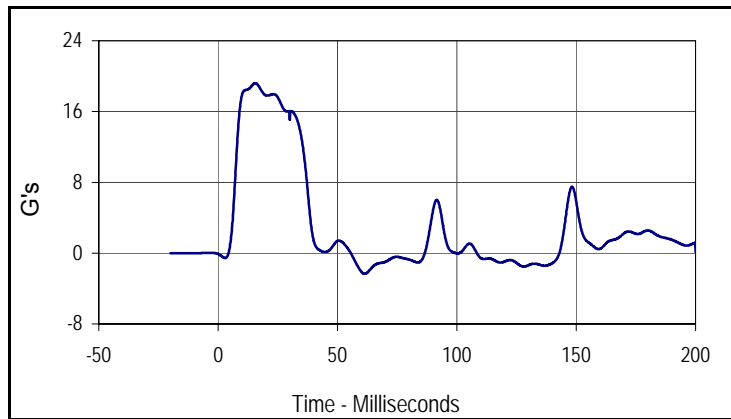

Curve Description			
Pendulum Deceleration			
CURNO	Type	SAE Class	Units
001	FIL	60	G's
Max	Time	Min	Time
19.2	15.6	-2.3	61.4

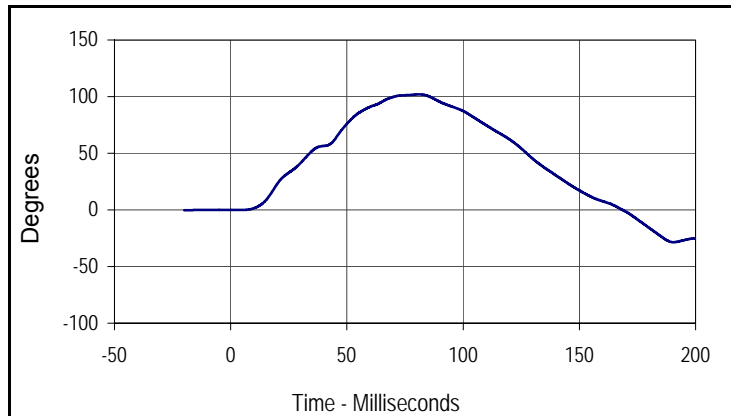

Curve Description			
"D" Plane Rotation			
CURNO	Type	SAE Class	Units
003	FIL	60	Degrees
Max	Time	Min	Time
102.0	81.0	-28.5	190.5

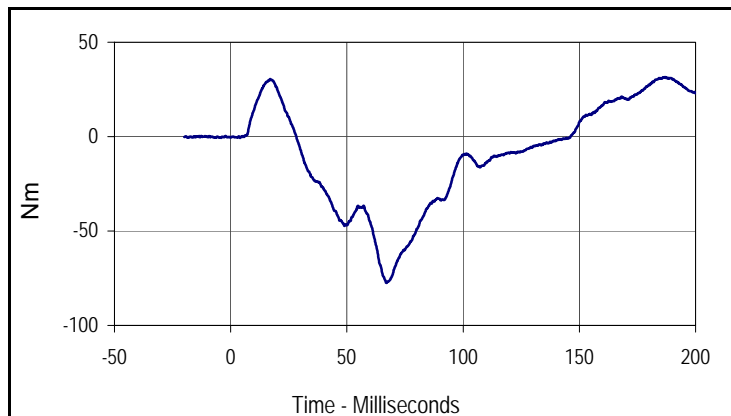

Curve Description			
Moment About Occipital Condyle			
CURNO	Type	SAE Class	Units
004	FIL	600	Nm
Max	Time	Min	Time
31.5	186.9	-77.5	67.0

Test Program: Hybrid III 50th Percentile Male Knee Impact Test

Test Date: 1/16/08

ATD Serial No.: 034

Test I.D.: LK12B , RK12B



Left Knee

Tested Parameter	Units	Specification	Result	Pass/Fail
Laboratory Temperature	°C	18.9 to 25.6	21.1	Pass
Laboratory Relative Humidity	%	10 to 70	30	Pass
Pendulum Velocity at T=0	m/sec	2.07 to 2.13	2.10	Pass
Peak Probe Force	Newtons	4715 to 5782	5605	Pass
Overall Test Results				Pass

Right Knee

Pendulum Velocity at T=0	m/sec	2.07 to 2.13	2.12	Pass
Peak Probe Force	Newtons	4715 to 5782	5732	Pass
Overall Test Results				Pass

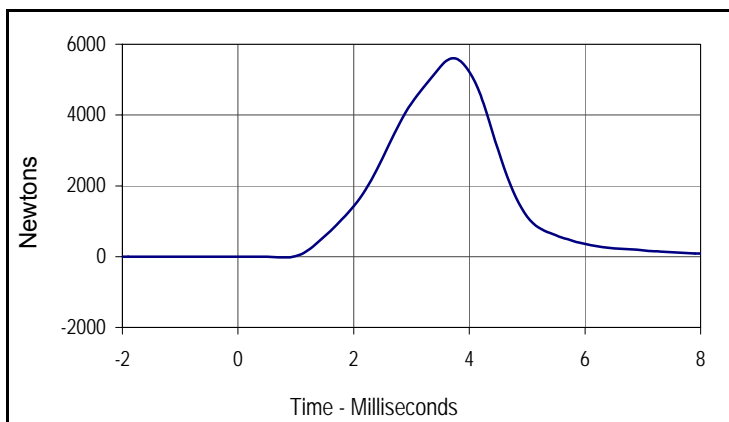

Curve Description			
Left Knee Probe Force			
CURNO	Type	SAE Class	Units
001	FIL	600	Newtons
Max	Time	Min	Time
5604.8	3.7	-21.3	0.8

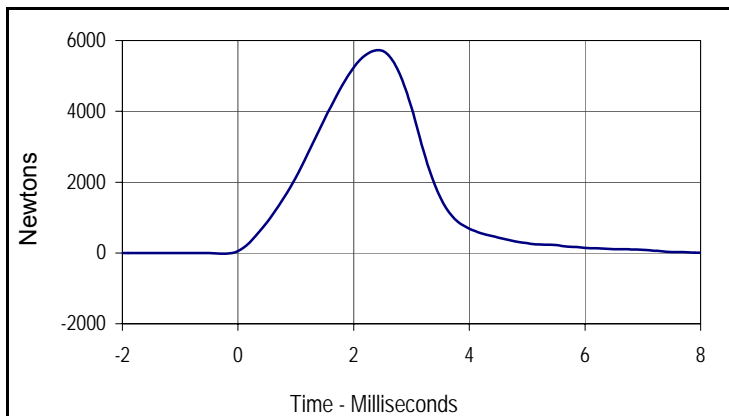

Curve Description			
Right Knee Probe Force			
CURNO	Type	SAE Class	Units
002	FIL	600	Newtons
Max	Time	Min	Time
5732.4	2.4	-24.2	9.8

Test Program: Hybrid III 50th Percentile Male External Measurements

Test Date: 1/16/08

ATD Serial No.: 034

Test I.D.: N/A



Tested Parameter	Units	Specification	Result	Pass/Fail
Laboratory Temperature	°C	20.6 to 22.2	21.1	Pass
Laboratory Relative Humidity	%	10 to 70	30	Pass
A - Total sitting height	mm	879 to 889	881	Pass
B - Shoulder pivot height	mm	505 to 521	516	Pass
C - "H" point height	mm	84 to 89	88	Pass
D - "H" point from seat back	mm	135 to 140	137	Pass
E - Shoulder pivot from back	mm	84 to 94	90	Pass
F - Thigh clearance	mm	140 to 155	150	Pass
G - Elbow back to wrist pivot	mm	290 to 305	300	Pass
H - Skull cap to back line	mm	41 to 46	45	Pass
I - Shoulder to elbow length	mm	330 to 345	341	Pass
J - Elbow rest height	mm	190 to 211	193	Pass
K - Buttock to knee length	mm	579 to 604	597	Pass
L - Popliteal length	mm	429 to 455	450	Pass
M - Knee pivot height	mm	485 to 500	489	Pass
N - Buttock popliteal length	mm	452 to 477	470	Pass
O - Chest depth	mm	213 to 229	216	Pass
P - Foot length	mm	251 to 267	260	Pass
V - Shoulder breadth	mm	422 to 437	430	Pass
W - Foot breadth	mm	91 to 107	100	Pass
Y - Chest circumference	mm	970 to 1001	992	Pass
Z - Waist circumference	mm	836 to 866	860	Pass
AA - Location for chest circumference	mm	429 to 434	430	Pass
BB - Location for waist circumference	mm	226 to 231	230	Pass
Overall Test Results				Pass

Test Program: Dummy Damage Checklist
 ATD Serial No.: 035

Test Date: 1/15/08
 Test I.D.: N/A



GENERAL	DAMAGED	OK
Outer skin on entire dummy		X
Head ballast secure		X
Gashes, rips, general appearance, etc.		X
Neck-Broken or cracks in rubber		X
Check that upper neck bracket is firmly attached to lwr neck bracket		X
Three rubber bumpers in place		X
Spine- Broken or cracks in rubber		X
Check for looseness at the condyle joint		X
Nodding blocks- cracked or out of position		X
Ribs- Check all ribs and rib supports for damage (bent or broken)		X
Check damping material or separation or cracks		X
OTHER		
CHEST DISPLACEMENT ASSEMBLY		
Bent shaft		X
Slider arm riding correctly, in track		X
TRANSDUCER LEADS		
Torn cables		X
ACCELEROMETER MOUNTINGS		
Check for secure mounting		X
KNEES		
Check outer skin, insert and casting (without removing insert)		X
Knee sliders - Wires intact		X
Knee sliders- Rubber returned to "at rest position"		X
LIMBS		
Check for normal movement and adjustment		X
PELVIS		
Inspect for breakage, especially at iliac crest		X

Comments on repair or replacement parts:

Test Program: Dummy Damage Checklist
 ATD Serial No.: 034

Test Date: 1/15/08
 Test I.D.: N/A



GENERAL	DAMAGED	OK
Outer skin on entire dummy		X
Head ballast secure		X
Gashes, rips, general appearance, etc.		X
Neck-Broken or cracks in rubber		X
Check that upper neck bracket is firmly attached to lwr neck bracket		X
Three rubber bumpers in place		X
Spine- Broken or cracks in rubber		X
Check for looseness at the condyle joint		X
Nodding blocks- cracked or out of position		X
Ribs- Check all ribs and rib supports for damage (bent or broken)		X
Check damping material or separation or cracks		X
OTHER		
CHEST DISPLACEMENT ASSEMBLY		
Bent shaft		X
Slider arm riding correctly, in track		X
TRANSDUCER LEADS		
Torn cables		X
ACCELEROMETER MOUNTINGS		
Check for secure mounting		X
KNEES		
Check outer skin, insert and casting (without removing insert)		X
Knee sliders - Wires intact		X
Knee sliders- Rubber returned to "at rest position"		X
LIMBS		
Check for normal movement and adjustment		X
PELVIS		
Inspect for breakage, especially at iliac crest		X

Comments on repair or replacement parts:

APPENDIX D
CHILD RESTRAINT SYSTEM

REPORT NUMBER TR-P28001-16-NC

**NEW CAR ASSESMENT PROGRAM
FRONTAL BARRIER IMPACT TEST**

**TOYOTA MOTOR MANUFACTURING, INDIANA, INC.
2008 TOYOTA SEQUOIA SR5
5-DOOR MPV**

NHTSA NUMBER: M85115

**Prepared By:
KARCO ENGINEERING, LLC
9270 HOLLY ROAD
ADELANTO, CALIFORNIA 92301**



JANUARY 22, 2008

FINAL REPORT

**PREPARED FOR:
U.S. DEPARTMENT OF TRANSPORTATION
NATIONAL HIGHWAY TRAFFIC SAFETY ADMINISTRATION
OFFICE OF CRASHWORTHINESS STANDARDS
RULEMAKING
MAIL CODE: NVS-111
1200 NEW JERSEY AVE SE, ROOM W43-410
WASHINGTON, D.C. 20590**

This final test report was prepared for the U.S. Department of Transportation, National Highway Traffic Safety Administration, in response to Contract Number DTNH22-06-D-00027.

This publication is distributed by the U.S. Department of Transportation, National Highway Traffic Safety Administration, in the interest of information exchange. The opinions, findings and conclusions expressed in this publication are those of the author(s) and not necessarily those of the Department of Transportation or the National Highway Traffic Safety Administration. The United States Government assumes no liability for its contents or use thereof. If trade or manufacturers' names or products are mentioned it is only because they are considered essential to the object of the publication and should not be construed as an endorsement. The United States Government does not endorse products or manufacturers.

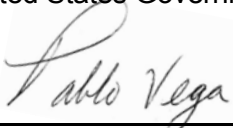
Prepared by: 
Mr. Pablo Vega, Test Engineer
KARCO Engineering, LLC

Date: January 22, 2008

Reviewed by: 
Mr. Michael L. Dunlap, Director of Operations
KARCO Engineering, LLC

Date: January 22, 2008

Approved by: 
Mr. Frank D. Richardson, Program Manager
KARCO Engineering, LLC

Date: January 22, 2008

FINAL REPORT ACCEPTED BY:

Manager, New Car Assessment Program

Date of Acceptance

COTR, NCAP Frontal Impact Program

Date of Acceptance

Technical Report Documentation Page

1. Report No. TR-P28001-16-NC	2. Government Accession No.	3. Recipients Catalog No.	
4. Title and Subtitle Final report of one (1) Graco Snugride CRS. Final report of one (1) Graco Infant Safe Seat CRS. NHTSA No. M85115		5. Report Date January 22, 2008	
		6. Performing Organization Code KAR	
7. Authors Mr. Pablo Vega, Project Engineer, KARCO Mr. Frank Richardson, Program Manager, KARCO		8. Performing Organization Report No. TR-P28001-16-NC	
9. Performing Organization Name and Address Karco Engineering, LLC 9270 Holly Rd. Adelanto, CA, 92301		10. Work Unit No.	
		11. Contract or Grant No. DTNH22-06-D-00027	
12. Sponsoring Agency Name and Address U. S. Department of Transportation National Highway Traffic Safety Administration Rulemaking Office of Crashworthiness Standards Mail Code NVS-111 1200 New Jersey Ave., SE, Room W43-410 Washington, D.C 20590		13. Type of Report and Period Covered Final Test Report	
		14. Sponsoring Agency Code DOT/NHTSA/NRM/OCS	
15. Supplementary Notes			
16. Abstract A frontal impact crash test was conducted on one (1) Graco Snugride CRS, and one (1) Graco Infant Safe Seat CRS, in conjunction with frontal barrier impact NCAP testing on a 2008 Toyota Sequoia SR5 5-Door MPV, and in accordance with the specifications of the Office of Crashworthiness Standards Test Procedure for the determination of CRS crashworthiness. This test was conducted at KARCO Engineering, LLC on January 22, 2008.			
Measurement Description	Units	Threshold	Left Rear (P4)
Head Injury Criteria (HIC 15)	N/A	390	914.5
3 msec. Chest Clip	G's	50	77.9
			Right Rear (P3)
			560.7
			65.1
17. Key Words New Car Assessment Program (NCAP) Final report of a Graco Snugride CRS Final report of a Graco Infant Safe Seat		18. Distribution Statement Copies of this report are available from: National Highway Traffic Safety Admin. NHTSA Technical Reference Division 1200 New Jersey Ave., SE, Room W43-410 Washington, DC 20590	
19. Security Classification of this report UNCLASSIFIED	20. Security Classification of this page UNCLASSIFIED	21. No. of Pages 69	22. Price

Form DOT F1700.7 (8-72)

TR-P28001-16-NC

TABLE OF CONTENTS

<u>Section</u>	<u>Description</u>	<u>Page</u>
D1	Purpose and Summary of Test M85115	D1-1 to D1-8
D2	Photographs	D2-1 to D2-36
D3	CRABI Response and CRS Data Traces	D3-1 to D3-4
D4	CRABI Calibration Information	D4-1 to D4-12
<u>Data Sheet</u>	<u>Description</u>	<u>Page</u>
1	Crash Test Summary	D1-2
2	Vehicle Parameter Data	D1-3
3	CRABI Positioning in Vehicle	D1-4
4	CRS Performance Data	D1-6
5	CRS Accelerometer Locations	D1-7
6	CRS Camera Locations and Data	D1-8

SECTION D1

PURPOSE AND SUMMARY OF TEST M85115

The purpose of this test is to obtain CRS performance data during 35 mph (56.3 km/h) frontal barrier impact NCAP test.

The frontal barrier impact NCAP test was conducted in accordance with the Office of Crashworthiness Standards (OCS) NCAP Laboratory Test Procedure.

SUMMARY

Two 12-month old CRABI's (P3 & P4) were instrumented with head, chest, and six-axis upper neck load cells. Tri-axial accelerometers were installed on both CRS's and the CRS bases.

The left rear (Serial No. 017) and right rear (Serial No. 022) CRABI's were calibrated prior to this test. CRABI calibration information is found in Section D-4.

CHILD DUMMY VALUES		
Location	HIC 15 Values	3 msec. Chest Clip
CRABI P3	560.7	65.1
CRABI P4	914.5	77.9

**DATA SHEET NO. 1
CRASH TEST SUMMARY**

Test Vehicle: 2008 Toyota Sequoia SR5 5-Door MPV
 Test Program: NHTSA 35mph NCAP

NHTSA No.: M85115
 Test Date: 01/22/08

CHILD RESTRAINT SYSTEM INFORMATION

Description	Position No. 3 CRS	Position No. 4 CRS
Manufacturer	Graco	Graco
Model Name	Snugride	Infant Safe Seat
Serial Number	8F09DH03	JJ200705240213
Type	Infant	Infant
Forward/Rearward	Rearward	Rearward

VISIBLE DUMMY CONTACT POINTS

Description	Position No. 3 CRS	Position No. 4 CRS
Head Contact	Headrest	Headrest
Chest Contact	None	None
Abdoment Contact	None	None
Left Knee Contact	None	None
Right Knee Contact	None	None
Left Toe Contact	None	None
Right Toe Contact	Seat Back	None

POST-TEST DOOR OPENINGS

Description	Position No. 3 CRS	Position No. 4 CRS
Rear Door	Remained closed and latched, opened without tools	Remained closed and latched, opened without tools

CAMERA COVERAGE

Description	Standard
High Speed	4
Real Time	0
Total	4

DATA CHANNELS

CRABI P3 & P4 Sensors	26
Belt Sensors	4
CRS Sensors	12
Total	42

DATA SHEET NO. 2**VEHICLE PARAMETER DATA**Test Vehicle: 2008 Toyota Sequoia SR5 5-Door MPVNHTSA No.: M85115Test Program: NHTSA 35mph NCAPTest Date: 01/22/08**TEST VEHICLE WEIGHTS**

	Units	As-Delivered Weights (UVW)			As-Tested Weights (ATW)		
		Front	Rear	Total	Front	Rear	Total
Left	kg	709	671	1380	767	695	1462
Right	kg	663	624	1287	714	640	1354
Ratio	%	51.4	48.6	100.0	52.6	47.4	100.0
Total	kg	1372	1295	2667	1481	1335	2816

TARGET TEST WEIGHT CALCULATION

Measured Parameter	Units	Value
Total Delivered Weight (UVW)	kg	2816
Weight of 2 P572 ATD's	kg	152
Rated Cargo/Luggage Weight (RCLW)	kg	5
Calculated Vehicle Target Weight (TVTW)	kg	2824

DATA SHEET NO. 3

CRABI POSITIONING IN VEHICLE

Test Vehicle: 2008 Toyota Sequoia SR5 5-Door MPV

NHTSA No.: M85115

Test Program: NHTSA 35mph NCAP

Test Date: 01/22/08

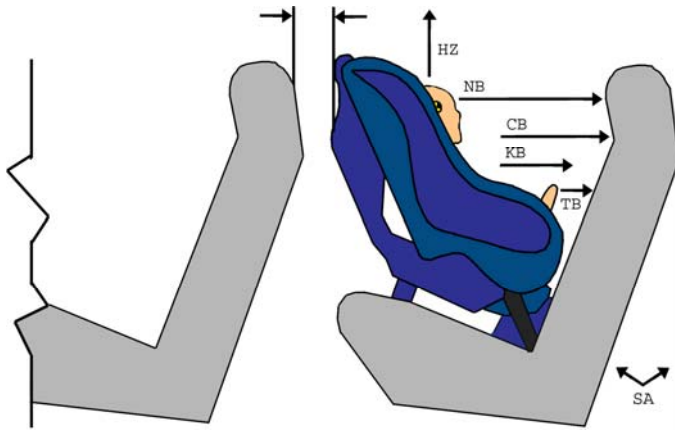

- | | |
|----|---------------------|
| AD | Arm to Door |
| CD | Chest to Door |
| HD | H-Point to Door |
| HS | Head to Side Window |
| KK | Knee to Knee |
| TT | Toe to Toe |

- | | |
|----|--------------------|
| CB | Chest to Seat Back |
| HZ | Head to Roof |
| KB | Knee to Seat Back |
| NB | Nose to Seat Back |
| SA | Seat Back Angle |
| TB | Toe to Seat Back |

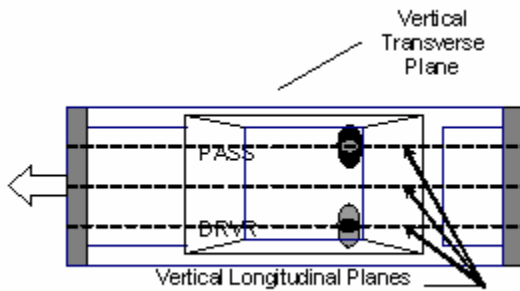
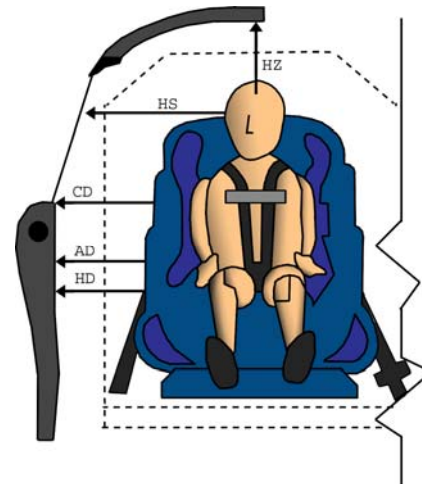

DUMMY MEASUREMENTS FOR REAR SEAT OCCUPANTS

DATA SHEET NO. 3...(CONTINUED)

CRABI POSITIONING IN VEHICLE

Test Vehicle: 2008 Toyota Sequoia SR5 5-Door MPV

NHTSA No.: M85115

Test Program: NHTSA 35mph NCAP

Test Date: 01/22/08

CRABI POSITION MEASUREMENTS

Code	Measurement	P3 (Passenger's Side)		P4 (Driver's Side)	
		Length (mm)	Angle (°)	Length (mm)	Angle (°)
SA	Seat Back Angle		22.0		22.0
HZ	Head to Roof (Z)	465		453	
CD	Chest to Door	400		395	
KK	Knee to Knee (Y)	120		110	
HS	Head to Side Window	468		440	
HD	Head to Door (Y)	310		340	
AD	Arm to Door	270		270	
NB	Nose to Seat Back	542		515	
CB	Chest to Seat Back	475		462	
FF	Foot to Foot	100		120	
KB-Left	Left Knee to Seat Back	225		200	
KB-Right	Right Knee to Seat Back	230		200	
TB-Left	Left Toe to Seat Back	80		55	
TB-Right	Right Toe to Seat Back	92		52	

DATA SHEET NO. 4

CRS PERFORMANCE DATA

Test Vehicle: 2008 Toyota Sequoia SR5 5-Door MPV

NHTSA No.: M85115

Test Program: NHTSA 35mph NCAP

Test Date: 01/22/08

CRS PERFORMANCE DATA

Location	CRS (P3)		CRS (P4)	
	Pre-Test	Post-Test	Pre-Test	Post-Test
Upper Tether Strap				
Upper Tether Buckle				
Upper Tether Hook				
Veh. Upper Tether Anchor				
Lower Anchor Strap	None	None	None	None
Lower Anchor Buckle	None	None	None	None
Lower Anchor Hooks	None	None	None	None
Veh. Lower CRS Anchors	None	None	None	None
5-Point Harness Connections	None	None	None	None
Cracks on CRS	None	None	None	None
Fabric Tears on CRS	None	None	None	None
Vehicle Seat Structure	None	None	None	None
Vehicle Seat Fabric Tears	None	None	None	None

DATA SHEET NO. 5

CRS ACCELEROMETER LOCATIONS

Test Vehicle: 2008 Toyota Sequoia SR5 5-Door MPV

NHTSA No.: M85115

Test Program: NHTSA 35mph NCAP

Test Date: 01/22/08

VEHICLE ACCELEROMETER PRE-TEST LOCATIONS

No.	Accelerometer Location	Measurement		
		X	Y	Z
1	CRS P3	2290	506	1104
2	CRS P3 Base	1880	506	600
3	CRS P4	2214	-575	1080
4	CRS P4 Base	2105	-575	982

Reference Planes: X=From Rear Surface of Vehicle, Y=Vehicle Centerline, Z=Ground Plane

DATA SHEET NO. 6**CRS CAMERA LOCATIONS AND DATA**Test Vehicle: 2008 Toyota Sequoia SR5 5-Door MPVNHTSA No.: M85115Test Program: NHTSA 35mph NCAPTest Date: 01/22/08**VEHICLE CAMERA MEASUREMENT TABLE**

No.	Camera View	Location			Angle (deg.)	Film Plane to Head	Lens (mm)	Speed (fps)
		X	Y	Z				
1	Driver Side Upper CRS View	-128.5	-31.5	-67	-2	1110	12	1000
2	Passenger Side Upper CRS View	129	29.5	-67.5	-2	1070	12	1000

SECTION D2
PHOTOGRAPHS

LIST OF PHOTOGRAPHS

Figure		Page
1	Position 3 CRS Label	D2-1
2	Pre-Test Frontal View of Position 3 CRS	D2-2
3	Post-Test Frontal View of Position 3 CRS	D2-3
4	Pre-Test Rear View of Position 3 CRS	D2-4
5	Post-Test Rear View of Position 3 CRS	D2-5
6	Pre-Test Left Side View of Position 3 CRS	D2-6
7	Post-Test Left Side View of Position 3 CRS	D2-7
8	Pre-Test Right Side View of Position 3 CRS	D2-8
9	Post-Test Right Side View of Position 3 CRS	D2-9
10	Pre-Test Position 3 Front View (Head and Seat Belt Position)	D2-10
11	Post-Test Position 3 Front View (Head and Seat Belt Position)	D2-11
12	Pre-Test Position 3 Front View (Seat Belt Position)	D2-12
13	Post-Test Position 3 Front View (Seat Belt Position)	D2-13
14	Pre-Test Position 3 Right Side View	D2-14
15	Post-Test Position 3 Right Side View	D2-15
16	Pre-Test Position 3 Right Side View (Through Window)	D2-16
17	Post-Test Position 3 Right Side View (Through Window)	D2-17
18	Post-Test Position 3 Dummy Legs	D2-18
19	Position 4 CRS Label	D2-1
20	Pre-Test Frontal View of Position 4 CRS	D2-2
21	Post-Test Frontal View of Position 4 CRS	D2-3
22	Pre-Test Rear View of Position 4 CRS	D2-4
23	Post-Test Rear View of Position 4 CRS	D2-5
24	Pre-Test Left Side View of Position 4 CRS	D2-6
25	Post-Test Left Side View of Position 4 CRS	D2-7
26	Pre-Test Right Side View of Position 4 CRS	D2-8
27	Post-Test Right Side View of Position 4 CRS	D2-9
28	Pre-Test Position 4 Front View (Head and Seat Belt Position)	D2-10
29	Post-Test Position 4 Front View (Head and Seat Belt Position)	D2-11
30	Pre-Test Position 4 Front View (Seat Belt Position)	D2-12
31	Post-Test Position 4 Front View (Seat Belt Position)	D2-13
32	Pre-Test Position 4 Right Side View	D2-14
33	Post-Test Position 4 Right Side View	D2-15
34	Pre-Test Position 4 Right Side View (Through Window)	D2-16
35	Post-Test Position 4 Right Side View (Through Window)	D2-17
36	Post-Test Position 4 Dummy Legs	D2-18

MODEL **8F09DH03**

NAME **SNUGRIDE**

Manufactured in 122007 10

GRACO CHILDREN'S PRODUCTS, INC.
EXTON, PA 19341 1-800-345-4109

PB-25777

Made in U.S.A.

Figure D2-1: Position 3 CRS Label



D2-2

TR-P28001-16-NC

Figure D2-2: Pre-Test Frontal View of Position 3 CRS



Figure D2-3: Post-Test Frontal View of Position 3 CRS



Date of delivery:
Finished size: 20" x 24"
Net weight of filling material: 5 oz.
Federal ID#:
PFD ASSEMBLED IN MEXICO

**2008 Toyota Sequoia SR5
M85115
P-3
GRACO
SNUGRIDE**

GRACO

Figure D2-4: Pre-Test Rear View of Position 3 CRS



D2-5

TR-P28001-16-NC

Figure D2-5: Post-Test Rear View of Position 3 CRS



2008 Toyota Sequoia SR5
M85115
P-3
GRACO
SNUGRIDE

Figure D2-6: Pre-Test Right Side View of Position 3 CRS



Figure D2-7: Post-Test Right Side View of Position 3 CRS



Figure D2-8: Pre-Test Left Side View of Position 3 CRS



D2-9

TR-P28001-16-NC

Figure D2-9: Post-Test Left Side View of Position 3 CRS



Figure D2-10: Pre-Test Position 3 Front View (Head and Seat Belt Position)



Figure D2-11: Post-Test Position 3 Front View (Head and Seat Belt Position)



Figure D2-12: Pre-Test Position 3 Front View (Seat Belt Position)



Figure D2-13: Post-Test Position 3 Front View (Seat Belt Position)



Figure D2-14: Pre-Test Position 3 Right Side View



Figure D2-15: Post-Test Position 3 Right Side View



Figure D2-16: Pre-Test Position 3 Right Side View (Through Window)



Figure D2-17: Post-Test Position 3 Right Side View (Through Window)



Figure D2-18: Post-Test Position 3 Dummy Legs

available
1-800-345-4109
8184).

Si un deuxième socle n'est pas
disponible chez votre détaillant,
appelez 1-800-667-8184.

Si una base separada
disponible en su
al 1-800-345-4109

MODEL 8A06INC

NAME: Infant SafeSeat™

SERIAL JJ200705240213

Manufactured in 20070524

GRACO CHILDREN'S PRODUCTS, INC.

EXTON, PA 19341 1-800-345-4109

Made in China

D2-19

TR-P28001-16-NC

Figure D2-19: Position 4 CRS Label



Figure D2-20: Pre-Test Frontal View of Position 4 CRS



2008 Toyota Sequoia SR5
M85115
P-4
GRACO
SafeSeat

Figure D2-21: Post-Test Frontal View of Position 4 CRS



D2-22

TR-P28001-16-NC

Figure D2-22: Pre-Test Rear View of Position 4 CRS



D2-23

TR-P28001-16-NC

Figure D2-23: Post-Test Rear View of Position 4 CRS



Figure D2-24: Pre-Test Right Side View of Position 4 CRS



Figure D2-25: Post-Test Right Side View of Position 4 CRS



D2-26

TR-P28001-16-NC

Figure D2-26: Pre-Test Left Side View of Position 4 CRS



Figure D2-27: Post-Test Left Side View of Position 4 CRS



Figure D2-28: Pre-Test Position 4 Front View (Head & Seat Belt Position)



Figure D2-29: Post-Test Position 4 Front View (Head & Seat Belt Position)



Figure D2-30: Pre-Test Position 4 Front View (Seat Belt Position)



Figure D2-31: Post-Test Position 4 Front View (Seat Belt Position)



Figure D2-32: Pre-Test Position 4 Left Side View



Figure D2-33: Post-Test Position 4 Left Side View



D2-34

TR-P28001-16-NC

Figure D2-34: Pre-Test Position 4 Left Side View



Figure D2-35: Post-Test Position 4 Left Side View



Figure D2-36: Post-Test Position 4 Dummy Legs

SECTION D3
CRABI RESPONSE AND CRS DATA TRACES

LIST OF DATA PLOTS

Data Plot		Page
D3-1	Right Rear CRABI (P4) Head X	D3-1
	Right Rear CRABI (P4) Head Y	D3-1
	Right Rear CRABI (P4) Head Z	D3-1
	Right Rear CRABI (P4) Head Resultant	D3-1
D3-2	Right Rear CRABI (P4) Chest X	D3-2
	Right Rear CRABI (P4) Chest Y	D3-2
	Right Rear CRABI (P4) Chest Z	D3-2
	Right Rear CRABI (P4) Chest Resultant	D3-2
D3-3	Right Rear CRABI (P3) Head X	D3-3
	Right Rear CRABI (P3) Head Y	D3-3
	Right Rear CRABI (P3) Head Z	D3-3
	Right Rear CRABI (P3) Head Resultant	D3-3
D3-4	Right Rear CRABI (P3) Chest X	D3-4
	Right Rear CRABI (P3) Chest Y	D3-4
	Right Rear CRABI (P3) Chest Z	D3-4
	Right Rear CRABI (P3) Chest Resultant	D3-4

Test Vehicle: 2008 Toyota Sequoia SR5 5-Door MPV
 Test Program: NHTSA 35mph NCAP

Test Date: 1/22/08
 NHTSA No.: M85115

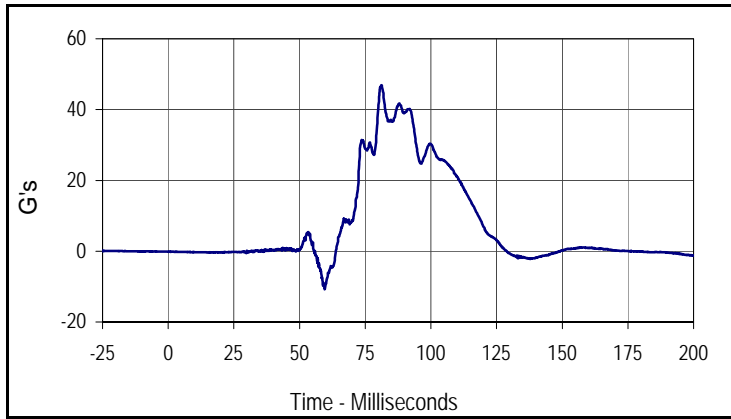

Curve Description			
CRABI Head X (P4)			
CURNO	Type	SAE Class	Units
142	FIL	1000	G's
Max	Time	Min	Time
46.9	81.2	-10.8	59.6

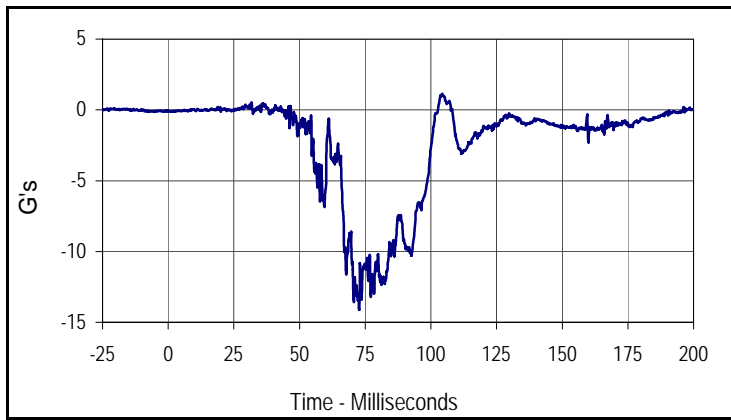

Curve Description			
CRABI Head Y (P4)			
CURNO	Type	SAE Class	Units
143	FIL	1000	G's
Max	Time	Min	Time
1.1	104.3	-14.1	72.7

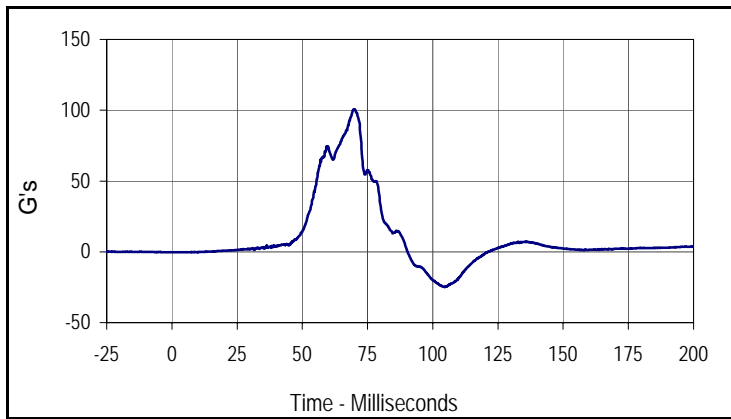

Curve Description			
CRABI Head Z (P4)			
CURNO	Type	SAE Class	Units
144	FIL	1000	G's
Max	Time	Min	Time
100.6	70.1	-24.8	104.6

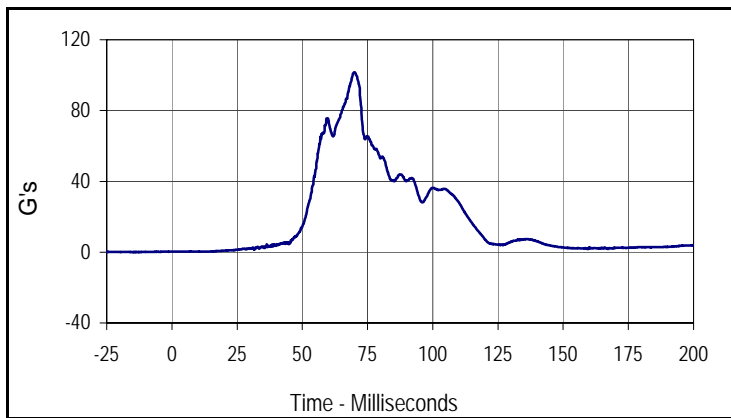

Curve Description			
CRABI Head Resultant (P4)			
CURNO	Type	SAE Class	Units
142	RES	1000	G's
Max	Time	Min	Time
101.6	70.1	0.3	11.3

Test Vehicle: 2008 Toyota Sequoia SR5 5-Door MPV
 Test Program: NHTSA 35mph NCAP

Test Date: 1/22/08
 NHTSA No.: M85115

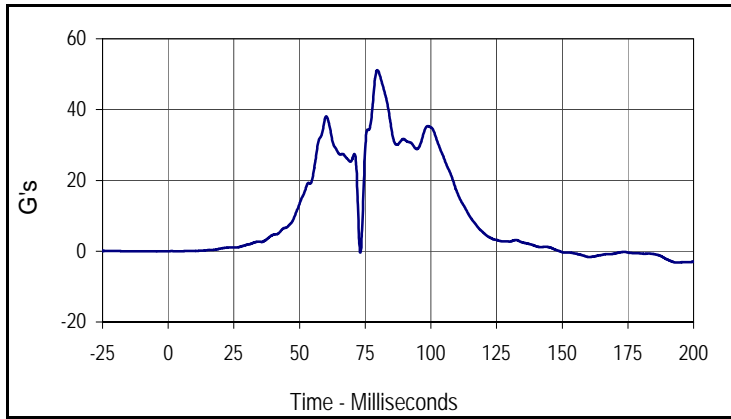

Curve Description			
CRABI Chest X (P4)			
CURNO	Type	SAE Class	Units
145	FIL	180	G's
Max	Time	Min	Time
51.1	79.6	-3.2	193.4

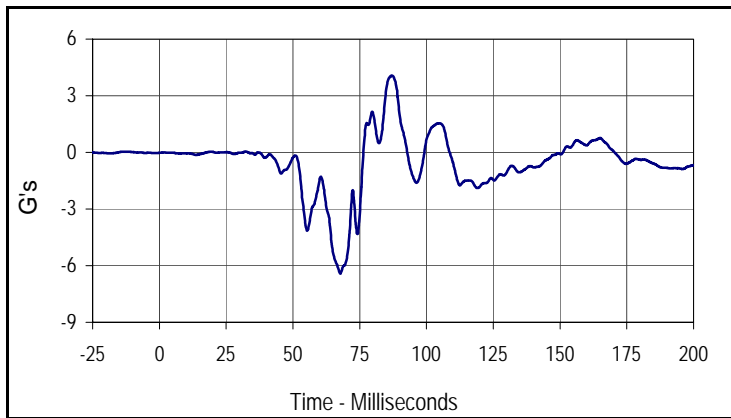

Curve Description			
CRABI Chest Y (P4)			
CURNO	Type	SAE Class	Units
146	FIL	180	G's
Max	Time	Min	Time
4.1	87.1	-6.4	67.7

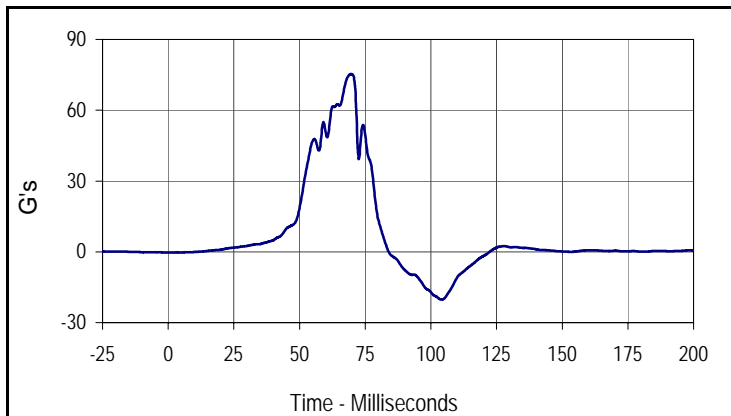

Curve Description			
CRABI Chest Z (P4)			
CURNO	Type	SAE Class	Units
147	FIL	180	G's
Max	Time	Min	Time
75.3	69.6	-20.2	104.1

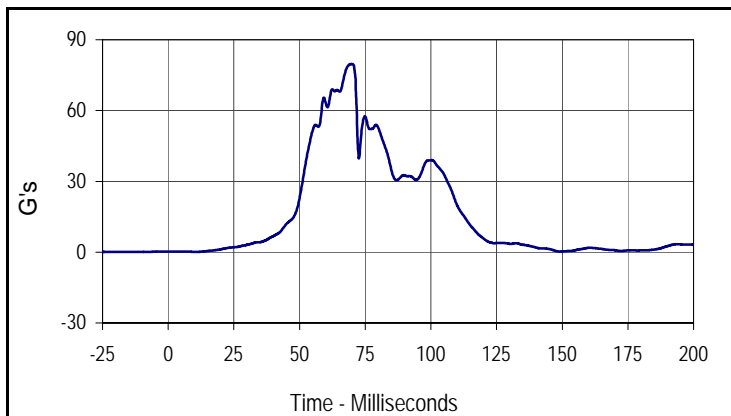

Curve Description			
CRABI Chest Resultant (P4)			
CURNO	Type	SAE Class	Units
145	RES	180	G's
Max	Time	Min	Time
79.7	70.0	0.1	11.2

Test Vehicle: 2008 Toyota Sequoia SR5 5-Door MPV
 Test Program: NHTSA 35mph NCAP

Test Date: 1/22/08
 NHTSA No.: M85115

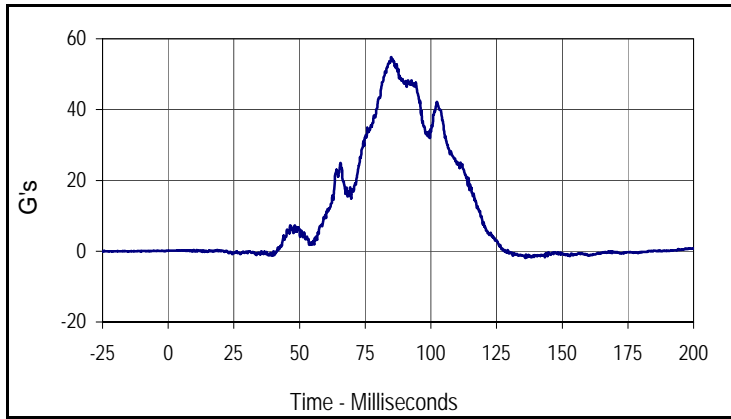

Curve Description			
CRABI Head X (P3)			
CURNO	Type	SAE Class	Units
163	FIL	1000	G's
Max	Time	Min	Time
54.8	84.9	-2.0	135.9

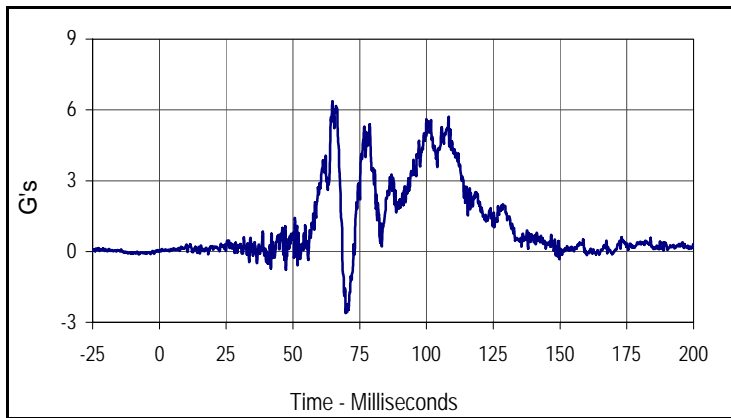

Curve Description			
CRABI Head Y (P3)			
CURNO	Type	SAE Class	Units
164	FIL	1000	G's
Max	Time	Min	Time
6.4	64.8	-2.6	69.8

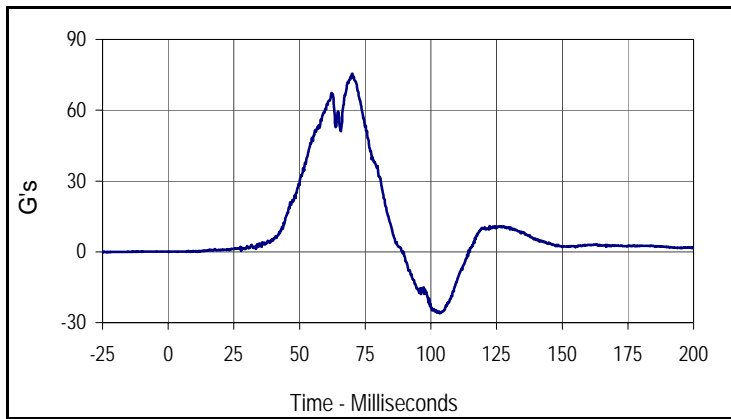

Curve Description			
CRABI Head Z (P3)			
CURNO	Type	SAE Class	Units
165	FIL	1000	G's
Max	Time	Min	Time
75.5	70.0	-26.1	103.4

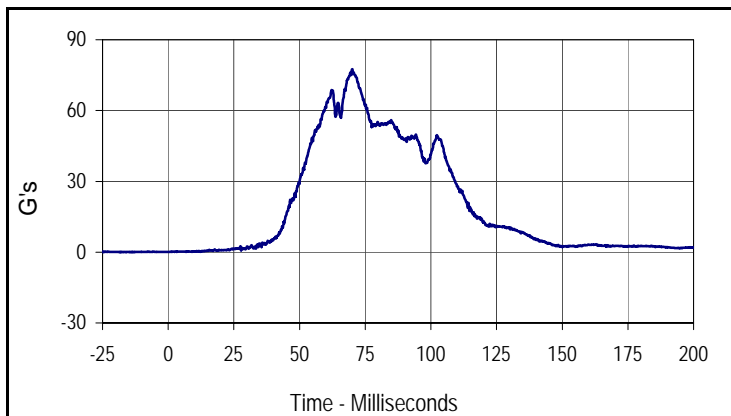

Curve Description			
CRABI Head Resultant (P3)			
CURNO	Type	SAE Class	Units
163	RES	1000	G's
Max	Time	Min	Time
77.5	70.0	0.1	6.8

Test Vehicle: 2008 Toyota Sequoia SR5 5-Door MPV
 Test Program: NHTSA 35mph NCAP

Test Date: 1/22/08
 NHTSA No.: M85115

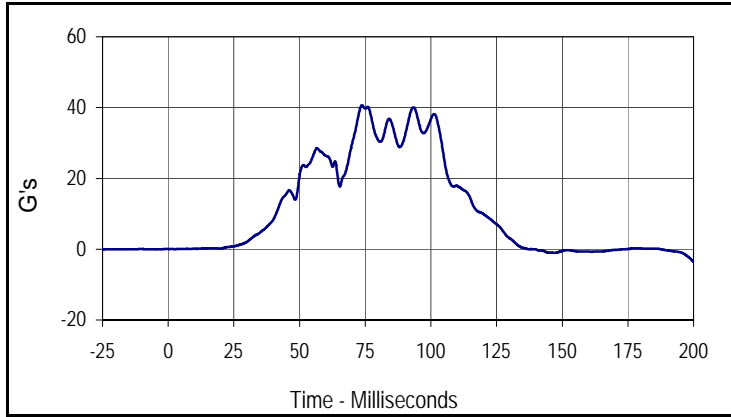

Curve Description			
CRABI Chest X (P3)			
CURNO	Type	SAE Class	Units
166	FIL	180	G's
Max	Time	Min	Time
40.7	73.7	-3.6	200.0

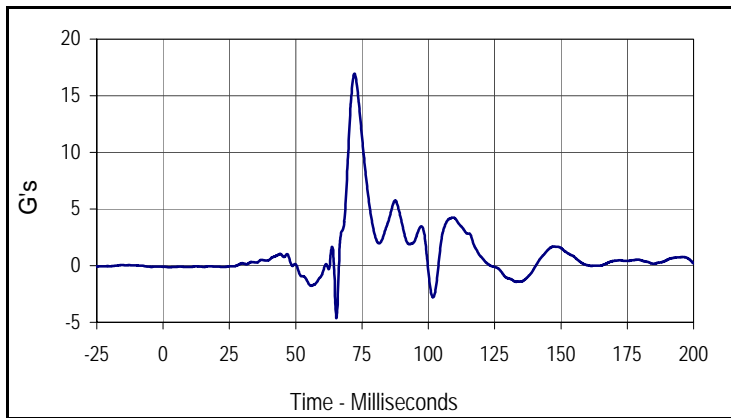

Curve Description			
CRABI Chest Y (P3)			
CURNO	Type	SAE Class	Units
167	FIL	180	G's
Max	Time	Min	Time
16.9	72.1	-4.6	65.4

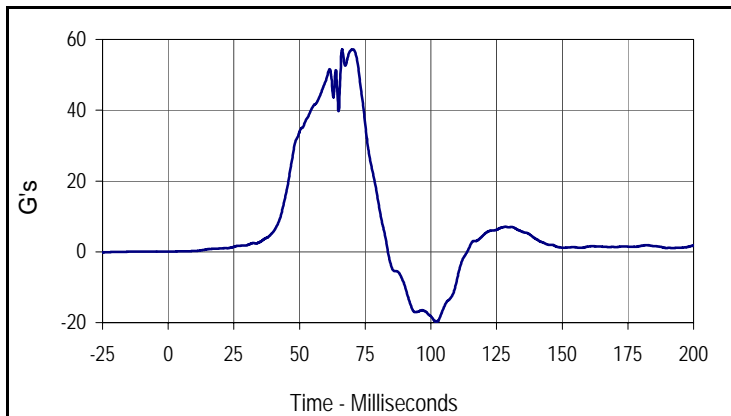

Curve Description			
CRABI Chest Z (P3)			
CURNO	Type	SAE Class	Units
168	FIL	180	G's
Max	Time	Min	Time
57.2	70.3	-19.7	102.0

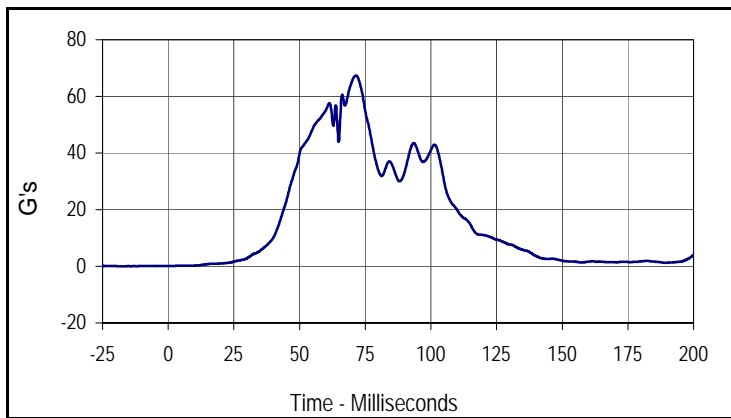

Curve Description			
CRABI Chest Resultant (P3)			
CURNO	Type	SAE Class	Units
166	RES	180	G's
Max	Time	Min	Time
67.3	71.5	0.1	0.0

SECTION D4
CRABI CALIBRATION INFORMATION

Test Program: CRABI 12 Month Old Frontal Head Drop Test

Test Date: 1/15/08

ATD Serial No.: 017

Test I.D.: FHD12C



Tested Parameter	Units	Specification	Result	Pass/Fail
Laboratory Temperature	°C	18.9 to 25.6	21.1	Pass
Laboratory Relative Humidity	%	10 to 70	30	Pass
Peak Resultant Acceleration	G's	100.0 to 120.0	110.1	Pass
Peak Lateral Acceleration	G's	≤15.0	4.6	Pass
Is Acceleration Unimodal?	Yes/No	Yes	Yes	Pass
Overall Test Results				Pass

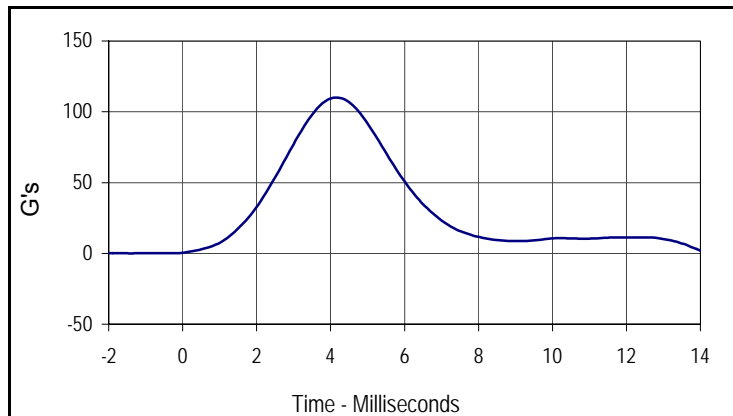

Curve Description			
Head Resultant			
CURNO	Type	SAE Class	Units
001	RES	1000	G's
Max	Time	Min	Time
110.1	4.2	0.0	-1.4

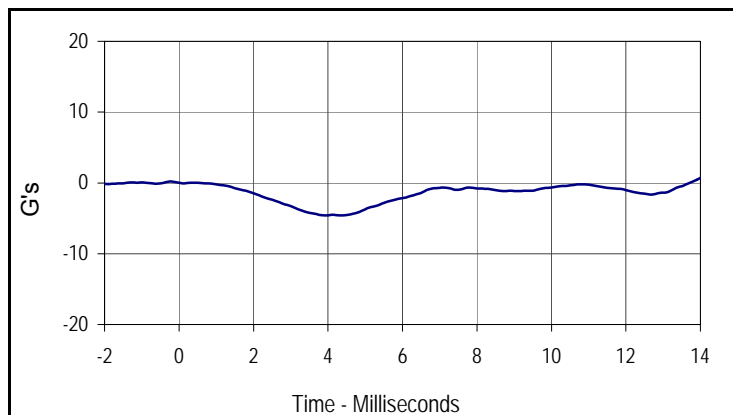

Curve Description			
Head Y			
CURNO	Type	SAE Class	Units
002	FIL	1000	G's
Max	Time	Min	Time
0.2	-0.2	-4.6	3.9

Test Program: CRABI 12 Month Old Rear Head Drop Test

Test Date: 1/16/08

ATD Serial No.: 017

Test I.D.: RHD12C



Tested Parameter	Units	Specification	Result	Pass/Fail
Laboratory Temperature	°C	18.9 to 25.6	21.1	Pass
Laboratory Relative Humidity	%	10 to 70	30	Pass
Peak Resultant Acceleration	G's	55.0 to 71.0	58.3	Pass
Peak Lateral Acceleration	G's	≤15.0	7.6	Pass
Is Acceleration Unimodal?	Yes/No	Yes	Yes	Pass
Overall Test Results			Pass	

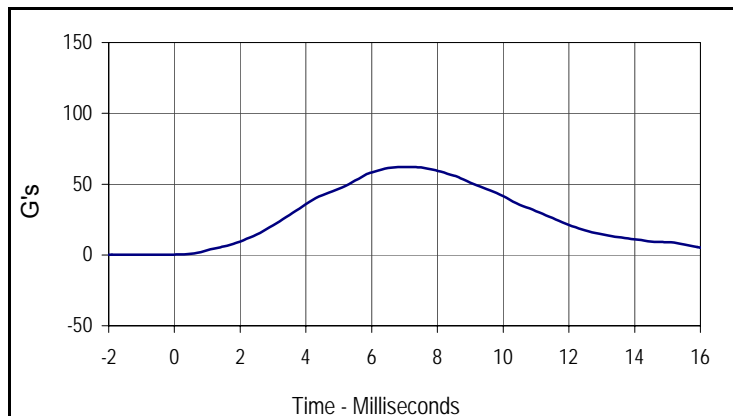

Curve Description			
Head Resultant			
CURNO	Type	SAE Class	Units
001	RES	1000	G's
Max	Time	Min	Time
58.3	6.0	0.1	-0.9

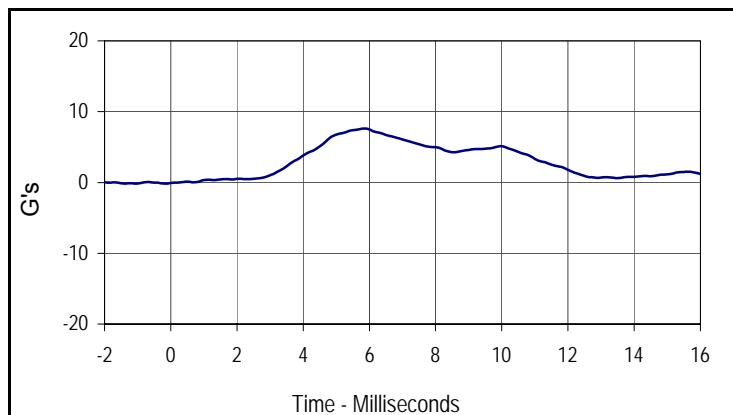

Curve Description			
Head Y			
CURNO	Type	SAE Class	Units
002	FIL	1000	G's
Max	Time	Min	Time
7.6	5.8	-0.2	-1.4

Test Program: CRABI 12 Month Old Thorax Impact Test

Test Date: 1/16/08

ATD Serial No.: 017

Test I.D.: CH12C



Tested Parameter	Units	Specification	Result	Pass/Fail
Laboratory Temperature	°C	20.6 to 22.2	21.1	Pass
Laboratory Relative Humidity	%	10 to 70	30	Pass
Pendulum Velocity at T=0	m/sec	4.90 to 5.10	4.95	Pass
Peak Probe Force	Newtons	-1514 to -1796	-1633	Pass
Overall Test Results				Pass

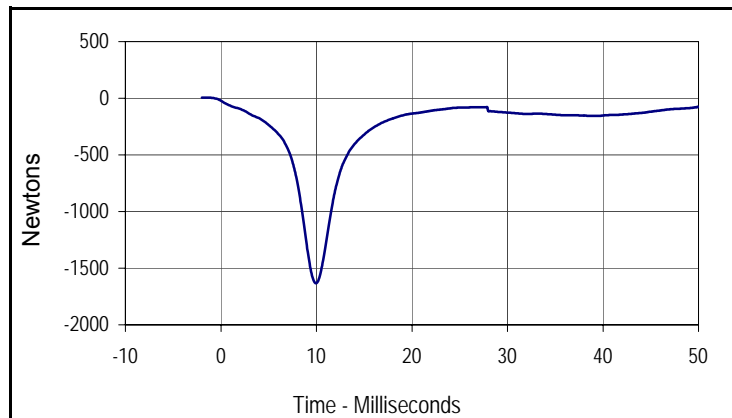

Curve Description			
Probe Force			
CURNO	Type	SAE Class	Units
001	FIL	180	Newtons
Max	Time	Min	Time
6.1	-1.7	-1633.2	10.0

Test Program: CRABI 12 Month Old Neck Flexion Test
 ATD Serial No.: 017

Test Date: 1/16/08
 Test I.D.: NF12C



Tested Parameter	Units	Specification	Result	Pass/Fail	
Laboratory Temperature	°C	20.6 to 22.2	21.1	Pass	
Laboratory Relative Humidity	%	10 to 70	30	Pass	
Pendulum Velocity	m/s	5.10 to 5.30	5.13	Pass	
Pendulum Deceleration	10 Msec.	m/s	1.6 to 2.3	2.0	Pass
	20 Msec.	m/s	3.4 to 4.2	4.1	Pass
	25 Msec.	m/s	4.3 to 5.2	5.1	Pass
"D" Plane Rotation	Max	Degrees	75.0 to 86.0	76.1	Pass
Peak Moment in Rotation	Max	Nm	36.0 to 45.0	42.0	Pass
Positive Moment Decay, Time To 5 Nm	Msec.	60.0 to 80.0	71.0	Pass	
Overall Test Results				Pass	

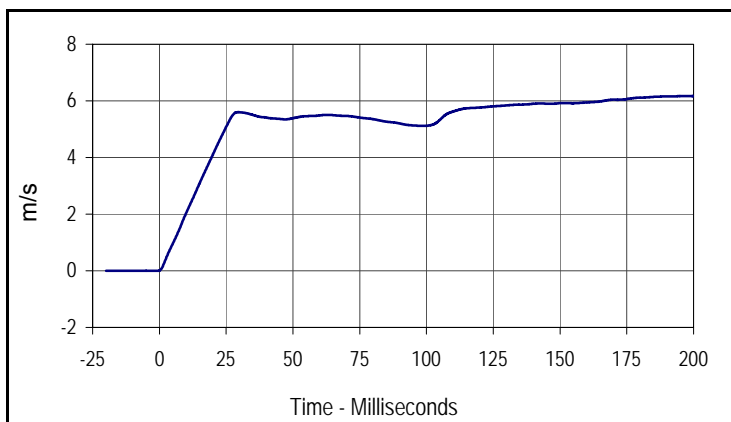

Curve Description			
Pendulum Velocity			
CURNO	Type	SAE Class	Units
001	FIL	180	m/s
Max	Time	Min	Time
6.2	199.3	0.0	-0.7

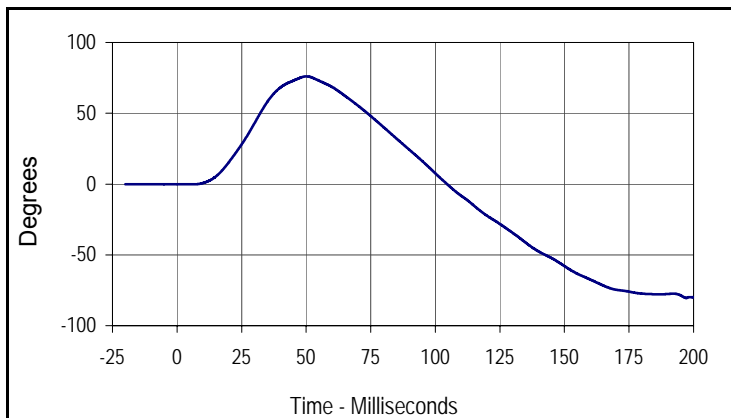

Curve Description			
"D" Plane Rotation			
CURNO	Type	SAE Class	Units
003	FIL	60	Degrees
Max	Time	Min	Time
76.1	50.1	-80.5	197.1

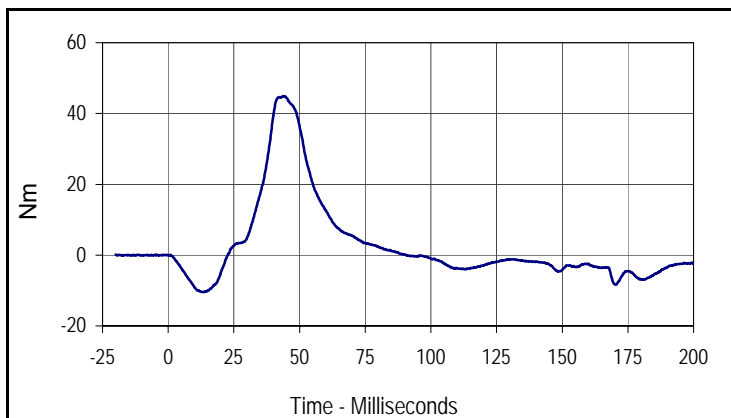

Curve Description			
Upper Neck Force Y			
CURNO	Type	SAE Class	Units
002	FIL	600	Nm
Max	Time	Min	Time
44.9	44.3	-10.4	13.5

Test Program: CRABI 12 Month Old Neck Extension Test
 ATD Serial No.: 017

Test Date: 1/15/08
 Test I.D.: NE12C



Tested Parameter	Units	Specification	Result	Pass/Fail	
Laboratory Temperature	°C	20.6 to 22.2	21.1	Pass	
Laboratory Relative Humidity	%	10 to 70	30	Pass	
Pendulum Velocity	m/s	2.4 to 2.6	2.40	Pass	
Pendulum Deceleration	6 Msec.	m/s	0.8 to 1.2	0.9	Pass
	10 Msec.	m/s	1.5 to 2.1	1.7	Pass
	14 Msec.	m/s	2.2 to 2.9	2.7	Pass
"D" Plane Rotation	Max	Degrees	80.0 to 92.0	91.7	Pass
Peak Moment in Rotation	Max	Nm	-12 to -23	-22.6	Pass
Positive Moment Decay, Time To -5 Nm	Msec.		76.0 to 90.0	77.9	Pass
Overall Test Results				Pass	

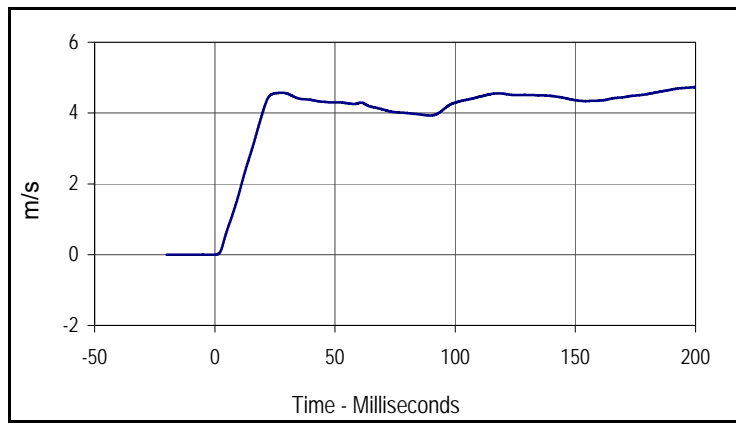

Curve Description			
Pendulum Velocity			
CURNO	Type	SAE Class	Units
001	FIL	180	m/s
Max	Time	Min	Time
4.7	200.0	0.0	0.1

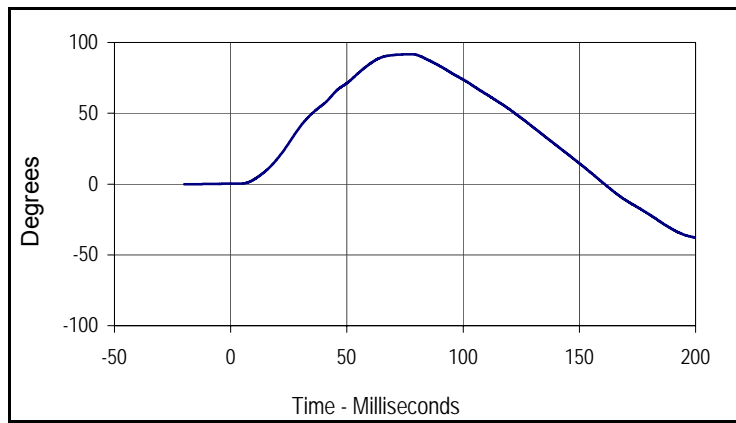

Curve Description			
"D" Plane Rotation			
CURNO	Type	SAE Class	Units
003	FIL	60	Degrees
Max	Time	Min	Time
91.7	77.5	-37.8	200.0

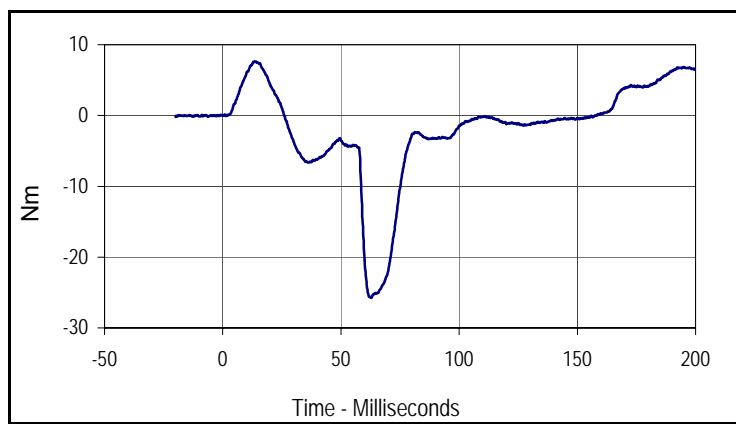

Curve Description			
Upper Neck Moment Y			
CURNO	Type	SAE Class	Units
002	FIL	600	Nm
Max	Time	Min	Time
7.6	13.2	-25.8	62.8

Test Program: CRABI 12 Month Old External Dimensions

Test Date: 1/15/08

ATD Serial No.: 017

Test I.D.: N/A



Tested Parameter	Units	Specification	Result	Pass/Fail
Laboratory Temperature	°C	20.6 to 22.2	21.1	Pass
Laboratory Relative Humidity	%	10 to 70	30	Pass
A - Total sitting height	mm	456.0 to 471.2	463	Pass
B - Shoulder pivot height	mm	276.6 to 291.8	288	Pass
C - "H" point height	mm	27.9 to 38.1	35	Pass
D - "H" point from backline	mm	40.1 to 50.3	46	Pass
E - Shoulder pivot from back	mm	50.3 to 60.5	58	Pass
F - Thigh clearance	mm	63.0 to 73.2	69	Pass
G - Elbow pivot to fingertip	mm	176.6 to 191.8	188	Pass
I - Shoulder pivot to elbow pivot	mm	99.1 to 114.3	110	Pass
J - Elbow rest height	mm	150.1 to 165.3	160	Pass
K - Buttock to knee length	mm	202.7 to 217.9	210	Pass
L - Popliteal length	mm	138.7 to 153.9	139	Pass
M - Knee pivot height	mm	165.1 to 180.3	171	Pass
N - Buttock popliteal length	mm	144.8 to 160.0	150	Pass
O - Chest depth with jacket	mm	107.5 to 122.7	119	Pass
P - Foot length	mm	92.4 to 102.6	95	Pass
Q- Stature	mm	727.7 to 753.1	N/A	N/A
R - Buttock to knee pivot length	mm	178.5 to 188.7	184	Pass
S - Head Breadth	mm	124.4 to 134.6	130	Pass
T - Head Depth	mm	149.9 to 165.1	160	Pass
U - Hip breadth	mm	158.5 to 173.7	164	Pass
V - Shoulder breadth	mm	200.7 to 215.9	210	Pass
W - Foot breadth	mm	39.1 to 49.3	42	Pass
Y - Chest circumference with jacket	mm	452.4 to 477.8	462	Pass
Z - Waist circumference	mm	447.0 to 472.4	455	Pass
AA - Reference location for dimension Y & O	mm	256.5 to 266.7	260	Pass
BB - Reference Location For dimension Z	mm	106.7 to 116.9	109	Pass
CC - Shoulder Height	mm	299.7 to 314.9	303	Pass
DD - Chin Height	mm	289.6 to 304.8	295	Pass
Overall Test Results				Pass

Test Program: CRABI 12 Month Old Frontal Head Drop Test

Test Date: 1/15/08

ATD Serial No.: 022

Test I.D.: FHD12D



Tested Parameter	Units	Specification	Result	Pass/Fail
Laboratory Temperature	°C	18.9 to 25.6	21.1	Pass
Laboratory Relative Humidity	%	10 to 70	30	Pass
Peak Resultant Acceleration	G's	100.0 to 120.0	119.2	Pass
Peak Lateral Acceleration	G's	≤15.0	5.0	Pass
Is Acceleration Unimodal?	Yes/No	Yes	Yes	Pass
Overall Test Results				Pass

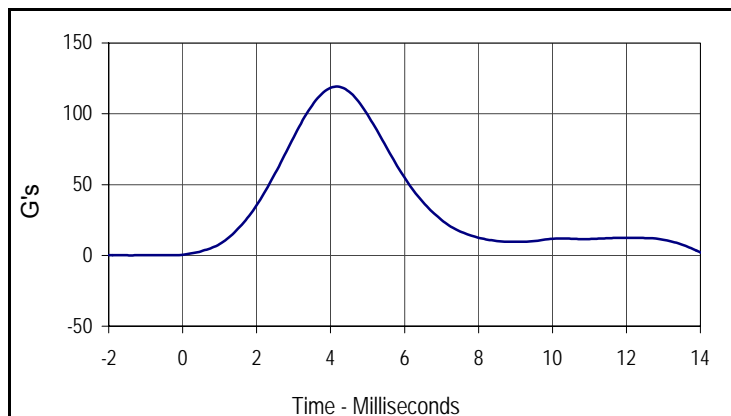

Curve Description			
Head Resultant			
CURNO	Type	SAE Class	Units
001	RES	1000	G's
Max	Time	Min	Time
119.2	4.2	0.0	-1.4

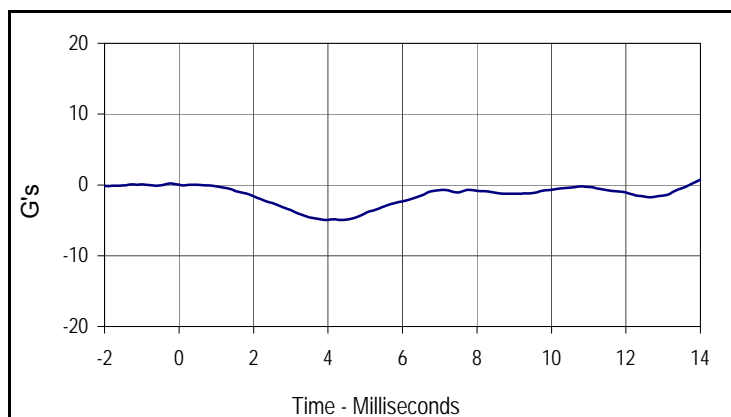

Curve Description			
Head Y			
CURNO	Type	SAE Class	Units
002	FIL	1000	G's
Max	Time	Min	Time
0.2	-0.2	-5.0	4.4

Test Program: CRABI 12 Month Old Rear Head Drop Test
 ATD Serial No.: 022

Test Date: 1/16/08
 Test I.D.: RHD12D



Tested Parameter	Units	Specification	Result	Pass/Fail
Laboratory Temperature	°C	18.9 to 25.6	21.1	Pass
Laboratory Relative Humidity	%	10 to 70	30	Pass
Peak Resultant Acceleration	G's	55.0 to 71.0	63.9	Pass
Peak Lateral Acceleration	G's	≤15.0	9.2	Pass
Is Acceleration Unimodal?	Yes/No	Yes	Yes	Pass
Overall Test Results			Pass	

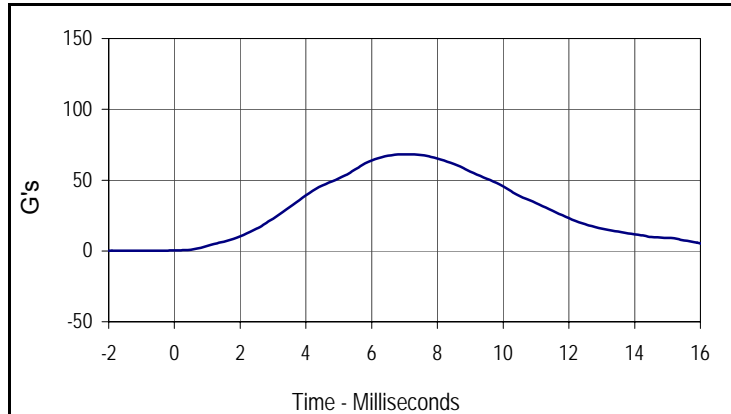

Curve Description			
Head Resultant			
CURNO	Type	SAE Class	Units
001	RES	1000	G's
Max	Time	Min	Time
63.9	6.0	0.1	-0.9

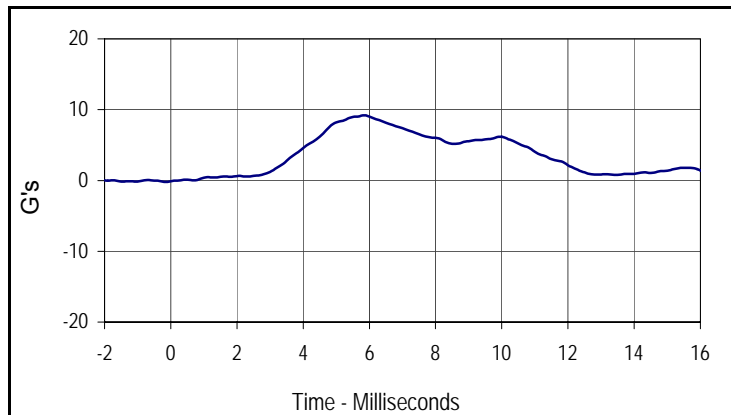

Curve Description			
Head Y			
CURNO	Type	SAE Class	Units
002	FIL	1000	G's
Max	Time	Min	Time
9.2	5.9	-0.2	-0.2

Test Program: CRABI 12 Month Old Thorax Impact Test

Test Date: 1/16/08

ATD Serial No.: 022

Test I.D.: CH12D



Tested Parameter	Units	Specification	Result	Pass/Fail
Laboratory Temperature	°C	20.6 to 22.2	21.1	Pass
Laboratory Relative Humidity	%	10 to 70	30	Pass
Pendulum Velocity at T=0	m/sec	4.90 to 5.10	4.97	Pass
Peak Probe Force	Newtons	-1514 to -1796	-1767	Pass
Overall Test Results				Pass

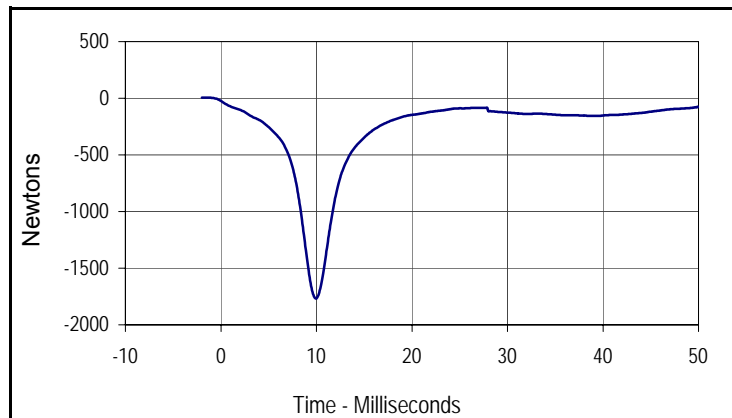

Curve Description			
Probe Force			
CURNO	Type	SAE Class	Units
001	FIL	180	Newtons
Max	Time	Min	Time
6.2	-1.6	-1767.0	10.0

Test Program: CRABI 12 Month Old Neck Flexion Test
 ATD Serial No.: 022

Test Date: 1/16/08
 Test I.D.: NF12D



Tested Parameter	Units	Specification	Result	Pass/Fail	
Laboratory Temperature	°C	20.6 to 22.2	21.1	Pass	
Laboratory Relative Humidity	%	10 to 70	30	Pass	
Pendulum Velocity	m/s	5.10 to 5.30	5.11	Pass	
Pendulum Deceleration	10 Msec.	m/s	1.6 to 2.3	1.9	Pass
	20 Msec.	m/s	3.4 to 4.2	3.9	Pass
	25 Msec.	m/s	4.3 to 5.2	4.8	Pass
"D" Plane Rotation	Max	Degrees	75.0 to 86.0	76.1	Pass
Peak Moment in Rotation	Max	Nm	36.0 to 45.0	43.4	Pass
Positive Moment Decay, Time To 5 Nm	Msec.	60.0 to 80.0	71.5	Pass	
Overall Test Results				Pass	

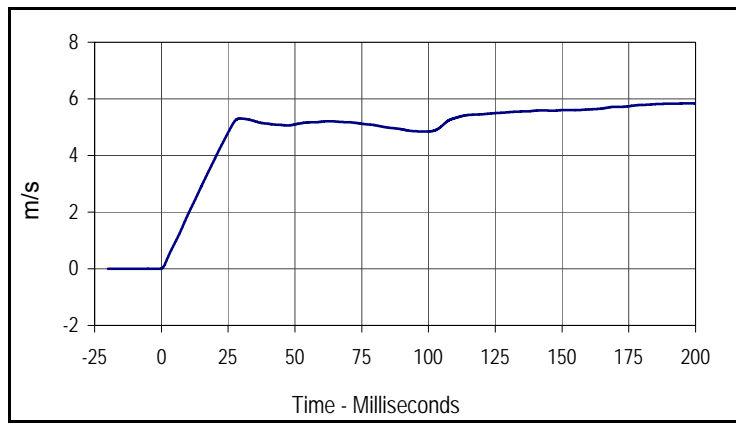

Curve Description			
Pendulum Velocity			
CURNO	Type	SAE Class	Units
001	FIL	180	m/s
Max	Time	Min	Time
5.8	199.3	0.0	-0.7

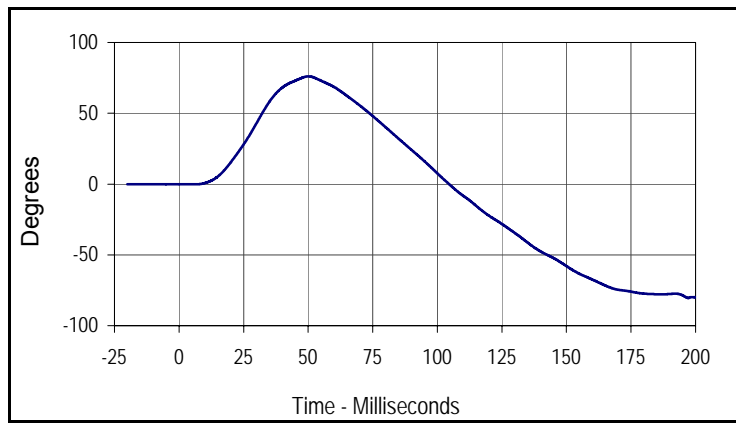

Curve Description			
"D" Plane Rotation			
CURNO	Type	SAE Class	Units
003	FIL	60	Degrees
Max	Time	Min	Time
76.1	50.1	-80.5	197.1

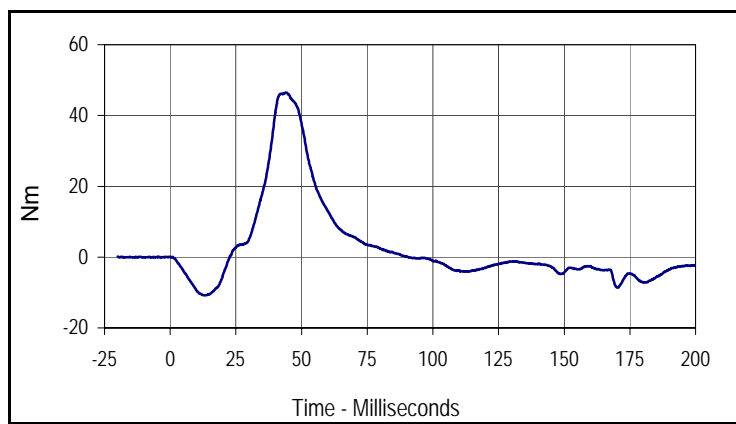

Curve Description			
Upper Neck Force Y			
CURNO	Type	SAE Class	Units
002	FIL	600	Nm
Max	Time	Min	Time
46.4	44.3	-10.8	13.5

Test Program: CRABI 12 Month Old Neck Extension Test
 ATD Serial No.: 022

Test Date: 1/15/08
 Test I.D.: NE12D



Tested Parameter	Units	Specification	Result	Pass/Fail	
Laboratory Temperature	°C	20.6 to 22.2	21.1	Pass	
Laboratory Relative Humidity	%	10 to 70	30	Pass	
Pendulum Velocity	m/s	2.4 to 2.6	2.47	Pass	
Pendulum Deceleration	6 Msec.	m/s	0.8 to 1.2	0.9	Pass
	10 Msec.	m/s	1.5 to 2.1	1.8	Pass
	14 Msec.	m/s	2.2 to 2.9	2.8	Pass
"D" Plane Rotation	Max	Degrees	80.0 to 92.0	89.5	Pass
Peak Moment in Rotation	Max	Nm	-12 to -23	-14.4	Pass
Positive Moment Decay, Time To -5 Nm	Msec.		76.0 to 90.0	78.1	Pass
Overall Test Results				Pass	

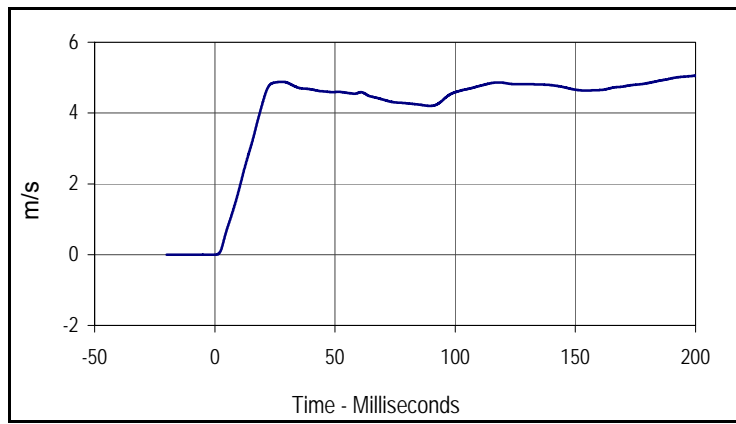

Curve Description			
Pendulum Velocity			
CURNO	Type	SAE Class	Units
001	FIL	180	m/s
Max	Time	Min	Time
5.1	200.0	0.0	0.1

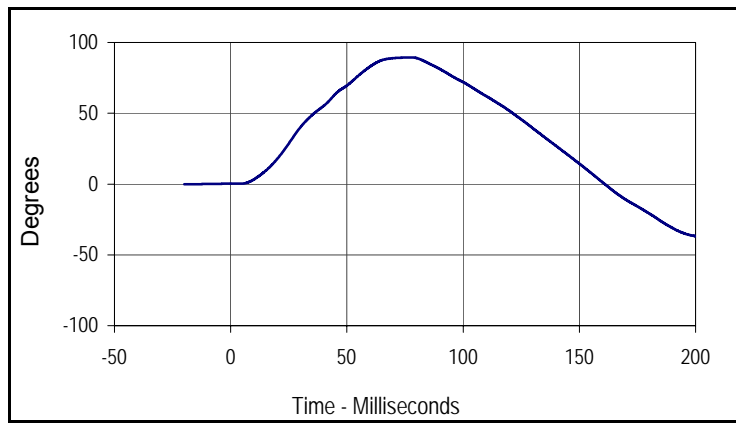

Curve Description			
"D" Plane Rotation			
CURNO	Type	SAE Class	Units
003	FIL	60	Degrees
Max	Time	Min	Time
89.5	77.5	-36.8	200.0

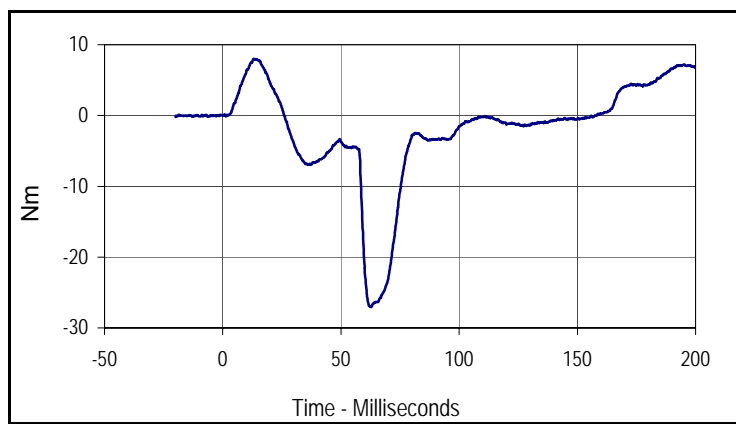

Curve Description			
Upper Neck Moment Y			
CURNO	Type	SAE Class	Units
002	FIL	600	Nm
Max	Time	Min	Time
8.0	13.2	-27.0	62.8

Test Program: CRABI 12 Month Old External Dimensions

Test Date: 1/15/08

ATD Serial No.: 022

Test I.D.: N/A



Tested Parameter	Units	Specification	Result	Pass/Fail
Laboratory Temperature	°C	20.6 to 22.2	21.1	Pass
Laboratory Relative Humidity	%	10 to 70	30	Pass
A - Total sitting height	mm	456.0 to 471.2	463	Pass
B - Shoulder pivot height	mm	276.6 to 291.8	286	Pass
C - "H" point height	mm	27.9 to 38.1	34	Pass
D - "H" point from backline	mm	40.1 to 50.3	46	Pass
E - Shoulder pivot from back	mm	50.3 to 60.5	58	Pass
F - Thigh clearance	mm	63.0 to 73.2	69	Pass
G - Elbow pivot to fingertip	mm	176.6 to 191.8	182	Pass
I - Shoulder pivot to elbow pivot	mm	99.1 to 114.3	110	Pass
J - Elbow rest height	mm	150.1 to 165.3	155	Pass
K - Buttock to knee length	mm	202.7 to 217.9	204	Pass
L - Popliteal length	mm	138.7 to 153.9	146	Pass
M - Knee pivot height	mm	165.1 to 180.3	172	Pass
N - Buttock popliteal length	mm	144.8 to 160.0	150	Pass
O - Chest depth with jacket	mm	107.5 to 122.7	116	Pass
P - Foot length	mm	92.4 to 102.6	95	Pass
Q- Stature	mm	727.7 to 753.1	N/A	N/A
R - Buttock to knee pivot length	mm	178.5 to 188.7	183	Pass
S - Head Breadth	mm	124.4 to 134.6	127	Pass
T - Head Depth	mm	149.9 to 165.1	152	Pass
U - Hip breadth	mm	158.5 to 173.7	161	Pass
V - Shoulder breadth	mm	200.7 to 215.9	210	Pass
W - Foot breadth	mm	39.1 to 49.3	46	Pass
Y - Chest circumference with jacket	mm	452.4 to 477.8	455	Pass
Z - Waist circumference	mm	447.0 to 472.4	449	Pass
AA - Reference location for dimension Y & O	mm	256.5 to 266.7	263	Pass
BB - Reference Location For dimension Z	mm	106.7 to 116.9	113	Pass
CC - Shoulder Height	mm	299.7 to 314.9	301	Pass
DD - Chin Height	mm	289.6 to 304.8	297	Pass
			Overall Test Results	Pass