

REPORT NUMBER TR-P28001-10-NC

**NEW CAR ASSESSMENT PROGRAM
FRONTAL BARRIER IMPACT TEST**

**CHRYSLER LLC
2008 DODGE RAM 1500 SXT
4-DOOR TRUCK**

NHTSA NUMBER: M80308

**PREPARED BY:
KARCO ENGINEERING, LLC
9270 HOLLY ROAD
ADELANTO, CALIFORNIA 92301**



NOVEMBER 8, 2007

FINAL REPORT

**PREPARED FOR:
U.S. DEPARTMENT OF TRANSPORTATION
NATIONAL HIGHWAY TRAFFIC SAFETY ADMINISTRATION
RULEMAKING
OFFICE OF CRASHWORTHINESS STANDARDS
MAIL CODE: NVS-111
1200 NEW JERSEY AVE, SE, ROOM W43-410
WASHINGTON, D.C. 20590**

This final test report was prepared for the U.S. Department of Transportation, National Highway Traffic Safety Administration, in response to Contract Number DTNH22-06-D-00027

This publication is distributed by the U.S. Department of Transportation, National Highway Traffic Safety Administration, in the interest of information exchange. The opinions, findings and conclusions expressed in this publication are those of the author(s) and not necessarily those of the Department of Transportation or the National Highway Traffic Safety Administration. The United States Government assumes no liability for its contents or use thereof. If trade or manufacturers' names or products are mentioned, it is only because they are considered essential to the object of the publication and should not be construed as an endorsement. The United States Government does not endorse products or manufacturers.

Prepared by:  Date: November 8, 2007
Mr. Pablo Vega, Test Engineer
KARCO Engineering, LLC

Reviewed by:  Date: November 8, 2007
Mr. Michael Dunlap, Director of Operations
KARCO Engineering, LLC

Approved by:  Date: November 8, 2007
Mr. Frank D. Richardson, Program Manager
KARCO Engineering, LLC

FINAL REPORT ACCEPTED BY:

Manager, New Car Assessment Program

Date of Acceptance

COTR, NCAP Frontal Impact Program

Date of Acceptance

Technical Report Documentation Page

1. Report No. TR-P28001-10-NC	2. Government Accession No.	3. Recipients Catalog No.																										
4. Title and Subtitle Final Report of New Car Assessment Program Testing of a 2008 Dodge Ram 1500 SXT 4-Door Truck NHTSA No. M80308		5. Report Date November 8, 2007																										
		6. Performing Organization Code KAR																										
7. Authors Mr. Pablo Vega, Test Engineer, Karco Mr. Frank Richardson, Program Manager, Karco		8. Performing Organization Report No. TR-P28001-10-NC																										
		10. Work Unit No.																										
9. Performing Organization Name and Address Karco Engineering, LLC 9270 Holly Rd. Adelanto, CA, 92301		11. Contract or Grant No. DTNH22-06-D-00027																										
		13. Type of Report and Period Covered Final Test Report																										
12. Sponsoring Agency Name and Address U. S. Department of Transportation National Highway Traffic Safety Administration Rulemaking Office of Crashworthiness Standards Mail Code NVS-111 1200 New Jersey Ave, SE, Room W43-410 Washington, D.C 20590		14. Sponsoring Agency Code DOT/NHTSA/NRM/OCS																										
		15. Supplementary Notes																										
16. Abstract <p>A 35 mph (56.3 km/h) frontal barrier impact was conducted on a 2008 Dodge Ram 1500 SXT 4-Door Truck at Karco Engineering, LLC on November 8, 2007. This test was conducted to obtain data indicant of FMVSS 208, 212, 219 (partial), 301, and footwell intrusion performance. The impact velocity is 56.30 km/h. The ambient temperature at the barrier face at the time of impact is 25.0 degrees Celcius. The vehicle's maximum post-test static crush is 591 mm at the vehicle's centerline. The test vehicle is equipped with a 3-point continuous belt system and second generation supplemental airbags in both front outboard seating positions. With respect to FMVSS 208 "Occupant Crash Protection", the occupant injury criteria summary is as follows:</p> <table border="1" style="width: 100%; border-collapse: collapse; margin-top: 10px;"> <thead> <tr> <th style="width: 35%;">Measurement Description</th> <th style="width: 10%;">Units</th> <th style="width: 10%;">Threshold</th> <th style="width: 15%;">Driver ATD</th> <th style="width: 30%;">Passenger ATD</th> </tr> </thead> <tbody> <tr> <td>Head Injury Criteria (HIC)</td> <td>N/A</td> <td>1000</td> <td style="background-color: #ffffcc;">309.5</td> <td style="background-color: #ffffcc;">531.4</td> </tr> <tr> <td>Max. Chest Accel. (3 msec Clip)</td> <td>G's</td> <td>60</td> <td style="background-color: #ffffcc;">36.6</td> <td style="background-color: #ffffcc;">40.4</td> </tr> <tr> <td>Left Femur Force</td> <td>Newtons</td> <td>10008</td> <td style="background-color: #ffffcc;">-4153.0</td> <td style="background-color: #ffffcc;">-3140.4</td> </tr> <tr> <td>Right Femur Force</td> <td>Newtons</td> <td>10008</td> <td style="background-color: #ffffcc;">-3357.8</td> <td style="background-color: #ffffcc;">-2594.0</td> </tr> </tbody> </table>				Measurement Description	Units	Threshold	Driver ATD	Passenger ATD	Head Injury Criteria (HIC)	N/A	1000	309.5	531.4	Max. Chest Accel. (3 msec Clip)	G's	60	36.6	40.4	Left Femur Force	Newtons	10008	-4153.0	-3140.4	Right Femur Force	Newtons	10008	-3357.8	-2594.0
Measurement Description	Units	Threshold	Driver ATD	Passenger ATD																								
Head Injury Criteria (HIC)	N/A	1000	309.5	531.4																								
Max. Chest Accel. (3 msec Clip)	G's	60	36.6	40.4																								
Left Femur Force	Newtons	10008	-4153.0	-3140.4																								
Right Femur Force	Newtons	10008	-3357.8	-2594.0																								
17. Key Words 56.3 km/h NCAP Frontal Barrier Impact Test New Car Assessment Program (NCAP) 2008 Dodge Ram 1500 SXT 4-Door Truck NHTSA No. M80308		18. Distribution of Statement Copies of this report available from: NHTSA Technical Reference Division National Highway Traffic Safety Admin. 1200 New Jersey Ave, SE, Room W43-410 Washington, D.C. 20590																										
19. Security Classification (this report) Unclassified	20. Security Classification (this page) Unclassified	21. No. of Pages 200	22. Price																									

TABLE OF CONTENTS

Section	Description	Page
1	Purpose and Summary of Test M80308	1
2	Occupant and Vehicle Information/Data Sheets	3

Data Sheet	Description	Page
1	Crash Test Summary	4
2	General Test and Vehicle Parameter Data	5
3	Post-Test Impact Data	8
4	Test Vehicle Information	9
5	Dummy Positioning in Vehicle	11
6	Seat Belt Positioning Data	13
7	Vehicle Accelerometer Location	14
8	Seat Belt Assessment Test Data	15
9	Summary of FMVSS 212 Data	16
10	Windshield Zone Intrusion FMVSS 219 Data (Partial)	17
11	FMVSS 301 Fuel System Integrity Post-Impact Data	18
12	FMVSS 301 Static Rollover Data	19
13	Vehicle Measurements	21
14	Camera Locations	24
15	Photographic Reference Target Locations	25
16	Vehicle Intrusion Measurements	26
17	Fixed Barrier Load Cell Locations	31
18	Accident Investigation Division Data	32
19	Dummy/Vehicle Temperature Stabilization	33

Appendix	Description	Appendix
A	Photographs	A
B	Data Plots	B
C	Dummy Calibration Data	C
D	Child Restraint System	D

SECTION 1

PURPOSE AND SUMMARY OF TEST M80308

1.1 PURPOSE

This 35 mph (56.3 km/h) frontal barrier impact test is part of the New Car Assessment Program (NCAP) sponsored by the National Highway Traffic Safety Administration (NHTSA) under Contract No. DTNH22-06-D-00027. The purpose of this test was to obtain vehicle crashworthiness and occupant restraint system performance data for an impact speed in excess of the current 30 mph (48.3 km/h) requirements.

The 35 mph (56.3 km/h) frontal barrier impact test was conducted in accordance with the Office of Crashworthiness Standards (OCS) New Car Assessment Program (NCAP) Laboratory Indicant Test Procedure, dated July 2005. Data was obtained indicant of FMVSS 208 "Occupant Crash Protection", FMVSS 212, "Windshield Retention", FMVSS 219, "Windshield Zone Intrusion (Partial)", and FMVSS 301 "Fuel System Integrity", performance. Procedures for receiving, inspection, testing and reporting of test results are described in the test procedures and are not repeated in this report.

1.2 SUMMARY

A load cell barrier consisting of 36 load cells was impacted by a 2008 Dodge Ram 1500 SXT 4-Door Truck at a velocity of 56.30 km/h. The test was performed at Karco Engineering, LLC on November 8, 2007.

Three (3) real-time and fourteen (14) high-speed cameras were used to document the frontal barrier impact event. Camera locations and other pertinent camera information can be found in Data Sheet number 14 (page number 24) of this report.

Two Part 572E, 50th percentile male anthropomorphic test devices (ATDs), were placed in the driver and right-front passenger seating positions according to dummy placement instructions specified in the Laboratory Indicant Test Procedure.

Both ATDs were fully instrumented with head (primary and redundant), chest (primary and redundant) and pelvis triaxial accelerometers, chest displacement potentiometers, six-axis upper neck transducers, right/left femur load cells, and lower leg instrumentation. Seat belt load cells were placed on the driver's and passenger's lap and shoulder belts to measure dummy torso and pelvic section loading. Shoulder belt spool-off was measured for the driver and passenger dummies. The driver (position 1) ATD (Serial No. 034) and the right-front passenger (position 2) ATD (Serial No. 035) were calibrated two tests prior to this test.

One hundred and thirty-two (132) channels of data were recorded using a TDAS data acquisition system. Appendix A contains Pre and Post-Test Photographs, Appendix B contains the Dummy Response data traces, Appendix C contains the Dummy Calibration data, and Appendix D contains the Child Restraint System Report.

There was 100 percent windshield retention and there was no intrusion into the protected zone of the windshield during the impact event. There was no stoddard solvent leakage after the event or during any phase of the static rollover.

The maximum static crush of the vehicle was 591 mm at the vehicle's centerline and both the driver and the passenger side doors remained closed and latched during the impact event, and were operable after the impact.

The driver's visible contact points were as follows: The driver ATD's head and chest contacted the airbag. The head also contacted the headrest. Both the left and right knees contacted the knee bolster.

The passenger's visible contact points were as follows: The passenger ATD's head contacted the airbag and headrest. The chest also contacted the airbag. Both knees contacted the glove box.

Occupant injury data is contained in table below.

OCCUPANT DATA SUMMARY

ATD Position	HIC	3 msec Clip (g)	Chest Defl. (mm)	Left Femur (N)	Right Femur (N)
Driver	309.4	36.6	-36.3	-4153.0	-3357.8
Passenger	531.4	40.4	-28.6	-3140.4	-2594.0

Additional data plots for this test are available in the research and development section of the NHTSA website. The website can be found at: www.NHTSA.Dot.Gov

SECTION 2

OCCUPANT AND VEHICLE INFORMATION/DATA SHEETS

Test Vehicle: 2008 Dodge Ram 1500 SXT 4-Door Truck

NHTSA No.: M80308

Test Program: NHTSA 35mph NCAP

Test Date: 11/8/07

CONVERSION FACTORS USED IN THIS REPORT*

Quantity	Typical Application	Std Units	Metric Unit	Multiply By
Mass	Vehicle Weight	lb	kg	0.4536
Linear Velocity	Impact Velocity	miles/hr	km/hr	1.609
Length or Distance	Measurements	in	mm	25.4
Volume	Fuel Systems	gal	liter	3.785
Volume	Small Fluids	oz	mL	29.573
Pressure	Tire Pressures	lbf/in ²	kPa	7.0
Volume	Liquid	gal	liter	3.785
Temperature	General Use	°F	°C	$=(tf - 32)/1.8$
Force	Dynamic Forces	lbf	N	4.448
Moment	Torque	lbf/ft	Nm	1.355

* Based on the Recommended Practice in SAE J916, May 85

DATA SHEET NO. 1
CRASH TEST SUMMARY

Test Vehicle: 2008 Dodge Ram 1500 SXT 4-Door Truck

NHTSA No.: M80308

Test Program: NHTSA 35mph NCAP

Test Date: 11/8/07

PRIMARY IMPACT DATA

Measured Parameter	Units	Value
Velocity at Impact	km/h	56.30
Test Weight	kg	2700
Impact Angle	degrees	0
Average Rebound	mm	281
Maximum Static Crush	mm	591

DOOR OPENING AND SEAT TRACK INFORMATION

Description	Driver	Passenger
Front Door opening	Remained closed and latched, opened w/o tools	Remained closed and latched, opened w/o tools
Rear Door Opening	Remained closed and latched, opened w/o tools	Remained closed and latched, opened w/o tools
Seat Track Shift (mm)	None	None
Seat Back Failure	No	No

TEST DUMMY INFORMATION

Description	Driver	Passenger
Dummy Type/ Serial No.	50% Male Hybrid III No. 034	50% Male Hybrid III No. 035
Head Contact	Airbag, Headrest	Airbag, Headrest
Chest Contact	Airbag	Airbag
Abdomen Contact	None	None
Left Knee Contact	Bolster	Glovebox
Right Knee Contact	Bolster	Glovebox

MOVIE COVERAGE

Cameras	Standard	Additional
High Speed	14	0
Real Time	1	2
Total	15	2

DATA CHANNELS

Driver ATD Sensors	40
Passenger ATD Sensors	40
Belt Assessment Sensors	8
Vehicle Structure Accelerometers	8
Rigid Barrier Load Cells	36
Total	132

DATA SHEET NO. 2

GENERAL TEST AND VEHICLE PARAMETER DATA

Test Vehicle: 2008 Dodge Ram 1500 SXT 4-Door Truck

NHTSA No.: M80308

Test Program: NHTSA 35mph NCAP

Test Date: 11/8/07

TEST VEHICLE INFORMATION AND OPTIONS

NHTSA No.	M80308
Make	Dodge
Model	Ram 1500 SXT
Body Style	4-Door Truck
Vin No.	1D7HU18298J121656
Color	Silver
Delivery Date	10/30/2007
Odometer (Miles)	159.0
Dealer	Haddad Auto Center
Transmission	5-Speed Automatic
Final Drive	4wd
Type/No. Cyl.	V8
Engine Disp. (L)	5.7
Engine Placement	Longitudinal
Roof Rack	No
Sunroof/T-Top	No
Tinted Glass	Yes
Traction Control	Yes
Power Brakes	Yes
Front Disc	Yes
Rear Disc	Yes

Anti-Lock Brakes	Yes
All Wheel Drive	No
Power Steering	Yes
Driver Front Airbag	Yes
Driver Side Airbag	No
Driver Head Airbag	No
Driver Curtain Airbag	No
Pass. Airbag	Yes
Pass. Side Airbag	No
Pass. Head Airbag	No
Pass. Curtain Airbag	No
Pre-Tensioners	Yes
Load Limiters	Yes
Bucket Seats	Yes
Air. Cond.	Yes
AM/FM CD	Yes
Tilt Steering	Yes
Automatic Door Locks	Yes
Power Windows	Yes
Power Seats	Yes
Other	N/A

Does Owners Manual provide instructions to turn off automatic door locks.

Yes

DATA FROM MANUFACTURER

Manufactured By	Chrysler LLC
Date of Manufacture	Aug-07

GVWR (kg)	3040
GAWR Front (kg)	1770
GAWR Rear (kg)	1770

VEHICLE SEATING AND CAPACITY WEIGHT INFORMATION

Measured Parameter	Front	Rear	Third	Total
Type of Seats	Bucket	Bench		
Number of Occupants	3	3		6
Capacity Weight (VCW) (kg)				578
Cargo Weight (RCLW) (kg)				136

DATA SHEET NO. 2...(CONTINUED)

GENERAL TEST AND VEHICLE PARAMETER DATA

Test Vehicle: 2008 Dodge Ram 1500 SXT 4-Door Truck

NHTSA No.: M80308

Test Program: NHTSA 35mph NCAP

Test Date: 11/8/07

Collect year, make, model, VIN, items circled in red, and tire manufacturer and tire name.

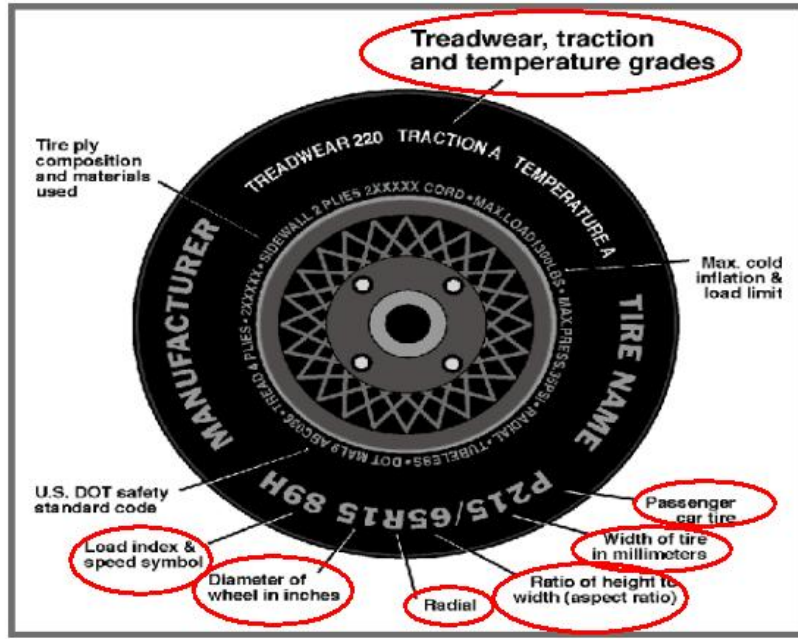

TIRE INFORMATION

Measured Parameter	Front	Rear
Max. Tire Pressure (kpa)	308	308
Cold Pressure (kpa)	240	240
Recommended Tire Size	P265/70R17	P265/70R17
Tire Size on Vehicle	P265/70R17	P265/70R17
Tire Manufacturer	Goodyear	Goodyear
Treadwear	500	500
Traction	A	A
Temperature Grades	B	B
Tire Plies Sidewall	2 Polyester	2 Polyester
Tire Plies Body	2 Polyester, 2 Steel,	2 Polyester, 2 Steel,
Load Index/Speed Symbol	113R	113R
Tire Material	Polyester, Steel,	Polyester, Steel,
DOT Safety Code Right	4BT6 EXWR 3207	4BT6 EXWR 3207
DOT Safety Code Left	4BT6 EXWR 3207	4BT6 EXWR 3207

DATA SHEET NO. 2...(CONTINUED)

GENERAL TEST AND VEHICLE PARAMETER DATA

Test Vehicle: 2008 Dodge Ram 1500 SXT 4-Door Truck

NHTSA No.: M80308

Test Program: NHTSA 35mph NCAP

Test Date: 11/8/07

TEST VEHICLE WEIGHTS

	Units	As Delivered Weights (UVW)			As Tested Weights (ATW)		
		Front Axle	Rear Axle	Total	Front Axle	Rear Axle	Total
Left	kg	728	508	1236	792	572	1364
Right	kg	697	484	1181	731	605	1336
Ratio	%	59.0%	41.0%	100.0%	56.4%	43.6%	100.0%
Totals	kg	1425	992	2417	1523	1177	2700

TARGET TEST WEIGHT CALCULATION

Measured Parameter	Units	Value
Total Delivered Weight (UVW)	kg	2417
Weight of 2 P572 ATD's	kg	152
Rated Cargo/Luggage Wt. (RCLW)	kg	136
Calculated Vehicle Target Wt. (TVTW)	kg	2705

TEST VEHICLE ATTITUDE AND CG

	Units	LF	RF	LR	RR	CG (aft of front axle)
As Delivered	mm	949	969	1026	1040	1466
As Tested	mm	935	954	992	1001	1557

Vehicle Wheel Base (mm) 3572

Weight of Ballast Secured in cargo area (kg) 21

Weight of Items Removed (kg) 46

Vehicle Components Removed Spare Tire with tools

* Ballast weight does not include cameras, instrumentation and brake abort system.

FUEL SYSTEM DATA

Fuel System Capacity From Owners Manual (L) 98.41

Actual Test Volume with entire fuel System Filled (L) 91.52

Test Fluid Type: Stoddard Solvent

Kinematic Viscosity: as per ASTM Standard D484-71 Red

Is Vehicle Fuel Pump Electric or Mechanical? Electric

If electric, does pump operate with ignition switch "On" & engine "OFF" Yes

Fuel System Particulars: Electric fuel pump. Activated when electrical system is activated.
Fuel pump will run during the operation of the engine.

DATA SHEET NO. 3

POST-TEST IMPACT DATA

Test Vehicle: 2008 Dodge Ram 1500 SXT 4-Door Truck

NHTSA No.: M80308

Test Program: NHTSA 35mph NCAP

Test Date: 11/8/07

SPEED TRAP DATA

Measured Parameter	Units	Requirement	Value
Trap No.1 Velocity (Primary)	km/h	55.51 to 57.12	56.30
Trap No.2 Velocity (Redun.)	km/h	55.51 to 57.12	56.25

VEHICLE STATIC CRUSH

Measured Parameter	Units	Pre-Test	Post-Test	Difference
Left Side	mm	5543	5194	-349
Center	mm	5785	5194	-591
Right Side	mm	5543	5190	-353

VEHICLE REBOUND FROM BARRIER

Measured Parameter	Units	Value
Left Side	mm	245
Center	mm	305
Right Side	mm	292
Average	mm	281

DATA SHEET NO. 4

TEST VEHICLE INFORMATION

Test Vehicle: 2008 Dodge Ram 1500 SXT 4-Door Truck

NHTSA No.: M80308

Test Program: NHTSA 35mph NCAP

Test Date: 11/8/07

NOMINAL DESIGN RIDING POSITION

The driver and passenger seat backs are positioned to the manufacturer's designated angle. The procedure is as follows: Seat back angle was measured at the headrest of the seat using a digital inclinometer.

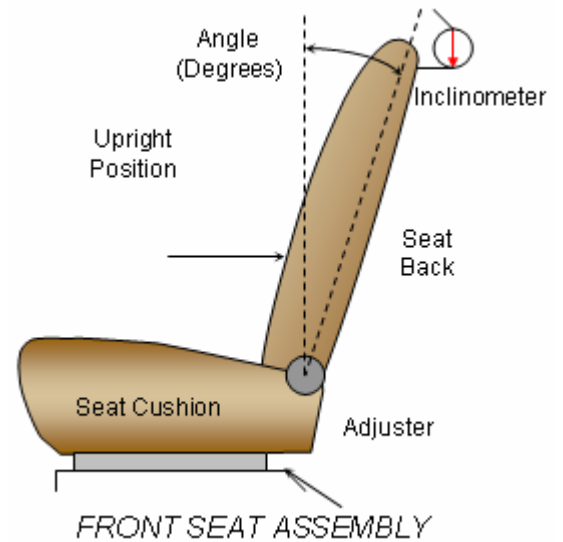

SEAT BACK ANGLES

	Deg.
Driver w/seated Dummy	8.0 @ Headrest
Passenger w/seated Dummy	8.0 @ Headrest

SEAT FORE/AFT POSITIONS

The total seat travel was measured from forward most position to rearmost position, irrespective of vertical seat height in those positions. The seat was set at the longitudinal mid position. There were vertical adjustments on the seats that were equipped with the vehicle. They were placed at the lowermost position.

SEAT FORE/AFT POSITIONING

	Total Fore/Aft Travel	Placed in Position
Driver Seat	24 Detents	13th Detent
Passenger Seat	24 Detents	13th Detent

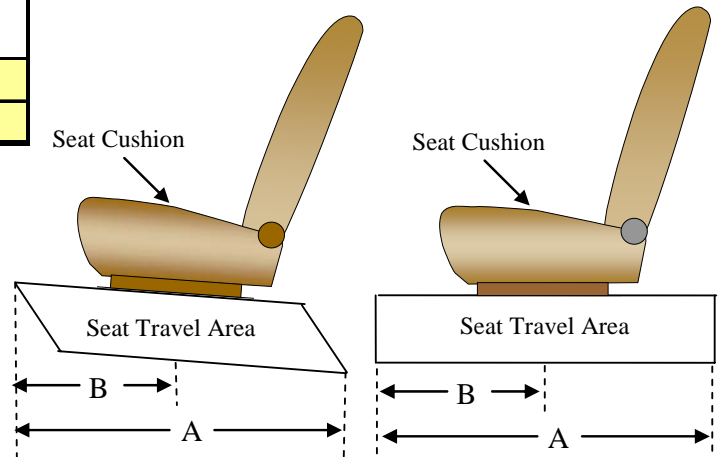

SEAT BELT UPPER ANCHORAGE

Position number one (1), the uppermost position.

SEAT BELT UPPER ANCHORAGE

	Total # of Positions	Placed in Position #
Driver Seat	4	1
Passenger Seat	4	1

DATA SHEET NO. 4...(CONTINUED)

TEST VEHICLE INFORMATION

Test Vehicle: 2008 Dodge Ram 1500 SXT 4-Door Truck

NHTSA No.: M80308

Test Program: NHTSA 35mph NCAP

Test Date: 11/8/07

FUEL TANK CAPACITY

	Liters
Usable Capacity of "Standard Tank"	98.41
Usable Capacity of "Optional" Tank	
Usable Capacity used for FMVSS 301	90.53 to 92.51
Actual Amount of Solvent used	91.52

The test vehicle is equipped with an electric fuel pump. The fuel pump operates for approximately two seconds after the ignition is placed in the "ON" position, after which the fuel pump automatically shuts off. The fuel filler door is located on the left rear fender. The standard fuel tank occupies the area under the rear seat.

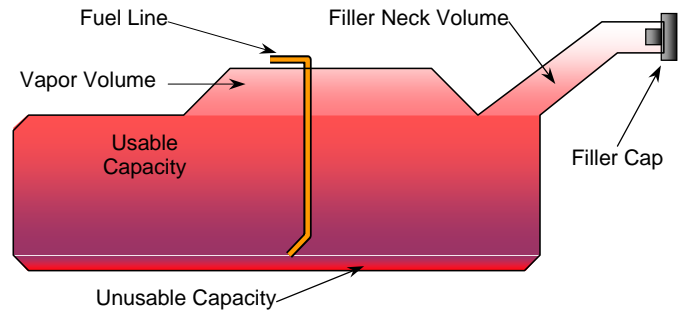

VEHICLE FUEL TANK ASSEMBLY

STEERING COLUMN ADJUSTMENT

Steering wheel and column adjustments are made so that the steering wheel hub is at the geometric center of the locus it describes when moved through its full range of motion. An aluminum plate is placed across the rim of the steering wheel, an inclinometer is placed on the plate and the angle is measured.

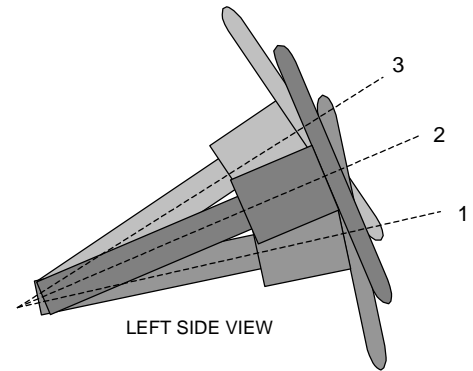

STEERING COLUMN ASSEMBLY

STEERING COLUMN POSITIONS

	Degrees	Fore/Aft Position (mm)
Lowermost position No. 1	14.0	
Geometric center position No. 2	22.8	
Uppermost position No. 3	31.5	

DATA SHEET NO. 5

DUMMY POSITIONING IN VEHICLE

Test Vehicle: 2008 Dodge Ram 1500 SXT 4-Door Truck

NHTSA No.: M80308

Test Program: NHTSA 35mph NCAP

Test Date: 11/8/07

TEST DUMMY POSITION MEASUREMENTS

Code	Measurement Description	Driver		Passenger	
		Length (mm)	Angle (deg)	Length (mm)	Angle (deg)
WA	Windshield Angle		29.4		
SWA	Steering Wheel Angle		67.2		
SCA	Steering Column Angle		22.8		
SA	Seat Back Angle		8.0 @ Headrest		8.0 @ Headrest
HZ	Head to Roof (Z)	244	90.0	251	90.0
HH	Head to Header	412		430	
HW	Head to Windshield	680		671	
HR	Head to Side Header (Y)	249		258	
NR	Nose to Rim	402	15.0		
CD	Chest to Dash	564		606	
CS	Chest to Steering Hub	348			
RA	Rim to Abdomen	201			
KDL	Left Knee to Dash	134	21.8	136	
KDR	Right Knee to Dash	108		144	21.5
PA	Pelvic Angle		23.8		21.1
TA	Tibia Angle		52.0		55.9
KK	Knee to Knee (Y)	311		294	
SK	Striker to Knee	645	7.8	625	7.1
ST	Striker to Head	650	86.3	610	82.5
SH	Striker to H-Point	310	13.6	310	8.7
SHY	Striker to H-Point (Y)	38		34	
HS	Head to Side Window	328		338	
HD	H-Point to Door (Y)	170		172	
AD	Arm to Door (Y)	126		144	

DATA SHEET NO. 5...(CONTINUED)

DUMMY POSITIONING IN VEHICLE

Test Vehicle: 2008 Dodge Ram 1500 SXT 4-Door Truck

NHTSA No.: M80308

Test Program: NHTSA 35mph NCAP

Test Date: 11/8/07

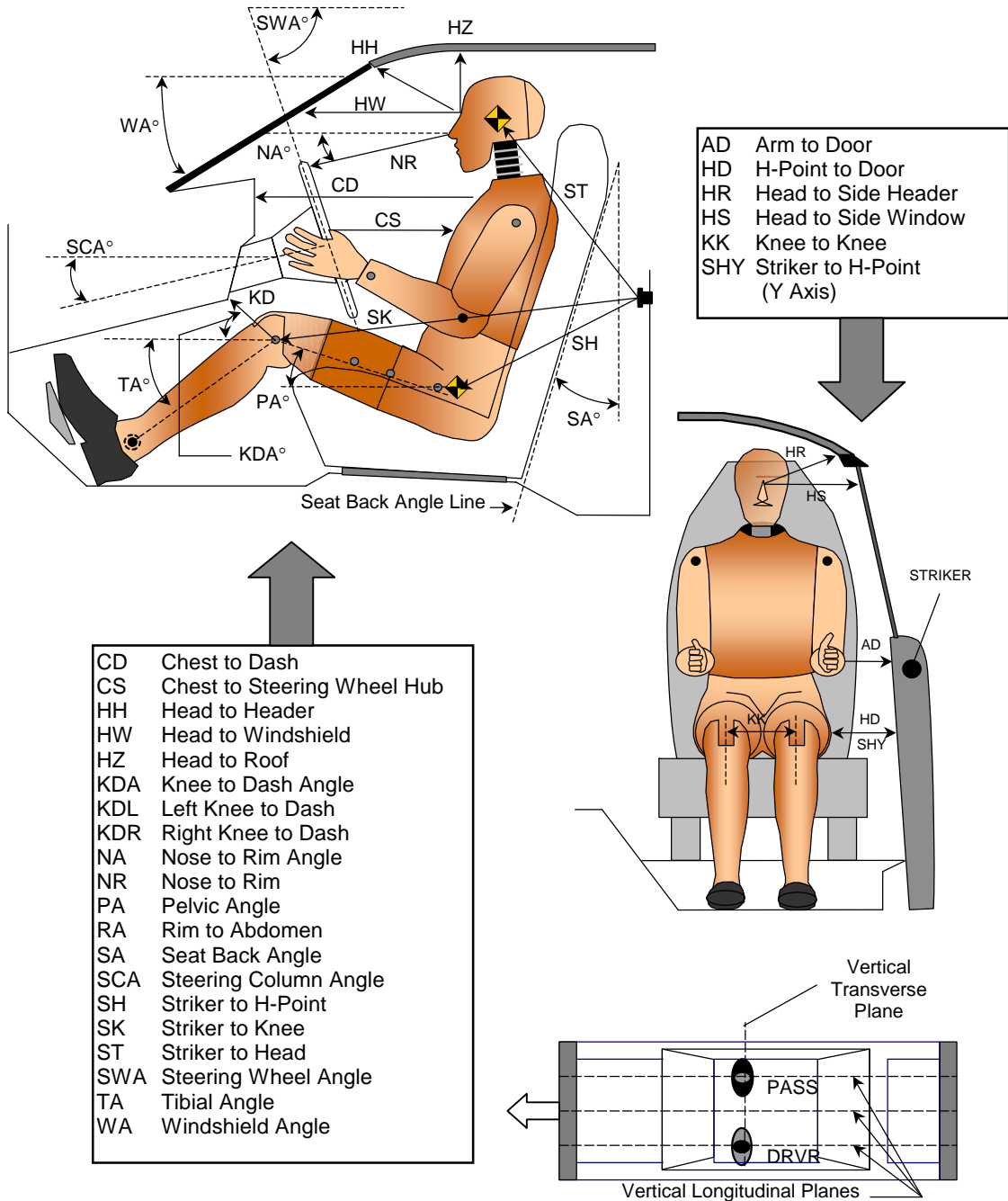

- CD Chest to Dash
- CS Chest to Steering Wheel Hub
- HH Head to Header
- HW Head to Windshield
- HZ Head to Roof
- KDA Knee to Dash Angle
- KDL Left Knee to Dash
- KDR Right Knee to Dash
- NA Nose to Rim Angle
- NR Nose to Rim
- PA Pelvic Angle
- RA Rim to Abdomen
- SA Seat Back Angle
- SCA Steering Column Angle
- SH Striker to H-Point
- SK Striker to Knee
- ST Striker to Head
- SWA Steering Wheel Angle
- TA Tibial Angle
- WA Windshield Angle

DUMMY MEASUREMENTS FOR FRONT SEAT OCCUPANTS

DATA SHEET NO. 6

SEAT BELT POSITIONING DATA

Test Vehicle: 2008 Dodge Ram 1500 SXT 4-Door Truck

NHTSA No.: M80308

Test Program: NHTSA 35mph NCAP

Test Date: 11/8/07

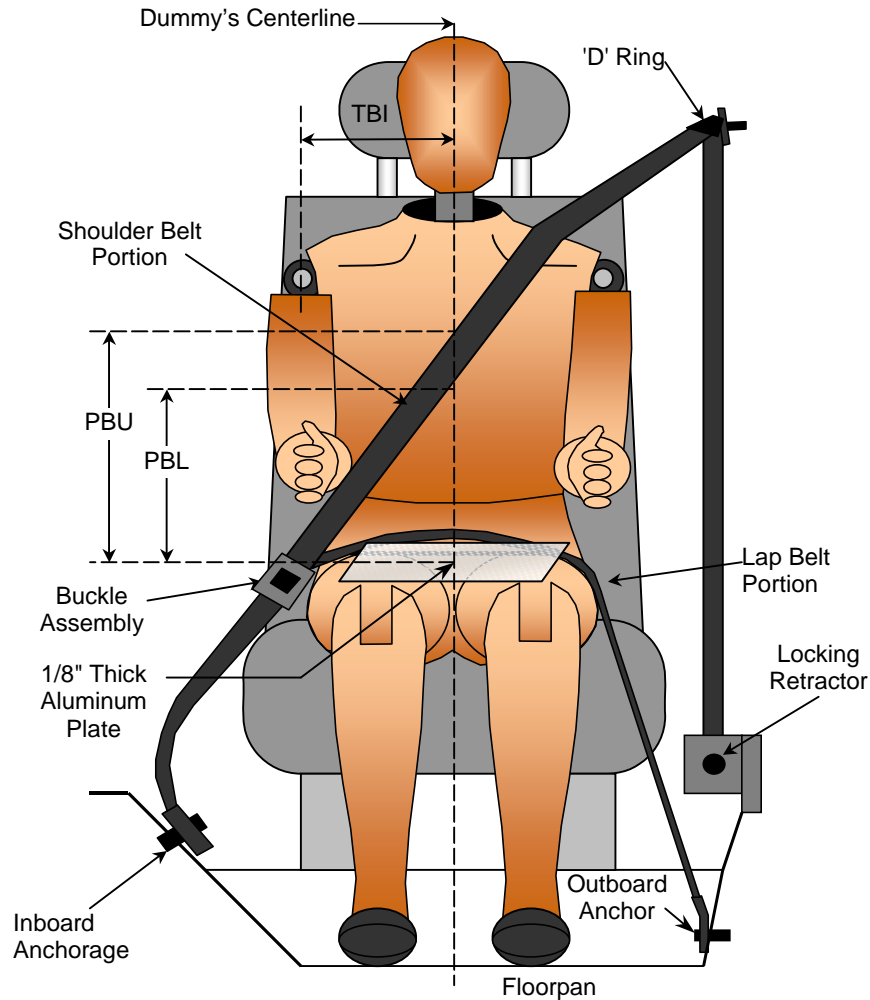

SEAT BELT POSITIONING MEASUREMENTS

Measured Parameter	Units	Driver	Passenger
TBI - Dummy C/L to Lap/Shoulder Belt Intersect	mm	213	190
PBU - Top Surface of reference to belt upper edge	mm	285	352
PBL - Top Surface of reference to belt lower edge	mm	203	266
Lap Belt Tension	Newtons	10	10
Shoulder Belt Tension	N/A	Retractor	Retractor

DATA SHEET NO. 7

VEHICLE ACCELEROMETER LOCATION

Test Vehicle: 2008 Dodge Ram 1500 SXT 4-Door Truck

NHTSA No.: M80308

Test Program: NHTSA 35mph NCAP

Test Date: 11/8/07

REPLACE

DATA SHEET NO. 8

SEAT BELT ASSESSMENT TEST DATA

Test Vehicle: 2008 Dodge Ram 1500 SXT 4-Door Truck

NHTSA No.: M80308

Test Program: NHTSA 35mph NCAP

Test Date: 11/8/07

SEAT BELT POSITIONING MEASUREMENTS

Measurement Description	Units	Driver	Passenger
Retractor Reel to "D" ring	mm	860	860
Shoulder Belt length as measured on ATD	mm	862	865
Lap Belt length as measured on ATD	mm	573	580
Remainder of belt on reel	mm	887	1113
Total belt length for continuous webbing systems	mm	3182	3418

SHOULDER BELT SPOOL-OFF DATA

Measurement Description	Units	Driver	Passenger
As determined mechanically	mm	235	250
As determined electronically	mm	*	289

*Channel Failed

BELT STRETCH DATA

Measurement Description	Units	Driver	Passenger
Electronically between belt load cell and "D" ring	mm/cm	*	*
Mechanically	mm/cm		

* Not used with shoulder belt pre-tensioner systems

DATA SHEET NO. 9

SUMMARY OF FMVSS 212 DATA

Test Vehicle: 2008 Dodge Ram 1500 SXT 4-Door Truck

NHTSA No.: M80308

Test Program: NHTSA 35mph NCAP

Test Date: 11/8/07

Windshield Mounting Details: Windshield glass is secured to the vehicle frame with a rubber type adhesive, and rubber molding.

The standard requires that the post-test retention measurement be a minimum of 75 percent of the pretest total periphery measurement for vehicles not equipped with occupant passive restraints and 50 percent for each side of the windshield for vehicles that are equipped with occupant passive restraints.

Temperature of windshield molding during test: 20.0 °C

WINDSHIELD PERIPHERY MEASUREMENTS

Measurement	Pre-Test(mm)	Post-Test(mm)	% of Retention
Left Side	2473	2473	100
Right Side	2473	2473	100
Total	4946	4946	100

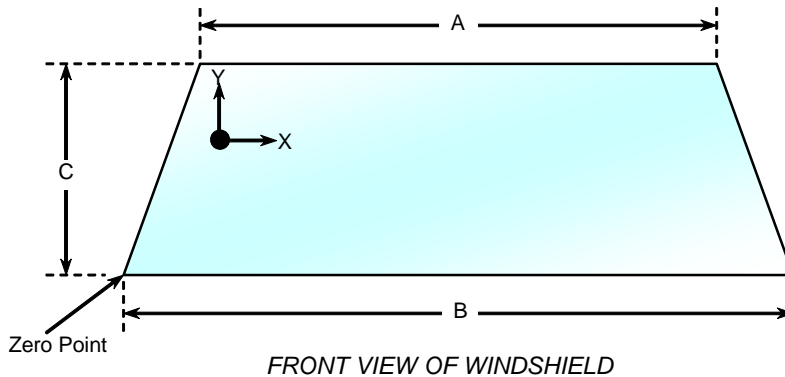

WINDSHIELD DIMENSIONS

Item	Units	Segment Length	Molding Width
A	mm	1385	0
B	mm	1720	150
C-Left	mm	920	16
C-Right	mm	920	16

DATA SHEET NO. 10

WINDSHIELD ZONE INTRUSION FMVSS 219 DATA (PARTIAL)

Test Vehicle: 2008 Dodge Ram 1500 SXT 4-Door Truck

NHTSA No.: M80308

Test Program: NHTSA 35mph NCAP

Test Date: 11/8/07

WINDSHIELD AND PROTECTED ZONE

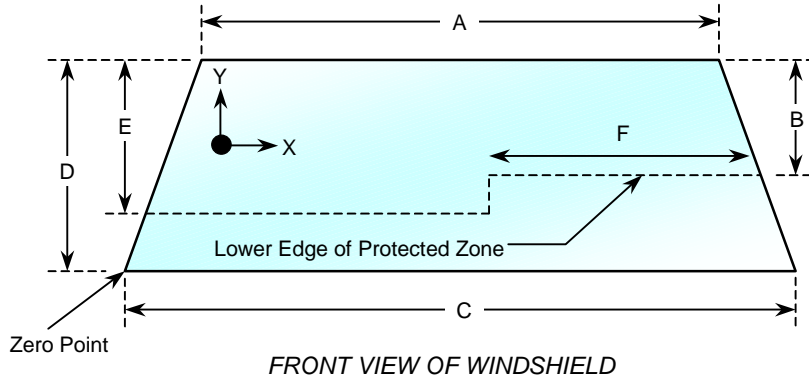

Item	Units	Value
A	mm	1385
B	mm	530
C	mm	1720
D	mm	920
E	mm	547
F	mm	397

AREA OF PROTECTED ZONE FAILURES

- A. Provide coordinates of the area that the protected zone was penetrated more than 0.25 in. by a vehicle component other than one that is normally in contact with the windshield.

X	Y

- B. Provide coordinates of the area beneath the protected zone that the inner surface of the windshield was penetrated by a vehicle component.

X	Y

DATA SHEET NO. 11

FMVSS 301 FUEL SYSTEM INTEGRITY POST-IMPACT DATA

Test Vehicle: 2008 Dodge Ram 1500 SXT 4-Door Truck NHTSA No.: M80308
Test Program: NHTSA 35mph NCAP Test Date: 11/8/07

Test Time: 12:08 PM

Temperature: 25.0 ° C

STODDARD SOLVENT SPILLAGE MEASUREMENTS

- A. From impact until vehicle motion ceases: 0.0 oz.
(Maximum Allowable = 1 ounce)
- B. For the 5 minute period after motion ceases: 0.0 oz.
(Maximum Allowable = 5 ounces)
- C. For the following 25 minutes: 0.0 oz.
(Maximum Allowable = 1 oz./minute)
- D. Spillage Location Details: No leakage occurred

DATA SHEET NO. 12

FMVSS 301 STATIC ROLLOVER DATA

Test Vehicle: 2008 Dodge Ram 1500 SXT 4-Door Truck

NHTSA No.: M80308

Test Program: NHTSA 35mph NCAP

Test Date: 11/8/07

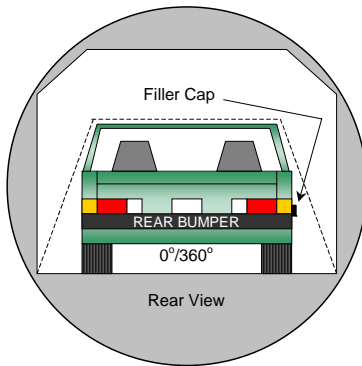

0° to 90°

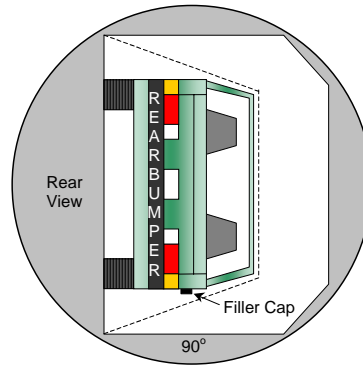

90° to 180°

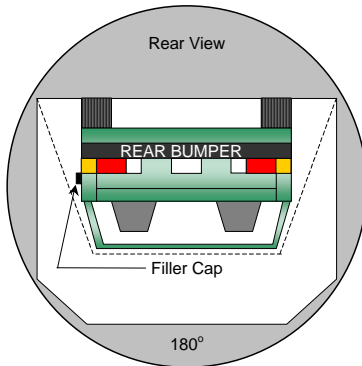
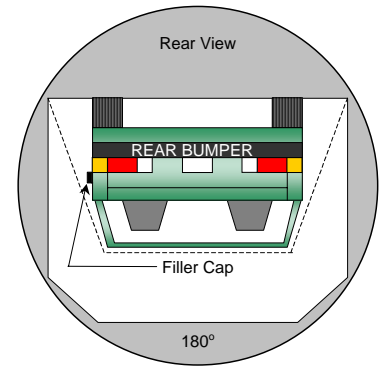

180° to 270°

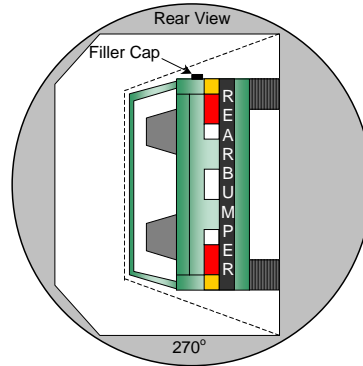

270° to 360°

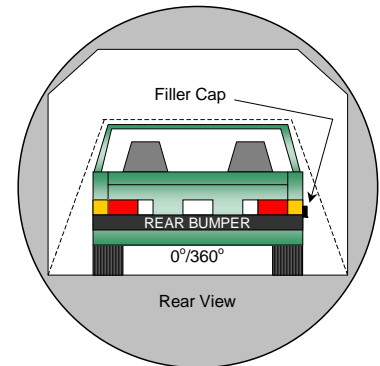

1. The specified fixture rollover rate for each 90° of rotation is 60 to 120 seconds.
2. The position hold time at each position is 300 seconds (minimum).
3. No solvent leakage occurred during rollover.

DATA SHEET NO. 12...(CONTINUED)

FMVSS 301 STATIC ROLLOVER DATA

Test Vehicle: 2008 Dodge Ram 1500 SXT 4-Door Truck

NHTSA No.: M80308

Test Program: NHTSA 35mph NCAP

Test Date: 11/8/07

SOLVENT COLLECTION TIME TABLE IN SECONDS

Test Phase	Rotation Time	Hold Time	Total Time
0° to 90°	85	303	388
90° to 180°	84	301	385
180° to 270°	77	311	388
270° to 360°	82	308	390

FMVSS 301 SPILLAGE TABLE REQUIREMENT (oz.)

First 5 Minutes	5.0
Sixth Minute	1.0
Seventh Minute	1.0
Eighth Minute	1.0

ACTUAL TEST VEHICLE SOLVENT SPILLAGE TABLE (oz.)

Test Phase	First 5 Minutes	Sixth Minute	Seventh Minute	Eighth Minute
0° to 90°	0	0	0	0
90° to 180°	0	0	0	0
180° to 270°	0	0	0	0
270° to 360°	0	0	0	0

SOLVENT SPILLAGE LOCATION TABLE

Test Phase	Spillage Location
0° to 90°	None
90° to 180°	None
180° to 270°	None
270° to 360°	None

DATA SHEET NO. 13

VEHICLE MEASUREMENTS

Test Vehicle: 2008 Dodge Ram 1500 SXT 4-Door Truck

NHTSA No.: M80308

Test Program: NHTSA 35mph NCAP

Test Date: 11/8/07

VEHICLE MEASUREMENT TABLE

No.	Measurement Description	Units	Pre-Test	Post-Test	Diff.
1	Total length of vehicle at centerline	mm	5785	5194	-591
2	RSOV to front of engine	mm	4985	4904	-81
3	RSOV to firewall centerline	mm	4631	4622	-9
4	RSOV to leading edge of right door	mm	4298	4324	26
5	RSOV to leading edge of left door	mm	4302	4335	33
6	RSOV to lower leading edge of right door	mm	4186	4214	28
7	RSOV to lower leading edge of left door	mm	4182	4218	36
8	RSOV to upper trailing edge of right door	mm	3107	3138	31
9	RSOV to upper trailing edge of left door	mm	3108	3152	44
10	RSOV to lower trailing edge of right door	mm	3087	3113	26
11	RSOV to lower trailing edge of left door	mm	3082	3120	38
12	RSOV to bottom of right 'A' pillar	mm	4111	4200	89
13	RSOV to bottom of left 'A' pillar	mm	4110	4152	42
14	RSOV to firewall on right side	mm	4605	4607	2
15	RSOV to firewall on left side	mm	4628	4643	15
16	RSOV to steering column	mm	3745	3860	115
17	Center of steering column to left 'A' pillar	mm	435	440	5
18	Center of steering column to headlining	mm	465	475	10
19	RSOV to right side of front bumper	mm	5543	5190	-353
20	RSOV to left side of front bumper	mm	5543	5194	-349
21	Length of engine block	mm	570	570	0
RD	RSOV to right side of dash panel	mm	4016	4051	35
CD	RSOV to center of dash panel	mm	3970	3990	20
LD	RSOV to left side of dash panel	mm	4018	4056	38

DATA SHEET NO. 13...(CONTINUED)

VEHICLE STRUCTURAL MEASUREMENTS

Test Vehicle: 2008 Dodge Ram 1500 SXT 4-Door Truck

NHTSA No.: M80308

Test Program: NHTSA 35mph NCAP

Test Date: 11/8/07

VEHICLE STRUCTURAL MEASUREMENT TABLE

No.	Measurement Description	Units	Pre-Test	Post-Test	Diff.
1	Total length	mm	5785	5194	-591
2	Total width	mm	2005	2023	18
3	Bumper top height	mm	798	840	42
4	Bumper bottom height	mm	280	335	55
5	Longitudinal member top height	mm	655	646	-9
6	Longitudinal member bottom height	mm	530	496	-34
7	Distance between longitudinal members	mm	910	960	50
8	Longitudinal member width	mm	125	126	1
9	Engine top height	mm	1015	1065	50
10	Engine bottom height	mm	347	389	42
11	Engine and gear box width	mm	680	680	0
12	Front bumper to engine distance	mm	800	285	-515
13	Front shock absorber fixing width	mm	785	830	45
14	Bonnet leading edge height	mm	1220	1335	115
15	Front shock absorber fixing width	mm	1030	1035	5
16	Front bumper to front axle distance	mm	985	1075	90
17	Front axle to 'A' pillar distance	mm	490	510	20
18	'A' pillar to 'B' pillar distance	mm	1174	1190	16
19	'B' pillar to rear axle distance	mm	1901	1917	16
20	'B' pillar to 'C' pillar distance	mm	845	850	5
21	Roof sill bottom height	mm	1730	1770	40
22	Roof sill top height	mm	1915	1897	-18
23	Floor sill bottom height	mm	370	370	0
24	Floor sill top height	mm	555	560	5

DATA SHEET NO. 13...(CONTINUED)

VEHICLE MEASUREMENTS

Test Vehicle: 2008 Dodge Ram 1500 SXT 4-Door Truck

NHTSA No.: M80308

Test Program: NHTSA 35mph NCAP

Test Date: 11/8/07

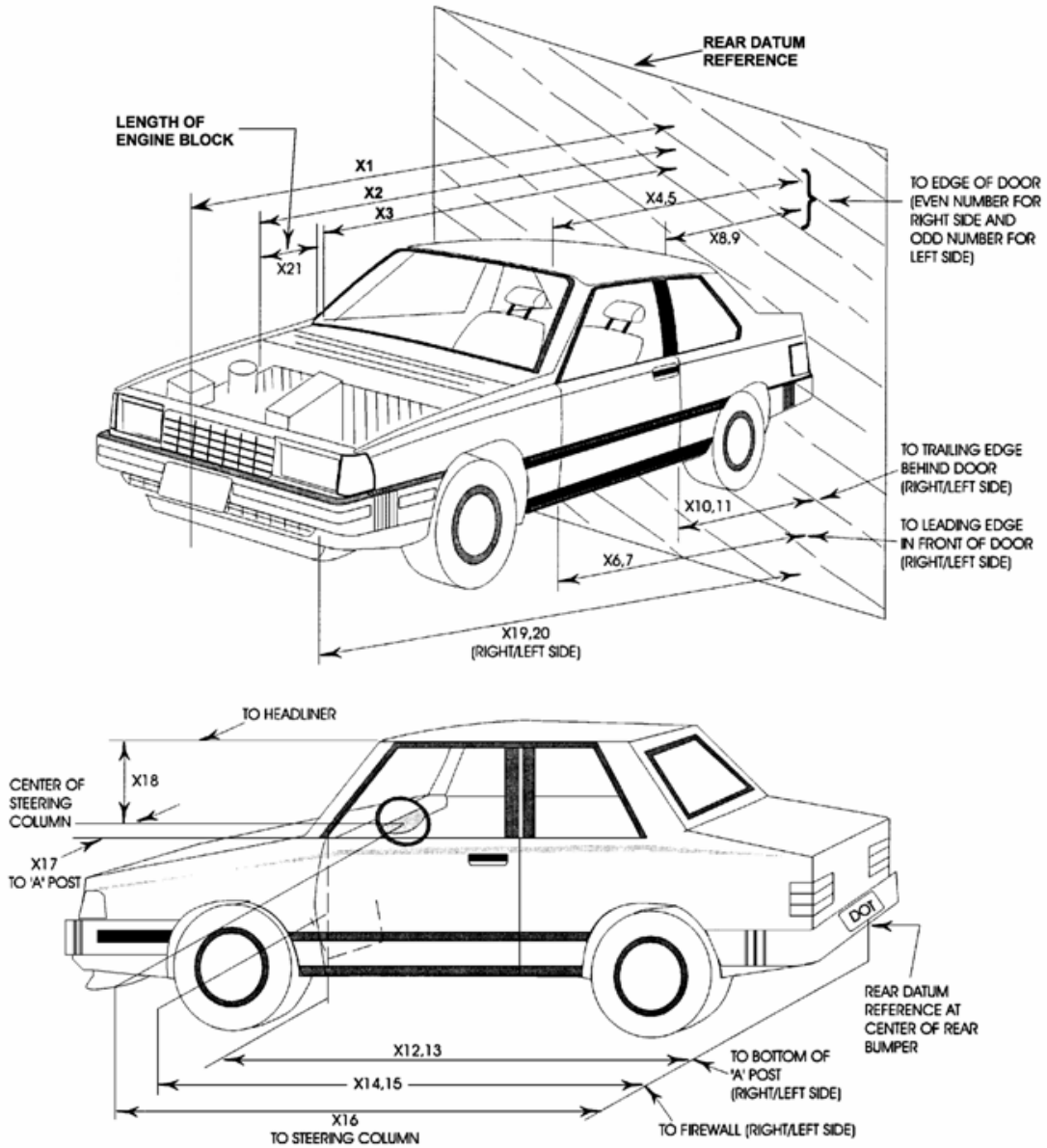

DATA SHEET NO. 14**CAMERA LOCATIONS**Test Vehicle: 2008 Dodge Ram 1500 SXT 4-Door TruckNHTSA No.: M80308Test Program: NHTSA 35mph NCAPTest Date: 11/8/07**VEHICLE CAMERA MEASUREMENT TABLE**

No.	Camera View	Location (mm)			Angle (deg.)	Film Plane to Head	Lens (mm)	Speed (fps)
		X	Y	Z				
1	Real Time Camera (Panning)	-11412	-8150	-1484	0			30
2	Overall Left Side	-3010	-8080	-1281	0	8842	20mm	1000
3	Closeup Left Side	-2160	-7409	-1293	0	8164	50mm	1000
4	Driver and Interior View	-6696	-5987	-1071	-17	8126	ZOOM	1000
5	Steering Column (Bottom)	-1972	-8184	-2879	-13	9477	35mm	1000
6	Steering Column (Top)	-1966	-8141	-3258	-13	9610	35mm	1000
7	Overall Right Side	-2607	8219	-1231	0	8245	20mm	1000
8	Closeup Right Side	-1589	7009	-1297	0	7134	50mm	1000
9	Passenger and Interior View	-5136	9516	-2460	-10	10306	ZOOM	1000
10	Right Side View	-1582	7995	-1713	-6	8201	ZOOM	1000
11	Windshield View	-354	0	-5749	-90		24mm	1000
12	Driver Front View	363	-543	-2548	-34		25mm	1000
13	Passenger Front View	381	445	-2548	-34		25mm	1000
14	Pit View of Engine	-756	0	1495	90		12mm	1000
15	Pit View of Fuel Tank	-3398	0	1495	90		8mm	1000
16	Real Time Driver	-1926	-8089	-1704	-1			30
17	Real Time Passenger	-1433	8047	-1704	-1			30

All measurements are made relative to the point of impact.

DATA SHEET NO. 15

PHOTOGRAPHIC REFERENCE TARGET LOCATIONS

Test Vehicle: 2008 Dodge Ram 1500 SXT 4-Door Truck

NHTSA No.: M80308

Test Program: NHTSA 35mph NCAP

Test Date: 11/8/07

All Dimensions in (mm)	
Item	Value
A	485
B	1002
C	2275
D	615
E	2910
F	155
G	1885
H	2358
I	1565
J	1235
K	1235
L	1755
M	2361
N	1755
O	1230
P	1230
Q	1565

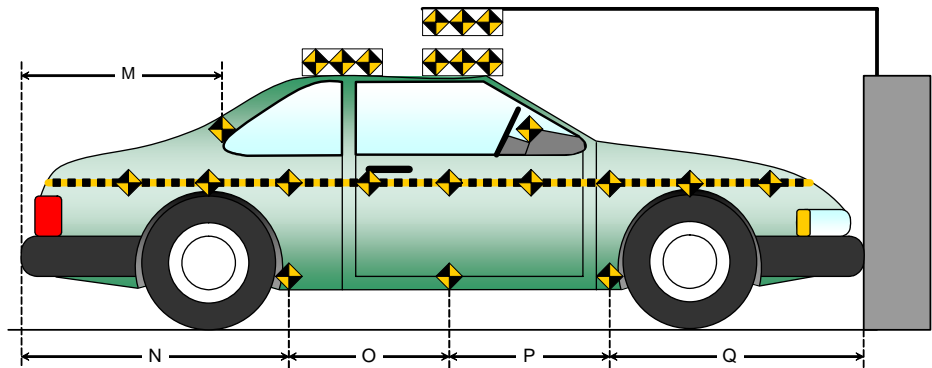
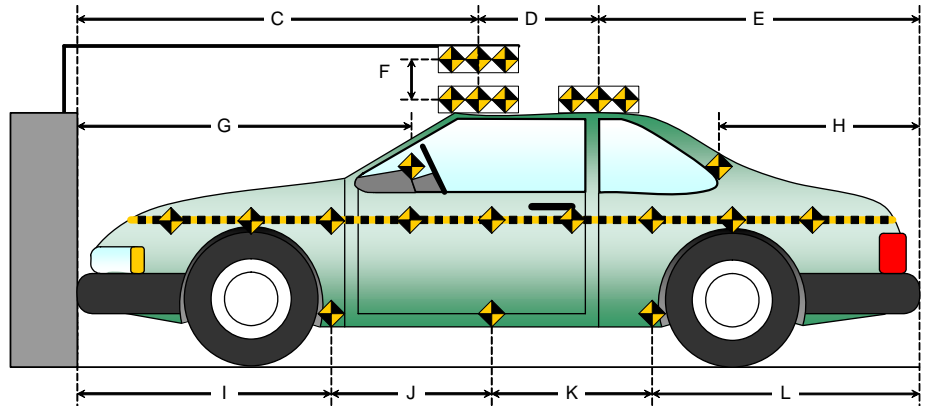
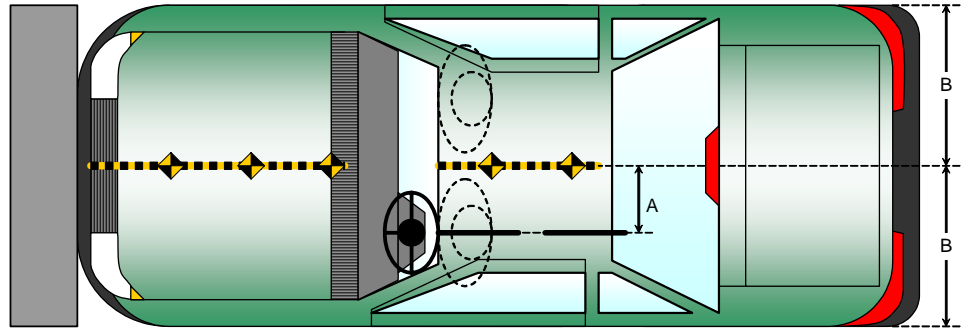

DATA SHEET NO. 16

VEHICLE INTRUSION MEASUREMENTS

Test Vehicle: 2008 Dodge Ram 1500 SXT 4-Door Truck

NHTSA No.: M80308

Test Program: NHTSA 35mph NCAP

Test Date: 11/8/07

DOOR OPENING WIDTH TABLE

Item	Description	Units	Pre-Test	Post-Test	Diff.
1L	Left Side	mm	999	999	0
2L	Left Side (Diagonally)	mm	1586	1586	0
3L	Left Side (Diagonally)	mm	1191	1191	0
1R	Right Side	mm	999	999	0
2R	Right Side (Diagonally)	mm	1581	1581	0
3R	Right Side (Diagonally)	mm	1181	1181	0

WHEELBASE MEASUREMENT TABLE

Item	Description	Units	Pre-Test	Post-Test	Diff.
C	Left Side Wheel Base	mm	3572	3513	-59
F	Right Side Wheel Base	mm	3572	3513	-59

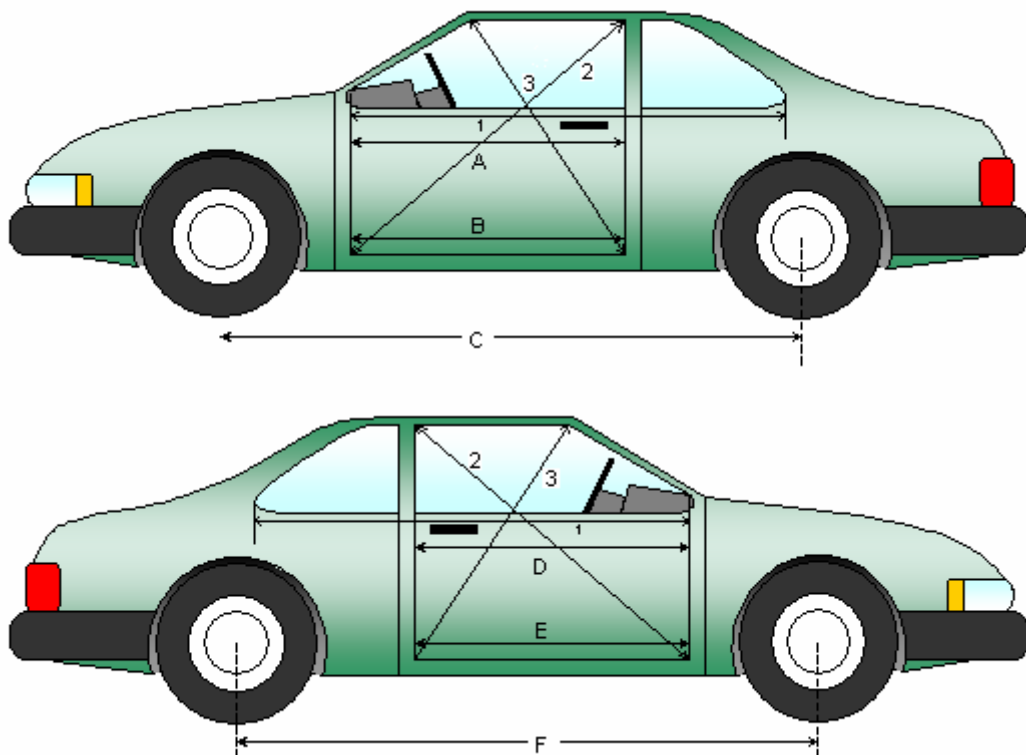

DATA SHEET NO. 16...(CONTINUED)

VEHICLE INTRUSION MEASUREMENTS

Test Vehicle: 2008 Dodge Ram 1500 SXT 4-Door Truck

NHTSA No.: M80308

Test Program: NHTSA 35mph NCAP

Test Date: 11/8/07

DRIVER COMPARTMENT INTRUSION TABLE

Item	Description	Units	Pre-Test	Post-Test	Diff.
AB	Door Opening (Inside window jam)	mm	999	999	0
CX	Left Knee Bolster to X	mm	255	280	25
DX	Right Knee Bolster to X	mm	195	260	65
EX	Brake Pedal to X	mm	480	470	-10
FX	Foot Rest to X	mm	595	560	-35
GX	Center of Steering Wheel Hub to X	mm	95	170	75

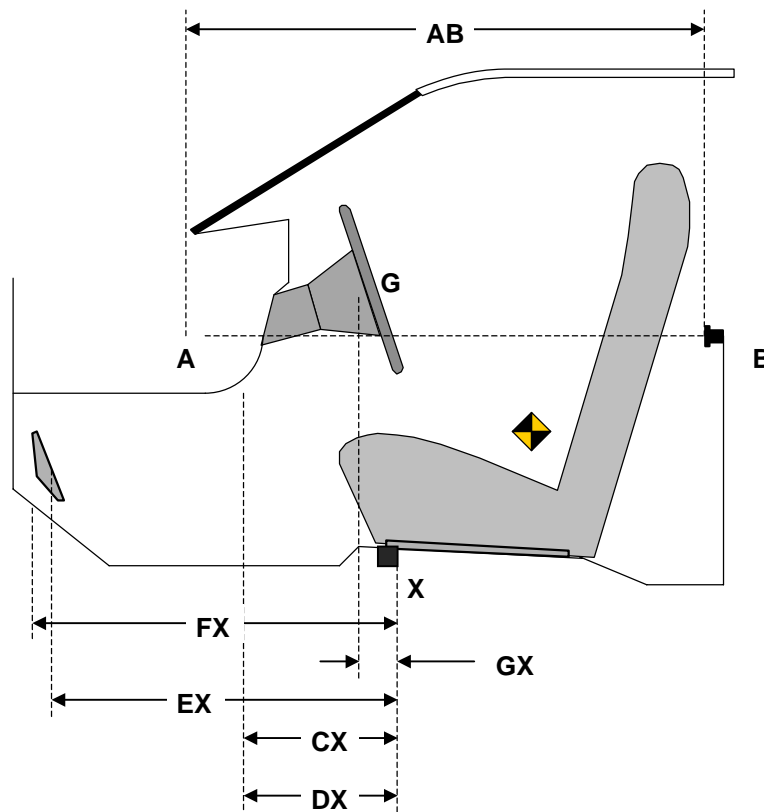

DATA SHEET NO. 16...(CONTINUED)
VEHICLE INTRUSION MEASUREMENTS

Test Vehicle: 2008 Dodge Ram 1500 SXT 4-Door Truck

NHTSA No.: M80308

Test Program: NHTSA 35mph NCAP

Test Date: 11/8/07

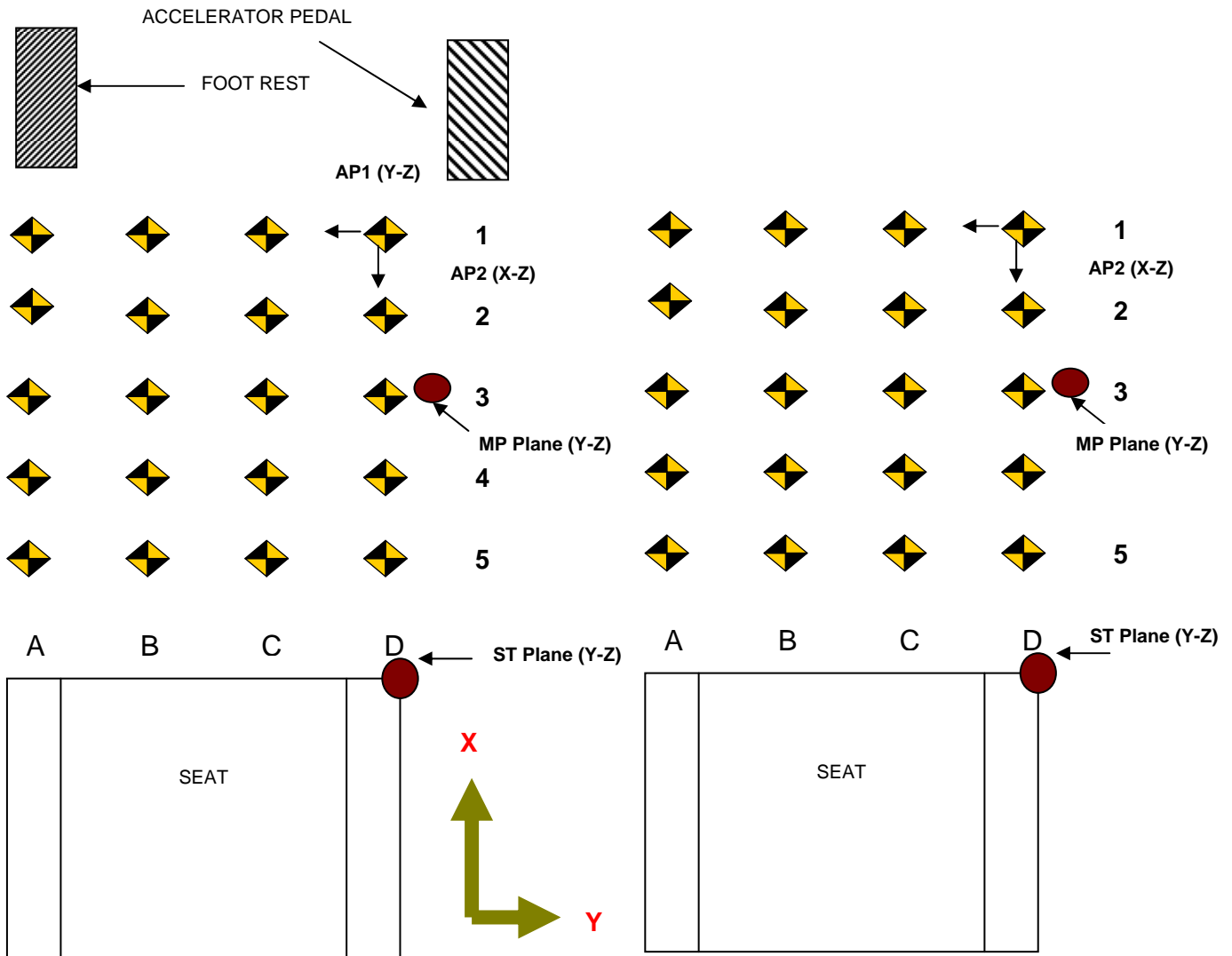

- AP1: Y-Z Plane passing through D1
- AP2: X-Z Plane passing through D1
- AP3: X-Y plane passing through D1
- MP: Y-Z plane, halfway between the ST plane and AP1 plane
- CF Plane: X-Z plane passes through center of footrest.
- BP Plane: X-Z plane passes through center of brake pedal
- TP Plane: Y-Z plane, intersection of BP Plane and the intersection of the toe pan and floorboard
- Column A: intersection of vehicle and CF plane
- Column D: Intersection of vehicle and AP2 plane
- Row 1: intersection of the vehicle and the AP3 Plane
- Row 3: intersection of the vehicle and TP plane
- Row 5: intersection of the vehicle and MP plane
- Row 2: evenly spaced between row 1 and 3
- Row 4: evenly spaced between row 3 and 5

DATA SHEET NO. 16...(CONTINUED)
VEHICLE INTRUSION MEASUREMENTS

Test Vehicle: 2008 Dodge Ram 1500 SXT 4-Door Truck

NHTSA No.: M80308

Test Program: NHTSA 35mph NCAP

Test Date: 11/8/07

All measurements in mm

DRIVER FLOOR PAN X-AXIS

	Pre-Test				Post-Test				Difference			
	A	B	C	D	A	B	C	D	A	B	C	D
1	621	620	619	615	617	615	610	598	-4	-5	-9	-17
2	538	535	535	534	537	534	532	527	-1	-1	-3	-7
3	443	442	440	441	441	439	443	442	-2	-3	3	1
4	311	314	316	316	309	313	314	316	-2	-1	-2	0
5	183	183	185	188	182	183	184	188	-1	0	-1	0

DRIVER FLOOR PAN Y-AXIS

	Pre-Test				Post-Test				Difference			
	A	B	C	D	A	B	C	D	A	B	C	D
1	-43	66	176	313	-47	62	170	308	-4	-4	-6	-5
2	-44	65	177	315	-47	61	171	308	-3	-4	-6	-7
3	-41	67	177	315	-46	62	170	308	-5	-5	-7	-7
4	-42	67	178	312	-47	62	173	306	-5	-5	-5	-6
5	-40	68	181	310	-45	64	175	308	-5	-4	-6	-2

DRIVER FLOOR PAN Z-AXIS

	Pre-Test				Post-Test				Difference			
	A	B	C	D	A	B	C	D	A	B	C	D
1	-4	-3	-6	-11	-12	-7	-13	-24	-8	-4	-7	-13
2	40	39	37	33	38	38	34	29	-2	-1	-3	-4
3	83	80	78	74	76	77	79	79	-7	-3	1	5
4	86	83	81	79	81	83	84	84	-5	0	3	5
5	85	81	80	75	80	81	85	83	-5	0	5	8

DATA SHEET NO. 16...(CONTINUED)

VEHICLE INTRUSION MEASUREMENTS

Test Vehicle: 2008 Dodge Ram 1500 SXT 4-Door Truck

NHTSA No.: M80308

Test Program: NHTSA 35mph NCAP

Test Date: 11/8/07

All measurements in mm

PASSENGER FLOOR PAN X-AXIS

	Pre-Test				Post-Test				Difference			
	A	B	C	D	A	B	C	D	A	B	C	D
1	581	631	630	624	542	599	611	617	-39	-32	-19	-7
2	503	554	552	550	465	529	543	547	-38	-25	-9	-3
3	421	448	453	454	388	430	443	449	-33	-18	-10	-5
4	312	319	323	326	289	303	313	321	-23	-16	-10	-5
5	187	187	194	197	165	172	185	193	-22	-15	-9	-4

PASSENGER FLOOR PAN Y-AXIS

	Pre-Test				Post-Test				Difference			
	A	B	C	D	A	B	C	D	A	B	C	D
1	-289	-185	-62	45	-314	-220	-97	11	-25	-35	-35	-34
2	-294	-177	-59	50	-314	-207	-90	19	-20	-30	-31	-31
3	-304	-177	-57	54	-323	-200	-80	28	-19	-23	-23	-26
4	-310	-175	-56	52	-326	-190	-71	35	-16	-15	-15	-17
5	-301	-165	-55	52	-311	-173	-64	43	-10	-8	-9	-9

PASSENGER FLOOR PAN Z-AXIS

	Pre-Test				Post-Test				Difference			
	A	B	C	D	A	B	C	D	A	B	C	D
1	-110	-11	-9	-9	-135	-32	-24	-25	-25	-21	-15	-16
2	-60	34	34	33	-82	14	25	25	-22	-20	-9	-8
3	1	82	80	82	-16	71	71	72	-17	-11	-9	-10
4	88	88	87	89	83	84	81	81	-5	-4	-6	-8
5	85	84	81	84	86	83	78	78	1	-1	-3	-6

DATA SHEET NO. 17

FIXED BARRIER LOAD CELL LOCATIONS

Test Vehicle: 2008 Dodge Ram 1500 SXT 4-Door Truck

NHTSA No.: M80308

Test Program: NHTSA 35mph NCAP

Test Date: 11/8/07

**36 Load Cell Rigid Barrier (NHTSA Standard)
Load Cell Locations on Fixed Barrier**

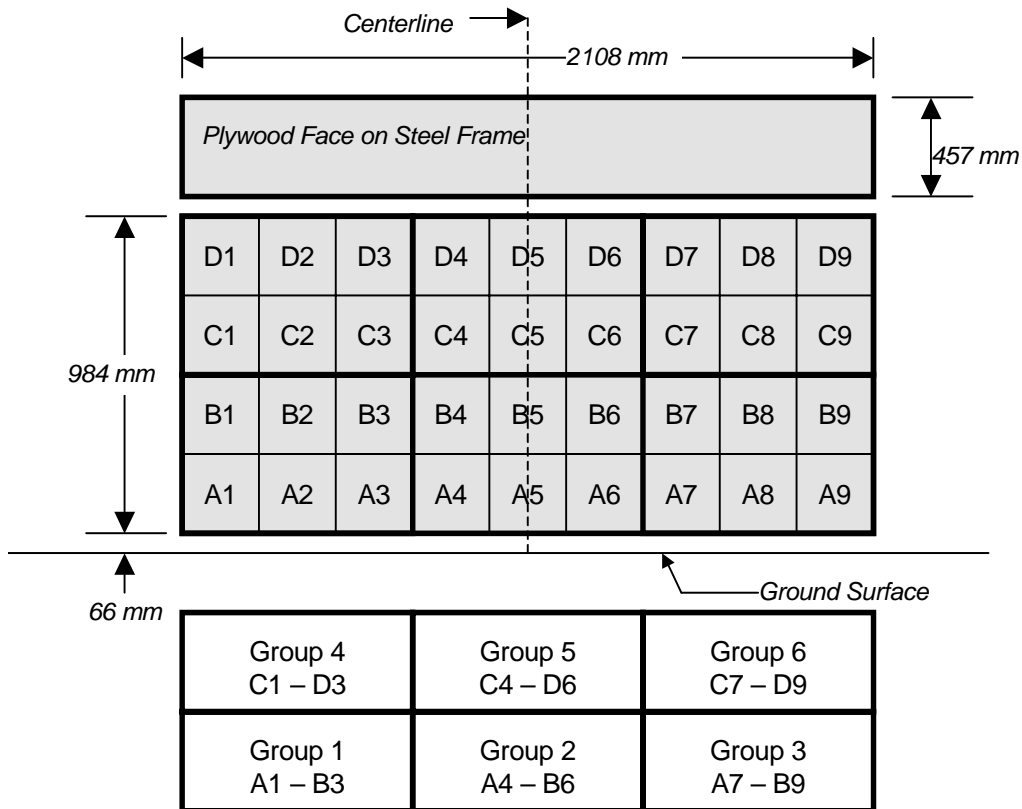

6 Groups of 6 Load Cells Each

DATA SHEET NO. 18

ACCIDENT INVESTIGATION DIVISION DATA

Test Vehicle: 2008 Dodge Ram 1500 SXT 4-Door Truck

NHTSA No.: M80308

Test Program: NHTSA 35mph NCAP

Test Date: 11/8/07

VEHICLE INFORMATION

VIN: 1D7HU18298J121656

Wheel base (mm): 3572

Vehicle Size Category: 4-Door Truck

Test Weight (kg): 2700

ACCELEROMETER DATA

Accelerometer Location: Left rear cross member

Cal. Procedure/Interval: 6 months / drop test

Integration Algorithm: NHTSA Standard

Linearity: Good

Impact Velocity (km/h): 56.30

Velocity Change (km/h): 63.4

Time of Separation (msec): 73.7

CRUSH PROFILE

Collision Deformation Classification: 12FDEW6

Midpoint of Damage: Vehicle Centerline

Damage Region Length (mm): 1728

Impact Mode: Full Frontal

No.	Measurement Description	Units	Pre-Test	Post-Test	Difference
C1	Crush zone 1 at left side	mm	242	591	-349
C2	Crush zone 2 on left side	mm	75	565	-490
C3	Crush zone 3 on left side	mm	20	586	-566
C4	Crush zone 4 on right side	mm	20	596	-576
C5	Crush zone 5 on right side	mm	75	582	-507
C6	Crush zone 6 at right side	mm	242	594	-352

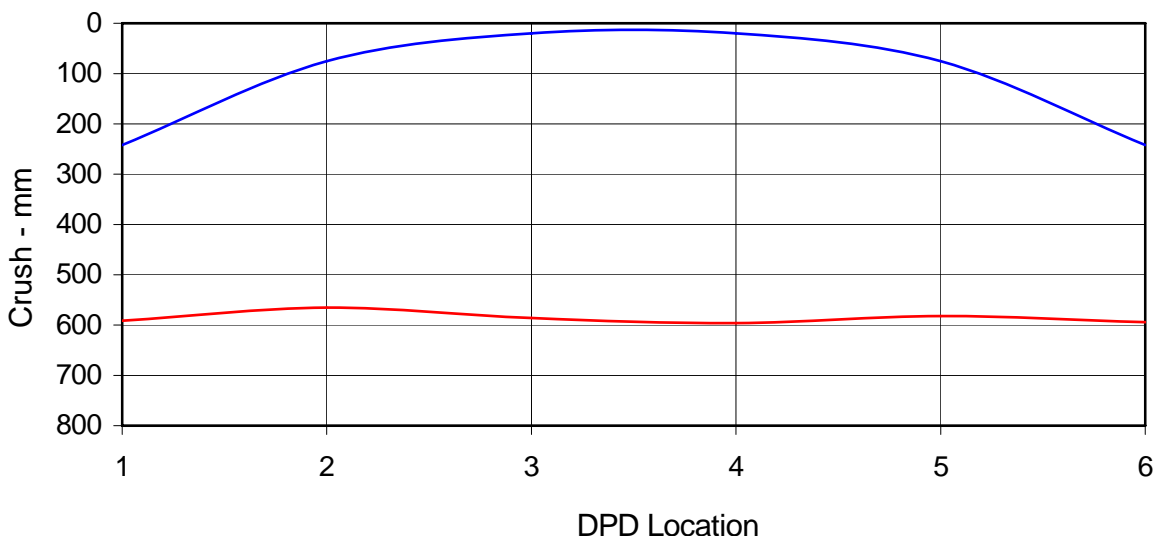

DATA SHEET NO. 19

DUMMY/VEHICLE TEMPERATURE STABILIZATION

Test Vehicle: 2008 Dodge Ram 1500 SXT 4-Door Truck

NHTSA No.: M80308

Test Program: NHTSA 35mph NCAP

Test Date: 11/8/07

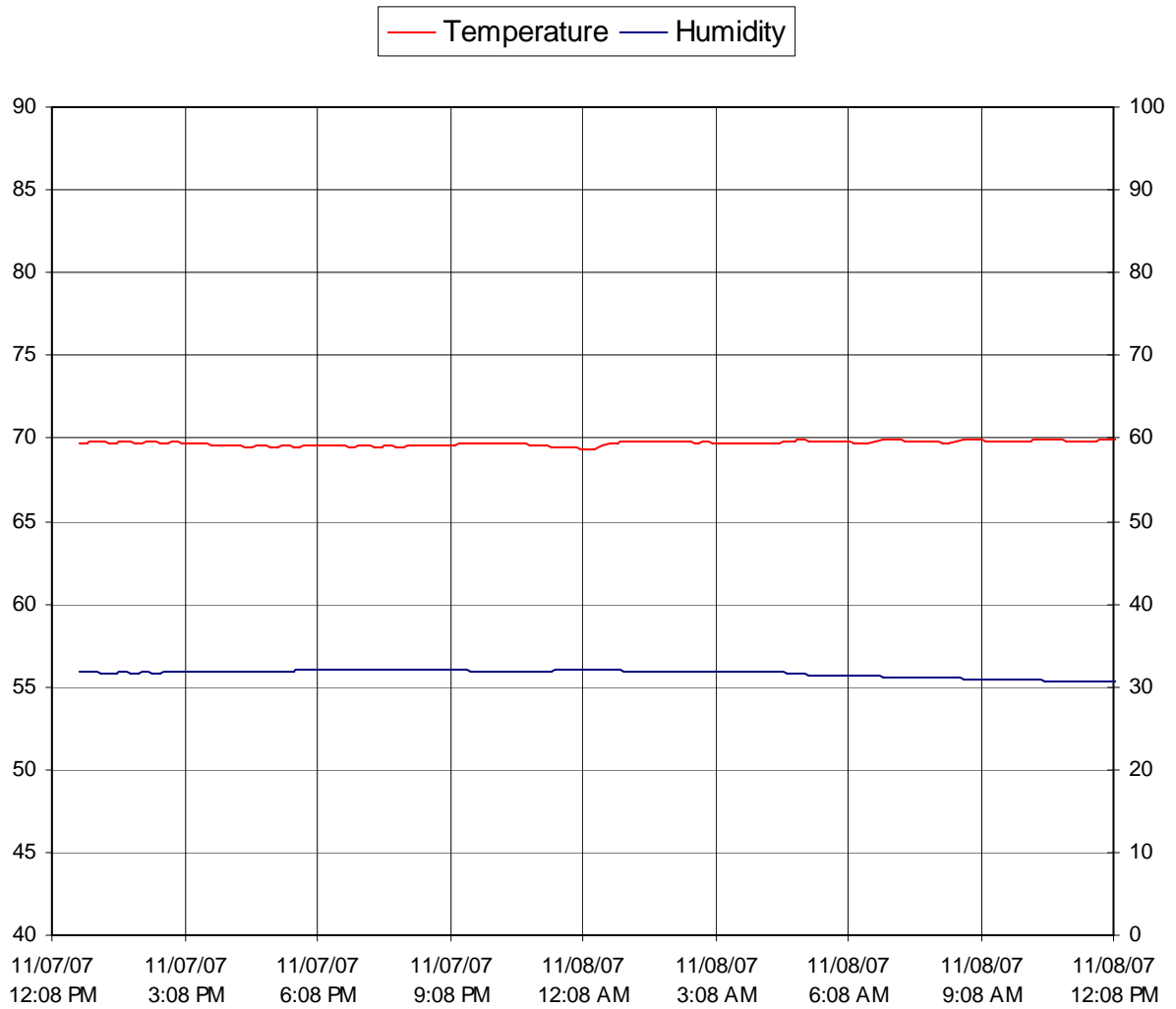

APPENDIX A
PHOTOGRAPHS

LIST OF PHOTOGRAPHS

Figure		Page
A-1	Load Cell Location	A-1
A-2	Manufacturer's Label	A-2
A-3	Tire Placard	A-3
A-4	Right Front $\frac{3}{4}$ View, As Received	A-4
A-5	Left Rear $\frac{3}{4}$ View, As Received	A-5
A-6	Pre-Test Front View	A-6
A-7	Post-Test Front View	A-7
A-8	Pre-Test Left Side View	A-8
A-9	Post-Test Left Side View	A-9
A-10	Pre-Test Right Side View	A-10
A-11	Post-Test Right Side View	A-11
A-12	Pre-Test Right Front $\frac{3}{4}$ View	A-12
A-13	Post-Test Right Front $\frac{3}{4}$ View	A-13
A-14	Pre-Test Left Rear $\frac{3}{4}$ View	A-14
A-15	Post-Test Left Rear $\frac{3}{4}$ View	A-15
A-16	Post-Test Left Side $\frac{3}{4}$ View of Doors After Impact	A-16
A-17	Post-Test Right Side $\frac{3}{4}$ View of Doors After Impact	A-17
A-18	Pre-Test Windshield	A-18
A-19	Post-Test Windshield	A-19
A-20	Pre-Test Engine Compartment	A-20
A-21	Post-Test Engine Compartment (Vehicle Moved)	A-21
A-22	Pre-Test Fuel Cap	A-22
A-23	Post-Test Fuel Cap	A-23
A-24	Pre-Test Front Underbody	A-24
A-25	Post-Test Front Underbody	A-25
A-26	Pre-Test Mid Underbody	A-26
A-27	Post-Test Mid Underbody	A-27
A-28	Pre-Test Rear Underbody	A-28
A-29	Post-Test Rear Underbody	A-29
A-30	Pre-Test Driver Dummy Front View (Head Position)	A-30
A-31	Post-Test Driver Dummy Front View (Head Position)	A-31
A-32	Pre-Test Driver Dummy (Through Window)	A-32
A-33	Post-Test Driver Dummy (Through Window)	A-33
A-34	Pre-Test Driver Dummy (Door Open)	A-34
A-35	Post-Test Driver Dummy (Door Open)	A-35

LIST OF PHOTOGRAPHS...(CONTINUED)

Figure		Page
A-36	Pre-Test Driver Dummy Feet	A-36
A-37	Post-Test Driver Dummy Feet	A-37
A-38	Pre-Test Driver Side Knee Bolster	A-38
A-39	Post-Test Driver Side Knee Bolster	A-39
A-40	Pre-Test Driver Side Floor Pan	A-40
A-41	Post-Test Driver Side Floor Pan	A-41
A-42	Post-Test Driver Dummy Head	A-42
A-43	Post-Test Driver Dummy Airbag Contact	A-43
A-44	Pre-Test Passenger Dummy Front View (Head Position)	A-44
A-45	Post-Test Passenger Dummy Front View (Head Position)	A-45
A-46	Pre-Test Passenger Dummy Front (Through Window)	A-46
A-47	Post-Test Passenger Dummy Front (Through Window)	A-47
A-48	Pre-Test Passenger Dummy (Door Open)	A-48
A-49	Post-Test Passenger Dummy (Door Open)	A-49
A-50	Pre-Test Passenger Dummy Feet	A-50
A-51	Post-Test Passenger Dummy Feet	A-51
A-52	Pre-Test Passenger Side Glove Box	A-52
A-53	Post-Test Passenger Side Glove Box	A-53
A-54	Pre-Test Passenger Side Floor Pan	A-54
A-55	Post-Test Passenger Side Floor Pan	A-55
A-56	Post-Test Passenger Dummy Head	A-56
A-57	Post-Test Passenger Dummy Airbag Contact	A-57
A-58	Vehicle on Rollover Device (0°)	A-58
A-59	Vehicle on Rollover Device (90°)	A-59
A-60	Vehicle on Rollover Device (180°)	A-60
A-61	Vehicle on Rollover Device (270°)	A-61
A-62	Vehicle Impact	A-62

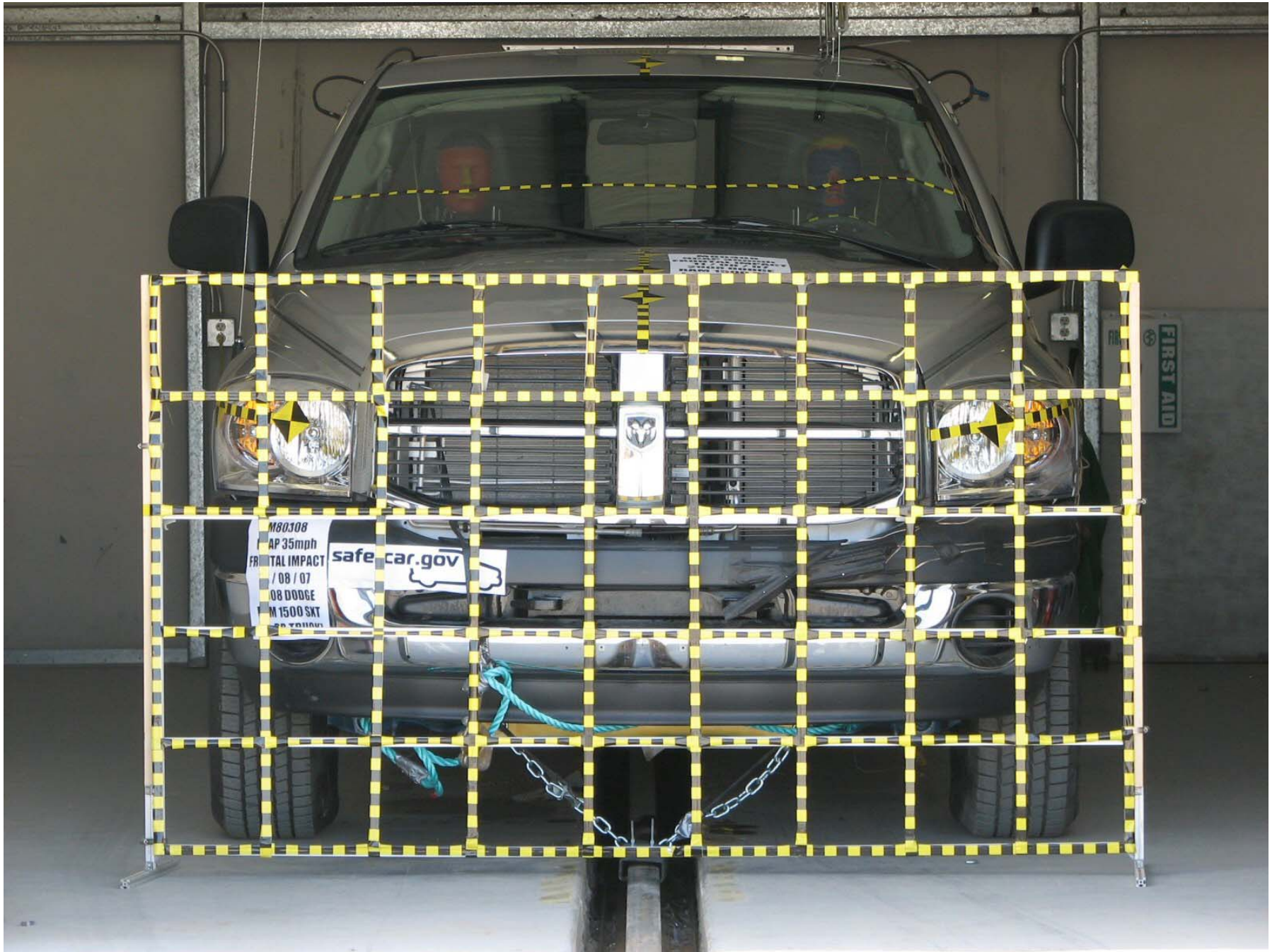

Figure A-1: Load Cell Location

This Space Intentionally Left Blank

MFD BY **CHRYSLER LLC**

DATE OF MFR
8-07

GVWR
3040 KG(06700 LB)

GVWR FRONT	WITH TIRES	RIMS AT	COLD
1770 KG(3900 LB)	P265/70R17	17X8.0	240 KPA(35 PSI)
GVWR REAR	WITH TIRES	RIMS AT	COLD
1770 KG(3900 LB)	P265/70R17	17X8.0	240 KPA(35 PSI)

THIS VEHICLE CONFORMS TO ALL APPLICABLE U.S.A. FEDERAL MOTOR VEHICLE SAFETY AND THEFT PREVENTION STANDARDS IN EFFECT ON THE DATE OF MANUFACTURE SHOWN ABOVE.

VIN: 1D7HU18298J121656 TYPE: TRUCK SINGLE X DUAL



MDH: 082718 843AA PNT:PS2 VEHICLE MADE IN U.S.A. TRM:P9D5 4648503

Figure A-2: Manufacturer's Label



TIRE AND LOADING INFORMATION

SEATING CAPACITY – TOTAL **6** FRONT **3** REAR **3**

THE COMBINED WEIGHT OF OCCUPANTS AND CARGO SHOULD NEVER EXCEED
578 KG OR 1275 LB

TIRE	FRONT	REAR	SPARE
ORIGINAL TIRE SIZE	P265/70R17	P265/70R17	P265/70R17
COLD TIRE INFLATION PRESSURE	240 kPa, 35 PSI	240 kPa, 35 PSI	240 kPa, 35 PSI

SEE OWNERS MANUAL FOR ADDITIONAL INFORMATION



8J121656

Figure A-3: Tire Placard



Figure A-4: Right Front $\frac{3}{4}$ View, As Received



Figure A-5: Left Rear $\frac{3}{4}$ View, as Received



Figure A-6: Pre-Test Front View



Figure A-7: Post-Test Front View (Vehicle Moved)



Figure A-8: Pre-Test Left Side View



Figure A-9: Post-Test Left Side View



Figure A-10: Pre-Test Right Side View



Figure A-11: Post-Test Right Side View



Figure A-12: Pre-Test Right Front 3/4 View



Figure A-13: Post-Test Right Front ¾ View (Vehicle Moved)



Figure A-15: Post-Test Left Rear ¾ View



Figure A-16: Post-Test Left Side 3/4 View of Doors After Impact



Figure A-17: Post-Test Right Side $\frac{3}{4}$ View of Doors After Impact

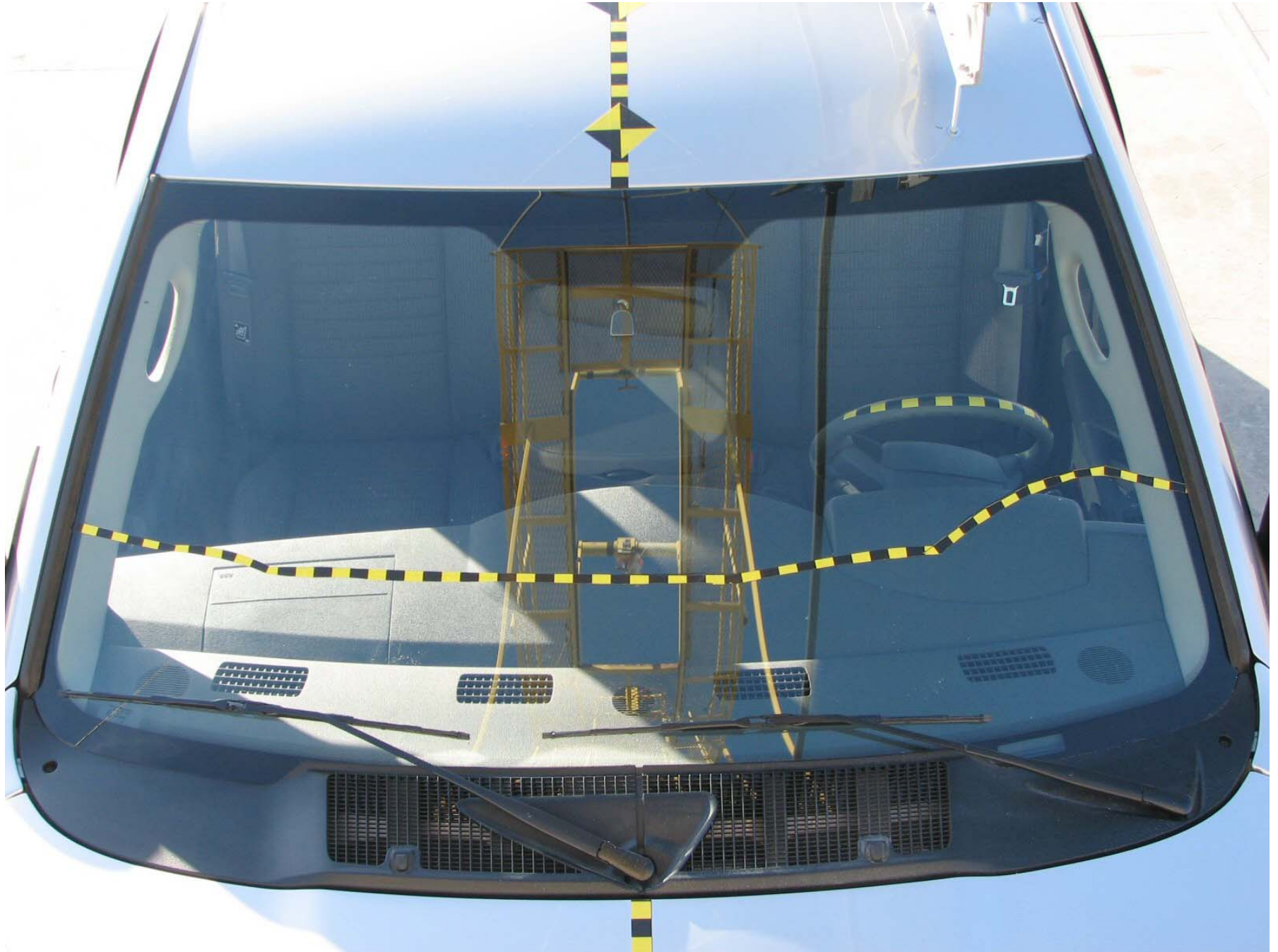

Figure A-18: Pre-Test Windshield



Figure A-19: Post-Test Windshield



Figure A-20: Pre-Test Engine Compartment

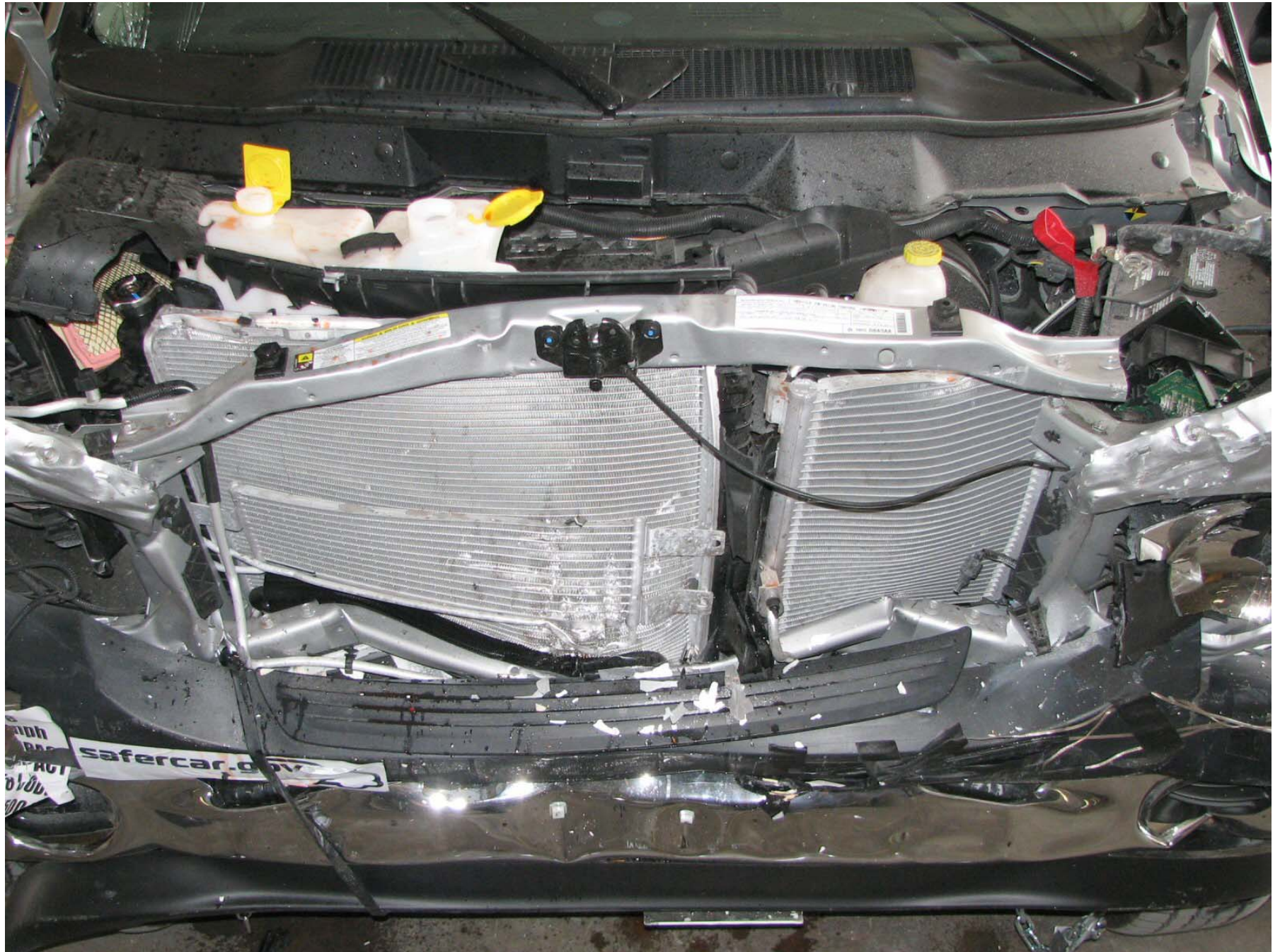

Figure A-21: Post-Test Engine Compartment (Vehicle Moved)



2008 Dodge Ram
1500 SXT
M80308
STODDARD SOLVENT ADDED
24.18 GALLONS
(91.52 LITERS)

Figure A-22: Pre-Test Fuel Cap



**2008 Dodge Ram
1500 SXT
M80308
STODDARD SOLVENT ADDED
24.18 GALLONS
(91.52 LITERS)**

Figure A-23: Post-Test Fuel Cap



Figure A-24: Pre-Test Front Underbody

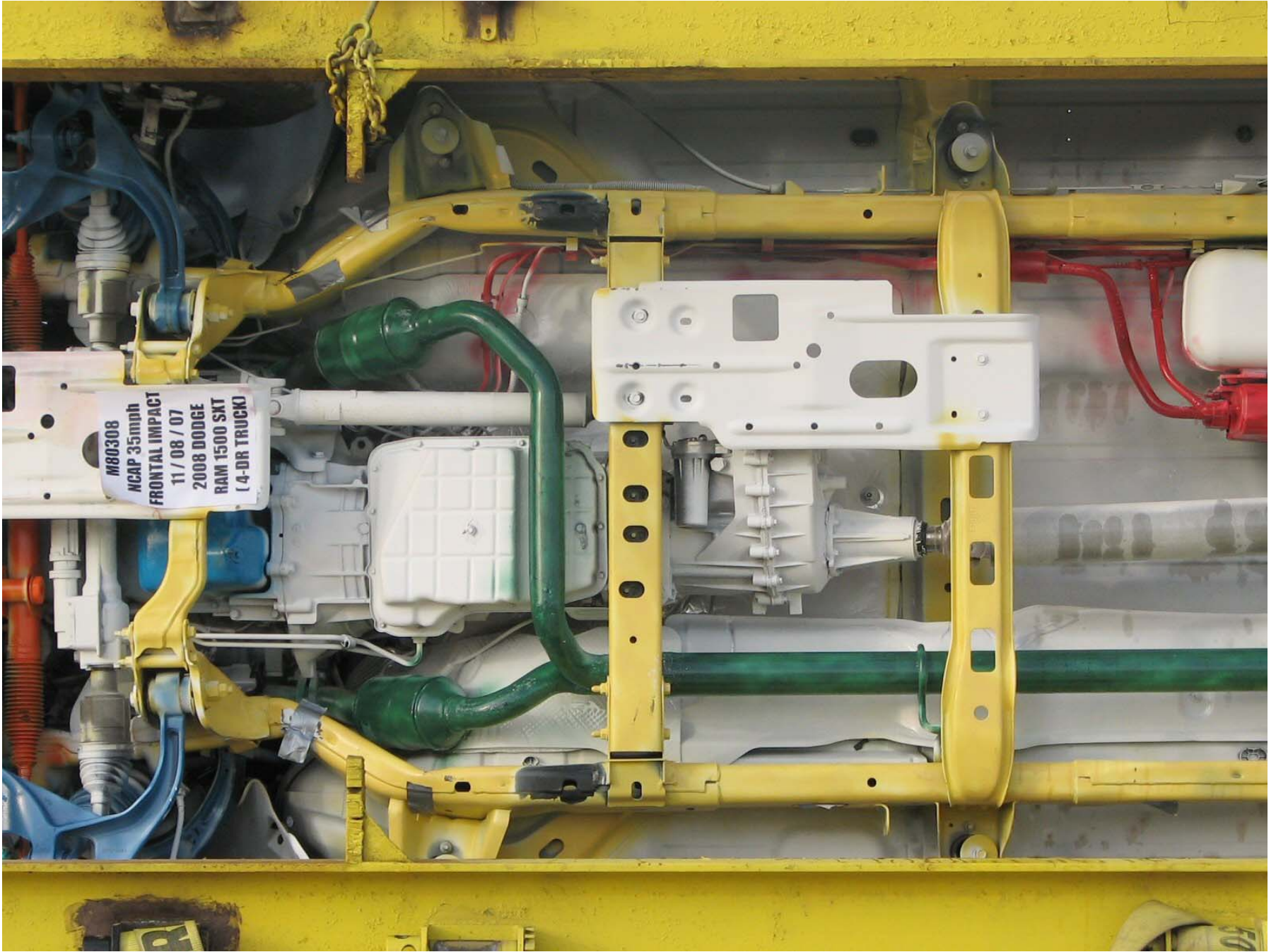

Figure A-25: Post-Test Front Underbody

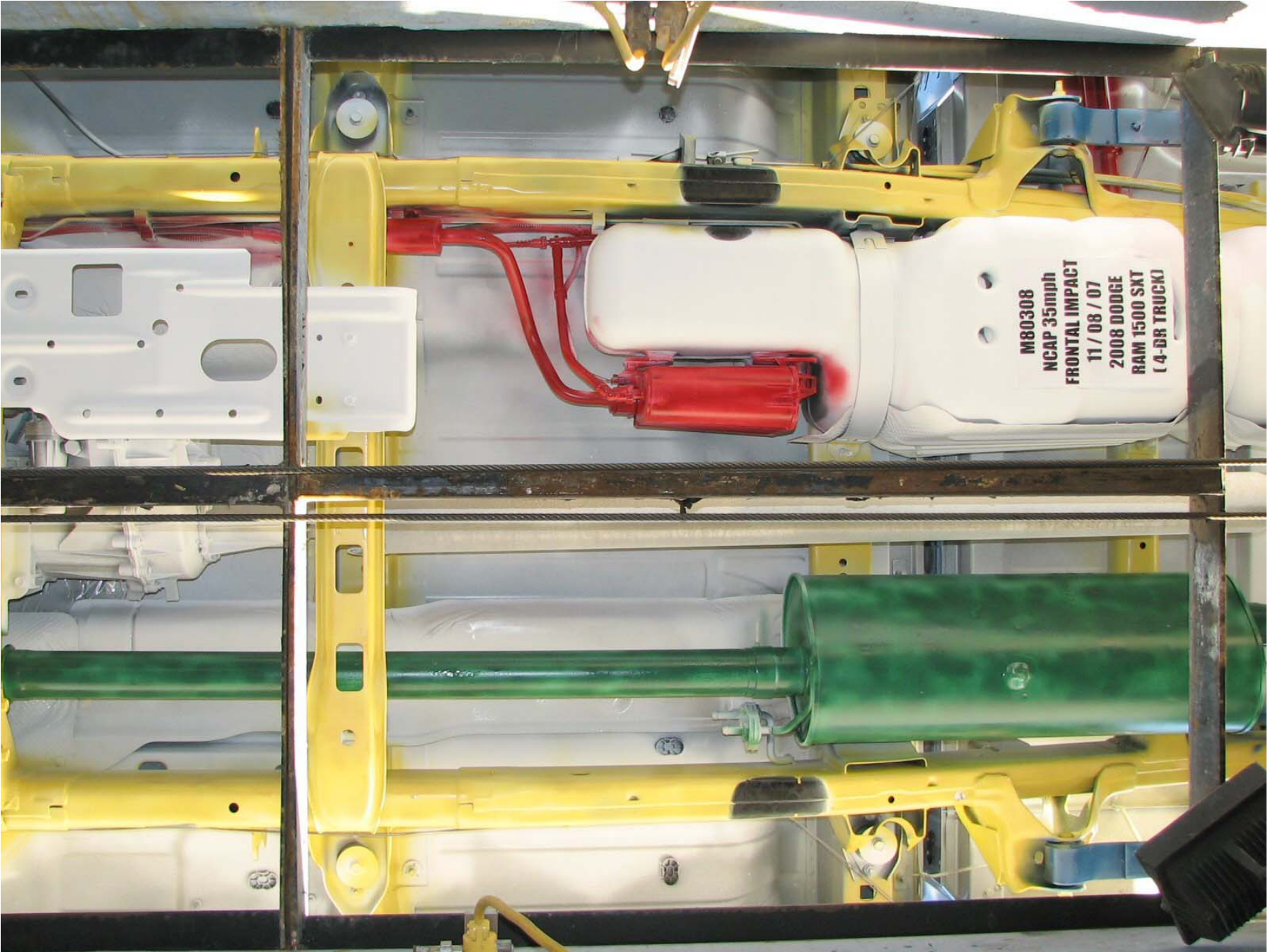

Figure A-26: Pre-Test Mid Underbody

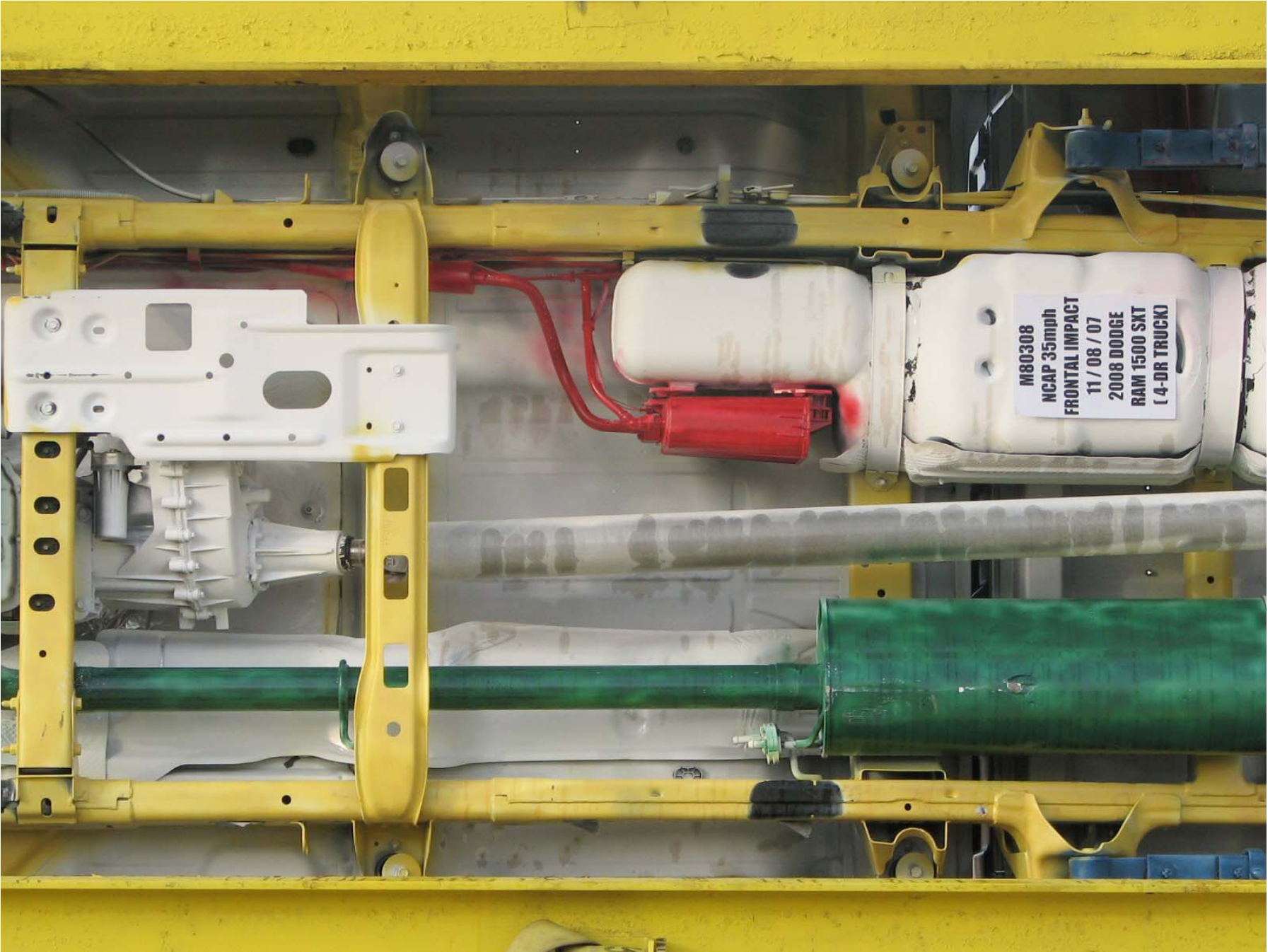

Figure A-27: Post-Test Mid Underbody



Figure A-28: Pre-Test Rear Underbody

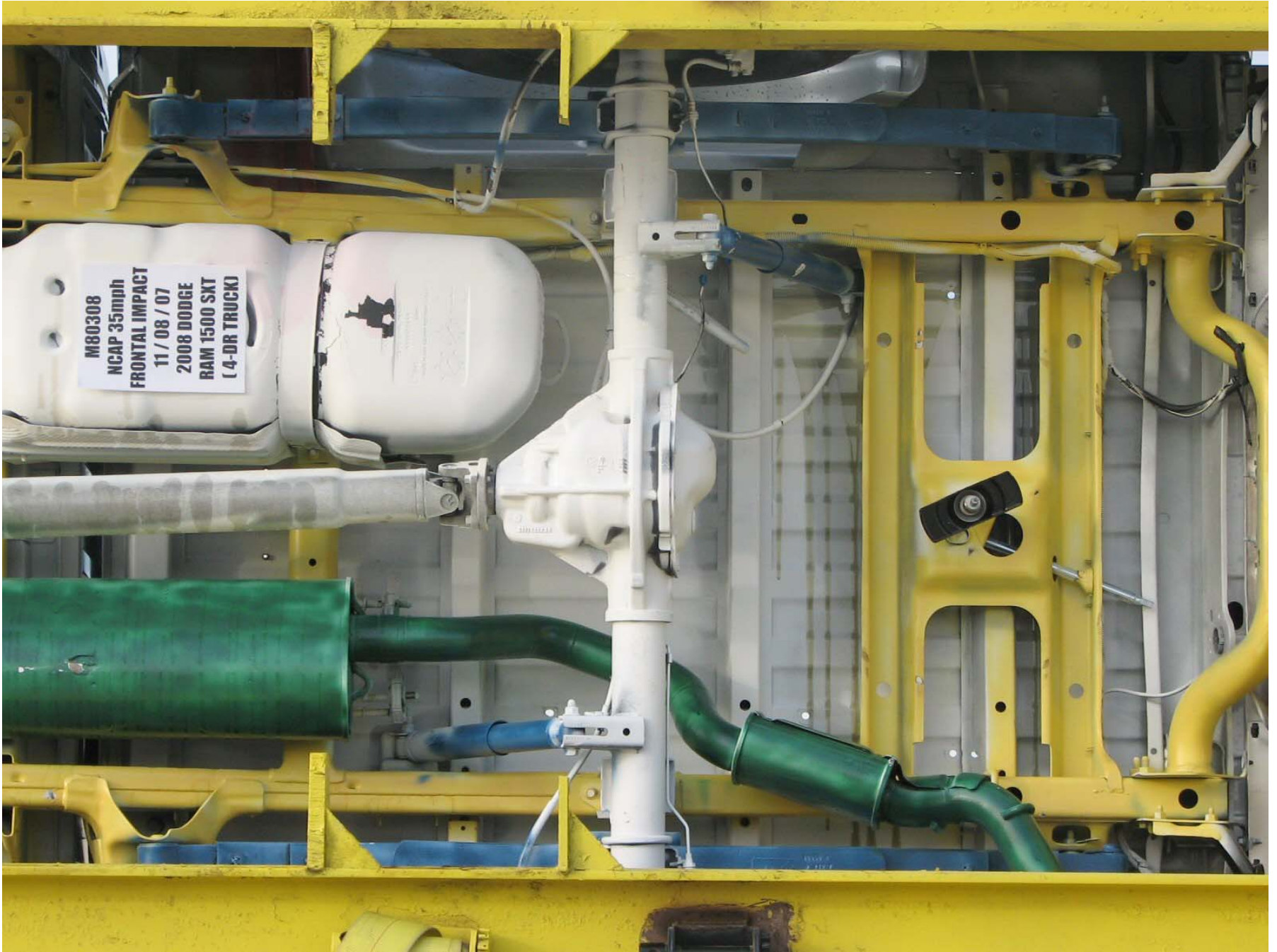

Figure A-29: Post-Test Rear Underbody



Figure A-30: Pre-Test Driver Dummy Front View (Head Position)



Figure A-31: Post-Test Driver Dummy Front View (Head Position)



Figure A-32: Pre-Test Driver Dummy (Through Window)



Figure A-33: Post-Test Driver Dummy (Through Window)



Figure A-34: Pre-Test Driver Dummy (Door Open)



Figure A-35: Post-Test Driver Dummy (Door Open)



A-36

TR-P28001-10-NC

Figure A-36: Pre-Test Driver Dummy Feet



Figure A-37: Post-Test Driver Dummy Feet



Figure A-38: Pre-Test Driver Side Knee Bolster



Figure A-39: Post-Test Driver Side Knee Bolster



Figure A-40: Pre-Test Driver Side Floor Pan

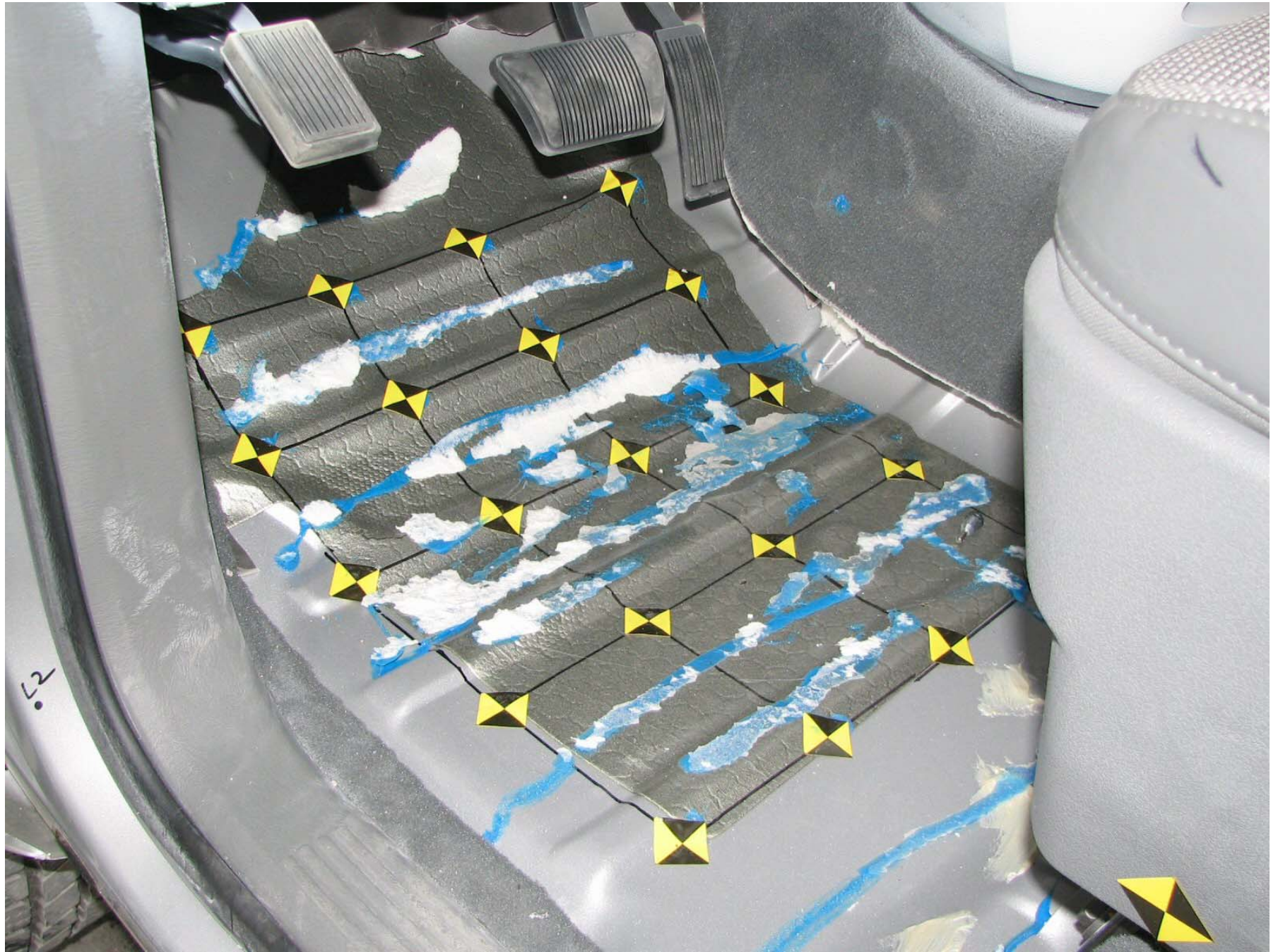

Figure A-41: Post-Test Driver Side Floor Pan



Figure A-42: Post-Test Driver Dummy Head



Figure A-43: Post-Test Driver Dummy Airbag Contact



Figure A-44: Pre-Test Passenger Dummy Front View (Head Position)



Figure A-45: Post-Test Passenger Dummy Front View (Head Position)



Figure A-46: Pre-Test Passenger Dummy (Through Window)



M80308

Figure A-47: Post-Test Passenger Dummy (Through Window)



Figure A-48: Pre-Test Passenger Dummy (Door Open)



Figure A-49: Post-Test Passenger Dummy (Door Open)



Figure A-50: Pre-Test Passenger Dummy Feet



Figure A-51: Post-Test Passenger Dummy Feet



Figure A-52: Pre-Test Passenger Side Glove Box



Figure A-53: Post-Test Passenger Side Glove Box

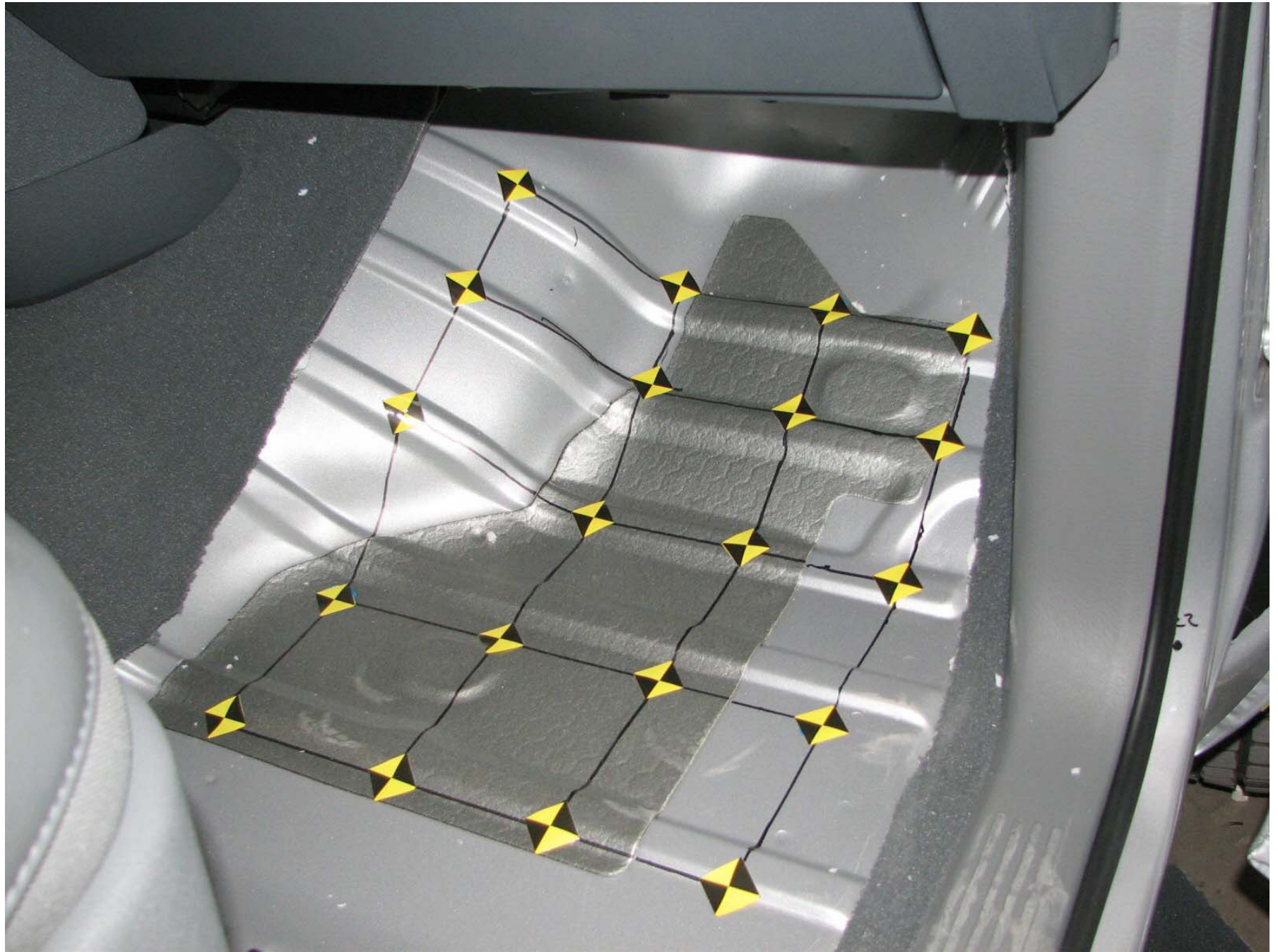

Figure A-54: Pre-Test Passenger Side Floor Pan

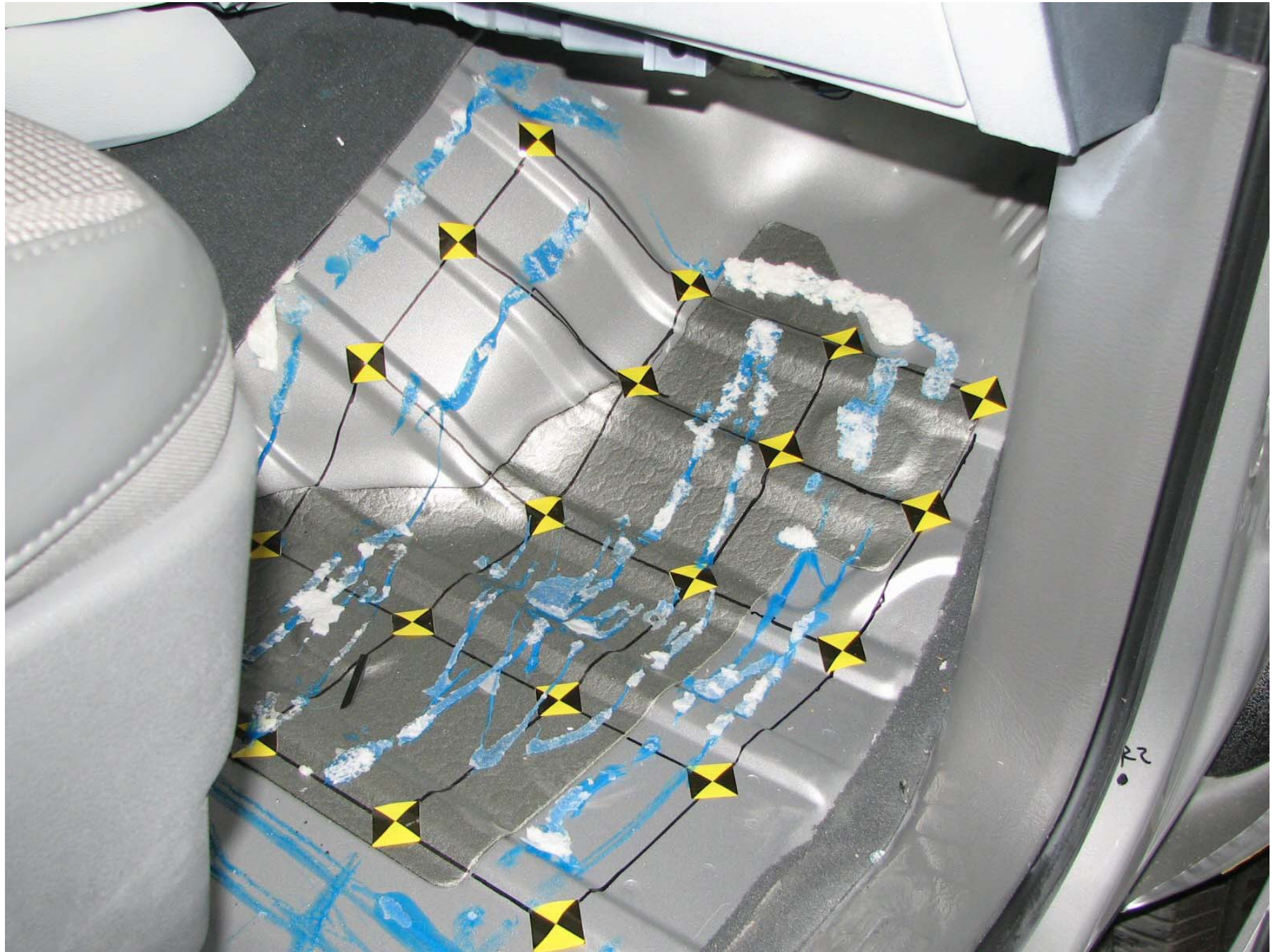

Figure A-55: Post-Test Passenger Side Floor Pan



Figure A-56: Post-Test Passenger Dummy Head



Figure A-57: Post-Test Passenger Dummy Airbag Contact



Figure A-58: Vehicle on Rollover Device (0°)

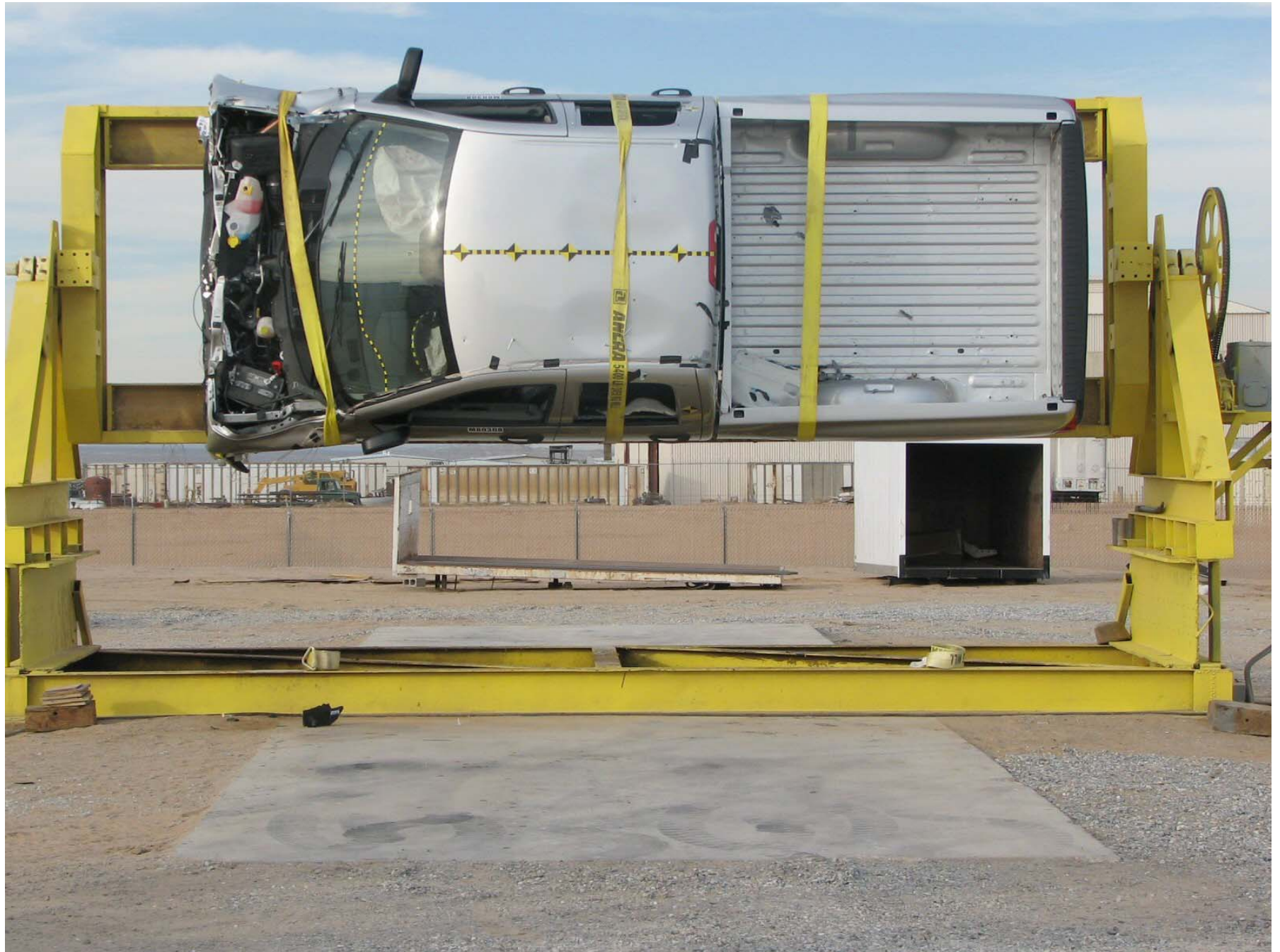

A-59

TR-P28001-10-NC

Figure A-59: Vehicle on Rollover Device (90°)



Figure A-60: Vehicle on Rollover Device (180°)

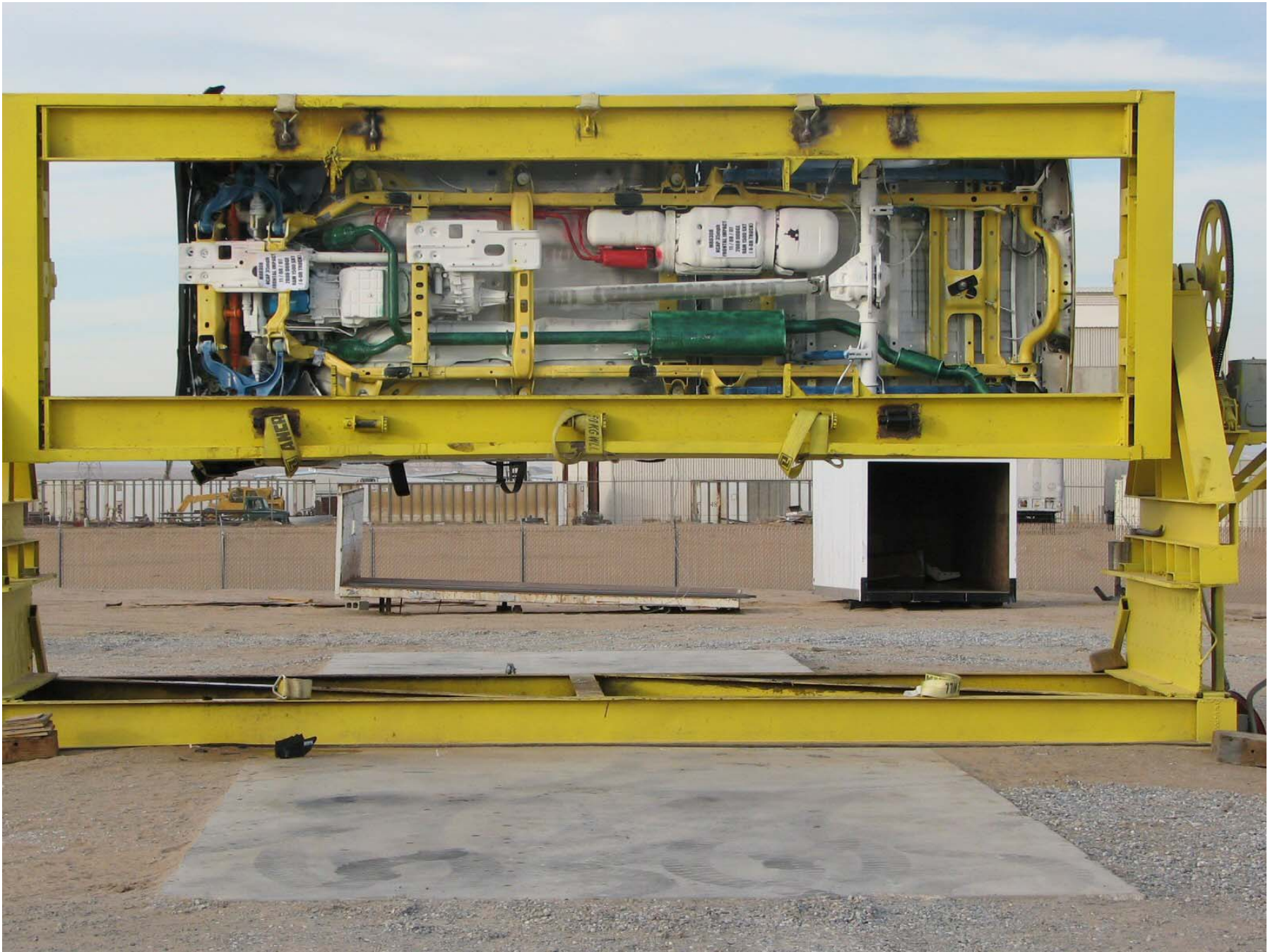

Figure A-61: Vehicle on Rollover Device (270°)



Figure A-62: Vehicle Impact

APPENDIX B
DATA PLOTS

LIST OF DATA PLOTS

Data Plot	Page	
B-1	Driver Head Primary X	B-1
	Driver Head Primary Y	B-1
	Driver Head Primary Z	B-1
	Driver Head Resultant Primary	B-1
B-2	Driver Chest Primary X	B-2
	Driver Chest Primary Y	B-2
	Driver Chest Primary Z	B-2
	Driver Chest Resultant Primary	B-2
B-3	Driver Left Femur Force Z	B-3
	Driver Right Femur Force Z	B-3
B-4	Passenger Head Primary X	B-4
	Passenger Head Primary Y	B-4
	Passenger Head Primary Z	B-4
	Passenger Head Resultant Primary	B-4
B-5	Passenger Chest Primary X	B-5
	Passenger Chest Primary Y	B-5
	Passenger Chest Primary Z	B-5
	Passenger Chest Resultant Primary	B-5
B-6	Passenger Left Femur Force Z	B-6
	Passenger Right Femur Force Z	B-6

LIST OF DATA PLOTS...(CONTINUED)

The following additional data plots for this test can be obtained from the research and development section of the NHTSA website. The website can be found at www.NHTSA.dot.gov.

Driver Head Primary X Velocity
Driver Head Primary X Displacement
Driver Head Redundant X
Driver Head Redundant Y
Driver Head Redundant Z
Driver Head Resultant Redundant
Driver Head Redundant X Velocity
Driver Head Redundant X Displacement
Driver Upper Neck Force X
Driver Upper Neck Force Y
Driver Upper Neck Force Z
Driver Upper Neck Force Resultant
Driver Upper Neck Moment X
Driver Upper Neck Moment Y
Driver Upper Neck Moment Z
Driver Upper Neck Moment Resultant
Driver Chest Primary X Velocity
Driver Chest Primary X Displacement
Driver Chest Redundant X
Driver Chest Redundant Y
Driver Chest Redundant Z
Driver Chest Resultant Redundant
Driver Chest Redundant X Velocity
Driver Chest Redundant X Displacement
Driver Chest Displacement
Driver Pelvis X
Driver Pelvis Y
Driver Pelvis Z
Driver Pelvis Resultant
Driver Pelvis X Velocity
Driver Pelvis X Displacement
Driver Left Upper Tibia Moment X
Driver Left Upper Tibia Moment Y
Driver Right Upper Tibia Moment X

LIST OF DATA PLOTS...(CONTINUED)

Driver Right Upper Tibia Moment Y
Driver Left Lower Tibia Moment X
Driver Left Lower Tibia Moment Y
Driver Left Lower Tibia Force Z
Driver Right Lower Tibia Moment X
Driver Right Lower Tibia Moment Y
Driver Right Lower Tibia Force Z
Driver Left Foot Aft X
Driver Left Foot Aft Z
Driver Left Foot Fore Z
Driver Right Foot Aft X
Driver Right Foot Aft Z
Driver Right Foot Fore Z
Driver Lap Belt Force
Driver Shoulder Belt Force
Driver Shoulder Belt Pullout
Driver Shoulder Belt Elongation
Passenger Head Primary X Velocity
Passenger Head Primary X Displacement
Passenger Head Redundant X
Passenger Head Redundant Y
Passenger Head Redundant Z
Passenger Head Resultant Redundant
Passenger Head Redundant X Velocity
Passenger Head Redundant X Displacement
Passenger Upper Neck Force X
Passenger Upper Neck Force Y
Passenger Upper Neck Force Z
Passenger Upper Neck Force Resultant
Passenger Upper Neck Moment X
Passenger Upper Neck Moment Y
Passenger Upper Neck Moment Z
Passenger Upper Neck Moment Resultant
Passenger Chest Primary X Velocity
Passenger Chest Primary X Displacement
Passenger Chest Redundant X

LIST OF DATA PLOTS...(CONTINUED)

Passenger Chest Redundant Y
Passenger Chest Redundant Z
Passenger Chest Resultant Redundant
Passenger Chest Redundant X Velocity
Passenger Chest Redundant X Displacement
Passenger Chest Displacement
Passenger Pelvis X
Passenger Pelvis Y
Passenger Pelvis Z
Passenger Pelvis Resultant
Passenger Pelvis X Velocity
Passenger Pelvis X Displacement
Passenger Left Femur Force
Passenger Right Femur Force
Passenger Left Upper Tibia Moment X
Passenger Left Upper Tibia Moment Y
Passenger Right Upper Tibia Moment X
Passenger Right Upper Tibia Moment Y
Passenger Left Lower Tibia Moment X
Passenger Left Lower Tibia Moment Y
Passenger Left Lower Tibia Force Z
Passenger Right Lower Tibia Moment X
Passenger Right Lower Tibia Moment Y
Passenger Right Lower Tibia Force Z
Passenger Left Foot Aft X
Passenger Left Foot Aft Z
Passenger Left Foot Fore Z
Passenger Right Foot Aft X
Passenger Right Foot Aft Z
Passenger Right Foot Fore Z
Passenger Lap Belt Force
Passenger Shoulder Belt Force
Passenger Shoulder Belt Pullout
Passenger Shoulder Belt Elongation
Vehicle Left Rear X
Vehicle Left Rear X Velocity

LIST OF DATA PLOTS...(CONTINUED)

Vehicle Left Rear X Displacement
Vehicle Right Rear X
Vehicle Right Rear X Velocity
Vehicle Right Rear X Displacement
Vehicle Engine Top
Vehicle Engine Top Velocity
Vehicle Engine Top Displacement
Vehicle Engine Bottom
Vehicle Engine Bottom Velocity
Vehicle Engine Bottom Displacement
Vehicle Left Brake Caliper
Vehicle Left Brake Caliper Velocity
Vehicle Left Brake Caliper Displacement
Vehicle Right Brake Caliper
Vehicle Right Brake Caliper Velocity
Vehicle Right Brake Caliper Displacement
Vehicle Instrument Panel
Vehicle Instrument Panel Velocity
Vehicle Instrument Panel Displacement
Vehicle Left Rear Z
Vehicle Left Rear Z Velocity
Vehicle Left Rear Z Displacement
Vehicle Right Rear Z
Vehicle Right Rear Z Velocity
Vehicle Right Rear Z Displacement

Test Vehicle: 2008 Dodge Ram 1500 SXT 4-Door Truck
 Test Program: NHTSA 35mph NCAP

Test Date: 11/8/07
 NHTSA No.: M80308

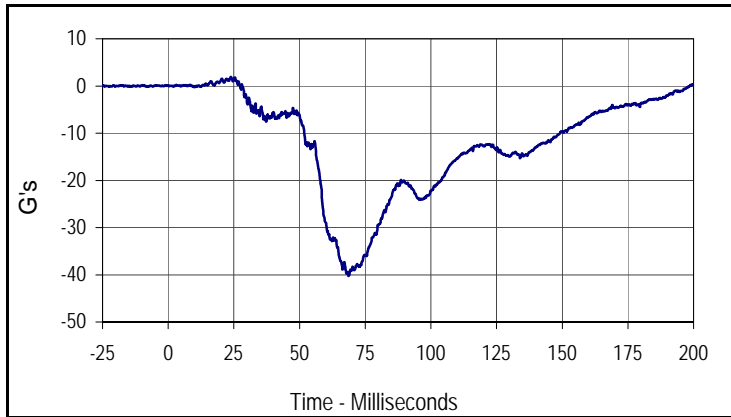

Curve Description			
Driver Head Primary X			
CURNO	Type	SAE Class	Units
001	FIL	1000	G's
Max	Time	Min	Time
2.0	23.8	-40.3	68.7

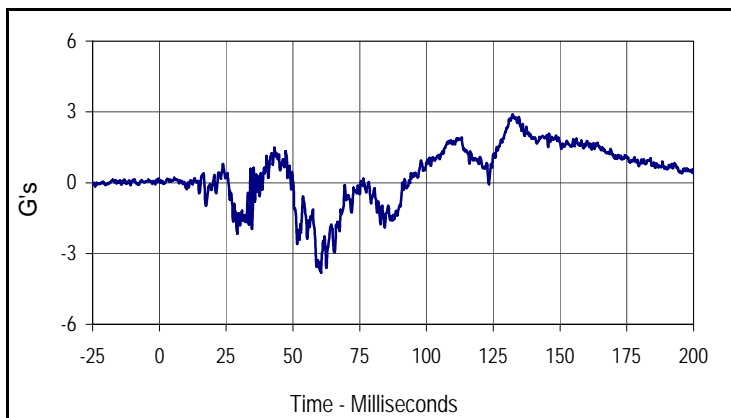

Curve Description			
Driver Head Primary Y			
CURNO	Type	SAE Class	Units
002	FIL	1000	G's
Max	Time	Min	Time
2.9	132.3	-3.8	60.5

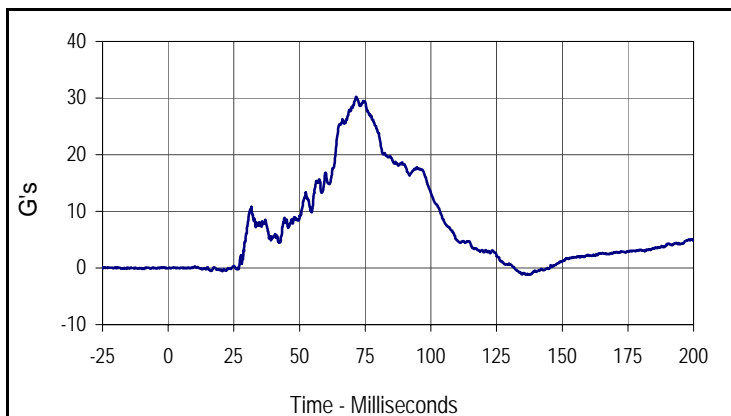

Curve Description			
Driver Head Primary Z			
CURNO	Type	SAE Class	Units
003	FIL	1000	G's
Max	Time	Min	Time
30.2	71.6	-1.2	136.2

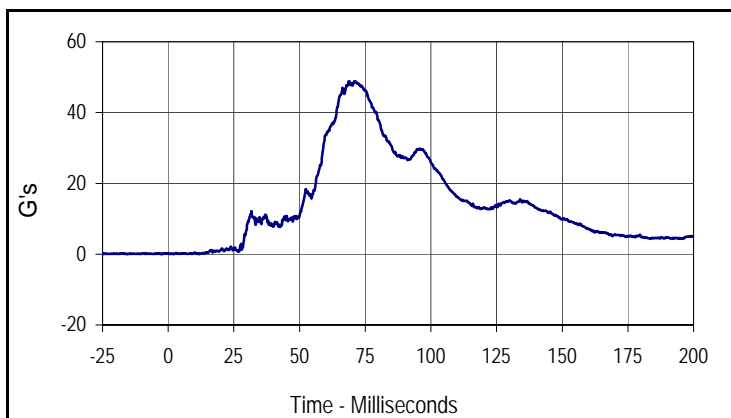

Curve Description			
Driver Head Resultant Primary			
CURNO	Type	SAE Class	Units
001	RES	1000	G's
Max	Time	Min	Time
48.9	71.0	0.0	2.1

Test Vehicle: 2008 Dodge Ram 1500 SXT 4-Door Truck
 Test Program: NHTSA 35mph NCAP

Test Date: 11/8/07
 NHTSA No.: M80308

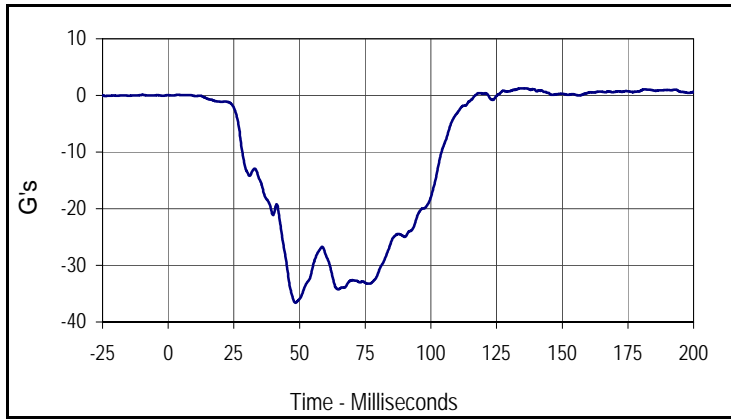

Curve Description			
Driver Chest Primary X			
CURNO	Type	SAE Class	Units
004	FIL	180	G's
Max	Time	Min	Time
1.3	134.9	-36.6	48.4

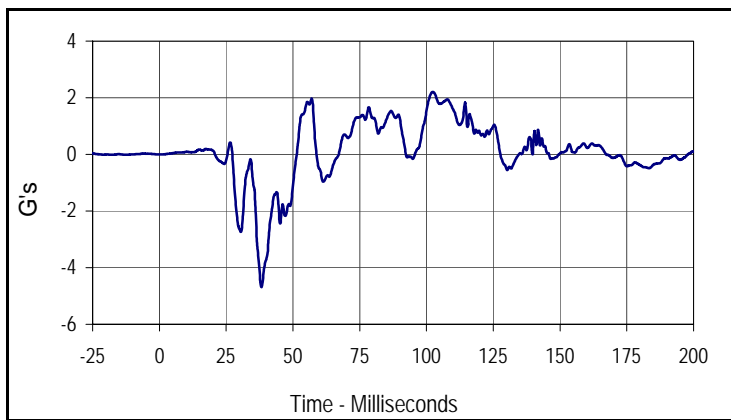

Curve Description			
Driver Chest Primary Y			
CURNO	Type	SAE Class	Units
005	FIL	180	G's
Max	Time	Min	Time
2.2	102.3	-4.7	38.2

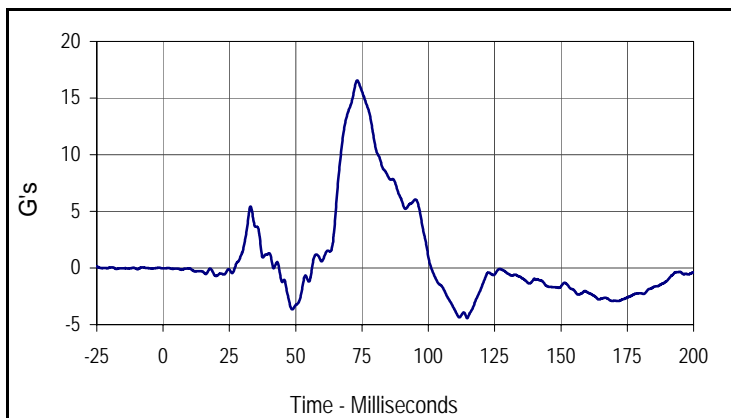

Curve Description			
Driver Chest Primary Z			
CURNO	Type	SAE Class	Units
006	FIL	180	G's
Max	Time	Min	Time
16.6	73.2	-4.4	114.6

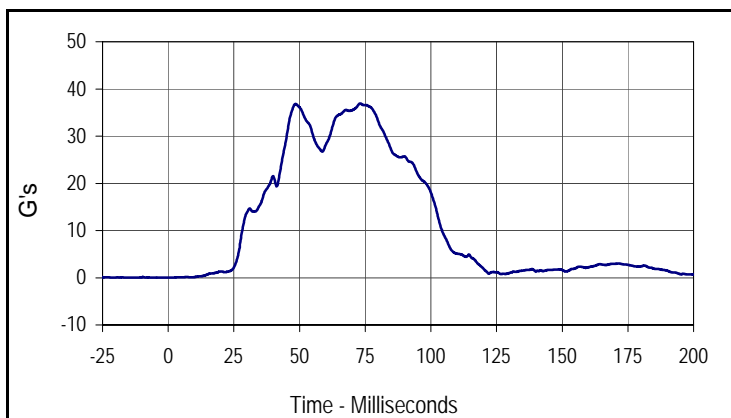

Curve Description			
Driver Chest Resultant Primary			
CURNO	Type	SAE Class	Units
004	RES	180	G's
Max	Time	Min	Time
36.9	73.1	0.0	2.1

Test Vehicle: 2008 Dodge Ram 1500 SXT 4-Door Truck
 Test Program: NHTSA 35mph NCAP

Test Date: 11/8/07
 NHTSA No.: M80308

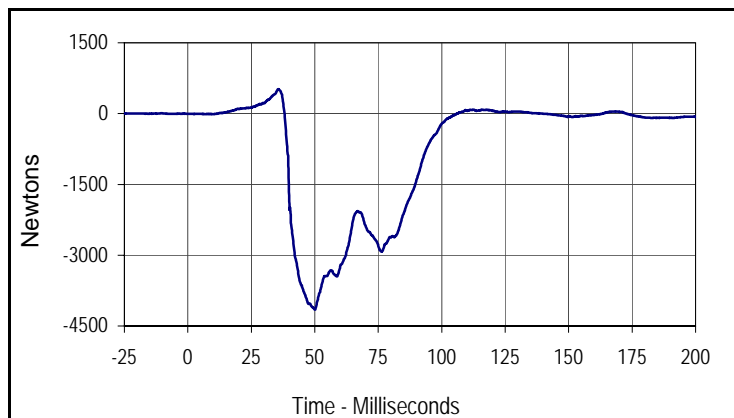

Curve Description			
Driver Left Femur Force Z			
CURNO	Type	SAE Class	Units
007	FIL	600	Newtons
Max	Time	Min	Time
515.7	35.6	-4153.0	50.0

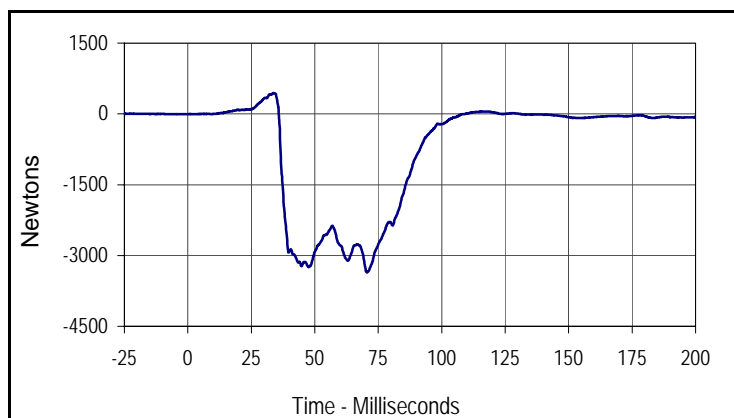

Curve Description			
Driver Right Femur Force Z			
CURNO	Type	SAE Class	Units
008	FIL	600	Newtons
Max	Time	Min	Time
442.7	33.7	-3357.8	70.5

Test Vehicle: 2008 Dodge Ram 1500 SXT 4-Door Truck
 Test Program: NHTSA 35mph NCAP

Test Date: 11/8/07
 NHTSA No.: M80308

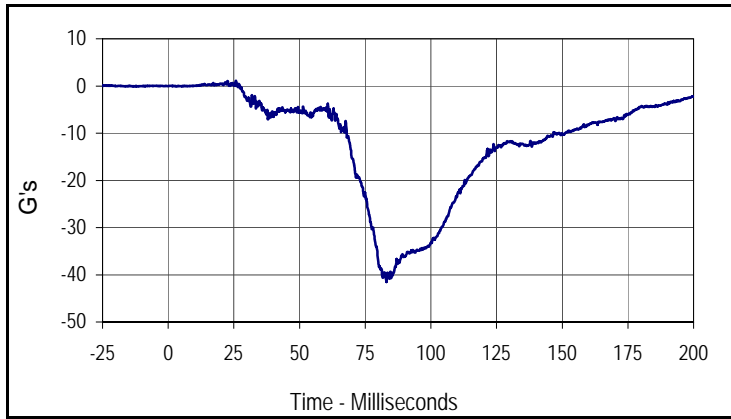

Curve Description			
Passenger Head Primary X			
CURNO	Type	SAE Class	Units
009	FIL	1000	G's
Max	Time	Min	Time
1.1	25.8	-41.6	83.0

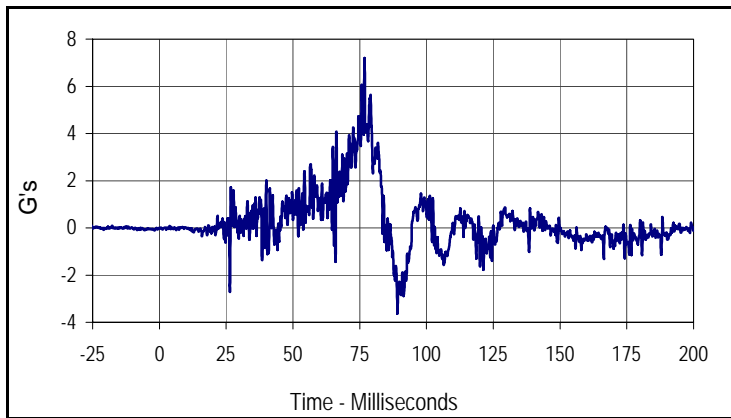

Curve Description			
Passenger Head Primary Y			
CURNO	Type	SAE Class	Units
010	FIL	1000	G's
Max	Time	Min	Time
7.2	76.8	-3.6	89.1

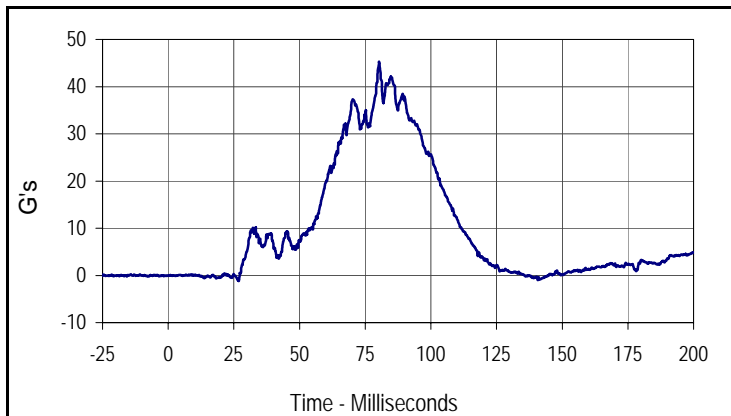

Curve Description			
Passenger Head Primary Z			
CURNO	Type	SAE Class	Units
011	FIL	1000	G's
Max	Time	Min	Time
45.3	80.3	-1.2	26.9

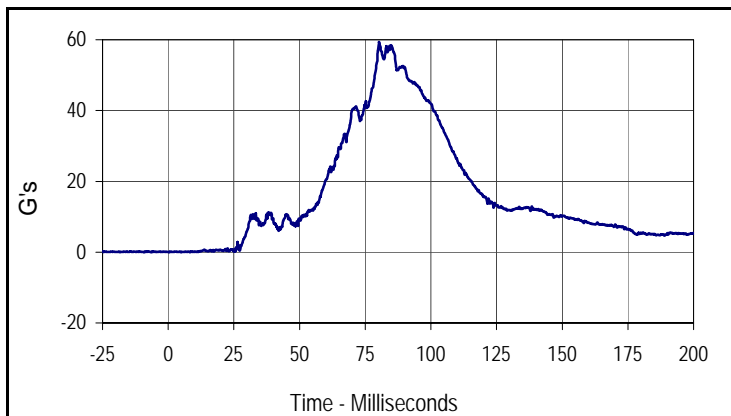

Curve Description			
Passenger Head Resultant Primary			
CURNO	Type	SAE Class	Units
009	RES	1000	G's
Max	Time	Min	Time
59.4	80.3	0.0	0.3

Test Vehicle: 2008 Dodge Ram 1500 SXT 4-Door Truck
 Test Program: NHTSA 35mph NCAP

Test Date: 11/8/07
 NHTSA No.: M80308

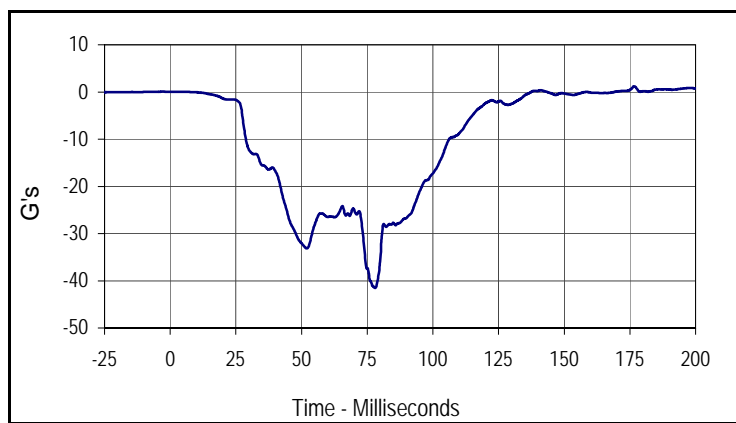

Curve Description			
Passenger Chest Primary X			
CURNO	Type	SAE Class	Units
012	FIL	180	G's
Max	Time	Min	Time
1.2	176.7	-41.5	78.0

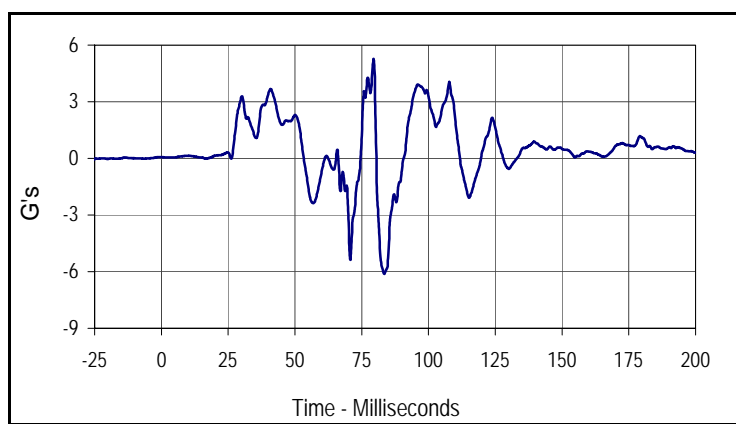

Curve Description			
Passenger Chest Primary Y			
CURNO	Type	SAE Class	Units
013	FIL	180	G's
Max	Time	Min	Time
5.3	79.5	-6.1	83.4

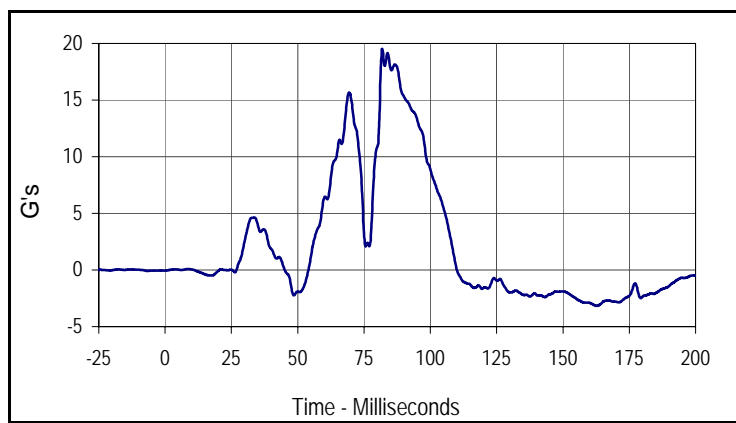

Curve Description			
Passenger Chest Primary Z			
CURNO	Type	SAE Class	Units
014	FIL	180	G's
Max	Time	Min	Time
19.5	81.8	-3.2	162.6

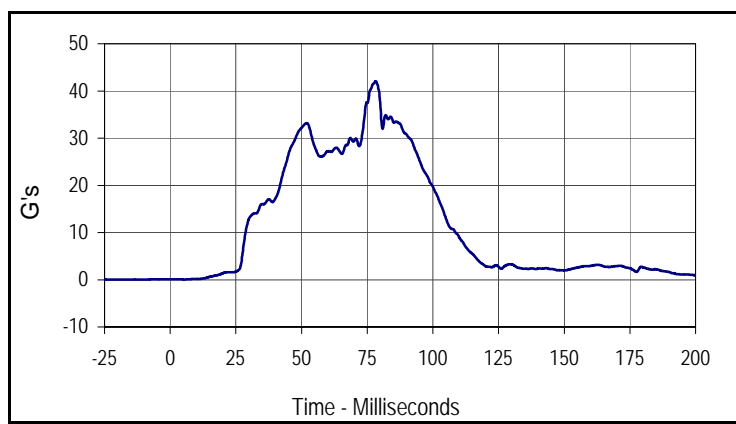

Curve Description			
Passenger Chest Resultant Primary			
CURNO	Type	SAE Class	Units
012	RES	180	G's
Max	Time	Min	Time
42.0	78.3	0.1	5.3

Test Vehicle: 2008 Dodge Ram 1500 SXT 4-Door Truck
 Test Program: NHTSA 35mph NCAP

Test Date: 11/8/07
 NHTSA No.: M80308

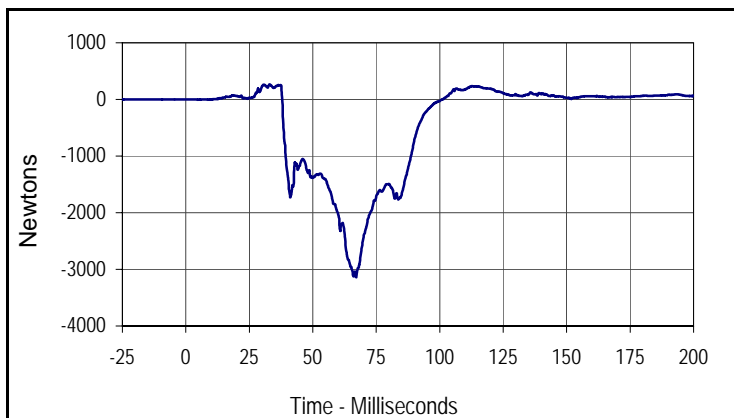

Curve Description			
Passenger Left Femur Force Z			
CURNO	Type	SAE Class	Units
015	FIL	600	Newtons
Max	Time	Min	Time
266.4	33.0	-3140.4	67.1

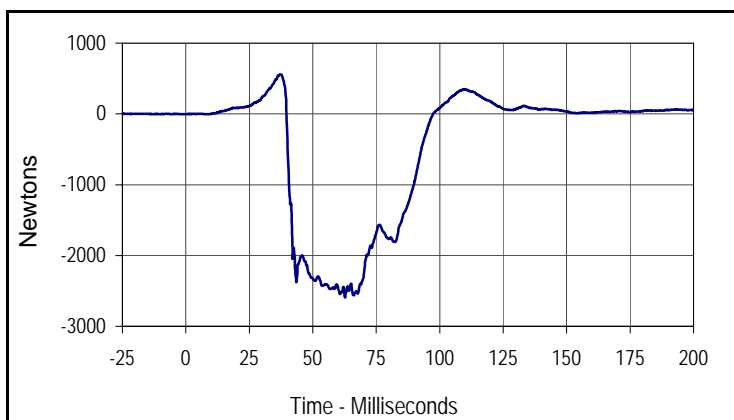

Curve Description			
Passenger Right Femur Force Z			
CURNO	Type	SAE Class	Units
016	FIL	600	Newtons
Max	Time	Min	Time
557.4	37.5	-2594.0	62.7

APPENDIX C
DUMMY CALIBRATION DATA

Test Program: Hybrid III 50th Percentile Male Head Drop Test

Test Date: 10/25/07

ATD Serial No.: 034

Test I.D.: HD10S



Tested Parameter	Units	Specification	Result	Pass/Fail
Laboratory Temperature	°C	18.9 to 25.6	21.1	Pass
Laboratory Relative Humidity	%	10 to 70	30	Pass
Peak Resultant Acceleration	G's	225.0 to 275.0	232.0	Pass
Peak Lateral Acceleration	G's	≤15.0	14.8	Pass
Is Acceleration Unimodal?	Yes/No	Yes	Yes	Pass
Overall Test Results			Pass	

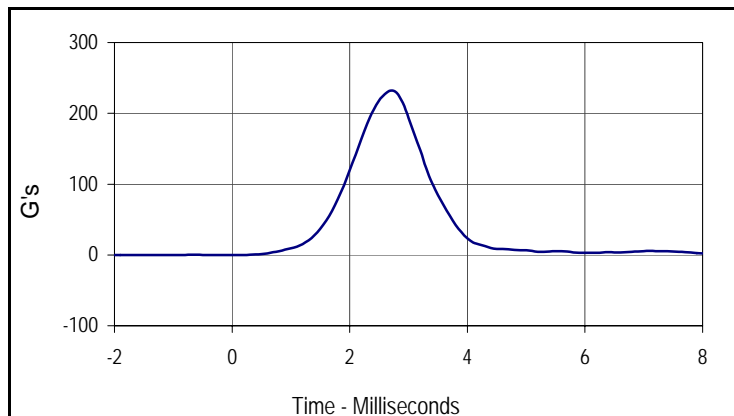

Curve Description			
Head Resultant			
CURNO	Type	SAE Class	Units
001	RES	1000	G's
Max	Time	Min	Time
232.0	2.7	0.0	0.0

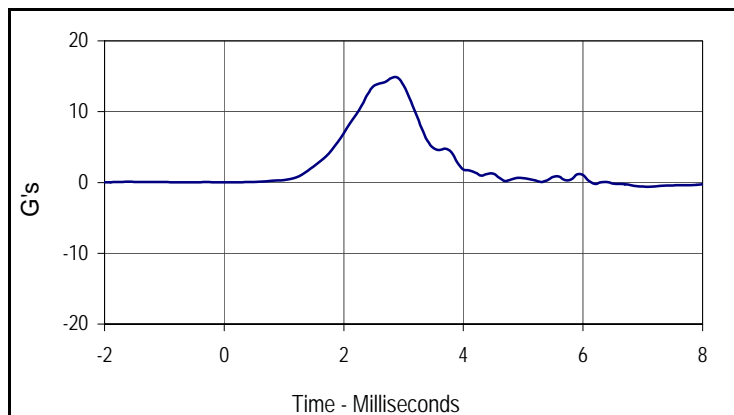

Curve Description			
Head Y			
CURNO	Type	SAE Class	Units
002	FIL	1000	G's
Max	Time	Min	Time
14.8	2.9	0.0	0.0

Test Program: Hybrid III 50th Percentile Male Thorax Impact Test

Test Date: 10/25/07

ATD Serial No.: 034

Test I.D.: CH10S



Tested Parameter	Units	Specification	Result	Pass/Fail
Laboratory Temperature	°C	20.6 to 22.2	21.1	Pass
Laboratory Relative Humidity	%	10 to 70	30	Pass
Probe Velocity	m/s	6.58 to 6.82	6.63	Pass
Peak Probe Force	Newtons	5159 to 5893	5613	Pass
Peak Sternum Deflection	CM	6.35 to 7.26	7.02	Pass
Internal Hysteresis	%	69 to 85	72.2	Pass
Overall Test Results				Pass

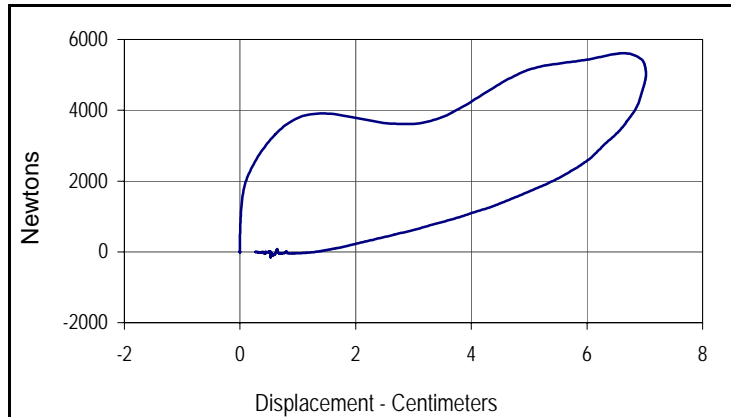

Curve Description			
Probe Force vs. Chest Deflection			
CURNO	Type	SAE Class	Hysteresis
001	FIL	180	72.2
Peak Probe Force		Peak Chest Deflection	
5613		7.02	

Test Program: Hybrid III 50th Percentile Male Neck Flexion Test

Test Date: 10/25/07

ATD Serial No.: 034

Test I.D.: NF10S



Tested Parameter	Units	Specification	Result	Pass/Fail	
Laboratory Temperature	°C	20.6 to 22.2	21.1	Pass	
Laboratory Relative Humidity	%	10 to 70	30	Pass	
Pendulum Velocity	m/s	6.89 to 7.13	7.05	Pass	
Pendulum Deceleration	10 Msec.	G's	22.5 to 27.5	22.8	Pass
	20 Msec.	G's	17.6 to 22.6	22.4	Pass
	30 Msec.	G's	12.5 to 18.5	15.1	Pass
Peak Pendulum Decel. after 30 Msec.	G's	≤ 29.0	15.1	Pass	
Deceleration Decay, Time to Cross 5 G's	Msec.	34.0 to 42.0	39.9	Pass	
Maximum "D" Plane Rotation	Max	Degrees	64.0 to 78.0	71.2	Pass
	Time	Msec.	57.0 to 64.0	62.7	Pass
"D" Plane Rotation Decay, Time To Zero Crossing	Msec.	113.0 to 128.0	115.4	Pass	
Moment About Occ. Condyle	Max	Nm	84.1 to 108.5	99.3	Pass
	Time	Msec.	47.0 to 58.0	52.1	Pass
Positive Moment Decay, Time To Zero Crossing	Msec.	97.0 to 107.0	97.0	Pass	
Overall Test Results				Pass	

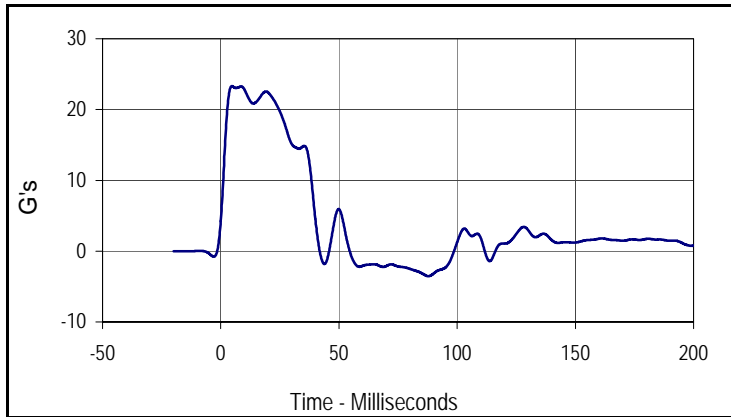

Curve Description			
Pendulum Deceleration			
CURNO	Type	SAE Class	Units
001	FIL	60	G's
Max	Time	Min	Time
23.3	4.7	-3.5	87.8

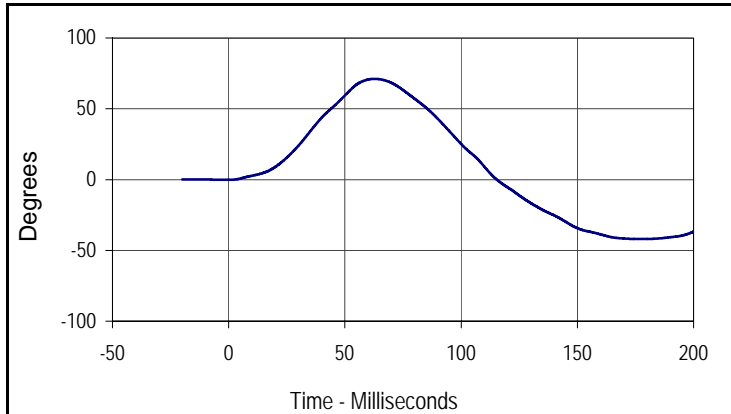

Curve Description			
"D" Plane Rotation			
CURNO	Type	SAE Class	Units
003	FIL	60	Degrees
Max	Time	Min	Time
71.2	62.7	-42.0	178.6

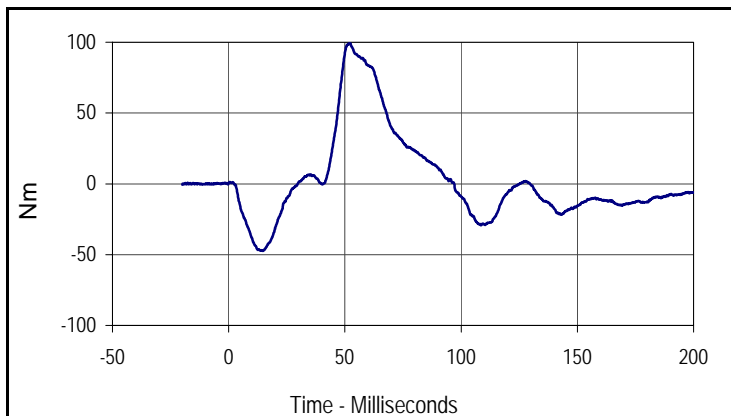

Curve Description			
Moment About Occipital Condyle			
CURNO	Type	SAE Class	Units
004	FIL	600	Nm
Max	Time	Min	Time
99.3	52.1	-47.4	14.7

Test Program: Hybrid III 50th Percentile Male Neck Extension Test

Test Date: 10/25/07

ATD Serial No.: 034

Test I.D.: NE10S



Tested Parameter	Units	Specification	Result	Pass/Fail	
Laboratory Temperature	°C	20.6 to 22.2	21.1	Pass	
Laboratory Relative Humidity	%	10 to 70	30	Pass	
Pendulum Velocity	m/s	5.94 to 6.19	6.05	Pass	
Pendulum Deceleration	10 Msec.	G's	17.2 to 21.2	18.7	Pass
	20 Msec.	G's	14.0 to 19.0	17.8	Pass
	30 Msec.	G's	11.0 to 16.0	14.0	Pass
Peak Pendulum Decel. after 30 Msec.	G's	≤ 22.0	14.0	Pass	
Deceleration Decay, Time to Cross 5 G's	Msec.	38.0 to 46.0	41.6	Pass	
Maximum "D" Plane Rotation	Max	Degrees	81.0 to 106.0	104.3	Pass
	Time	Msec.	72.0 to 82.0	72.4	Pass
"D" Plane Rotation Decay, Time To Zero Crossing	Msec.	147.0 to 174.0	152.4	Pass	
Moment About Occ. Condyle	Max	Nm	-52.9 to- 79.9	-76.5	Pass
	Time	Msec.	65.0 to 79.0	67.0	Pass
Positive Moment Decay, Time To Zero Crossing	Msec.	120.0 to 148.0	140.8	Pass	
Overall Test Results				Pass	

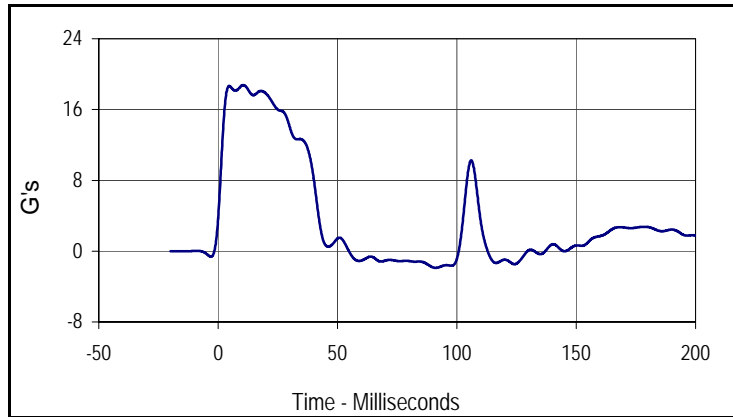

Curve Description			
Pendulum Deceleration			
CURNO	Type	SAE Class	Units
001	FIL	60	G's
Max	Time	Min	Time
18.8	10.5	-1.9	91.2

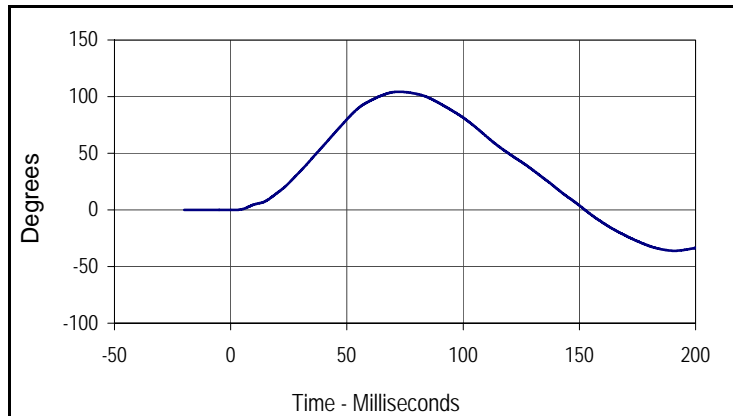

Curve Description			
"D" Plane Rotation			
CURNO	Type	SAE Class	Units
003	FIL	60	Degrees
Max	Time	Min	Time
104.3	72.4	-36.1	190.9

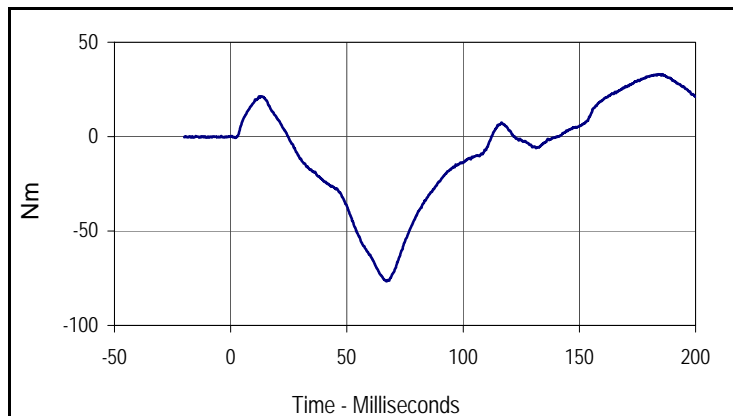

Curve Description			
Moment About Occipital Condyle			
CURNO	Type	SAE Class	Units
004	FIL	600	Nm
Max	Time	Min	Time
33.1	184.8	-76.5	67.0

Test Program: Hybrid III 50th Percentile Male Knee Impact Test

Test Date: 10/25/07

ATD Serial No.: 034

Test I.D.: LK10S , RK10S



Left Knee

Tested Parameter	Units	Specification	Result	Pass/Fail
Laboratory Temperature	°C	18.9 to 25.6	21.1	Pass
Laboratory Relative Humidity	%	10 to 70	30	Pass
Pendulum Velocity at T=0	m/sec	2.07 to 2.13	2.10	Pass
Peak Probe Force	Newtons	4715 to 5782	5442	Pass
Overall Test Results				Pass

Right Knee

Pendulum Velocity at T=0	m/sec	2.07 to 2.13	2.09	Pass
Peak Probe Force	Newtons	4715 to 5782	5482	Pass
Overall Test Results				Pass

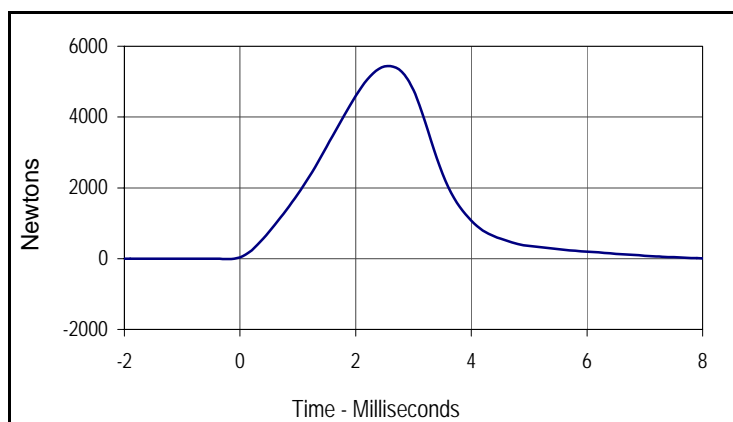

Curve Description			
Left Knee Probe Force			
CURNO	Type	SAE Class	Units
001	FIL	600	Newtons
Max	Time	Min	Time
5442.4	2.6	-14.7	-0.2

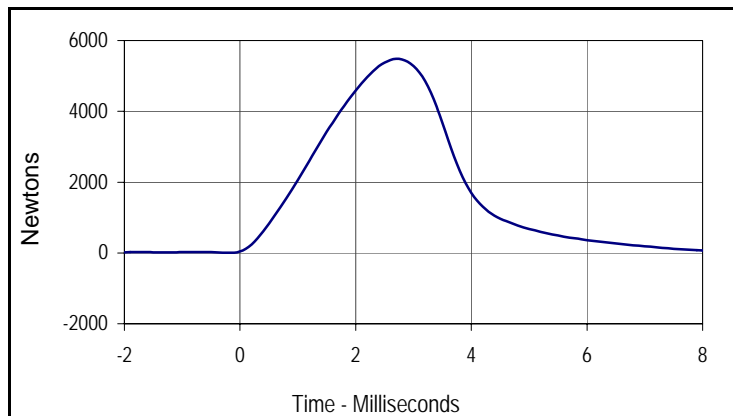

Curve Description			
Right Knee Probe Force			
CURNO	Type	SAE Class	Units
002	FIL	600	Newtons
Max	Time	Min	Time
5482.2	2.7	-2.6	9.8

Test Program: Hybrid III 50th Percentile Male External Measurements

Test Date: 10/25/07

ATD Serial No.: 034

Test I.D.: N/A



Tested Parameter	Units	Specification	Result	Pass/Fail
Laboratory Temperature	°C	20.6 to 22.2	21.1	Pass
Laboratory Relative Humidity	%	10 to 70	30	Pass
A - Total sitting height	mm	879 to 889	882	Pass
B - Shoulder pivot height	mm	505 to 521	510	Pass
C - "H" point height	mm	84 to 89	89	Pass
D - "H" point from seat back	mm	135 to 140	136	Pass
E - Shoulder pivot from back	mm	84 to 94	89	Pass
F - Thigh clearance	mm	140 to 155	150	Pass
G - Elbow back to wrist pivot	mm	290 to 305	296	Pass
H - Skull cap to back line	mm	41 to 46	44	Pass
I - Shoulder to elbow length	mm	330 to 345	335	Pass
J - Elbow rest height	mm	190 to 211	204	Pass
K - Buttock to knee length	mm	579 to 604	597	Pass
L - Popliteal length	mm	429 to 455	443	Pass
M - Knee pivot height	mm	485 to 500	491	Pass
N - Buttock popliteal length	mm	452 to 477	476	Pass
O - Chest depth	mm	213 to 229	213	Pass
P - Foot length	mm	251 to 267	256	Pass
V - Shoulder breadth	mm	422 to 437	428	Pass
W - Foot breadth	mm	91 to 107	100	Pass
Y - Chest circumference	mm	970 to 1001	993	Pass
Z - Waist circumference	mm	836 to 866	842	Pass
AA - Location for chest circumference	mm	429 to 434	430	Pass
BB - Location for waist circumference	mm	226 to 231	229	Pass
Overall Test Results				Pass

Test Program: Hybrid III 50th Percentile Male Head Drop Test

Test Date: 10/25/07

ATD Serial No.: 035

Test I.D.: HD10T



Tested Parameter	Units	Specification	Result	Pass/Fail
Laboratory Temperature	°C	18.9 to 25.6	21.1	Pass
Laboratory Relative Humidity	%	10 to 70	30	Pass
Peak Resultant Acceleration	G's	225.0 to 275.0	233.9	Pass
Peak Lateral Acceleration	G's	≤15.0	10.3	Pass
Is Acceleration Unimodal?	Yes/No	Yes	Yes	Pass
Overall Test Results			Pass	

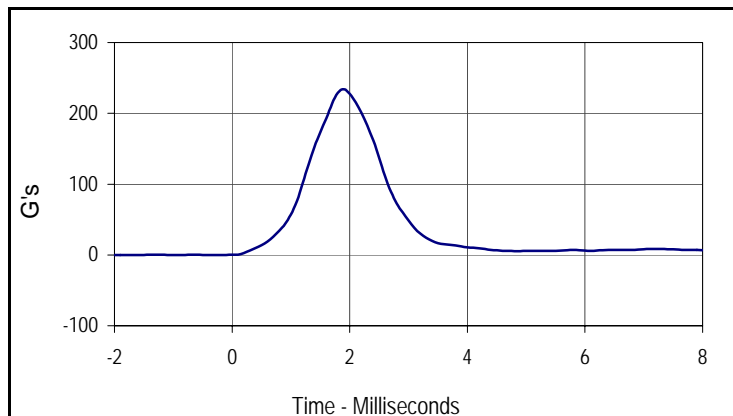

Curve Description			
Head Resultant			
CURNO	Type	SAE Class	Units
001	RES	1000	G's
Max	Time	Min	Time
233.9	1.9	0.0	-0.2

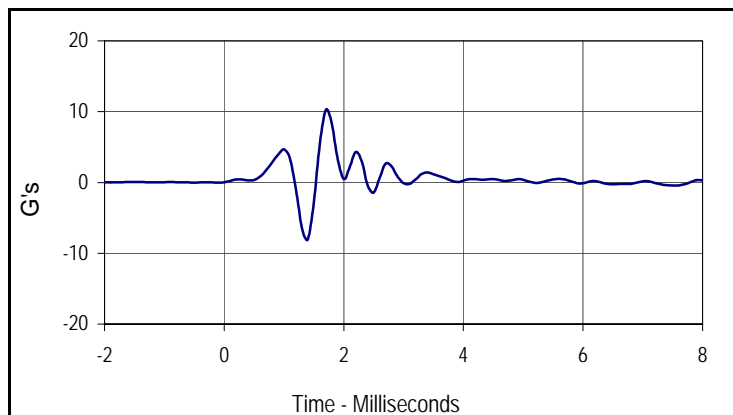

Curve Description			
Head Y			
CURNO	Type	SAE Class	Units
002	FIL	1000	G's
Max	Time	Min	Time
10.3	1.7	-8.1	1.4

Test Program: Hybrid III 50th Percentile Male Thorax Impact Test

Test Date: 10/25/07

ATD Serial No.: 035

Test I.D.: CH10T



Tested Parameter	Units	Specification	Result	Pass/Fail
Laboratory Temperature	°C	20.6 to 22.2	21.1	Pass
Laboratory Relative Humidity	%	10 to 70	30	Pass
Probe Velocity	m/s	6.58 to 6.82	6.80	Pass
Peak Probe Force	Newtons	5159 to 5893	5777	Pass
Peak Sternum Deflection	CM	6.35 to 7.26	7.08	Pass
Internal Hysteresis	%	69 to 85	73.2	Pass
Overall Test Results				Pass

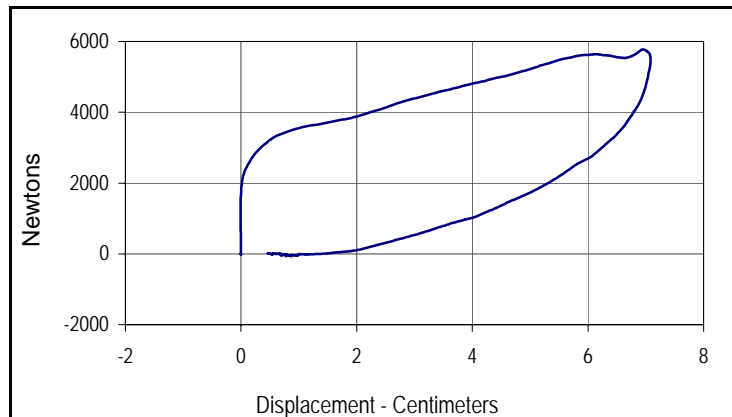

Curve Description			
Probe Force vs. Chest Deflection			
CURNO	Type	SAE Class	Hysteresis
001	FIL	180	73.2
Peak Probe Force		Peak Chest Deflection	
5777		7.08	

Test Program: Hybrid III 50th Percentile Male Neck Flexion Test

Test Date: 10/25/07

ATD Serial No.: 035

Test I.D.: NF10T



Tested Parameter	Units	Specification	Result	Pass/Fail	
Laboratory Temperature	°C	20.6 to 22.2	21.1	Pass	
Laboratory Relative Humidity	%	10 to 70	30	Pass	
Pendulum Velocity	m/s	6.89 to 7.13	7.04	Pass	
Pendulum Deceleration	10 Msec.	G's	22.5 to 27.5	23.2	Pass
	20 Msec.	G's	17.6 to 22.6	22.4	Pass
	30 Msec.	G's	12.5 to 18.5	17.0	Pass
Peak Pendulum Decel. after 30 Msec.	G's	≤ 29.0	17.0	Pass	
Deceleration Decay, Time to Cross 5 G's	Msec.	34.0 to 42.0	41.9	Pass	
Maximum "D" Plane Rotation	Max	Degrees	64.0 to 78.0	71.6	Pass
	Time	Msec.	57.0 to 64.0	62.8	Pass
"D" Plane Rotation Decay, Time To Zero Crossing	Msec.	113.0 to 128.0	115.3	Pass	
Moment About Occ. Condyle	Max	Nm	84.1 to 108.5	98.1	Pass
	Time	Msec.	47.0 to 58.0	52.1	Pass
Positive Moment Decay, Time To Zero Crossing	Msec.	97.0 to 107.0	97.0	Pass	
Overall Test Results				Pass	

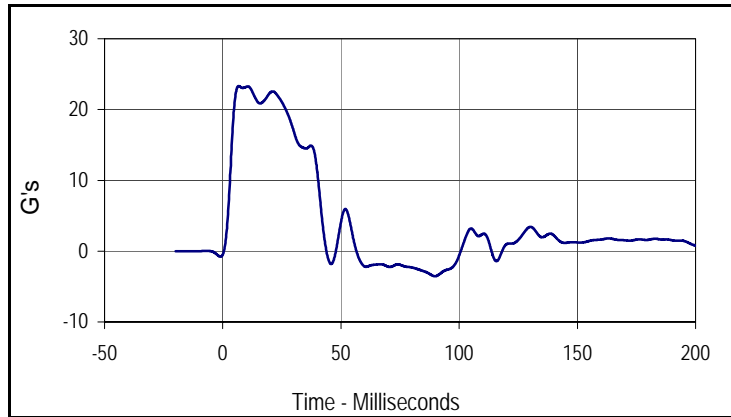

Curve Description			
Pendulum Deceleration			
CURNO	Type	SAE Class	Units
001	FIL	60	G's
Max	Time	Min	Time
23.3	6.7	-3.5	89.8

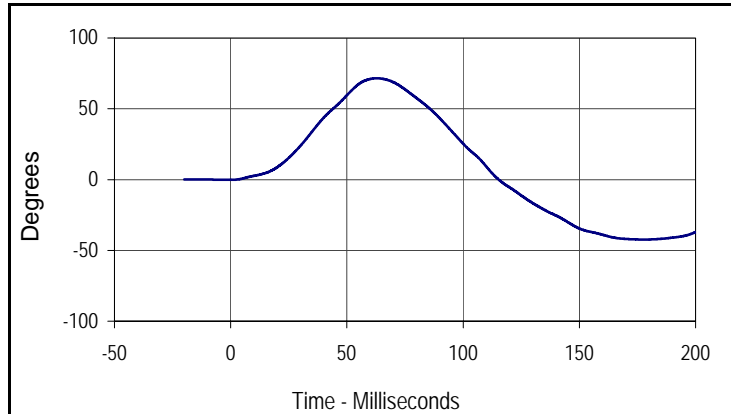

Curve Description			
"D" Plane Rotation			
CURNO	Type	SAE Class	Units
003	FIL	60	Degrees
Max	Time	Min	Time
71.6	62.8	-42.3	178.6

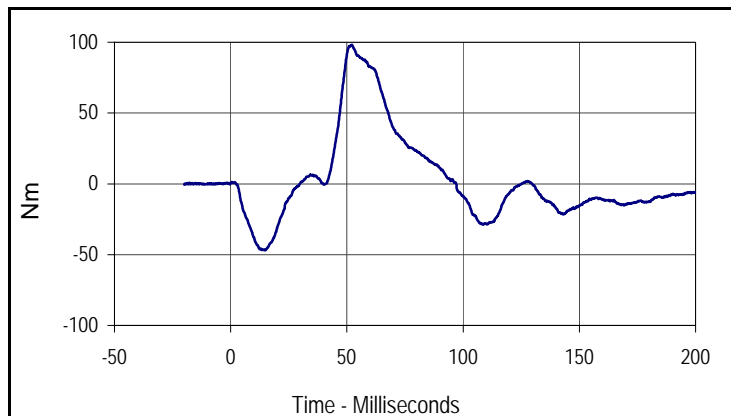

Curve Description			
Moment About Occipital Condyle			
CURNO	Type	SAE Class	Units
004	FIL	600	Nm
Max	Time	Min	Time
98.1	52.1	-47.0	14.7

Test Program: Hybrid III 50th Percentile Male Neck Extension Test

Test Date: 10/25/07

ATD Serial No.: 035

Test I.D.: NE10T



Tested Parameter	Units	Specification	Result	Pass/Fail	
Laboratory Temperature	°C	20.6 to 22.2	21.1	Pass	
Laboratory Relative Humidity	%	10 to 70	30	Pass	
Pendulum Velocity	m/s	5.94 to 6.19	6.07	Pass	
Pendulum Deceleration	10 Msec.	G's	17.2 to 21.2	17.9	Pass
	20 Msec.	G's	14.0 to 19.0	17.2	Pass
	30 Msec.	G's	11.0 to 16.0	14.8	Pass
Peak Pendulum Decel. after 30 Msec.	G's	≤ 22.0	14.8	Pass	
Deceleration Decay, Time to Cross 5 G's	Msec.	38.0 to 46.0	39.6	Pass	
Maximum "D" Plane Rotation	Max	Degrees	81.0 to 106.0	92.7	Pass
	Time	Msec.	72.0 to 82.0	73.7	Pass
"D" Plane Rotation Decay, Time To Zero Crossing	Msec.	147.0 to 174.0	154.3	Pass	
Moment About Occ. Condyle	Max	Nm	-52.9 to- 79.9	-63.8	Pass
	Time	Msec.	65.0 to 79.0	66.4	Pass
Positive Moment Decay, Time To Zero Crossing	Msec.	120.0 to 148.0	135.0	Pass	
Overall Test Results				Pass	

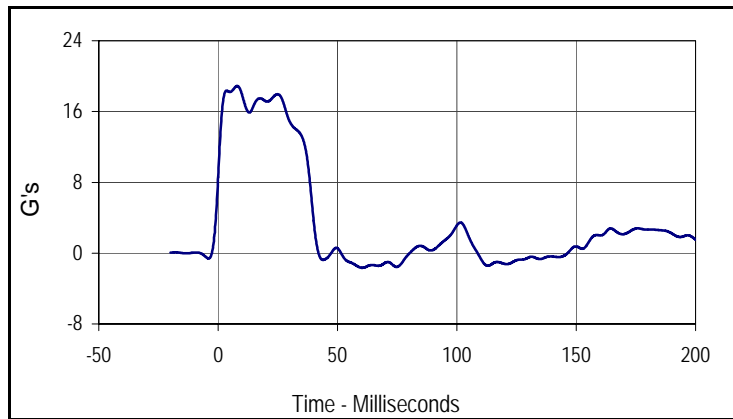

Curve Description			
Pendulum Deceleration			
CURNO	Type	SAE Class	Units
001	FIL	60	G's
Max	Time	Min	Time
18.9	8.0	-1.7	60.3

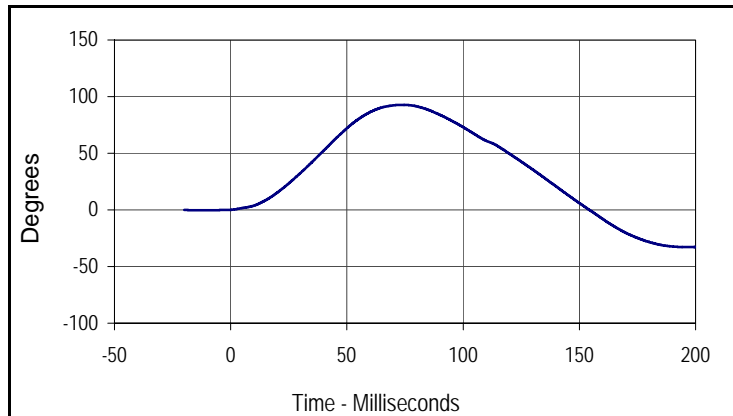

Curve Description			
"D" Plane Rotation			
CURNO	Type	SAE Class	Units
003	FIL	60	Degrees
Max	Time	Min	Time
92.7	73.7	-32.8	196.1

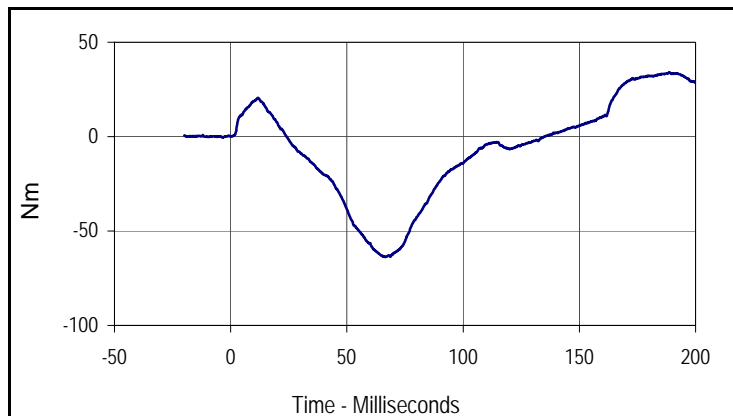

Curve Description			
Moment About Occipital Condyle			
CURNO	Type	SAE Class	Units
004	FIL	600	Nm
Max	Time	Min	Time
34.0	188.9	-63.8	66.4

Test Program: Hybrid III 50th Percentile Male Knee Impact Test

Test Date: 10/25/07

ATD Serial No.: 035

Test I.D.: LK10T , RK10T



Left Knee

Tested Parameter	Units	Specification	Result	Pass/Fail
Laboratory Temperature	°C	18.9 to 25.6	21.1	Pass
Laboratory Relative Humidity	%	10 to 70	30	Pass
Pendulum Velocity at T=0	m/sec	2.07 to 2.13	2.10	Pass
Peak Probe Force	Newtons	4715 to 5782	5136	Pass
Overall Test Results				Pass

Right Knee

Pendulum Velocity at T=0	m/sec	2.07 to 2.13	2.10	Pass
Peak Probe Force	Newtons	4715 to 5782	5223	Pass
Overall Test Results				Pass

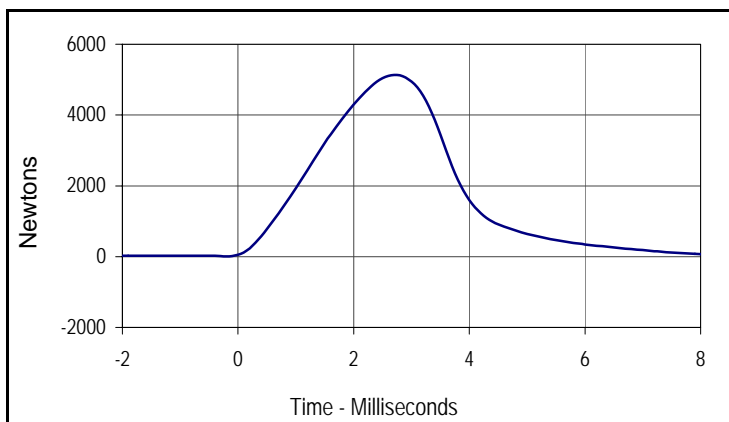

Curve Description			
Left Knee Probe Force			
CURNO	Type	SAE Class	Units
001	FIL	600	Newtons
Max	Time	Min	Time
5136.3	2.7	3.7	9.8

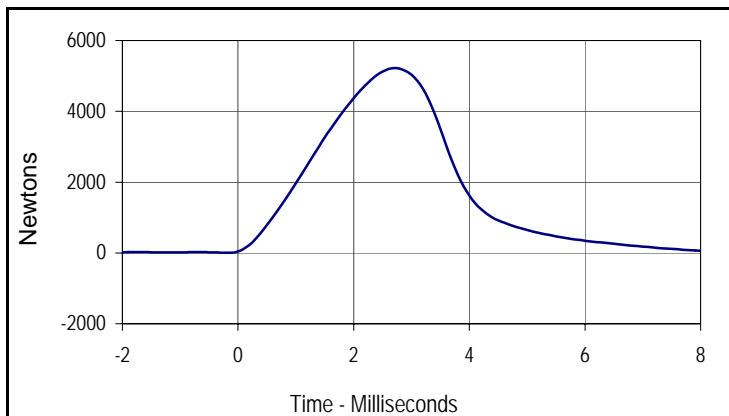

Curve Description			
Right Knee Probe Force			
CURNO	Type	SAE Class	Units
002	FIL	600	Newtons
Max	Time	Min	Time
5223.3	2.7	-2.6	9.8

Test Program: Hybrid III 50th Percentile Male External Measurements

Test Date: 10/25/07

ATD Serial No.: 035

Test I.D.: N/A



Tested Parameter	Units	Specification	Result	Pass/Fail
Laboratory Temperature	°C	20.6 to 22.2	21.1	Pass
Laboratory Relative Humidity	%	10 to 70	30	Pass
A - Total sitting height	mm	879 to 889	882	Pass
B - Shoulder pivot height	mm	505 to 521	515	Pass
C - "H" point height	mm	84 to 89	88	Pass
D - "H" point from seat back	mm	135 to 140	139	Pass
E - Shoulder pivot from back	mm	84 to 94	87	Pass
F - Thigh clearance	mm	140 to 155	150	Pass
G - Elbow back to wrist pivot	mm	290 to 305	300	Pass
H - Skull cap to back line	mm	41 to 46	42	Pass
I - Shoulder to elbow length	mm	330 to 345	334	Pass
J - Elbow rest height	mm	190 to 211	209	Pass
K - Buttock to knee length	mm	579 to 604	596	Pass
L - Popliteal length	mm	429 to 455	448	Pass
M - Knee pivot height	mm	485 to 500	497	Pass
N - Buttock popliteal length	mm	452 to 477	473	Pass
O - Chest depth	mm	213 to 229	220	Pass
P - Foot length	mm	251 to 267	255	Pass
V - Shoulder breadth	mm	422 to 437	427	Pass
W - Foot breadth	mm	91 to 107	103	Pass
Y - Chest circumference	mm	970 to 1001	985	Pass
Z - Waist circumference	mm	836 to 866	860	Pass
AA - Location for chest circumference	mm	429 to 434	430	Pass
BB - Location for waist circumference	mm	226 to 231	229	Pass
Overall Test Results				Pass

Test Program: Dummy Damage Checklist
 ATD Serial No.: 034

Test Date: 10/25/07
 Test I.D.: N/A



GENERAL	DAMAGED	OK
Outer skin on entire dummy		X
Head ballast secure		X
Gashes, rips, general appearance, etc.		X
Neck-Broken or cracks in rubber		X
Check that upper neck bracket is firmly attached to lwr neck bracket		X
Three rubber bumpers in place		X
Spine- Broken or cracks in rubber		X
Check for looseness at the condyle joint		X
Nodding blocks- cracked or out of position		X
Ribs- Check all ribs and rib supports for damage (bent or broken)		X
Check damping material or separation or cracks		X
OTHER		
CHEST DISPLACEMENT ASSEMBLY		
Bent shaft		X
Slider arm riding correctly, in track		X
TRANSDUCER LEADS		
Torn cables		X
ACCELEROMETER MOUNTINGS		
Check for secure mounting		X
KNEES		
Check outer skin, insert and casting (without removing insert)		X
Knee sliders - Wires intact		X
Knee sliders- Rubber returned to "at rest position"		X
LIMBS		
Check for normal movement and adjustment		X
PELVIS		
Inspect for breakage, especially at iliac crest		X

Comments on repair or replacement parts:

Test Program: Dummy Damage Checklist
 ATD Serial No.: 035

Test Date: 10/25/07
 Test I.D.: N/A



GENERAL	DAMAGED	OK
Outer skin on entire dummy		X
Head ballast secure		X
Gashes, rips, general appearance, etc.		X
Neck-Broken or cracks in rubber		X
Check that upper neck bracket is firmly attached to lwr neck bracket		X
Three rubber bumpers in place		X
Spine- Broken or cracks in rubber		X
Check for looseness at the condyle joint		X
Nodding blocks- cracked or out of position		X
Ribs- Check all ribs and rib supports for damage (bent or broken)		X
Check damping material or separation or cracks		X
OTHER		
CHEST DISPLACEMENT ASSEMBLY		
Bent shaft		X
Slider arm riding correctly, in track		X
TRANSDUCER LEADS		
Torn cables		X
ACCELEROMETER MOUNTINGS		
Check for secure mounting		X
KNEES		
Check outer skin, insert and casting (without removing insert)		X
Knee sliders - Wires intact		X
Knee sliders- Rubber returned to "at rest position"		X
LIMBS		
Check for normal movement and adjustment		X
PELVIS		
Inspect for breakage, especially at iliac crest		X

Comments on repair or replacement parts:

APPENDIX D
CHILD RESTRAINT SYSTEM

REPORT NUMBER TR-P28001-10-NC

**NEW CAR ASSESSMENT PROGRAM
FRONTAL BARRIER IMPACT TEST**

**CHRYSLER LLC
2008 DODGE RAM 1500 SXT
4-DOOR TRUCK**

NHTSA NUMBER: M80308

**PREPARED BY:
KARCO ENGINEERING, LLC
9270 HOLLY ROAD
ADELANTO, CALIFORNIA 92301**



NOVEMBER 8, 2007

FINAL REPORT

**PREPARED FOR:
U.S. DEPARTMENT OF TRANSPORTATION
NATIONAL HIGHWAY TRAFFIC SAFETY ADMINISTRATION
RULEMAKING
OFFICE OF CRASHWORTHINESS STANDARDS
MAIL CODE: NVS-111
1200 NEW JERSEY AVE, SE, ROOM W43-410
WASHINGTON, D.C. 20590**

This final test report was prepared for the U.S. Department of Transportation, National Highway Traffic Safety Administration, in response to Contract Number DTNH22-06-D-00027.

This publication is distributed by the U.S. Department of Transportation, National Highway Traffic Safety Administration, in the interest of information exchange. The opinions, findings and conclusions expressed in this publication are those of the author(s) and not necessarily those of the Department of Transportation or the National Highway Traffic Safety Administration. The United States Government assumes no liability for its contents or use thereof. If trade or manufacturers' names or products are mentioned, it is only because they are considered essential to the object of the publication and should not be construed as an endorsement. The United States Government does not endorse products or manufacturers.

Prepared by:  Date: November 8, 2007
Mr. Pablo Vega, Test Engineer
KARCO Engineering, LLC

Reviewed by:  Date: November 8, 2007
Mr. Michael L. Dunlap, Director of Operations
KARCO Engineering, LLC

Approved by:  Date: November 8, 2007
Mr. Frank D. Richardson, Program Manager
KARCO Engineering, LLC

FINAL REPORT ACCEPTED BY:

Manager, New Car Assessment Program

Date of Acceptance

COTR, NCAP Frontal Impact Program

Date of Acceptance

Technical Report Documentation Page

1. Report No. TR-P28001-10-NC	2. Government Accession No.	3. Recipients Catalog No.			
4. Title and Subtitle Final Report of one (1) Combi Centre DX CRS Final Report of one (1) Graco Infant Safe Seat CRS NHTSA NO. M80308		5. Report Date November 8, 2007			
		6. Performing Organization Code KAR			
7. Authors Mr. Pablo Vega, Test Engineer, Karco Mr. Frank Richardson, Program Manager, Karco		8. Performing Organization Report No. TR-P28001-10-NC			
9. Performing Organization Name and Address Karco Engineering, LLC 9270 Holly Rd. Adelanto, CA, 92301		10. Work Unit No.			
		11. Contract or Grant No. DTNH22-06-D-00027			
12. Sponsoring Agency Name and Address U. S. Department of Transportation National Highway Traffic Safety Administration Rulemaking Office of Crashworthiness Standards Mail Code NVS-111 1200 New Jersey Ave, SE, Room W43-410 Washington, D.C 20590		13. Type of Report and Period Covered Final Test Report Base Year			
		14. Sponsoring Agency Code DOT/NHTSA/NRM/OCS			
15. Supplementary Notes					
16. Abstract A frontal impact test was conducted on one (1) Combi Centre DX CRS and one (1) Graco Infant Safe Seat CRS in conjunction with frontal barrier impact NCAP testing on a 2008 Dodge Ram 1500 SXT 4-Door Truck and in accordance with the specifications of the Office of Crashworthiness Standards Test Procedure for the determination of CRS crashworthiness. This test was conducted at Karco Engineering, LLC on November 8, 2007.					
Measurement Description		Units	Threshold	Left Rear (P4)	Right Rear (P3)
Head Injury Criteria (HIC15)		N/A	390	565.1	471.0
3 msec. Chest Clip		G's	50	58.8	45.7
17. Key Words New Car Assessment Program (Frontal NCAP) Frontal Barrier Impact Test Final Report of a Combi Centre DX CRS Final Report of a Graco Infant Safe Seat CRS			18. Distribution of Statement Copies of this report available from: NHTSA Technical Reference Division National Highway Traffic Safety Admin. 1200 New Jersey Ave, SE, Room W43-410 Washington, D.C. 20590		
19. Security Classification (this report) Unclassified	20. Security Classification (this page) Unclassified	21. No. of Pages 69	22. Price		

TABLE OF CONTENTS

<u>Section</u>	<u>Description</u>	<u>Page</u>
D1	Purpose and Summary of Test M80308	D1-1 to D1-8
D2	Photographs	D2-1 to D2-36
D3	CRABI Response and CRS Data Traces	D3-1 to D3-4
D4	CRABI Calibration Information	D4-1 to D4-12
<u>Data Sheet</u>	<u>Description</u>	<u>Page</u>
1	Crash Test Summary	D1-2
2	Vehicle Parameter Data	D1-3
3	CRABI Positioning in Vehicle	D1-4
4	CRS Performance Data	D1-6
5	CRS Accelerometer Locations	D1-7
6	CRS Camera Locations and Data	D1-8

SECTION D1

PURPOSE AND SUMMARY OF TEST M80308

The purpose of this test is to obtain CRS performance data during 35 mph (56.3 km/h) frontal barrier impact NCAP test.

The frontal barrier impact NCAP test was conducted in accordance with the Office of Crashworthiness Standards (OCS) NCAP Laboratory Test Procedure.

SUMMARY

Two 12-month old CRABI's (P3 & P4) were instrumented with head, chest, and six-axis upper neck load cells. Tri-axial accelerometers were installed on both CRS's and the CRS bases.

The left rear (Serial No. 017) and right rear (Serial No. 022) CRABI's were calibrated two test prior to this test. CRABI calibration information is found in Section D-4.

CHILD DUMMY VALUES		
Location	HIC15 Values	3 Msec. Chest Clip
CRABI (P3)	471.0	45.7
CRABI (P4)	565.1	58.8

DATA SHEET NO.1
CRASH TEST SUMMARY

Test Vehicle: 2008 Dodge Ram 1500 SXT 4-Door Truck

NHTSA No.: M80308

Test Program: NHTSA 35mph NCAP

Test Date: 11/8/07

CHILD RESTRAINT SYSTEM INFORMATION

Description	Position #3 CRS	Position #4 CRS
Manufacturer	Graco	Combi
Model Name	Infant Safe Seat	Centre DX
Serial No.	JJ0208070476	927500
Type	Infant	Infant
Forward/Rearward	Rearward	Rearward

VISIBLE DUMMY CONTACT POINTS

Description	Position #3 CRS	Position #4 CRS
Head Contact	None	Rear Driver Seat
Chest Contact	None	None
Abdomen Contact	None	None
Left Knee Contact	None	None
Right Knee Contact	None	None
Left Toe Contact	Seatback	None
Right Toe Contact	None	None

POST-TEST DOOR OPENINGS

Description	Position #3 CRS	Position #4 CRS
Right Rear Door	Remained closed and latched, opened w/o tools	Remained closed and latched, opened w/o tools

CAMERA COVERAGE

Description	Standard
High Speed	4
Real Time	0
Total	4

DATA CHANNELS

CRABI (P3 & P4) Sensors	26
Belt Sensors	4
CRS Sensors	12
Total	42

DATA SHEET NO.2
VEHICLE PARAMETER DATA

Test Vehicle: 2008 Dodge Ram 1500 SXT 4-Door Truck

NHTSA No.: M80308

Test Program: NHTSA 35mph NCAP

Test Date: 11/8/07

TEST VEHICLE WEIGHTS

	Units	As Delivered Weights (UVW)			As Tested Weights (ATW)		
		Front Axle	Rear Axle	Total	Front Axle	Rear Axle	Total
Left	kg	728	508	1236	792	572	1364
Right	kg	697	484	1181	731	605	1336
Ratio	%	59.0%	41.0%	100.0%	56.4%	43.6%	100.0%
Totals	kg	1425	992	2417	1523	1177	2700

TARGET TEST WEIGHT CALCULATION

Measured Parameter	Units	Value
Total Delivered Weight (UVW)	kg	2417
Weight of 2 P572 ATD's	kg	152
Rated Cargo/Luggage Wt. (RCLW)	kg	136
Calculated Vehicle Target Wt. (TVTWT)	kg	2705

DATA SHEET NO.3

CRABI POSITIONING IN VEHICLE

Test Vehicle: 2008 Dodge Ram 1500 SXT 4-Door Truck

NHTSA No.: M80308

Test Program: NHTSA 35mph NCAP

Test Date: 11/8/07

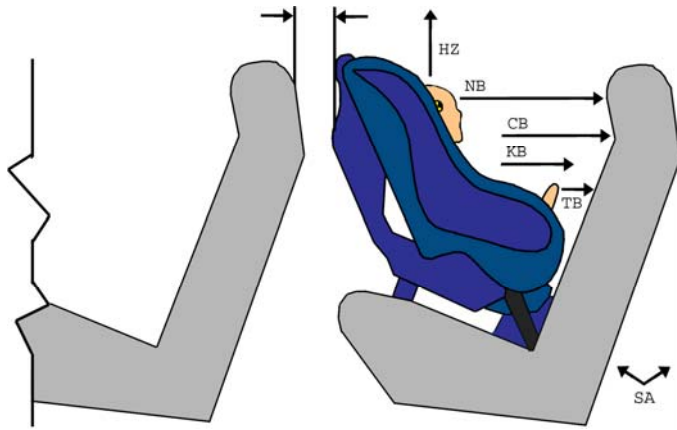

- | | |
|----|---------------------|
| AD | Arm to Door |
| CD | Chest to Door |
| HD | H-Point to Door |
| HS | Head to Side Window |
| KK | Knee to Knee |
| TT | Toe to Toe |

- | | |
|----|--------------------|
| CB | Chest to Seat Back |
| HZ | Head to Roof |
| KB | Knee to Seat Back |
| NB | Nose to Seat Back |
| SA | Seat Back Angle |
| TB | Toe to Seat Back |

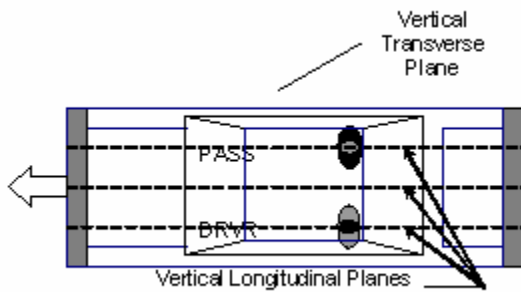
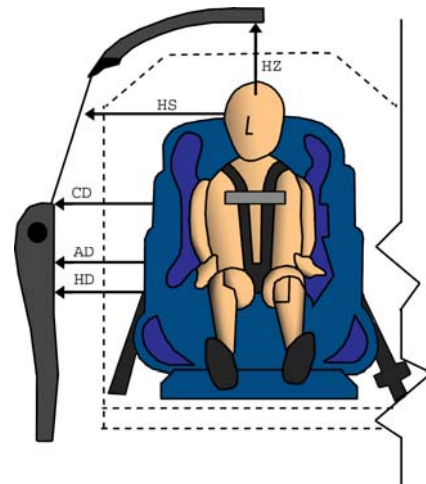

DUMMY MEASUREMENTS FOR REAR SEAT OCCUPANTS

DATA SHEET NO.3

CRABI POSITIONING IN VEHICLE...(CONTINUED)

Test Vehicle: 2008 Dodge Ram 1500 SXT 4-Door Truck

NHTSA No.: M80308

Test Program: NHTSA 35mph NCAP

Test Date: 11/8/07

CRABI POSITION MEASUREMENTS

Code	Measurement	P3 (Passenger's Side)		P4 (Driver's Side)	
		Length (mm)	Angle (°)	Length (mm)	Angle (°)
SA	Seat Back Angle		81.0		81.0
HZ	Head to Roof (Z)	497		482	
CD	Chest to Door	420		397	
KK	Knee to Knee (Y)	120		100	
HS	Head to Side Window	430		403	
HD	H-Point to Door (Y)	351		329	
AD	Arm to Door	303		272	
NB	Nose to Seat Back	485		498	
CB	Chest to Seat Back	393		382	
FF	Foot to Foot	97		81	
KB-Left	Knee to Seat Back	170		212	
KB-Right	Knee to Seat Back	172		211	
TB-Left	Toe to Seat Back	35		43	
TB-Right	Toe to Seat Back	40		38	

DATA SHEET NO.4
CRS PERFORMANCE DATA

Test Vehicle: 2008 Dodge Ram 1500 SXT 4-Door Truck

NHTSA No.: M80308

Test Program: NHTSA 35mph NCAP

Test Date: 11/8/07

CRS PERFORMANCE DATA

Location	CRS (P4)		CRS (P3)	
	Damage	Post-Test	Damage	Post-Test
Upper Tether Strap				
Upper Tether Buckle				
Upper Tether Hook				
Veh. Upper Tether Anchor				
Lower Anchor Strap				
Lower Anchor Buckle				
Lower Anchor Hooks	No	None	No	None
Veh. Lower CRS Anchors	No	None	No	None
5-Point Harness Connections	No	None	No	None
Cracks on CRS	Yes	Base Anchors	No	None
Fabric Tears on CRS	No	None	No	None
Vehicle Seat Structure	No	None	No	None
Vehicle Seat Fabric Tears	No	None	No	None

* CRS in P4 position became detached during the test.

DATA SHEET NO.5

CRS ACCELEROMETER LOCATIONS

Test Vehicle: 2008 Dodge Ram 1500 SXT 4-Door Truck

NHTSA No.: M80308

Test Program: NHTSA 35mph NCAP

Test Date: 11/8/07

DATA SHEET NO.6**CRS CAMERA LOCATIONS AND DATA**Test Vehicle: 2008 Dodge Ram 1500 SXT 4-Door TruckNHTSA No.: M80308Test Program: NHTSA 35mph NCAPTest Date: 11/8/07**CAMERA LOCATIONS**

No.	Camera View	Location(mm)			Angle (Deg.)	Film Plane to Head	Lens (mm)	Speed (fps)
		X	Y	Z				
1	Driver Side Upper CRS View	-2975	291	-1781	-2		12	1000
2	Passenger Side Upper CRS View	-2975	-287	-1781	2		12	1000
3	Driver Side Lower CRS View	-3105	763	-1739	-2		10	1000
4	Passenger Side Lower CRS View	-2813	-763	-1740	2		12	1000

SECTION D2
PHOTOGRAPHS

LIST OF PHOTOGRAPHS

Figure		Page
1	Position 3 CRS Label	D2-1
2	Pre-Test Frontal View of Position 3 CRS	D2-2
3	Post-Test Frontal View of Position 3 CRS	D2-3
4	Pre-Test Rear View of Position 3 CRS	D2-4
5	Post-Test Rear View of Position 3 CRS	D2-5
6	Pre-Test Left Side View of Position 3 CRS	D2-6
7	Post-Test Left Side View of Position 3 CRS	D2-7
8	Pre-Test Right Side View of Position 3 CRS	D2-8
9	Post-Test Right Side View of Position 3 CRS	D2-9
10	Pre-Test Position 3 Front View (Head and Seat Belt Position)	D2-10
11	Post-Test Position 3 Front View (Head and Seat Belt Position)	D2-11
12	Pre-Test Position 3 Front View (Seat Belt Position)	D2-12
13	Post-Test Position 3 Front View (Seat Belt Position)	D2-13
14	Pre-Test Position 3 Right Side View	D2-14
15	Post-Test Position 3 Right Side View	D2-15
16	Pre-Test Position 3 Right Side View (Through Window)	D2-16
17	Post-Test Position 3 Right Side View (Through Window)	D2-17
18	Post-Test Position 3 Dummy Legs	D2-18
19	Position 4 CRS Label	D2-1
20	Pre-Test Frontal View of Position 4 CRS	D2-2
21	Post-Test Frontal View of Position 4 CRS	D2-3
22	Pre-Test Rear View of Position 4 CRS	D2-4
23	Post-Test Rear View of Position 4 CRS	D2-5
24	Pre-Test Left Side View of Position 4 CRS	D2-6
25	Post-Test Left Side View of Position 4 CRS	D2-7
26	Pre-Test Right Side View of Position 4 CRS	D2-8
27	Post-Test Right Side View of Position 4 CRS	D2-9
28	Pre-Test Position 4 Front View (Head and Seat Belt Position)	D2-10
29	Post-Test Position 4 Front View (Head and Seat Belt Position)	D2-11
30	Pre-Test Position 4 Front View (Seat Belt Position)	D2-12
31	Post-Test Position 4 Front View (Seat Belt Position)	D2-13
32	Pre-Test Position 4 Right Side View	D2-14
33	Post-Test Position 4 Right Side View	D2-15
34	Pre-Test Position 4 Right Side View (Through Window)	D2-16
35	Post-Test Position 4 Right Side View (Through Window)	D2-17
36	Post-Test Position 4 Dummy Legs	D2-18

disponible chez votre détaillant,
appelez 1-800-667-8184.

disponible en su
al 1-800-345-41

MODEL 8A06INC

NAME: Infant SafeSeat™

SERIAL JJ 0 2 0 8 0 7 0 4 7 6

Manufactured in 020807

GRACO CHILDREN'S PRODUCTS, INC.

EXTON, PA 19341 1-888-224-6549

Made in China

LAPZ0004B

Figure D2-1: Position 3 CRS Label



**2008 Dodge Ram
1500 SXT
M80308
P-3
GRACO
SAFE SEAT**

Figure D2-2: Pre-Test Frontal View of Position 3 CRS



Figure D2-3: Post-Test Frontal View of Position 3 CRS



D2-4

TR-P28001-10-NC

Figure D2-4: Pre-Test Rear View of Position 3 CRS



D2-5

TR-P28001-10-NC

Figure D2-5: Post-Test Rear View of Position 3 CRS



D2-6

TR-P28001-10-NC

Figure D2-6: Pre-Test Right Side View of Position 3 CRS



D2-7

TR-P28001-10-NC

Figure D2-7: Post-Test Right Side View of Position 3 CRS



Figure D2-8: Pre-Test Left Side View of Position 3 CRS

D2-8

TR-P28001-10-NC



D2-9

TR-P28001-10-NC

Figure D2-9: Post-Test Left Side View of Position 3 CRS



Figure D2-10: Pre-Test Position 3 Front View (Head and Seat Belt Position)



Figure D2-11: Post-Test Position 3 Front View (Head and Seat Belt Position)



Figure D2-12: Pre-Test Position 3 Front View (Seat Belt Position)



Figure D2-13: Post-Test Position 3 Front View (Seat Belt Position)



Figure D2-14: Pre-Test Position 3 Right Side View



Figure D2-15: Post-Test Position 3 Right Side View



Figure D2-16: Pre-Test Position 3 Right Side View (Through Window)



Figure D2-17: Post-Test Position 3 Right Side View (Through Window)



Figure D2-18: Post-Test Position 3 Dummy Legs

Model Name : Centre Base
Model Number : 927500
Manufactured in : 08-25-2007
CC43C0314BC00625



B

Figure D2-19: Position 4 CRS Label



D2-20

TR-P28001-10-NC

Figure D2-20: Pre-Test Frontal View of Position 4 CRS



Figure D2-21: Post-Test Frontal View of Position 4 CRS



WARNING **ADVERTENCIA**
Do not use if carry car seat is not properly installed. No use if any part of the seat is damaged or if the seat is not properly installed. No use if any part of the seat is damaged or if the seat is not properly installed.

MADE FOR
COMBI USA, INC.
1962 Highway 150 West, Suite #100
Fort Mill, SC 29708-9027
Delivery Date: **08 25 07**
MADE IN CHINA
THIS ARTICLE MEETS
THE FLAMMABILITY
REQUIREMENTS
OF CALIFORNIA
FURNITURE HOME
TEXTILES
TECHNICAL
RULES

**2008 Dodge Ram
1500 SKT
M80308
P-4
COMBI
CENTRE**

D2-22

TR-P28001-10-NC

Figure D2-22: Pre-Test Rear View of Position 4 CRS



WARNING **ADVERTENCIA**

For use only in accordance with use.
MODELO P20
COMBI USA, INC.
190 Highway 100 West, Suite P100
Furman, SC 29728-4327
Delivery Date: **08 25 07**
Model: 010000
THIS ARTICLE MEETS
THE FLAMMABILITY
REQUIREMENTS
OF CALIFORNIA
AND ALL OF HOME
FURNISHINGS
TECHNICAL
BULLETIN 117

**2008 Dodge Ram
1500 SXT
M80308
P-4
COMBI
CENTRE**

D2-23

TR-P28001-10-NC

Figure D2-23: Post-Test Rear View of Position 4 CRS



D2-24

TR-P28001-10-NC

Figure D2-24: Pre-Test Right Side View of Position 4 CRS



D2-25

TR-P28001-10-NC

Figure D2-25: Post-Test Right Side View of Position 4 CRS



D2-26

TR-P28001-10-NC

Figure D2-26: Pre-Test Left Side View of Position 4 CRS



D2-27

TR-P28001-10-NC

Figure D2-27: Post-Test Left Side View of Position 4 CRS



Figure D2-28: Pre-Test Position 4 Front View (Head & Seat Belt Position)



WARNING

DO NOT place rear-facing child seat on front seat with air bag. DEATH OR SERIOUS INJURY can occur.

The back seat is the safest place for children 12 and under.



NO coloque el asiento infantil para el automóvil orientado hacia atrás en el asiento delantero de seguridad. El niño vehiculo que tenga una bolsa de aire puede sufrir lesiones graves o la muerte. El niño vehiculo que tenga una bolsa de aire puede sufrir lesiones graves o la muerte. El niño vehiculo que tenga una bolsa de aire puede sufrir lesiones graves o la muerte.

Figure D2-29: Post-Test Position 4 Front View (Head & Seat Belt Position)



Figure D2-30: Pre-Test Position 4 Front View (Seat Belt Position)



Figure D2-31: Post-Test Position 4 Front View (Seat Belt Position)



Figure D2-32: Pre-Test Position 4 Left Side View

D2-32

TR-P28001-10-NC



D2-33

TR-P28001-10-NC

Figure D2-33: Post-Test Position 4 Left Side View



Figure D2-34: Pre-Test Position 4 Left Side View

D2-34

TR-P28001-10-NC



D2-35

TR-P28001-10-NC

Figure D2-35: Post-Test Position 4 Left Side View



D2-36

TR-P28001-10-NC

Figure D2-36: Post-Test Position 4 Dummy Legs

SECTION D3

CRABI RESPONSE AND CRS DATA TRACES

LIST OF DATA PLOTS

<u>Data Plot</u>	<u>Page</u>	
D3-1	Right Rear CRABI (P4) Head X	D3-1
	Right Rear CRABI (P4) Head Y	D3-1
	Right Rear CRABI (P4) Head Z	D3-1
	Right Rear CRABI (P4) Head Resultant	D3-1
D3-2	Right Rear CRABI (P4) Chest X	D3-2
	Right Rear CRABI (P4) Chest Y	D3-2
	Right Rear CRABI (P4) Chest Z	D3-2
	Right Rear CRABI (P4) Chest Resultant	D3-2
D3-3	Right Rear CRABI (P3) Head X	D3-3
	Right Rear CRABI (P3) Head Y	D3-3
	Right Rear CRABI (P3) Head Z	D3-3
	Right Rear CRABI (P3) Head Resultant	D3-3
D3-4	Right Rear CRABI (P3) Chest X	D3-4
	Right Rear CRABI (P3) Chest Y	D3-4
	Right Rear CRABI (P3) Chest Z	D3-4
	Right Rear CRABI (P3) Chest Resultant	D3-4

Test Vehicle: 2008 Dodge Ram 1500 SXT 4-Door Truck
 Test Program: NHTSA 35mph NCAP

Test Date: 11/8/07
 NHTSA No.: M80308

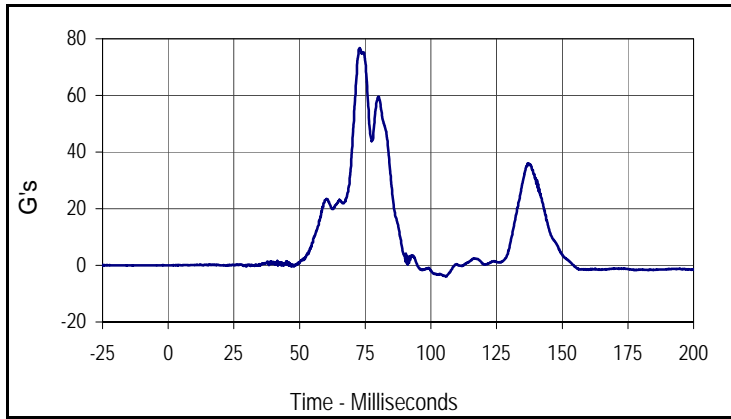

Curve Description			
CRABI Head X (P4)			
CURNO	Type	SAE Class	Units
142	FIL	1000	G's
Max	Time	Min	Time
76.7	72.9	-3.9	105.8

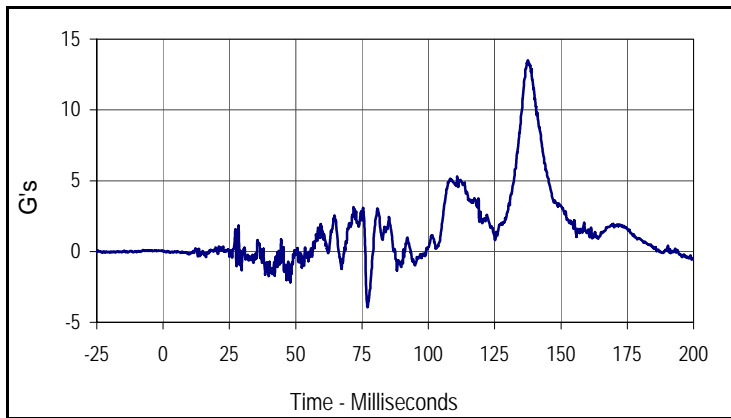

Curve Description			
CRABI Head Y (P4)			
CURNO	Type	SAE Class	Units
143	FIL	1000	G's
Max	Time	Min	Time
13.5	137.5	-3.9	77.1

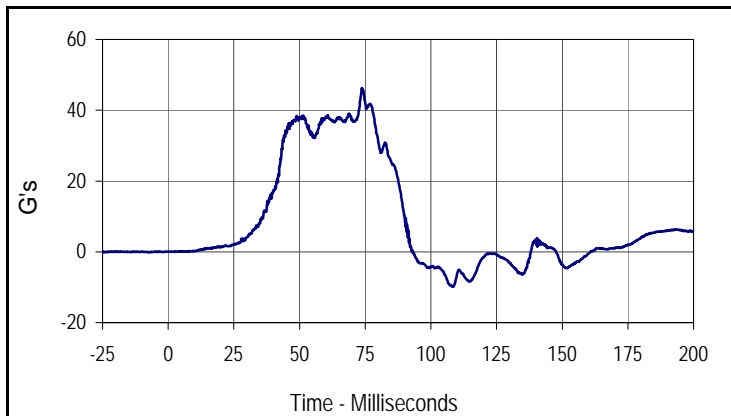

Curve Description			
CRABI Head Z (P4)			
CURNO	Type	SAE Class	Units
144	FIL	1000	G's
Max	Time	Min	Time
46.2	73.8	-9.9	108.4

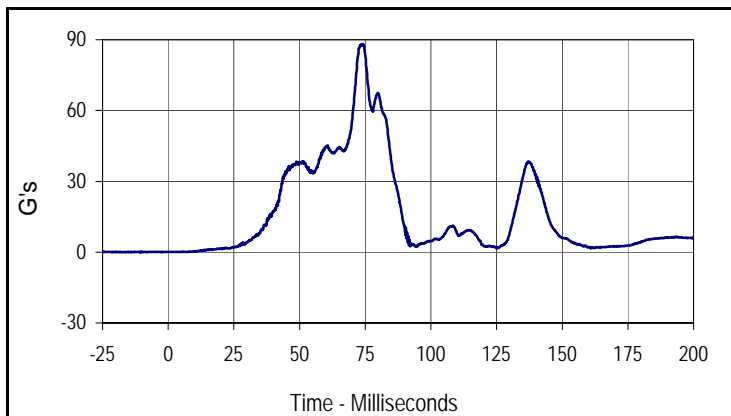

Curve Description			
CRABI Head Resultant (P4)			
CURNO	Type	SAE Class	Units
142	RES	1000	G's
Max	Time	Min	Time
88.1	73.7	0.1	4.9

Test Vehicle: 2008 Dodge Ram 1500 SXT 4-Door Truck
 Test Program: NHTSA 35mph NCAP

Test Date: 11/8/07
 NHTSA No.: M80308

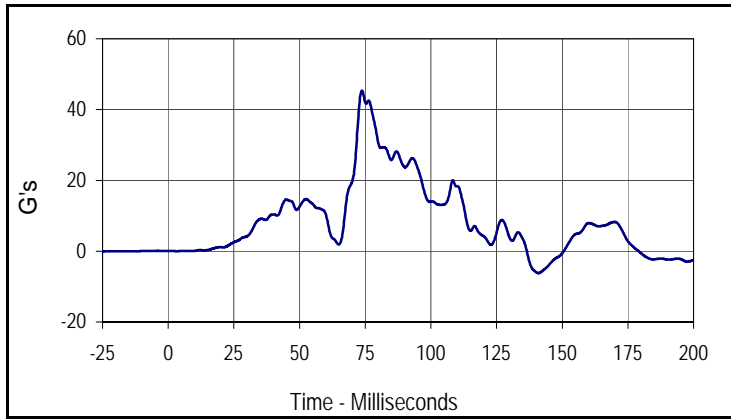

Curve Description			
CRABI Chest X (P4)			
CURNO	Type	SAE Class	Units
145	FIL	180	G's
Max	Time	Min	Time
45.3	73.7	-6.2	140.9

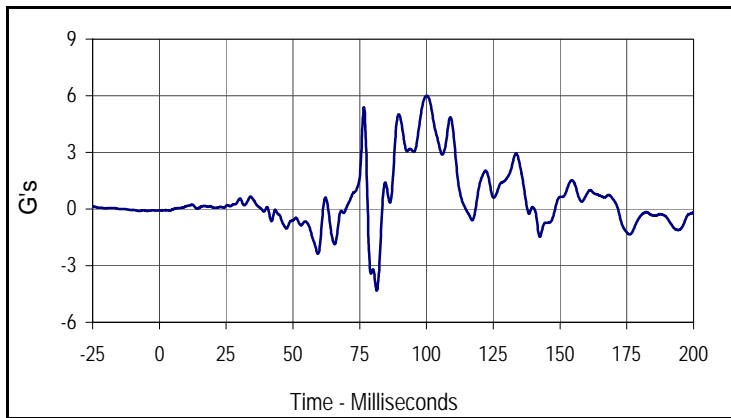

Curve Description			
CRABI Chest Y (P4)			
CURNO	Type	SAE Class	Units
146	FIL	180	G's
Max	Time	Min	Time
6.0	100.1	-4.3	81.4

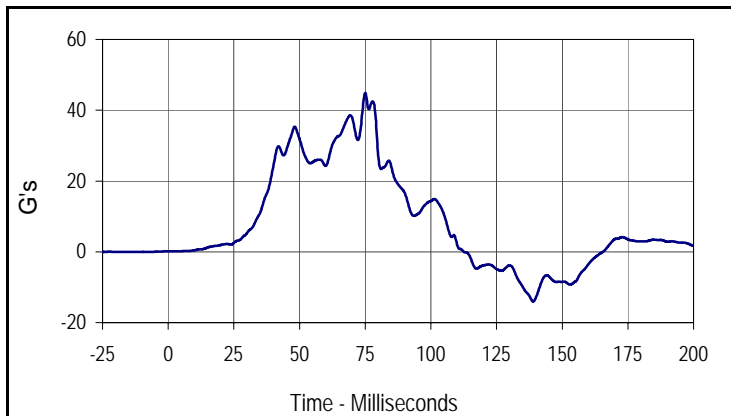

Curve Description			
CRABI Chest Z (P4)			
CURNO	Type	SAE Class	Units
147	FIL	180	G's
Max	Time	Min	Time
44.9	75.0	-14.0	138.9

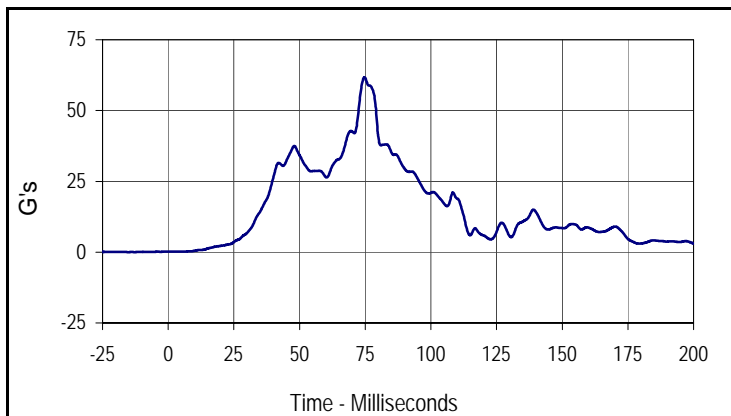

Curve Description			
CRABI Chest Resultant (P4)			
CURNO	Type	SAE Class	Units
145	RES	180	G's
Max	Time	Min	Time
61.7	74.7	0.2	0.0

Test Vehicle: 2008 Dodge Ram 1500 SXT 4-Door Truck
 Test Program: NHTSA 35mph NCAP

Test Date: 11/8/07
 NHTSA No.: M80308

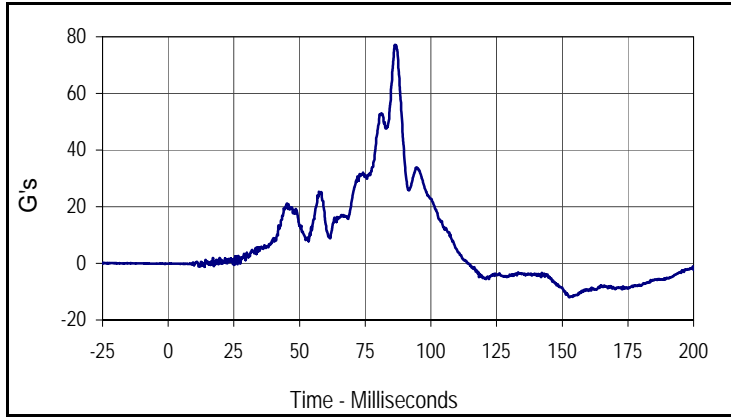

Curve Description			
CRABI Head X (P3)			
CURNO	Type	SAE Class	Units
163	FIL	1000	G's
Max	Time	Min	Time
77.2	86.3	-12.0	152.8

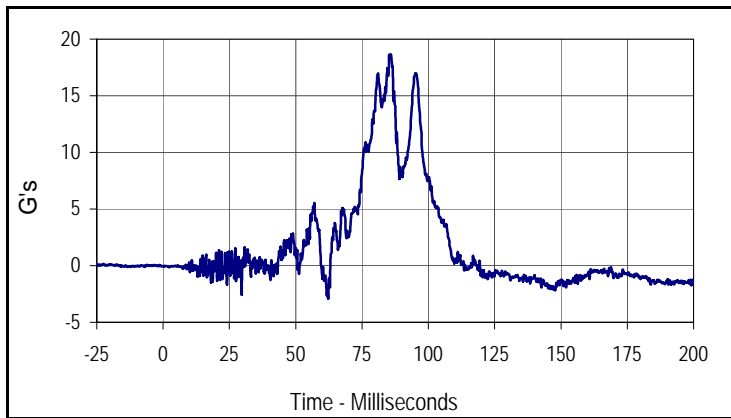

Curve Description			
CRABI Head Y (P3)			
CURNO	Type	SAE Class	Units
164	FIL	1000	G's
Max	Time	Min	Time
18.6	85.9	-2.9	62.2

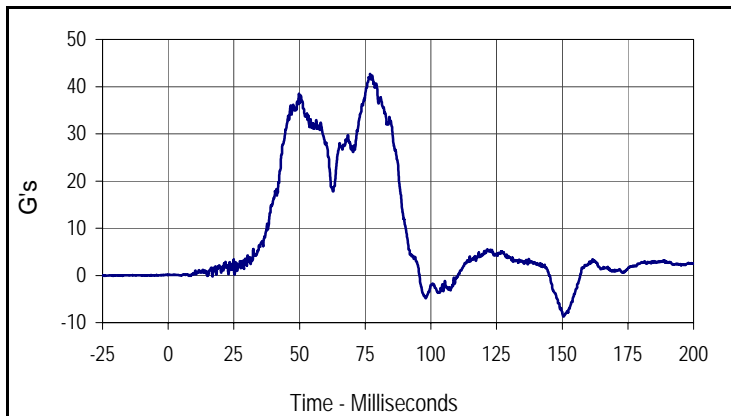

Curve Description			
CRABI Head Z (P3)			
CURNO	Type	SAE Class	Units
165	FIL	1000	G's
Max	Time	Min	Time
42.7	76.9	-8.7	150.5

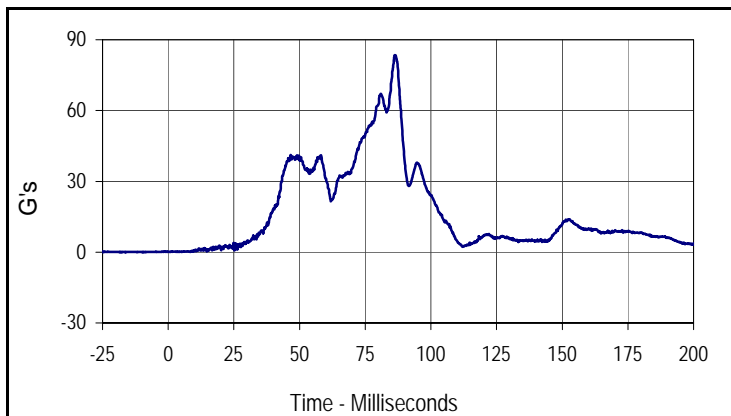

Curve Description			
CRABI Head Resultant (P3)			
CURNO	Type	SAE Class	Units
163	RES	1000	G's
Max	Time	Min	Time
83.5	86.3	0.1	4.2

Test Vehicle: 2008 Dodge Ram 1500 SXT 4-Door Truck
 Test Program: NHTSA 35mph NCAP

Test Date: 11/8/07
 NHTSA No.: M80308

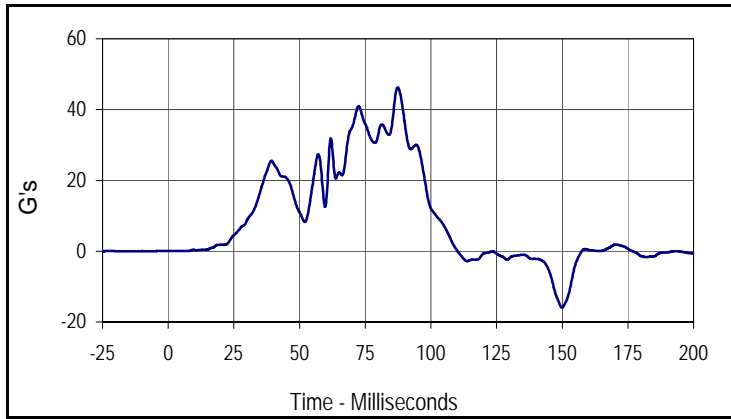

Curve Description			
CRABI Chest X (P3)			
CURNO	Type	SAE Class	Units
166	FIL	180	G's
Max	Time	Min	Time
46.3	87.4	-15.9	149.9

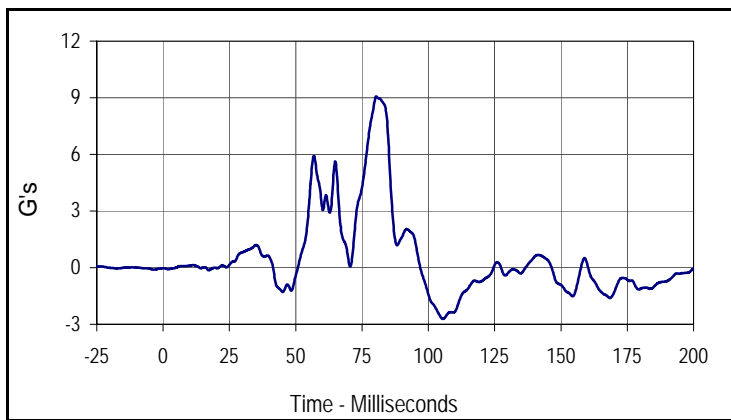

Curve Description			
CRABI Chest Y (P3)			
CURNO	Type	SAE Class	Units
167	FIL	180	G's
Max	Time	Min	Time
9.1	80.4	-2.7	105.4

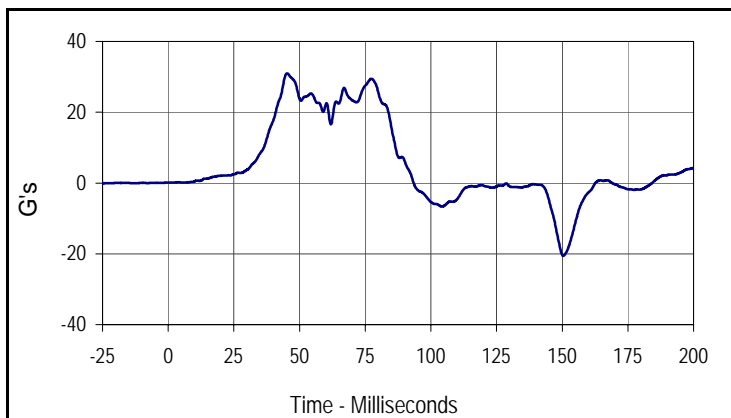

Curve Description			
CRABI Chest Z (P3)			
CURNO	Type	SAE Class	Units
168	FIL	180	G's
Max	Time	Min	Time
30.9	45.2	-20.6	150.4

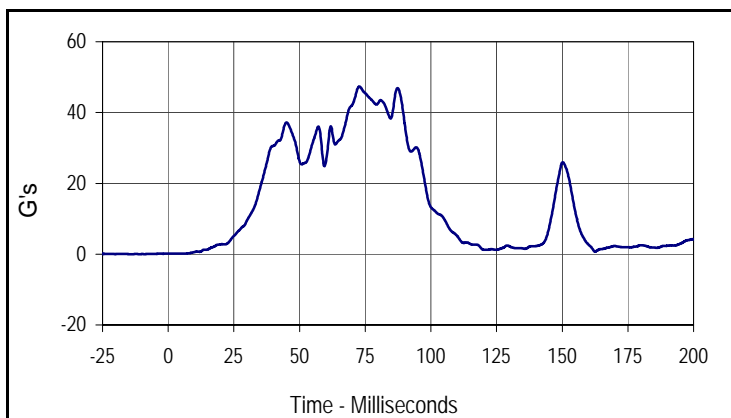

Curve Description			
CRABI Chest Resultant (P3)			
CURNO	Type	SAE Class	Units
166	RES	180	G's
Max	Time	Min	Time
47.3	72.8	0.1	0.7

SECTION D4

CRABI CALIBRATION INFORMATION

Test Program: CRABI 12 Month Old Frontal Head Drop Test

Test Date: 10/24/07

ATD Serial No.: 017

Test I.D.: FHD10U



Tested Parameter	Units	Specification	Result	Pass/Fail
Laboratory Temperature	°C	18.9 to 25.6	21.1	Pass
Laboratory Relative Humidity	%	10 to 70	30	Pass
Peak Resultant Acceleration	G's	100.0 to 120.0	118.9	Pass
Peak Lateral Acceleration	G's	≤15.0	4.6	Pass
Is Acceleration Unimodal?	Yes/No	Yes	Yes	Pass
Overall Test Results				Pass

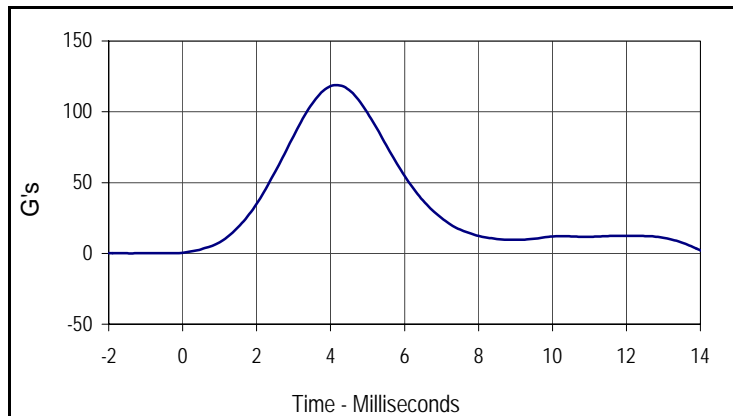

Curve Description			
Head Resultant			
CURNO	Type	SAE Class	Units
001	RES	1000	G's
Max	Time	Min	Time
118.9	4.2	0.0	-1.4

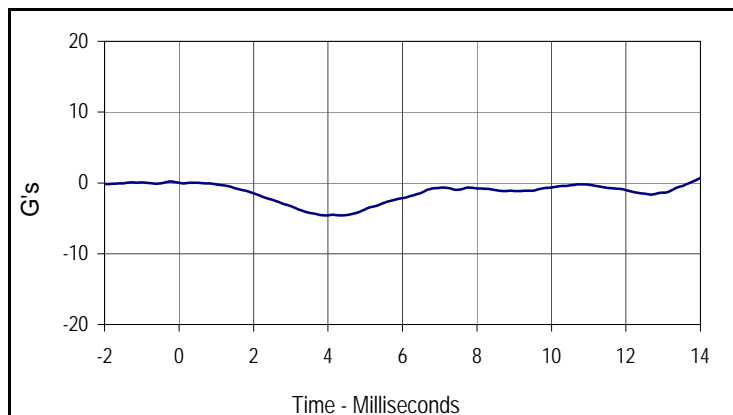

Curve Description			
Head Y			
CURNO	Type	SAE Class	Units
002	FIL	1000	G's
Max	Time	Min	Time
0.2	-0.2	-4.6	3.9

Test Program: CRABI 12 Month Old Rear Head Drop Test
 ATD Serial No.: 017

Test Date: 10/24/07
 Test I.D.: RHD10U



Tested Parameter	Units	Specification	Result	Pass/Fail
Laboratory Temperature	°C	18.9 to 25.6	21.1	Pass
Laboratory Relative Humidity	%	10 to 70	30	Pass
Peak Resultant Acceleration	G's	55.0 to 71.0	65.3	Pass
Peak Lateral Acceleration	G's	≤15.0	7.6	Pass
Is Acceleration Unimodal?	Yes/No	Yes	Yes	Pass
Overall Test Results			Pass	

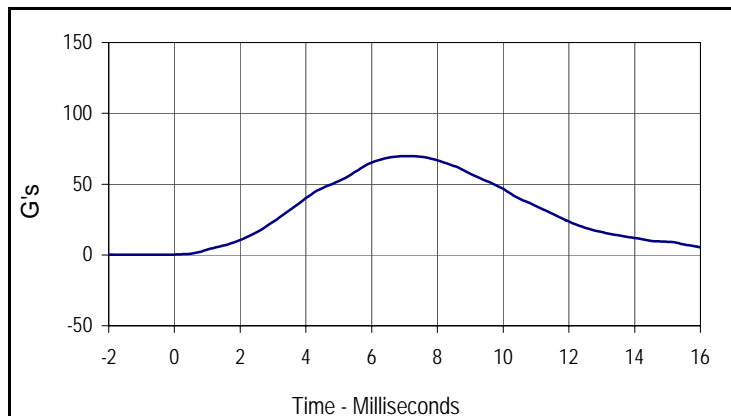

Curve Description			
Head Resultant			
CURNO	Type	SAE Class	Units
001	RES	1000	G's
Max	Time	Min	Time
65.3	6.0	0.1	-0.9

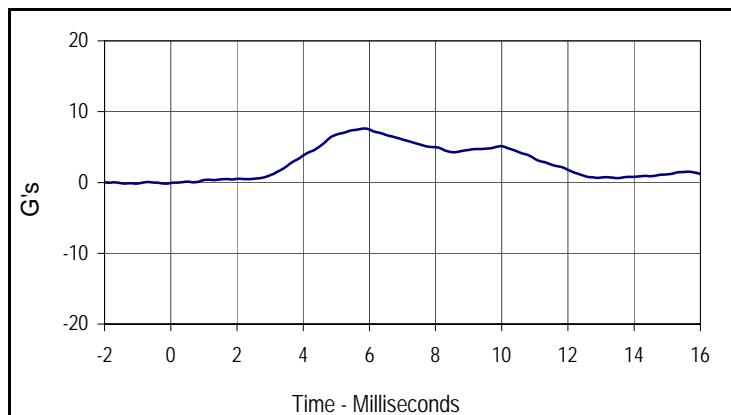

Curve Description			
Head Y			
CURNO	Type	SAE Class	Units
002	FIL	1000	G's
Max	Time	Min	Time
7.6	5.8	-0.2	-1.4

Test Program: CRABI 12 Month Old Thorax Impact Test

Test Date: 10/25/07

ATD Serial No.: 017

Test I.D.: CH10U



Tested Parameter	Units	Specification	Result	Pass/Fail
Laboratory Temperature	°C	20.6 to 22.2	21.1	Pass
Laboratory Relative Humidity	%	10 to 70	30	Pass
Pendulum Velocity at T=0	m/sec	4.90 to 5.10	4.95	Pass
Peak Probe Force	Newtons	-1514 to -1796	-1736	Pass
Overall Test Results				Pass

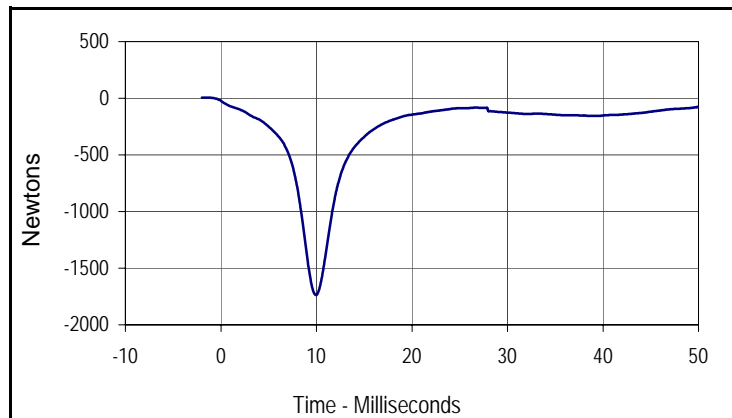

Curve Description			
Probe Force			
CURNO	Type	SAE Class	Units
001	FIL	180	Newtons
Max	Time	Min	Time
6.2	-1.6	-1736.1	10.0

Test Program: CRABI 12 Month Old Neck Flexion Test
 ATD Serial No.: 017

Test Date: 10/25/07
 Test I.D.: NF10U



Tested Parameter	Units	Specification	Result	Pass/Fail	
Laboratory Temperature	°C	20.6 to 22.2	21.1	Pass	
Laboratory Relative Humidity	%	10 to 70	30	Pass	
Pendulum Velocity	m/s	5.10 to 5.30	5.15	Pass	
Pendulum Deceleration	10 Msec.	m/s	1.6 to 2.3	1.9	Pass
	20 Msec.	m/s	3.4 to 4.2	3.9	Pass
	25 Msec.	m/s	4.3 to 5.2	4.8	Pass
"D" Plane Rotation	Max	Degrees	75.0 to 86.0	76.1	Pass
Peak Moment in Rotation	Max	Nm	36.0 to 45.0	41.3	Pass
Positive Moment Decay, Time To 5 Nm	Msec.		60.0 to 80.0	70.9	Pass
Overall Test Results				Pass	

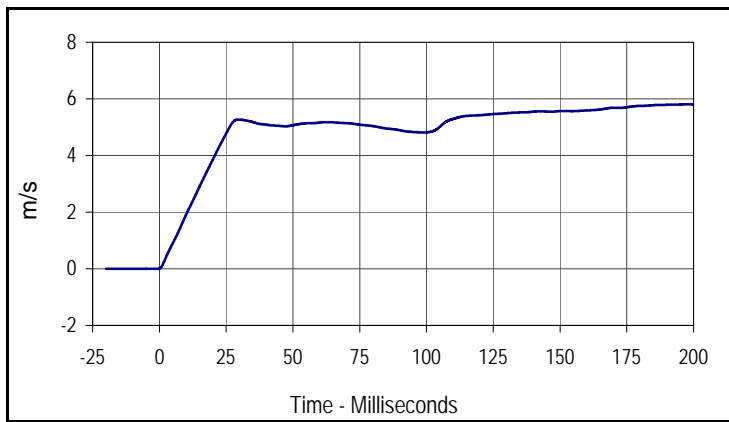

Curve Description			
Pendulum Velocity			
CURNO	Type	SAE Class	Units
001	FIL	180	m/s
Max	Time	Min	Time
5.8	199.3	0.0	-0.7

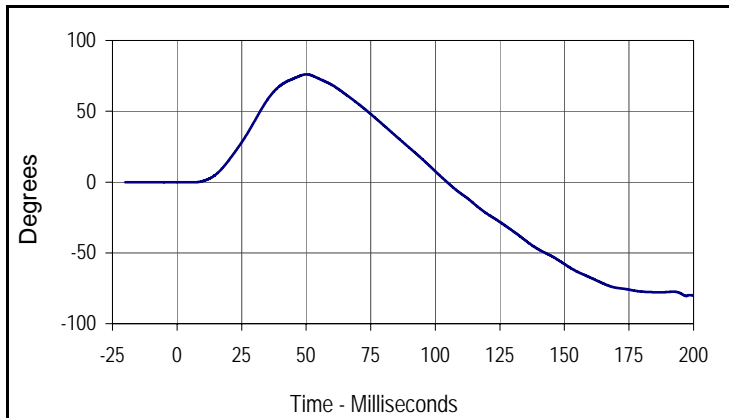

Curve Description			
"D" Plane Rotation			
CURNO	Type	SAE Class	Units
003	FIL	60	Degrees
Max	Time	Min	Time
76.1	50.1	-80.5	197.1

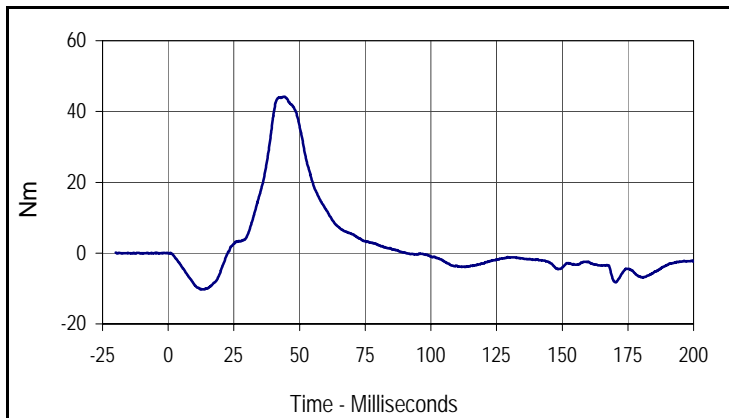

Curve Description			
Upper Neck Force Y			
CURNO	Type	SAE Class	Units
002	FIL	600	Nm
Max	Time	Min	Time
44.2	44.3	-10.3	13.5

Test Program: CRABI 12 Month Old Neck Extension Test
 ATD Serial No.: 017

Test Date: 10/24/07
 Test I.D.: NE10U



Tested Parameter	Units	Specification	Result	Pass/Fail	
Laboratory Temperature	°C	20.6 to 22.2	21.1	Pass	
Laboratory Relative Humidity	%	10 to 70	30	Pass	
Pendulum Velocity	m/s	2.4 to 2.6	2.41	Pass	
Pendulum Deceleration	6 Msec.	m/s	0.8 to 1.2	0.9	Pass
	10 Msec.	m/s	1.5 to 2.1	1.9	Pass
	14 Msec.	m/s	2.2 to 2.9	2.9	Pass
"D" Plane Rotation	Max	Degrees	80.0 to 92.0	91.4	Pass
Peak Moment in Rotation	Max	Nm	-12 to -23	-17.1	Pass
Positive Moment Decay, Time To -5 Nm	Msec.		76.0 to 90.0	77.8	Pass
Overall Test Results				Pass	

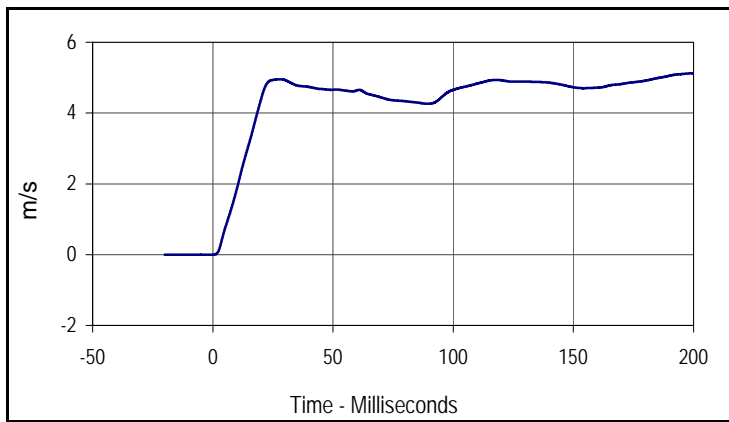

Curve Description			
Pendulum Velocity			
CURNO	Type	SAE Class	Units
001	FIL	180	m/s
Max	Time	Min	Time
5.1	200.0	0.0	0.1

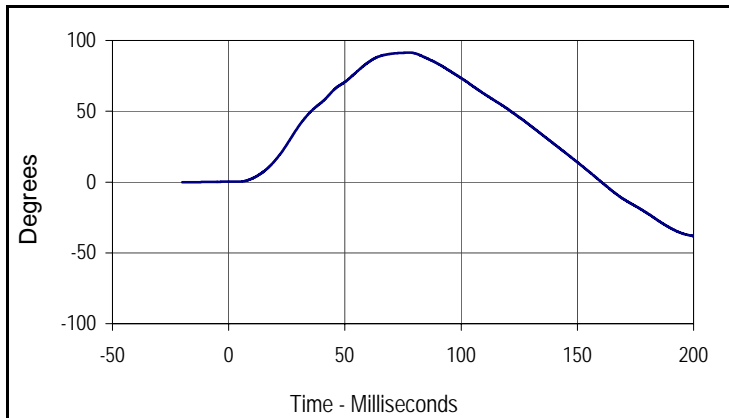

Curve Description			
"D" Plane Rotation			
CURNO	Type	SAE Class	Units
003	FIL	60	Degrees
Max	Time	Min	Time
91.4	77.7	-38.1	200.0

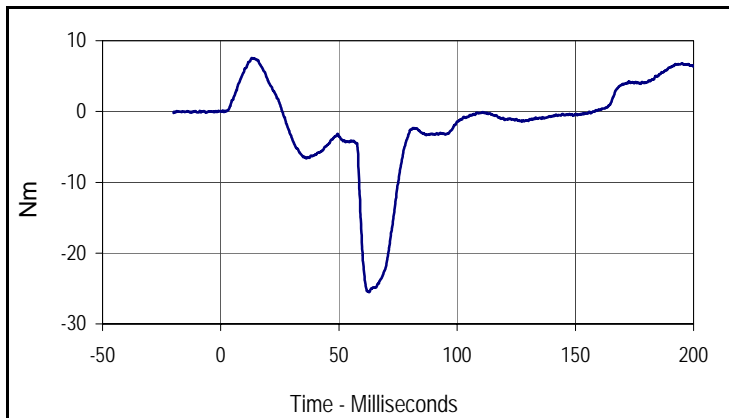

Curve Description			
Upper Neck Moment Y			
CURNO	Type	SAE Class	Units
002	FIL	600	Nm
Max	Time	Min	Time
7.5	13.2	-25.5	62.8

Test Program: CRABI 12 Month Old External Dimensions

Test Date: 10/24/07

ATD Serial No.: 017

Test I.D.: N/A



Tested Parameter	Units	Specification	Result	Pass/Fail
Laboratory Temperature	°C	20.6 to 22.2	21.1	Pass
Laboratory Relative Humidity	%	10 to 70	30	Pass
A - Total sitting height	mm	456.0 to 471.2	462	Pass
B - Shoulder pivot height	mm	276.6 to 291.8	284	Pass
C - "H" point height	mm	27.9 to 38.1	31	Pass
D - "H" point from backline	mm	40.1 to 50.3	44	Pass
E - Shoulder pivot from back	mm	50.3 to 60.5	52	Pass
F - Thigh clearance	mm	63.0 to 73.2	69	Pass
G - Elbow pivot to fingertip	mm	176.6 to 191.8	189	Pass
I - Shoulder pivot to elbow pivot	mm	99.1 to 114.3	105	Pass
J - Elbow rest height	mm	150.1 to 165.3	157	Pass
K - Buttock to knee length	mm	202.7 to 217.9	210	Pass
L - Popliteal length	mm	138.7 to 153.9	144	Pass
M - Knee pivot height	mm	165.1 to 180.3	173	Pass
N - Buttock popliteal length	mm	144.8 to 160.0	150	Pass
O - Chest depth with jacket	mm	107.5 to 122.7	114	Pass
P - Foot length	mm	92.4 to 102.6	100	Pass
Q- Stature	mm	727.7 to 753.1	N/A	N/A
R - Buttock to knee pivot length	mm	178.5 to 188.7	184	Pass
S - Head Breadth	mm	124.4 to 134.6	130	Pass
T - Head Depth	mm	149.9 to 165.1	150	Pass
U - Hip breadth	mm	158.5 to 173.7	163	Pass
V - Shoulder breadth	mm	200.7 to 215.9	210	Pass
W - Foot breadth	mm	39.1 to 49.3	46	Pass
Y - Chest circumference with jacket	mm	452.4 to 477.8	467	Pass
Z - Waist circumference	mm	447.0 to 472.4	452	Pass
AA - Reference location for dimension Y & O	mm	256.5 to 266.7	263	Pass
BB - Reference Location For dimension Z	mm	106.7 to 116.9	110	Pass
CC - Shoulder Height	mm	299.7 to 314.9	307	Pass
DD - Chin Height	mm	289.6 to 304.8	293	Pass
Overall Test Results				Pass

Test Program: CRABI 12 Month Old Frontal Head Drop Test

Test Date: 10/22/07

ATD Serial No.: 022

Test I.D.: FHD10R



Tested Parameter	Units	Specification	Result	Pass/Fail
Laboratory Temperature	°C	18.9 to 25.6	21.1	Pass
Laboratory Relative Humidity	%	10 to 70	30	Pass
Peak Resultant Acceleration	G's	100.0 to 120.0	114.3	Pass
Peak Lateral Acceleration	G's	≤15.0	6.4	Pass
Is Acceleration Unimodal?	Yes/No	Yes	Yes	Pass
Overall Test Results				Pass

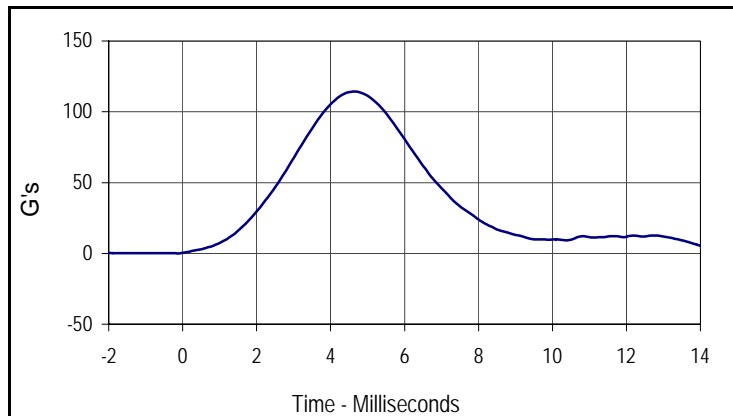

Curve Description			
Head Resultant			
CURNO	Type	SAE Class	Units
001	RES	1000	G's
Max	Time	Min	Time
114.3	4.6	0.0	-0.1

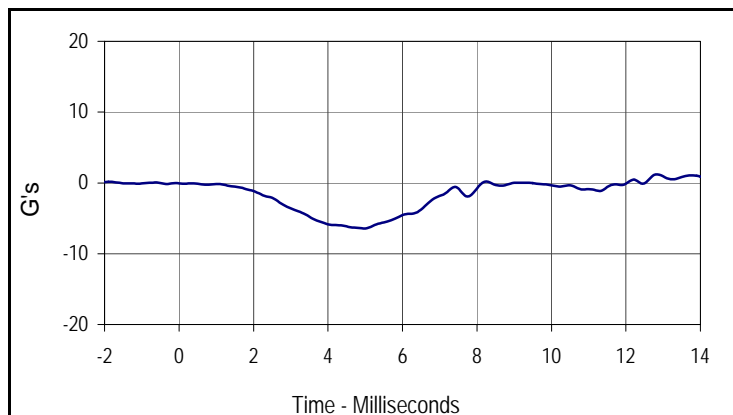

Curve Description			
Head Y			
CURNO	Type	SAE Class	Units
002	FIL	1000	G's
Max	Time	Min	Time
0.1	-1.9	-6.4	5.0

Test Program: CRABI 12 Month Old Rear Head Drop Test

Test Date: 10/22/07

ATD Serial No.: 022

Test I.D.: RHD10R



Tested Parameter	Units	Specification	Result	Pass/Fail
Laboratory Temperature	°C	18.9 to 25.6	21.1	Pass
Laboratory Relative Humidity	%	10 to 70	30	Pass
Peak Resultant Acceleration	G's	55.0 to 71.0	59.6	Pass
Peak Lateral Acceleration	G's	≤15.0	2.6	Pass
Is Acceleration Unimodal?	Yes/No	Yes	Yes	Pass
Overall Test Results			Pass	

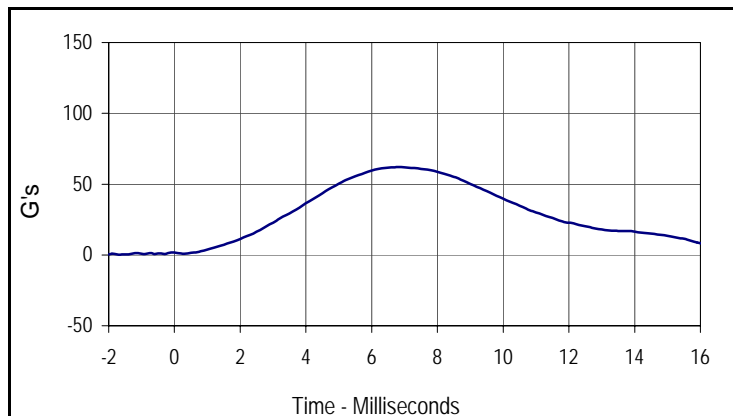

Curve Description			
Head Resultant			
CURNO	Type	SAE Class	Units
001	RES	1000	G's
Max	Time	Min	Time
59.6	6.0	0.3	-1.7

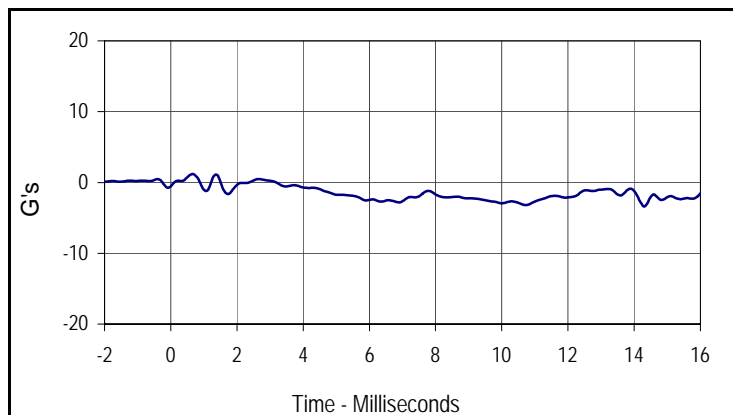

Curve Description			
Head Y			
CURNO	Type	SAE Class	Units
002	FIL	1000	G's
Max	Time	Min	Time
1.1	0.7	-2.6	5.9

Test Program: CRABI 12 Month Old Thorax Impact Test

Test Date: 10/22/07

ATD Serial No.: 022

Test I.D.: CH10R



Tested Parameter	Units	Specification	Result	Pass/Fail
Laboratory Temperature	°C	20.6 to 22.2	21.1	Pass
Laboratory Relative Humidity	%	10 to 70	30	Pass
Pendulum Velocity at T=0	m/sec	4.90 to 5.10	4.96	Pass
Peak Probe Force	Newtons	-1514 to -1796	-1701	Pass
Overall Test Results				Pass

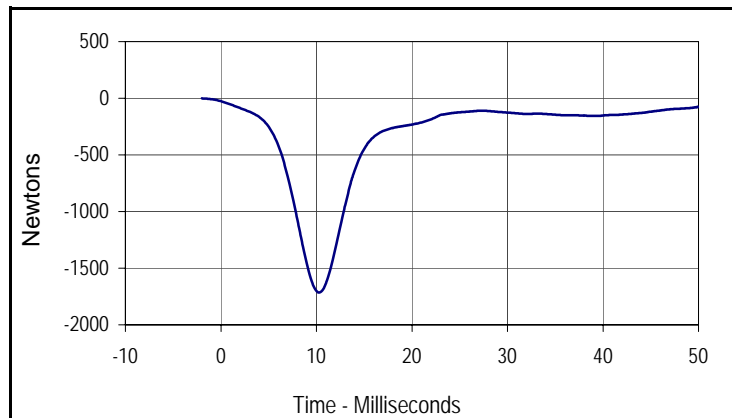

Curve Description			
Probe Force			
CURNO	Type	SAE Class	Units
001	FIL	60	Newtons
Max	Time	Min	Time
-1.2	-2.0	-1700.9	10.0

Test Program: CRABI 12 Month Old Neck Flexion Test
 ATD Serial No.: 022

Test Date: 10/22/07
 Test I.D.: NF10R



Tested Parameter	Units	Specification	Result	Pass/Fail	
Laboratory Temperature	°C	20.6 to 22.2	21.1	Pass	
Laboratory Relative Humidity	%	10 to 70	30	Pass	
Pendulum Velocity	m/s	5.10 to 5.30	5.16	Pass	
Pendulum Deceleration	10 Msec.	m/s	1.6 to 2.3	2.0	Pass
	20 Msec.	m/s	3.4 to 4.2	4.1	Pass
	25 Msec.	m/s	4.3 to 5.2	5.1	Pass
"D" Plane Rotation	Max	Degrees	75.0 to 86.0	76.1	Pass
Peak Moment in Rotation	Max	Nm	36.0 to 45.0	45.0	Pass
Positive Moment Decay, Time To 5 Nm	Msec.		60.0 to 80.0	71.8	Pass
Overall Test Results				Pass	

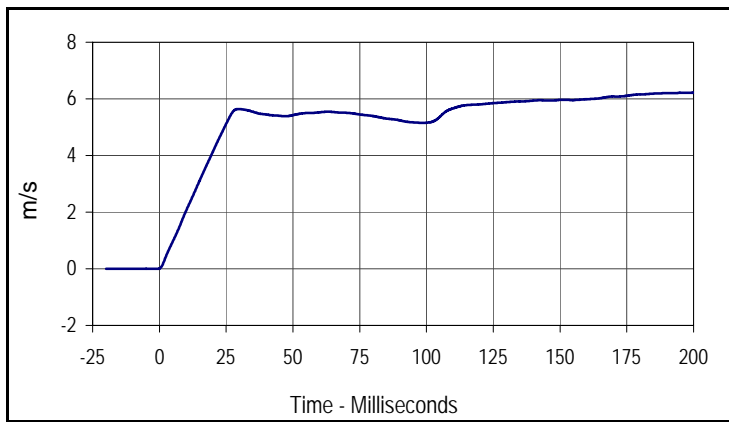

Curve Description			
Pendulum Velocity			
CURNO	Type	SAE Class	Units
001	FIL	180	m/s
Max	Time	Min	Time
6.2	199.3	0.0	-0.7

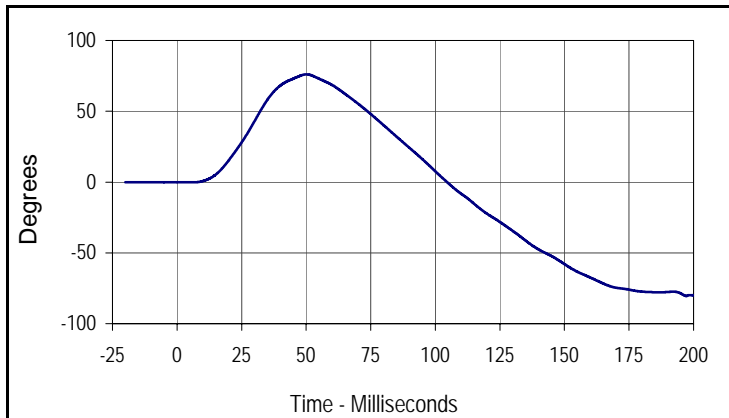

Curve Description			
"D" Plane Rotation			
CURNO	Type	SAE Class	Units
003	FIL	60	Degrees
Max	Time	Min	Time
76.1	50.1	-80.5	197.1

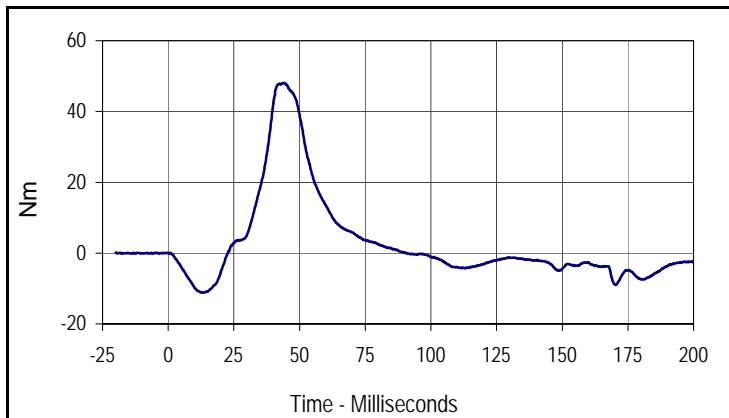

Curve Description			
Upper Neck Force Y			
CURNO	Type	SAE Class	Units
002	FIL	600	Nm
Max	Time	Min	Time
48.1	44.3	-11.2	13.5

Test Program: CRABI 12 Month Old Neck Extension Test
 ATD Serial No.: 022

Test Date: 10/22/07
 Test I.D.: NE10R



Tested Parameter	Units	Specification	Result	Pass/Fail	
Laboratory Temperature	°C	20.6 to 22.2	21.1	Pass	
Laboratory Relative Humidity	%	10 to 70	30	Pass	
Pendulum Velocity	m/s	2.4 to 2.6	2.41	Pass	
Pendulum Deceleration	6 Msec.	m/s	0.8 to 1.2	0.9	Pass
	10 Msec.	m/s	1.5 to 2.1	1.9	Pass
	14 Msec.	m/s	2.2 to 2.9	2.9	Pass
"D" Plane Rotation	Max	Degrees	80.0 to 92.0	91.4	Pass
Peak Moment in Rotation	Max	Nm	-12 to -23	-20.4	Pass
Positive Moment Decay, Time To -5 Nm	Msec.		76.0 to 90.0	78.3	Pass
Overall Test Results				Pass	

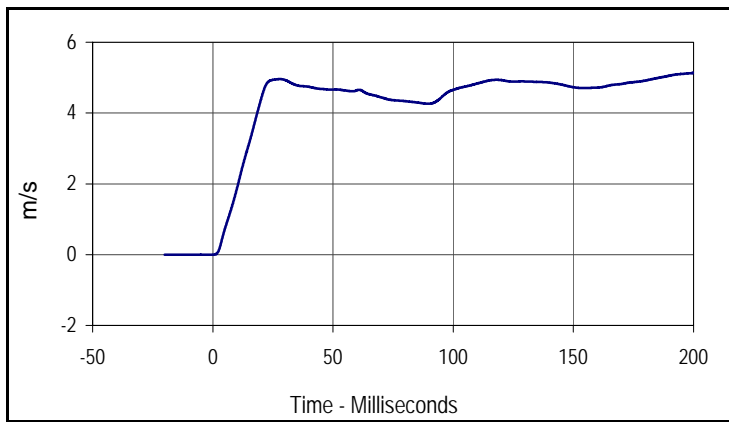

Curve Description			
Pendulum Velocity			
CURNO	Type	SAE Class	Units
001	FIL	180	m/s
Max	Time	Min	Time
5.1	200.0	0.0	0.1

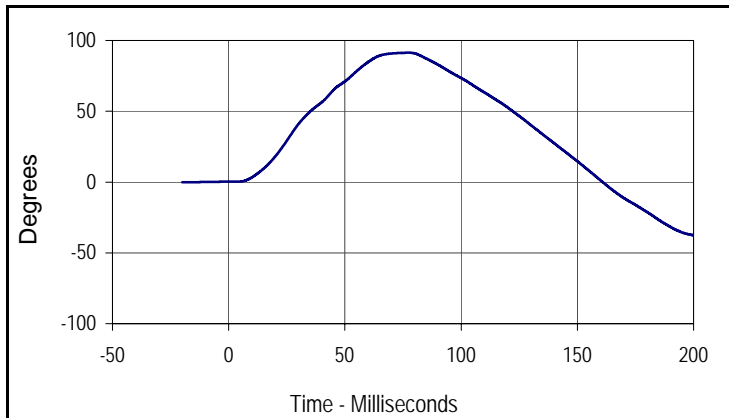

Curve Description			
"D" Plane Rotation			
CURNO	Type	SAE Class	Units
003	FIL	60	Degrees
Max	Time	Min	Time
91.4	77.5	-37.6	200.0

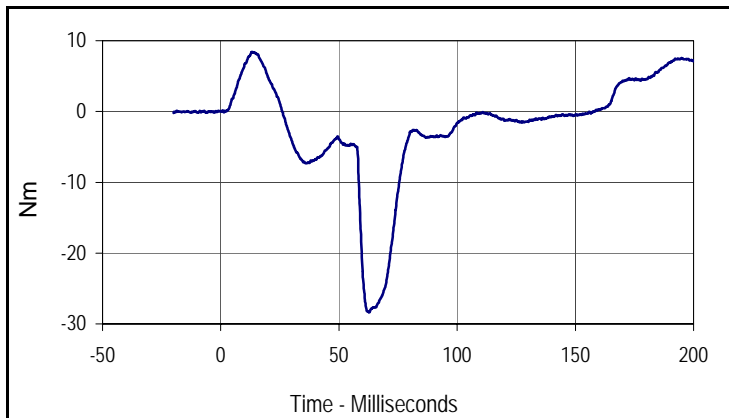

Curve Description			
Upper Neck Moment Y			
CURNO	Type	SAE Class	Units
002	FIL	600	Nm
Max	Time	Min	Time
8.4	13.2	-28.4	62.8

Test Program: CRABI 12 Month Old External Dimensions

Test Date: 10/22/07

ATD Serial No.: 022

Test I.D.: N/A



Tested Parameter	Units	Specification	Result	Pass/Fail
Laboratory Temperature	°C	20.6 to 22.2	21.1	Pass
Laboratory Relative Humidity	%	10 to 70	30	Pass
A - Total sitting height	mm	456.0 to 471.2	463	Pass
B - Shoulder pivot height	mm	276.6 to 291.8	284	Pass
C - "H" point height	mm	27.9 to 38.1	33	Pass
D - "H" point from backline	mm	40.1 to 50.3	47	Pass
E - Shoulder pivot from back	mm	50.3 to 60.5	56	Pass
F - Thigh clearance	mm	63.0 to 73.2	70	Pass
G - Elbow pivot to fingertip	mm	176.6 to 191.8	185	Pass
I - Shoulder pivot to elbow pivot	mm	99.1 to 114.3	110	Pass
J - Elbow rest height	mm	150.1 to 165.3	160	Pass
K - Buttock to knee length	mm	202.7 to 217.9	210	Pass
L - Popliteal length	mm	138.7 to 153.9	147	Pass
M - Knee pivot height	mm	165.1 to 180.3	169	Pass
N - Buttock popliteal length	mm	144.8 to 160.0	150	Pass
O - Chest depth with jacket	mm	107.5 to 122.7	112	Pass
P - Foot length	mm	92.4 to 102.6	100	Pass
Q- Stature	mm	727.7 to 753.1	N/A	N/A
R - Buttock to knee pivot length	mm	178.5 to 188.7	182	Pass
S - Head Breadth	mm	124.4 to 134.6	129	Pass
T - Head Depth	mm	149.9 to 165.1	150	Pass
U - Hip breadth	mm	158.5 to 173.7	164	Pass
V - Shoulder breadth	mm	200.7 to 215.9	213	Pass
W - Foot breadth	mm	39.1 to 49.3	47	Pass
Y - Chest circumference with jacket	mm	452.4 to 477.8	463	Pass
Z - Waist circumference	mm	447.0 to 472.4	470	Pass
AA - Reference location for dimension Y & O	mm	256.5 to 266.7	263	Pass
BB - Reference Location For dimension Z	mm	106.7 to 116.9	112	Pass
CC - Shoulder Height	mm	299.7 to 314.9	303	Pass
DD - Chin Height	mm	289.6 to 304.8	297	Pass
Overall Test Results				Pass