

DTS-TRC-06-011

40% Offset Vehicle to Deformable

Barrier Crash Test

Ford Motor Co.

2007 Ford F-250 XLT Super Duty 4-door pickup

NHTSA Number: R70203

TRC Inc. Test Number: 070913

Prepared By:

Transportation Research Center Inc.

10820 State Route 347

East Liberty, OH 43319



Final Report

September 26, 2007

Prepared For:

U. S. Department of Transportation

Volpe National Transportation Systems Center

55 Broadway, Kendall Square

Cambridge, MA 02142

This publication is distributed by the U. S. Department of Transportation, Volpe National Transportation Systems Center, in the interest of information exchange. The opinions, findings and conclusions expressed in this publication are those of the author(s) and not necessarily those of the Department of Transportation or the Volpe National Transportation Systems Center. The United States Government assumes no liability for its contents or use thereof. If trade or manufacturers' names or products are mentioned, it is only because they are considered essential to the object of the publication and should not be construed as an endorsement. The United States Government does not endorse products or manufacturers.

Test Performed By: John Shultz, Supervisor

Report Approved By:

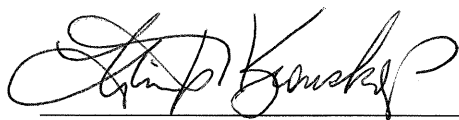

Christopher Krouskop, Project Manager
Transportation Research Center Inc.

Date 9-26-07

FINAL REPORT ACCEPTANCE BY COTR:

Contracting Officer's Technical Representative (COTR),
USDOT, Volpe National Transportation Systems Center

Date _____

1. Report No. DTS-TRC-06-011	2. Government Accession No.	3. Recipient's Catalog No.	
4. Title and Subtitle Final Report of a 40% Frontal Offset Vehicle to Deformable Barrier Crash Test of a 2007 Ford F-250 XLT Super Duty 4-door pickup, NHTSA No. R70203		5. Report Date Sept. 26, 2007	
		6. Performing Organization Code TRC Inc.	
7. Author(s) Michael R. Tonneman, Project Manager		8. Performing Organization Report No. 070913	
9. Performing Organization Name and Address Transportation Research Center Inc. 10820 State Route 347 East Liberty, OH 43319-0367		10. Work Unit No. (TRAIS)	
		11. Contract or Grant No. DTRS57-05-D-30108	
12. Sponsoring Agency Name and Address U. S. Department of Transportation Volpe National Transportation Systems Center 55 Broadway, Kendall Square Cambridge, MA 02142		13. Type of Report and Period Covered Final Report September 2007	
		14. Sponsoring Agency Code DTS-85	
15. Supplemental Notes			
16. Abstract <p>A 56.0 km/h 40% frontal offset vehicle to deformable barrier crash test was conducted on a 2007 Ford F-250 XLT Super Duty 4-door pickup, NHTSA No. R70203, at Transportation Research Center Inc. on September 13, 2007. This test was conducted in accordance with Volpe Task Order No. 1, for the evaluation of vehicle and occupant responses. The barrier impact velocity was 56.1 km/h. The vehicle's maximum static crush was 715 millimeters. The ambient temperature was 21° C.</p> <p>The driver's 15 millisecond Head Injury Criteria (HIC) was 182. The driver's chest maximum resultant acceleration with three (3) milliseconds minimum duration was 29.2 g. The driver's maximum chest deflection was 29 millimeters. The driver's left and right femur maximum axial compressive forces were -1811 N and -1259 N, respectively.</p> <p>The right front passenger's 15 millisecond Head Injury Criteria (HIC) was 288. The right front passenger's chest maximum resultant acceleration with three (3) milliseconds minimum duration was 48.7 g. The right front passenger's maximum chest deflection was 25 millimeters. The right front passenger's left and right femur maximum axial compressive forces were -4914 N and -3134 N, respectively.</p>			
17. Key Words Frontal Barrier Impact Test		18. Distribution Statement Copies of this report are available from: National Highway Traffic Safety Admin. NHTSA Technical Reference Division 400 Seventh Street, S. W., Room 5108 Washington, DC 20590	
19. Security Classif. (of this report) Unclassified	20. Security Classif. (of this page) Unclassified	21. Number of Pages 572	22. Price

Table of Contents

<u>Section</u>	<u>Description</u>	<u>Page</u>
1.0	Purpose and Test Procedure	1-1
2.0	Offset Deformable Barrier Test Summary	2-1
Appendix A	Photographs	A-1
Appendix B	Dummy, Vehicle and Barrier Data Plots	B-1
Appendix C	Dummy Configuration and Performance Verification Data	C-1
Appendix D	Customer Provided Seating Procedure	D-1
Appendix E	Test Equipment and Instrumentation Calibration Information	D-1
Appendix F	INSIA Report on Structural Measurements	F-1

Data Sheets

<u>Number</u>	<u>Description</u>	<u>Page</u>
1	Crash Test Summary	2-5
2	General Test and Vehicle Parameter Data	2-7
3	Post-Impact Test Data	2-10
4	Test Vehicle Information	2-11
5	Dummy Positioning in Vehicle	2-13
6	Seat Belt Positioning	2-14
7	Vehicle Accelerometer Location and Data Summary	2-15
8	Dummy Injury Criteria Values	2-18
9	Seat Belt Performance Data	2-22
10	Summary of FMVSS 212 Data	2-23
11	FMVSS 219 (Partial) Windshield Zone Intrusion Data	2-24
12	FMVSS 301 Fuel System Integrity Data	2-25
13	FMVSS 301 Static Rollover Data	2-26
14	Vehicle Measurements	2-27
15	Camera Data	2-31
16	Reference Photo Targets	2-33
17	Post Test Air Bag Data	2-34
18	Accident Investigation Division Data	2-35
19	Offset Barrier and Vehicle Orientation	2-36
20	Deformable Barrier Honeycomb Crush	2-37
21	Deformable Barrier Load Cell Locations	2-38

List of Photographs

<u>Description</u>	<u>Figure</u>
Pre-Test Front View	A-1
Post-Test Front View	A-2
Pre-Test Left Front View	A-3
Post-Test Left Front View	A-4
Pre-Test Left Side View	A-5
Post-Test Left Side View	A-6
Pre-Test Left Rear View	A-7
Post-Test Left Rear View	A-8
Pre-Test Rear View	A-9
Post-Test Rear View	A-10
Pre-Test Right Rear View	A-11
Post-Test Right Rear View	A-12
Pre-Test Right Side View	A-13
Post-Test Right Side View	A-14
Pre-Test Right Front View	A-15
Post-Test Right Front View	A-16
Pre-Test Overhead View	A-17
Post-Test Overhead View	A-18
Pre-Test Impact Alignment View	A-19
Pre-Test Front Underbody View	A-20
Post-Test Front Underbody View	A-21
Pre-Test Mid Front Underbody View	A-22
Post-Test Mid Front Underbody View	A-23
Pre-Test Mid Underbody View	A-24
Post-Test Mid Underbody View	A-25
Pre-Test Mid Rear Underbody View	A-26
Post-Test Mid Rear Underbody View	A-27
Pre-Test Rear Underbody View	A-28

List of Photographs, Continued

<u>Description</u>	<u>Figure</u>
Post-Test Rear Underbody View	A-29
Pre-Test Fuel Tank View	A-30
Post-Test Fuel Tank View	A-31
Pre-Test Fuel Filler Neck View	A-32
Post-Test Fuel Filler Neck View	A-33
Pre-Test Fuel Filler Cap View	A-34
Post-Test Fuel Filler Cap View	A-35
Pre-Test Engine Compartment View	A-36
Post-Test Engine Compartment View	A-37
Pre-Test Windshield View	A-38
Post-Test Windshield View	A-39
Pre-Test Windshield - Driver and Right Front Passenger Dummies View	A-40
Post-Test Windshield - Driver and Right Front Passenger Dummies View	A-41
Pre-Test Windshield - Driver Dummy View	A-42
Post-Test Windshield - Driver Dummy View	A-43
Pre-Test Driver Dummy - View 1	A-44
Post-Test Driver Dummy - View 1	A-45
Pre-Test Driver Dummy - View 2	A-46
Post-Test Driver Dummy - View 2	A-47
Pre-Test Driver Dummy - View 3	A-48
Post-Test Driver Dummy - View 3	A-49
Post-Test Driver Dummy Overall View	A-50
Post-Test Driver Dummy Head Contact - View 1	A-51
Post-Test Driver Dummy Head Contact - View 2	A-52
Post-Test Driver Dummy Knee Contact - View 1	A-53
Post-Test Driver Dummy Knee Contact - View 2	A-54
Pre-Test Driver Floorboard Deformation - View 1	A-55
Post-Test Driver Floorboard Deformation - View 1	A-56

List of Photographs, Continued

<u>Description</u>	<u>Figure</u>
Post-Test Driver Floorboard Deformation - View 2	A-57
Post-Test Driver Toeboard Deformation View	A-58
Post-Test Driver Instrument Panel Damage View	A-59
Pre-Test Windshield - Right Front Passenger View	A-60
Post-Test Windshield - Right Front Passenger View	A-61
Pre-Test Right Front Passenger Dummy - View 1	A-62
Post-Test Right Front Passenger Dummy - View 1	A-63
Pre-Test Right Front Passenger Dummy - View 2	A-64
Post-Test Right Front Passenger Dummy - View 2	A-65
Pre-Test Right Front Passenger Dummy - View 3	A-66
Post-Test Right Front Passenger Dummy - View 3	A-67
Post-Test Right Front Passenger Dummy Overall View	A-68
Post-Test Right Front Passenger Dummy Head Contact -View 1	A-69
Post-Test Right Front Passenger Dummy Head Contact -View 2	A-70
Post-Test Right Front Passenger Dummy Knee Contact View	A-71
Pre-Test Right Front Passenger Floorboard Deformation - View 1	A-72
Post-Test Right Front Passenger Floorboard Deformation - View 1	A-73
Post-Test Right Front Passenger Floorboard Deformation - View 2	A-74
Post-Test Right Front Passenger Toeboard Deformation View	A-75
Post-Test Right Front Passenger Instrument Panel Damage View	A-76
Pre-Test Barrier Front View	A-77
Post-Test Barrier Front View	A-78
Pre-Test Barrier Left Side View	A-79
Post-Test Barrier Left Side View	A-80
Pre-Test Barrier Right Side View	A-81
Post-Test Barrier Right Side View	A-82
Pre-Test Barrier Top View	A-83
Post-Test Barrier Top View	A-84

List of Photographs, Continued

<u>Description</u>	<u>Figure</u>
Vehicle on Rollover Device - 90°	A-85
Vehicle on Rollover Device - 180°	A-86
Vehicle on Rollover Device - 270°	A-87
Vehicle on Rollover Device - 360°	A-88
Vehicle Certification Label View	A-89
Vehicle Tire Load Label View	A-90
Pre-Test Ballast View	A-91
Post-Test Digital Light Trap Read-Out - View 1	A-92
Post-Test Digital Light Trap Read-Out - View 2	A-93
Pre-Test Driver Toeboard - View 1	A-94
Pre-Test Driver Toeboard - View 2	A-95
Pre-Test Driver Toeboard - View 3	A-96
Pre-Test Driver Toeboard - View 4	A-97
Pre-Test Driver Toeboard - View 1	A-98
Pre-Test Driver Toeboard - View 6	A-99
Pre-Test Driver Toeboard - View 7	A-100
Pre-Test Driver Toeboard - View 8	A-101
Pre-Test Driver Toeboard - View 9	A-102
Pre-Test Driver Toeboard - View 10	A-103
Pre-Test Driver Toeboard - View 11	A-104
Pre-Test Driver Toeboard - View 12	A-105
Pre-Test Driver Toeboard - View 13	A-106
Pre-Test Driver Toeboard - View 14	A-107
Pre-Test Driver Toeboard - View 15	A-108
Pre-Test Driver Toeboard - View 16	A-109
Post-Test Driver Toeboard - View 16	A-110
Pre-Test Driver Toeboard - View 17	A-111
Post-Test Driver Toeboard - View 17	A-112

List of Photographs, Continued

<u>Description</u>	<u>Figure</u>
Pre-Test Driver Toeboard - View 18	A-113
Post-Test Driver Toeboard - View 18	A-114
Post-Test Driver Toeboard - View 19	A-115
Post-Test Driver Toeboard - View 20	A-116
Pre-Test Driver Toeboard - View 21	A-117
Post-Test Driver Toeboard - View 21	A-118
Pre-Test Driver Toeboard - View 22	A-119
Post-Test Driver Toeboard - View 22	A-120
Pre-Test Driver Toeboard - View 23	A-121
Post-Test Driver Toeboard - View 23	A-122
Post-Test Driver Toeboard - View 24	A-123
Post-Test Driver Toeboard - View 25	A-124
Pre-Test Right Front Passenger Toeboard - View 1	A-125
Post-Test Right Front Passenger Toeboard - View 1	A-126
Pre-Test Right Front Passenger Toeboard - View 2	A-127
Post-Test Right Front Passenger Toeboard - View 2	A-128
Pre-Test Right Front Passenger Toeboard - View 3	A-129
Post-Test Right Front Passenger Toeboard - View 3	A-130
Pre-Test Right Front Passenger Toeboard - View 4	A-131
Pre-Test Right Front Passenger Toeboard - View 5	A-132
Pre-Test Right Front Passenger Toeboard - View 6	A-133
Pre-Test Right Front Passenger Toeboard - View 7	A-134
Post-Test Right Front Passenger Toeboard - View 7	A-135
Pre-Test Right Front Passenger Toeboard - View 8	A-136
Post-Test Right Front Passenger Toeboard - View 8	A-137
Pre-Test Right Front Passenger Toeboard - View 9	A-138
Post-Test Right Front Passenger Toeboard - View 9	A-139

Section 1.0

Purpose and Summary of Tests

Purpose

This 56.0 km/h (target speed) Left 40% Offset Deformable Barrier test was conducted for the Volpe National Transportation Systems Center (Volpe) by Transportation Research Center Inc. (TRC Inc).

The purpose of this testing was to evaluate and compare vehicle and occupant responses during 40% frontal offset vehicle to deformable barrier crash tests. For this test, the subject vehicle was a 2007 Ford F-250 XLT Super Duty 4-door pickup with a 50th percentile driver dummy and a 50th percentile right front passenger dummy.

Test Procedure

This test was conducted in accordance with VNTSC's instructions for a 40% offset vehicle to deformable barrier crash test. Data was obtained relative to FMVSS 208, "Occupant Crash Protection" performance, FMVSS 212, "Windshield Retention"; FMVSS 219, "Windshield Zone Intrusion"; and FMVSS 301, "Fuel System Integrity," performance.

The test vehicle, a 2007 Ford F-250 XLT Super Duty 4-door pickup, was instrumented with twelve (12) accelerometers to measure longitudinal axis accelerations, four (4) accelerometers to measure lateral axis accelerations, and six (6) accelerometers to measure vertical axis accelerations. The test vehicle was also instrumented with four (4) seat belt force channels and four (4) switches. The driver's primary and secondary airbag signals were monitored with inductive pickups. The vehicle impacted a 40% left offset deformable barrier. The vehicle's specified impact velocity range was 55.2 to 56.8 km/h.

The test vehicle contained two (2) Part 572E 50th percentile adult male Hybrid III anthropomorphic test devices (dummies) in the driver and right front passenger positions. The 50th percentile dummies were positioned in the front outboard designated seating positions according to a procedure provided by the NHTSA COTR on October 27, 2006. The seating procedure is included as Appendix D. The driver dummy was restrained with a 3-point seat belt and a front dual stage airbag. The right front passenger dummy was restrained with a 3-point seat belt and a front dual stage airbag.

Each dummy was instrumented with an array of six (6) accelerometers in the head, six (6) accelerometers in the chest, and three (3) accelerometers in the pelvis oriented to measure longitudinal, lateral, and vertical accelerations. Each dummy was also instrumented with 6-channel upper neck moment and force load cells, left and right femur load cells to measure axial forces, a chest deflection potentiometer, and knee displacement potentiometers. Each dummy was equipped with THOR-LX legs, which included upper and lower tibia load cells to measure forces and moments, longitudinal and lateral tibia accelerometers, three (3) foot accelerometers on each foot to measure accelerations in three (3) axes and three (3) rotary potentiometers at each ankle to measure foot rotations about three (3) axes.

The vehicle impacted a deformable barrier instrumented with 90 load cells to measure longitudinal forces.

The 244 data channels were digitally sampled and recorded at 12,500 samples per second and processed per SAE J211 March 1995.

The crash event was recorded by one (1) real-time panning motion picture camera and seventeen (17) high-speed digital motion picture cameras. The pre-test and post-test conditions were recorded by one (1) real-time motion picture camera.

The 40% left frontal offset vehicle to deformable barrier crash test summary data and all occupant, camera, vehicle, and deformable barrier face measurements are presented in Section 2.0. Appendix A contains the still photographs. Appendix B contains the dummy, vehicle, and barrier data plots. Appendix C contains the dummy verification data. Appendix D contains customer provided seating procedure. Appendix E contains miscellaneous test information. Appendix F contains an INSIA report that was the basis for the Structural Measurements presented in Table 8 of this report.

Section 2.0

Offset Deformable Barrier Test Summary

Test Results Summary

This 56.0 km/h (target speed) left 40% offset vehicle to deformable barrier crash test was conducted by TRC Inc. on September 13, 2007.

The test vehicle, a 2007 Ford F-250 XLT Super Duty 4-door pickup, NHTSA Number R70203, was equipped with a 4.0-liter 8-cylinder longitudinally-placed engine, automatic transmission, power steering, power brakes and dual stage front airbags. The vehicle's test weight was 3291.4 kg. The vehicle's impact speed was 56.1 km/h. The vehicle sustained 715 mm of static crush during the impact.

The occupant injury assessment values are summarized below.

Injury Criterion	Limits	Driver	Right Front Passenger
Head			
HIC 36	1000	305	454
HIC 15	700	182	288
Neck			
Upper Neck Tension (N)	4170	1264	970
Upper Neck Compression (N)	-4000	-133	-179
Neck Injury (NIJ) NTE	1.0	0.2	0.2
Neck Injury (NIJ) NTF	1.0	0.3	0.2
Neck Injury (NIJ) NCE	1.0	0.0	0.1
Neck Injury (NIJ) NCF	1.0	0.0	0.0
Chest			
3 ms Clip (g)	60	29	49
Chest Displacement (mm)	63	-29	-25
Femur			
Left Femur Force (N)	-9040	-1811	-4914
Right Femur Force (N)	-9040	-1259	-3134
Tibia			
Left Upper Tibia Index	0.91	0.54	0.36
Right Upper Tibia Index	0.91	0.33	0.45
Left Lower Tibia Index	0.91	0.61	0.26
Right Lower Tibia Index	0.91	0.39	0.50
Left Upper Tibia Force (N)	-5600	-1668	-682
Right Upper Tibia Force (N)	-5600	-2088	-1980
Left Lower Tibia Force (N)	-5200	-2798	-767
Right Lower Tibia Force (N)	-5200	-3113	-2714

Test Results Summary, Continued

Injury Criterion	Limits	Driver	Right Front Passenger
Ankle			
Left Inversion (degrees)	-35	-30	-1
Left Eversion (degrees)	35	0	27
Left Plantarflexion (degrees)	-	-27	-5
Left Dorsiflexion (degrees)	35	15	7
Left External Rotation (degrees)	-	2	-2
Left Internal Rotation (degrees)	-	13	2
Right Eversion (degrees)	-35	-16	-1
Right Inversion (degrees)	35	9	9
Right Plantarflexion (degrees)	-	-19	-23
Right Dorsiflexion (degrees)	35	18	14
Right Internal Rotation (degrees)	-	3	0
Right External Rotation (degrees)	-	22	14

Data Acquisition Explanations

Electronic data anomalies are summarized below:

Channel Number	Sensor Type	Sensor Location	Sensor Attachment (Name)	Axis	Problem/Action
12	LC	Dummy	11NECKUP00H3MOZA	Z	Recorded questionable data between 226 and 244 milliseconds.
23	LC	Dummy	11FEMRLL00H3FOZA	Z	Recorded questionable data between 58 and 65 milliseconds.
59	Accel	Dummy	11FOOTRILXH3ACYA	Y	Recorded questionable data throughout the event.
63	Accel	Dummy	13HEADCGRDH3ACZA	Z	Recorded questionable data throughout the event.
77	Accel	Dummy	13CHSTCGRDH3ACYA	Y	Exceeded full scale at 137 milliseconds.
138	Accel	Vehicle	11PEBR000000ACYA	Y	Exceeded full scale at 127 milliseconds.
148	IND	Vehicle	11AIRBFR0200EV0A		Recorded no valid data throughout the event.
162	LC	Barrier	L0FBAR000008FOXA	X	Recorded questionable data throughout the event.
179	LC	Barrier	L0FBAR000079FOXA	X	Recorded questionable data throughout the event.
220	LC	Barrier	L0FBAR000066FOXA	X	Exceeded full scale at 45 milliseconds.

DATA SHEET NO. 1
CRASH VEHICLE SUMMARY

Vehicle NHTSA No.: R70203 Test Mode: Left 40% Offset Deformable Barrier
Test Date: 09/13/07 Time: 15:36 Temperature: 21 °C
Vehicle Make/Model/Body Style: 2007/Ford/F-250 XLT Super Duty/4-door pickup
Vehicle Test Weight: 3291.4 kg
Vehicle/Barrier Impact Angle: 0 °
Vehicle/Barrier Impact Accuracy: 5 mm up
 10 mm left
Impact Velocity: 56.1 km/h
Maximum Static Crush: 715 mm
Vehicle Rebound: N/A mm

DUMMIES:

DRIVER #001

**RIGHT FRONT
PASSENGER #855**

Type:	<u> HIII 50th </u>	<u> HIII 50th </u>
Type Lower Leg / Serial Number:	<u> THOR-LX/045& 046 </u>	<u> THOR-LX/103 & 104 </u>
Restraint System:	<u> 3-pt. seat belt, airbag </u>	<u> 3-pt. seat belt, airbag </u>

Number of Data Channels: 120
Number of Cameras: 1 Real-Time
 17 High-Speed Digital

<u>DOOR OPENING DATA:</u>	<u> Tools </u>	- Left Front
	<u> Easy </u>	- Right Front
	<u> Tools </u>	- Left Rear
	<u> Easy </u>	- Right Rear

DATA SHEET NO. 1 (continued)
CRASH VEHICLE SUMMARY

<u>FRONT SEAT(S) DATA:</u>	<u>DRIVER</u>	<u>RIGHT FRONT PASSENGER</u>
Seat Track Failure (mm of shift):	<u>None</u>	<u>Moved to full forward</u>
Seat Back Failure:	<u>None</u>	<u>None</u>
<u>REAR SEAT(S) DATA:</u>	<u>LEFT REAR PASSENGER</u>	<u>RIGHT REAR PASSENGER</u>
Seat Track Failure (mm of shift):	<u>N/A</u>	<u>N/A</u>
Seat Back Failure:	<u>N/A</u>	<u>N/A</u>
<u>VISIBLE DUMMY CONTACT POINTS :</u>	<u>DRIVER</u>	<u>RIGHT FRONT PASSENGER</u>
Head:	<u>Airbag, head restraint</u>	<u>Airbag, head restraint</u>
Chest:	<u>None</u>	<u>None</u>
Abdomen:	<u>None</u>	<u>None</u>
Left Knee:	<u>Knee bolster</u>	<u>Glove box</u>
Right Knee:	<u>Knee bolster</u>	<u>Glove box</u>

DATA SHEET NO. 2
GENERAL TEST AND VEHICLE PARAMETER DATA

TEST VEHICLE INFORMATION:

Year/Make/Model/Body Style: 2007/Ford/F-250 XLT Super Duty/4-door pickup
NHTSA No.: R70203 VIN: 1FTSX21587EA19550 Color: White
Engine Data: 8 Cylinders CID 4 Liters 5400 cc
Placement: X Longitudinal or In-line Transverse or Lateral
Transmission Data: 4 Speeds Manual X Automatic X Overdrive
Final Drive: Rear Wheel Front Wheel X Four Wheel
Major Options: X A/C X Pwr. Steering X Pwr. Brakes Pwr. Seats
 Cruise
X Tilt Wheel X Pwr. Windows X Pwr. Locks X Control
Date Received: 08/23/2007 Odometer Reading: 2462 miles
Selling Dealer: _____
& Address: _____

DATA FROM TIRE VEHICLE'S CERTIFICATION LABEL:

Vehicle Manufactured by: Ford Motor Co.
Date of Manufacture 06/06
GVWR: 4173 kg; GAWR: 2359 kg FRONT; 2767 kg REAR

DATA FROM TIRE OR TIRE PLACARD:

Tire Pressure with Maximum Capacity Vehicle Load: 550 kPa FRONT
550 kPa REAR
Load Index & Speed Symbol: 121/118R
Recommended Tire Size: LT265/70R17E
* Recommended Cold Tire Pressure: 515 kPa FRONT; 515 kPa REAR
Tire Grades: N/A Treadwear; N/A Temperature; N/A Traction
BF Goodrich, Rugged
Size of Tires on Test Vehicle: LT265/70R17 ; Manufacturer: Trail T/A

Vehicle Capacity Data:
Type of Front Seats: X Bench; Bucket; Split Bench
Number of
Occupants: 2 Front; 3 Rear; 5 Total
Vehicle Capacity Weight (VCW) = 1144 kg
No. of Occupants x 68 kg = 340 kg
Rated Cargo/Luggage Weight (RCLW) = 136 kg

*Tire pressure used for test

DATA SHEET NO. 2 (continued)
GENERAL TEST AND VEHICLE PARAMETER DATA

Vehicle Year/Make/Model/Body Style: 2007/Ford/F-250 XLT Super Duty/4-door pickup
 NHTSA Test No.: R70203 Test Date: 09/13/07

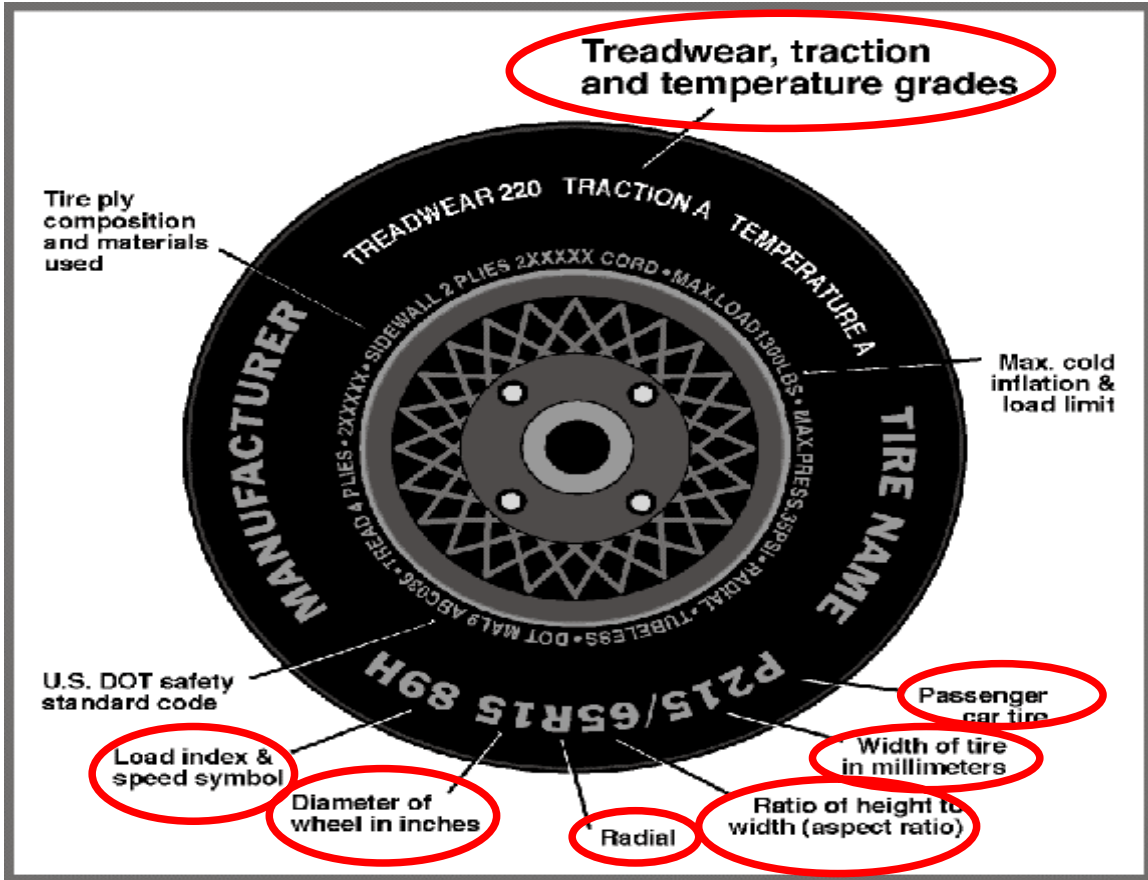

DATA RECORDED FROM ACTUAL TIRES ON TEST VEHICLE

	Front	Rear
Manufacturer	BF Goodrich	BF Goodrich
Brand Name	Rugged Trail T/A	Rugged Trail T/A
Tire Size (ex. P215/65R15)	LT265/70R17	LT265/70R17
Load Index and Speed Symbol	121/118R	121/118R
Treadwear	N/A	N/A
Traction	N/A	N/A
Temperature	N/A	N/A

DATA SHEET NO. 2 (continued)
GENERAL TEST AND VEHICLE PARAMETER DATA

Vehicle Year/Make/Model/Body Style: 2007/Ford/F-250 XLT Super Duty/4-door pickup
 NHTSA Test No.: R70203 Test Date: 09/13/07

WEIGHT OF TEST VEHICLE AS RECEIVED FROM DEALER (with max. fluids) = UDW:

Right Front = <u>835.2</u> kg	Right Rear = <u>657.2</u> kg
Left Front = <u>848.2</u> kg	Left Rear = <u>671.4</u> kg
TOTAL FRONT = <u>1683.4</u> kg	TOTAL REAR = <u>1328.6</u> kg
TOTAL DELIVERED WEIGHT = <u>3012</u> kg	
% of Total Front of Vehicle Weight = <u>55.9</u> %	
% of Total Rear of Vehicle Weight = <u>44.1</u> %	

CALCULATION OF VEHICLE'S TARGET TEST WEIGHT :

Total Delivered Weight (UDW)	=	<u>3012.0</u>	kg
Rated Cargo/Luggage Weight (RCLW)	=	<u>136.0</u>	kg
Weight of Two Part 572E Dummies @ 76 each	=	<u>152.0</u>	kg
TARGET TEST WEIGHT	=	<u>3300.0</u>	kg

WEIGHT OF TEST VEHICLE WITH TWO DUMMIES:

Right Front = <u>886.0</u> kg	Right Rear = <u>770.0</u> kg
Left Front = <u>859.6</u> kg	Left Rear = <u>775.8</u> kg
TOTAL FRONT = <u>1745.6</u> kg	TOTAL REAR = <u>1545.8</u> kg
TOTAL TEST WEIGHT = <u>3291.4</u> kg	
% of Total Front of Vehicle Weight = <u>53.0</u> %	
% of Total Rear of Vehicle Weight = <u>47.0</u> %	
Weight of Ballast Secured in Vehicle Trunk Area = <u>53.5</u> kg	
Vehicle Components Removed for Weight Reduction: <u>None</u>	

VEHICLE ATTITUDE (all dimension in millimeters):

AS DELIVERED : RF	<u>1021</u>	LF	<u>1013</u>	RR	<u>1054</u>	LR	<u>1044</u>
FULLY LOADED : RF	<u>1015</u>	LF	<u>1011</u>	RR	<u>1028</u>	LR	<u>1024</u>
AS TESTED : RF	<u>1014</u>	LF	<u>1008</u>	RR	<u>1035</u>	LR	<u>1025</u>
Vehicle's Wheel Base :	<u>3610</u>	mm					
Location of Vehicle's C.G.:	<u>1695</u>	mm rearward of front wheel center.					

DATA SHEET NO. 2 (continued)
GENERAL TEST AND VEHICLE PARAMETER DATA

Vehicle Year/Make/Model/Body Style: 2007/Ford/F-250 XLT Super Duty/4-door pickup
NHTSA Test No.: R70203 Test Date: 09/13/07

FUEL SYSTEM DATA :

Fuel System Capacity From Owner's Manual = 115.6 liters
Usable Capacity Figure Furnished by COTR = N/A liters
Test Volume Range (92 to 94% of Usable Capacity) = 106.4 to 108.7 liters
ACTUAL TEST VOLUME = 107.5 liters (with entire fuel system filled)
Test Fluid Type: Stoddard ; Specific Gravity = 0.764
Kinematic Viscosity = 0.99 centistokes; Color = Purple
Type of Fuel Pump: Electric- X ; Mechanical-
Does Electric Pump operate with ignition switch "ON" & engine "OFF" Yes- X No-
Details of Fuel System: The fuel tank is located in front of the rear axel between left frame rail and prop shaft. The fuel filler neck is located on left rear corner. The fuel filler cap is located on left rear bed side. The fuel lines run inside driver's frame rail.

DATA SHEET NO. 3
POST IMPACT DATA

Vehicle Year/Make/Model/Body Style: 2007/Ford/F-250 XLT Super Duty/4-door pickup
NHTSA Test No.: R70203 Test Date: 09/13/07

TYPE OF TEST:

Type of Test: Left 40% Offset Deformable Barrier Impact Angle: 0 °
Test Date: 09/13/07 Time: 15:36 Temperature: 21 °C
Vehicle NHTSA No.: R70203
Required Impact Velocity Range: 55.2 to 56.8 km/h

BARRIER IMPACT VELOCITY:

Trap No. 1 = 56.1 km/h; Trap No. 2 = 56.1 km/h

VEHICLE STATIC CRUSH: (mm)

Vehicle Length:

Pre-Test Right = 5621 ; C/L = 5845 ; Left = 5628
Post-Test Right = 5858 ; C/L = 5293 ; Left = 4762
Crush Right = -237 ; C/L = 552 ; Left = 866
AVERAGE = 394 mm

DATA SHEET NO. 4
TEST VEHICLE INFORMATION

Vehicle Year/Make/Model/Body Style: 2007/Ford/F-250 XLT Super Duty/4-door pickup
NHTSA Test No.: R70203 Test Date: 09/13/07

Nominal Design Riding Position for adjustable driver and passenger seat backs. Please describe how to position the inclinometer to measure the seat back angle. Include description of the location of the adjustment latch detent, if applicable.

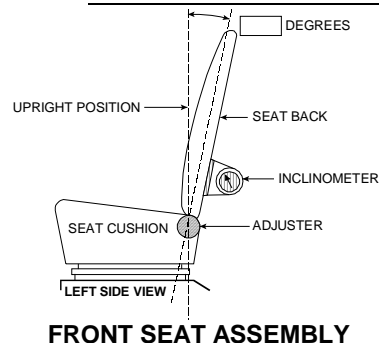

Left Front Seat Cushion Placement: Detent 16 of 19

Total Length of Fore/Aft Adjustment Travel: 185 mm

Total Number of Adjustment Positions or Detents: 19

Left Front Seat Back Adjustment Position: 10.4° measured at head restraint

Left Front Head Restraint Placement: Full up

Left D-Ring Placement: Fixed

Right Front Seat Cushion Placement: Full rear

Total Length of Fore/Aft Adjustment Travel: 185 mm

Total Number of Adjustment Positions or Detents: 18

Right Front Seat Back Adjustment Position: 10.0° measured at head restraint

Right Front Head Restraint Placement: Full up

Right D-Ring Placement: Fixed

Adjustable Steering Column Position: Fixed

Window Positions:

Right Front: Open

Right Rear: Closed

Left Front: Open

Left Rear: Closed

Amount of Stoddard Solvent In Fuel Tank:

115.6 liters (fuel tank usable capacity)

107.5 liters used in test (92% - 94% of fuel tank usable capacity)

Vehicle Year/Make/Model/Body Style: 2007/Ford/F-250 XLT Super Duty/4-door pickup
 NHTSA Test No.: R70203 Test Date: 09/13/07

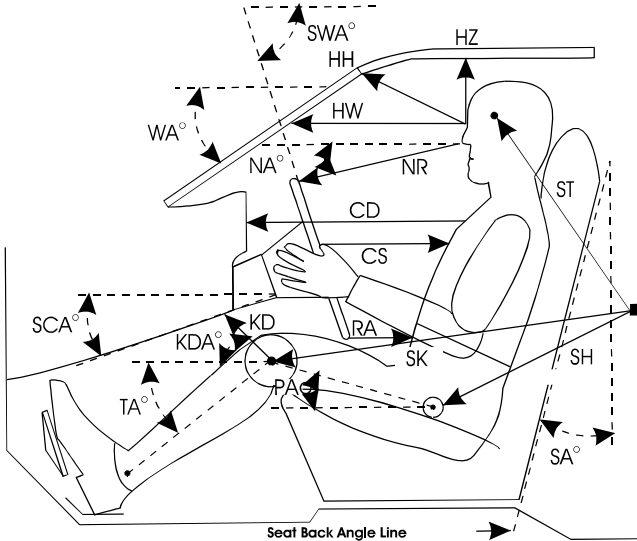

- | | |
|-----|-----------------------------|
| AD | Arm to Door |
| HD | H-Point to Door |
| HR | Head to Side Header |
| HS | Head to Side Window |
| KK | Knee to Knee |
| SHY | Striker to H-Point (Y-Axis) |

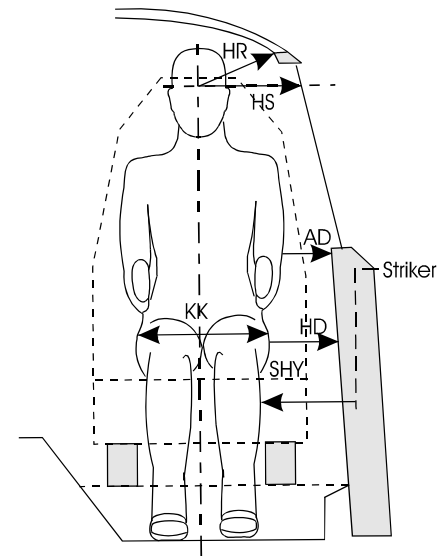
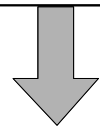

- | | |
|-----|-----------------------------|
| CD | Chest to Dash |
| CS | Chest to Steering Wheel Hub |
| HH | Head to Header |
| HW | Head to Windshield |
| HZ | Head to Roof |
| KDA | Knee to Dash Angle |
| KDL | Left Knee to Dash |
| NA | Nose to Rim Angle |
| NR | Nose to Rim |
| PA | Pelvic Angle |
| RA | Rim to Abdomen |
| SA | Seat Back Angle |
| SCA | Steering Column Angle |
| SH | Striker to H-Point |
| SK | Striker to Knee |
| ST | Striker to Head |
| SWA | Steering Wheel Angle |
| TA | Tibial Angle |
| WA | Windshield Angle |

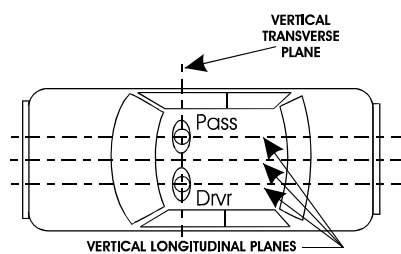

DUMMY MEASUREMENTS FOR FRONT SEAT OCCUPANTS

DATA SHEET NO. 5
FRONT SEAT DUMMY POSITIONING MEASUREMENTS IN VEHICLE

Vehicle Year/Make/Model/Body Style: 2007/Ford/F-250 XLT Super Duty/4-door pickup
 NHTSA Test No.: R70203 Test Date: 09/13/07

	DRIVER (Serial #001)			RIGHT FRONT PASSENGER (Serial #855)		
WA°	33.3°					
SWA°	66.5°					
SCA°	23.5°					
SA°	11.7°			10.3°		
HZ	275 mm			304 mm		
HW	773 mm			842 mm		
HH	525 mm			554 mm		
HR	264 mm			282 mm		
NR	482 mm					
NA°	9.2°			°		
CD	671 mm			706 mm		
CS	368 mm					
RA	269 mm					
KDL	240 mm	Angle (KDA)	10.7°	278 mm		
KDR	229 mm			286 mm	Angle (KDA)	1.9°
PA°	24.3°			27.0°		
TA°	43.1°			47.5°		
KK	339 mm			288 mm		
ST	684 mm	Angle	-76.7°	652 mm	Angle	-79.4°
SK	682 mm	Angle	-8.2°	670 mm	Angle	-9.3°
SH	284 mm	Angle	-0.9°	266 mm	Angle	-0.9°
SHY	162 mm			179 mm		
HS	366 mm			366 mm		
HD	142 mm			126 mm		
AD	213 mm			232 mm		

DATA SHEET NO. 6
SEAT BELT POSITIONING DATA

Vehicle Year/Make/Model/Body Style: 2007/Ford/F-250 XLT Super Duty/4-door pickup
 NHTSA Test No.: R70203 Test Date: 09/13/07

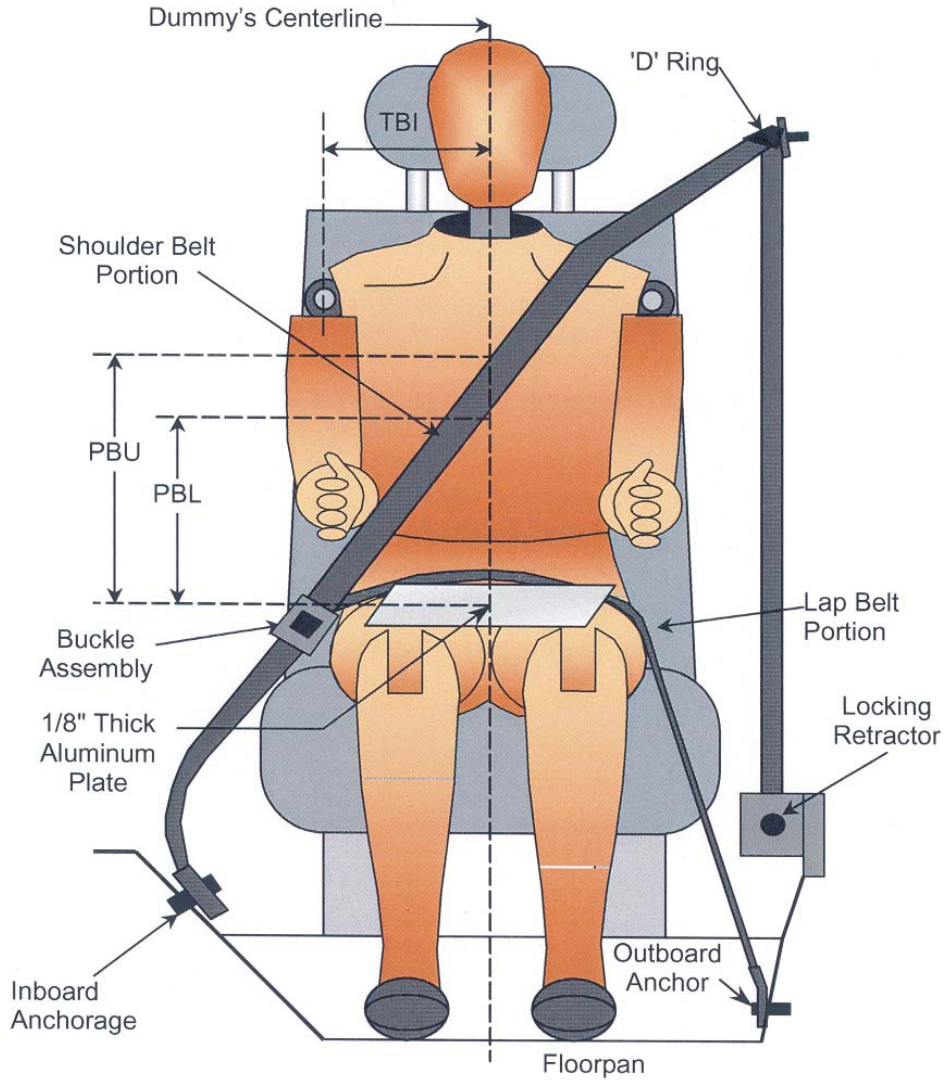

	Driver Dummy	Passenger Dummy
PBU - Top surface of aluminum plate to belt upper edge, mm	350	320
PBL - Top surface of aluminum plate to belt lower edge, mm	265	235

DATA SHEET NO. 7

Vehicle Year/Make/Model/Body Style: 2007/Ford/F-250 XLT Super Duty/4-door pickup

NHTSA Test No.: R70203 Test Date: 09/13/07

**VEHICLE ACCELEROMETER LOCATION
AND DATA SUMMARY**

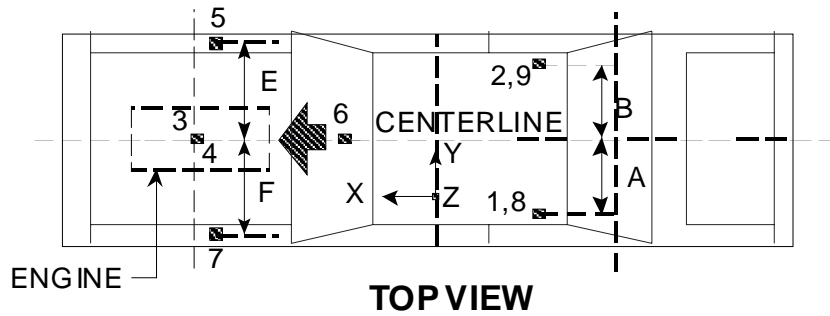

REAR SEAT CUSHION
ASSY. FRONT ATTACHMENT
BRACKET SUPPORT

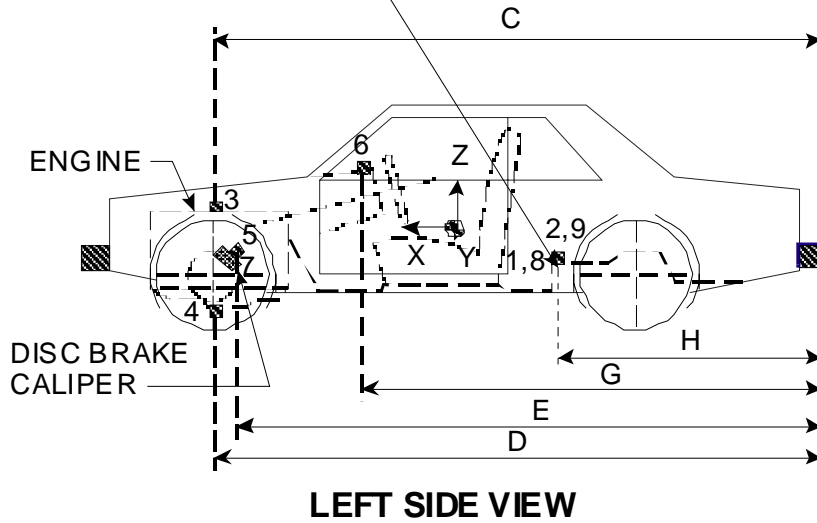

NOTE: Vehicle accelerometer location and data summary shown in DATA SHEET NO. 7.

DATA SHEET NO. 7 (continued)
VEHICLE ACCELEROMETER LOCATIONS AND DATA SUMMARY

Vehicle Year/Make/Model/Body Style: 2007/Ford/F-250 XLT Super Duty/4-door pickup
 NHTSA Test No.: R70203 Test Date: 09/13/07

DIMENSION	LENGTH (mm)
	PRE-TEST VALUES
A Left Rear Seat Crossmember Y	760
B Right Rear Seat Crossmember Y	760
C Top of Engine X	5363
D Bottom of Engine X	5090
E Right Brake Calipers X	5079
F Left Brake Calipers X	5079
G Instrument Panel X	4502
H Left Rear Seat Cross Member X	3330
I Right Rear Seat Cross Member X	3330
Left Side Driver Mid Seat Track X	3835
Vehicle Center of Gravity X	
Accel Pedal Heel Location X	4572
Accel Pedal Heel Location Y	720
Brake Pedal Heel Location X	4572
Brake Pedal Heel Location Y	780
Foot Rest X	4572
Foot Rest Y	780

DATA SHEET NO. 7 (continued)
VEHICLE ACCELEROMETER LOCATIONS AND DATA SUMMARY

Vehicle Year/Make/Model/Body Style: 2007/Ford/F-250 XLT Super Duty/4-door pickup
 NHTSA Test No.: R70203 Test Date: 09/13/07

LOCATION NUMBER	DESCRIPTION	MAXIMUM VALUE (g's)			
		Positive	Time, ms	Negative	Time, ms
1	Left Rear Seat Cross Member X	1.8	262.6	34.3	65.8
2	Right Rear Seat Cross Member X	2.2	211.4	19.2	52.2
3	Top of Engine Block X	5.2	97.6	34.1	73.1
4	Bottom of Engine Block X	20.5	107.1	35.3	64.7
5	Disc Brake Caliper @ Right Side X	20.8	82.2	24.8	72.6
6	Instrument Panel X	24.1	77.8	34.4	71.3
7	Disc Brake Caliper @ Left Side X	35.4	64.2	63.4	49.0
8	Left Rear Seat Cross Member Z	11.3	68.7	14.2	117.4
9	Right Rear Seat Cross Member Z	12.0	140.3	14.1	103.1
10	Left Side Driver Mid Seat Track X	1.7	262.9	23.3	86.0
11	Vehicle Center of Gravity X	1.4	212.8	22.5	66.5
	Vehicle Center of Gravity Y	13.7	101.6	7.7	121.6
	Vehicle Center of Gravity Z	21.4	102.1	23.7	96.6
	Vehicle Center of Gravity R	29.0	101.9		
12	Accel Pedal Heel Location X	15.0	111.5	45.0	65.4
	Accel Pedal Heel Location Y	28.8	65.4	12.2	113.7
	Accel Pedal Heel Location Z	18.4	85.8	19.6	64.4
	Accel Pedal Heel Location R	56.2	65.3		
13	Brake Pedal Heel Location X	2.0	257.1	26.3	92.2
	Brake Pedal Heel Location Y	44.1	163.3	1040.1	138.9
	Brake Pedal Heel Location Z	25.5	85.7	19.0	101.1
	Brake Pedal Heel Location R	1040.1	138.9		
14	Outside Footrest X	40.1	99.4	26.7	92.2
	Outside Footrest Y	26.0	64.7	15.1	113.9
	Outside Footrest Z	15.7	49.0	27.7	102.7
	Outside Footrest R	44.1	99.6		

DATA SHEET NO. 8
DUMMY INJURY CRITERIA VALUES

Vehicle Year/Make/Model/Body Style: 2007/Ford/F-250 XLT Super Duty/4-door pickup
 NHTSA Test No.: R70203 Test Date: 09/13/07

		MAXIMUM VALUE							
		Driver				Right Front Passenger			
DESCRIPTION	Unit	Positive	Time, ms	Negative	Time, ms	Positive	Time, ms	Negative	Time, ms
Head X	g	0.7	185.7	40.5	119.4	2.2	108.6	49.0	141.4
Head Y	g	10.6	199.3	8.6	108.7	31.5	153.2	2.5	117.4
Head Z	g	22.0	113.2	3.2	60.7	31.8	128.8	95.5	4.0
Head Resultant	g	45.3	117.5			95.5	4.0		
Head Redundant X	g	1.6	191.1	41.1	119.6	3.1	111.0	49.5	141.0
Head Redundant Y	g	1.7	189.3	17.0	305.1	37.5	150.6	3.3	118.8
Head Redundant Z	g	23.9	111.8	2.5	60.0	16.6	124.5	4.8	96.2
Head Resultant Red.	g	46.2	118.1			54.5	150.6		
Upper Neck Fx	N	389.7	126.4	275.6	94.9	906.0	142.3	72.9	215.8
Upper Neck Fy	N	391.7	201.1	155.9	296.4	213.8	194.2	147.7	134.9
Upper Neck Fz	N	1263.9	113.9	132.7	59.8	969.8	131.1	179.3	96.8
Upper Neck Mx	N-m	30.1	197.7	25.5	125.8	20.7	187.3	14.5	153.2
Upper Neck My	N-m	45.3	126.3	17.3	91.6	44.9	147.4	7.2	183.0
Upper Neck Mz	N-m	57.1	226.4	45.0	243.6	9.6	243.8	24.5	168.9
Chest X	g	0.5	310.0	28.4	113.9	0.3	223.6	47.2	136.5
Chest Y	g	13.6	145.9	6.2	89.8	9.3	140.0	1.0	199.9
Chest Z	g	9.7	93.2	3.5	167.8	16.1	141.3	5.1	181.1
Chest Resultant	g	29.8	114.1			49.6	135.8		
Chest Redundant X	g	0.7	310.0	27.8	113.8	0.3	223.5	47.7	136.6
Chest Redundant Y	g	13.9	145.4	6.3	92.0	1060.2	142.0	3.0	134.1
Chest Redundant Z	g	9.7	93.1	3.8	172.4	16.4	141.3	5.1	178.9
Chest Resultant Redundant	g	29.4	113.9			1061.1	142.0		
Chest Displacement	mm	0.2	49.0	29.1	126.2	0.1	103.0	24.6	149.1
Pelvis X	g	0.7	307.8	31.4	90.8	2.4	67.3	32.5	120.0
Pelvis Y	g	13.5	120.8	6.9	88.3	10.4	127.6	6.5	141.8
Pelvis Z	g	1.2	229.9	11.4	142.6	6.7	149.2	13.8	115.9
Pelvis Resultant	g	31.8	90.8			34.8	120.0		
Left Femur Z	N	2187.5	58.8	1810.7	64.3	64.8	308.9	4914.4	97.0
Right Femur Z	N	1230.6	88.9	1259.0	110.2	143.8	77.5	3134.3	108.6

DATA SHEET NO. 8 (continued)
DUMMY INJURY CRITERIA VALUES

Vehicle Year/Make/Model/Body Style: 2007/Ford/F-250 XLT Super Duty/4-door pickup
 NHTSA Test No.: R70203 Test Date: 09/13/07

		MAXIMUM VALUE							
		Driver				Right Front Passenger			
DESCRIPTION	Unit	Positive	Time, ms	Negative	Time, ms	Positive	Time, ms	Negative	Time, ms
Left Knee Displacement X	mm	1.0	125.9	1.3	102.5	0.0	310.0	4.3	139.9
Left Upper Tibia Fx	N	208.5	122.5	602.7	87.5	71.6	124.4	323.2	109.8
Left Upper Tibia Fz	N	389.9	82.4	1667.9	90.7	425.0	103.1	681.9	132.0
Left Upper Tibia Mx	N-m	18.5	105.5	58.6	90.5	63.7	122.6	8.9	145.6
Left Upper Tibia My	N-m	78.8	90.2	20.7	229.0	76.2	109.1	36.2	188.7
Left Tibia X	g	10.2	122.1	82.1	87.4	1.8	240.6	40.9	108.3
Left Tibia Y	g	22.5	99.7	111.6	93.5	19.4	109.7	7.2	158.8
Left Lower Tibia Fx	N	40.9	47.8	705.7	90.2	94.3	188.6	468.1	108.1
Left Lower Tibia Fy	N	113.2	102.6	381.6	89.5	248.2	123.0	30.8	144.3
Left Lower Tibia Fz	N	213.0	81.9	2798.4	91.6	37.5	155.4	766.9	71.8
Left Lower Tibia Mx	N-m	30.6	89.6	32.5	105.0	16.9	83.4	20.7	111.5
Left Lower Tibia My	N-m	18.9	122.1	92.0	89.6	10.2	253.5	56.9	109.2
Left Foot Angular Displacement X	°	0.0	81.4	30.2	131.9	27.0	86.7	0.8	15.4
Left Foot Angular Displacement Y	°	15.1	148.0	26.7	60.1	7.1	95.8	4.9	20.0
Left Foot Angular Displacement Z	°	12.7	139.7	2.2	28.8	1.7	107.8	1.6	80.1
Left Foot X	g	44.0	83.7	205.7	84.1	17.1	96.0	37.2	107.2
Left Foot Y	g	69.7	81.8	36.3	84.9	20.9	108.2	19.2	103.3
Left Foot Z	g	214.8	83.4	120.3	87.9	14.0	134.7	23.5	105.8
Left Foot Resultant	g	224.6	83.4			46.2	107.2		
Right Knee Displacement X	mm	0.0	24.4	1.1	86.2	6.6	176.2	10.1	71.4
Right Upper Tibia Fx	N	44.9	112.2	362.9	74.0	1300.2	110.6	368.4	91.3
Right Upper Tibia Fz	N	201.9	59.8	2087.6	88.2	82.7	66.0	1979.6	92.0
Right Upper Tibia Mx	N-m	31.4	143.8	18.3	81.9	26.0	151.6	24.6	115.1
Right Upper Tibia My	N-m	50.0	94.4	26.8	239.0	59.2	91.8	80.4	109.1
Right Tibia X	g	1.4	50.7	46.6	72.3	12.3	99.8	114.3	92.3
Right Tibia Y	g	25.5	85.0	6.7	79.9	13.2	92.2	7.2	153.5

DATA SHEET NO. 8 (continued)
DUMMY INJURY CRITERIA VALUES

Vehicle Year/Make/Model/Body Style: 2007/Ford/F-250 XLT Super Duty/4-door pickup
 NHTSA Test No.: R70203 Test Date: 09/13/07

		MAXIMUM VALUE							
		Driver				Right Front Passenger			
DESCRIPTION	Unit	Positive	Time, ms	Negative	Time, ms	Positive	Time, ms	Negative	Time, ms
Right Lower Tibia Fx	N	53.8	285.0	555.4	94.3	395.4	111.1	632.2	91.9
Right Lower Tibia Fy	N	239.0	87.5	107.2	82.7	253.2	156.6	128.9	116.3
Right Lower Tibia Fz	N	132.9	59.4	3113.3	87.4	72.0	68.1	2714.4	91.0
Right Lower Tibia Mx	N-m	7.0	79.6	30.1	87.7	11.2	116.0	13.1	177.3
Right Lower Tibia My	N-m	11.5	225.6	44.3	73.0	51.4	109.4	67.9	92.2
Right Foot Angular Displacement X	°	8.9	242.9	16.5	155.4	8.7	132.0	1.4	198.2
Right Foot Angular Displacement Y	°	18.1	109.9	18.5	59.2	13.8	110.2	23.0	68.8
Right Foot Angular Displacement Z	°	21.6	144.6	2.7	10.4	13.8	198.1	0.1	101.1
Right Foot X	g	29.4	93.8	77.6	71.0	34.6	71.0	70.1	87.4
Right Foot Y	g	64.3	283.2	23.2	142.4	32.1	102.6	8.9	149.2
Right Foot Z	g	36.7	78.6	84.2	83.3	37.4	102.3	72.6	93.0
Right Foot Resultant	g	111.0	71.0			89.0	93.1		
Lap Belt Load	N	5074.2	94.4	7.2	28.4	1907.1	131.2	4.1	51.5
Shoulder Belt	N	3665.5	96.2	2.1	19.0	4239.4	131.4	25.7	70.9

DATA SHEET NO. 8 (continued)
DUMMY INJURY CRITERIA VALUES

Vehicle Year/Make/Model/Body Style: 2007/Ford/F-250 XLT Super Duty/4-door pickup
 NHTSA Test No.: R70203 Test Date: 09/13/07

	HEAD INJURY CRITERIA			
	HIC**	t₁ (ms)	t₂ (ms)	Average Acceleration t₁ to t₂ (g's)
Left Front - Driver	182	113.1	128.2	43.00
Right Front - Passenger	288	137.3	152.3	51.6
Left Rear - Passenger				
Right Rear - Passenger				

** Head Injury Criteria (HIC) is as defined in FMVSS 208. The maximum time interval from t₁ to t₂ is 0.015 seconds.

	CLIP SUMMARY*			
	CLIP (g's)	t₁ (ms)	t₂ (ms)	Chest Severity Index
Left Front - Driver	29.2	112.9	115.9	196
Right Front - Passenger	48.7	134.7	137.7	363
Left Rear - Passenger				
Right Rear - Passenger				

* The maximum chest resultant acceleration (clip) is defined as the maximum acceleration that exceeds 0.003 seconds in duration.

DATA SHEET NO. 9
SEAT BELT PERFORMANCE ASSESSMENT TEST DATA

Vehicle Year/Make/Model/Body Style: 2007/Ford/F-250 XLT Super Duty/4-door pickup
 NHTSA Test No.: R70203 Test Date: 09/13/07

<u>BELT LENGTH DATA:</u>	<u>Driver*</u>	<u>Right Front Passenger *</u>
Total belt length.	<u>2260</u>	<u>2265</u>
Shoulder belt length as measured on Part 572 Dummy.	<u>815</u>	<u>845</u>
Lap belt length as measured on Part 572 Dummy.	<u>580</u>	<u>630</u>
<u>SHOULDER BELT SPOOL-OFF DATA:</u>	<u>Driver*</u>	<u>Right Front Passenger*</u>
As determined mechanically.	<u>N/A</u>	<u>N/A</u>

NOTE:

* All measurements in millimeters.

¹ Belt spool data not part of test request.

DATA SHEET NO. 10
SUMMARY OF FMVSS 212 DATA

Vehicle Year/Make/Model/Body Style: 2007/Ford/F-250 XLT Super Duty/4-door pickup
 NHTSA Test No.: R70203 Test Date: 09/13/07

FMVSS No. 212 – “Windshield Mounting” Data

Details Of Windshield Mounting Such As

Retention Method, Trim Type, Etc.: Adhesive, Plastic trim

FMVSS 212 Requirements

The Post-Test periphery retention amount must be at least 75% of the Pre-Test periphery measurement for vehicles NOT equipped with automatic restraints, and 50% for each side of the windshield for vehicles equipped with automatic restraint systems for front occupants.

	Windshield Periphery		% of Retention
	Pre-Test (mm)	Post-Test (mm)	
Right Side	2332.5	2332.5	100.0
Left Side	2332.5	2332.5	100.0
Total	4665	4665	100.0

Area of Retention Failure: None

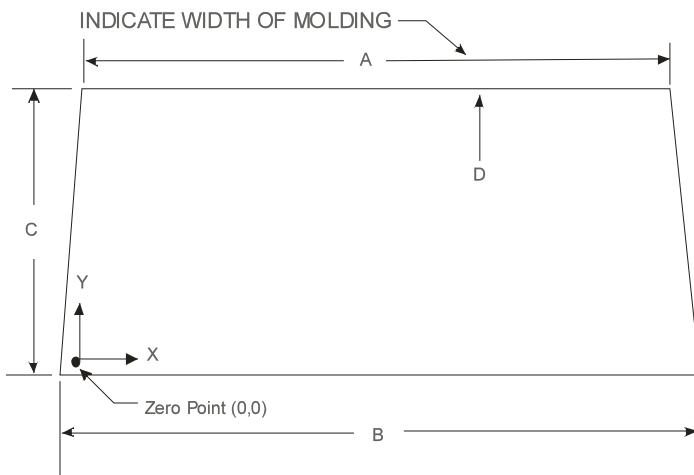

Dimensions (mm)	
A	1430
B	1775
C	730
D	25

FRONT VIEW OF WINDSHIELD

Failure Details

DATA SHEET NO. 11

FMVSS 219 (PARTIAL) – “WINDSHIELD ZONE INTRUSION” DATA

Vehicle Year/Make/Model/Body Style: 2007/Ford/F-250 XLT Super Duty/4-door pickup
 NHTSA Test No.: R70203 Test Date: 09/13/07

Protected Zone Lower Edge Requirement

The lower edge of the protected zone is determined by placing a 165 mm diameter rigid sphere weighing 6.8 kg in a position such that it simultaneously contacts the inner surface of the windshield and the top of the instrument panel including padding. The locus of points is drawn on the inner surface of the windshield contacted by the sphere across the width of the instrument panel. From the outermost contactable points extend the locus line horizontally to the edges of the windshield; then draw a line on the inner surface of the windshield below and 13 mm distant from the locus line. The LOWER EDGE OF THE PROTECTED ZONE is the longitudinal projection of this line onto the outer surface of the windshield.

FMVSS 219 Test Data

(Dimensions in mm)

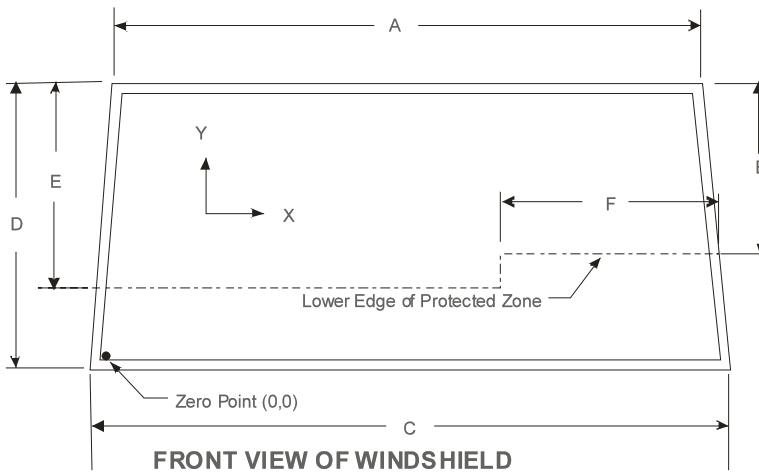

Dimensions	
A	1430
B	455
C	1775
D	730
E	490
F	410

(Show location of penetration on the above sketch)

Details of Windshield Glass Penetration Greater Than 6 mm: None

COORDINATES		
	X	Y
1.		
2.		
3.		
4.		

DATA SHEET NO. 12

FMVSS NO. 301-75 "FUEL SYSTEM INTEGRITY" POST IMPACT TEST DATA

Vehicle Year/Make/Model/Body Style: 2007/Ford/F-250 XLT Super Duty/4-door pickup
 NHTSA Test No.: R70203 Test Date: 09/13/07

The test vehicle was filled from 92% to 94% of the manufacturer's "usable" capacity. The electric fuel pump was operating if it will operate without engine operation. Two Part 572 anthropomorphic test devices were located at each of the front designated seating positions.

TEST VEHICLE IMPACT TYPE

X	Frontal (56 kph)
	Oblique (48 kph) with _____ deg. barrier face first contacting _____ side (driver / passenger)
	Rear Moving Barrier (48 kph)
	Lateral Moving Barrier (32 kph)

FUEL SPILLAGE MEASUREMENT

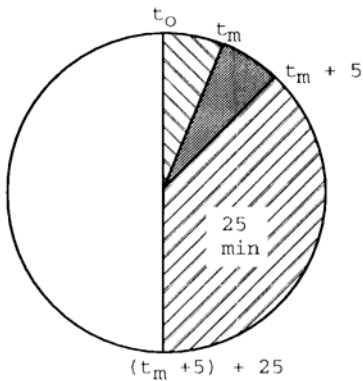

	ACTUAL	MAX. ALLOWED
1. From impact until vehicle motion ceases	0.0 g	28 g
2. For 5 minute period after vehicle motion ceases	0.0 g	141 g
3. For next 25 minutes	0.0 g	28 g/min.

SOLVENT SPILLAGE DETAILS

None

DATA SHEET NO. 13
FMVSS 301 STATIC ROLLOVER DATA SHEET

Vehicle Year/Make/Model/Body Style: 2007/Ford/F-250 XLT Super Duty/4-door pickup
 NHTSA Test No.: R70203 Test Date: 09/13/07

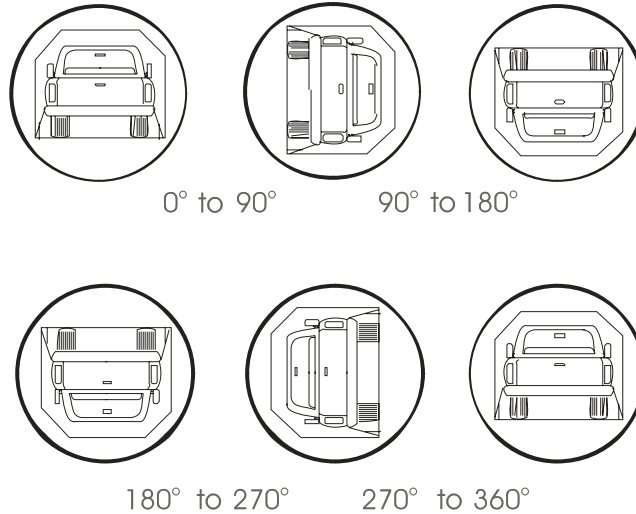

1. The specified fixture rollover rate for each 90° of rotation is 60 to 120 seconds.
2. The position hold time at each position is 300 seconds (minimum).

Details of Stoddard Solvent Spillage Locations

None

Test Phase	Rotation Time (sec.)	Hold Time (sec.)	Spillage (oz.)
0° to 90°	60	300	0
90° to 180°	60	300	0
180° to 270°	60	300	0
270° to 360°	60	300	0

DATA SHEET NO. 14

TEST VEHICLE MEASUREMENTS

Vehicle Year/Make/Model/Body Style: 2007/Ford/F-250 XLT Super Duty/4-door pickup
 NHTSA Test No.: R70203 Test Date: 09/13/07

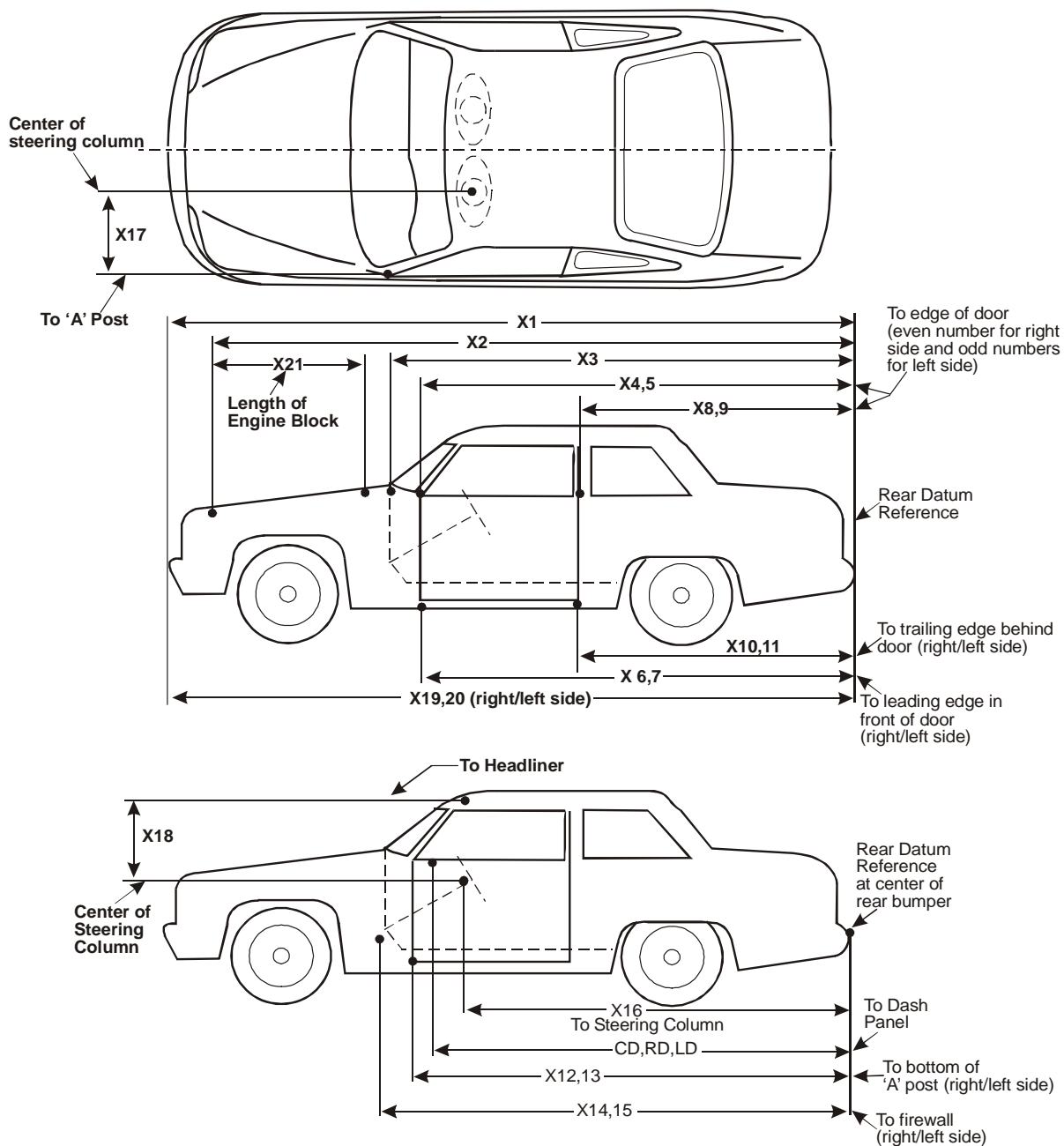

DATA SHEET NO. 14 (continued)
VEHICLE MEASUREMENTS

Vehicle Year/Make/Model/Body Style: 2007/Ford/F-250 XLT Super Duty/4-door pickup
 NHTSA Test No.: R70203 Test Date: 09/13/07

No.	Type of measurement	Pre-Test	Post-Test	Difference
X1	Total Length of Vehicle at Centerline	5845	5293	552
X2	Rear Surface of Vehicle to Front of Engine Block	4997	4960	37
X3	Rear Surface of Vehicle to Firewall	4653	4663	-10
X4	Rear Surface of Vehicle to Upper Leading Edge of Right Door	4269	4224	45
X5	Rear Surface of Vehicle to Upper Leading Edge of Left Door	4274	4372	-98
X6	Rear Surface of Vehicle to Lower Leading Edge of Right Door	4176	4064	112
X7	Rear Surface of Vehicle to Lower Leading Edge of Left Door	4166	4212	-46
X8	Rear Surface of Vehicle to Upper Trailing Edge of Right Door	3038	2997	41
X9	Rear Surface of Vehicle to Upper Trailing Edge of Left Door	3042	3134	-92
X10	Rear Surface of Vehicle to Lower Trailing Edge of Right Door	3046	2962	84
X11	Rear Surface of Vehicle to Lower Trailing Edge of Left Door	3050	3102	-52
X12	Rear Surface of Vehicle to Bottom of " A " Post on Right Side	4206	4159	47
X13	Rear Surface of Vehicle to Bottom of " A " Post on Left Side	4220	4275	-55
X14	Rear Surface of Vehicle to Firewall-Right Side	4569	4599	-30
X15	Rear Surface of Vehicle to Firewall-Left Side	3657	4652	-995
X16	Rear Surface of Vehicle to Steering Wheel Center	3700	3813	-113
X17	Center of Steering Column to " A " Post	295	280	15
X18	Center of Steering Column to Headliner	480	420	60
X19	Rear Surface of Vehicle to Right Side of Front Bumper	5621	5858	-237
X20	Rear Surface of Vehicle to Left Side of Front Bumper	5628	4762	866
X21	Length of Engine Block	500	500	0
RD	Rear Surface of Vehicle to Right Side of Dash Panel	4080	4081	-1
CD	Rear Surface of Vehicle to Center of Dash Panel	3980	4015	-35
LD	Rear Surface of Vehicle to Left Side of Dash Panel	4000	4050	-50

All measurements are in millimeters.

DATA SHEET NO. 14 (continued)
VEHICLE MEASUREMENTS

Vehicle Year/Make/Model/Body Style: 2007/Ford/F-250 XLT Super Duty/4-door pickup
 NHTSA Test No.: R70203 Test Date: 09/13/07

DOOR OPENING WIDTH

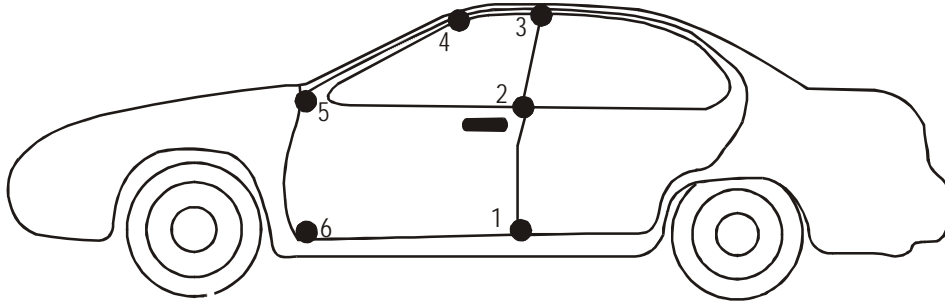

Left Front

Point Location	PRE-TEST (mm)			POST-TEST (mm)			CHANGE (mm)		
	X	Y	Z	X	Y	Z	X	Y	Z
1	3099	-903	-175	3191	-671	-100	92	232	75
2	3059	-918	-552	3167	-709	-478	108	209	74
3	3085	-767	-1335	3209	-598	-1265	124	169	70
4	3727	-730	-1325	3806	-491	-1308	79	239	17
5	4187	-887	-568	4246	-538	-495	59	349	73
6	4139	-887	-199	4211	-493	-125	72	394	74

Right Front

Point Location	PRE-TEST (mm)			POST-TEST (mm)			CHANGE (mm)		
	X	Y	Z	X	Y	Z	X	Y	Z
1	4125	886	-193	4075	1196	-251	-50	310	-58
2	3053	901	-561	3003	1107	-599	-50	206	-38
3	3717	724	-1336	3682	955	-1381	-35	231	-45
4	3079	757	-1341	3040	932	-1372	-39	175	-31
5	4185	885	-553	4136	1187	-612	-49	302	-59
6	3090	899	-189	3041	1124	-227	-49	225	-38

DATA SHEET NO. 14 (continued)
VEHICLE MEASUREMENTS

Vehicle Year/Make/Model/Body Style: 2007/Ford/F-250 XLT Super Duty/4-door pickup
 NHTSA Test No.: R70203 Test Date: 09/13/07

	Elements	Pre-Test
1	Total Length	5845
2	Total Width	2060
3	Bumper Top Height	740
4	Bumper Bottom Height	490
5	Longitudinal Member Top Height	753
6	Longitudinal Member Bottom Height	620
7	Distance Between Longitudinal Members	1065
7'	Longitudinal Member Width	95
8	Engine Top Height	1374
9	Engine Bottom Height	440
10	Engine and Gearbox Width	780
11	Front Bumper - Engine Distance	811
12	Front Shock Absorber Fixing Height	920
13	Bonnet Leading Edge Height	1273
14	Front Shock Absorber Fixing Width	1044
15	Front Bumper - Front Axle Distance	913
16	Front Axle - A Pillar Distance	750
17	A Pillar - B Pillar Distance	1130
18	B Pillar - Rear Axle Distance	1717
19	B Pillar - C Pillar Distance	592
20	Roof Sill Bottom Height	1830
21	Roof Sill Top Height	1940
22	Floor Sill Bottom Height	638
23	Floor Sill Top Height	662

All distance measurements are in millimeters.

¹ Taken from INSIA report, "Structural Survey of Cars, Methodology of the Main Resistant Elements in the Car Body", March 1999. This report is included in Appendix F.

DATA SHEET NO. 14 (continued)
VEHICLE MEASUREMENTS

Vehicle Year/Make/Model/Body Style: 2007/Ford/F-250 XLT Super Duty/4-door pickup
 NHTSA Test No.: R70203 Test Date: 09/13/07

STATIC FOOTWELL DEFORMATION

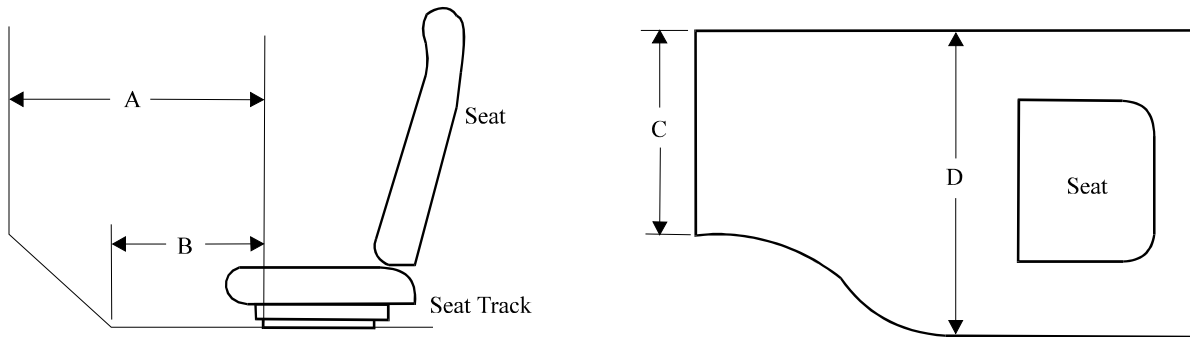

DRIVER

Measurement	Pre-Test	Post-Test	Difference
A	579	500	-79
B	407	361	-46
C	385	344	-41
D	391	378	-13

All units in millimeters

PASSENGER

Measurement	Pre-Test	Post-Test	Difference
A	431	410	-21
B	374	363	-11
C	-326	-329	-3
D	-380	-376	4

All units in millimeters

DATA SHEET NO. 14 (continued)
VEHICLE MEASUREMENTS

Vehicle Year/Make/Model/Body Style: 2007/Ford/F-250 XLT Super Duty/4-door pickup
 NHTSA Test No.: R70203 Test Date: 09/13/07

STATIC PASSENGER COMPARTMENT INTRUSION

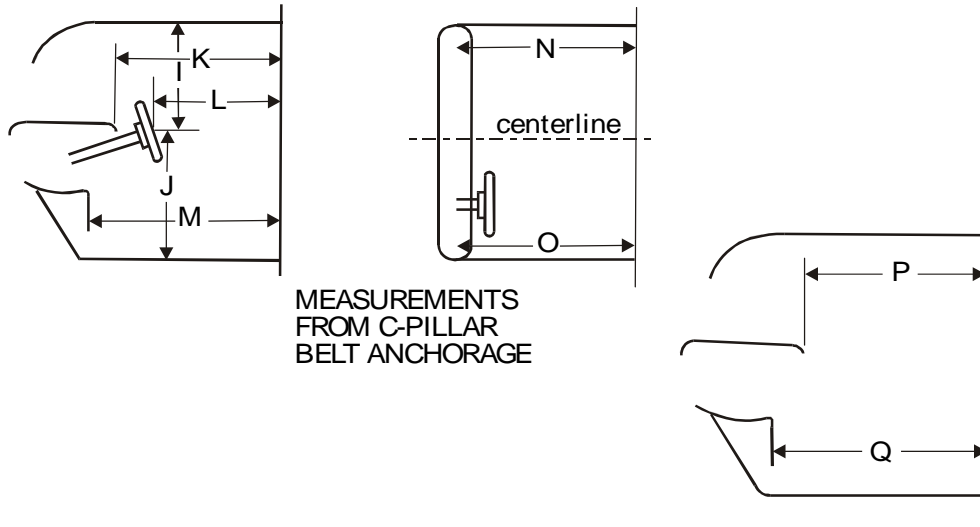

Measurement	Pre-Test	Post-Test	Difference
I	485	455	30
J	710	748	-38
K	1550	1475	75
L	1346	1272	74
M	1720	1640	80
N	1648	1645	3
O	1565	1518	47
P = K (PASS.)	1630	1632	-2
Q = M (PASS.)	1757	1762	-5

All units in millimeters

DATA SHEET NO. 14 (continued)
VEHICLE MEASUREMENTS

Vehicle Year/Make/Model/Body Style: 2007/Ford/F-250 XLT Super Duty/4-door pickup
 NHTSA Test No.: R70203 Test Date: 09/13/07

FLOORBOARD DEFORMATION

DRIVERS SIDE

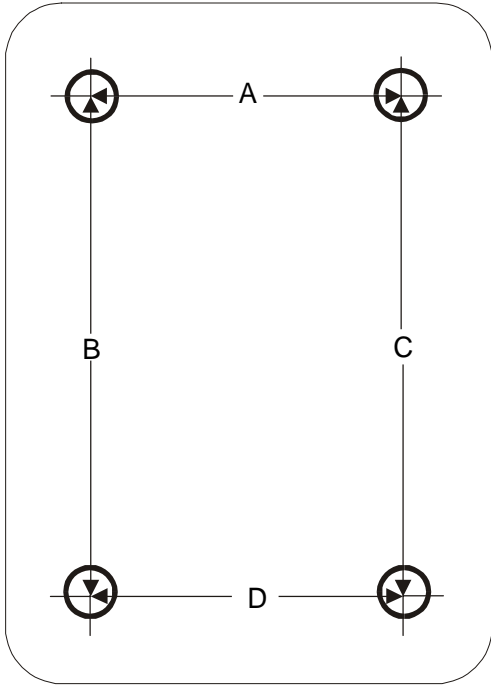

PASSENGERS SIDE

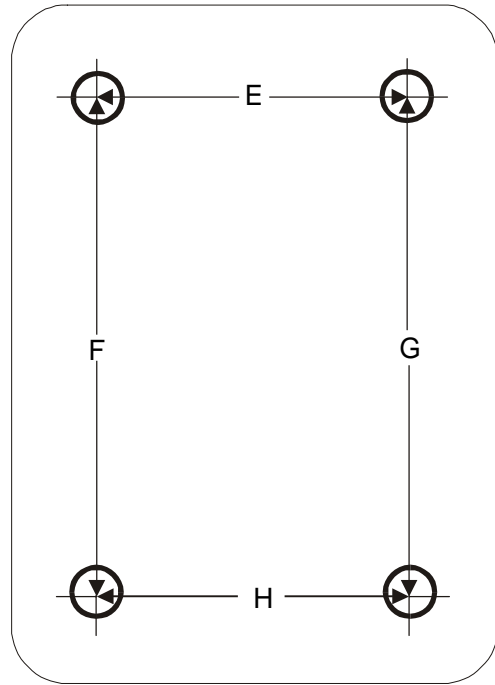

TOP VIEW THROUGH FLOOR PAN

Measurement	Pre-Test	Post-Test	Difference
A	417	374	-43
B	407	361	-46
C	387	240	-147
D	391	378	-13
E	357	355	-2
F	374	363	-11
G	396	394	-2
H	380	376	-4

All units in millimeters

DATA SHEET NO. 14 (continued)
VEHICLE MEASUREMENTS

Vehicle Year/Make/Model/Body Style: 2007/Ford/F-250 XLT Super Duty/4-door pickup
 NHTSA Test No.: R70203 Test Date: 09/13/07

Bottom of Front Bumper

Pre-Test				Post-Test			Difference		
Index	X, mm	Y, mm	Z, mm	X, mm	Y, mm	Z, mm	X, mm	Y, mm	Z, mm
1	5454	-941	-11	4822	-523	-64	-632	418	-53
2	5622	-909	-62	4964	-500	-125	-658	409	-63
3	5741	-704	-64	5098	-310	-88	-643	394	-24
4	5826	-474	-60	5179	-89	-71	-647	385	-11
5	5853	-244	-61	5138	126	-127	-715	370	-66
6	5861	7	-56	5274	280	-112	-587	273	-56

Top of Front Bumper

Pre-Test				Post-Test			Difference		
Index	X, mm	Y, mm	Z, mm	X, mm	Y, mm	Z, mm	X, mm	Y, mm	Z, mm
1	5416	-983	-233	4760	-468	-281	-656	515	-48
2	5634	-922	-233	4966	-472	-295	-668	450	-62
3	5751	-711	-236	5120	-291	-258	-631	420	-22
4	5840	-481	-233	5206	-100	-250	-634	381	-17
5	5868	-244	-234	5142	128	-253	-726	372	-19
6	5878	5	-235	5269	279	-262	-609	274	-27

Center of Grill

Pre-Test				Post-Test			Difference		
Index	X, mm	Y, mm	Z, mm	X, mm	Y, mm	Z, mm	X, mm	Y, mm	Z, mm
1	5570	-844	-522	N/A ¹	N/A ¹	N/A ¹	N/A	N/A	N/A
2	5763	-513	-521	5227	-111	-545	-536	402	-24
3	5766	-164	-524	5165	221	-579	-601	385	-55
4	5764	173	-531	5465	381	-588	-299	208	-57
5	5759	519	-529	5772	545	-598	13	26	-69
6	5559	861	-528	5545	1092	-449	-14	231	79

Front of Hood

Pre-Test				Post-Test			Difference		
Index	X, mm	Y, mm	Z, mm	X, mm	Y, mm	Z, mm	X, mm	Y, mm	Z, mm
1	5528	-846	-669	5104	-521	-852	-424	325	-183
2	5703	-520	-762	5118	-183	-840	-585	337	-78
3	5743	-170	-775	5115	163	-847	-628	333	-72
4	5741	186	-776	5368	388	-832	-373	202	-56
5	5700	533	-765	5493	715	-852	-207	182	-87
6	5522	860	-674	5442	1092	-878	-80	232	-204

¹ Measurement point could not be located post-test.

DATA SHEET NO. 14 (continued)
VEHICLE MEASUREMENTS

Vehicle Year/Make/Model/Body Style: 2007/Ford/F-250 XLT Super Duty/4-door pickup
 NHTSA Test No.: R70203 Test Date: 09/13/07

TOE PAN FLOORBOARD INTRUSION

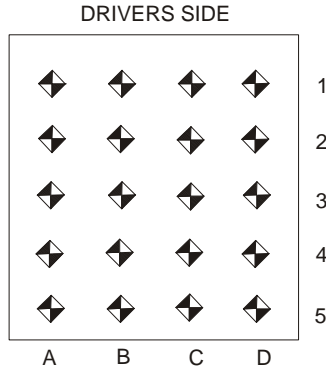

Driver Side Toe Pan and Floorboard Measurements

Intrusion Location	PRE-TEST (mm)			POST-TEST (mm)			CHANGE (mm)		
	X	Y	Z	X	Y	Z	X	Y	Z
A1	4360	-688	-273	4340	-260	-259	-20	428	14
B1	4345	-571	-272	4275	-164	-279	-70	407	-7
C1	4345	-445	-270	4232	-49	-308	-113	396	-38
D1	4354	-303	-252	4247	84	-292	-107	387	-40
A2	4288	-692	-212	4292	-266	-175	4	426	37
B2	4274	-564	-220	4228	-157	-206	-46	407	14
C2	4268	-441	-222	4173	-52	-240	-95	389	-18
D2	4265	-296	-207	4165	86	-239	-100	382	-32
A3	4188	-700	-172	4201	-296	-128	13	404	44
B3	4185	-557	-174	4153	-163	-142	-32	394	32
C3	4182	-431	-174	4112	-46	-165	-70	385	9
D3	4174	-283	-169	4070	78	-224	-104	361	-55
A4	3977	-701	-169	4002	-361	-111	25	340	58
B4	3978	-573	-171	3965	-248	-157	-13	325	14
C4	3978	-439	-170	3930	-130	-212	-48	309	-42
D4	3984	-294	-174	3909	-8	-253	-75	286	-79
A5	3781	-681	-167	3840	-368	-38	59	313	129
B5	3784	-567	-169	3819	-258	-63	35	309	106
C5	3780	-428	-170	3819	-121	-85	39	307	85
D5	3787	-290	-174	3830	10	-127	43	300	47
BP	4210	-457	-383	4141	-90	-425	-69	367	-42
LB	4004	-631	-648	4039	-314	-615	35	317	33
RB	4005	-327	-647	4036	-11	-632	31	316	15
SW	3754	-471	-885	3788	-199	-909	34	272	-24
AB	3684	-612	-241	3758	-322	-140	74	290	101

BP=Brake Pedal, LB=Left side of bolster, RB=Right side of bolster, SW=Steering wheel center, AB=Front outboard seat anchor bolt.

Procedure for measuring interior points is located in Appendix E.

DATA SHEET NO. 14 (continued)
VEHICLE MEASUREMENTS

Vehicle Year/Make/Model/Body Style: 2007/Ford/F-250 XLT Super Duty/4-door pickup
 NHTSA Test No.: R70203 Test Date: 09/13/07

ADDITIONAL TOE PAN FLOORBOARD INTRUSION



Driver Side Toe Pan and Floorboard Measurements

Intrusion Location	PRE-TEST (mm)			POST-TEST (mm)			CHANGE (mm)		
	X	Y	Z	X	Y	Z	X	Y	Z
1	4393	-735	-300	4386	-296	-281	-7	439	19
2	4390	-623	-298	4330	-203	-308	-60	420	-10
3	4386	-498	-296	4270	-99	-338	-116	399	-42
4	4376	-366	-299	4235	27	-351	-141	393	-52
5	4329	-738	-229	4342	-301	-197	13	437	32
6	4313	-630	-250	4282	-214	-232	-31	416	18
7	4306	-505	-247	4230	-102	-256	-76	403	-9
8	4309	-380	-234	4203	10	-266	-106	390	-32
9	4240	-737	-193	4265	-319	-145	25	418	48
10	4235	-648	-201	4231	-236	-156	-4	412	45
11	4228	-501	-199	4165	-110	-192	-63	391	7
12	4229	-373	-192	4144	12	-198	-85	385	-6
13	4083	-728	-148	4112	-352	-96	29	376	52
14	4085	-621	-170	4080	-257	-144	-5	364	26
15	4077	-496	-171	4032	-148	-173	-45	348	-2
16	4073	-355	-168	4000	-23	-233	-73	332	-65
17	4322	-248	-263	4222	141	-292	-100	389	-29
18	4190	-219	-181	4071	142	-254	-119	361	-73
19	4271	-201	-358	4194	171	-402	-77	372	-44
20	4312	-811	-279	4353	-388	-231	41	423	48

Additional points identified by COTR.

DATA SHEET NO. 14 (continued)
VEHICLE MEASUREMENTS

Vehicle Year/Make/Model/Body Style: 2007/Ford/F-250 XLT Super Duty/4-door pickup
 NHTSA Test No.: R70203 Test Date: 09/13/07

TOE PAN FLOORBOARD INTRUSION

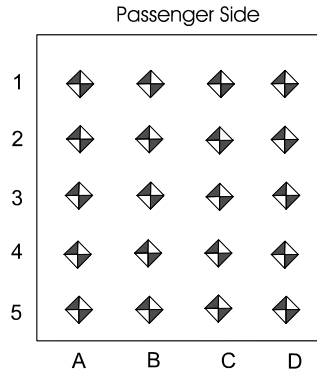

Passenger Side Toe Pan and Floorboard Measurements

Intrusion Location	PRE-TEST (mm)			POST-TEST (mm)			CHANGE (mm)		
	X	Y	Z	X	Y	Z	X	Y	Z
A1	4239	380	-365	4214	697	-404	-25	317	-39
B1	4357	500	-337	4332	819	-380	-25	319	-43
C1	4357	593	-340	4327	915	-385	-30	322	-45
D1	4363	706	-346	4325	1026	-396	-38	320	-50
A2	4219	378	-295	4197	696	-333	-22	318	-38
B2	4287	490	-274	4264	808	-314	-23	318	-40
C2	4294	592	-276	4266	910	-319	-28	318	-43
D2	4294	707	-285	4257	1024	-335	-37	317	-50
A3	4182	353	-184	4167	668	-220	-15	315	-36
B3	4179	490	-182	4158	805	-221	-21	315	-39
C3	4173	601	-180	4143	916	-225	-30	315	-45
D3	4170	710	-180	4131	1023	-231	-39	313	-51
A4	3986	332	-172	3978	635	-197	-8	303	-25
B4	3975	451	-172	3957	751	-209	-18	300	-37
C4	3974	588	-173	3945	887	-216	-29	299	-43
D4	3960	702	-175	3922	999	-219	-38	297	-44
A5	3808	319	-173	3804	606	-179	-4	287	-6
B5	3788	451	-173	3772	737	-188	-16	286	-15
C5	3775	606	-176	3746	889	-201	-29	283	-25
D5	3774	699	-176	3737	982	-209	-37	283	-33

Procedure for measuring interior points is located in Appendix E.

DATA SHEET NO. 14 (continued)
VEHICLE MEASUREMENTS

Vehicle Year/Make/Model/Body Style: 2007/Ford/F-250 XLT Super Duty/4-door pickup
 NHTSA Test No.: R70203 Test Date: 09/13/07

BUMPER BEAM MEASUREMENTS

Index	PRE-TEST			POST-TEST			CHANGE		
	X	Y	Z	X	Y	Z	X	Y	Z
1	5454	-941	-11	4822	-523	-64	-632	418	-53
2	5622	-909	-62	4964	-500	-125	-658	409	-63
3	5741	-704	-64	5098	-310	-88	-643	394	-24
4	5826	-474	-60	5179	-89	-71	-647	385	-11
5	5853	-244	-61	5138	126	-127	-715	370	-66
6	5861	7	-56	5274	280	-112	-587	273	-56
7	5856	244	-61	5485	388	-114	-368	144	-53
8	5825	488	-62	5661	559	-128	-164	71	-66
9	5742	707	-61	5775	762	-149	33	55	-88
10	5625	912	-62	5860	981	-201	235	69	-139
11	5457	950	-19	5771	1138	-151	314	188	-132

All units in millimeters

DATA SHEET NO. 15
CAMERA POSITIONS FOR FRONTAL IMPACTS

Vehicle Year/Make/Model/Body Style: 2007/Ford/F-250 XLT Super Duty/4-door pickup
 NHTSA Test No.: R70203 Test Date: 09/13/07

NOTE: Camera information shown in DATA SHEET NO. 15.

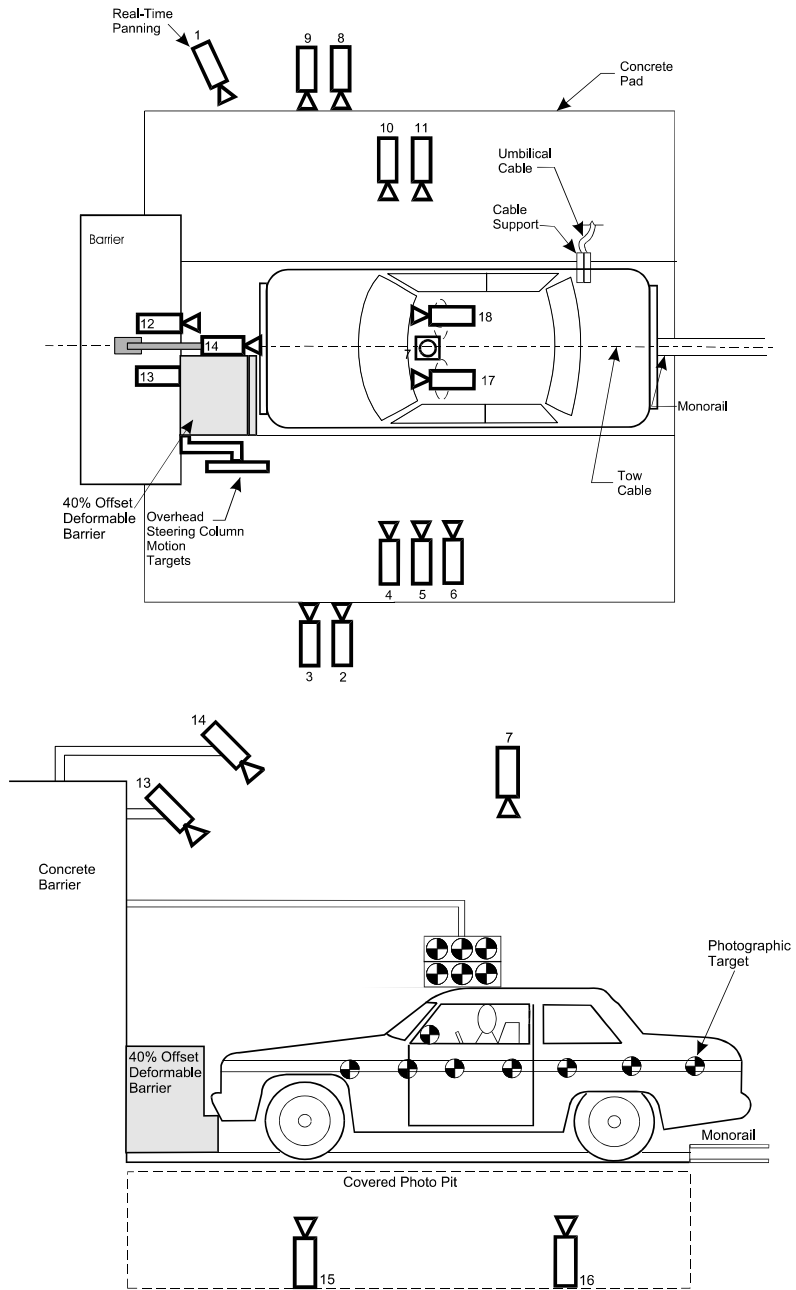

DATA SHEET NO. 15 (continued)
HIGH-SPEED CAMERA LOCATIONS

Vehicle Year/Make/Model/Body Style: 2007/Ford/F-250 XLT Super Duty/4-door pickup
 NHTSA Test No.: R70203 Test Date: 09/13/07

CAMERA NO.	VIEW	CAMERA POSITIONS (mm)*			ANGLE (deg)**	FILM PLANE TO HEAD TARGET (mm)	LENS (mm)	SPEED (fps)
		X	Y	Z				
1	Real-Time Camera	---	---	---	---	---	zoom	30
2	Overall Left Side	2680	6670	-1300	3.3	6400	12.5	1000
3	Left Side View	150	4910	-980	1.5	5200	25	1000
4	Driver View	1550	7420	-1550	1.1	7230	50	1000
5	Steering Column Top	1880	7300	-2200	6.9	6980	25	1000
6	Steering Column Bottom	1800	6900	-1300	0.9	6750	50	1000
7	Top View	200	0	-5620	90.0	4040	12.5	1000
8	Overall Right Side	1280	6660	-1270	3.1	6250	12.5	1000
9	Right Side View	150	6700	-970	0.9	6500	25	1000
10	Passenger View	1460	7100	-1600	3.3	6600	25	1000
11	Passenger & Interior View	1750	6840	-1600	0.6	6250	50	1000
12	Driver Front Angled View	1950	800	-2230	11.2	4730	25	1000
13	Driver Front View	1950	450	-2230	11.2	4730	25	1000
14	Windshield View	1950	0	-2230	20.9	4730	12.5	1000
15	Pit View of Engine	300	0	-3340	90.0	4870	25	1000
16	Pit View of Fuel Tank	2450	0	-3340	90.0	4870	12.5	1000
17	Driver Lower Leg View	--- ¹	--- ¹	--- ¹	1.4	N/A	6.5	--- ¹
18	Passenger Lower Leg View	--- ¹	--- ¹	--- ¹	1.4	N/A	6.5	--- ¹

*X = film plane to impact location

Y = film plane to monorail centerline

Z = film plane to ground

**Angle = referenced to horizontal plane

¹ Camera did not run.

DATA SHEET NO. 16
VEHICLE REFERENCE PHOTO TARGET LOCATIONS

Vehicle Year/Make/Model/Body Style: 2007/Ford/F-250 XLT Super Duty/4-door pickup
 NHTSA Test No.: R70203 Test Date: 09/13/07

A	470
B	820
C	610
D	0
E	414
F	1121
G	1180
H	1270
I	-959
J	1308
K	306
L	2834
M	258
N	-810
O	1249
P	1210
Q	2685
R	440
S	1286

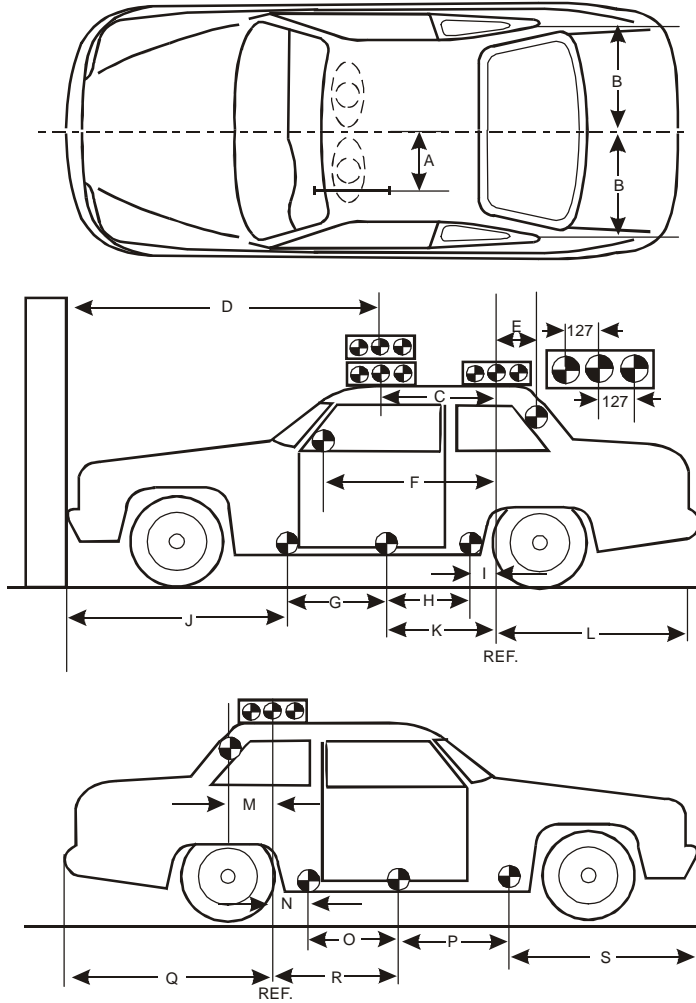

All measurements in millimeters

DATA SHEET NO. 17
POST TEST AIR BAG DATA

Vehicle Year/Make/Model/Body Style: 2007/Ford/F-250 XLT Super Duty/4-door pickup
 NHTSA Test No.: R70203 Test Date: 09/13/07

NHTSA No.: R70203 Test Date: 09/13/07 Technician: John Shultz

Vehicle Model Year/Make/Model: 2007/Ford/F-250 XLT Super Duty

- A. No. of vent holes: 2 -Driver 0 -Passenger
- B. Size of vent holes: (mm²) 30 -Driver N/A -Passenger
- C. Total vent area: (mm²) 60 -Driver N/A -Passenger
- D. Deflated air bag length and width dimensions or, if round, diameter. (mm)
- Driver: 430 -Length; 520 -Width; N/A -Diameter
- Passenger: 700 -Height; 730 -Width; N/A -Depth
- E. Is the air bag tethered?
- Driver: -Yes; X -No; If yes, record length of tether (mm)- N/A
- Passenger: -Yes; X -No; If yes, record length of tether (mm)- N/A

Sketch the air bag showing the location of the vent holes, how the bag is tethered, and where the bag is tethered. Also describe how the tethers are attached to the bag and the steering wheel.

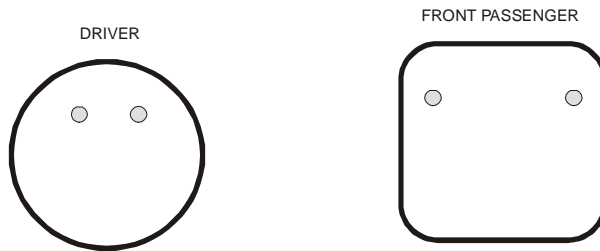

(Note: Not to scale; V_n = Vent hole_n, T_n = Tether_n).

- F. Record part numbers and manufacturer name of the airbag and gas generator.
- Driver: TRW/Arizona, USA 2006/Queen Creek
1DLV143T10059, 21ZM136T12175
- Passenger: Ford, 6C34 25044R74 CB33TC, 2G14510F8
2003642A

DATA SHEET NO. 18
ACCIDENT INVESTIGATION DIVISION DATA

Vehicle Year/Make/Model/Body Style: 2007/Ford/F-250 XLT Super Duty/4-door pickup
 NHTSA Test No.: R70203 Test Date: 09/13/07

FOR FRONTAL BARRIER IMPACT

NHTSA Test No.: R70203 VIN: 1FTSX21587EA19550
 Model Year: 2007 Build Date: 06/06 Test Date: 09/13/07
 Vehicle Size Category: Pickup Test Weight: 3291.4 kg
 Vehicle Wheelbase: 3610 mm; Front Overhang: 913 mm; Overall Width: 2060 mm
 Collision Deformation Classification (CDC) Code: 12FDEW4

Crush Depth Dimensions with Bumper

	PRE-TEST	POST-TEST	DIFFERENCE	
C1 =	N/A	N/A	N/A	mm
C2 =	N/A	N/A	N/A	mm
C3 =	N/A	N/A	N/A	mm
C4 =	N/A	N/A	N/A	mm
C5 =	N/A	N/A	N/A	mm
C6 =	N/A	N/A	N/A	mm

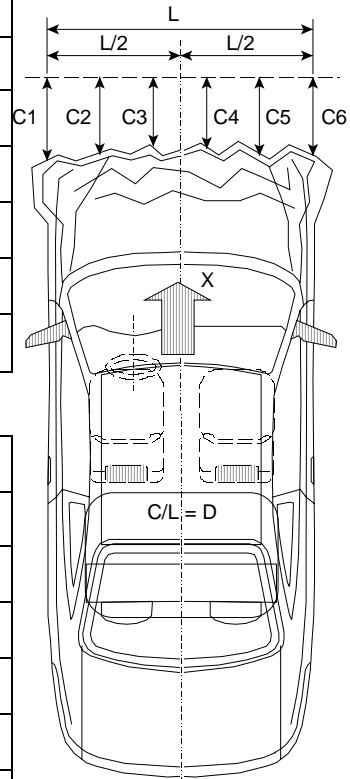

Crush Depth Dimensions without Bumper

	PRE-TEST	POST-TEST	DIFFERENCE	
C1 =	5454	4822	632	mm
C2 =	5741	5098	643	mm
C3 =	5853	5138	715	mm
C4 =	5853	5485	368	mm
C5 =	5742	5775	-33	mm
C6 =	5457	5771	-314	mm

Midpoint of Damage: $D = \underline{\text{Vehicle Centerline (Longitudinal)}}$

Length of Damaged Region
 $L1 = \underline{2060}$ mm
 $L2 = \underline{1030}$ mm
 $L3 = \underline{1030}$ mm

DATA SHEET NO. 19
OFFSET BARRIER AND VEHICLE ORIENTATION

Vehicle Year/Make/Model/Body Style: 2007/Ford/F-250 XLT Super Duty/4-door pickup
 NHTSA Test No.: R70203 Test Date: 09/13/07

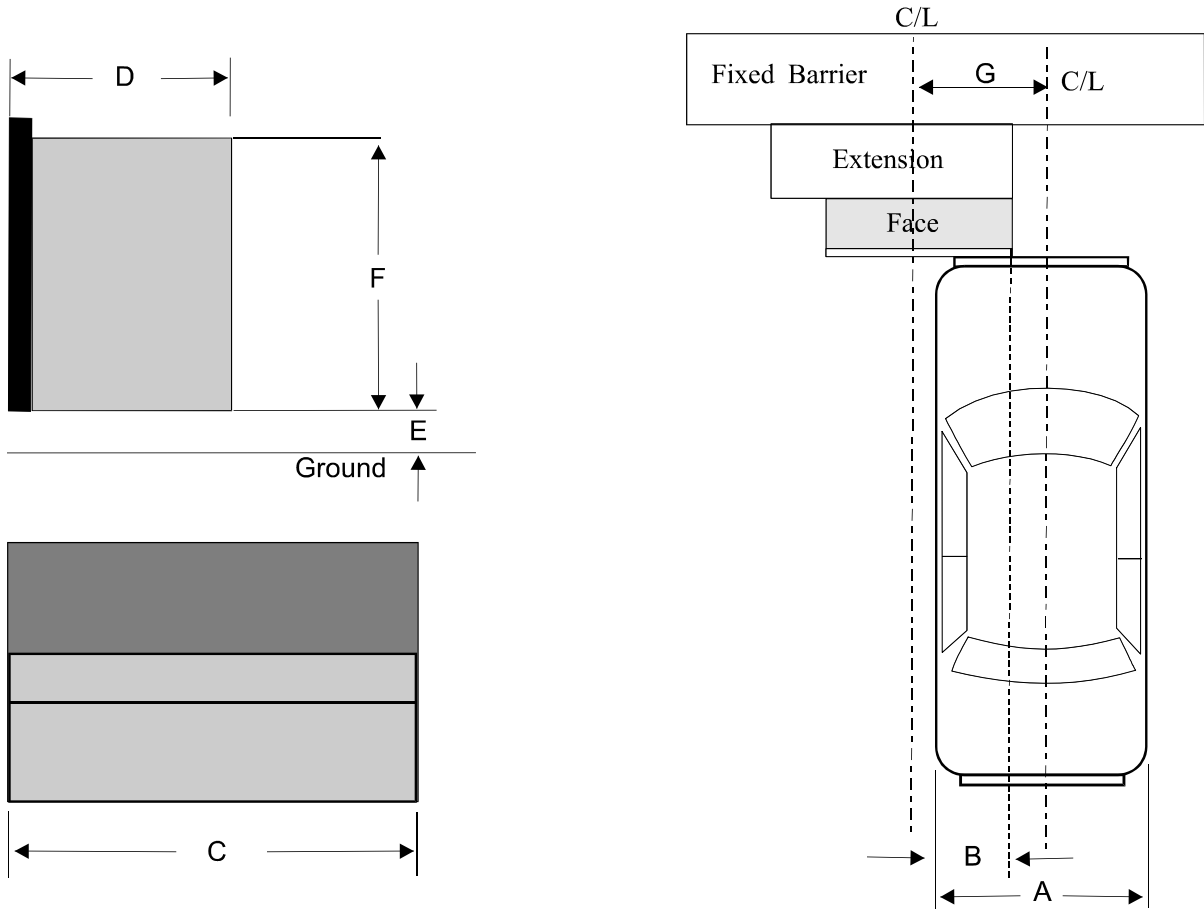

A. Total Vehicle Width	<u>2060</u> mm
B. 40% Overlap Distance	<u>766</u> mm
C. Deformable Face Width	<u>1000</u> mm
D. Single Stage Honeycomb Depth	<u>450</u> mm
E. Lower Edge Height From Ground	<u>200</u> mm
F. Bumper Element Height	<u>330</u> mm
G. Offset Distance	<u>650</u> mm

DATA SHEET NO. 20
DEFORMABLE BARRIER HONEYCOMB CRUSH

Vehicle Year/Make/Model/Body Style: 2007/Ford/F-250 XLT Super Duty/4-door pickup
NHTSA Test No.: R70203 Test Date: 09/13/07

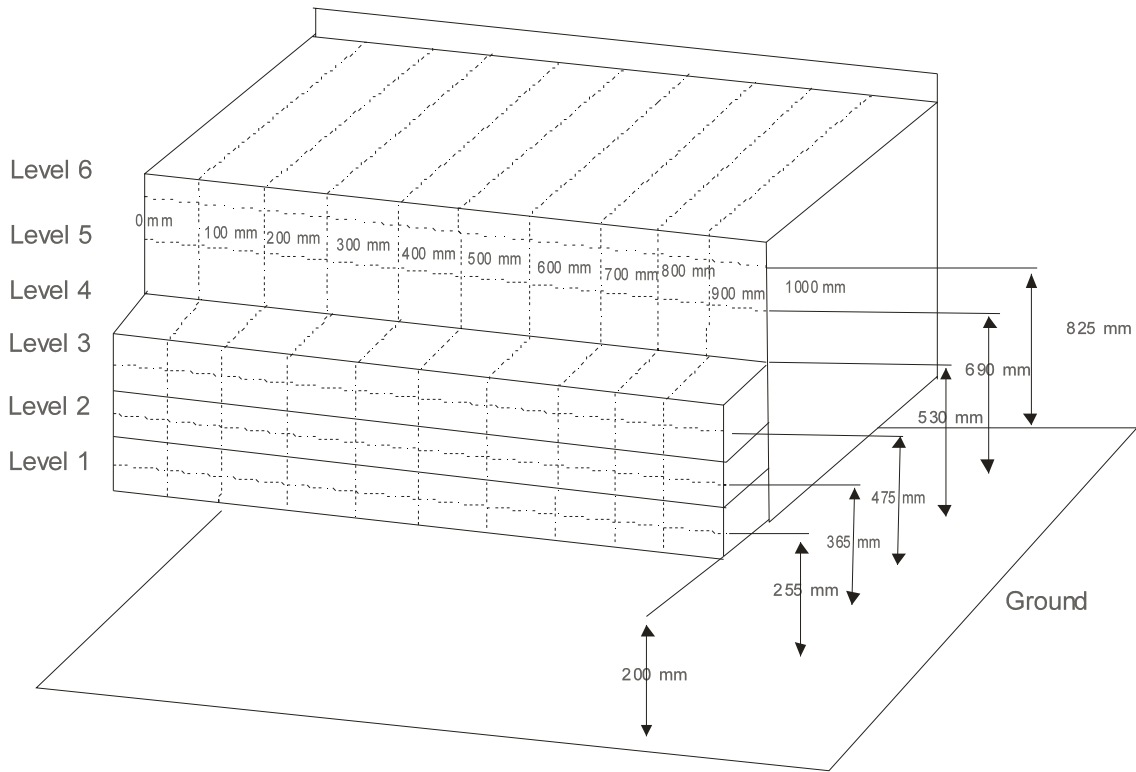

Deformable Barrier Face Profile

Pre-Test

Index	Xmm	Ymm	Zmm
1	-455.4	493.2	47.2
2	-455.6	402.5	47.2
3	-455.4	302.4	47.3
4	-455.2	203.1	47.3
5	-455.1	102.9	47.2
6	-454.9	2.9	47.6
7	-454.9	-97.5	47.4
8	-454.7	-197.4	47.6
9	-454.5	-297.1	47.8
10	-454.6	-397.4	47.8
11	-454.3	-497.1	47.8
12	-455.4	493.0	-87.2
13	-455.5	398.2	-87.2
14	-455.3	298.3	-87.1
15	-455.1	198.5	-87.1
16	-454.9	98.7	-87.4
17	-454.8	-1.5	-86.8
18	-454.7	-101.7	-86.9
19	-454.6	-202.0	-86.7
20	-454.4	-301.5	-86.6
21	-454.2	-401.9	-86.6
22	-454.2	-496.1	-86.8

Post-Test

Index	Xmm	Ymm	Zmm
1	-434.9	458.9	45.2
2	-422.1	369.3	43.3
3	-396.8	273.5	36.6
4	-367.9	179.7	35.7
5	-306.6	106.6	41.4
6	-227.3	50.0	44.4
7	-144.1	-5.8	40.7
8	-91.1	-96.3	30.9
9	-54.0	-187.1	30.3
10	-27.5	-283.2	20.8
11	-30.6	-430.8	-64.3
12	-432.7	461.2	-89.1
13	-423.4	366.8	-90.8
14	-412.3	267.5	-92.3
15	-356.3	194.5	-87.8
16	-280.6	135.7	-84.1
17	-222.1	54.6	-89.4
18	-145.2	-10.2	-92.0
19	-37.5	-76.7	-73.5
20	-13.5	-163.2	-77.7
21	-42.9	-350.2	-202.1
22	-29.5	-442.0	-199.5

Difference

Index	Xmm	Ymm	Zmm
1	-20.5	34.3	2.0
2	-33.5	33.2	3.9
3	-58.6	28.9	10.7
4	-87.3	23.4	11.6
5	-148.5	-3.7	5.8
6	-227.6	-47.1	3.2
7	-310.8	-91.7	6.7
8	-363.6	-101.1	16.7
9	-400.5	-110.0	17.5
10	-427.1	-114.2	27.0
11	-423.7	-66.3	112.1
12	-22.7	31.8	1.9
13	-32.1	31.4	3.6
14	-43.0	30.8	5.2
15	-98.8	4.0	0.7
16	-174.3	-37.0	-3.3
17	-232.7	-56.1	2.6
18	-309.5	-91.5	5.1
19	-417.1	-125.3	-13.2
20	-440.9	-138.3	-8.9
21	-411.3	-51.7	115.5
22	-424.7	-54.1	112.7

Deformable Barrier Face Profile Cont'd.

Pre-Test

Index	Xmm	Ymm	Zmm
23	-455.3	493.4	-228.1
24	-455.3	398.4	-227.7
25	-455.1	298.1	-227.6
26	-455.0	198.3	-227.5
27	-454.8	98.6	-227.6
28	-454.7	-1.9	-227.6
29	-454.6	-102.0	-227.8
30	-454.5	-201.5	-227.5
31	-454.3	-301.9	-227.5
32	-454.3	-402.0	-227.6
33	-454.4	-497.0	-227.7
34	-545.3	494.2	-304.3
35	-545.0	398.4	-304.2
36	-544.8	298.5	-304.1
37	-544.7	198.7	-304.1
38	-544.5	99.2	-304.0
39	-544.5	-0.8	-303.7
40	-544.3	-100.8	-303.6
41	-544.2	-201.1	-303.7
42	-544.1	-300.9	-303.4
43	-544.1	-401.0	-303.5
44	-544.1	-495.9	-303.3

Post-Test

Index	Xmm	Ymm	Zmm
23	-409.1	466.9	-225.1
24	-389.7	374.0	-222.1
25	-376.1	274.7	-224.0
26	-335.0	197.5	-215.8
27	-281.4	88.6	-237.6
28	-242.1	-2.0	-256.5
29	-201.2	-88.8	-282.6
30	-157.8	-169.6	-317.3
31	--- ¹	--- ¹	--- ¹
32	--- ¹	--- ¹	--- ¹
33	--- ¹	--- ¹	--- ¹
34	-451.7	447.1	-319.3
35	-442.5	352.3	-308.6
36	-432.8	253.4	-297.3
37	-419.6	155.9	-283.5
38	-384.3	60.8	-270.8
39	-342.8	-32.5	-262.9
40	-264.8	-146.1	-275.3
41	-202.5	-208.1	-314.7
42	-152.5	-288.4	-318.7
43	-78.6	-409.9	-299.4
44	-49.9	-446.7	-305.8

Difference

Index	Xmm	Ymm	Zmm
23	-46.2	26.5	-3.0
24	-65.6	24.4	-5.6
25	-79.0	23.4	-3.6
26	-120.0	0.8	-11.7
27	-173.4	10.0	10.0
28	-212.6	0.1	28.9
29	-253.4	-13.2	54.8
30	-296.7	-31.9	89.8
31	--- ¹	--- ¹	--- ¹
32	--- ¹	--- ¹	--- ¹
33	--- ¹	--- ¹	--- ¹
34	-93.6	47.1	15.0
35	-102.5	46.1	4.4
36	-112.0	45.1	-6.8
37	-125.1	42.8	-20.6
38	-160.2	38.4	-33.2
39	-201.7	31.7	-40.8
40	-279.5	45.3	-28.3
41	-341.7	7.0	11.0
42	-391.6	-12.5	15.3
43	-465.5	8.9	-4.1
44	-494.2	-49.2	2.5

¹ Measurement could not taken due to missing target post-test.

Deformable Barrier Face Profile Cont'd.

Pre-Test

Index	Xmm	Ymm	Zmm
45	-545.2	494.6	-414.0
46	-545.0	399.7	-413.9
47	-544.7	299.7	-414.4
48	-544.5	200.1	-414.2
49	-544.4	99.8	-413.9
50	-544.3	-0.3	-413.8
51	-544.3	-100.4	-414.2
52	-544.1	-200.4	-413.9
53	-544.0	-300.4	-414.1
54	-544.0	-400.9	-413.6
55	-544.0	-495.9	-413.5
56	-544.5	496.5	-530.4
57	-544.9	401.2	-529.8
58	-544.6	300.6	-529.6
59	-544.4	201.1	-529.5
60	-544.1	100.5	-529.3
61	-544.2	0.7	-528.9
62	-544.2	-99.6	-528.8
63	-544.1	-199.6	-528.3
64	-544.0	-299.3	-528.2
65	-544.1	-399.4	-528.1
66	-544.2	-494.5	-527.9

Post-Test

Index	Xmm	Ymm	Zmm
45	-413.8	479.0	-414.0
46	-413.9	384.2	-415.8
47	-413.7	284.0	-418.3
48	-412.4	184.2	-419.5
49	-412.8	84.2	-419.2
50	-402.5	-15.1	-413.5
51	-381.7	-113.9	-407.3
52	-378.2	-228.7	-409.0
53	-341.3	-321.7	-410.0
54	-298.0	-412.7	-415.7
55	-261.5	-499.4	-419.3
56	-387.0	485.7	-523.4
57	-390.9	390.5	-524.9
58	-394.4	289.9	-526.9
59	-398.0	190.7	-528.4
60	-402.1	90.2	-528.8
61	-405.7	-9.5	-527.7
62	-410.6	-109.9	-526.1
63	-411.1	-243.1	-528.4
64	-390.8	-339.4	-544.8
65	-370.0	-436.1	-561.4
66	-350.5	-528.0	-577.2

Difference

Index	Xmm	Ymm	Zmm
45	-131.4	15.6	0.0
46	-131.1	15.5	1.9
47	-131.0	15.7	3.9
48	-132.1	15.9	5.3
49	-131.6	15.6	5.3
50	-141.8	14.8	-0.3
51	-162.6	13.5	-6.9
52	-165.9	28.3	-4.9
53	-202.7	21.3	-4.1
54	-246.0	11.8	2.1
55	-282.5	3.5	5.8
56	-157.5	10.8	-7.0
57	-154.0	10.7	-4.9
58	-150.2	10.7	-2.7
59	-146.4	10.4	-1.1
60	-142.0	10.3	-0.5
61	-138.5	10.2	-1.2
62	-133.6	10.3	-2.7
63	-133.0	43.5	0.1
64	-153.2	40.1	16.6
65	-174.1	36.7	33.3
66	-193.7	33.5	49.3

Deformable Barrier Face Profile 1-11

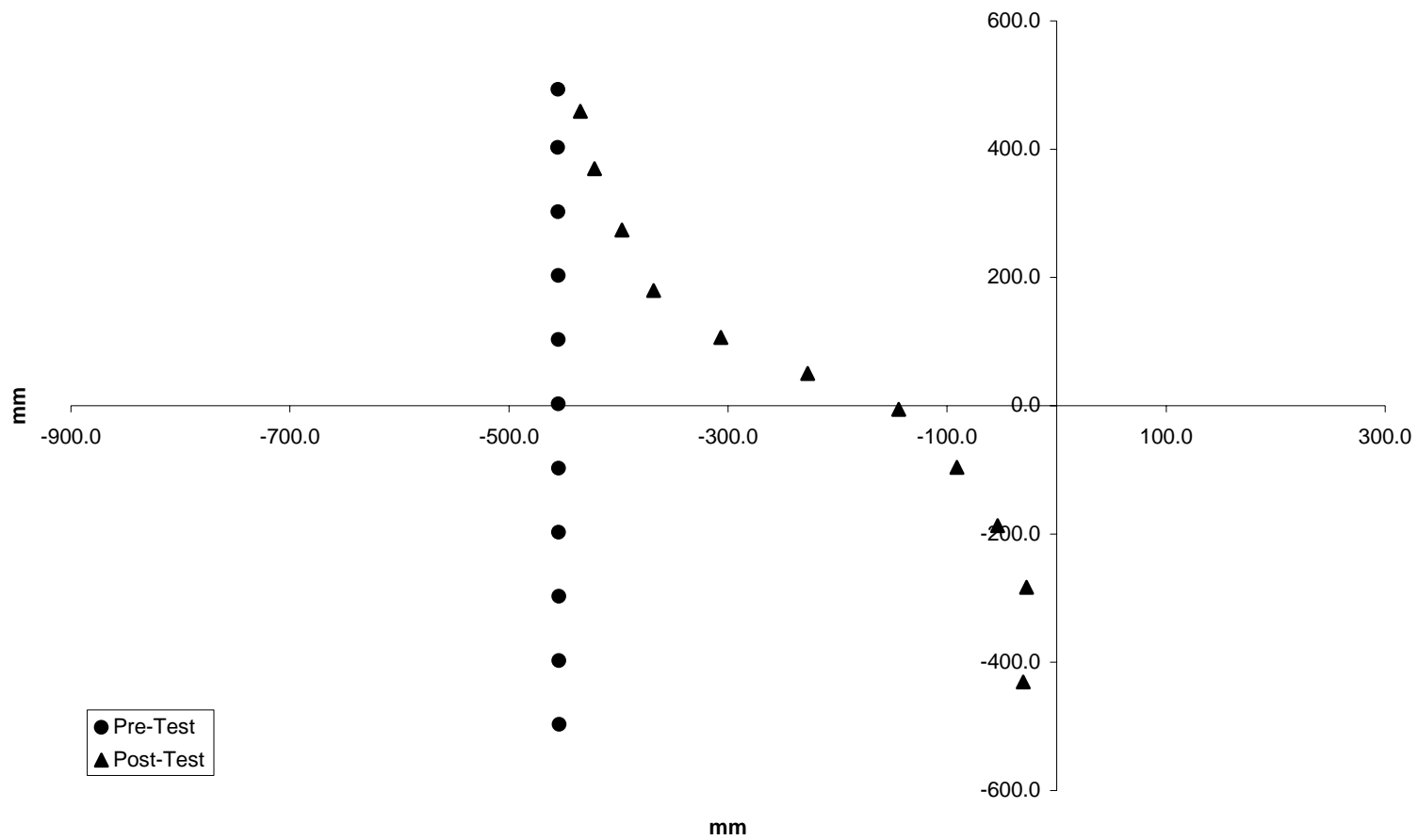

2-50

070913

Deformable Barrier Face Profile 12-22

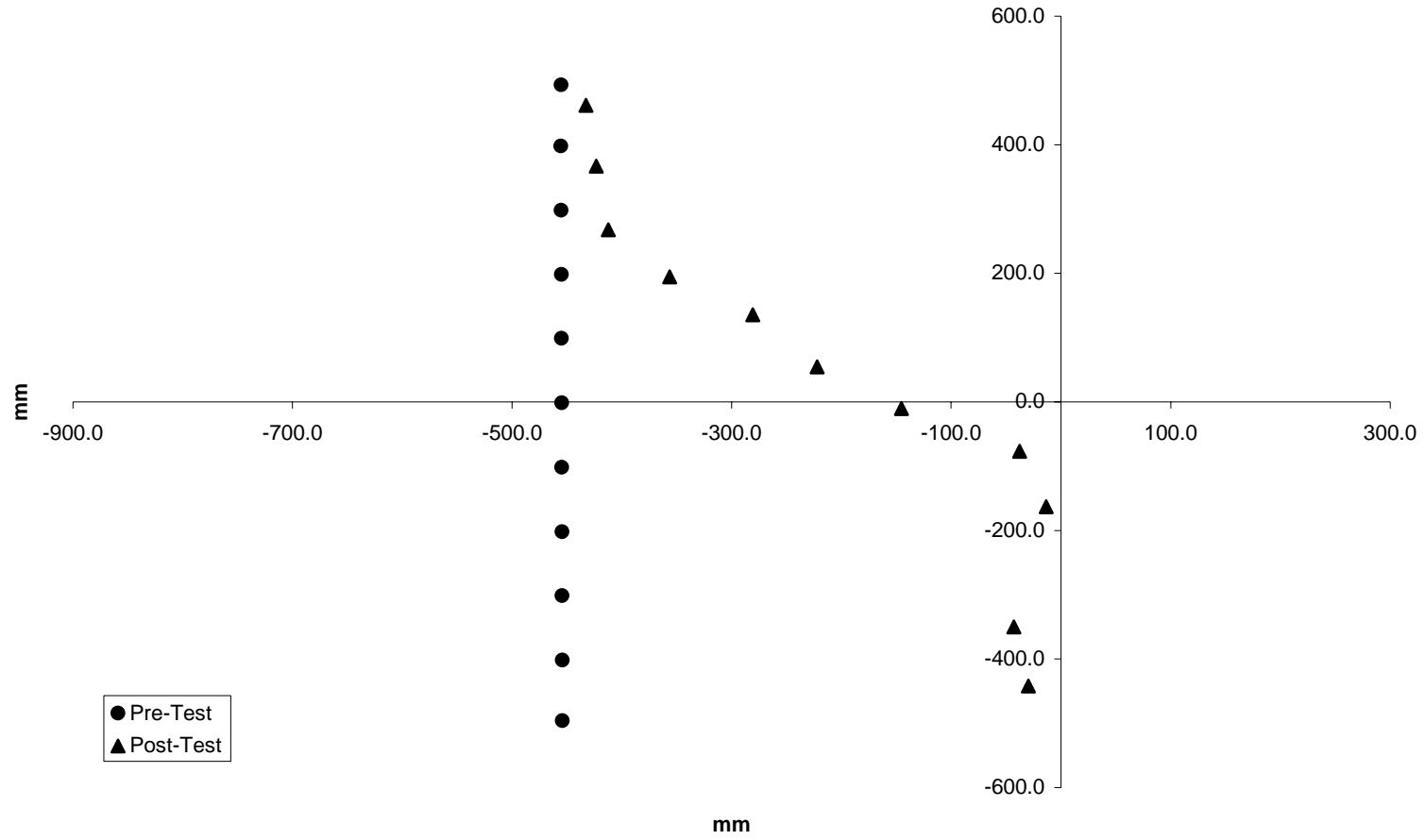

2-51

070913

Deformable Barrier Face Profile 23-33

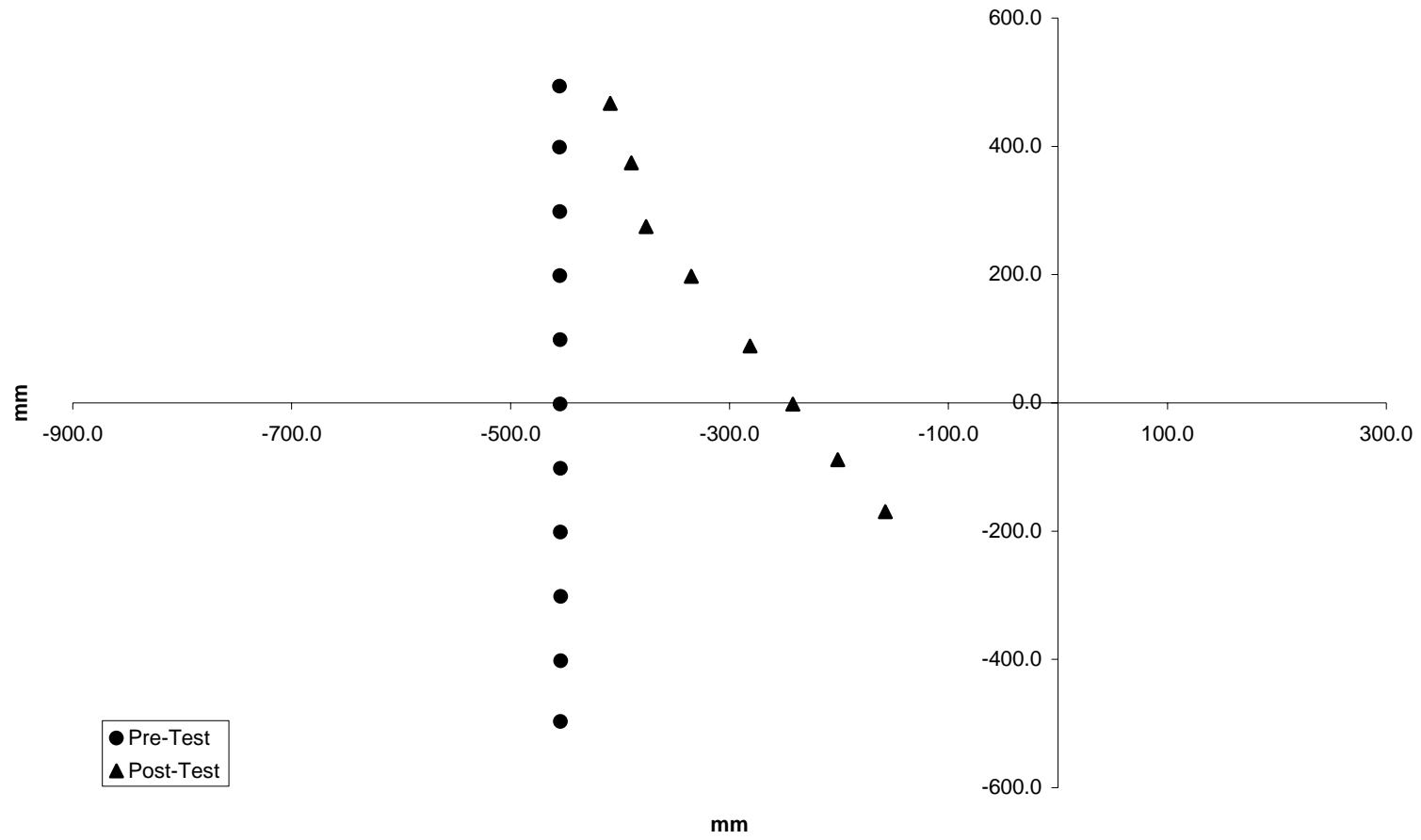

2-52

070913

Deformable Barrier Face Profile 34-44

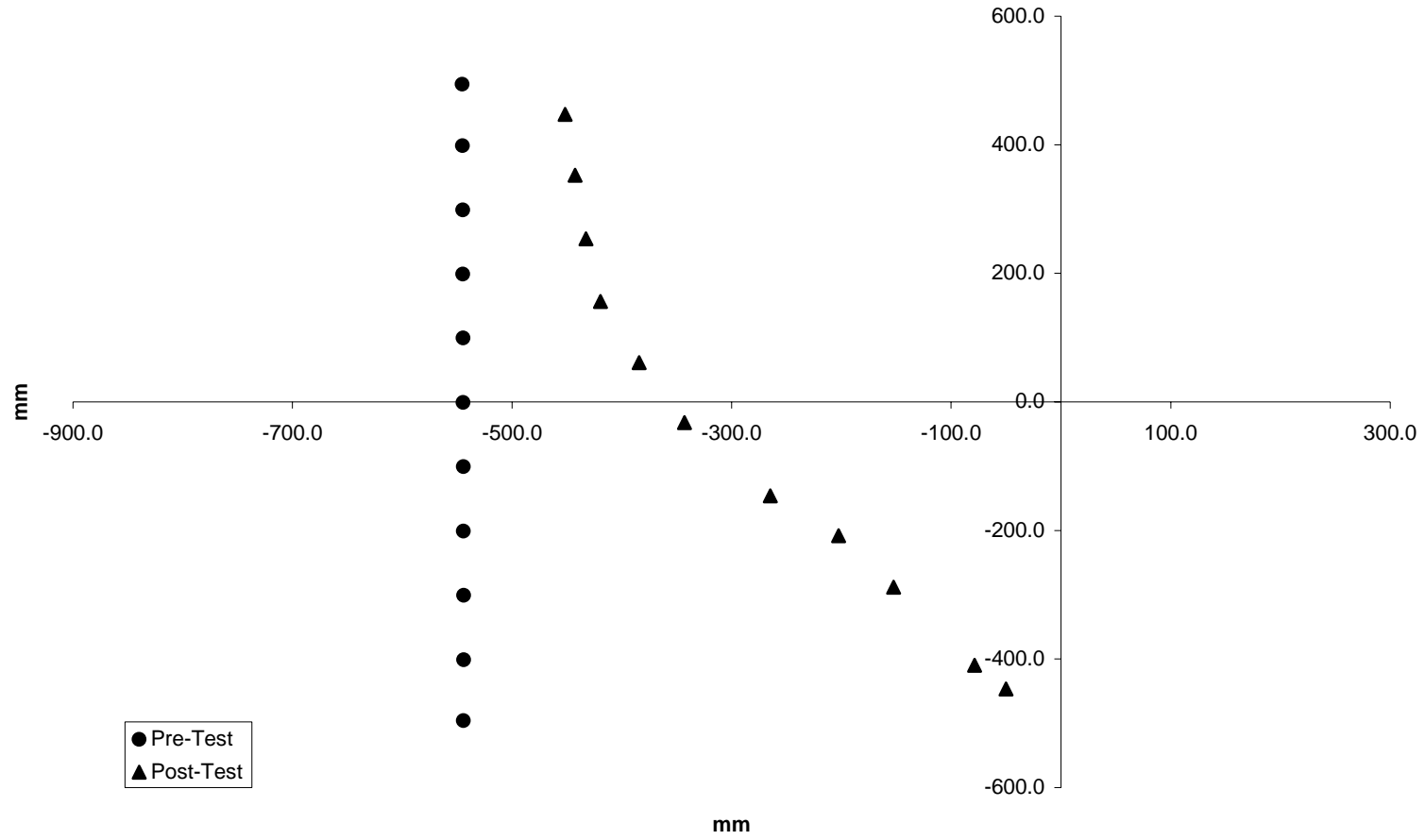

2-53

070913

Deformable Barrier Face Profile 45-55

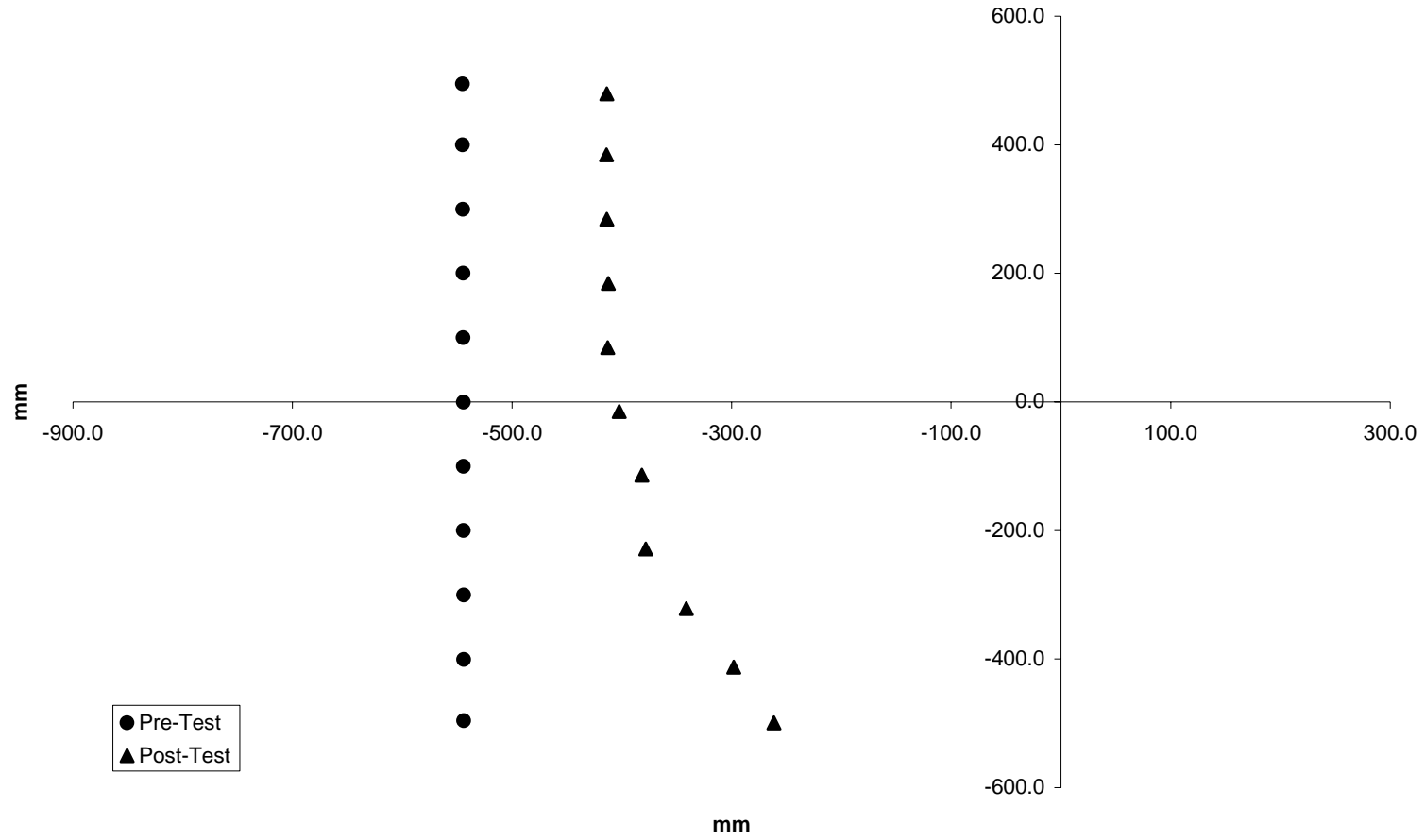

2-54

070913

Deformable Barrier Face Profile 56-66

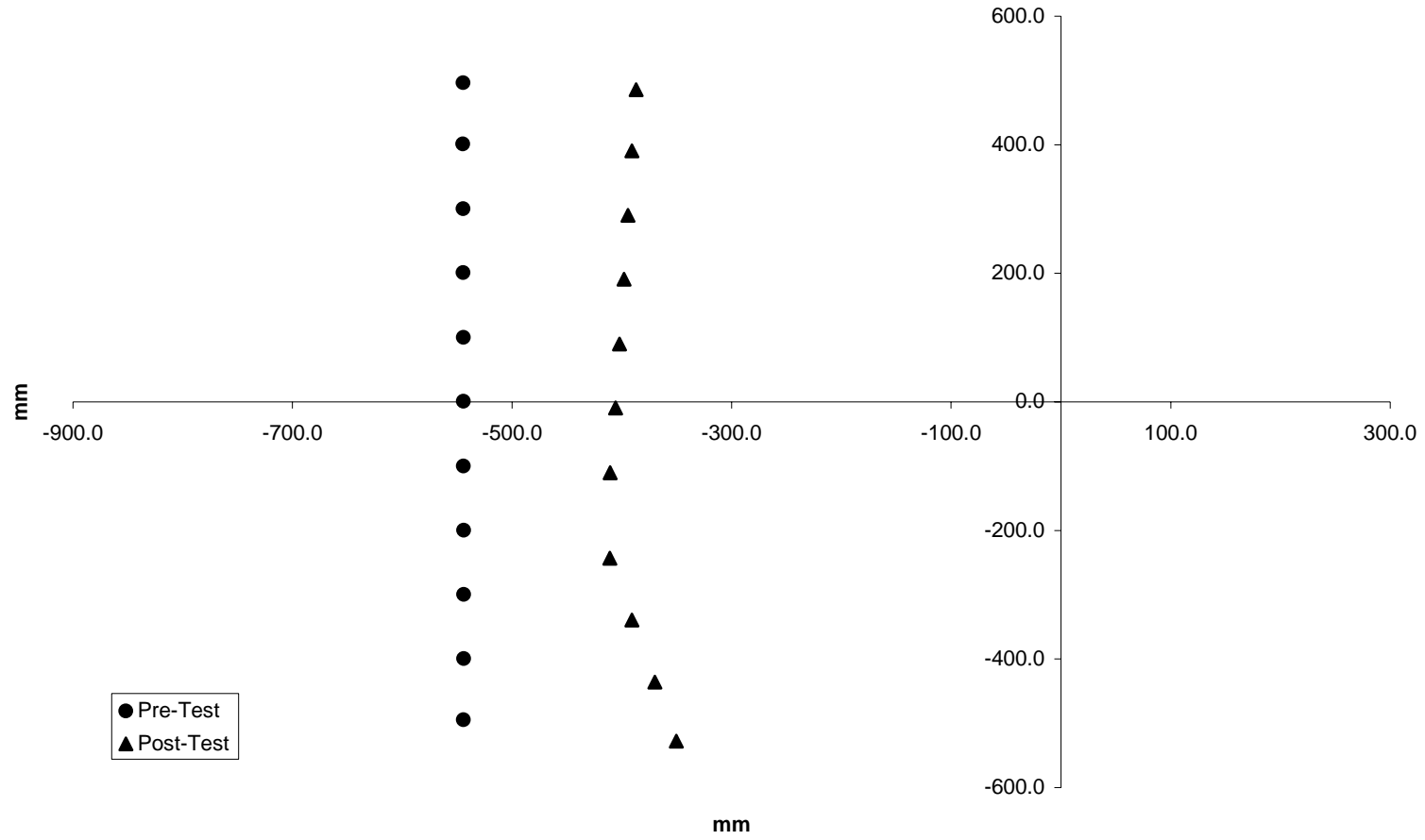

2-55

070913

DATA SHEET NO. 21
DEFORMABLE BARRIER LOAD CELL LOCATIONS

Vehicle Year/Make/Model/Body Style: 2007/Ford/F-250 XLT Super Duty/4-door pickup
 NHTSA Test No.: R70203 Test Date: 09/13/07

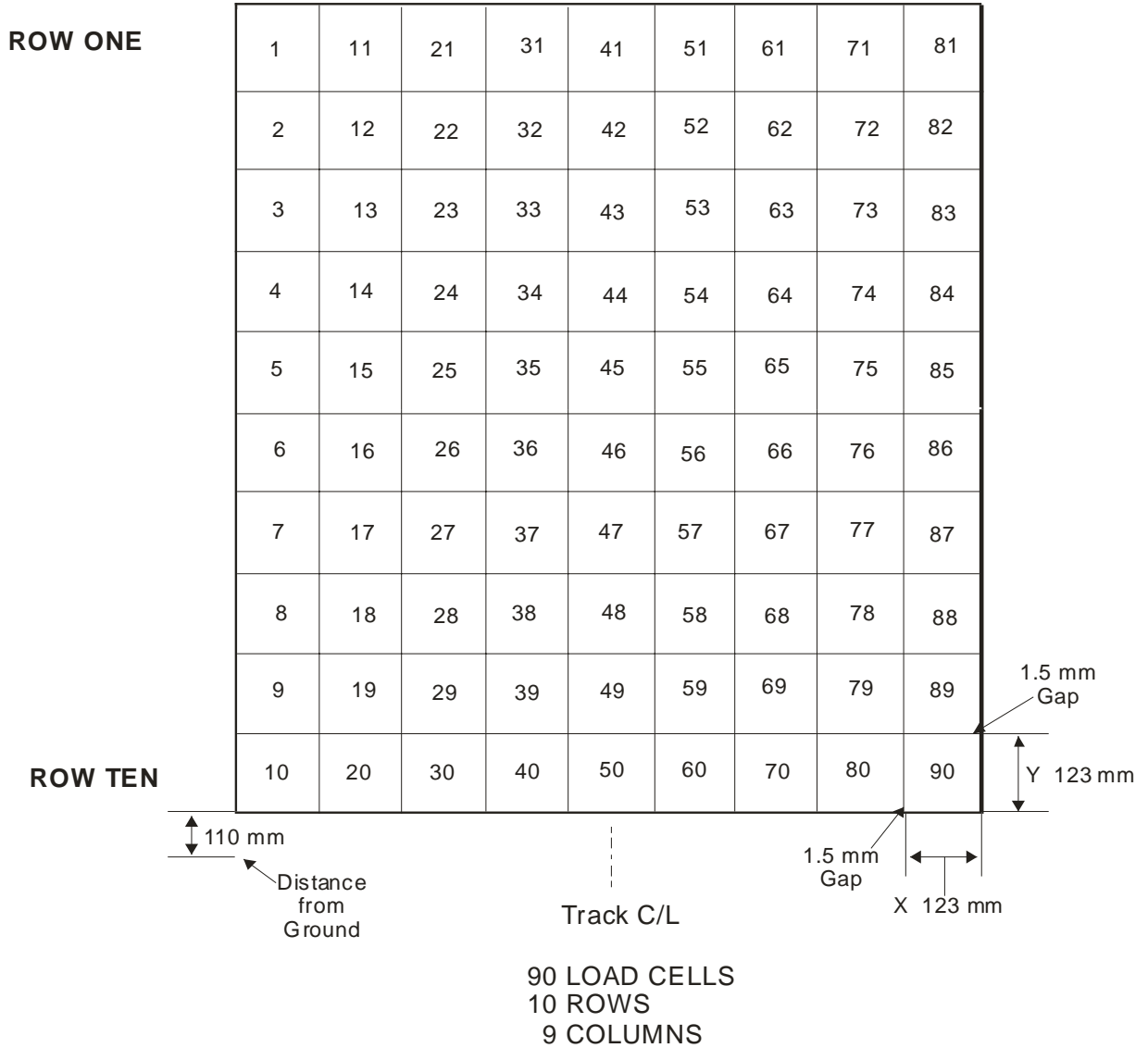

FRONT VIEW

Appendix A

Photographs



Figure A-1 Pre-Test Front View



Figure A-2 Post-Test Front View



Figure A-3 Pre-Test Left Front View



Figure A-4 Post-Test Left Front View



Figure A-5 Pre-Test Left Side View



Figure A-6 Post-Test Left Side View



Figure A-7 Pre-Test Left Rear View



Figure A-8 Post-Test Left Rear View



Figure A-9 Pre-Test Rear View

A-10

070913



Figure A-10 Post-Test Rear View

A-11

070913



Figure A-11 Pre-Test Right Rear View

A-12

070913



Figure A-12 Post-Test Right Rear View

A-13

070913



Figure A-13 Pre-Test Right Side View

A-14

070913



Figure A-14 Post-Test Right Side View

A-15

070913



Figure A-15 Pre-Test Right Front View

A-16

070913



Figure A-16 Post-Test Right Front View

A-17

070913

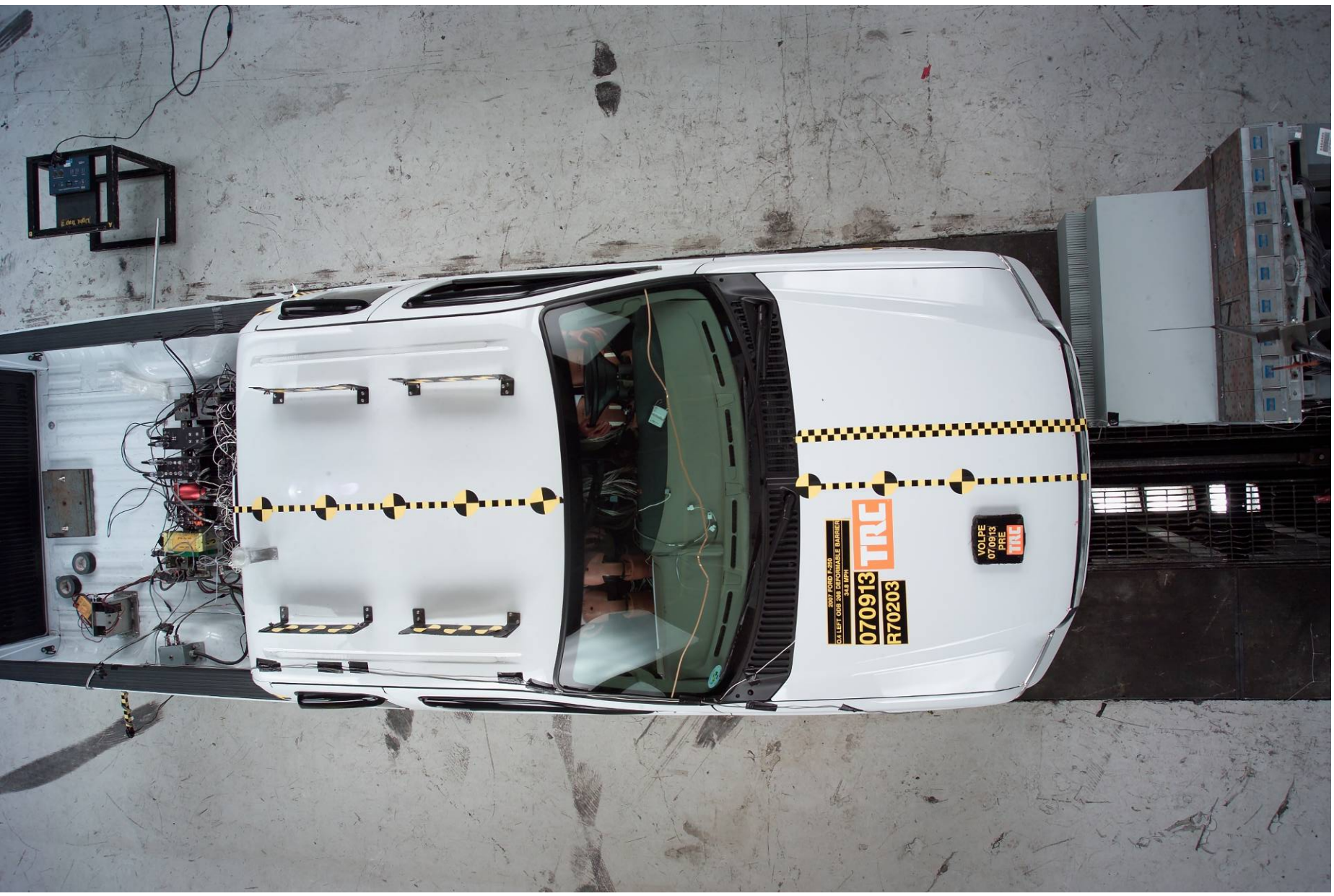

Figure A-17 Pre-Test Overhead View

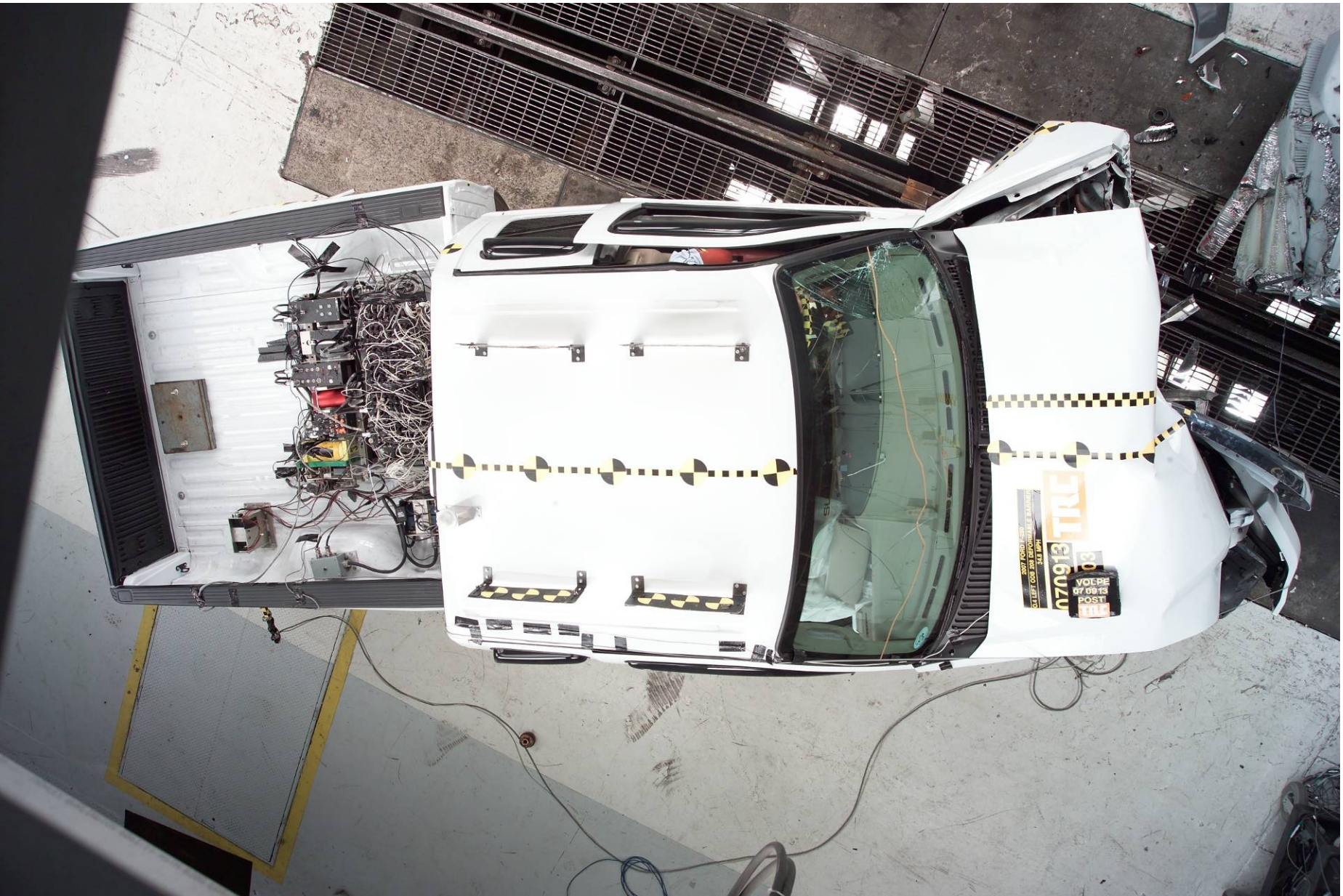

Figure A-18 Post-Test Overhead View



Figure A-19 Pre-Test Impact Alignment View



Figure A-20 Pre-Test Front Underbody View



Figure A-21 Post-Test Front Underbody View

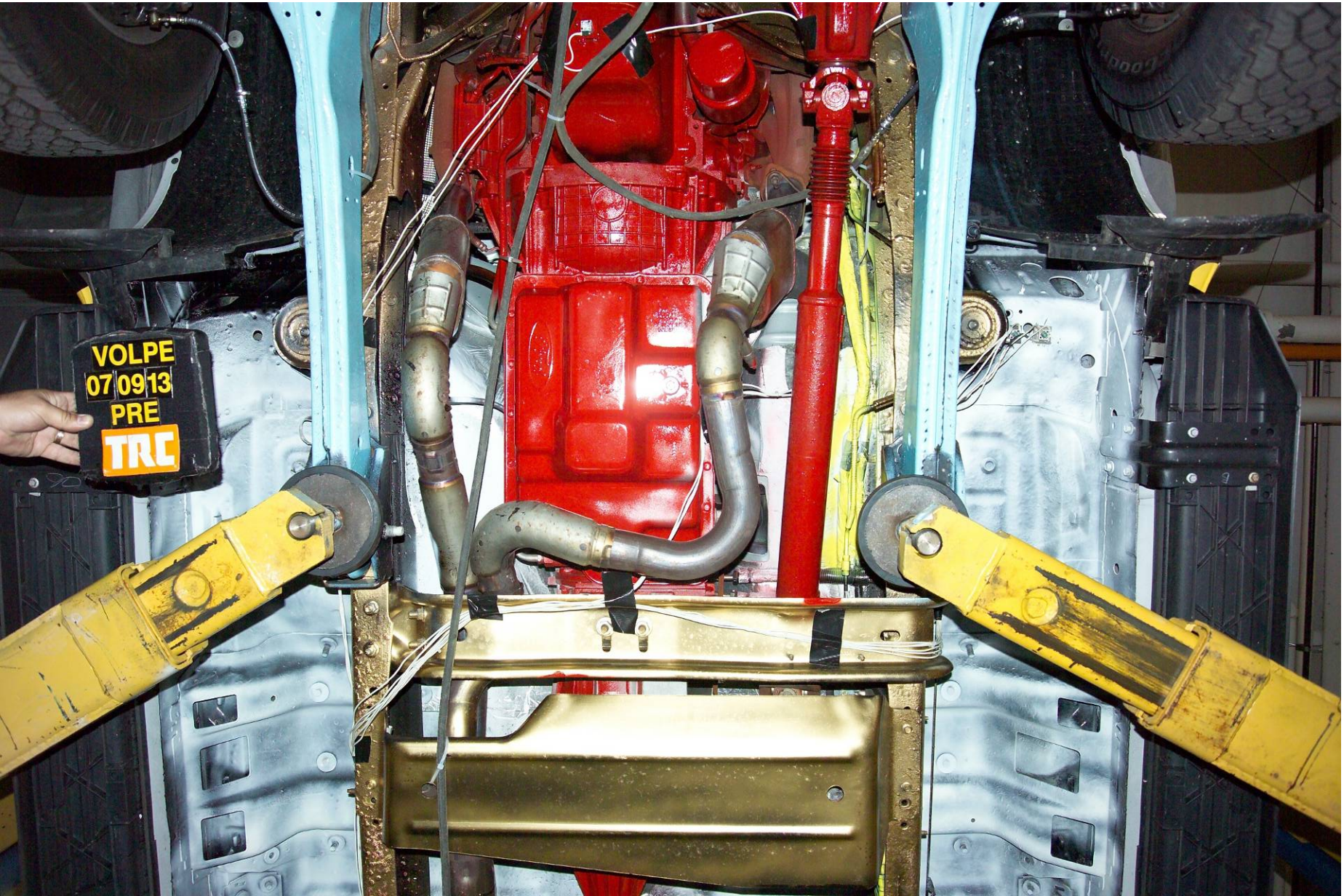

Figure A-22 Pre-Test Mid Front Underbody View

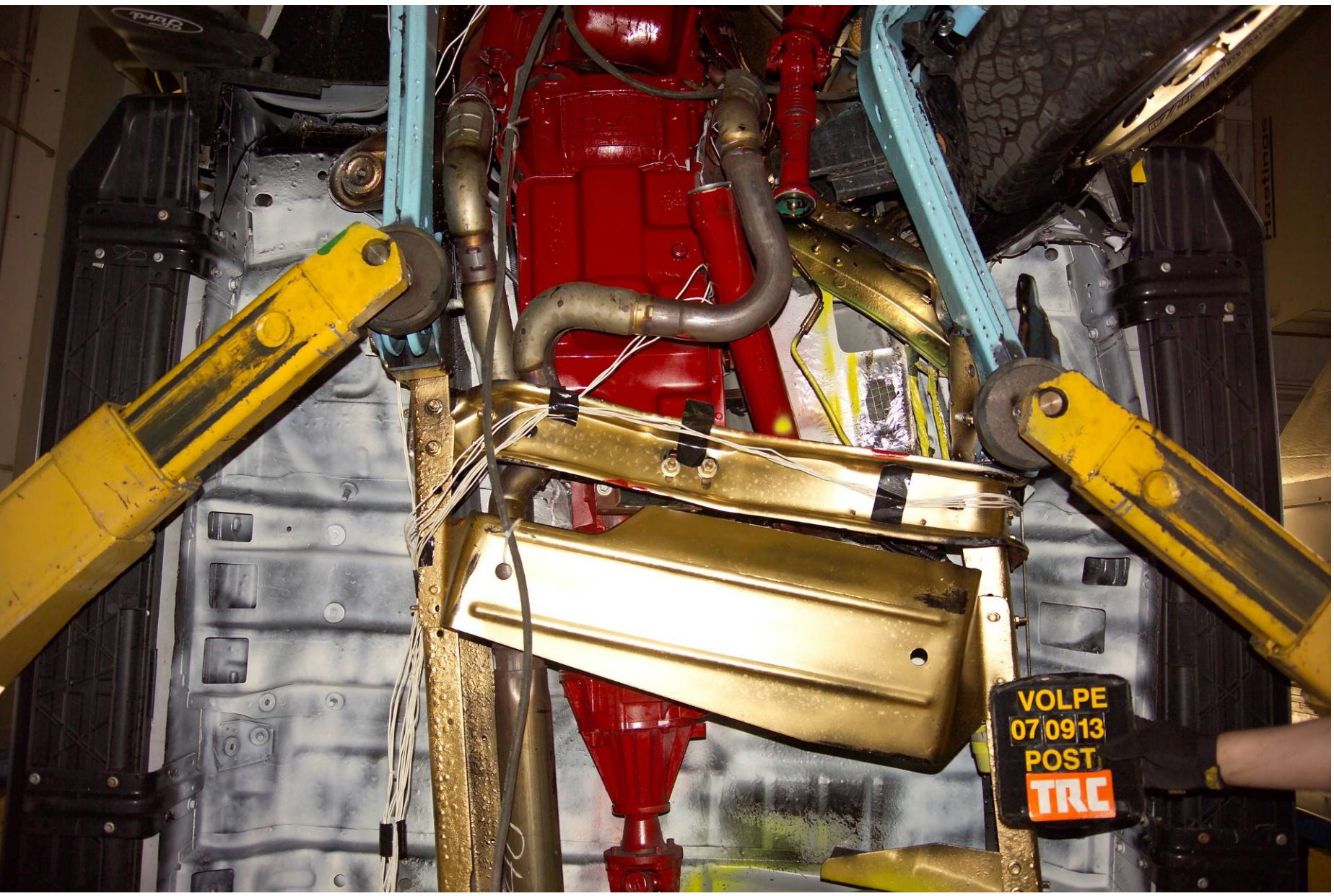

Figure A-23 Post-Test Mid Front Underbody View

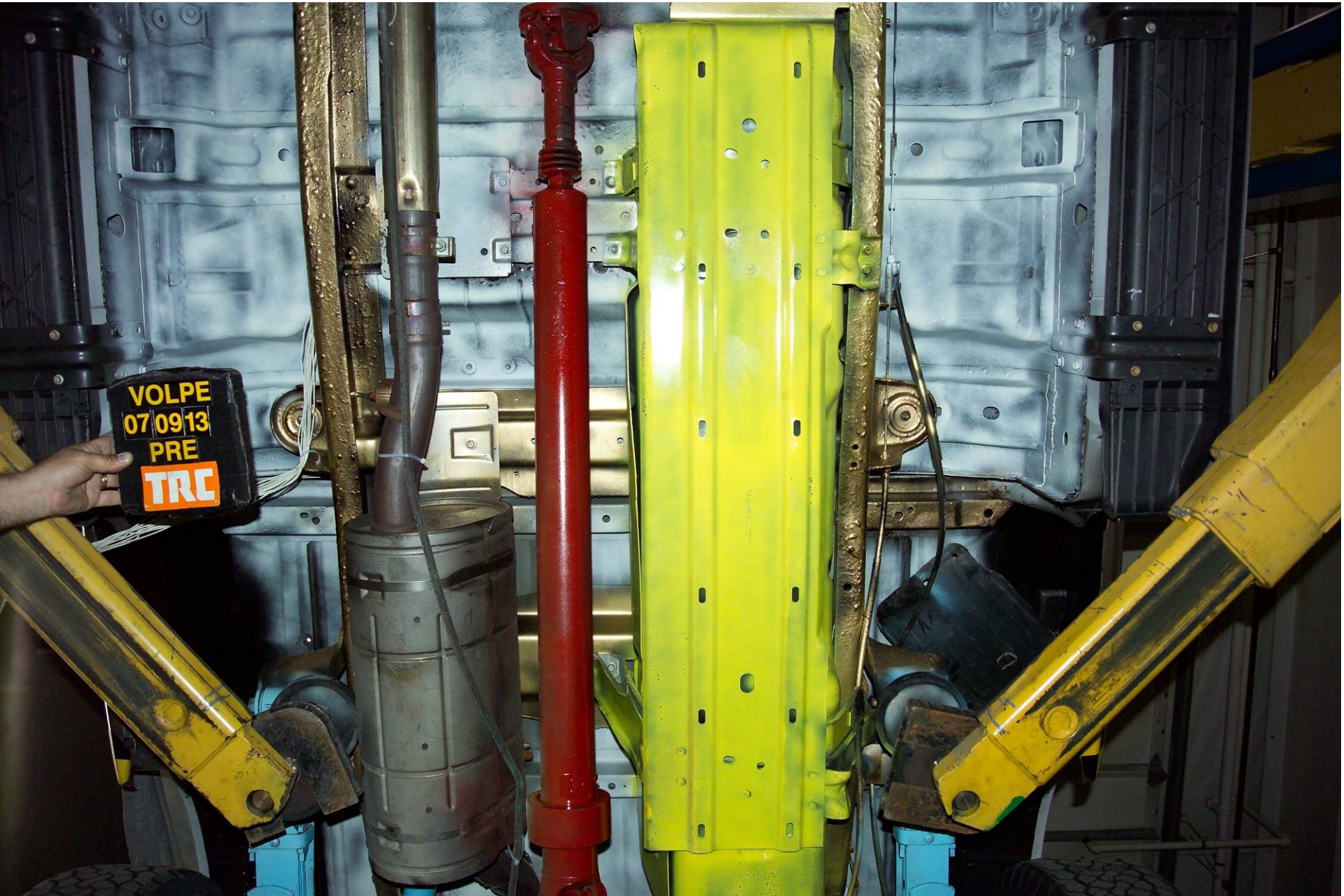

Figure A-24 Pre-Test Mid Underbody View

A-25

070913



Figure A-25 Post-Test Mid Underbody View

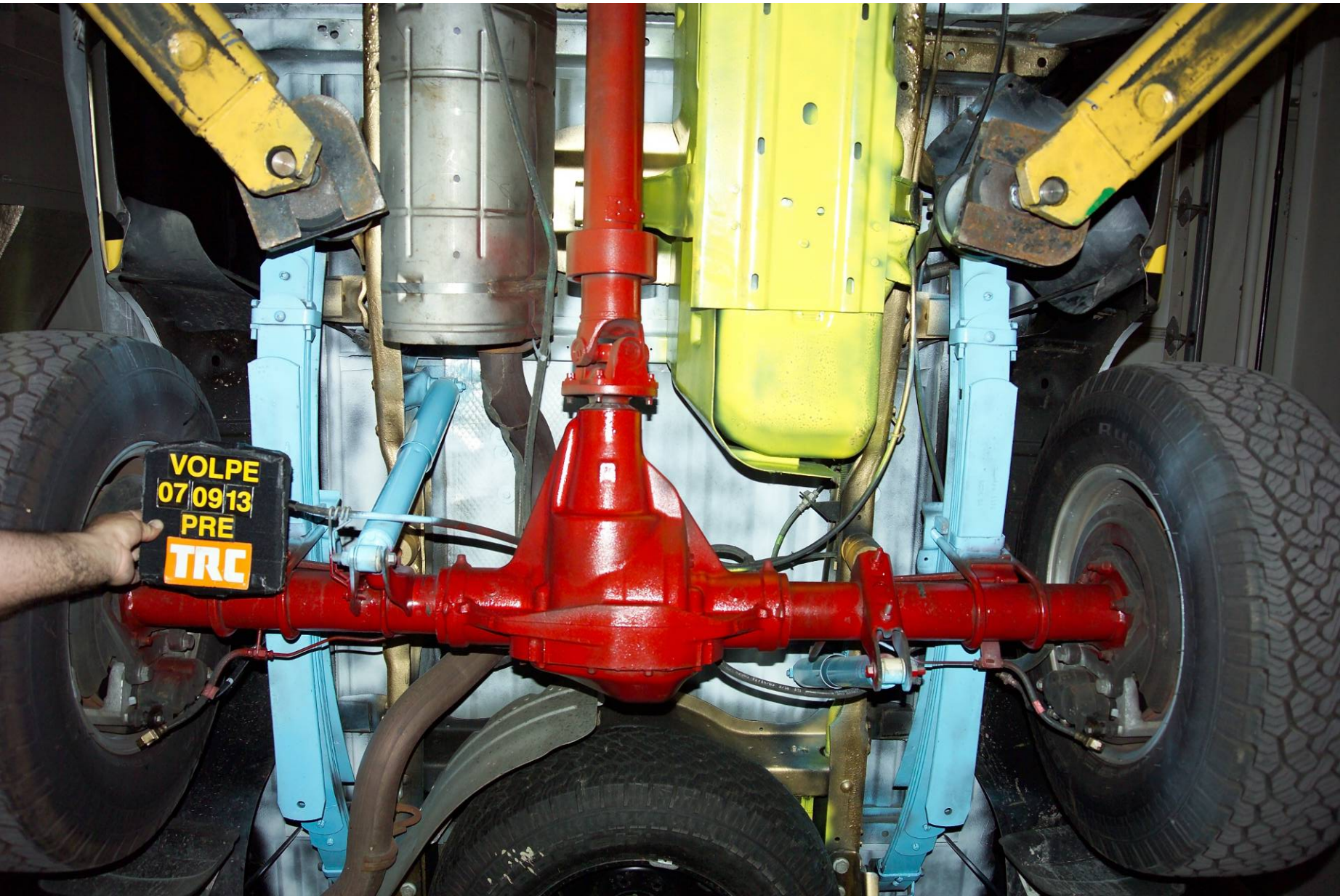

Figure A-26 Pre-Test Mid Rear Underbody View



Figure A-27 Post-Test Mid Rear Underbody View

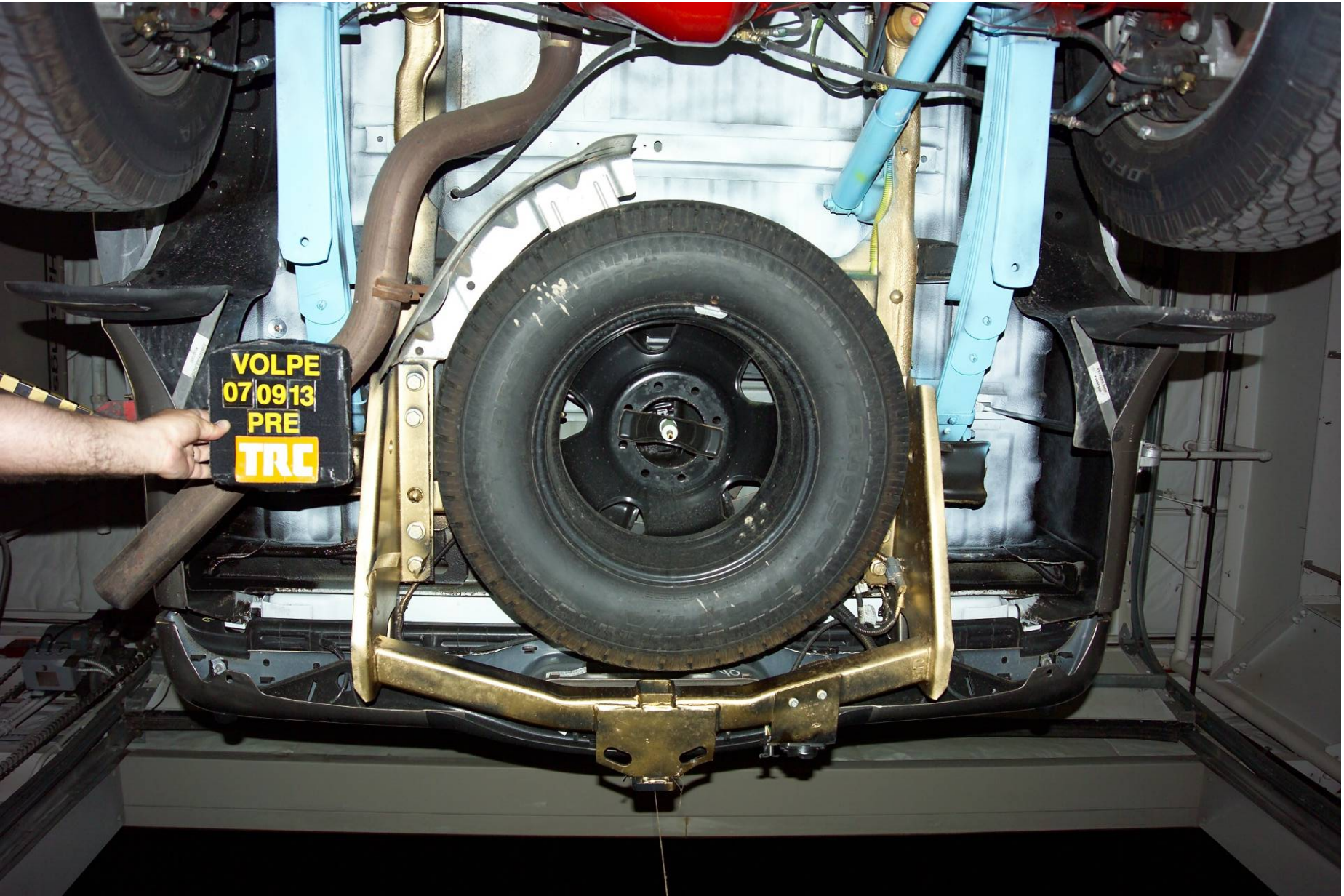

Figure A-28 Pre-Test Rear Underbody View

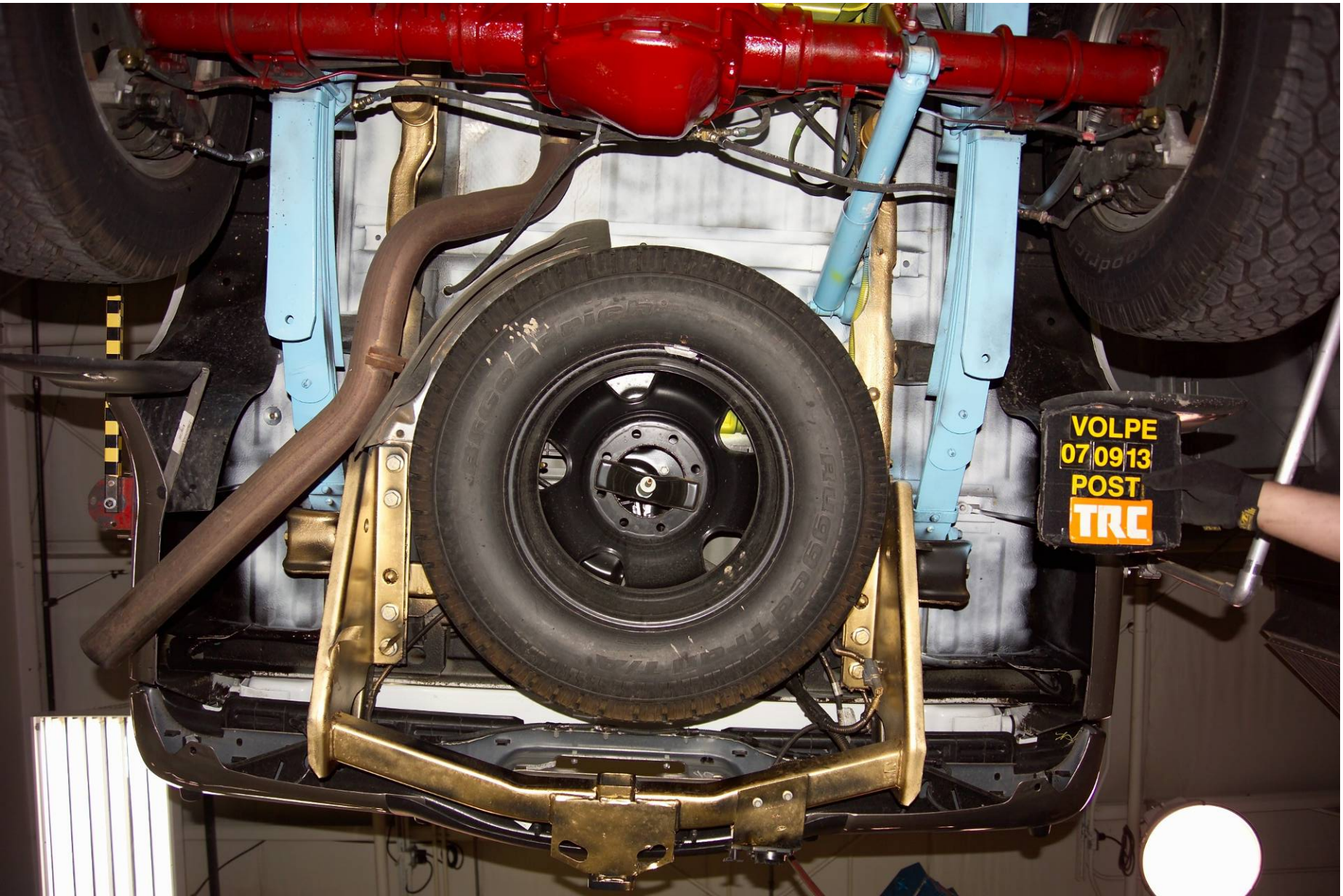

Figure A-29 Post-Test Rear Underbody View



Figure A-30 Pre-Test Fuel Tank View

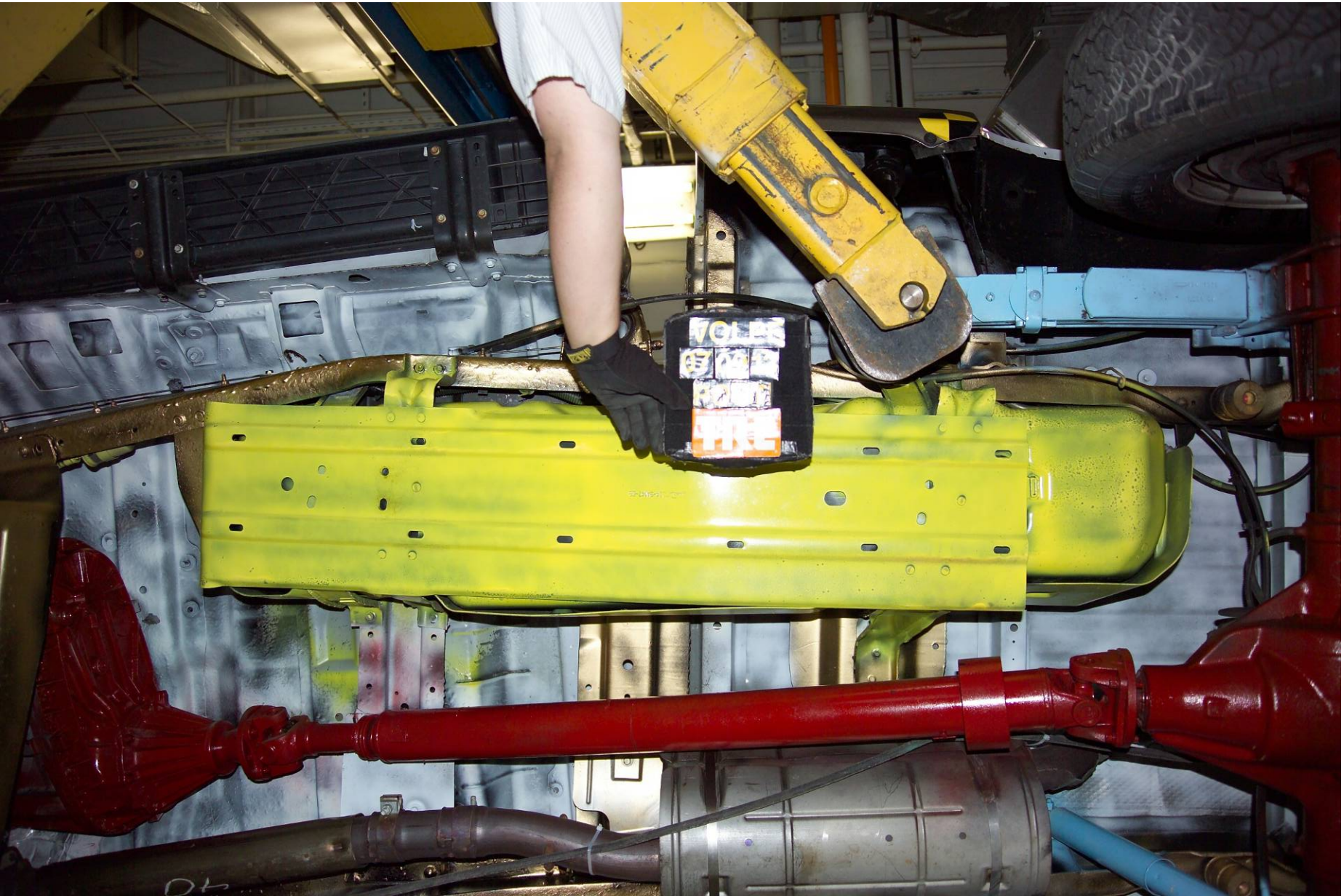

Figure A-31 Post-Test Fuel Tank View



Figure A-32 Pre-Test Fuel Filler Neck View



Figure A-33 Post-Test Fuel Filler Neck View



Figure A-34 Pre-Test Fuel Filler Cap View



Figure A-35 Post-Test Fuel Filler Cap View



VOLFE
07 09 13
PRE



7 x 26



SAFETY INFORMATION
READ THE MANUAL OF INSTRUCTIONS
BEFORE OPERATING THE VEHICLE.
DO NOT OPERATE THE VEHICLE
IF YOU ARE DRUG OR ALCOHOL
IMPAIRED.
DO NOT OPERATE THE VEHICLE
IF YOU ARE TIRED OR FATIGUED.
DO NOT OPERATE THE VEHICLE
IF YOU ARE UNDER THE INFLUENCE
OF ANY MEDICATION.
DO NOT OPERATE THE VEHICLE
IF YOU ARE UNWELL.
DO NOT OPERATE THE VEHICLE
IF YOU ARE NOT PROPERLY
SEATED AND BELTED IN.
DO NOT OPERATE THE VEHICLE
IF YOU ARE NOT WEARING YOUR
SEATBELT.
DO NOT OPERATE THE VEHICLE
IF YOU ARE NOT WEARING YOUR
SEATBELT.
DO NOT OPERATE THE VEHICLE
IF YOU ARE NOT WEARING YOUR
SEATBELT.
DO NOT OPERATE THE VEHICLE
IF YOU ARE NOT WEARING YOUR
SEATBELT.

Figure A-36 Pre-Test Engine Compartment View



Figure A-37 Post-Test Engine Compartment View

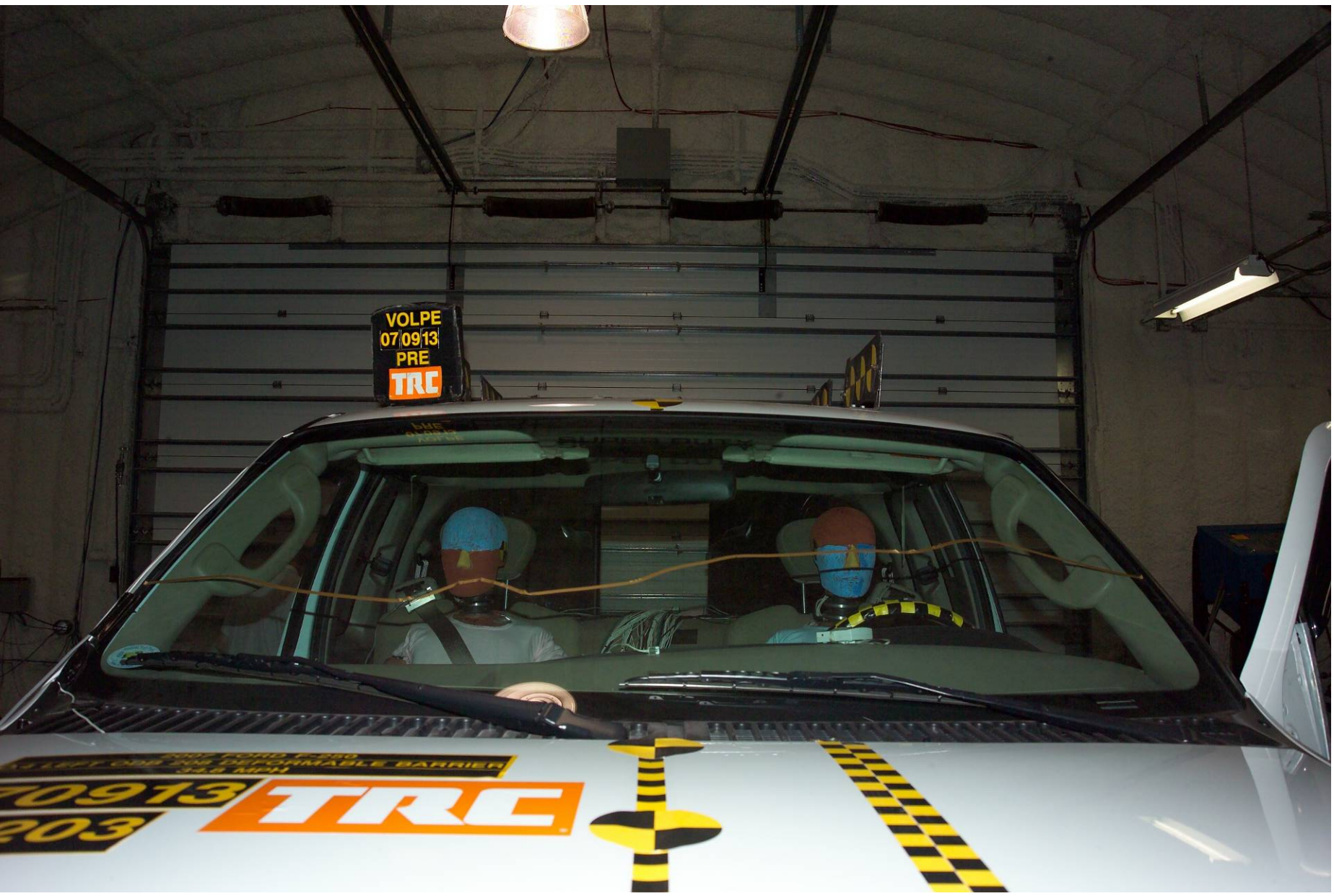

Figure A-38 Pre-Test Windshield View



Figure A-39 Post-Test Windshield View

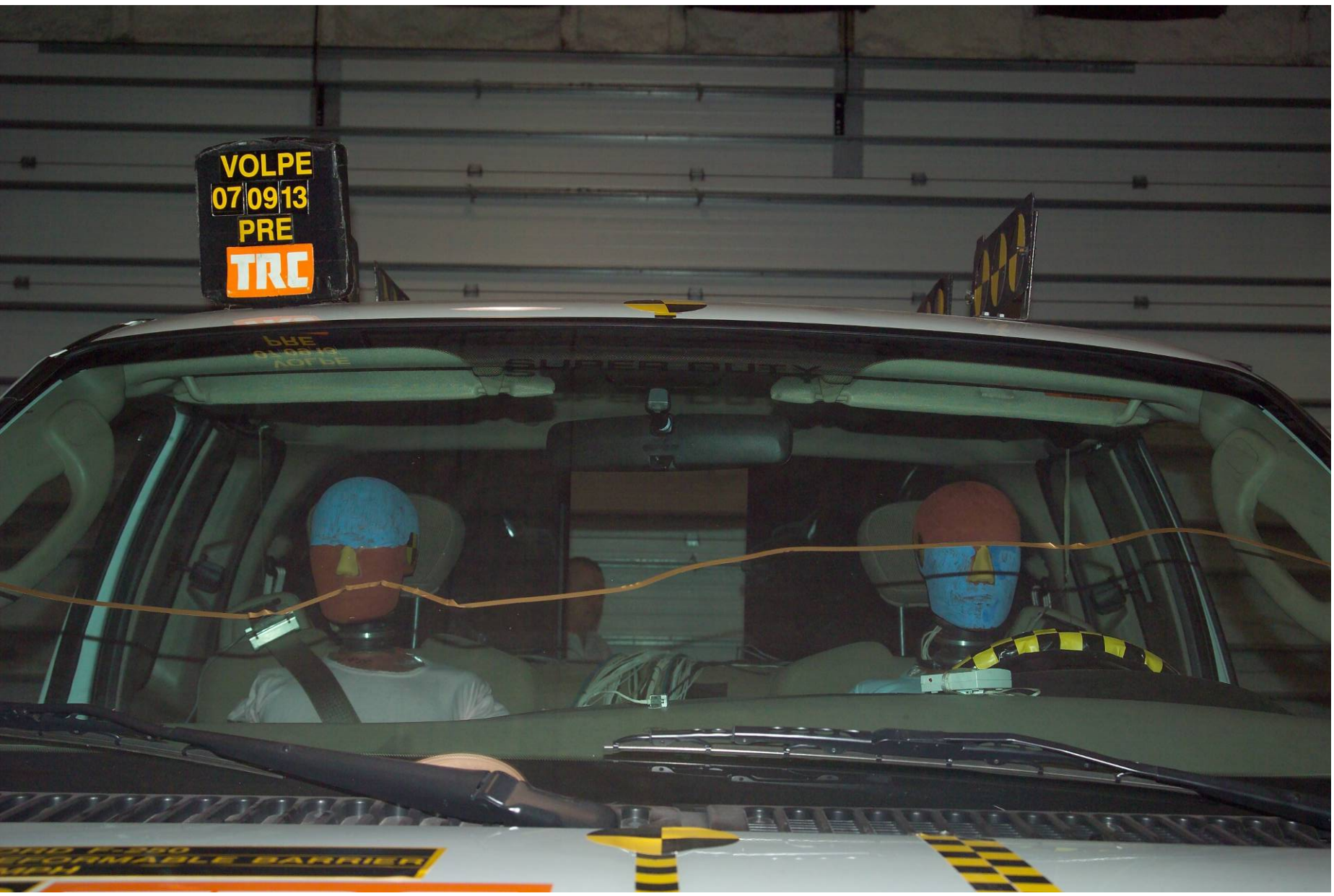

Figure A-40 Pre-Test Windshield - Driver and Right Front Passenger Dummies View



Figure A-41 Post-Test Windshield - Driver and Right Front Passenger Dummies View

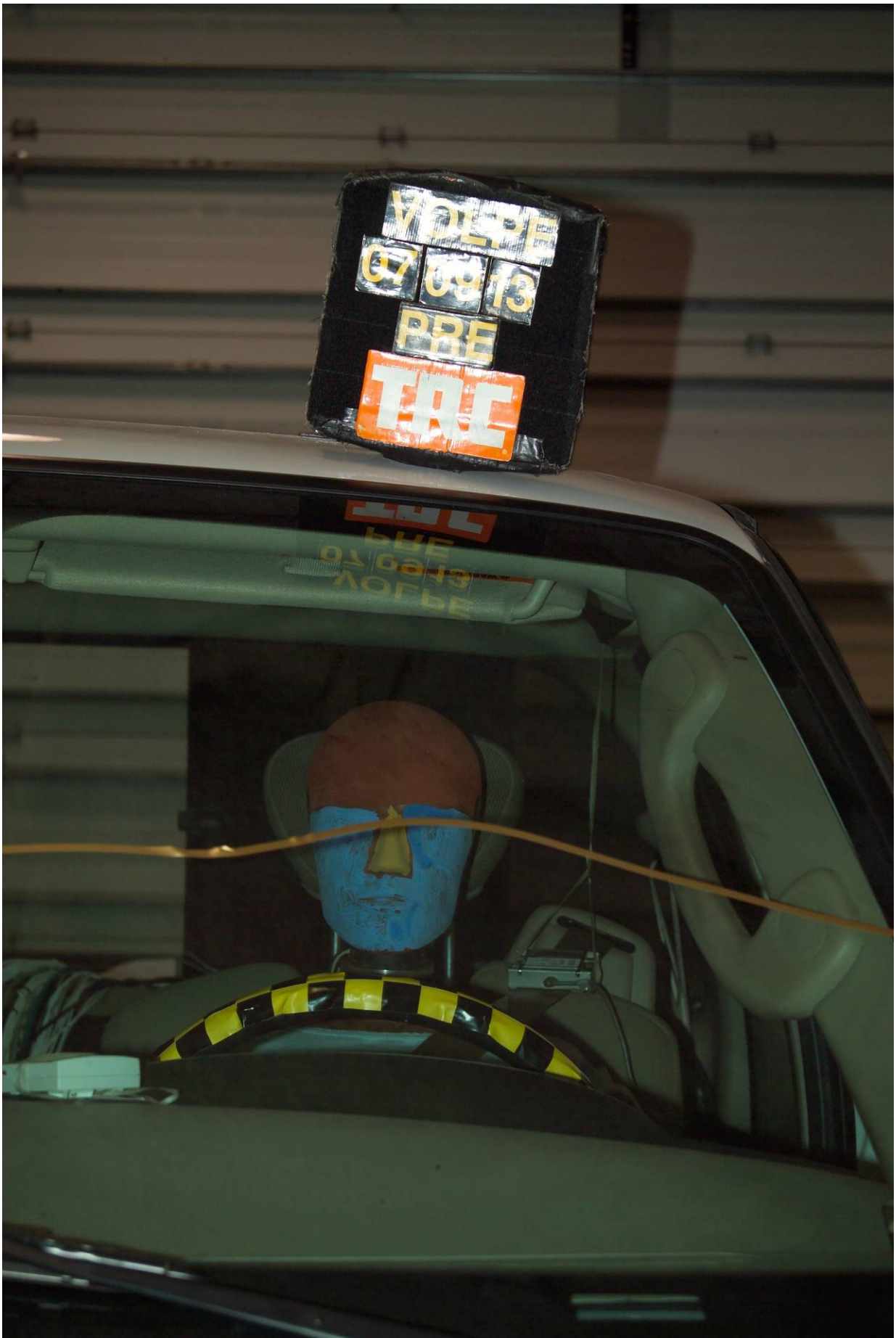

Figure A-42 Pre-Test Windshield - Driver Dummy View

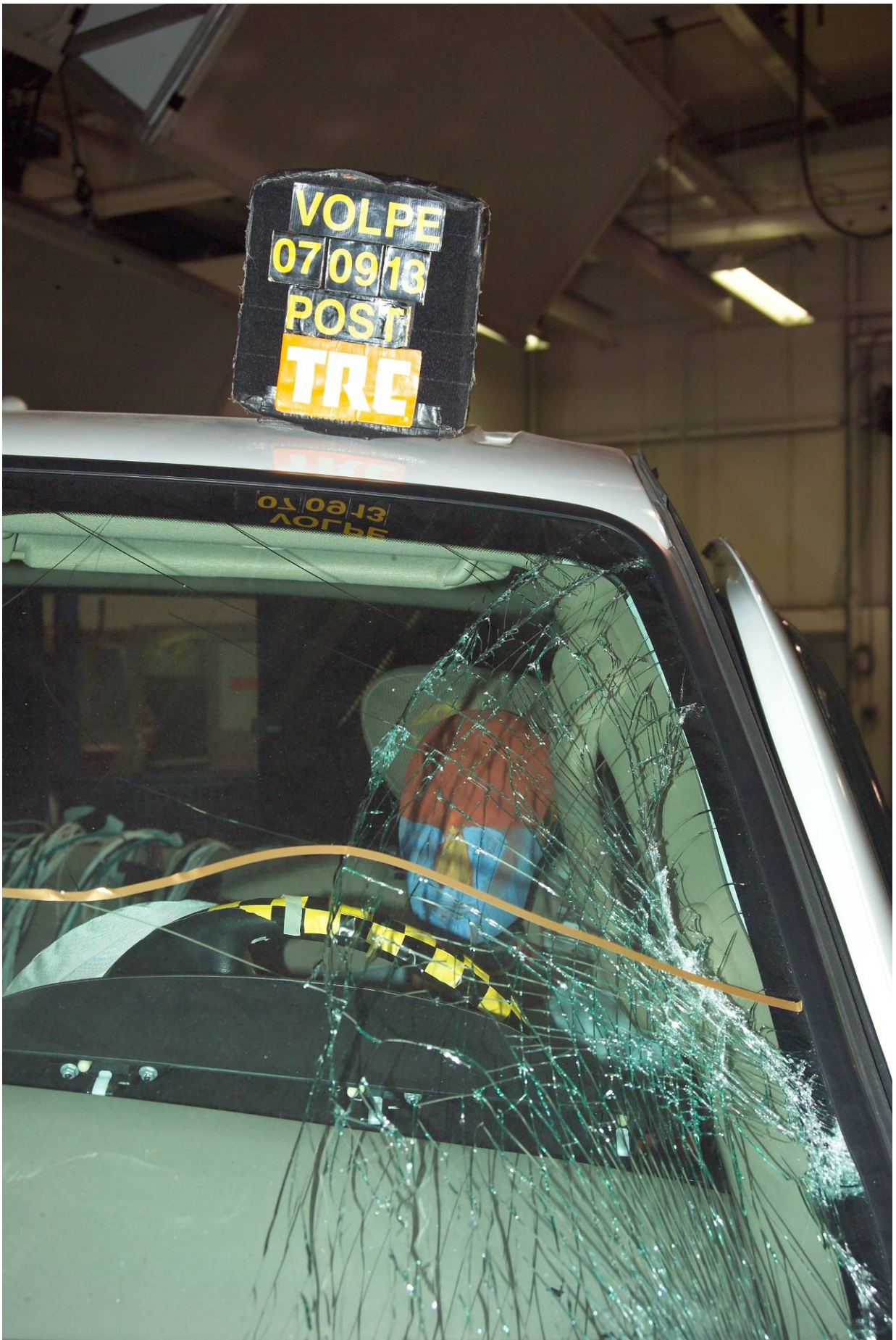

Figure A-43 Post-Test Windshield - Driver Dummy View



Figure A-44 Pre-Test Driver Dummy - View 1



Figure A-45 Post-Test Driver Dummy - View 1



Figure A-46 Pre-Test Driver Dummy - View 2



Figure A-47 Post-Test Driver Dummy - View 2



Figure A-48 Pre-Test Driver Dummy - View 3



Figure A-49 Post-Test Driver Dummy - View 3



Figure A-50 Post-Test Driver Dummy Overall View



Figure A-51 Post-Test Driver Dummy Head Contact - View 1



Figure A-52 Post-Test Driver Dummy Head Contact - View 2



Figure A-53 Post-Test Driver Dummy Knee Contact - View 1



Figure A-54 Post-Test Driver Dummy Knee Contact - View 2

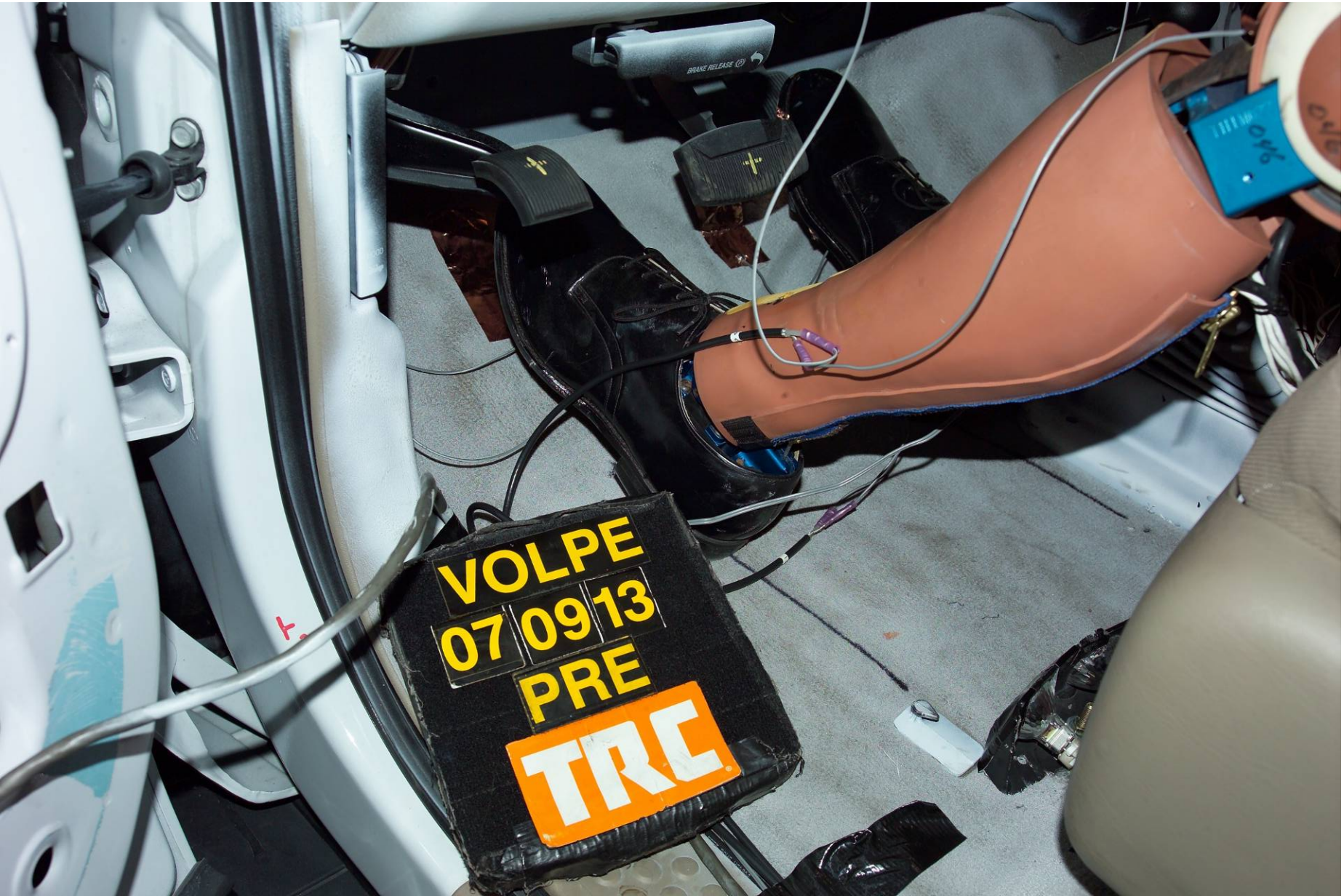

Figure A-55 Pre-Test Driver Floorboard Deformation - View 1

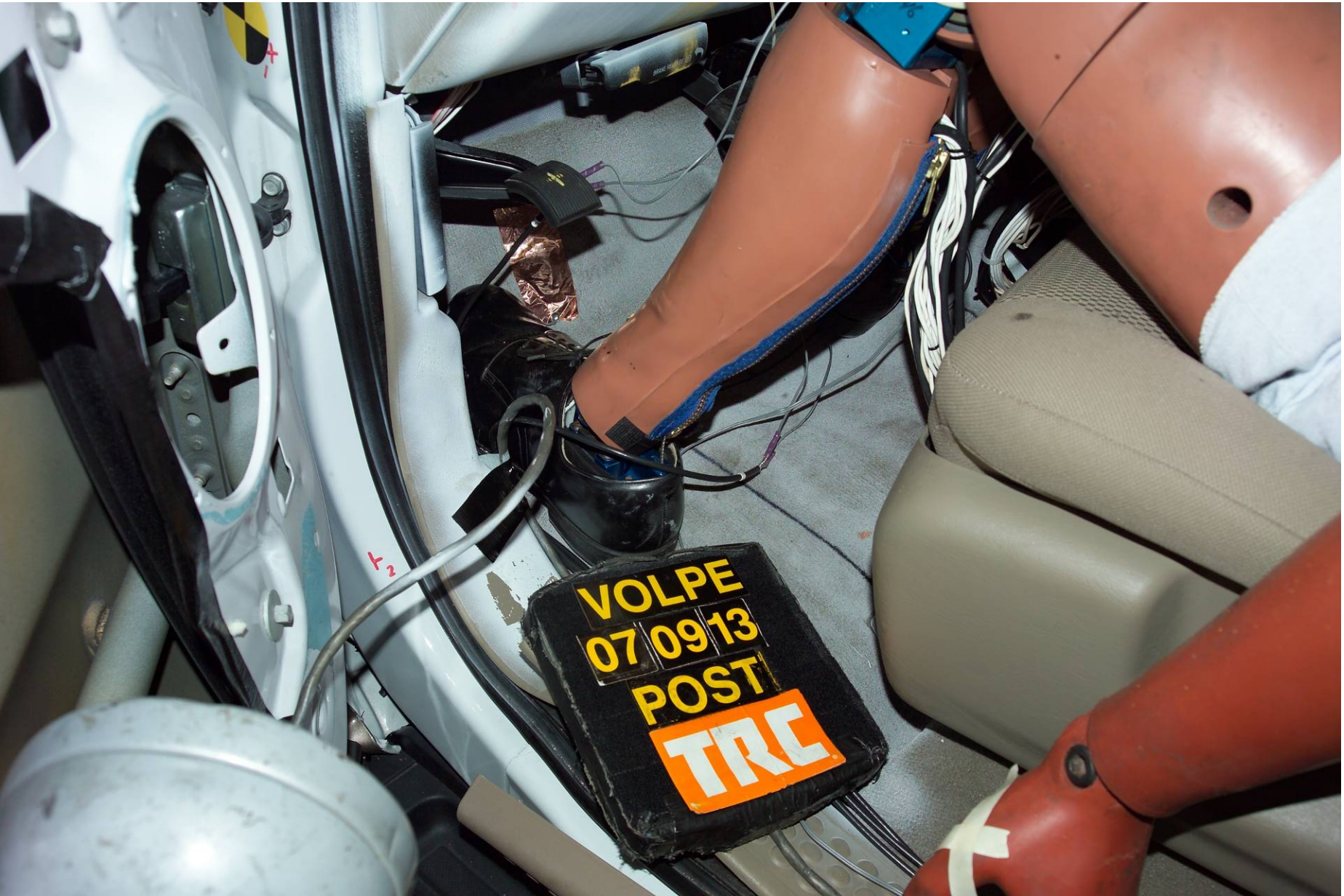

Figure A-56 Post-Test Driver Floorboard Deformation - View 1



Figure A-57 Post-Test Driver Floorboard Deformation - View 2



Figure A-58 Post-Test Driver Toeboard Deformation View



Figure A-59 Post-Test Driver Instrument Panel Damage View

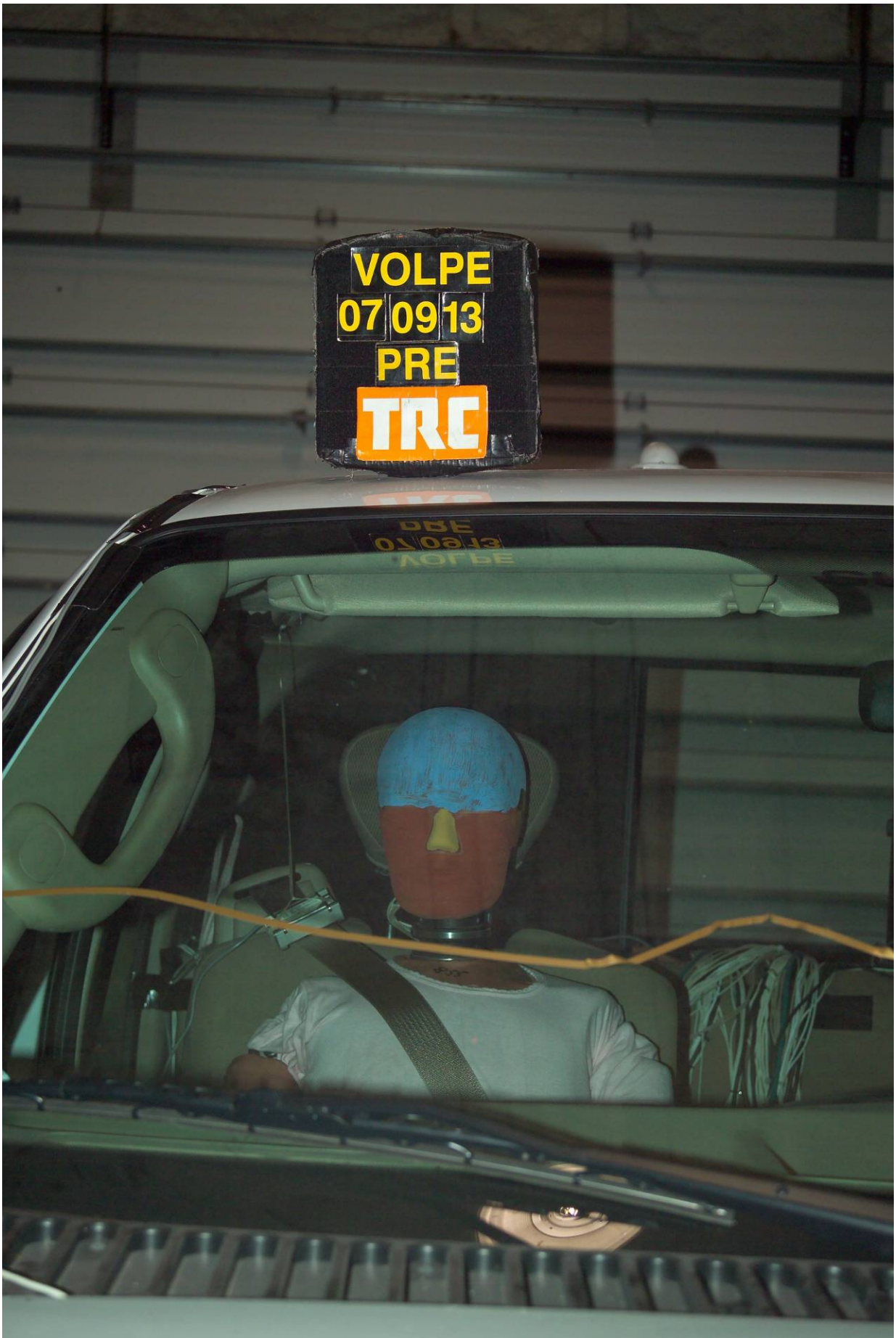

Figure A-60 Pre-Test Windshield - Right Front Passenger View



Figure A-61 Post-Test Windshield - Right Front Passenger View



Figure A-62 Pre-Test Right Front Passenger Dummy - View 1



Figure A-63 Post-Test Right Front Passenger Dummy - View 1

A-64

070913



Figure A-64 Pre-Test Right Front Passenger Dummy - View 2

A-65

070913



Figure A-65 Post-Test Right Front Passenger Dummy - View 2

A-66

070913



Figure A-66 Pre-Test Right Front Passenger Dummy - View 3



Figure A-67 Post-Test Right Front Passenger Dummy - View 3



Figure A-68 Post-Test Right Front Passenger Dummy Overall View



Figure A-69 Post-Test Right Front Passenger Dummy Head Contact - View 1



Figure A-70 Post-Test Right Front Passenger Dummy Head Contact - View 2



Figure A-71 Post-Test Right Front Passenger Dummy Knee Contact View



Figure A-72 Pre-Test Right Front Passenger Floorboard Deformation - View 1



Figure A-73 Post-Test Right Front Passenger Floorboard Deformation - View 1



Figure A-74 Post-Test Right Front Passenger Floorboard Deformation - View 2



Figure A-75 Post-Test Right Front Passenger Toeboard Deformation View



Figure A-76 Post-Test Right Front Passenger Instrument Panel Damage View



Figure A-77 Pre-Test Barrier Front View

A-78

070913



Figure A-78 Post-Test Barrier Front View

A-79

070913



Figure A-79 Pre-Test Barrier Left Side View

A-80

070913



Figure A-80 Post-Test Barrier Left Side View



Figure A-81 Pre-Test Barrier Right Side View

A-82

070913



Figure A-82 Post-Test Barrier Right Side View



Figure A-83 Pre-Test Barrier Top View



Figure A-84 Post-Test Barrier Top View

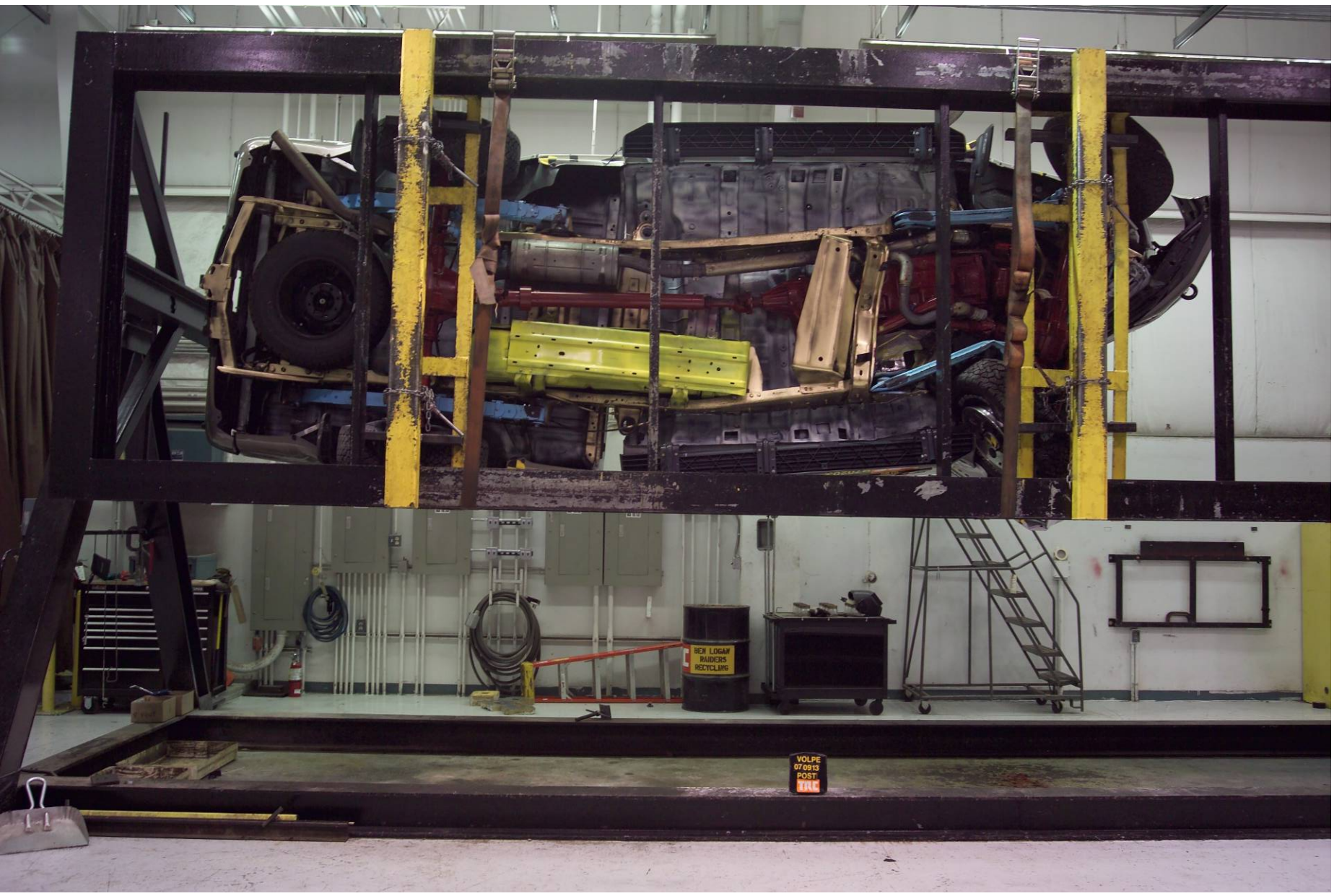

Figure A-85 Vehicle on Rollover Device - 90°

A-86

070913



Figure A-86 Vehicle on Rollover Device - 180°

A-87

070913



Figure A-87 Vehicle on Rollover Device - 270°

A-88

070913



Figure A-88 Vehicle on Rollover Device - 360°

Figure A-89 Vehicle Certification Label View

A-90

070913



TIRE AND LOADING INFORMATION

SEATING CAPACITY TOTAL : 5 FRONT: 2 REAR: 3

The combined weight of occupants and cargo should never exceed : 1144 kg or 2524 lbs.

TIRE	SIZE	COLD TIRE PRESSURE
FRONT	LT265/70R17E	515 KPA, 75 PSI
REAR	LT265/70R17E	515 KPA, 75 PSI
SPARE	LT265/70R17E	515 KPA, 75 PSI

SEE OWNERS MANUAL FOR ADDITIONAL INFORMATION

1FTSX21587EA19550

373

2.376
373

5USA-1532-AA (TLU)

Figure A-90 Vehicle Tire Load Label View



Figure A-91 Pre-Test Ballast View

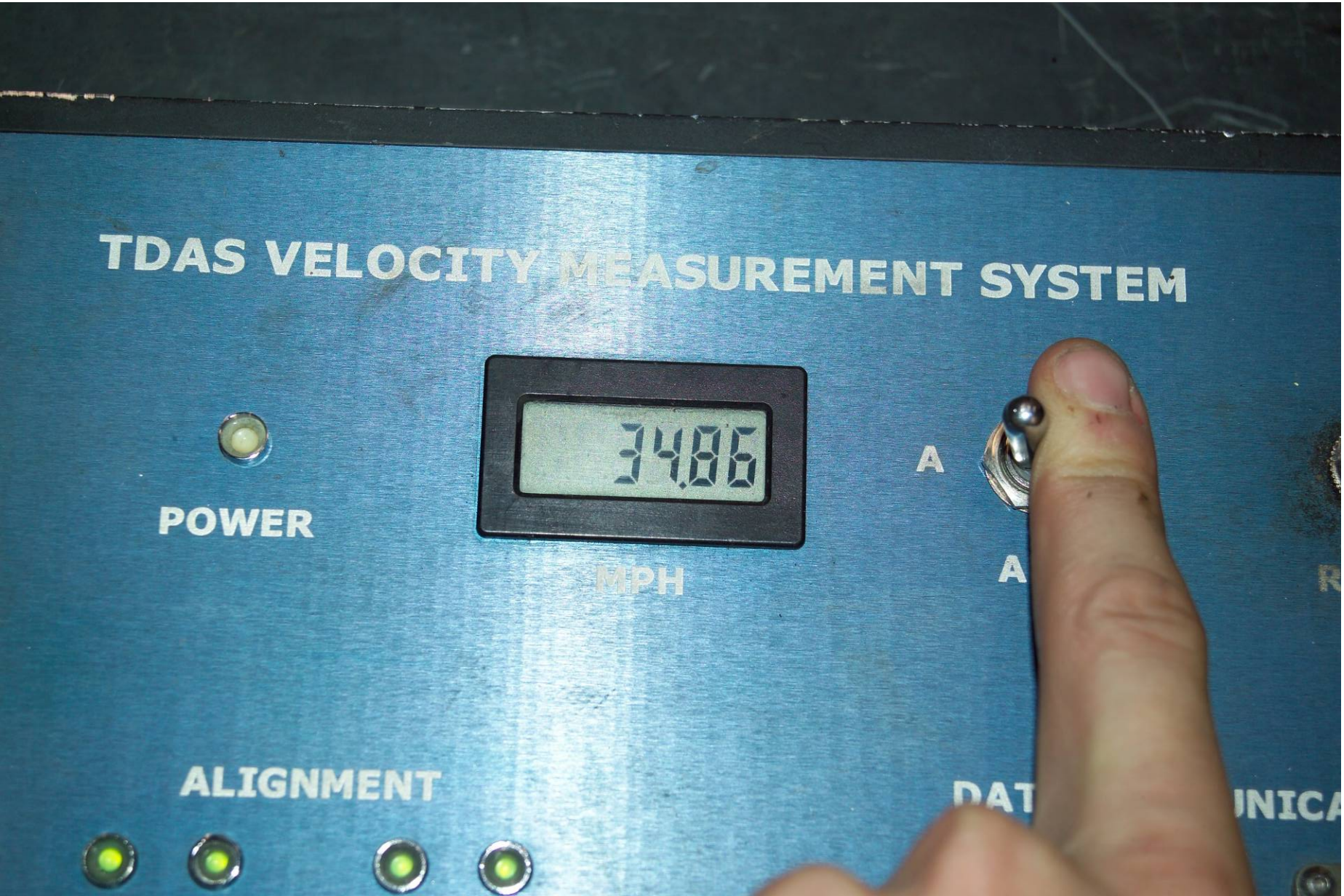

Figure A-92 Post-Test Digital Light Trap Read-Out - View 1

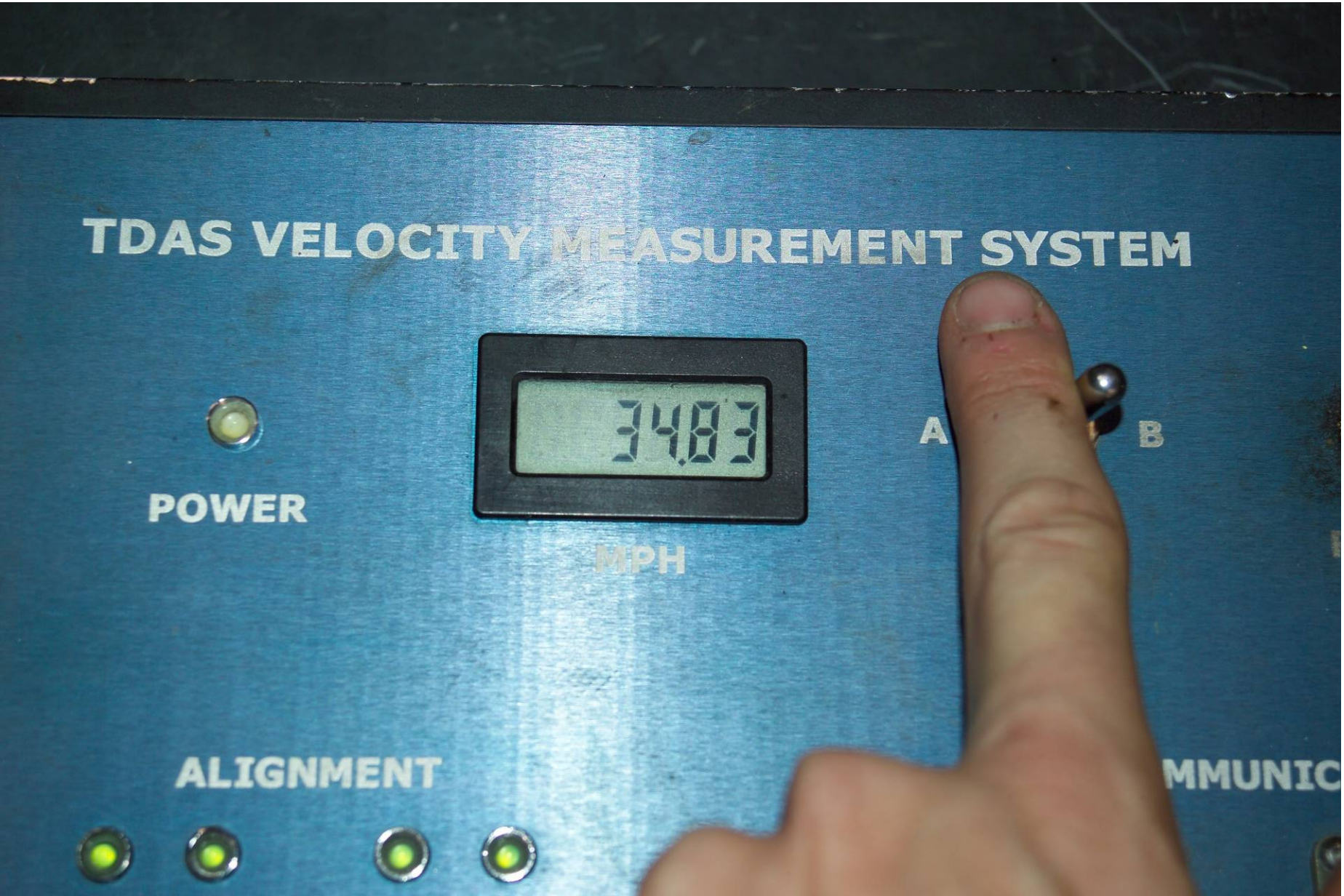

Figure A-93 Post-Test Digital Light Trap Read-Out - View 2



Figure A-94 Pre-Test Driver Toeboard - View 1



Figure A-95 Pre-Test Driver Toeboard - View 2



Figure A-96 Pre-Test Driver Toeboard - View 3

A-97

070913



Figure A-97 Pre-Test Driver Toeboard - View 4

A-98

070913



Figure A-98 Pre-Test Driver Toeboard - View 5



Figure A-99 Pre-Test Driver Toeboard - View 6



Figure A-100 Pre-Test Driver Toeboard - View 7

A-101

070913



Figure A-101 Pre-Test Driver Toeboard - View 8



Figure A-102 Pre-Test Driver Toeboard - View 9



Figure A-103 Pre-Test Driver Toeboard - View 10

A-104

070913



Figure A-104 Pre-Test Driver Toeboard - View 11

A-105

070913



Figure A-105 Pre-Test Driver Toeboard - View 12

A-106

070913



Figure A-106 Pre-Test Driver Toeboard - View 13



Figure A-107 Pre-Test Driver Toeboard - View 14



Figure A-108 Pre-Test Driver Toeboard - View 15



Figure A-109 Pre-Test Driver Toeboard - View 16

A-110

070913



Figure A-110 Post-Test Driver Toeboard - View 16

A-111

070913



Figure A-112 Post-Test Driver Toeboard - View 17

A-113

070913



Figure A-113 Pre-Test Driver Toeboard - View 18

A-114

070913



Figure A-114 Post-Test Driver Toeboard - View 18

A-115

070913



Figure A-115 Post-Test Driver Toeboard - View 19

A-116

070913

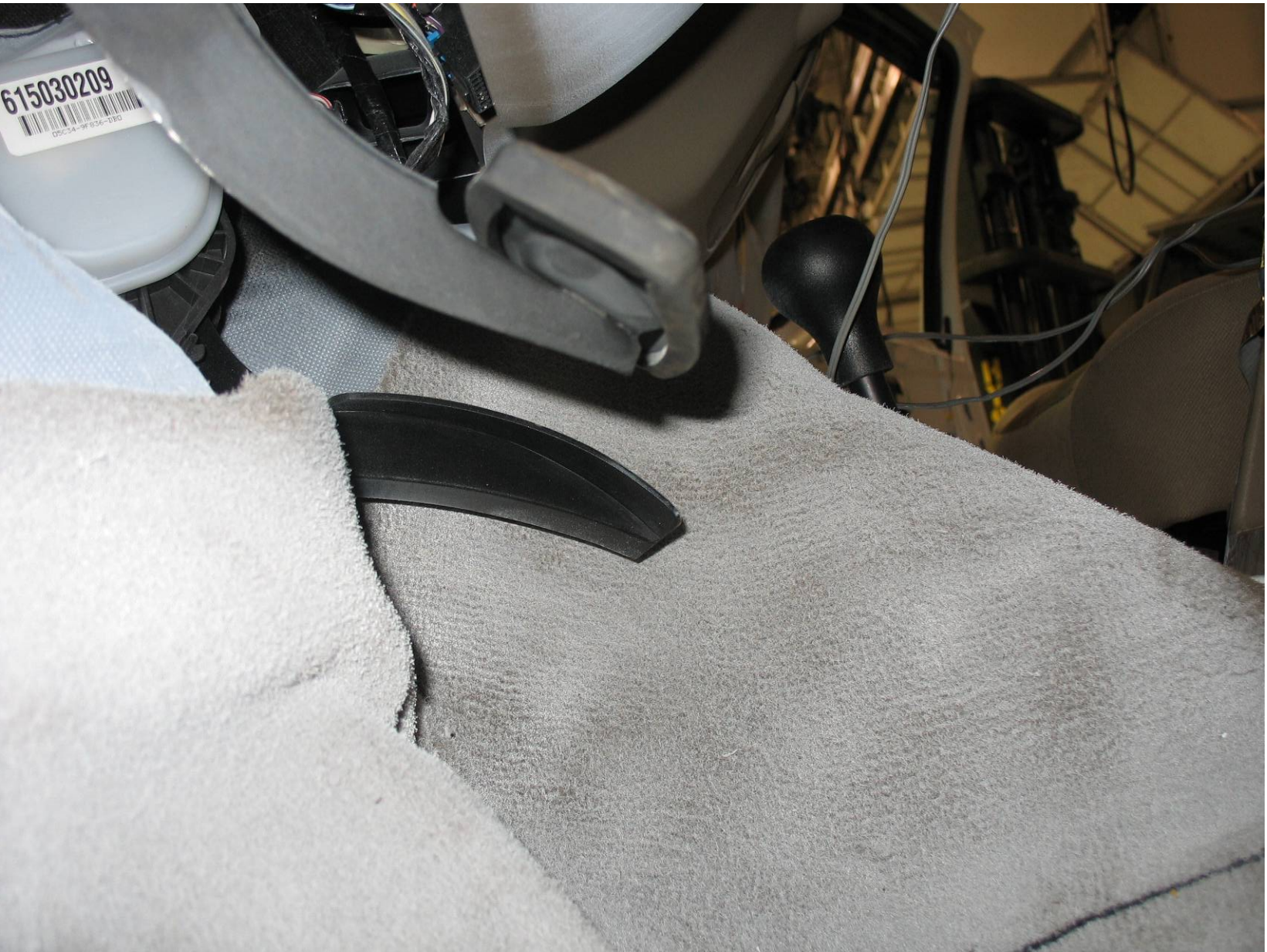

Figure A-116 Post-Test Driver Toeboard - View 20

A-117

070913

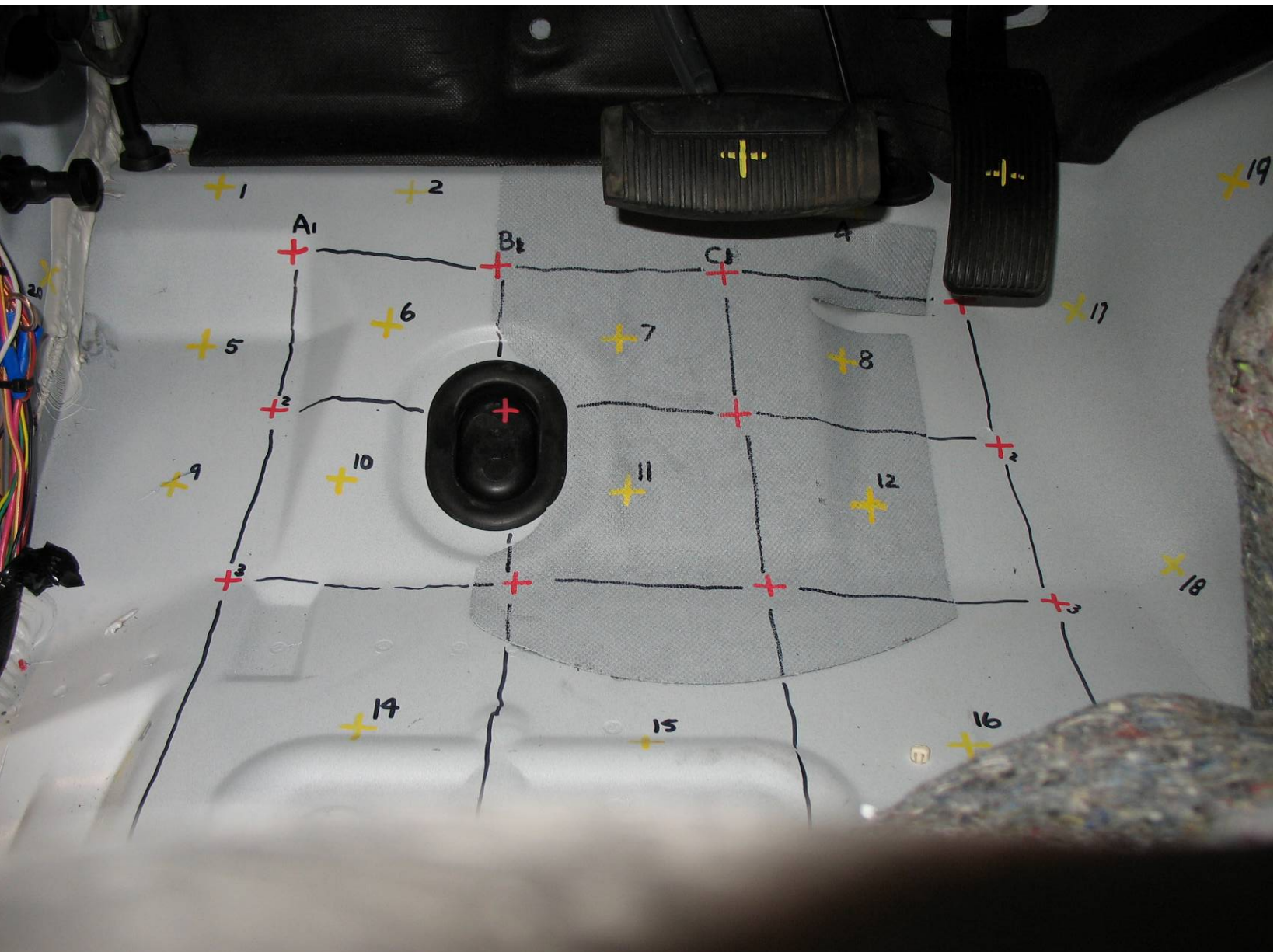

Figure A-117 Pre-Test Driver Toeboard - View 21

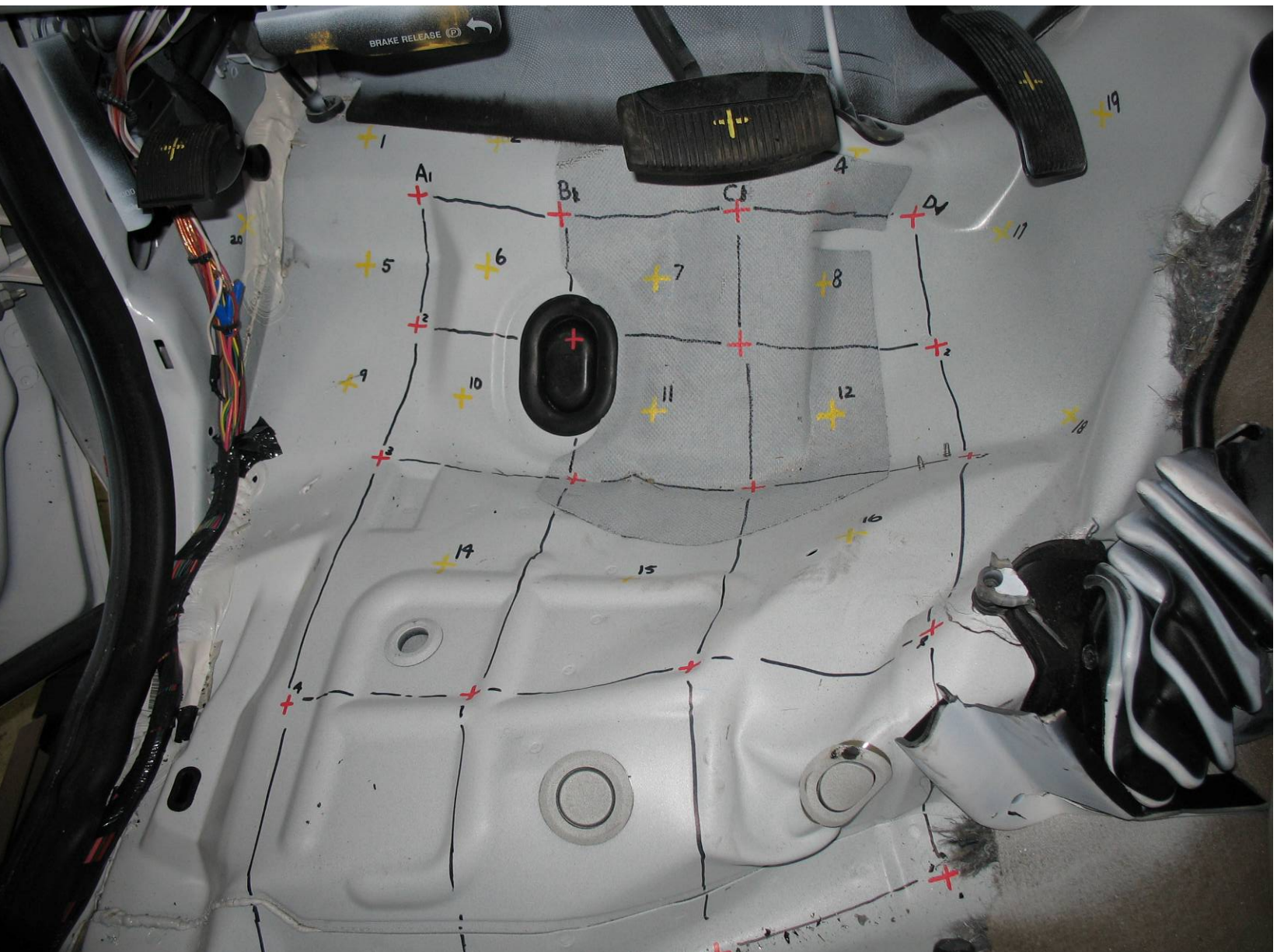

Figure A-118 Post-Test Driver Toeboard - View 21



Figure A-119 Pre-Test Driver Toeboard - View 22

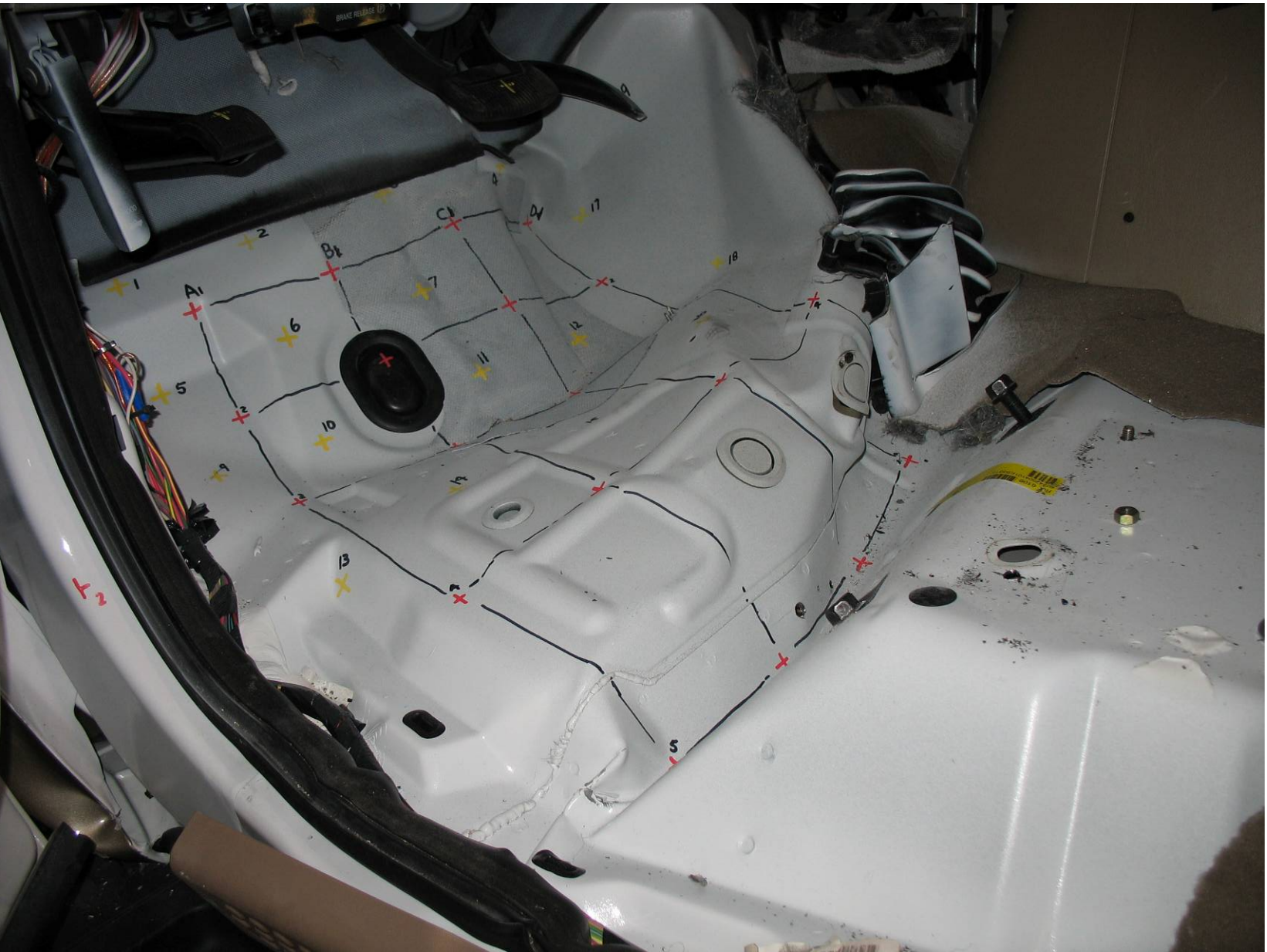

Figure A-120 Post-Test Driver Toeboard - View 22

A-121

070913



Figure A-121 Pre-Test Driver Toeboard - View 23

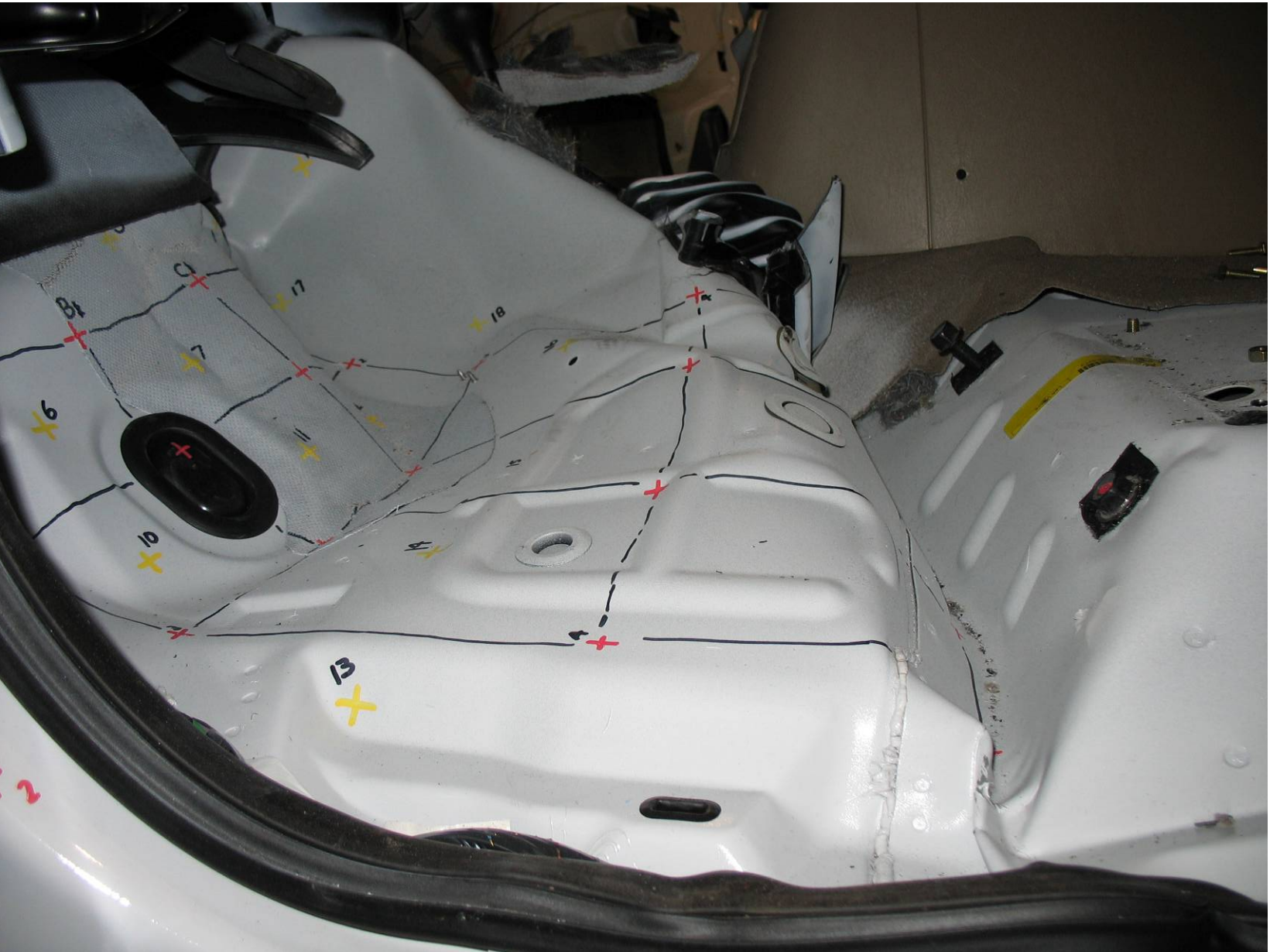

Figure A-122 Post-Test Driver Toeboard - View 23



Figure A-123 Post-Test Driver Toeboard - View 24

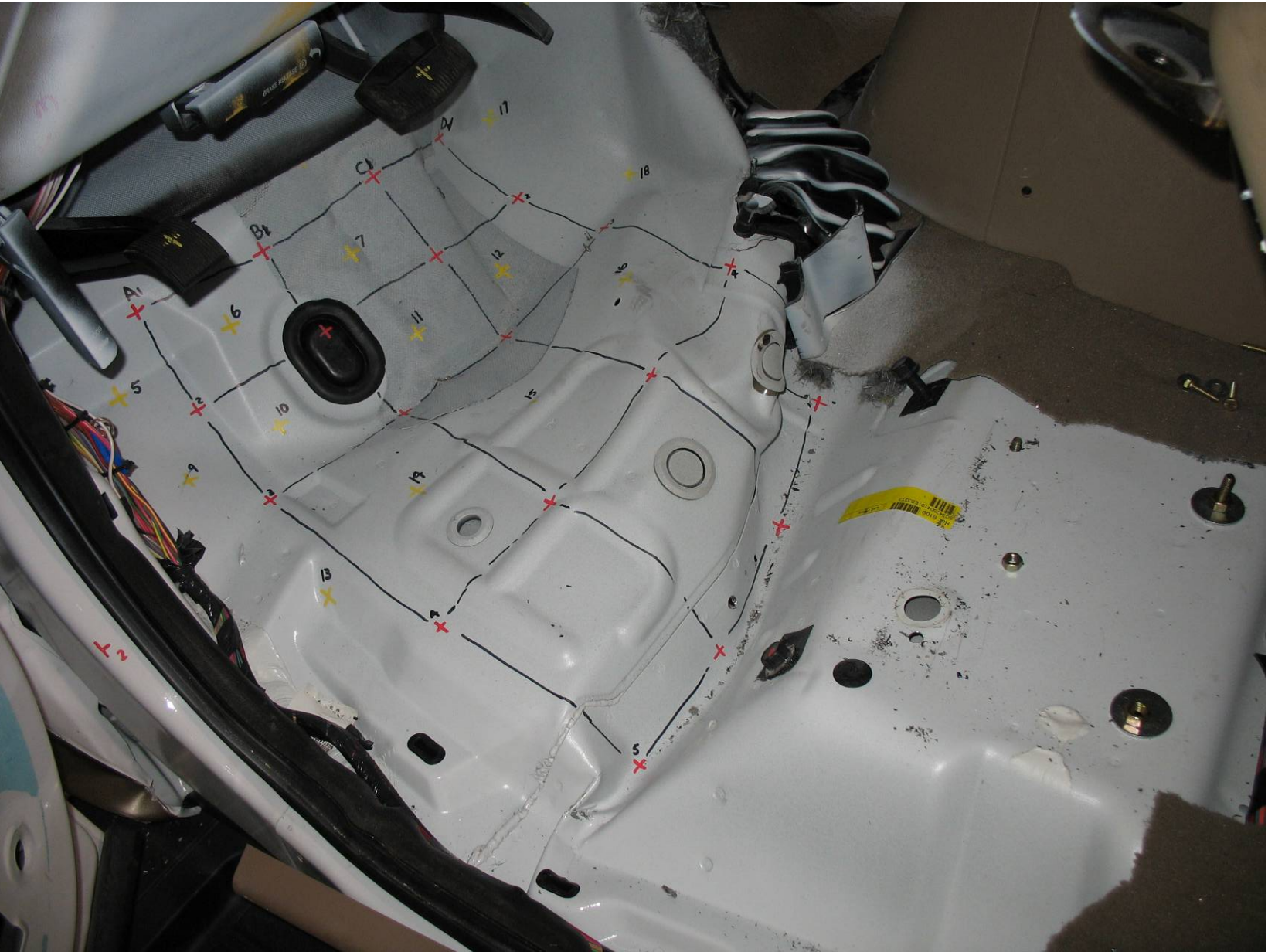

Figure A-124 Post-Test Driver Toeboard - View 25

A-125

070913



Figure A-125 Pre-Test Right Front Passenger Toeboard - View 1

A-126

070913



Figure A-126 Post-Test Right Front Passenger Toeboard - View 1

A-127

070913



Figure A-127 Pre-Test Right Front Passenger Toeboard - View 2

A-128

070913



Figure A-128 Post-Test Right Front Passenger Toeboard - View 2

A-129

070913



Figure A-129 Pre-Test Right Front Passenger Toeboard - View 3

A-130

070913



Figure A-130 Post-Test Right Front Passenger Toeboard - View 3



Figure A-131 Pre-Test Right Front Passenger Toeboard - View 4

A-132

070913



Figure A-132 Pre-Test Right Front Passenger Toeboard - View 5

A-133

070913



Figure A-133 Pre-Test Right Front Passenger Toeboard - View 6

A-134

070913

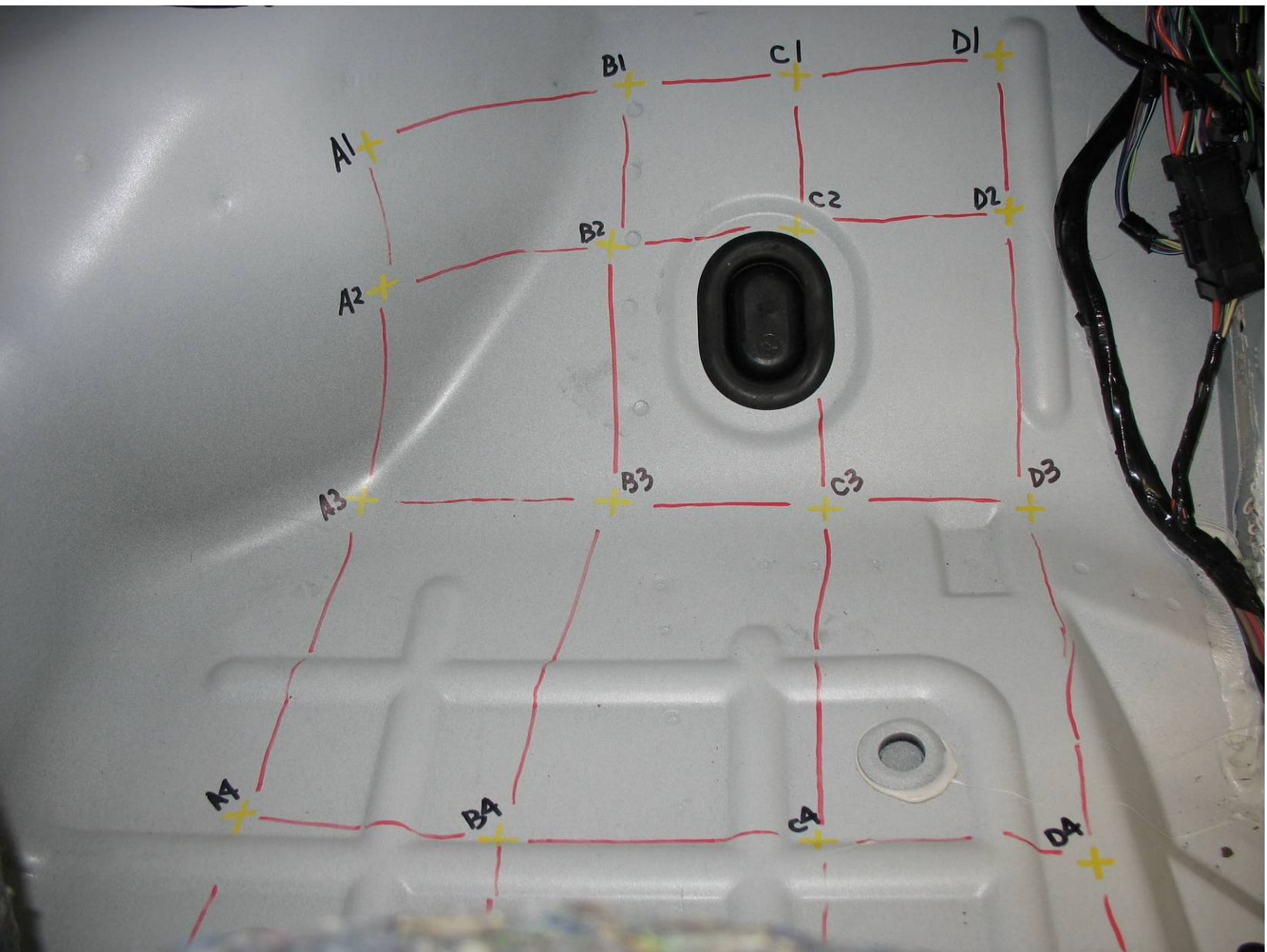

Figure A-134 Pre-Test Right Front Passenger Toeboard - View 7



Figure A-135 Post-Test Right Front Passenger Toeboard - View 7



Figure A-136 Pre-Test Right Front Passenger Toeboard - View 8

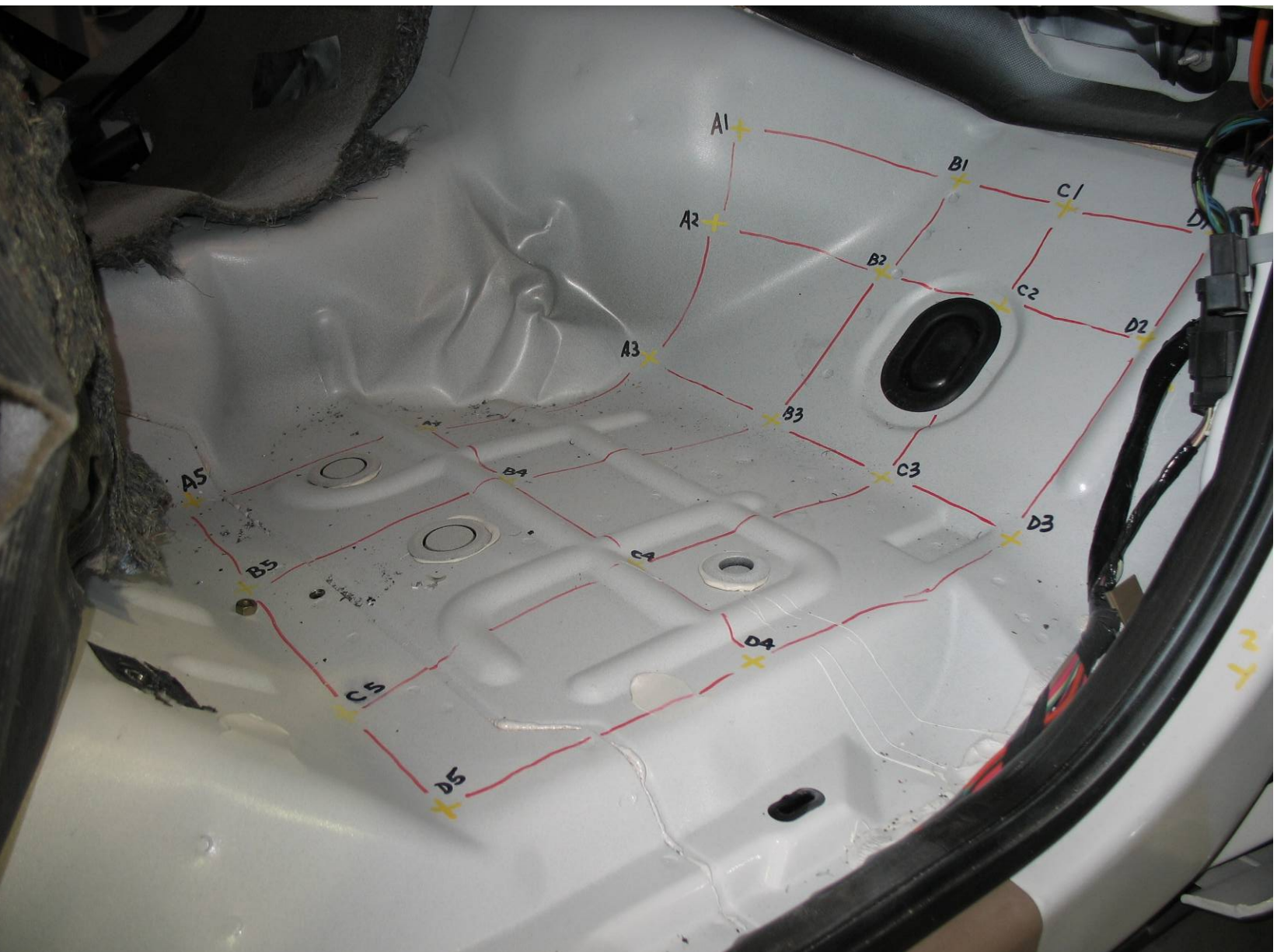

Figure A-137 Post-Test Right Front Passenger Toeboard - View 8



Figure A-138 Pre-Test Right Front Passenger Toeboard - View 9



Figure A-139 Post-Test Right Front Passenger Toeboard - View 9

Appendix B

Dummy, Vehicle, and Load Cell Barrier Data Plots

Table of Data Plots
Curve Number Corresponds to NHTSA Database Sequence

<u>Curve No.</u>	<u>Data Plot Title</u>	<u>Page</u>
1	Driver Head X-Axis Acceleration	B-11
2	Driver Head Y-Axis Acceleration	B-12
3	Driver Head Z-Axis Acceleration	B-13
--- ¹	Driver Head Resultant Acceleration	B-14
4	Driver Head X-Axis Redundant Acceleration	B-15
5	Driver Head Y-Axis Redundant Acceleration	B-16
6	Driver Head Z-Axis Redundant Acceleration	B-17
--- ¹	Driver Head Redundant Resultant Acceleration	B-18
7	Driver Upper Neck X-Axis Shear Force	B-19
8	Driver Upper Neck Y-Axis Shear Force	B-20
9	Driver Upper Neck Z-Axis Axial Force	B-21
10	Driver Upper Neck Moment About X Axis	B-22
11	Driver Upper Neck Moment About Y Axis	B-23
12	Driver Upper Neck Moment About Z Axis	B-24
13	Driver Chest X-Axis Acceleration	B-25
14	Driver Chest Y-Axis Acceleration	B-26
15	Driver Chest Z-Axis Acceleration	B-27
16	Driver Chest Resultant Acceleration	B-28
17	Driver Chest X-Axis Redundant Acceleration	B-29
18	Driver Chest Y-Axis Redundant Acceleration	B-30
19	Driver Chest Z-Axis Redundant Acceleration	B-31
20	Driver Chest Redundant Resultant Acceleration	B-32
21	Driver Chest Displacement	B-33
22	Driver Pelvis X-Axis Acceleration	B-34
23	Driver Pelvis Y-Axis Acceleration	B-35
24	Driver Pelvis Z-Axis Acceleration	B-36
25	Driver Pelvis Resultant Acceleration	B-37
26	Driver Left Femur Z-Axis Force	B-38
27	Driver Right Femur Z-Axis Force	B-39
--- ¹	Driver Left Knee Displacement	B-40
28	Driver Left Upper Tibia X-Axis Force	B-41

Table of Data Plots, Continued

<u>Curve No.</u>	<u>Data Plot Title</u>	<u>Page</u>
29	Driver Left Upper Tibia Z-Axis Force	B-42
30	Driver Left Upper Tibia Moment About X Axis	B-43
--- ¹	Driver Left Upper Tibia Moment About Y Axis	B-44
31	Driver Left Tibia X-Axis Acceleration	B-45
32	Driver Left Tibia Y-Axis Acceleration	B-46
33	Driver Left Lower Tibia X-Axis Force	B-47
34	Driver Left Lower Tibia Y-Axis Force	B-48
--- ¹	Driver Left Lower Tibia Z-Axis Force	B-49
35	Driver Left Lower Tibia Moment About X-Axis	B-50
36	Driver Left Lower Tibia Moment About Y-Axis	B-51
37	Driver Left Foot X-Axis Rotation	B-52
38	Driver Left Foot Y-Axis Rotation	B-53
39	Driver Left Foot Z-Axis Rotation	B-54
40	Driver Left Foot X-Axis Acceleration	B-55
41	Driver Left Foot Y-Axis Acceleration	B-56
42	Driver Left Foot Z-Axis Acceleration	B-57
43	Driver Left Foot Resultant Acceleration	B-58
44	Driver Right Knee Displacement	B-59
45	Driver Right Upper Tibia X-Axis Force	B-60
46	Driver Right Upper Tibia Z-Axis Force	B-61
47	Driver Right Upper Tibia Moment About X-Axis	B-62
48	Driver Right Upper Tibia Moment About Y-Axis	B-63
49	Driver Right Tibia X-Axis Acceleration	B-64
50	Driver Right Tibia Y-Axis Acceleration	B-65
51	Driver Right Lower Tibia X-Axis Force	B-66
52	Driver Right Lower Tibia Y-Axis Force	B-67
53	Driver Right Lower Tibia Z-Axis Force	B-68
54	Driver Right Lower Tibia Moment About X-Axis	B-69
--- ¹	Driver Right Lower Tibia Moment About Y-Axis	B-70
55	Driver Right Foot X-Axis Rotation	B-71
56	Driver Right Foot Y-Axis Rotation	B-72
57	Driver Right Foot Z-Axis Rotation	B-73
58	Driver Right Foot X-Axis Acceleration	B-74

Table of Data Plots, Continued

<u>Curve No.</u>	<u>Data Plot Title</u>	<u>Page</u>
59	Driver Right Foot Y-Axis Acceleration	B-75
60	Driver Right Foot Z-Axis Acceleration	B-76
61	Driver Right Foot Resultant Acceleration	B-77
62	Passenger Head X-Axis Acceleration	B-78
63	Passenger Head Y-Axis Acceleration	B-79
64	Passenger Head Z-Axis Acceleration	B-80
65	Passenger Head Resultant Acceleration	B-81
66	Passenger Head X-Axis Redundant Acceleration	B-82
67	Passenger Head Y-Axis Redundant Acceleration	B-83
68	Passenger Head Z-Axis Redundant Acceleration	B-84
69	Passenger Head Redundant Resultant Acceleration	B-85
70	Passenger Upper Neck X-Axis Shear Force	B-86
71	Passenger Upper Neck Y-Axis Shear Force	B-87
72	Passenger Upper Neck Z-Axis Axial Force	B-88
--- ¹	Passenger Upper Neck Moment About X Axis	B-89
73	Passenger Upper Neck Moment About Y Axis	B-90
74	Passenger Upper Neck Moment About Z Axis	B-91
75	Passenger Chest X-Axis Acceleration	B-92
--- ¹	Passenger Chest Y-Axis Acceleration	B-93
76	Passenger Chest Z-Axis Acceleration	B-94
77	Passenger Chest Resultant Acceleration	B-95
78	Passenger Chest X-Axis Redundant Acceleration	B-96
--- ¹	Passenger Chest Y-Axis Redundant Acceleration	B-97
79	Passenger Chest Z-Axis Redundant Acceleration	B-98
80	Passenger Chest Redundant Resultant Acceleration	B-99
81	Passenger Chest Displacement	B-100
82	Passenger Pelvis X-Axis Acceleration	B-101
83	Passenger Pelvis Y-Axis Acceleration	B-102
84	Passenger Pelvis Z-Axis Acceleration	B-103
85	Passenger Pelvis Resultant Acceleration	B-104
86	Passenger Left Femur Z-Axis Force	B-105
87	Passenger Right Femur Z-Axis Force	B-106
88	Passenger Left Knee Displacement	B-107

Table of Data Plots, Continued

<u>Curve No.</u>	<u>Data Plot Title</u>	<u>Page</u>
89	Passenger Left Upper Tibia X-Axis Force	B-108
90	Passenger Left Upper Tibia Z-Axis Force	B-109
91	Passenger Left Upper Tibia Moment About X Axis	B-110
92	Passenger Left Upper Tibia Moment About Y Axis	B-111
93	Passenger Left Tibia X-Axis Acceleration	B-112
94	Passenger Left Tibia Y-Axis Acceleration	B-113
95	Passenger Left Lower Tibia X-Axis Force	B-114
96	Passenger Left Lower Tibia Y-Axis Force	B-115
97	Passenger Left Lower Tibia Z-Axis Force	B-116
98	Passenger Left Lower Tibia Moment About X-Axis	B-117
99	Passenger Left Lower Tibia Moment About Y-Axis	B-118
--- ¹	Passenger Left Foot X-Axis Rotation	B-119
100	Passenger Left Foot Y-Axis Rotation	B-120
101	Passenger Left Foot Z-Axis Rotation	B-121
102	Passenger Left Foot X-Axis Acceleration	B-122
--- ¹	Passenger Left Foot Y-Axis Acceleration	B-123
103	Passenger Left Foot Z-Axis Acceleration	B-124
104	Passenger Left Foot Resultant Acceleration	B-125
105	Passenger Right Knee Displacement	B-126
106	Passenger Right Upper Tibia X-Axis Force	B-127
--- ¹	Passenger Right Upper Tibia Z-Axis Force	B-128
107	Passenger Right Upper Tibia Moment About X-Axis	B-129
108	Passenger Right Upper Tibia Moment About Y-Axis	B-130
109	Passenger Right Tibia X-Axis Acceleration	B-131
110	Passenger Right Tibia Y-Axis Acceleration	B-132
111	Passenger Right Lower Tibia X-Axis Force	B-133
112	Passenger Right Lower Tibia Y-Axis Force	B-134
113	Passenger Right Lower Tibia Z-Axis Force	B-135
114	Passenger Right Lower Tibia Moment About X-Axis	B-136
115	Passenger Right Lower Tibia Moment About Y-Axis	B-137
116	Passenger Right Foot X-Axis Rotation	B-138
117	Passenger Right Foot Y-Axis Rotation	B-139
118	Passenger Right Foot Z-Axis Rotation	B-140

Table of Data Plots, Continued

<u>Curve No.</u>	<u>Data Plot Title</u>	<u>Page</u>
119	Passenger Right Foot X-Axis Acceleration	B-141
120	Passenger Right Foot Y-Axis Acceleration	B-142
121	Passenger Right Foot Z-Axis Acceleration	B-143
122	Passenger Right Foot Resultant Acceleration	B-144
123	Left Rear Seat Crossmember X-Axis Acceleration	B-145
124	Right Rear Seat Crossmember X-Axis Acceleration	B-146
125	Left Rear Seat Crossmember Z-Axis Acceleration	B-147
126	Right Rear Seat Crossmember Z-Axis Acceleration	B-148
--- ¹	Top of Engine Block X-Axis Acceleration	B-149
127	Bottom of Engine Block X-Axis Acceleration	B-150
128	Right Front Brake Caliper X-Axis Acceleration	B-151
129	Left Front Brake Caliper X-Axis Acceleration	B-152
130	Instrument Panel X-Axis Acceleration	B-153
131	Left Side Driver Mid Seat Track X-Axis Acceleration	B-154
132	Vehicle CG X-Axis Acceleration	B-155
133	Vehicle CG X-Axis Velocity	B-156
134	Vehicle CG X-Axis Displacement	B-157
135	Vehicle CG Y-Axis Acceleration	B-158
136	Vehicle CG Y-Axis Velocity	B-159
137	Vehicle CG Y-Axis Displacement	B-160
138	Vehicle CG Z-Axis Acceleration	B-161
139	Vehicle CG Z-Axis Velocity	B-162
140	Vehicle CG Z-Axis Displacement	B-163
141	Vehicle CG Resultant Acceleration	B-164
142	Under Accel Pedal (Centered) X-Axis Acceleration	B-165
143	Under Accel Pedal (Centered) Y-Axis Acceleration	B-166
144	Under Accel Pedal (Centered) Z-Axis Acceleration	B-167
--- ¹	Under Accel Pedal (Centered) Resultant Acceleration	B-168
145	Under Brake Pedal (Centered) X-Axis Acceleration	B-169
146	Under Brake Pedal (Centered) Y-Axis Acceleration	B-170
147	Under Brake Pedal (Centered) Z-Axis Acceleration	B-171
148	Under Brake Pedal (Centered) Resultant Acceleration	B-172
149	Outside Footrest X-Axis Acceleration	B-173

Table of Data Plots, Continued

<u>Curve No.</u>	<u>Data Plot Title</u>	<u>Page</u>
150	Outside Footrest Y-Axis Acceleration	B-174
151	Outside Footrest Z-Axis Acceleration	B-175
152	Outside Footrest Resultant Acceleration	B-176
153	Driver Lap Belt Force	B-177
154	Driver Shoulder Belt Force	B-178
155	Passenger Lap Belt Force	B-179
156	Passenger Shoulder Belt Force	B-180
157	Driver Front Airbag 1 Inductor	B-181
158	Driver Front Airbag 2 Inductor	B-182
159	Passenger Front Airbag 1 Inductor	B-183
160	Passenger Front Airbag 2 Inductor	B-184
161	Driver Right Foot Contact Switch	B-185
162	Driver Left Foot Contact Switch	B-186
163	Driver Left Knee Contact Switch	B-187
---1	Driver Right Knee Contact Switch	B-188
164	Load Cell Row 1 Column 1	B-189
165	Load Cell Row 2 Column 1	B-190
166	Load Cell Row 3 Column 1	B-191
---1	Load Cell Row 4 Column 1	B-192
167	Load Cell Row 5 Column 1	B-193
168	Load Cell Row 6 Column 1	B-194
169	Load Cell Row 7 Column 1	B-195
---1	Load Cell Row 8 Column 1	B-196
170	Load Cell Row 9 Column 1	B-197
171	Load Cell Row 10 Column 1	B-198
172	Load Cell Row 1 Column 2	B-199
---1	Load Cell Row 2 Column 2	B-200
173	Load Cell Row 3 Column 2	B-201
174	Load Cell Row 4 Column 2	B-202
175	Load Cell Row 5 Column 2	B-203
176	Load Cell Row 6 Column 2	B-204
177	Load Cell Row 7 Column 2	B-205
178	Load Cell Row 8 Column 2	B-206

Table of Data Plots, Continued

<u>Curve No.</u>	<u>Data Plot Title</u>	<u>Page</u>
179	Load Cell Row 9 Column 2	B-207
180	Load Cell Row 10 Column 2	B-208
181	Load Cell Row 1 Column 3	B-209
182	Load Cell Row 2 Column 3	B-210
183	Load Cell Row 3 Column 3	B-211
184	Load Cell Row 4 Column 3	B-212
185	Load Cell Row 5 Column 3	B-213
186	Load Cell Row 6 Column 3	B-214
187	Load Cell Row 7 Column 3	B-215
188	Load Cell Row 8 Column 3	B-216
189	Load Cell Row 9 Column 3	B-217
190	Load Cell Row 10 Column 3	B-218
191	Load Cell Row 1 Column 4	B-219
192	Load Cell Row 2 Column 4	B-220
193	Load Cell Row 3 Column 4	B-221
194	Load Cell Row 4 Column 4	B-222
195	Load Cell Row 5 Column 4	B-223
196	Load Cell Row 6 Column 4	B-224
197	Load Cell Row 7 Column 4	B-225
198	Load Cell Row 8 Column 4	B-226
199	Load Cell Row 9 Column 4	B-227
200	Load Cell Row 10 Column 4	B-228
201	Load Cell Row 1 Column 5	B-229
202	Load Cell Row 2 Column 5	B-230
203	Load Cell Row 3 Column 5	B-231
204	Load Cell Row 4 Column 5	B-232
205	Load Cell Row 5 Column 5	B-233
206	Load Cell Row 6 Column 5	B-234
207	Load Cell Row 7 Column 5	B-235
208	Load Cell Row 8 Column 5	B-236
209	Load Cell Row 9 Column 5	B-237
210	Load Cell Row 10 Column 5	B-238
211	Load Cell Row 1 Column 6	B-239

Table of Data Plots, Continued

<u>Curve No.</u>	<u>Data Plot Title</u>	<u>Page</u>
212	Load Cell Row 2 Column 6	B-240
213	Load Cell Row 3 Column 6	B-241
214	Load Cell Row 4 Column 6	B-242
215	Load Cell Row 5 Column 6	B-243
216	Load Cell Row 6 Column 6	B-244
217	Load Cell Row 7 Column 6	B-245
218	Load Cell Row 8 Column 6	B-246
219	Load Cell Row 9 Column 6	B-247
220	Load Cell Row 10 Column 6	B-248
221	Load Cell Row 1 Column 7	B-249
222	Load Cell Row 2 Column 7	B-250
223	Load Cell Row 3 Column 7	B-251
224	Load Cell Row 4 Column 7	B-252
225	Load Cell Row 5 Column 7	B-253
226	Load Cell Row 6 Column 7	B-254
227	Load Cell Row 7 Column 7	B-255
228	Load Cell Row 8 Column 7	B-256
229	Load Cell Row 9 Column 7	B-257
230	Load Cell Row 10 Column 7	B-258
231	Load Cell Row 1 Column 8	B-259
232	Load Cell Row 2 Column 8	B-260
233	Load Cell Row 3 Column 8	B-261
234	Load Cell Row 4 Column 8	B-262
235	Load Cell Row 5 Column 8	B-263
236	Load Cell Row 6 Column 8	B-264
237	Load Cell Row 7 Column 8	B-265
238	Load Cell Row 8 Column 8	B-266
239	Load Cell Row 9 Column 8	B-267
240	Load Cell Row 10 Column 8	B-268
241	Load Cell Row 1 Column 9	B-269
242	Load Cell Row 2 Column 9	B-270
243	Load Cell Row 3 Column 9	B-271
244	Load Cell Row 4 Column 9	B-272

Table of Data Plots, Continued

<u>Curve No.</u>	<u>Data Plot Title</u>	<u>Page</u>
245	Load Cell Row 5 Column 9	B-273
246	Load Cell Row 6 Column 9	B-274
247	Load Cell Row 7 Column 9	B-275
248	Load Cell Row 8 Column 9	B-276
249	Load Cell Row 9 Column 9	B-277
250	Load Cell Row 10 Column 9	B-278

¹ Curve is not included in NHTSA database.



2007 Ford F-250 into Left 40% Offset Deformable LCB at 56 kph

Date: 09/13/2007
Time: 15:46

Driver Head X-Axis Acceleration

Customer: Volpe
Test Number: R70203

11HEADCG00H3ACXA

TRC Inc. Test Lab: CTF
Test Number: 070913

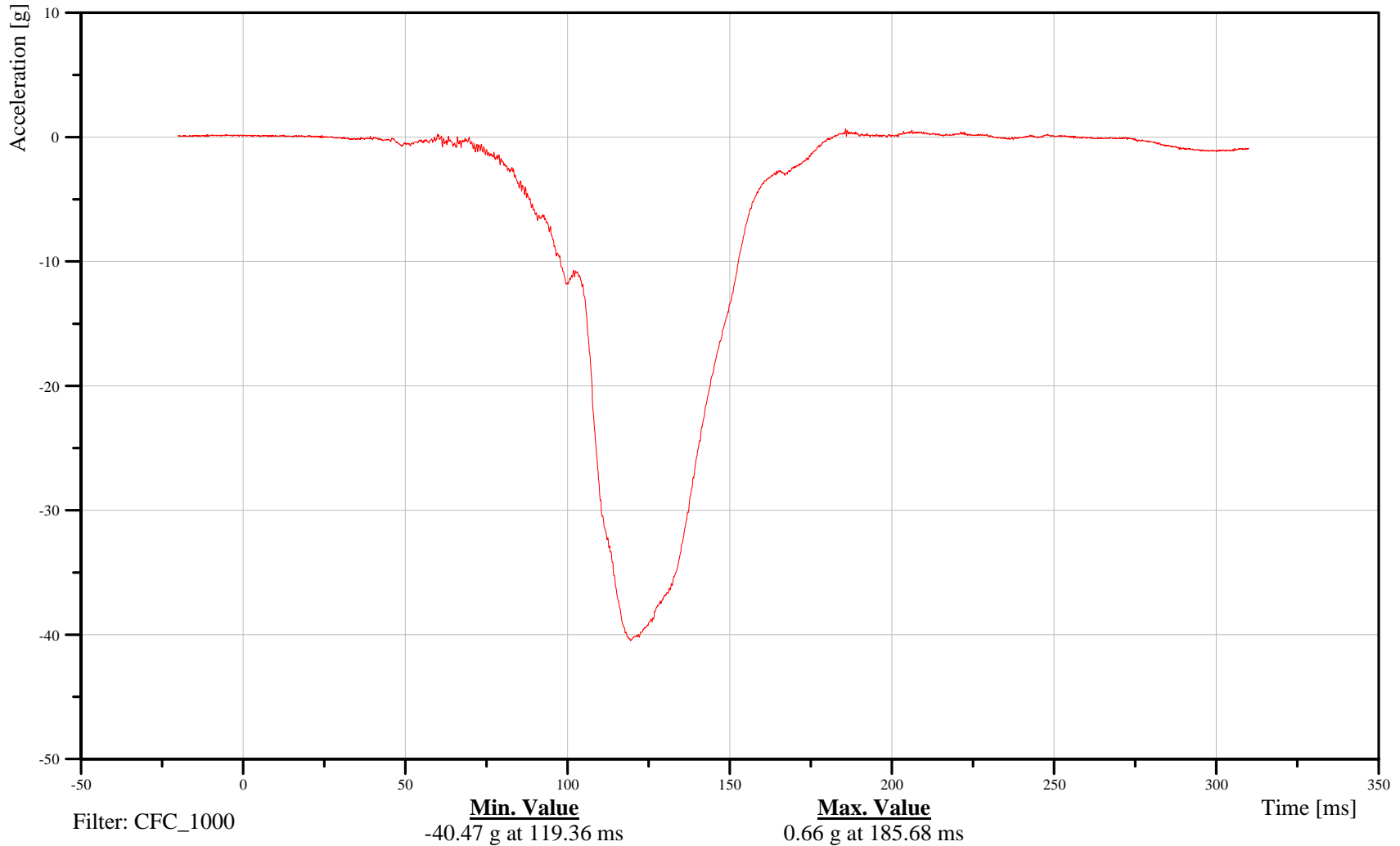

B-11

070913



2007 Ford F-250 into Left 40% Offset Deformable LCB at 56 kph

Date: 09/13/2007
Time: 15:46

Driver Head Y-Axis Acceleration

Customer: Volpe
Test Number: R70203

11HEADCG00H3ACYA

TRC Inc. Test Lab: CTF
Test Number: 070913

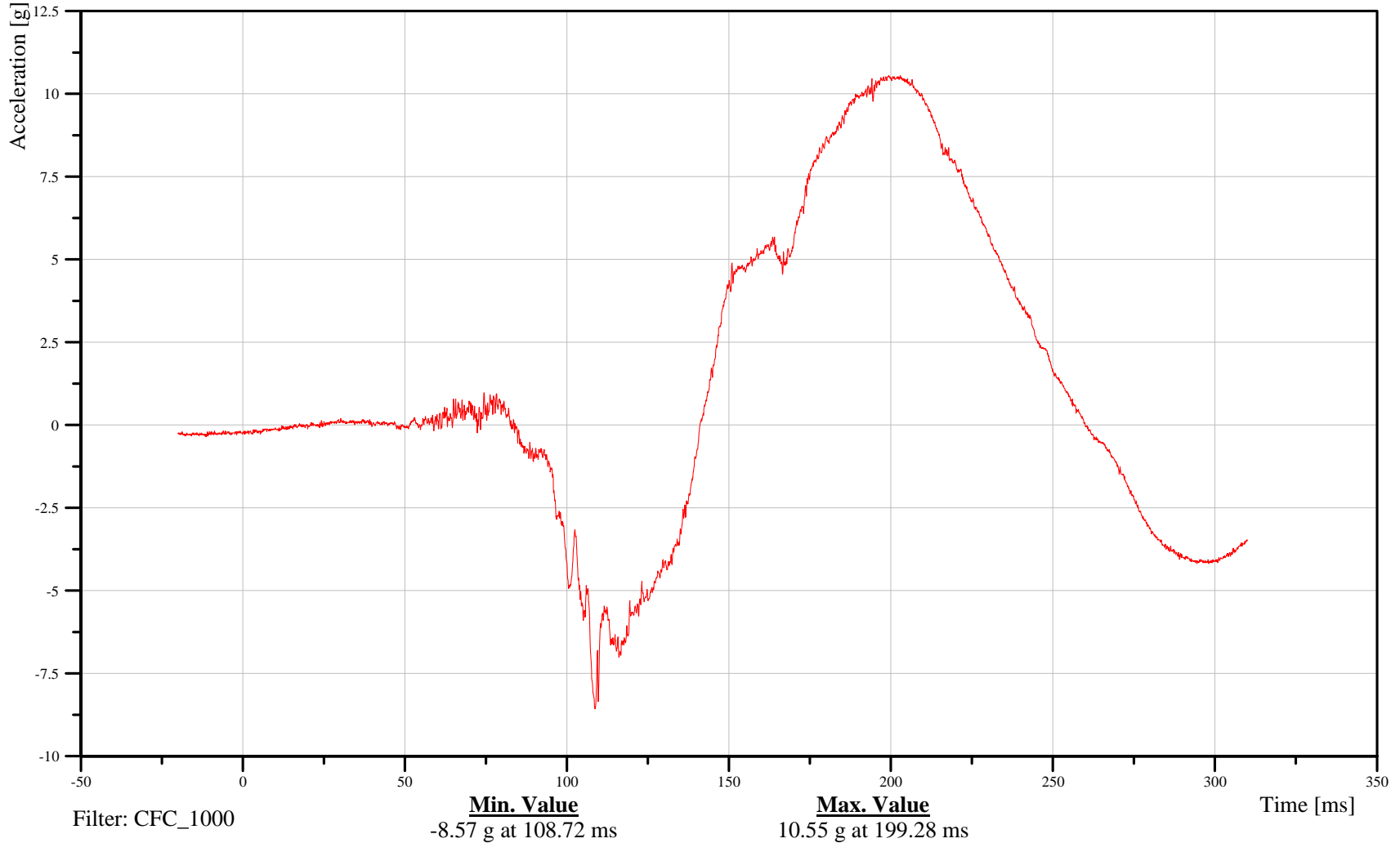

B-12

070913



2007 Ford F-250 into Left 40% Offset Deformable LCB at 56 kph

Date: 09/13/2007
Time: 15:46

Driver Head Z-Axis Acceleration

Customer: Volpe
Test Number: R70203

11HEADCG00H3ACZA

TRC Inc. Test Lab: CTF
Test Number: 070913

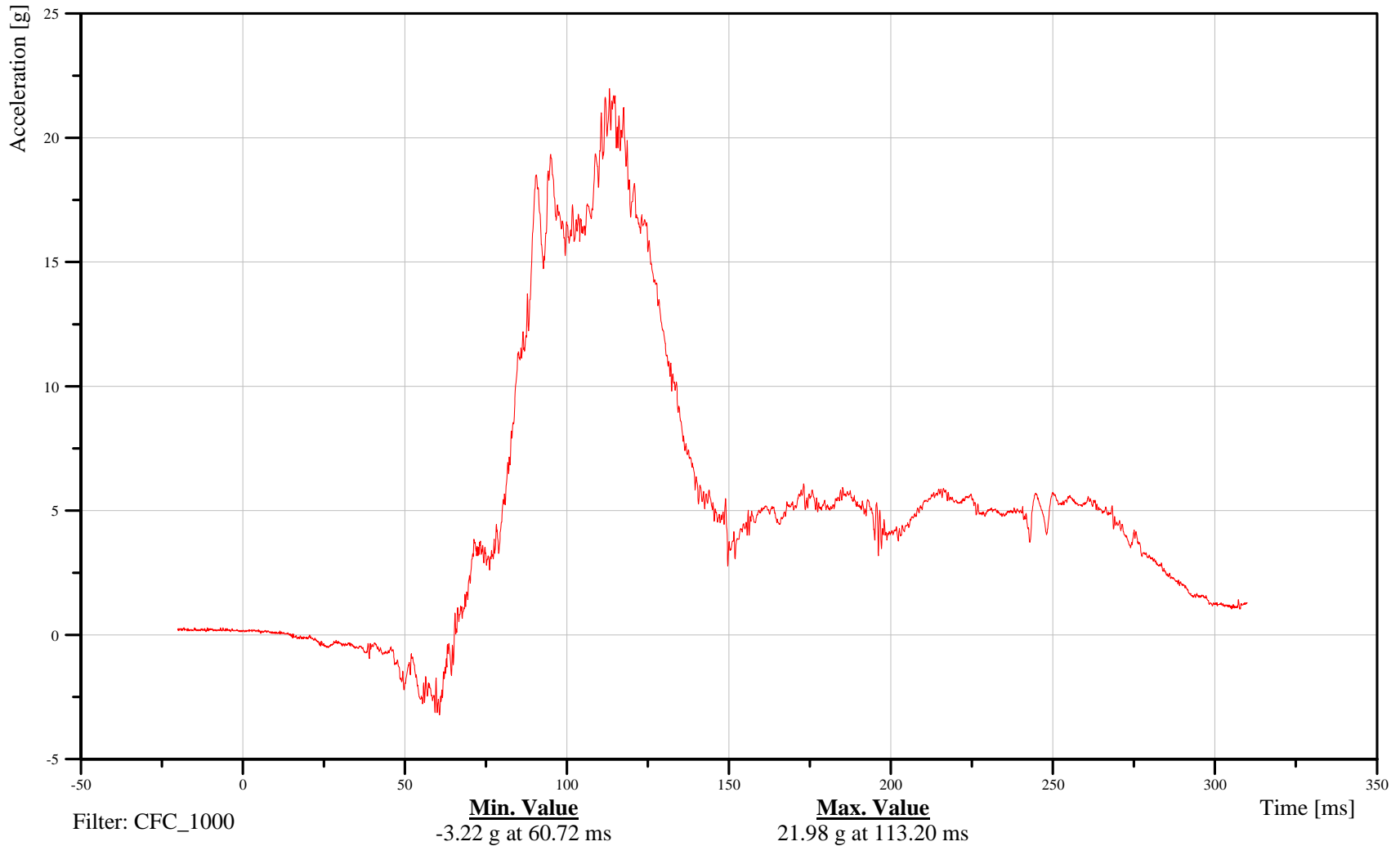

B-13

070913



2007 Ford F-250 into Left 40% Offset Deformable LCB at 56 kph

Date: 09/13/2007
Time: 15:46

Driver Head Resultant Acceleration

Customer: Volpe
Test Number: R70203

11HEADCG00H3ACRA

TRC Inc. Test Lab: CTF
Test Number: 070913

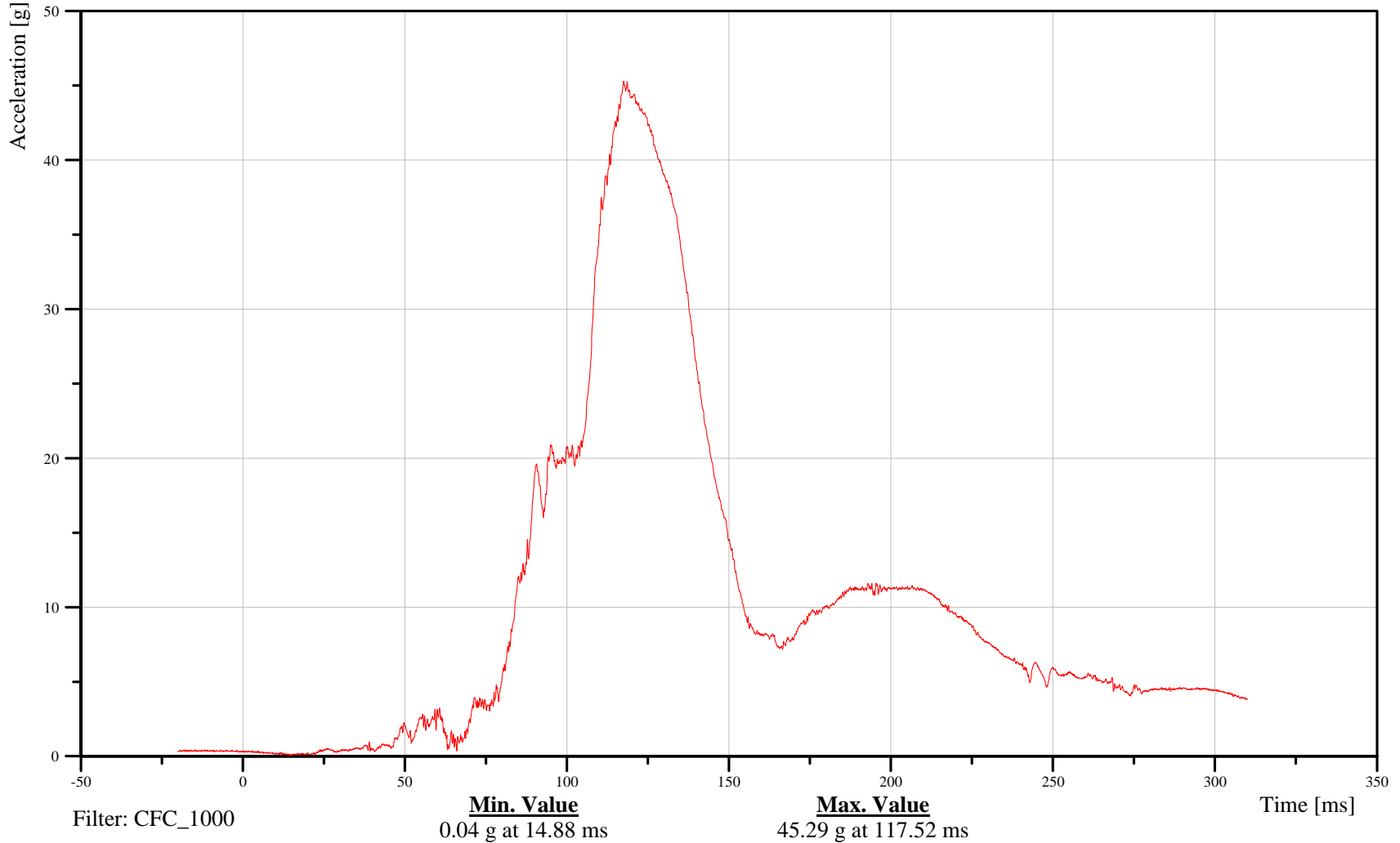

B-14

070913



2007 Ford F-250 into Left 40% Offset Deformable LCB at 56 kph

Date: 09/13/2007
Time: 15:46

Driver Head X-Axis Redundant Acceleration

Customer: Volpe
Test Number: R70203

11HEADCGRDH3ACXA

TRC Inc. Test Lab: CTF
Test Number: 070913

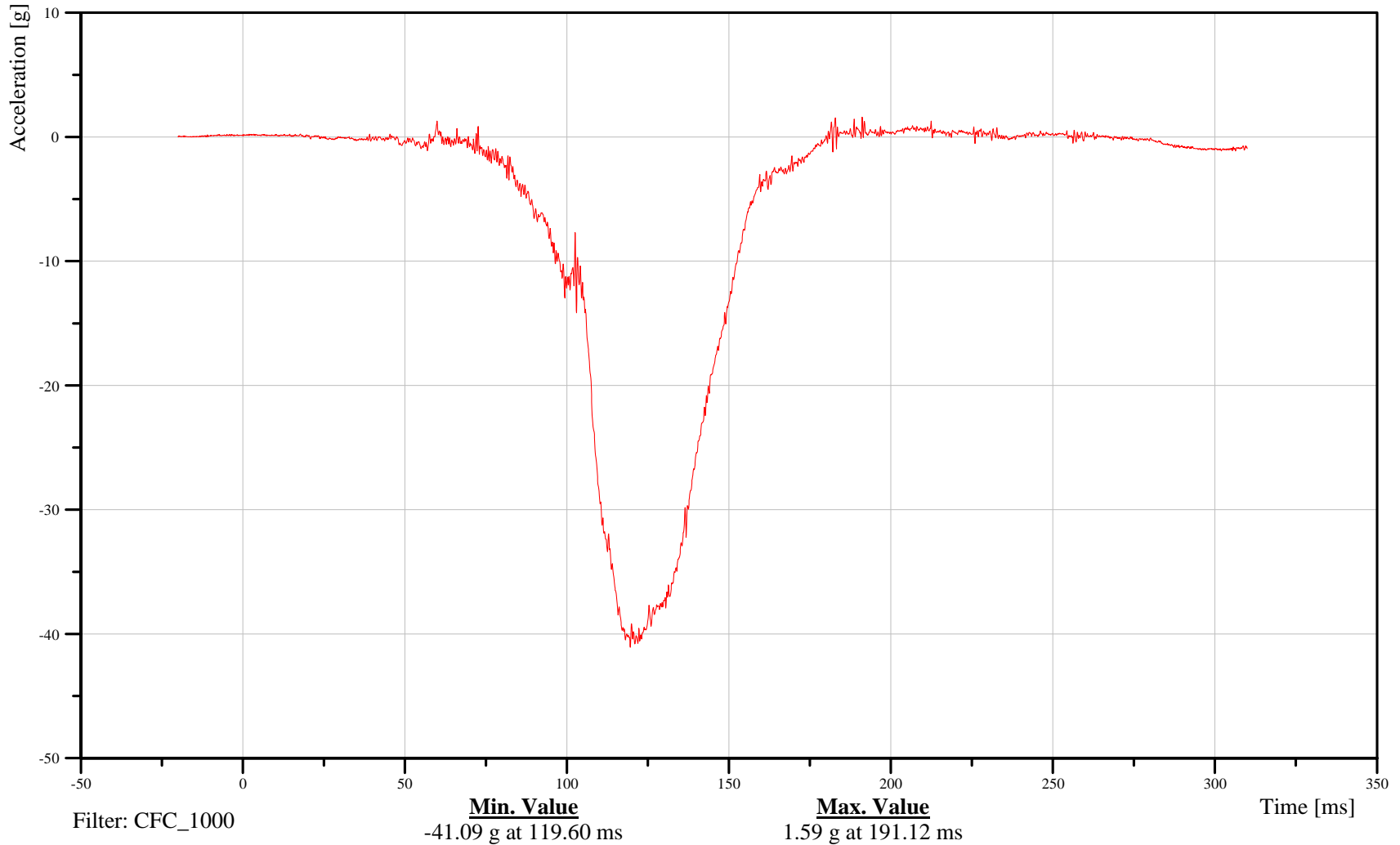

B-15

070913



2007 Ford F-250 into Left 40% Offset Deformable LCB at 56 kph

Date: 09/13/2007
Time: 15:46

Driver Head Y-Axis Redundant Acceleration

Customer: Volpe
Test Number: R70203

11HEADCGRDH3ACYA

TRC Inc. Test Lab: CTF
Test Number: 070913

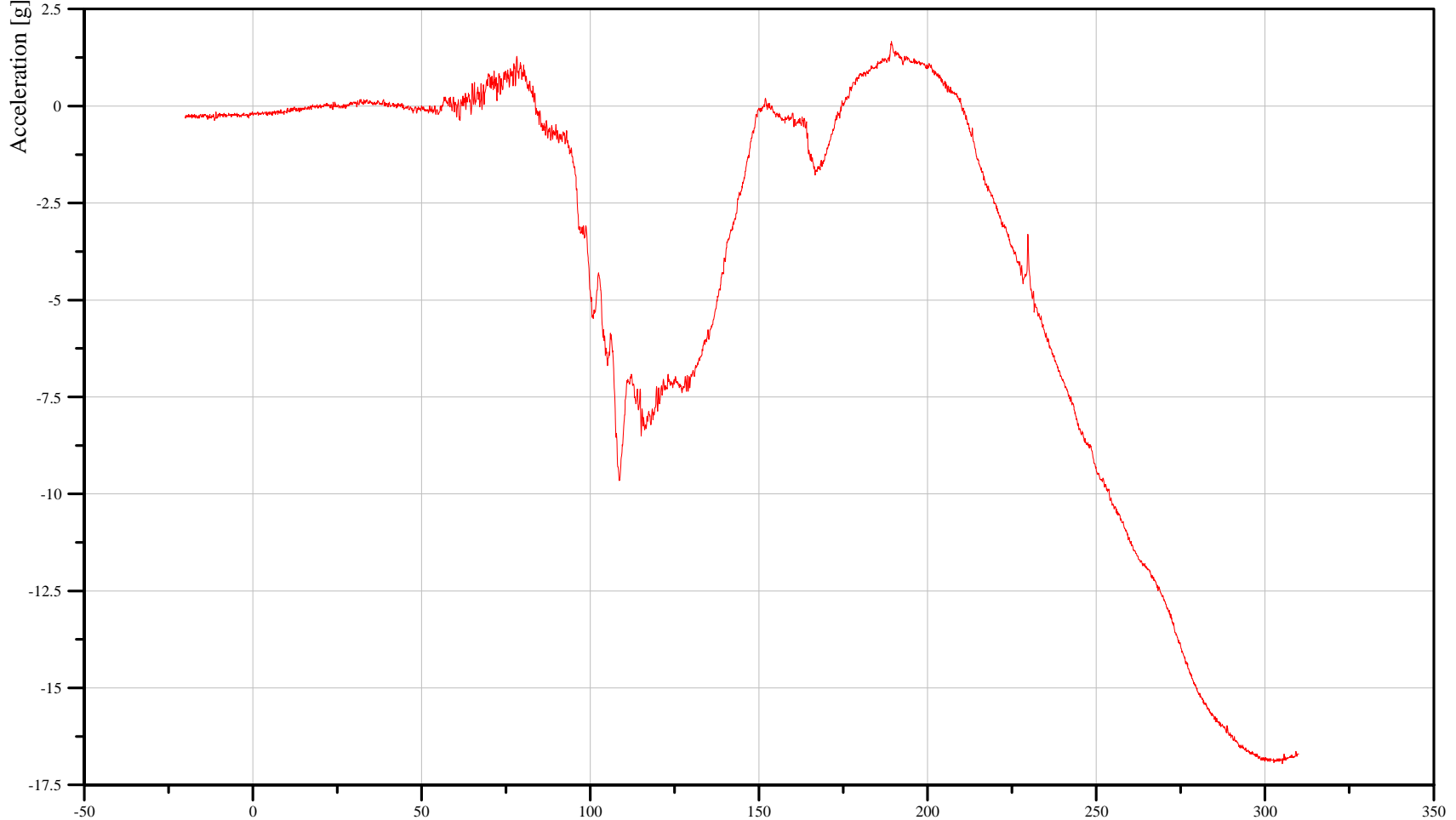

Filter: CFC_1000

Min. Value
-16.95 g at 305.12 ms

Max. Value
1.66 g at 189.28 ms

Time [ms]

B-16

070913



2007 Ford F-250 into Left 40% Offset Deformable LCB at 56 kph

Date: 09/13/2007
Time: 15:46

Driver Head Z-Axis Redundant Acceleration

Customer: Volpe
Test Number: R70203

11HEADCGRDH3ACZA

TRC Inc. Test Lab: CTF
Test Number: 070913

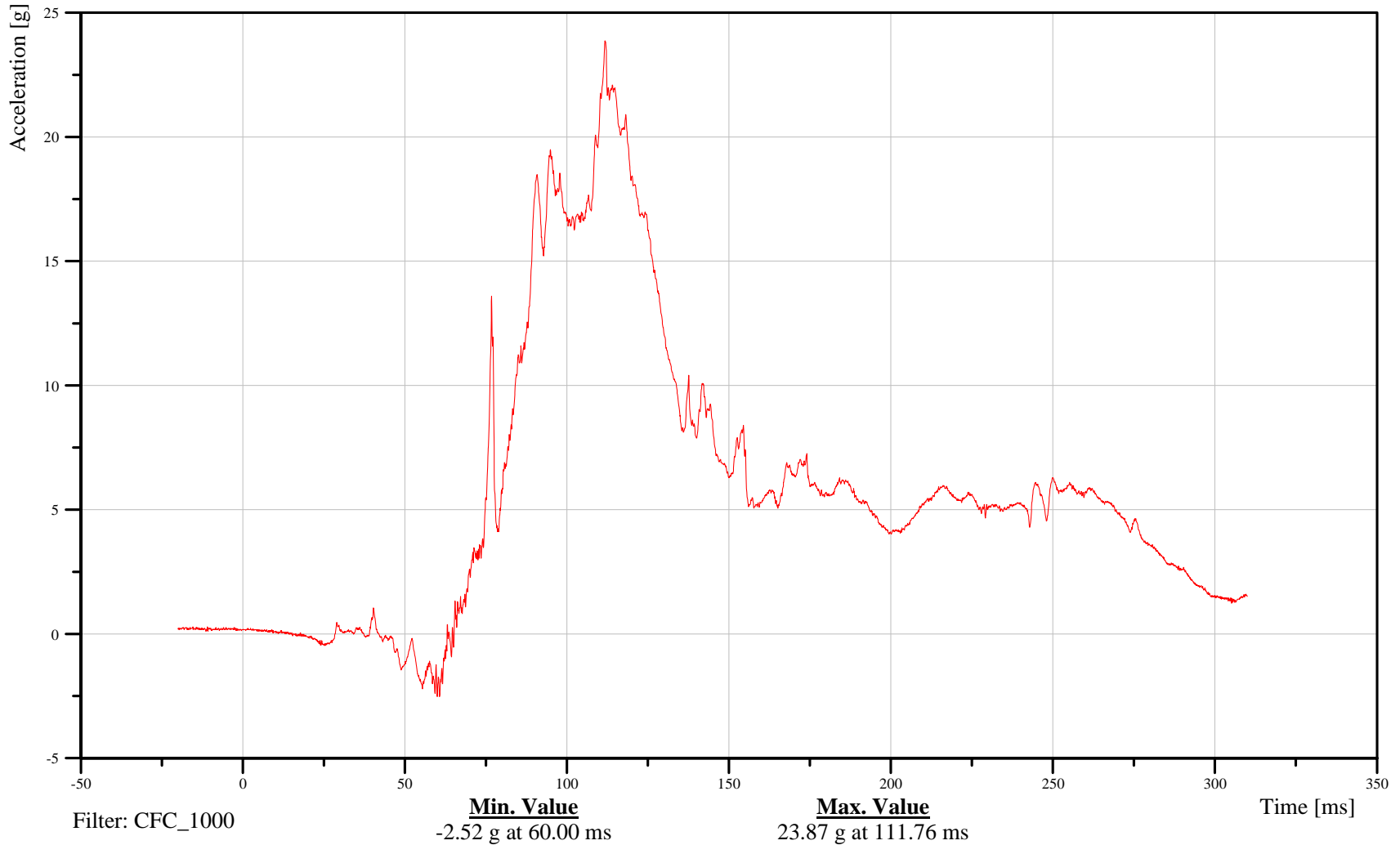

B-17

070913



2007 Ford F-250 into Left 40% Offset Deformable LCB at 56 kph

Date: 09/13/2007
Time: 15:46

Driver Head Redundant Resultant Acceleration

Customer: Volpe
Test Number: R70203

11HEADCGRDH3ACRA

TRC Inc. Test Lab: CTF
Test Number: 070913

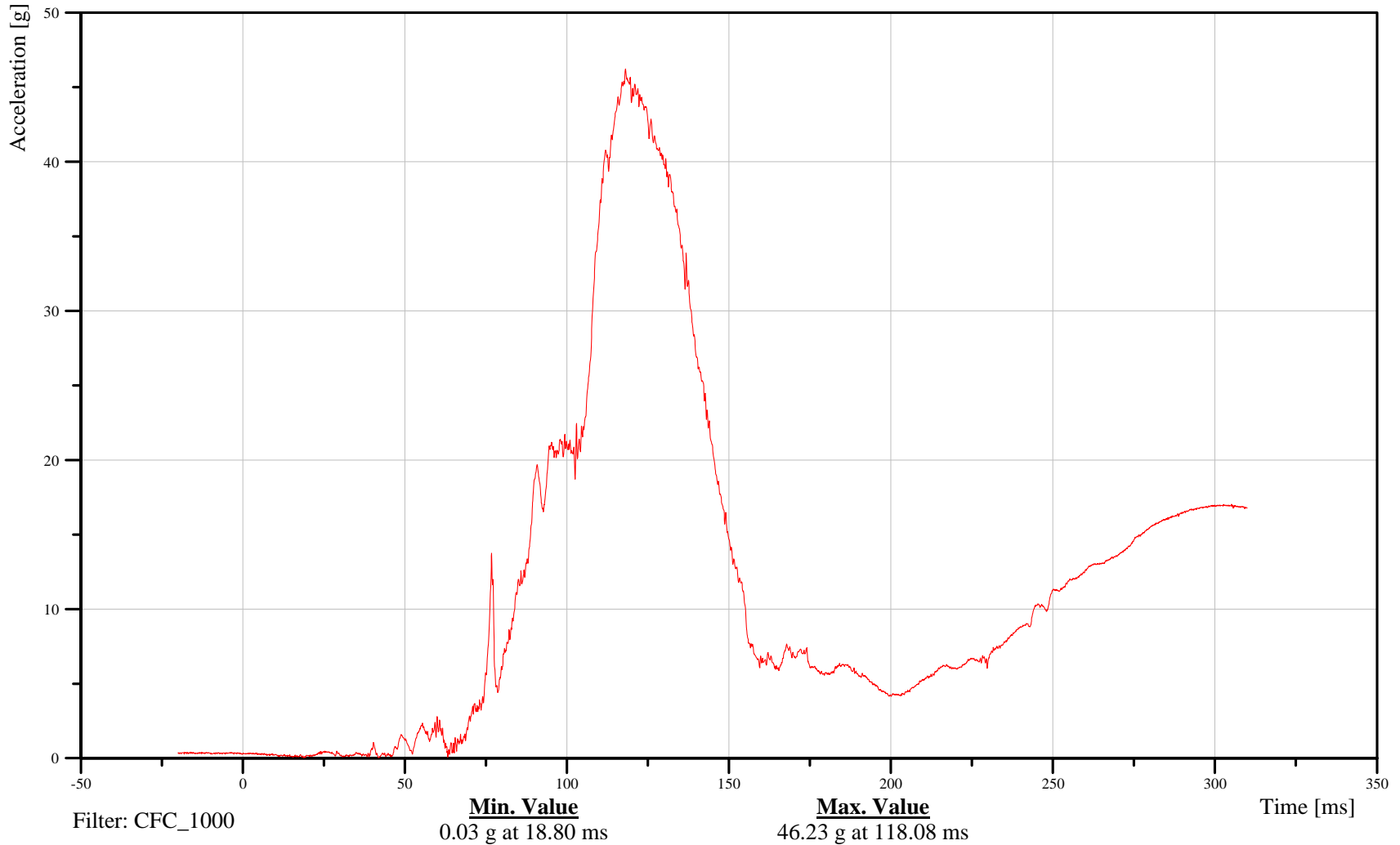

B-18

070913



2007 Ford F-250 into Left 40% Offset Deformable LCB at 56 kph

Date: 09/13/2007
Time: 15:46

Driver Upper Neck X-Axis Force

Customer: Volpe
Test Number: R70203

11NECKUP00H3FOXA

TRC Inc. Test Lab: CTF
Test Number: 070913

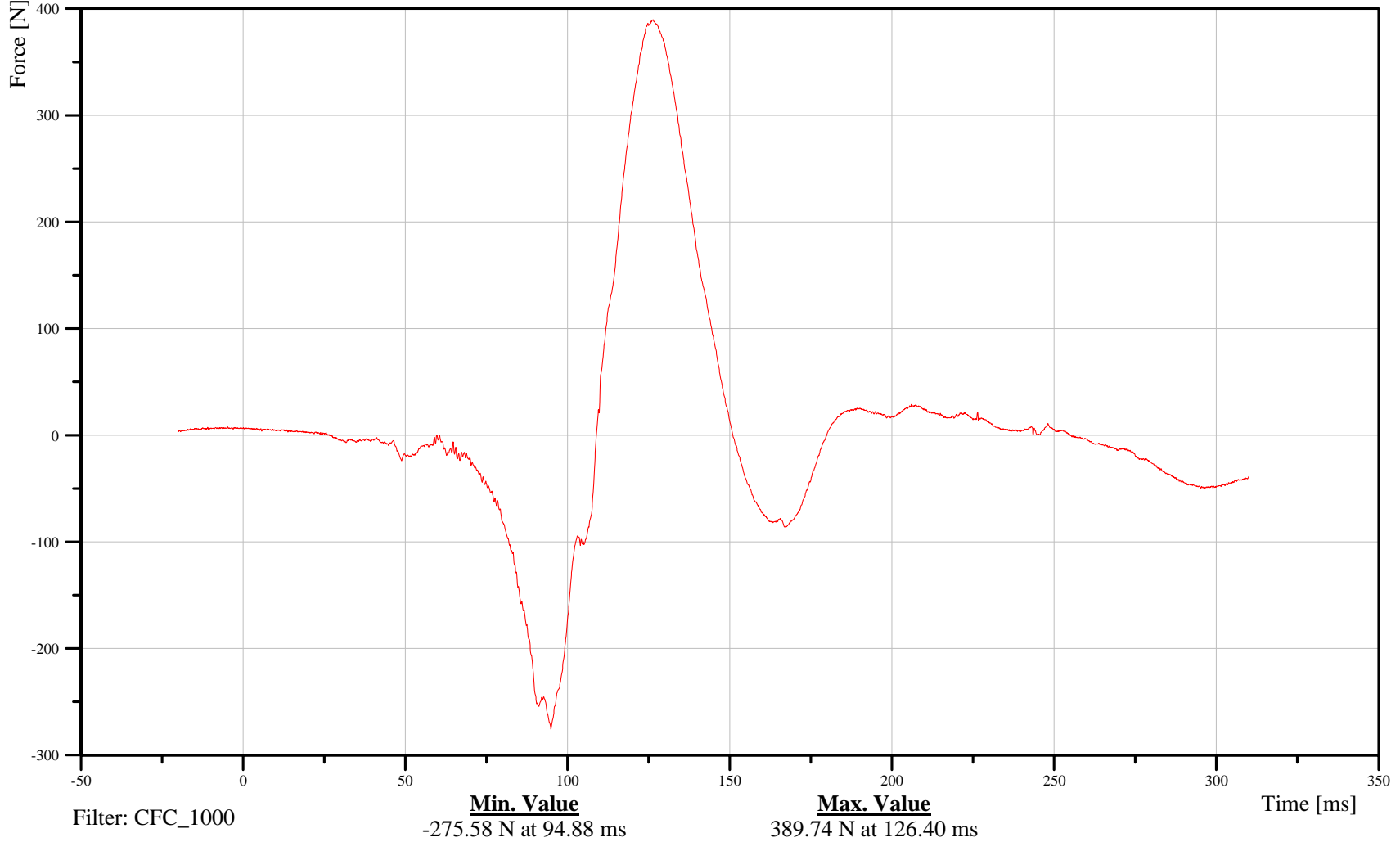

B-19

070913



2007 Ford F-250 into Left 40% Offset Deformable LCB at 56 kph

Date: 09/13/2007
Time: 15:46

Driver Upper Neck Y-Axis Force

Customer: Volpe
Test Number: R70203

11NECKUP00H3FOYA

TRC Inc. Test Lab: CTF
Test Number: 070913

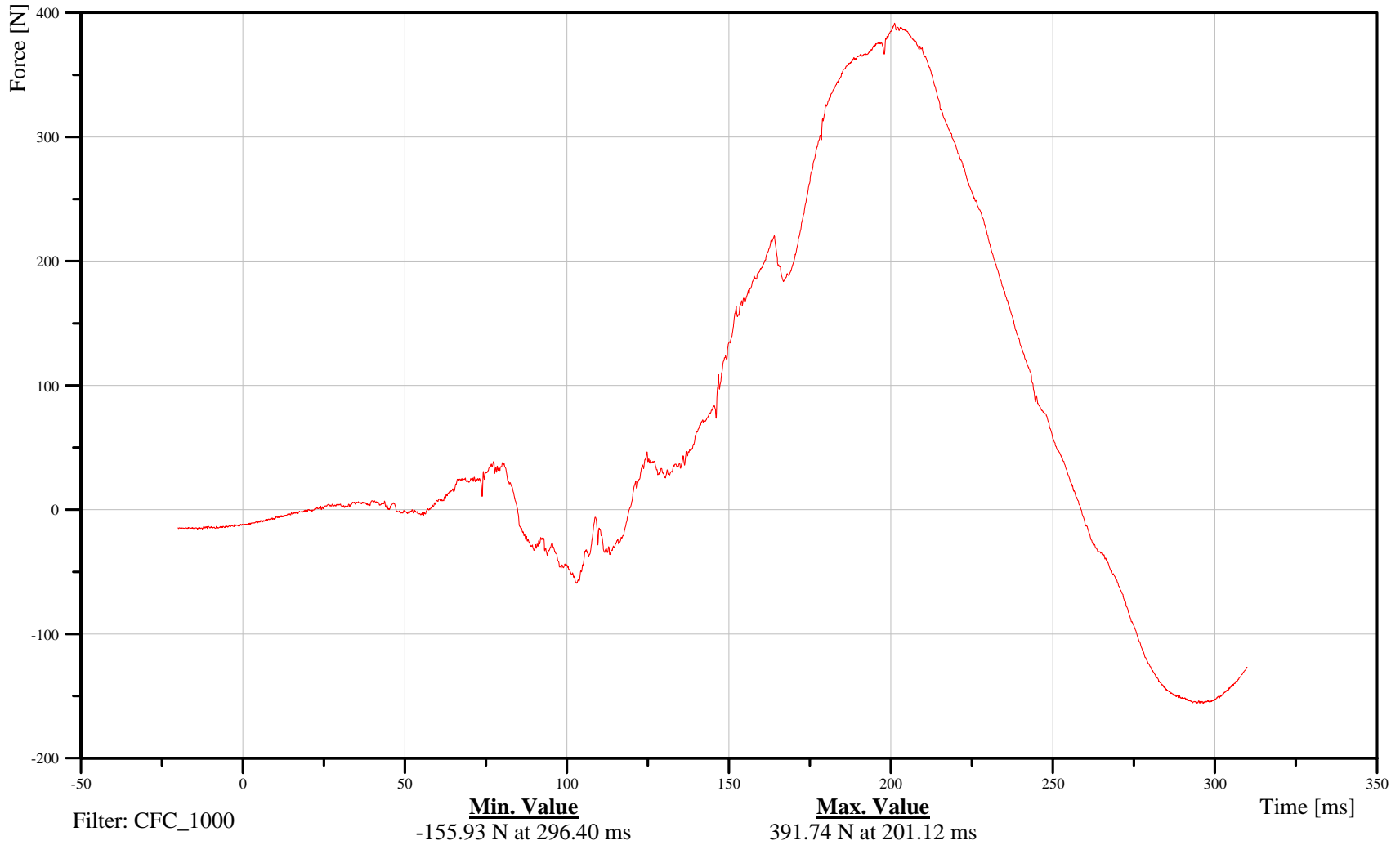

B-20

070913



2007 Ford F-250 into Left 40% Offset Deformable LCB at 56 kph

Date: 09/13/2007
Time: 15:46

Driver Upper Neck Z-Axis Force

Customer: Volpe
Test Number: R70203

11NECKUP00H3FOZA

TRC Inc. Test Lab: CTF
Test Number: 070913

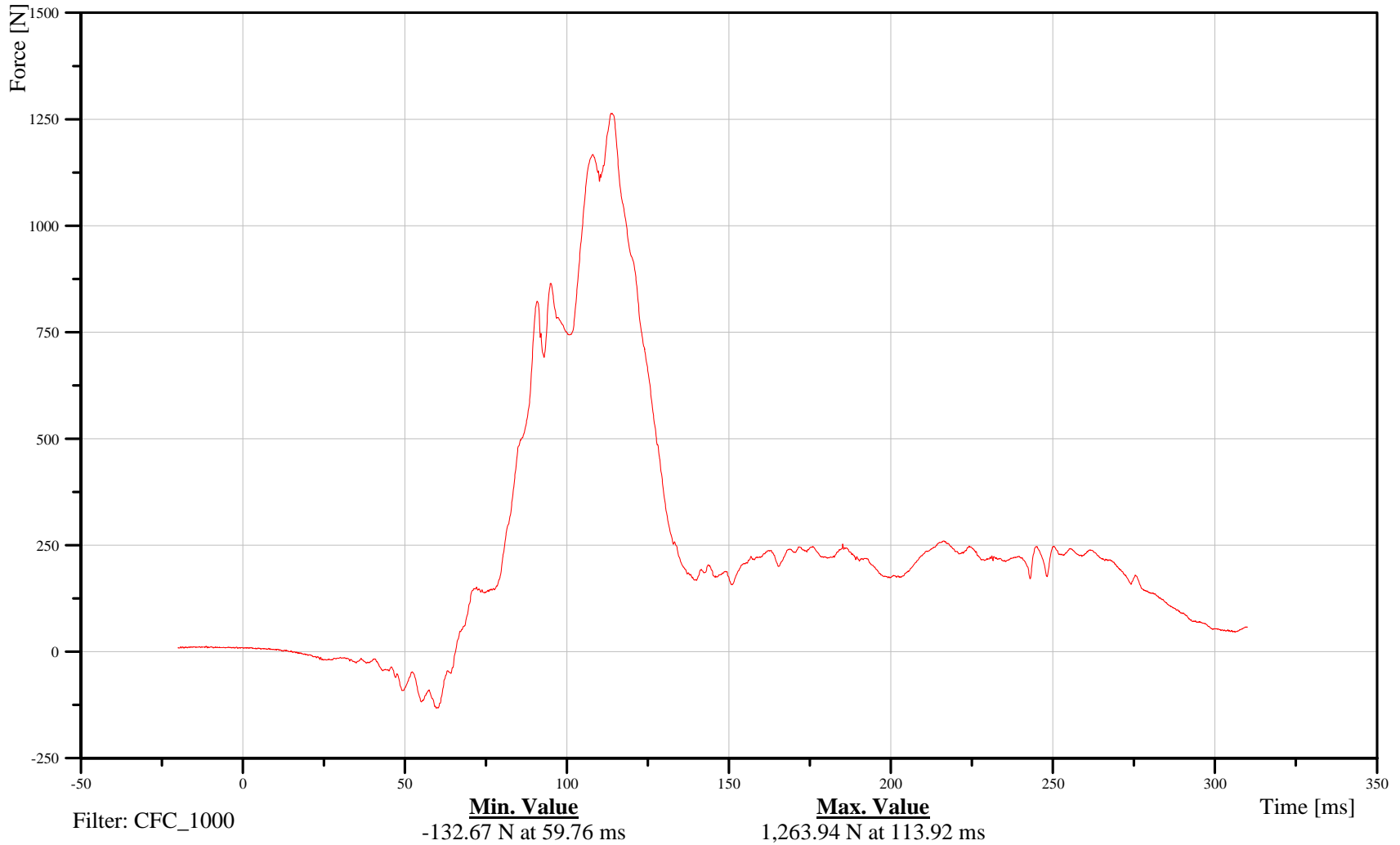

B-21

070913



2007 Ford F-250 into Left 40% Offset Deformable LCB at 56 kph

Date: 09/13/2007
Time: 15:46

Driver Upper Neck Moment About X Axis

Customer: Volpe
Test Number: R70203

11NECKUP00H3MOXB

TRC Inc. Test Lab: CTF
Test Number: 070913

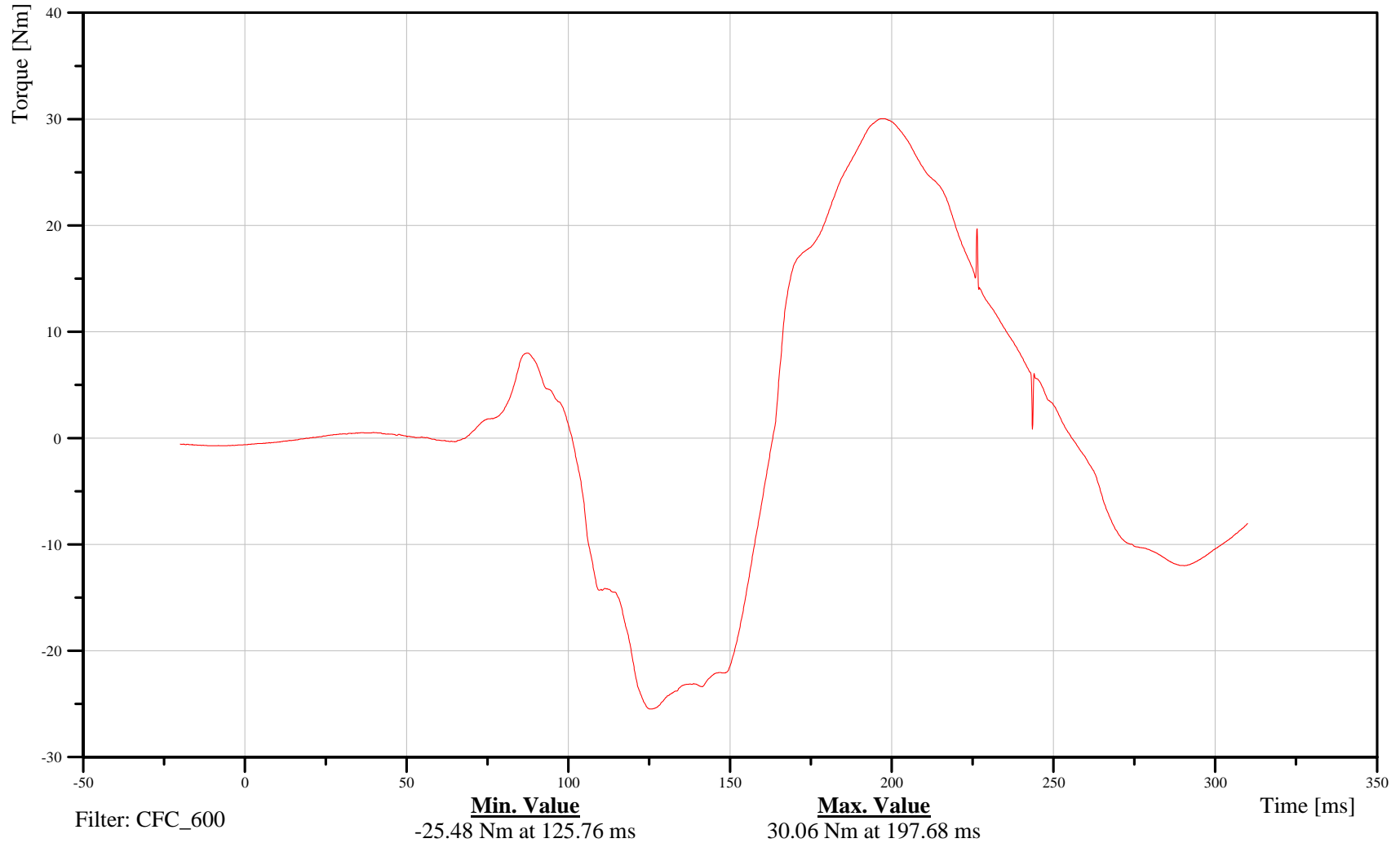

B-22

070913



2007 Ford F-250 into Left 40% Offset Deformable LCB at 56 kph

Date: 09/13/2007
Time: 15:46

Driver Upper Neck Moment About Y Axis

Customer: Volpe
Test Number: R70203

11NECKUP00H3MOYB

TRC Inc. Test Lab: CTF
Test Number: 070913

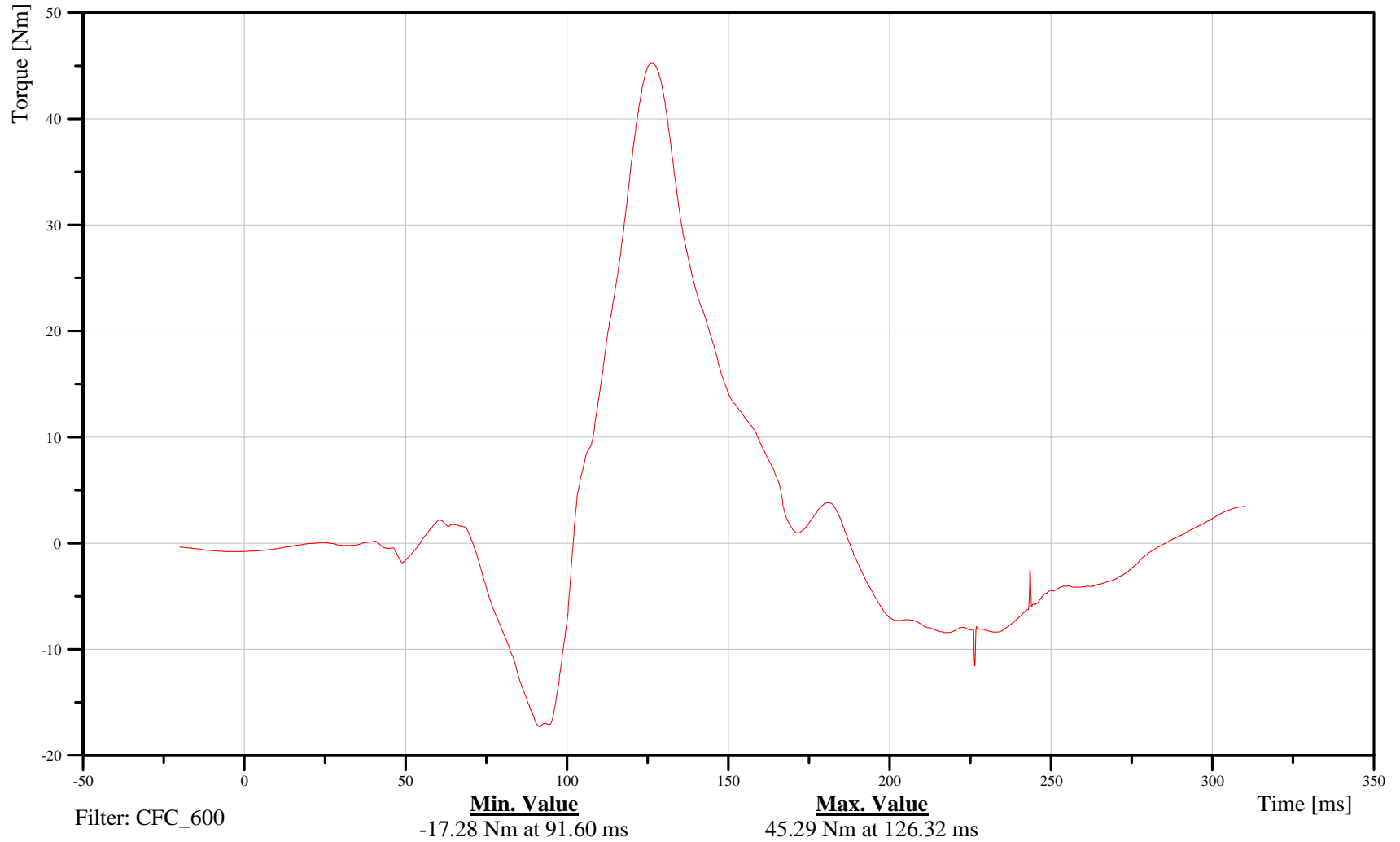

B-23

070913



2007 Ford F-250 into Left 40% Offset Deformable LCB at 56 kph

Date: 09/13/2007
Time: 15:46

Driver Upper Neck Moment About Z Axis

Customer: Volpe
Test Number: R70203

11NECKUP00H3MOZB

TRC Inc. Test Lab: CTF
Test Number: 070913

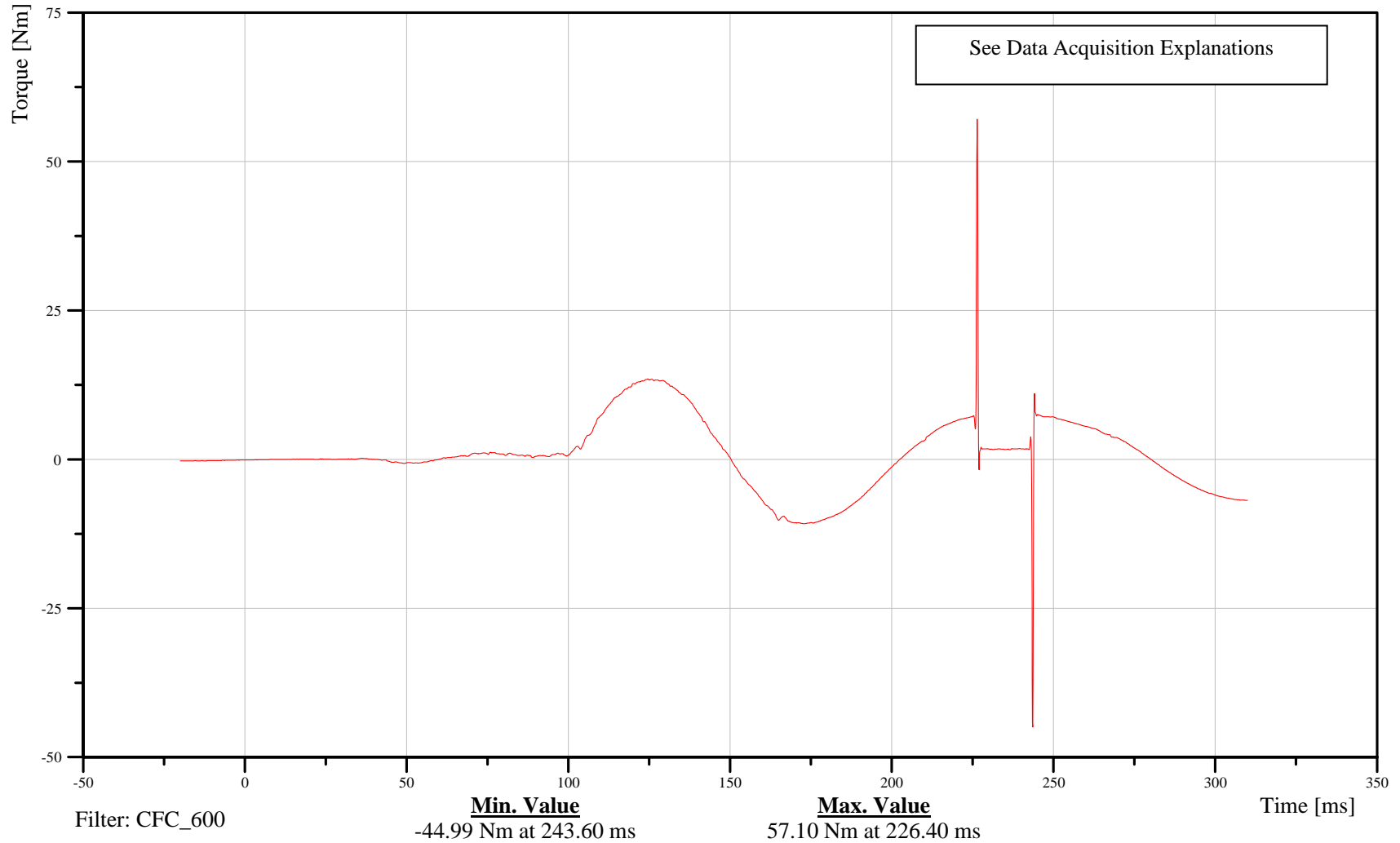

B-24

070913



2007 Ford F-250 into Left 40% Offset Deformable LCB at 56 kph

Date: 09/13/2007
Time: 15:46

Driver Chest X-Axis Acceleration

Customer: Volpe
Test Number: R70203

11CHSTCG00H3ACXC

TRC Inc. Test Lab: CTF
Test Number: 070913

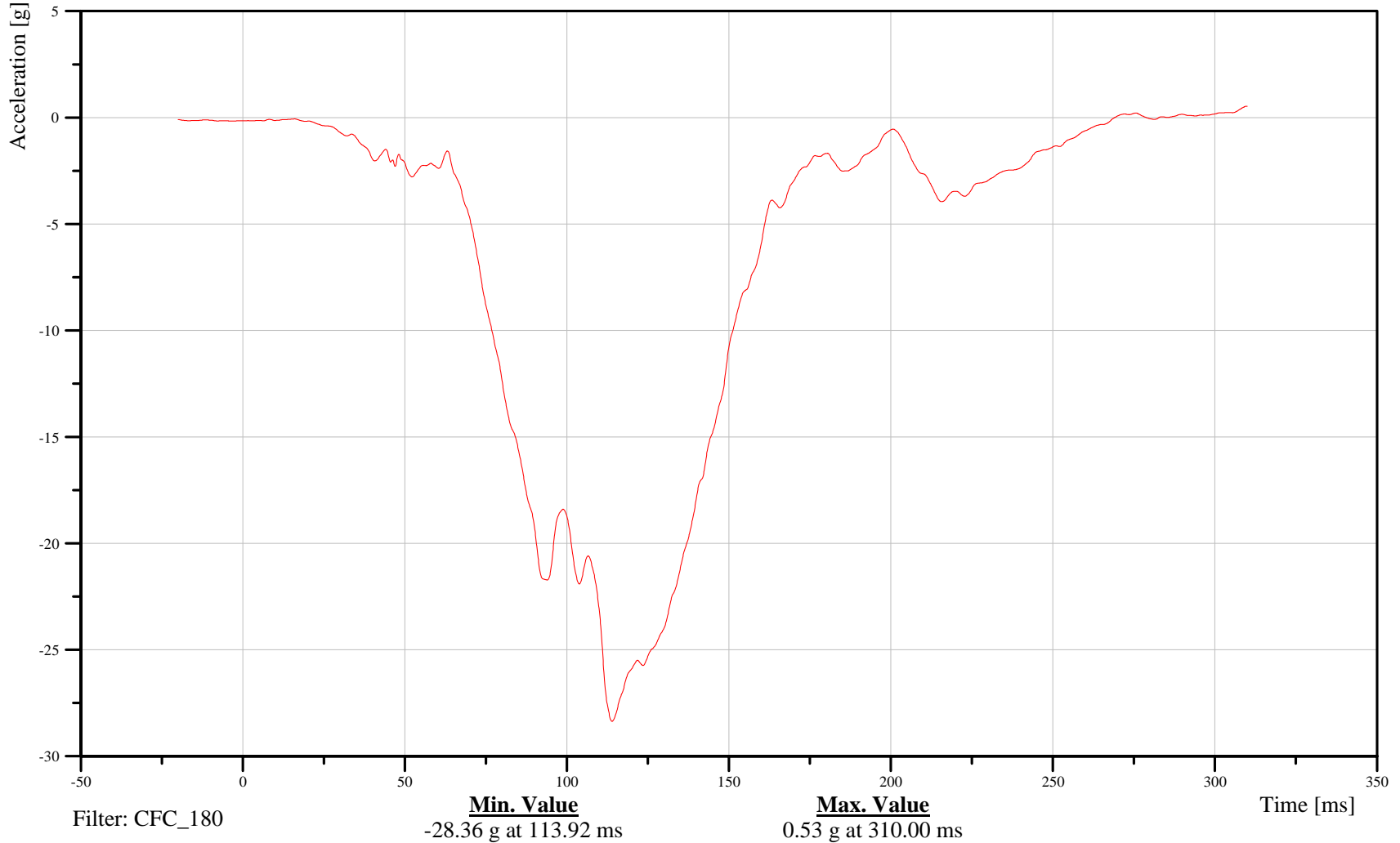

B-25

070913



2007 Ford F-250 into Left 40% Offset Deformable LCB at 56 kph

Date: 09/13/2007
Time: 15:46

Driver Chest Y-Axis Acceleration

Customer: Volpe
Test Number: R70203

11CHSTCG00H3ACYC

TRC Inc. Test Lab: CTF
Test Number: 070913

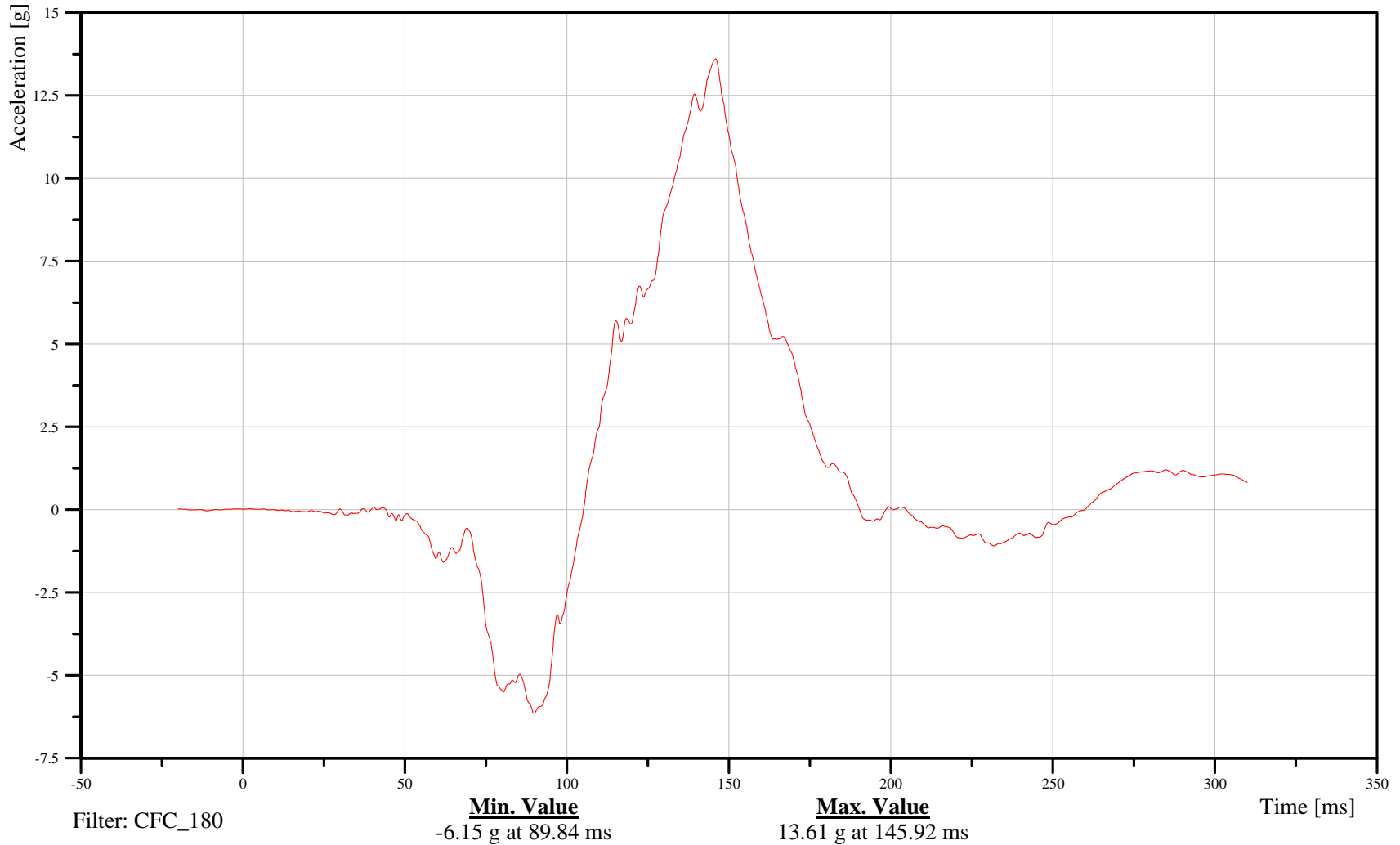

B-26

070913



2007 Ford F-250 into Left 40% Offset Deformable LCB at 56 kph

Date: 09/13/2007
Time: 15:46

Driver Chest Z-Axis Acceleration

Customer: Volpe
Test Number: R70203

11CHSTCG00H3ACZC

TRC Inc. Test Lab: CTF
Test Number: 070913

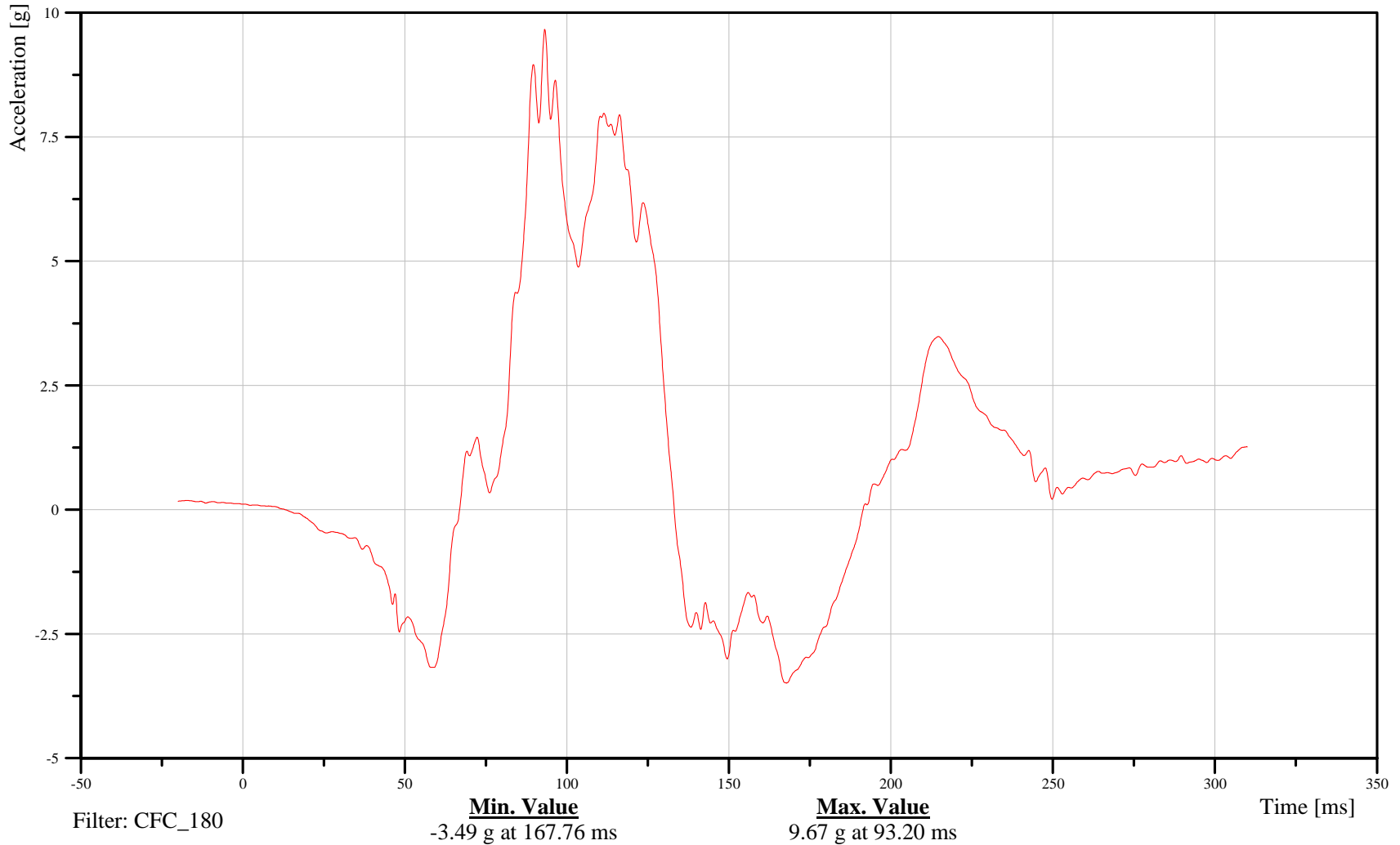

B-27

070913



2007 Ford F-250 into Left 40% Offset Deformable LCB at 56 kph

Date: 09/13/2007
Time: 15:46

Driver Chest Resultant Acceleration

Customer: Volpe
Test Number: R70203

11CHSTCG00H3ACRC

TRC Inc. Test Lab: CTF
Test Number: 070913

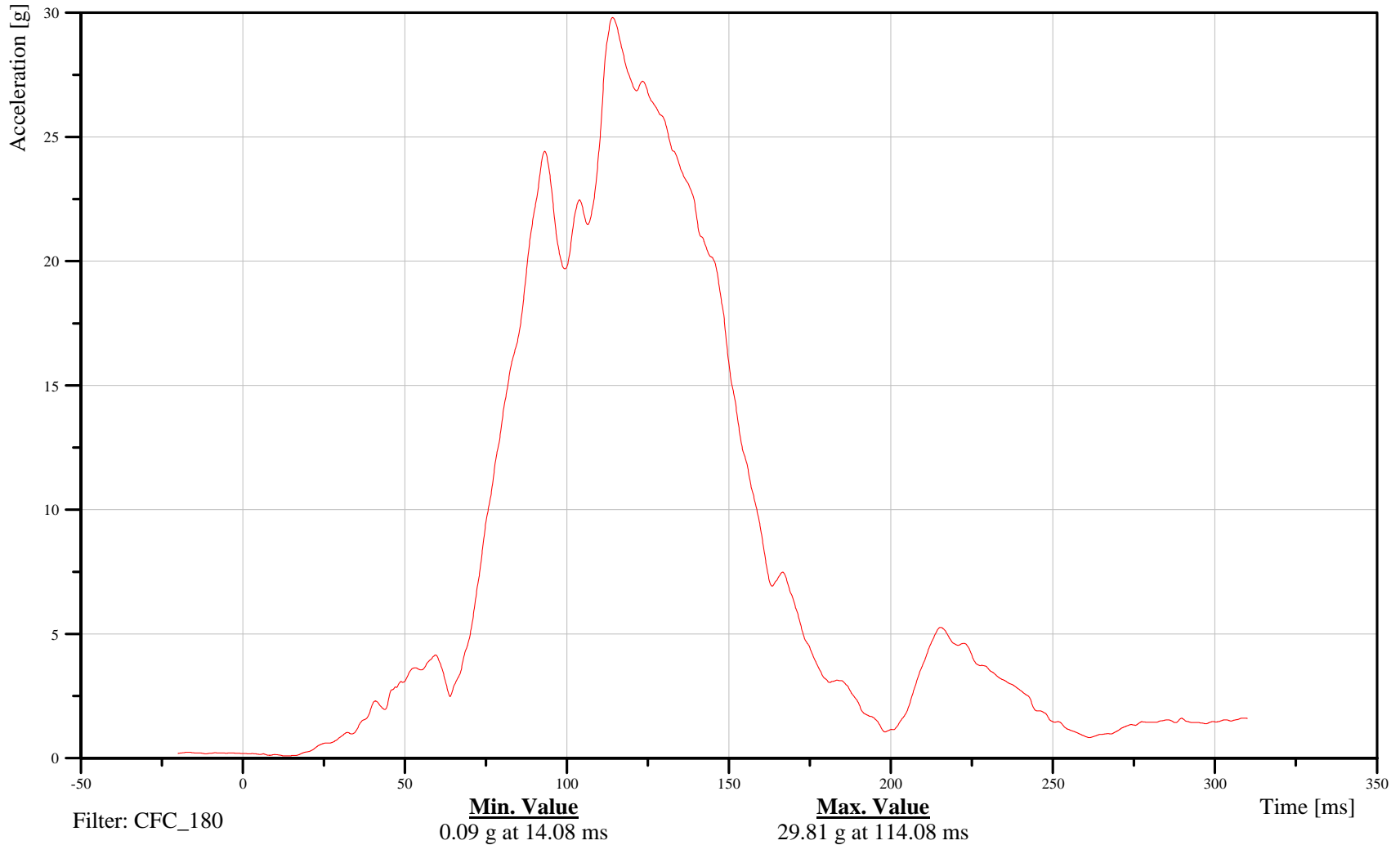

B-28

070913



2007 Ford F-250 into Left 40% Offset Deformable LCB at 56 kph

Date: 09/13/2007
Time: 15:46

Driver Chest X-Axis Redundant Acceleration

Customer: Volpe
Test Number: R70203

11CHSTCGRDH3ACXC

TRC Inc. Test Lab: CTF
Test Number: 070913

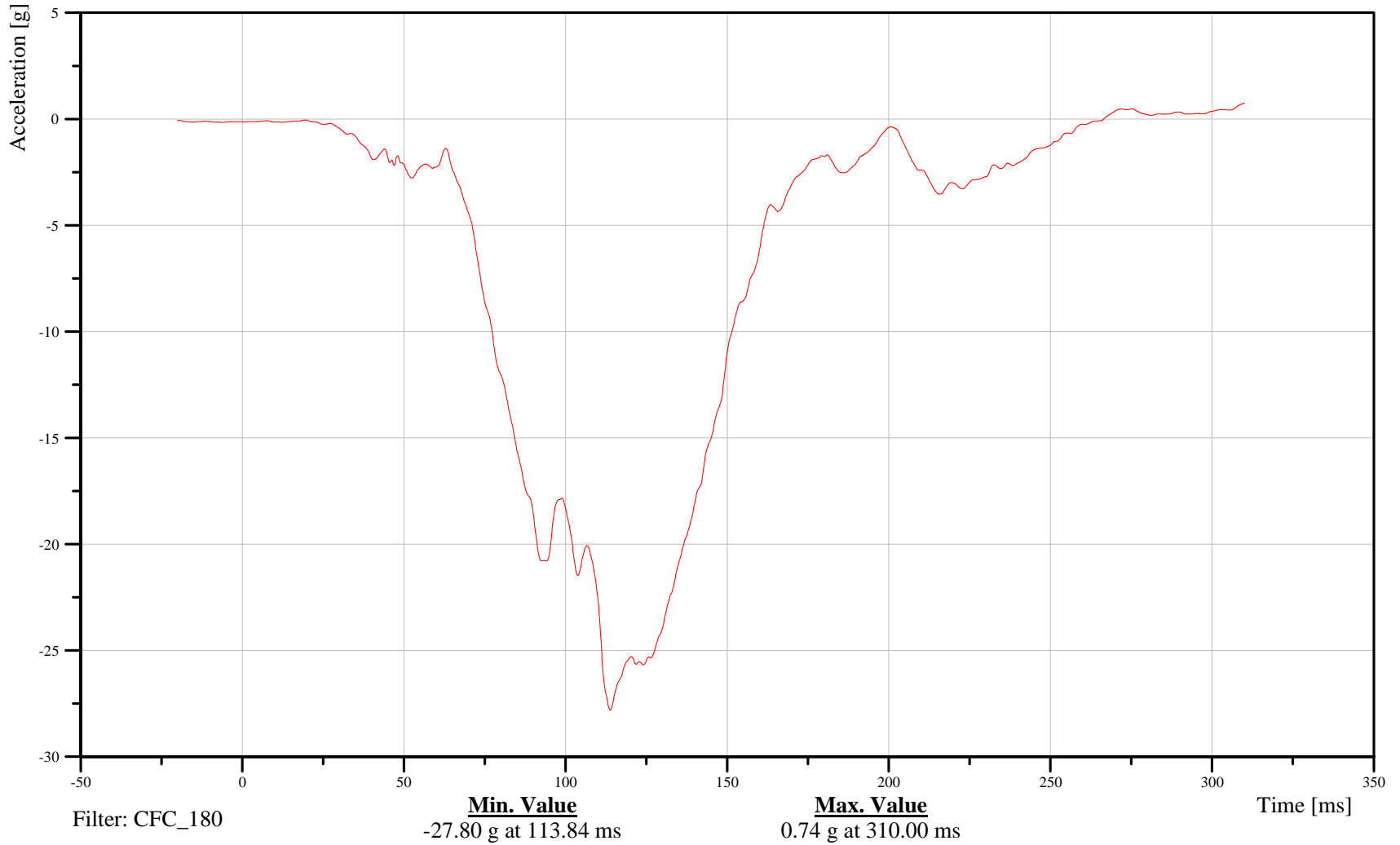

B-29

070913



2007 Ford F-250 into Left 40% Offset Deformable LCB at 56 kph

Date: 09/13/2007
Time: 15:46

Driver Chest Y-Axis Redundant Acceleration

Customer: Volpe
Test Number: R70203

11CHSTCGRDH3ACYC

TRC Inc. Test Lab: CTF
Test Number: 070913

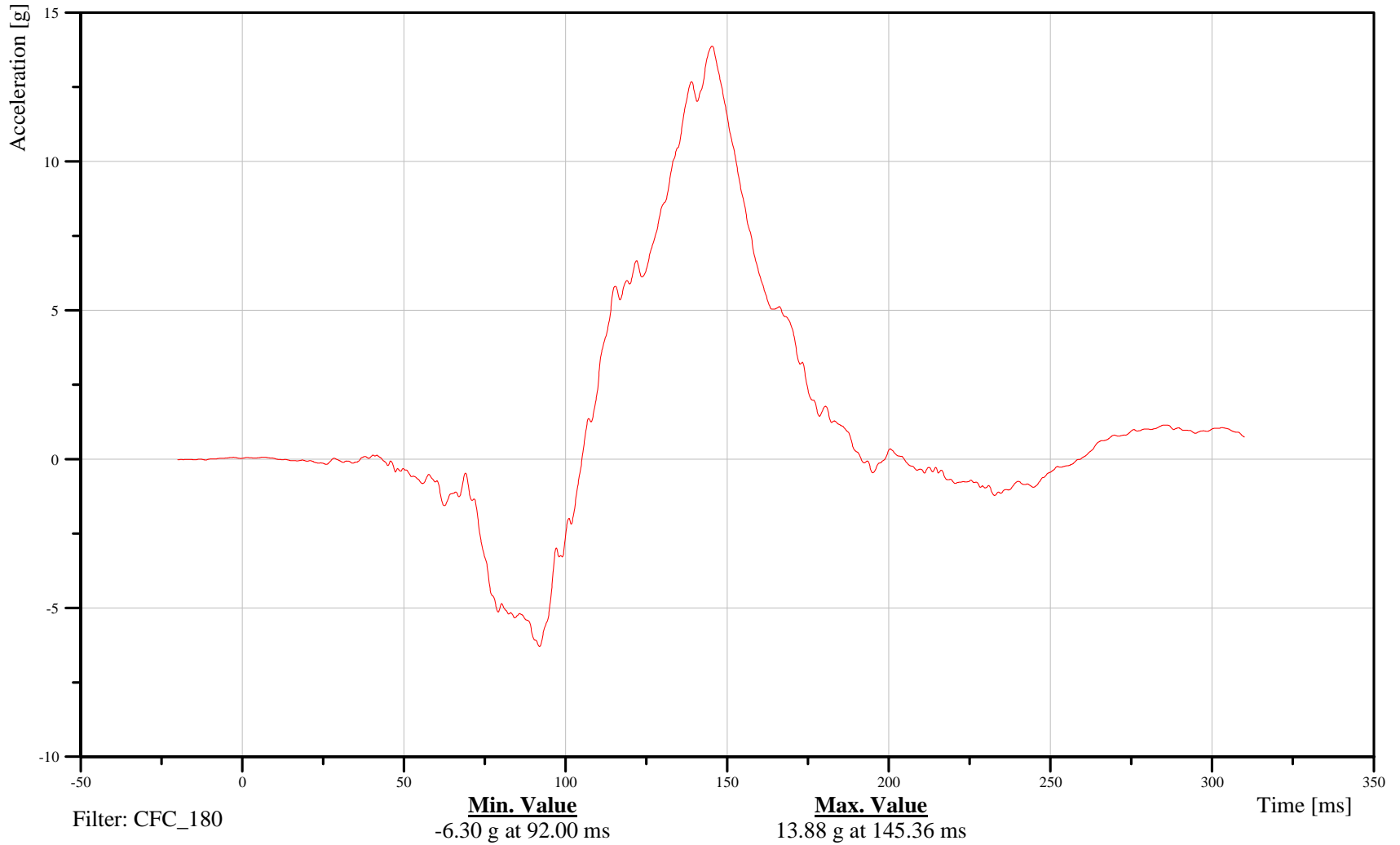

B-30

070913



2007 Ford F-250 into Left 40% Offset Deformable LCB at 56 kph

Date: 09/13/2007
Time: 15:46

Driver Chest Z-Axis Redundant Acceleration

Customer: Volpe
Test Number: R70203

11CHSTCGRDH3ACZC

TRC Inc. Test Lab: CTF
Test Number: 070913

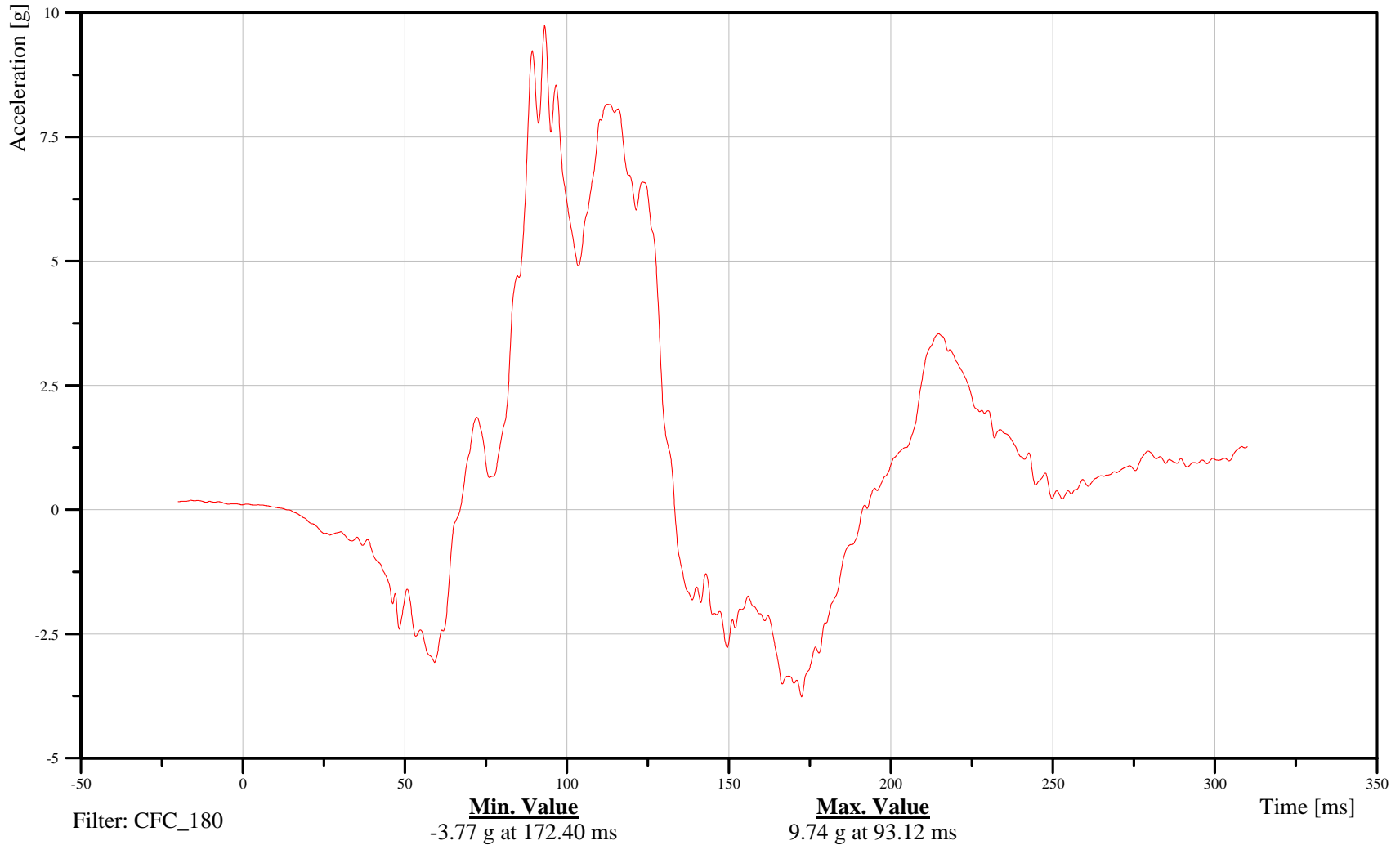

B-31

070913



2007 Ford F-250 into Left 40% Offset Deformable LCB at 56 kph

Date: 09/13/2007
Time: 15:46

Driver Chest Redundant Resultant Acceleration

Customer: Volpe
Test Number: R70203

11CHSTCGRDH3ACRC

TRC Inc. Test Lab: CTF
Test Number: 070913

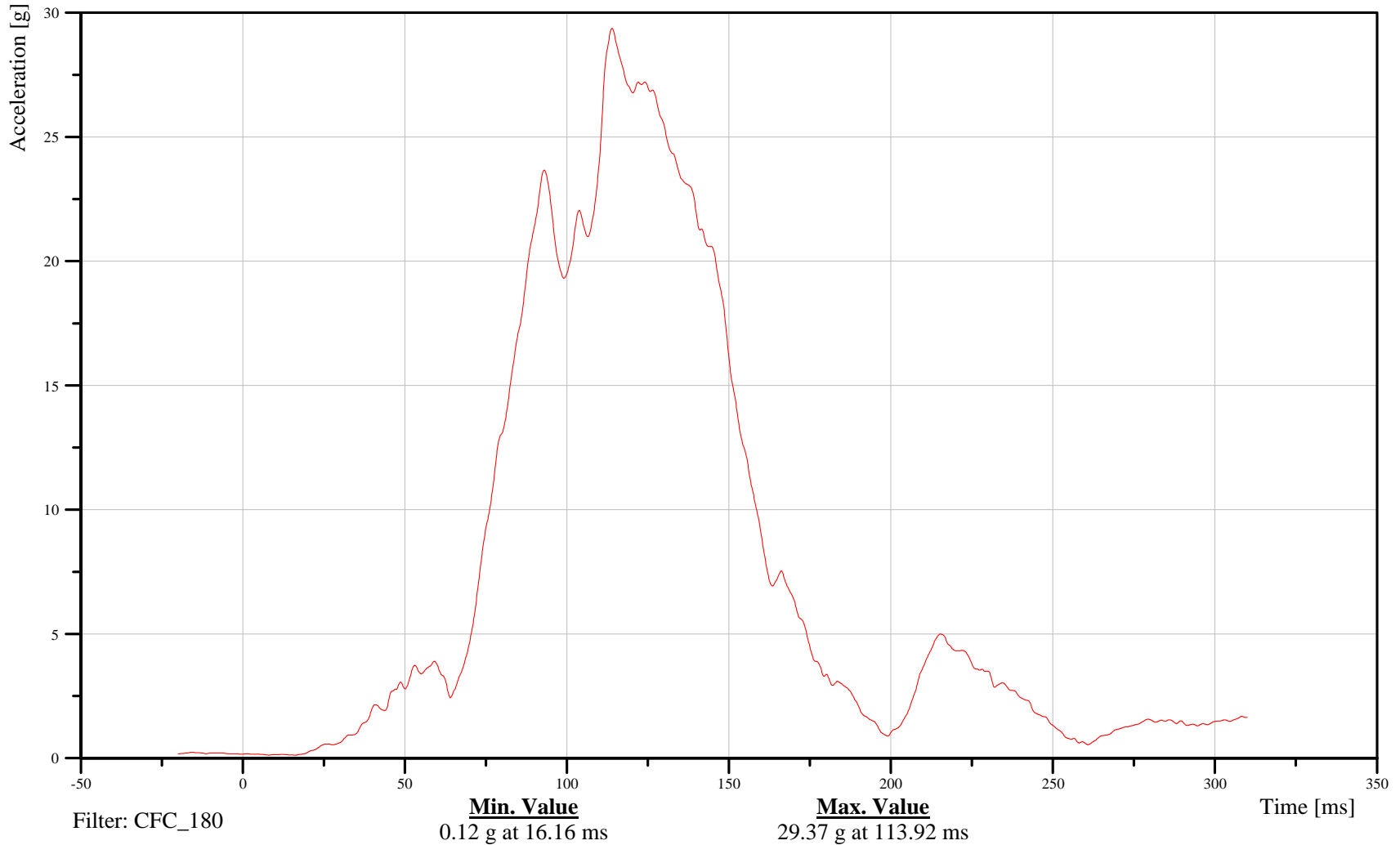

B-32

070913



2007 Ford F-250 into Left 40% Offset Deformable LCB at 56 kph

Date: 09/13/2007
Time: 15:46

Driver Chest Displacement

Customer: Volpe
Test Number: R70203

11CHST0000H3DSXB

TRC Inc. Test Lab: CTF
Test Number: 070913

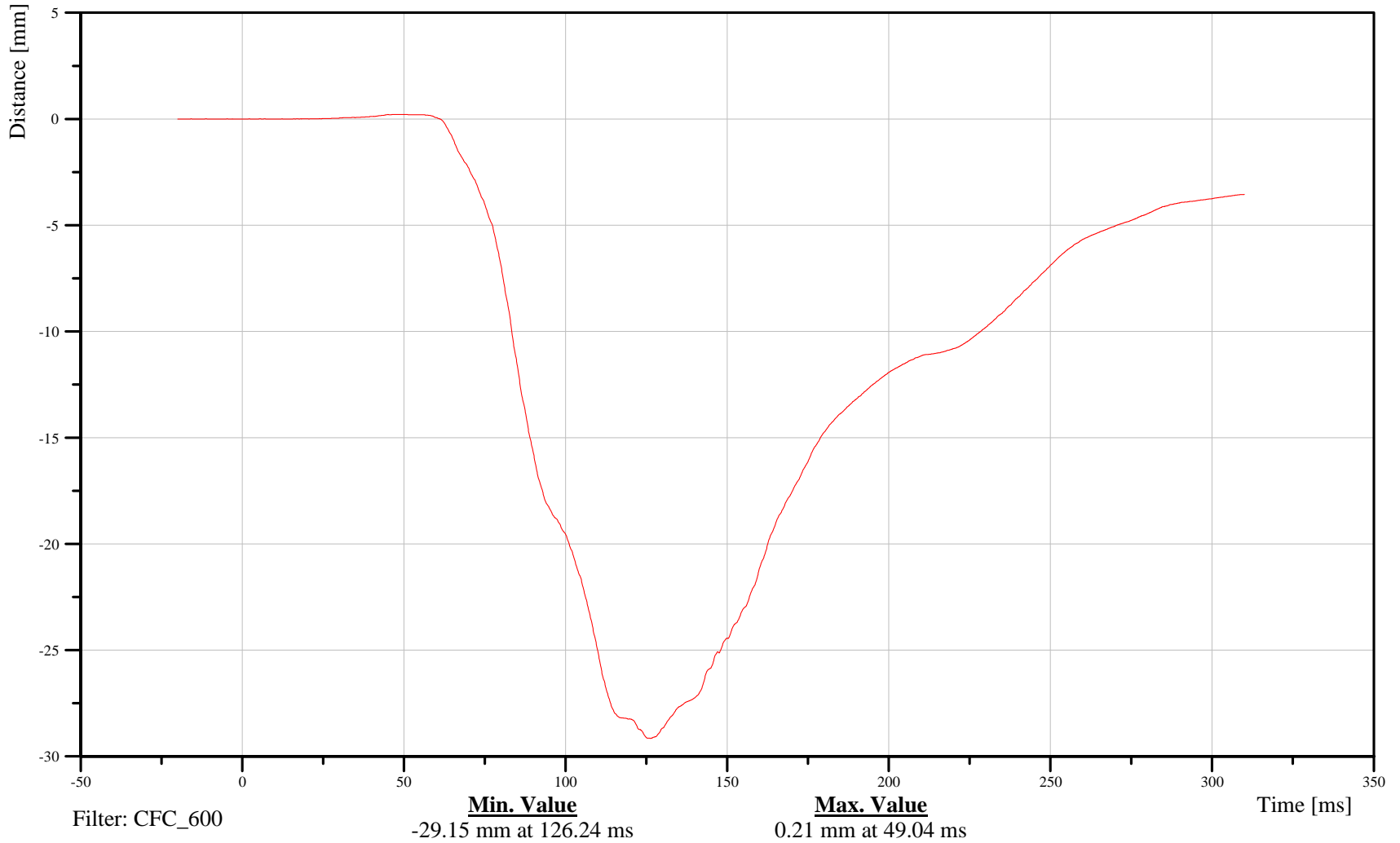

B-33

070913



2007 Ford F-250 into Left 40% Offset Deformable LCB at 56 kph

Date: 09/13/2007
Time: 15:46

Driver Pelvis X-Axis Acceleration

Customer: Volpe
Test Number: R70203

11PELVCG00H3ACXA

TRC Inc. Test Lab: CTF
Test Number: 070913

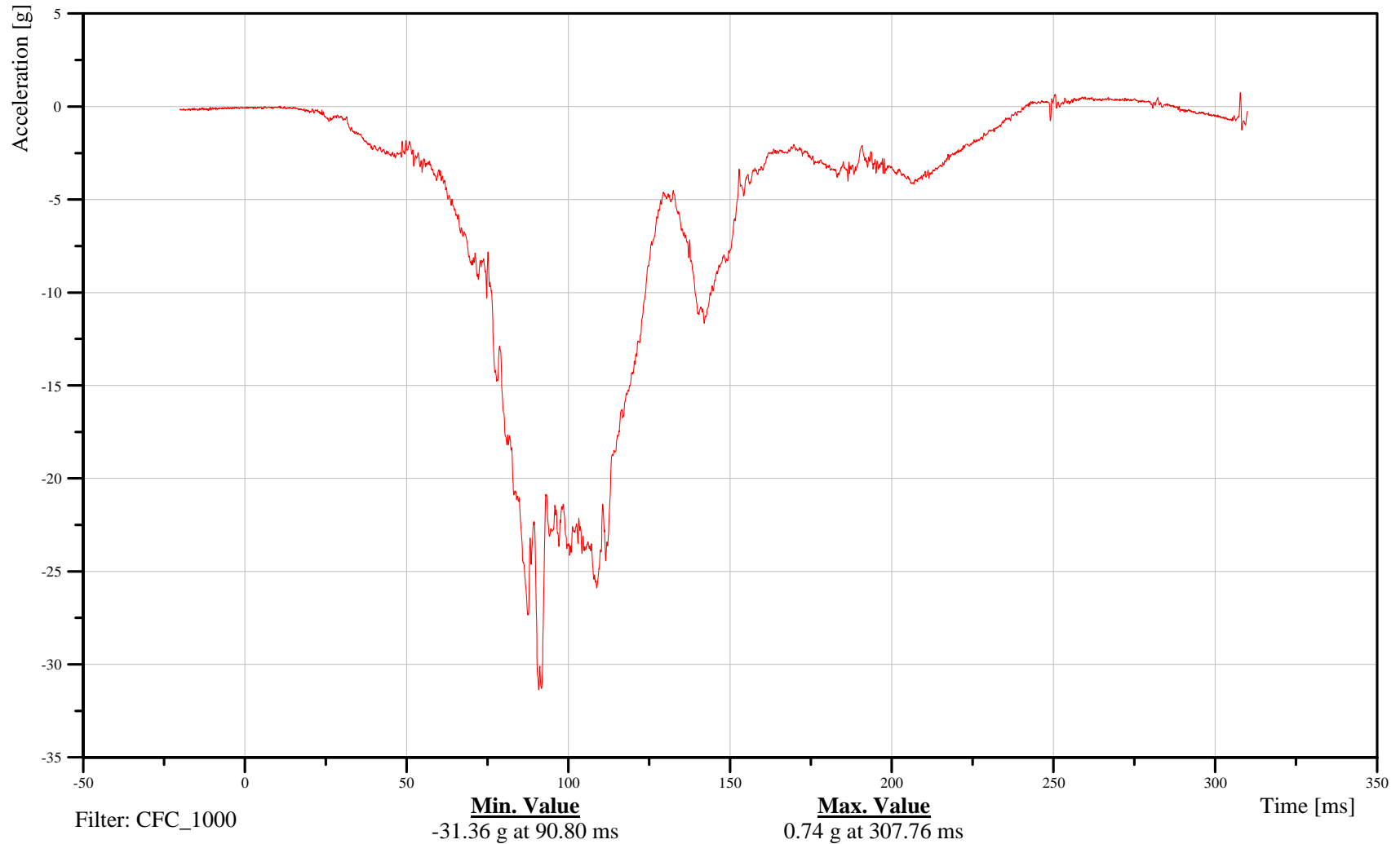

B-34

070913



2007 Ford F-250 into Left 40% Offset Deformable LCB at 56 kph

Date: 09/13/2007
Time: 15:46

Driver Pelvis Y-Axis Acceleration

Customer: Volpe
Test Number: R70203

11PELVCG00H3ACYA

TRC Inc. Test Lab: CTF
Test Number: 070913

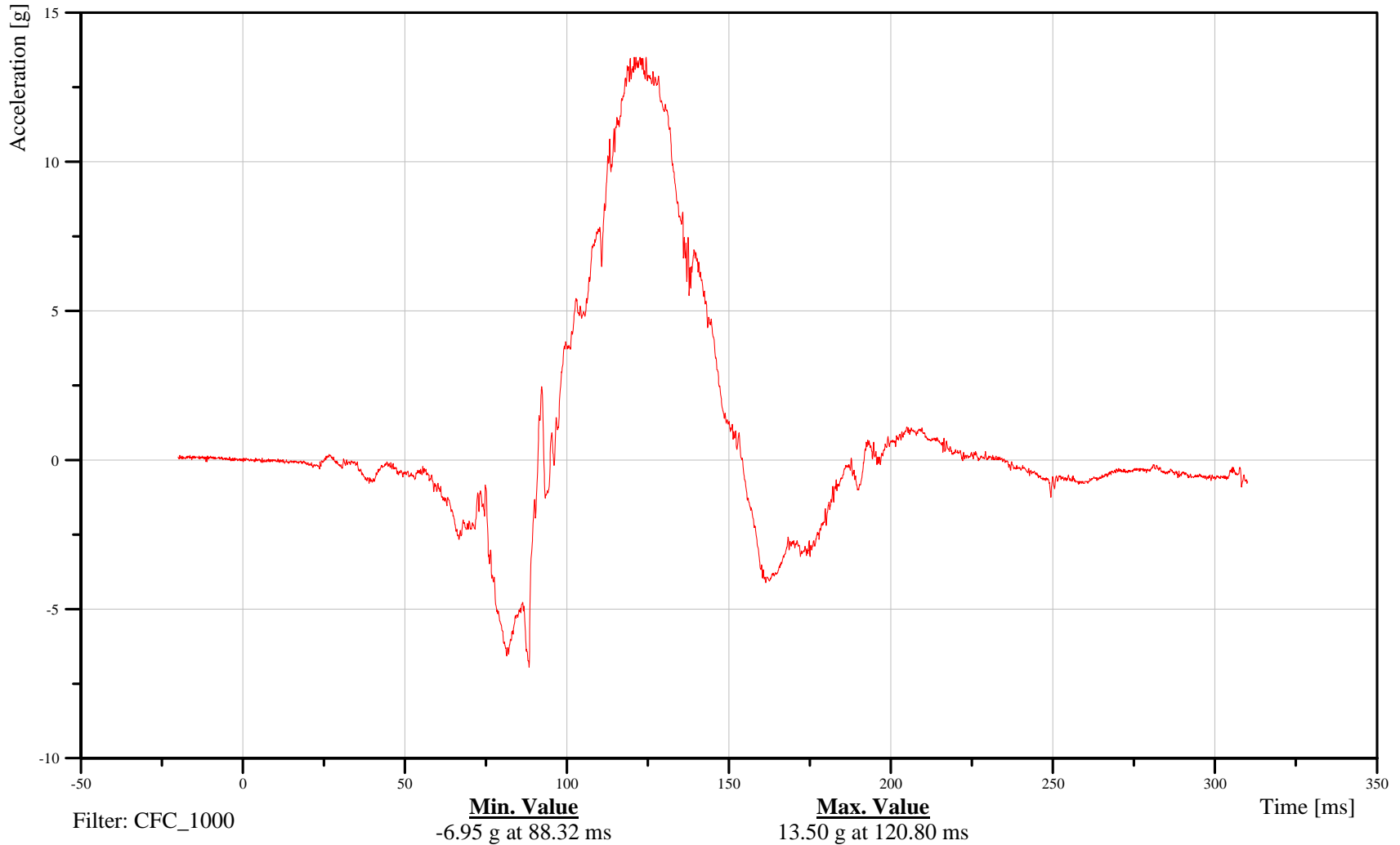

B-35

070913



2007 Ford F-250 into Left 40% Offset Deformable LCB at 56 kph

Date: 09/13/2007
Time: 15:46

Driver Pelvis Z-Axis Acceleration

Customer: Volpe
Test Number: R70203

11PELVCG00H3ACZA

TRC Inc. Test Lab: CTF
Test Number: 070913

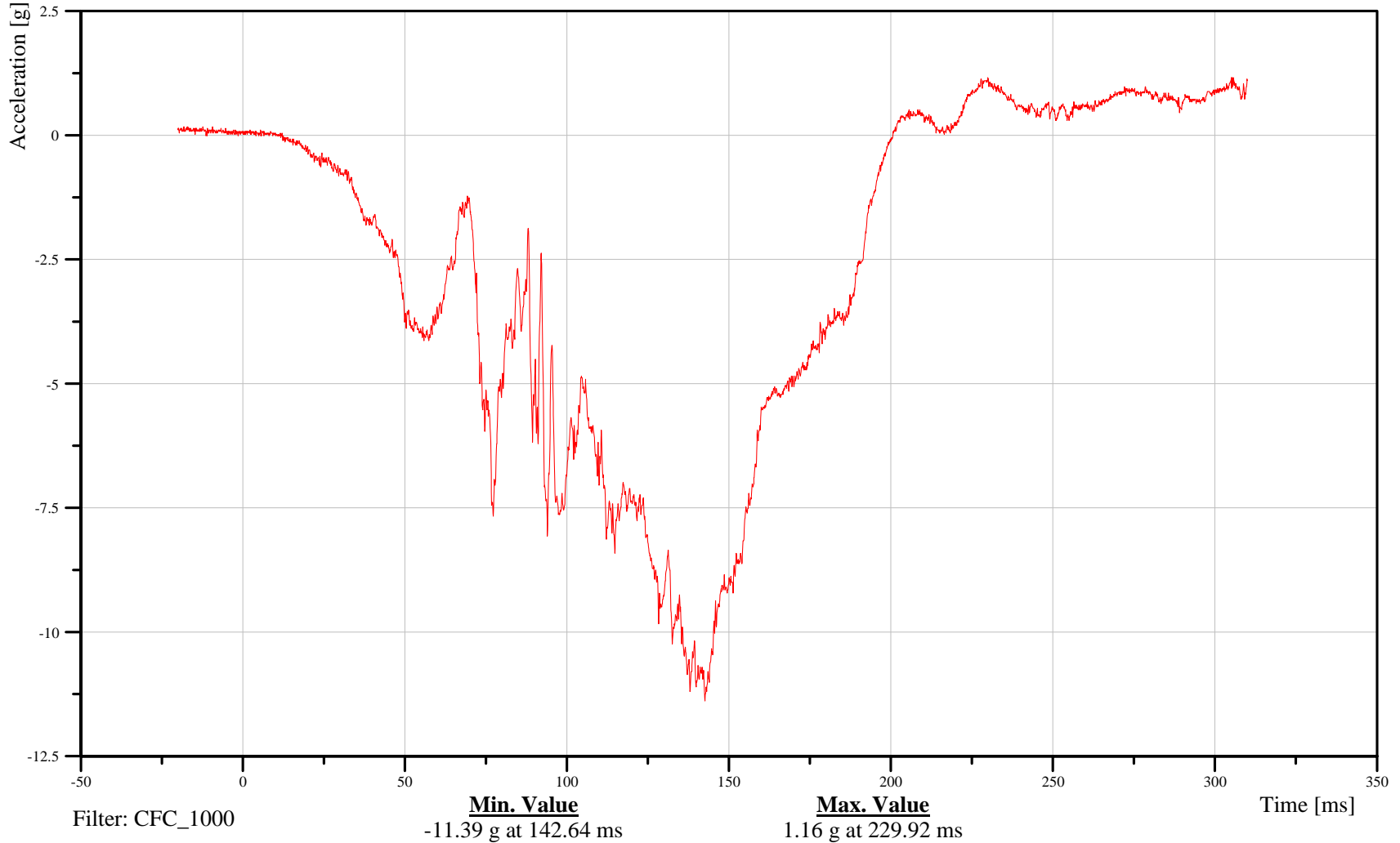

B-36

070913



2007 Ford F-250 into Left 40% Offset Deformable LCB at 56 kph

Date: 09/13/2007
Time: 15:46

Driver Pelvis Resultant Acceleration

Customer: Volpe
Test Number: R70203

11PELVCG00H3ACRA

TRC Inc. Test Lab: CTF
Test Number: 070913

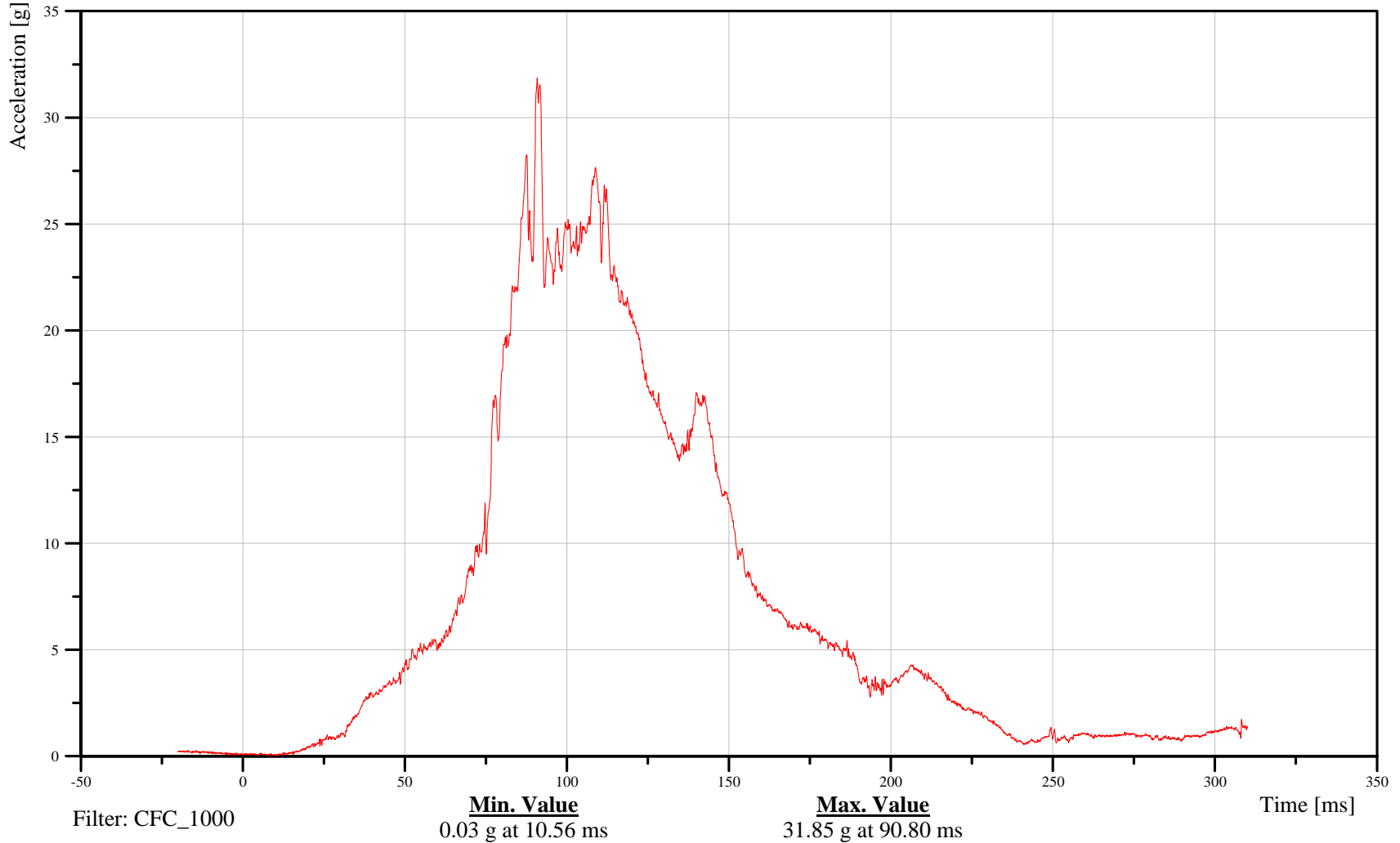

B-37

070913



2007 Ford F-250 into Left 40% Offset Deformable LCB at 56 kph

Date: 09/13/2007
Time: 15:46

Driver Left Femur Z-Axis Force

Customer: Volpe
Test Number: R70203

11FEMRLL00H3FOZB

TRC Inc. Test Lab: CTF
Test Number: 070913

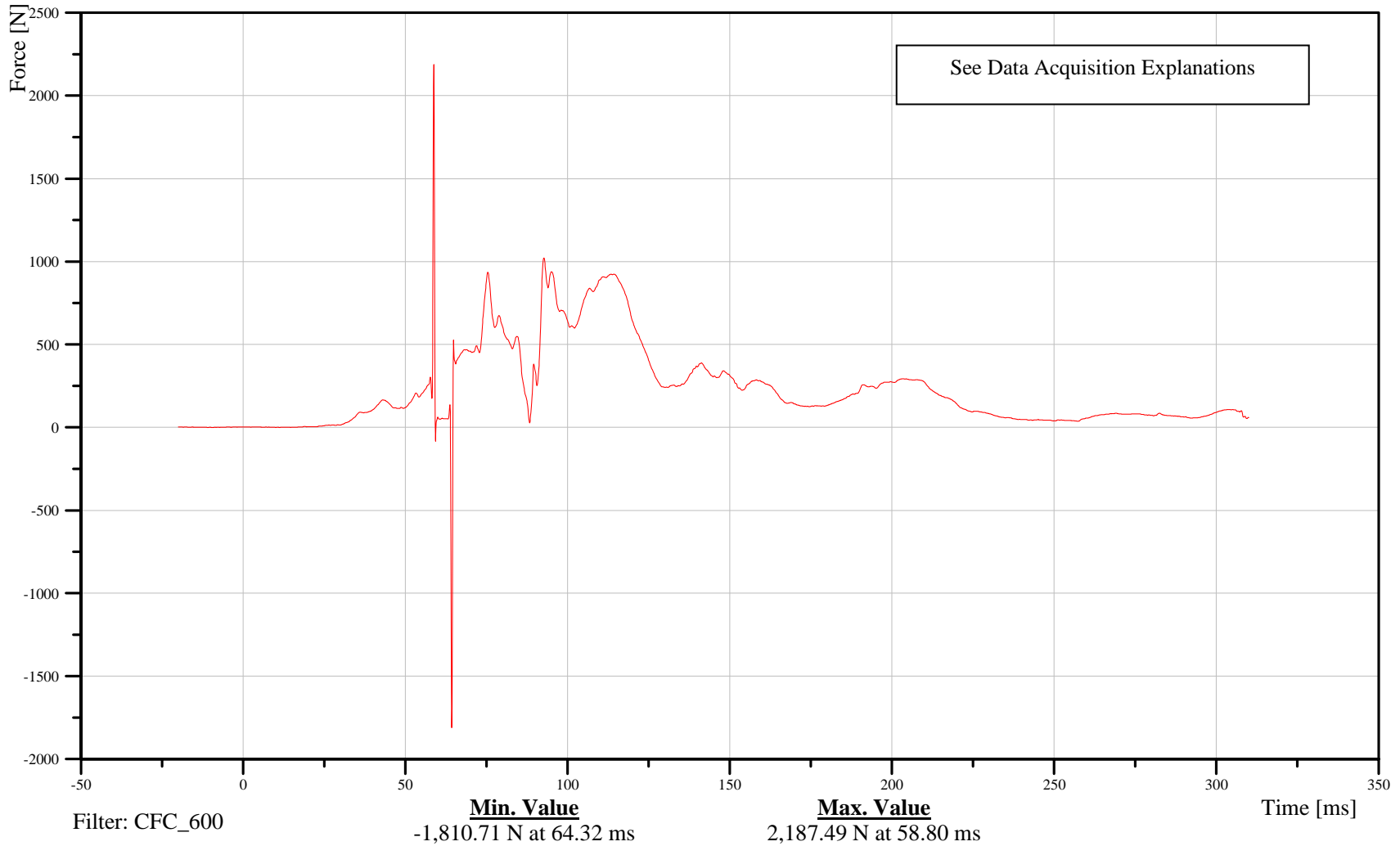

B-38

070913



2007 Ford F-250 into Left 40% Offset Deformable LCB at 56 kph

Date: 09/13/2007
Time: 15:46

Driver Right Femur Z-Axis Force

Customer: Volpe
Test Number: R70203

11FEMRRL00H3FOZB

TRC Inc. Test Lab: CTF
Test Number: 070913

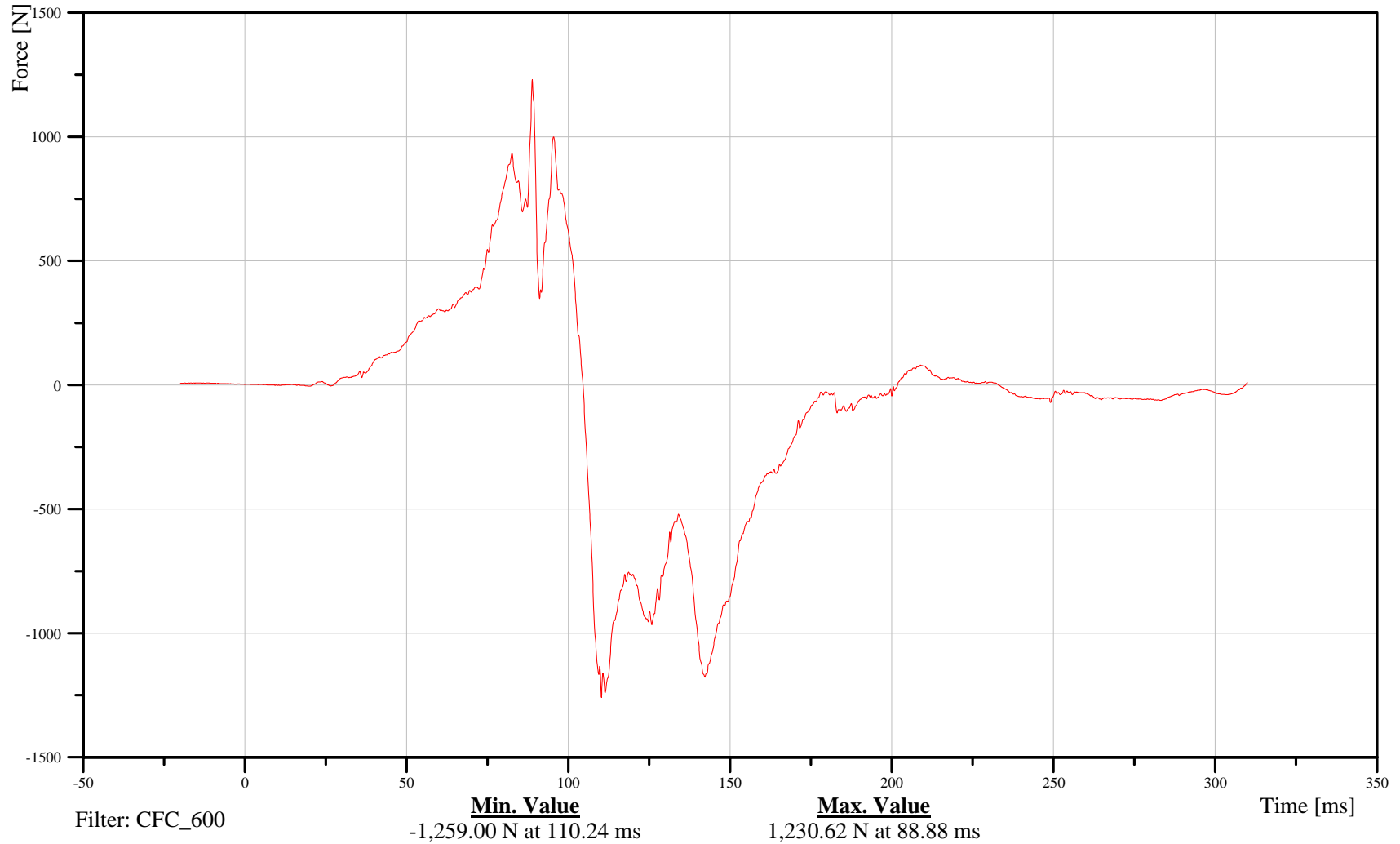

B-39

070913



2007 Ford F-250 into Left 40% Offset Deformable LCB at 56 kph

Date: 09/13/2007
Time: 15:46

Driver Left Knee Displacement

Customer: Volpe
Test Number: R70203

11KNSLLE00H3DSXC

TRC Inc. Test Lab: CTF
Test Number: 070913

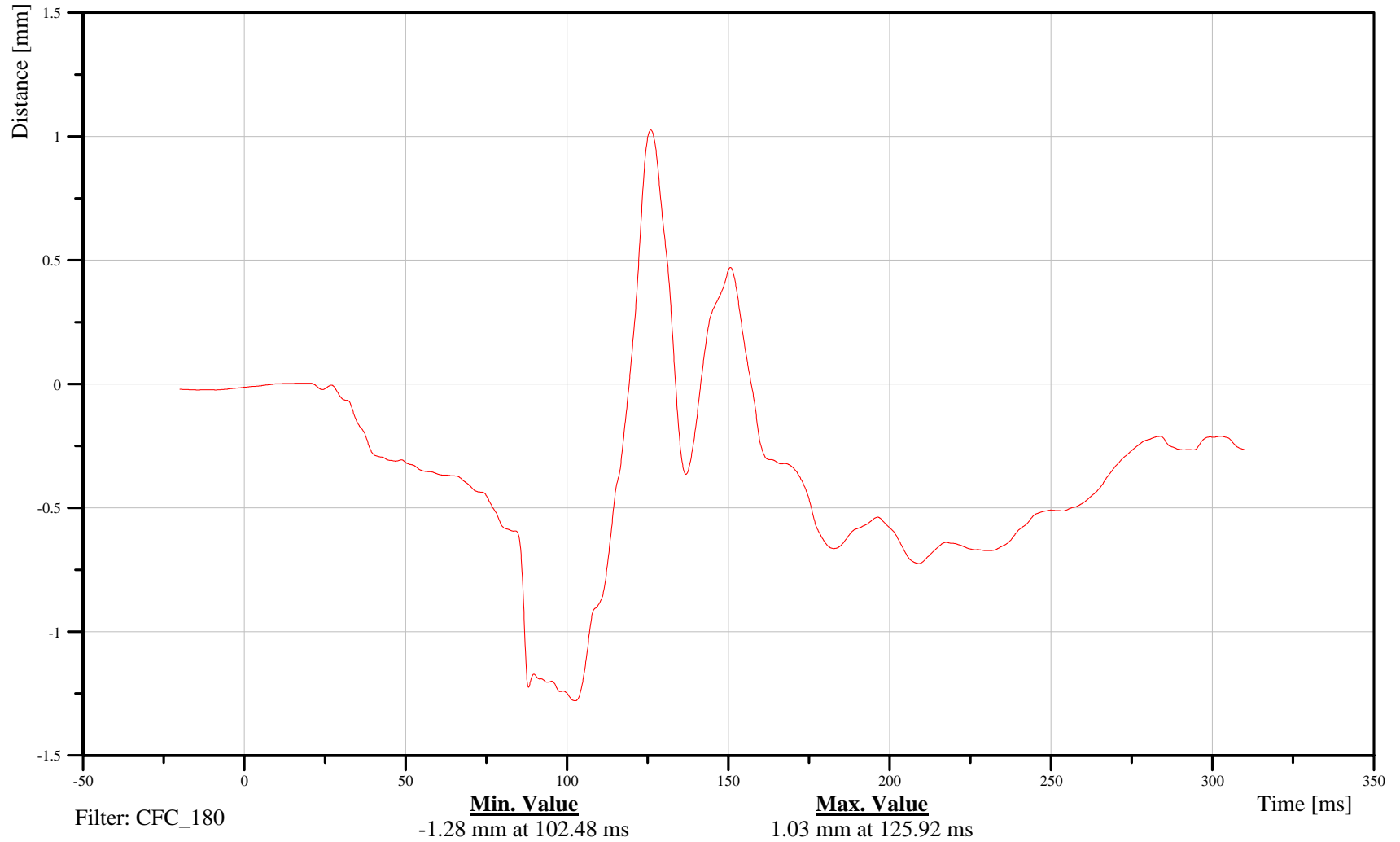

B-40

070913



2007 Ford F-250 into Left 40% Offset Deformable LCB at 56 kph

Date: 09/13/2007
Time: 15:46

Driver Left Upper Tibia X-Axis Force

Customer: Volpe
Test Number: R70203

11TIBILULXH3FOXB

TRC Inc. Test Lab: CTF
Test Number: 070913

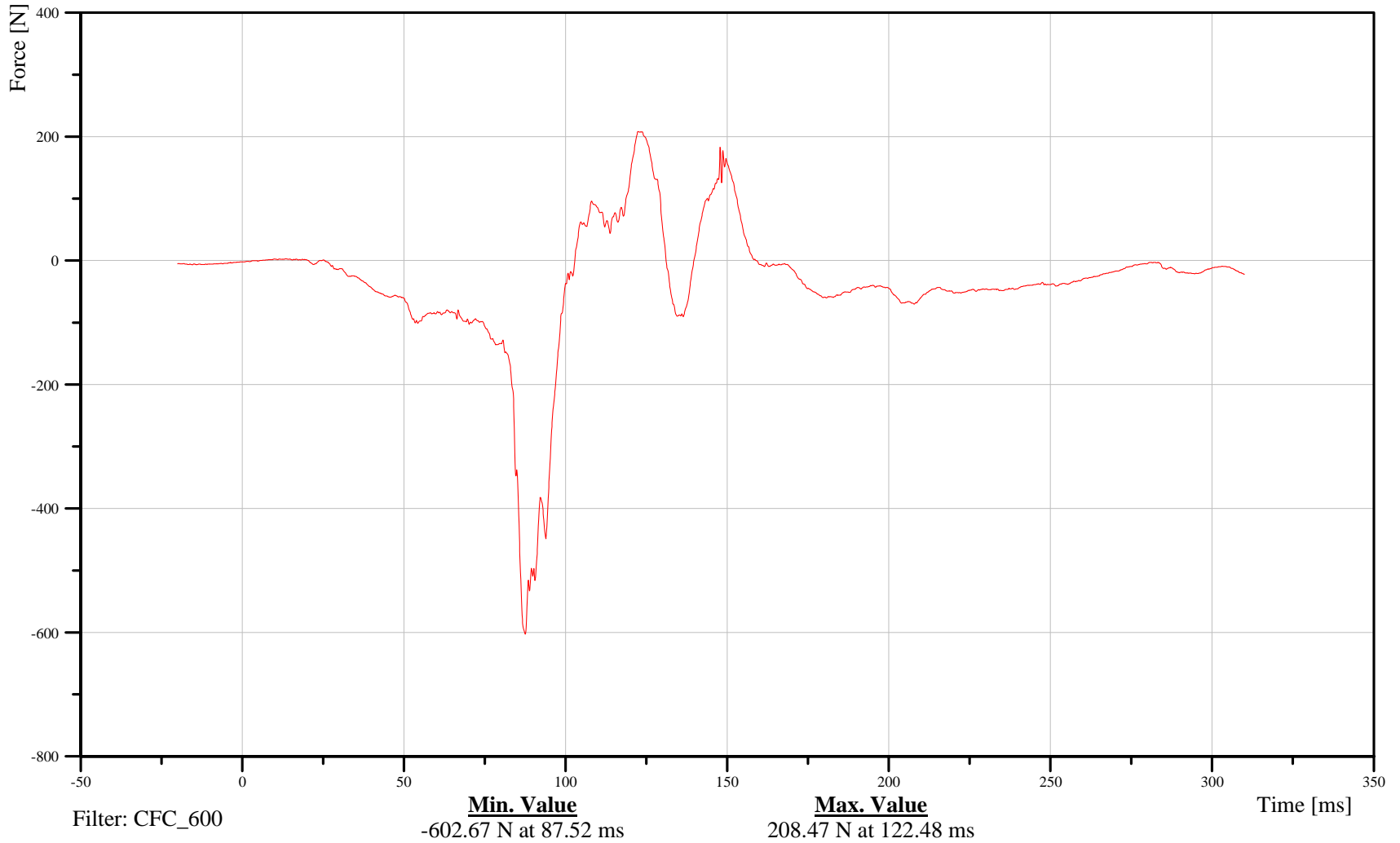

B-41

070913



2007 Ford F-250 into Left 40% Offset Deformable LCB at 56 kph

Date: 09/13/2007
Time: 15:46

Driver Left Upper Tibia Z-Axis Force

Customer: Volpe
Test Number: R70203

11TIBILULXH3FOZB

TRC Inc. Test Lab: CTF
Test Number: 070913

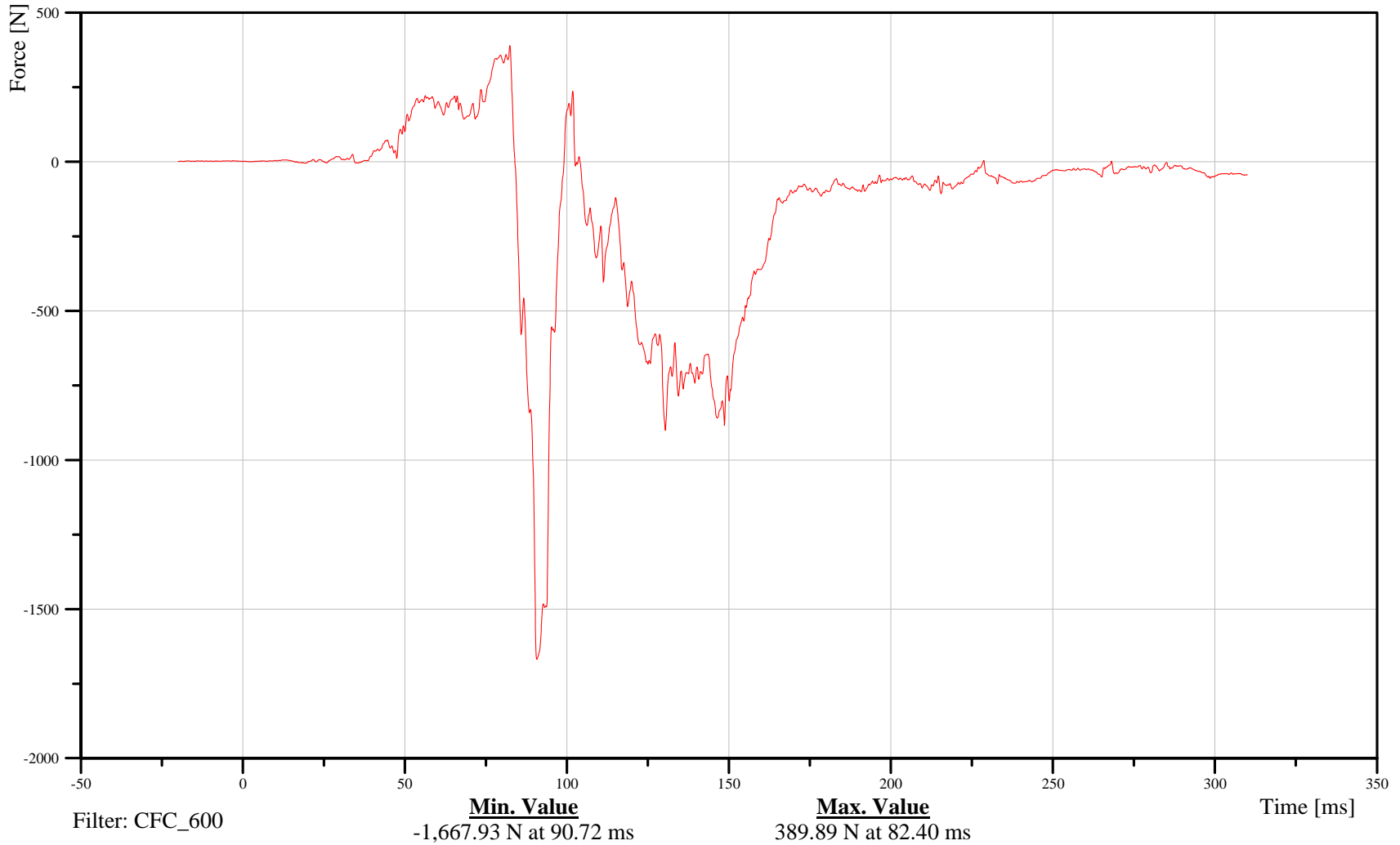

B-42

070913



2007 Ford F-250 into Left 40% Offset Deformable LCB at 56 kph

Date: 09/13/2007
Time: 15:46

Driver Left Upper Tibia Moment About X Axis

Customer: Volpe
Test Number: R70203

11TIBILULXH3MOXB

TRC Inc. Test Lab: CTF
Test Number: 070913

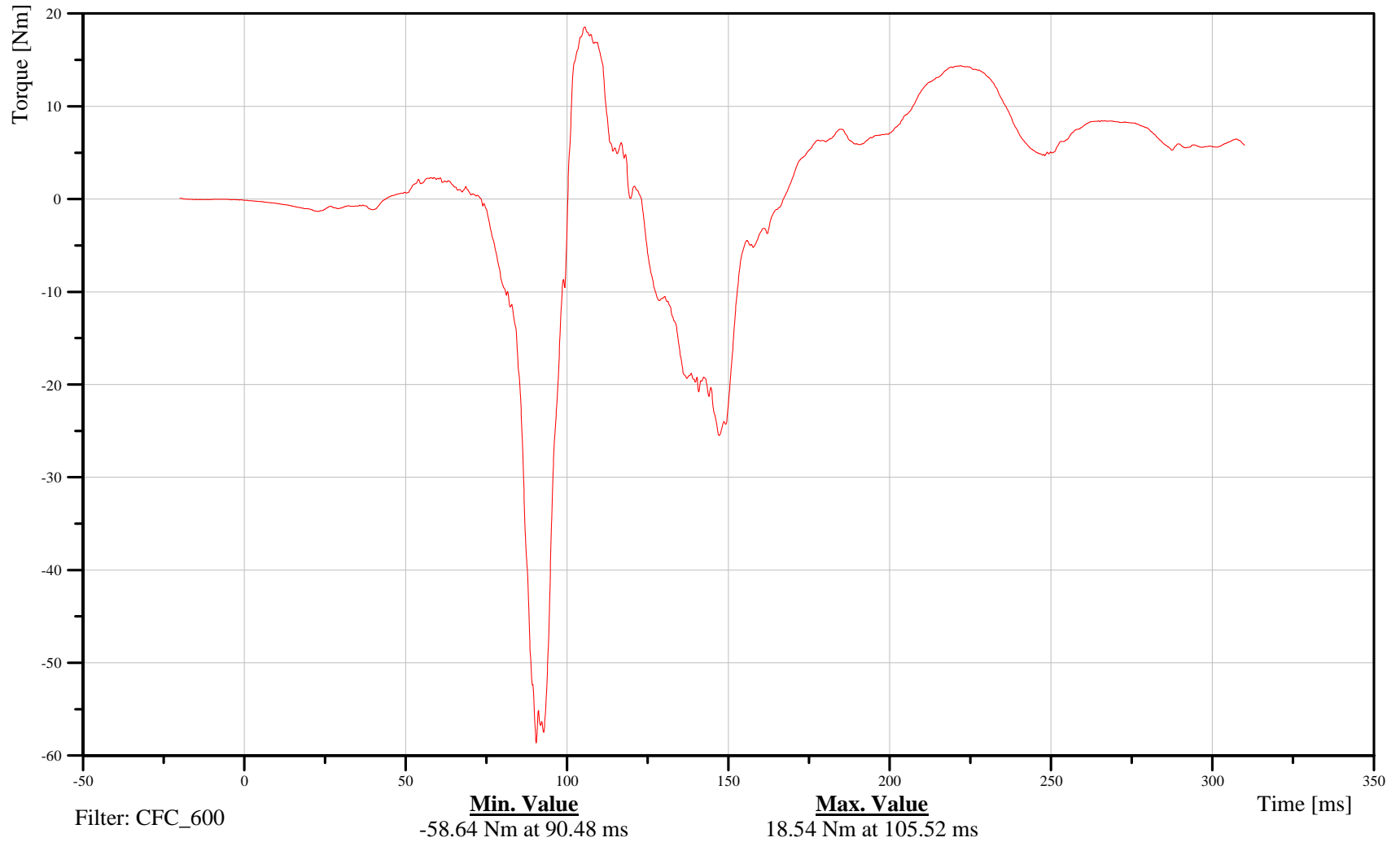

B-43

070913



2007 Ford F-250 into Left 40% Offset Deformable LCB at 56 kph

Date: 09/13/2007
Time: 15:46

Driver Left Upper Tibia Moment About Y Axis

Customer: Volpe
Test Number: R70203

11TIBILULXH3MOYB

TRC Inc. Test Lab: CTF
Test Number: 070913

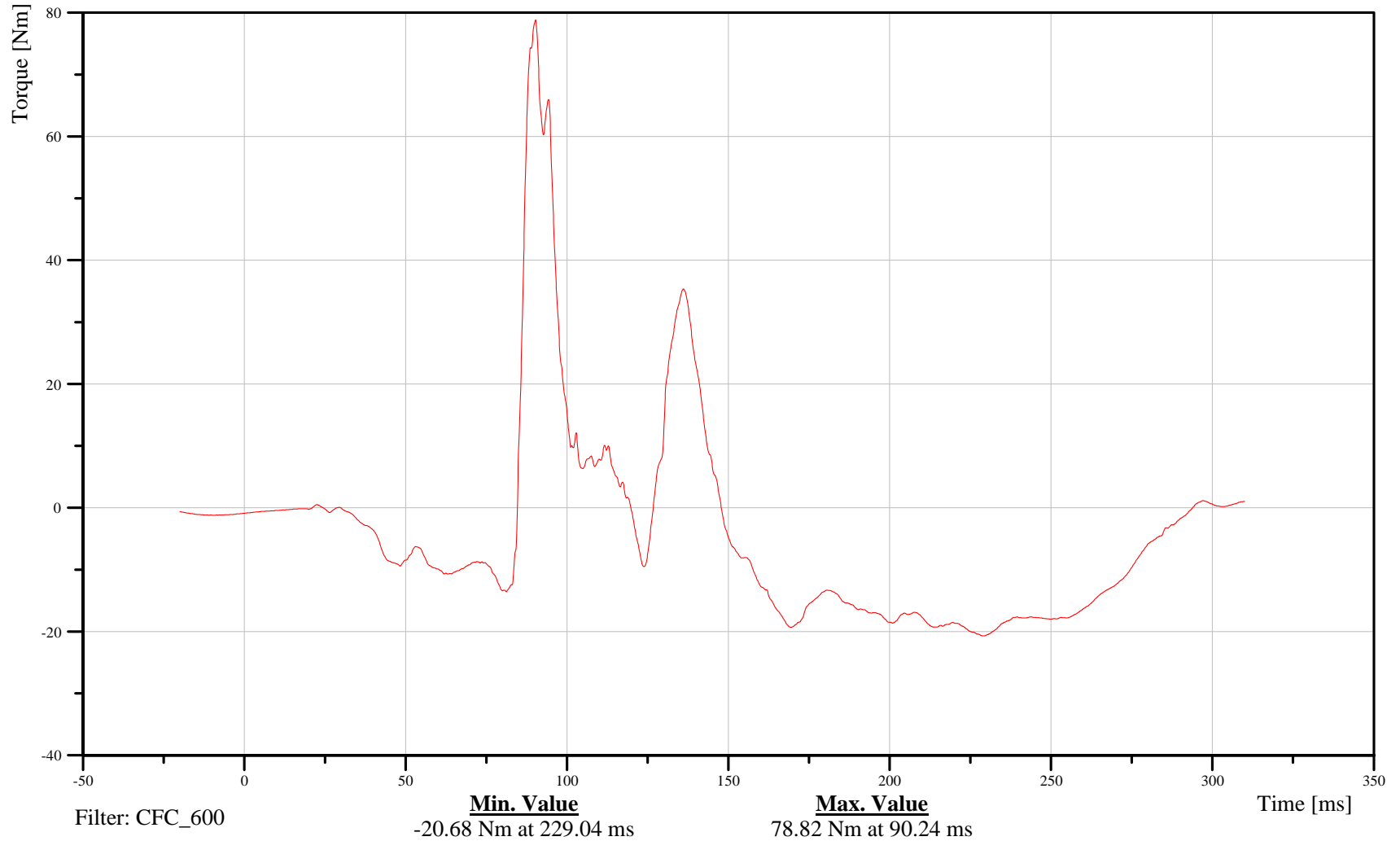

B-44

070913



2007 Ford F-250 into Left 40% Offset Deformable LCB at 56 kph

Date: 09/13/2007
Time: 15:46

Driver Left Tibia X-Axis Acceleration

Customer: Volpe
Test Number: R70203

11TIBILELXH3ACXA

TRC Inc. Test Lab: CTF
Test Number: 070913

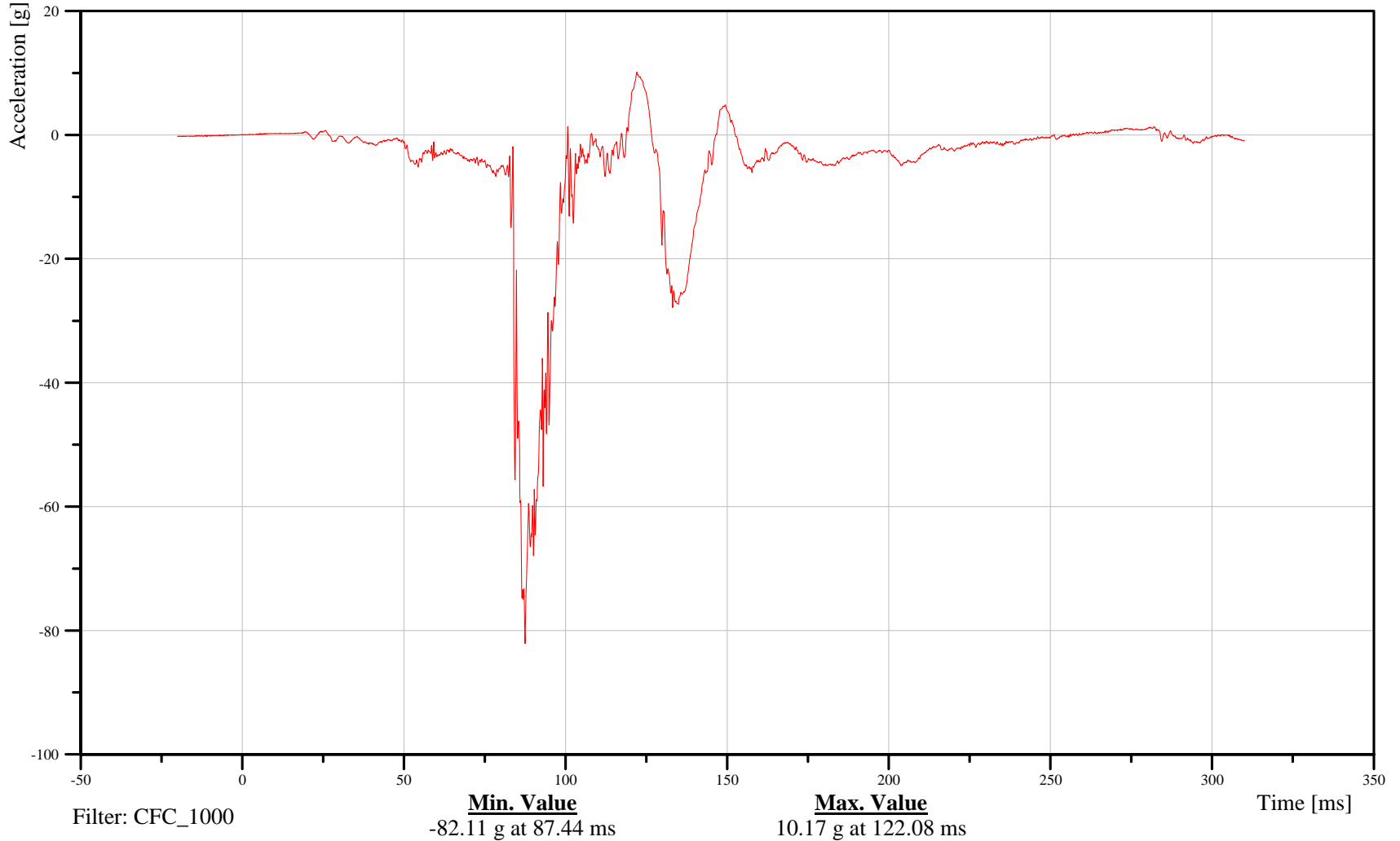

B-45

070913



2007 Ford F-250 into Left 40% Offset Deformable LCB at 56 kph

Date: 09/13/2007
Time: 15:46

Driver Left Tibia Y-Axis Acceleration

Customer: Volpe
Test Number: R70203

11TIBILELXH3ACYA

TRC Inc. Test Lab: CTF
Test Number: 070913

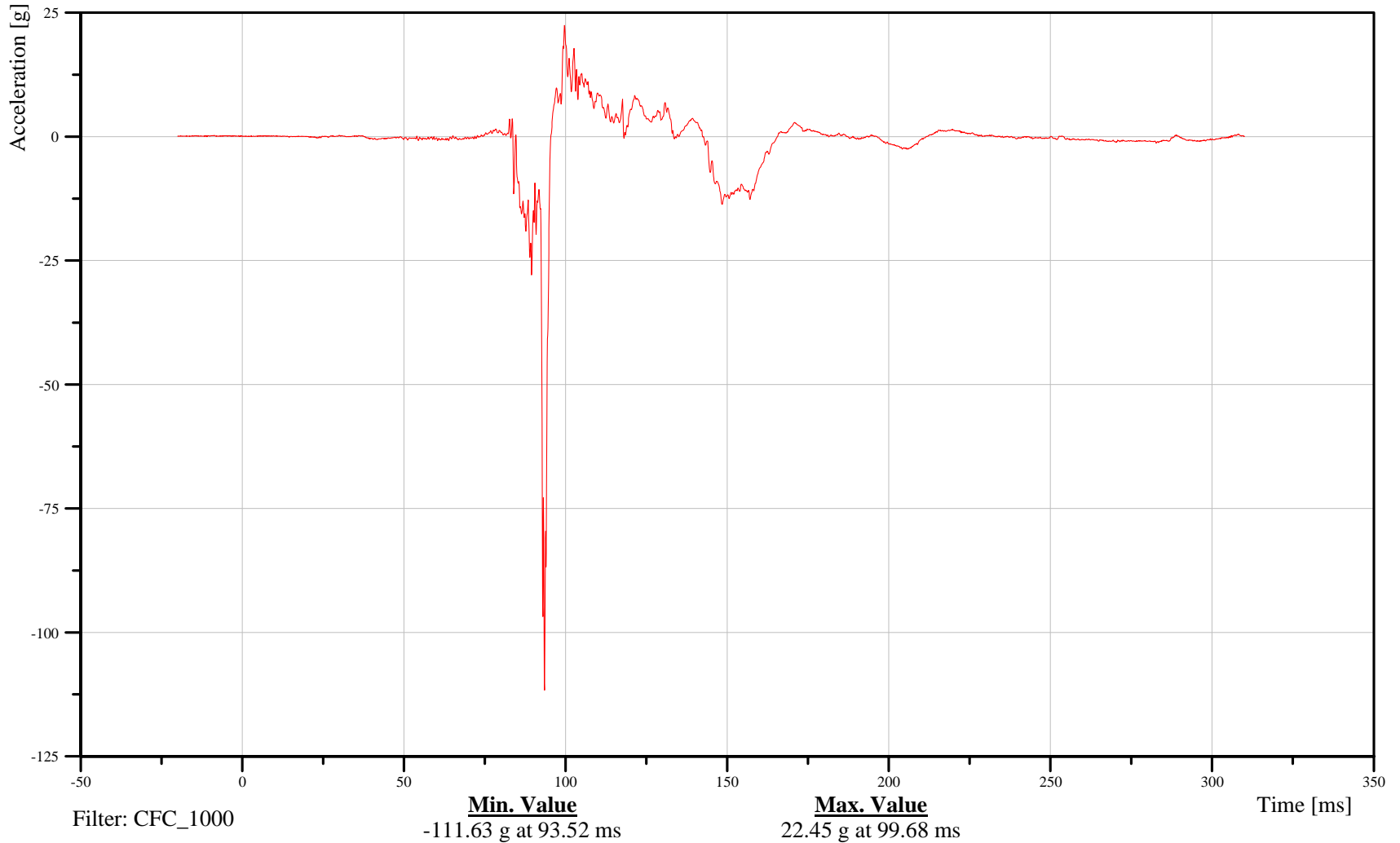

B-46

070913



2007 Ford F-250 into Left 40% Offset Deformable LCB at 56 kph

Date: 09/13/2007
Time: 15:46

Driver Left Lower Tibia X-Axis Force

Customer: Volpe
Test Number: R70203

11TIBILLXH3FOXB

TRC Inc. Test Lab: CTF
Test Number: 070913

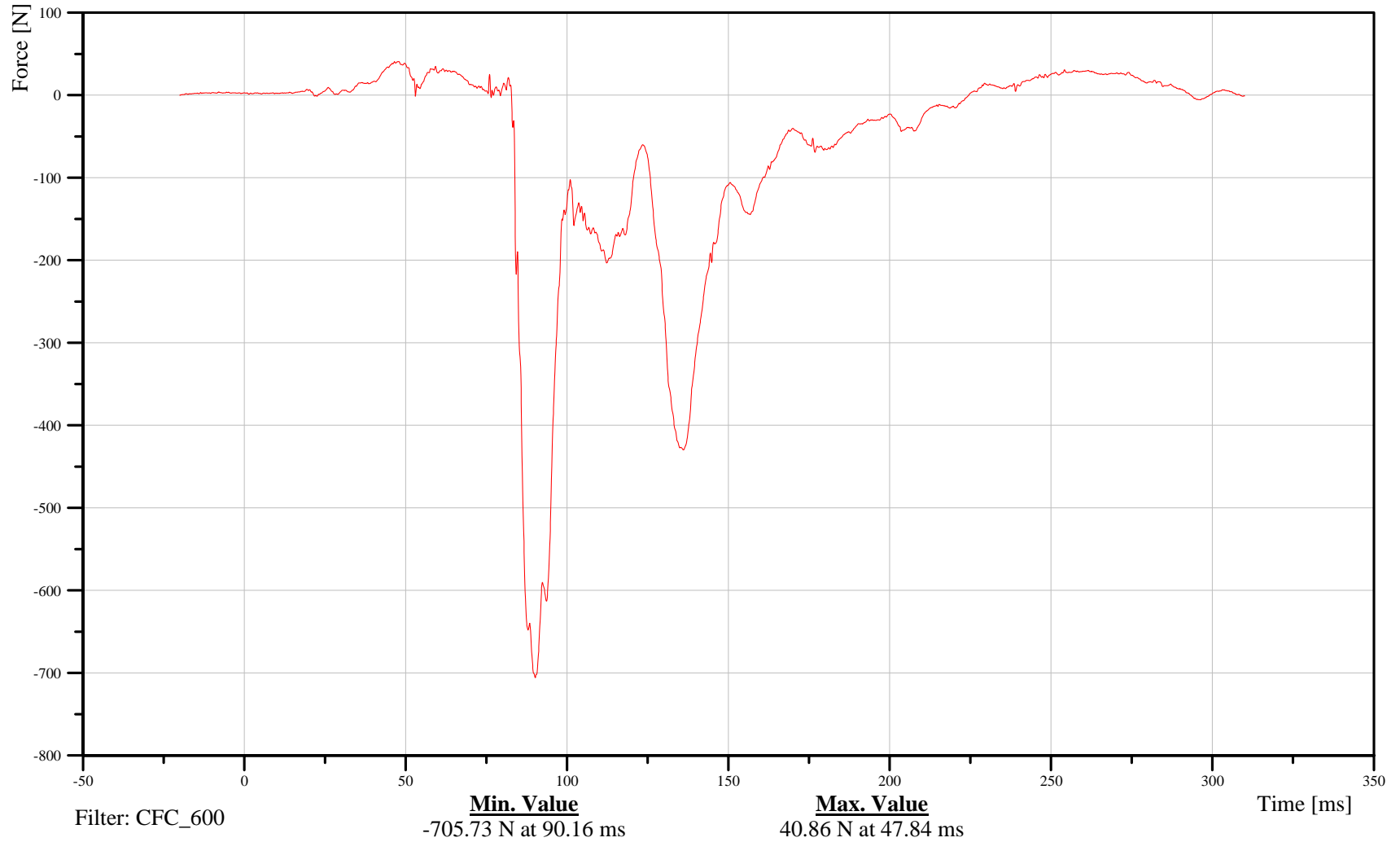

B-47

070913



2007 Ford F-250 into Left 40% Offset Deformable LCB at 56 kph

Date: 09/13/2007
Time: 15:46

Driver Left Lower Tibia Y-Axis Force

Customer: Volpe
Test Number: R70203

11TIBILLXH3FOYB

TRC Inc. Test Lab: CTF
Test Number: 070913

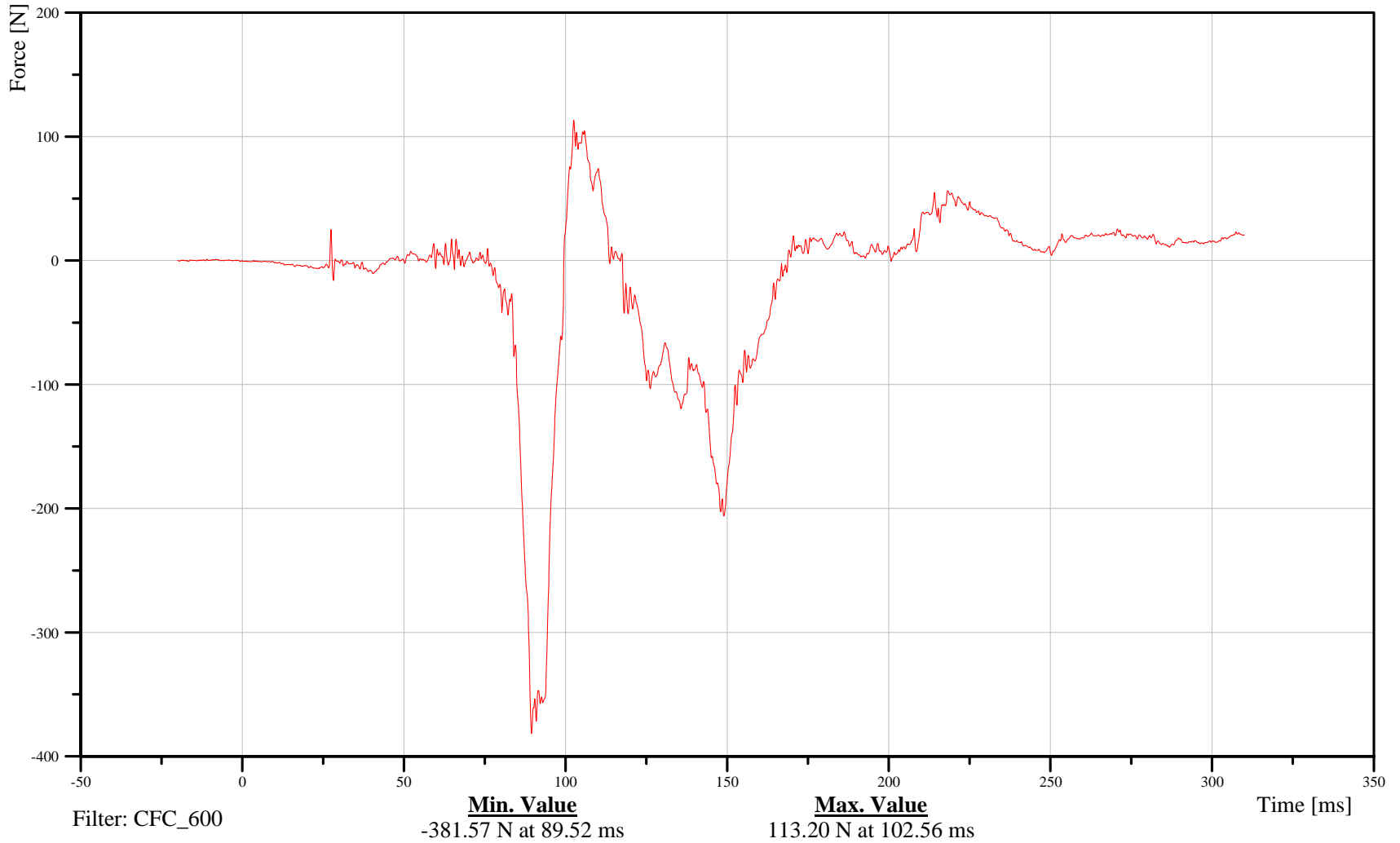

B-48

070913



2007 Ford F-250 into Left 40% Offset Deformable LCB at 56 kph

Date: 09/13/2007
Time: 15:46

Driver Left Lower Tibia Z-Axis Force

Customer: Volpe
Test Number: R70203

11TIBILLXH3FOZB

TRC Inc. Test Lab: CTF
Test Number: 070913

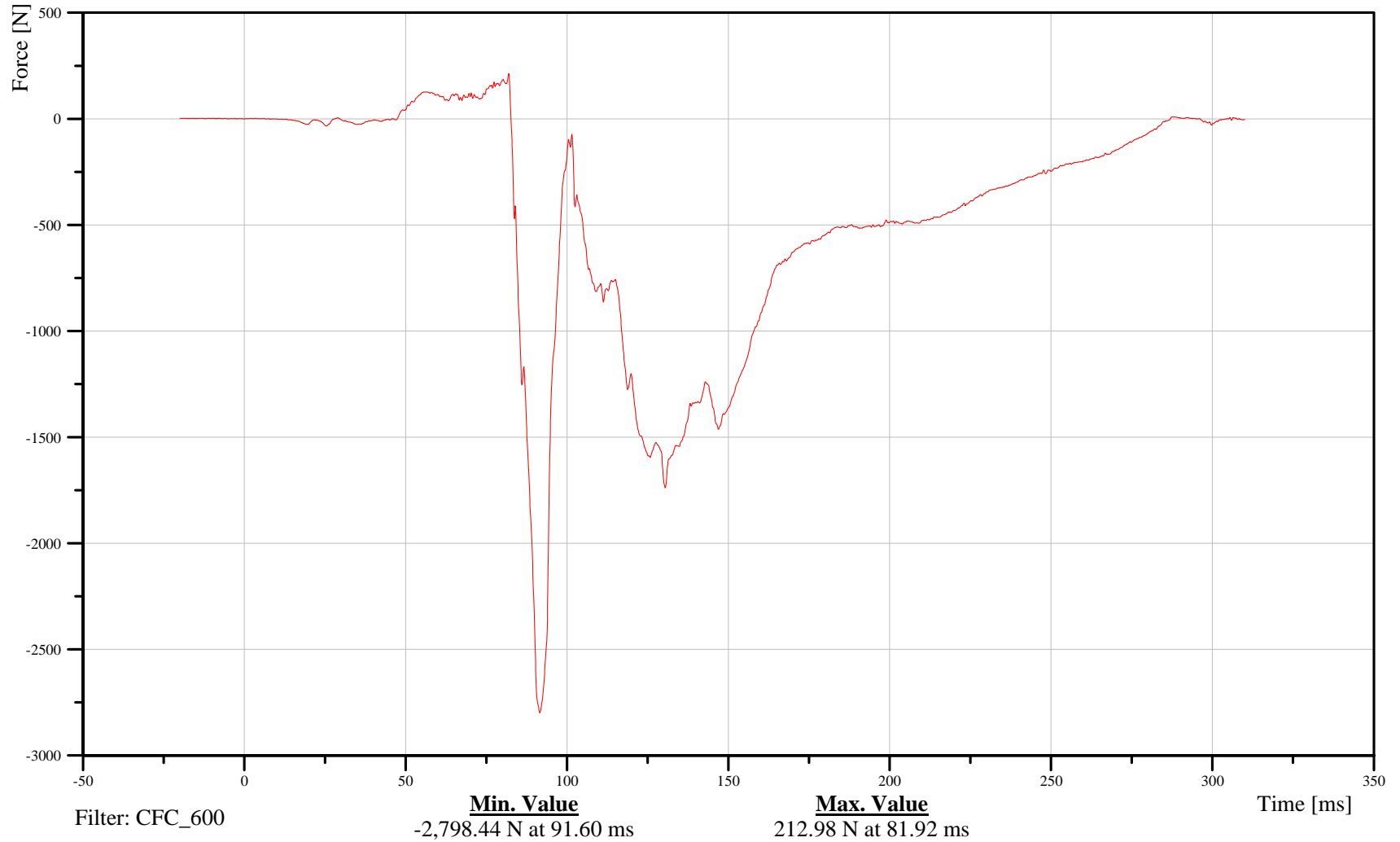

B-49

070913



2007 Ford F-250 into Left 40% Offset Deformable LCB at 56 kph

Date: 09/13/2007
Time: 15:46

Driver Left Lower Tibia Moment About X Axis

Customer: Volpe
Test Number: R70203

11TIBILLXH3MOXB

TRC Inc. Test Lab: CTF
Test Number: 070913

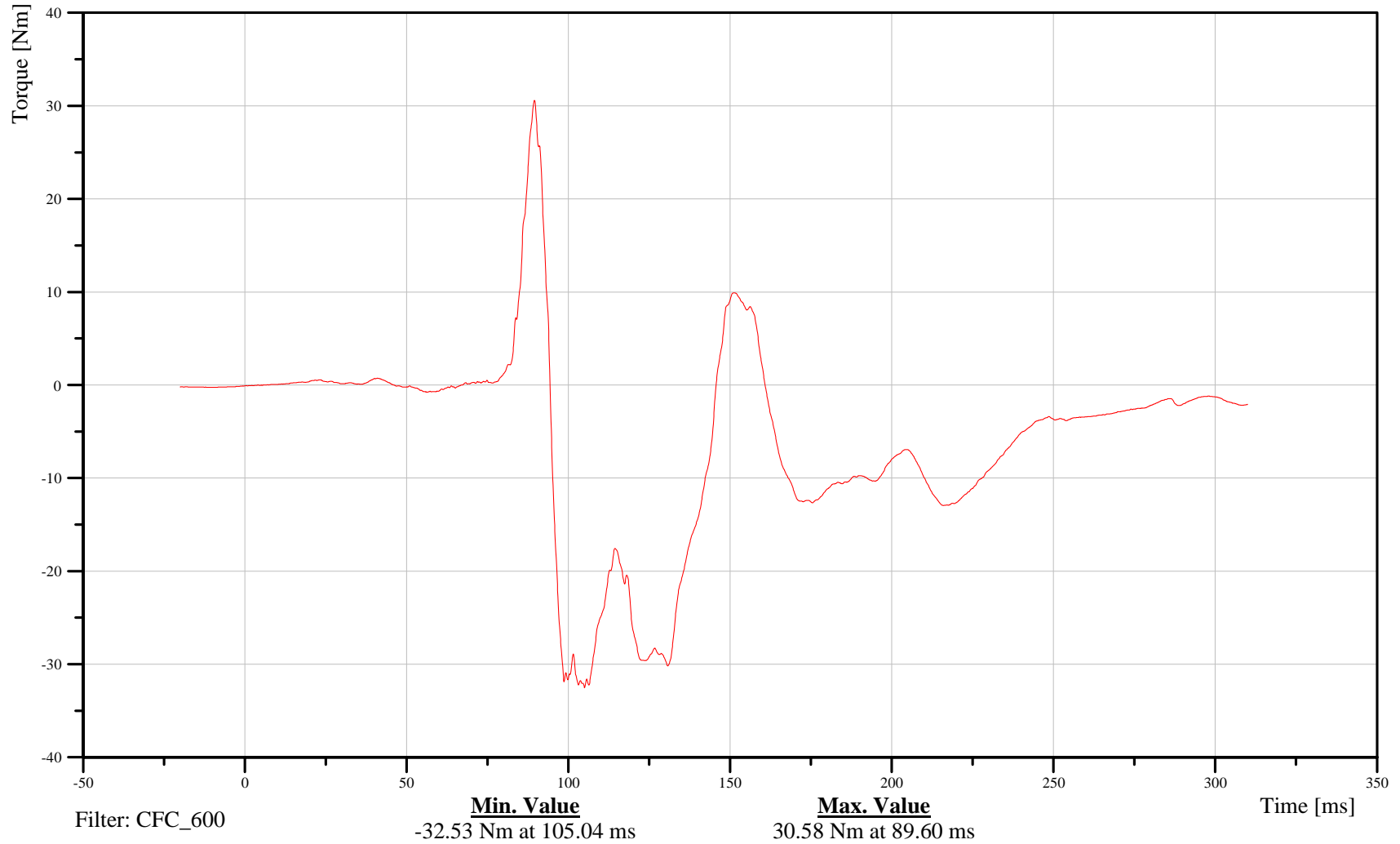

B-50

070913



2007 Ford F-250 into Left 40% Offset Deformable LCB at 56 kph

Date: 09/13/2007
Time: 15:46

Driver Left Lower Tibia Moment About Y Axis

Customer: Volpe
Test Number: R70203

11TIBILLXH3MOYB

TRC Inc. Test Lab: CTF
Test Number: 070913

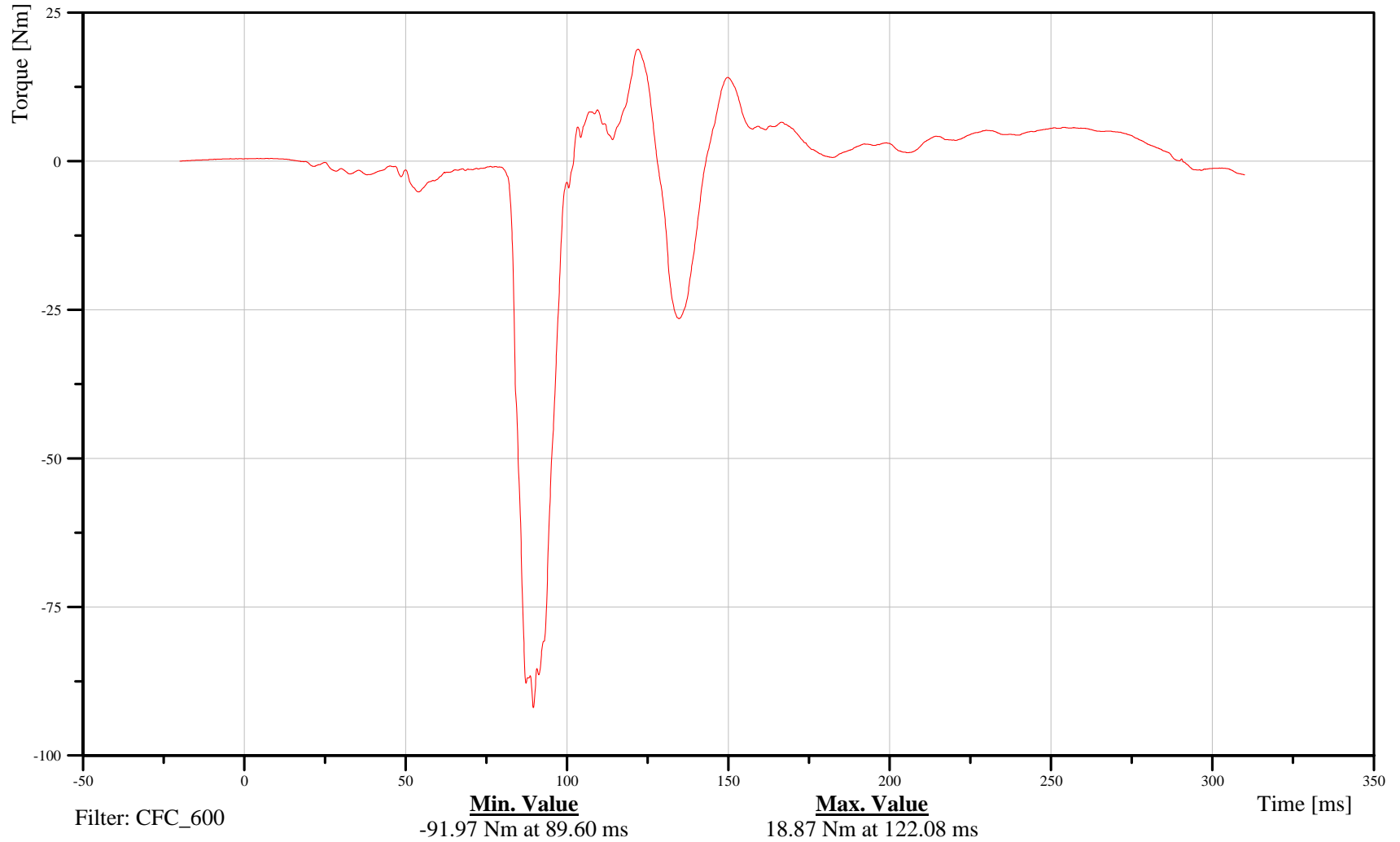

B-51

070913



2007 Ford F-250 into Left 40% Offset Deformable LCB at 56 kph

Date: 09/13/2007
Time: 15:46

Driver Left Foot X-Axis Rotation

Customer: Volpe
Test Number: R70203

11FOOTLELXH3ANXC

TRC Inc. Test Lab: CTF
Test Number: 070913

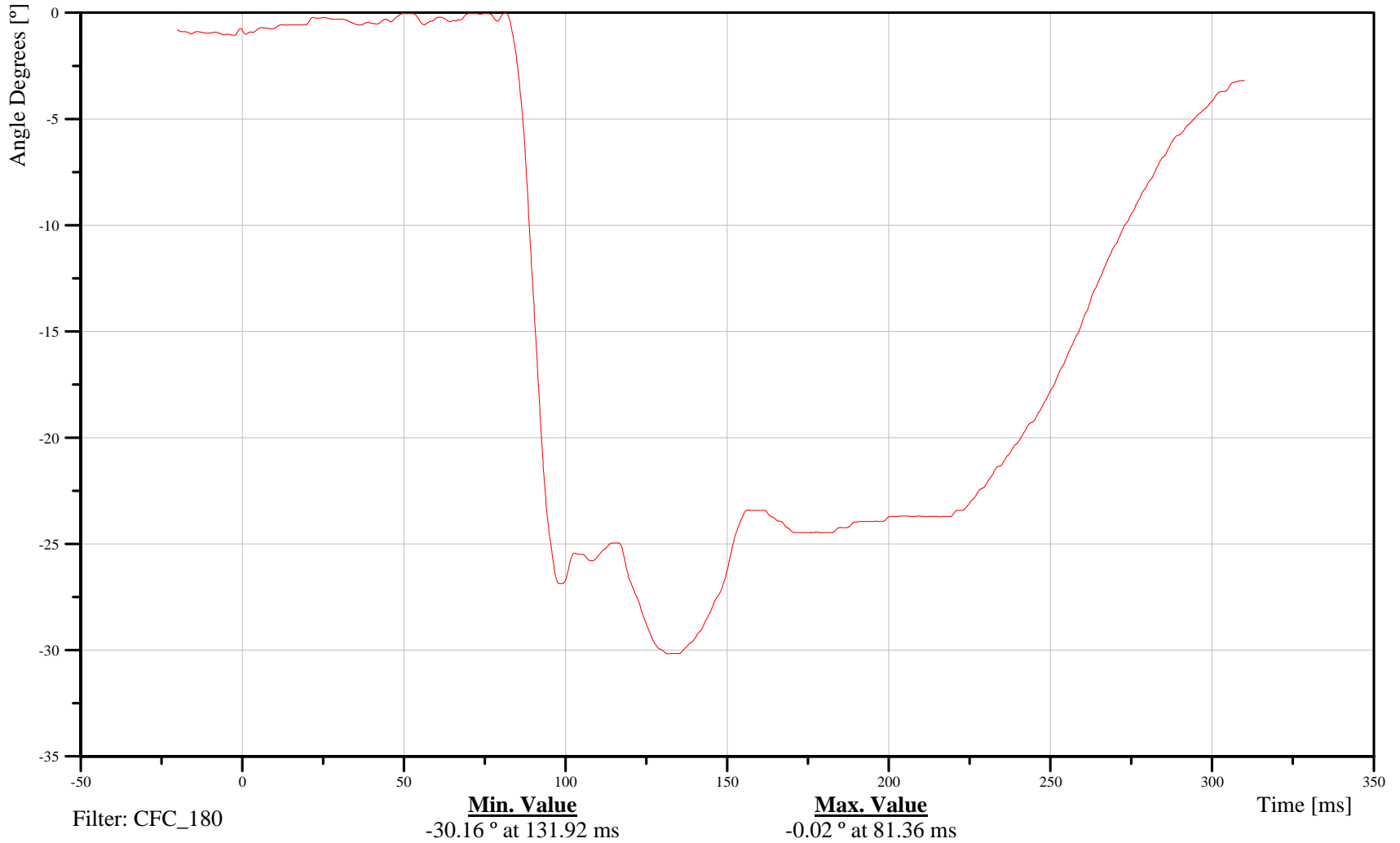

B-52

070913



2007 Ford F-250 into Left 40% Offset Deformable LCB at 56 kph

Date: 09/13/2007
Time: 15:46

Driver Left Foot Y-Axis Rotation

Customer: Volpe
Test Number: R70203

11FOOTLELXH3ANYC

TRC Inc. Test Lab: CTF
Test Number: 070913

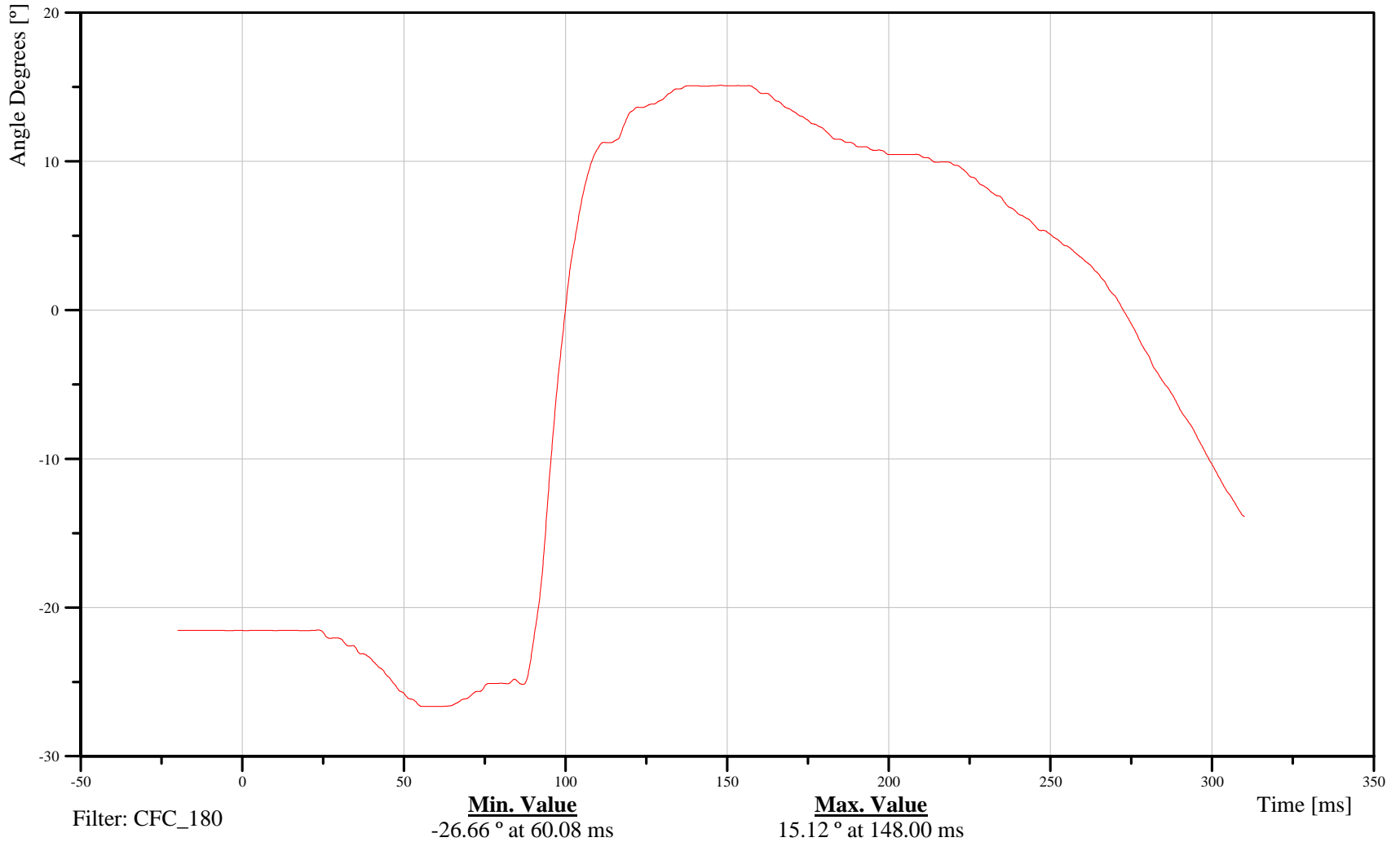

B-53

070913



2007 Ford F-250 into Left 40% Offset Deformable LCB at 56 kph

Date: 09/13/2007
Time: 15:46

Driver Left Foot Z-Axis Rotation

Customer: Volpe
Test Number: R70203

11FOOTLELXH3ANZC

TRC Inc. Test Lab: CTF
Test Number: 070913

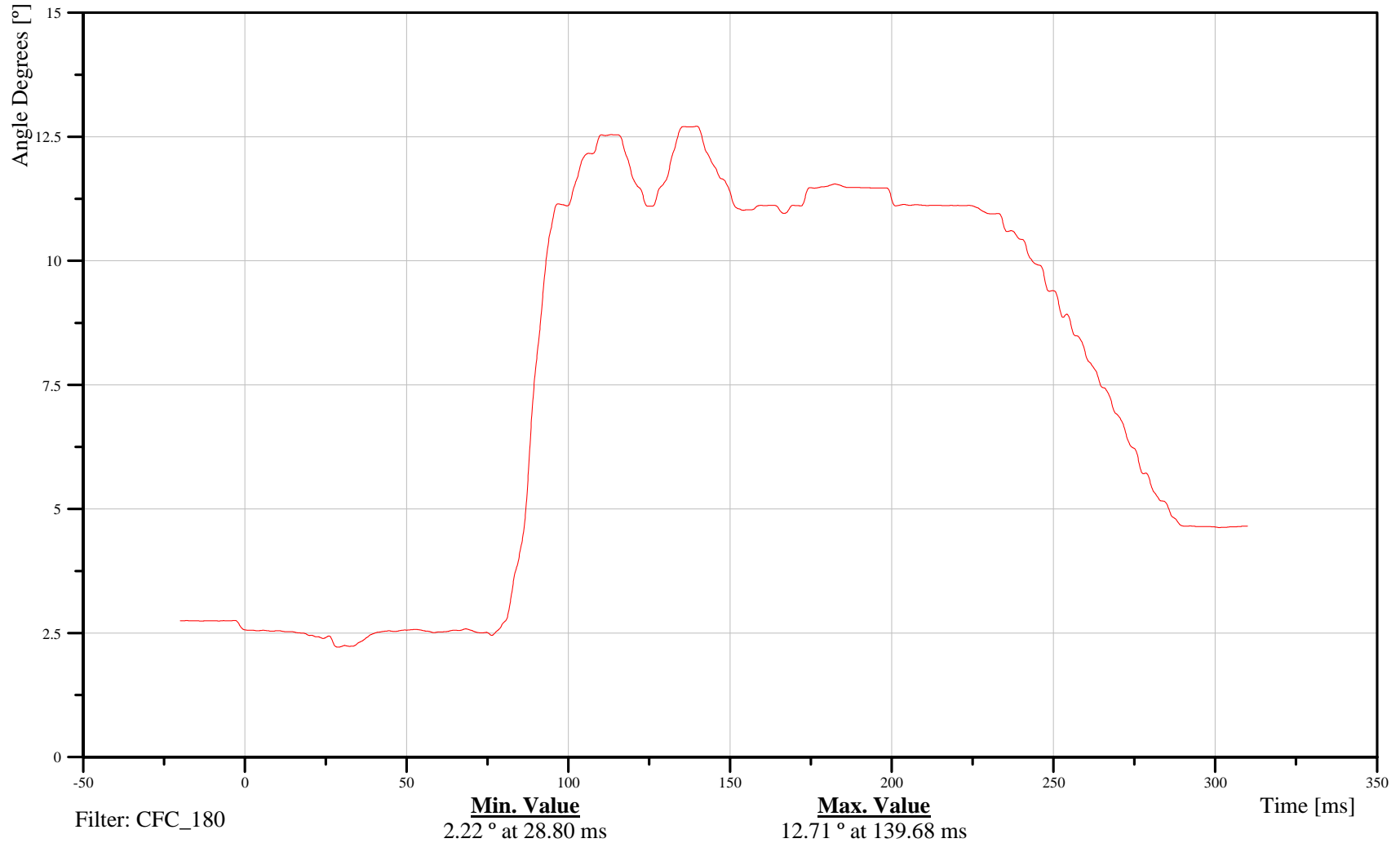

B-54

070913



2007 Ford F-250 into Left 40% Offset Deformable LCB at 56 kph

Date: 09/13/2007
Time: 15:46

Driver Left Foot X-Axis Acceleration

Customer: Volpe
Test Number: R70203

11FOOTLELXH3ACXA

TRC Inc. Test Lab: CTF
Test Number: 070913

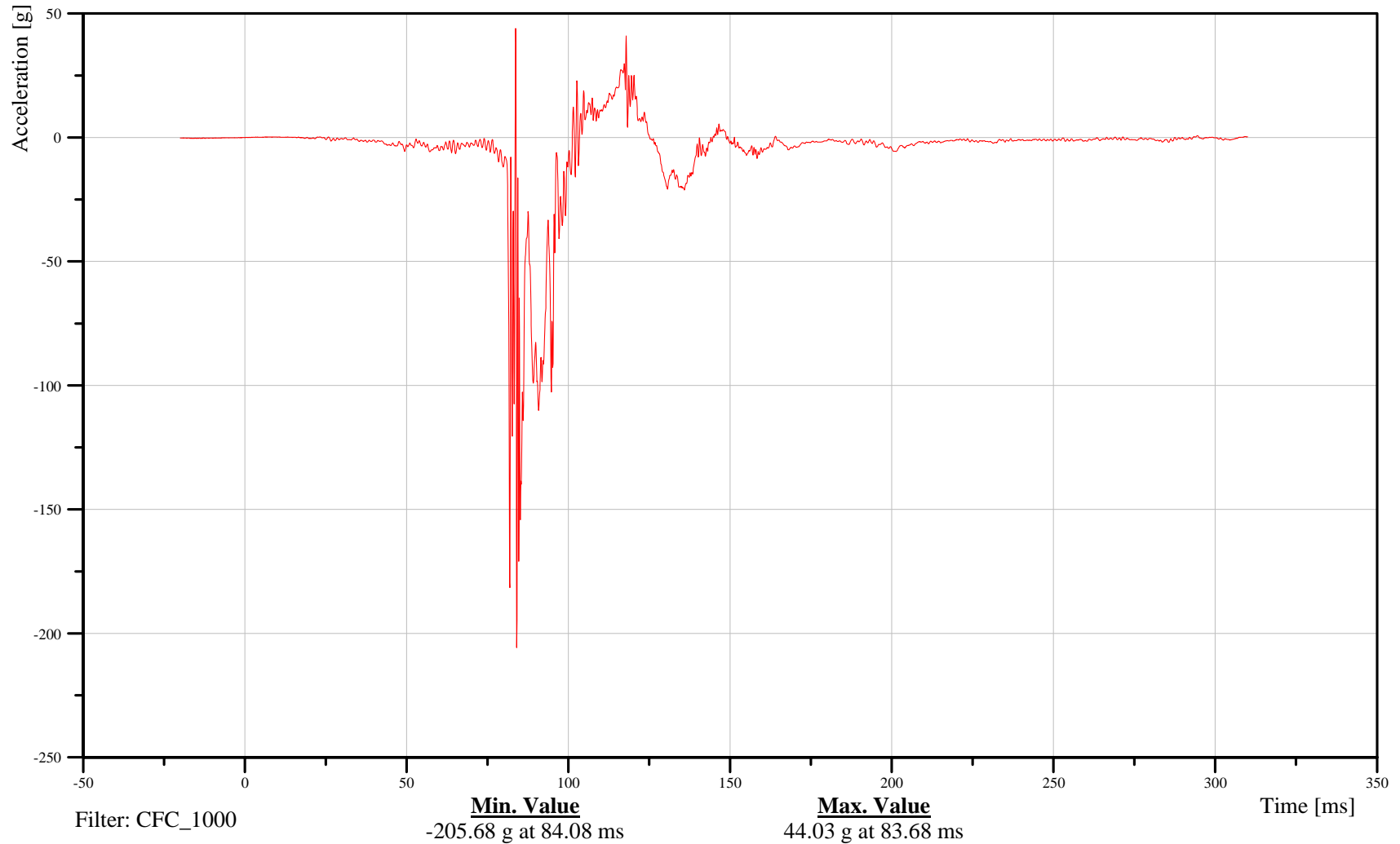

B-55

070913



2007 Ford F-250 into Left 40% Offset Deformable LCB at 56 kph

Date: 09/13/2007
Time: 15:46

Driver Left Foot Y-Axis Acceleration

Customer: Volpe
Test Number: R70203

11FOOTLELXH3ACYA

TRC Inc. Test Lab: CTF
Test Number: 070913

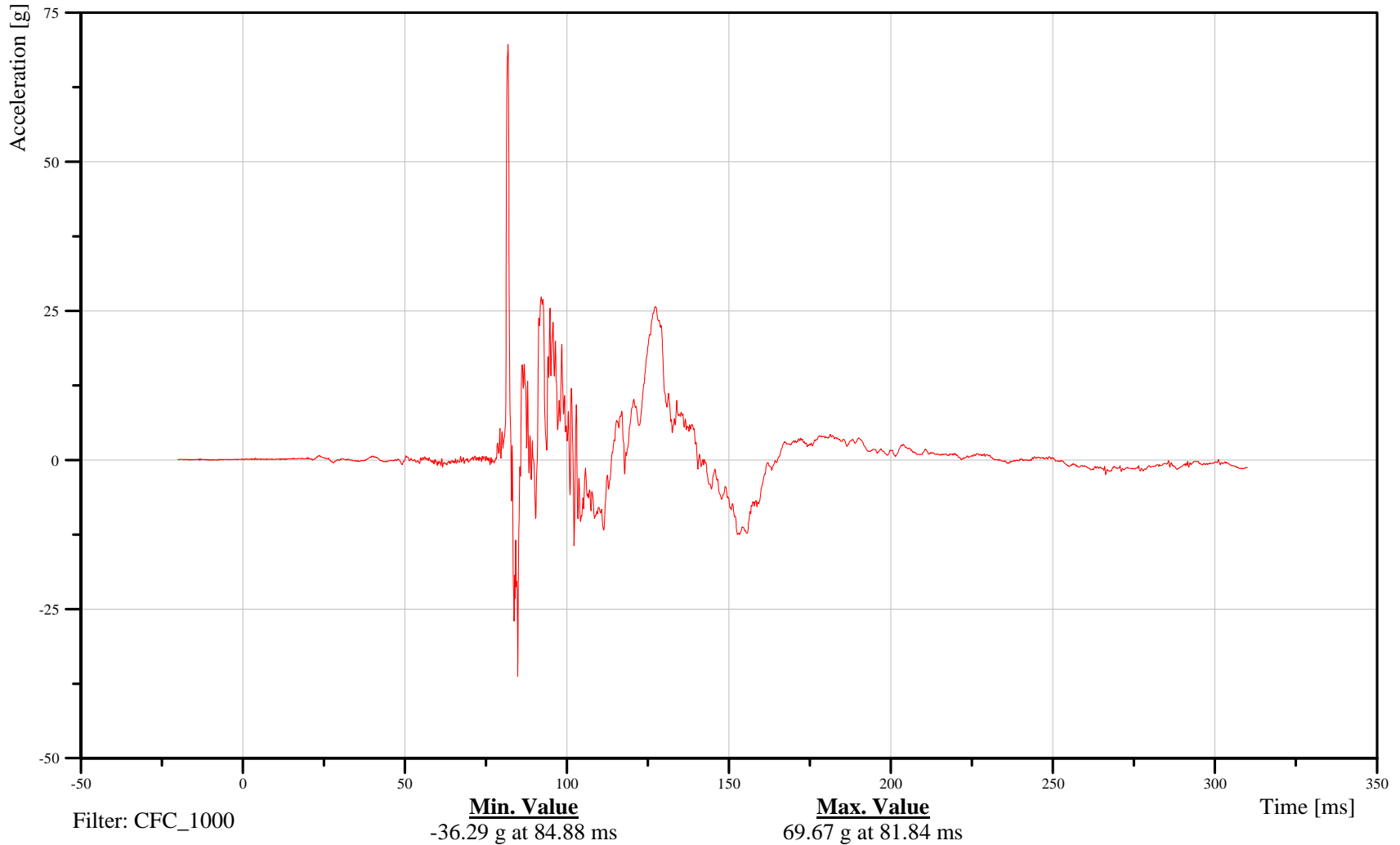

B-56

070913



2007 Ford F-250 into Left 40% Offset Deformable LCB at 56 kph

Date: 09/13/2007
Time: 15:46

Driver Left Foot Z-Axis Acceleration

Customer: Volpe
Test Number: R70203

11FOOTLELXH3ACZA

TRC Inc. Test Lab: CTF
Test Number: 070913

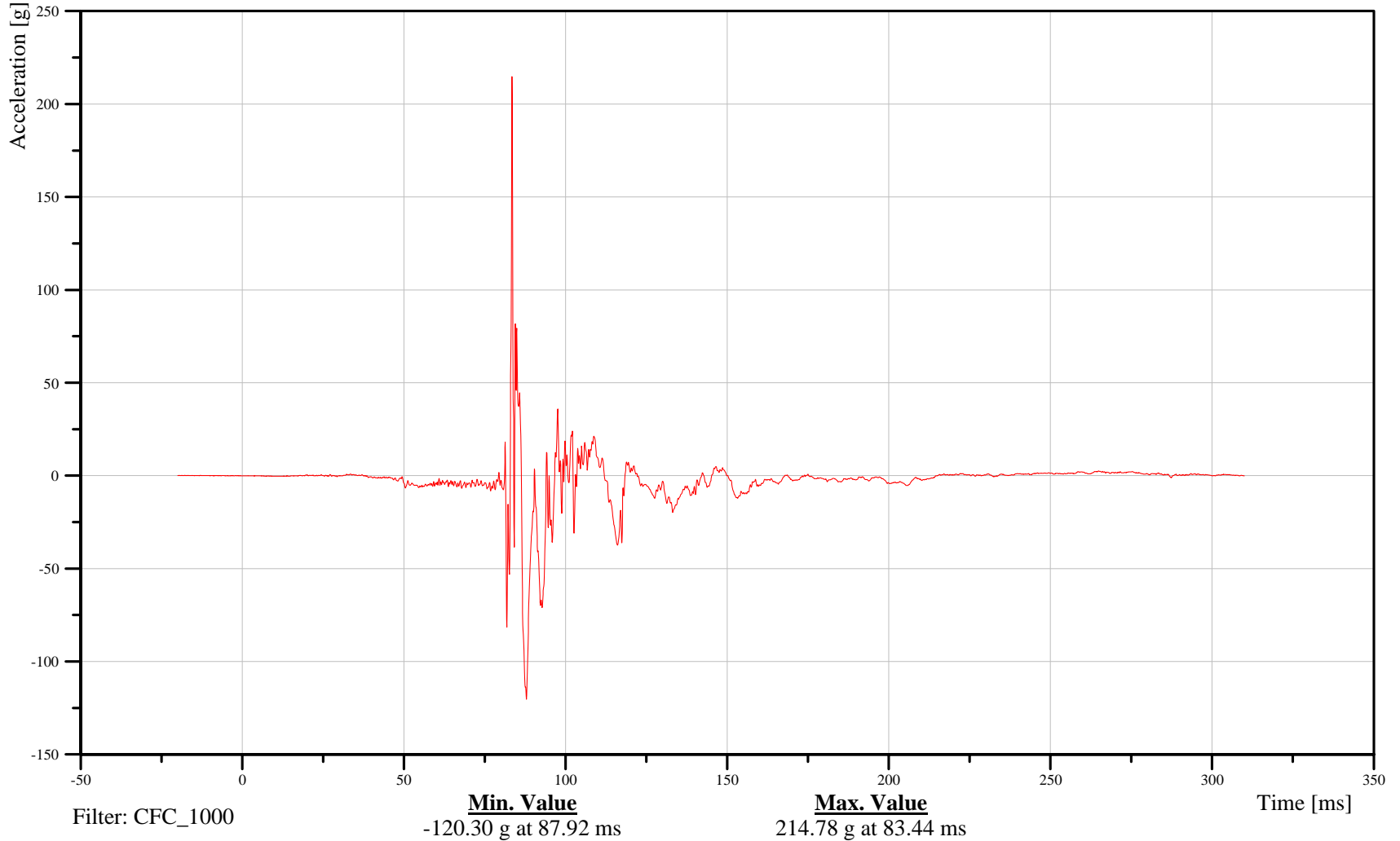

B-57

070913



2007 Ford F-250 into Left 40% Offset Deformable LCB at 56 kph

Date: 09/13/2007
Time: 15:46

Driver Left Foot Resultant Acceleration

Customer: Volpe
Test Number: R70203

11FOOTLELXH3ACRA

TRC Inc. Test Lab: CTF
Test Number: 070913

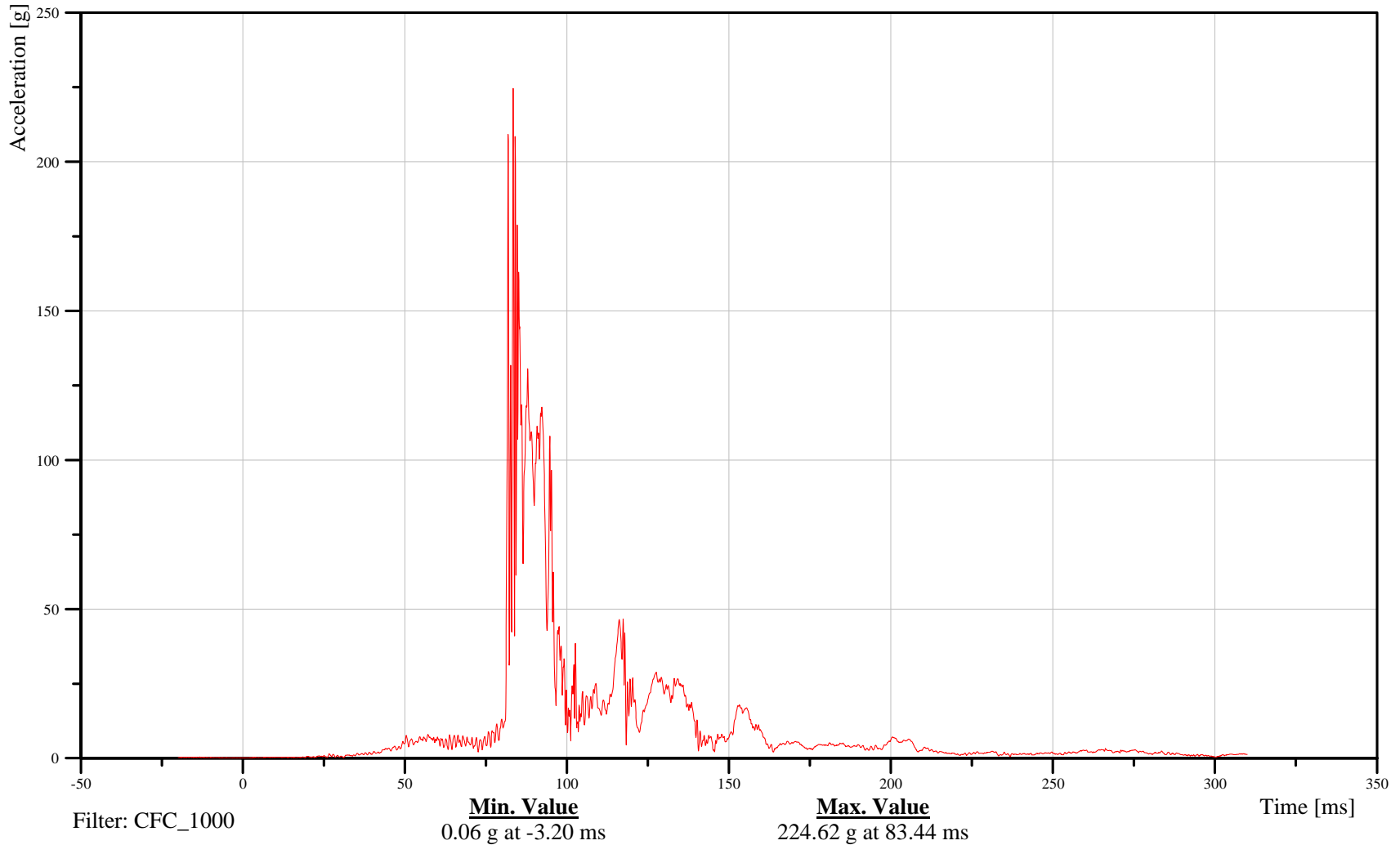

B-58

070913



2007 Ford F-250 into Left 40% Offset Deformable LCB at 56 kph

Date: 09/13/2007
Time: 15:46

Driver Right Knee Displacement

Customer: Volpe
Test Number: R70203

11KNSLRI00H3DSXC

TRC Inc. Test Lab: CTF
Test Number: 070913

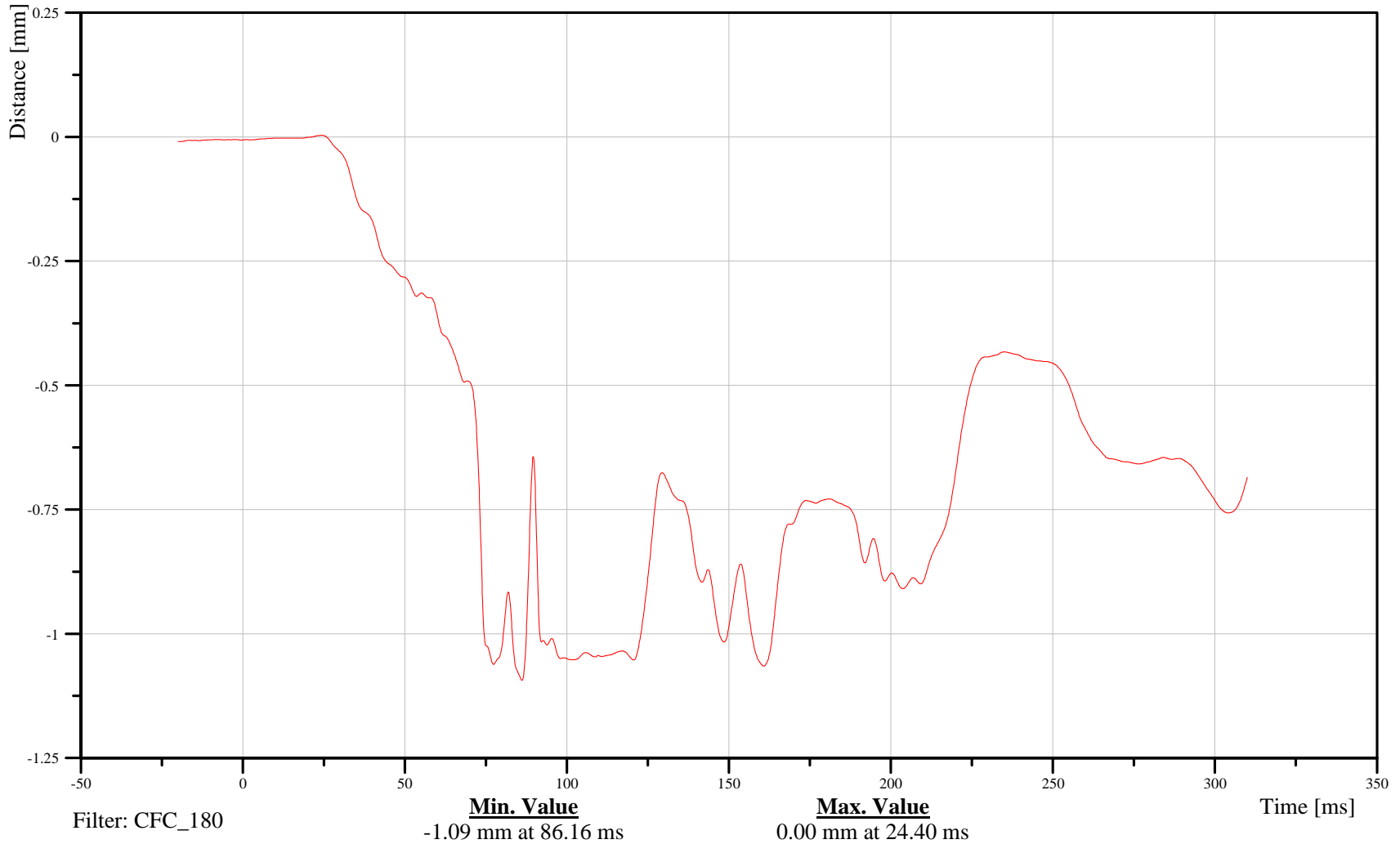

B-59

070913



2007 Ford F-250 into Left 40% Offset Deformable LCB at 56 kph

Date: 09/13/2007
Time: 15:46

Driver Right Upper Tibia X-Axis Force

Customer: Volpe
Test Number: R70203

11TIBIRULXH3FOXB

TRC Inc. Test Lab: CTF
Test Number: 070913

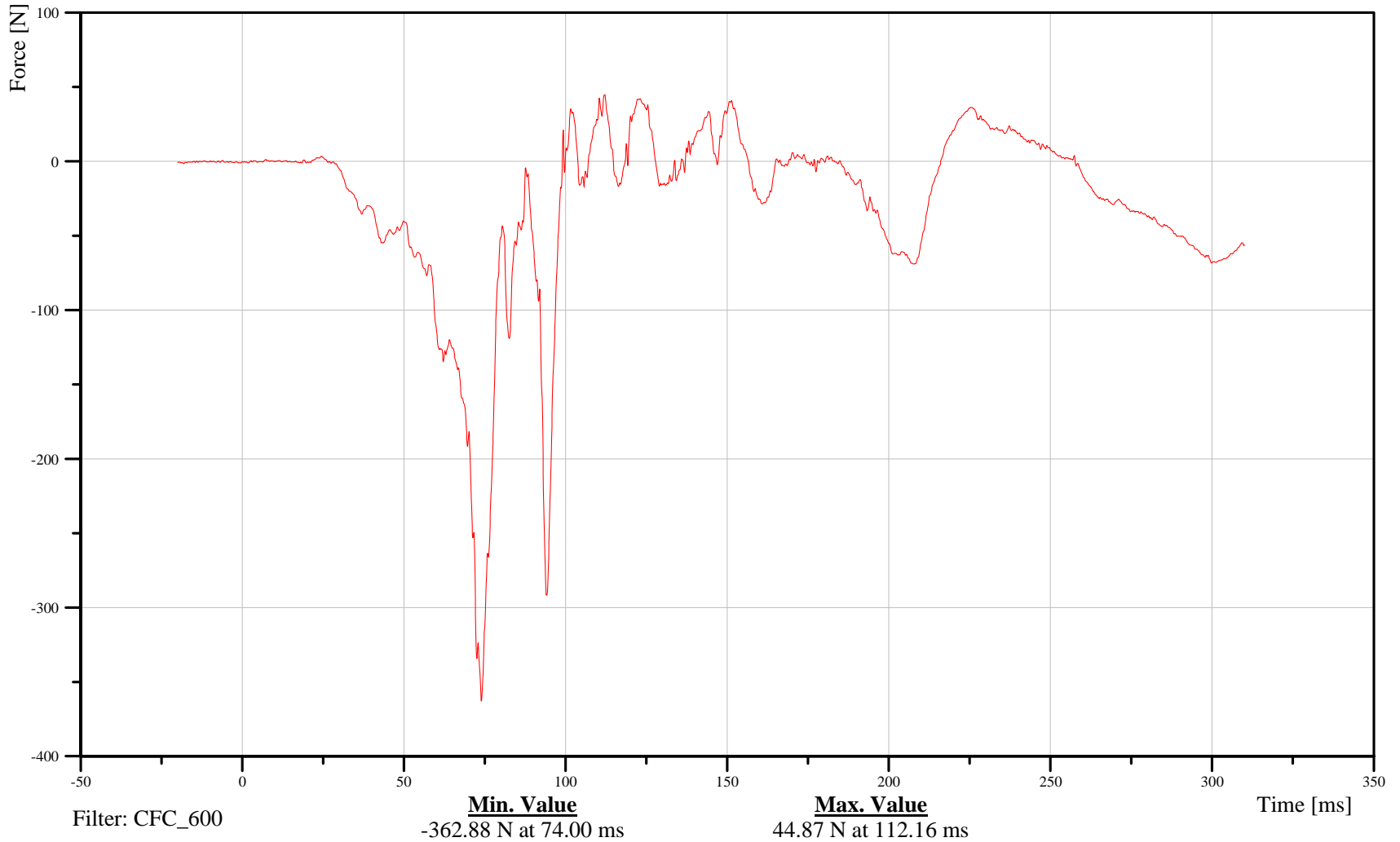

B-60

070913



2007 Ford F-250 into Left 40% Offset Deformable LCB at 56 kph

Date: 09/13/2007
Time: 15:46

Driver Right Upper Tibia Z-Axis Force

Customer: Volpe
Test Number: R70203

11TIBIRULXH3FOZB

TRC Inc. Test Lab: CTF
Test Number: 070913

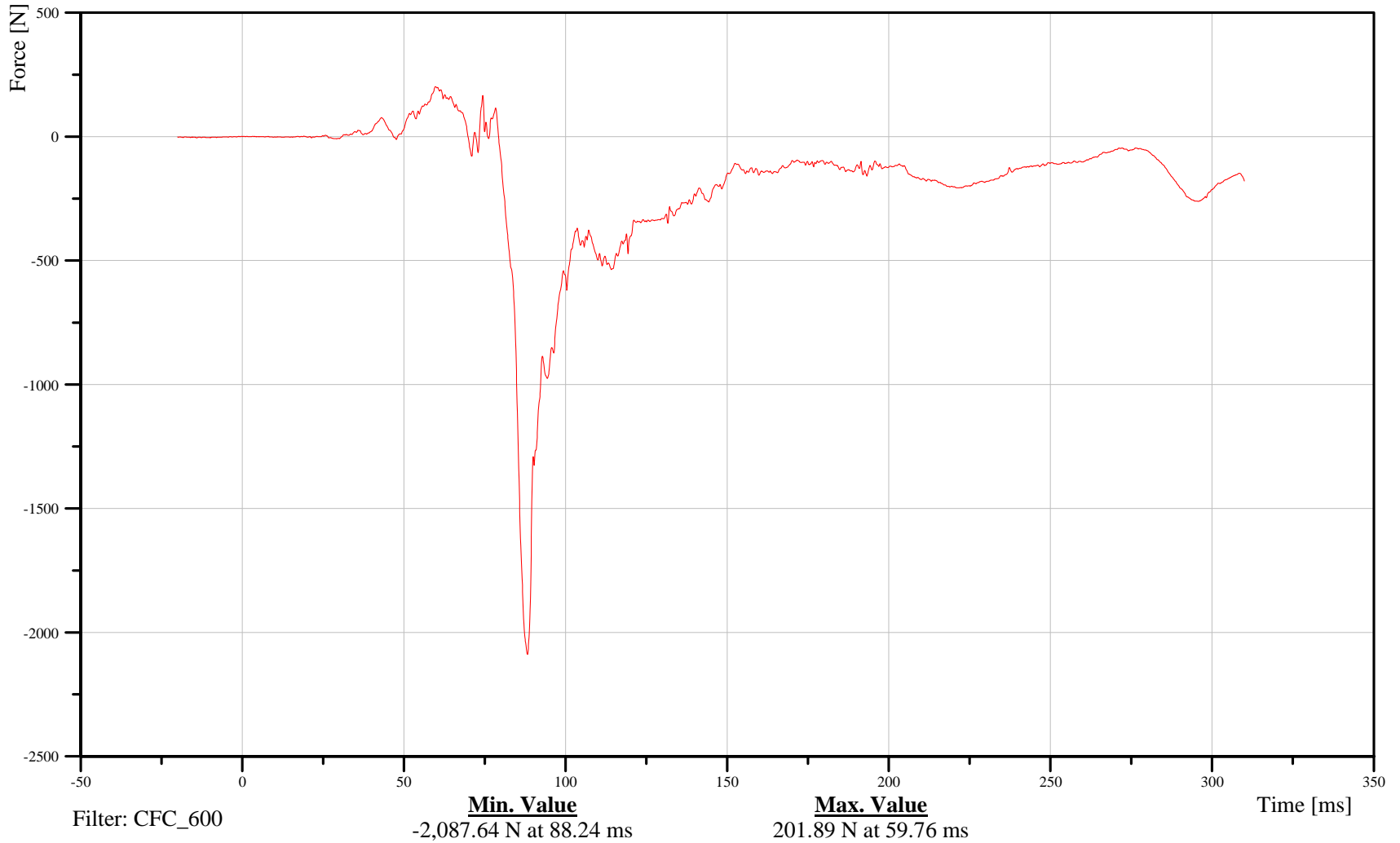

B-61

070913



2007 Ford F-250 into Left 40% Offset Deformable LCB at 56 kph

Date: 09/13/2007
Time: 15:46

Driver Right Upper Tibia Moment About X Axis

Customer: Volpe
Test Number: R70203

11TIBIRULXH3MOXB

TRC Inc. Test Lab: CTF
Test Number: 070913

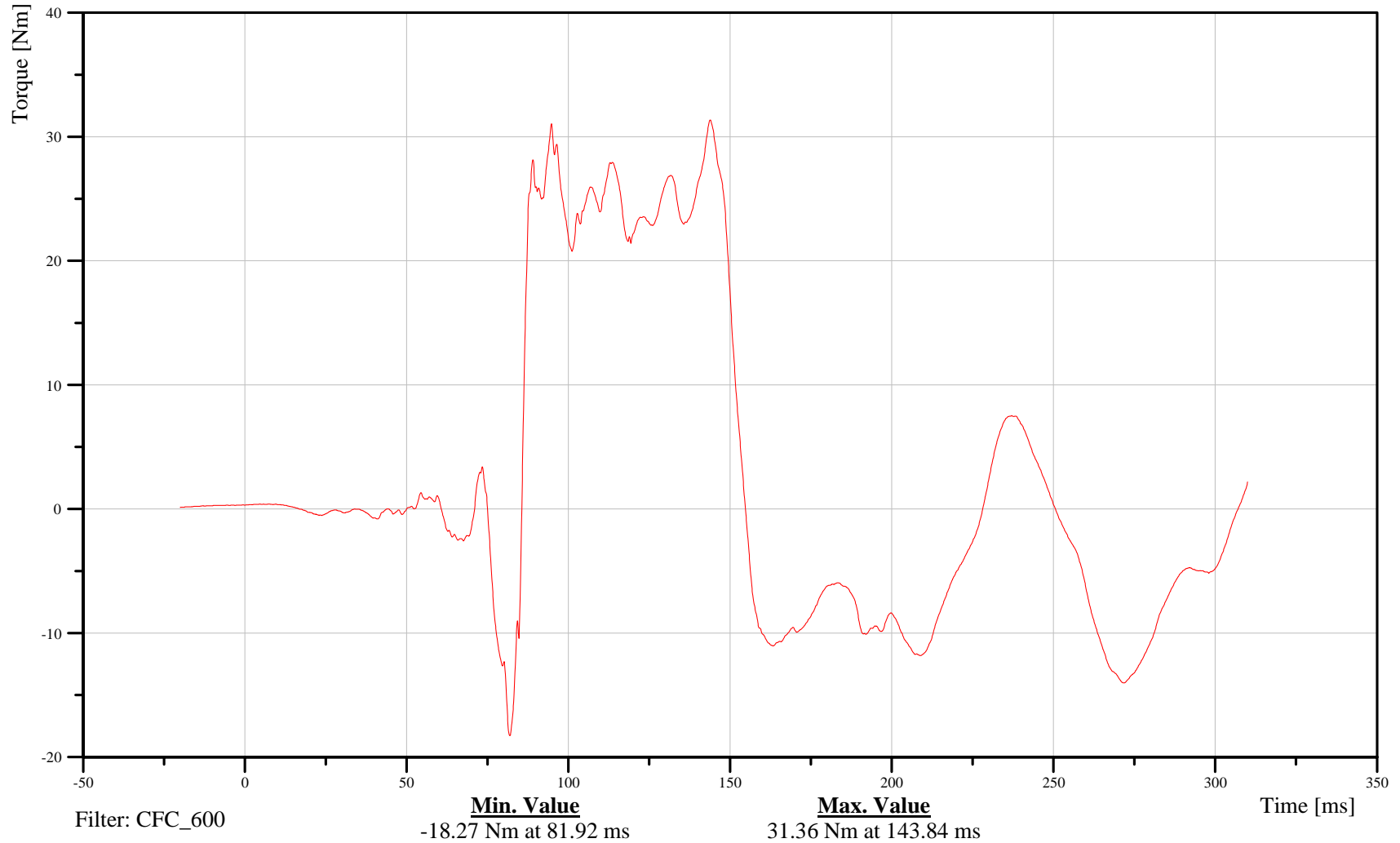

B-62

070913



2007 Ford F-250 into Left 40% Offset Deformable LCB at 56 kph

Date: 09/13/2007
Time: 15:46

Driver Right Upper Tibia Moment About Y Axis

Customer: Volpe
Test Number: R70203

11TIBIRULXH3MOYB

TRC Inc. Test Lab: CTF
Test Number: 070913

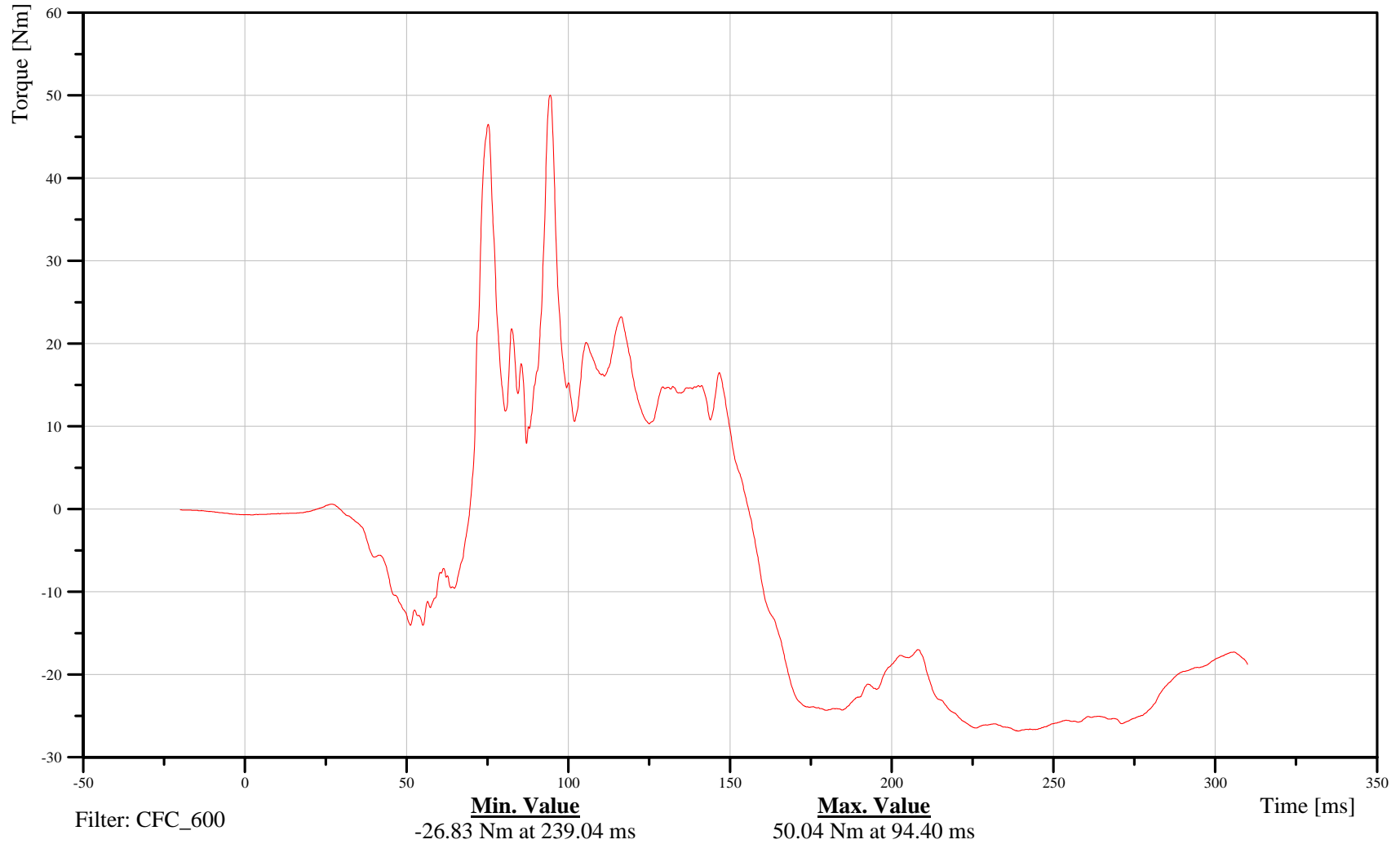

B-63

070913



2007 Ford F-250 into Left 40% Offset Deformable LCB at 56 kph

Date: 09/13/2007
Time: 15:46

Driver Right Tibia X-Axis Acceleration

Customer: Volpe
Test Number: R70203

11TIBIRILXH3ACXA

TRC Inc. Test Lab: CTF
Test Number: 070913

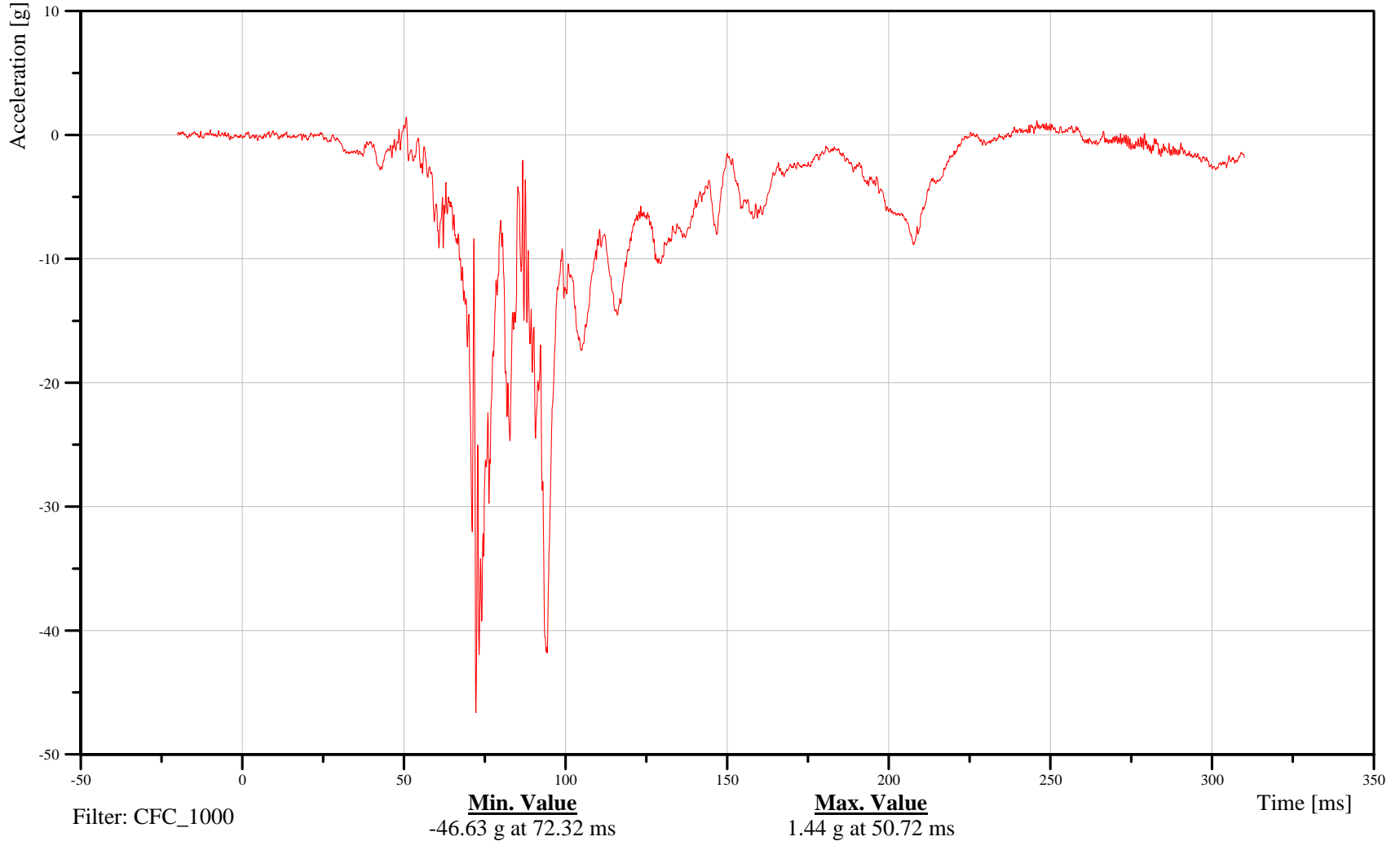

B-64

070913



2007 Ford F-250 into Left 40% Offset Deformable LCB at 56 kph

Date: 09/13/2007
Time: 15:46

Driver Right Tibia Y-Axis Acceleration

Customer: Volpe
Test Number: R70203

11TIBIRILXH3ACYA

TRC Inc. Test Lab: CTF
Test Number: 070913

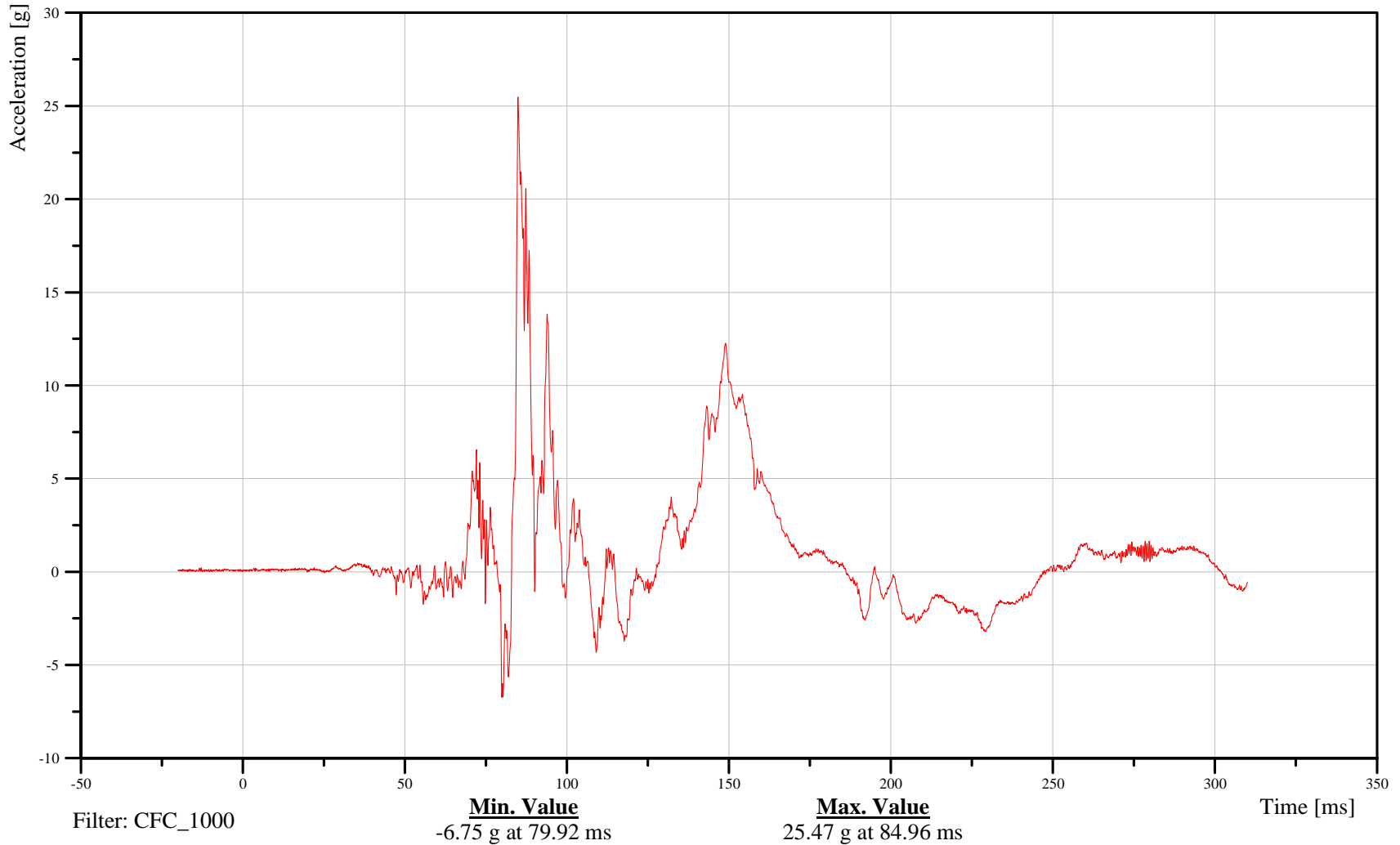

B-65

070913



2007 Ford F-250 into Left 40% Offset Deformable LCB at 56 kph

Date: 09/13/2007
Time: 15:46

Driver Right Lower Tibia X-Axis Force

Customer: Volpe
Test Number: R70203

11TIBIRLLXH3FOXB

TRC Inc. Test Lab: CTF
Test Number: 070913

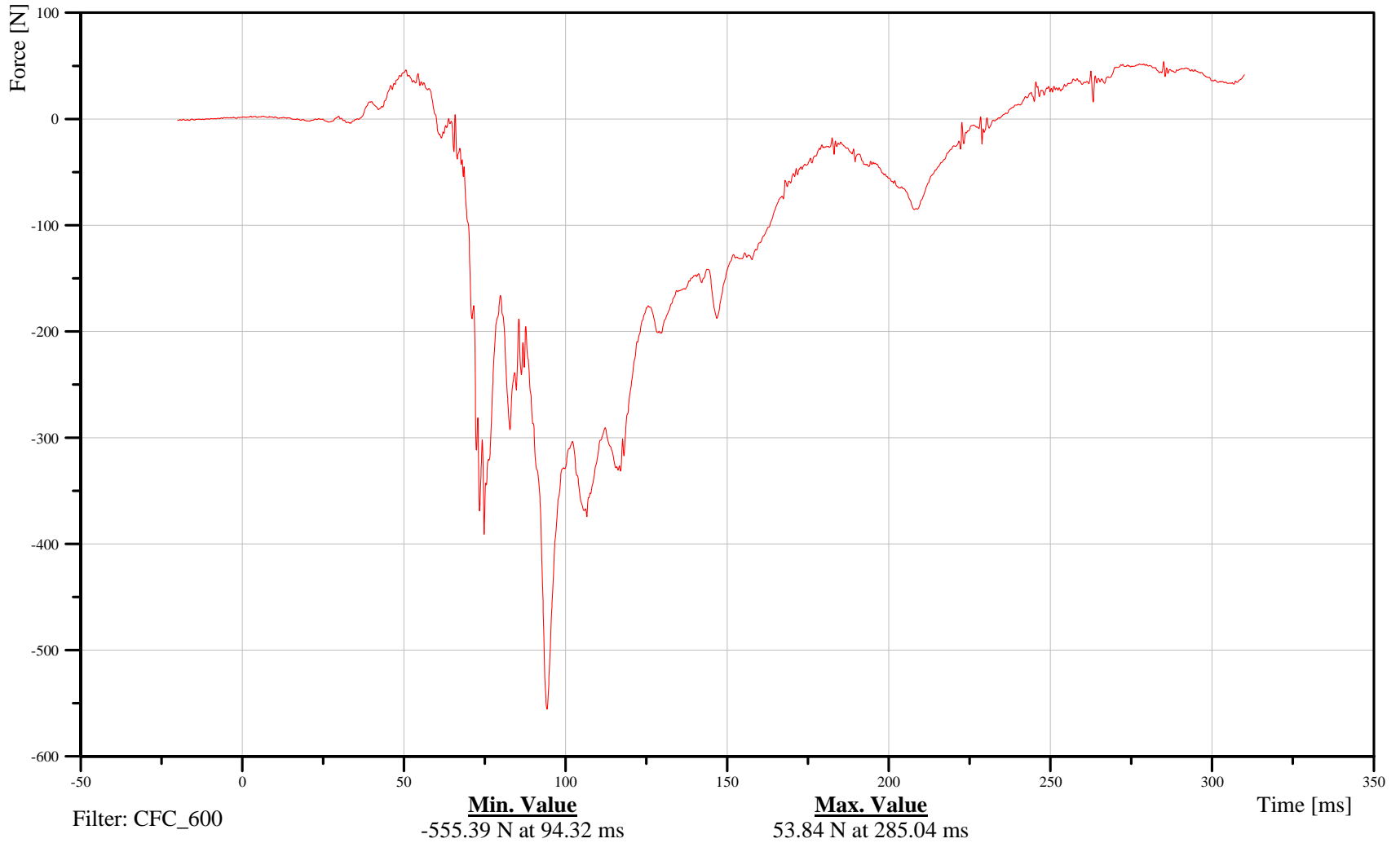

B-66

070913



2007 Ford F-250 into Left 40% Offset Deformable LCB at 56 kph

Date: 09/13/2007
Time: 15:46

Driver Right Lower Tibia Y-Axis Force

Customer: Volpe
Test Number: R70203

11TIBIRLLXH3FOYB

TRC Inc. Test Lab: CTF
Test Number: 070913

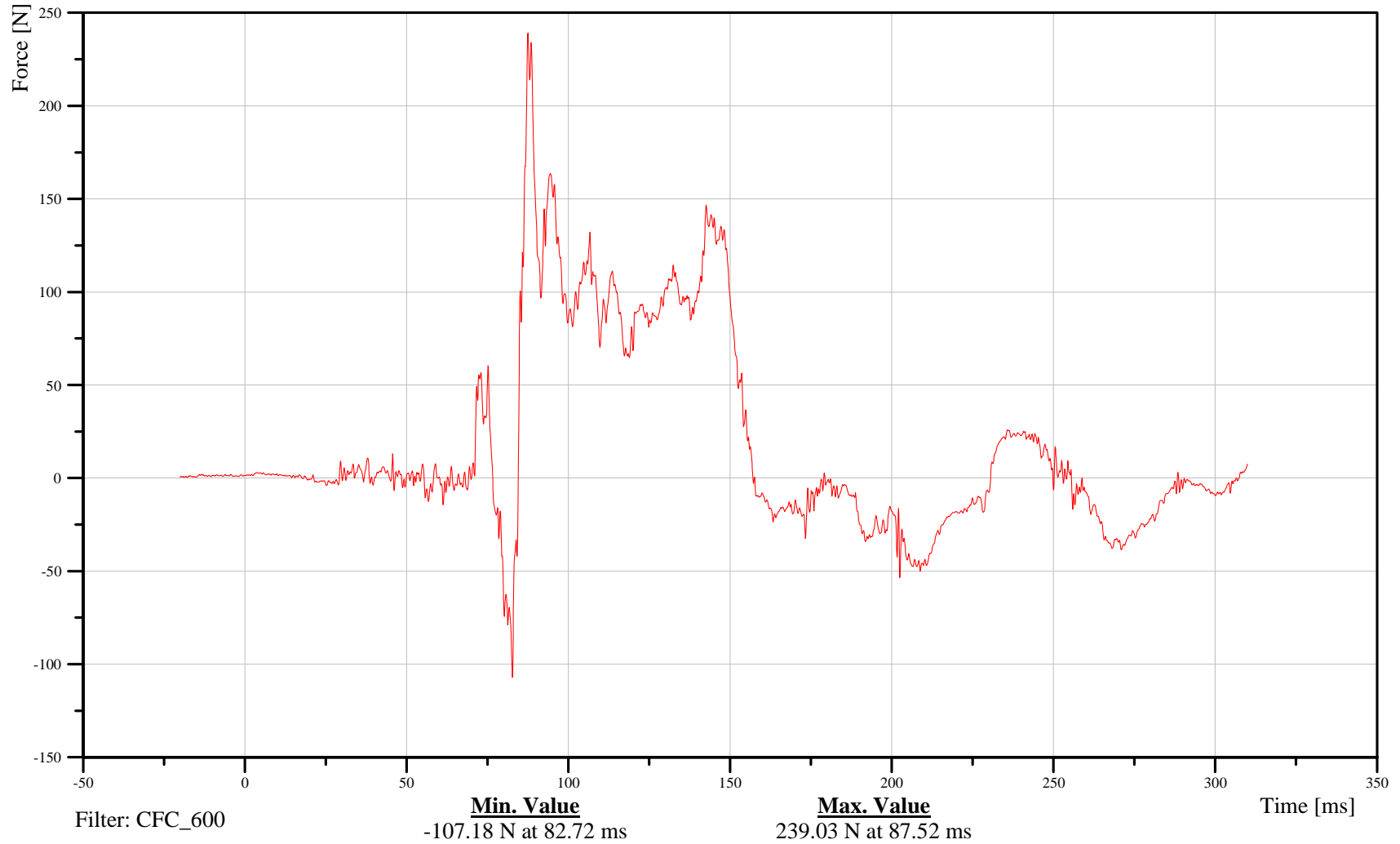

B-67

070913



2007 Ford F-250 into Left 40% Offset Deformable LCB at 56 kph

Date: 09/13/2007
Time: 15:46

Driver Right Lower Tibia Z-Axis Force

Customer: Volpe
Test Number: R70203

11TIBIRLLXH3FOZB

TRC Inc. Test Lab: CTF
Test Number: 070913

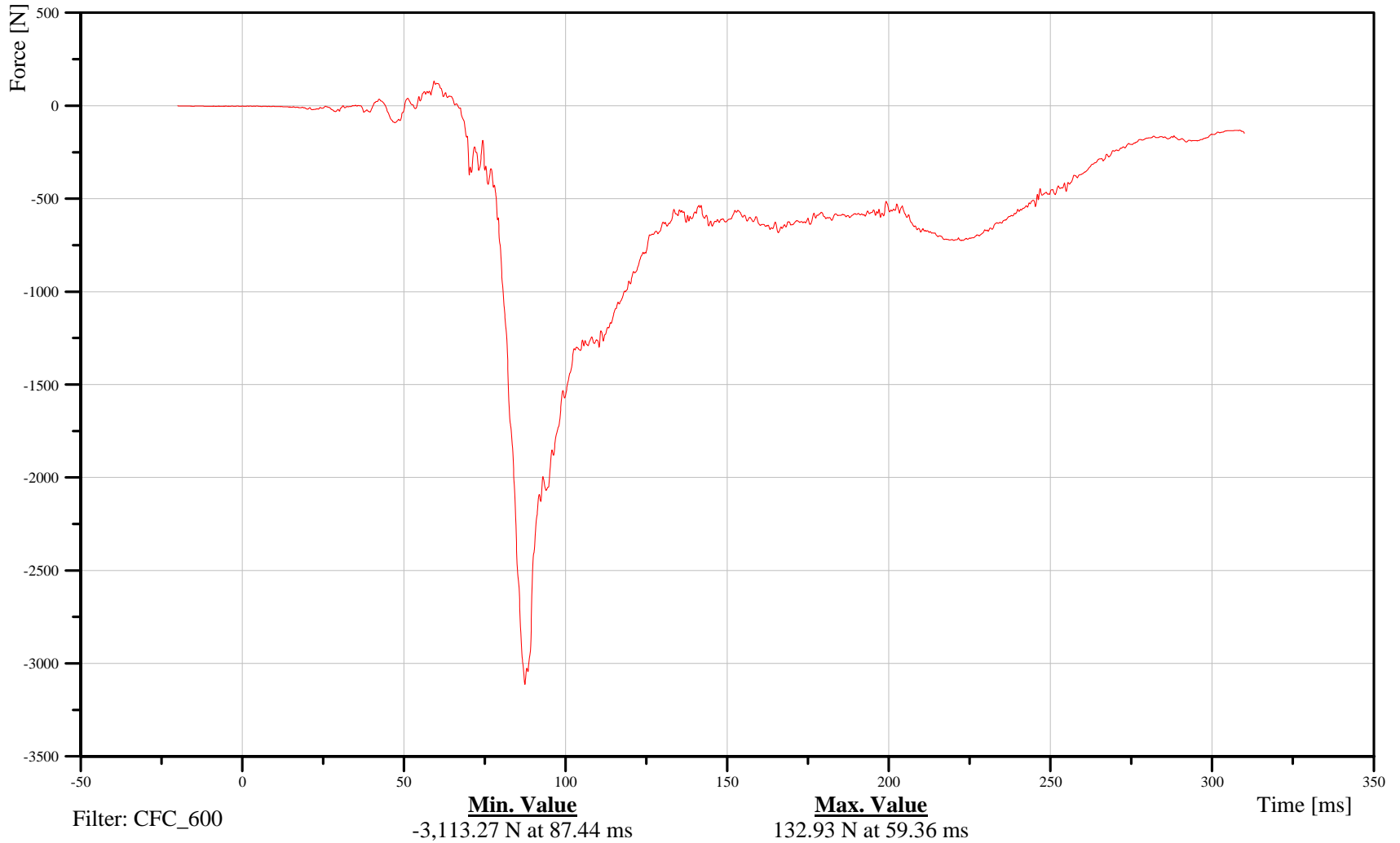

B-68

070913



2007 Ford F-250 into Left 40% Offset Deformable LCB at 56 kph

Date: 09/13/2007
Time: 15:46

Driver Right Lower Tibia Moment About X Axis

Customer: Volpe
Test Number: R70203

11TIBIRLLXH3MOXB

TRC Inc. Test Lab: CTF
Test Number: 070913

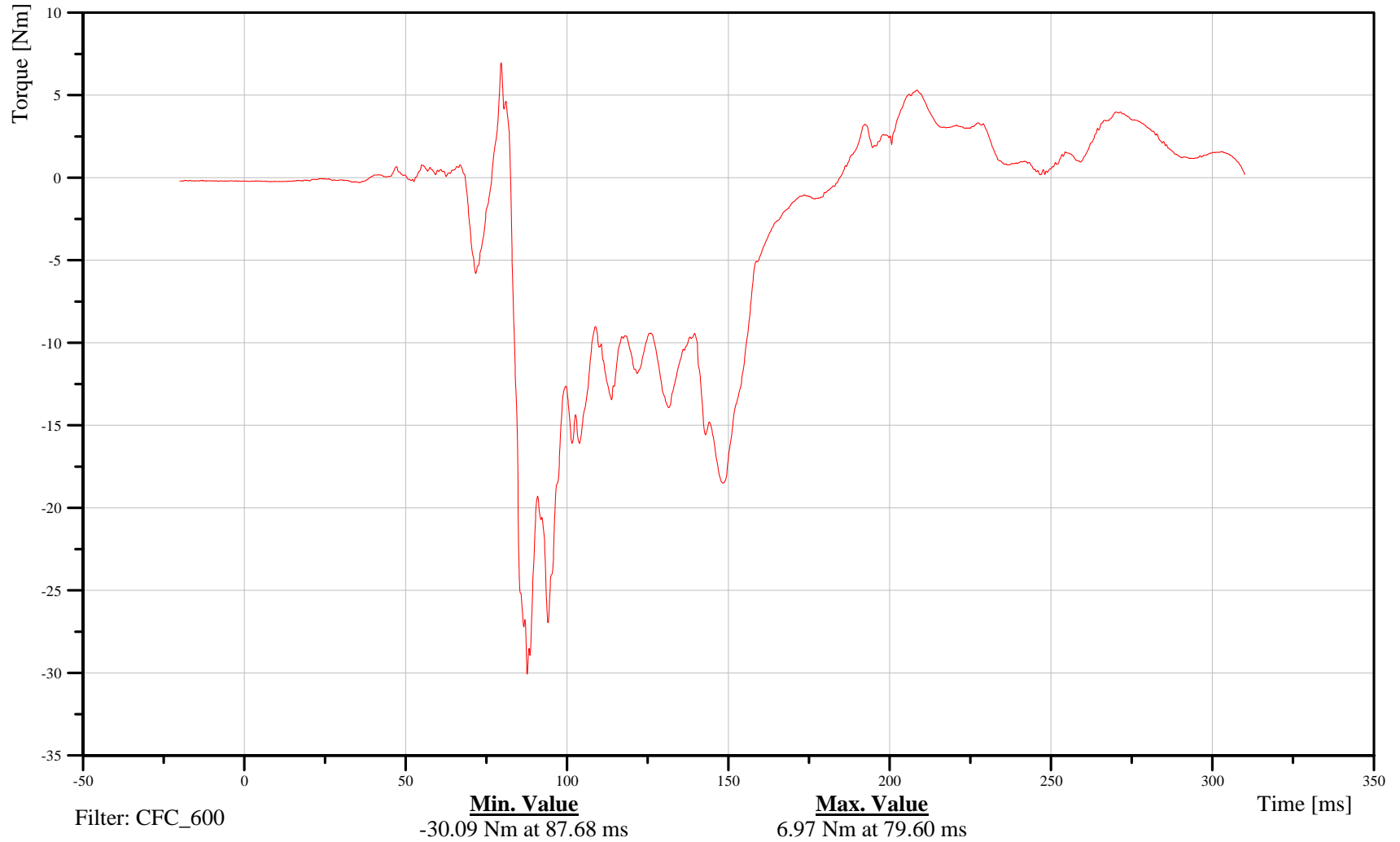

B-69

070913



2007 Ford F-250 into Left 40% Offset Deformable LCB at 56 kph

Date: 09/13/2007
Time: 15:46

Driver Right Lower Tibia Moment About Y Axis

Customer: Volpe
Test Number: R70203

11TIBIRLLXH3MOYB

TRC Inc. Test Lab: CTF
Test Number: 070913

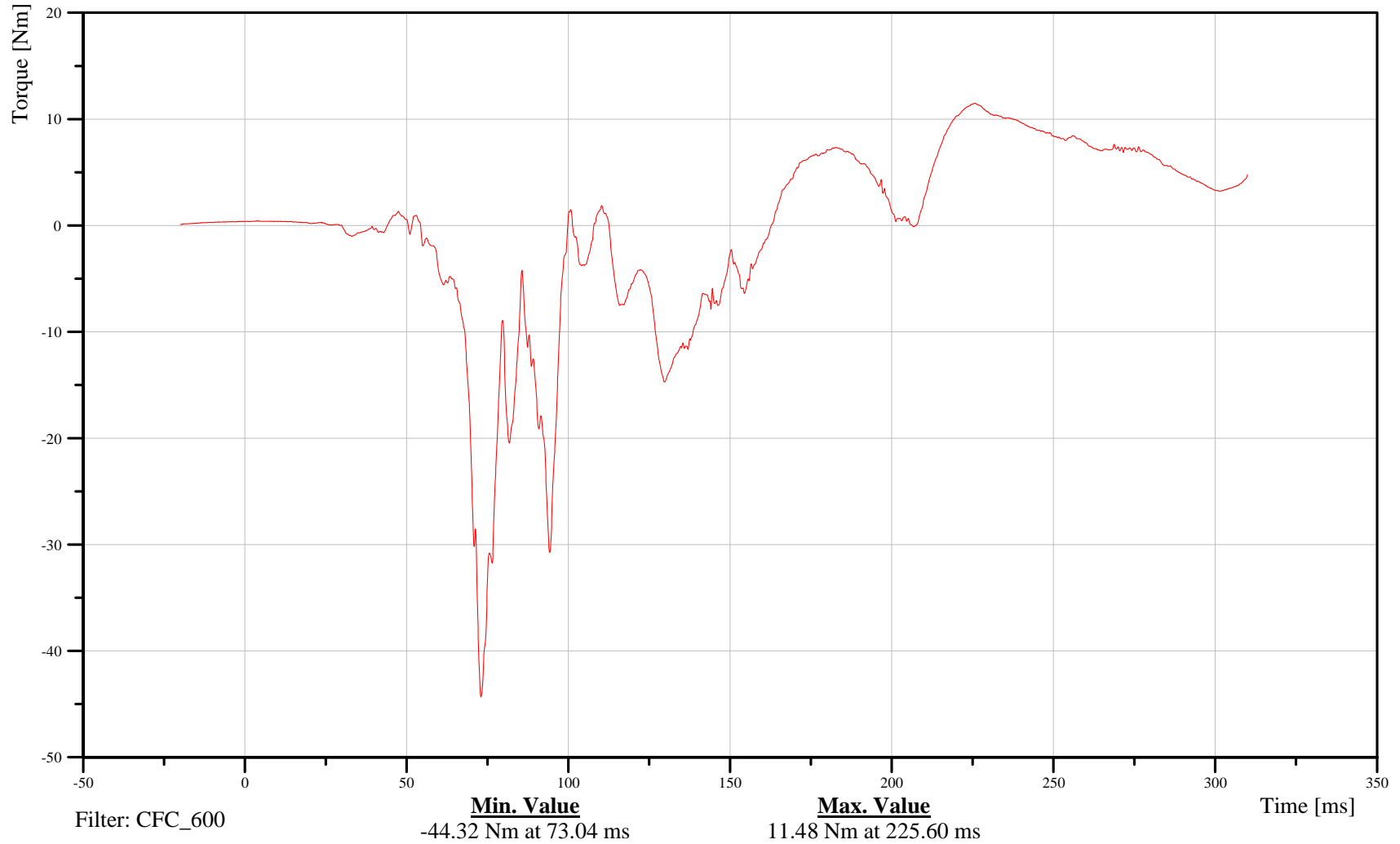

B-70

070913



2007 Ford F-250 into Left 40% Offset Deformable LCB at 56 kph

Date: 09/13/2007
Time: 15:46

Driver Right Foot X-Axis Rotation

Customer: Volpe
Test Number: R70203

11FOOTRILXH3ANXC

TRC Inc. Test Lab: CTF
Test Number: 070913

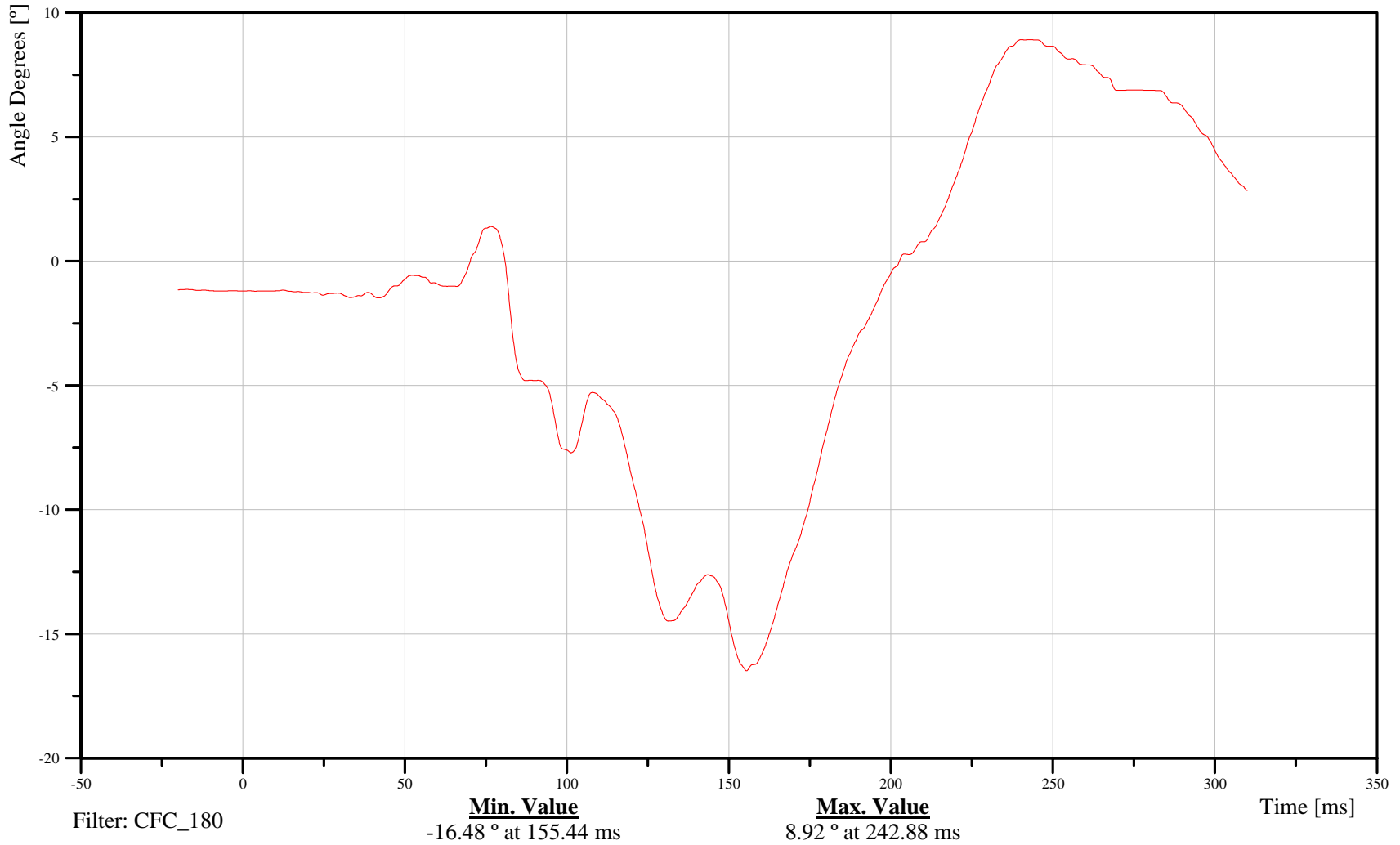

B-71

070913



2007 Ford F-250 into Left 40% Offset Deformable LCB at 56 kph

Date: 09/13/2007
Time: 15:46

Driver Right Foot Y-Axis Rotation

Customer: Volpe
Test Number: R70203

11FOOTRILXH3ANYC

TRC Inc. Test Lab: CTF
Test Number: 070913

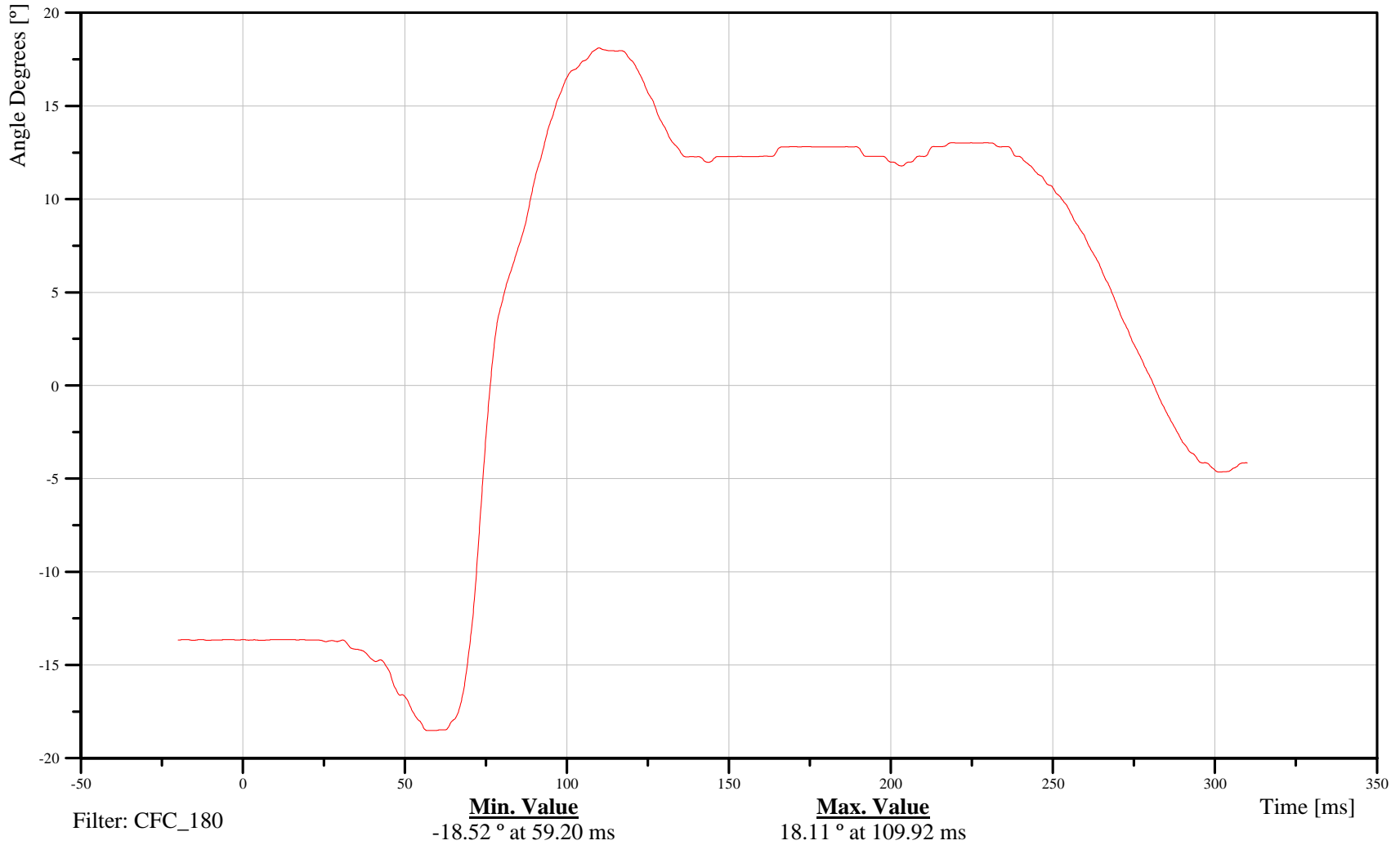

B-72

070913



2007 Ford F-250 into Left 40% Offset Deformable LCB at 56 kph

Date: 09/13/2007
Time: 15:46

Driver Right Foot Z-Axis Rotation

Customer: Volpe
Test Number: R70203

11FOOTRILXH3ANZC

TRC Inc. Test Lab: CTF
Test Number: 070913

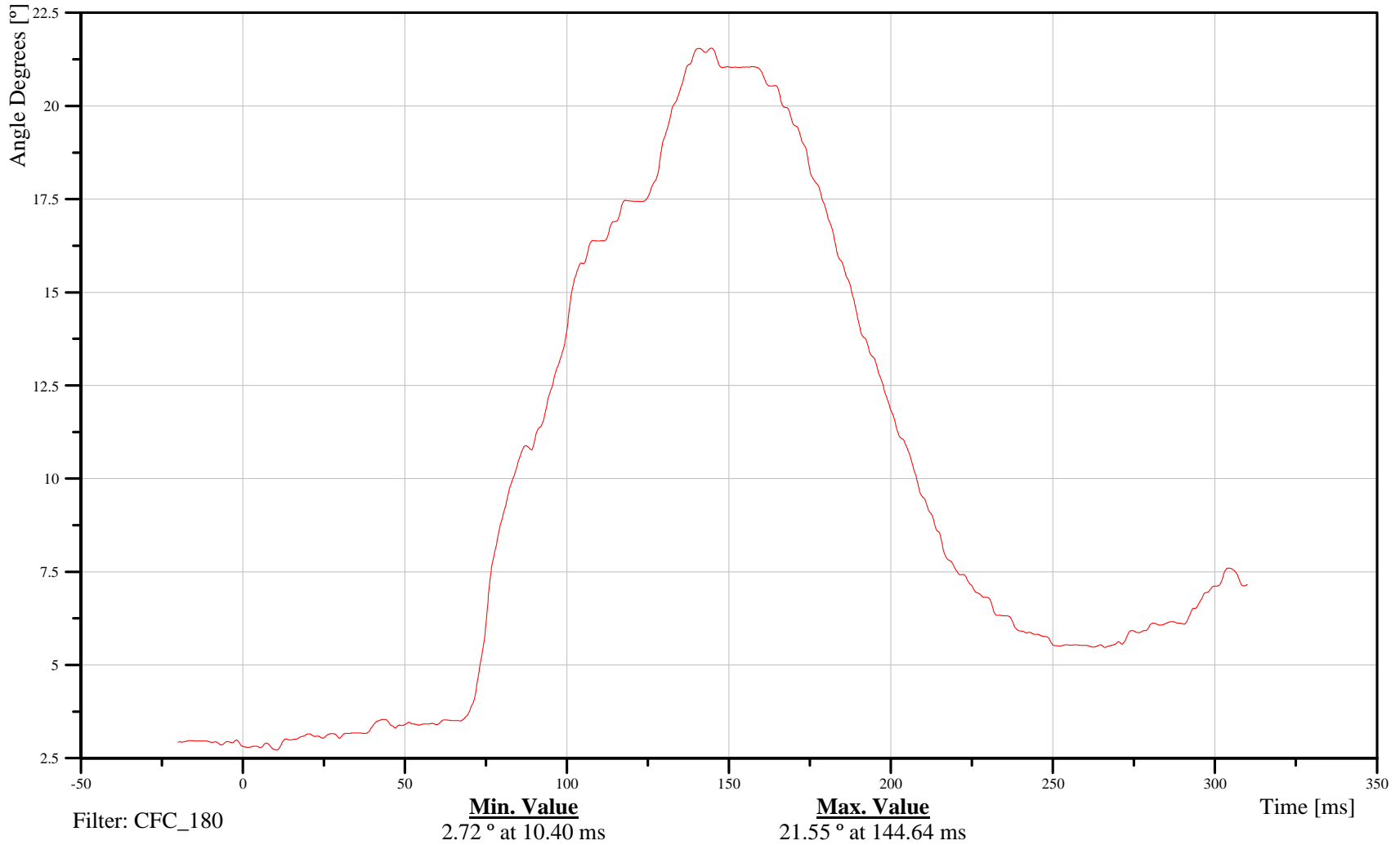

B-73

070913



2007 Ford F-250 into Left 40% Offset Deformable LCB at 56 kph

Date: 09/13/2007
Time: 15:46

Driver Right Foot X-Axis Acceleration

Customer: Volpe
Test Number: R70203

11FOOTRILXH3ACXA

TRC Inc. Test Lab: CTF
Test Number: 070913

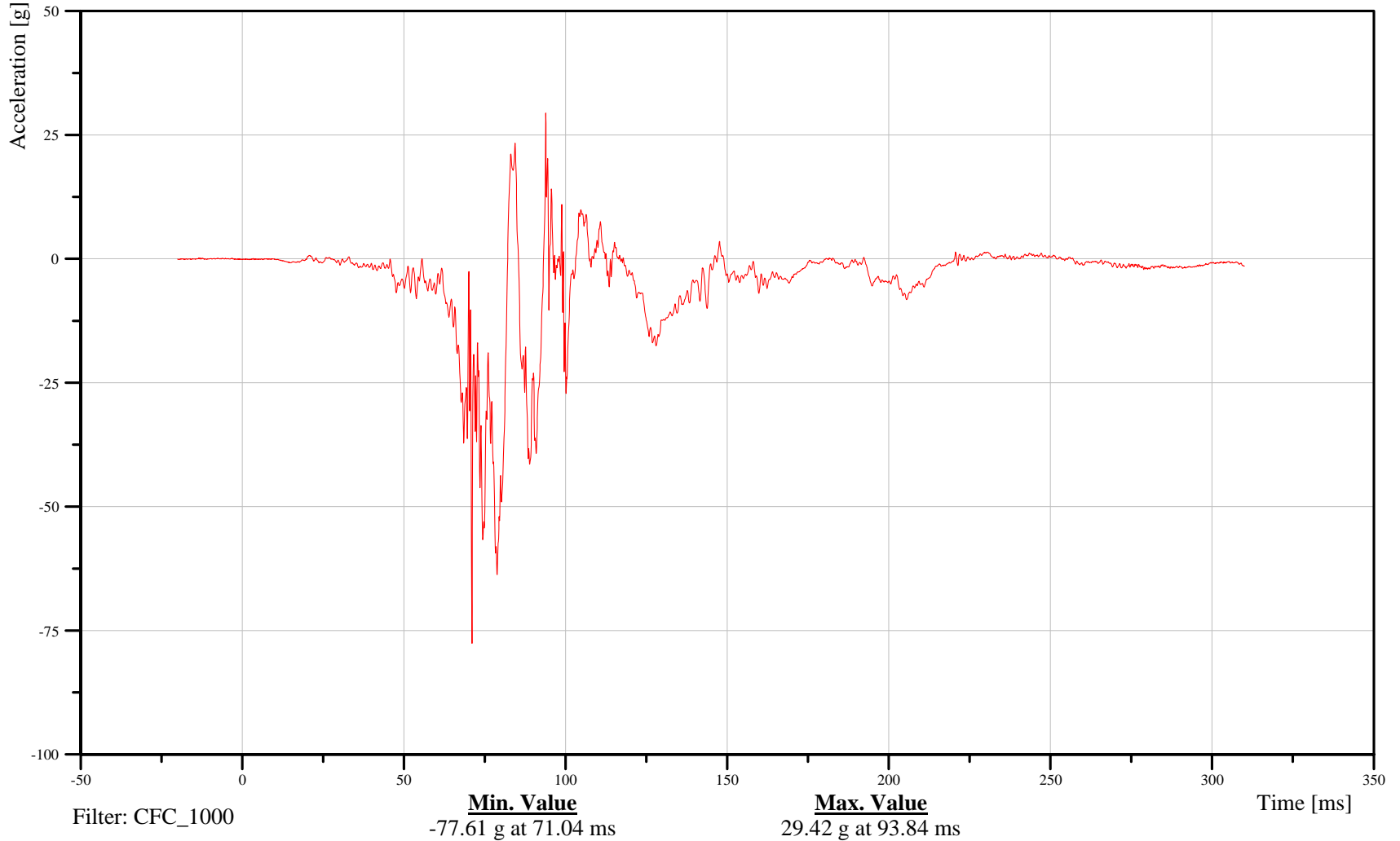

B-74

070913



2007 Ford F-250 into Left 40% Offset Deformable LCB at 56 kph

Date: 09/13/2007
Time: 15:46

Driver Right Foot Y-Axis Acceleration

Customer: Volpe
Test Number: R70203

11FOOTRILXH3ACYA

TRC Inc. Test Lab: CTF
Test Number: 070913

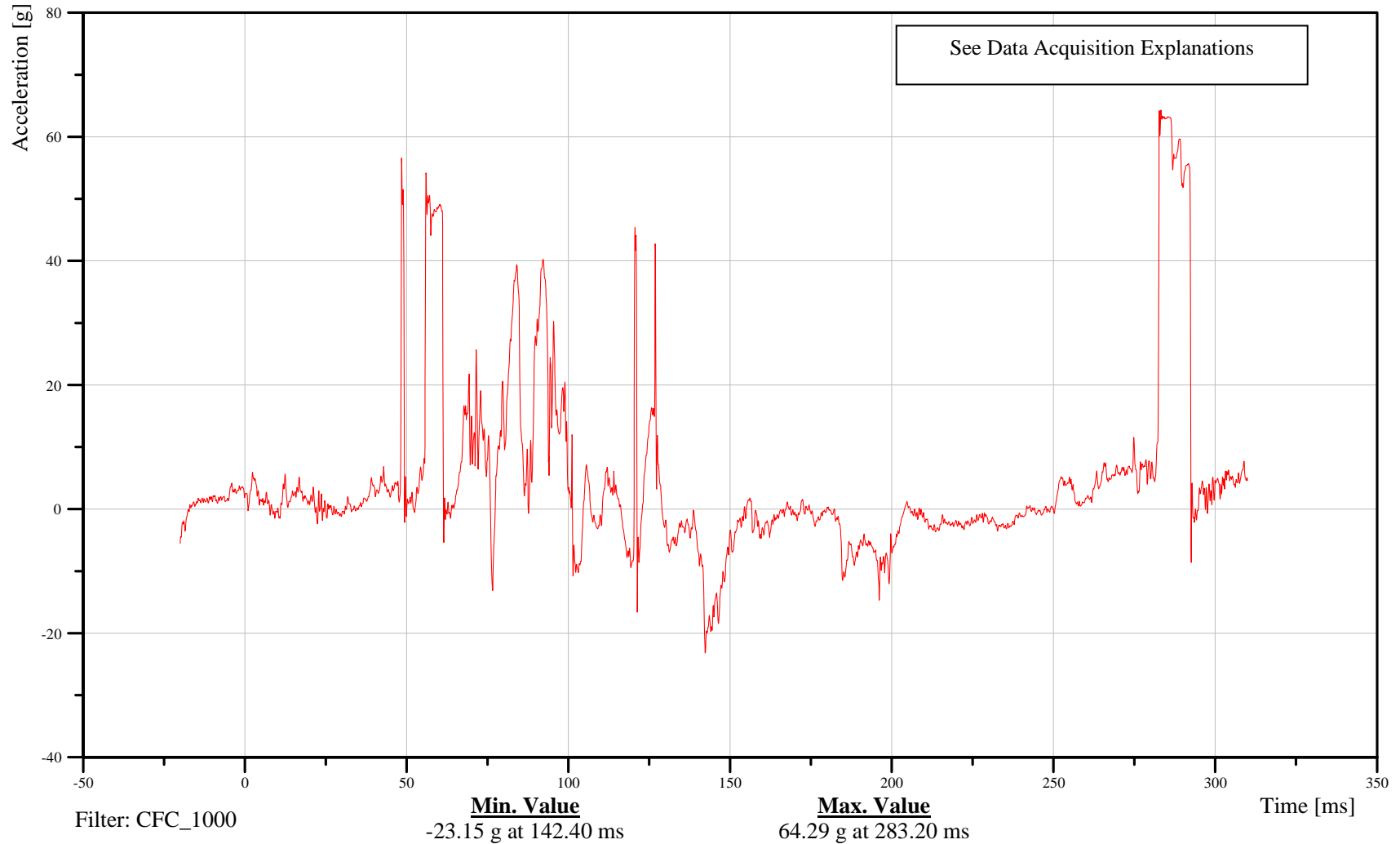

B-75

070913



2007 Ford F-250 into Left 40% Offset Deformable LCB at 56 kph

Date: 09/13/2007
Time: 15:46

Driver Right Foot Z-Axis Acceleration

Customer: Volpe
Test Number: R70203

11FOOTRILXH3ACZA

TRC Inc. Test Lab: CTF
Test Number: 070913

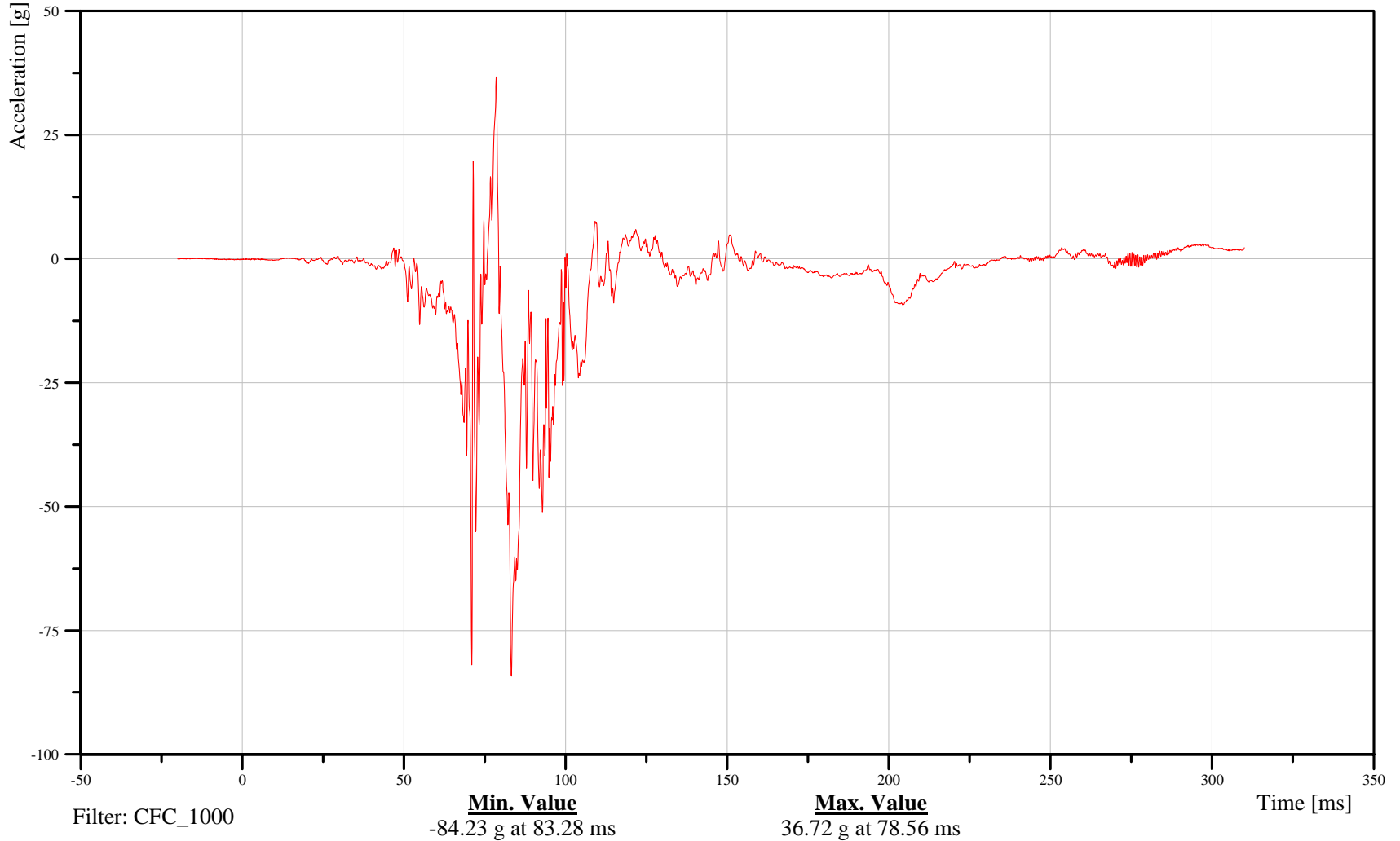

B-76

070913



2007 Ford F-250 into Left 40% Offset Deformable LCB at 56 kph

Date: 09/13/2007
Time: 15:46

Driver Right Foot Resultant Acceleration

Customer: Volpe
Test Number: R70203

11FOOTRILXH3ACRA

TRC Inc. Test Lab: CTF
Test Number: 070913

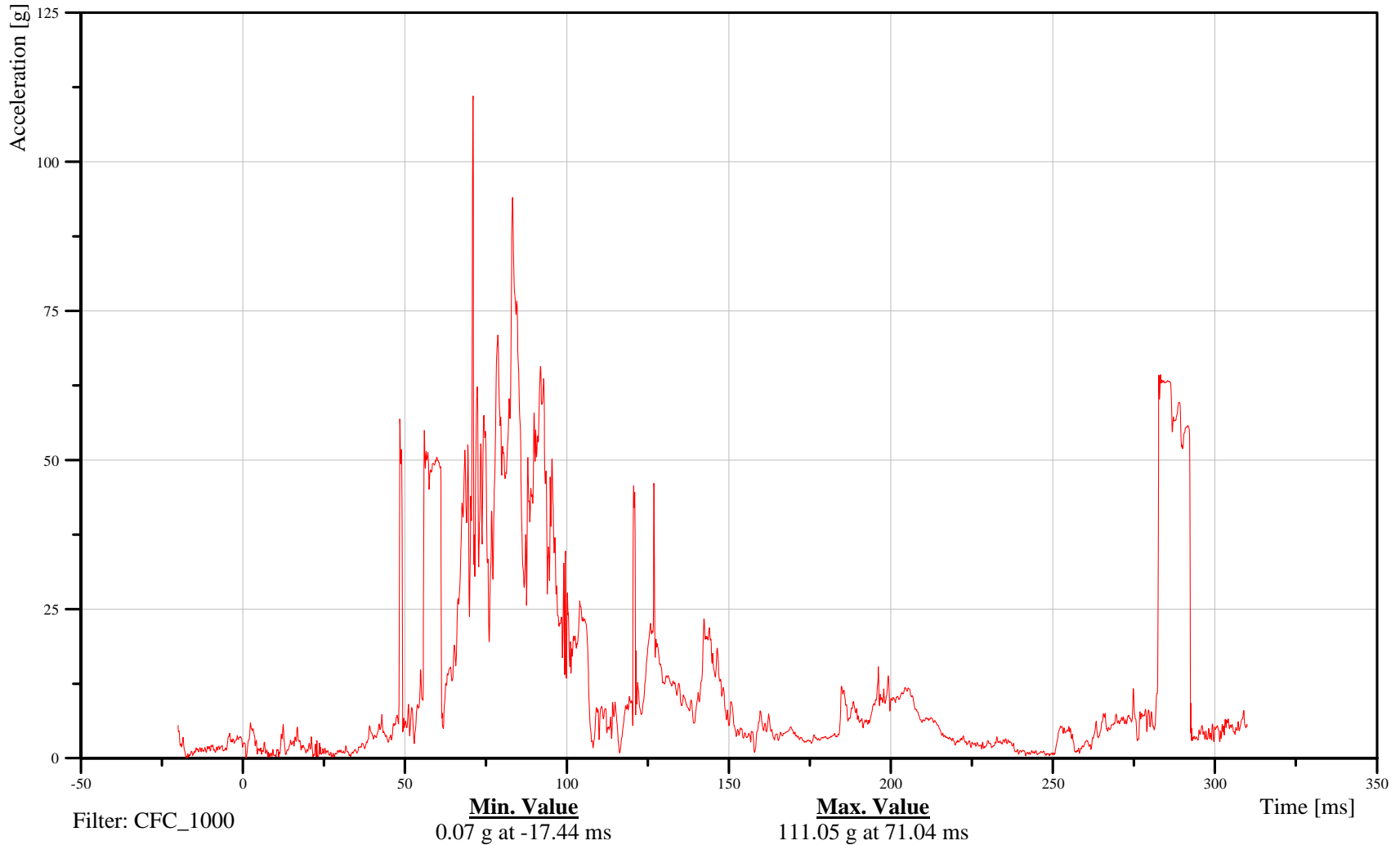

B-77

070913



2007 Ford F-250 into Left 40% Offset Deformable LCB at 56 kph

Date: 09/13/2007
Time: 15:46

Passenger Head X-Axis Acceleration

Customer: Volpe
Test Number: R70203

13HEADCG00H3ACXA

TRC Inc. Test Lab: CTF
Test Number: 070913

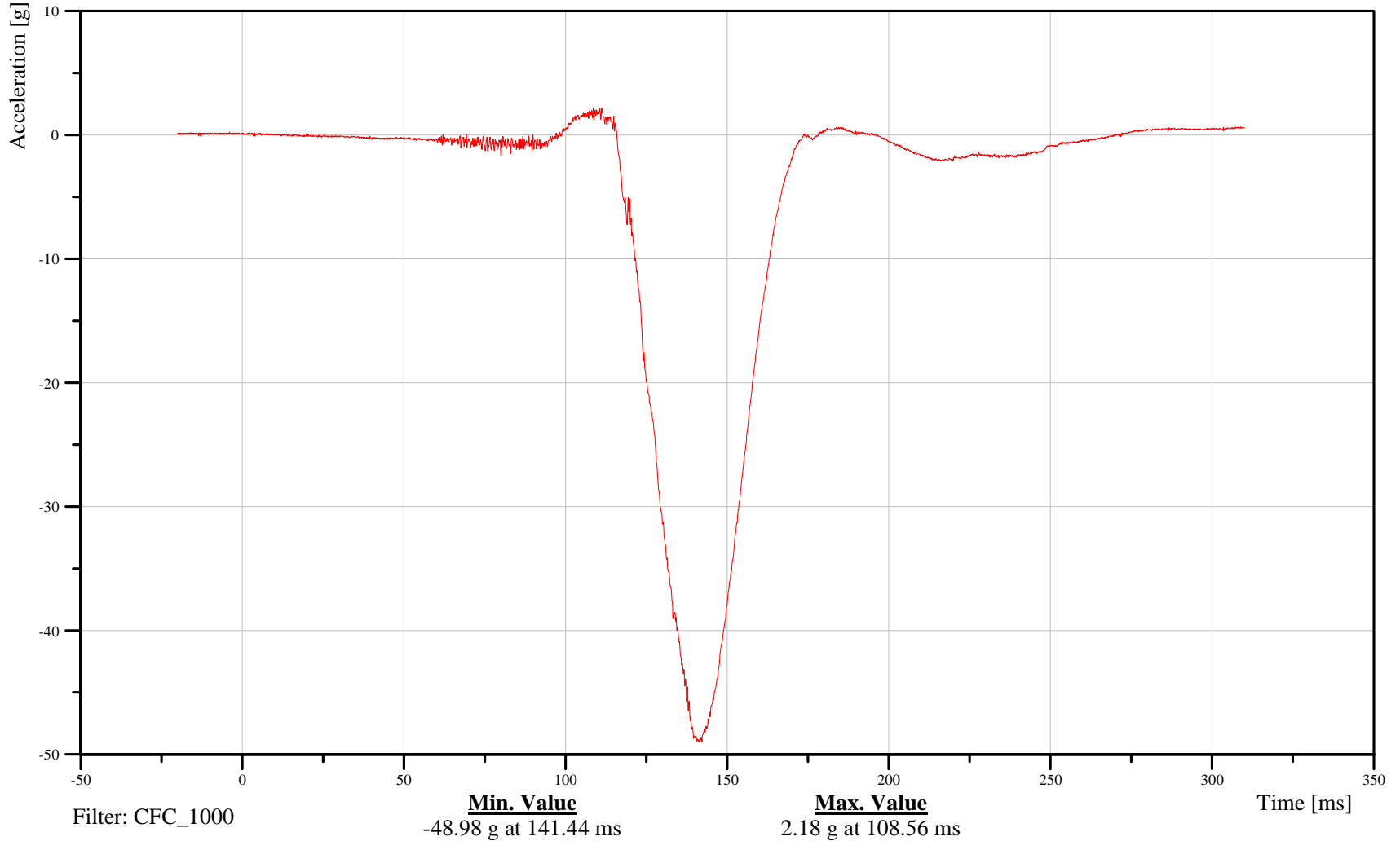

B-78

070913



2007 Ford F-250 into Left 40% Offset Deformable LCB at 56 kph

Date: 09/13/2007
Time: 15:46

Passenger Head Y-Axis Acceleration

Customer: Volpe
Test Number: R70203

13HEADCG00H3ACYA

TRC Inc. Test Lab: CTF
Test Number: 070913

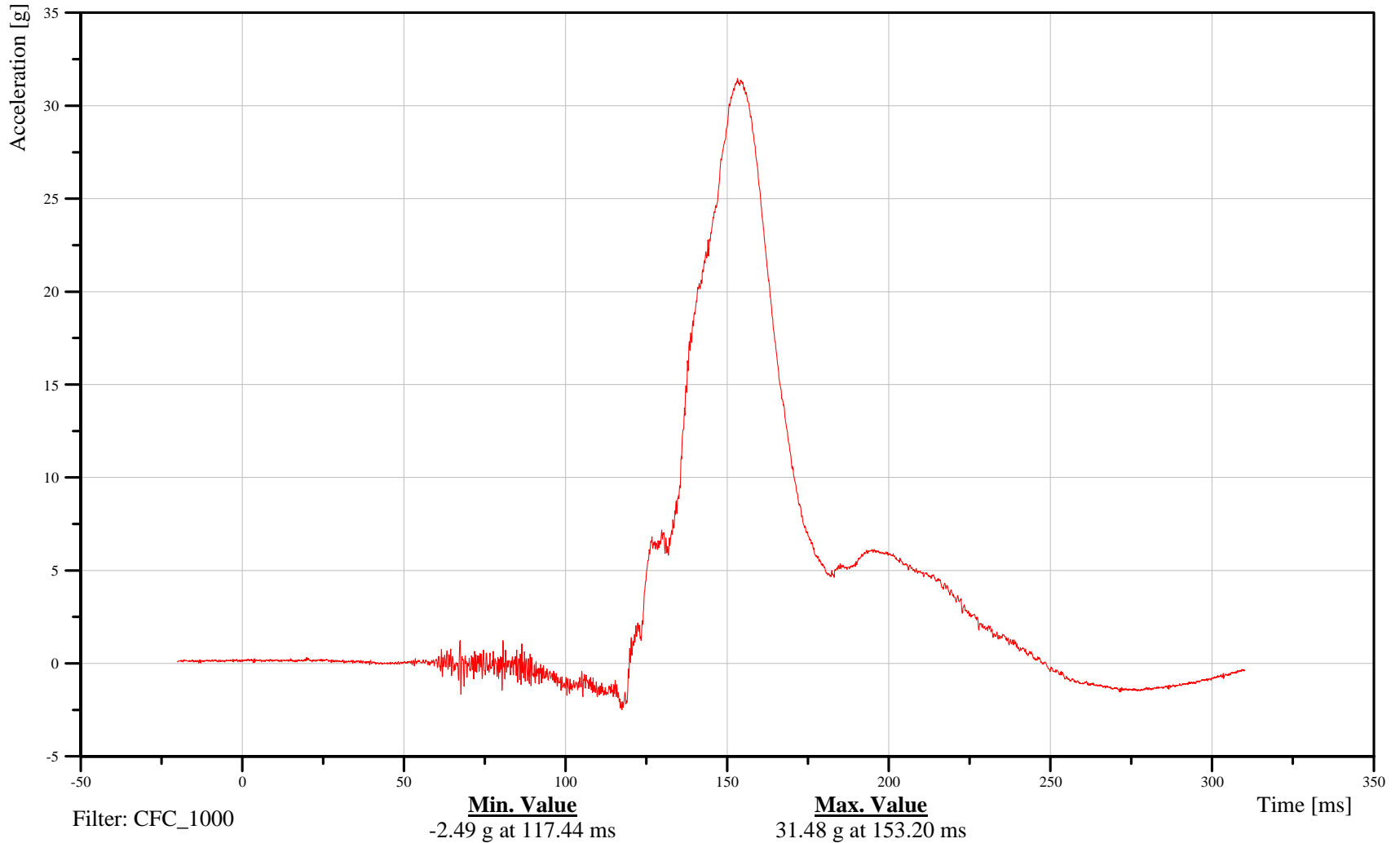

B-79

070913



2007 Ford F-250 into Left 40% Offset Deformable LCB at 56 kph

Date: 09/13/2007
Time: 15:46

Passenger Head Z-Axis Acceleration

Customer: Volpe
Test Number: R70203

13HEADCG00H3ACZA

TRC Inc. Test Lab: CTF
Test Number: 070913

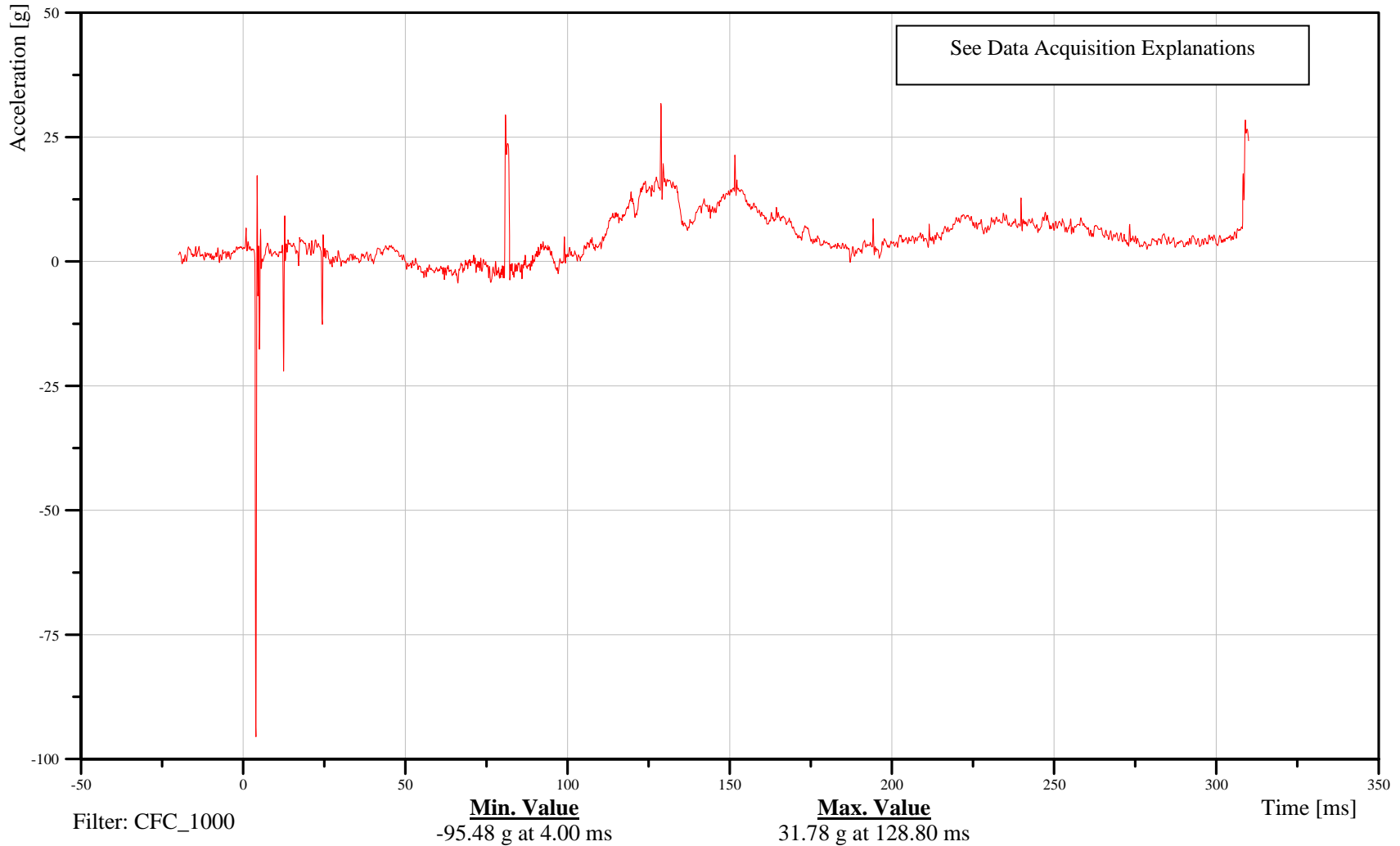

B-80

070913



2007 Ford F-250 into Left 40% Offset Deformable LCB at 56 kph

Date: 09/13/2007
Time: 15:46

Passenger Head Resultant Acceleration

Customer: Volpe
Test Number: R70203

13HEADCG00H3ACRA

TRC Inc. Test Lab: CTF
Test Number: 070913

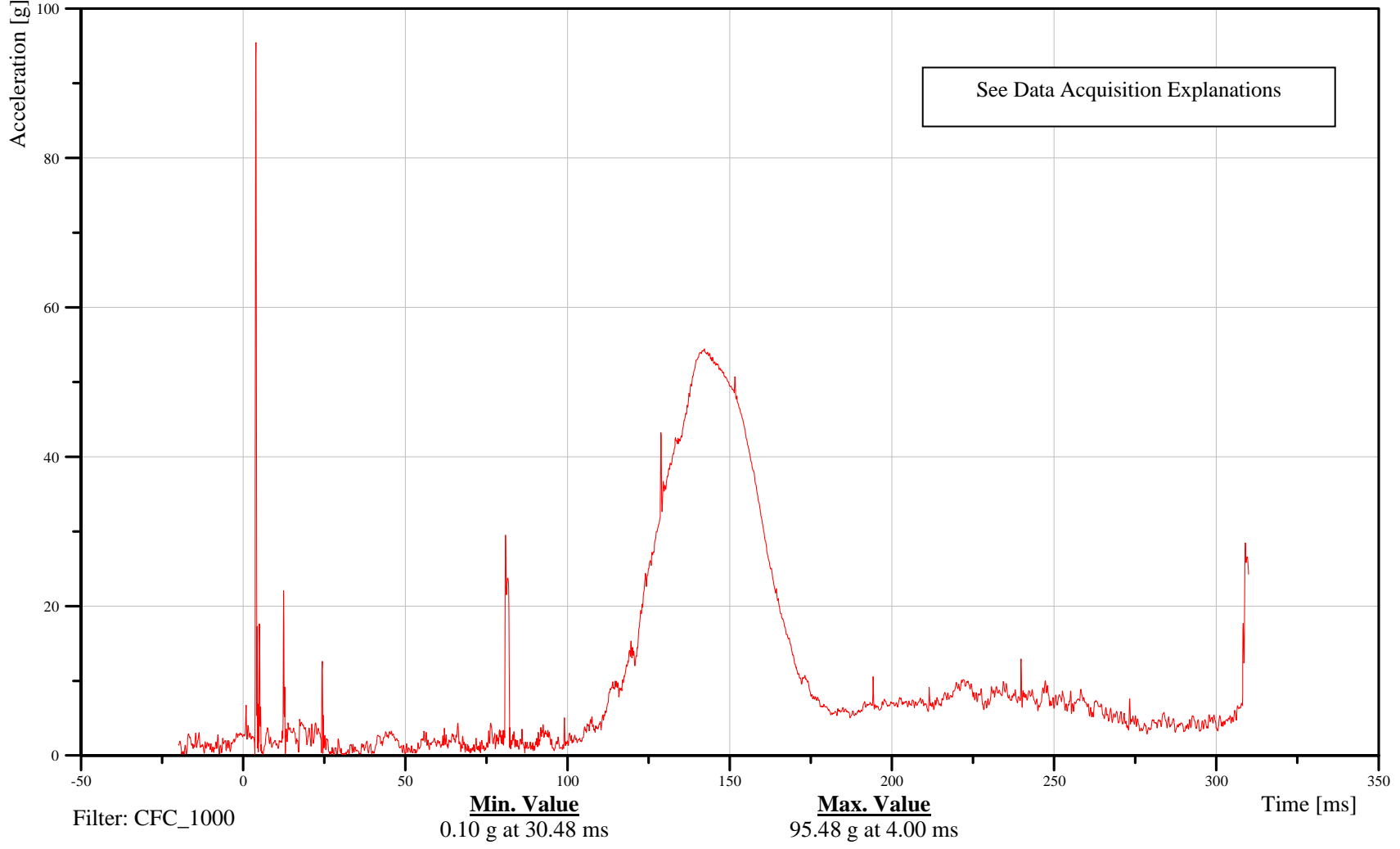

B-81

070913



2007 Ford F-250 into Left 40% Offset Deformable LCB at 56 kph

Date: 09/13/2007
Time: 15:46

Passenger Head X-Axis Redundant Acceleration

Customer: Volpe
Test Number: R70203

13HEADCGRDH3ACXA

TRC Inc. Test Lab: CTF
Test Number: 070913

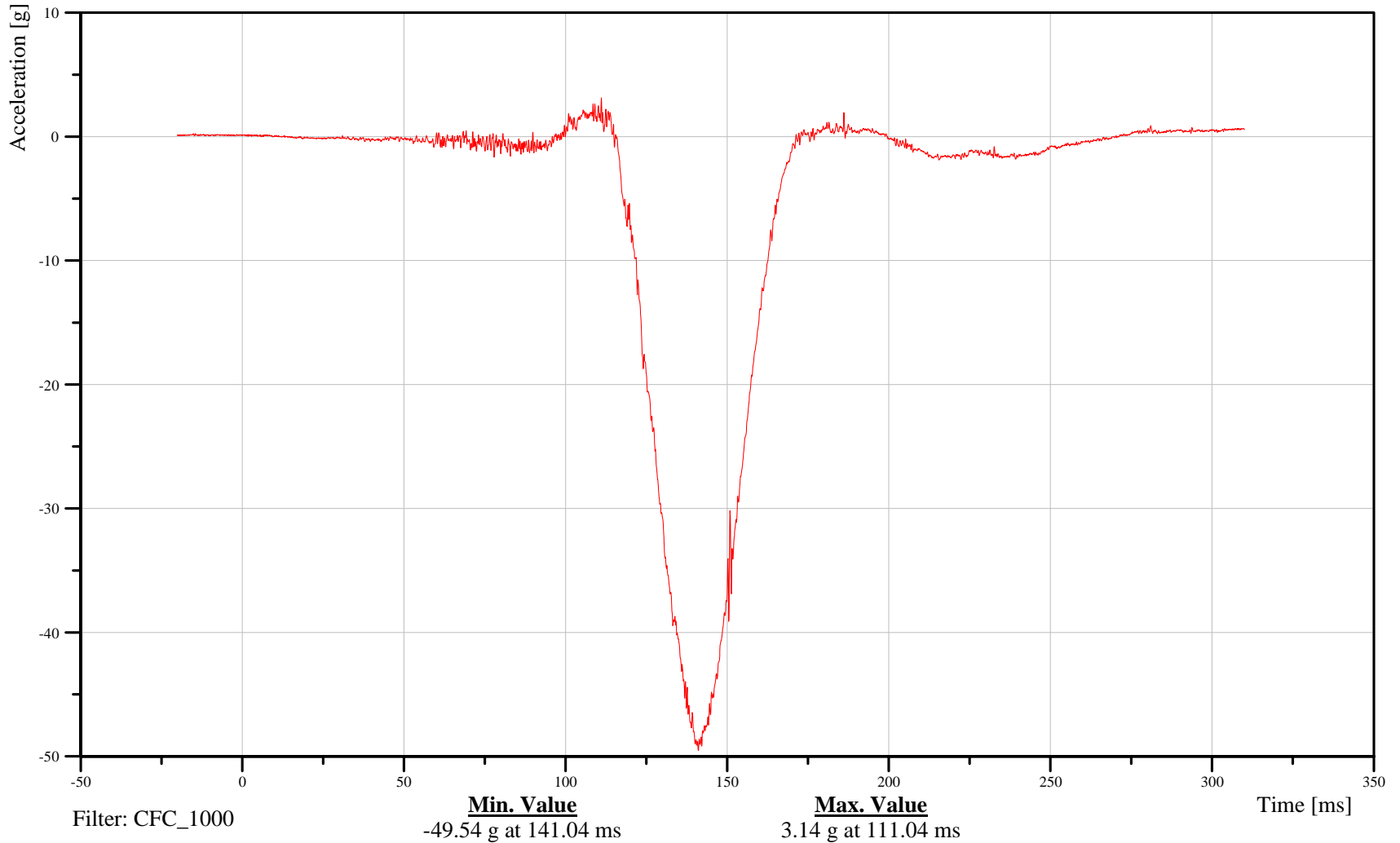

B-82

070913



2007 Ford F-250 into Left 40% Offset Deformable LCB at 56 kph

Date: 09/13/2007
Time: 15:46

Passenger Head Y-Axis Redundant Acceleration

Customer: Volpe
Test Number: R70203

13HEADCGRDH3ACYA

TRC Inc. Test Lab: CTF
Test Number: 070913

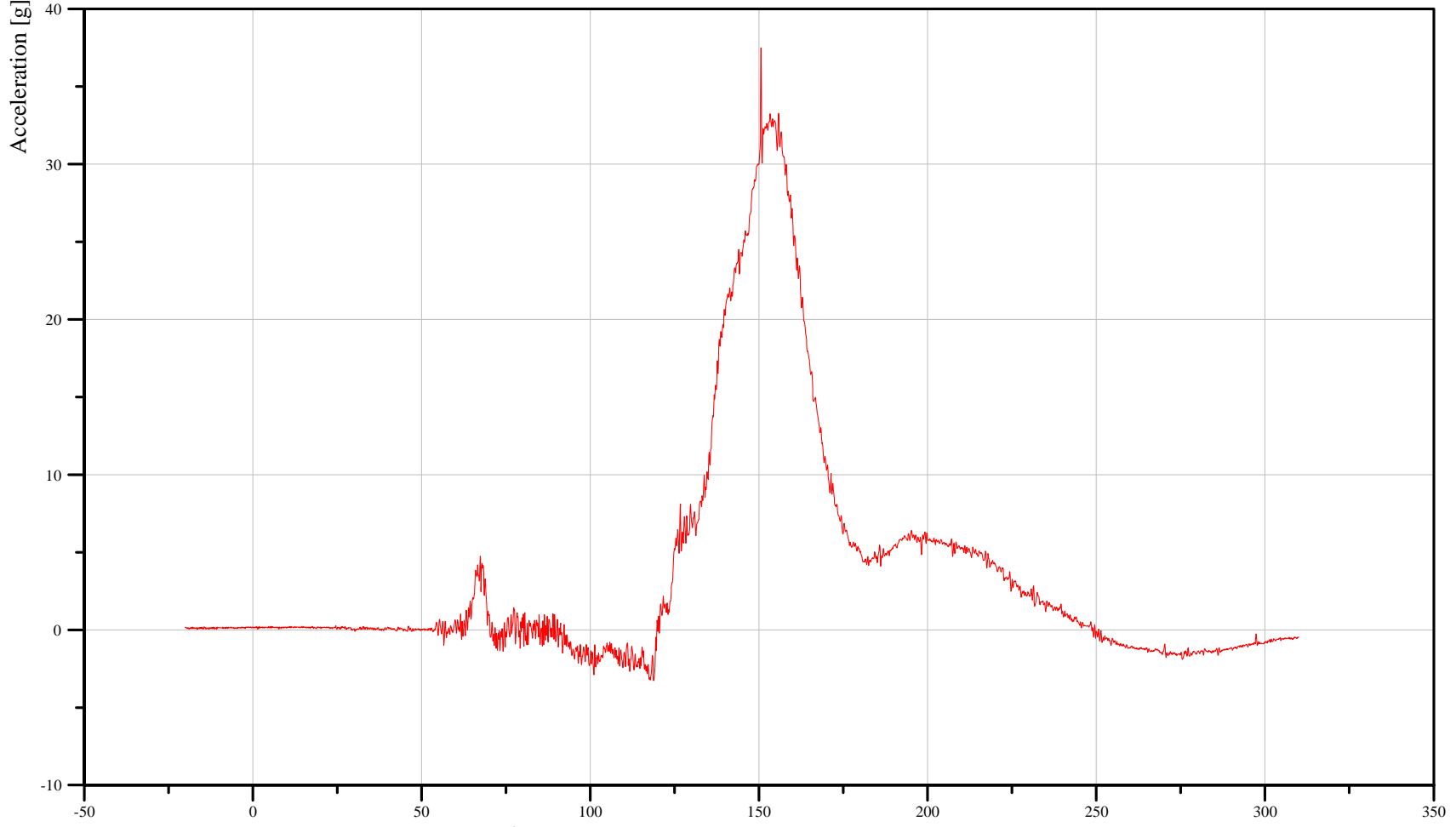

Filter: CFC_1000

Min. Value
-3.27 g at 118.80 ms

Max. Value
37.51 g at 150.64 ms

Time [ms]

B-83

070913



2007 Ford F-250 into Left 40% Offset Deformable LCB at 56 kph

Date: 09/13/2007
Time: 15:46

Passenger Head Z-Axis Redundant Acceleration

Customer: Volpe
Test Number: R70203

13HEADCGRDH3ACZA

TRC Inc. Test Lab: CTF
Test Number: 070913

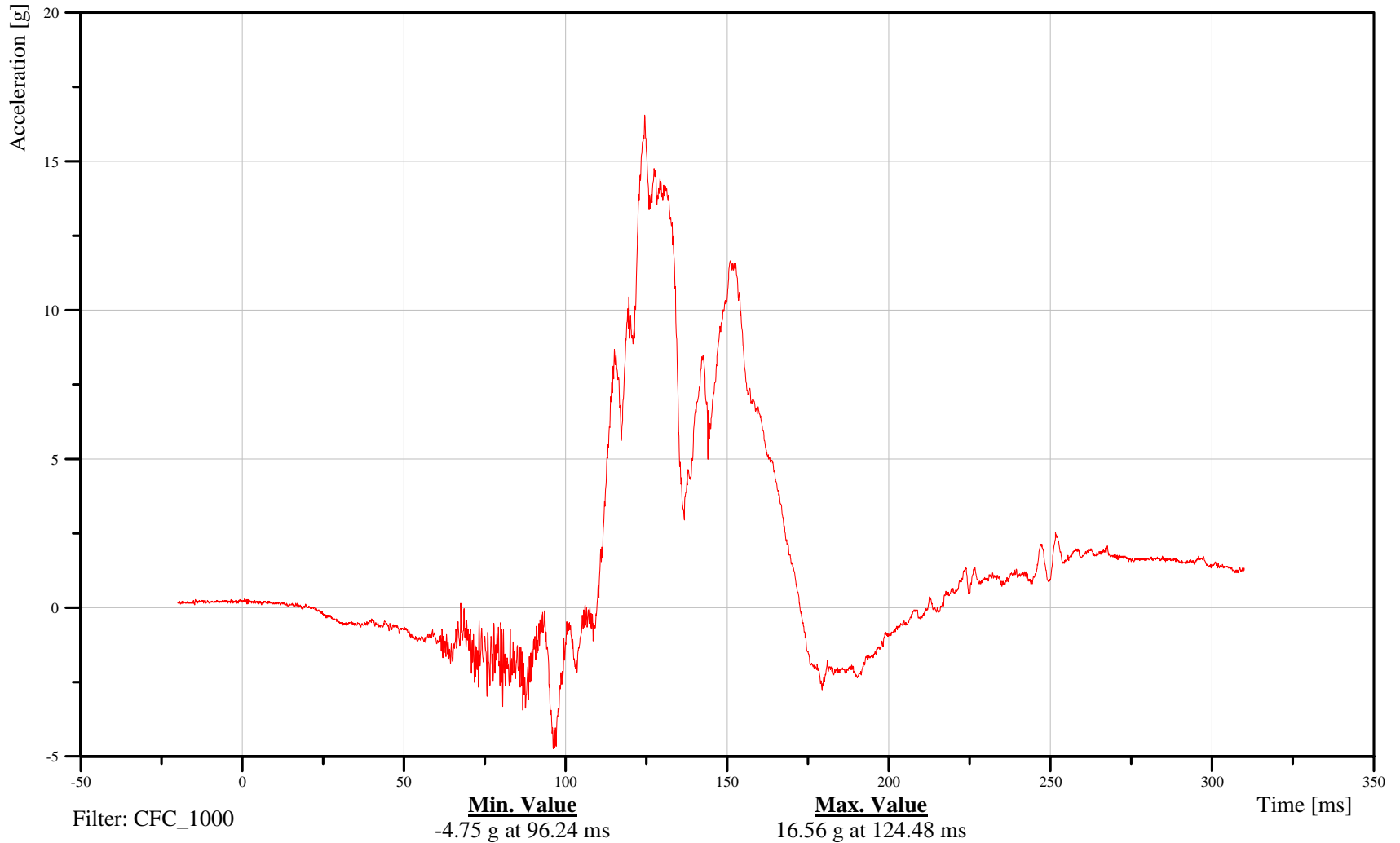

B-84

070913



2007 Ford F-250 into Left 40% Offset Deformable LCB at 56 kph

Date: 09/13/2007
Time: 15:46

Passenger Head Redundant Resultant Acceleration

Customer: Volpe
Test Number: R70203

13HEADCGRDH3ACRA

TRC Inc. Test Lab: CTF
Test Number: 070913

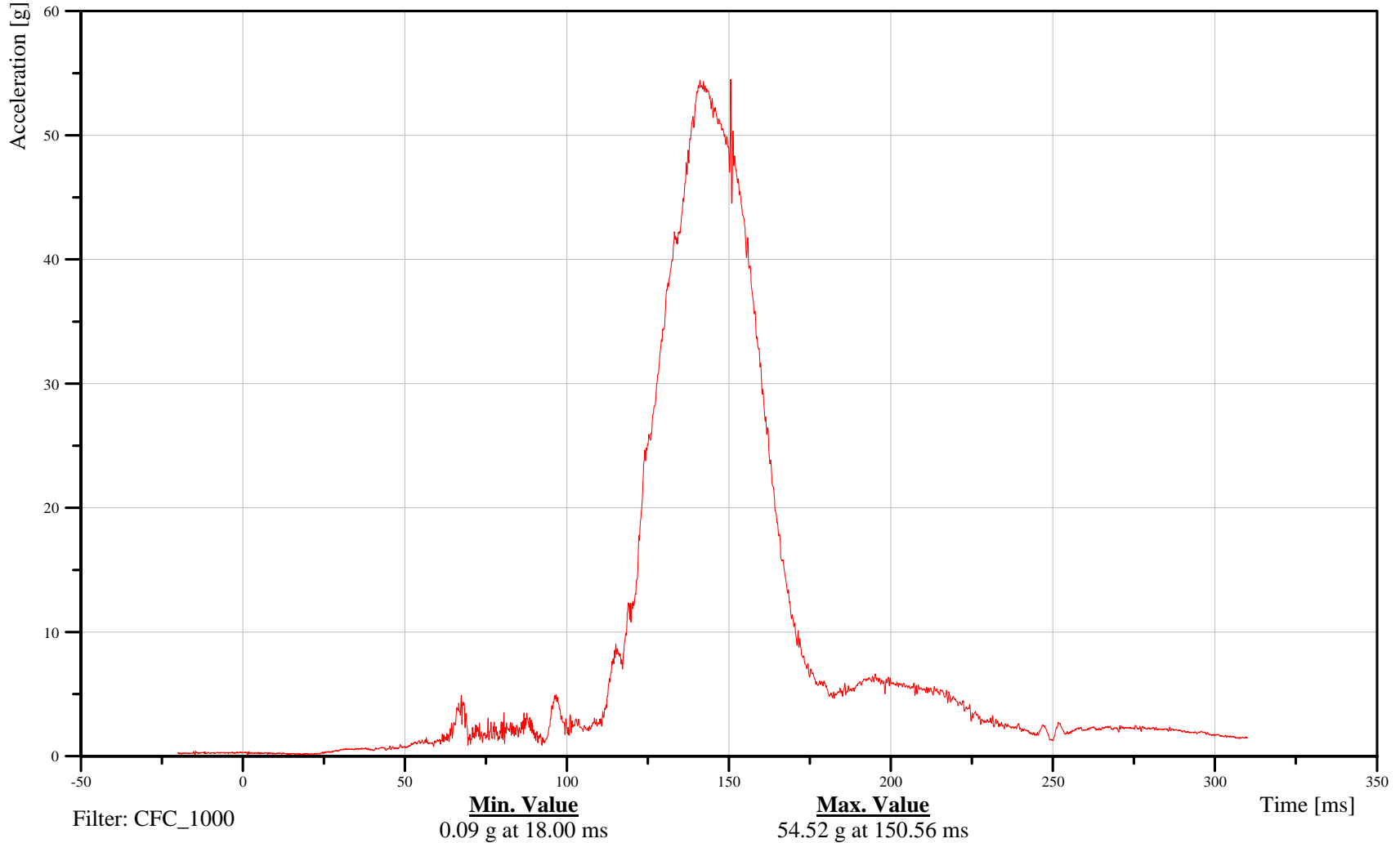

B-85

070913



2007 Ford F-250 into Left 40% Offset Deformable LCB at 56 kph

Date: 09/13/2007
Time: 15:46

Passenger Upper Neck X-Axis Force

Customer: Volpe
Test Number: R70203

13NECKUP00H3FOXA

TRC Inc. Test Lab: CTF
Test Number: 070913

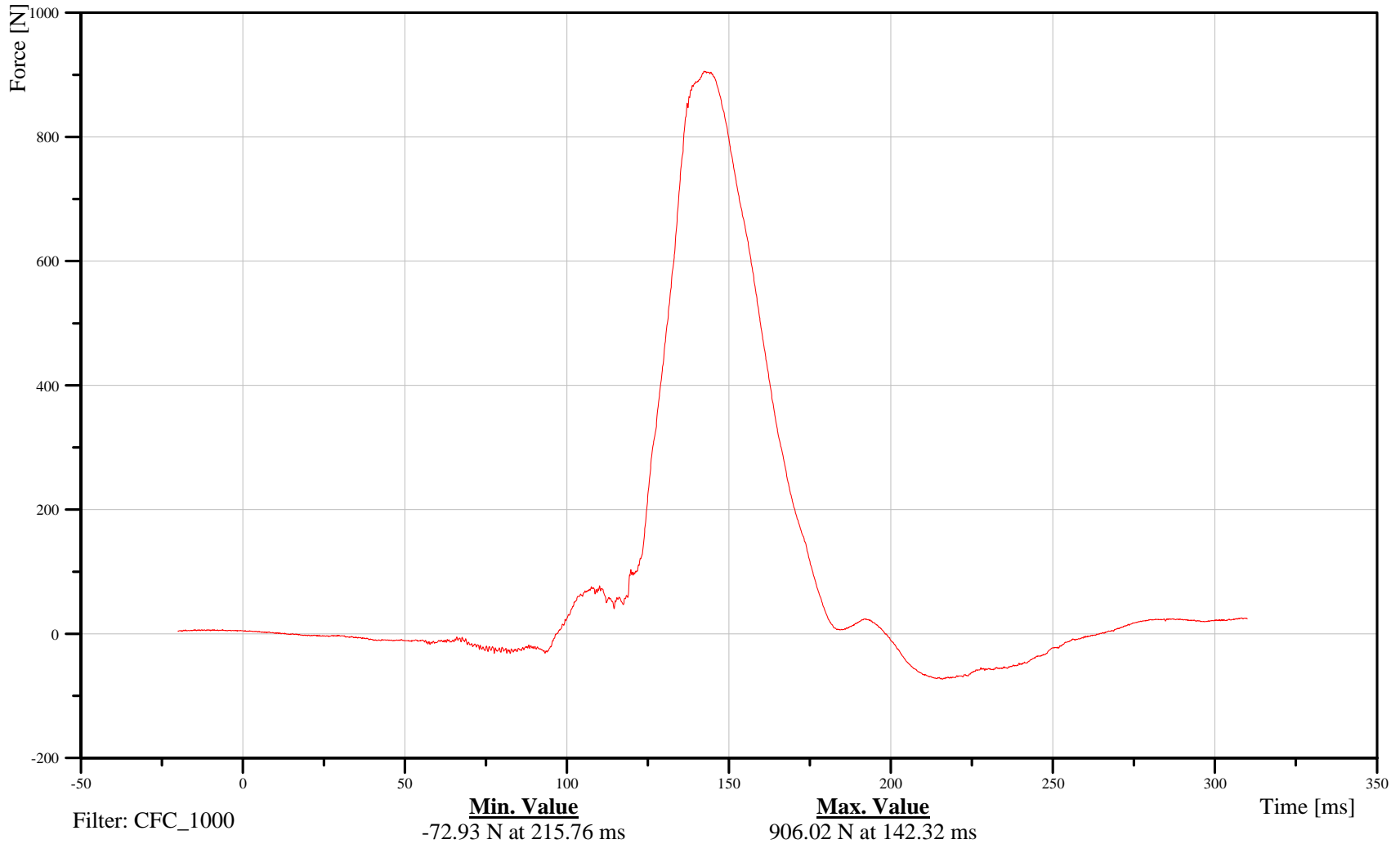

B-86

070913



2007 Ford F-250 into Left 40% Offset Deformable LCB at 56 kph

Date: 09/13/2007
Time: 15:46

Passenger Upper Neck Y-Axis Force

Customer: Volpe
Test Number: R70203

13NECKUP00H3FOYA

TRC Inc. Test Lab: CTF
Test Number: 070913

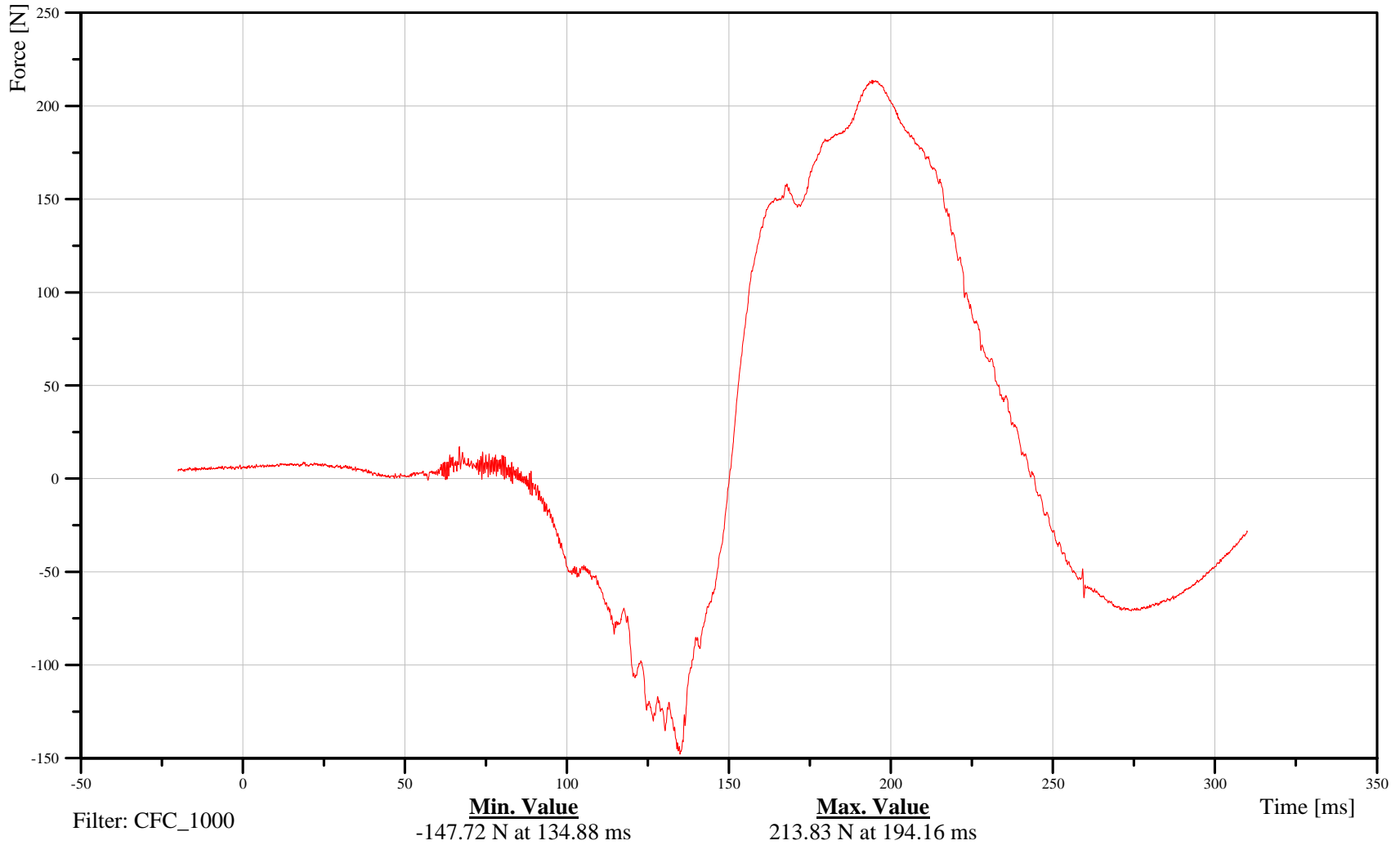

B-87

070913



2007 Ford F-250 into Left 40% Offset Deformable LCB at 56 kph

Date: 09/13/2007
Time: 15:46

Passenger Upper Neck Z-Axis Force

Customer: Volpe
Test Number: R70203

13NECKUP00H3FOZA

TRC Inc. Test Lab: CTF
Test Number: 070913

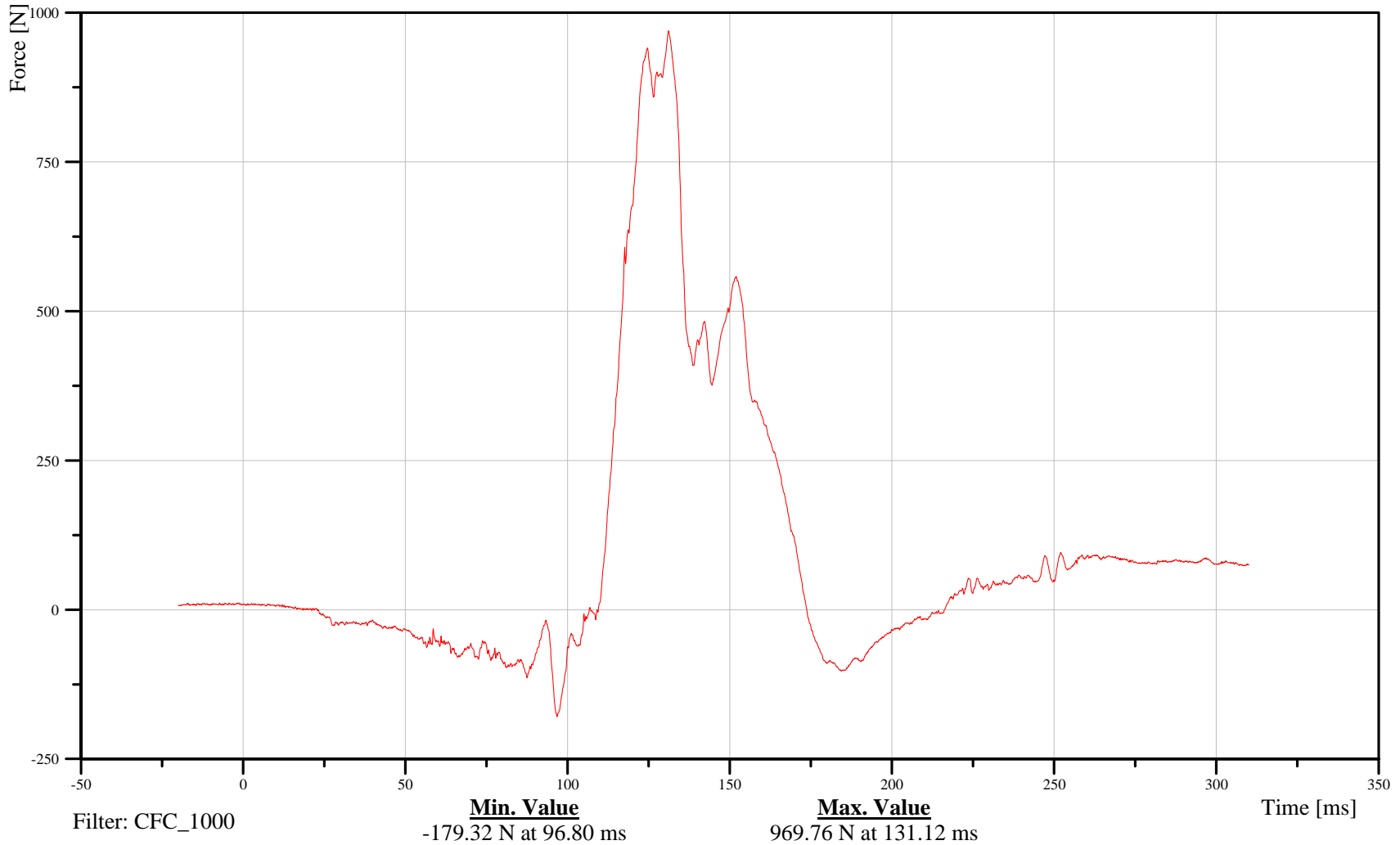

B-88

070913



2007 Ford F-250 into Left 40% Offset Deformable LCB at 56 kph

Date: 09/13/2007
Time: 15:46

Passenger Upper Neck Moment About X Axis

Customer: Volpe
Test Number: R70203

13NECKUP00H3MOXB

TRC Inc. Test Lab: CTF
Test Number: 070913

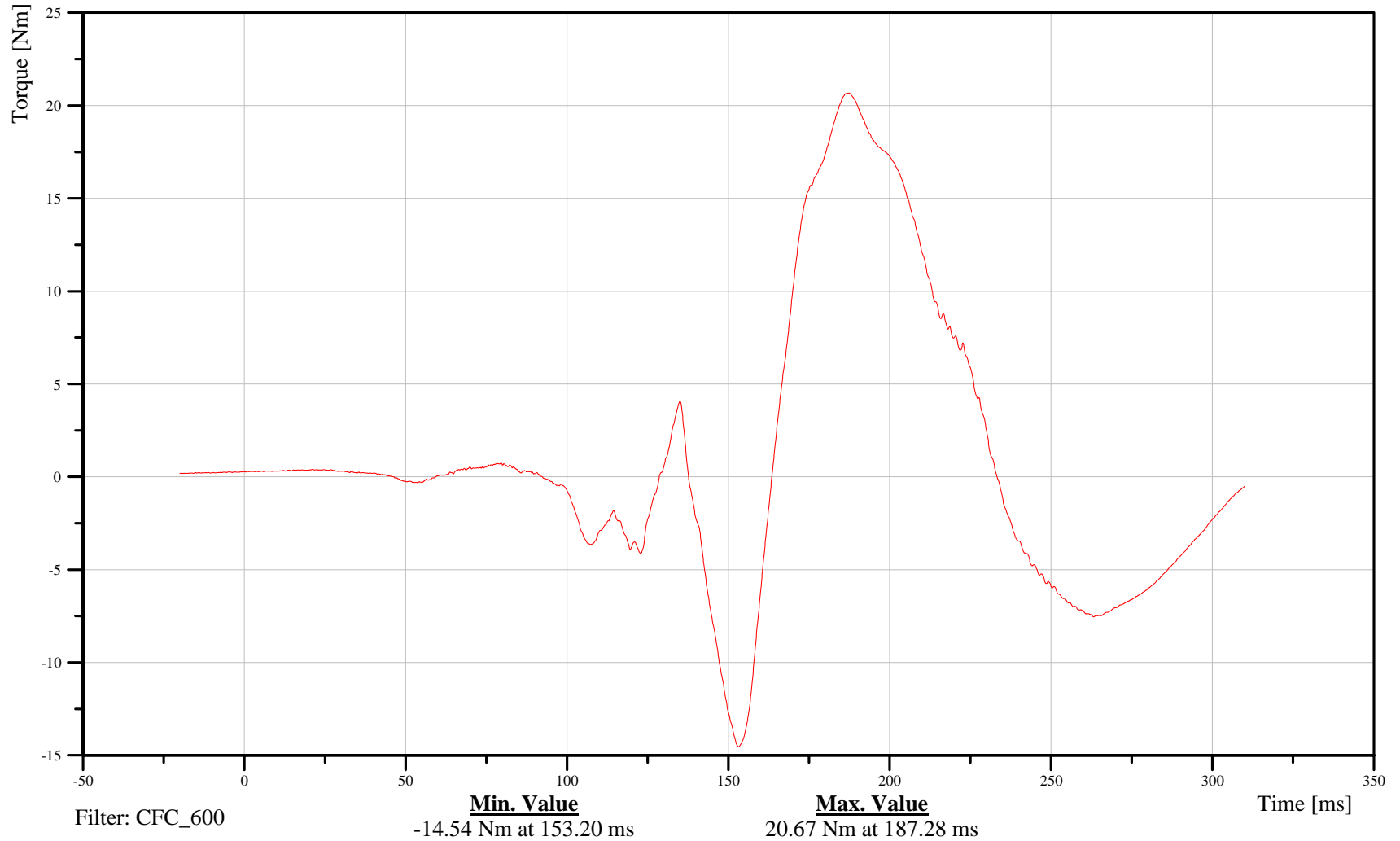

B-89

070913



2007 Ford F-250 into Left 40% Offset Deformable LCB at 56 kph

Date: 09/13/2007
Time: 15:46

Passenger Upper Neck Moment About Y Axis

Customer: Volpe
Test Number: R70203

13NECKUP00H3MOYB

TRC Inc. Test Lab: CTF
Test Number: 070913

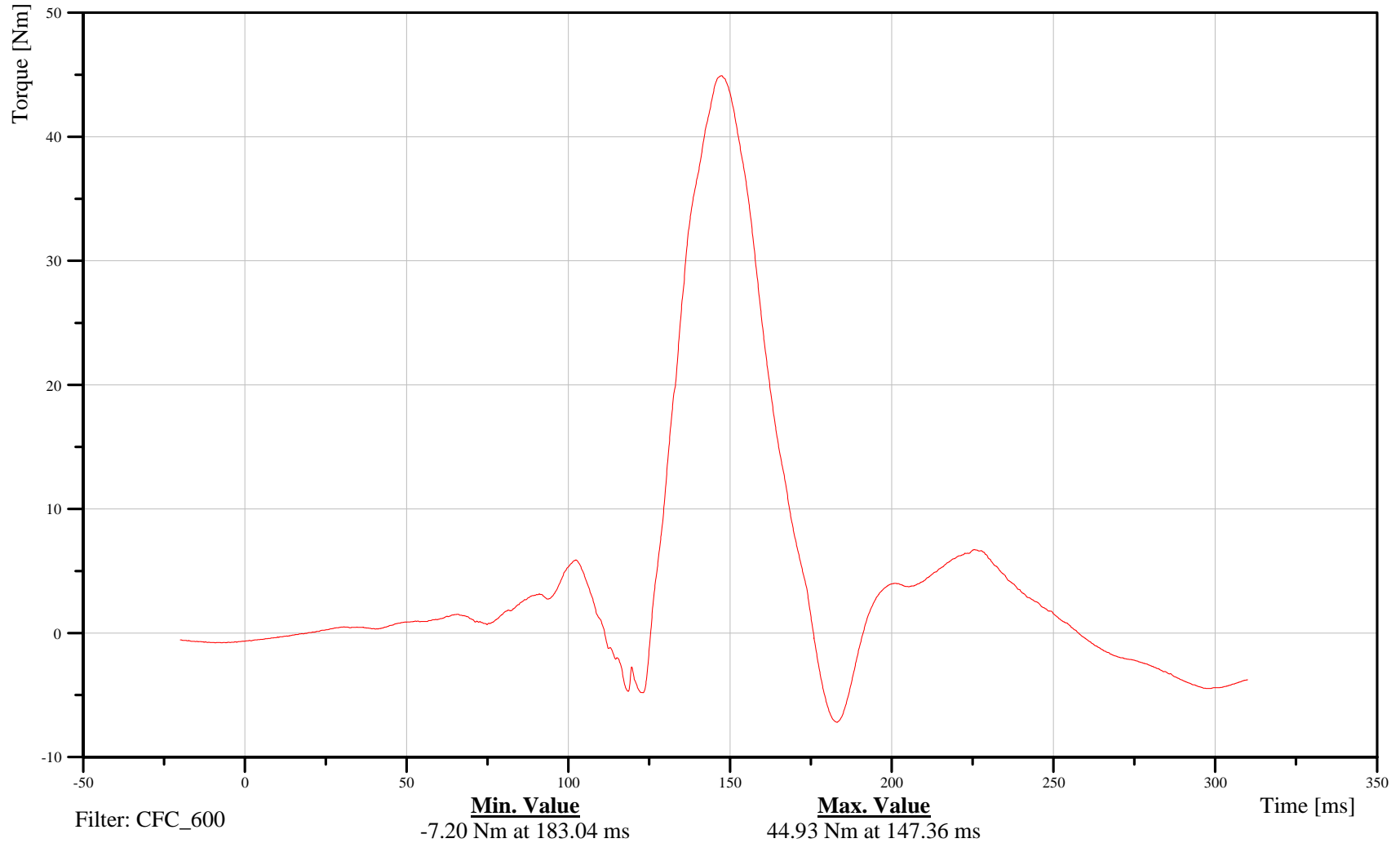

B-90

070913



2007 Ford F-250 into Left 40% Offset Deformable LCB at 56 kph

Date: 09/13/2007
Time: 15:46

Passenger Upper Neck Moment About Z Axis

Customer: Volpe
Test Number: R70203

13NECKUP00H3MOZB

TRC Inc. Test Lab: CTF
Test Number: 070913

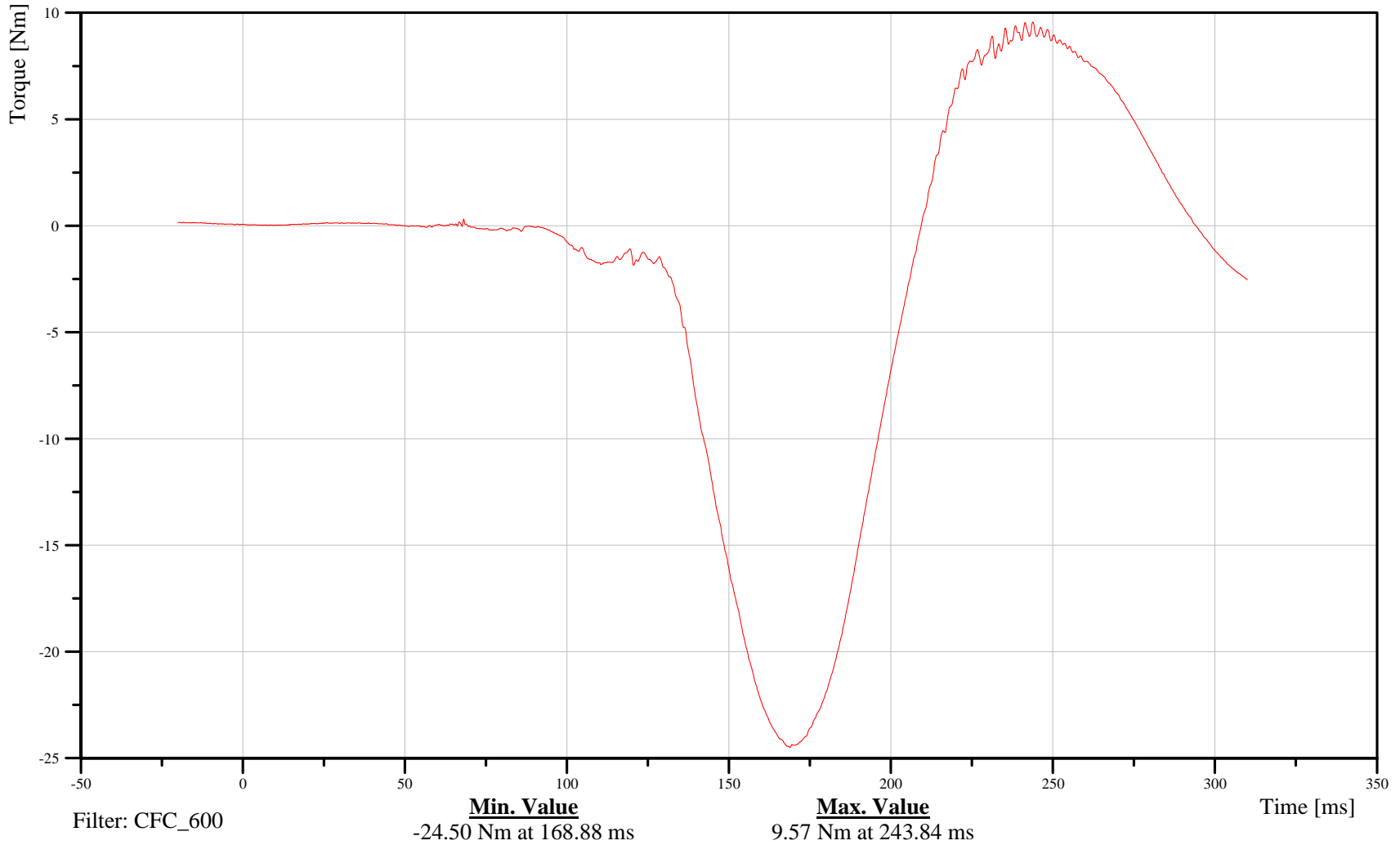

B-91

070913



2007 Ford F-250 into Left 40% Offset Deformable LCB at 56 kph

Date: 09/13/2007
Time: 15:46

Passenger Chest X-Axis Acceleration

Customer: Volpe
Test Number: R70203

13CHSTCG00H3ACXC

TRC Inc. Test Lab: CTF
Test Number: 070913

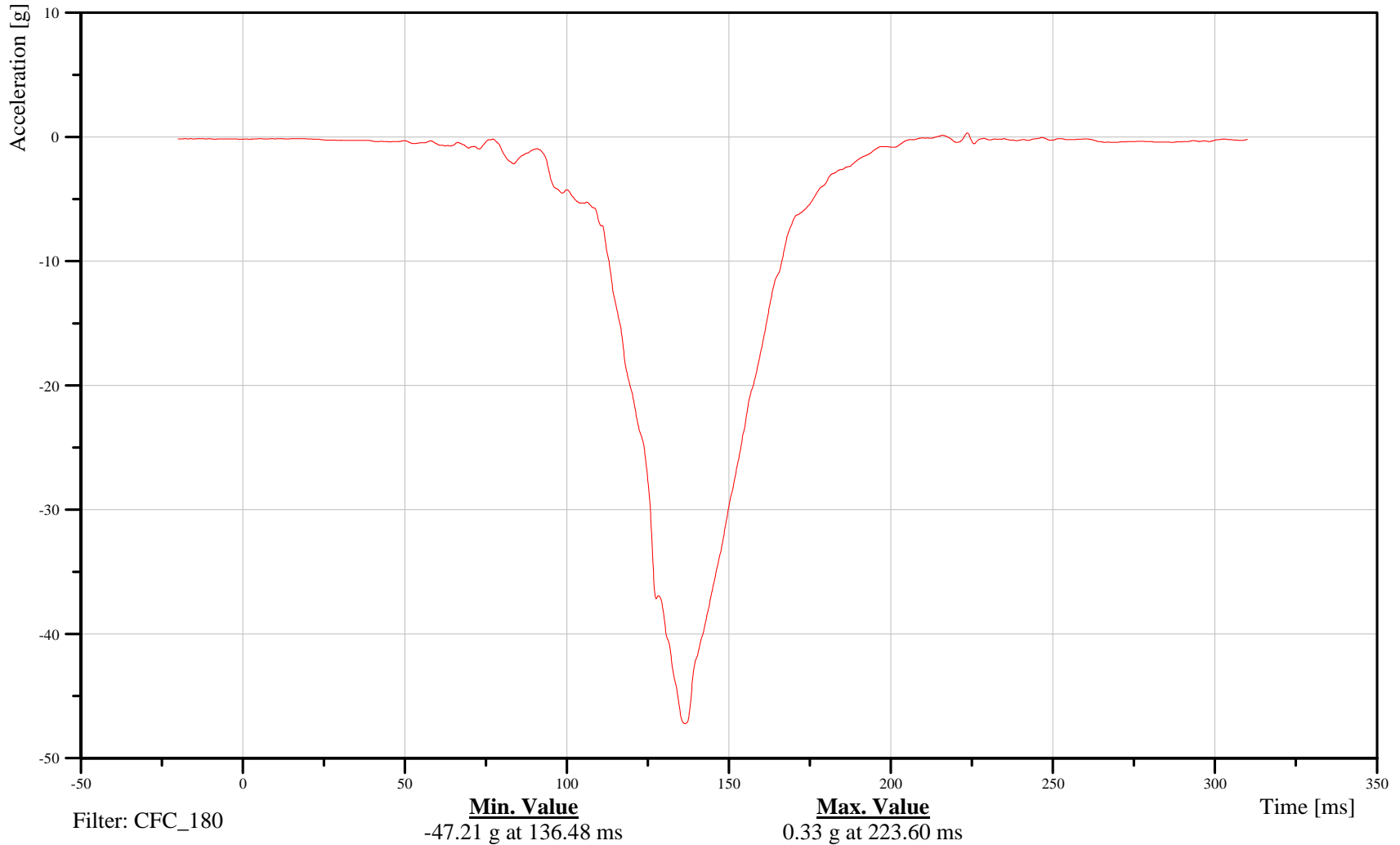

B-92

070913



2007 Ford F-250 into Left 40% Offset Deformable LCB at 56 kph

Date: 09/13/2007
Time: 15:46

Passenger Chest Y-Axis Acceleration

Customer: Volpe
Test Number: R70203

13CHSTCG00H3ACYC

TRC Inc. Test Lab: CTF
Test Number: 070913

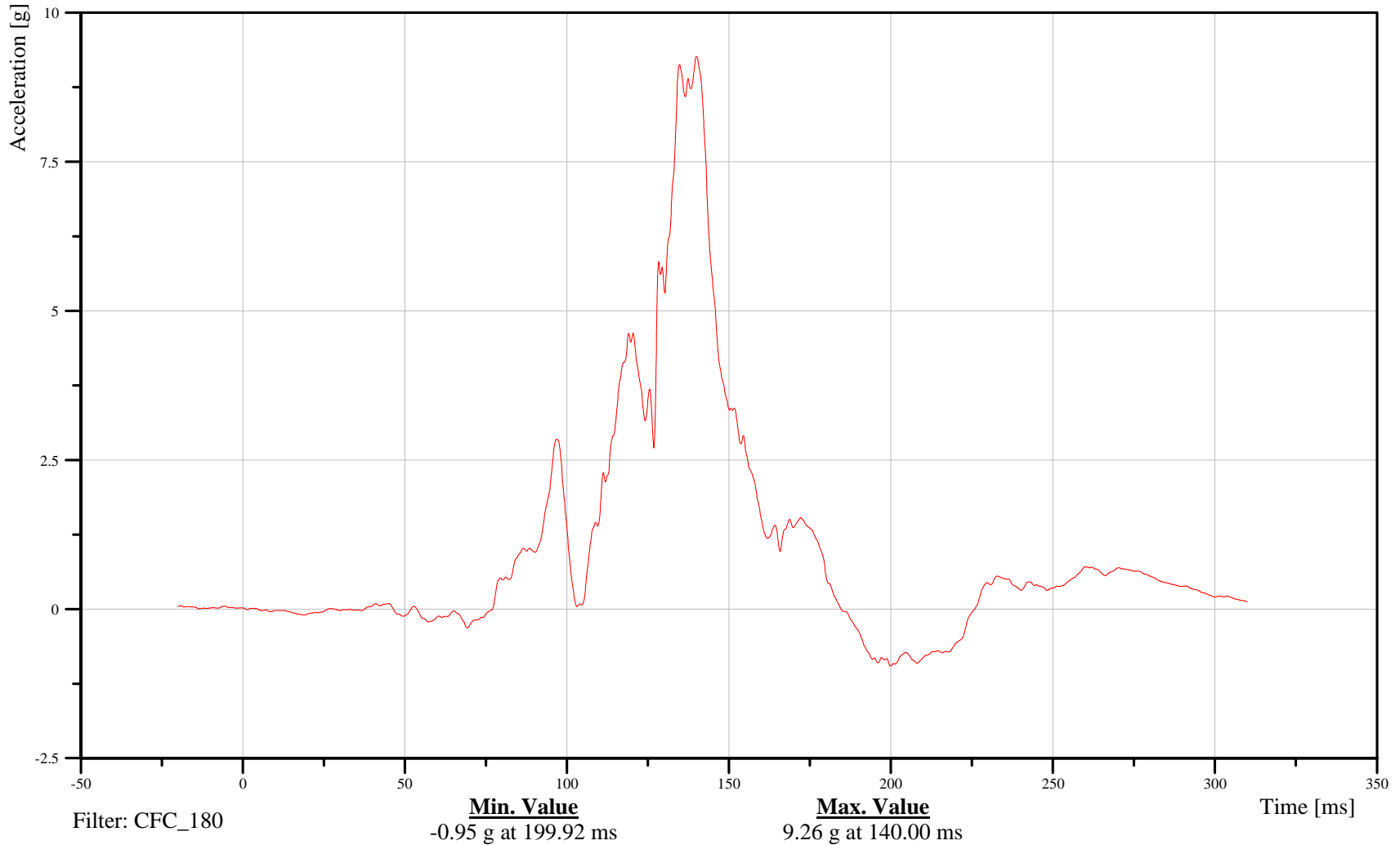

B-93

070913



2007 Ford F-250 into Left 40% Offset Deformable LCB at 56 kph

Date: 09/13/2007
Time: 15:46

Passenger Chest Z-Axis Acceleration

Customer: Volpe
Test Number: R70203

13CHSTCG00H3ACZC

TRC Inc. Test Lab: CTF
Test Number: 070913

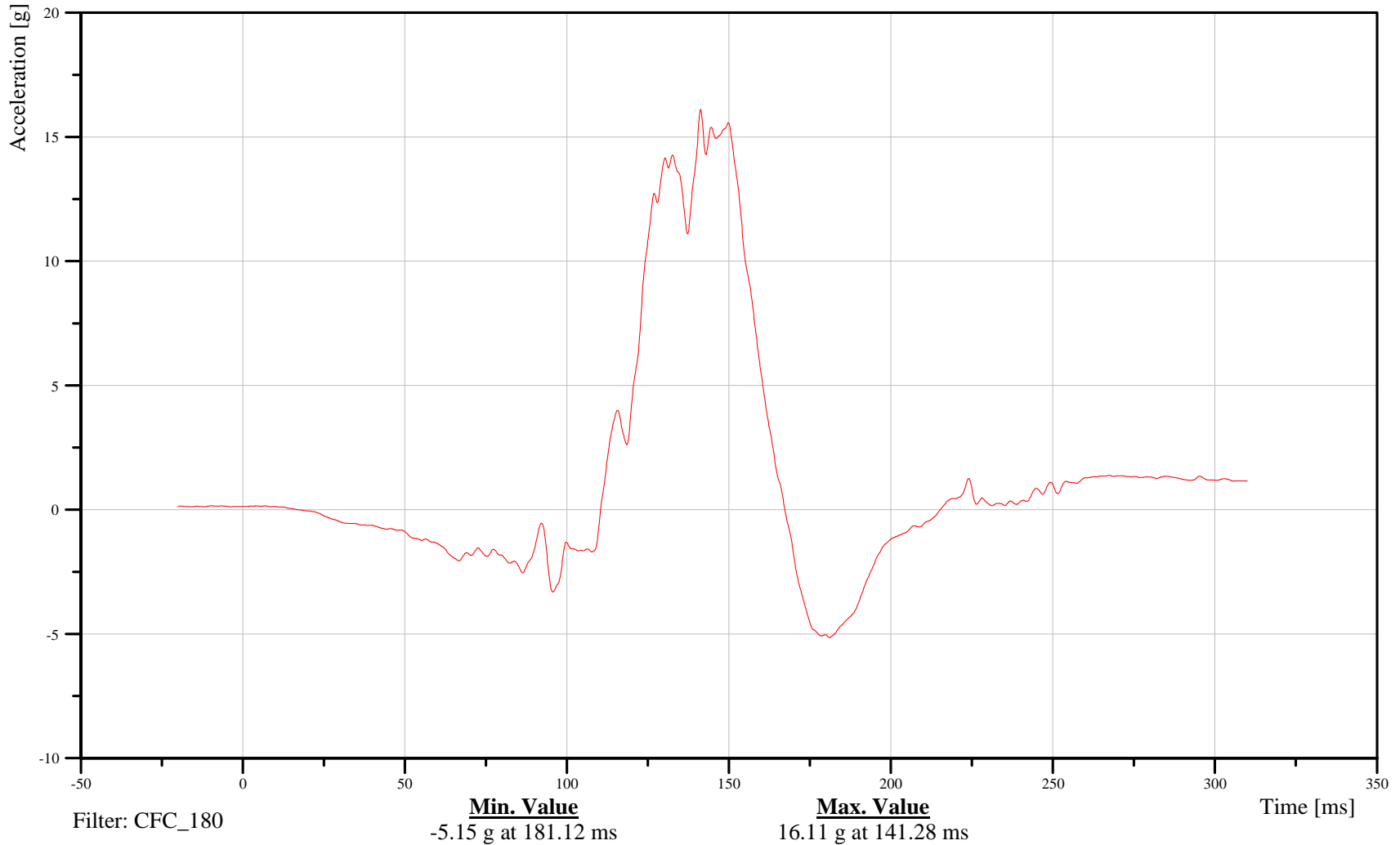

B-94

070913



2007 Ford F-250 into Left 40% Offset Deformable LCB at 56 kph

Date: 09/13/2007
Time: 15:46

Passenger Chest Resultant Acceleration

Customer: Volpe
Test Number: R70203

13CHSTCG00H3ACRC

TRC Inc. Test Lab: CTF
Test Number: 070913

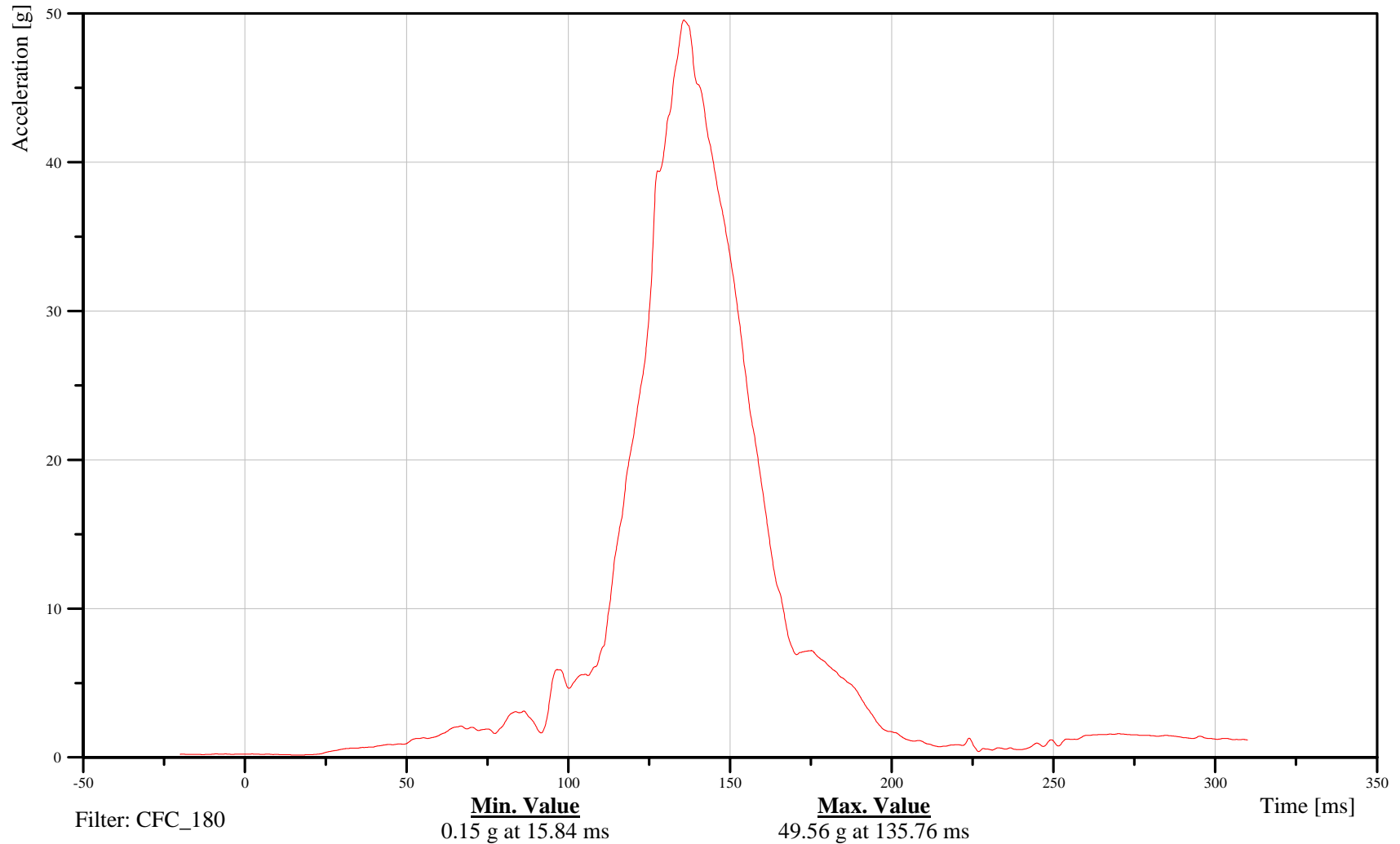

B-95

070913



2007 Ford F-250 into Left 40% Offset Deformable LCB at 56 kph

Date: 09/13/2007
Time: 15:46

Passenger Chest X-Axis Redundant Acceleration

Customer: Volpe
Test Number: R70203

13CHSTCGRDH3ACXC

TRC Inc. Test Lab: CTF
Test Number: 070913

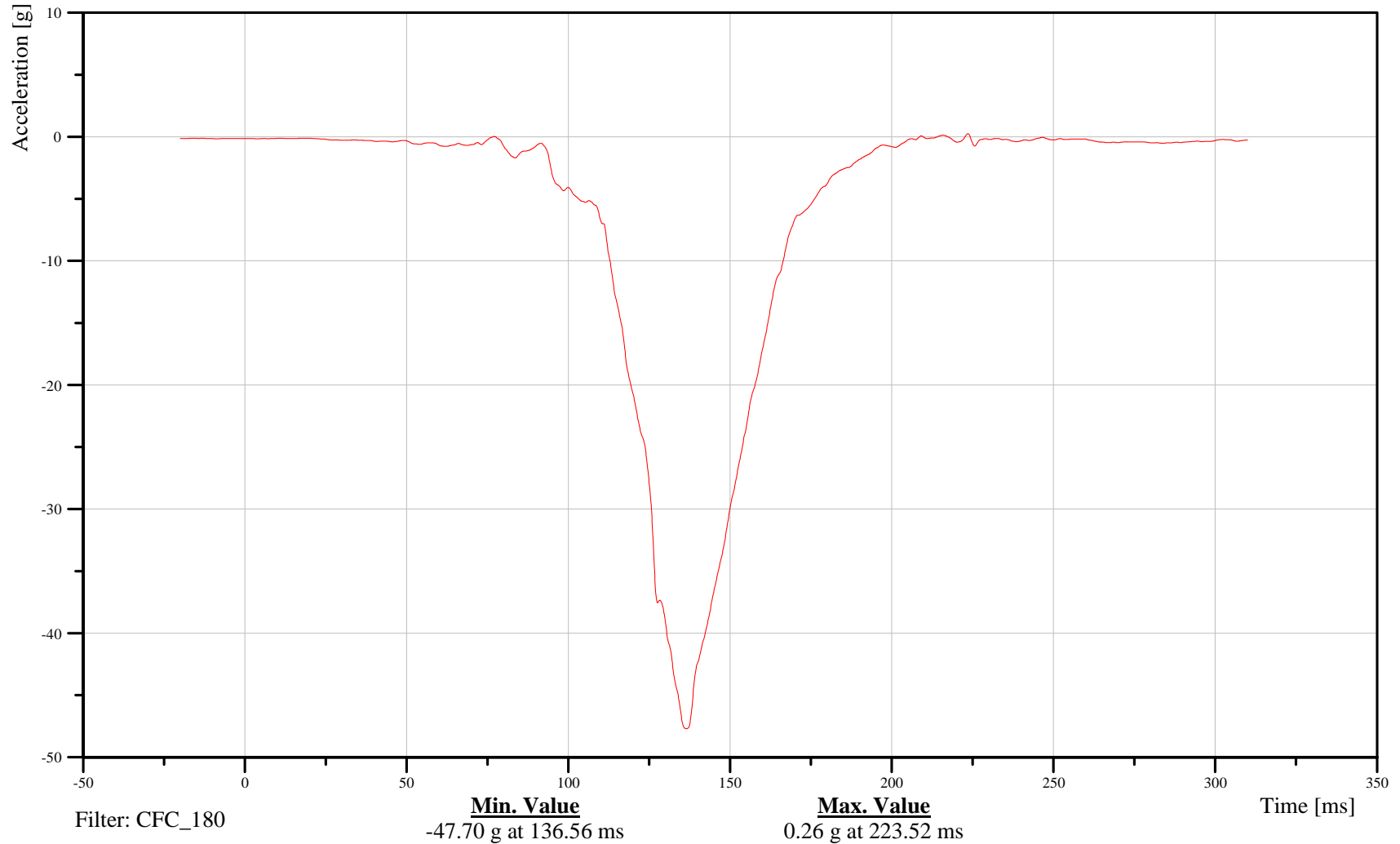

B-96

070913



2007 Ford F-250 into Left 40% Offset Deformable LCB at 56 kph

Date: 09/13/2007
Time: 15:46

Passenger Chest Y-Axis Redundant Acceleration

Customer: Volpe
Test Number: R70203

13CHSTCGRDH3ACYC

TRC Inc. Test Lab: CTF
Test Number: 070913

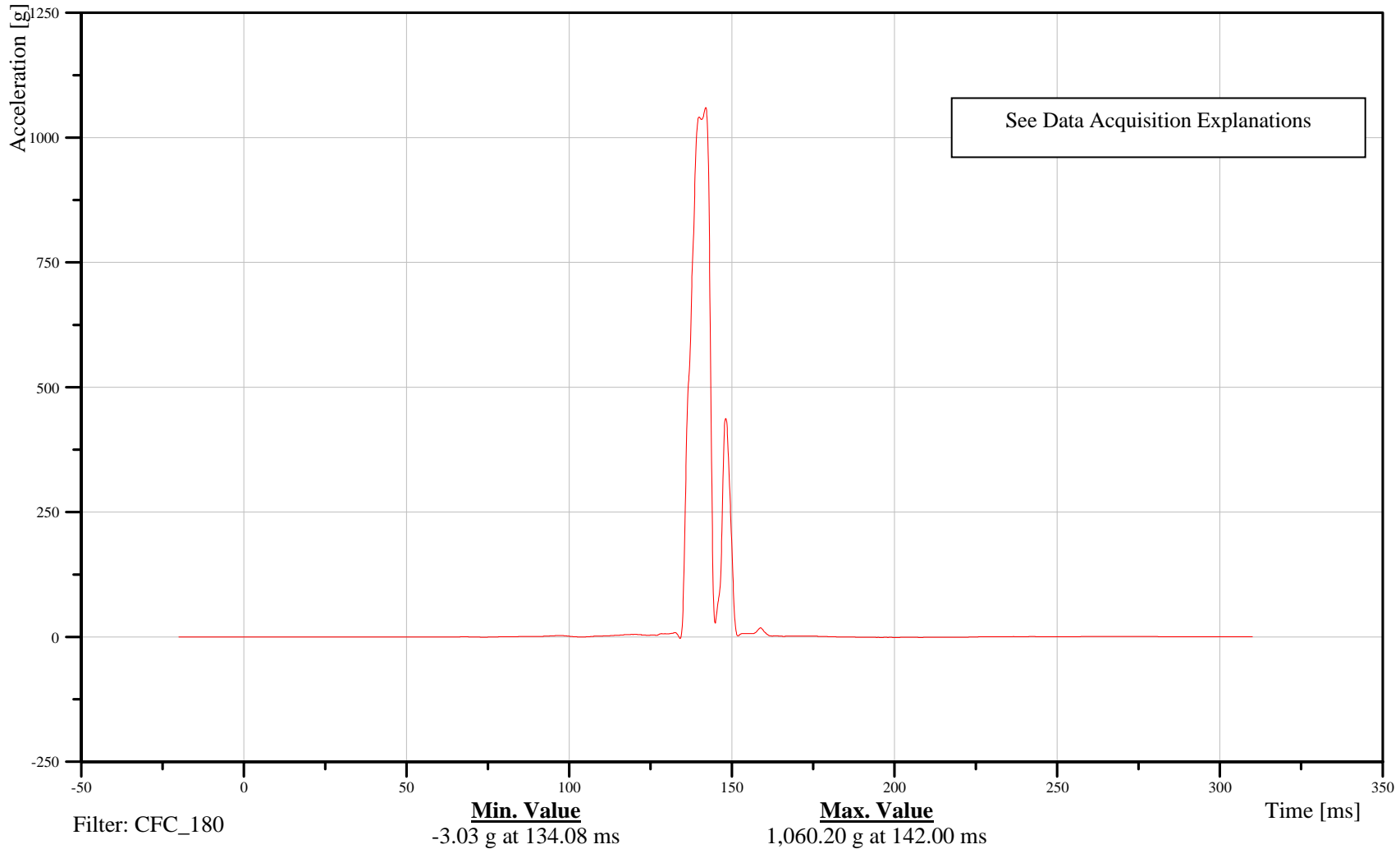

B-97

070913



2007 Ford F-250 into Left 40% Offset Deformable LCB at 56 kph

Date: 09/13/2007
Time: 15:46

Passenger Chest Z-Axis Redundant Acceleration

Customer: Volpe
Test Number: R70203

13CHSTCGRDH3ACZC

TRC Inc. Test Lab: CTF
Test Number: 070913

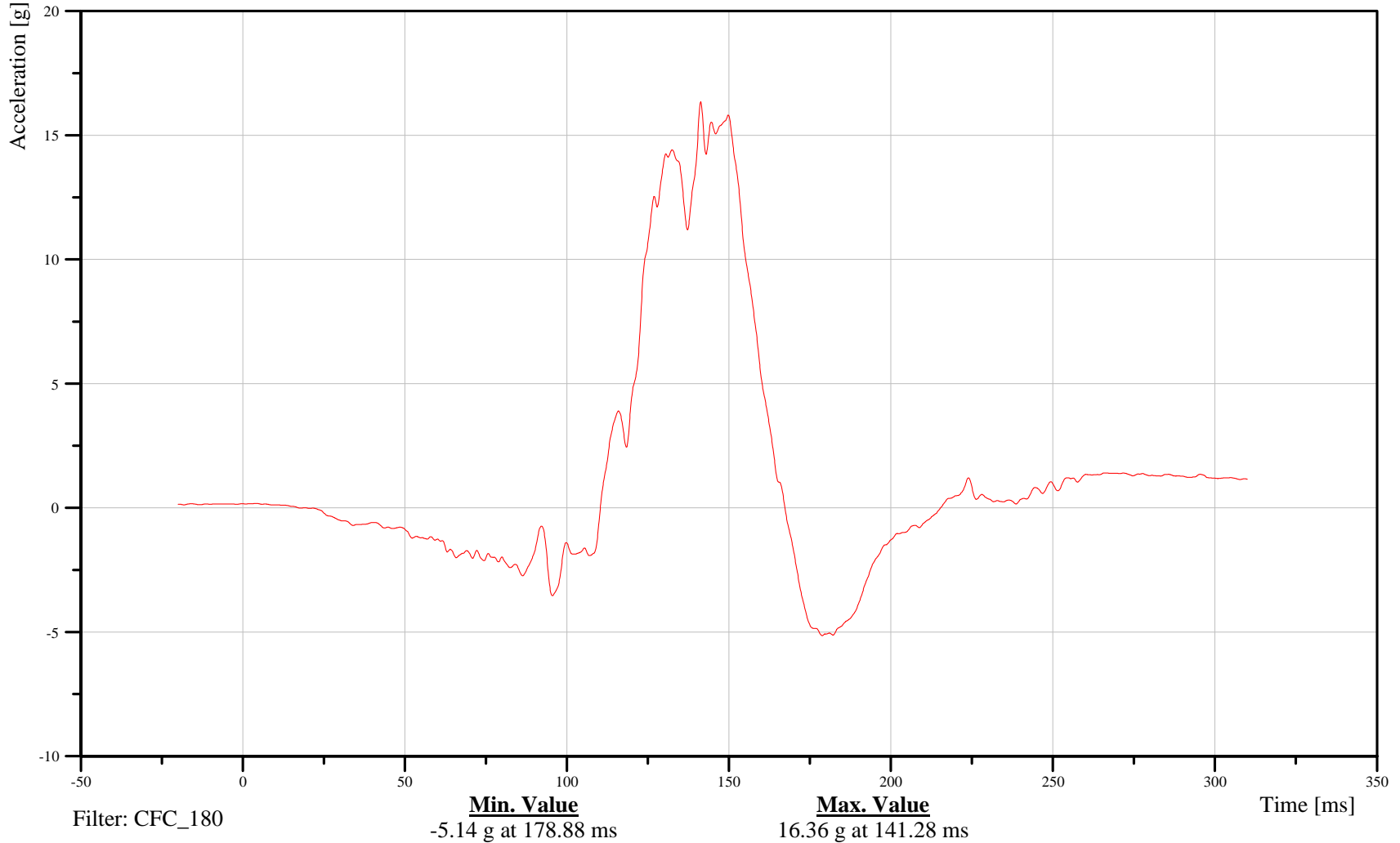

B-98

070913



2007 Ford F-250 into Left 40% Offset Deformable LCB at 56 kph

Date: 09/13/2007
Time: 15:46

Passenger Chest Redundant Resultant Acceleration

Customer: Volpe
Test Number: R70203

13CHSTCGRDH3ACRC

TRC Inc. Test Lab: CTF
Test Number: 070913

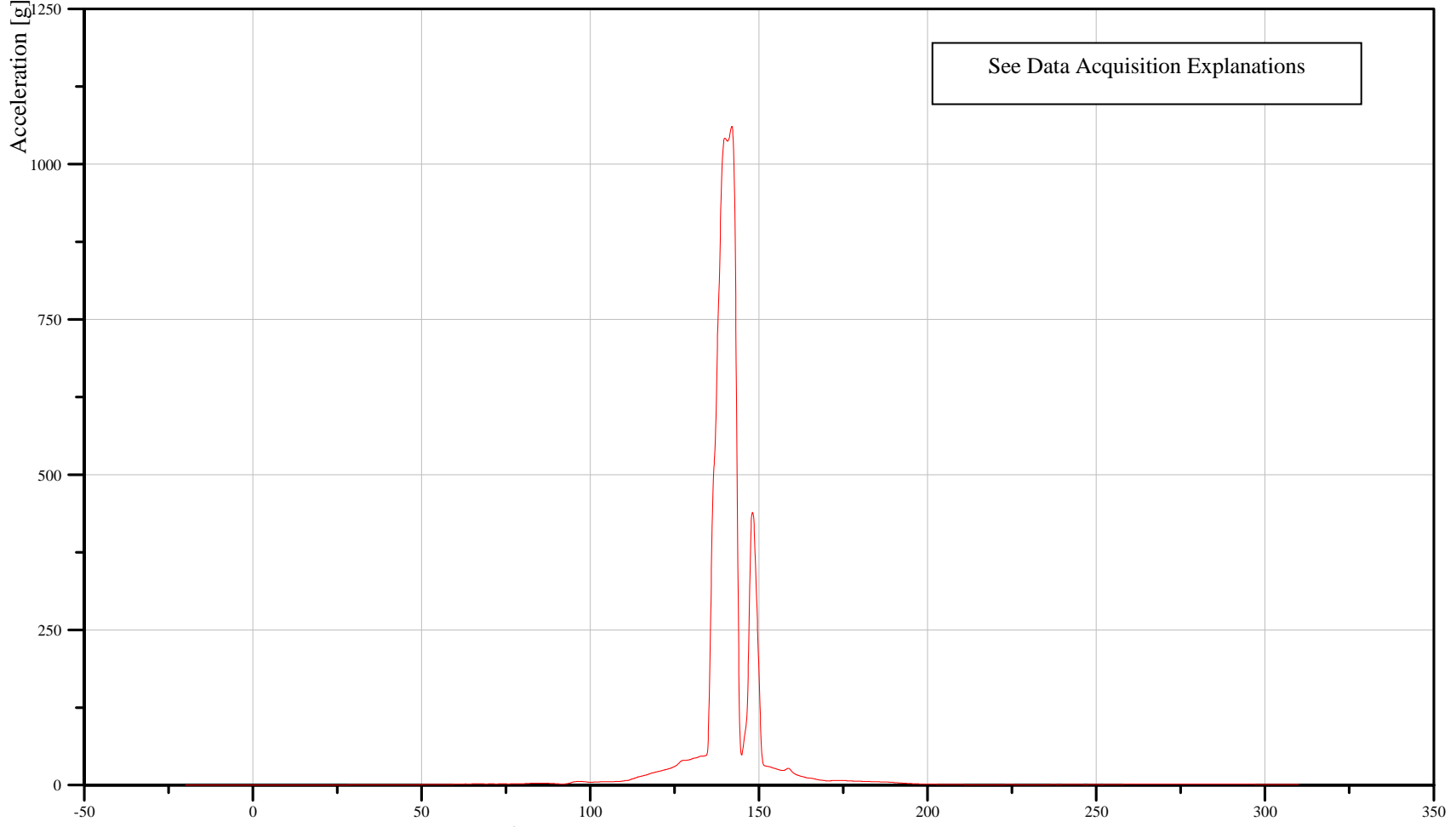

Filter: CFC_180

Min. Value
0.13 g at 18.16 ms

Max. Value
1,061.08 g at 142.00 ms

B-99

070913



2007 Ford F-250 into Left 40% Offset Deformable LCB at 56 kph

Date: 09/13/2007
Time: 15:46

Passenger Chest Displacement

Customer: Volpe
Test Number: R70203

13CHST0000H3DSXB

TRC Inc. Test Lab: CTF
Test Number: 070913

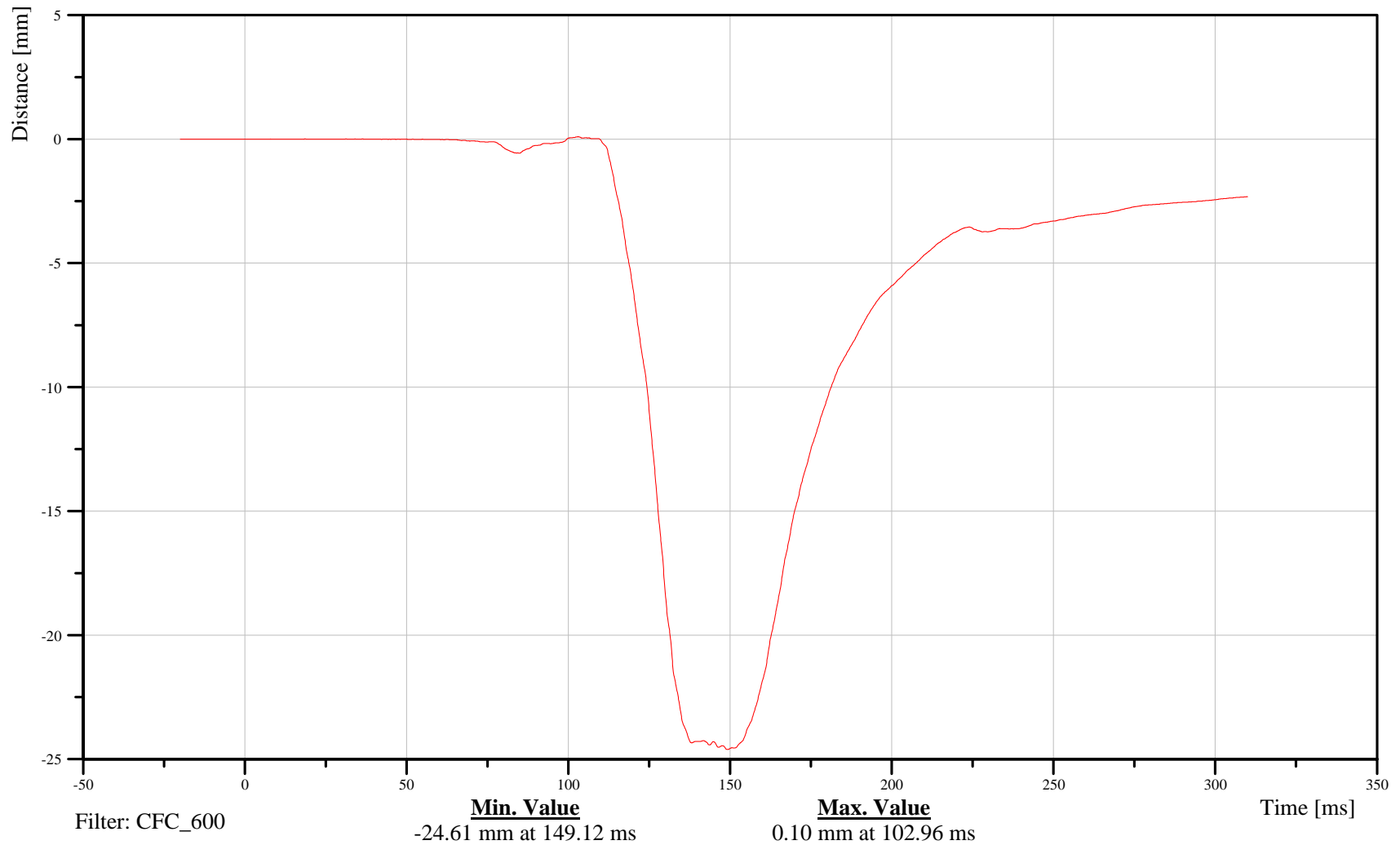

B-100

070913



2007 Ford F-250 into Left 40% Offset Deformable LCB at 56 kph

Date: 09/13/2007
Time: 15:46

Passenger Pelvis X-Axis Acceleration

Customer: Volpe
Test Number: R70203

13PELVCG00H3ACXA

TRC Inc. Test Lab: CTF
Test Number: 070913

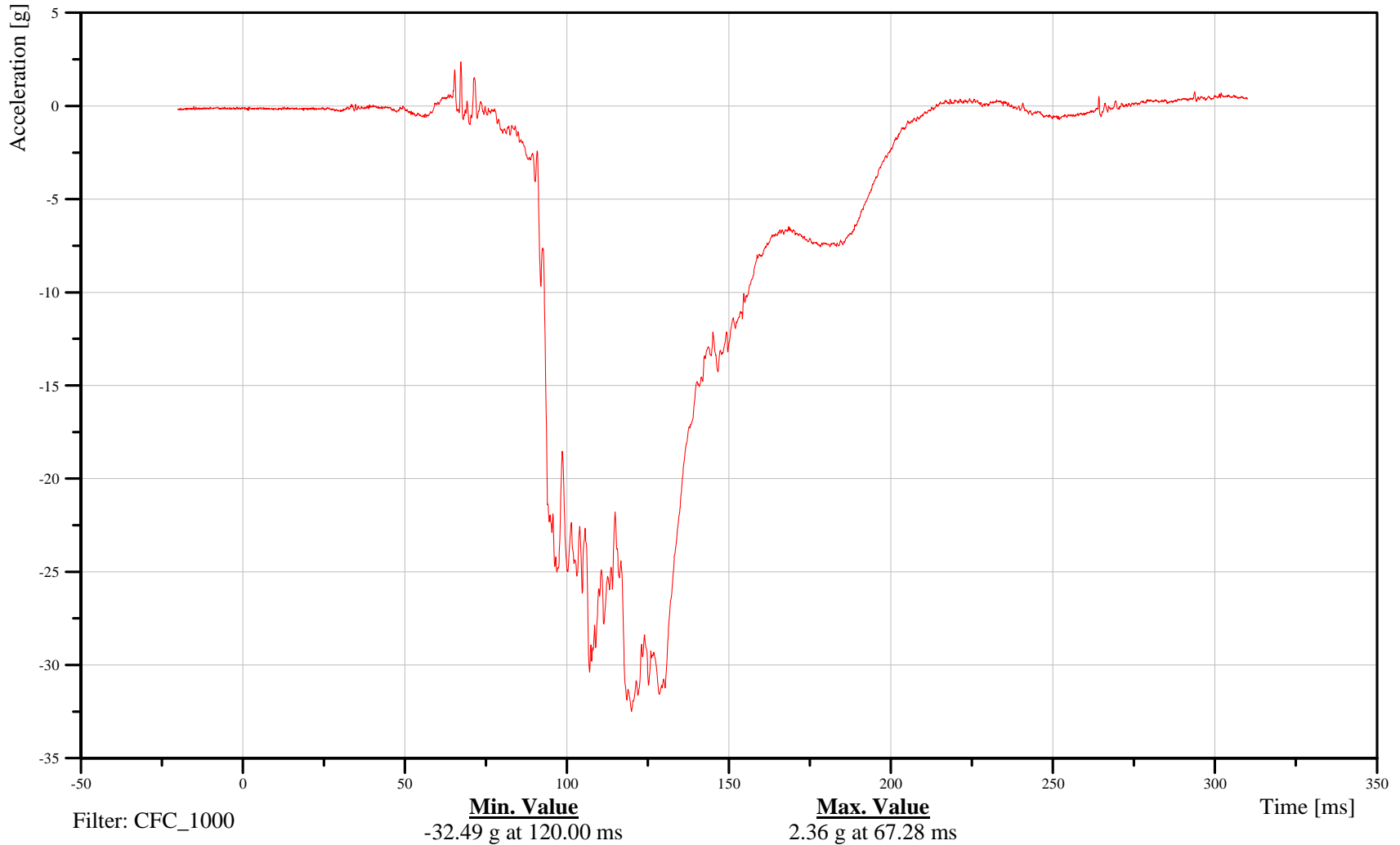

B-101

070913



2007 Ford F-250 into Left 40% Offset Deformable LCB at 56 kph

Date: 09/13/2007
Time: 15:46

Passenger Pelvis Y-Axis Acceleration

Customer: Volpe
Test Number: R70203

13PELVCG00H3ACYA

TRC Inc. Test Lab: CTF
Test Number: 070913

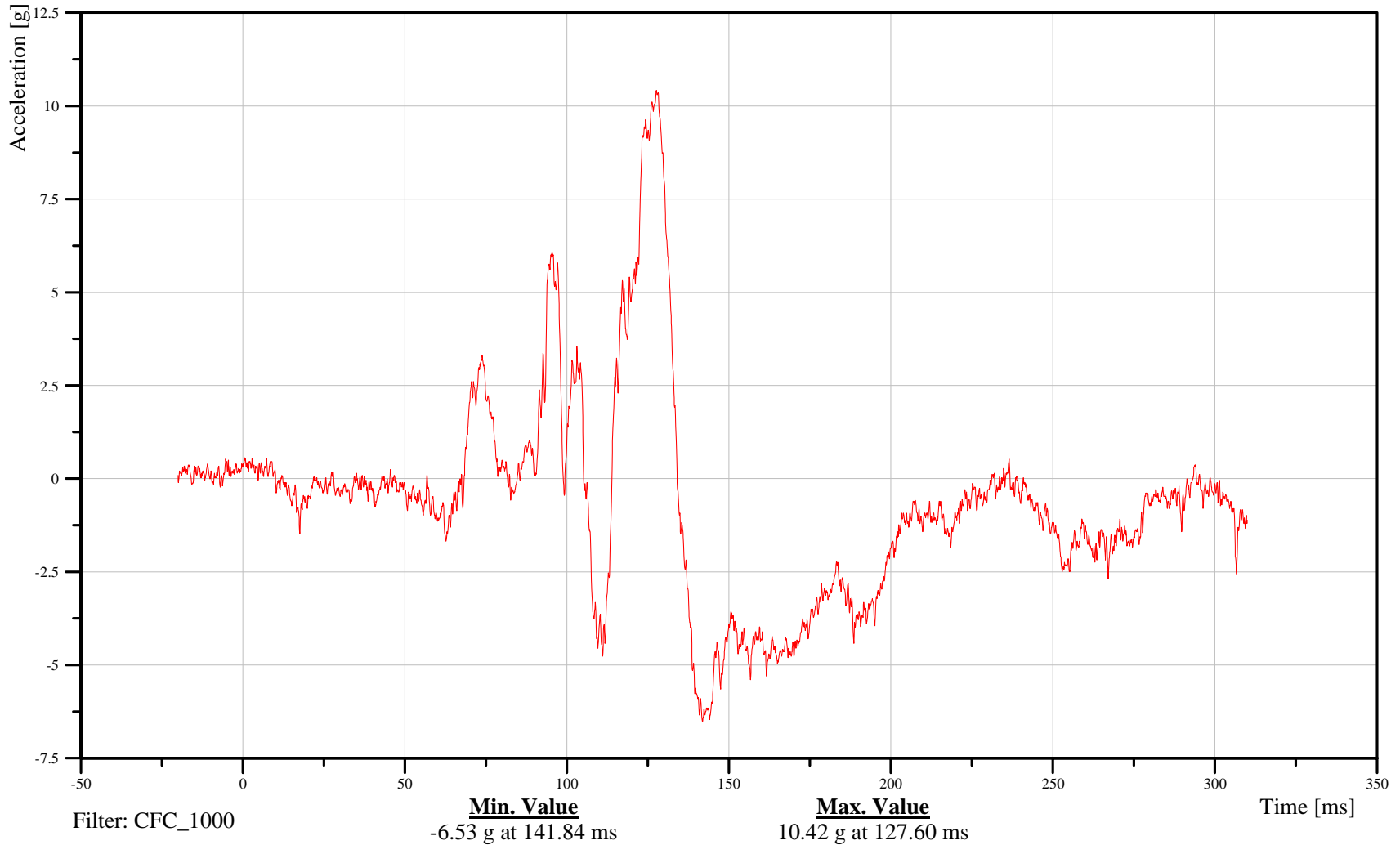

B-102

070913



2007 Ford F-250 into Left 40% Offset Deformable LCB at 56 kph

Date: 09/13/2007
Time: 15:46

Passenger Pelvis Z-Axis Acceleration

Customer: Volpe
Test Number: R70203

13PELVCG00H3ACZA

TRC Inc. Test Lab: CTF
Test Number: 070913

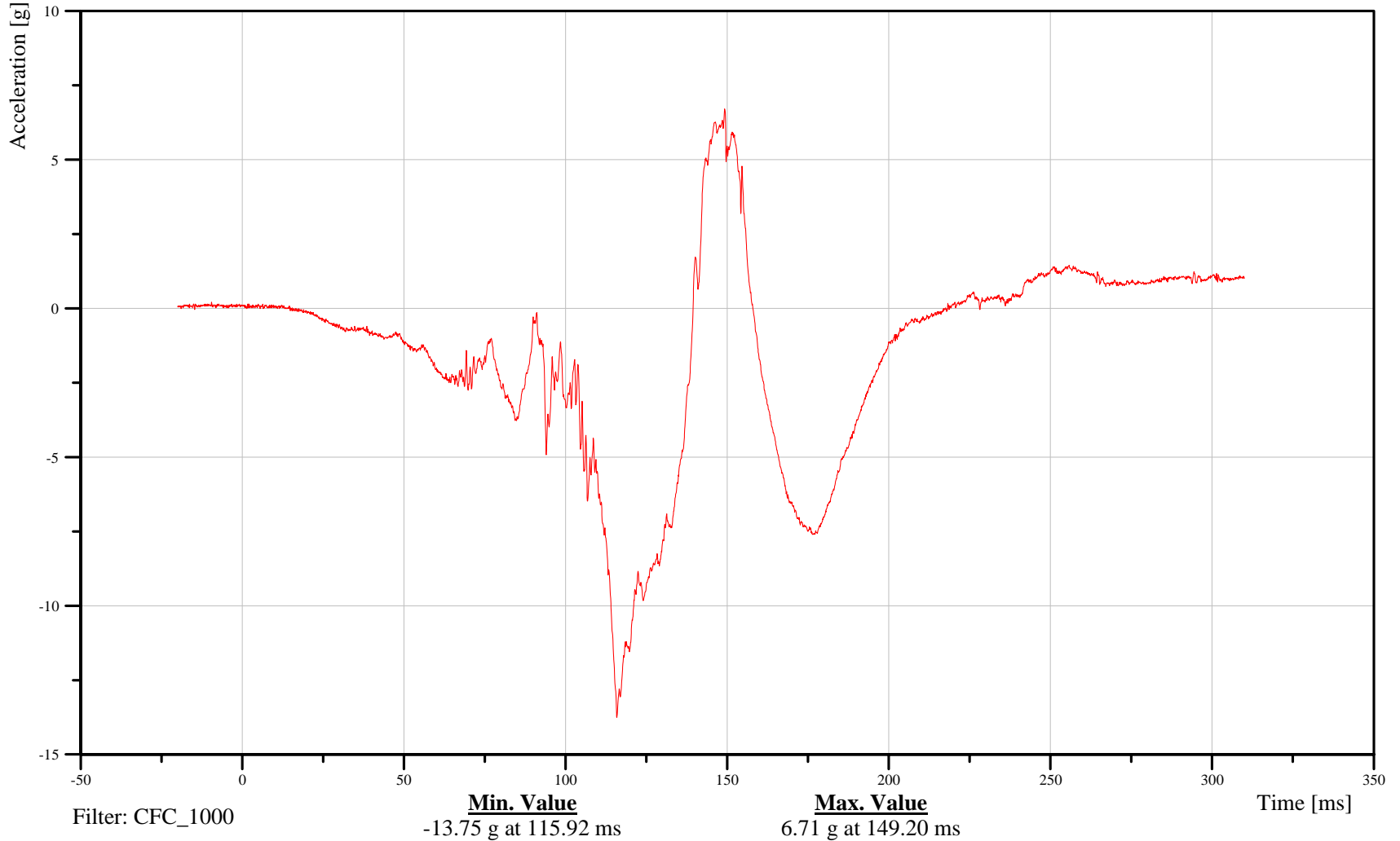

B-103

070913



2007 Ford F-250 into Left 40% Offset Deformable LCB at 56 kph

Date: 09/13/2007
Time: 15:46

Passenger Pelvis Resultant Acceleration

Customer: Volpe
Test Number: R70203

13PELVCG00H3ACRA

TRC Inc. Test Lab: CTF
Test Number: 070913

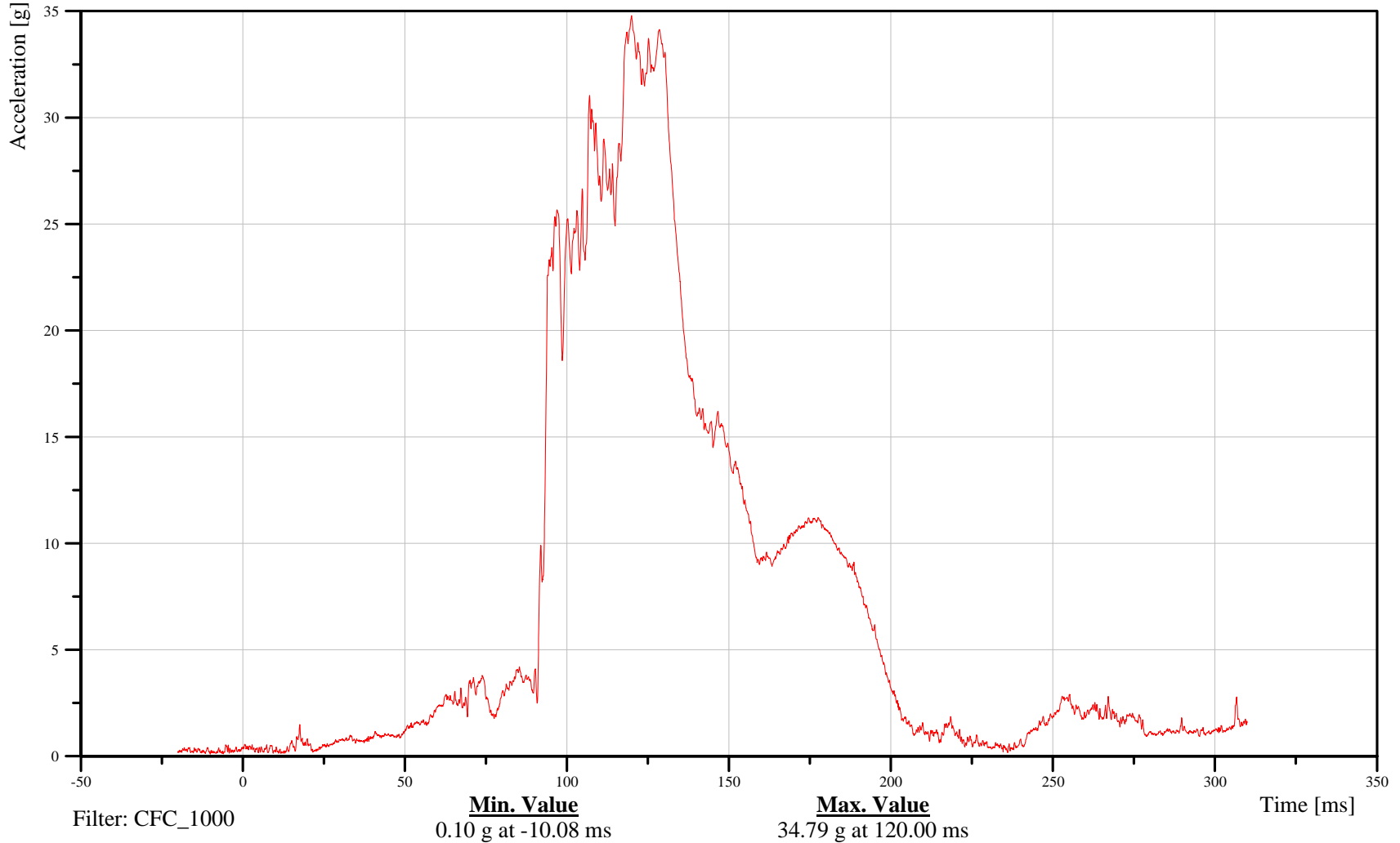

B-104

070913



2007 Ford F-250 into Left 40% Offset Deformable LCB at 56 kph

Date: 09/13/2007
Time: 15:46

Passenger Left Femur Z-Axis Force

Customer: Volpe
Test Number: R70203

13FEMRLL00H3FOZB

TRC Inc. Test Lab: CTF
Test Number: 070913

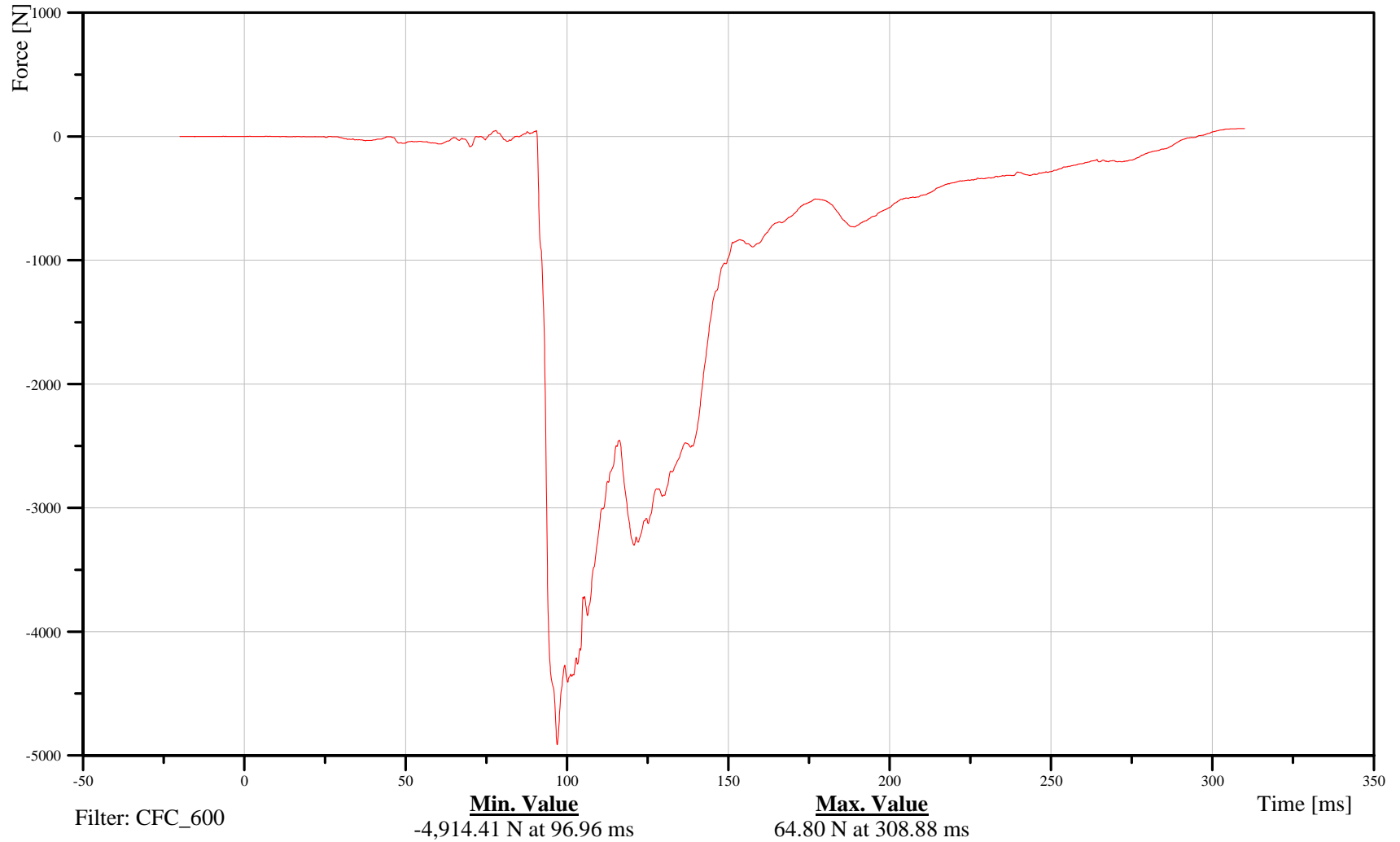

B-105

070913



2007 Ford F-250 into Left 40% Offset Deformable LCB at 56 kph

Date: 09/13/2007
Time: 15:46

Passenger Right Femur Z-Axis Force

Customer: Volpe
Test Number: R70203

13FEMRRL00H3FOZB

TRC Inc. Test Lab: CTF
Test Number: 070913

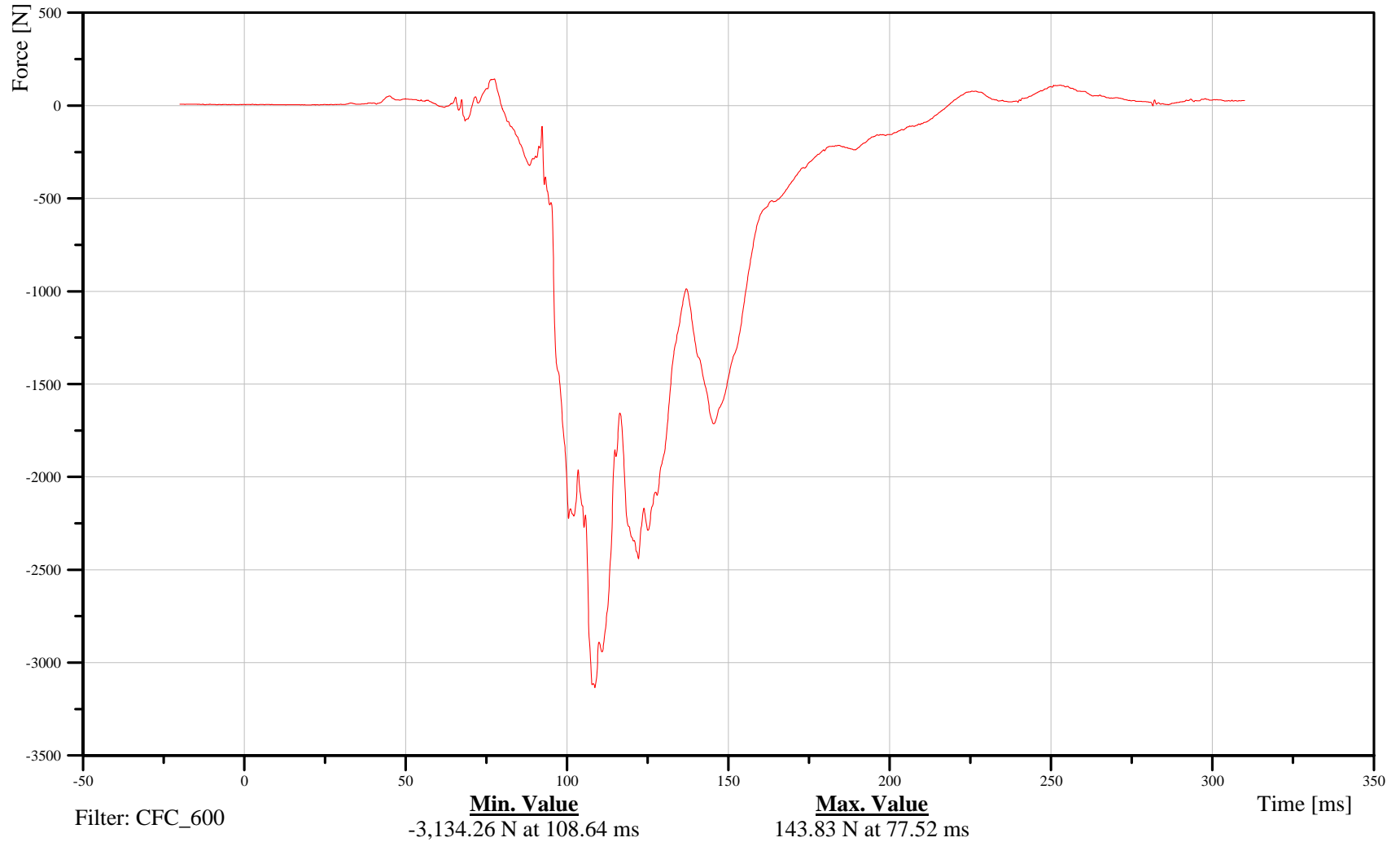

B-106

070913



2007 Ford F-250 into Left 40% Offset Deformable LCB at 56 kph

Date: 09/13/2007
Time: 15:46

Passenger Left Knee Displacement

Customer: Volpe
Test Number: R70203

13KNSLLE00H3DSXC

TRC Inc. Test Lab: CTF
Test Number: 070913

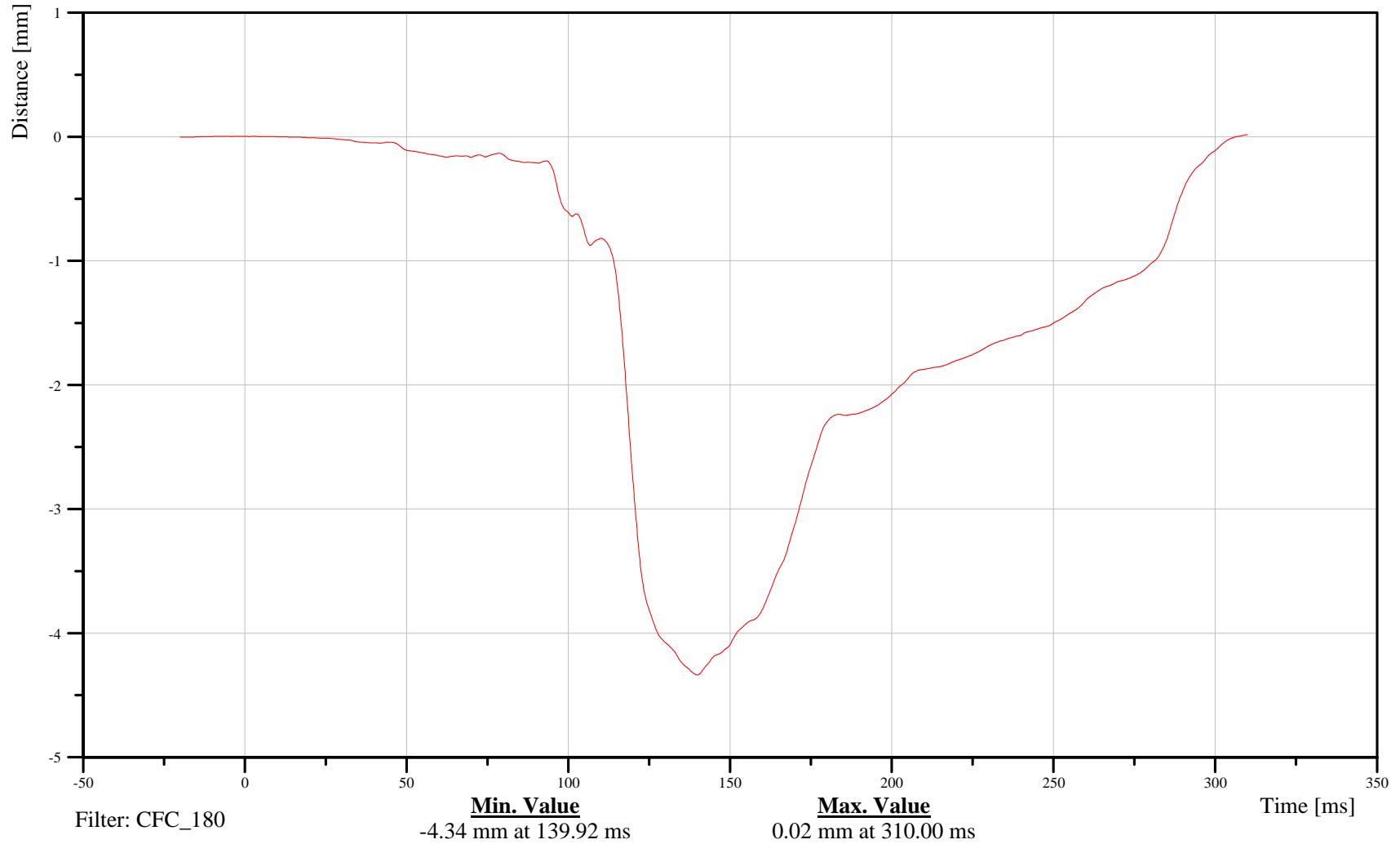

B-107

070913



2007 Ford F-250 into Left 40% Offset Deformable LCB at 56 kph

Date: 09/13/2007
Time: 15:46

Passenger Left Upper Tibia X-Axis Force

Customer: Volpe
Test Number: R70203

13TIBILULXH3FOXB

TRC Inc. Test Lab: CTF
Test Number: 070913

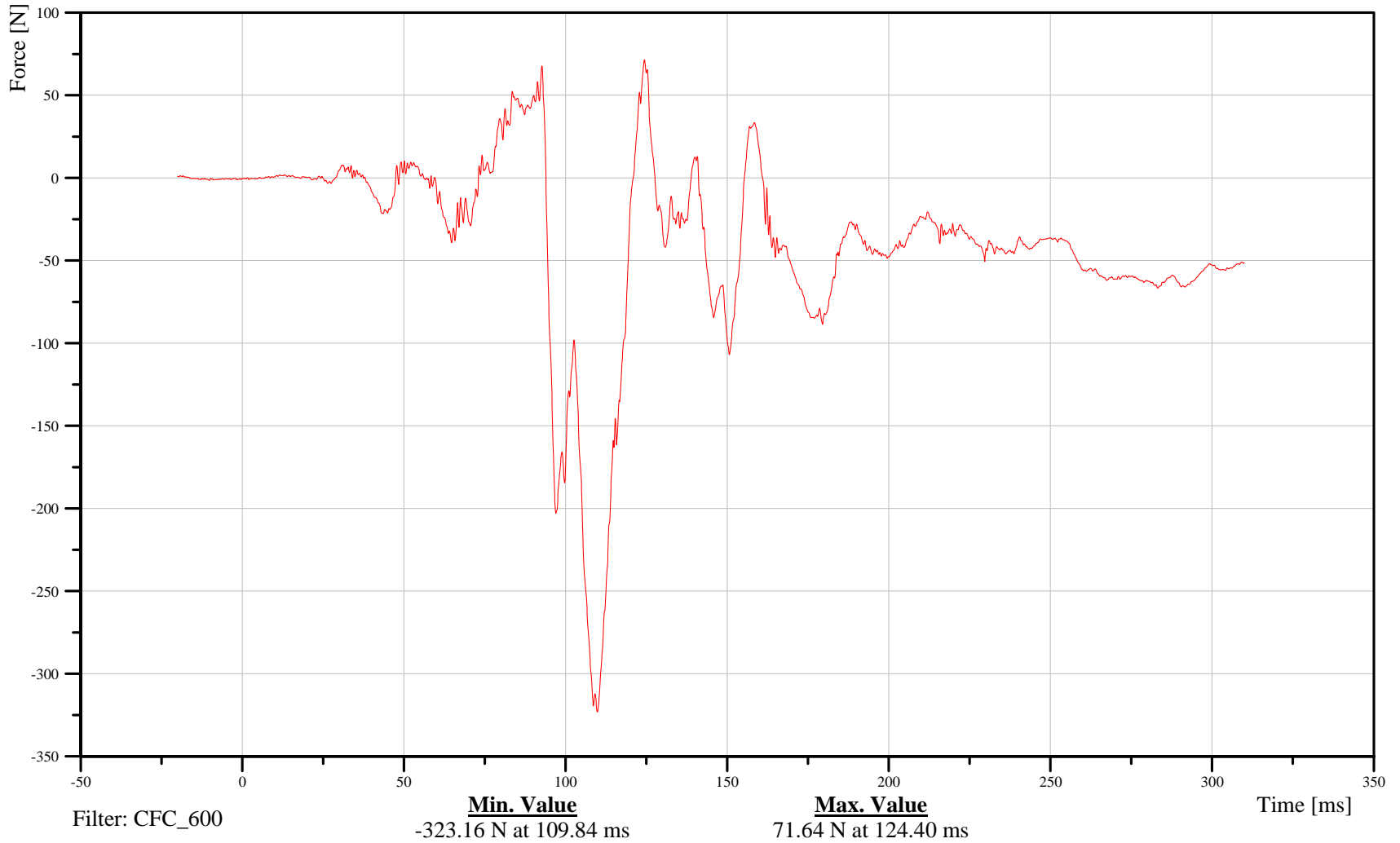

B-108

070913



2007 Ford F-250 into Left 40% Offset Deformable LCB at 56 kph

Date: 09/13/2007
Time: 15:46

Passenger Left Upper Tibia Z-Axis Force

Customer: Volpe
Test Number: R70203

13TIBILULXH3FOZB

TRC Inc. Test Lab: CTF
Test Number: 070913

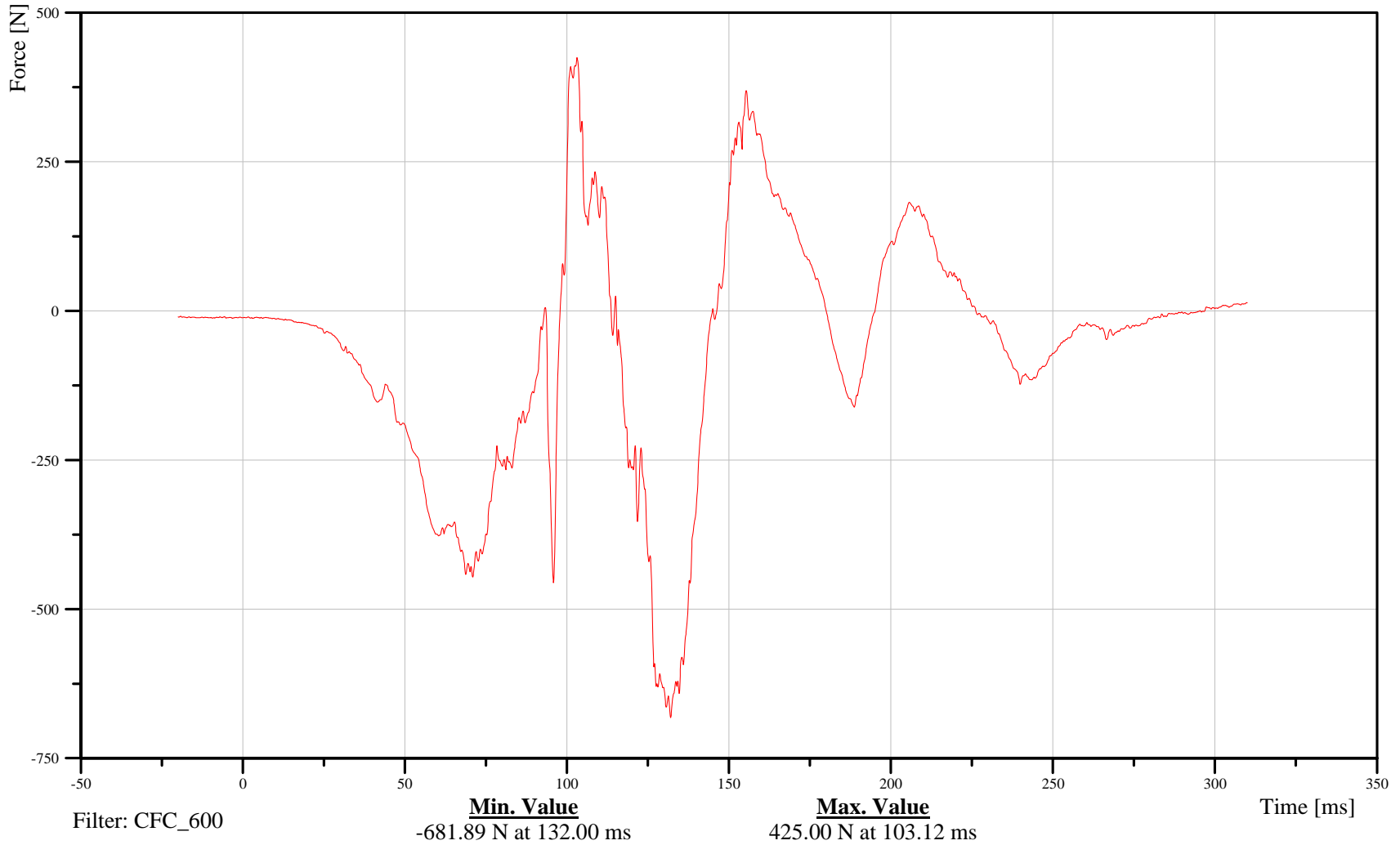

B-109

070913



2007 Ford F-250 into Left 40% Offset Deformable LCB at 56 kph

Date: 09/13/2007
Time: 15:46

Passenger Left Upper Tibia Moment About X Axis

Customer: Volpe
Test Number: R70203

13TIBILULXH3MOXB

TRC Inc. Test Lab: CTF
Test Number: 070913

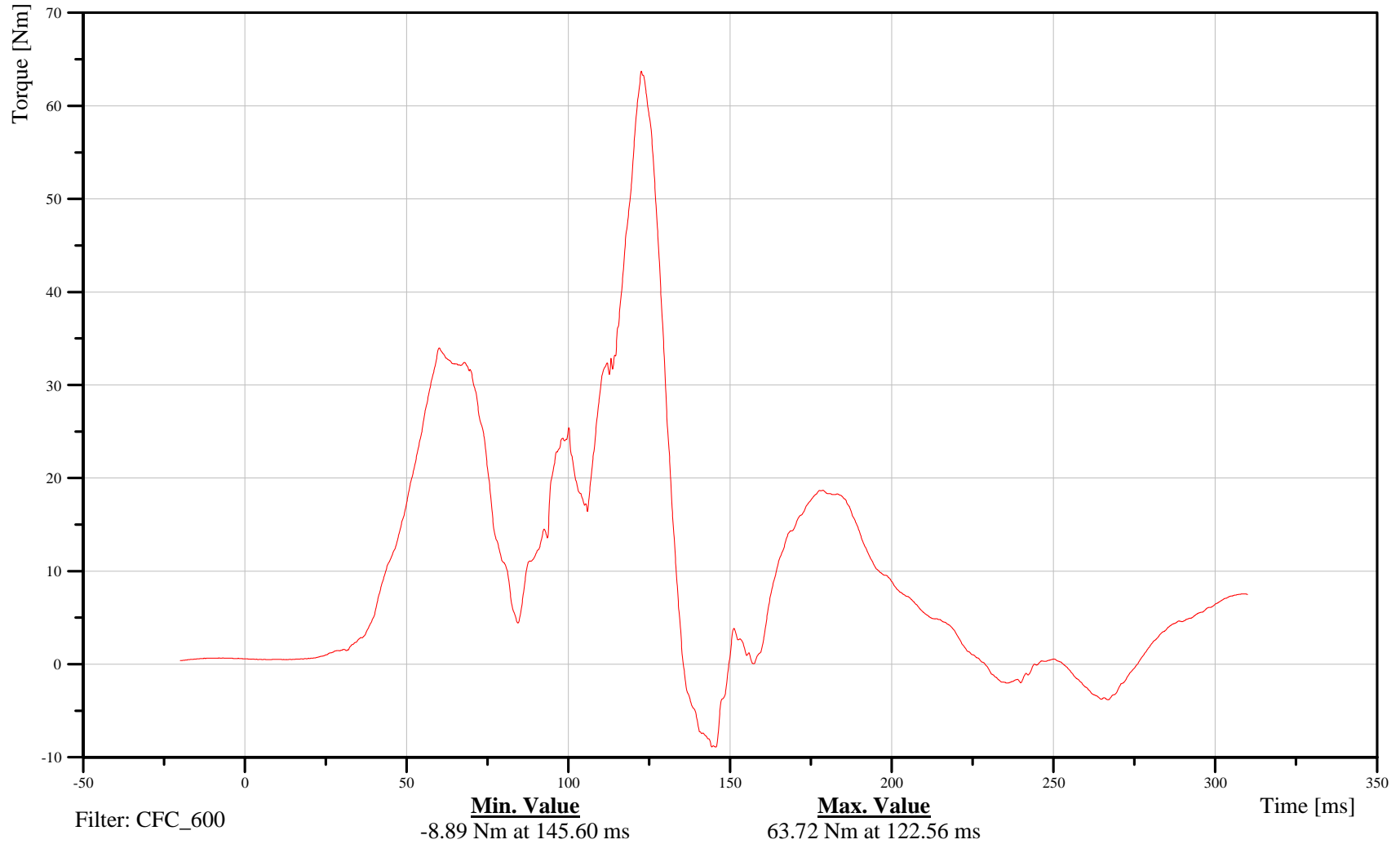

B-110

070913



2007 Ford F-250 into Left 40% Offset Deformable LCB at 56 kph

Date: 09/13/2007
Time: 15:46

Passenger Left Upper Tibia Moment About Y Axis

Customer: Volpe
Test Number: R70203

13TIBILULXH3MOYB

TRC Inc. Test Lab: CTF
Test Number: 070913

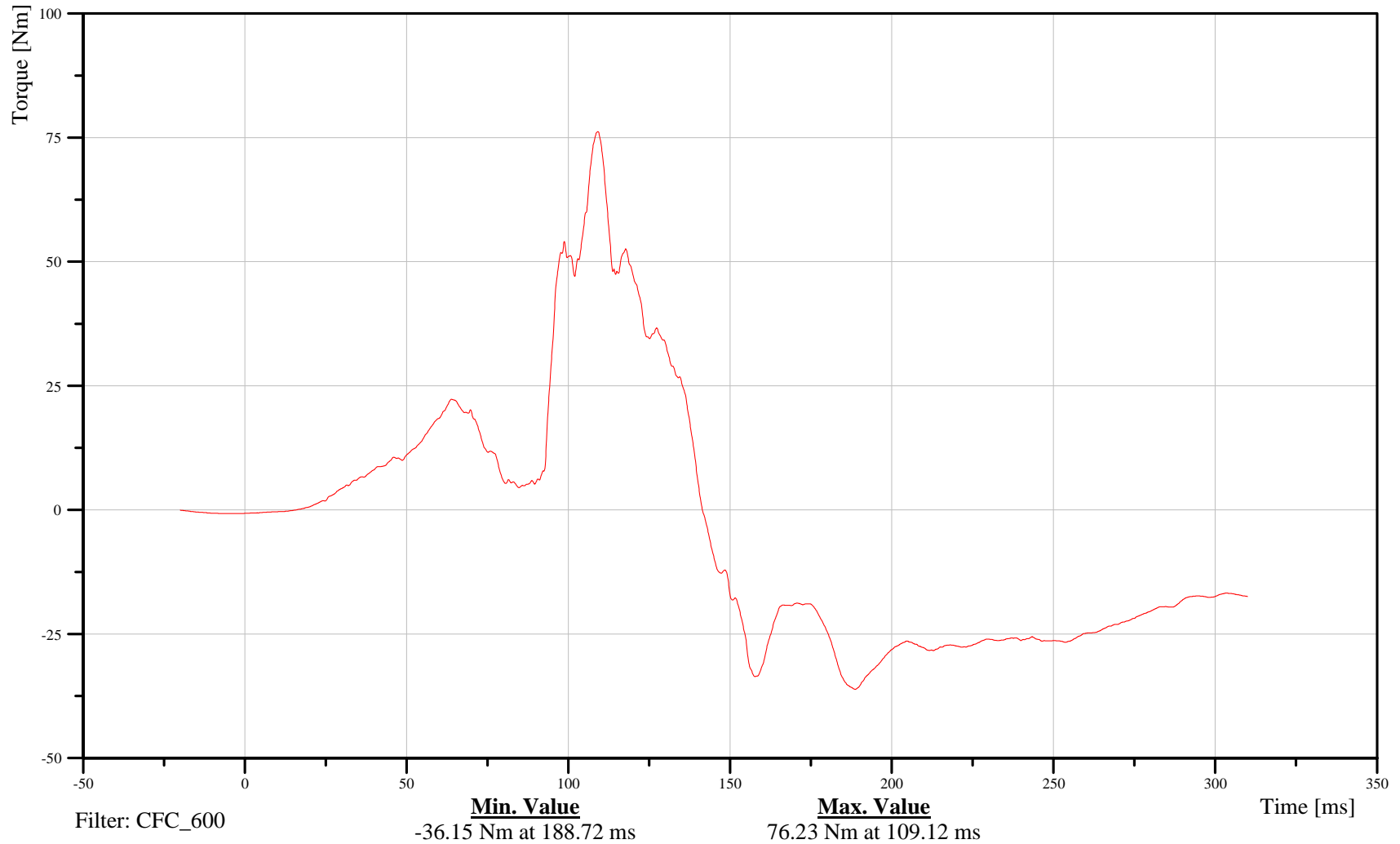

B-111

070913



2007 Ford F-250 into Left 40% Offset Deformable LCB at 56 kph

Date: 09/13/2007
Time: 15:46

Passenger Left Tibia X-Axis Acceleration

Customer: Volpe
Test Number: R70203

13TIBILELXH3ACXA

TRC Inc. Test Lab: CTF
Test Number: 070913

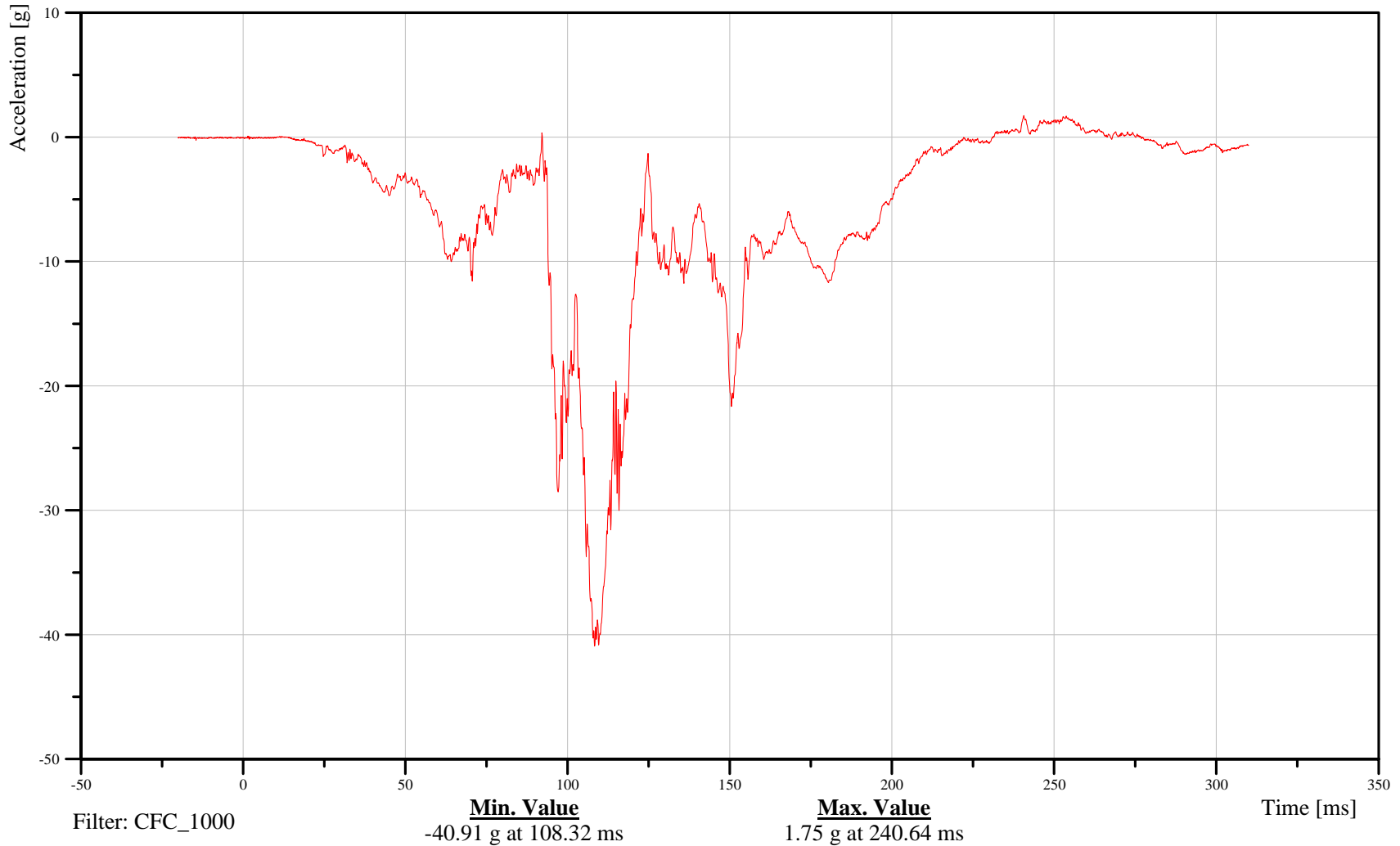

B-112

070913



2007 Ford F-250 into Left 40% Offset Deformable LCB at 56 kph

Date: 09/13/2007
Time: 15:46

Passenger Left Tibia Y-Axis Acceleration

Customer: Volpe
Test Number: R70203

13TIBILELXH3ACYA

TRC Inc. Test Lab: CTF
Test Number: 070913

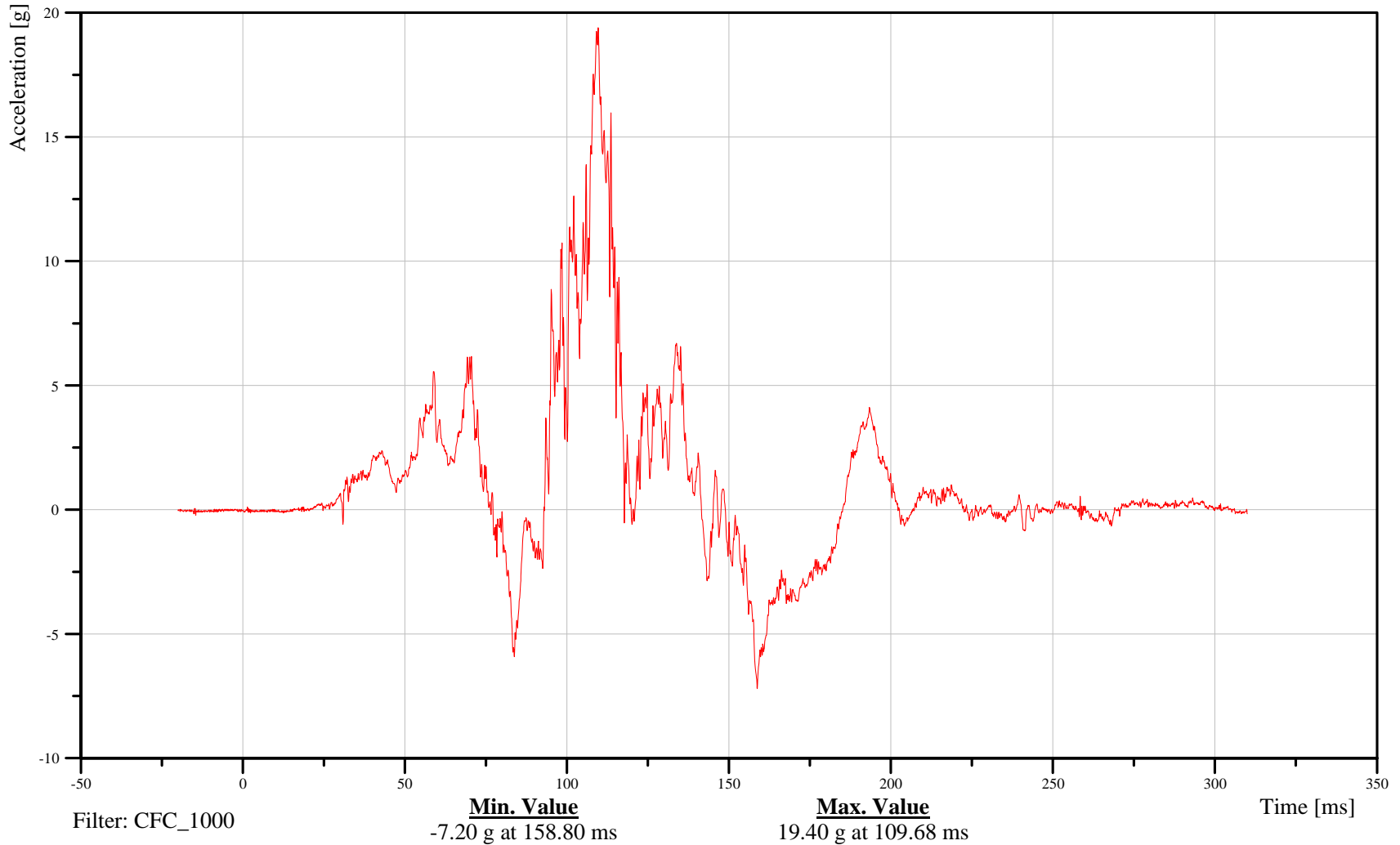

B-113

070913



2007 Ford F-250 into Left 40% Offset Deformable LCB at 56 kph

Date: 09/13/2007
Time: 15:46

Passenger Left Lower Tibia X-Axis Force

Customer: Volpe
Test Number: R70203

13TIBILLXH3FOXB

TRC Inc. Test Lab: CTF
Test Number: 070913

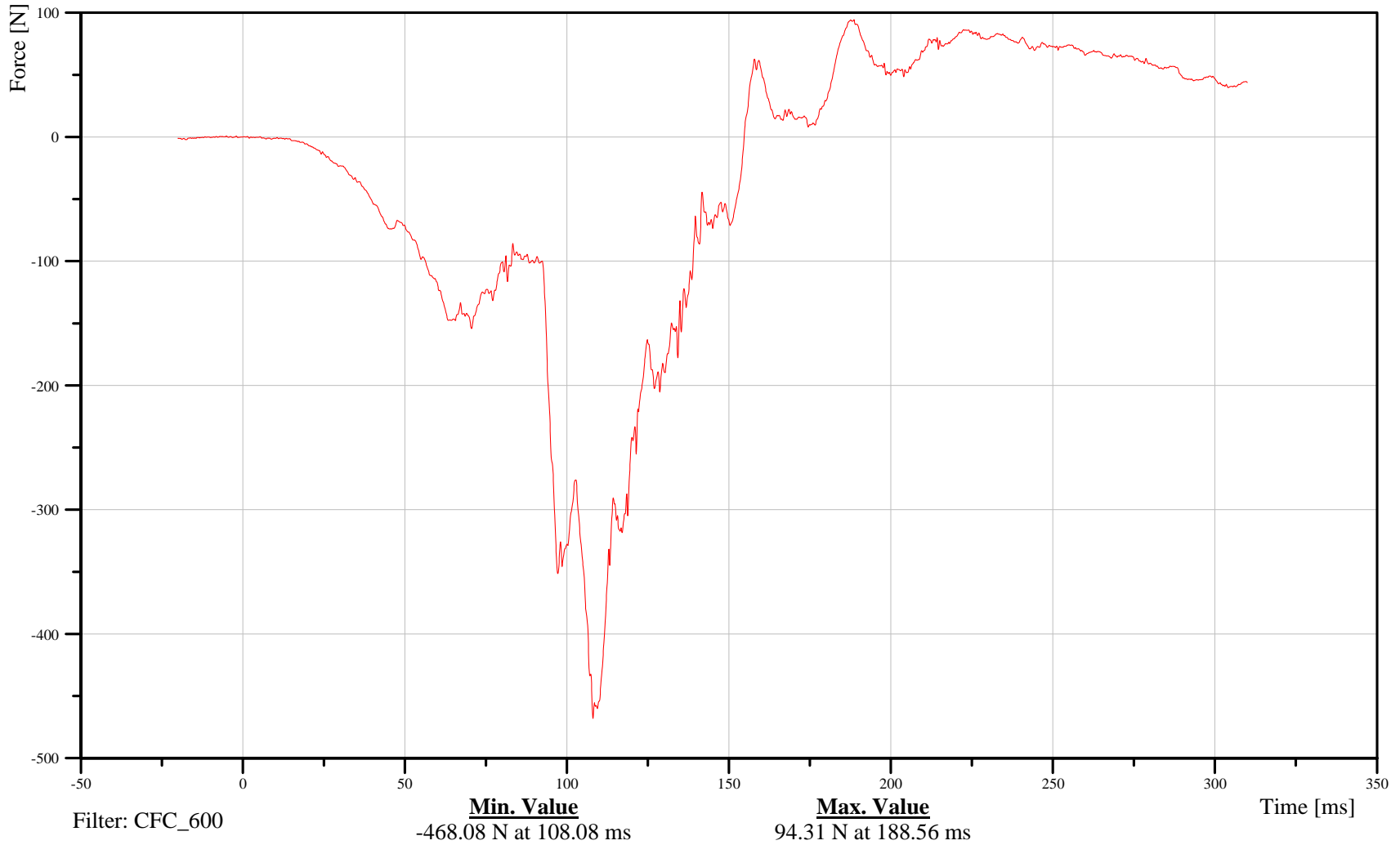

B-114

070913



2007 Ford F-250 into Left 40% Offset Deformable LCB at 56 kph

Date: 09/13/2007
Time: 15:46

Passenger Left Lower Tibia Y-Axis Force

Customer: Volpe
Test Number: R70203

13TIBILLXH3FOYB

TRC Inc. Test Lab: CTF
Test Number: 070913

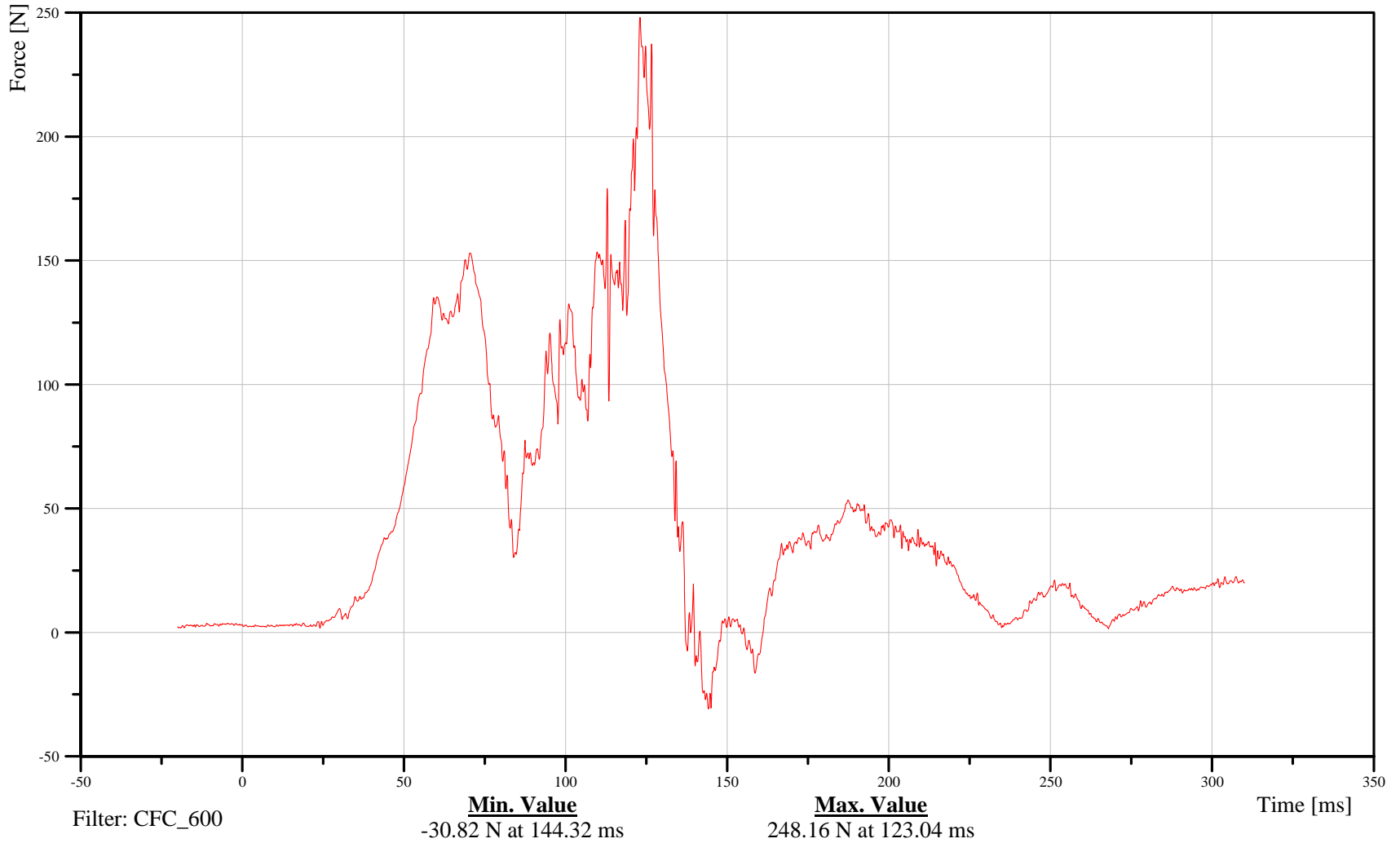

B-115

070913



2007 Ford F-250 into Left 40% Offset Deformable LCB at 56 kph

Date: 09/13/2007
Time: 15:46

Passenger Left Lower Tibia Z-Axis Force

Customer: Volpe
Test Number: R70203

13TIBILLXH3FOZB

TRC Inc. Test Lab: CTF
Test Number: 070913

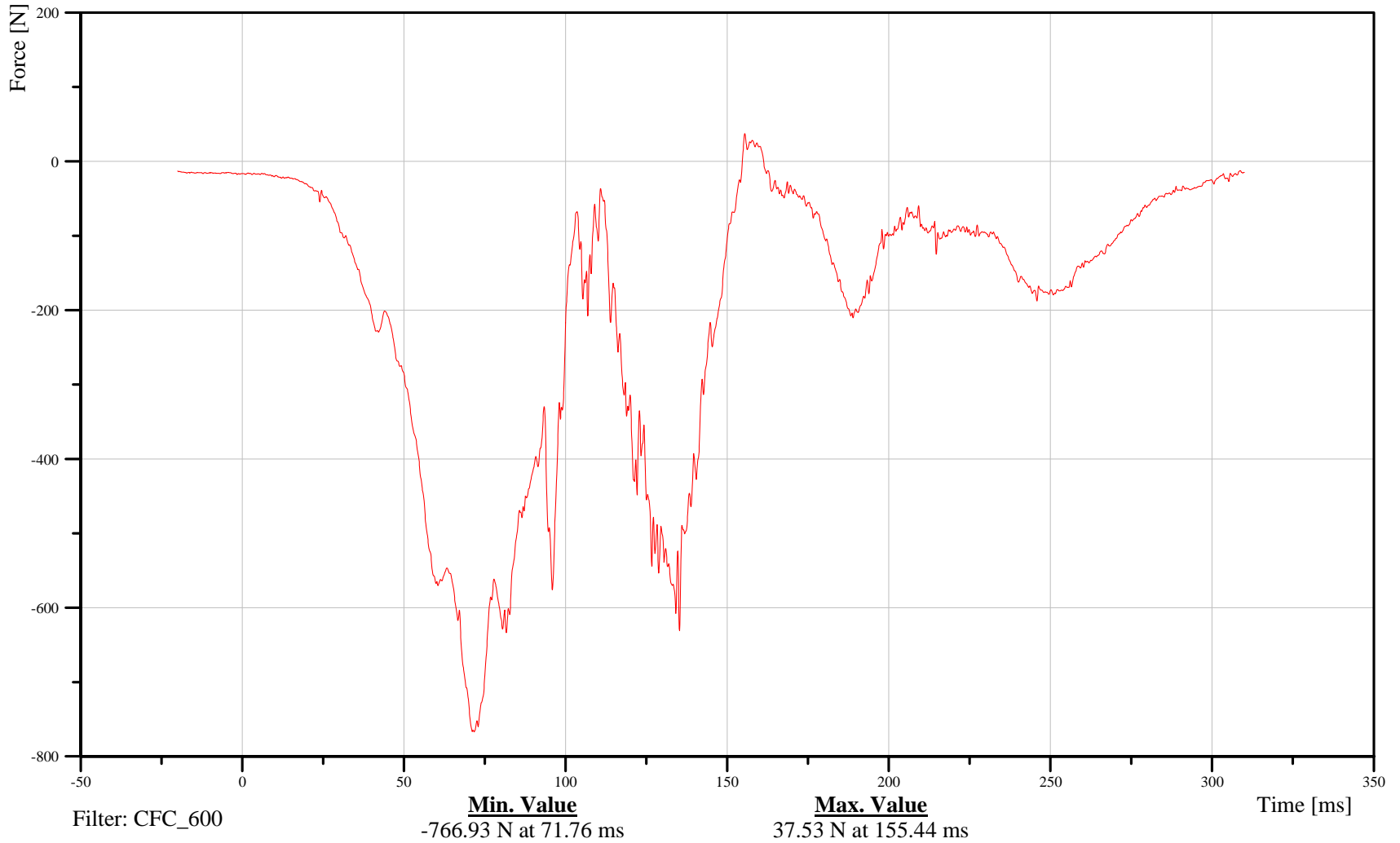

B-116

070913



2007 Ford F-250 into Left 40% Offset Deformable LCB at 56 kph

Date: 09/13/2007
Time: 15:46

Passenger Left Lower Tibia Moment About X Axis

Customer: Volpe
Test Number: R70203

13TIBILLXH3MOXB

TRC Inc. Test Lab: CTF
Test Number: 070913

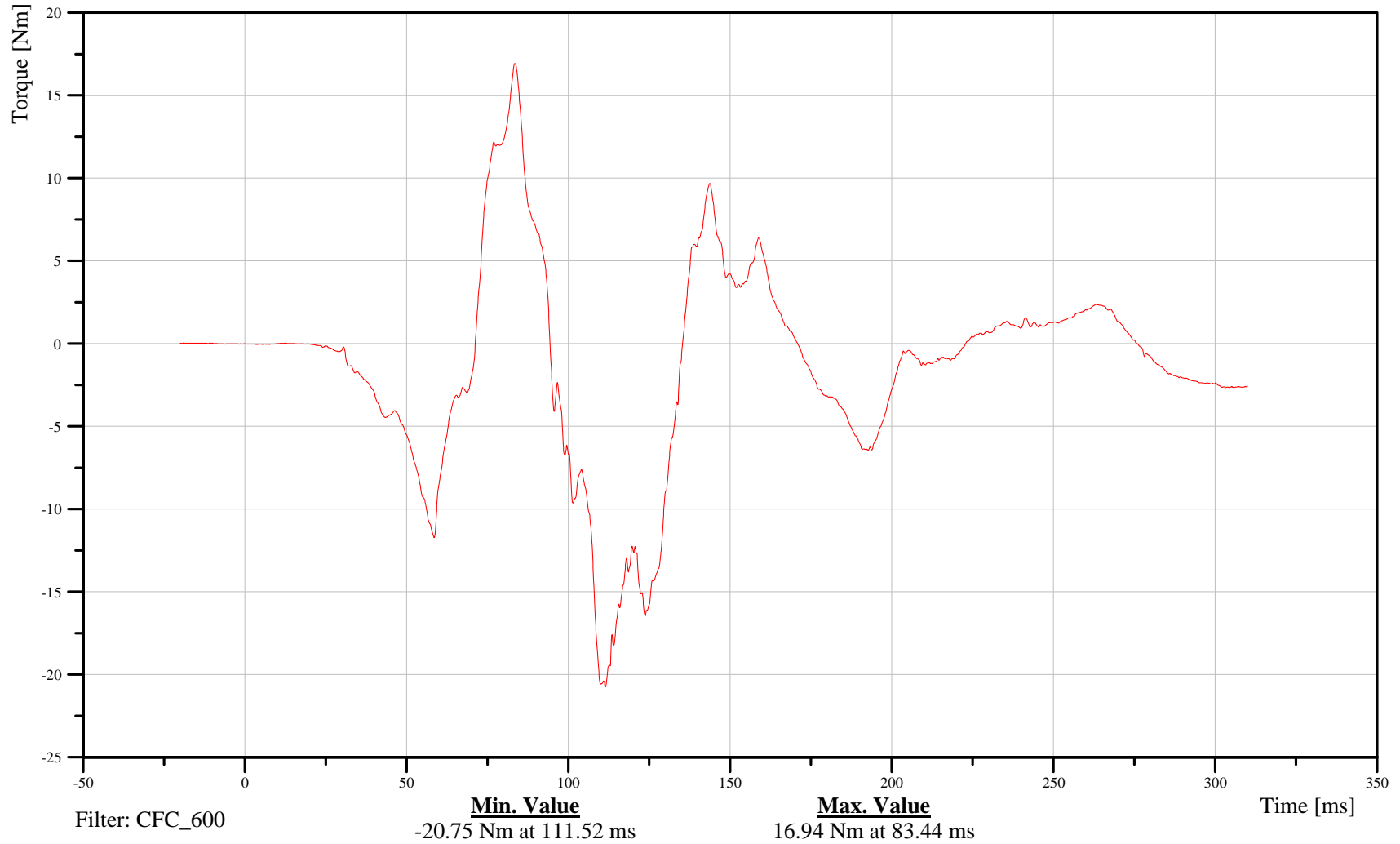

B-117

070913



2007 Ford F-250 into Left 40% Offset Deformable LCB at 56 kph

Date: 09/13/2007
Time: 15:46

Passenger Left Lower Tibia Moment About Y Axis

Customer: Volpe
Test Number: R70203

13TIBILLXH3MOYB

TRC Inc. Test Lab: CTF
Test Number: 070913

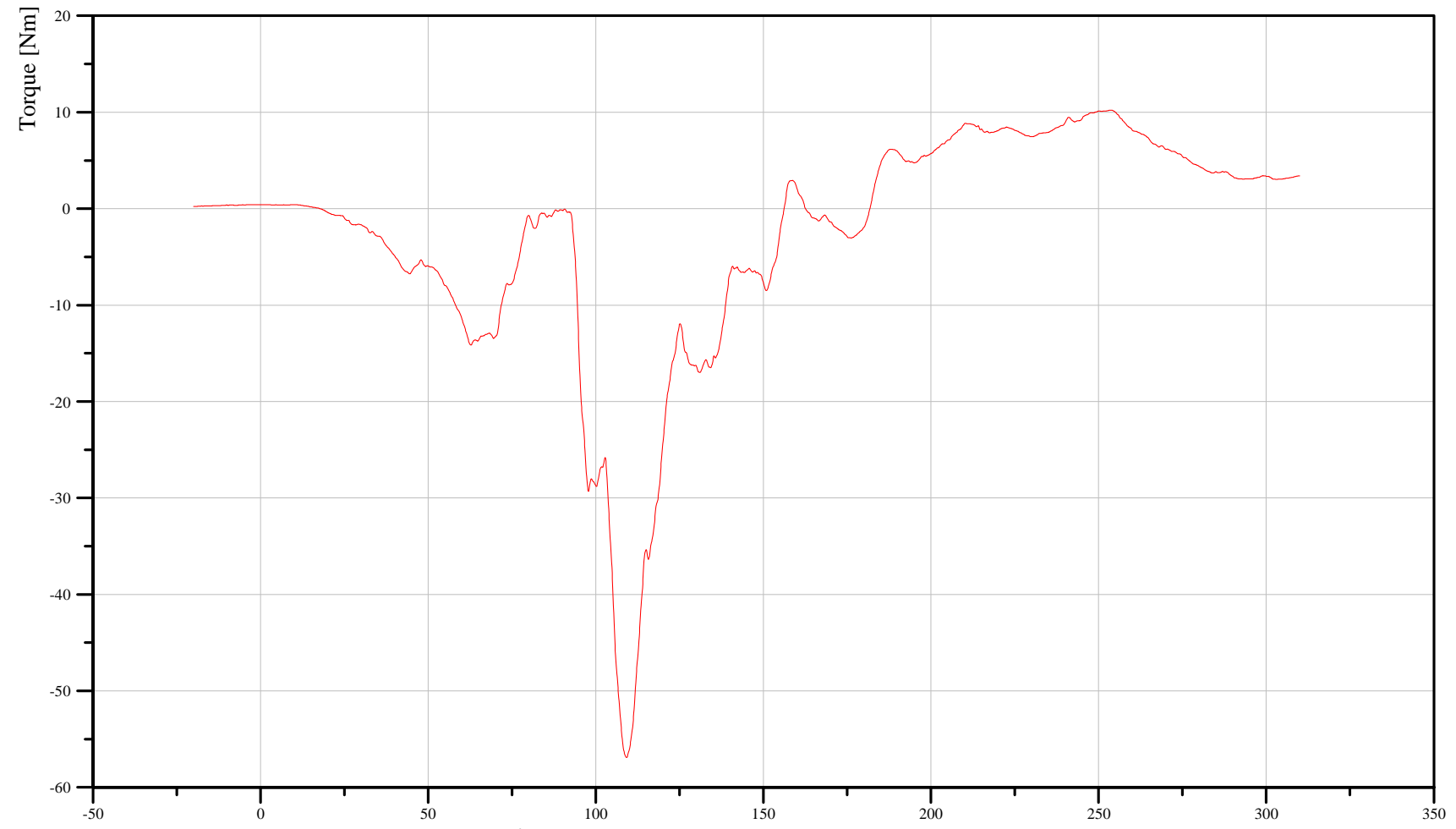

Filter: CFC_600

Min. Value
-56.91 Nm at 109.20 ms

Max. Value
10.22 Nm at 253.52 ms

Time [ms]

B-118

070913



2007 Ford F-250 into Left 40% Offset Deformable LCB at 56 kph

Date: 09/13/2007
Time: 15:46

Passenger Left Foot X-Axis Rotation

Customer: Volpe
Test Number: R70203

13FOOTLELXH3ANXC

TRC Inc. Test Lab: CTF
Test Number: 070913

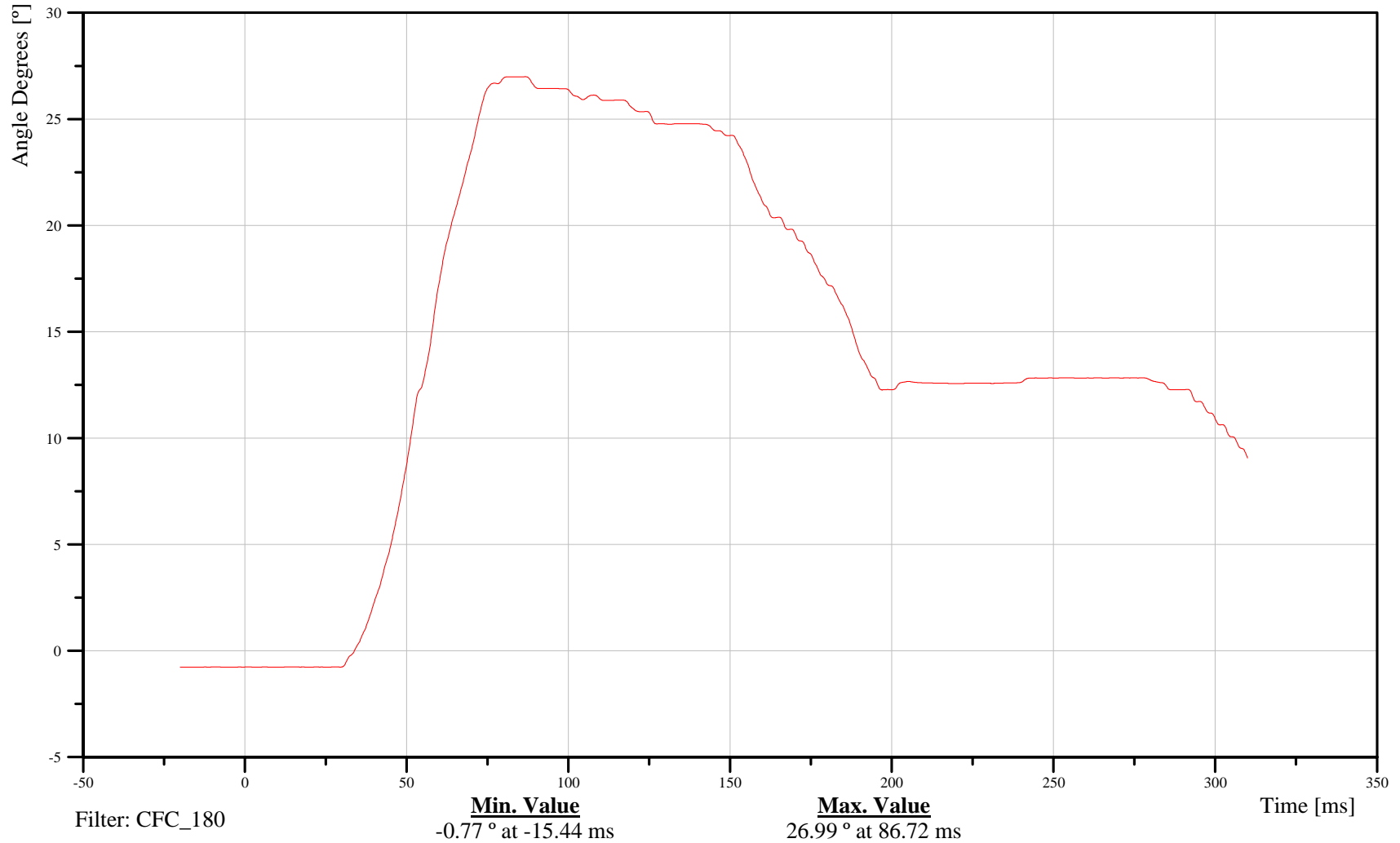

B-119

070913



2007 Ford F-250 into Left 40% Offset Deformable LCB at 56 kph

Date: 09/13/2007
Time: 15:46

Passenger Left Foot Y-Axis Rotation

Customer: Volpe
Test Number: R70203

13FOOTLELXH3ANYC

TRC Inc. Test Lab: CTF
Test Number: 070913

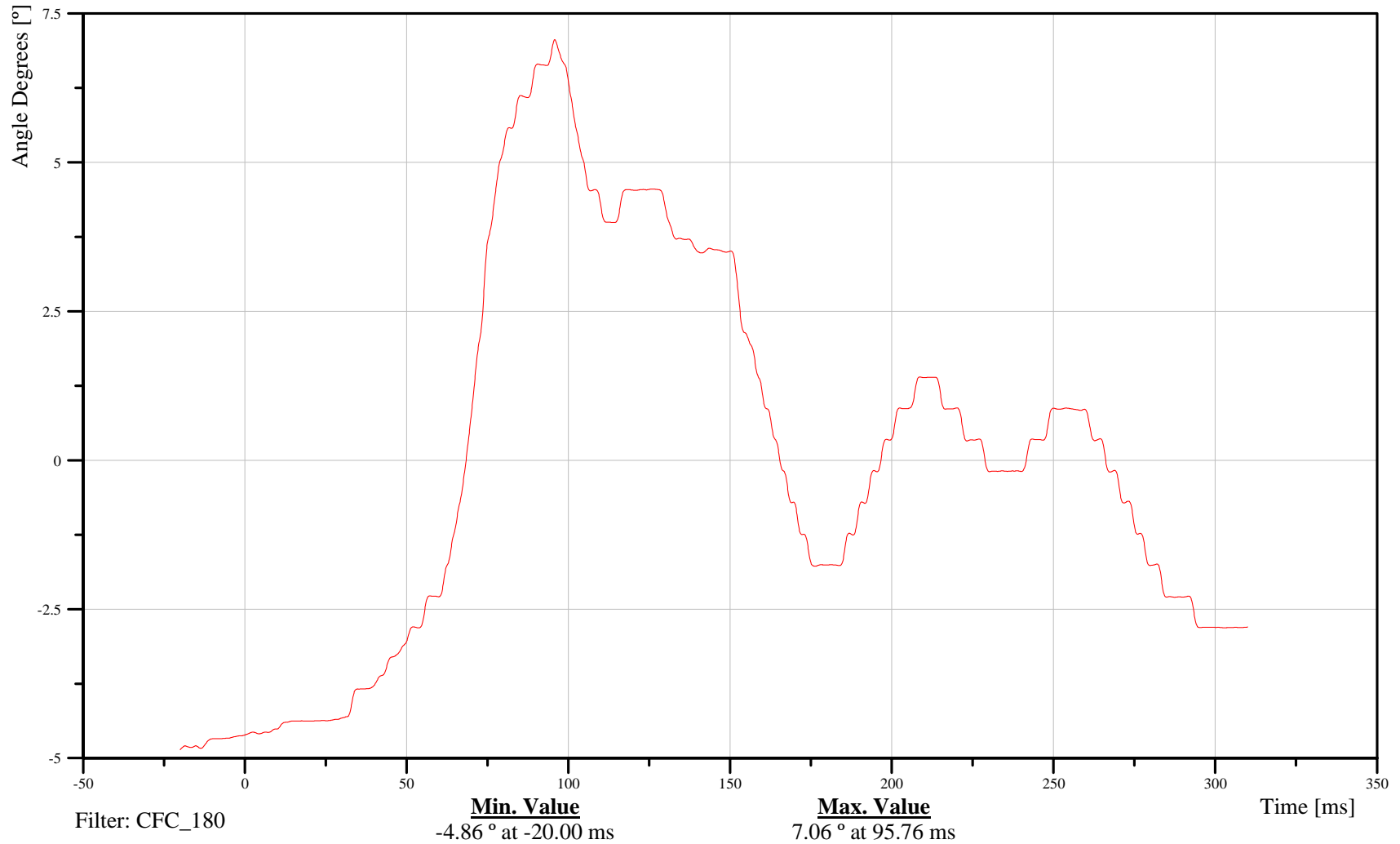

B-120

070913



2007 Ford F-250 into Left 40% Offset Deformable LCB at 56 kph

Date: 09/13/2007
Time: 15:46

Passenger Left Foot Z-Axis Rotation

Customer: Volpe
Test Number: R70203

13FOOTLELXH3ANZC

TRC Inc. Test Lab: CTF
Test Number: 070913

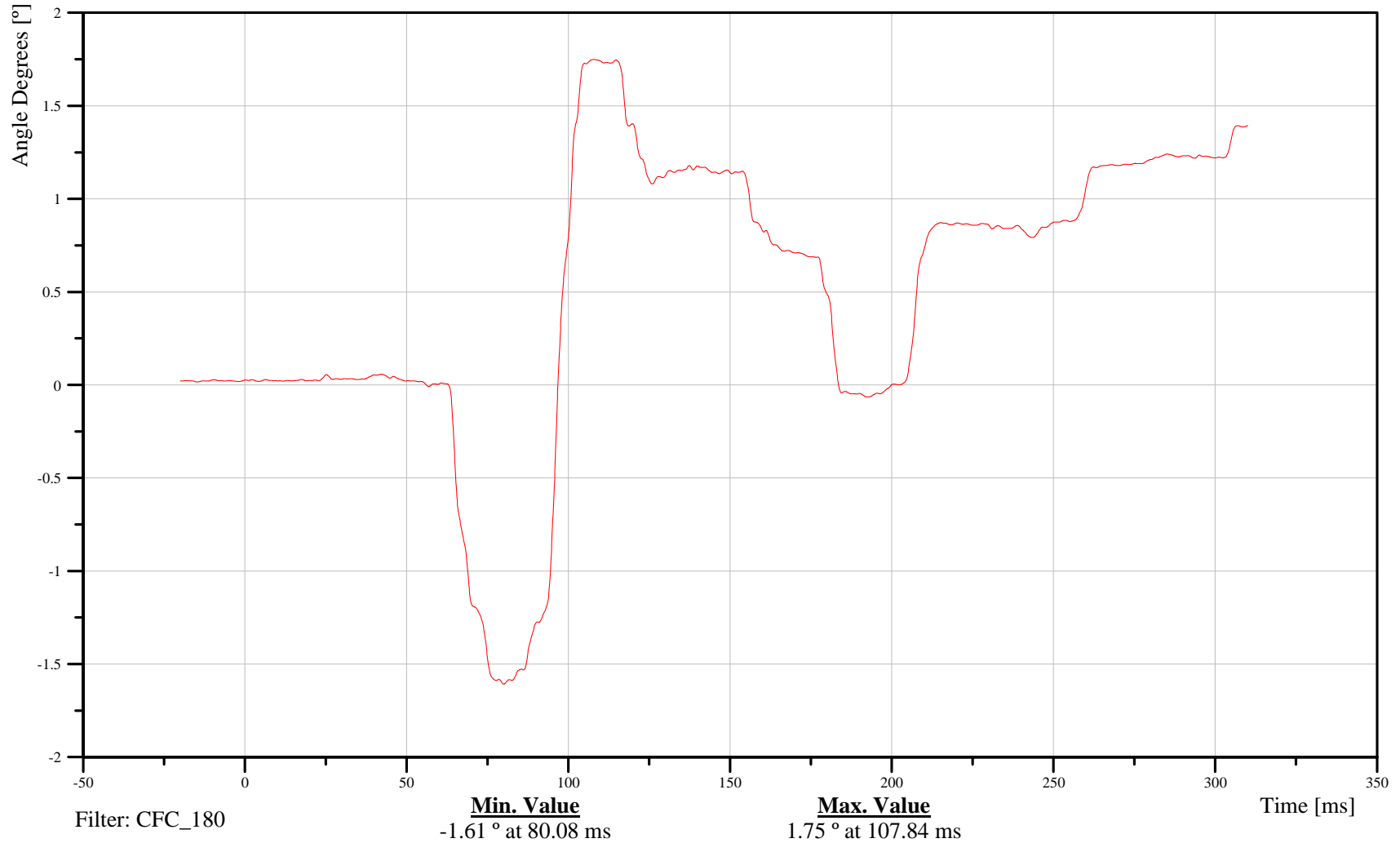

B-121

070913



2007 Ford F-250 into Left 40% Offset Deformable LCB at 56 kph

Date: 09/13/2007
Time: 15:46

Passenger Left Foot X-Axis Acceleration

Customer: Volpe
Test Number: R70203

13FOOTLELXH3ACXA

TRC Inc. Test Lab: CTF
Test Number: 070913

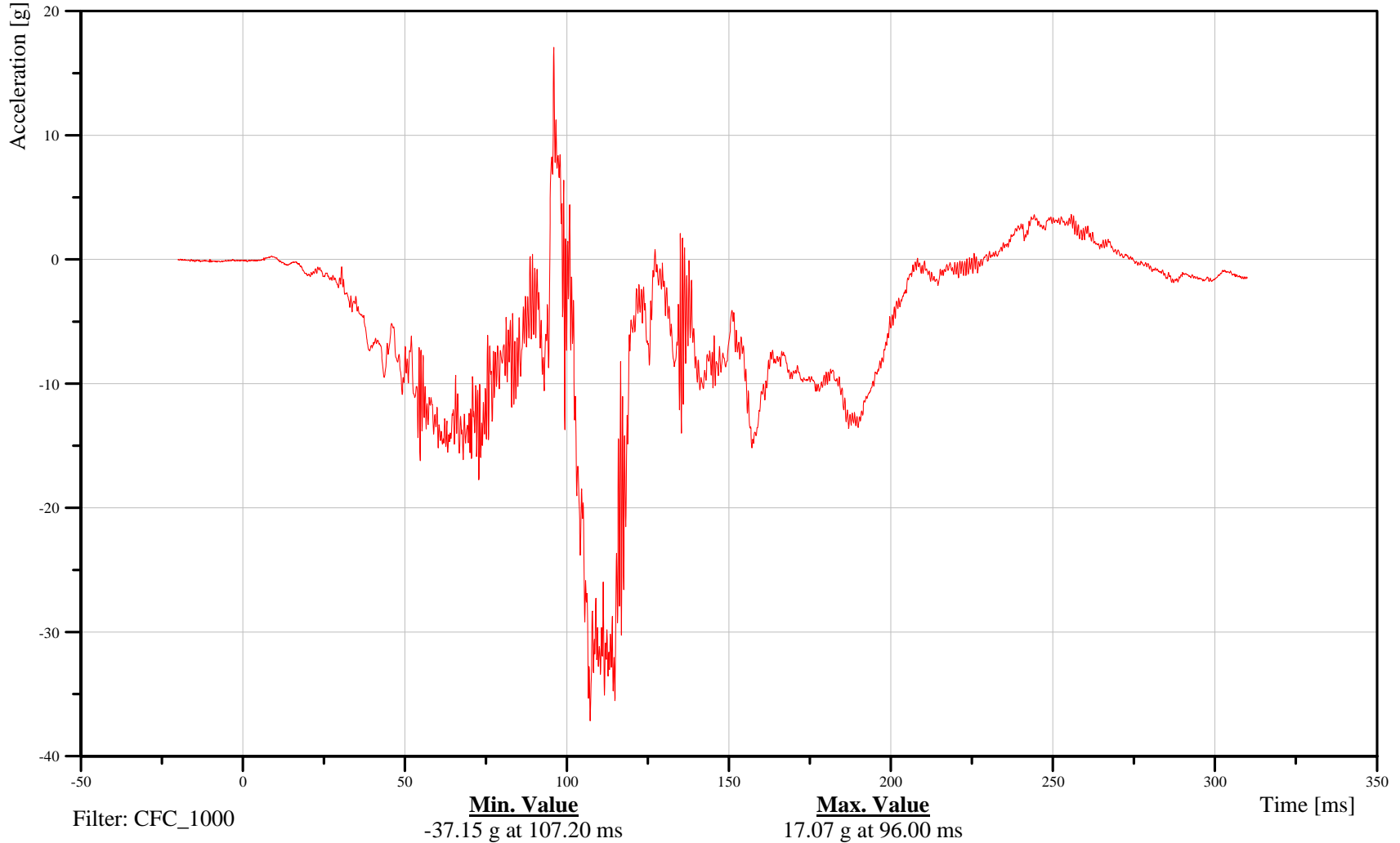

B-122

070913



2007 Ford F-250 into Left 40% Offset Deformable LCB at 56 kph

Date: 09/13/2007
Time: 15:46

Passenger Left Foot Y-Axis Acceleration

Customer: Volpe
Test Number: R70203

13FOOTLELXH3ACYA

TRC Inc. Test Lab: CTF
Test Number: 070913

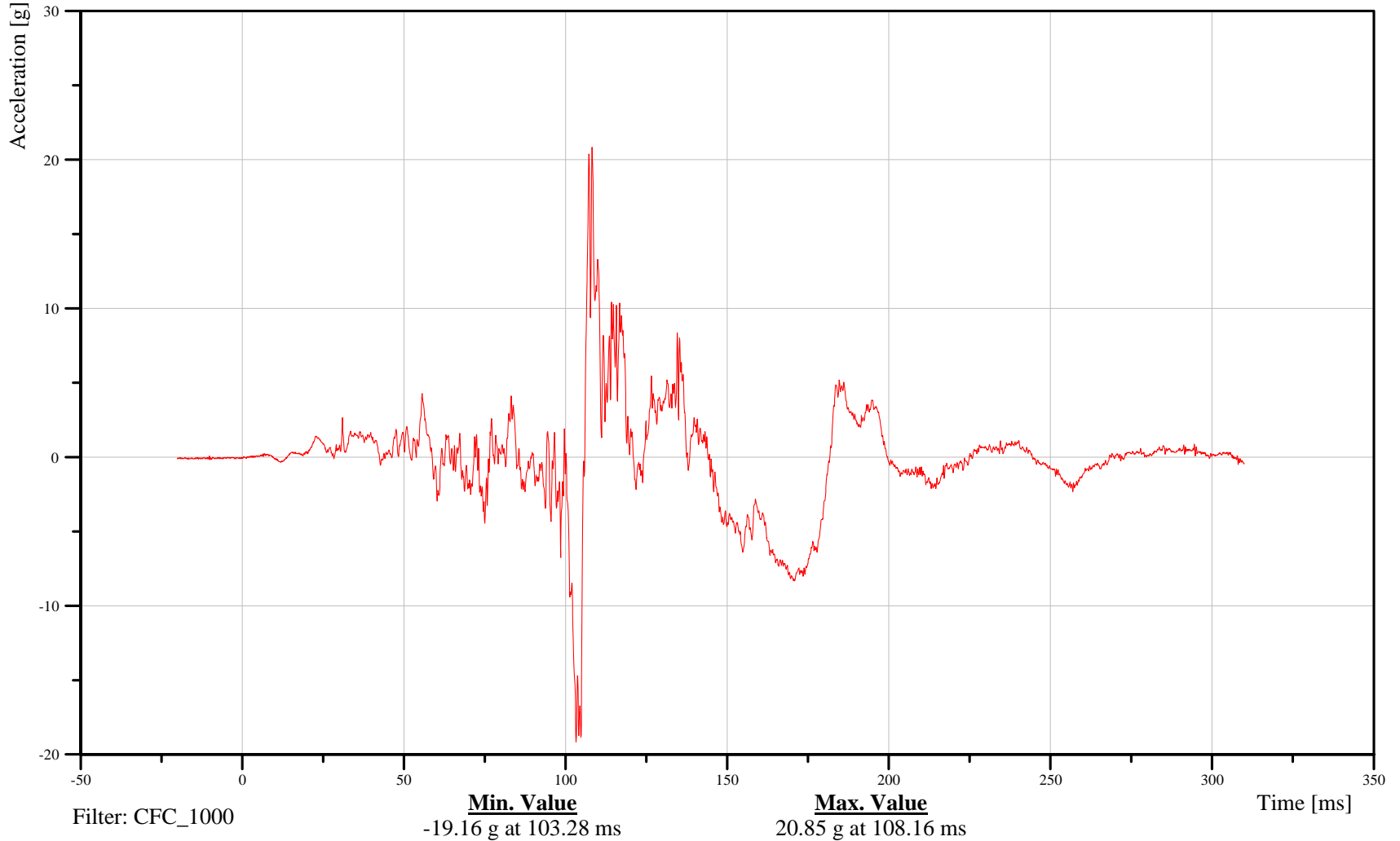

B-123

070913



2007 Ford F-250 into Left 40% Offset Deformable LCB at 56 kph

Date: 09/13/2007
Time: 15:46

Passenger Left Foot Z-Axis Acceleration

Customer: Volpe
Test Number: R70203

13FOOTLELXH3ACZA

TRC Inc. Test Lab: CTF
Test Number: 070913

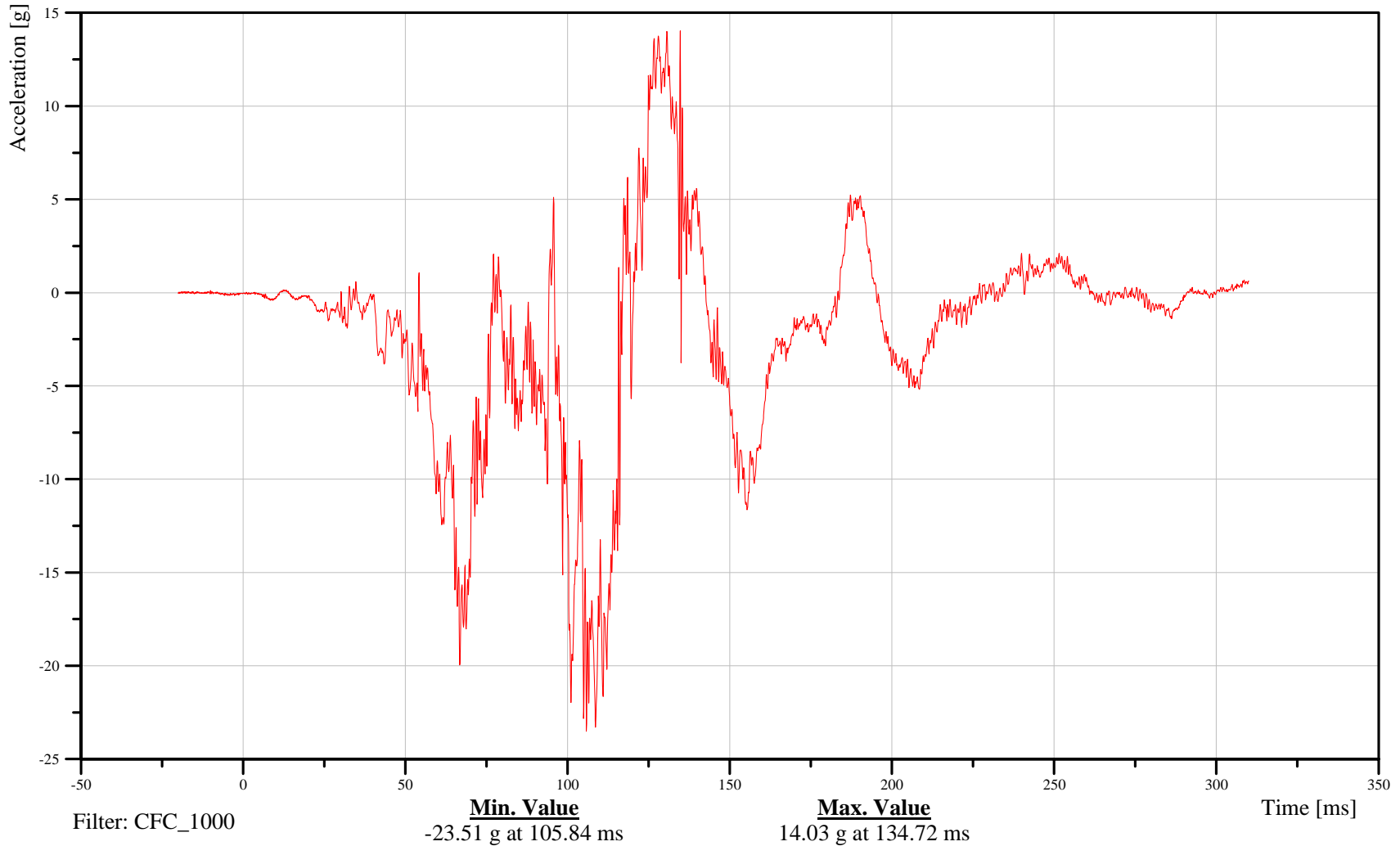

B-124

070913



2007 Ford F-250 into Left 40% Offset Deformable LCB at 56 kph

Date: 09/13/2007
Time: 15:46

Passenger Left Foot Resultant Acceleration

Customer: Volpe
Test Number: R70203

13FOOTLELXH3ACRA

TRC Inc. Test Lab: CTF
Test Number: 070913

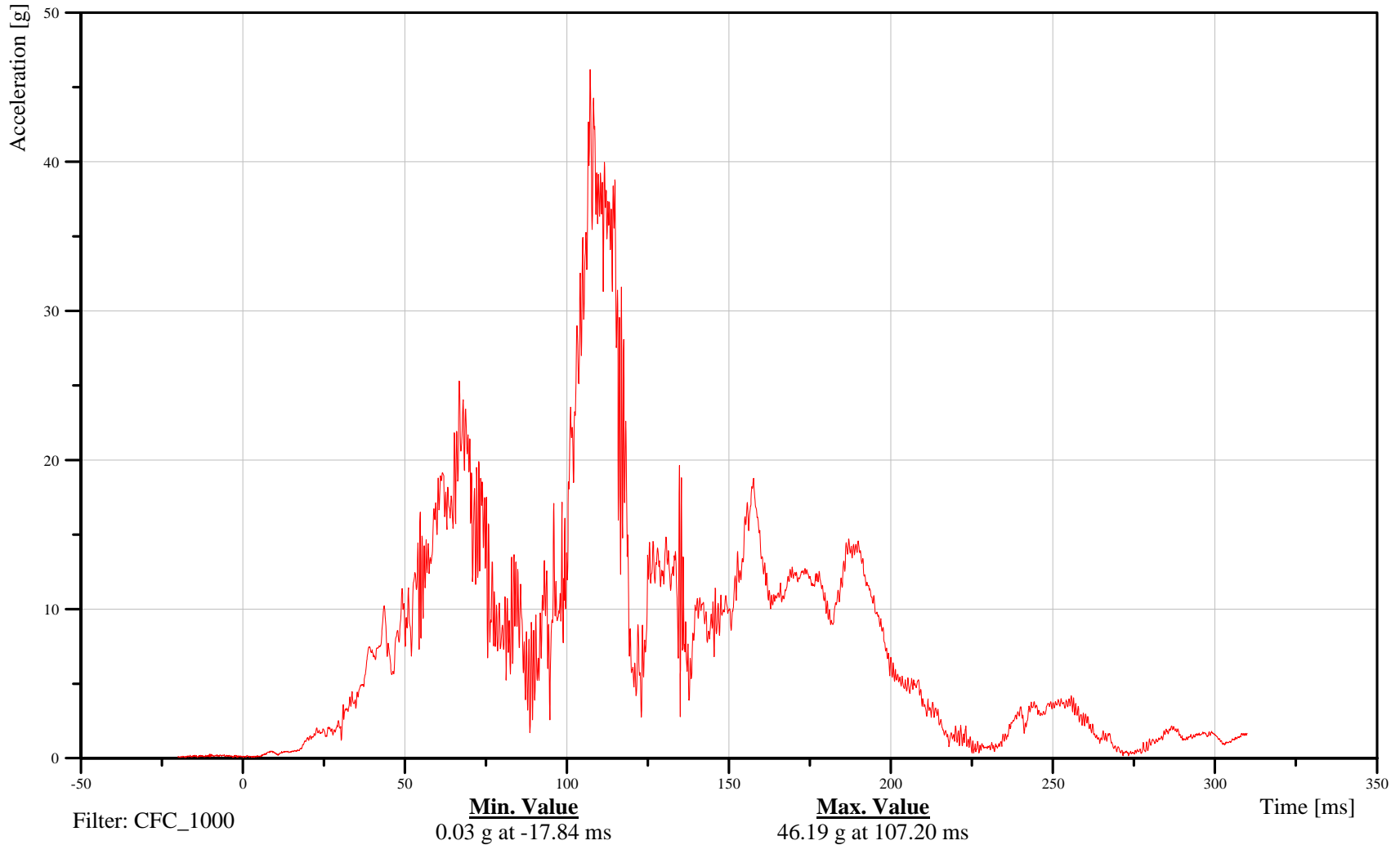

B-125

070913



2007 Ford F-250 into Left 40% Offset Deformable LCB at 56 kph

Date: 09/13/2007
Time: 15:46

Passenger Right Knee Displacement

Customer: Volpe
Test Number: R70203

13KNSLRI00H3DSXC

TRC Inc. Test Lab: CTF
Test Number: 070913

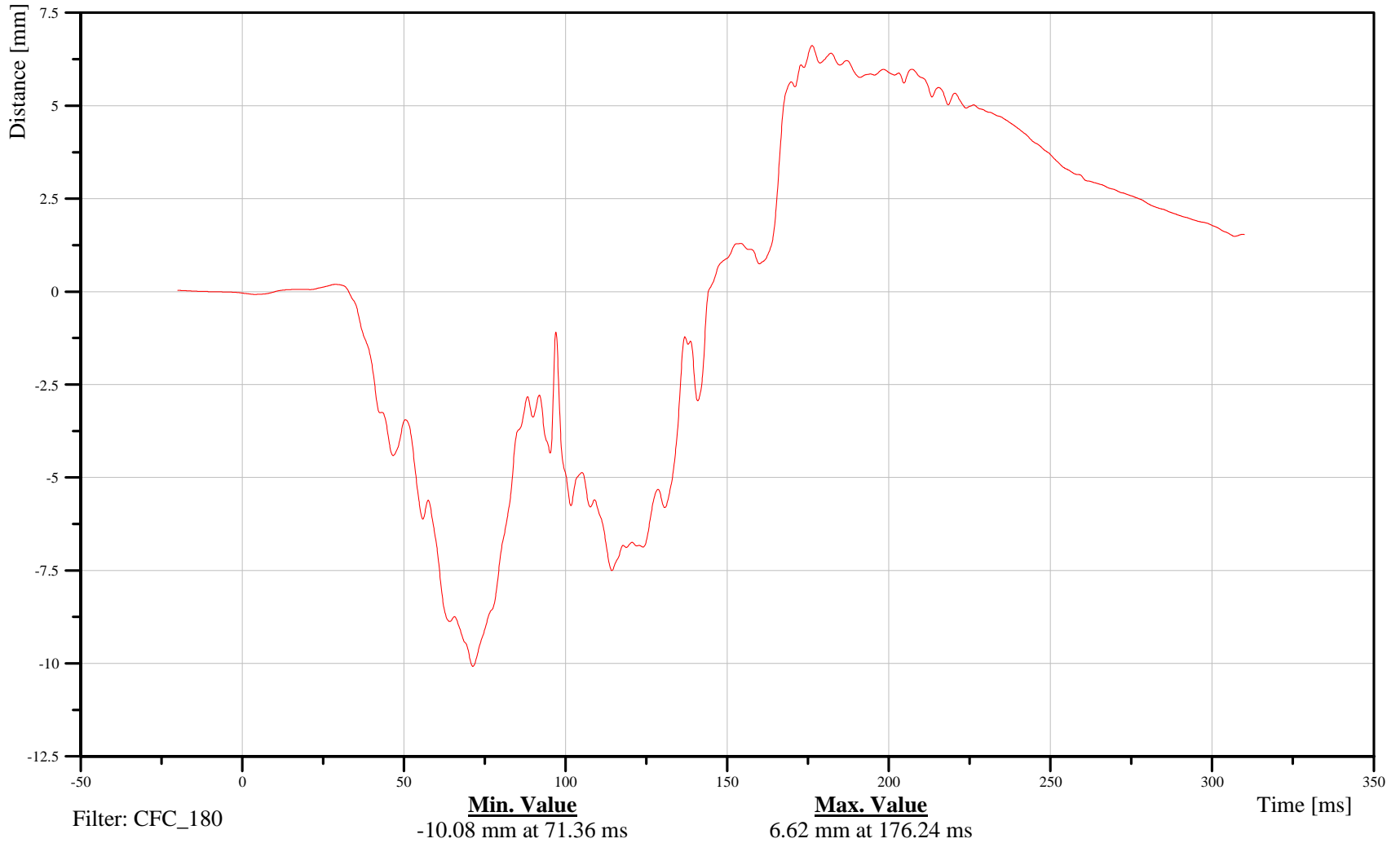

B-126

070913



2007 Ford F-250 into Left 40% Offset Deformable LCB at 56 kph

Date: 09/13/2007
Time: 15:46

Passenger Right Upper Tibia X-Axis Force

Customer: Volpe
Test Number: R70203

13TIBIRULXH3FOXB

TRC Inc. Test Lab: CTF
Test Number: 070913

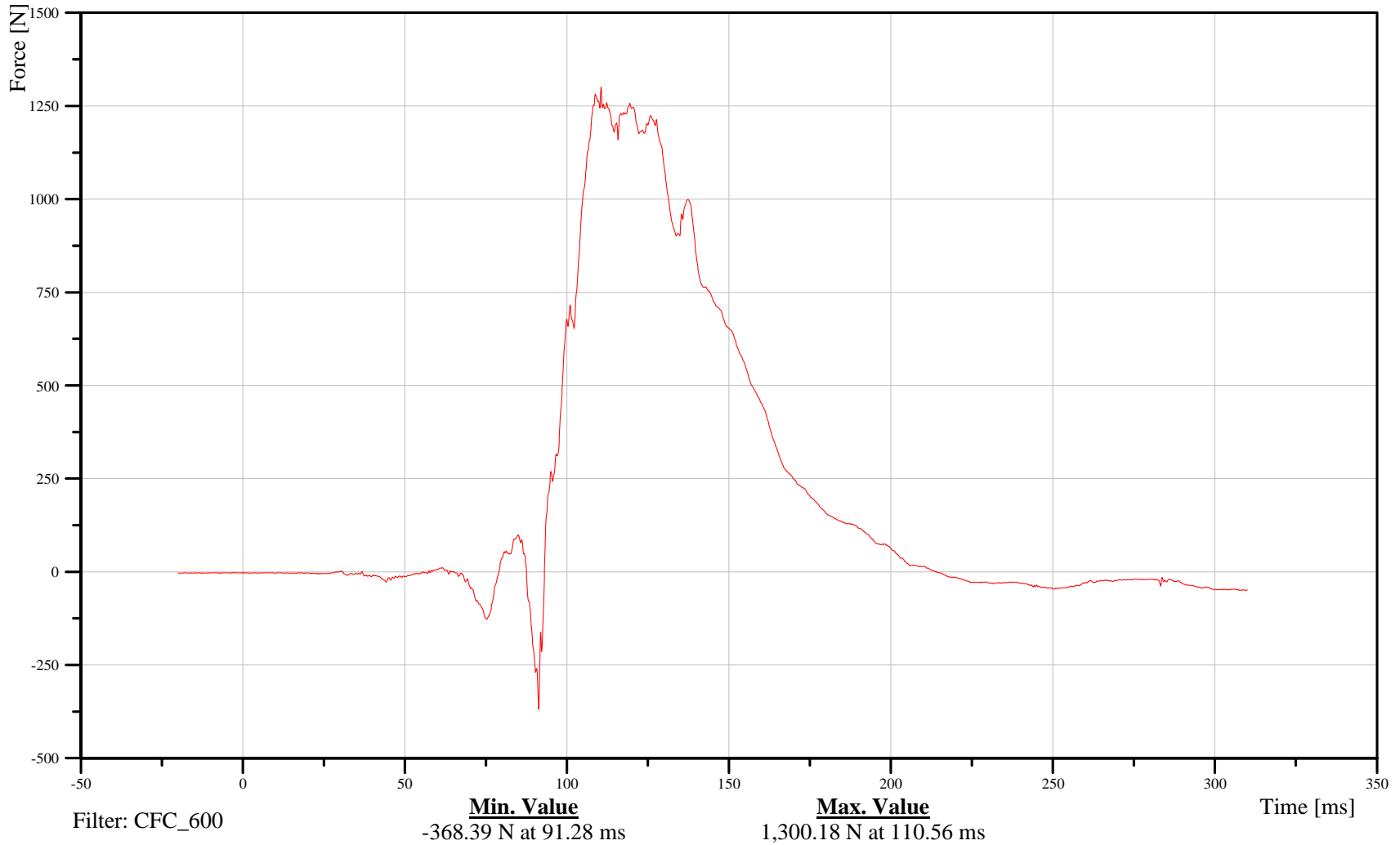

B-127

070913



2007 Ford F-250 into Left 40% Offset Deformable LCB at 56 kph

Date: 09/13/2007
Time: 15:46

Passenger Right Upper Tibia Z-Axis Force

Customer: Volpe
Test Number: R70203

13TIBIRULXH3FOZB

TRC Inc. Test Lab: CTF
Test Number: 070913

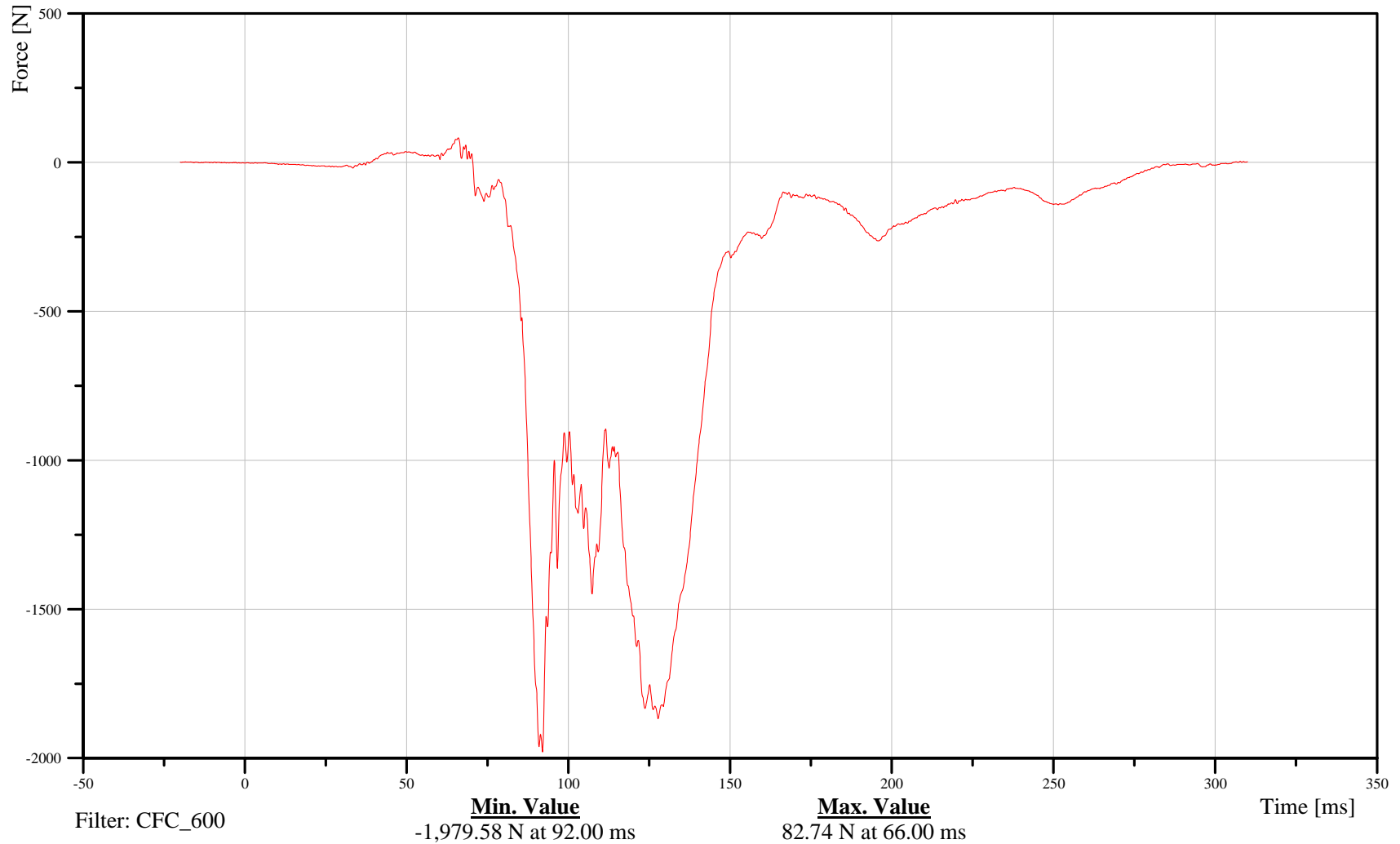

B-128

070913



2007 Ford F-250 into Left 40% Offset Deformable LCB at 56 kph

Date: 09/13/2007
Time: 15:46

Passenger Right Upper Tibia Moment About X Axis

Customer: Volpe
Test Number: R70203

13TIBIRULXH3MOXB

TRC Inc. Test Lab: CTF
Test Number: 070913

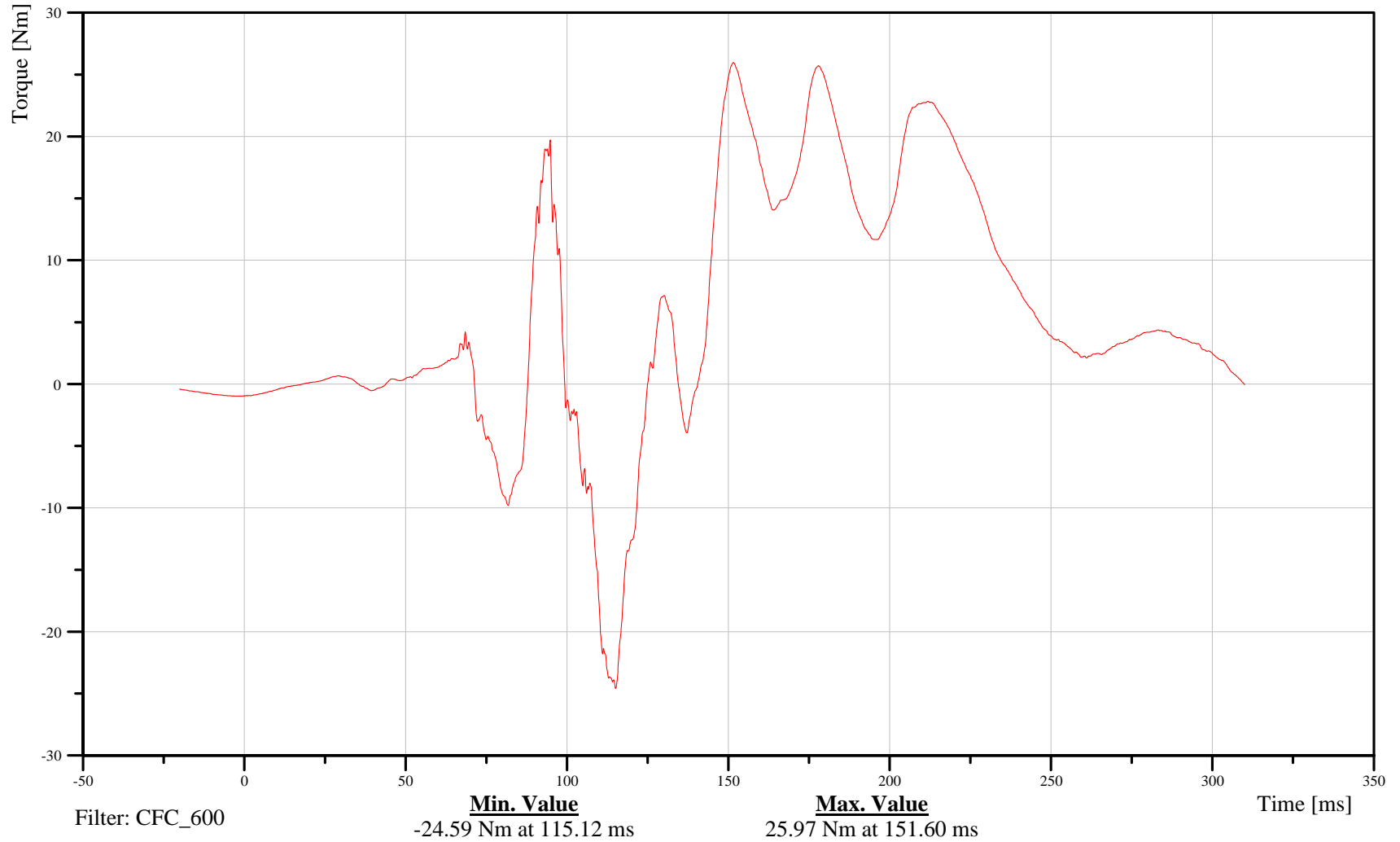

B-129

070913



2007 Ford F-250 into Left 40% Offset Deformable LCB at 56 kph

Date: 09/13/2007
Time: 15:46

Passenger Right Upper Tibia Moment About Y Axis

Customer: Volpe
Test Number: R70203

13TIBIRULXH3MOYB

TRC Inc. Test Lab: CTF
Test Number: 070913

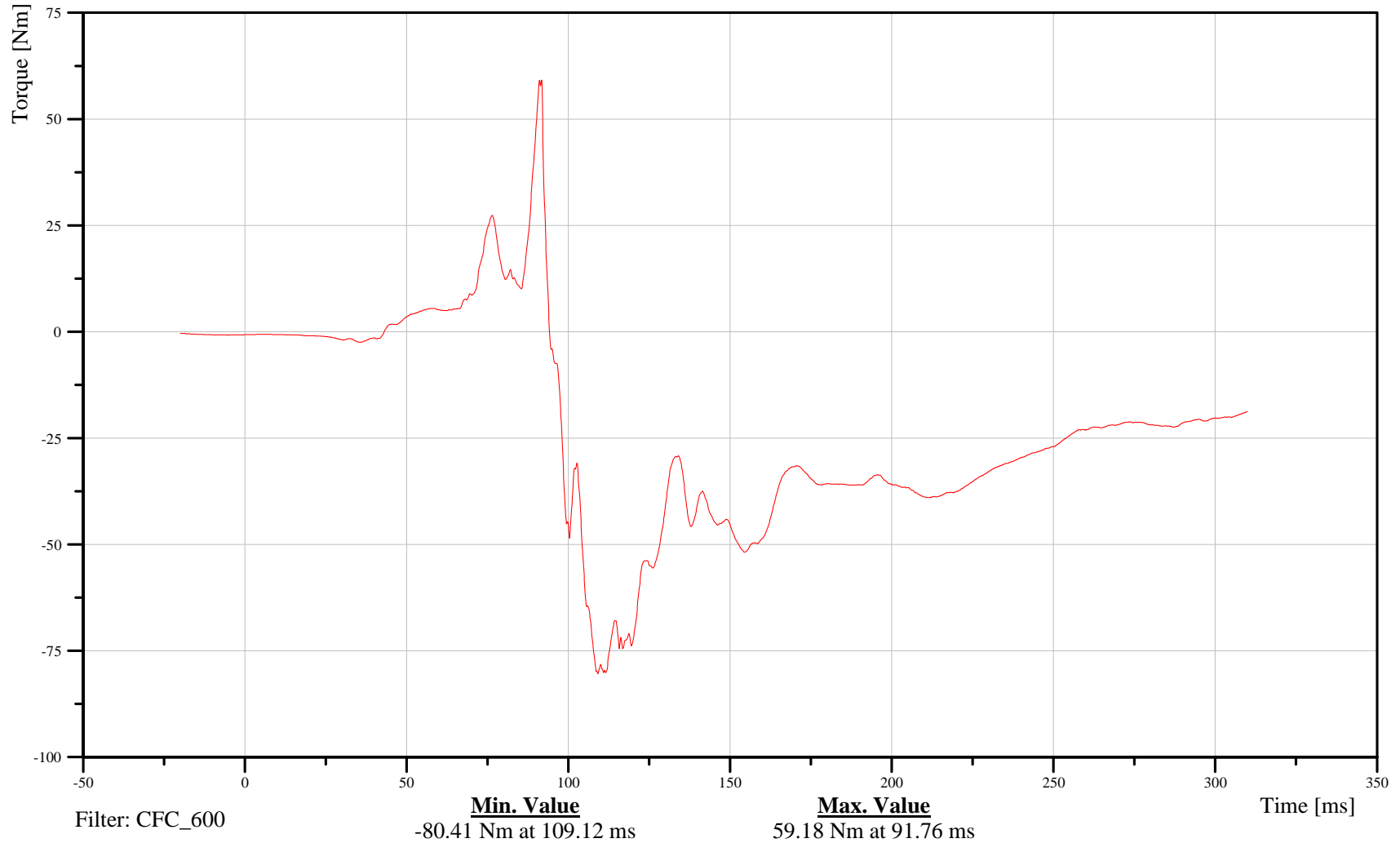

B-130

070913



2007 Ford F-250 into Left 40% Offset Deformable LCB at 56 kph

Date: 09/13/2007
Time: 15:46

Passenger Right Tibia X-Axis Acceleration

Customer: Volpe
Test Number: R70203

13TIBIRILXH3ACXA

TRC Inc. Test Lab: CTF
Test Number: 070913

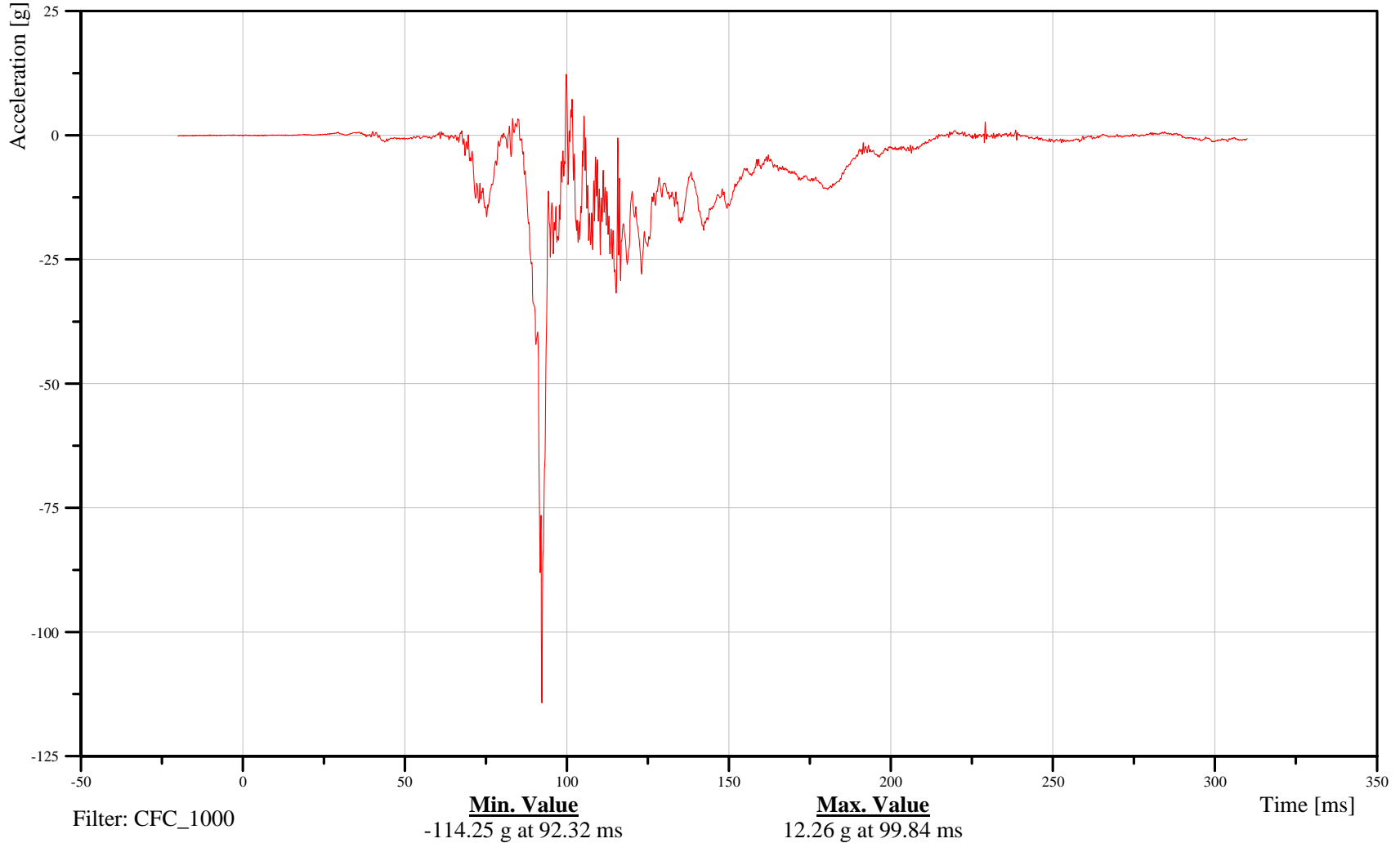

B-131

070913



2007 Ford F-250 into Left 40% Offset Deformable LCB at 56 kph

Date: 09/13/2007
Time: 15:46

Passenger Right Tibia Y-Axis Acceleration

Customer: Volpe
Test Number: R70203

13TIBIRILXH3ACYA

TRC Inc. Test Lab: CTF
Test Number: 070913

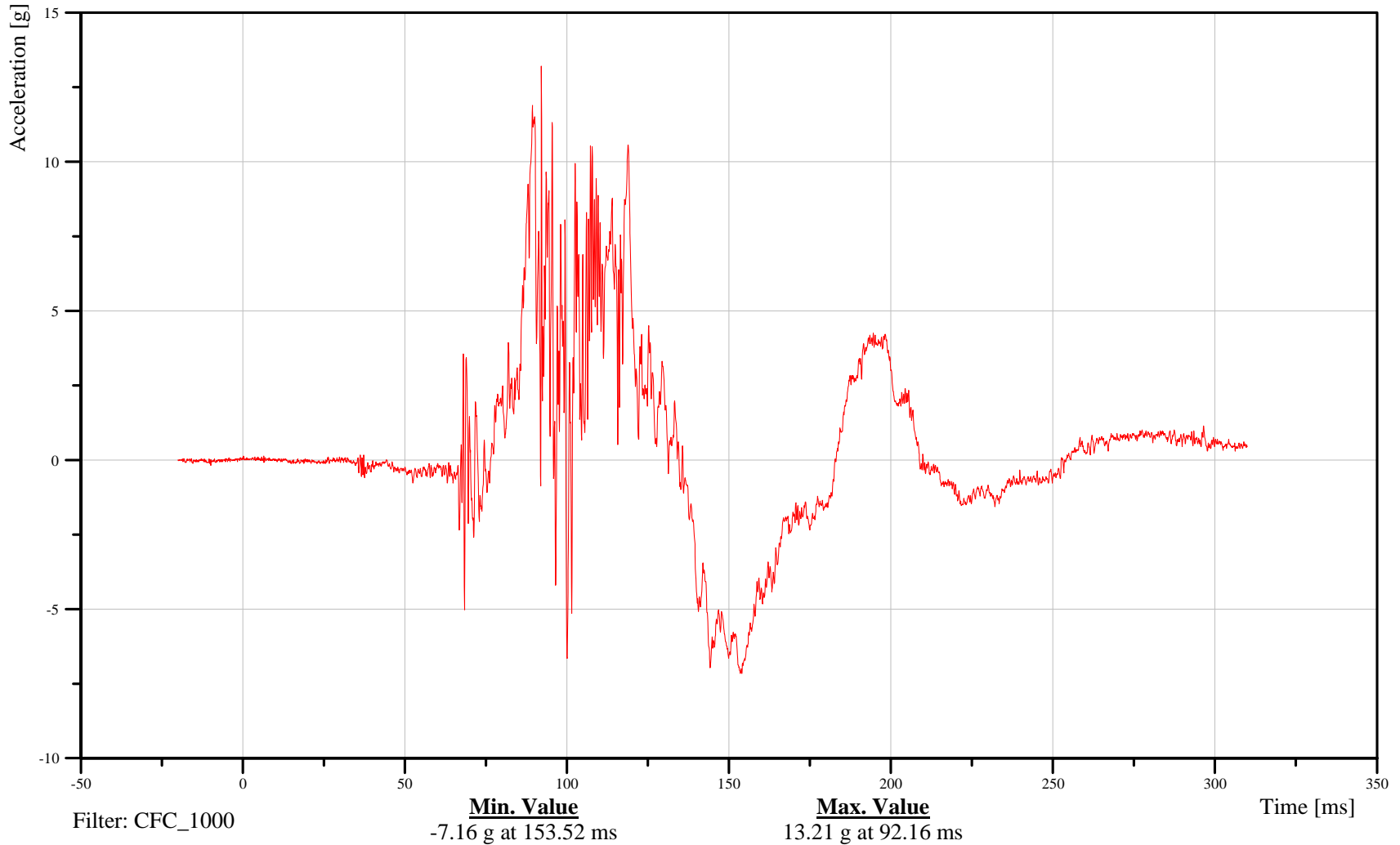

B-132

070913



2007 Ford F-250 into Left 40% Offset Deformable LCB at 56 kph

Date: 09/13/2007
Time: 15:46

Passenger Right Lower Tibia X-Axis Force

Customer: Volpe
Test Number: R70203

13TIBIRLLXH3FOXB

TRC Inc. Test Lab: CTF
Test Number: 070913

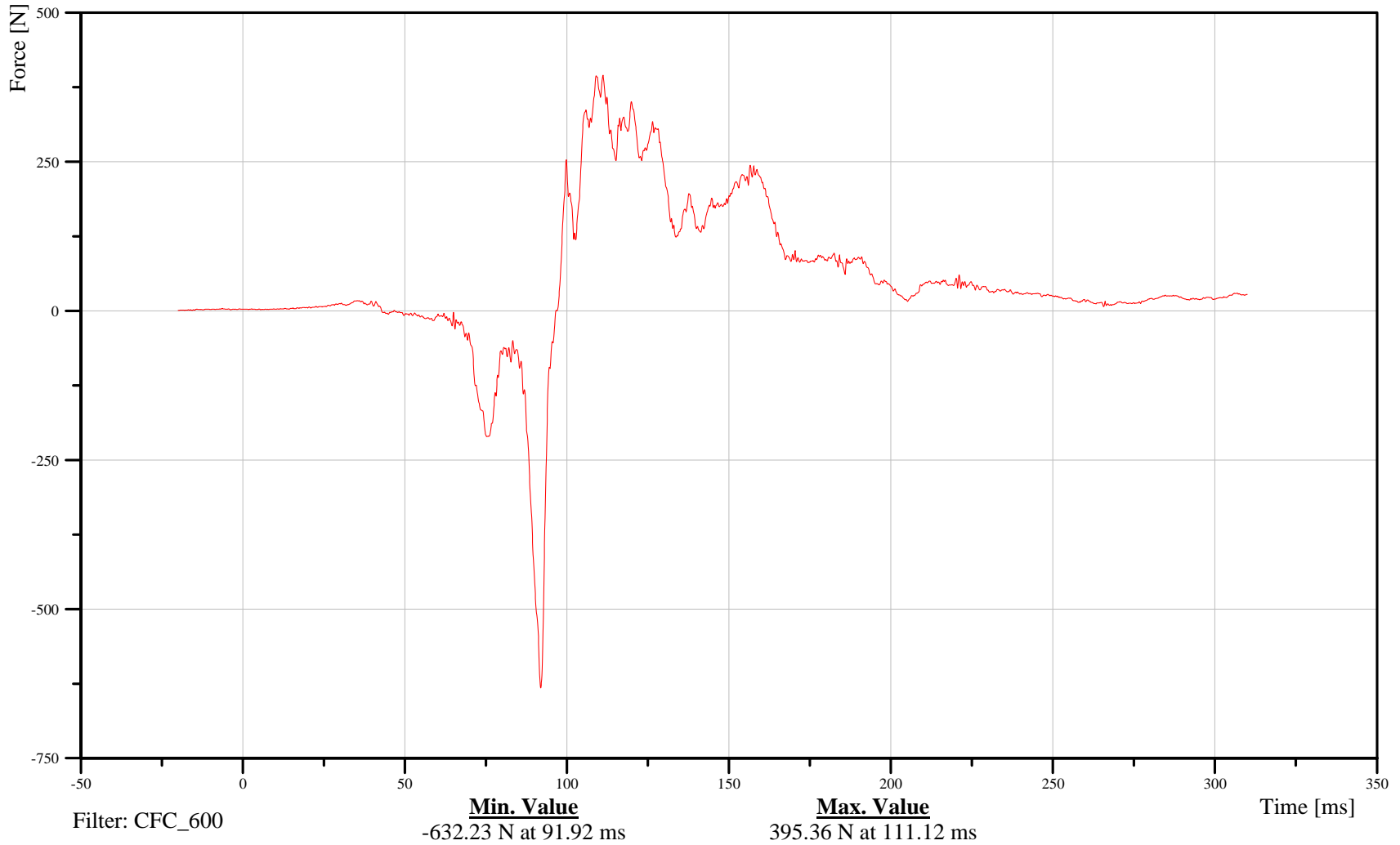

B-133

070913



2007 Ford F-250 into Left 40% Offset Deformable LCB at 56 kph

Date: 09/13/2007
Time: 15:46

Passenger Right Lower Tibia Y-Axis Force

Customer: Volpe
Test Number: R70203

13TIBIRLLXH3FOYB

TRC Inc. Test Lab: CTF
Test Number: 070913

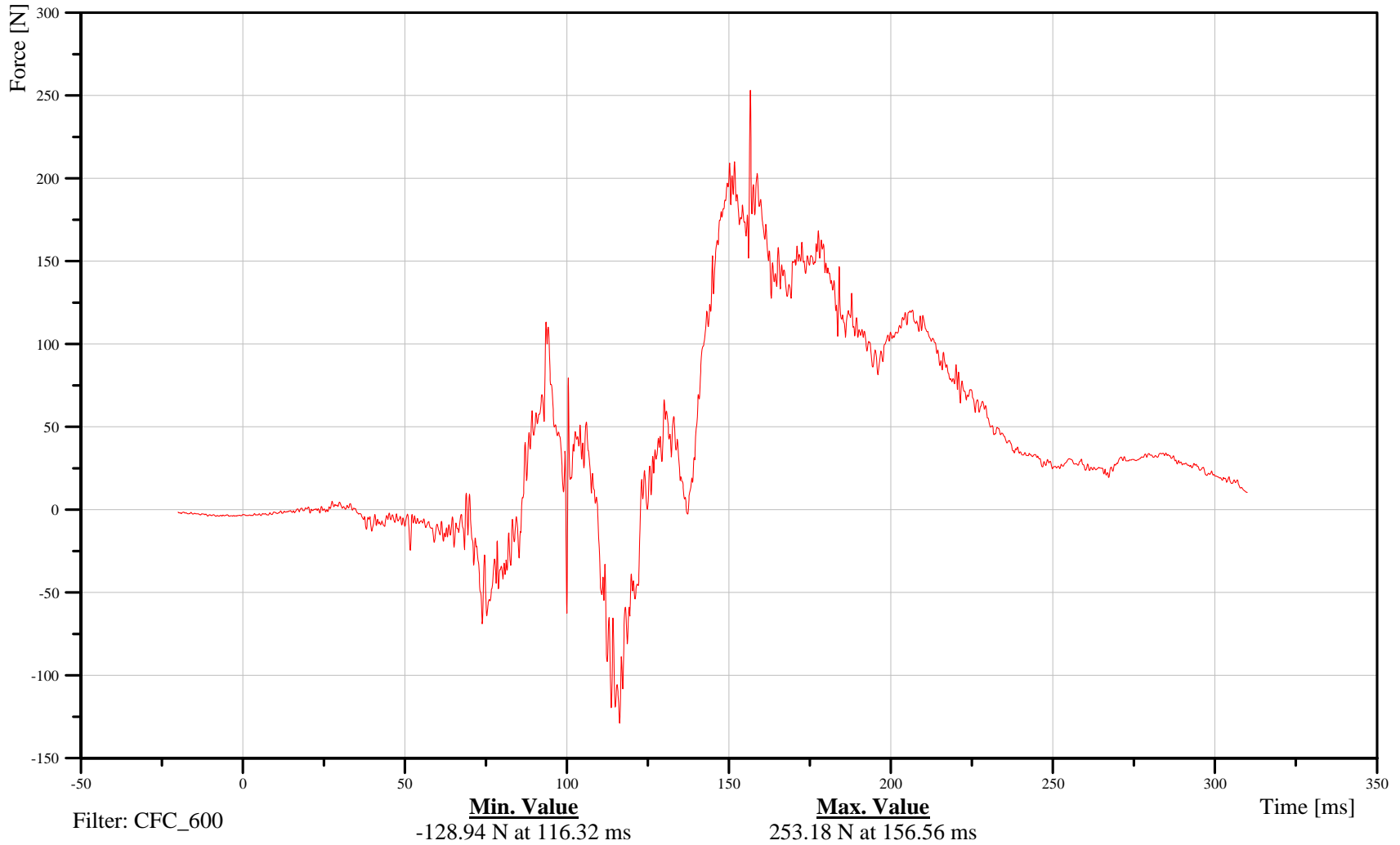

B-134

070913



2007 Ford F-250 into Left 40% Offset Deformable LCB at 56 kph

Date: 09/13/2007
Time: 15:46

Passenger Right Lower Tibia Z-Axis Force

Customer: Volpe
Test Number: R70203

13TIBIRLLXH3FOZB

TRC Inc. Test Lab: CTF
Test Number: 070913

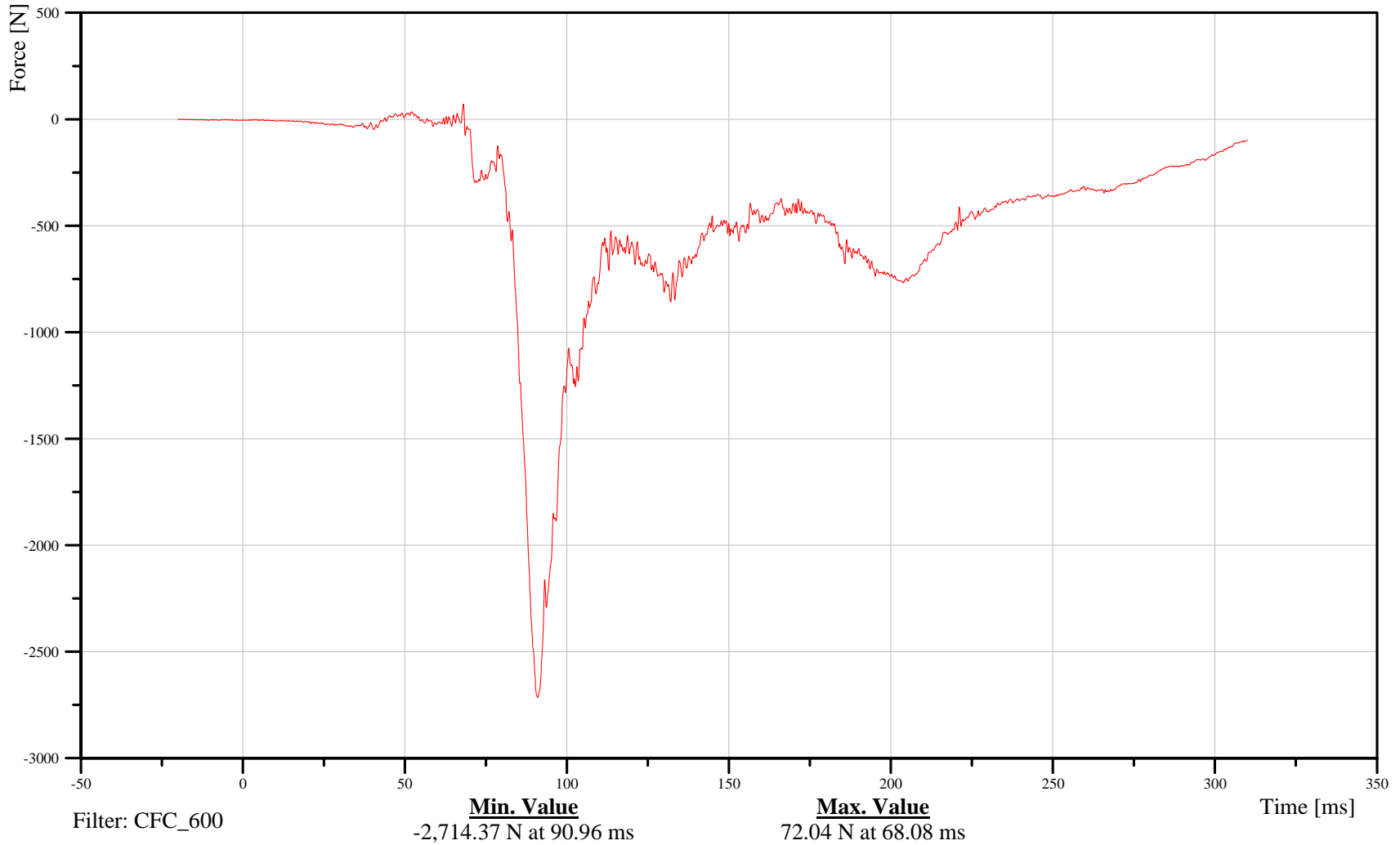

B-135

070913



2007 Ford F-250 into Left 40% Offset Deformable LCB at 56 kph

Date: 09/13/2007
Time: 15:46

Passenger Right Lower Tibia Moment About X Axis

Customer: Volpe
Test Number: R70203

13TIBIRLLXH3MOXB

TRC Inc. Test Lab: CTF
Test Number: 070913

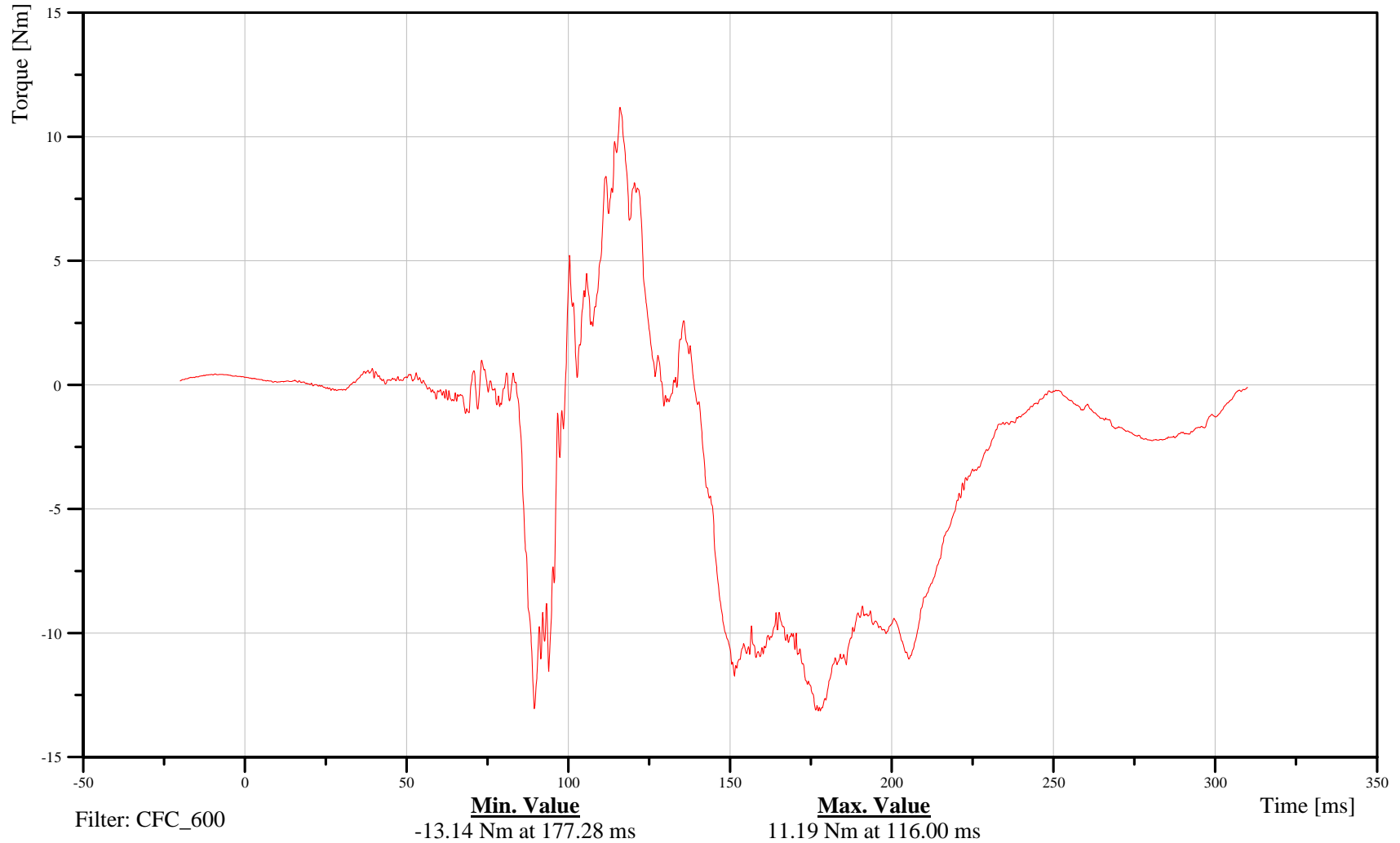

B-136

070913



2007 Ford F-250 into Left 40% Offset Deformable LCB at 56 kph

Date: 09/13/2007
Time: 15:46

Passenger Right Lower Tibia Moment About Y Axis

Customer: Volpe
Test Number: R70203

13TIBIRLLXH3MOYB

TRC Inc. Test Lab: CTF
Test Number: 070913

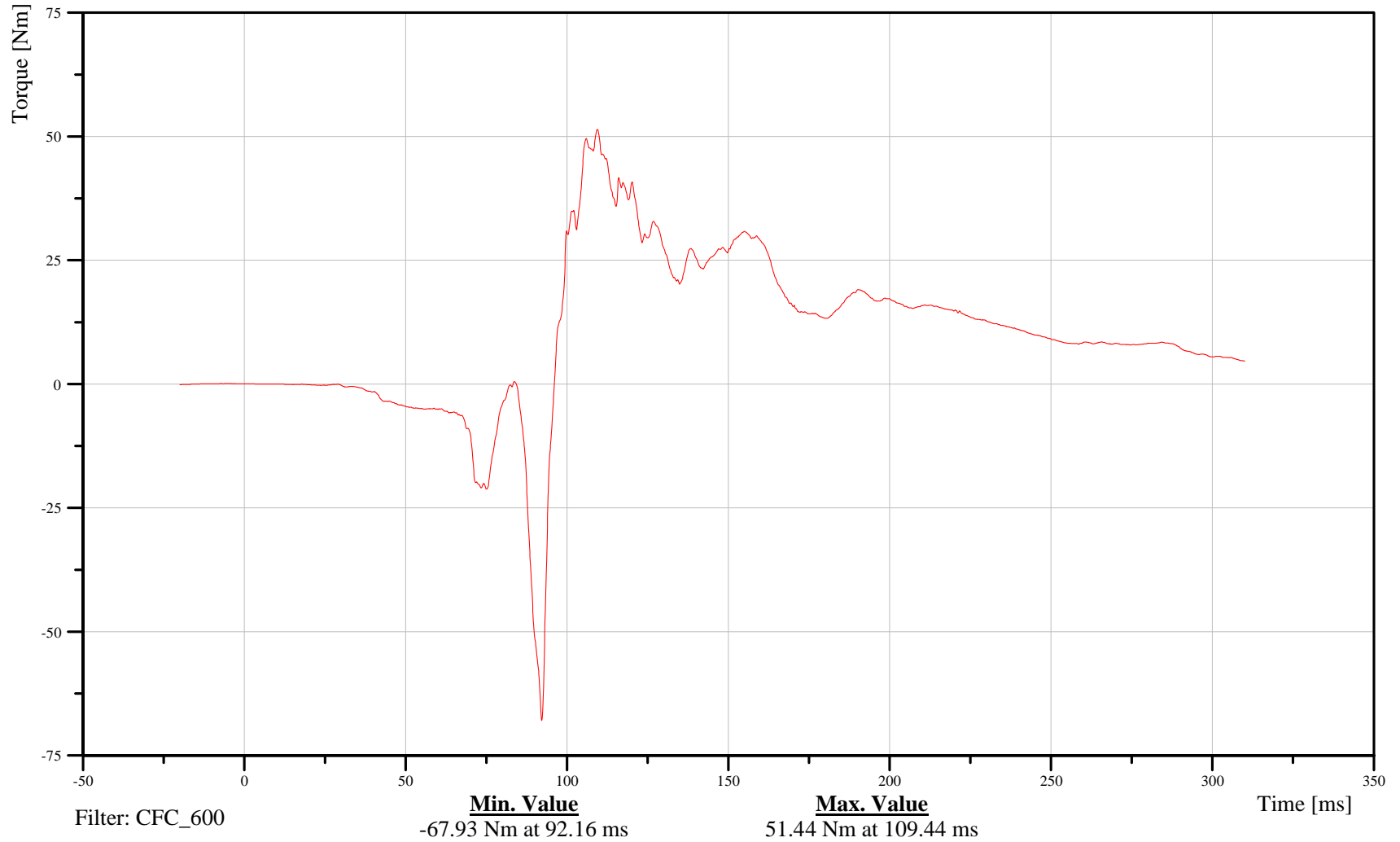

B-137

070913



2007 Ford F-250 into Left 40% Offset Deformable LCB at 56 kph

Date: 09/13/2007
Time: 15:46

Passenger Right Foot X-Axis Rotation

Customer: Volpe
Test Number: R70203

13FOOTRILXH3ANXC

TRC Inc. Test Lab: CTF
Test Number: 070913

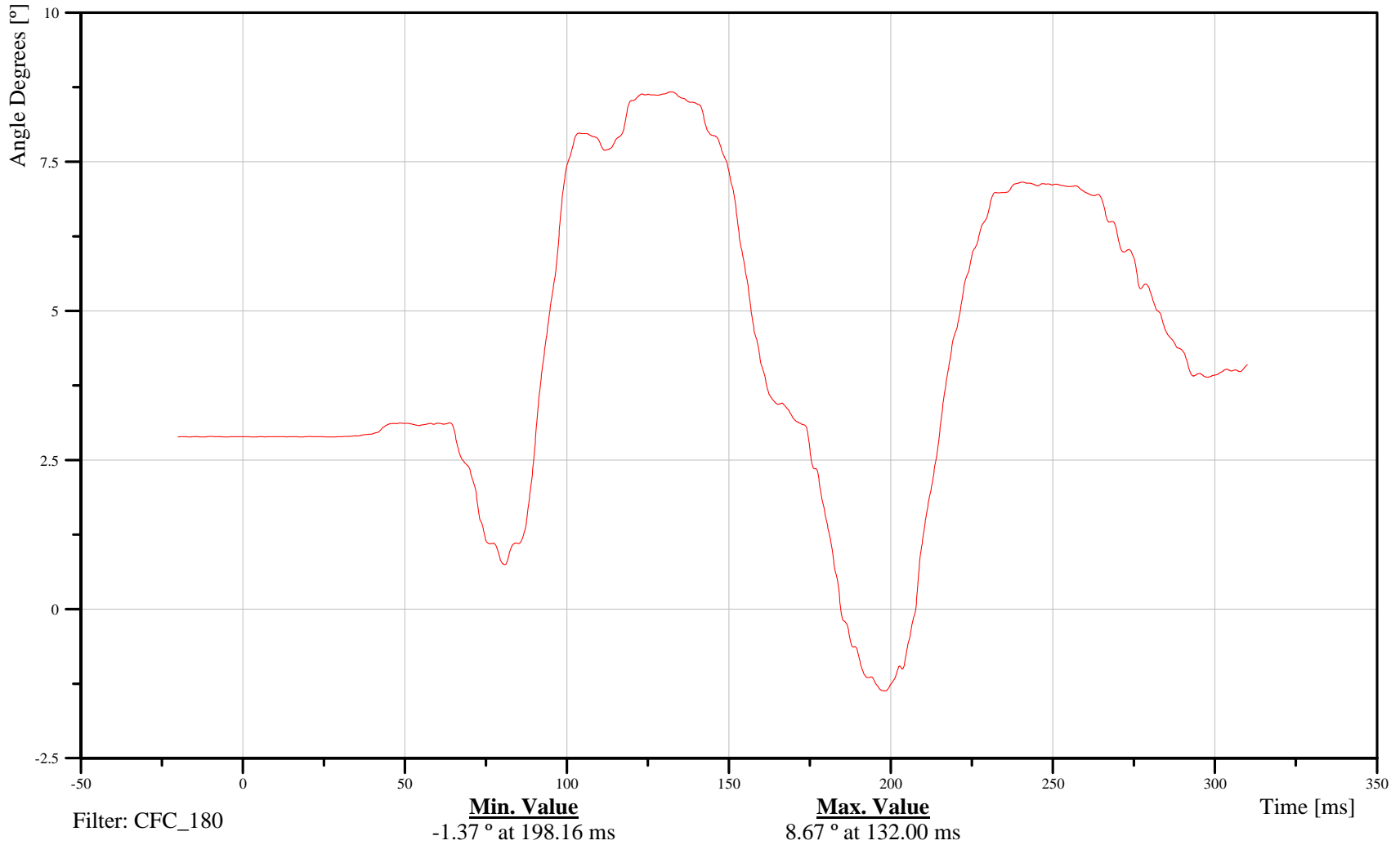

B-138

070913



2007 Ford F-250 into Left 40% Offset Deformable LCB at 56 kph

Date: 09/13/2007
Time: 15:46

Passenger Right Foot Y-Axis Rotation

Customer: Volpe
Test Number: R70203

13FOOTRILXH3ANYC

TRC Inc. Test Lab: CTF
Test Number: 070913

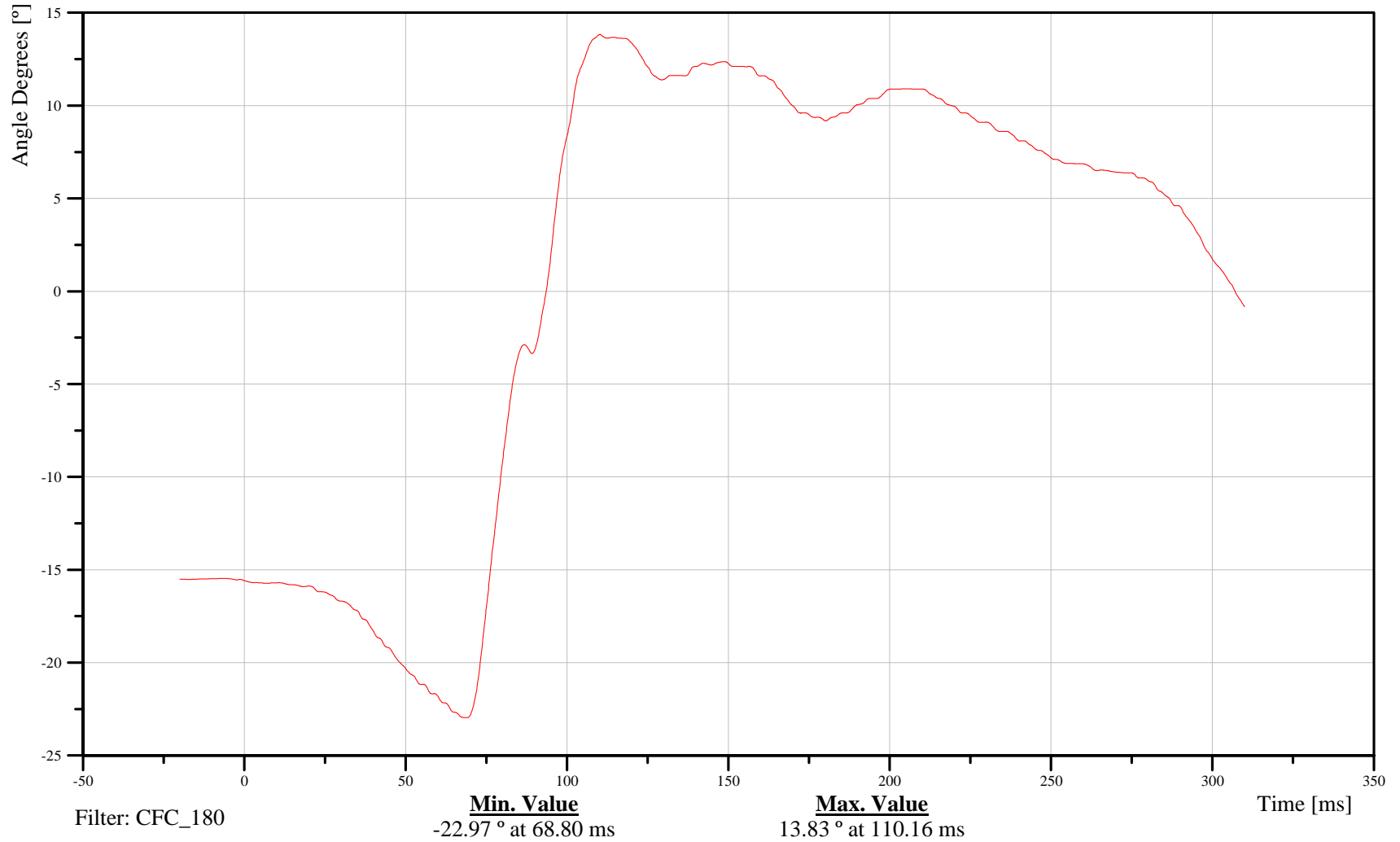

B-139

070913



2007 Ford F-250 into Left 40% Offset Deformable LCB at 56 kph

Date: 09/13/2007
Time: 15:46

Passenger Right Foot Z-Axis Rotation

Customer: Volpe
Test Number: R70203

13FOOTRILXH3ANZC

TRC Inc. Test Lab: CTF
Test Number: 070913

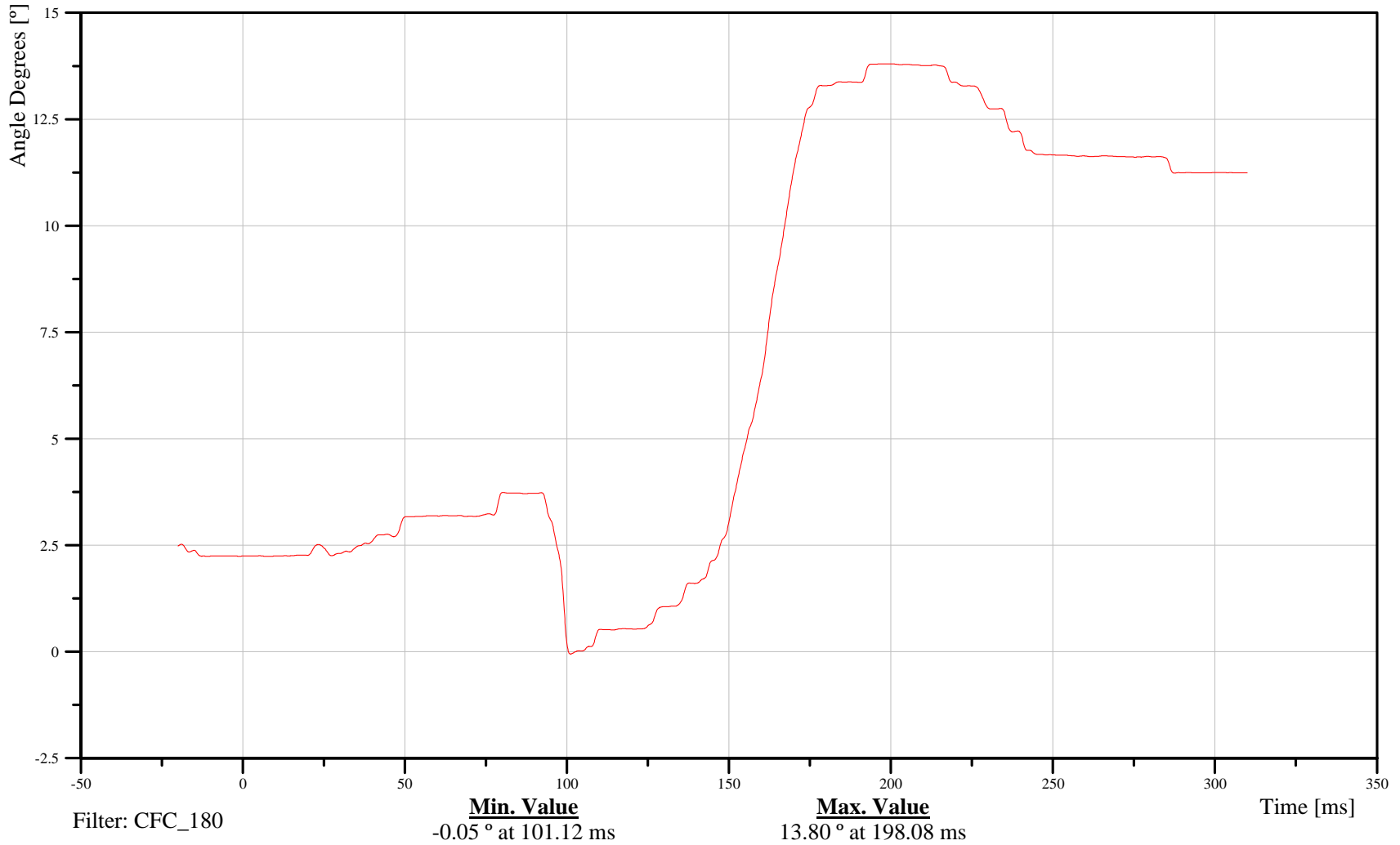

B-140

070913



2007 Ford F-250 into Left 40% Offset Deformable LCB at 56 kph

Date: 09/13/2007
Time: 15:46

Passenger Right Foot X-Axis Acceleration

Customer: Volpe
Test Number: R70203

13FOOTRILXH3ACXA

TRC Inc. Test Lab: CTF
Test Number: 070913

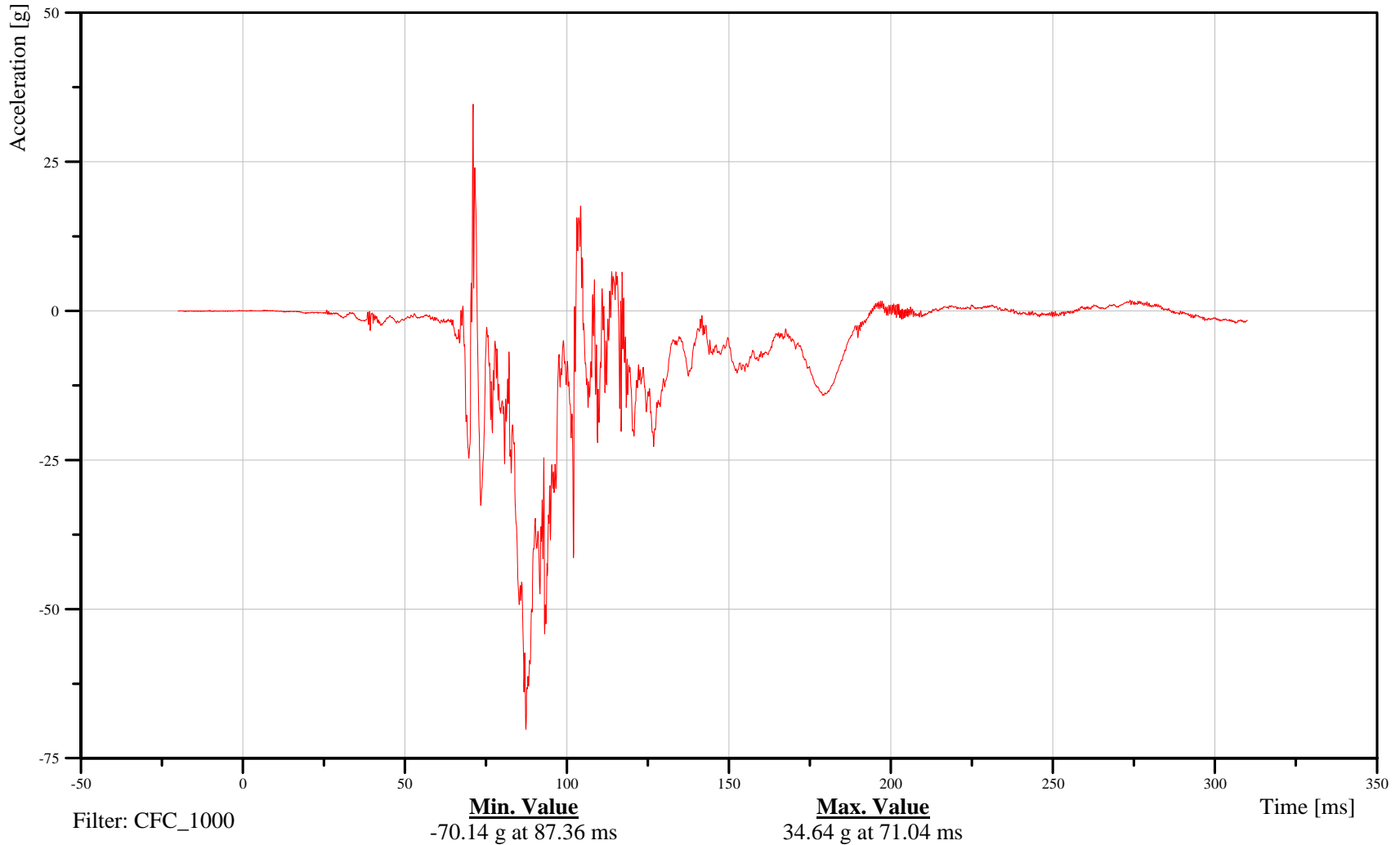

B-141

070913



2007 Ford F-250 into Left 40% Offset Deformable LCB at 56 kph

Date: 09/13/2007
Time: 15:46

Passenger Right Foot Y-Axis Acceleration

Customer: Volpe
Test Number: R70203

13FOOTRILXH3ACYA

TRC Inc. Test Lab: CTF
Test Number: 070913

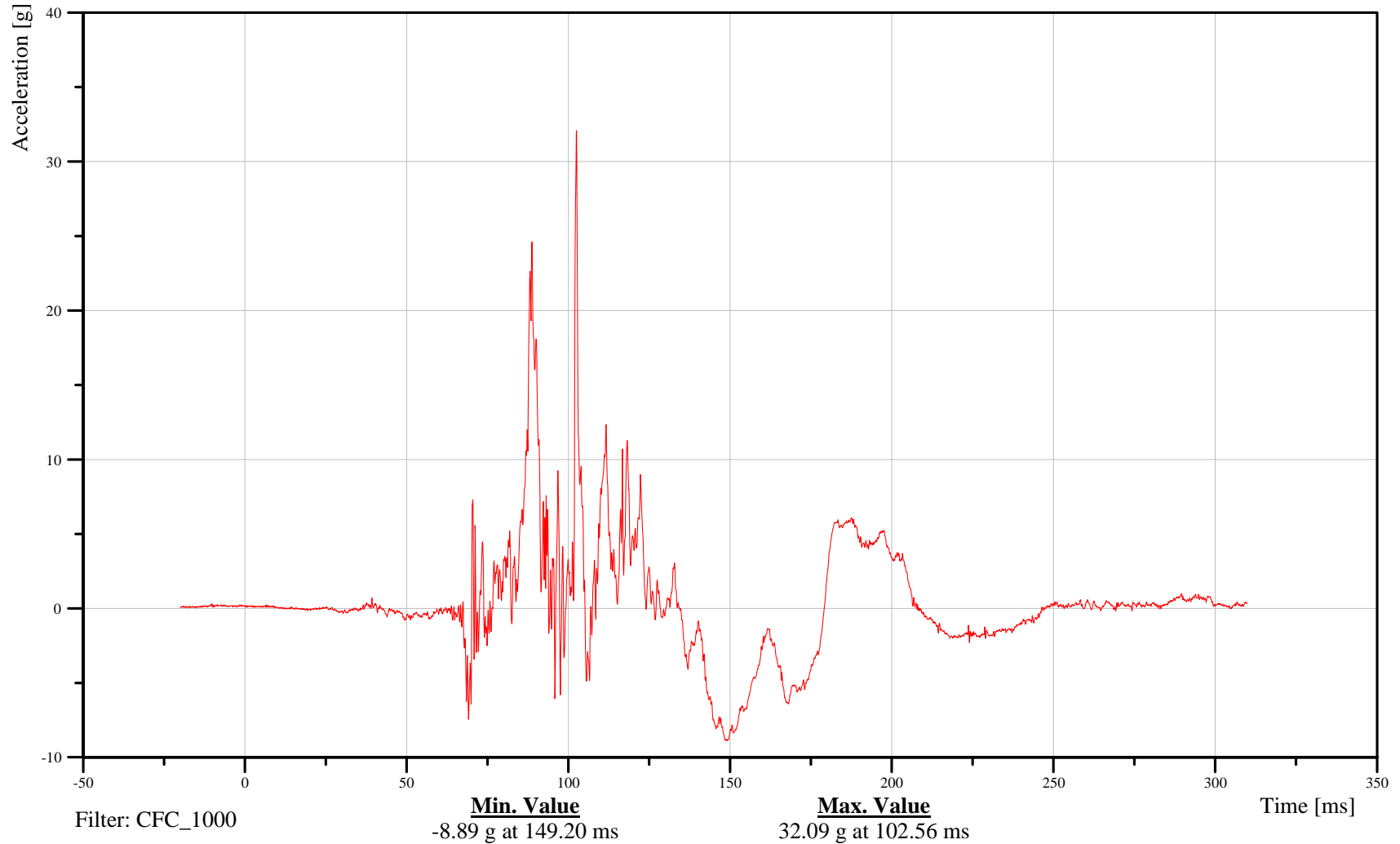

B-142

070913



2007 Ford F-250 into Left 40% Offset Deformable LCB at 56 kph

Date: 09/13/2007
Time: 15:46

Passenger Right Foot Z-Axis Acceleration

Customer: Volpe
Test Number: R70203

13FOOTRILXH3ACZA

TRC Inc. Test Lab: CTF
Test Number: 070913

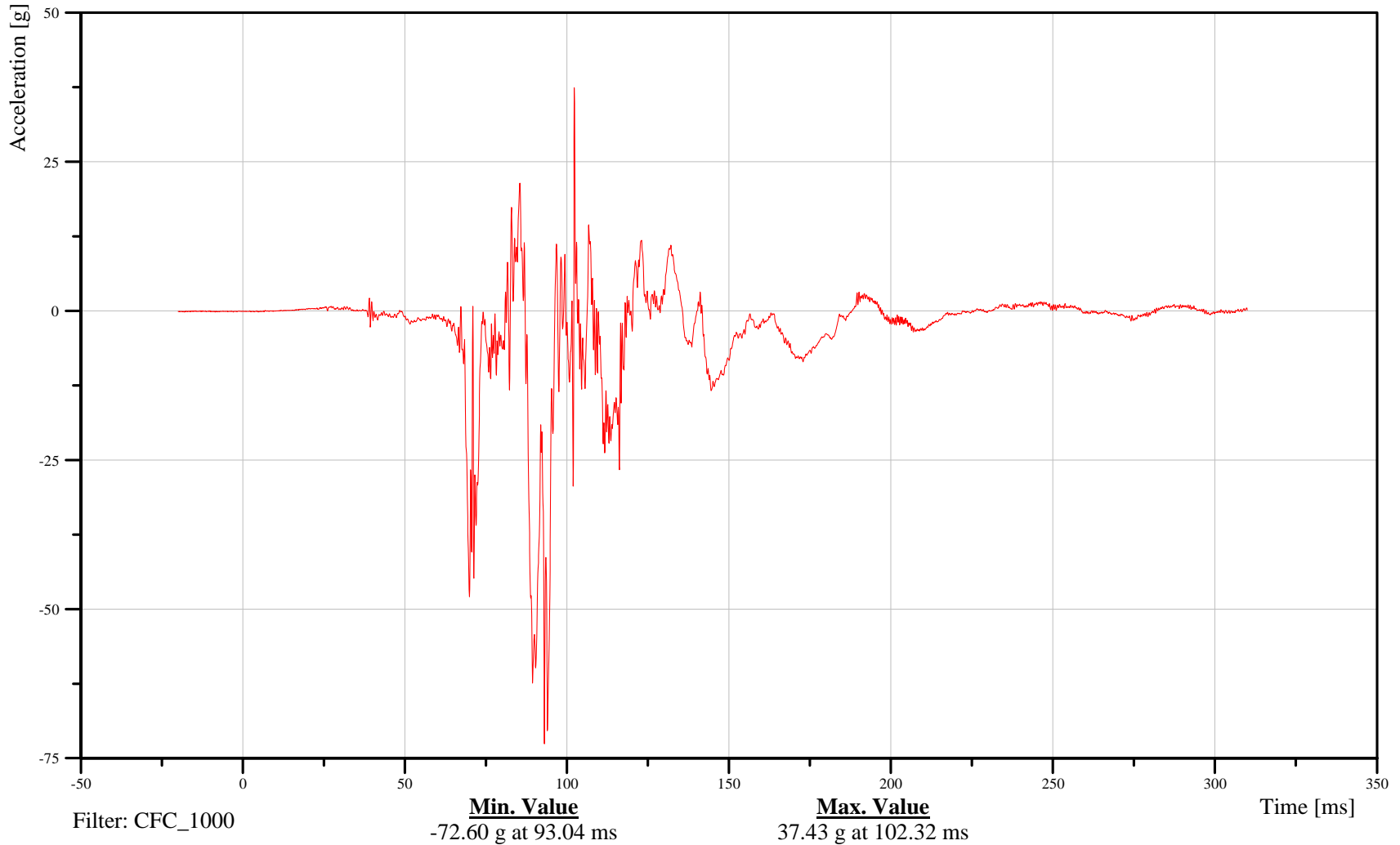

B-143

070913



2007 Ford F-250 into Left 40% Offset Deformable LCB at 56 kph

Date: 09/13/2007
Time: 15:46

Passenger Right Foot Resultant Acceleration

Customer: Volpe
Test Number: R70203

13FOOTRILXH3ACRA

TRC Inc. Test Lab: CTF
Test Number: 070913

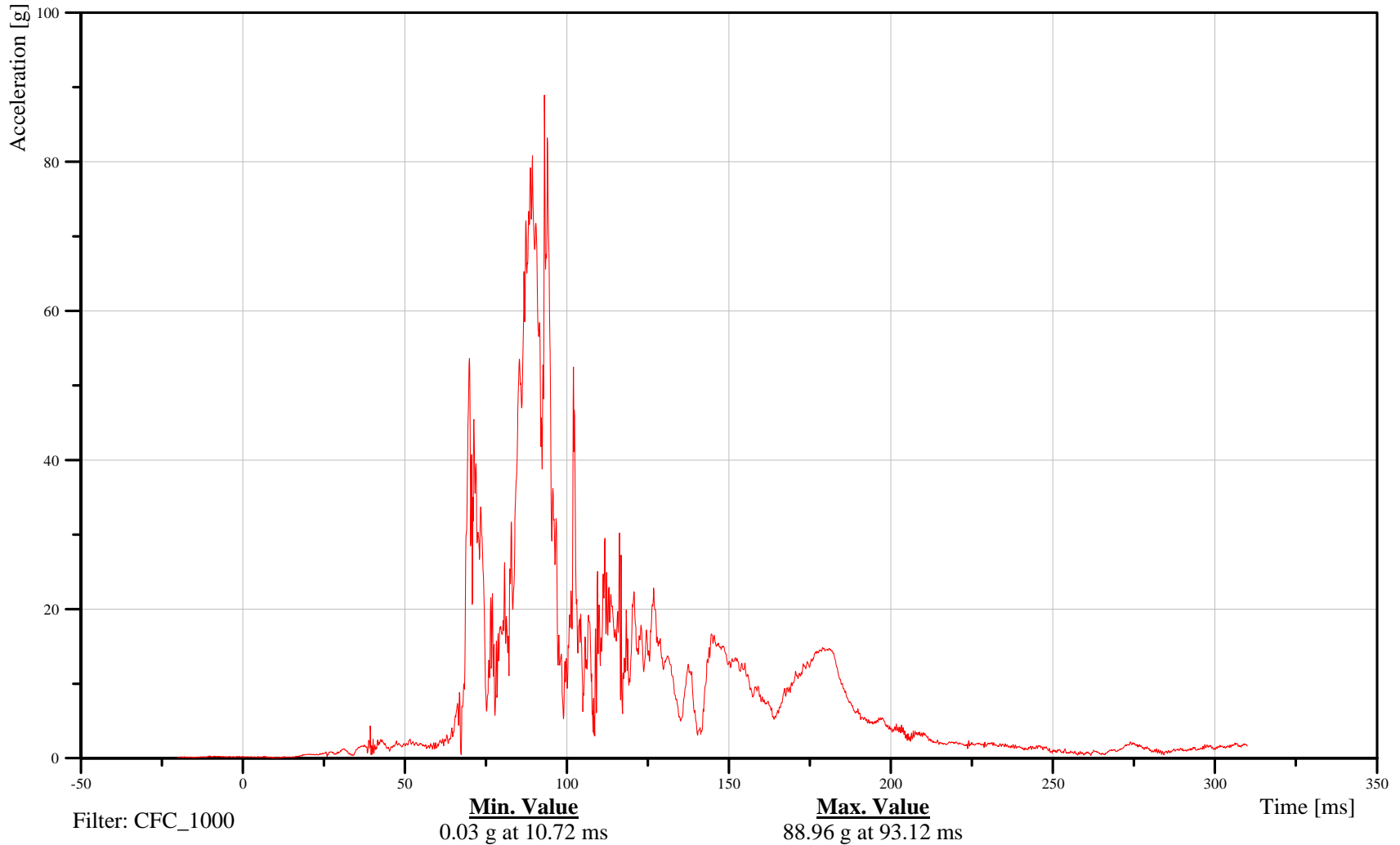

B-144

070913



2007 Ford F-250 into Left 40% Offset Deformable LCB at 56 kph

Date: 09/13/2007
Time: 15:46

Left Rear Seat Cross-Member X-Axis Acceleration

Customer: Volpe
Test Number: R70203

14CRME000000ACXD

TRC Inc. Test Lab: CTF
Test Number: 070913

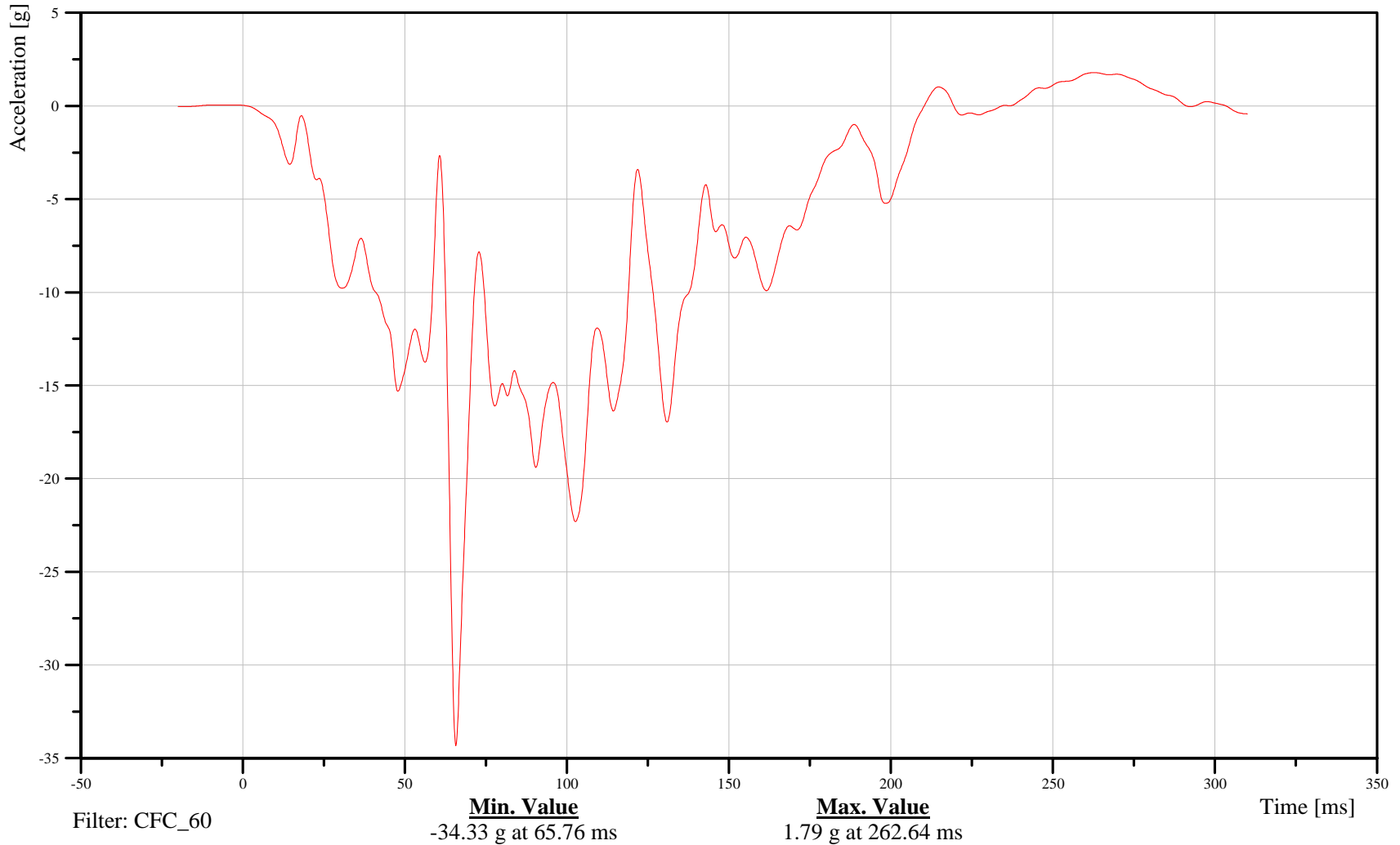

B-145

070913



2007 Ford F-250 into Left 40% Offset Deformable LCB at 56 kph

Date: 09/13/2007
Time: 15:46

Right Rear Seat Cross-Member X-Axis Acceleration

Customer: Volpe
Test Number: R70203

16CRME000000ACXD

TRC Inc. Test Lab: CTF
Test Number: 070913

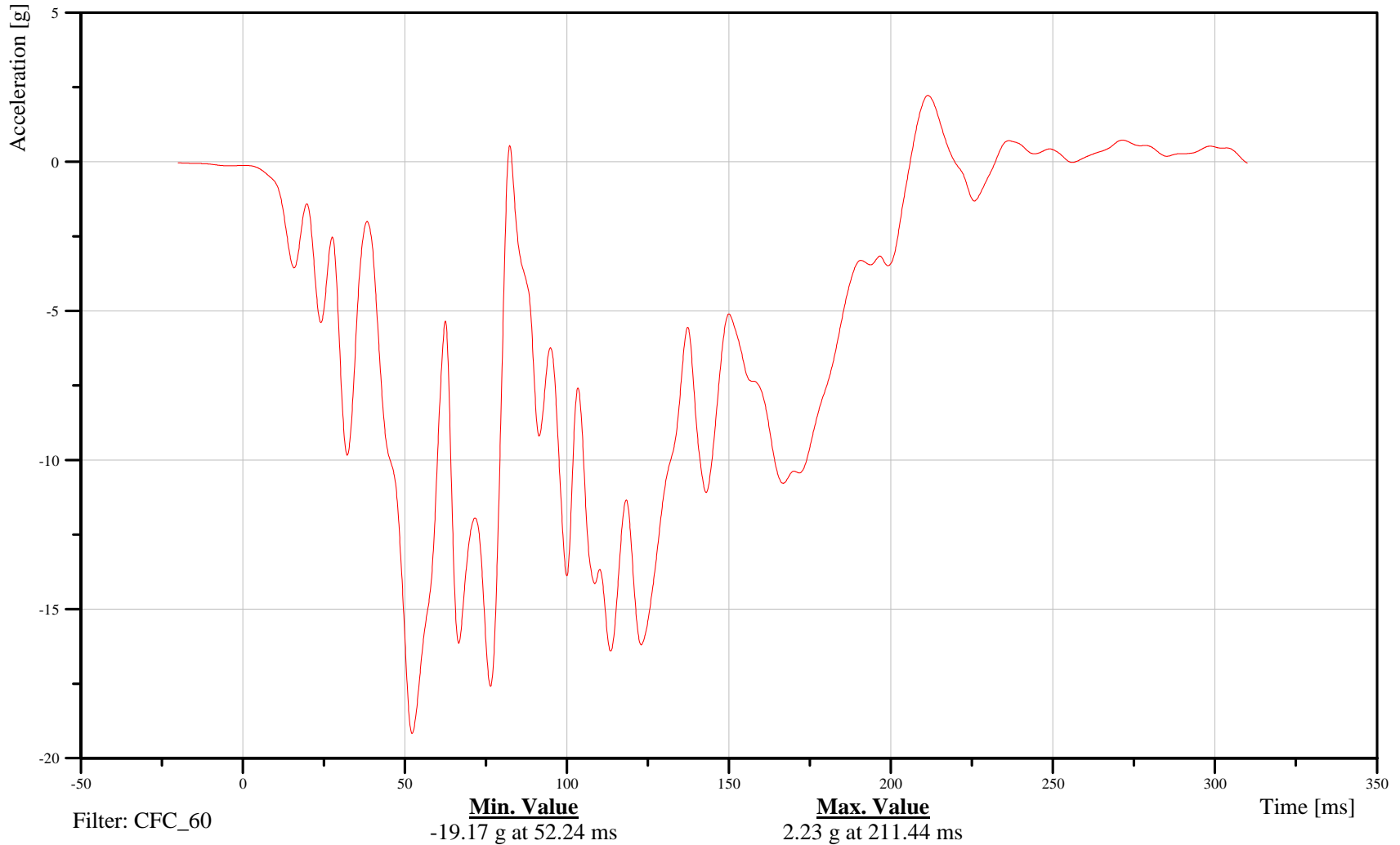

B-146

070913



2007 Ford F-250 into Left 40% Offset Deformable LCB at 56 kph

Date: 09/13/2007
Time: 15:46

Left Rear Seat Cross-Member Z-Axis Acceleration

Customer: Volpe
Test Number: R70203

14CRME000000ACZD

TRC Inc. Test Lab: CTF
Test Number: 070913

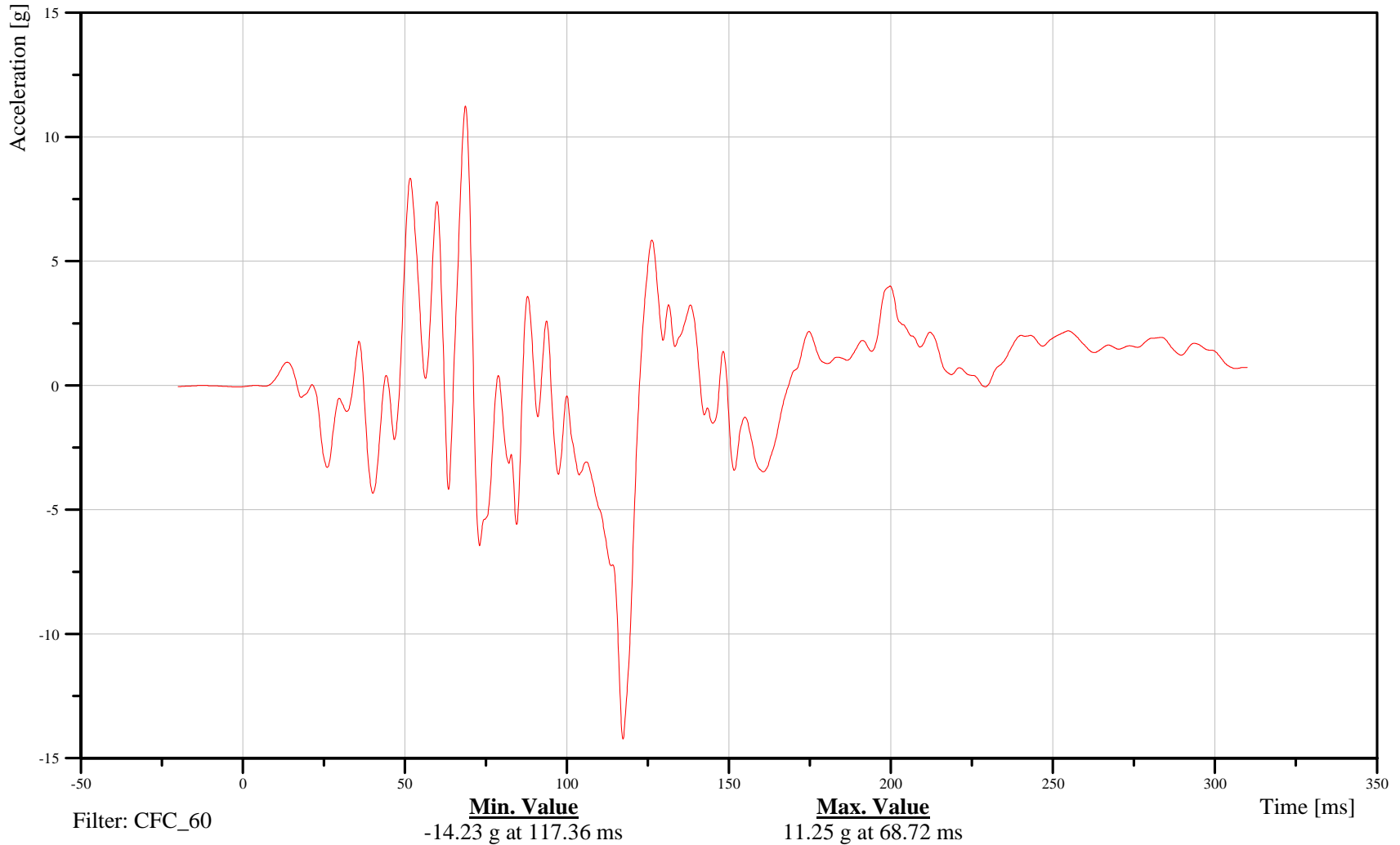

B-147

070913



2007 Ford F-250 into Left 40% Offset Deformable LCB at 56 kph

Date: 09/13/2007
Time: 15:46

Right Rear Seat Cross-Member Z-Axis Acceleration

Customer: Volpe
Test Number: R70203

16CRME000000ACZD

TRC Inc. Test Lab: CTF
Test Number: 070913

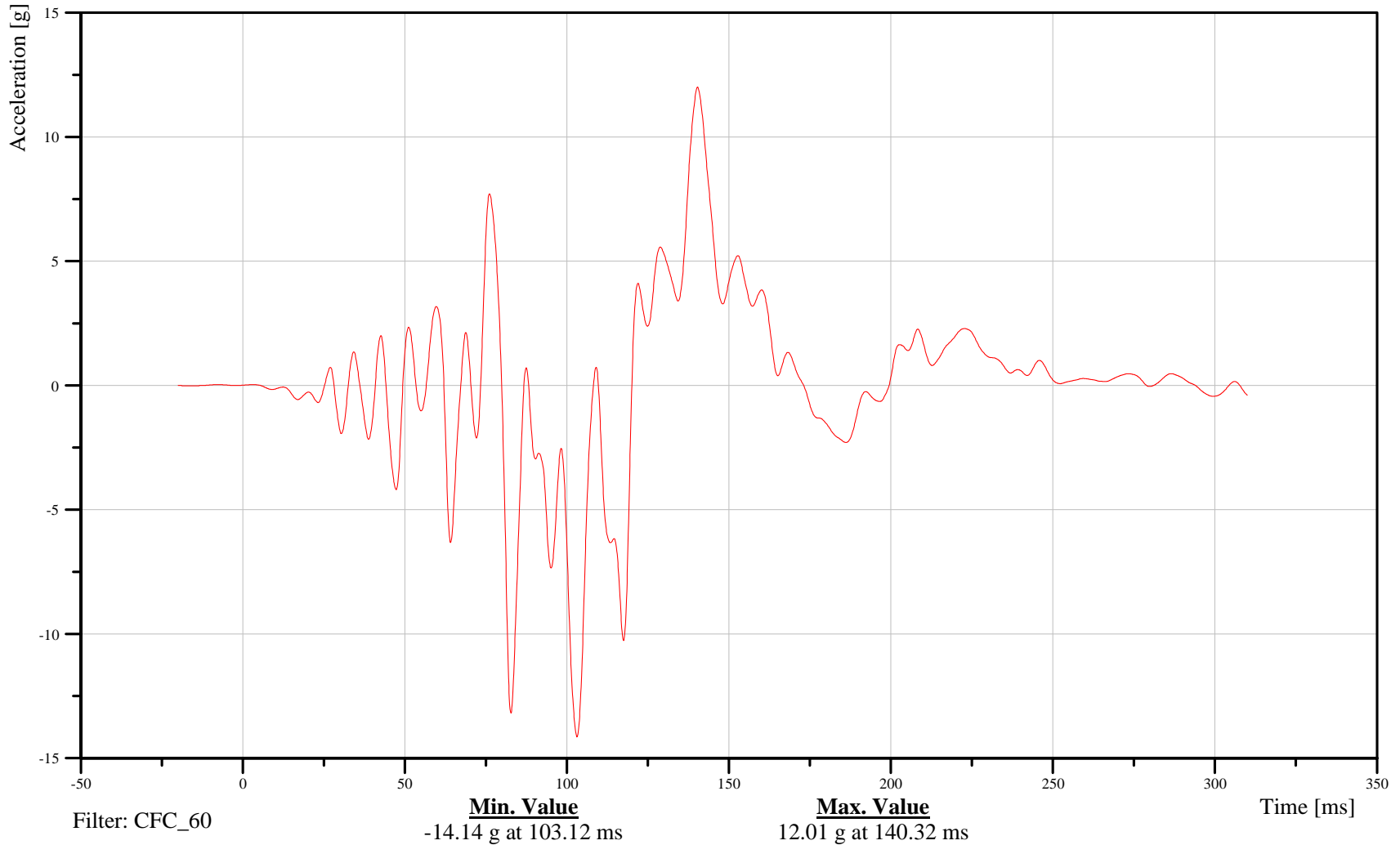

B-148

070913



2007 Ford F-250 into Left 40% Offset Deformable LCB at 56 kph

Date: 09/13/2007
Time: 15:46

Top of Engine Block X-Axis Acceleration

Customer: Volpe
Test Number: R70203

12ENGNTTP0000ACXD

TRC Inc. Test Lab: CTF
Test Number: 070913

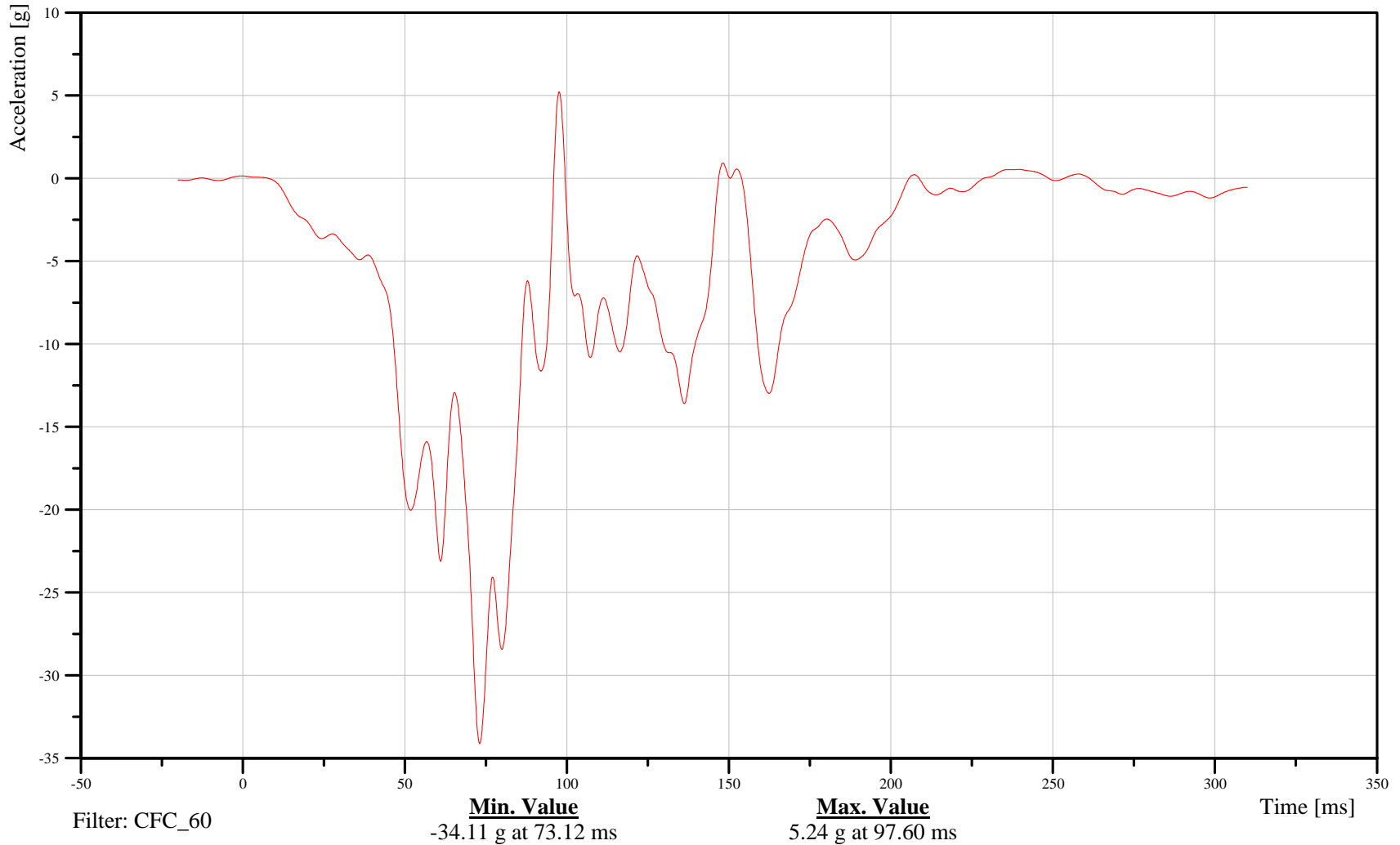

B-149

070913



2007 Ford F-250 into Left 40% Offset Deformable LCB at 56 kph

Date: 09/13/2007
Time: 15:46

Bottom of Engine Block X-Axis Acceleration

Customer: Volpe
Test Number: R70203

12ENGNB00000ACXD

TRC Inc. Test Lab: CTF
Test Number: 070913

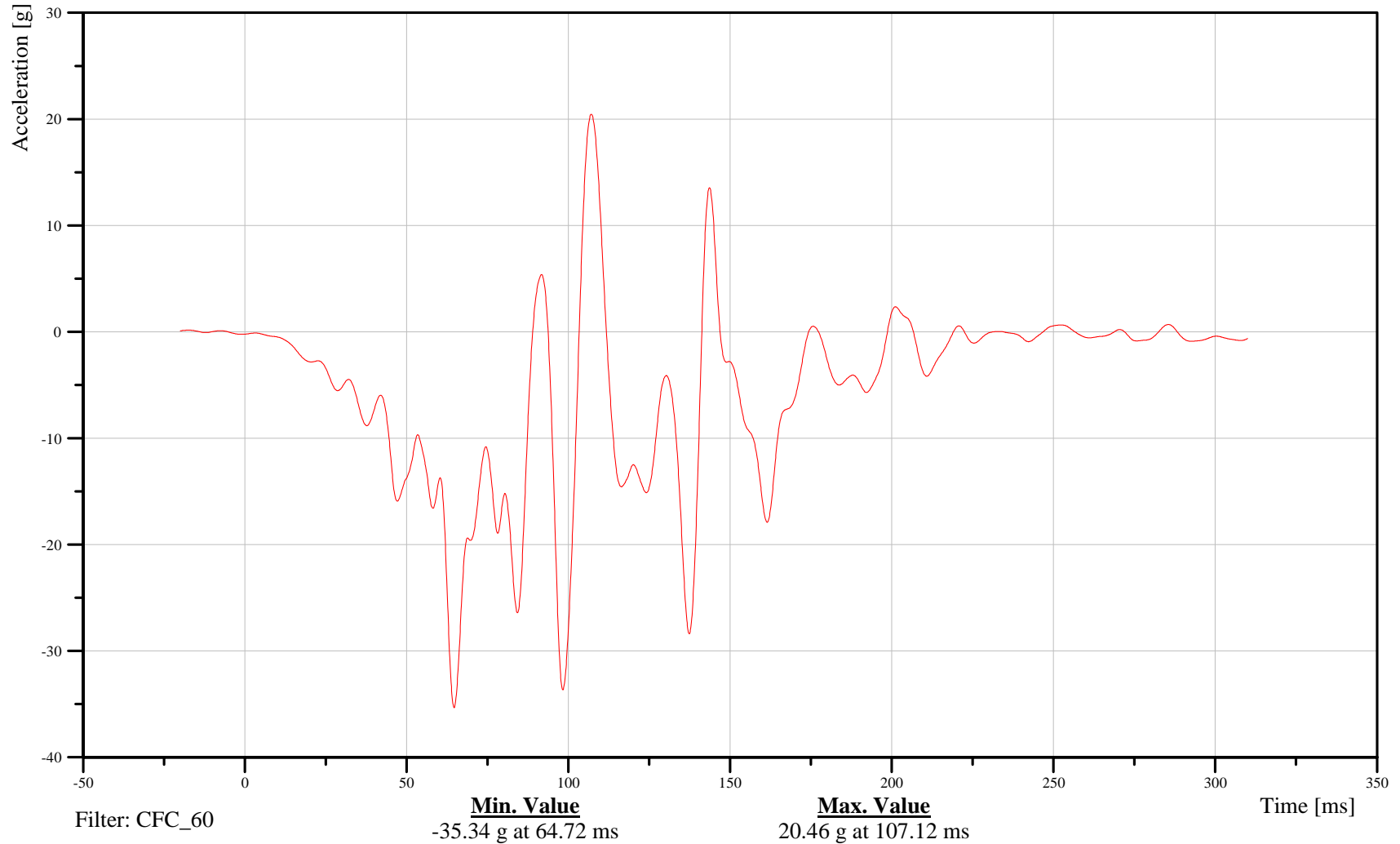

B-150

070913



2007 Ford F-250 into Left 40% Offset Deformable LCB at 56 kph

Date: 09/13/2007
Time: 15:46

Right Brake Caliper X-Axis Acceleration

Customer: Volpe
Test Number: R70203

13VEHCRI0000ACXD

TRC Inc. Test Lab: CTF
Test Number: 070913

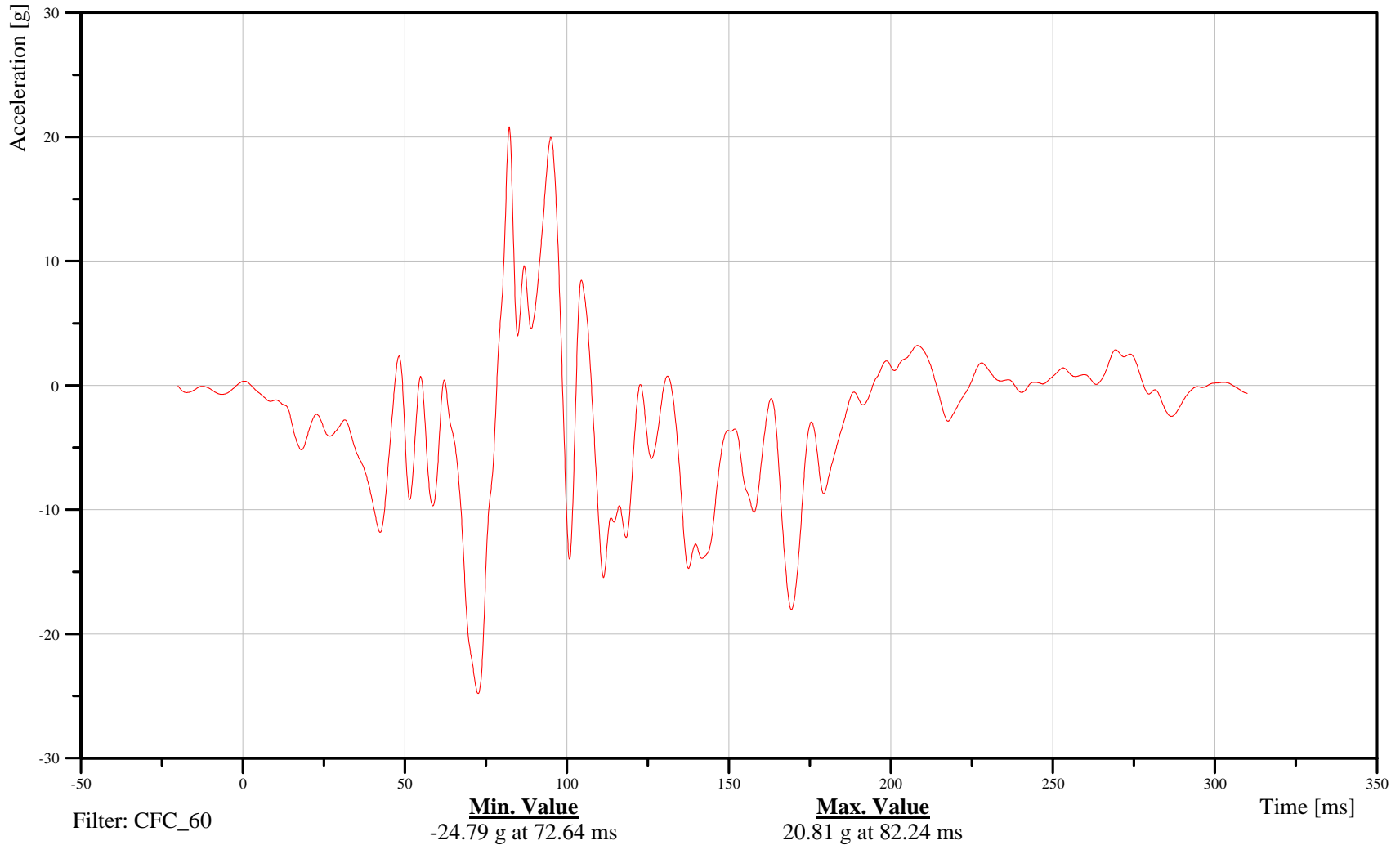

B-151

070913



2007 Ford F-250 into Left 40% Offset Deformable LCB at 56 kph

Date: 09/13/2007
Time: 15:46

Left Brake Caliper X-Axis Acceleration

Customer: Volpe
Test Number: R70203

11VEHICLE0000ACXD

TRC Inc. Test Lab: CTF
Test Number: 070913

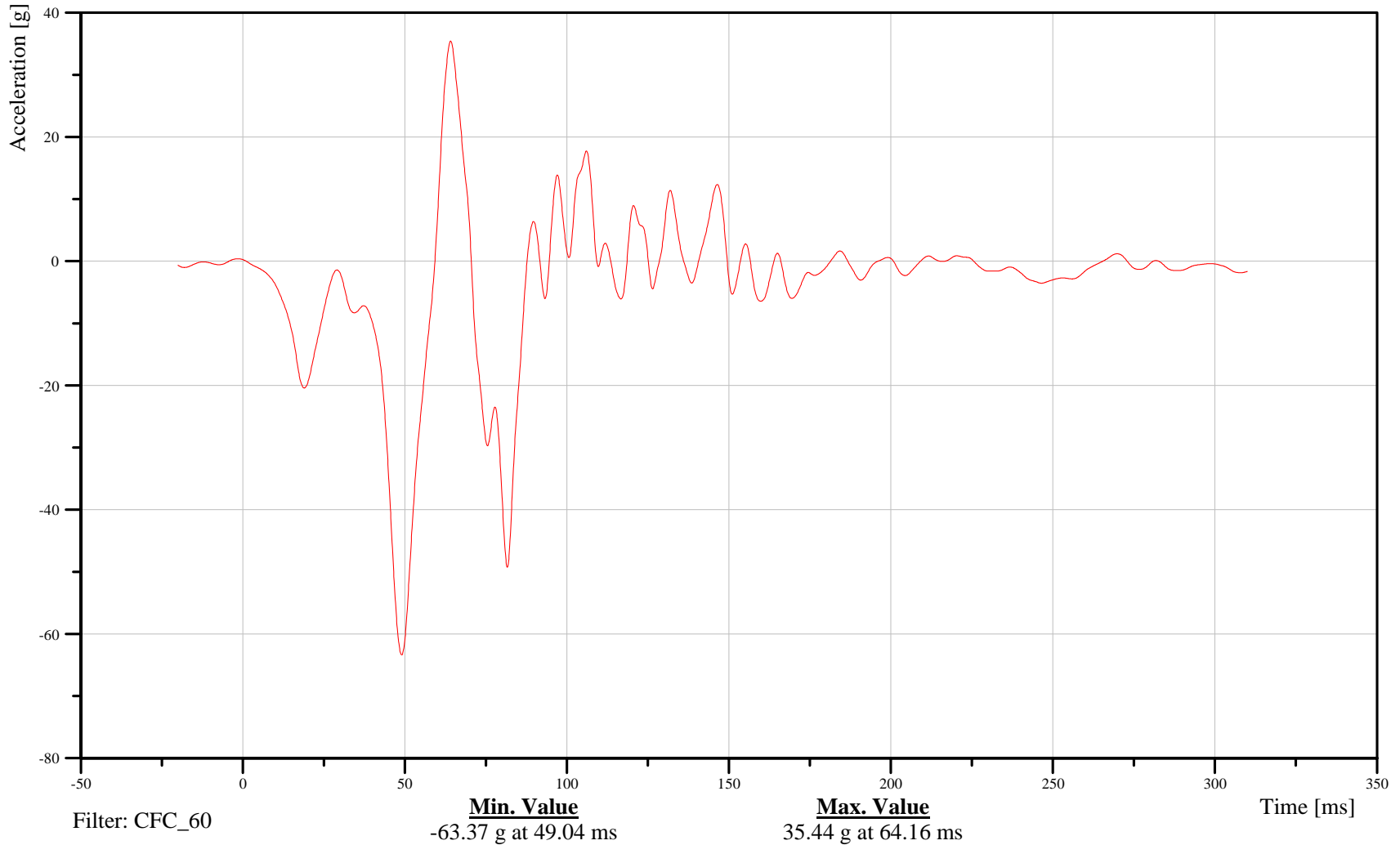

B-152

070913



2007 Ford F-250 into Left 40% Offset Deformable LCB at 56 kph

Date: 09/13/2007
Time: 15:46

Instrument Panel X-Axis Acceleration

Customer: Volpe
Test Number: R70203

12DASH000000ACXD

TRC Inc. Test Lab: CTF
Test Number: 070913

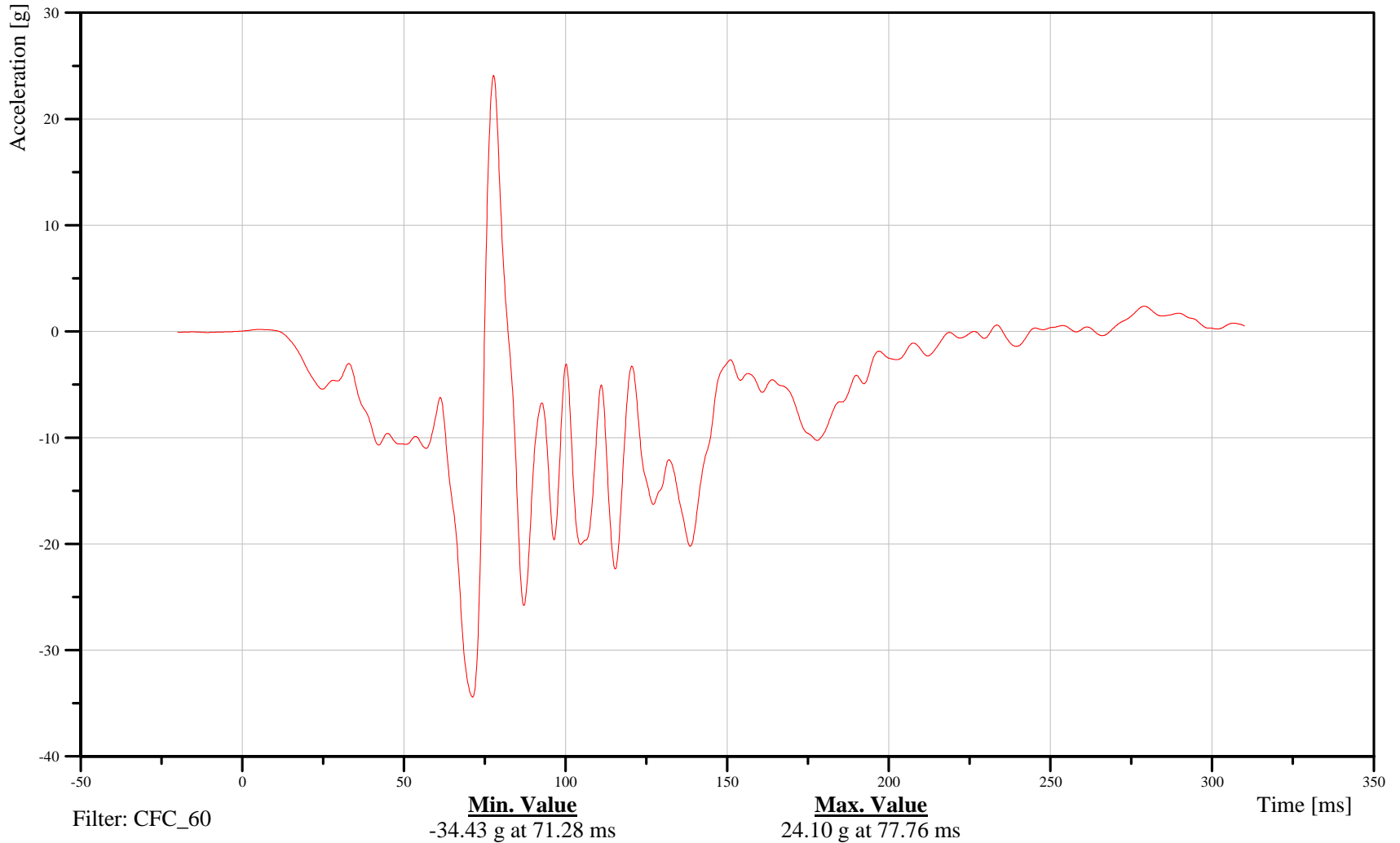

B-153

070913



2007 Ford F-250 into Left 40% Offset Deformable LCB at 56 kph

Date: 09/13/2007
Time: 15:46

Left Side Driver Mid Seat Track X-Axis Acceleration

Customer: Volpe
Test Number: R70203

11SETR000000ACXD

TRC Inc. Test Lab: CTF
Test Number: 070913

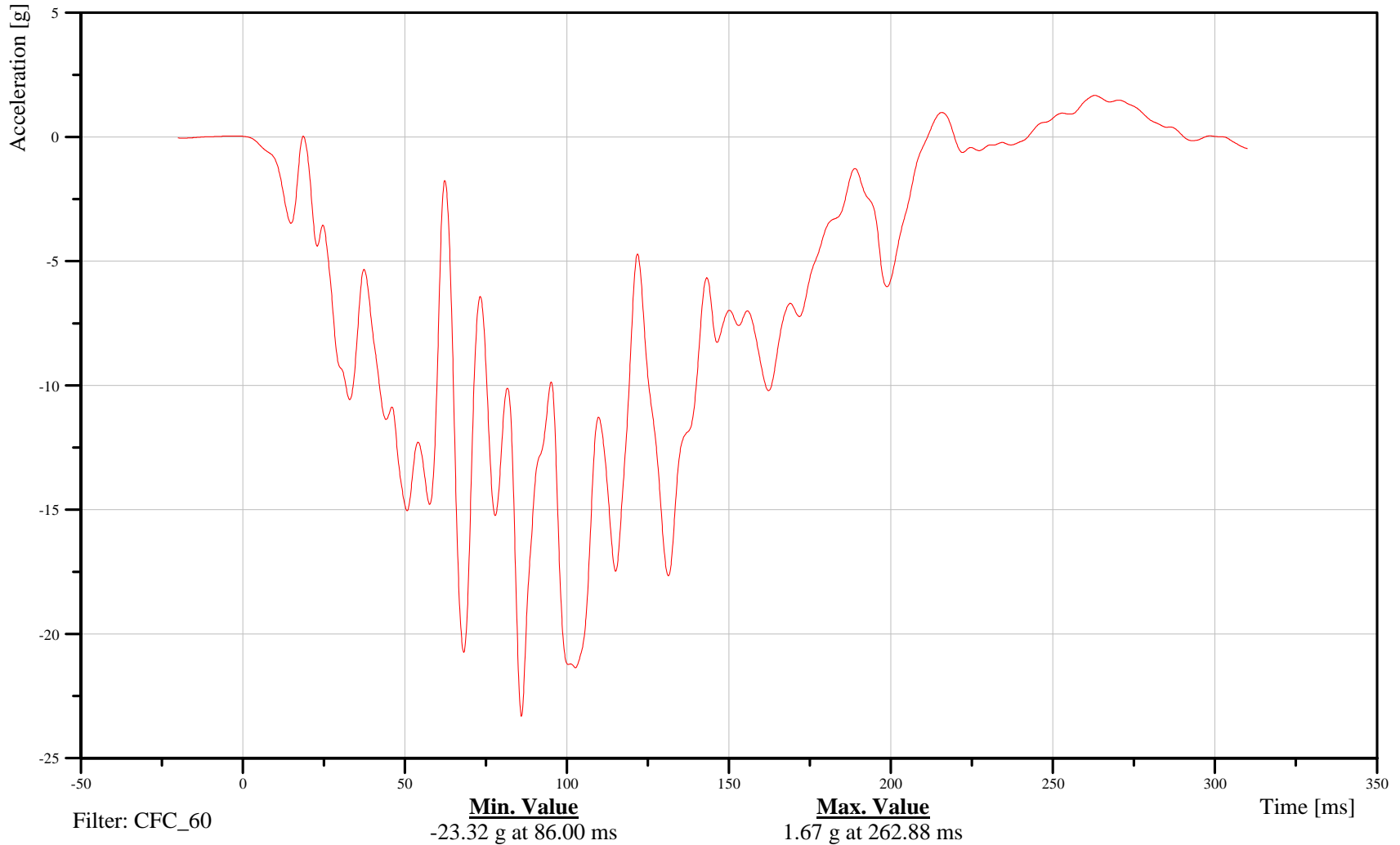

B-154

070913



2007 Ford F-250 into Left 40% Offset Deformable LCB at 56 kph

Date: 09/13/2007
Time: 15:46

Vehicle CG X-Axis Acceleration

Customer: Volpe
Test Number: R70203

10VEHCCG0000ACXD

TRC Inc. Test Lab: CTF
Test Number: 070913

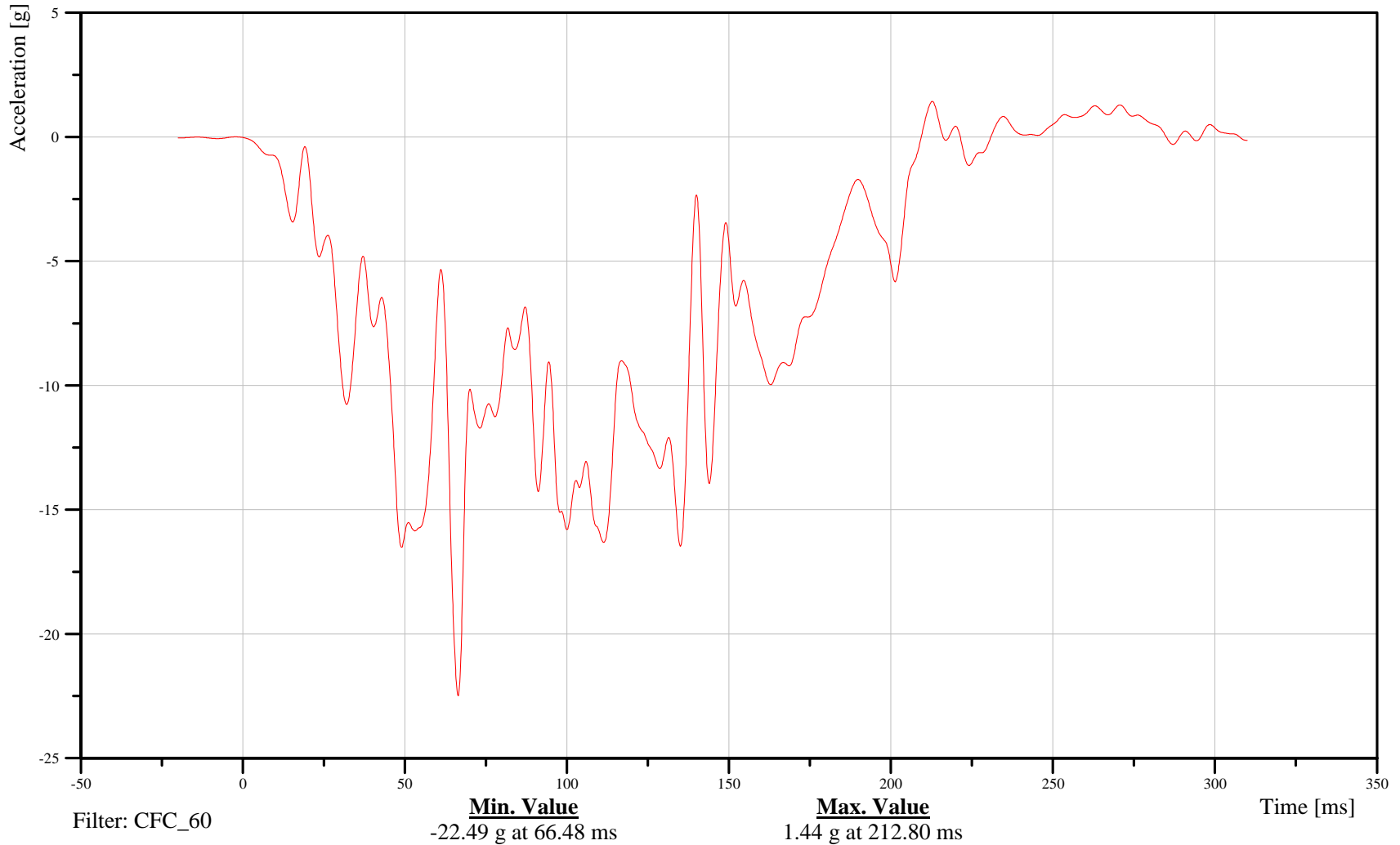

B-155

070913



2007 Ford F-250 into Left 40% Offset Deformable LCB at 56 kph

Date: 09/13/2007
Time: 15:46

Vehicle CG X-Axis Velocity

Customer: Volpe
Test Number: R70203

10VEHCCG0000VEXC

TRC Inc. Test Lab: CTF
Test Number: 070913

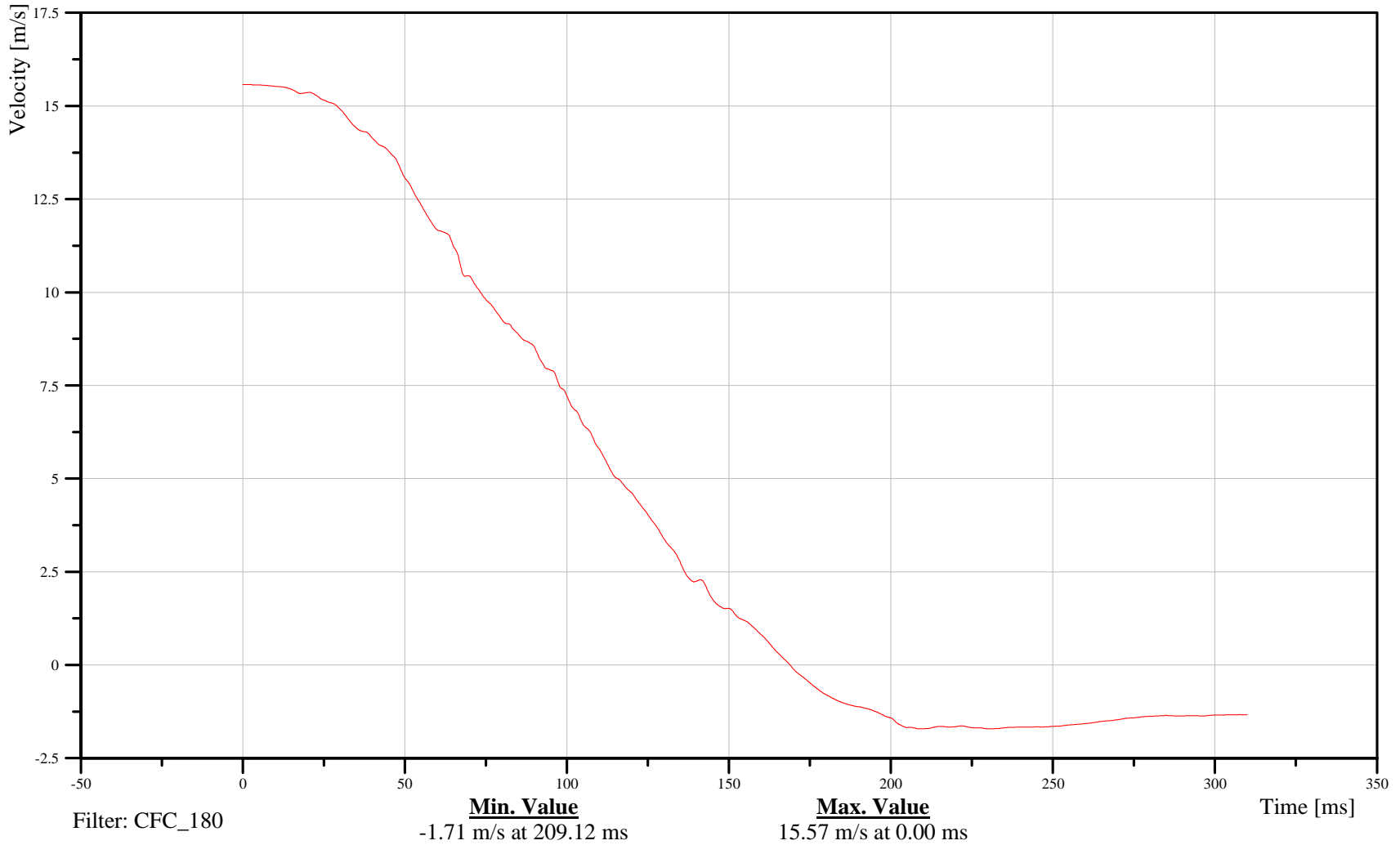

B-156

070913



2007 Ford F-250 into Left 40% Offset Deformable LCB at 56 kph

Date: 09/13/2007
Time: 15:46

Vehicle CG X-Axis Displacement

Customer: Volpe
Test Number: R70203

10VEHCCG0000DCXC

TRC Inc. Test Lab: CTF
Test Number: 070913

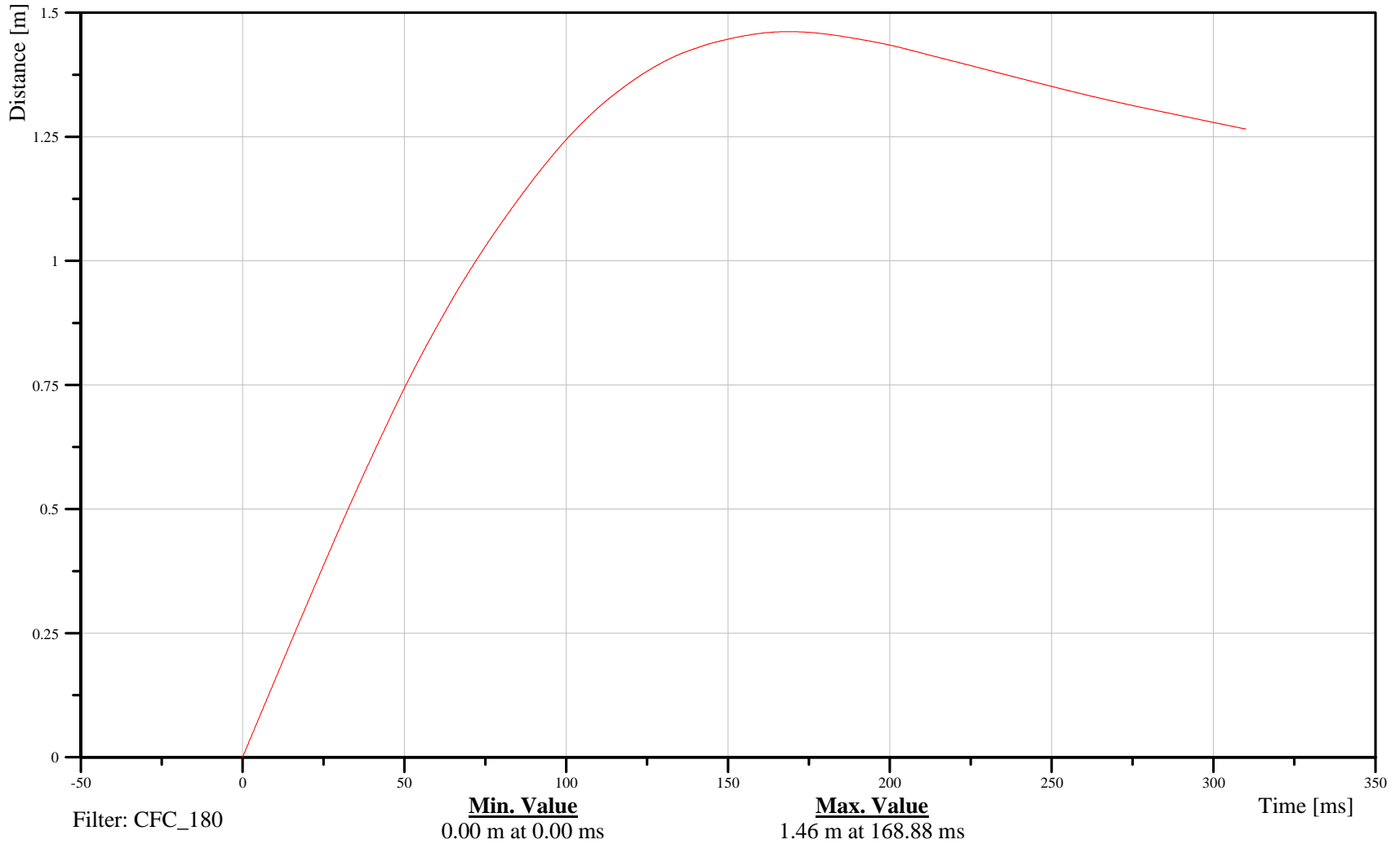

B-157

070913



2007 Ford F-250 into Left 40% Offset Deformable LCB at 56 kph

Date: 09/13/2007
Time: 15:46

Vehicle CG Y-Axis Acceleration

Customer: Volpe
Test Number: R70203

10VEHCCG0000ACYD

TRC Inc. Test Lab: CTF
Test Number: 070913

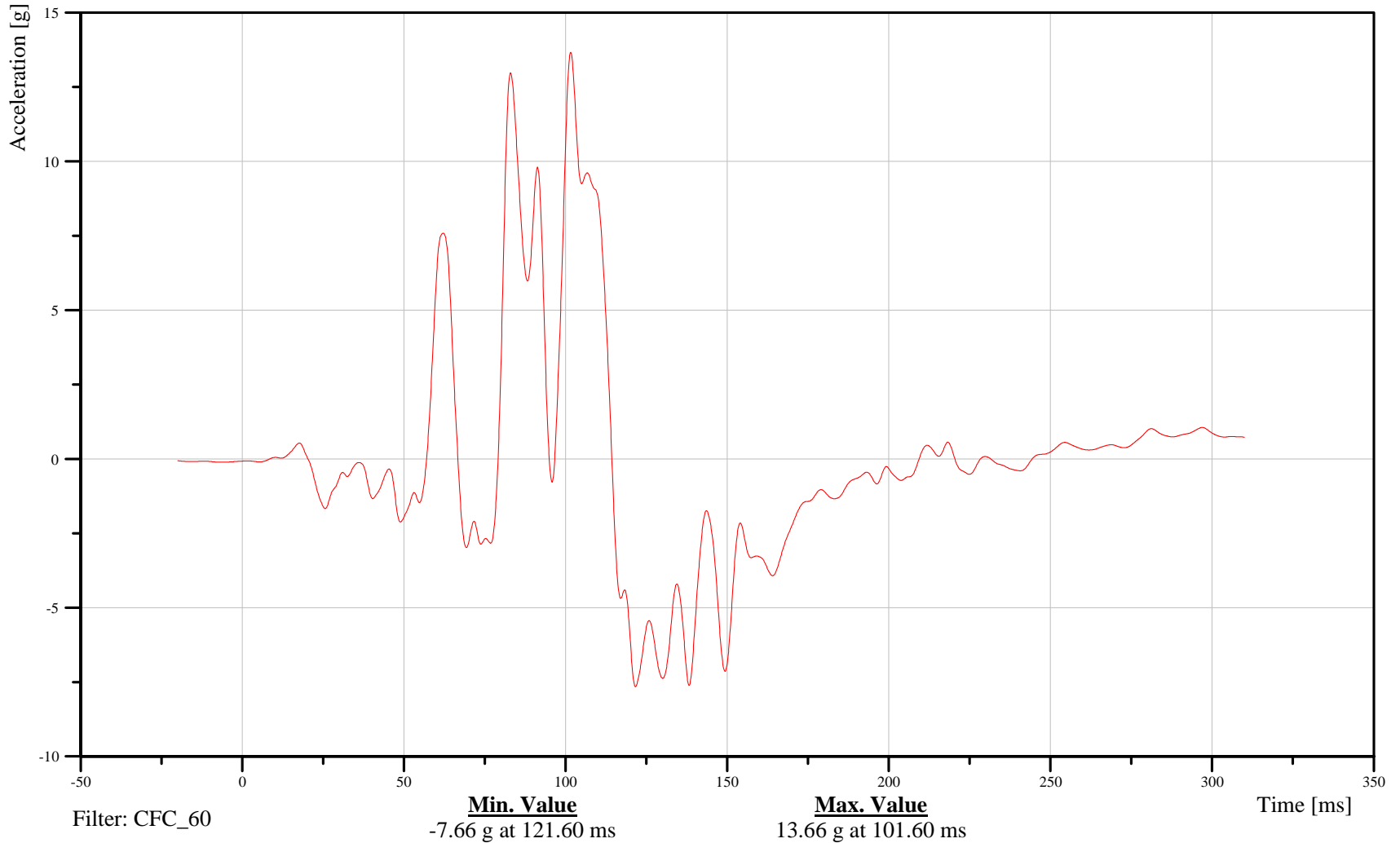

B-158

070913



2007 Ford F-250 into Left 40% Offset Deformable LCB at 56 kph

Date: 09/13/2007
Time: 15:46

Vehicle CG Y-Axis Velocity

Customer: Volpe
Test Number: R70203

10VEHCCG0000VEYC

TRC Inc. Test Lab: CTF
Test Number: 070913

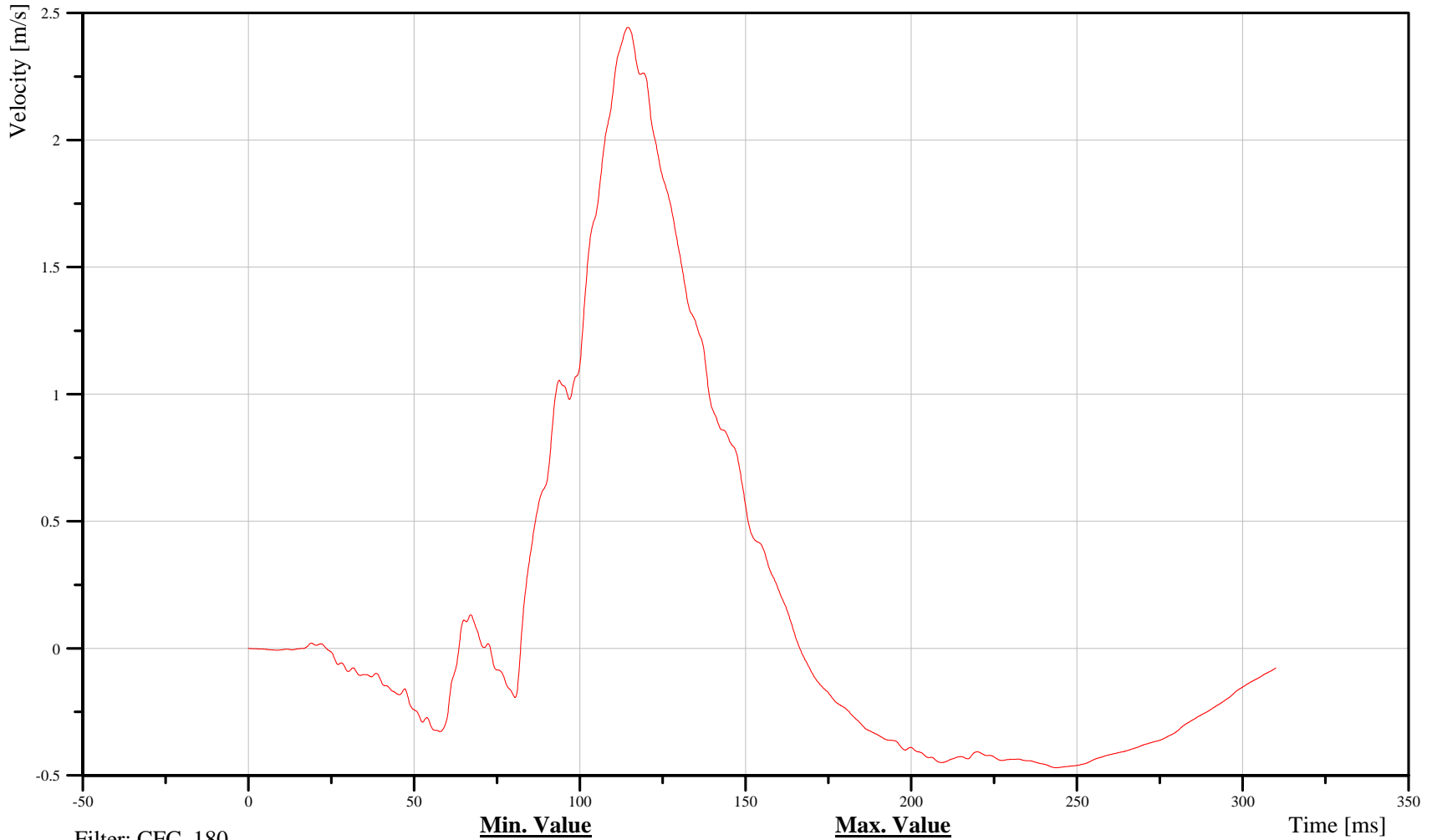

Filter: CFC_180

Min. Value
-0.47 m/s at 243.68 ms

Max. Value
2.44 m/s at 114.48 ms

Time [ms]

B-159

070913



2007 Ford F-250 into Left 40% Offset Deformable LCB at 56 kph

Date: 09/13/2007
Time: 15:46

Vehicle CG Y-Axis Displacement

Customer: Volpe
Test Number: R70203

10VEHCCG0000DCYC

TRC Inc. Test Lab: CTF
Test Number: 070913

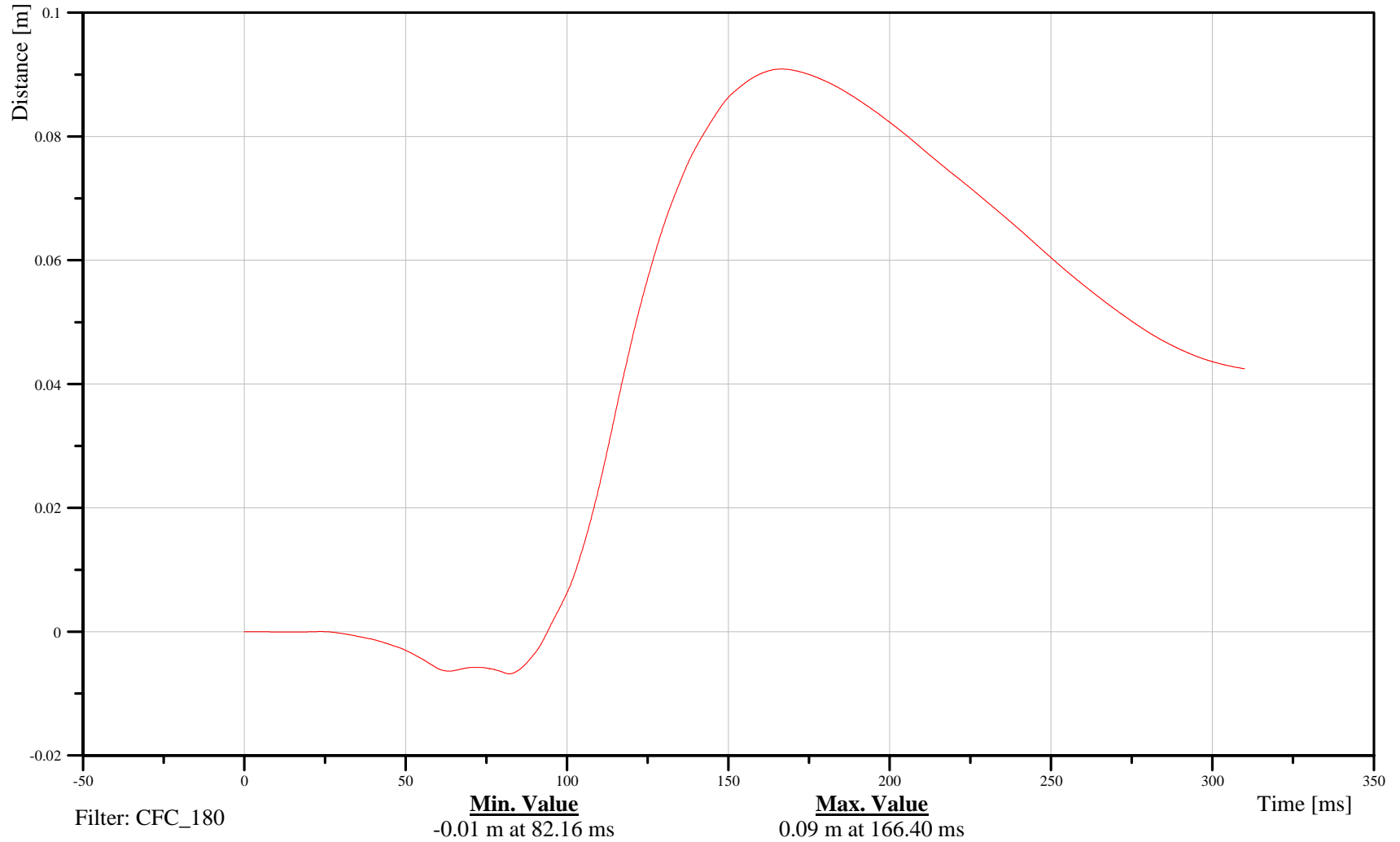

B-160

070913



2007 Ford F-250 into Left 40% Offset Deformable LCB at 56 kph

Date: 09/13/2007
Time: 15:46

Vehicle CG Z-Axis Acceleration

Customer: Volpe
Test Number: R70203

10VEHCCG0000ACZD

TRC Inc. Test Lab: CTF
Test Number: 070913

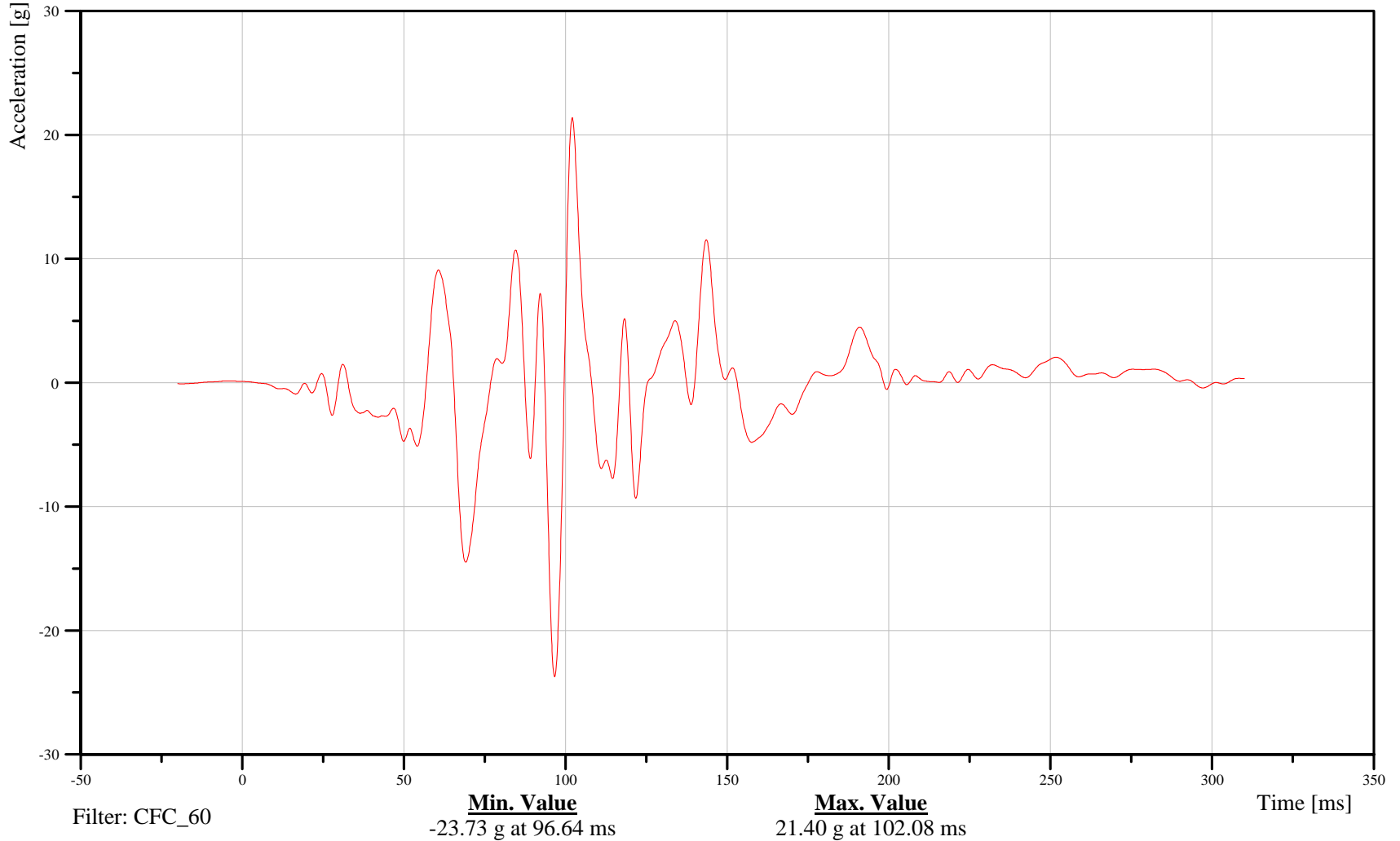

B-161

070913



2007 Ford F-250 into Left 40% Offset Deformable LCB at 56 kph

Date: 09/13/2007
Time: 15:46

Vehicle CG Z-Axis Velocity

Customer: Volpe
Test Number: R70203

10VEHCCG0000VEZC

TRC Inc. Test Lab: CTF
Test Number: 070913

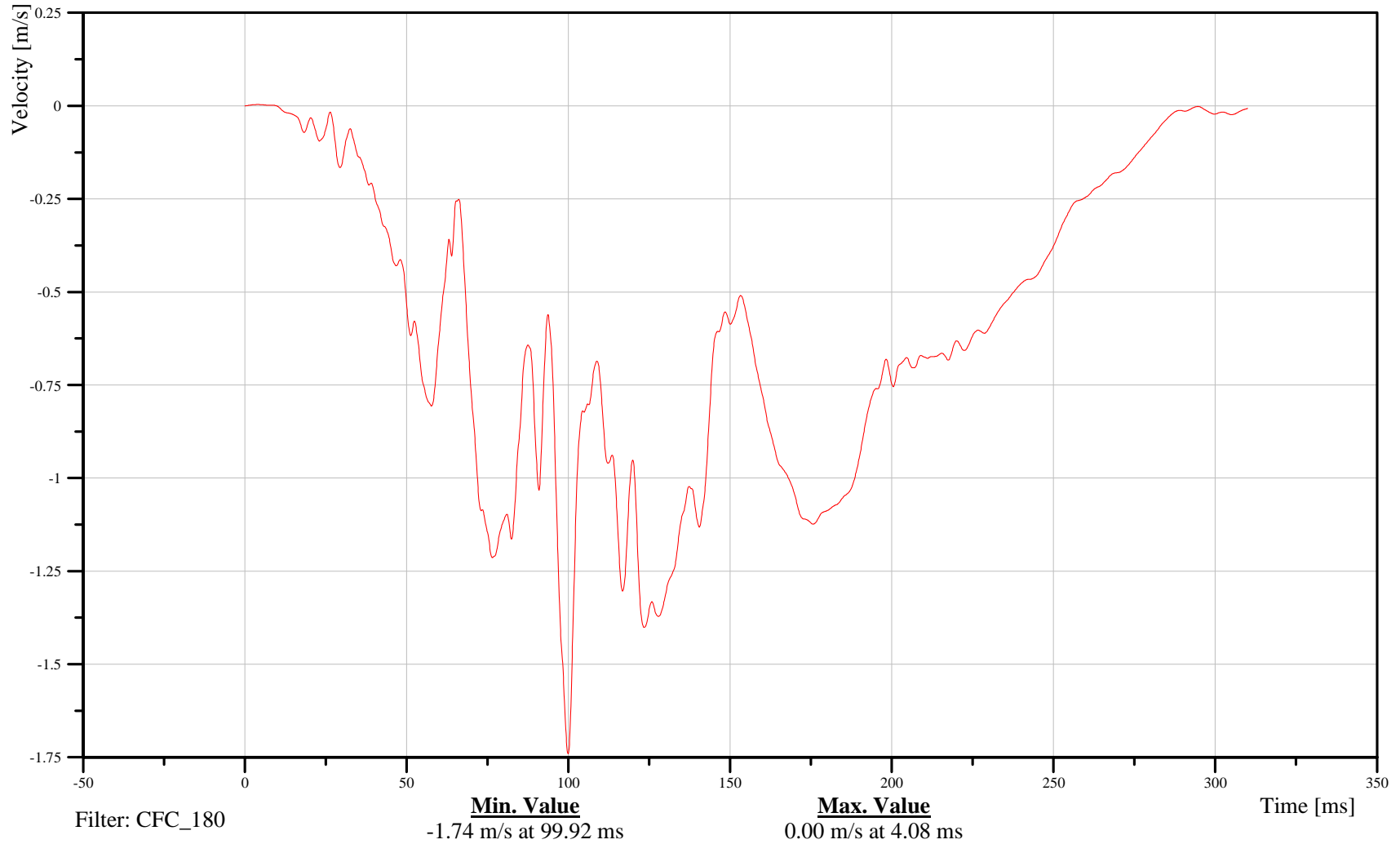

B-162

070913



2007 Ford F-250 into Left 40% Offset Deformable LCB at 56 kph

Date: 09/13/2007
Time: 15:46

Vehicle CG Z-Axis Displacement

Customer: Volpe
Test Number: R70203

10VEHCCG0000DCZC

TRC Inc. Test Lab: CTF
Test Number: 070913

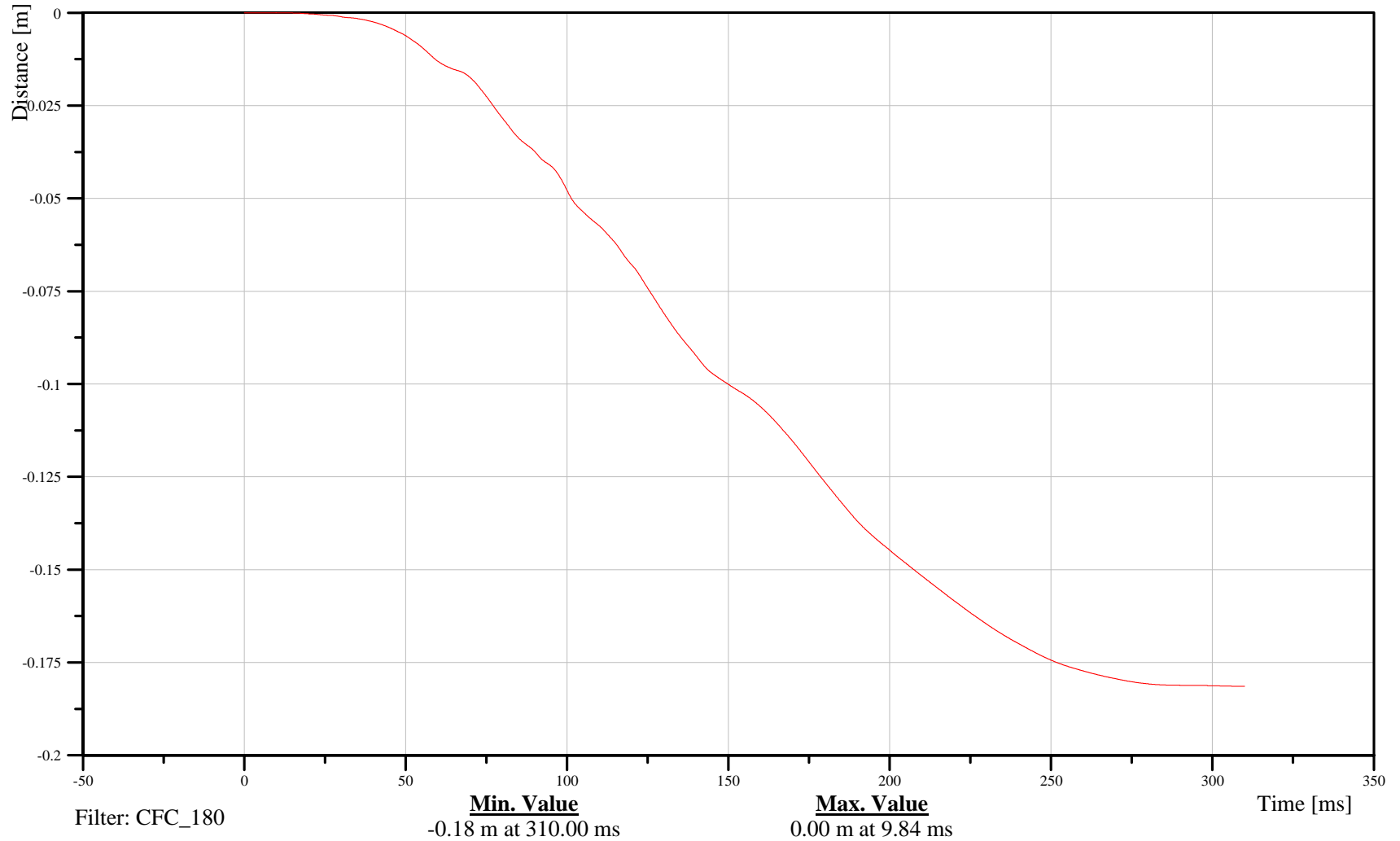

B-163

070913



2007 Ford F-250 into Left 40% Offset Deformable LCB at 56 kph

Date: 09/13/2007
Time: 15:46

Vehicle CG Resultant Acceleration

Customer: Volpe
Test Number: R70203

10VEHCCG0000ACRD

TRC Inc. Test Lab: CTF
Test Number: 070913

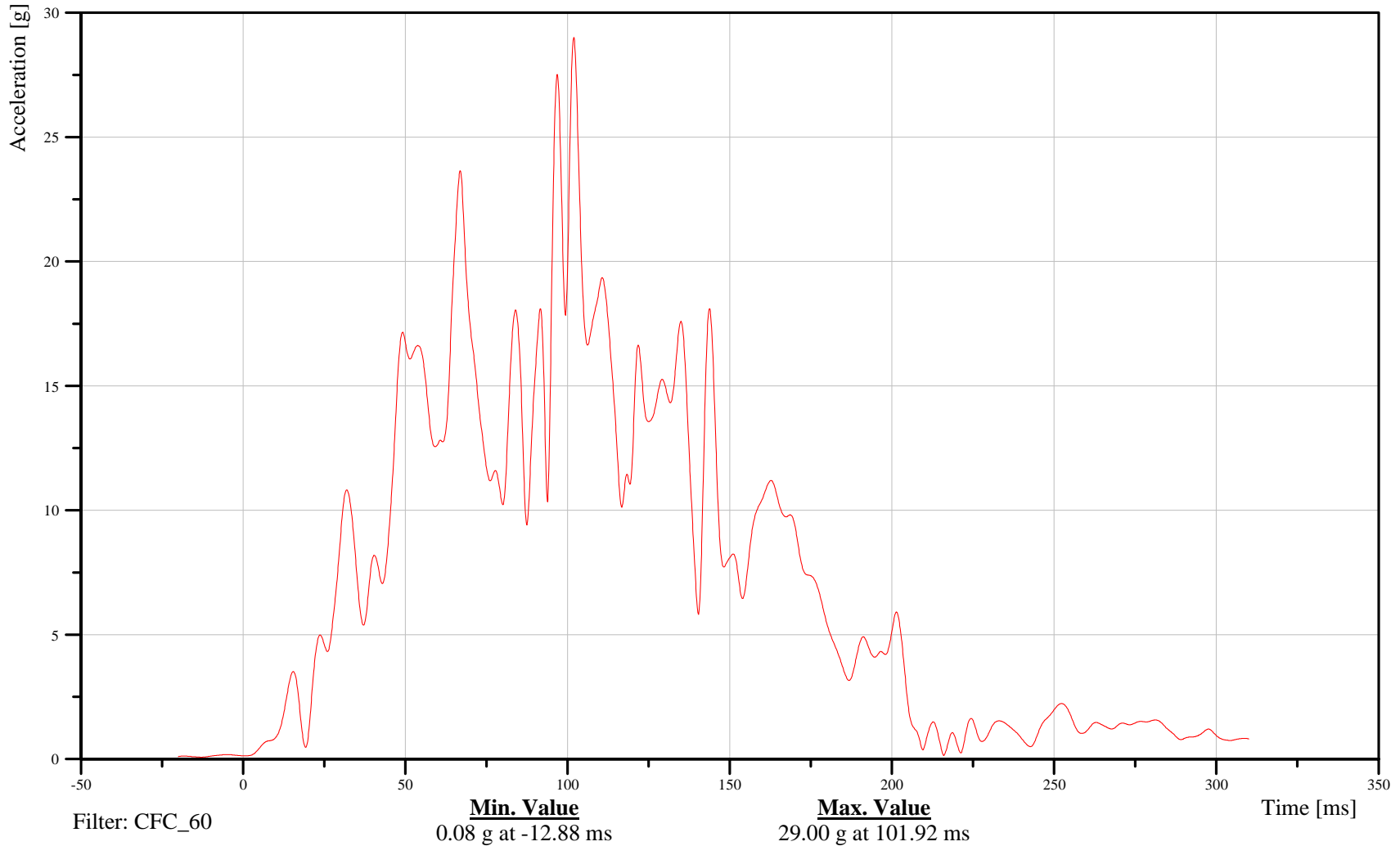

B-164

070913



2007 Ford F-250 into Left 40% Offset Deformable LCB at 56 kph

Date: 09/13/2007
Time: 15:46

Under Accel Pedal (Centered) X-Axis Acceleration

Customer: Volpe
Test Number: R70203

11PEAC000000ACXD

TRC Inc. Test Lab: CTF
Test Number: 070913

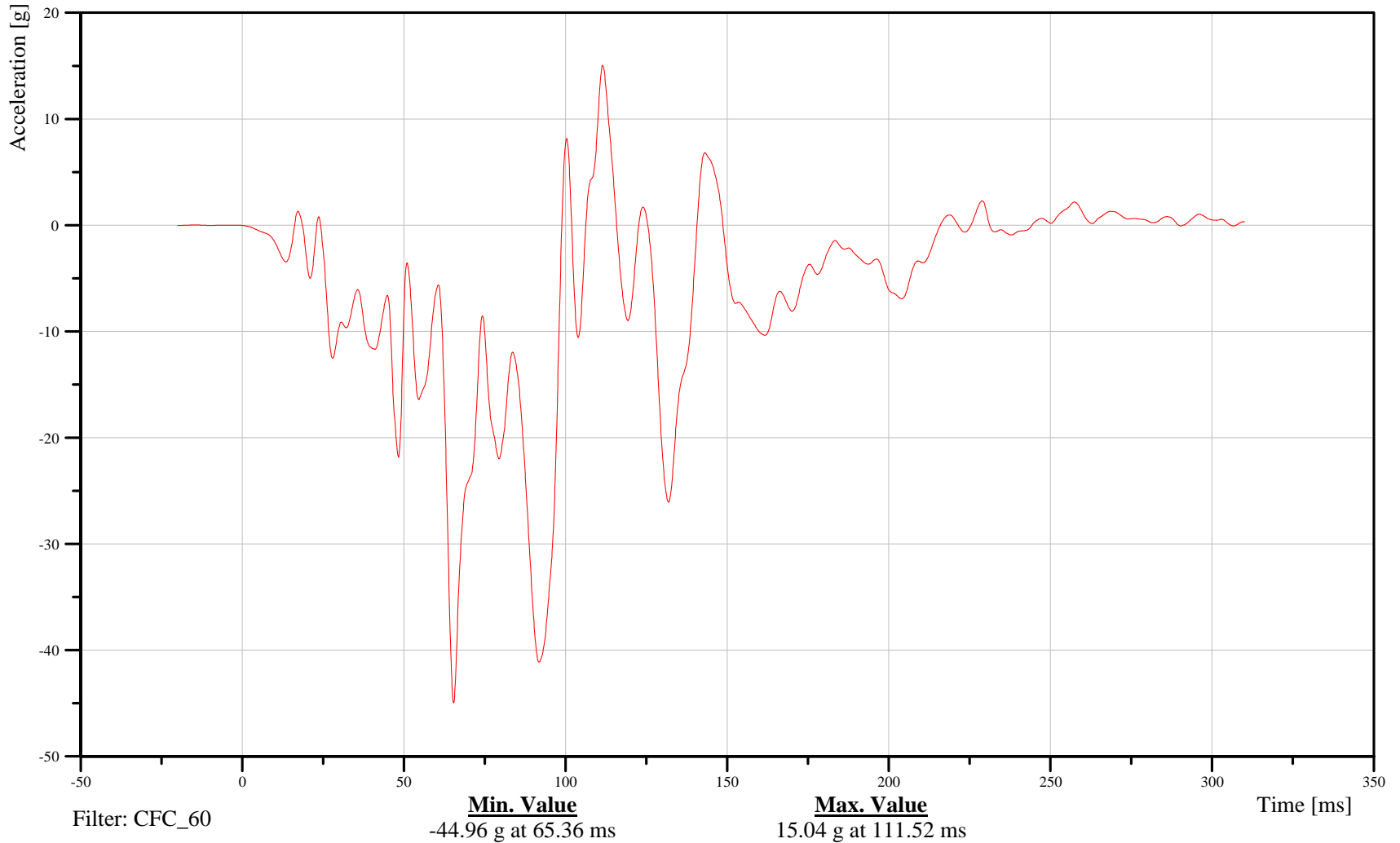

B-165

070913



2007 Ford F-250 into Left 40% Offset Deformable LCB at 56 kph

Date: 09/13/2007
Time: 15:46

Under Accel Pedal (Centered) Y-Axis Acceleration

Customer: Volpe
Test Number: R70203

11PEAC000000ACYD

TRC Inc. Test Lab: CTF
Test Number: 070913

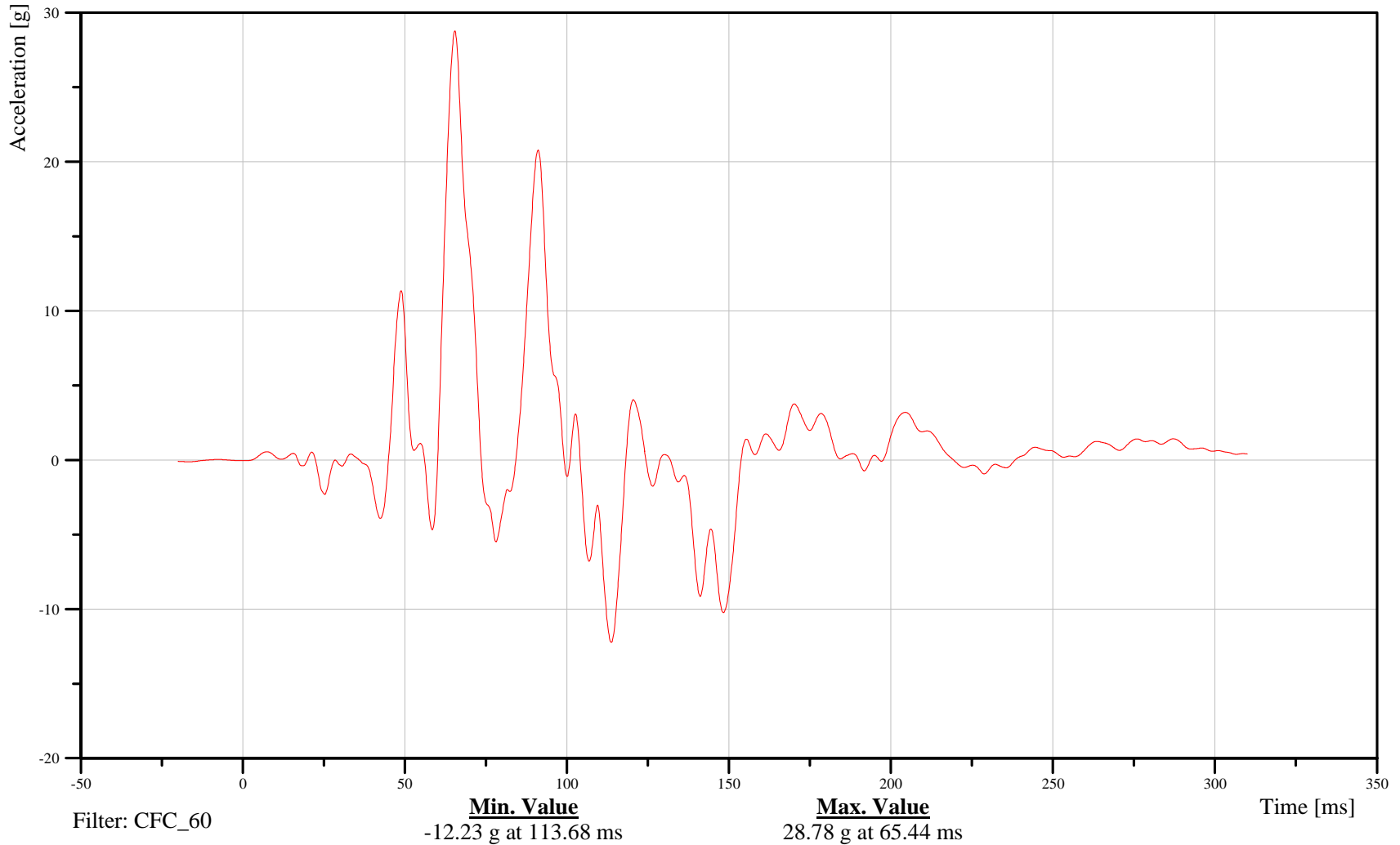

B-166

070913



2007 Ford F-250 into Left 40% Offset Deformable LCB at 56 kph

Date: 09/13/2007
Time: 15:46

Under Accel Pedal (Centered) Z-Axis Acceleration

Customer: Volpe
Test Number: R70203

11PEAC000000ACZD

TRC Inc. Test Lab: CTF
Test Number: 070913

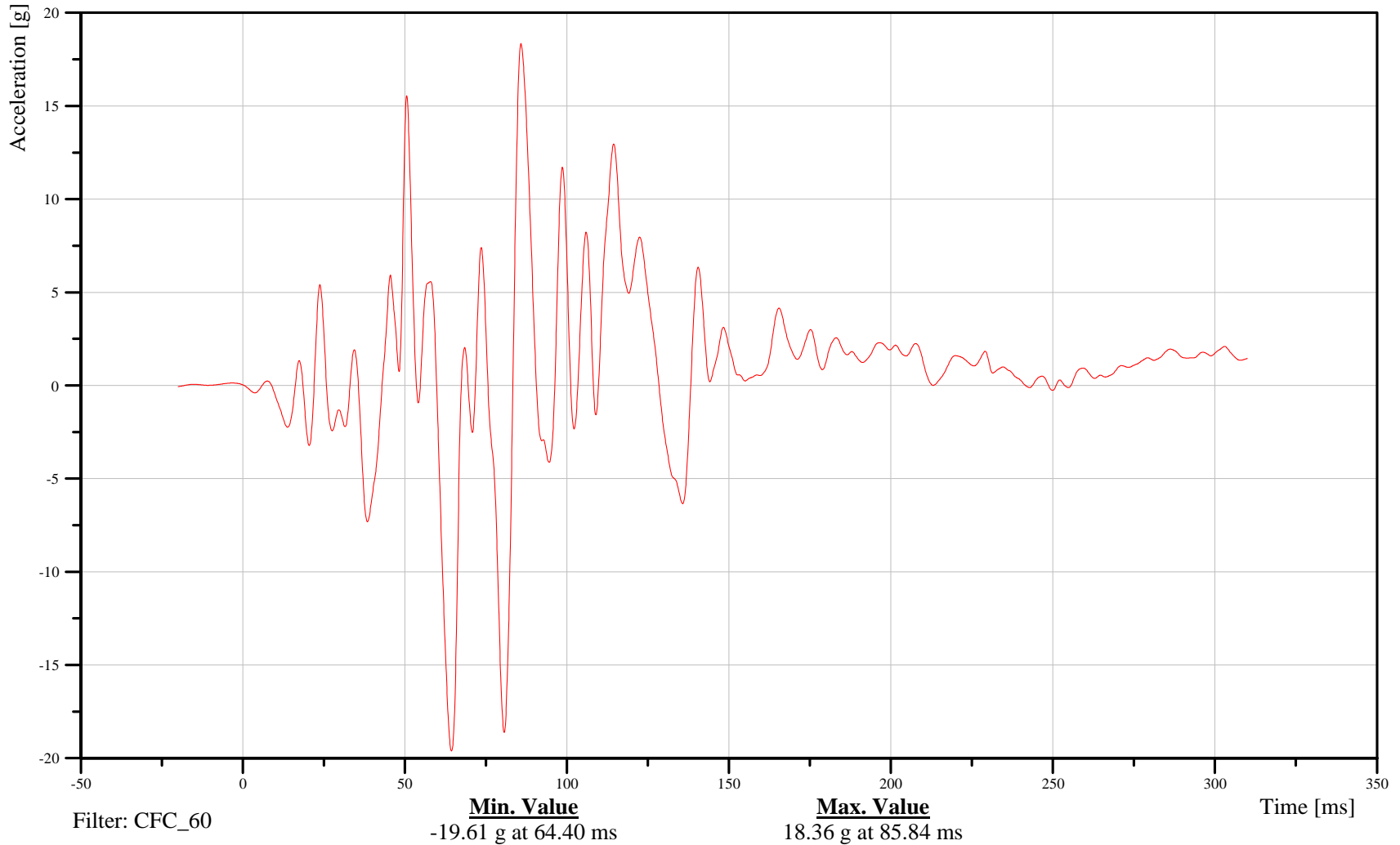

B-167

070913



2007 Ford F-250 into Left 40% Offset Deformable LCB at 56 kph

Date: 09/13/2007
Time: 15:46

Under Accel Pedal (Centered) Resultant Acceleration

Customer: Volpe
Test Number: R70203

11PEAC000000ACRD

TRC Inc. Test Lab: CTF
Test Number: 070913

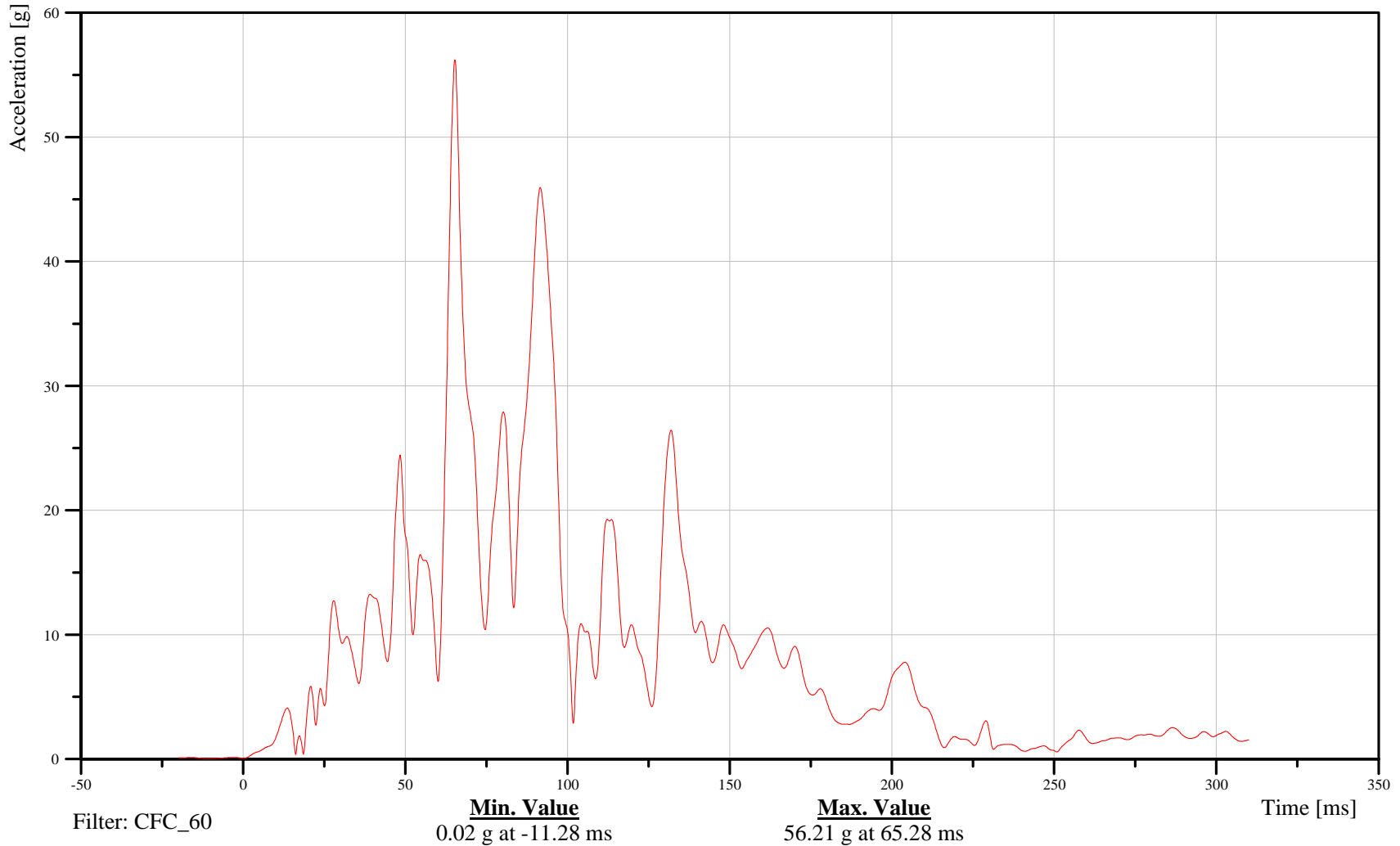

B-168

070913



2007 Ford F-250 into Left 40% Offset Deformable LCB at 56 kph

Date: 09/13/2007
Time: 15:46

Under Brake Pedal (Centered) X-Axis Acceleration

Customer: Volpe
Test Number: R70203

11PEBR000000ACXD

TRC Inc. Test Lab: CTF
Test Number: 070913

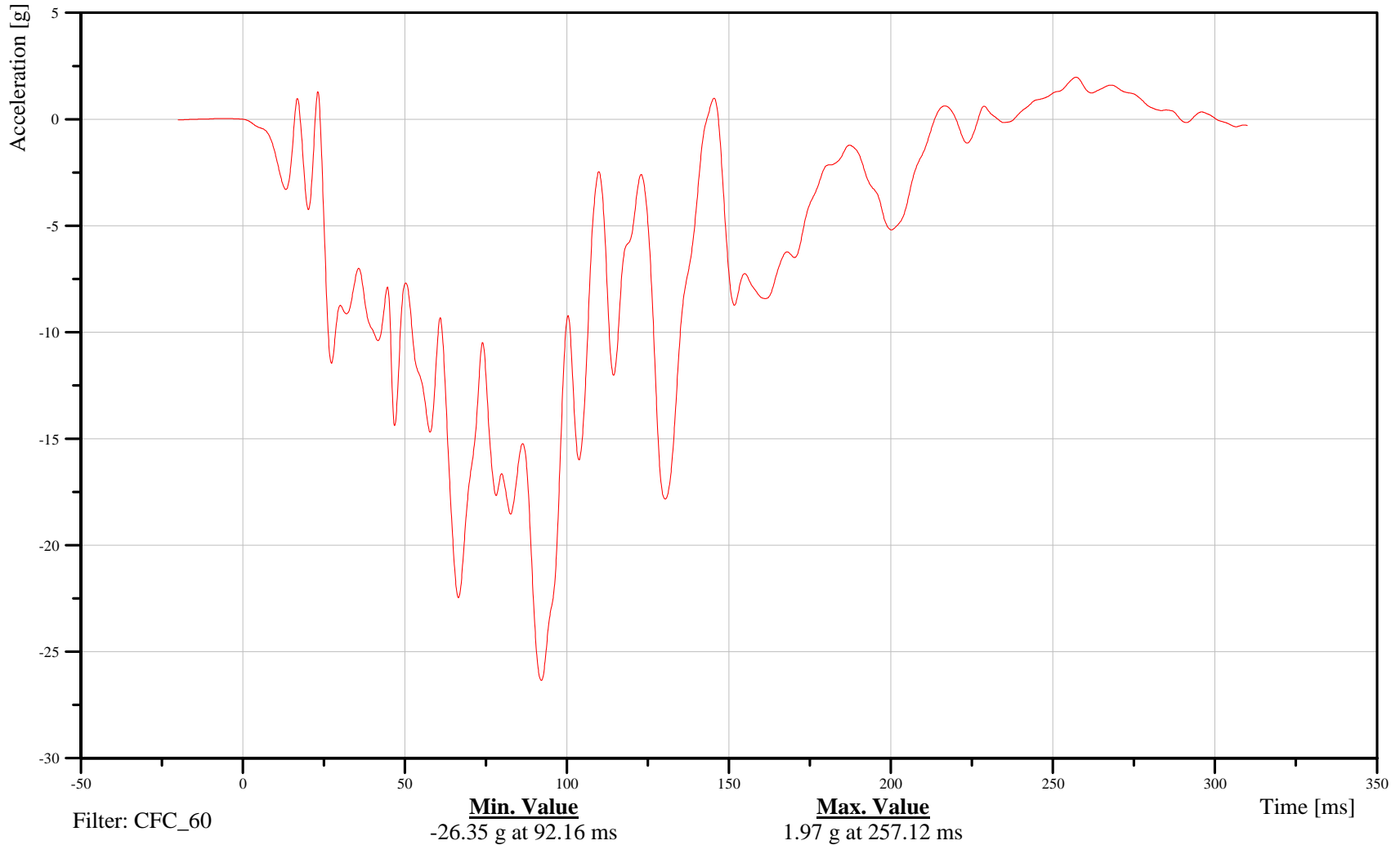

B-169

070913



2007 Ford F-250 into Left 40% Offset Deformable LCB at 56 kph

Date: 09/13/2007
Time: 15:46

Under Brake Pedal (Centered) Y-Axis Acceleration

Customer: Volpe
Test Number: R70203

11PEBR000000ACYD

TRC Inc. Test Lab: CTF
Test Number: 070913

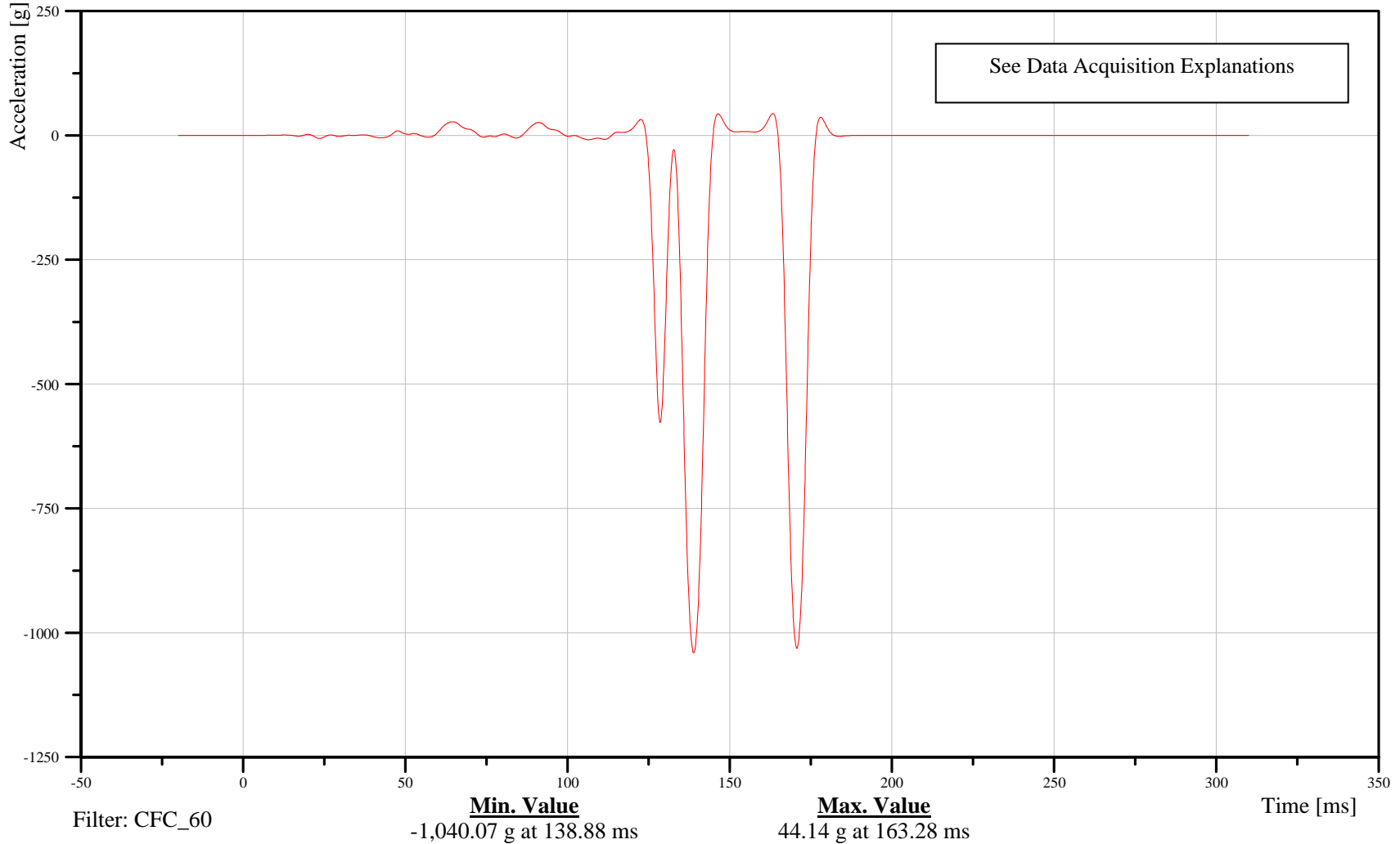

B-170

070913



2007 Ford F-250 into Left 40% Offset Deformable LCB at 56 kph

Date: 09/13/2007
Time: 15:46

Under Brake Pedal (Centered) Z-Axis Acceleration

Customer: Volpe
Test Number: R70203

11PEBR000000ACZD

TRC Inc. Test Lab: CTF
Test Number: 070913

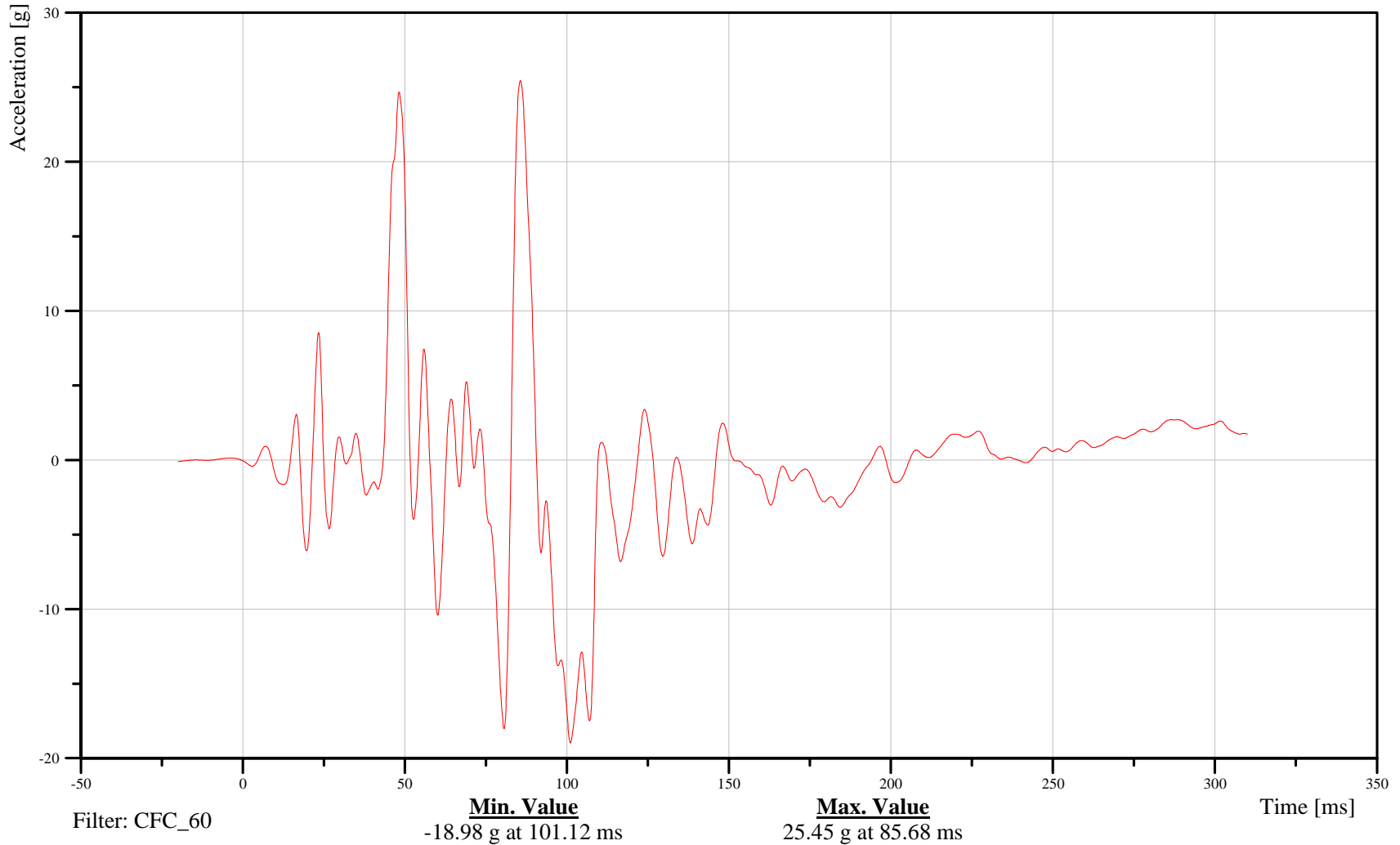

B-171

070913



2007 Ford F-250 into Left 40% Offset Deformable LCB at 56 kph

Date: 09/13/2007
Time: 15:46

Under Brake Pedal (Centered) Resultant Acceleration

Customer: Volpe
Test Number: R70203

11PEBR000000ACRD

TRC Inc. Test Lab: CTF
Test Number: 070913

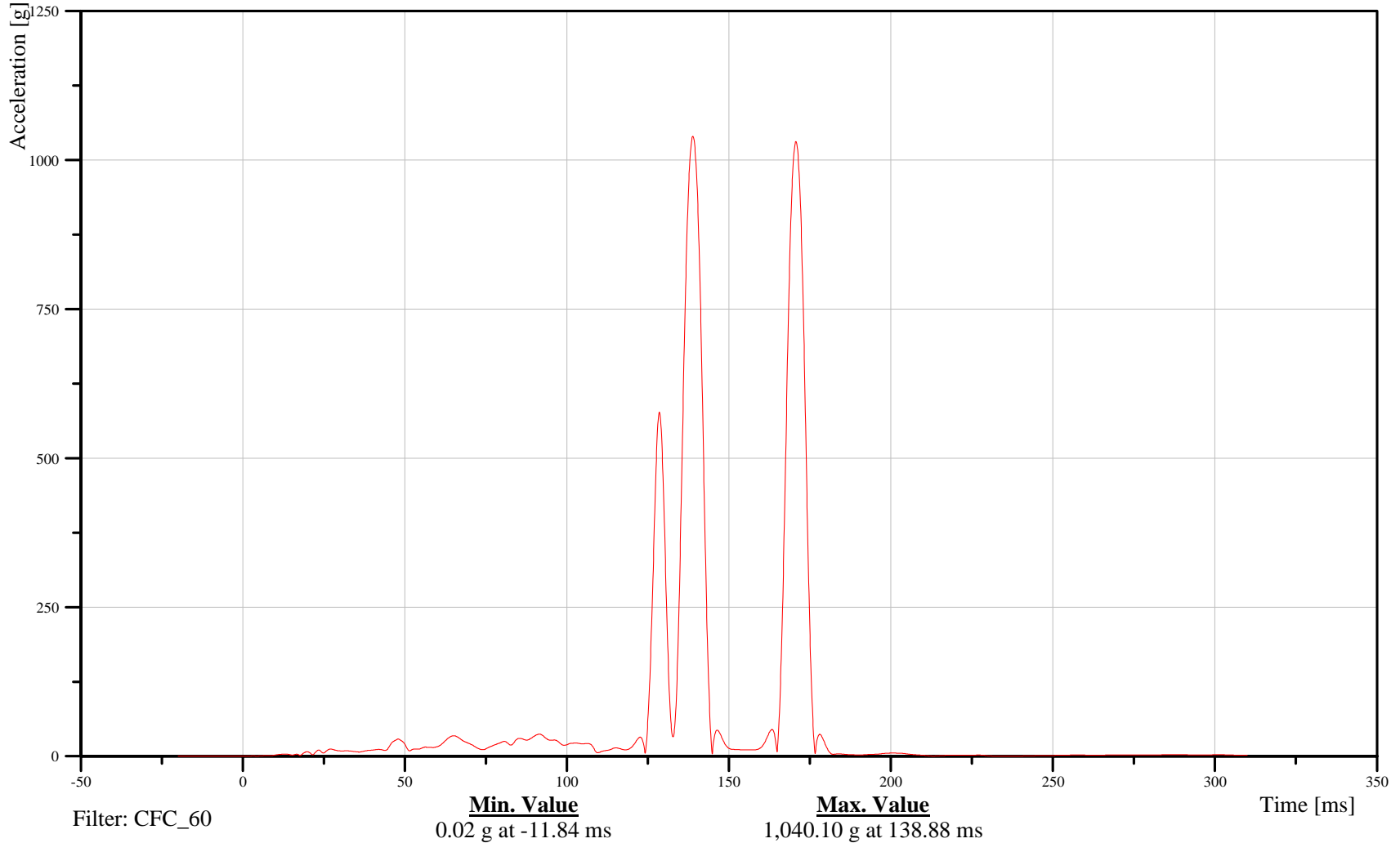

B-172

070913



2007 Ford F-250 into Left 40% Offset Deformable LCB at 56 kph

Date: 09/13/2007
Time: 15:46

Outside Footrest X-Axis Acceleration

Customer: Volpe
Test Number: R70203

11VEHC000001ACXD

TRC Inc. Test Lab: CTF
Test Number: 070913

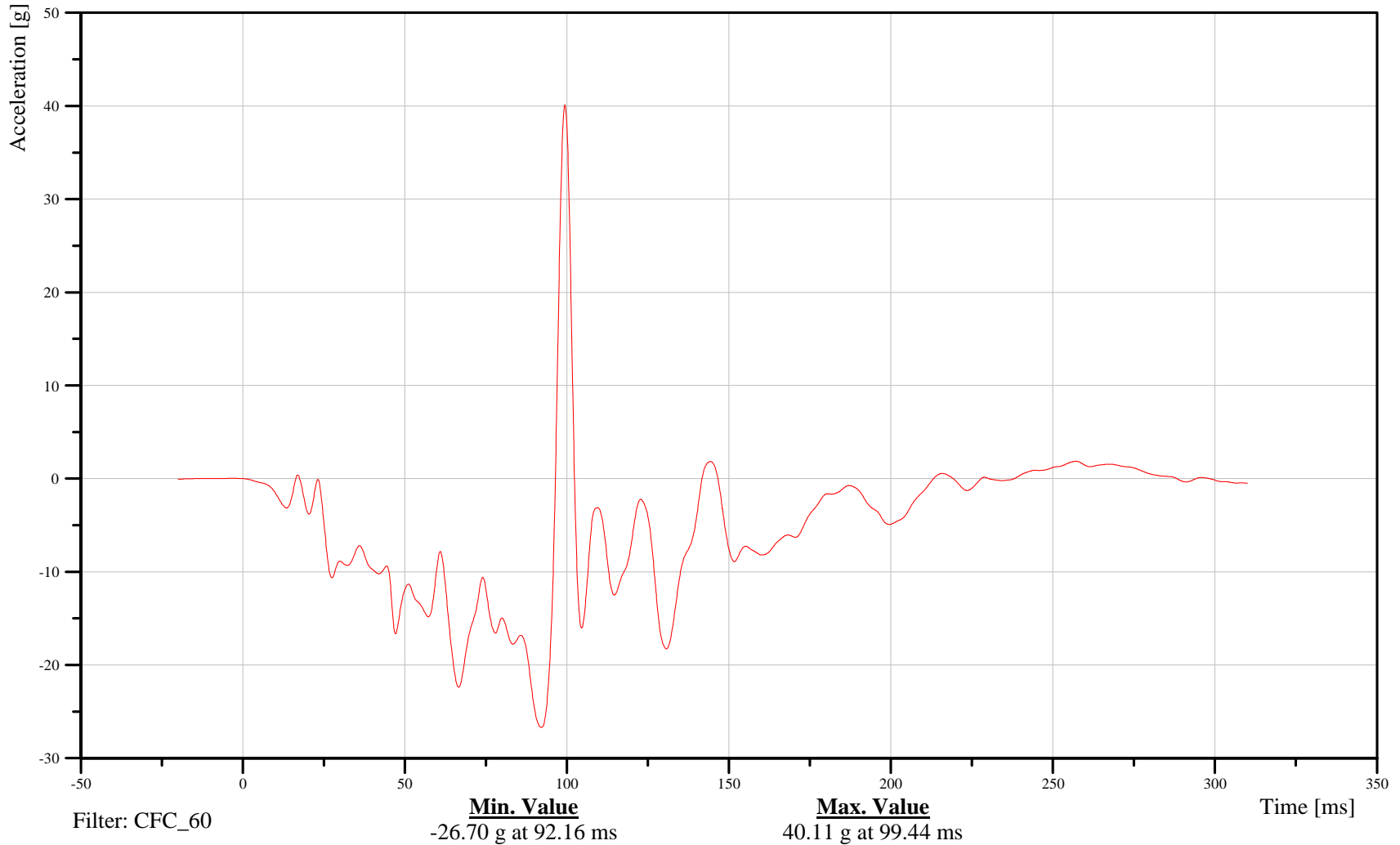

B-173

070913



2007 Ford F-250 into Left 40% Offset Deformable LCB at 56 kph

Date: 09/13/2007
Time: 15:46

Outside Footrest Y-Axis Acceleration

Customer: Volpe
Test Number: R70203

11VEHC000001ACYD

TRC Inc. Test Lab: CTF
Test Number: 070913

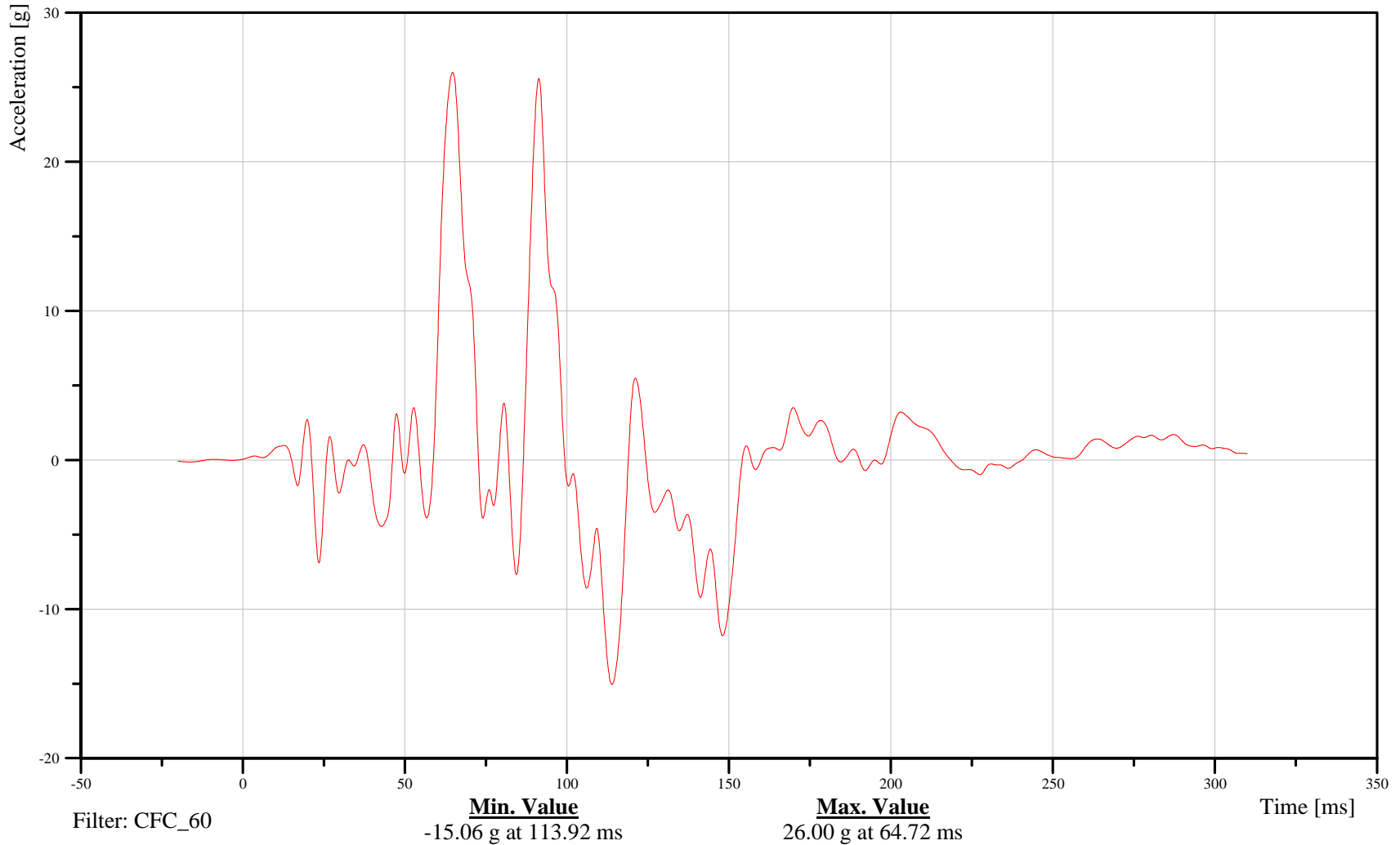

B-174

070913



2007 Ford F-250 into Left 40% Offset Deformable LCB at 56 kph

Date: 09/13/2007
Time: 15:46

Outside Footrest Z-Axis Acceleration

Customer: Volpe
Test Number: R70203

11VEHC000001ACZD

TRC Inc. Test Lab: CTF
Test Number: 070913

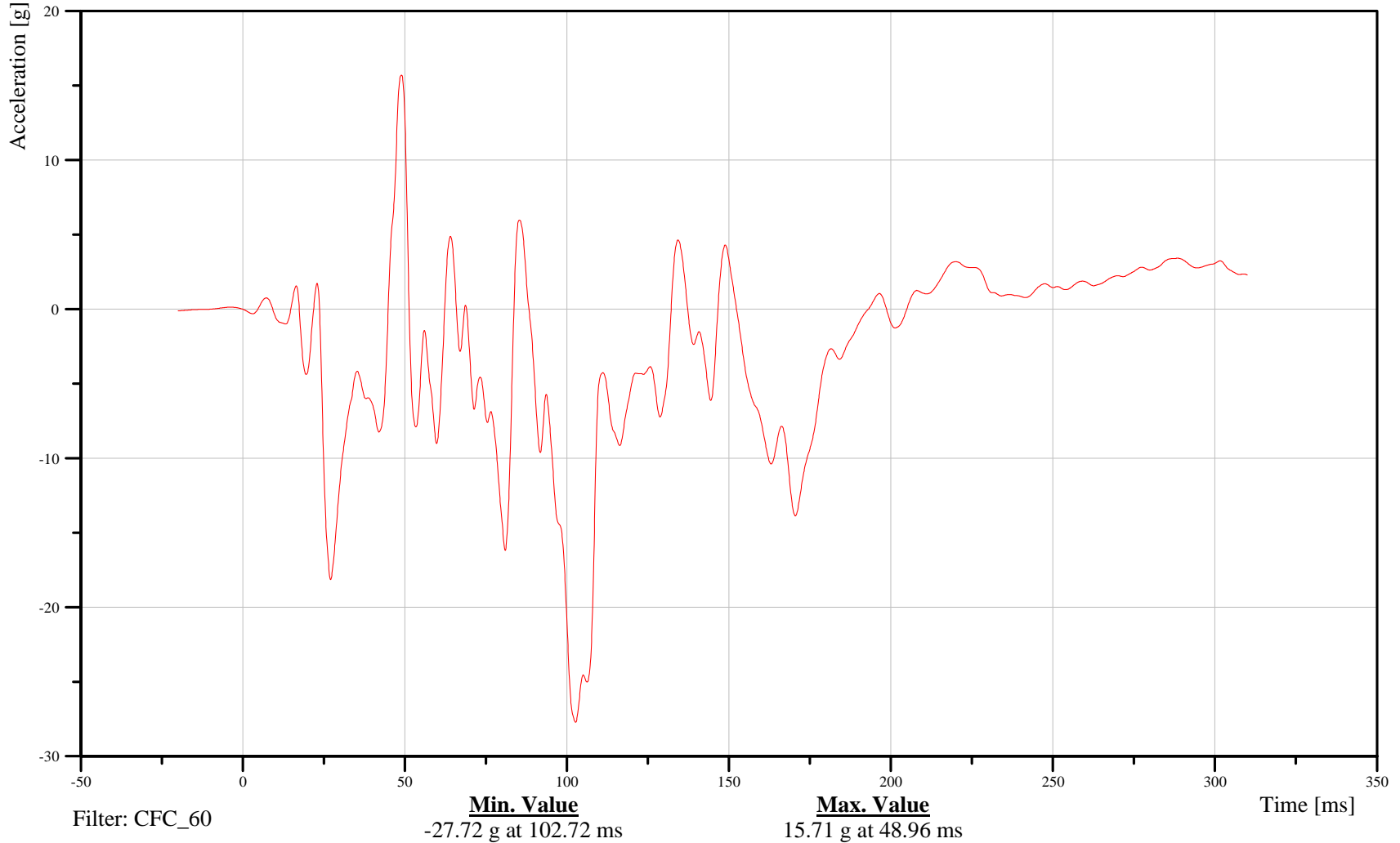

B-175

070913



2007 Ford F-250 into Left 40% Offset Deformable LCB at 56 kph

Date: 09/13/2007
Time: 15:46

Outside Footrest Resultant Acceleration

Customer: Volpe
Test Number: R70203

11VEHC000001ACRD

TRC Inc. Test Lab: CTF
Test Number: 070913

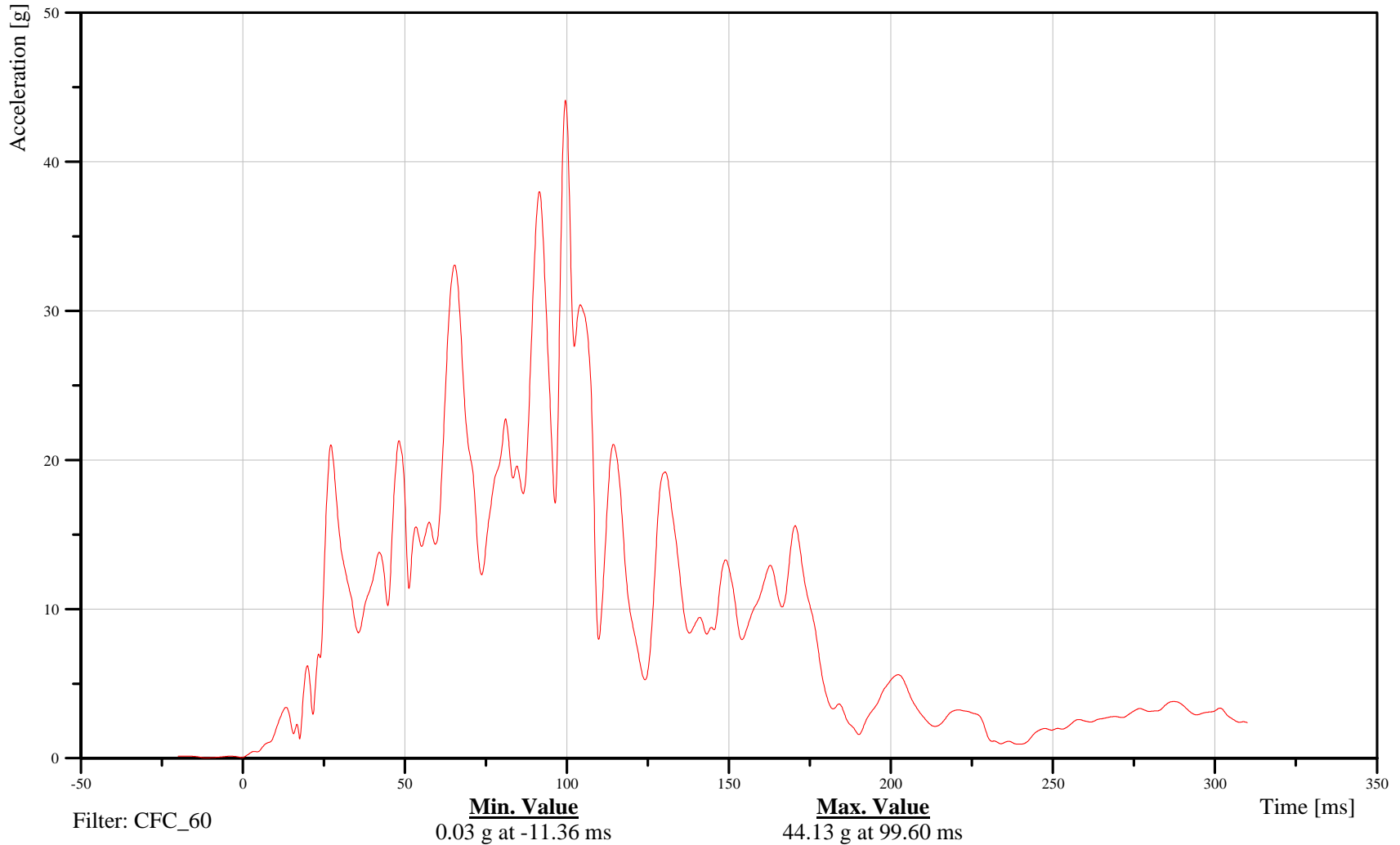

B-176

070913



2007 Ford F-250 into Left 40% Offset Deformable LCB at 56 kph

Date: 09/13/2007
Time: 15:46

Driver Lap Belt Force

Customer: Volpe
Test Number: R70203

11SEBE0000B5FOOD

TRC Inc. Test Lab: CTF
Test Number: 070913

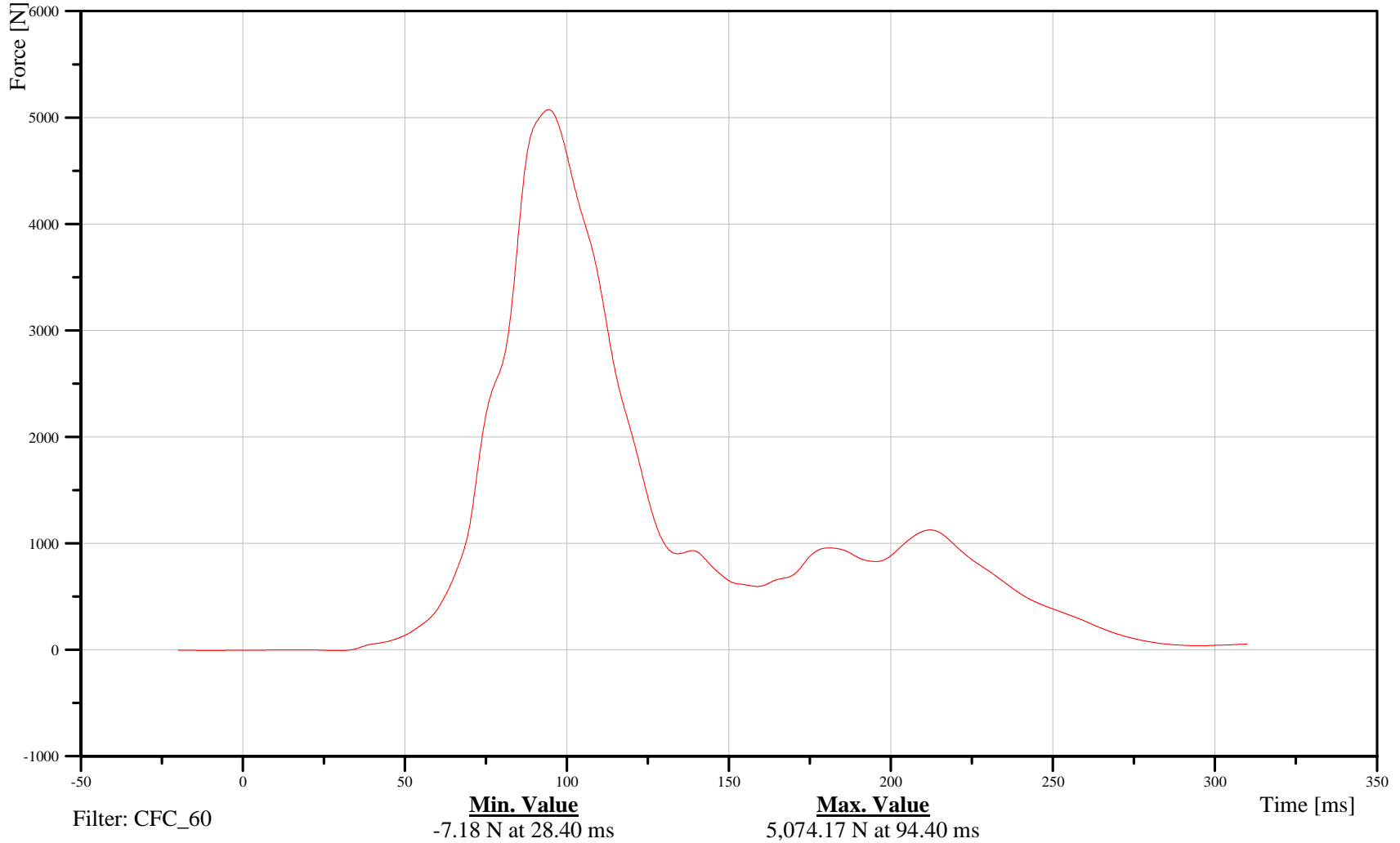

B-177

070913



2007 Ford F-250 into Left 40% Offset Deformable LCB at 56 kph

Date: 09/13/2007
Time: 15:46

Driver Shoulder Belt Force

Customer: Volpe
Test Number: R70203

11SEBE0000B3FOOD

TRC Inc. Test Lab: CTF
Test Number: 070913

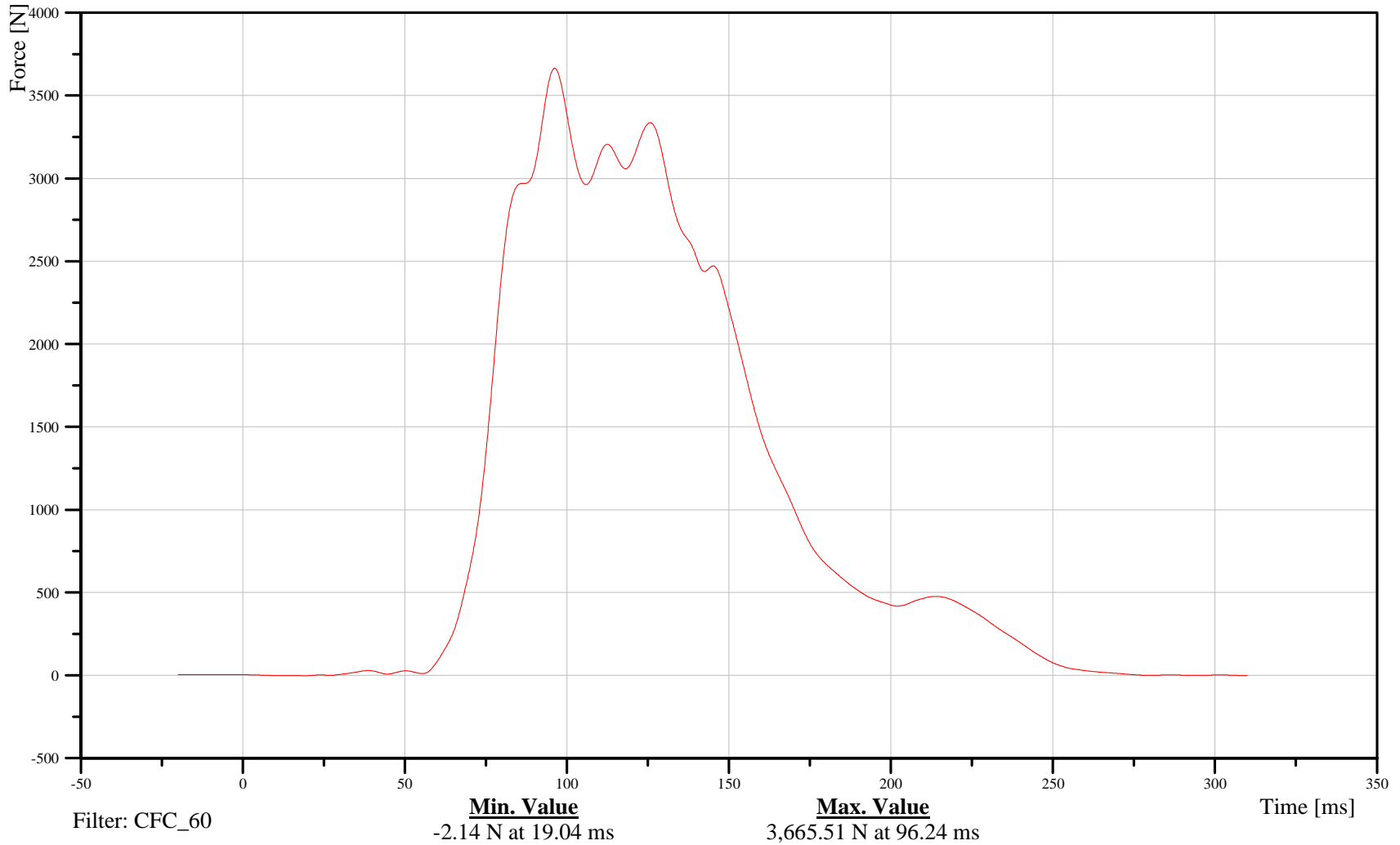

B-178

070913



2007 Ford F-250 into Left 40% Offset Deformable LCB at 56 kph

Date: 09/13/2007
Time: 15:46

Passenger Lap Belt Force

Customer: Volpe
Test Number: R70203

13SEBE0000B5FOOD

TRC Inc. Test Lab: CTF
Test Number: 070913

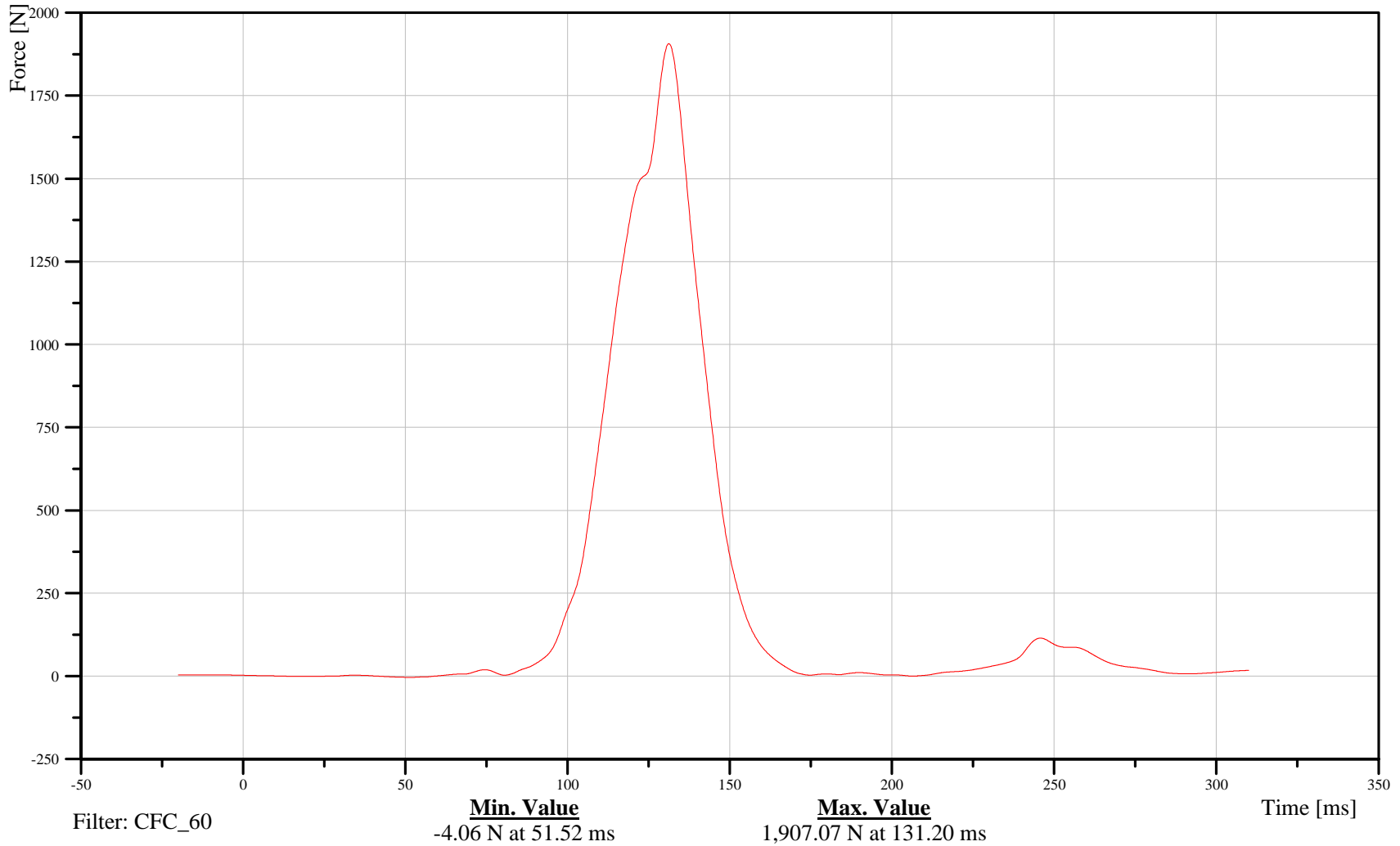

B-179

070913



2007 Ford F-250 into Left 40% Offset Deformable LCB at 56 kph

Date: 09/13/2007
Time: 15:46

Passenger Shoulder Belt Force

Customer: Volpe
Test Number: R70203

13SEBE0000B3FOOD

TRC Inc. Test Lab: CTF
Test Number: 070913

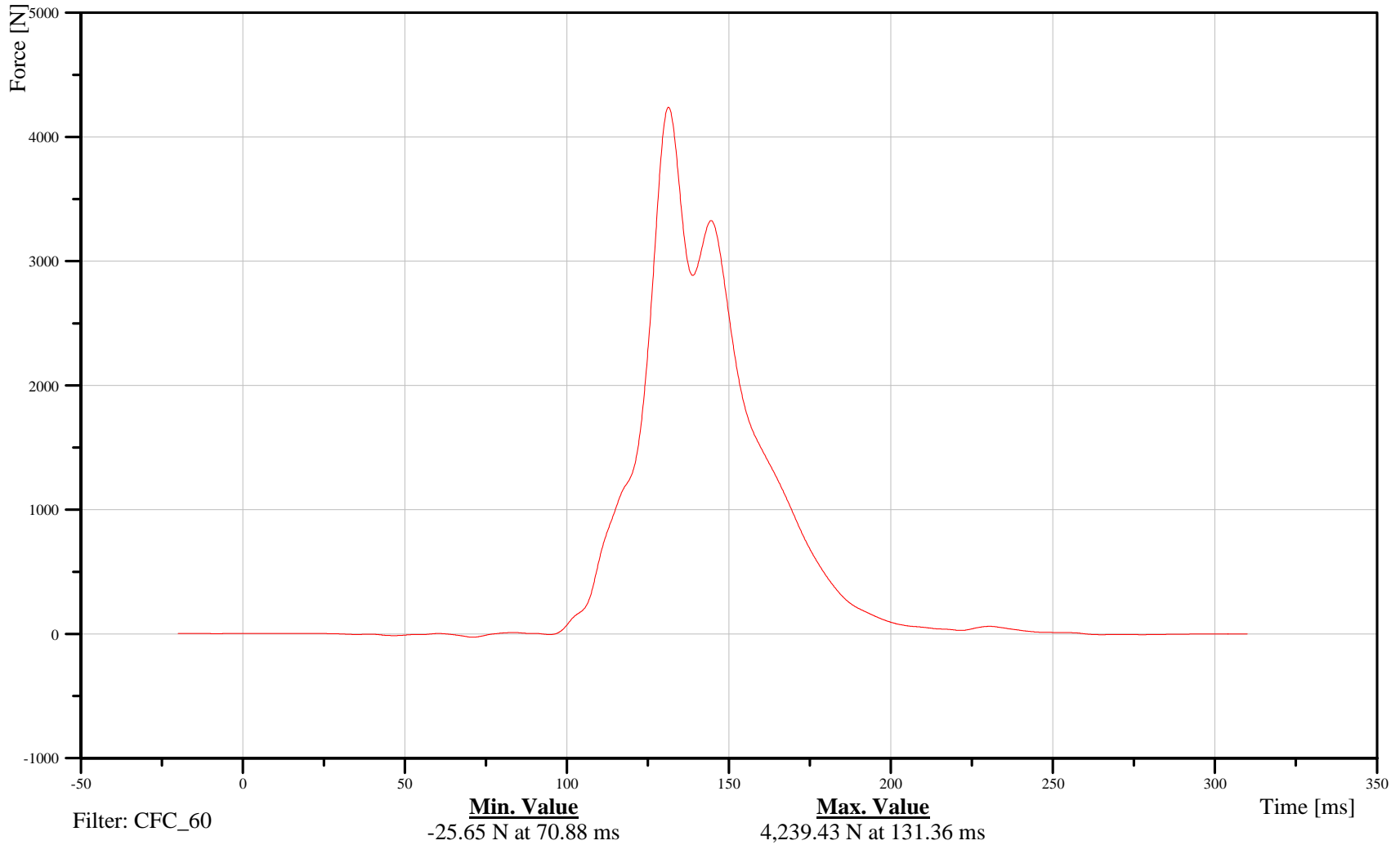

B-180

070913



2007 Ford F-250 into Left 40% Offset Deformable LCB at 56 kph

Date: 09/13/2007
Time: 15:46

Driver Front Airbag 1 Inductor

Customer: Volpe
Test Number: R70203

11AIRBFR0100EVOA

TRC Inc. Test Lab: CTF
Test Number: 070913

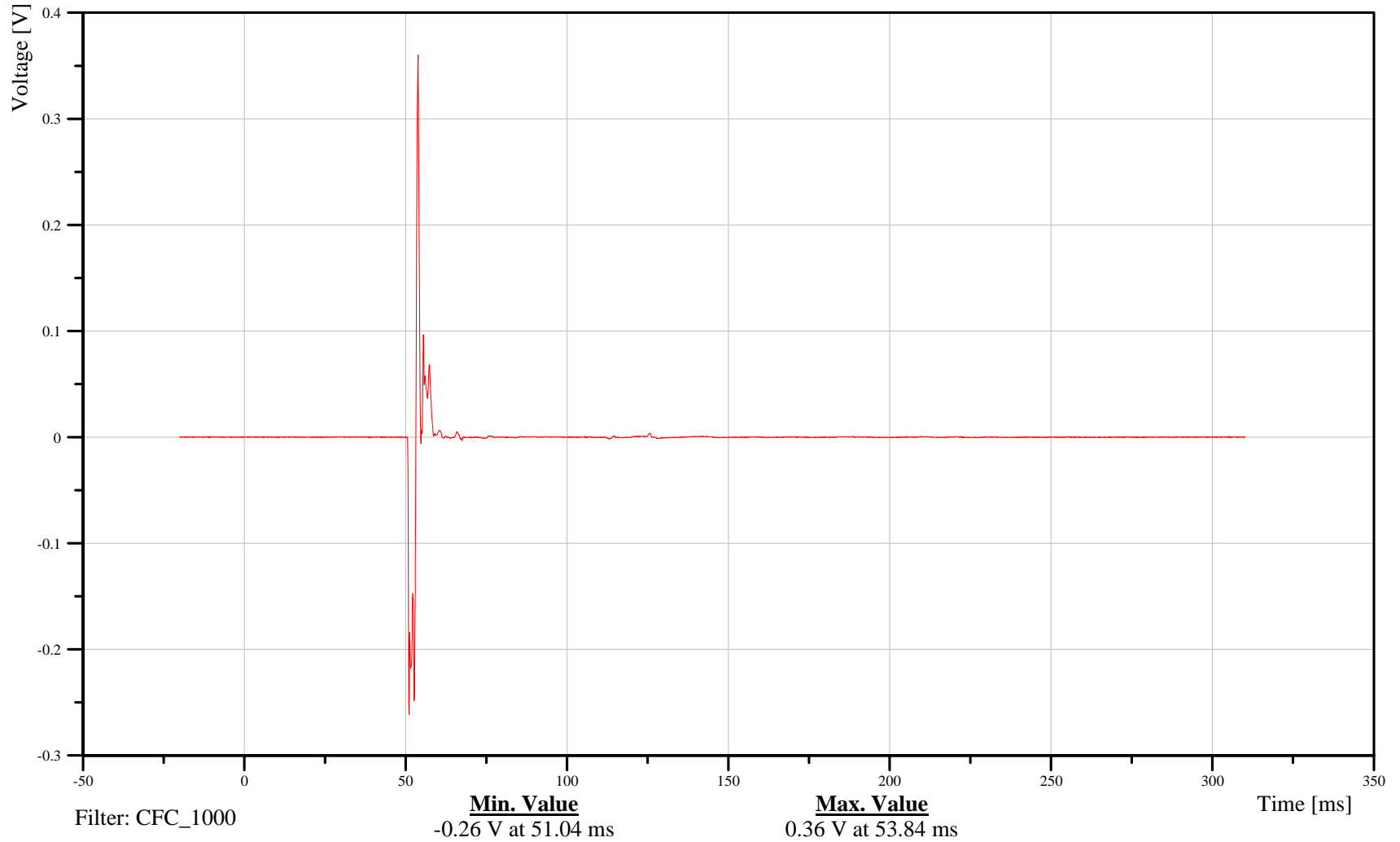

B-181

070913



2007 Ford F-250 into Left 40% Offset Deformable LCB at 56 kph

Date: 09/13/2007
Time: 15:46

Driver Front Airbag 2 Inductor

Customer: Volpe
Test Number: R70203

11AIRBFR0200EVOA

TRC Inc. Test Lab: CTF
Test Number: 070913

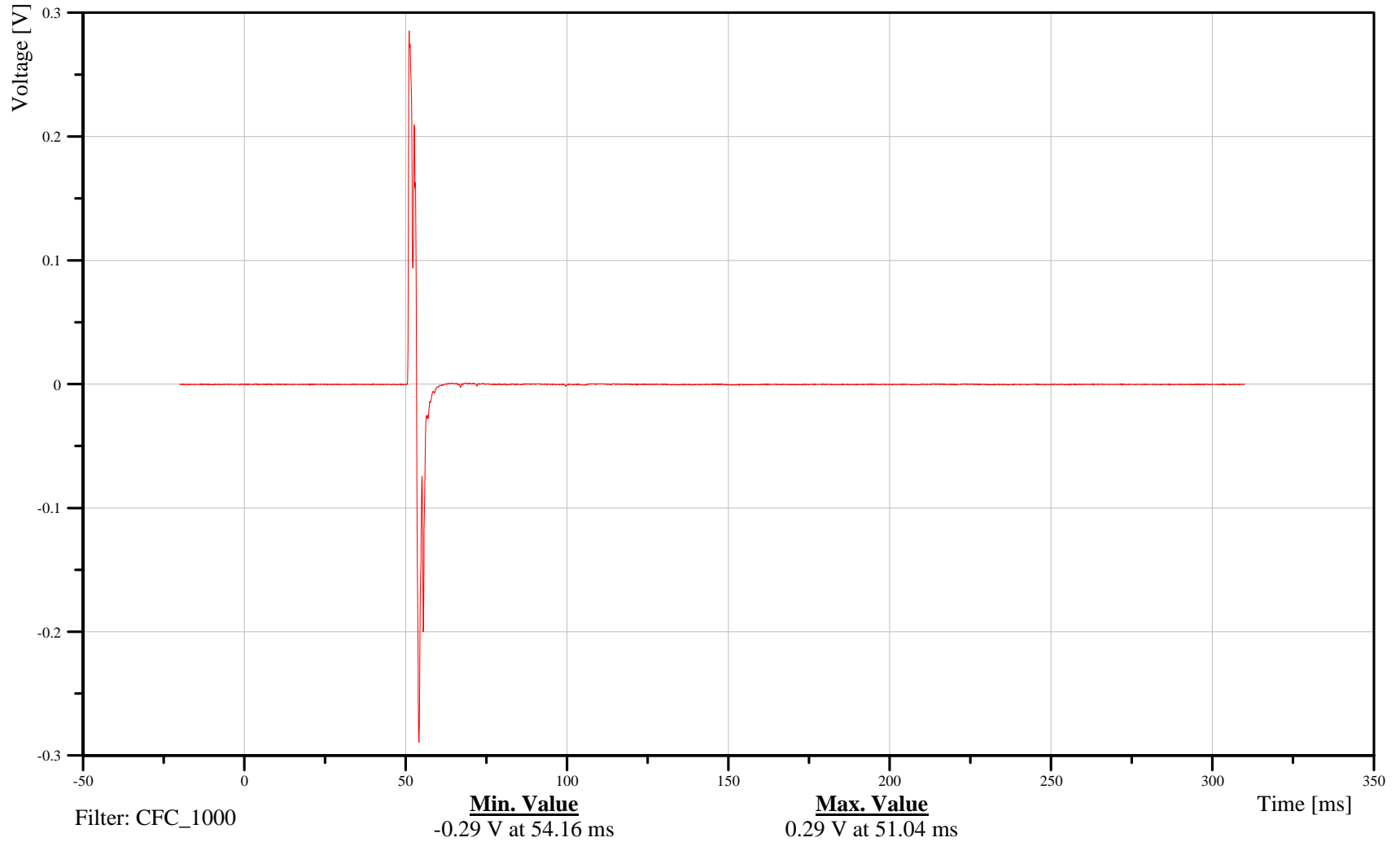

B-182

070913



2007 Ford F-250 into Left 40% Offset Deformable LCB at 56 kph

Date: 09/13/2007
Time: 15:46

Passenger Front Airbag 1 Inductor

Customer: Volpe
Test Number: R70203

13AIRBFR0100EVOA

TRC Inc. Test Lab: CTF
Test Number: 070913

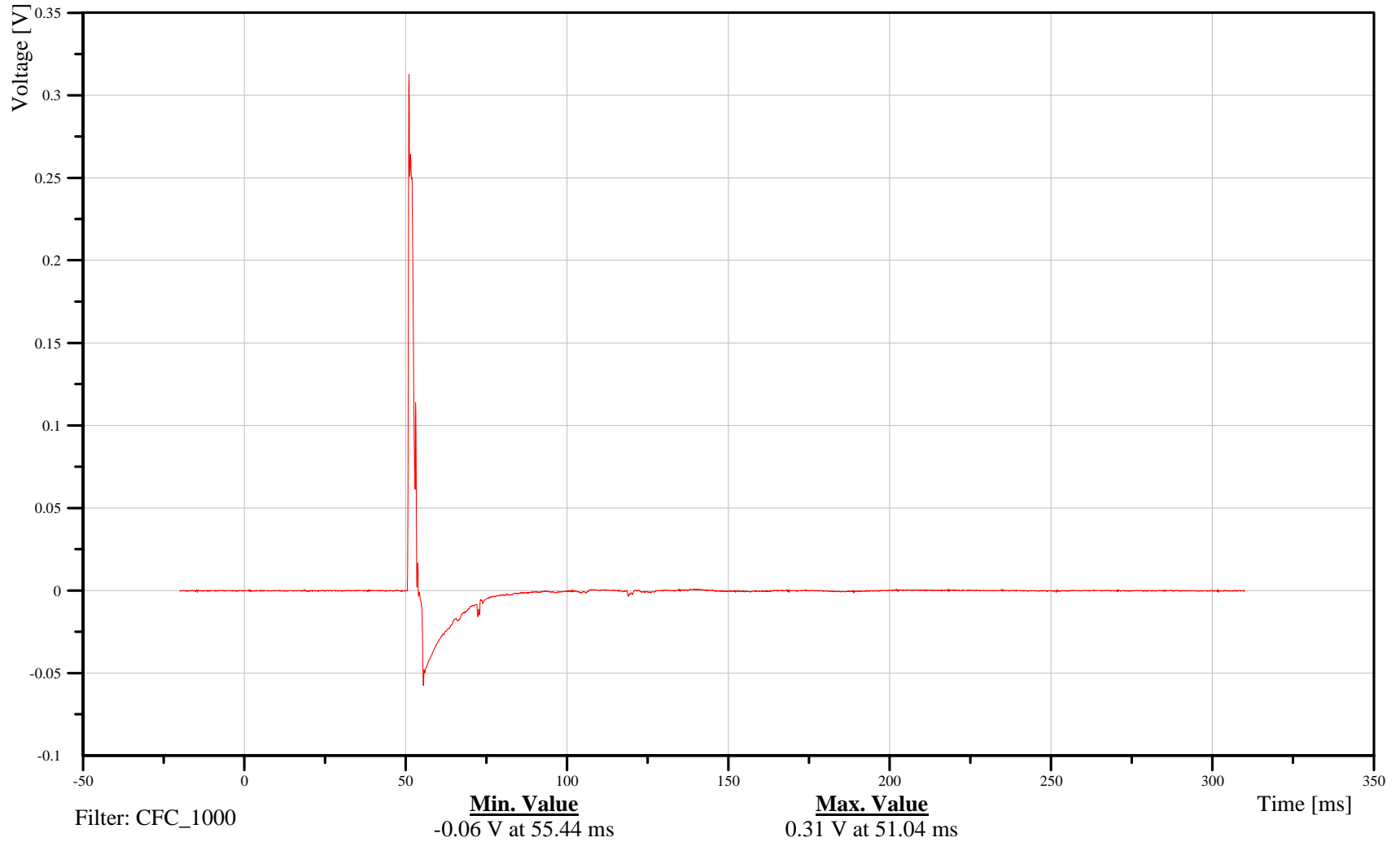

B-183

070913



2007 Ford F-250 into Left 40% Offset Deformable LCB at 56 kph

Date: 09/13/2007
Time: 15:46

Passenger Front Airbag 2 Inductor

Customer: Volpe
Test Number: R70203

13AIRBFR0200EVOA

TRC Inc. Test Lab: CTF
Test Number: 070913

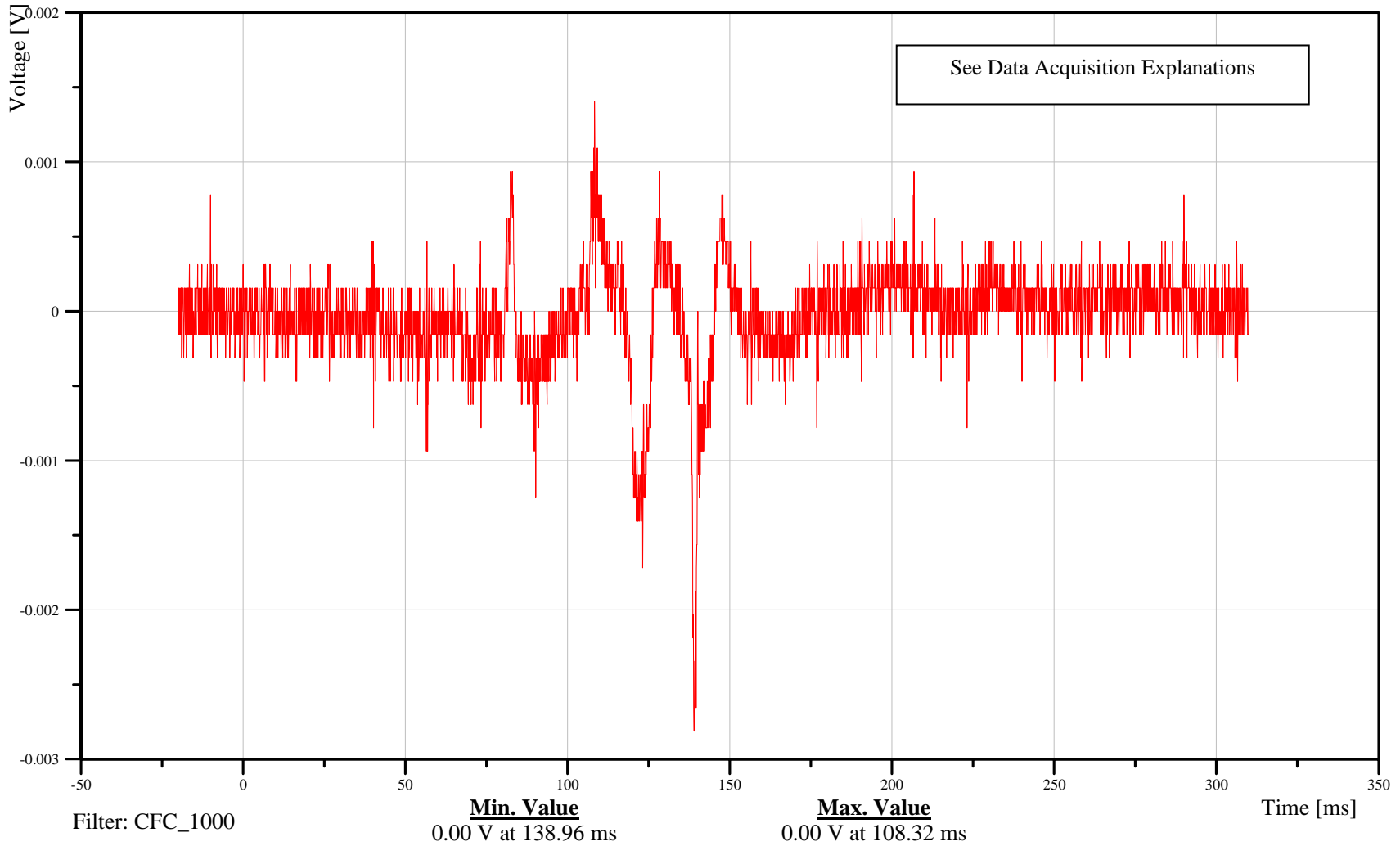

B-184

070913



2007 Ford F-250 into Left 40% Offset Deformable LCB at 56 kph

Date: 09/13/2007
Time: 15:46

Driver Right Foot Contact Switch

Customer: Volpe
Test Number: R70203

11CONT000001VO00

TRC Inc. Test Lab: CTF
Test Number: 070913

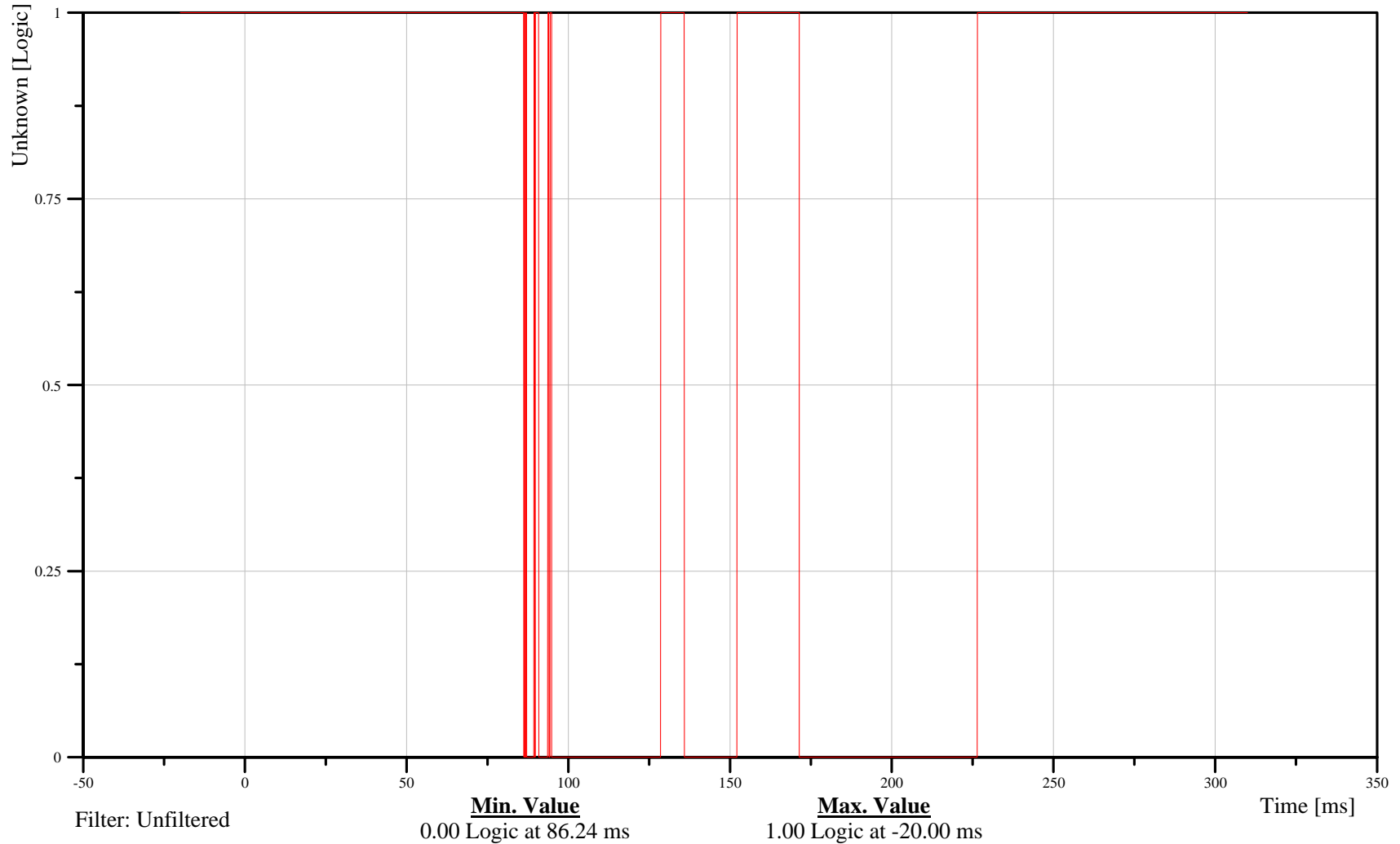

B-185

070913



2007 Ford F-250 into Left 40% Offset Deformable LCB at 56 kph

Date: 09/13/2007
Time: 15:46

Driver Left Foot Contact Switch

Customer: Volpe
Test Number: R70203

11CONT000002VO00

TRC Inc. Test Lab: CTF
Test Number: 070913

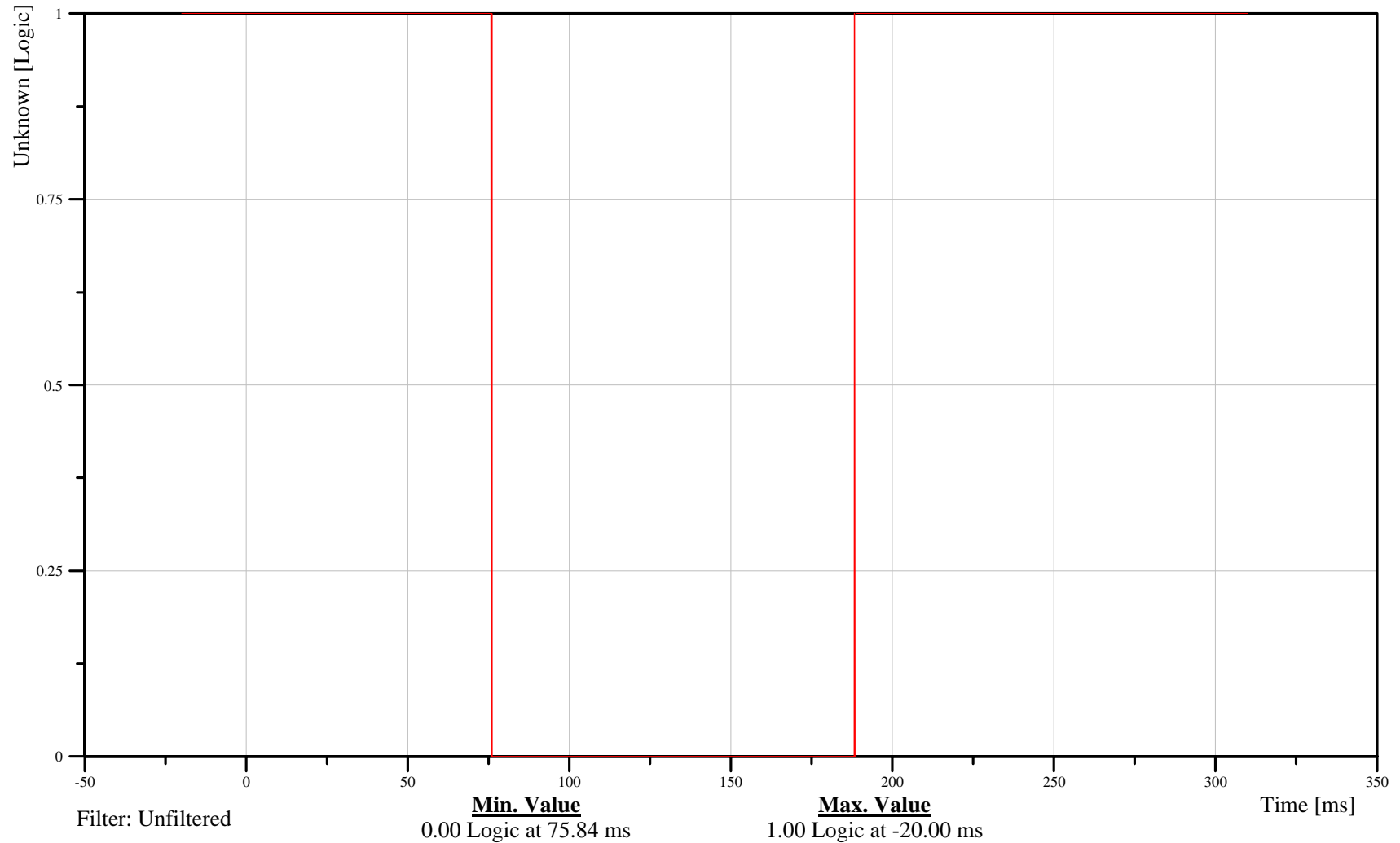

B-186

070913



2007 Ford F-250 into Left 40% Offset Deformable LCB at 56 kph

Date: 09/13/2007
Time: 15:46

Driver Left Knee Contact Switch

Customer: Volpe
Test Number: R70203

11CONT000003VO00

TRC Inc. Test Lab: CTF
Test Number: 070913

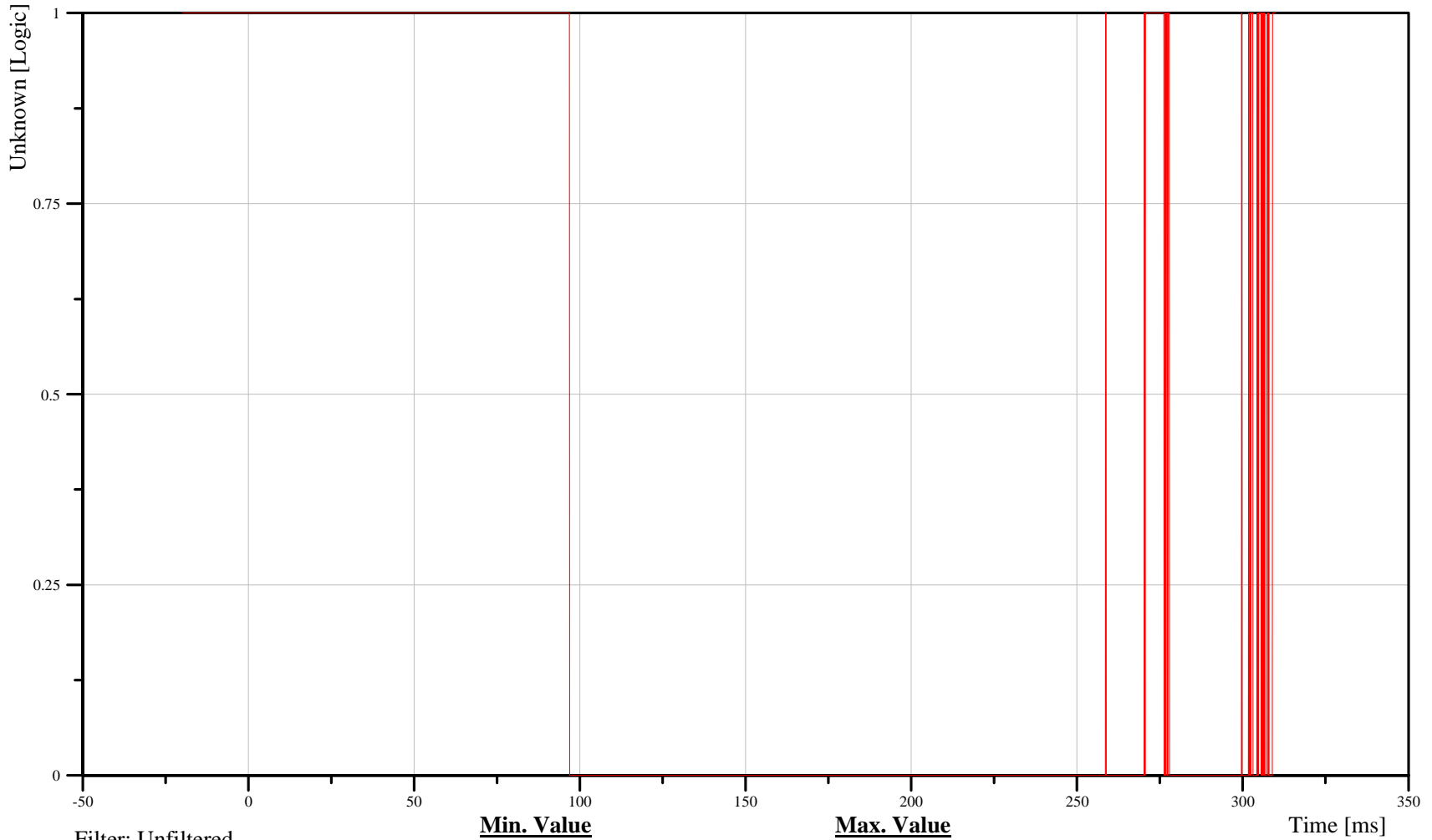

B-187

070913



2007 Ford F-250 into Left 40% Offset Deformable LCB at 56 kph

Date: 09/13/2007
Time: 15:46

Driver Right Knee Contact Switch

Customer: Volpe
Test Number: R70203

11CONT000004VO00

TRC Inc. Test Lab: CTF
Test Number: 070913

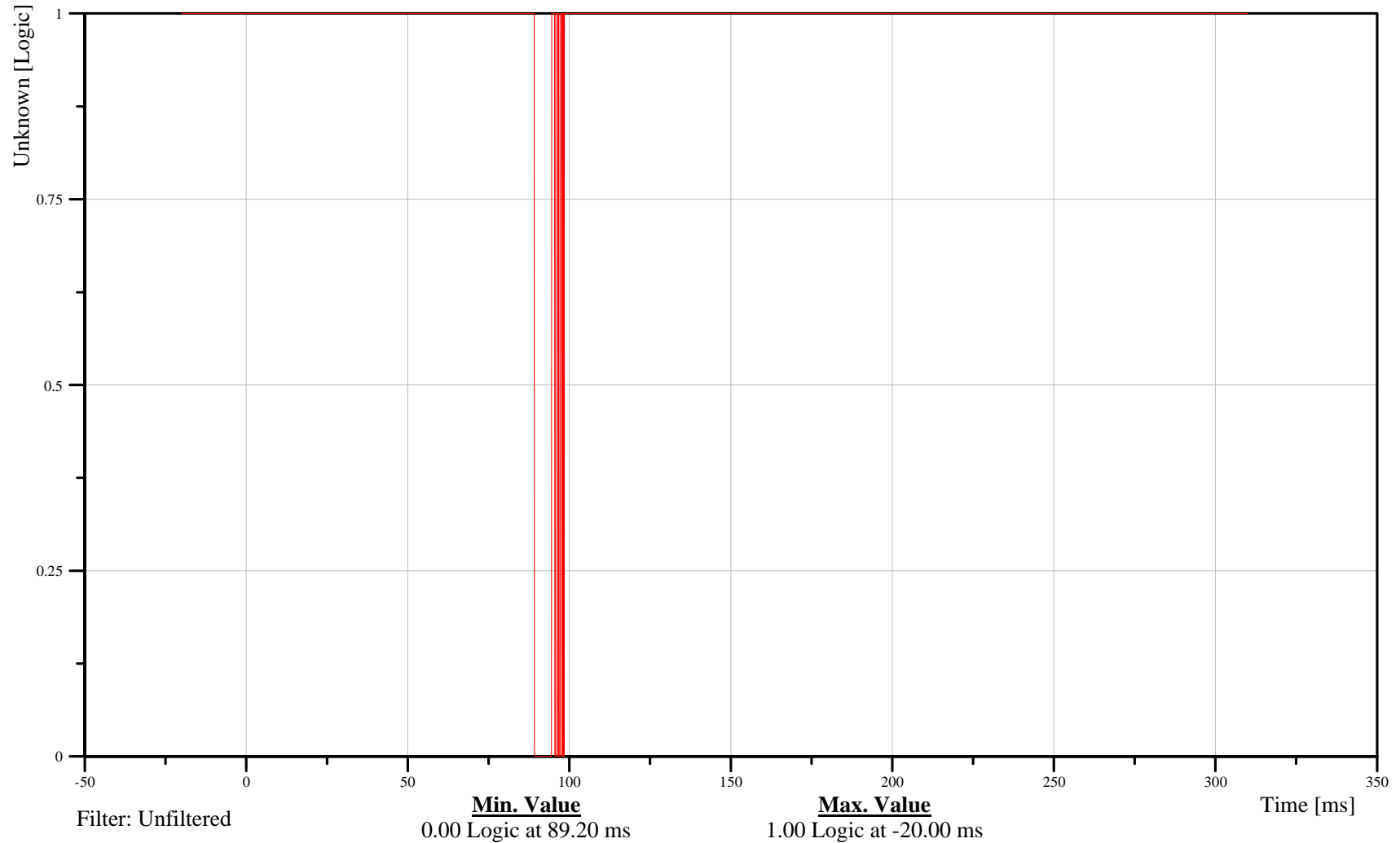

B-188

070913



2007 Ford F-250 into Left 40% Offset Deformable LCB at 56 kph

Date: 09/13/2007
Time: 15:46

Load Cell Row 1 Column 1

Customer: Volpe
Test Number: R70203

LOFBAR000001FOXD

TRC Inc. Test Lab: CTF
Test Number: 070913

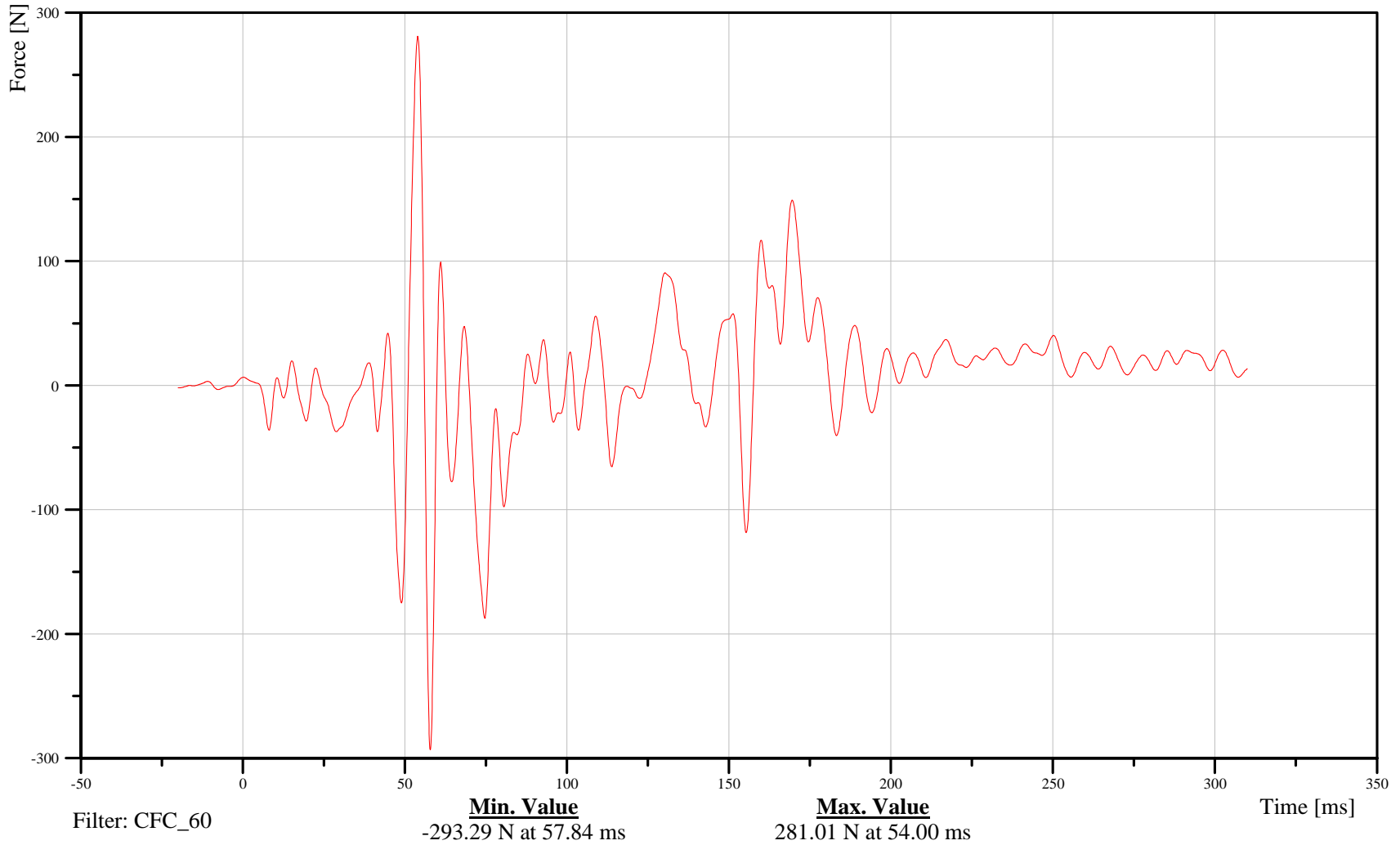

B-189

070913



2007 Ford F-250 into Left 40% Offset Deformable LCB at 56 kph

Date: 09/13/2007
Time: 15:46

Load Cell Row 2 Column 1

Customer: Volpe
Test Number: R70203

LOFBAR000002FOXD

TRC Inc. Test Lab: CTF
Test Number: 070913

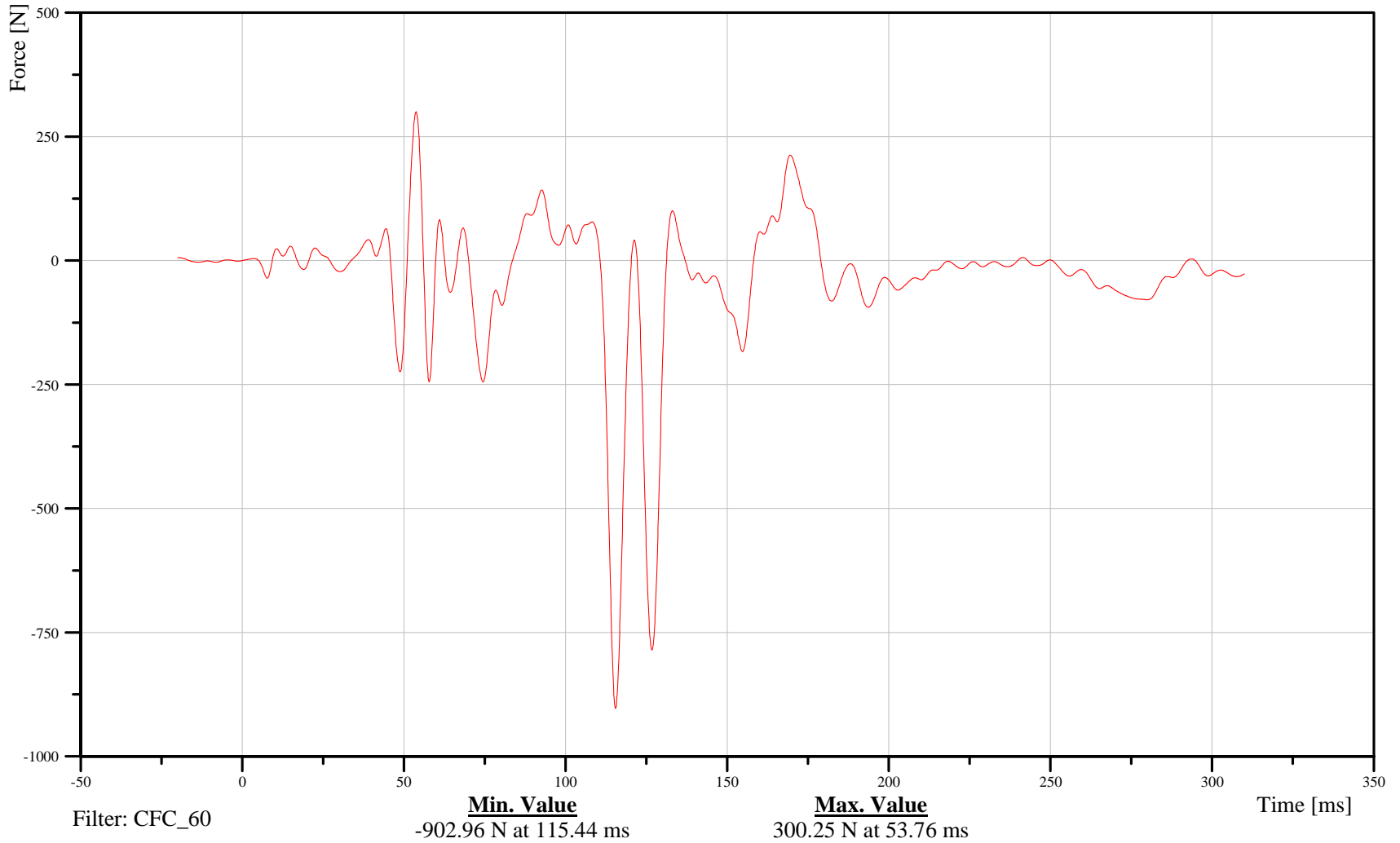

B-190

070913



2007 Ford F-250 into Left 40% Offset Deformable LCB at 56 kph

Date: 09/13/2007
Time: 15:46

Load Cell Row 3 Column 1

Customer: Volpe
Test Number: R70203

LOFBAR000003FOXD

TRC Inc. Test Lab: CTF
Test Number: 070913

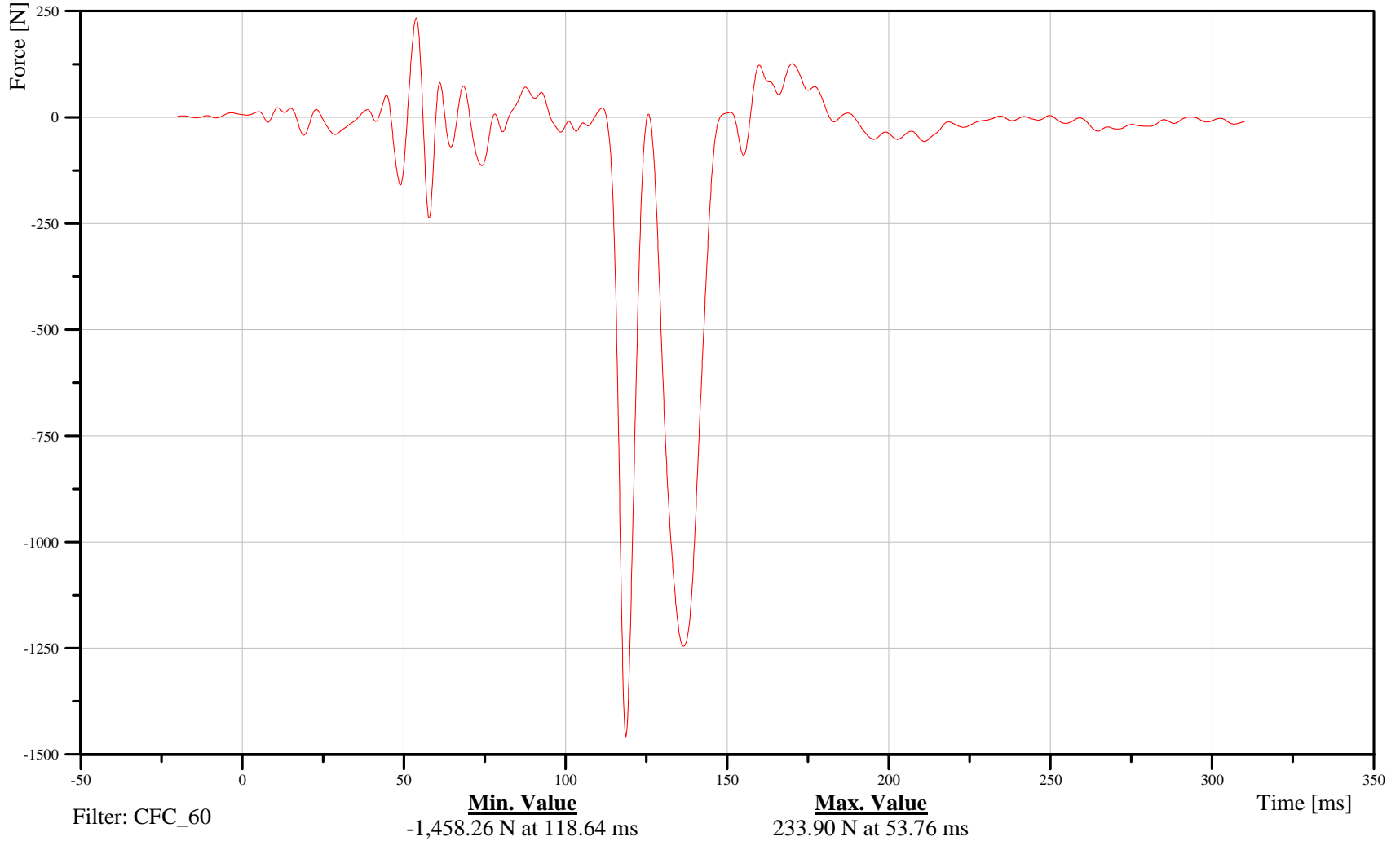

B-191

070913



2007 Ford F-250 into Left 40% Offset Deformable LCB at 56 kph

Date: 09/13/2007
Time: 15:46

Load Cell Row 4 Column 1

Customer: Volpe
Test Number: R70203

LOFBAR000004FOXD

TRC Inc. Test Lab: CTF
Test Number: 070913

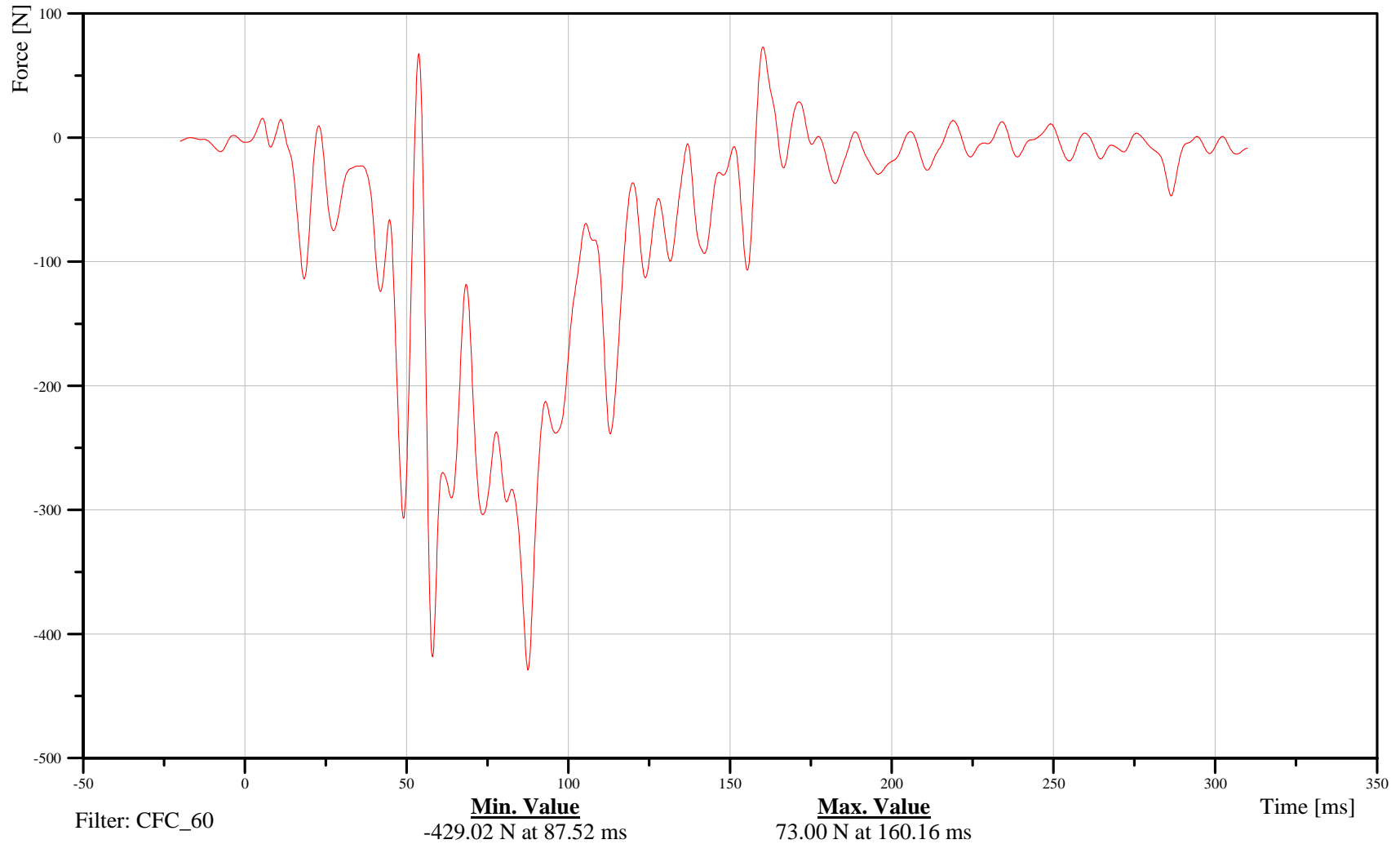

B-192

070913



2007 Ford F-250 into Left 40% Offset Deformable LCB at 56 kph

Date: 09/13/2007
Time: 15:46

Load Cell Row 5 Column 1

Customer: Volpe
Test Number: R70203

LOFBAR000005FOXD

TRC Inc. Test Lab: CTF
Test Number: 070913

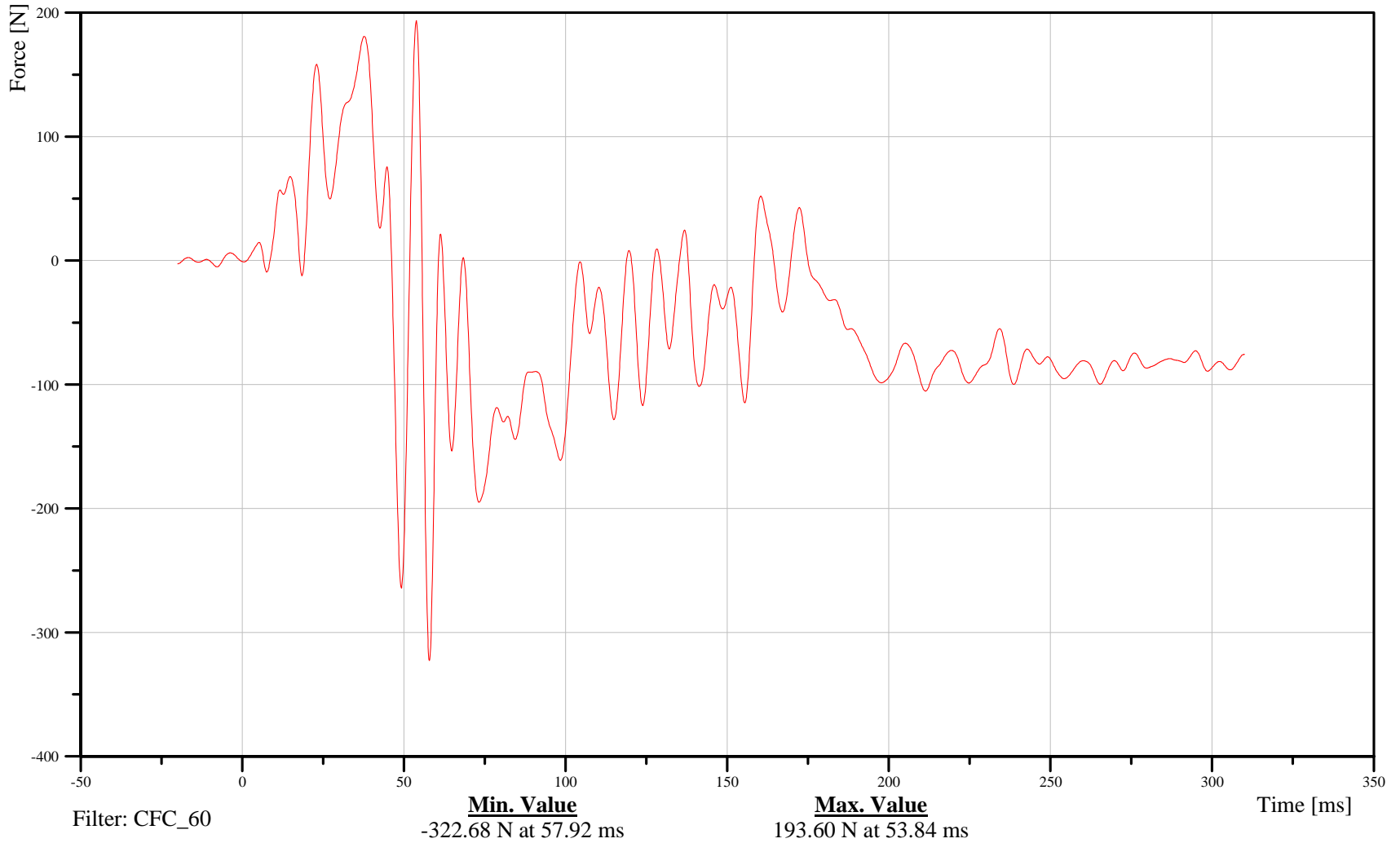

B-193

070913



2007 Ford F-250 into Left 40% Offset Deformable LCB at 56 kph

Date: 09/13/2007
Time: 15:46

Load Cell Row 6 Column 1

Customer: Volpe
Test Number: R70203

LOFBAR000006FOXD

TRC Inc. Test Lab: CTF
Test Number: 070913

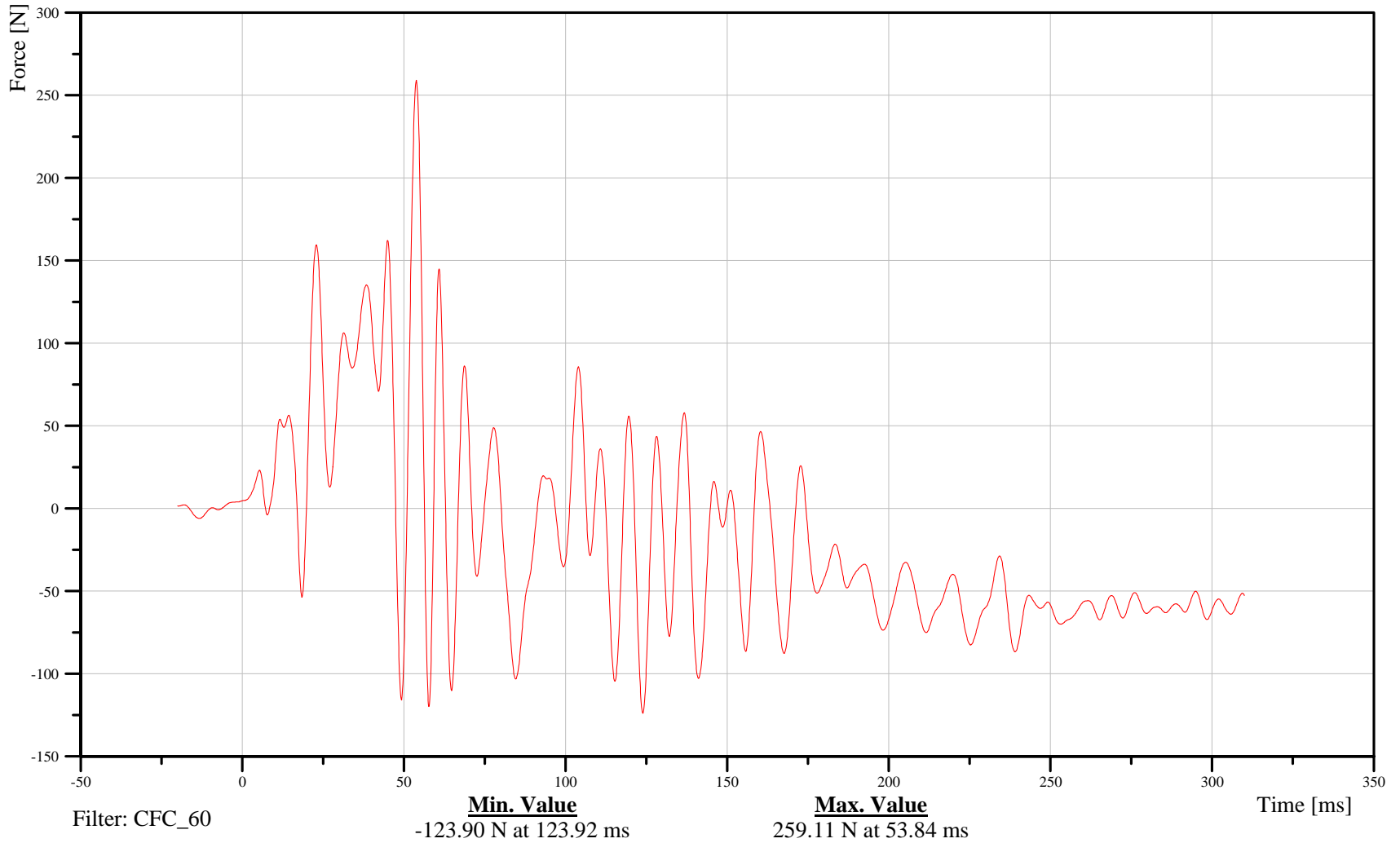

B-194

070913



2007 Ford F-250 into Left 40% Offset Deformable LCB at 56 kph

Date: 09/13/2007
Time: 15:46

Load Cell Row 7 Column 1

Customer: Volpe
Test Number: R70203

LOFBAR000007FOXD

TRC Inc. Test Lab: CTF
Test Number: 070913

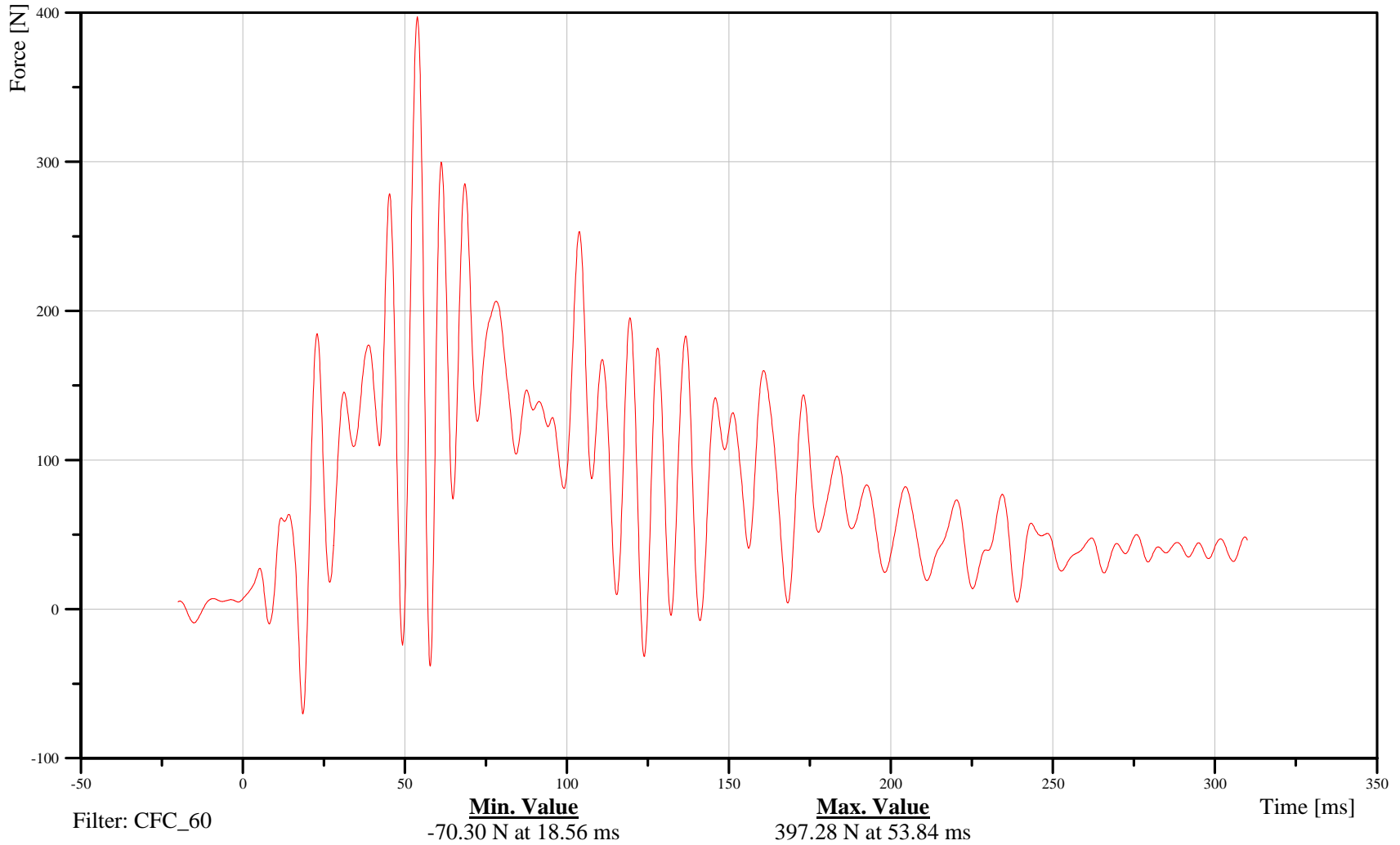

B-195

070913



2007 Ford F-250 into Left 40% Offset Deformable LCB at 56 kph

Date: 09/13/2007
Time: 15:46

Load Cell Row 8 Column 1

Customer: Volpe
Test Number: R70203

LOFBAR000008FOXD

TRC Inc. Test Lab: CTF
Test Number: 070913

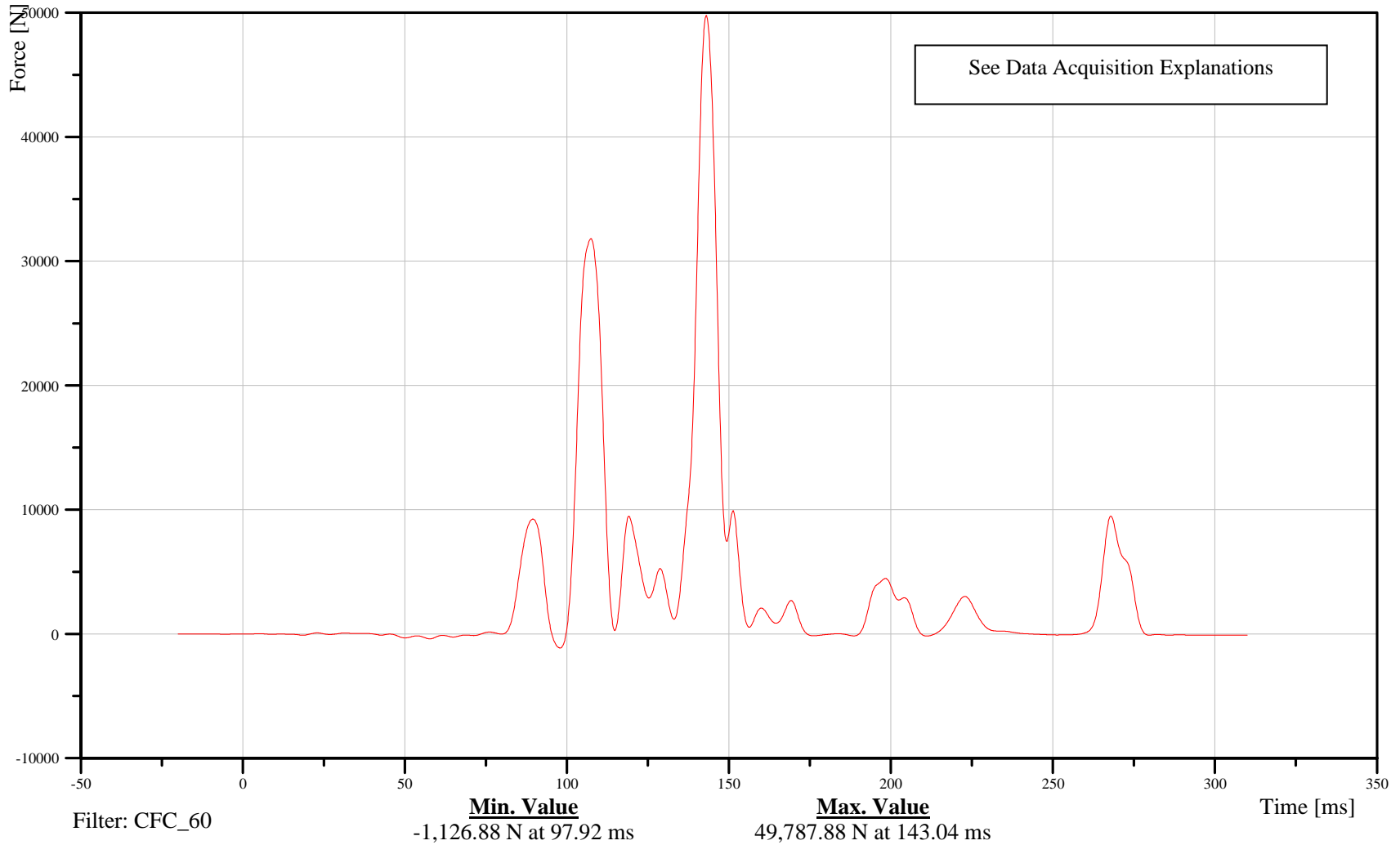

B-196

070913



2007 Ford F-250 into Left 40% Offset Deformable LCB at 56 kph

Date: 09/13/2007
Time: 15:46

Load Cell Row 9 Column 1

Customer: Volpe
Test Number: R70203

LOFBAR000009FOXD

TRC Inc. Test Lab: CTF
Test Number: 070913

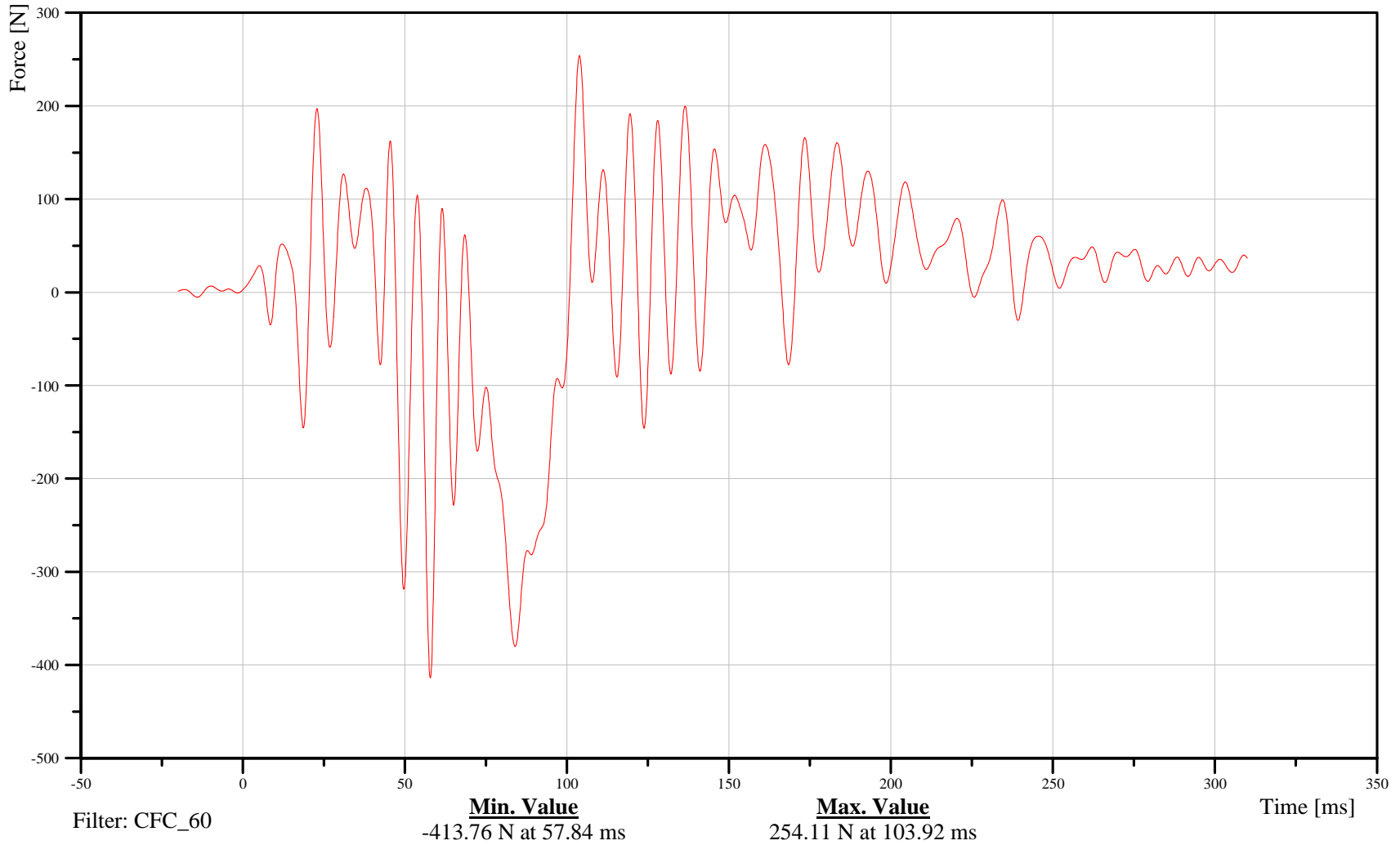

B-197

070913



2007 Ford F-250 into Left 40% Offset Deformable LCB at 56 kph

Date: 09/13/2007
Time: 15:46

Load Cell Row 10 Column 1

Customer: Volpe
Test Number: R70203

LOFBAR000010FOXD

TRC Inc. Test Lab: CTF
Test Number: 070913

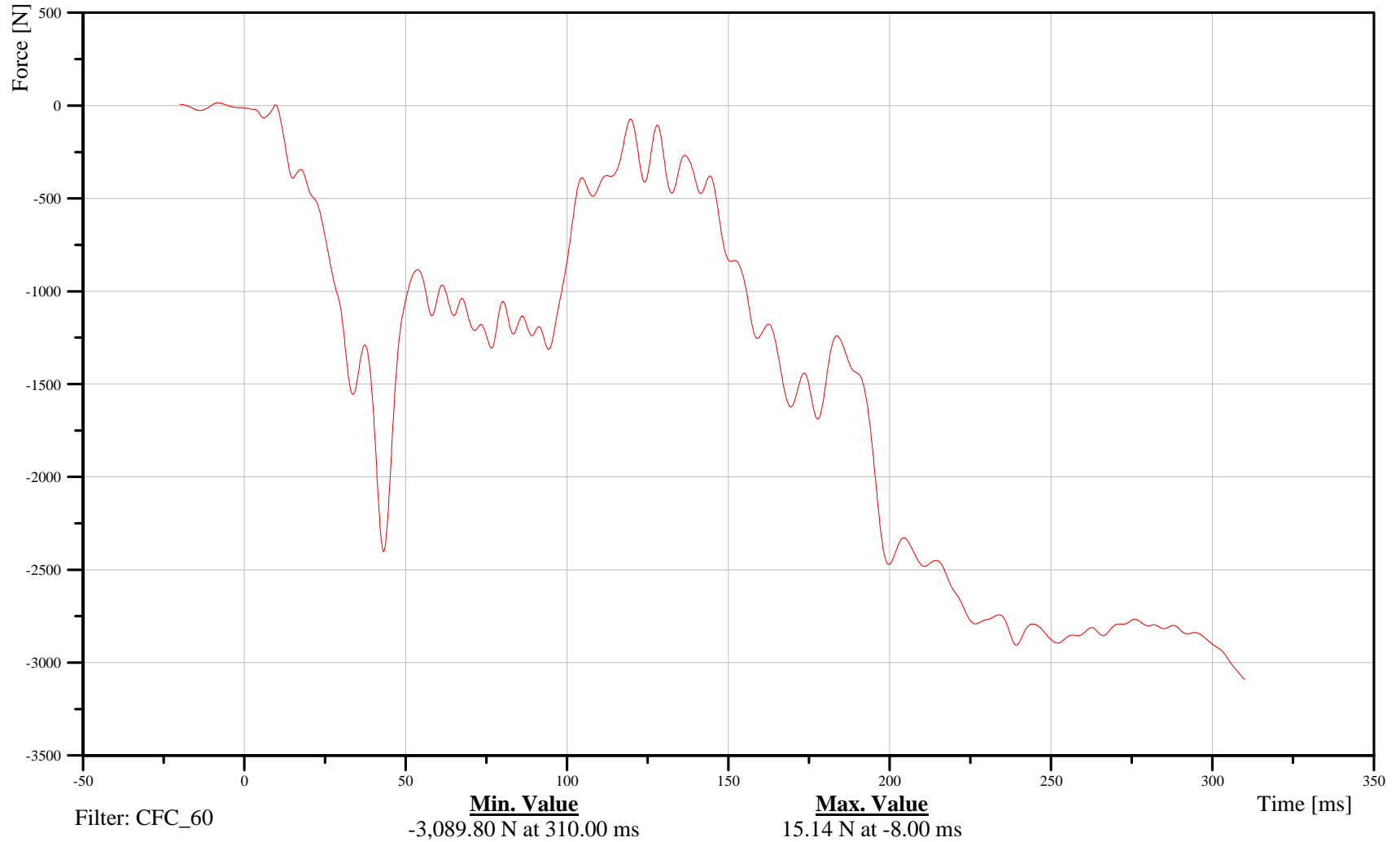

B-198

070913



2007 Ford F-250 into Left 40% Offset Deformable LCB at 56 kph

Date: 09/13/2007
Time: 15:46

Load Cell Row 1 Column 2

Customer: Volpe
Test Number: R70203

LOFBAR000011FOXD

TRC Inc. Test Lab: CTF
Test Number: 070913

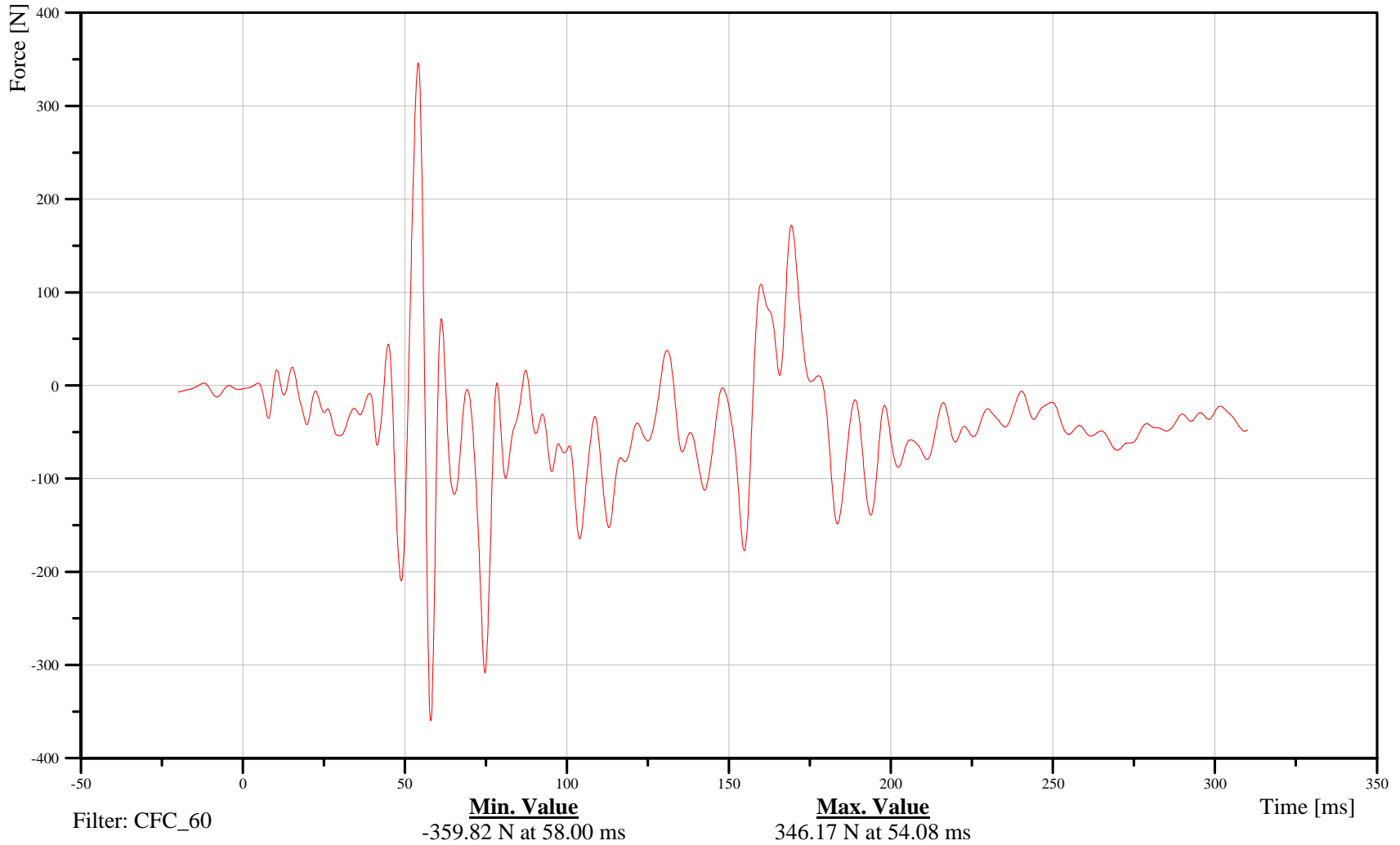

B-199

070913



2007 Ford F-250 into Left 40% Offset Deformable LCB at 56 kph

Date: 09/13/2007
Time: 15:46

Load Cell Row 2 Column 2

Customer: Volpe
Test Number: R70203

LOFBAR000012FOXD

TRC Inc. Test Lab: CTF
Test Number: 070913

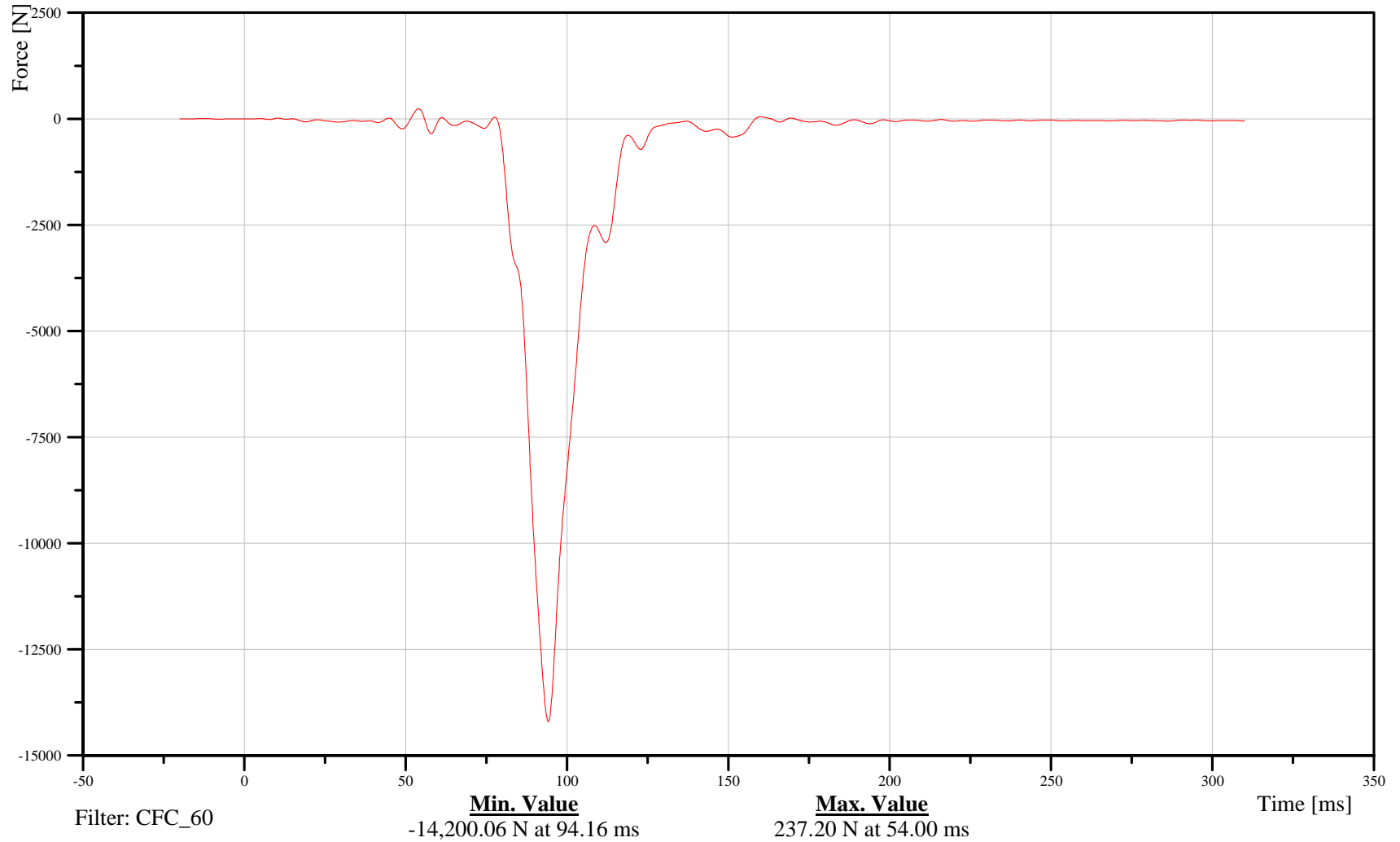

B-200

070913



2007 Ford F-250 into Left 40% Offset Deformable LCB at 56 kph

Date: 09/13/2007
Time: 15:46

Load Cell Row 3 Column 2

Customer: Volpe
Test Number: R70203

LOFBAR000013FOXD

TRC Inc. Test Lab: CTF
Test Number: 070913

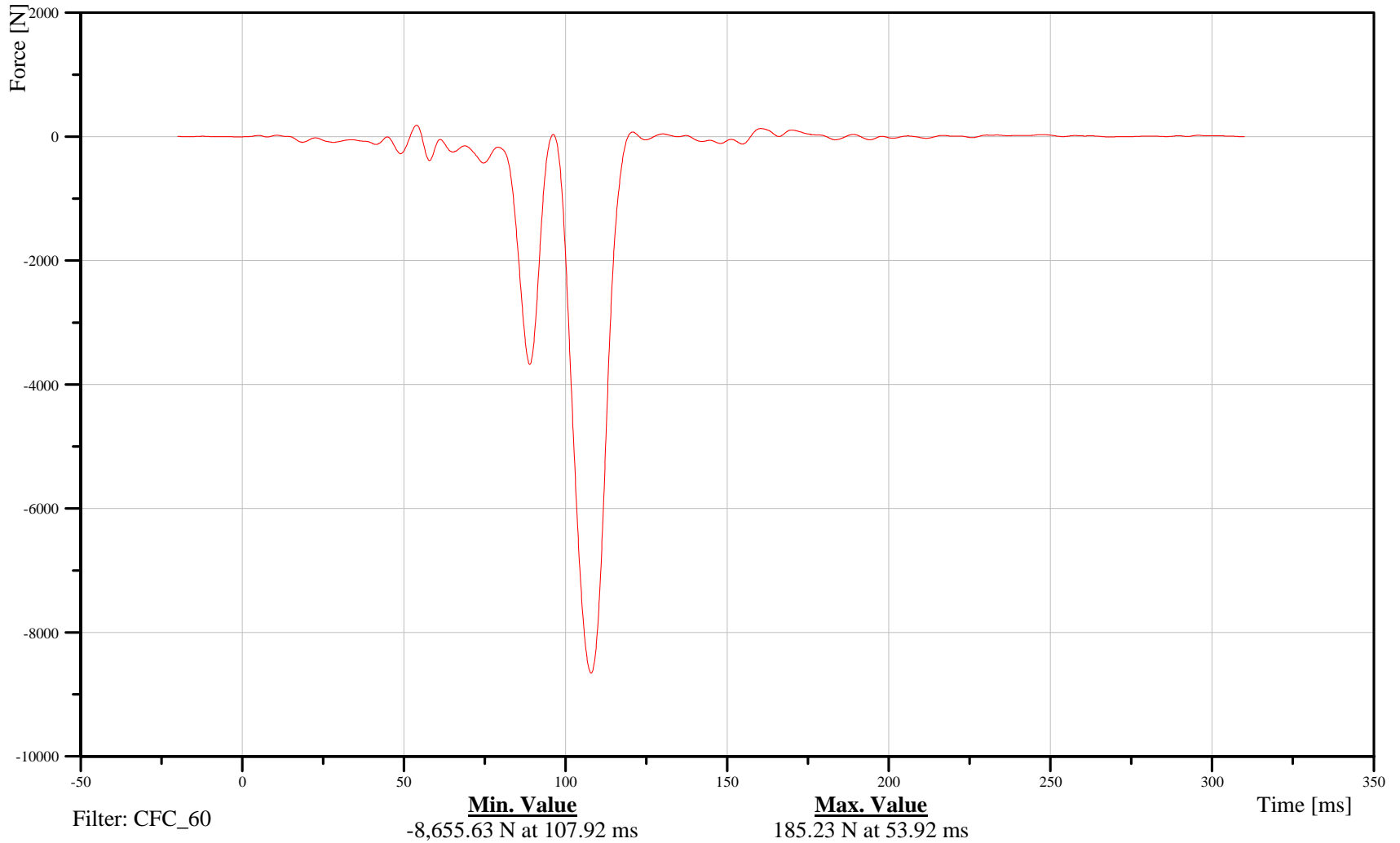

B-201

070913



2007 Ford F-250 into Left 40% Offset Deformable LCB at 56 kph

Date: 09/13/2007
Time: 15:46

Load Cell Row 4 Column 2

Customer: Volpe
Test Number: R70203

LOFBAR000014FOXD

TRC Inc. Test Lab: CTF
Test Number: 070913

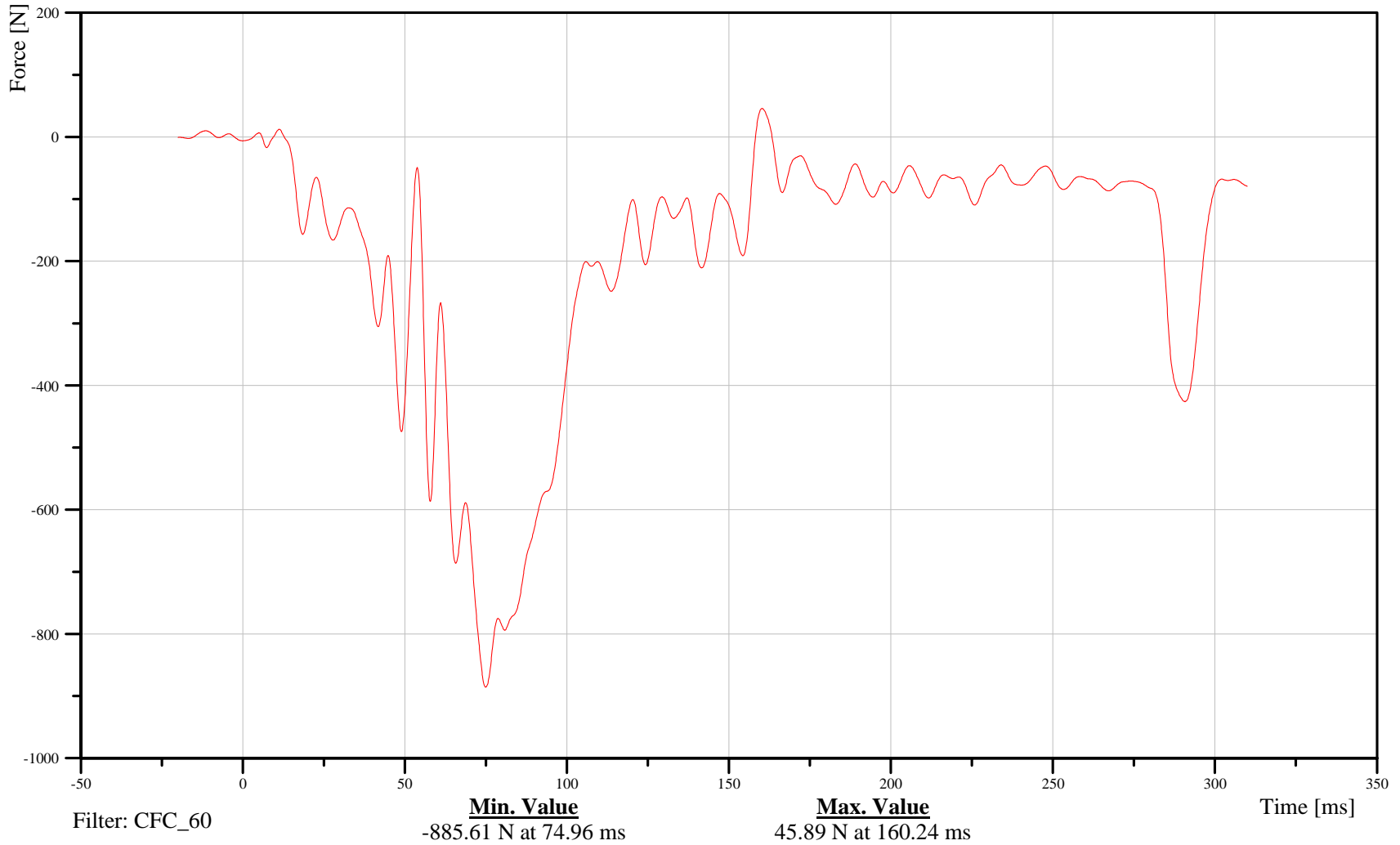

B-202

070913



2007 Ford F-250 into Left 40% Offset Deformable LCB at 56 kph

Date: 09/13/2007
Time: 15:46

Load Cell Row 5 Column 2

Customer: Volpe
Test Number: R70203

LOFBAR000015FOXD

TRC Inc. Test Lab: CTF
Test Number: 070913

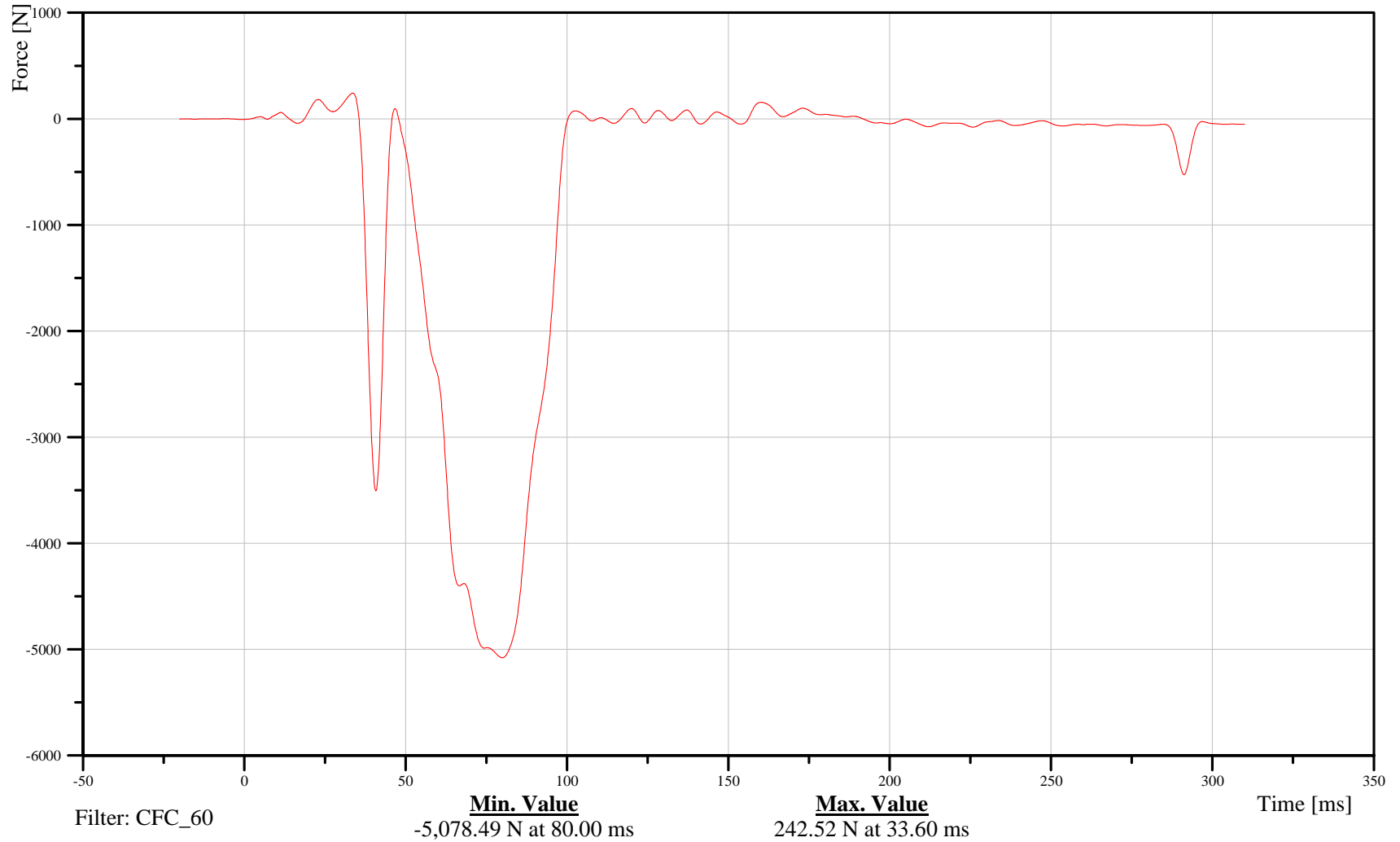

B-203

070913



2007 Ford F-250 into Left 40% Offset Deformable LCB at 56 kph

Date: 09/13/2007
Time: 15:46

Load Cell Row 6 Column 2

Customer: Volpe
Test Number: R70203

LOFBAR000016FOXD

TRC Inc. Test Lab: CTF
Test Number: 070913

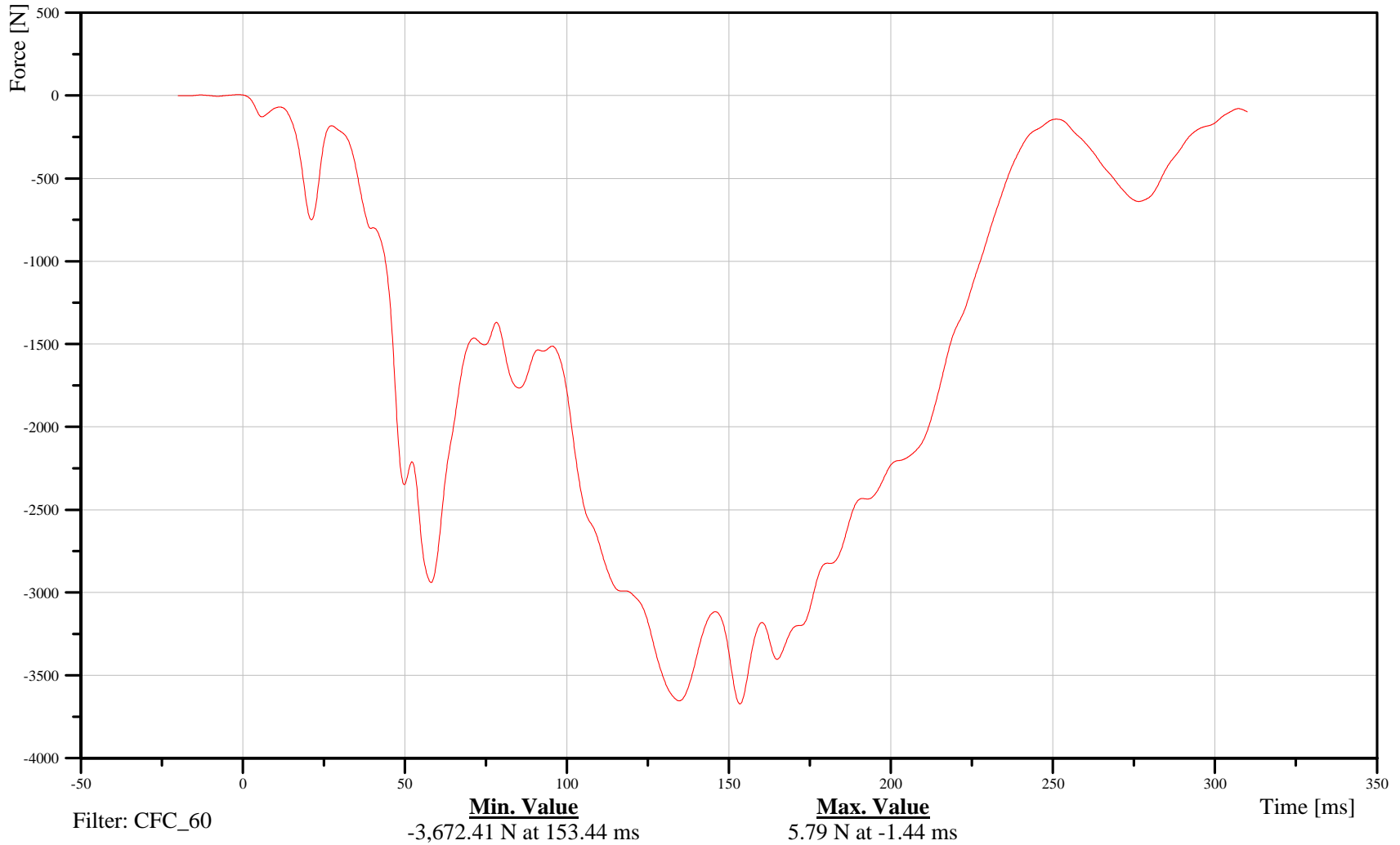

B-204

070913



2007 Ford F-250 into Left 40% Offset Deformable LCB at 56 kph

Date: 09/13/2007
Time: 15:46

Load Cell Row 7 Column 2

Customer: Volpe
Test Number: R70203

LOFBAR000017FOXD

TRC Inc. Test Lab: CTF
Test Number: 070913

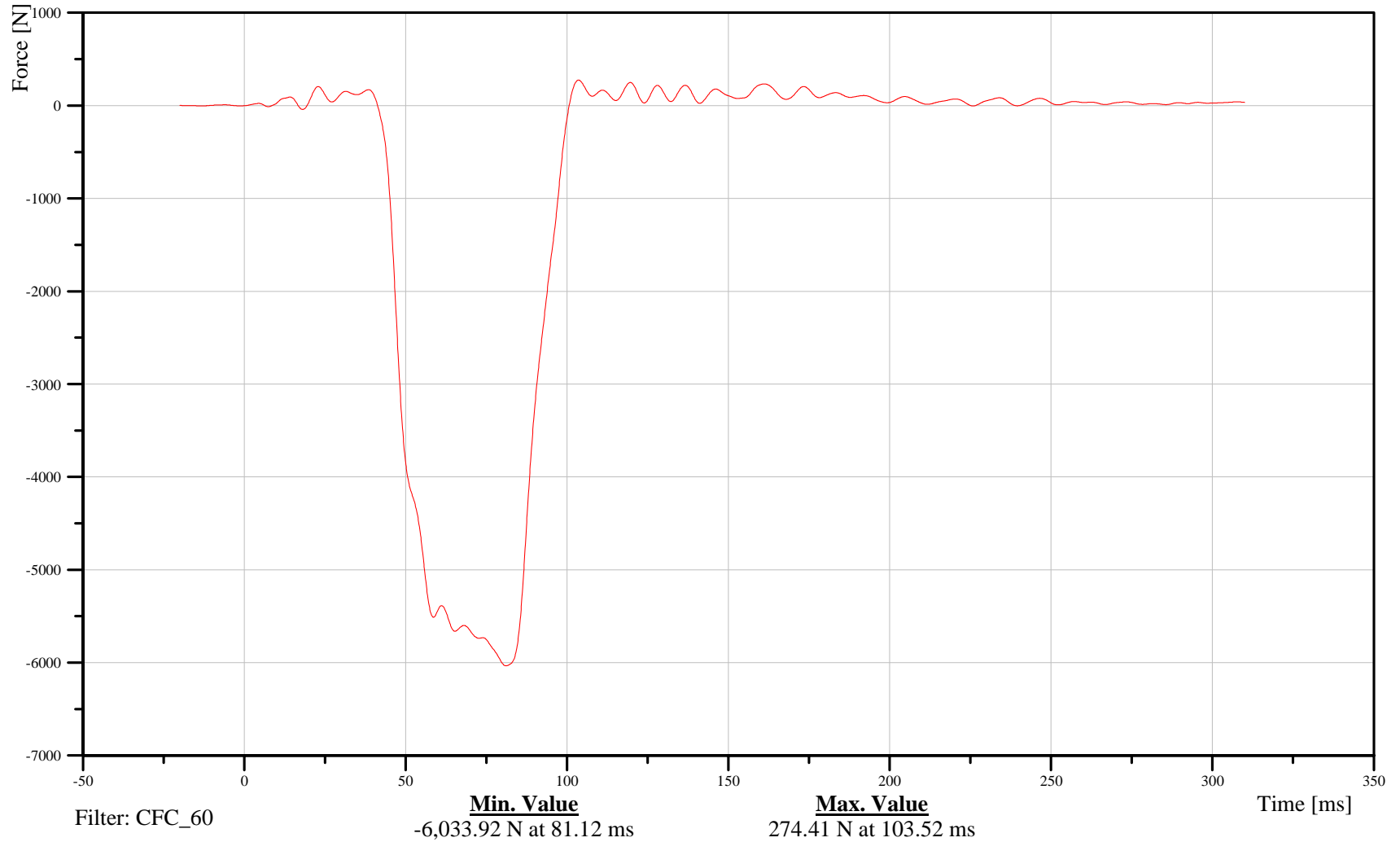

B-205

070913



2007 Ford F-250 into Left 40% Offset Deformable LCB at 56 kph

Date: 09/13/2007
Time: 15:46

Load Cell Row 8 Column 2

Customer: Volpe
Test Number: R70203

LOFBAR000018FOXD

TRC Inc. Test Lab: CTF
Test Number: 070913

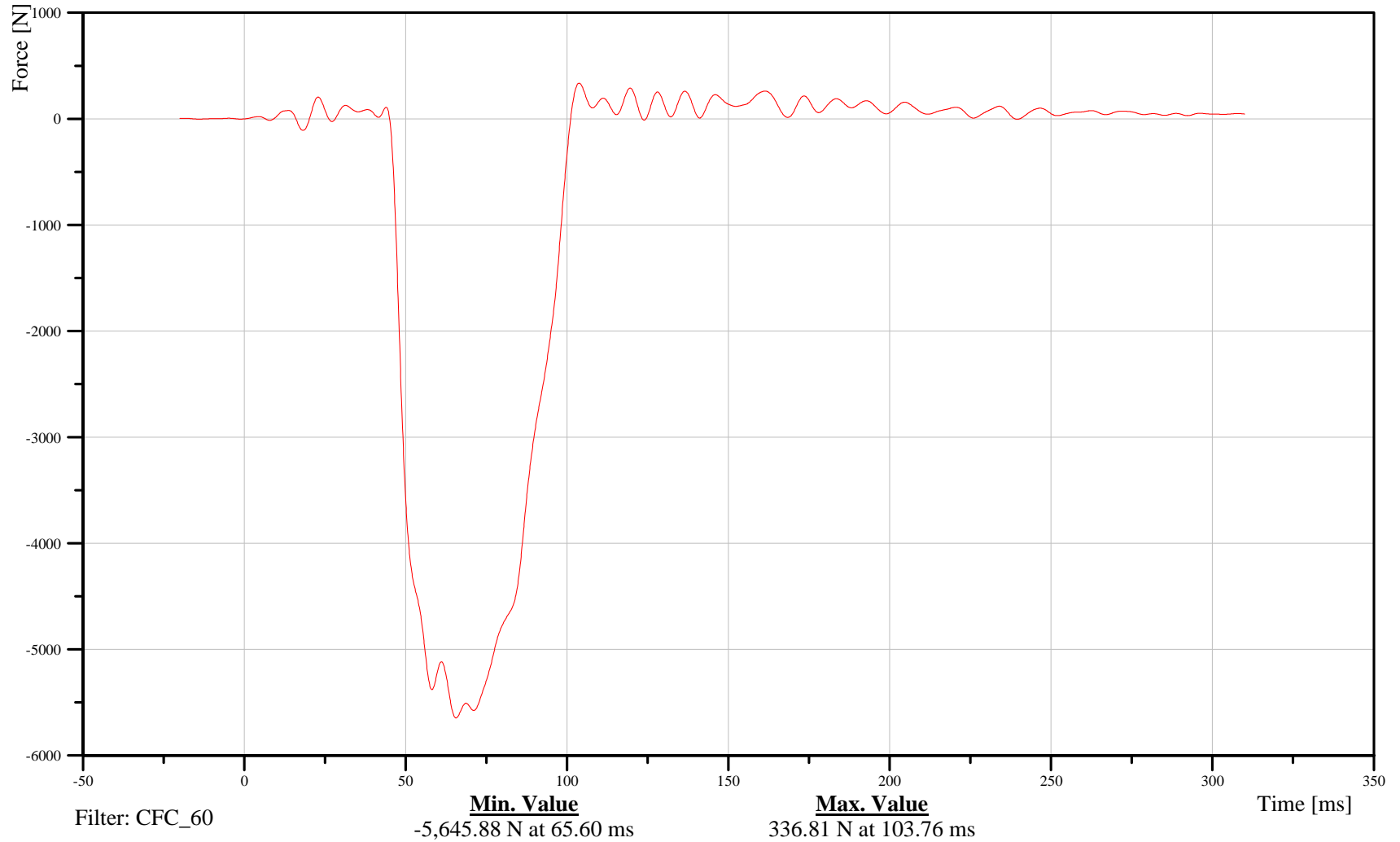

B-206

070913



2007 Ford F-250 into Left 40% Offset Deformable LCB at 56 kph

Date: 09/13/2007
Time: 15:46

Load Cell Row 9 Column 2

Customer: Volpe
Test Number: R70203

LOFBAR000019FOXD

TRC Inc. Test Lab: CTF
Test Number: 070913

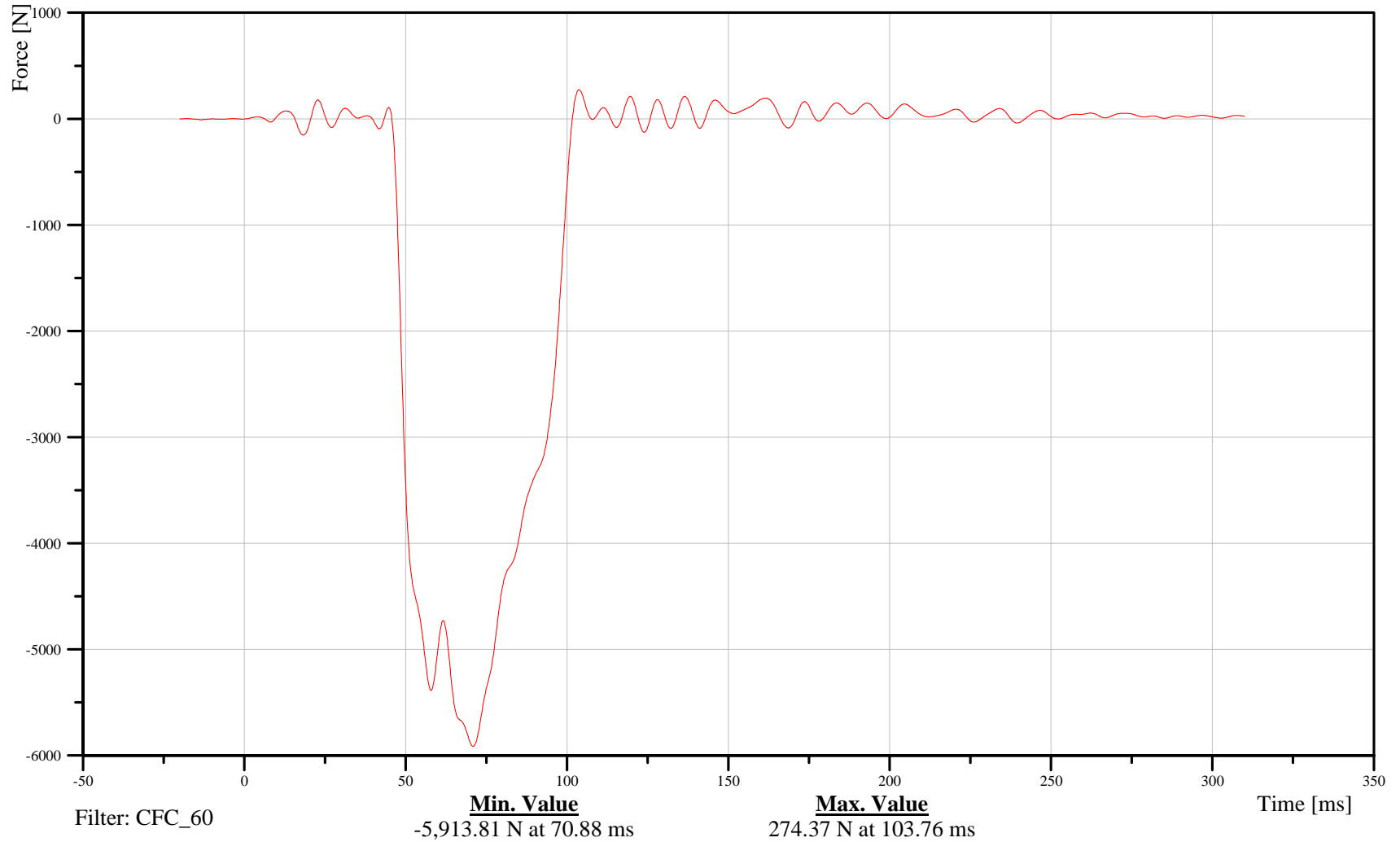

B-207

070913



2007 Ford F-250 into Left 40% Offset Deformable LCB at 56 kph

Date: 09/13/2007
Time: 15:46

Load Cell Row 10 Column 2

Customer: Volpe
Test Number: R70203

LOFBAR000020FOXD

TRC Inc. Test Lab: CTF
Test Number: 070913

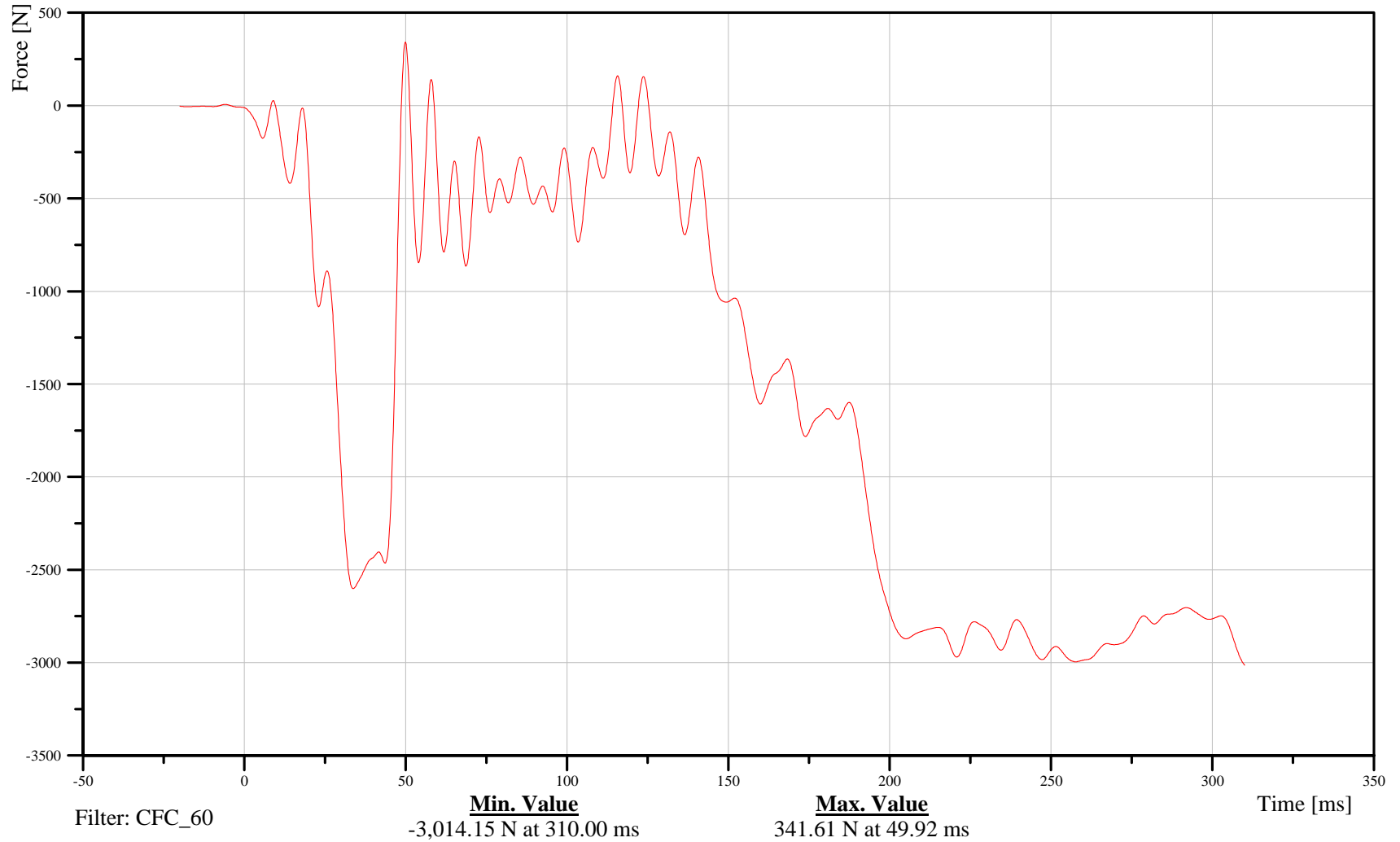

B-208

070913



2007 Ford F-250 into Left 40% Offset Deformable LCB at 56 kph

Date: 09/13/2007
Time: 15:46

Load Cell Row 1 Column 3

Customer: Volpe
Test Number: R70203

LOFBAR000021FOXD

TRC Inc. Test Lab: CTF
Test Number: 070913

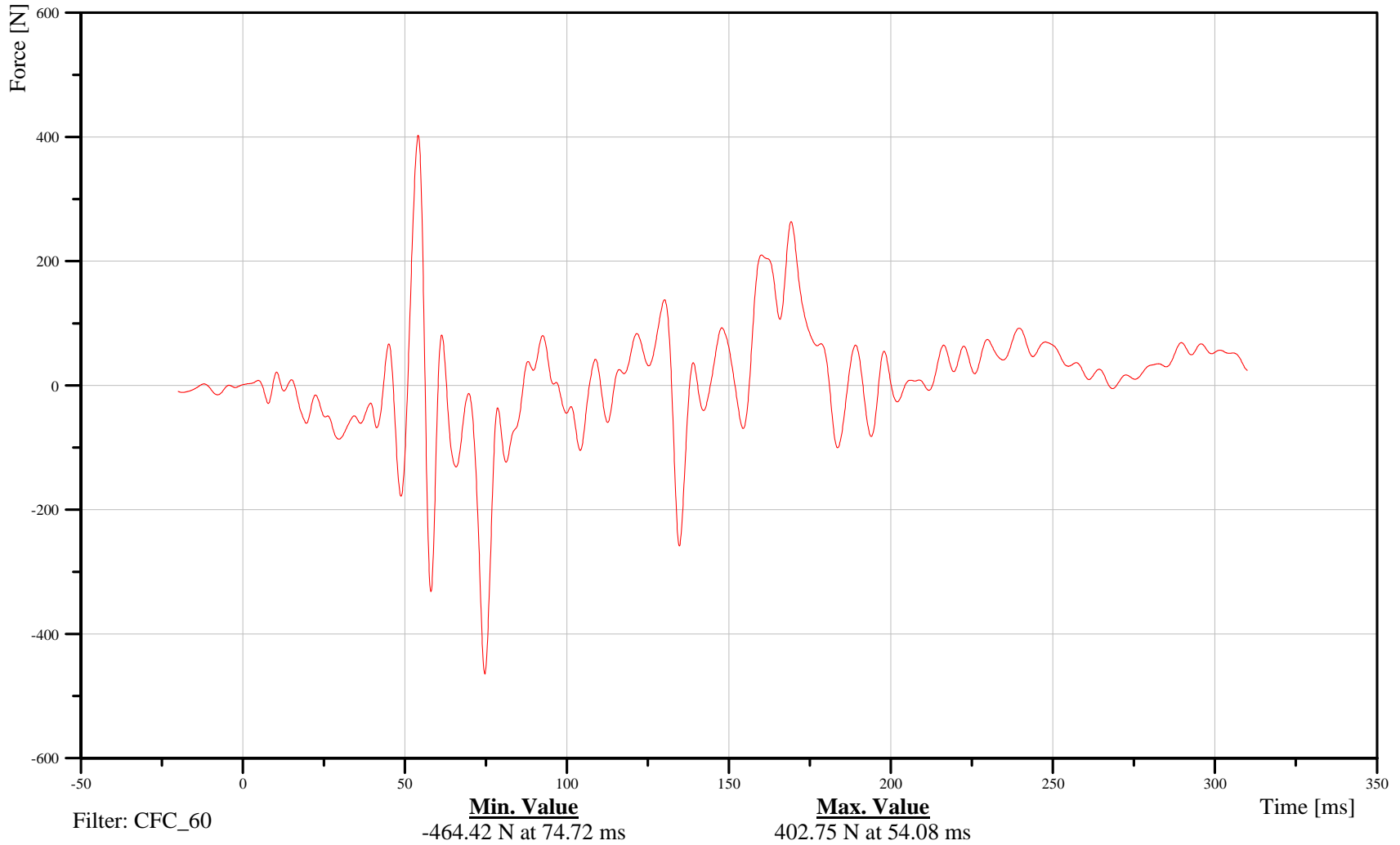

B-209

070913



2007 Ford F-250 into Left 40% Offset Deformable LCB at 56 kph

Date: 09/13/2007
Time: 15:46

Load Cell Row 2 Column 3

Customer: Volpe
Test Number: R70203

LOFBAR000022FOXD

TRC Inc. Test Lab: CTF
Test Number: 070913

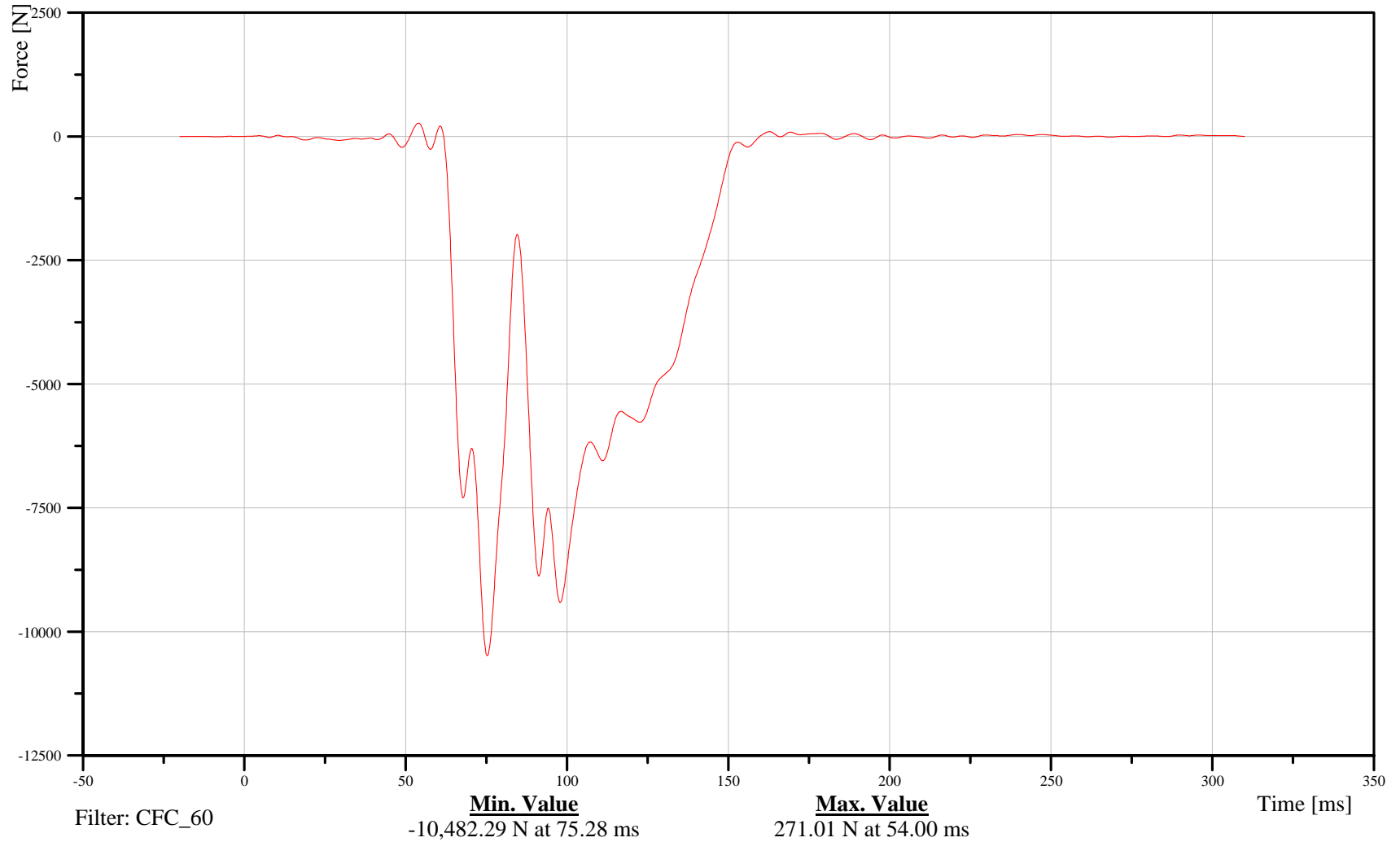

B-210

070913



2007 Ford F-250 into Left 40% Offset Deformable LCB at 56 kph

Date: 09/13/2007
Time: 15:46

Load Cell Row 3 Column 3

Customer: Volpe
Test Number: R70203

LOFBAR000023FOXD

TRC Inc. Test Lab: CTF
Test Number: 070913

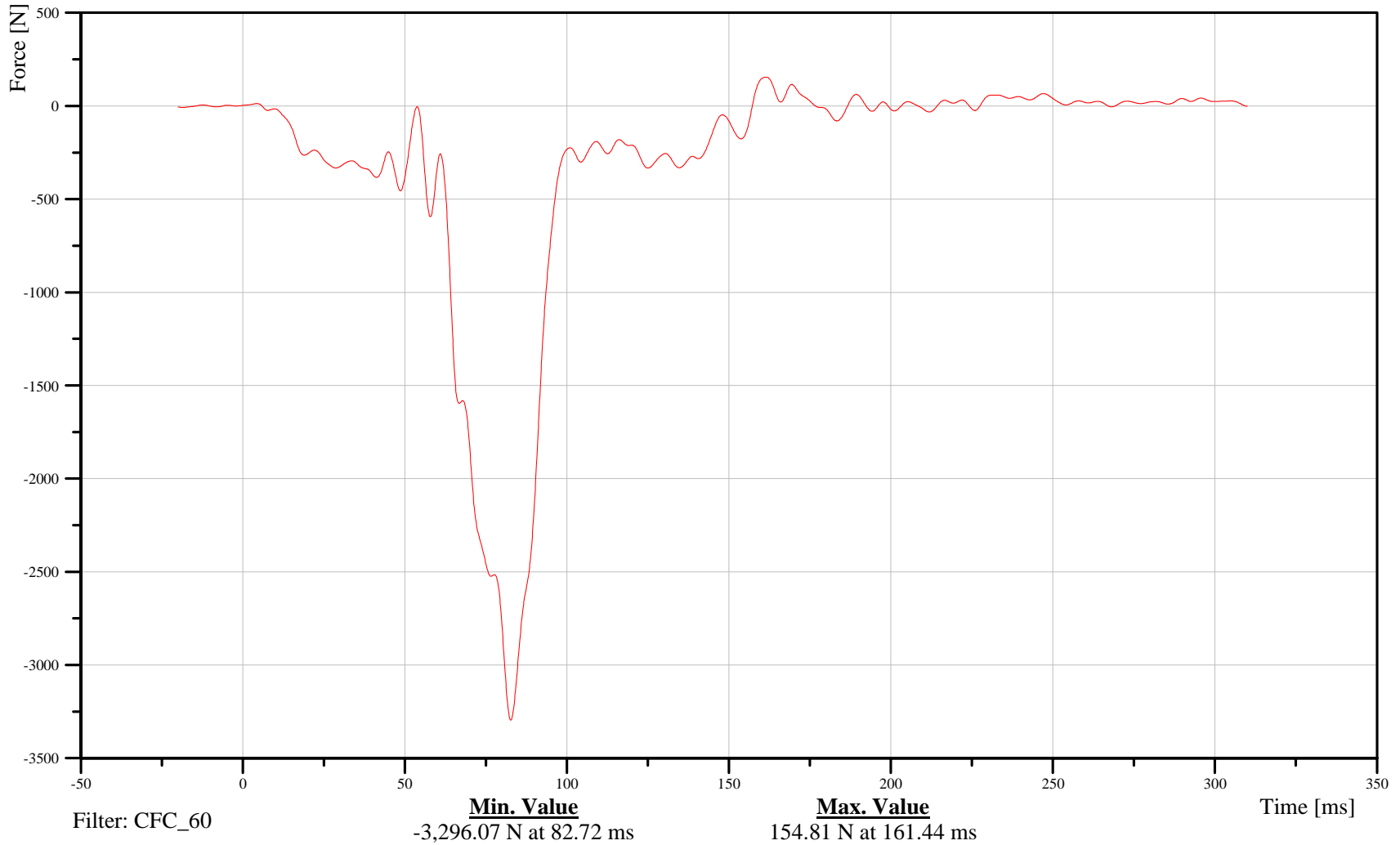

B-211

070913



2007 Ford F-250 into Left 40% Offset Deformable LCB at 56 kph

Date: 09/13/2007
Time: 15:46

Load Cell Row 4 Column 3

Customer: Volpe
Test Number: R70203

LOFBAR000024FOXD

TRC Inc. Test Lab: CTF
Test Number: 070913

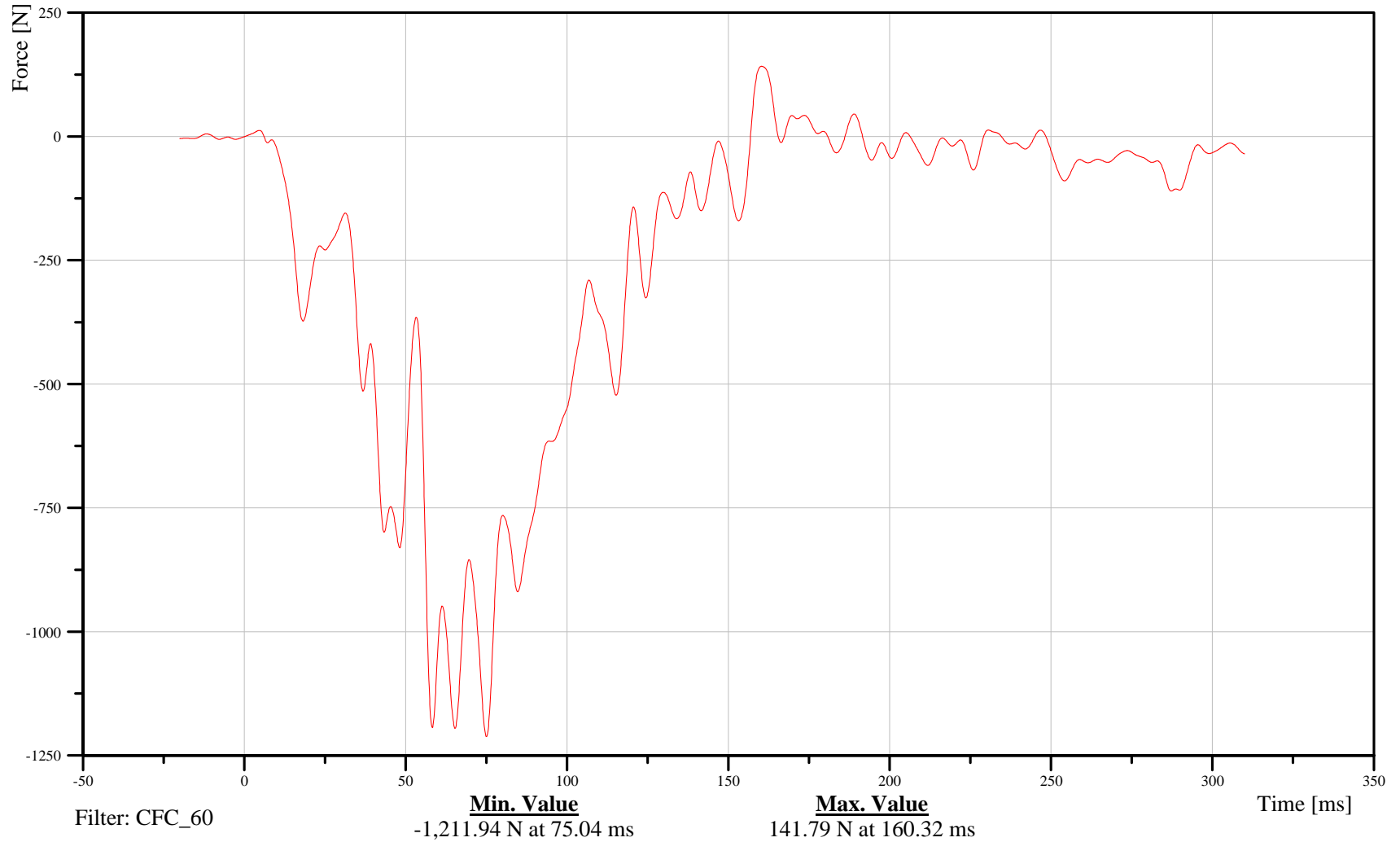

B-212

070913



2007 Ford F-250 into Left 40% Offset Deformable LCB at 56 kph

Date: 09/13/2007
Time: 15:46

Load Cell Row 5 Column 3

Customer: Volpe
Test Number: R70203

L0FBAR000025FOXD

TRC Inc. Test Lab: CTF
Test Number: 070913

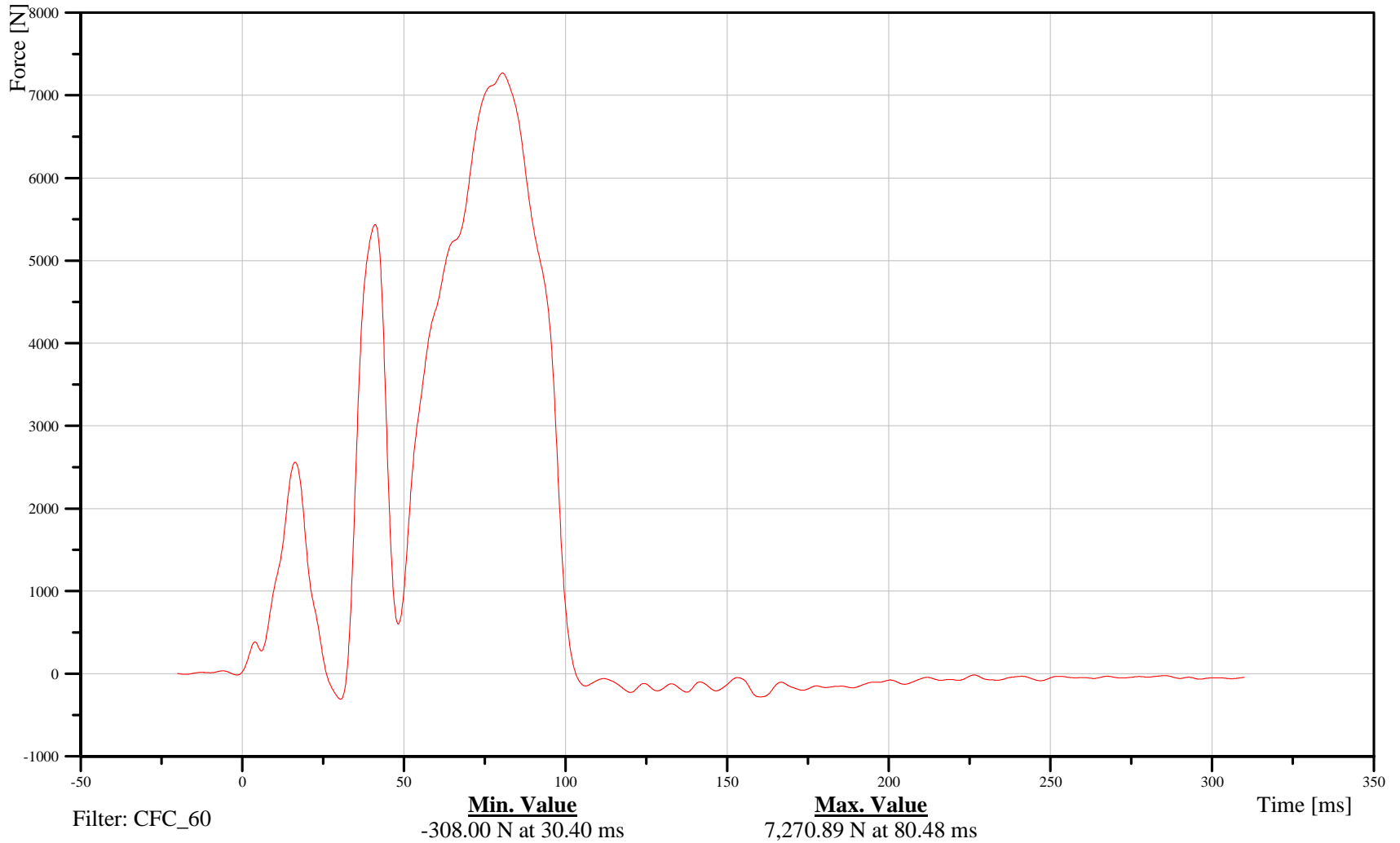

B-213

070913



2007 Ford F-250 into Left 40% Offset Deformable LCB at 56 kph

Date: 09/13/2007
Time: 15:46

Load Cell Row 6 Column 3

Customer: Volpe
Test Number: R70203

LOFBAR000026FOXD

TRC Inc. Test Lab: CTF
Test Number: 070913

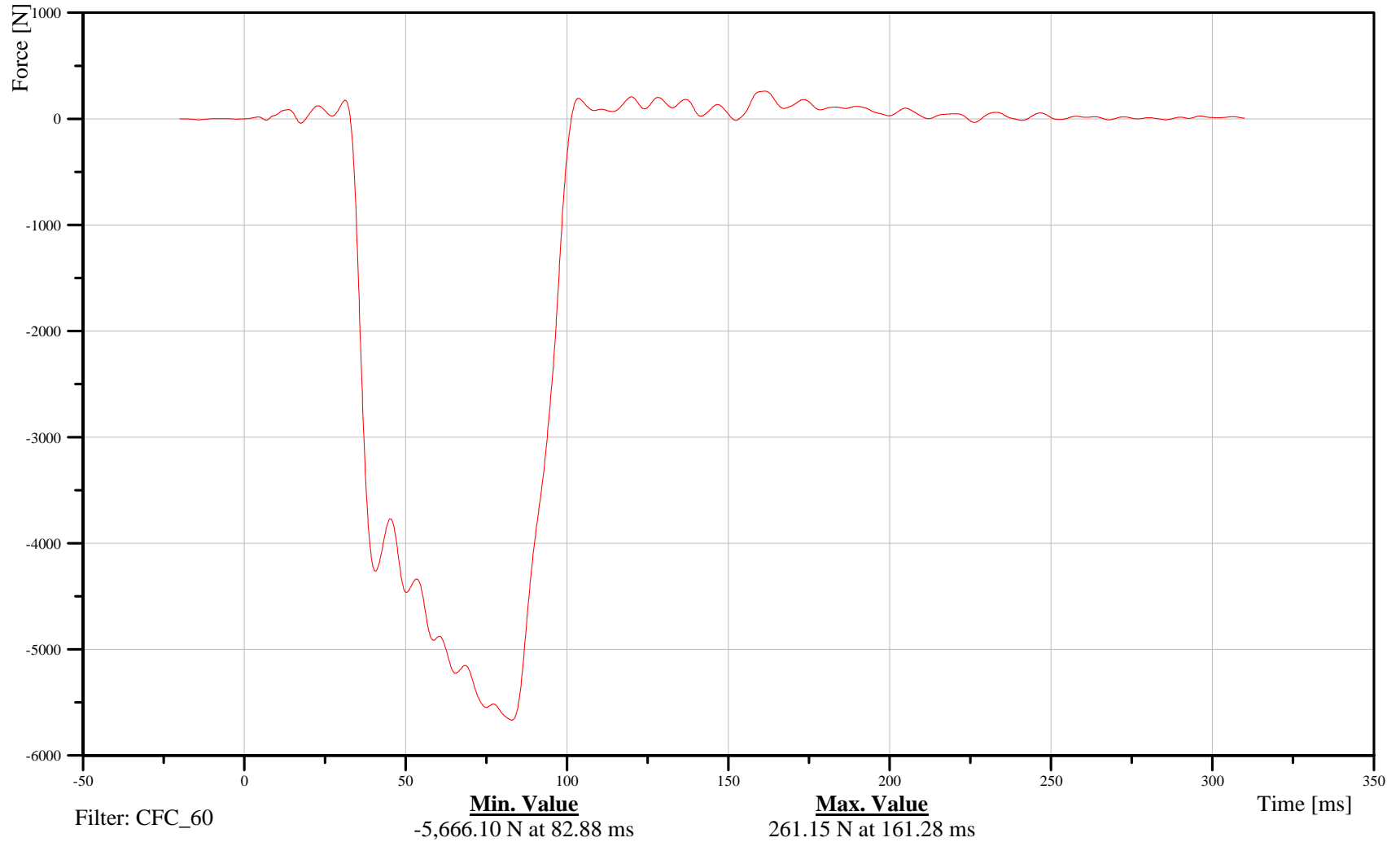

B-214

070913



2007 Ford F-250 into Left 40% Offset Deformable LCB at 56 kph

Date: 09/13/2007
Time: 15:46

Load Cell Row 7 Column 3

Customer: Volpe
Test Number: R70203

LOFBAR000027FOXD

TRC Inc. Test Lab: CTF
Test Number: 070913

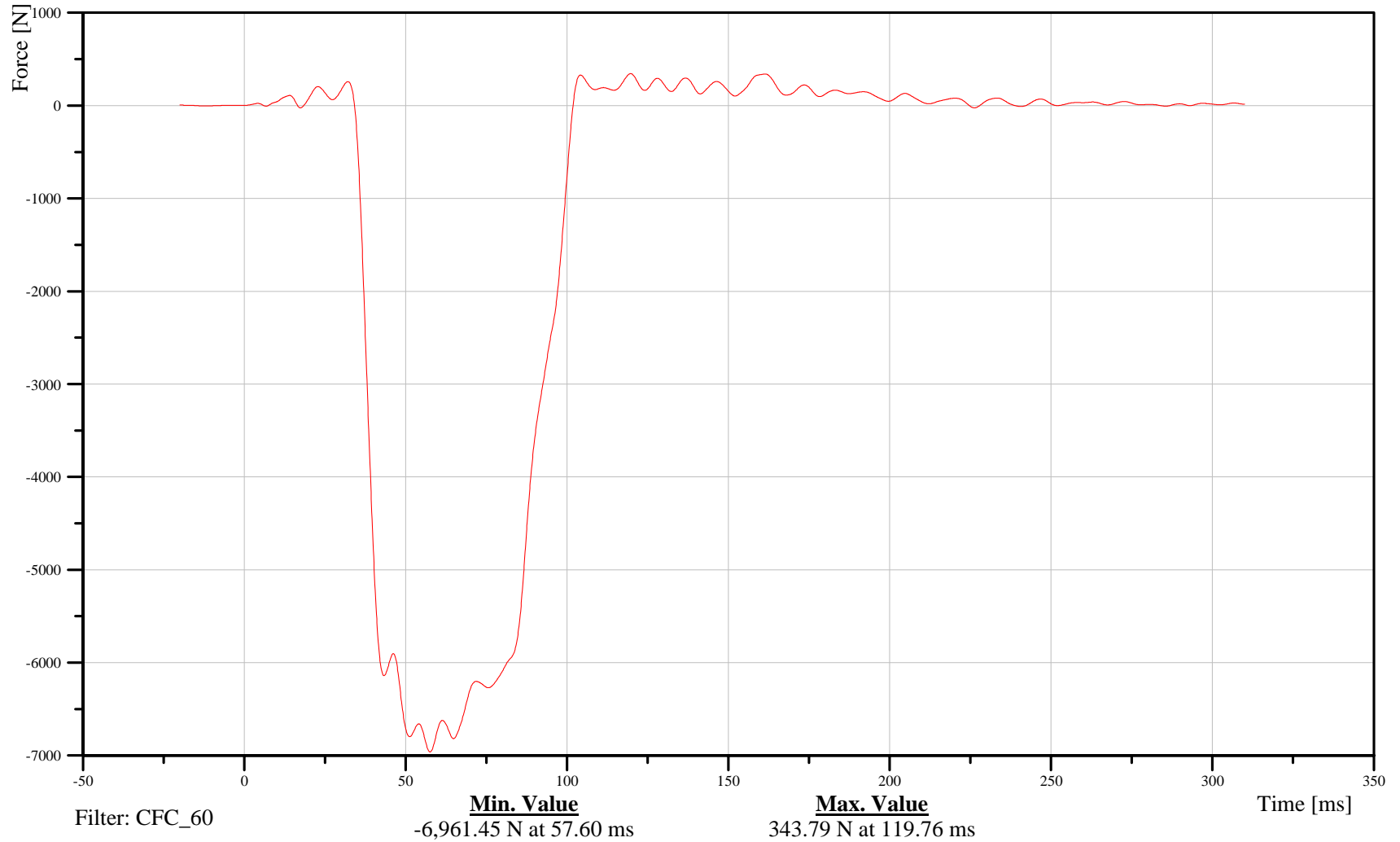

B-215

070913



2007 Ford F-250 into Left 40% Offset Deformable LCB at 56 kph

Date: 09/13/2007
Time: 15:46

Load Cell Row 8 Column 3

Customer: Volpe
Test Number: R70203

LOFBAR000028FOXD

TRC Inc. Test Lab: CTF
Test Number: 070913

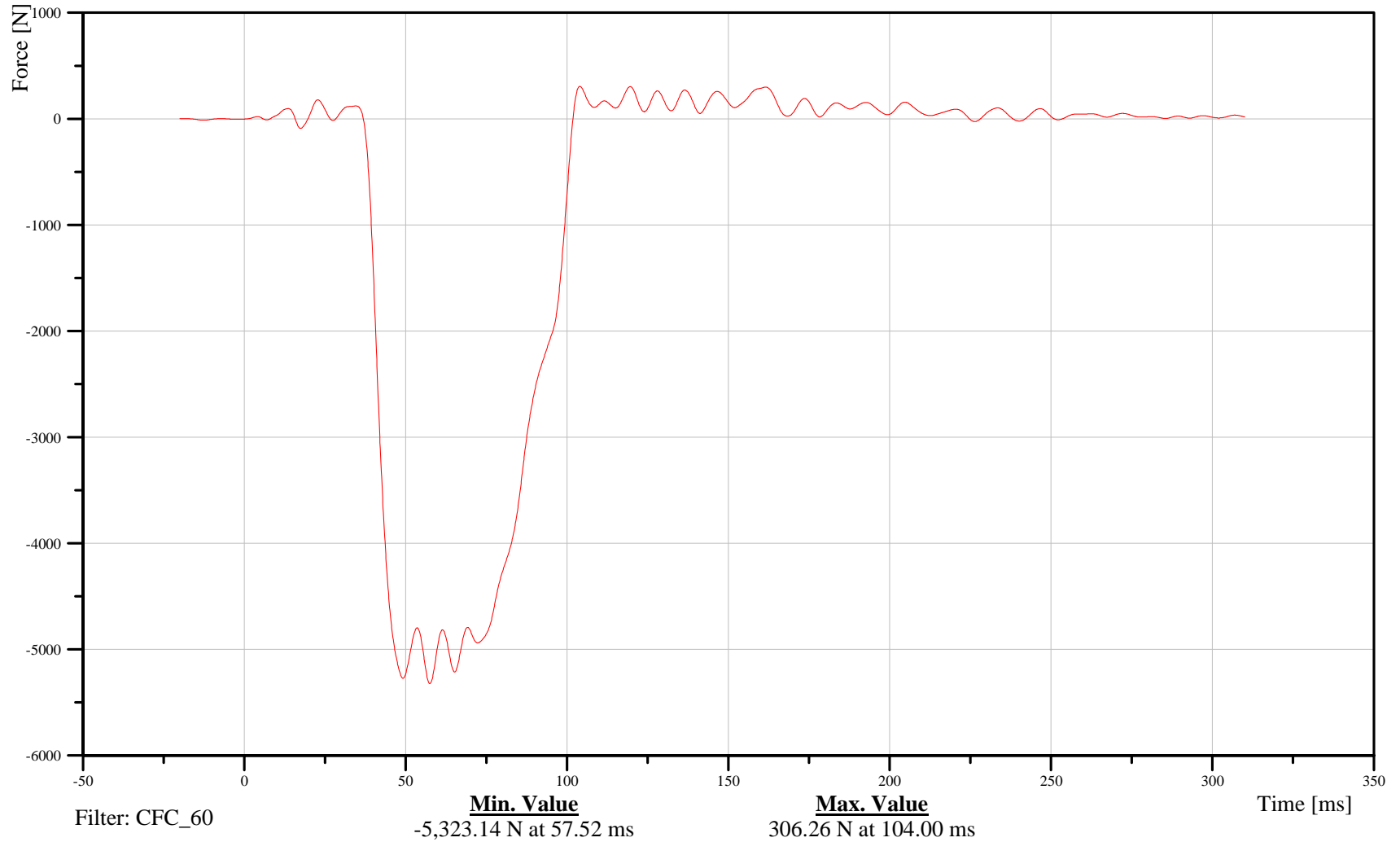

B-216

070913



2007 Ford F-250 into Left 40% Offset Deformable LCB at 56 kph

Date: 09/13/2007
Time: 15:46

Load Cell Row 9 Column 3

Customer: Volpe
Test Number: R70203

L0FBAR000029FOXD

TRC Inc. Test Lab: CTF
Test Number: 070913

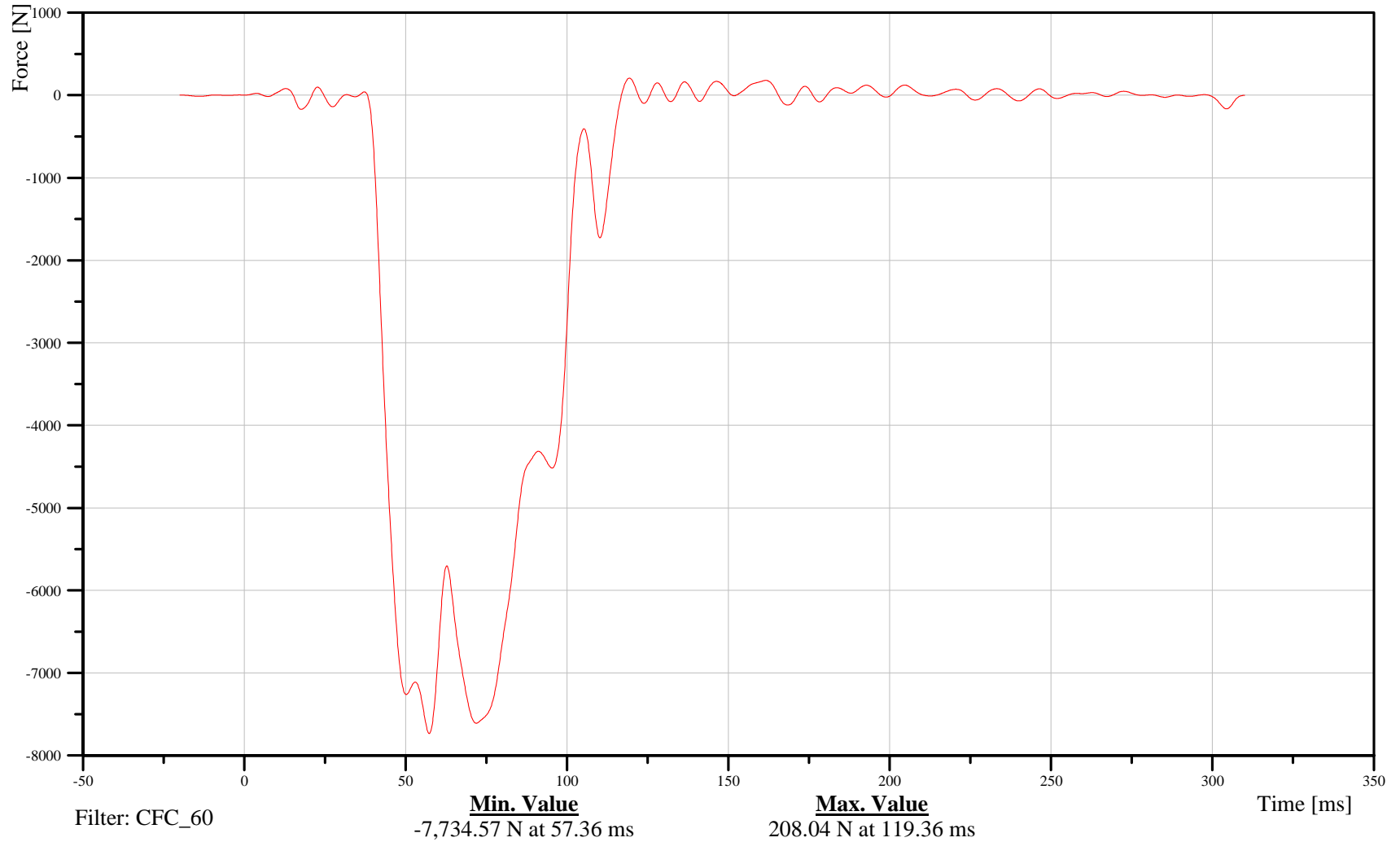

B-217

070913



2007 Ford F-250 into Left 40% Offset Deformable LCB at 56 kph

Date: 09/13/2007
Time: 15:46

Load Cell Row 10 Column 3

Customer: Volpe
Test Number: R70203

LOFBAR000030FOXD

TRC Inc. Test Lab: CTF
Test Number: 070913

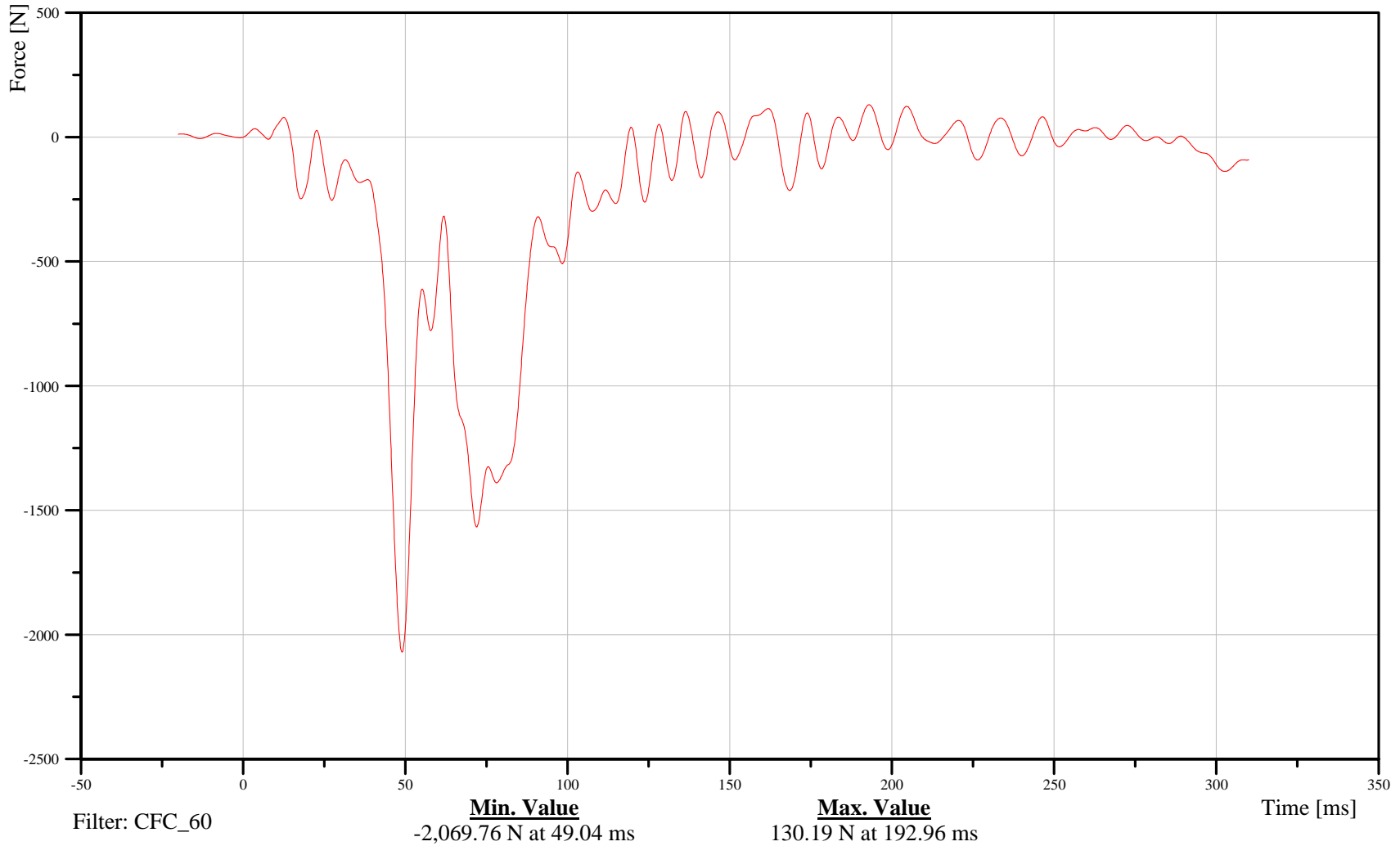

B-218

070913



2007 Ford F-250 into Left 40% Offset Deformable LCB at 56 kph

Date: 09/13/2007
Time: 15:46

Load Cell Row 1 Column 4

Customer: Volpe
Test Number: R70203

LOFBAR000031FOXD

TRC Inc. Test Lab: CTF
Test Number: 070913

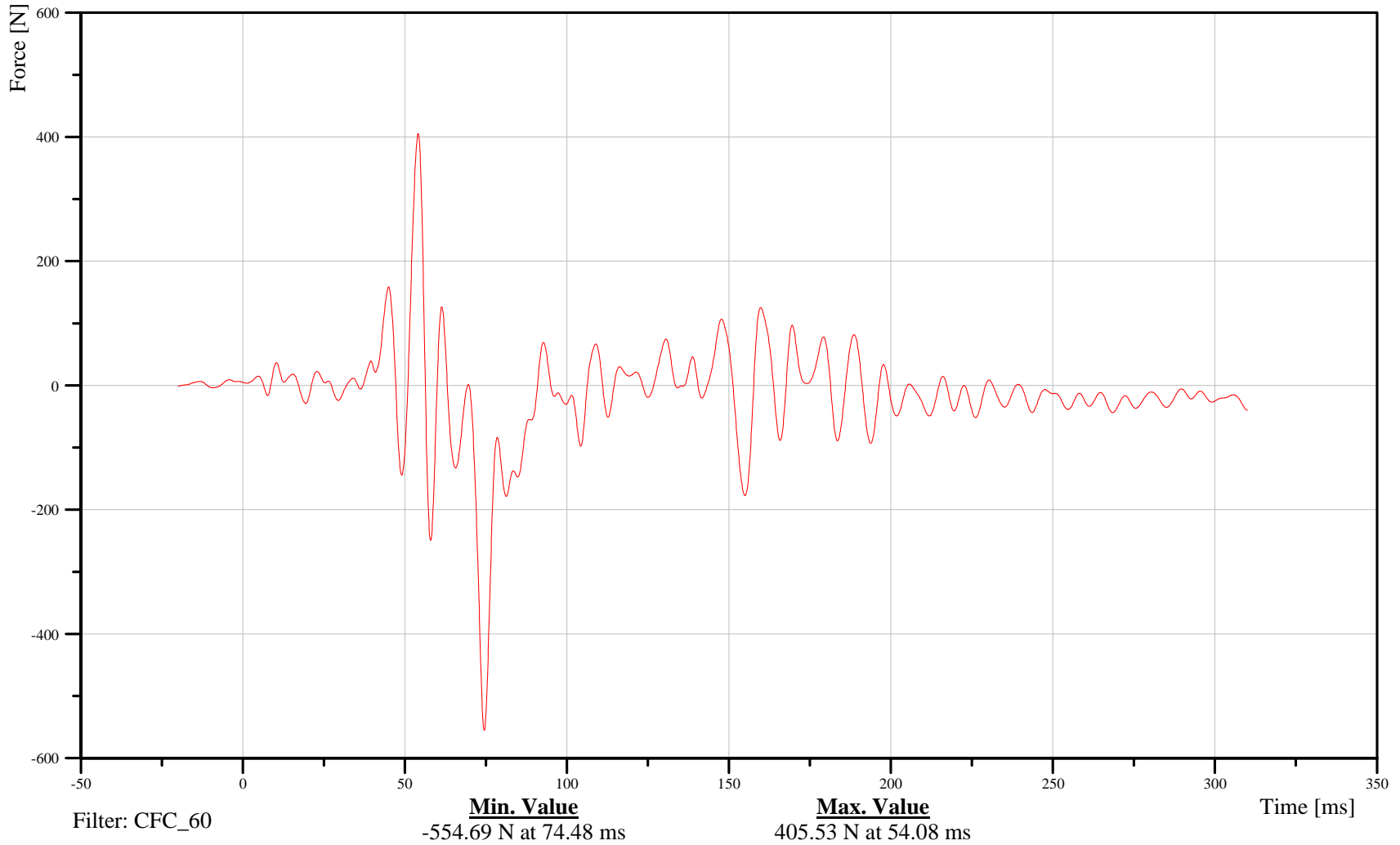

B-219

070913



2007 Ford F-250 into Left 40% Offset Deformable LCB at 56 kph

Date: 09/13/2007
Time: 15:46

Load Cell Row 2 Column 4

Customer: Volpe
Test Number: R70203

LOFBAR000032FOXD

TRC Inc. Test Lab: CTF
Test Number: 070913

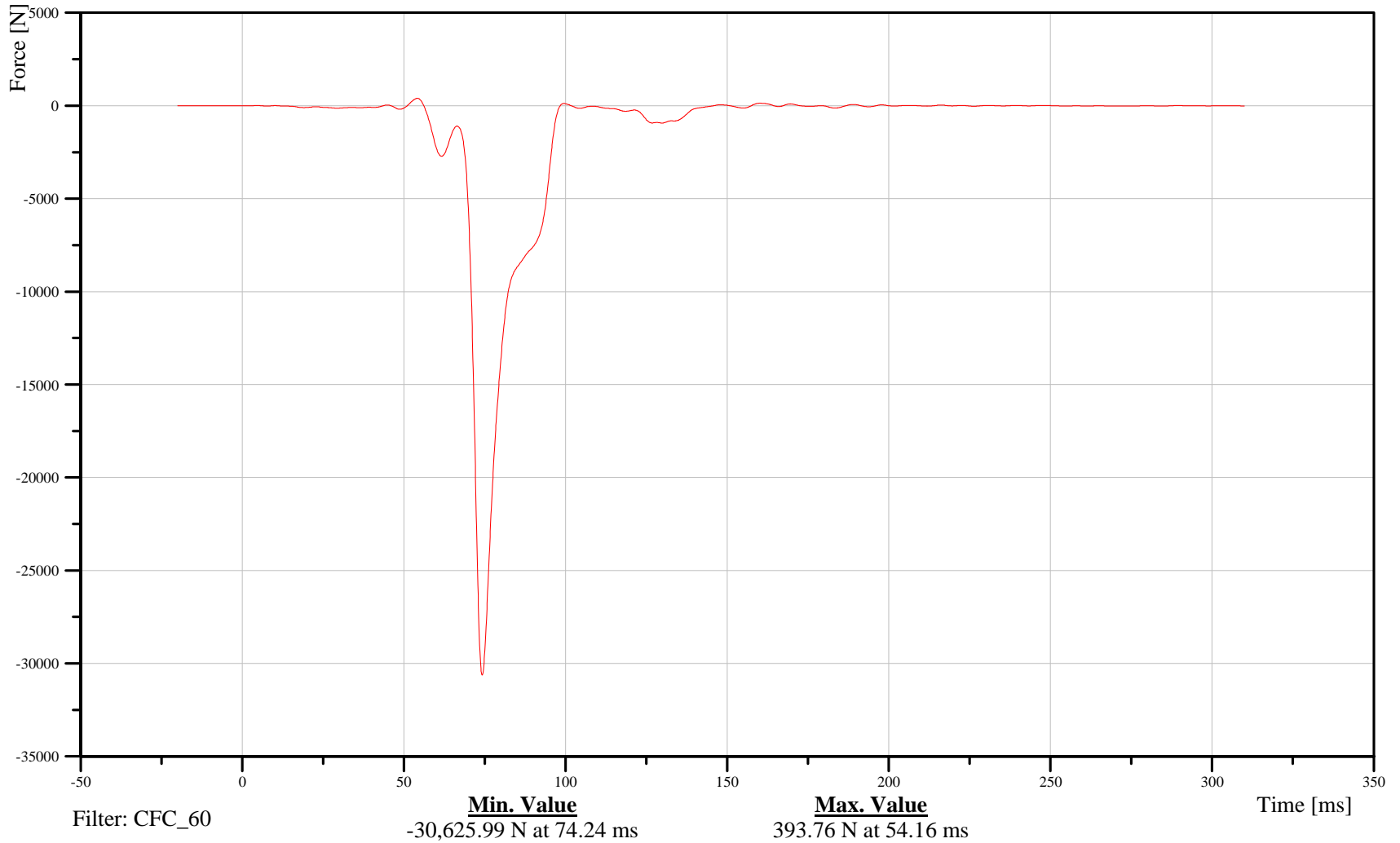

B-220

070913



2007 Ford F-250 into Left 40% Offset Deformable LCB at 56 kph

Date: 09/13/2007
Time: 15:46

Load Cell Row 3 Column 4

Customer: Volpe
Test Number: R70203

LOFBAR000033FOXD

TRC Inc. Test Lab: CTF
Test Number: 070913

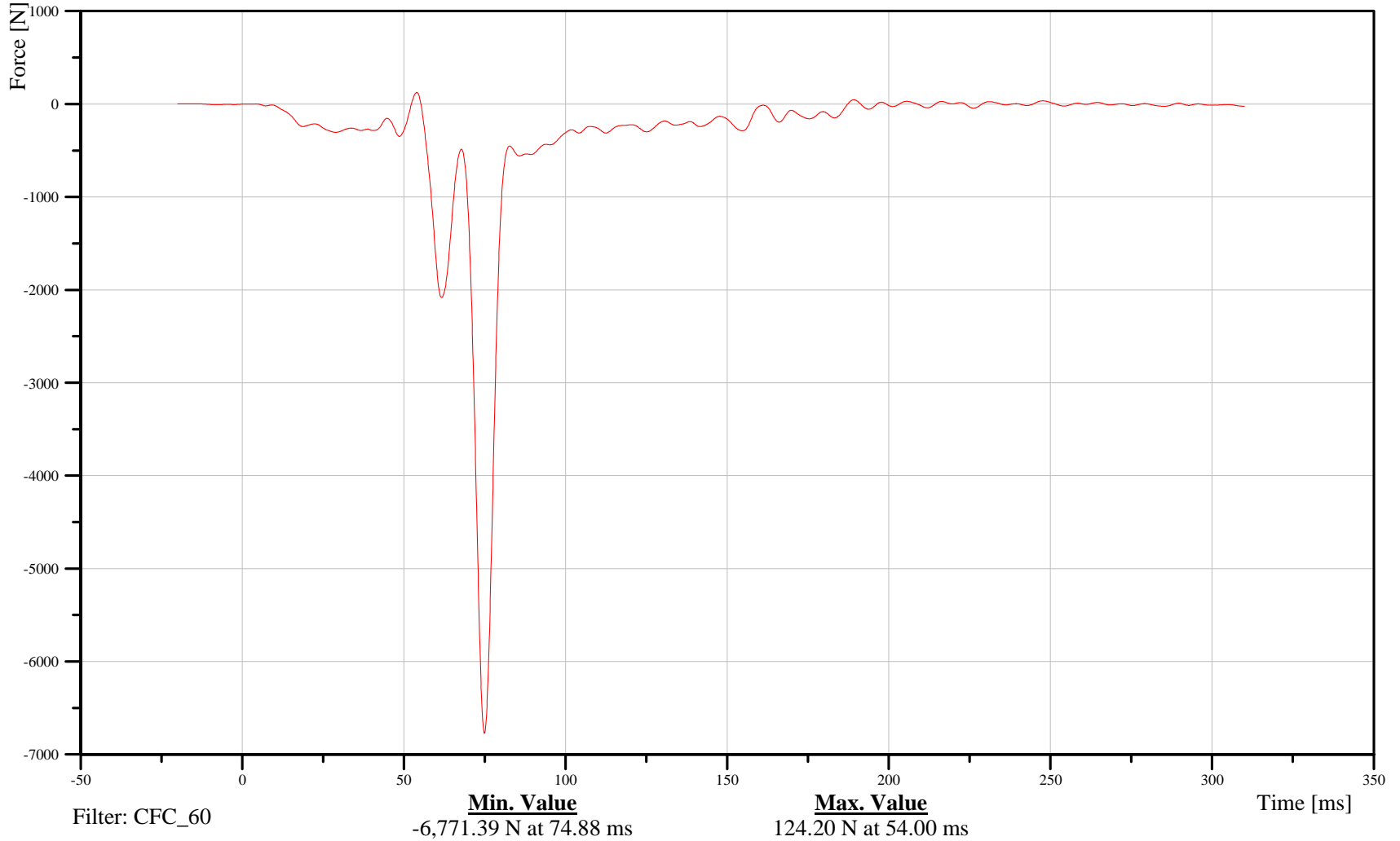

B-221

070913



2007 Ford F-250 into Left 40% Offset Deformable LCB at 56 kph

Date: 09/13/2007
Time: 15:46

Load Cell Row 4 Column 4

Customer: Volpe
Test Number: R70203

LOFBAR000034FOXD

TRC Inc. Test Lab: CTF
Test Number: 070913

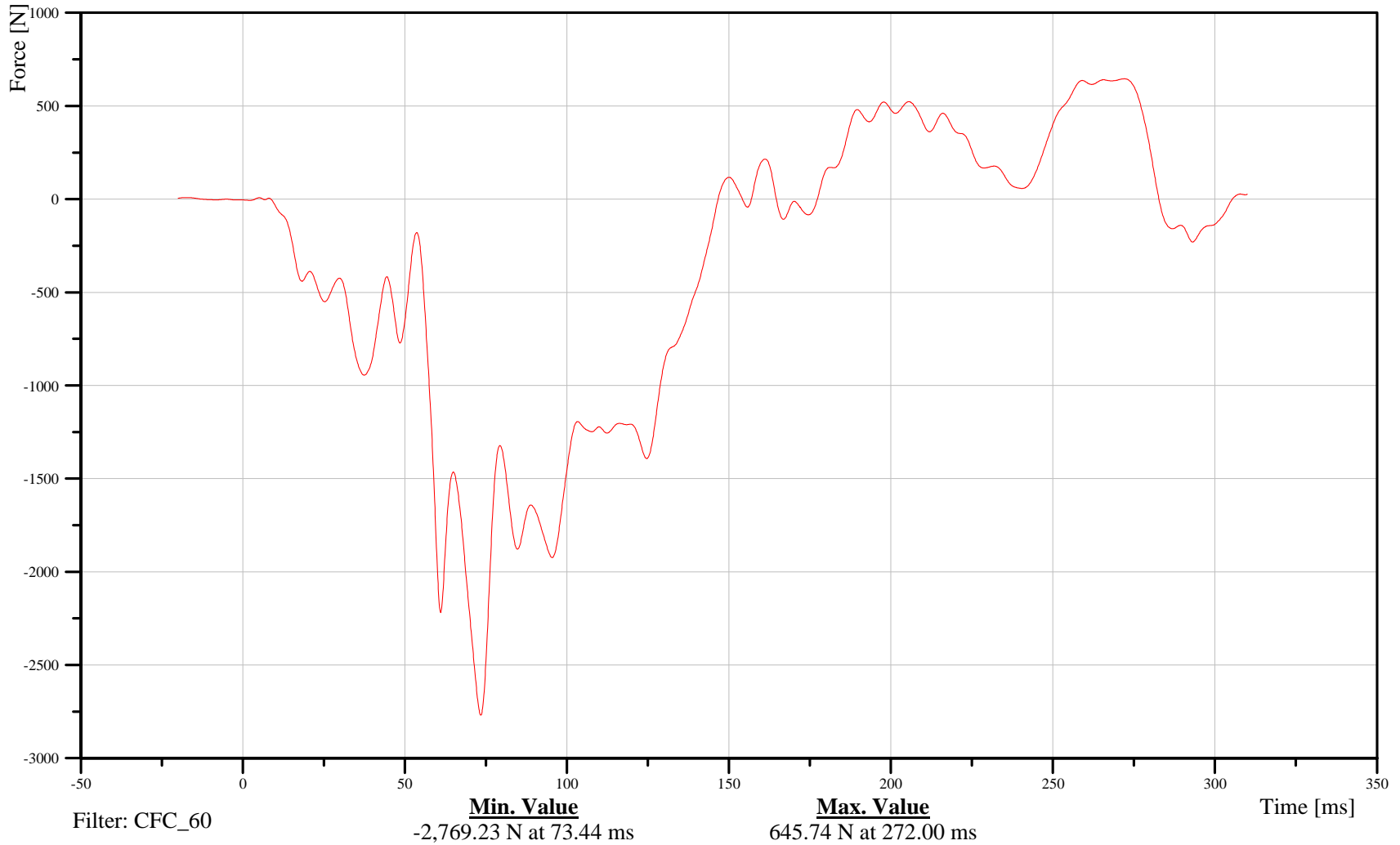

B-222

070913



2007 Ford F-250 into Left 40% Offset Deformable LCB at 56 kph

Date: 09/13/2007
Time: 15:46

Load Cell Row 5 Column 4

Customer: Volpe
Test Number: R70203

LOFBAR000035FOXD

TRC Inc. Test Lab: CTF
Test Number: 070913

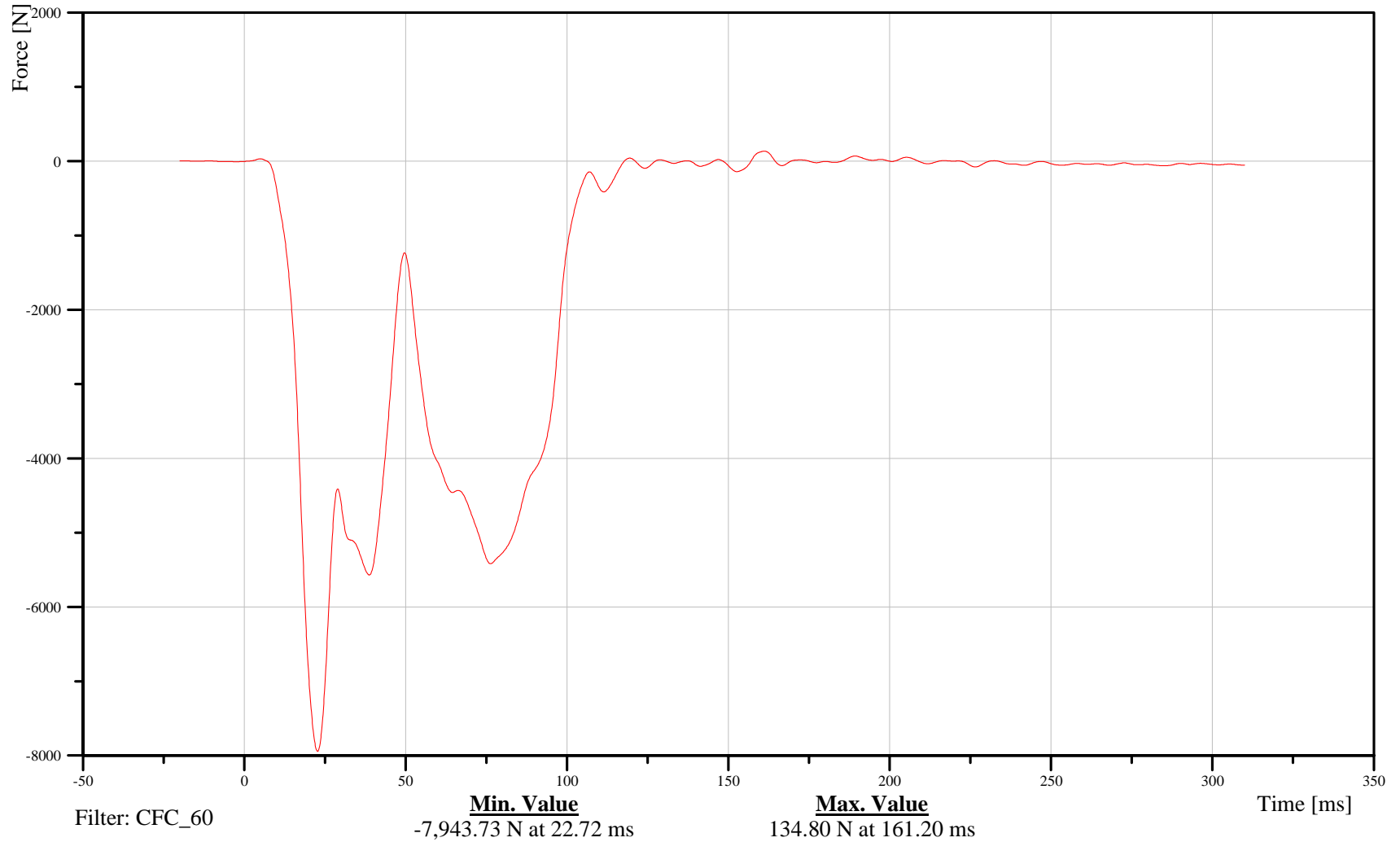

B-223

070913



2007 Ford F-250 into Left 40% Offset Deformable LCB at 56 kph

Date: 09/13/2007
Time: 15:46

Load Cell Row 6 Column 4

Customer: Volpe
Test Number: R70203

LOFBAR000036FOXD

TRC Inc. Test Lab: CTF
Test Number: 070913

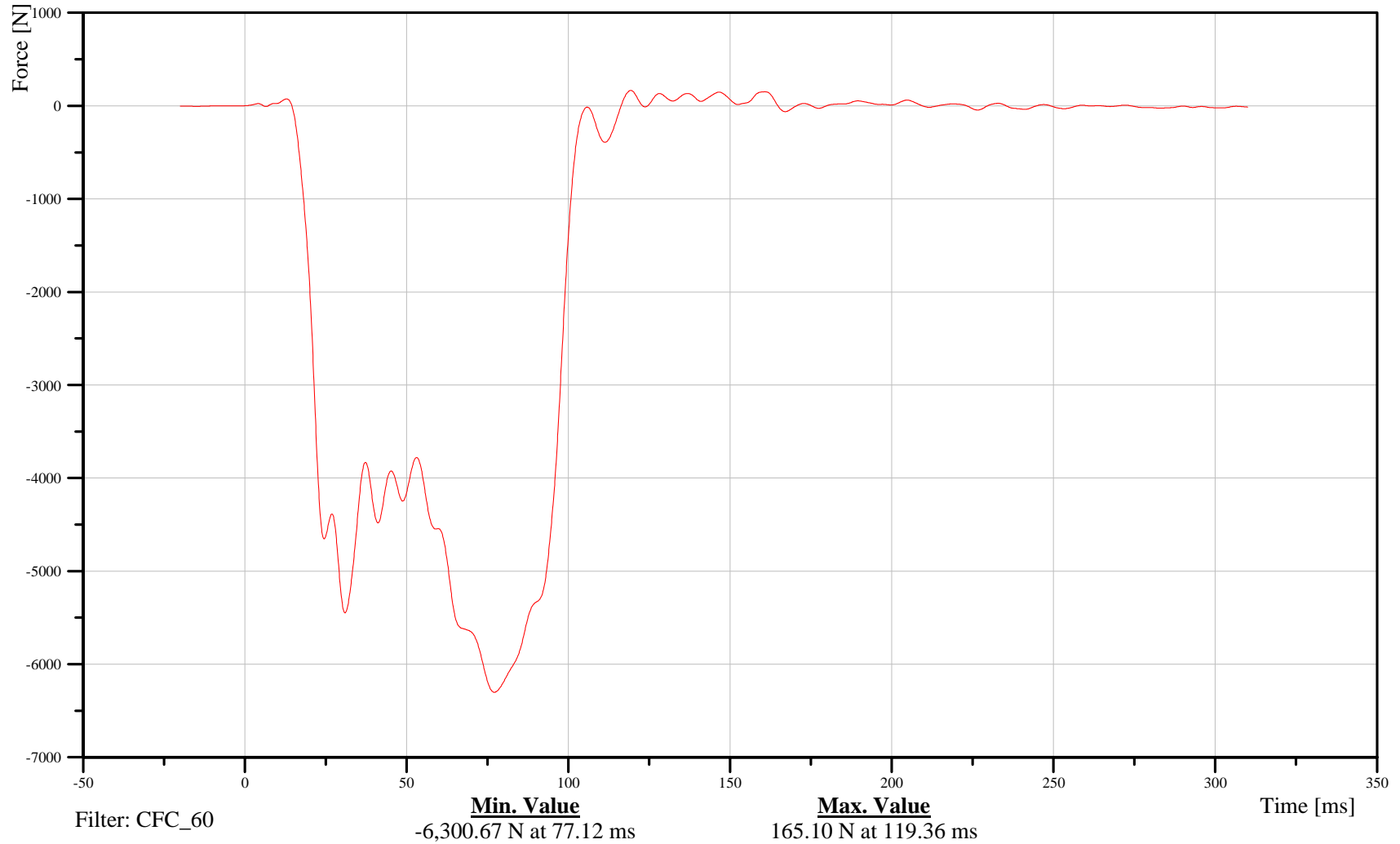

B-224

070913



2007 Ford F-250 into Left 40% Offset Deformable LCB at 56 kph

Date: 09/13/2007
Time: 15:46

Load Cell Row 7 Column 4

Customer: Volpe
Test Number: R70203

LOFBAR000037FOXD

TRC Inc. Test Lab: CTF
Test Number: 070913

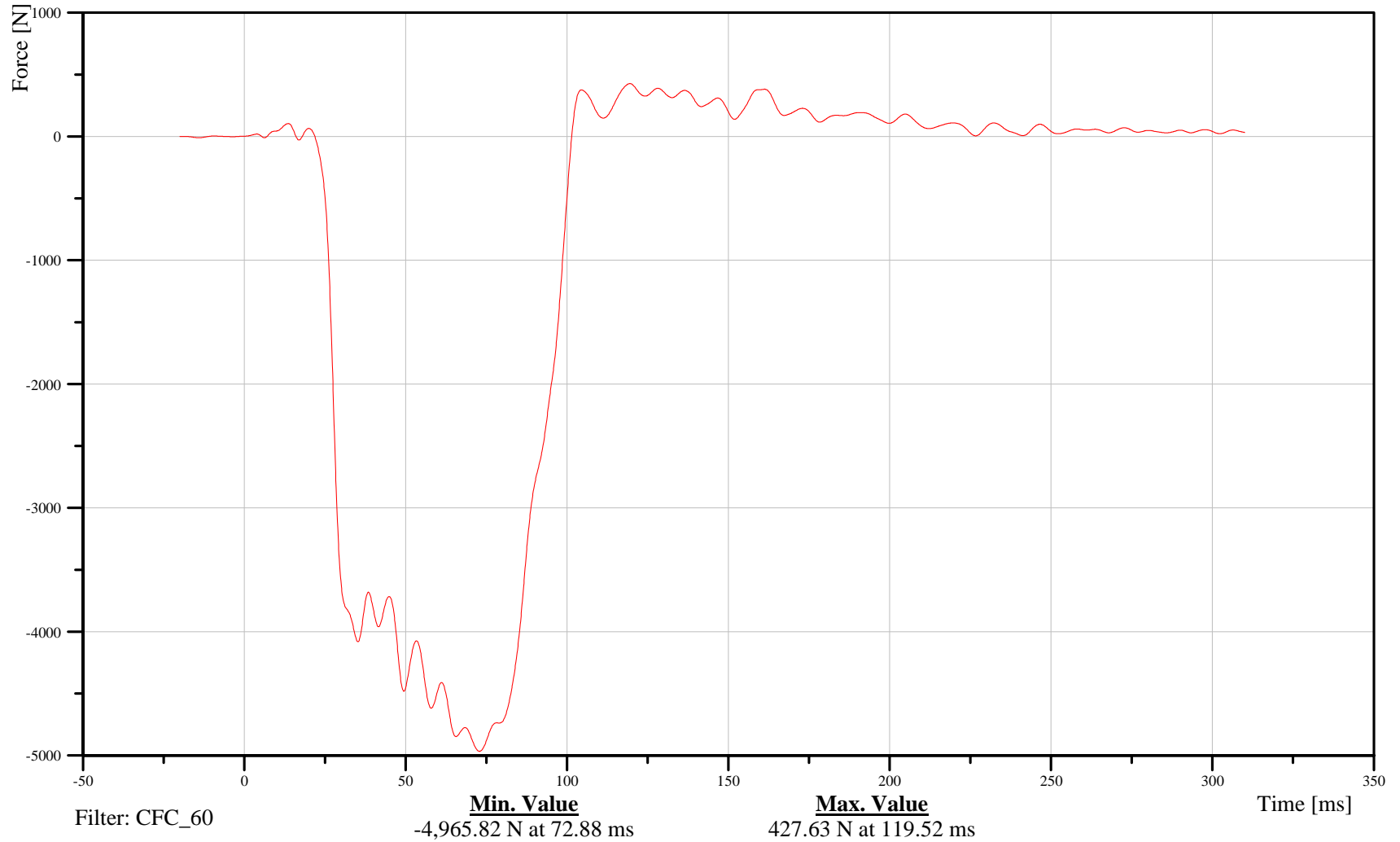

B-225

070913



2007 Ford F-250 into Left 40% Offset Deformable LCB at 56 kph

Date: 09/13/2007
Time: 15:46

Load Cell Row 8 Column 4

Customer: Volpe
Test Number: R70203

LOFBAR000038FOXD

TRC Inc. Test Lab: CTF
Test Number: 070913

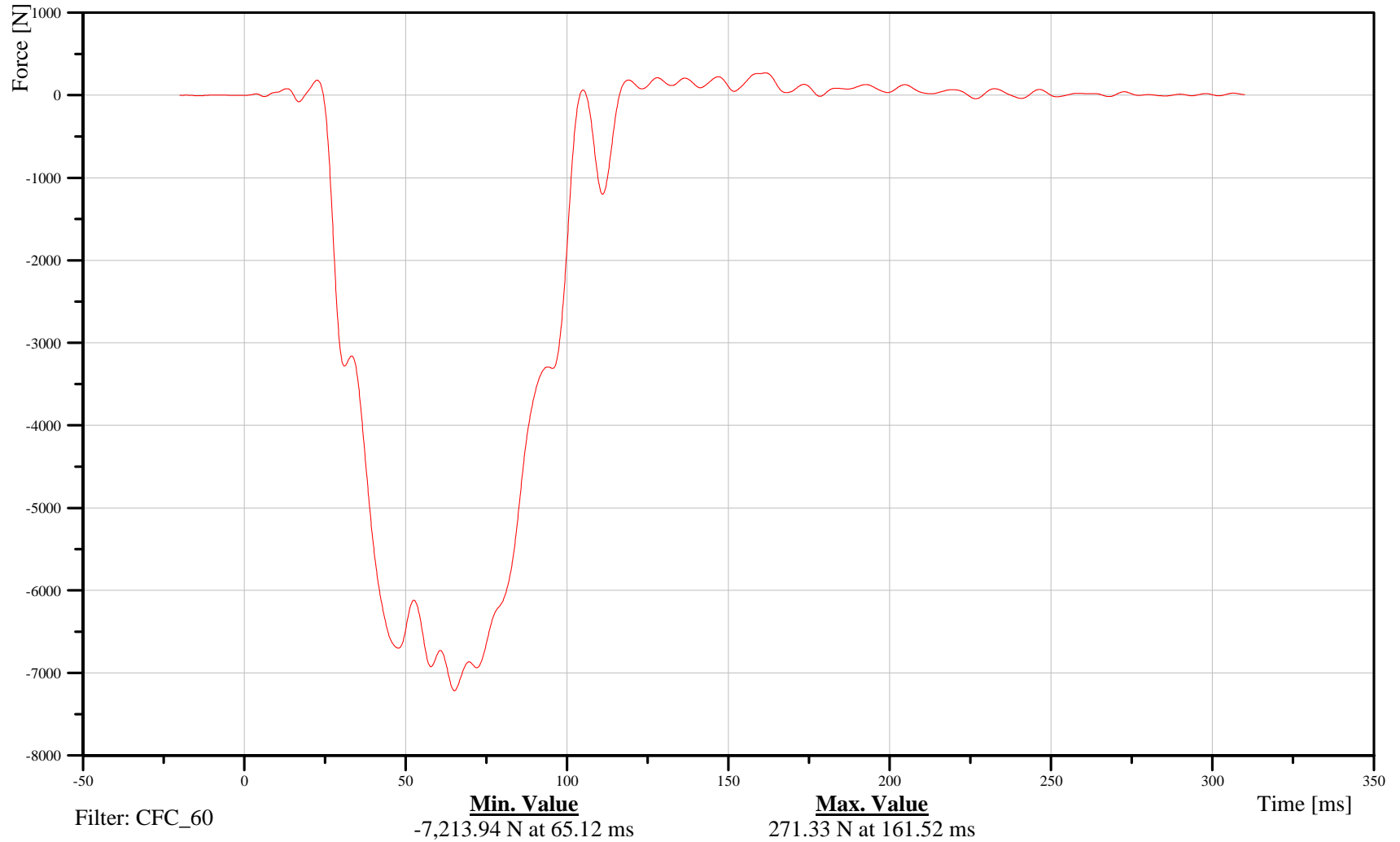

B-226

070913



2007 Ford F-250 into Left 40% Offset Deformable LCB at 56 kph

Date: 09/13/2007
Time: 15:46

Load Cell Row 9 Column 4

Customer: Volpe
Test Number: R70203

LOFBAR000039FOXD

TRC Inc. Test Lab: CTF
Test Number: 070913

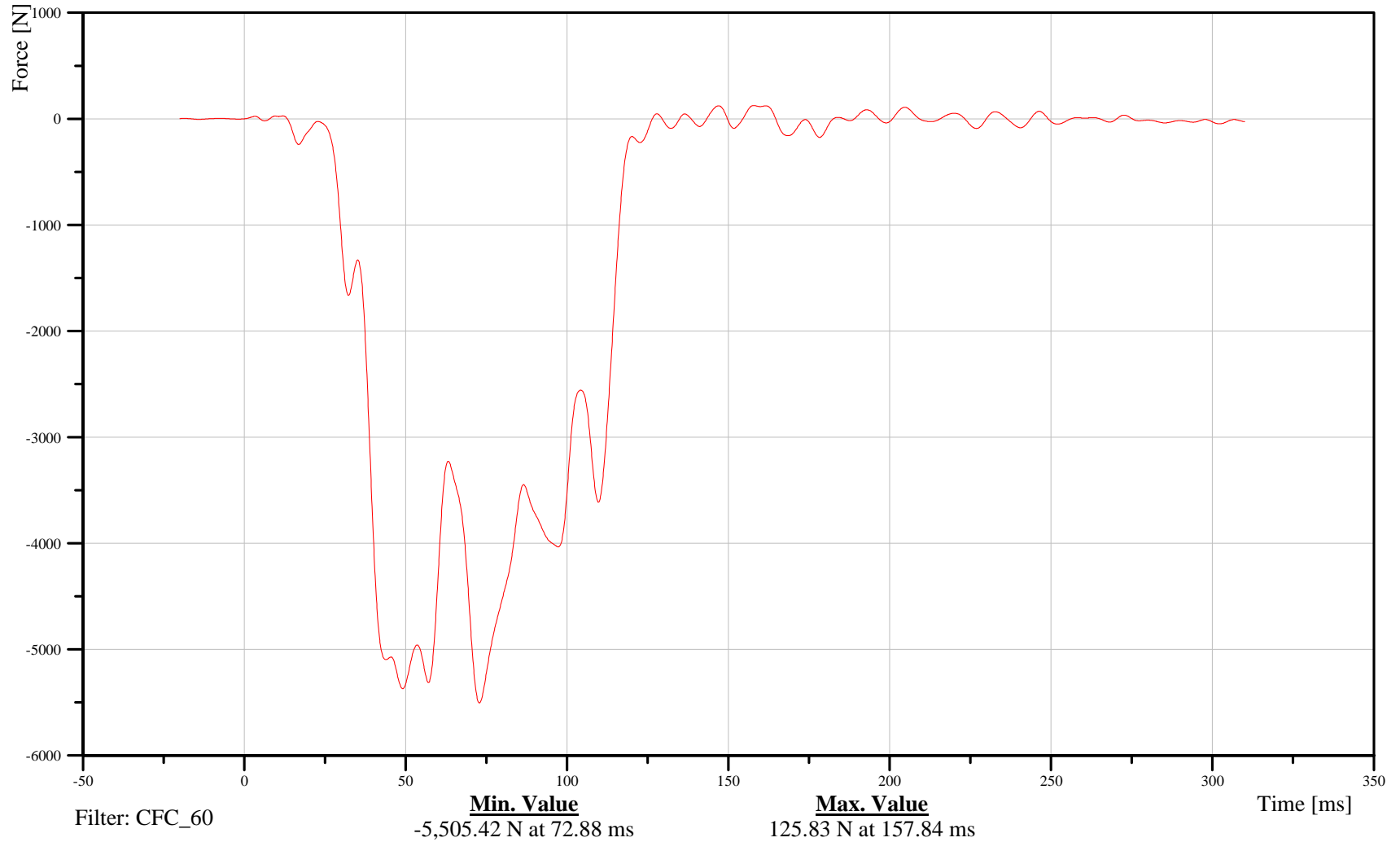

B-227

070913



2007 Ford F-250 into Left 40% Offset Deformable LCB at 56 kph

Date: 09/13/2007
Time: 15:46

Load Cell Row 10 Column 4

Customer: Volpe
Test Number: R70203

LOFBAR000040FOXD

TRC Inc. Test Lab: CTF
Test Number: 070913

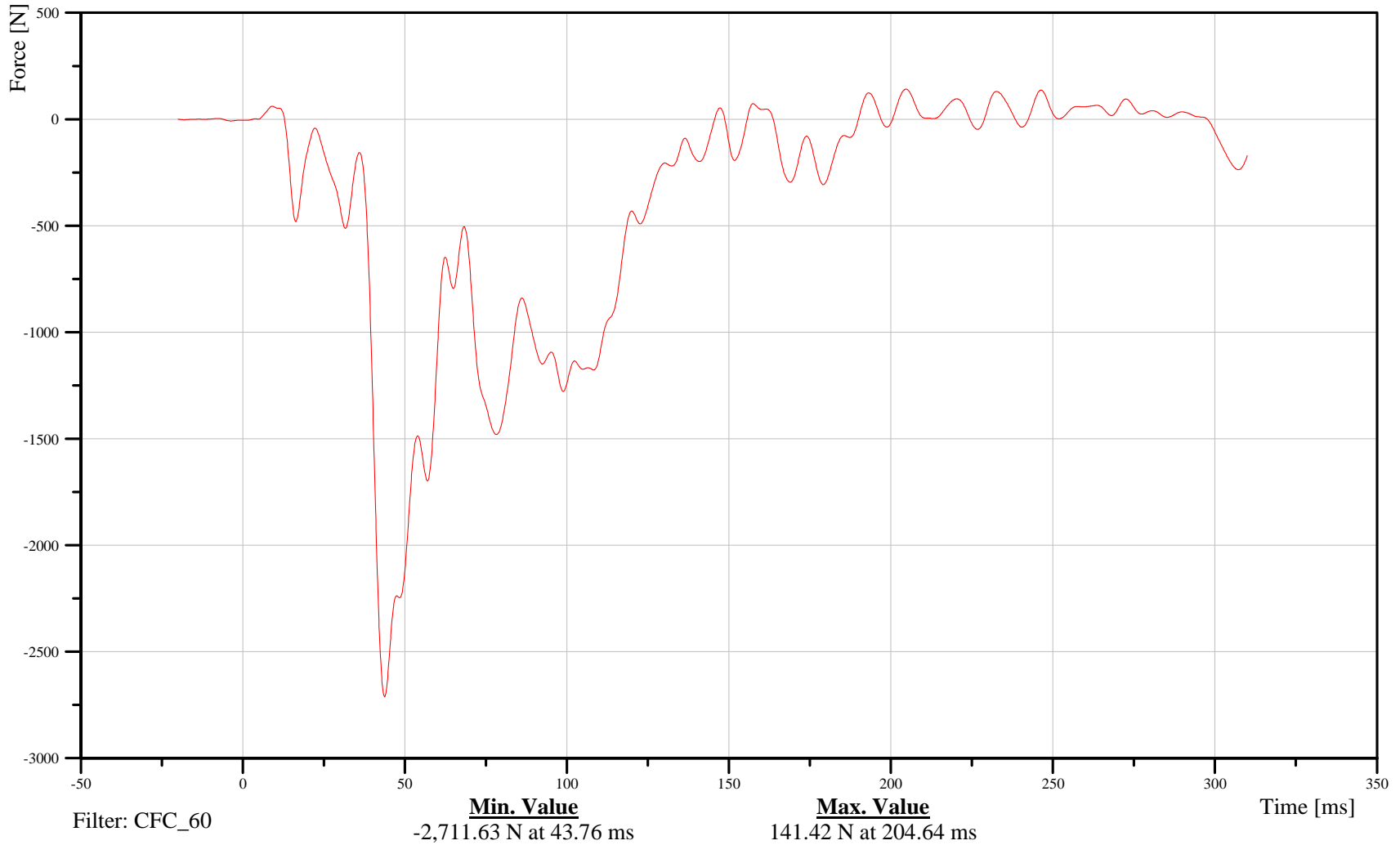

B-228

070913



2007 Ford F-250 into Left 40% Offset Deformable LCB at 56 kph

Date: 09/13/2007
Time: 15:46

Load Cell Row 1 Column 5

Customer: Volpe
Test Number: R70203

LOFBAR000041FOXD

TRC Inc. Test Lab: CTF
Test Number: 070913

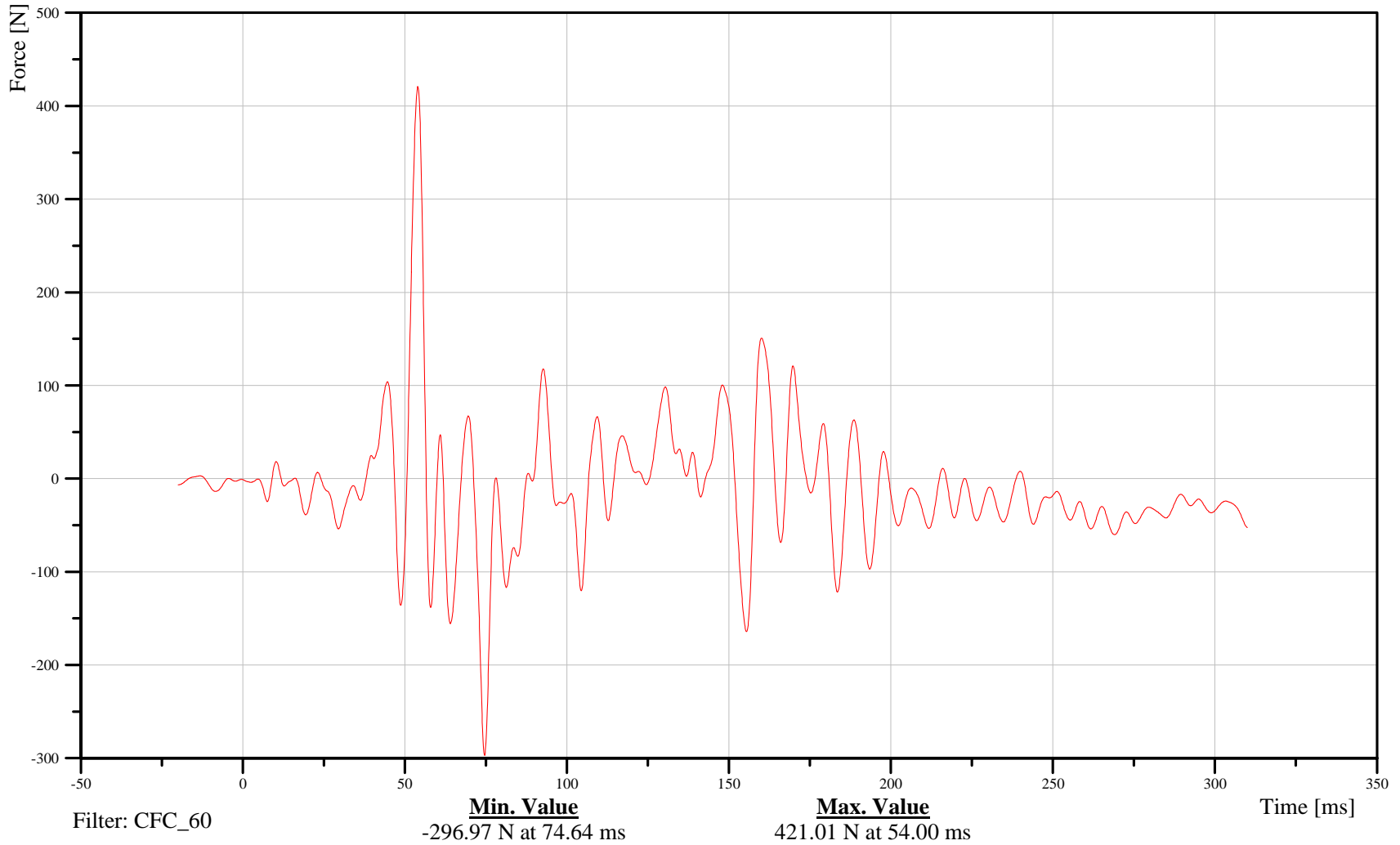

B-229

070913



2007 Ford F-250 into Left 40% Offset Deformable LCB at 56 kph

Date: 09/13/2007
Time: 15:46

Load Cell Row 2 Column 5

Customer: Volpe
Test Number: R70203

LOFBAR000042FOXD

TRC Inc. Test Lab: CTF
Test Number: 070913

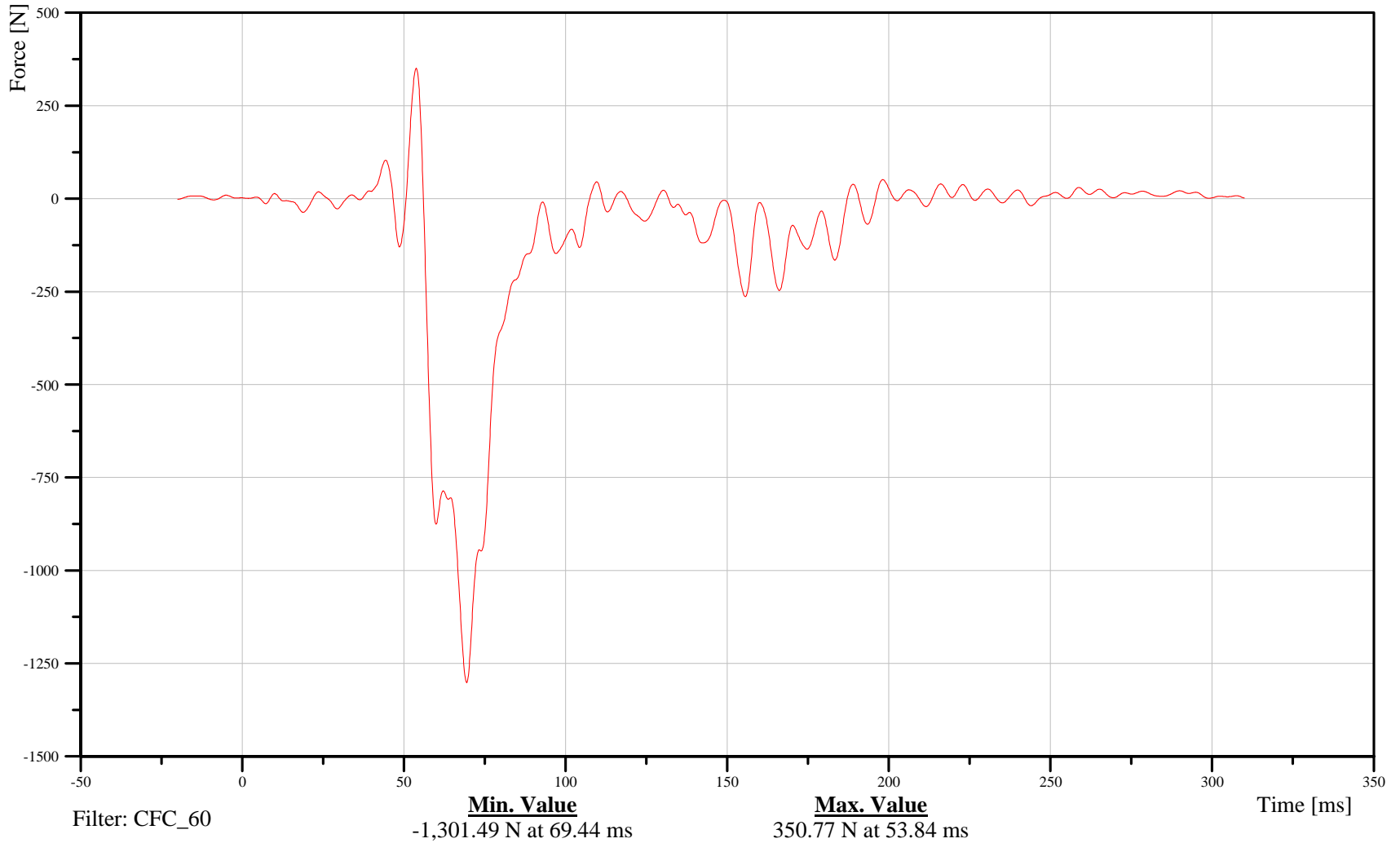

B-230

070913



2007 Ford F-250 into Left 40% Offset Deformable LCB at 56 kph

Date: 09/13/2007
Time: 15:46

Load Cell Row 3 Column 5

Customer: Volpe
Test Number: R70203

LOFBAR000043FOXD

TRC Inc. Test Lab: CTF
Test Number: 070913

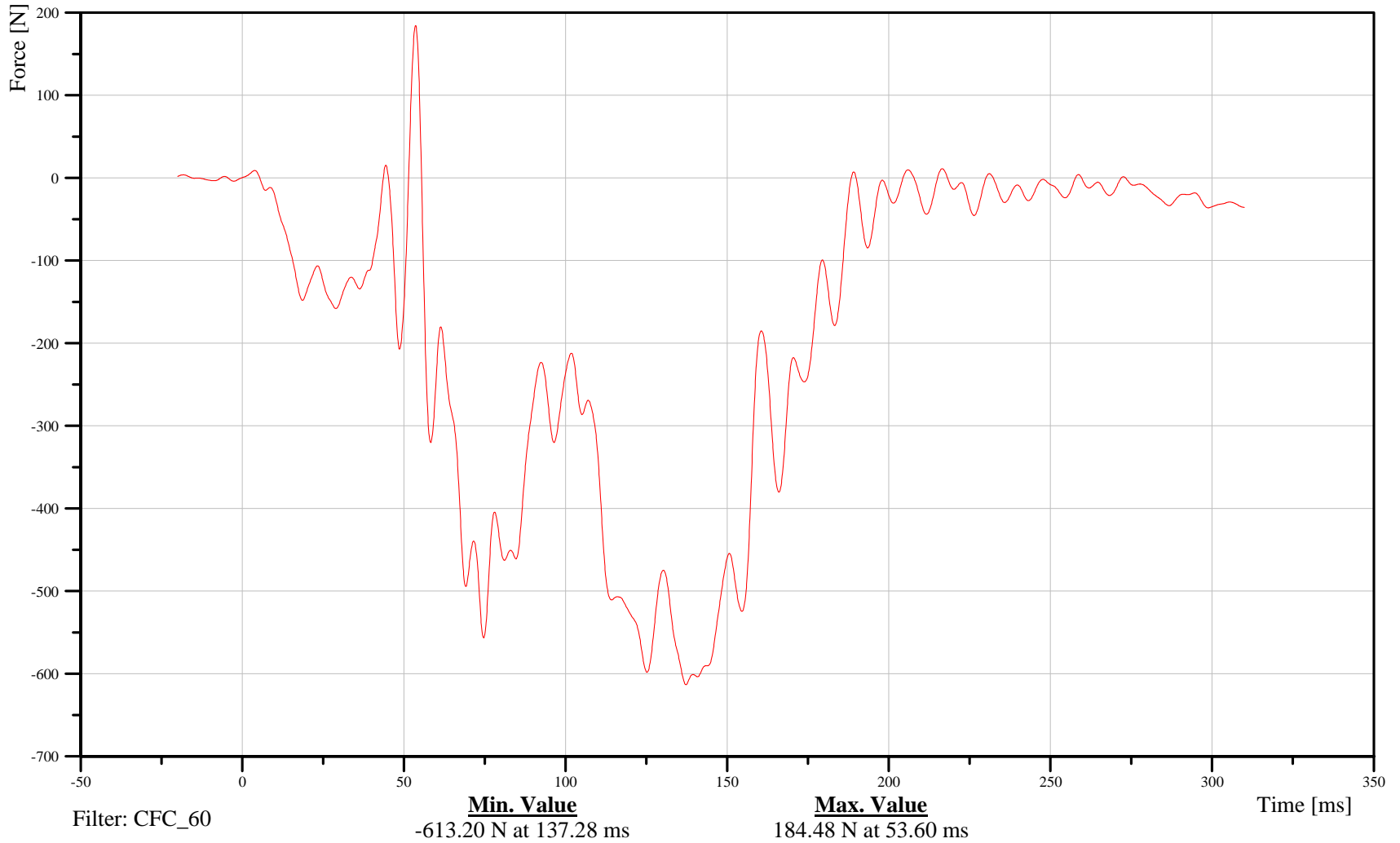

B-231

070913



2007 Ford F-250 into Left 40% Offset Deformable LCB at 56 kph

Date: 09/13/2007
Time: 15:46

Load Cell Row 4 Column 5

Customer: Volpe
Test Number: R70203

LOFBAR000044FOXD

TRC Inc. Test Lab: CTF
Test Number: 070913

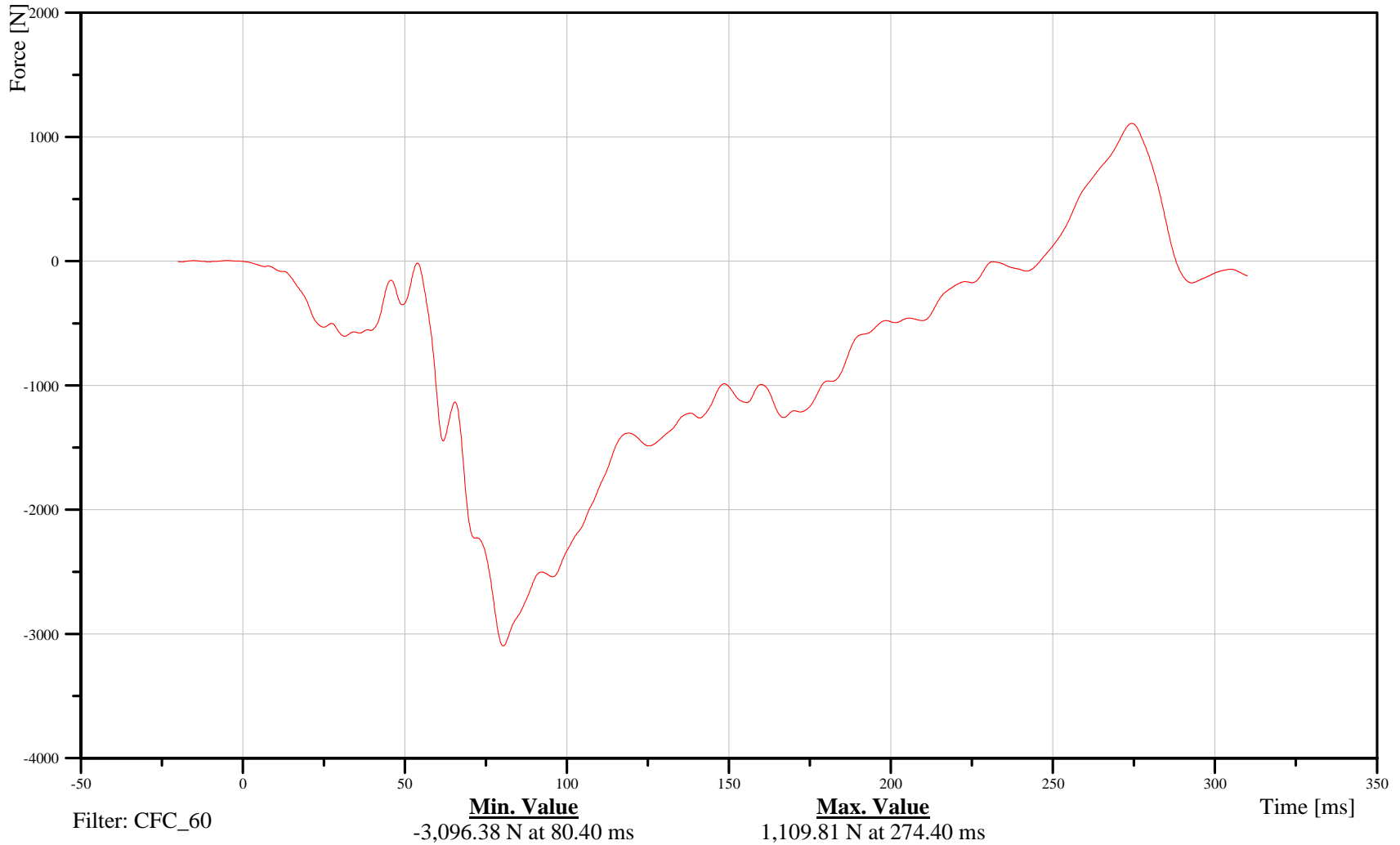

B-232

070913



2007 Ford F-250 into Left 40% Offset Deformable LCB at 56 kph

Date: 09/13/2007
Time: 15:46

Load Cell Row 5 Column 5

Customer: Volpe
Test Number: R70203

LOFBAR000045FOXD

TRC Inc. Test Lab: CTF
Test Number: 070913

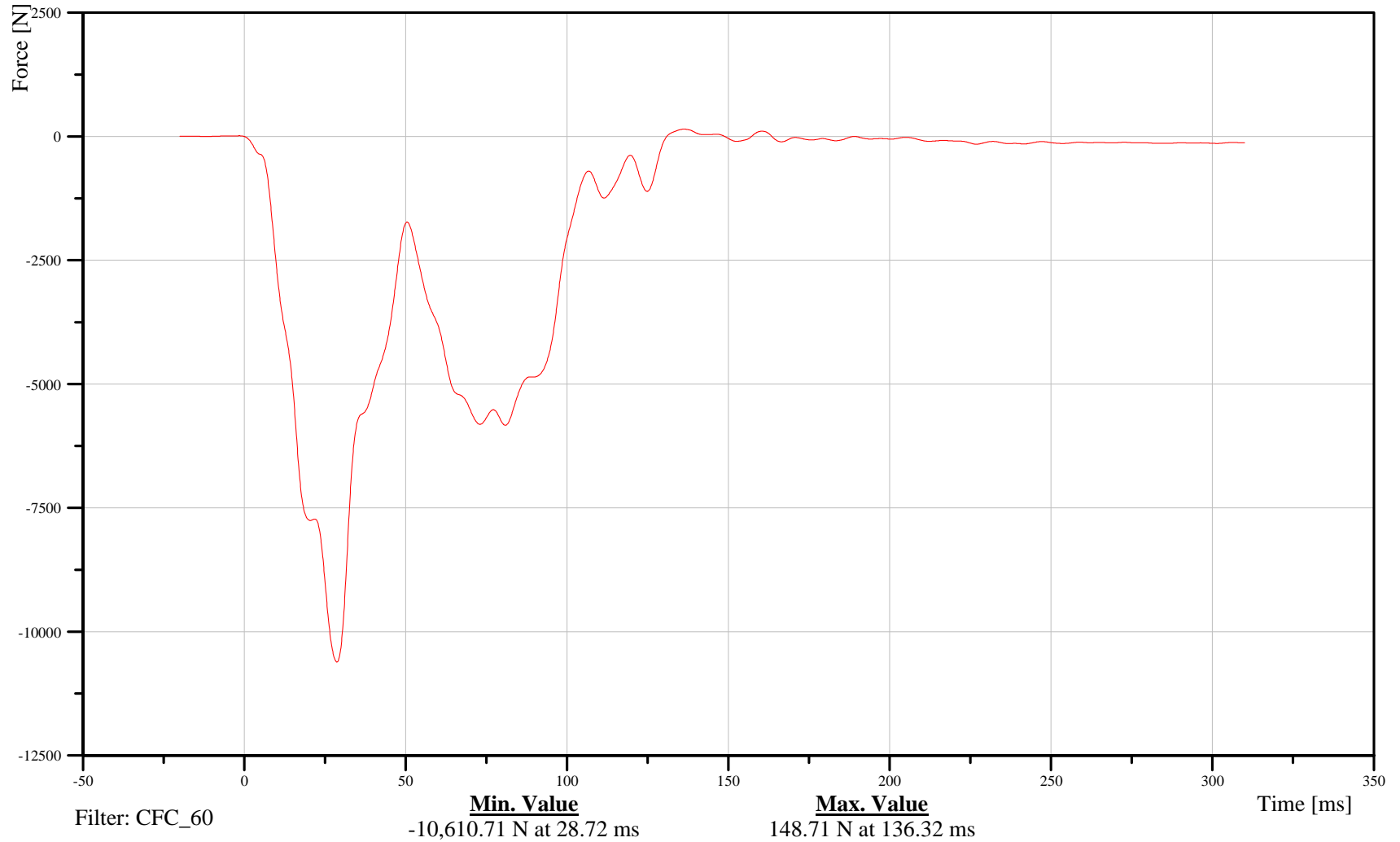

B-233

070913



2007 Ford F-250 into Left 40% Offset Deformable LCB at 56 kph

Date: 09/13/2007
Time: 15:46

Load Cell Row 6 Column 5

Customer: Volpe
Test Number: R70203

LOFBAR000046FOXD

TRC Inc. Test Lab: CTF
Test Number: 070913

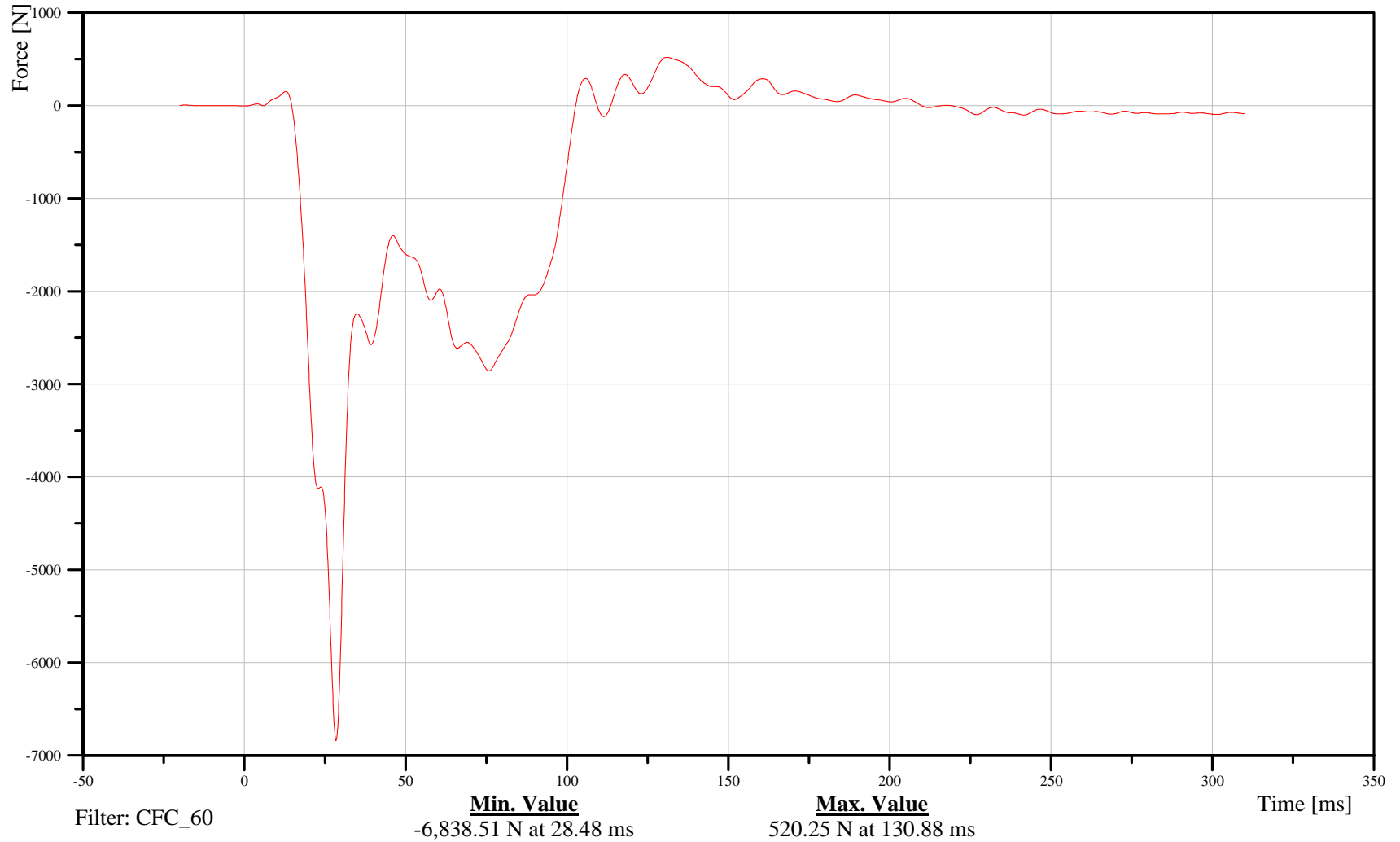

B-234

070913



2007 Ford F-250 into Left 40% Offset Deformable LCB at 56 kph

Date: 09/13/2007
Time: 15:46

Load Cell Row 7 Column 5

Customer: Volpe
Test Number: R70203

LOFBAR000047FOXD

TRC Inc. Test Lab: CTF
Test Number: 070913

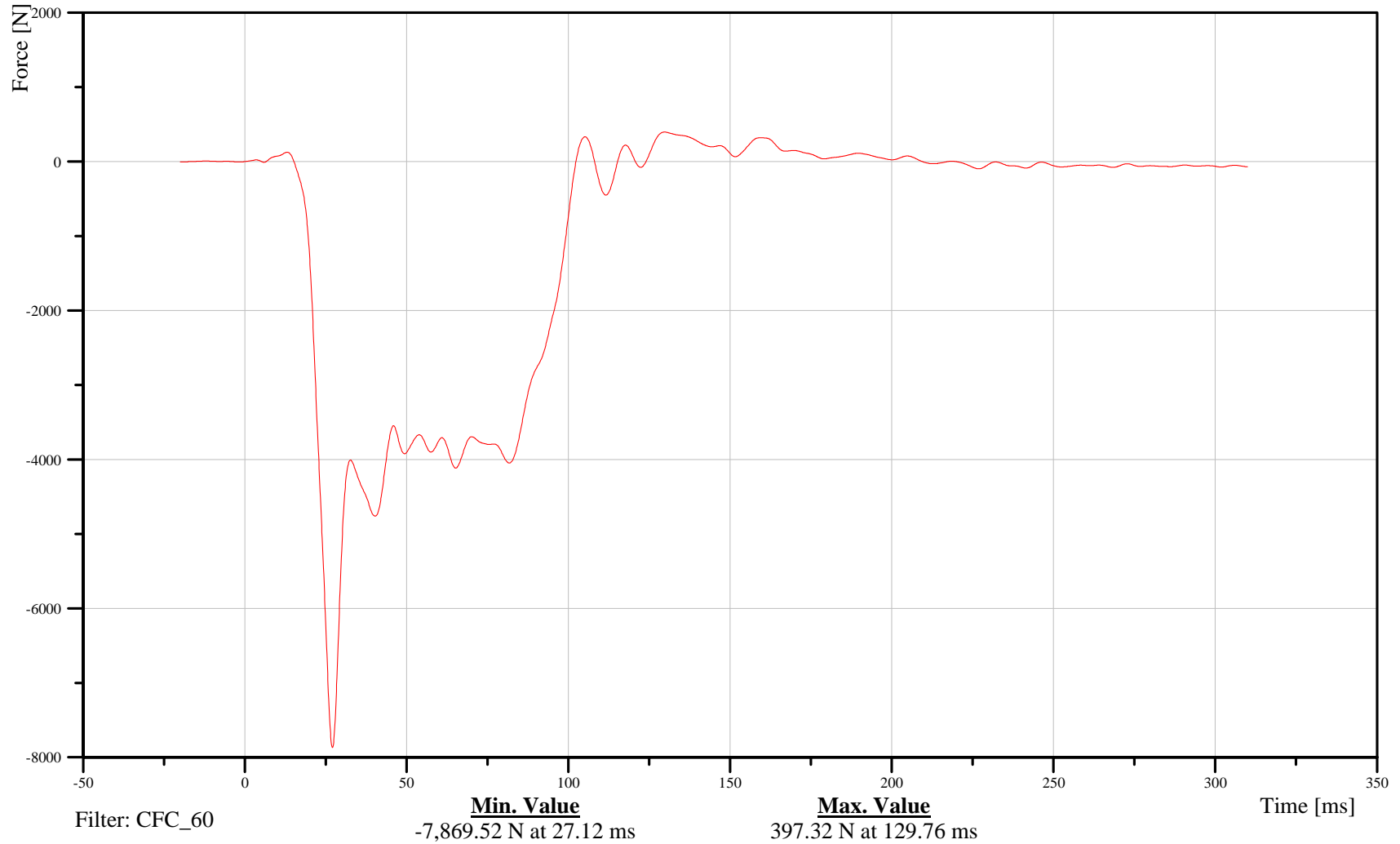

B-235

070913



2007 Ford F-250 into Left 40% Offset Deformable LCB at 56 kph

Date: 09/13/2007
Time: 15:46

Load Cell Row 8 Column 5

Customer: Volpe
Test Number: R70203

LOFBAR000048FOXD

TRC Inc. Test Lab: CTF
Test Number: 070913

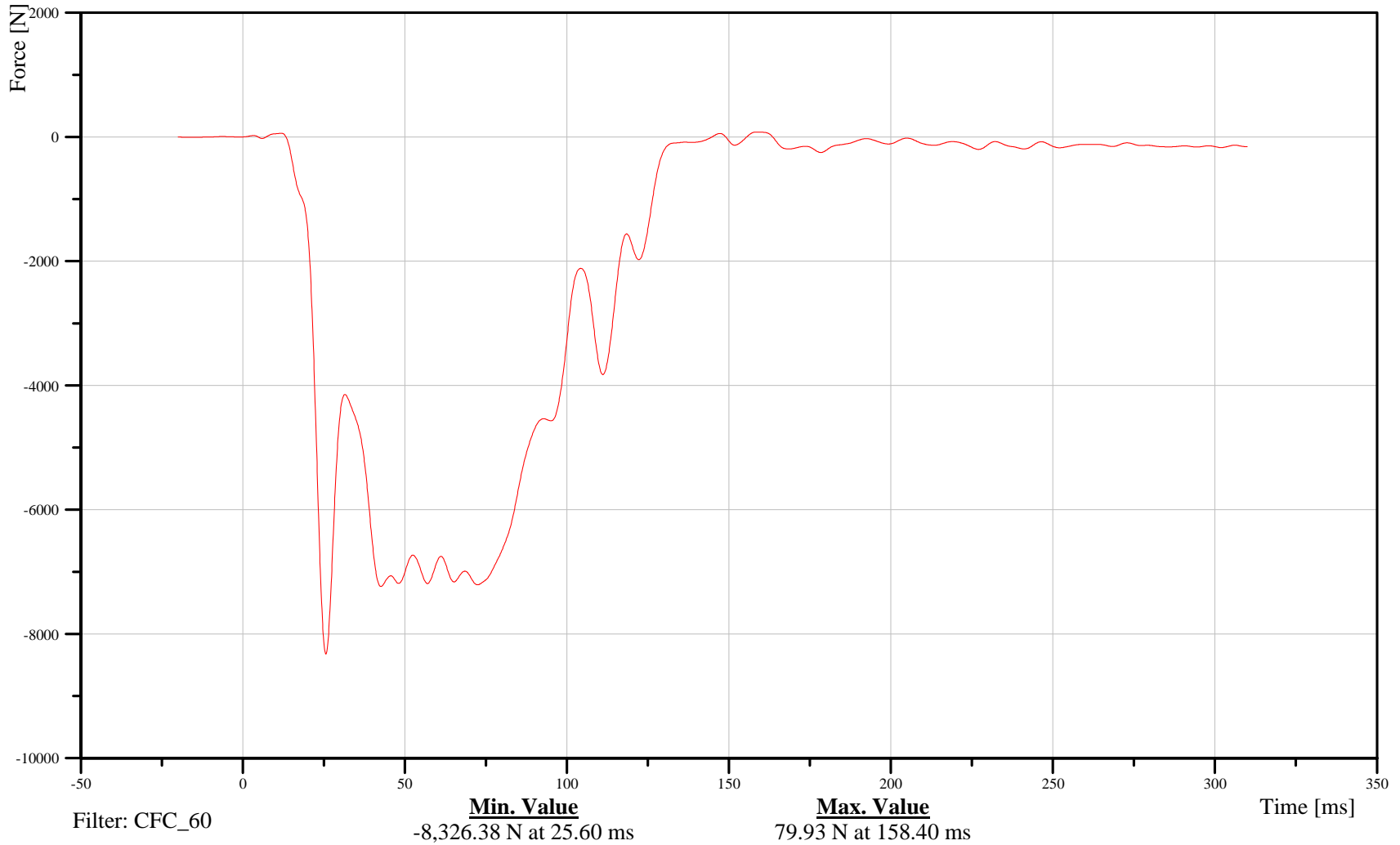

B-236

070913



2007 Ford F-250 into Left 40% Offset Deformable LCB at 56 kph

Date: 09/13/2007
Time: 15:46

Load Cell Row 9 Column 5

Customer: Volpe
Test Number: R70203

L0FBAR000049FOXD

TRC Inc. Test Lab: CTF
Test Number: 070913

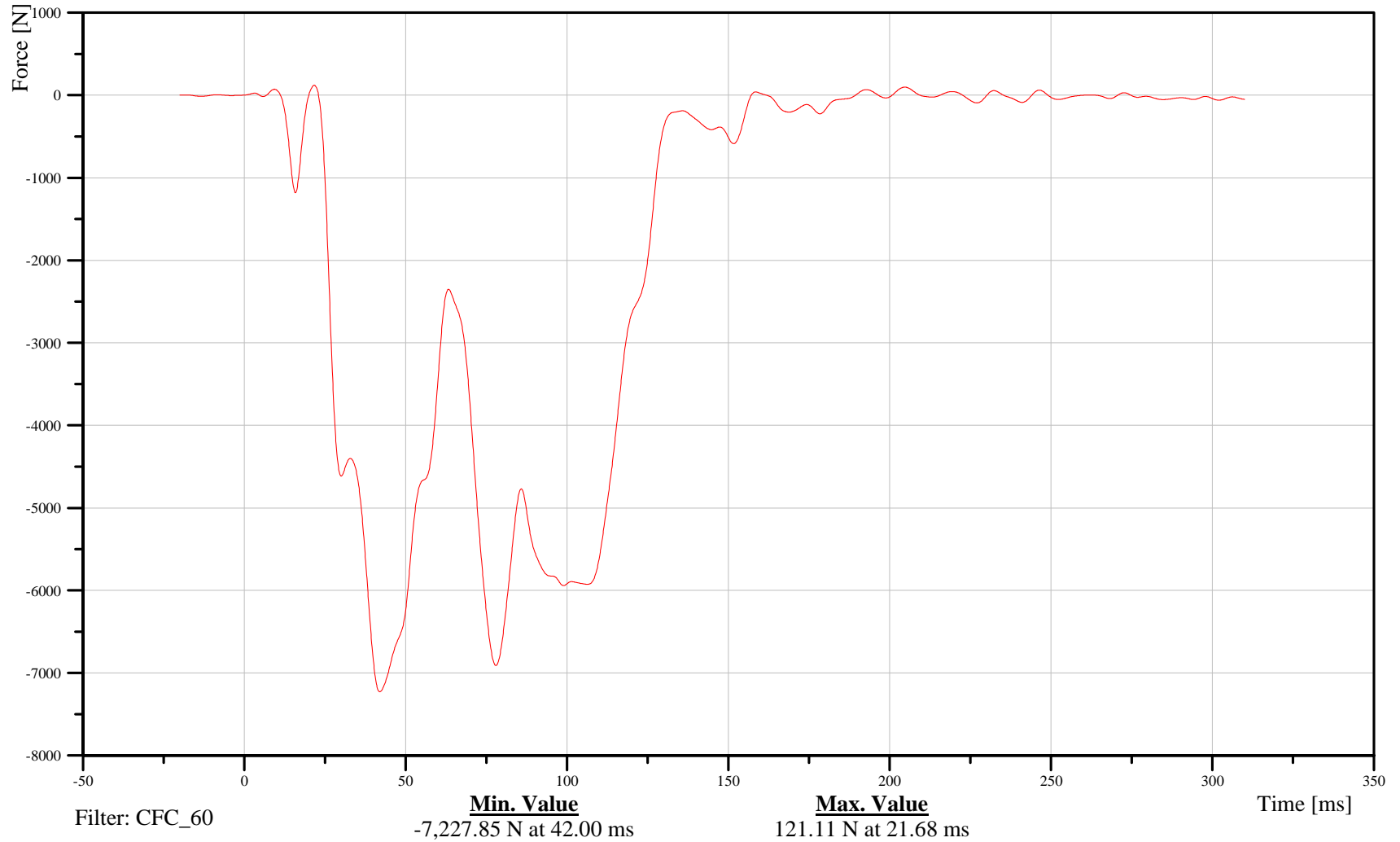

B-237

070913



2007 Ford F-250 into Left 40% Offset Deformable LCB at 56 kph

Date: 09/13/2007
Time: 15:46

Load Cell Row 10 Column 5

Customer: Volpe
Test Number: R70203

LOFBAR000050FOXD

TRC Inc. Test Lab: CTF
Test Number: 070913

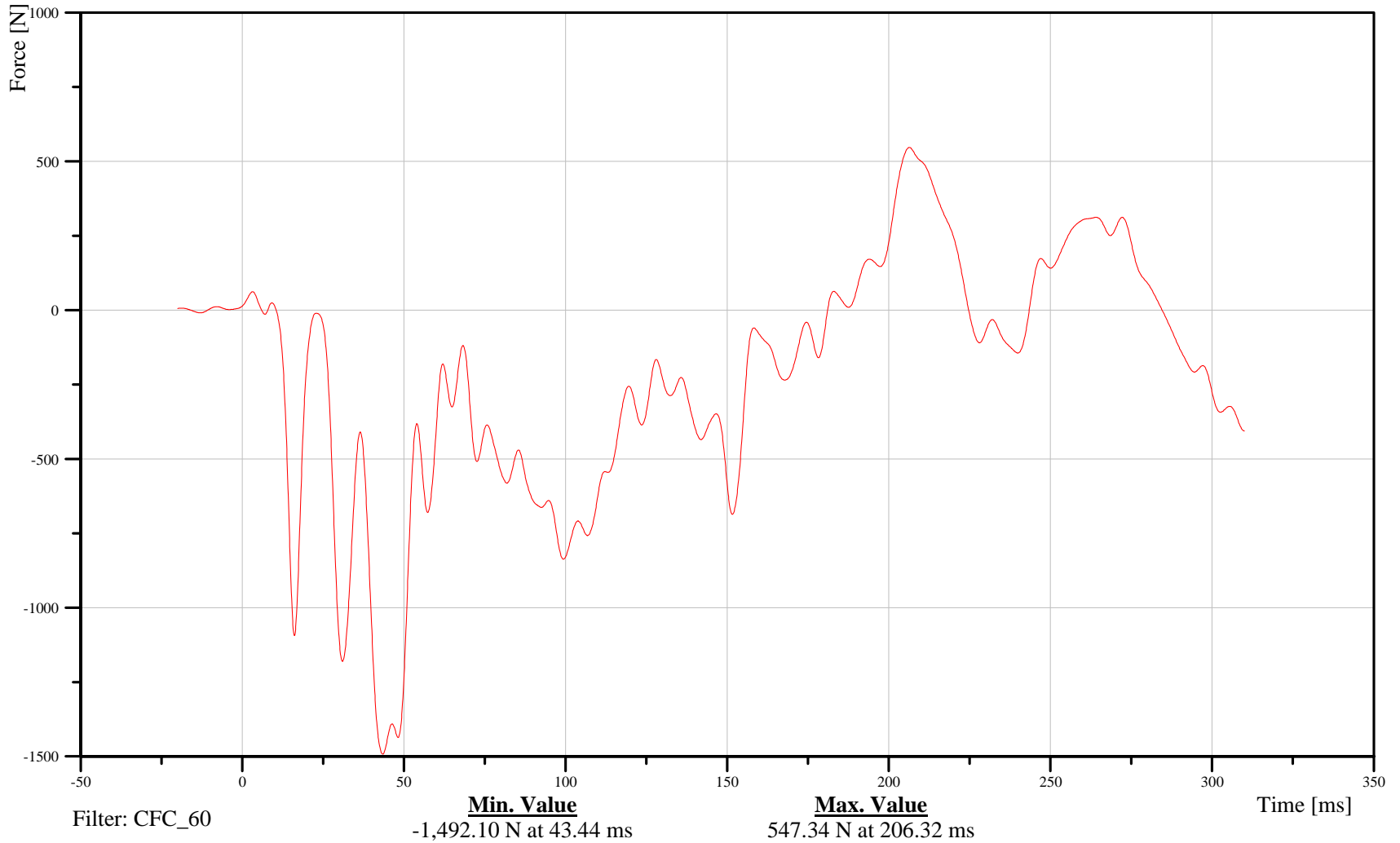

B-238

070913



2007 Ford F-250 into Left 40% Offset Deformable LCB at 56 kph

Date: 09/13/2007
Time: 15:46

Load Cell Row 1 Column 6

Customer: Volpe
Test Number: R70203

LOFBAR000051FOXD

TRC Inc. Test Lab: CTF
Test Number: 070913

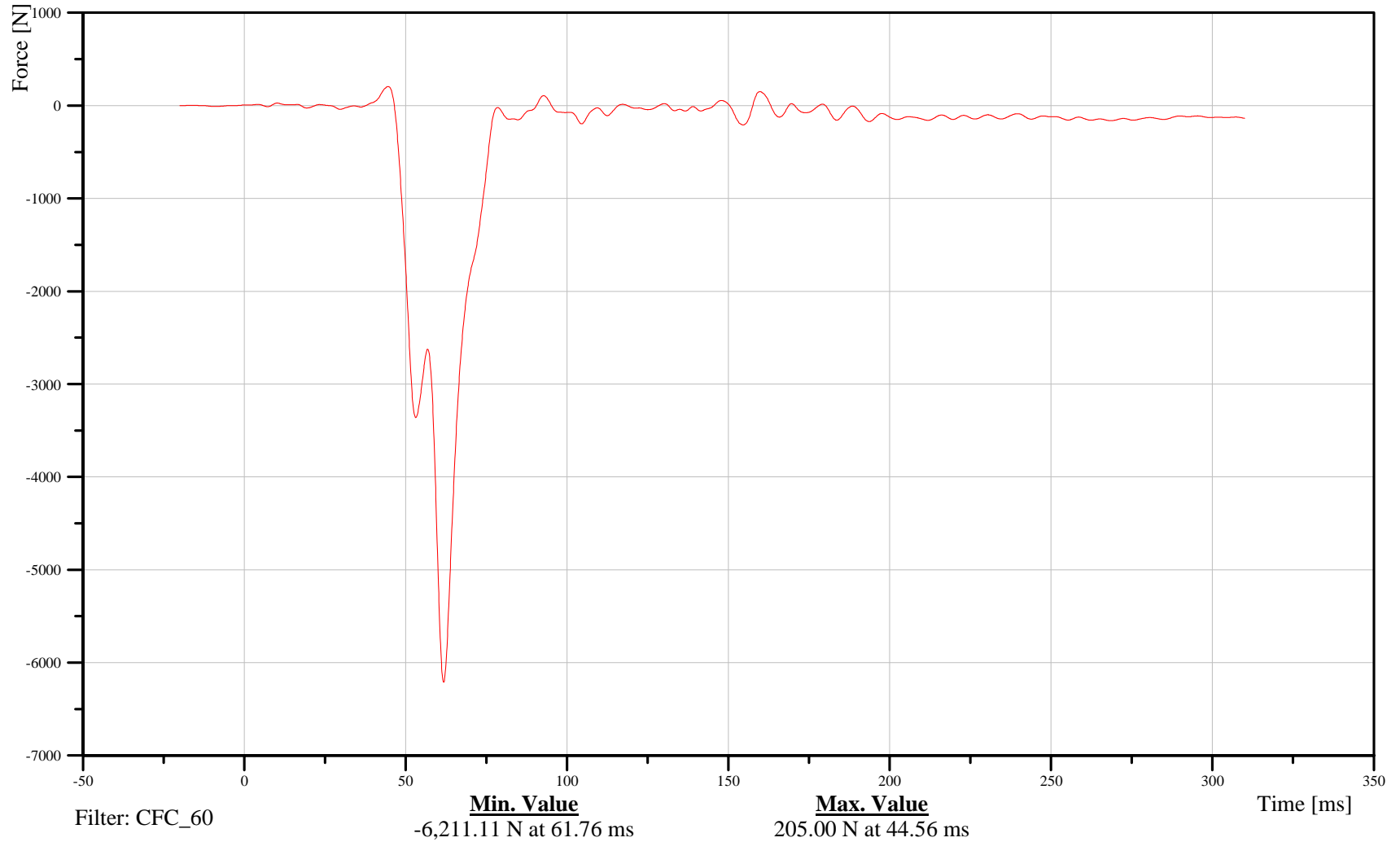

B-239

070913



2007 Ford F-250 into Left 40% Offset Deformable LCB at 56 kph

Date: 09/13/2007
Time: 15:46

Load Cell Row 2 Column 6

Customer: Volpe
Test Number: R70203

LOFBAR000052FOXD

TRC Inc. Test Lab: CTF
Test Number: 070913

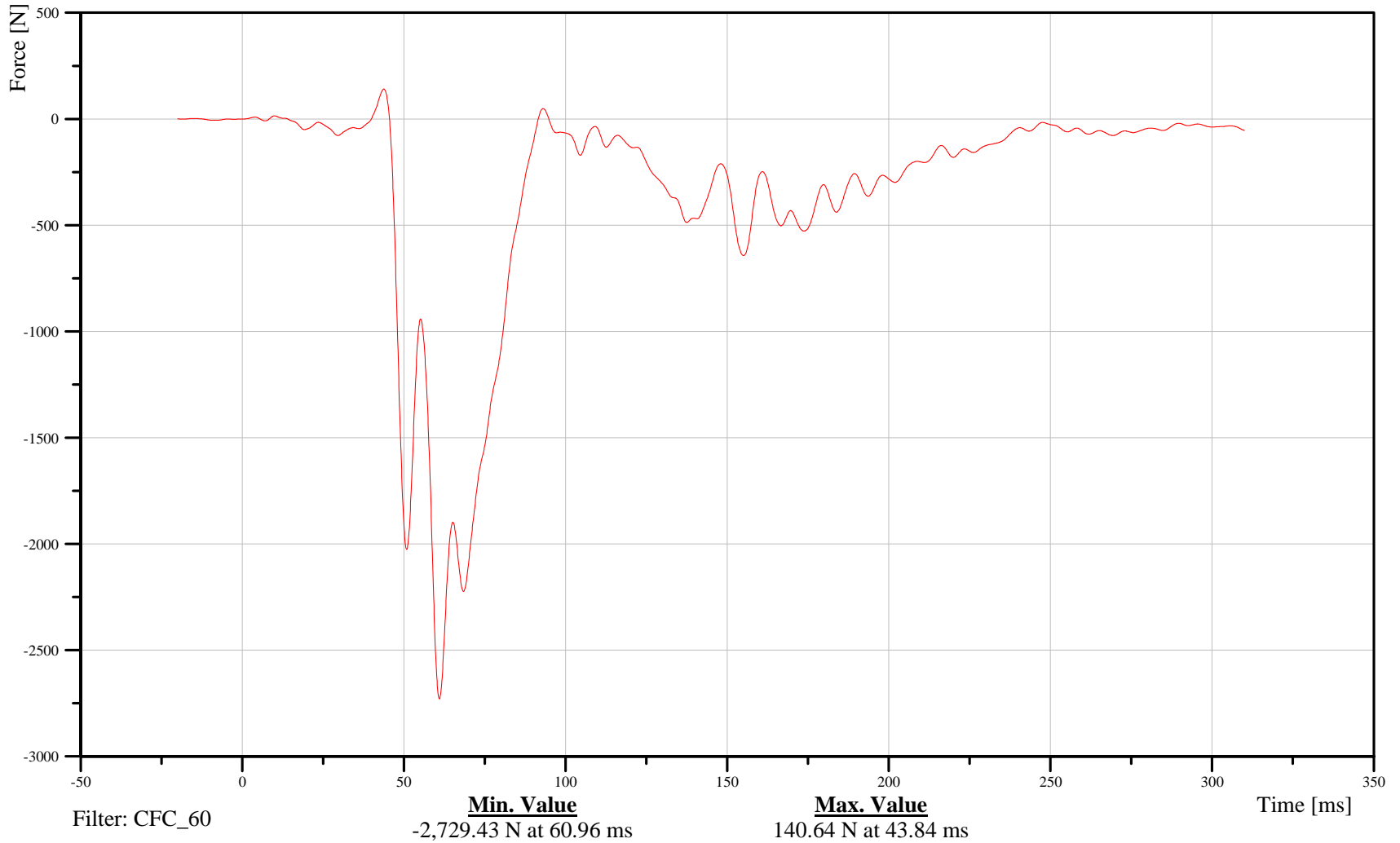

B-240

070913



2007 Ford F-250 into Left 40% Offset Deformable LCB at 56 kph

Date: 09/13/2007
Time: 15:46

Load Cell Row 3 Column 6

Customer: Volpe
Test Number: R70203

LOFBAR000053FOXD

TRC Inc. Test Lab: CTF
Test Number: 070913

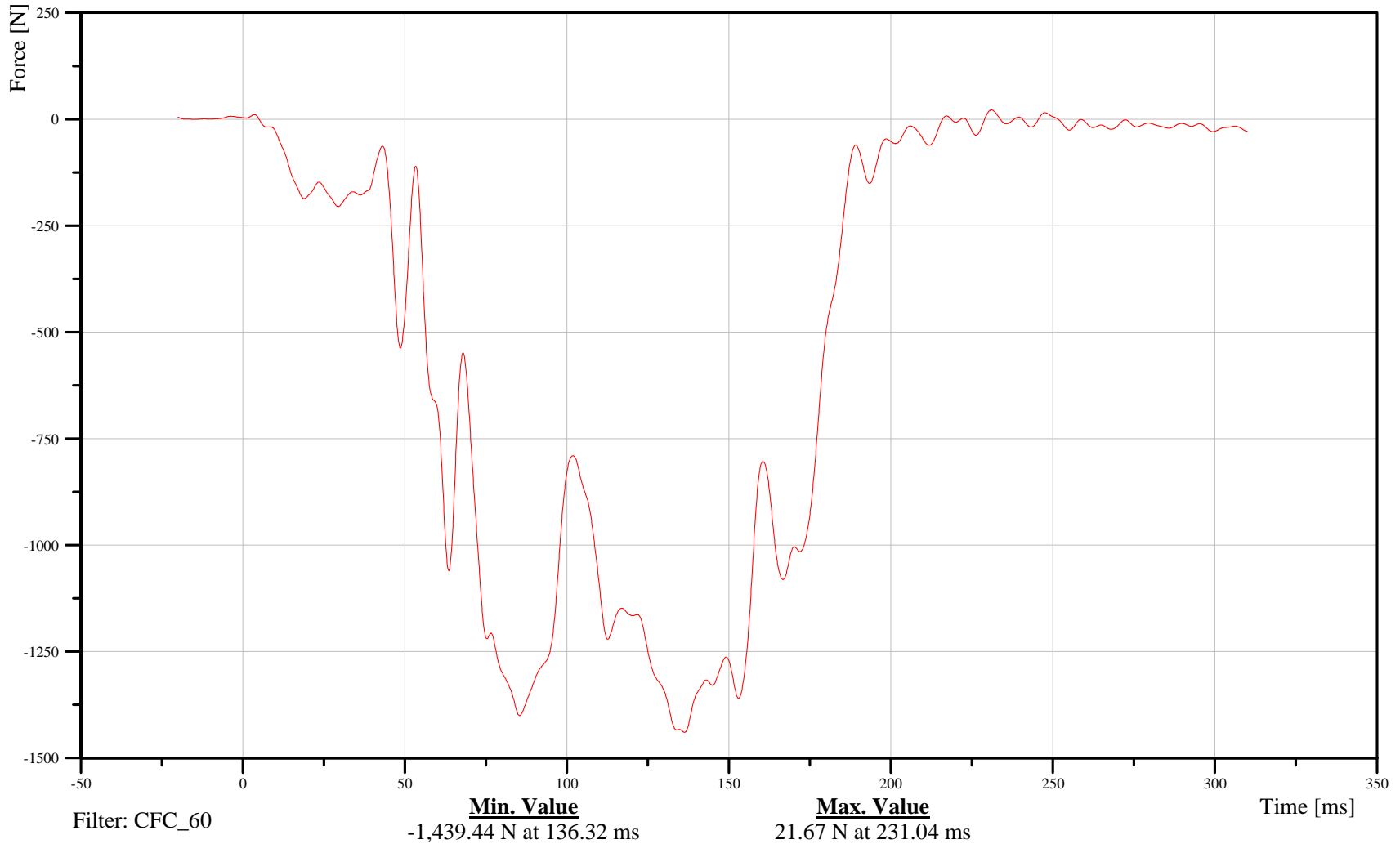

B-241

070913



2007 Ford F-250 into Left 40% Offset Deformable LCB at 56 kph

Date: 09/13/2007
Time: 15:46

Load Cell Row 4 Column 6

Customer: Volpe
Test Number: R70203

LOFBAR000054FOXD

TRC Inc. Test Lab: CTF
Test Number: 070913

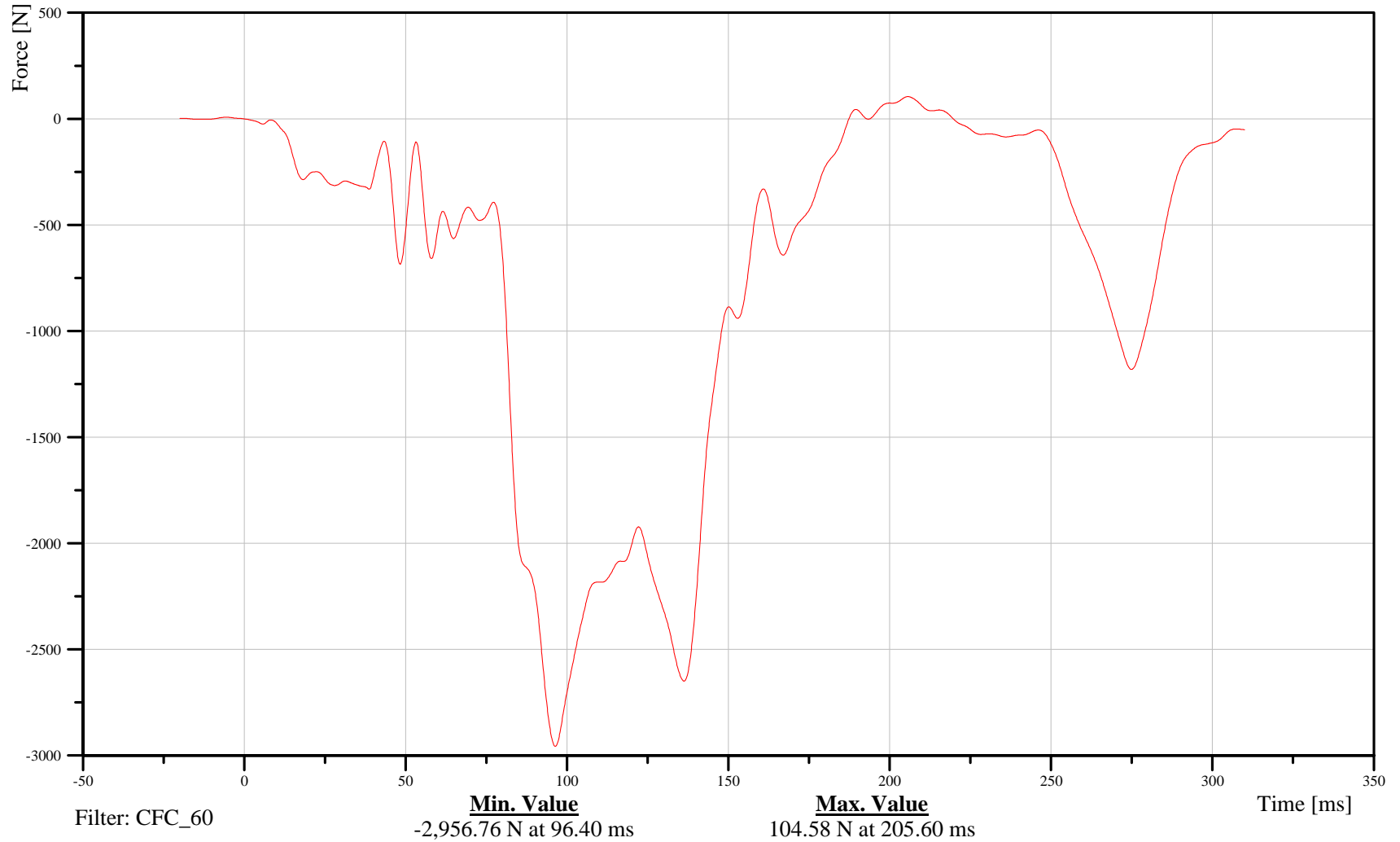

B-242

070913



2007 Ford F-250 into Left 40% Offset Deformable LCB at 56 kph

Date: 09/13/2007
Time: 15:46

Load Cell Row 5 Column 6

Customer: Volpe
Test Number: R70203

LOFBAR000055FOXD

TRC Inc. Test Lab: CTF
Test Number: 070913

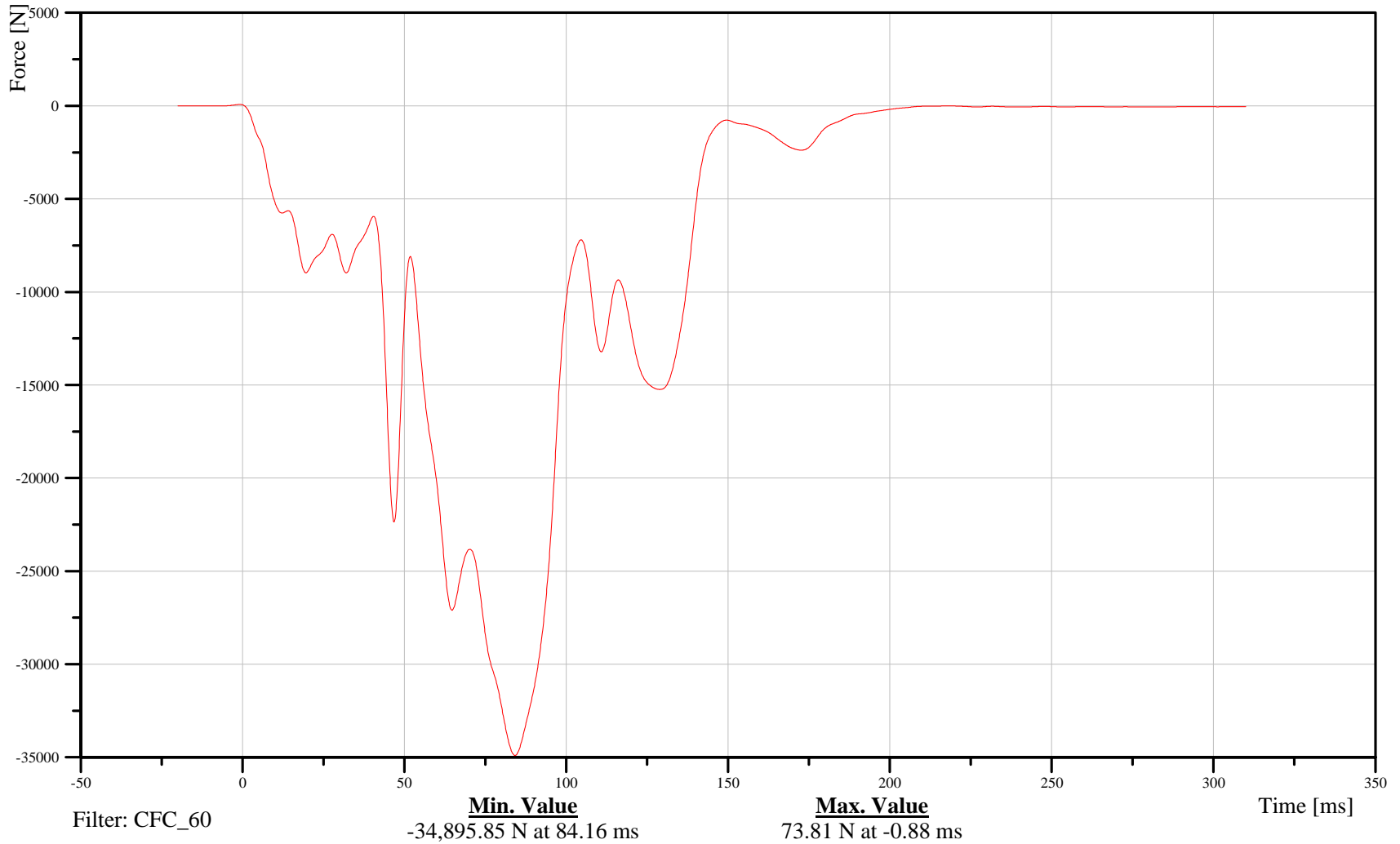

B-243

070913



2007 Ford F-250 into Left 40% Offset Deformable LCB at 56 kph

Date: 09/13/2007
Time: 15:46

Load Cell Row 6 Column 6

Customer: Volpe
Test Number: R70203

LOFBAR000056FOXD

TRC Inc. Test Lab: CTF
Test Number: 070913

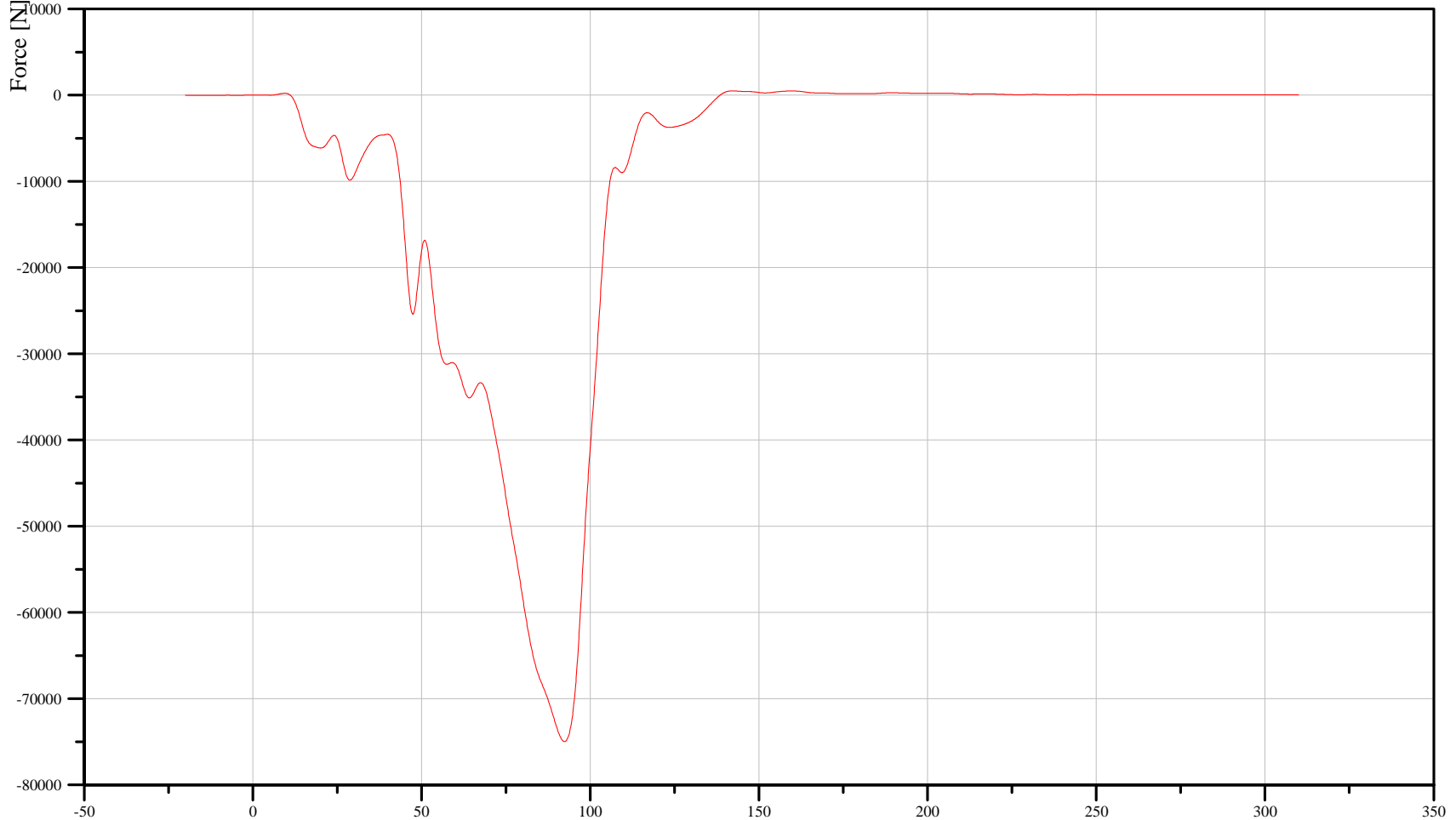

Filter: CFC_60

Min. Value
-74,964.70 N at 92.40 ms

Max. Value
505.74 N at 142.24 ms

Time [ms]

B-244

070913



2007 Ford F-250 into Left 40% Offset Deformable LCB at 56 kph

Date: 09/13/2007
Time: 15:46

Load Cell Row 7 Column 6

Customer: Volpe
Test Number: R70203

LOFBAR000057FOXD

TRC Inc. Test Lab: CTF
Test Number: 070913

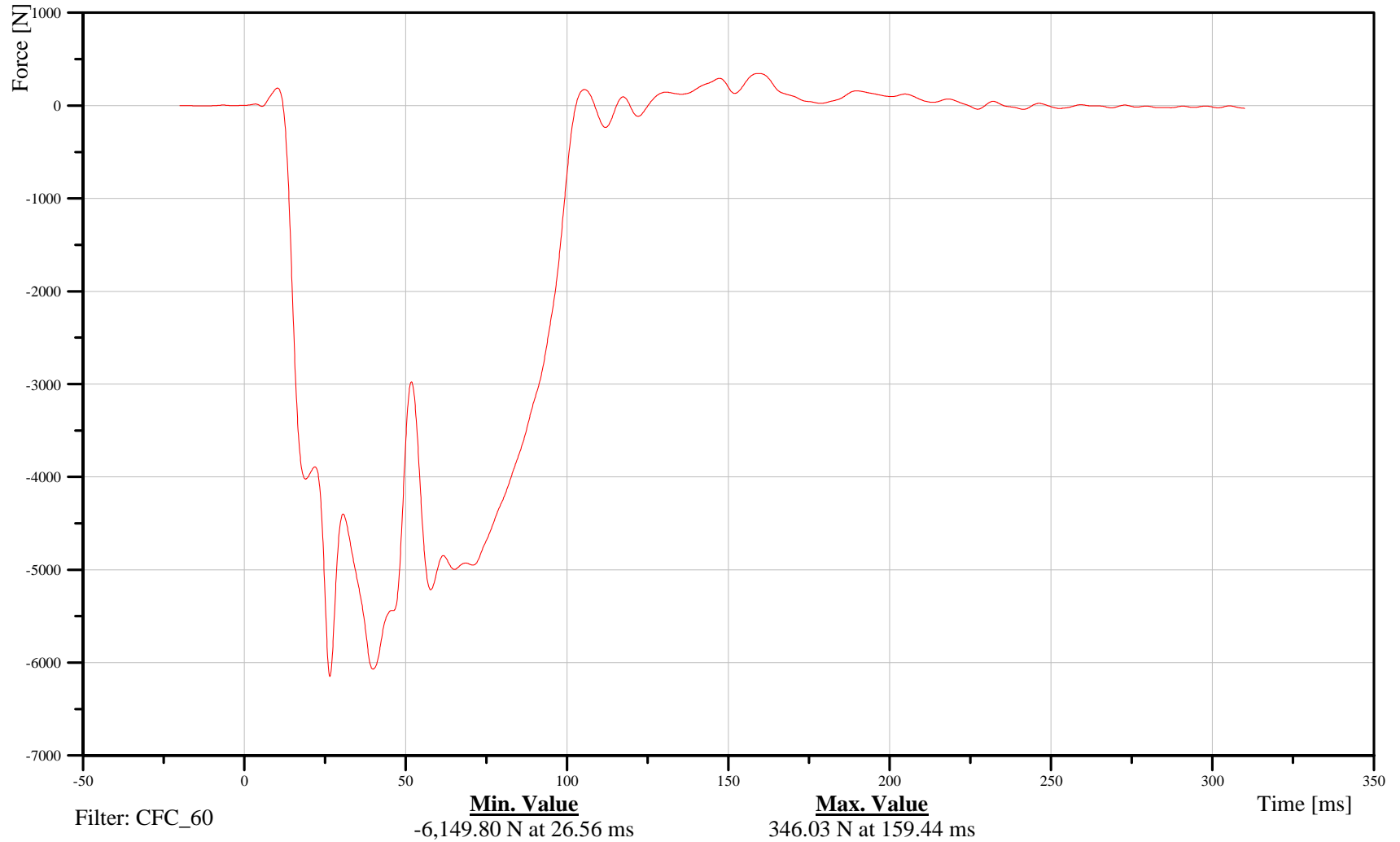

B-245

070913



2007 Ford F-250 into Left 40% Offset Deformable LCB at 56 kph

Date: 09/13/2007
Time: 15:46

Load Cell Row 8 Column 6

Customer: Volpe
Test Number: R70203

LOFBAR000058FOXD

TRC Inc. Test Lab: CTF
Test Number: 070913

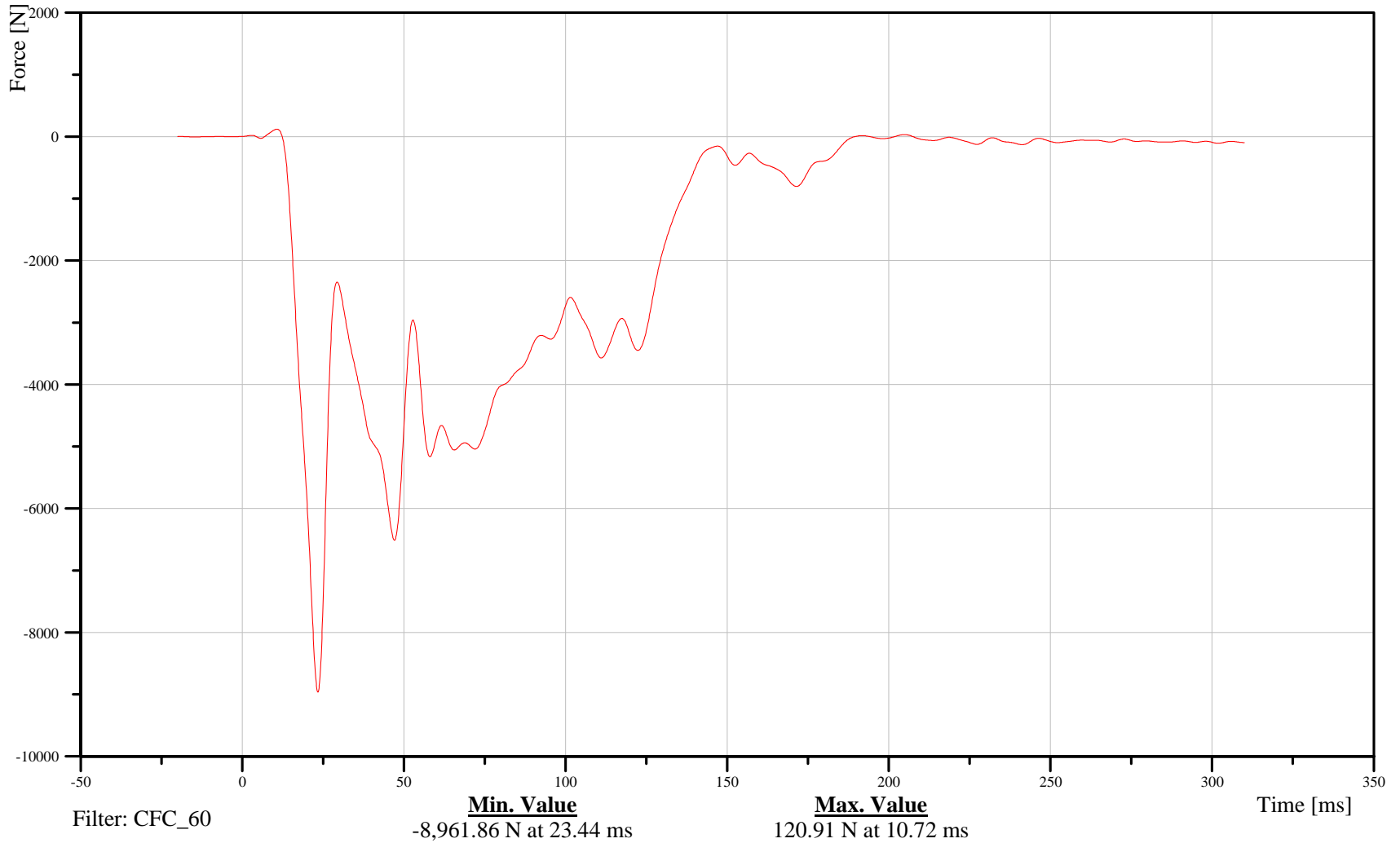

B-246

070913



2007 Ford F-250 into Left 40% Offset Deformable LCB at 56 kph

Date: 09/13/2007
Time: 15:46

Load Cell Row 9 Column 6

Customer: Volpe
Test Number: R70203

LOFBAR000059FOXD

TRC Inc. Test Lab: CTF
Test Number: 070913

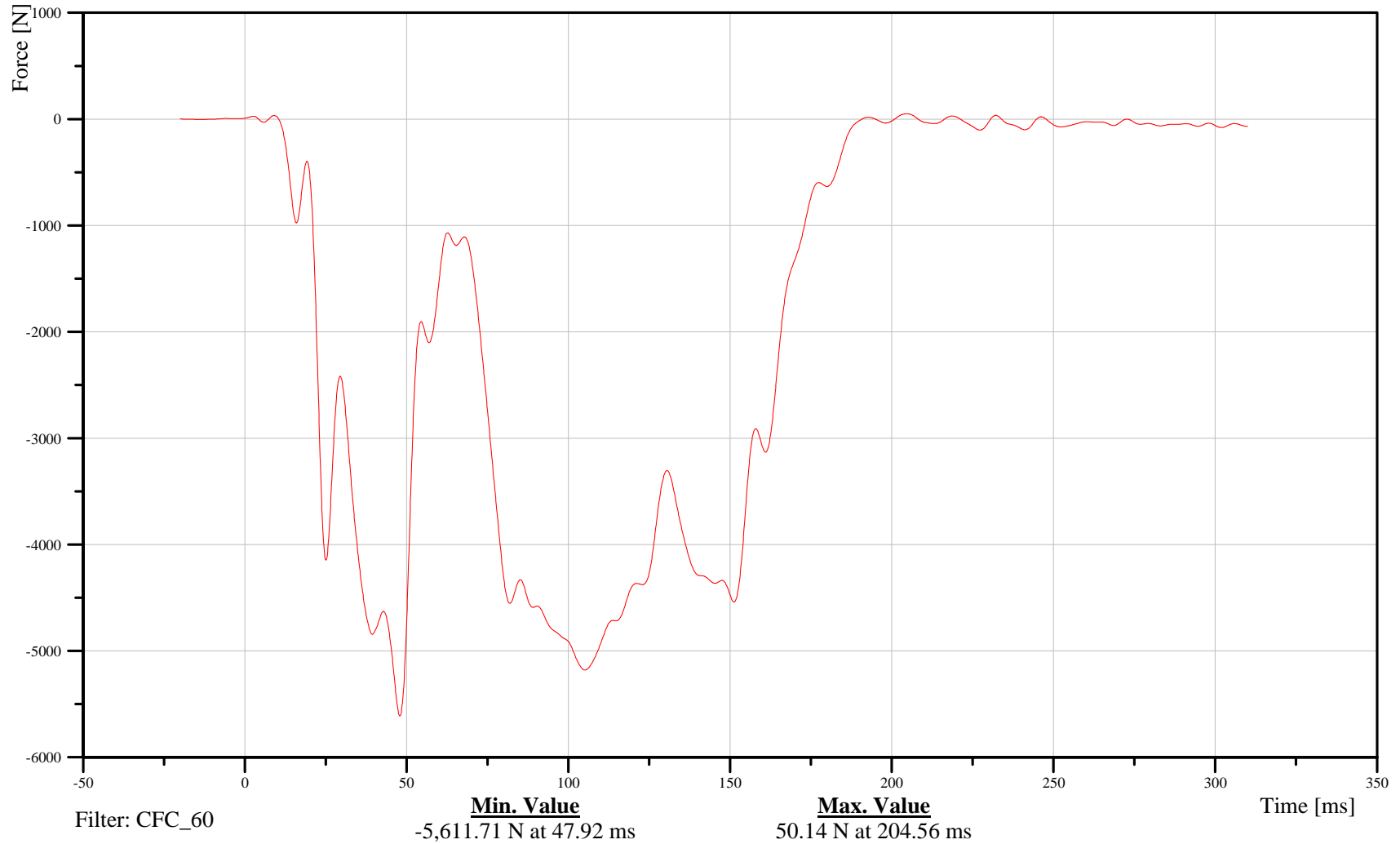

B-247

070913



2007 Ford F-250 into Left 40% Offset Deformable LCB at 56 kph

Date: 09/13/2007
Time: 15:46

Load Cell Row 10 Column 6

Customer: Volpe
Test Number: R70203

LOFBAR000060FOXD

TRC Inc. Test Lab: CTF
Test Number: 070913

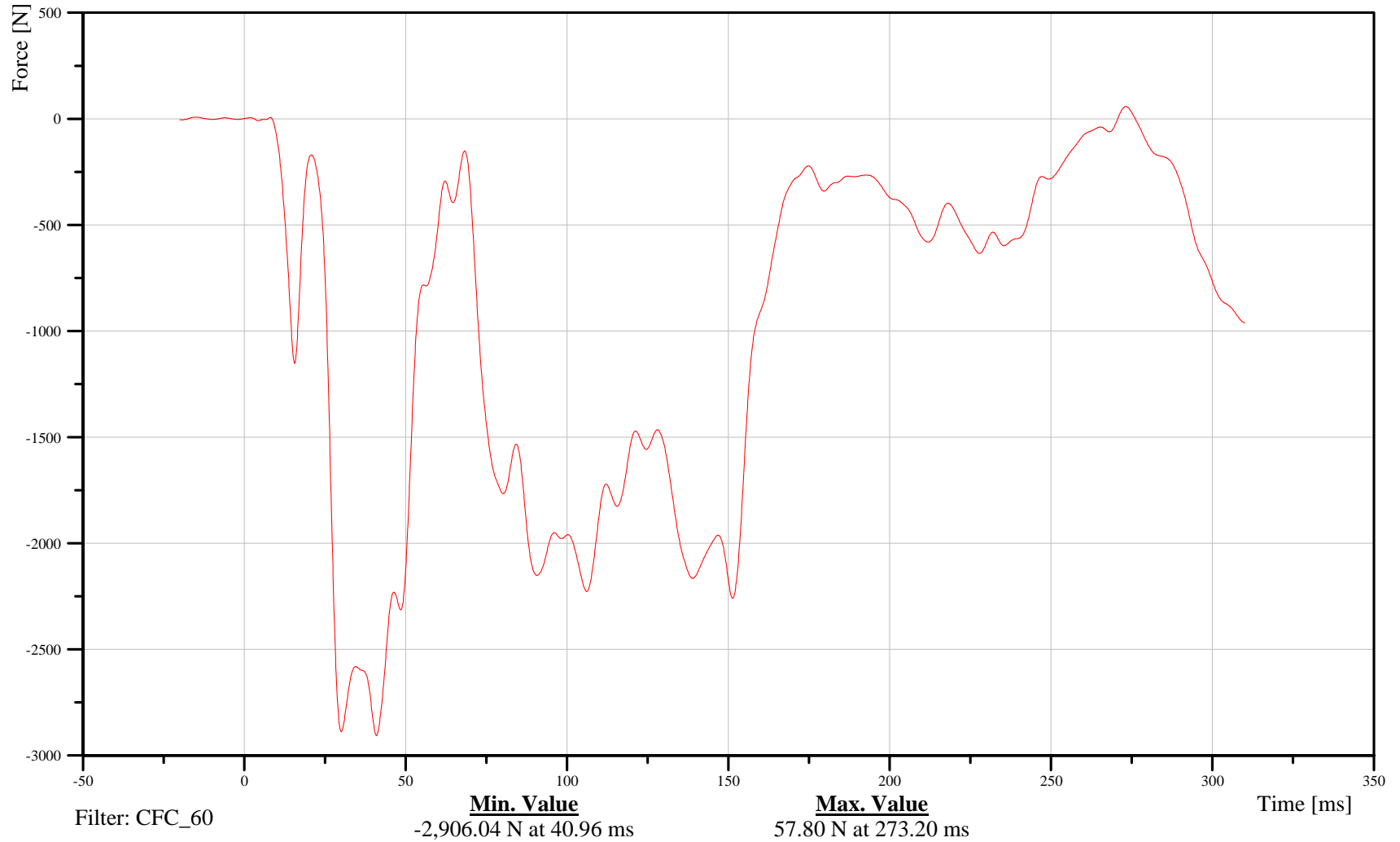

B-248

070913



2007 Ford F-250 into Left 40% Offset Deformable LCB at 56 kph

Date: 09/13/2007
Time: 15:46

Load Cell Row 1 Column 7

Customer: Volpe
Test Number: R70203

LOFBAR000061FOXD

TRC Inc. Test Lab: CTF
Test Number: 070913

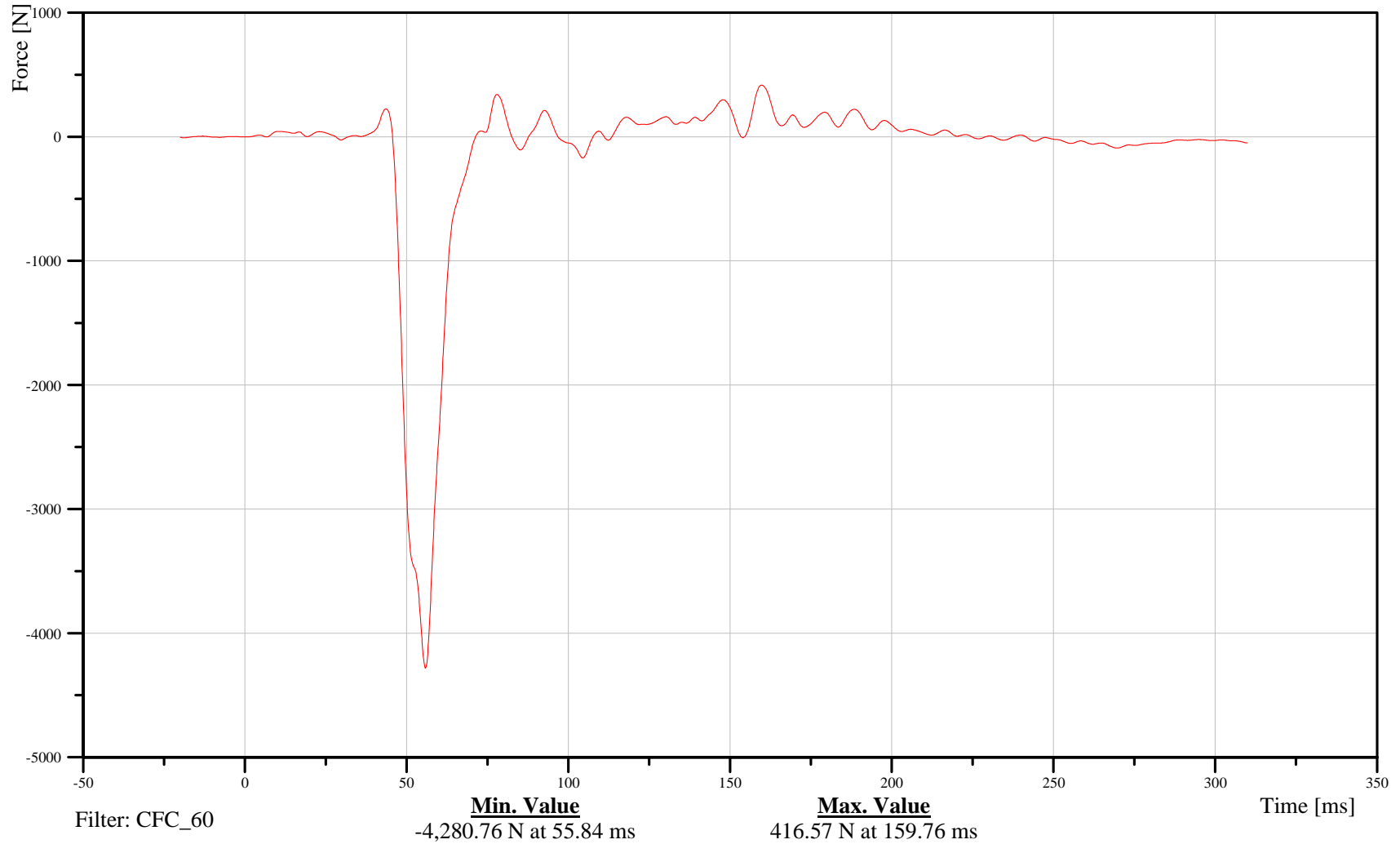

B-249

070913



2007 Ford F-250 into Left 40% Offset Deformable LCB at 56 kph

Date: 09/13/2007
Time: 15:46

Load Cell Row 2 Column 7

Customer: Volpe
Test Number: R70203

LOFBAR000062FOXD

TRC Inc. Test Lab: CTF
Test Number: 070913

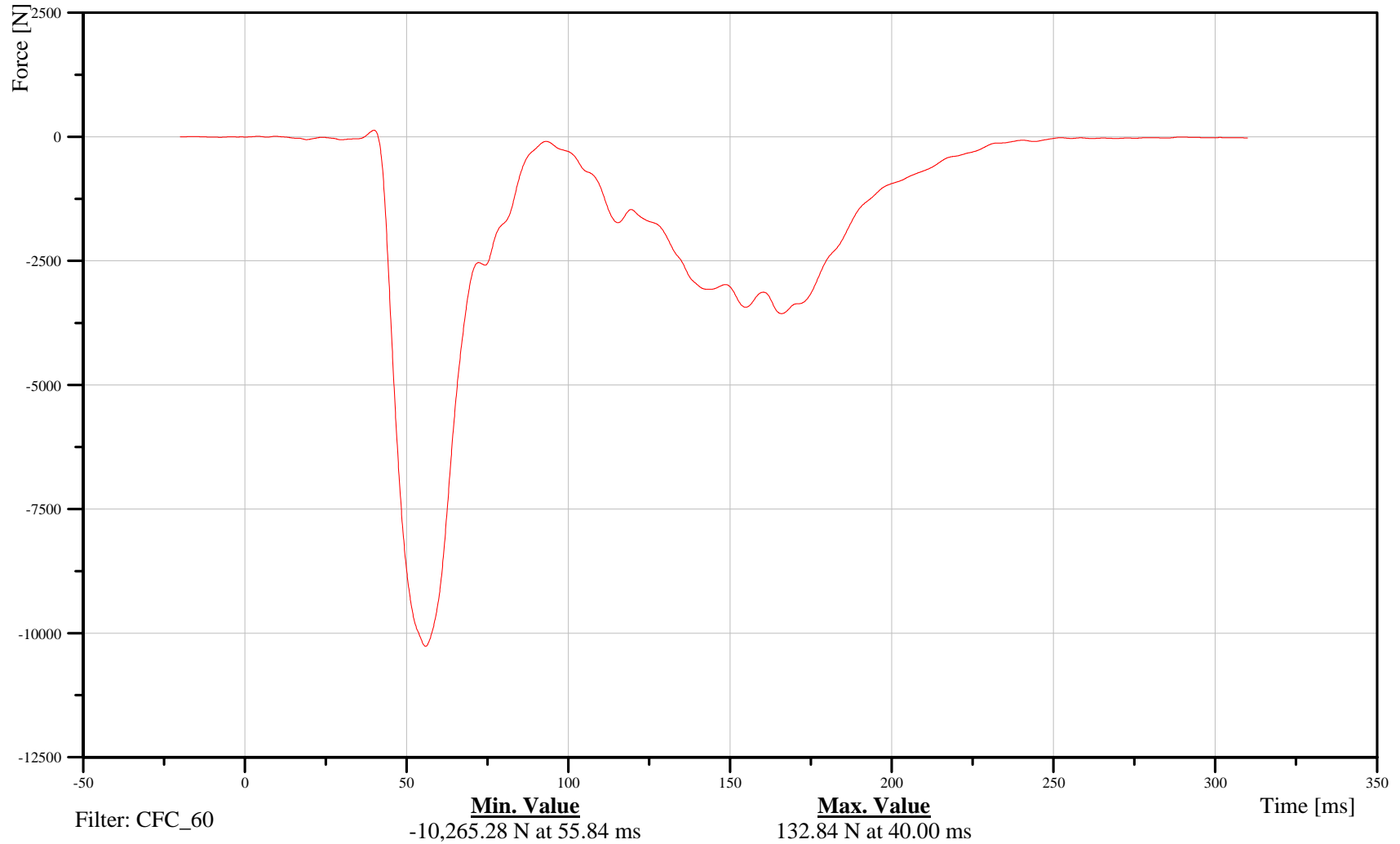

B-250

070913



2007 Ford F-250 into Left 40% Offset Deformable LCB at 56 kph

Date: 09/13/2007
Time: 15:46

Load Cell Row 3 Column 7

Customer: Volpe
Test Number: R70203

LOFBAR000063FOXD

TRC Inc. Test Lab: CTF
Test Number: 070913

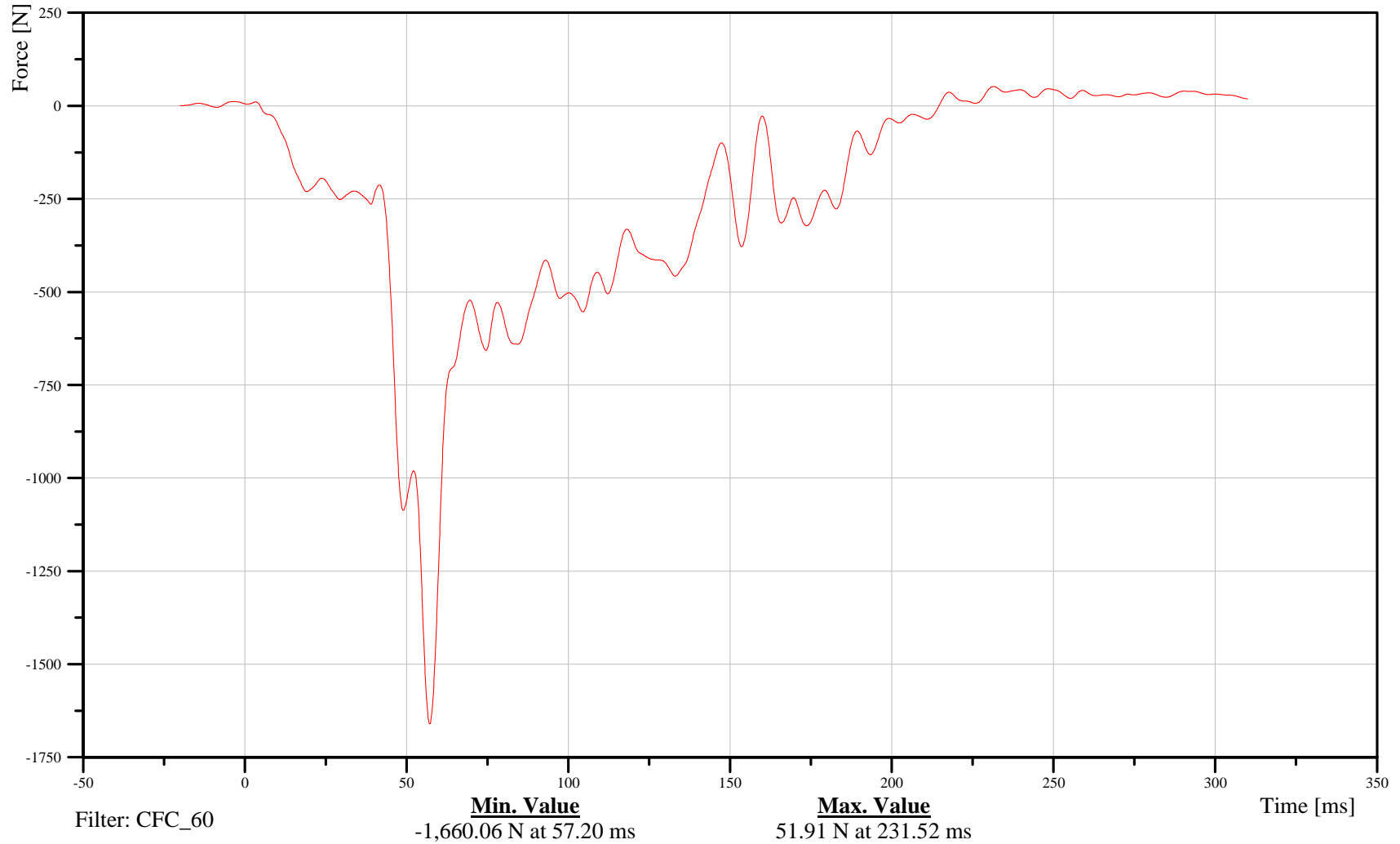

B-251

070913



2007 Ford F-250 into Left 40% Offset Deformable LCB at 56 kph

Date: 09/13/2007
Time: 15:46

Load Cell Row 4 Column 7

Customer: Volpe
Test Number: R70203

LOFBAR000064FOXD

TRC Inc. Test Lab: CTF
Test Number: 070913

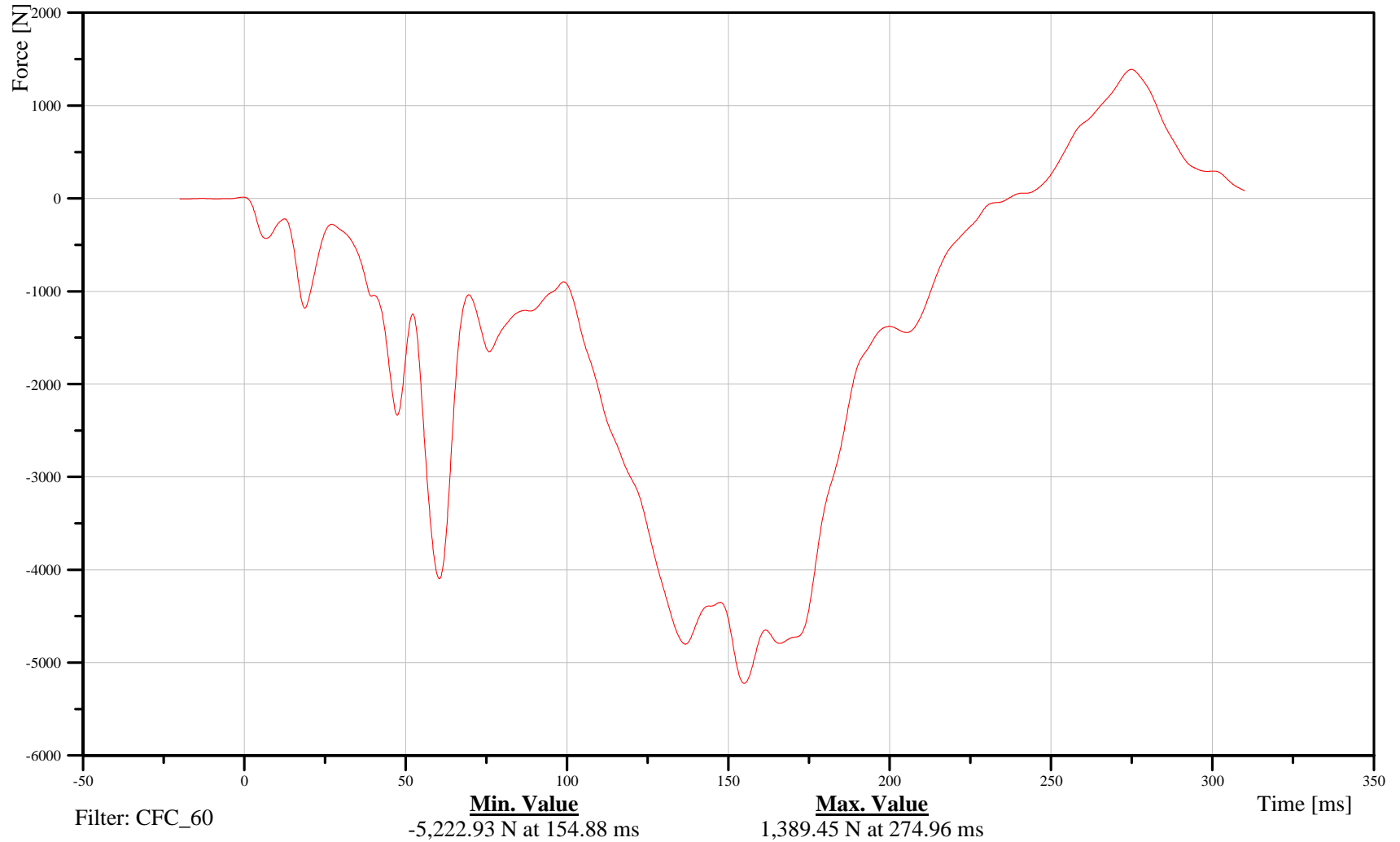

B-252

070913



2007 Ford F-250 into Left 40% Offset Deformable LCB at 56 kph

Date: 09/13/2007
Time: 15:46

Load Cell Row 5 Column 7

Customer: Volpe
Test Number: R70203

LOFBAR000065FOXD

TRC Inc. Test Lab: CTF
Test Number: 070913

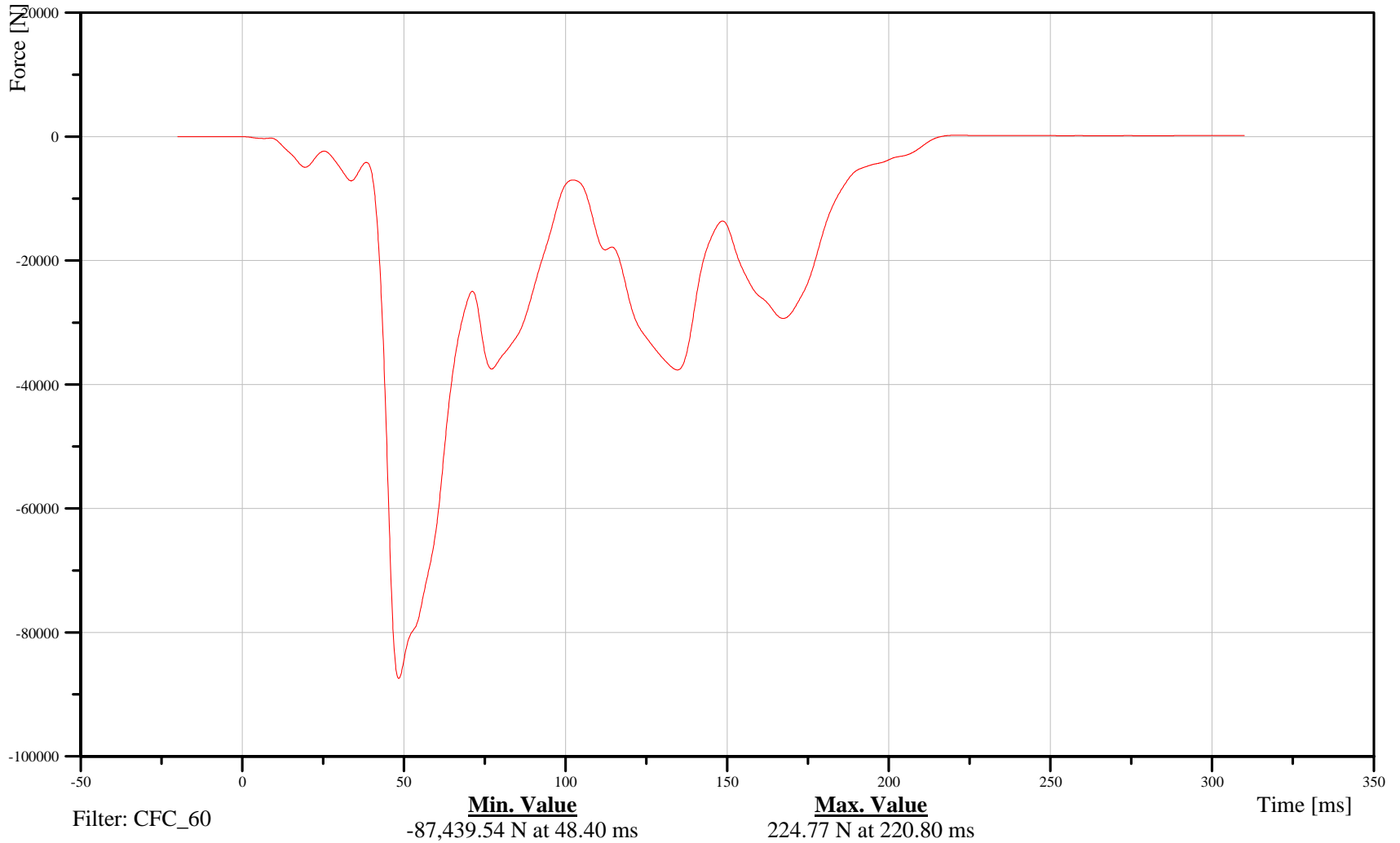

B-253

070913



2007 Ford F-250 into Left 40% Offset Deformable LCB at 56 kph

Date: 09/13/2007
Time: 15:46

Load Cell Row 6 Column 7

Customer: Volpe
Test Number: R70203

LOFBAR000066FOXD

TRC Inc. Test Lab: CTF
Test Number: 070913

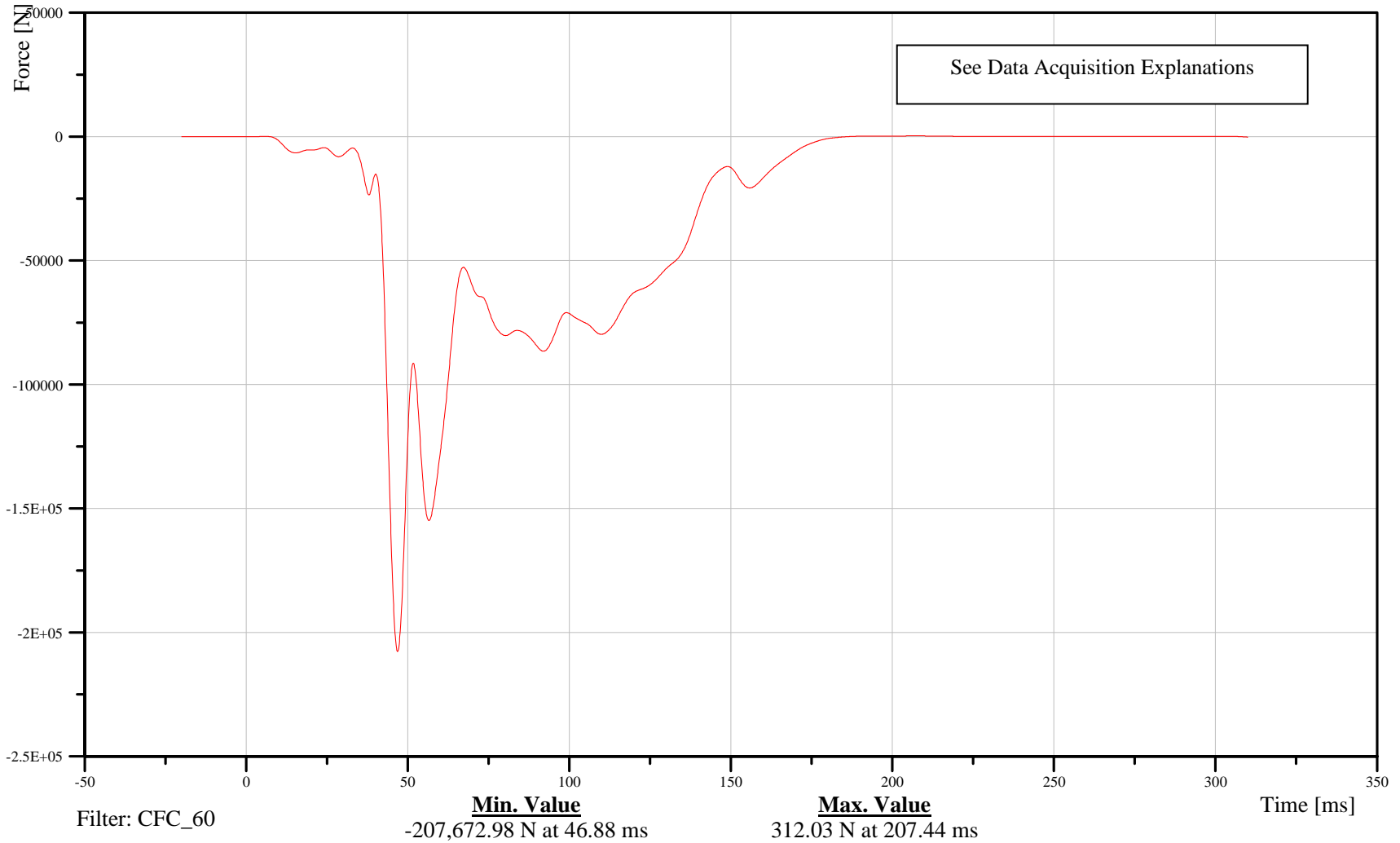

B-254

070913



2007 Ford F-250 into Left 40% Offset Deformable LCB at 56 kph

Date: 09/13/2007
Time: 15:46

Load Cell Row 7 Column 7

Customer: Volpe
Test Number: R70203

LOFBAR000067FOXD

TRC Inc. Test Lab: CTF
Test Number: 070913

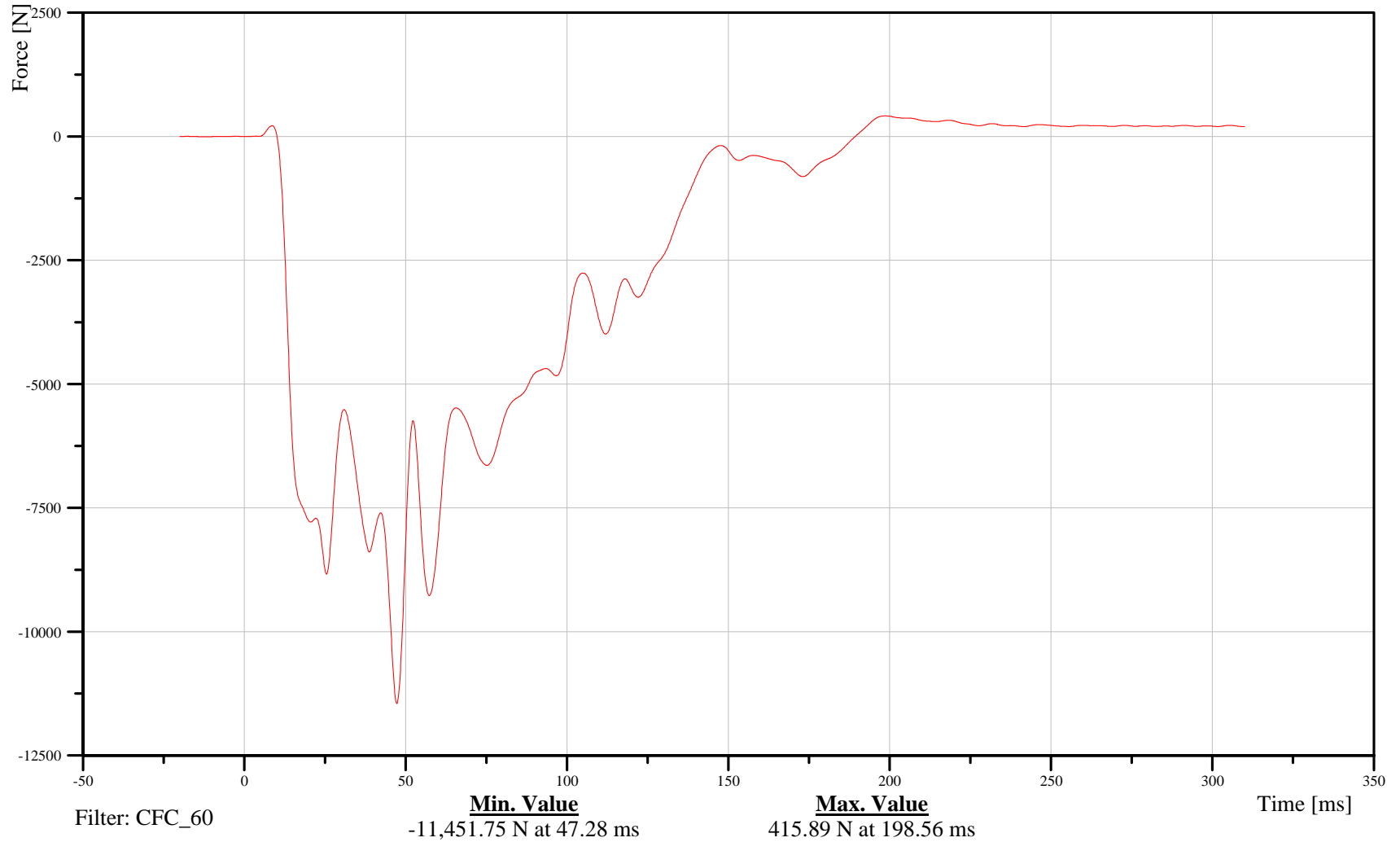

B-255

070913



2007 Ford F-250 into Left 40% Offset Deformable LCB at 56 kph

Date: 09/13/2007
Time: 15:46

Load Cell Row 8 Column 7

Customer: Volpe
Test Number: R70203

LOFBAR000068FOXD

TRC Inc. Test Lab: CTF
Test Number: 070913

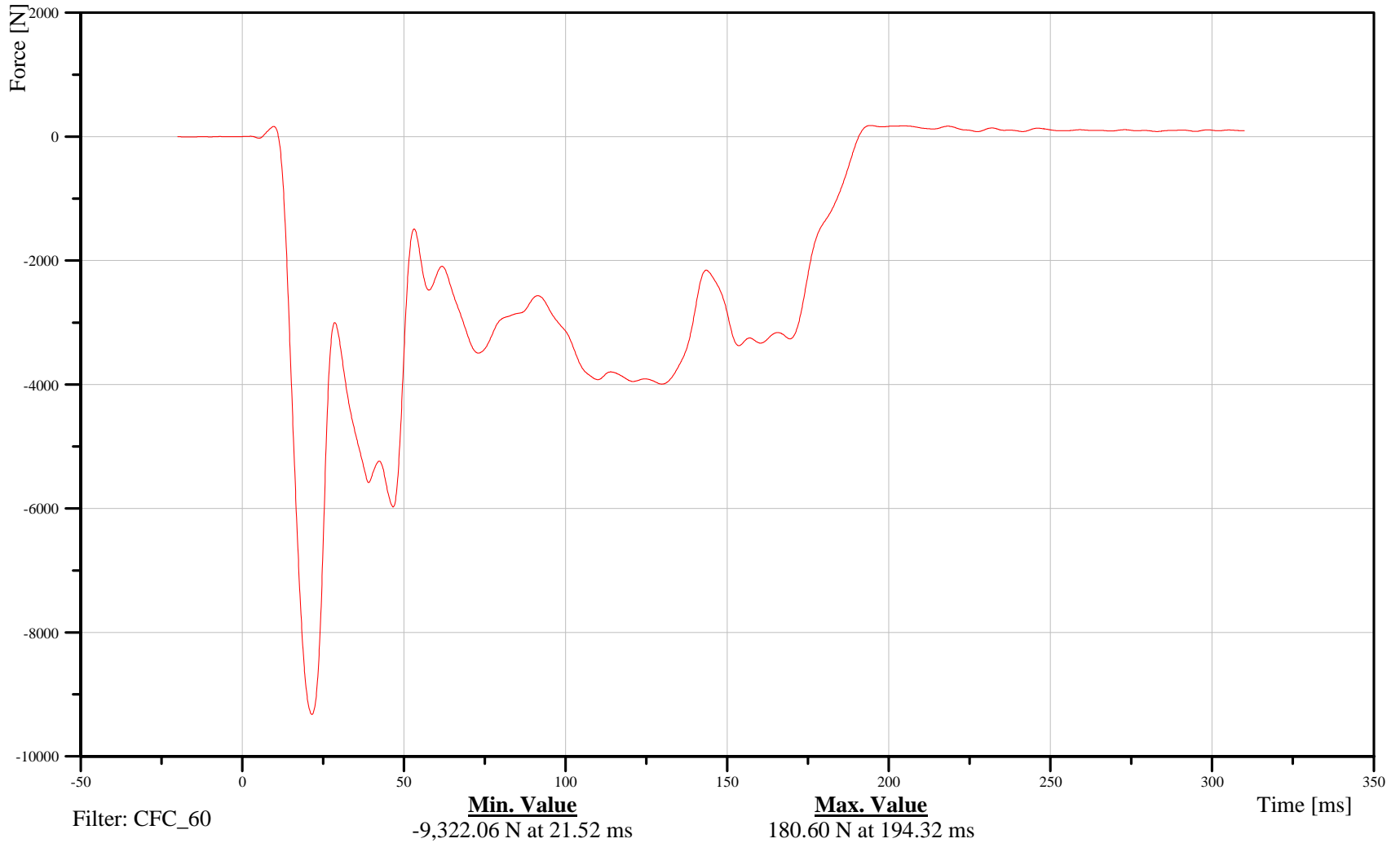

B-256

070913



2007 Ford F-250 into Left 40% Offset Deformable LCB at 56 kph

Date: 09/13/2007
Time: 15:46

Load Cell Row 9 Column 7

Customer: Volpe
Test Number: R70203

LOFBAR000069FOXD

TRC Inc. Test Lab: CTF
Test Number: 070913

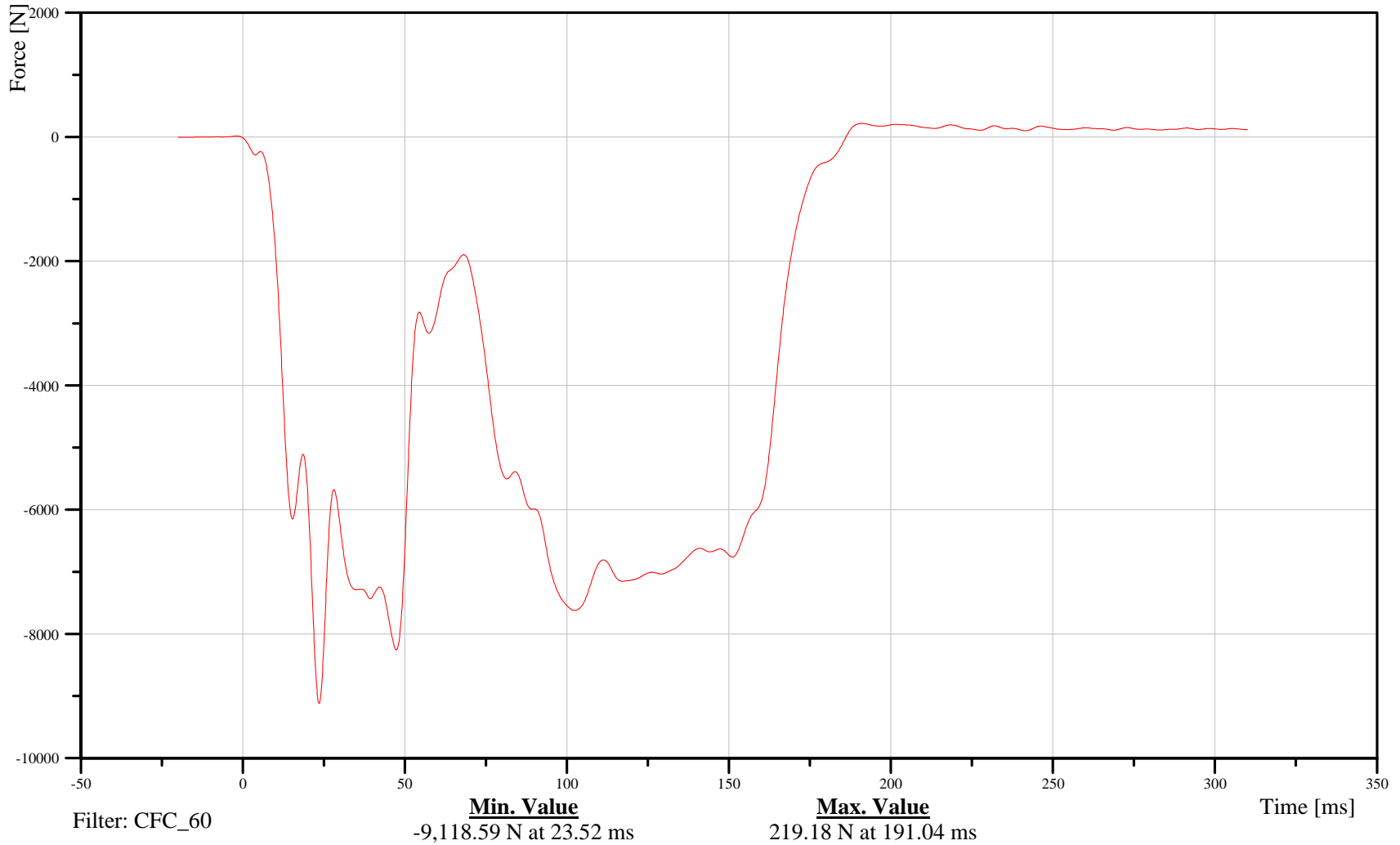

B-257

070913



2007 Ford F-250 into Left 40% Offset Deformable LCB at 56 kph

Date: 09/13/2007
Time: 15:46

Load Cell Row 10 Column 7

Customer: Volpe
Test Number: R70203

LOFBAR000070FOXD

TRC Inc. Test Lab: CTF
Test Number: 070913

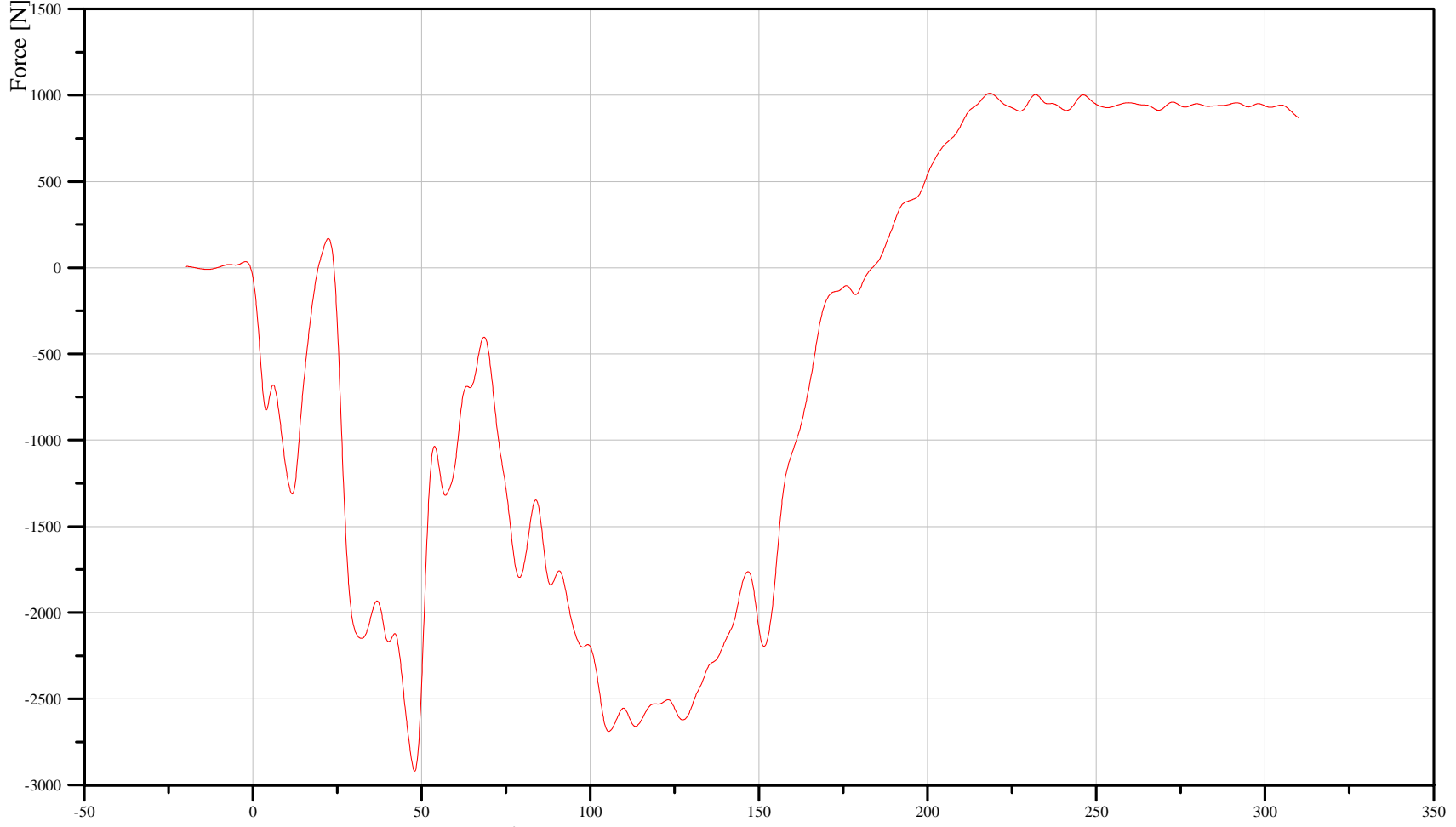

Filter: CFC_60

Min. Value
-2,918.86 N at 48.00 ms

Max. Value
1,011.08 N at 218.48 ms

Time [ms]

B-258

070913



2007 Ford F-250 into Left 40% Offset Deformable LCB at 56 kph

Date: 09/13/2007
Time: 15:46

Load Cell Row 1 Column 8

Customer: Volpe
Test Number: R70203

LOFBAR000071FOXD

TRC Inc. Test Lab: CTF
Test Number: 070913

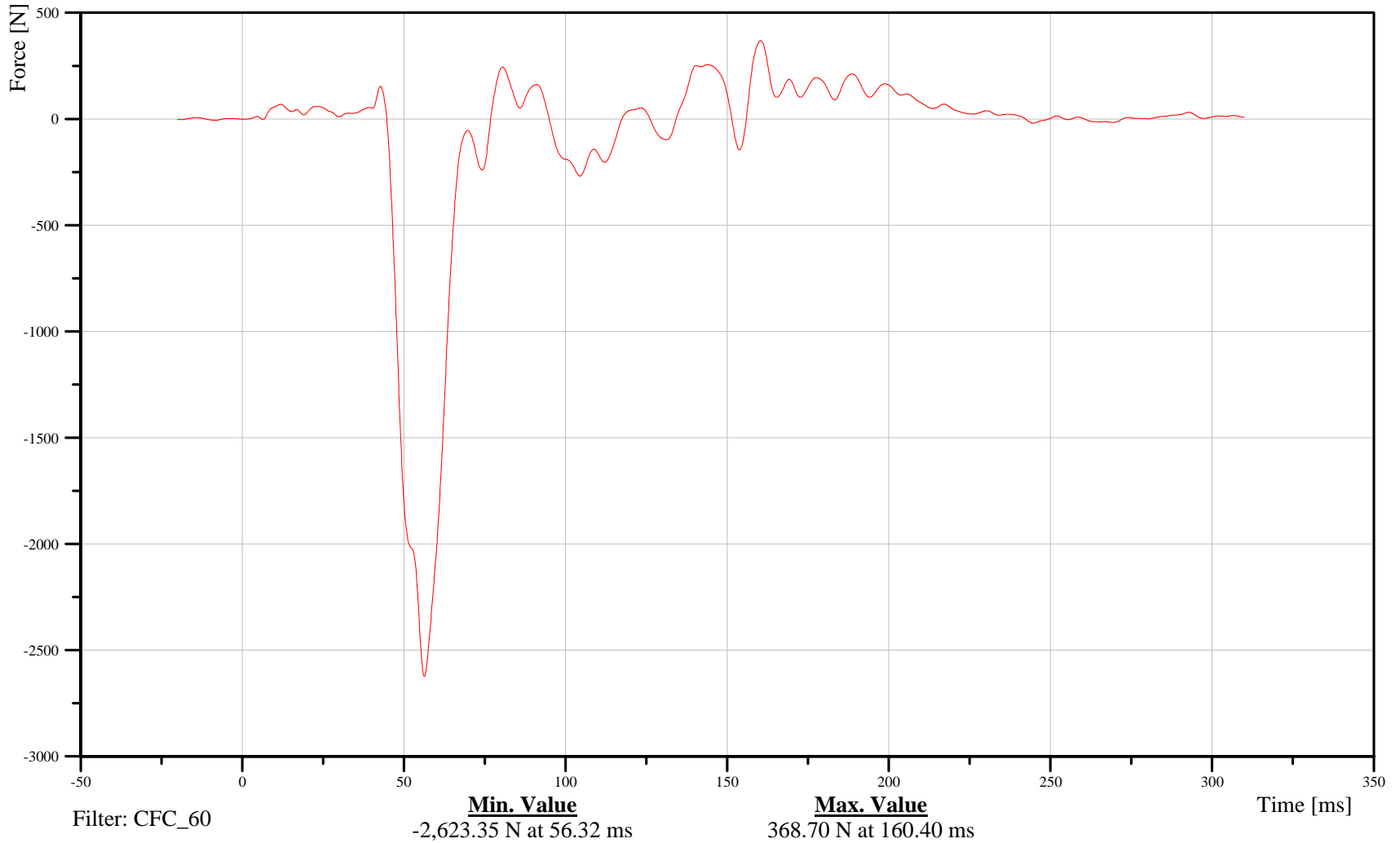

B-259

070913



2007 Ford F-250 into Left 40% Offset Deformable LCB at 56 kph

Date: 09/13/2007
Time: 15:46

Load Cell Row 2 Column 8

Customer: Volpe
Test Number: R70203

LOFBAR000072FOXD

TRC Inc. Test Lab: CTF
Test Number: 070913

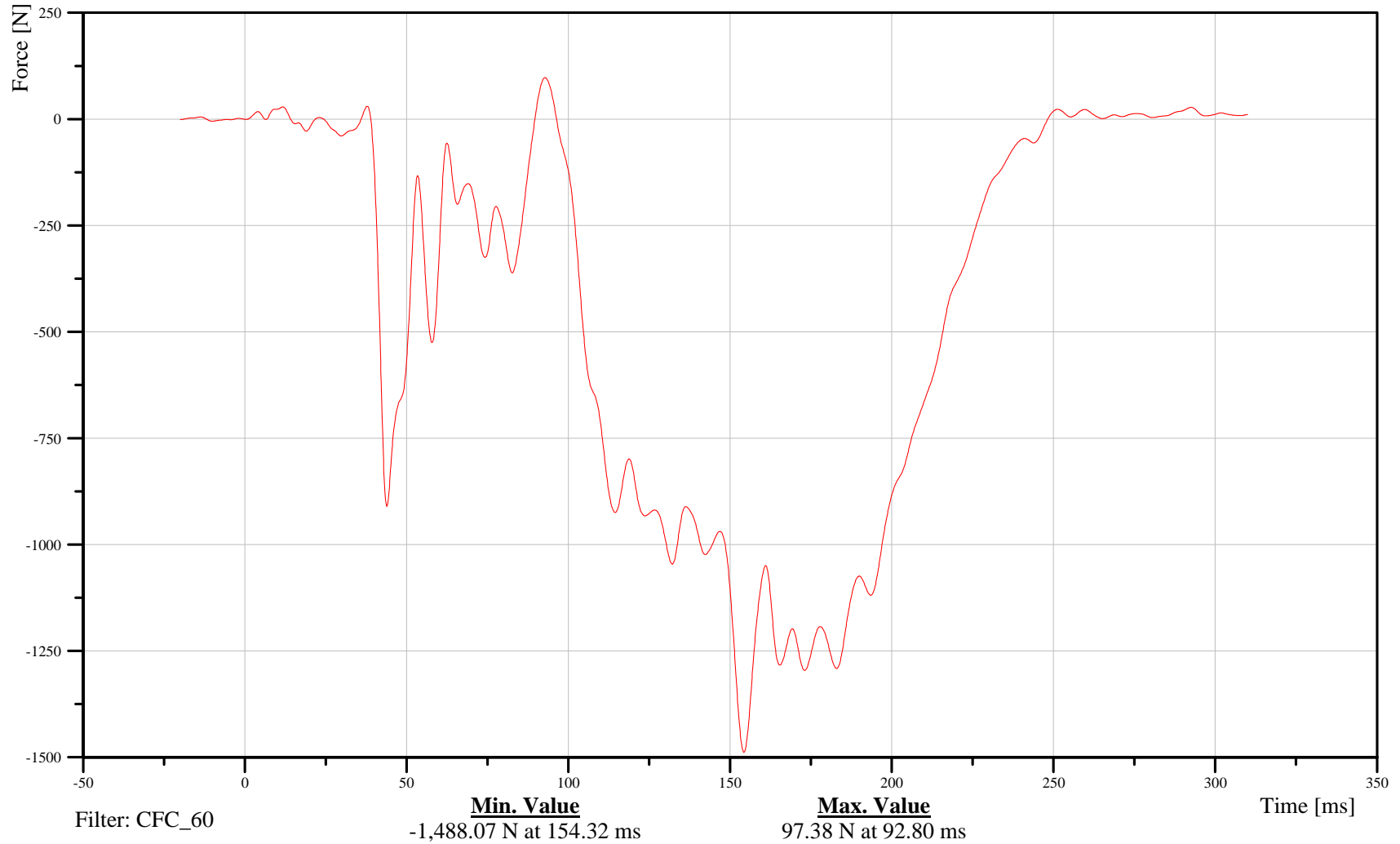

B-260

070913



2007 Ford F-250 into Left 40% Offset Deformable LCB at 56 kph

Date: 09/13/2007
Time: 15:46

Load Cell Row 3 Column 8

Customer: Volpe
Test Number: R70203

L0FBAR000073FOXD

TRC Inc. Test Lab: CTF
Test Number: 070913

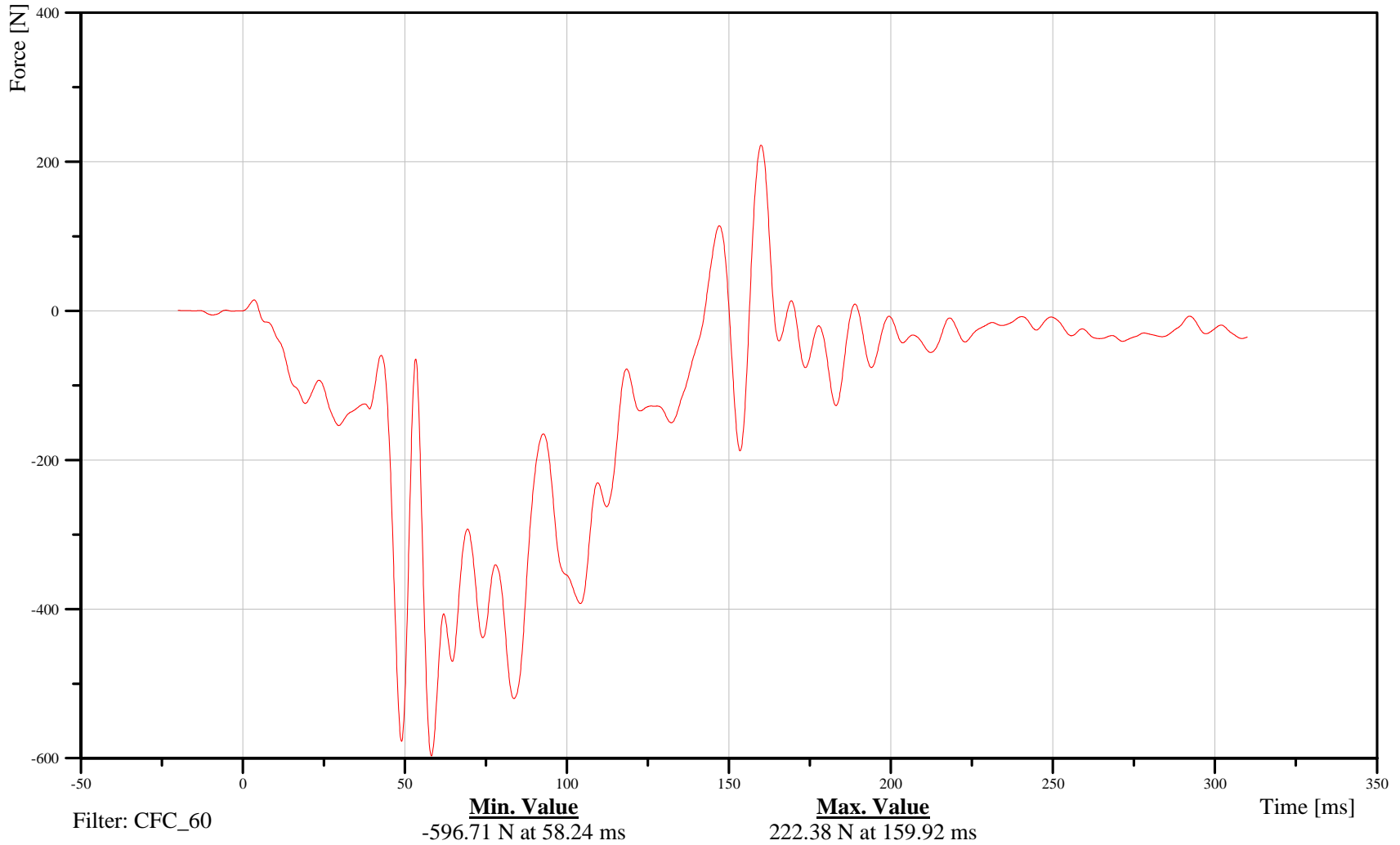

B-261

070913



2007 Ford F-250 into Left 40% Offset Deformable LCB at 56 kph

Date: 09/13/2007
Time: 15:46

Load Cell Row 4 Column 8

Customer: Volpe
Test Number: R70203

LOFBAR000074FOXD

TRC Inc. Test Lab: CTF
Test Number: 070913

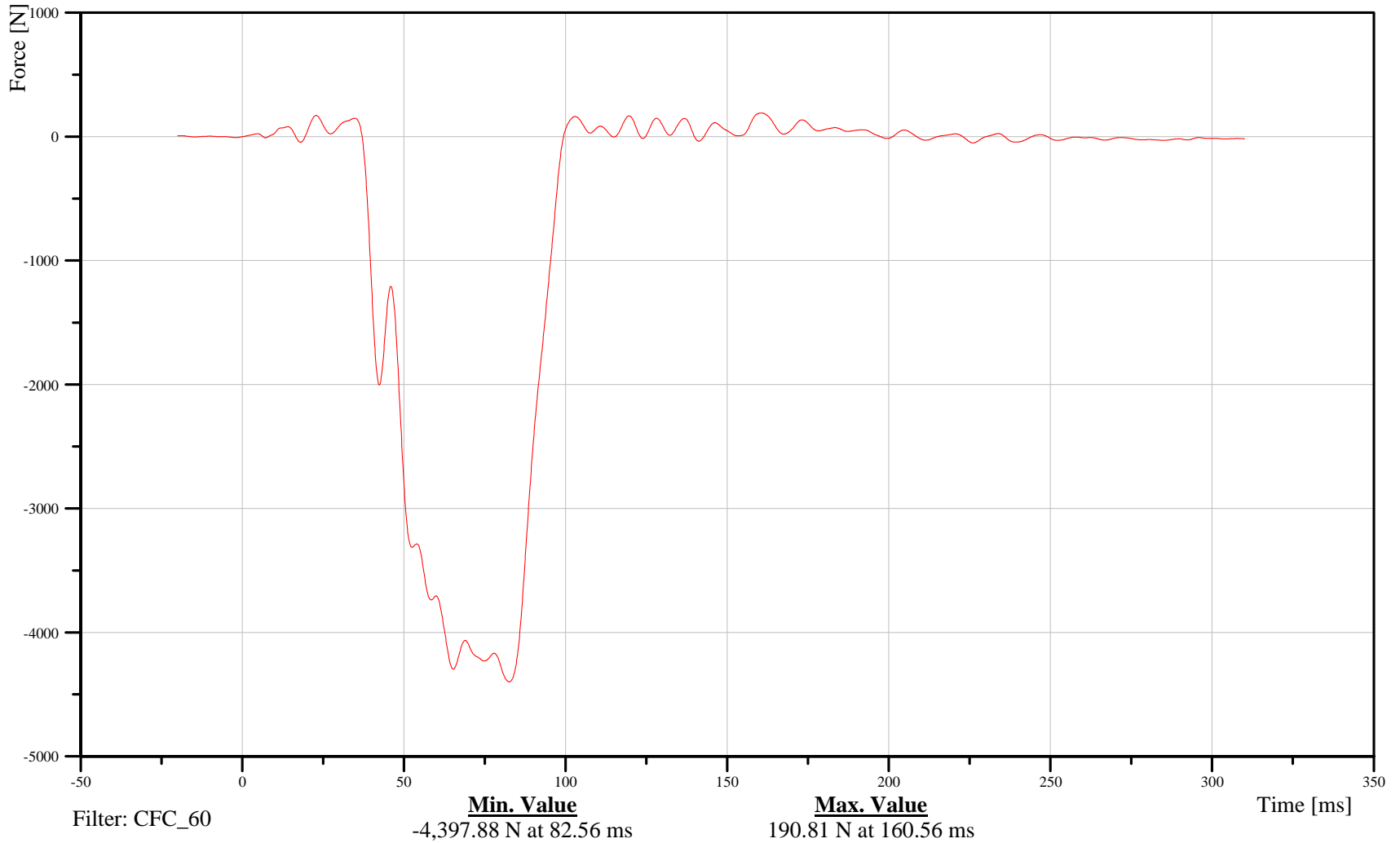

B-262

070913



2007 Ford F-250 into Left 40% Offset Deformable LCB at 56 kph

Date: 09/13/2007
Time: 15:46

Load Cell Row 5 Column 8

Customer: Volpe
Test Number: R70203

LOFBAR000075FOXD

TRC Inc. Test Lab: CTF
Test Number: 070913

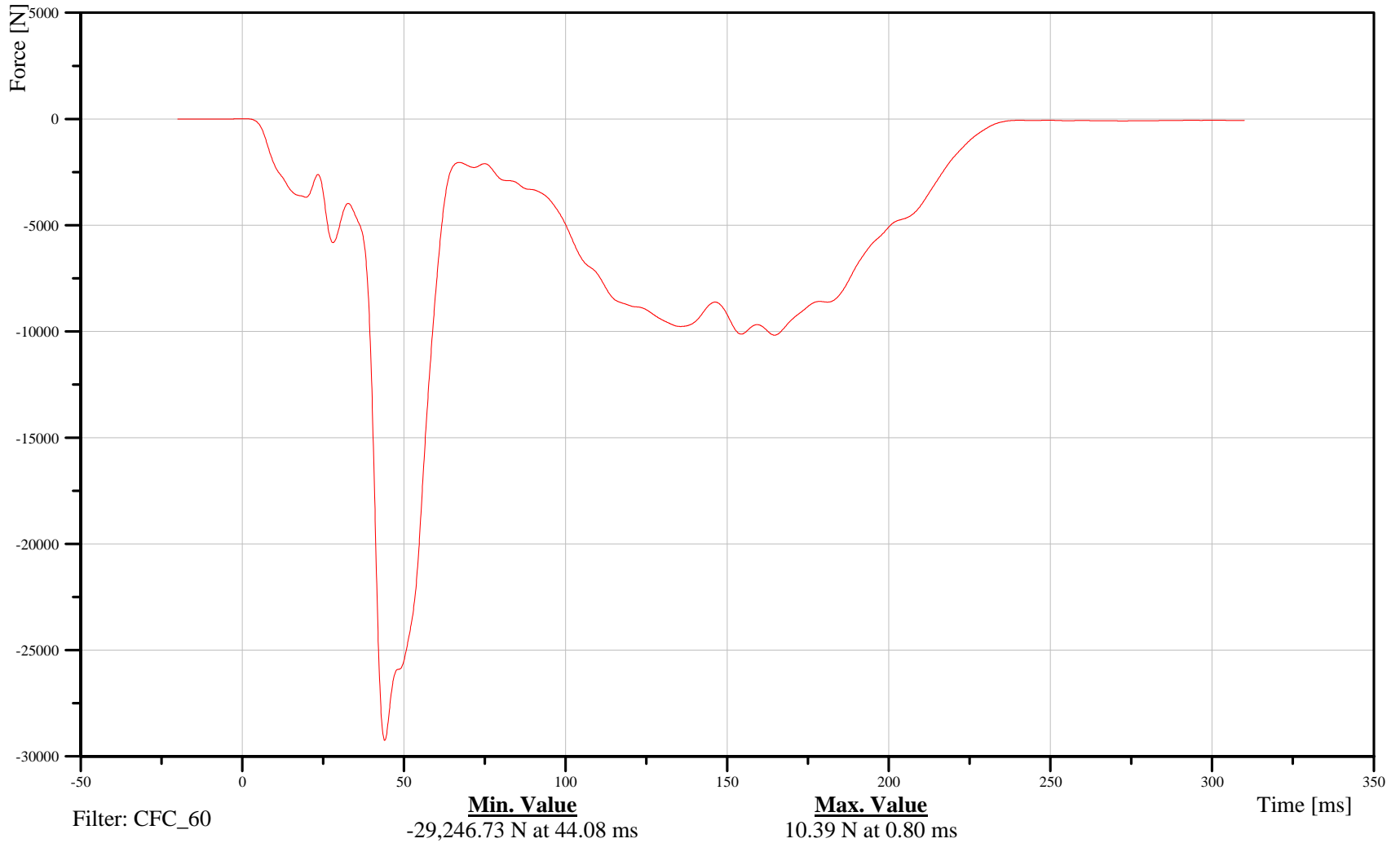

B-263

070913



2007 Ford F-250 into Left 40% Offset Deformable LCB at 56 kph

Date: 09/13/2007
Time: 15:46

Load Cell Row 6 Column 8

Customer: Volpe
Test Number: R70203

LOFBAR000076FOXD

TRC Inc. Test Lab: CTF
Test Number: 070913

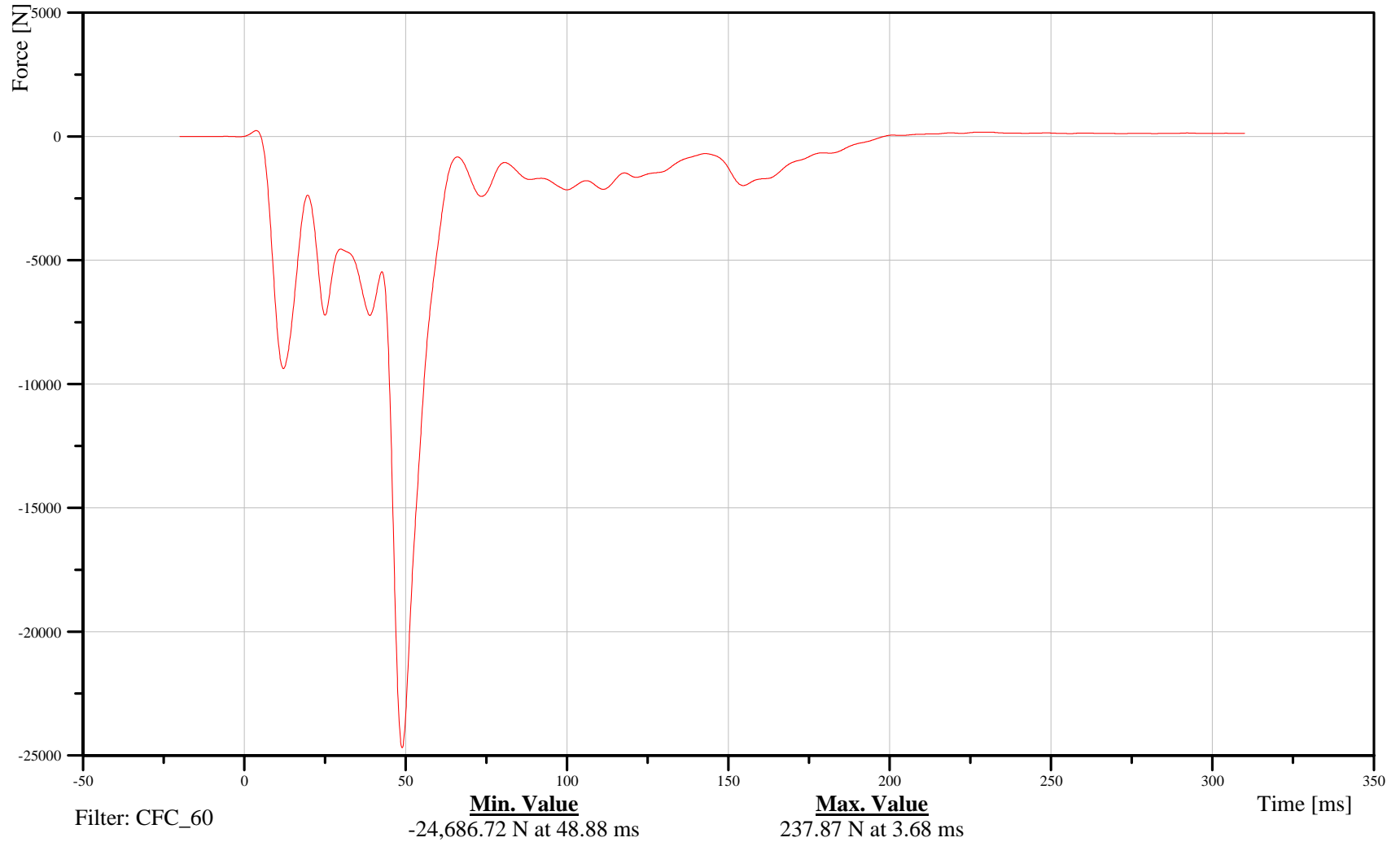

B-264

070913



2007 Ford F-250 into Left 40% Offset Deformable LCB at 56 kph

Date: 09/13/2007
Time: 15:46

Load Cell Row 7 Column 8

Customer: Volpe
Test Number: R70203

LOFBAR000077FOXD

TRC Inc. Test Lab: CTF
Test Number: 070913

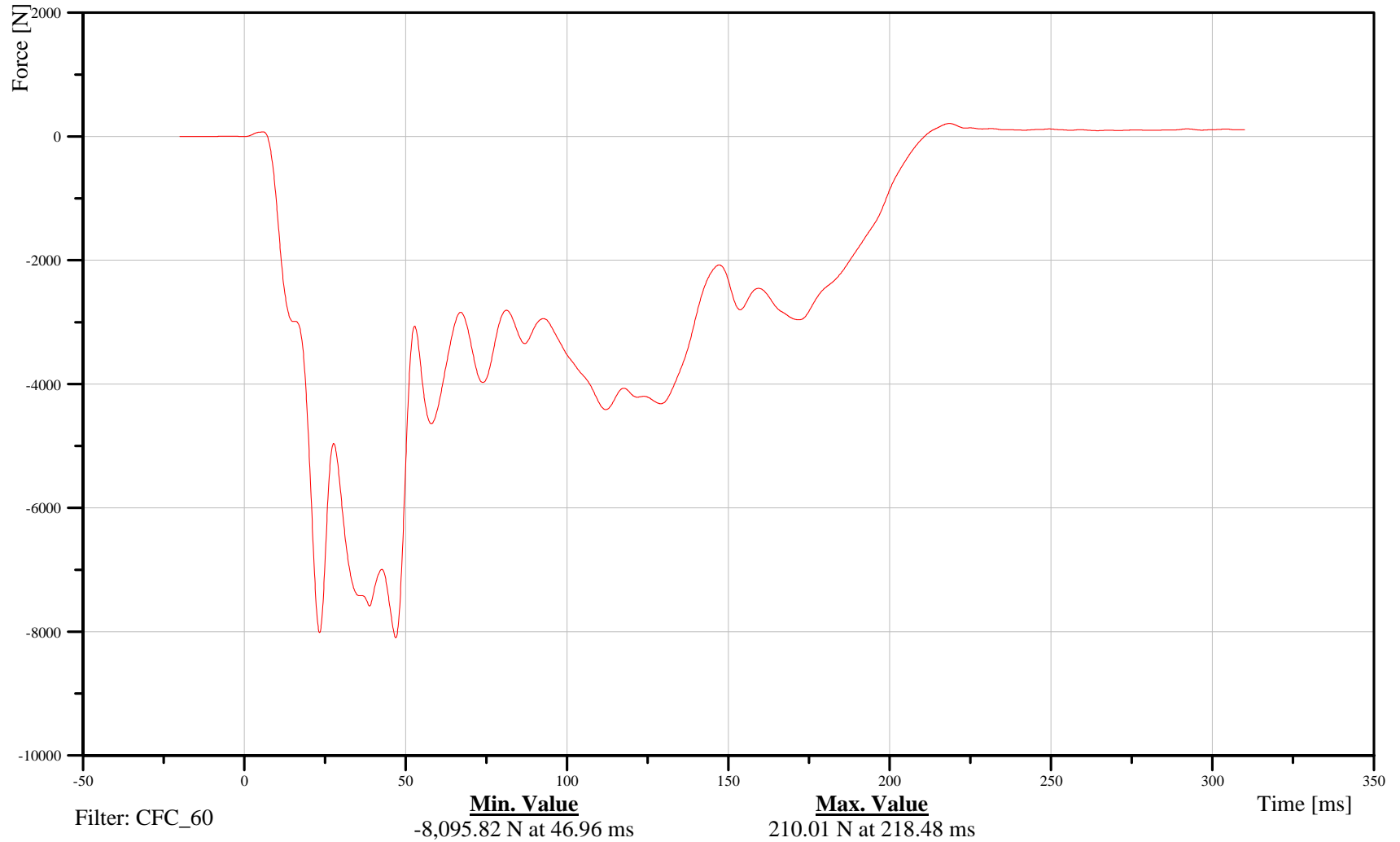

B-265

070913



2007 Ford F-250 into Left 40% Offset Deformable LCB at 56 kph

Date: 09/13/2007
Time: 15:46

Load Cell Row 8 Column 8

Customer: Volpe
Test Number: R70203

LOFBAR000078FOXD

TRC Inc. Test Lab: CTF
Test Number: 070913

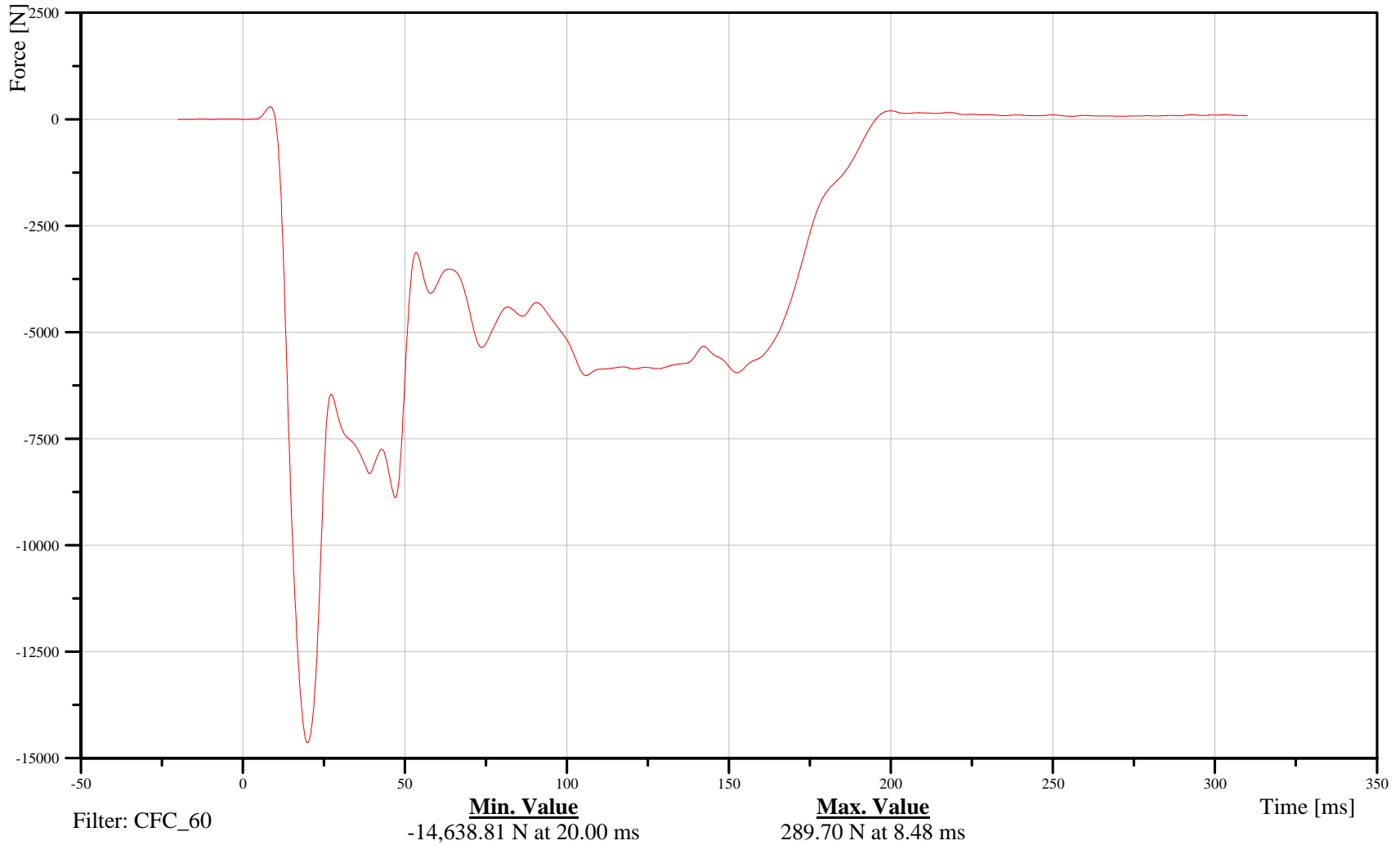

B-266

070913



2007 Ford F-250 into Left 40% Offset Deformable LCB at 56 kph

Date: 09/13/2007
Time: 15:46

Load Cell Row 9 Column 8

Customer: Volpe
Test Number: R70203

LOFBAR000079FOXD

TRC Inc. Test Lab: CTF
Test Number: 070913

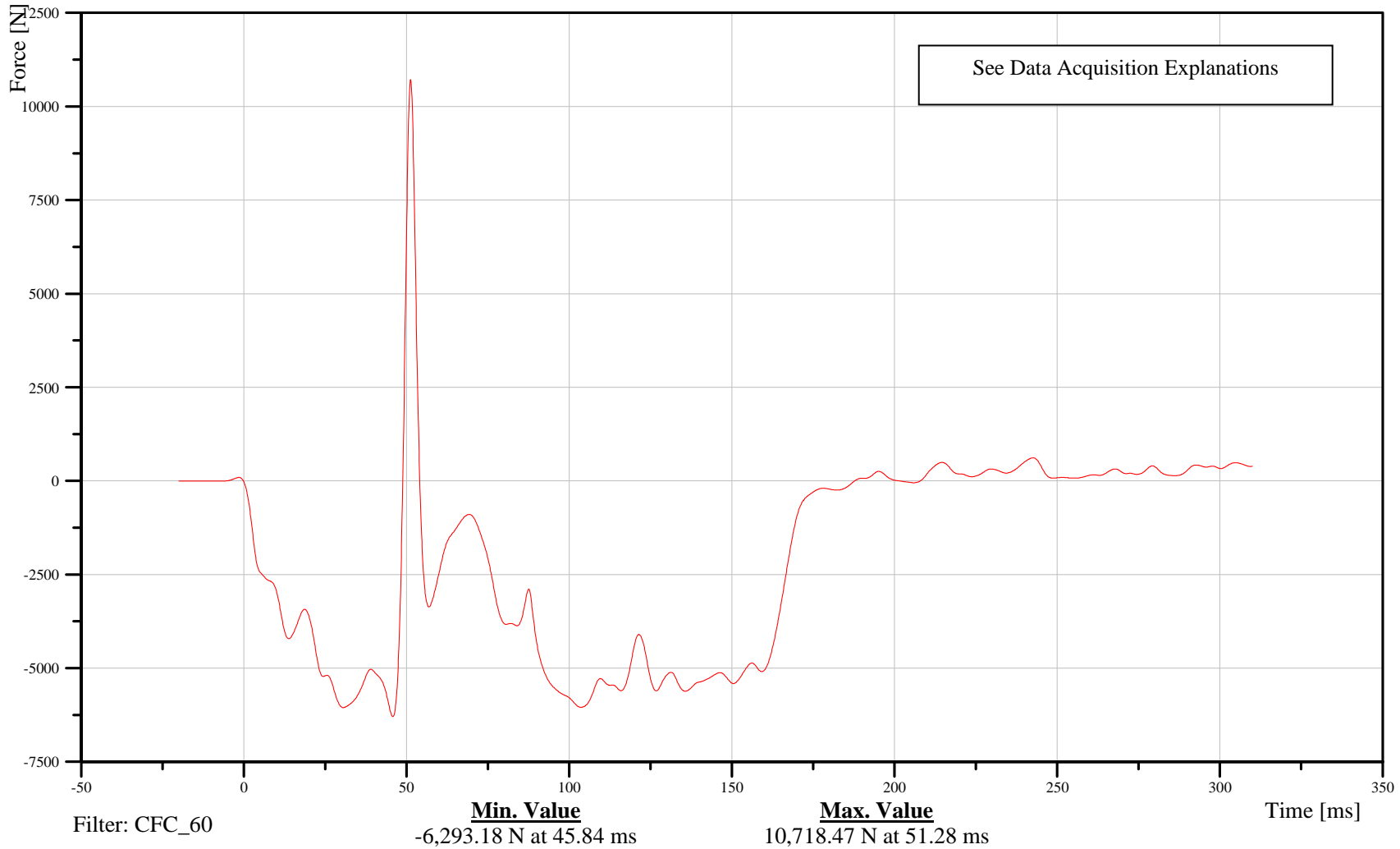

B-267

070913



2007 Ford F-250 into Left 40% Offset Deformable LCB at 56 kph

Date: 09/13/2007
Time: 15:46

Load Cell Row 10 Column 8

Customer: Volpe
Test Number: R70203

LOFBAR000080FOXD

TRC Inc. Test Lab: CTF
Test Number: 070913

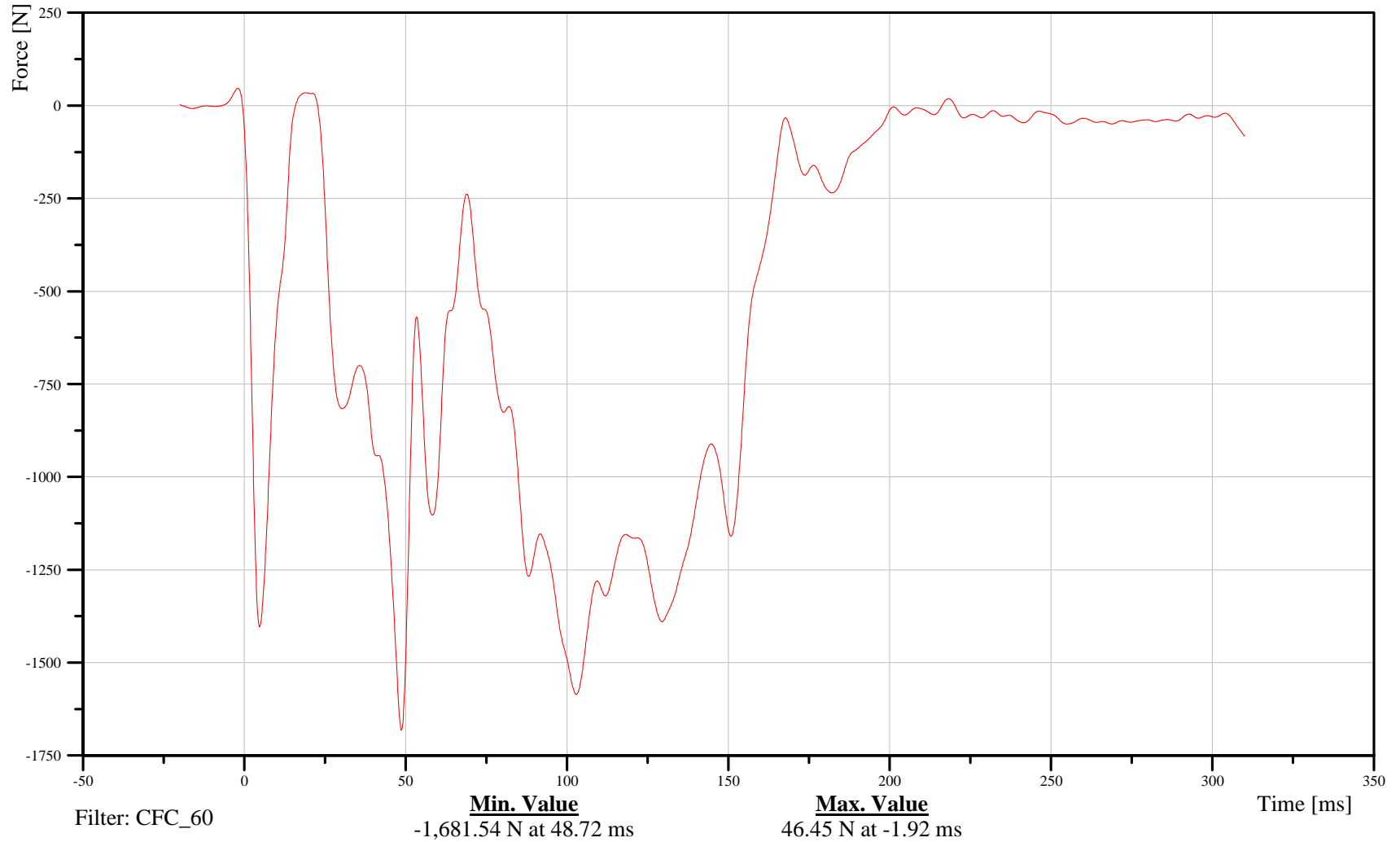

B-268

070913



2007 Ford F-250 into Left 40% Offset Deformable LCB at 56 kph

Date: 09/13/2007
Time: 15:46

Load Cell Row 1 Column 9

Customer: Volpe
Test Number: R70203

LOFBAR000081FOXD

TRC Inc. Test Lab: CTF
Test Number: 070913

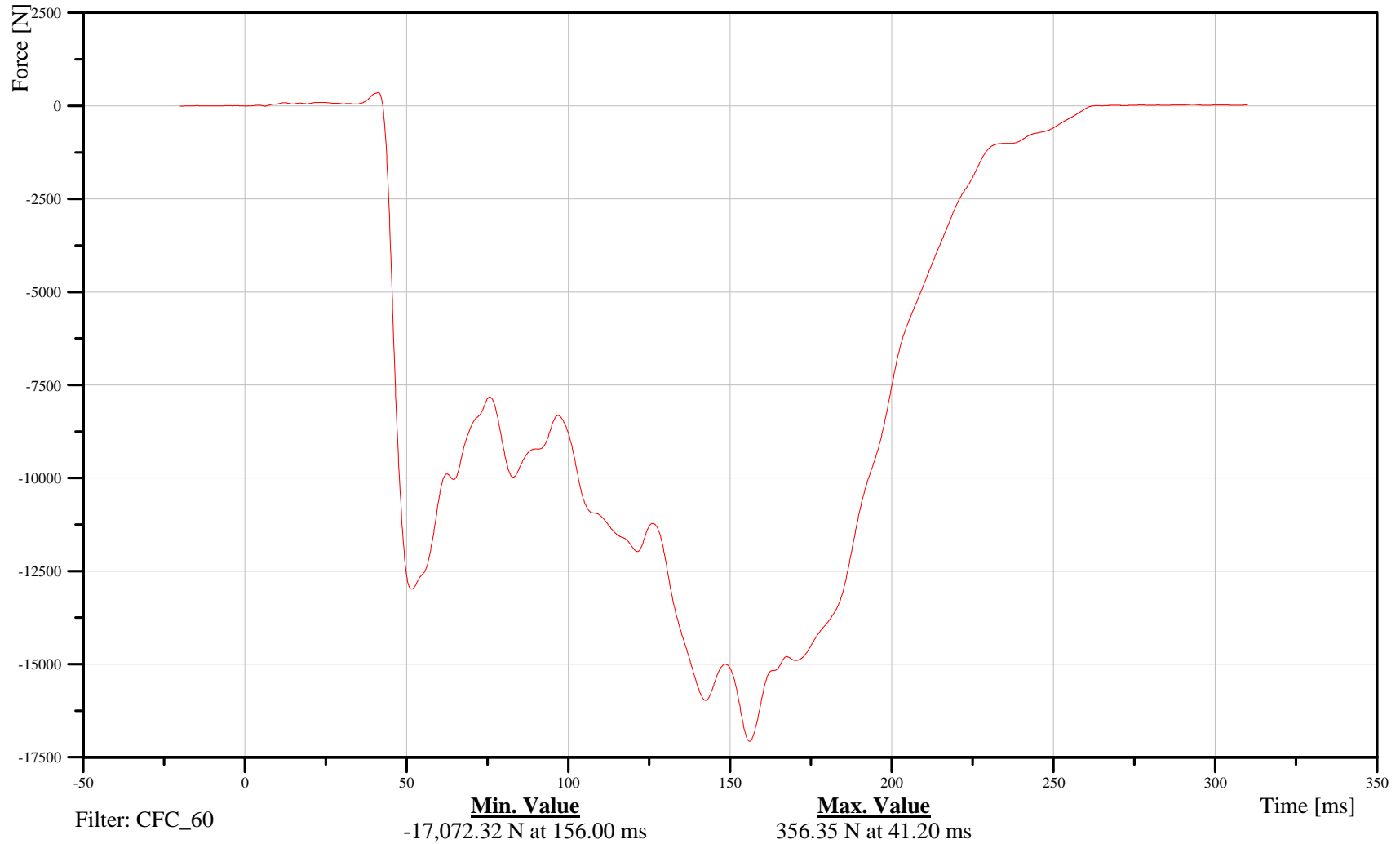

B-269

070913



2007 Ford F-250 into Left 40% Offset Deformable LCB at 56 kph

Date: 09/13/2007
Time: 15:46

Load Cell Row 2 Column 9

Customer: Volpe
Test Number: R70203

LOFBAR000082FOXD

TRC Inc. Test Lab: CTF
Test Number: 070913

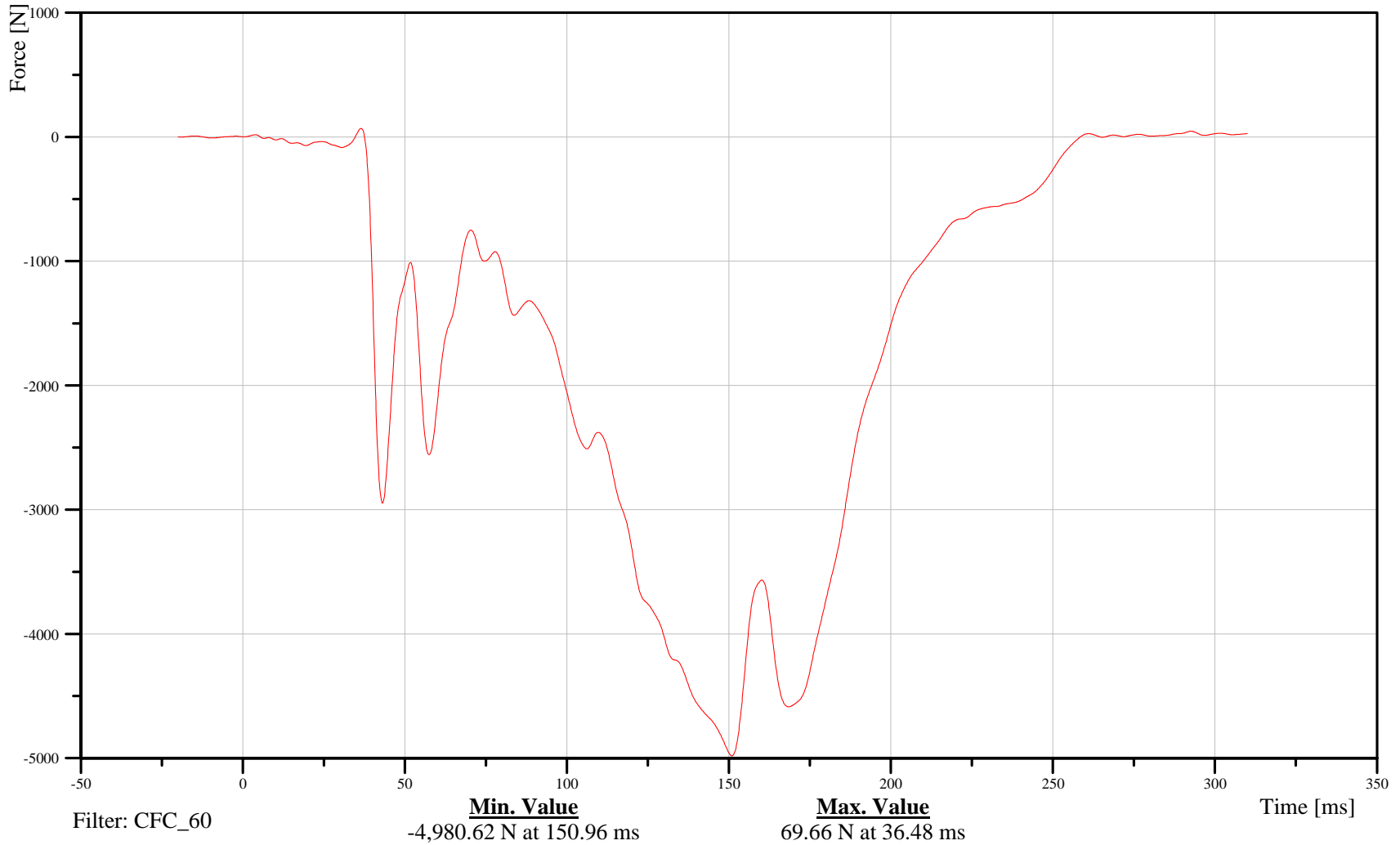

B-2770

070913



2007 Ford F-250 into Left 40% Offset Deformable LCB at 56 kph

Date: 09/13/2007
Time: 15:46

Load Cell Row 3 Column 9

Customer: Volpe
Test Number: R70203

LOFBAR000083FOXD

TRC Inc. Test Lab: CTF
Test Number: 070913

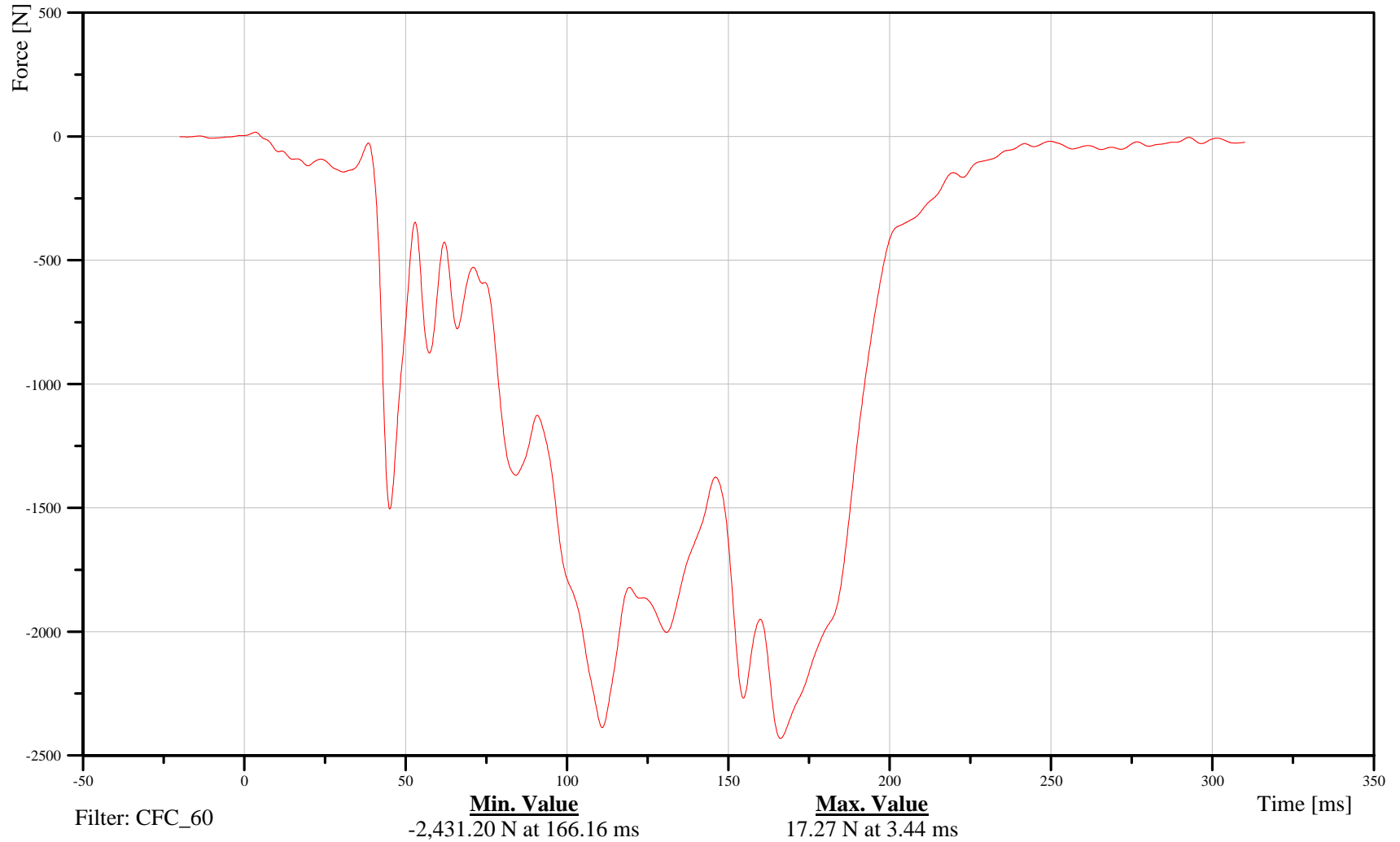

B-271

070913



2007 Ford F-250 into Left 40% Offset Deformable LCB at 56 kph

Date: 09/13/2007
Time: 15:46

Load Cell Row 4 Column 9

Customer: Volpe
Test Number: R70203

LOFBAR000084FOXD

TRC Inc. Test Lab: CTF
Test Number: 070913

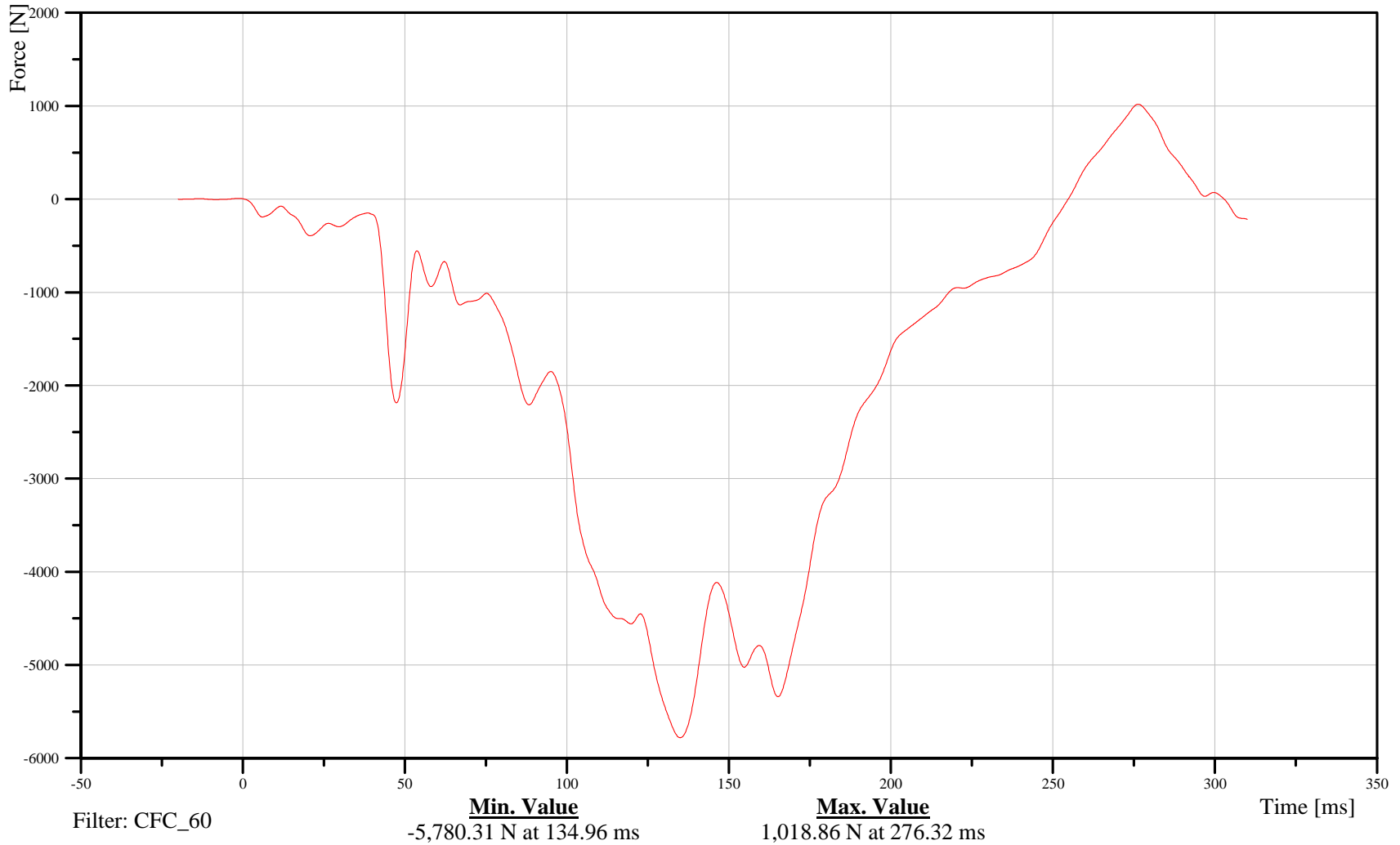

B-2772

070913



2007 Ford F-250 into Left 40% Offset Deformable LCB at 56 kph

Date: 09/13/2007
Time: 15:46

Load Cell Row 5 Column 9

Customer: Volpe
Test Number: R70203

LOFBAR000085FOXD

TRC Inc. Test Lab: CTF
Test Number: 070913

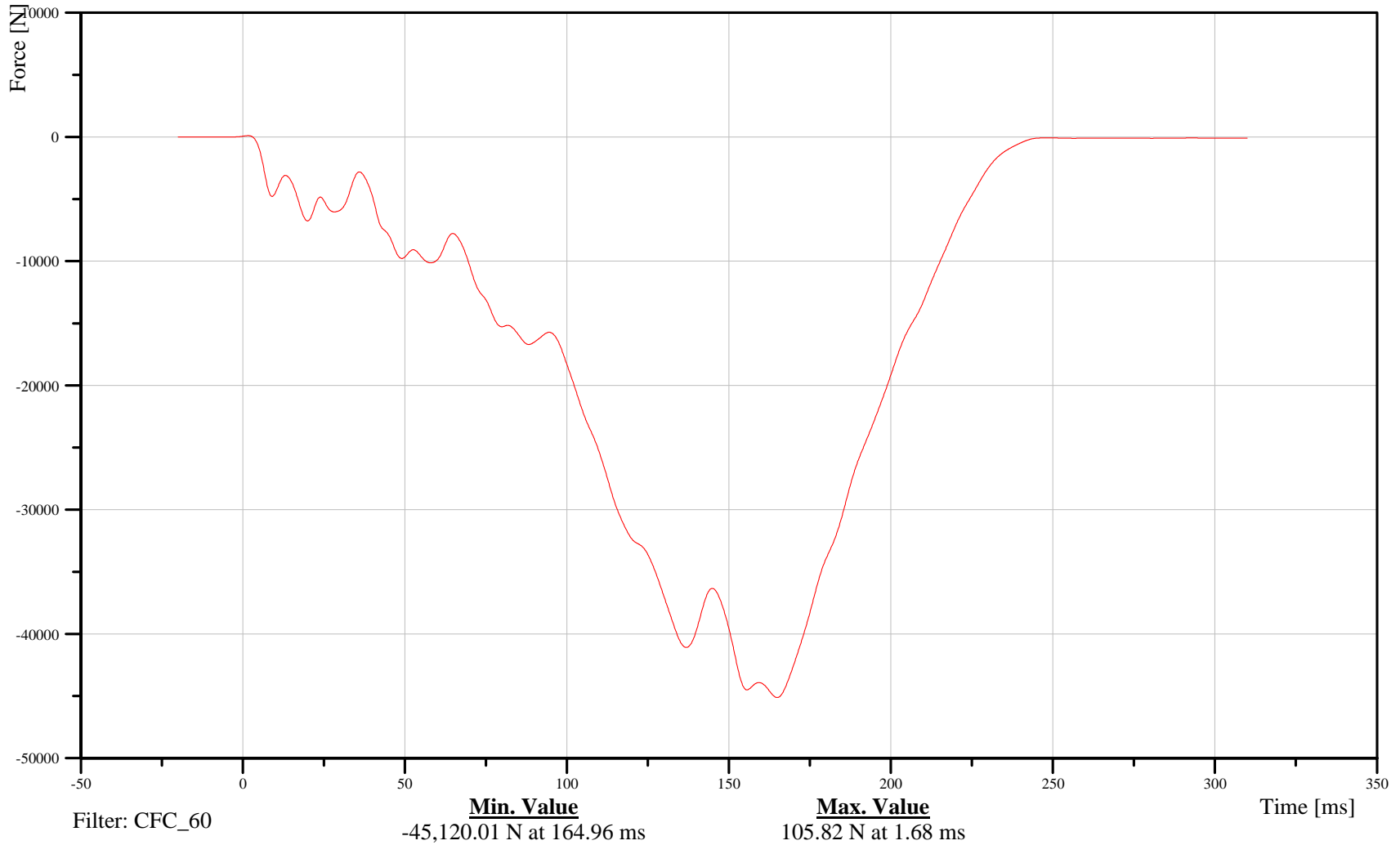

B-273

070913



2007 Ford F-250 into Left 40% Offset Deformable LCB at 56 kph

Date: 09/13/2007
Time: 15:46

Load Cell Row 6 Column 9

Customer: Volpe
Test Number: R70203

LOFBAR000086FOXD

TRC Inc. Test Lab: CTF
Test Number: 070913

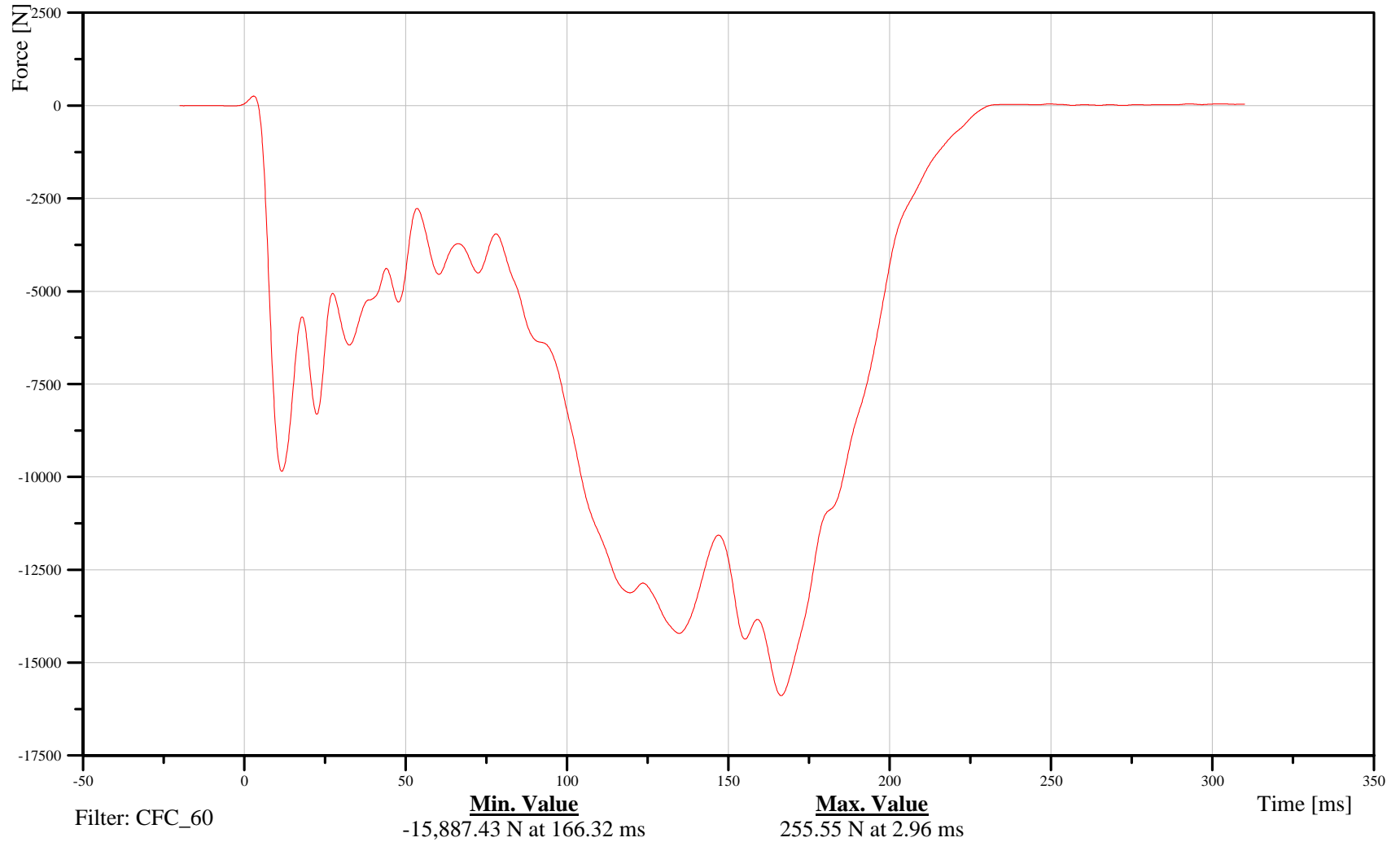

B-274

070913



2007 Ford F-250 into Left 40% Offset Deformable LCB at 56 kph

Date: 09/13/2007
Time: 15:46

Load Cell Row 7 Column 9

Customer: Volpe
Test Number: R70203

LOFBAR000087FOXD

TRC Inc. Test Lab: CTF
Test Number: 070913

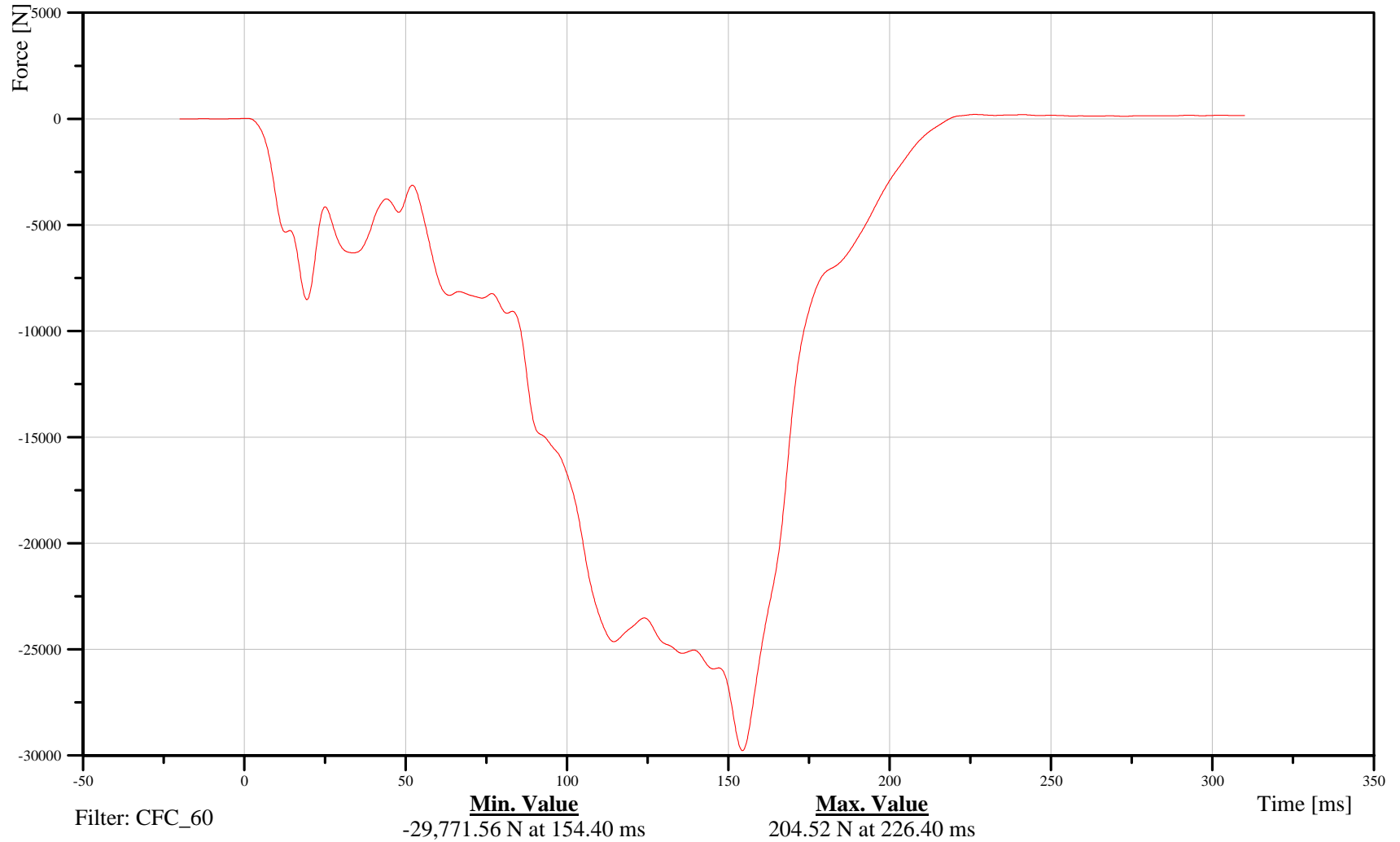

B-275

070913



2007 Ford F-250 into Left 40% Offset Deformable LCB at 56 kph

Date: 09/13/2007
Time: 15:46

Load Cell Row 8 Column 9

Customer: Volpe
Test Number: R70203

LOFBAR000088FOXD

TRC Inc. Test Lab: CTF
Test Number: 070913

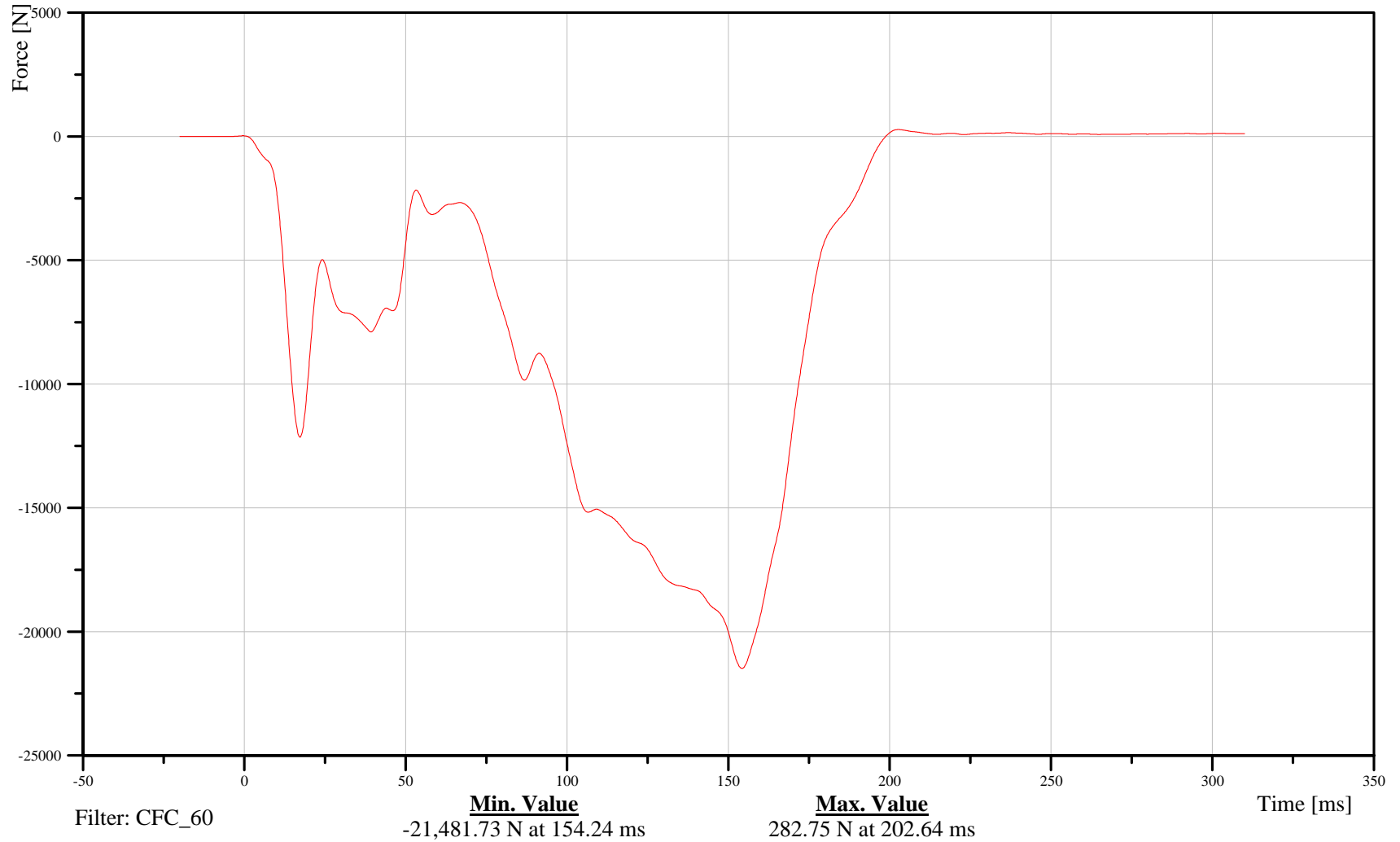

B-276

070913



2007 Ford F-250 into Left 40% Offset Deformable LCB at 56 kph

Date: 09/13/2007
Time: 15:46

Load Cell Row 9 Column 9

Customer: Volpe
Test Number: R70203

LOFBAR000089FOXD

TRC Inc. Test Lab: CTF
Test Number: 070913

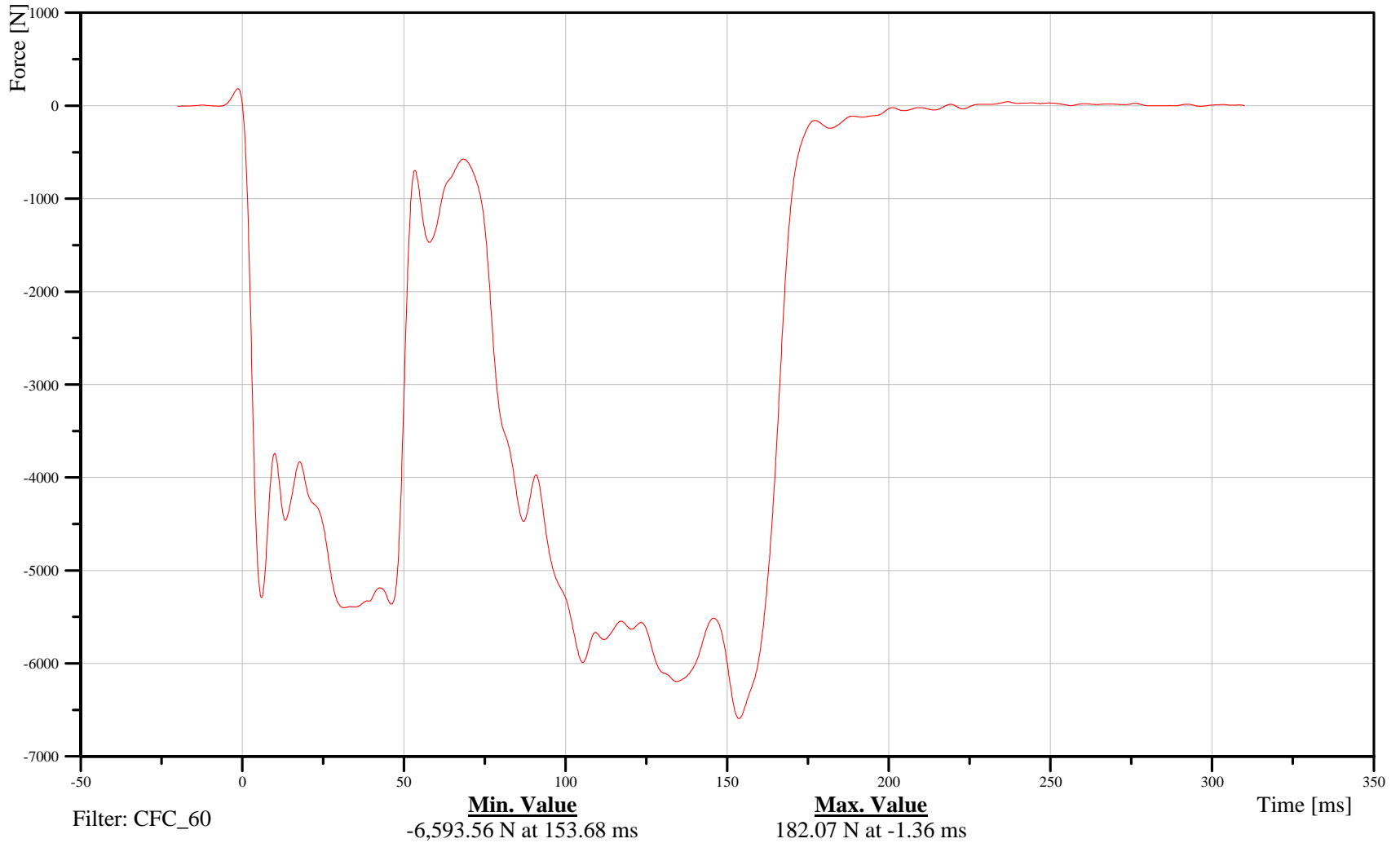

B-277

070913



2007 Ford F-250 into Left 40% Offset Deformable LCB at 56 kph

Date: 09/13/2007
Time: 15:46

Load Cell Row 10 Column 9

Customer: Volpe
Test Number: R70203

LOFBAR000090FOXD

TRC Inc. Test Lab: CTF
Test Number: 070913

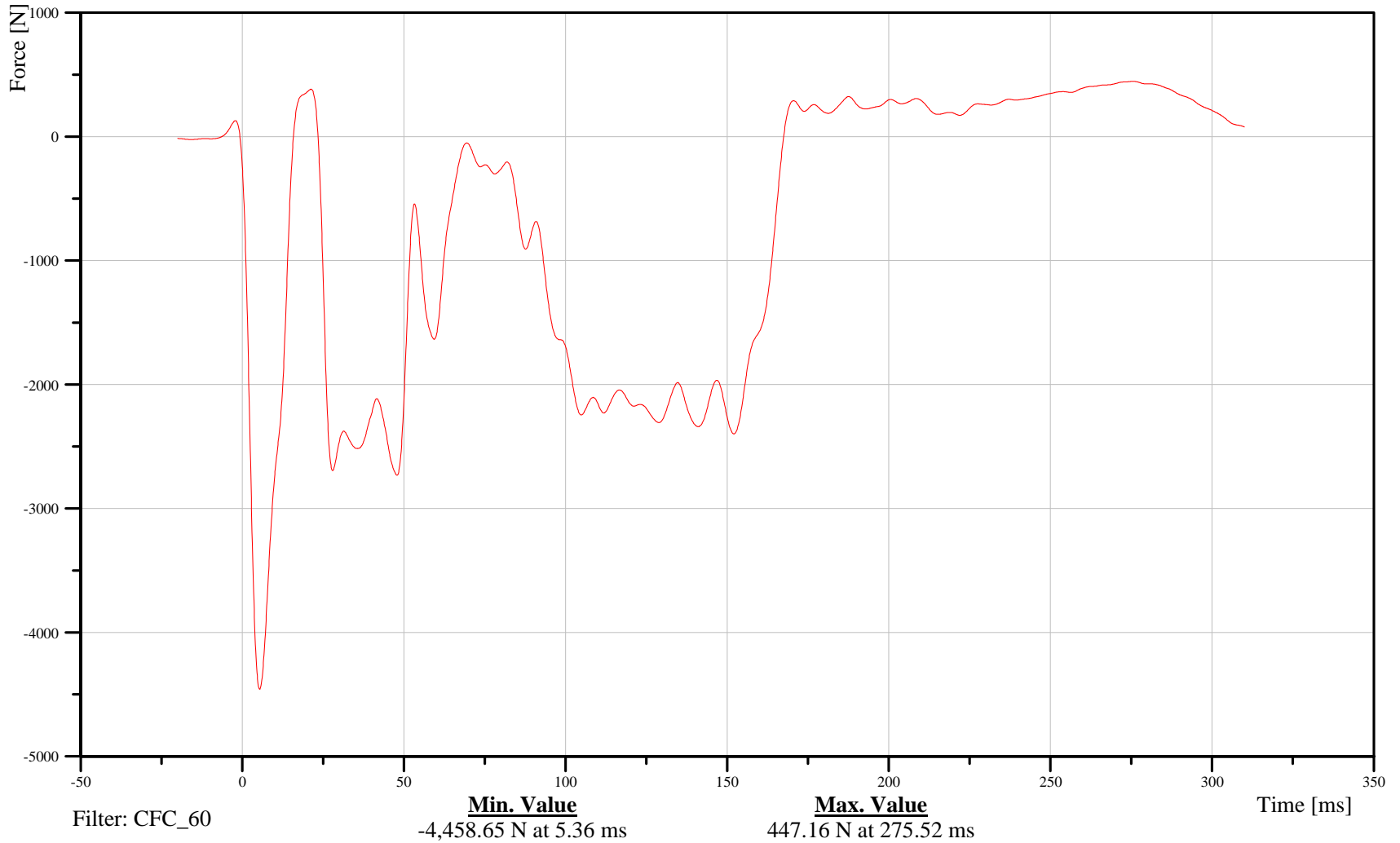

B-278

070913

Appendix C

Dummy Certification Data

Pre-test Dummy Configuration and Performance Verification Data



Driver Dummy S/N: 001

Transportation Research Center Inc.
572E HIII 50th Male Dummy
External Dimensions
Serial No. 001 Calibration No. 04

Symbol	Description	Specification	Results	Pass
		mm	mm	
A	Total Sitting Height	878.8 - 889.0	880	Yes
B	Shoulder Pivot Height	505.5 - 520.7	515	Yes
C	H-Point Height	83.8 - 88.9	84	Yes
D	H-Point From Seatback	134.6 - 139.7	136	Yes
E	Shoulder Pivot From Backline	83.8 - 94.0	94	Yes
F	Thigh Clearance	139.7 - 154.9	154	Yes
G	Back Of Elbow To Wrist Pivot	289.6 - 304.8	298	Yes
H	Skull Cap To Backline	40.6 - 45.7	45	Yes
I	Shoulder-Elbow Length	330.2 - 345.4	342	Yes
J	Elbow Rest Height	190.5 - 210.8	201	Yes
K	Buttock Knee Length	579.1 - 604.5	591	Yes
L	Popliteal Height	429.3 - 454.7	432	Yes
M	Knee Pivot Height	485.1 - 500.4	499	Yes
N	Buttock Popliteal Length	452.1 - 477.5	460	Yes
O	Chest Depth	213.4 - 228.6	227	Yes
P	Foot Length	251.5 - 266.7	260	Yes
V	Shoulder Breadth	421.6 - 436.9	425	Yes
W	Foot Breadth	91.4 - 106.7	99	Yes
Y	Chest Circumference	970.3 - 1000.8	984	Yes
Z	Waist Circumference	835.7 - 866.1	853	Yes
AA	Location For Chest Circumference	429.3 - 434.3	432	Yes
BB	Location For Waist Circumference	226.1 - 231.1	229	Yes

Technician

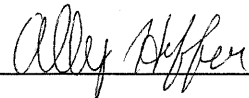
Approved

Transportation Research Center Inc.

Front Head Drop

HIII 50th Serial No. 001 Certification No. 4-1

Test Date: 7/10/2007

Test Parameter	Specification	Test Results	Pass
Temperature	18.9 - 25.5 °C	21.2 °C	Yes
Relative Humidity	10 - 70 %	52 %	Yes
Peak Head Resultant Acceleration	225 - 275 g	268.9 g	Yes
Peak Head Lateral Acceleration	(-15) - 15 g	2.9 g	Yes
Is Acceleration Curve Unimodal within 10% of Peak?	Yes	Yes	Yes

Test meets specifications.

Comments:

Technician



Approved



Transportation Research Center Inc.

Front Head Drop

HIII 50th Serial No. 001 Certification No. 4-1

Test Date: 7/10/2007

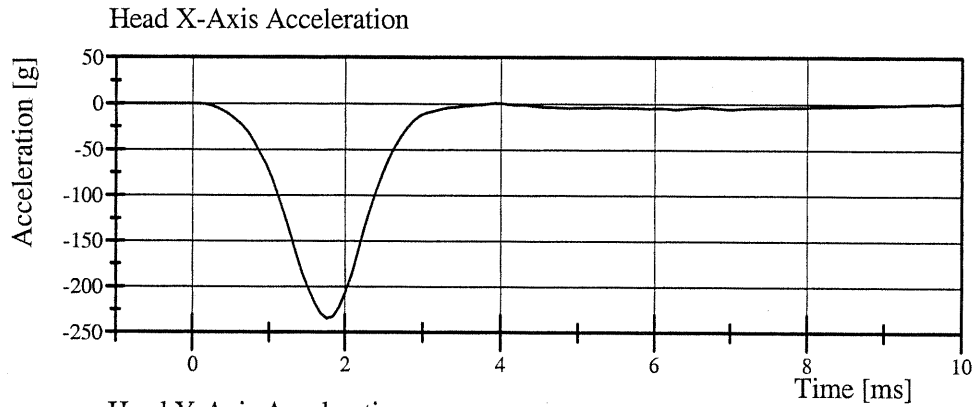

Filter Class: CFC_1000

Max: 0.9 g at 10.0 ms

Min: -234.9 g at 1.8 ms

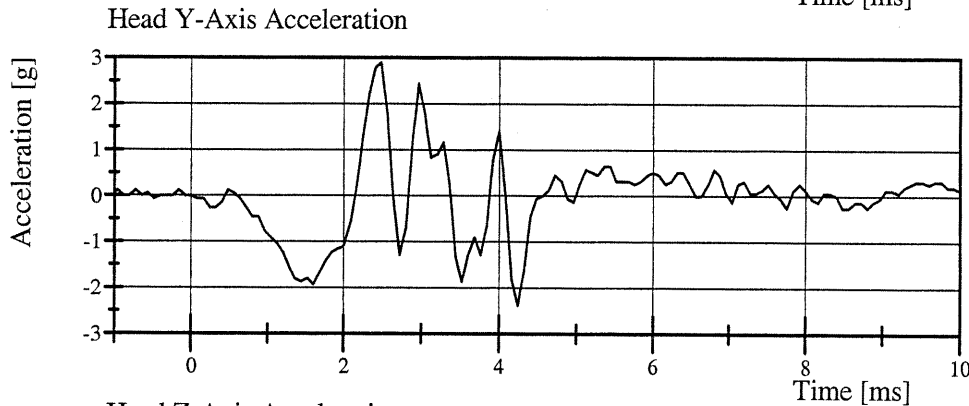

Filter Class: CFC_1000

Max: 2.9 g at 2.5 ms

Min: -2.4 g at 4.2 ms

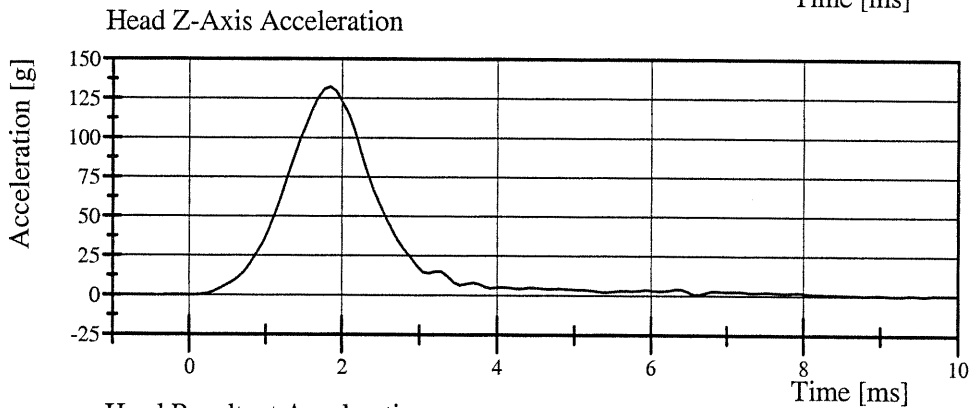

Filter Class: CFC_1000

Max: 132.6 g at 1.8 ms

Min: -0.1 g at -1.0 ms

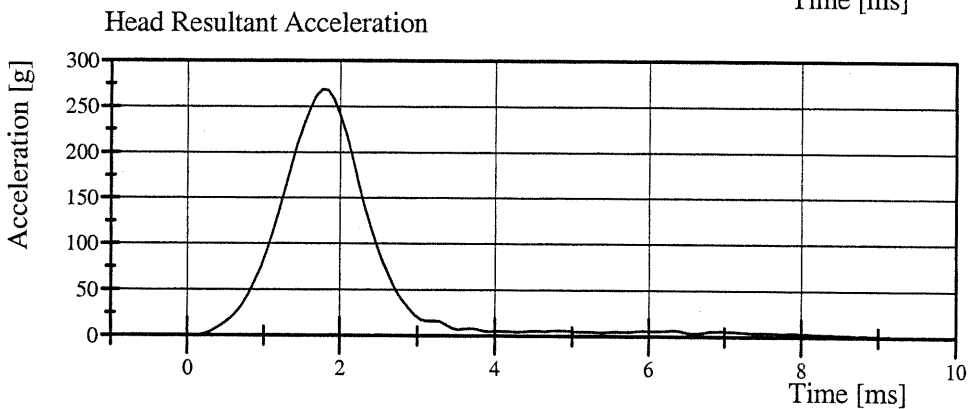

Filter Class: CFC_1000

Max: 268.9 g at 1.8 ms

Min: 0.0 g at -1.0 ms

Transportation Research Center Inc.

Neck Flexion

HIII 50th Serial No. 001 Certification No. 4-1

Test Date: 7/10/2007

Test Parameter	Specification	Test Results	Pass
Temperature	20.6 - 22.2 °C	21.4 °C	Yes
Relative Humidity	10 - 70 %	53 %	Yes
Pendulum Velocity	6.89 - 7.13 m/s	6.948 m/s	Yes
Pendulum Acceleration Decay Crossing -5g	34 - 42 ms	39.0 ms	Yes
Pendulum Acceleration at 10ms	(-22.5) - (-27.5) g	-23.78 g	Yes
Pendulum Acceleration at 20ms	(-17.6) - (-22.6) g	-19.80 g	Yes
Pendulum Acceleration at 30ms	(-12.5) - (-18.5) g	-15.99 g	Yes
Pendulum Acceleration > 30ms	>= (-29.0) g	-15.99 g	Yes
Total Head D-Plane Rotation Peak	(-64) - (-78) °	-65.0 °	Yes
Time of Peak	57 - 64 ms	60.2 ms	Yes
Total Head D-Plane Rotation Decay to 0°	113 - 128 ms	116.6 ms	Yes
Total Neck Occipital Condyles Moment Peak	88 - 108 N·m	97.5 N·m	Yes
Time of Peak	47 - 58 ms	52.2 ms	Yes
Total Neck Occipital Condyles Moment Decay to 0 N·m	97 - 107 ms	101.3 ms	Yes

Test meets specifications.

Comments:

Technician



Approved

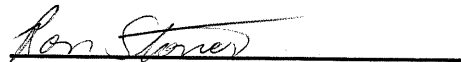

Transportation Research Center Inc.

Neck Flexion

HIII 50th Serial No. 001 Certification No. 4-1

Test Date: 7/10/2007

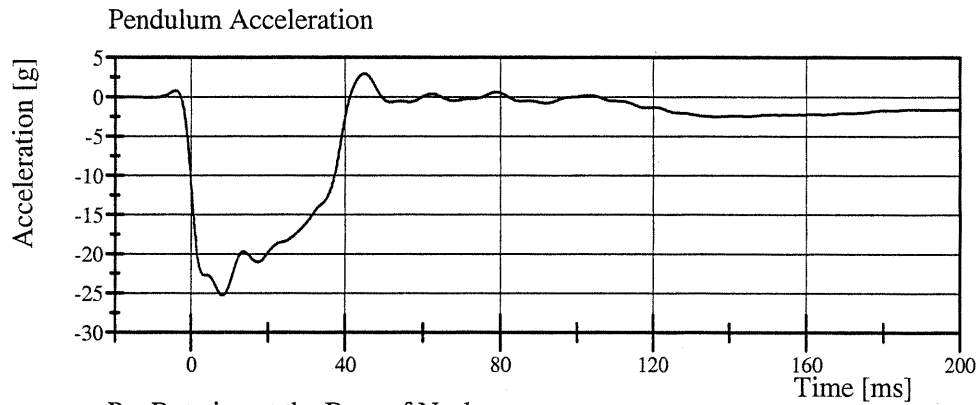

Filter Class: CFC_60

Max: 3.0 g at 44.9 ms

Min: -25.2 g at 8.2 ms

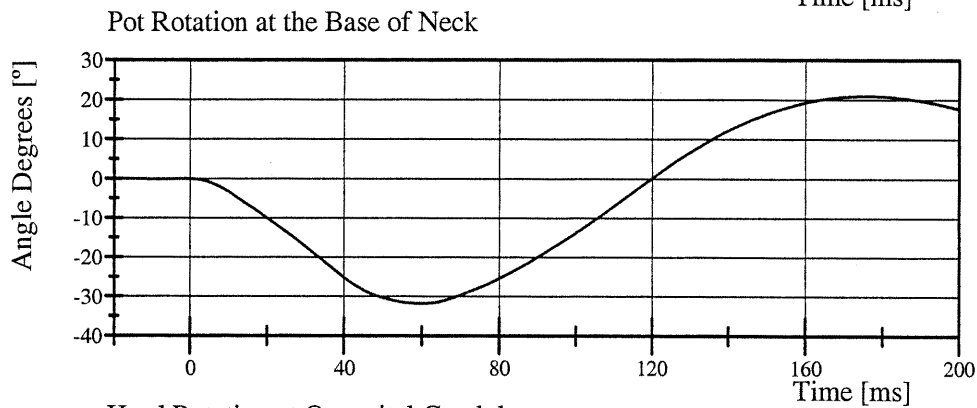

Filter Class: CFC_60

Max: 21.0 ° at 175.8 ms

Min: -31.8 ° at 59.8 ms

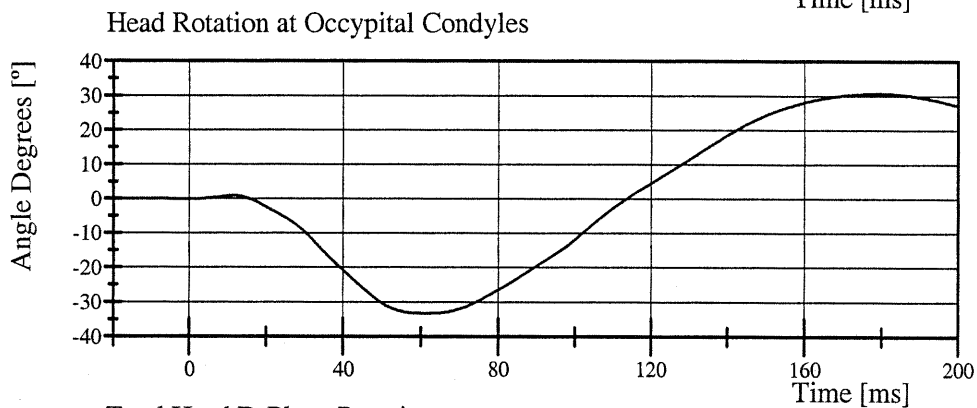

Filter Class: CFC_60

Max: 30.7 ° at 179.0 ms

Min: -33.3 ° at 61.0 ms

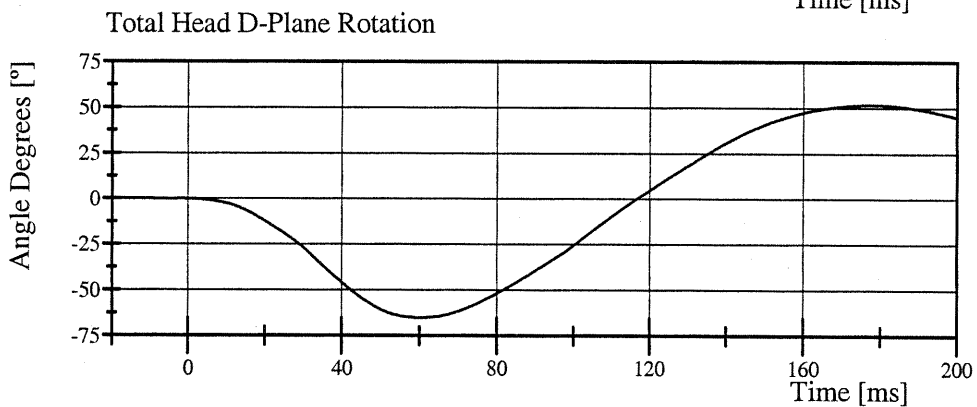

Filter Class: CFC_60

Max: 51.8 ° at 177.8 ms

Min: -65.0 ° at 60.2 ms



Transportation Research Center Inc.

Neck Flexion

HIII 50th Serial No. 001 Certification No. 4-1

Test Date: 7/10/2007

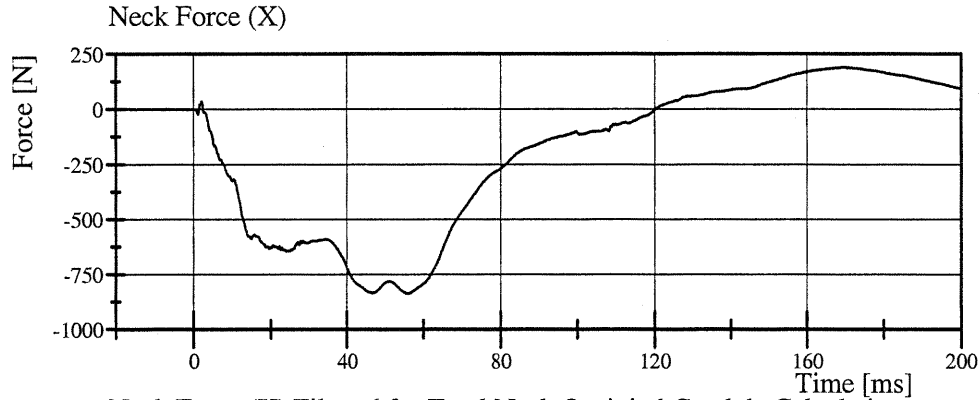

Filter Class: CFC_1000
Max: 189.7 N at 169.7 ms
Min: -836.7 N at 56.2 ms

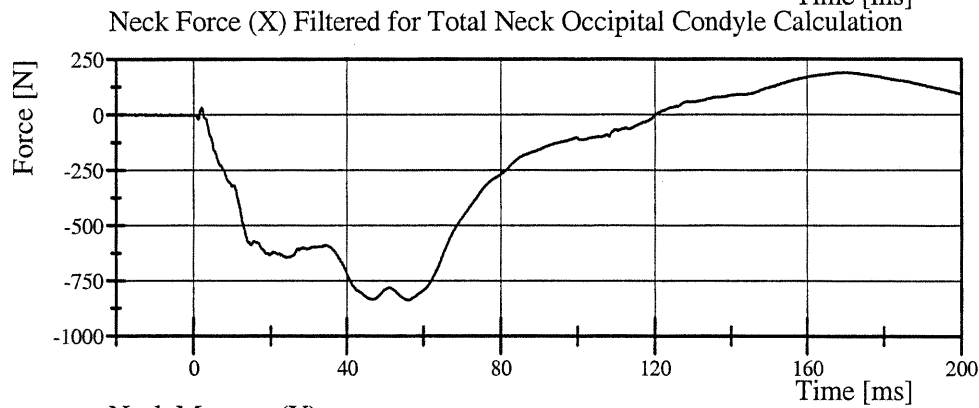

Filter Class: CFC_600
Max: 189.7 N at 169.8 ms
Min: -836.5 N at 56.2 ms

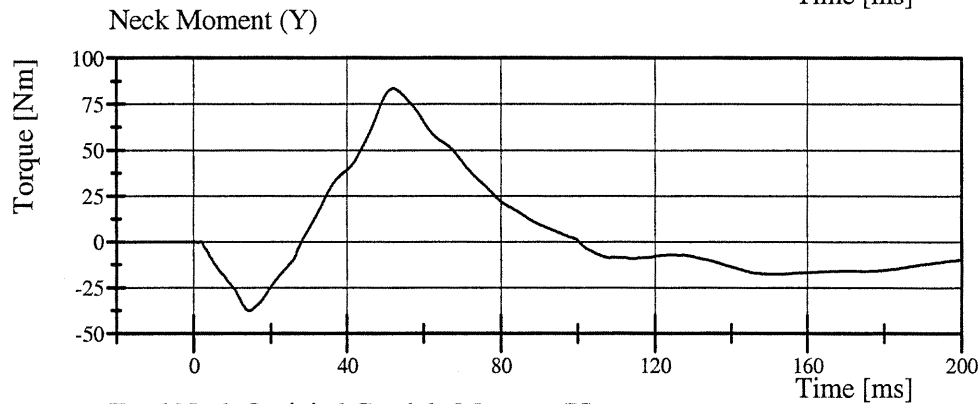

Filter Class: CFC_600
Max: 83.6 Nm at 52.1 ms
Min: -37.6 Nm at 14.2 ms

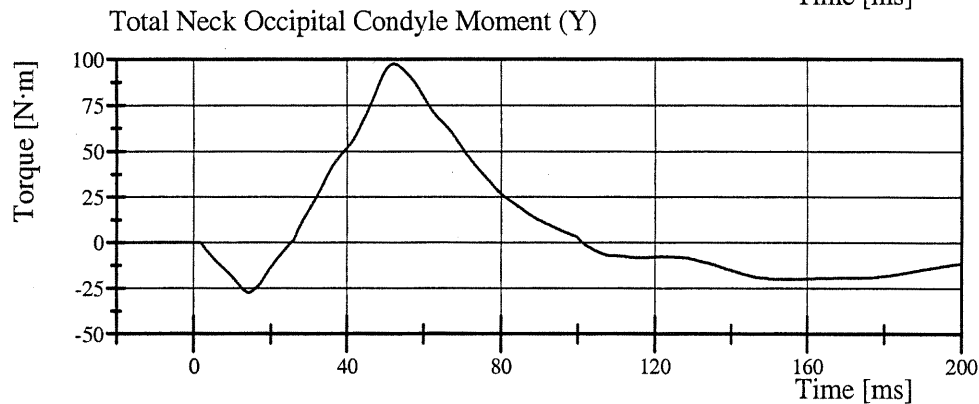

Filter Class: CFC_600
Max: 97.5 N·m at 52.2 ms
Min: -27.4 N·m at 14.2 ms



Transportation Research Center Inc.

Neck Extension

HIII 50th Serial No. 001 Certification No. 4-2

Test Date: 7/10/2007

Test Parameter	Specification	Test Results	Pass
Temperature	20.6 - 22.2 °C	20.9 °C	Yes
Relative Humidity	10 - 70 %	52 %	Yes
Pendulum Velocity	(-5.95) - (-6.18) m/s	-5.988 m/s	Yes
Pendulum Acceleration Decay Crossing 5g	38 - 46 ms	43.4 ms	Yes
Pendulum Acceleration at 10ms	17.2 - 21.2 g	17.95 g	Yes
Pendulum Acceleration at 20ms	14.0 - 19.0 g	15.95 g	Yes
Pendulum Acceleration at 30ms	11.0 - 16.0 g	13.12 g	Yes
Pendulum Acceleration > 30ms	<= 22.0 g	13.45 g	Yes
Total Head D-Plane Rotation Peak	81 - 106 °	90.0 °	Yes
Time of Peak	72 - 82 ms	78.6 ms	Yes
Total Head D-Plane Rotation Decay to 0°	147 - 174 ms	159.4 ms	Yes
Total Neck Occipital Condyles Moment Peak	(-53) - (-80) N·m	-65.7 N·m	Yes
Time of Peak	65 - 79 ms	74.2 ms	Yes
Total Neck Occipital Condyles Moment Decay to 0 N·m	120 - 148 ms	144.9 ms	Yes

Test meets specifications.

Comments:

Technician

Raul Borau

Approved

Ron Stone

Transportation Research Center Inc.

Neck Extension

HIII 50th Serial No. 001 Certification No. 4-2

Test Date: 7/10/2007

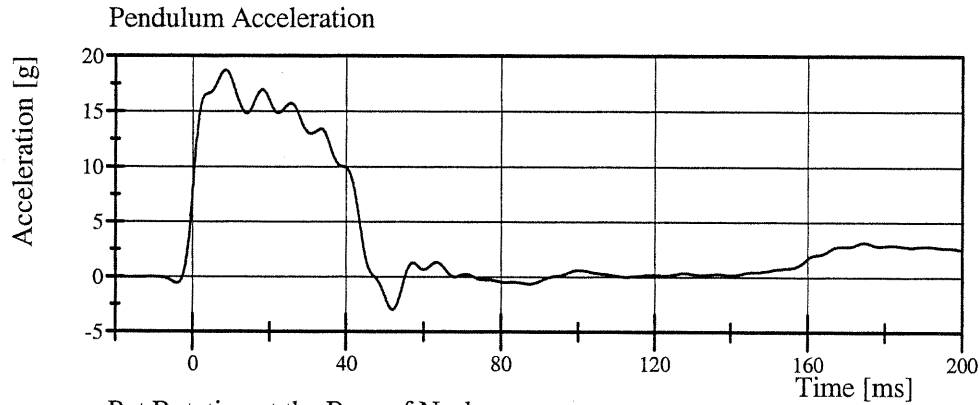

Filter Class: CFC_60
Max: 18.7 g at 8.4 ms
Min: -3.0 g at 51.8 ms

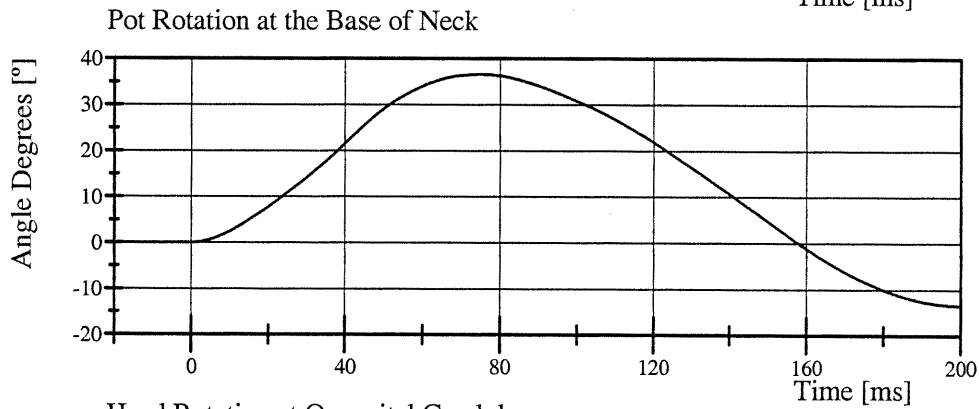

Filter Class: CFC_60
Max: 36.6 ° at 75.0 ms
Min: -13.4 ° at 200.0 ms

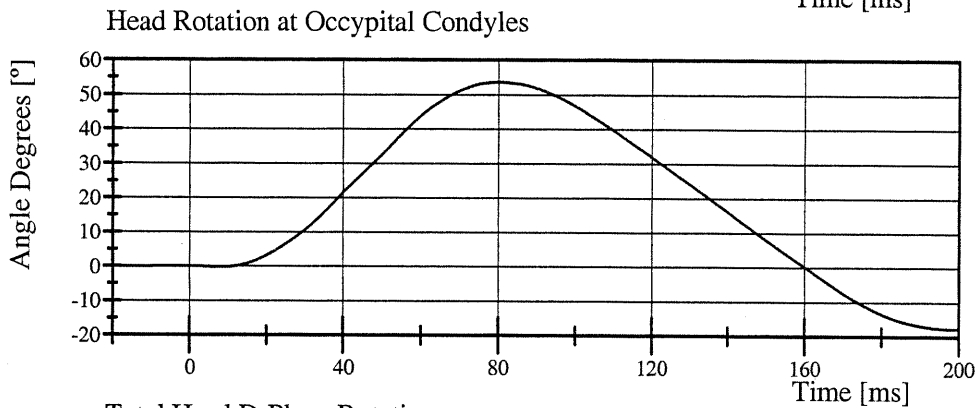

Filter Class: CFC_60
Max: 53.6 ° at 80.3 ms
Min: -17.7 ° at 199.2 ms

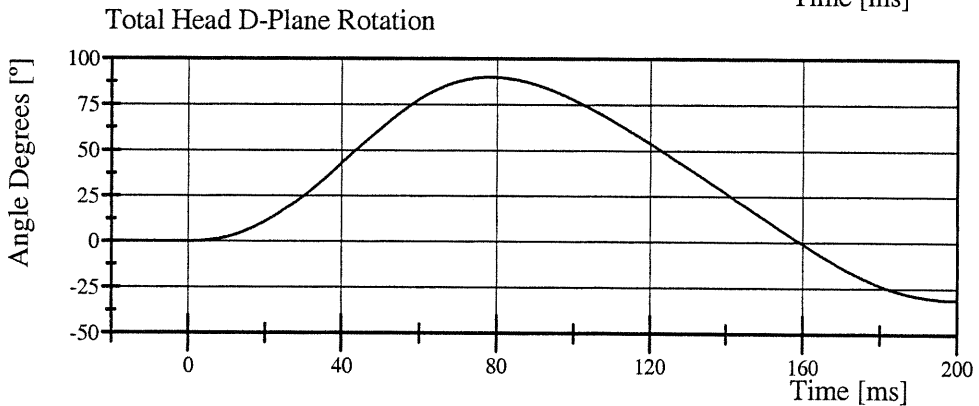

Filter Class: CFC_60
Max: 90.0 ° at 78.6 ms
Min: -31.1 ° at 199.5 ms

Transportation Research Center Inc.

Neck Extension

HIII 50th Serial No. 001 Certification No. 4-2

Test Date: 7/10/2007

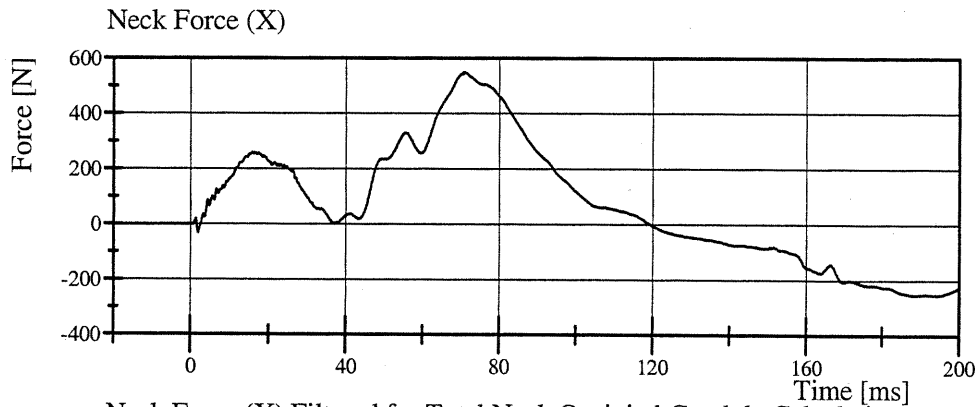

Filter Class: CFC_1000
Max: 550.8 N at 70.8 ms
Min: -253.1 N at 188.5 ms

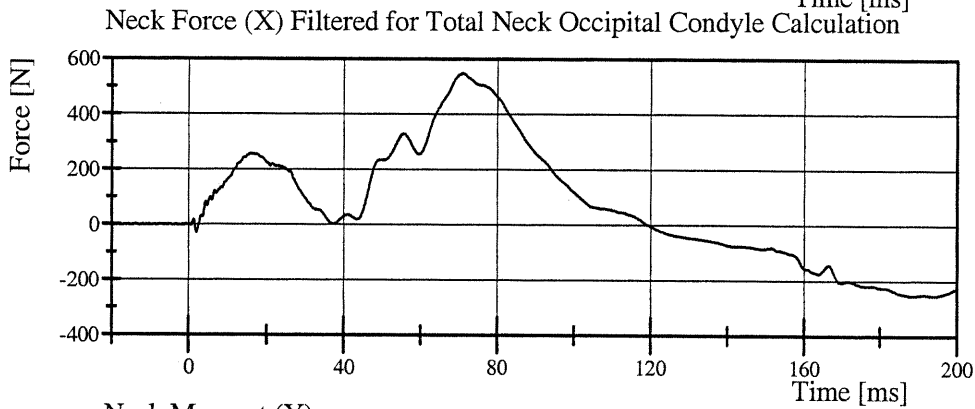

Filter Class: CFC_600
Max: 549.9 N at 70.9 ms
Min: -252.7 N at 188.4 ms

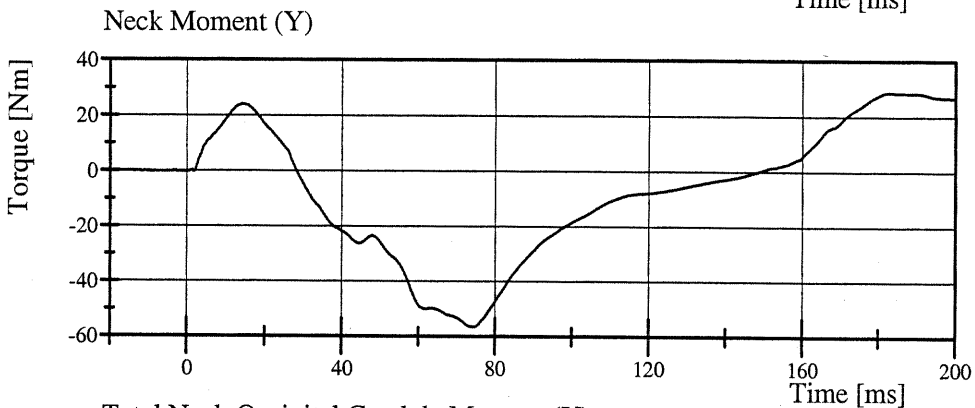

Filter Class: CFC_600
Max: 28.8 Nm at 182.9 ms
Min: -56.6 Nm at 74.3 ms

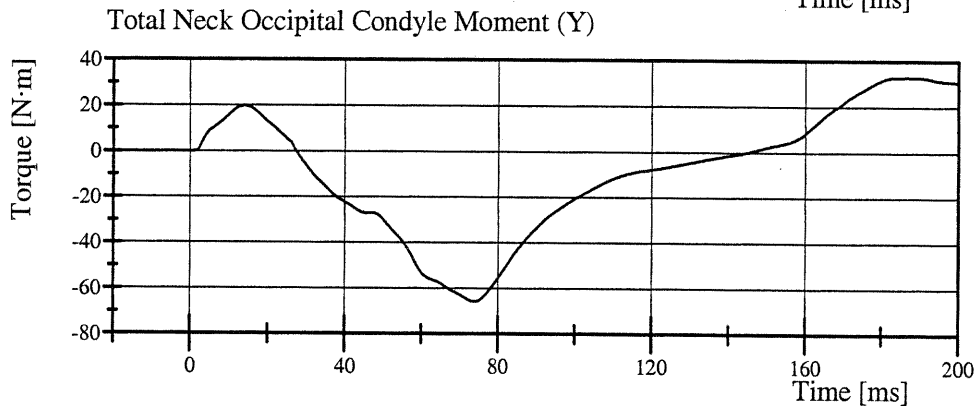

Filter Class: CFC_600
Max: 33.0 N·m at 186.4 ms
Min: -65.7 N·m at 74.2 ms

Transportation Research Center Inc.

Front Thorax

HIII 50th Serial No. 001 Certification No. 4-1

Test Date: 7/10/2007

Test Parameter	Specification	Test Results	Pass
Temperature	20.6 - 22.2 °C	21.3 °C	Yes
Relative Humidity	10 - 70 %	54 %	Yes
Probe Velocity	6.59 - 6.83 m/s	6.636 m/s	Yes
Probe Force Peak	(-5,160) - (-5,893) N	-5,824.9 N	Yes
Maximum Chest Compression	(-63.5) - (-72.6) mm	-68.27 mm	Yes
Internal Hysteresis	65 - 85 %	73.0 %	Yes

Test meets specifications.

Comments:

Technician



Approved



Transportation Research Center Inc.

Front Thorax

HIII 50th Serial No. 001 Certification No. 4-1

Test Date: 7/10/2007

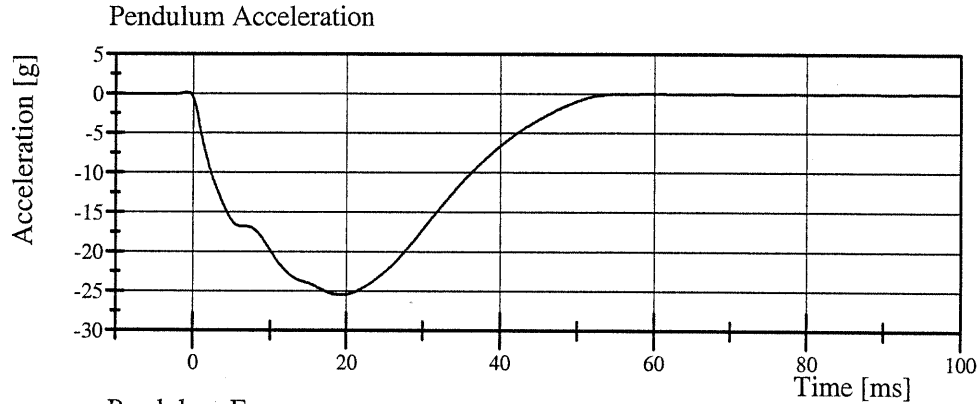

Filter Class: CFC_180
Max: 0.2 g at -0.8 ms
Min: -25.4 g at 19.2 ms

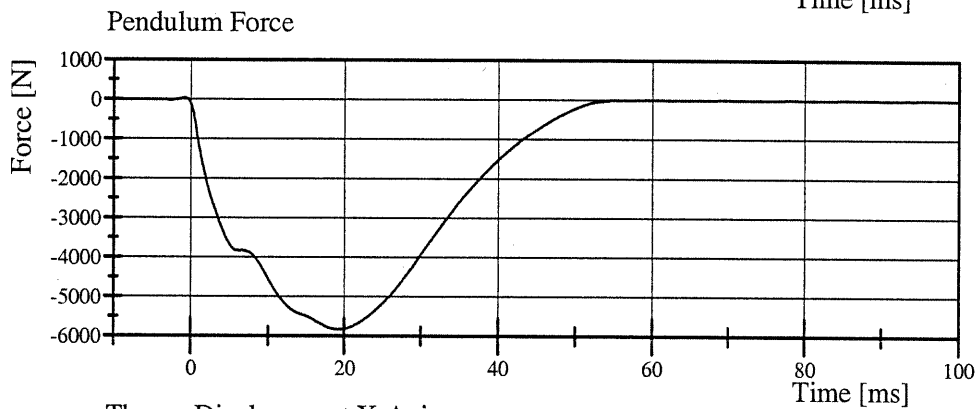

Filter Class: CFC_180
Max: 35.9 N at -0.8 ms
Min: -5,824.9 N at 19.2 ms

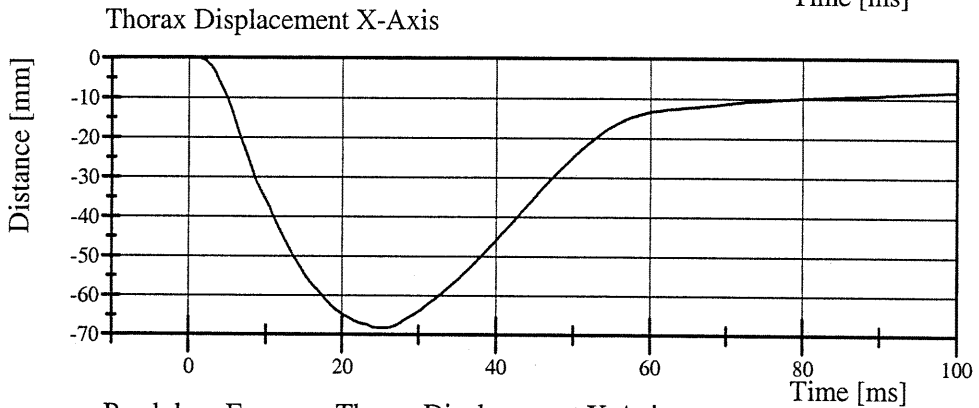

Filter Class: CFC_600
Max: 0.0 mm at -2.9 ms
Min: -68.3 mm at 25.4 ms

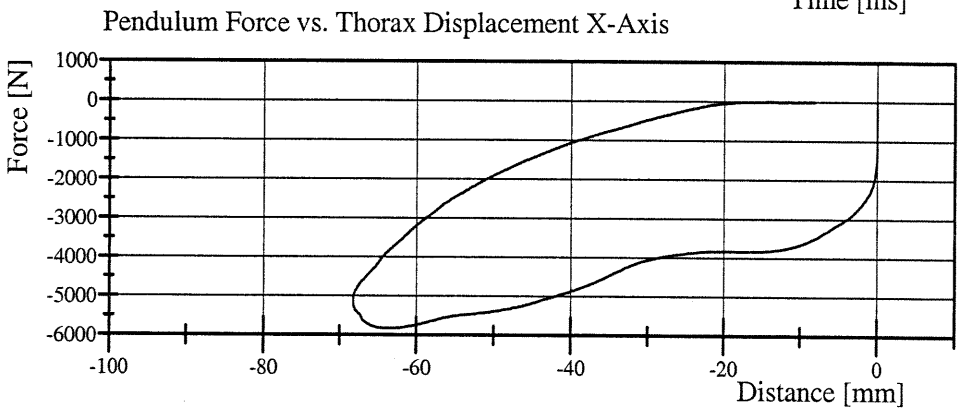

Filter Class: CFC_180
Max: 35.9 N at -0.0 mm
Min: -5,824.9 N at -63.7 mm

Applied Safety Technologies Corp.

Hybrid III Hip Range of Motion

Serial Number: 001L
 Test Number: 001C04
 Comments:

Date: 07/10/2007
 Time: 10:27

TEST PARAMETER	SPECIFICATION	TEST RESULTS	
Temperature	18.9 - 25.6	21.1 °C	Pass
Humidity	10 - 70	60 %	Pass
Moment at 30 deg	<= 94.9	75.8 Nm	Pass
Angle at 203 Nm	40.0 - 50.0	41.2 deg	Pass
Average Velocity	5.0 - 10.0	7.4 deg/sec	Pass

Moment About H-Point
 Peak Moment: 210.6 Nm at 41.5 deg
 Peak Angle: 41.5 deg at 210.6 Nm

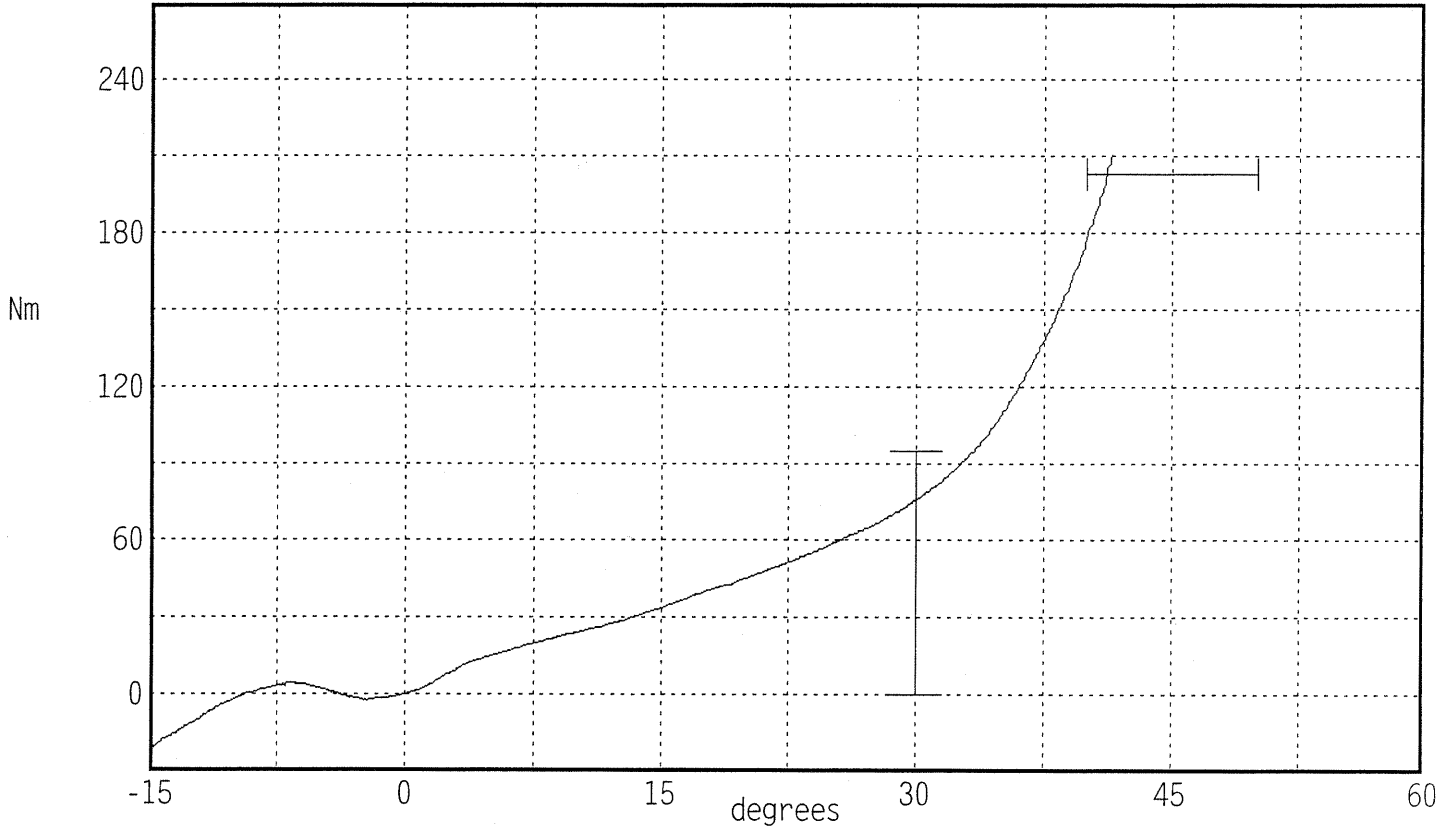

Angular Velocity Max: 8.0 deg/sec Min: 6.9 deg/sec

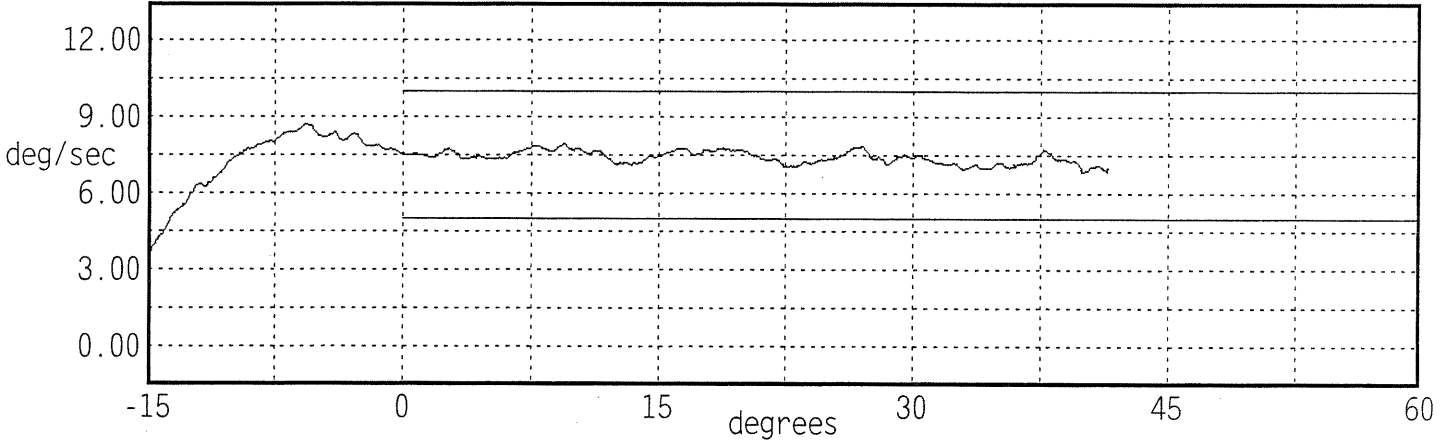

Applied Safety Technologies Corp.

Hybrid III Hip Range of Motion

Serial Number: 001R
Test Number: 001C04
Comments:

Date: 07/10/2007
Time: 10:35

TEST PARAMETER	SPECIFICATION	TEST RESULTS	
Temperature	18.9 - 25.6	21.0 °C	Pass
Humidity	10 - 70	57 %	Pass
Moment at 30 deg	<= 94.9	94.1 Nm	Pass
Angle at 203 Nm	40.0 - 50.0	40.2 deg	Pass
Average Velocity	5.0 - 10.0	7.4 deg/sec	Pass

Moment About H-Point
Peak Moment: 210.9 Nm at 40.6 deg
Peak Angle: 40.6 deg at 210.9 Nm

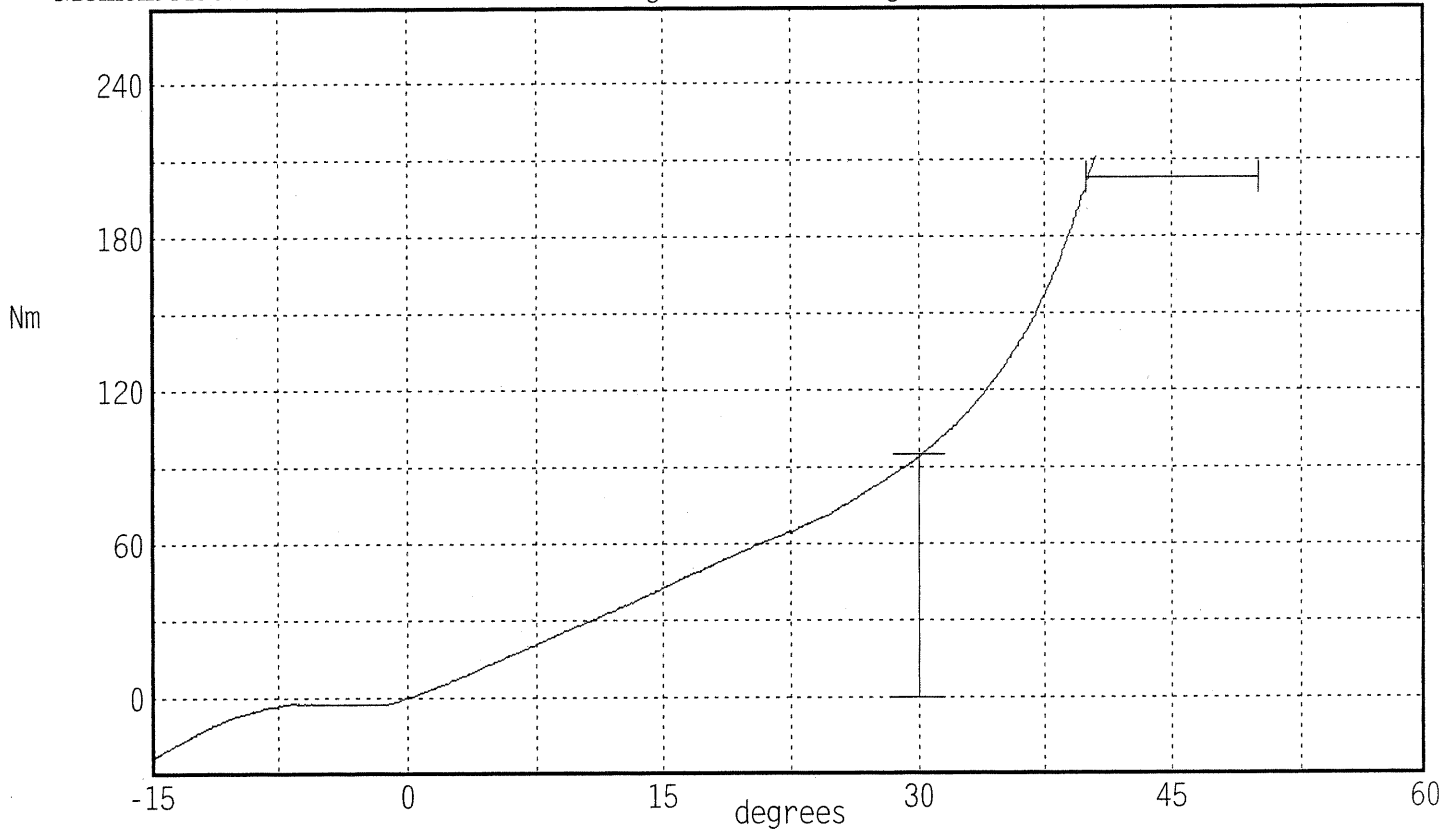

Angular Velocity Max: 7.9 deg/sec Min: 7.0 deg/sec

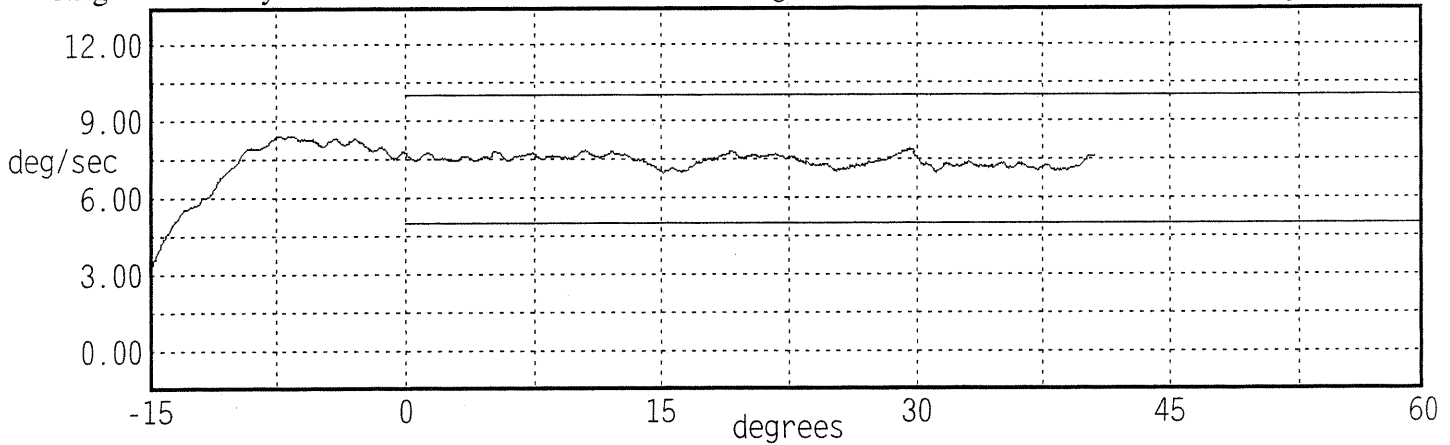



Test Date: 09/13/07 (5th %, 50th %, 95th %, 10 YO and 6YO)
 Type: 50% S/N: 001 Mfg.: UTAMA
 Proj./Seg. No.: 20040479/ 1050 Test Eng: Michael R. Tonneman

ITEM	PRE-USE	POST-USE
HEAD:		
Skull Cap Bolts: tight and no wires pinched	X	
Head Skin Condition	X	X
* Neck Load Cell Cables: secure, taped, and with strain relief	X	
NECK:		
Bracket at specified setting, Serration Alignment, Bolt Actual: 0	X	X
Condyle Pin, Set Screws	X	
* Rubber Condition	X	X
* Neck Cable Torque (5 th /50 th /95 th : 10-14 in-lb) (6YO: 1.8 – 2.2 in-lb) Actual: <u>11</u>	X	
* Nodding Blocks Condition and Position (Nodding Joint Function)	X	X
ARMS AND HANDS:		
Clavicle and Shoulder Bumpers Condition	X	
Range of Motion Stops: Elbow, Top and Rear Shoulder		X
THORAX:		
Front and Rear Rib Bolts, Rib Ends Position, Rib Spacing	X	
Chest Pot Arm, Ball Movement, Set Screws	X	X
Sternum Bolts and Sternum Bumpers Condition	X	X
Jacket Condition	X	X
Abdominal Insert Condition	X	X
Rib Damping Material and Stiffeners Condition	X	X
Accel. Mount Bolts	X	
Lumbar Spine Rubber Condition, Spine Angle (10YO), 4 Attachment Bolts	X	X
LUMBAR/PELVIS:		
Iliac Crest Bone	X	X
Flesh Condition	X	X
Accel. Mount Bolt	X	
10YO: Lumbar Block Adjustment Position as requested. Actual: _____	N/A	
Lumbar Block Bolts	X	
Range of Motion Bumpers & Leg Cavity	X	X
LEGS AND FEET:		
Femur Load Cell Bolts (5 th /50 th /95 th : 30 ft-lb / 6YO: 16 ft-lb)	X	
Knee Joint Function and Range of Motion	X	
Knee Skins, Casting, and Inserts Condition	X	X
Knee Slider Zero Position	X	
Ankle Range of Motion, Bumper Condition	X	
Foot Condition	X	X
OTHER:		
Cleanliness / Skin Condition & Position	X	
Target Position	X	
Clothes and Shoes BLUE	X	
One G Joint Adjustments	X	
Verify channels against assembly and Check connectors (intact & labeled)	X	
ATTACH TEMPERATURE LOGGER TO DUMMY / DOWNLOAD	X	X

* Items checked during calibration; these items need checked when the dummy is used without recalibration

Pre Test Inspection Completed By: J. Clarridge Date: 09/12/07

Post Test Inspection Completed By: J. Clarridge Date: 09/14/07

Pre-test Dummy Configuration and Performance Verification Data

Right Front Passenger Dummy S/N: 855

Transportation Research Center Inc.
572E HIII 50th Male Dummy
External Dimensions
Serial No. 855
Calibration No. 06

Symbol	Description	Specification	Results	Pass
		mm	mm	
A	Total Sitting Height	878.8 - 889.0	887	Yes
B	Shoulder Pivot Height	505.5 - 520.7	506	Yes
C	H-Point Height	83.8 - 88.9	85	Yes
D	H-Point From Seatback	134.6 - 139.7	138	Yes
E	Shoulder Pivot From Backline	83.8 - 94.0	86	Yes
F	Thigh Clearance	139.7 - 154.9	149	Yes
G	Back Of Elbow To Wrist Pivot	289.6 - 304.8	299	Yes
H	Skull Cap To Backline	40.6 - 45.7	45	Yes
I	Shoulder-Elbow Length	330.2 - 345.4	332	Yes
J	Elbow Rest Height	190.5 - 210.8	192	Yes
K	Buttock Knee Length	579.1 - 604.5	601	Yes
L	Popliteal Height	429.3 - 454.7	430	Yes
M	Knee Pivot Height	485.1 - 500.4	490	Yes
N	Buttock Popliteal Length	452.1 - 477.5	477	Yes
O	Chest Depth	213.4 - 228.6	227	Yes
P	Foot Length	251.5 - 266.7	260	Yes
V	Shoulder Breadth	421.6 - 436.9	426	Yes
W	Foot Breadth	91.4 - 106.7	95	Yes
Y	Chest Circumference	970.3 - 1000.8	990	Yes
Z	Waist Circumference	835.7 - 866.1	847	Yes
AA	Location For Chest Circumference	429.3 - 434.3	430	Yes
BB	Location For Waist Circumference	226.1 - 231.1	230	Yes

Comment:

Technician

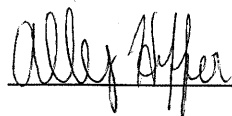

Approved



Transportation Research Center Inc.

Front Head Drop

HIII 50th Serial No. 855 Certification No. 6-5

Test Date: 7/12/2007

Test Parameter	Specification	Test Results	Pass
Temperature	18.9 - 25.5 °C	20.8 °C	Yes
Relative Humidity	10 - 70 %	45 %	Yes
Peak Head Resultant Acceleration	225 - 275 g	232.7 g	Yes
Peak Head Lateral Acceleration	(-15) - 15 g	8.6 g	Yes
Is Acceleration Curve Unimodal within 10% of Peak?	Yes	Yes	Yes

Test meets specifications.

Comments:

Technician

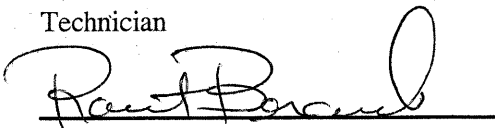

Approved



Transportation Research Center Inc.

Front Head Drop

HIII 50th Serial No. 855 Certification No. 6-5

Test Date: 7/12/2007

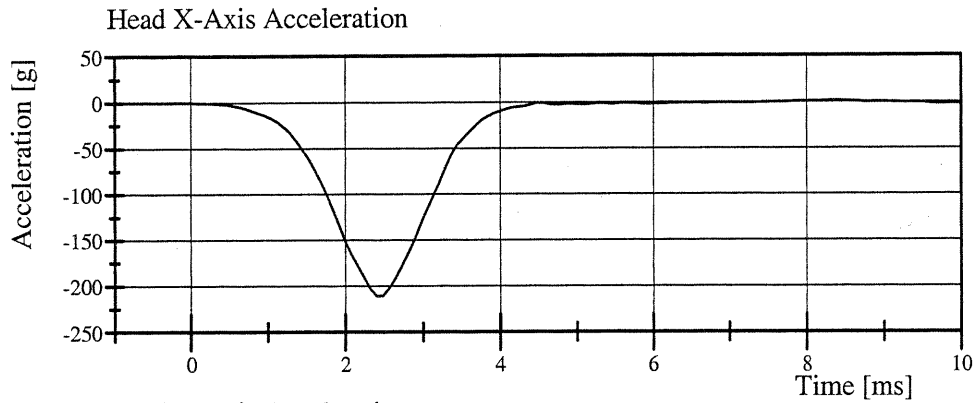

Filter Class: CFC_1000

Max: 1.3 g at 8.3 ms

Min: -211.0 g at 2.4 ms

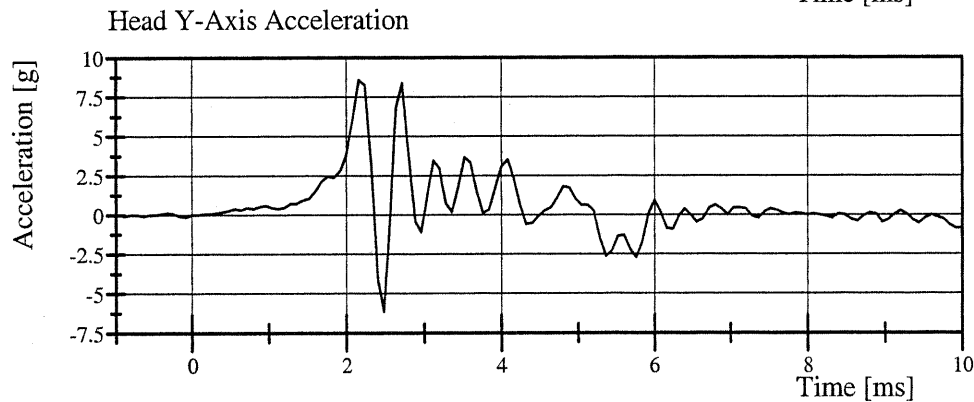

Filter Class: CFC_1000

Max: 8.6 g at 2.2 ms

Min: -6.1 g at 2.5 ms

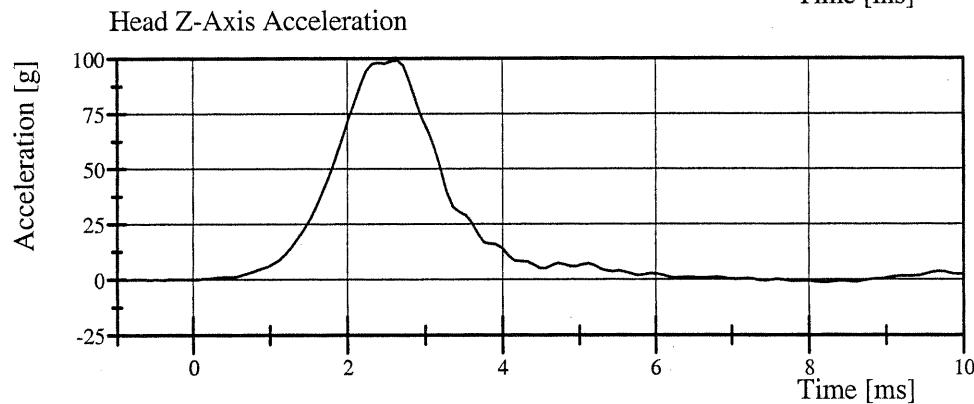

Filter Class: CFC_1000

Max: 99.1 g at 2.6 ms

Min: -1.2 g at 8.2 ms

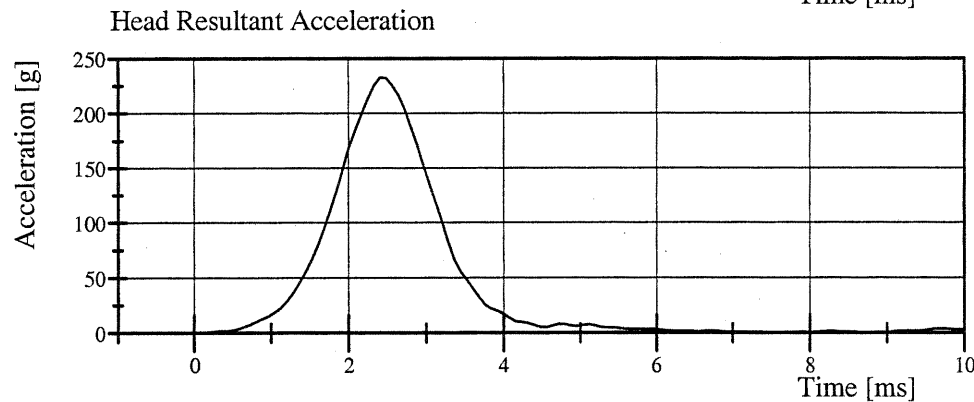

Filter Class: CFC_1000

Max: 232.7 g at 2.4 ms

Min: 0.0 g at -1.0 ms

Transportation Research Center Inc.

Neck Flexion

HIII 50th Serial No. 855 Certification No. 6-1

Test Date: 7/10/2007

Test Parameter	Specification	Test Results	Pass
Temperature	20.6 - 22.2 °C	21.4 °C	Yes
Relative Humidity	10 - 70 %	54 %	Yes
Pendulum Velocity	6.89 - 7.13 m/s	6.942 m/s	Yes
Pendulum Acceleration Decay Crossing -5g	34 - 42 ms	36.8 ms	Yes
Pendulum Acceleration at 10ms	(-22.5) - (-27.5) g	-24.97 g	Yes
Pendulum Acceleration at 20ms	(-17.6) - (-22.6) g	-21.76 g	Yes
Pendulum Acceleration at 30ms	(-12.5) - (-18.5) g	-15.51 g	Yes
Pendulum Acceleration > 30ms	>= (-29.0) g	-15.51 g	Yes
Total Head D-Plane Rotation Peak	(-64) - (-78) °	-64.4 °	Yes
Time of Peak	57 - 64 ms	58.0 ms	Yes
Total Head D-Plane Rotation Decay to 0°	113 - 128 ms	117.8 ms	Yes
Total Neck Occipital Condyles Moment Peak	88 - 108 N·m	97.3 N·m	Yes
Time of Peak	47 - 58 ms	49.7 ms	Yes
Total Neck Occipital Condyles Moment Decay to 0 N·m	97 - 107 ms	99.1 ms	Yes

Test meets specifications.

Comments:

Technician

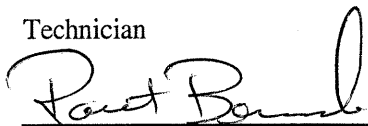

Approved



Transportation Research Center Inc.

Neck Flexion

HIII 50th Serial No. 855 Certification No. 6-1

Test Date: 7/10/2007

Pendulum Acceleration

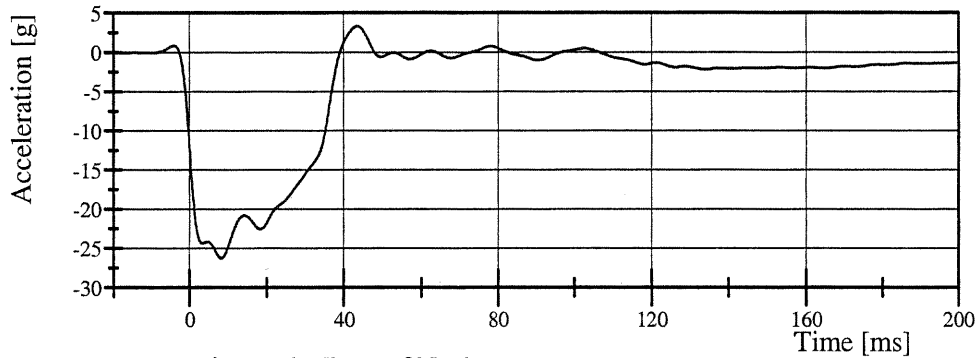

Filter Class: CFC_60

Max: 3.3 g at 43.5 ms

Min: -26.2 g at 8.3 ms

Pot Rotation at the Base of Neck

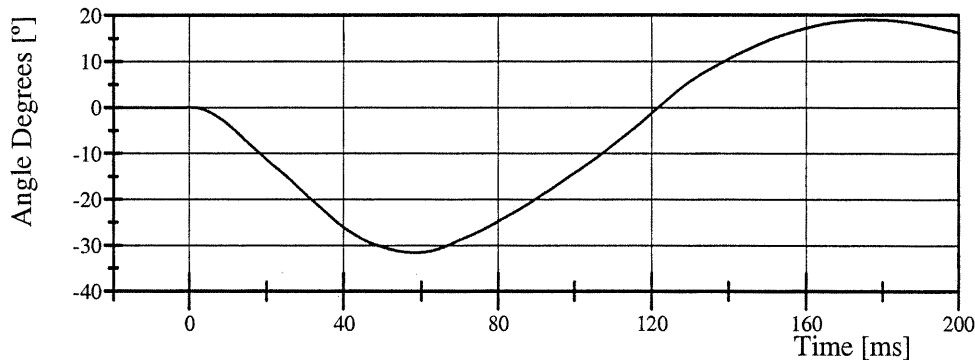

Filter Class: CFC_60

Max: 19.0 ° at 176.9 ms

Min: -31.5 ° at 58.6 ms

Head Rotation at Occipital Condyles

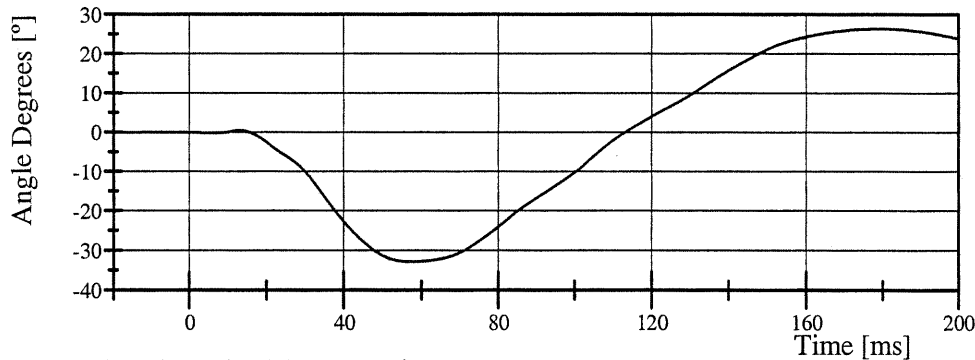

Filter Class: CFC_60

Max: 26.4 ° at 179.3 ms

Min: -32.9 ° at 57.7 ms

Total Head D-Plane Rotation

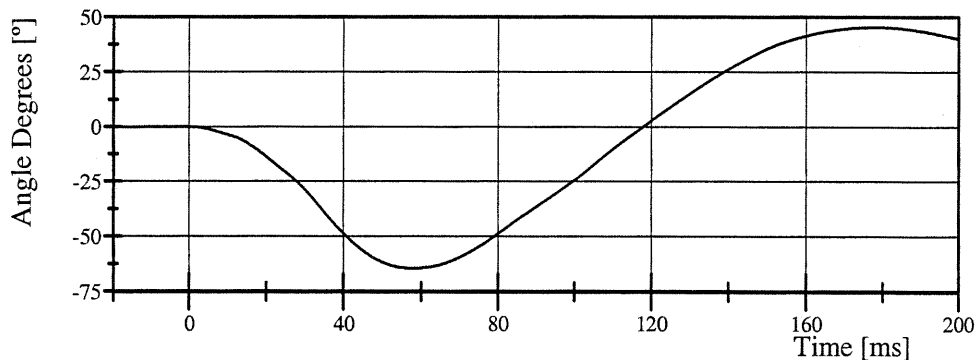

Filter Class: CFC_60

Max: 45.4 ° at 178.2 ms

Min: -64.4 ° at 58.0 ms

Transportation Research Center Inc.

Neck Flexion

HIII 50th Serial No. 855 Certification No. 6-1

Test Date: 7/10/2007

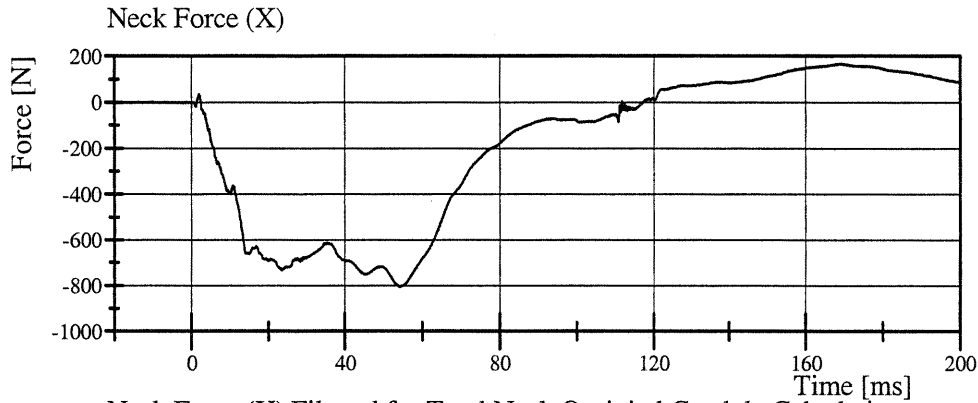

Filter Class: CFC_1000
Max: 166.0 N at 169.0 ms
Min: -803.4 N at 54.2 ms

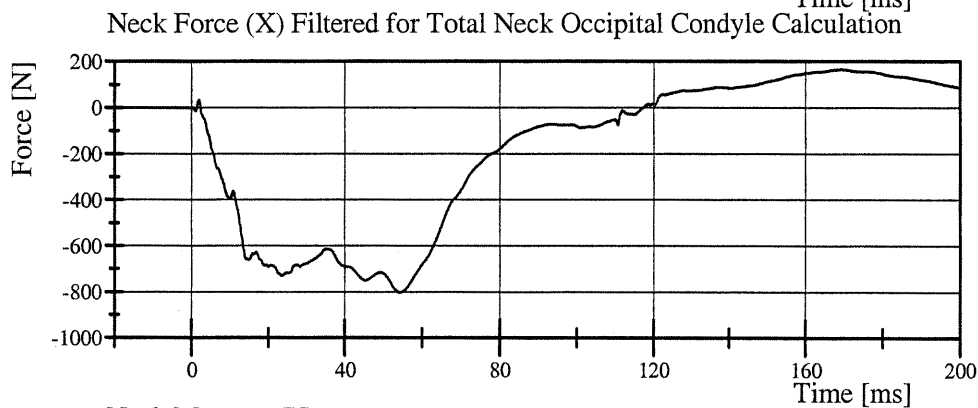

Filter Class: CFC_600
Max: 166.0 N at 169.1 ms
Min: -803.3 N at 54.2 ms

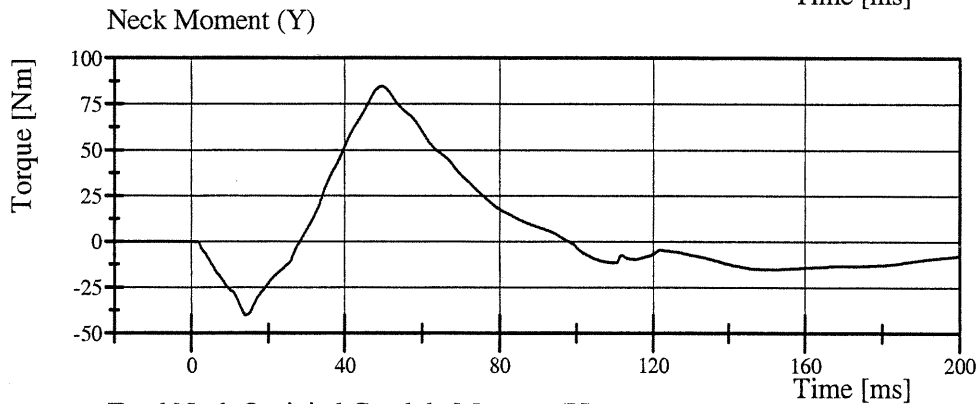

Filter Class: CFC_600
Max: 84.6 Nm at 49.7 ms
Min: -40.2 Nm at 14.1 ms

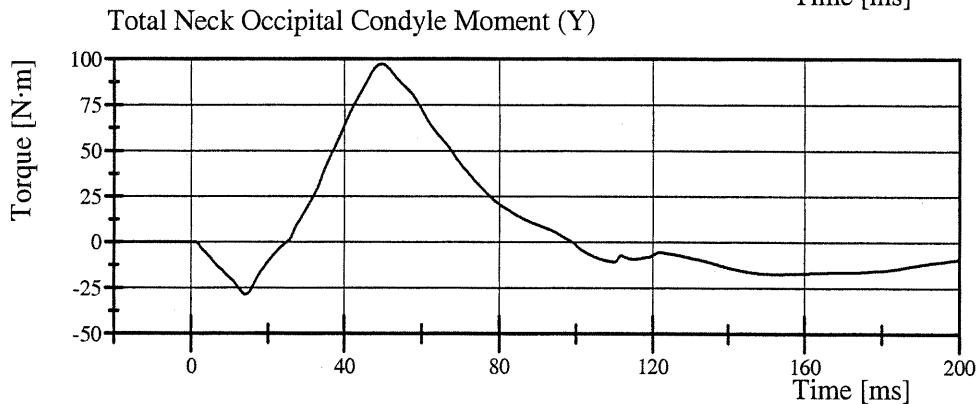

Filter Class: CFC_600
Max: 97.3 N·m at 49.7 ms
Min: -28.6 N·m at 14.1 ms

Transportation Research Center Inc.

Neck Extension

HIII 50th Serial No. 855 Certification No. 6-1

Test Date: 7/10/2007

Test Parameter	Specification	Test Results	Pass
Temperature	20.6 - 22.2 °C	21.2 °C	Yes
Relative Humidity	10 - 70 %	52 %	Yes
Pendulum Velocity	(-5.95) - (-6.18) m/s	-5.972 m/s	Yes
Pendulum Acceleration Decay Crossing 5g	38 - 46 ms	41.4 ms	Yes
Pendulum Acceleration at 10ms	17.2 - 21.2 g	19.85 g	Yes
Pendulum Acceleration at 20ms	14.0 - 19.0 g	16.19 g	Yes
Pendulum Acceleration at 30ms	11.0 - 16.0 g	13.29 g	Yes
Pendulum Acceleration > 30ms	<= 22.0 g	13.29 g	Yes
Total Head D-Plane Rotation Peak	81 - 106 °	87.6 °	Yes
Time of Peak	72 - 82 ms	76.0 ms	Yes
Total Head D-Plane Rotation Decay to 0°	147 - 174 ms	157.7 ms	Yes
Total Neck Occipital Condyles Moment Peak	(-53) - (-80) N·m	-69.6 N·m	Yes
Time of Peak	65 - 79 ms	71.8 ms	Yes
Total Neck Occipital Condyles Moment Decay to 0 N·m	120 - 148 ms	144.2 ms	Yes

Test meets specifications.

Comments:

Technician



Approved



Transportation Research Center Inc.

Neck Extension

HIII 50th Serial No. 855 Certification No. 6-1

Test Date: 7/10/2007

Pendulum Acceleration

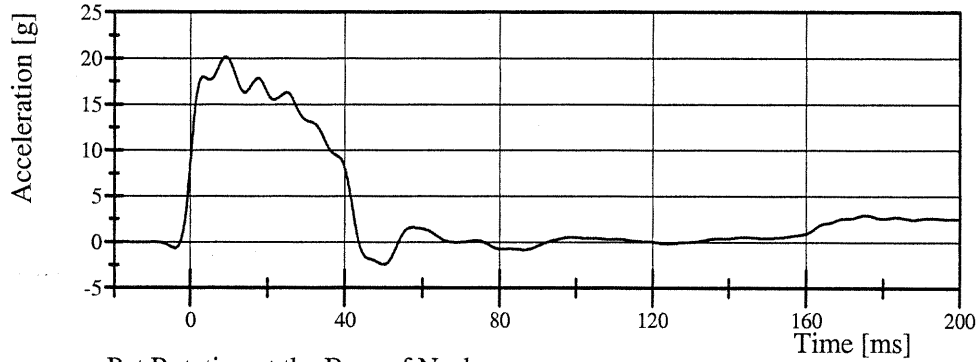

Filter Class: CFC_60
Max: 20.2 g at 9.0 ms
Min: -2.4 g at 50.0 ms

Pot Rotation at the Base of Neck

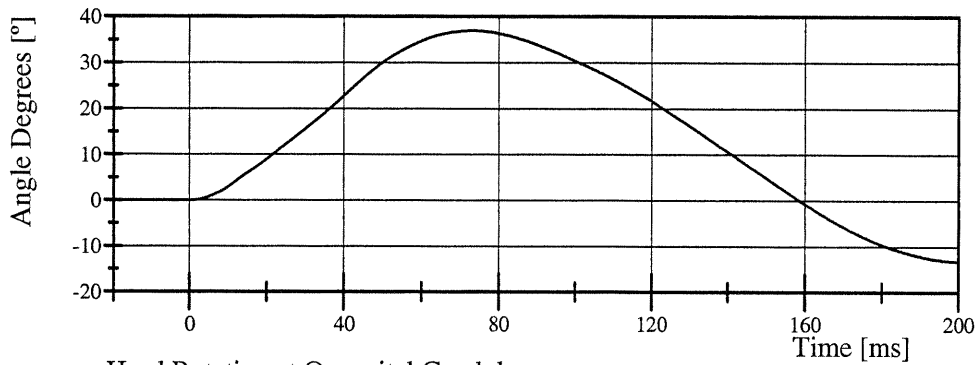

Filter Class: CFC_60
Max: 36.9 ° at 73.1 ms
Min: -13.3 ° at 200.0 ms

Head Rotation at Occypital Condyles

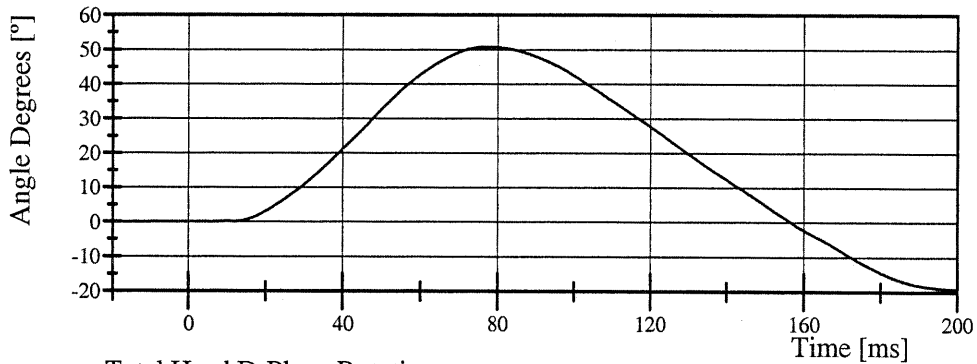

Filter Class: CFC_60
Max: 50.8 ° at 77.6 ms
Min: -19.1 ° at 200.0 ms

Total Head D-Plane Rotation

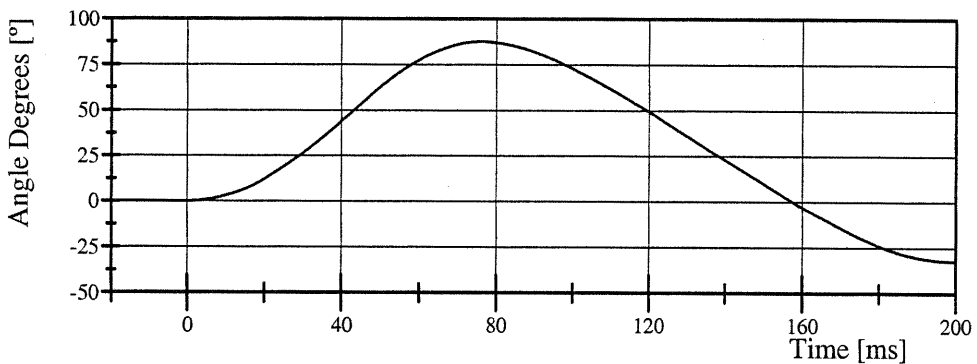

Filter Class: CFC_60
Max: 87.6 ° at 76.0 ms
Min: -32.4 ° at 200.0 ms

Transportation Research Center Inc.

Neck Extension

HIII 50th Serial No. 855 Certification No. 6-1

Test Date: 7/10/2007

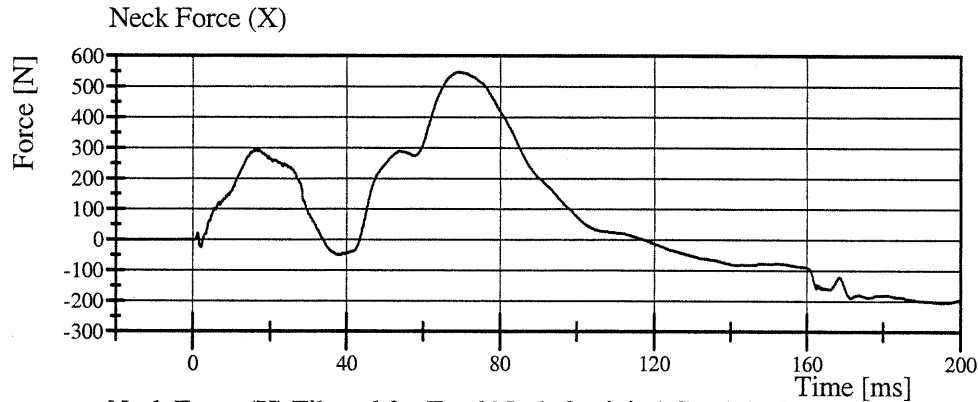

Filter Class: CFC_1000
Max: 547.1 N at 69.0 ms
Min: -204.9 N at 194.9 ms

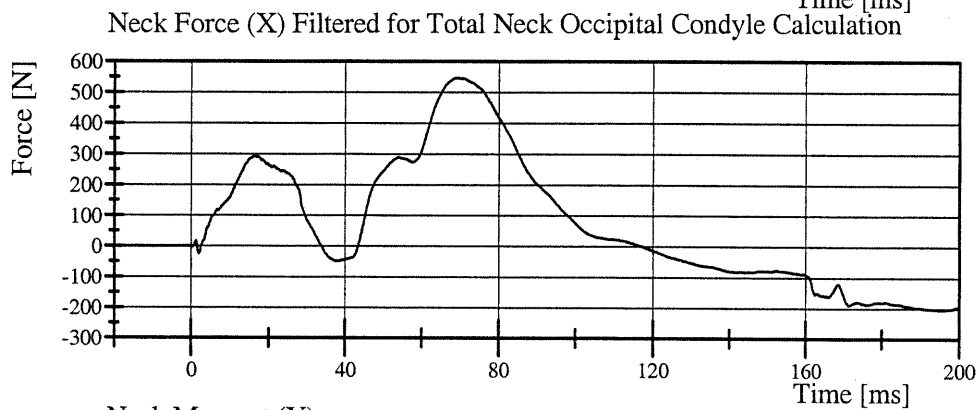

Filter Class: CFC_600
Max: 546.6 N at 69.0 ms
Min: -204.6 N at 195.0 ms

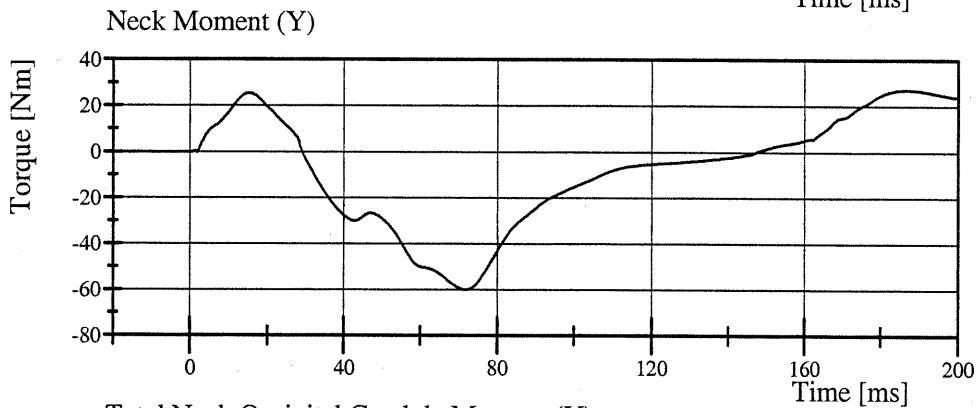

Filter Class: CFC_600
Max: 27.2 Nm at 187.1 ms
Min: -60.1 Nm at 72.0 ms

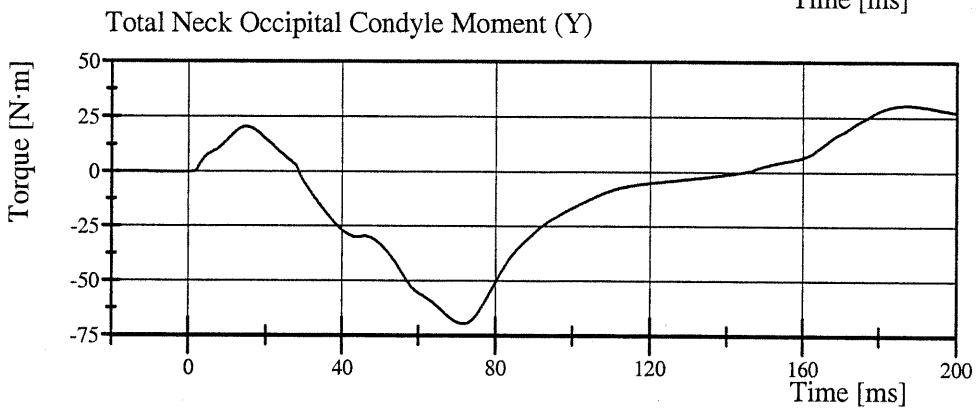

Filter Class: CFC_600
Max: 30.6 N·m at 187.2 ms
Min: -69.6 N·m at 71.8 ms



Transportation Research Center Inc.

Front Thorax

HIII 50th Serial No. 855 Certification No. 6-1

Test Date: 7/11/2007

Test Parameter	Specification	Test Results	Pass
Temperature	20.6 - 22.2 °C	21.3 °C	Yes
Relative Humidity	10 - 70 %	60 %	Yes
Probe Velocity	6.59 - 6.83 m/s	6.726 m/s	Yes
Probe Force Peak	(-5,160) - (-5,893) N	-5,730.9 N	Yes
Maximum Chest Compression	(-63.5) - (-72.6) mm	-65.00 mm	Yes
Internal Hysteresis	65 - 85 %	76.6 %	Yes

Test meets specifications.

Comments:

Technician

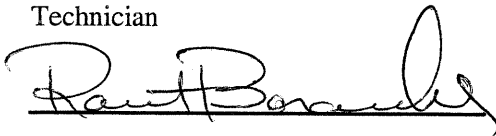

Approved



Transportation Research Center Inc.

Front Thorax

HIII 50th Serial No. 855 Certification No. 6-1

Test Date: 7/11/2007

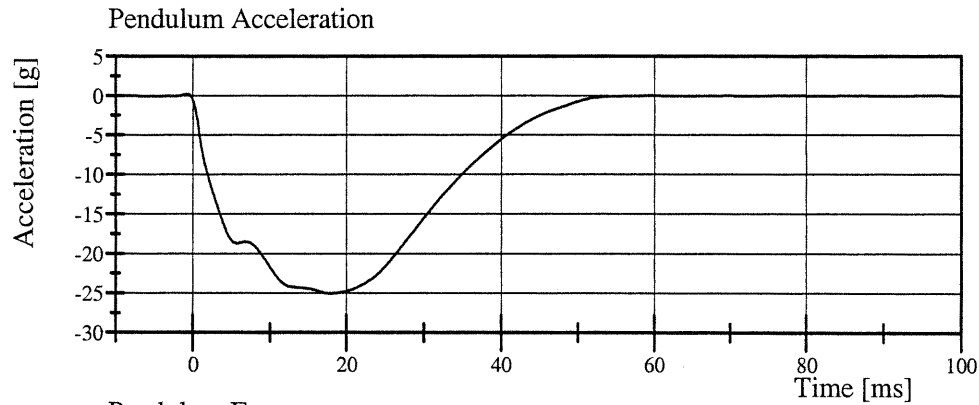

Filter Class: CFC_180
Max: 0.2 g at -0.7 ms
Min: -25.0 g at 17.9 ms

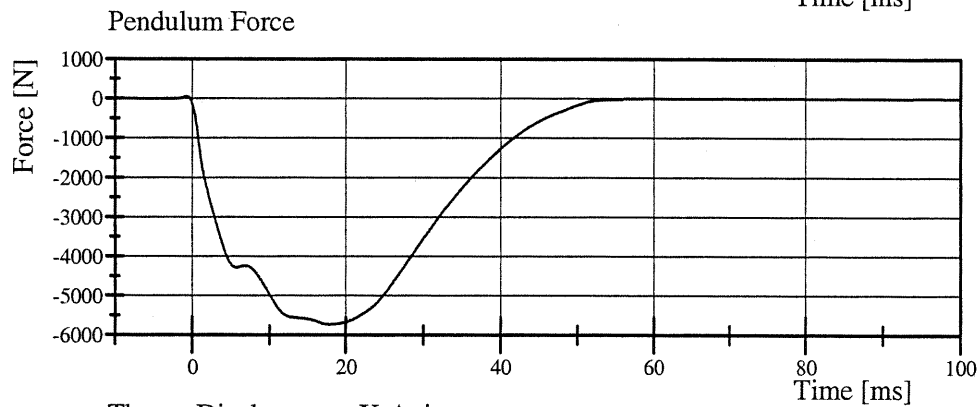

Filter Class: CFC_180
Max: 50.8 N at -0.7 ms
Min: -5,730.9 N at 17.9 ms

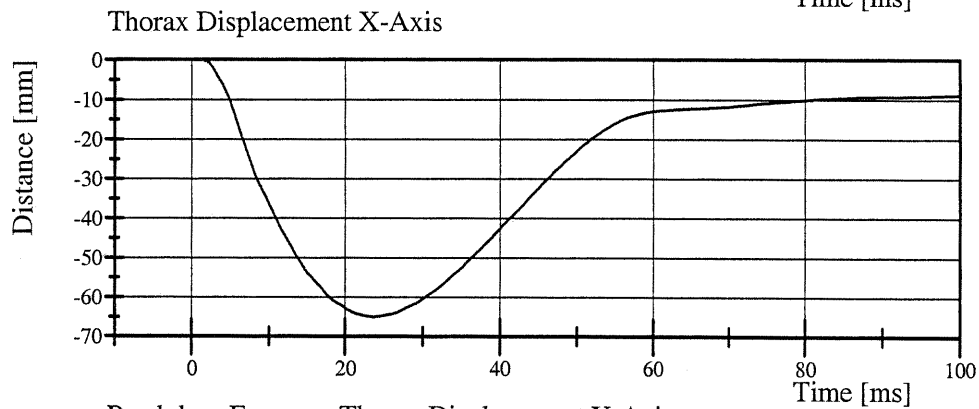

Filter Class: CFC_600
Max: 0.0 mm at -8.1 ms
Min: -65.0 mm at 23.6 ms

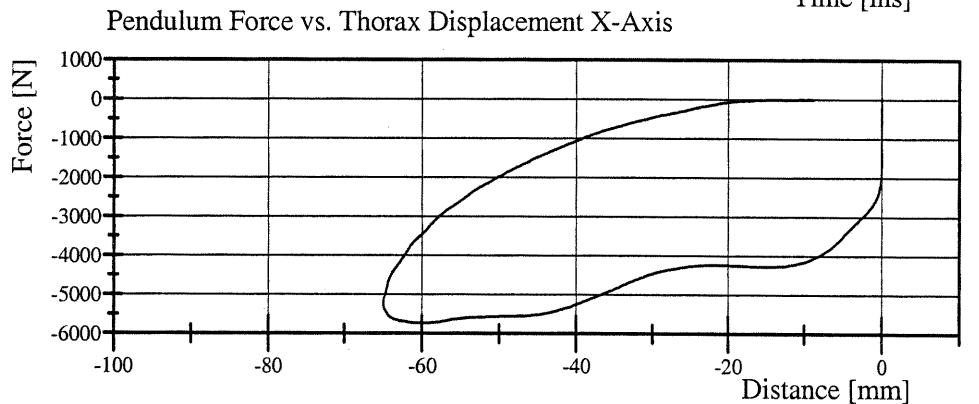

Filter Class: CFC_180
Max: 50.8 N at -0.0 mm
Min: -5,730.9 N at -60.0 mm

Applied Safety Technologies Corp.

Hybrid III Hip Range of Motion

Serial Number: 855L
 Test Number: 855C06
 Comments:

Date: 07/10/2007
 Time: 15:08

TEST PARAMETER	SPECIFICATION	TEST RESULTS	
Temperature	18.9 - 25.6	21.1 °C	Pass
Humidity	10 - 70	55 %	Pass
Moment at 30 deg	<= 94.9	88.6 Nm	Pass
Angle at 203 Nm	40.0 - 50.0	40.7 deg	Pass
Average Velocity	5.0 - 10.0	7.4 deg/sec	Pass

Moment About H-Point
 Peak Moment: 210.2 Nm at 41.0 deg
 Peak Angle: 41.0 deg at 210.2 Nm

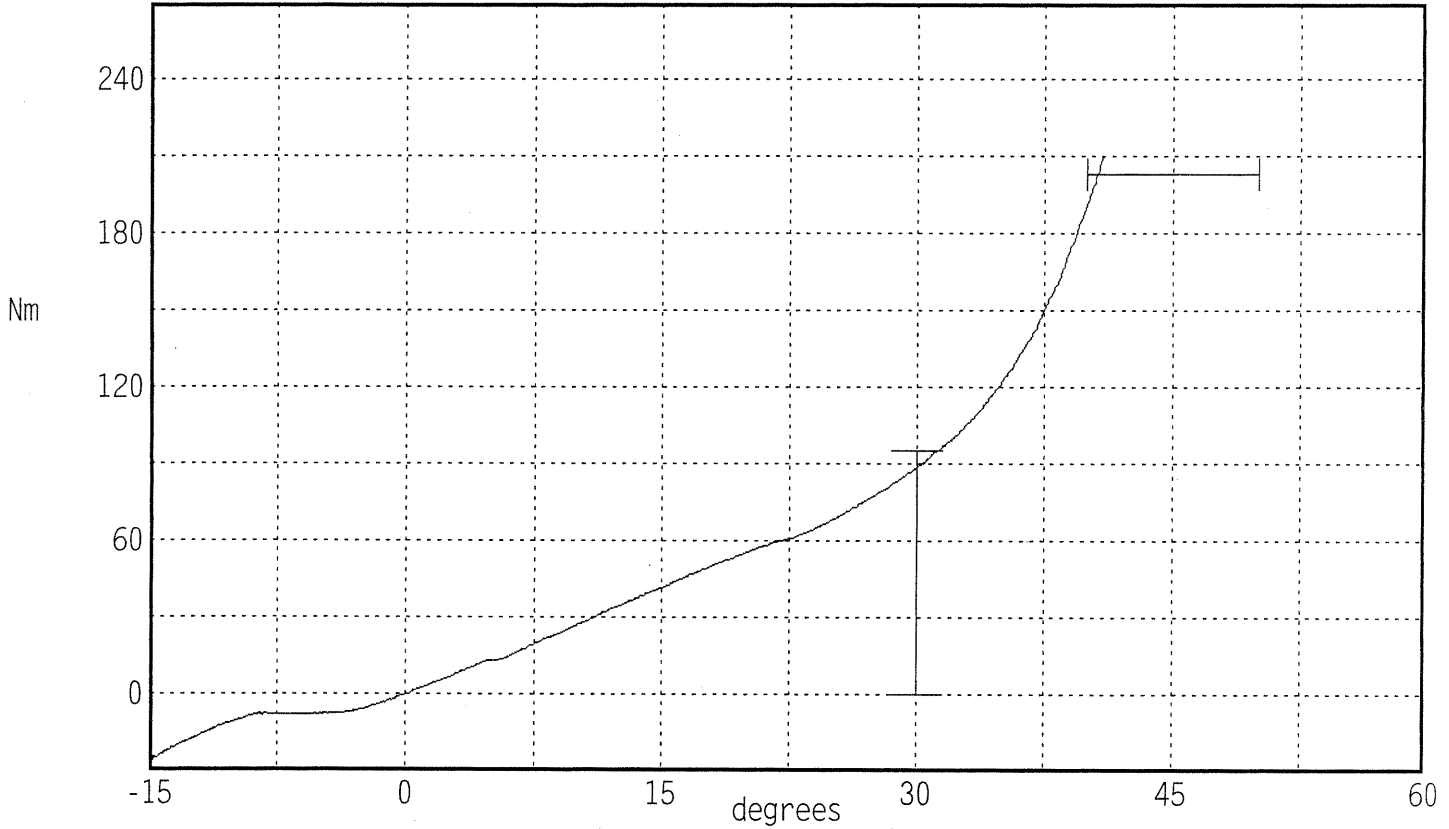

Angular Velocity Max: 8.1 deg/sec Min: 7.0 deg/sec

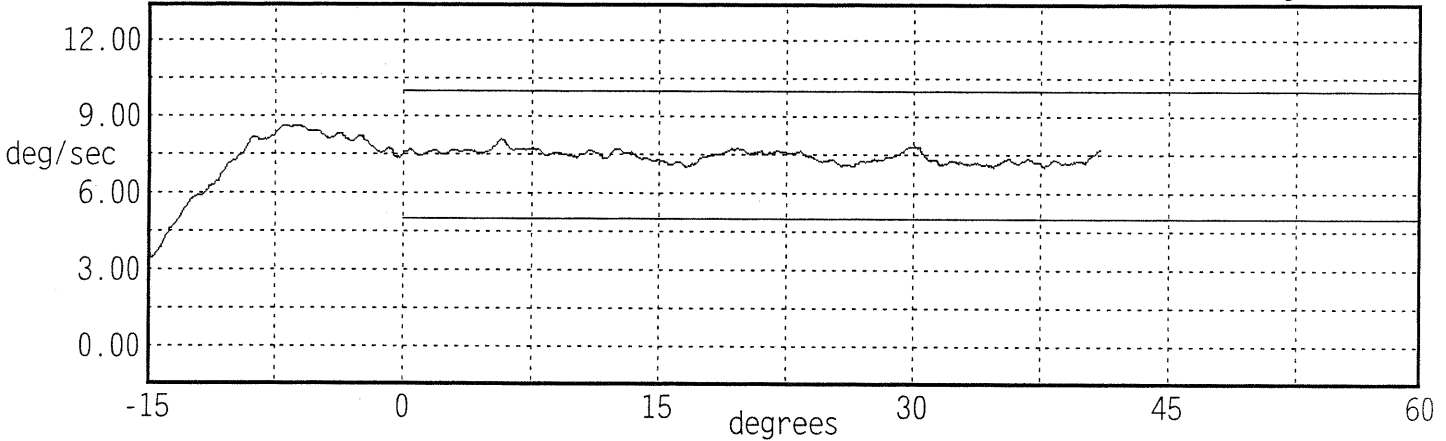

Applied Safety Technologies Corp.

Hybrid III Hip Range of Motion

Serial Number: 855R
Test Number: 855C06
Comments:

Date: 07/10/2007
Time: 15:16

TEST PARAMETER	SPECIFICATION	TEST RESULTS	
Temperature	18.9 - 25.6	20.7 °C	Pass
Humidity	10 - 70	59 %	Pass
Moment at 30 deg	<= 94.9	88.9 Nm	Pass
Angle at 203 Nm	40.0 - 50.0	41.4 deg	Pass
Average Velocity	5.0 - 10.0	7.4 deg/sec	Pass

Moment About H-Point
Peak Moment: 210.9 Nm at 41.7 deg
Peak Angle: 41.7 deg at 210.9 Nm

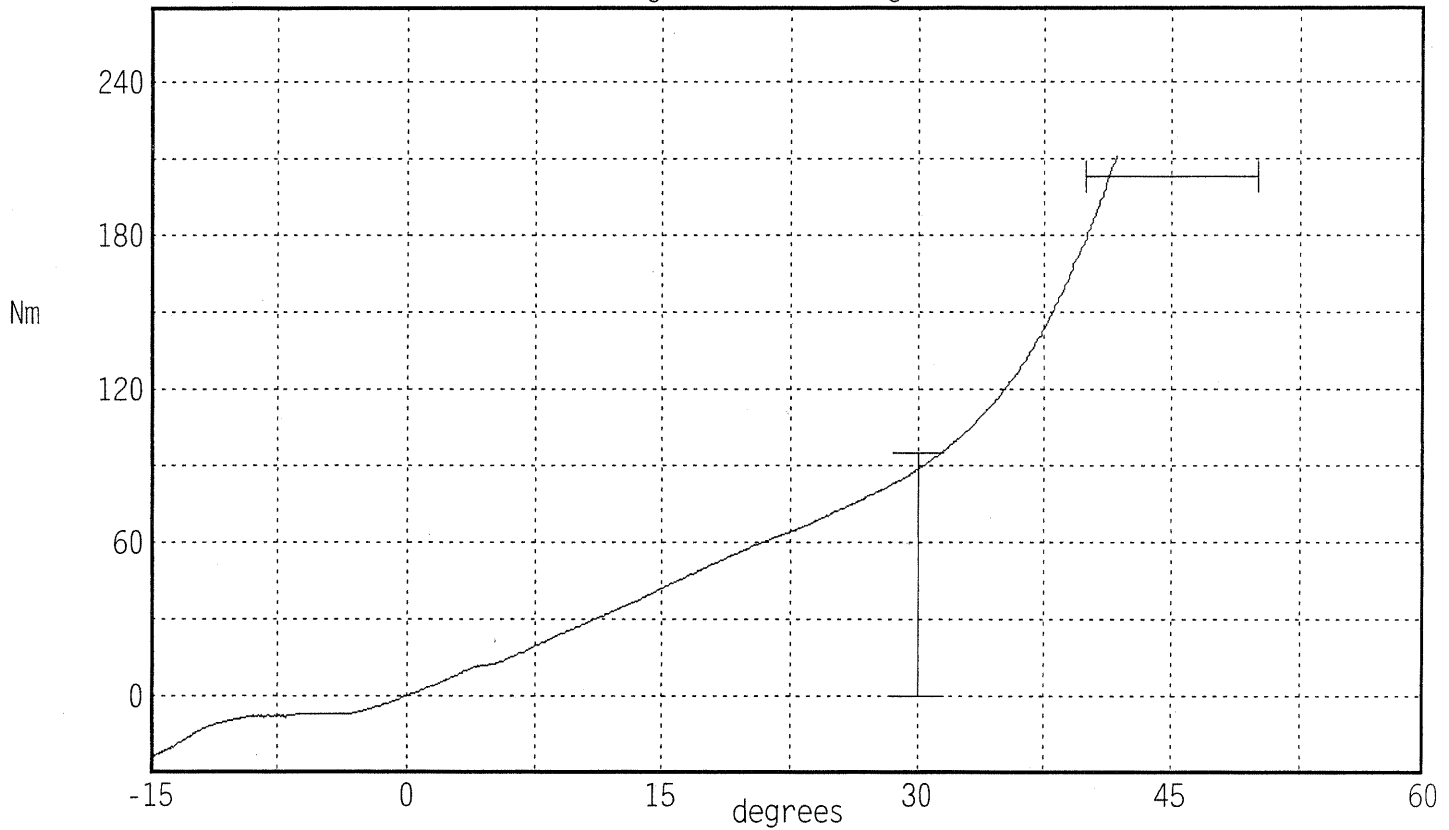

Angular Velocity Max: 8.1 deg/sec Min: 7.1 deg/sec

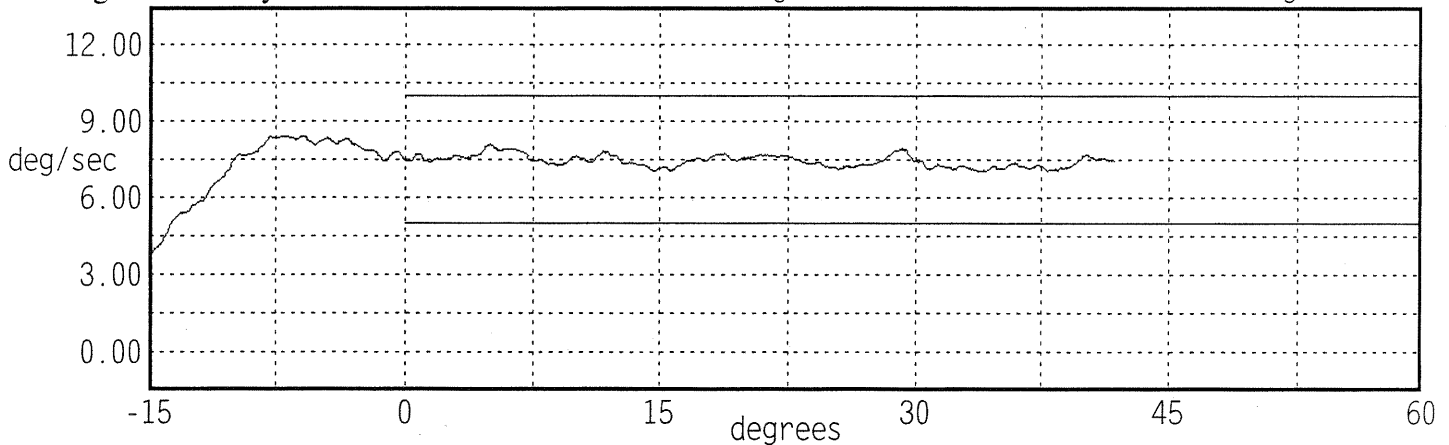

Transportation Research Center Inc.

Left Knee Femur Response Test

HIII 50th Serial No. LX103104 Certification No. 5-4

Test Date: 1/29/2007

Test Parameter	Specification	Test Results	Pass
Temperature	18.9 - 25.5 °C	21.1 °C	Yes
Relative Humidity	10 - 70 %	23 %	Yes
Probe Velocity	2.08 - 2.13 m/s	2.106 m/s	Yes
Peak Femur Force	(-4,715.2) - (-5,782.6) N	-5,736.93 N	Yes

Test meets specifications.

Comments:

Technician

Charles Bell

Approved

Ron Stone



Transportation Research Center Inc.

Left Knee Femur Response Test

HIII 50th Serial No. LX103104 Certification No. 5-4

Test Date: 1/29/2007

Pendulum Acceleration

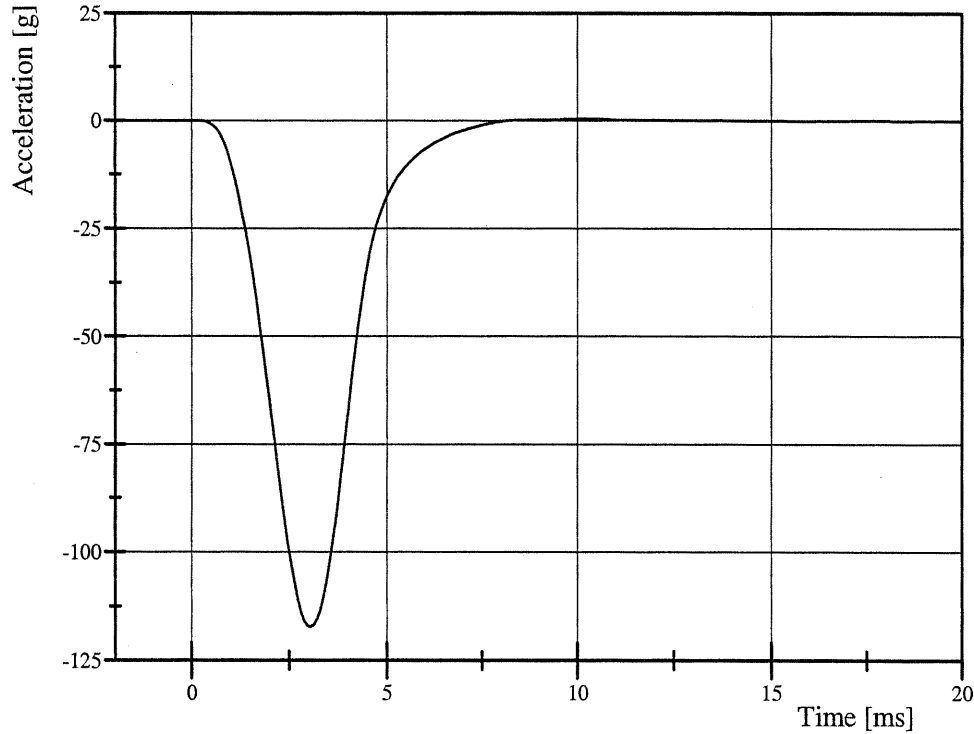

Filter Class: CFC_600
Max: 0.5 g at 10.3 ms
Min: -117.2 g at 3.0 ms

Pendulum Force

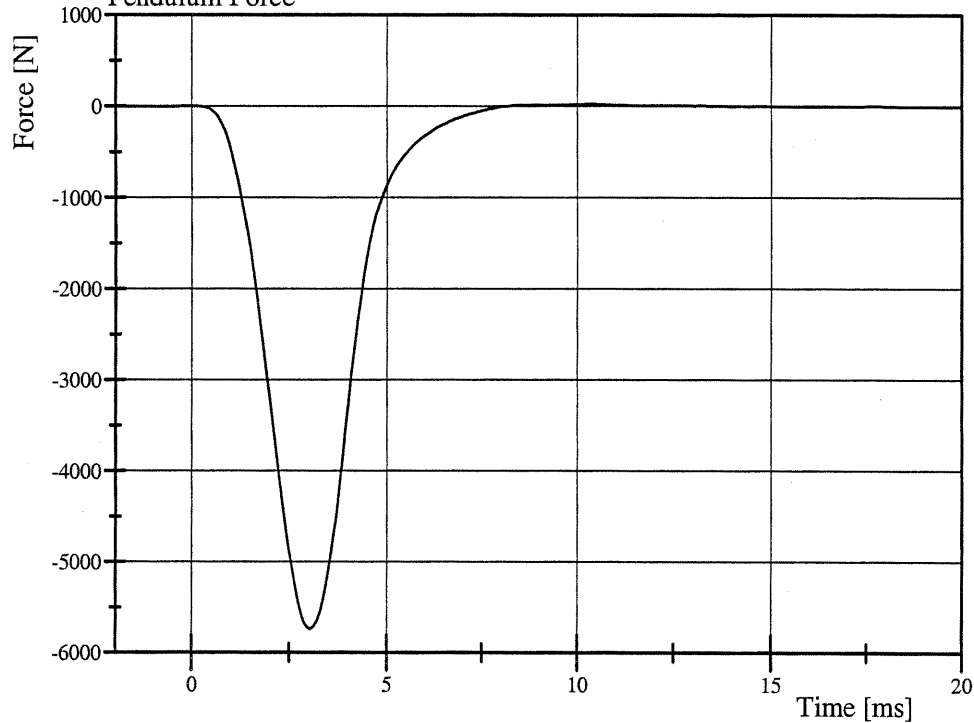

Filter Class: CFC_600
Max: 23.8 N at 10.3 ms
Min: -5,736.9 N at 3.0 ms

Transportation Research Center Inc.

Right Knee Femur Response Test

HIII 50th Serial No. LX103104 Certification No. 5-5

Test Date: 1/30/2007

Test Parameter	Specification	Test Results	Pass
Temperature	18.9 - 25.5 °C	21.4 °C	Yes
Relative Humidity	10 - 70 %	26 %	Yes
Probe Velocity	2.08 - 2.13 m/s	2.102 m/s	Yes
Peak Femur Force	(-4,715.2) - (-5,782.6) N	-5,532.65 N	Yes

Test meets specifications.

Comments:

Technician

Charles Bell

Approved

Ken Stovus

Transportation Research Center Inc.

Right Knee Femur Response Test

HIII 50th Serial No. LX103104 Certification No. 5-5

Test Date: 1/30/2007

Pendulum Acceleration

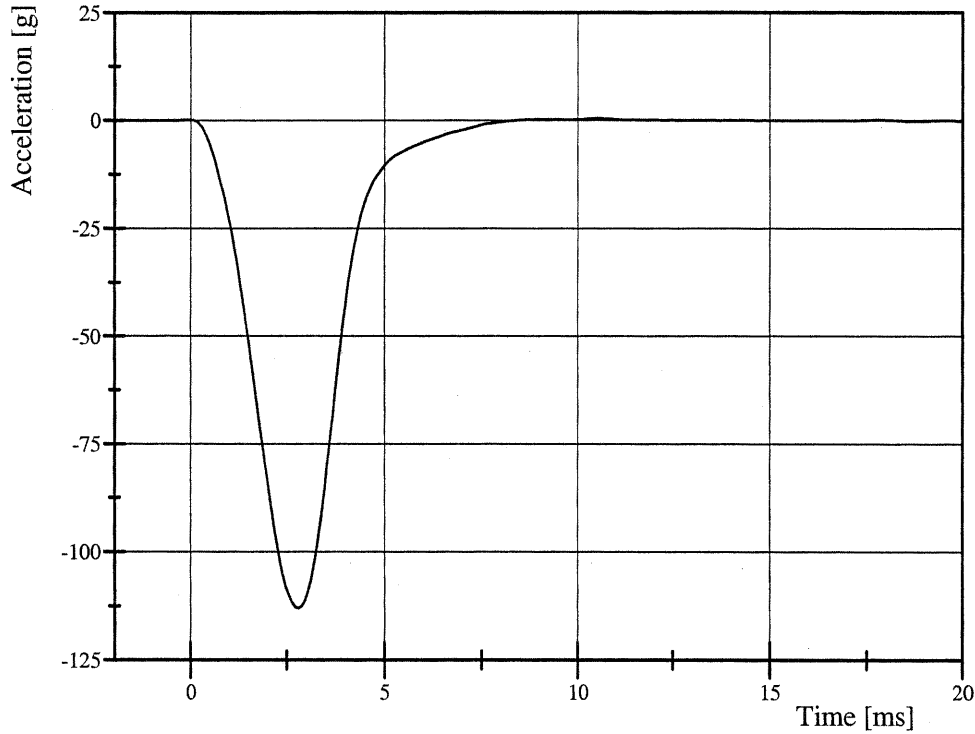

Filter Class: CFC_600
Max: 0.5 g at 10.5 ms
Min: -113.1 g at 2.8 ms

Pendulum Force

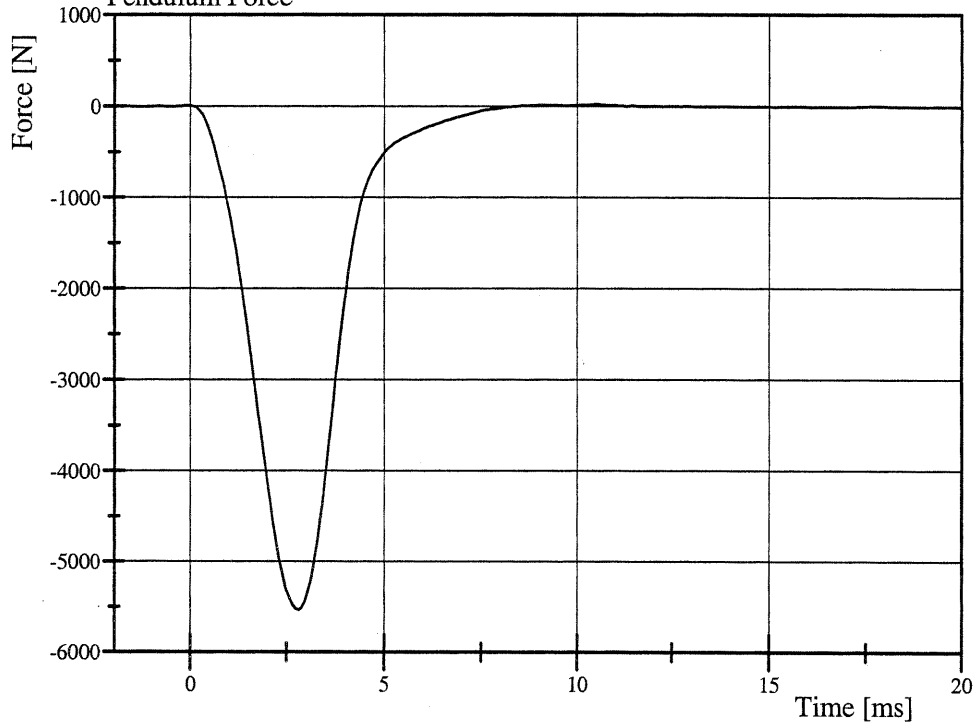

Filter Class: CFC_600
Max: 22.6 N at 10.5 ms
Min: -5,532.7 N at 2.8 ms

Transportation Research Center Inc.

Left Knee Slider

HIII 50th Serial No. LX103104 Certification No. 5-3

Test Date: 2/1/2007

Test Parameter	Specification	Test Results	Pass
Temperature	18.9 - 25.5 °C	21.7 °C	Yes
Relative Humidity	10 - 70 %	25 %	Yes
Probe Velocity	2.70 - 2.80 m/s	2.746 m/s	Yes
Force Peak at 10.0 mm Deflection	(-1,260) - (-1,720) N	-1,504.2 N	Yes
Force Peak at 18.0 mm Deflection	(-2,270) - (-3,100) N	-2,846.8 N	Yes

Test meets specifications.

Comments:

Technician

Charles Bell

Approved

Ron Stoner

Transportation Research Center Inc.

Left Knee Slider

HIII 50th Serial No. LX103104 Certification No. 5-3

Test Date: 2/1/2007

Knee Slider Displacement

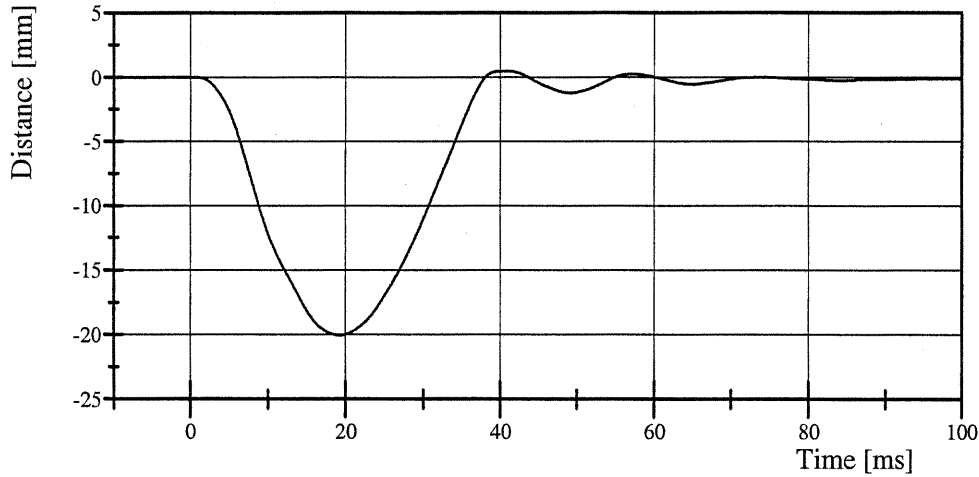

Filter Class: CFC_180
Max: 0.5 mm at 40.9 ms
Min: -20.1 mm at 19.3 ms

Femur Force

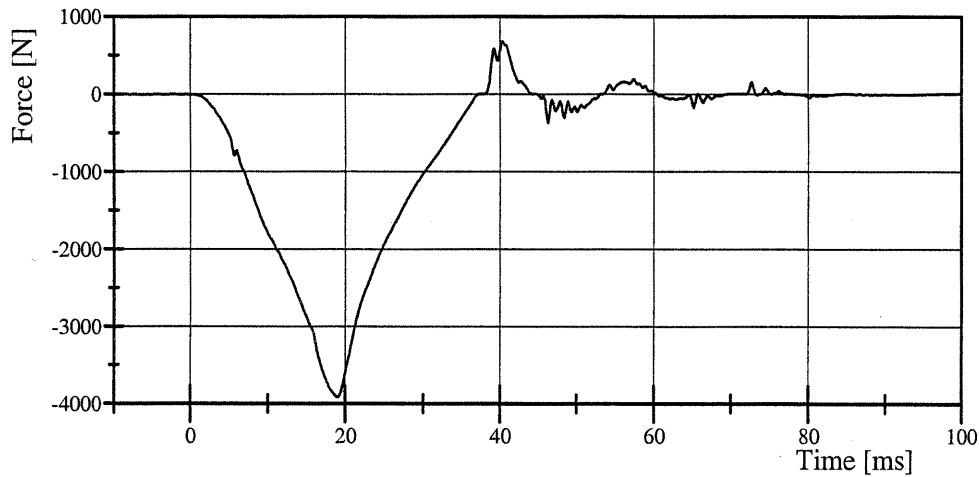

Filter Class: CFC_600
Max: 683.1 N at 40.3 ms
Min: -3,913.6 N at 19.0 ms

Femur Force vs. Knee Slider Displacement

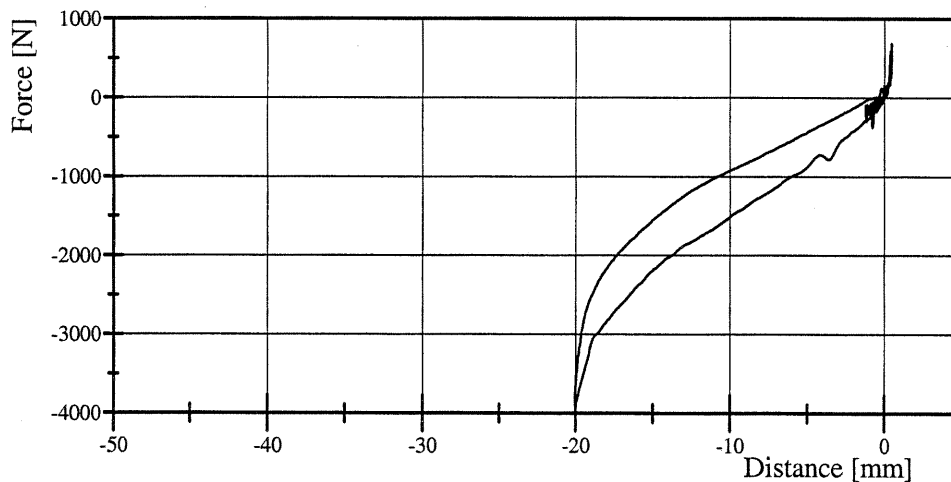

Filter Class: CFC_600
Max: 683.1 N at 0.5 mm
Min: -3,913.6 N at -20.0 mm

Transportation Research Center Inc.

Right Knee Slider

HIII 50th Serial No. LX103104 Certification No. 5-1

Test Date: 1/31/2007

Test Parameter	Specification	Test Results	Pass
Temperature	18.9 - 25.5 °C	21.1 °C	Yes
Relative Humidity	10 - 70 %	21 %	Yes
Probe Velocity	2.70 - 2.80 m/s	2.749 m/s	Yes
Force Peak at 10.0 mm Deflection	(-1,260) - (-1,720) N	-1,581.7 N	Yes
Force Peak at 18.0 mm Deflection	(-2,270) - (-3,100) N	-2,937.3 N	Yes

Test meets specifications.

Comments:

Technician

Charles Hall

Approved

Don Stoner

Transportation Research Center Inc.

Right Knee Slider

HIII 50th Serial No. LX103104 Certification No. 5-1

Test Date: 1/31/2007

Knee Slider Displacement

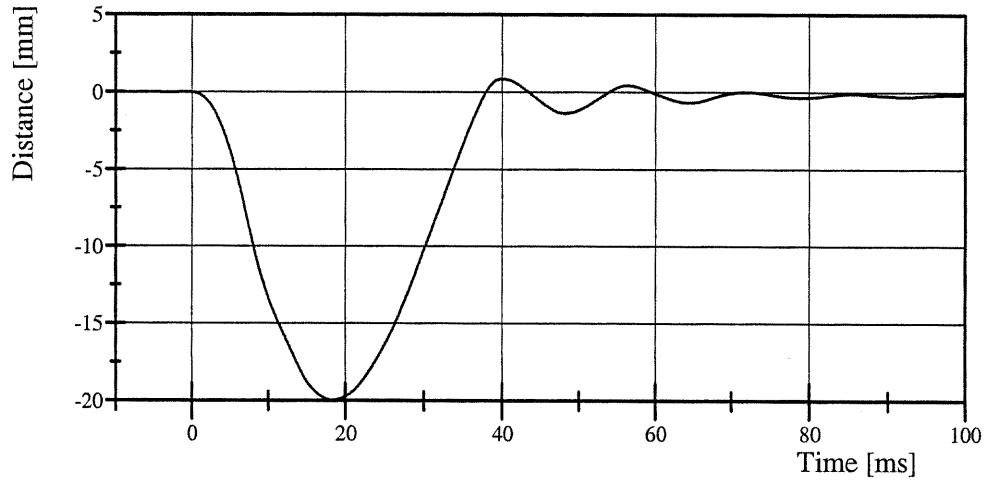

Filter Class: CFC_180
Max: 0.9 mm at 40.0 ms
Min: -19.9 mm at 18.3 ms

Femur Force

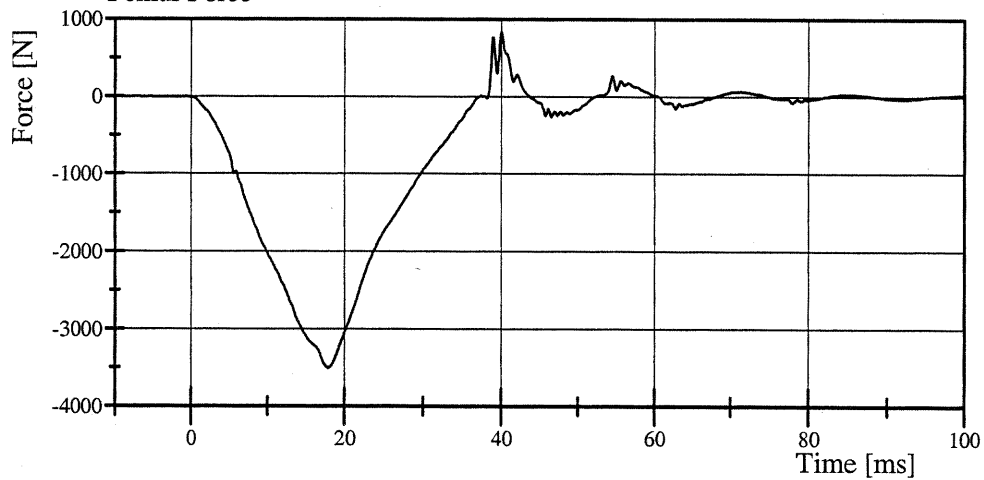

Filter Class: CFC_600
Max: 840.9 N at 40.0 ms
Min: -3,500.6 N at 17.9 ms

Femur Force vs. Knee Slider Displacement

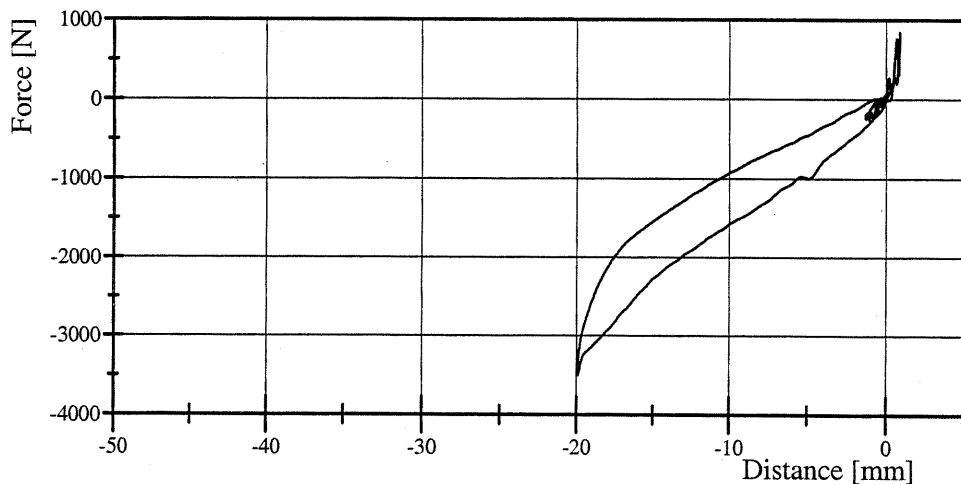

Filter Class: CFC_600
Max: 840.9 N at 0.9 mm
Min: -3,500.6 N at -19.9 mm





Test Date: 09/13/07 (5th %, 50th %, 95th %, 10 YO and 6YO)
 Type: 50% S/N: 855 Mfg.: First Tech
 Proj./Seg. No.: 20040479/ 1050 Test Eng: Michael R. Tonneman

ITEM	PRE-USE	POST-USE
HEAD:		
Skull Cap Bolts: tight and no wires pinched	X	
Head Skin Condition	X	X
* Neck Load Cell Cables: secure, taped, and with strain relief	X	
NECK:		
Bracket at specified setting, Serration Alignment, Bolt Actual: 0	X	X
Condyle Pin, Set Screws	X	
* Rubber Condition	X	X
* Neck Cable Torque (5 th /50 th /95 th : 10-14 in-lb) (6YO: 1.8 – 2.2 in-lb) Actual: <u>12</u>	X	
* Nodding Blocks Condition and Position (Nodding Joint Function)	X	X
ARMS AND HANDS:		
Clavicle and Shoulder Bumpers Condition	X	
Range of Motion Stops: Elbow, Top and Rear Shoulder		X
THORAX:		
Front and Rear Rib Bolts, Rib Ends Position, Rib Spacing	X	
Chest Pot Arm, Ball Movement, Set Screws	X	X
Sternum Bolts and Sternum Bumpers Condition	X	X
Jacket Condition	X	X
Abdominal Insert Condition	X	X
Rib Damping Material and Stiffeners Condition	X	X
Accel. Mount Bolts	X	
Lumbar Spine Rubber Condition, Spine Angle (10YO), 4 Attachment Bolts	X	X
LUMBAR/PELVIS:		
Iliac Crest Bone	X	X
Flesh Condition	X	X
Accel. Mount Bolt	X	
10YO: Lumbar Block Adjustment Position as requested. Actual: _____	N/A	
Lumbar Block Bolts	X	
Range of Motion Bumpers & Leg Cavity	X	X
LEGS AND FEET:		
Femur Load Cell Bolts (5 th /50 th /95 th : 30 ft-lb / 6YO: 16 ft-lb)	X	
Knee Joint Function and Range of Motion	X	
Knee Skins, Casting, and Inserts Condition	X	X
Knee Slider Zero Position	X	
Ankle Range of Motion, Bumper Condition	X	
Foot Condition	X	X
OTHER:		
Cleanliness / Skin Condition & Position	X	
Target Position	X	
Clothes and Shoes Pink	X	
One G Joint Adjustments	X	
Verify channels against assembly and Check connectors (intact & labeled)	X	
ATTACH TEMPERATURE LOGGER TO DUMMY / DOWNLOAD	X	X

* Items checked during calibration; these items need checked when the dummy is used without recalibration

Pre Test Inspection Completed By: J. Clarridge Date: 09/12/07

Post Test Inspection Completed By: J. Clarridge Date: 09/14/07

Appendix D

Customer Provided Seating Procedure

A.2 Driver side (with Brake and clutch pedals in place while avoiding pedal interaction)

1. Position the seat's adjustable lumbar supports so that the lumbar supports are in the lowest, retracted or deflated adjustment positions. (S16.2.10.1, S20.1.9.1, S20.4.1, S22.1.7.1)
 N/A – No lumbar adjustment
2. Position any adjustable parts of the seat that provide additional support so that they are in the lowest or most open adjustment position. (S16.2.10.2, S20.1.9.2, S20.4.1, S22.1.7.1, S22.4.2.1, S22.4.3.1, S24.4.2.1, S26.2.3, S26.3.1)
 N/A – No additional support adjustment
3. Position an adjustable leg support system in its rearmost position. (8/27/04 interpretation to Toyota)
 N/A – No adjustable leg support system
4. Mark a point (seat cushion reference point) on the side of the seat cushion that is between 150 mm and 250 mm from the front edge of the seat cushion. (S16.3.1.12)
5. Draw a line (seat cushion reference line) through the seat cushion reference point. (S16.3.1.13)
6. Use only the controls that primarily move the seat in the fore-aft direction to move the seat cushion reference point to the rearmost position. (S16.2.10.3.1, S22.1.7.3)
7. If the seat cushion adjusts fore-aft, independent of the seat back, use only the controls that primarily move the seat cushion in the fore-aft direction to move the seat cushion reference point to the rearmost position. (S16.2.10.3.1, S20.1.9.3)
 N/A – No independent fore-aft seat cushion adjustment
8. Use any part of any control, other than the parts just used for fore-aft positioning, to determine the range of angles of the seat cushion reference line and to set the seat cushion reference line at the mid-angle. (S16.2.10.3.1)
Maximum angle _____
Minimum angle _____
Mid-angle _____
9. If the seat and/or seat cushion height is adjustable, use any part of any control other than the parts which primarily move the seat or seat cushion fore-aft, to put the seat cushion reference point in its lowest position with the seat cushion reference line angle at the mid-angle found in 8. (S16.2.10.3.1)
 N/A – No seat height adjustment
10. Use only the controls that primarily move the seat in the fore-aft direction to verify the seat is in the rearmost position.
12. Use only the controls that primarily move the seat in the fore-aft direction to place the seat in the rearmost position.
14. Visually mark for future reference the seat back angle at the manufacturer's nominal design riding position for a 50th percentile adult male in the manner specified by the manufacturer for the rearmost seat position. (S20.1.9.5, S22.1.7.5, S22.4.2.1, S22.4.3.1, S24.1.2, S24.4.2.1, S26.2.3, S26.3.1)
 N/A – No seat back angle adjustment
Manufacturer's design seat back angle _____
15. Is the seat a bucket seat?
 Yes, go to 16 and skip 17
 No, go to 17 and skip 16
16. Bucket seats:
Locate and mark for future reference the longitudinal centerline of the seat cushion. The intersection of the vertical longitudinal plane that passes through the SgRP and the seat cushion upper surface determines the longitudinal centerline of a bucket seat cushion. (S16.3.1.10 & S20.1.10)
17. Bench seats
Locate and mark for future reference the longitudinal line on the seat cushion that marks the intersection of the vertical longitudinal plane through the centerline of the steering wheel and the seat cushion upper surface.
18. Head Restraint Position
 N/A Vehicle contains automatic head restraints.
 N/A, there is no head restraint adjustment
 Adjust the head restraint to its highest position. (S8.1.3)

- ___19. Place any adjustable seat belt anchorages at the vehicle manufacturer's nominal design position for a 50th percentile adult male occupant (S8.1.3)
 ___N/A – No adjustable upper seat belt anchorage
 Manufacturer's specified anchorage position. _____
 Tested anchorage position _____
- ___20. Place adjustable pedals in the full forward position (towards the front of the vehicle.)
 ___N/A – the pedals are not adjustable.
- ___21. Locate and mark the right heel point (RHP) on the carpet.
 Flat accelerator pedals: Extend a line through the axis of symmetry (that is closest to the vertical plane) of the accelerator pedal. The RHP is the intersection of that line with the floorpan.
 Curved accelerator pedals: Construct a line in the side view tangent to the accelerator pedal such that the distance from the contact point on the pedal to the floorpan, along the tangent line, is 200 mm. The RHP is at the intersection of this tangent line and the floorpan
- ___22. Locate a longitudinal line L1 and a transverse line T1 on the floorpan through the RHP. Locate a Left Heel Point (LHP) point on the line T1 that is to the left of the seat centerline at the same distance from the seat centerline as the RHP. Locate a longitudinal line L2 through the LHP.
- ___23. Set the steering wheel hub at the geometric center of the full range of driving positions including any telescoping positions as determined in data sheet 14.3.
- ___24. Verify that the seat is in the rearmost seat track position and full down height adjustment with the seat cushion at the mid-angle with the seat back at the manufacturer's nominal seat back angle.
- ___25. With the seat in the rearmost, full down, mid-angle position, determine the H-point using SAE J826 and the FMVSS 208 leg and thigh dimensions.
- ___26. Place the dummy in the seat such that the midsagittal plane is coincident with the longitudinal seat cushion markings and the upper torso resting against the seat back. (S10.4.1.1 & S10.4.1.2)
- ___27. Rest the thighs on the seat cushion. (S10.5)
- ___28. Set the distance between the outboard knee clevis flange surfaces at 10.6 inches.
 ___measured distance (10.6 inches) (S10.5)
- ___29. Set the heels of the feet on the floor pan.
- ___30. Position the H-point of the dummy within 0.5 inch of the vertical dimension and 0.5 inch of the horizontal dimension of a point 0.25 inch below the H-point determined in Data Sheet 15. (S10.4.2.1)
 Then measure the pelvic angle with respect to the horizontal using the pelvic angle gage. Adjust the dummy position until these three measurements are within the specifications. (S10.4.2.1 and S10.4.2.2)
 ___horizontal inches from the point 0.25 below the determined H-point (0.5 inch max.) (S10.4.2.1)
 ___vertical inches from the point 0.25 below the determined H-point (0.5 inch max.) (S10.4.2.1)
 ___pelvic angle (20° to 25°)
- The H-point and pelvic angle are not adjusted after this step.**
- ___31. Set the left and right feet in the neutral position (longitudinal centerline of foot in the same plane as the lower leg/thigh, foot at -15 degrees +/- 2 degrees to lower leg), as determined by the output of the potentiometers at the ankle.
- ___32. Without moving the seat, and while keeping the right thigh and leg in the same vertical plane, set the right foot heel on Line L1. If the vehicle interior prevents the heel from reaching L1, place the heel as close to L1 as possible, while maintaining a clearance of 0.25" from the vehicle interior.
- ___32.1. Without moving the seat, and while keeping the left thigh and leg in the same vertical plane, move the left foot laterally to the left until any of the following occurs first:
- The right edge of the foot is clear of the brake or clutch pedal by 0.25" laterally
 - The left heel is on Line L2
 - The left edge of the shoe contacts the vehicle interior
- ___33. Place a 100 N +0, -5N weight (e.g. 100 N shot bag), no larger than 4" x 4", on each knee-thigh area. The weight should be centered on the assembly-hole on the top of the knee.
- ___34. Raise the heels off the floor pan so that the seat can be moved forward.

- ___35. Using only the control that primarily moves the seat in the fore-aft direction, move the seat forward and rest the rearmost point of the right foot heel on the floor pan such that:
- the heel is on the line L1
 - the foot is in the same plane as the lower leg/thigh, foot at -15 degrees +/- 2 degrees (about the Y-axis) to lower leg,
 - foot is contacting the accelerator pedal
 - the thighs are resting on the seat cushion
 - the thigh, leg and foot are in the same vertical plane
- If the heel is unable to reach line L1 because the foot contacts the vehicle interior, place the foot as close to the line L1 as possible while maintaining a gap of no more than 5 mm between the shoe and the vehicle interior.
- If the left foot contacts the brake or clutch pedals or the vehicle interior, then stop the forward movement of the left foot, raising the left knee off the seat cushion if needed. The pedals should not be depressed.
- ___36. If the right foot does not reach the accelerator pedal, move the adjustable pedal until it contacts the foot. Locate a new heel point. Repeat steps 21 – 35 to re-position the seat. If the pedals are not adjustable, place the heel at the point closest to the pedal, in the same longitudinal vertical plane as the line L1.
- ___N/A – the accelerator pedal is not adjustable
 ___N/A – the accelerator pedal did not need to be moved.
- ___37. Verify that the left thigh and leg are in a vertical longitudinal plane, the foot in the neutral position (longitudinal centerline of foot in the same plane as the lower leg/thigh, foot at -15 degrees +/- 2 degrees (Y-axis) to lower leg), the heel on the floor pan. Place the heel on the line L2, unless the left edge of the shoe contacts the vehicle, preventing the heel from reaching Line L2.
- ___38. Remove the leg weights.
- ___39. Verify that the right foot is in the neutral position, at the lateral location determined in step 32, and is contacting the accelerator pedal. If the foot is not contacting the accelerator pedal, move the seat forward to rest the right foot on the accelerator pedal, keeping the foot in the neutral position.
- ___40. While holding the thighs in place, push with a 50 lb force on a 3 inch diameter area of the chest that is centered 5" (127mm) vertically below the chin on the midsagittal plane of the dummy.
- ___41.1 Fasten the seat belt around the dummy.
- ___41.2 Remove all slack from the lap belt portion. (S10.9)
- ___41.3 Pull the upper torso webbing out of the retractor and allow it to retract; repeat this four times. (S10.9)
- ___41.4 Apply a 2 to 4 pound tension load to the lap belt. (S10.9)
- ___pound load applied
- ___41.5 Is the belt system equipped with a tension-relieving device?
- ___Yes, continue
 ___No, go to 42
- ___41.6 Introduce the maximum amount of slack into the upper torso belt that is recommended by the vehicle manufacturer in the vehicle owner's manual. (S10.9).
- ___42. Place the upper arms adjacent to the torso with the centerline as close to a vertical plane as possible. (S10.2.1)
- ___43. Adjust the head level within ± 0.5 degrees using the seat back adjustment. Check the head angle after pushing on the chest with a 50 lb force on a 3 inch diameter area of the chest that is centered 5" (127mm) vertically below the chin on the midsagittal plane of the dummy, while holding the thighs in place, and releasing.
- ___43.1 No seat back adjustment. Adjust the neck bracket to achieve head level within ± 0.5 degrees Record neck bracket setting. _____
- ___44. Maintaining the head alignment as determined above place the right hand with the palm in contact with the steering wheel at the rim's horizontal centerline and with the thumb over the steering wheel. (S10.3.1)
- ___45. Maintaining the head alignment as determined above place the left hand with the palm in contact with the steering wheel at the rim's horizontal centerline and with the thumb over the steering wheel. (S10.3.1)
- ___46. If the hands don't reach the steering wheel at the horizontal centerline, maintaining the head alignment place them at symmetric location on the wheel, below the horizontal centerline.

- __47. Tape the thumb of each hand to the steering wheel by using masking tape with a width of 0.25 inch. The length of the tape shall only be enough to go around the thumb and steering wheel one time.
- __48. Verify that the feet are in the neutral position (± 2 deg), and at lateral locations determined in step 32 (right foot) and step 37 (left foot), and the head is level (± 0.5 deg). Adjust and repeat until the feet position and angles and head angles are within this range.

A.4 Passenger Side

1. The seat is a bench seat for which the adjustments have already been made for the driver and there are no independent adjustments that can be made for the passenger. Go to 16.
 N/A – the passenger seat adjusts independently of the driver seat.
2. Position the seat's adjustable lumbar supports so that the lumbar supports are in the lowest, retracted or deflated adjustment positions. (S16.2.10.1, S20.1.9.1, S20.4.1, S22.1.7.1)
 N/A – No additional support adjustment
3. Position any adjustable parts of the seat that provide additional support so that they are in the lowest or most open adjustment position. (S16.2.10.2, S20.1.9.2, S20.4.1, S22.1.7.1, S22.4.2.1, S22.4.3.1, S24.4.2.1, S26.2.3, S26.3.1)
 N/A – No additional support adjustment
4. Position an adjustable leg support system in its rearmost position. (8/27/04 interpretation to Toyota)
 N/A – No adjustable support system
5. Mark a point (seat cushion reference point) on the side of the seat cushion that is between 150 mm and 250 mm from the front edge of the seat cushion. (S16.3.1.12)
6. Draw a line (seat cushion reference line) through the seat cushion reference point. (S16.3.1.13)
7. Use only the controls that primarily move the seat in the fore-aft direction to move the seat cushion reference point to the rearmost position. (S16.2.10.3.1, S22.1.7.3)
8. If the seat cushion adjusts fore-aft, independent of the seat back, use only the controls that primarily move the seat cushion in the fore-aft direction to move the seat cushion reference point to the rearmost position. (S16.2.10.3.1, S20.1.9.3)
 N/A – No independent fore-aft seat cushion adjustment
9. Use any part of any control, other than the parts just used for fore-aft positioning, to determine the range of angles of the seat cushion reference line and to set the seat cushion reference line at the mid-angle. (S16.2.10.3.1)
Maximum angle _____
Minimum angle _____
Mid-angle _____
10. If the seat and/or seat cushion height is adjustable, use any part of any control other than the parts which primarily move the seat or seat cushion fore-aft, to put the seat cushion reference point in its lowest position with the seat cushion reference line angle at the mid-angle found in 8. (S16.2.10.3.1)
 N/A – No seat height adjustment
11. Use only the controls that primarily move the seat in the fore-aft direction to verify the seat is in the rearmost position.
13. Use only the controls that primarily move the seat in the fore-aft direction to place the seat in the rearmost position.
14. N/A – No seat height adjustment. Go to 14
15. Visually **mark** for future reference the seat back angle at the manufacturer's nominal design riding position for a **50th percentile adult male** in the manner specified by the manufacturer for the rearmost seat position. (S20.1.9.5, S22.1.7.5, S22.4.2.1, S22.4.3.1, S24.1.2, S24.4.2.1, S26.2.3, S26.3.1)
 N/A – No seat back angle adjustment
Manufacturer's design seat back angle _____
16. Is the seat a bucket seat?
 Yes, go to 16 and skip 17
 No, go to 17 and skip 16
17. Bucket seats:
Locate and **mark** for future reference the longitudinal centerline of the seat cushion. The intersection of the vertical longitudinal plane that passes through the SgRP and the seat cushion upper surface determines the longitudinal centerline of a bucket seat cushion. (S16.3.1.10 & S20.1.10)
18. Bench seats
Locate and **mark** for future reference the longitudinal line on the passenger seat cushion. The longitudinal centerline is the same distance from the longitudinal centerline of the vehicle as the center of the steering wheel. (S20.2.1.3, S22.2.1.3, S24.2.3, S20.4., S22.2.1(b), S22.2.2.3(b), S22.2.2.4(a), S22.2.2.5(a), S22.2.2.6(a), S22.2.2.7(a), S24.2.3(a))

Record the distance from the longitudinal centerline of the vehicle to the center of the steering wheel.

Record the distance from the longitudinal centerline of the vehicle to the longitudinal centerline of the seat cushion. (The vertical plane through this longitudinal centerline is Plane B for suppression.) _____

- ___ 19. Head Restraint Position
___ N/A Vehicle contains automatic head restraints.
___ N/A, there is no head restraint adjustment
___ Adjust the head restraint to its highest position. (S8.1.3)
- ___ 20. Place any adjustable seat belt anchorages at the vehicle manufacturer's nominal design position for a 50th percentile adult male occupant (S8.1.3)
___ N/A – No adjustable upper seat belt anchorage
Manufacturer's specified anchorage position. _____
Tested anchorage position _____
- ___ 21. Verify that the seat is in the rearmost seat track position and full down height adjustment with the seat cushion at the mid-angle, the seat back at the manufacturer's nominal design position for the 50th male.
- ___ 21.1 With the seat in the rearmost, full down, mid-angle position, seat back at the manufacturer's nominal design position for the 50th male, determine the H-point using SAE J826 and the FMVSS 208 leg and thigh dimensions.
- ___ 22. Place the dummy in the seat such that the midsagittal plane is coincident with the longitudinal seat cushion markings and the upper torso resting against the seat back. (S10.4.1.1 & S10.4.1.2)
- ___ 23. Rest the thighs on the seat cushion. (S10.5)
- ___ 24. Set the distance between the outboard knee clevis flange surfaces at 9¼ inches, with the leg-knee-thigh in the same vertical plane.
___ measured distance (8 inches) (S10.5)
- ___ 25. Set the heels of the feet on the floor pan.
- ___ 26. Position the H-point of the dummy within 0.5 inch of the vertical dimension and 0.5 inch of the horizontal dimension of a point 0.25 inch below the H-point determined in Step 21.1 as per Data Sheet 15. (S10.4.2.1)
Then measure the pelvic angle with respect to the horizontal using the pelvic angle gage. Adjust the dummy position until these three measurements are within the specifications. (S10.4.2.1 and S10.4.2.2)
___ horizontal inches from the point 0.25 below the determined H-point (0.5 inch max.) (S10.4.2.1)
___ vertical inches from the point 0.25 below the determined H-point (0.5 inch max.) (S10.4.2.1)
___ pelvic angle (20° to 25°)
- The H-point and pelvic angle are not adjusted again after this step.**
- ___ 27. Place a 100 N +0, -5N weight (e.g. 100 N shot bag), no larger than 4" x 4", on each knee-thigh area. The weight should be centered on the assembly-hole on the top of the knee.
- ___ 28. Set the left and right feet such that the following conditions are met after the feet are placed:
___ The foot is in neutral position.
___ The leg and thigh are in the same plane.
___ The thighs are resting on the seat cushion.
___ The heel is in contact with the floor pan.
- ___ 29. Lift the feet off the floor and set the toe towards the floorpan (Y angle = 25 +/- 2 deg). Using controls that move the seat fore-aft, move the seat forward until either foot contacts vehicle interior. Position the feet at that seat location with the heels on the floor and the feet in neutral position. If the vehicle interior prevents the feet from reaching the neutral position, place the feet as close as possible to the neutral position while maintaining a distance of 5 mm from the vehicle interior.
- ___ 30. Move the seat forward while maintaining the foot orientations (+/- 2 deg) until either foot contacts the vehicle interior.
- ___ 31. Keeping the thigh-leg in the same vertical plane, move the feet apart symmetrically about the dummy midsagittal plane until the either foot contacts the vehicle interior or the knee spacing of 10.6 inches is attained, whichever comes first. Place the feet in neutral position unless contact with the vehicle interior prevents the feet from reaching the neutral position.
Check all that applies:
___ The right foot contacted a flat part of the toe board.
___ The right foot contacted the right side of vehicle interior.
___ The right foot contacted is at neutral position.
___ The left foot contacted a flat part of the toe board.

- ___ The left foot contacted the left side of the vehicle interior.
- ___ The left foot contacted is at neutral position.
- ___ 32. Remove the leg weights.
- ___ 33. While holding the thighs in place, push with a 50 lb force on a 3 inch diameter area of the chest that is centered 5" (127 mm) vertically below the chin on the midsagittal plane of the dummy.
- ___ 34. Seat belt
 - ___ 34.1 Fasten the seat belt around the dummy.
 - ___ 34.2 Remove all slack from the lap belt portion. (S10.9)
 - ___ 34.3 Pull the upper torso webbing out of the retractor and allow it to retract; repeat this four times. (S10.9)
 - ___ 34.4 Apply a 2 to 4 pound tension load to the lap belt. (S10.9)
 - ___ pound load applied
 - ___ 34.5 Is the belt system equipped with a tension-relieving device?
 - ___ Yes, continue
 - ___ No, go to 36
 - ___ 34.6 Introduce the maximum amount of slack into the upper torso belt that is recommended by the vehicle manufacturer in the vehicle owner's manual. (S10.9)
- ___ 35. Place the upper arms adjacent to the torso with the centerline as close to a vertical plane as possible. (S10.2.1)
- ___ 36. Place the right upper arm in contact with the seat back and side of the torso. (S10.2.2)
- ___ 37. Place the left hand palm in contact with the outside of the left thigh and the little finger in contact with the seat cushion. (S10.3.2)
- ___ 38. Place the right hand palm in contact with the outside of the right thigh and the little finger in contact with the seat cushion. (S10.3.2)
- ___ 39. Adjust the head level within ± 0.5 degrees using the seat back adjustment. Check the head angle after pushing on the chest with a 50 lb force on a 3 inch diameter area of the chest that is centered 5" (127 mm) vertically below the chin on the midsagittal plane of the dummy, while holding the thighs in place, and releasing.
- ___ 40.1 No seat back adjustment. Adjust the neck bracket to achieve head level within ± 0.5 degrees. Record neck bracket setting. _____

Appendix E

Test Equipment and Instrumentation Information

Sign Convention
SAE J211 MAR95

Accelerometers:

+X: Forward
+Y: Rightward
+Z: Downward

Potentiometers:

+Chest longitudinal deflection: Outward
+Chest lateral deflection: Rightward
+Seat belt displacement: Outward
+Seat belt extension: Elongation
+Knee slider displacement: Distance between femur and tibia increased (in relation to a seated dummy)

Rotation potentiometers:

+About the X-axis: Left foot-eversion
Right foot-inversion
+About the Y-axis: Left/right foot-dorsiflexion
+About the Z-axis: Left foot-internal
Right foot-external

Load cells:

+Femur force: Tension
+Seat belt force: Tension
+Barrier force: Tension

Neck load cells:

+X force: Head pushed rearward
+Y force: Head pushed leftward
+Z force: Head pulled upward (tension on neck)
+X moment: Left ear rotating toward left shoulder
+Y moment: Chin rotating toward chest
+Z moment: Chin rotating toward left shoulder

Tibia load cells:

+X force: Ankle forward, knee rearward
+Y force: Ankle rightward, knee leftward
+Z force: Tension
+X moment: Bottom of tibia moving leftward
+Y moment: Bottom of tibia moving rearward

Frequency Response Classes
SAE J211 MAR95

<u>Typical Test Measurements</u>	<u>Channel Class</u>
Vehicle Structural Accelerations for use in:	
Total vehicle comparison	60
Collision simulation input	60
Component analysis	600
Integration for velocity or displacement	180
Barrier Face Forces	60
Belt Restraint System Loads	60
Anthropomorphic Test Device	
Head accelerations (linear and angular)	1000
Neck	
Forces	1000
Moments	600
Thorax	
Spine accelerations	180
Rib accelerations	1000
Sternum accelerations	1000
Deflections	600
Lumbar	
Forces	1000
Moments	1000
Pelvis	
Accelerations	1000
Forces	1000
Moments	1000
Femur/Knee/Tibia/Ankle	
Forces	600
Moments	600
Displacements	180
Sled Accelerations	60
Steering Column Loads	600
Head form Accelerations	1000

The direction column on the following sheets describes the transducer output as mounted and wired in the test location. The polarity column indicates whether a polarity change occurred during data acquisition to conform to J211 MAR95. See Report Sign Convention sheet for description of data output as presented in the report: occasionally channels have been adjusted in post-acquisition processing to conform to J211 MAR95.

Channel Report Test Number 070913 R70203

Ref	Transducer ID	ISO Signal Identifier	Description	FScale	Units	DAS		Assembly
						Flip	Positive Polarity	
1	Trig D1	10ZERO000000VO0A	EVENT		1 Logic	+	Bipolar	
2	P15345	11HEADCG00H3ACXA	Head Accel X	1000	g	-	Rearward	1-001 VRTC H3 50th.001
3	P46524	11HEADCG00H3ACYA	Head Accel Y	1000	g	-	Leftward	1-001 VRTC H3 50th.002
4	J32220	11HEADCG00H3ACZA	Head Accel Z	1000	g	-	Upward	1-001 VRTC H3 50th.003
5	J23914	11HEADCGRDH3ACXA	Head Accel X Redundant	1000	g	-	Rearward	1-001 VRTC H3 50th.004
6	AE833	11HEADCGRDH3ACYA	Head Accel Y Redundant	1000	g	-	Leftward	1-001 VRTC H3 50th.005
7	J18730	11HEADCGRDH3ACZA	Head Accel Z Redundant	1000	g	-	Upward	1-001 VRTC H3 50th.006
8	1716A-1872-FX	11NECKUP00H3FOXA	Neck Force X	8896	N	-	Head forward, chest rearward	1-001 VRTC H3 50th.007
9	1716A-1872-FY	11NECKUP00H3FOYA	Neck Force Y	8896	N	+	Head leftward, chest rightward	1-001 VRTC H3 50th.008
10	1716A-1872-FZ	11NECKUP00H3FOZA	Neck Force Z	13344	N	+	Head upward, chest downward	1-001 VRTC H3 50th.009
11	1716A-1872-MX	11NECKUP00H3MOXA	Neck Moment X	282.5	Nm	-	Right ear toward right shoulder	1-001 VRTC H3 50th.010
12	1716A-1872-MY	11NECKUP00H3MOYA	Neck Moment Y	282.5	Nm	+	Chin toward sternum	1-001 VRTC H3 50th.011
13	1716A-1872-MZ	11NECKUP00H3MOZA	Neck Moment Z	282.5	Nm	+	Chin toward left shoulder	1-001 VRTC H3 50th.012
14	03E03D30-N22	11CHSTCG00H3ACXA	Chest Accel X	1000	g	+	Forward	1-001 VRTC H3 50th.013
15	J32100	11CHSTCG00H3ACYA	Chest Accel Y	1000	g	-	Leftward	1-001 VRTC H3 50th.014
16	P52159	11CHSTCG00H3ACZA	Chest Accel Z	1000	g	-	Upward	1-001 VRTC H3 50th.015
17	ACCY2	11CHSTCGRDH3ACXA	Chest Accel X Redundant	1000	g	+	Forward	1-001 VRTC H3 50th.016
18	J20125	11CHSTCGRDH3ACYA	Chest Accel Y Redundant	1000	g	-	Leftward	1-001 VRTC H3 50th.017
19	J35562	11CHSTCGRDH3ACZA	Chest Accel Z Redundant	1000	g	-	Upward	1-001 VRTC H3 50th.018
20	CST001	11CHST0000H3DSXA	Chest Deflection X	100	mm	+	Forward	1-001 VRTC H3 50th.019
21	P52154	11PELVCG00H3ACXA	Pelvis Accel X	1000	g	-	Rearward	1-001 VRTC H3 50th.020
22	P49192	11PELVCG00H3ACYA	Pelvis Accel Y	1000	g	-	Leftward	1-001 VRTC H3 50th.021
23	P49170	11PELVCG00H3ACZA	Pelvis Accel Z	1000	g	-	Upward	1-001 VRTC H3 50th.022
24	2121AJ-1519	11FEMRLL00H3FOZA	Left Femur Force Z	13344	N	+	Knee forward, pelvis rearward	1-001 VRTC H3 50th.023
25	2121A-1420	11FEMRRL00H3FOZA	Right Femur Force Z	13344	N	+	Knee forward, pelvis rearward	1-001 VRTC H3 50th.024
26	150-0121VR-022689	11KNSLLE00H3DSXA	Left Knee Displacement X	40	mm	-	Hold femur in place, tibia rearward	1-LX045-046 VOLPE THOR LEGS.001
27	4509-95-FX	11TIBILULXH3FOXA	Left Upper Tibia Force X	11120	N	+	Tibia forward, knee rearward	1-LX045-046 VOLPE THOR LEGS.002
28	4509-95-FZ	11TIBILULXH3FOZA	Left Upper Tibia Force Z	11120.5	N	+	Tibia downward, femur upward	1-LX045-046 VOLPE THOR LEGS.003
29	4509-95-MX	11TIBILULXH3MOXA	Left Upper Tibia Moment X	395.4	Nm	+	Ankle leftward, hold knee in place	1-LX045-046 VOLPE THOR LEGS.004

E-5

070913

Channel Report Test Number 070913 R70203

Ref	Transducer ID	ISO Signal Identifier	Description	FScale	Units	DAS Flip	Positive Polarity	Assembly
30	4509-95-MY	11TIBILULXH3MOYA	Left Upper Tibia Moment Y	395.4	Nm	+	Ankle forward, hold knee in place	1-LX045-046 VOLPE THOR LEGS.005
31	02I02I05-F16	11TIBILELXH3ACXA	Left Tibia Accel X	1000	g	+	Tibia forward	1-LX045-046 VOLPE THOR LEGS.006
32	04J04I07-Z15	11TIBILELXH3ACYA	Left Tibia Accel Y	1000	g	+	Tibia right	1-LX045-046 VOLPE THOR LEGS.007
33	4929J-139-FX	11TIBILLLXH3FOXA	Left Lower Tibia Force X	11120.5	N	+	Ankle forward, knee rearward	1-LX045-046 VOLPE THOR LEGS.008
34	4929J-139-FY	11TIBILLLXH3FOYA	Left Lower Tibia Force Y	11120.5	N	+	Ankle rightward, knee leftward	1-LX045-046 VOLPE THOR LEGS.009
35	4929J-139-FZ	11TIBILLLXH3FOZA	Left Lower Tibia Force Z	11120.5	N	+	Ankle downward, knee upward	1-LX045-046 VOLPE THOR LEGS.010
36	4929J-139-MX	11TIBILLLXH3MOXA	Left Lower Tibia Moment X	395.4	Nm	+	Ankle leftward, hold knee in place	1-LX045-046 VOLPE THOR LEGS.011
37	4929J-139-MY	11TIBILLLXH3MOYA	Left Lower Tibia Moment Y	395.4	Nm	+	Ankle forward, hold knee in place	1-LX045-046 VOLPE THOR LEGS.012
38	7921-0525-PD210-4B-426	11FOOTLELXH3ANXA	Left Foot Angular Dis. X LX104X	318	°	-	Inversion	1-LX045-046 VOLPE THOR LEGS.013
39	7921-0524-PD210-4B-424	11FOOTLELXH3ANYA	Left Foot Angular Dis. Y LX104Y	318	°	+	Dorsiflexion	1-LX045-046 VOLPE THOR LEGS.014
40	7921-0523-PD210-4B-423	11FOOTLELXH3ANZA	Left Foot Angular Dis. Z LX104Z	318	°	-	External rotation	1-LX045-046 VOLPE THOR LEGS.015
41	05H31-Z12	11FOOTLELXH3ACXA	Left Foot Accel X	1000	g	+	Foot forward	1-LX045-046 VOLPE THOR LEGS.016
42	04J04I20-Z06	11FOOTLELXH3ACYA	Left Foot Accel Y	1000	g	+	Foot rightward	1-LX045-046 VOLPE THOR LEGS.017
43	02I02I05-F22	11FOOTLELXH3ACZA	Left Foot Accel Z	1000	g	+	Foot down	1-LX045-046 VOLPE THOR LEGS.018
44	150-0121VL-33646	11KNSLR100H3DSXA	Right Knee Displacement X	40	mm	-	Hold femur in place, tibia rearward	1-LX045-046 VOLPE THOR LEGS.019
45	4509-88-FX	11TIBIRULXH3FOXA	Right Upper Tibia Force X	11120.5	N	+	Tibia forward, knee rearward	1-LX045-046 VOLPE THOR LEGS.020
46	4509-88-FZ	11TIBIRULXH3FOZA	Right Upper Tibia Force Z	11120.5	N	+	Tibia downward, femur upward	1-LX045-046 VOLPE THOR LEGS.021
47	4509-88-MX	11TIBIRULXH3MOXA	Right Upper Tibia Moment X	395.4	Nm	+	Ankle leftward, hold knee in place	1-LX045-046 VOLPE THOR LEGS.022
48	4509-88-MY	11TIBIRULXH3MOYA	Right Upper Tibia Moment Y	395.4	Nm	+	Ankle forward, hold knee in place	1-LX045-046 VOLPE THOR LEGS.023
49	04J04I01-R09	11TIBIRILXH3ACXA	Right Tibia Accel X	1000	g	+	Tibia forward	1-LX045-046 VOLPE THOR LEGS.024
50	01G25-N06	11TIBIRILXH3ACYA	Right Tibia Accel Y	1000	g	+	Tibia right	1-LX045-046 VOLPE THOR LEGS.025
51	4929J-138-FX	11TIBIRLLXH3FOXA	Right Lower Tibia Force X	11120.5	N	+	Ankle forward, knee rearward	1-LX045-046 VOLPE THOR LEGS.026
52	4929J-138-FY	11TIBIRLLXH3FOYA	Right Lower Tibia Force Y	11120.5	N	+	Ankle rightward, knee leftward	1-LX045-046 VOLPE THOR LEGS.027
53	4929J-138-FZ	11TIBIRLLXH3FOZA	Right Lower Tibia Force Z	11120.5	N	+	Ankle downward, knee upward	1-LX045-046 VOLPE THOR LEGS.028

E-6

070913

Channel Report Test Number 070913 R70203

Ref	Transducer ID	ISO Signal Identifier	Description	FScale	Units	DAS Flip	Positive Polarity	Assembly	
54	4929J-138-MX	11TIBIRLLXH3MOXA	Right Lower Tibia Moment X	395.4	Nm	+	Ankle leftward, hold knee in place	1-LX045-046 VOLPE THOR LEGS.029	
55	4929J-138-MY	11TIBIRLLXH3MOYA	Right Lower Tibia Moment Y	395.4	Nm	+	Ankle forward, hold knee in place	1-LX045-046 VOLPE THOR LEGS.030	
56	7921-0528-PD210-4B-427	11FOOTRILXH3ANXA	Right Foot Angular Dis. X AK037X	318	°	-	Eversion	1-LX045-046 VOLPE THOR LEGS.031	
57	7921-0526-PD210-4B-425	11FOOTRILXH3ANYA	Right Foot Angular Dis. Y AK225Y	318	°	+	Dorsiflexion	1-LX045-046 VOLPE THOR LEGS.032	
58	7921-0527-PD210-4B-422	11FOOTRILXH3ANZA	Right Foot Angular Dis. Z AK039Z	318	°	-	Internal rotation	1-LX045-046 VOLPE THOR LEGS.033	
59	01J02-F22	11FOOTRILXH3ACXA	Right Foot Accel X	1000	g	+	Foot forward	1-LX045-046 VOLPE THOR LEGS.034	
60	05G20-L06	11FOOTRILXH3ACYA	Right Foot Accel Y	1000	g	+	Foot rightward	1-LX045-046 VOLPE THOR LEGS.035	
61	04J04I20-A17	11FOOTRILXH3ACZA	Right Foot Accel Z	1000	g	+	Foot down	1-LX045-046 VOLPE THOR LEGS.036	
62	05H06-L26	13HEADCG00H3ACXA	Head Accel X	1000	g	-	Rearward	3-855 HIII 50th FTSS.001	
63	05G20-L20	13HEADCG00H3ACYA	Head Accel Y	1000	g	-	Leftward	3-855 HIII 50th FTSS.002	
64	05G15-L02	13HEADCG00H3ACZA	Head Accel Z	1000	g	-	Upward	3-855 HIII 50th FTSS.003	
65	J23772	13HEADCGRDH3ACXA	Head Accel X Redundant	1000	g	-	Rearward	3-855 HIII 50th FTSS.004	
66	J14668	13HEADCGRDH3ACYA	Head Accel Y Redundant	1000	g	-	Leftward	3-855 HIII 50th FTSS.005	
67	BD88J	13HEADCGRDH3ACZA	Head Accel Z Redundant	1000	g	-	Upward	3-855 HIII 50th FTSS.006	
68	1716A-1037-FX	13NECKUP00H3FOXA	Neck Force X	8896	N	-	Head forward, chest rearward	3-855 HIII 50th FTSS.007	
E-7	69	1716A-1037-FY	13NECKUP00H3FOYA	Neck Force Y	8896	N	+	Head leftward, chest rightward	3-855 HIII 50th FTSS.008
	70	1716A-1037-FZ	13NECKUP00H3FOZA	Neck Force Z	13344	N	+	Head upward, chest downward	3-855 HIII 50th FTSS.009
	71	1716A-1037-MX	13NECKUP00H3MOXA	Neck Moment X	282.5	Nm	-	Right ear toward right shoulder	3-855 HIII 50th FTSS.010
	72	1716A-1037-MY	13NECKUP00H3MOYA	Neck Moment Y	282.5	Nm	+	Chin toward sternum	3-855 HIII 50th FTSS.011
	73	1716A-1037-MZ	13NECKUP00H3MOZA	Neck Moment Z	282.5	Nm	+	Chin toward left shoulder	3-855 HIII 50th FTSS.012
	74	01G19-F02	13CHSTCG00H3ACXA	Chest Accel X	1000	g	+	Forward	3-855 HIII 50th FTSS.013
	75	01G25-N10	13CHSTCG00H3ACYA	Chest Accel Y	1000	g	-	Leftward	3-855 HIII 50th FTSS.014
	76	01H02-N07	13CHSTCG00H3ACZA	Chest Accel Z	1000	g	-	Upward	3-855 HIII 50th FTSS.015
	77	J14189	13CHSTCGRDH3ACXA	Chest Accel X Redundant	1000	g	+	Forward	3-855 HIII 50th FTSS.016
	78	BR34J	13CHSTCGRDH3ACYA	Chest Accel Y Redundant	1000	g	-	Leftward	3-855 HIII 50th FTSS.017
	79	J19611	13CHSTCGRDH3ACZA	Chest Accel Z Redundant	1000	g	-	Upward	3-855 HIII 50th FTSS.018
	80	CST855	13CHST0000H3DSXA	Chest Deflection X	100	mm	+	Forward	3-855 HIII 50th FTSS.019
	81	05G20-L21	13PELVCG00H3ACXA	Pelvis Accel X	1000	g	-	Rearward	3-855 HIII 50th FTSS.020
	82	02I02I10-N24	13PELVCG00H3ACYA	Pelvis Accel Y	1000	g	-	Leftward	3-855 HIII 50th FTSS.021
	83	05G11-X33	13PELVCG00H3ACZA	Pelvis Accel Z	1000	g	-	Upward	3-855 HIII 50th FTSS.022
	84	2121A-1394-FZ	13FEMRLL00H3FOZA	Left Femur Force Z	13344	N	+	Knee forward, pelvis rearward	3-855 HIII 50th FTSS.023
070913	85	2121A-1396	13FEMRRL00H3FOZA	Right Femur Force Z	13344	N	+	Knee forward, pelvis rearward	3-855 HIII 50th FTSS.024

Channel Report Test Number 070913 R70203

Ref	Transducer ID	ISO Signal Identifier	Description	FScale	Units	DAS		Assembly
						Flip	Positive Polarity	
86	150-0121VR-022701	13KNSLLE00H3DSXA	Left Knee Displacement X		33 mm	-	Hold femur in place, tibia rearward	3-LX103-104.001
87	4509-110-FX	13TIBILULXH3FOXA	Left Upper Tibia Force X	11120.5 N		+	Tibia forward, knee rearward	3-LX103-104.002
88	4509-110-FZ	13TIBILULXH3FOZA	Left Upper Tibia Force Z	11120.5 N		+	Tibia downward, femur upward	3-LX103-104.003
89	4509-110-MX	13TIBILULXH3MOXA	Left Upper Tibia Moment X	395.4 Nm		+	Ankle leftward, hold knee in place	3-LX103-104.004
90	4509-110-MY	13TIBILULXH3MOYA	Left Upper Tibia Moment Y	395.4 Nm		+	Ankle forward, hold knee in place	3-LX103-104.005
91	03E03E20-N14	13TIBILELXH3ACXA	Left Tibia Accel X	1000 g		+	Tibia forward	3-LX103-104.006
92	P49166	13TIBILELXH3ACYA	Left Tibia Accel Y	1000 g		+	Tibia right	3-LX103-104.007
93	4929J-78-FX	13TIBILLLXH3FOXA	Left Lower Tibia Force X	11120.5 N		+	Ankle forward, knee rearward	3-LX103-104.008
94	4929J-78-FY	13TIBILLLXH3FOYA	Left Lower Tibia Force Y	11120.5 N		+	Ankle rightward, knee leftward	3-LX103-104.009
95	4929J-78-FZ	13TIBILLLXH3FOZA	Left Lower Tibia Force Z	11120.5 N		+	Ankle downward, knee upward	3-LX103-104.010
96	4929J-78-MX	13TIBILLLXH3MOXA	Left Lower Tibia Moment X	395.4 Nm		+	Ankle leftward, hold knee in place	3-LX103-104.011
97	4929J-78-MY	13TIBILLLXH3MOYA	Left Lower Tibia Moment Y	395.4 Nm		+	Ankle forward, hold knee in place	3-LX103-104.012
98	PD210-4B-7921-0118	13FOOTLELXH3ANXA	Left Foot Angular Dis. X	LX104X	318 °	+	Eversion	3-LX103-104.013
99	PD210-4B-7921-0229	13FOOTLELXH3ANYA	Left Foot Angular Dis. Y	LX104Y	318 °	+	Dorsiflexion	3-LX103-104.014
100	PD210-4B-7921-0224	13FOOTLELXH3ANZA	Left Foot Angular Dis. Z	LX104Z	318 °	+	Internal rotation	3-LX103-104.015
101	P51275	13FOOTLELXH3ACXA	Left Foot Accel X	1000 g		+	Foot forward	3-LX103-104.016
102	P52150	13FOOTLELXH3ACYA	Left Foot Accel Y	1000 g		+	Foot rightward	3-LX103-104.017
103	P52158	13FOOTLELXH3ACZA	Left Foot Accel Z	1000 g		+	Foot down	3-LX103-104.018
104	150-0121VL-013723	13KNSLR100H3DSXA	Right Knee Displacement X		33 mm	-	Hold femur in place, tibia rearward	3-LX103-104.019
105	4509-108-FX	13TIBIRULXH3FOXA	Right Upper Tibia Force X	11120.5 N		+	Tibia forward, knee rearward	3-LX103-104.020
106	4509-108-FZ	13TIBIRULXH3FOZA	Right Upper Tibia Force Z	11120.5 N		+	Tibia downward, femur upward	3-LX103-104.021
107	4509-108-MX	13TIBIRULXH3MOXA	Right Upper Tibia Moment X	395.4 Nm		+	Ankle leftward, hold knee in place	3-LX103-104.022

E-8

070913

Channel Report Test Number 070913 R70203

Ref	Transducer ID	ISO Signal Identifier	Description	FScale	Units	DAS Flip	Positive Polarity	Assembly
108	4509-108-MY	13TIBIRULXH3MOYA	Right Upper Tibia Moment Y	395.4	Nm	+	Ankle forward, hold knee in place	3-LX103-104.023
109	P52153	13TIBIRILXH3ACXA	Right Tibia Accel X	1000	g	+	Tibia forward	3-LX103-104.024
110	P51304	13TIBIRILXH3ACYA	Right Tibia Accel Y	1000	g	+	Tibia right	3-LX103-104.025
111	4929J-76-FX	13TIBIRLLXH3FOXA	Right Lower Tibia Force X	11120.5	N	+	Ankle forward, knee rearward	3-LX103-104.026
112	4929J-76-FY	13TIBIRLLXH3FOYA	Right Lower Tibia Force Y	11120.5	N	+	Ankle rightward, knee leftward	3-LX103-104.027
113	4929J-76-FZ	13TIBIRLLXH3FOZA	Right Lower Tibia Force Z	11120.5	N	+	Ankle downward, knee upward	3-LX103-104.028
114	4929J-76-MX	13TIBIRLLXH3MOXA	Right Lower Tibia Moment X	395.4	Nm	+	Ankle leftward, hold knee in place	3-LX103-104.029
115	4929J-76-MY	13TIBIRLLXH3MOYA	Right Lower Tibia Moment Y	395.4	Nm	+	Ankle forward, hold knee in place	3-LX103-104.030
116	PD210-4B-7921-0037	13FOOTRILXH3ANXA	Right Foot Angular Dis. X AK037X	318	°	+	Inversion	3-LX103-104.031
117	PD210-4B-7921-0225	13FOOTRILXH3ANYA	Right Foot Angular Dis. Y AK225Y	318	°	+	Dorsiflexion	3-LX103-104.032
118	PD210-4B-7921-0039	13FOOTRILXH3ANZA	Right Foot Angular Dis. Z AK039Z	318	°	+	External rotation	3-LX103-104.033
119	P51290	13FOOTRILXH3ACXA	Right Foot Accel X	1000	g	+	Foot forward	3-LX103-104.034
120	P49159	13FOOTRILXH3ACYA	Right Foot Accel Y	1000	g	+	Foot rightward	3-LX103-104.035
121	05H25-L15	13FOOTRILXH3ACZA	Right Foot Accel Z	1000	g	+	Foot down	3-LX103-104.036
122	P48122	14CRME000000ACXA	Left Rear Seat Cross-member X-axis Acceleration	1000	g	+	Forward	
123	P57012	16CRME000000ACXA	Right Rear Seat Cross-member X-axis Acceleration	1000	g	+	Forward	
124	P54332	14CRME000000ACZA	Left Rear Seat Cross-member Z-axis Acceleration	1000	g	-	Upward	
125	P57021	16CRME000000ACZA	Right Rear Seat Cross-member Z-axis Acceleration	1000	g	-	Upward	
126	P56918	12ENGNT000000ACXA	Top of Engine Block X-axis acceleration	1500	g	+	Forward	
127	P57002	12ENGNB000000ACXA	Bottom of Engine Block X-axis acceleration	1500	g	-	Rearward	
128	P56915	13VEHCRI000000ACXA	Right Brake Caliper X-axis Acceleration	1500	g	-	Rearward	
129	P57011	11VEHCLE000000ACXA	Left Brake Caliper X-axis Acceleration	1500	g	-	Rearward	
130	P56927	12DASH000000ACXA	Instrument Panel X-axis Acceleration	1500	g	+	Forward	
131	P57006	11SETR000000ACXA	Left Side Driver Mid Seat Track X-axis Acceleration	1000	g	-	Rearward	
132	P47556	10VEHCCG000000ACXA	Vehicle CG X-axis acceleration	1000	g	+	Forward	
133	P54843	10VEHCCG000000ACYA	Vehicle CG Y-axis acceleration	1000	g	-	Leftward	
134	P47386	10VEHCCG000000ACZA	Vehicle CG Z-axis acceleration	1000	g	-	Upward	
135	P56985	11PEAC000000ACXA	Under Accel Pedal X-axis Acceleration	1000	g	+	Forward	
136	P56916	11PEAC000000ACYA	Under Accel Pedal Y-axis Acceleration	1000	g	+	Rightward	
137	P57028	11PEAC000000ACZA	Under Accel Pedal Z-axis Acceleration	1000	g	+	Downward	
138	P56989	11PEBR000000ACXA	Under Brake Pedal X-axis Acceleration	1000	g	-	Rearward	
139	P57023	11PEBR000000ACYA	Under Brake Pedal Y-axis Acceleration	1000	g	-	Leftward	
140	P57024	11PEBR000000ACZA	Under Brake Pedal Z-axis Acceleration	1000	g	+	Downward	
141	P54547	11VEHC000001ACXA	Outside Footrest X-axis Acceleration	1000	g	-	Rearward	
142	P47538	11VEHC000001ACYA	Outside Footrest Y-axis Acceleration	1000	g	-	Leftward	
143	P48633	11VEHC000001ACZA	Outside Footrest Z-axis Acceleration	1000	g	+	Downward	

E-9

070913

Channel Report Test Number 070913 R70203

Ref	Transducer ID	ISO Signal Identifier	Description	FScale	Units	DAS		Assembly
						Flip	Positive Polarity	
144	3419T-808	11SEBE0000B5FOOA	Driver lap belt	13500	N	+	Tension	
145	3419T-828	11SEBE0000B3FOOA	Driver shoulder belt	13500	N	+	Tension	
146	3419-807	13SEBE0000B5FOOA	Passenger lap belt	13500	N	+	Tension	
147	3419T-739	13SEBE0000B3FOOA	Passenger shoulder belt	13500	N	+	Tension	
148	ABFire1	11AIRBFR0100EV0A	Driver Front Airbag 1 IND	5	V	+	Bipolar	
149	ABFire2	11AIRBFR0200EV0A	Driver Front Airbag 2 IND	5	V	+	Bipolar	
150	ABFire3	13AIRBFR0100EV0A	Passenger Front Airbag 1 IND	5	V	+	Bipolar	
151	ABFire4	13AIRBFR0200EV0A	Passenger Front Airbag 2 IND	5	V	+	Bipolar	
152	Bit.00	11CONT000001VO00	Driver right foot contact switch	1	Logic	+	Bipolar	
153	Bit.06	11CONT000002VO00	Driver left foot contact switch	1	Logic	+	Bipolar	
154	Bit.09	11CONT000003VO00	Driver left knee contact switch	1	Logic	+	Bipolar	
155	Bit.10	11CONT000004VO00	Driver right knee contact switch	1	Logic	+	Bipolar	
156	476830002	L0FBAR000001FOXA	Load Cell Row 1 Column 1	222411	N	+	Tension force	0-Barrier VRTC 90 channel Offset.001
157	476830015	L0FBAR000002FOXA	Load Cell Row 2 Column 1	222411	N	+	Tension force	0-Barrier VRTC 90 channel Offset.002
158	476830082	L0FBAR000003FOXA	Load Cell Row 3 Column 1	222411	N	+	Tension force	0-Barrier VRTC 90 channel Offset.003
159	476830086	L0FBAR000004FOXA	Load Cell Row 4 Column 1	222411	N	+	Tension force	0-Barrier VRTC 90 channel Offset.004
160	476830023	L0FBAR000005FOXA	Load Cell Row 5 Column 1	222411	N	+	Tension force	0-Barrier VRTC 90 channel Offset.005
161	476830017	L0FBAR000006FOXA	Load Cell Row 6 Column 1	222411	N	+	Tension force	0-Barrier VRTC 90 channel Offset.006
162	476830043	L0FBAR000007FOXA	Load Cell Row 7 Column 1	222411	N	+	Tension force	0-Barrier VRTC 90 channel Offset.007
163	476830080	L0FBAR000008FOXA	Load Cell Row 8 Column 1	222411	N	+	Tension force	0-Barrier VRTC 90 channel Offset.008
164	476830007	L0FBAR000009FOXA	Load Cell Row 9 Column 1	222411	N	+	Tension force	0-Barrier VRTC 90 channel Offset.009
165	476830069	L0FBAR000010FOXA	Load Cell Row 10 Column 1	222411	N	+	Tension force	0-Barrier VRTC 90 channel Offset.010
166	476830044	L0FBAR000011FOXA	Load Cell Row 1 Column 2	222411	N	+	Tension force	0-Barrier VRTC 90 channel Offset.011
167	476830006	L0FBAR000012FOXA	Load Cell Row 2 Column 2	222411	N	+	Tension force	0-Barrier VRTC 90 channel Offset.012
168	476830014	L0FBAR000013FOXA	Load Cell Row 3 Column 2	222411	N	+	Tension force	0-Barrier VRTC 90 channel Offset.013
169	476830001	L0FBAR000014FOXA	Load Cell Row 4 Column 2	222411	N	+	Tension force	0-Barrier VRTC 90 channel Offset.014
170	476830048	L0FBAR000015FOXA	Load Cell Row 5 Column 2	222411	N	+	Tension force	0-Barrier VRTC 90 channel Offset.015
171	476830059	L0FBAR000016FOXA	Load Cell Row 6 Column 2	222411	N	+	Tension force	0-Barrier VRTC 90 channel Offset.016
172	476830049	L0FBAR000017FOXA	Load Cell Row 7 Column 2	222411	N	+	Tension force	0-Barrier VRTC 90 channel Offset.017
173	476830076	L0FBAR000018FOXA	Load Cell Row 8 Column 2	222411	N	+	Tension force	0-Barrier VRTC 90 channel Offset.018
174	476830028	L0FBAR000019FOXA	Load Cell Row 9 Column 2	222411	N	+	Tension force	0-Barrier VRTC 90 channel Offset.019
175	476830053	L0FBAR000020FOXA	Load Cell Row 10 Column 2	222411	N	+	Tension force	0-Barrier VRTC 90 channel Offset.020
176	476830034	L0FBAR000021FOXA	Load Cell Row 1 Column 3	222411	N	+	Tension force	0-Barrier VRTC 90 channel Offset.021
177	476830060	L0FBAR000022FOXA	Load Cell Row 2 Column 3	222411	N	+	Tension force	0-Barrier VRTC 90 channel Offset.022
178	476830022	L0FBAR000023FOXA	Load Cell Row 3 Column 3	222411	N	+	Tension force	0-Barrier VRTC 90 channel Offset.023
179	476830062	L0FBAR000024FOXA	Load Cell Row 4 Column 3	222411	N	+	Tension force	0-Barrier VRTC 90 channel Offset.024
180	476830092	L0FBAR000025FOXA	Load Cell Row 5 Column 3	222411	N	+	Tension force	0-Barrier VRTC 90 channel Offset.025
181	476830020	L0FBAR000026FOXA	Load Cell Row 6 Column 3	222411	N	+	Tension force	0-Barrier VRTC 90 channel Offset.026
182	476830088	L0FBAR000027FOXA	Load Cell Row 7 Column 3	222411	N	+	Tension force	0-Barrier VRTC 90 channel Offset.027
183	476830012	L0FBAR000028FOXA	Load Cell Row 8 Column 3	222411	N	+	Tension force	0-Barrier VRTC 90 channel Offset.028
184	476830077	L0FBAR000029FOXA	Load Cell Row 9 Column 3	222411	N	+	Tension force	0-Barrier VRTC 90 channel Offset.029
185	476830011	L0FBAR000030FOXA	Load Cell Row 10 Column 3	222411	N	+	Tension force	0-Barrier VRTC 90 channel Offset.030
186	476830065	L0FBAR000031FOXA	Load Cell Row 1 Column 4	222411	N	+	Tension force	0-Barrier VRTC 90 channel Offset.031
187	476830078	L0FBAR000032FOXA	Load Cell Row 2 Column 4	222411	N	+	Tension force	0-Barrier VRTC 90 channel Offset.032
188	476830035	L0FBAR000033FOXA	Load Cell Row 3 Column 4	222411	N	+	Tension force	0-Barrier VRTC 90 channel Offset.033

E-10

070913

Channel Report Test Number 070913 R70203

Ref	Transducer ID	ISO Signal Identifier	Description	FScale	Units	DAS		Assembly
						Flip	Positive Polarity	
189	476830031	L0FBAR000034FOXA	Load Cell Row 4 Column 4	222411	N	+	Tension force	0-Barrier VRTC 90 channel Offset.034
190	476830046	L0FBAR000035FOXA	Load Cell Row 5 Column 4	222411	N	+	Tension force	0-Barrier VRTC 90 channel Offset.035
191	476830033	L0FBAR000036FOXA	Load Cell Row 6 Column 4	222411	N	+	Tension force	0-Barrier VRTC 90 channel Offset.036
192	476830019	L0FBAR000037FOXA	Load Cell Row 7 Column 4	222411	N	+	Tension force	0-Barrier VRTC 90 channel Offset.037
193	476830093	L0FBAR000038FOXA	Load Cell Row 8 Column 4	222411	N	+	Tension force	0-Barrier VRTC 90 channel Offset.038
194	476830074	L0FBAR000039FOXA	Load Cell Row 9 Column 4	222411	N	+	Tension force	0-Barrier VRTC 90 channel Offset.039
195	476830030	L0FBAR000040FOXA	Load Cell Row 10 Column 4	222411	N	+	Tension force	0-Barrier VRTC 90 channel Offset.040
196	476830036	L0FBAR000041FOXA	Load Cell Row 1 Column 5	222411	N	+	Tension force	0-Barrier VRTC 90 channel Offset.041
197	476830010	L0FBAR000042FOXA	Load Cell Row 2 Column 5	222411	N	+	Tension force	0-Barrier VRTC 90 channel Offset.042
198	476830079	L0FBAR000043FOXA	Load Cell Row 3 Column 5	222411	N	+	Tension force	0-Barrier VRTC 90 channel Offset.043
199	476830045	L0FBAR000044FOXA	Load Cell Row 4 Column 5	222411	N	+	Tension force	0-Barrier VRTC 90 channel Offset.044
200	476830025	L0FBAR000045FOXA	Load Cell Row 5 Column 5	222411	N	+	Tension force	0-Barrier VRTC 90 channel Offset.045
201	476830039	L0FBAR000046FOXA	Load Cell Row 6 Column 5	222411	N	+	Tension force	0-Barrier VRTC 90 channel Offset.046
202	476830047	L0FBAR000047FOXA	Load Cell Row 7 Column 5	222411	N	+	Tension force	0-Barrier VRTC 90 channel Offset.047
203	476830057	L0FBAR000048FOXA	Load Cell Row 8 Column 5	222411	N	+	Tension force	0-Barrier VRTC 90 channel Offset.048
204	476830032	L0FBAR000049FOXA	Load Cell Row 9 Column 5	222411	N	+	Tension force	0-Barrier VRTC 90 channel Offset.049
205	476830037	L0FBAR000050FOXA	Load Cell Row 10 Column 5	222411	N	+	Tension force	0-Barrier VRTC 90 channel Offset.050
206	476830038	L0FBAR000051FOXA	Load Cell Row 1 Column 6	222411	N	+	Tension force	0-Barrier VRTC 90 channel Offset.051
207	476830054	L0FBAR000052FOXA	Load Cell Row 2 Column 6	222411	N	+	Tension force	0-Barrier VRTC 90 channel Offset.052
208	476830024	L0FBAR000053FOXA	Load Cell Row 3 Column 6	222411	N	+	Tension force	0-Barrier VRTC 90 channel Offset.053
209	476830041	L0FBAR000054FOXA	Load Cell Row 4 Column 6	222411	N	+	Tension force	0-Barrier VRTC 90 channel Offset.054
210	476830004	L0FBAR000055FOXA	Load Cell Row 5 Column 6	222411	N	+	Tension force	0-Barrier VRTC 90 channel Offset.055
211	476830091	L0FBAR000056FOXA	Load Cell Row 6 Column 6	222411	N	+	Tension force	0-Barrier VRTC 90 channel Offset.056
212	476830087	L0FBAR000057FOXA	Load Cell Row 7 Column 6	222411	N	+	Tension force	0-Barrier VRTC 90 channel Offset.057
213	476830064	L0FBAR000058FOXA	Load Cell Row 8 Column 6	222411	N	+	Tension force	0-Barrier VRTC 90 channel Offset.058
214	476830083	L0FBAR000059FOXA	Load Cell Row 9 Column 6	222411	N	+	Tension force	0-Barrier VRTC 90 channel Offset.059
215	476830018	L0FBAR000060FOXA	Load Cell Row 10 Column 6	222411	N	+	Tension force	0-Barrier VRTC 90 channel Offset.060
216	476830008	L0FBAR000061FOXA	Load Cell Row 1 Column 7	222411	N	+	Tension force	0-Barrier VRTC 90 channel Offset.061
217	476830013	L0FBAR000062FOXA	Load Cell Row 2 Column 7	222411	N	+	Tension force	0-Barrier VRTC 90 channel Offset.062
218	476830021	L0FBAR000063FOXA	Load Cell Row 3 Column 7	222411	N	+	Tension force	0-Barrier VRTC 90 channel Offset.063
219	476830003	L0FBAR000064FOXA	Load Cell Row 4 Column 7	222411	N	+	Tension force	0-Barrier VRTC 90 channel Offset.064
220	476830051	L0FBAR000065FOXA	Load Cell Row 5 Column 7	222411	N	+	Tension force	0-Barrier VRTC 90 channel Offset.065
221	476830067	L0FBAR000066FOXA	Load Cell Row 6 Column 7	222411	N	+	Tension force	0-Barrier VRTC 90 channel Offset.066
222	476830009	L0FBAR000067FOXA	Load Cell Row 7 Column 7	222411	N	+	Tension force	0-Barrier VRTC 90 channel Offset.067
223	476830026	L0FBAR000068FOXA	Load Cell Row 8 Column 7	222411	N	+	Tension force	0-Barrier VRTC 90 channel Offset.068
224	476830089	L0FBAR000069FOXA	Load Cell Row 9 Column 7	222411	N	+	Tension force	0-Barrier VRTC 90 channel Offset.069
225	476830016	L0FBAR000070FOXA	Load Cell Row 10 Column 7	222411	N	+	Tension force	0-Barrier VRTC 90 channel Offset.070
226	476830071	L0FBAR000071FOXA	Load Cell Row 1 Column 8	222411	N	+	Tension force	0-Barrier VRTC 90 channel Offset.071
227	476830072	L0FBAR000072FOXA	Load Cell Row 2 Column 8	222411	N	+	Tension force	0-Barrier VRTC 90 channel Offset.072
228	476830029	L0FBAR000073FOXA	Load Cell Row 3 Column 8	222411	N	+	Tension force	0-Barrier VRTC 90 channel Offset.073
229	476830058	L0FBAR000074FOXA	Load Cell Row 4 Column 8	222411	N	+	Tension force	0-Barrier VRTC 90 channel Offset.074
230	476830027	L0FBAR000075FOXA	Load Cell Row 5 Column 8	222411	N	+	Tension force	0-Barrier VRTC 90 channel Offset.075
231	476830052	L0FBAR000076FOXA	Load Cell Row 6 Column 8	222411	N	+	Tension force	0-Barrier VRTC 90 channel Offset.076
232	476830063	L0FBAR000077FOXA	Load Cell Row 7 Column 8	222411	N	+	Tension force	0-Barrier VRTC 90 channel Offset.077
233	476830075	L0FBAR000078FOXA	Load Cell Row 8 Column 8	222411	N	+	Tension force	0-Barrier VRTC 90 channel Offset.078

E-11

070913

Channel Report Test Number 070913 R70203

Ref	Transducer ID	ISO Signal Identifier	Description	FScale	Units	DAS		Assembly
						Flip	Positive Polarity	
234	476830070	L0FBAR000079FOXA	Load Cell Row 9 Column 8	222411	N	+	Tension force	0-Barrier VRTC 90 channel Offset.079
235	476830042	L0FBAR000080FOXA	Load Cell Row 10 Column 8	222411	N	+	Tension force	0-Barrier VRTC 90 channel Offset.080
236	476830068	L0FBAR000081FOXA	Load Cell Row 1 Column 9	222411	N	+	Tension force	0-Barrier VRTC 90 channel Offset.081
237	476830084	L0FBAR000082FOXA	Load Cell Row 2 Column 9	222411	N	+	Tension force	0-Barrier VRTC 90 channel Offset.082
238	476830056	L0FBAR000083FOXA	Load Cell Row 3 Column 9	222411	N	+	Tension force	0-Barrier VRTC 90 channel Offset.083
239	476830085	L0FBAR000084FOXA	Load Cell Row 4 Column 9	222411	N	+	Tension force	0-Barrier VRTC 90 channel Offset.084
240	476830073	L0FBAR000085FOXA	Load Cell Row 5 Column 9	222411	N	+	Tension force	0-Barrier VRTC 90 channel Offset.085
241	476830055	L0FBAR000086FOXA	Load Cell Row 6 Column 9	222411	N	+	Tension force	0-Barrier VRTC 90 channel Offset.086
242	476830090	L0FBAR000087FOXA	Load Cell Row 7 Column 9	222411	N	+	Tension force	0-Barrier VRTC 90 channel Offset.087
243	476830061	L0FBAR000088FOXA	Load Cell Row 8 Column 8	222411	N	+	Tension force	0-Barrier VRTC 90 channel Offset.088
244	476830005	L0FBAR000089FOXA	Load Cell Row 9 Column 9	222411	N	+	Tension force	0-Barrier VRTC 90 channel Offset.089
245	476830050	L0FBAR000090FOXA	Load Cell Row 10 Column 9	222411	N	+	Tension force	0-Barrier VRTC 90 channel Offset.090

Command File Test Number 070913 R70203

Channel	ISO mnemonic	Channel Title	Filter Class	Flip	Zero	Full Scale
1	11HEADCG00H3ACXA	Driver Head X-Axis Acceleration	1000	+	yes	1000
2	11HEADCG00H3ACYA	Driver Head Y-Axis Acceleration	1000	+	yes	1000
3	11HEADCG00H3ACZA	Driver Head Z-Axis Acceleration	1000	+	yes	1000
3A	11HEADCG00H3ACRA	Driver Head Resultant Acceleration	1000			
4	11HEADCGRDH3ACXA	Driver Head X-Axis Redundant Acceleration	1000	+	yes	1000
5	11HEADCGRDH3ACYA	Driver Head Y-Axis Redundant Acceleration	1000	+	yes	1000
6	11HEADCGRDH3ACZA	Driver Head Z-Axis Redundant Acceleration	1000	+	yes	1000
6A	11HEADCGRDH3ACRA	Driver Head Redundant Resultant Acceleration	1000			
7	11NECKUP00H3FOXA	Driver Upper Neck X-Axis Force	1000	+	yes	8896
8	11NECKUP00H3FOYA	Driver Upper Neck Y-Axis Force	1000	+	yes	8896
9	11NECKUP00H3FOZA	Driver Upper Neck Z-Axis Force	1000	+	yes	13344
10	11NECKUP00H3MOXA	Driver Upper Neck Moment About X Axis	600	+	yes	282.5
11	11NECKUP00H3MOYA	Driver Upper Neck Moment About Y Axis	600	+	yes	282.5
12	11NECKUP00H3MOZA	Driver Upper Neck Moment About Z Axis	600	+	yes	282.5
13	11CHSTCG00H3ACXA	Driver Chest X-Axis Acceleration	180	+	yes	1000
14	11CHSTCG00H3ACYA	Driver Chest Y-Axis Acceleration	180	+	yes	1000
15	11CHSTCG00H3ACZA	Driver Chest Z-Axis Acceleration	180	+	yes	1000
15A	11CHSTCG00H3ACRA	Driver Chest Resultant Acceleration	180			
16	11CHSTCGRDH3ACXA	Driver Chest X-Axis Redundant Acceleration	180	+	yes	1000
17	11CHSTCGRDH3ACYA	Driver Chest Y-Axis Redundant Acceleration	180	+	yes	1000
18	11CHSTCGRDH3ACZA	Driver Chest Z-Axis Redundant Acceleration	180	+	yes	1000
18A	11CHSTCGRDH3ACRA	Driver Chest Redundant Resultant Acceleration	180			
19	11CHST0000H3DSXA	Driver Chest Displacement	600	+	yes	100
20	11PELVCG00H3ACXA	Driver Pelvis X-Axis Acceleration	1000	+	yes	1000
21	11PELVCG00H3ACYA	Driver Pelvis Y-Axis Acceleration	1000	+	yes	1000
22	11PELVCG00H3ACZA	Driver Pelvis Z-Axis Acceleration	1000	+	yes	1000
22A	11PELVCG00H3ACRA	Driver Pelvis Resultant Acceleration	1000			
23	11FEMRLL00H3FOZA	Driver Left Femur Z-Axis Force	600	+	yes	13344
24	11FEMRRL00H3FOZA	Driver Right Femur Z-Axis Force	600	+	yes	13344
25	11KNSLLE00H3DSXA	Driver Left Knee Displacement	180	+	yes	40
26	11TIBILULXH3FOXA	Driver Left Upper Tibia X-Axis Force	600	+	yes	11120
27	11TIBILULXH3FOZA	Driver Left Upper Tibia Z-Axis Force	600	+	yes	11120.5
28	11TIBILULXH3MOXA	Driver Left Upper Tibia Moment About X Axis	600	+	yes	395.4
29	11TIBILULXH3MOYA	Driver Left Upper Tibia Moment About Y Axis	600	+	yes	395.4
30	11TIBILELXH3ACXA	Driver Left Tibia X-Axis Acceleration	1000	+	yes	1000
31	11TIBILELXH3ACYA	Driver Left Tibia Y-Axis Acceleration	1000	+	yes	1000
32	11TIBILLLXH3FOXA	Driver Left Lower Tibia X-Axis Force	600	+	yes	11120.5

Command File Test Number 070913 R70203

Channel	ISO mnemonic	Channel Title	Filter Class	Flip	Zero	Full Scale
33	11TIBILLX3H3FOYA	Driver Left Lower Tibia Y-Axis Force	600	+	yes	11120.5
34	11TIBILLX3H3FOZA	Driver Left Lower Tibia Z-Axis Force	600	+	yes	11120.5
35	11TIBILLX3H3MOXA	Driver Left Lower Tibia Moment About X Axis	600	+	yes	395.4
36	11TIBILLX3H3MOYA	Driver Left Lower Tibia Moment About Y Axis	600	+	yes	395.4
37	11FOOTLELXH3ANXA	Driver Left Foot X-Axis Rotation	180	+	no	318
38	11FOOTLELXH3ANYA	Driver Left Foot Y-Axis Rotation	180	+	no	318
39	11FOOTLELXH3ANZA	Driver Left Foot Z-Axis Rotation	180	+	no	318
40	11FOOTLELXH3ACXA	Driver Left Foot X-Axis Acceleration	1000	+	yes	1000
41	11FOOTLELXH3ACYA	Driver Left Foot Y-Axis Acceleration	1000	+	yes	1000
42	11FOOTLELXH3ACZA	Driver Left Foot Z-Axis Acceleration	1000	+	yes	1000
42A	11FOOTLELXH3ACRA	Driver Left Foot Resultant Acceleration	1000			
43	11KNSLRI00H3DSXA	Driver Right Knee Displacement	180	+	yes	40
44	11TIBIRULXH3FOXA	Driver Right Upper Tibia X-Axis Force	600	+	yes	11120.5
45	11TIBIRULXH3FOZA	Driver Right Upper Tibia Z-Axis Force	600	+	yes	11120.5
46	11TIBIRULXH3MOXA	Driver Right Upper Tibia Moment About X Axis	600	+	yes	395.4
47	11TIBIRULXH3MOYA	Driver Right Upper Tibia Moment About Y Axis	600	+	yes	395.4
48	11TIBIRILXH3ACXA	Driver Right Tibia X-Axis Acceleration	1000	+	yes	1000
49	11TIBIRILXH3ACYA	Driver Right Tibia Y-Axis Acceleration	1000	+	yes	1000
50	11TIBIRLLXH3FOXA	Driver Right Lower Tibia X-Axis Force	600	+	yes	11120.5
51	11TIBIRLLXH3FOYA	Driver Right Lower Tibia Y-Axis Force	600	+	yes	11120.5
52	11TIBIRLLXH3FOZA	Driver Right Lower Tibia Z-Axis Force	600	+	yes	11120.5
53	11TIBIRLLXH3MOXA	Driver Right Lower Tibia Moment About X Axis	600	+	yes	395.4
54	11TIBIRLLXH3MOYA	Driver Right Lower Tibia Moment About Y Axis	600	+	yes	395.4
55	11FOOTRILXH3ANXA	Driver Right Foot X-Axis Rotation	180	+	no	318
56	11FOOTRILXH3ANYA	Driver Right Foot Y-Axis Rotation	180	+	no	318
57	11FOOTRILXH3ANZA	Driver Right Foot Z-Axis Rotation	180	+	no	318
58	11FOOTRILXH3ACXA	Driver Right Foot X-Axis Acceleration	1000	+	yes	1000
59	11FOOTRILXH3ACYA	Driver Right Foot Y-Axis Acceleration	1000	+	yes	1000
60	11FOOTRILXH3ACZA	Driver Right Foot Z-Axis Acceleration	1000	+	yes	1000
60A	11FOOTRILXH3ACRA	Driver Right Foot Resultant Acceleration	1000			
61	13HEADCG00H3ACXA	Passenger Head X-Axis Acceleration	1000	+	yes	1000
62	13HEADCG00H3ACYA	Passenger Head Y-Axis Acceleration	1000	+	yes	1000
63	13HEADCG00H3ACZA	Passenger Head Z-Axis Acceleration	1000	+	yes	1000
63A	13HEADCG00H3ACRA	Passenger Head Resultant Acceleration	1000			
64	13HEADCGRDH3ACXA	Passenger Head X-Axis Redundant Acceleration	1000	+	yes	1000
65	13HEADCGRDH3ACYA	Passenger Head Y-Axis Redundant Acceleration	1000	+	yes	1000
66	13HEADCGRDH3ACZA	Passenger Head Z-Axis Redundant Acceleration	1000	+	yes	1000

Command File Test Number 070913 R70203

Channel	ISO mnemonic	Channel Title	Filter Class	Flip	Zero	Full Scale
66A	13HEADCGRDH3ACRA	Passenger Head Redundant Resultant Acceleration	1000			
67	13NECKUP00H3FOXA	Passenger Upper Neck X-Axis Force	1000	+	yes	8896
68	13NECKUP00H3FOYA	Passenger Upper Neck Y-Axis Force	1000	+	yes	8896
69	13NECKUP00H3FOZA	Passenger Upper Neck Z-Axis Force	1000	+	yes	13344
70	13NECKUP00H3MOXA	Passenger Upper Neck Moment About X Axis	600	+	yes	282.5
71	13NECKUP00H3MOYA	Passenger Upper Neck Moment About Y Axis	600	+	yes	282.5
72	13NECKUP00H3MOZA	Passenger Upper Neck Moment About Z Axis	600	+	yes	282.5
73	13CHSTCG00H3ACXA	Passenger Chest X-Axis Acceleration	180	+	yes	1000
74	13CHSTCG00H3ACYA	Passenger Chest Y-Axis Acceleration	180	+	yes	1000
75	13CHSTCG00H3ACZA	Passenger Chest Z-Axis Acceleration	180	+	yes	1000
75A	13CHSTCG00H3ACRA	Passenger Chest Resultant Acceleration	180			
76	13CHSTCGRDH3ACXA	Passenger Chest X-Axis Redundant Acceleration	180	+	yes	1000
77	13CHSTCGRDH3ACYA	Passenger Chest Y-Axis Redundant Acceleration	180	+	yes	1000
78	13CHSTCGRDH3ACZA	Passenger Chest Z-Axis Redundant Acceleration	180	+	yes	1000
78A	13CHSTCGRDH3ACRA	Passenger Chest Redundant Resultant Acceleration	180			
79	13CHST0000H3DSXA	Passenger Chest Displacement	600	+	yes	100
80	13PELVCG00H3ACXA	Passenger Pelvis X-Axis Acceleration	1000	+	yes	1000
81	13PELVCG00H3ACYA	Passenger Pelvis Y-Axis Acceleration	1000	+	yes	1000
82	13PELVCG00H3ACZA	Passenger Pelvis Z-Axis Acceleration	1000	+	yes	1000
82A	13PELVCG00H3ACRA	Passenger Pelvis Resultant Acceleration	1000			
83	13FEMRLL00H3FOZA	Passenger Left Femur Z-Axis Force	600	+	yes	13344
84	13FEMRRL00H3FOZA	Passenger Right Femur Z-Axis Force	600	+	yes	13344
85	13KNSLLE00H3DSXA	Passenger Left Knee Displacement	180	+	yes	33
86	13TIBILULXH3FOXA	Passenger Left Upper Tibia X-Axis Force	600	+	yes	11120.5
87	13TIBILULXH3FOZA	Passenger Left Upper Tibia Z-Axis Force	600	+	yes	11120.5
88	13TIBILULXH3MOXA	Passenger Left Upper Tibia Moment About X Axis	600	+	yes	395.4
89	13TIBILULXH3MOYA	Passenger Left Upper Tibia Moment About Y Axis	600	+	yes	395.4
90	13TIBILELXH3ACXA	Passenger Left Tibia X-Axis Acceleration	1000	+	yes	1000
91	13TIBILELXH3ACYA	Passenger Left Tibia Y-Axis Acceleration	1000	+	yes	1000
92	13TIBILLLXH3FOXA	Passenger Left Lower Tibia X-Axis Force	600	+	yes	11120.5
93	13TIBILLLXH3FOYA	Passenger Left Lower Tibia Y-Axis Force	600	+	yes	11120.5
94	13TIBILLLXH3FOZA	Passenger Left Lower Tibia Z-Axis Force	600	+	yes	11120.5
95	13TIBILLLXH3MOXA	Passenger Left Lower Tibia Moment About X Axis	600	+	yes	395.4
96	13TIBILLLXH3MOYA	Passenger Left Lower Tibia Moment About Y Axis	600	+	yes	395.4
97	13FOOTLELXH3ANXA	Passenger Left Foot X-Axis Rotation	180	+	no	318
98	13FOOTLELXH3ANYA	Passenger Left Foot Y-Axis Rotation	180	+	no	318
99	13FOOTLELXH3ANZA	Passenger Left Foot Z-Axis Rotation	180	+	no	318

Command File Test Number 070913 R70203

Channel	ISO mnemonic	Channel Title	Filter Class	Flip	Zero	Full Scale
100	13FOOTLELXH3ACXA	Passenger Left Foot X-Axis Acceleration	1000	+	yes	1000
101	13FOOTLELXH3ACYA	Passenger Left Foot Y-Axis Acceleration	1000	+	yes	1000
102	13FOOTLELXH3ACZA	Passenger Left Foot Z-Axis Acceleration	1000	+	yes	1000
102A	13FOOTLELXH3ACRA	Passenger Left Foot Resultant Acceleration	1000			
103	13KNSLR100H3DSXA	Passenger Right Knee Displacement	180	+	yes	33
104	13TIBIRULXH3FOXA	Passenger Right Upper Tibia X-Axis Force	600	+	yes	11120.5
105	13TIBIRULXH3FOZA	Passenger Right Upper Tibia Z-Axis Force	600	+	yes	11120.5
106	13TIBIRULXH3MOXA	Passenger Right Upper Tibia Moment About X Axis	600	+	yes	395.4
107	13TIBIRULXH3MOYA	Passenger Right Upper Tibia Moment About Y Axis	600	+	yes	395.4
108	13TIBIRILXH3ACXA	Passenger Right Tibia X-Axis Acceleration	1000	+	yes	1000
109	13TIBIRILXH3ACYA	Passenger Right Tibia Y-Axis Acceleration	1000	+	yes	1000
110	13TIBIRLLXH3FOXA	Passenger Right Lower Tibia X-Axis Force	600	+	yes	11120.5
111	13TIBIRLLXH3FOYA	Passenger Right Lower Tibia Y-Axis Force	600	+	yes	11120.5
112	13TIBIRLLXH3FOZA	Passenger Right Lower Tibia Z-Axis Force	600	+	yes	11120.5
113	13TIBIRLLXH3MOXA	Passenger Right Lower Tibia Moment About X Axis	600	+	yes	395.4
114	13TIBIRLLXH3MOYA	Passenger Right Lower Tibia Moment About Y Axis	600	+	yes	395.4
115	13FOOTRILXH3ANXA	Passenger Right Foot X-Axis Rotation	180	+	no	318
116	13FOOTRILXH3ANYA	Passenger Right Foot Y-Axis Rotation	180	+	no	318
117	13FOOTRILXH3ANZA	Passenger Right Foot Z-Axis Rotation	180	+	no	318
118	13FOOTRILXH3ACXA	Passenger Right Foot X-Axis Acceleration	1000	+	yes	1000
119	13FOOTRILXH3ACYA	Passenger Right Foot Y-Axis Acceleration	1000	+	yes	1000
120	13FOOTRILXH3ACZA	Passenger Right Foot Z-Axis Acceleration	1000	+	yes	1000
120A	13FOOTRILXH3ACRA	Passenger Right Foot Resultant Acceleration	1000			
121	14CRME000000ACXA	Left Rear Seat Cross-Member X-Axis Acceleration	60	+	yes	1000
122	16CRME000000ACXA	Right Rear Seat Cross-Member X-Axis Acceleration	60	+	yes	1000
123	14CRME000000ACZA	Left Rear Seat Cross-Member Z-Axis Acceleration	60	+	yes	1000
124	16CRME000000ACZA	Right Rear Seat Cross-Member Z-Axis Acceleration	60	+	yes	1000
125	12ENGNT000000ACXA	Top of Engine Block X-Axis Acceleration	60	+	yes	1500
126	12ENGNB000000ACXA	Bottom of Engine Block X-Axis Acceleration	60	+	yes	1500
127	13VEHCRI000000ACXA	Right Brake Caliper X-Axis Acceleration	60	+	yes	1500
128	11VEHCLE000000ACXA	Left Brake Caliper X-Axis Acceleration	60	+	yes	1500
129	12DASH000000ACXA	Instrument Panel X-Axis Acceleration	60	+	yes	1500
130	11SETR000000ACXA	Left Side Driver Mid Seat Track X-Axis Acceleration	60	+	yes	1000
131	10VEHCCG000000ACXA	Vehicle CG X-Axis Acceleration	60	+	yes	1000
131A	10VEHCCG0000VEXA	Vehicle CG X-Axis Velocity	180			
131B	10VEHCCG0000DCXA	Vehicle CG X-Axis Displacement	180			
132	10VEHCCG0000ACYA	Vehicle CG Y-Axis Acceleration	60	+	yes	1000

Command File Test Number 070913 R70203

Channel	ISO mnemonic	Channel Title	Filter Class	Flip	Zero	Full Scale
132A	10VEHCCG0000VEYA	Vehicle CG Y-Axis Velocity	180			
132B	10VEHCCG0000DCYA	Vehicle CG Y-Axis Displacement	180			
133	10VEHCCG0000ACZA	Vehicle CG Z-Axis Acceleration	60	+	yes	1000
133A	10VEHCCG0000VEZA	Vehicle CG Z-Axis Velocity	180			
133B	10VEHCCG0000DCZA	Vehicle CG Z-Axis Displacement	180			
133C	10VEHCCG0000ACRA	Vehicle CG Resultant Acceleration	60			
134	11PEAC000000ACXA	Under Accel Pedal (Centered) X-Axis Acceleration	60	+	yes	1000
135	11PEAC000000ACYA	Under Accel Pedal (Centered) Y-Axis Acceleration	60	+	yes	1000
136	11PEAC000000ACZA	Under Accel Pedal (Centered) Z-Axis Acceleration	60	+	yes	1000
136A	11PEAC000000ACRA	Under Accel Pedal (Centered) Resultant Acceleration	60			
137	11PEBR000000ACXA	Under Brake Pedal (Centered) X-Axis Acceleration	60	+	yes	1000
138	11PEBR000000ACYA	Under Brake Pedal (Centered) Y-Axis Acceleration	60	+	yes	1000
139	11PEBR000000ACZA	Under Brake Pedal (Centered) Z-Axis Acceleration	60	+	yes	1000
139A	11PEBR000000ACRA	Under Brake Pedal (Centered) Resultant Acceleration	60			
140	11VEHC000001ACXA	Outside Footrest X-Axis Acceleration	60	+	yes	1000
141	11VEHC000001ACYA	Outside Footrest Y-Axis Acceleration	60	+	yes	1000
142	11VEHC000001ACZA	Outside Footrest Z-Axis Acceleration	60	+	yes	1000
142A	11VEHC000001ACRA	Outside Footrest Resultant Acceleration	60			
143	11SEBE0000B5FOOA	Driver Lap Belt Force	60	+	yes	13500
144	11SEBE0000B3FOOA	Driver Shoulder Belt Force	60	+	yes	13500
145	13SEBE0000B5FOOA	Passenger Lap Belt Force	60	+	yes	13500
146	13SEBE0000B3FOOA	Passenger Shoulder Belt Force	60	+	yes	13500
147	11AIRBFR0100EV0A	Driver Front Airbag 1 Inductor	1000	+	no	5
148	11AIRBFR0200EV0A	Driver Front Airbag 2 Inductor	1000	+	no	5
149	13AIRBFR0100EV0A	Passenger Front Airbag 1 Inductor	1000	+	no	5
150	13AIRBFR0200EV0A	Passenger Front Airbag 2 Inductor	1000	+	no	5
151	11CONT000001VO00	Driver Right Foot Contact Switch	0	+	no	1
152	11CONT000002VO00	Driver Left Foot Contact Switch	0	+	no	1
153	11CONT000003VO00	Driver Left Knee Contact Switch	0	+	no	1
154	11CONT000004VO00	Driver Right Knee Contact Switch	0	+	no	1
155	L0FBAR000001FOXA	Load Cell Row 1 Column 1	60	+	yes	222411
156	L0FBAR000002FOXA	Load Cell Row 2 Column 1	60	+	yes	222411
157	L0FBAR000003FOXA	Load Cell Row 3 Column 1	60	+	yes	222411
158	L0FBAR000004FOXA	Load Cell Row 4 Column 1	60	+	yes	222411
159	L0FBAR000005FOXA	Load Cell Row 5 Column 1	60	+	yes	222411
160	L0FBAR000006FOXA	Load Cell Row 6 Column 1	60	+	yes	222411
161	L0FBAR000007FOXA	Load Cell Row 7 Column 1	60	+	yes	222411

Command File Test Number 070913 R70203

Channel	ISO mnemonic	Channel Title	Filter Class	Flip	Zero	Full Scale
162	L0FBAR000008FOXA	Load Cell Row 8 Column 1	60	+	yes	222411
163	L0FBAR000009FOXA	Load Cell Row 9 Column 1	60	+	yes	222411
164	L0FBAR000010FOXA	Load Cell Row 10 Column 1	60	+	yes	222411
165	L0FBAR000011FOXA	Load Cell Row 1 Column 2	60	+	yes	222411
166	L0FBAR000012FOXA	Load Cell Row 2 Column 2	60	+	yes	222411
167	L0FBAR000013FOXA	Load Cell Row 3 Column 2	60	+	yes	222411
168	L0FBAR000014FOXA	Load Cell Row 4 Column 2	60	+	yes	222411
169	L0FBAR000015FOXA	Load Cell Row 5 Column 2	60	+	yes	222411
170	L0FBAR000016FOXA	Load Cell Row 6 Column 2	60	+	yes	222411
171	L0FBAR000017FOXA	Load Cell Row 7 Column 2	60	+	yes	222411
172	L0FBAR000018FOXA	Load Cell Row 8 Column 2	60	+	yes	222411
173	L0FBAR000019FOXA	Load Cell Row 9 Column 2	60	+	yes	222411
174	L0FBAR000020FOXA	Load Cell Row 10 Column 2	60	+	yes	222411
175	L0FBAR000021FOXA	Load Cell Row 1 Column 3	60	+	yes	222411
176	L0FBAR000022FOXA	Load Cell Row 2 Column 3	60	+	yes	222411
177	L0FBAR000023FOXA	Load Cell Row 3 Column 3	60	+	yes	222411
178	L0FBAR000024FOXA	Load Cell Row 4 Column 3	60	+	yes	222411
179	L0FBAR000025FOXA	Load Cell Row 5 Column 3	60	+	yes	222411
180	L0FBAR000026FOXA	Load Cell Row 6 Column 3	60	+	yes	222411
181	L0FBAR000027FOXA	Load Cell Row 7 Column 3	60	+	yes	222411
182	L0FBAR000028FOXA	Load Cell Row 8 Column 3	60	+	yes	222411
183	L0FBAR000029FOXA	Load Cell Row 9 Column 3	60	+	yes	222411
184	L0FBAR000030FOXA	Load Cell Row 10 Column 3	60	+	yes	222411
185	L0FBAR000031FOXA	Load Cell Row 1 Column 4	60	+	yes	222411
186	L0FBAR000032FOXA	Load Cell Row 2 Column 4	60	+	yes	222411
187	L0FBAR000033FOXA	Load Cell Row 3 Column 4	60	+	yes	222411
188	L0FBAR000034FOXA	Load Cell Row 4 Column 4	60	+	yes	222411
189	L0FBAR000035FOXA	Load Cell Row 5 Column 4	60	+	yes	222411
190	L0FBAR000036FOXA	Load Cell Row 6 Column 4	60	+	yes	222411
191	L0FBAR000037FOXA	Load Cell Row 7 Column 4	60	+	yes	222411
192	L0FBAR000038FOXA	Load Cell Row 8 Column 4	60	+	yes	222411
193	L0FBAR000039FOXA	Load Cell Row 9 Column 4	60	+	yes	222411
194	L0FBAR000040FOXA	Load Cell Row 10 Column 4	60	+	yes	222411
195	L0FBAR000041FOXA	Load Cell Row 1 Column 5	60	+	yes	222411
196	L0FBAR000042FOXA	Load Cell Row 2 Column 5	60	+	yes	222411
197	L0FBAR000043FOXA	Load Cell Row 3 Column 5	60	+	yes	222411
198	L0FBAR000044FOXA	Load Cell Row 4 Column 5	60	+	yes	222411

E-18

070913

Command File Test Number 070913 R70203

Channel	ISO mnemonic	Channel Title	Filter Class	Flip	Zero	Full Scale
199	L0FBAR000045FOXA	Load Cell Row 5 Column 5	60	+	yes	222411
200	L0FBAR000046FOXA	Load Cell Row 6 Column 5	60	+	yes	222411
201	L0FBAR000047FOXA	Load Cell Row 7 Column 5	60	+	yes	222411
202	L0FBAR000048FOXA	Load Cell Row 8 Column 5	60	+	yes	222411
203	L0FBAR000049FOXA	Load Cell Row 9 Column 5	60	+	yes	222411
204	L0FBAR000050FOXA	Load Cell Row 10 Column 5	60	+	yes	222411
205	L0FBAR000051FOXA	Load Cell Row 1 Column 6	60	+	yes	222411
206	L0FBAR000052FOXA	Load Cell Row 2 Column 6	60	+	yes	222411
207	L0FBAR000053FOXA	Load Cell Row 3 Column 6	60	+	yes	222411
208	L0FBAR000054FOXA	Load Cell Row 4 Column 6	60	+	yes	222411
209	L0FBAR000055FOXA	Load Cell Row 5 Column 6	60	+	yes	222411
210	L0FBAR000056FOXA	Load Cell Row 6 Column 6	60	+	yes	222411
211	L0FBAR000057FOXA	Load Cell Row 7 Column 6	60	+	yes	222411
212	L0FBAR000058FOXA	Load Cell Row 8 Column 6	60	+	yes	222411
213	L0FBAR000059FOXA	Load Cell Row 9 Column 6	60	+	yes	222411
214	L0FBAR000060FOXA	Load Cell Row 10 Column 6	60	+	yes	222411
215	L0FBAR000061FOXA	Load Cell Row 1 Column 7	60	+	yes	222411
216	L0FBAR000062FOXA	Load Cell Row 2 Column 7	60	+	yes	222411
217	L0FBAR000063FOXA	Load Cell Row 3 Column 7	60	+	yes	222411
218	L0FBAR000064FOXA	Load Cell Row 4 Column 7	60	+	yes	222411
219	L0FBAR000065FOXA	Load Cell Row 5 Column 7	60	+	yes	222411
220	L0FBAR000066FOXA	Load Cell Row 6 Column 7	60	+	yes	222411
221	L0FBAR000067FOXA	Load Cell Row 7 Column 7	60	+	yes	222411
222	L0FBAR000068FOXA	Load Cell Row 8 Column 7	60	+	yes	222411
223	L0FBAR000069FOXA	Load Cell Row 9 Column 7	60	+	yes	222411
224	L0FBAR000070FOXA	Load Cell Row 10 Column 7	60	+	yes	222411
225	L0FBAR000071FOXA	Load Cell Row 1 Column 8	60	+	yes	222411
226	L0FBAR000072FOXA	Load Cell Row 2 Column 8	60	+	yes	222411
227	L0FBAR000073FOXA	Load Cell Row 3 Column 8	60	+	yes	222411
228	L0FBAR000074FOXA	Load Cell Row 4 Column 8	60	+	yes	222411
229	L0FBAR000075FOXA	Load Cell Row 5 Column 8	60	+	yes	222411
230	L0FBAR000076FOXA	Load Cell Row 6 Column 8	60	+	yes	222411
231	L0FBAR000077FOXA	Load Cell Row 7 Column 8	60	+	yes	222411
232	L0FBAR000078FOXA	Load Cell Row 8 Column 8	60	+	yes	222411
233	L0FBAR000079FOXA	Load Cell Row 9 Column 8	60	+	yes	222411
234	L0FBAR000080FOXA	Load Cell Row 10 Column 8	60	+	yes	222411
235	L0FBAR000081FOXA	Load Cell Row 1 Column 9	60	+	yes	222411

Command File Test Number 070913 R70203

Channel	ISO mnemonic	Channel Title	Filter Class	Flip	Zero	Full Scale
236	L0FBAR000082FOXA	Load Cell Row 2 Column 9	60	+	yes	222411
237	L0FBAR000083FOXA	Load Cell Row 3 Column 9	60	+	yes	222411
238	L0FBAR000084FOXA	Load Cell Row 4 Column 9	60	+	yes	222411
239	L0FBAR000085FOXA	Load Cell Row 5 Column 9	60	+	yes	222411
240	L0FBAR000086FOXA	Load Cell Row 6 Column 9	60	+	yes	222411
241	L0FBAR000087FOXA	Load Cell Row 7 Column 9	60	+	yes	222411
242	L0FBAR000088FOXA	Load Cell Row 8 Column 9	60	+	yes	222411
243	L0FBAR000089FOXA	Load Cell Row 9 Column 9	60	+	yes	222411
244	L0FBAR000090FOXA	Load Cell Row 10 Column 9	60	+	yes	222411

2007FORD F-250 INTO LEFT 40% OFFSET DEFORMABLE LCB AT 56 KPH

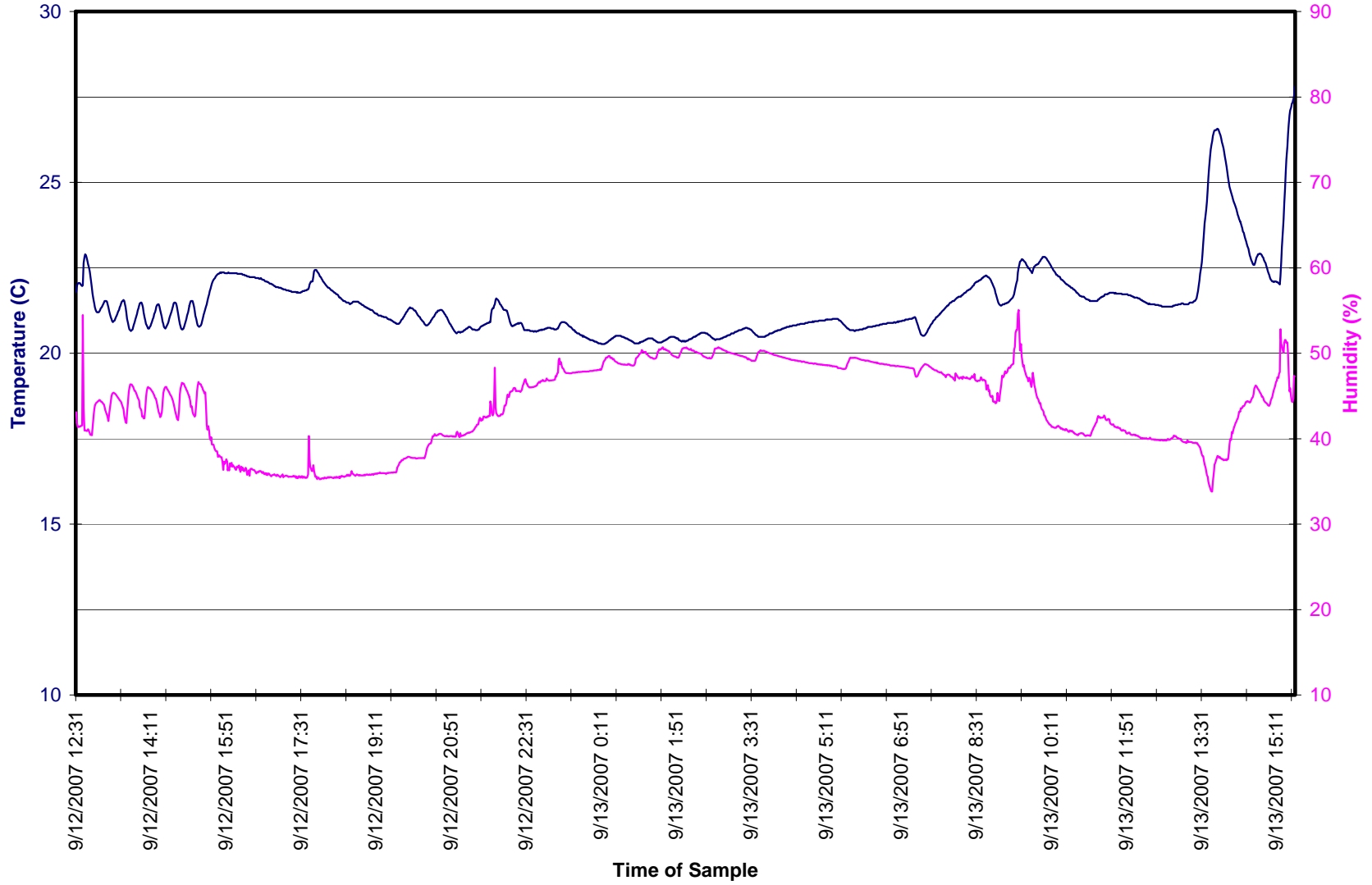

E-21

070913



OFFSET FRONTAL BARRIER CERTIFICATION

Date: June 28, 2007
To: USDOT/NHTSA
10820 STATE ROUTE 347
BLDG. 60
EAST LIBERTY, OH. 44319

PURCHASE ORDER INFORMATION

Customer P.O. Number: CREDIT_CARD
Work Order Number: 180312
Plascore Part Number: 20670
Quantity: 01 piece

CORE INFORMATION

Block Number: 143B0307
002A0507
Unit Number: B060720

This is to certify that the aluminum honeycomb core supplied, under the unit number provided, meets the crush requirements of 223-248 psi per DWG# WG11 & 44.63-49.59 psi per DWG # WG11.

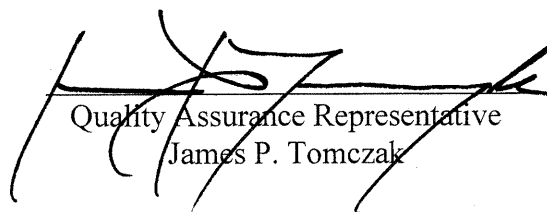

Quality Assurance Representative
James P. Tomczak



BLOCK # 143B0407 Sample ID: IN242168

E-23

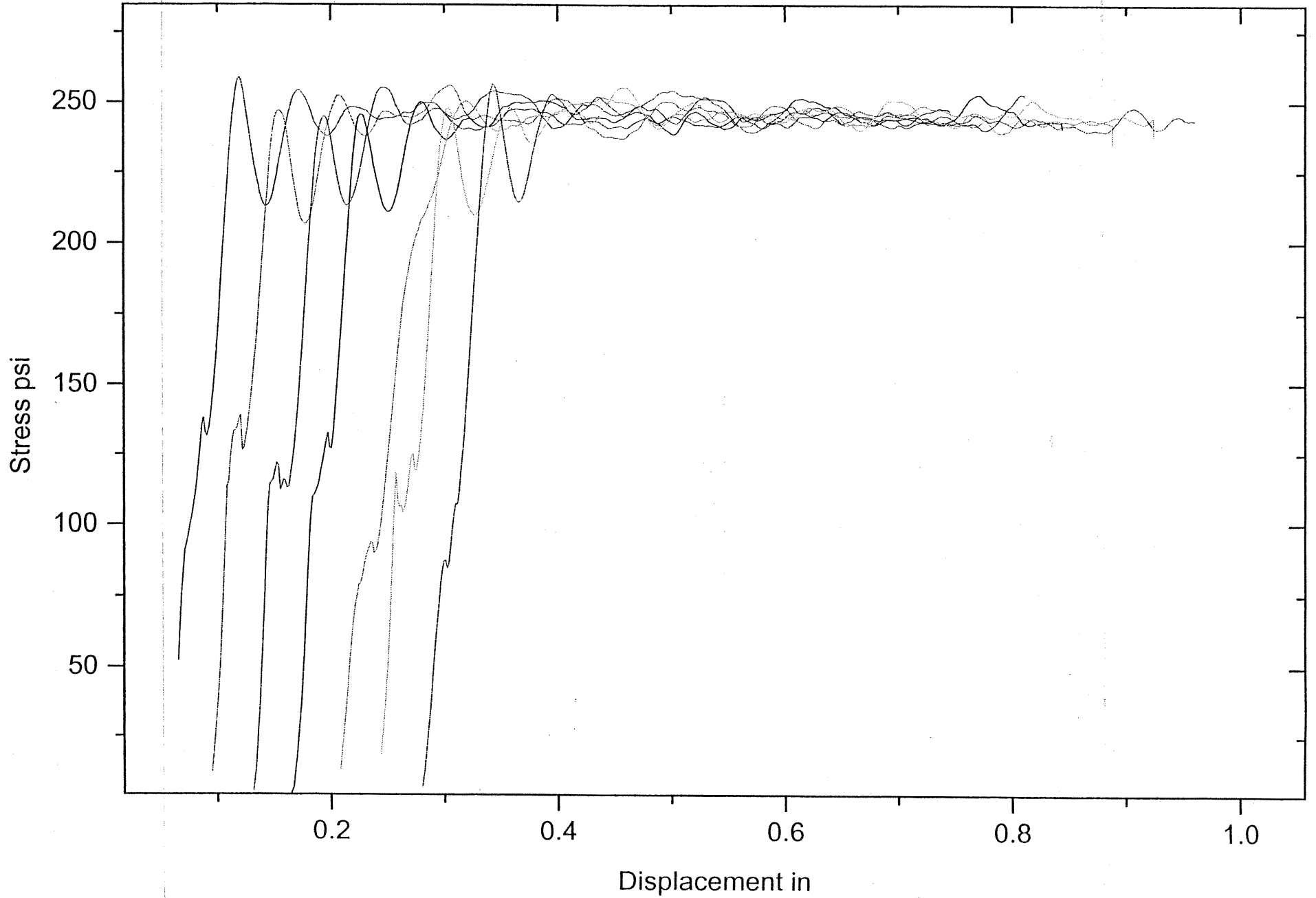
070913



BLOCK # 002A0507 Sample ID: IN242671

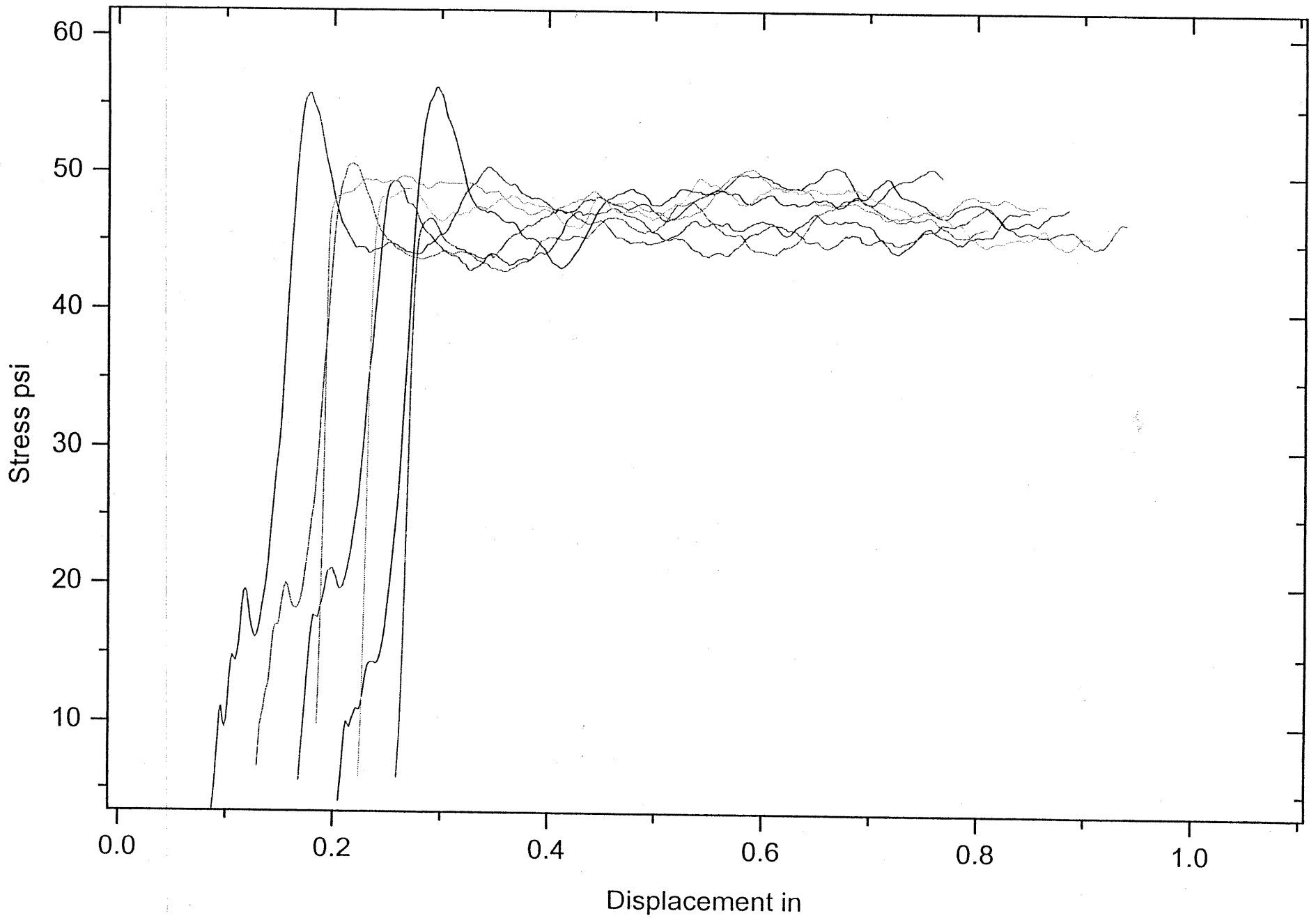

E-24

070913

Crush Data
223-248 psi per DWG # DSL-WG11

Block Number: 143B0307

<u>Specimen Number</u>	<u>Zone 1</u>	<u>Zone 2</u>	<u>Zone 3</u>
1	243.73	242.87	244.20
2	243.42	246.52	243.53
3	245.87	246.73	243.43
4	243.75	246.23	246.33
5	245.60	246.47	244.40
6	245.80	245.32	246.50
7	244.89	243.99	242.95

Crush Data
44.64 – 49.6 psi per DWG # DSL-WG11

Block Number: 002A0507

<u>Specimen Number</u>	<u>Zone 1</u>	<u>Zone 2</u>	<u>Zone 3</u>
1	48.36	48.28	49.34
2	45.45	45.84	47.37
3	46.52	46.34	45.48
4	48.38	48.27	47.06
5	47.67	48.79	47.41
6	48.12	48.49	45.99
7	45.15	45.37	46.36

Appendix F

INSIA Report on Structural Measurements

STRUCTURAL SURVEY OF CARS. MEASUREMENT METHODOLOGY OF THE MAIN RESISTANT ELEMENTS IN THE CAR BODY

**APARICIO IZQUIERDO, FRANCISCO
PÁEZ AYUSO, FRANCISCO JAVIER**

**INSIA
Carretera de Valencia, km. 7
Campus Sur de la Universidad Politécnica de Madrid
28031 – MADRID – (SPAIN)**

March, 1999

REPORT DOCUMENTATION PAGE**Title:**

STRUCTURAL SURVEY OF CARS. MEASUREMENT METHODOLOGY OF THE MAIN RESISTANT ELEMENTS IN THE CAR BODY

Author(s):

Aparicio Izquierdo, Francisco
Páez Ayuso, Francisco Javier

Performing Organisation name and address:

INSIA – University Institute for Automobile Research
Carretera de Valencia, Km. 7 – Campus Sur de la Universidad Politécnica de Madrid
28031 – Madrid – Spain

Supplementary notes:

Under contract to:

THE EUROPEAN COMMUNITY

Project: “Improvement of Crash Compatibility between Cars”
Contract N°: RO – 97 – SC.1064

Abstract:

The main aim of this working package -*Structural Survey of Cars*- is the reduction of incompatibilities, both structural and geometric, between passenger vehicles and their potential collision partners. The understanding of these incompatibilities needs a previous step for the knowledge of the existing car fleet.

Firstly, it is necessary to select the main resistant elements in the car body. These elements have to be chosen from the point of view of the sort of collision that we want to study, that is to say, frontal and side impacts.

Detailed measurements have been taken from exterior and interior elements, spread to a total number of 74 models selected from the main vehicle manufacturers at Spain. All of them are being sold this year. Using the information available from the previous measurements in vehicles, the geometric characteristics of the main resistant elements involved in the geometric compatibility between cars will be defined.

This report shows the methodology followed to get these measurements.

Subject terms:

Crash compatibility, geometric compatibility, resistant elements, measure methodology

Date:

March, 1999

1.- METHODOLOGY.

Detailed measurements have been taken from exterior and interior elements. Using the information available from the previous measurements in vehicles, the geometric characteristics of the main resistant elements involved in the geometric compatibility between cars have been defined. These elements are presented in the following figures, and have been divided in two main groups according to the vehicle zones studied in this project.

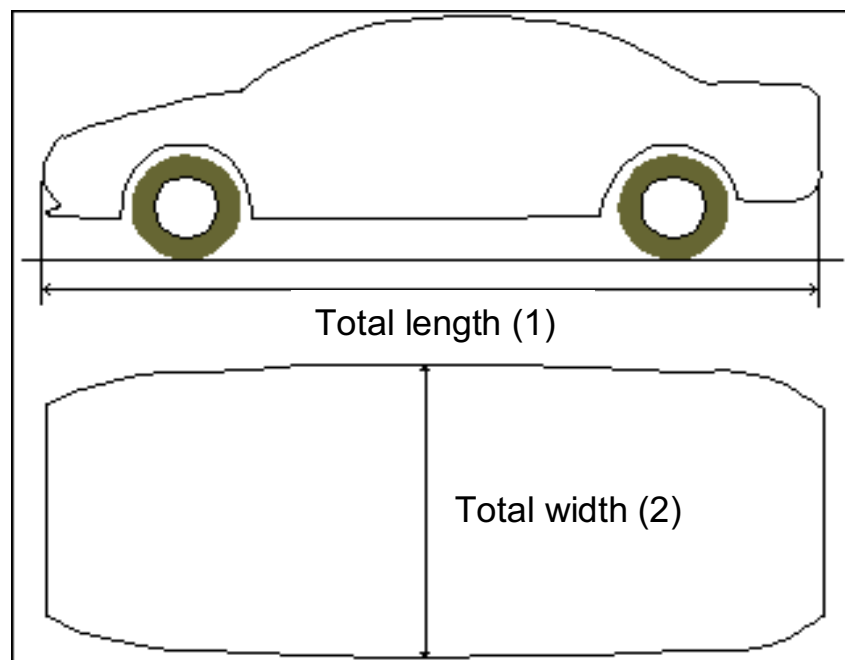

Figure 1.- Definition of the main resistant elements. General dimensions.

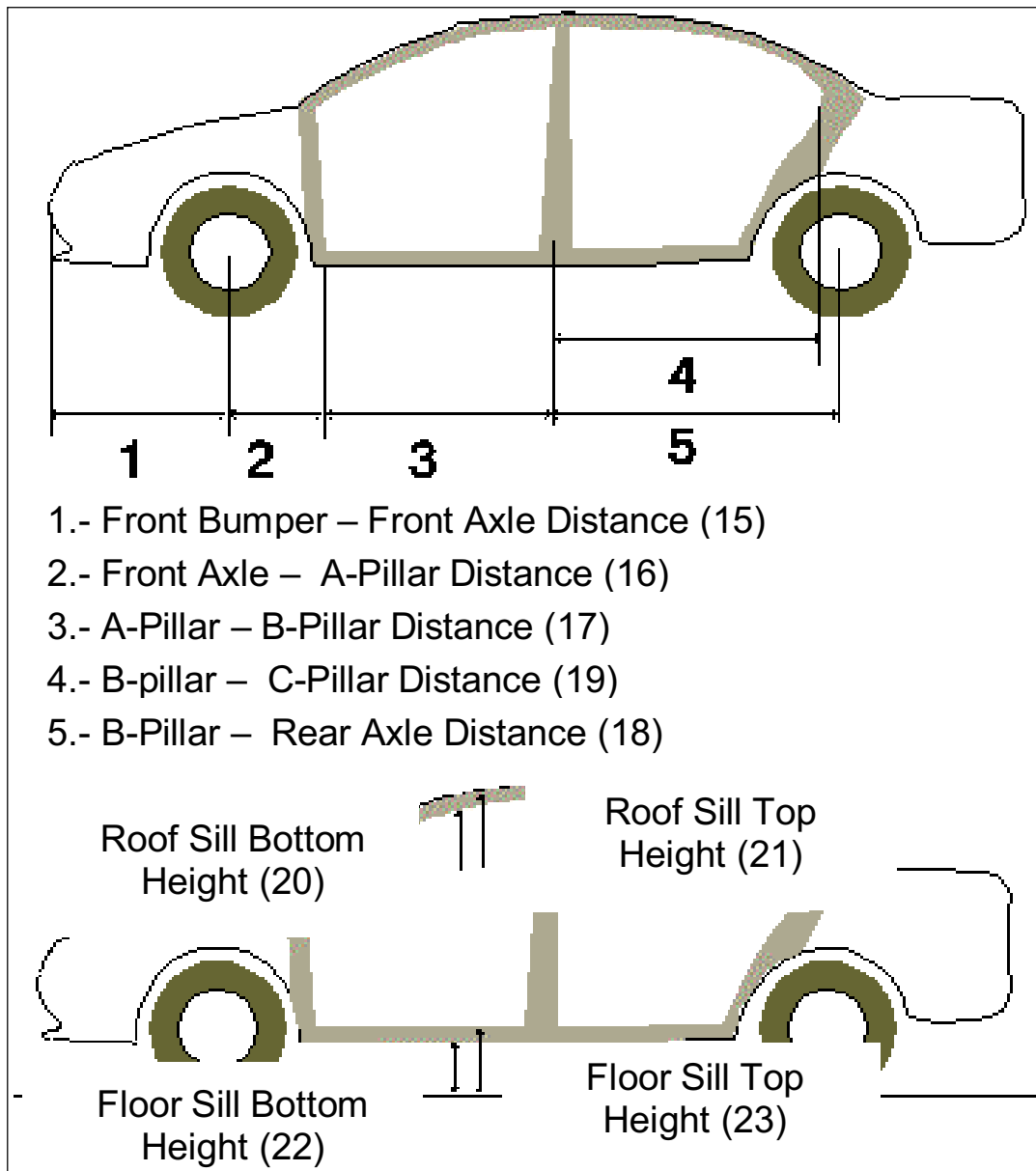

Figure 2.- Definition of the main resistant elements. Side elements.

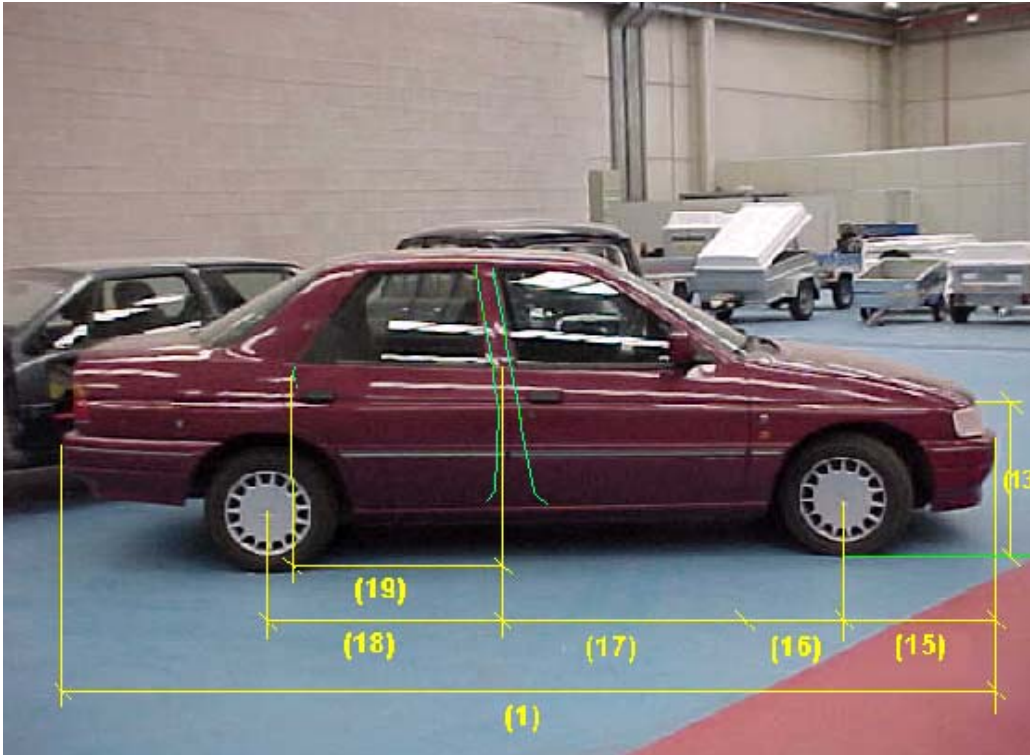
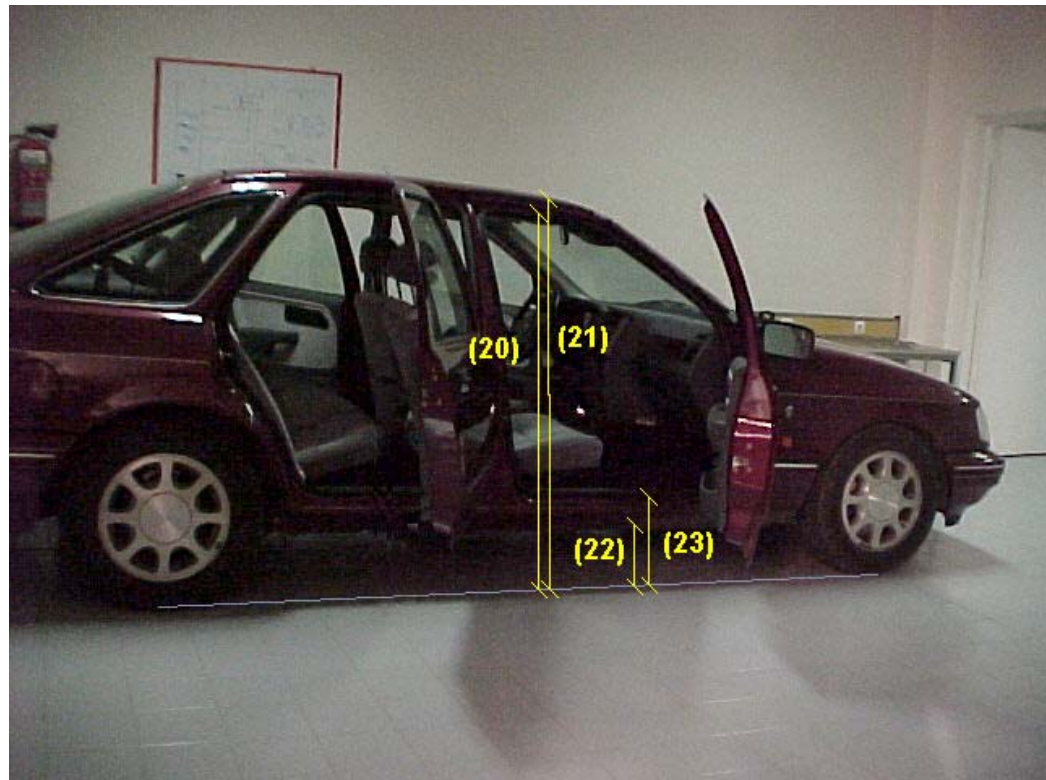

Figure 3.-
Measurements of
the side resistant
elements (outer).

Figure 4.- Measurements
of the side resistant
elements (inner).



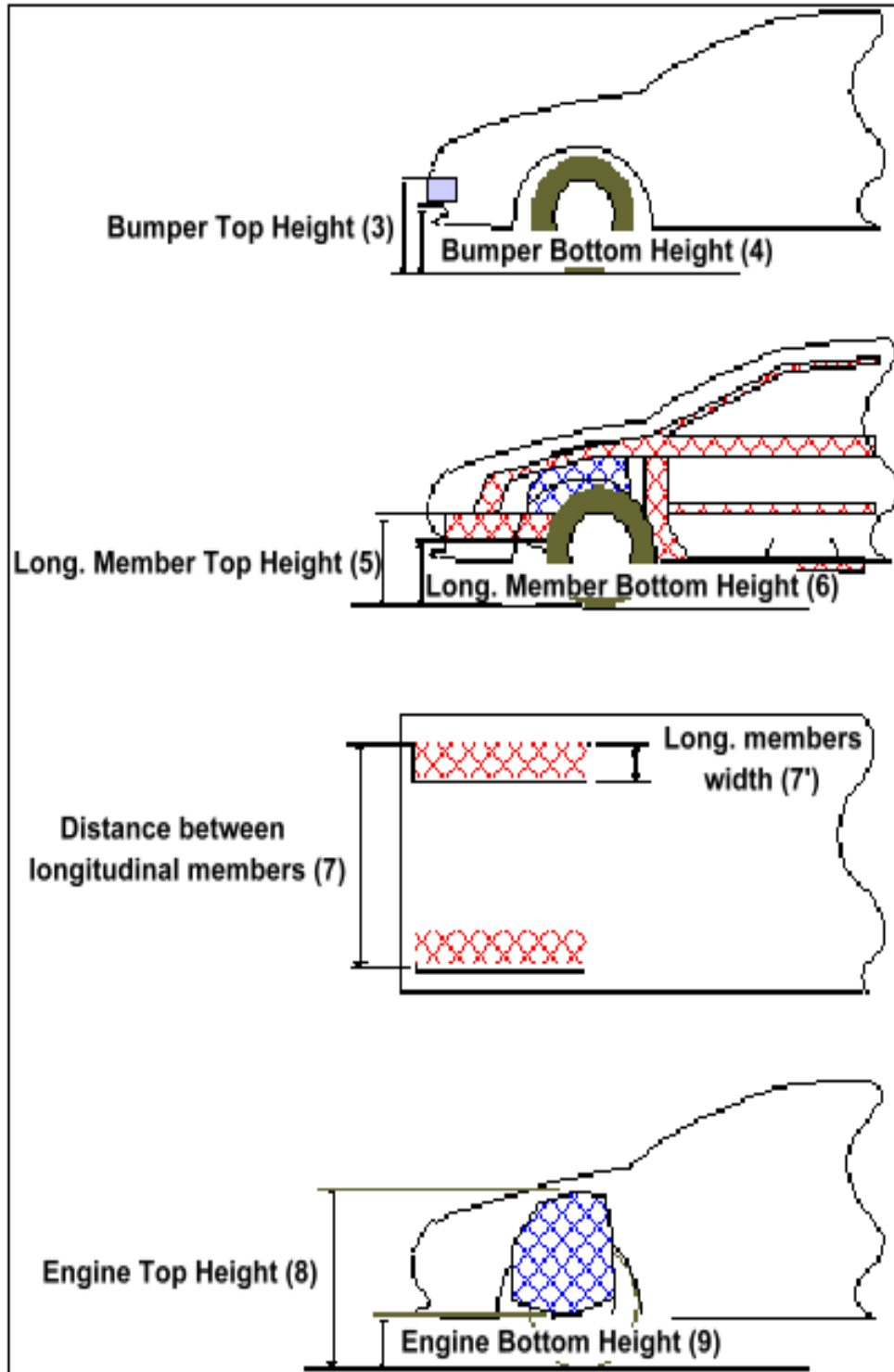

Figure 5.- Definition of the main resistant elements. Front elements.

Figure 6.-
Measurements of the
main resistant elements.
Front elements 1.

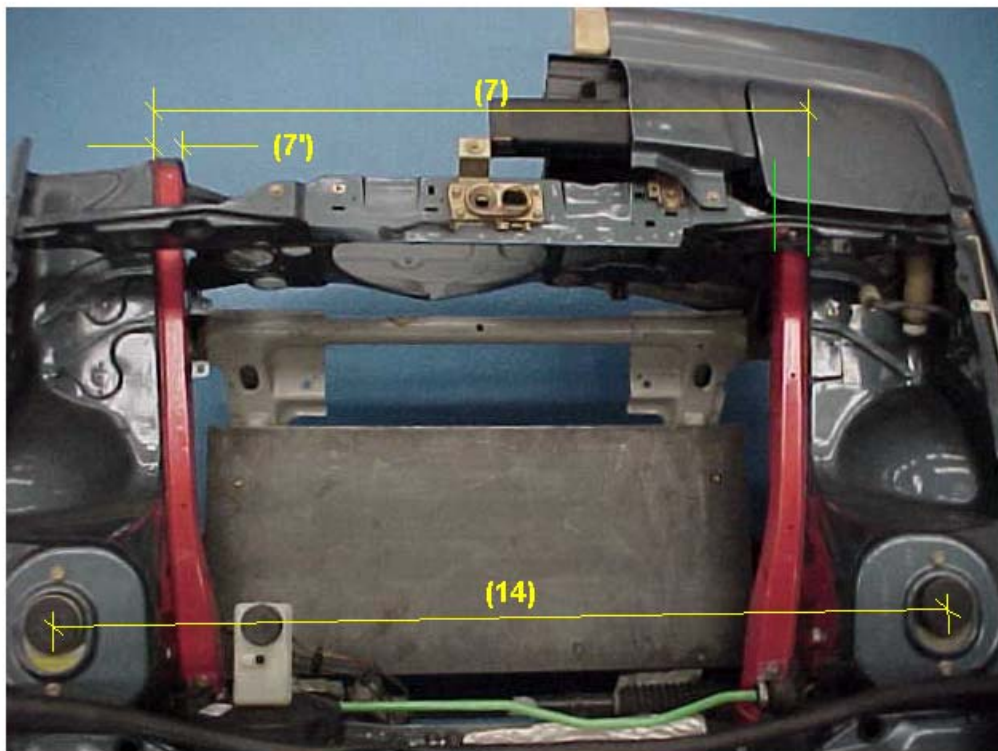
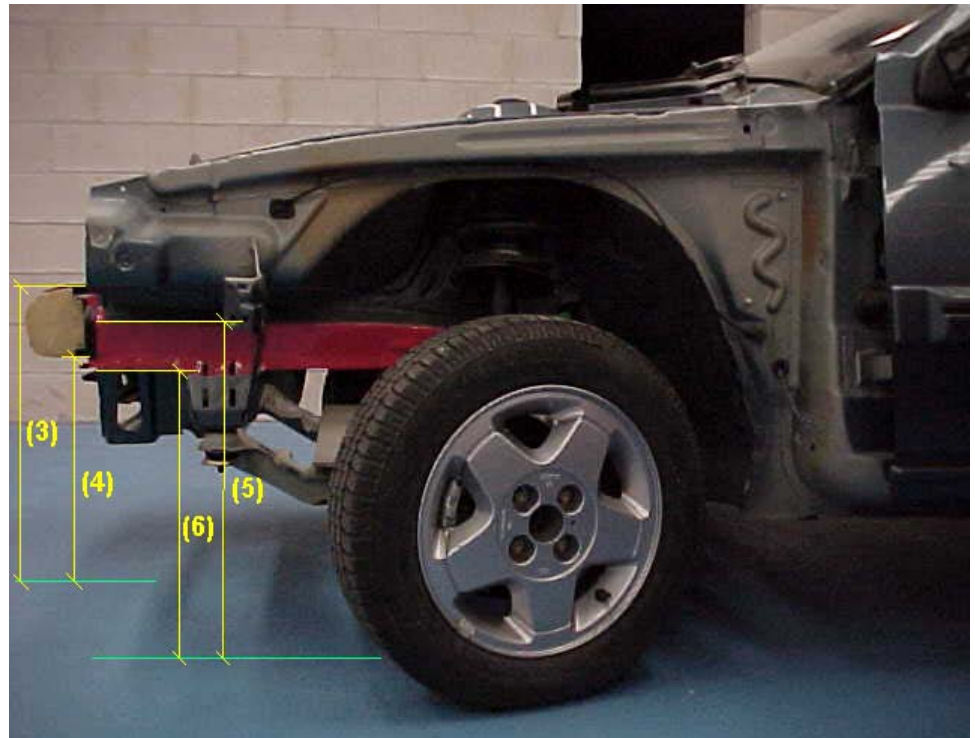

Figure 7.-
Measurements
of the main
resistant
elements. Front
elements 2.

Figure 8.-
Measurements of
the main resistant
elements. Front
elements 3.

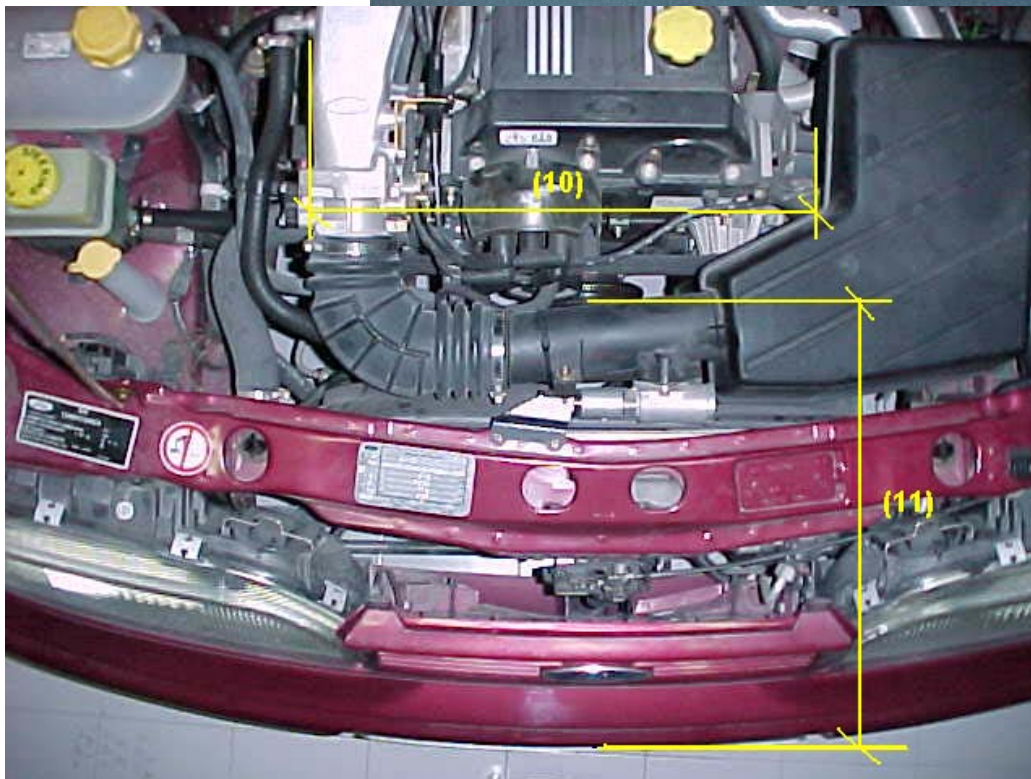
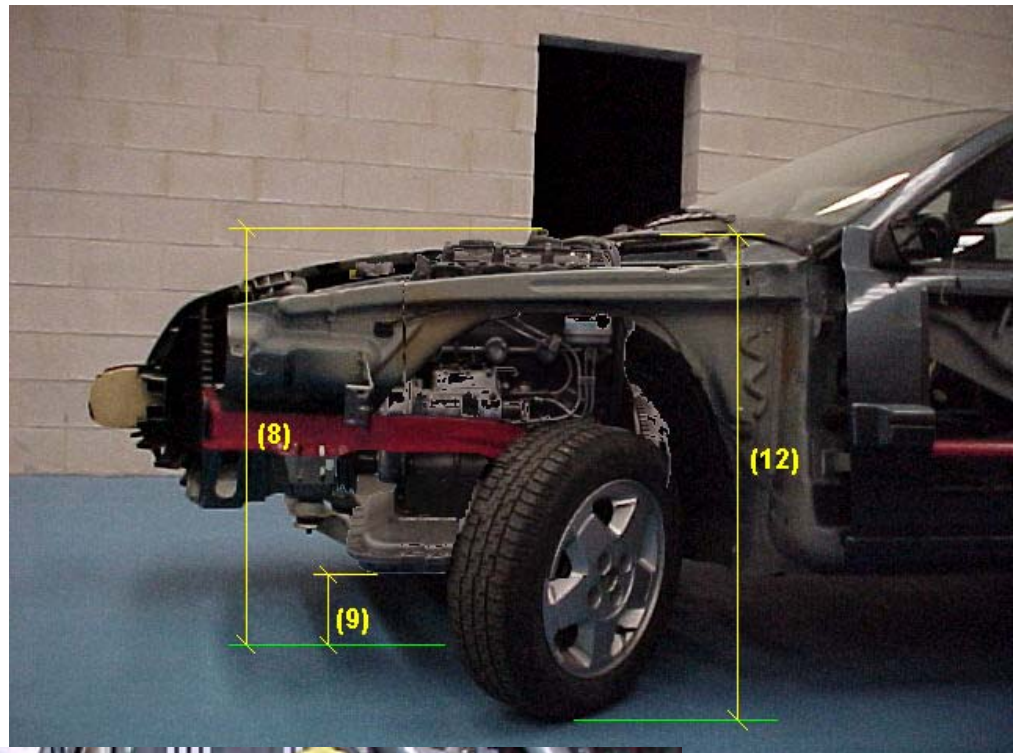

Figure 9.-
Definition of
the main
resistant
elements. Front
elements
(Longitudinal
engine).

The procedure considered to measure these elements is described as follows, where it is indicated the location of these ones in the Excel Sheet (SURVEY.XLS) into brackets:

FRONT ELEMENTS

- **Total Length –(1)- (Side & Front Sheets - C column):** distance between the point in the front bumper further on and the point in the rear bumper further back.
- **Weight (Side & Front Sheets - D column):** mass, including an average driver weight (70 kg), and the fuel tank mass (at half-capacity).
- **Total Width –(2)- (Side & Front Sheets - E column):** distance between the outer side points in a transverse plane of the vehicle (middle plane between the front and rear axles).
- **Bumper bottom height –(4)- (Front Sheet G column):** distance between the ground and the lowest point on the front bumper, being a resistant member (aerodynamic elements under the front bumper are not considered).
- **Bumper top height –(3)- (Front Sheet H column):** distance between the ground and the highest point on the front bumper, being a resistant member (aerodynamic elements are not considered).
- **Longitudinal member top height –(5)- (Front Sheet I column):** distance between the ground and the highest point on the longitudinal members, measured approximately in the front bumper-longitudinal member joint (when accessible).
- **Longitudinal member bottom height –(6)- (Front Sheet J column):** distance between the ground and the lowest point on the longitudinal members, measured approximately in the front bumper-longitudinal member joint.
- **Distance between longitudinal members (Front Sheet K column):** transverse distance between extreme points in longitudinal members, measured approximately in the front bumper-longitudinal member joint.

Depending on the accessibility of these members, the extreme points are the inner points (I) or the outer points (O).

- **Longitudinal member width -7'- (Front Sheet L column):** width of one of the longitudinal members, measured approximately in the front bumper-longitudinal member joint.

-
- **Engine top height (8) (Front Sheet N column):** distance between the ground and the highest point on the engine that can be a resistant member in case of accident (usually, the highest point on the head, or the highest point of the inlet or exhaust manifolds).
 - **Engine bottom height (9) (Front Sheet M column):** distance between the ground and the lowest point on the engine (usually, the lowest point on the crankcase).
 - **Engine and Gearbox width (10) (Front Sheet O & P columns):**
 - *Transverse configuration engine:* distance between extreme points in the gearbox-cylinder block unit or others resistant members attached to the cylinder block unit, i.e. fan belts (from a front point of view).
 - *Longitudinal configuration engine:* distance between extreme points in the cylinder block unit (from a front point of view).
 - **Front bumper - Engine distance (11) (Front Sheet Q column):** distance between the point in the front bumper further on and the point in the engine further on that is a resistant element, i.e. the further on point of the exhaust manifold placed in the front of the engine.
 - **Front shock absorber fixing width (14) (Front Sheet R column):** transverse distance between the front shock absorber - body car joints.
 - **Front shock absorber fixing height (12) (Front Sheet S column):** distance between the ground and the front shock absorber-body car joint.
 - **Bonnet leading edge height (Front Sheet T column):** distance between the ground and the bonnet edge further on.

SIDE ELEMENTS

- **Front bumper - Front axle distance (15) (Side Sheet G column):** distance between the point in the front bumper further on and the middle point in the front tyre-road contact patch.
- **Front axle - A Pillar distance (16) (Side Sheet H column):** distance between the middle point in the front tyre-road contact patch and the point in the A-pillar further back.
- **A Pillar - B Pillar distance (17) (Side Sheet I column):** distance between the point in the A-pillar further back and the middle point in the B-pillar.
- **B Pillar - C Pillar distance (19) (Side Sheet J column):** distance between the middle point in the B-pillar and the point in the C-pillar further back (only 4/5-door vehicles).
- **B Pillar - Rear axle distance (18) (Side Sheet K column):** distance between the middle point in the B-pillar and the middle point in the rear tyre-road contact patch.
- **Roof sill bottom height (20) (Side Sheet L column):** distance between the ground and the lowest point on the roof sill, measured in the front door middle point.
- **Roof sill top height (21) (Side Sheet M column):** distance between the ground and the highest point on the roof sill (usually located in the sill-roof joint), measured in the front door middle point.
- **Floor sill bottom height (22) (Side Sheet N column):** distance between the ground and the lowest point on the floor sill, measured in the front door middle point.
- **Floor sill top height (23) (Side Sheet O column):** distance between the ground and the highest point on the floor sill, measured in the front door middle point.

NOTE

- N/A: dimension not available.