

REPORT NUMBER TR-P27148-01-NC

**NEW CAR ASSESSMENT PROGRAM
SIDE IMPACT TEST**

**FORD MOTOR COMPANY
2007 FORD EXPLORER XLT
5-DOOR MPV**

NHTSA NUMBER: F80200

**Prepared By:
KARCO ENGINEERING, LLC
9270 HOLLY ROAD
ADELANTO, CALIFORNIA 92301**



JUNE 8, 2007

FINAL REPORT

**PREPARED FOR:
U.S. DEPARTMENT OF TRANSPORTATION
NATIONAL HIGHWAY TRAFFIC SAFETY ADMINISTRATION
OFFICE OF CRASHWORTHINESS STANDARDS
RULEMAKING
MAIL CODE: NVS-111
1200 NEW JERSEY AVE SE, ROOM W43-410
WASHINGTON, D.C. 20590**

This final test report was prepared for the U.S. Department of Transportation, National Highway Traffic Safety Administration, in response to Contract Number DTNH22-03-D-32005.

This publication is distributed by the U.S. Department of Transportation, National Highway Traffic Safety Administration, in the interest of information exchange. The opinions, findings and conclusions expressed in this publication are those of the author(s) and not necessarily those of the Department of Transportation or the National Highway Traffic Safety Administration. The United States Government assumes no liability for its contents or use thereof. If trade or manufacturers' names or products are mentioned it is only because they are considered essential to the object of the publication and should not be construed as an endorsement. The United States Government does not endorse products or manufacturers.

Prepared by:  _____ Date: June 8, 2007
Mr. Johnny H. Dutto Project Engineer
KARCO Engineering, LLC

Reviewed by:  _____ Date: June 8, 2007
Mr. Michael L. Dunlap, Director of Operations
KARCO Engineering, LLC

Approved by:  _____ Date: June 8, 2007
Mr. Frank D. Richardson, Program Manager
KARCO Engineering, LLC

FINAL REPORT ACCEPTED BY:

Manager, Side Impact NCAP

Date of Acceptance

Technical Report Documentation Page

1. Report No. TR-P27148-01-NC	2. Government Accession No.	3. Recipients Catalog No.																			
4. Title and Subtitle Final Report of Side Impact New Car Assessment Program Testing of a 2007 Ford Explorer XLT 5-Door MPV NHTSA No.F80200		5. Report Date June 8, 2007																			
		6. Performing Organization Code KAR																			
7. Authors Mr. Johnny H. Dutto, Project Engineer, Karco Mr. Frank Richardson, Program Manager, Karco		8. Performing Organization Report No. TR-P27148-01-NC																			
		10. Work Unit No.																			
9. Performing Organization Name and Address Karco Engineering, LLC 9270 Holly Rd. Adelanto, CA, 92301		11. Contract or Grant No. DTNH22-03-D-32005																			
		13. Type of Report and Period Covered Final Test Report																			
12. Sponsoring Agency Name and Address U. S. Department of Transportation National Highway Traffic Safety Administration Rulemaking Office of Crashworthiness Standards Mail Code NVS-111 1200 New Jersey Ave., SE, Room W43-410 Washington, D.C 20590		14. Sponsoring Agency Code DOT/NHTSA/NRM/OCS																			
		15. Supplementary Notes																			
16. Abstract <p>A 55/28 km/h 90 deg. Moving Deformable Barrier Side Impact NCAP Test was conducted on the subject 2007 Ford Explorer XLT 5-Door MPV in accordance with the specifications of the Office of Crash Worthiness Standards Test Procedures for the generation of consumer information on vehicle side crash protection. The test was conducted at KARCO Engineering, LLC in Adelanto, CA, on June 8, 2007. The impact velocity of the Moving Deformable Barrier was 61.95 km/h and the outside ambient temperature at the struck (driver's) side of the vehicle was 26.1 deg. C. The target vehicle's maximum post-test static crush was 256 mm located at level 3. The test vehicle's occupant performance data is as follows:</p> <table border="1" style="width: 100%; border-collapse: collapse; margin-top: 10px;"> <thead> <tr> <th style="width: 60%;">Measurement Description</th> <th style="width: 20%;">Driver SID/HIII</th> <th style="width: 20%;">Pass. SID/HIII</th> </tr> </thead> <tbody> <tr> <td>Left Upper Rib (LUR) G's</td> <td style="text-align: center;">29.4</td> <td style="text-align: center;">27.6</td> </tr> <tr> <td>Left Lower Rib (LLR) G's</td> <td style="text-align: center;">28.7</td> <td style="text-align: center;">23.8</td> </tr> <tr> <td>Lower Spine (T₁₂) G's</td> <td style="text-align: center;">34.1</td> <td style="text-align: center;">26.6</td> </tr> <tr> <td>Thoracic Trauma Index (TTI) G's</td> <td style="text-align: center;">32.0</td> <td style="text-align: center;">27.0</td> </tr> <tr> <td>Pelvis (PEV) G's</td> <td style="text-align: center;">64.0</td> <td style="text-align: center;">38.0</td> </tr> </tbody> </table>				Measurement Description	Driver SID/HIII	Pass. SID/HIII	Left Upper Rib (LUR) G's	29.4	27.6	Left Lower Rib (LLR) G's	28.7	23.8	Lower Spine (T ₁₂) G's	34.1	26.6	Thoracic Trauma Index (TTI) G's	32.0	27.0	Pelvis (PEV) G's	64.0	38.0
Measurement Description	Driver SID/HIII	Pass. SID/HIII																			
Left Upper Rib (LUR) G's	29.4	27.6																			
Left Lower Rib (LLR) G's	28.7	23.8																			
Lower Spine (T ₁₂) G's	34.1	26.6																			
Thoracic Trauma Index (TTI) G's	32.0	27.0																			
Pelvis (PEV) G's	64.0	38.0																			
17. Key Words New Car Assessment Program (NCAP) Side Impact Moving Deformable Barrier (MDB) Side Impact Dummy (SID/HIII)		18. Distribution Statement Copies of this report are available from: National Highway Traffic Safety Admin. NHTSA Technical Reference Division 1200 New Jersey Ave., SE, Room W43-410 Washington, DC 20590																			
		19. Security Classification of this report UNCLASSIFIED	20. Security Classification of this page UNCLASSIFIED	21. No. of Pages 179	22. Price																

TABLE OF CONTENTS

Section		Page
1	Purpose and Test Procedure	1
2	Summary of Side Impact Test	2
3	Occupant and Vehicle Information Sheets	4

Data Sheet No.		Page
1	General Test and Vehicle Parameter Data	5
2	Test Vehicle Summary of Results	10
3	Moving Deformable Barrier (MDB) Summary of Results	11
4	Post-Test Observations	12
5	Vehicle Pre-Test and Post-Test Measurements	13
6	SID/HIII Longitudinal Clearance Dimensions	14
7	SID/HIII Lateral Clearance Dimensions	15
8	Vehicle Side Measurements	16
9	Vehicle Exterior Crush Profiles	17
10	Vehicle Damage Profile Distances	19
11	Deformable Barrier Honeycomb Face Static Crush	20
12	Vehicle Accelerometer Locations	21
13	MDB Accelerometer Locations	23
14	High Speed Camera Locations and Data	24
15	FMVSS 301 Fuel System Integrity Post-Impact Data	25
16	FMVSS 301 Static Rollover Data Sheet	26
17	Dummy / Vehicle Temperature Stabilization	27

Appendix		
A	Photographs	A
B	SID/HIII, Vehicle and MDB Response Data	B
C	SID/HIII Configuration and Performance Verification Data	C
D	Child Restraint System	D

SECTION 1

PURPOSE AND TEST PROCEDURE

1.1 PURPOSE

This Side Impact NCAP test is conducted as part of the FY' 2007 test program sponsored by the National Highway Traffic Safety Administration (NHTSA), under contract No. DTNH22-03-D-32005. The purpose of this test is to generate comparative side impact data on a 2007 Ford Explorer XLT 5-Door MPV manufactured by Ford Motor Company.

1.2 TEST PROCEDURE

The side impact test was conducted in accordance with the current National Highway Traffic Safety Administration (NHTSA), Office of Crashworthiness Standards (OCS), laboratory test procedure NCAP Side Impact Testing, dated November 2002. The procedures for receiving, inspection, testing, and reporting of test results are described in the test procedures and are not repeated in this report.

SECTION 2
SUMMARY OF SIDE IMPACT TEST

2.1 SUMMARY OF SIDE IMPACT NCAP TEST

A model year 2007 Ford Explorer XLT 5-Door MPV was impacted on the left (driver's) side by a Moving Deformable Barrier (MDB) which was moving forward in a 27° crabbed position to the tow road guidance system at a velocity of 61.95 km/h. The specified impact velocity range is from 61.14 to 62.75 km/h. The test (target) vehicle was stationary and positioned 63° to the line of forward motion. The weight of the vehicle as tested was 2382 kg and the test weight of the MDB was 1361 kg. The test was conducted at KARCO Engineering, LLC in Adelanto, California, on June 8, 2007.

Two (2) real-time cameras and ten (10) high-speed video cameras were used to document the impact event. Camera locations and pertinent camera information is documented in the data sheets. Pre- and post-test photographs of the vehicle and SID/HIIIs can be found in Appendix A. Two 50th percentile adult male Side Impact Dummies, Hybrid III (SID/HIIIs) were placed in the driver's and left rear passenger designated seating positions according to the test procedure. Each SID/HIII is instrumented with contact switches on the pelvis, thorax and six-axis neck load cells, and fourteen accelerometers in the following locations:

- Left Upper Rib (LUR) uni-axial accelerometer (Y-axis primary and redundant)
- Left Lower Rib (LLR) uni-axial accelerometer (Y-axis primary and redundant)
- Lower Thoracic Spine (T12) uni-axial accelerometer (Y-axis primary and redundant)
- Pelvic (PEV) section uni-axial accelerometer (Y-axis primary and redundant)
- Head Center of Gravity (CG) tri-axial accelerometers (X, Y, and Z axes primary and redundant)

SUPPLEMENTAL RESTRAINT INFORMATION

Restraint Type	Left Front Driver		Left Rear (Passenger)	
	Installed	Deployed	Installed	Deployed
Front Airbag	Yes	No	No	
Side Torso Airbag	Yes	Yes	No	
Head Airbag	No		No	
Curtain Airbag	Yes	Yes	Yes	Yes

SECTION 2...(CONTINUED)

The test vehicle was instrumented with twenty-one (21) structural accelerometers and the MDB was instrumented with five (5) accelerometers and one (1) contact switch on the right bumper to compare left side to right side bumper impact timing. All data channels were recorded with the fully self contained on-board Data Acquisition System (DAS). The data was digitally sampled at 10,000 samples per second and processed per Appendix V of the Test Procedure.

2.2 GENERAL COMMENTS

The driver and passenger doors remained closed during impact. The test vehicle sustained a maximum static crush of 256 mm at level 3, 1650 mm rearward of the left vertical impact point. The driver SID/Hybrid III, Serial No. 274 and the passenger SID/Hybrid III, Serial No. 275 were calibrated prior to this test. The SID/Hybrid III injury criteria is summarized as follows:

Measurement	Units	Driver	Passenger
Thoracic Trauma Index (TTI)	G's	32	64
Peak Pelvic G's (PEV)	G's	27	38

Tests summaries and post-test observations are presented in Section 3. Appendix A contains the still photograph prints. Appendix B contains the driver and passenger SID/HIIIs, vehicle, and MDB response data traces. Appendix C contains the SID Configuration and performance verification data. Appendix contains the Child Restraint System data.

SECTION 3

OCCUPANT AND VEHICLE INFORMATION SHEETS

Test Vehicle: 2007 Ford Explorer XLT 5-Door MPV

NHTSA No.: F80200

Test Program: 55/28 km/h Side Impact NCAP

Test Date: 6/8/07

CONVERSION FACTORS USED IN THIS REPORT*

Quantity	Typical Application	Std Units	Metric Unit	Multiply By
Mass	Vehicle Weight	lb	kg	0.4536
Linear Velocity	Impact Velocity	mile/h	km/h	1.609
Length or Distance	Measurements	in	mm	25.4
Volume	Fuel Systems	gal	liter	3.785
Volume	Small Fluids	oz	mL	29.573
Pressure	Tire Pressures	lbf/in ²	kPa	7.0
Volume	Liquid	gal	liter	3.785
Temperature	General Use	°F	°C	$=(tf - 32)/1.8$
Force	Dynamic Forces	lbf	N	4.448
Moment	Torque	lbf/ft	Nm	1.355

* Based on the Recommended Practice in SAE J916, May 85

DATA SHEET NO. 1

GENERAL TEST AND VEHICLE PARAMETER DATA

Test Vehicle: 2007 Ford Explorer XLT 5-Door MPV NHTSA No.: F80200
 Test Program: 55/28 km/h Side Impact NCAP Test Date: 6/8/07

TEST VEHICLE INFORMATION AND OPTIONS

NHTSA No.	F80200	Anti-Lock Brakes	Yes
Make	Ford	All Wheel Drive	Yes
Model	Explorer XLT	Power Steering	Yes
Body Style	5-Door MPV	Driver Front Airbag	Yes
Vin No.	1FMEU73E47UA98118	Driver Side Torso Airbag	Yes
Color	White	Driver Side Head Airbag	No
Delivery Date	6/4/2007	Driver Curtain/Airbag	Yes
Odometer (Miles)	52.0	Rear Pass. Airbag	No
Dealer	Sunland Ford	Rear Pass. Side Airbag	No
Transmission	5-Speed Automatic	Rear Pass. Head Airbag	No
Final Drive	4wd	Rear Pass. Curtain/Airbag	Yes
Type/No. Cyl.	V-6	Pre-Tensioners	Yes
Engine Disp. (L)	4.0	Load Limiters	Yes
Engine Placement	Longitudinal	Bucket Seats	Yes
Roof Rack	Yes	Air Cond.	Yes
Sunroof/T-Top	No	AM/FM CD	Yes
Tinted Glass	Yes	Tilt Steering	Yes
Traction Control	Yes	Automatic Door Locks	Yes
Power Brakes	Yes	Power Windows	Yes
Front Disc	Yes	Power Seats	No
Rear Disc	Yes	Other	None

Does Owners Manual provide instructions to turn off automatic door locks.

Yes

DATA FROM CERTIFICATION LABEL

Manufactured By	Ford Motor Company	GVWR (kg)	2803
Date of Manufacture	Jan-07	GAWR Front (kg)	1343
		GAWR Rear (kg)	1542

VEHICLE SEATING AND CAPACITY WEIGHT INFORMATION

Measured Parameter	Front	Rear	Third	Total
Type of Seats	Bucket	Bench		
Number of Occupants	2	3		5
Capacity Weight (VCW) (kg)				667
Cargo Weight (RCLW) (kg)				136

DATA SHEET NO. 1...(CONTINUED)

GENERAL TEST AND VEHICLE PARAMETER DATA

Test Vehicle: 2007 Ford Explorer XLT 5-Door MPV

NHTSA No.: F80200

Test Program: 55/28 km/h Side Impact NCAP

Test Date: 6/8/07

Collect year, make, model, VIN, items circled in red, and tire manufacturer and tire name.

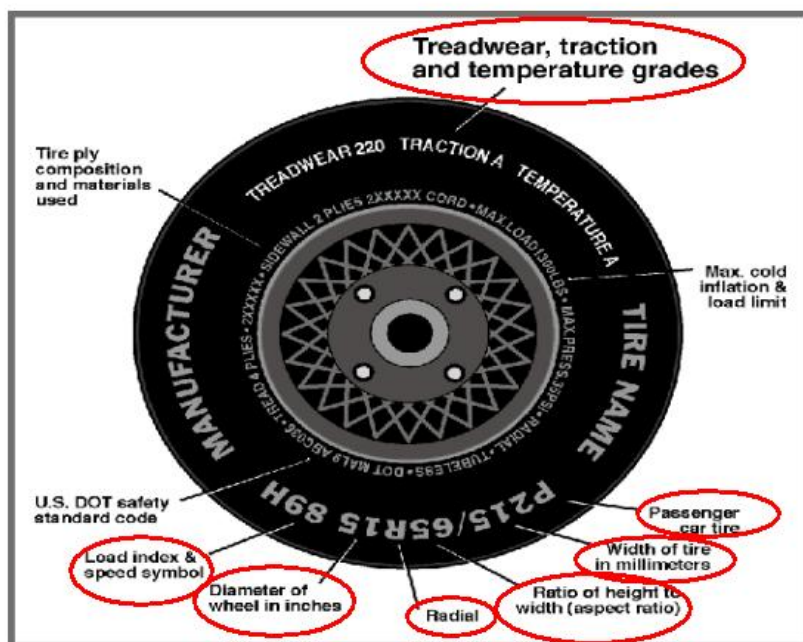

TIRE INFORMATION

Measured Parameter	Front	Rear
Max. Tire Pressure (kpa)	308	308
Cold Pressure (kpa)	240	240
Recommended Tire Size	P235/70R16	P235/70R16
Tire Size on Vehicle	P235/70R16	P235/70R16
Tire Manufacturer	Goodyear	Goodyear
Treadwear	540	540
Traction	A	A
Temperature Grades	B	B
Tire Plies Sidewall	2 Polyester	2 Polyester
Tire Plies Body	2 Polyester, 2 Steel	2 Polyester, 2 Steel
Load Index/Speed Symbol	104S	104S
Tire Material	Polyester, Steel	Polyester, Steel
DOT Safety Code Right	4B08-F4WR	4B08-F4WR
DOT Safety Code Left	4B08-F4WR	4B08-F4WR

DATA SHEET NO. 1...(CONTINUED)

GENERAL TEST AND VEHICLE PARAMETER DATA

Test Vehicle: 2007 Ford Explorer XLT 5-Door MPV

NHTSA No.: F80200

Test Program: 55/28 km/h Side Impact NCAP

Test Date: 6/8/07

TEST VEHICLE WEIGHTS

	Units	As Delivered Weights (UWV)			As Tested Weights (ATW)		
		Front Axle	Rear Axle	Total	Front Axle	Rear Axle	Total
Left	kg	552	406	958	607	619	1226
Right	kg	566	412	978	572	584	1156
Ratio	%	53.3	46.7	100	49.5	50.5	100
Totals	kg	1118	818	1936	1179	1203	2382

TARGET TEST WEIGHT CALCULATION

Measured Parameter	Units	Value
Total Delivered Weight (UWV)	kg	2094
Weight of 2 P572 ATD's	kg	161
Rated Cargo/Luggage Wt. (RCLW)	kg	136
Calculated Vehicle Target Wt. (TVTWT)	kg	2391

TEST VEHICLE ATTITUDE AND CG

	Units	LF	RF	LR	RR	CG (aft of front axle)
As Delivered	mm	970	978	990	995	1223
As Tested	mm	960	966	961	975	1461
Fully Loaded	mm	958	960	950	973	

GENERAL TEST VEHICLE DATA

Measurement Description	Units	Value
Test Vehicle Wheel Base	mm	2893
Total Vehicle Length at Left Side	mm	3927
Total Vehicle Length at Centerline	mm	4923
Total Vehicle Length at Right Side	mm	3524
Weight of Ballast In Cargo Area	kg	72
Amount of Stoddard Solvent in Fuel Tank	liters	79.12

TEST VEHICLE VERTICAL IMPACT LINE DATA

Measurement Description	Units	Value
Test Vehicle Wheel Base	mm	2893
Target Impact Point Aft of Front Axle	mm	507
Actual Impact Point Aft of Front Axle	mm	507

DATA SHEET NO. 1...(CONTINUED)

GENERAL TEST AND VEHICLE PARAMETER DATA

Test Vehicle: 2007 Ford Explorer XLT 5-Door MPV

NHTSA No.: F80200

Test Program: 55/28 km/h Side Impact NCAP

Test Date: 6/8/07

NOMINAL DESIGN RIDING POSITION

The driver and passenger seat backs are positioned to the manufacturer's designated angle. The procedure is as follows: Seat back angle was measured at the seat back using a digital inclinometer.

SEAT BACK ANGLES

	Deg.
Driver w/seated Dummy	18.0 @ Seat back
Passenger w/seated Dummy	N/A

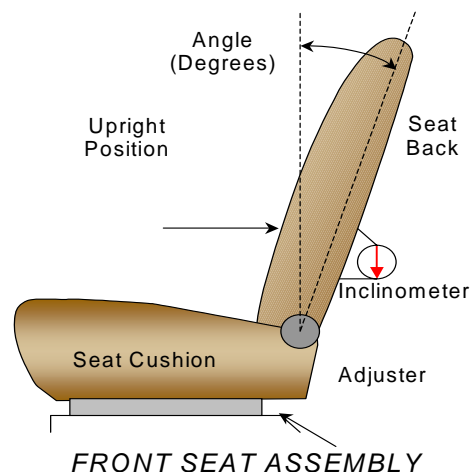

SEAT FORE/AFT POSITIONS

The total seat travel was measured from forward most position at the highest vertical seat height to rearmost position at the lowest vertical seat height. The seat was set at the longitudinal mid position. There were vertical adjustments on the driver seat that was equipped with the vehicle. There were no adjustments on the passenger seat. The driver seat was placed at the lowermost position.

SEAT FORE/AFT POSITIONING

	Total Fore/Aft Travel	Placed in Position #
Driver Seat	33 Detents	17th Detent
Rear Seat	N/A	N/A

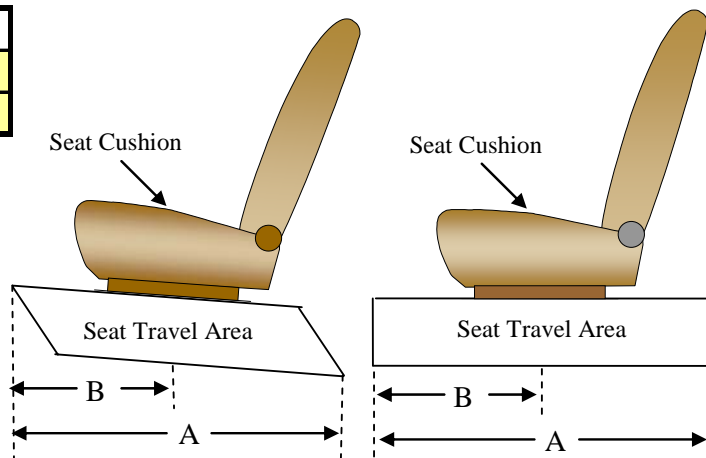

SEAT BELT UPPER ANCHORAGE

Position number one (1) is the uppermost position

SEAT BELT UPPER ANCHORAGE

	Total # of Positions	Placed in Position #
Driver Seat	5	2
Rear Seat	Fixed	Fixed

DATA SHEET NO. 1...(CONTINUED)

GENERAL TEST AND VEHICLE PARAMETER DATA

Test Vehicle: 2007 Ford Explorer XLT 5-Door MPV

NHTSA No.: F80200

Test Program: 55/28 km/h Side Impact NCAP

Test Date: 6/8/07

FUEL TANK CAPACITY

	Liters
Usable Capacity of "Standard Tank"	85.16
Usable Capacity of "Optional" Tank	
Usable Capacity used for FMVSS 301	78.34 to 80.05
Actual Amount of Solvent used	79.12

The test vehicle is equipped with an electric fuel pump. The fuel pump will operate for approximately two (2) seconds with the ignition in the "ON" position, after which the fuel pump automatically shuts off. The fuel filler door is located on the right rear fender. The standard fuel tank occupies the area under the rear seat.

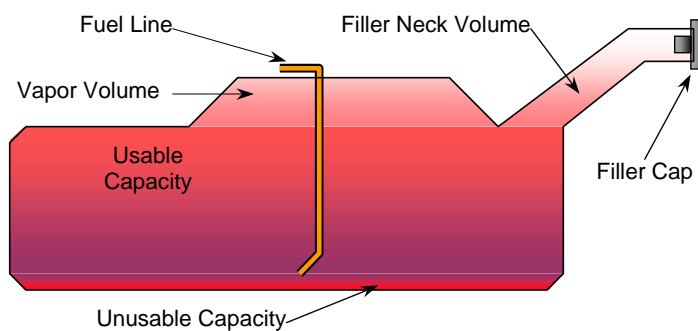

VEHICLE FUEL TANK ASSEMBLY

STEERING COLUMN ADJUSTMENT

Steering wheel and column adjustments are made so that the steering wheel hub is at the geometric center of the locus it describes when moved through its full range of motion. An aluminum plate is placed across the rim of the steering wheel, an inclinometer is placed on the plate and the angle is measured.

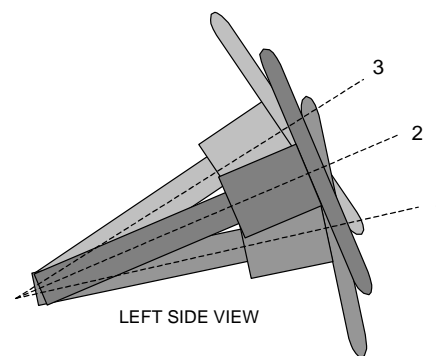

STEERING COLUMN ASSEMBLY

STEERING COLUMN POSITIONS

	Degrees	Fore/Aft Position (mm)
Lowermost position No. 1	16.9	
Geometric center position No. 2	20.6	
Uppermost position No. 3	24.4	

DATA SHEET NO. 2

TEST VEHICLE SUMMARY OF RESULTS

Test Vehicle: 2007 Ford Explorer XLT 5-Door MPV

NHTSA No.: F80200

Test Program: 55/28 km/h Side Impact NCAP

Test Date: 6/8/07

MAXIMUM EXTERIOR STATIC CRUSH

Level	Measured Parameter	Units	Maximum Crush	Above Ground
Level 1	Sill Top Height	mm	194	412
Level 2	Occupant H-Point	mm	246	758
Level 3	Mid Door	mm	256	751
Level 4	Window Sill	mm	196	1093
Level 5	Window top	mm	54	1646
N/A	Maximum Penetration	mm	256	

INSTRUMENTATION

Driver SID/Hybrid III Accelerometers	20
Passenger SID/Hybrid III Accelerometers	20
Vehicle Structure Accelerometers	21
MDB Accelerometers	5
Total No. of Contact Switches	5
Total	71

CAMERA COVERAGE

High Speed, Vehicle On-Board	3
High Speed, Off-Board	4
High Speed, MDB On-Board	3
Real Time, Panning	2
Total	12

DATA SHEET NO. 3

MOVING DEFORMABLE BARRIER (MDB) SUMMARY OF RESULTS

Test Vehicle: 2007 Ford Explorer XLT 5-Door MPV

NHTSA No.: F80200

Test Program: 55/28 km/h Side Impact NCAP

Test Date: 6/8/07

MDB SPECIFICATIONS (mm)

Measurement Description	Length
Overall Width of Framework Carriage	1252
Overall Length including Honeycomb Face	4115
Wheel Base of Framework Carriage	2590
C.G. location aft of Front Axle	1127

MDB WEIGHTS

	Units	Front Axle	Rear Axle	Total
Left	kg	384	308	
Right	kg	385	284	
Ratio	%	56.5	43.5	
Totals	kg	769	592	1361

SPEED AND IMPACT DATA

Measured Parameter	Units	Requirement	Value
Trap No. 1 Velocity (Primary)	km/h	61.1 to 62.7	61.95
Trap No. 2 Velocity (Redundant)	km/h	61.1 to 62.7	61.93
MDB CL to Target Vehicle CL	degrees	88.5 to 91.5	89.5

MAXIMUM STATIC CRUSH OF HONEYCOMB FACE (mm)

Vertical Location			From Centerline		Max. Crush
Row	Description	Height	Distance	Direction	
A	Center of Bumper	432	800	Right	236
B	Top of Bumper	533	800	Right	185
C	Mid Level	686	800	Left	173
D	Top of Stack	813	700	Left	139

MDB INSTRUMENTATION AND CAMERAS

Accelerometers	5
Contact Switches	1
High Speed Cameras	2

DATA SHEET NO. 4

POST-TEST OBSERVATIONS

Test Vehicle: 2007 Ford Explorer XLT 5-Door MPV

NHTSA No.: F80200

Test Program: 55/28 km/h Side Impact NCAP

Test Date: 6/8/07

TEST DUMMY INFORMATION AND CONTACT POINTS

Description	Front Seat SID/Hybrid III	Rear Seat SID/Hybrid III
Dummy Type / Serial No.	P572F, SID / No. 274	P572F, SID / No. 275
Head Contact	Curtain Airbag / Side Header	Curtain Airbag / Side Header
Upper Torso Contact	Side Torso Bag	Door Panel
Lower Torso Contact	Door Panel	Door Panel
Left Knee Contact	Door Panel	Right Knee
Right Knee Contact	None	None

POST-TEST DOOR OPENING AND SEAT TRACK INFORMATION

Description	Front	Rear
Left Side Door Opening	Door remained closed and latched, jammed	Door remained closed and latched, jammed
Right Side Door Opening	Remained closed and latched, operational	Remained closed and latched, operational
Seat Movement	None	None
Seat Back Failure	None	None

POST-TEST STRUCTURAL OBSERVATIONS

Critical Areas of Performance	Observations and Conclusions
Pillar Performance	No separation
Sill Separation	Front & Rear passenger side sill separated
Windshield Damage	Cracked
Window Damage	Driver Side Window Broken
Other Notable Effects	None

SUPPLEMENTAL RESTRAINT SYSTEM INFORMATION

Restraint Type	Left Front (Driver) Occupant Location 01		Left Rear (Passenger) Occupant Location 04	
	Installed	Operation	Installed	Operation
Front Airbag	Yes	No	No	
Side Torso Airbag	Yes	Yes	No	
Head Airbag	No		No	
Curtain Airbag	Yes	Yes	Yes	Yes
Seat Belt Pretensioner	Yes		No	
Seat Belt Load Limiter	Yes		No	

MDB LEFT EDGE IMPACT POINT DATA

Measured Parameter	Units	Requirement	Value
Horizontal Offset	mm	+/- 50	0
Vertical Offset	mm	+/- 20	0

DATA SHEET NO. 5

VEHICLE PRE-TEST AND POST-TEST MEASUREMENTS

Test Vehicle: 2007 Ford Explorer XLT 5-Door MPV

NHTSA No.: F80200

Test Program: 55/28 km/h Side Impact NCAP

Test Date: 6/8/07

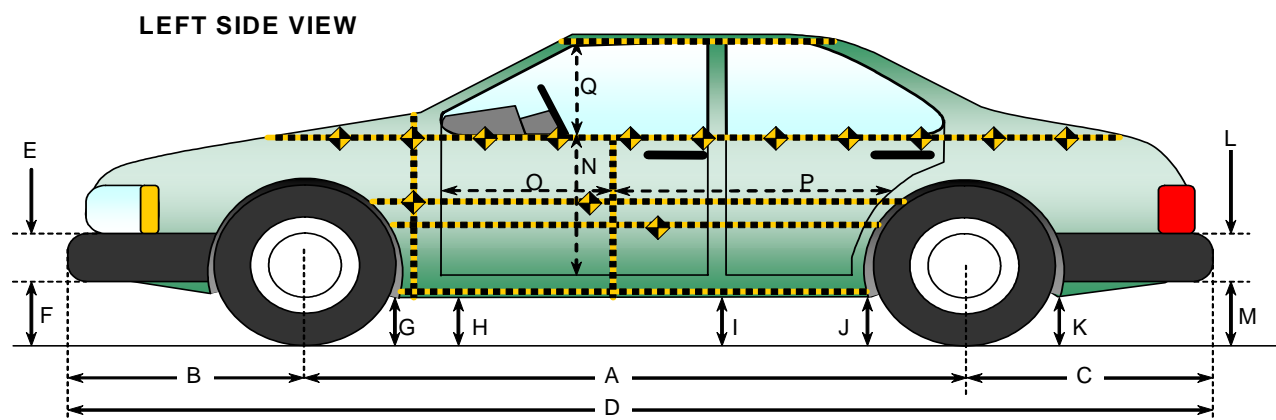

VEHICLE PRE AND POST-TEST MEASUREMENT INFORMATION

Code	Measurement Description	Pre-Test	Post-Test	Difference
A	Wheelbase	2893	2885	-8
B	Front Axle to FSOV	900	914	14
C	Rear Axle to RSOV	1128	1135	7
D	Total Length at Centerline	4923	4918	-5
E	Front Bumper Thickness	399	399	0
F	Front Bumper Bottom to Ground	272	268	-4
G	Sill Height at Front Wheel Well	363	369	6
H	Sill Height at Front Door Leading Edge	383	353	-30
I	Sill Height at "B" Pillar	395	398	3
J1	Sill Height at Rear Wheel Well	234	266	32
J2	Pinch Weld Height at Rear Wheel Well	373	368	-5
K	Sill Height aft of Rear Wheel Well	393	427	34
L	Rear Bumper Thickness	210	210	0
M	Rear Bumper Bottom to Ground	425	460	35
N	Sill Height to Window Bottom Sill	755	760	5
O	Front Door Leading Edge to Impact CL	737	728	-9
P	Rear Door Trailing Edge to Impact CL	1379	1338	-41
Q	Front Window Opening	494	495	1
R	Right Side Length	3085	3075	-10
S	Left Side Length	3085	3048	-37
T	Vehicle Width at "B" Post	1815	1620	-195

All Dimensions shown in millimeters

DATA SHEET NO. 6

SID/HIII LONGITUDINAL CLEARANCE DIMENSIONS

Test Vehicle: 2007 Ford Explorer XLT 5-Door MPV

NHTSA No.: F80200

Test Program: 55/28 km/h Side Impact NCAP

Test Date: 6/8/07

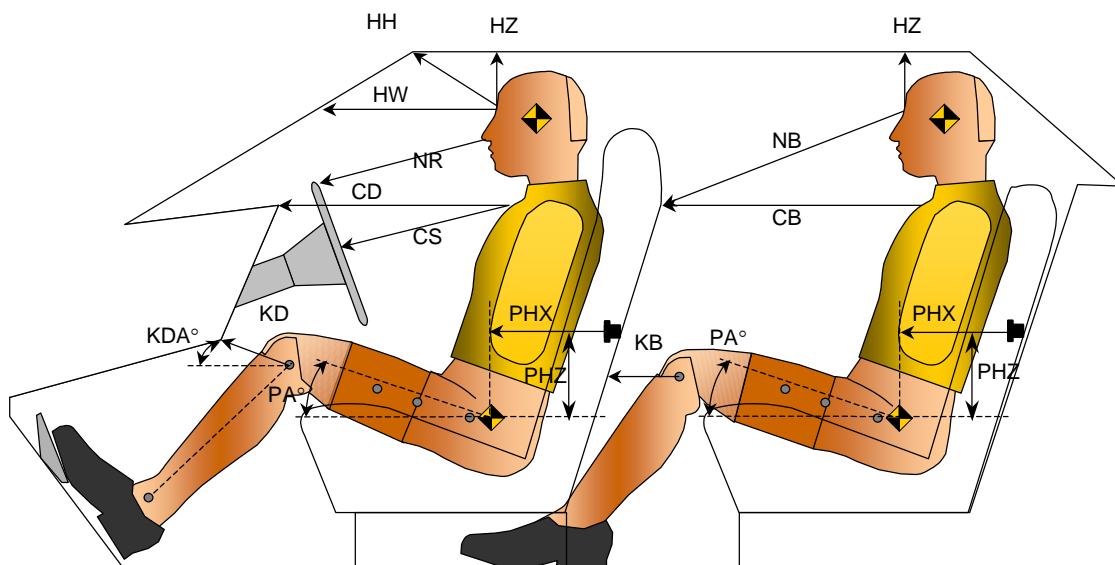

LONGITUDINAL CLEARANCE DIMENSION INFORMATION

Driver Code	Pass. Code	Measurement Description	Driver		Passenger	
			Length(mm)	Angle	Length(mm)	Angle
HH		Head to Header	390	12.8		
HW		Head to Windshield	527	0.0		
HZ	HZ	Head to Roof	180	90.0	185	90.0
NR	NB	Nose to Rim/Nose to Seat Back	376	20.0	643	15.6
CD	CB	Chest to Dash or Seat Back	548	2.0	608	2.6
CS		Chest to Steering Wheel	265	0.0		
KDL	KBL	Left Knee to Dash or Seat Back	190	7.4	268	0.0
KDR	KBR	Right Knee to Dash or Seat Back	160		288	
PA	PA	Pelvic Angle		23.8		23.5
PHX	PHX	H-Point to Striker (X-Axis)	218		282	
PHZ	PHZ	H-Point to Striker (Z-Axis)	38		168	

DATA SHEET NO. 7

SID/HII LATERAL CLEARANCE DIMENSIONS

Test Vehicle: 2007 Ford Explorer XLT 5-Door MPV

NHTSA No.: F80200

Test Program: 55/28 km/h Side Impact NCAP

Test Date: 6/8/07

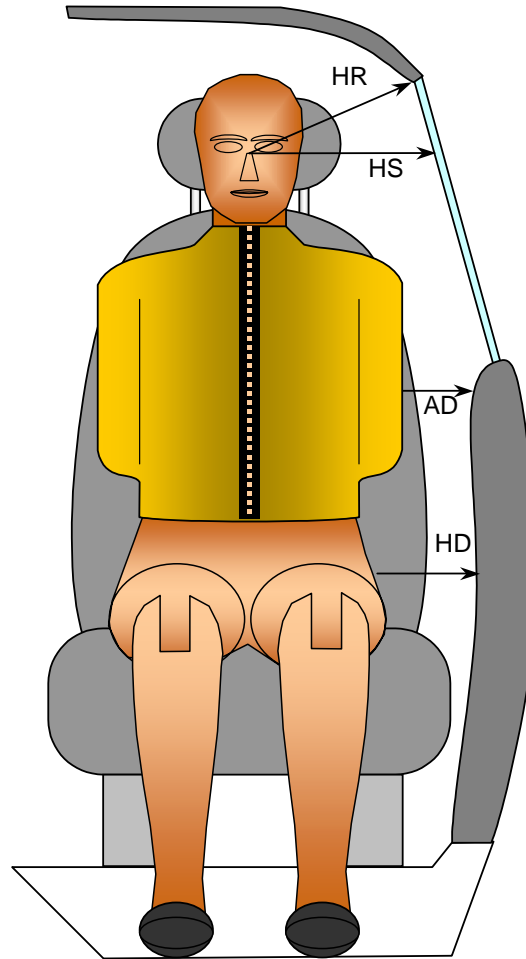

FRONT VIEW OF DUMMY

LATERAL CLEARANCE DIMENSION INFORMATION

Code	Measurement Description	Units	Driver	Passenger
HR	Head to Side Header	mm	270	223
HS	Head to Side Window	mm	325	290
AD	Arm to Door	mm	118	78
HD	H-Point to Door	mm	140	90

DATA SHEET NO. 8
VEHICLE SIDE MEASUREMENTS

Test Vehicle: 2007 Ford Explorer XLT 5-Door MPV

NHTSA No.: F80200

Test Program: 55/28 km/h Side Impact NCAP

Test Date: 6/8/07

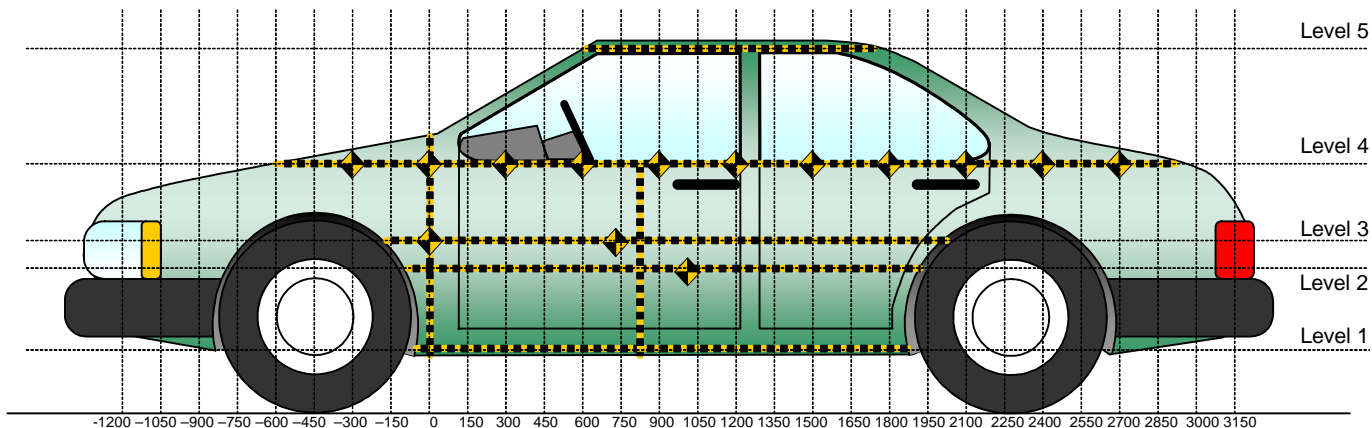

All Measurements Shown in mm

LEFT SIDE VIEW

Measurements are taken with vehicle in the as tested condition.

Measurements taken 900 mm right of impact reference.

All measurements below in mm.

Level	Measurement Description	Height Above Ground
1	Sill Top	412
2	Occupant H-Point	758
3	Mid Door	751
4	Window Sill	1093
5	Window Top	1646

All Dimensions shown in millimeters

DATA SHEET NO. 9

VEHICLE EXTERIOR CRUSH PROFILES

Test Vehicle: 2007 Ford Explorer XLT 5-Door MPV

NHTSA No.: F80200

Test Program: 55/28 km/h Side Impact NCAP

Test Date: 6/8/07

	Pre-Test					Post-Test					Difference				
	1	2	3	4	5	1	2	3	4	5	1	2	3	4	5
-900															
-750															
-600															
-450															
-300				658					687					29	
-150		576	586	641			626	617	697			50	31	56	
0	636	607	609	641		713	659	656	689		77	52	47	48	
150	651	606	608	641		807	742	730	668		156	136	122	27	
300	653	606	612	639		830	809	803	697		177	203	191	58	
450	653	608	610	630		835	830	835	698		182	222	225	68	
600	643	601	600	628	863	835	840	846	706	916	192	239	246	78	53
750	643	599	599	630	850	836	845	847	715	904	193	246	248	85	54
900	645	599	599	623	860	835	832	831	728	777	190	233	232	105	-83
1050	649	600	598	621	850	829	839	840	739	778	180	239	242	118	-72
1200	650	599	598	622	840	844	809	808	759	785	194	210	210	137	-55
1350	650	600	599	621	843	833	833	836	817	856	183	233	237	196	13
1500	653	603	600	621	843	826	842	853	776	828	173	239	253	155	-15
1650	652	608	599	623	841	813	846	855	739	776	161	238	256	116	-65
1800	657	606	602	625	842	806	838	834	703	800	149	232	232	78	-42
1950	647	601	608	625	843	717	719	779	663	881	70	118	171	38	38
2100		573	605	629	843		684	721	637	876		111	116	8	33
2250				629	838				679	876				50	38
2400				633					676					43	
2550															
2700															
2850															

All Dimensions shown in millimeters

DATA SHEET NO. 9...(CONTINUED)
VEHICLE EXTERIOR CRUSH PROFILES

Test Vehicle: 2007 Ford Explorer XLT 5-Door MPV

NHTSA No.: F80200

Test Program: 55/28 km/h Side Impact NCAP

Test Date: 6/8/07

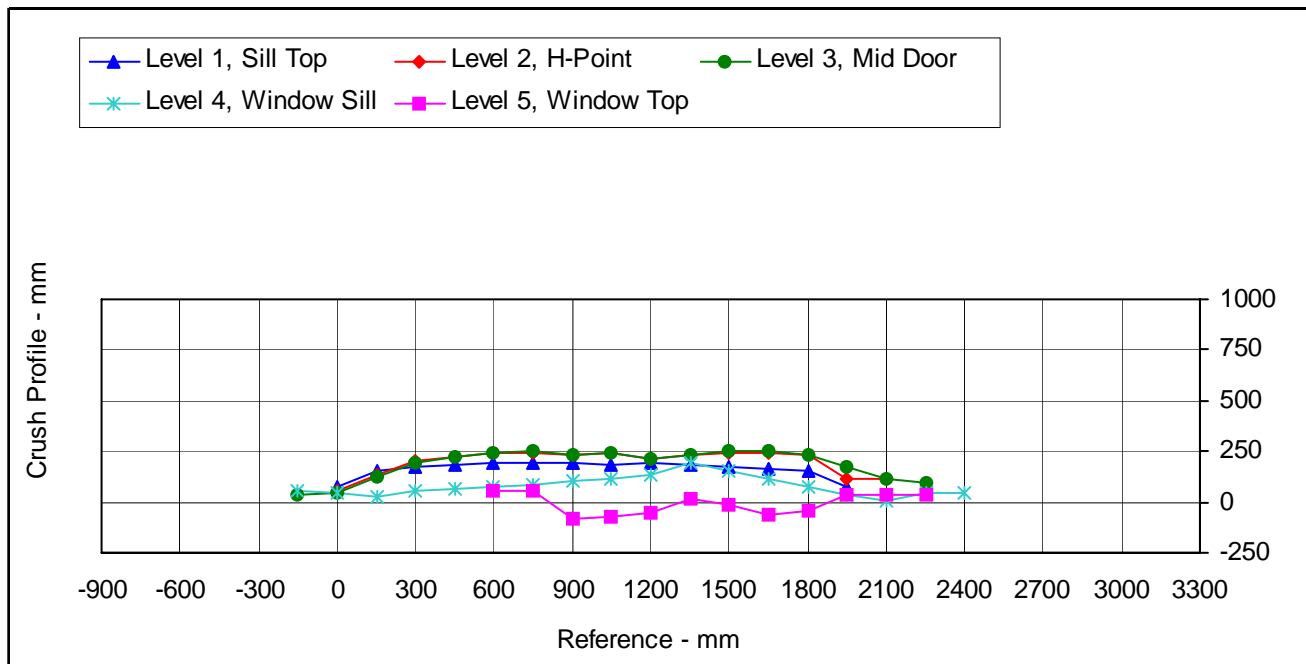

	Units	Level 1	Level 2	Level 3	Level 4	Level 5
Maximum Crush	mm	194	246	256	196	54
Distance from Impact	mm	1500	1950	1950	900	2400

DATA SHEET NO. 10

VEHICLE DAMAGE PROFILE DISTANCES

Test Vehicle: 2007 Ford Explorer XLT 5-Door MPV

NHTSA No.: F80200

Test Program: 55/28 km/h Side Impact NCAP

Test Date: 6/8/07

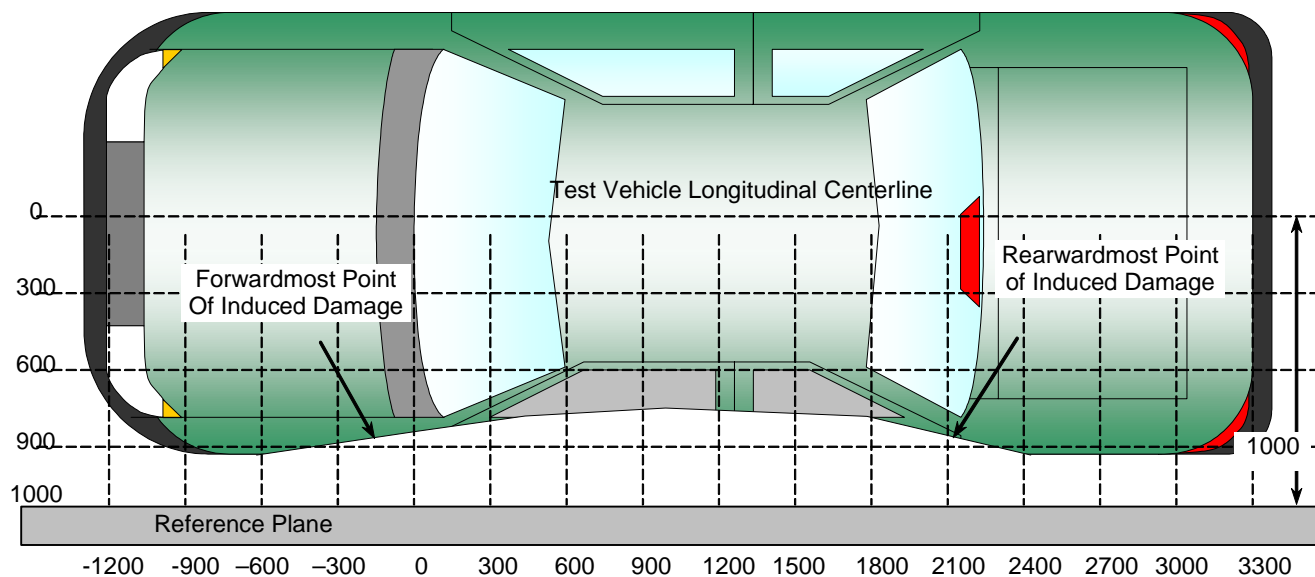

All Dimensions Shown in millimeters

TOP VIEW

DAMAGE PROFILE DISTANCES

DPD	Distance From Impact Point in mm	Level	Pre-Test (mm)	Post-Test (mm)	Max. Static Crush (mm)
1	2100	3	605	721	116
2	1650	3	599	855	256
3	1200	2	599	809	210
4	750	3	599	847	248
5	300	2	606	809	203
6	-150	4	641	697	56

DATA SHEET NO. 11

DEFORMABLE BARRIER HONEYCOMB FACE STATIC CRUSH

Test Vehicle: 2007 Ford Explorer XLT 5-Door MPV

NHTSA No.: F80200

Test Program: 55/28 km/h Side Impact NCAP

Test Date: 6/8/07

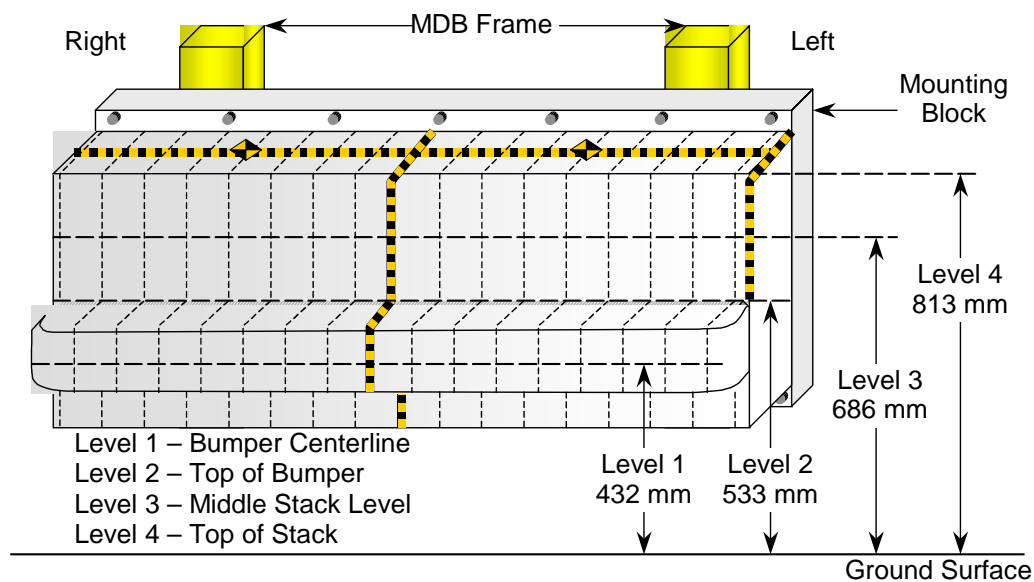

DEFORMABLE BARRIER STATIC CRUSH

Stack Level	Distance Right of Center								C/L	Distance Left of Center							
	800	700	600	500	400	300	200	100		0	100	200	300	400	500	600	700
1	754	747	748	739	735	733	728	728	711	703	698	692	688	683	678	686	700
2	805	798	794	766	763	763	753	753	748	742	741	740	737	733	730	733	742
3	751	743	722	717	717	725	738	743	718	703	694	692	685	693	703	723	793
4	750	726	713	711	723	743	738	713	703	707	697	690	694	711	733	759	733

All Dimensions in mm

DATA SHEET NO. 12

VEHICLE ACCELEROMETER LOCATIONS

Test Vehicle: 2007 Ford Explorer XLT 5-Door MPV

NHTSA No.: F80200

Test Program: 55/28 km/h Side Impact NCAP

Test Date: 6/8/07

LEFT SIDE VIEW

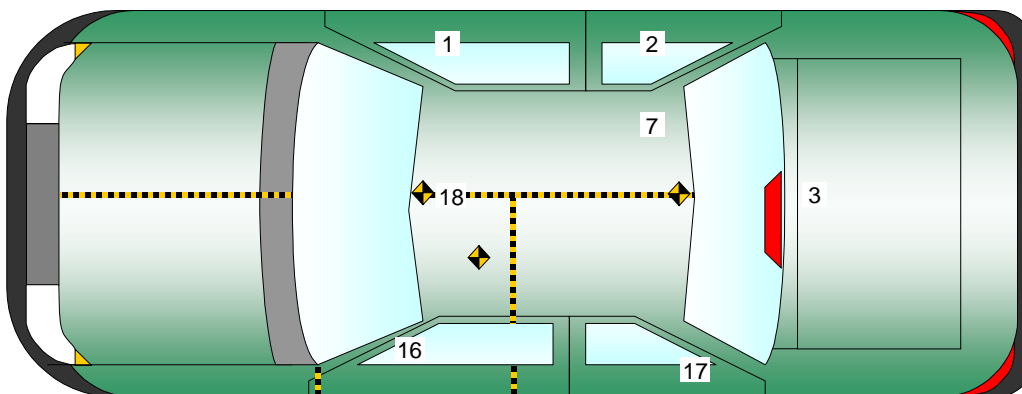
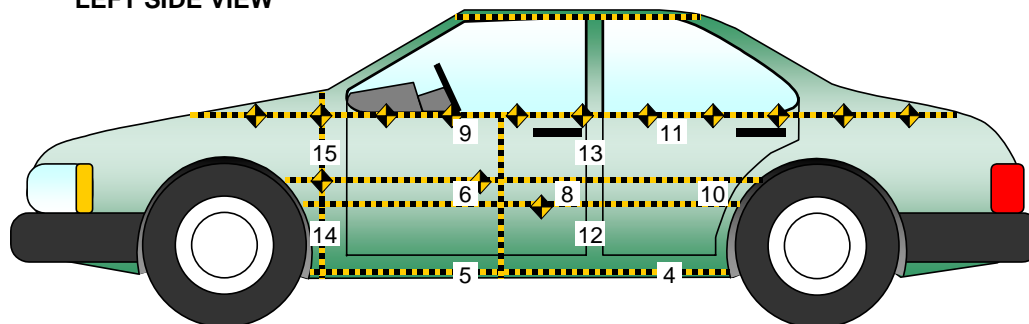

No.	Location
1	Right Sill at Front Seat
2	Right Sill at Rear Seat
3	Rear Floorpan Above Axle
4	Left Sill at Rear Door
5	Left Sill at Front Door
6	Left Front Door Centerline
7	Right Rear Occupant Compartment
8	Left Front Door Mid-Rear
9	Left Front Door Upper Centerline

No.	Location
10	Left Rear Door Mid-Rear
11	Left Rear Door Upper Centerline
12	Left Lower B-Post
13	Left Middle B-Post
14	Left Lower A-Post
15	Left Middle A-Post
16	Front Seat Track
17	Rear Seat Track or Structure
18	Vehicle CG

DATA SHEET NO. 12...(CONTINUED)
VEHICLE ACCELEROMETER LOCATIONS

Test Vehicle: 2007 Ford Explorer XLT 5-Door MPV

NHTSA No.: F80200

Test Program: 55/28 km/h Side Impact NCAP

Test Date: 6/8/07

VEHICLE ACCELEROMETER PRE-TEST LOCATIONS

Loc. No.	Accelerometer Location	Measurements (mm)		
		X	Y	Z
1	Right Sill at Front Seat	2580	695	500
2	Right Sill at Rear Seat	1750	690	510
3	Rear Floorpan Above Axle	2930	475	835
4	Left Sill at Rear Door	2100	-650	215
5	Left Sill at Front Door	2640	-650	215
6	Front Door Centerline			
7	Rt. Rear Occ. Compartment	2270	400	490
8	Front Door Mid-Rear			
9	Front Door Upper Centerline			
10	Rear Door Mid-Rear			
11	Rear Door Upper Centerline			
12	B-Post Lower	2280	-690	1005
13	B-Post Middle	3375	-690	760
14	A-Post Lower	3375	-820	535
15	A-Post Middle	3375	-820	730
16	Front Seat Track	2890	-575	530
17	Rear Seat Structure			
18	Vehicle CG	2930	294	530

Reference Planes: X=From Rear Surface of Vehicle, Y=Vehicle Centerline, Z=Ground Plane

1.) Not installed

DATA SHEET NO. 13
MDB ACCELEROMETER LOCATIONS

Test Vehicle: 2007 Ford Explorer XLT 5-Door MPV
 Test Program: 55/28 km/h Side Impact NCAP

NHTSA No.: F80200
 Test Date: 6/8/07

MDB ACCELEROMETER LOCATIONS

Loc. No.	Accelerometer Locations	Measurements (mm)		
		X	Y	Z
1	MDB CG	-1195	0	430
2	MDB Rear	-2642	-593	608

Reference Points: X - MDB Front Axle
 Y - MDB Centerline
 Z - Ground Plane

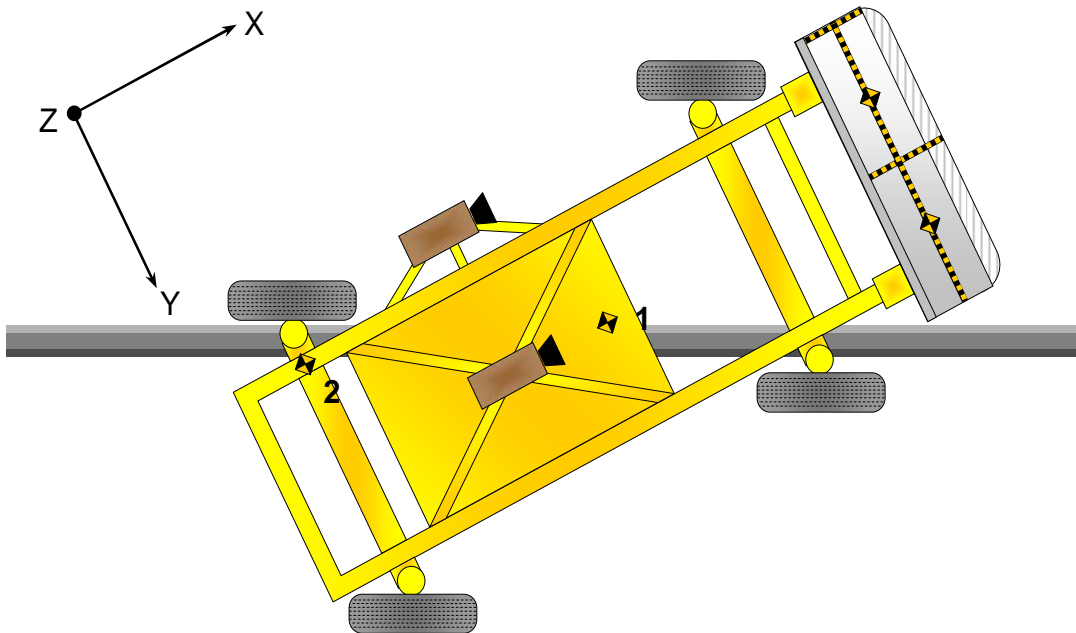

DATA SHEET NO. 14

HIGH SPEED CAMERA LOCATIONS AND DATA

Test Vehicle: 2007 Ford Explorer XLT 5-Door MPV

NHTSA No.: F80200

Test Program: 55/28 km/h Side Impact NCAP

Test Date: 6/8/07

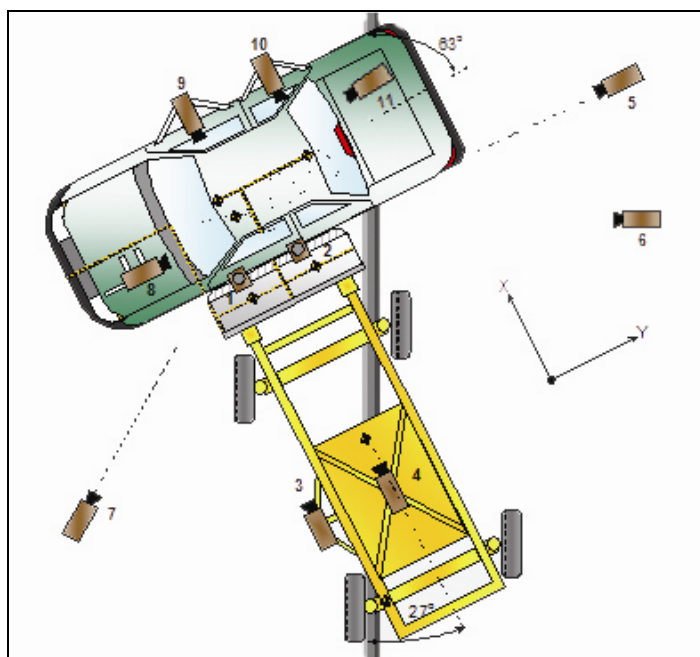

No.	Camera View	Location (mm)			Angle (deg.)	Lens (mm)	Film Speed (fps)
		X	Y	Z			
Doc	Real Time Inrun	-2484	-3958	-1506	0		30
Doc	Real Time Left Front	-2266	3549	-1475	-2		30
1	Overhead Overall	1220	2287	-5486	-90	14mm	1000
2	Overhead Close Up	609	2287	-5102	-90	Zoom	1000
3	Left Impact Point (MDB)	-2134	0	-1143	-2	12mm	1000
4	Side Overall (MDB)	-3912	838	-1829	-4	12mm	1000
5	Rear	-64	20485	-1348	0	105mm	1000
6	Left Rear (MDB)	-2137	-1302	-339	-4	85mm	1000
7	Left Front	-2266	-3564	-1475	-2	24mm	1000
8	Driver Front (O.B.)	580	-765	-1530	-7	35mm	1000
9	Driver Side (O.B.)	1735	832	-1257	-2	20mm	1000
10	Passenger Side (O.B.)	1735	1711	-1257	-2	20mm	1000

X = Barrier Face Y = Monorail Centerline Z = Ground DNR = Did Not Run NTM = No Timing Marks

DATA SHEET NO. 15

FMVSS 301 FUEL SYSTEM INTEGRITY POST-IMPACT DATA

Test Vehicle: 2007 Ford Explorer XLT 5-Door MPV NHTSA No.: F80200

Test Program: 55/28 km/h Side Impact NCAP Test Date: 6/8/07

Test Time: 12:21 PM Temperature: 26.1 Deg. C.

Stoddard Solvent Spillage Measurements

- A. From impact until vehicle motion ceases: 0.0 oz.
(Maximum Allowable = 1 ounce)
- B. For the 5 minute period after motion ceases: 0.0 oz.
(Maximum Allowable = 5 ounces)
- C. For the following 25 minutes: 0.0 oz.
(Maximum Allowable = 1 oz./minute)
- D. Spillage Details: No leakage occurred

DATA SHEET NO. 16

FMVSS 301 STATIC ROLLOVER DATA

Test Vehicle: 2007 Ford Explorer XLT 5-Door MPV

NHTSA No.: F80200

Test Program: 55/28 km/h Side Impact NCAP

Test Date: 6/8/07

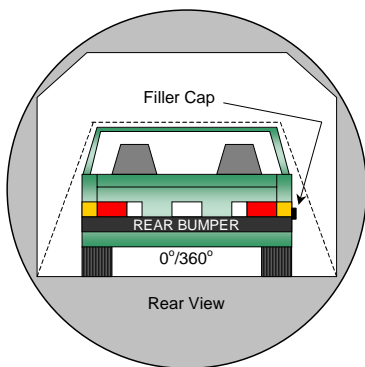

0° to 90°

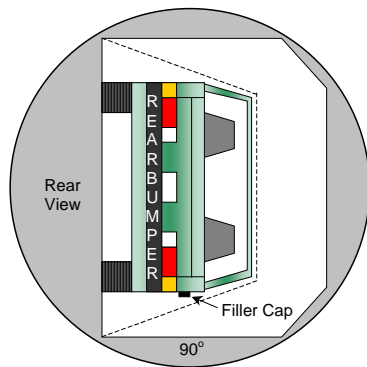

90° to 180°

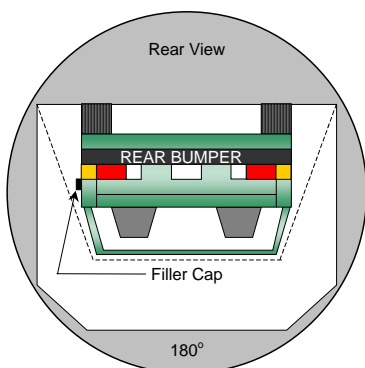
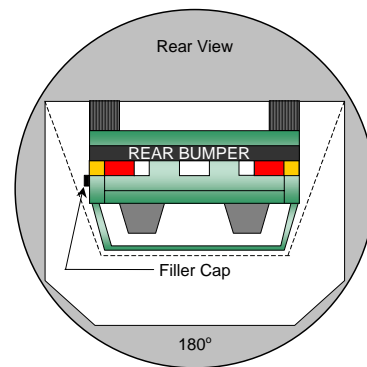

180° to 270°

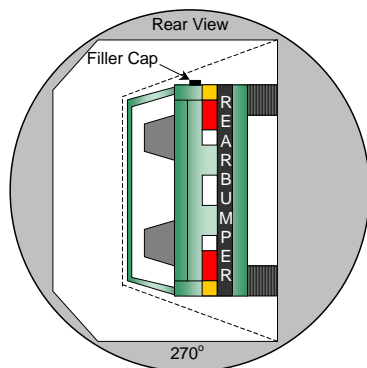

270° to 360°

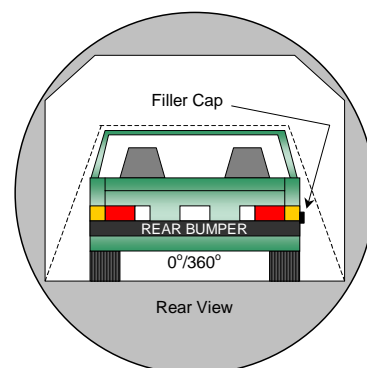

1. The specified fixture rollover rate for each 90° of rotation is 60 to 120 seconds.
2. The position hold time at each position is 300 seconds (minimum).
3. Details of Stoddard Solvent spillage locations.
No solvent leakage occurred during static rollover testing.

DATA SHEET NO. 16...(CONTINUED)

FMVSS 301 STATIC ROLLOVER DATA SHEET

Test Vehicle: 2007 Ford Explorer XLT 5-Door MPV

NHTSA No.: F80200

Test Program: 55/28 km/h Side Impact NCAP

Test Date: 6/8/07

SOLVENT COLLECTION TIME TABLE IN SECONDS

Test Phase	Rotation Time	Hold Time	Total Time
0° to 90°	82	300	382
90° to 180°	84	300	384
180° to 270°	81	300	381
270° to 360°	83	300	383

FMVSS 301 SPILLAGE TABLE REQUIREMENT (oz.)

First 5 Minutes	5.0
Sixth Minute	1.0
Seventh Minute	1.0
Eighth Minute	1.0

Test Phase	First 5 Minutes	Sixth Minute	Seventh Minute	Eighth Minute
0° to 90°	0	0	0	0
90° to 180°	0	0	0	0
180° to 270°	0	0	0	0
270° to 360°	0	0	0	0

SOLVENT SPILLAGE LOCATION TABLE

Test Phase	Spillage Location
0° to 90°	None
90° to 180°	None
180° to 270°	None
270° to 360°	None

DATA SHEET NO. 17

DUMMY / VEHICLE TEMPERATURE STABILIZATION

Test Vehicle: 2007 Ford Explorer XLT 5-Door MPV

NHTSA No.: F80200

Test Program: 55/28 km/h Side Impact NCAP

Test Date: 6/8/07

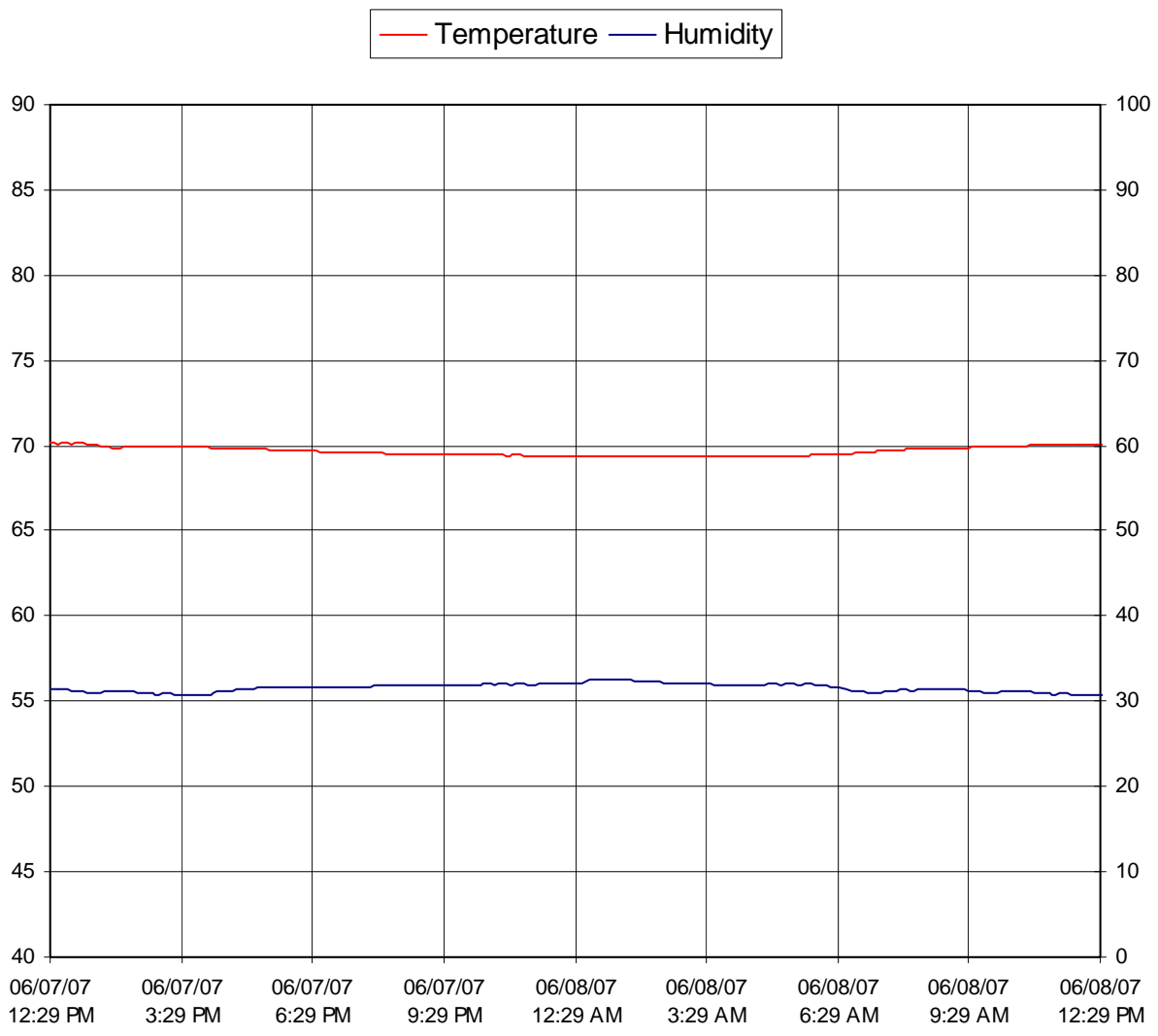

**APPENDIX A
PHOTOGRAPHS**

LIST OF PHOTOGRAPHS

Figure		Page
A-1	Left Front $\frac{3}{4}$ View, as Received	A-1
A-2	Right Rear $\frac{3}{4}$ View, as Received	A-2
A-3	Manufacturer's Label	A-3
A-4	Tire Placard	A-4
A-5	Pre-Test Front View	A-5
A-6	Post-Test Front View	A-6
A-7	Pre-Test Left Front $\frac{3}{4}$ View	A-7
A-8	Post-Test Left Front $\frac{3}{4}$ View	A-8
A-9	Pre-Test Left Side View	A-9
A-10	Post-Test Left Side View	A-10
A-11	Pre-Test Left Rear $\frac{3}{4}$ View	A-11
A-12	Post-Test Left Rear $\frac{3}{4}$ View	A-12
A-13	Pre-Test Rear View	A-13
A-14	Post-Test Rear View	A-14
A-15	Pre-Test Right Rear $\frac{3}{4}$ View	A-15
A-16	Post-Test Right Rear $\frac{3}{4}$ View	A-16
A-17	Pre-Test Right Side View	A-17
A-18	Post-Test Right Side View	A-18
A-19	Pre-Test Right Front $\frac{3}{4}$ View	A-19
A-20	Post-Test Right Front $\frac{3}{4}$ View	A-20
A-21	Pre-Test Overhead View	A-21
A-22	Post-Test Overhead View	A-22
A-23	Pre-Test Overhead Close-up View	A-23
A-24	Post-Test Overhead Close-up View	A-24
A-25	Pre-Test Left Impact Point	A-25
A-26	Post-Test Left Impact Point	A-26
A-27	Pre-Test Front $\frac{3}{4}$ View of Left Side Doors	A-27
A-28	Post-Test Front $\frac{3}{4}$ View of Left Side Doors	A-28
A-29	Pre-Test Rear $\frac{3}{4}$ View of Left Side Doors	A-29
A-30	Post-Test Rear $\frac{3}{4}$ View of Left Side Doors	A-30
A-31	Pre-Test Left Front Door	A-31
A-32	Post-Test Left Front Door	A-32
A-33	Pre-Test Left Rear Door	A-33
A-34	Post-Test Left Rear Door	A-34

LIST OF PHOTOGRAPHS...(CONTINUED)

Figure		Page
A-35	Pre-Test Driver Dummy (Door Open)	A-35
A-36	Pre-Test Driver Dummy (Through Window)	A-36
A-37	Post-Test Driver Dummy (Through Window)	A-37
A-38	Pre-Test Driver Dummy Clearance from Door	A-38
A-39	Post-Test Driver Dummy Clearance from Door	A-39
A-40	Pre-Test Driver Dummy Right Side View	A-40
A-41	Post-Test Driver Dummy Right Side View	A-41
A-42	Pre-Test Front Door Panel (Interior)	A-42
A-43	Post-Test Front Door Panel (Interior)	A-43
A-44	Pre-Test Passenger Dummy Left Side (Door Open)	A-44
A-45	Pre-Test Passenger Dummy Left Side (Through Window)	A-45
A-46	Post-Test Passenger Dummy Left Side (Through Window)	A-46
A-47	Pre-Test Passenger Dummy Clearance from Door	A-47
A-48	Post-Test Passenger Dummy Clearance from Door	A-48
A-49	Pre-Test Passenger Dummy Right Side View	A-49
A-50	Post-Test Passenger Dummy Right Side View	A-50
A-51	Pre-Test Rear Door Panel (Interior)	A-51
A-52	Post-Test Rear Door Panel (Interior)	A-52
A-53	Pre-Test Front View of Deformable Barrier	A-53
A-54	Post-Test Front View of Deformable Barrier	A-54
A-55	Pre-Test Top View of Deformable Barrier	A-55
A-56	Post-Test Top View of Deformable Barrier	A-56
A-57	Pre-Test Right Side View of Deformable Barrier	A-57
A-58	Post-Test Right Side View of Deformable Barrier	A-58
A-59	Pre-Test Left Side View of Deformable Barrier	A-59
A-60	Post-Test Left Side View of Deformable Barrier	A-60
A-61	Vehicle on Rollover Device (0°)	A-61
A-62	Vehicle on Rollover Device (90°)	A-62
A-63	Vehicle on Rollover Device (180°)	A-63
A-64	Vehicle on Rollover Device (270°)	A-64
A-65	Vehicle Impact	A-65



Figure A-1: Left Front $\frac{3}{4}$ View, as Received



Figure A-2: Right Rear ¾ View, as Received

MFD. BY FORD MOTOR CO.

DATE: 01/07
FRONT GAWR: 2960LB
1343KG
P235/70R16
16X7.0J
AT 240 kPa/ 35 PSI COLD

GVWR: 6180LB/ 2803KG
REAR GAWR: 3400LB
1542KG
P235/70R16
16X7.0J
AT 240 kPa/ 35 PSI COLD

WITH TIRES RIMS
WITH TIRES RIMS

THIS VEHICLE CONFORMS TO ALL APPLICABLE FEDERAL MOTOR VEHICLE SAFETY STANDARDS IN EFFECT ON THE DATE OF MANUFACTURE SHOWN ABOVE.

VIN: 1FMEU73E47UA98118
TYPE: MPV

F0199
T0721

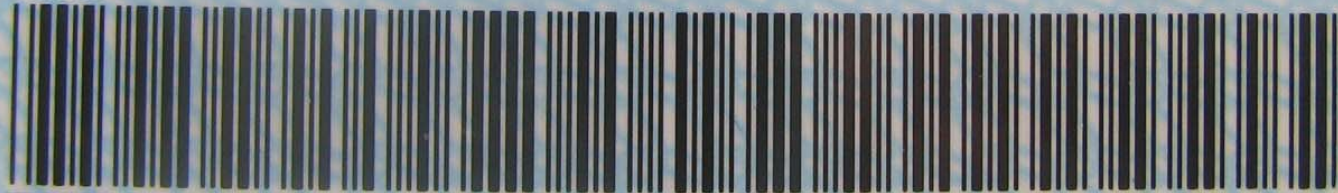

EXT PNT:	YZ	RC:	71	DSO:			
WB	INT TR	TP/PS	R	AXLE	TR	SPR	6U51A
114	RL		A	46	V	EECC	40B
		1200701193752		UTC		▽5U5A-1520472-BA	

Figure A-3: Manufacturer's Label



TIRE AND LOADING INFORMATION

SEATING CAPACITY TOTAL : 5 FRONT: 2 REAR: 3

The combined weight of occupants and cargo should never exceed : **667 kg or 1471 lbs.**

▽5U5A-1532-AA (TLU)

TIRE	SIZE	COLD TIRE PRESSURE	SEE OWNERS MANUAL FOR ADDITIONAL INFORMATION
FRONT	P235/70R16	240 KPA, 35 PSI	
REAR	P235/70R16	240 KPA, 35 PSI	
SPARE	P235/70R16	240 KPA, 35 PSI	

1FMEU73E47UA98118



Figure A-4: Tire Placard



Figure A-5: Pre-Test Front View



Figure A-6: Post-Test Front View



Figure A-7: Pre-Test Left Front ¾ View



Figure A-8: Post-Test Left Front $\frac{3}{4}$ View



Figure A-9: Pre-Test Left Side View



Figure A-10: Post-Test Left Side View



Figure A-11: Pre-Test Left Rear $\frac{3}{4}$ View



Figure A-12: Post-Test Left Rear ¾ View



Figure A-13: Pre-Test Rear View



Figure A-14: Post-Test Rear View



A-15

TR-P27148-01-NC

Figure A-15: Pre-Test Right Rear ¾ View



A-16

TR-P27148-01-NC

Figure A-16: Post-Test Right Rear ¾ View



Figure A-17: Pre-Test Right Side View



Figure A-18: Post-Test Right Side View



A-19

TR-P27148-01-NC

Figure A-19: Pre-Test Right Front 3/4 View



A-20

TR-P27148-01-NC

Figure A-20: Post-Test Right Front $\frac{3}{4}$ View



Figure A-21: Pre-Test Overhead View



Figure A-22: Post-Test Overhead View

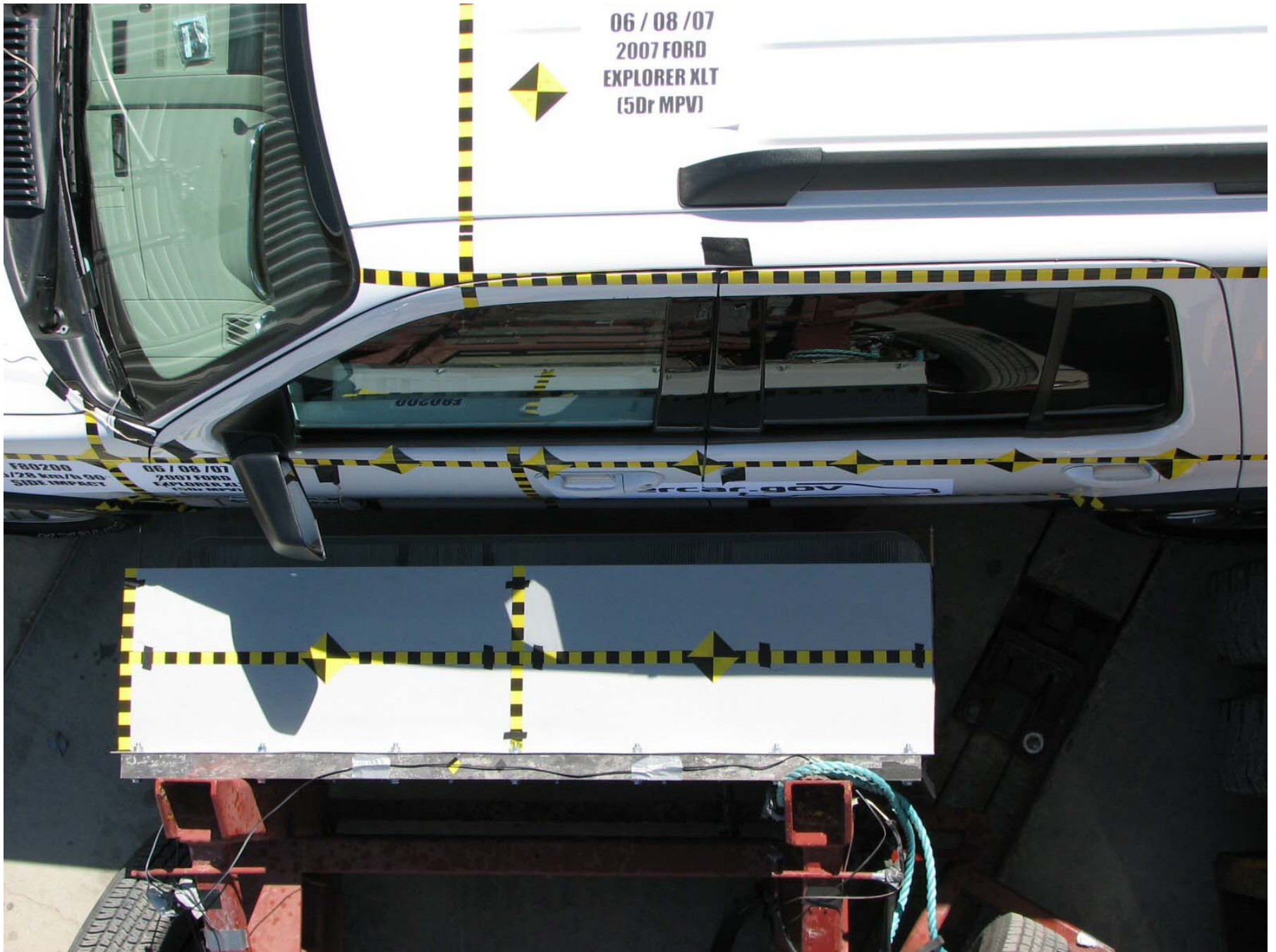

Figure A-23: Pre-Test Overhead Close-up View



Figure A-24: Post-Test Overhead Close-up View



Figure A-25: Pre-Test Left Impact Point

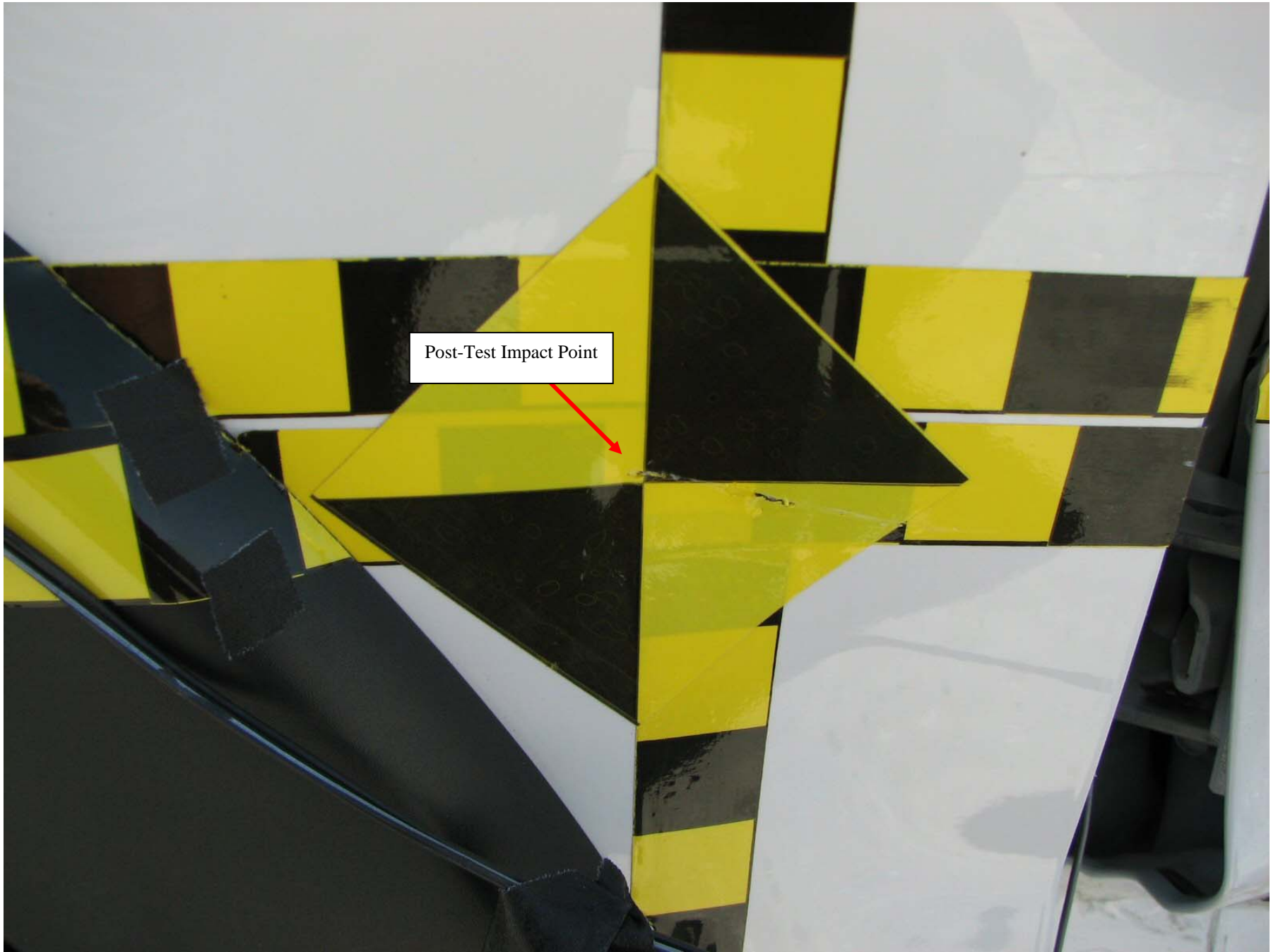

Figure A-26: Post-Test Left Impact Point



**F80200
55/28 km/h 90°
SIDE IMPACT**

**06 / 08 / 07
2007 FORD
EXPLORER XLT
(5Dr MPV)**

safercar.gov

EXPLORER

Figure A-27: Pre-Test Front ¾ View of Left Side Door



Figure A-28: Post-Test Front ¾ View of Left Side Door



Figure A-29: Pre-Test Rear ¾ View of Left Side Door



Figure A-30: Post-Test Rear ¾ View of Left Side Door



Figure A-31: Pre-Test Left Front Door



Figure A-32: Post-Test Left Front Door



Figure A-33: Pre-Test Left Rear Door



Figure A-34: Post-Test Left Rear Door



Figure A-35: Pre-Test Driver Dummy (Door Open)

This Space Intentionally Left Blank



Figure A-36: Pre-Test Driver Dummy (Through Window)



Figure A-37: Post-Test Driver Dummy (Through Window)



Figure A-38: Pre-Test Driver Dummy Clearance From Door



Figure A-39: Post-Test Driver Dummy Clearance From Door



Figure A-40: Pre-Test Driver Dummy Right Side View



Figure A-41: Post-Test Driver Dummy Right Side View



Figure A-42: Pre-Test Front Door Panel (Interior)



Figure A-43: Post-Test Front Door Panel (Interior)



Figure A-44: Pre-Test Passenger Dummy Left Side (Door Open)

This Space Intentionally Left Blank



Figure A-45: Pre-Test Passenger Dummy Left Side (Through Window)



Figure A-46: Post-Test Passenger Dummy Left Side (Through Window)



Figure A-47: Pre-Test Passenger Dummy Clearance From Door

NI L01111111
(5Dr MPV)



Figure A-48: Post-Test Passenger Dummy Clearance From Door



Figure A-50: Post-Test Passenger Dummy Right Side View



Figure A-51: Pre-Test Rear Door Panel (Interior)



Figure A-52: Post-Test Rear Door Panel (Interior)



Figure A-53: Pre-Test Front View of Deformable Barrier



Figure A-54: Post-Test Front View of Deformable Barrier



A-55

TR-P27148-01-NC

Figure A-55: Pre-Test Top View of Deformable Barrier

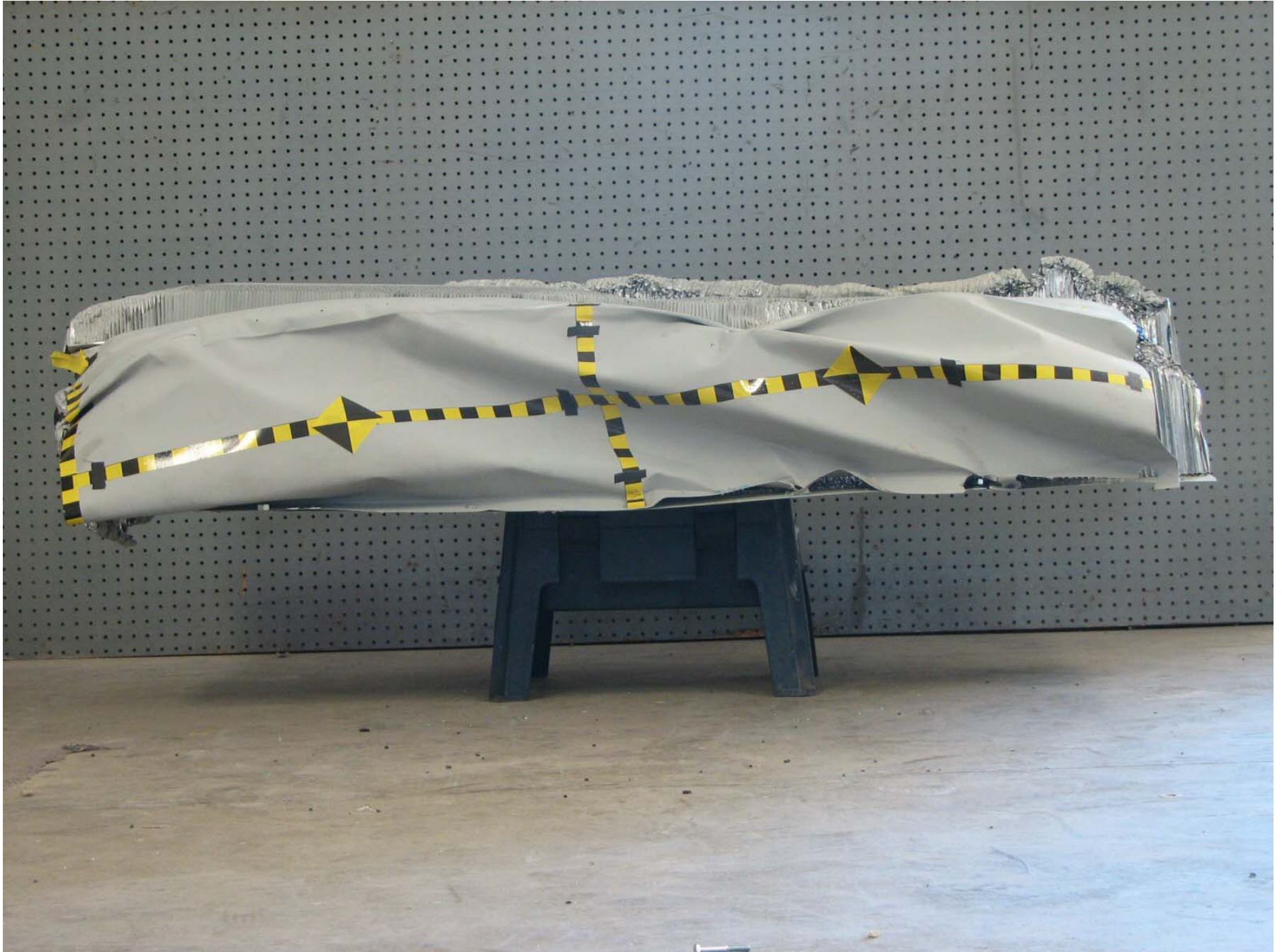

Figure A-56: Post-Test Top View of Deformable Barrier



Figure A-57: Pre-Test Right Side View of Deformable Barrier

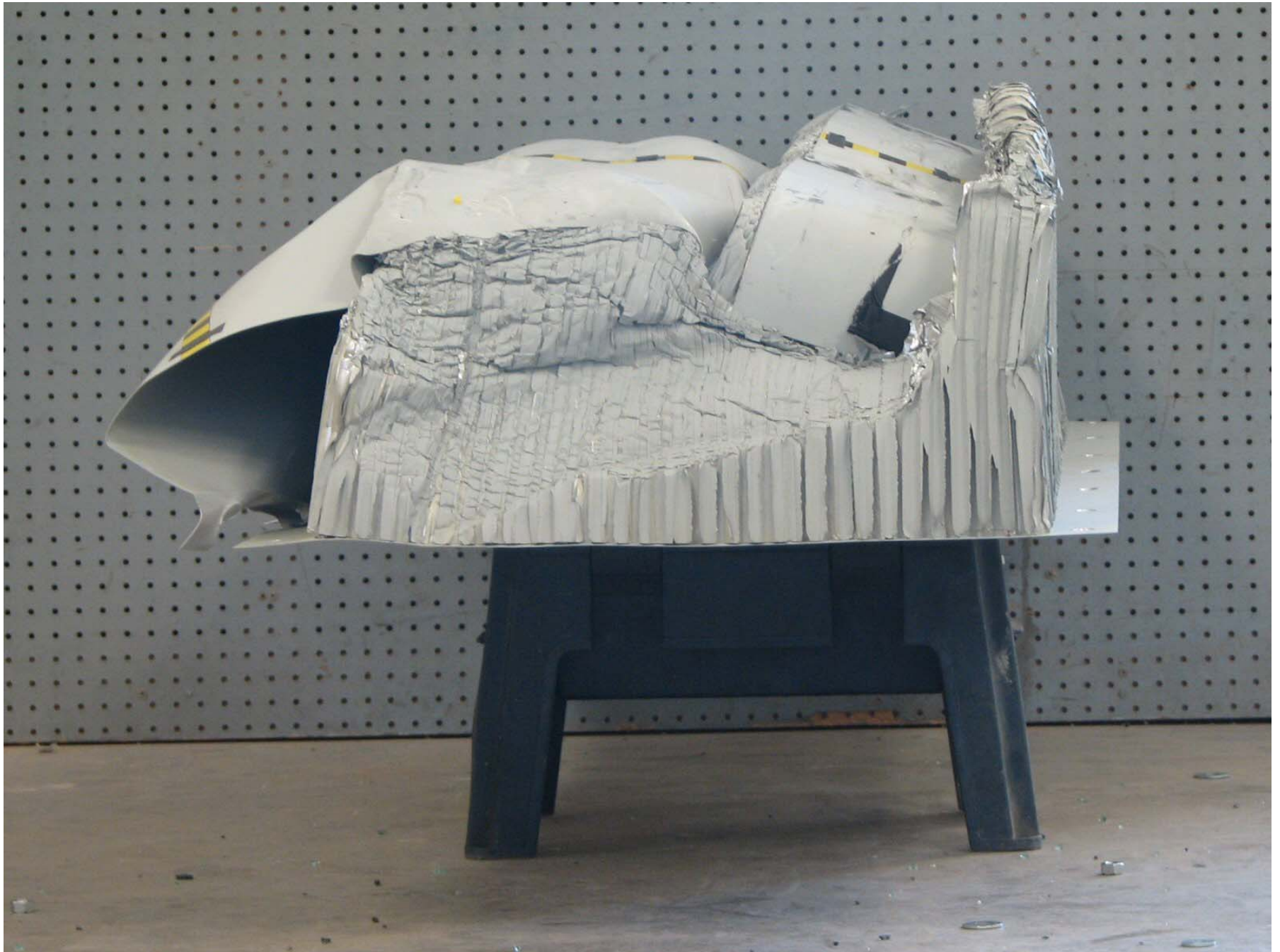

Figure A-58: Post-Test Right Side View of Deformable Barrier

A-59

TR-P27148-01-NC



Figure A-59: Pre-Test Left Side View of Deformable Barrier



Figure A-60: Post-Test Left Side View of Deformable Barrier



Figure A-61: Vehicle on Rollover Device (0°)



Figure A-62: Vehicle on Rollover Device (90°)



Figure A-63: Vehicle on Rollover Device (180°)

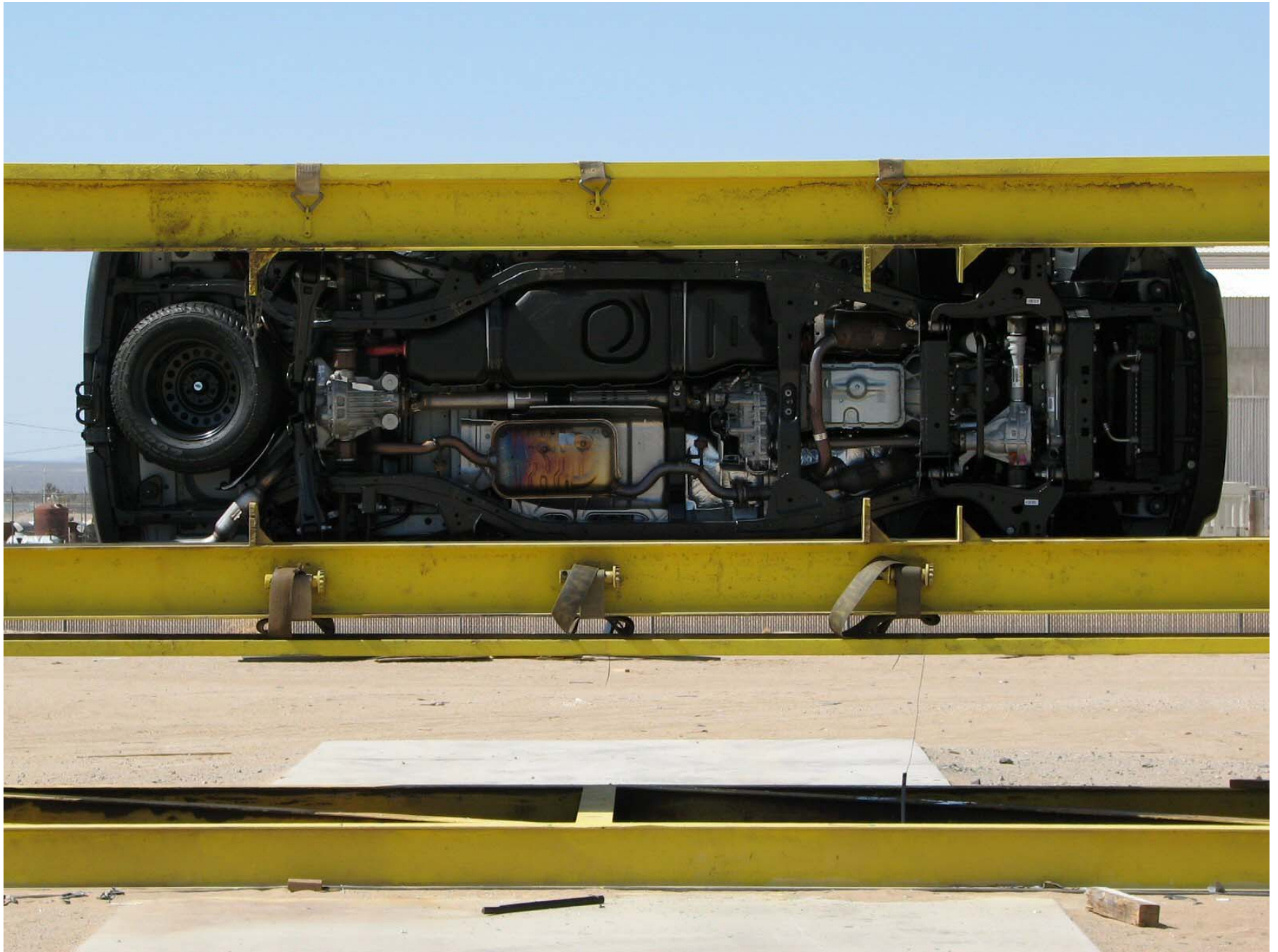

Figure A-64: Vehicle on Rollover Device (270°)

A-64

TR-P27148-01-NC



Figure A-65: Vehicle Impact

APPENDIX B
SID/HIII, VEHICLE AND MDB RESPONSE DATA

LIST OF DATA PLOTS

<u>Data Plot</u>		<u>Page</u>
B-1	Driver Upper Rib Primary Y	B-1
	Driver Lower Rib Primary Y	B-1
	Driver Lower Spine Primary Y	B-1
	Driver Pelvis Primary Y	B-1
B-2	Passenger Upper Rib Primary Y	B-2
	Passenger Lower Rib Primary Y	B-2
	Passenger Lower Spine Primary Y	B-2
	Passenger Pelvis Primary Y	B-2

The following additional data plots for this test can be obtained from the research and development section of the NHTSA website. The website can be found at www.NHTSA.dot.gov

LIST OF DATA PLOTS...(CONTINUED)

Driver Head X Primary
Driver Head Y Primary
Driver Head Z Primary
Driver Head Resultant Primary
Driver Head Primary X Velocity
Driver Head Primary Y Velocity
Driver Head Primary Z Velocity
Driver Head X Redundant
Driver Head Y Redundant
Driver Head Z Redundant
Driver Head Resultant Redundant
Driver Head Redundant X Velocity
Driver Head Redundant Y Velocity
Driver Head Redundant Z Velocity
Driver Upper Neck Force X
Driver Upper Neck Force Y
Driver Upper Neck Force Z
Driver Upper Neck Force Resultant
Driver Upper Neck Moment X
Driver Upper Neck Moment Y
Driver Upper Neck Moment Z
Driver Upper Neck Moment Resultant
Driver Upper Rib Primary Y Velocity
Driver Lower Rib Primary Y Velocity
Driver Lower Spine Primary Y Velocity
Driver Pelvis Primary Y Velocity
Driver Upper Rib Redundant Y
Driver Lower Rib Redundant Y
Driver Lower Spine Redundant Y
Driver Pelvis Redundant Y

LIST OF DATA PLOTS...(CONTINUED)

Driver Upper Rib Redundant Y Velocity
Driver Lower Rib Redundant Y Velocity
Driver Lower Spine Redundant Y Velocity
Driver Pelvis Redundant Y Velocity
Driver Thorax Contact
Driver Pelvis Contact
Passenger Head X Primary
Passenger Head Y Primary
Passenger Head Z Primary
Passenger Head Resultant Primary
Passenger Head Primary X Velocity
Passenger Head Primary Y Velocity
Passenger Head Primary Z Velocity
Passenger Head X Redundant
Passenger Head Y Redundant
Passenger Head Z Redundant
Passenger Head Resultant Redundant
Passenger Head Redundant X Velocity
Passenger Head Redundant Y Velocity
Passenger Head Redundant Z Velocity
Passenger Upper Neck Force X
Passenger Upper Neck Force Y
Passenger Upper Neck Force Z
Passenger Upper Neck Force Resultant
Passenger Upper Neck Moment X
Passenger Upper Neck Moment Y
Passenger Upper Neck Moment Z
Passenger Upper Neck Moment Resultant

LIST OF DATA PLOTS...(CONTINUED)

Passenger Upper Rib Primary Y Velocity
Passenger Lower Rib Primary Y Velocity
Passenger Lower Spine Primary Y Velocity
Passenger Pelvis Primary Y Velocity
Passenger Upper Rib Redundant Y
Passenger Lower Rib Redundant Y
Passenger Lower Spine Redundant Y
Passenger Pelvis Redundant Y
Passenger Upper Rib Redundant Y Velocity
Passenger Lower Rib Redundant Y Velocity
Passenger Lower Spine Redundant Y Velocity
Passenger Pelvis Redundant Y Velocity
Passenger Thorax Contact
Passenger Pelvis Contact
Vehicle Right Sill at Front Seat X
Vehicle Right Sill at Front Seat Y
Vehicle Right Sill at Front Seat Z
Vehicle Right Sill Front Seat Resultant
Vehicle Right Sill at Front Seat X Velocity
Vehicle Right Sill at Front Seat Y Velocity
Vehicle Right Sill at Front Seat Z Velocity
Vehicle Right Sill at Rear Seat X
Vehicle Right Sill at Rear Seat Y
Vehicle Right Sill at Rear Seat Z
Vehicle Right Sill Rear Seat Resultant
Vehicle Right Sill at Rear Seat X Velocity
Vehicle Right Sill at Rear Seat Y Velocity
Vehicle Right Sill at Rear Seat Z Velocity
Vehicle Rear Floor Above Axle X
Vehicle Rear Floor Above Axle Y
Vehicle Rear Floor Above Axle Z
Vehicle Rear Floor Above Axle Resultant
Vehicle Rear Floor Above Axle X Velocity
Vehicle Rear Floor Above Axle Y Velocity
Vehicle Rear Floor Above Axle Z Velocity

LIST OF DATA PLOTS...(CONTINUED)

Vehicle Left Sill at Rear Door Y
Vehicle Left Sill at Front Door Y
Vehicle Left Sill at Rear Door Y Velocity
Vehicle Left Sill at Front Door Y Velocity
Vehicle Left Front Door C/L Y
Vehicle Right Rear Occupant Compartment
Vehicle Left Front Door Mid Rear Y
Vehicle Left Front Door Upper CL Y
Vehicle Left Front Door CL Y Velocity
Vehicle Right Rear Occupant Compartment Y Velocity
Vehicle Left Front Door Mid Rear Y Velocity
Vehicle Left Rear Door Upper CL Y Velocity
Vehicle Left Rear Door Mid Rear Y
Vehicle Left Rear Door Upper C/L Y
Vehicle Left Rear Door Mid Rear Y Velocity
Vehicle Left Rear Door Upper CL Y Velocity
Vehicle B-Post Lower Y
Vehicle B-Post Middle Y
Vehicle B-Post Lower Y Velocity
Vehicle B-Post Middle Y Velocity
Vehicle A-Post Lower Y
Vehicle A-Post Middle Y
Vehicle A-Post Lower Y Velocity
Vehicle A-Post Middle Y Velocity
Vehicle Left Front Seat Track
Vehicle Rear Seat Structure
Vehicle Left Front Seat Track Y Velocity
Vehicle Rear Seat Structure Y Velocity
Vehicle CG X
Vehicle CG Y
Vehicle CG Z
Vehicle CG Resultant
Vehicle CG X Velocity
Vehicle CG Y Velocity
Vehicle CG Z Velocity

LIST OF DATA PLOTS...(CONTINUED)

Driver Upper Rib Primary Y
Driver Lower Rib Primary Y
Driver Lower Spine Primary Y
Driver Pelvis Primary Y
Driver Upper Rib Redundant Y
Driver Lower Rib Redundant Y
Driver Lower Spine Redundant Y
Driver Pelvis Redundant Y
Passenger Upper Rib Primary Y
Passenger Lower Rib Primary Y
Passenger Lower Spine Primary Y
Passenger Pelvis Primary Y
Passenger Upper Rib Redundant Y
Passenger Lower Rib Redundant Y
Passenger Lower Spine Redundant Y
Passenger Pelvis Redundant Y
MDB CG X
MDB CG Y
MDB CG Z
MDB CG Resultant
MDB CG X Velocity
MDB CG Y Velocity
MDB CG Z Velocity
MDB Rear X
MDB Rear Y
MDB Rear X Velocity
MDB Rear Y Velocity
MDB Right Bumper Contact

Test Vehicle: 2007 Ford Explorer XLT 5-Door MPV
 Test Program: 55/28 km/h Side Impact NCAP

Test Date: 6/8/07
 NHTSA No.: F80200

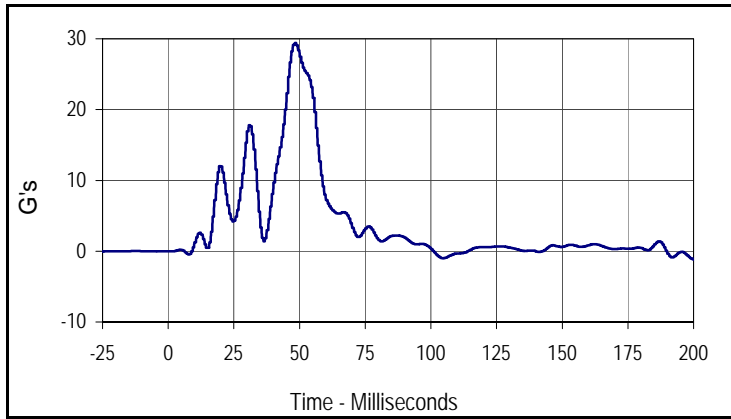

Curve Description			
Driver Upper Rib Y Primary			
CURNO	Type	SAE Class	Units
001	FIR	FIR100	G's
Max	Time	Min	Time
29.4	48.2	-1.2	200.7

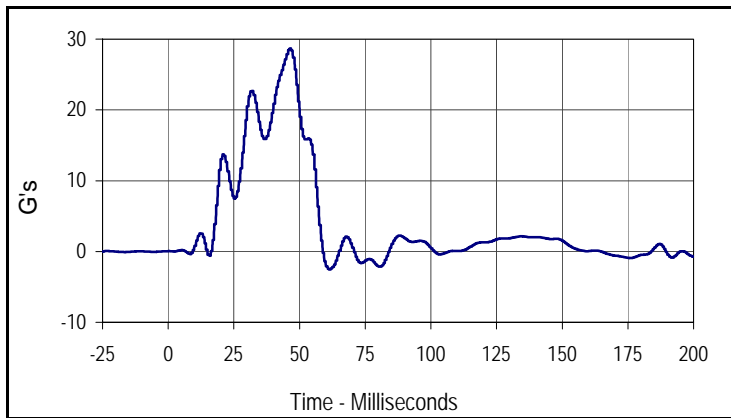

Curve Description			
Driver Lower Rib Y Primary			
CURNO	Type	SAE Class	Units
002	FIR	FIR100	G's
Max	Time	Min	Time
28.7	46.3	-2.5	61.3

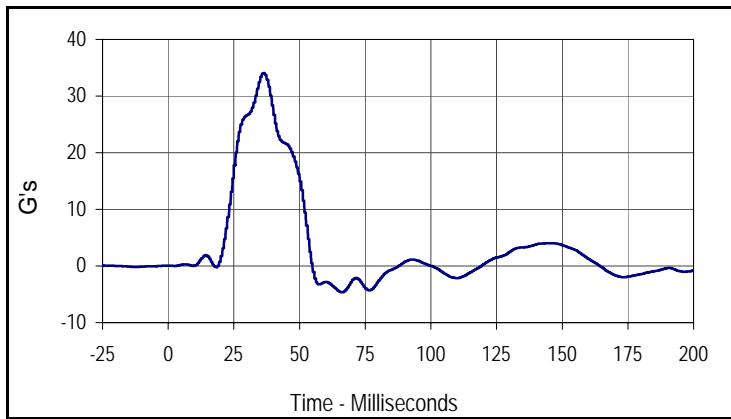

Curve Description			
Driver Lower Spine Y Primary			
CURNO	Type	SAE Class	Units
003	FIR	FIR100	G's
Max	Time	Min	Time
34.1	36.3	-4.6	65.7

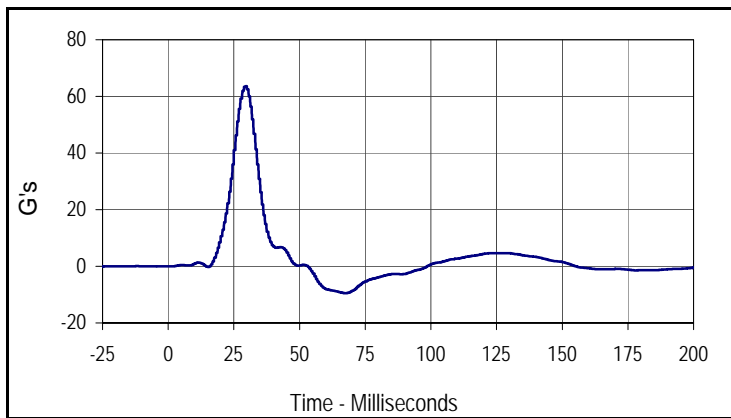

Curve Description			
Driver Pelvis Y Primary			
CURNO	Type	SAE Class	Units
004	FIR	FIR100	G's
Max	Time	Min	Time
63.6	29.4	-9.5	67.5

Test Vehicle: 2007 Ford Explorer XLT 5-Door MPV
 Test Program: 55/28 km/h Side Impact NCAP

Test Date: 6/8/07
 NHTSA No.: F80200

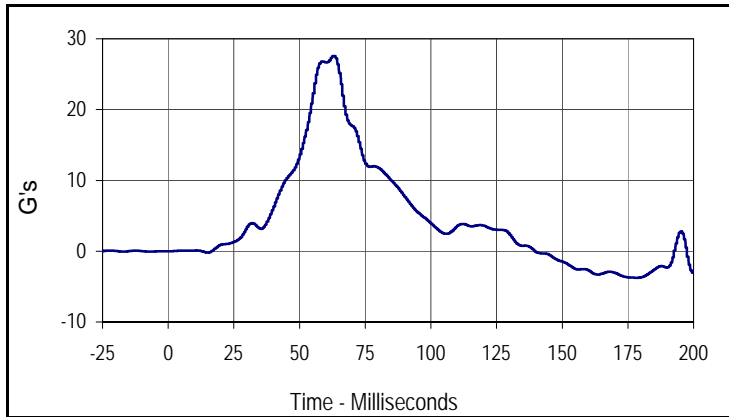

Curve Description			
Passenger Upper Rib Y Primary			
CURNO	Type	SAE Class	Units
005	FIR	FIR100	G's
Max	Time	Min	Time
27.6	63.2	-3.8	178.2

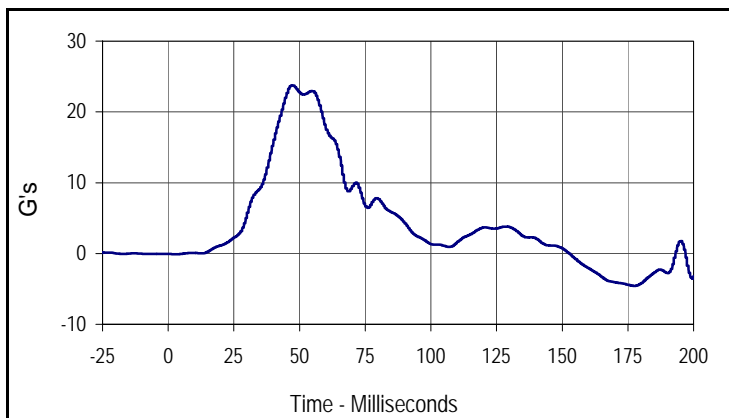

Curve Description			
Passenger Lower Rib Y Primary			
CURNO	Type	SAE Class	Units
006	FIR	FIR100	G's
Max	Time	Min	Time
23.8	46.9	-4.6	177.5

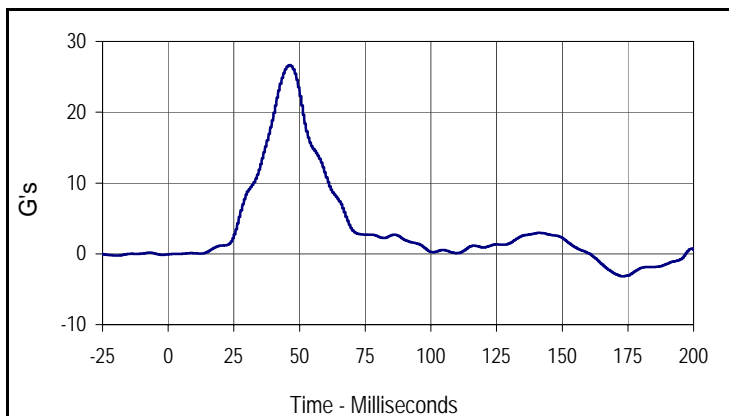

Curve Description			
Passenger Lower Spine Y Primary			
CURNO	Type	SAE Class	Units
007	FIR	FIR100	G's
Max	Time	Min	Time
26.6	46.3	-3.2	173.2

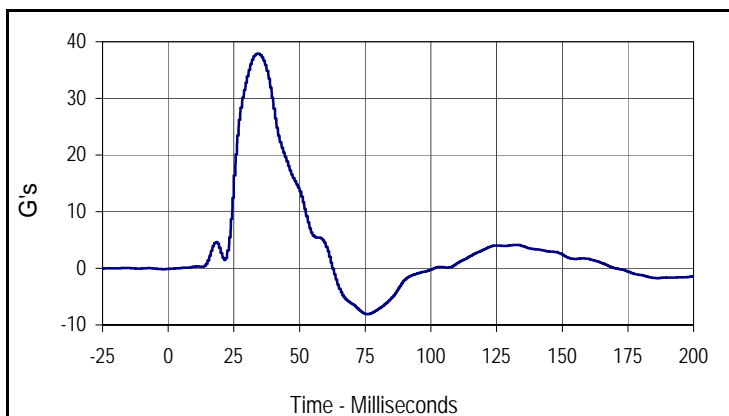

Curve Description			
Passenger Pelvis Primary Y			
CURNO	Type	SAE Class	Units
008	FIR	FIR100	G's
Max	Time	Min	Time
37.9	33.8	-8.1	75.7

APPENDIX C
SID/HIII CONFIGURATION AND PERFORMANCE VERIFICATION DATA

APPENDIX C
PRE-TEST SID / HIII CONFIGURATION AND PERFORMANCE VERIFICATION DATA

Test Program: SID / HIII External Measurements

Test Date: 6/7/07

ATD Serial No.: 274

Test I.D.: N/A



Tested Parameter	Units	Specification	Result	Pass/Fail
Laboratory Temperature	°C	18.9 to 25.6	21.1	Pass
Laboratory Relative Humidity	%	10 to 70	30	Pass
SH- Seated Height	mm	889 to 909	892	Pass
HP- Hip Point Height	mm	99 (reference)	99	Pass
RH- Rib Height	mm	502 to 520	510	Pass
KH- Knee Pivot From Back Line	mm	511 to 526	518	Pass
KV- Knee Pivot From Floor	mm	490 to 505	500	Pass
HW- Hip Width	mm	356 to 391	375	Pass
Overall Test Results				Pass

Test Program: SID / HIII Thorax Lateral Impact
 ATD Serial No.: 274

Test Date: 6/7/07
 Test I.D.: TH06D



Tested Parameter	Units	Specification	Result	Pass/Fail
Laboratory Temperature	°C	18.9 to 25.6	21.1	Pass
Laboratory Relative Humidity	%	10 to 70	30	Pass
Probe Velocity	m/s	4.21 to 4.33	4.26	Pass
Upper Rib Acceleration	G's	37.0 to 46.0	40.6	Pass
Lower Rib Acceleration	G's	37.0 to 46.0	39.8	Pass
Thoracic Spine Acceleration	G's	15.0 to 22.0	19.3	Pass
Overall Test Results			Pass	

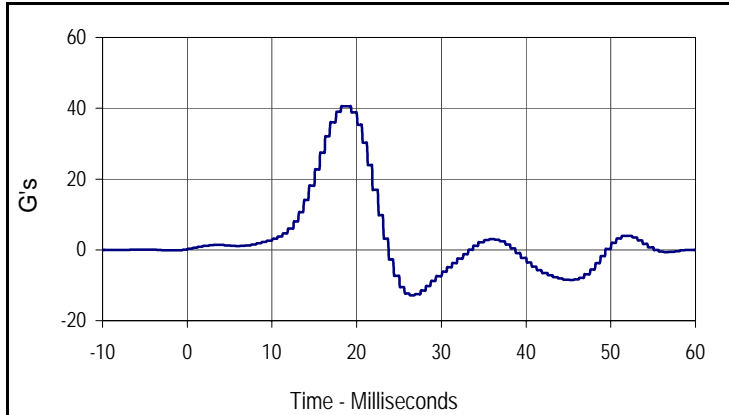

Curve Description			
Upper Rib Y Primary			
CURNO	Type	SAE Class	Units
001	FIL	FIR100	G's
Max	Time	Min	Time
40.6	18.2	-12.8	26.3

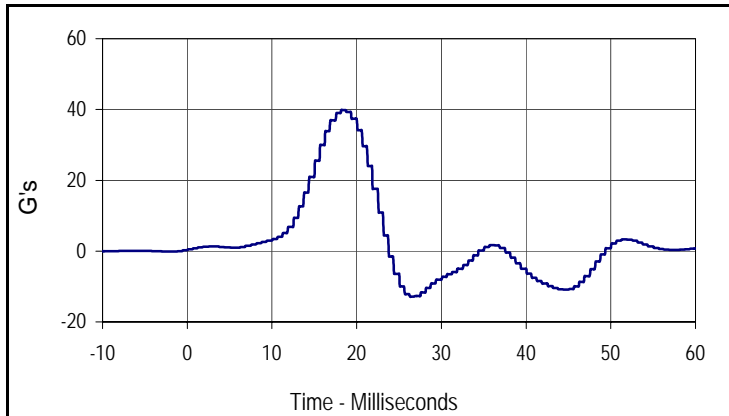

Curve Description			
Lower Rib Y Primary			
CURNO	Type	SAE Class	Units
002	FIL	FIR100	G's
Max	Time	Min	Time
39.8	18.2	-12.9	26.3

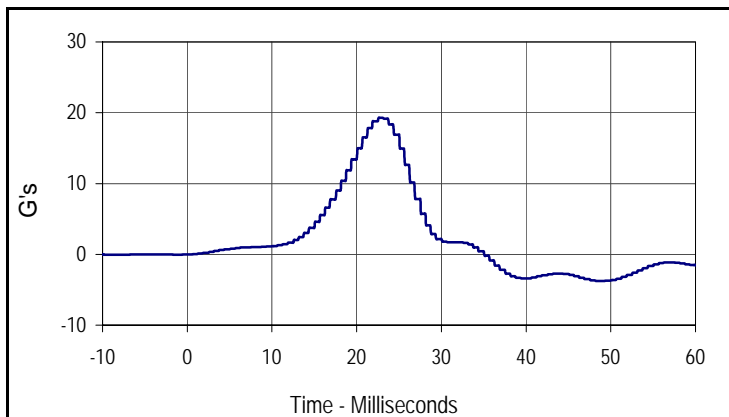

Curve Description			
Lower Spine Y Primary			
CURNO	Type	SAE Class	Units
003	FIL	FIR100	G's
Max	Time	Min	Time
19.3	22.6	-3.8	48.8

Test Program: SID / HIII Pelvis Lateral Impact
 ATD Serial No.: 274

Test Date: 6/7/07
 Test I.D.: PL06D



Tested Parameter	Units	Specification	Result	Pass/Fail
Laboratory Temperature	°C	18.9 to 25.6	21.1	Pass
Laboratory Relative Humidity	%	10 to 70	30	Pass
Probe Velocity	m/s	4.21 to 4.33	4.32	Pass
Peak Pelvis Acceleration	G's	40.0 to 60.0	48.0	Pass
Acceleration Time Above 20 G's	Msec.	3.0 to 7.0	4.90	Pass
Overall Test Results				Pass

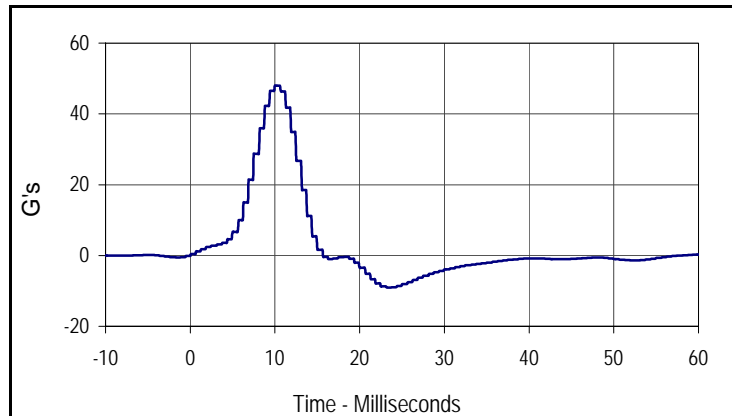

Curve Description			
Pelvis Y Primary			
CURNO	Type	SAE Class	Units
001	FIL	FIR100	G's
Max	Time	Min	Time
48.0	10.0	-9.0	23.2

Test Program: SID / HIII Head Drop Lateral Impact Test
 ATD Serial No.: 274

Test Date: 6/7/07
 Test I.D.: HD06D



Tested Parameter	Units	Specification	Result	Pass/Fail
Laboratory Temperature	°C	18.9 to 25.6	21.7	Pass
Laboratory Relative Humidity	%	10 to 70	30	Pass
Peak Resultant Acceleration	G's	120.0 to 150.0	145.0	Pass
Peak Longitudinal Acceleration	G's	≤15.0	6.3	Pass
Is Acceleration Unimodal?	Yes/No	Yes	Yes	Pass
Oscillations After Main Pulse	%	<15	3.1	Pass
Overall Test Results			Pass	

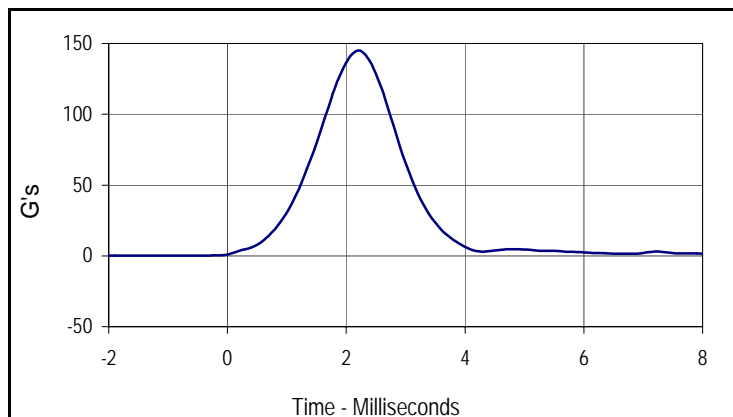

Curve Description			
Head Resultant			
CURNO	Type	SAE Class	Units
001	RES	1000	G's
Max	Time	Min	Time
145.0	2.2	0.1	-1.9

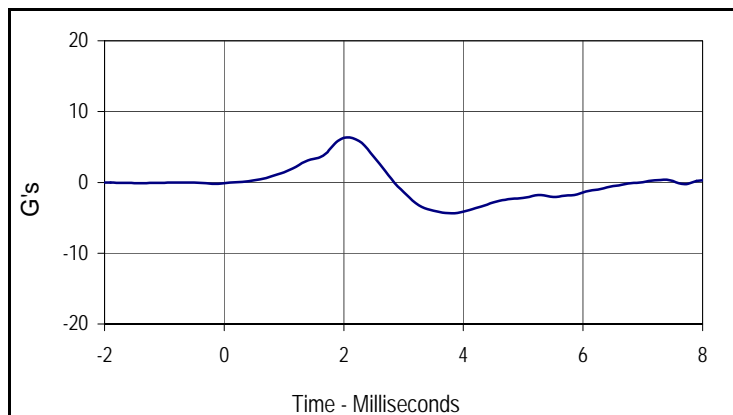

Curve Description			
Head X			
CURNO	Type	SAE Class	Units
002	FIL	1000	G's
Max	Time	Min	Time
6.3	2.1	-4.4	3.8

Test Program: SID / HIII Neck Pendulum Lateral Test
 ATD Serial No.: 274

Test Date: 6/7/07
 Test I.D.: NB06D



Tested Parameter	Units	Specification	Result	Pass/Fail	
Laboratory Temperature	°C	20.6 to 22.2	21.1	Pass	
Laboratory Relative Humidity	%	10 to 70	30	Pass	
Pendulum Velocity	m/sec	6.89 to 7.13	7.10	Pass	
Pendulum Deceleration	10 Msec.	m/sec	1.96 to 2.55	2.32	Pass
	20 Msec.	m/sec	4.12 to 5.10	4.81	Pass
	30 Msec.	m/sec	5.73 to 7.01	6.86	Pass
	40 to 70	m/sec	6.27 to 7.64	7.53	Pass
"D" Plane Rotation	Max	Degrees	66.0 to 82.0	73.3	Pass
Max Rotation Time After Peak Moment	Msec.	2.0 to 16.0	9.7	Pass	
Rotation Time From Peak to Zero Angle	Msec.	58.0 to 67.0	60.3	Pass	
Moment About Occipital Condyle	Nm	73.0 to 88.0	85.1	Pass	
Positive Moment Decay, Time To 0 Nm	Msec.	49.0 to 64.0	49.7	Pass	
Overall Test Results				Pass	

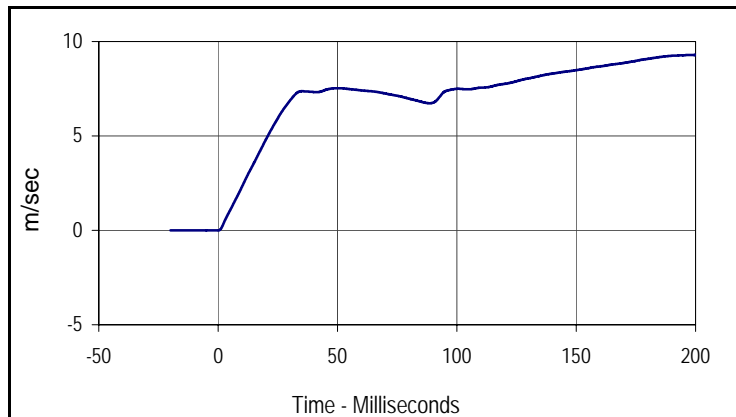

Curve Description			
Pendulum Velocity			
CURNO	Type	SAE Class	Units
001	FIL	180	m/sec
Max	Time	Min	Time
9.3	198.6	0.0	-0.1

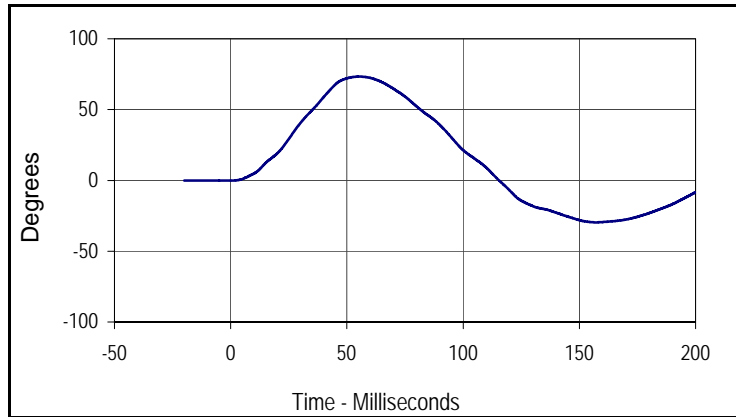

Curve Description			
"D" Plane Rotation			
CURNO	Type	SAE Class	Units
003	FIL	60	Degrees
Max	Time	Min	Time
73.3	55.2	-29.6	157.1

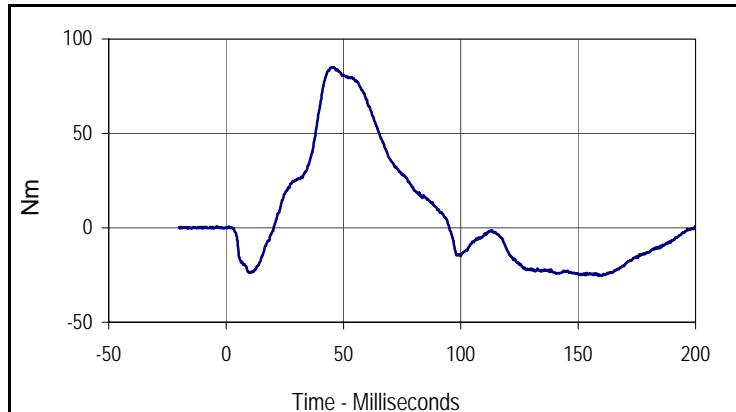

Curve Description			
Moment About Occipital Condyle			
CURNO	Type	SAE Class	Units
004	FIL	600	Nm
Max	Time	Min	Time
85.1	45.5	-25.5	160.2

Test Program: SID / HIII External Measurements

Test Date: 6/7/07

ATD Serial No.: 275

Test I.D.: N/A



Tested Parameter	Units	Specification	Result	Pass/Fail
Laboratory Temperature	°C	18.9 to 25.6	21.1	Pass
Laboratory Relative Humidity	%	10 to 70	30	Pass
SH- Seated Height	mm	889 to 909	895	Pass
HP- Hip Point Height	mm	99 (reference)	99	Pass
RH- Rib Height	mm	502 to 520	513	Pass
KH- Knee Pivot From Back Line	mm	511 to 526	520	Pass
KV- Knee Pivot From Floor	mm	490 to 505	501	Pass
HW- Hip Width	mm	356 to 391	378	Pass
Overall Test Results				Pass

Test Program: SID / HIII Thorax Lateral Impact
 ATD Serial No.: 275

Test Date: 6/7/07
 Test I.D.: TH06C



Tested Parameter	Units	Specification	Result	Pass/Fail
Laboratory Temperature	°C	18.9 to 25.6	21.1	Pass
Laboratory Relative Humidity	%	10 to 70	30	Pass
Probe Velocity	m/s	4.21 to 4.33	4.25	Pass
Upper Rib Acceleration	G's	37.0 to 46.0	40.1	Pass
Lower Rib Acceleration	G's	37.0 to 46.0	37.4	Pass
Thoracic Spine Acceleration	G's	15.0 to 22.0	19.4	Pass
Overall Test Results			Pass	

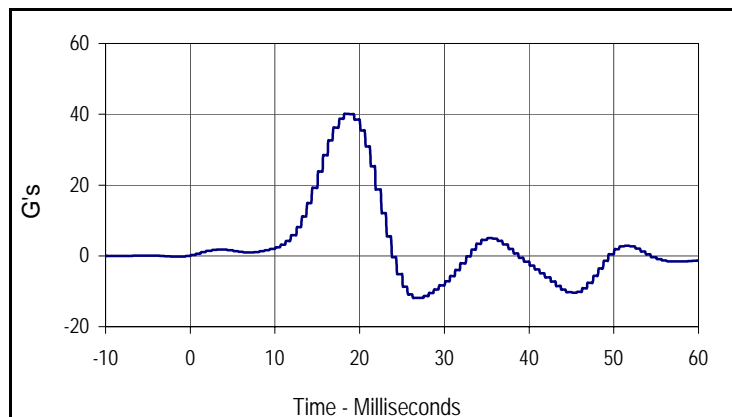

Curve Description			
Upper Rib Y Primary			
CURNO	Type	SAE Class	Units
001	FIL	FIR100	G's
Max	Time	Min	Time
40.1	18.2	-11.9	26.9

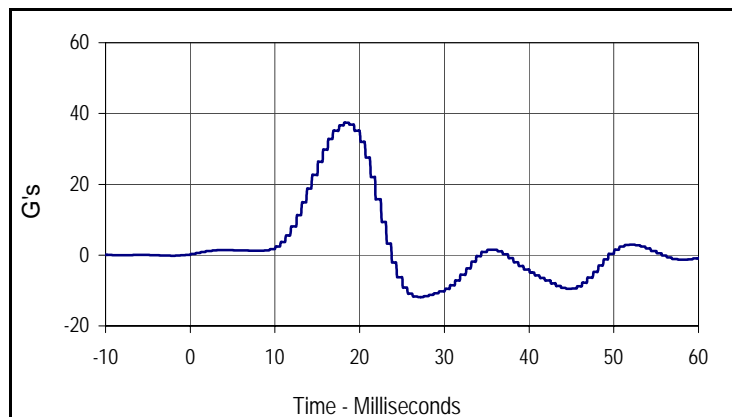

Curve Description			
Lower Rib Y Primary			
CURNO	Type	SAE Class	Units
002	FIL	FIR100	G's
Max	Time	Min	Time
37.4	18.2	-11.8	26.9

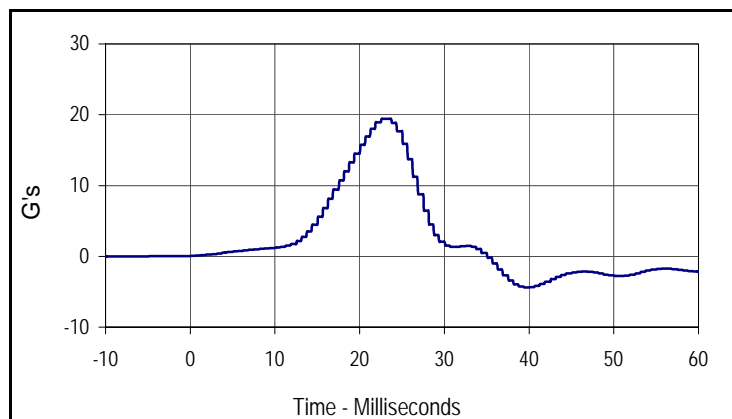

Curve Description			
Lower Spine Y Primary			
CURNO	Type	SAE Class	Units
003	FIL	FIR100	G's
Max	Time	Min	Time
19.4	23.2	-4.4	39.4

Test Program: SID / HIII Pelvis Lateral Impact
 ATD Serial No.: 275

Test Date: 6/7/07
 Test I.D.: PL06C



Tested Parameter	Units	Specification	Result	Pass/Fail
Laboratory Temperature	°C	18.9 to 25.6	21.1	Pass
Laboratory Relative Humidity	%	10 to 70	30	Pass
Probe Velocity	m/s	4.21 to 4.33	4.28	Pass
Peak Pelvis Acceleration	G's	40.0 to 60.0	46.4	Pass
Acceleration Time Above 20 G's	Msec.	3.0 to 7.0	6.70	Pass
Overall Test Results				Pass

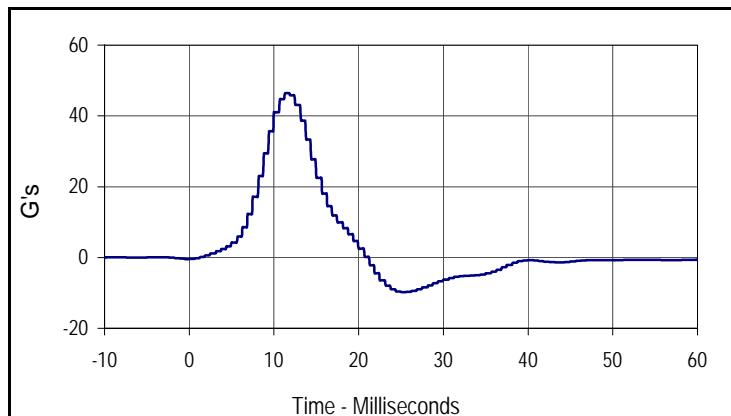

Curve Description			
Pelvis Y Primary			
CURNO	Type	SAE Class	Units
001	FIL	FIR100	G's
Max	Time	Min	Time
46.4	11.3	-9.8	25.0

Test Program: SID / HIII Head Drop Lateral Impact Test
 ATD Serial No.: 275

Test Date: 6/7/07
 Test I.D.: HD06C



Tested Parameter	Units	Specification	Result	Pass/Fail
Laboratory Temperature	°C	18.9 to 25.6	21.7	Pass
Laboratory Relative Humidity	%	10 to 70	30	Pass
Peak Resultant Acceleration	G's	120.0 to 150.0	138.8	Pass
Peak Longitudinal Acceleration	G's	≤15.0	8.0	Pass
Is Acceleration Unimodal?	Yes/No	Yes	Yes	Pass
Oscillations After Main Pulse	%	<15	4.0	Pass
Overall Test Results			Pass	

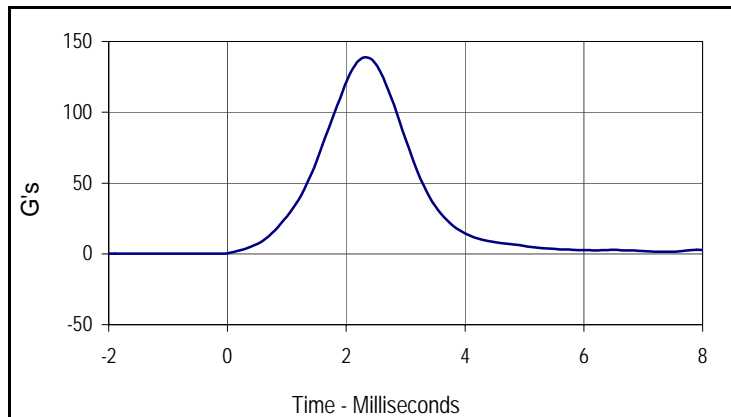

Curve Description			
Head Resultant			
CURNO	Type	SAE Class	Units
001	RES	1000	G's
Max	Time	Min	Time
138.8	2.3	0.1	-0.9

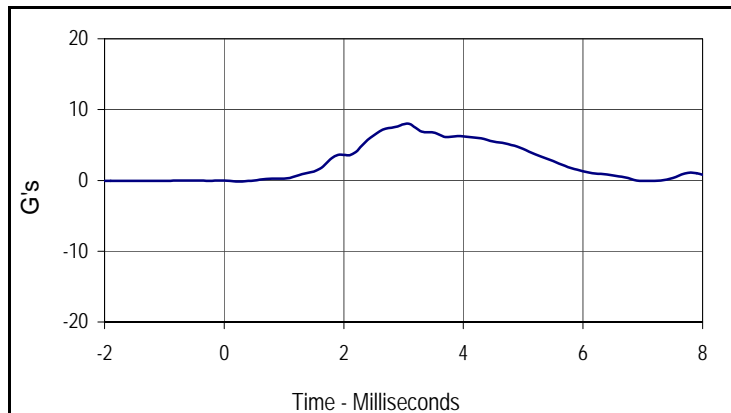

Curve Description			
Head X			
CURNO	Type	SAE Class	Units
002	FIL	1000	G's
Max	Time	Min	Time
8.0	3.1	-0.1	0.2

Test Program: SID / HIII Neck Pendulum Lateral Test
 ATD Serial No.: 275

Test Date: 6/7/07
 Test I.D.: NB06C



Tested Parameter	Units	Specification	Result	Pass/Fail	
Laboratory Temperature	°C	20.6 to 22.2	21.1	Pass	
Laboratory Relative Humidity	%	10 to 70	30	Pass	
Pendulum Velocity	m/sec	6.89 to 7.13	7.10	Pass	
Pendulum Deceleration	10 Msec.	m/sec	1.96 to 2.55	2.07	Pass
	20 Msec.	m/sec	4.12 to 5.10	4.33	Pass
	30 Msec.	m/sec	5.73 to 7.01	6.39	Pass
	40 to 70	m/sec	6.27 to 7.64	7.43	Pass
"D" Plane Rotation	Max	Degrees	66.0 to 82.0	76.6	Pass
Max Rotation Time After Peak Moment	Msec.	2.0 to 16.0	11.0	Pass	
Rotation Time From Peak to Zero Angle	Msec.	58.0 to 67.0	61.5	Pass	
Moment About Occipital Condyle	Nm	73.0 to 88.0	86.6	Pass	
Positive Moment Decay, Time To 0 Nm	Msec.	49.0 to 64.0	49.2	Pass	
Overall Test Results				Pass	

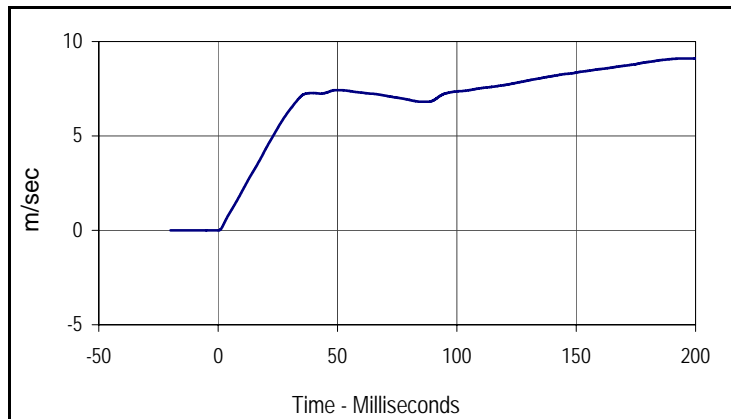

Curve Description			
Pendulum Velocity			
CURNO	Type	SAE Class	Units
001	FIL	180	m/sec
Max	Time	Min	Time
9.1	195.5	0.0	-0.2

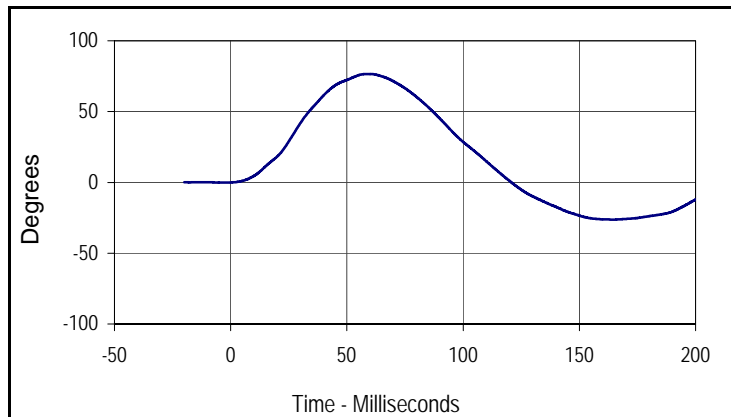

Curve Description			
"D" Plane Rotation			
CURNO	Type	SAE Class	Units
003	FIL	60	Degrees
Max	Time	Min	Time
76.6	59.3	-26.3	164.5

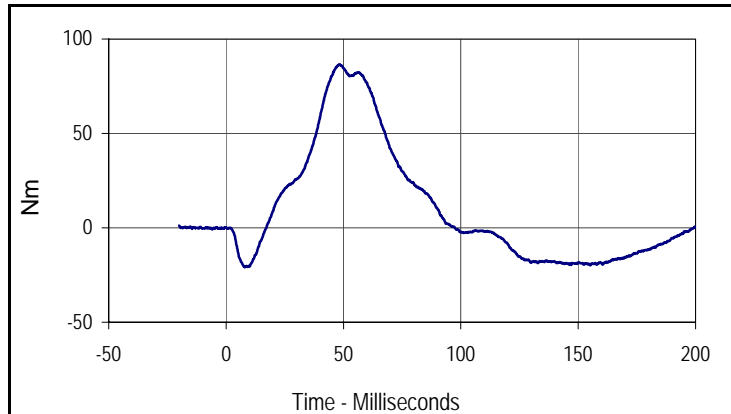

Curve Description			
Moment About Occipital Condyle			
CURNO	Type	SAE Class	Units
004	FIL	600	Nm
Max	Time	Min	Time
86.6	48.3	-20.8	8.1

APPENDIX C
POST-TEST SID / HIII CONFIGURATION AND PERFORMANCE VERIFICATION DATA

Test Program: SID / HIII External Measurements

Test Date: 6/11/07

ATD Serial No.: 274

Test I.D.: N/A



Tested Parameter	Units	Specification	Result	Pass/Fail
Laboratory Temperature	°C	18.9 to 25.6	21.1	Pass
Laboratory Relative Humidity	%	10 to 70	30	Pass
SH- Seated Height	mm	889 to 909	895	Pass
HP- Hip Point Height	mm	99 (reference)	99	Pass
RH- Rib Height	mm	502 to 520	516	Pass
KH- Knee Pivot From Back Line	mm	511 to 526	520	Pass
KV- Knee Pivot From Floor	mm	490 to 505	498	Pass
HW- Hip Width	mm	356 to 391	380	Pass
Overall Test Results				Pass

Test Program: SID / HIII Thorax Lateral Impact
 ATD Serial No.: 274

Test Date: 6/11/07
 Test I.D.: TH06F



Tested Parameter	Units	Specification	Result	Pass/Fail
Laboratory Temperature	°C	18.9 to 25.6	21.1	Pass
Laboratory Relative Humidity	%	10 to 70	30	Pass
Probe Velocity	m/s	4.21 to 4.33	4.31	Pass
Upper Rib Acceleration	G's	37.0 to 46.0	43.2	Pass
Lower Rib Acceleration	G's	37.0 to 46.0	45.2	Pass
Thoracic Spine Acceleration	G's	15.0 to 22.0	20.3	Pass
Overall Test Results				Pass

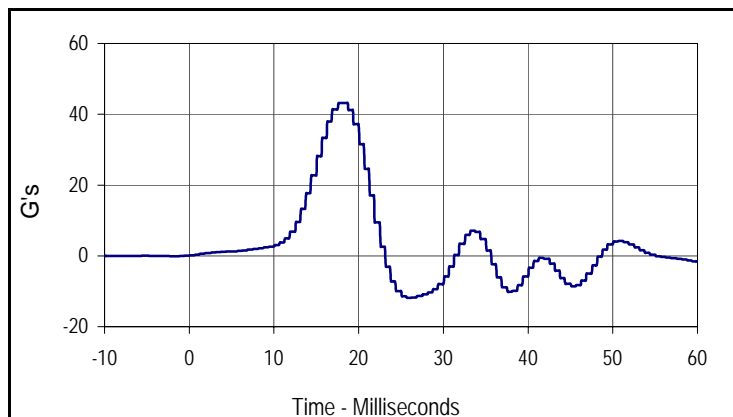

Curve Description			
Upper Rib Y Primary			
CURNO	Type	SAE Class	Units
001	FIL	FIR100	G's
Max	Time	Min	Time
43.2	17.6	-11.9	25.7

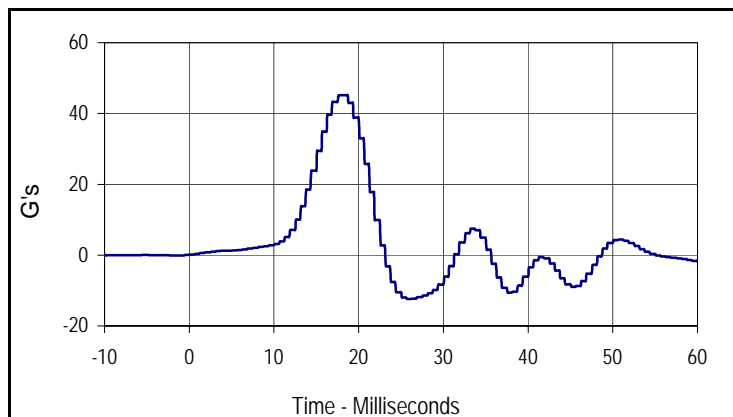

Curve Description			
Lower Rib Y Primary			
CURNO	Type	SAE Class	Units
002	FIL	FIR100	G's
Max	Time	Min	Time
45.2	17.6	-12.4	25.7

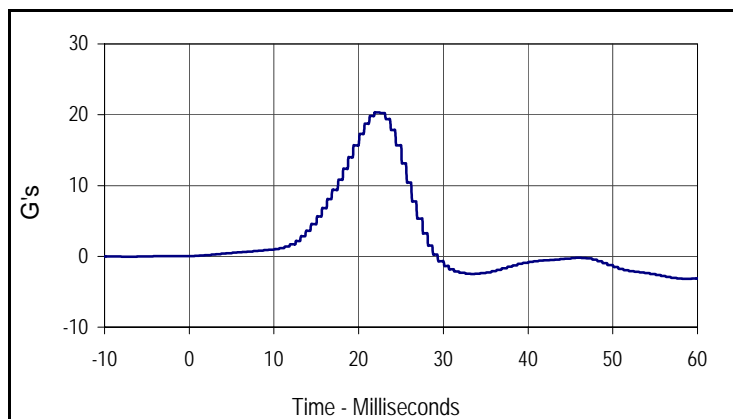

Curve Description			
Lower Spine Y Primary			
CURNO	Type	SAE Class	Units
003	FIL	FIR100	G's
Max	Time	Min	Time
20.3	21.9	-3.2	58.8

Test Program: SID / HIII Pelvis Lateral Impact
 ATD Serial No.: 274

Test Date: 6/11/07
 Test I.D.: PL06F



Tested Parameter	Units	Specification	Result	Pass/Fail
Laboratory Temperature	°C	18.9 to 25.6	21.1	Pass
Laboratory Relative Humidity	%	10 to 70	30	Pass
Probe Velocity	m/s	4.21 to 4.33	4.26	Pass
Peak Pelvis Acceleration	G's	40.0 to 60.0	44.0	Pass
Acceleration Time Above 20 G's	Msec.	3.0 to 7.0	4.90	Pass
Overall Test Results				Pass

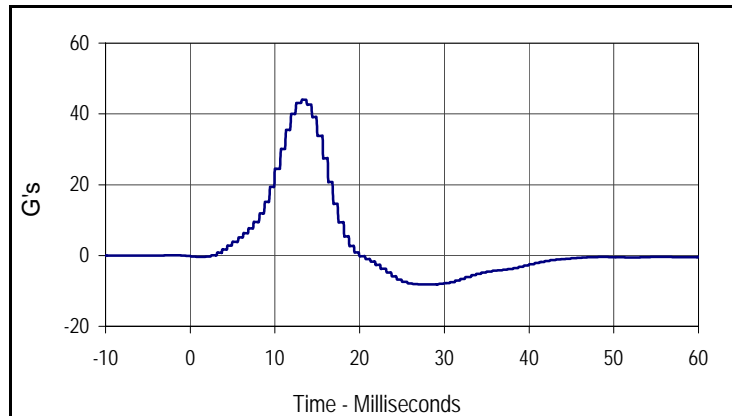

Curve Description			
Pelvis Y Primary			
CURNO	Type	SAE Class	Units
001	FIL	FIR100	G's
Max	Time	Min	Time
44.0	13.2	-8.2	27.5

Test Program: SID / HIII Head Drop Lateral Impact Test
 ATD Serial No.: 274

Test Date: 6/11/07
 Test I.D.: HD06F



Tested Parameter	Units	Specification	Result	Pass/Fail
Laboratory Temperature	°C	18.9 to 25.6	21.7	Pass
Laboratory Relative Humidity	%	10 to 70	30	Pass
Peak Resultant Acceleration	G's	120.0 to 150.0	147.3	Pass
Peak Longitudinal Acceleration	G's	≤15.0	13.5	Pass
Is Acceleration Unimodal?	Yes/No	Yes	Yes	Pass
Oscillations After Main Pulse	%	<15	3.8	Pass
Overall Test Results			Pass	

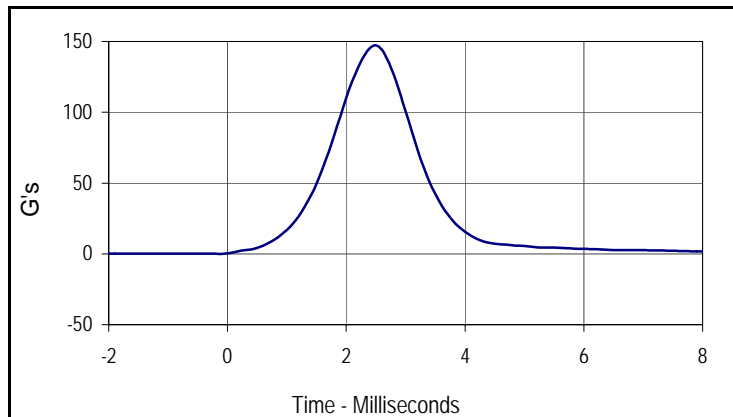

Curve Description			
Head Resultant			
CURNO	Type	SAE Class	Units
001	RES	1000	G's
Max	Time	Min	Time
147.3	2.5	0.0	-0.1

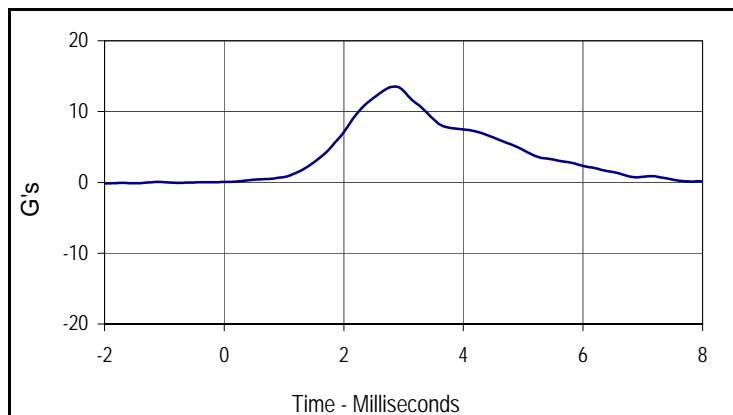

Curve Description			
Head X			
CURNO	Type	SAE Class	Units
002	FIL	1000	G's
Max	Time	Min	Time
13.5	2.8	-0.1	-2.0

Test Program: SID / HIII Neck Pendulum Lateral Test
 ATD Serial No.: 274

Test Date: 6/11/07
 Test I.D.: NB06F



Tested Parameter	Units	Specification	Result	Pass/Fail	
Laboratory Temperature	°C	20.6 to 22.2	21.1	Pass	
Laboratory Relative Humidity	%	10 to 70	30	Pass	
Pendulum Velocity	m/sec	6.89 to 7.13	7.09	Pass	
Pendulum Deceleration	10 Msec.	m/sec	1.96 to 2.55	2.25	Pass
	20 Msec.	m/sec	4.12 to 5.10	4.63	Pass
	30 Msec.	m/sec	5.73 to 7.01	6.57	Pass
	40 to 70	m/sec	6.27 to 7.64	7.37	Pass
"D" Plane Rotation	Max	Degrees	66.0 to 82.0	79.8	Pass
Max Rotation Time After Peak Moment	Msec.	2.0 to 16.0	15.5	Pass	
Rotation Time From Peak to Zero Angle	Msec.	58.0 to 67.0	61.6	Pass	
Moment About Occipital Condyle	Nm	73.0 to 88.0	85.2	Pass	
Positive Moment Decay, Time To 0 Nm	Msec.	49.0 to 64.0	50.4	Pass	
Overall Test Results				Pass	

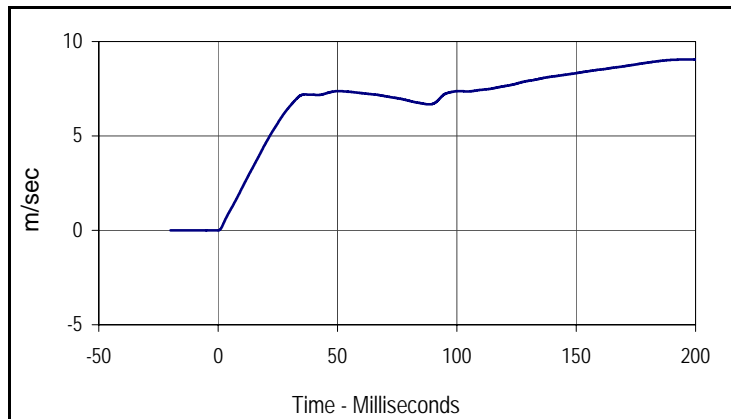

Curve Description			
Pendulum Velocity			
CURNO	Type	SAE Class	Units
001	FIL	180	m/sec
Max	Time	Min	Time
9.1	196.6	0.0	-0.1

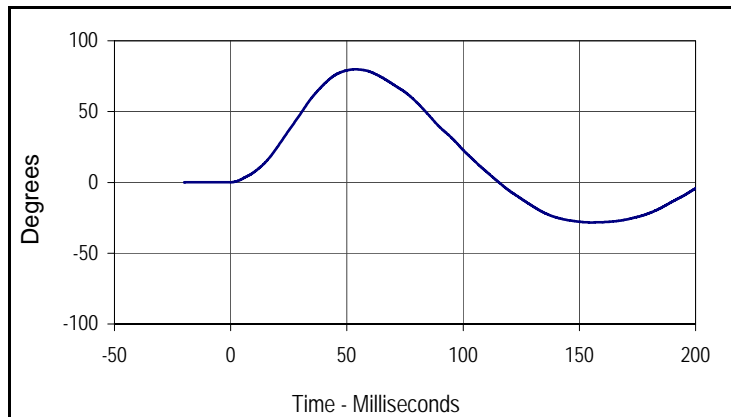

Curve Description			
"D" Plane Rotation			
CURNO	Type	SAE Class	Units
003	FIL	60	Degrees
Max	Time	Min	Time
79.8	53.8	-28.3	155.3

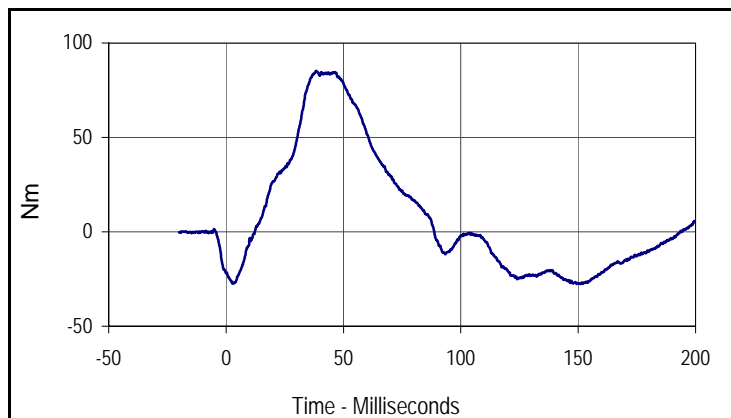

Curve Description			
Moment About Occipital Condyle			
CURNO	Type	SAE Class	Units
004	FIL	600	Nm
Max	Time	Min	Time
85.2	38.3	-27.7	151.0

Test Program: SID / HIII External Measurements

Test Date: 6/11/07

ATD Serial No.: 275

Test I.D.: N/A



Tested Parameter	Units	Specification	Result	Pass/Fail
Laboratory Temperature	°C	18.9 to 25.6	21.1	Pass
Laboratory Relative Humidity	%	10 to 70	30	Pass
SH- Seated Height	mm	889 to 909	898	Pass
HP- Hip Point Height	mm	99 (reference)	99	Pass
RH- Rib Height	mm	502 to 520	505	Pass
KH- Knee Pivot From Back Line	mm	511 to 526	520	Pass
KV- Knee Pivot From Floor	mm	490 to 505	498	Pass
HW- Hip Width	mm	356 to 391	375	Pass
Overall Test Results				Pass

Test Program: SID / HIII Thorax Lateral Impact
 ATD Serial No.: 275

Test Date: 6/11/07
 Test I.D.: TH06G



Tested Parameter	Units	Specification	Result	Pass/Fail
Laboratory Temperature	°C	18.9 to 25.6	21.1	Pass
Laboratory Relative Humidity	%	10 to 70	30	Pass
Probe Velocity	m/s	4.21 to 4.33	4.30	Pass
Upper Rib Acceleration	G's	37.0 to 46.0	42.0	Pass
Lower Rib Acceleration	G's	37.0 to 46.0	41.7	Pass
Thoracic Spine Acceleration	G's	15.0 to 22.0	20.4	Pass
Overall Test Results				Pass



Curve Description			
Upper Rib Y Primary			
CURNO	Type	SAE Class	Units
001	FIL	FIR100	G's
Max	Time	Min	Time
42.0	20.7	-18.8	27.6

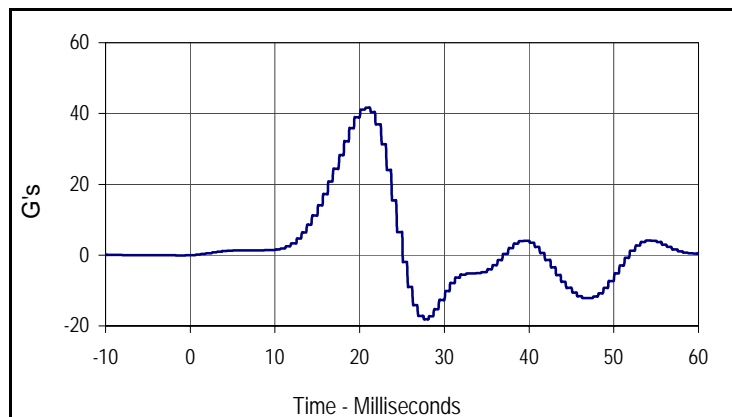

Curve Description			
Lower Rib Y Primary			
CURNO	Type	SAE Class	Units
002	FIL	FIR100	G's
Max	Time	Min	Time
41.7	20.7	-18.1	27.6

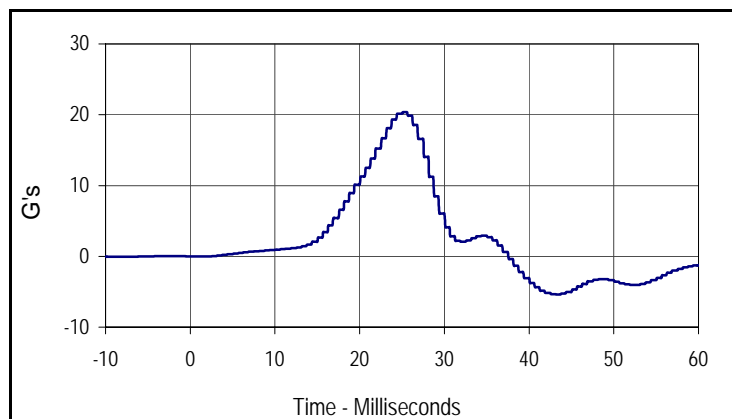

Curve Description			
Lower Spine Y Primary			
CURNO	Type	SAE Class	Units
003	FIL	FIR100	G's
Max	Time	Min	Time
20.4	25.1	-5.4	43.2

Test Program: SID / HIII Pelvis Lateral Impact
 ATD Serial No.: 275

Test Date: 6/11/07
 Test I.D.: PL06G



Tested Parameter	Units	Specification	Result	Pass/Fail
Laboratory Temperature	°C	18.9 to 25.6	21.1	Pass
Laboratory Relative Humidity	%	10 to 70	30	Pass
Probe Velocity	m/s	4.21 to 4.33	4.32	Pass
Peak Pelvis Acceleration	G's	40.0 to 60.0	46.7	Pass
Acceleration Time Above 20 G's	Msec.	3.0 to 7.0	4.90	Pass
Overall Test Results				Pass

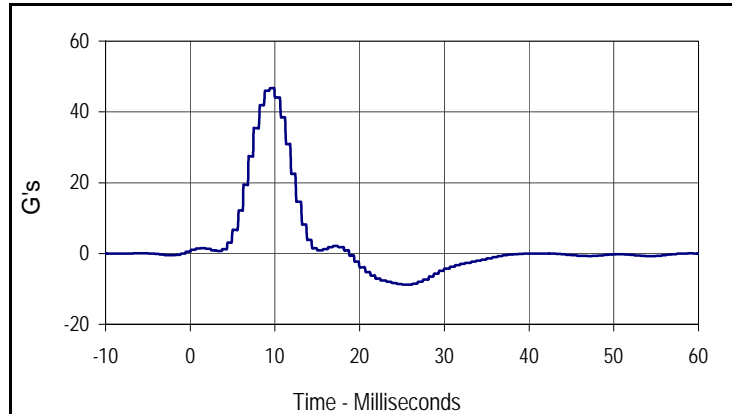

Curve Description			
Pelvis Y Primary			
CURNO	Type	SAE Class	Units
001	FIL	FIR100	G's
Max	Time	Min	Time
46.7	9.4	-8.8	25.0

Test Program: SID / HIII Head Drop Lateral Impact Test
 ATD Serial No.: 275

Test Date: 6/11/07
 Test I.D.: HD06G



Tested Parameter	Units	Specification	Result	Pass/Fail
Laboratory Temperature	°C	18.9 to 25.6	21.7	Pass
Laboratory Relative Humidity	%	10 to 70	30	Pass
Peak Resultant Acceleration	G's	120.0 to 150.0	147.7	Pass
Peak Longitudinal Acceleration	G's	≤15.0	14.2	Pass
Is Acceleration Unimodal?	Yes/No	Yes	Yes	Pass
Oscillations After Main Pulse	%	<15	5.1	Pass
Overall Test Results			Pass	

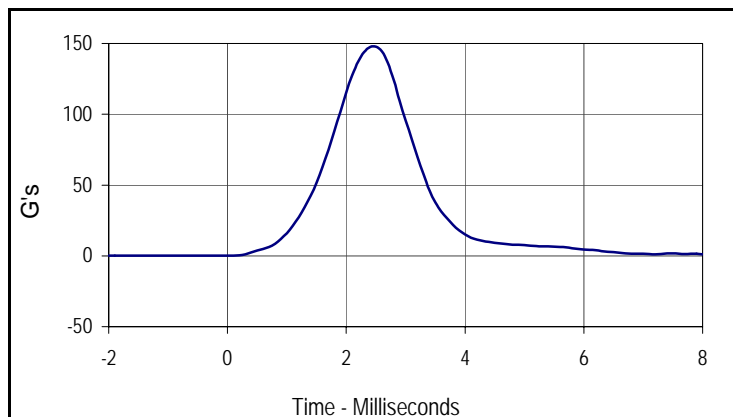

Curve Description			
Head Resultant			
CURNO	Type	SAE Class	Units
001	RES	1000	G's
Max	Time	Min	Time
147.7	2.5	0.1	-0.1

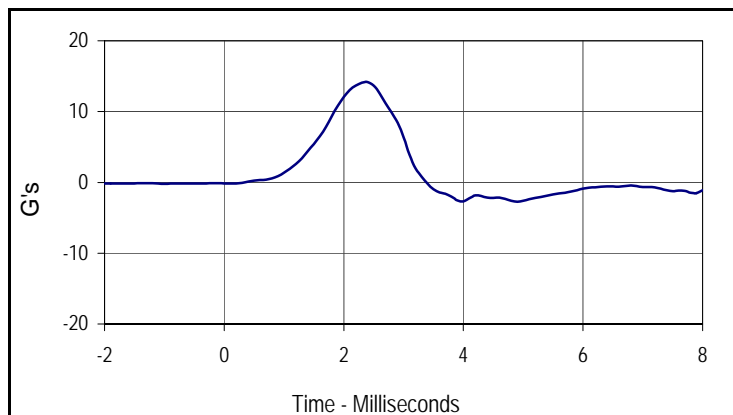

Curve Description			
Head X			
CURNO	Type	SAE Class	Units
002	FIL	1000	G's
Max	Time	Min	Time
14.2	2.4	-2.7	4.9

Test Program: SID / HIII Neck Pendulum Lateral Test
 ATD Serial No.: 275

Test Date: 6/11/07
 Test I.D.: NB06G



Tested Parameter	Units	Specification	Result	Pass/Fail	
Laboratory Temperature	°C	20.6 to 22.2	21.1	Pass	
Laboratory Relative Humidity	%	10 to 70	30	Pass	
Pendulum Velocity	m/sec	6.89 to 7.13	7.11	Pass	
Pendulum Deceleration	10 Msec.	m/sec	1.96 to 2.55	2.32	Pass
	20 Msec.	m/sec	4.12 to 5.10	4.79	Pass
	30 Msec.	m/sec	5.73 to 7.01	6.79	Pass
	40 to 70	m/sec	6.27 to 7.64	7.61	Pass
"D" Plane Rotation	Max	Degrees	66.0 to 82.0	79.8	Pass
Max Rotation Time After Peak Moment	Msec.	2.0 to 16.0	15.5	Pass	
Rotation Time From Peak to Zero Angle	Msec.	58.0 to 67.0	61.6	Pass	
Moment About Occipital Condyle	Nm	73.0 to 88.0	84.1	Pass	
Positive Moment Decay, Time To 0 Nm	Msec.	49.0 to 64.0	50.4	Pass	
Overall Test Results				Pass	

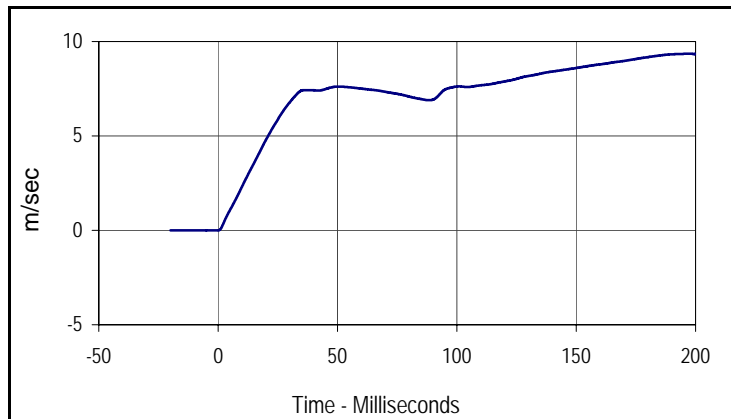

Curve Description			
Pendulum Velocity			
CURNO	Type	SAE Class	Units
001	FIL	180	m/sec
Max	Time	Min	Time
9.3	196.6	0.0	-0.1

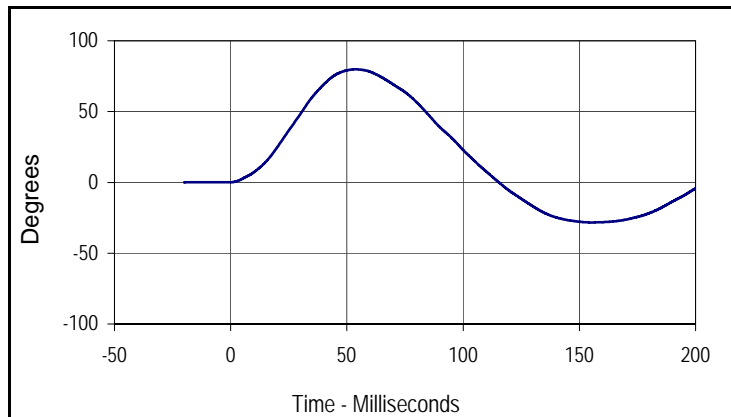

Curve Description			
"D" Plane Rotation			
CURNO	Type	SAE Class	Units
003	FIL	60	Degrees
Max	Time	Min	Time
79.8	53.8	-28.3	155.3

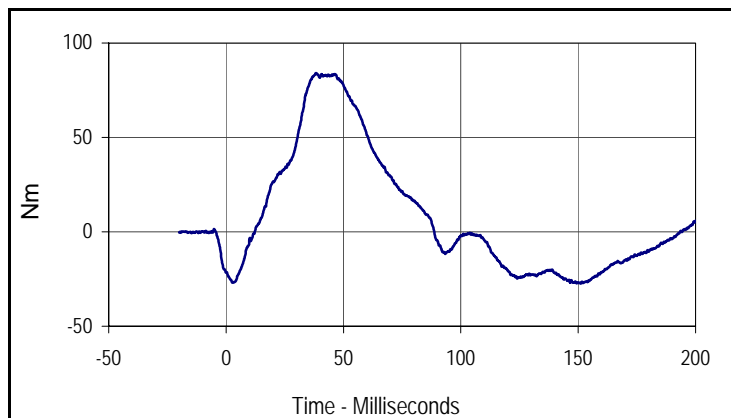

Curve Description			
Moment About Occipital Condyle			
CURNO	Type	SAE Class	Units
004	FIL	600	Nm
Max	Time	Min	Time
84.1	38.3	-27.4	151.0

APPENDIX D
CHILD RESTRAINT SYSTEM

REPORT NUMBER TR-P27148-01-NC

**NEW CAR ASSESSMENT PROGRAM
SIDE IMPACT TEST**

**FORD MOTOR COMPANY
2007 FORD EXPLORER XLT
5-DOOR MPV**

NHTSA NUMBER: F80200

**PREPARED BY:
KARCO ENGINEERING, LLC
9270 HOLLY ROAD
ADELANTO, CALIFORNIA 92301**



JUNE 8, 2007

FINAL REPORT

**PREPARED FOR:
U.S. DEPARTMENT OF TRANSPORTATION
NATIONAL HIGHWAY TRAFFIC SAFETY ADMINISTRATION
RULEMAKING
OFFICE OF CRASHWORTHINESS STANDARDS
MAIL CODE: NVS-111
1200 NEW JERSEY AVE SE, ROOM W43-410
WASHINGTON, D.C. 20590**

This final test report was prepared for the U.S. Department of Transportation, National Highway Traffic Safety Administration, in response to Contract Number DTNH22-03-D-32005.

This publication is distributed by the U.S. Department of Transportation, National Highway Traffic Safety Administration, in the interest of information exchange. The opinions, findings and conclusions expressed in this publication are those of the author(s) and not necessarily those of the Department of Transportation or the National Highway Traffic Safety Administration. The United States Government assumes no liability for its contents or use thereof. If trade or manufacturers' names or products are mentioned, it is only because they are considered essential to the object of the publication and should not be construed as an endorsement. The United States Government does not endorse products or manufacturers.

Prepared by:  Date: June 8, 2007
Mr. Johnny H. Dutto, Project Engineer
KARCO Engineering, LLC

Reviewed by:  Date: June 8, 2007
Mr. Michael L. Dunlap, Quality Assurance Manager
KARCO Engineering, LLC

Approved by:  Date: June 8, 2007
Mr. Frank D. Richardson, Program Manager
KARCO Engineering, LLC

FINAL REPORT ACCEPTED BY:

Manager, New Car Assessment Program

Date of Acceptance

COTR, NCAP Frontal Impact Program

Date of Acceptance

Technical Report Documentation Page

1. Report No. TR-P27148-01-NC	2. Government Accession No.	3. Recipients Catalog No.	
4. Title and Subtitle Final Report of a Chicco Keyfit CRS NHTSA No. F80200		5. Report Date June 8, 2007	
		6. Performing Organization Code KAR	
7. Authors Mr. Johnny H. Dutto, Project Engineer, Karco Mr. Frank Richardson, Program Manager, Karco		8. Performing Organization Report No. TR-P27148-01-NC	
9. Performing Organization Name and Address Karco Engineering, LLC 9270 Holly Rd. Adelanto, CA, 92301		10. Work Unit No.	
		11. Contract or Grant No. DTNH22-03-D-32005	
12. Sponsoring Agency Name and Address U. S. Department of Transportation National Highway Traffic Safety Administration Rulemaking Office of Crashworthiness Standards Mail Code NVS-111 1200 New Jersey Ave SE, Room W43-410 Washington, D.C 20590		13. Type of Report and Period Covered Final Test Report	
		14. Sponsoring Agency Code DOT/NHTSA/NRM/OCS	
15. Supplementary Notes			
16. Abstract A side impact test was conducted on the subject CRS Chico Keyfit in conjunction with side impact NCAP testing on a 2007 Ford Explorer XLT 5-Door MPV and in accordance with the specifications of the Office of Crashworthiness Standards Test Procedure for the determination of CRS crashworthiness. This test was conducted at Karco Engineering, LLC on June 8, 2007.			
Measurement Description	Units	Threshold	Right Rear (P3)
Head Injury Criteria (HIC15)	N/A	390	20.7
3 msec. Chest Clip	G's	50	17.9
17. Key Words New Car Assesment Program (Side Impact NCAP) Side Impact Moving Deformable Barrier (MDB) Final Report of a Chicco Keyfit CRS			18. Distribution of Statement Copies of this report available from: NHTSA Technical Reference Division National Highway Traffic Safety Admin. 1200 New Jersey Ave SE, W43-410 Washington, D.C. 20590
19. Security Classification (this report) Unclassified	20. Security Classification (this page) Unclassified	21. No. of Pages 44	22. Price

TABLE OF CONTENTS

<u>Section</u>	<u>Description</u>	<u>Page</u>
D-1	Purpose and Summary of Test F80200	D1-1 to D1-8
D-2	Photographs	D2-1 to D2-18
D-3	CRABI Response and CRS Data Traces	D3-1 to D3-2
D-4	CRABI Calibration Information	D4-1 to D4-6
<u>Data Sheet</u>	<u>Description</u>	<u>Page</u>
1	Crash Test Summary	D1-2
2	Vehicle Parameter Data	D1-3
3	CRABI Positioning in Vehicle	D1-4
4	CRS Performance Data	D1-6
5	CRS Accelerometer Locations	D1-7
6	CRS Camera Locations and Data	D1-8

SECTION D-1

PURPOSE AND SUMMARY OF TEST F80200

The purpose of this test is to obtain CRS performance data during a 55/28 km/h 90 deg. Moving Deformable Barrier Side Impact NCAP Test

The Side Impact NCAP test was conducted in accordance with the Office of Crashworthiness Standards (OCS) NCAP Laboratory Test Procedure.

SUMMARY

One 12-month old CRABI (P3) was instrumented with head, chest, and six-axis upper neck load cells. A tri-axial accelerometer was installed on the CRS and the CRS base. Seat belt load cells were placed on the inboard and outboard lower tethers.

The right rear (Serial No. 022) CRABI was calibrated prior to this test. CRABI calibration information is found in Section D-4.

CHILD DUMMY VALUES		
Location	HIC15 Value	3 Msec. Chest Clip
CRABI (P3)	20.7	17.9

DATA SHEET NO.1
CRASH TEST SUMMARY

Test Vehicle: 2007 Ford Explorer XLT 5-Door MPV

NHTSA No.: F80200

Test Program: 55/28 km/h Side Impact NCAP

Test Date: 6/8/07

CHILD RESTRAINT SYSTEM INFORMATION

Description	Position #3 CRS
Manufacturer	Chicco
Model Name	Keyfit
Model No.	04 060414 860 070
Type	Infant
Forward/Rearward	Rearward

VISIBLE DUMMY CONTACT POINTS

Description	Position #3 CRS
Head Contact	Left and Right Side of CRS
Chest Contact	None
Abdomen Contact	None
Left Knee Contact	None
Right Knee Contact	None
Left Toe Contact	None
Right Toe Contact	None

POST-TEST DOOR OPENINGS

Description	Position #3 CRS
Right Rear Door	Opened without tools, Remained closed during test

CAMERAS

Description	Standard
High Speed	1
Real Time	0
Total	1

DATA CHANNELS

CRABI (P3) Sensors	13
Belt Sensors	2
CRS Sensors	6
Total	21

DATA SHEET NO.2
VEHICLE PARAMETER DATA

Test Vehicle: 2007 Ford Explorer XLT 5-Door MPV

NHTSA No.: F80200

Test Program: 55/28 km/h Side Impact NCAP

Test Date: 6/8/07

TEST VEHICLE WEIGHTS

	Units	As Delivered Weights (UVW)			As Tested Weights (ATW)		
		Front Axle	Rear Axle	Total	Front Axle	Rear Axle	Total
Left	kg	552	406	958	607	619	1226
Right	kg	566	412	978	572	584	1156
Ratio	%	53.3	46.7	100	49.5	50.5	100
Totals	kg	1118	818	1936	1179	1203	2382

TARGET TEST WEIGHT CALCULATION

Measured Parameter	Units	Value
Total Delivered Weight (UVW)	kg	2094
Weight of 2 P572 ATD's	kg	161
Rated Cargo/Luggage Wt. (RCLW)	kg	136
Calculated Vehicle Target Wt. (TVTWT)	kg	2391

DATA SHEET NO.3
CRABI POSITIONING IN VEHICLE

Test Vehicle: 2007 Ford Explorer XLT 5-Door MPV

NHTSA No.: F80200

Test Program: 55/28 km/h Side Impact NCAP

Test Date: 6/8/07

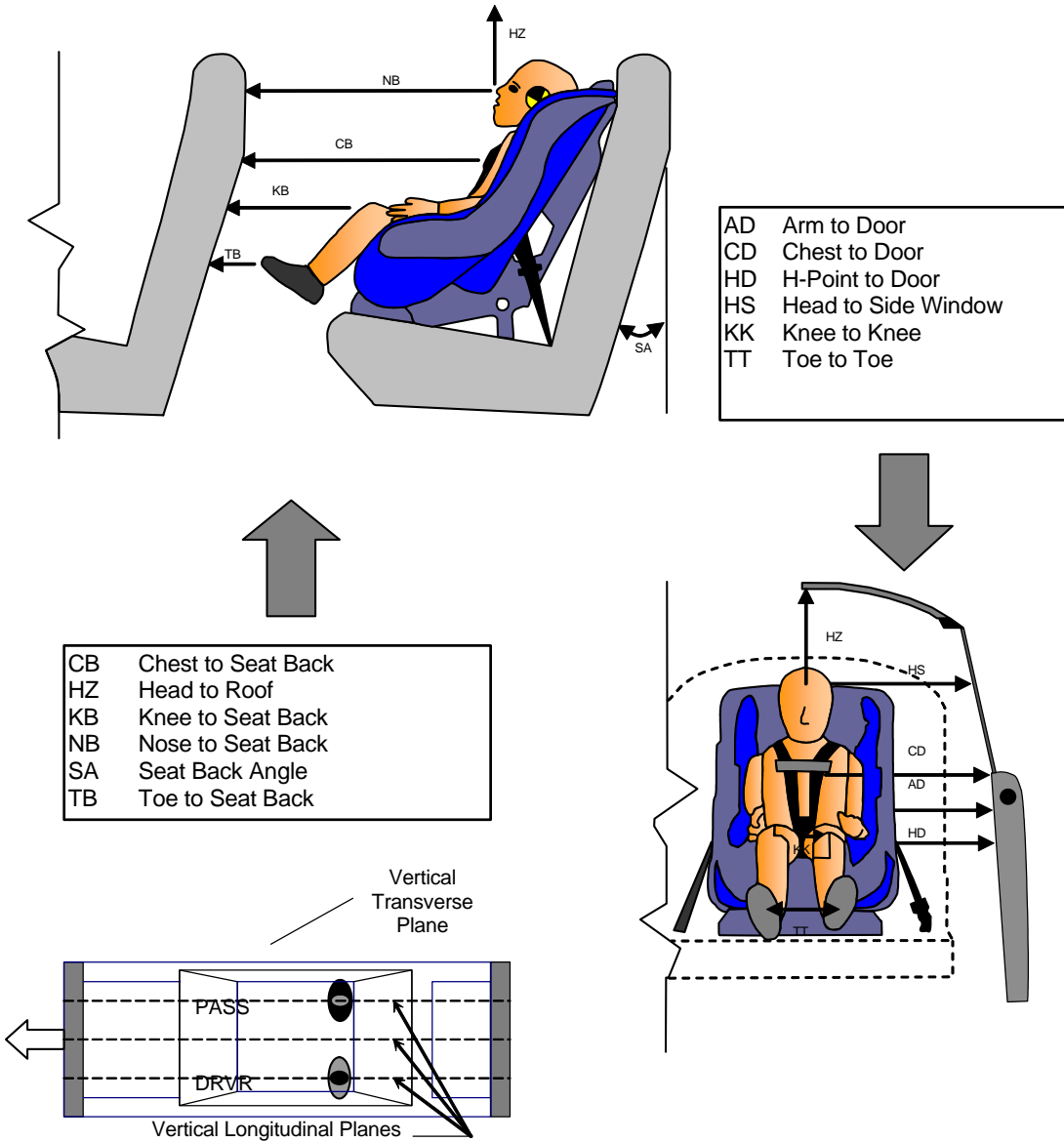

DUMMY MEASUREMENTS FOR REAR SEAT OCCUPANTS

DATA SHEET NO.3
CRABI POSITIONING IN VEHICLE...(CONTINUED)

Test Vehicle: 2007 Ford Explorer XLT 5-Door MPV

NHTSA No.: F80200

Test Program: 55/28 km/h Side Impact NCAP

Test Date: 6/8/07

CRABI POSITION MEASUREMENTS

Code	Measurement	P3 (Passenger's Side)	
		Length (mm)	Angle (°)
SA	Seat Back Angle		25.1
HZ	Head to Roof (Z)	460	
CD	Chest to Door	330	
KK	Knee to Knee (Y)	125	
HS	Head to Side Window	350	
HD	H-Point to Door (Y)	270	
AD	Arm to Door	220	
NB	Nose to Seat Back	490	
CB	Chest to Seat Back	462	
FF	Foot to Foot	120	
KB-Left	Knee to Seat Back	170	
KB-Right	Knee to Seat Back	182	
TB-Left	Toe to Seat Back	75	
TB-Right	Toe to Seat Back	80	

DATA SHEET NO.4
CRS PERFORMANCE DATA

Test Vehicle: 2007 Ford Explorer XLT 5-Door MPV

NHTSA No.: F80200

Test Program: 55/28 km/h Side Impact NCAP

Test Date: 6/8/07

CRS PERFORMANCE DATA

Location	CRS (P3)	
	Damage	Post-Test
Upper Tether Strap		
Upper Tether Buckle		
Upper Tether Hook		
Veh. Upper Tether Anchor		
Lower Anchor Strap	No	None
Lower Anchor Buckle	No	None
Lower Anchor Hooks	No	None
Veh. Lower CRS Anchors	No	None
5-Point Harness Connections	No	None
Cracks on CRS	No	None
Fabric Tears on CRS	No	None
Vehicle Seat Structure	No	None
Vehicle Seat Fabric Tears	No	None

DATA SHEET NO. 5...(CONTINUED)
CRS ACCELEROMETER LOCATIONS

Test Vehicle: 2007 Ford Explorer XLT 5-Door MPV

NHTSA No.: F80200

Test Program: 55/28 km/h Side Impact NCAP

Test Date: 6/8/07

CRS ACCELEROMETER PRE-TEST LOCATIONS

Loc. No.	Accelerometer Location	Measurements (mm)		
		X	Y	Z
1	CRS	1954	640	955
2	CRS Base	1954	640	894

Reference Planes: X=From Rear Surface of Vehicle, Y=Vehicle Centerline, Z=Ground Plane

DATA SHEET NO.6
CRS CAMERA LOCATIONS AND DATA

Test Vehicle: 2007 Ford Explorer XLT 5-Door MPV

NHTSA No.: F80200

Test Program: 55/28 km/h Side Impact NCAP

Test Date: 6/8/07

CAMERA LOCATIONS

No.	Camera View	Location(mm)			Angle (Deg.)	Film Plane to Head	Lens (mm)	Speed (fps)
		X	Y	Z				
1	Passenger CRS (O.B.)	1000	2290	-1499	-2	n/a	10	1000

X = Barrier Face Y = Monorail Centerline Z = Ground DNR = Did Not Run NTM = No Time Marks

SECTION D2
PHOTOGRAPHS

LIST OF PHOTOGRAPHS

Figure		Page
1	Close-up, Position 3 CRS Label	D-1
2	Pre-Test Frontal View of Position 3 CRS	D-2
3	Post-Test Frontal View of Position 3 CRS	D-3
4	Pre-Test Rear View of Position 3 CRS	D-4
5	Post-Test Rear View of Position 3 CRS	D-5
6	Pre-Test Left Side View of Position 3 CRS	D-6
7	Post-Test Left Side View of Position 3 CRS	D-7
8	Pre-Test Right Side View of Position 3 CRS	D-8
9	Post-Test Right Side View of Position 3 CRS	D-9
10	Pre-Test Position 3 Front View (Head and Seat Belt Position)	D-10
11	Post-Test Position 3 Front View (Head and Seat Belt Position)	D-11
12	Pre-Test Position 3 Front View (Seat Belt Position)	D-12
13	Post-Test Position 3 Front View (Seat Belt Position)	D-13
14	Pre-Test Position 3 Right Side View	D-14
15	Post-Test Position 3 Right Side View	D-15
16	Pre-Test Position 3 Left Side View	D-16
17	Post-Test Position 3 Left Side View	D-17
18	Post-Test Position 3 Dummy Legs	D-18

MODEL NAME KEYFIT
MODEL NO.04 060414 860 070
SERIAL NO. 0081
MANUFACTURED IN 09 FEB 07
DO NOT USE AFTER 09 FEB 13
CHICCO USA, INC.LANCASTER,PA 17601

Patent pending
Made in China
20071-01

Figure D2-1: Position 3 CRS Label

This Space Intentionally Left Blank



D2-2

TR-P27148-01-NC

Figure D2-2: Pre-Test Frontal View of Position 3 CRS



Figure D2-3: Post-Test Frontal View of Position 3 CRS



D2-4

TR-P27148-01-NC

Figure D2-4: Pre-Test Rear View of Position 3 CRS



D2-5

TR-P27148-01-NC

Figure D2-5: Post-Test Rear View of Position 3 CRS



Figure D2-6: Pre-Test Left Side View of Position 3 CRS



Figure D2-7: Post-Test Left Side View of Position 3 CRS



Figure D2-8: Pre-Test Right Side View of Position 3 CRS



Figure D2-9: Post-Test Right Side View of Position 3 CRS



Figure D2-10: Pre-Test Position 3 Front View (Head and Seat Belt Position)



Figure D2-11: Post-Test Position 3 Front View (Head and Seat Belt Position)



Figure D2-12: Pre-Test Position 3 Front View (Seat Belt Position)



Figure D2-13: Post-Test Position 3 Front View (Seat Belt Position)



Figure D2-14: Pre-Test Position 3 Right Side View



Figure D2-15: Post-Test Position 3 Right Side View



Figure D2-16: Pre-Test Position 3 Right Side View (Through Window)

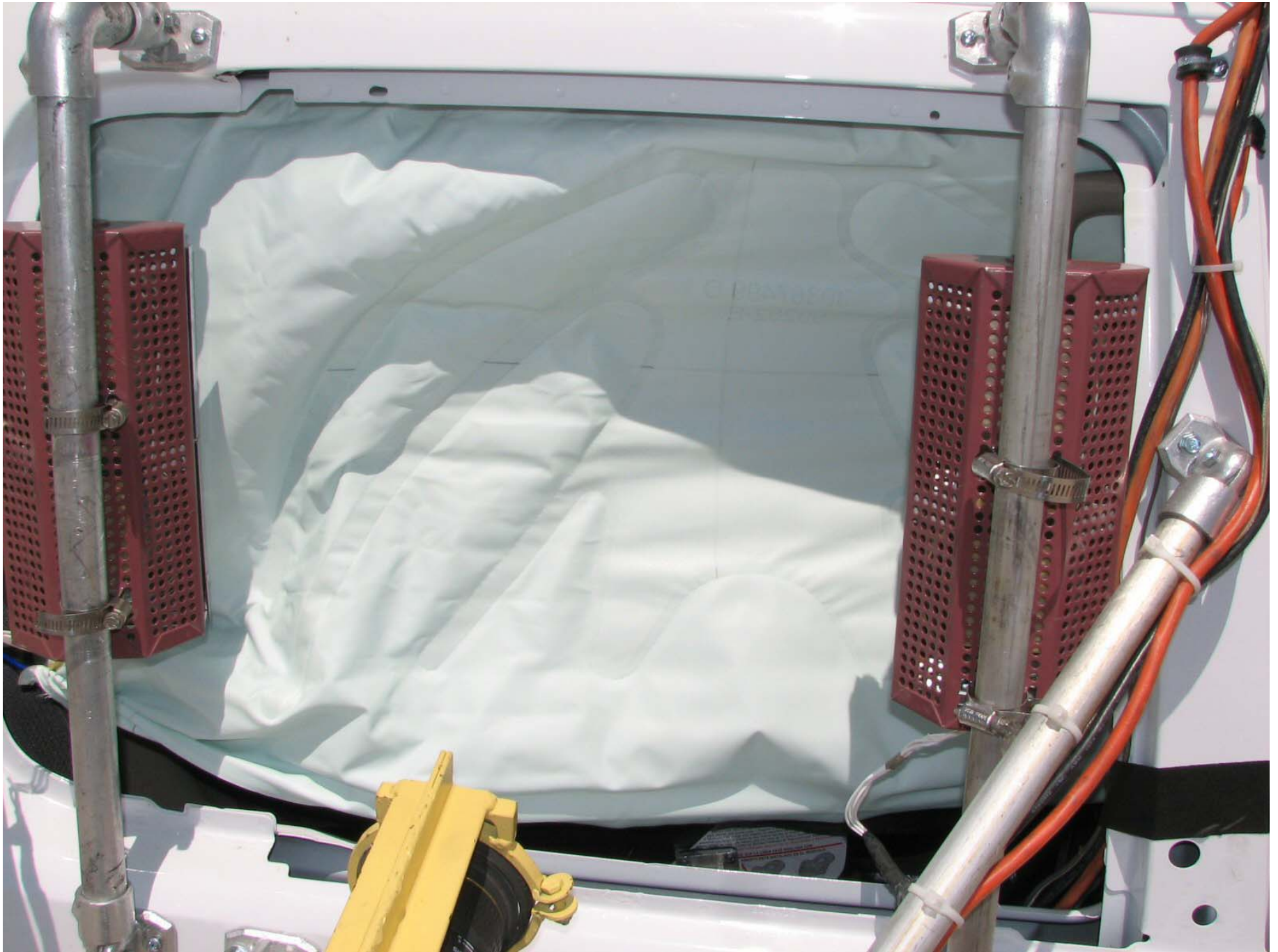

Figure D2-17: Post-Test Position 3 Right Side View (Through Window)



D2-18

TR-P27148-01-NC

SECTION D3

CRABI RESPONSE AND CRS DATA TRACES

LIST OF DATA PLOTS

<u>Data Plot</u>		<u>Page</u>
D3-1	Right Rear CRABI Head X	D3-1
	Right Rear CRABI Head Y	D3-1
	Right Rear CRABI Head Z	D3-1
	Right Rear CRABI Head Resultant	D3-1
D3-2	Right Rear CRABI Chest X	D3-2
	Right Rear CRABI Chest Y	D3-2
	Right Rear CRABI Chest Z	D3-2
	Right Rear CRABI Chest Resultant	D3-2

Test Vehicle: 2007 Ford Explorer XLT 5-Door MPV
 Test Program: 55/28 km/h Side Impact NCAP

Test Date: 6/8/07
 NHTSA No.: F80200

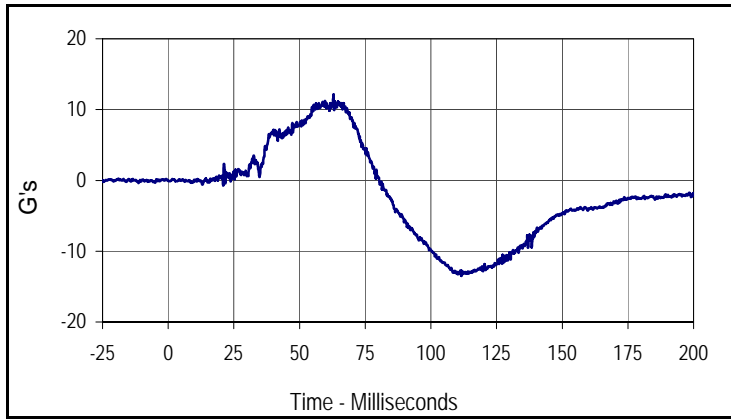

Curve Description			
CRABI Head X (P3)			
CURNO	Type	SAE Class	Units
072	FIL	1000	G's
Max	Time	Min	Time
12.2	62.9	-13.5	111.5

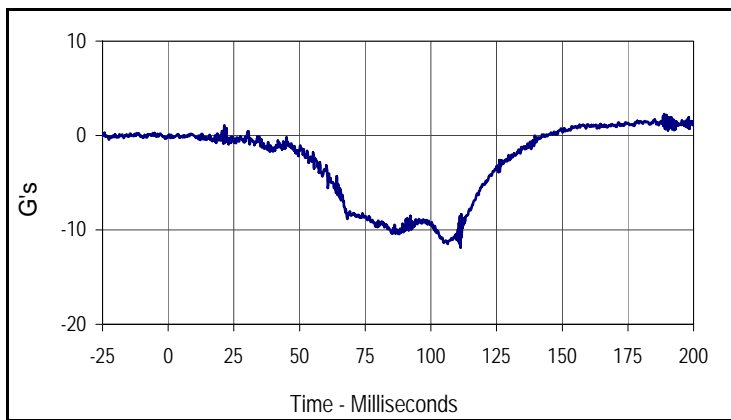

Curve Description			
CRABI Head Y (P3)			
CURNO	Type	SAE Class	Units
073	FIL	1000	G's
Max	Time	Min	Time
2.3	188.8	-11.8	111.3

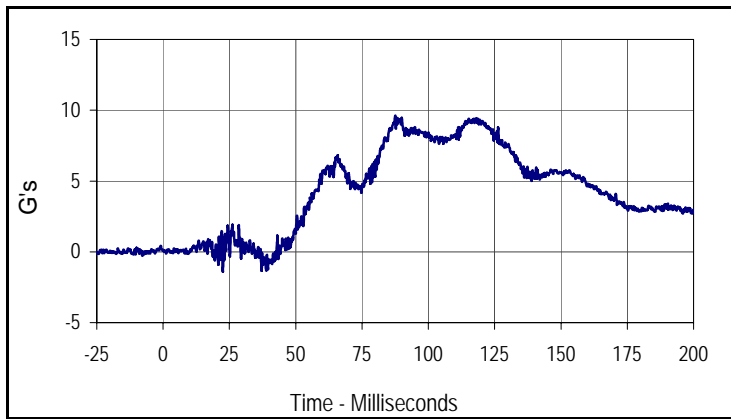

Curve Description			
CRABI Head Z (P3)			
CURNO	Type	SAE Class	Units
074	FIL	1000	G's
Max	Time	Min	Time
9.6	87.5	-1.4	22.5

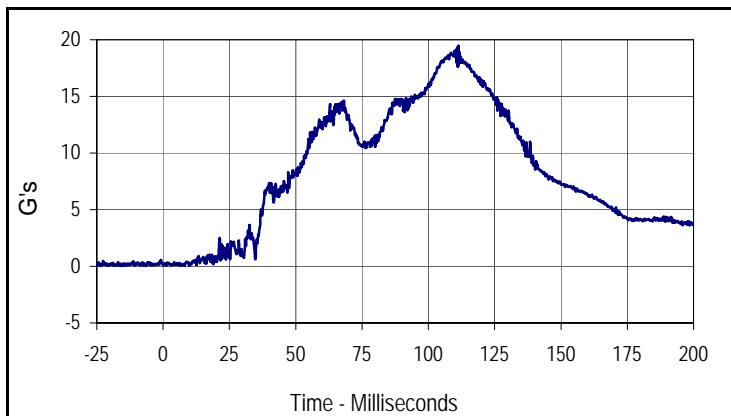

Curve Description			
CRABI Head Resultant (P3)			
CURNO	Type	SAE Class	Units
072	RES	1000	G's
Max	Time	Min	Time
19.5	111.3	0.1	6.9

Test Vehicle: 2007 Ford Explorer XLT 5-Door MPV
 Test Program: 55/28 km/h Side Impact NCAP

Test Date: 6/8/07
 NHTSA No.: F80200

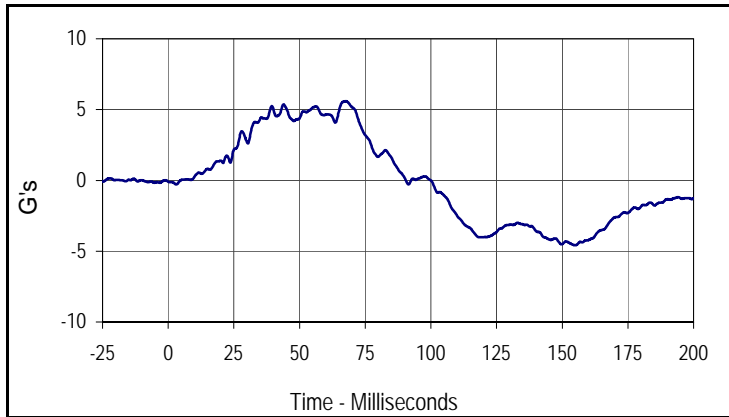

Curve Description			
CRABI Chest X (P3)			
CURNO	Type	SAE Class	Units
082	FIL	180	G's
Max	Time	Min	Time
5.6	67.7	-4.6	155.0

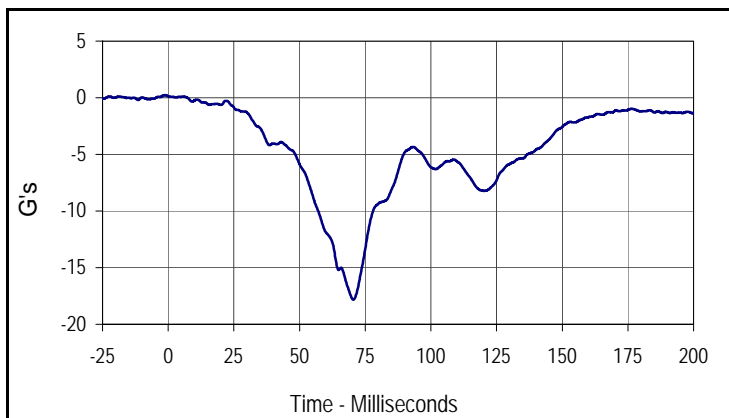

Curve Description			
CRABI Chest Y (P3)			
CURNO	Type	SAE Class	Units
083	FIL	180	G's
Max	Time	Min	Time
0.1	0.0	-17.8	70.5

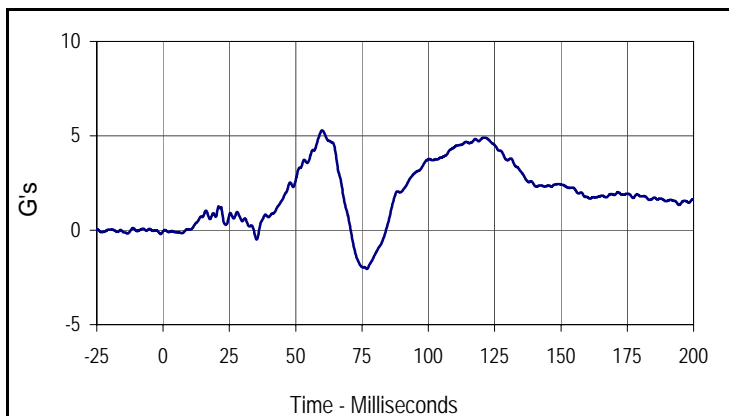

Curve Description			
CRABI Chest Z (P3)			
CURNO	Type	SAE Class	Units
084	FIL	180	G's
Max	Time	Min	Time
5.3	60.0	-2.1	76.9

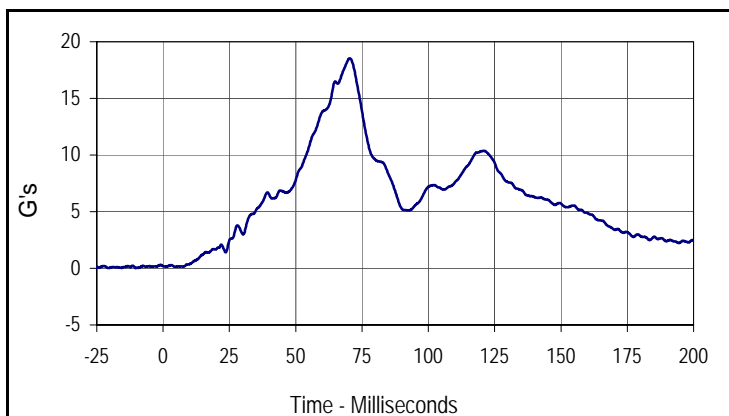

Curve Description			
CRABI Chest Resultant (P3)			
CURNO	Type	SAE Class	Units
082	RES	180	G's
Max	Time	Min	Time
18.5	70.4	0.1	4.6

SECTION D4

CRABI CALIBRATION INFORMATION

Test Program: CRABI 12 Month Old Frontal Head Drop Test

Test Date: 6/5/07

ATD Serial No.: 022

Test I.D.: FHD06E



Tested Parameter	Units	Specification	Result	Pass/Fail
Laboratory Temperature	°C	18.9 to 25.6	21.1	Pass
Laboratory Relative Humidity	%	10 to 70	30	Pass
Peak Resultant Acceleration	G's	100.0 to 120.0	112.1	Pass
Peak Lateral Acceleration	G's	≤15.0	8.4	Pass
Is Acceleration Unimodal?	Yes/No	Yes	Yes	Pass
Overall Test Results			Pass	



Curve Description			
Head Resultant			
CURNO	Type	SAE Class	Units
001	RES	1000	G's
Max	Time	Min	Time
112.1	4.2	0.0	-1.4

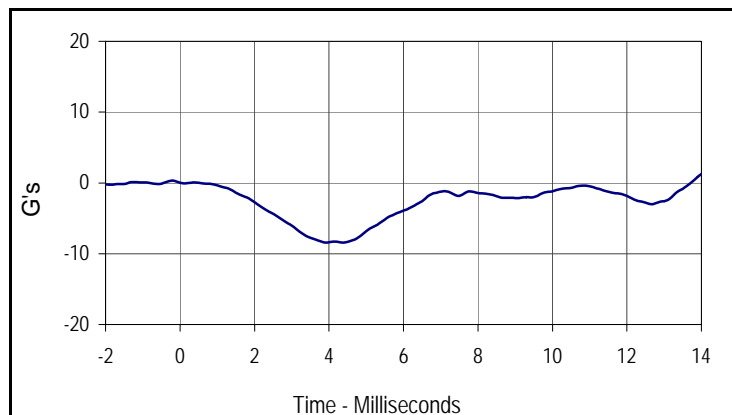

Curve Description			
Head Y			
CURNO	Type	SAE Class	Units
002	FIL	1000	G's
Max	Time	Min	Time
0.3	-0.2	-8.4	4.4

Test Program: CRABI 12 Month Old Rear Head Drop Test

Test Date: 6/5/07

ATD Serial No.: 022

Test I.D.: RHD06E



Tested Parameter	Units	Specification	Result	Pass/Fail
Laboratory Temperature	°C	18.9 to 25.6	21.1	Pass
Laboratory Relative Humidity	%	10 to 70	30	Pass
Peak Resultant Acceleration	G's	55.0 to 71.0	56.2	Pass
Peak Lateral Acceleration	G's	≤15.0	7.6	Pass
Is Acceleration Unimodal?	Yes/No	Yes	Yes	Pass
Overall Test Results			Pass	

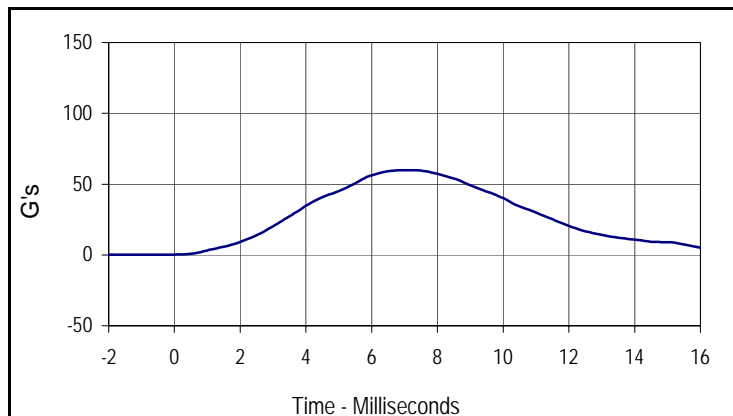

Curve Description			
Head Resultant			
CURNO	Type	SAE Class	Units
001	RES	1000	G's
Max	Time	Min	Time
56.2	6.0	0.1	-0.9

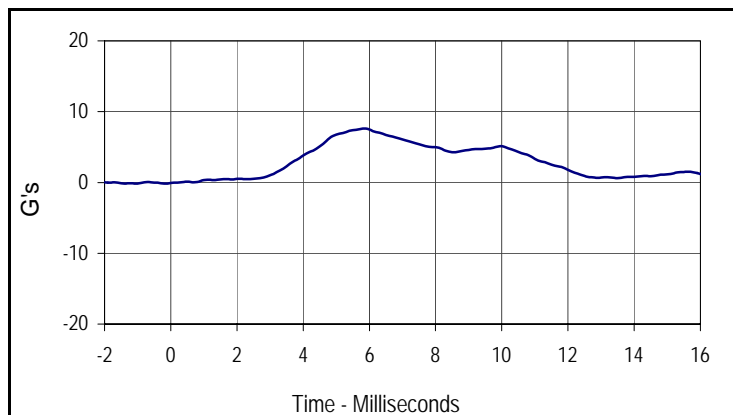

Curve Description			
Head Y			
CURNO	Type	SAE Class	Units
002	FIL	1000	G's
Max	Time	Min	Time
7.6	5.8	-0.2	-1.4

Test Program: CRABI 12 Month Old Thorax Impact Test

Test Date: 6/5/07

ATD Serial No.: 022

Test I.D.: CH06E



Tested Parameter	Units	Specification	Result	Pass/Fail
Laboratory Temperature	°C	20.6 to 22.2	21.1	Pass
Laboratory Relative Humidity	%	10 to 70	30	Pass
Pendulum Velocity at T=0	m/sec	4.90 to 5.10	4.95	Pass
Peak Probe Force	Newtons	-1514 to -1796	-1641	Pass
Overall Test Results				Pass

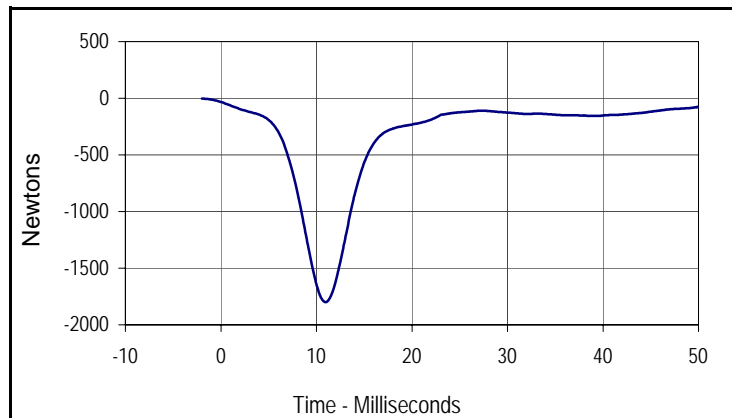

Curve Description			
Probe Force			
CURNO	Type	SAE Class	Units
001	FIL	60	Newtons
Max	Time	Min	Time
-2.3	-2.0	-1640.6	10.0

Test Program: CRABI 12 Month Old Neck Flexion Test
 ATD Serial No.: 022

Test Date: 6/5/07
 Test I.D.: NF06E



Tested Parameter	Units	Specification	Result	Pass/Fail	
Laboratory Temperature	°C	20.6 to 22.2	21.1	Pass	
Laboratory Relative Humidity	%	10 to 70	30	Pass	
Pendulum Velocity	m/s	5.10 to 5.30	5.11	Pass	
Pendulum Deceleration	10 Msec.	m/s	1.6 to 2.3	1.9	Pass
	20 Msec.	m/s	3.4 to 4.2	3.9	Pass
	25 Msec.	m/s	4.3 to 5.2	4.8	Pass
"D" Plane Rotation	Max	Degrees	75.0 to 86.0	76.1	Pass
Peak Moment in Rotation	Max	Nm	36.0 to 45.0	42.0	Pass
Positive Moment Decay, Time To 5 Nm	Msec.		60.0 to 80.0	71.0	Pass
Overall Test Results				Pass	

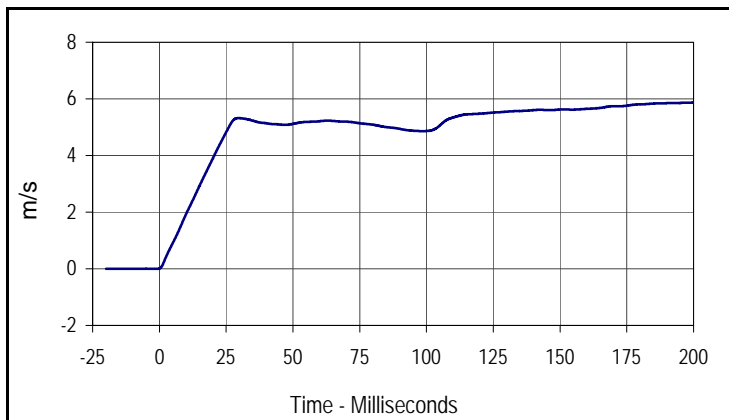

Curve Description			
Pendulum Velocity			
CURNO	Type	SAE Class	Units
001	FIL	180	m/s
Max	Time	Min	Time
5.9	199.3	0.0	-0.7

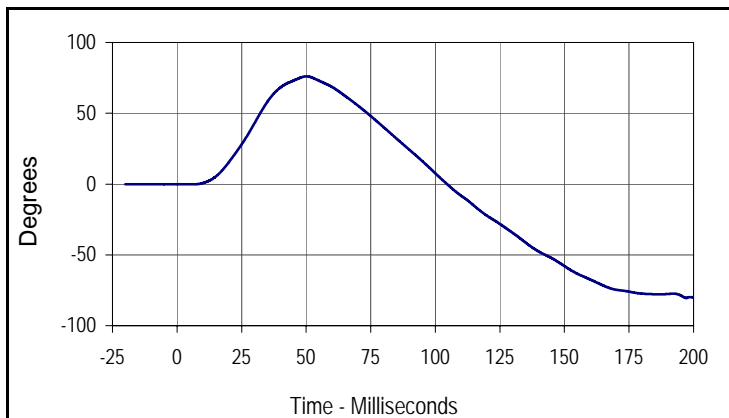

Curve Description			
"D" Plane Rotation			
CURNO	Type	SAE Class	Units
003	FIL	60	Degrees
Max	Time	Min	Time
76.1	50.1	-80.5	197.1

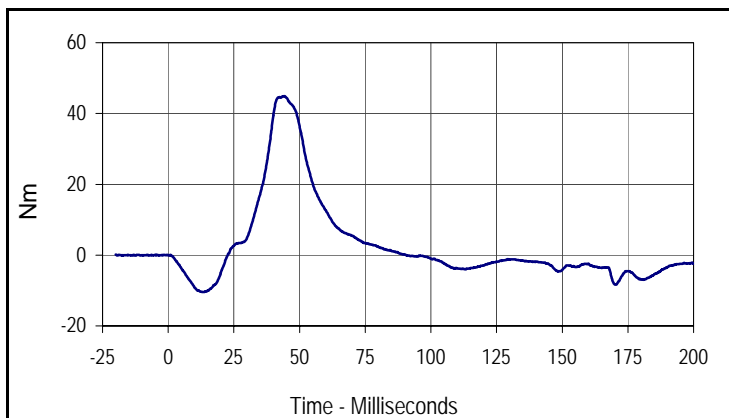

Curve Description			
Upper Neck Force Y			
CURNO	Type	SAE Class	Units
002	FIL	600	Nm
Max	Time	Min	Time
44.9	44.3	-10.4	13.5

Test Program: CRABI 12 Month Old Neck Extension Test
 ATD Serial No.: 022

Test Date: 6/5/07
 Test I.D.: NE06E



Tested Parameter	Units	Specification	Result	Pass/Fail	
Laboratory Temperature	°C	20.6 to 22.2	21.1	Pass	
Laboratory Relative Humidity	%	10 to 70	30	Pass	
Pendulum Velocity	m/s	2.4 to 2.6	2.42	Pass	
Pendulum Deceleration	6 Msec.	m/s	0.8 to 1.2	0.9	Pass
	10 Msec.	m/s	1.5 to 2.1	1.9	Pass
	14 Msec.	m/s	2.2 to 2.9	2.9	Pass
"D" Plane Rotation	Max	Degrees	80.0 to 92.0	91.6	Pass
Peak Moment in Rotation	Max	Nm	-12 to -23	-21.5	Pass
Positive Moment Decay, Time To -5 Nm	Msec.		76.0 to 90.0	77.8	Pass
Overall Test Results				Pass	

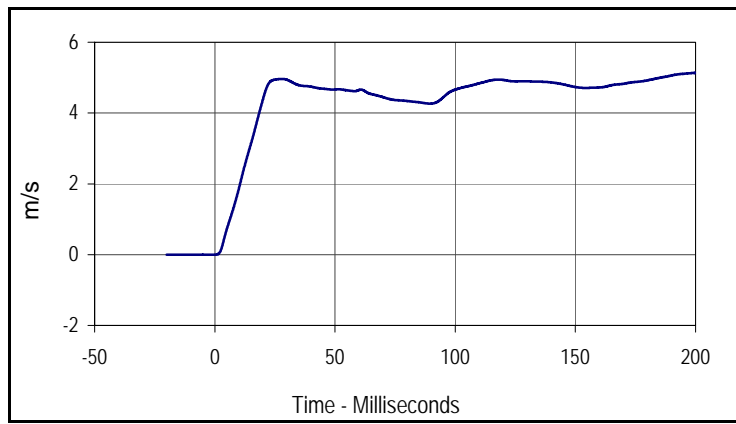

Curve Description			
Pendulum Velocity			
CURNO	Type	SAE Class	Units
001	FIL	180	m/s
Max	Time	Min	Time
5.1	200.0	0.0	0.1

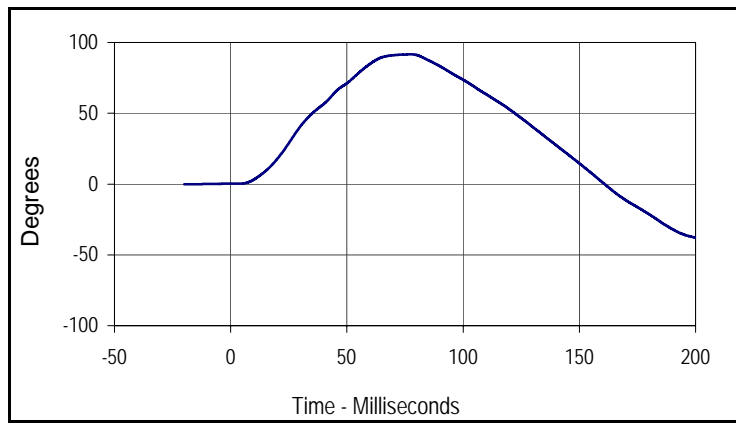

Curve Description			
"D" Plane Rotation			
CURNO	Type	SAE Class	Units
003	FIL	60	Degrees
Max	Time	Min	Time
91.6	77.5	-37.8	200.0

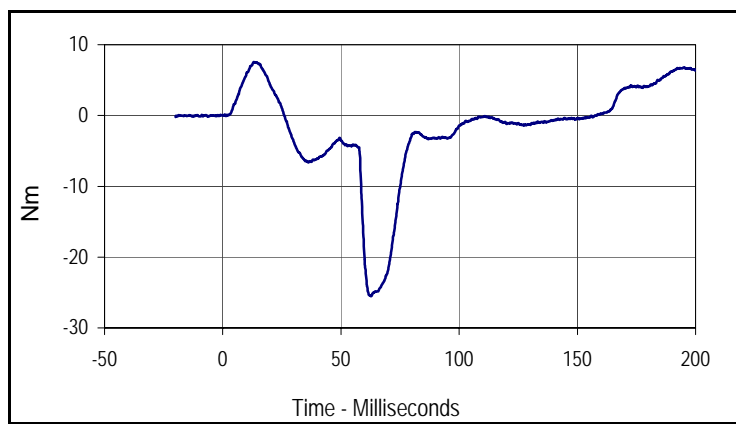

Curve Description			
Upper Neck Moment Y			
CURNO	Type	SAE Class	Units
002	FIL	600	Nm
Max	Time	Min	Time
7.5	13.2	-25.5	62.8

Test Program: CRABI 12 Month Old External Dimensions

Test Date: 6/5/07

ATD Serial No.: 022

Test I.D.: N/A



Tested Parameter	Units	Specification	Result	Pass/Fail
Laboratory Temperature	°C	20.6 to 22.2	21.1	Pass
Laboratory Relative Humidity	%	10 to 70	30	Pass
A - Total sitting height	mm	456.0 to 471.2	460	Pass
B - Shoulder pivot height	mm	276.6 to 291.8	284	Pass
C - "H" point height	mm	27.9 to 38.1	36	Pass
D - "H" point from backline	mm	40.1 to 50.3	47	Pass
E - Shoulder pivot from back	mm	50.3 to 60.5	54	Pass
F - Thigh clearance	mm	63.0 to 73.2	66	Pass
G - Elbow pivot to fingertip	mm	176.6 to 191.8	185	Pass
I - Shoulder pivot to elbow pivot	mm	99.1 to 114.3	106	Pass
J - Elbow rest height	mm	150.1 to 165.3	160	Pass
K - Buttock to knee length	mm	202.7 to 217.9	205	Pass
L - Popliteal length	mm	138.7 to 153.9	140	Pass
M - Knee pivot height	mm	165.1 to 180.3	170	Pass
N - Buttock popliteal length	mm	144.8 to 160.0	155	Pass
O - Chest depth with jacket	mm	107.5 to 122.7	108	Pass
P - Foot length	mm	92.4 to 102.6	101	Pass
Q- Stature	mm	727.7 to 753.1	N/A	N/A
R - Buttock to knee pivot length	mm	178.5 to 188.7	182	Pass
S - Head Breadth	mm	124.4 to 134.6	130	Pass
T - Head Depth	mm	149.9 to 165.1	152	Pass
U - Hip breadth	mm	158.5 to 173.7	161	Pass
V - Shoulder breadth	mm	200.7 to 215.9	213	Pass
W - Foot breadth	mm	39.1 to 49.3	45	Pass
Y - Chest circumference with jacket	mm	452.4 to 477.8	460	Pass
Z - Waist circumference	mm	447.0 to 472.4	452	Pass
AA - Reference location for dimension Y & O	mm	256.5 to 266.7	262	Pass
BB - Reference Location For dimension Z	mm	106.7 to 116.9	107	Pass
CC - Shoulder Height	mm	299.7 to 314.9	300	Pass
DD - Chin Height	mm	289.6 to 304.8	299	Pass
Overall Test Results				Pass