

REPORT NUMBER: 214-CAL-07-03

**SAFETY COMPLIANCE TESTING FOR FMVSS 214
SIDE IMPACT PROTECTION
INDICANT**

**GENERAL MOTORS CORPORATION
2007 PONTIAC SOLSTICE
2-DOOR CONVERTIBLE**

NHTSA NUMBER: C70101

**PREPARED BY:
CALSPAN CORPORATION
P.O. BOX 400
BUFFALO, NEW YORK 14225**



Test Date: October 17, 2006

FINAL REPORT

**PREPARED FOR:
U.S. DEPARTMENT OF TRANSPORTATION
NATIONAL HIGHWAY TRAFFIC SAFETY ADMINISTRATION
ENFORCEMENT
OFFICE OF VEHICLE SAFETY COMPLIANCE
MAIL CODE: NVS-220
400 SEVENTH STREET, SW, ROOM 6111
WASHINGTON, D.C. 20590**

This final test report was prepared for the U.S. Department of Transportation, National Highway Traffic Safety Administration, in response to Contract Number DTNH22-02-D-01114.

This publication is distributed by the U.S. Department of Transportation, National Highway Traffic Safety Administration, in the interest of information exchange. The opinions, findings and conclusions expressed in this publication are those of the author(s) and not necessarily those of the Department of Transportation or the National Highway Traffic Safety Administration. The United States Government assumes no liability for its contents or use thereof. If trade or manufacturers' names or products are mentioned it is only because they are considered essential to the object of the publication and should not be construed as an endorsement. The United States Government does not endorse products or manufacturers.

Prepared by: _____
Lawrence Q. Valvo, Project Engineer

Date: _____

Reviewed by: _____
Michael J. Kilgallon, Program Manager
Transportation Sciences Center

Date: _____

Technical Report Documentation Page

1. <i>Report No.</i> 214-CAL-07-03	2. <i>Government Accession No.</i>	3. <i>Recipient's Catalog No.</i>																						
4. <i>Title and Subtitle</i> Final Report of FMVSS 214 Compliance Side Impact Testing of a 2007 Pontiac Solstice 2-Door Convertible NHTSA No.: C70101		5. <i>Report Date</i> October 17, 2006																						
		6. <i>Performing Organization Code</i> CAL																						
7. <i>Author(s)</i> Lawrence Q. Valvo, Project Engineer		8. <i>Performing Organization Report No.</i> 8675-F214-33																						
9. <i>Performing Organization Name and Address</i> Calspan Corporation Transportation Sciences Center P.O. Box 400 Buffalo, New York 14225		10. <i>Work Unit No.</i>																						
		11. <i>Contract or Grant No.</i> DTNH22-02-D-01114																						
12. <i>Sponsoring Agency Name and Address</i> U.S. Department of Transportation National Highway Traffic Safety Administration Office of Vehicle Safety Compliance 400 Seventh Street, SW, Room 6111 Washington, D.C. 20590		13. <i>Type of Report and Period Covered:</i> <i>Final Report</i> October 2006 – November 2006																						
		14. <i>Sponsoring Agency Code</i> NVS-220																						
15. <i>Supplementary Notes</i>																								
16. <i>Abstract</i> A 55/28 km/h 90° Moving Deformable Barrier FMVSS 214 Indicant side impact was conducted on the subject 2007 Pontiac Solstice 2-Door Convertible to obtain new car assessment and research data indicant of FMVSS No. 214D performance. The test was conducted at the Calspan Corporation Transportation Sciences Center in Buffalo, New York, on October 17, 2006. The impact velocity of the Moving Deformable Barrier (MDB) was 62.28 km/h, and the ambient temperature at the struck side (driver side) of the vehicle was 21.1°C. The target vehicle's maximum post test static crush was 194 mm at level 3. The test vehicle's occupant performance is as follows:																								
<table style="width: 100%; border-collapse: collapse;"> <thead> <tr> <th style="width: 50%;"></th> <th style="width: 25%; text-align: center;"><u>DRIVER</u></th> <th style="width: 25%; text-align: center;"><u>PASSENGER*</u></th> </tr> </thead> <tbody> <tr> <td>Left Upper Rib (LUR) Accel., g</td> <td style="text-align: center;">54.4</td> <td style="text-align: center;">-</td> </tr> <tr> <td>Left Lower Rib (LLR) Accel., g</td> <td style="text-align: center;">52.3</td> <td style="text-align: center;">-</td> </tr> <tr> <td>Lower Spine (T₁₂) Accel., g</td> <td style="text-align: center;">64.0</td> <td style="text-align: center;">-</td> </tr> <tr> <td>Thoracic Trauma Index (TTI)</td> <td style="text-align: center;">59</td> <td style="text-align: center;">-</td> </tr> <tr> <td>Pelvis (PEV) Accel., g</td> <td style="text-align: center;">71</td> <td style="text-align: center;">-</td> </tr> <tr> <td>HIC</td> <td style="text-align: center;">304.6</td> <td style="text-align: center;">-</td> </tr> </tbody> </table>					<u>DRIVER</u>	<u>PASSENGER*</u>	Left Upper Rib (LUR) Accel., g	54.4	-	Left Lower Rib (LLR) Accel., g	52.3	-	Lower Spine (T ₁₂) Accel., g	64.0	-	Thoracic Trauma Index (TTI)	59	-	Pelvis (PEV) Accel., g	71	-	HIC	304.6	-
	<u>DRIVER</u>	<u>PASSENGER*</u>																						
Left Upper Rib (LUR) Accel., g	54.4	-																						
Left Lower Rib (LLR) Accel., g	52.3	-																						
Lower Spine (T ₁₂) Accel., g	64.0	-																						
Thoracic Trauma Index (TTI)	59	-																						
Pelvis (PEV) Accel., g	71	-																						
HIC	304.6	-																						
* This two-seat vehicle does not have rear seating positions. The door on the struck side of the vehicle did not separate from the body at the hinges or latches and the opposite door did not open during the side impact event.																								
17. <i>Key Words</i> Compliance Testing Side Impact Protection FMVSS 214 Side Impact Dummy (SID)		18. <i>Distribution Statement</i> <u>Copies of this report are available from:</u> National Highway Traffic Safety Administration Technical Reference Division (TIS) Room 5108 (NPO-230) 400 Seventh St., S.W. Washington, D.C. 20590 Telephone No. (202) 366-4946																						
19. <i>Security Class. (of this report)</i> Unclassified	20. <i>Security Class. (of this page)</i> Unclassified	21. <i>No. of Pages</i> 91	22. <i>Price</i>																					

TABLE OF CONTENTS

<u>Section</u>		<u>Page No.</u>
1	Purpose and Test Procedure	1-1
2	Summary of FMVSS 214 Indicant Side Impact Test	2-1
<u>Data Sheet No.</u>		<u>Page No.</u>
1	General Test and Vehicle Parameter Data	2-3
2	Test Vehicle Tire Information	2-5
3	Test Vehicle Information	2-6
4	Moving Deformable Barrier (MDB) Summary of Results	2-8
5	Post Test Observations	2-9
6	Vehicle Pre-Test and Post Test Measurements	2-10
7	SID/HIII Longitudinal Clearance Dimensions	2-11
8	SID/HIII Lateral Clearance Dimensions	2-12
9	Vehicle Side Measurements	2-13
10	Vehicle Exterior Crush Profiles	2-14
11	Vehicle Damage Profile Distances	2-15
12	Deformable Barrier Honeycomb Face Static Crush	2-16
13	Vehicle Accelerometer Locations	2-17
14	MDB Accelerometer Locations	2-18
15	Vehicle Structural Measurements	2-19
16	High Speed Camera Locations and Data	2-20
17	Summary of FMVSS 301 Data	2-21
<u>Appendix</u>		<u>Page No</u>
A	Photographs	A-1
B	SID/HIII, Vehicle and MDB Response Data	B-1
C	SID/HIII Configuration and Performance Verification Data	C-1
D	Test Equipment and Calibration Information	D-1

SECTION 1
PURPOSE AND TEST PROCEDURE

PURPOSE

This side impact test is part of the FMVSS 214 Side Impact Protection Compliance Test Program sponsored by the National Highway Traffic Safety Administration (NHTSA) under Contract No. DTNH22-02-D-01114. The purpose of this indicant test was to evaluate side impact protection in a 2007 Pontiac Solstice 2-Door Convertible when tested at the New Car Assessment Program (NCAP) target test velocity of 62.0 kph, which is 8 kph faster than the target velocity required by the Office of Vehicle Safety Compliance's Laboratory Test Procedure (TP-214D-06, dated July 26, 2001).

SECTION 2

SUMMARY OF FMVSS 214 INDICANT SIDE IMPACT TEST

This Side Impact Protection Indicant Test was performed at the New Car Assessment Program (NCAP) target test velocity of 62.0 kph, which is 8 kph faster than the target velocity required by the Office of Vehicle Safety Compliance's Laboratory Test Procedure (TP-214D-06, dated July 26, 2001).

A model year 2007 Pontiac Solstice 2-Door Convertible was impacted on the left (driver's) side by a Moving Deformable Barrier (MDB) which was moving forward in a 27° crabbed position to the tow road guidance system at a velocity of 62.28 km/h. The specified impact velocity range is from 61.1 to 62.7 km/h. The test (target) vehicle was stationary and positioned 63° to the line of forward motion. The weight of the vehicle as tested was 1423.0 kg and the test weight of the MDB was 1362.5 kg. The test was conducted at the Calspan Corporation Transportation Sciences Center on October 17, 2006.

One (1) real-time motion picture camera and eight (8) high-speed motion picture cameras were used to document the impact event. The pre-test and post-test conditions were recorded by one (1) real-time motion picture camera. Camera locations and pertinent camera information are documented in the data sheets. Pre- and post-test photographs of the vehicle and Side Impact Dummy (SID/HIII) can be found in Appendix A.

One 50th percentile adult male SID/HIII was placed in the driver (P1) designated seating position according to instructions specified in the Laboratory Test Procedure for New Car Assessment Program Side Impact Testing dated July 1997. The SID/HIII was instrumented in the following locations:

- Left Upper Rib (LUR) uni-axial accelerometer (Y-axis primary and redundant)
- Left Lower Rib (LLR) uni-axial accelerometer (Y-axis primary and redundant)
- Lower Thoracic Spine (T12) uni-axial accelerometer (Y-axis primary and redundant)
- Pelvic (PEV) section uni-axial accelerometer (Y-axis primary and redundant)
- Head Center of Gravity (CG) tri-axial accelerometers (X, Y and Z axes primary and redundant)
- Upper Neck load cell (Fx, Fy, Fz, Mx, My, Mz)

The test vehicle was instrumented with twenty (20) structural accelerometers and the MDB was instrumented with five (5) accelerometers.

2.2 GENERAL COMMENTS

The test vehicle sustained a maximum static crush of 194 mm at level 3, 1350 mm rearward of the left vertical impact point. The driver SID/HIII, Serial No. 906, was calibrated just prior to this test.

Test data and observations are presented in this section of the report. Appendix A contains the still photograph prints. Appendix B contains the driver SID/HIII, vehicle, and MDB response data traces. Appendix C contains the SID/HIII configuration and performance verification data. Appendix D contains the test equipment information.

The occupant data is summarized below:

ATD position	HIC(36)	T ₁	T ₂	TTI (G's)	Peak Pelvis (G's)
Driver	304.6	32.5	34.1	59	71
Passenger *	-	-	-	-	-

SUPPLEMENTAL RESTRAINT INFORMATION

Restraint Type	Left Front (Driver)		Left Rear (Passenger) *	
	Installed	Deployed	Installed	Deployed
Front Airbag	Yes	No	-	-
Side Torso Airbag	NA	NA	-	-
Side Head/Torso Combination Airbag	NA	NA	-	-
Curtain Airbag	NA	NA	-	-

* This two-seat vehicle does not have rear seating positions.

The test instrumentation data listed in Appendix B can be found on the NHTSA website:
www.nhtsa.dot.gov.

DATA SHEET NO. 1

GENERAL TEST AND VEHICLE PARAMETER DATA

Test Vehicle:	2007 Pontiac Solstice	NHTSA No.	C70101
Test Program:	FMVSS 214 Indicant Side Impact	Test Date:	October 17, 2006

TEST VEHICLE INFORMATION AND VEHICLE OPTIONS

Make	General Motors Corporation	Driver Front Airbag	Yes
Model	Solstice	Driver Side Curtain Airbag	No
Body Style	2-Door Convertible	Driver Side Torso Airbag	No
NHTSA No.	C70101	Driver Pretensioners	Yes
VIN	1G2MB35B57Y106547	Driver Load Limiters	Yes
Color	Yellow	Driver Power Seats	No
Engine Disp.(L)	2.4	Rear Pass. Side Curtain Airbag	-
Engine Cylinders	4	Rear Pass. Side Torso Airbag	-
Engine Placement	Longitudinal	Rear Pass. Pretensioners	-
Transmission Type	Manual	Rear Pass. Load Limiters	-
Transmission Speeds	5	Rear Pass. Power Seats	-
Final Drive	Rear	Tilt Wheel	Yes
Air Conditioning	Yes	Anti-lock Brakes	No
Power Steering	Yes	Traction Control	Yes
Power Brakes	Yes	Power Windows	Yes
Delivery Date	09/15/2006	Power Door Locks	Yes
Odometer Reading (km)	802	Automatic Door Locks (ADL)	Yes
Dealer	Jim Murphy Pontiac Buick GMC, Inc., Depew, NY 14043-2608	Owner's Manual Details Instructions on Disabling ADLs	No

DATA FROM CERTIFICATION LABEL

Manufactured By	General Motors Corporation	GVWR (kg)	1543
		GAWR Front (kg)	774
Date of Manufacture	07/06	GAWR Rear (kg)	769

VEHICLE CAPACITY DATA

Measured Parameter	Front	Rear	Third	Total
Type of Seats	Bucket			
Number Of Occupants	2			2
Capacity Wt. (VCW) (kg)				164
Cargo Wt. (RCLW) (kg)				27.9

DATA SHEET NO. 1 (continued)

GENERAL TEST AND VEHICLE PARAMETER DATA

Test Vehicle: 2007 Pontiac Solstice NHTSA No. C70101
 Test Program: FMVSS 214 Indicant Side Impact Test Date: October 17, 2006

TEST VEHICLE WEIGHTS

	Units	As Delivered (UVW) (Axle)			Fully Loaded (Axle)			As Tested (ATW) (Axle)		
		Front	Rear	Total	Front	Rear	Total	Front	Rear	Total
Left	kg	339.5	316.5		364.5	367.5		351.5	363.5	
Right	kg	350.5	314.0		354.0	346.0		355.5	352.5	
Ratio	%	52.3	47.7		50.2	49.8		49.7	50.3	
Totals	kg	690.0	630.5	1320.5	718.5	713.5	1432.0	707.0	716.0	1423.0

TARGET TEST WEIGHT CALCULATION

Measured Parameter	Units	Value
Total Delivered Weight (UVW)	kg	1320.5
Weight of 2 P572E ATDs (81.2 kg each)	kg	81.2
Rated Cargo/Luggage Weight (RCLW)	kg	27.9
Calculated Vehicle Target Weight (TVTW)	kg	1429.6

* Actual As Tested Weight (ATW) will be TVTW -4.5/-9.1 kg

Weight of Ballast (including instrumentation package and cameras): 21.3 kg

TEST VEHICLE ATTITUDES

	Units	LF	RF	LR	RR
As Delivered	mm	732	727	742	748
Fully Loaded	mm	725	723	724	734
As Tested	mm	727	727	730	734

TEST VEHICLE VERTICAL IMPACT LINE AND CG

Measurement Description	Units	Value
Test Vehicle Wheel Base	mm	2420
Target Impact Point Aft of Front Axle	mm	270
Actual Impact Point Aft of Front Axle	mm	264
As Tested CG (aft of front axle)	mm	1218

DATA SHEET NO. 2

TEST VEHICLE TIRE INFORMATION

Test Vehicle:	2007 Pontiac Solstice	NHTSA No.	C70101
Test Program:	FMVSS 214 Indicant Side Impact	Test Date:	October 17, 2006

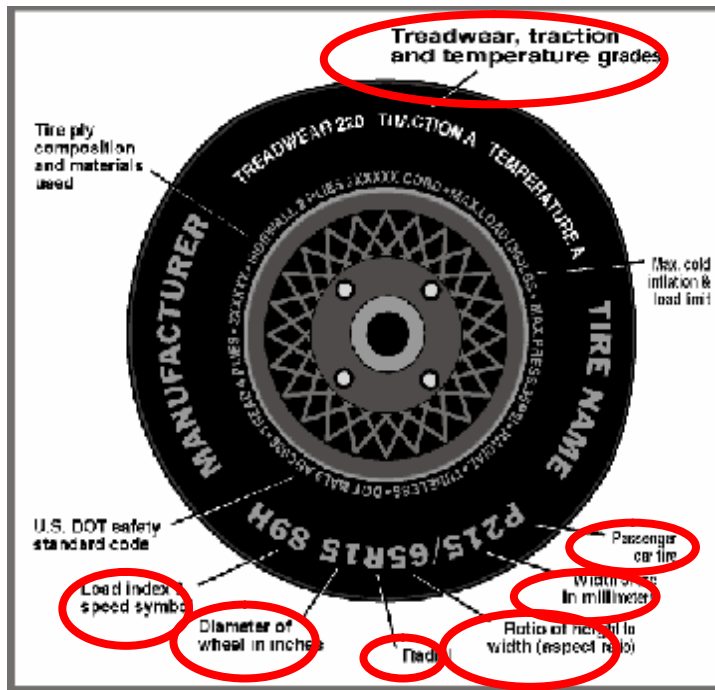

DATA FROM TIRE PLACARD

Measured Parameter	Front	Rear
Maximum Tire Pressure (kPa)	300	300
Cold / Test Pressure (kPa)	200	200
Recommended Tire Size	P245/45R18	P245/45R18
Tire Size on Vehicle	P245/45R18	P245/45R18
Tire Manufacturer	Goodyear	Goodyear
Tire Name	Eagle RS-A	Eagle RS-A
Tire Type	P	P
Tire Width (mm)	245	245
Ratio of Height to Width (aspect ratio)	45	45
Radial	R	R
Wheel Diameter	18	18
Load Index & Speed Symbol	96V	96V
Treadwear	260	260
Traction Grade	A	A
Temperature Grade	A	A

DATA SHEET NO. 3

TEST VEHICLE INFORMATION

Test Vehicle: 2007 Pontiac Solstice	NHTSA No. C70101
Test Program: FMVSS 214 Indicant Side Impact	Test Date: October 17, 2006

NORMAL DESIGN RIDING POSITION

The driver and passenger seat back is positioned to the manufacturer's designated angle.

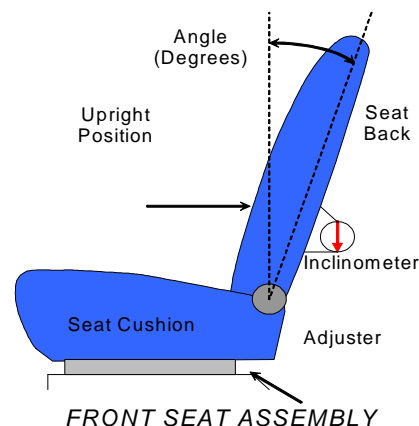

SEAT BACK POSITION

	Driver Seat	Rear Seat*
Test Detent (forward-most detent defined as 0)	NA	-
Angle (deg. from forward-most locking position)	NA	-
Alternative Measurements to Verify Test Position	Set outboard seatback recliner bracket to 10.6° back from vertical	-

SEAT FORE/AFT POSITIONS

The total seat travel was measured from forward most position to rearmost position irrespective of vertical seat height in those positions. The seat was set at the longitudinal mid position with vertical adjustment at the lowest position obtainable for both the driver and passenger.

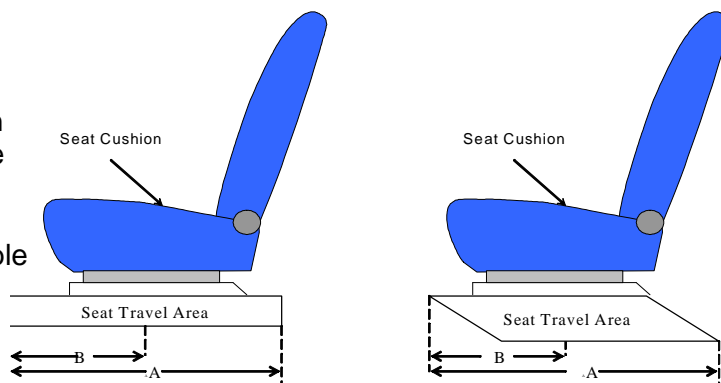

SEAT FORE/AFT POSITION

	Driver Seat	Rear Seat*
Total Fore/Aft Travel (A) (mm)	210	-
Test Position (B) (mm)	110	-
Test Detent (forward-most detent defined as 0)	Detent 11	-
Total Number of Detents (including 0)	22	-

* This two-seat vehicle does not have rear seating positions.

DATA SHEET NO. 3 (CONTINUED)

TEST VEHICLE INFORMATION

Test Vehicle: 2007 Pontiac Solstice NHTSA No. C70101
 Test Program: FMVSS 214 Indicant Side Impact Test Date: October 17, 2006

FUEL SYSTEM INFORMATION

The test vehicle is equipped with an electric fuel pump. The fuel pump operates for approximately two seconds after the ignition is placed in the "ON" position, after which the fuel pump automatically shuts off. The fuel filler door is located on the left rear fender. The standard fuel tank occupies the area under the rear seat.

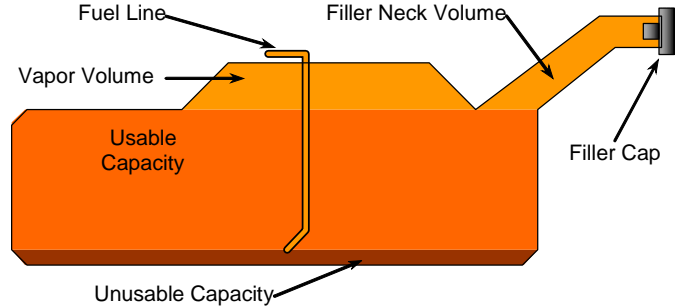

VEHICLE FUEL TANK ASSEMBLY

FUEL TANK CAPACITY

	Liters
Usable Capacity of "Standard" Fuel Tank	51.48
Usable Capacity of "Optional" Fuel Tank	-
Stoddard Used For Test (92%-94% of Fuel Tank Usable Capacity)	47.70

STEERING COLUMN ADJUSTMENT

Steering wheel and column adjustments are made so that the steering wheel hub is at the geometric center of the locus it describes when moved through its full range of motion. An aluminum plate is placed across the rim of the steering wheel, an inclinometer is placed on the plate and the angle is measured.

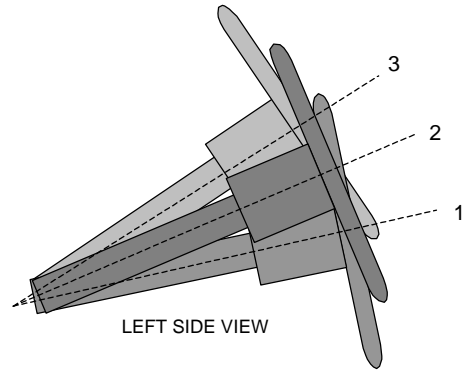

STEERING COLUMN ASSEMBLY

STEERING COLUMN POSITION

	Fore/Aft Position (mm)	Tilt (degrees)	Tilt (detent)
Lowermost Position No. 1	NA	16.00	NA
Geometric Center Position No. 2 *	NA	18.25	NA
Uppermost Position No. 3	NA	20.50	NA

* Test position.

DATA SHEET NO. 4**MOVING DEFORMABLE BARRIER (MDB) SUMMARY OF RESULTS**

Test Vehicle:	2007 Pontiac Solstice	NHTSA No.	C70101
Test Program:	FMVSS 214 Indicant Side Impact	Test Date:	October 17, 2006

MDB SPECIFICATIONS

Measurement Description	Length (mm)
Overall Width of Framework Carriage	1250
Overall Length Including Honeycomb Face	4120
Wheel base of Framework Carriage	2590
Tread of Framework Carriage (front & rear)	1875
C.G. Location aft of Front Axle	1104

MDB WEIGHTS

	Units	Front Axle	Rear Axle	Total
Left	kg	409.5	281.5	
Right	kg	372.5	299.0	
Ratio	%	57.4	42.6	
Totals	kg	782.0	580.5	1362.5

MDB SPEED AND IMPACT ANGLE DATA

Measured Parameter	Units	Requirement	Value
Trap No. 1 Velocity (Primary)	km/h	61.1 to 62.7	62.28
Trap No. 2 Velocity (Redundant)	km/h	61.1 to 62.7	62.28

POST TEST OBSERVATIONS**MDB LEFT EDGE IMPACT POINT DATA**

Measured Parameter	Units	Requirement	Value
Horizontal Offset	mm	+/- 50	6 mm forward
Vertical Offset	mm	+/-20	5 mm below

DATA SHEET NO. 5

POST TEST OBSERVATIONS

Test Vehicle: 2007 Pontiac Solstice NHTSA No. C70101
 Test Program: FMVSS 214 Indicant Side Impact Test Date: October 17, 2006

TEST DUMMY INFORMATION AND CONTACT POINTS

Description	Front Seat SID/HIII	Rear Seat SID/HIII*
Dummy Type / Serial No.	SID/HIII / 906	SID/HIII / -
Head Contact	Top of head to side header	-
Upper Torso Contact	Left arm to door trim above arm rest	-
Lower Torso Contact	Pelvis to door trim below arm rest	-
Left Knee Contact	Left knee to door trim	-
Right Knee Contact	Right knee to left knee	-

POST TEST DOOR OPENING AND SEAT TRACK INFORMATION

Description	Front	Rear*
Locked/Unlocked Doors	Doors were unlocked	-
Left Side Door Opening	Door remained closed and latched	-
Right Side Door Opening	Door remained closed and latched; Door opened without tools	-
Seat Movement	0	-
Seat Back Failure	None	-

POST TEST STRUCTURAL OBSERVATIONS

Critical Areas of Performance	Observations and Conclusions
Pillar Performance	No Separation
Sill Separation	None
Windshield Damage	Windshield cracked along the left edge
Window Damage	Left window shattered during the impact
Other Notable Effects	None

SUPPLEMENTAL RESTRAINT INFORMATION

Restraint Type	Left Front (Driver)		Left Rear (Passenger)*	
	Installed	Deployed	Installed	Deployed
Front Airbag	Yes	No	-	-
Side Torso Airbag	NA	NA	-	-
Side Head/Torso Combination Airbag	NA	NA	-	-
Curtain Airbag	NA	NA	-	-

* This two-seat vehicle does not have rear seating positions.

DATA SHEET NO. 6

VEHICLE PRE-TEST AND POST-TEST MEASUREMENTS

Test Vehicle: 2007 Pontiac Solstice NHTSA No. C70101
 Test Program: FMVSS 214 Indicant Side Impact Test Date: October 17, 2006

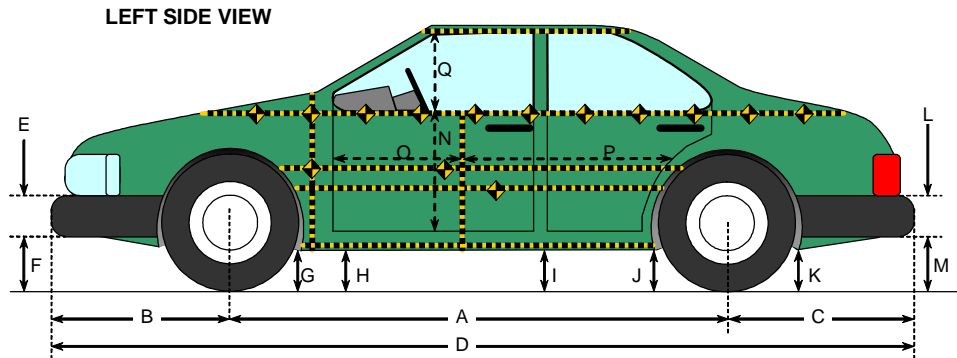

All Measurements in mm

Code	Measurement Description	Pre-Test (delivered)	Pre-Test (as tested)	Post-Test (as tested)	Difference
A	Wheelbase	2415	2420	2412	8
B	Front Axle to FSOV	767	765	784	-19
C	Rear Axle to RSOV	808	805	785	20
D	Total Length at Centerline	3990	3990	3981	9
E	Front Bumper Thickness	477	477	477	0
F	Front Bumper Bottom to Ground	142	137	158	-21
G	Sill Height at Front Wheel Well	123	113	167	-54
H	Sill Height at Front Door Leading Edge	136	125	148	-23
I	Sill Height at "B" Pillar	152	137	142	-5
J1	Sill Height at Rear Wheel Well	165	149	151	-2
J2	Pinch Weld Height at Rear Wheel Well	152	136	136	0
K	Sill Height Aft of Rear Wheel Well	237	218	234	-16
L	Rear Bumper Thickness	245	245	245	0
M	Rear Bumper Bottom to Ground	248	229	245	-16
N	Sill Height to Window Bottom Sill	574	574	568	6
O	Front Door Leading Edge to Impact CL	783	783	749	34
P	Front Door Trailing Edge to Impact CL	993	993	823	170
Q	Front Window Opening	291	291	279	12
R	Right Side Length	3822	3822	3826	-4
S	Left Side Length	3822	3822	3820	2
T	Vehicle Width at "B" Post	1796	1796	1730	66

DATA SHEET NO. 7

SID/HIII LONGITUDINAL CLEARANCE DIMENSIONS

Test Vehicle:	2007 Pontiac Solstice	NHTSA No.	C70101
Test Program:	FMVSS 214 Indicant Side Impact	Test Date:	October 17, 2006

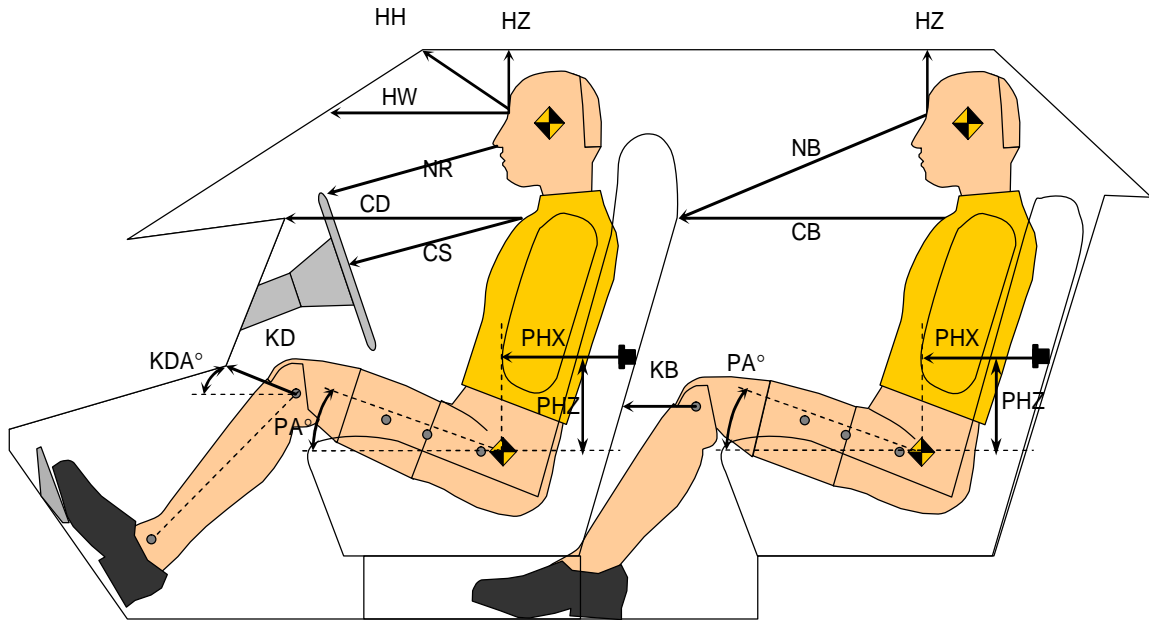

Driver Code	Pass. Code	Measurement Description	Driver S/N 906		Passenger *	
			Length(mm)	Angle(°)	Length(mm)	Angle(°)
HH		Head to Header	356			
HW		Head to Windshield	660			
HZ	HZ	Head to Roof	178		-	
NR	NB	Nose to Rim/Nose to Seatback	427		-	
CD	CB	Chest to Dash or Seatback	628		-	
CS		Chest to Steering Wheel	328			
KDL	KBL	Left Knee to Dash or Seatback	164	35	-	-
KDR	KBR	Right Knee to Dash or Seatback	162	35	-	-
PA	PA	Pelvic Angle		23.2		-
PHX	PHX	H-Point to Striker (X-Axis)	316		-	
PHZ	PHZ	H-Point to Striker (Z-Axis)	273		-	

* This two-seat vehicle does not have rear seating positions.

DATA SHEET NO. 8

SID/HIII LATERAL CLEARANCE DIMENSIONS

Test Vehicle:	2007 Pontiac Solstice	NHTSA No.	C70101
Test Program:	FMVSS 214 Indicant Side Impact	Test Date:	October 17, 2006

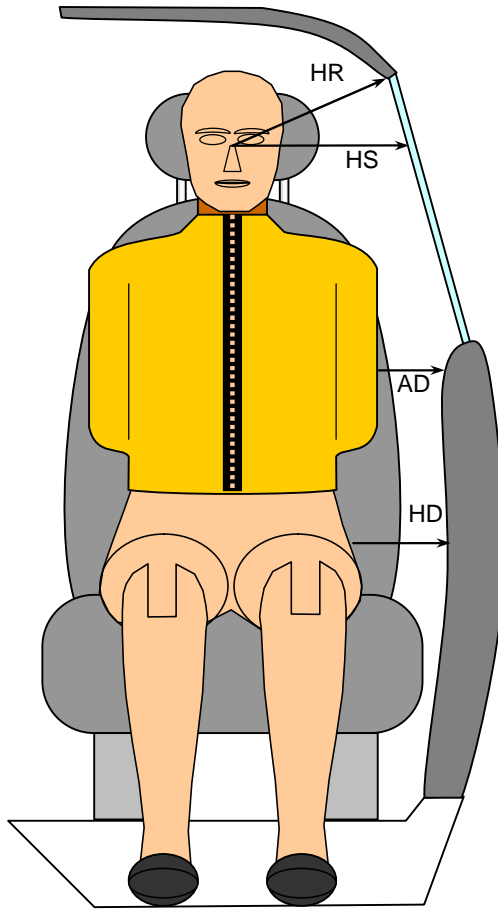

FRONT VIEW OF DUMMY

Code	Measurement Description	Units	Driver S/N 906	Passenger *
HR	Head to Side Header	mm	185	-
HS	Head to Side Window	mm	265	-
AD ₁	Arm to Door (at upper rib level)	mm	50	-
AD ₂	Arm to Door (at lower rib level)	mm	76	-
HD	H-Point to Door	mm	102	-

* This two-seat vehicle does not have rear seating positions.

DATA SHEET NO. 9

VEHICLE SIDE MEASUREMENTS

Test Vehicle: 2007 Pontiac Solstice NHTSA No. C70101
 Test Program: FMVSS 214 Indicant Side Impact Test Date: October 17, 2006

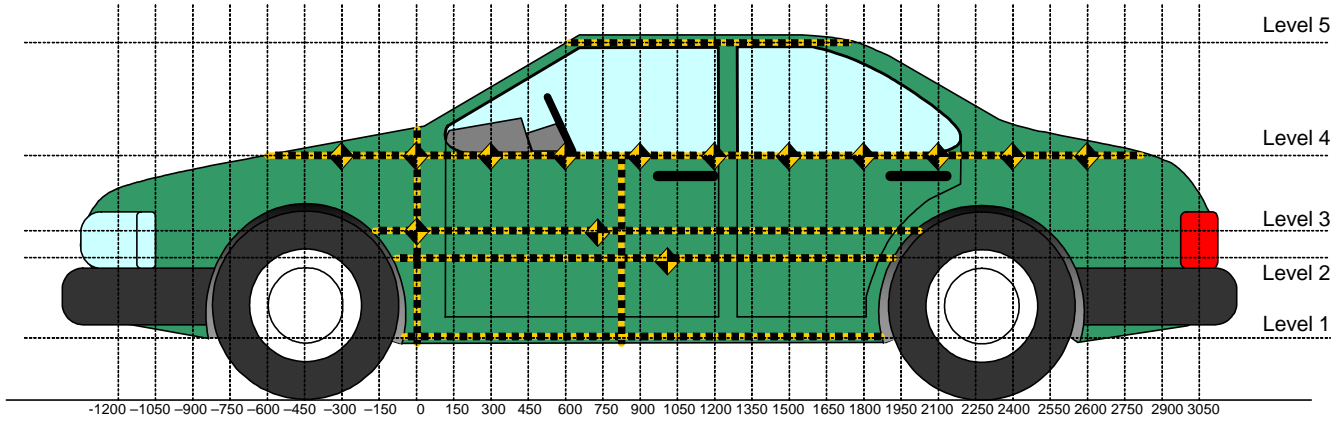

All Measurements Shown in mm

LEFT SIDE VIEW

Measurements are taken with vehicle in the as tested condition.
 Measurements along the vertical 750 mm.
 All measurements below in mm.

Level	Measurement Description	Maximum Exterior Static Crush	Height Above Ground	Distance From Impact
1	Sill Top	66	200	600
2	Occupant H-Point	182	354	1200
3	Mid Door	194	550	1350
4	Window Sill	144	792	1500
5	Window	6	1132	1200
	Maximum Penetration	194		

DATA SHEET NO. 10

VEHICLE EXTERIOR CRUSH PROFILES

Test Vehicle: 2007 Pontiac Solstice NHTSA No. C70101
 Test Program: FMVSS 214 Indicant Side Impact Test Date: October 17, 2006

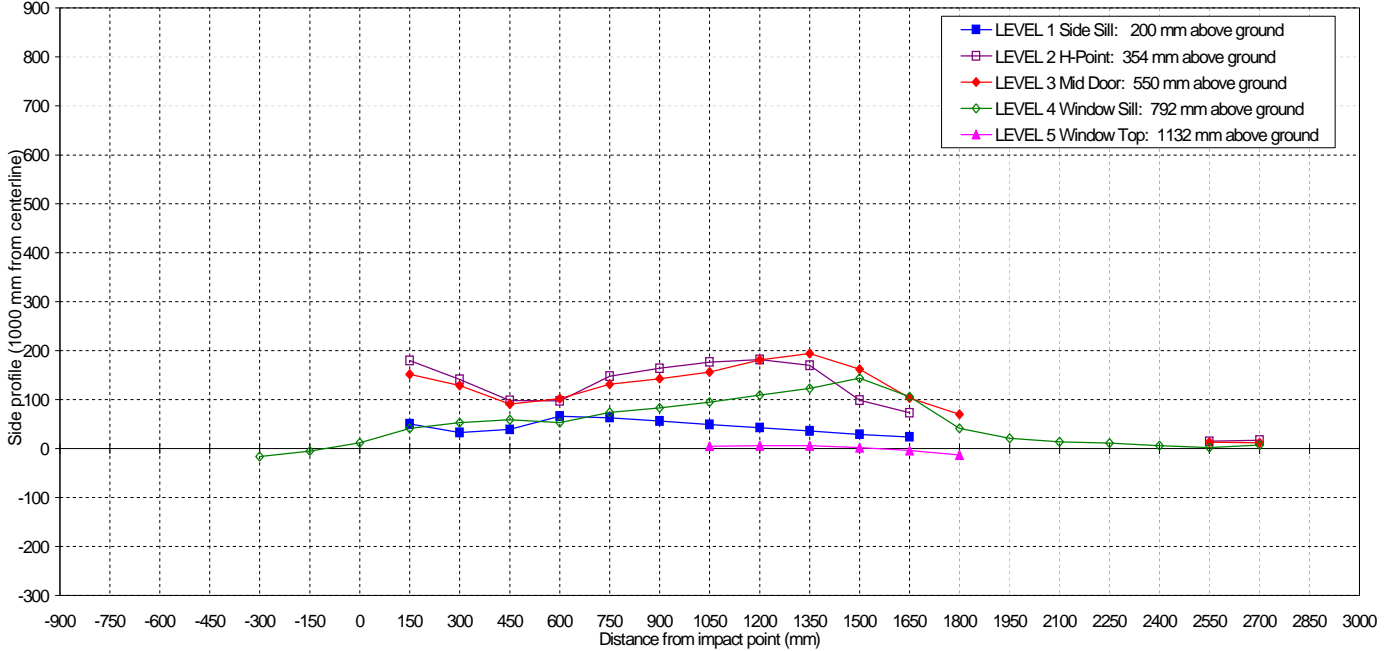

NOTE: All dimensions are in millimeters with a tolerance of ± 3 mm

		DISTANCE IN MILLIMETERS (mm) FROM IMPACT POINT																													
LEVEL	HEIGHT (mm)		-900	-750	-600	-450	-300	-150	0	150	300	450	600	750	900	1050	1200	1350	1500	1650	1800	1950	2100	2250	2400	2550	2700	2850	3000		
LEVEL 1 SIDE SILL	200	PRE	--	--	--	--	--	--	--	166	189	202	206	208	211	214	215	216	210	193	--	--	--	--	--	--	--	--	--	--	
		POST	--	--	--	--	--	--	--	--	216	222	241	272	271	267	263	258	252	239	217	--	--	--	--	--	--	--	--	--	
		CRUSH	N/A	N/A	N/A	N/A	N/A	N/A	N/A	N/A	50	33	39	66	63	56	49	43	36	29	24	N/A	N/A	N/A	N/A	N/A	N/A	N/A	N/A	N/A	
LEVEL 2 H POINT	354	PRE	--	--	--	--	--	--	--	127	144	152	157	161	163	165	166	165	161	142	--	--	--	--	--	--	174	313	--	--	
		POST	--	--	--	--	--	--	--	--	307	285	250	254	309	327	342	348	335	260	215	--	--	--	--	--	--	189	330	--	--
		CRUSH	N/A	N/A	N/A	N/A	N/A	N/A	N/A	N/A	180	141	98	97	148	164	177	182	170	99	73	N/A	N/A	N/A	N/A	N/A	N/A	15	17	N/A	N/A
LEVEL 3 MID DOOR	550	PRE	--	--	--	--	--	--	--	116	142	134	140	143	145	146	146	144	140	127	98	--	--	--	--	--	159	269	--	--	
		POST	--	--	--	--	--	--	--	--	268	271	225	242	274	288	302	327	338	302	230	168	--	--	--	--	--	172	281	--	--
		CRUSH	N/A	N/A	N/A	N/A	N/A	N/A	N/A	N/A	152	129	91	102	131	143	156	181	194	162	103	70	N/A	N/A	N/A	N/A	N/A	13	12	N/A	N/A
LEVEL 4 WINDOW SILL	792	PRE	--	--	--	--	209	181	180	186	188	188	187	187	185	183	180	176	184	163	146	130	117	120	149	205	289	--	--		
		POST	--	--	--	--	193	176	192	227	241	247	240	261	268	278	289	299	328	269	187	151	131	131	155	207	296	--	--		
		CRUSH	N/A	N/A	N/A	N/A	-16	-5	12	41	53	59	53	74	83	95	109	123	144	106	41	21	14	11	6	2	7	N/A	N/A		
LEVEL 5 WINDOW TOP	1132	PRE	--	--	--	--	--	--	--	--	--	--	--	--	--	415	400	394	390	429	479	--	--	--	--	--	--	--	--		
		POST	--	--	--	--	--	--	--	--	--	--	--	--	--	--	420	406	400	392	425	466	--	--	--	--	--	--	--	--	
		CRUSH	N/A	N/A	N/A	N/A	N/A	N/A	N/A	N/A	N/A	N/A	N/A	N/A	N/A	N/A	5	6	6	2	-4	-13	N/A	N/A	N/A	N/A	N/A	N/A	N/A	N/A	

DATA SHEET NO. 11

VEHICLE DAMAGE PROFILE DISTANCES

Test Vehicle: 2007 Pontiac Solstice NHTSA No. C70101
 Test Program: FMVSS 214 Indicant Side Impact Test Date: October 17, 2006

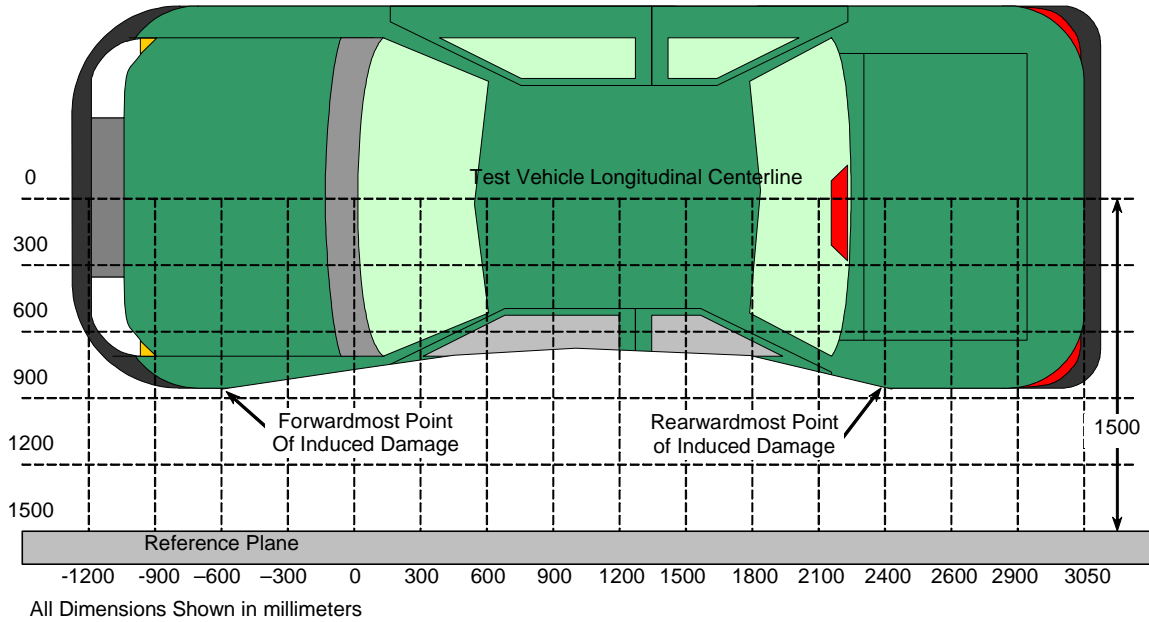

TOP VIEW

DAMAGE PROFILE DISTANCES

DPD	Distance from Impact Point in mm	Level	Pre-Test (mm)	Post-Test (mm)	Max Static Crush (mm)
1 (LR)	2450	792	168	172	4
2	1944	792	131	152	21
3	1438	550	142	317	175
4	932	354	163	330	167
5	426	354	151	256	105
6 (LF)	-80	792	181	183	2

Reference plane is parallel to test vehicle longitudinal centerline.
 Given dimensions = Reference plane to vehicle body.

DATA SHEET NO. 12

DEFORMABLE BARRIER HONEYCOMB FACE STATIC CRUSH

Test Vehicle:	2007 Pontiac Solstice	NHTSA No.	C70101
Test Program:	FMVSS 214 Indicant Side Impact	Test Date:	October 17, 2006

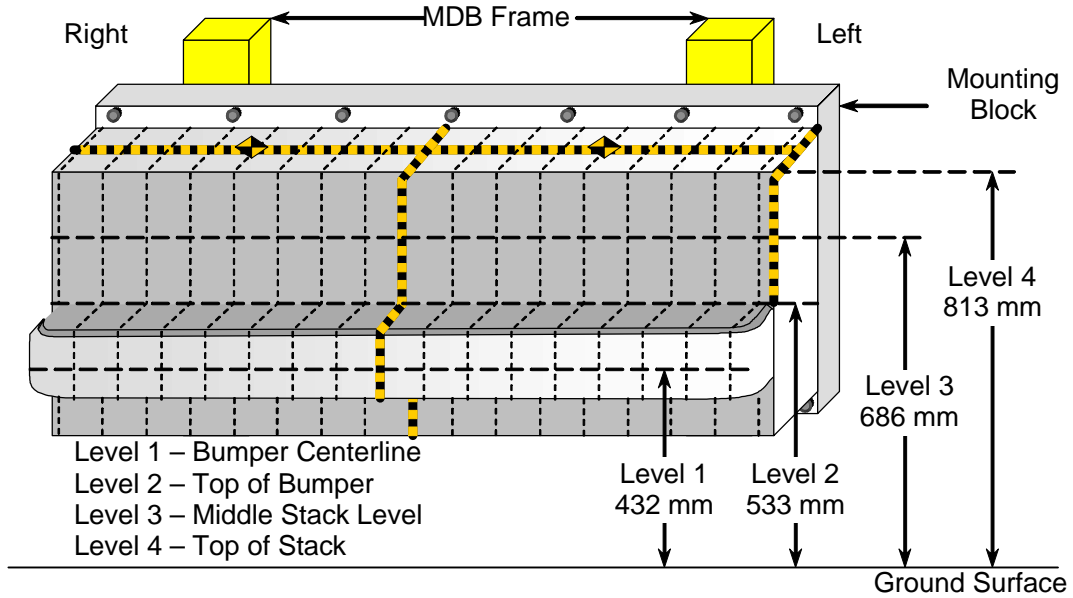

NOTE: All dimensions are in millimeters with a tolerance of ± 3 mm

LEVEL	HEIGHT AT CL (mm)*		DISTANCE RIGHT OF CENTER (mm)									0	DISTANCE LEFT OF CENTER (mm)								
			800	700	600	500	400	300	200	100	0		100	200	300	400	500	600	700	800	
LEVEL 4 TOP STACK	813	PRE	619	619	619	619	619	619	619	619	619	619	619	619	619	619	619	619	619		
		POST	764	686	627	622	620	618	620	627	634	644	653	680	689	681	681	681	697		
		CRUSH	145	67	8	3	1	-1	1	8	15	25	34	61	70	62	62	62	78		
LEVEL 3 MID LEVEL	686	PRE	619	619	619	619	619	619	619	619	619	619	619	619	619	619	619	619			
		POST	800	716	655	643	644	641	637	635	638	647	673	709	717	699	673	664	671		
		CRUSH	181	97	36	24	25	22	18	16	19	28	54	90	98	80	54	45	52		
LEVEL 2 TOP BUMPER	533	PRE	619	619	619	619	619	619	619	619	619	619	619	619	619	619	619	619			
		POST	842	770	698	679	689	688	691	691	697	705	718	739	754	736	711	692	678		
		CRUSH	223	151	79	60	70	69	72	72	78	86	99	120	135	117	92	73	59		
LEVEL 1 MID BUMPER	432	PRE	535	519	518	518	518	518	518	518	518	518	518	518	518	518	519	535			
		POST	804	771	719	662	626	612	612	614	617	623	642	682	696	669	636	617	614		
		CRUSH	269	252	201	144	108	94	94	96	99	105	124	164	178	151	118	98	79		

*Heights measured above ground level.

DATA SHEET NO. 13

VEHICLE ACCELEROMETER LOCATIONS

Test Vehicle:	2007 Pontiac Solstice	NHTSA No.:	C70101
Test Program:	FMVSS 214 Indicant Side Impact	Test Date:	October 17, 2006

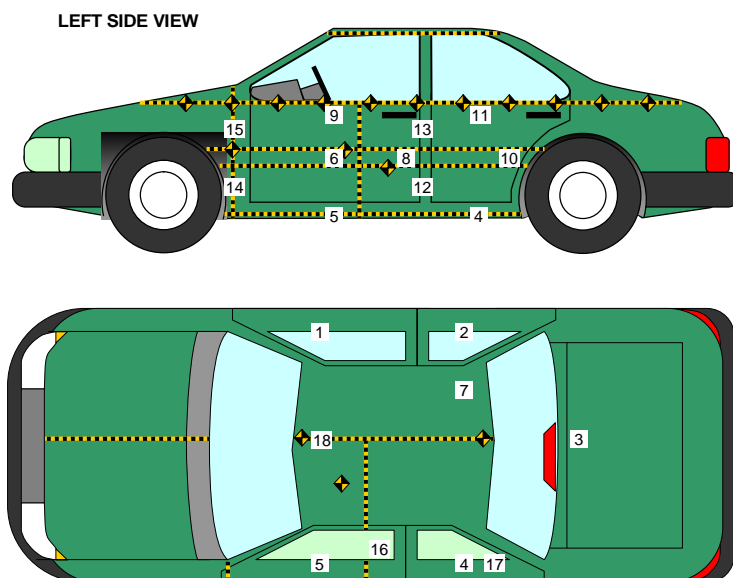

Loc. No.	Accelerometer Location	Measurements (mm)		
		X	Y	Z
1	Right Sill at Front Seat	2070	653	225
2	Right Sill at Rear Seat	1362	670	354
3	Rear Floorpan Above Axle	966	10	713
4	Left Sill at Rear Door	1412	-629	248
5	Left Sill at Front Door	2087	-611	239
6	Left Front Door C/L**	-	-	-
7	Rear Occupant Compartment	1911	601	171
8	Left Front Door Mid-Rear**	-	-	-
9	Left Front Door Upper C/L**	-	-	-
10	Left Rear Door Mid-Rear**	-	-	-
11	Left Rear Door Upper C/L**	-	-	-
12	Left Lower B-Post	1322	-663	406
13	Left Middle B-Post	1027	-687	893
14	Left Lower A-Post	2355	-643	425
15	Left Middle A-Post	2215	-654	834
16	Front Seat Track	1519	-586	209
17	Rear Seat Track or Structure	-	-	-
18	Vehicle CG	1706	25	485

Reference Points X - Test Vehicle Rear Bumper (+ forward)
 Y - Test Vehicle Centerline (+ to right)
 Z - Ground Plane (+ down)

** Accelerometer was not requested by the COTR.

DATA SHEET NO. 14

MDB ACCELEROMETER LOCATIONS

Test Vehicle: 2007 Pontiac Solstice NHTSA No. C70101
 Test Program: FMVSS 214 Indicant Side Impact Test Date: October 17, 2006

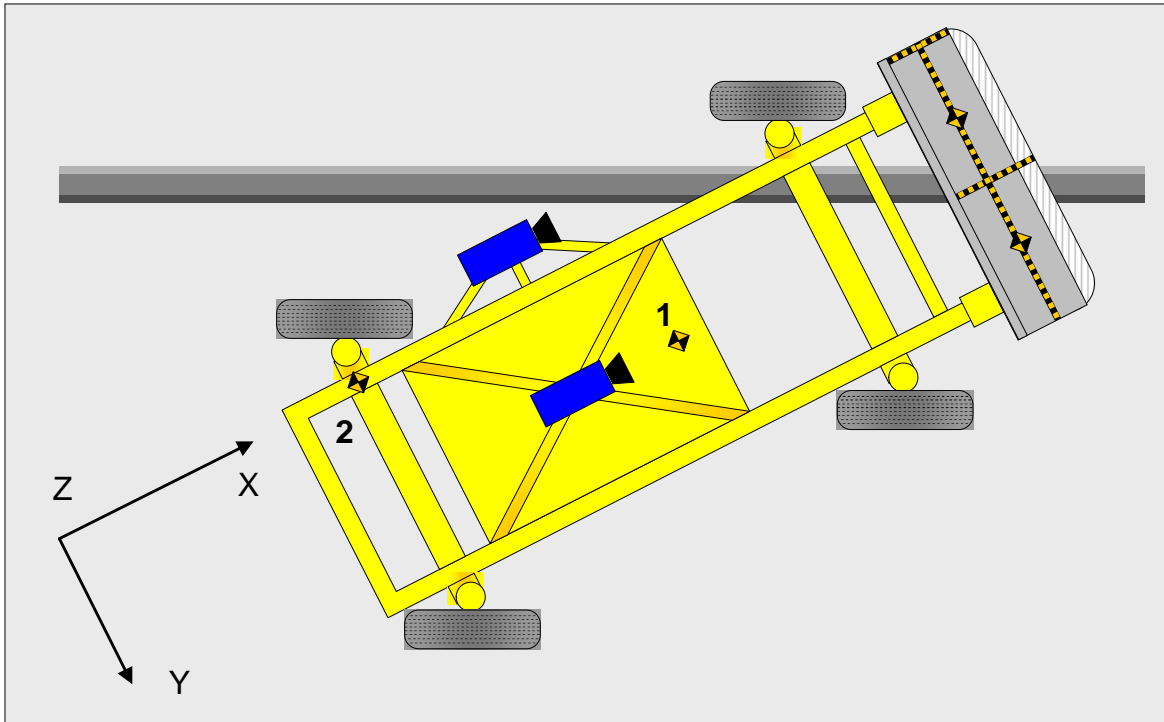

Loc. No.	Accelerometer Location	Measurements (mm)		
		X	Y	Z
1	MDB CG	1859	0	-330
2	MDB Rear	386	-660	-660

Reference Points X - MDB Rear Bumper (+ forward)
 Y - MDB Centerline (+ to right)
 Z - Ground Plane (+ down)

DATA SHEET NO. 15**VEHICLE STRUCTURAL MEASUREMENTS**

Test Vehicle: 2007 Pontiac Solstice NHTSA No. C70101
Test Program: FMVSS 214 Indicant Side Impact Test Date: October 17, 2006

	Elements	Pre-Test (mm)
1	Total Length	3990
2	Total Width	1796
3	Bumper Top Height	490
4	Bumper Bottom Height	380
5	Longitudinal Member Top Height	490
6	Distance between Longitudinal Members	872
7	Longitudinal Member Width	90
8	Engine Top Height	803
9	Engine Bottom Height	380
10	Engine and gearbox width	559
11	Front bumper-engine distance	721
12	Front shock absorber fixing height	566
13	Bonnet leading edge height	613
14	Front shock absorber fixing width	920
15	Front bumper – front axle distance	769
16	Front axle – a pillar distance	913
17	A-pillar – B-pillar distance	1104
18	B-Pillar – rear axle distance	402
19	B-pillar – C-pillar distance	0
20	Roof sill bottom height	1085
21	Roof sill top height	1140
22	Floor sill bottom height	171
23	Floor sill top height	319

DATA SHEET NO. 16

HIGH SPEED CAMERA LOCATIONS AND DATA

Test Vehicle: 2007 Pontiac Solstice NHTSA No. C70101
 Test Program: FMVSS 214 Indicant Side Impact Test Date: October 17, 2006

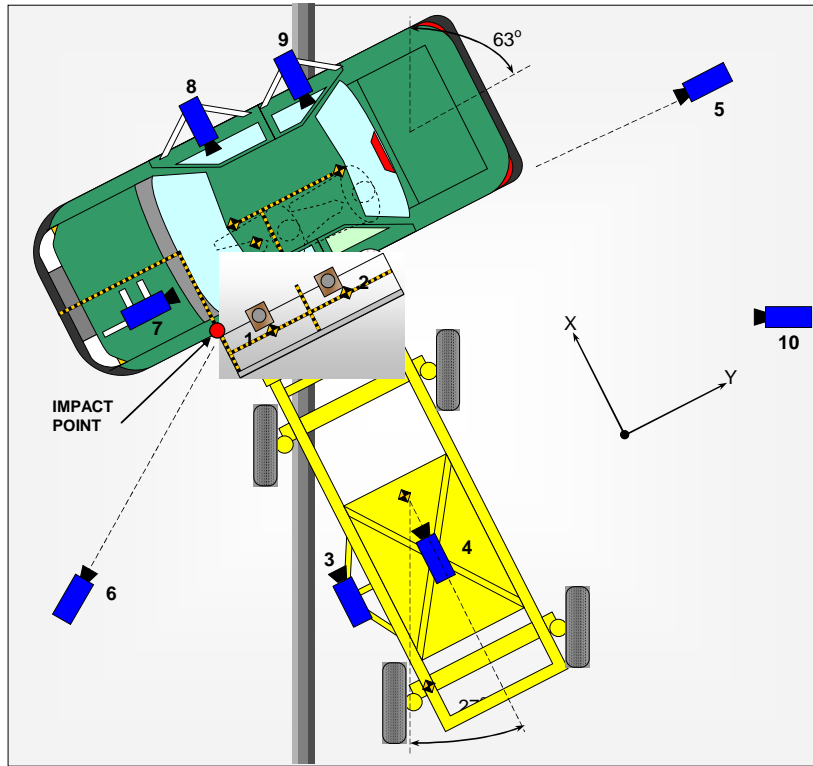

No.	Camera View	Location (mm)			Angle (deg)	Lens (mm)	Film Speed (fps)
		X	Y	Z			
1	Overhead Close-up	72	812	-4880	-90	20	1000
2	Overhead Overall	195	855	-4880	-90	28	1000
3	MDB Onboard, Impact Point Close-up	-1470	0	-847	0	13	1000
4	MDB Onboard, Centerline of Impact	-1140	838	-1587	-17	7.5	1000
5	Right Side, Ground Level, Overall	0	9891	-1100	-5	50	1000
6	Left Side, Ground Level, Overall	-1952	-2176	-938	-6	28	1000
7	Vehicle Onboard Front SID/HIII, Front	565	-299	-1182	-3	25	1000
8	Vehicle Onboard Front SID/HIII, Side	1537	1346	-961	-14	12.5	1000
9	Vehicle Onboard Rear SID/HIII, Side	-	-	-	-	-	-
10	Real Time Coverage						30

Reference Points X - Impact Line
 Y - MDB Left Edge Impact Point
 Z - Ground Plane

**DATA SHEET NO. 17
SUMMARY OF FMVSS 301 DATA**

Test Vehicle: 2007 Pontiac Solstice NHTSA No. C70101
 Test Program: FMVSS 214 Indicant Side Impact Test Date: October 17, 2006

FUEL SYSTEM INTEGRITY POST IMPACT DATA

Time Interval	FMVSS 301 Maximum Allowable Spillage	Spillage (g)
Impact Until Motion Ceases	28 g	0
First Five Minutes Following Impact	142 g	0
Next 25 Minutes	28 g / 1 minute	0

Spillage Location(s)	None
----------------------	------

STATIC ROLLOVER DATA

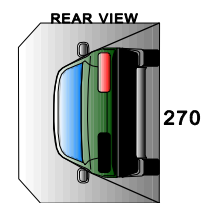
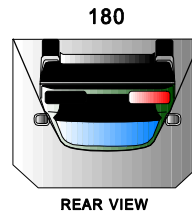
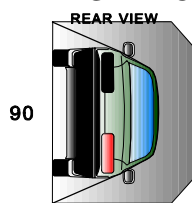
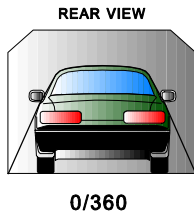

Rollover Stage	Rotation Time (spec. 1 -3 min)				FMVSS 301 Hold Time		Total Time				Next Whole Minute Interval	
	minutes	seconds	minutes	seconds	minutes	seconds	minutes	seconds	minutes	seconds	minutes	seconds
0° - 90°	1	7	5	6	7	7	7	7	7	7	7	7
90° - 180°	1	7	5	6	7	7	7	7	7	7	7	7
180°-270°	1	8	5	6	8	7	8	8	8	8	7	7
270°-360°	1	8	5	6	8	7	8	8	8	8	7	7

Rollover Stage	Spillage (g)			
	First 5 min. from onset of rotation	6 th min.	7 th min.	8 th min. (if required)
0° - 90°	0	0	0	-
90° - 180°	0	0	0	-
180°-270°	0	0	0	-
270°-360°	0	0	0	-
FMVSS 301 Maximum Allowable (for each 90° stage)	142	28	28	28

Rollover Stage	Spillage Location(s)
0° - 90°	None
90° - 180°	None
180°-270°	None
270°-360°	None

APPENDIX A
PHOTOGRAPHS

TABLE OF PHOTOGRAPHS

FIGURE	TITLE	PAGE
A-1	As Received Left Front $\frac{3}{4}$ View	A-4
A-2	As Received Right Rear $\frac{3}{4}$ View	A-4
A-3	Vehicle Certification Label	A-5
A-4	Vehicle Tire Placard Label	A-5
A-5	Pre-Test Front View	A-6
A-6	Post-Test Front View	A-6
A-7	Pre-Test Left Front $\frac{3}{4}$ View	A-7
A-8	Post-Test Left Front $\frac{3}{4}$ View	A-7
A-9	Pre-Test Left Side View	A-8
A-10	Post-Test Left Side View	A-8
A-11	Pre-Test Left Rear $\frac{3}{4}$ View	A-9
A-12	Post-Test Left Rear $\frac{3}{4}$ View	A-9
A-13	Pre-Test Rear View	A-10
A-14	Post-Test Rear View	A-10
A-15	Pre-Test Right Rear $\frac{3}{4}$ View	A-11
A-16	Post-Test Right Rear $\frac{3}{4}$ View	A-11
A-17	Pre-Test Right Side View	A-12
A-18	Post-Test Right Side View	A-12
A-19	Pre-Test Right Front $\frac{3}{4}$ View	A-13
A-20	Post-Test Right Front $\frac{3}{4}$ View	A-13
A-21	Pre-Test Frontal View of MDB Impactor Face	A-14
A-22	Post-Test Frontal View of MDB Impactor Face	A-14
A-23	Pre-Test Left Side View of MDB Impactor Face	A-15
A-24	Post-Test Left Side View of MDB Impactor Face	A-15
A-25	Pre-Test Right Side View of MDB Impactor Face	A-16
A-26	Post-Test Right Side View of MDB Impactor Face	A-16
A-27	Pre-Test Top View of MDB Impactor Face	A-17
A-28	Post-Test Top View of MDB Impactor Face	A-17
A-29	Pre-Test Left Side View of Aligned MDB and Vehicle	A-18
A-30	Pre-Test Right Side View of Aligned MDB and Vehicle	A-18
A-31	Pre-Test Overhead View of Aligned MDB and Vehicle	A-19
A-32	Post-Test Overhead View of MDB and Vehicle	A-19
A-33	Pre-Test Close-Up View of Impact Point Target	A-20
A-34	Post-Test Close-Up View of Impact Point Target	A-20

TABLE OF PHOTOGRAPHS (continued)

FIGURE	TITLE	PAGE
A-35	Pre-Test Right Occupant Compartment View of Driver	A-21
A-36	Post-Test Right Occupant Compartment View of Driver	A-21
A-37	Pre-Test Left Occupant Compartment View of Driver	A-22
A-38	Post-Test Left Occupant Compartment View of Driver	A-22
A-39	Pre-Test Left Front Interior Trim	A-23
A-40	Post-Test Left Front Interior Trim	A-23
A-41	Pre-Test Left Front $\frac{3}{4}$ View of Left Side Doors	A-24
A-42	Post-Test Left Front $\frac{3}{4}$ View of Left Side Doors	A-24
A-43	Pre-Test Left Rear $\frac{3}{4}$ View of Left Side Doors	A-25
A-44	Post-Test Left Rear $\frac{3}{4}$ View of Left Side Doors	A-25
A-45	Rollover 90 Degrees	A-26
A-46	Rollover 180 Degrees	A-26
A-47	Rollover 270 Degrees	A-27
A-48	Rollover 360 Degrees	A-27
A-49	Impact Photo	A-28



Figure A-1: As Received Left Front $\frac{3}{4}$ View



Figure A-2: As Received Right Rear $\frac{3}{4}$ View

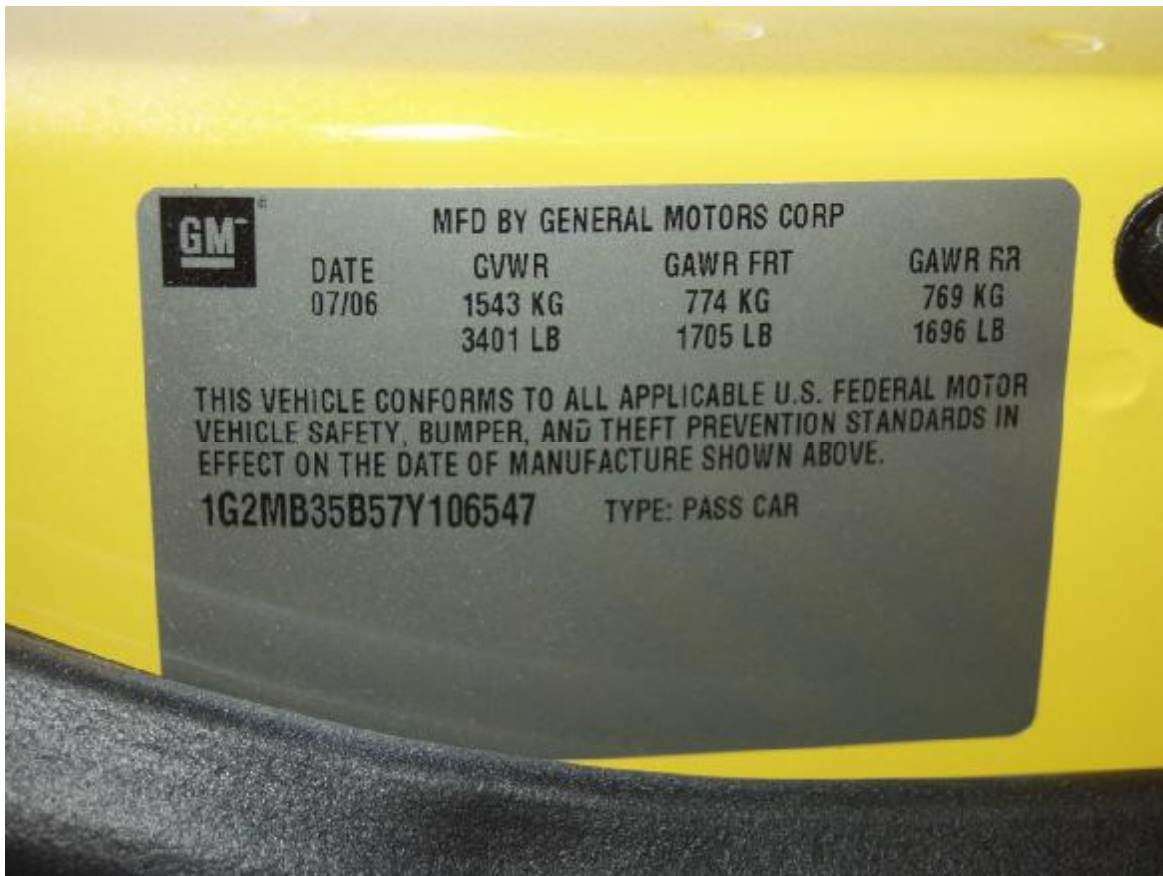

Figure A-3: Vehicle Certification Label



Figure A-4: Vehicle Tire Placard Label



Figure A-5: Pre-Test Front View



Figure A-6: Post-Test Front View



Figure A-7: Pre-Test Left Front $\frac{3}{4}$ View



Figure A-8: Post-Test Left Front $\frac{3}{4}$ View



Figure A-9: Pre-Test Left Side View



Figure A-10: Post-Test Left Side View



Figure A-11: Pre-Test Left Rear $\frac{3}{4}$ View



Figure A-12: Post-Test Left Rear $\frac{3}{4}$ View



Figure A-13: Pre-Test Rear View



Figure A-14: Post-Test Rear View



Figure A-15: Pre-Test Right Rear $\frac{3}{4}$ View



Figure A-16: Post-Test Right Rear $\frac{3}{4}$ View



Figure A-17: Pre-Test Right Side View



Figure A-18: Post-Test Right Side View



Figure A-19: Pre-Test Right Front 3/4 View



Figure A-20: Post-Test Right Front 3/4 View

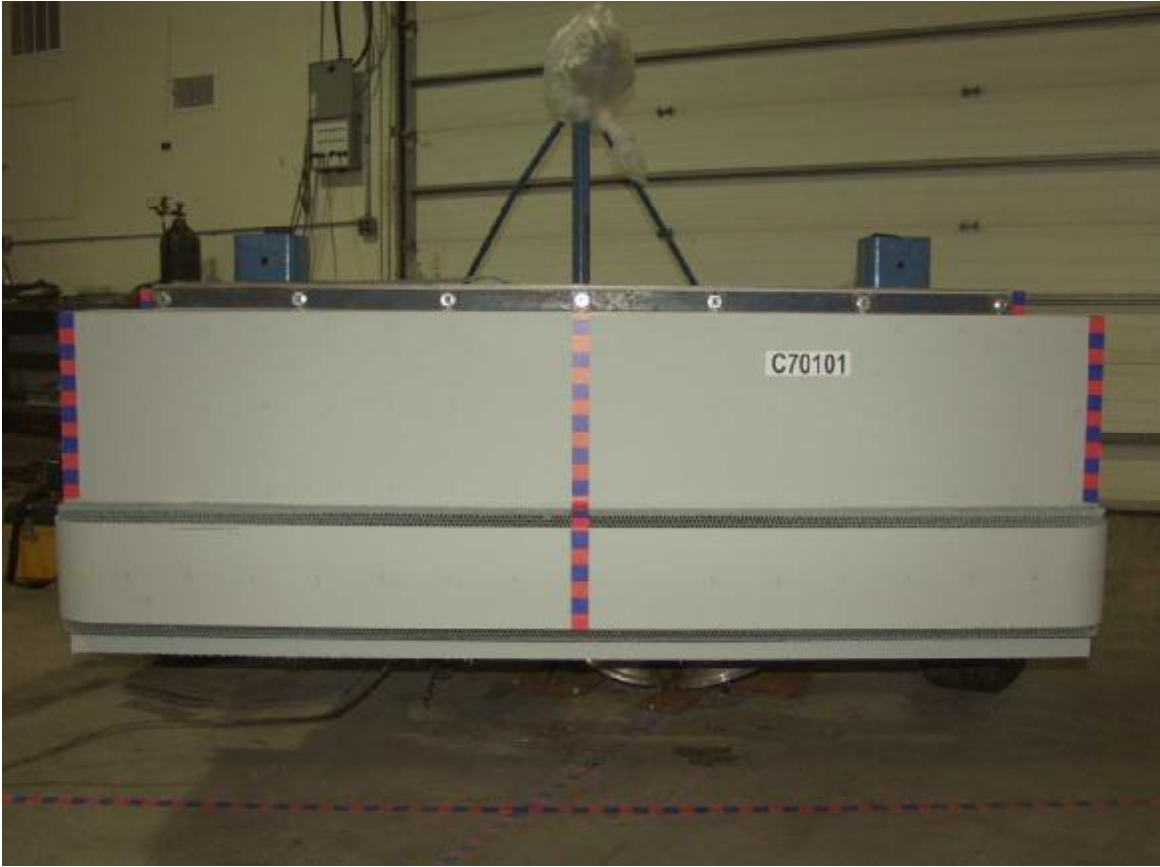

Figure A-21: Pre-Test Frontal View of MDB Impactor Face



Figure A-22: Post-Test Frontal View of MDB Impactor Face



Figure A-23: Pre-Test Left Side View of MDB Impactor Face



Figure A-24: Post-Test Left Side View of MDB Impactor Face



Figure A-25: Pre-Test Right Side View of MDB Impactor Face



Figure A-26: Post-Test Right Side View of MDB Impactor Face



Figure A-27: Pre-Test Top View of MDB Impactor Face



Figure A-28: Post-Test Top View of MDB Impactor Face



Figure A-29: Pre-Test Left Side View of Aligned MDB and Vehicle



Figure A-30: Pre-Test Right Side View of Aligned MDB and Vehicle



Figure A-31: Pre-Test Overhead View of Aligned MDB and Vehicle



Figure A-32: Post-Test Overhead View of MDB and Vehicle



Figure A-33: Pre-Test Close-Up View of Impact Point Target



Figure A-34: Post-Test Close-Up View of Impact Point Target



Figure A-35: Pre-Test Right Occupant Compartment View of Driver



Figure A-36: Post-Test Right Occupant Compartment View of Driver



Figure A-37: Pre-Test Left Occupant Compartment View of Driver



Figure A-38: Post-Test Left Occupant Compartment View of Driver



Figure A-39: Pre-Test Left Front Interior Trim



Figure A-40: Post-Test Left Front Interior Trim



Figure A-41: Pre-Test Left Front $\frac{3}{4}$ View of Left Side Doors



Figure A-42: Post-Test Left Front $\frac{3}{4}$ View of Left Side Doors



Figure A-43: Pre-Test Left Rear $\frac{3}{4}$ View of Left Side Doors



Figure A-44: Post-Test Left Rear $\frac{3}{4}$ View of Left Side Doors



Figure A-45: Rollover 90 Degrees



Figure A-46: Rollover 180 Degrees



Figure A-47: Rollover 270 Degrees



Figure A-48: Rollover 360 Degrees



Figure A-49: Impact Photo

APPENDIX B
SID/HIII, VEHICLE AND MDB RESPONSE DATA
(SAE sign convention)

DATA CHANNEL FILTER CLASS SUMMARY

Data Type	SAE Filter Class
Dummy Head Accelerations	CFC 1000
Rib Accelerations	FIR 100
Spine Accelerations	FIR 100
Pelvis Accelerations	FIR 100

DATA CHANNEL TITLE KEY

Prefix	Suffix
V1 = Vehicle 1 (Moving Barrier)	Ax = Acceleration, X-direction
V2 = Vehicle 2 (Test Vehicle)	Ay = Acceleration, Y-direction
P1 = Left Front Seating Position (Driver)	Az = Acceleration, Z-direction
P4 = Left Second Row Seating Position (Passenger)	Fx = Force, X-direction
A1-A18 = Accelerometer Location Number	Fy = Force, Y-direction
	Fz = Force, Z-direction
	Mx = Moment about X
	My = Moment about Y
	Mz = Moment about Z

TABLE OF DATA PLOTS

PLOT	PLOT NAME[UNITS, CHANNEL FILTER CLASS]	PAGE
1	V2P1 Head Ax [g, CFC_1000]	B-5
2	V2P1 Head Ay [g, CFC_1000]	B-5
3	V2P1 Head Az [g, CFC_1000]	B-5
4	V2P1 Head Ar [g, CFC_1000]	B-5
5	V1P1 Upper Rib Ay [g, FIR_100]	B-6
6	V1P1 Lower Rib Ay [g, FIR_100]	B-6
7	V1P1 Lower Spine Ay [g, FIR_100]	B-6
8	V1P1 Pelvic Ay [g, FIR_100]	B-6

The following dummy, vehicle and load cell response data can be found in the research and development section of the NHTSA website at: www.nhtsa.dot.gov

V2P1 Head Ax	V2A3 Rear Floorpan Ax
V2P1 Head Ay	V2A3 Rear Floorpan Ay
V2P1 Head Az	V2A3 Rear Floorpan Az
V2P1 Upper Neck Fx	V2A4 Left Rear Sill Ay
V2P1 Upper Neck Fy	V2A5 Left Front Sill Ay
V2P1 Upper Neck Fz	V2A7 Right Rear Compartment Ay
V2P1 Upper Neck Mx	V2A12 Left Lower B Post Ay
V2P1 Upper Neck My	V2A13 Left Mid B Post Ay
V2P1 Upper Neck Mz	V2A14 Left Lower A Post Ay
V2P1 Upper Rib Ay	V2A15 Left Mid A Post Ay
V2P1 Upper Rib Redundant Ay	V2A16 Front Seat Track Ay
V2P1 Lower Rib Ay	V2A18 Target CG Ax
V2P1 Lower Rib Redundant Ay	V2A18 Target CG Ay
V2P1 Lower Spine Ay	V2A18 Target CG Az
V2P1 Lower Spine Redundant Ay	V1 Moving Barrier CG Ax
V2P1 Pelvic Ay	V1 Moving Barrier CG Ay
V2P1 Pelvic Redundant Ay	V1 Moving Barrier CG Az
V2A1 Right Front Sill Ax	V1 Moving Barrier Left Rail Ax
V2A1 Right Front Sill Ay	V1 Moving Barrier Left Rail Ay
V2A1 Right Front Sill Az	
V2A2 Right Rear Sill Ax	
V2A2 Right Rear Sill Ay	
V2A2 Right Rear Sill Az	

TEST NOTES

The following channel anomalies occurred:
None

2007 NHTSA FMVSS 214D Indicant - 2007 Pontiac Solstice C70101 - October 17, 2006

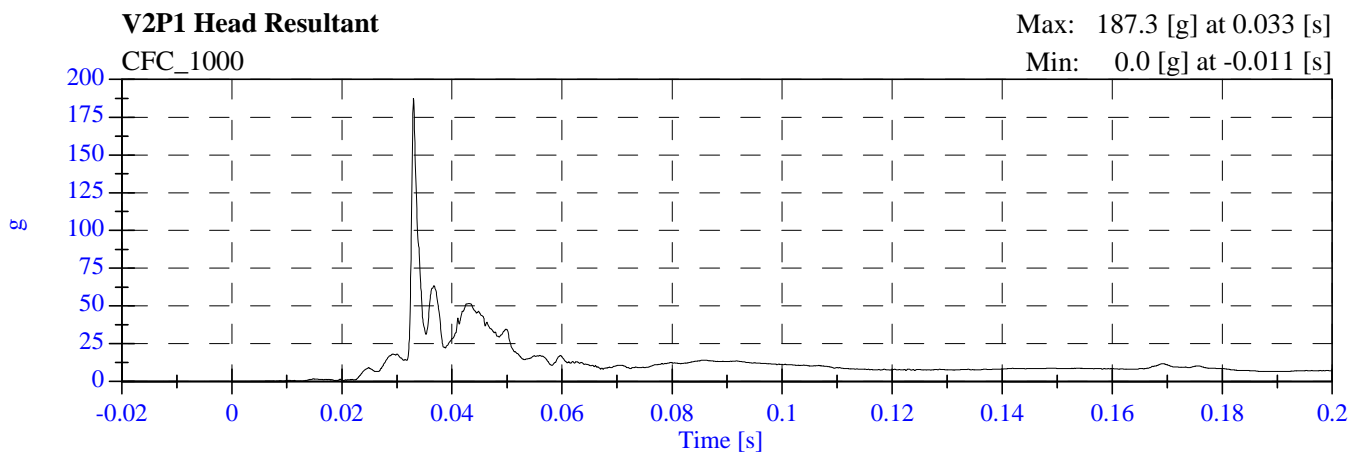
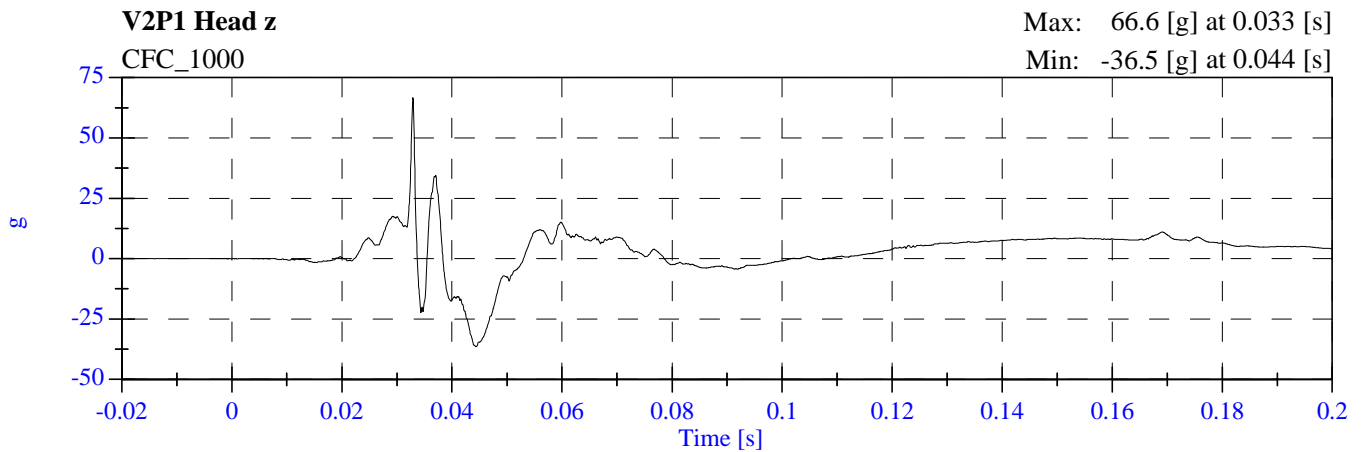
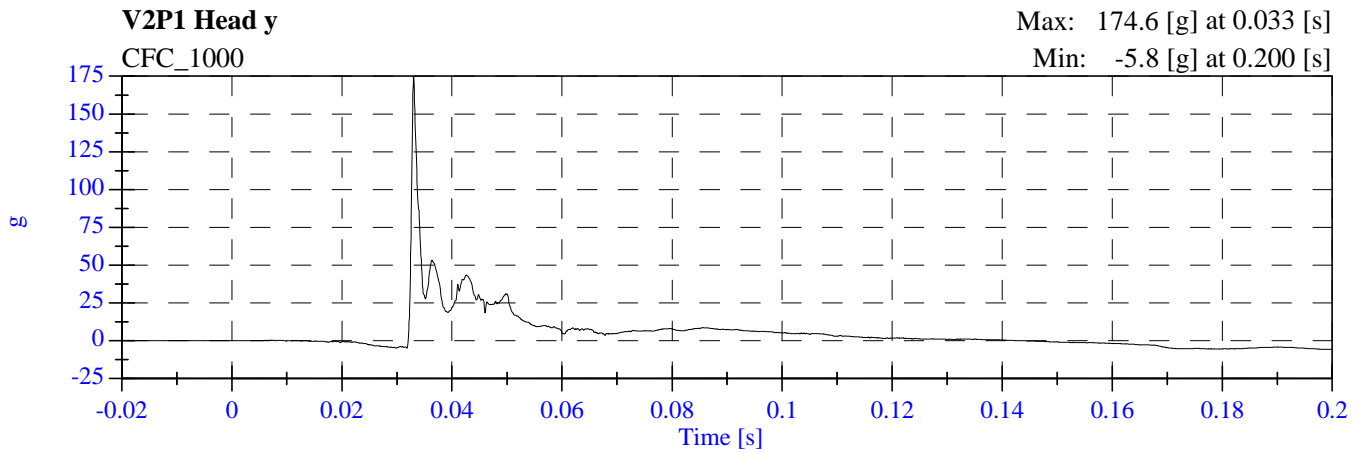
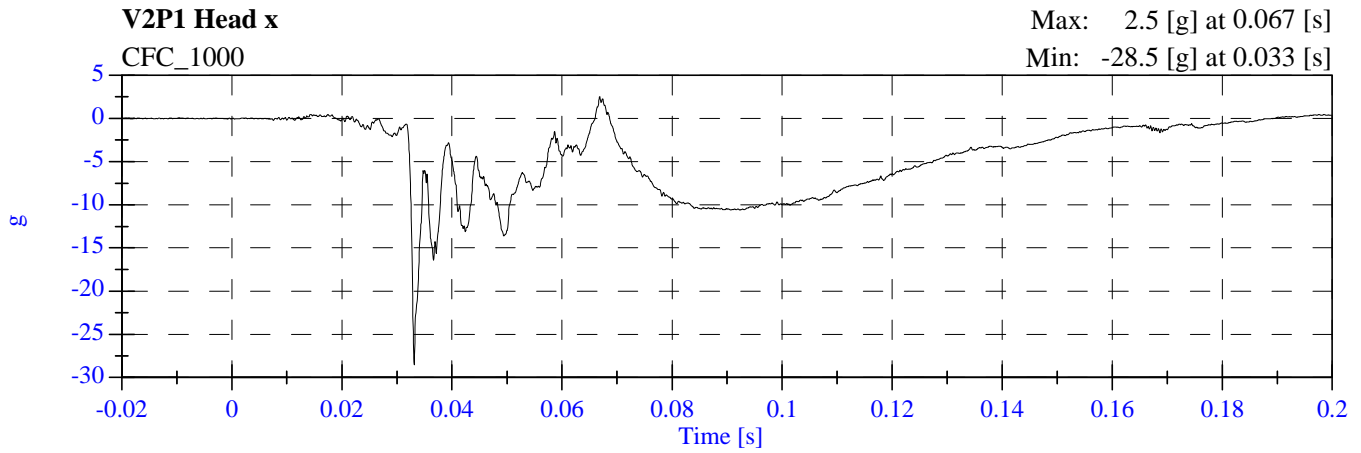

2007 NHTSA FMVSS 214D Indicant - 2007 Pontiac Solstice C70101 - October 17, 2006

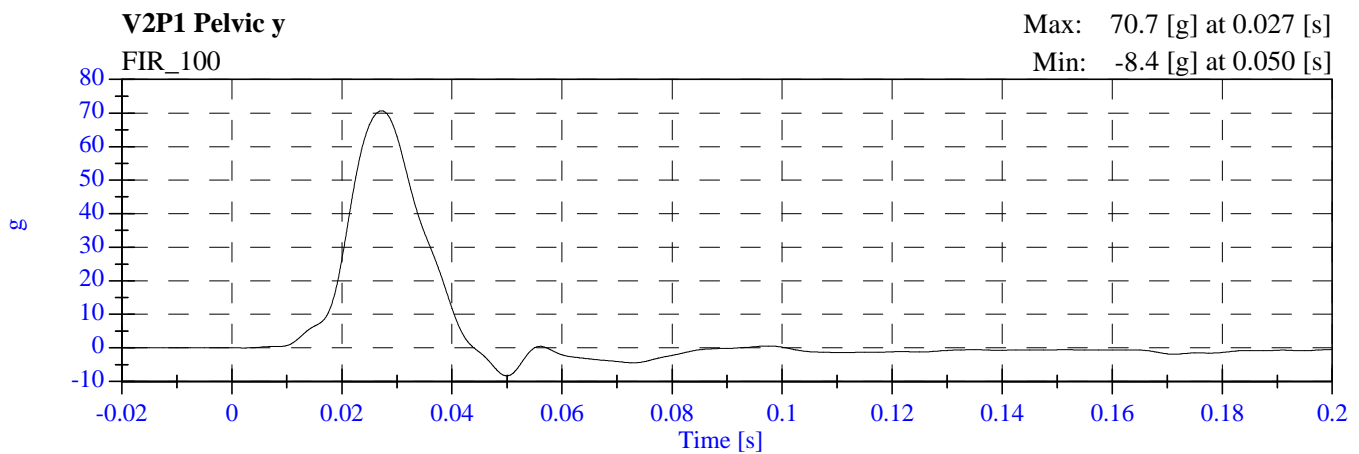
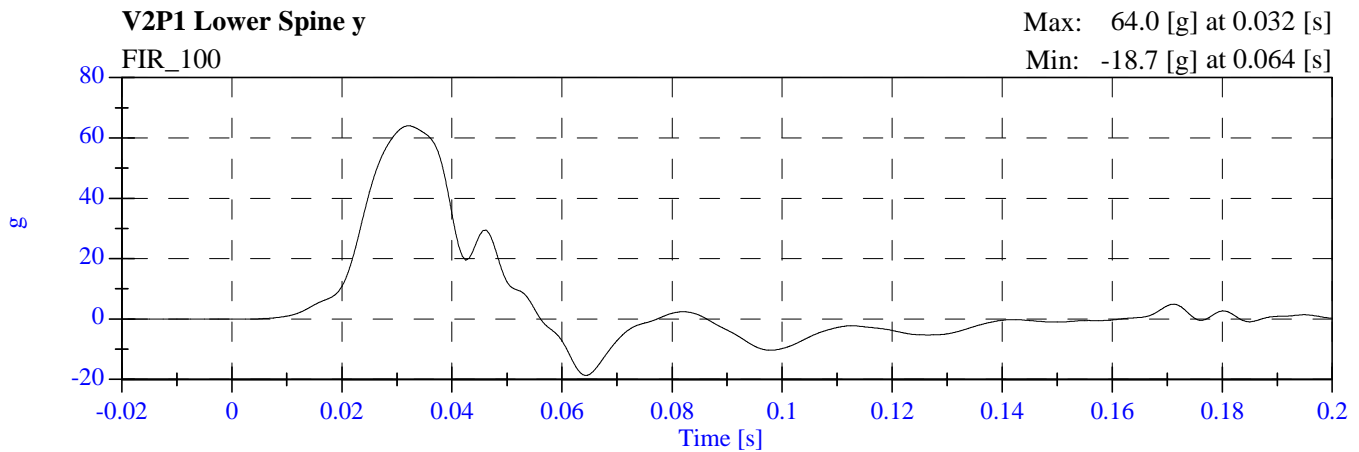
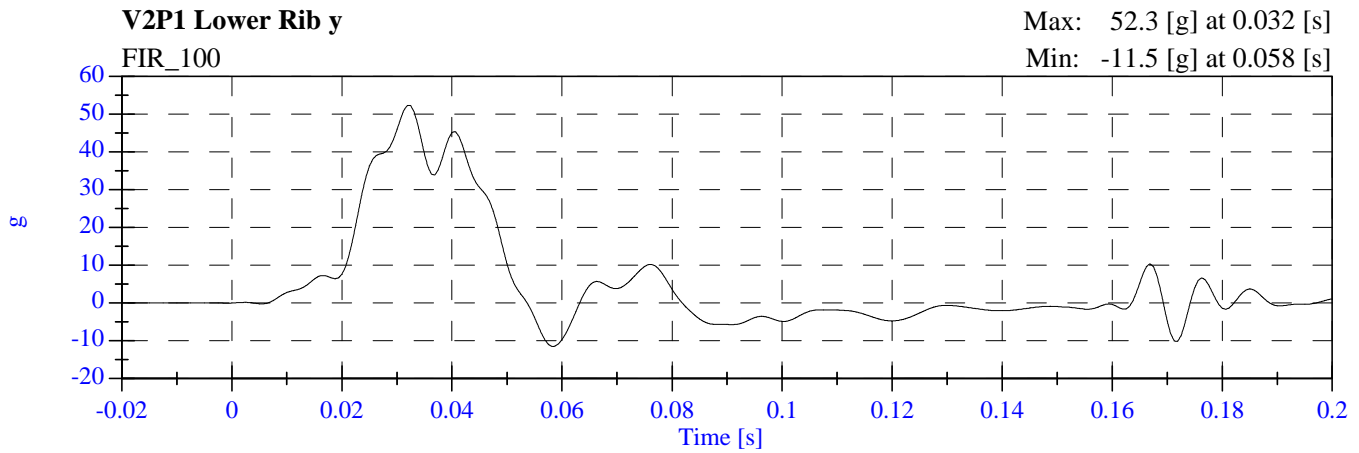
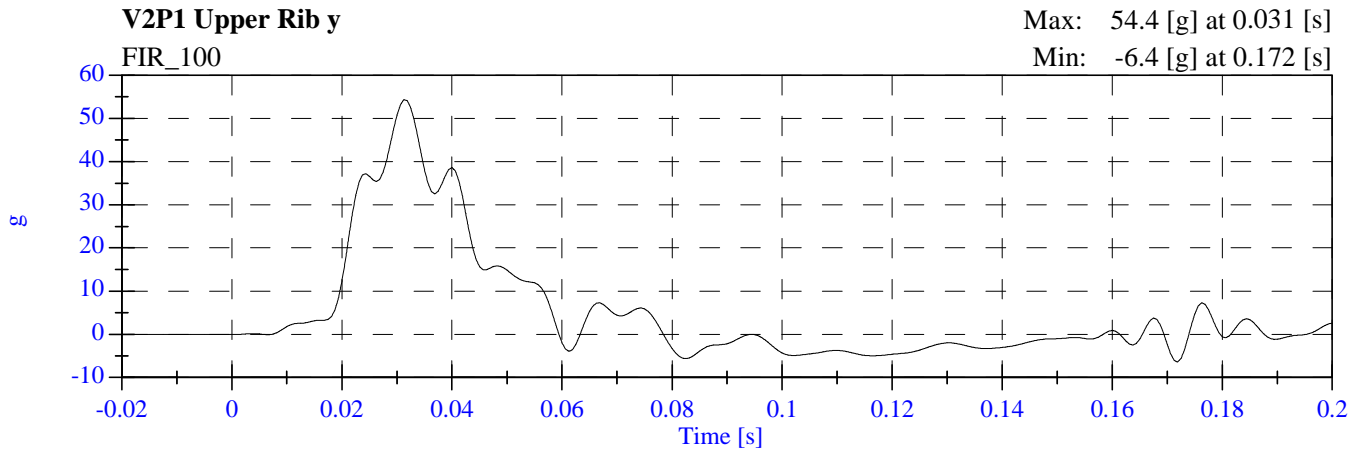

APPENDIX C

DUMMY CONFIGURATION AND PERFORMANCE VERIFICATION DATA

SUMMARY
SID H3 PRE & POST TEST CALIBRATION
CONFIGURED FOR LEFT SIDE IMPACT

Date: 09/13/2006

Sequential Test Number:
Laboratory Technician:

1.1
B. Swiecicki

TEST PARAMETER	SPECIFICATION	SID H3 NO.: 906		SID H3 NO.: -	
		PRE TEST	POST TEST	PRE TEST	POST TEST
SH- Seated Height (mm)	889 - 909	907	907	-	-
RH- Rib Height (mm)	501 - 521	516	514	-	-
HP- Hip Pivot Height (mm)	99 ref.	99	99	-	-
RD- Rib from Back Line (mm)	229 - 241	241	240	-	-
KV- Knee Pivot from Back Line (mm)	511 - 526	518	517	-	-
SW- Knee Pivot to Floor (mm)	490 - 505	493	494	-	-
HW- Hip Width (mm)	356 - 391	381	381	-	-
THORAX IMPACTS					
TEMPERATURE (• C)	18.9 - 25.5	21.1	21.1	-	-
RELATIVE HUMIDITY (%)	10 - 70	50.0	37.0	-	-
PROBE SPEED (m/s)	4.27 - 4.33	4.30	4.33	-	-
UPPER RIB (g's)	37 - 46	40.53	44.97	-	-
LOWER RIB (g's)	37 - 46	42.27	44.57	-	-
LOWER SPINE (g's)	15 - 22	20.55	21.82	-	-
PELVIS IMPACT					
TEMPERATURE (• C)	18.9 - 25.5	21.1	21.1	-	-
RELATIVE HUMIDITY (%)	10 - 70	50.0	37.0	-	-
PROBE SPEED (m/s)	4.27 - 4.33	4.30	4.32	-	-
PELVIS (g's)	40 - 60	47.93	49.13	-	-

REMARKS: None

CALIBRATION TEST RESULTS

PRE-TEST

SID H3 NO.: 906

CONFIGURED FOR LEFT SIDE IMPACT

**CALIBRATION TEST RESULTS SUMMARY
PRE-TEST**

CONFIGURED FOR LEFT SIDE IMPACT

SID H3 Serial No.: 906 Sequential Test Number: 1
Date: September 13, 2006 Laboratory Technician: B. Swiecicki

TEST	COMMENTS
EXTERNAL DIMENSIONS	Passed all requirements.
THORACIC SHOCK ABSORBER TEST	Passed all requirements.
LATERAL THORAX IMPACT TEST	Passed all requirements.
LATERAL PELVIS IMPACT TEST	Passed all requirements.
HEAD DROP TEST*	Passed all requirements.
LATERAL NECK BEND TEST*	Passed all requirements.
ABDOMINAL COMPRESSION TEST*	Passed all requirements.
LUMBAR FLEXION TEST*	Passed all requirements.

* Test not required for SID certification.

REMARKS: None

**EXTERNAL DIMENSIONS
PRE-TEST**

CONFIGURED FOR LEFT SIDE IMPACT

SID H3 Serial No.: 906 Sequential Test Number: 1
Date: September 13, 2006 Laboratory Technician: B. Swiecicki

TEST PARAMETER	SPECIFICATION	TEST RESULTS
SH- Seated Height (mm)	889 – 909	907
RH- Rib Height (mm)	502 – 520	516
HP- Hip Pivot Height (mm)	99 ref.	99
RD- Rib from Back Line (mm)	229 – 241	241
KH- Knee Pivot from Back Line (mm)	511 – 526	518
KV- Knee Pivot to Floor (mm)	490 – 505	493
HW- Hip Width (mm)	356 - 391	381

REMARKS: None

SID Shock Test S/N:906 (3.05 m/s)
PRE TEST
CONFIGURED FOR LEFT SIDE IMPACT

ATD Serial No: 906
 Date: September 11, 2006

Sequential Test Number: 1 File: 905SH
 Laboratory Technician: B. Swiecicki

<u>TEST PARAMETER</u>	<u>SPECIFICATION</u>	<u>TEST RESULTS</u>	<u>STATUS</u>
Lab Temperature:	18.9-25.5 C	21.1 C	Passed
Lab Humidity:	10-70 %	50.00 %	Passed
Displacement:	30.00-35.00 mm	30.05 mm	Passed
Maximum Force:	836.00-1125.00 N	1109.43 N	Passed
Impact Test Velocity:	3.05 m/s		
Damper Identification:	906		
Damper Setting:	5		

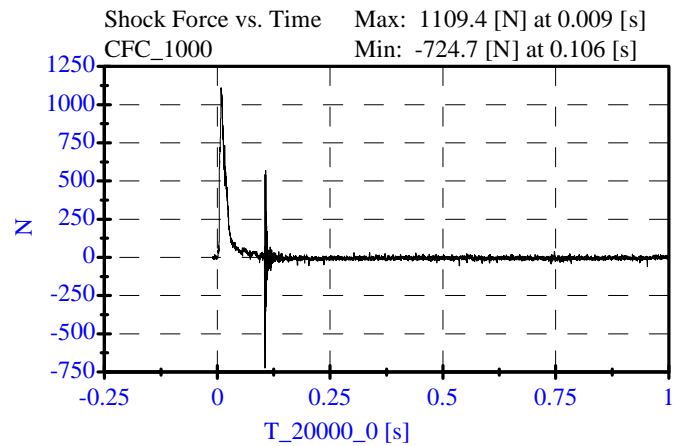
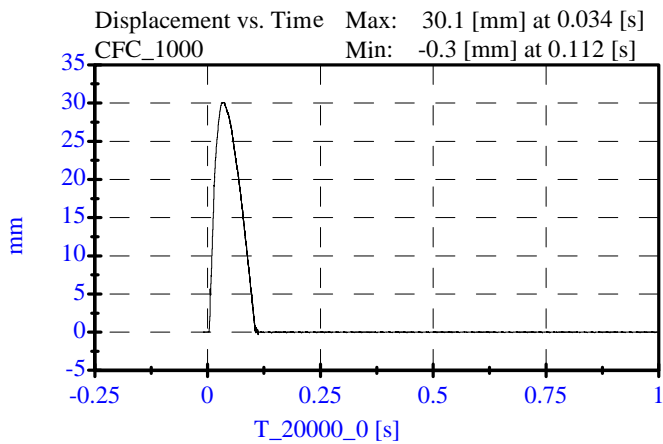

SID Mid Speed Shock Test S/N:906 (4.27 m/s)

PRE TEST

CONFIGURED FOR LEFT SIDE IMPACT

ATD Serial No: 906
Date: September 11, 2006

Sequential Test Number: 1 File: 906SH
Laboratory Technician: B. Swiecicki

<u>TEST PARAMETER</u>	<u>SPECIFICATION</u>	<u>TEST RESULTS</u>	<u>STATUS</u>
Lab Temperature:	18.9-25.5 C	21.1 C	Passed
Lab Humidity:	10-70 %	50.00 %	Passed
Displacement:	32.00-37.00 mm	33.58 mm	Passed
Maximum Force:	1730.00-2099.00 N	2042.90 N	Passed

Impact Test Velocity: 4.27 m/s
Damper Identification: 906
Damper Setting: 5

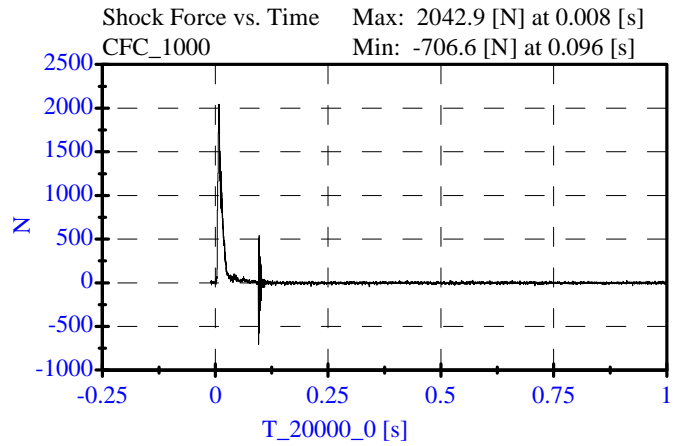
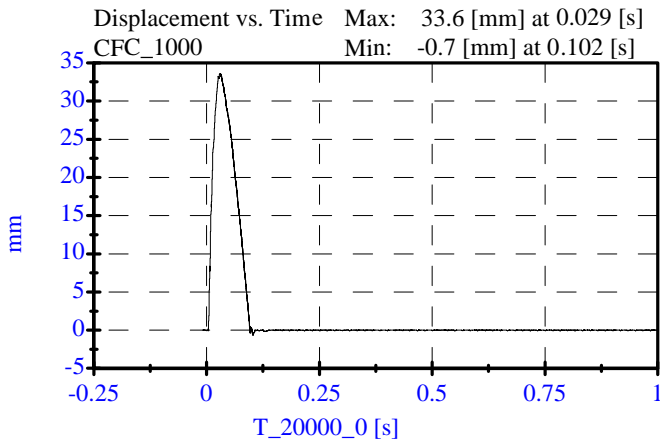

SID High Speed Shock Test S/N:906 (6.10 m/s)

PRE TEST

CONFIGURED FOR LEFT SIDE IMPACT

ATD Serial No: 906
Date: September 11, 2006

Sequential Test Number: 1 File: 906SH
Laboratory Technician: B. Swiecicki

<u>TEST PARAMETER</u>	<u>SPECIFICATION</u>	<u>TEST RESULTS</u>	<u>STATUS</u>
Lab Temperature:	18.9-25.5 C	21.1 C	Passed
Lab Humidity:	10-70 %	50.00 %	Passed
Displacement:	33.00-40.00 mm	36.58 mm	Passed
Maximum Force:	3741.00-4448.00 N	4389.60 N	Passed

Impact Test Velocity: 6.10 m/s
Damper Identification: 906
Damper Setting: 5

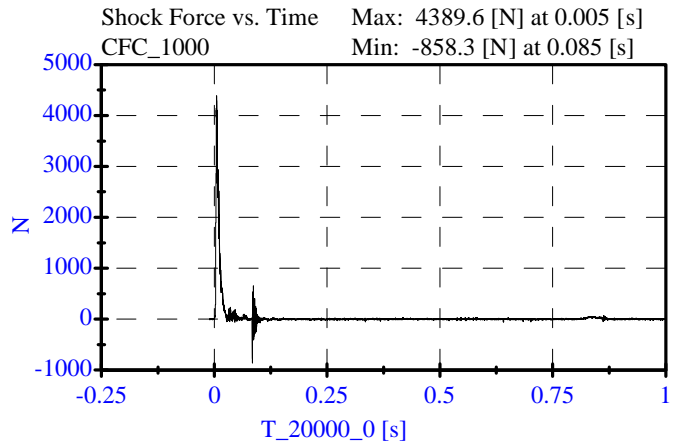
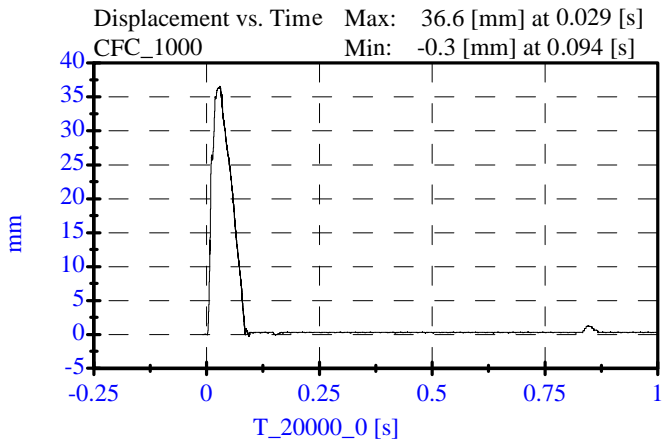

SID Thorax Test S/N:906
Pre-Test
CONFIGURED FOR LEFT SIDE IMPACT

ATD Serial No: 906
 Date: September 13, 2006

Sequential Test Number: 1 File: test1
 Laboratory Technician: B. Swiecicki

<u>TEST PARAMETER</u>	<u>SPECIFICATION</u>	<u>TEST RESULTS</u>	<u>STATUS</u>
Lab Temperature:	18.9-25.5 C	21.7 C	Passed
Lab Humidity:	10-70 %	50.00 %	Passed
Probe Velocity:	4.27- 4.33 m/s	4.30 m/s	Passed
Upper Rib Acceleration:	37.00-46.00 g	40.53 g	Passed
Lower Rib Acceleration:	37.00-46.00 g	42.27 g	Passed
Lower Spine Acceleration:	15.00-22.00 g	20.55 g	Passed

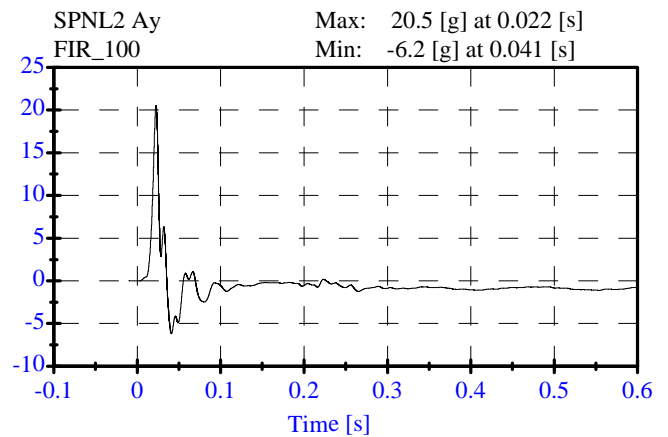
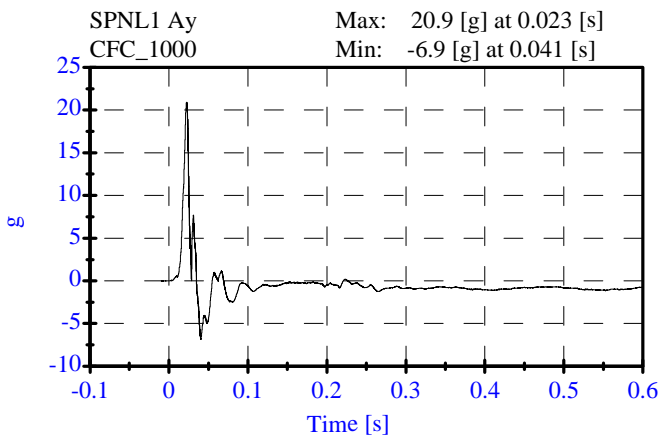
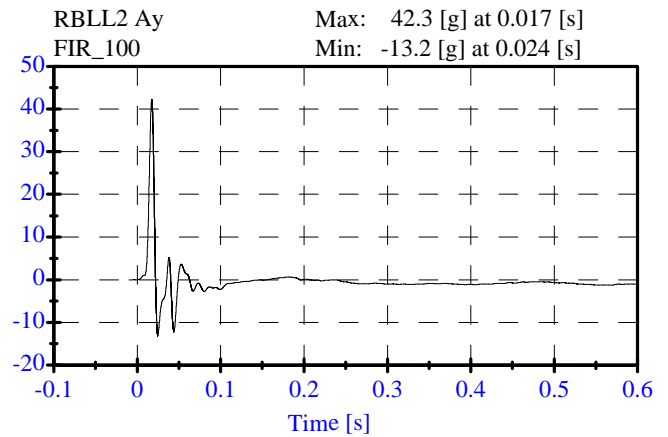
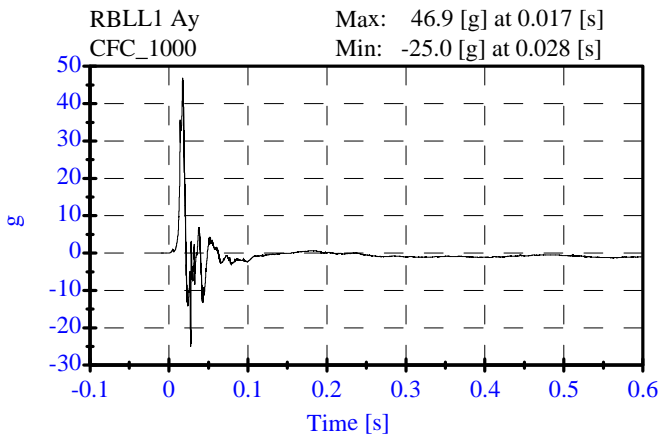
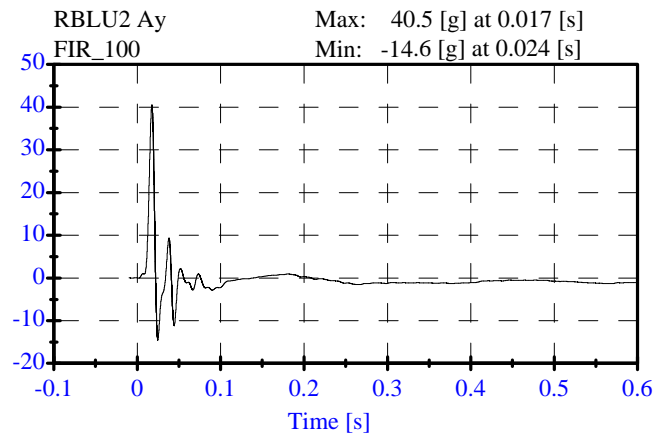
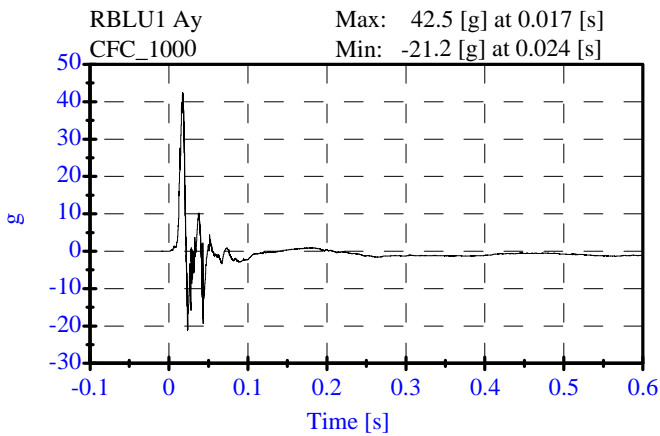

SID Pelvis Test S/N:906

Pre-Test

CONFIGURED FOR LEFT SIDE IMPACT

ATD Serial No: 906
Date: September 13, 2006

Sequential Test Number: 1 File: 905T
Laboratory Technician: B. Swiecicki

<u>TEST PARAMETER</u>	<u>SPECIFICATION</u>	<u>TEST RESULTS</u>	<u>STATUS</u>
Lab Temperature:	18.9-25.5 C	21.1 C	Passed
Lab Humidity:	10-70 %	50.00 %	Passed
Probe Velocity:	4.27- 4.33 m/s	4.30 m/s	Passed
Pelvis Y Acceleration:	40.00-60.00 g	47.93 g	Passed
Time Above 20 Gs	3.0-7.0 ms	5.9 ms	Passed

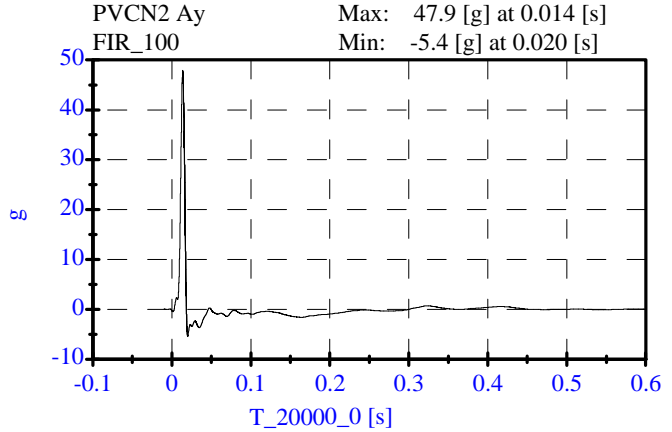
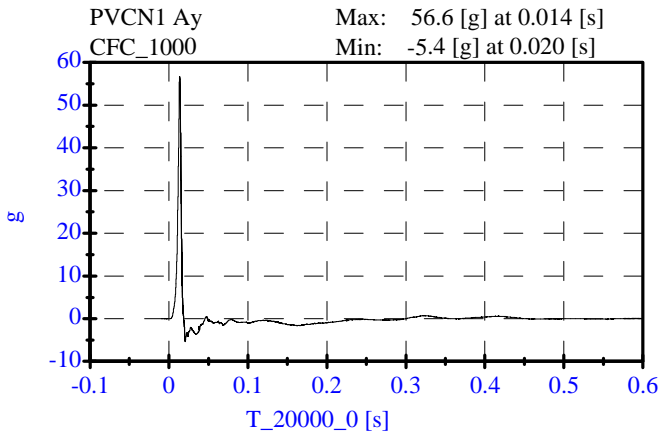

SID HYIII Head Drop Test S/N:906
Pre-Test
CONFIGURED FOR LEFT SIDE IMPACT

ATD Serial No: 906
 Date: September 11, 2006

Sequential Test Number: 1 File: 906H
 Laboratory Technician: B. Swiecicki

<u>TEST PARAMETER</u>	<u>SPECIFICATION</u>	<u>TEST RESULTS</u>	<u>STATUS</u>
Lab Temperature:	18.9-25.6 C	21.1 C	Passed
Lab Humidity:	10-70 %	50.00 %	Passed
Peak Resultant Accel.:	120-150 Gs	133.95 Gs	Passed
Peak Lateral Accel.:	15 Gs Max	4.77 Gs	Passed
Curve PerCent NonModal:	< 15%	4.82 %	Passed

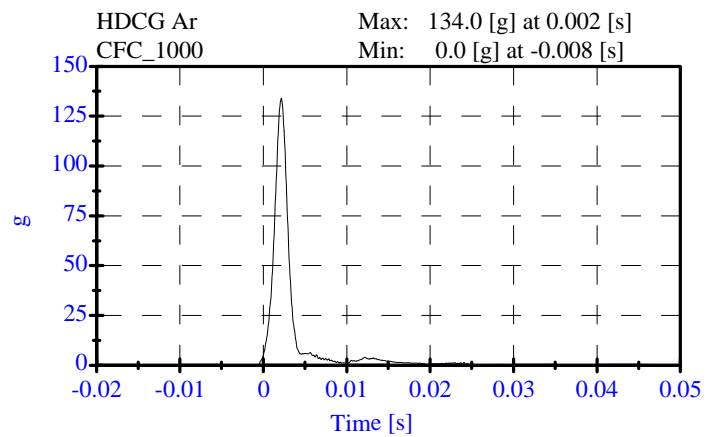
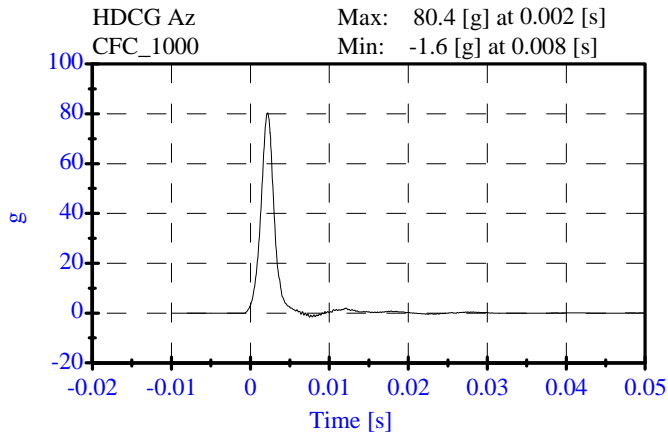
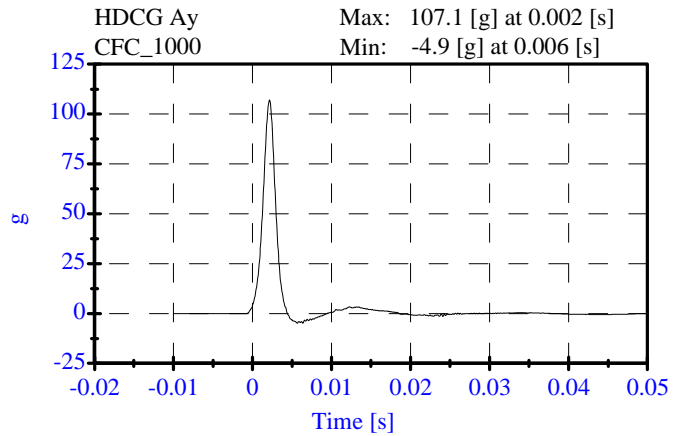
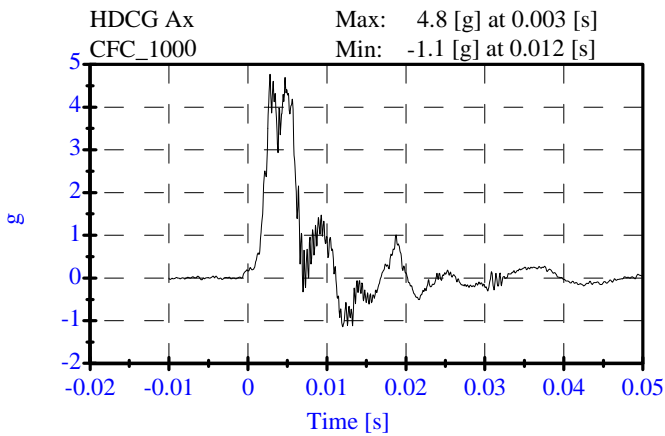

SID Head Neck Test S/N:906**Pre-Test****CONFIGURED FOR LEFT SIDE IMPACT**

ATD Serial No: 906
 Date: September 11, 2006

Sequential Test Number: 1 File: 905N
 Laboratory Technician: B. Swiecicki

<u>TEST PARAMETER</u>	<u>SPECIFICATION</u>	<u>TEST RESULTS</u>	<u>STATUS</u>
Lab Temperature:	20.6-22.2 C	21.1 C	Passed
Lab Humidity:	10-70 %	50.00 %	Passed
Impact Velocity:	6.89- 7.13 m/s	6.92 m/s	Passed
PENDULUM DELTA V			
Delta V at 10 ms:	1.96- 2.55 m/s	2.25 m/s	Passed
Delta V at 20 ms:	4.12- 5.10 m/s	4.59 m/s	Passed
Delta V at 30 ms:	5.73- 7.01 m/s	6.62 m/s	Passed
Delta V between 40-70 ms:	6.27- 7.64 m/s	7.18 m/s	Passed
D PLANE ROTATION			
Maximum Rotation:	66.0-82.0 Deg	71.76 Deg	Passed
Rotation Angle Decay:	58.0-67.0 ms	61.40 ms	Passed
MOMENT ABOUT THE OCCIPITAL CONDYLE			
Max Occipital Moment:	73.00- 88.00 N-m	81.21 N-m	Passed
Occipital Moment Decay:	49.0-64.0 ms	60.75 ms	Passed
HEAD ROTATION TIME WITH RESPECT TO THE OCCIPITAL CONDYLE MOMENT			
Moment to Rotation Peak:	2.0-16.0 ms	11.05 ms	Passed

SID Head Neck Test S/N:906
Pre-Test
CONFIGURED FOR LEFT SIDE IMPACT

ATD Serial No: 906
 Date: September 11, 2006

Sequential Test Number: 1 File: 905N
 Laboratory Technician: B. Swiecicki

Pend Ax CFC_180 Max: 29.5 [] at 0.009 [s]
 Min: -5.2 [] at 0.041 [s]

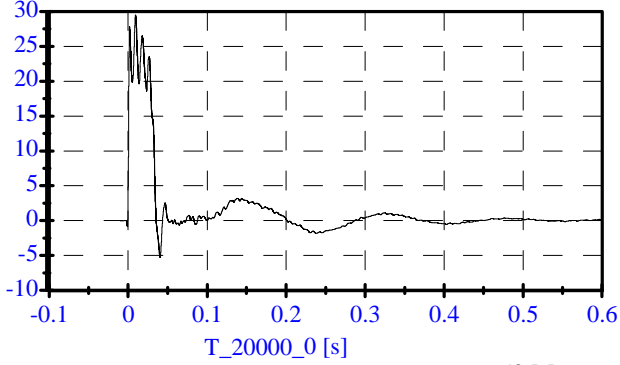

Pend Vx CFC_180 Max: 8.8 [m/s] at 0.201 [s]
 Min: -0.0 [m/s] at -0.000 [s]

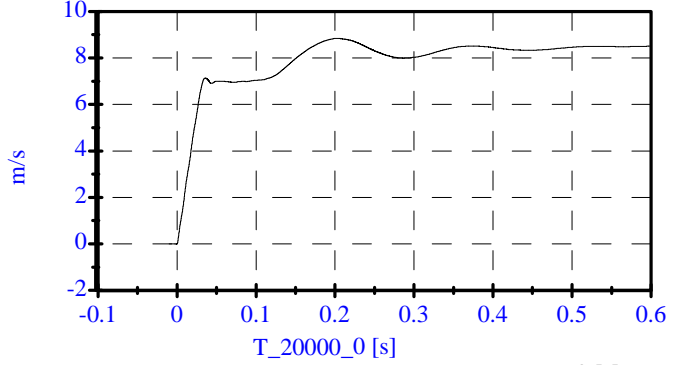

Head Rot CFC_180 Max: 40.2 [deg] at 0.053 [s]
 Min: -13.1 [deg] at 0.141 [s]

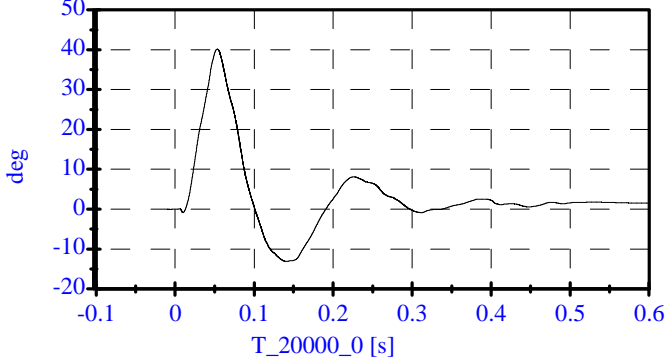

Arm Rot CFC_180 Max: 38.5 [deg] at 0.069 [s]
 Min: -20.7 [deg] at 0.171 [s]

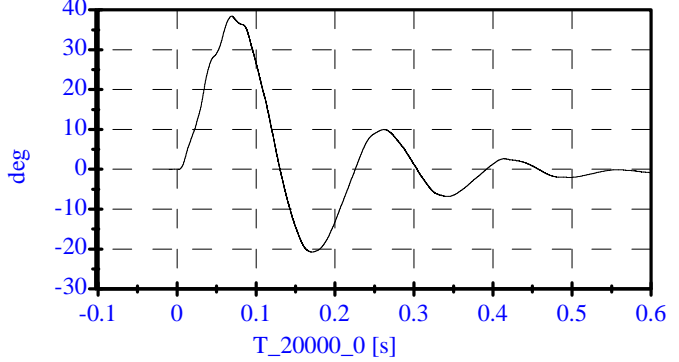

Neck Mx CFC_600 Max: 67.0 [N-m] at 0.047 [s]
 Min: -23.1 [N-m] at 0.012 [s]

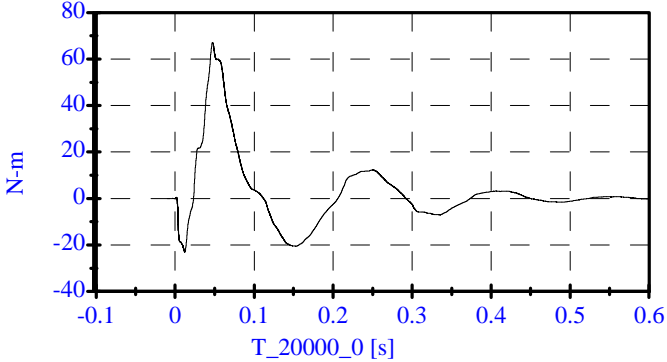

Neck Fy CFC_1000 Max: 870.5 [N] at 0.053 [s]
 Min: -270.9 [N] at 0.151 [s]

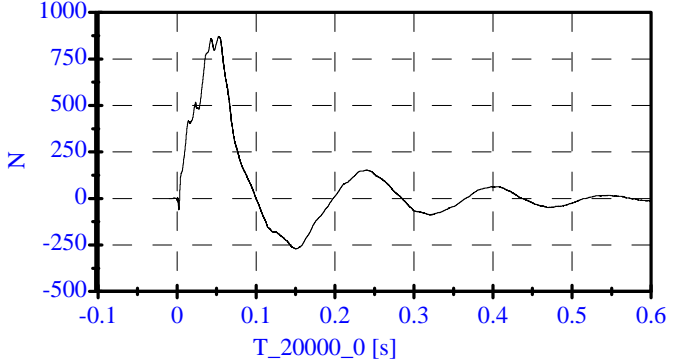

Tot Rot CFC_180 Max: 71.8 [deg] at 0.059 [s]
 Min: -29.7 [deg] at 0.159 [s]

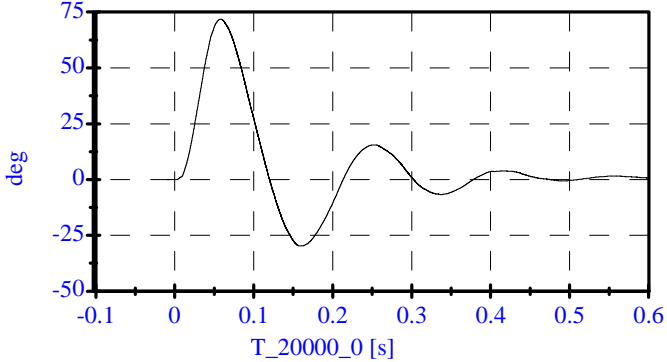

MOCX Max: 81.2 [N-m] at 0.048 [s]
 Min: -25.4 [N-m] at 0.152 [s]

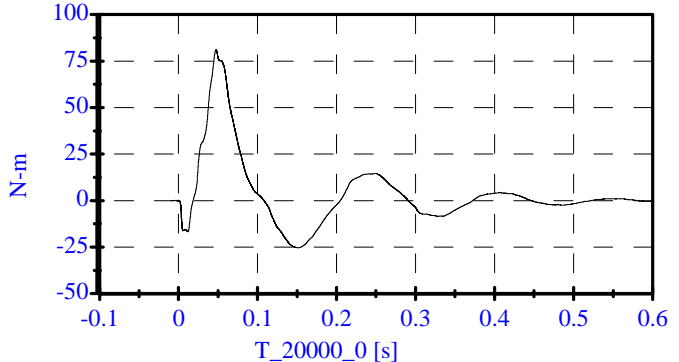

SID Abdominal Test
Pre-Test
CONFIGURED FOR LEFT SIDE IMPACT

ATD Serial No: 906
 Date: 9-13-2006

Sequential Test Number: 1 File: 906 abdominal 09-06-test1
 Laboratory Technician: B. Swiecicki

<u>TEST PARAMETER</u>	<u>SPECIFICATION</u>	<u>TEST RESULTS</u>	<u>STATUS</u>
Lab Temperature:	18.9-25.5 C	21.1 C	Passed
Lab Humidity:	10-70 %	50.00 %	Passed
Force at 12.95 mm :	104.00-162.00 N	109.24 N	Passed
Force at 19.05 mm :	162.98-220.99 N	178.38 N	Passed
Force at 25.40 mm :	221.97-280.02 N	261.20 N	Passed
Force at 33.02 mm :	324.99-391.00 N	385.06 N	Passed

ABDOMINAL COMPRESSION TEST

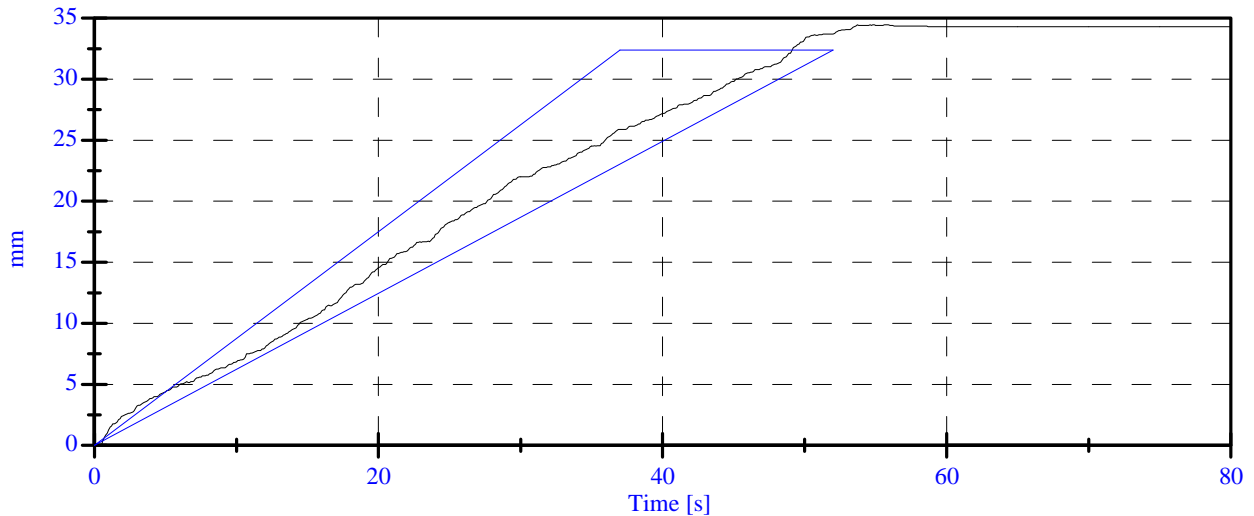
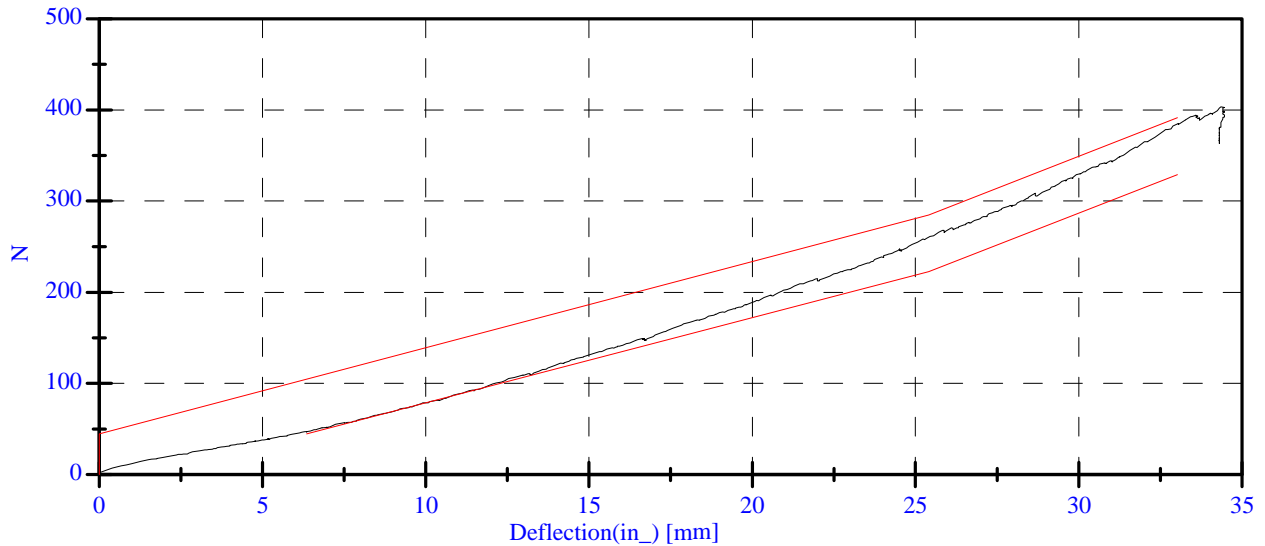

Lumbar Spine Test

Pre-Test

CONFIGURED FOR LEFT SIDE IMPACT

ATD Serial No: 906

Date: 9-12-2006

Sequential Test Number: 1 File: 906 spine 09-09-test1

Laboratory Technician: B. Swiecicki

<u>TEST PARAMETER</u>	<u>SPECIFICATION</u>	<u>TEST RESULTS</u>	<u>STATUS</u>
Lab Temperature:	18.9-25.5 C	21.1 C	Passed
Lab Humidity:	10-70 %	50.00 %	Passed
Force at 0 Deg:	0.00-26.69 N	20.69 N	Passed
Force at 20 Deg:	97.86-151.24 N	123.73 N	Passed
Force at 30 Deg:	151.24-204.62 N	187.41 N	Passed
Force at 40 Deg:	204.62-258.00 N	254.10 N	Passed
Return Angle	12 Deg Max	8.62 deg	Passed

LUMBAR SPINE FLEXION TEST

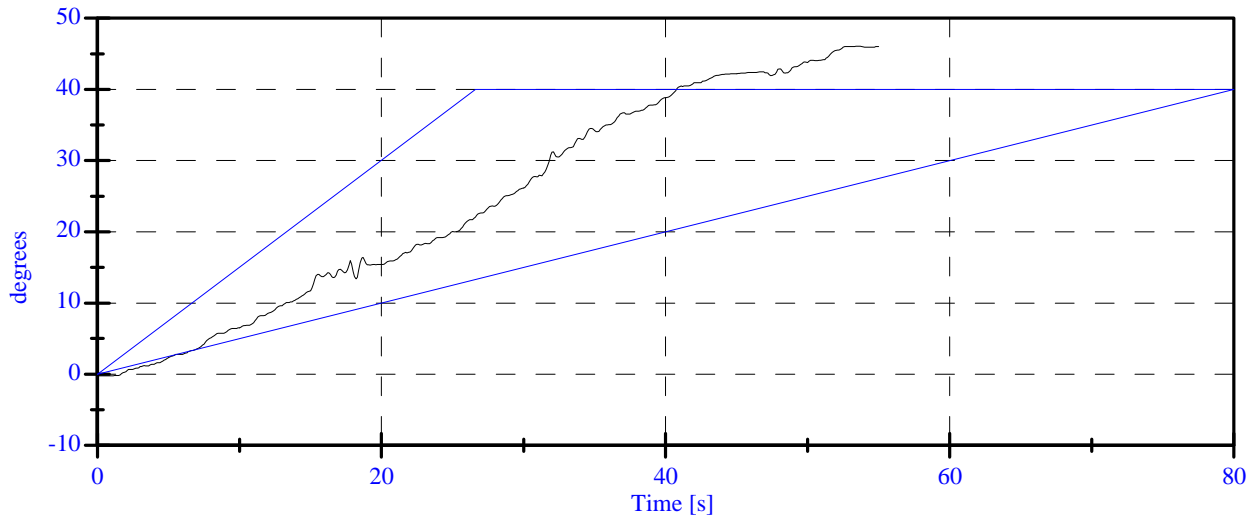
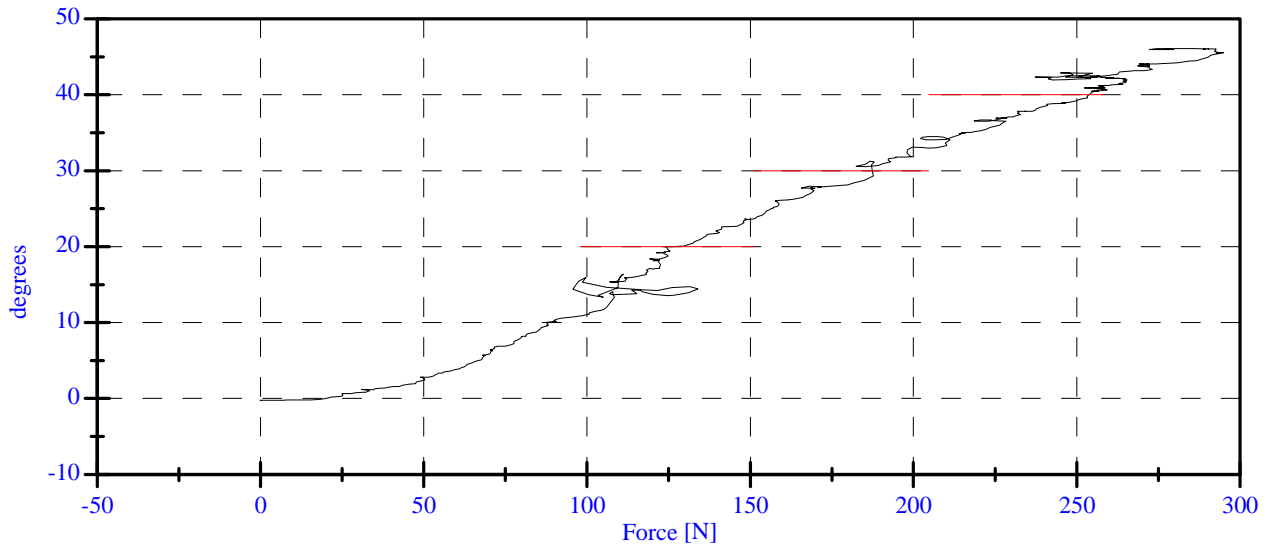

PRE-TEST DUMMY INSPECTION LIST
CONFIGURED FOR LEFT SIDE IMPACT

SID H3 Serial No.: 906 Sequential Test Number: 1
 Date: September 13, 2006 Laboratory Technician: B. Swiecicki

PART	ITEMS CHECKED	COMMENTS
SKIN	VISUAL INSPECTION	OK
HEAD	VISUAL, BALLAST, ACCELEROMETER MOUNT	OK
NECK	VISUAL, CABLE TORQUE	OK
SPINE BOX	VISUAL, BALLAST, WELDMENT, ACCELEROMETER MOUNT	OK
RIB CAGE	VISUAL, MEASURE, STIFFENERS	OK
STERNUM	VISUAL	OK
LUMBAR SPINE	VISUAL	OK
ABDOMEN	VISUAL	OK
PELVIS	VISUAL, PALPATE, ACCELEROMETER MOUNT	OK
UPPER LEGS	VISUAL	OK
KNEES	VISUAL, STOPS, INSERTS	OK
LOWER LEGS	VISUAL, RANGE OF MOTION	OK
ANKLES	VISUAL, RANGE OF MOTION	OK
FEET	VISUAL, RANGE OF MOTION	OK
JOINTS	1 TO 2 g RANGE	OK
OTHER	NONE	-

REMARKS: None

CALIBRATION TEST RESULTS

POST TEST

SID H3 NO.: 906

CONFIGURED FOR LEFT SIDE IMPACT

**CALIBRATION TEST RESULTS SUMMARY
POST TEST**

CONFIGURED FOR LEFT SIDE IMPACT

SID H3 Serial No.: 906 Sequential Test Number: 1
Date: October 19, 2006 Laboratory Technician: B. Swiecicki

TEST	COMMENTS
EXTERNAL DIMENSIONS	Passed all requirements.
LATERAL THORAX IMPACT TEST	Passed all requirements.
LATERAL PELVIS IMPACT TEST	Passed all requirements.
HEAD DROP TEST*	Passed all requirements.
LATERAL NECK BEND TEST*	Passed all requirements.
ABDOMINAL COMPRESSION TEST*	Passed all requirements.
LUMBAR FLEXION TEST*	Passed all requirements.

* Test not required for SID certification.

REMARKS: None

**EXTERNAL DIMENSIONS
POST TEST**

CONFIGURED FOR LEFT SIDE IMPACT

SID H3 Serial No.: 906 Sequential Test Number: 1
Date: October 19, 2006 Laboratory Technician: B. Swiecicki

TEST PARAMETER	SPECIFICATION	TEST RESULTS
SH- Seated Height (mm)	889 - 909	907
RH- Rib Height (mm)	502 - 520	514
HP- Hip Pivot Height (mm)	99 ref.	99
RD- Rib from Back Line (mm)	229 - 241	240
KH- Knee Pivot from Back Line (mm)	511 - 526	517
KV- Knee Pivot to Floor (mm)	490 - 505	494
HW- Hip Width (mm)	356 - 391	381

REMARKS: None

Thorax Impact

Post-Test

CONFIGURED FOR LEFT SIDE IMPACT

ATD Serial No: 906

Date: 10-18-06

Sequential Test Number: 1 File: 906T2 10-18-06

Laboratory Technician: B. Swiecicki

<u>TEST PARAMETER</u>	<u>SPECIFICATION</u>	<u>TEST RESULTS</u>	<u>STATUS</u>
Lab Temperature:	18.9-25.5 C	21.1 C	Passed
Lab Humidity:	10-70 %	37.00 %	Passed
Probe Velocity:	4.27- 4.33 m/s	4.33 m/s	Passed
Upper Rib Acceleration:	37.00-46.00 G's	44.97 G's	Passed
Lower Rib Acceleration:	37.00-46.00 G's	44.57 G's	Passed
Lower Spine Acceleration:	15.00-22.00 G's	21.82 G's	Passed

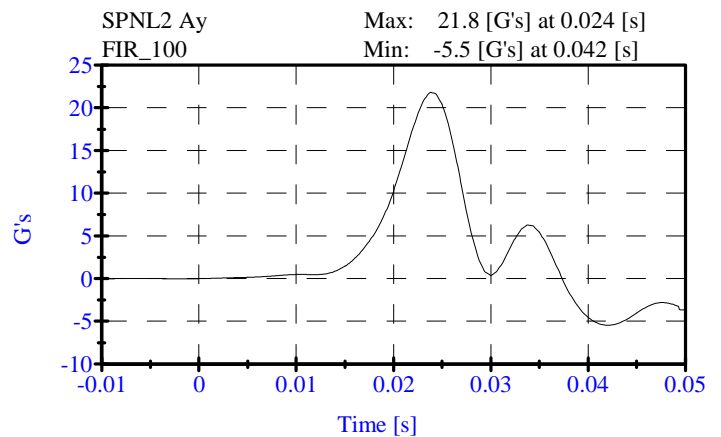
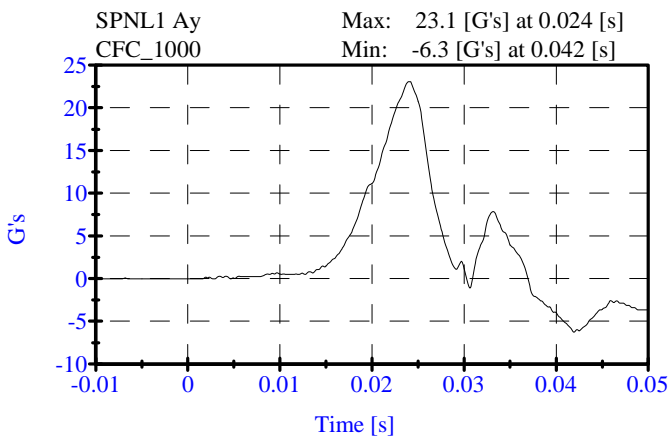
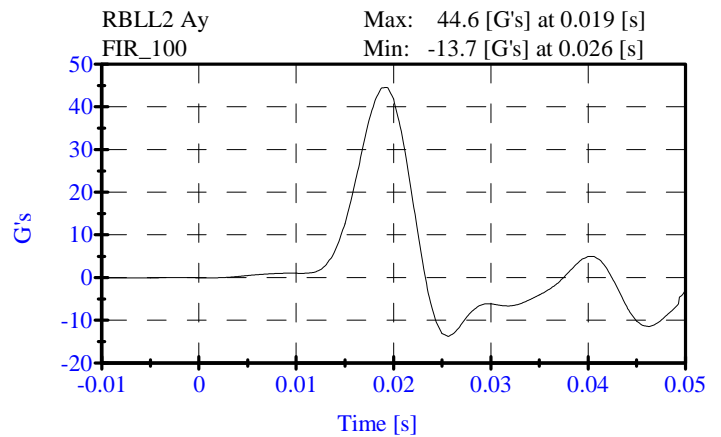
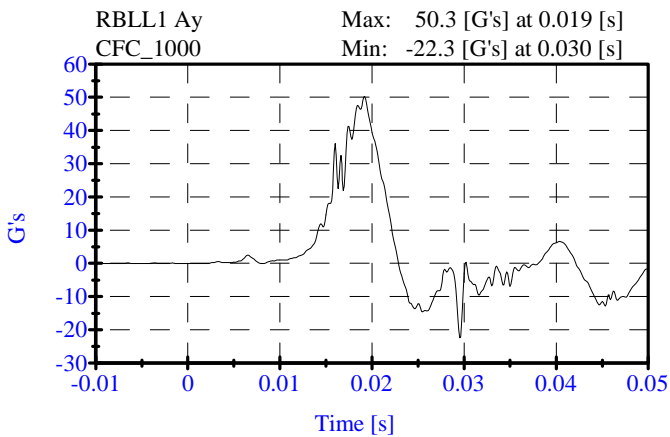
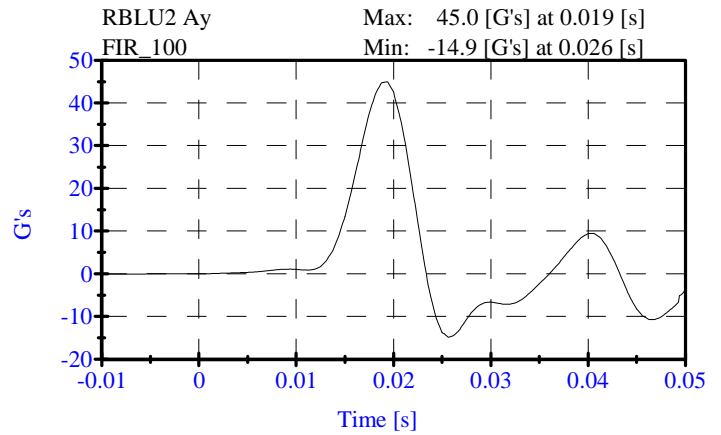
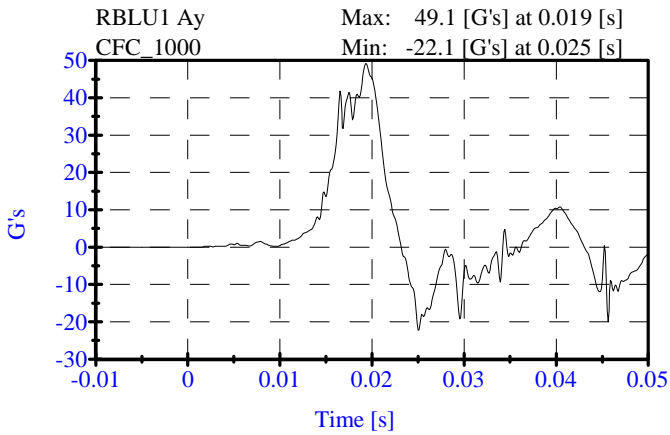

**Pelvis Test
POST TEST**

CONFIGURED FOR LEFT SIDE IMPACT

ATD Serial No: 906
Date: 10-18-06

Sequential Test Number: 1 File: 906P 10-18-06
Laboratory Technician: B. Swiecicki

<u>TEST PARAMETER</u>	<u>SPECIFICATION</u>	<u>TEST RESULTS</u>	<u>STATUS</u>
Lab Temperature:	18.9-25.5 C	21.1 C	Passed
Lab Humidity:	10-70 %	37.00 %	Passed
Probe Velocity:	4.27- 4.33 m/s	4.32 m/s	Passed
Pelvis Y Acceleration:	40.00-60.00 G's	49.13 G's	Passed
Time Above 20 Gs	3.0-7.0 ms	5.6 ms	Passed

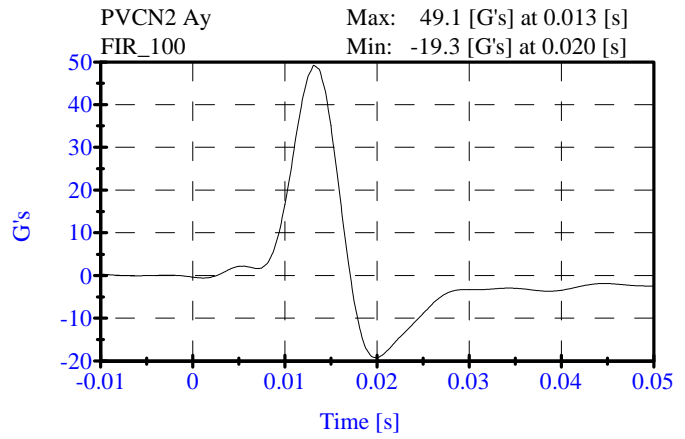
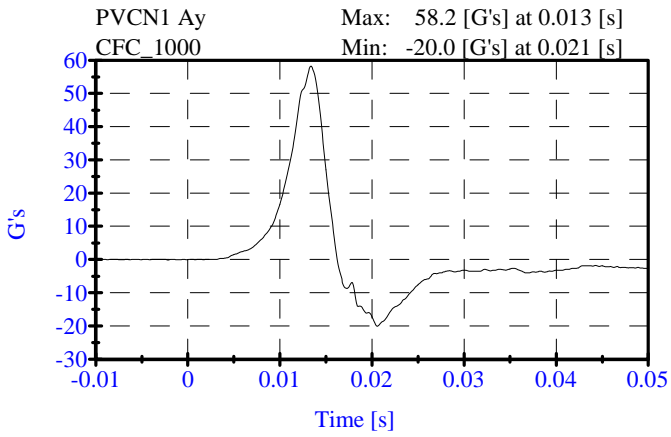

Head Drop POST TEST

CONFIGURED FOR LEFT SIDE IMPACT

ATD Serial No: 906
Date: 10-18-06

Sequential Test Number: 1 File: 906H 10-18-06
Laboratory Technician: B. Swiecicki

<u>TEST PARAMETER</u>	<u>SPECIFICATION</u>	<u>TEST RESULTS</u>	<u>STATUS</u>
Lab Temperature:	66.0-78.0 F	70.0 F	Passed
Lab Humidity:	10-70 %	37.00 %	Passed
Peak Resultant Accel.:	120-150 Gs	146.87 Gs	Passed
Peak Lateral Accel.:	15 Gs Max	11.04 Gs	Passed
Curve PerCent NonModal:	< 15%	4.66 %	Passed

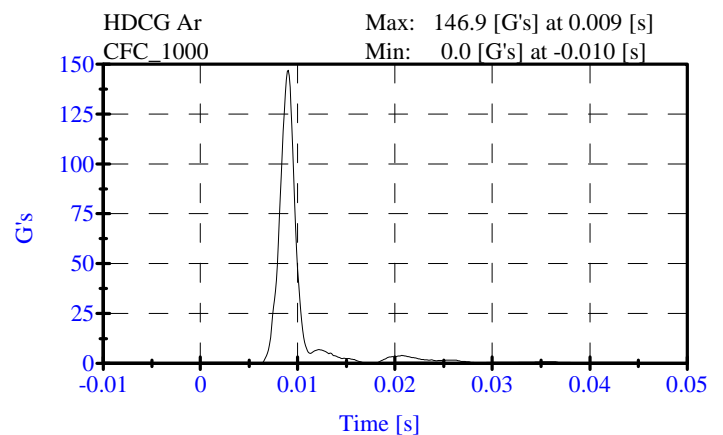
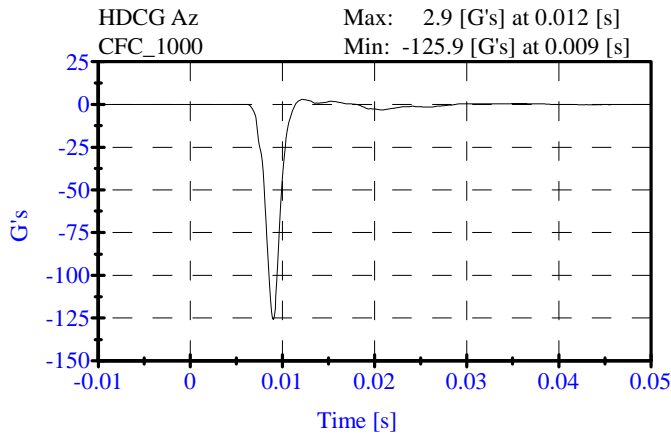
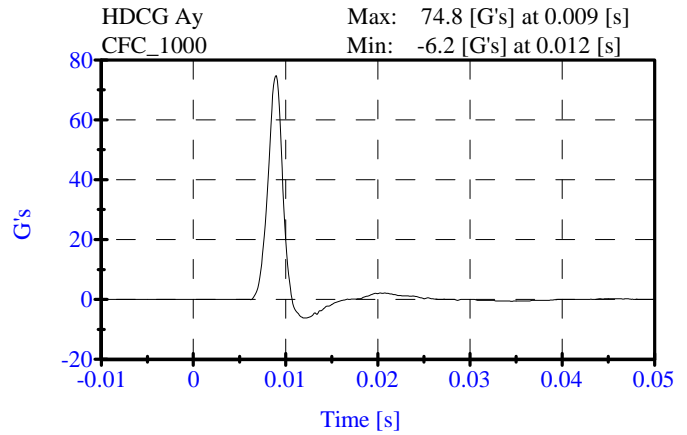
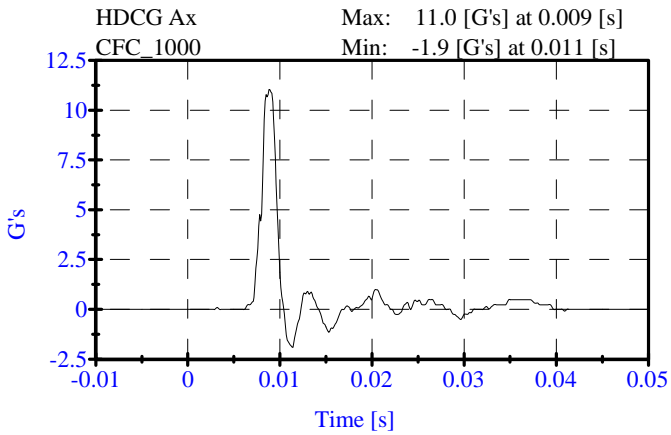

Neck test
POST TEST

CONFIGURED FOR LEFT SIDE IMPACT

ATD Serial No: 906
Date: 10-18-06

Sequential Test Number: 1 File: 906N_new 10-18-06
Laboratory Technician: B. Swiecicki

<u>TEST PARAMETER</u>	<u>SPECIFICATION</u>	<u>TEST RESULTS</u>	<u>STATUS</u>
Lab Temperature:	20.6-22.2 C	21.1 C	Passed
Lab Humidity:	10-70 %	37.00 %	Passed
Impact Velocity:	6.89- 7.13 m/s	6.99 m/s	Passed
PENDULUM DELTA V			
Delta V at 10 ms:	1.96- 2.55 m/s	2.14 m/s	Passed
Delta V at 20 ms:	4.12- 5.10 m/s	4.36 m/s	Passed
Delta V at 30 ms:	5.73- 7.01 m/s	6.25 m/s	Passed
Delta V between 40-70 ms:	6.27- 7.64 m/s	6.98 m/s	Passed
D PLANE ROTATION			
Maximum Rotation:	66.0-82.0 Deg	71.39 Deg	Passed
Rotation Angle Decay:	58.0-67.0 ms	61.90 ms	Passed
MOMENT ABOUT THE OCCIPITAL CONDYLE			
Max Occipital Moment:	73.00- 88.00 N-m	81.57 N-m	Passed
Occipital Moment Decay:	49.0-64.0 ms	58.20 ms	Passed
HEAD ROTATION TIME WITH RESPECT TO THE OCCIPITAL CONDYLE MOMENT			
Moment to Rotation Peak:	2.0-16.0 ms	8.90 ms	Passed

**Neck test
POST TEST**

CONFIGURED FOR LEFT SIDE IMPACT

ATD Serial No: 906

Date: 10-18-06

Sequential Test Number: 1 File: 906N_new 10-18-06

Laboratory Technician: B. Swiecicki

Pend Ax Max: 27.4 [] at 0.010 [s]
CFC_180 Min: -4.5 [] at 0.042 [s]

Pend Vx Max: 8.5 [m/s] at 0.200 [s]
CFC_180 Min: -0.0 [m/s] at -0.000 [s]

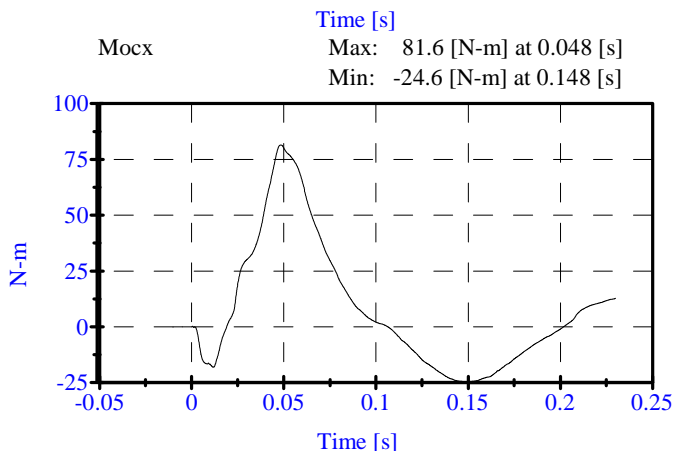
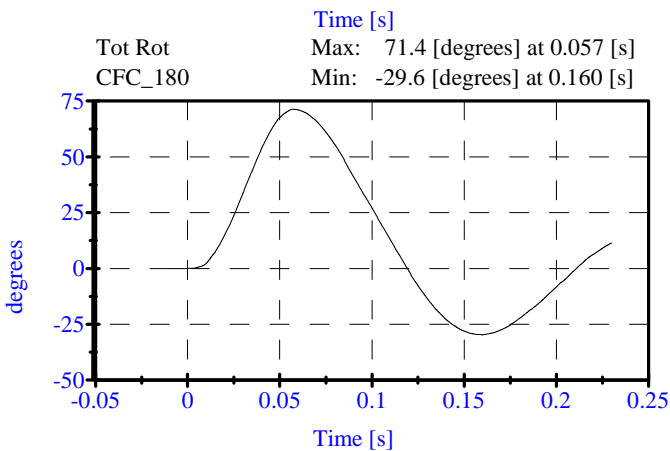
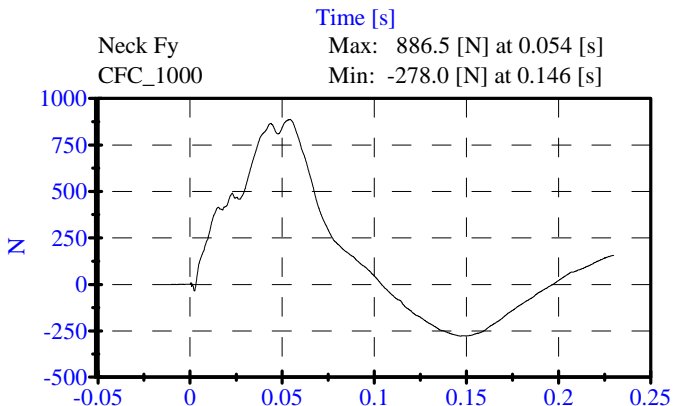
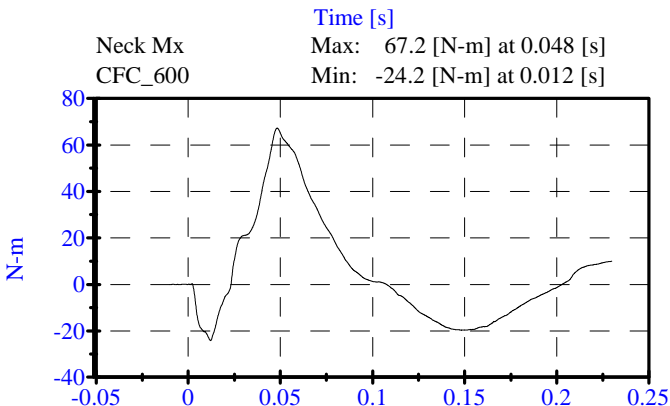
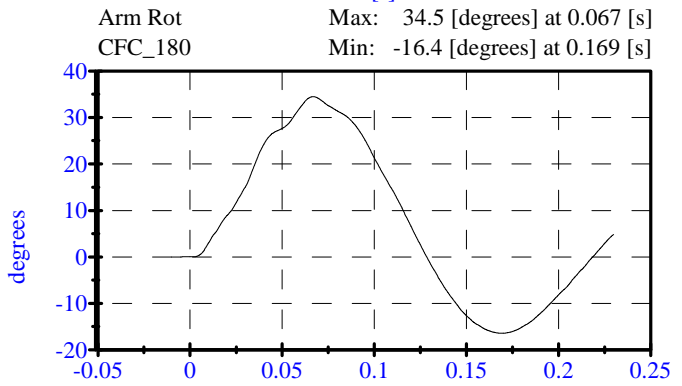
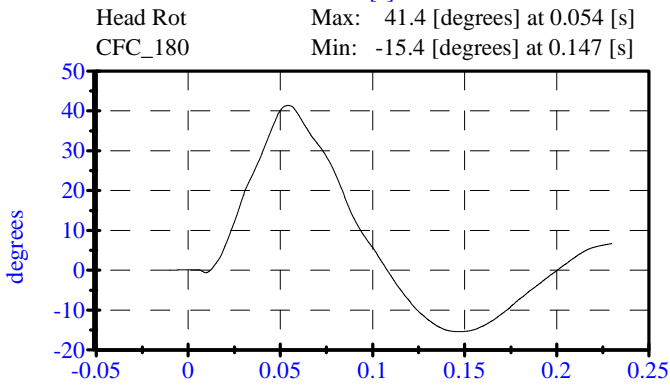
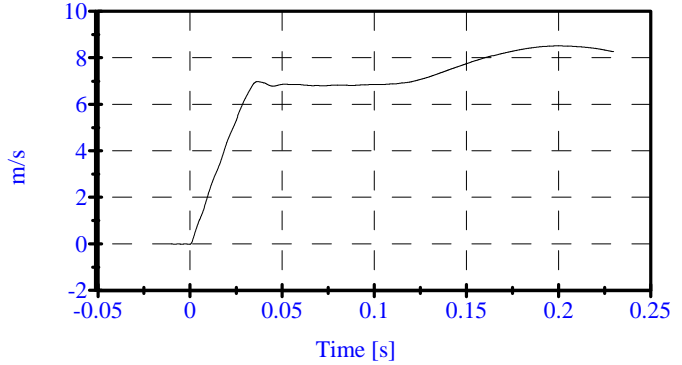
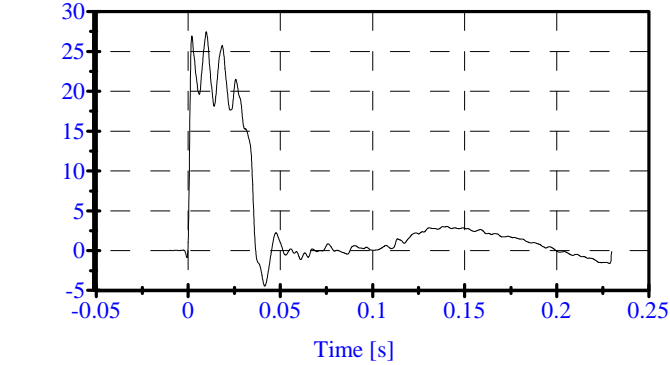

Abdomen Test

Post-Test

CONFIGURED FOR LEFT SIDE IMPACT

ATD Serial No: 906

Date: 10-19-06

Sequential Test Number: 1 File: 906ab 10-19-06

Laboratory Technician: B. Swiecicki

<u>TEST PARAMETER</u>	<u>SPECIFICATION</u>	<u>TEST RESULTS</u>	<u>STATUS</u>
Lab Temperature:	18.9-25.5 C	21.1 C	Passed
Lab Humidity:	10-70 %	33.00 %	Passed
Force at 12.95 mm :	104.00-162.00 N	124.04 N	Passed
Force at 19.05 mm :	162.98-220.99 N	192.91 N	Passed
Force at 25.40 mm :	221.97-280.02 N	274.83 N	Passed
Force at 33.02 mm :	324.99-391.00 N	380.32 N	Passed

ABDOMINAL COMPRESSION TEST

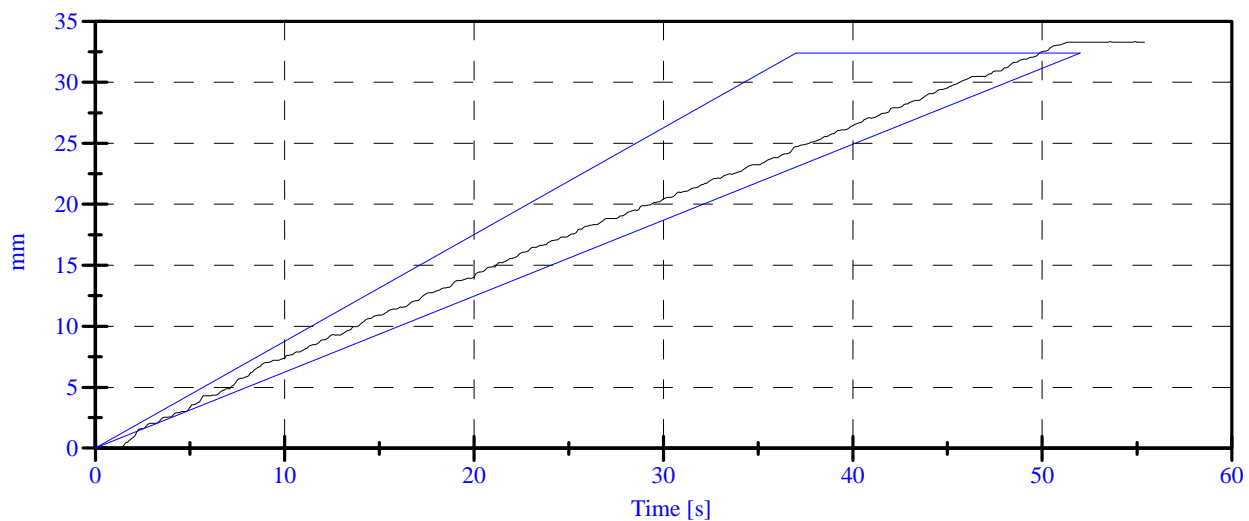
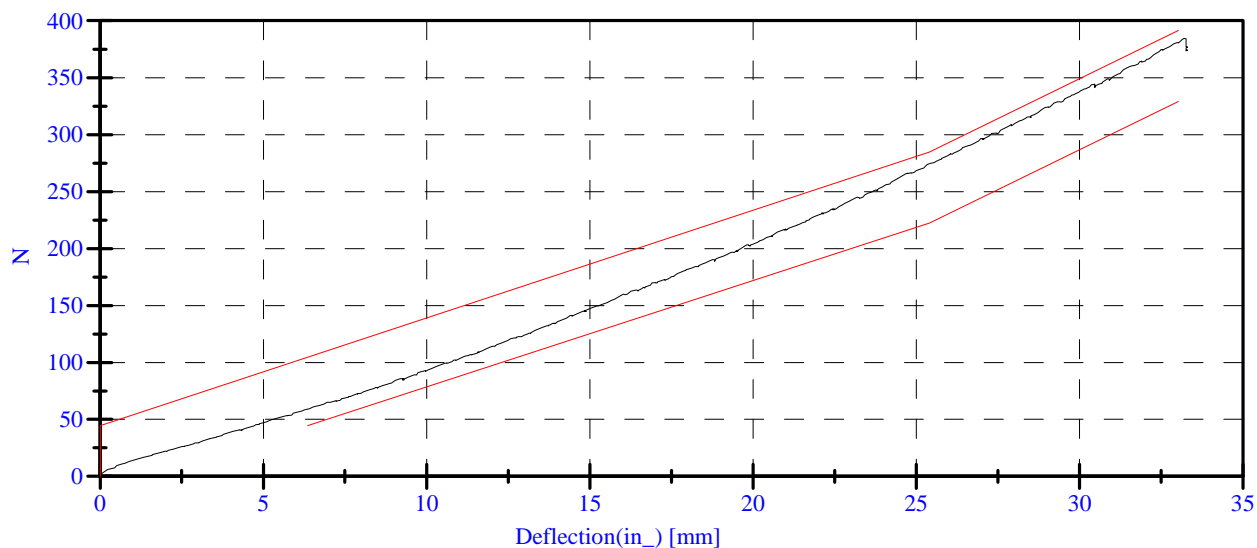

**Lumbar Spine
POST TEST**

CONFIGURED FOR LEFT SIDE IMPACT

ATD Serial No: 906
Date: 10-19-06

Sequential Test Number: 1 File: 906spine 10-19-06
Laboratory Technician: B. Swiecicki

<u>TEST PARAMETER</u>	<u>SPECIFICATION</u>	<u>TEST RESULTS</u>	<u>STATUS</u>
Lab Temperature:	18.9-25.5 C	21.1 C	Passed
Lab Humidity:	10-70 %	33.00 %	Passed
Force at 0 Deg:	0.00-26.69 N	0.40 N	Passed
Force at 20 Deg:	97.86-151.24 N	120.00 N	Passed
Force at 30 Deg:	151.24-204.62 N	169.62 N	Passed
Force at 40 Deg:	204.62-258.00 N	228.64 N	Passed
Return Angle	12 Deg Max	7.15 deg	Passed

LUMBAR SPINE FLEXION TEST

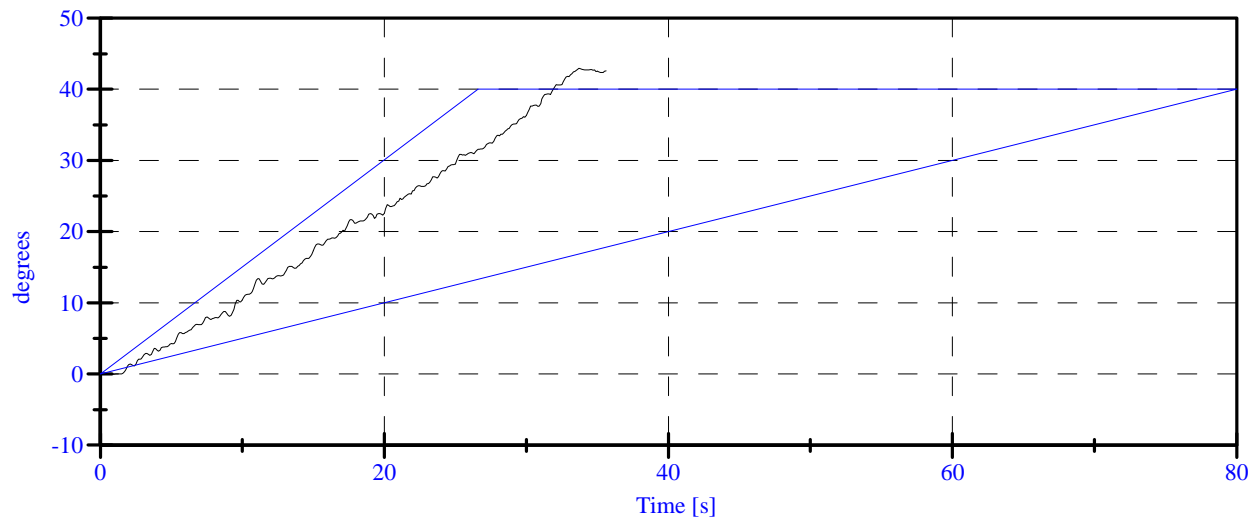
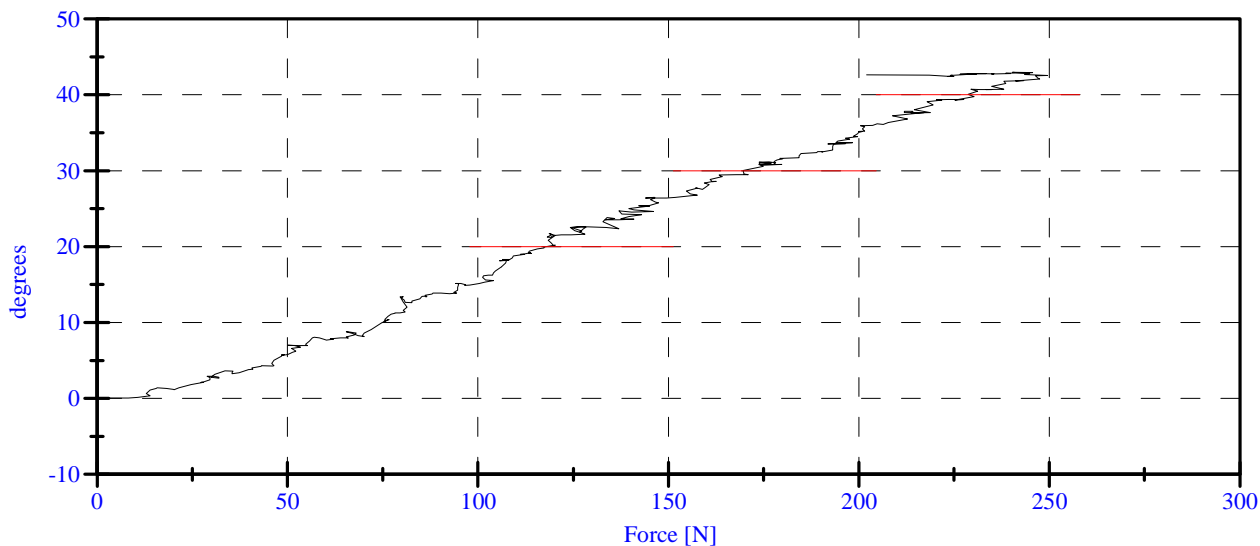

POST TEST DUMMY INSPECTION LIST
CONFIGURED FOR LEFT SIDE IMPACT

SID H3 Serial No.: 906 Sequential Test Number: 1
 Date: October 19, 2006 Laboratory Technician: B. Swiecicki

PART	ITEMS CHECKED	COMMENTS
SKIN	VISUAL INSPECTION	OK
HEAD	VISUAL, BALLAST, ACCELEROMETER MOUNT	OK
NECK	VISUAL, CABLE TORQUE	OK
SPINE BOX	VISUAL, BALLAST, WELDMENT, ACCELEROMETER MOUNT	OK
RIB CAGE	VISUAL, MEASURE, STIFFENERS	OK
STERNUM	VISUAL	OK
LUMBAR SPINE	VISUAL	OK
ABDOMEN	VISUAL	OK
PELVIS	VISUAL, PALPATE, ACCELEROMETER MOUNT	OK
UPPER LEGS	VISUAL	OK
KNEES	VISUAL, STOPS, INSERTS	OK
LOWER LEGS	VISUAL, RANGE OF MOTION	OK
ANKLES	VISUAL, RANGE OF MOTION	OK
FEET	VISUAL, RANGE OF MOTION	OK
JOINTS	1 TO 2 g RANGE	OK
OTHER	NONE	-

REMARKS: None

TEMPERATURE TRACE

2007 Pontiac Solstice C70101 Environmental Conditions

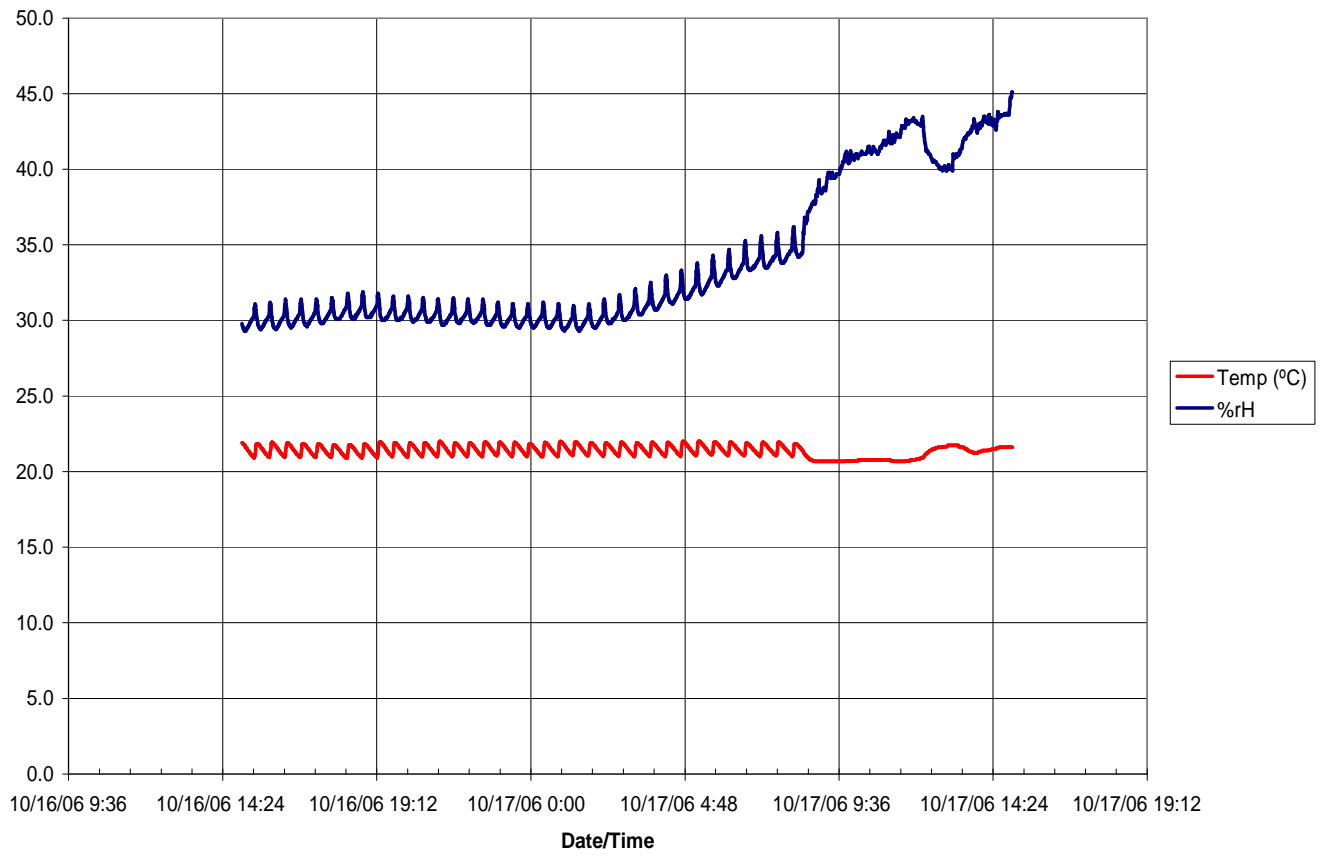

APPENDIX D
TEST EQUIPMENT AND CALIBRATION INFORMATION

TEST EQUIPMENT LIST AND CALIBRATION INFORMATION

SID/HIII INSTRUMENTATION

FRONT SID/HIII NO.: 906			
	SERIAL NUMBER	MANUFACTURER	CALIBRATION DATE
HEAD AX	AC-P23788	ENDEVCO	6-Jul-06
HEAD AY	AC-P21393	ENDEVCO	6-Jul-06
HEAD AZ	AC-P16845	ENDEVCO	6-Jul-06
UPPER NECK FX	LC-798FX	DENTON	6-Jul-06
UPPER NECK FY	LC-798FY	DENTON	6-Jul-06
UPPER NECK FZ	LC-798FZ	DENTON	6-Jul-06
UPPER NECK MX	LC-798MX	DENTON	6-Jul-06
UPPER NECK MY	LC-798MY	DENTON	6-Jul-06
UPPER NECK MZ	LC-798MZ	DENTON	6-Jul-06
UPPER RIB	AC-P16862	ENDEVCO	6-Jul-06
LOWER RIB	AC-P16866	ENDEVCO	6-Jul-06
LOWER SPINE	AC-P16645	ENDEVCO	6-Jul-06
PELVIS	AC-P23139	ENDEVCO	6-Jul-06
UPPER RIB REDUNDANT	AC-P23156	ENDEVCO	6-Jul-06
LOWER RIB REDUNDANT	AC-P16656	ENDEVCO	6-Jul-06
LOWER SPINE REDUNDANT	AC-P19343	ENDEVCO	6-Jul-06
PELVIS REDUNDANT	AC-P17539	ENDEVCO	6-Jul-06

REMARKS: None

TEST EQUIPMENT LIST AND CALIBRATION INFORMATION

VEHICLE AND MDB INSTRUMENTATION

	VEHICLE AND MDB INSTRUMENTS		
	SERIAL NUMBER	MANUFACTURER	CALIBRATION DATE
RIGHT FRONT SILL (X)	AC-P17237	ENDEVCO	5-Jul-06
RIGHT FRONT SILL (Y)	AC-J32838	ENDEVCO	7-Jul-06
RIGHT FRONT SILL (Z)	AC-P16625	ENDEVCO	18-Jul-06
RIGHT REAR SILL (X)	AC-P23993	ENDEVCO	19-Jul-06
RIGHT REAR SILL (Y)	AC-P23999	ENDEVCO	19-Jul-06
RIGHT REAR SILL (Z)	AC-P23939	ENDEVCO	19-Jul-06
REAR FLOORPAN ABOVE AXLE (X)	AC-P18628	ENDEVCO	6-Jul-06
REAR FLOORPAN ABOVE AXLE (Y)	AC-P23976	ENDEVCO	6-Jul-06
REAR FLOORPAN ABOVE AXLE (Z)	AC-P18718	ENDEVCO	5-Jul-06
LEFT REAR SILL (Y)	AC-P35789	ENDEVCO	18-Jul-06
LEFT FRONT SILL (Y)	AC-P26266	ENDEVCO	7-Aug-06
LEFT FRONT DOOR CENTERLINE (Y)	-	-	-
RIGHT REAR SEAT OCCUPANT COMP. (Y)	AC-P17242	ENDEVCO	18-Jul-06
MID REAR OF LEFT FRONT DOOR (Y)	-	-	-
LEFT FRONT DOOR UPPER C/L (Y)	-	-	-
MID REAR OF LEFT REAR DOOR (Y)	-	-	-
LEFT REAR DOOR UPPER C/L (Y)	-	-	-
LOWER LEFT B- PILLAR (Y)	AC-P18728	ENDEVCO	28-Jun-06
MIDDLE LEFT B-PILLAR (Y)	AC-P17141	ENDEVCO	18-Jul-06
LOWER LEFT A-PILLAR (Y)	AC-P35803	ENDEVCO	18-Jul-06
UPPER LEFT A-PILLAR (Y)	AC-P39743	ENDEVCO	18-Jul-06
FRONT SEAT TRACK (Y)	AC-P16616	ENDEVCO	5-Jul-06
REAR SEAT TRACK (Y)	-	-	-
VEHICLE CG (X)	AC-P23161	ENDEVCO	19-Jul-06
VEHICLE CG (Y)	AC-P15534	ENDEVCO	14-Jun-06
VEHICLE CG (Z)	AC-P24011	ENDEVCO	7-Jul-06
MDB CG (X)	AC-C16433	ENDEVCO	27-Jun-06
MDB CG (Y)	AC-C16416	ENDEVCO	27-Jun-06
MDB CG (Z)	AC-C16499	ENDEVCO	27-Jun-06
MDB REAR FRAME MEMBER (X)	AC-C14948	ENDEVCO	27-Jun-06
MDB REAR FRAME MEMBER (Y)	AC-C16680	ENDEVCO	27-Jun-06

REMARKS: None