

**REPORT NUMBER TR-P26168-01-NC**

**NEW CAR ASSESSMENT PROGRAM  
SIDE IMPACT TEST**

**AUDI AG  
2007 AUDI Q7  
5-DOOR MPV**

**Prepared By:  
KARCO ENGINEERING, LLC  
9270 HOLLY ROAD  
ADELANTO, CALIFORNIA 92301**

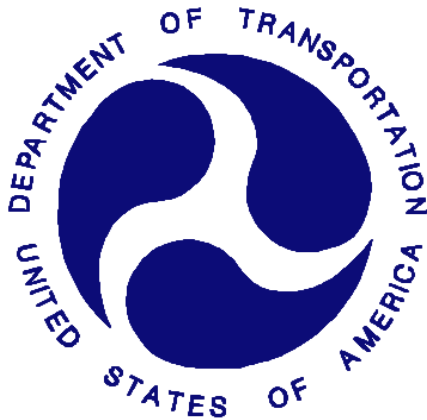

**SEPTEMBER 28, 2006**

**FINAL REPORT**

**PREPARED FOR:  
U.S. DEPARTMENT OF TRANSPORTATION  
NATIONAL HIGHWAY TRAFFIC SAFETY ADMINISTRATION  
OFFICE OF CRASHWORTHINESS STANDARDS  
RULEMAKING  
MAIL CODE: NVS-111  
400 SEVENTH STREET, SW, ROOM 5311  
WASHINGTON, D.C. 20590**

This final test report was prepared for the U.S. Department of Transportation, National Highway Traffic Safety Administration, in response to Contract Number DTNH22-03-D-32005.

This publication is distributed by the U.S. Department of Transportation, National Highway Traffic Safety Administration, in the interest of information exchange. The opinions, findings and conclusions expressed in this publication are those of the author(s) and not necessarily those of the Department of Transportation or the National Highway Traffic Safety Administration. The United States Government assumes no liability for its contents or use thereof. If trade or manufacturers' names or products are mentioned it is only because they are considered essential to the object of the publication and should not be construed as an endorsement. The United States Government does not endorse products or manufacturers.



Prepared by: \_\_\_\_\_  
Mr. Rupesh B. Patel, Project Engineer  
KARCO Engineering, LLC

Date: September 28, 2006



Reviewed by: \_\_\_\_\_  
Mr. Michael L. Dunlap, T&E Manager  
KARCO Engineering, LLC

Date: September 28, 2006



Approved by: \_\_\_\_\_  
Mr. Frank D. Richardson, Program Manager  
KARCO Engineering, LLC

Date: September 28, 2006

FINAL REPORT ACCEPTED BY:

\_\_\_\_\_  
Manager, Side Impact NCAP

\_\_\_\_\_  
Date of Acceptance

## Technical Report Documentation Page

<b>1. Report No.</b> TR-26168-01-NC	<b>2. Government Accession No.</b>	<b>3. Recipients Catalog No.</b>																									
<b>4. Title and Subtitle</b> Final Report of Side Impact New Car Assessment Program Testing of a 2007 Audi Q7 5-Door MPV NHTSA No. V75802		<b>5. Report Date</b> September 28, 2006																									
		<b>6. Performing Organization Code</b> KAR																									
<b>7. Authors</b> Mr. Rupesh B. Patel, Project Engineer, Karco Mr. Frank Richardson, Project Manager, Karco		<b>8. Performing Organization Report No.</b> TR-26168-01-NC																									
<b>9. Performing Organization Name and Address</b> Karco Engineering, LLC 9270 Holly Rd. Adelanto, CA, 92301		<b>10. Work Unit No.</b>																									
		<b>11. Contract or Grant No.</b> DTNH22-03-D-32005																									
<b>12. Sponsoring Agency Name and Address</b> U. S. Department of Transportation National Highway Traffic Safety Administration Rulemaking Office of Crashworthiness Standards Mail Code NVS-111 400 Seventh Street, SW, Room 5311 Washington, D.C 20590		<b>13. Type of Report and Period Covered</b> Final Test Report																									
		<b>14. Sponsoring Agency Code</b> DOT/NHTSA/NRM/OCS																									
<b>15. Supplementary Notes</b>																											
<b>16. Abstract</b> A 55/28 km/h 90 deg. Moving Deformable Barrier Side Impact NCAP Test was conducted on the subject 2007 Audi Q7 5-Door MPV in accordance with the specifications of the Office of Crash Worthiness Standards Test Procedures for the generation of consumer information on vehicle side crash protection. The test was conducted at KARCO Engineering, LLC in Adelanto, California, on September 28, 2006. The impact velocity of the Moving Deformable Barrier was 61.75 km/h and the outside ambient temperature at the struck (driver's) side of the vehicle was 34.4 deg. C. The target vehicle's maximum post-test static crush was 237 mm located at level 2. The test vehicle's occupant performance data is as follows:																											
<table border="1" style="width: 100%; border-collapse: collapse;"> <thead> <tr> <th style="width: 35%;">Measurement Description</th> <th style="width: 15%;">Driver SID/HIII</th> <th style="width: 15%;">Pass. SID/HIII</th> <th style="width: 35%;"></th> </tr> </thead> <tbody> <tr> <td>Left Upper Rib (LUR) G's</td> <td style="text-align: center;">14.0</td> <td style="text-align: center;">30.6</td> <td></td> </tr> <tr> <td>Left Lower Rib (LLR) G's</td> <td style="text-align: center;">15.4</td> <td style="text-align: center;">27.7</td> <td></td> </tr> <tr> <td>Lower Spine (T<sub>12</sub>) G's</td> <td style="text-align: center;">12.7</td> <td style="text-align: center;">28.0</td> <td></td> </tr> <tr> <td>Thoracic Trauma Index (TTI) G's</td> <td style="text-align: center;">14.0</td> <td style="text-align: center;">29.0</td> <td></td> </tr> <tr> <td>Pelvis (PEV) G's</td> <td style="text-align: center;">18.0</td> <td style="text-align: center;">34.0</td> <td></td> </tr> </tbody> </table>				Measurement Description	Driver SID/HIII	Pass. SID/HIII		Left Upper Rib (LUR) G's	14.0	30.6		Left Lower Rib (LLR) G's	15.4	27.7		Lower Spine (T <sub>12</sub> ) G's	12.7	28.0		Thoracic Trauma Index (TTI) G's	14.0	29.0		Pelvis (PEV) G's	18.0	34.0	
Measurement Description	Driver SID/HIII	Pass. SID/HIII																									
Left Upper Rib (LUR) G's	14.0	30.6																									
Left Lower Rib (LLR) G's	15.4	27.7																									
Lower Spine (T <sub>12</sub> ) G's	12.7	28.0																									
Thoracic Trauma Index (TTI) G's	14.0	29.0																									
Pelvis (PEV) G's	18.0	34.0																									
<b>17. Key Words</b> New Car Assessment Program (NCAP) Side Impact Moving Deformable Barrier (MDB) Side Impact Dummy (SID/HIII)		<b>18. Distribution Statement</b> Copies of this report are available from: National Highway Traffic Safety Admin. NHTSA Technical Reference Division 400 Seventh St., SW, Room 5108 Washington, DC 20590																									
<b>19. Security Classification of this report</b> UNCLASSIFIED	<b>20. Security Classification of this page</b> UNCLASSIFIED	<b>21. No. of Pages</b> 133	<b>22. Price</b>																								

## TABLE OF CONTENTS

Section		Page
1	Purpose and Test Procedure	1
2	Summary of Side Impact Test	2
3	Occupant and Vehicle Information Sheets	4

Data Sheet No.		Page
1	General Test and Vehicle Parameter Data	5
2	Test Vehicle Summary of Results	10
3	Moving Deformable Barrier (MDB) Summary of Results	11
4	Post-Test Observations	12
5	Vehicle Pre-Test and Post-Test Measurements	13
6	SID/HIII Longitudinal Clearance Dimensions	14
7	SID/HIII Lateral Clearance Dimensions	15
8	Vehicle Side Measurements	16
9	Vehicle Exterior Crush Profiles	17
10	Vehicle Damage Profile Distances	19
11	Deformable Barrier Honeycomb Face Static Crush	20
12	Vehicle Accelerometer Locations	21
13	MDB Accelerometer Locations	23
14	High Speed Camera Locations and Data	24
15	FMVSS 301 Fuel System Integrity Post-Impact Data	25
16	FMVSS 301 Static Rollover Data Sheet	26

Appendix		
A	Photographs	A
B	SID/HIII, Vehicle and MDB Response Data	B
C	SID/HIII Configuration and Performance Verification Data	C

**SECTION 1**  
**PURPOSE AND TEST PROCEDURE**

**1.1 PURPOSE**

This Side Impact NCAP test is conducted as part of the FY' 2007 test program sponsored by the National Highway Traffic Safety Administration (NHTSA), under contract No. DTNH22-03-D-32005. The purpose of this test is to generate comparative side impact data on a 2007 Audi Q7 5-Door MPV manufactured by Audi AG.

**1.2 TEST PROCEDURE**

The side impact test was conducted in accordance with the current National Highway Traffic Safety Administration (NHTSA), Office of Crashworthiness Standards (OCS), laboratory test procedure NCAP Side Impact Testing, dated November 2002. The procedures for receiving, inspection, testing, and reporting of test results are described in the test procedures and are not repeated in this report.

**SECTION 2**  
**SUMMARY OF SIDE IMPACT TEST**

**2.1 SUMMARY OF SIDE IMPACT NCAP TEST**

A model year 2007 Audi Q7 5-Door MPV was impacted on the left (driver's) side by a Moving Deformable Barrier (MDB) which was moving forward in a 27° crabbed position to the tow road guidance system at a velocity of 61.75 km/h. The specified impact velocity range is from 61.14 to 62.75 km/h. The test (target) vehicle was stationary and positioned 63° to the line of forward motion. The weight of the vehicle as tested was 2584 kg and the test weight of the MDB was 1361 kg. The test was conducted at KARCO Engineering, LLC in Adelanto, California, on September 28, 2006. The Vehicle was subjected to Static Stability Factor (SSF) and NCAP Rollover Test.

Two (2) real-time cameras and eleven (11) high-speed video cameras were used to document the impact event. Camera locations and pertinent camera information is documented in the data sheets. Pre- and post-test photographs of the vehicle and SID/HIIIs can be found in Appendix A. Two 50th percentile adult male Side Impact Dummies, Hybrid III (SID/HIIIs) were placed in the driver's and left rear passenger designated seating positions according to the test procedure. Each SID/HIII is instrumented with contact switches on the pelvis, thorax and six-axis neck load cells, and fourteen accelerometers in the following locations:

- Left Upper Rib (LUR) uni-axial accelerometer (Y-axis primary and redundant)
- Left Lower Rib (LLR) uni-axial accelerometer (Y-axis primary and redundant)
- Lower Thoracic Spine (T12) uni-axial accelerometer (Y-axis primary and redundant)
- Pelvic (PEV) section uni-axial accelerometer (Y-axis primary and redundant)
- Head Center of Gravity (CG) tri-axial accelerometers (X, Y, and Z axes primary and redundant)

**SUPPLEMENTAL RESTRAINT INFORMATION**

Restraint Type	Left Front Driver		Left Rear (Passenger)	
	Installed	Deployed	Installed	Deployed
Front Airbag	Yes	No	No	
Side Torso Airbag	Yes	Yes	No	
Head Airbag	No		No	
Curtain Airbag	Yes	Yes	Yes	Yes

## SECTION 2...(CONTINUED)

The test vehicle was instrumented with twenty-one (21) structural accelerometers and the MDB was instrumented with five (5) accelerometers and one (1) contact switch on the right bumper to compare left side to right side bumper impact timing. All data channels were recorded with the fully self contained on-board Data Acquisition System (DAS). The data was digitally sampled at 10,000 samples per second and processed per Appendix V of the Test Procedure.

### 2.2 GENERAL COMMENTS

The driver and passenger doors remained closed during impact. The test vehicle sustained a maximum static crush of 237 mm at level 2, 900 mm rearward of the left vertical impact point. The driver SID/Hybrid III, Serial No. 274 and the passenger SID/Hybrid III, Serial No. 275 were calibrated prior to this test. The SID/Hybrid III injury criteria is summarized as follows:

Measurement	Units	Driver	Passenger
Thoracic Trauma Index (TTI)	G's	14.0	29.0
Peak Pelvic G's (PEV)	G's	18.0	34.0

Tests summaries and post-test observations are presented in Section 3. Appendix A contains the still photograph prints. Appendix B contains the driver and passenger SID/HIIs, vehicle, and MDB response data traces. Appendix C contains the SID Configuration and performance verification data.

### SECTION 3

#### OCCUPANT AND VEHICLE INFORMATION SHEETS

Test Vehicle: 2007 Audi Q7 5-Door MPV

NHTSA No.: V75802

Test Program: 55/28 km/h Side Impact NCAP

Test Date: 9/28/06

#### CONVERSION FACTORS USED IN THIS REPORT\*

Quantity	Typical Application	Std Units	Metric Unit	Multiply By
Mass	Vehicle Weight	lb	kg	0.4536
Linear Velocity	Impact Velocity	mile/h	km/h	1.609
Length or Distance	Measurements	in	mm	25.4
Volume	Fuel Systems	gal	liter	3.785
Volume	Small Fluids	oz	mL	29.573
Pressure	Tire Pressures	lbf/in <sup>2</sup>	kPa	7.0
Volume	Liquid	gal	liter	3.785
Temperature	General Use	°F	°C	$=(tf - 32)/1.8$
Force	Dynamic Forces	lbf	N	4.448
Moment	Torque	lbf/ft	Nm	1.355

\* Based on the Recommended Practice in SAE J916, May 85

**DATA SHEET NO. 1**

**GENERAL TEST AND VEHICLE PARAMETER DATA**

Test Vehicle: 2007 Audi Q7 5-Door MPV  
 Test Program: 55/28 km/h Side Impact NCAP

NHTSA No.: V75802  
 Test Date: 9/28/06

**TEST VEHICLE INFORMATION AND OPTIONS**

NHTSA No.	V75802
Make	Audi
Model	Q7
Body Style	5-Door MPV
Vin No.	WA1AY74L27D032374
Color	White
Delivery Date	9/27/2006
Odometer (Miles)	179
Dealer	Midwestern Auto Group
Transmission	6-Speed Automatic
Final Drive	Awd
Type/No. Cyl.	V6
Engine Disp. (L)	3.6
Engine Placement	Longitudinal
Roof Rack	No
Sunroof/T-Top	No
Tinted Glass	Yes
Traction Control	Yes
Power Brakes	Yes
Front Disc	Yes
Rear Disc	Yes

Anti-Lock Brakes	Yes
All Wheel Drive	Yes
Power Steering	Yes
Driver Front Airbag	Yes
Driver Side Torso Airbag	Yes
Driver Side Head Airbag	No
Driver Curtain/Airbag	Yes
Rear Pass. Airbag	No
Rear Pass. Side Airbag	No
Rear Pass. Head Airbag	No
Rear Pass. Curtain/Airbag	Yes
Pre-Tensioners	Yes
Load Limiters	Yes
Bucket Seats	Yes
Air Cond.	Yes
AM/FM CD	Yes
Tilt Steering	Yes
Automatic Door Locks	Yes
Power Windows	Yes
Power Seats	Yes
Other	None

Does Owners Manual provide instructions to turn off automatic door locks.

**Yes**

**DATA FROM CERTIFICATION LABEL**

Manufactured By	Audi AG
Date of Manufacture	Jul-06

GVWR (kg)	2980
GAWR Front (kg)	1435
GAWR Rear (kg)	1770

**VEHICLE SEATING AND CAPACITY WEIGHT INFORMATION**

Measured Parameter	Front	Rear	Third	Total
Type of Seats	Bucket	Bench	Bucket	
Number of Occupants	2	3	2	7
Capacity Weight (VCW) (kg)				600
Cargo Weight (RCLW) (kg)				124



**DATA SHEET NO. 1...(CONTINUED)**  
**GENERAL TEST AND VEHICLE PARAMETER DATA**

Test Vehicle: 2007 Audi Q7 5-Door MPV

NHTSA No.: V75802

Test Program: 55/28 km/h Side Impact NCAP

Test Date: 9/28/06

**TEST VEHICLE WEIGHTS**

	Units	As Delivered Weights (UVW)			As Tested Weights (ATW)		
		Front Axle	Rear Axle	Total	Front Axle	Rear Axle	Total
Left	kg	593	574		647	674	
Right	kg	588	550		622	641	
Ratio	%	51.2	48.8		49.1	50.9	
Totals	kg	1181	1124	2305	1269	1315	2584

**TARGET TEST WEIGHT CALCULATION**

Measured Parameter	Units	Value
Total Delivered Weight (UVW)	kg	2305
Weight of 2 P572 ATD's	kg	162
Rated Cargo/Luggage Wt. (RCLW)	kg	124
Calculated Vehicle Target Wt. (TVTW)	kg	2591

**TEST VEHICLE ATTITUDE AND CG**

	Units	LF	RF	LR	RR	CG (aft of front axle)
As Delivered	mm	844	839	856	852	1470
As Tested	mm	833	835	827	834	1533
Fully Loaded	mm	832	831	823	823	

**GENERAL TEST VEHICLE DATA**

Measurement Description	Units	Value
Test Vehicle Wheel Base	mm	3012
Total Vehicle Length at Left Side	mm	3535
Total Vehicle Length at Centerline	mm	5087
Total Vehicle Length at Right Side	mm	3535
Weight of Ballast In Cargo Area	kg	113
Amount of Stoddard Solvent in Fuel Tank	liters	94.85

**TEST VEHICLE VERTICAL IMPACT LINE DATA**

Measurement Description	Units	Value
Test Vehicle Wheel Base	mm	3012
Target Impact Point Aft of Front Axle	mm	998
Actual Impact Point Aft of Front Axle	mm	668

**DATA SHEET NO. 1...(CONTINUED)**

**GENERAL TEST AND VEHICLE PARAMETER DATA**

Test Vehicle: 2007 Audi Q7 5-Door MPV  
 Test Program: 55/28 km/h Side Impact NCAP

NHTSA No.: V75802  
 Test Date: 9/28/06

**NOMINAL DESIGN RIDING POSITION**

The driver and passenger seat backs are positioned to the manufacturer's designated angle. The procedure is as follows: Seat back angle was measured at the seatback using a digital inclinometer.

**SEAT BACK ANGLES**

	Deg.
Driver Seat Back Angle	17 @ seat back
Rear Seat Back Angle	19 @ seat back

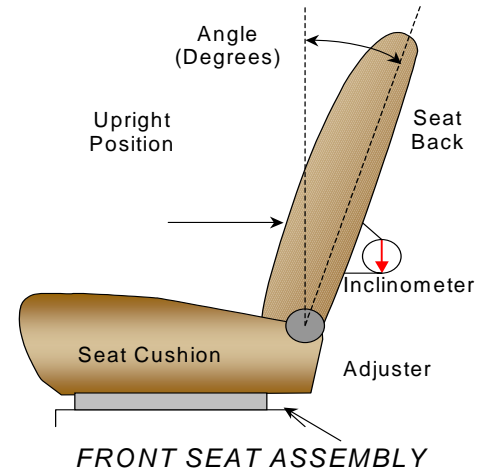

**SEAT FORE/AFT POSITIONS**

The total seat travel was measured from forward most position at the highest vertical seat height to rearmost position at the lowest vertical seat height. The seat was set at the longitudinal mid position with the vertical adjustment at the lowest position obtainable for the driver and passenger.

**SEAT FORE/AFT POSITIONING**

	Total Fore/Aft Travel	Placed in Position #
Driver Seat	298 mm	149 mm
Rear Seat	11 detents	6 detents

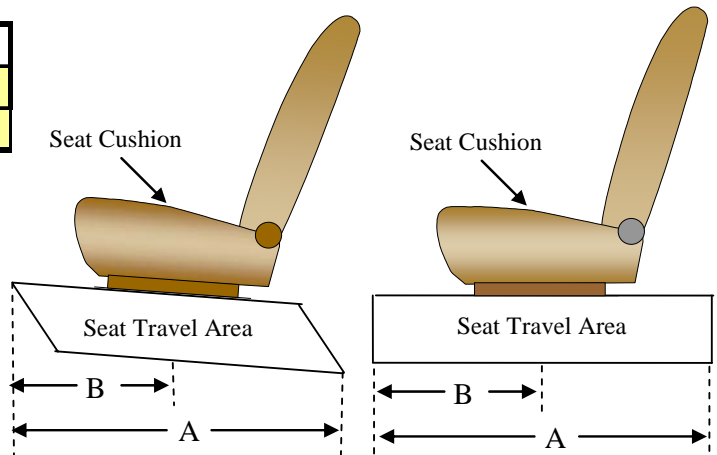

**SEAT BELT UPPER ANCHORAGE**

Position number one (1) is the uppermost position

**SEAT BELT UPPER ANCHORAGE**

	Total # of Positions	Placed in Position #
Driver Seat	5	1
Rear Seat	4	1

**DATA SHEET NO. 1...(CONTINUED)**

**GENERAL TEST AND VEHICLE PARAMETER DATA**

Test Vehicle: 2007 Audi Q7 5-Door MPV  
 Test Program: 55/28 km/h Side Impact NCAP

NHTSA No.: V75802  
 Test Date: 9/28/06

**FUEL TANK CAPACITY**

	Liters
Usable Capacity of "Standard Tank"	102.01
Usable Capacity of "Optional" Tank	
Usable Capacity used for FMVSS 301	94.00 to 95.87
Actual Amount of Solvent used	94.90

The test vehicle is equipped with an electric fuel pump. The fuel pump will operate for approximately three (3) seconds with the ignition in the "ON" position, after which the fuel pump automatically shuts off. The fuel filler door is located on the right rear fender.

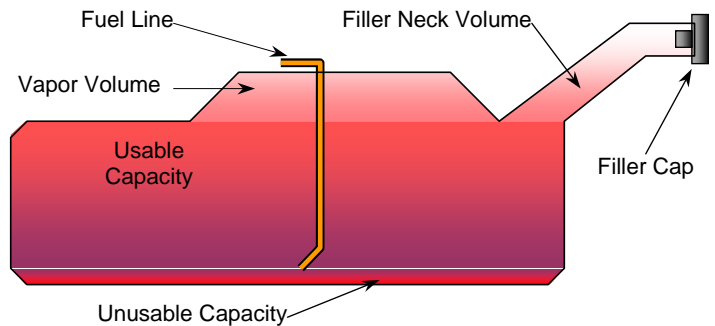

VEHICLE FUEL TANK ASSEMBLY

**STEERING COLUMN ADJUSTMENT**

Steering wheel and column adjustments are made so that the steering wheel hub is at the geometric center of the locus it describes when moved through its full range of motion. An aluminum plate is placed across the rim of the steering wheel, an inclinometer is placed on the plate and the angle is measured.

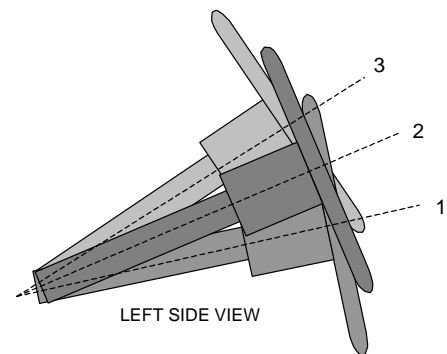

STEERING COLUMN ASSEMBLY

**STEERING COLUMN POSITIONS**

	Degrees	Fore/Aft Position (mm)
Lowermost position No. 1	18.5	145
Geometric center position No. 2	21.6	168
Uppermost position No. 3	24.8	192

**DATA SHEET NO. 2**

**TEST VEHICLE SUMMARY OF RESULTS**

Test Vehicle: 2007 Audi Q7 5-Door MPV

NHTSA No.: V75802

Test Program: 55/28 km/h Side Impact NCAP

Test Date: 9/28/06

**TEST VEHICLE WEIGHTS**

	Units	As Delivered Weights (UWW)			As Tested Weights (ATW)		
		Front Axle	Rear Axle	Total	Front Axle	Rear Axle	Total
Left	kg	593	574		647	674	
Right	kg	588	550		622	641	
Ratio	%	51.2	48.8		49.1	50.9	
Totals	kg	1181	1124	2305	1269	1315	2584

**MAXIMUM EXTERIOR STATIC CRUSH**

Level	Measured Parameter	Units	Maximum Crush	Above Ground
Level 1	Sill Top Height	mm	129	362
Level 2	Occupant H-Point	mm	237	741
Level 3	Mid Door	mm	227	746
Level 4	Window Sill	mm	68	1111
Level 5	Window top	mm	62	1608
N/A	Maximum Penetration	mm	237	

**INSTRUMENTATION**

Driver SID/Hybrid III Accelerometers	20
Passenger SID/Hybrid III Accelerometers	20
Vehicle Structure Accelerometers	21
MDB Accelerometers	5
Total No. of Contact Switches	5
<b>Total</b>	<b>71</b>

**CAMERA COVERAGE**

High Speed, Vehicle On-Board	3
High Speed, Off-Board	4
High Speed, MDB On-Board	3
Real Time, Panning	2
<b>Total</b>	<b>12</b>

**DATA SHEET NO. 3**

**MOVING DEFORMABLE BARRIER (MDB) SUMMARY OF RESULTS**

Test Vehicle: 2007 Audi Q7 5-Door MPV  
 Test Program: 55/28 km/h Side Impact NCAP

NHTSA No.: V75802  
 Test Date: 9/28/06

**MDB SPECIFICATIONS (mm)**

Measurement Description	Length
Overall Width of Framework Carriage	1252
Overall Length including Honeycomb Face	4115
Wheel Base of Framework Carriage	2590
C.G. location aft of Front Axle	1127

**MDB WEIGHTS**

	Units	Front Axle	Rear Axle	Total
Left	kg	384	308	
Right	kg	385	284	
Ratio	%	56.5	43.5	
Totals	kg	769	592	1361

**SPEED AND IMPACT DATA**

Measured Parameter	Units	Requirement	Value
Trap No. 1 Velocity (Primary)	km/h	61.1 to 62.7	61.75
Trap No. 2 Velocity (Redundant)	km/h	61.1 to 62.7	61.70
MDB CL to Target Vehicle CL	degrees	88.5 to 91.5	89.5

**MAXIMUM STATIC CRUSH OF HONEYCOMB FACE (mm)**

Vertical Location			From Centerline		Max. Crush
Row	Description	Height	Distance	Direction	
A	Center of Bumper	432	800	Right	823
B	Top of Bumper	533	800	Right	816
C	Mid Level	686	300	Right	841
D	Top of Stack	813	300	Right	813

**MDB INSTRUMENTATION AND CAMERAS**

Accelerometers	5
Contact Switches	1
High Speed Cameras	2

**DATA SHEET NO. 4**  
**POST-TEST OBSERVATIONS**

Test Vehicle: 2007 Audi Q7 5-Door MPV  
Test Program: 55/28 km/h Side Impact NCAP

NHTSA No.: V75802  
Test Date: 9/28/06

**TEST DUMMY INFORMATION AND CONTACT POINTS**

Description	Front Seat SID/Hybrid III	Rear Seat SID/Hybrid III
Dummy Type / Serial No.	P572F, SID / No. 274	P572F, SID / No. 275
Head Contact	Curtain Airbag	Curtain Airbag & Side Header
Upper Torso Contact	Side Airbag	Door Panel
Lower Torso Contact	Side Airbag	Door Panel
Left Knee Contact	Door Panel	Door Panel
Right Knee Contact	None	Left knee

**POST-TEST DOOR OPENING AND SEAT TRACK INFORMATION**

Description	Front	Rear
Left Side Door Opening	Door remained closed and latched, jammed	Door remained closed and latched, jammed
Right Side Door Opening	Remained closed and latched, operational	Remained closed and latched, operational
Seat Movement	None	None
Seat Back Failure	None	None

**POST-TEST STRUCTURAL OBSERVATIONS**

Critical Areas of Performance	Observations and Conclusions
Pillar Performance	No separation
Sill Separation	Front & Rear passenger side sill separated
Windshield Damage	None
Window Damage	None
Other Notable Effects	None

**SUPPLEMENTAL RESTRAINT SYSTEM INFORMATION**

Restraint Type	Left Front (Driver) Occupant Location 01		Left Rear (Passenger) Occupant Location 04	
	Installed	Operation	Installed	Operation
Front Airbag	Yes	No	No	
Side Torso Airbag	Yes	Yes	No	
Head Airbag	No		No	
Curtain Airbag	Yes	Yes	Yes	Yes
Seat Belt Pretensioner	Yes		No	
Seat Belt Load Limiter	Yes		No	

**MDB LEFT EDGE IMPACT POINT DATA**

Measured Parameter	Units	Requirement	Value
Horizontal Offset	mm	+/- 50	+12 (right)
Vertical Offset	mm	+/- 20	0

**DATA SHEET NO. 5**

**VEHICLE PRE-TEST AND POST-TEST MEASUREMENTS**

Test Vehicle: 2007 Audi Q7 5-Door MPV  
 Test Program: 55/28 km/h Side Impact NCAP

NHTSA No.: V75802  
 Test Date: 9/28/06

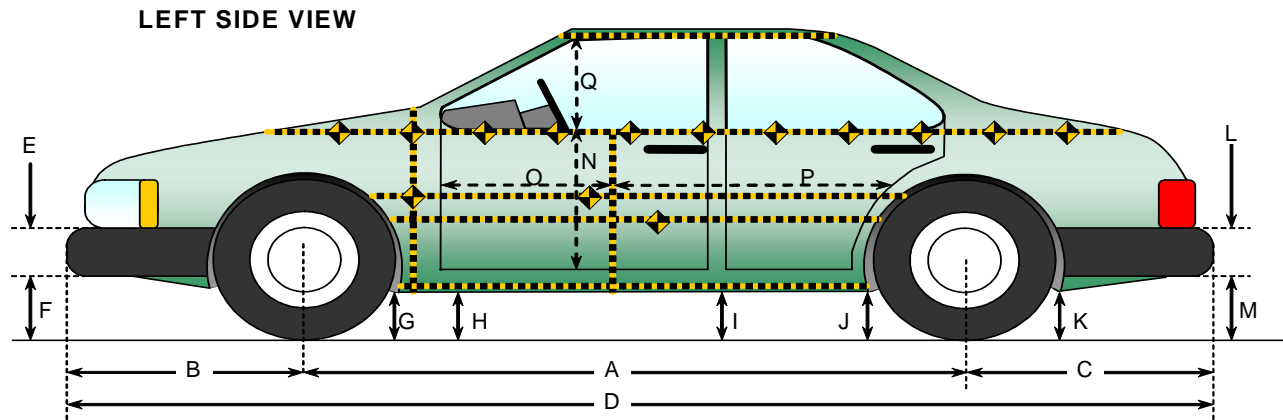

**VEHICLE PRE AND POST-TEST MEASUREMENT INFORMATION**

Code	Measurement Description	Pre-Test	Post-Test	Difference
A	Wheelbase	3012	2995	17
B	Front Axle to FSOV	968	994	-26
C	Rear Axle to RSOV	1111	1120	-9
D	Total Length at Centerline	5087	5091	-4
E	Front Bumper Thickness	510	510	0
F	Front Bumper Bottom to Ground	292	312	-20
G	Sill Height at Front Wheel Well	307	330	-23
H	Sill Height at Front Door Leading Edge	310	318	-8
I	Sill Height at "B" Pillar	312	317	-5
J1	Sill Height at Rear Wheel Well	277	316	-39
J2	Pinch Weld Height at Rear Wheel Well	320	326	-6
K	Sill Height aft of Rear Wheel Well	299	333	-34
L	Rear Bumper Thickness	406	406	0
M	Rear Bumper Bottom to Ground	385	425	-40
N	Sill Height to Window Bottom Sill	875	824	51
O	Front Door Leading Edge to Impact CL	780	768	12
P	Rear Door Trailing Edge to Impact CL	1500	1325	175
Q	Front Window Opening	408	408	0
R	Right Side Length	3535	3536	-1
S	Left Side Length	3535	3522	13
T	Vehicle Width at "B" Post	1943	1860	83

All Dimensions Shown in millimeters

**DATA SHEET NO. 6**

**SID/HIII LONGITUDINAL CLEARANCE DIMENSIONS**

Test Vehicle: 2007 Audi Q7 5-Door MPV  
 Test Program: 55/28 km/h Side Impact NCAP

NHTSA No.: V75802  
 Test Date: 9/28/06

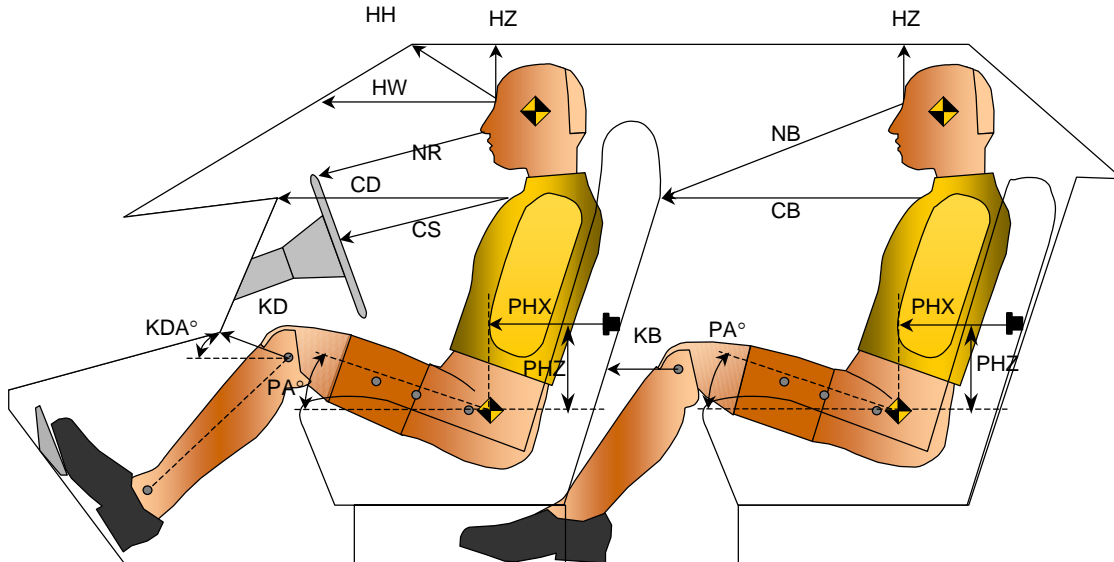

**LONGITUDINAL CLEARANCE DIMENSION INFORMATION**

Driver Code	Pass. Code	Measurement Description	Driver		Passenger	
			Length(mm)	Angle	Length(mm)	Angle
HH		Head to Header	355	18.2		
HW		Head to Windshield	548	0.0		
HZ	HZ	Head to Roof	169	90.0	210	90.0
NR	NB	Nose to Rim/Nose to Seat Back	378	18.8	638	15.4
CD	CB	Chest to Dash or Seat Back	635	0.5	605	2.5
CS		Chest to Steering Wheel	301	14.4		
KDL	KBL	Left Knee to Dash or Seat Back	161	33.3	285	0.0
KDR	KBR	Right Knee to Dash or Seat Back	158		280	
PA	PA	Pelvic Angle		23.0		23.2
PHX	PHX	H-Point to Striker (X-Axis)	236	0.0	308	0.0
PHZ	PHZ	H-Point to Striker (Z-Axis)	155	0.0	260	0.0

**DATA SHEET NO. 7**

**SID/HIII LATERAL CLEARANCE DIMENSIONS**

Test Vehicle: 2007 Audi Q7 5-Door MPV

NHTSA No.: V75802

Test Program: 55/28 km/h Side Impact NCAP

Test Date: 9/28/06

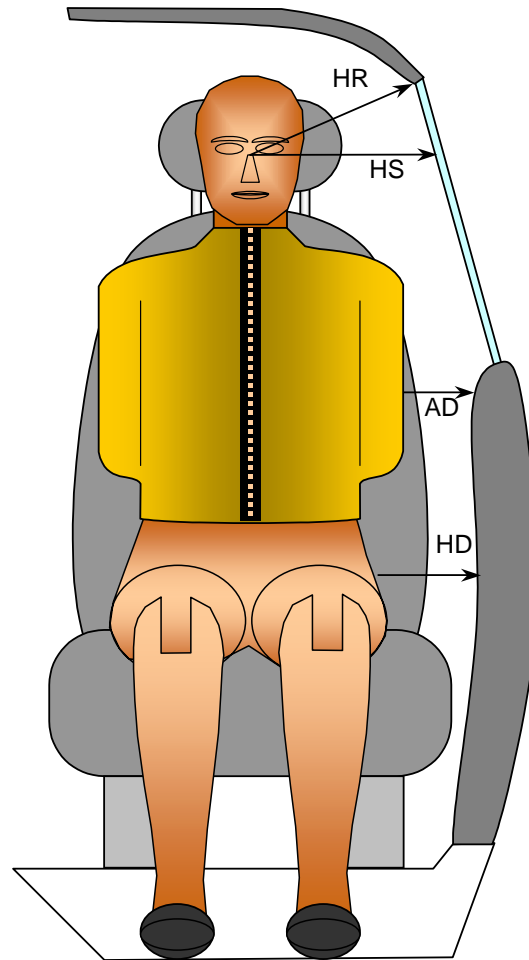

*FRONT VIEW OF DUMMY*

**LATERAL CLEARANCE DIMENSION INFORMATION**

Code	Measurement Description	Units	Driver	Passenger
HR	Head to Side Header	mm	282	285
HS	Head to Side Window	mm	355	262
AD	Arm to Door	mm	106	112
HD	H-Point to Door	mm	120	182

**DATA SHEET NO. 8**  
**VEHICLE SIDE MEASUREMENTS**

Test Vehicle: 2007 Audi Q7 5-Door MPV  
 Test Program: 55/28 km/h Side Impact NCAP

NHTSA No.: V75802  
 Test Date: 9/28/06

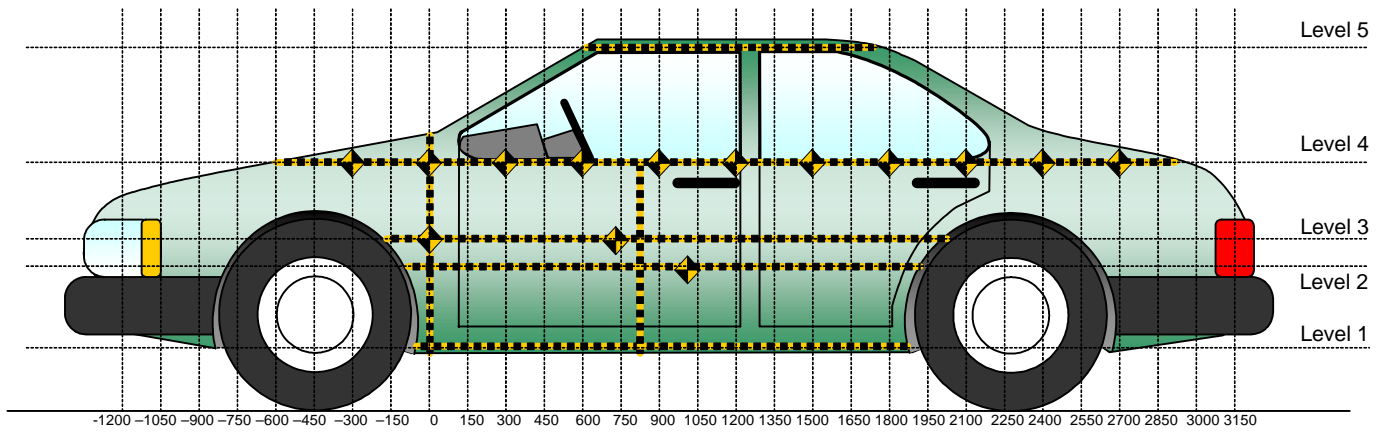

All Measurements Shown in mm

**LEFT SIDE VIEW**

Level	Measurement Description	Height Above Ground
1	Sill Top	362
2	Occupant H-Point	741
3	Mid Door	746
4	Window Sill	1111
5	Window Top	1608

All Dimensions Shown in millimeters

**DATA SHEET NO. 9**

**VEHICLE EXTERIOR CRUSH PROFILES**

Test Vehicle: 2007 Audi Q7 5-Door MPV  
 Test Program: 55/28 km/h Side Impact NCAP

NHTSA No.: V75802  
 Test Date: 9/28/06

	Pre-Test					Post-Test					Difference				
	1	2	3	4	5	1	2	3	4	5	1	2	3	4	5
-900															
-750															
-600															
-450															
-300			528					546					18		
-150		531	536	653			553	556	668			22	20	15	
0	574	549	547	641		587	562	559	663		13	13	12	22	
150	576	548	544	631		612	628	642	631		36	80	98	0	
300	567	543	541	615		651	707	707	626		84	164	166	11	
450	562	539	536	603		661	742	738	611		99	203	202	8	
600	558	535	533	594		666	751	747	662		108	216	214	68	
750	559	532	529	589		667	768	753	611		108	236	224	22	
900	556	531	529	584		676	768	756	612		120	237	227	28	
1050	554	533	528	576	818	678	757	747	616	836	124	224	219	40	18
1200	554	534	529	579	807	683	685	697	621	838	129	151	168	42	31
1350	551	532	529	578	806	677	668	694	636	833	126	136	165	58	27
1500	551	533	531	572	808	674	728	742	627	786	123	195	211	55	-22
1650	552	536	534	571	809	672	763	756	622	781	120	227	222	51	-28
1800	556	538	535	568	806	659	769	761	619	776	103	231	226	51	-30
1950	554	541	539	569	806	627	695	718	606	841	73	154	179	37	35
2100		536	533	573	808		572	565	601	846		36	32	28	38
2250		513	512	577	812		512	489	593	856		-1	-23	16	44
2400				581	810				609	861				28	51
2550				596	814				623	876				27	62
2700				621					630					9	
2850															
3000															

All Dimensions Shown in millimeters.

**DATA SHEET NO. 9...(CONTINUED)**  
**VEHICLE EXTERIOR CRUSH PROFILES**

Test Vehicle: 2007 Audi Q7 5-Door MPV  
 Test Program: 55/28 km/h Side Impact NCAP

NHTSA No.: V75802  
 Test Date: 9/28/06

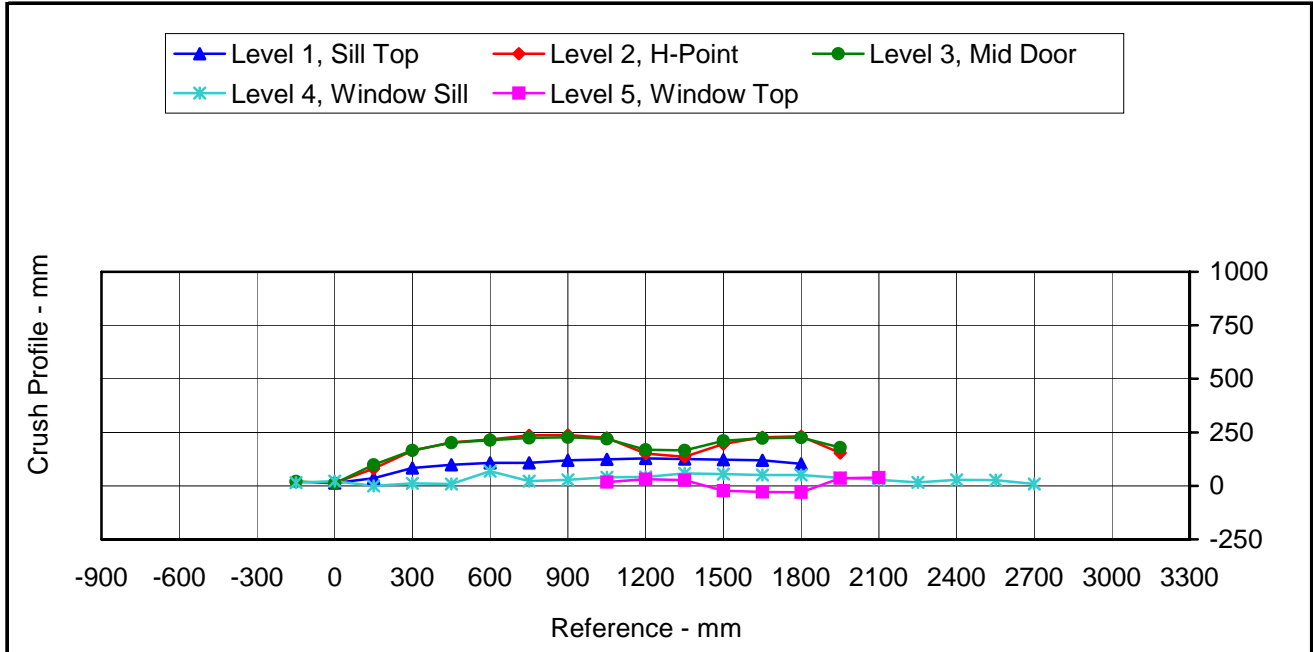

	Units	Level 1	Level 2	Level 3	Level 4	Level 5
Maximum Crush	mm	129	237	227	68	62
Distance from Impact	mm	1200	900	900	600	2550

**DATA SHEET NO. 10**

**VEHICLE DAMAGE PROFILE DISTANCES**

Test Vehicle: 2007 Audi Q7 5-Door MPV  
 Test Program: 55/28 km/h Side Impact NCAP

NHTSA No.: V75802  
 Test Date: 9/28/06

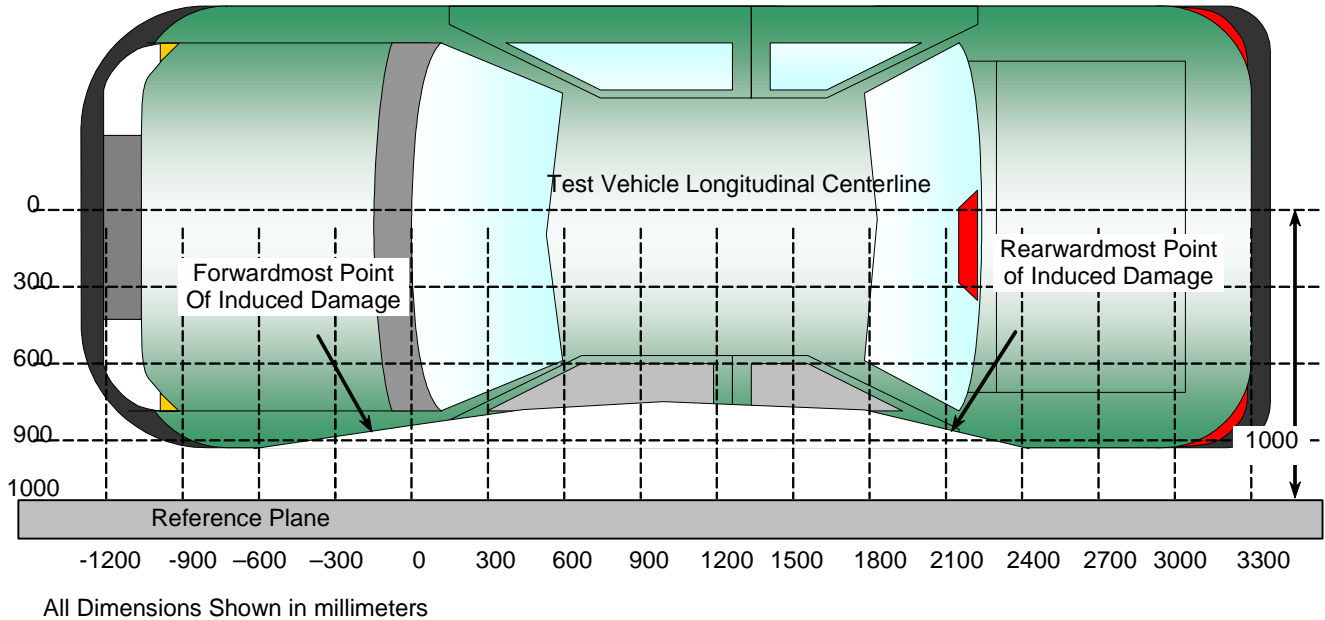

**TOP VIEW**

**DAMAGE PROFILE DISTANCES**

DPD	Distance From Impact Point in mm	Level	Pre-Test (mm)	Post-Test (mm)	Max. Static Crush (mm)
1	2250	2	513	512	-1
2	1800	2	538	769	231
3	1350	2	532	668	136
4	900	2	531	768	237
5	450	2	539	742	203
6	-150	2	531	553	22

**DATA SHEET NO. 11**

**DEFORMABLE BARRIER HONEYCOMB FACE STATIC CRUSH**

Test Vehicle: 2007 Audi Q7 5-Door MPV  
 Test Program: 55/28 km/h Side Impact NCAP

NHTSA No.: V75802  
 Test Date: 9/28/06

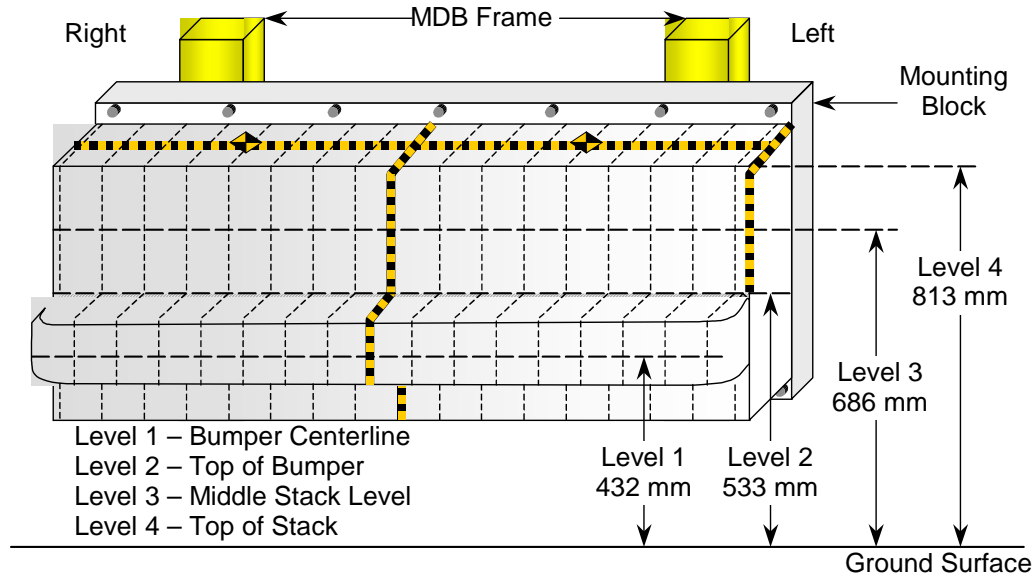

**DEFORMABLE BARRIER STATIC CRUSH**

Stack Level	Distance Right of Center								C/L	Distance Left of Center							
	800	700	600	500	400	300	200	100		0	100	200	300	400	500	600	700
1	823	809	806	800	796	792	789	787	791	779	778	775	772	771	769	772	783
2	816	815	805	796	783	784	784	781	784	792	796	793	791	789	787	786	806
3	758	746	756	786	811	841	786	732	713	709	703	702	708	715	726	747	799
4	776	765	758	764	795	813	787	741	726	722	724	720	722	731	739	766	796

All Dimensions in mm

DATA SHEET NO. 12

VEHICLE ACCELEROMETER LOCATIONS

Test Vehicle: 2007 Audi Q7 5-Door MPV  
 Test Program: 55/28 km/h Side Impact NCAP

NHTSA No.: V75802  
 Test Date: 9/28/06

LEFT SIDE VIEW

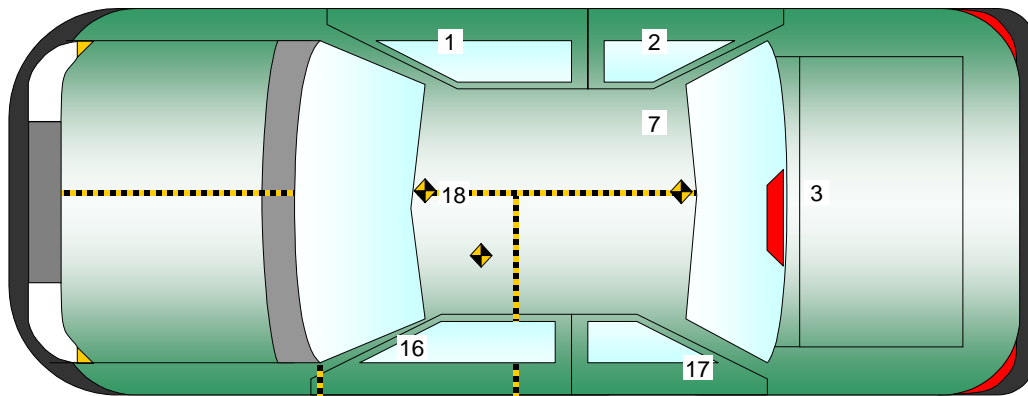
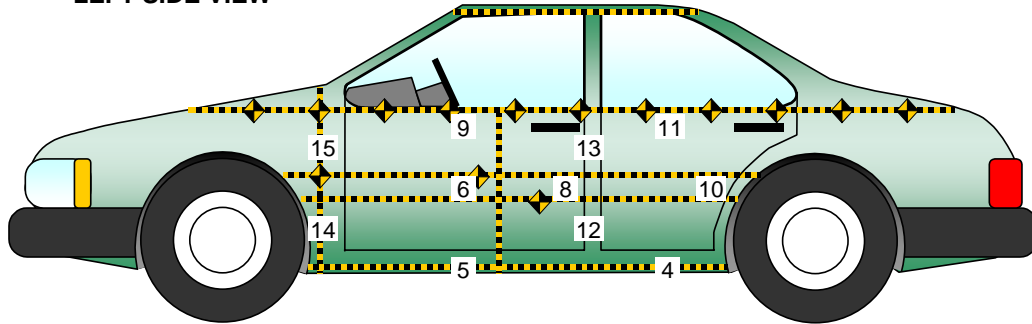

No.	Location
1	Right Sill at Front Seat
2	Right Sill at Rear Seat
3	Rear Floorpan Above Axle
4	Left Sill at Rear Door
5	Left Sill at Front Door
6	Left Front Door Centerline
7	Right Rear Occupant Compartment
8	Left Front Door Mid-Rear
9	Left Front Door Upper Centerline

No.	Location
10	Left Rear Door Mid-Rear
11	Left Rear Door Upper Centerline
12	Left Lower B-Post
13	Left Middle B-Post
14	Left Lower A-Post
15	Left Middle A-Post
16	Front Seat Track
17	Rear Seat Track or Structure
18	Vehicle CG

**DATA SHEET NO. 12...(CONTINUED)**  
**VEHICLE ACCELEROMETER LOCATIONS**

Test Vehicle: 2007 Audi Q7 5-Door MPV

NHTSA No.: V75802

Test Program: 55/28 km/h Side Impact NCAP

Test Date: 9/28/06

**VEHICLE ACCELEROMETER PRE-TEST LOCATIONS**

Loc. No.	Accelerometer Location	Measurements (mm)		
		X	Y	Z
1	Right Sill at Front Seat	2853	749	472
2	Right Sill at Rear Seat	1909	749	472
3	Rear Floorpan Above Axle	575	400	615
4	Left Sill at Rear Door	1659	-798	263
5	Left Sill at Front Door	2695	-798	263
6	Front Door Centerline			
7	Rt. Rear Occ. Compartment	2162	225	472
8	Front Door Mid-Rear			
9	Front Door Upper Centerline			
10	Rear Door Mid-Rear			
11	Rear Door Upper Centerline			
12	B-Post Lower	2210	-820	790
13	B-Post Middle	2210	-820	965
14	A-Post Lower	3395	-825	785
15	A-Post Middle	3395	-825	958
16	Front Seat Track			
17	Rear Seat Structure	1963	-553	599
18	Vehicle CG	3332	295	472

Reference Planes: X=From Rear Surface of Vehicle, Y=Vehicle Centerline, Z=Ground Plane

1.) Not installed

**DATA SHEET NO. 13**  
**MDB ACCELEROMETER LOCATIONS**

Test Vehicle: 2007 Audi Q7 5-Door MPV  
Test Program: 55/28 km/h Side Impact NCAP

NHTSA No.: V75802  
Test Date: 9/28/06

**MDB ACCELEROMETER LOCATIONS**

Loc. No.	Accelerometer Locations	Measurements (mm)		
		X	Y	Z
1	MDB CG	-1195	0	430
2	MDB Rear	-2642	-593	608

Reference Points: X - MDB Front Axle  
Y - MDB Centerline  
Z - Ground Plane

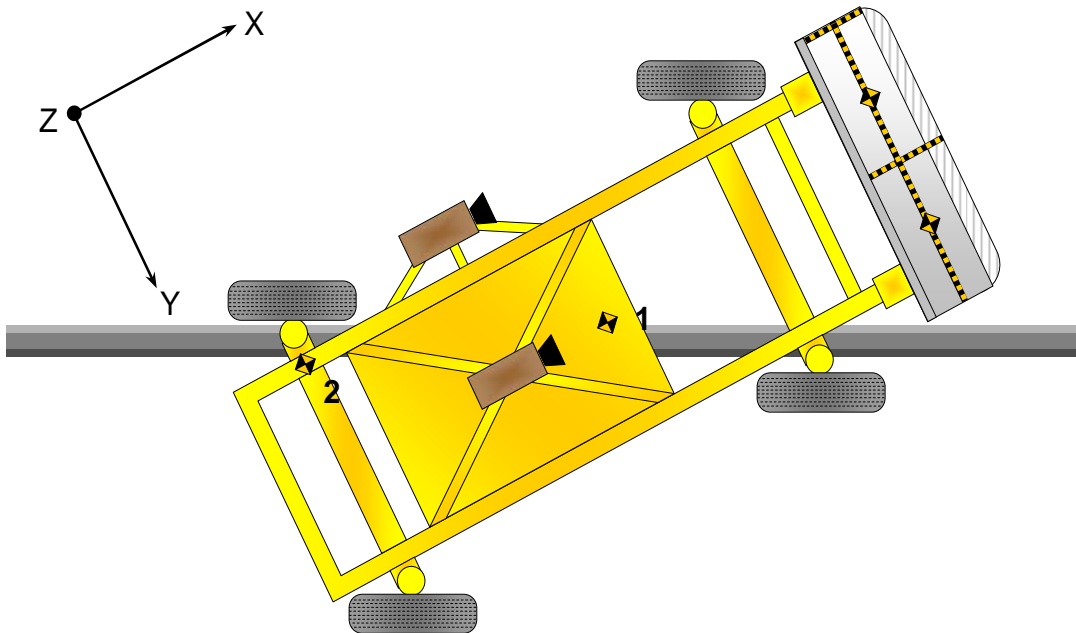

**DATA SHEET NO. 14**

**HIGH SPEED CAMERA LOCATIONS AND DATA**

Test Vehicle: 2007 Audi Q7 5-Door MPV

NHTSA No.: V75802

Test Program: 55/28 km/h Side Impact NCAP

Test Date: 9/28/06

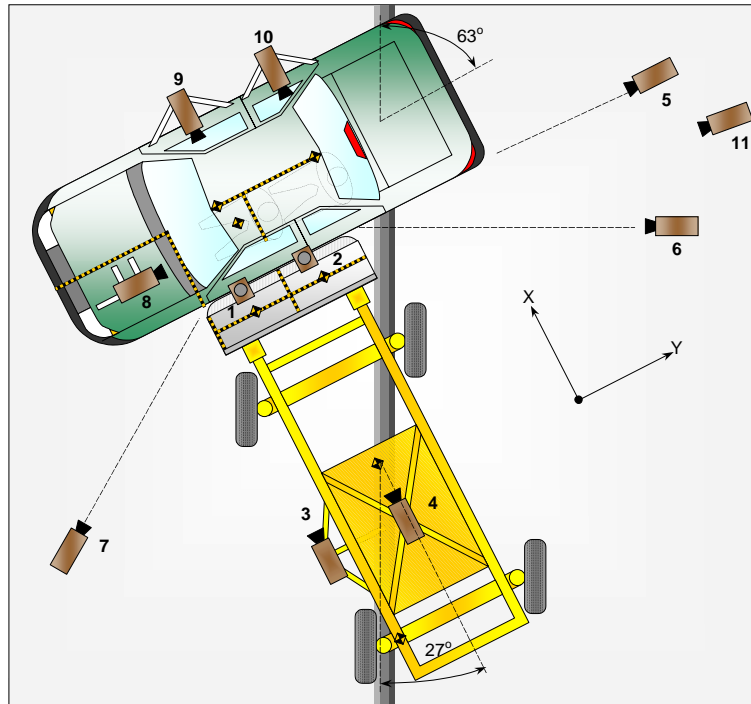

No.	Camera View	Location			Angle (Deg.)	Lens (mm)	Speed (fps)
		X	Y	Z			
DOC	REAL TIME DIGITAL	-7239	16851	-1806	-2	N/A	30
1	OVERHEAD OVERALL	1224	2281	-5484	-90	14mm	1000
2	OVERHEAD CLOSE UP	612	2286	-5452	-90	ZOOM	1000
3	LEFT IMPACT POINT (MDB)	-2124	0	-1137	-7	25mm	1000
4	SIDE OVERALL (MDB)	-3912	838	-1829	-11	12mm	1000
5	REAR	-273	14865	-1352	0	ZOOM	1000
6	LEFT REAR	-7186	16532	-849	0	ZOOM	1000
7	LEFT FRONT	-2673	3549	-1587	-4	24mm	1000
8	DRIVER FRONT (O.B.)	534	-273	-1297	-15	35mm	1000
9	DRIVER SIDE (O.B.)	2076	342	-1298	-2	20mm	1000
10	PASSENGER SIDE (O.B.)	2003	827	-1251	-2	20mm	1000
DOC	REAL TIME DIGITAL	345	15798	-1364	0	N/A	30

All camera measurements were made relative to the point of impact.

**DATA SHEET NO. 15**

**FMVSS 301 FUEL SYSTEM INTEGRITY POST-IMPACT DATA**

Test Vehicle: 2007 Audi Q7 5-Door MPV NHTSA No.: V75802  
Test Program: 55/28 km/h Side Impact NCAP Test Date: 9/28/06

Test Time: 11:02 AM Temperature: 34.4 Deg. C.

**Stoddard Solvent Spillage Measurements**

- A. From impact until vehicle motion ceases: 0.0 oz.  
(Maximum Allowable = 1 ounce)
- B. For the 5 minute period after motion ceases: 0.0 oz.  
(Maximum Allowable = 5 ounces)
- C. For the following 25 minutes: 0.0 oz.  
(Maximum Allowable = 1 oz./minute)
- D. Spillage Details: No leakage occurred

**DATA SHEET NO. 16**  
**FMVSS 301 STATIC ROLLOVER DATA**

Test Vehicle: 2007 Audi Q7 5-Door MPV  
 Test Program: 55/28 km/h Side Impact NCAP

NHTSA No.: V75802  
 Test Date: 9/28/06

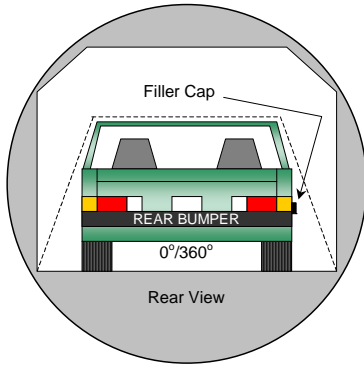

**0° to 90°**

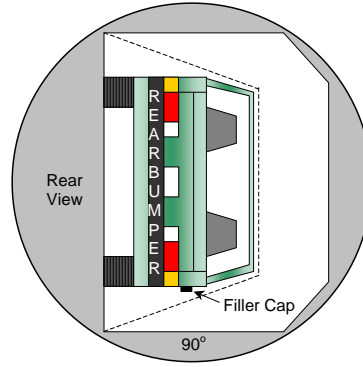

**90° to 180°**

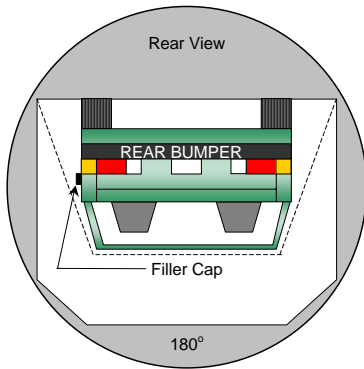
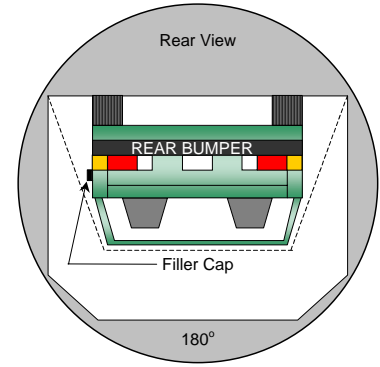

**180° to 270°**

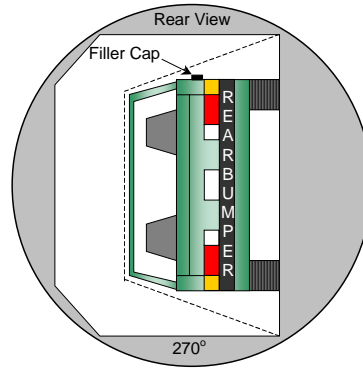

**270° to 360°**

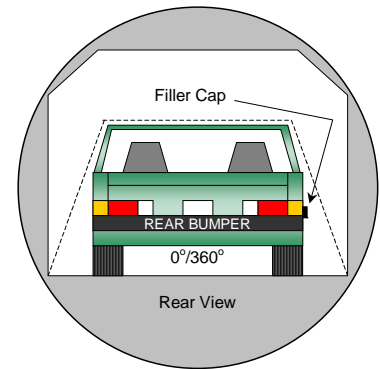

1. The specified fixture rollover rate for each 90° of rotation is 60 to 120 seconds.
2. The position hold time at each position is 300 seconds (minimum).
3. Details of Stoddard Solvent spillage locations.

**DATA SHEET NO. 16...(CONTINUED)**  
**FMVSS 301 STATIC ROLLOVER DATA SHEET**

Test Vehicle: 2007 Audi Q7 5-Door MPV  
 Test Program: 55/28 km/h Side Impact NCAP

NHTSA No.: V75802  
 Test Date: 9/28/06

**SOLVENT COLLECTION TIME TABLE IN SECONDS**

Test Phase	Rotation Time	Hold Time	Total Time
0° to 90°	81	300	381
90° to 180°	80	300	380
180° to 270°	79	300	379
270° to 360°	79	300	379

**FMVSS 301 SPILLAGE TABLE REQUIREMENT (oz.)**

First 5 Minutes	5.0
Sixth Minute	1.0
Seventh Minute	1.0
Eighth Minute	1.0

Test Phase	First 5 Minutes	Sixth Minute	Seventh Minute	Eighth Minute
0° to 90°	0	0	0	0
90° to 180°	0	0	0	0
180° to 270°	0	0	0	0
270° to 360°	0	0	0	0

\* Trace amounts were collected but could not be measured.

**SOLVENT SPILLAGE LOCATION TABLE**

Test Phase	Spillage Location
0° to 90°	None
90° to 180°	None
180° to 270°	None
270° to 360°	None

**APPENDIX A  
PHOTOGRAPHS**

## LIST OF PHOTOGRAPHS

Figure		Page
A-1	Left Front $\frac{3}{4}$ View, as Received	A-1
A-2	Right Rear $\frac{3}{4}$ View, as Received	A-2
A-3	Manufacturer's Label	A-3
A-4	Tire Placard	A-4
A-5	Pre-Test Front View	A-5
A-6	Post-Test Front View	A-6
A-7	Pre-Test Left Front $\frac{3}{4}$ View	A-7
A-8	Post-Test Left Front $\frac{3}{4}$ View	A-8
A-9	Pre-Test Left Side View	A-9
A-10	Post-Test Left Side View	A-10
A-11	Pre-Test Left Rear $\frac{3}{4}$ View	A-11
A-12	Post-Test Left Rear $\frac{3}{4}$ View	A-12
A-13	Pre-Test Rear View	A-13
A-14	Post-Test Rear View	A-14
A-15	Pre-Test Right Rear $\frac{3}{4}$ View	A-15
A-16	Post-Test Right Rear $\frac{3}{4}$ View	A-16
A-17	Pre-Test Right Side View	A-17
A-18	Post-Test Right Side View	A-18
A-19	Pre-Test Right Front $\frac{3}{4}$ View	A-19
A-20	Post-Test Right Front $\frac{3}{4}$ View	A-20
A-21	Pre-Test Overhead View	A-21
A-22	Post-Test Overhead View	A-22
A-23	Pre-Test Overhead Close-up View	A-23
A-24	Post-Test Overhead Close-up View	A-24
A-25	Pre-Test Left Impact Point	A-25
A-26	Post-Test Left Impact Point	A-26
A-27	Pre-Test Front $\frac{3}{4}$ View of Left Side Doors	A-27
A-28	Post-Test Front $\frac{3}{4}$ View of Left Side Doors	A-28
A-29	Pre-Test Rear $\frac{3}{4}$ View of Left Side Doors	A-29
A-30	Post-Test Rear $\frac{3}{4}$ View of Left Side Doors	A-30
A-31	Pre-Test Left Front Door	A-31
A-32	Post-Test Left Front Door	A-32
A-33	Pre-Test Left Rear Door	A-33
A-34	Post-Test Left Rear Door	A-34

LIST OF PHOTOGRAPHS...(CONTINUED)

Figure		Page
A-35	Pre-Test Driver Dummy (Door Open)	A-35
A-36	Pre-Test Driver Dummy (Through Window)	A-36
A-37	Post-Test Driver Dummy (Through Window)	A-37
A-38	Pre-Test Driver Dummy Clearance from Door	A-38
A-39	Post-Test Driver Dummy Clearance from Door	A-39
A-40	Pre-Test Driver Dummy Right Side View	A-40
A-41	Post-Test Driver Dummy Right Side View	A-41
A-42	Pre-Test Front Door Panel (Interior)	A-42
A-43	Post-Test Front Door Panel (Interior)	A-43
A-44	Pre-Test Passenger Dummy Left Side (Door Open)	A-44
A-45	Pre-Test Passenger Dummy Left Side (Through Window)	A-45
A-46	Post-Test Passenger Dummy Left Side (Through Window)	A-46
A-47	Pre-Test Passenger Dummy Clearance from Door	A-47
A-48	Post-Test Passenger Dummy Clearance from Door	A-48
A-49	Pre-Test Passenger Dummy Right Side View	A-49
A-50	Post-Test Passenger Dummy Right Side View	A-50
A-51	Pre-Test Rear Door Panel (Interior)	A-51
A-52	Post-Test Rear Door Panel (Interior)	A-52
A-53	Pre-Test Front View of Deformable Barrier	A-53
A-54	Post-Test Front View of Deformable Barrier	A-54
A-55	Pre-Test Top View of Deformable Barrier	A-55
A-56	Post-Test Top View of Deformable Barrier	A-56
A-57	Pre-Test Right Side View of Deformable Barrier	A-57
A-58	Post-Test Right Side View of Deformable Barrier	A-58
A-59	Pre-Test Left Side View of Deformable Barrier	A-59
A-60	Post-Test Left Side View of Deformable Barrier	A-60
A-61	Vehicle on Rollover Device (0°)	A-61
A-62	Vehicle on Rollover Device (90°)	A-62
A-63	Vehicle on Rollover Device (180°)	A-63
A-64	Vehicle on Rollover Device (270°)	A-64
A-65	Vehicle Impact	A-65



Figure A-1: Left Front  $\frac{3}{4}$  View, as Received



A-2

TR-P26168-01-NC

Figure A-2: Right Rear  $\frac{3}{4}$  View, as Received

MFD. BY AUDI AG 07 06

GVWR LBS 6570, KG 2980

GAWR FRONT LBS 3164, KG 1435

FRONT-TIRES 235/60 R18 XL

7.5JX18 RIMS, AT 300 KPA 44 PSI COLD

GAWR REAR LBS 3902, KG 1770

REAR-TIRES 235/60 R18 XL

7.5JX18 RIMS, AT 340 KPA 49 PSI COLD



**Audi**

THIS VEHICLE CONFORMS TO ALL APPLICABLE  
U.S. FEDERAL MOTOR VEHICLE SAFETY AND  
THEFT PREVENTION STANDARDS IN EFFECT ON  
THE DATE OF MANUFACTURE SHOWN ABOVE.  
SLOVAKIA

WA1AY74L27D032374

TYPE:  
MPV



Figure A-3: Manufacturer's Label



## TIRE AND LOADING INFORMATION

SEATING CAPACITY TOTAL 7 FRONT 2 CENTER 3 REAR 2

The combined weight of occupants and cargo should never exceed 600 kg or 1323 lbs.

TIRE	SIZE	COLD TIRE PRESSURE	SEE OWNER'S MANUAL FOR ADDITIONAL INFORMATION
FRONT	235/60 R18 107H XL	300 KPA, 44 PSI	
REAR	235/60 R18 107H XL	340 KPA, 49 PSI	
SPARE	195/75-18	350 KPA, 51 PSI	

410-010-502-BC

Figure A-4: Tire Placard



Figure A-5: Pre-Test Front View



Figure A-6: Post-Test Front View



Figure A-7: Pre-Test Left Front 3/4 View



Figure A-8: Post-Test Left Front  $\frac{3}{4}$  View



Figure A-9: Pre-Test Left Side View



Figure A-10: Post-Test Left Side View



A-11

TR-P26168-01-NC

Figure A-11: Pre-Test Left Rear ¾ View



Figure A-12: Post-Test Left Rear 3/4 View



Figure A-13: Pre-Test Rear View



Figure A-14: Post-Test Rear View



Figure A-15: Pre-Test Right Rear ¾ View



Figure A-16: Post-Test Right Rear  $\frac{3}{4}$  View



Figure A-17: Pre-Test Right Side View



Figure A-18: Post-Test Right Side View



A-19

TR-P26168-01-NC

Figure A-19: Pre-Test Right Front ¾ View



Figure A-20: Post-Test Right Front  $\frac{3}{4}$  View



Figure A-21: Pre-Test Overhead View



Figure A-22: Post-Test Overhead View



Figure A-23: Pre-Test Overhead Close-up View



Figure A-24: Post-Test Overhead Close-up View



Figure A-25: Pre-Test Left Impact Point



Post-Test Impact Point

Figure A-26: Post-Test Left Impact Point



Figure A-27: Pre-Test Front ¾ View of Left Side Door



Figure A-28: Post-Test Front ¾ View of Left Side Door



Figure A-29: Pre-Test Rear 3/4 View of Left Side Door



Figure A-30: Post-Test Rear 3/4 View of Left Side Door



Figure A-31: Pre-Test Left Front Door



Figure A-32: Post-Test Left Front Door



Figure A-33: Pre-Test Left Rear Door



Figure A-34: Post-Test Left Rear Door



Figure A-35: Pre-Test Driver Dummy (Door Open)



Figure A-36: Pre-Test Driver Dummy (Through Window)



Figure A-37: Post-Test Driver Dummy (Through Window)

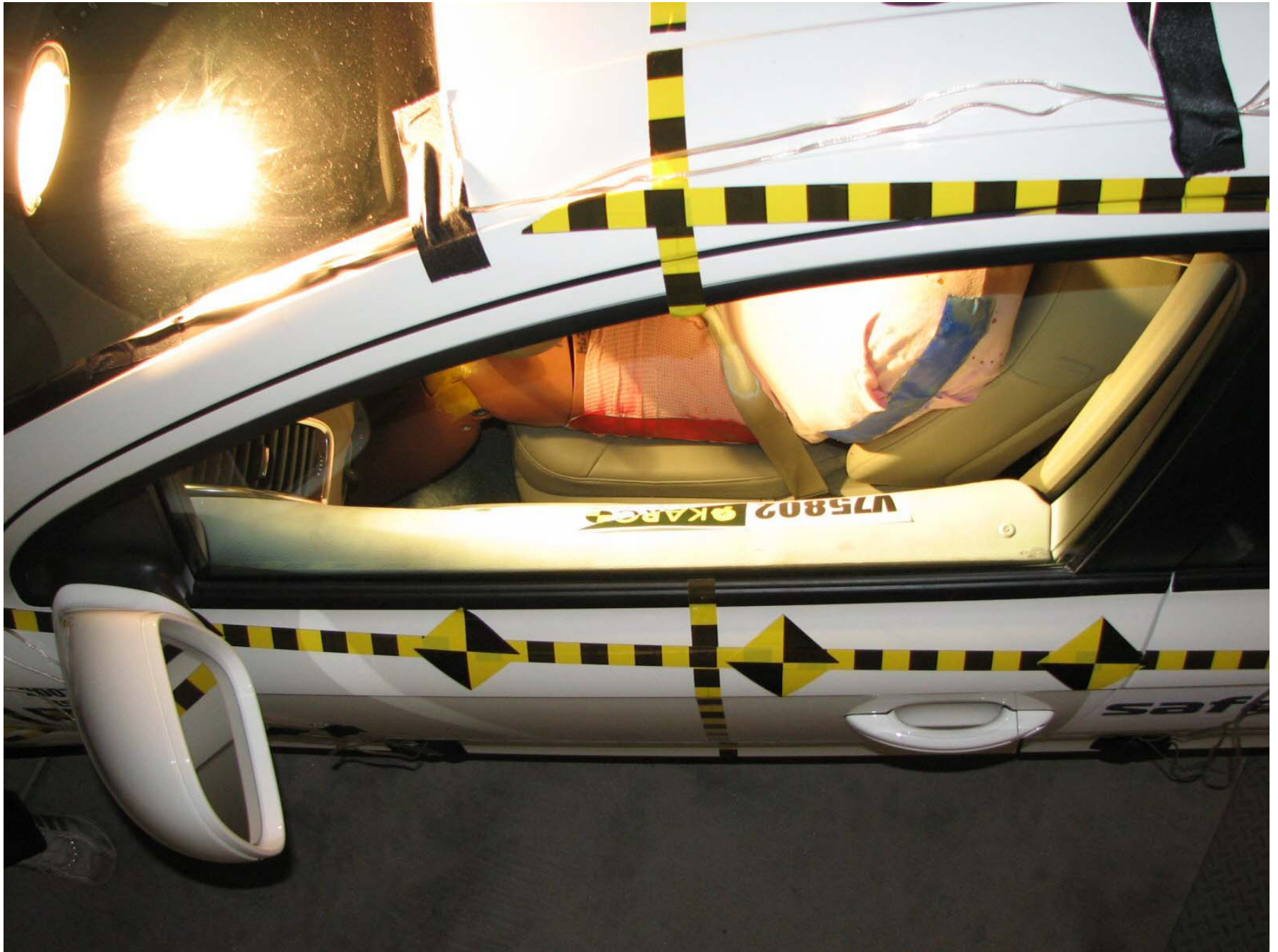

Figure A-38: Pre-Test Driver Dummy Clearance From Door



Figure A-39: Post-Test Driver Dummy Clearance From Door



Figure A-40: Pre-Test Driver Dummy Right Side View



Figure A-41: Post-Test Driver Dummy Right Side View



Figure A-42: Pre-Test Front Door Panel (Interior)



Figure A-43: Post-Test Front Door Panel (Interior)



Figure A-44: Pre-Test Passenger Dummy Left Side (Door Open)



Figure A-45: Pre-Test Passenger Dummy Left Side (Through Window)



Figure A-46: Post-Test Passenger Dummy Left Side (Through Window)



Figure A-47: Pre-Test Passenger Dummy Clearance From Door

JUL 20 11:11 AM  
**SIDE IMPACT**  
**09 / 28 / 06**



A-48

TR-P26168-01-NC

Figure A-48: Post-Test Passenger Dummy Clearance From Door



Figure A-49: Pre-Test Passenger Dummy Right Side View



Figure A-50: Post-Test Passenger Dummy Right Side View



Figure A-51: Pre-Test Rear Door Panel (Interior)



Figure A-52: Post-Test Rear Door Panel (Interior)



Figure A-53: Pre-Test Front View of Deformable Barrier



A-54

TR-P26168-01-NC

Figure A-54: Post-Test Front View of Deformable Barrier



A-55

TR-P26168-01-NC

Figure A-55: Pre-Test Top View of Deformable Barrier



Figure A-56: Post-Test Top View of Deformable Barrier



Figure A-57: Pre-Test Right Side View of Deformable Barrier



Figure A-58: Post-Test Right Side View of Deformable Barrier

A-59

TR-P26168-01-NC



Figure A-59: Pre-Test Left Side View of Deformable Barrier



Figure A-60: Post-Test Left Side View of Deformable Barrier



Figure A-61: Vehicle on Rollover Device (0°)



Figure A-62: Vehicle on Rollover Device (90°)



Figure A-63: Vehicle on Rollover Device (180°)

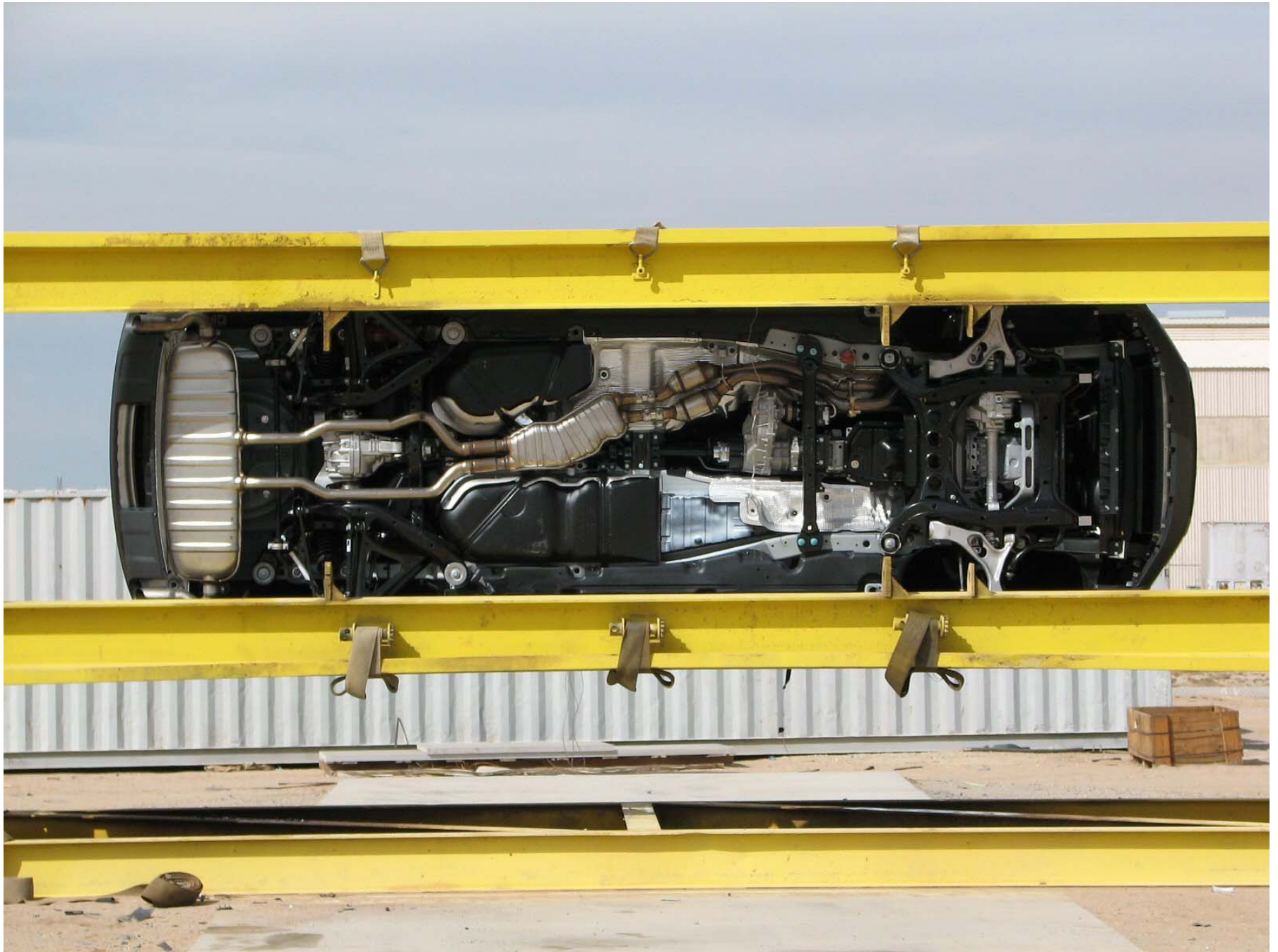

Figure A-64: Vehicle on Rollover Device (270°)

A-64

TR-P26168-01-NC



Figure A-65: Vehicle Impact



**APPENDIX B**  
**SID/HIII, VEHICLE AND MDB RESPONSE DATA**

## LIST OF DATA PLOTS

<u>Data Plot</u>	<u>Page</u>	
B-1	Driver Upper Rib Primary Y	B-1
	Driver Lower Rib Primary Y	B-1
	Driver Lower Spine Primary Y	B-1
	Driver Pelvis Primary Y	B-1
B-2	Passenger Upper Rib Primary Y	B-2
	Passenger Lower Rib Primary Y	B-2
	Passenger Lower Spine Primary Y	B-2
	Passenger Pelvis Primary Y	B-2

The following additional data plots for this test can be obtained from the research and development section of the NHTSA website. The website can be found at [www.NHTSA.dot.gov](http://www.NHTSA.dot.gov)

LIST OF DATA PLOTS...(CONTINUED)

Driver Head X Primary  
Driver Head Y Primary  
Driver Head Z Primary  
Driver Head Resultant Primary  
Driver Head Primary X Velocity  
Driver Head Primary Y Velocity  
Driver Head Primary Z Velocity  
Driver Head X Redundant  
Driver Head Y Redundant  
Driver Head Z Redundant  
Driver Head Resultant Redundant  
Driver Head Redundant X Velocity  
Driver Head Redundant Y Velocity  
Driver Head Redundant Z Velocity  
Driver Upper Neck Force X  
Driver Upper Neck Force Y  
Driver Upper Neck Force Z  
Driver Upper Neck Force Resultant  
Driver Upper Neck Moment X  
Driver Upper Neck Moment Y  
Driver Upper Neck Moment Z  
Driver Upper Neck Moment Resultant  
Driver Upper Rib Primary Y Velocity  
Driver Lower Rib Primary Y Velocity  
Driver Lower Spine Primary Y Velocity  
Driver Pelvis Primary Y Velocity  
Driver Upper Rib Redundant Y  
Driver Lower Rib Redundant Y  
Driver Lower Spine Redundant Y  
Driver Pelvis Redundant Y

LIST OF DATA PLOTS...(CONTINUED)

Driver Upper Rib Redundant Y Velocity  
Driver Lower Rib Redundant Y Velocity  
Driver Lower Spine Redundant Y Velocity  
Driver Pelvis Redundant Y Velocity  
Driver Thorax Contact  
Driver Pelvis Contact  
Passenger Head X Primary  
Passenger Head Y Primary  
Passenger Head Z Primary  
Passenger Head Resultant Primary  
Passenger Head Primary X Velocity  
Passenger Head Primary Y Velocity  
Passenger Head Primary Z Velocity  
Passenger Head X Redundant  
Passenger Head Y Redundant  
Passenger Head Z Redundant  
Passenger Head Resultant Redundant  
Passenger Head Redundant X Velocity  
Passenger Head Redundant Y Velocity  
Passenger Head Redundant Z Velocity  
Passenger Upper Neck Force X  
Passenger Upper Neck Force Y  
Passenger Upper Neck Force Z  
Passenger Upper Neck Force Resultant  
Passenger Upper Neck Moment X  
Passenger Upper Neck Moment Y  
Passenger Upper Neck Moment Z  
Passenger Upper Neck Moment Resultant

LIST OF DATA PLOTS...(CONTINUED)

Passenger Upper Rib Primary Y Velocity  
Passenger Lower Rib Primary Y Velocity  
Passenger Lower Spine Primary Y Velocity  
Passenger Pelvis Primary Y Velocity  
Passenger Upper Rib Redundant Y  
Passenger Lower Rib Redundant Y  
Passenger Lower Spine Redundant Y  
Passenger Pelvis Redundant Y  
Passenger Upper Rib Redundant Y Velocity  
Passenger Lower Rib Redundant Y Velocity  
Passenger Lower Spine Redundant Y Velocity  
Passenger Pelvis Redundant Y Velocity  
Passenger Thorax Contact  
Passenger Pelvis Contact  
Vehicle Right Sill at Front Seat X  
Vehicle Right Sill at Front Seat Y  
Vehicle Right Sill at Front Seat Z  
Vehicle Right Sill Front Seat Resultant  
Vehicle Right Sill at Front Seat X Velocity  
Vehicle Right Sill at Front Seat Y Velocity  
Vehicle Right Sill at Front Seat Z Velocity  
Vehicle Right Sill at Rear Seat X  
Vehicle Right Sill at Rear Seat Y  
Vehicle Right Sill at Rear Seat Z  
Vehicle Right Sill Rear Seat Resultant  
Vehicle Right Sill at Rear Seat X Velocity  
Vehicle Right Sill at Rear Seat Y Velocity  
Vehicle Right Sill at Rear Seat Z Velocity  
Vehicle Rear Floor Above Axle X  
Vehicle Rear Floor Above Axle Y  
Vehicle Rear Floor Above Axle Z  
Vehicle Rear Floor Above Axle Resultant  
Vehicle Rear Floor Above Axle X Velocity  
Vehicle Rear Floor Above Axle Y Velocity  
Vehicle Rear Floor Above Axle Z Velocity

LIST OF DATA PLOTS...(CONTINUED)

Vehicle Left Sill at Rear Door Y  
Vehicle Left Sill at Front Door Y  
Vehicle Left Sill at Rear Door Y Velocity  
Vehicle Left Sill at Front Door Y Velocity  
Vehicle Left Front Door C/L Y  
Vehicle Right Rear Occupant Compartment  
Vehicle Left Front Door Mid Rear Y  
Vehicle Left Front Door Upper CL Y  
Vehicle Left Front Door CL Y Velocity  
Vehicle Right Rear Occupant Compartment Y Velocity  
Vehicle Left Front Door Mid Rear Y Velocity  
Vehicle Left Rear Door Upper CL Y Velocity  
Vehicle Left Rear Door Mid Rear Y  
Vehicle Left Rear Door Upper C/L Y  
Vehicle Left Rear Door Mid Rear Y Velocity  
Vehicle Left Rear Door Upper CL Y Velocity  
Vehicle B-Post Lower Y  
Vehicle B-Post Middle Y  
Vehicle B-Post Lower Y Velocity  
Vehicle B-Post Middle Y Velocity  
Vehicle A-Post Lower Y  
Vehicle A-Post Middle Y  
Vehicle A-Post Lower Y Velocity  
Vehicle A-Post Middle Y Velocity  
Vehicle Left Front Seat Track  
Vehicle Rear Seat Structure  
Vehicle Left Front Seat Track Y Velocity  
Vehicle Rear Seat Structure Y Velocity  
Vehicle CG X  
Vehicle CG Y  
Vehicle CG Z  
Vehicle CG Resultant  
Vehicle CG X Velocity  
Vehicle CG Y Velocity  
Vehicle CG Z Velocity

LIST OF DATA PLOTS...(CONTINUED)

Driver Upper Rib Primary Y  
Driver Lower Rib Primary Y  
Driver Lower Spine Primary Y  
Driver Pelvis Primary Y  
Driver Upper Rib Redundant Y  
Driver Lower Rib Redundant Y  
Driver Lower Spine Redundant Y  
Driver Pelvis Redundant Y  
Passenger Upper Rib Primary Y  
Passenger Lower Rib Primary Y  
Passenger Lower Spine Primary Y  
Passenger Pelvis Primary Y  
Passenger Upper Rib Redundant Y  
Passenger Lower Rib Redundant Y  
Passenger Lower Spine Redundant Y  
Passenger Pelvis Redundant Y  
MDB CG X  
MDB CG Y  
MDB CG Z  
MDB CG Resultant  
MDB CG X Velocity  
MDB CG Y Velocity  
MDB CG Z Velocity  
MDB Rear X  
MDB Rear Y  
MDB Rear X Velocity  
MDB Rear Y Velocity  
MDB Right Bumper Contact

Test Vehicle: 2007 Audi Q7 5-Door MPV  
 Test Program: 55/28 km/h Side Impact NCAP

Test Date: 9/28/06  
 NHTSA No.: V75802

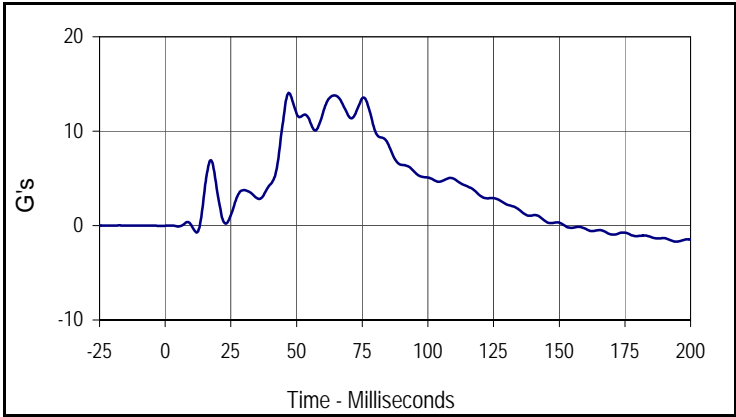

Curve Description			
Driver Upper Rib Primary Y			
CURNO	Type	SAE Class	Units
001	FIR	FIR100	G's
Max	Time	Min	Time
14.0	46.9	-1.7	194.4

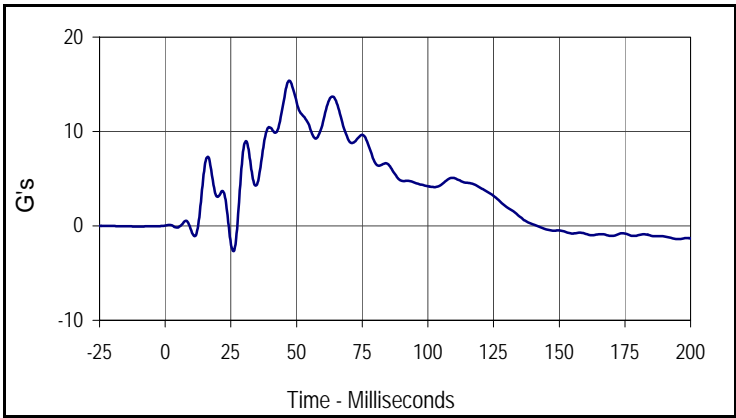

Curve Description			
Driver Lower Rib Primary Y			
CURNO	Type	SAE Class	Units
002	FIR	FIR100	G's
Max	Time	Min	Time
15.4	47.5	-2.6	25.6

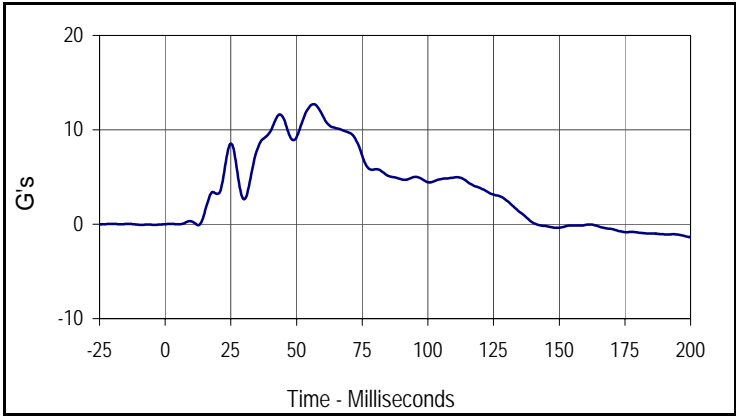

Curve Description			
Driver Lower Spine Primary Y			
CURNO	Type	SAE Class	Units
003	FIR	FIR100	G's
Max	Time	Min	Time
12.7	56.3	-1.4	200.0

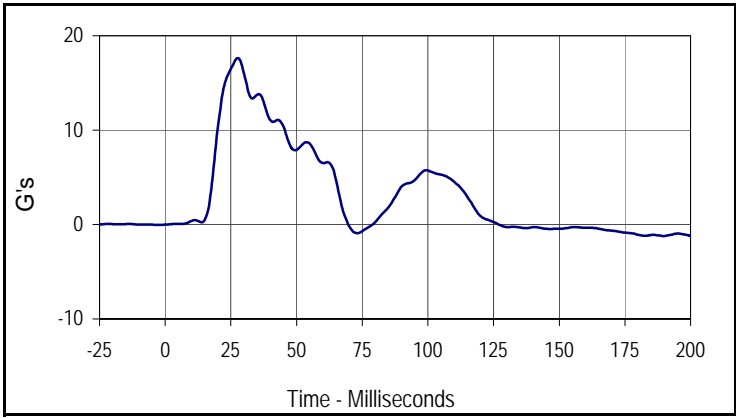

Curve Description			
Driver Pelvis Primary Y			
CURNO	Type	SAE Class	Units
004	FIR	FIR100	G's
Max	Time	Min	Time
17.6	27.5	-1.2	190.0

Test Vehicle: 2007 Audi Q7 5-Door MPV  
 Test Program: 55/28 km/h Side Impact NCAP

Test Date: 9/28/06  
 NHTSA No.: V75802

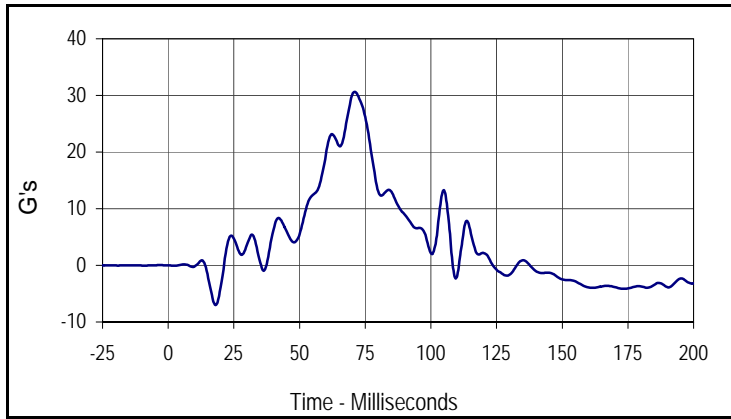

Curve Description			
Passenger Upper Rib Primary Y			
CURNO	Type	SAE Class	Units
005	FIR	FIR100	G's
Max	Time	Min	Time
30.6	71.3	-7.0	18.1

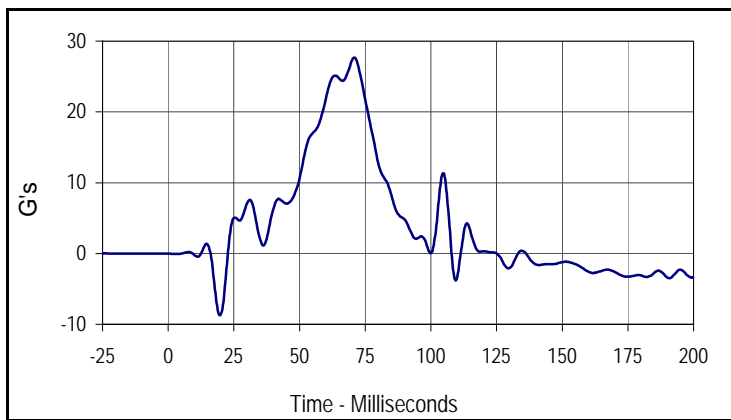

Curve Description			
Passenger Lower Rib Primary Y			
CURNO	Type	SAE Class	Units
006	FIR	FIR100	G's
Max	Time	Min	Time
27.7	70.6	-8.7	20.0

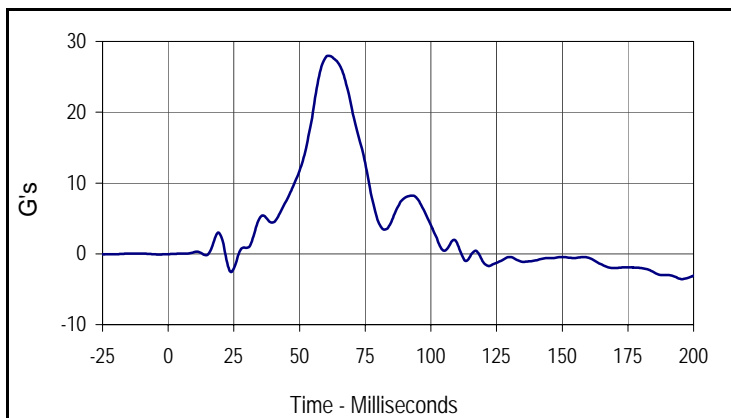

Curve Description			
Passenger Lower Spine Primary Y			
CURNO	Type	SAE Class	Units
007	FIR	FIR100	G's
Max	Time	Min	Time
28.0	61.3	-3.6	195.6

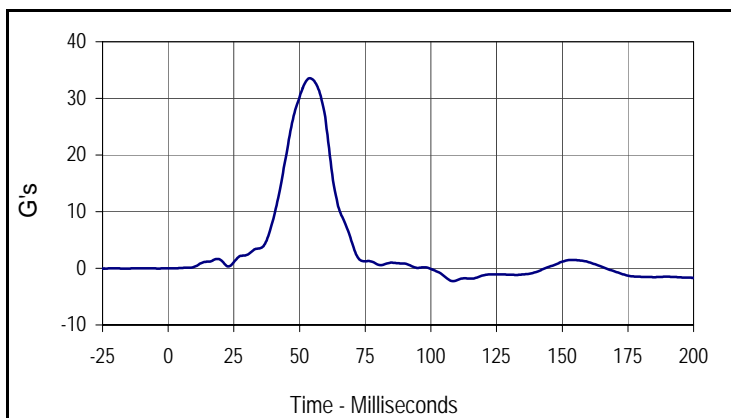

Curve Description			
Passenger Pelvis Primary Y			
CURNO	Type	SAE Class	Units
008	FIR	FIR100	G's
Max	Time	Min	Time
33.5	53.8	-2.3	108.8

**APPENDIX C**  
**SID/HIII CONFIGURATION AND PERFORMANCE VERIFICATION DATA**

**APPENDIX C**  
**PRE-TEST SID / HIII CONFIGURATION AND PERFORMANCE VERIFICATION DATA**

Test Program: SID / HIII External Measurements

Test Date: 9/27/06

ATD Serial No.: 274

Test I.D.: N/A



Tested Parameter	Units	Specification	Result	Pass/Fail
Laboratory Temperature	°C	18.9 to 25.6	21.1	Pass
Laboratory Relative Humidity	%	10 to 70	34	Pass
SH- Seated Height	mm	889 to 909	903	Pass
HP- Hip Point Height	mm	99 (reference)	99	Pass
RH- Rib Height	mm	502 to 520	504	Pass
KH- Knee Pivot From Back Line	mm	511 to 526	512	Pass
KV- Knee Pivot From Floor	mm	490 to 505	492	Pass
HW- Hip Width	mm	356 to 391	364	Pass
Overall Test Results				Pass

Test Program: SID / HIII Thorax Lateral Impact  
 ATD Serial No.: 274

Test Date: 9/27/06  
 Test I.D.: TH09AC



Tested Parameter	Units	Specification	Result	Pass/Fail
Laboratory Temperature	°C	18.9 to 25.6	21.1	Pass
Laboratory Relative Humidity	%	10 to 70	30	Pass
Probe Velocity	m/s	4.21 to 4.33	4.27	Pass
Upper Rib Acceleration	G's	37.0 to 46.0	39.4	Pass
Lower Rib Acceleration	G's	37.0 to 46.0	38.3	Pass
Thoracic Spine Acceleration	G's	15.0 to 22.0	16.9	Pass
Overall Test Results			Pass	

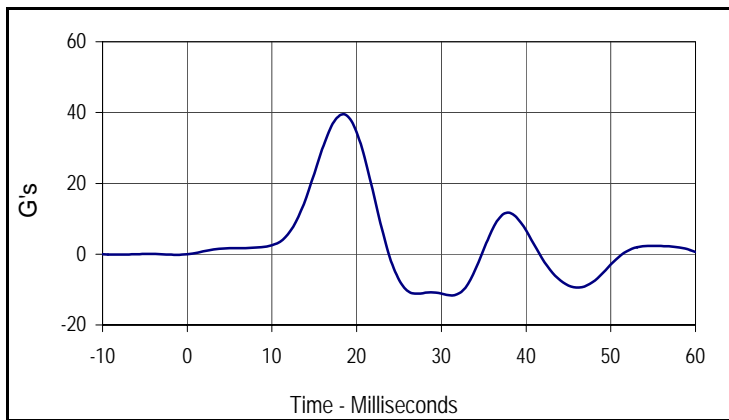

Curve Description			
Upper Rib Primary Y			
CURNO	Type	SAE Class	Units
001	FIL	FIR100	G's
Max	Time	Min	Time
39.4	18.1	-11.7	31.3

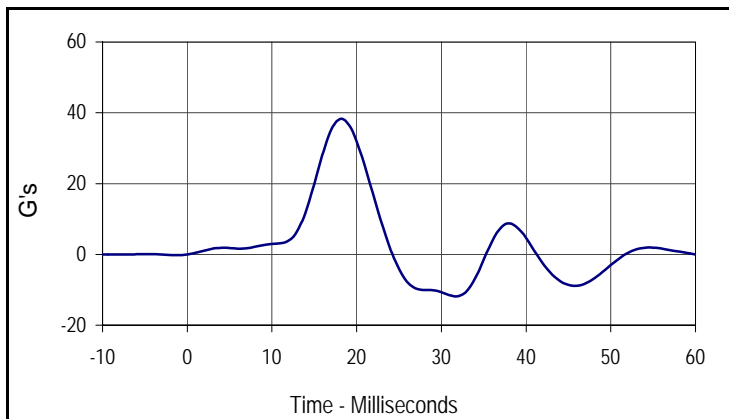

Curve Description			
Lower Rib Primary Y			
CURNO	Type	SAE Class	Units
002	FIL	FIR100	G's
Max	Time	Min	Time
38.3	18.1	-11.8	31.9

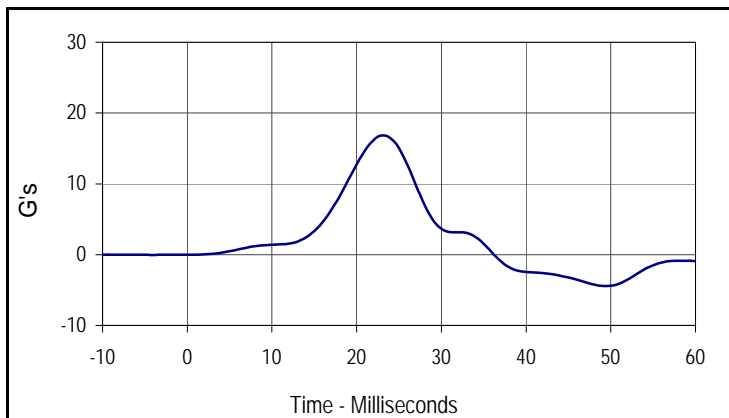

Curve Description			
Lower Spine Primary Y			
CURNO	Type	SAE Class	Units
003	FIL	FIR100	G's
Max	Time	Min	Time
16.9	23.1	-4.5	49.4

Test Program: SID / HIII Pelvis Lateral Impact  
 ATD Serial No.: 274

Test Date: 9/27/06  
 Test I.D.: PL09BC



Tested Parameter	Units	Specification	Result	Pass/Fail
Laboratory Temperature	°C	18.9 to 25.6	21.1	Pass
Laboratory Relative Humidity	%	10 to 70	30	Pass
Probe Velocity	m/s	4.21 to 4.33	4.29	Pass
Peak Pelvis Acceleration	G's	40.0 to 60.0	52.5	Pass
Acceleration Time Above 20 G's	Msec.	3.0 to 7.0	5.63	Pass
Overall Test Results				Pass

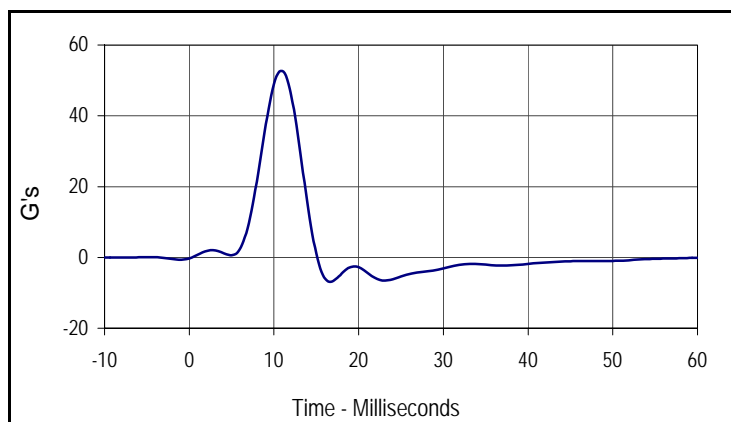

Curve Description			
Pelvis Primary Y			
CURNO	Type	SAE Class	Units
001	FIL	FIR100	G's
Max	Time	Min	Time
52.5	10.6	-6.8	16.9

Test Program: SID / HIII Head Drop Lateral Impact Test  
 ATD Serial No.: 274

Test Date: 9/27/06  
 Test I.D.: HD09L



Tested Parameter	Units	Specification	Result	Pass/Fail
Laboratory Temperature	°C	18.9 to 25.6	21.9	Pass
Laboratory Relative Humidity	%	10 to 70	30	Pass
Peak Resultant Acceleration	G's	120.0 to 150.0	128.6	Pass
Peak Longitudinal Acceleration	G's	≤15.0	8.3	Pass
Is Acceleration Unimodal?	Yes/No	Yes	Yes	Pass
Oscillations After Main Pulse	%	<15	4.9	Pass
Overall Test Results				Pass

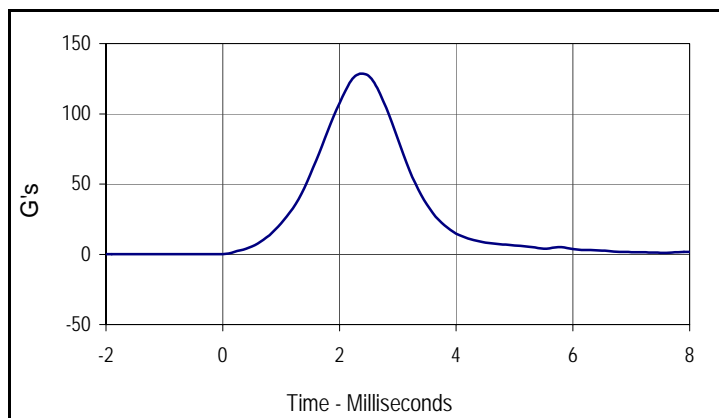

Curve Description			
Head Resultant			
CURNO	Type	SAE Class	Units
001	RES	1000	G's
Max	Time	Min	Time
128.6	2.4	0.1	-1.3

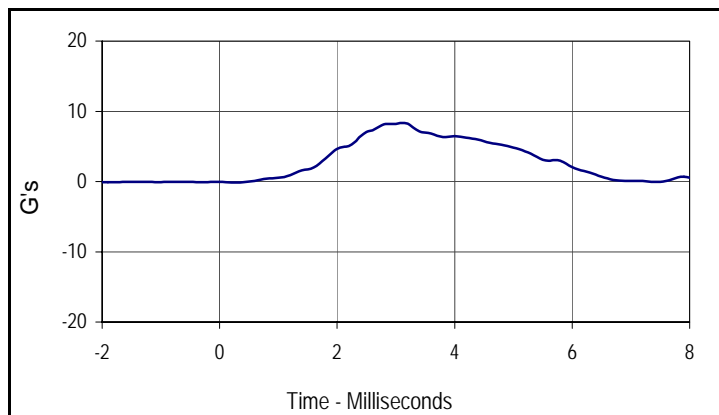

Curve Description			
Head X			
CURNO	Type	SAE Class	Units
002	FIL	1000	G's
Max	Time	Min	Time
8.3	3.1	-0.1	0.3

Test Program: SID / HIII Neck Pendulum Lateral Test  
 ATD Serial No.: 274

Test Date: 9/27/06  
 Test I.D.: NB09AE



Tested Parameter	Units	Specification	Result	Pass/Fail	
Laboratory Temperature	°C	20.6 to 22.2	21.9	Pass	
Laboratory Relative Humidity	%	10 to 70	30	Pass	
Pendulum Velocity	m/sec	6.89 to 7.13	6.97	Pass	
Pendulum Deceleration	10 Msec.	m/sec	1.96 to 2.55	1.99	Pass
	20 Msec.	m/sec	4.12 to 5.10	4.17	Pass
	30 Msec.	m/sec	5.73 to 7.01	5.96	Pass
	40 to 70	m/sec	6.27 to 7.64	7.39	Pass
"D" Plane Rotation	Max	Degrees	66.0 to 82.0	74.2	Pass
Max Rotation Time After Peak Moment	Msec.	2.0 to 16.0	9.7	Pass	
Rotation Time From Peak to Zero Angle	Msec.	58.0 to 67.0	58.4	Pass	
Moment About Occipital Condyle	Nm	73.0 to 88.0	85.6	Pass	
Positive Moment Decay, Time To 0 Nm	Msec.	49.0 to 64.0	52.6	Pass	
Overall Test Results				Pass	

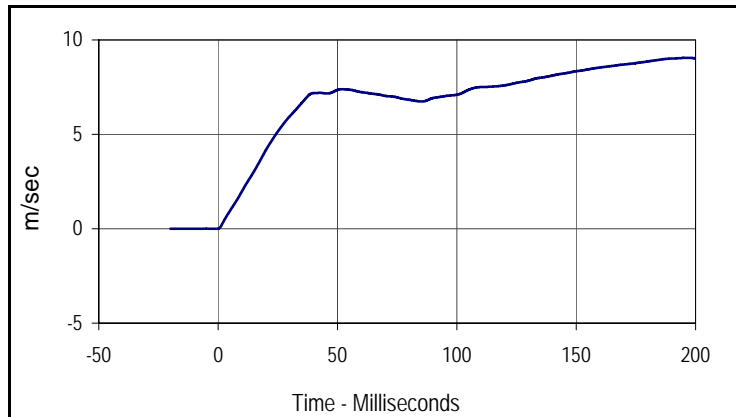

Curve Description			
Pendulum Velocity			
CURNO	Type	SAE Class	Units
001	FIL	180	m/sec
Max	Time	Min	Time
9.1	196.2	0.0	-0.4

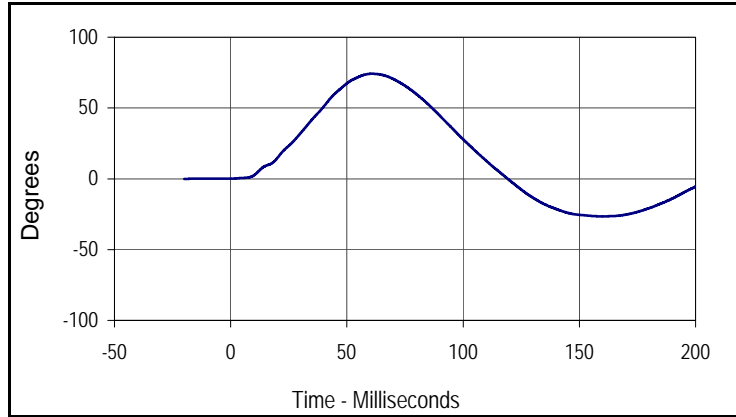

Curve Description			
"D" Plane Rotation			
CURNO	Type	SAE Class	Units
003	FIL	60	Degrees
Max	Time	Min	Time
74.2	60.8	-26.5	159.3

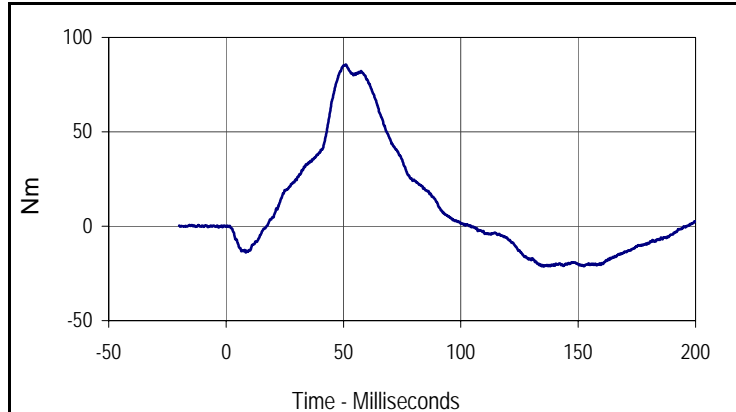

Curve Description			
Moment About Occipital Condyle			
CURNO	Type	SAE Class	Units
004	FIL	600	Nm
Max	Time	Min	Time
85.6	51.1	-21.3	135.4

Test Program: SID / HIII External Measurements

Test Date: 9/27/06

ATD Serial No.: 275

Test I.D.: N/A



Tested Parameter	Units	Specification	Result	Pass/Fail
Laboratory Temperature	°C	18.9 to 25.6	21.1	Pass
Laboratory Relative Humidity	%	10 to 70	32	Pass
SH- Seated Height	mm	889 to 909	905	Pass
HP- Hip Point Height	mm	99 (reference)	99	Pass
RH- Rib Height	mm	502 to 520	505	Pass
KH- Knee Pivot From Back Line	mm	511 to 526	519	Pass
KV- Knee Pivot From Floor	mm	490 to 505	495	Pass
HW- Hip Width	mm	356 to 391	364	Pass
Overall Test Results				Pass

Test Program: SID / HIII Thorax Lateral Impact  
 ATD Serial No.: 275

Test Date: 9/27/06  
 Test I.D.: TH09D



Tested Parameter	Units	Specification	Result	Pass/Fail
Laboratory Temperature	°C	18.9 to 25.6	21.1	Pass
Laboratory Relative Humidity	%	10 to 70	30	Pass
Probe Velocity	m/s	4.21 to 4.33	4.27	Pass
Upper Rib Acceleration	G's	37.0 to 46.0	38.7	Pass
Lower Rib Acceleration	G's	37.0 to 46.0	37.4	Pass
Thoracic Spine Acceleration	G's	15.0 to 22.0	21.2	Pass
Overall Test Results			Pass	

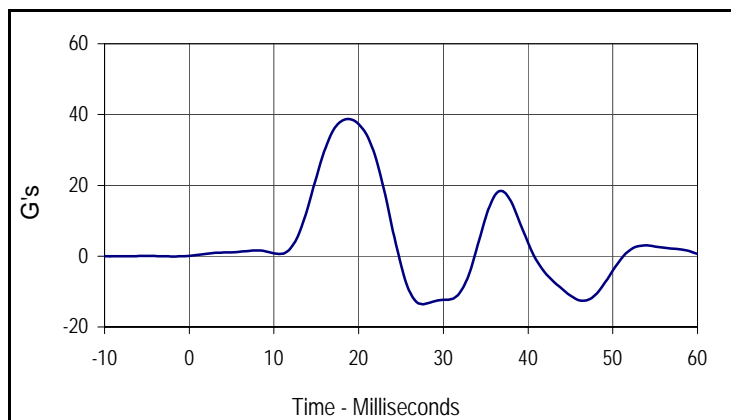

Curve Description			
Upper Rib Primary			
CURNO	Type	SAE Class	Units
001	FIL	FIR100	G's
Max	Time	Min	Time
38.7	18.8	-13.6	27.5

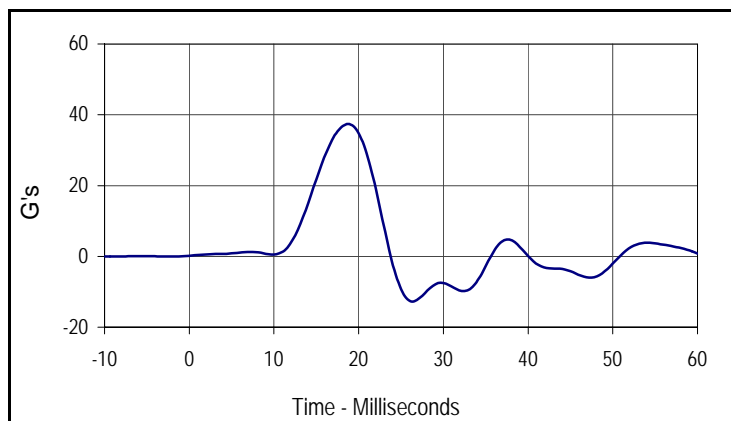

Curve Description			
Lower Rib Primary			
CURNO	Type	SAE Class	Units
002	FIL	FIR100	G's
Max	Time	Min	Time
37.4	18.8	-12.7	26.3

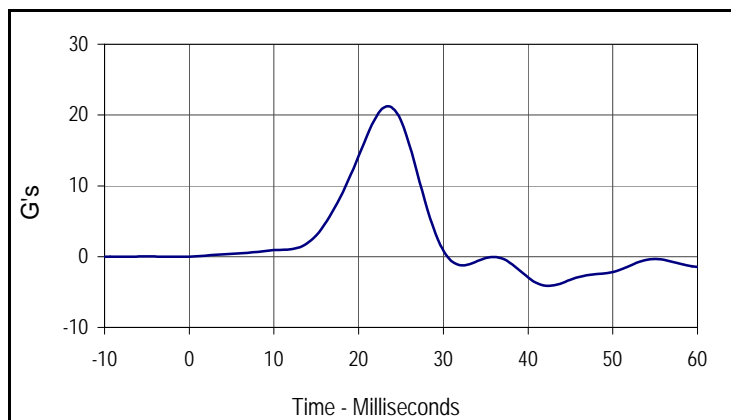

Curve Description			
Lower Spine Primary			
CURNO	Type	SAE Class	Units
003	FIL	FIR100	G's
Max	Time	Min	Time
21.2	23.8	-4.1	42.5

Test Program: SID / HIII Pelvis Lateral Impact  
 ATD Serial No.: 275

Test Date: 9/27/06  
 Test I.D.: PL09AD



Tested Parameter	Units	Specification	Result	Pass/Fail
Laboratory Temperature	°C	18.9 to 25.6	21.9	Pass
Laboratory Relative Humidity	%	10 to 70	30	Pass
Probe Velocity	m/s	4.21 to 4.33	4.27	Pass
Peak Pelvis Acceleration	G's	40.0 to 60.0	44.9	Pass
Acceleration Time Above 20 G's	Msec.	3.0 to 7.0	6.25	Pass
Overall Test Results				Pass

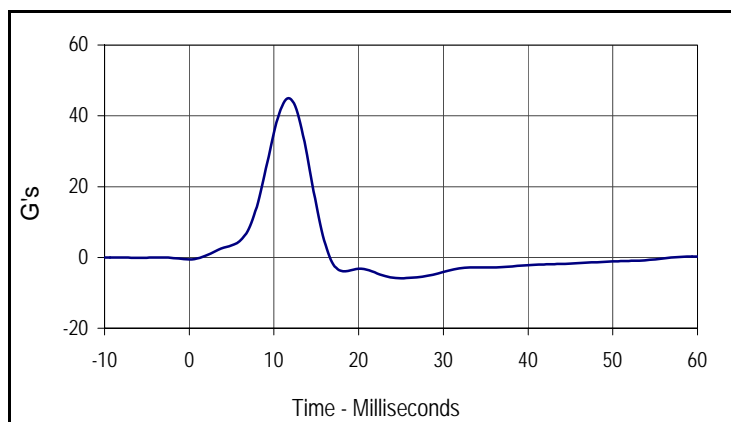

Curve Description			
Pelvis Primary Y			
CURNO	Type	SAE Class	Units
001	FIL	FIR100	G's
Max	Time	Min	Time
44.9	11.9	-5.9	25.0

Test Program: SID / HIII Head Drop Lateral Impact Test  
 ATD Serial No.: 275

Test Date: 9/27/06  
 Test I.D.: HD09AB



Tested Parameter	Units	Specification	Result	Pass/Fail
Laboratory Temperature	°C	18.9 to 25.6	21.1	Pass
Laboratory Relative Humidity	%	10 to 70	30	Pass
Peak Resultant Acceleration	G's	120.0 to 150.0	144.5	Pass
Peak Longitudinal Acceleration	G's	≤15.0	5.3	Pass
Is Acceleration Unimodal?	Yes/No	Yes	Yes	Pass
Oscillations After Main Pulse	%	<15	4.8	Pass
Overall Test Results			Pass	Pass

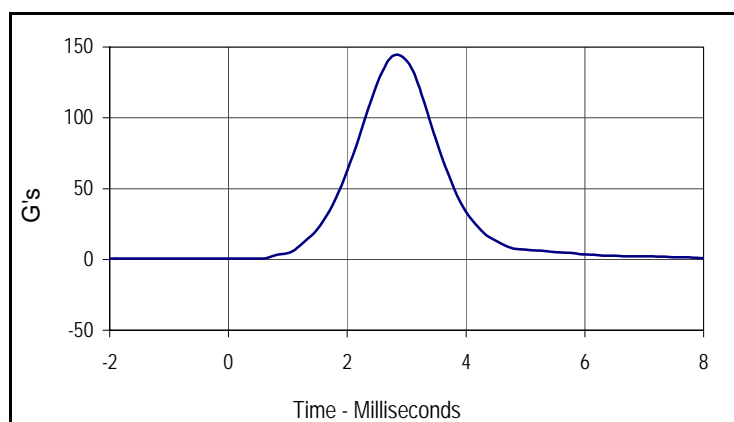

Curve Description			
Head Resultant			
CURNO	Type	SAE Class	Units
001	RES	1000	G's
Max	Time	Min	Time
144.5	2.8	0.5	0.5

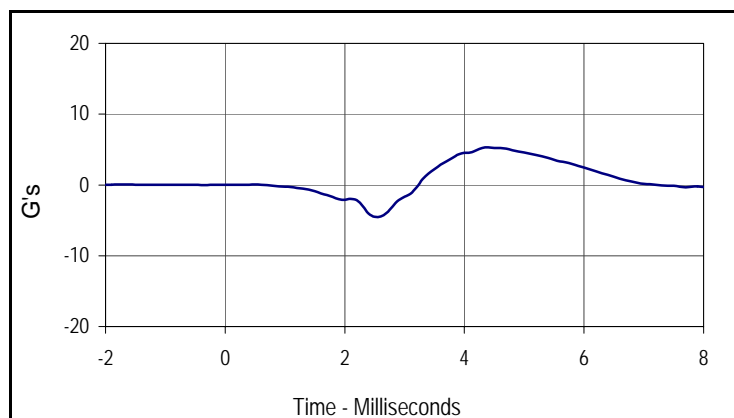

Curve Description			
Head X			
CURNO	Type	SAE Class	Units
002	FIL	1000	G's
Max	Time	Min	Time
5.3	4.4	-4.5	2.5

Test Program: SID / HIII Neck Pendulum Lateral Test  
 ATD Serial No.: 275

Test Date: 9/27/06  
 Test I.D.: NB9AE



Tested Parameter	Units	Specification	Result	Pass/Fail	
Laboratory Temperature	°C	20.6 to 22.2	21.9	Pass	
Laboratory Relative Humidity	%	10 to 70	30	Pass	
Pendulum Velocity	m/sec	6.89 to 7.13	6.97	Pass	
Pendulum Deceleration	10 Msec.	m/sec	1.96 to 2.55	2.20	Pass
	20 Msec.	m/sec	4.12 to 5.10	4.48	Pass
	30 Msec.	m/sec	5.73 to 7.01	6.49	Pass
	40 to 70	m/sec	6.27 to 7.64	7.54	Pass
"D" Plane Rotation	Max	Degrees	66.0 to 82.0	77.5	Pass
Max Rotation Time After Peak Moment	Msec.	2.0 to 16.0	9.4	Pass	
Rotation Time From Peak to Zero Angle	Msec.	58.0 to 67.0	59.4	Pass	
Moment About Occipital Condyle	Nm	73.0 to 88.0	75.8	Pass	
Positive Moment Decay, Time To 0 Nm	Msec.	49.0 to 64.0	50.4	Pass	
Overall Test Results				Pass	

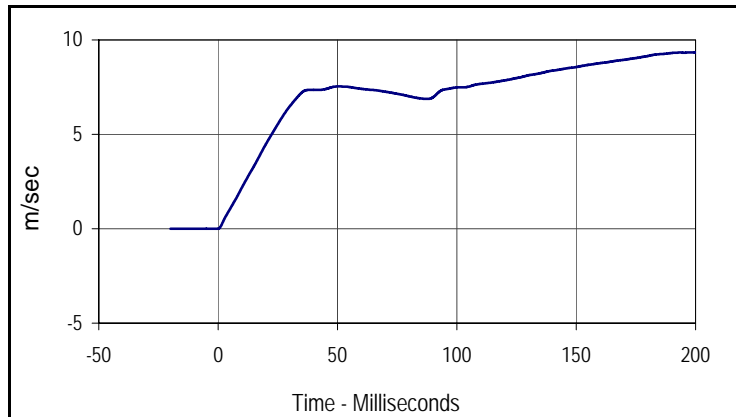

Curve Description			
Pendulum Velocity			
CURNO	Type	SAE Class	Units
001	FIL	180	m/sec
Max	Time	Min	Time
9.3	198.8	0.0	-0.5

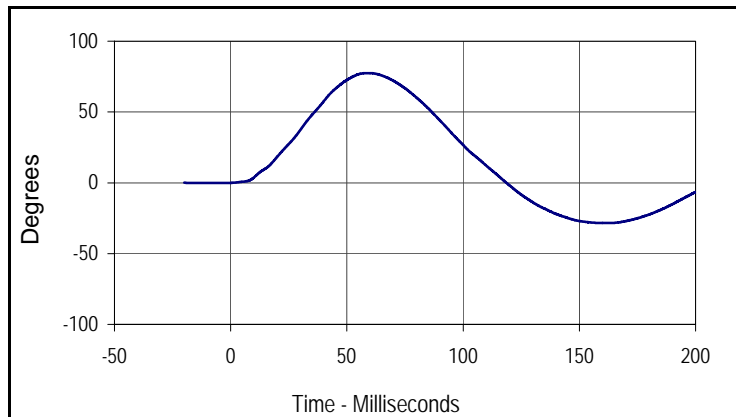

Curve Description			
"D" Plane Rotation			
CURNO	Type	SAE Class	Units
003	FIL	60	Degrees
Max	Time	Min	Time
77.5	59.2	-28.4	161.2

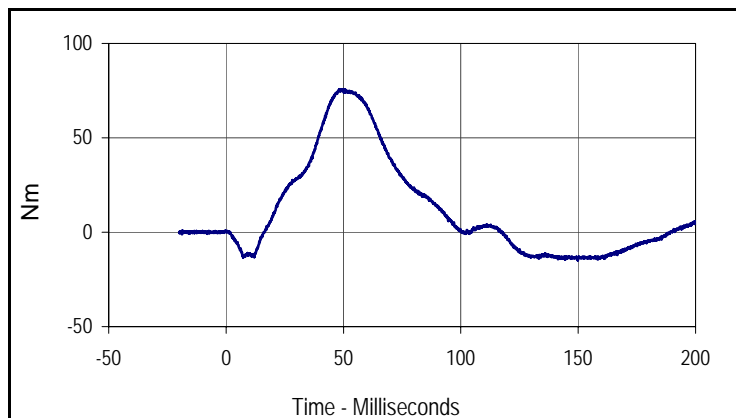

Curve Description			
Moment About Occipital Condyle			
CURNO	Type	SAE Class	Units
004	FIL	60	Nm
Max	Time	Min	Time
75.8	49.8	-14.9	149.8

**APPENDIX C**  
**POST-TEST SID / HIII CONFIGURATION AND PERFORMANCE VERIFICATION DATA**

Test Program: SID / HIII External Measurements

Test Date: 9/28/06

ATD Serial No.: 274

Test I.D.: N/A



Tested Parameter	Units	Specification	Result	Pass/Fail
Laboratory Temperature	°C	18.9 to 25.6	21.1	Pass
Laboratory Relative Humidity	%	10 to 70	31	Pass
SH- Seated Height	mm	889 to 909	903	Pass
HP- Hip Point Height	mm	99 (reference)	99	Pass
RH- Rib Height	mm	502 to 520	504	Pass
KH- Knee Pivot From Back Line	mm	511 to 526	515	Pass
KV- Knee Pivot From Floor	mm	490 to 505	496	Pass
HW- Hip Width	mm	356 to 391	360	Pass
Overall Test Results				Pass

Test Program: SID / HIII Thorax Lateral Impact  
 ATD Serial No.: 274

Test Date: 9/28/06  
 Test I.D.: TH09E



Tested Parameter	Units	Specification	Result	Pass/Fail
Laboratory Temperature	°C	18.9 to 25.6	21.1	Pass
Laboratory Relative Humidity	%	10 to 70	30	Pass
Probe Velocity	m/s	4.21 to 4.33	4.31	Pass
Upper Rib Acceleration	G's	37.0 to 46.0	37.7	Pass
Lower Rib Acceleration	G's	37.0 to 46.0	37.3	Pass
Thoracic Spine Acceleration	G's	15.0 to 22.0	20.8	Pass
Overall Test Results			Pass	

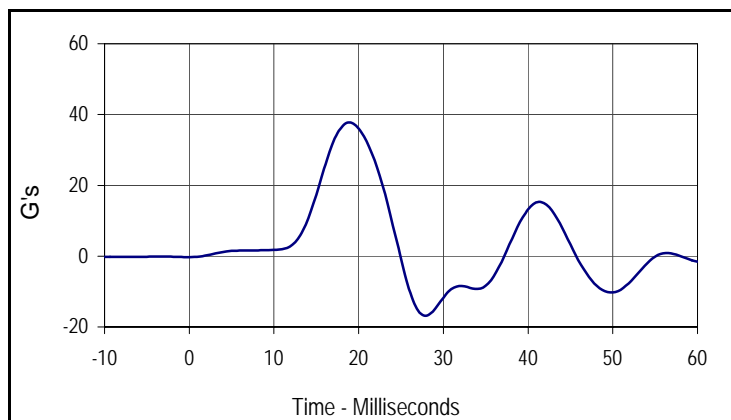

Curve Description			
Upper Rib Primary			
CURNO	Type	SAE Class	Units
001	FIL	FIR100	G's
Max	Time	Min	Time
37.7	18.8	-16.7	28.1

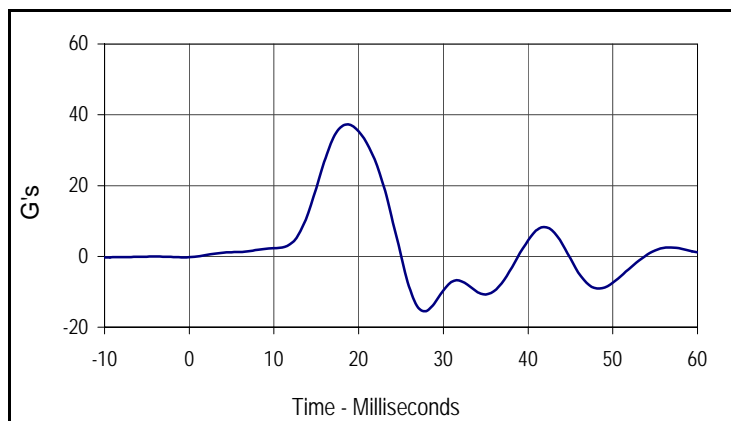

Curve Description			
Lower Rib Primary			
CURNO	Type	SAE Class	Units
002	FIL	FIR100	G's
Max	Time	Min	Time
37.3	18.8	-15.4	27.5

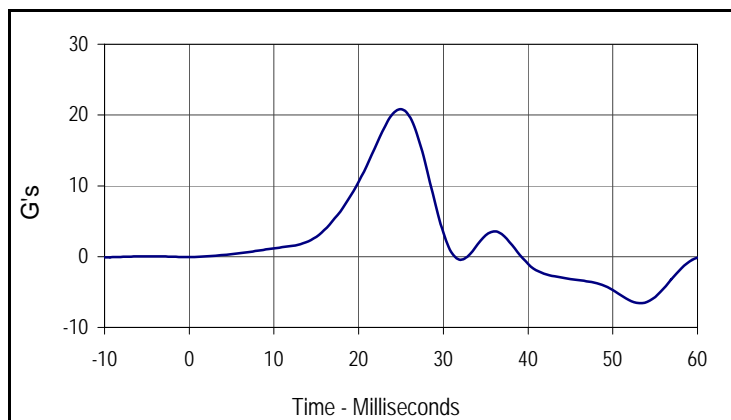

Curve Description			
Lower Spine Primary			
CURNO	Type	SAE Class	Units
003	FIL	FIR100	G's
Max	Time	Min	Time
20.8	25.0	-6.6	53.1

Test Program: SID / HIII Pelvis Lateral Impact  
 ATD Serial No.: 274

Test Date: 9/28/06  
 Test I.D.: PL09J



Tested Parameter	Units	Specification	Result	Pass/Fail
Laboratory Temperature	°C	18.9 to 25.6	21.1	Pass
Laboratory Relative Humidity	%	10 to 70	30	Pass
Probe Velocity	m/s	4.21 to 4.33	4.29	Pass
Peak Pelvis Acceleration	G's	40.0 to 60.0	43.1	Pass
Acceleration Time Above 20 G's	Msec.	3.0 to 7.0	5.00	Pass
Overall Test Results				Pass

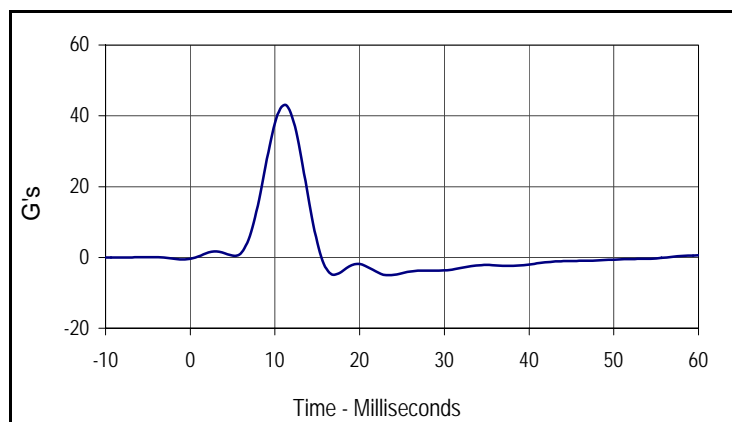

Curve Description			
Pelvis Primary Y			
CURNO	Type	SAE Class	Units
001	FIL	FIR100	G's
Max	Time	Min	Time
43.1	11.3	-5.0	23.8

Test Program: SID / HIII Head Drop Lateral Impact Test

Test Date: 9/28/06



ATD Serial No.: 274

Test I.D.: HD09D

Tested Parameter	Units	Specification	Result	Pass/Fail
Laboratory Temperature	°C	18.9 to 25.6	21.1	Pass
Laboratory Relative Humidity	%	10 to 70	30	Pass
Peak Resultant Acceleration	G's	120.0 to 150.0	128.7	Pass
Peak Longitudinal Acceleration	G's	≤15.0	6.9	Pass
Is Acceleration Unimodal?	Yes/No	Yes	Yes	Pass
Oscillations After Main Pulse	%	<15	4.6	Pass
Overall Test Results				Pass

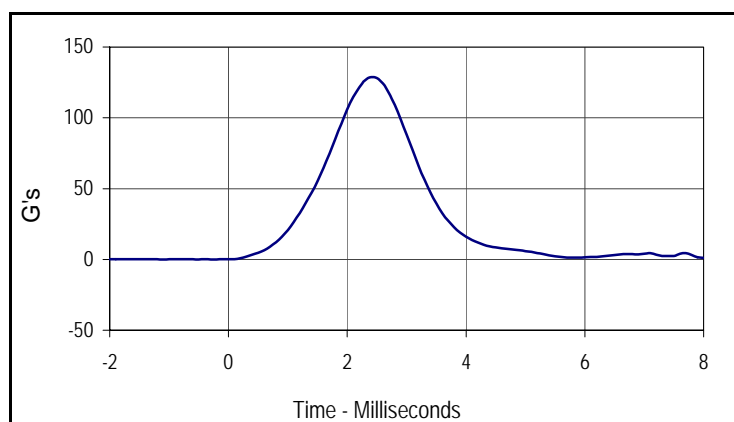

Curve Description			
Head Resultant			
CURNO	Type	SAE Class	Units
001	RES	1000	G's
Max	Time	Min	Time
128.7	2.4	0.0	-0.2

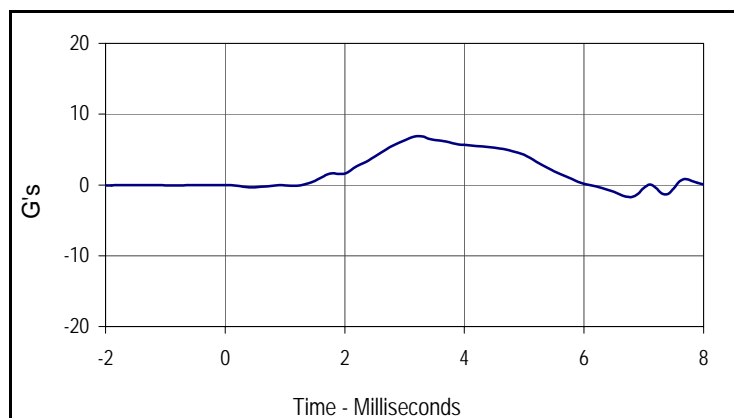

Curve Description			
Head X			
CURNO	Type	SAE Class	Units
002	FIL	1000	G's
Max	Time	Min	Time
6.9	3.2	-0.3	0.4

Test Program: SID / HIII Neck Pendulum Lateral Test  
 ATD Serial No.: 274

Test Date: 9/28/06  
 Test I.D.: NB09G



Tested Parameter	Units	Specification	Result	Pass/Fail	
Laboratory Temperature	°C	20.6 to 22.2	21.1	Pass	
Laboratory Relative Humidity	%	10 to 70	30	Pass	
Pendulum Velocity	m/sec	6.89 to 7.13	6.98	Pass	
Pendulum Deceleration	10 Msec.	m/sec	1.96 to 2.55	1.98	Pass
	20 Msec.	m/sec	4.12 to 5.10	4.15	Pass
	30 Msec.	m/sec	5.73 to 7.01	5.84	Pass
	40 to 70	m/sec	6.27 to 7.64	7.40	Pass
"D" Plane Rotation	Max	Degrees	66.0 to 82.0	78.6	Pass
Max Rotation Time After Peak Moment	Msec.	2.0 to 16.0	6.9	Pass	
Rotation Time From Peak to Zero Angle	Msec.	58.0 to 67.0	58.9	Pass	
Moment About Occipital Condyle	Nm	73.0 to 88.0	87.1	Pass	
Positive Moment Decay, Time To 0 Nm	Msec.	49.0 to 64.0	55.5	Pass	
Overall Test Results				Pass	

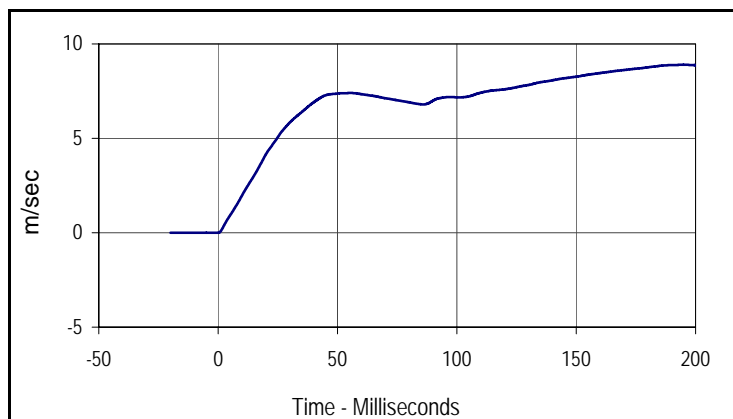

Curve Description			
Pendulum Velocity			
CURNO	Type	SAE Class	Units
001	FIL	180	m/sec
Max	Time	Min	Time
8.9	195.0	0.0	-0.2

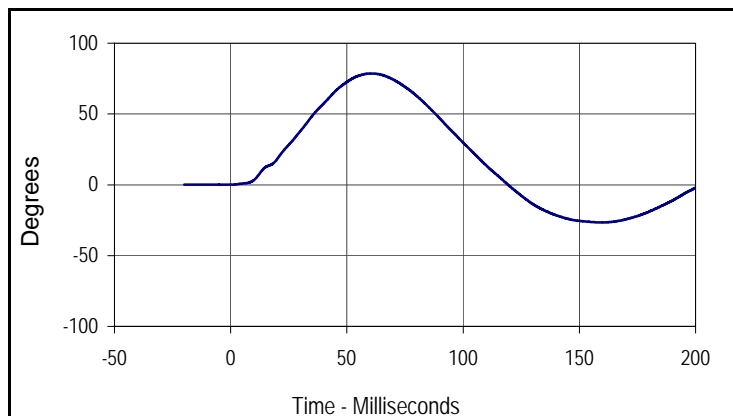

Curve Description			
"D" Plane Rotation			
CURNO	Type	SAE Class	Units
003	FIL	60	Degrees
Max	Time	Min	Time
78.6	60.5	-26.5	159.9

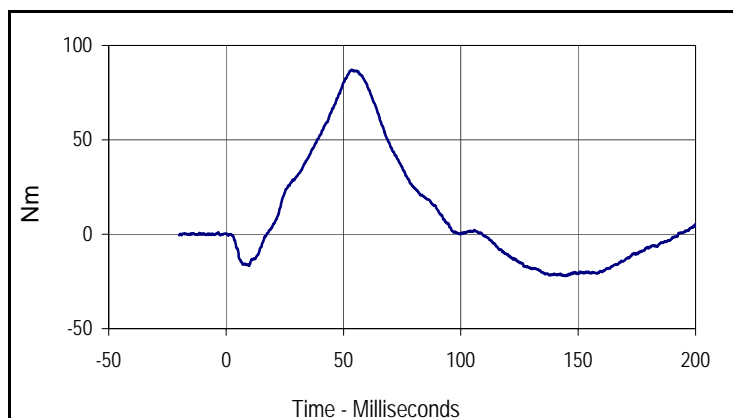

Curve Description			
Moment About Occipital Condyle			
CURNO	Type	SAE Class	Units
004	FIL	600	Nm
Max	Time	Min	Time
87.1	53.6	-22.1	144.6

Test Program: SID / HIII External Measurements

Test Date: 9/28/06

ATD Serial No.: 275

Test I.D.: N/A



Tested Parameter	Units	Specification	Result	Pass/Fail
Laboratory Temperature	°C	18.9 to 25.6	21.1	Pass
Laboratory Relative Humidity	%	10 to 70	33	Pass
SH- Seated Height	mm	889 to 909	900	Pass
HP- Hip Point Height	mm	99 (reference)	99	Pass
RH- Rib Height	mm	502 to 520	503	Pass
KH- Knee Pivot From Back Line	mm	511 to 526	512	Pass
KV- Knee Pivot From Floor	mm	490 to 505	494	Pass
HW- Hip Width	mm	356 to 391	360	Pass
Overall Test Results				Pass

Test Program: SID / HIII Thorax Lateral Impact  
 ATD Serial No.: 275

Test Date: 9/28/06  
 Test I.D.: TH09D



Tested Parameter	Units	Specification	Result	Pass/Fail
Laboratory Temperature	°C	18.9 to 25.6	21.1	Pass
Laboratory Relative Humidity	%	10 to 70	30	Pass
Probe Velocity	m/s	4.21 to 4.33	4.27	Pass
Upper Rib Acceleration	G's	37.0 to 46.0	38.7	Pass
Lower Rib Acceleration	G's	37.0 to 46.0	37.4	Pass
Thoracic Spine Acceleration	G's	15.0 to 22.0	21.2	Pass
Overall Test Results			Pass	

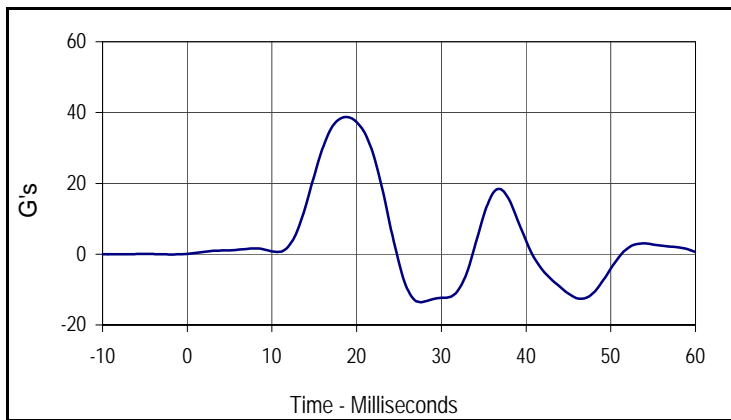

Curve Description			
Upper Rib Primary			
CURNO	Type	SAE Class	Units
001	FIL	FIR100	G's
Max	Time	Min	Time
38.7	18.8	-13.6	27.5

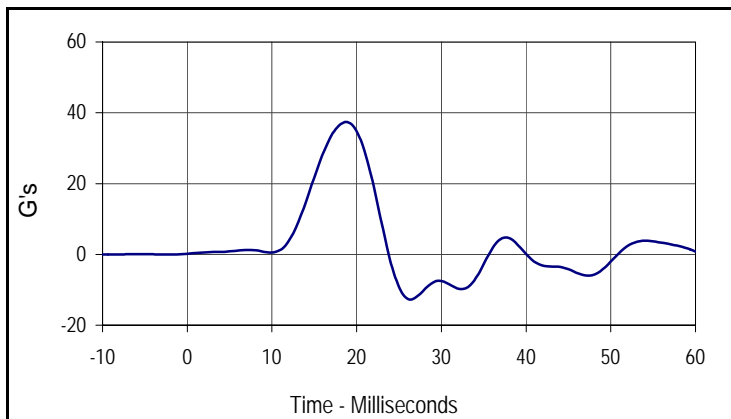

Curve Description			
Lower Rib Primary			
CURNO	Type	SAE Class	Units
002	FIL	FIR100	G's
Max	Time	Min	Time
37.4	18.8	-12.7	26.3

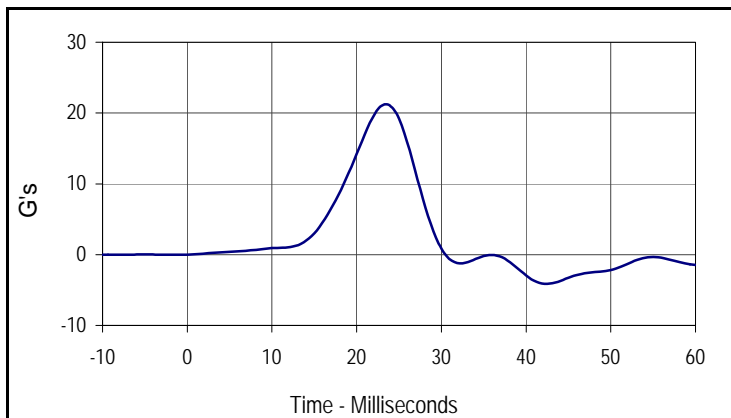

Curve Description			
Lower Spine Primary			
CURNO	Type	SAE Class	Units
003	FIL	FIR100	G's
Max	Time	Min	Time
21.2	23.8	-4.1	42.5

Test Program: SID / HIII Pelvis Lateral Impact  
 ATD Serial No.: 275

Test Date: 9/28/06  
 Test I.D.: PL09E



Tested Parameter	Units	Specification	Result	Pass/Fail
Laboratory Temperature	°C	18.9 to 25.6	21.1	Pass
Laboratory Relative Humidity	%	10 to 70	30	Pass
Probe Velocity	m/s	4.21 to 4.33	4.31	Pass
Peak Pelvis Acceleration	G's	40.0 to 60.0	44.5	Pass
Acceleration Time Above 20 G's	Msec.	3.0 to 7.0	6.88	Pass
Overall Test Results				Pass

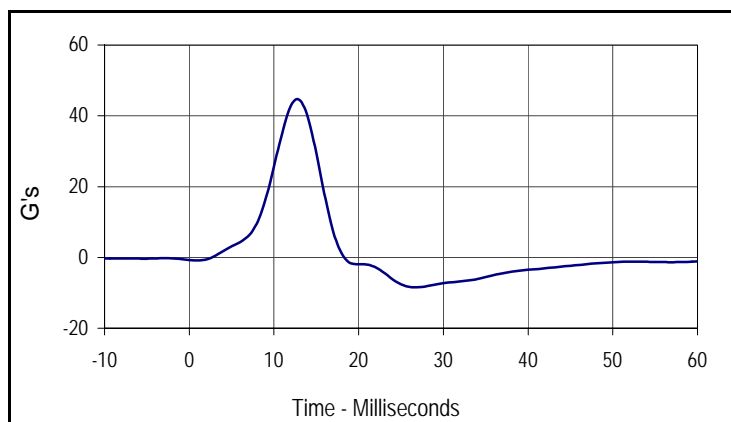

Curve Description			
Pelvis Primary Y			
CURNO	Type	SAE Class	Units
001	FIL	FIR100	G's
Max	Time	Min	Time
44.5	12.5	-8.5	26.9

Test Program: SID / HIII Head Drop Lateral Impact Test  
 ATD Serial No.: 275

Test Date: 9/28/06  
 Test I.D.: HD09A



Tested Parameter	Units	Specification	Result	Pass/Fail
Laboratory Temperature	°C	18.9 to 25.6	21.1	Pass
Laboratory Relative Humidity	%	10 to 70	30	Pass
Peak Resultant Acceleration	G's	120.0 to 150.0	145.2	Pass
Peak Longitudinal Acceleration	G's	≤15.0	6.9	Pass
Is Acceleration Unimodal?	Yes/No	Yes	Yes	Pass
Oscillations After Main Pulse	%	<15	4.6	Pass
Overall Test Results				Pass

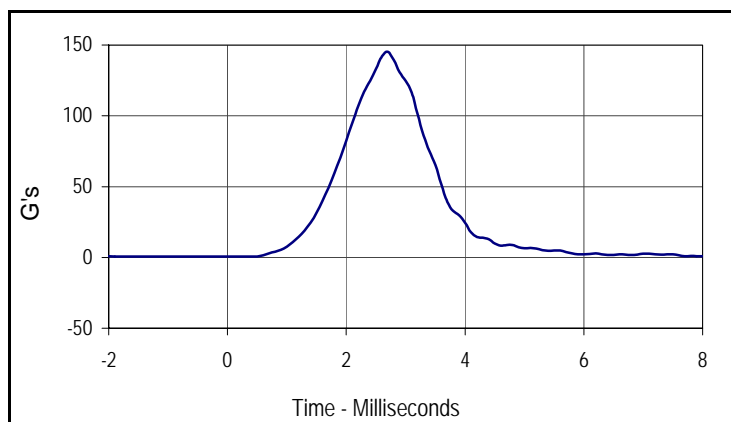

Curve Description			
Head Resultant			
CURNO	Type	SAE Class	Units
001	RES	1000	G's
Max	Time	Min	Time
145.2	2.7	0.5	0.4

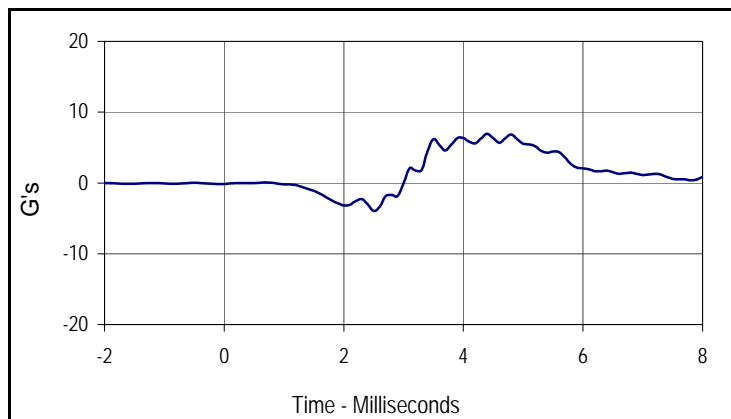

Curve Description			
Head X			
CURNO	Type	SAE Class	Units
002	FIL	1000	G's
Max	Time	Min	Time
6.9	4.4	-3.9	2.5

Test Program: SID / HIII Neck Pendulum Lateral Test  
 ATD Serial No.: 275

Test Date: 9/28/06  
 Test I.D.: NB09A



Tested Parameter	Units	Specification	Result	Pass/Fail	
Laboratory Temperature	°C	20.6 to 22.2	21.1	Pass	
Laboratory Relative Humidity	%	10 to 70	30	Pass	
Pendulum Velocity	m/sec	6.89 to 7.13	7.13	Pass	
Pendulum Deceleration	10 Msec.	m/sec	1.96 to 2.55	1.99	Pass
	20 Msec.	m/sec	4.12 to 5.10	4.17	Pass
	30 Msec.	m/sec	5.73 to 7.01	5.96	Pass
	40 to 70	m/sec	6.27 to 7.64	7.39	Pass
"D" Plane Rotation	Max	Degrees	66.0 to 82.0	74.2	Pass
Max Rotation Time After Peak Moment	Msec.	2.0 to 16.0	9.7	Pass	
Rotation Time From Peak to Zero Angle	Msec.	58.0 to 67.0	58.4	Pass	
Moment About Occipital Condyle	Nm	73.0 to 88.0	85.6	Pass	
Positive Moment Decay, Time To 0 Nm	Msec.	49.0 to 64.0	52.6	Pass	
Overall Test Results				Pass	

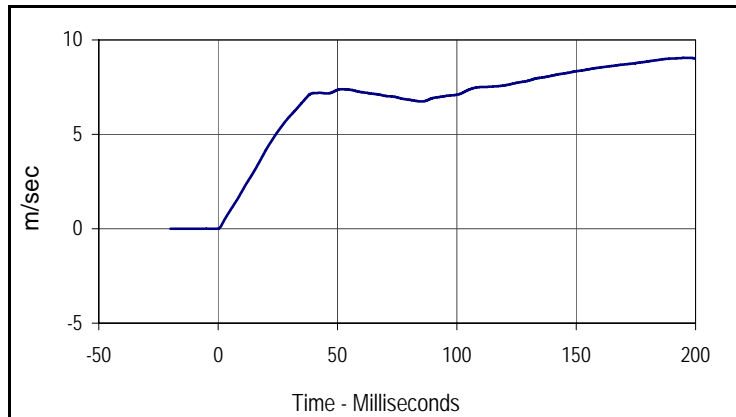

Curve Description			
Pendulum Velocity			
CURNO	Type	SAE Class	Units
001	FIL	180	m/sec
Max	Time	Min	Time
9.1	196.2	0.0	-0.4

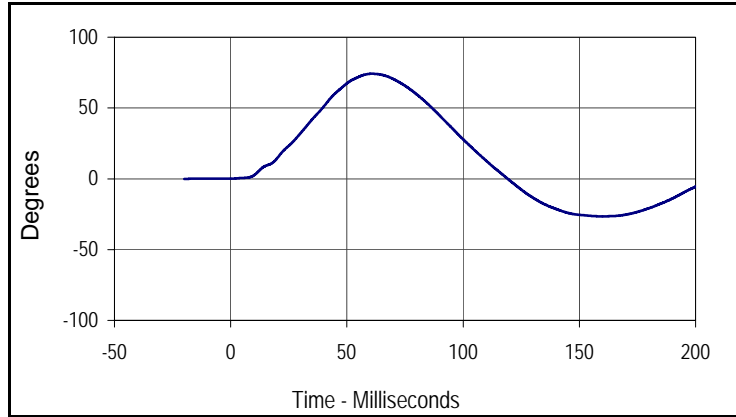

Curve Description			
"D" Plane Rotation			
CURNO	Type	SAE Class	Units
003	FIL	60	Degrees
Max	Time	Min	Time
74.2	60.8	-26.5	159.3

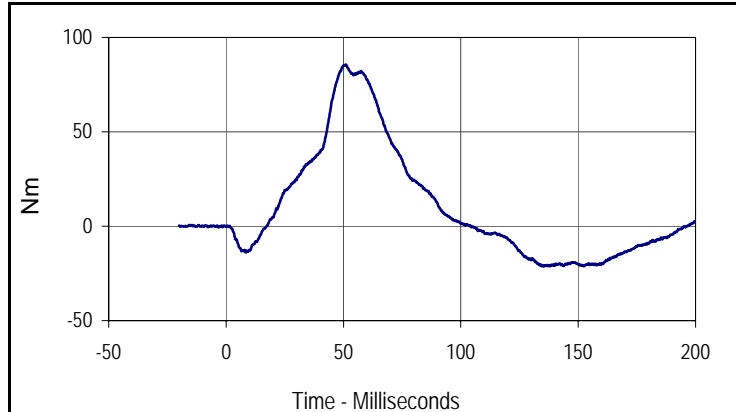

Curve Description			
Moment About Occipital Condyle			
CURNO	Type	SAE Class	Units
004	FIL	600	Nm
Max	Time	Min	Time
85.6	51.1	-21.3	135.4