

REPORT NUMBER: 208-MGA-2006-011

**VEHICLE SAFETY COMPLIANCE TESTING
FOR
FMVSS 208, OCCUPANT CRASH PROTECTION
FMVSS 212, WINDSHIELD MOUNTING
FMVSS 219, WINDSHIELD INTRUSION (PARTIAL)
FMVSS 301, FUEL SYSTEM INTEGRITY**

**General Motors Corporation
2006 Pontiac G6 Passenger Car
NHTSA No.: C60104**

**PREPARED BY:
MGA RESEARCH CORPORATION
5000 WARREN ROAD
BURLINGTON, WI 53105**



Test Dates: June 9, 2006 – August 24, 2006

Final Report Date: November 30, 2006

FINAL REPORT

**PREPARED FOR:
U.S. DEPARTMENT OF TRANSPORTATION
NATIONAL HIGHWAY TRAFFIC SAFETY ADMINISTRATION
OFFICE OF ENFORCEMENT
OFFICE OF VEHICLE SAFETY COMPLIANCE
MAIL CODE: NVS-220
400 SEVENTH STREET, SW, ROOM 6115
WASHINGTON, D.C. 20590**

This final test report was prepared for the U.S. Department of Transportation, National Highway Traffic Safety Administration, in response to Contract Number DTNH22-03-D-11002.

This publication is distributed by the U.S. Department of Transportation, National Highway Traffic Safety Administration, in the interest of information exchange. The opinions, findings and conclusions expressed in this publication are those of the author(s) and not necessarily those of the Department of Transportation or the National Highway Traffic Safety Administration. The United States Government assumes no liability for its contents or use thereof. If trade or manufacturers' names or products are mentioned it is only because they are considered essential to the object of the publication and should not be construed as an endorsement. The United States Government does not endorse products or manufacturers.

Prepared by: Jeff Lewandowski Date: November 30, 2006
Jeff Lewandowski, Project Engineer

Reviewed by: David Winkelbauer Date: November 30, 2006
David Winkelbauer, Facility Director

FINAL REPORT ACCEPTED BY OVSC:

Accepted By: Charles R. Case

Acceptance Date: November 30, 2006

Technical Report Documentation Page

1. Report No. 208-MGA-2006-011	2. Government Accession No.	3. Recipient's Catalog No.	
4. Title and Subtitle Final Report of FMVSS 208 Compliance Testing of a 2006 Pontiac G6 NHTSA No.: C60104		5. Report Date November 30, 2006	
		6. Performing Organization Code MGA	
7. Author(s) Jeff Lewandowski, Project Engineer		8. Performing Organization Report No. 208-MGA-2006-011	
9. Performing Organization Name and Address MGA Research Corporation 5000 Warren Road Burlington, WI 53105		10. Work Unit No.	
		11. Contract or Grant No. DTNH22-03-D-11002	
12. Sponsoring Agency Name and Address U.S. Department of Transportation National Highway Traffic Safety Administration Office of Enforcement Office of Vehicle Safety Compliance 400 Seventh St., S.W., Room 6115 NVS-220 Washington, D.C. 20590		13. Type of Report and Period Covered 6/9/06 - 11/30/06	
		14. Sponsoring Agency Code NVS-220	
15. Supplementary Notes			
16. Abstract Compliance tests were conducted on the subject 2006 Pontiac G6 in accordance with the specifications of the Office of Vehicle Safety Compliance Test Procedure No. TP208-13 for the determination of FMVSS 208 compliance. Test failures identified were as follows: TP208-13, Data Sheet 8, Step 19; The left rear, center rear, and right rear belt would not lock at the minimum length. S7.1.1.5(c)(7) The difference between the measurements recorded under S7.1.1.5(c)(6) and (4) shall not exceed 2 inches. A seat belt lockability test was performed with no child restraint installed, with the seat belts fastened and with all the seat belt webbing retracted. The seat belts did not lock in this position. No further action was taken because with child restraints installed the webbing would be spooled out enough that the seat belt would lock to secure the child restraint.			
17. Key Words Frontal Impact 40 kmph Vehicle Safety Compliance Testing FMVSS 208, "Occupant Crash Protection" FMVSS 212, "Windshield Mounting" FMVSS 219, (partial), "Windshield Zone Intrusion" FMVSS 301, "Fuel System Integrity"		18. Distribution Statement Copies of this report are available from the following: NHTSA Technical Information Services (TIS), Mail Code: NPO-230 400 Seventh Street, S.W., Room 5108 Washington, D.C. 20590 Tel. No.: (202) 366-4946	
19. Security Classif. (of this report) Unclassified	20. Security Classif. (of this page) Unclassified	21. No. of Pages 334	22. Price

TABLE OF CONTENTS

<u>Section</u>		<u>Page No</u>
1	Purpose of Compliance Test	1
2	Tests Performed	2
3	Injury Result Summary	4
4	Discussion of Test (if applicable)	6
5	Test Data Sheets	7
<u>Data Sheet</u>		
1	COTR Vehicle Work Order	8
2	Report of Vehicle Condition	12
3	Certification Label and Tire Placard Information	14
4	Rear Outboard Seating Position Seat Belts	15
5	Air Bag Labels	16
6	Readiness Indicator	28
7	Passenger Air Bag Manual Cut-Off Device	29
8	Lap Belt Lockability	32
9	Seat Belt Warning System	44
10	Belt Contact Force	46
11	Latch Plate Access	52
12	Seat Belt Retraction	54
13	Seat Belt Guides and Hardware	56
14	Marking of Reference Points for Various Test Positions & Points	62
16	Air Bag Suppression Telltale	70
17	Suppression Test Using 12-Month CRABI Dummy	71
18	Suppression Test Using Newborn Infant Dummy	78
19	Suppression Test Using 3-YO Dummy and Booster Seats	79
20	Suppression Test Using 3-YO Dummy and Fwd Facing Restraints	81
21	Suppression Test Using an Unbelted 3-YO Dummy	84
22H	Suppression Test Using a Representative 6-YO Child and Booster Seats	85
23H	Suppression Test Using an Unbelted Representative 6-YO Child	88
29	Summary of Low Risk Deployment Using an Unbelted 5 th % Dummy Position 1	89
30	Summary of Low Risk Deployment Using an Unbelted 5 th % Dummy Position 2	90
32	Vehicle Weight, Fuel Tank, and Attitude Data	91
33	Vehicle Accelerometer Locations and Measurements	95
34	Photographic Targets	98

<u>Data Sheet</u>		<u>Page No</u>
35	Camera Locations	104
36	Dummy Positioning	106
37	Dummy Measurements	118
38	Crash Test	121
40	Accident Investigation Measurements	123
41	Windshield Mounting (FMVSS 212)	125
42	Windshield Zone Intrusion (FMVSS 219)	127
43	Fuel System Integrity (FMVSS 301)	129

Appendix

A	Crash Test Data	A-1
B	Low Risk Test Data	B-1
C	Crash Test Photographs	C-1
D	Low Risk Photographs	D-1
E	Suppression Photographs	E-1
F	Instrumentation Calibration	F-1
G	Notice of Test Failure (If Applicable)	G-1

SECTION 1
PURPOSE OF COMPLIANCE TEST

The tests performed are part of a program conducted for the National Highway Traffic Safety Administration (NHTSA) by MGA Research Corporation (MGA) under Contract No. DTNH22-03-D-11002. The purpose of this test was to determine whether the subject vehicle, a 2006 Pontiac G6, NHTSA No. C60104, meets certain performance requirements of FMVSS 208, "Occupant Crash Protection"; FMVSS 212, "Windshield Mounting"; FMVSS 219, "Windshield Zone Intrusion"; and FMVSS 301, "Fuel System Integrity". The compliance test was conducted in accordance with OVSC Laboratory Test Procedure No. TP208-13 dated July 27, 2005.

SECTION 2
TESTS PERFORMED

Test Vehicle: 2006 Pontiac G6
Test Program: FMVSS 208 Compliance

NHTSA No.: C60104
Test Dates: 6/9/06 - 8/24/06

The following checked items indicate the tests that were performed:

- | | | |
|-------------------------------------|-----|---|
| <input checked="" type="checkbox"/> | 1. | Rear outboard seating position seat belts (S4.1.1.2(b) & (S4.2.4)) |
| <input checked="" type="checkbox"/> | 2. | Air bag labels (S4.5.1) |
| <input checked="" type="checkbox"/> | 3. | Readiness indicator (S4.5.2) |
| <input checked="" type="checkbox"/> | 4. | Passenger air bag manual cut-off device (S4.5.4) |
| <input checked="" type="checkbox"/> | 5. | Lap belt lockability (S7.1.1.5) |
| <input checked="" type="checkbox"/> | 6. | Seat belt warning system (S7.3) |
| <input checked="" type="checkbox"/> | 7. | Seat belt contact force (S7.4.4) |
| <input checked="" type="checkbox"/> | 8. | Seat belt latch plate access (S7.4.4) |
| <input checked="" type="checkbox"/> | 9. | Seat belt retraction (S7.4.5) |
| <input checked="" type="checkbox"/> | 10. | Seat belt guides and hardware (S7.4.6) |
| <input checked="" type="checkbox"/> | 11. | Suppression tests with 12-month-old CRABI dummy (Part 572, Subpart R) |
| <input checked="" type="checkbox"/> | 12. | Suppression tests with newborn infant (Part 572, Subpart K) |
| <input checked="" type="checkbox"/> | 13. | Suppression tests with 3-year-old dummy (Part 572, Subpart P) |
| <input checked="" type="checkbox"/> | 14. | Suppression tests with 6-year-old child |
| <input checked="" type="checkbox"/> | 15. | Test of reactivation of the passenger air bag system with an unbelted 5 th percentile female human |
| <input type="checkbox"/> | 16. | Low risk deployment test with 12-month-old dummy (Part 572, Subpart R) |
| <input type="checkbox"/> | 17. | Low risk deployment test with 3-year-old dummy (Part 572, Subpart P) |
| <input type="checkbox"/> | 18. | Low risk deployment test with 6-year-old dummy (Part 572, Subpart N) |
| <input checked="" type="checkbox"/> | 19. | Low risk deployment test with 5 th female dummy (Part 572, Subpart O) |
| <input checked="" type="checkbox"/> | 20. | Impact Tests |
| <input type="checkbox"/> | | Frontal Oblique |
| <input type="checkbox"/> | | Belted 50 th male dummy driver and passenger (0 to 48 kmph) (S5.1.1(a)) |
| <input type="checkbox"/> | | Unbelted 50 th male dummy driver and passenger (0 to 48 kmph) (S5.1.2(a)(1)) |
| <input type="checkbox"/> | | Unbelted 50 th male dummy driver and passenger (32 to 40 kmph) (S5.1.2(a) (1) or S5.1.2(b)) |
| <input checked="" type="checkbox"/> | | Frontal 0° |
| <input type="checkbox"/> | | Belted 50 th male dummy driver (0 to 48 kmph) (S5.1.1.(b)(1) or S5.1.1(a)) |
| <input type="checkbox"/> | | Belted 50 th male dummy passenger (0 to 48 kmph) (S5.1.1.(b)(1) or S5.1.1(a)) |
| <input type="checkbox"/> | | Belted 5 th female dummy driver (0 to 48 kmph) (S16.1(a)) |
| <input type="checkbox"/> | | Belted 5 th female dummy passenger (0 to 48 kmph) (S16.1(a)) |
| <input type="checkbox"/> | | Belted 50 th male dummy driver and passenger (0 to 56 kmph) (S5.1.1.(b)(2)) |
| <input type="checkbox"/> | | Unbelted 50 th male dummy driver and passenger (0 to 48 kmph) (S5.1.2(a) (1)) |
| <input type="checkbox"/> | | Unbelted 50 th male dummy driver (32 to 40 kmph) (S5.1.2.(a)(2) or S5.1.2(b)) |
| <input type="checkbox"/> | | Unbelted 50 th male dummy passenger (32 to 40 kmph) (S5.1.2.(a)(2) or S5.1.2(b)) |

<input checked="" type="checkbox"/>	Unbelted 5 th female dummy driver (32 to 40 kmph) (S16.1(b))
<input checked="" type="checkbox"/>	Unbelted 5 th female dummy passenger (32 to 40 kmph) (S16.1(b))
<input type="checkbox"/>	40% Offset 0° Belted 5 th male dummy driver and passenger (0 to 40 kmph) (S18.1)
<input type="checkbox"/>	21. Sled Test: unbelted 50 th male dummy driver and passenger (S13)
<input type="checkbox"/>	22. FMVSS 204 Indicant Test
<input checked="" type="checkbox"/>	23. FMVSS 212 Indicant Test
<input checked="" type="checkbox"/>	24. FMVSS 219 Indicant Test
<input checked="" type="checkbox"/>	25. FMVSS 301 Frontal Indicant Test

For the crash tests, the vehicle was instrumented with 8 accelerometers. The accelerometer data from the vehicle and dummies were sampled at 10,000 samples per second and processed as specified in SAE J211/1 MAR95 and FMVSS 208, S4.13.

The dynamic tests were recorded using high-speed film and high-speed digital video.

The vehicle does not appear to meet all of the performance requirements to which it was tested: TP208-13, Data Sheet 8, Step 19; The left rear, center rear, and right rear belt would not lock at the minimum length. S7.1.1.5(c)(7) The difference between the measurements recorded under S7.1.1.5(c)(6) and (4) shall not exceed 2 inches.

A seat belt lockability test was performed with no child restraint installed, with the seat belts fastened and with all the seat belt webbing retracted. The seat belts did not lock in this position. No further action was taken because with child restraints installed the webbing would be spooled out enough that the seat belt would lock to secure the child restraint.

SECTION 3

INJURY RESULT SUMMARY FOR FMVSS 208 TESTS

Test Vehicle: 2006 Pontiac G6
 Test Program: FMVSS 208 Compliance

NHTSA No.: C60104
 Test Date: 8/8/06

5th Percentile Female Low Risk Deployments

5th Percentile Female SN 505 Position 1 (Chin On Module) 8-8-06

Injury Criteria	Max. Allowable Injury Assessment Values	Measured Value
HIC15	700	11
Peak Nij (Nte)	1.0	0.2
Time (ms)	NA	88.8
Peak Nij (Ntf)	1.0	0.3
Time (ms)	NA	31.3
Peak Nij (Nce)	1.0	0.0
Time (ms)	NA	0.1
Peak Nij (Ncf)	1.0	0.0
Time (ms)	NA	3.9
Neck Tension	2070 N	527
Neck Compression	2520 N	7
Chest g	60 g	12
Chest Displacement	52 mm	7
Left Femur	6805 N	51
Right Femur	6805 N	34

Second stage fire time of 100 ms; Injuries calculated on 0 ms to 225 ms

5th Percentile Female SN 510 Position 2 (Chin On Rim) 8-8-06

Injury Criteria	Max. Allowable Injury Assessment Values	Measured Value
HIC15	700	14
Peak Nij (Nte)	1.0	0.5
Time (ms)	NA	23.5
Peak Nij (Ntf)	1.0	0.2
Time (ms)	NA	62.3
Peak Nij (Nce)	1.0	0.0
Time (ms)	NA	175.9
Peak Nij (Ncf)	1.0	0.1
Time (ms)	NA	68.0
Neck Tension	2070 N	826
Neck Compression	2520 N	83
Chest g	60 g	12
Chest Displacement	52 mm	14
Left Femur	6805 N	708
Right Femur	6805 N	443

Second stage fire time of 100 ms; Injuries calculated on 0 ms to 225 ms

SECTION 3
INJURY RESULT SUMMARY FOR FMVSS 208 TESTS

Test Vehicle: 2006 Pontiac G6 NHTSA No.: C60104
 Test Program: FMVSS 208 Compliance Test Date: 8/24/06

40 kmph Frontal Crash

Impact Angle: Zero degrees

Belted Dummies: Yes No
 Speed Range: 0 to 40 kmph 32 to 40 kmph
 0 to 48 kmph 0 to 56 kmph

Test Speed: 39.8 kmph Test Weight: 1649.7 kg

Driver Dummy: 5th female 50th male
 Passenger Dummy: 5th female 50th male

5th Percentile Female Frontal Crash Test
Vehicles certified to S16.1(a), S16.1(b), or S18.1

Injury Criteria	Max. Allowable Injury Assessment Values	Driver	Passenger
HIC15	700	56	146
N _{te}	1.0	0.4	0.3
N _{tf}	1.0	0.2	0.3
N _{ce}	1.0	0.1	0.2
N _{cf}	1.0	0.2	0.3
Neck Tension	2620 N	945	515
Neck Compression	2520 N	62	547
Chest g	60 g	28	29
Chest Displacement	52 mm	16	1
Left Femur	6805 N	4548	5450
Right Femur	6805 N	4633	5079

SECTION 4 DISCUSSION OF TESTS

Test Vehicle: 2006 Pontiac G6
Test Program: FMVSS 208 Compliance

NHTSA No.: C60104
Test Dates: 6/9/06 - 8/24/06

The vehicle did not meet all performance requirements.

TP208-13, Data Sheet 8, Step 19; The left rear, center rear, and right rear belt would not lock at the minimum length. S7.1.1.5(c)(7) The difference between the measurements recorded under S7.1.1.5(c)(6) and (4) shall not exceed 2 inches.

A seat belt lockability test was performed with no child restraint installed, with the seat belts fastened and with all the seat belt webbing retracted. The seat belts did not lock in this position. No further action was taken because with child restraints installed the webbing would be spooled out enough that the seat belt would lock to secure the child restraint.

A blanket and visor were not used in the suppression testing because they did not affect the sensing system used on the vehicle.

The vehicle was certified with human subjects for suppression of 6-year-olds and reactivation with 5th percentile human subjects. This is detailed in the Suppression Data Sheet summaries.

The front passenger sensing system was developed to recognize the pattern of a human for passenger air bag deployment during a frontal impact crash. However, a dummy is used in the FMVSS 208 crash test. Per FMVSS 208, Section 4.12, the system was bypassed to duplicate the signal of a 5th percentile human subject sitting in the seat. This suppression bypass system is shown below.



There was no valid data after 40 msec on the Bottom of Engine (X) accelerometer during the frontal impact crash test.

SECTION 5
TEST DATA SHEETS

Test Vehicle: 2006 Pontiac G6
Test Program: FMVSS 208 Compliance

NHTSA No.: C60104
Test Dates: 6/9/06 - 8/24/06

DATA SHEET 1
COTR VEHICLE WORK ORDER

Test Vehicle: 2006 Pontiac G6
Test Program: FMVSS 208 Compliance

NHTSA No.: C60104
Test Dates: 6/9/06 - 8/24/06

COTR Signature: Charles R. Case

Test to be performed for this vehicle are checked below:

- | | |
|-------------------------------------|---|
| <input checked="" type="checkbox"/> | 1. Rear Outboard Seating Position Seat Belts (S4.1.2(b)) & (S4.2.4) |
| <input checked="" type="checkbox"/> | 2. Air Bag Labels (S4.5.1) |
| <input checked="" type="checkbox"/> | 3. Readiness Indicator (S4.5.2) |
| <input checked="" type="checkbox"/> | 4. Passenger Air Bag Manual Cut-off Device (S4.5.4) |
| <input checked="" type="checkbox"/> | 5. Lap Belt Lockability (S7.1.1.5) |
| <input checked="" type="checkbox"/> | 6. Seat Belt Warning System (S7.3) |
| <input checked="" type="checkbox"/> | 7. Seat Belt Contact Force (S7.4.4) |
| <input checked="" type="checkbox"/> | 8. Seat Belt Latch Plate Access (S7.4.4) |
| <input checked="" type="checkbox"/> | 9. Seat Belt Retraction (S7.4.5) |
| <input checked="" type="checkbox"/> | 10. Seat Belt Guides and Hardware (S7.4.6) |
| <input checked="" type="checkbox"/> | 11. Suppression tests with 12-month-old CRABI dummy (Part 572, Subpart R) using the following indicated child restraints. |

Section B

<input checked="" type="checkbox"/>	Britax Handle with Care 191	<input checked="" type="checkbox"/>	Full Rearward	<input checked="" type="checkbox"/>	Mid Position	<input checked="" type="checkbox"/>	Full Forward
	Century Assura 4553		Full Rearward		Mid Position		Full Forward
	Century Avanta SE 41530		Full Rearward		Mid Position		Full Forward
	Century Smart Fit 4543		Full Rearward		Mid Position		Full Forward
	Cosco Arriva 02727		Full Rearward		Mid Position		Full Forward
	Cosco Opus 35 02603		Full Rearward		Mid Position		Full Forward
	Evenflo Discovery Adjust Right 212		Full Rearward		Mid Position		Full Forward
<input checked="" type="checkbox"/>	Evenflo First Choice 204	<input checked="" type="checkbox"/>	Full Rearward	<input checked="" type="checkbox"/>	Mid Position	<input checked="" type="checkbox"/>	Full Forward
	Evenflo On My Way Position Right V 282		Full Rearward		Mid Position		Full Forward
<input checked="" type="checkbox"/>	Graco Infant 8457	<input checked="" type="checkbox"/>	Full Rearward	<input checked="" type="checkbox"/>	Mid Position	<input checked="" type="checkbox"/>	Full Forward

Section C

<input checked="" type="checkbox"/>	Britax Roundabout 161	<input checked="" type="checkbox"/>	Full Rearward	<input checked="" type="checkbox"/>	Mid Position	<input checked="" type="checkbox"/>	Full Forward
<input checked="" type="checkbox"/>	Century Encore 4612	<input checked="" type="checkbox"/>	Full Rearward	<input checked="" type="checkbox"/>	Mid Position	<input checked="" type="checkbox"/>	Full Forward
	Century STE 1000 4416		Full Rearward		Mid Position		Full Forward
	Cosco Olympian 02803		Full Rearward		Mid Position		Full Forward
	Cosco Touriva 02519		Full Rearward		Mid Position		Full Forward
	Evenflo Horizon V 425		Full Rearward		Mid Position		Full Forward
<input checked="" type="checkbox"/>	Evenflo Medallion 254	<input checked="" type="checkbox"/>	Full Rearward	<input checked="" type="checkbox"/>	Mid Position	<input checked="" type="checkbox"/>	Full Forward

- | | |
|-------------------------------------|---|
| <input checked="" type="checkbox"/> | 12. Suppression tests with newborn infant (Part 572, Subpart K) using the following indicated child restraints. |
|-------------------------------------|---|

Section A

<input checked="" type="checkbox"/>	Cosco Dream Ride 02-719	<input checked="" type="checkbox"/>	Full Rearward	<input checked="" type="checkbox"/>	Mid Position	<input checked="" type="checkbox"/>	Full Forward
-------------------------------------	-------------------------	-------------------------------------	---------------	-------------------------------------	--------------	-------------------------------------	--------------

- | | |
|-------------------------------------|---|
| <input checked="" type="checkbox"/> | 13. Suppression tests with 3-year-old dummy (Part 572, Subpart P) using the following indicated child restraints where a child restraint is required. |
|-------------------------------------|---|

Section C

<input checked="" type="checkbox"/>	Britax Roundabout 161	<input checked="" type="checkbox"/>	Full Rearward	<input checked="" type="checkbox"/>	Mid Position	<input checked="" type="checkbox"/>	Full Forward
<input checked="" type="checkbox"/>	Century Encore 4612	<input checked="" type="checkbox"/>	Full Rearward	<input checked="" type="checkbox"/>	Mid Position	<input checked="" type="checkbox"/>	Full Forward
<input type="checkbox"/>	Century STE 1000 4416	<input type="checkbox"/>	Full Rearward	<input type="checkbox"/>	Mid Position	<input type="checkbox"/>	Full Forward
<input type="checkbox"/>	Cosco Olympian 02803	<input type="checkbox"/>	Full Rearward	<input type="checkbox"/>	Mid Position	<input type="checkbox"/>	Full Forward
<input type="checkbox"/>	Cosco Touriva 02519	<input type="checkbox"/>	Full Rearward	<input type="checkbox"/>	Mid Position	<input type="checkbox"/>	Full Forward
<input type="checkbox"/>	Evenflo Horizon V 425	<input type="checkbox"/>	Full Rearward	<input type="checkbox"/>	Mid Position	<input type="checkbox"/>	Full Forward
<input checked="" type="checkbox"/>	Evenflo Medallion 254	<input checked="" type="checkbox"/>	Full Rearward	<input checked="" type="checkbox"/>	Mid Position	<input checked="" type="checkbox"/>	Full Forward

Section D

<input type="checkbox"/>	Britax Roadster 9004	<input type="checkbox"/>	Full Rearward	<input type="checkbox"/>	Mid Position	<input type="checkbox"/>	Full Forward
<input checked="" type="checkbox"/>	Century Next Step 4920	<input checked="" type="checkbox"/>	Full Rearward	<input checked="" type="checkbox"/>	Mid Position	<input checked="" type="checkbox"/>	Full Forward
<input checked="" type="checkbox"/>	Cosco High Back Booster 02-442	<input checked="" type="checkbox"/>	Full Rearward	<input checked="" type="checkbox"/>	Mid Position	<input checked="" type="checkbox"/>	Full Forward
<input type="checkbox"/>	Evenflo Right Fit 245	<input type="checkbox"/>	Full Rearward	<input type="checkbox"/>	Mid Position	<input type="checkbox"/>	Full Forward

14. Suppression tests with representative 3-year-old child using the following indicated child restraints where a child restraint is required. (Appendix H, Data Sheet 16H and 17H)

Section C

<input type="checkbox"/>	Britax Roundabout 161	<input type="checkbox"/>	Full Rearward	<input type="checkbox"/>	Mid Position	<input type="checkbox"/>	Full Forward
<input type="checkbox"/>	Century Encore 4612	<input type="checkbox"/>	Full Rearward	<input type="checkbox"/>	Mid Position	<input type="checkbox"/>	Full Forward
<input type="checkbox"/>	Century STE 1000 4416	<input type="checkbox"/>	Full Rearward	<input type="checkbox"/>	Mid Position	<input type="checkbox"/>	Full Forward
<input type="checkbox"/>	Cosco Olympian 02803	<input type="checkbox"/>	Full Rearward	<input type="checkbox"/>	Mid Position	<input type="checkbox"/>	Full Forward
<input type="checkbox"/>	Cosco Touriva 02519	<input type="checkbox"/>	Full Rearward	<input type="checkbox"/>	Mid Position	<input type="checkbox"/>	Full Forward
<input type="checkbox"/>	Evenflo Horizon V 425	<input type="checkbox"/>	Full Rearward	<input type="checkbox"/>	Mid Position	<input type="checkbox"/>	Full Forward
<input type="checkbox"/>	Evenflo Medallion 254	<input type="checkbox"/>	Full Rearward	<input type="checkbox"/>	Mid Position	<input type="checkbox"/>	Full Forward

Section D

<input type="checkbox"/>	Britax Roadster 9004	<input type="checkbox"/>	Full Rearward	<input type="checkbox"/>	Mid Position	<input type="checkbox"/>	Full Forward
<input type="checkbox"/>	Century Next Step 4920	<input type="checkbox"/>	Full Rearward	<input type="checkbox"/>	Mid Position	<input type="checkbox"/>	Full Forward
<input type="checkbox"/>	Cosco High Back Booster 02-442	<input type="checkbox"/>	Full Rearward	<input type="checkbox"/>	Mid Position	<input type="checkbox"/>	Full Forward
<input type="checkbox"/>	Evenflo Right Fit 245	<input type="checkbox"/>	Full Rearward	<input type="checkbox"/>	Mid Position	<input type="checkbox"/>	Full Forward

15. Suppression tests with 3-year-old dummy (Part 572, Subpart P) in the following Forward, Middle, and Rearward seat track positions

<input checked="" type="checkbox"/>	Sitting on seat with back against seat back (S22.2.2.1)
<input checked="" type="checkbox"/>	Sitting on seat with back against reclined seat back (S22.2.2.2)
<input checked="" type="checkbox"/>	Sitting on seat with back not against seat back (S22.2.2.3)
<input checked="" type="checkbox"/>	Sitting on seat edge, spine vertical, hands by the child's side (S22.2.2.4)
<input checked="" type="checkbox"/>	Standing on seat, facing forward (S22.2.2.5)
<input checked="" type="checkbox"/>	Kneeling on seat facing forward (S22.2.2.6)
<input checked="" type="checkbox"/>	Kneeling on seat facing rearward (S22.2.2.7)
<input type="checkbox"/>	Lying on seat (S22.2.2.8)

16. Suppression tests with representative 3-year-old child in the following positions

<input type="checkbox"/>	Sitting on seat with back against seat back (S22.2.2.1)
<input type="checkbox"/>	Sitting on seat with back against reclined seat back (S22.2.2.2)
<input type="checkbox"/>	Sitting on seat with back not against seat back (S22.2.2.3)
<input type="checkbox"/>	Sitting on seat edge, spine vertical, hands by the child's side (S22.2.2.4)
<input type="checkbox"/>	Standing on seat, facing forward (S22.2.2.5)
<input type="checkbox"/>	Kneeling on seat facing forward (S22.2.2.6)
<input type="checkbox"/>	Kneeling on seat facing rearward (S22.2.2.7)
<input type="checkbox"/>	Lying on seat (S22.2.2.8)

17. Suppression tests with 6-year-old dummy (Part 572, Subpart N) using the following indicated child restraints where a child restraint is required.

Section D

	Britax Roadster 9004		Full Rearward		Mid Position		Full Forward
	Century Next Step 4920		Full Rearward		Mid Position		Full Forward
	Cosco High Back Booster 02-442		Full Rearward		Mid Position		Full Forward
	Evenflo Right Fit 245		Full Rearward		Mid Position		Full Forward

X 18. Suppression tests with representative 6-year-old child using the following indicated child restraints where a child restraint is required.

Section D

	Britax Roadster 9004		Full Rearward		Mid Position		Full Forward
X	Century Next Step 4920	X	Full Rearward	X	Mid Position	X	Full Forward
X	Cosco High Back Booster 02-442	X	Full Rearward	X	Mid Position	X	Full Forward
X	Evenflo Right Fit 245	X	Full Rearward	X	Mid Position	X	Full Forward

19. Suppression tests with 6-year-old dummy (Part 572, Subpart N) in the following Forward, Middle, and Rearward seat track positions

	Sitting on seat with back against seat back (S22.2.2.1)
	Sitting on seat with back against reclined seat back (S22.2.2.2)
	Sitting on seat edge, spine vertical, hands by the child's side (S22.2.2.4)
	Sitting back in the seat and leaning on the right front passenger door (S24.2.3)

X 20. Suppression tests with representative 6-year-old child in the following positions

X	Sitting on seat with back against seat back (S22.2.2.1)
X	Sitting on seat with back against reclined seat back (S22.2.2.2)
X	Sitting on seat edge, spine vertical, hands by the child's side (S22.2.2.4)
X	Sitting back in the seat and leaning on the right front passenger door (S24.2.3)

21. Test of Reactivation of the Passenger Air Bag System with an Unbelted 5th percentile female dummy (S20.3, 22.3, S24.3). Perform this test after the following suppression tests: After each restraint.

X 22. Test of Reactivation of the passenger air bag system with a representative 5th percentile female (S20.3, 22.3, S24.3). Perform this test after the following suppression tests:

23. Low risk deployment test with 12-month-old dummy (Part 572, Subpart R) using the following indicated child restraints.

Section B

	Britax Handle with Care 191		Full Rearward		Mid Position		Full Forward
	Century Assura 4553		Full Rearward		Mid Position		Full Forward
	Century Avanta SE 41530		Full Rearward		Mid Position		Full Forward
	Century Smart Fit 4543		Full Rearward		Mid Position		Full Forward
	Cosco Arriva 02727		Full Rearward		Mid Position		Full Forward
	Cosco Opus 35 02603		Full Rearward		Mid Position		Full Forward
	Evenflo Discovery Adjust Right 212		Full Rearward		Mid Position		Full Forward
	Evenflo First Choice 204		Full Rearward		Mid Position		Full Forward
	Evenflo On My Way Position Right V 282		Full Rearward		Mid Position		Full Forward
	Graco Infant 8457		Full Rearward		Mid Position		Full Forward

Section C

	Britax Roundabout 161		Full Rearward		Mid Position		Full Forward
	Century Encore 4612		Full Rearward		Mid Position		Full Forward
	Century STE 1000 4416		Full Rearward		Mid Position		Full Forward
	Cosco Olympian 02803		Full Rearward		Mid Position		Full Forward
	Cosco Touriva 02519		Full Rearward		Mid Position		Full Forward
	Evenflo Horizon V 425		Full Rearward		Mid Position		Full Forward
	Evenflo Medallion 254		Full Rearward		Mid Position		Full Forward

- 24. Low risk deployment test with 3-year-old dummy (Part 572, Subpart P) in the following positions
 - Position 1
 - Position 2
- 25. Low risk deployment test with 6-year-old dummy (Part 572, Subpart N) in the following positions
 - Position 1
 - Position 2
- 26. Low risk deployment test with 5th percentile female dummy (Part 572, Subpart O) in the following positions
 - Position 1
 - Position 2
- 27. Impact Tests
 - Frontal Oblique – Test Speed:
 - Belted 50th male dummy driver and passenger (0 to 48 kmph) (S5.1.1(a))
 - Unbelted 50th male dummy driver and passenger (0 to 48 kmph) (S5.1.2(a)(1))
 - Unbelted 50th male dummy driver and passenger (32 to 40 kmph) (S5.1.2(a) (1) or S5.1.2(b))
 - Frontal 0° - Test Speed: 39.8 kmph
 - Belted 50th male dummy driver (0 to 48 kmph) (S5.1.1.(b)(1) or S5.1.1(a))
 - Belted 50th male dummy passenger (0 to 48 kmph) (S5.1.1.(b)(1) or S5.1.1(a))
 - Belted 5th female dummy driver (0 to 48 kmph) (S16.1(a))
 - Belted 5th female dummy passenger (0 to 48 kmph) (S16.1(a))
 - Belted 50th male dummy driver and passenger (0 to 56 kmph) (S5.1.1.(b)(2))
 - Unbelted 50th male dummy driver and passenger (0 to 48 kmph) (S5.1.2(a) (1))
 - Unbelted 50th male dummy driver (32 to 40 kmph) (S5.1.2.(a)(2) or S5.1.2(b))
 - Unbelted 50th male dummy passenger (32 to 40 kmph) (S5.1.2.(a)(2) or S5.1.2(b))
 - Unbelted 5th female dummy driver (32 to 40 kmph) (S16.1(b))
 - Unbelted 5th female dummy passenger (32 to 40 kmph) (S16.1(b))
 - 40% Offset 0° Belted 5th male dummy driver and passenger (0 to 40 kmph) (S18.1) – Test Speed:
- 28. Sled Test: Unbelted 50th male dummy driver and passenger (S13)
- 29. FMVSS 204 Indicant Test
- 30. FMVSS 212 Indicant Test
- 31. FMVSS 219 Indicant Test
- 32. FMVSS 301 Frontal Indicant Test

DATA SHEET 2
REPORT OF VEHICLE CONDITION

Test Vehicle: 2006 Pontiac G6
Test Program: FMVSS 208 Compliance

NHTSA No.: C60104
Test Dates: 6/9/06 - 8/24/06

CONTRACT NO. DTNH22- 03-D-11002 Date: 8/29/06
FROM (Lab and rep name): MGA Research Corporation
TO: NHTSA, OVSC (NVS-220)

PURPOSE: (X) Initial Receipt () Received via Transfer (X) Present vehicle condition

MODEL YEAR/MAKE/MODEL/BODY STYLE: 2006 Pontiac G6 Sedan
MANUFACTURE DATE: 05/06
NHTSA NO. C60104 GVWR: 1920 kg (4234 lbs)
BODY COLOR: Ivory White GAWR (Fr): 1019 kg (2247 lbs)
VIN: 1G2ZF55B264278160 GAWR (Rr): 901 kg (1987 lbs)

ODOMETER READINGS: ARRIVAL (miles): 47 DATE: 6/5/06
COMPLETION (miles): 50 DATE: 8/24/06

PURCHASE PRICE: (\$) 16,270

DEALER'S NAME: Lake Geneva Chevrolet - 715 Wells St. Lake Geneva, 53147

- A. All options listed on window sticker are present on the test vehicle:
 Yes No
- B. Tires and wheel rims are new and the same as listed: Yes No
- C. There are no dents or other interior or exterior flaws: Yes No
- D. The vehicle has been properly prepared and is in running condition:
 Yes No
- E. Keyless remote is available and working: Yes No
- F. The glove box contains an owner's manual, warranty document, consumer information, and extra set of keys: Yes No
- G. Proper fuel filler cap is supplied on the test vehicle: Yes No
- H. Using permanent marker, identify vehicle with NHTSA number and FMVSS test type(s) on roof line above driver door or for school buses, place a placard with NHTSA number inside the windshield and to the exterior front and rear side of bus:
 Yes No
- I. Place vehicle in storage area: Yes No
- J. Inspect the vehicle's interior and exterior, including all windows, seats, doors, etc. to confirm that each system is complete and functional per the manufacturer's specifications. Any damage, misadjustment, or other unusual condition that could influence the test program or test results shall be recorded. Report any abnormal condition to the NHTSA COTR before beginning any test:
 Vehicle OK Conditions reported below

REPORT OF VEHICLE CONDITION AT THE COMPLETION OF TESTING

LIST OF FMVSS TESTS PERFORMED BY THIS LAB: FMVSS 208, 212, 219, 301

VEHICLE: 2006 Pontiac G6 NHTSA NO. C60104

REMARKS:

Equipment that is no longer on the test vehicle as noted on previous page:

Spare tire, jack and tools, rear seat bottom, and trunk interior

Explanation for equipment removal:

Components removed for instrumentation installation and to meet target weight.

Test Vehicle Condition:

25 mph frontal impact damage- front suspension & structure damaged, hood & front quarter panels damaged, radiator damaged, air bags & pretensioners deployed, Stoddard in fuel system

RECORDED BY: Jeff Lewandowski DATE: 8/29/2006

APPROVED BY: David Winkelbauer DATE: 8/29/2006

#####

RELEASE OF TEST VEHICLE

The vehicle described above is released from MGA to be delivered to:

Date: Time: Odometer:

Lab Rep's Signature:

Title:

Carrier/Customer Rep:

Date:

DATA SHEET 3

CERTIFICATION LABEL AND TIRE PLACARD INFORMATION

Test Vehicle: 2006 Pontiac G6
 Test Program: FMVSS 208 Compliance
 Test Technician: Nick Kosinski

NHTSA No.: C60104
 Test Date: 8/24/06

Certification Label	
Manufacturer:	General Motors Corporation
Date of Manufacture:	May 2006
VIN:	1G2ZF55B264278160
Vehicle Certified As (Pass. Car/MPV/Truck/Bus):	Passenger Car
Front Axle GVWR:	1019 kg (2247 lbs)
Rear Axle GVWR:	901 kg (1987 lbs)
Total GVWR:	1920 kg (4234 lbs)

Tire Placard	
Not applicable, vehicle is not a passenger car and does not have a tire placard.	Passenger Car
This is not a passenger car, but all or part of this information is still contained on a vehicle label and is reported here.	Passenger Car
Vehicle Capacity Weight:	404 kg (891 lbs)
Designated Seating Capacity Front:	2
Designated Seating Capacity Rear:	3
Total Designated Seating Capacity:	5
Recommended Cold Tire Inflation Pressure Front:	210 kpa (30 psi)
Recommended Cold Tire Inflation Pressure Rear:	210 kpa (30 psi)
Recommended Tire Size:	P215/60R16

Signature: 

Date: 8/24/06

DATA SHEET 4

REAR OUTBOARD SEATING POSITION SEAT BELTS

Test Vehicle: 2006 Pontiac G6
Test Program: FMVSS 208 Compliance
Test Technician: Wayne Dahlke

NHTSA No.: C60104
Test Date: 6/9/06

	Yes	No
Do all rear outboard seating positions have Type 2 seat belts?	X	

If NO, describe the seat belt installed, the seat location, and any other information about the seat that would explain why a Type 2 seat belt was not installed.

REMARKS:

Signature: Wayne Dahlke

Date: 6/9/06

DATA SHEET 5
AIR BAG LABELS (S4.5.1)

Test Vehicle: 2006 Pontiac G6
 Test Program: FMVSS 208 Compliance
 Test Technician: Wayne Dahlke

NHTSA No.: C60104
 Test Date: 6/9/06

1. Air bag maintenance label and owner's manual instructions: (S4.5.1(a))
- 1.1 Does the manufacturer recommend periodic maintenance or replacement of the air bag?
 Yes, go to 1.2
 No – go to 2
- 1.2 Does the vehicle have a label specifying air bag maintenance or replacement?
 Yes – Pass
 No – Fail
- 1.3 Does the label contain one of the following?
 Yes – Pass
 No – Fail
- Check applicable schedule:
 Schedule on label specifies month and year (Record date_____)
 Schedule on label specified vehicle mileage (Record mileage_____)
 Schedule on label specifies interval measured from date on certification label
 (Record interval_____)
- 1.4 Is the label permanently affixed within the passenger compartment such that it cannot be removed without destroying or defacing the label or the sunvisor? (3/19/01 legal interpretation to Todd Mitchell)
 Yes – Pass
 No – Fail
- 1.5 Is the label lettered in English?
 Yes – Pass
 No – Fail
- 1.6 Is the label in block capitals and numerals?
 Yes – Pass
 No – Fail
- 1.7 Are the letters and numerals at least 3/32 inches high?
 Yes – Pass
 No – Fail
- 1.8 Does the owner's manual set forth the recommended schedule for maintenance or replacement?
2. Does the owner's manual: (S4.5.1(f))
- 2.1 Include a description of the vehicle's air bag system in an easily understandable format?
 Yes – Pass
 No – Fail
- 2.2 Include a statement that the vehicle is equipped with an air bag and a lap/shoulder belt at the front outboard seating position?
 Yes – Pass
 No – Fail

- 2.3 Include a statement that the air bag is a supplement restraint at the front outboard seating position?
 Yes – Pass
 No – Fail
- 2.4 Emphasize that all occupants, including the driver, should always wear their seat belts whether or not an air bag is also provided at their seating positions to minimize the risk of severe injury or death in the event of a crash?
 Yes – Pass
 No – Fail
- 2.5 Provide any necessary precautions regarding the proper positioning of occupants, including children, at seating positions equipped with air bags to ensure maximum safety protection for those occupants?
 Yes – Pass
 No – Fail
- 2.6 Explain that no objects should be placed over or near the air bag on the steering wheel or on the instrument panel, because any such objects could cause harm if the vehicle is in a crash severe enough to cause the air bag to inflate?
 Yes – Pass
 No – Fail
- 2.7 Is the vehicle certified to meet the requirements of S14.5, S15, S17, S19, S21, S23, and S25? (Obtain answer from COTR) (S4.5.1(f)(2))
 Yes – (Go to 2.7.1)
 No – (Go to 3.)
- 2.7.1 Explain the proper functioning of the advanced air bag system? (S4.5.1(f)(2))
 Yes – Pass
 No – Fail
- 2.7.2 Provide a summary of the actions that may affect the proper functioning of the system? (S4.5.1(f)(2))
 Yes – Pass
 No – Fail
- 2.7.3 Present and explain the main components of the advanced passenger air bag system? (S4.5.1(f)(2)(i))
 Yes – Pass
 No – Fail
- 2.7.4 Explain how the components function together as part of the advanced passenger air bag system? (S4.5.1(f)(2)(ii))
 Yes – Pass
 No – Fail
- 2.7.5 Contain the basic requirements for proper operation, including an explanation of the actions that may affect the proper functioning of the system? (S4.5.1(f)(2)(iii))
 Yes – Pass
 No – Fail
- 2.7.6 Is the vehicle certified to the requirements of S19.2, S21.2, or 23.2 (automatic suppression)?
 Yes, continue with 2.7.6
 No, go to 2.7.7
- 2.7.6.1 Contain a complete description of the passenger air bag suppression system installed in the vehicle, including a discussion of any suppression zone? (S4.5.1(f)(2)(iv))
 Yes – Pass
 No – Fail

- 2.7.6.2 Discuss the telltale light, specifying its location in the vehicle and explaining when the light is illuminated?
- Yes – Pass
 No – Fail
- 2.7.7 Explain the interaction of the advanced passenger air bag system with other vehicle components, such as seat belts, seats or other components? (S4.5.1(f)(2)(v))
- Yes – Pass
 No – Fail
- 2.7.8 Summarize the expected outcomes when child restraint systems, children and small teenagers or adults are both properly and improperly positioned in the passenger seat, including cautionary advice against improper placement of child restraint systems? (S4.5.1(f)(2)(vi))
- Yes – Pass
 No – Fail
- 2.7.9 Provide information on how to contact the vehicle manufacturer concerning modifications for persons with disabilities that may affect the advanced air bag system? (S4.5.1(f)(2)(vii))
- Yes – Pass
 No – Fail
3. Sun Visor Air Bag Warning Label (S4.5.1(b)) Check only one of the following:
- The vehicle is not certified to meet the requirements of S19, S21, and S23 (Obtain answer from COTR) (S4.5.1(b)(1)) Go to 3.1 and skip 3.2
- The vehicle is certified to meet the requirements of S19, S21, and S23 on 9/1/03 or later. (Obtain answer from COTR) (S4.5.1(b)(3)) Go to 3.2 and skip 3.1
- 3.1 Vehicles not certified to meet the requirements of S19, S21, and S23.
- 3.1.1 Is the label permanently affixed (including permanent marking on the visor material or molding into the visor material) to either side of the sun visor at each front outboard seating position such that it cannot be removed without destroying or defacing the label or sun visor? (S4.5.1(b)(1)) (3/19/01 legal interpretation to Todd Mitchell)
- Driver Side, Yes – Pass
 Driver Side, No – Fail
 Passenger Side, Yes – Pass
 Passenger Side, No – Fail



3.1.2

Does the label conform in content to the label shown in either Figure 6A or 6B (Figure 6b is for vehicles with passenger air bag on-off switches), as appropriate, at each front outboard seating position? (S4.5.1(b)(1)) (Vehicles without back seats may omit the statement: "The back seat is the safest place for children." (S4.5.1(b)(1)(iv))



Figure 6a. Sun Visor Label Visible When Visor is in Down Position.



Figure 6b. Sun Visor Label Visible When Visor is in Down Position.

- Driver Side, Yes – Pass
- Driver Side, No – Fail
- Passenger Side, Yes – Pass
- Passenger Side, No – Fail



3.1.3

Is the label heading area yellow with the word "WARNING" and the alert symbol in black? (S4.5.1(b)(1)(i))

- Driver Side, Yes – Pass
- Driver Side, No – Fail
- Passenger Side, Yes – Pass
- Passenger Side, No – Fail



3.1.4

Is the message area white with black text? (S4.5.1(b)(1)(ii))

- Driver Side, Yes – Pass
- Driver Side, No – Fail
- Passenger Side, Yes – Pass
- Passenger Side, No – Fail

- 3.1.5 Is the message area at least 30 cm²? (S4.5.1(b)(1)(ii))
The message area consists of the total label area minus the yellow heading area and the pictogram. The pictogram is enclosed on the left side and bottom by the edge of the label and on the top by line that borders the yellow heading area. The right side of the pictogram is defined by a vertical line midway between the rightmost edge of the pictogram and the left most edge of the text, including any bullets. (See 5/6/03 interpretation to Gerald Plante on behalf of Subaru)
 Driver Side: Length_____, Width_____
 Passenger Side: Length_____, Width_____
 Actual message area _____ cm²
- Driver Side, Yes – Pass
 - Driver Side, No – Fail
 - Passenger Side, Yes – Pass
 - Passenger Side, No – Fail
- 3.1.6 Is the pictogram black with a red circle and slash on a white background? (S4.5.1(b)(2)(iii))
- Driver Side, Yes – Pass
 - Driver Side, No – Fail
 - Passenger Side, Yes – Pass
 - Passenger Side, No – Fail
- 3.1.7 Is the pictogram at least 30 mm in diameter? (S4.5.1(b)(2)(iii))
- Actual diameter_____mm
- Driver Side, Yes – Pass
 - Driver Side, No – Fail
 - Passenger Side, Yes – Pass
 - Passenger Side, No – Fail
- 3.2 Vehicles certified to meet the requirements of S19, S21, and S23 on 9/1/03 and later. (S4.5.1(b)(3))
- 3.2.1 Is the label permanently affixed (including permanent marking on the visor material or molding into the visor material) to either side of the sun visor at each front outboard seating position such that it cannot be removed without destroying or defacing the label or the sun visor? (S4.5.1(b)(3)) (3/19/01 legal interpretation to Todd Mitchell)
- Driver Side, Yes – Pass
 - Driver Side, No – Fail
 - Passenger Side, Yes – Pass
 - Passenger Side, No – Fail

X

3.2.2

Does the label conform in content to the label shown in Figure 11 at each front outboard seating position? (S4.5.1(b)(2)) (Vehicles without back seats may omit the statement: "The back seat is the safest place for children." (S4.5.1(b)(3)(iv)) Vehicles without back seats or the back seat is too small to accommodate a rear-facing child restraint may omit the statement "Never put a rear-facing child seat in the front."(S4.5.1(b)(3)(v))



Figure 8. Sun Visor Label Visible when Visor is in Down Position.



Figure 11. Sun Visor Label Visible when Visor is in Down Position.

X

Driver Side, Yes – Pass

Driver Side, No – Fail

X

Passenger Side, Yes – Pass

Passenger Side, No – Fail

X

3.2.3

Is the label heading area yellow with the word "WARNING" and the alert symbol in black? (S4.5.1(b)(3)(i))

X

Driver Side, Yes – Pass

Driver Side, No – Fail

X

Passenger Side, Yes – Pass

Passenger Side, No – Fail

X

3.2.4

Is the message area white with black text? (S4.5.1(b)(3)(ii))

X

Driver Side, Yes – Pass

Driver Side, No – Fail

X

Passenger Side, Yes – Pass

Passenger Side, No – Fail

- X** 3.2.5 Is the message area at least 30 cm²? (S4.5.1(b)(3)(ii)) The message area consists of the total label area minus the yellow heading area and the pictogram. The pictogram is enclosed on the left side and bottom by the edge of the label. The top edge of the pictogram area is defined by a horizontal line midway between the uppermost edge of the pictogram and the lowermost edge of the text. The right side of the pictogram is defined by a vertical line midway between the rightmost edge of the pictogram and the left most edge of the text, including any bullets. (See 5/6/03 interpretation to Gerald Plante on behalf of Subaru)
- Driver Side: Length 3.5 cm, Width 12.5 cm
 Passenger Side: Length 3.5 cm, Width 12.5 cm
 Actual message area 43.75 cm²
- X** Driver Side, Yes – Pass
 Driver Side, No – Fail
X Passenger Side, Yes – Pass
 Passenger Side, No – Fail
- X** 3.2.6 Is the pictogram black on a white background? (S4.5.1(b)(3)(iii))
- X** Driver Side, Yes – Pass
 Driver Side, No – Fail
X Passenger Side, Yes – Pass
 Passenger Side, No – Fail
- X** 3.2.7 Is the pictogram at least 30 mm (1.2 inches) in length? (S4.5.1(b)(3)(iii))
- Driver Side: Length 31 mm
 Passenger Side: Length 31 mm
- X** Driver Side, Yes – Pass
 Driver Side, No – Fail
X Passenger Side, Yes – Pass
 Passenger Side, No – Fail
- X** 3.3 Is the same side of the sun visor that contains the air bag warning label free of other information with the exception of the air bag maintenance label and/or the rollover-warning label? (S4.5.1(b)(5)(i))
- X** Driver Side, Yes – Pass
 Driver Side, No – Fail
X Passenger Side, Yes – Pass
 Passenger Side, No – Fail
- X** 3.4 Is the sun visor free of other information about air bags or the need to wear seat belts with the exception of the air bag alert label and/or the rollover-warning label? (S4.5.1(b)(5)(ii))
- X** Driver Side, Yes – Pass
 Driver Side, No – Fail
X Passenger Side, Yes – Pass
 Passenger Side, No – Fail

- 3.5 Does the driver side visor contain a rollover-warning label on the same side of the visor as the air bag warning label?
 ___ Yes, go to 3.6.1
 No, go to 4 (skipping 3.5.1 through 3.5.3)
- 3.5.1 Are both the rollover-warning label and the air bag warning label surrounded by a continuous solid-lined border?
 ___ Yes, go to 3.5.2 and skip 3.5.3
 ___ No, go to 3.5.3 and skip 3.5.2
- 3.5.2 Is the shortest distance from the border of the rollover label to the border of the air bag warning label at least 1 cm? (575.105 (d)(1)(iv)(B))
 _____ actual distance
- 3.5.3 Is the shortest distance from any of the lettering or graphics on the rollover-warning label to any of the lettering or graphics of the air bag warning label at least 3 cm? (575.105 (d)(1)(iv)(A))
 _____ actual distance
 ___ Yes-Pass ___ No-FAIL
4. Air Bag Alert Label (S4.5.1(c) (A "Rollover Warning Label" or "Rollover Alert Label" may be on the same side of the driver's sun visor as the "Air Bag Alert Label." 575.105(d))
- 4.1 Is the sun visor warning label visible when the sun visor is in the stowed position?
- If yes for driver and passenger, go to 5.**
- Driver Side, Yes
 Driver Side, No
 Passenger Side, Yes
 Passenger Side, No
- 4.2 Is the air bag alert label permanently affixed (including permanent marking on the visor material or molding into the visor material) to the sun visor at each front outboard seating position such that it cannot be removed without destroying or defacing the label or the sun visor? (S4.5.1(c)) (3/19/01 legal interpretation to Todd Mitchell)
- Driver Side, Yes – Pass
 Driver Side, No – Fail
 Passenger Side, Yes – Pass
 Passenger Side, No – Fail
- 4.3 Is the air bag alert label visible when the visor is in the stowed position? (S4.5.1(c))
- Driver Side, Yes – Pass
 Driver Side, No – Fail
 Passenger Side, Yes – Pass
 Passenger Side, No – Fail



4.4 Does the label conform in content to the label shown in Figure 6C? (S4.5.1(c))

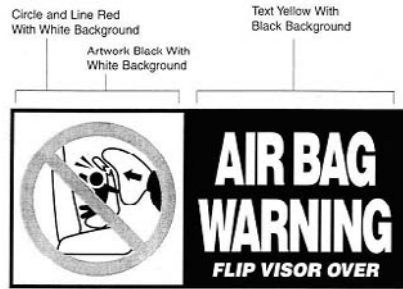

Figure 6c. Sun Visor Label Visible When Visor is in Up Position.

- Driver Side, Yes – Pass
- Driver Side, No – Fail
- Passenger Side, Yes – Pass
- Passenger Side, No – Fail



4.5 Is the message area black with yellow text? (S4.5.1(c)(1))

- Driver Side, Yes – Pass
- Driver Side, No – Fail
- Passenger Side, Yes – Pass
- Passenger Side, No – Fail



4.6 Is the message area at least 20 cm²? (S4.5.1(c)(1)) The message area consists of the black part of the label.

Driver Side: Length ____, Width ____
 Passenger Side: Length ____, Width ____
 Actual message area ____cm²

- Driver Side, Yes – Pass
- Driver Side, No – Fail
- Passenger Side, Yes – Pass
- Passenger Side, No – Fail



4.7 Is the pictogram black with a red circle and slash on a white background? (S4.5.1(c)(2))

- Driver Side, Yes – Pass
- Driver Side, No – Fail
- Passenger Side, Yes – Pass
- Passenger Side, No – Fail



4.8 Is the pictogram at least 20 mm in diameter? (S4.5.1(c)(2))

Driver Side Diameter ____mm
 Passenger Side Diameter ____mm

- Driver Side, Yes – Pass
- Driver Side, No – Fail
- Passenger Side, Yes – Pass
- Passenger Side, No – Fail

- 5. Label on the Dashboard
- 5.1 Is the vehicle certified to meet the requirements of S19, S21, and S23? (Obtain answer from COTR) (S4.5.1(e)(3))
 - Yes, go to 5.1.1 and **skip 5.2**
 - No, go to 5.2, skipping 5.1.1 through 5.1.6
- 5.1.1 Does the vehicle have a label on the dash or steering wheel hub? (S4.5.1(e)(3))
 - Yes – Pass
 - No – Fail
- 5.1.2 Is the label clearly visible from all front seating positions? (S4.5.1(e)(3))
 - Yes – Pass
 - No - Fail
- 5.1.3 Does the label conform in content to the label shown in Figure 12? (S4.5.1(e)(3))

Vehicles without back seats may omit the statement: “The back seat is the safest place for children.” Vehicles without back seats or too small to accommodate a rear-facing child restraint consistent with S4.5.4.1 as determined in DATA SHEET 7 may omit the statement “Never put a rear-facing child seat in the front.” (S4.5.1(e)(3)(iii))

 - Yes – Pass
 - No - Fail

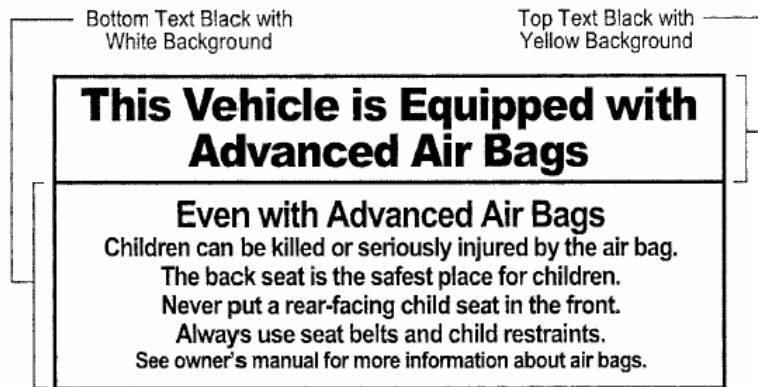

Figure 12. Removable Label on Dash.

- 5.1.4 Is the heading area yellow with black text? (S4.5.1(e)(3)(i))
 - Yes – Pass
 - No - Fail
- 5.1.5 Is the message white with black text? (S4.5.1(e)(3)(ii))
 - Yes – Pass
 - No - Fail

5.1.6 Is the message area at least 30 cm²? (S4.5.1(e)(3)(ii)) The message area consists of the total label area minus the yellow heading area. (See 5/6/03 interpretation to Gerald Plante on behalf of Subaru)

Length 10.4 cm Width 4.7 cm

Actual message area 48.9 cm²

Yes – Pass

No - Fail

5.2 Does the vehicle have a label on the dash or steering wheel hub? (S4.5.1(e)(1))

Yes – Pass

No - Fail

5.2.1 Is the label clearly visible from all front seating positions? (S4.5.1(e)(1))

Yes – Pass

No - Fail

5.2.2 Does the label conform in content to the label shown in Figure 7? (S4.5.1(e)(1)(iii))
Vehicles without back seats may omit the statement: "The back seat is the safest place for children." (S4.5.1(e)(1)(iii))

Yes – Pass

No - Fail

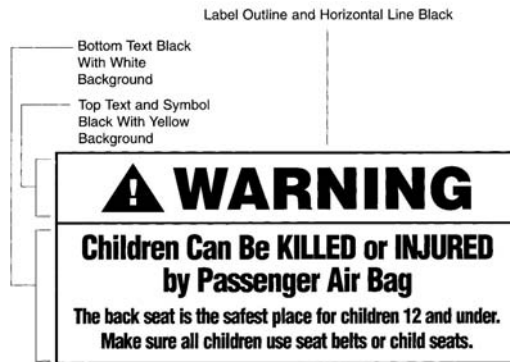

Figure 7. Removable Label on Dash.

5.2.3 Is the heading area yellow with the word "WARNING" and the alert symbol in black? (S4.5.1(e)(1)(i))

Yes – Pass

No - Fail

5.2.4 Is the message white with black text? (S4.5.1(e)(1)(ii))

Yes – Pass

No - Fail

5.2.5 Is the message area at least 30 cm²? (S4.5.1(e)(1)(ii)) The message area consists of the total label area minus the yellow heading area. (See 5/6/03 interpretation to Gerald Plante on behalf of Subaru)

Length _____, Width _____

Actual message area _____ cm²

Yes – Pass

No - Fail

REMARKS:

I certify that I have read and performed each instruction.

Signature: Wayne J. Ahl

Date: 6/9/06

DATA SHEET 6

FMVSS 208 READINESS INDICATOR (S4.5.2)

Test Vehicle: 2006 Pontiac G6
Test Program: FMVSS 208 Compliance
Test Technician: Wayne Dahlke

NHTSA No.: C60104
Test Date: 6/9/06

An occupant restraint system that deploys in the event of a crash shall have a monitoring system with a readiness indicator. A totally mechanical system is exempt from this requirement. (11/8/94 legal interpretation to Lawrence F. Hennegerger on behalf of Breed)

- 1. Is the system totally mechanical? If Yes, this data sheet is complete.
 - Yes
 - No
- 2. Describe the location of the readiness indicator: *Center Left*
- 3. Is the readiness indicator clearly visible to the driver?
 - Yes – Pass
 - No - Fail
- 4. Is a list of the elements in the occupant restraint system, being monitored by the readiness indicator, provided on a label or in the owner's manual?
 - Yes – Pass
 - No - Fail
- 5. Does the vehicle have an on-off switch for the passenger air bag?
 - If Yes, go to 6
 - If No, this form is complete.
- 6. Is the air bag readiness indicator off when the passenger air bag switch is in the off position?
 - Yes – Pass
 - No - Fail

REMARKS:

I certify that I have read and performed each instruction.

Signature: Wayne Dahlke

Date: 6/9/06

DATA SHEET 7

PASSENGER AIR BAG MANUAL CUT-OFF DEVICE (S4.5.4)

Test Vehicle: 2006 Pontiac G6
 Test Program: FMVSS 208 Compliance
 Test Technician: Wayne Dahlke

NHTSA No.: C60104
 Test Date: 6/9/06

- | | | |
|-------------------------------------|----|--|
| <input checked="" type="checkbox"/> | 1. | Is the vehicle equipped with an on-off switch that deactivates the air bag installed at the right front outboard seating position? |
| | | <input type="checkbox"/> Yes, go to 2 |
| | | <input checked="" type="checkbox"/> No, this sheet is complete |
- | | | |
|--------------------------|----|---|
| <input type="checkbox"/> | 2. | Does the vehicle have any forward-facing rear designated seating positions? (S4.5.4.1(a)) |
| | | <input type="checkbox"/> Yes, go to 3 |
| | | <input type="checkbox"/> No, go to 4 |
- | | | |
|--------------------------|----|---|
| <input type="checkbox"/> | 3. | Verification there is room for a child restraint in the rear seat behind the driver's seat. (S4.5.4(b)) |
|--------------------------|----|---|
- | | | |
|--------------------------|-----|---|
| <input type="checkbox"/> | 3.1 | Using all the controls that affect the fore-aft movement of the seat, move the seat to the rearmost position. Mark this position. |
| | | <input type="checkbox"/> N/A, the seat does not have fore-aft adjustment |
- | | | |
|--------------------------|-----|---|
| <input type="checkbox"/> | 3.2 | Using all the controls that affect the fore-aft movement of the seat, move the seat to the foremost position. Mark this position. |
| | | <input type="checkbox"/> N/A, the seat does not have fore-aft adjustment |
- | | | |
|--------------------------|-----|--|
| <input type="checkbox"/> | 3.3 | Move the seat to the middle of the foremost and rearmost positions. (S8.1.2) |
| | | <input type="checkbox"/> N/A, the seat does not have a fore-aft adjustment |
- | | | |
|--------------------------|-----|--|
| <input type="checkbox"/> | 3.4 | If the driver's seat height is adjustable, use all the controls that affect height to put it in the lowest position while maintaining the middle fore-aft position. (S8.1.2) |
| | | <input type="checkbox"/> N/A, No seat height adjustment |
- | | | |
|--------------------------|-----|--|
| <input type="checkbox"/> | 3.5 | Position the driver's seat adjustable lumbar supports so that the lumbar support is in its lowest, retracted or deflated adjustment position. (S8.1.3) |
| | | <input type="checkbox"/> N/A, No lumbar adjustment |
- | | | |
|--------------------------|-----|---|
| <input type="checkbox"/> | 3.6 | The driver's seat back angle, if adjustable, is set at the manufacturer's nominal design riding position for a 50th percentile adult male in the manner specified by the manufacturer. (S4.5.4.1(b) and S8.1.3) |
| | | <input type="checkbox"/> N/A, No seat back angle adjustment |
| | | <input type="checkbox"/> Manufacturer's design driver's seat back angle _____ |
| | | <input type="checkbox"/> Tested driver's seat back angle _____ |
- | | | |
|--------------------------|-----|--------------------------------------|
| <input type="checkbox"/> | 3.7 | Is the driver seat a bucket seat? |
| | | ___ Yes, go to 3.7.1 and skip 3.7.2. |
| | | ___ No, go to 3.7.2 and skip 3.7.1. |
- | | | |
|--------------------------|-------|---------------|
| <input type="checkbox"/> | 3.7.1 | Bucket seats: |
|--------------------------|-------|---------------|
- | | | |
|--------------------------|---------|--|
| <input type="checkbox"/> | 3.7.1.1 | Locate and mark a vertical Plane B through the longitudinal centerline of the driver's seat cushion. The longitudinal centerline of a bucket seat cushion is determined at SgRP. (S16.3.1.10) (S4.5.4.1(b)(1)) |
|--------------------------|---------|--|

- 3.7.1.2 Locate the longitudinal horizontal line in plane B that is tangent to the highest point of the rear seat cushion behind the driver's seat. Measure along this line from the front of the seat back of the rear seat to the rear of the seat back of the driver's seat.
 _____ mm distance
 less than 720 mm – Pass
 more than 720 mm – **FAIL**
 Go to 4
- 3.2 Bench seats (including split bench seats):
- 3.7.2.1 Locate and mark a vertical Plane B through the center of the steering wheel parallel to the vehicle longitudinal centerline. (S4.5.4.1(b)(2))
- 3.7.2.2 Locate the longitudinal horizontal line in plane B that is tangent to the highest point of the rear seat cushion. Measure along this line from the front of the seat back of the rear seat to the rear of the seat back of the front seat.
 _____ mm distance
 less than 720 mm – Pass
 more than 720 mm - **FAIL**
 Go to 4
4. Does the device turn the air bag on and off using the vehicle's ignition key? (S4.5.4.2)
 Yes – Pass
 No – Fail
5. Is the on-off device separate from the ignition switch? (S4.5.4.2)
 Yes – Pass
 No – Fail
6. Is there a telltale light that comes on when the passenger air bag is turned off? (S4.5.4.2)
 Yes – Pass
 No – Fail
7. Telltale light (S4.5.4.3)
- 7.1 Is the light yellow? S4.5.4.3(a)
 Yes – Pass
 No – Fail
- 7.2 Are the words "PASSENGER AIR BAG OFF" or "PASS AIR BAG OFF" (S4.5.4.3(b))
- 7.2.1 on the telltale?
 Yes – Pass, go to 7.3
 No – go to 7.2.2
- 7.2.2 within 25 mm of the telltale?
 Measurement from the edge of the telltale light (mm):
 Yes – Pass
 No – Fail
- 7.3 Does the telltale remain illuminated while the air bag is turned off? (S4.5.4.3c) (Leave the air bag off for 5 minutes.)
 Yes – Pass
 No – Fail

- 7.4 Is the telltale illuminated while the air bag is turned on? (S4.5.4.3(d))
- Yes – Fail
- No – Pass
- 7.5 Is the telltale combined with the air bag readiness indicator? (S4.5.4.3(e))
- Yes – Fail
- No – Pass
8. Owner's Manual
- 8.1 Does the owner's manual contain complete instructions on the operation of the on-off switch? (S4.5.4.4(a))
- Yes – Pass
- No – Fail
- 8.2 Does the owner's manual contain a statement that the on-off switch should only be used when a member of one of the following risk groups is occupying the right front passenger seating position? (S4.5.4.4(b))
- Infants: there is no back seat
the rear seat is too small to accommodate a child restraint
there is a medical condition that must be monitored constantly
- Children: there is no back seat
aged space is not always available in the rear seat
1 to 12: there is a medical condition that must be monitored constantly
- Medical: medical risk causes special risk for passenger
condition: greater risk for harm than with the air bag on
- Yes – Pass
- No – Fail
- 8.3 Does the owner's manual contain a warning about the safety consequences of using the on-off switch at other times?
- Yes – Pass
- No – Fail

REMARKS:

I certify that I have read and performed each instruction.

Signature:

Wayne Gahl

Date:

6/9/06

DATA SHEET 8

LAP BELT LOCKABILITY

Passenger cars, trucks, buses, and multipurpose passenger Vehicles with a GVWR of 10,000 pounds or less. (S7.1.1.5)

Test Vehicle: 2006 Pontiac G6
Test Program: FMVSS 208 Compliance
Test Technician: Wayne Dahlke

NHTSA No.: C60104
Test Date: 6/9/06

Complete one of these forms for **each** designated seating position that can be adjusted to forward-facing or that is a forward-facing seat, other than the driver's seat (S7.1.1.5(a), **and** that has seat belt retractors that are not solely automatic locking retractors. (S7.1.1.5(c))

DESIGNATED SEATING POSITION: **Front Passenger**

- | | |
|-------------------------------------|--|
| <input type="checkbox"/> | N/A – no retractor is at this position |
| <input type="checkbox"/> | N/A – the retractor is an automatic locking retractor ONLY |
| <input checked="" type="checkbox"/> | 1. Record test fore-aft seat position: FULL REAR (S7.1.1.5(c)(1)) (Any position is acceptable) |
| <input checked="" type="checkbox"/> | 2. Does the lap belt portion of the seat belt in the forward-facing seat or seat that can be adjusted to forward-facing consist of a locking device that does NOT have to be attached by the vehicle user to the seat belt webbing, retractor, or any other part of the vehicle. (S7.1.1.5 (a)) |
| <input checked="" type="checkbox"/> | Yes – Pass |
| <input type="checkbox"/> | No – Fail |
| <input checked="" type="checkbox"/> | 3. Does the lap belt portion of the seat belt in the forward-facing seat or seat that can be adjusted to forward-facing consist of a locking device that does NOT require inverting, twisting or deforming of the belt webbing. (S7.1.1.5 (a)) |
| <input checked="" type="checkbox"/> | Yes – Pass |
| <input type="checkbox"/> | No – Fail |
| <input checked="" type="checkbox"/> | 4. Place any adjustable seat belt anchorage in the lowest adjustment position. |
| <input type="checkbox"/> | N/A The anchorage is not adjustable. |
| <input checked="" type="checkbox"/> | 5. Buckle the seat belt. (S7.1.1.5(c)(1)) |
| <input checked="" type="checkbox"/> | 6. Locate a reference point A on the seat belt buckle. (S7.1.1.5(c)(2)) |
| <input checked="" type="checkbox"/> | 7. Locate a reference point B on the attachment hardware or retractor assembly at the other end of the lap belt or lap belt portion of the seat belt assembly. (S7.1.1.5(c)(2)) |
| <input checked="" type="checkbox"/> | 8. Does the vehicle user need to take some action to activate the locking feature on the lap belt portion of the seat belt in any forward-facing seat or seat that can be adjusted to forward-facing? |
| <input checked="" type="checkbox"/> | Yes, go to 8.1 |
| <input type="checkbox"/> | No, go to 9. |
| <input checked="" type="checkbox"/> | 8.1 Does the vehicle owner's manual include a description in words and/or diagrams describing how to activate the locking feature so that the seat belt assembly can tightly secure a child restraint system and how to deactivate the locking feature to remove the child restraint system. (S7.1.1.5(b)) |
| <input checked="" type="checkbox"/> | Yes – Pass |
| <input type="checkbox"/> | No – Fail |

- X** 9. Adjust the lap belt or lap belt portion of the seat belt assembly according to any procedures recommended in the vehicle owner's manual to activate any locking feature so that the webbing between points A and B is at the maximum length allowed by the belt system. (S7.1.1.5(c)(2) & S7.1.1.5(c)(1))
- X** 10. Measure and record the distance between points A and B along the longitudinal centerline of the webbing for the lap belt or lap belt portion of the seat belt assembly. (S7.1.1.5(c)(2))
Measured distance between A and B (inches): 65 ½ inches
- X**
X 11. Readjust the belt system so that the webbing between points A and B is at 1/2 the maximum length of the webbing. (S7.1.1.5(c)(3))
- X** 12. To the lap belt or lap belt portion of the seat belt assembly, apply a preload of 10 pounds using the webbing tension pull device in Figure 5. Apply the load in a vertical plane parallel to the longitudinal axis of the vehicle and passing through the seating reference point of the designated seating position. Apply the preload in a horizontal direction toward the front of the vehicle with a force application angle of not less than 5 degrees nor more than 15 degrees above the horizontal. (S7.1.1.5(c)(4))
Measured force application angle (Spec. 5-15 degrees): 9.1°
- X**
X 13. Measure the length between points A and B along the longitudinal centerline of the webbing while the preload is being applied. (S7.1.1.5(c)(4))
Measured distance between A and B (inches): 31 ½ inches
- X**
X 14. Increase the load to 50 pounds at a rate of no more than 50 pounds per second. Attain the load in not more than 5 seconds. (If webbing sensitive emergency locking retractors are installed as part of the lap belt or lap belt portion of the seat belt assembly, apply the load at a rate less than the threshold value for lock-up specified by the manufacturer.) Maintain the load for at least 5 seconds. Measure and record the distance between points A and B along the longitudinal centerline of the webbing. (S7.1.1.5(c)(5))
Record onset rate (lb/sec) (spec. 10 to 50 lb/sec) (S7.1.1.5(c)(5)): 30lbs./sec
Measured distance between A and B (inches) (S7.1.1.5(c)(6)): 31 5/8 inches
- X**
X
X
X 15. Let the seat belt webbing retract to its minimum length with the seat belt still buckled
- X** 16. To the lap belt or lap belt portion of the seat belt assembly, apply a preload of 10 pounds using the webbing tension pull device in Figure 5. Apply the load in a vertical plane parallel to the longitudinal axis of the vehicle and passing through the seating reference point of the designated seating position. Apply the preload in a horizontal direction toward the front of the vehicle with a force application angle of not less than 5 degrees nor more than 15 degrees above the horizontal. (S7.1.1.5(c)(4))
Measured force application angle 9° spec. 5 - 15 degrees)
- X** 17. Measure the length between points A and B along the longitudinal centerline of the webbing while the preload is being applied. (S7.1.1.5(c)(4))
Measured distance between A and B 17 ¼ inches

18. Increase the load to 50 pounds at a rate of no more than 50 pounds per second. Attain the load in not more than 5 seconds. (If webbing sensitive emergency locking retractors are installed as part of the lap belt or lap belt portion of the seat belt assembly, apply the load at a rate less than the threshold value for lock-up specified by the manufacturer.) Maintain the load for at least 5 seconds. Measure and record the distance between points A and B along the longitudinal centerline of the webbing. (S7.1.1.5(c)(5))
Record onset rate 30lb/sec (spec. 10 to 50 lb/sec) (S7.1.1.5(c)(5))
Measured distance between A and B 17 1/2 inches (S7.1.1.5(c)(6))
19. Subtract the measurement in 13 from the measurement in 14 and the measurement in 17 from the measurement in 18. Is the difference 2 inches or less for both?
(S7.1.1.5(c)(7))
 14-13 = 31 5/8 - 31 1/2 = 1/8 inch
 18-17 = 17 1/2 - 17 1/4 = 1/4 inches
 Yes – Pass
 No – Fail
20. Subtract the measurement in 14 from the measurement in 10 and the measurement in 18 from the measurement in 10. Is the difference 3 inches or more for both?
(S7.1.1.5(c)(8))
 10-14 = 65 1/2 - 31 5/8 = 33 7/8 inches
 10-18 = 65 1/2 - 17 1/2 = 48 inches
 Yes – Pass
 No – Fail

REMARKS:

I certify that I have read and performed each instruction.

Signature: Wayne J. Hill

Date: 6/9/06

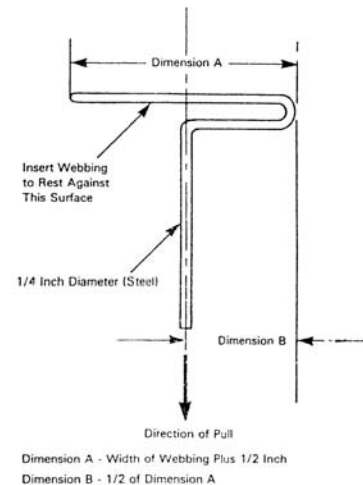

Figure 5. - Webbing Tension Pull Device

DATA SHEET 8

LAP BELT LOCKABILITY

Passenger cars, trucks, buses, and multipurpose passenger Vehicles with a GVWR of 10,000 pounds or less. (S7.1.1.5)

Test Vehicle: 2006 Pontiac G6
Test Program: FMVSS 208 Compliance
Test Technician: Wayne Dahlke

NHTSA No.: C60104
Test Date: 6/9/06

Complete one of these forms for **each** designated seating position that can be adjusted to forward-facing or that is a forward-facing seat, other than the driver's seat (S7.1.1.5(a), **and** that has seat belt retractors that are not solely automatic locking retractors. (S7.1.1.5(c))

DESIGNATED SEATING POSITION: **Left Rear Passenger**

- | | |
|-------------------------------------|--|
| <input type="checkbox"/> | N/A – no retractor is at this position |
| <input type="checkbox"/> | N/A – the retractor is an automatic locking retractor ONLY |
| <input checked="" type="checkbox"/> | 1. Record test fore-aft seat position:
(S7.1.1.5(c)(1)) (Any position is acceptable) FIXED |
| <input checked="" type="checkbox"/> | 2. Does the lap belt portion of the seat belt in the forward-facing seat or seat that can be adjusted to forward-facing consist of a locking device that does NOT have to be attached by the vehicle user to the seat belt webbing, retractor, or any other part of the vehicle. (S7.1.1.5 (a)) |
| <input checked="" type="checkbox"/> | Yes – Pass |
| <input type="checkbox"/> | No – Fail |
| <input checked="" type="checkbox"/> | 3. Does the lap belt portion of the seat belt in the forward-facing seat or seat that can be adjusted to forward-facing consist of a locking device that does NOT require inverting, twisting or deforming of the belt webbing. (S7.1.1.5 (a)) |
| <input checked="" type="checkbox"/> | Yes – Pass |
| <input type="checkbox"/> | No – Fail |
| <input checked="" type="checkbox"/> | 4. Place any adjustable seat belt anchorage in the lowest adjustment position. |
| <input checked="" type="checkbox"/> | N/A The anchorage is not adjustable. |
| <input checked="" type="checkbox"/> | 5. Buckle the seat belt. (S7.1.1.5(c)(1)) |
| <input checked="" type="checkbox"/> | 6. Locate a reference point A on the seat belt buckle. (S7.1.1.5(c)(2)) |
| <input checked="" type="checkbox"/> | 7. Locate a reference point B on the attachment hardware or retractor assembly at the other end of the lap belt or lap belt portion of the seat belt assembly. (S7.1.1.5(c)(2)) |
| <input checked="" type="checkbox"/> | 8. Does the vehicle user need to take some action to activate the locking feature on the lap belt portion of the seat belt in any forward-facing seat or seat that can be adjusted to forward-facing? |
| <input checked="" type="checkbox"/> | Yes, go to 8.1 |
| <input type="checkbox"/> | No, go to 9. |
| <input checked="" type="checkbox"/> | 8.1 Does the vehicle owner's manual include a description in words and/or diagrams describing how to activate the locking feature so that the seat belt assembly can tightly secure a child restraint system and how to deactivate the locking feature to remove the child restraint system. (S7.1.1.5(b)) |
| <input checked="" type="checkbox"/> | Yes – Pass |
| <input type="checkbox"/> | No – Fail |

- X** 9. Adjust the lap belt or lap belt portion of the seat belt assembly according to any procedures recommended in the vehicle owner's manual to activate any locking feature so that the webbing between points A and B is at the maximum length allowed by the belt system. (S7.1.1.5(c)(2) & S7.1.1.5(c)(1))
- X** 10. Measure and record the distance between points A and B along the longitudinal centerline of the webbing for the lap belt or lap belt portion of the seat belt assembly. (S7.1.1.5(c)(2))
Measured distance between A and B (inches): 69 ¼ inches
- X**
X 11. Readjust the belt system so that the webbing between points A and B is at 1/2 the maximum length of the webbing. (S7.1.1.5(c)(3))
- X** 12. To the lap belt or lap belt portion of the seat belt assembly, apply a preload of 10 pounds using the webbing tension pull device in Figure 5. Apply the load in a vertical plane parallel to the longitudinal axis of the vehicle and passing through the seating reference point of the designated seating position. Apply the preload in a horizontal direction toward the front of the vehicle with a force application angle of not less than 5 degrees nor more than 15 degrees above the horizontal. (S7.1.1.5(c)(4))
Measured force application angle (Spec. 5-15 degrees): 12°
- X**
X 13. Measure the length between points A and B along the longitudinal centerline of the webbing while the preload is being applied. (S7.1.1.5(c)(4))
Measured distance between A and B (inches): 27 inches
- X**
X 14. Increase the load to 50 pounds at a rate of no more than 50 pounds per second. Attain the load in not more than 5 seconds. (If webbing sensitive emergency locking retractors are installed as part of the lap belt or lap belt portion of the seat belt assembly, apply the load at a rate less than the threshold value for lock-up specified by the manufacturer.) Maintain the load for at least 5 seconds. Measure and record the distance between points A and B along the longitudinal centerline of the webbing. (S7.1.1.5(c)(5))
Record onset rate (lb/sec) (spec. 10 to 50 lb/sec) (S7.1.1.5(c)(5)): 35lbs/sec
Measured distance between A and B (inches) (S7.1.1.5(c)(6)): 27 ½ inches
- X**
X
X
X 15. Let the seat belt webbing retract to its minimum length with the seat belt still buckled
16. To the lap belt or lap belt portion of the seat belt assembly, apply a preload of 10 pounds using the webbing tension pull device in Figure 5. Apply the load in a vertical plane parallel to the longitudinal axis of the vehicle and passing through the seating reference point of the designated seating position. Apply the preload in a horizontal direction toward the front of the vehicle with a force application angle of not less than 5 degrees nor more than 15 degrees above the horizontal. (S7.1.1.5(c)(4))
Measured force application angle _____ (spec. 5 - 15 degrees)
Failed; minimum won't lock
- X** 17. Measure the length between points A and B along the longitudinal centerline of the webbing while the preload is being applied. (S7.1.1.5(c)(4))
Measured distance between A and B _____ **Failed; minimum won't lock**
- X** 18. Increase the load to 50 pounds at a rate of no more than 50 pounds per second. Attain the load in not more than 5 seconds. (If webbing sensitive emergency locking retractors are installed as part of the lap belt or lap belt portion of the seat belt assembly, apply the load at a rate less than the threshold value for lock-up specified by the manufacturer.) Maintain the load for at least 5 seconds. Measure and record the distance between points A and B along the longitudinal centerline of the webbing. (S7.1.1.5(c)(5))
Record onset rate _____(spec. 10 to 50 lb/sec) (S7.1.1.5(c)(5))
Measured distance between A and B _____ (S7.1.1.5(c)(6))
Failed; minimum won't lock

19. Subtract the measurement in 13 from the measurement in 14 and the measurement in 17 from the measurement in 18. Is the difference 2 inches or less for both?
(S7.1.1.5(c)(7))
14-13 = $27\frac{1}{2} - 27 = \frac{1}{2}$ inch
18-17 = **Failed; minimum won't lock**
- Yes – Pass
 No – Fail
20. Subtract the measurement in 14 from the measurement in 10 and the measurement in 18 from the measurement in 10. Is the difference 3 inches or more for both?
(S7.1.1.5(c)(8))
10-14 = $69\frac{1}{4} - 27\frac{1}{2} = 41\frac{3}{4}$ inches
10-18 = **Failed; minimum won't lock**
- Yes – Pass
 No – Fail

REMARKS:

I certify that I have read and performed each instruction.

Signature: Wayne Zuhl

Date: 6/9/06

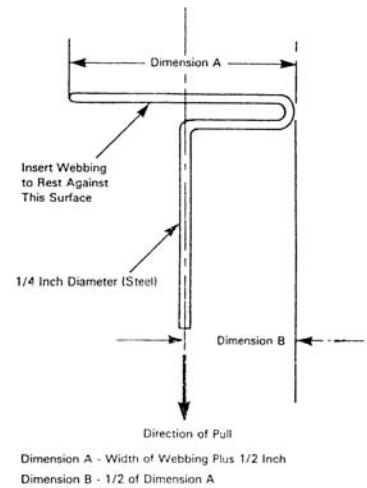

Figure 5. - Webbing Tension Pull Device

DATA SHEET 8

LAP BELT LOCKABILITY

Passenger cars, trucks, buses, and multipurpose passenger
Vehicles with a GVWR of 10,000 pounds or less. (S7.1.1.5)

Test Vehicle: 2006 Pontiac G6
Test Program: FMVSS 208 Compliance
Test Technician: Wayne Dahlke

NHTSA No.: C60104
Test Date: 6/9/06

Complete one of these forms for **each** designated seating position that can be adjusted to forward-facing or that is a forward-facing seat, other than the driver's seat (S7.1.1.5(a), **and** that has seat belt retractors that are not solely automatic locking retractors. (S7.1.1.5(c))

DESIGNATED SEATING POSITION: **Center Rear Passenger**

- | | |
|-------------------------------------|--|
| <input type="checkbox"/> | N/A – no retractor is at this position |
| <input type="checkbox"/> | N/A – the retractor is an automatic locking retractor ONLY |
| <input checked="" type="checkbox"/> | 1. Record test fore-aft seat position: FIXED (S7.1.1.5(c)(1)) (Any position is acceptable) |
| <input checked="" type="checkbox"/> | 2. Does the lap belt portion of the seat belt in the forward-facing seat or seat that can be adjusted to forward-facing consist of a locking device that does NOT have to be attached by the vehicle user to the seat belt webbing, retractor, or any other part of the vehicle. (S7.1.1.5 (a)) |
| <input checked="" type="checkbox"/> | Yes – Pass |
| <input type="checkbox"/> | No – Fail |
| <input checked="" type="checkbox"/> | 3. Does the lap belt portion of the seat belt in the forward-facing seat or seat that can be adjusted to forward-facing consist of a locking device that does NOT require inverting, twisting or deforming of the belt webbing. (S7.1.1.5 (a)) |
| <input checked="" type="checkbox"/> | Yes – Pass |
| <input type="checkbox"/> | No – Fail |
| <input checked="" type="checkbox"/> | 4. Place any adjustable seat belt anchorage in the lowest adjustment position. |
| <input checked="" type="checkbox"/> | N/A The anchorage is not adjustable. |
| <input checked="" type="checkbox"/> | 5. Buckle the seat belt. (S7.1.1.5(c)(1)) |
| <input checked="" type="checkbox"/> | 6. Locate a reference point A on the seat belt buckle. (S7.1.1.5(c)(2)) |
| <input checked="" type="checkbox"/> | 7. Locate a reference point B on the attachment hardware or retractor assembly at the other end of the lap belt or lap belt portion of the seat belt assembly. (S7.1.1.5(c)(2)) |
| <input checked="" type="checkbox"/> | 8. Does the vehicle user need to take some action to activate the locking feature on the lap belt portion of the seat belt in any forward-facing seat or seat that can be adjusted to forward-facing? |
| <input checked="" type="checkbox"/> | Yes, go to 8.1 |
| <input type="checkbox"/> | No, go to 9 |
| <input checked="" type="checkbox"/> | 8.1 Does the vehicle owner's manual include a description in words and/or diagrams describing how to activate the locking feature so that the seat belt assembly can tightly secure a child restraint system and how to deactivate the locking feature to remove the child restraint system. (S7.1.1.5(b)) |
| <input checked="" type="checkbox"/> | Yes – Pass |
| <input type="checkbox"/> | No – Fail |

- X** 9. Adjust the lap belt or lap belt portion of the seat belt assembly according to any procedures recommended in the vehicle owner's manual to activate any locking feature so that the webbing between points A and B is at the maximum length allowed by the belt system. (S7.1.1.5(c)(2) & S7.1.1.5(c)(1))
- X** 10. Measure and record the distance between points A and B along the longitudinal centerline of the webbing for the lap belt or lap belt portion of the seat belt assembly. (S7.1.1.5(c)(2))
Measured distance between A and B (inches): 68 inches
- X**
X 11. Readjust the belt system so that the webbing between points A and B is at 1/2 the maximum length of the webbing. (S7.1.1.5(c)(3))
- X** 12. To the lap belt or lap belt portion of the seat belt assembly, apply a preload of 10 pounds using the webbing tension pull device in Figure 5. Apply the load in a vertical plane parallel to the longitudinal axis of the vehicle and passing through the seating reference point of the designated seating position. Apply the preload in a horizontal direction toward the front of the vehicle with a force application angle of not less than 5 degrees nor more than 15 degrees above the horizontal. (S7.1.1.5(c)(4))
Measured force application angle (Spec. 5-15 degrees): 8°
- X**
X 13. Measure the length between points A and B along the longitudinal centerline of the webbing while the preload is being applied. (S7.1.1.5(c)(4))
Measured distance between A and B (inches): 27 inches
- X**
X 14. Increase the load to 50 pounds at a rate of no more than 50 pounds per second. Attain the load in not more than 5 seconds. (If webbing sensitive emergency locking retractors are installed as part of the lap belt or lap belt portion of the seat belt assembly, apply the load at a rate less than the threshold value for lock-up specified by the manufacturer.) Maintain the load for at least 5 seconds. Measure and record the distance between points A and B along the longitudinal centerline of the webbing. (S7.1.1.5(c)(5))
Record onset rate (lb/sec) (spec. 10 to 50 lb/sec) (S7.1.1.5(c)(5)): 30lbs/sec
Measured distance between A and B (inches) (S7.1.1.5(c)(6)): 27 3/8 inches
- X**
X
X
X 15. Let the seat belt webbing retract to its minimum length with the seat belt still buckled
- X** 16. To the lap belt or lap belt portion of the seat belt assembly, apply a preload of 10 pounds using the webbing tension pull device in Figure 5. Apply the load in a vertical plane parallel to the longitudinal axis of the vehicle and passing through the seating reference point of the designated seating position. Apply the preload in a horizontal direction toward the front of the vehicle with a force application angle of not less than 5 degrees nor more than 15 degrees above the horizontal. (S7.1.1.5(c)(4))
Measured force application angle ____ (spec. 5 - 15 degrees)
Failed; minimum won't lock
- X** 17. Measure the length between points A and B along the longitudinal centerline of the webbing while the preload is being applied. (S7.1.1.5(c)(4))
Measured distance between A and B _____
Failed; minimum won't lock

18. Increase the load to 50 pounds at a rate of no more than 50 pounds per second. Attain the load in not more than 5 seconds. (If webbing sensitive emergency locking retractors are installed as part of the lap belt or lap belt portion of the seat belt assembly, apply the load at a rate less than the threshold value for lock-up specified by the manufacturer.) Maintain the load for at least 5 seconds. Measure and record the distance between points A and B along the longitudinal centerline of the webbing. (S7.1.1.5(c)(5))
 Record onset rate _____ (spec. 10 to 50 lb/sec) (S7.1.1.5(c)(5))
 Measured distance between A and B _____ (S7.1.1.5(c)(6))
19. Subtract the measurement in 13 from the measurement in 14 and the measurement in 17 from the measurement in 18. Is the difference 2 inches or less for both? (S7.1.1.5(c)(7))
 14-13 = $27 \frac{3}{8} - 27 = \frac{3}{8}$ inches
 18-17 = **Failed; minimum won't lock**
- Yes – Pass
 No – Fail
20. Subtract the measurement in 14 from the measurement in 10 and the measurement in 18 from the measurement in 10. Is the difference 3 inches or more for both? (S7.1.1.5(c)(8))
 10-14 = $68 - 27 \frac{3}{8} = 40 \frac{5}{8}$ inches
 10-18 = **Failed; minimum won't lock**
- Yes – Pass
 No – Fail

REMARKS:

I certify that I have read and performed each instruction.

Signature: Wayne Gahl

Date: 6/9/06

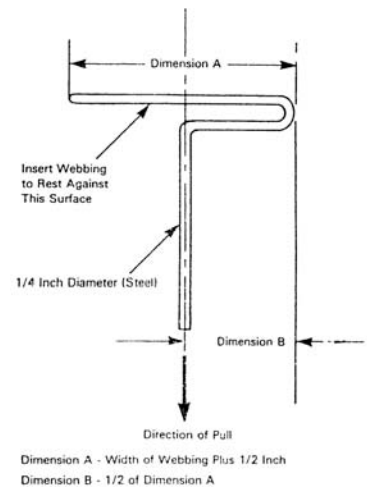

Figure 5. - Webbing Tension Pull Device

DATA SHEET 8

LAP BELT LOCKABILITY

**Passenger cars, trucks, buses, and multipurpose passenger
Vehicles with a GVWR of 10,000 pounds or less. (S7.1.1.5)**

Test Vehicle: 2006 Pontiac G6
 Test Program: FMVSS 208 Compliance
 Test Technician: Wayne Dahlke

NHTSA No.: C60104
 Test Date: 6/9/06

Complete one of these forms for **each** designated seating position that can be adjusted to forward-facing or that is a forward-facing seat, other than the driver's seat (S7.1.1.5(a), **and** that has seat belt retractors that are not solely automatic locking retractors. (S7.1.1.5(c))

DESIGNATED SEATING POSITION:	Right Rear Passenger
------------------------------	----------------------

- | | | |
|-------------------------------------|-----|--|
| <input type="checkbox"/> | | N/A – no retractor is at this position |
| <input type="checkbox"/> | | N/A – the retractor is an automatic locking retractor ONLY |
| <input checked="" type="checkbox"/> | 1. | Record test fore-aft seat position: FIXED (S7.1.1.5(c)(1)) (Any position is acceptable) |
| <input checked="" type="checkbox"/> | 2. | Does the lap belt portion of the seat belt in the forward-facing seat or seat that can be adjusted to forward-facing consist of a locking device that does NOT have to be attached by the vehicle user to the seat belt webbing, retractor, or any other part of the vehicle. (S7.1.1.5 (a)) |
| | | <input checked="" type="checkbox"/> Yes – Pass |
| | | <input type="checkbox"/> No – Fail |
| <input checked="" type="checkbox"/> | 3. | Does the lap belt portion of the seat belt in the forward-facing seat or seat that can be adjusted to forward-facing consist of a locking device that does NOT require inverting, twisting or deforming of the belt webbing. (S7.1.1.5 (a)) |
| | | <input checked="" type="checkbox"/> Yes – Pass |
| | | <input type="checkbox"/> No – Fail |
| <input checked="" type="checkbox"/> | 4. | Place any adjustable seat belt anchorage in the lowest adjustment position. |
| | | <input checked="" type="checkbox"/> N/A The anchorage is not adjustable. |
| <input checked="" type="checkbox"/> | 5. | Buckle the seat belt. (S7.1.1.5(c)(1)) |
| <input checked="" type="checkbox"/> | 6. | Locate a reference point A on the seat belt buckle. (S7.1.1.5(c)(2)) |
| <input checked="" type="checkbox"/> | 7. | Locate a reference point B on the attachment hardware or retractor assembly at the other end of the lap belt or lap belt portion of the seat belt assembly. (S7.1.1.5(c)(2)) |
| <input type="checkbox"/> | 8. | Does the vehicle user need to take some action to activate the locking feature on the lap belt portion of the seat belt in any forward-facing seat or seat that can be adjusted to forward-facing? |
| | | <input checked="" type="checkbox"/> Yes, go to 8.1 |
| | | <input type="checkbox"/> No, go to 9. |
| <input checked="" type="checkbox"/> | 8.1 | Does the vehicle owner's manual include a description in words and/or diagrams describing how to activate the locking feature so that the seat belt assembly can tightly secure a child restraint system and how to deactivate the locking feature to remove the child restraint system. (S7.1.1.5(b)) |
| | | <input checked="" type="checkbox"/> Yes – Pass |
| | | <input type="checkbox"/> No – Fail |

- X** 9. Adjust the lap belt or lap belt portion of the seat belt assembly according to any procedures recommended in the vehicle owner's manual to activate any locking feature so that the webbing between points A and B is at the maximum length allowed by the belt system. (S7.1.1.5(c)(2) & S7.1.1.5(c)(1))
- X** 10. Measure and record the distance between points A and B along the longitudinal centerline of the webbing for the lap belt or lap belt portion of the seat belt assembly. (S7.1.1.5(c)(2))
Measured distance between A and B (inches): 67 ¼ inches
- X**
X 11. Readjust the belt system so that the webbing between points A and B is at 1/2 the maximum length of the webbing. (S7.1.1.5(c)(3))
- X** 12. To the lap belt or lap belt portion of the seat belt assembly, apply a preload of 10 pounds using the webbing tension pull device in Figure 5. Apply the load in a vertical plane parallel to the longitudinal axis of the vehicle and passing through the seating reference point of the designated seating position. Apply the preload in a horizontal direction toward the front of the vehicle with a force application angle of not less than 5 degrees nor more than 15 degrees above the horizontal. (S7.1.1.5(c)(4))
Measured force application angle (Spec. 5-15 degrees): 9°
- X**
X 13. Measure the length between points A and B along the longitudinal centerline of the webbing while the preload is being applied. (S7.1.1.5(c)(4))
Measured distance between A and B (inches): 27 5/8 inches
- X**
X 14. Increase the load to 50 pounds at a rate of no more than 50 pounds per second. Attain the load in not more than 5 seconds. (If webbing sensitive emergency locking retractors are installed as part of the lap belt or lap belt portion of the seat belt assembly, apply the load at a rate less than the threshold value for lock-up specified by the manufacturer.) Maintain the load for at least 5 seconds. Measure and record the distance between points A and B along the longitudinal centerline of the webbing. (S7.1.1.5(c)(5))
Record onset rate (lb/sec) (spec. 10 to 50 lb/sec) (S7.1.1.5(c)(5)): 35lbs/sec
Measured distance between A and B (inches) (S7.1.1.5(c)(6)): 27 ¾ inches
- X**
X
X
X 15. Let the seat belt webbing retract to its minimum length with the seat belt still buckled
16. To the lap belt or lap belt portion of the seat belt assembly, apply a preload of 10 pounds using the webbing tension pull device in Figure 5. Apply the load in a vertical plane parallel to the longitudinal axis of the vehicle and passing through the seating reference point of the designated seating position. Apply the preload in a horizontal direction toward the front of the vehicle with a force application angle of not less than 5 degrees nor more than 15 degrees above the horizontal. (S7.1.1.5(c)(4))
Measured force application angle _____(spec. 5 - 15 degrees)
Failed; minimum won't lock
- X** 17. Measure the length between points A and B along the longitudinal centerline of the webbing while the preload is being applied. (S7.1.1.5(c)(4))
Measured distance between A and B _____
Failed; minimum won't lock

18. Increase the load to 50 pounds at a rate of no more than 50 pounds per second. Attain the load in not more than 5 seconds. (If webbing sensitive emergency locking retractors are installed as part of the lap belt or lap belt portion of the seat belt assembly, apply the load at a rate less than the threshold value for lock-up specified by the manufacturer.) Maintain the load for at least 5 seconds. Measure and record the distance between points A and B along the longitudinal centerline of the webbing. (S7.1.1.5(c)(5))
 Record onset rate _____ (spec. 10 to 50 lb/sec) (S7.1.1.5(c)(5))
 Measured distance between A and B _____(S7.1.1.5(c)(6))

19. Subtract the measurement in 13 from the measurement in 14 and the measurement in 17 from the measurement in 18. Is the difference 2 inches or less for both?
 (S7.1.1.5(c)(7))

14-13 = $27 \frac{3}{4} - 27 \frac{5}{8} = 1/8$ inch

18-17 = **Failed; minimum won't lock**

Yes – Pass

No – Fail

20. Subtract the measurement in 14 from the measurement in 10 and the measurement in 18 from the measurement in 10. Is the difference 3 inches or more for both?
 (S7.1.1.5(c)(8))

10-14 = $67 \frac{1}{4} - 27 \frac{3}{4} = 39 \frac{1}{2}$ inches

10-18 = **Failed; minimum won't lock**

Yes – Pass

No – Fail

REMARKS:

I certify that I have read and performed each instruction.

Signature: Wayne Zable

Date: 6/9/06

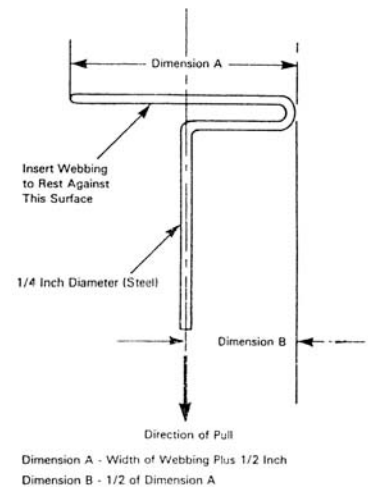

Figure 5. - Webbing Tension Pull Device

DATA SHEET 9

FMVSS 208 SEAT BELT WARNING SYSTEM CHECK (S7.3)

Test Vehicle: 2006 Pontiac G6
 Test Program: FMVSS 208 Compliance
 Test Technician: Wayne Dahlke

NHTSA No.: C60104
 Test Date: 6/9/06

- | | | |
|---|-----|---|
| X | 1. | The occupant is in the driver's seat. |
| X | 2. | The seat belt is in the stowed position. |
| X | 3. | The key is in the "on" or "start" position. |
| X | 4. | The time duration of the audible signal beginning with key "on" or "start" is |
| X | | Seconds: 5 |
| X | 5. | The occupant is in the driver's seat. |
| X | 6. | The seat belt is in the stowed position. |
| X | 7. | The key is in the "on" or "start" position. |
| X | 8. | The time duration of the warning light beginning with key "on" or "start" is |
| X | | Seconds: >60 |
| X | 9. | The occupant is in the driver's seat. |
| X | 10. | The seat belt is in the latched position and with at least 4 inches of belt webbing extended. |
| X | 11. | The key is in the "on" or "start" position. |
| X | 12. | The time duration of the warning light beginning with key "on" or "start" is |
| X | | Seconds: 0 |
| X | 13. | Complete the following table with the data from 4, 8, and 12 to determine which option is used. |

		Warning light	Warning light specification	Audible signal	Audible signal specification*
S7.3 (a)(1)	Belt stowed & key on or start	Item 8: >60	60 seconds minimum	Item 4: 5	4 to 8 seconds
S7.3 (a)(2)	Belt latched & key on or start	Item 12: 0	4 to 8 seconds		
	Belt stowed & key on or start	Item 8: >60	4 to 8 seconds	Item 4: 5	4 to 8 seconds

* 49 USCS @ 30124 does NOT allow an audible signal to operate for more than 8 seconds. A voluntary audible signal after the 4 to 8 second required signal may be provided. It must be differentiated from the required signal (5/25/2001 legal interpretation to Longacre and Associates).

14. The seat belt warning system meets the requirements of (manufacturers may comply with either section)
- S7.3 (a)(1)
 - S7.3 (a)(2)
 - FAIL – does not meet the requirements of either option
15. Note wording of visual warning: (S7.3(a)(1) and S7.3(a)(2))
- Fasten seat belts
 - Fasten belts
 - Symbol 101 -  or
 - FAIL – does not use any of the above wording or symbol

REMARKS:

I certify that I have read and performed each instruction.

Signature: Wayne Zahl

Date: 6/9/06

DATA SHEET 10
BELT CONTACT FORCE (S7.4.3)

Test Vehicle: 2006 Pontiac G6
 Test Program: FMVSS 208 Compliance
 Test Technician: Wayne Dahlke

NHTSA No.: C60104
 Test Date: 6/9/06

Test all Type 2 seat belts other than those in walk-in van-type vehicles and those at front outboard designated seating positions in passenger cars. Complete a form for each applicable seat belt.

DESIGNATED SEATING POSITION:	Left Rear Passenger
------------------------------	---------------------

- | | |
|----------|--|
| X | 1. Does the vehicle incorporate a webbing tension-relieving device? |
| | <input type="checkbox"/> Yes, this form is complete |
| | <input checked="" type="checkbox"/> No, continue with this check sheet |
- | | |
|----------|--|
| X | 2. Position the seat's adjustable lumbar supports so that the lumbar support is in its lowest, retracted or deflated adjustment position. (S8.1.3) |
| | <input checked="" type="checkbox"/> N/A, no lumbar adjustment |
- | | |
|----------|--|
| X | 3. Position any adjustable parts of the seat that provide additional support so that they are in the lowest or most open adjustment position. (S16.2.10.2) |
| | <input checked="" type="checkbox"/> N/A, no additional support adjustment |
- | | |
|----------|---|
| X | 4. Is the fore-aft position of the seat adjustable? |
| | <input checked="" type="checkbox"/> No- go to 5 |
| | <input type="checkbox"/> Yes – Put the seat in the mid fore-aft and full down height position determined in Data Sheet 14.2 |
- | | |
|----------|--|
| X | 5. Is the seat back angle adjustable? |
| | <input checked="" type="checkbox"/> No- go to 6 |
| | <input type="checkbox"/> Yes-Use the seat back angle determined in Data Sheet 14.2 |
- | | |
|----------|--|
| X | 6. Position the test dummies according to dummy position placement instructions in Appendix F. Complete the Appendix F check sheets, but include them in the test report ONLY if there is a test failure. |
|----------|--|
- | | |
|----------|--------------------------------|
| X | 7. Fasten the seat belt latch. |
|----------|--------------------------------|
- | | |
|----------|--|
| X | 8. Pull either 12 inches of belt webbing or the maximum available amount of belt webbing, whichever is less, from the retractor and then release it, allowing the belt webbing to return to the dummy's chest. |
|----------|--|
- | | |
|----------|--|
| X | 9. Locate the point where the centerline of the upper torso belt webbing crosses the midsagittal line on the dummy's chest. At that point pull the belt webbing out 3 inches from the dummy's chest and release until it is within one inch from the dummy's chest. (S10.8) Using a force measuring gage with a full scale range of no more than 1.5 pounds, measure the contact force perpendicular to the dummy's chest exerted by the belt webbing. |
| | Contact Force (lb): |
| | <input checked="" type="checkbox"/> 0.0 to 0.7 pounds – Pass <u>0.4 lbs</u> |
| | <input type="checkbox"/> Greater than 0.7 pounds - Fail |

REMARKS:

I certify that I have read and performed each instruction.

Signature: Wayne Stahl

Date: 6/9/06

DATA SHEET 10
BELT CONTACT FORCE (S7.4.3)

Test Vehicle: 2006 Pontiac G6
 Test Program: FMVSS 208 Compliance
 Test Technician: Wayne Dahlke

NHTSA No.: C60104
 Test Date: 6/9/06

Test all Type 2 seat belts other than those in walk-in van-type vehicles and those at front outboard designated seating positions in passenger cars. Complete a form for each applicable seat belt.

DESIGNATED SEATING POSITION:	Center Rear Passenger
------------------------------	-----------------------

- | | | |
|----------|----|---|
| X | 1. | Does the vehicle incorporate a webbing tension-relieving device?
<input type="checkbox"/> Yes, this form is complete
<input checked="" type="checkbox"/> No, continue with this check sheet |
| X | 2. | Position the seat's adjustable lumbar supports so that the lumbar support is in its lowest, retracted or deflated adjustment position. (S8.1.3)
<input checked="" type="checkbox"/> N/A, no lumbar adjustment |
| X | 3. | Position any adjustable parts of the seat that provide additional support so that they are in the lowest or most open adjustment position. (S16.2.10.2)
<input checked="" type="checkbox"/> N/A, no additional support adjustment |
| X | 4. | Is the fore-aft position of the seat adjustable?
<input checked="" type="checkbox"/> No- go to 5
<input type="checkbox"/> Yes – Put the seat in the mid fore-aft and full down height position determined in Data Sheet 14.2 |
| X | 5. | Is the seat back angle adjustable?
<input checked="" type="checkbox"/> No- go to 6
<input type="checkbox"/> Yes-Use the seat back angle determined in Data Sheet 14.2 |
| X | 6. | Position the test dummies according to dummy position placement instructions in Appendix F. Complete the Appendix F check sheets, but include them in the test report ONLY if there is a test failure. |
| X | 7. | Fasten the seat belt latch. |
| X | 8. | Pull either 12 inches of belt webbing or the maximum available amount of belt webbing, whichever is less, from the retractor and then release it, allowing the belt webbing to return to the dummy's chest. |
| X | 9. | Locate the point where the centerline of the upper torso belt webbing crosses the midsagittal line on the dummy's chest. At that point pull the belt webbing out 3 inches from the dummy's chest and release until it is within one inch from the dummy's chest. (S10.8) Using a force measuring gage with a full scale range of no more than 1.5 pounds, measure the contact force perpendicular to the dummy's chest exerted by the belt webbing. |
| X | | Contact Force (lb):
<input checked="" type="checkbox"/> 0.0 to 0.7 pounds – Pass <u>0.6 lbs</u>
<input type="checkbox"/> Greater than 0.7 pounds - Fail |

REMARKS:

I certify that I have read and performed each instruction.

Signature: Wayne Zuhl

Date: 6/9/06

DATA SHEET 10
BELT CONTACT FORCE (S7.4.3)

Test Vehicle: 2006 Pontiac G6
 Test Program: FMVSS 208 Compliance
 Test Technician: Wayne Dahlke

NHTSA No.: C60104
 Test Date: 6/9/06

Test all Type 2 seat belts other than those in walk-in van-type vehicles and those at front outboard designated seating positions in passenger cars. Complete a form for each applicable seat belt.

DESIGNATED SEATING POSITION:	Right Rear Passenger
------------------------------	----------------------

- | | |
|----------|---|
| X | 1. Does the vehicle incorporate a webbing tension-relieving device? |
| | <input type="checkbox"/> Yes, this form is complete
<input checked="" type="checkbox"/> No, continue with this check sheet |
- | | |
|----------|--|
| X | 2. Position the seat's adjustable lumbar supports so that the lumbar support is in its lowest, retracted or deflated adjustment position. (S8.1.3) |
| | <input checked="" type="checkbox"/> N/A, no lumbar adjustment |
- | | |
|----------|--|
| X | 3. Position any adjustable parts of the seat that provide additional support so that they are in the lowest or most open adjustment position. (S16.2.10.2) |
| | <input checked="" type="checkbox"/> N/A, no additional support adjustment |
- | | |
|----------|--|
| X | 4. Is the fore-aft position of the seat adjustable? |
| | <input checked="" type="checkbox"/> No- go to 5
<input type="checkbox"/> Yes – Put the seat in the mid fore-aft and full down height position determined in Data Sheet 14.2 |
- | | |
|----------|---|
| X | 5. Is the seat back angle adjustable? |
| | <input checked="" type="checkbox"/> No- go to 6
<input type="checkbox"/> Yes-Use the seat back angle determined in Data Sheet 14.2 |
- | | |
|----------|--|
| X | 6. Position the test dummies according to dummy position placement instructions in Appendix F. Complete the Appendix F check sheets, but include them in the test report ONLY if there is a test failure. |
|----------|--|
- | | |
|----------|--------------------------------|
| X | 7. Fasten the seat belt latch. |
|----------|--------------------------------|
- | | |
|----------|--|
| X | 8. Pull either 12 inches of belt webbing or the maximum available amount of belt webbing, whichever is less, from the retractor and then release it, allowing the belt webbing to return to the dummy's chest. |
|----------|--|
- | | |
|----------|--|
| X | 9. Locate the point where the centerline of the upper torso belt webbing crosses the midsagittal line on the dummy's chest. At that point pull the belt webbing out 3 inches from the dummy's chest and release until it is within one inch from the dummy's chest. (S10.8) Using a force measuring gage with a full scale range of no more than 1.5 pounds, measure the contact force perpendicular to the dummy's chest exerted by the belt webbing. |
|----------|--|
- | | |
|----------|---|
| X | Contact Force (lb): |
| | <input checked="" type="checkbox"/> 0.0 to 0.7 pounds – Pass <u>0.4 lbs.</u>
<input type="checkbox"/> Greater than 0.7 pounds - Fail |

REMARKS:

I certify that I have read and performed each instruction.

Signature: Wesley Gahl

Date: 6/9/06

DATA SHEET 11
LATCH PLATE ACCESS (S7.4.4)

Test Vehicle: 2006 Pontiac G6
 Test Program: FMVSS 208 Compliance
 Test Technician: Wayne Dahlke

NHTSA No.: C60104
 Test Date: 6/9/06

Test all front outboard seat belts **other than those in** walk-in van-type vehicles and those at front outboard designated seating positions in **passenger cars**. Complete a form for each applicable seat belt.

DESIGNATED SEATING POSITION:	Not Applicable For Any Position - Passenger Car
------------------------------	---

- | | | |
|---|-----|--|
| <input style="width: 20px; height: 15px;" type="checkbox"/> | 1. | Put the seat in the forwardmost fore-aft and full down height position determined in Data Sheet 14.2. (S10.7) |
| <input style="width: 20px; height: 15px;" type="checkbox"/> | 2. | Put the seat back angle in the position determined in Data Sheet 14.2. |
| <input style="width: 20px; height: 15px;" type="checkbox"/> | 3. | Position the test dummy using the procedures in Appendix F. (Some modifications to the positioning procedure may need to be made because the seat is in its forward most position. Note on the Appendix F positioning check sheet any deviations necessary to position the Part 572, Subpart E dummy.) Complete the Appendix F check sheets, but include them in the test report ONLY if there is a test failure. |
| <input style="width: 20px; height: 15px;" type="checkbox"/> | 4. | Position the adjustable seat belt anchorage in the manufacturer's nominal design position for a 50 th percentile adult male occupant. |
| <input style="width: 20px; height: 15px;" type="checkbox"/> | 5. | Attach the inboard reach string to the base of the head following the instructions on Figure 3. |
| <input style="width: 20px; height: 15px;" type="checkbox"/> | 6. | Attach the outboard reach string to the torso sheath following the instructions on Figure 3. |
| <input style="width: 20px; height: 15px;" type="checkbox"/> | 7. | Place the latch plate in the stowed position. |
| <input style="width: 20px; height: 15px;" type="checkbox"/> | 8. | Extend inboard reach string in front of the dummy and then backward and outboard to the latch plate to generate an arc of the reach envelope of the test dummy's arms. Is the latch plate within the reach envelope? |
| | | <input style="width: 20px; height: 15px;" type="checkbox"/> Yes – Pass |
| | | <input style="width: 20px; height: 15px;" type="checkbox"/> No |
| <input style="width: 20px; height: 15px;" type="checkbox"/> | 9. | Extend outboard reach string in front of the dummy and then backward and outboard to the latch plate to generate arcs of the reach envelope of the test dummy's arms. Is the latch plate within the reach envelope? |
| | | <input style="width: 20px; height: 15px;" type="checkbox"/> Yes – Pass |
| | | <input style="width: 20px; height: 15px;" type="checkbox"/> No |
| <input style="width: 20px; height: 15px;" type="checkbox"/> | 10. | Is the latch plate within the inboard (item 10) or outboard (item 11) reach envelope? |
| | | <input style="width: 20px; height: 15px;" type="checkbox"/> Yes – Pass |
| | | <input style="width: 20px; height: 15px;" type="checkbox"/> No – Fail |
| <input style="width: 20px; height: 15px;" type="checkbox"/> | 11. | Using the clearance test block, specified in Figure 4, is there sufficient clearance between the vehicle seat and the side of vehicle interior to allow the test block to move unhindered to the latch plate or buckle? |
| | | <input style="width: 20px; height: 15px;" type="checkbox"/> Yes – Pass |
| | | <input style="width: 20px; height: 15px;" type="checkbox"/> No – Fail |

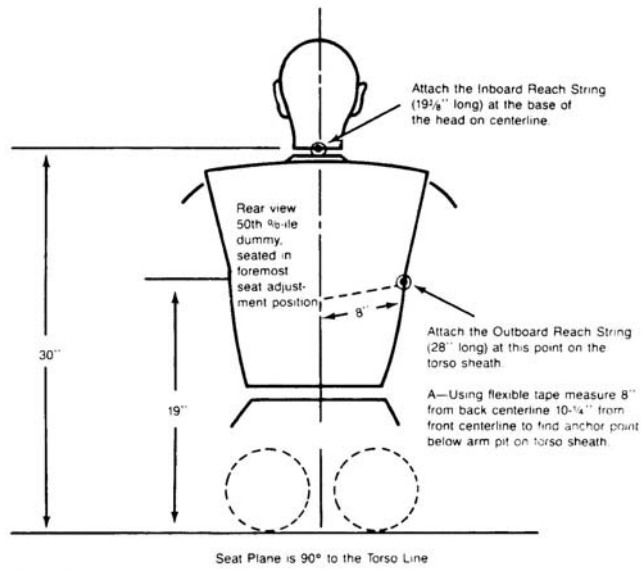

Figure 3. Location of Anchoring Points for Latchplate Reach Limiting Chains or Strings to Test for Latchplate Accessibility Using Subpart E Test Device

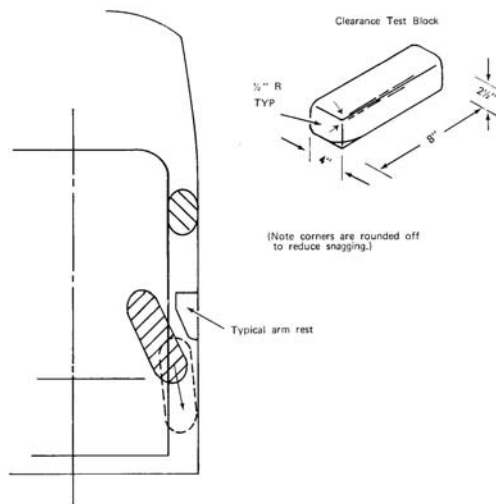

Figure 4—USE OF CLEARANCE TEST BLOCK TO DETERMINE HAND/ARM ACCESS

REMARKS:

I certify that I have read and performed each instruction.

Signature: Wayne Zable

Date: 6/9/06

DATA SHEET 12

SEAT BELT RETRACTION (S7.4.5)

Test Vehicle: 2006 Pontiac G6
 Test Program: FMVSS 208 Compliance
 Test Technician: Wayne Dahlke

NHTSA No.: C60104
 Test Date: 6/9/06

Test all front outboard seat belts other than those in walk-in van-type vehicles and those at front outboard designated seating positions in passenger cars. Complete a form for each applicable seat belt.

DESIGNATED SEATING POSITION:	Not Applicable For Any Position - Passenger Car
GVWR:	

- | | | | | | | | | | |
|-------------------------------------|--|----------------------------|--|-------------------------------------|--|----------------------------|--------------------------|--|----|
| <input checked="" type="checkbox"/> | | 1. | Is the vehicle a passenger car or walk-in van-type vehicle? | | | | | | |
| | | | <table style="border: none; margin-left: 20px;"> <tr> <td style="width: 5%; text-align: center; vertical-align: middle;"><input checked="" type="checkbox"/></td> <td style="width: 5%;"></td> <td>Yes, this form is complete</td> </tr> <tr> <td style="text-align: center; vertical-align: middle;"><input type="checkbox"/></td> <td></td> <td>No</td> </tr> </table> | <input checked="" type="checkbox"/> | | Yes, this form is complete | <input type="checkbox"/> | | No |
| <input checked="" type="checkbox"/> | | Yes, this form is complete | | | | | | | |
| <input type="checkbox"/> | | No | | | | | | | |
- | | | | |
|--------------------------|--|----|--|
| <input type="checkbox"/> | | 2. | Put the seat in the mid fore-aft and full down height position determined in Data Sheet 14.2. (S8.1.2) |
|--------------------------|--|----|--|
- | | | | |
|--------------------------|--|----|--|
| <input type="checkbox"/> | | 3. | Put the seat back angle in the position determined in Data Sheet 14.2. (8.1.3) |
|--------------------------|--|----|--|
- | | | | |
|--------------------------|--|----|--|
| <input type="checkbox"/> | | 4. | Position the Part 572 Subpart E test dummy according to dummy position placement instructions in Appendix F. Complete the Appendix F check sheets, but include them in the test report ONLY if there is a test failure. |
|--------------------------|--|----|--|
- | | | | |
|--------------------------|--|----|--|
| <input type="checkbox"/> | | 5. | Fasten the seat belt around the dummy. |
|--------------------------|--|----|--|
- | | | | |
|--------------------------|--|----|---|
| <input type="checkbox"/> | | 6. | Remove all slack from the lap belt portion. (S10.9) |
|--------------------------|--|----|---|
- | | | | |
|--------------------------|--|--|---|
| <input type="checkbox"/> | | | N/A, the seat does not have a fore-aft adjustment |
|--------------------------|--|--|---|
- | | | | |
|--------------------------|--|----|--|
| <input type="checkbox"/> | | 7. | Pull the upper torso webbing out of the retractor and allow it to retract; repeat this four times. (S10.9) |
|--------------------------|--|----|--|
- | | | | |
|--------------------------|--|----|--|
| <input type="checkbox"/> | | 8. | Apply a 2 to 4 pound tension load to the lap belt. (S10.9) |
|--------------------------|--|----|--|
- | | | | |
|--------------------------|--|--|----------------------------|
| <input type="checkbox"/> | | | Pound load applied: |
|--------------------------|--|--|----------------------------|
- | | | | | | | | | | |
|--------------------------|--|---------------|--|--------------------------|--|---------------|--------------------------|--|--------------|
| <input type="checkbox"/> | | 9. | Is the belt system equipped with a tension relieving device? | | | | | | |
| | | | <table style="border: none; margin-left: 20px;"> <tr> <td style="width: 5%; text-align: center; vertical-align: middle;"><input type="checkbox"/></td> <td style="width: 5%;"></td> <td>Yes, continue</td> </tr> <tr> <td style="text-align: center; vertical-align: middle;"><input type="checkbox"/></td> <td></td> <td>No, go to 12</td> </tr> </table> | <input type="checkbox"/> | | Yes, continue | <input type="checkbox"/> | | No, go to 12 |
| <input type="checkbox"/> | | Yes, continue | | | | | | | |
| <input type="checkbox"/> | | No, go to 12 | | | | | | | |
- | | | | |
|--------------------------|--|-----|--|
| <input type="checkbox"/> | | 10. | Introduce the maximum amount of slack into the upper torso bet that is recommended by the vehicle manufacturer in the vehicle owner's manual. (S10.9). |
|--------------------------|--|-----|--|
- | | | | |
|--------------------------|--|-----|--|
| <input type="checkbox"/> | | 11. | Check the statement that applies to this test vehicle: |
|--------------------------|--|-----|--|
- | | | | | | | | | | |
|--------------------------|--|---------------------|---|--------------------------|--|---------------------|--------------------------|--|-----------------|
| <input type="checkbox"/> | | 11.1 | Check the statement that applies to this test vehicle:
The torso and lap belt webbing of the seat belt system automatically retracts to a stowed position when the adjacent vehicle door is in an open position and the seat belt latch plate is released. | | | | | | |
| | | | <table style="border: none; margin-left: 20px;"> <tr> <td style="width: 5%; text-align: center; vertical-align: middle;"><input type="checkbox"/></td> <td style="width: 5%;"></td> <td>Yes – Pass go to 12</td> </tr> <tr> <td style="text-align: center; vertical-align: middle;"><input type="checkbox"/></td> <td></td> <td>No – go to 11.2</td> </tr> </table> | <input type="checkbox"/> | | Yes – Pass go to 12 | <input type="checkbox"/> | | No – go to 11.2 |
| <input type="checkbox"/> | | Yes – Pass go to 12 | | | | | | | |
| <input type="checkbox"/> | | No – go to 11.2 | | | | | | | |
- | | | | | | | | | | |
|--------------------------|--|---------------------|---|--------------------------|--|---------------------|--------------------------|--|-----------------|
| <input type="checkbox"/> | | 11.2 | The torso and lap belt webbing of the seat belt system automatically retracts when the seat belt latch plate is released. | | | | | | |
| | | | <table style="border: none; margin-left: 20px;"> <tr> <td style="width: 5%; text-align: center; vertical-align: middle;"><input type="checkbox"/></td> <td style="width: 5%;"></td> <td>Yes – Pass go to 12</td> </tr> <tr> <td style="text-align: center; vertical-align: middle;"><input type="checkbox"/></td> <td></td> <td>No – go to 11.3</td> </tr> </table> | <input type="checkbox"/> | | Yes – Pass go to 12 | <input type="checkbox"/> | | No – go to 11.3 |
| <input type="checkbox"/> | | Yes – Pass go to 12 | | | | | | | |
| <input type="checkbox"/> | | No – go to 11.3 | | | | | | | |
- | | | | | | | |
|--------------------------|--|------|--|--------------------------|--|------|
| <input type="checkbox"/> | | 11.3 | Neither 11.1 nor 11.2 apply. | | | |
| | | | <table style="border: none; margin-left: 20px;"> <tr> <td style="width: 5%; text-align: center; vertical-align: middle;"><input type="checkbox"/></td> <td style="width: 5%;"></td> <td>Fail</td> </tr> </table> | <input type="checkbox"/> | | Fail |
| <input type="checkbox"/> | | Fail | | | | |

12. With the webbing and hardware in the stowed position are the webbing and hardware prevented from being pinched when the door is closed?
- Yes – Pass
 No – Fail
13. If this test vehicle has an open body (without doors) and has a belt system with a tension-relieving device, does the belt system fully retract when the tension-relieving device is deactivated?
- N/A
 Yes – Pass
 No – Fail

REMARKS:

I certify that I have read and performed each instruction.

Signature: Wayne J. Ahl

Date: 6/9/06

DATA SHEET 13

SEAT BELT GUIDES AND HARDWARE (S7.4.6)

Test Vehicle: 2006 Pontiac G6
Test Program: FMVSS 208 Compliance
Test Technician: Wayne Dahlke

NHTSA No.: C60104
Test Date: 6/9/06

Test seat belts except those in walk-in van-type vehicles and those at front outboard designated seating positions in passenger cars. Complete a form for each applicable seat belt.

DESIGNATED SEATING POSITION: **Left Rear Passenger**

1. Is the seat cushion movable so that the seat back serves a function other than seating? (S7.4.6.1 (b))
 Yes, this form is complete
 No, go to 2
2. Is the seat removable? (S7.4.6.1(b))
 Yes, this form is complete
 No, go to 3
3. Is the seat movable so that the space formerly occupied by the seat can be used for a secondary function? (S7.4.6.1(b))
 Yes, this form is complete
 No, go to 4
4. Is the webbing designed to pass through the seat cushion or between the seat cushion and seat back? (S7.4.6.1(a))
 Yes, go to 5
 No, this form is complete
5. Does one of the following three parts, the seat belt latch plate, the buckle, or the seat belt webbing, stay on top of or above the seat cushion under normal conditions (i.e., conditions other than when belt hardware is intentionally pushed behind the seat by a vehicle occupant)? (S7.4.6.1(a))
 Yes – Pass
 No – Fail
Identify the part(s) on top or above the seat.
 Seat belt latch plate
 Buckle
 Seat belt webbing
6. Are the remaining two seat belt parts accessible under normal conditions?
 Yes – Pass
 No – Fail
7. The buckle and latch plate do not pass through the guides or conduits provided and fall behind the seat when the belt is completely retracted or, if the belt is nonretractable, the belt is unlatched. (S7.4.6.2)
 Yes – Pass
 No – Fail

8. The buckle and latch plate do not pass through the guides or conduits provided and fall behind the seat when the seat is moved to any position to which it is designed to be adjusted. (S7.4.6.2)
- Yes – Pass
 No – Fail
9. The buckle and latch plate do not pass through the guides or conduits provided and fall behind the seat back, if foldable, is folded forward as far as possible and then moved backward into position. (S7.4.6.2)
- Yes – Pass
 No – Fail
10. Is the inboard receptacle end of the seat belt assembly, installed in the front outboard designated seating position, accessible with the center armrest in any position to which it can be adjusted (without moving the armrest)? (S7.4.6.2)
- Yes – Pass
 No – Fail
 N/A – Rear seat

REMARKS:

I certify that I have read and performed each instruction.

Signature: Wayne Gahl

Date: 6/9/06

DATA SHEET 13

SEAT BELT GUIDES AND HARDWARE (S7.4.6)

Test Vehicle: 2006 Pontiac G6
Test Program: FMVSS 208 Compliance
Test Technician: Wayne Dahlke

NHTSA No.: C60104
Test Date: 6/9/06

Test seat belts except those in walk-in van-type vehicles and those at front outboard designated seating positions in passenger cars. Complete a form for each applicable seat belt.

DESIGNATED SEATING POSITION: **Center Rear Passenger**

1. Is the seat cushion movable so that the seat back serves a function other than seating? (S7.4.6.1 (b))
 Yes, this form is complete
 No, go to 2
2. Is the seat removable? (S7.4.6.1(b))
 Yes, this form is complete
 No, go to 3
3. Is the seat movable so that the space formerly occupied by the seat can be used for a secondary function? (S7.4.6.1(b))
 Yes, this form is complete
 No, go to 4
4. Is the webbing designed to pass through the seat cushion or between the seat cushion and seat back? (S7.4.6.1(a))
 Yes, go to 5
 No, this form is complete
5. Does one of the following three parts, the seat belt latch plate, the buckle, or the seat belt webbing, stay on top of or above the seat cushion under normal conditions (i.e., conditions other than when belt hardware is intentionally pushed behind the seat by a vehicle occupant)? (S7.4.6.1(a))
 Yes – Pass
 No – Fail
Identify the part(s) on top or above the seat.
 Seat belt latch plate
 Buckle
 Seat belt webbing
6. Are the remaining two seat belt parts accessible under normal conditions?
 Yes – Pass
 No – Fail
7. The buckle and latch plate do not pass through the guides or conduits provided and fall behind the seat when the belt is completely retracted or, if the belt is nonretractable, the belt is unlatched. (S7.4.6.2)
 Yes – Pass
 No – Fail

8. The buckle and latch plate do not pass through the guides or conduits provided and fall behind the seat when the seat is moved to any position to which it is designed to be adjusted. (S7.4.6.2)
- Yes – Pass
 No – Fail
9. The buckle and latch plate do not pass through the guides or conduits provided and fall behind the seat back, if foldable, is folded forward as far as possible and then moved backward into position. (S7.4.6.2)
- Yes – Pass
 No – Fail
10. Is the inboard receptacle end of the seat belt assembly, installed in the front outboard designated seating position, accessible with the center armrest in any position to which it can be adjusted (without moving the armrest)? (S7.4.6.2)
- Yes – Pass
 No – Fail
 N/A – Rear seat

REMARKS:

I certify that I have read and performed each instruction.

Signature: Wayne Zuhl

Date: 6/9/06

DATA SHEET 13

SEAT BELT GUIDES AND HARDWARE (S7.4.6)

Test Vehicle: 2006 Pontiac G6
Test Program: FMVSS 208 Compliance
Test Technician: Wayne Dahlke

NHTSA No.: C60104
Test Date: 6/9/06

Test seat belts except those in walk-in van-type vehicles and those at front outboard designated seating positions in passenger cars. Complete a form for each applicable seat belt.

DESIGNATED SEATING POSITION: **Right Rear Passenger**

1. Is the seat cushion movable so that the seat back serves a function other than seating? (S7.4.6.1 (b))
 Yes, this form is complete
 No, go to 2
2. Is the seat removable? (S7.4.6.1(b))
 Yes, this form is complete
 No, go to 3
3. Is the seat movable so that the space formerly occupied by the seat can be used for a secondary function? (S7.4.6.1(b))
 Yes, this form is complete
 No, go to 4
4. Is the webbing designed to pass through the seat cushion or between the seat cushion and seat back? (S7.4.6.1(a))
 Yes, go to 5
 No, this form is complete
5. Does one of the following three parts, the seat belt latch plate, the buckle, or the seat belt webbing, stay on top of or above the seat cushion under normal conditions (i.e., conditions other than when belt hardware is intentionally pushed behind the seat by a vehicle occupant)? (S7.4.6.1(a))
 Yes – Pass
 No – Fail
Identify the part(s) on top or above the seat.
 Seat belt latch plate
 Buckle
 Seat belt webbing
6. Are the remaining two seat belt parts accessible under normal conditions?
 Yes – Pass
 No – Fail
7. The buckle and latch plate do not pass through the guides or conduits provided and fall behind the seat when the belt is completely retracted or, if the belt is nonretractable, the belt is unlatched. (S7.4.6.2)
 Yes – Pass
 No – Fail

8. The buckle and latch plate do not pass through the guides or conduits provided and fall behind the seat when the seat is moved to any position to which it is designed to be adjusted. (S7.4.6.2)
- Yes – Pass
 No – Fail
9. The buckle and latch plate do not pass through the guides or conduits provided and fall behind the seat back, if foldable, is folded forward as far as possible and then moved backward into position. (S7.4.6.2)
- Yes – Pass
 No – Fail
10. Is the inboard receptacle end of the seat belt assembly, installed in the front outboard designated seating position, accessible with the center armrest in any position to which it can be adjusted (without moving the armrest)? (S7.4.6.2)
- Yes – Pass
 No – Fail
 N/A – Rear seat

REMARKS:

I certify that I have read and performed each instruction.

Signature: Wayne Zuhl

Date: 6/9/06

DATA SHEET 14

MARKING OF REFERENCE POINTS FOR VARIOUS TEST POSITIONS AND POINTS

Test Vehicle: 2006 Pontiac G6
Test Program: FMVSS 208 Compliance
Test Technician: Jim Hansen

NHTSA No.: C60104
Test Date: 8/8/06

DATA SHEET 14.1

MARKING OF REFERENCE POINTS FOR 5th FEMALE

Driver Seat Passenger Seat

1. Seat Position

- 1.1 Position the seat's adjustable lumbar supports so that the lumbar supports are in the lowest, retracted or deflated adjustment positions. (S16.2.10.1, S20.1.9.1, S20.4.1, S22.1.7.1)
 N/A – No lumbar adjustment
- 1.2 Position any adjustable parts of the seat that provide additional support so that they are in the lowest or most open adjustment position. (S16.2.10.2, S20.1.9.2, S20.4.1, S22.1.7.1, S22.4.2.1, S22.4.3.1, S24.4.2.1, S26.2.3, S26.3.1)
 N/A – No additional support adjustment
- 1.3 Position an adjustable leg support system in its rearmost position. (8/27/04 interpretation to Toyota)
 N/A – No adjustable leg support system
- 1.4 **Mark** a point (seat cushion reference point) on the side of the seat cushion that is between 150 mm and 250 mm from the front edge of the seat cushion. (S16.3.1.12)
- 1.5 Draw a line (seat cushion reference line) through the seat cushion reference point. (S16.3.1.13)
- 1.6 Use only the controls that primarily move the seat in the fore-aft direction to move the seat cushion reference point to the rearmost position. (S16.2.10.3.1, S22.1.7.3)
- 1.7 If the seat cushion adjusts fore-aft, independent of the seat back, use only the controls that primarily move the seat cushion in the fore-aft direction to move the seat cushion reference point to the rearmost position. (S16.2.10.3.1, S20.1.9.3)
 N/A – No independent fore-aft seat cushion adjustment
- 1.8 Use any part of any control, other than the parts just used for fore-aft positioning, to determine the range of angles of the seat cushion reference line and to set the seat cushion reference line at the mid-angle. (S16.2.10.3.1)
Maximum angle 2.9 Nose down
Minimum angle 1.1 Nose Up
Mid-angle 0.9 Nose down
- 1.9 If the seat and/or seat cushion height is adjustable, use any part of any control other than the parts which primarily move the seat or seat cushion fore-aft, to put the seat cushion reference point in its lowest position with the seat cushion reference line angle at the mid-angle found in 1.8. (S16.2.10.3.1)
 N/A – No seat height adjustment
- 1.10 Use only the controls that primarily move the seat in the fore-aft direction to verify the seat is in the rearmost position.

- 1.11 Use only the controls that primarily move the seat in the fore-aft direction to **mark** for future reference the fore-aft seat positions. **Mark** each position so that there is a visual indication when the seat is at a particular position. For manual seats, move the seat forward one detent at a time and **mark** each detent. For power seats, **mark** only the rearmost, middle, and foremost positions. Label three of the positions with the following: F for foremost, M for mid-position (if there is no mid-position, label the closest adjustment position to the rear of the mid-point), and R for rearmost.
- 1.12 Use only the controls that primarily move the seat in the fore-aft direction to place the seat in the rearmost position.
- 1.13 Use any part of any control, other than the parts which primarily move the seat or seat cushion fore-aft, to find and visually **mark** for future reference the maximum, minimum, and middle height of the seat cushion reference point with the seat cushion reference line at the mid-angle determined in 1.8. (S20.1.9.4, S22.1.2, S22.1.7.4, S22.3.1, S22.4.3.1, S24.1.2, S24.3.1, S24.4.3.1, S26.2.3, S26.3.1)
 N/A – No seat height adjustment. Go to 1.18
- 1.14 Use only the controls that primarily move the seat and/or seat cushion in the fore-aft direction to place the seat in the mid-fore-aft position.
- 1.15 Use any part of any control, other than the parts which primarily move the seat or seat cushion fore-aft, to find and visually **mark** for future reference the maximum, minimum, and middle height of the seat cushion reference point with the seat cushion reference line at the mid-angle determined in 1.8. (S20.1.9.4, S22.1.2, S22.1.7.4, S22.3.1, S24.1.2, S24.3.1)
- 1.16 Use only the control that change the seat in the fore-aft direction to place the seat in the foremost position. (S16.2.10.3.2)
- 1.17 Use any part of any control, other than the parts which primarily move the seat or seat cushion fore-aft, to find and visually **mark** for future reference the maximum, minimum, and middle height of the seat cushion reference point with the seat cushion reference line at the mid-angle determined in 1.8. (S16.2.10.3.3, S20.1.9.4, S22.1.2, S22.1.7.4, S22.3.1, S24.1.2, S24.3.1)
- 1.18. Visually **mark** for future reference the seat back angle at the manufacturer's nominal design riding position for a **50th percentile adult male** in the manner specified by the manufacturer for the rearmost, mid, and foremost seat positions. (S20.1.9.5, S22.1.7.5, S22.4.2.1, S22.4.3.1, S24.1.2, S24.4.2.1, S26.2.3, S26.3.1)
 N/A – No seat back angle adjustment
 Manufacturer's design seat back angle 19.0 Degrees
- 1.19. Is the seat a bucket seat?
 Yes, go to 1.20 and skip 1.21
 No, go to 1.21 and skip 1.20
- 1.20 Bucket seats:
 Locate and **mark** for future reference the longitudinal centerline of the seat cushion. The intersection of the vertical longitudinal plane that passes through the SgRP and the seat cushion upper surface determines the longitudinal centerline of a bucket seat cushion. (S16.3.1.10 & S20.1.10)
- 1.21 Bench seats (complete ONLY the one that is applicable to the seat being marked):
 1.21.1 Driver Seat
 Locate and **mark** for future reference the longitudinal line on the seat cushion that marks the intersection of the vertical longitudinal plane through the centerline of the steering wheel and the seat cushion upper surface.

1.21.2 Passenger Seat

Locate and **mark** for future reference the longitudinal centerline of the passenger seat cushion. The longitudinal centerline is the same distance from the longitudinal centerline of the vehicle as the center of the steering wheel. (S20.2.1.3, S22.2.1.3, S24.2.3, S20.4.4, S22.2.2.1(b), S22.2.2.3(b), S22.2.2.4(a), S22.2.2.5(a), S22.2.2.6(a), S22.2.2.7(a), S24.2.3(a))

Record the distance from the longitudinal centerline of the vehicle to the center of the steering wheel. _____

Record the distance from the longitudinal centerline of the vehicle to the longitudinal centerline of the seat cushion. (The vertical plane through this longitudinal centerline is Plane B for suppression.) _____

2. Head Restraint Position

 N/A Vehicle contains automatic head restraints.

 N/A, there is no head restraint adjustment

2.1 Adjust the head restraint to its lowest position. (S16.2.10.2, S20.1.9.6 S20.4.1, S22.1.7.6, S22.4.2.1, S22.4.3.1, S24.4.3.1, S26.2.3, S26.3.1)

2.2 All adjustments of the head restraint shall be used to position it full forward. For example, if it rotates, rotate it such that the head restraint extends as far forward as possible. **Mark** the foremost position. (S16.2.10.2 & S16.3.4.4 & S20.1.9.6, S20.4.1, S22.4.2.1, S22.4.3.1, S24.4.3.1, S26.2.3, S26.3.1)

2.3 Measure the vertical distance from the top most point of the head restraint to the bottom most point. Locate and **mark** a horizontal plane through the midpoint of this distance. (S16.3.4.3)

Vertical height of head restraint 180 mm

Mid-point height 90 mm

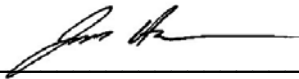

I certify that I have read and performed each instruction.

8/8/06

Date

DATA SHEET 14.1

MARKING OF REFERENCE POINTS FOR 5th FEMALE

Driver Seat Passenger Seat

1. Seat Position

- 1.1 Position the seat's adjustable lumbar supports so that the lumbar supports are in the lowest, retracted or deflated adjustment positions. (S16.2.10.1, S20.1.9.1, S20.4.1, S22.1.7.1)
 N/A – No lumbar adjustment
- 1.2 Position any adjustable parts of the seat that provide additional support so that they are in the lowest or most open adjustment position. (S16.2.10.2, S20.1.9.2, S20.4.1, S22.1.7.1, S22.4.2.1, S22.4.3.1, S24.4.2.1, S26.2.3, S26.3.1)
 N/A – No additional support adjustment
- 1.3 Position an adjustable leg support system in its rearmost position. (8/27/04 interpretation to Toyota)
 N/A – No adjustable leg support system
- 1.4 **Mark** a point (seat cushion reference point) on the side of the seat cushion that is between 150 mm and 250 mm from the front edge of the seat cushion. (S16.3.1.12)
- 1.5 Draw a line (seat cushion reference line) through the seat cushion reference point. (S16.3.1.13)
- 1.6 Use only the controls that primarily move the seat in the fore-aft direction to move the seat cushion reference point to the rearmost position. (S16.2.10.3.1, S22.1.7.3)
- 1.7 If the seat cushion adjusts fore-aft, independent of the seat back, use only the controls that primarily move the seat cushion in the fore-aft direction to move the seat cushion reference point to the rearmost position. (S16.2.10.3.1, S20.1.9.3)
 N/A – No independent fore-aft seat cushion adjustment
- 1.8 Use any part of any control, other than the parts just used for fore-aft positioning, to determine the range of angles of the seat cushion reference line and to set the seat cushion reference line at the mid-angle. (S16.2.10.3.1) **NO ADJUSTMENT**
Maximum angle Zero
Minimum angle Zero
Mid-angle Zero
- 1.9 If the seat and/or seat cushion height is adjustable, use any part of any control other than the parts which primarily move the seat or seat cushion fore-aft, to put the seat cushion reference point in its lowest position with the seat cushion reference line angle at the mid-angle found in 1.8. (S16.2.10.3.1)
 N/A – No seat height adjustment
- 1.10 Use only the controls that primarily move the seat in the fore-aft direction to verify the seat is in the rearmost position.
- 1.11 Use only the controls that primarily move the seat in the fore-aft direction to **mark** for future reference the fore-aft seat positions. **Mark** each position so that there is a visual indication when the seat is at a particular position. For manual seats, move the seat forward one detent at a time and **mark** each detent. For power seats, **mark** only the rearmost, middle, and foremost positions. Label three of the positions with the following: F for foremost, M for mid-position (if there is no mid-position, label the closest adjustment position to the rear of the mid-point), and R for rearmost.
- 1.12 Use only the controls that primarily move the seat in the fore-aft direction to place the seat in the rearmost position.

- 1.13 Use any part of any control, other than the parts which primarily move the seat or seat cushion fore-aft, to find and visually **mark** for future reference the maximum, minimum, and middle height of the seat cushion reference point with the seat cushion reference line at the mid-angle determined in 1.8. (S20.1.9.4, S22.1.2, S22.1.7.4, S22.3.1, S22.4.3.1, S24.1.2, S24.3.1, S24.4.3.1, S26.2.3, S26.3.1)
 N/A – No seat height adjustment. Go to 1.18
- 1.14 Use only the controls that primarily move the seat and/or seat cushion in the fore-aft direction to place the seat in the mid-fore-aft position.
- 1.15 Use any part of any control, other than the parts which primarily move the seat or seat cushion fore-aft, to find and visually **mark** for future reference the maximum, minimum, and middle height of the seat cushion reference point with the seat cushion reference line at the mid-angle determined in 1.8. (S20.1.9.4, S22.1.2, S22.1.7.4, S22.3.1, S24.1.2, S24.3.1)
- 1.16 Use only the control that change the seat in the fore-aft direction to place the seat in the foremost position. (S16.2.10.3.2)
- 1.17 Use any part of any control, other than the parts which primarily move the seat or seat cushion fore-aft, to find and visually **mark** for future reference the maximum, minimum, and middle height of the seat cushion reference point with the seat cushion reference line at the mid-angle determined in 1.8. (S16.2.10.3.3, S20.1.9.4, S22.1.2, S22.1.7.4, S22.3.1, S24.1.2, S24.3.1)
- 1.18. Visually **mark** for future reference the seat back angle at the manufacturer's nominal design riding position for a **50th percentile adult male** in the manner specified by the manufacturer for the rearmost, mid, and foremost seat positions. (S20.1.9.5, S22.1.7.5, S22.4.2.1, S22.4.3.1, S24.1.2, S24.4.2.1, S26.2.3, S26.3.1)
 N/A – No seat back angle adjustment
 Manufacturer's design seat back angle 19.0 Degrees
- 1.19. Is the seat a bucket seat?
 Yes, go to 1.20 and skip 1.21
 No, go to 1.21 and skip 1.20
- 1.20 Bucket seats:
 Locate and **mark** for future reference the longitudinal centerline of the seat cushion. The intersection of the vertical longitudinal plane that passes through the SgRP and the seat cushion upper surface determines the longitudinal centerline of a bucket seat cushion. (S16.3.1.10 & S20.1.10)
- 1.21 Bench seats (complete ONLY the one that is applicable to the seat being marked):
- 1.21.1 Driver Seat
 Locate and **mark** for future reference the longitudinal line on the seat cushion that marks the intersection of the vertical longitudinal plane through the centerline of the steering wheel and the seat cushion upper surface.
- 1.21.2 Passenger Seat
 Locate and **mark** for future reference the longitudinal centerline of the passenger seat cushion. The longitudinal centerline is the same distance from the longitudinal centerline of the vehicle as the center of the steering wheel. (S20.2.1.3, S22.2.1.3, S24.2.3, S20.4.4, S22.2.2.1(b), S22.2.2.3(b), S22.2.2.4(a), S22.2.2.5(a), S22.2.2.6(a), S22.2.2.7(a), S24.2.3(a))
 Record the distance from the longitudinal centerline of the vehicle to the center of the steering wheel. _____
 Record the distance from the longitudinal centerline of the vehicle to the longitudinal centerline of the seat cushion. (The vertical plane through this longitudinal centerline is Plane B for suppression.) _____

2. Head Restraint Position

N/A Vehicle contains automatic head restraints.

N/A, there is no head restraint adjustment

2.1 Adjust the head restraint to its lowest position. (S16.2.10.2, S20.1.9.6 S20.4.1, S22.1.7.6, S22.4.2.1, S22.4.3.1, S24.4.3.1, S26.2.3, S26.3.1)

2.2 All adjustments of the head restraint shall be used to position it full forward. For example, if it rotates, rotate it such that the head restraint extends as far forward as possible. **Mark** the foremost position. (S16.2.10.2 & S16.3.4.4 & S20.1.9.6, S20.4.1, S22.4.2.1, S22.4.3.1, S24.4.3.1, S26.2.3, S26.3.1)

2.3 Measure the vertical distance from the top most point of the head restraint to the bottom most point. Locate and **mark** a horizontal plane through the midpoint of this distance. (S16.3.4.3)

Vertical height of head restraint 180 mm

Mid-point height 90 mm

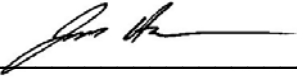

I certify that I have read and performed each instruction.

6/27/06

Date

DATA SHEET 14.3

MARKING OF REFERENCE POINTS FOR STEERING WHEEL

- X 1. Is the steering wheel adjustable up and down and/or in and out?
X Yes – go to 2
__ No – this form is complete
- X 2. Find and **mark** for future reference each up and down position. Label three of the positions with the following: H for highest, M for mid-position (if there is no mid-position, label the next lowest adjustment position), and L for lowest.
__ N/A – steering wheel is not adjustable up and down
- X 3. Find and **mark** for future references each in and out position. Label three of the positions with the following: F for foremost, M for mid-position (if there is no mid-position, label the next rearmost adjustment position), and R for rearmost.
__ N/A – steering wheel is not adjustable in and out.



I certify that I have read and performed each instruction.

8/8/06

Date

DATA SHEET 14.4

MARKING OF REFERENCE POINTS FOR DRIVER LOW RISK DEPLOYMENT

Position 1 Position 2

- 1. Position the steering wheel so the front wheels are in the straight-ahead position. (S26.2.1)
- 2. Position any adjustable parts of the steering controls to the mid-position as determined in Data Sheet 14.3 above. If a mid-position adjustment is not achievable, position the controls to the next lowest detent position. (S26.2.1)
- 3. Locate and **mark** the point that is defined by the intersection of the steering wheel cover and a line between the volumetric center of the smallest volume that can encompass the folded undeployed air bag and the volumetric center of the static fully inflated air bag. The vertical plane parallel to the vehicle longitudinal centerline through this point is referred to as "Plane E." (Check determination method below.) (S26.2.2)
Measurements with respect to measurement reference points:

The longitudinal centerline of the air bag was used.

Point determined using manufacturer's information supplied by the COTR .
(Include manufacturer's information in the test report.)

OR

Point determined by test lab personnel and approved by the COTR.
(Include supporting documentation in the test report.)

- 4. Locate the highest point of the air bag module cover. The horizontal plane through this point is referred to as "Plane F." (Check determination method below.) (S26.2.6)
Measurements with respect to measurement reference points:

The point is located 8 mm below the emblem on the steering wheel.

Point determined using manufacturer's information supplied by the COTR .
(Include manufacturer's information in the test report.)

OR

Point determined by test lab personnel and approved by the COTR.
(Include supporting documentation in the test report.)

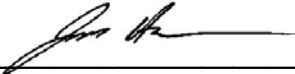

I certify that I have read and performed each instruction.

8/8/06

Date

DATA SHEET 16

AIR BAG SUPPRESSION TELLTALE (S19.2.2)

Test Vehicle: 2006 Pontiac G6
Test Program: FMVSS 208 Compliance
Test Technician: Jim Hansen

NHTSA No.: C60104
Test Date: 6/27/06

- X 1. Is the vehicle certified to any suppression performance standards of FMVSS 208?
X 2. Does telltale emit yellow light when the air bag is suppressed? (S19.2.2(a))
X 3. Are the words "PASSENGER AIR BAG OFF" or "PASS AIR BAG OFF" (S19.2.2(b))
X 3.1 on the telltale? (S19.2.2(b))
3.2 within 25 mm of the telltale? (S19.2.2(b))
X 4. Is the telltale separate from the air bag readiness indicator? (S19.2.2(c))
X 5. Is the telltale within the interior of the vehicle? (S19.2.2(d))
X 6. Is the telltale forward of and above the design H-point of both the driver's and the front outboard passenger's seat when the seats are in their forwardmost seating positions? (S19.2.2(d))
X 7. Is the telltale away from surfaces that can be used for temporary or permanent storage of objects that could obscure the telltale from either the driver's or front outboard passenger's view? (S19.2.2(d))
X 8. Is the telltale located so that it is not obscured from the driver or front outboard passenger by a rear-facing child restraint in Appendix A installed in the front outboard passenger seat? (S19.2.2(d))
X 9. Is the telltale visible or recognizable during the night? (S19.2.2(e))
X 10. Is the telltale visible or recognizable during the day? (S19.2.2(e))
X 11. If there is a visibility adjustment, do all the adjustment levels make the telltale visible and recognizable? (S19.2.2(g))
X 12. Does the telltale remain illuminated while the air bag is suppressed? (S19.2.2(h)) (Leave the air bag suppressed for 5 minutes.)
X 13. Is the telltale off while the air bag is activated? (S19.2.2(h)) (Leave the air bag activated for 5 minutes.)

I certify that I have read and performed each instruction.

6/27/06
Date

DATA SHEET 17 SUMMARY

Suppression Test Using 12-month-old CRABI Dummy (Part 572, Subpart R)
Section B Rear Facing CRS

NHTSA No.:	C60104	TEST DATE:	6/27/06
LABORATORY:	MGA	TECHNICIANS:	TB
DUMMY TYPE:	12 Month Old	DUMMY SERIAL NO.:	084

CHILD RESTRAINT NAME:	Britax
CHILD RESTRAINT MODEL:	Handle With Care 191
DATE OF MANUFACTURE:	5-26-2000

Base: On Off N/A-Restraint does not have a removable base

Manufacturer's design seat back angle: 19.0° On Seat Back Frame
 Tested seat back angle: 19.0° On Seat Back Frame
 Manufacturer's specified anchorage position: Middle
 Tested anchorage position: Middle

A blanket and visor were not used in the suppression testing because they did not affect the weight sensing system used on the vehicle.

Test Summary

Seat Belt	Seat Slide	Cinch Load (N)	Result
Belted Rear Facing	Forward	133	Suppressed
	Middle	133	Suppressed
	Rearward	133	Suppressed
Unbelted Rear Facing	Forward	N/A	Suppressed
	Middle	N/A	Suppressed
	Rearward	N/A	Suppressed
Unbelted Forward Facing	Forward	N/A	Suppressed
	Middle	N/A	Suppressed
	Rearward	N/A	Suppressed

Successful Unbelted Representative 5th Percentile Female Reactivation was performed with the seat in the Rearward position. (Human Identification Code 036; 48.5 kg 149.9 cm)

DATA SHEET 17 SUMMARY

Suppression Test Using 12-month-old CRABI Dummy (Part 572, Subpart R)
Section B Rear Facing CRS

NHTSA No.:	C60104	TEST DATE:	6/27/06
LABORATORY:	MGA	TECHNICIANS:	TB
DUMMY TYPE:	12 Month Old	DUMMY SERIAL NO.:	084

CHILD RESTRAINT NAME:	Evenflo
CHILD RESTRAINT MODEL:	First Choice 204
DATE OF MANUFACTURE:	6-20-2000

Base: On Off N/A-Constraint does not have a removable base

Manufacturer's design seat back angle: 19.0° On Seat Back Frame
 Tested seat back angle: 19.0° On Seat Back Frame
 Manufacturer's specified anchorage position: Middle
 Tested anchorage position: Middle

A blanket and visor were not used in the suppression testing because they did not affect the weight sensing system used on the vehicle.

Test Summary

Seat Belt	Seat Slide	Cinch Load (N)	Result
Belted Rear Facing	Forward	132	Suppressed
	Middle	131	Suppressed
	Rearward	133	Suppressed
Unbelted Rear Facing	Forward	N/A	Suppressed
	Middle	N/A	Suppressed
	Rearward	N/A	Suppressed
Unbelted Forward Facing	Forward	N/A	Suppressed
	Middle	N/A	Suppressed
	Rearward	N/A	Suppressed

Successful Unbelted Representative 5th Percentile Female Reactivation was performed with the seat in the Forward position. (Human Identification Code 036; 48.5 kg 149.9 cm)

DATA SHEET 17 SUMMARY

Suppression Test Using 12-month-old CRABI Dummy (Part 572, Subpart R)
Section B Rear Facing CRS

NHTSA No.:	C60104	TEST DATE:	6/27/06
LABORATORY:	MGA	TECHNICIANS:	TB
DUMMY TYPE:	12 Month Old	DUMMY SERIAL NO.:	084

CHILD RESTRAINT NAME:	Graco
CHILD RESTRAINT MODEL:	Infant 8457
DATE OF MANUFACTURE:	8-31-2000

Base: On Off N/A-Constraint does not have a removable base

Manufacturer's design seat back angle: 19.0° On Seat Back Frame
 Tested seat back angle: 19.0° On Seat Back Frame
 Manufacturer's specified anchorage position: Middle
 Tested anchorage position: Middle

A blanket and visor were not used in the suppression testing because they did not affect the weight sensing system used on the vehicle.

Test Summary

Seat Belt	Seat Slide	Cinch Load (N)	Result
Belted Rear Facing	Forward	133	Suppressed
	Middle	133	Suppressed
	Rearward	133	Suppressed
Unbelted Rear Facing	Forward	N/A	Suppressed
	Middle	N/A	Suppressed
	Rearward	N/A	Suppressed
Unbelted Forward Facing	Forward	N/A	Suppressed
	Middle	N/A	Suppressed
	Rearward	N/A	Suppressed

DATA SHEET 17 SUMMARY

Suppression Test Using 12-month-old CRABI Dummy (Part 572, Subpart R)
Section B Rear Facing CRS

NHTSA No.:	C60104	TEST DATE:	6/27/06
LABORATORY:	MGA	TECHNICIANS:	TB
DUMMY TYPE:	12 Month Old	DUMMY SERIAL NO.:	084

CHILD RESTRAINT NAME:	Graco
CHILD RESTRAINT MODEL:	Infant 8457
DATE OF MANUFACTURE:	8-31-2000

Base: On Off N/A-Restraint does not have a removable base

Manufacturer's design seat back angle: 19.0° On Seat Back Frame
 Tested seat back angle: 19.0° On Seat Back Frame
 Manufacturer's specified anchorage position: Middle
 Tested anchorage position: Middle

A blanket and visor were not used in the suppression testing because they did not affect the weight sensing system used on the vehicle.

Test Summary

Seat Belt	Seat Slide	Cinch Load (N)	Result
Belted Rear Facing	Forward	127	Suppressed
	Middle	129	Suppressed
	Rearward	127	Suppressed
Unbelted Rear Facing	Forward	N/A	Suppressed
	Middle	N/A	Suppressed
	Rearward	N/A	Suppressed
Unbelted Forward Facing	Forward	N/A	Suppressed
	Middle	N/A	Suppressed
	Rearward	N/A	Suppressed

Successful Unbelted Representative 5th Percentile Female Reactivation was performed with the seat in the Middle position. (Human Identification Code 036; 48.5 kg 149.9 cm)

DATA SHEET 17 SUMMARY

Suppression Test Using 12-month-old CRABI Dummy (Part 572, Subpart R)
Section C Forward Facing Convertible CRS

NHTSA No.:	C60104	TEST DATE:	6/28/06
LABORATORY:	MGA	TECHNICIANS:	TB
DUMMY TYPE:	12 Month Old	DUMMY SERIAL NO.:	084

CHILD RESTRAINT NAME:	Britax
CHILD RESTRAINT MODEL:	Roundabout 161
DATE OF MANUFACTURE:	7-21-2000

Base: On Off N/A-Constraint does not have a removable base

Manufacturer's design seat back angle: 19.0° On Seat Back Frame
 Tested seat back angle: 19.0° On Seat Back Frame
 Manufacturer's specified anchorage position: Middle
 Tested anchorage position: Middle

A blanket was not used in the suppression testing because it did not affect the weight sensing system used on the vehicle.

Test Summary

Seat Belt	Seat Slide	Cinch Load (N)	Result
Belted Forward Facing	Forward	128	Suppressed
	Middle	127	Suppressed
	Rearward	133	Suppressed
Unbelted Forward Facing	Forward	N/A	Suppressed
	Middle	N/A	Suppressed
	Rearward	N/A	Suppressed
Belted Rear Facing	Forward	129	Suppressed
	Middle	133	Suppressed
	Rearward	131	Suppressed
Unbelted Rear Facing	Forward	N/A	Suppressed
	Middle	N/A	Suppressed
	Rearward	N/A	Suppressed

Successful Unbelted Representative 5th Percentile Female Reactivation was performed with the seat in the Rearward position. (Human Identification Code 036; 48.5 kg 149.9 cm)

DATA SHEET 17 SUMMARY

Suppression Test Using 12-month-old CRABI Dummy (Part 572, Subpart R)
Section C Forward Facing Convertible CRS

NHTSA No.:	C60104	TEST DATE:	6/28/06
LABORATORY:	MGA	TECHNICIANS:	TB
DUMMY TYPE:	12 Month Old	DUMMY SERIAL NO.:	084

CHILD RESTRAINT NAME:	Century
CHILD RESTRAINT MODEL:	Encore 4612
DATE OF MANUFACTURE:	8-16-2000

Base: On Off N/A-Constraint does not have a removable base

Manufacturer's design seat back angle: 19.0° On Seat Back Frame
 Tested seat back angle: 19.0° On Seat Back Frame
 Manufacturer's specified anchorage position: Middle
 Tested anchorage position: Middle

A blanket was not used in the suppression testing because it did not affect the weight sensing system used on the vehicle.

Test Summary

Seat Belt	Seat Slide	Cinch Load (N)	Result
Belted Forward Facing	Forward	132	Suppressed
	Middle	127	Suppressed
	Rearward	129	Suppressed
Unbelted Forward Facing	Forward	N/A	Suppressed
	Middle	N/A	Suppressed
	Rearward	N/A	Suppressed
Belted Rear Facing	Forward	130	Suppressed
	Middle	130	Suppressed
	Rearward	129	Suppressed
Unbelted Rear Facing	Forward	N/A	Suppressed
	Middle	N/A	Suppressed
	Rearward	N/A	Suppressed

Successful Unbelted Representative 5th Percentile Female Reactivation was performed with the seat in the Middle position. (Human Identification Code 036; 48.5 kg 149.9 cm)

DATA SHEET 17 SUMMARY

Suppression Test Using 12-month-old CRABI Dummy (Part 572, Subpart R)
Section C Forward Facing Convertible CRS

NHTSA No.:	C60104	TEST DATE:	6/28/06
LABORATORY:	MGA	TECHNICIANS:	TB
DUMMY TYPE:	12 Month Old	DUMMY SERIAL NO.:	084

CHILD RESTRAINT NAME:	Evenflo
CHILD RESTRAINT MODEL:	Medallion 254
DATE OF MANUFACTURE:	6-1-2000

Base: On Off N/A-Restraint does not have a removable base

Manufacturer's design seat back angle: 19.0° On Seat Back Frame
 Tested seat back angle: 19.0° On Seat Back Frame
 Manufacturer's specified anchorage position: Middle
 Tested anchorage position: Middle

A blanket was not used in the suppression testing because it did not affect the weight sensing system used on the vehicle.

Test Summary

Seat Belt	Seat Slide	Cinch Load (N)	Result
Belted Forward Facing	Forward	132	Suppressed
	Middle	133	Suppressed
	Rearward	130	Suppressed
Unbelted Forward Facing	Forward	N/A	Suppressed
	Middle	N/A	Suppressed
	Rearward	N/A	Suppressed
Belted Rear Facing	Forward	132	Suppressed
	Middle	133	Suppressed
	Rearward	133	Suppressed
Unbelted Rear Facing	Forward	N/A	Suppressed
	Middle	N/A	Suppressed
	Rearward	N/A	Suppressed

Successful Unbelted Representative 5th Percentile Female Reactivation was performed with the seat in the Forward position. (Human Identification Code 036; 48.5 kg 149.9 cm)

DATA SHEET 18 SUMMARY

Suppression Test Using Newborn Infant Dummy (Part 572, Subpart K) Section A Car Bed

NHTSA No.:	C60104	TEST DATE:	6/27/06
LABORATORY:	MGA	TECHNICIANS:	TB
DUMMY TYPE:	Newborn Infant	DUMMY SERIAL NO.:	003

CAR BED NAME:	Cosco
CAR BED MODEL:	Dream Ride 02-719
DATE OF MANUFACTURE:	6-16-2000

Base: On Off N/A-Constraint does not have a removable base
 (A car bed with a removable base shall be treated as two separate models, i.e. this form and test procedure will be completed with the base on and then repeated on a new form with the base off.

Manufacturer's design seat back angle: 19.0° On Seat Back Frame
 Tested seat back angle: 19.0° On Seat Back Frame
 Manufacturer's specified anchorage position: Middle
 Tested anchorage position: Middle

A blanket and visor were not used in the suppression testing because they did not affect the weight sensing system used on the vehicle.

Test Summary

Seat Belt	Seat Slide	Result
Belted	N/A	Won't Fit
	Middle	Suppressed
	Rearward	Suppressed

Successful Unbelted Representative 5th Percentile Female Reactivation was performed with the seat in the Rearward position. (Human Identification Code 036; 48.5 kg 149.9 cm)

DATA SHEET 19 SUMMARY

Suppression Test Using 3 Year Old Dummy And Booster Seats (Part 572, Subpart P)
Section D Forward Facing Belt Positioning Booster

NHTSA No.:	C60104	TEST DATE:	6/30/06
LABORATORY:	MGA	TECHNICIANS:	JL
DUMMY TYPE:	3 Year Old	DUMMY SERIAL NO.:	031

BOOSTER SEAT NAME:	Century
BOOSTER SEAT MODEL:	Next Step 4920
DATE OF MANUFACTURE:	8-16-2000

Manufacturer's design seat back angle:	<u>19.0° On Seat Back Frame</u>
Tested seat back angle:	<u>19.0° On Seat Back Frame</u>
Manufacturer's specified anchorage position:	<u>Middle</u>
Tested anchorage position:	<u>Middle</u>

Test Summary

Seat Belt	Seat Slide	Cinch Load (N)	Result
Belted Forward Facing Without Harness	Forward	17	Suppressed
	Middle	11	Suppressed
	Rearward	10	Suppressed
Belted Forward Facing Cinched With Harness	Forward	127	Suppressed
	Middle	128	Suppressed
	Rearward	129	Suppressed

Successful Unbelted Representative 5th Percentile Female Reactivation was performed with the seat in the Rearward position. (Human Identification Code 036; 48.5 kg 149.9 cm)

DATA SHEET 19 SUMMARY

Suppression Test Using 3 Year Old Dummy And Booster Seats (Part 572, Subpart P)
Section D Forward Facing Toddler Belt Positioning Booster Seat

NHTSA No.:	C60104	TEST DATE:	6/30/06
LABORATORY:	MGA	TECHNICIANS:	JL
DUMMY TYPE:	3 Year Old	DUMMY SERIAL NO.:	031

BOOSTER SEAT NAME:	Cosco
BOOSTER SEAT MODEL:	High Back Booster 02-442
DATE OF MANUFACTURE:	4-28-2000

Manufacturer's design seat back angle:	<u>19.0° On Seat Back Frame</u>
Tested seat back angle:	<u>19.0° On Seat Back Frame</u>
Manufacturer's specified anchorage position:	<u>Middle</u>
Tested anchorage position:	<u>Middle</u>

Test Summary

Seat Belt	Seat Slide	Cinch Load (N)	Result
Belted Forward Facing Without Harness	Forward	12	Suppressed
	Middle	12	Suppressed
	Rearward	12	Suppressed
Belted Forward Facing Cinched With Harness	Forward	133	Suppressed
	Middle	131	Suppressed
	Rearward	131	Suppressed

Successful Unbelted Representative 5th Percentile Female Reactivation was performed with the seat in the Middle position. (Human Identification Code 036; 48.5 kg 149.9 cm)

DATA SHEET 20 SUMMARY

Suppression Test Using 3 Year Old Dummy And Convertible Restraints (Part 572, Subpart P)
Section C Forward Facing Convertible CRS

NHTSA No.:	C60104	TEST DATE:	6/28/06
LABORATORY:	MGA	TECHNICIANS:	TB
DUMMY TYPE:	3 Year Old	DUMMY SERIAL NO.:	031

CHILD RESTRAINT NAME:	Britax
CHILD RESTRAINT MODEL:	Roundabout 161
DATE OF MANUFACTURE:	7-21-2000

Manufacturer's design seat back angle:	<u>19.0° On Seat Back Frame</u>
Tested seat back angle:	<u>19.0° On Seat Back Frame</u>
Manufacturer's specified anchorage position:	<u>Middle</u>
Tested anchorage position:	<u>Middle</u>

Test Summary

Seat Belt	Seat Slide	Cinch Load (N)	Result
Belted	Forward	133	Suppressed
	Middle	131	Suppressed
	Rearward	134	Suppressed

Successful Unbelted Representative 5th Percentile Female Reactivation was performed with the seat in the Rearward position. (Human Identification Code 036; 48.5 kg 149.9 cm)

DATA SHEET 20 SUMMARY

Suppression Test Using 3 Year Old Dummy And Convertible Restraints (Part 572, Subpart P)
Section C Forward Facing Convertible CRS

NHTSA No.:	C60104	TEST DATE:	6/28/06
LABORATORY:	MGA	TECHNICIANS:	TB
DUMMY TYPE:	3 Year Old	DUMMY SERIAL NO.:	031

CHILD RESTRAINT NAME:	Century
CHILD RESTRAINT MODEL:	Encore 4612
DATE OF MANUFACTURE:	8-16-2000

Manufacturer's design seat back angle: 19.0° On Seat Back Frame
 Tested seat back angle: 19.0° On Seat Back Frame
 Manufacturer's specified anchorage position: Middle
 Tested anchorage position: Middle

Test Summary

Seat Belt	Seat Slide	Cinch Load (N)	Result
Belted	Forward	133	Suppressed
	Middle	127	Suppressed
	Rearward	133	Suppressed

Successful Unbelted Representative 5th Percentile Female Reactivation was performed with the seat in the Middle position. (Human Identification Code 036; 48.5 kg 149.9 cm)

DATA SHEET 20 SUMMARY

Suppression Test Using 3 Year Old Dummy And Convertible Restraints (Part 572, Subpart P)
Section C Forward Facing Convertible CRS

NHTSA No.:	C60104	TEST DATE:	6/28/06
LABORATORY:	MGA	TECHNICIANS:	TB
DUMMY TYPE:	3 Year Old	DUMMY SERIAL NO.:	031

CHILD RESTRAINT NAME:	Evenflo
CHILD RESTRAINT MODEL:	Medallion 254
DATE OF MANUFACTURE:	6-1-2000

Manufacturer's design seat back angle: 19.0° On Seat Back Frame
 Tested seat back angle: 19.0° On Seat Back Frame
 Manufacturer's specified anchorage position: Middle
 Tested anchorage position: Middle

Test Summary

Seat Belt	Seat Slide	Cinch Load (N)	Result
Belted	Forward	131	Suppressed
	Middle	131	Suppressed
	Rearward	133	Suppressed

Successful Unbelted Representative 5th Percentile Female Reactivation was performed with the seat in the Forward position. (Human Identification Code 036; 48.5 kg 149.9 cm)

DATA SHEET 21 SUMMARY

Suppression Test Using An Unbelted 3 Year Old Dummy (Part 572, Subpart P)
No CRS

NHTSA No.:	C60104	TEST DATE:	6/30/06
LABORATORY:	MGA	TECHNICIANS:	JL
DUMMY TYPE:	3 Year Old	DUMMY SERIAL NO.:	031

Test Summary

Position	Seat Slide	Seat Back Angle	Result
Position 1 Sitting on seat with back against seat back	Forward	19°	Suppressed
	Middle	19°	Suppressed
	Rearward	19°	Suppressed
Position 2 Sitting on seat with back against reclined seat back	Forward	43.3°	Suppressed
	Middle	43.3°	Suppressed
	Rearward	43.3°	Suppressed
Position 3 Sitting on seat with back not against seat back	Forward	19°	Suppressed
	Middle	19°	Suppressed
	Rearward	19°	Suppressed
Position 4 Sitting on seat edge, spine vertical, hands at dummy's sides	Forward	19°	Suppressed
	Middle	19°	Suppressed
	Rearward	19°	Suppressed
Position 5 Standing on seat, facing forward	Forward	19°	Suppressed
	Middle	19°	Suppressed
	Rearward	19°	Suppressed
Position 6 Kneeling on seat, facing forward	Forward	19°	Suppressed
	Middle	19°	Suppressed
	Rearward	19°	Suppressed
Position 7 Kneeling on seat, facing rearward	Forward	19°	Suppressed
	Middle	19°	Suppressed
	Rearward	19°	Suppressed
Position 8 Lying on seat. (Three designated seating positions only)	Forward	N/A	N/A
	Middle	N/A	N/A
	Rearward	N/A	N/A

Successful Unbelted Representative 5th Percentile Female Reactivation was performed with the seat in the Middle position. (Human Identification Code 036; 48.5 kg 149.9 cm)

DATA SHEET 22H SUMMARY

Suppression Test Using a Representative 6-Year-Old Child and Booster Seats (S24.2.1)

NHTSA No.:	C60104	TEST DATE:	6/29/06
LABORATORY:	MGA	TECHNICIANS:	JL
SUBJECT TYPE:	6 Year Old	CHILD IDENTIFICATION CODE:	048

(Child Identification Code 048; 23.6 kg 119.4 cm)

BOOSTER SEAT NAME:	Century
BOOSTER SEAT MODEL:	Next Step 4920
DATE OF MANUFACTURE:	8-16-2000

Manufacturer's design seat back angle: 19.0° On Seat Back Frame
Tested seat back angle: 19.0° On Seat Back Frame
Manufacturer's specified anchorage position: Middle
Tested anchorage position: Middle

Test Summary

Seat Belt	Seat Slide	Belt Load (N)	Result
Belted	Forward	10	Suppressed
	Middle	12	Suppressed
	Rearward	15	Suppressed

Successful Unbelted Representative 5th Percentile Female Reactivation was performed with the seat in the Rearward position. (Human Identification Code 036; 48.5 kg 149.9 cm)

DATA SHEET 22H SUMMARY

Suppression Test Using a Representative 6-Year-Old Child and Booster Seats (S24.2.1)

NHTSA No.:	C60104	TEST DATE:	6/29/06
LABORATORY:	MGA	TECHNICIANS:	JL
SUBJECT TYPE:	6 Year Old	CHILD IDENTIFICATION CODE:	048

(Child Identification Code 048; 23.6 kg 119.4 cm)

BOOSTER SEAT NAME:	Cosco
BOOSTER SEAT MODEL:	High Back Booster 02-442
DATE OF MANUFACTURE:	4-28-2000

Manufacturer's design seat back angle:	<u>19.0° On Seat Back Frame</u>
Tested seat back angle:	<u>19.0° On Seat Back Frame</u>
Manufacturer's specified anchorage position:	<u>Middle</u>
Tested anchorage position:	<u>Middle</u>

Test Summary

Seat Belt	Seat Slide	Belt Load (N)	Result
Belted	Forward	15	Suppressed
	Middle	14	Suppressed
	Rearward	13	Suppressed

Successful Unbelted Representative 5th Percentile Female Reactivation was performed with the seat in the Rearward position. (Human Identification Code 036; 48.5 kg 149.9 cm)

DATA SHEET 22H SUMMARY

Suppression Test Using a Representative 6-Year-Old Child and Booster Seats (S24.2.1)

NHTSA No.:	C60104	TEST DATE:	6/29/06
LABORATORY:	MGA	TECHNICIANS:	JL
SUBJECT TYPE:	6 Year Old	CHILD IDENTIFICATION CODE:	048

(Child Identification Code 048; 23.6 kg 119.4 cm)

BOOSTER SEAT NAME:	Evenflo
BOOSTER SEAT MODEL:	Right Fit 245
DATE OF MANUFACTURE:	6-26-2000

Manufacturer's design seat back angle: 19.0° On Seat Back Frame
Tested seat back angle: 19.0° On Seat Back Frame
Manufacturer's specified anchorage position: Middle
Tested anchorage position: Middle

Test Summary

Seat Belt	Seat Slide	Belt Load (N)	Result
Belted	Forward	17	Suppressed
	Middle	14	Suppressed
	Rearward	9	Suppressed

Successful Unbelted Representative 5th Percentile Female Reactivation was performed with the seat in the Middle position. (Human Identification Code 036; 48.5 kg 149.9 cm)

DATA SHEET 23H SUMMARY

Suppression Tests Using an Unbelted Representative 6-Year-Old Child (S24.2.1)

NHTSA No.:	C60104	TEST DATE:	6/29/06
LABORATORY:	MGA	TECHNICIANS:	JL
SUBJECT TYPE:	6 Year Old	CHILD IDENTIFICATION CODE:	048

(Child Identification Code 048; 23.6 kg 119.4 cm)

Test Summary

Position	Seat Slide	Seat Back Angle	Result
Position 1 Sitting on seat with back against seat back	Forward	19°	Suppressed
	Middle	19°	Suppressed
	Rearward	19°	Suppressed
Position 2 Sitting on seat with back against reclined seat back	Forward	43.3°	Suppressed
	Middle	43.3°	Suppressed
	Rearward	43.3°	Suppressed
Position 3 Sitting on seat edge, spine vertical, hands at child's sides	Forward	19°	Suppressed
	Middle	19°	Suppressed
	Rearward	19°	Suppressed
Position 4 Sitting on seat with back against seat back then leaning on the door	Forward	19°	Suppressed
	Middle	19°	Suppressed
	Rearward	19°	Suppressed

Successful Unbelted Representative 5th Percentile Female Reactivation was performed with the seat in the Middle position. (Human Identification Code 036; 48.5 kg 149.9 cm)

DATA SHEET 29 SUMMARY

Low Risk Deployment Tests Using an Unbelted 5th Percentile Female
 Dummy (Part 572, Subpart O) (S26)
 Position 1 - Chin On Module (S26.2)

NHTSA No.:	C60104	TEST DATE:	8/8/06
LABORATORY:	MGA	TECHNICIANS:	JH/KA
DUMMY TYPE:	5 th Percentile Female	DUMMY SERIAL NO.:	505

Manufacturer's design seat back angle: 19.0° seat back angle
 Tested seat back angle: 18.7° seat back angle
 Tested seat position: Full Aft

Tested steering wheel angle: 21.7°
 Thorax cavity angle: 27.8°
 Bottom of chin height: 0 mm - At Module Height

Air Bag Deployment Timing

Stage No.	Firing time (ms)	Recorded firing time (ms)
1	0.0	0.0
2	100.0	100.1

5th Percentile Female SN 505 Position 1 (Chin On Module) 8-8-06

Injury Criteria	Max. Allowable Injury Assessment Values	Measured Value
HIC15	700	11
Peak Nij (Nte)	1.0	0.2
Time (ms)	NA	88.8
Peak Nij (Ntf)	1.0	0.3
Time (ms)	NA	31.3
Peak Nij (Nce)	1.0	0.0
Time (ms)	NA	0.1
Peak Nij (Ncf)	1.0	0.0
Time (ms)	NA	3.9
Neck Tension	2070 N	527
Neck Compression	2520 N	7
Chest g	60 g	12
Chest Displacement	52 mm	7
Left Femur	6805 N	51
Right Femur	6805 N	34

Calculated on data recorded for 125 ms after the initiation of the final stage of air bag deployment designed to deploy in any full frontal rigid barrier crash up to 26 km/h. (S4.11(d))
 Second stage fire time of 100 ms; Injuries calculated on 0 ms to 225 ms

DATA SHEET 30 SUMMARY

Low Risk Deployment Tests Using an Unbelted 5th Percentile Female

Dummy (Part 572, Subpart O) (S26)

Position 2 - Chin On Rim (S26.3)

NHTSA No.:	C60104	TEST DATE:	8/8/06
LABORATORY:	MGA	TECHNICIANS:	JH/KA
DUMMY TYPE:	5 th Percentile Female	DUMMY SERIAL NO.:	510

Manufacturer's design seat back angle: 19.0° seat back angle
 Tested seat back angle: 18.7° seat back angle
 Tested seat position: Full Rear

Tested steering wheel angle: 20.3°
 Thorax cavity angle: 26.3°
 Chin Point height: 1 mm Below Steering Wheel Target

Note: The chin on rim steering wheel target is 10 mm below the highest point on the steering wheel

*The dummy contacted the windshield with the steering wheel at mid position. The steering controls were adjusted to lower the upper steering wheel rim the necessary amount to bring the Chin Point coincident with the upper steering wheel rim. The rear thorax cavity was adjusted along with the steering wheel angle.

Air Bag Deployment Timing

Stage No.	Firing time (ms)	Recorded firing time (ms)
1	0.0	0.0
2	100.0	100.0

5th Percentile Female SN 510 Position 2 (Chin On Rim) 8-8-06

Injury Criteria	Max. Allowable Injury Assessment Values	Measured Value
HIC15	700	14
Peak Nij (Nte)	1.0	0.5
Time (ms)	NA	23.5
Peak Nij (Ntf)	1.0	0.2
Time (ms)	NA	62.3
Peak Nij (Nce)	1.0	0.0
Time (ms)	NA	175.9
Peak Nij (Ncf)	1.0	0.1
Time (ms)	NA	68.0
Neck Tension	2070 N	826
Neck Compression	2520 N	83
Chest g	60 g	12
Chest Displacement	52 mm	14
Left Femur	6805 N	708
Right Femur	6805 N	443

Calculated on data recorded for 125ms after the initiation of the final stage of air bag deployment designed to deploy in any full frontal rigid barrier crash up to 26 km/h. (S4.11(d))
 Second stage fire time of 100 ms; Injuries calculated on 0 ms to 225 ms

DATA SHEET 32

VEHICLE WEIGHT, FUEL TANK, AND ATTITUDE DATA

Test Vehicle: 2006 Pontiac G6
 Test Program: FMVSS 208 Compliance
 Test Technician: Nick Kosinski

NHTSA No.: C60104
 Test Date: 8/24/06

IMPACT ANGLE:	Zero Degrees		
BELTED DUMMIES (YES/NO):	No		
TEST SPEED:	<input checked="" type="checkbox"/> 32 to 40 kmph	<input type="checkbox"/> 0 to 48 kmph	<input type="checkbox"/> 0 to 56 kmph
DRIVER DUMMY:	<input checked="" type="checkbox"/> 5 th female	<input type="checkbox"/> 50 th male	
PASSENGER DUMMY:	<input checked="" type="checkbox"/> 5 th female	<input type="checkbox"/> 50 th male	

- 1. Fill the transmission with transmission fluid to the satisfactory range.
- 2. Drain fuel from vehicle
- 3. Run the engine until fuel remaining in the fuel delivery system is used and the engine stops.
- 4. Record the useable fuel tank capacity supplied by the COTR
Useable Fuel Tank Capacity supplied by COTR: 61.7 liters (16.3 gallons)
- 5. Record the fuel tank capacity supplied in the owner's manual.
Useable Fuel Tank Capacity in owner's manual: 61.7 liters (16.3 gallons)
- 6. Using purple dyed Stoddard solvent having the physical and chemical properties of Type 1 solvent or cleaning fluid, Table 1, ASTM Standard D484-71, "Standard Specifications for Hydrocarbon Dry-cleaning Solvents," or gasoline, fill the fuel tank.

Amount Added: 61.7 liters (16.3 gallons)
- 7. Fill the coolant system to capacity.
- 8. Fill the engine with motor oil to the Max. mark on the dip stick.
- 9. Fill the brake reservoir with brake fluid to its normal level.
- 10. Fill the windshield washer reservoir to capacity.
- 11. Inflate the tires to the tire pressure on the tire placard. If no tire placard is available, inflate the tires to the recommended pressure in the owner's manual.

Tire placard pressure:	RF:	30 psi	LF:	30 psi	RR:	30 psi	LR:	30 psi
Owner's manual pressure:	RF:	30 psi	LF:	30 psi	RR:	30 psi	LR:	30 psi
Actual inflated pressure:	RF:	30 psi	LF:	30 psi	RR:	30 psi	LR:	30 psi

- 12. Record the vehicle weight at each wheel to determine the unloaded vehicle weight (UVW), i.e. "as delivered" weight).

Right Front (kg):	452.7	Right Rear (kg):	289.4
Left Front (kg):	442.3	Left Rear (kg):	311.2
Total Front (kg):	895.0	Total Rear (kg):	600.6
% Total Weight:	59.8	% Total Weight:	40.2
UVW = TOTAL FRONT PLUS TOTAL REAR (KG):		1495.6	

- 13. UVW Test Vehicle Attitude: (All dimensions in millimeters)
- 13.1 Mark a point on the vehicle above the center of each wheel.
- 13.2 Place the vehicle on a level surface.

- 13.3 Measure perpendicular to the level surface to the 4 points marked on the body and record the measurements

RF:	712	LF:	718	RR:	721	LR:	712
-----	-----	-----	-----	-----	-----	-----	-----

14. Calculate the Rated Cargo and Luggage Weight (RCLW): 64 kg
- 14.1 Does the vehicle have the vehicle capacity weight (VCW) on the certification label or tire placard?
- Yes, go to 14.3
- No, go to 14.2
- 14.2 VCW = Gross Vehicle Weight – UVW

$$VCW = \underline{\hspace{2cm}} - \underline{\hspace{2cm}} = \underline{\hspace{2cm}}$$

- 14.3 VCW = 404 kg (891 lbs)
- 14.4 Does the certification or tire placard contain the Designated Seating Capacity (DSC)?
- Yes, go to 14.6
- No, go to 14.5 and skip 14.6
- 14.5 DSC = Total number of seat belt assemblies =
- 14.6 DSC = 5
- 14.7 RCLW = VCW – (68 kg x DSC) = 404 kg - (68 kg x 5) = 64 kg
- 14.8 Is the vehicle certified as a truck, MPV or bus (see the certification label on the door jamb)?
- Yes, if the calculated RCLW is greater than 136 kg, use 136 kg as the RCLW. (S8.1.1)

- No, use the RCLW calculated in 14.7

15. Fully Loaded Weight (100% fuel fill): 1657.5 kg
- 15.1 Place the appropriate test dummy in both front outboard seating positions.

Driver: 5th female ___ 50th male
 Passenger: 5th female ___ 50th male

- 15.2 Load the vehicle with the RCLW from 14.7 or 14.8 whichever is applicable.
- 15.3 Place the RCLW in the cargo area. Center the load over the longitudinal centerline of the vehicle. (S8.1.1 (d))
- 15.4 Record the vehicle weight at each wheel to determine the Fully Loaded Weight.

Right Front (kg):	482.2	Right Rear (kg):	341.6
Left Front (kg):	469.9	Left Rear (kg):	363.8
Total Front (kg):	952.1	Total Rear (kg):	705.4
% Total Weight:	57.4	% Total Weight:	46.2
% GVW	53.0	% GVW	46.9
(% GVW = Axle GVW divided by Vehicle GVW)			
Fully Loaded Weight = Total Front Plus Total Rear (kg):			1657.5

16. Fully Loaded Test Vehicle Attitude: (All dimensions in millimeters)
- 16.1 Place the vehicle on a level surface.

- 16.2 Measure perpendicular to the level surface to the 4 points marked on the body (see 13.1 above) and record the measurements

RF:	703	LF:	703	RR:	697	LR:	691
-----	-----	-----	-----	-----	-----	-----	-----

- 17. Drain the fuel system
- 18. Using purple dyed Stoddard solvent having the physical and chemical properties of Type 1 solvent or cleaning fluid, Table 1, ASTM Standard D484-71, "Standard Specifications for Hydrocarbon Dry-cleaning Solvents," fill the fuel tank to 92 - 94 percent of useable capacity.

Fuel tank capacity x .94 = 61.7 liters (16.3 gallons) x .94 = 58.0 liters (15.32 gallons)
 Amount added 57.9 liters (15.3 gallons) 93.8%

- 19. Crank the engine to fill the fuel delivery system with Stoddard solvent
- 20. Calculate the test weight range.
- 20.1 Calculated Weight = UVW (see 12 above) + RCLW (see 14 above) + 2x(dummy weight)

$$1657.6 \text{ kg} = 1495.6 \text{ kg} + 64.0 \text{ kg} + 98.0 \text{ kg}$$

- 20.2 Test Weight Range = Calculated Weight (- 4.5 kg, - 9 kg.)
 Max. Test Weight = Calculated Test Weight - 4.5 kg = 1653.1 kg
 Min. Test Weight = Calculated Test Weight - 9 kg = 1648.6 kg

- 21. Remove the RCLW from the cargo area.
- 22. Drain transmission fluid, engine coolant, motor oil, and windshield washer fluid from the test vehicle so that Stoddard solvent leakage from the fuel system will be evident.
- 23. Vehicle Components Removed For Weight Reduction:
Spare tire, tool and jack, wheel covers, and trunk interior
- 24. Secure the equipment and ballast in the load carrying area and distribute it, as nearly as possible, to obtain the proportion of axle weight indicated by the gross axle weight ratings and center it over the longitudinal centerline of the vehicle.

- 25. If necessary, add ballast to achieve the actual test weight.

N/A

Weight of Ballast: 34 kg

- 26. Ballast, including test equipment, must be contained so that it will not shift during the impact event or interfere with data collection or interfere with high-speed film recordings or affect the structural integrity of the vehicle or do anything else to affect test results. Care must be taken to assure that any attachment hardware added to the vehicle is not in the vicinity of the fuel tank or lines.

- 27. Record the vehicle weight at each wheel to determine the actual test weight.

Right Front (kg):	474.0	Right Rear (kg):	343.8
Left Front (kg):	465.8	Left Rear (kg):	366.1
Total Front (kg):	939.8	Total Rear (kg):	709.9
% Total Weight:	57.0	% Total Weight:	43.0
% GVW	53.0	% GVW	46.9
(% GVW = Axle GVW divided by Vehicle GVW)			
TOTAL FRONT PLUS TOTAL REAR (kg):			1649.7

28. Is the test weight between the Max. Weight and the Min. Weight (See 20.2)?
- Yes
 No, explain why not.
29. Test Weight Vehicle Attitude: (all dimensions in millimeters)
- 29.1 Place the vehicle on a level surface
- 29.2 Measure perpendicular to the level surface to the 4 points marked on the body (see 13 above) and record the measurements

RF:	710	LF:	713	RR:	700	LR:	693
-----	-----	-----	-----	-----	-----	-----	-----

30. Summary of test attitude
- 30.1 AS DELIVERED:

RF:	712	LF:	718	RR:	721	LR:	712
-----	-----	-----	-----	-----	-----	-----	-----

AS TESTED:

RF:	710	LF:	713	RR:	700	LR:	693
-----	-----	-----	-----	-----	-----	-----	-----

FULLY LOADED:

RF:	703	LF:	703	RR:	697	LR:	691
-----	-----	-----	-----	-----	-----	-----	-----

- 30.2 Is the "as tested" test attitude equal to or between the "fully loaded" and "as delivered" attitude?
- Yes
 No, explain why not.

REMARKS:

I certify that I have read and performed each instruction.

Signature:

Nick Kosinski

Date:

8/24/06

DATA SHEET 33

VEHICLE ACCELEROMETER LOCATION AND MEASUREMENT

Test Vehicle: 2006 Pontiac G6
 Test Program: FMVSS 208 Compliance
 Test Technician: Wayne Dahlke

NHTSA No.: C60104
 Test Date: 8/24/06

IMPACT ANGLE:	Zero Degrees		
BELTED DUMMIES (YES/NO):	No		
TEST SPEED:	X 32 to 40 kmph	0 to 48 kmph	0 to 56 kmph
DRIVER DUMMY:	X 5 th female	50 th male	
PASSENGER DUMMY:	X 5 th female	50 th male	

- 1. Find the location where the vertical plane parallel to the longitudinal centerline of the vehicle and through the center of the left front outboard seating position intersects the left rear seat cross member. Install an accelerometer at this intersection on the rear seat cross member to record x-direction accelerations. Record the location on the following chart.
- 2. Find the location where the vertical plane parallel to the longitudinal centerline of the vehicle and through the center of the right front outboard seating position intersects the right rear seat cross member. Install an accelerometer at this intersection on the rear seat cross member to record x-direction accelerations. Record the location on the following chart.
- 3. Find the location where a vertical plane through the longitudinal centerline of the vehicle and a vertical transverse plane through the center of the two wheels on opposite sides of the engine intersect at the top of the engine. Install an accelerometer at this intersection to record x-direction accelerations. Record the location on the following chart.
- 4. Find the location where a vertical plane through the longitudinal centerline of the vehicle and a vertical transverse plane through the center of the two wheels on opposite sides of the engine intersect the bottom of the engine. Install an accelerometer at this intersection to record x-direction accelerations. Record the location on the following chart.
- 5. Install an accelerometer on the right front brake caliper to record x-direction accelerations. Record the location on the following chart.
- 6. Find the location where a vertical plane through the longitudinal centerline of the vehicle intersects the top of the instrument panel. Install an accelerometer at this intersection to record x-direction accelerations. Record the location on the following chart.
- 7. Install an accelerometer on the left front brake caliper to record x-direction accelerations. Record the location on the following chart.
- 8. Find the location where a vertical plane through the longitudinal centerline of the vehicle intersects the floor of the trunk. Install an accelerometer on the trunk floor at this intersection to record z-direction accelerations. Record the location on the following chart.

REMARKS:

I certify that I have read and performed each instruction.

Signature: *Thick Krasinski*

Date: 8/24/06

VEHICLE ACCELEROMETER LOCATION AND DATA SUMMARY

CENTERLINE OF FRONT WHEELS

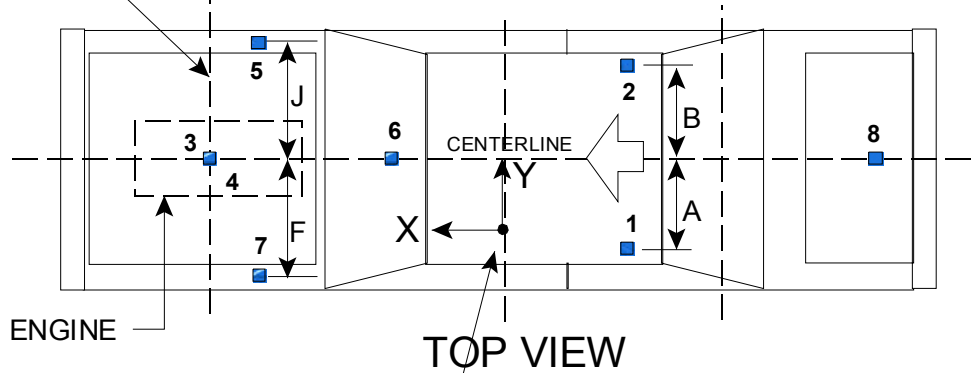

ACCELEROMETER COORDINATE SYSTEM (POSITIVE DIRECTION SHOWN)

REAR SEAT CUSHION ASSY. FRONT ATTACHMENT BRACKET SUPPORT

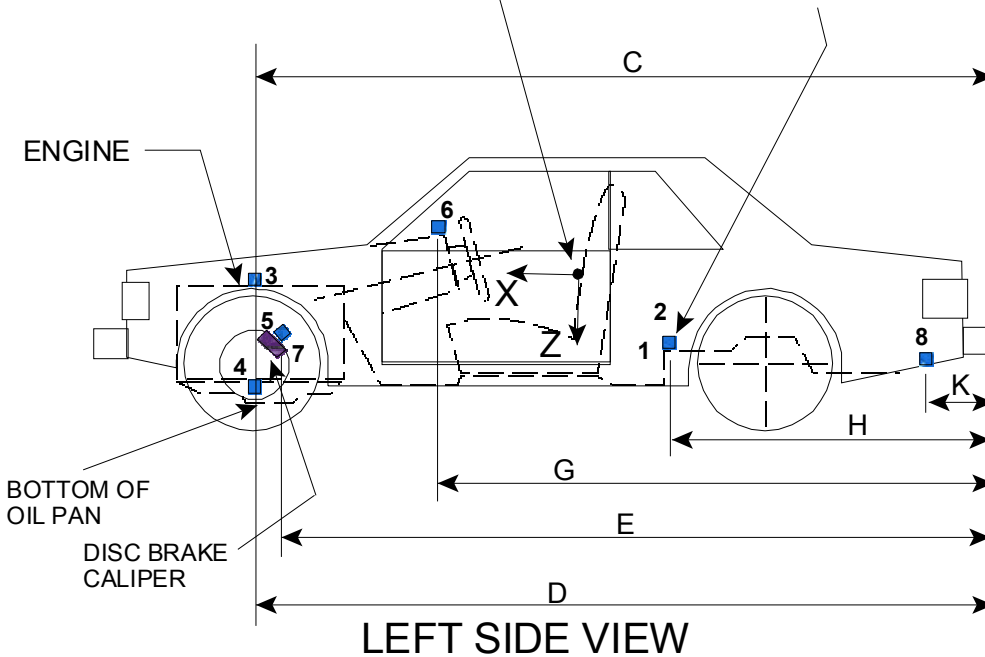

Dimensions Corresponding To The Letters "A" Through "K" (Excluding "I") Are Recorded In The Table On The Following Page.
Accelerometers Corresponding To The Numbers 1 Through 8 Are Specified On The Preceding Page.

DATA SHEET 33
VEHICLE ACCELEROMETER LOCATION AND MEASUREMENTS

<u>DIMENSION</u>	<u>LENGTH (mm)</u>			
PRETEST VALUES				
<u>A</u> (LH Rear Seat Xmbr)	340			
<u>B</u> (RH Rear Seat Xmbr)	338			
<u>C</u> (Engine Top)	3921			
<u>D</u> (Engine Bottom)	4021			
<u>E</u> (Caliper)	Right Side	3853	Left Side	3855
<u>F</u> (Left Caliper)	671			
<u>G</u> (IP)	3061			
<u>H</u> (Seat)	1672			
<u>J</u> (Right Caliper)	671			
<u>K</u> (Trunk)	932			
POST TEST VALUES				
<u>A</u> (LH Rear Seat Xmbr)	340			
<u>B</u> (RH Rear Seat Xmbr)	338			
<u>C</u> (Engine Top)	3752			
<u>D</u> (Engine Bottom)	3970			
<u>E</u> (Caliper)	Right Side	3823	Left Side	3835
<u>F</u> (Left Caliper)	671			
<u>G</u> (IP)	3015			
<u>H</u> (Seat)	1672			
<u>J</u> (Right Caliper)	676			
<u>K</u> (Trunk)	932			

DATA SHEET 34
PHOTOGRAPHIC TARGETS



Test Vehicle: 2006 Pontiac G6
 Test Program: FMVSS 208 Compliance
 Test Technician: Nick Kosinski

NHTSA No.: C60104
 Test Date: 8/24/06

IMPACT ANGLE:	Zero Degrees		
BELTED DUMMIES (YES/NO):	No		
TEST SPEED:	<u>X</u> 32 to 40 kmph	<u> </u> 0 to 48 kmph	<u> </u> 0 to 56 kmph
DRIVER DUMMY:	<u>X</u> 5 th female	<u> </u> 50 th male	
PASSENGER DUMMY:	<u>X</u> 5 th female	<u> </u> 50 th male	

- 1. FMVSS 208 vehicle targeting requirements (See Figures 28A and 28B)
- 1.1 Targets A1 and A2 are on flat rectangular panels.
- 1.2 Three circular targets at least 90 mm in diameter and with black and yellow quadrants are mounted at the front on the outboard sides of A1 and A2. The center of each circular target is 100 mm from the one next to it.
 Distance between targets (mm): 100 mm
- 1.3 Three circular targets at least 90 mm in diameter and with black and yellow quadrants are mounted at the back on the outboard sides of on A1 and A2. The center of each circular target is 100 mm from the one next to it.
 Distance between targets (mm): 100 mm
- 1.4 The distance between the first circular target at the front of A1 and A2 and the last circular target at the back of A1 and A2 is at least 915 mm.
 Distance between the first and last circular targets (mm): 915 mm
- 1.5 Firmly fix target A1 on the vehicle roof in the vertical longitudinal plane that is coincident with the midsagittal plane of the driver dummy.
- 1.6 Firmly fix target A2 on the vehicle roof in the vertical longitudinal plane that is coincident with the midsagittal plane of the passenger dummy.
- 1.7 Two circular targets (C1 and C2) at least 90 mm in diameter and with black and yellow quadrants are mounted on the outside of the driver door. The centers of each circular target are at least 610 mm apart.
 Distance between targets (mm): 612 mm
- 1.8 Two circular targets (C1 and C2) at least 90 mm in diameter and with black and yellow quadrants are mounted on the outside of the passenger door. The centers of each circular target are at least 610 mm apart.
 Distance between targets (mm): 612 mm
- 1.9 Place tape with squares having alternating colors on the top portion of the steering wheel.
- 1.10 Chalk the bottom portion of the steering wheel
- 1.11 Is this an offset test?
 Yes, continue with this section
 No, go to 2.
- 1.12 Measure the width of the vehicle.
 Vehicle width (mm):

- 1.13 Find the centerline of the vehicle. ($\frac{1}{2}$ of the vehicle width)
- 1.14 Find the line parallel to the centerline of the vehicle and 0.1 x vehicle width from the centerline of the vehicle.
- 1.15 Apply 25 mm wide tape with alternating black and yellow squares parallel to and on each side of the line found in 1.14. The edge of each tape shall be 50 mm from the line found in 1.14. The tape shall extend from the bottom of the bumper to the front edge of the windshield. (Figure 28D)
2. Barrier Targeting
- 2.1 Fix two stationary targets D1 and D2 to the barrier as shown in the Figure 28A. One target is in the vertical longitudinal plane that is coincident with the midsagittal plane of the driver dummy. The other is in the vertical longitudinal plane that is coincident with the midsagittal plane of the passenger dummy
- 2.2 Targets D1 and D2 are on a rectangular panel.
- 2.3 Three circular targets at least 90 mm in diameter and with black and yellow quadrants are mounted on the sides of the rectangular panel away from the longitudinal centerline of the vehicle. The center of each circular target is 100 mm from the one next to it.
- Distance between circular targets on D1 (mm): 100 mm
- Distance between circular targets on D2 (mm): 100 mm
3. FMVSS 208 Dummy Targeting Requirements
- 3.1 Place a circular target with black and yellow quadrants on both sides of the driver dummy head as close as possible to the center of gravity of the head in the x and z direction (relative to the measuring directions of the accelerometers).
- 3.2 Place a circular target with black and yellow quadrants on both sides of the passenger dummy head as close as possible to the center of gravity of the head in the x and z direction (relative to the measuring directions of the accelerometers).
- 3.3 Place a circular target with black and yellow quadrants on the outboard shoulder of the driver dummy. Place the target as high up on the arm as possible at the intersection of the arm and shoulder. The sleeve of the shirt on the dummy may be cut to make the target visible, but do not remove any material.
- 3.4 Place a circular target with black and yellow quadrants on the outboard shoulder of the passenger dummy. Place the target as high up on the arm as possible at the intersection of the arm and shoulder. The sleeve of the shirt on the dummy may be cut to make the target visible, but do not remove any material.
4. FMVSS 204 Targeting Requirements
- 4.1 Is an FMVSS 204 indicant test ordered on the "COTR Vehicle Work Order?"
- Yes, continue with this form.
- No, this form is complete.
- 4.2 Resection panel (Figure 28C)
- 4.2.1 The panel deviates no more than 6 mm from perfect flatness when suspended vertically
- 4.2.2 The 8 targets on the panel are circular targets at least 90 mm in diameter and with black and yellow quadrants.
- 4.2.3 The center of each of the 4 outer targets are placed within 1 mm of the corners of a square measuring 914 mm on each side.
- 4.2.4 Locate another square with 228 mm sides and with the center of this square coincident with the center of the 914 mm square.
- 4.2.5 The center of the 4 inner targets are placed at the midpoints of each of the 228 mm sides.

-  4.3 Place a circular target at least 90 mm in diameter and with black and yellow quadrants on a material (cardboard, metal, etc.) that can be taped to the top of the steering column.
-  4.4 Tape the target from 4.3 to the top of the steering column in a manner that does not interfere with the movement of the steering column in a crash

REMARKS:

I certify that I have read and performed each instruction.

Signature:

Patrick Kosinski

Date:

8/24/06

REFERENCE PHOTO TARGETS

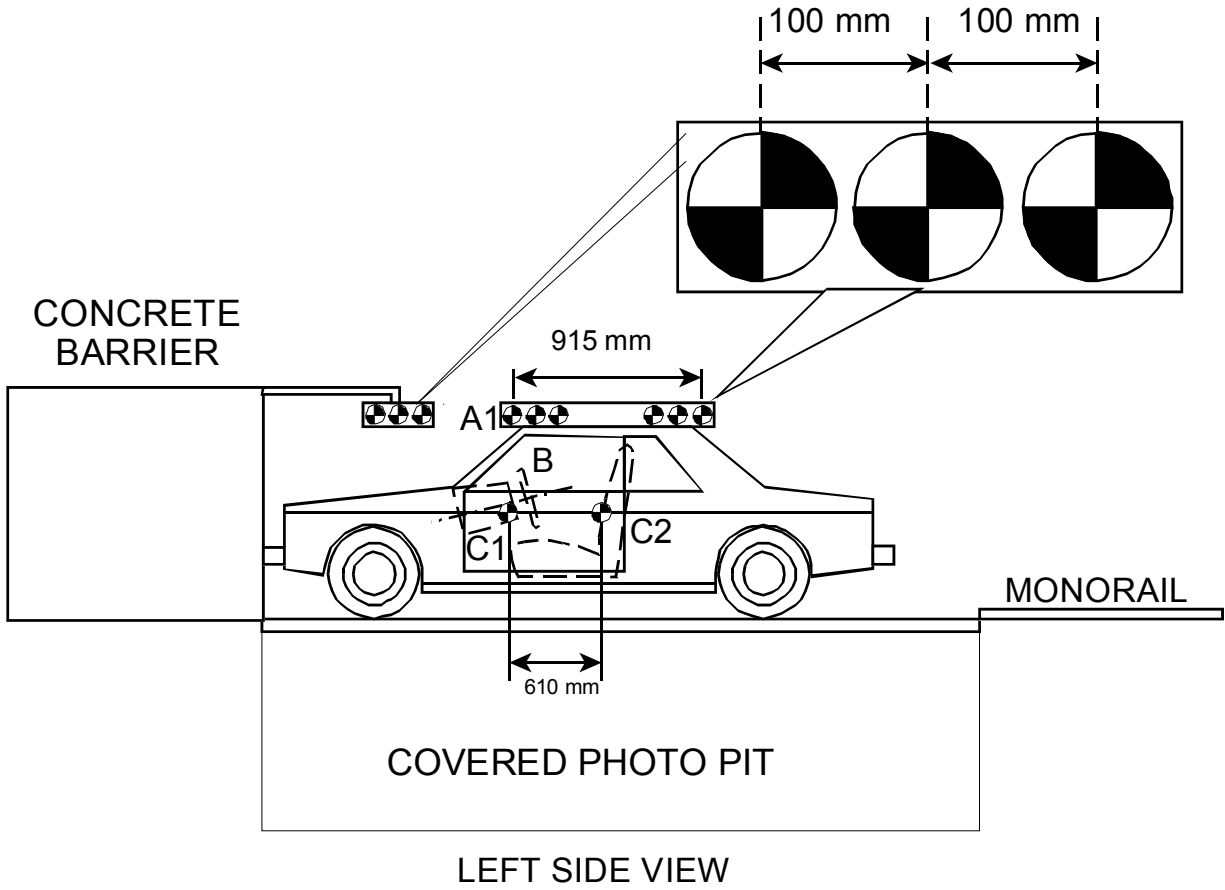

RESECTION PANEL TARGETING ALIGNMENT

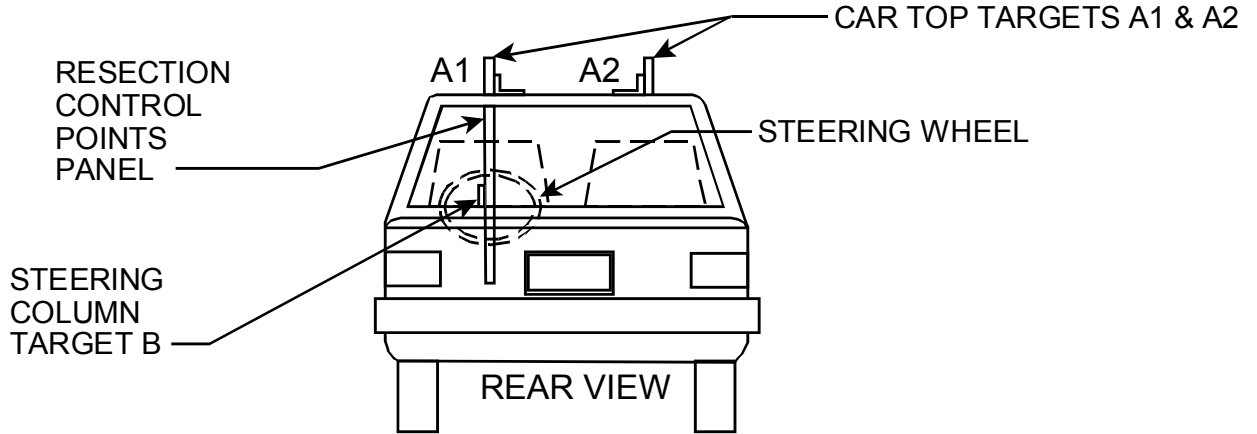

TEST RUN STEERING COLUMN CAMERA VIEW OF TYPICAL TIME ZERO VEHICLE POSITION

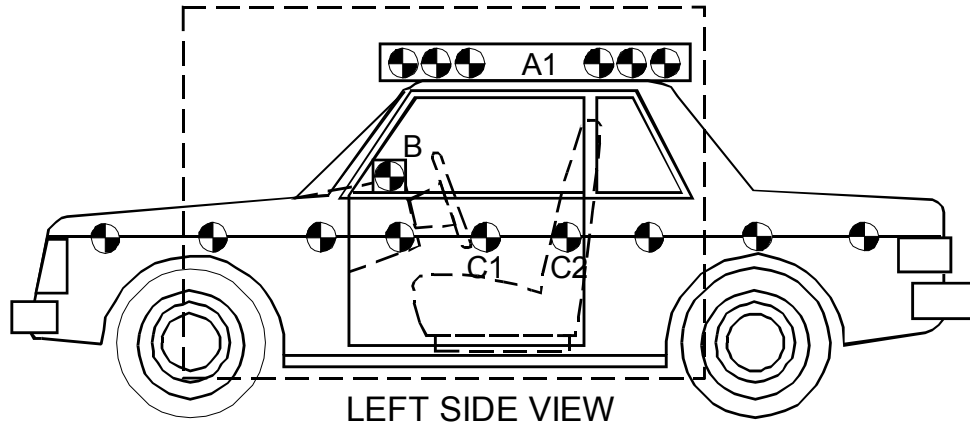

PRE-RUN STEERING COLUMN HIGH SPEED CAMERA VIEW

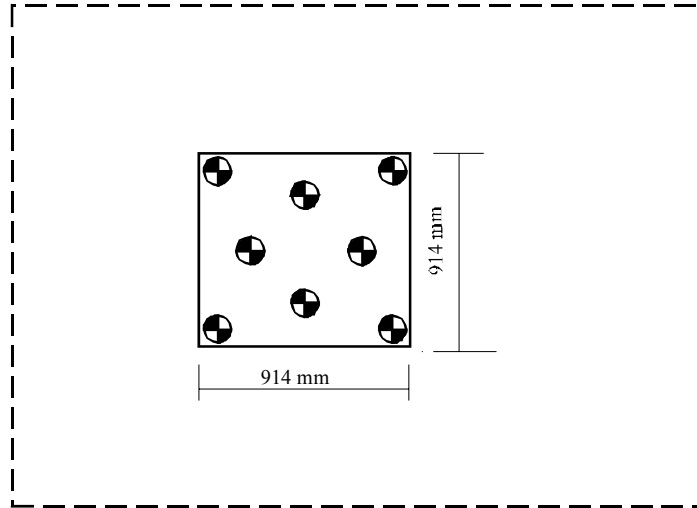

LEFT SIDE VIEW

DATA SHEET 35
CAMERA LOCATIONS

Test Vehicle: 2006 Pontiac G6
Test Program: FMVSS 208 Compliance

NHTSA No.: C60104
Test Date: 8/24/06
Time: 3:04 PM

CAMERA NO.	VIEW	CAMERA POSITIONS (mm) *			LENS (mm)	SPEED (fps)
		X	Y	Z		
1	Real Time Left Side View				13	24
2	Left Side View (Barrier face to front seat backs)	1115	-5150	1210	24	1500
3	Left Side View (Driver)	1705	-6575	1380	35	400
4	Left Side View (B-post aimed toward center of steering wheel)	6375	-5185	2000	50	400
5	Left Side View (Steering Column)	1430	-5300	1360	25	400
6	Left Side View (Steering Column)	1435	-5280	910	25	400
7	Right Side View (Overall)	2155	7565	1295	24	1500
8	Right Side View (Passenger)	1565	6175	1185	35	400
9	Right Side View (Angle)	6575	5305	1975	50	400
10	Right Side View (Front door)	1230	5325	1220	25	1500
11	Front View Windshield	-285	0	2370	12.5	400
12	Front View Driver	-155	-375	2200	24	1500
13	Front View Passenger	-160	505	2205	24	1500
14	Overhead Barrier Impact View	1195	0	5050	19	1500
15	Pit Camera Engine View	1095	0	-3160	24	1500
16	Pit Camera Fuel Tank View	3360	0	-3160	24	1500

*COORDINATES:

- +X - forward of impact plane
- +Y - right of monorail centerline
- +Z - above ground level

CAMERA POSITIONS FOR FMVSS 208

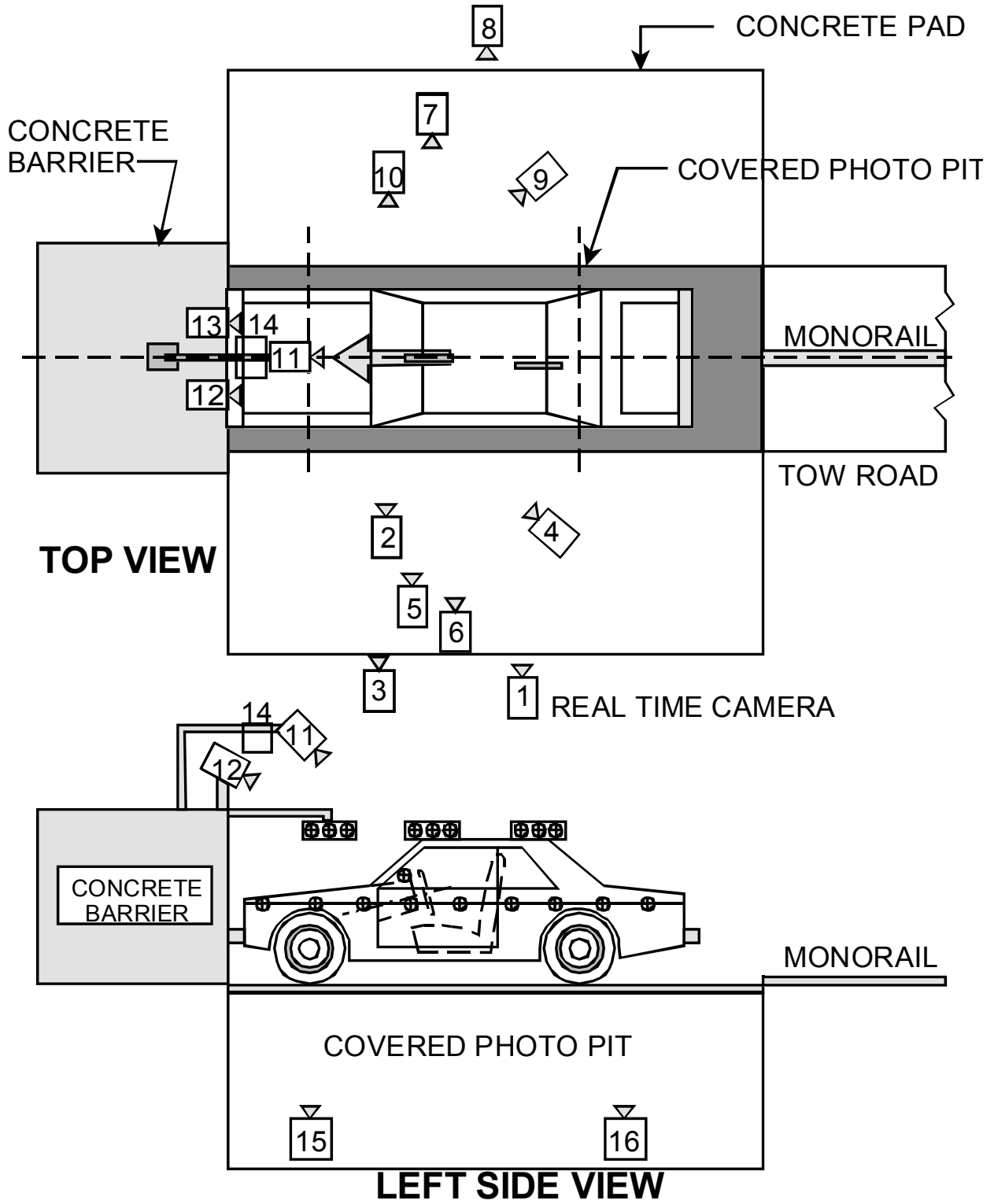

DATA SHEET 36
APPENDIX G
DUMMY POSITIONING PROCEDURES
FOR 5th% DRIVER TEST DUMMY CONFORMING TO SUBPART O OF PART 572

Test Vehicle: 2006 Pontiac G6
 Test Program: FMVSS 208 Compliance
 Test Technician: Eric Peschman

NHTSA No.: C60104
 Test Date: 8/24/06

IMPACT ANGLE:	Zero Degrees		
BELTED DUMMIES (YES/NO):	No		
TEST SPEED:	<input checked="" type="checkbox"/> 32 to 40 kmph	<input type="checkbox"/> 0 to 48 kmph	<input type="checkbox"/> 0 to 56 kmph
DRIVER DUMMY:	<input checked="" type="checkbox"/> 5 th female	<input type="checkbox"/> 50 th male	
PASSENGER DUMMY:	<input checked="" type="checkbox"/> 5 th female	<input type="checkbox"/> 50 th male	

- X 1. Using the markings made from data sheet 14.3 (If not done previously or steering repairs have been made, complete data sheet 14.3 at this time.) to position the steering controls in the mid-position or if applicable next lowest detent position. (S16.2.9)
- X 2. Place the SCRP in the full rearward, mid-height position, and mid-seat cushion angle, determined during the completion of Data Sheet 14.1. (S16.3.2.1.1)
- X 3. If the vehicle has an adjustable accelerator pedal, place it in the full forward position. (S16.3.2.2.1)
X N/A accelerator pedal not adjustable
- X 4. Fully recline the seat back. (S16.3.2.1.2)
 ___ N/A seat back not adjustable.
- X 5. Place the dummy in the seat with the legs at an angle of 120 degrees to the thighs. The calves should not be touching the seat cushion. (S16.3.2.1.2)
- X 6. Position the dummy in the seat such that the midsagittal plane is coincident with the longitudinal seat cushion markings as determined in Data Sheet 14.1. (S16.3.2.1.3 and S16.3.2.1.4)
- X 7. Hold down the dummy's thighs and push rearward on the upper torso to maximize the pelvic angle. (S16.3.2.1.5)
- X 8. Set the angle between the legs and the thighs to 120 degrees. (S16.3.2.1.6)
- X 9. Set the transverse distance between the centers of the front of the knees at 160 to 170 mm. (6.3 to 6.7 inches) Center the knee separation with respect to the longitudinal seat cushion marking as determined Data Sheet 14.1. (S16.3.2.1.6)
 Record Knee Separation 160
- X 10. Push rearward on the dummy's knees until the pelvis contacts the seat back, or the backs of the calves contact the seat cushion, whichever occurs first. (S16.3.2.1.6)
 ___ Pelvis contacted seat back.
X Calves contacted seat cushion.

11. Gently rock the upper torso ± 5 degrees (approximately 51 mm (2 inches)) side-to-side three times. (S16.3.2.1.7)
12. If needed, extend the legs until the feet do not contact the floor pan. The thighs should be resting on the seat cushion. (S16.3.2.1.8)
13. Position the right foot until the foot is in line with a longitudinal vertical plane passing through the center of the accelerator pedal. Maintain the leg and thigh in a vertical plane. (S16.3.2.1.8)
14. Rotate the left leg and thigh laterally to equalize the distance between each knee and the longitudinal seat cushion marking as determined in Data Sheet 14.1. (S16.3.2.1.8)
15. Attempt to return the seat to the foremost fore-aft position, mid-height, and seat cushion mid-angle as determined in Data Sheet 14.2. The foot may contact and depress the accelerator and/or change the angle of the foot with respect to the leg. (S16.3.2.1.8)
- Foremost position achieved. Proceed to step 20.
- Foremost not achieved because of foot interference. Proceed to step 17.
- Foremost not achieved because of steering wheel contact.
16. If either of the dummy's legs contact the steering wheel, move the steering wheel up the minimum amount required to avoid contact. If the steering wheel is not adjustable separate the knees the minimum required to avoid contact. (S16.3.2.1.8)
- N/A- there was no leg contact
- Steering wheel repositioned
- Knees separated
17. If the left foot interferes with the clutch or brake pedals, rotate the left foot about the leg to provide clearance. If this is not sufficient, rotate the thigh outboard at the hip the minimum amount required for clearance. (S16.3.2.1.8)
- N/A, No foot interference with pedals.
- Foot adjusted to provide clearance.
- Foot and Thigh adjusted to provide clearance.
18. Continue to move the seat. Use seat controls to line up the seat markings determined during the completion of Data Sheet 14.1 to set the foremost fore-aft position, mid-height position and the seat cushion mid-angle. If the dummy contacts the interior move the seat rearward until a maximum clearance of 5 mm (0.2 inches) is achieved or the seat is in the closest detent position that does not cause dummy contact. (S16.3.2.1.8)
- Foremost, mid-height position and the seat cushion mid-angle reached
- Dummy contact. Clearance set at maximum of 5mm
Measured Clearance _____
- Dummy Contact. Seat set at nearest detent position.
Seat position ____ detent positions rearward of foremost
(foremost is position zero)

19. If the steering wheel was repositioned in step 16, return the steering wheel to the original position. If the steering wheel contacts the dummy before reaching the original position, position the wheel until a maximum clearance of 5mm (.2 inches) is achieved, or the steering wheel is in the closest detent position that does not cause dummy contact. (S16.3.2.1.8)

N/A Steering wheel was not repositioned.

Original position achieved.

Dummy contact. Clearance set at maximum of 5mm

Measured Clearance _____

Dummy Contact. Steering wheel set at nearest detent position.

Steering wheel position detent positions upward of original position.

(Original position is position zero)

20. If the seat back is adjustable, rotate the seat back forward while holding the thighs in place. Continue rotating the seat back forward until the transverse instrument platform of the dummy head is level ± 0.5 degrees. If the head cannot be leveled using the seat back adjustment, or the seat back is not adjustable, use the lower neck bracket adjustment to level the head. If a level position cannot be achieved, minimize the angle. (S16.3.2.1.9)

Head Level Achieved. (Check all that apply)

Head leveled using the adjustable seat back

Head leveled using the neck bracket.

Head Angle 0.2 degrees

Head Level NOT Achieved. (Check all that apply)

Head adjusted using the adjustable seat back

Head adjusted using the neck bracket.

Head Angle _____ degrees

21. Verify the pelvis is not interfering with the seat bight. (S16.3.2.1.9)

No interference

Pelvis moved forward the minimum amount so that it is not caught in the seat bight.

22. Verify the dummy abdomen is properly installed. (S16.3.2.1.9)

Abdomen still seated properly into dummy

Abdomen was adjusted because it was not seated properly into dummy

23. Head Angle

N/A, neither the pelvis nor the abdomen were adjusted.

23.1 Head still level (Go to 24)

23.2 Head level adjusted

Head Level Achieved. (Check all that apply)

Head leveled using the adjustable seat back

Head leveled using the neck bracket.

Head Angle _____ degrees

Head Level NOT Achieved. (Check all that apply)

Head level adjusted using the adjustable seat back

Head level adjusted using the neck bracket.

Head Angle _____ degrees

24. If the dummy torso contacts the steering wheel while performing step 20, reposition the steering wheel in the following order to eliminate contact. (S16.3.2.1.9)

N/A, No dummy torso contact with the steering wheel.

24.1 Adjust telescoping mechanism.

N/A No telescoping adjustment.

Adjustment performed (fill in appropriate change)

Steering wheel moved _____ detent positions in the forward direction.

Steering wheel moved _____ mm in the forward direction.

24.2 Adjust tilt mechanism.

N/A No tilt adjustment.

No adjustment performed.

Adjustment performed.

Steering wheel moved _____ detent positions Upward/Downward.
(circle one)

Steering wheel moved _____ degrees Upward/Downward

24.3 Adjust Seat in the aft direction.

No Adjustment performed.

Seat moved aft _____ mm from original position.

Seat moved aft _____ detent positions from the original position.

25. Measure and set the pelvic angle using the pelvic angle gage TE-2504. The pelvic angle should be 20.0 degrees \pm 2.5 degrees. If the pelvic angle cannot be set to the specified range because the head will not be level or because the dummy will have need major repositioning, adjust the pelvis as closely as possible to the angle range, but keep the head level. (S16.3.2.1.11)

Pelvic angle set to 20.0 degrees \pm 2.5 degrees.

Pelvic angle of 20.0 degrees not achieved, the angular difference was minimized.

Record the pelvic angle. _____ 18.1 _____ degrees

26. Check the dummy for contact with the interior after completing adjustments.

(S16.3.2.1.12)

No contact.

Dummy in contact with interior.

Seat moved aft _____ mm from the previous position.

Seat moved aft _____ detent positions from the previous position.

27. Check the dummy to see if additional interior clearance is obtained, allowing the seat to be moved forward. (S16.3.2.1.12)

N/A, Seat already at foremost position.

Clearance unchanged. No adjustments required.

Additional clearance available

Seat moved Forward _____ mm from the previous position.

Seat moved Forward _____ detent positions from the previous position.

28. Driver's foot positioning, right foot. Place the foot perpendicular to the leg and determine if the heel contacts the floor pan at any leg position. If the heel contacts the floor pan proceed to step 29 otherwise, proceed to step 30. (S16.3.2.2.1)

29. Perform the following steps until either all steps are completed, or the foot contacts the accelerator pedal. Step 29.6 shall be completed in all cases. (S16.3.2.2.1(a))

29.1 With the rear of the heel contacting the floor pan, move the foot forward until pedal contact occurs or the foot is at the full forward position.

29.2 If the vehicle has an adjustable accelerator pedal, move the pedals rearward until pedal contact occurs or the pedals reach the full rearward position.

29.3 Extend the leg, allowing the heel to lose contact with the floor until the foot contacts the pedal. Do not raise the toe of the foot higher than the top of the accelerator pedal. If the foot does not contact the pedal, proceed to the next step. If pedal contact does occur, place a tapered foam block as shown in Figure G1 under the heel with the shallow part of the taper facing forward. (S16.3.2.2.3)

29.4 Angle the foot to achieve contact between the foot and the pedal. If the foot does not contact the pedal, return the foot to the perpendicular orientation. If pedal contact does occur, place a tapered foam block as shown in Figure G1 under the heel with the shallow part of the taper facing forward. (S16.3.2.2.3)

29.5 Align the centerline of the foot with the vertical-longitudinal plane passing through the center of the accelerator pedal. Place a tapered foam block as shown in Figure G1 under the heel with the shallow part of the taper facing forward. (S16.3.2.2.3)

29.6 Record foot position

Pedal Contact achieved. Contact occurred at step 29.1.

Heel contacts floor pan

Heel set _____ mm from floor pan.

Pedal Contact not achieved. Heel set _____ mm from the floor pan.

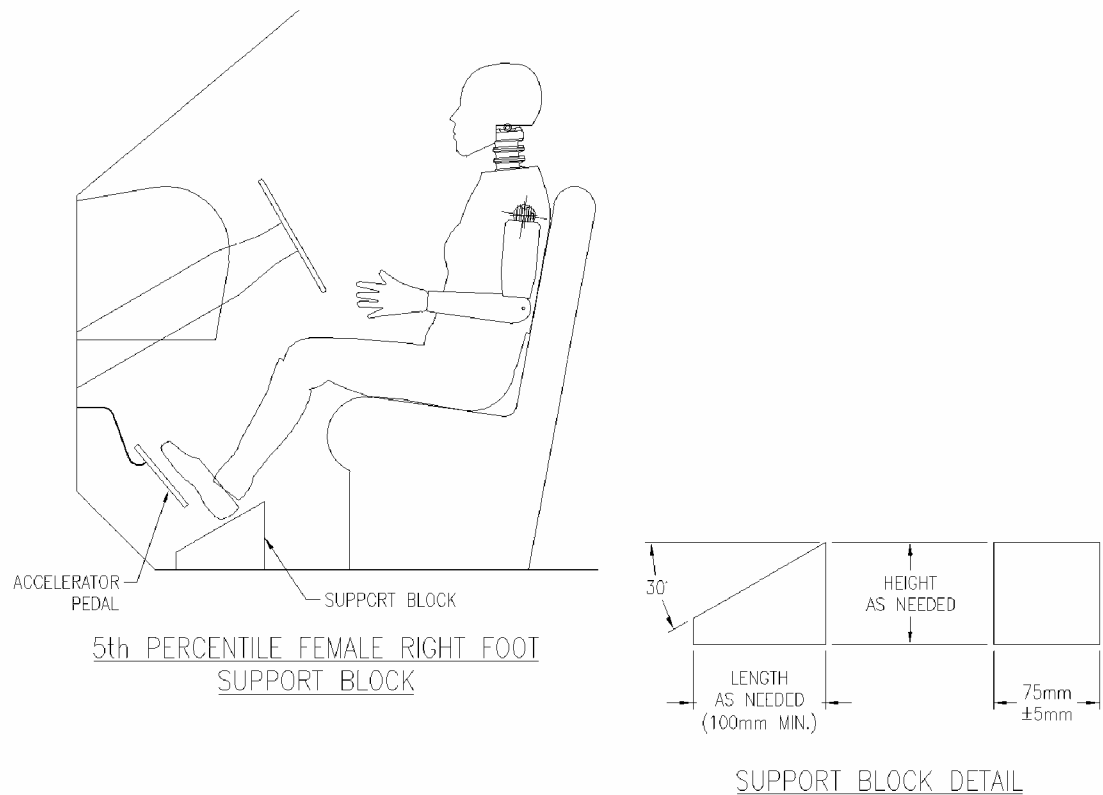

FIGURE G1

- __30. Perform the following steps until either all steps are completed, or the foot contacts the accelerator pedal. Step 30.5 shall be completed in all cases.
- __30.1 Extend the leg until the foot contacts the pedal. Do not raise the toe of the foot higher than the top of the accelerator pedal. If the foot does not contact the pedal, proceed to the next step. If pedal contact does occur, place a tapered foam block as shown in Figure G1 under the heel with the shallow part of the taper facing forward. (S16.3.2.2.1(b) & S16.3.2.2.3)
- __30.2 If the vehicle has an adjustable accelerator pedal, move the pedals rearward until pedal contact occurs or the pedals reach the full rearward position. If pedal contact does occur, place a tapered foam block as shown in Figure G1 under the heel with the shallow part of the taper facing forward. (S16.3.2.2.1(b) & S16.3.2.2.3)
- __N/A No pedal adjustment
- __30.3 Angle the foot to achieve contact between the foot and the pedal. If the foot does not contact the pedal, return the foot to the perpendicular orientation. If pedal contact does occur, place a tapered foam block as shown in Figure G1 under the heel with the shallow part of the taper facing forward. (S16.3.2.2.2 & S16.3.2.2.3)
- __30.4 Align the centerline of the foot in the same horizontal plane as the centerline of the accelerator pedal. Place a tapered foam block as shown in Figure G1 under the heel with the shallow part of the taper facing forward. (S16.3.2.2.3)

30.5 Record foot position

 Pedal Contact achieved. Contact occurred at step _____.

 Heel set _____ mm from floor pan.

 Pedal Contact not achieved. Heel set _____ mm from the floor pan.

X 31. Driver's foot positioning, left foot.

X 31.1 Place the foot perpendicular to the leg and determine if the heel contacts the floor pan at any leg position. If the heel contacts the floor pan proceed to step 31.2, otherwise position the leg as perpendicular to the thigh as possible with the foot parallel to the floor pan. (S16.2.2.6)

X 31.2 Place the foot on the toe board with the heel resting on the floor pan as close to the intersection of the floor pan and the toe board as possible. Adjust the angle of the foot if necessary to contact the toe board. If the foot will not contact the toe board, set the foot perpendicular to the leg, and set the heel on the floor pan as far forward as possible. Avoid contact with the brake pedal, clutch pedal, wheel well projection, and footrest. To avoid this contact use the following three manipulations in the order listed, with each subsequent option incorporating the previous, until contact is avoided: rotate the foot about the lower leg (abduction/adduction), plantar flex the foot, rotate the leg outboard about the hip. Movement should be the minimum amount necessary. If it is not possible to avoid all foot contact, give priority to avoiding brake or clutch pedal contact. (S16.2.2.4 & S16.2.2.5 & S16.2.2.7)

X No contact

 Foot rotated about the leg (abduction/adduction)

 Foot rotated about the leg, and foot plantar flexed

 Foot rotated about the leg, foot plantar flexed, and the leg rotated about the hip.

X 31.3 Record foot position.

 Heel does not contact floor pan.

X Heel on floor pan and foot on toe board.

 Heel on floor pan and foot not on toe board.

X 32. Driver arm/hand positioning.

X 32.1 Place the dummy's upper arms adjacent to the torso with the arm centerlines as close to a vertical longitudinal plane as possible. (S16.3.2.3.1)

X 32.2 Place the palms of the dummy in contact with the outer part of the steering wheel rim at its horizontal centerline with the thumbs over the steering wheel rim. (S16.3.2.3.2)

X 32.3 If it is not possible to position the thumbs inside the steering wheel rim at its horizontal centerline, then position them above and as close to the horizontal centerline of the steering wheel rim as possible. (S16.3.2.3.3)

X 32.4 Lightly tape the hands to the steering wheel rim so that if the hand of the test dummy is pushed upward by a force of not less than 9 N (2 lb) and not more than 22 N (5 lb), the tape releases the hand from the steering wheel rim. S16.3.2.3.4

X 33. Adjustable head restraints

 N/A, there is no head restraint adjustment

- 33.1 If the head restraint has an automatic adjustment, leave it where the system positions the restraint after the dummy is placed in the seat. (S16.3.4.1) Go to 34.
- 33.2 Adjust each head restraint vertically so that the mid-horizontal plane determined in Data Sheet 14.1 is aligned with the center of gravity (CG) of the dummy head. (S16.3.4.3)
- 33.3 If the above position is not attainable, move the vertical center of the head restraint to the closest detent below the center of the head CG. (S16.3.4.3)
 N/A midpoint position attained in previous step
 Headrest set at nearest detent below the head CG
- 33.4 If the head restraint has a fore and aft adjustment, place the restraint in the foremost position or until contact with the head is made, whichever occurs first. (S16.3.4.4)
34. Driver and passenger manual belt adjustment (for tests conducted with a belted dummy). (S16.3.5) UNBELTED TEST
- 34.1 If an adjustable seat belt D-ring anchorage exists, place it in the manufacturer's design position for a 5th percentile adult female. (S16.3.5.1) **This information will be supplied by the COTR.**
 Manufacturer's specified position _____
 Actual Position _____
- 34.2 Place the Type 2 manual belt around the test dummy and fasten the latch. (S16.3.5.2)
- 34.3 Ensure that the dummy's head remains as level as possible. (S16.3.5.3)
- 34.4 Remove all slack from the lap belt. Pull the upper torso webbing out of the retractor and allow it to retract; repeat this operation four times. Apply a 9 N (2 lbf) to 18 N (4 lbf) tension load to the lap belt. If the belt system is equipped with a tension-relieving device, introduce the maximum amount of slack into the upper torso belt that is recommended by the manufacturer. If the belt system is not equipped with a tension-relieving device, allow the excess webbing in the shoulder belt to be retracted by the retractive force of the retractor. (S16.3.5.4)

REMARKS:

I certify that I have read and performed each instruction.

Signature: 

Date: 8/24/06

10. If needed, extend the legs until the feet do not contact the floor pan. The thighs should be resting on the seat cushion. (S16.3.3.1.8)
11. Use seat controls to line up the seat markings determined during the completion of Data Sheet 14.1 to set the foremost fore-aft position, mid-height position and the seat cushion mid-angle. If the dummy contacts the interior move the seat rearward until a maximum clearance of 5 mm (0.2 inches) is achieved or the seat is in the closest detent position that does not cause dummy contact. (S16.3.3.1.8)
- Foremost, mid-height position and the seat cushion mid-angle reached
 Dummy contact. Clearance set at maximum of 5mm
Measured Clearance _____
 Dummy Contact. Seat set at nearest detent position.
Seat position ___ detent positions rearward of foremost
(foremost is position zero)
12. If the seat back is adjustable, rotate the seat back forward while holding the thighs in place. Continue rotating the seat back forward until the transverse instrument platform of the dummy head is level ± 0.5 degrees. If head cannot be leveled using the seat back adjustment, or the seat back is not adjustable, use the lower neck bracket adjustment to level the head. If a level position cannot be achieved, adjust the head as closely as possible to the ± 0.5 degree range. (S16.3.3.1.9 and S16.3.3.1.10)
(Check All That Apply)
- Seat back not adjustable
 Seat back not independent of driver side seat back
 Head Level Achieved. (Check all that apply)
- Head leveled using the adjustable seat back
 Head leveled using the neck bracket.
Head Angle 0.2 degrees
- Head Level NOT Achieved. (Check all that apply)
- Head adjusted using the adjustable seat back
 Head adjusted using the neck bracket.
Head Angle _____ degrees
13. Verify the pelvis is not interfering with the seat bight. (S16.3.3.1.9)
- No interference
 Pelvis moved forward the minimum amount so that it is not caught in the seat bight.
14. Verify the dummy abdomen is properly installed. (S16.3.3.1.9)
- Abdomen still seated properly into dummy
 Abdomen was adjusted because it was not seated properly into dummy
15. Head Angle
 N/A, neither the pelvis nor the abdomen were adjusted.
- 15.1 Head still level (Go to 16)

15.2 Head level adjusted

 Head Level Achieved. (Check all that apply)

 Head leveled using the adjustable seat back

 Head leveled using the neck bracket.

Head Angle _____ degrees

 Head Level NOT Achieved. (Check all that apply)

 Head adjusted using the adjustable seat back

 Head adjusted using the neck bracket.

Head Angle _____ degrees

X 16. Measure and set the pelvic angle using the pelvic angle gage TE-2504. The pelvic angle should be 20.0 degrees \pm 2.5 degrees. If the pelvic angle cannot be set to the specified range because the head will not be level or because the dummy will have need major repositioning, adjust the pelvis as closely as possible to the angle range, but keep the head level.

X Pelvic angle set to 20.0 degrees \pm 2.5 degrees.

 Pelvic angle of 20.0 degrees not achieved, the angular difference was minimized.

X Record the pelvic angle. 21.1 degrees

X 17. Check the dummy for contact with the interior after completing adjustments.

X No contact.

 Dummy in contact with interior.

 Seat moved aft _____ mm from the previous position.

 Seat moved aft _____ detent positions from the previous position.

X 18. Verify the transverse instrument platform of the dummy head is level +/- 0.5 degrees. Use the lower neck bracket adjustment to level the head. If a level position cannot be achieved, minimize the angle. (S16.3.3.1.9, S16.3.3.1.10, and S16.3.3.1.11)

X Head Level Achieved

Head Angle 0.2 degrees

 Head Level NOT Achieved.

Head Angle _____ degrees

X 19. Check the dummy to see if additional interior clearance is obtained, allowing the seat to be moved forward. (S16.3.3.1.12)

 N/A Bench Seat

X N/A Seat already at full forward position.

 Clearance unchanged. No adjustments required.

 Additional clearance available

 Seat moved Forward _____ mm from the previous position.

 Seat moved Forward _____ detent positions from the previous position.

 Seat moved Forward, Full Forward position reached.

X 20. Passenger foot positioning. (Indicate final position achieved) (S16.3.3.2)

 20.1 Place feet flat on the toe board; OR (S16.3.3.2.1)

X 20.2 If the feet cannot be placed flat on the toe board, set the feet perpendicular to the lower leg, and rest the heel as far forward on the floor pan as possible; OR (S16.3.3.2.2)

 20.3 If the heels do not touch the floor pan, set the legs as perpendicular to the thighs as possible and set the feet parallel to the floor pan. (S16.3.3.2.2)

21. Passenger arm/hand positioning. (S16.3.3.3)

21.1 Place the dummy's upper arms adjacent to the torso with the arm centerlines as close to a vertical longitudinal plane as possible. (S16.3.3.3.1)

21.2 Place the palms of the dummy in contact with the outer part of the thighs (S16.3.3.3.2)

21.3 Place the little fingers in contact with the seat cushion. (S16.3.3.3.3)

22. Adjustable head restraints (S16.3.4)

N/A, there is no head restraint adjustment

22.1 If the head restraint has an automatic adjustment, leave it where the system positions the restraint after the dummy is placed in the seat. (S16.3.4.1) Go to 23.

22.2 Adjust each head restraint vertically so that the horizontal plane determined in Data Sheet 14.1 is aligned with the center of gravity (CG) of the dummy head. (S16.3.4.3)

22.3 If the above position is not attainable, move the vertical center of the head restraint to the closest detent below the center of the head CG. (S16.3.4.3)

N/A midpoint position attained in previous step

Headrest set at nearest detent below the head CG

22.4 If the head restraint has a fore and aft adjustment, place the restraint in the foremost position or until contact with the head is made, whichever occurs first. (S16.3.4.4)

23. Manual belt adjustment (for tests conducted with a belted dummy) S16.3.5

N/A, Unbelted test

23.1 If an adjustable seat belt D-ring anchorage exists, place it in the manufacturer's design position for a 5th percentile adult female. **This information will be supplied by the COTR.** (S16.3.5.1)

Manufacturer's specified position _____

Actual Position _____

23.2 Place the Type 2 manual belt around the test dummy and fasten the latch. (S16.3.5.2)

23.3 Ensure that the dummy's head remains as level as possible. (S16.3.5.3)

23.4 Remove all slack from the lap belt. Pull the upper torso webbing out of the retractor and allow it to retract; repeat this operation four times. Apply a 9 N (2 lbf) to 18 N (4 lbf) tension load to the lap belt. If the belt system is equipped with a tension-relieving device, introduce the maximum amount of slack into the upper torso belt that is recommended by the manufacturer. If the belt system is not equipped with a tension-relieving device, allow the excess webbing in the shoulder belt to be retracted by the retractive force of the retractor. (S16.3.5.4)

REMARKS:

I certify that I have read and performed each instruction.



Signature: _____

Date: 8/24/06

DATA SHEET 37

DUMMY MEASUREMENTS

Test Vehicle: 2006 Pontiac G6
 Test Program: FMVSS 208 Compliance
 Test Technician: Eric Peschman

NHTSA No.: C60104
 Test Date: 8/24/06

DUMMY MEASUREMENTS FOR FRONT SEAT OCCUPANTS

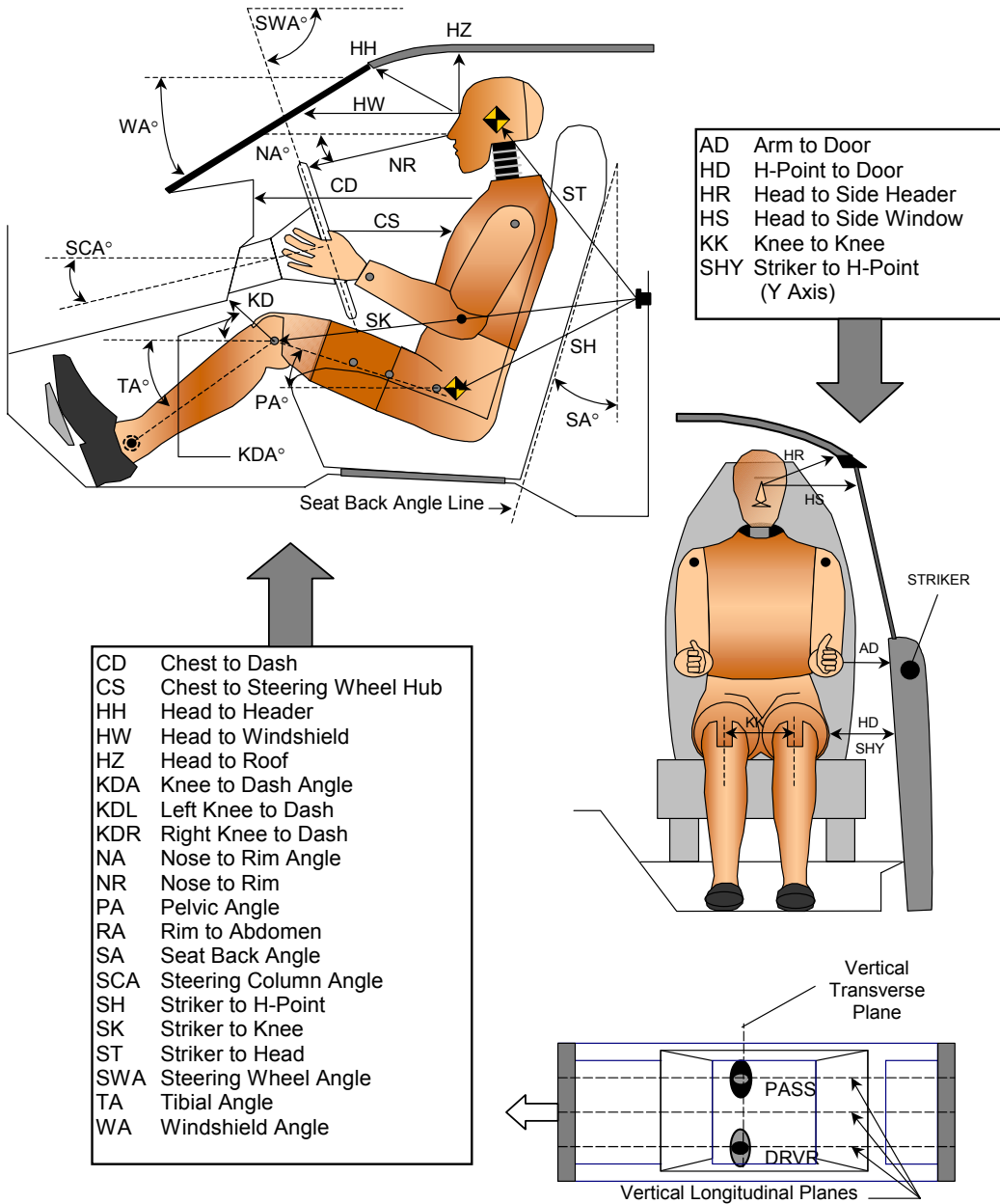

DATA SHEET 37
DUMMY MEASUREMENTS

Test Vehicle: 2006 Pontiac G6
 Test Program: FMVSS 208 Compliance
 Test Technician: Eric Peschman

NHTSA No.: C60104
 Test Date: 8/24/06

TEST DUMMY POSITION MEASUREMENTS

Code	Measurement Description	Driver SN 507		Passenger SN 511	
		Length (mm)	Angle (°)	Length (mm)	Angle (°)
WA	Windshield Angle		26.2		
SWA	Steering Wheel Angle		68.3		
SCA	Steering Column Angle		24.5		
SA	Seat Back Angle (On Headrest)		14.2		19.4
HZ	Head to Roof (Z)	188		261	
HH	Head to Header	295	46.6	365	43.4
HW	Head to Windshield	647	0	789	0
HR	Head to Side Header (Y)	227		256	
NR	Nose to Rim	282	0.7		
CD	Chest to Dash	455		489	
CS	Chest to Steering Hub	222	1.2		
RA	Rim to Abdomen	104	0		
KDL	Left Knee to Dash	121	38.7	164	
KDR	Right Knee to Dash	129		160	34.0
PA	Pelvic Angle		18.1		21.1
TA	Tibia Angle		46.3		43.8
KK	Knee to Knee (Y)	250		204	
SK	Striker to Knee	658	93.3	632	98.1
ST	Striker to Head	486	23.4	442	20.4
SH	Striker to H-Point	360	108.2	337	117.9
SHY	Striker to H-Point (Y)	301		301	
HS	Head to Side Window	357		360	
HD	H-Point to Door (Y)	162		171	
AD	Arm to Door (Y)	136		89	
AA	Ankle to Ankle	239		180	

SEAT BELT POSITIONING DATA

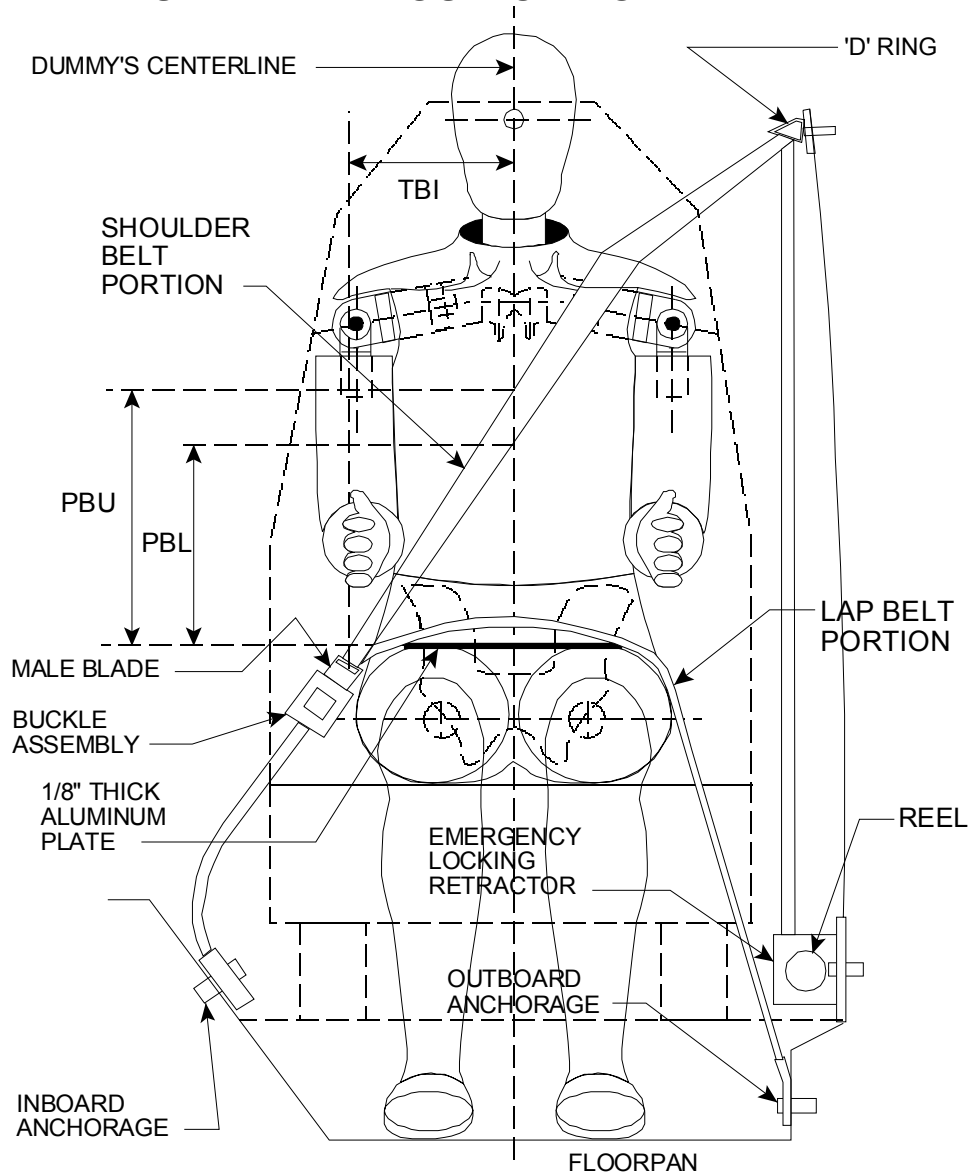

FRONT VIEW OF DUMMY

SEAT BELT POSITIONING MEASUREMENTS

Measurement Description	Units	Driver	Passenger
PBU - Top surface of reference to belt upper edge	mm	N/A	N/A
PBL - Top surface of reference to belt lower edge	mm	N/A	N/A

DATA SHEET 38

CRASH TEST

Test Vehicle: 2006 Pontiac G6
 Test Program: FMVSS 208 Compliance
 Test Technician: Eric Peschman

NHTSA No.: C60104
 Test Date: 8/24/06

IMPACT ANGLE:	Zero Degrees		
BELTED DUMMIES (YES/NO):	No		
TEST SPEED:	<u>X</u> 32 to 40 kmph	<u> </u> 0 to 48 kmph	<u> </u> 0 to 56 kmph
DRIVER DUMMY:	<u>X</u> 5 th female	<u> </u> 50 th male	
PASSENGER DUMMY:	<u>X</u> 5 th female	<u> </u> 50 th male	

- 1. Vehicle underbody painted
- 2. The speed measuring devices are in place and functioning.
- 3. The speed measuring devices are 1.0 m from the barrier (spec. 1.5m) and 30 cm from the barrier (spec. is 30 cm)
- 4. Convertible top is in the closed position.
- N/A, not a convertible
- 5. Instrumentation and wires are placed so the motion of the dummies during impact is not affected.
- 6. Tires inflated to pressure on tire placard or if it does not have a tire placard because it is not a passenger car, then inflated to the tire pressure specified in the owner information.

210 kpa front left tire 210 kpa specified on tire placard or in owner information
210 kpa front right tire 210 kpa specified on tire placard or in owner information
210 kpa rear left tire 210 kpa specified on tire placard or in owner information
210 kpa rear right tire 210 kpa specified on tire placard or in owner information

- 7. Time zero contacts on barrier in place.
- 8. Pre test zero and shunt calibration adjustments performed and recorded
- 9. Dummy temperature meets requirements of section 12.2 of the test procedure.
- 10. Vehicle hood closed and latched
- 11. Transmission placed in neutral
- 12. Parking brake off
- 13. Ignition in the ON position
- 14. Doors closed and latched but not locked
- 15. Posttest zero and shunt calibration checks performed and recorded
- 16. Actual test speed 39.8 kmph
- 17. Vehicle rebound from the barrier 405 cm
- 18. Describe whether the doors open after the test and what method is used to open the doors.
 - Left Front Door: Door remained closed and latched; Door opened without tools
 - Right Front Door: Door remained closed and latched; Door opened without tools
 - Left Rear Door: Door remained closed and latched; Door opened without tools
 - Right Rear Door: Door remained closed and latched; Door opened without tools

19. Describe the contact points of the dummy with the interior of the vehicle.
- Driver Dummy: Head to Air Bag and Visor; Chest to Air Bag; Knees to Knee Bolster
 - Passenger Dummy: Head to Air Bag; Chest to Air Bag; Knees to Glove Box

REMARKS:

I certify that I have read and performed each instruction.

Signature: 

Date: 8/24/06

DATA SHEET NO. 40

ACCIDENT INVESTIGATION DIVISION DATA

Test Vehicle: 2006 Pontiac G6
 Test Program: FMVSS 208 Compliance
 Test Technician: Nick Kosinski

NHTSA No.: C60104
 Test Date: 8/24/06

IMPACT ANGLE:	Zero Degrees		
BELTED DUMMIES (YES/NO):	No		
TEST SPEED:	<input checked="" type="checkbox"/> 32 to 40 kmph	<input type="checkbox"/> 0 to 48 kmph	<input type="checkbox"/> 0 to 56 kmph
DRIVER DUMMY:	<input checked="" type="checkbox"/> 5 th female	<input type="checkbox"/> 50 th male	
PASSENGER DUMMY:	<input checked="" type="checkbox"/> 5 th female	<input type="checkbox"/> 50 th male	

Vehicle Year/Make/Model/Body Style:	2006 Pontiac G6 Passenger Car
VIN:	1G2ZF55B264278160
Wheelbase:	2852 mm
Build Date:	05/06
Vehicle Size Category:	4
Test Weight:	1649.7 kg
Front Overhang:	1015 mm
Overall Width:	1752 mm
Overall Length Center:	4614 mm

Accelerometer Data	
Location:	As per measurements on Data Sheet 33
Linearity:	>99.9%

Integration Algorithm:	Trapezoidal
Vehicle Impact Speed:	39.8 kmph
Time of Separation:	120.0 ms
Velocity Change:	44.8 kmph

CRUSH PROFILE

Collision Deformation Classification: 12FDEW6
 Midpoint of Damage: Vehicle Longitudinal Centerline
 Damage Region Length (mm): 1192
 Impact Mode: Frontal Barrier

No.	Measurement Description	Units	Pre-Test	Post-Test	Difference
C1	Crush zone 1 at left side	mm	4534	4460	74
C2	Crush zone 2 at left side	mm	4576	4431	145
C3	Crush zone 3 at left side	mm	4599	4390	209
C4	Crush zone 4 at right side	mm	4597	4389	208
C5	Crush zone 5 at right side	mm	4577	4439	138
C6	Crush zone 6 at right side	mm	4536	4461	75

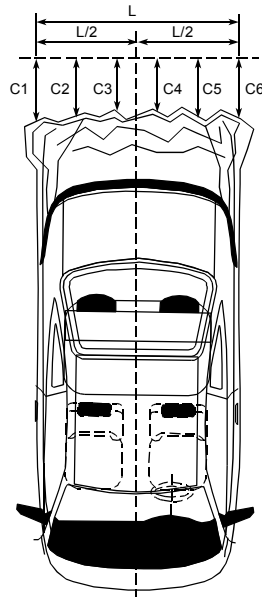

REMARKS:

I certify that I have read and performed each instruction.

Signature: *Aick Kosinski*

Date: 8/24/06

DATA SHEET 41
WINDSHIELD MOUNTING (FMVSS 212)

Test Vehicle: 2006 Pontiac G6
 Test Program: FMVSS 208 Compliance
 Test Technician: Nick Kosinski

NHTSA No.: C60104
 Test Date: 8/24/06

IMPACT ANGLE:	Zero Degrees		
BELTED DUMMIES (YES/NO):	No		
TEST SPEED:	<input checked="" type="checkbox"/> 32 to 40 kmph	<input type="checkbox"/> 0 to 48 kmph	<input type="checkbox"/> 0 to 56 kmph
DRIVER DUMMY:	<input checked="" type="checkbox"/> 5 th female	<input type="checkbox"/> 50 th male	
PASSENGER DUMMY:	<input checked="" type="checkbox"/> 5 th female	<input type="checkbox"/> 50 th male	

1. Pre-Crash
- 1.1 Describe from visual inspection how the windshield is mounted and describe any trim material.
- Retained with glue
Rubber trim
- 1.2 Mark the longitudinal centerline of the windshield
- 1.3 Measure pre-crash A, B, and C for the left side and record in the chart below.
- 1.4 Measure pre-crash C, D, and E for the right side and record in the chart below.
- 1.5 Measure from the edge of the retainer or molding to the edge of the windshield.
Dimension G (mm): 6 mm
2. Post Crash
- 2.1 Can a single thickness of copier type paper (as small a piece as necessary) slide between the windshield and the vehicle body?
- No – Pass. Skip to the table of measurements, complete it by repeating the pre-crash measurements in the post crash column, and calculate the retention percentage, which will be 100%.
- Yes, go to 2.2
- 2.2 Visibly mark the beginning and end of the portions of the periphery where the paper slides between the windshield and the vehicle body.
- 2.3 Measure and record post-crash A, B, C, D, E, and F such that the measurements do not include any of the parts of the windshield where the paper slides between the windshield and the vehicle body.
- 2.4 Calculate and record the percent retention for the right and left side of the windshield.
- 2.5 Is total right side percent retention less than 75%?
- Yes, Fail
- No, Pass
- 2.6 Is total left side percent retention less than 75%?
- Yes, Fail
- No, Pass

WINDSHIELD RETENTION MEASUREMENTS

	Dimension	Pre-Crash (mm)	Post-Crash (mm)	Percent Retention (Post-Test ÷ Pre-Crash)
Left Side	A	596	596	100%
	B	876	876	100%
	C	769	769	100%
	Total	2241	2241	100%
Right Side	D	595	595	100%
	E	876	876	100%
	F	771	771	100%
	Total	2242	2242	100%

Indicate area of mounting failure. NONE

FRONT VIEW OF WINDSHIELD

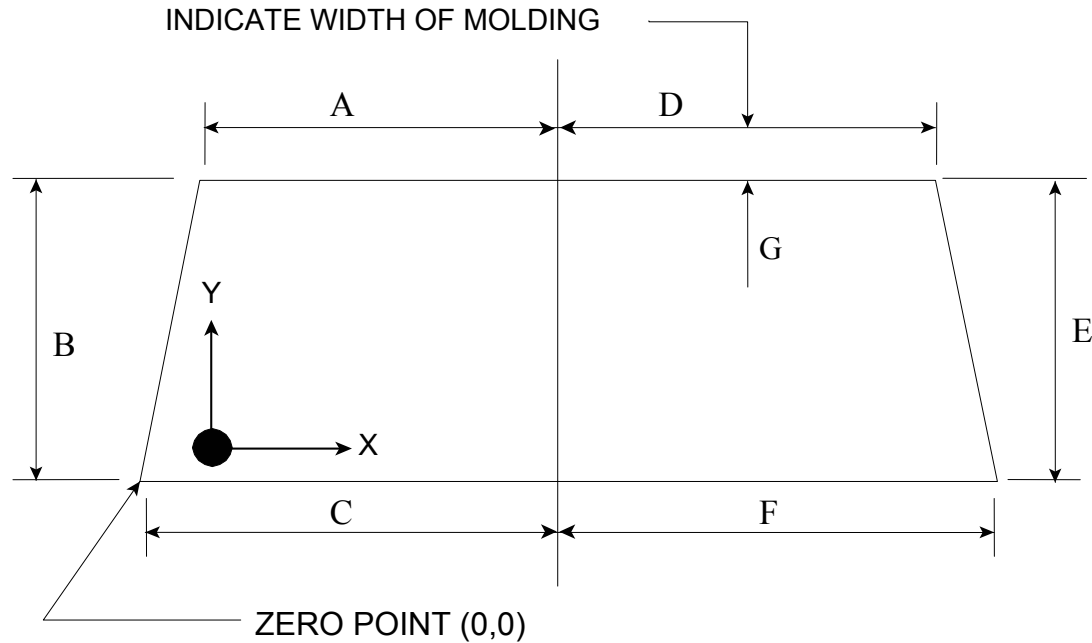

REMARKS:

I certify that I have read and performed each instruction.

Signature: *Nick Kosinski*

Date: 8/24/06

DATA SHEET 42
WINDSHIELD ZONE INTRUSION (FMVSS 219)

Test Vehicle: 2006 Pontiac G6
 Test Program: FMVSS 208 Compliance
 Test Technician: Nick Kosinski

NHTSA No.: C60104
 Test Date: 8/24/06

IMPACT ANGLE:	Zero Degrees		
BELTED DUMMIES (YES/NO):	No		
TEST SPEED:	<input checked="" type="checkbox"/> 32 to 40 kmph	<input type="checkbox"/> 0 to 48 kmph	<input type="checkbox"/> 0 to 56 kmph
DRIVER DUMMY:	<input checked="" type="checkbox"/> 5 th female	<input type="checkbox"/> 50 th male	
PASSENGER DUMMY:	<input checked="" type="checkbox"/> 5 th female	<input type="checkbox"/> 50 th male	

- 1. Place a 165 mm diameter rigid sphere, with a mass of 6.8 kg on the instrument panel so that it is simultaneously touching the instrument panel and the windshield. (571.219 S6.1(a))
- 2. Roll the sphere from one side of the windshield to the other while marking on the windshield where the sphere contacts the windshield. (571.219 S6.1(b))
- 3. From the outermost contactable points on the windshield draw a horizontal line to the edges of the windshield. (571.219 S6.1(b))
- 4. Draw a line on the inner surface of the windshield that is 13 mm below the line determined in items 2 and 3
- 5. After the crash test, record any points where a part of the exterior of the vehicle has marked, penetrated, or broken the windshield.

Provide all dimensions necessary to reproduce the protected area.

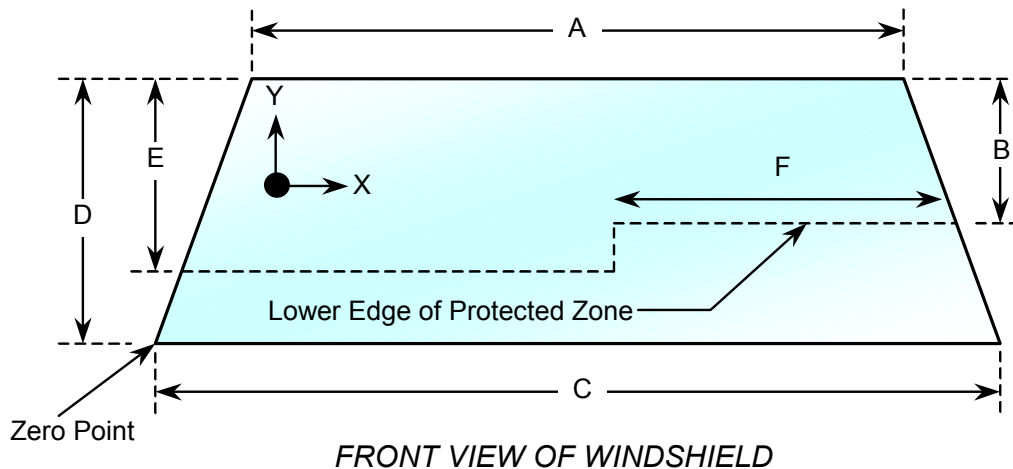

WINDSHIELD DIMENSIONS

Item	Units	Value
A	mm	1191
B	mm	557
C	mm	1540
D	mm	876
E	mm	566
F	mm	507

AREA OF PROTECTED ZONE FAILURES:

- B. Provide coordinates of the area that the protected zone was penetrated more than 0.25 inches by a vehicle component other than one which is normally in contact with the windshield.

X	Y
NONE	

- C. Provide coordinates of the area beneath the protected zone template that the inner surface of the windshield was penetrated by a vehicle component.

X	Y
NONE	

REMARKS:

I certify that I have read and performed each instruction.

Signature: *Tick Kosinski*

Date: 8/24/06

DATA SHEET 43

FUEL SYSTEM INTEGRITY (FMVSS 301)

Test Vehicle: 2006 Pontiac G6
Test Program: FMVSS 208 Compliance
Test Technician: Eric Peschman

NHTSA No.: C60104
Test Date: 8/24/06

TYPE OF IMPACT:	25 mph Unbelted Flat Frontal
-----------------	------------------------------

Stoddard Solvent Spillage Measurements

- A. From impact until vehicle motion ceases: 0.0 grams
(Maximum Allowable = 28 grams)
- B. For the 5 minute period after motion ceases: 0.0 grams
(Maximum Allowable = 142 grams)
- C. For the following 25 minutes: 0.0 grams
(Maximum Allowable = 28 grams/minute)
- D. Spillage: NONE

REMARKS: NO SPILLAGE

DATA SHEET NO. 43
FMVSS 301 STATIC ROLLOVER DATA

Test Vehicle: 2006 Pontiac G6
 Test Program: FMVSS 208 Compliance

NHTSA No.: C60104
 Test Date: 8/24/06

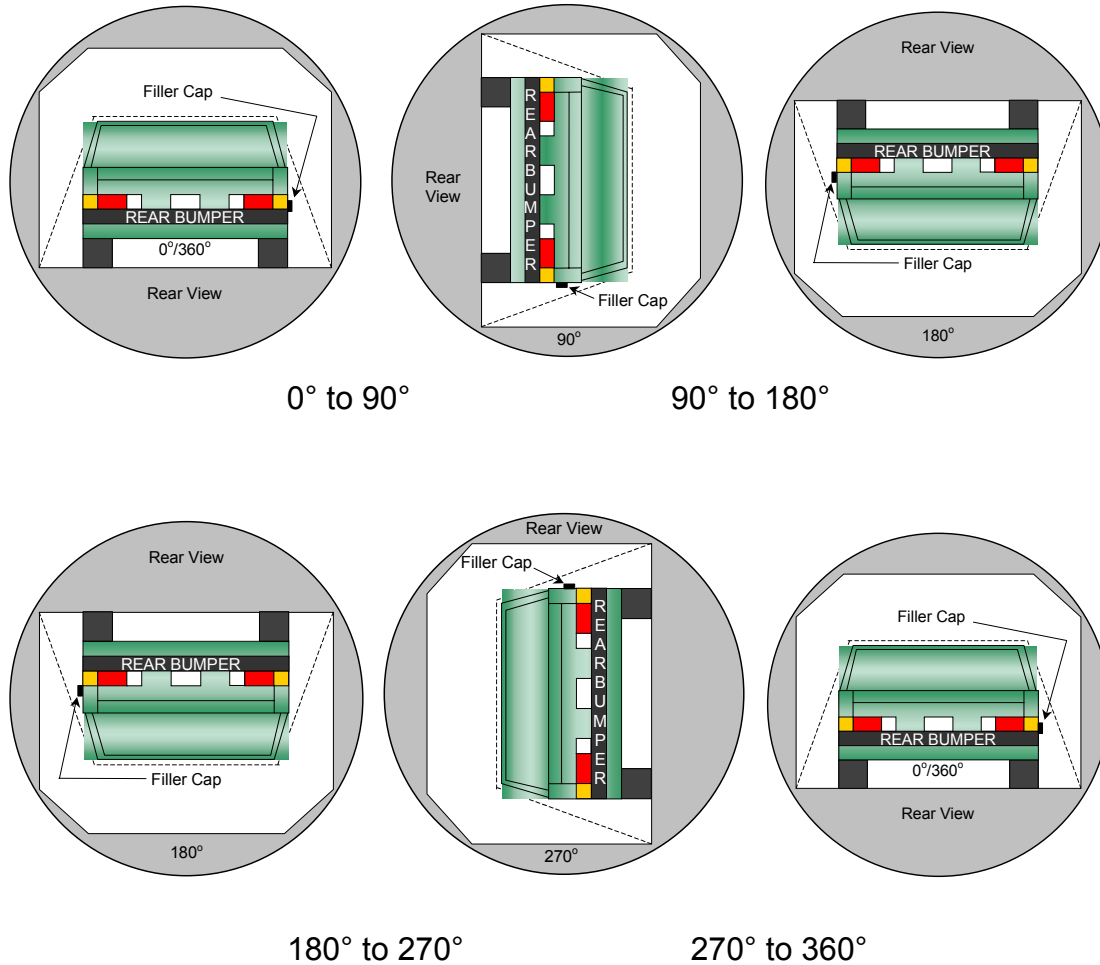

1. The specified fixture rollover rate for each 90° of rotation is 60 to 180 seconds.
2. The position hold time at each position is 300 seconds (minimum).
3. Details of Stoddard Solvent spillage locations: **None**

Test Phase	Rotation Time (sec.)	Hold Time (sec.)	Spillage (grams)
0° to 90°	120	300	0.0
90° to 180°	118	300	0.0
180° to 270°	109	300	0.0
270° to 360°	120	300	0.0

APPENDIX A
CRASH TEST DATA

TABLE OF DATA PLOTS

		<u>Page No.</u>
Figure No. 1.	Driver Head X Acceleration vs. Time	A-1
Figure No. 2.	Driver Head Y Acceleration vs. Time	A-1
Figure No. 3.	Driver Head Z Acceleration vs. Time	A-1
Figure No. 4.	Driver Head Resultant Acceleration vs. Time	A-1
Figure No. 5.	Driver Head X Velocity vs. Time	A-2
Figure No. 6.	Driver Head Y Velocity vs. Time	A-2
Figure No. 7.	Driver Head Z Velocity vs. Time	A-2
Figure No. 8.	Driver Neck Force X vs. Time	A-3
Figure No. 9.	Driver Neck Force Y vs. Time	A-3
Figure No. 10.	Driver Neck Force Z vs. Time	A-3
Figure No. 11.	Driver Neck Force Resultant vs. Time	A-3
Figure No. 12.	Driver Neck Moment X vs. Time	A-4
Figure No. 13.	Driver Neck Moment Y vs. Time	A-4
Figure No. 14.	Driver Neck Moment Z vs. Time	A-4
Figure No. 15.	Driver Neck Moment Resultant vs. Time	A-4
Figure No. 16.	Driver Chest X Acceleration vs. Time	A-5
Figure No. 17.	Driver Chest Y Acceleration vs. Time	A-5
Figure No. 18.	Driver Chest Z Acceleration vs. Time	A-5
Figure No. 19.	Driver Chest Resultant Acceleration vs. Time	A-5
Figure No. 20.	Driver Chest X Velocity vs. Time	A-6
Figure No. 21.	Driver Chest Y Velocity vs. Time	A-6
Figure No. 22.	Driver Chest Z Velocity vs. Time	A-6
Figure No. 23.	Driver Chest Displacement vs. Time	A-6
Figure No. 24.	Driver Left Femur Force vs. Time	A-7
Figure No. 25.	Driver Right Femur Force vs. Time	A-7
Figure No. 26.	Passenger Head X Acceleration vs. Time	A-8
Figure No. 27.	Passenger Head Y Acceleration vs. Time	A-8
Figure No. 28.	Passenger Head Z Acceleration vs. Time	A-8
Figure No. 29.	Passenger Head Resultant Acceleration vs. Time	A-8

		<u>Page No.</u>
Figure No. 30.	Passenger Head X Velocity vs. Time	A-9
Figure No. 31.	Passenger Head Y Velocity vs. Time	A-9
Figure No. 32.	Passenger Head Z Velocity vs. Time	A-9
Figure No. 33.	Passenger Neck Force X vs. Time	A-10
Figure No. 34.	Passenger Neck Force Y vs. Time	A-10
Figure No. 35.	Passenger Neck Force Z vs. Time	A-10
Figure No. 36.	Passenger Neck Force Resultant vs. Time	A-10
Figure No. 37.	Passenger Neck Moment X vs. Time	A-11
Figure No. 38.	Passenger Neck Moment Y vs. Time	A-11
Figure No. 39.	Passenger Neck Moment Z vs. Time	A-11
Figure No. 40.	Passenger Neck Moment Resultant vs. Time	A-11
Figure No. 41.	Passenger Chest X Acceleration vs. Time	A-12
Figure No. 42.	Passenger Chest Y Acceleration vs. Time	A-12
Figure No. 43.	Passenger Chest Z Acceleration vs. Time	A-12
Figure No. 44.	Passenger Chest Resultant Acceleration vs. Time	A-12
Figure No. 45.	Passenger Chest X Velocity vs. Time	A-13
Figure No. 46.	Passenger Chest Y Velocity vs. Time	A-13
Figure No. 47.	Passenger Chest Z Velocity vs. Time	A-13
Figure No. 48.	Passenger Chest Displacement vs. Time	A-13
Figure No. 49.	Passenger Left Femur Force vs. Time	A-14
Figure No. 50.	Passenger Right Femur Force vs. Time	A-14
Figure No. 51.	Driver Nij (N_{TF}) vs. Time	A-15
Figure No. 52.	Driver Nij (N_{TE}) vs. Time	A-15
Figure No. 53.	Driver Nij (N_{CF}) vs. Time	A-15
Figure No. 54.	Driver Nij (N_{CE}) vs. Time	A-15
Figure No. 55.	Passenger Nij (N_{TF}) vs. Time	A-16
Figure No. 56.	Passenger Nij (N_{TE}) vs. Time	A-16
Figure No. 57.	Passenger Nij (N_{CF}) vs. Time	A-16
Figure No. 58.	Passenger Nij (N_{CE}) vs. Time	A-16
Figure No. 59.	Driver Occipital Condyle Moment vs. Time	A-17

		<u>Page No.</u>
Figure No. 60.	Passenger Occipital Condyle Moment vs. Time	A-17
Figure No. 61.	Left Rear Seat Crossmember X Acceleration vs. Time	A-18
Figure No. 62.	Left Rear Seat Crossmember X Velocity vs. Time	A-18
Figure No. 63.	Right Rear Seat Crossmember X Acceleration vs. Time	A-18
Figure No. 64.	Right Rear Seat Crossmember X Velocity vs. Time	A-18
Figure No. 65.	Top of Engine X Acceleration vs. Time	A-19
Figure No. 66.	Top of Engine X Velocity vs. Time	A-19
Figure No. 67.	Bottom of Engine X Acceleration vs. Time	A-19
Figure No. 68.	Bottom of Engine X Velocity vs. Time	A-19
Figure No. 69.	Left Brake Caliper X Acceleration vs. Time	A-20
Figure No. 70.	Left Brake Caliper X Velocity vs. Time	A-20
Figure No. 71.	Right Brake Caliper X Acceleration vs. Time	A-20
Figure No. 72.	Right Brake Caliper X Velocity vs. Time	A-20
Figure No. 73.	Instrument Panel X Acceleration vs. Time	A-21
Figure No. 74.	Instrument Panel X Velocity vs. Time	A-21
Figure No. 75.	Trunk Z Acceleration vs. Time	A-21
Figure No. 76.	Trunk Z Velocity vs. Time	A-21
Figure No. 77.	Barrier Force – Upper Left vs. Time	A-22
Figure No. 78.	Barrier Force – Upper Center vs. Time	A-22
Figure No. 79.	Barrier Force – Upper Right vs. Time	A-22
Figure No. 80.	Barrier Force – Lower Left vs. Time	A-23
Figure No. 81.	Barrier Force – Lower Center vs. Time	A-23
Figure No. 82.	Barrier Force – Lower Right vs. Time	A-23
Figure No. 83.	Barrier Force – Sum Left vs. Time	A-24
Figure No. 84.	Barrier Force – Sum Center vs. Time	A-24
Figure No. 85.	Barrier Force – Sum Right vs. Time	A-24
Figure No. 86.	Barrier Force – Sum All vs. Time	A-24

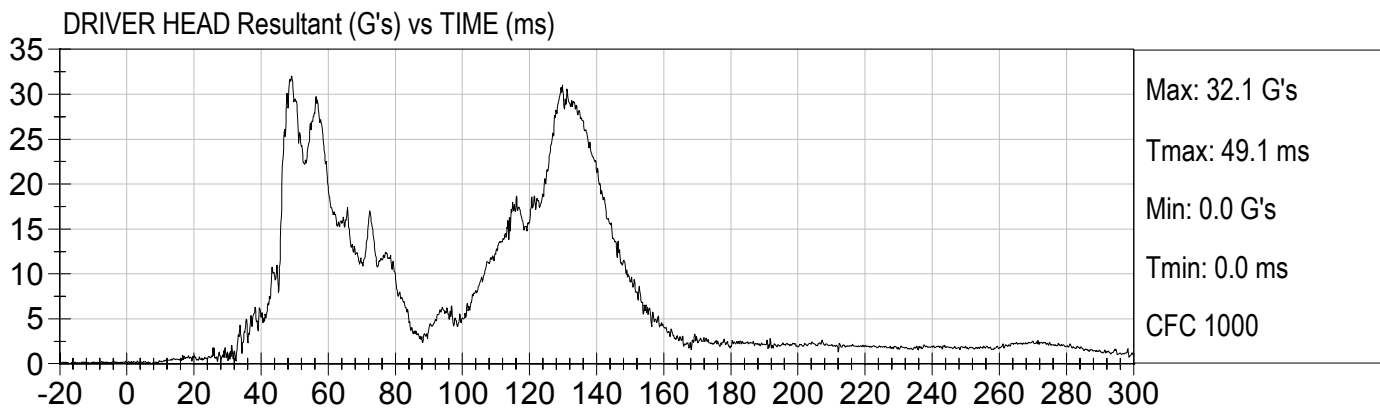
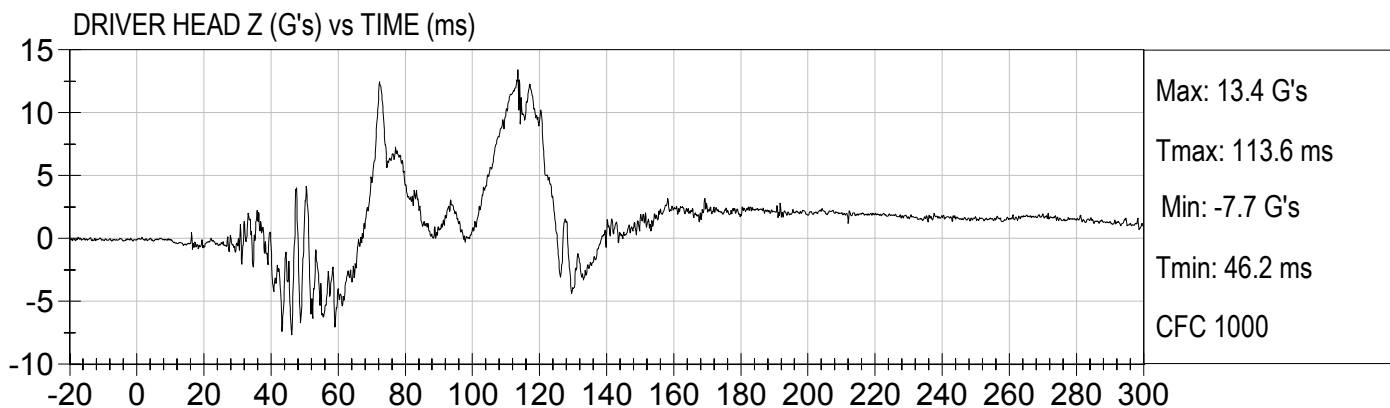
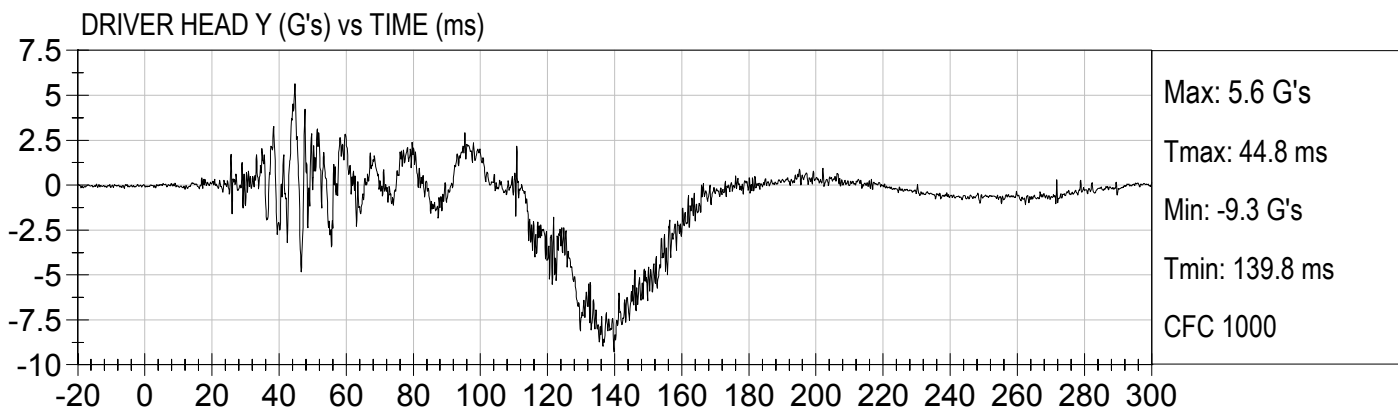
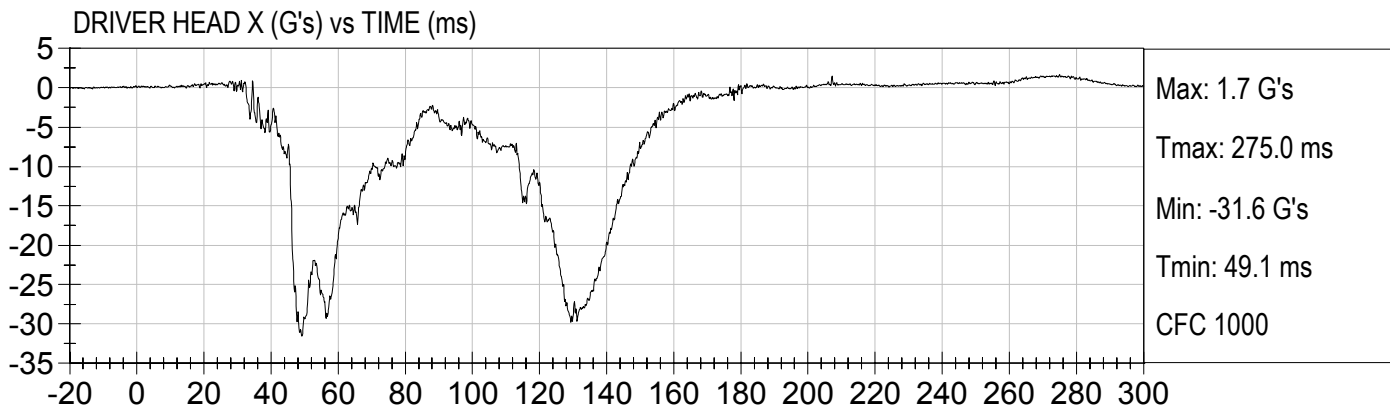

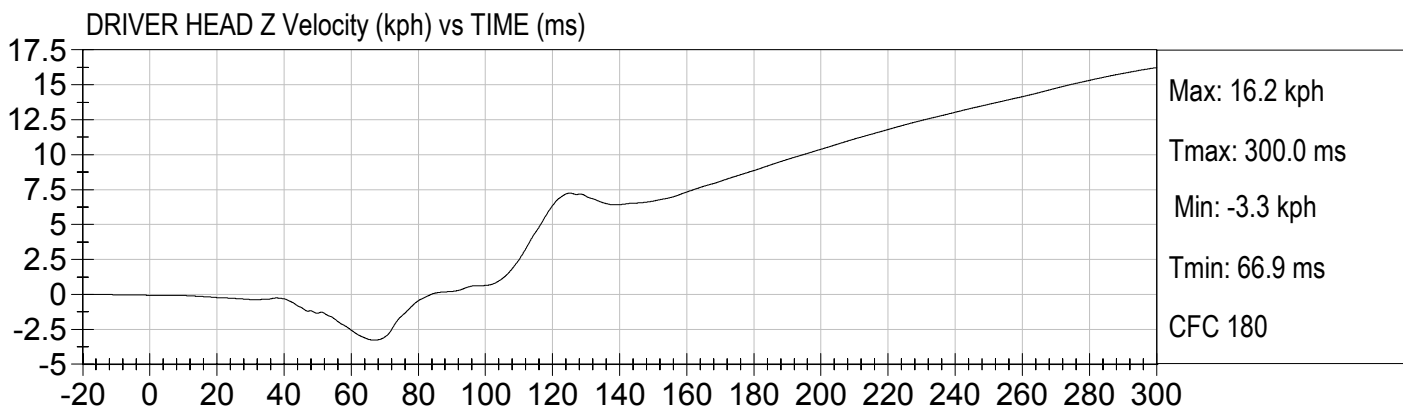
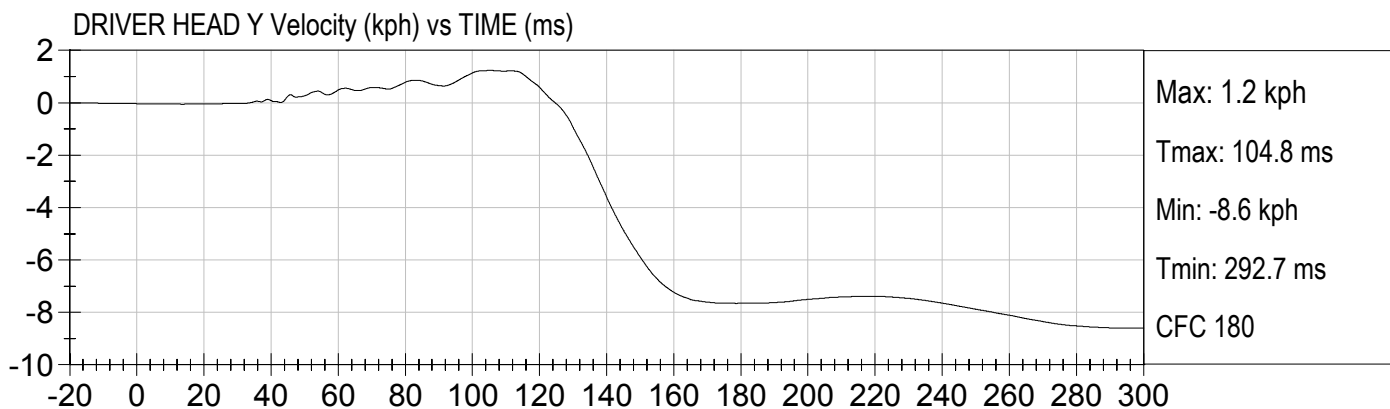
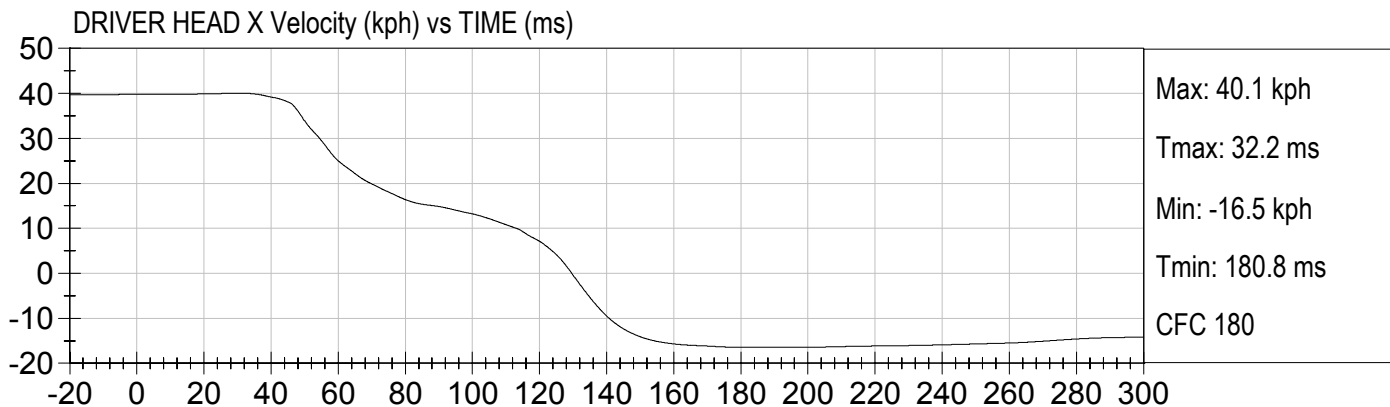



25 MPH FRONTAL UNBELTED
2006 PONTIAC G6 (C60104)

Test Date: 08/24/2006
Speed: 24.7 mph (39.8 km/h)

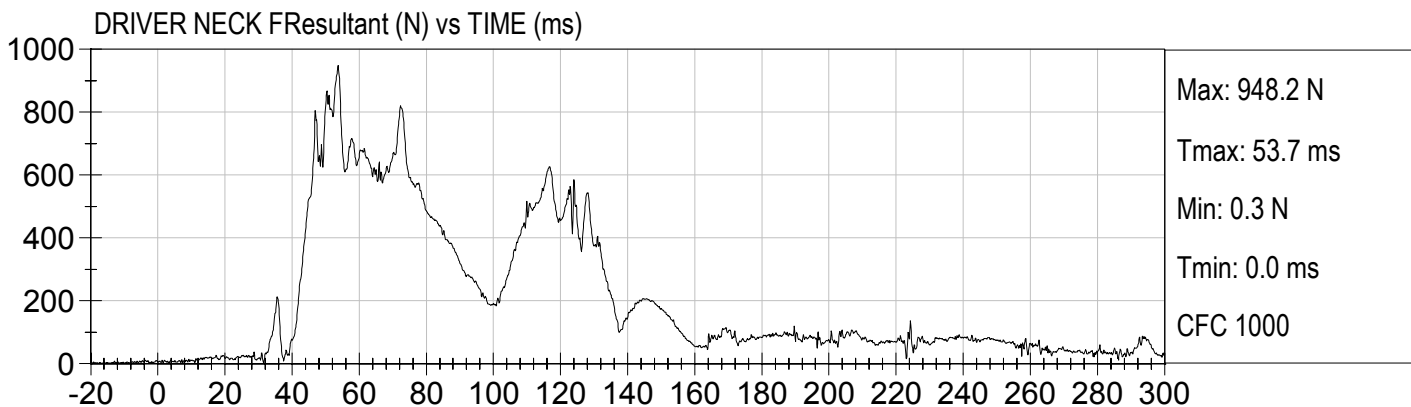
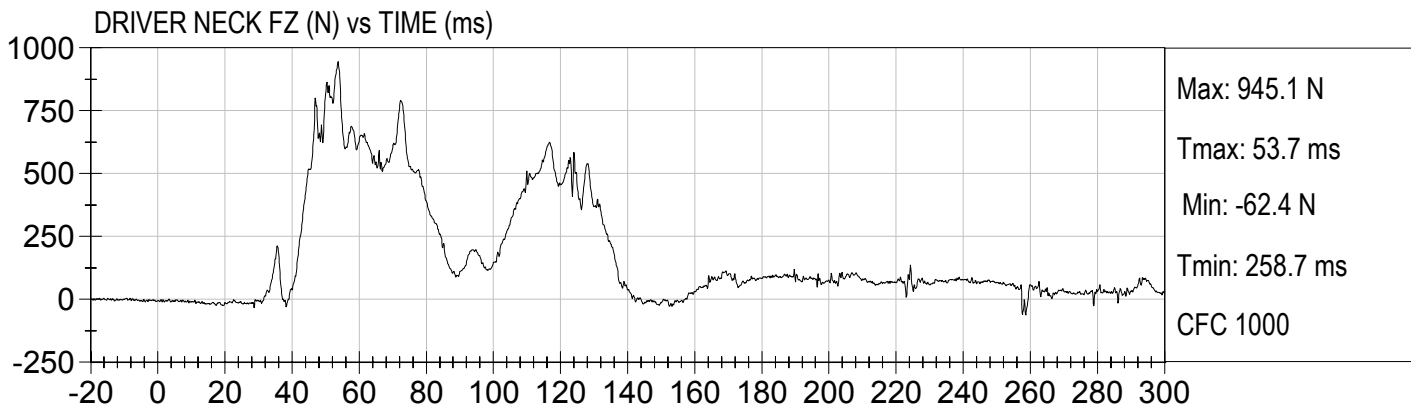
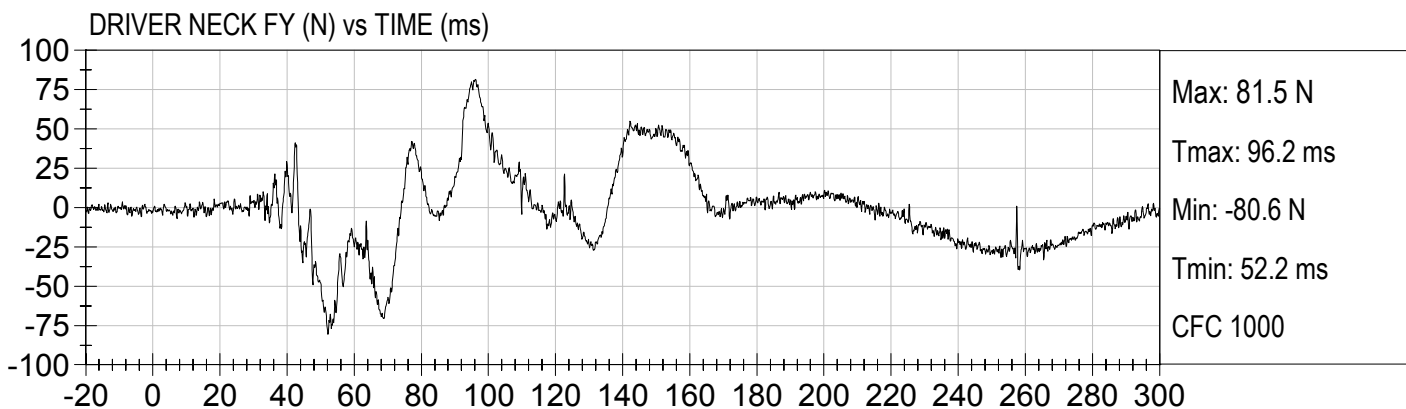
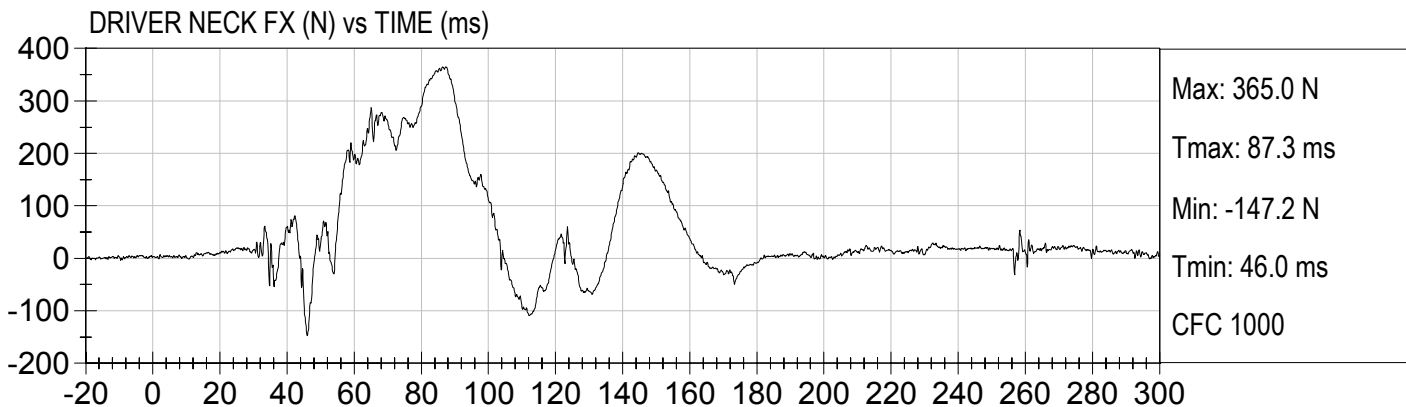



25 MPH FRONTAL UNBELTED
2006 PONTIAC G6 (C60104)

Test Date: 08/24/2006
Speed: 24.7 mph (39.8 km/h)

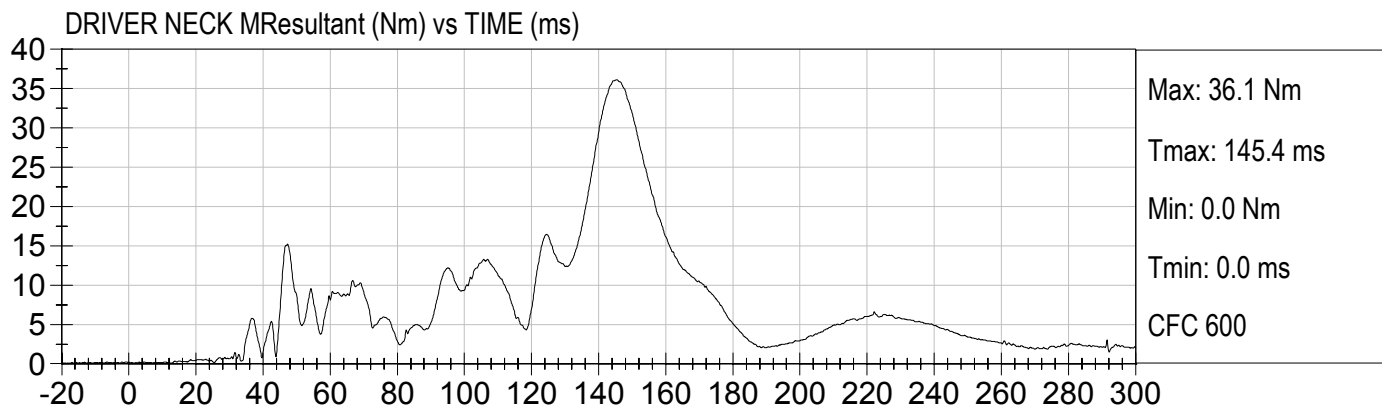
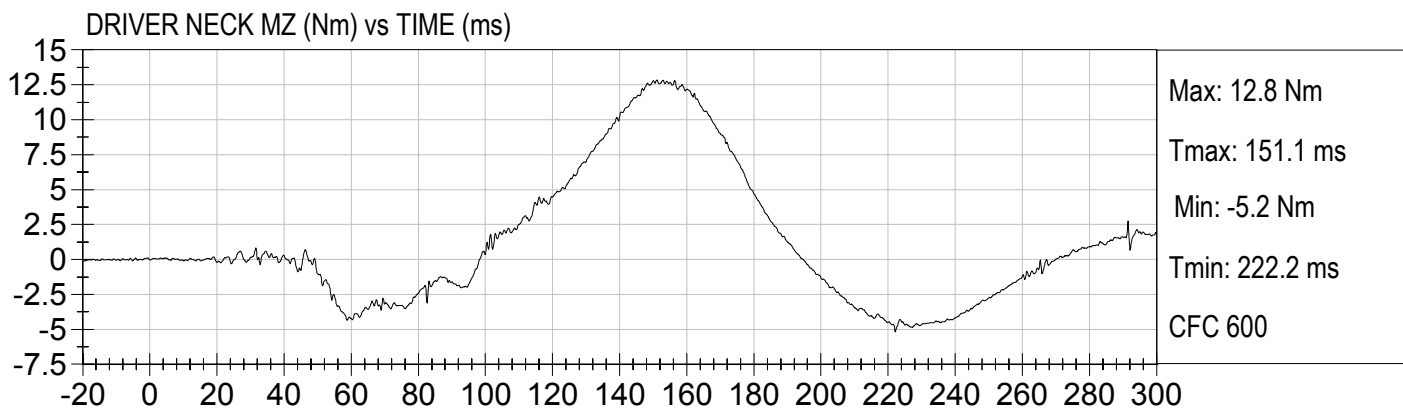
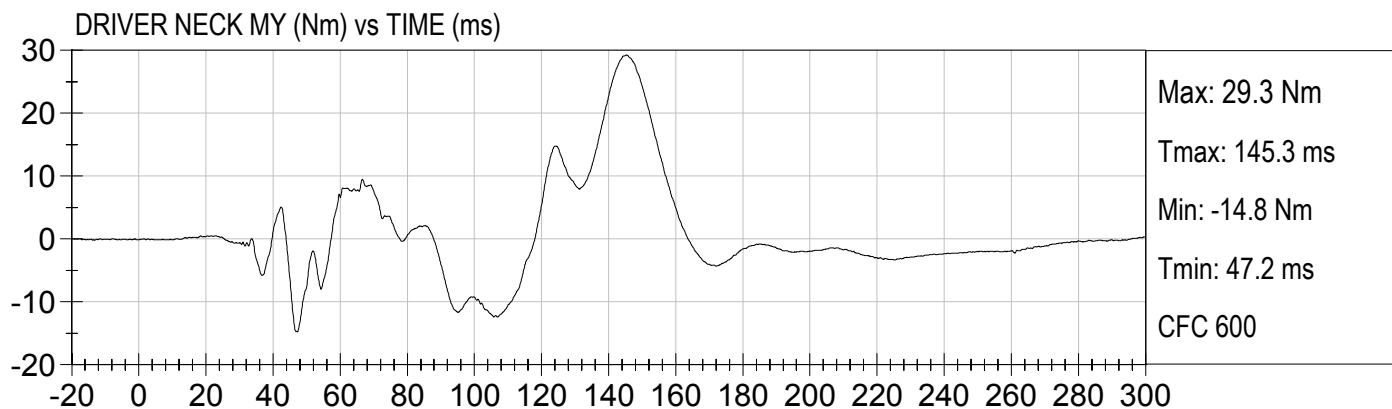
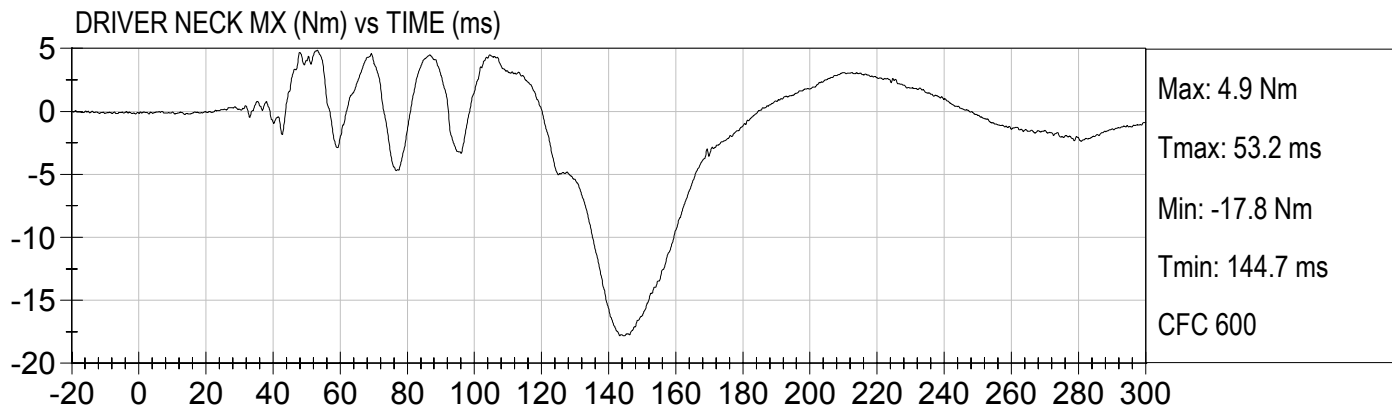

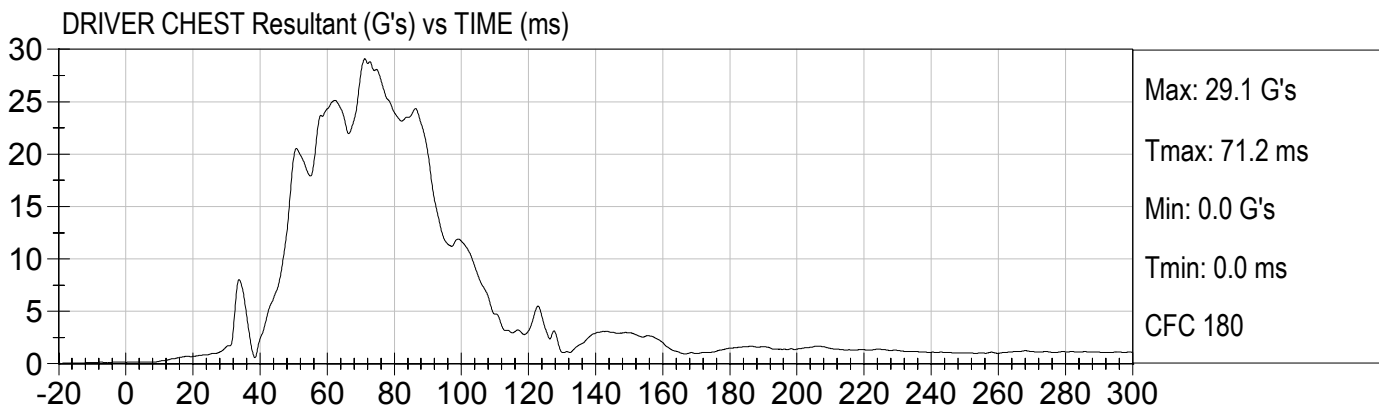
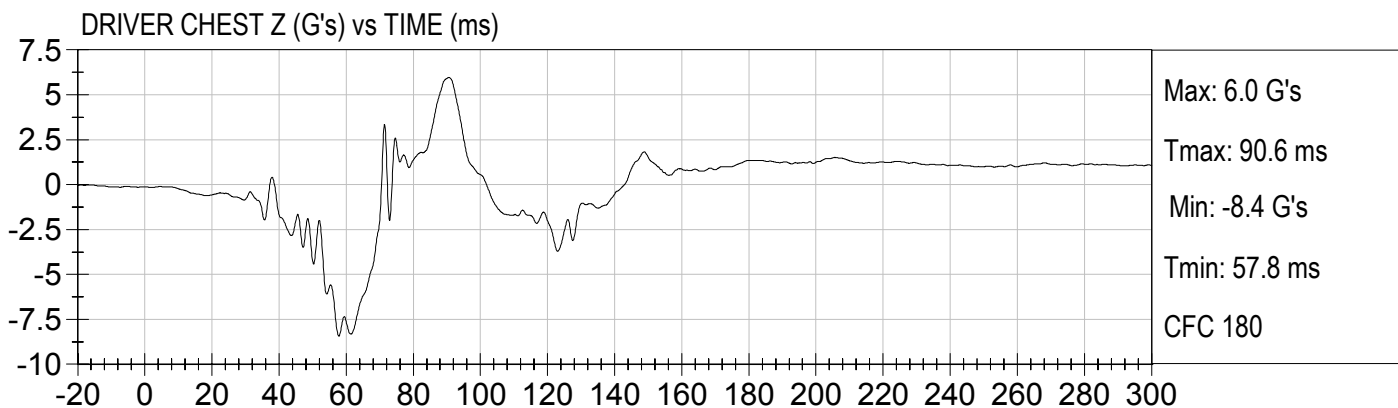
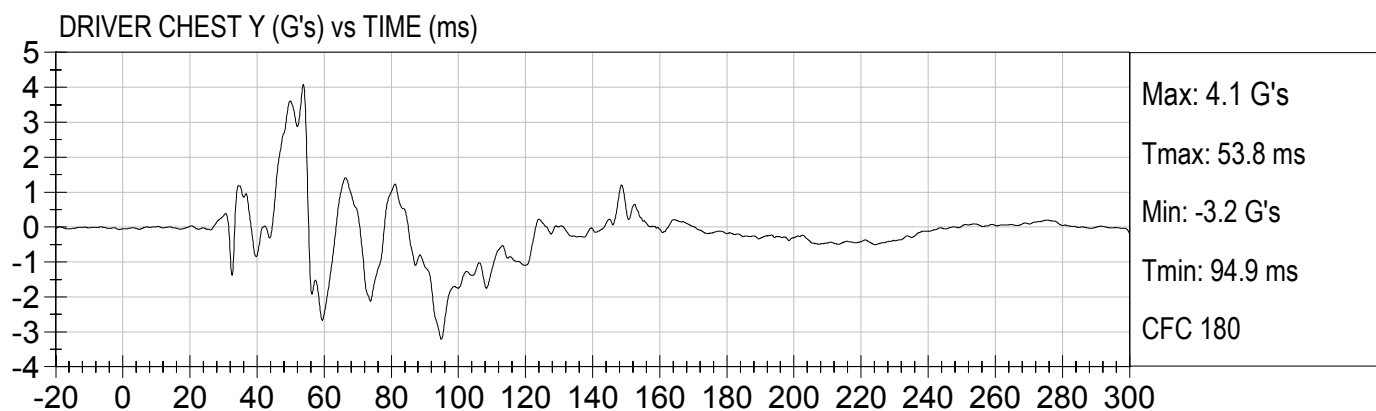
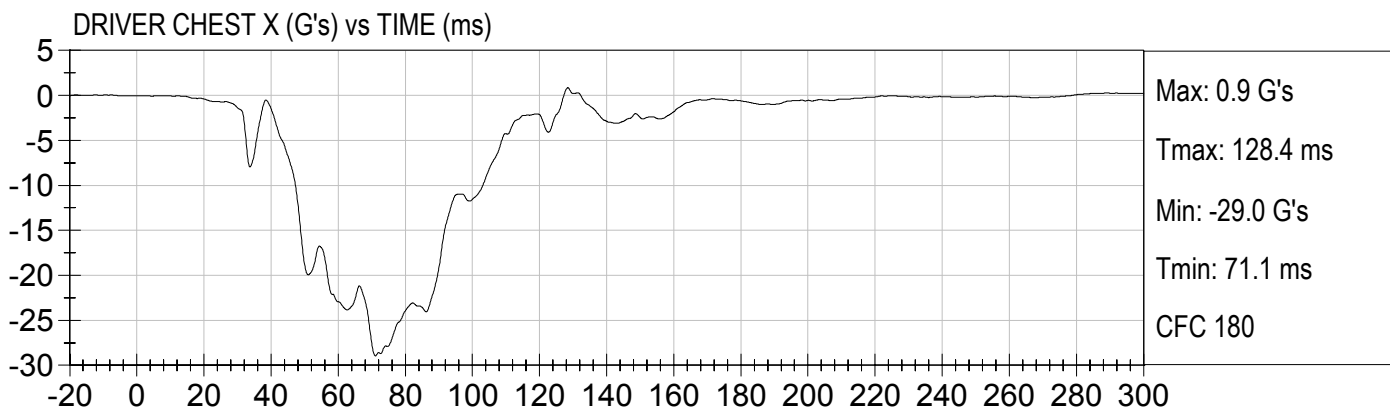

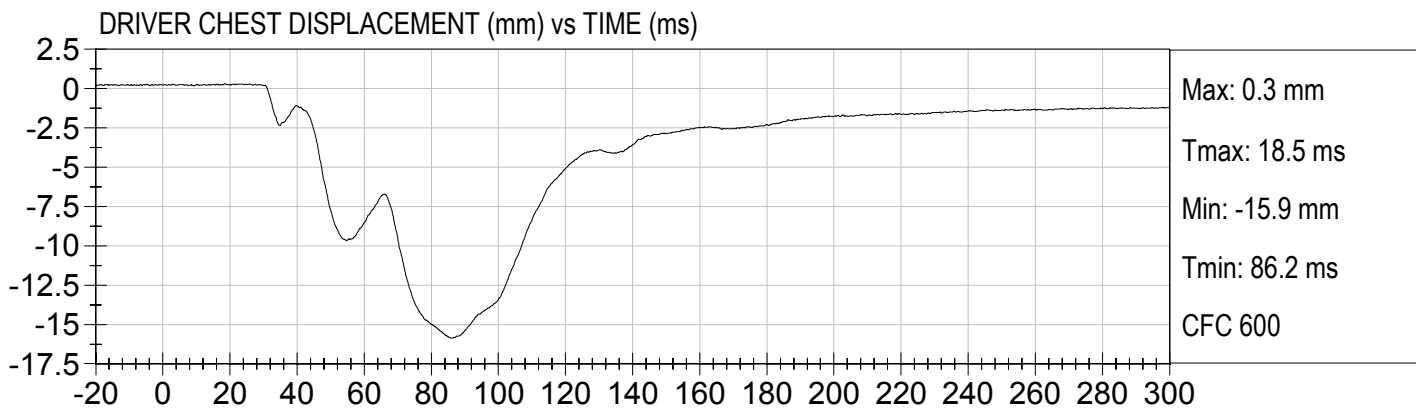
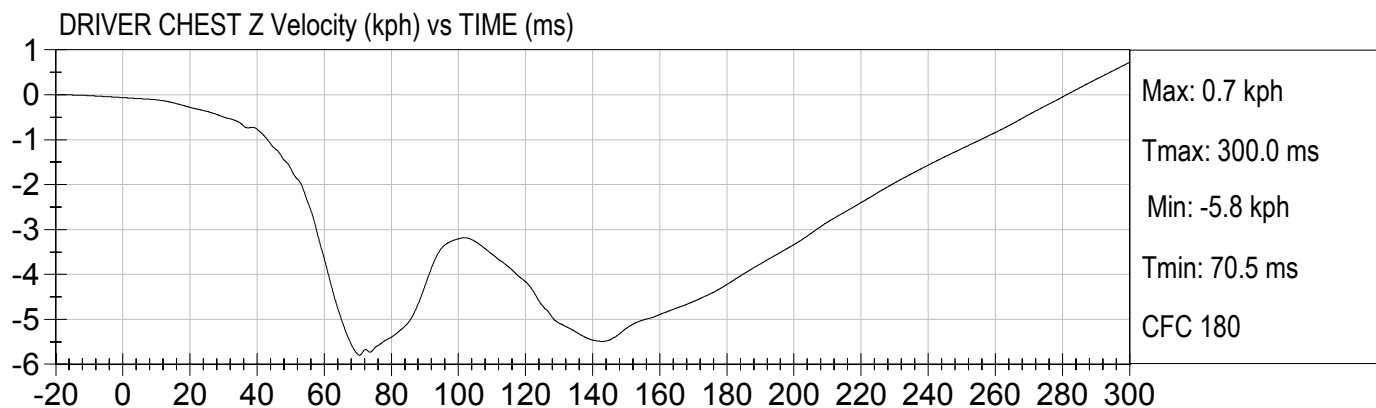
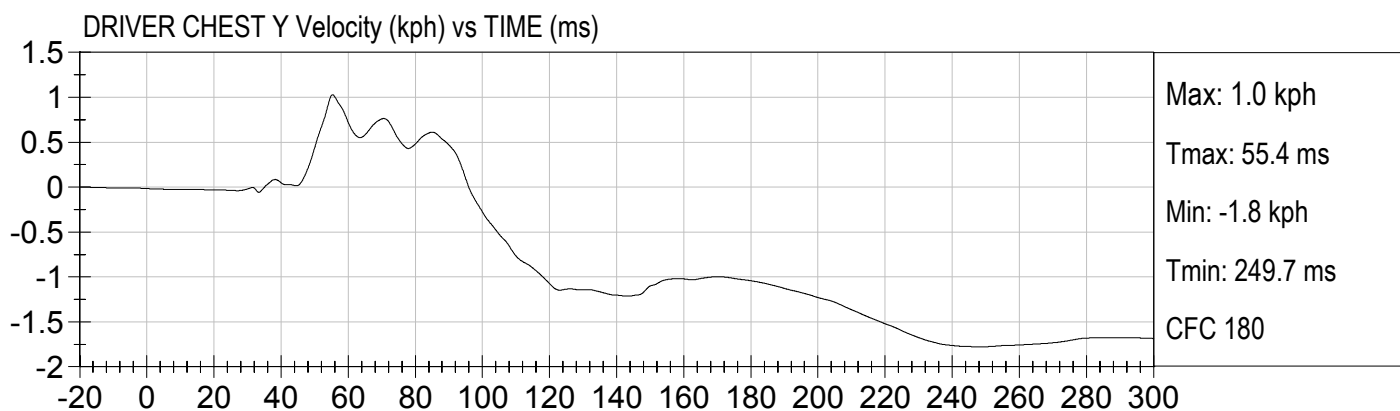
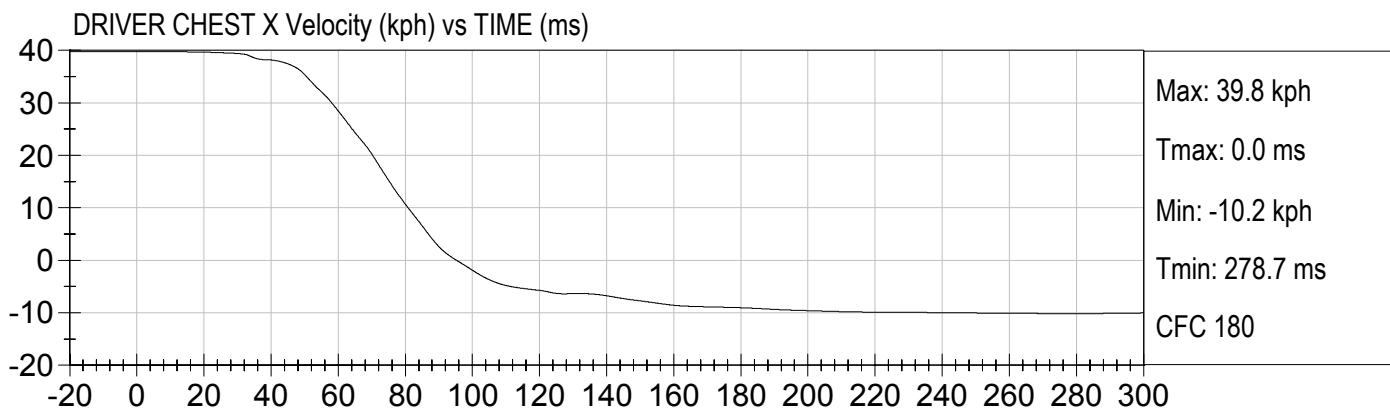



25 MPH FRONTAL UNBELTED
2006 PONTIAC G6 (C60104)

Test Date: 08/24/2006
Speed: 24.7 mph (39.8 km/h)

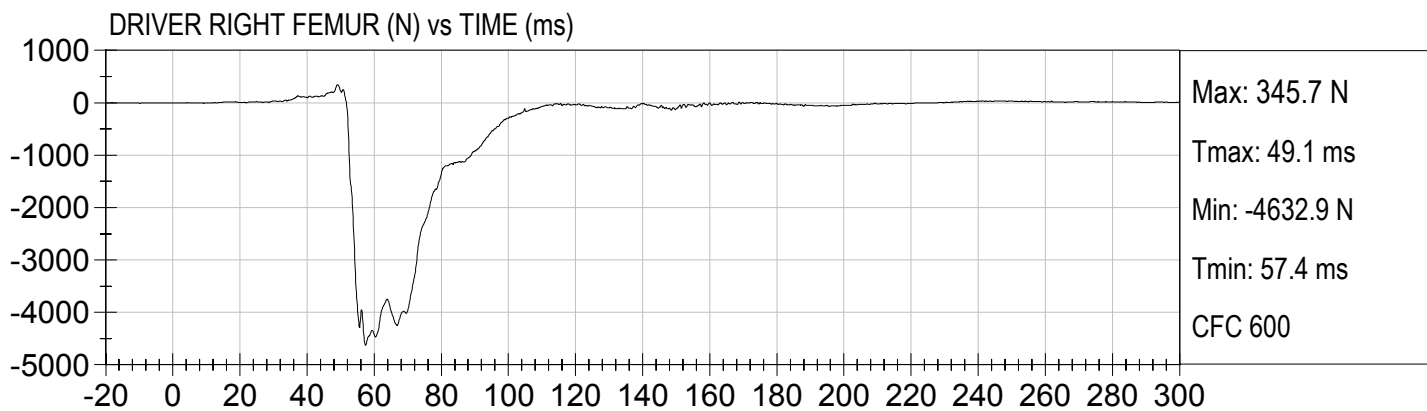
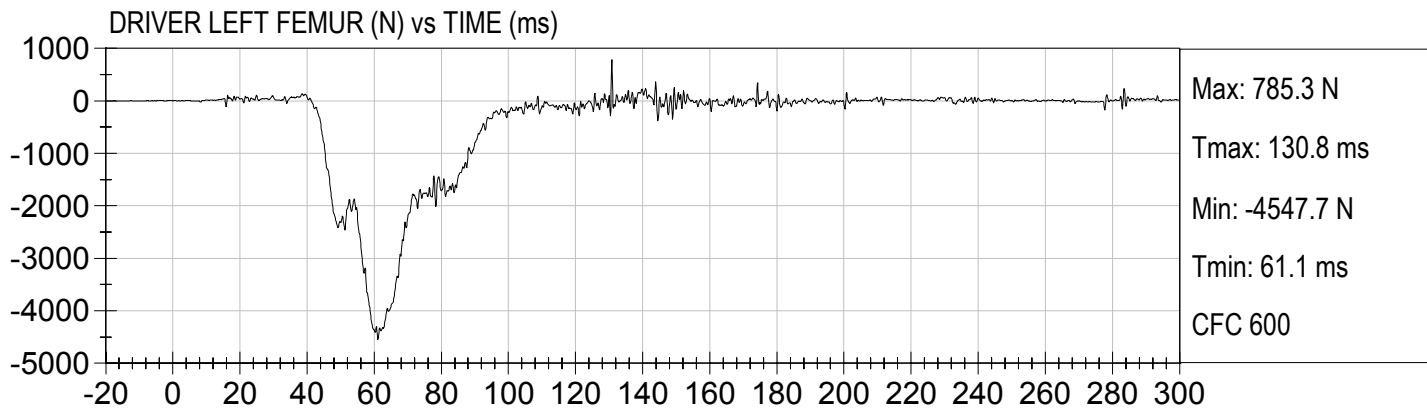



25 MPH FRONTAL UNBELTED
2006 PONTIAC G6 (C60104)

Test Date: 08/24/2006
Speed: 24.7 mph (39.8 km/h)

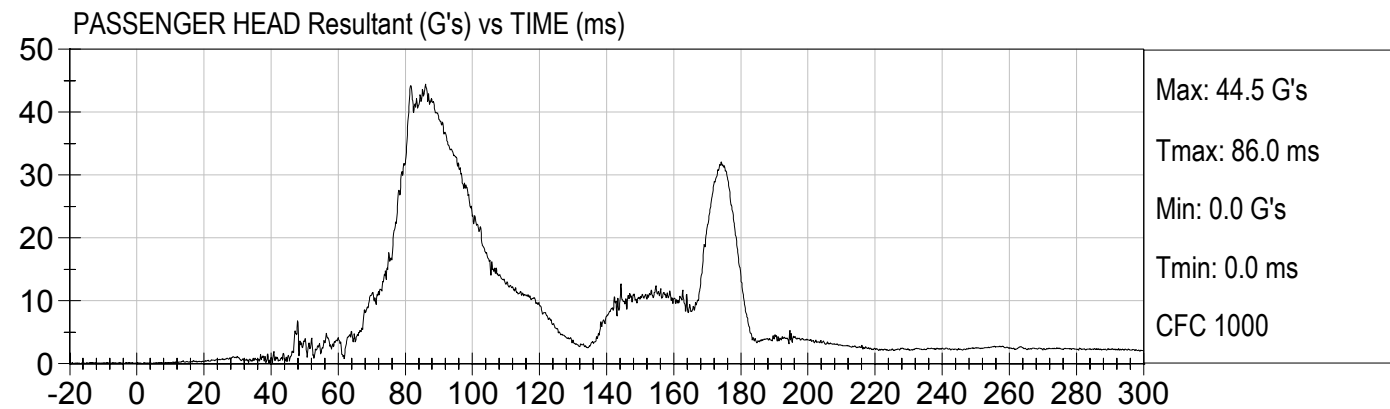
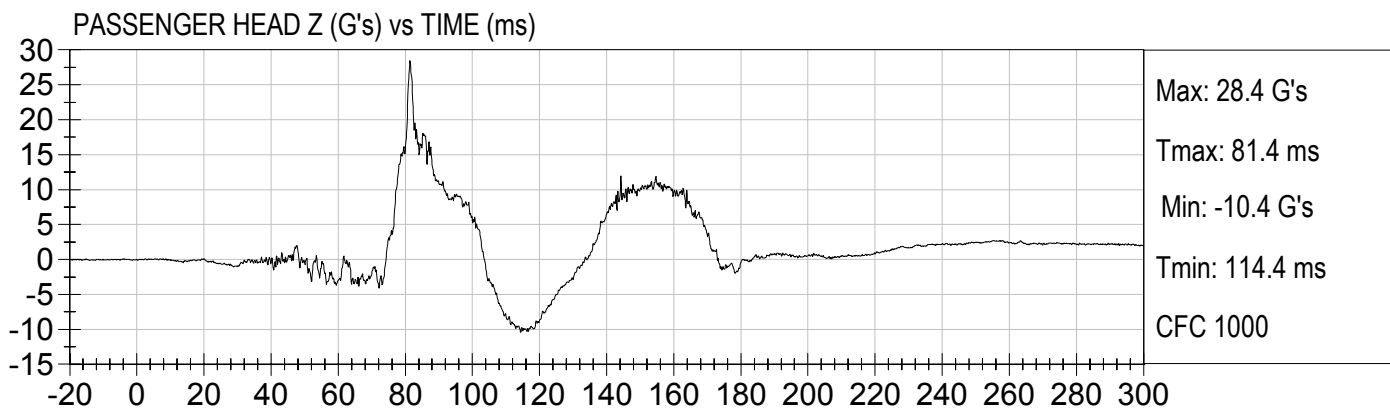
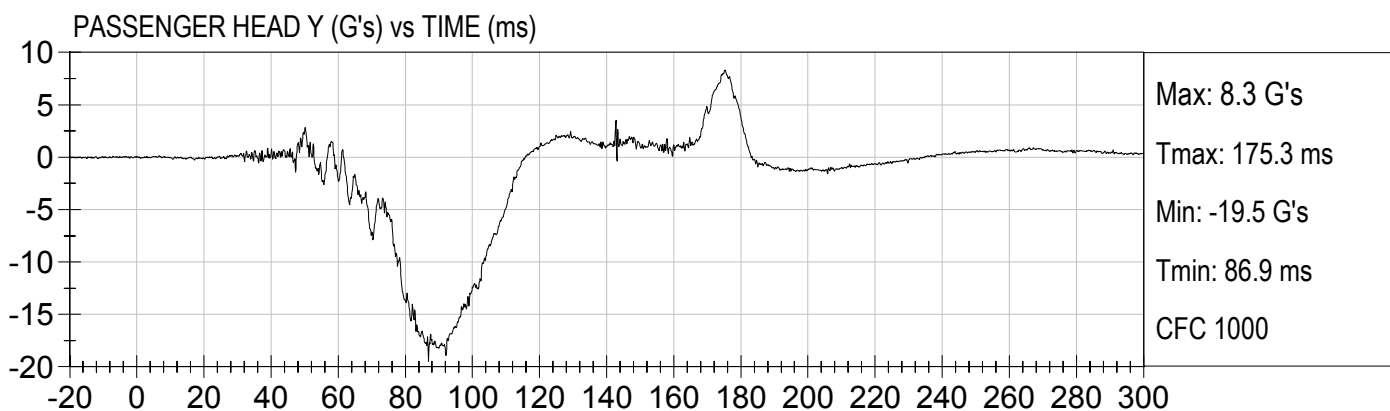
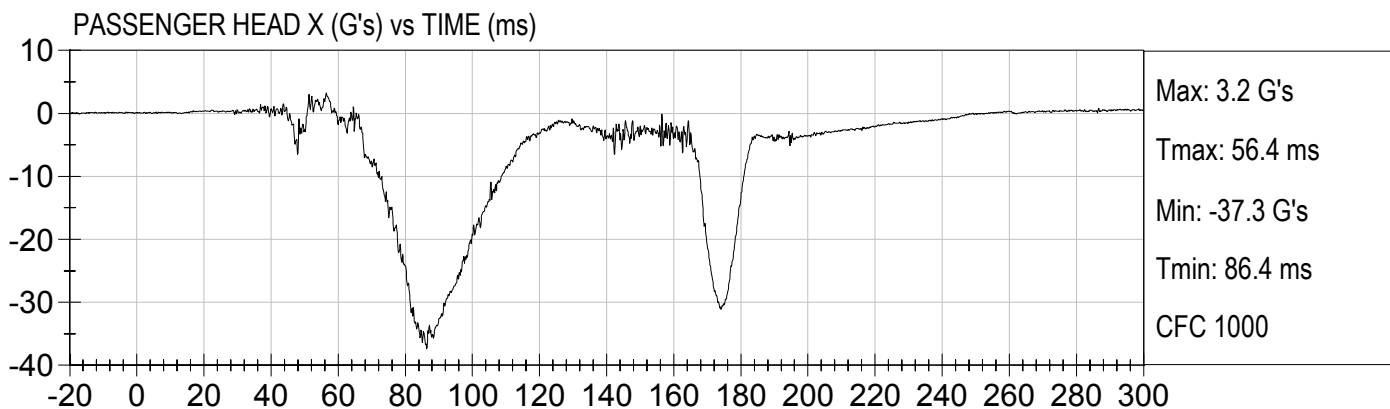



25 MPH FRONTAL UNBELTED
2006 PONTIAC G6 (C60104)

Test Date: 08/24/2006
Speed: 24.7 mph (39.8 km/h)

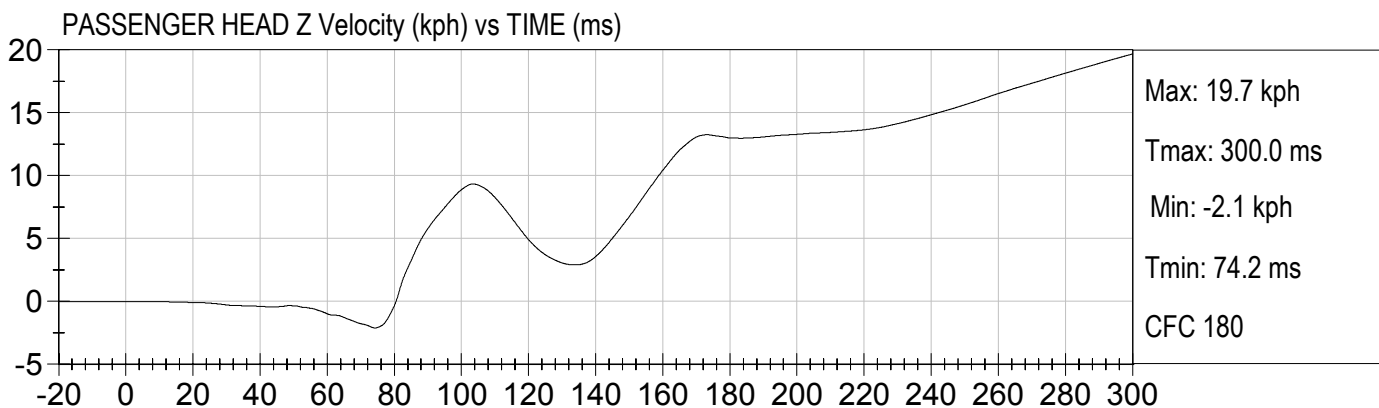
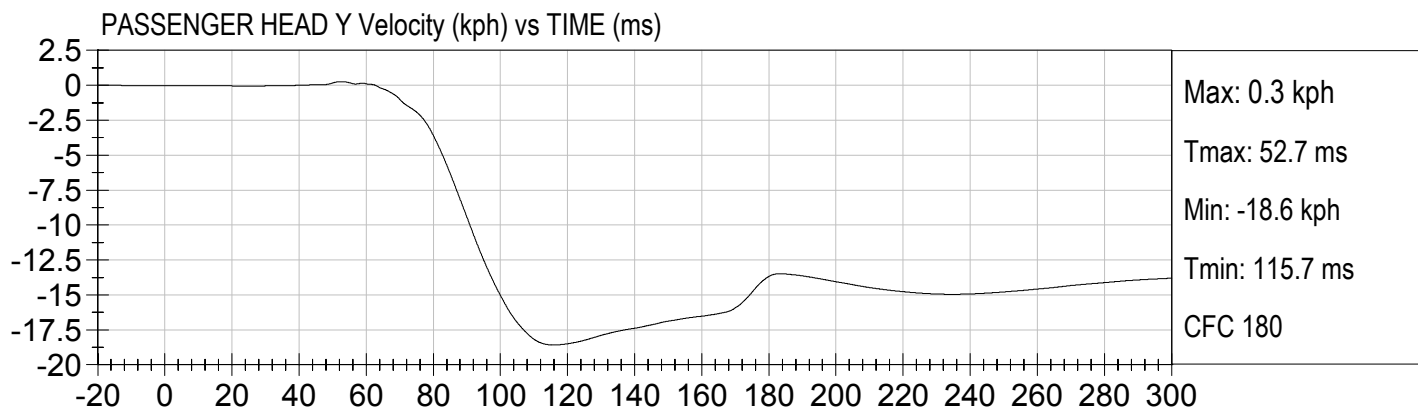
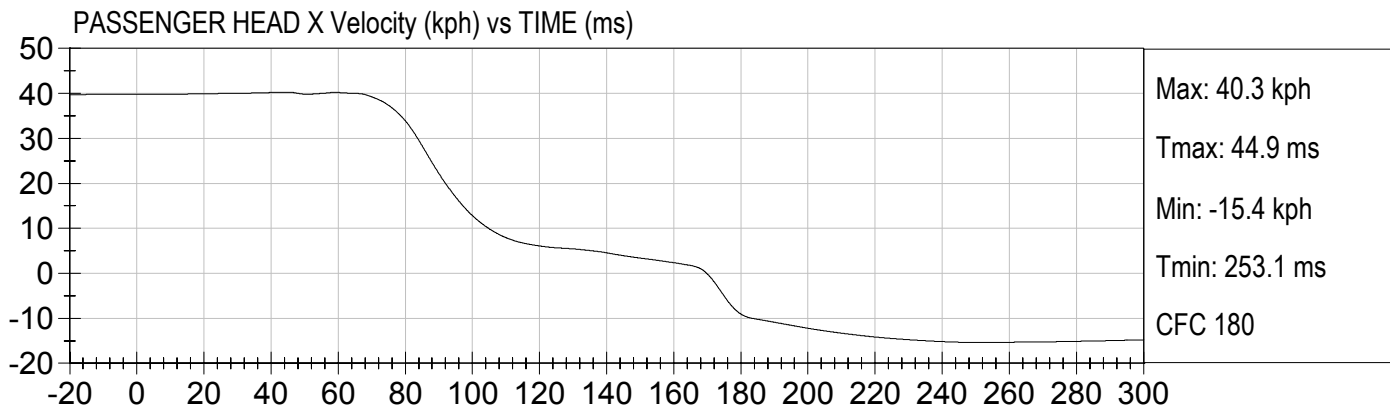



25 MPH FRONTAL UNBELTED
2006 PONTIAC G6 (C60104)

Test Date: 08/24/2006
Speed: 24.7 mph (39.8 km/h)

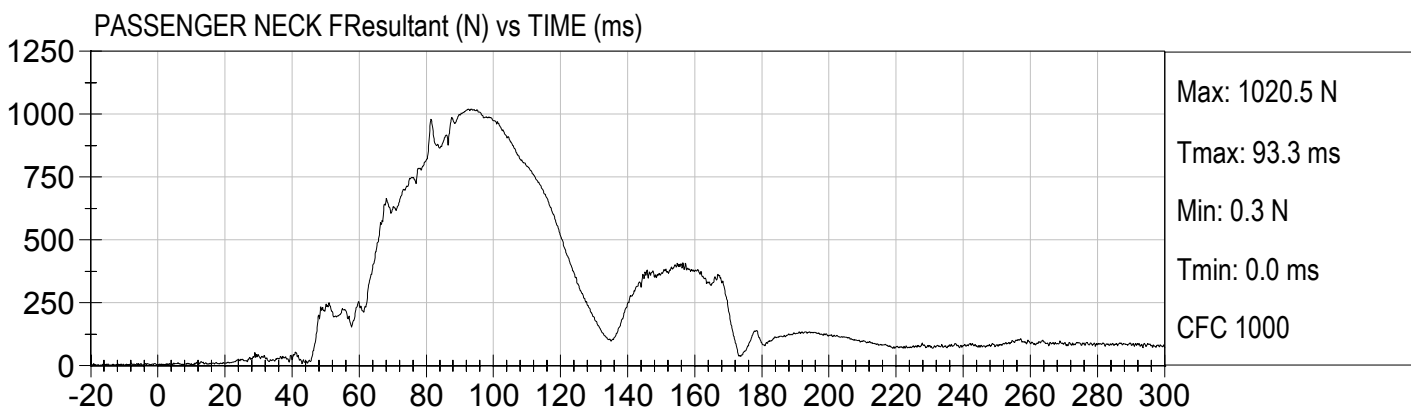
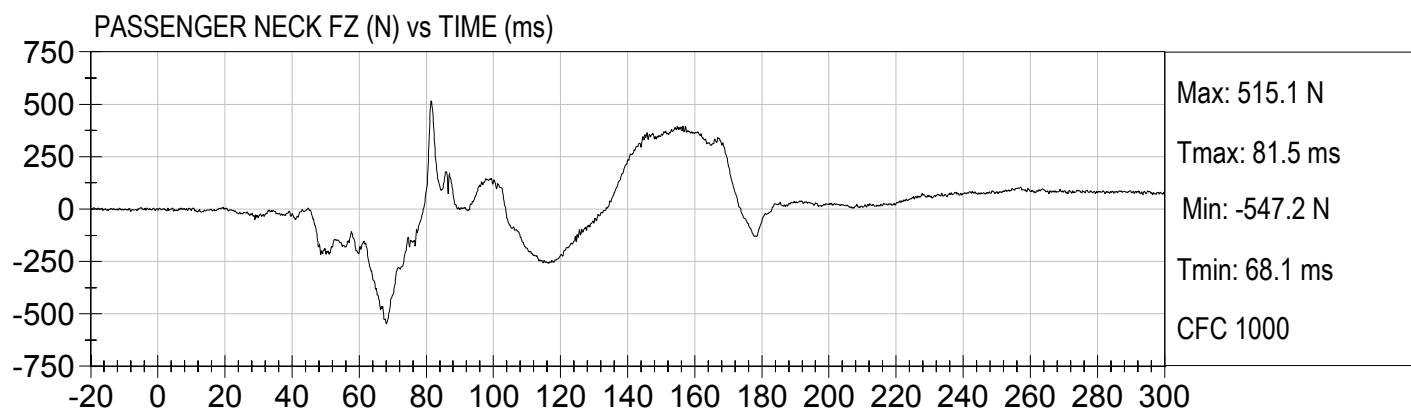
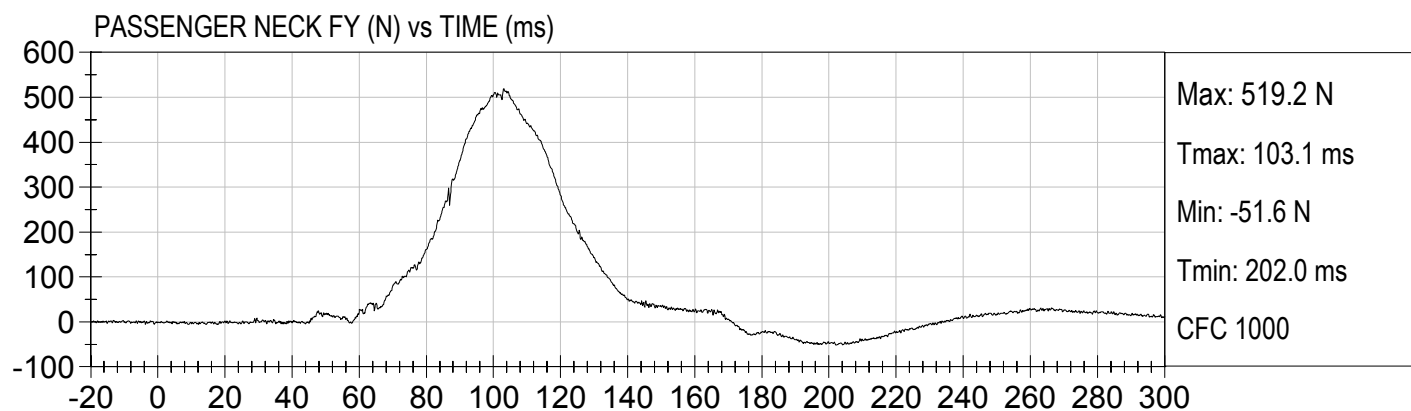
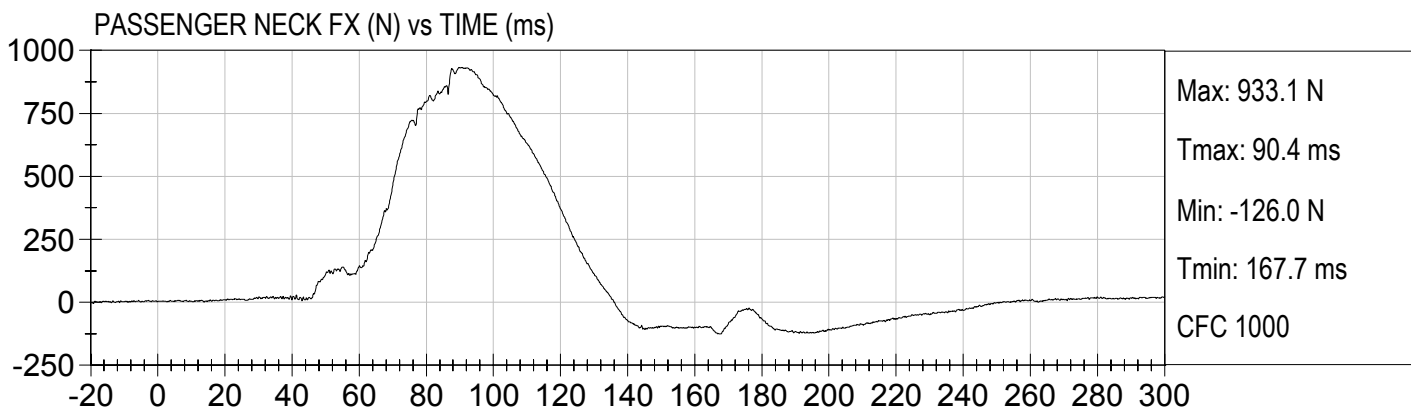



25 MPH FRONTAL UNBELTED
2006 PONTIAC G6 (C60104)

Test Date: 08/24/2006
Speed: 24.7 mph (39.8 km/h)

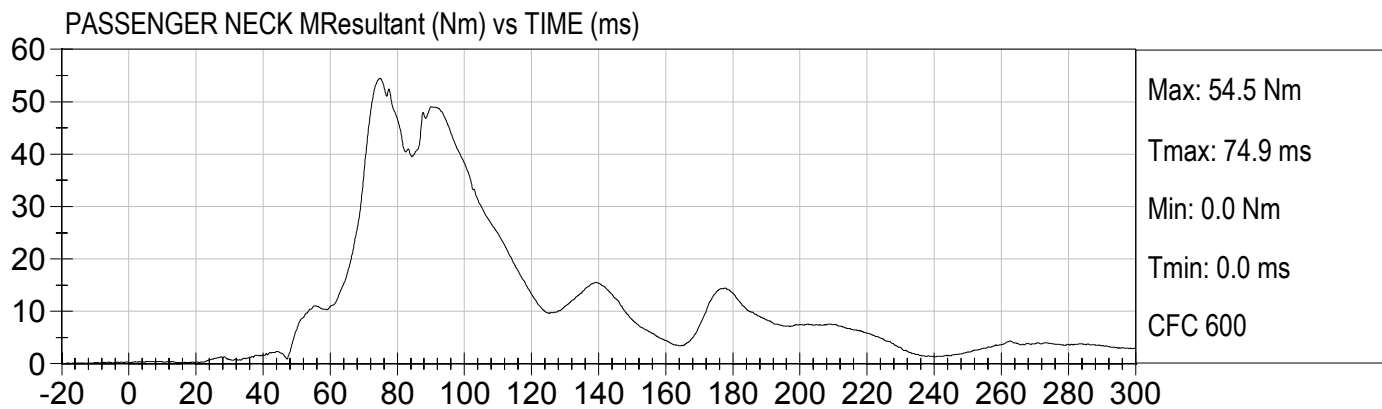
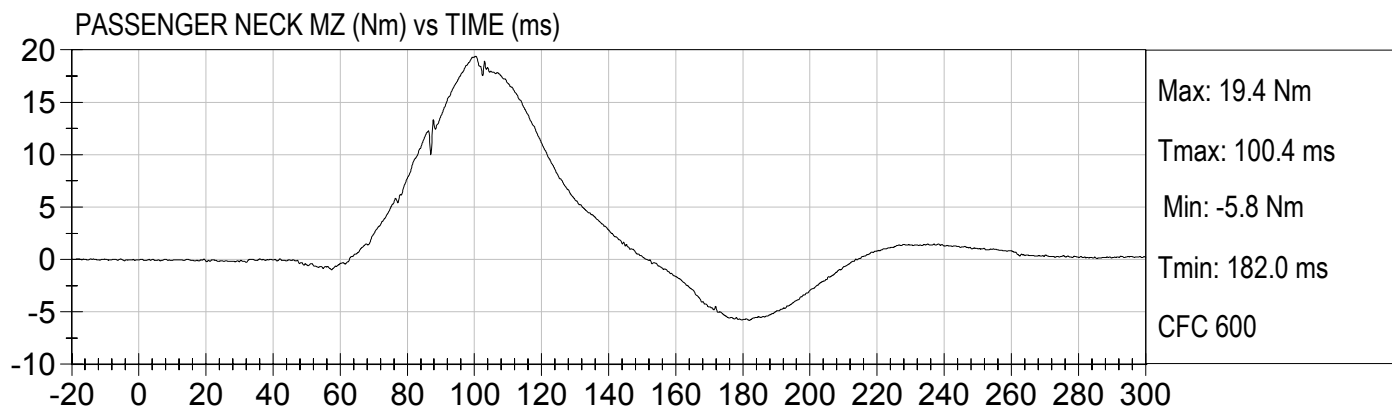
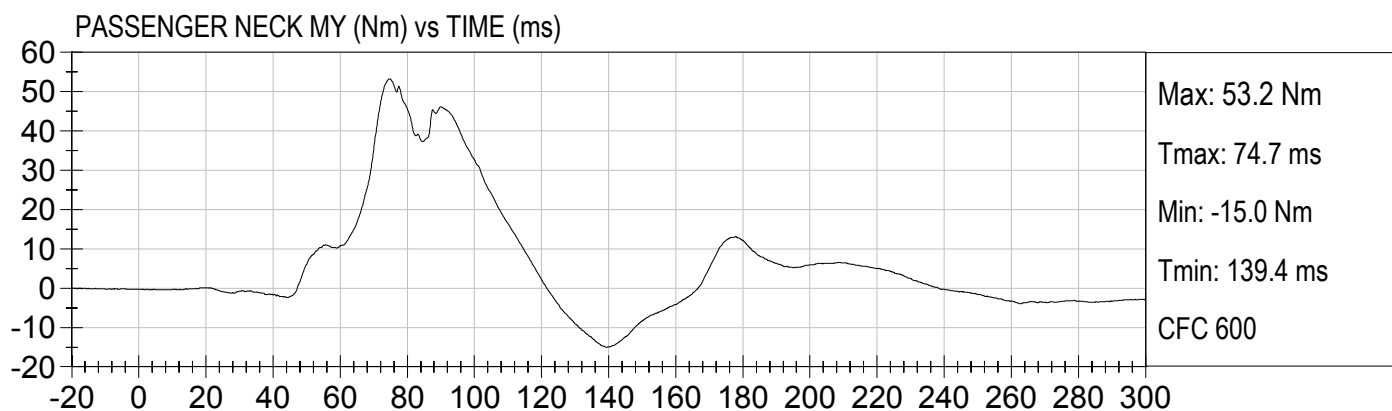
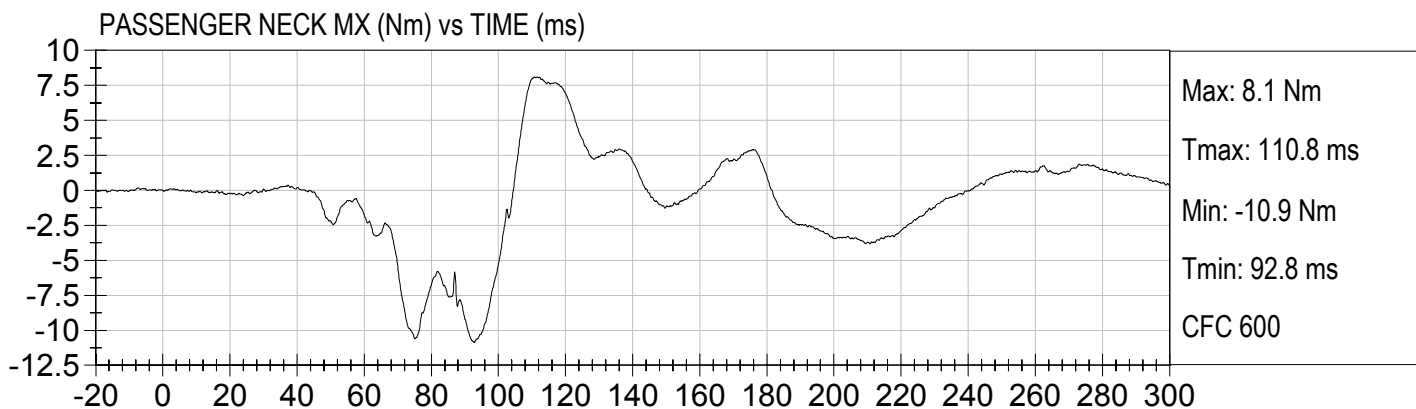



25 MPH FRONTAL UNBELTED
2006 PONTIAC G6 (C60104)

Test Date: 08/24/2006
Speed: 24.7 mph (39.8 km/h)

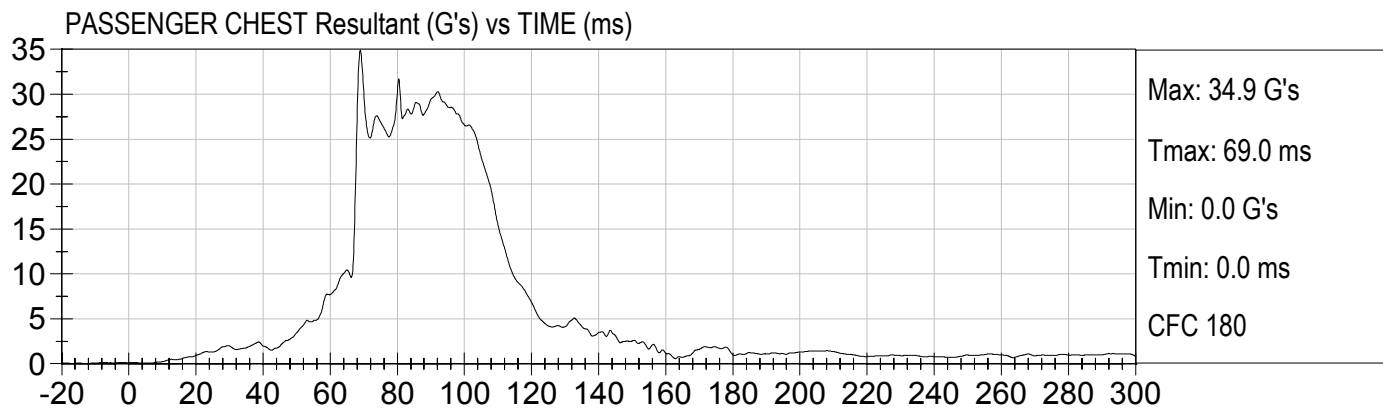
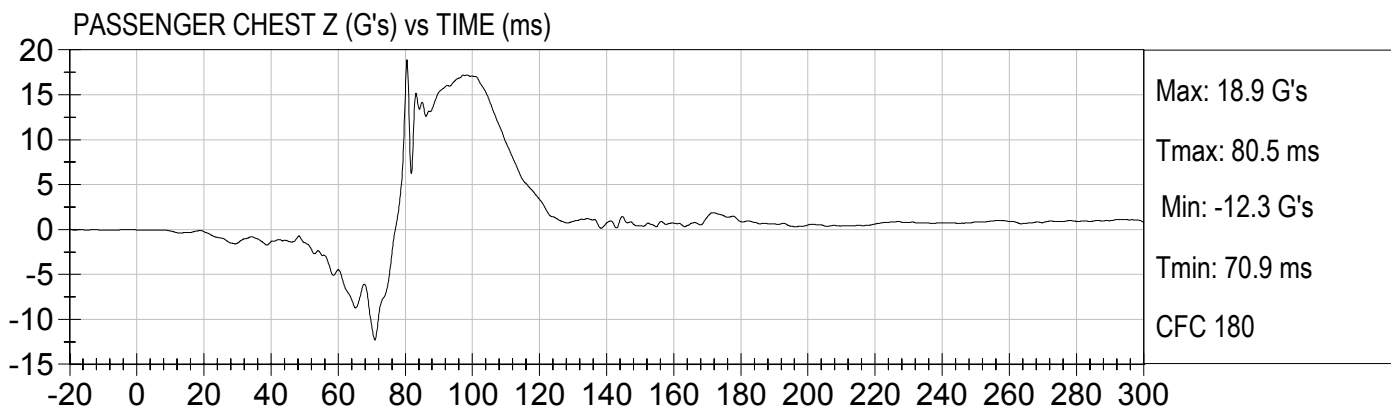
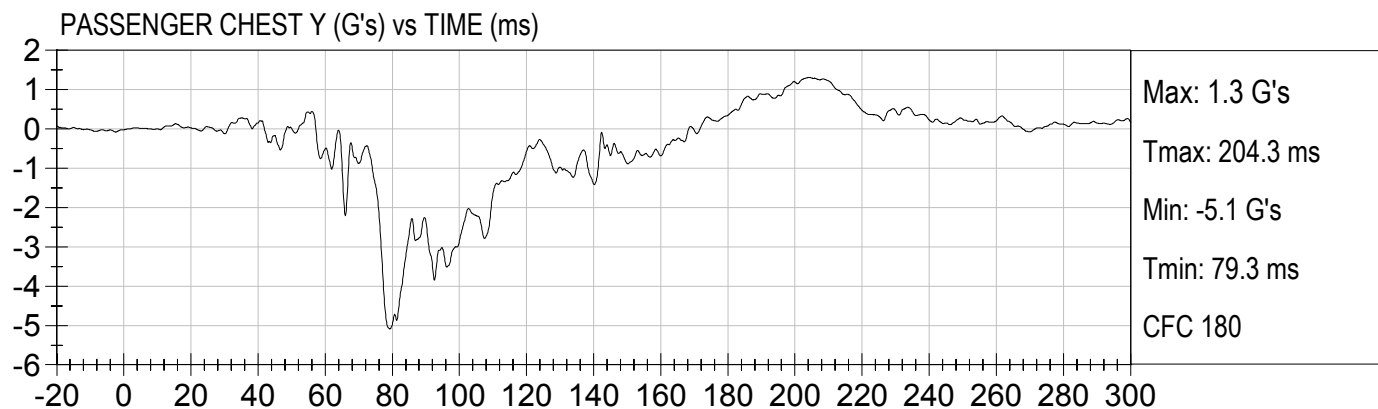
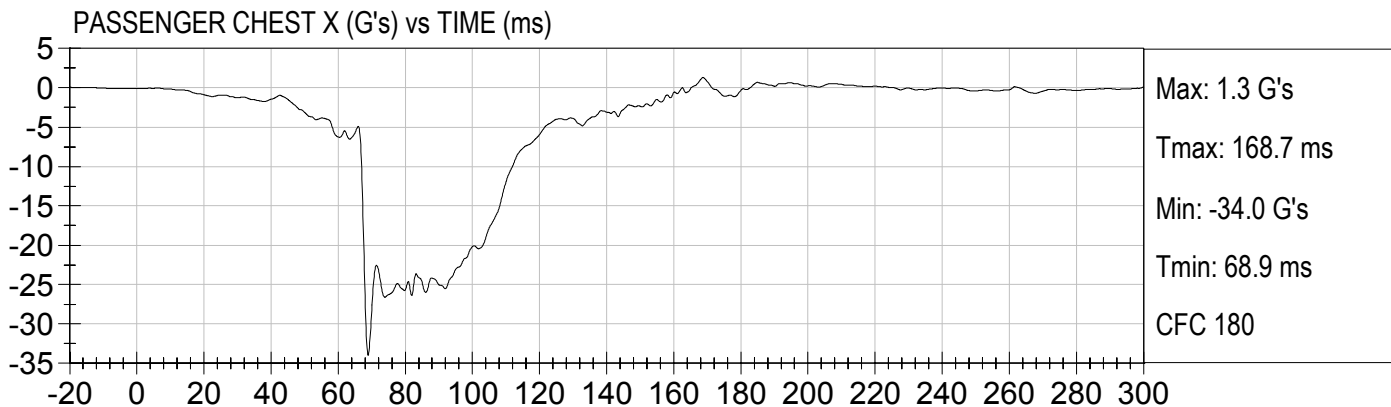

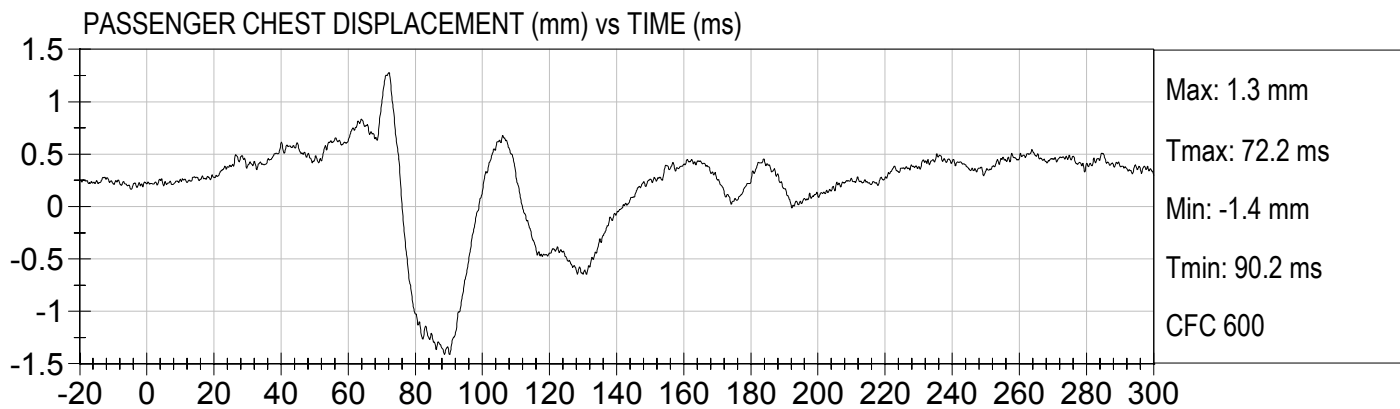
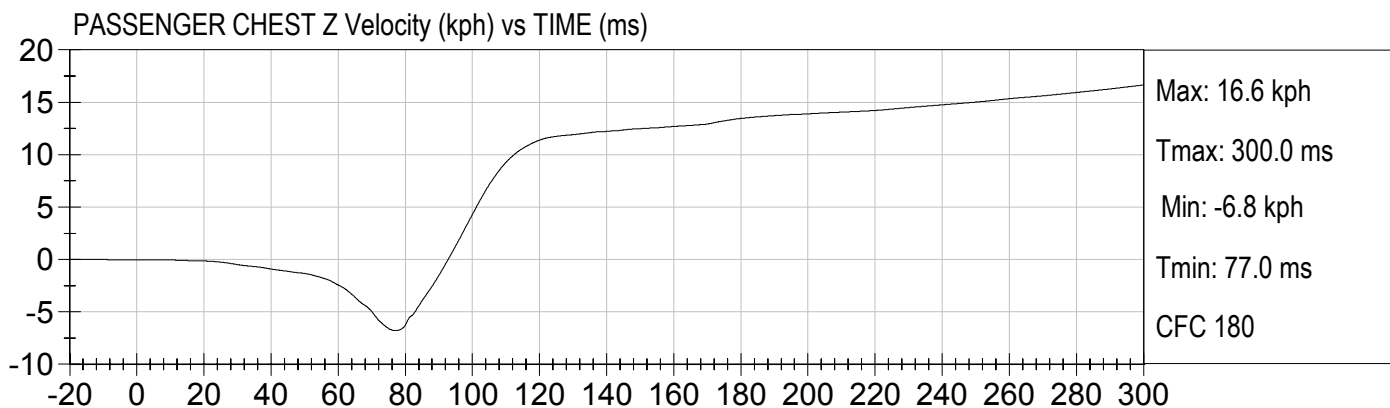
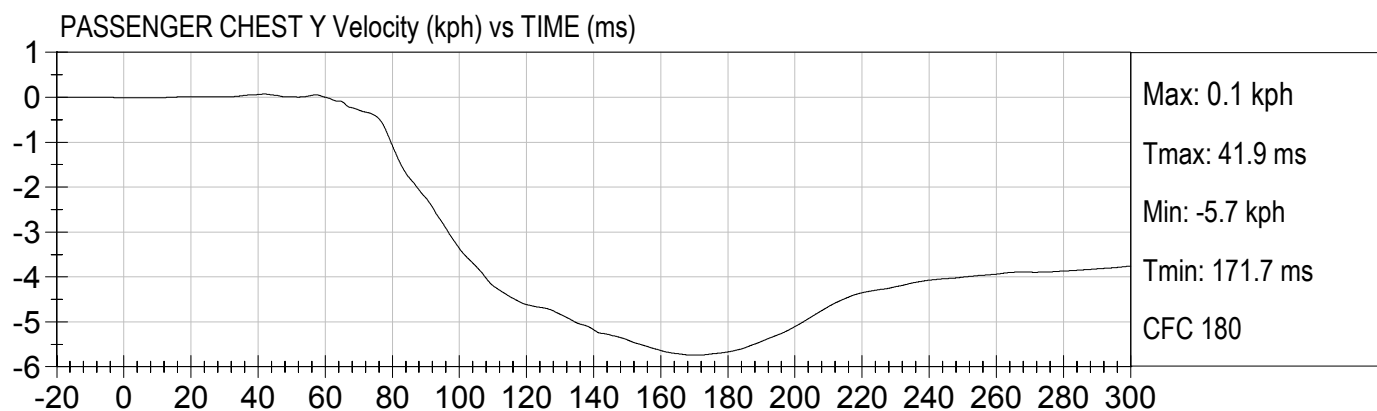
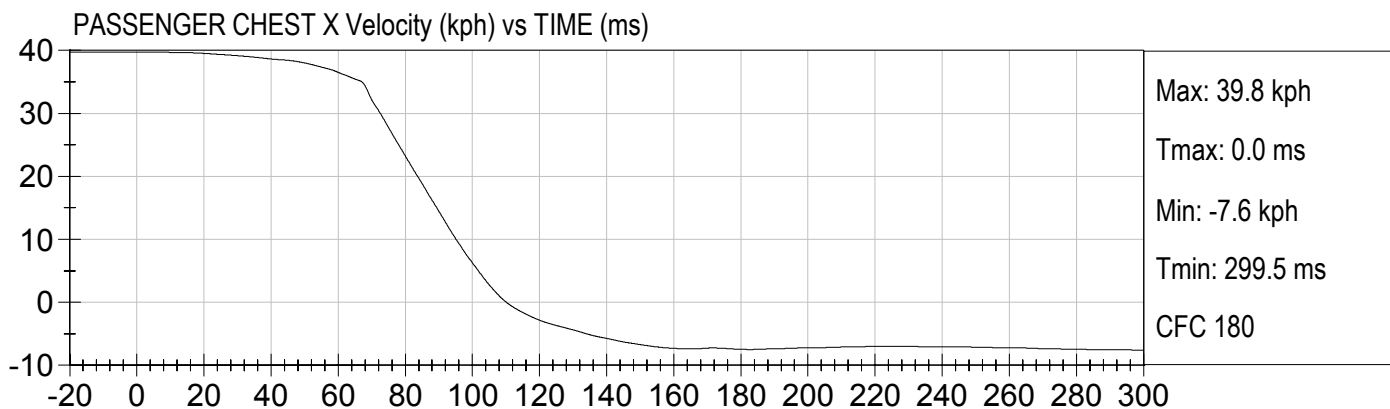



25 MPH FRONTAL UNBELTED
2006 PONTIAC G6 (C60104)

Test Date: 08/24/2006
Speed: 24.7 mph (39.8 km/h)

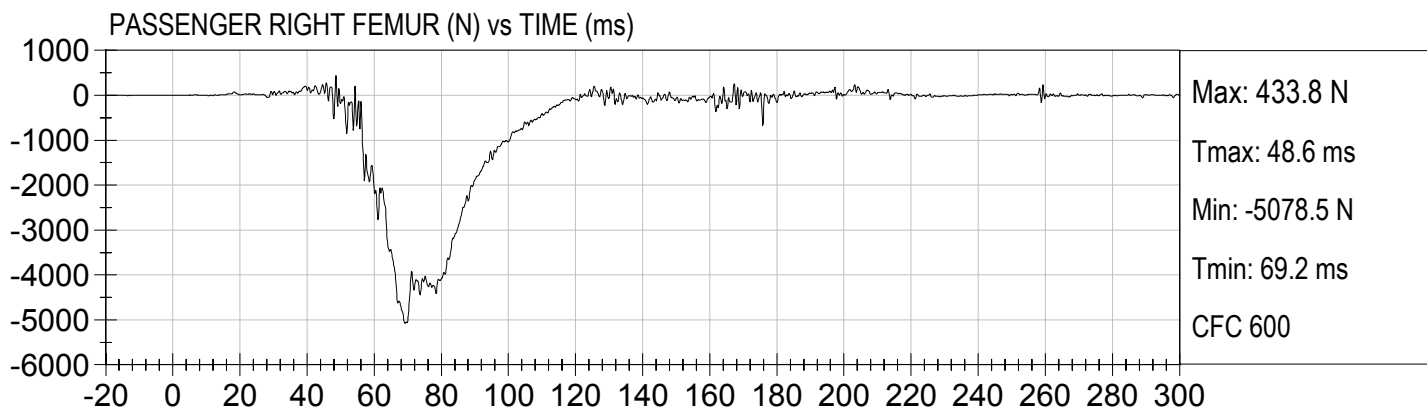
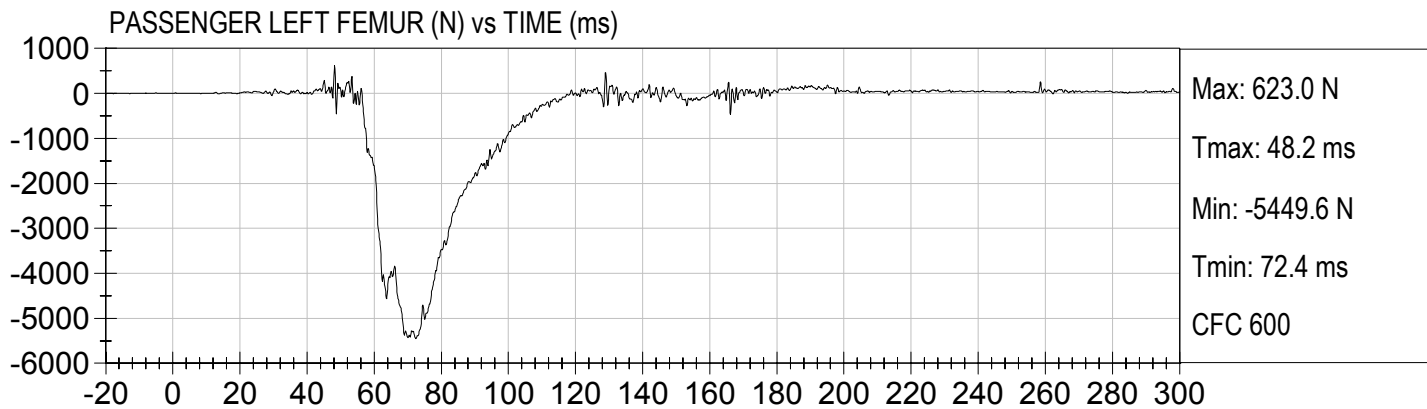



25 MPH FRONTAL UNBELTED
2006 PONTIAC G6 (C60104)

Test Date: 08/24/2006
Speed: 24.7 mph (39.8 km/h)

Drv. nij (NTF) () vs TIME (ms)

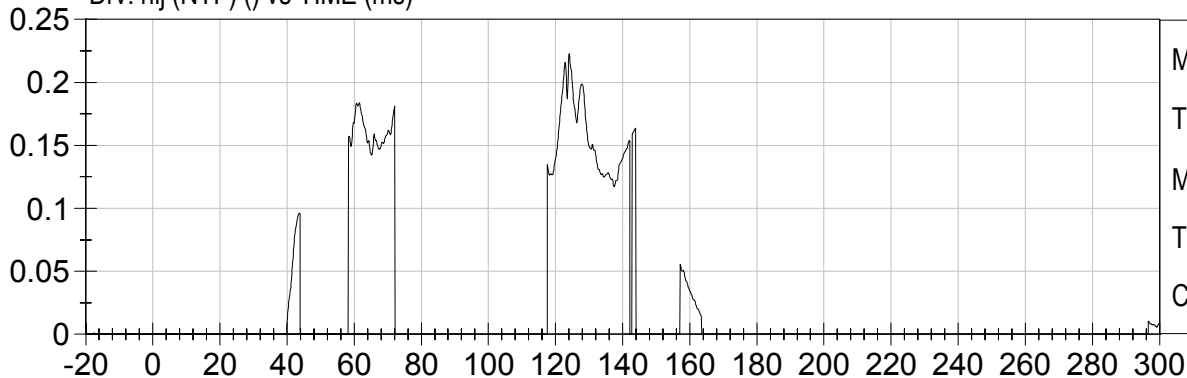

Max: 0.2
Tmax: 124.1 ms
Min: 0.0
Tmin: 0.0 ms
CFC 600

Drv. nij (NTE) () vs TIME (ms)

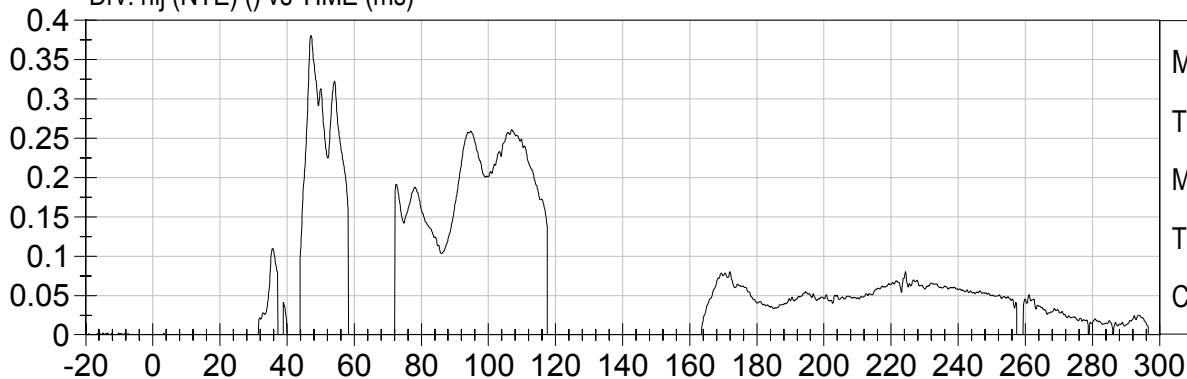

Max: 0.4
Tmax: 47.1 ms
Min: 0.0
Tmin: 0.0 ms
CFC 600

Drv. nij (NCF) () vs TIME (ms)

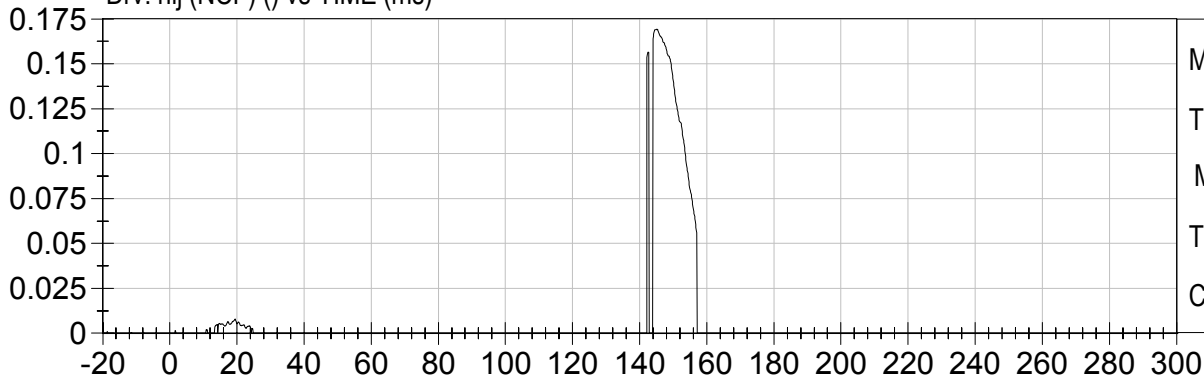

Max: 0.2
Tmax: 145.2 ms
Min: 0.0
Tmin: 0.0 ms
CFC 600

Drv. nij (NCE) () vs TIME (ms)

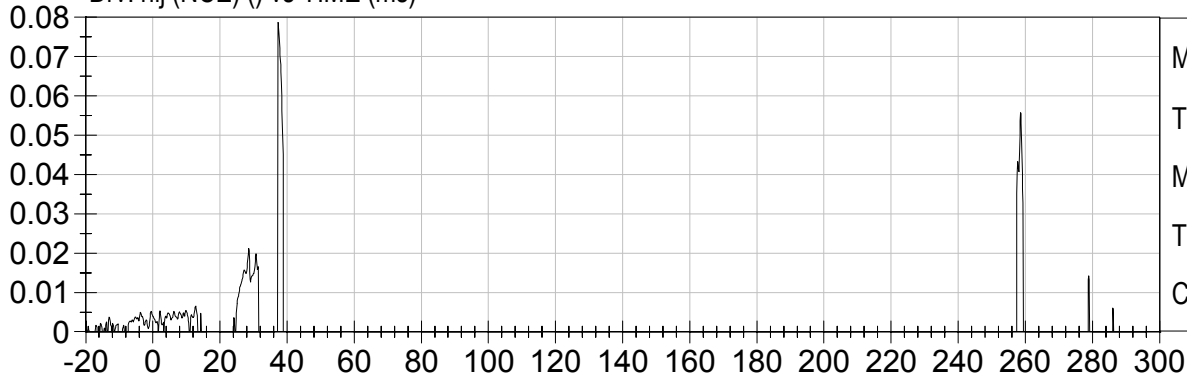

Max: 0.1
Tmax: 37.3 ms
Min: 0.0
Tmin: 0.0 ms
CFC 600



25 MPH FRONTAL UNBELTED
2006 PONTIAC G6 (C60104)

Test Date: 08/24/2006
Speed: 24.7 mph (39.8 km/h)

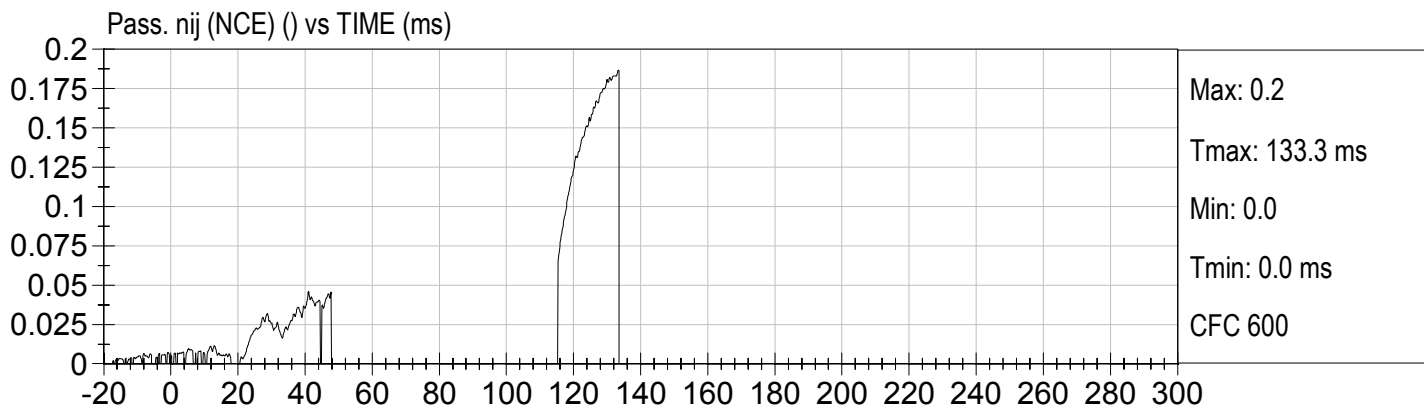
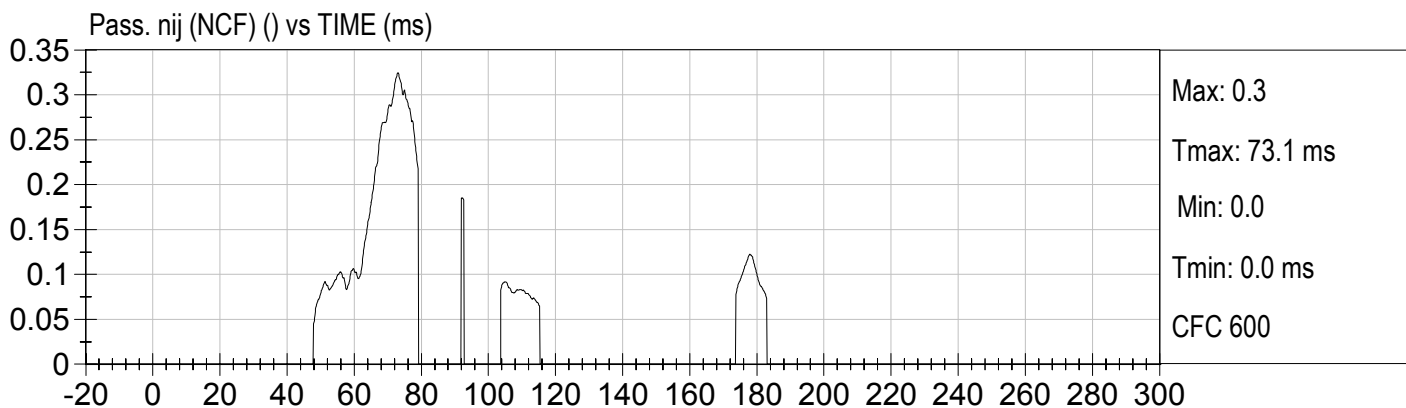
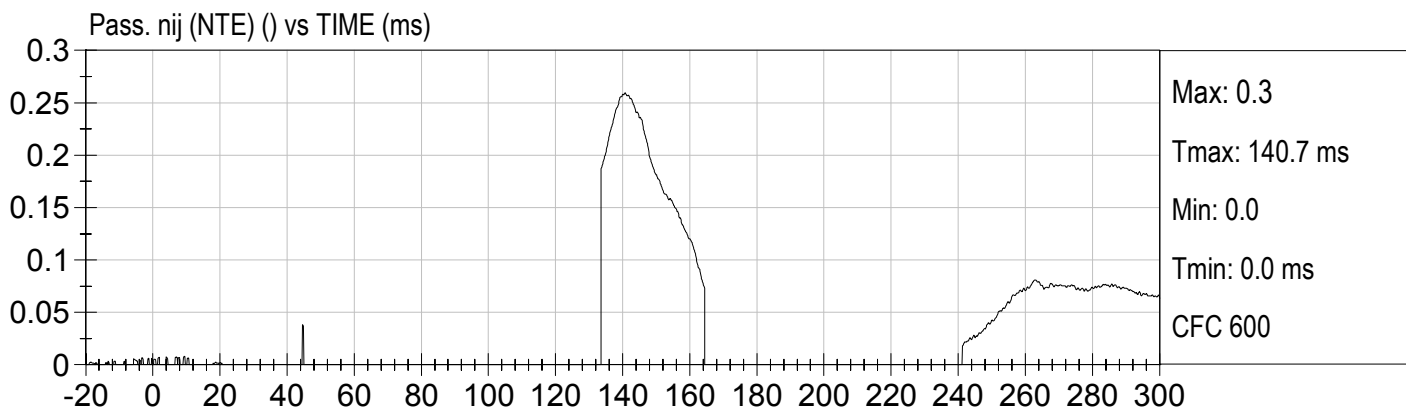
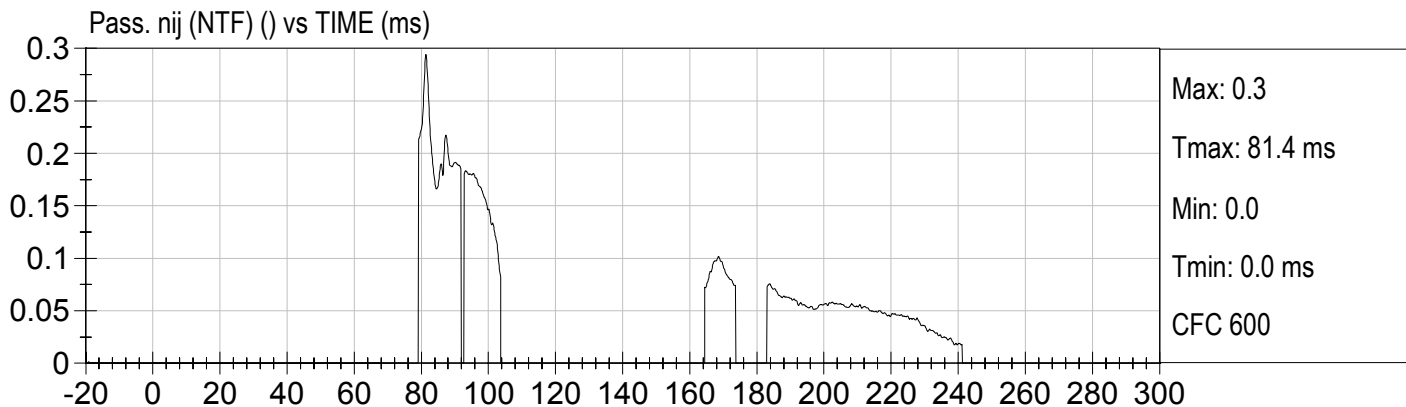



25 MPH FRONTAL UNBELTED
2006 PONTIAC G6 (C60104)

Test Date: 08/24/2006
Speed: 24.7 mph (39.8 km/h)

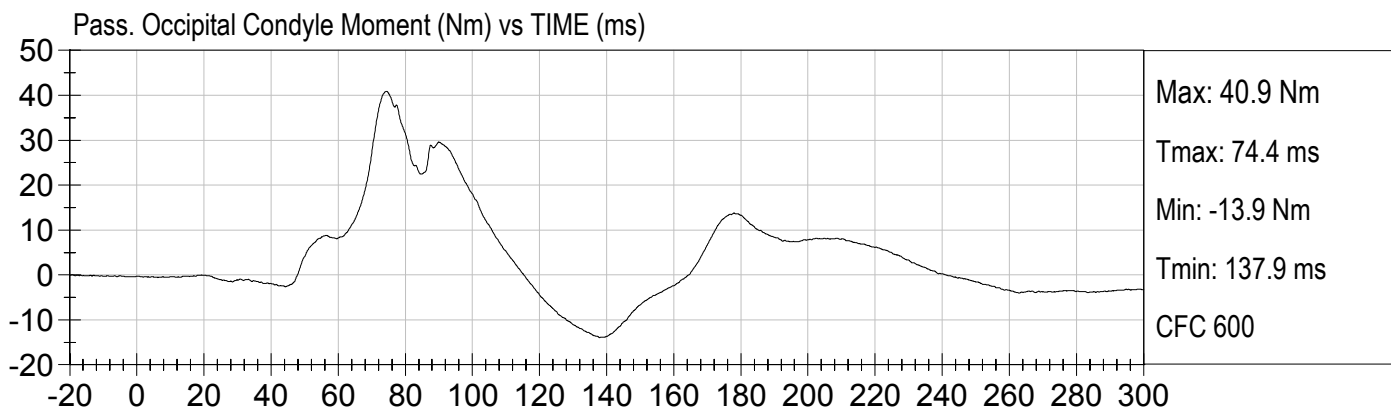
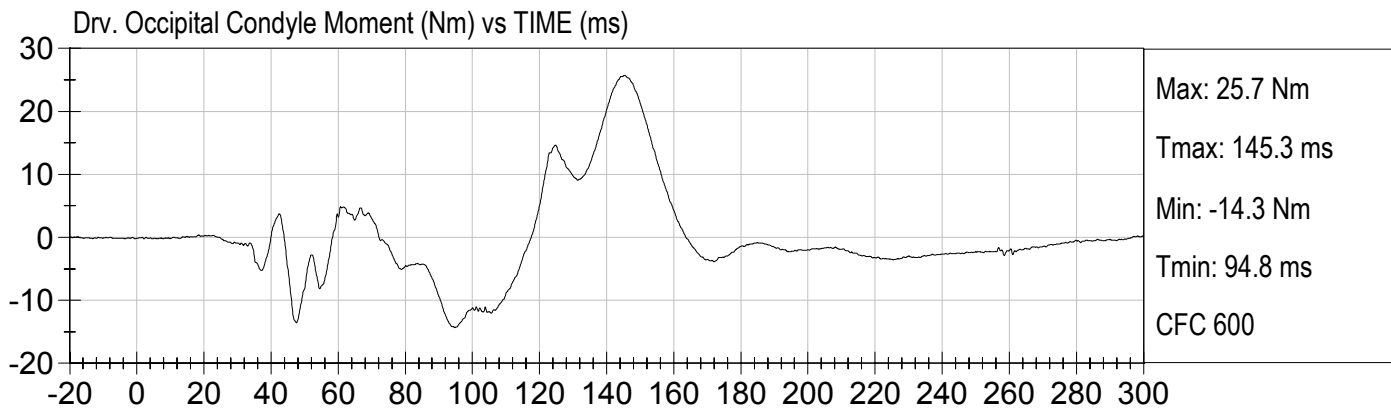

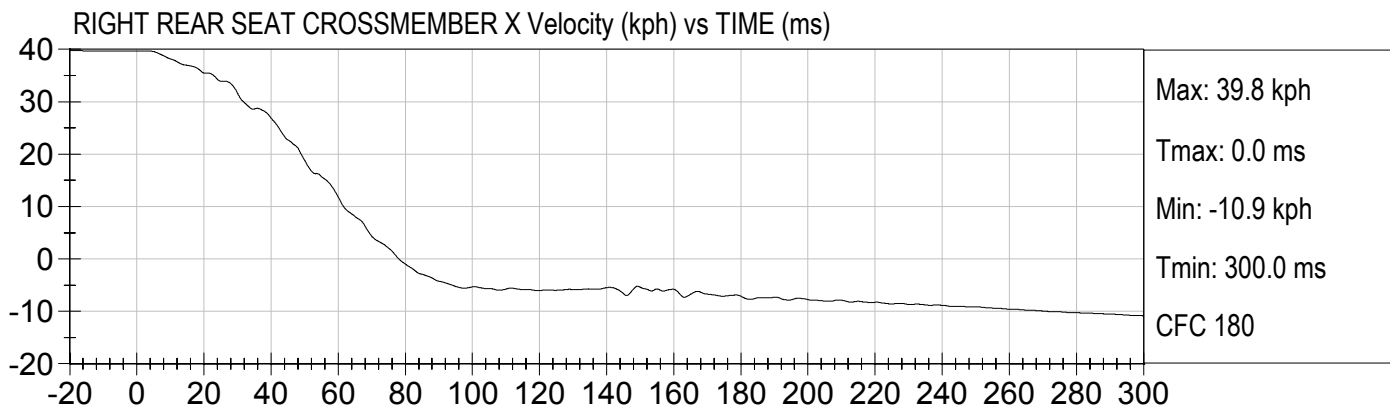
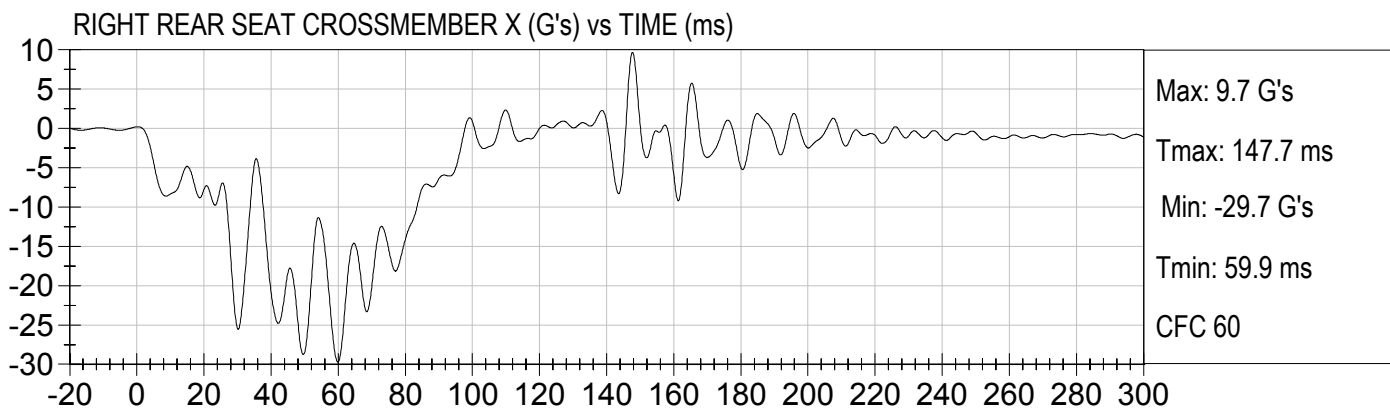
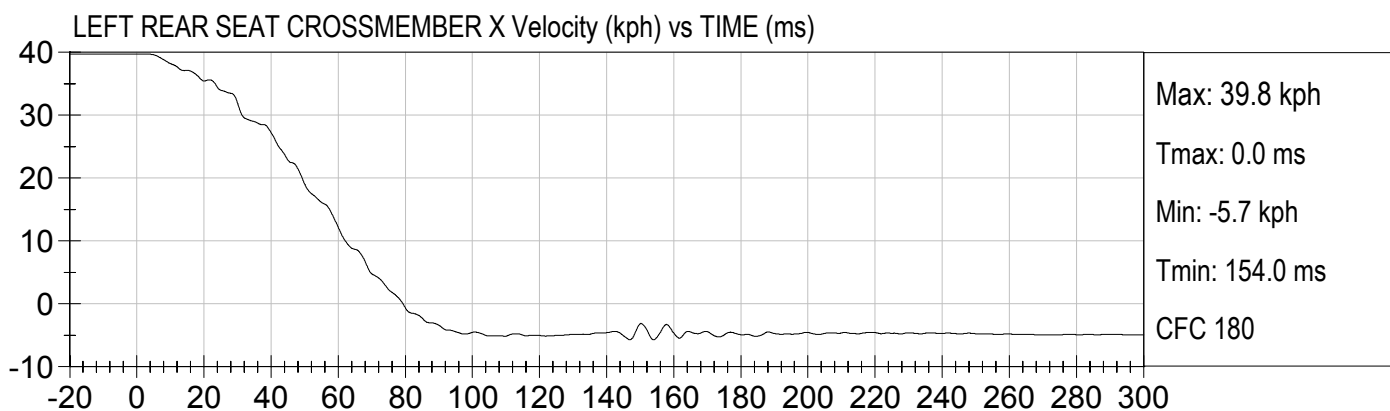
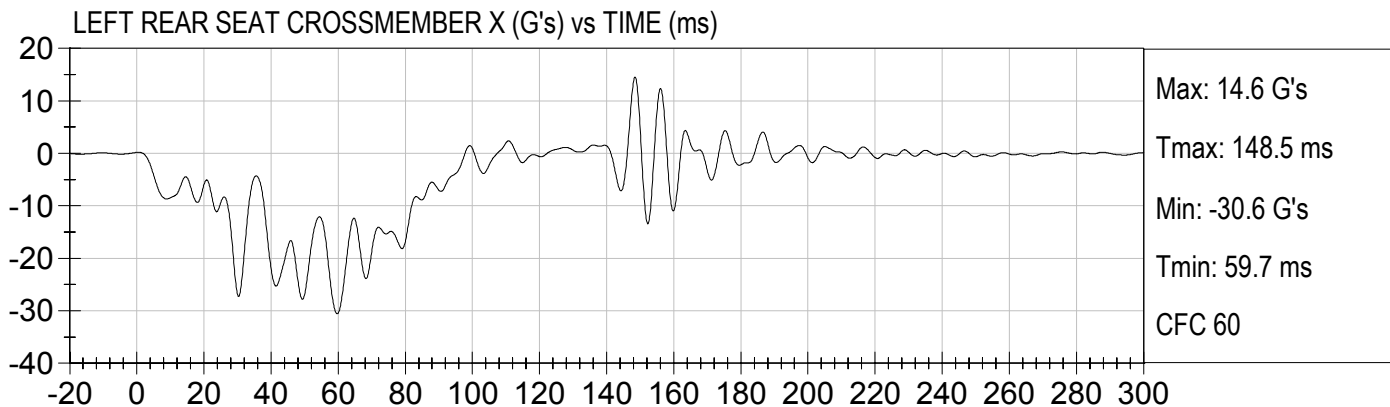

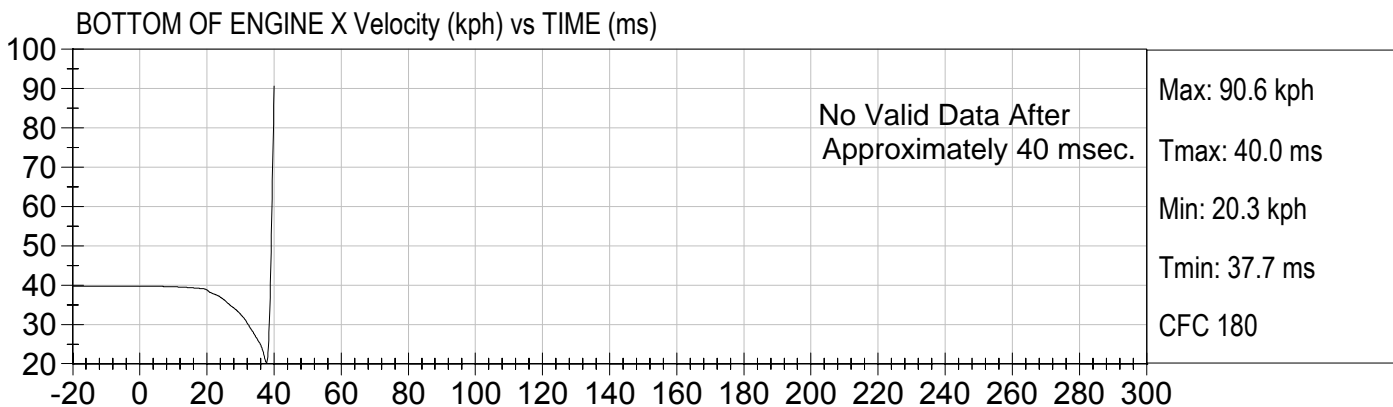
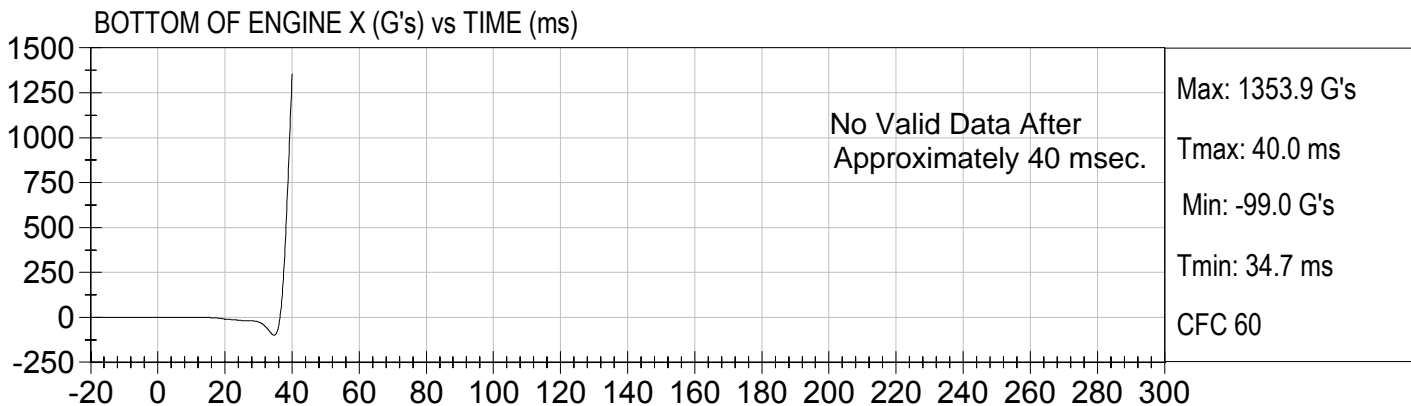
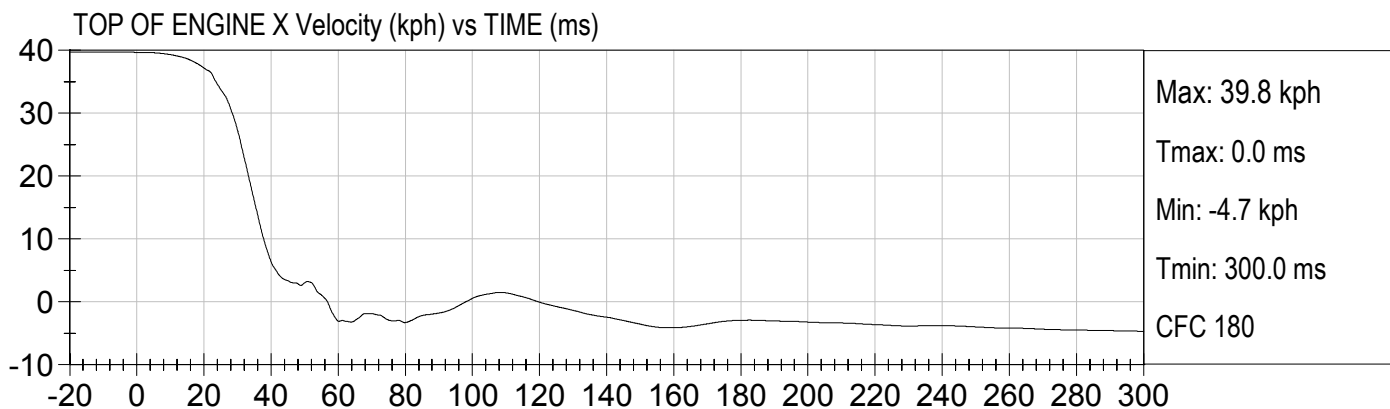
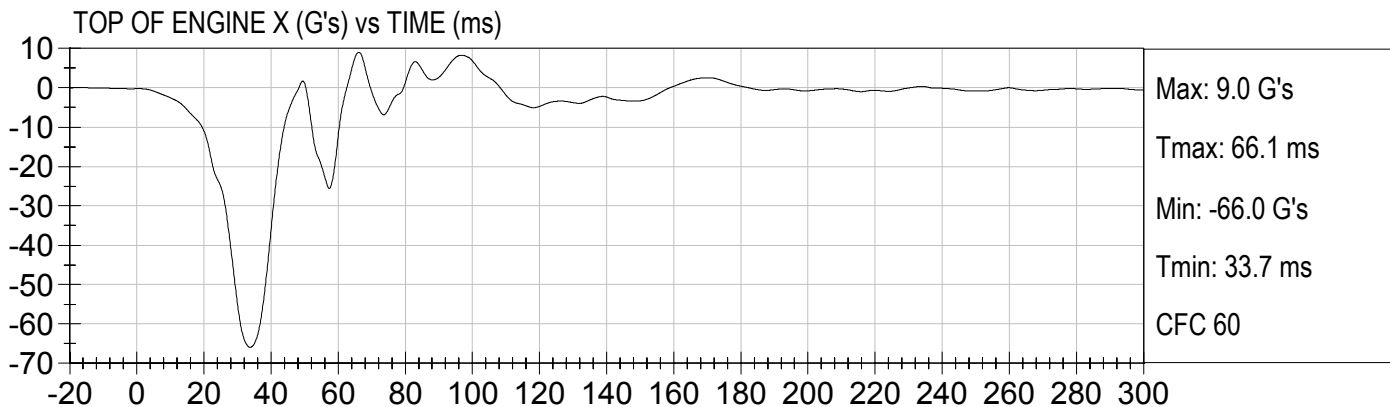

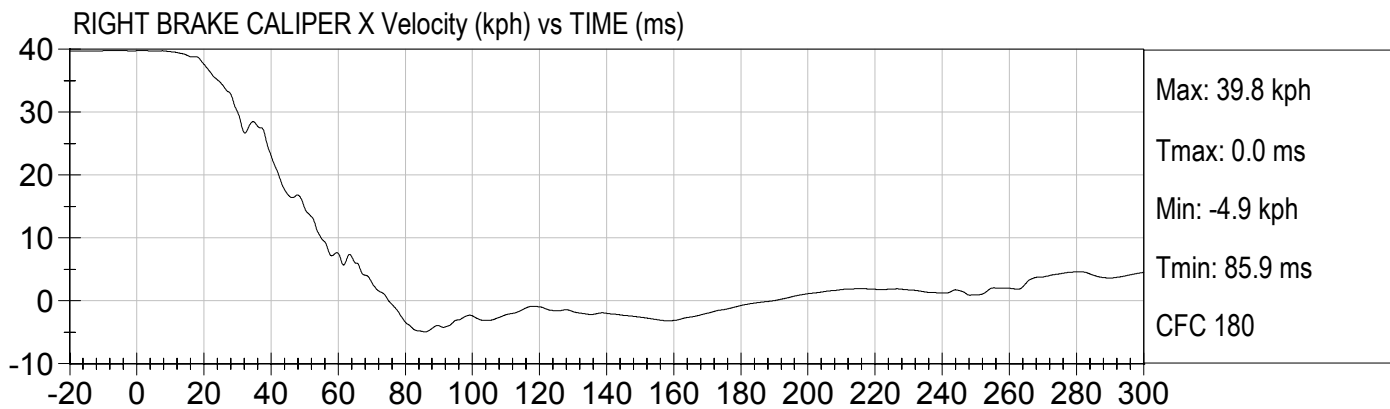
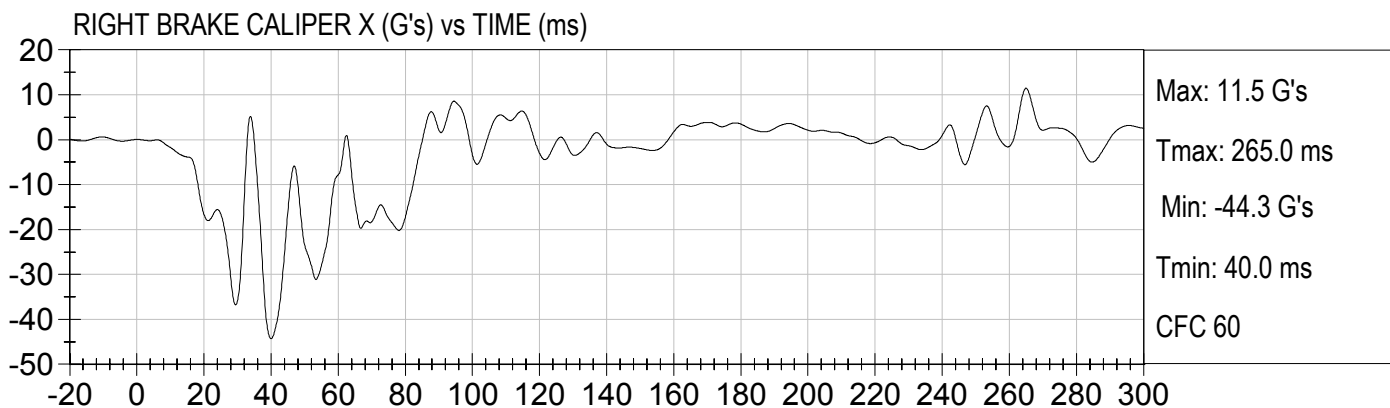
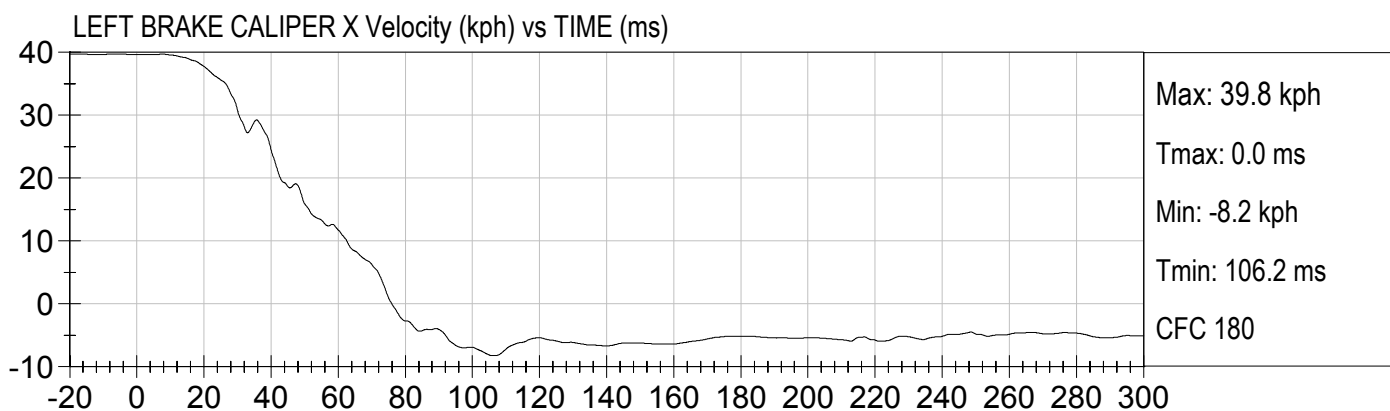
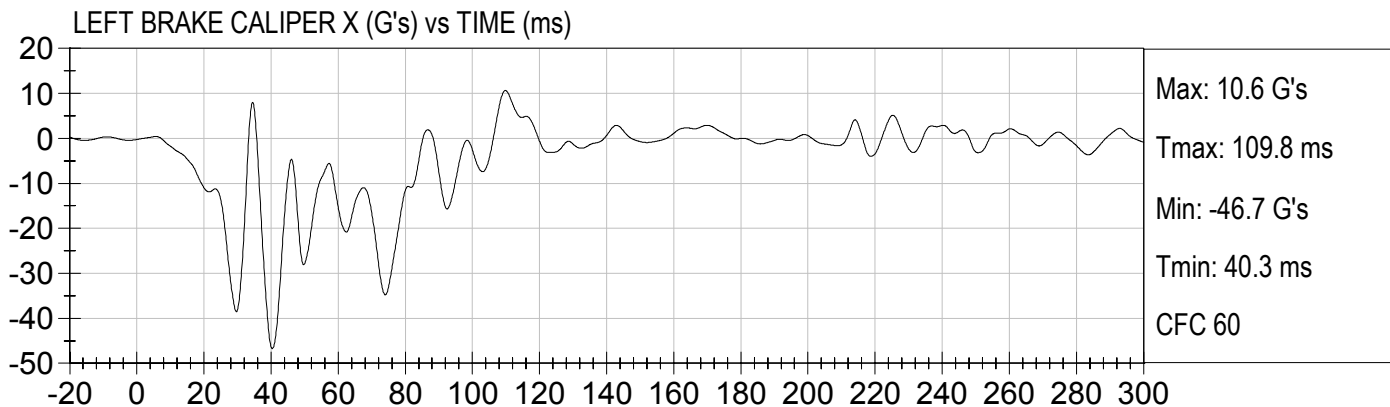

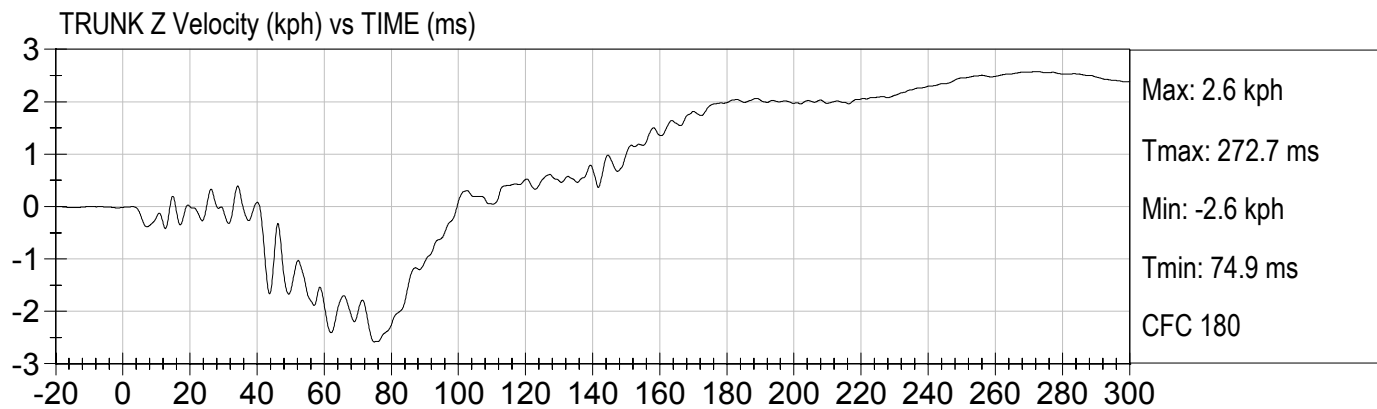
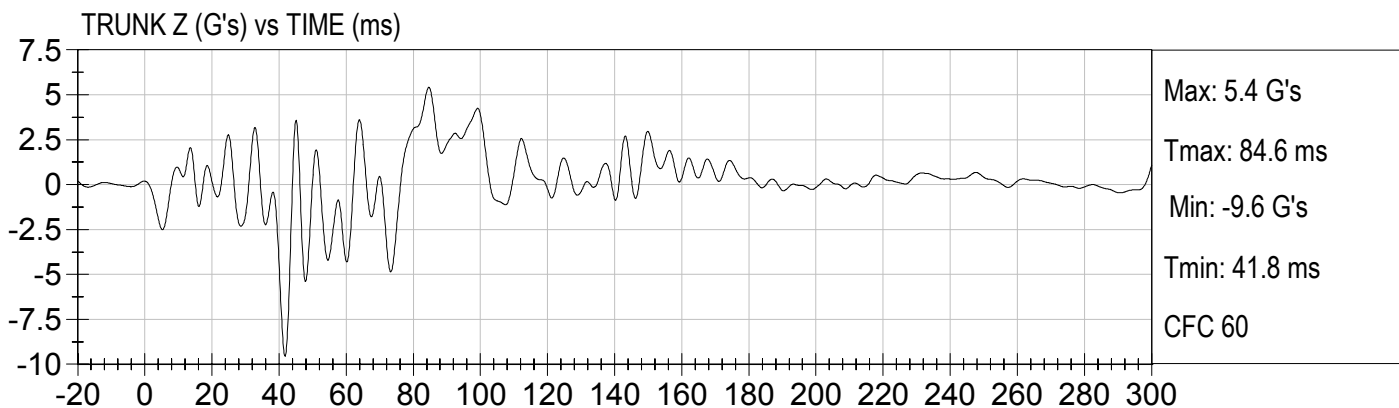
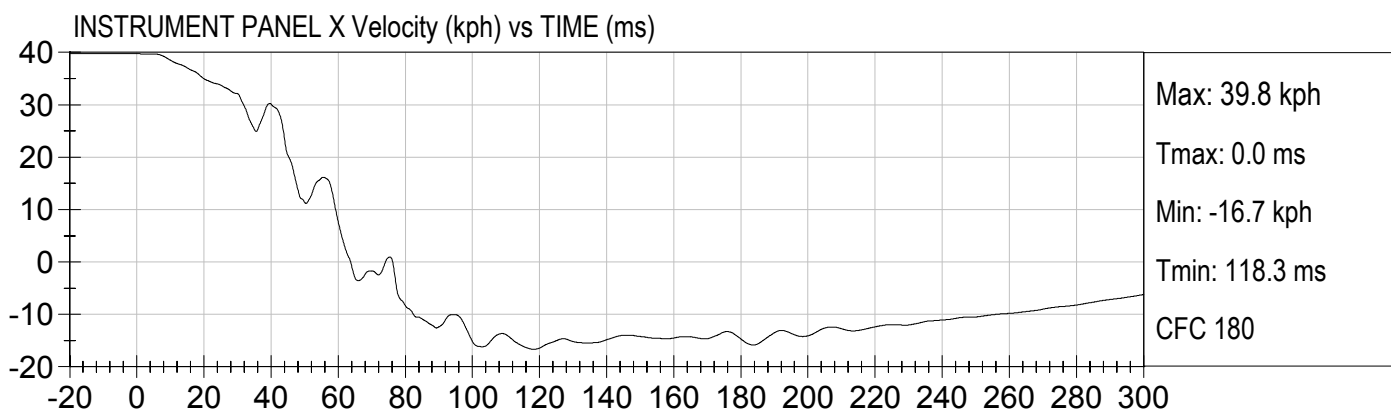
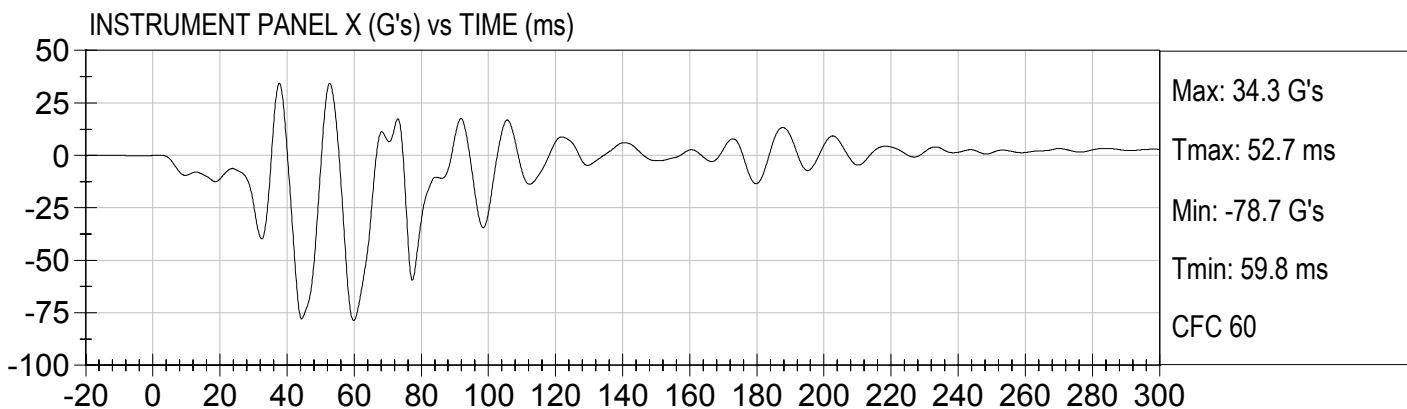



25 MPH FRONTAL UNBELTED
2006 PONTIAC G6 (C60104)

Test Date: 08/24/2006
Speed: 24.7 mph (39.8 km/h)

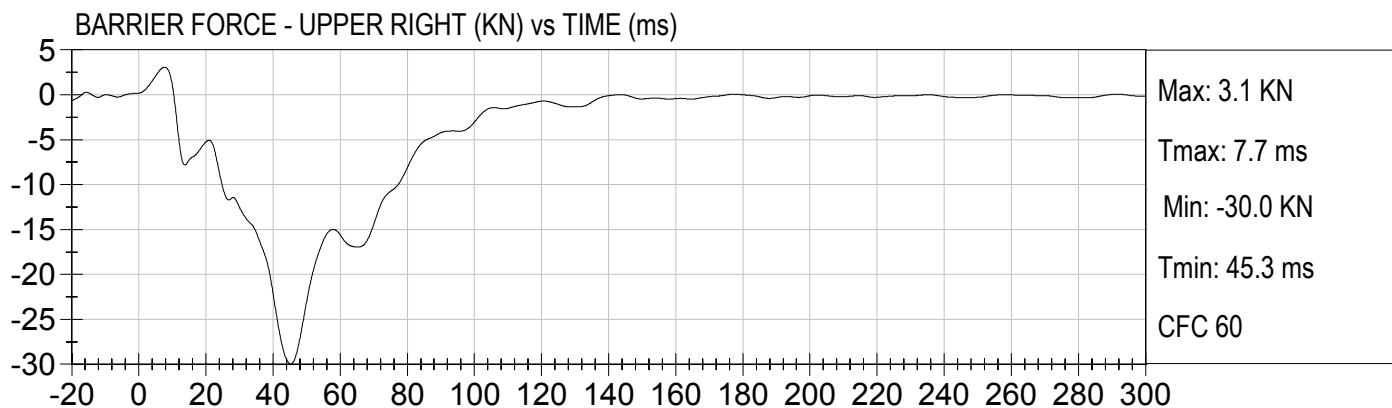
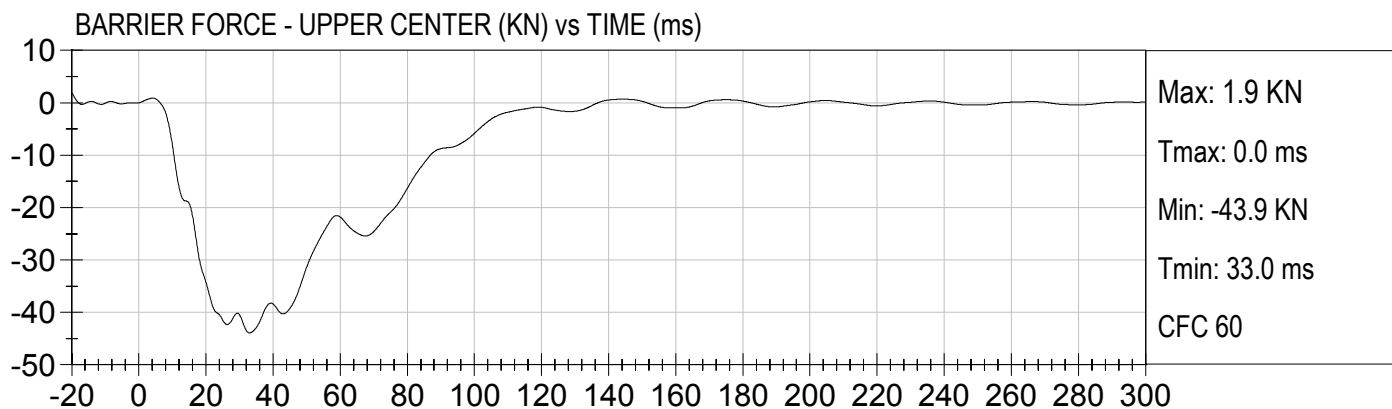
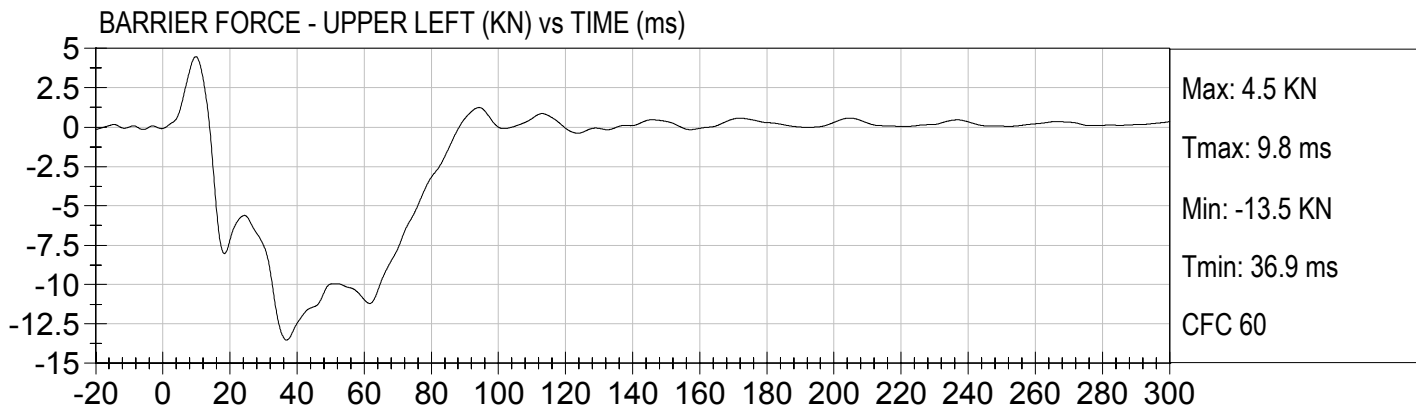



25 MPH FRONTAL UNBELTED
2006 PONTIAC G6 (C60104)

Test Date: 08/24/2006
Speed: 24.7 mph (39.8 km/h)

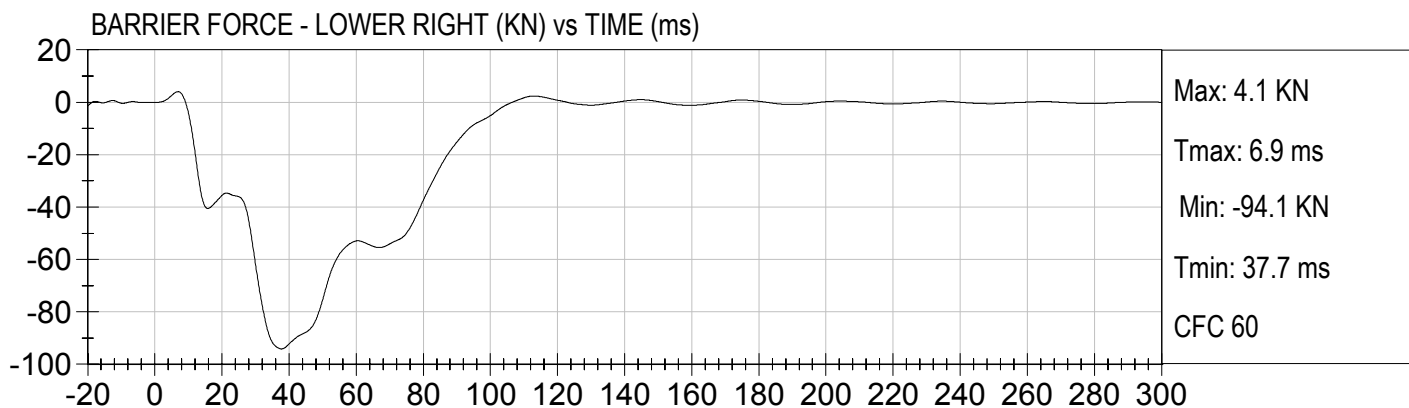
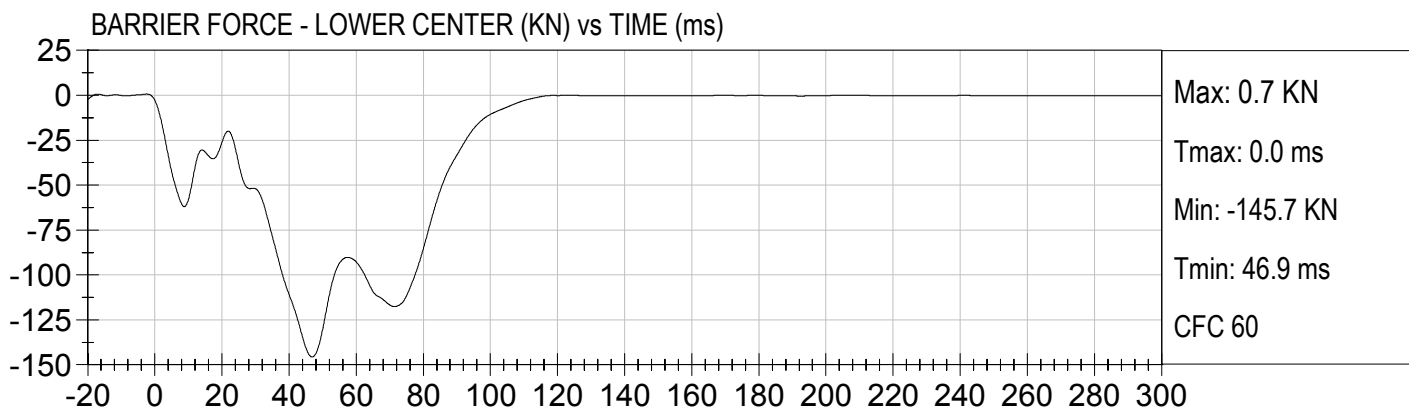
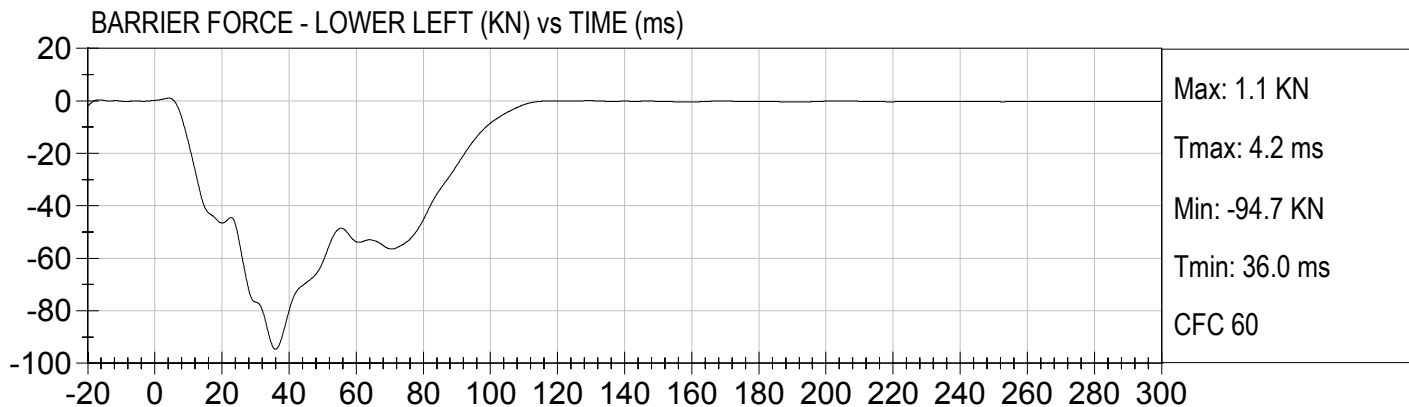



25 MPH FRONTAL UNBELTED
2006 PONTIAC G6 (C60104)

Test Date: 08/24/2006
Speed: 24.7 mph (39.8 km/h)

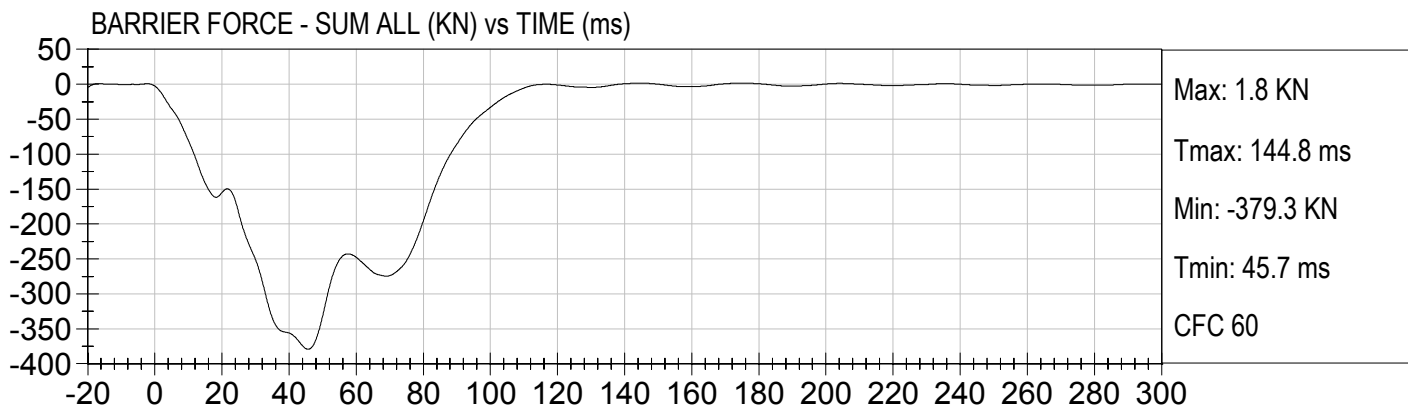
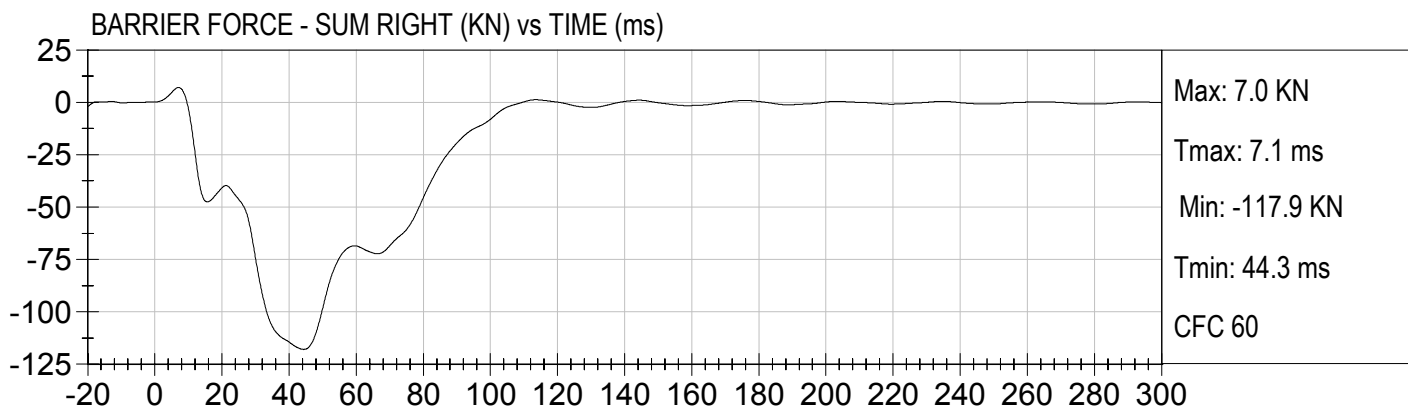
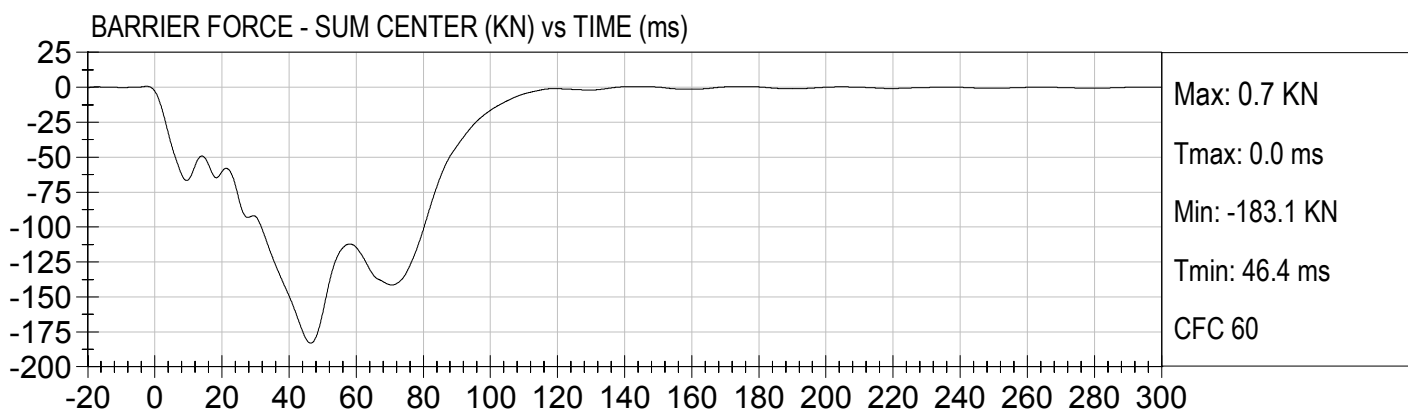
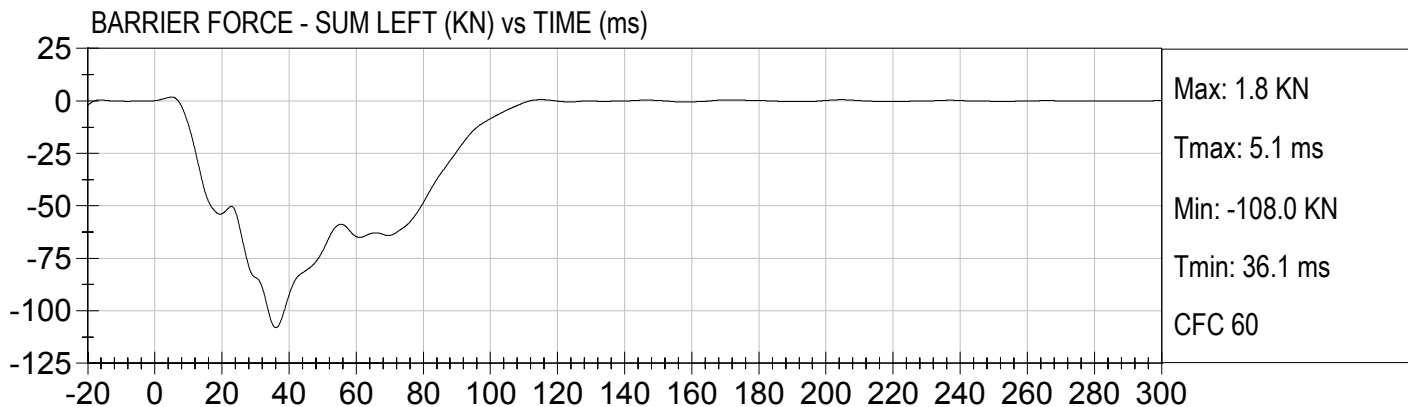

APPENDIX B
LOW RISK TEST DATA

TABLE OF DATA PLOTS

		<u>Page No.</u>
Figure No. 1.	5 th Fem. P1 Driver Head X Acceleration vs. Time	B-1
Figure No. 2.	5 th Fem. P1 Driver Head Y Acceleration vs. Time	B-1
Figure No. 3.	5 th Fem. P1 Driver Head Z Acceleration vs. Time	B-1
Figure No. 4.	5 th Fem. P1 Driver Head Resultant Acceleration vs. Time	B-1
Figure No. 5.	5 th Fem. P1 Driver Head X Velocity vs. Time	B-2
Figure No. 6.	5 th Fem. P1 Driver Head Y Velocity vs. Time	B-2
Figure No. 7.	5 th Fem. P1 Driver Head Z Velocity vs. Time	B-2
Figure No. 8.	5 th Fem. P1 Driver Neck Force X vs. Time	B-3
Figure No. 9.	5 th Fem. P1 Driver Neck Force Y vs. Time	B-3
Figure No. 10.	5 th Fem. P1 Driver Neck Force Z vs. Time	B-3
Figure No. 11.	5 th Fem. P1 Driver Neck Force Resultant vs. Time	B-3
Figure No. 12.	5 th Fem. P1 Driver Neck Moment X vs. Time	B-4
Figure No. 13.	5 th Fem. P1 Driver Neck Moment Y vs. Time	B-4
Figure No. 14.	5 th Fem. P1 Driver Neck Moment Z vs. Time	B-4
Figure No. 15.	5 th Fem. P1 Driver Occipital Condyle Moment vs. Time	B-4
Figure No. 16.	5 th Fem. P1 Driver Chest X Acceleration vs. Time	B-5
Figure No. 17.	5 th Fem. P1 Driver Chest Y Acceleration vs. Time	B-5
Figure No. 18.	5 th Fem. P1 Driver Chest Z Acceleration vs. Time	B-5
Figure No. 19.	5 th Fem. P1 Driver Chest Resultant Acceleration vs. Time	B-5
Figure No. 20.	5 th Fem. P1 Driver Chest X Velocity vs. Time	B-6
Figure No. 21.	5 th Fem. P1 Driver Chest Y Velocity vs. Time	B-6
Figure No. 22.	5 th Fem. P1 Driver Chest Z Velocity vs. Time	B-6
Figure No. 23.	5 th Fem. P1 Driver Chest Displacement vs. Time	B-6
Figure No. 24.	5 th Fem. P1 Driver Left Femur Force vs. Time	B-7
Figure No. 25.	5 th Fem. P1 Driver Right Femur Force vs. Time	B-7
Figure No. 26.	Fire Voltage #1 Voltage vs. Time	B-8
Figure No. 27.	Fire Current #1 Voltage vs. Time	B-8
Figure No. 28.	Fire Voltage #2 Voltage vs. Time	B-8
Figure No. 29.	Fire Current #2 Voltage vs. Time	B-8

	<u>Page No.</u>	
Figure No. 30.	5 th Fem. P1 Driver Nij (N_{TF}) vs. Time	B-9
Figure No. 31.	5 th Fem. P1 Driver Nij (N_{TE}) vs. Time	B-9
Figure No. 32.	5 th Fem. P1 Driver Nij (N_{CF}) vs. Time	B-9
Figure No. 33.	5 th Fem. P1 Driver Nij (N_{CE}) vs. Time	B-9
Figure No. 34.	5 th Fem. P2 Driver Head X Acceleration vs. Time	B-10
Figure No. 35.	5 th Fem. P2 Driver Head Y Acceleration vs. Time	B-10
Figure No. 36.	5 th Fem. P2 Driver Head Z Acceleration vs. Time	B-10
Figure No. 37.	5 th Fem. P2 Driver Head Resultant Acceleration vs. Time	B-10
Figure No. 38.	5 th Fem. P2 Driver Head X Velocity vs. Time	B-11
Figure No. 39.	5 th Fem. P2 Driver Head Y Velocity vs. Time	B-11
Figure No. 40.	5 th Fem. P2 Driver Head Z Velocity vs. Time	B-11
Figure No. 41.	5 th Fem. P2 Driver Neck Force X vs. Time	B-12
Figure No. 42.	5 th Fem. P2 Driver Neck Force Y vs. Time	B-12
Figure No. 43.	5 th Fem. P2 Driver Neck Force Z vs. Time	B-12
Figure No. 44.	5 th Fem. P2 Driver Neck Force Resultant vs. Time	B-12
Figure No. 45.	5 th Fem. P2 Driver Neck Moment X vs. Time	B-13
Figure No. 46.	5 th Fem. P2 Driver Neck Moment Y vs. Time	B-13
Figure No. 47.	5 th Fem. P2 Driver Neck Moment Z vs. Time	B-13
Figure No. 48.	5 th Fem. P2 Driver Occipital Condyle Moment vs. Time	B-13
Figure No. 49.	5 th Fem. P2 Driver Chest X Acceleration vs. Time	B-14
Figure No. 50.	5 th Fem. P2 Driver Chest Y Acceleration vs. Time	B-14
Figure No. 51.	5 th Fem. P2 Driver Chest Z Acceleration vs. Time	B-14
Figure No. 52.	5 th Fem. P2 Driver Chest Resultant Acceleration vs. Time	B-14
Figure No. 53.	5 th Fem. P2 Driver Chest X Velocity vs. Time	B-15
Figure No. 54.	5 th Fem. P2 Driver Chest Y Velocity vs. Time	B-15
Figure No. 55.	5 th Fem. P2 Driver Chest Z Velocity vs. Time	B-15
Figure No. 56.	5 th Fem. P2 Driver Chest Displacement vs. Time	B-15
Figure No. 57.	5 th Fem. P2 Driver Left Femur Force vs. Time	B-16
Figure No. 58.	5 th Fem. P2 Driver Right Femur Force vs. Time	B-16
Figure No. 59.	Fire Voltage #1 Voltage vs. Time	B-17

		<u>Page No.</u>
Figure No. 60.	Fire Current #1 Voltage vs. Time	B-17
Figure No. 61.	Fire Voltage #2 Voltage vs. Time	B-17
Figure No. 62.	Fire Current #2 Voltage vs. Time	B-17
Figure No. 63.	5 th Fem. P2 Driver Nij (N_{TF}) vs. Time	B-18
Figure No. 64.	5 th Fem. P2 Driver Nij (N_{TE}) vs. Time	B-18
Figure No. 65.	5 th Fem. P2 Driver Nij (N_{CF}) vs. Time	B-18
Figure No. 66.	5 th Fem. P2 Driver Nij (N_{CE}) vs. Time	B-18



Injury Values Calculated between 0ms and 225ms

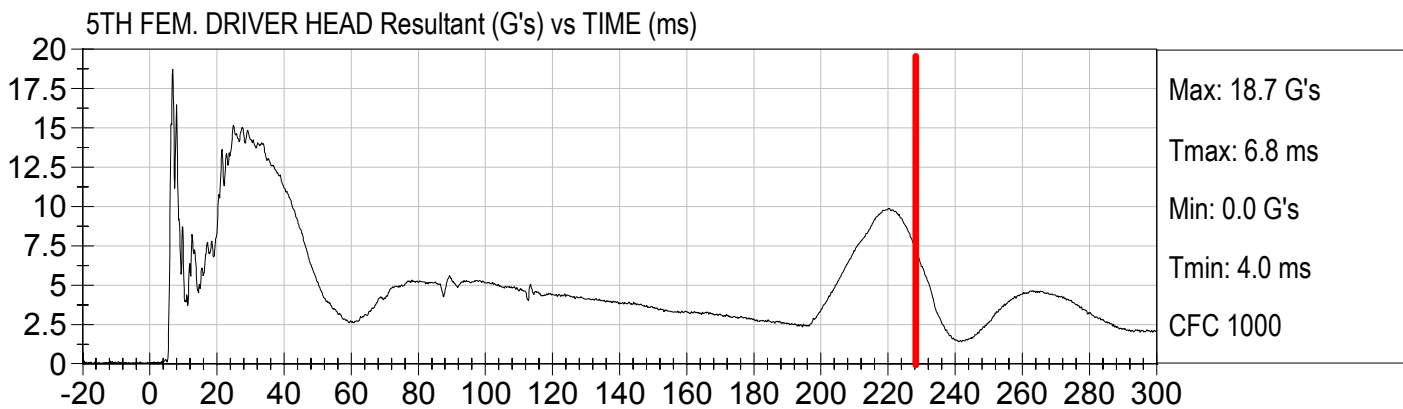
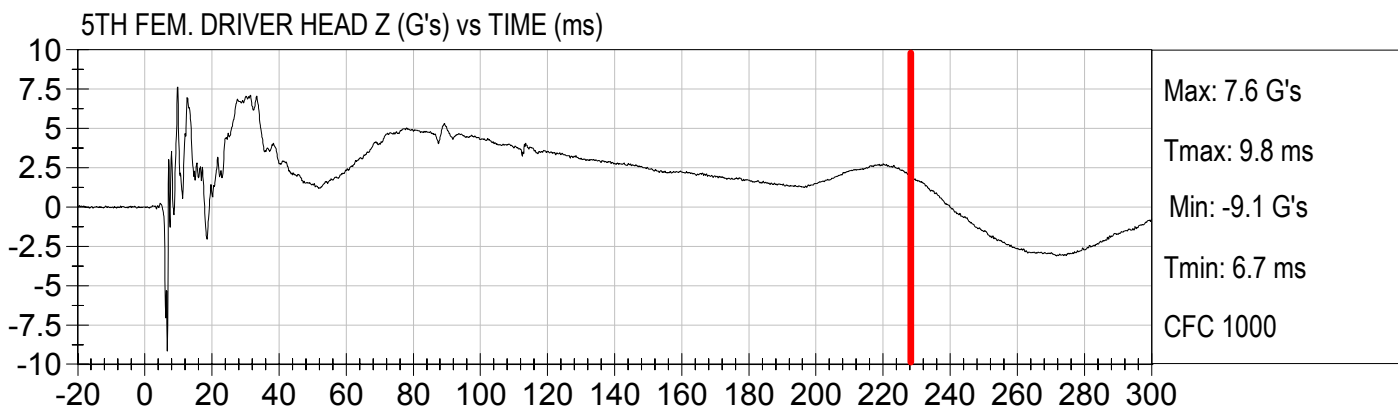
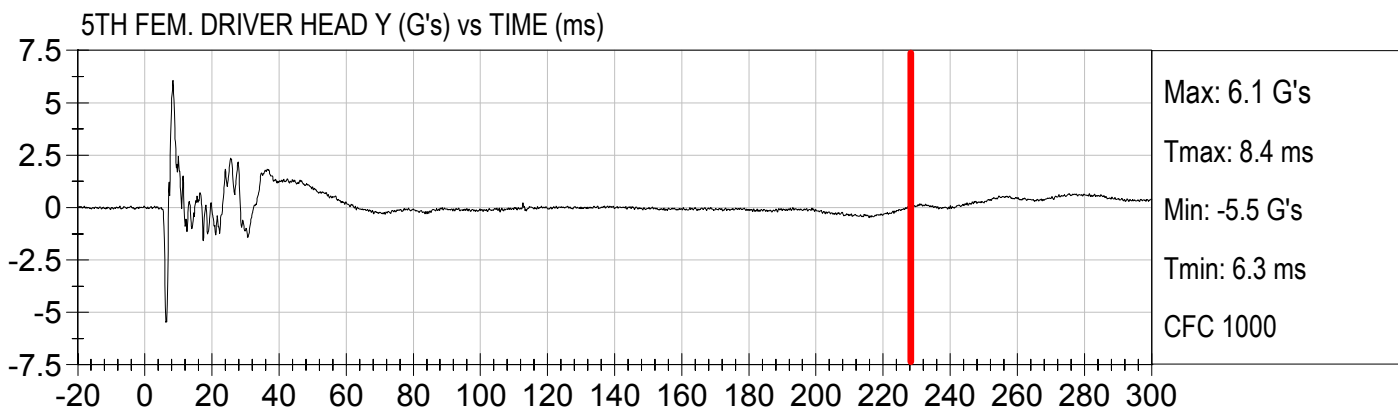
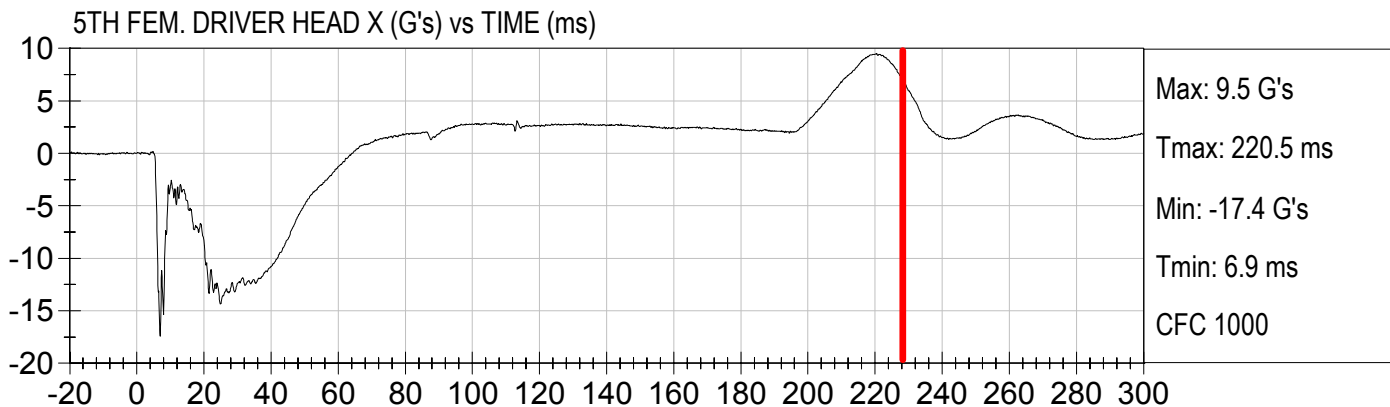



Injury Values Calculated between 0ms and 225ms

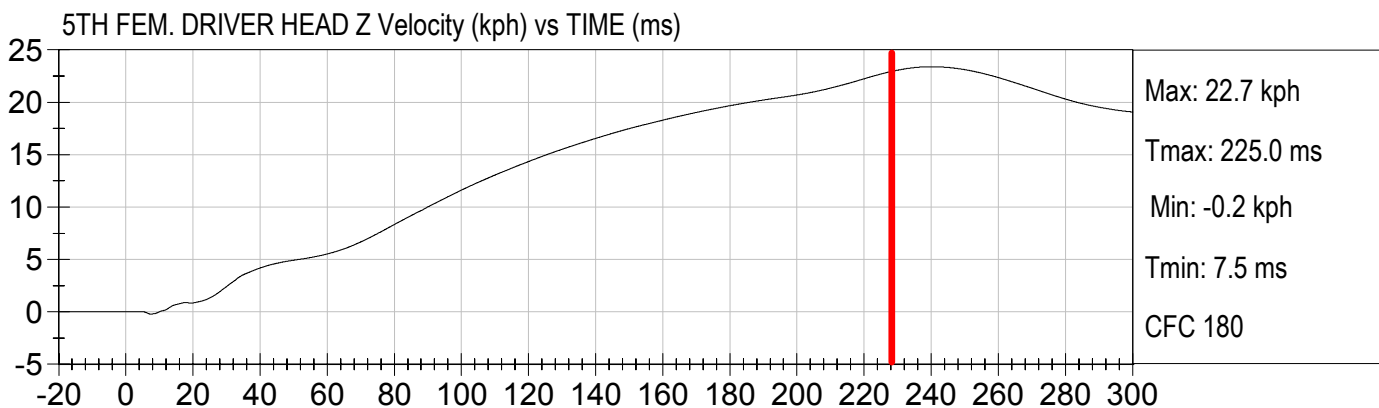
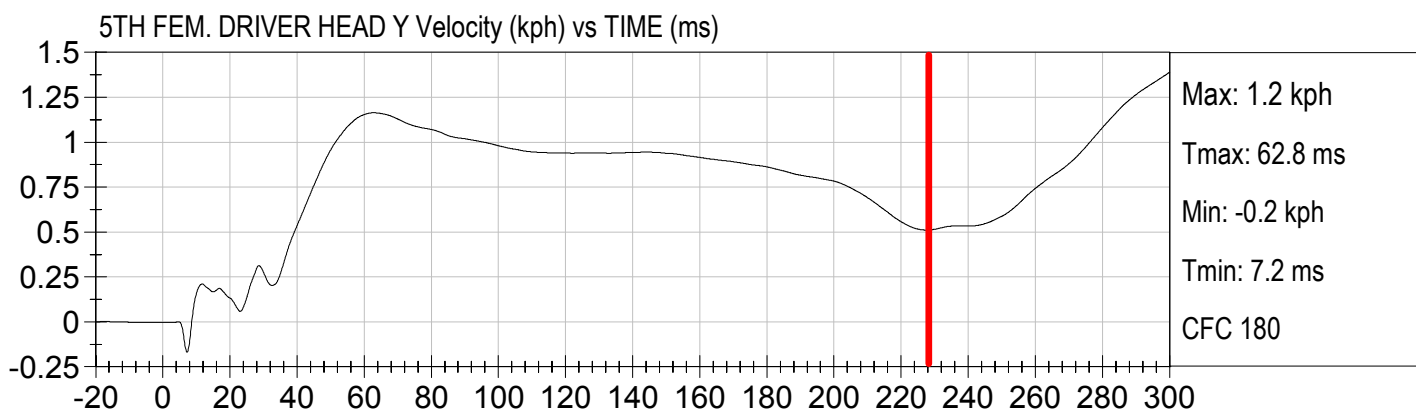
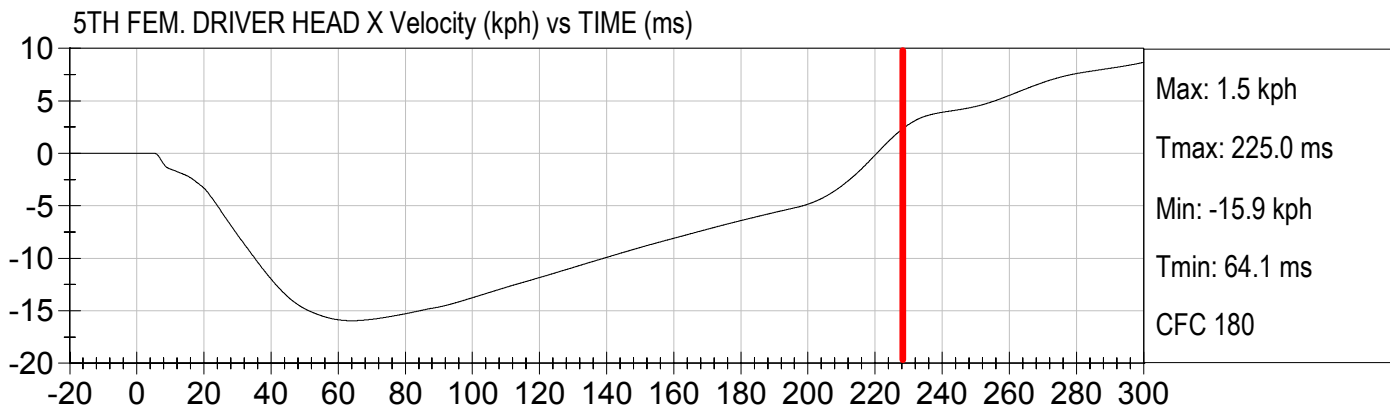



Injury Values Calculated between 0ms and 225ms

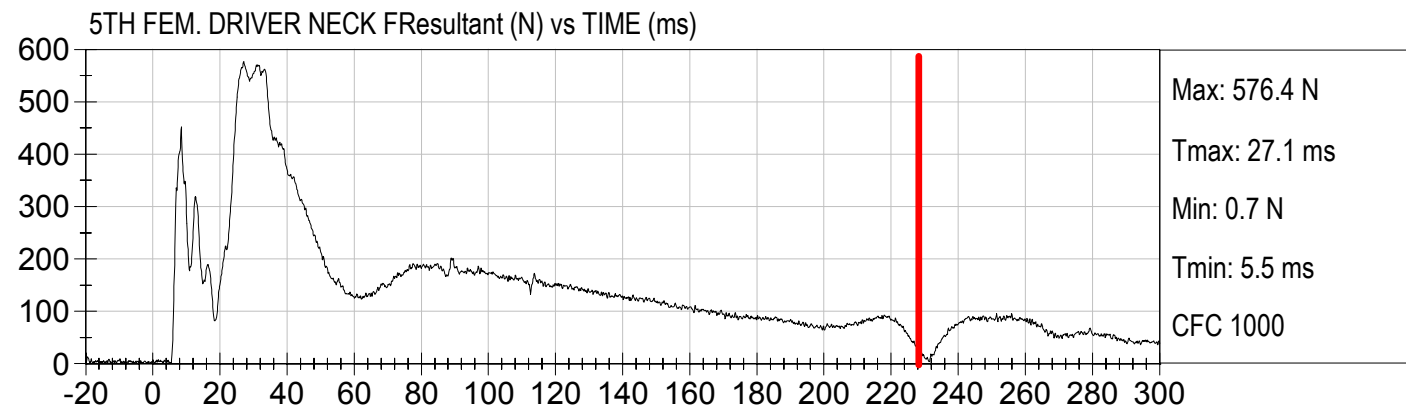
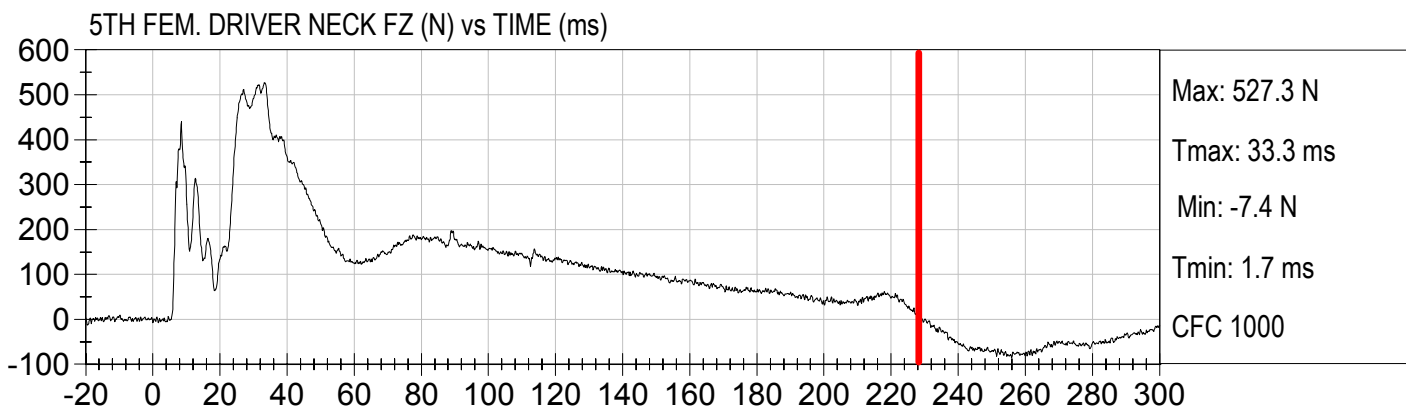
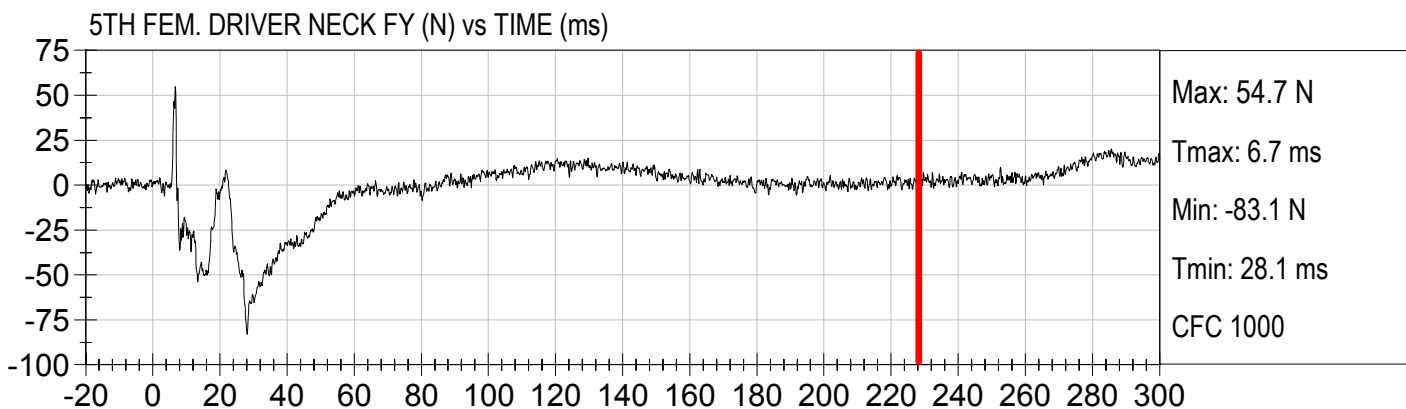
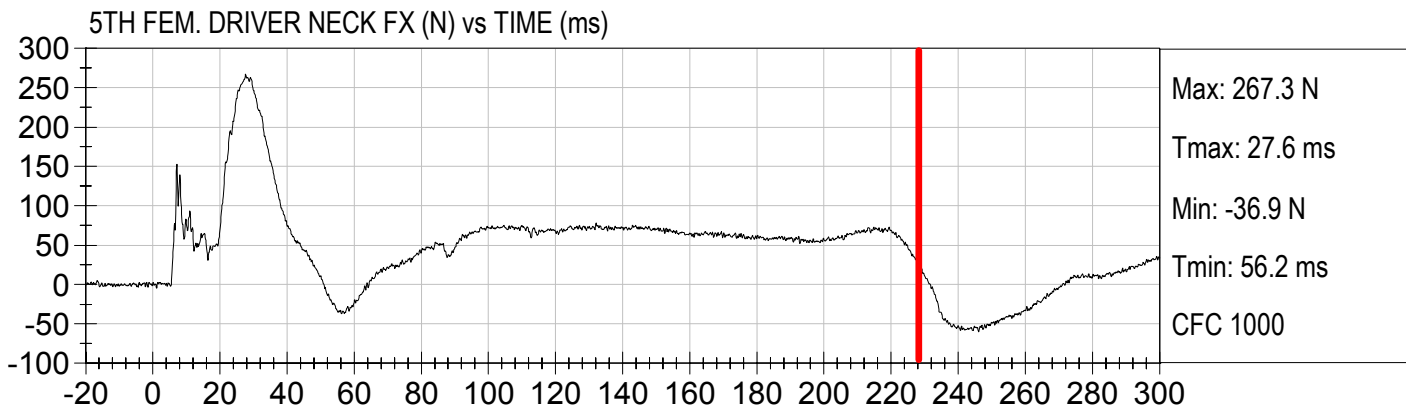



Injury Values Calculated between 0ms and 225ms

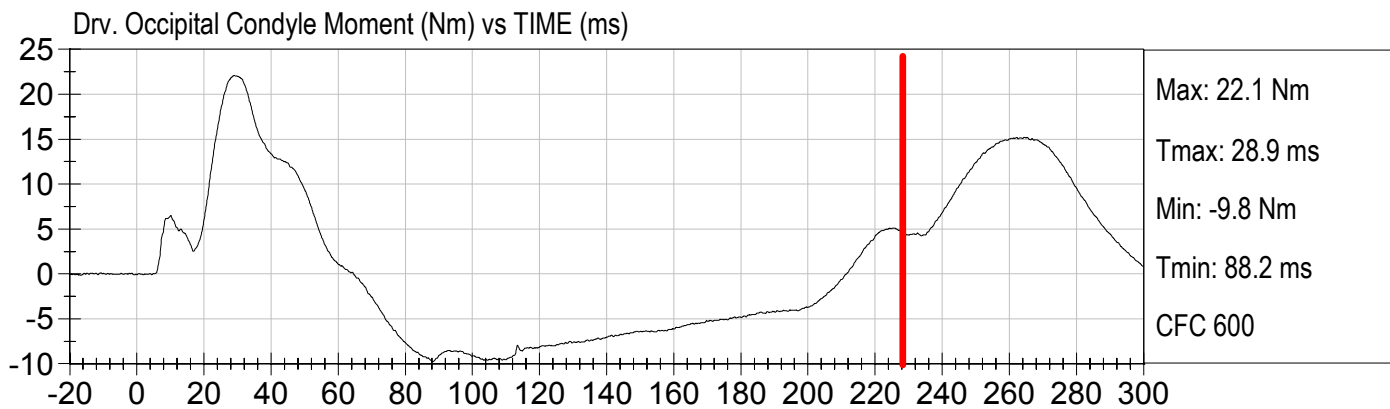
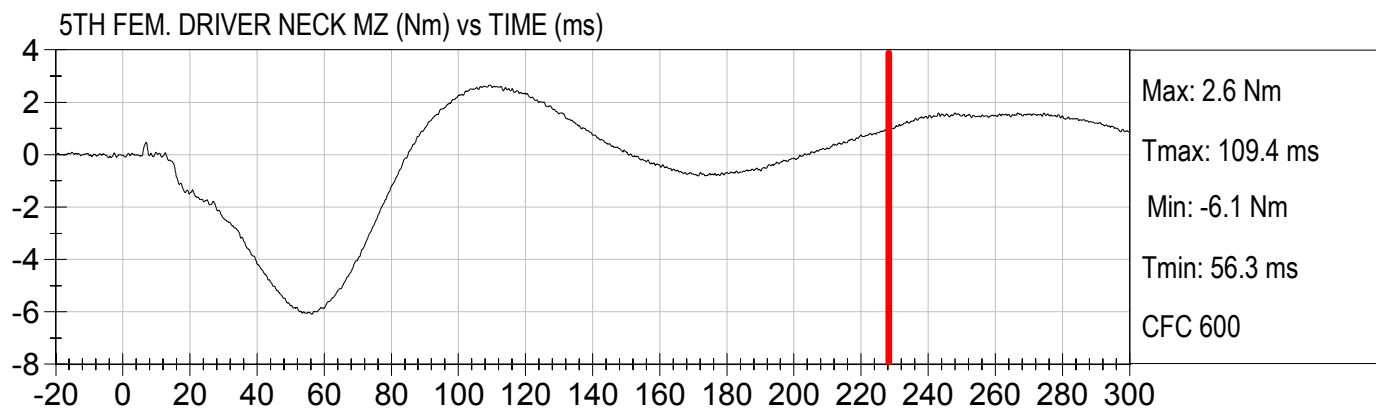
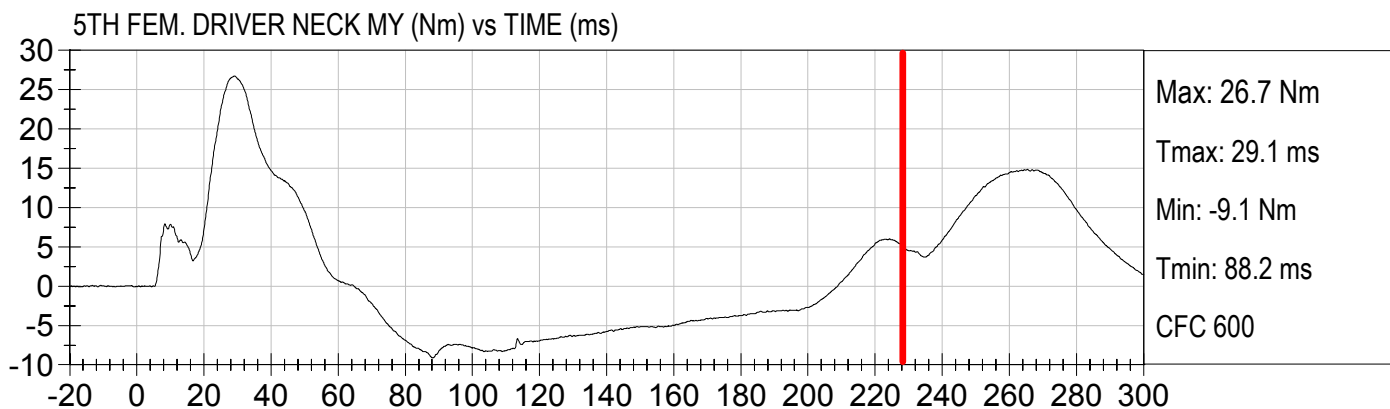
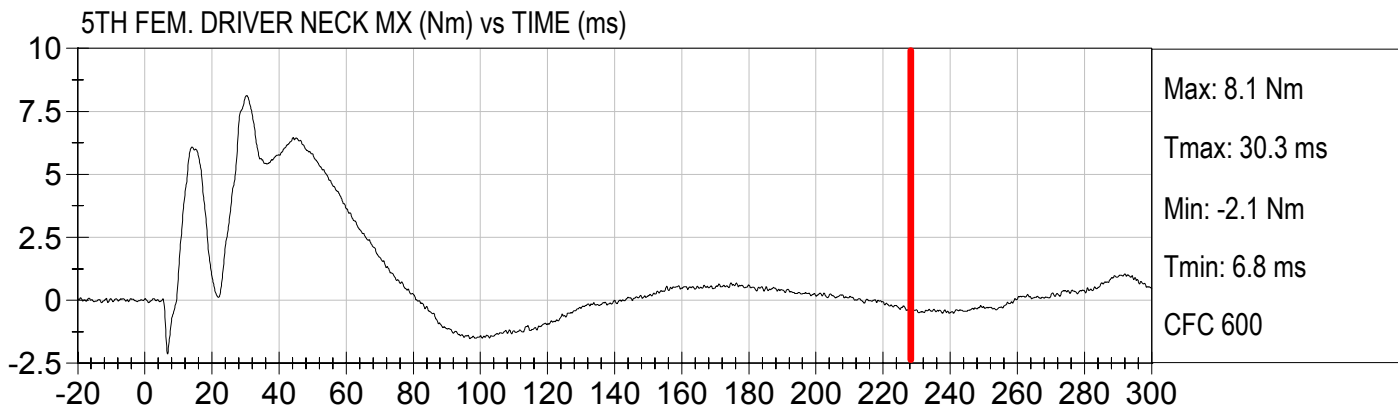



Injury Values Calculated between 0ms and 225ms

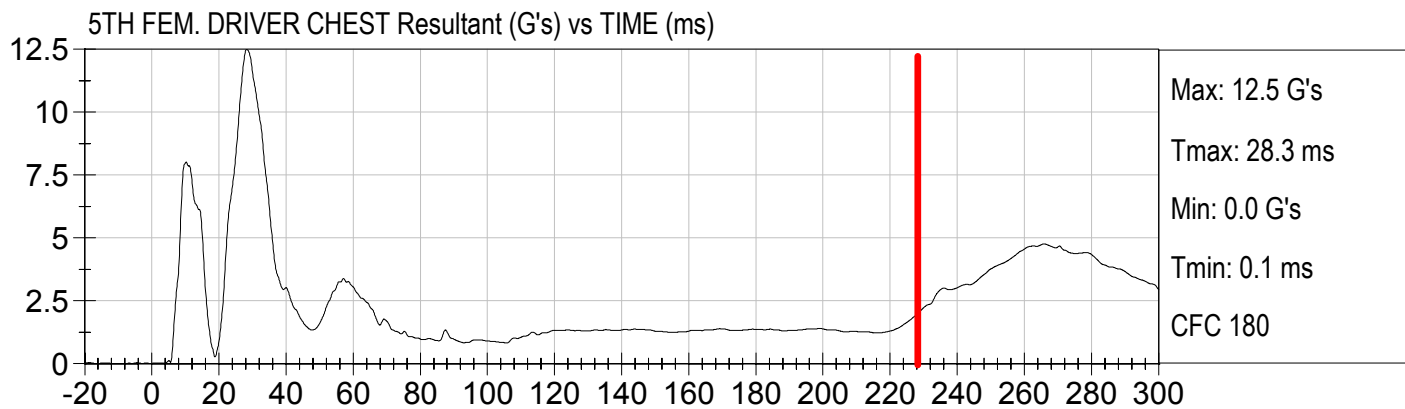
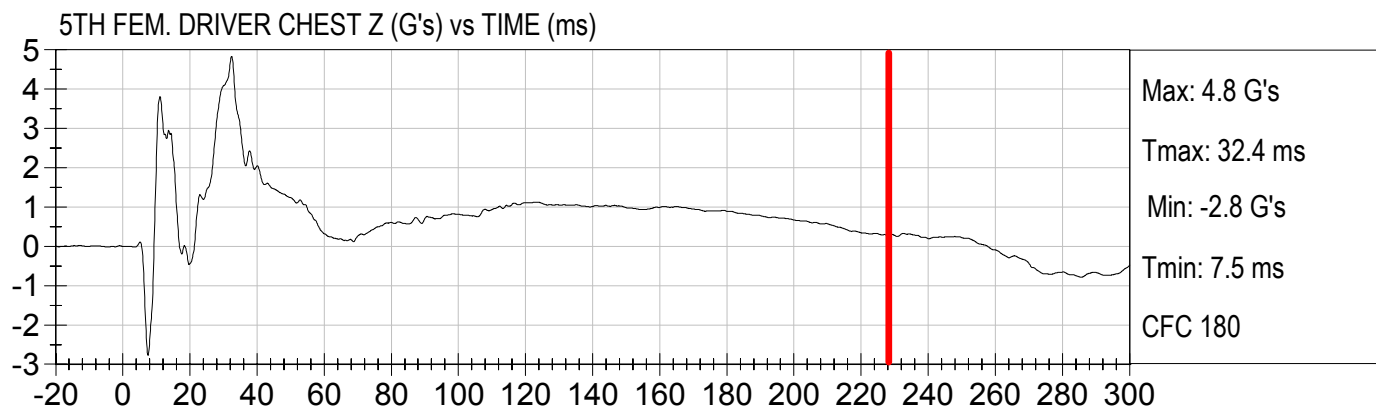
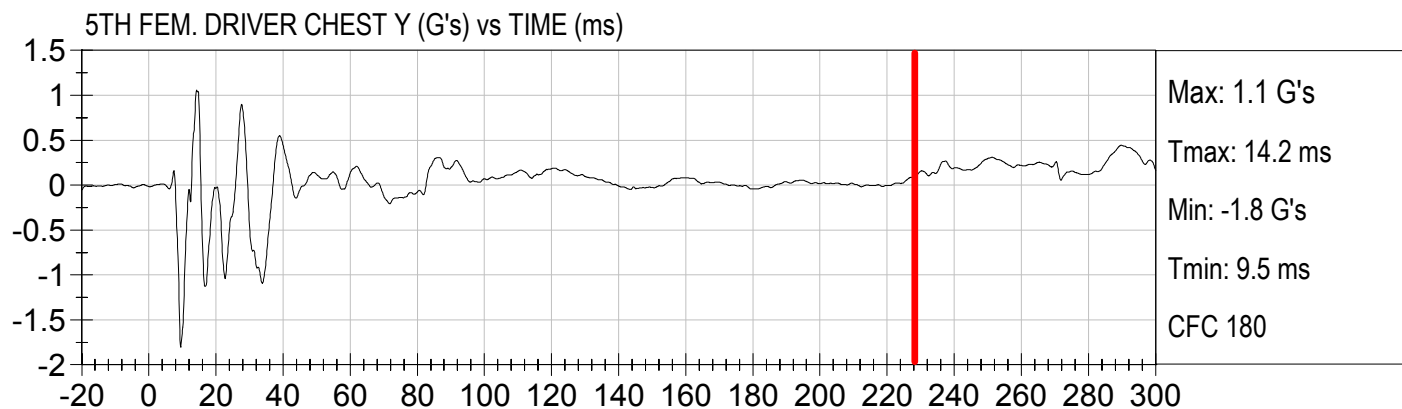
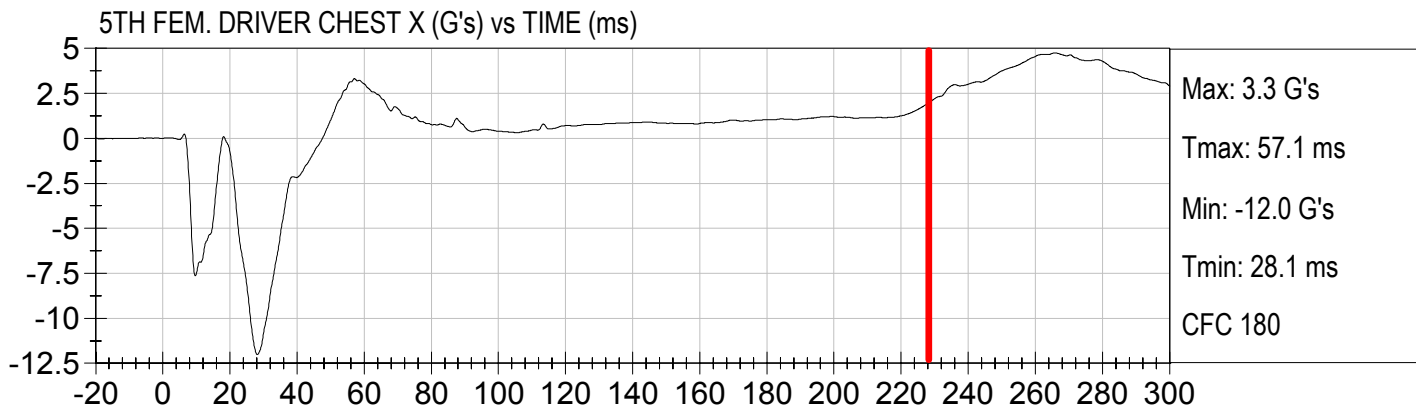



Injury Values Calculated between 0ms and 225ms

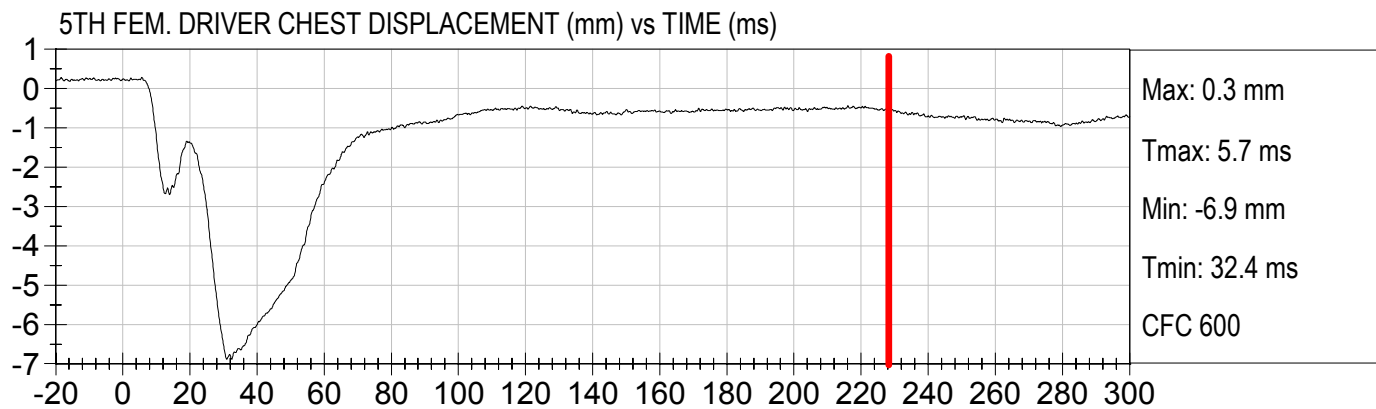
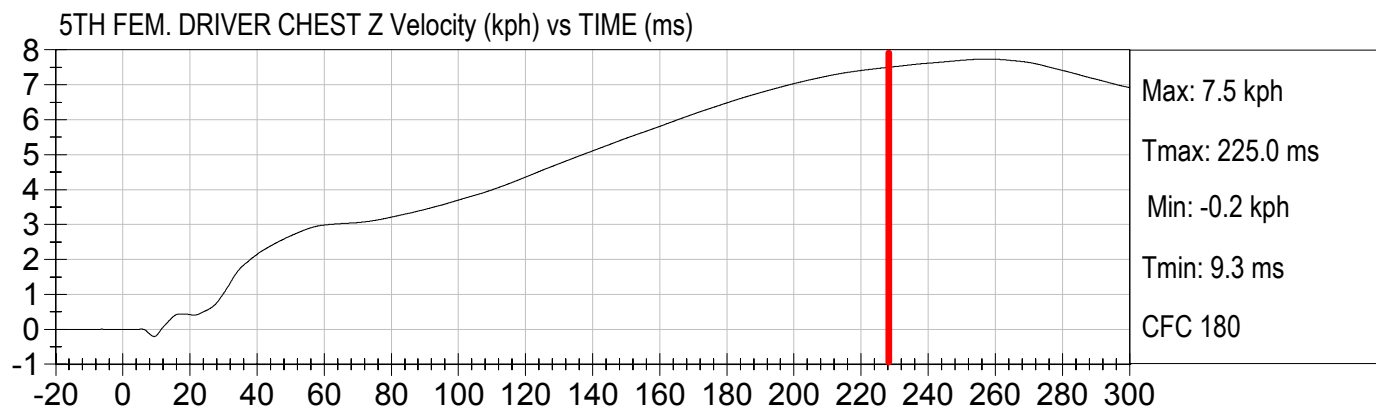
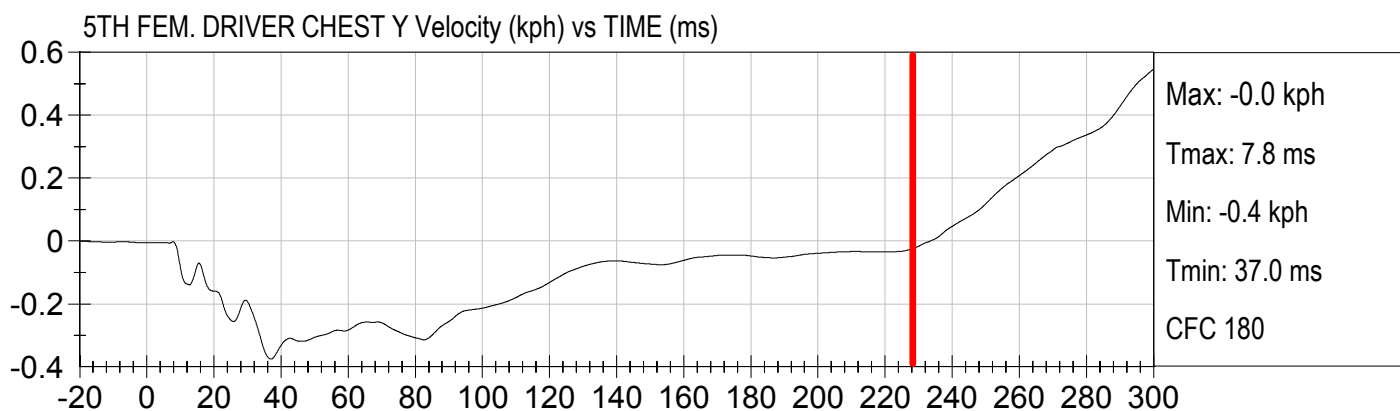
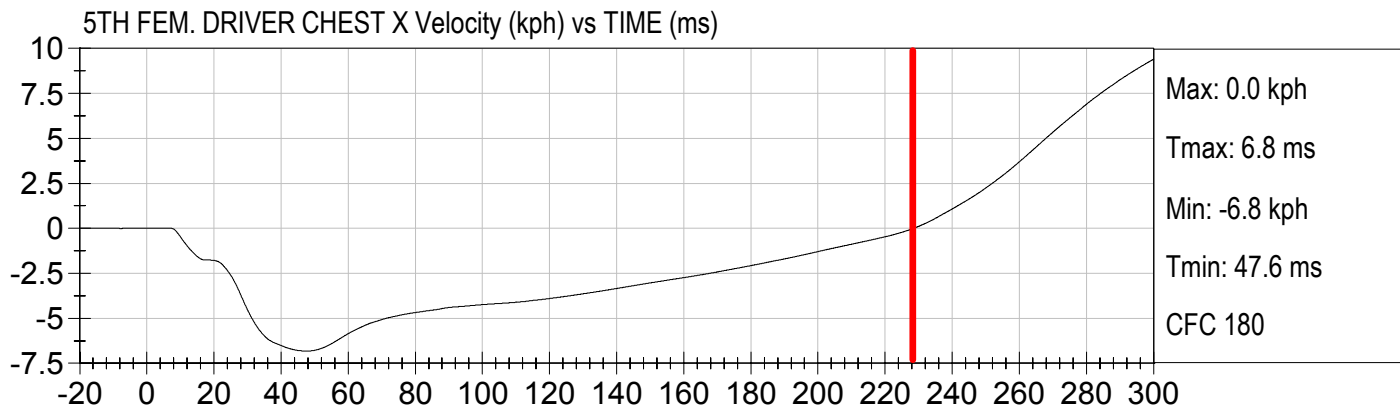



Injury Values Calculated between 0ms and 225ms

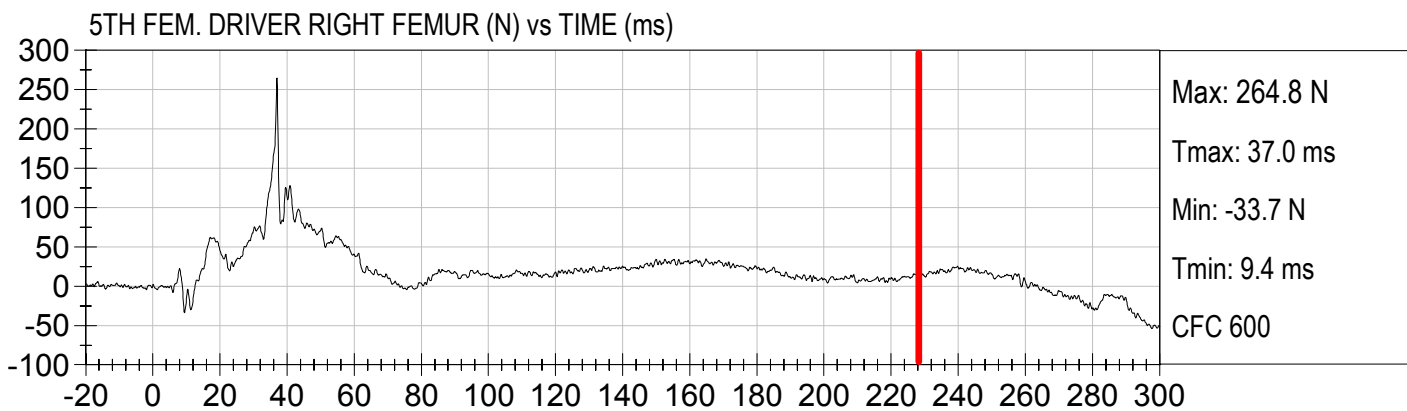
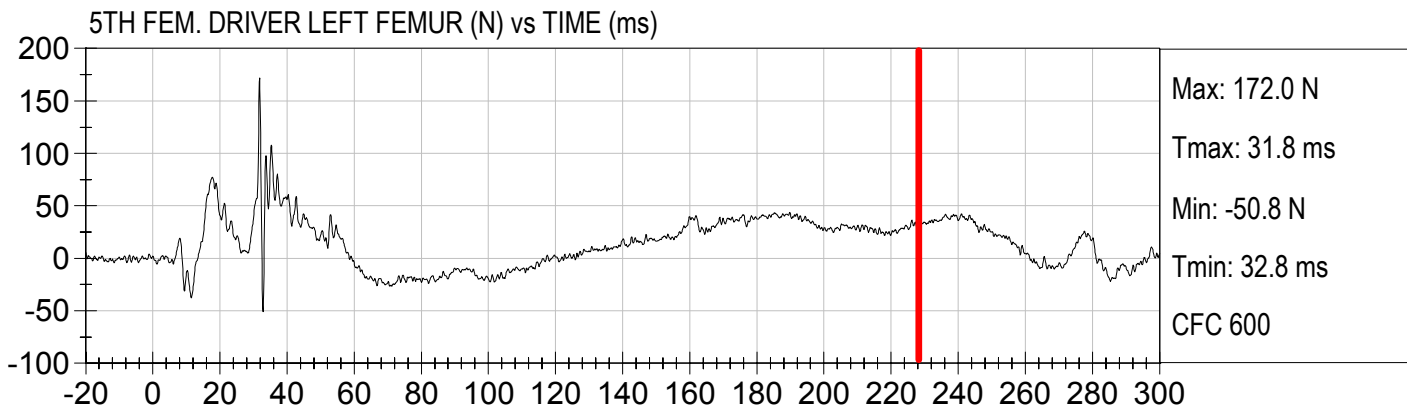



Injury Values Calculated between 0ms and 225ms

FIRE VOLTAGE #1 (Volts) vs TIME (ms)

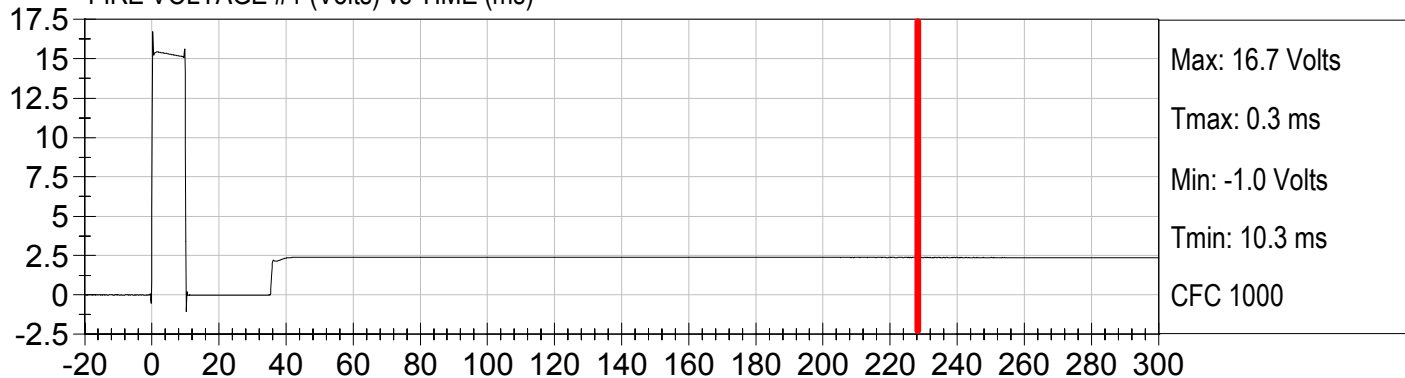

FIRE CURRENT #1 (Amps) vs TIME (ms)

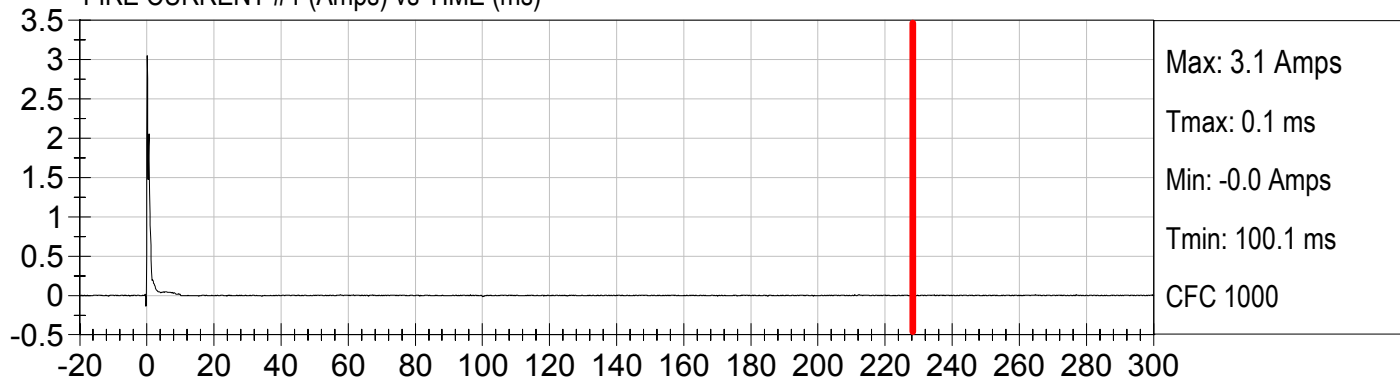

FIRE VOLTAGE #2 (Volts) vs TIME (ms)

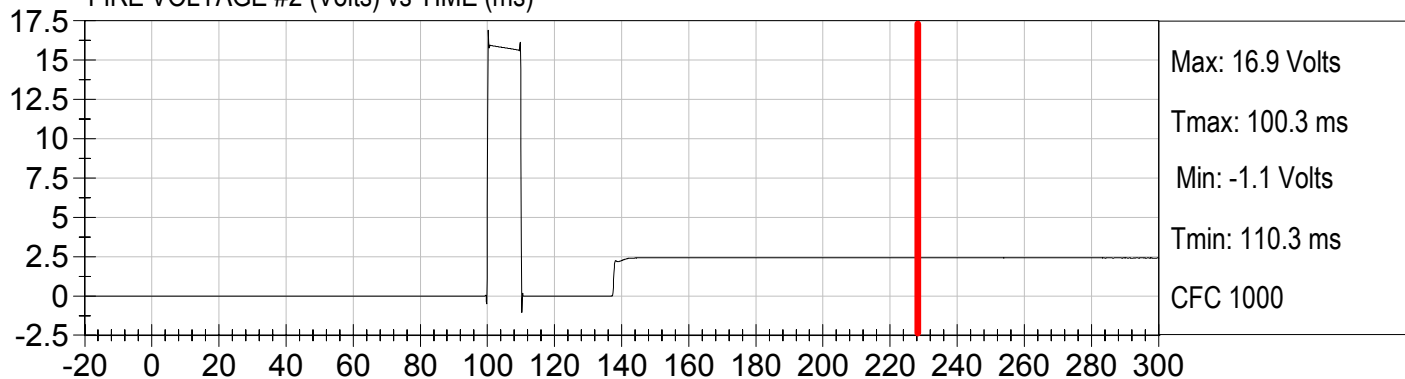

FIRE CURRENT #2 (Amps) vs TIME (ms)

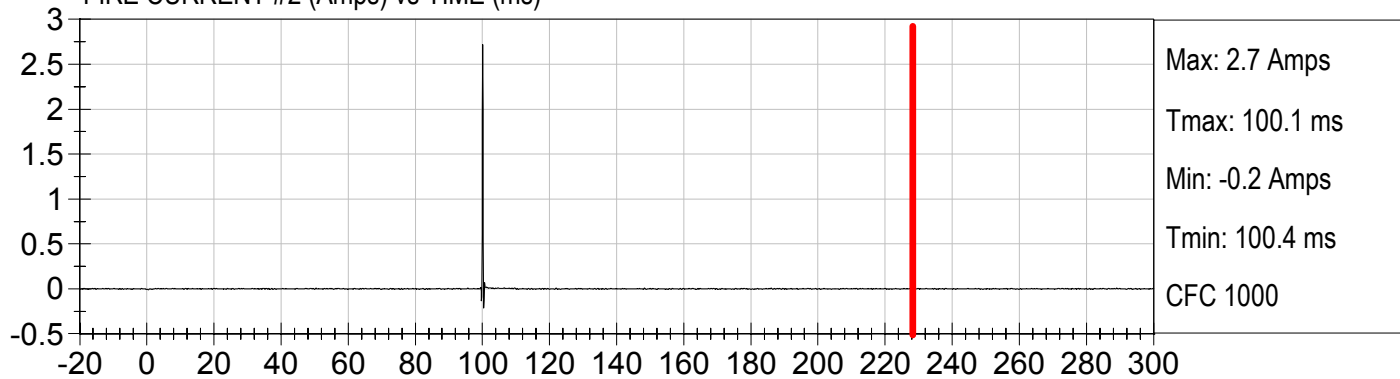

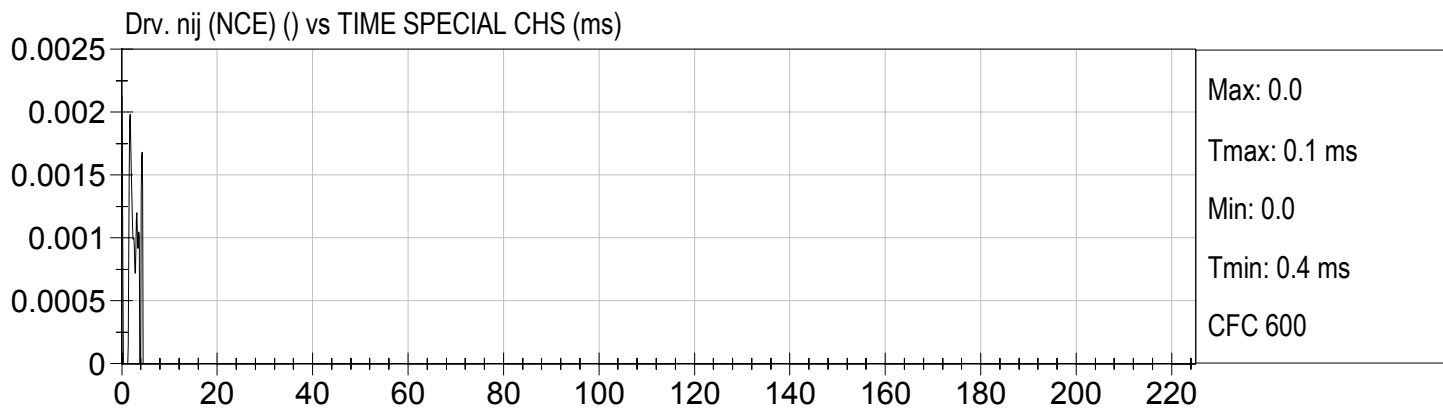
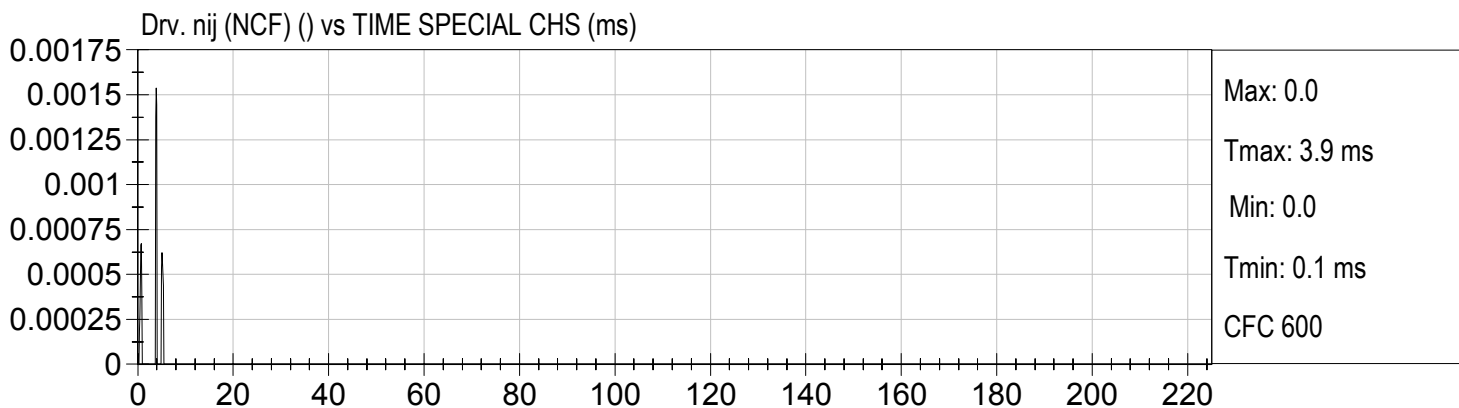
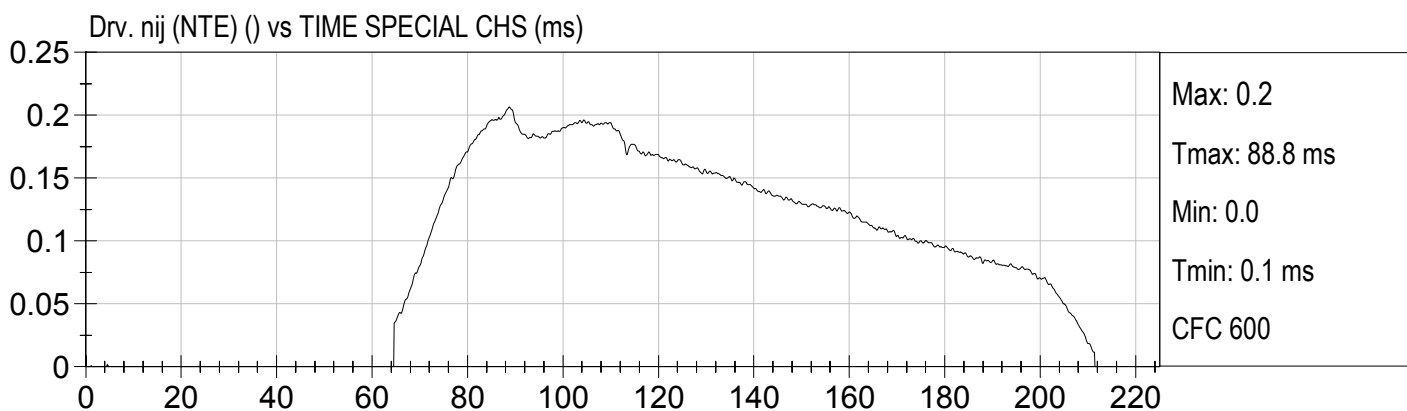
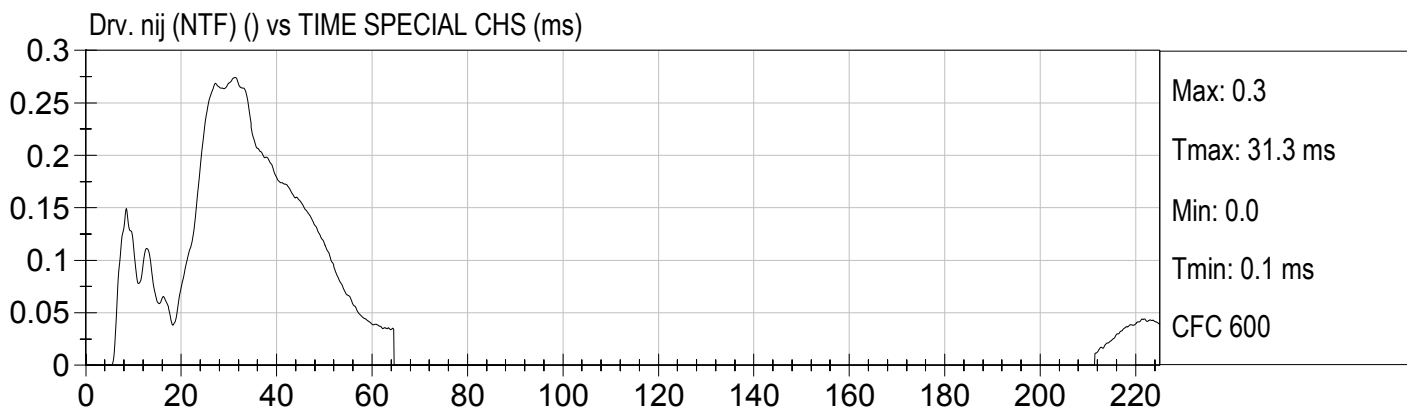



Injury Values Calculated between 0ms and 225ms

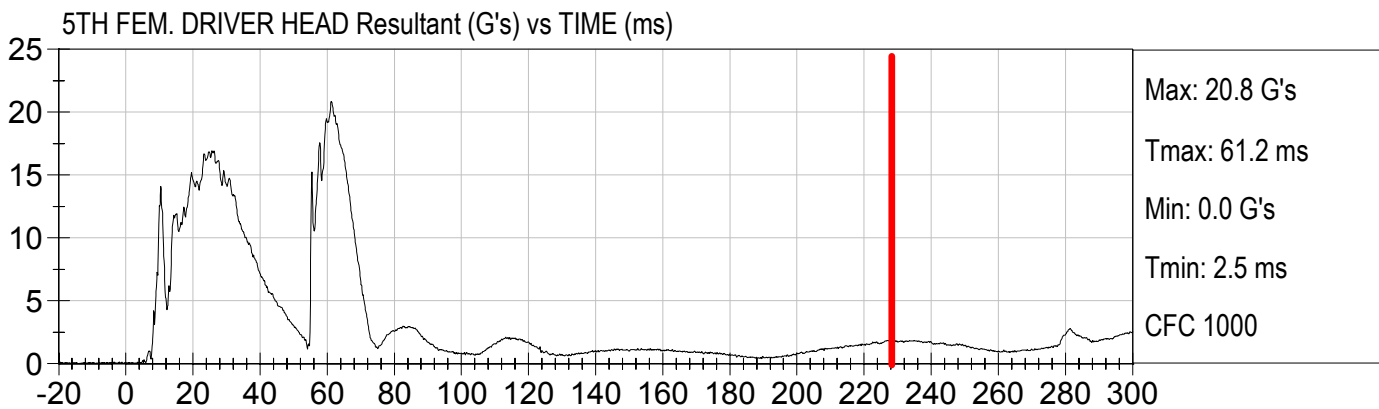
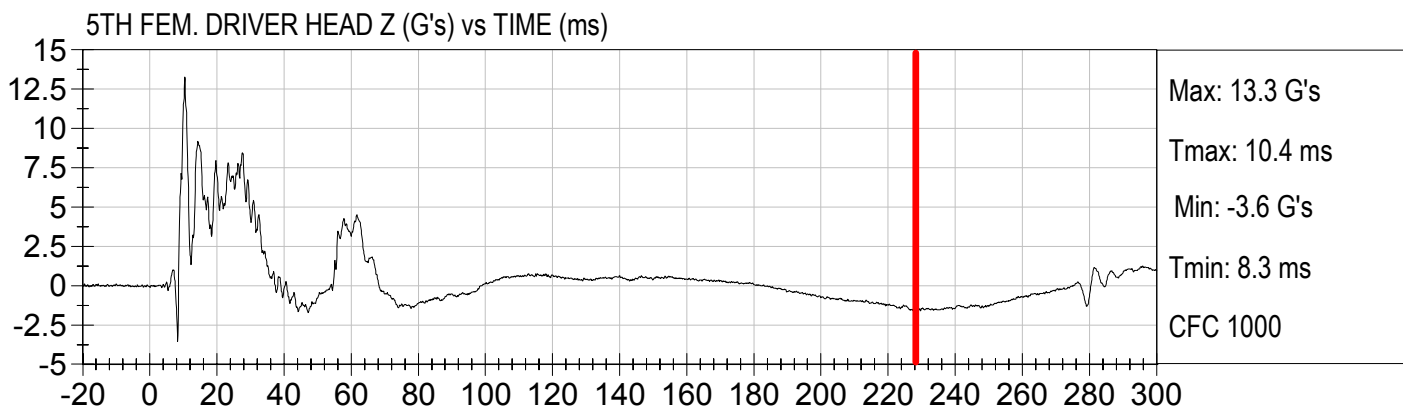
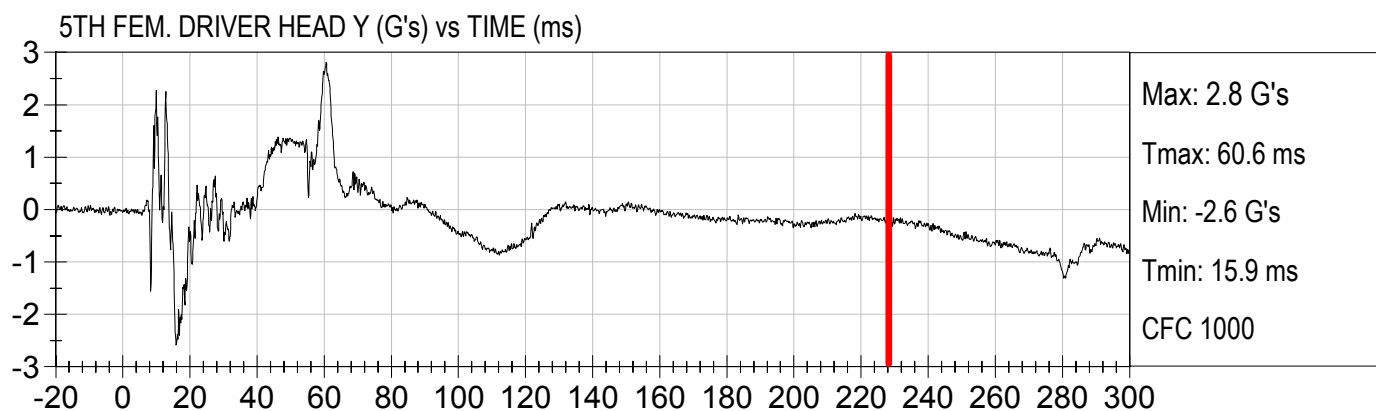
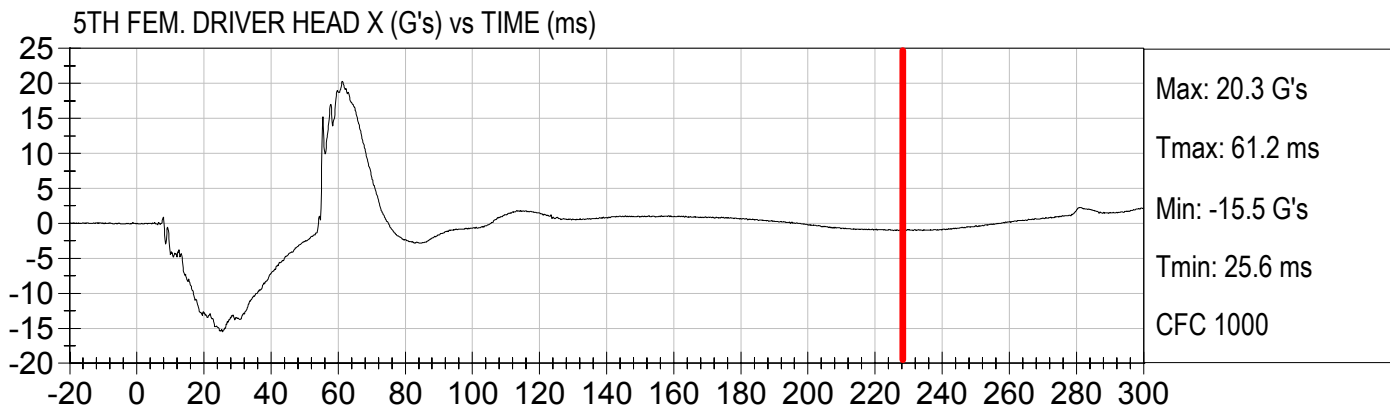



Injury Values Calculated between 0ms and 225ms

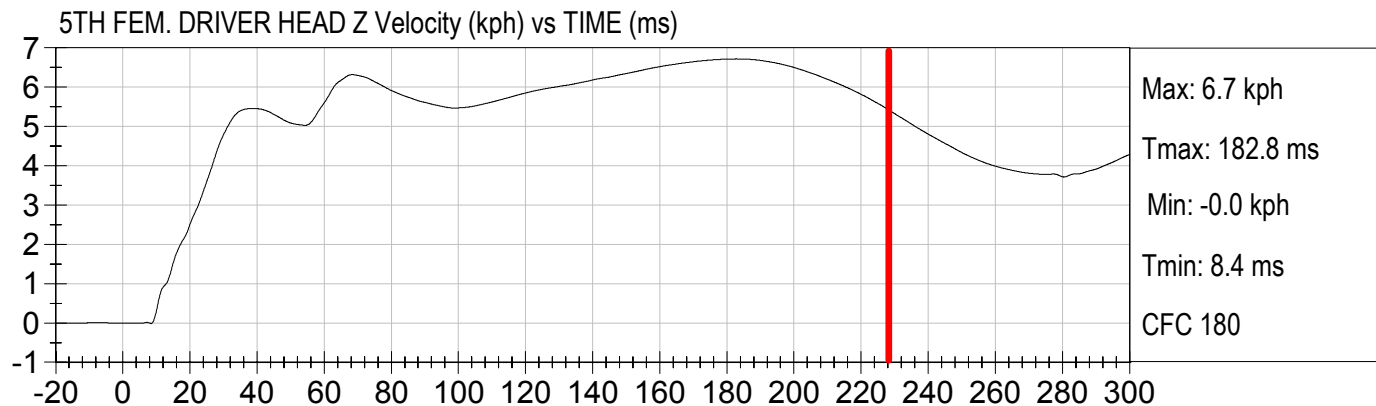
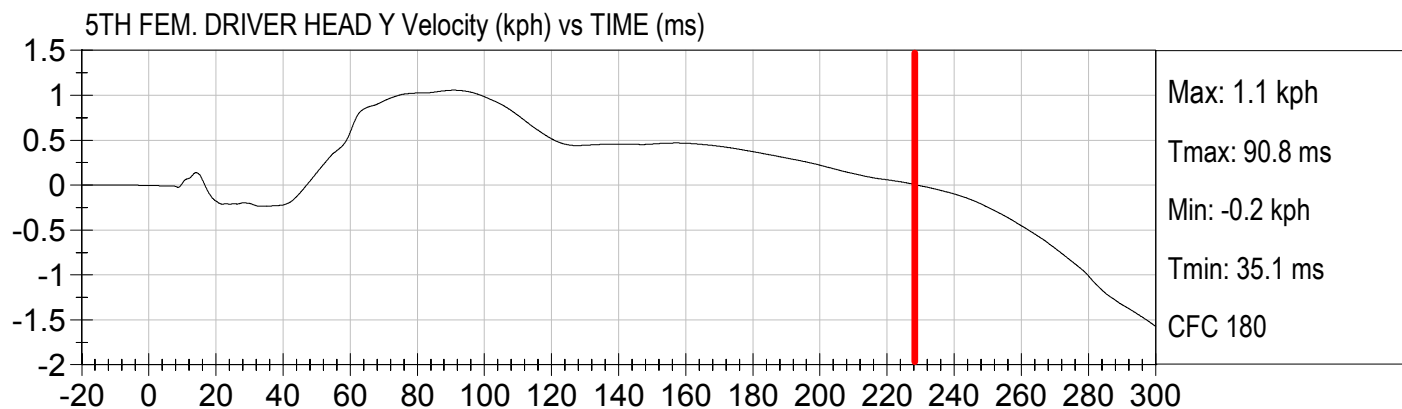
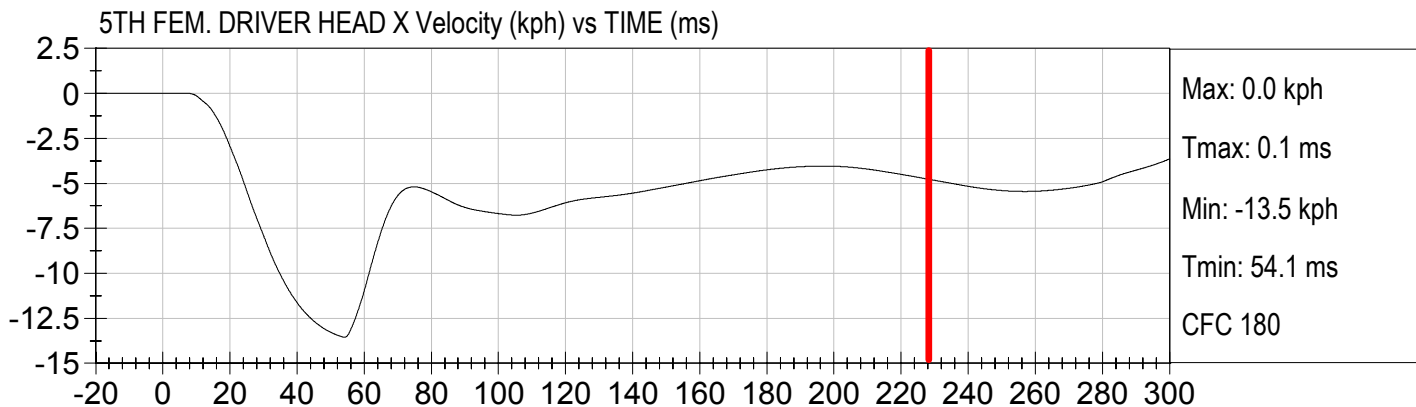



Injury Values Calculated between 0ms and 225ms

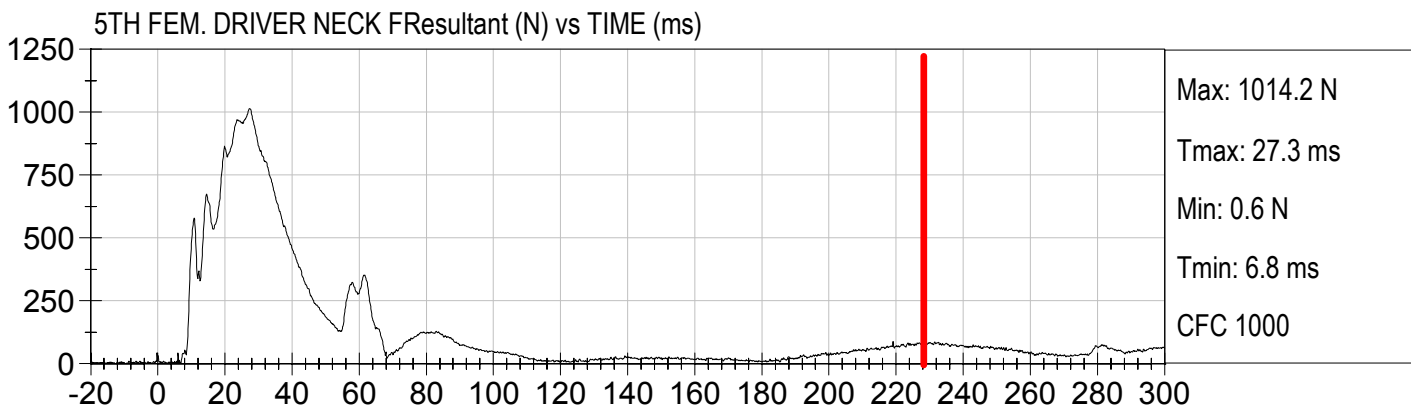
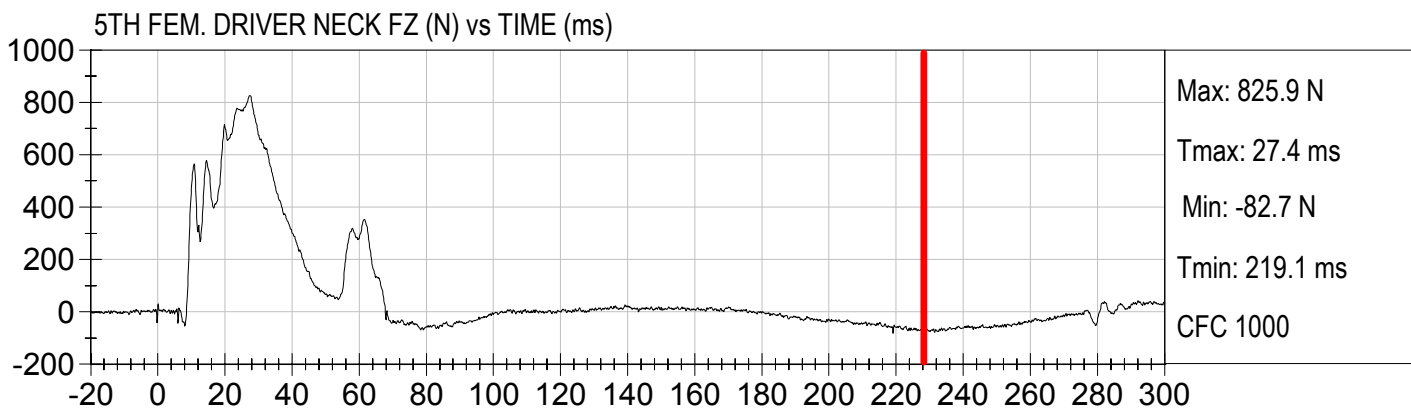
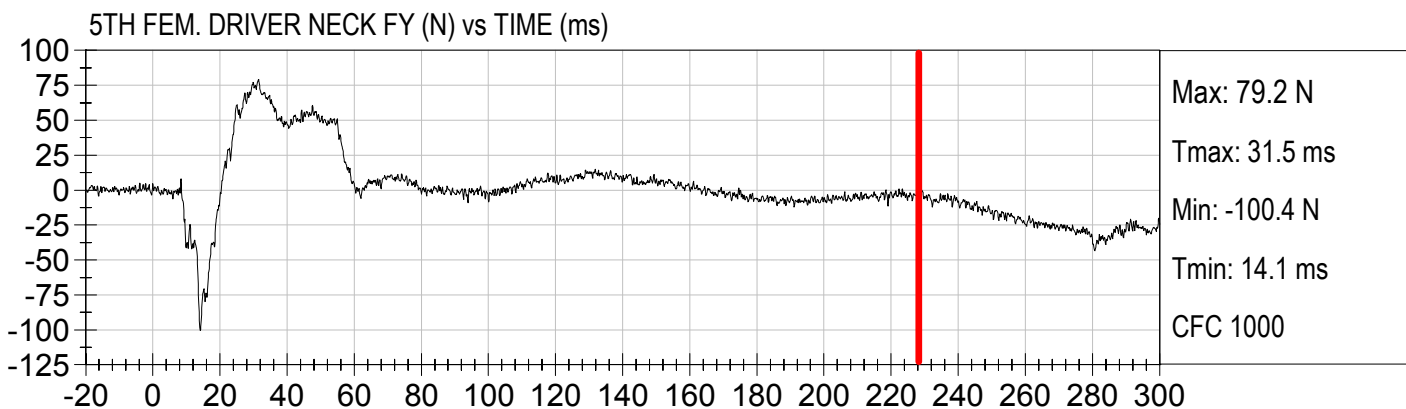
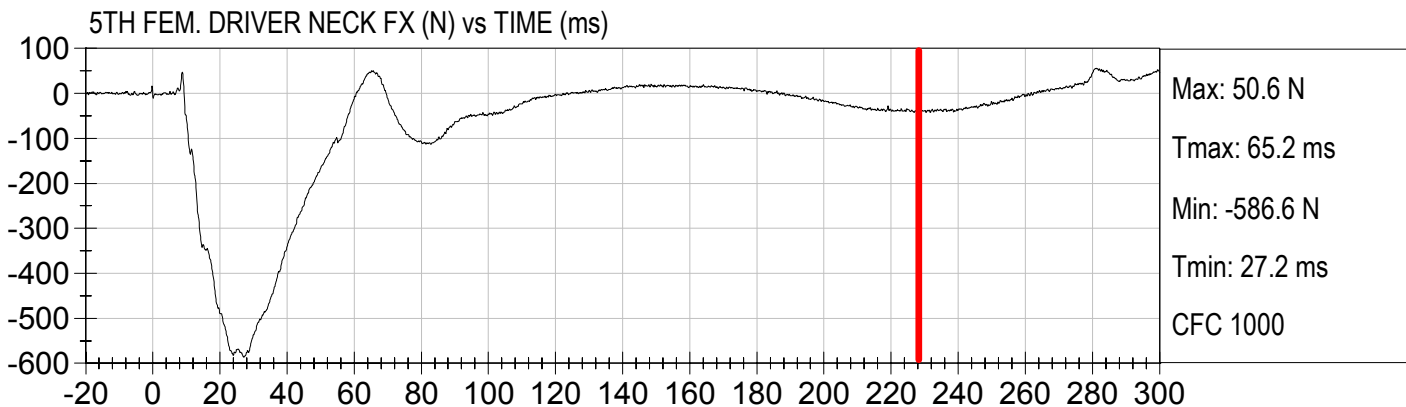



Injury Values Calculated between 0ms and 225ms

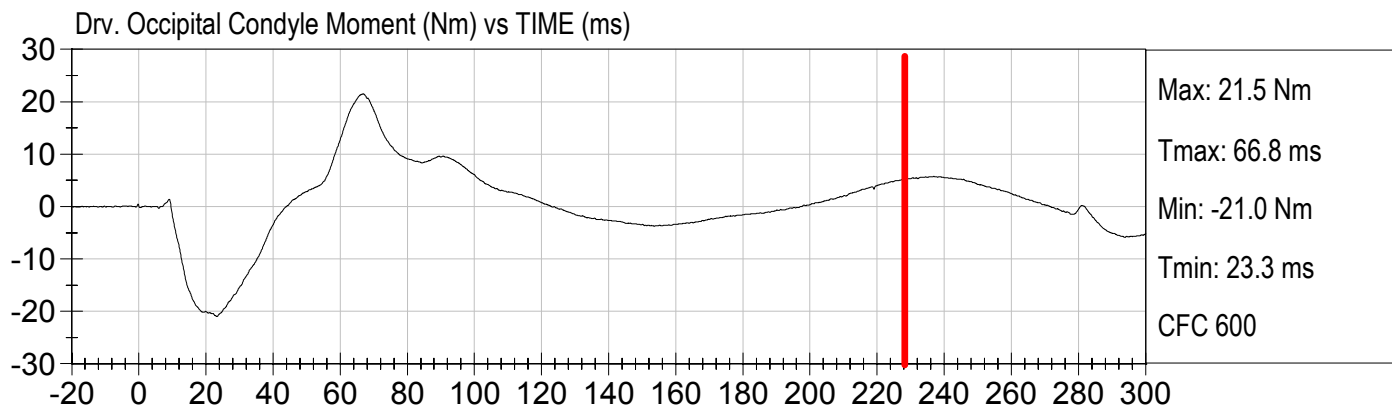
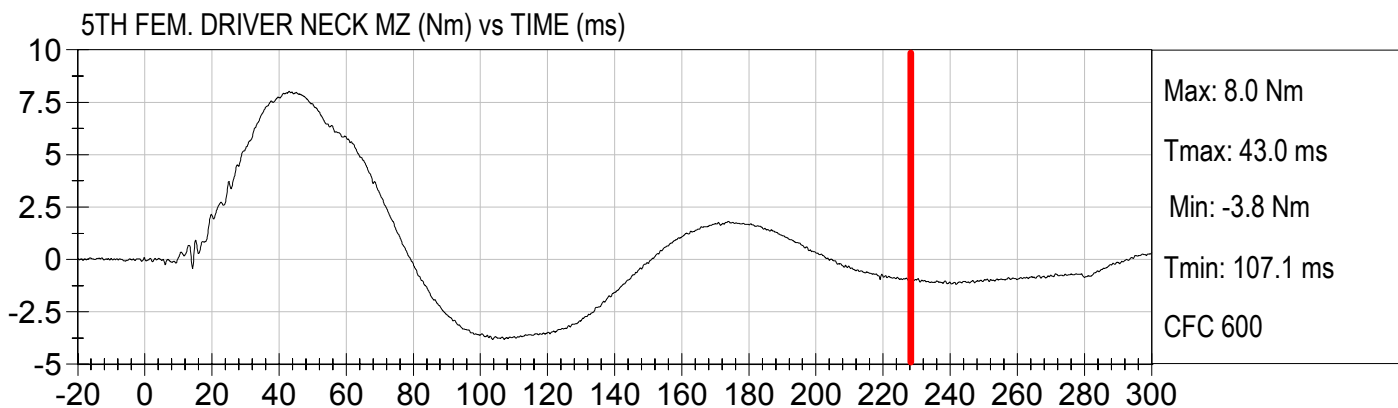
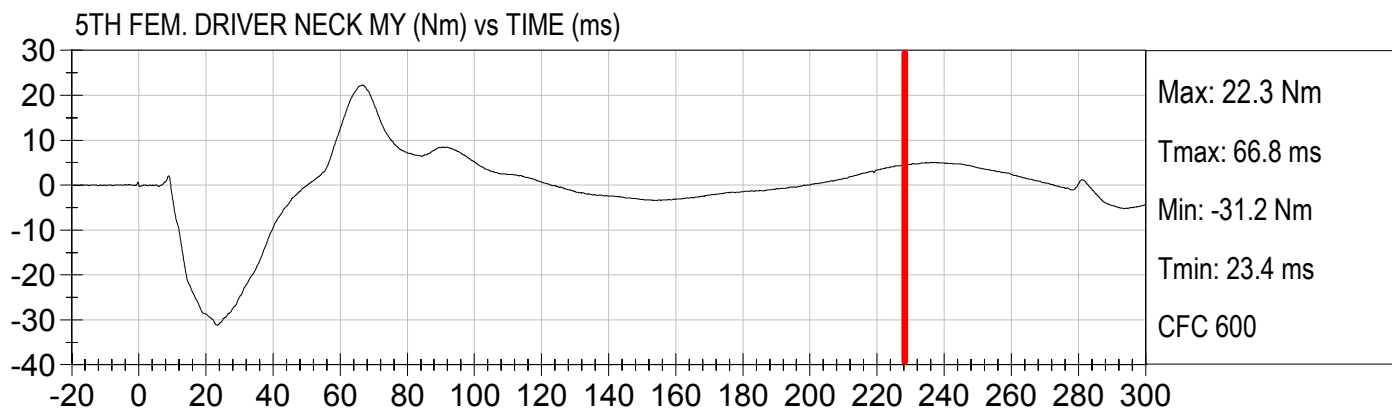
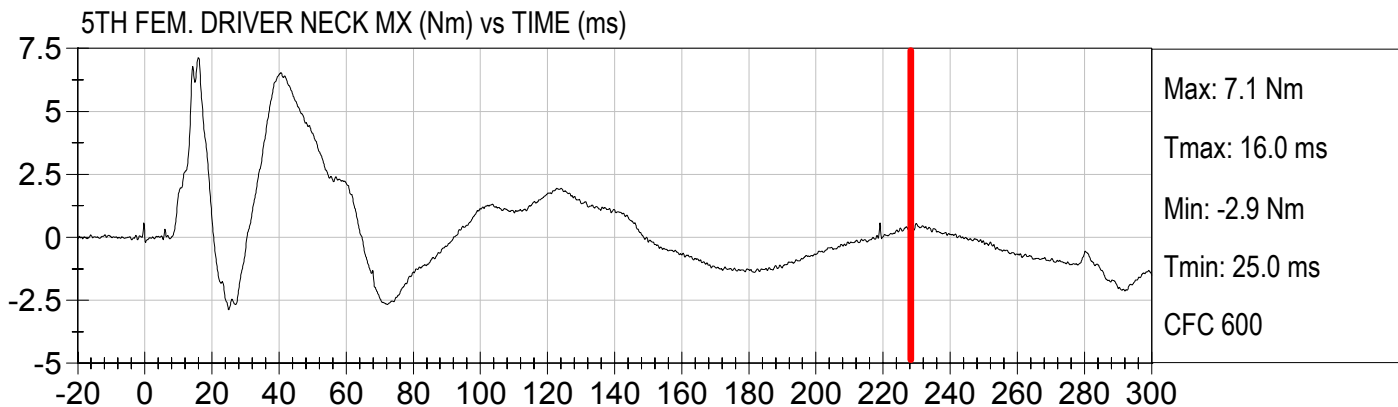



Injury Values Calculated between 0ms and 225ms

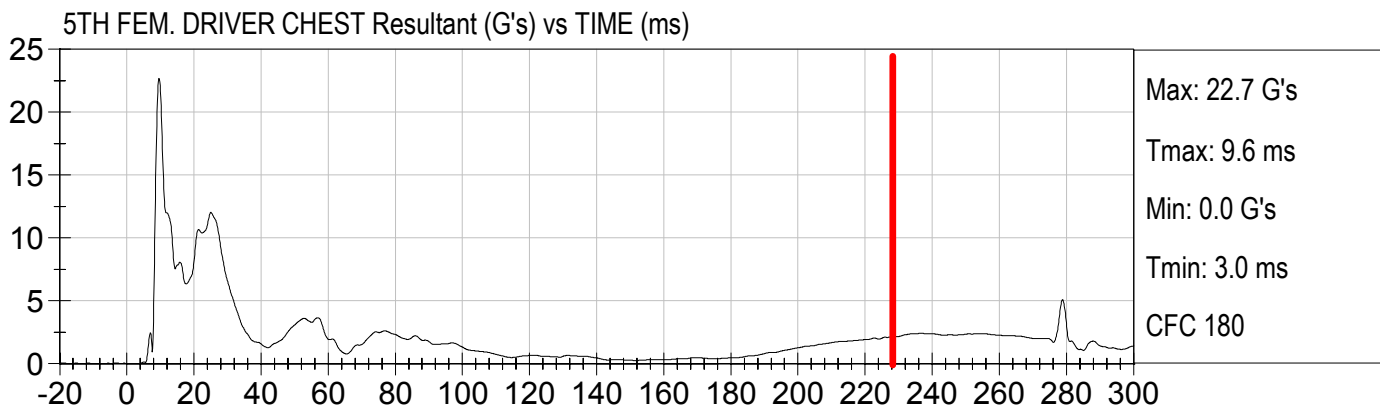
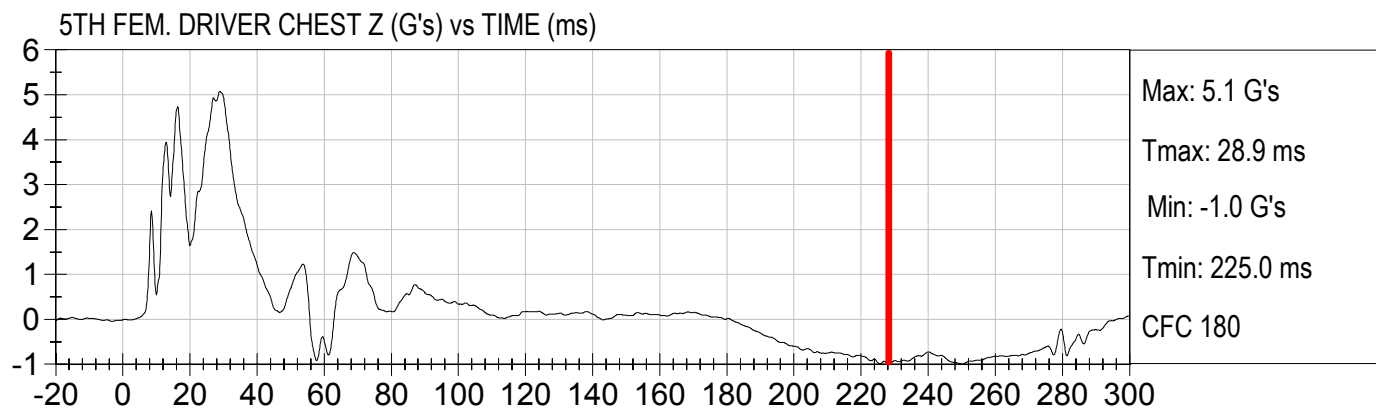
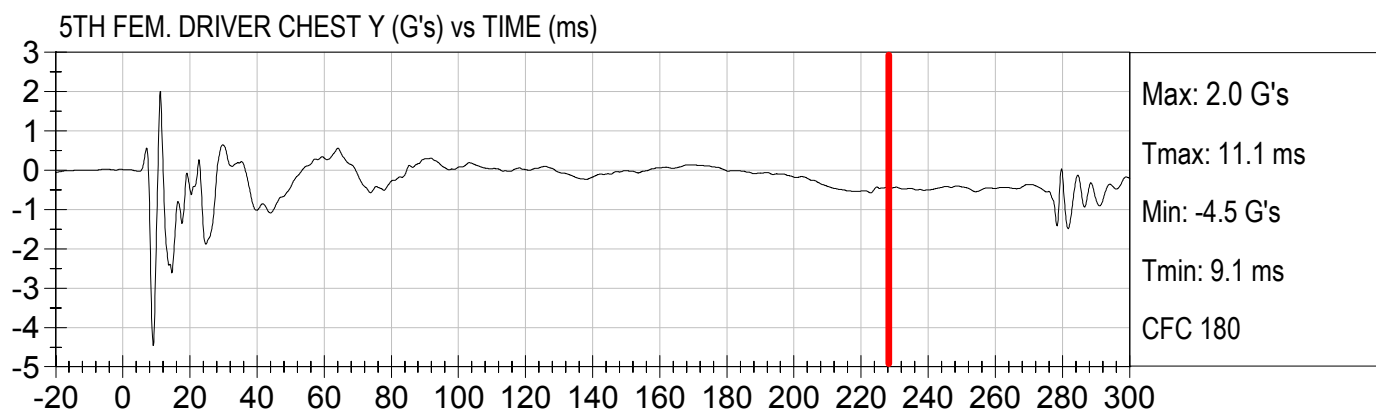
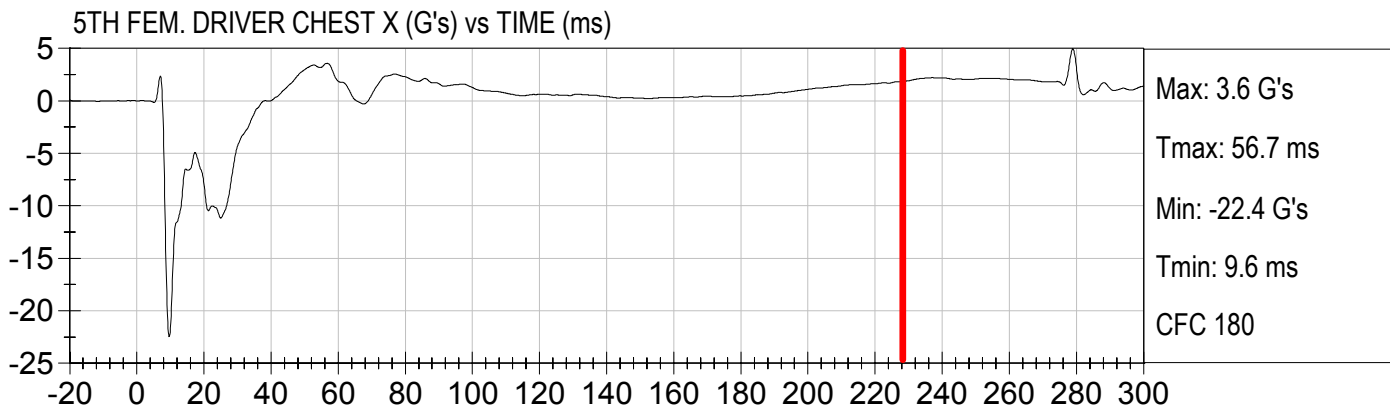



Injury Values Calculated between 0ms and 225ms

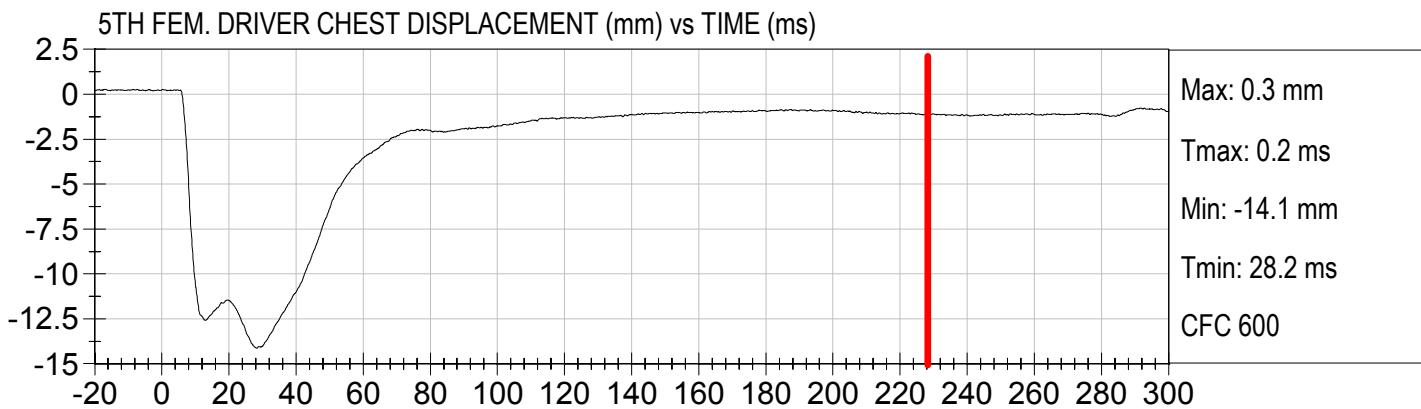
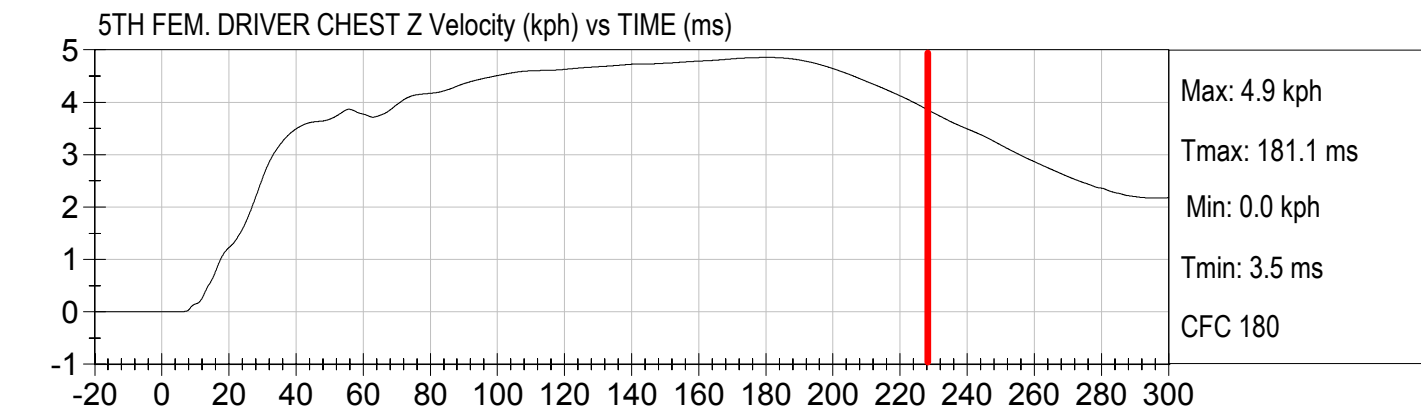
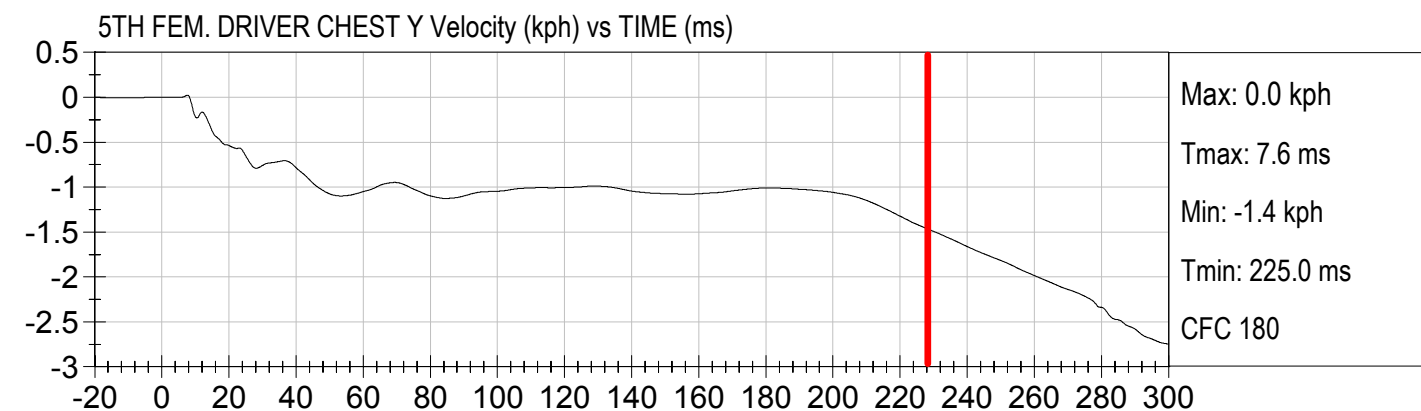
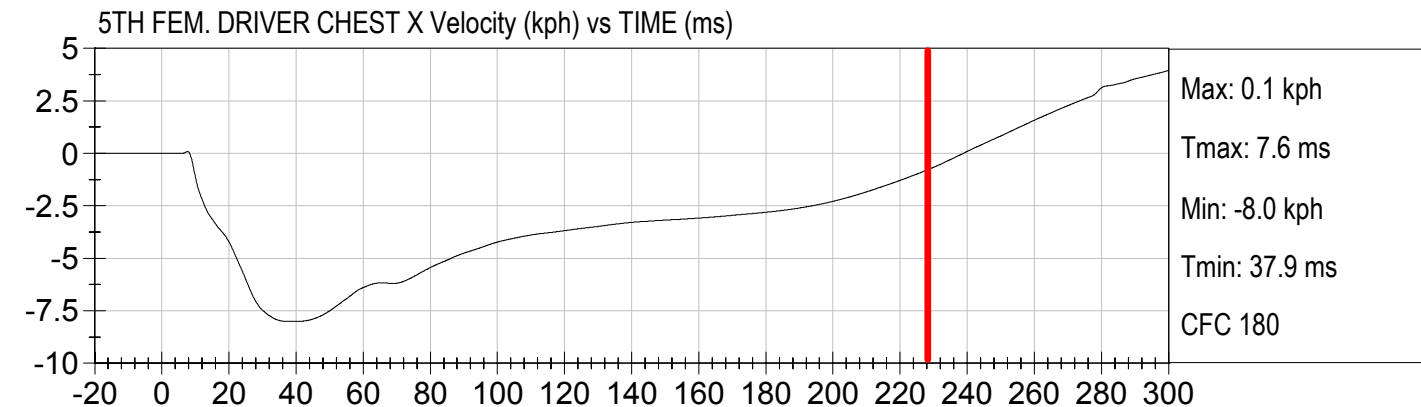



Injury Values Calculated between 0ms and 225ms

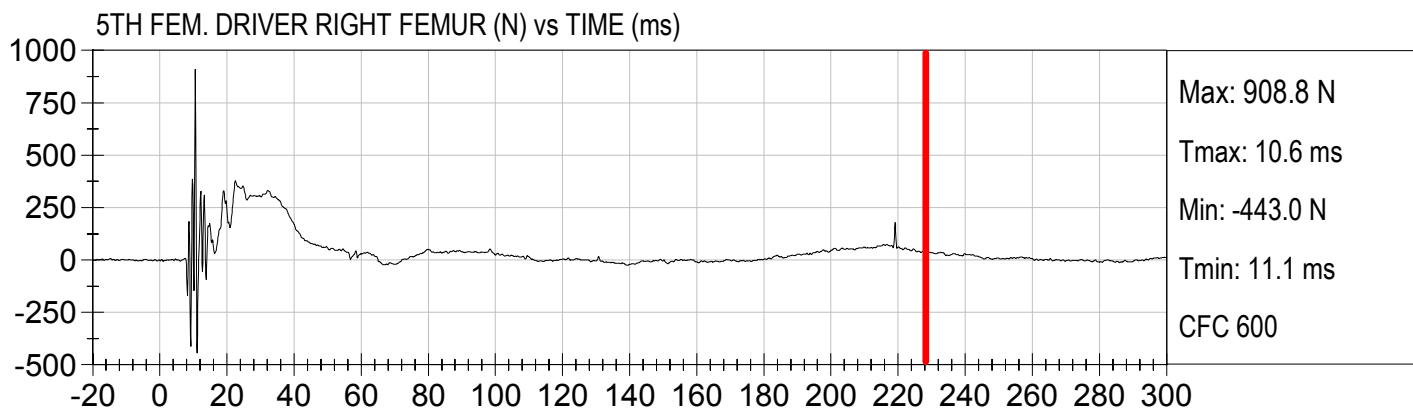
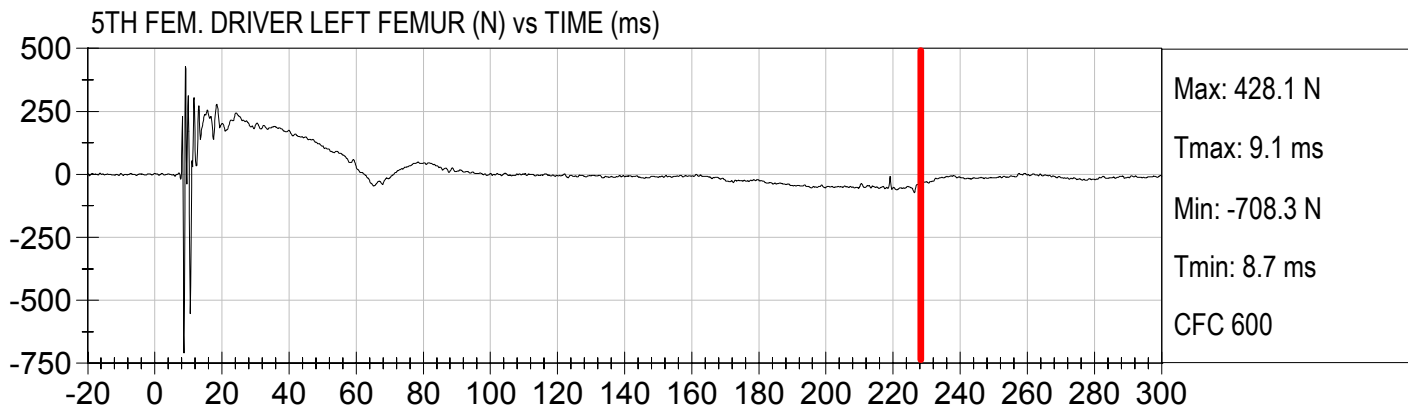



Injury Values Calculated between 0ms and 225ms

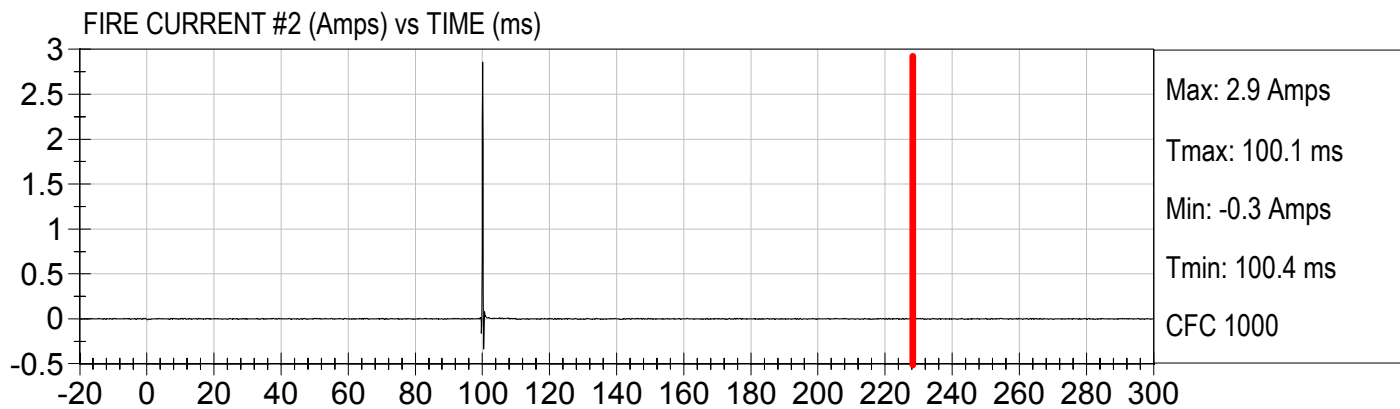
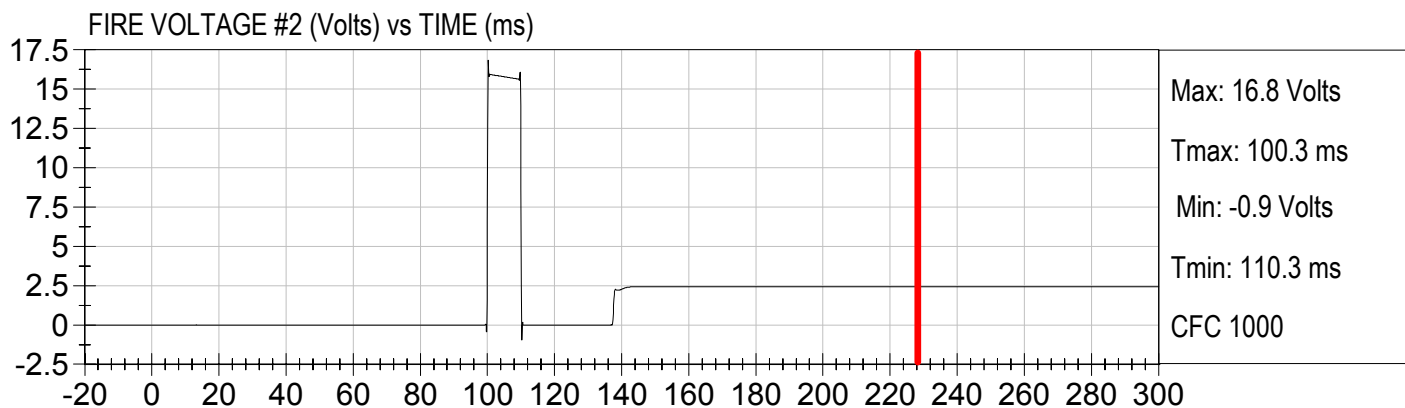
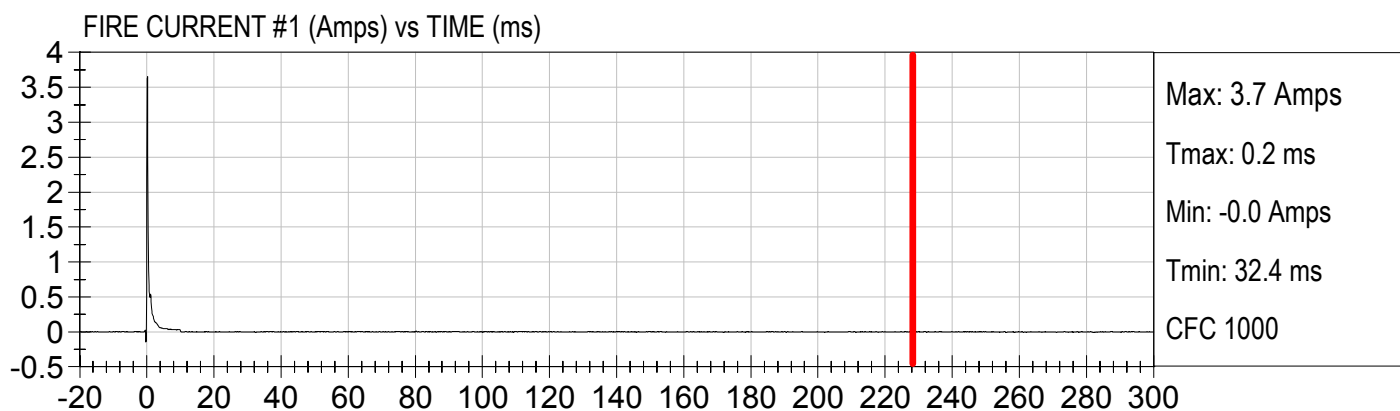
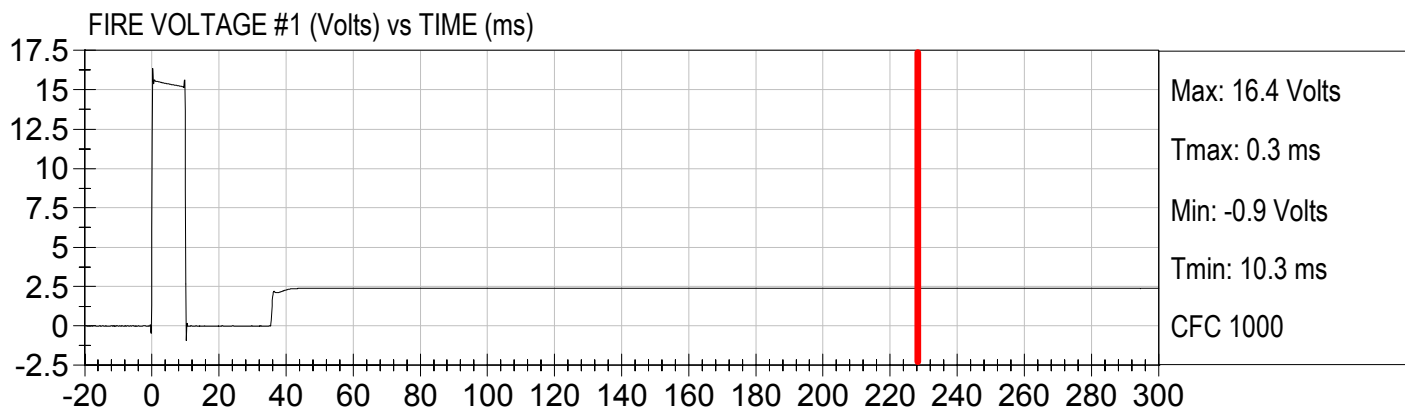

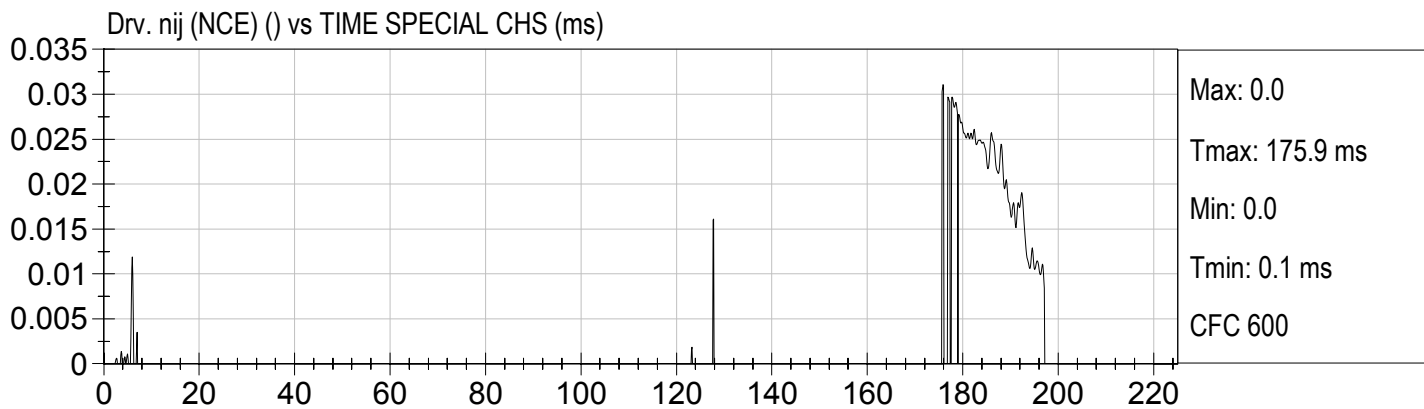
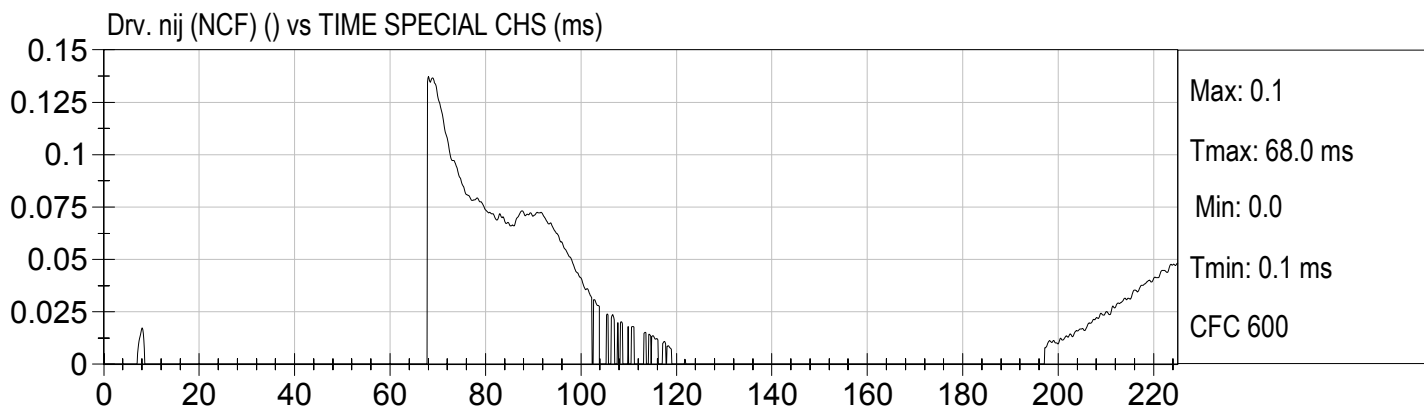
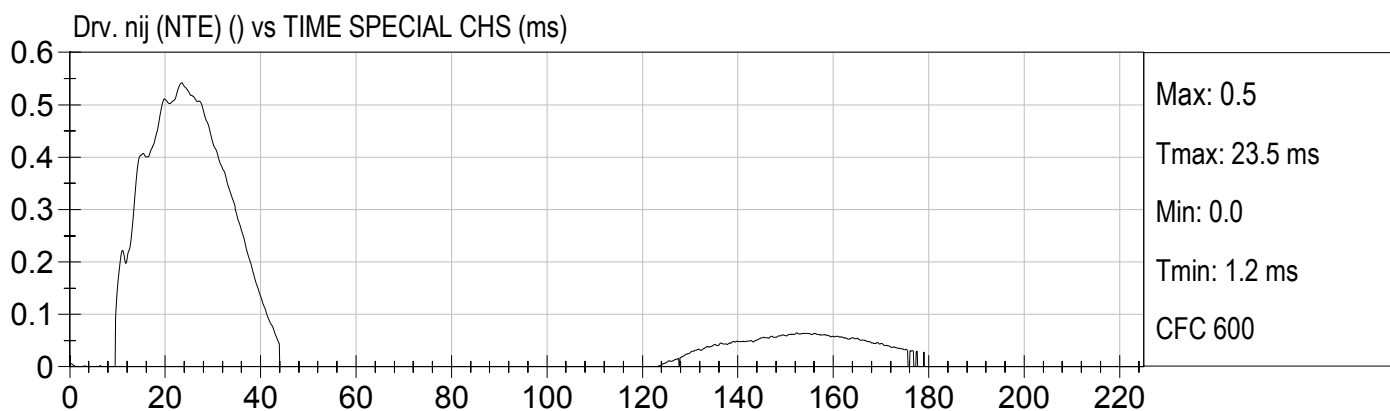
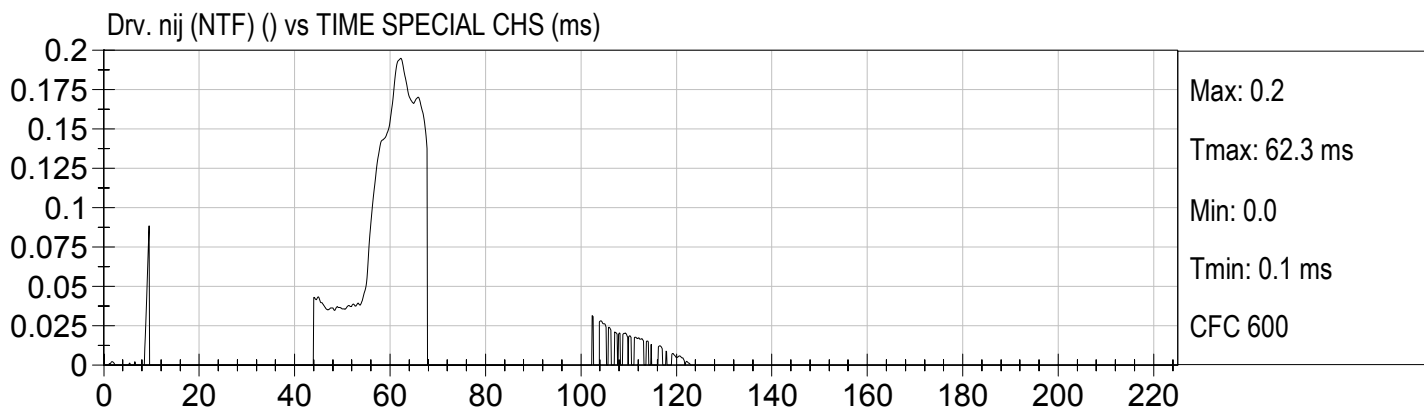

APPENDIX C
CRASH TEST PHOTOGRAPHS

TABLE OF PHOTOGRAPHS

		<u>Page No.</u>
Photo No. 1.	Vehicle Certification Label	C-1
Photo No. 2.	Tire Placard	C-2
Photo No. 3.	Pre-Test Front View of Test Vehicle	C-3
Photo No. 4.	Post-Test Front View of Test Vehicle	C-4
Photo No. 5.	Pre-Test Left Side View of Test Vehicle	C-5
Photo No. 6.	Post-Test Left Side View of Test Vehicle	C-6
Photo No. 7.	Pre-Test Right Side View of Test Vehicle	C-7
Photo No. 8.	Post-Test Right Side View of Test Vehicle	C-8
Photo No. 9.	Pre-Test Right Front Three-Quarter View of Test Vehicle	C-9
Photo No. 10.	Post-Test Right Front Three-Quarter View of Test Vehicle	C-10
Photo No. 11.	Pre-Test Left Front Three-Quarter View of Test Vehicle	C-11
Photo No. 12.	Post-Test Left Front Three-Quarter View of Test Vehicle	C-12
Photo No. 13.	Pre-Test Right Rear Three-Quarter View of Test Vehicle	C-13
Photo No. 14.	Post-Test Right Rear Three-Quarter View of Test Vehicle	C-14
Photo No. 15.	Pre-Test Left Rear Three-Quarter View of Test Vehicle	C-15
Photo No. 16.	Post-Test Left Rear Three-Quarter View of Test Vehicle	C-16
Photo No. 17.	Pre-Test Rear View of Test Vehicle	C-17
Photo No. 18.	Post-Test Rear View of Test Vehicle	C-18
Photo No. 19.	Pre-Test Windshield View	C-19
Photo No. 20.	Post-Test Windshield View	C-20
Photo No. 21.	Pre-Test Engine Compartment View	C-21
Photo No. 22.	Post-Test Engine Compartment View	C-22
Photo No. 23.	Pre-Test Fuel Filler Cap View	C-23
Photo No. 24.	Post-Test Fuel Filler Cap View	C-24
Photo No. 25.	Pre-Test Front Underbody View	C-25
Photo No. 26.	Post-Test Front Underbody View	C-26

Page No.

Photo No. 27.	Pre-Test Mid Underbody View	C-27
Photo No. 28.	Post-Test Mid Underbody View	C-28
Photo No. 29.	Pre-Test Rear Underbody View	C-29
Photo No. 30.	Post-Test Rear Underbody View	C-30
Photo No. 31.	Pre-Test Driver Dummy Front View (head position)	C-31
Photo No. 32.	Post-Test Driver Dummy Front View (head position)	C-32
Photo No. 33.	Pre-Test Driver Dummy Position Left Side View	C-33
Photo No. 34.	Post-Test Driver Dummy Position Left Side View	C-34
Photo No. 35.	Pre-Test Driver Dummy Position Left Side View (Door Open)	C-35
Photo No. 36.	Post-Test Driver Dummy Position Left Side View (Door Open)	C-36
Photo No. 37.	Pre-Test Driver Dummy Seat Position	C-37
Photo No. 38.	Post-Test Driver Dummy Seat Position	C-38
Photo No. 39.	Pre-Test Driver Dummy Feet Position	C-39
Photo No. 40.	Post-Test Driver Dummy Feet Position	C-40
Photo No. 41.	Pre-Test Driver Side Knee Bolster View	C-41
Photo No. 42.	Post-Test Driver Side Knee Bolster View	C-42
Photo No. 43.	Post-Test Driver Dummy Head Contact (visor)	C-43
Photo No. 44.	Post-Test Driver Dummy Knee Contact Left Side View	C-44
Photo No. 45.	Post-Test Driver Dummy Knee Contact Right Side View	C-45
Photo No. 46.	Post-Test Driver Dummy Airbag Contact	C-46
Photo No. 47.	Pre-Test Passenger Dummy Front View (head position)	C-47
Photo No. 48.	Post-Test Passenger Dummy Front View (head position)	C-48
Photo No. 49.	Pre-Test Passenger Dummy Position Right Side View	C-49
Photo No. 50.	Post-Test Passenger Dummy Position Right Side View	C-50
Photo No. 51.	Pre-Test Passenger Dummy Position Right Side View (Door Open)	C-51
Photo No. 52.	Pre-Test Passenger Dummy Seat Position	C-52
Photo No. 53.	Post-Test Passenger Dummy Seat Position	C-53
Photo No. 54.	Pre-Test Passenger Dummy Feet Position	C-54

Page No.

Photo No. 55.	Post-Test Passenger Dummy Feet Position	C-55
Photo No. 56.	Pre-Test Passenger Side Knee Bolster View	C-56
Photo No. 57.	Post-Test Passenger Side Knee Bolster View	C-57
Photo No. 58.	Post-Test Passenger Dummy Knee Contact	C-58
Photo No. 59.	Post-Test Passenger Dummy Airbag Contact	C-59
Photo No. 60.	Rollover 90 Degrees	C-60
Photo No. 61.	Rollover 180 Degrees	C-61
Photo No. 62.	Rollover 270 Degrees	C-62
Photo No. 63.	Rollover 360 Degrees	C-63
Photo No. 64.	Temperature Plot	C-64
Photo No. 65.	Vehicle in Relation to The Load Cell Grid	C-65



MFD BY GENERAL MOTORS CORP

DATE	GVWR	GAWR FRT	GAWR RR
05/06	1920 KG 4234 LB	1019 KG 2247 LB	901 KG 1987 LB

THIS VEHICLE CONFORMS TO ALL APPLICABLE U.S. FEDERAL MOTOR VEHICLE SAFETY, BUMPER, AND THEFT PREVENTION STANDARDS IN EFFECT ON THE DATE OF MANUFACTURE SHOWN ABOVE.

1G2ZF55B264278160 TYPE: PASS CAR

C-1

Vehicle Certification Label



TIRE AND LOADING INFORMATION

SEATING CAPACITY | TOTAL 5 | FRONT 2 | REAR 3

The combined weight of occupants and cargo should never exceed 404 kg or 891 lbs.

TIRE	ORIGINAL SIZE	COLD TIRE PRESSURE	SEE OWNER'S MANUAL FOR ADDITIONAL INFORMATION
FRONT	P215/60R16	210 kPa, 30 PSI	
REAR	P215/60R16	210 kPa, 30 PSI	
SPARE	T125/70D16	420 kPa, 60 PSI	

1G2ZF55B264278160

Tire Placard



Pre-Test Front View of Test Vehicle



Post-Test Front View of Test Vehicle

C-5



Pre-Test Left Side View of Test Vehicle



Post-Test Left Side View of Test Vehicle



Pre-Test Right Side View of Test Vehicle



Post-Test Right Side View of Test Vehicle



Pre-Test Right Front Three-Quarter View of Test Vehicle



Post-Test Right Front Three-Quarter View of Test Vehicle



Pre-Test Left Front Three-Quarter View of Test Vehicle



Post-Test Left Front Three-Quarter View of Test Vehicle



Pre-Test Right Rear Three-Quarter View of Test Vehicle



Post-Test Right Rear Three-Quarter View of Test Vehicle



Pre-Test Left Rear Three-Quarter View of Test Vehicle



Post-Test Left Rear Three-Quarter View of Test Vehicle



Pre-Test Rear View of Test Vehicle



Post-Test Rear View of Test Vehicle



Pre-Test Windshield View



Post-Test Windshield View



Pre-Test Engine Compartment View

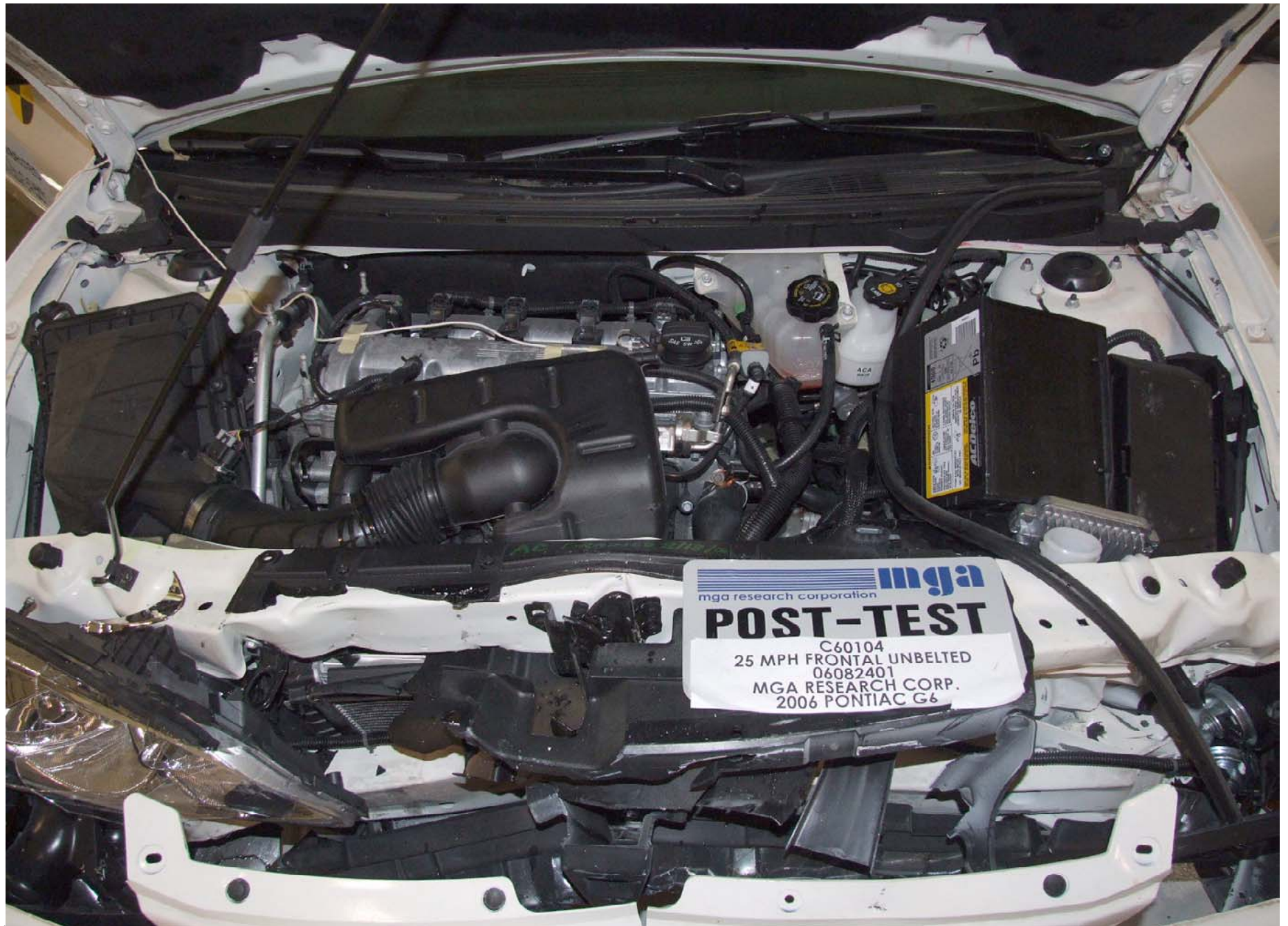

Post-Test Engine Compartment View



C-23

Pre-Test Fuel Filler Cap View



Post-Test Fuel Filler Cap View

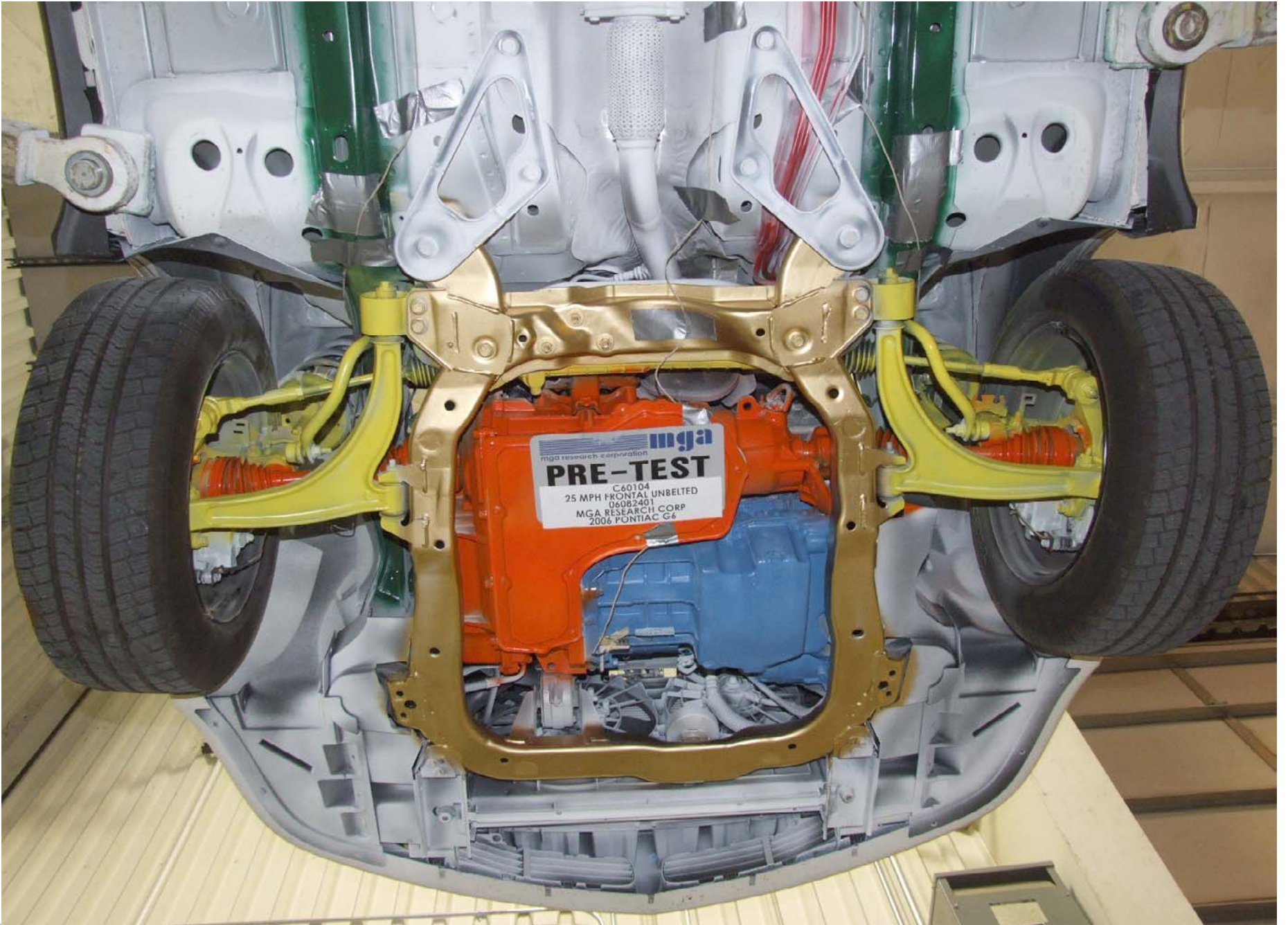

Pre-Test Front Underbody View



Post-Test Front Underbody View



Pre-Test Mid Underbody View



Post-Test Mid Underbody View

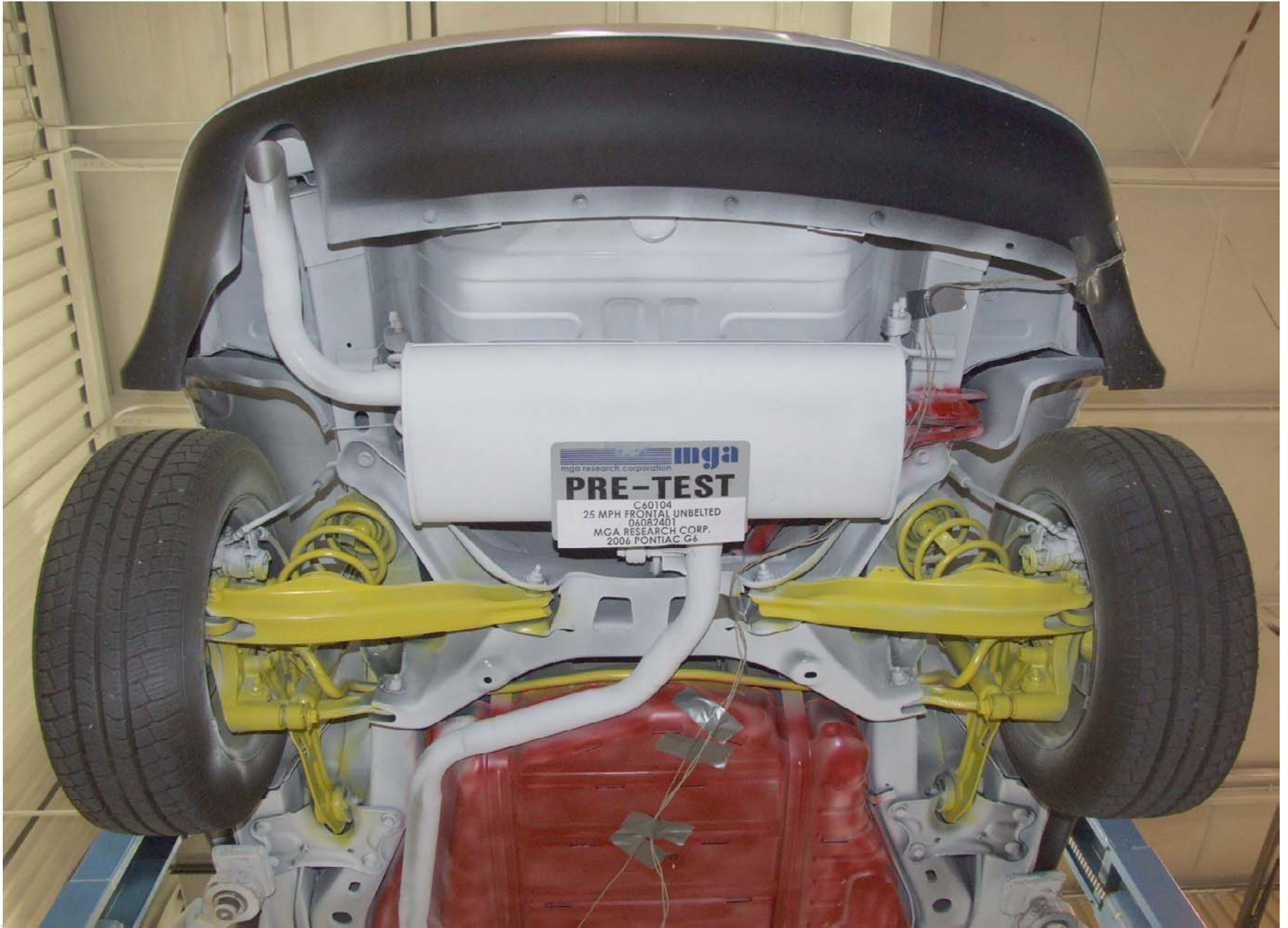

Pre-Test Rear Underbody View

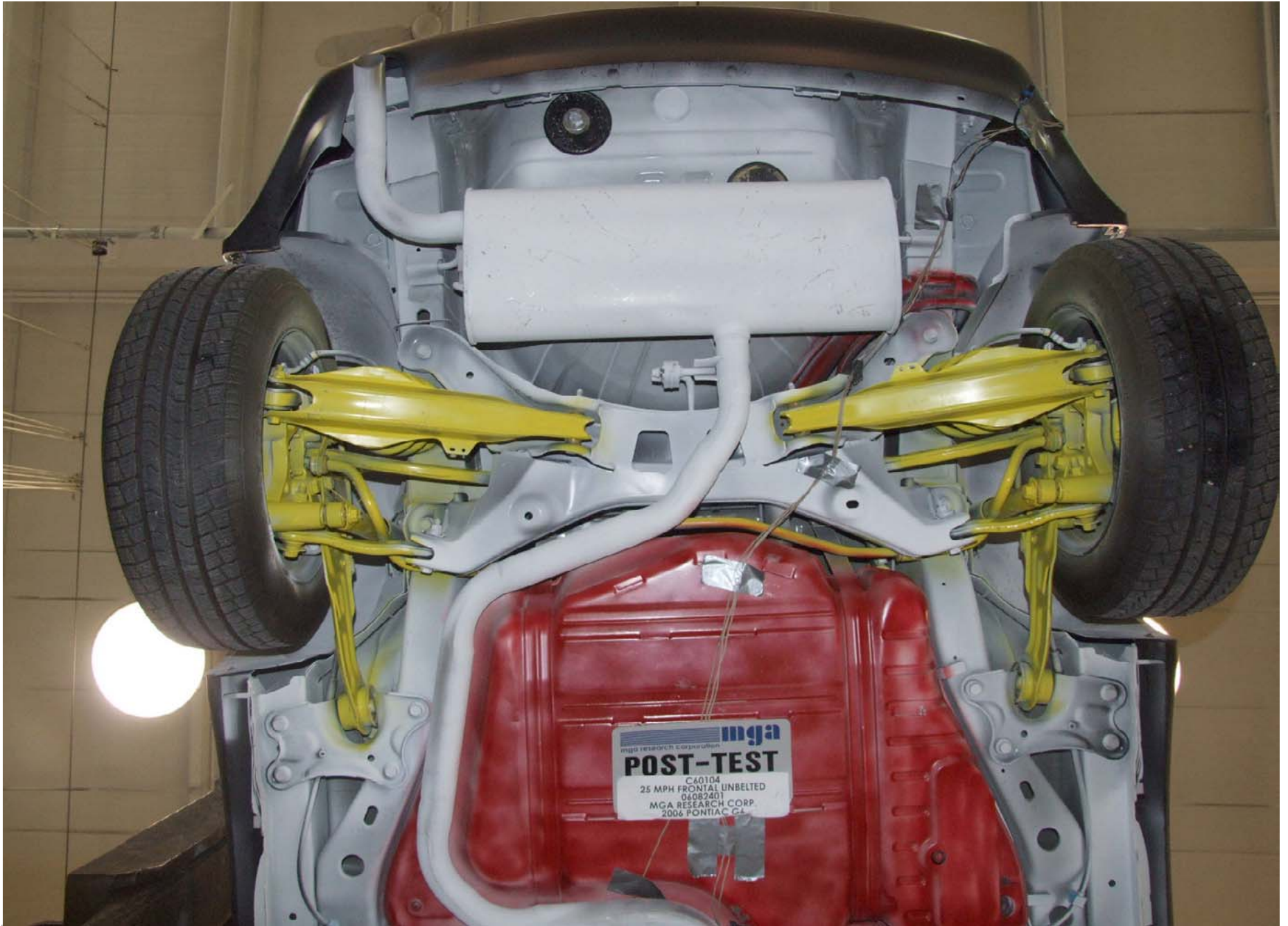

Post-Test Rear Underbody View



Pre-Test Driver Dummy Front View (head position)



Post-Test Driver Dummy Front View (head position)



Pre-Test Driver Dummy Position Left Side View



Post-Test Driver Dummy Position Left Side View



Pre-Test Driver Dummy Position Left Side View (Door Open)



Post-Test Driver Dummy Position Left Side View (Door Open)



Pre-Test Driver Dummy Seat Position



Post-Test Driver Dummy Seat Position



Pre-Test Driver Dummy Feet Position



Post-Test Driver Dummy Feet Position



Pre-Test Driver Side Knee Bolster View



Post-Test Driver Side Knee Bolster View



Post-Test Driver Dummy Knee Contact Left Side View

C-45



Post-Test Driver Dummy Knee Contact Right Side View



Post-Test Driver Dummy Airbag Contact



Pre-Test Passenger Dummy Front View (head position)



Post-Test Passenger Dummy Front View (head position)



Pre-Test Passenger Dummy Position Right Side View



Post-Test Passenger Dummy Position Right Side View



Pre-Test Passenger Dummy Position Right Side View (Door Open)



Pre-Test Passenger Dummy Seat Position



Post-Test Passenger Dummy Seat Position



Pre-Test Passenger Dummy Feet Position



Post-Test Passenger Dummy Feet Position



Pre-Test Passenger Side Knee Bolster View



Post-Test Passenger Side Knee Bolster View



Post-Test Passenger Dummy Knee Contact

C-59



Post-Test Passenger Dummy Airbag Contact



Rollover 90 Degrees

C-61



Rollover 180 Degrees

C-62

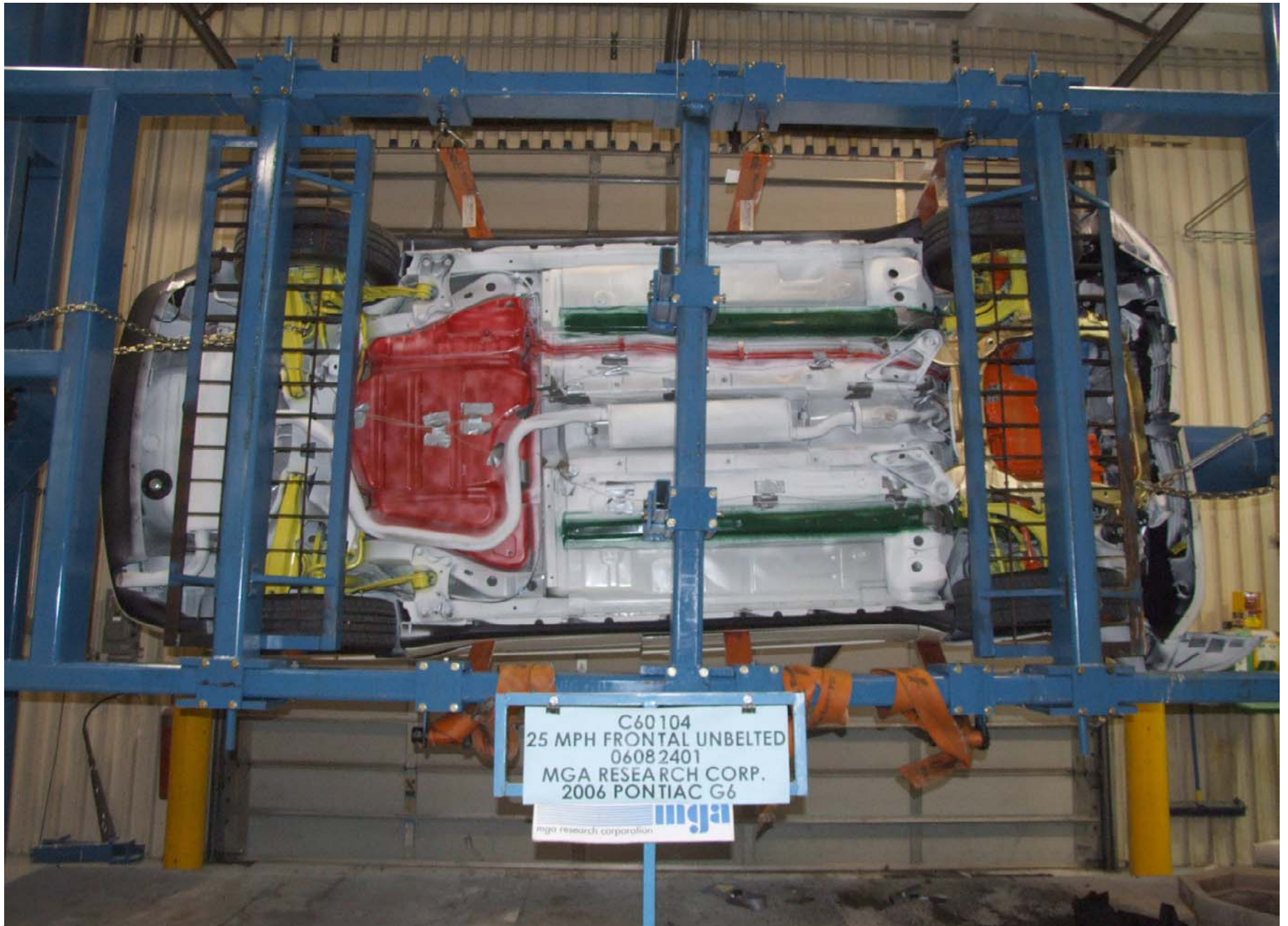

Rollover 270 Degrees



Rollover 360 Degrees

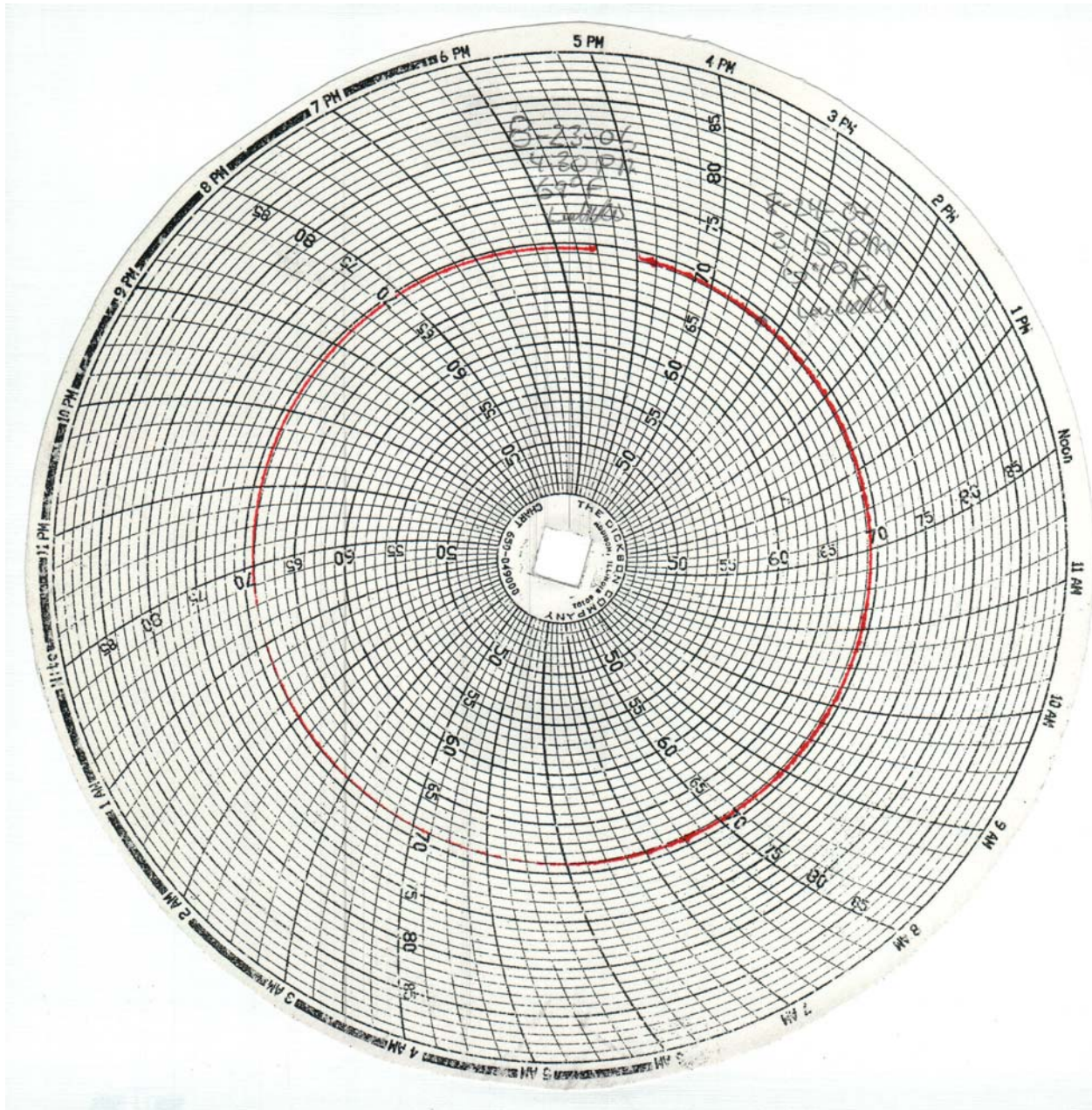

Temperature Plot

C-65



Vehicle in Relation to The Load Cell Grid

APPENDIX D
LOW RISK PHOTOGRAPHS

TABLE OF PHOTOGRAPHS

		<u>Page No.</u>
Photo No. 1.	Pre-Test 5 th Fem. P1 Driver Dummy Left Side View (Door Open)	D-1
Photo No. 2.	Post-Test 5 th Fem. P1 Driver Dummy Left Side View (Door Open)	D-2
Photo No. 3.	Pre-Test 5 th Fem. P1 Driver Dummy Right Side View (Door Open)	D-3
Photo No. 4.	Post-Test 5 th Fem. P1 Driver Dummy Right Side View (Door Open)	D-4
Photo No. 5.	Pre-Test 5 th Fem. P1 Driver Dummy Left Side Head Position View	D-5
Photo No. 6.	Post-Test 5 th Fem. P1 Driver Dummy Left Side Head Position View	D-6
Photo No. 7.	Pre-Test 5 th Fem. P1 Driver Dummy Right Side Head Position View	D-7
Photo No. 8.	Post-Test 5 th Fem. P1 Driver Dummy Right Side Head Position View	D-8
Photo No. 9.	Post-Test 5 th Fem. P1 Driver Dummy Airbag Left View	D-9
Photo No. 10.	Post-Test 5 th Fem. P1 Driver Dummy Airbag Right View	D-10
Photo No. 11.	Pre-Test 5 th Fem. P2 Driver Dummy Left Side View (Door Open)	D-11
Photo No. 12.	Post-Test 5 th Fem. P2 Driver Dummy Left Side View (Door Open)	D-12
Photo No. 13.	Pre-Test 5 th Fem. P2 Driver Dummy Right Side View (Door Open)	D-13
Photo No. 14.	Post-Test 5 th Fem. P2 Driver Dummy Right Side View (Door Open)	D-14
Photo No. 15.	Pre-Test 5 th Fem. P2 Driver Dummy Left Side Head Position View	D-15
Photo No. 16.	Post-Test 5 th Fem. P2 Driver Dummy Left Side Head Position View	D-16
Photo No. 17.	Pre-Test 5 th Fem. P2 Driver Dummy Right Side Head Position View	D-17
Photo No. 18.	Post-Test 5 th Fem. P2 Driver Dummy Right Side Head Position View	D-18
Photo No. 19.	Pre-Test 5 th Fem. P2 Driver Dummy Left Side Mid Position View	D-19
Photo No. 20.	Post-Test 5 th Fem. P2 Driver Dummy Left Side Mid Position View	D-20
Photo No. 21.	Post-Test 5 th Fem. P2 Driver Dummy Airbag Left View	D-21
Photo No. 22.	Post-Test 5 th Fem. P2 Driver Dummy Airbag Right View	D-22

D-1



Pre-Test 5th Fem. P1 Driver Dummy Left Side View (Door Open)



Post-Test 5th Fem. P1 Driver Dummy Left Side View (Door Open)



Pre-Test 5th Fem. P1 Driver Dummy Right Side View (Door Open)

D-4



Post-Test 5th Fem. P1 Driver Dummy Right Side View (Door Open)



Pre-Test 5th Fem. P1 Driver Dummy Left Side Head Position View



Post-Test 5th Fem. P1 Driver Dummy Left Side Head Position View



Pre-Test 5th Fem. P1 Driver Dummy Right Side Head Position View



Post-Test 5th Fem. P1 Driver Dummy Right Side Head Position View



Post-Test 5th Fem. P1 Driver Dummy Airbag Left View



Post-Test 5th Fem. P1 Driver Dummy Airbag Right View

D-11



Pre-Test 5th Fem. P2 Driver Dummy Left Side View (Door Open)



Post-Test 5th Fem. P2 Driver Dummy Left Side View (Door Open)



Pre-Test 5th Fem. P2 Driver Dummy Right Side View (Door Open)



Post-Test 5th Fem. P2 Driver Dummy Right Side View (Door Open)



Pre-Test 5th Fem. P2 Driver Dummy Left Side Head Position View



Post-Test 5th Fem. P2 Driver Dummy Left Side Head Position View



Pre-Test 5th Fem. P2 Driver Dummy Right Side Head Position View



Post-Test 5th Fem. P2 Driver Dummy Right Side Head Position View



Pre-Test 5th Fem. P2 Driver Dummy Left Side Mid Position View



Post-Test 5th Fem. P2 Driver Dummy Left Side Mid Position View



Post-Test 5th Fem. P2 Driver Dummy Airbag Left View



Post-Test 5th Fem. P2 Driver Dummy Airbag Right View

APPENDIX E
SUPPRESSION PHOTOGRAPHS

TABLE OF PHOTOGRAPHS

		<u>Page #</u>
Photo No. 1.	Cosco Dream Ride Car Bed With Belt, Middle Seat Track	E-1
Photo No. 2.	Cosco Dream Ride Car Bed With Belt, Rearward Seat Track	E-1
Photo No. 3.	Unbelted 5 th Percentile Female Reactivation, Rearward Seat Track	E-1
Photo No. 4.	Britax Handle With Care 191 With Belt, Forward Seat Track, Handle Down	E-2
Photo No. 5.	Britax Handle With Care 191 With Belt, Middle Seat Track, Handle Down	E-2
Photo No. 6.	Britax Handle With Care 191 With Belt, Rearward Seat Track, Handle Down	E-2
Photo No. 7.	Britax Handle With Care 191 Unbelted, Forward Seat Track, Handle Down	E-2
Photo No. 8.	Britax Handle With Care 191 Unbelted, Middle Seat Track, Handle Down	E-3
Photo No. 9.	Britax Handle With Care 191 Unbelted, Rearward Seat Track, Handle Down	E-3
Photo No. 10.	Britax Handle With Care 191 Fwd Facing Unbelted, Forward Seat Track, Handle Down	E-3
Photo No. 11.	Britax Handle With Care 191 Fwd Facing Unbelted, Middle Seat Track, Handle Down	E-3
Photo No. 12.	Britax Handle With Care 191 Fwd Facing Unbelted, Rearward Seat Track, Handle Down	E-4
Photo No. 13.	Unbelted 5 th Percentile Female Reactivation, Rearward Seat Track	E-4
Photo No. 14.	Evenflo First Choice 204 With Belt, Forward Seat Track, Handle Up	E-5
Photo No. 15.	Evenflo First Choice 204 With Belt, Middle Seat Track, Handle Up	E-5
Photo No. 16.	Evenflo First Choice 204 With Belt, Rearward Seat Track, Handle Down	E-5
Photo No. 17.	Evenflo First Choice 204 Unbelted, Forward Seat Track, Handle Up	E-5
Photo No. 18.	Evenflo First Choice 204 Unbelted, Middle Seat Track, Handle Up	E-6
Photo No. 19.	Evenflo First Choice 204 Unbelted, Rearward Seat Track, Handle Down	E-6
Photo No. 20.	Evenflo First Choice 204 Fwd Facing Unbelted, Forward Seat Track, Handle Up	E-6
Photo No. 21.	Evenflo First Choice 204 Fwd Facing Unbelted, Middle Seat Track, Handle Up	E-6
Photo No. 22.	Evenflo First Choice 204 Fwd Facing Unbelted, Rearward Seat Track, Handle Up	E-7
Photo No. 23.	Unbelted 5 th Percentile Female Reactivation, Forward Seat Track	E-7
Photo No. 24.	Graco Infant W/ Base With Belt, Forward Seat Track, Handle Up	E-8
Photo No. 25.	Graco Infant W/ Base With Belt, Middle Seat Track, Handle Down	E-8
Photo No. 26.	Graco Infant W/ Base With Belt, Rearward Seat Track, Handle Down	E-8
Photo No. 27.	Graco Infant W/ Base Unbelted, Forward Seat Track, Handle Up	E-8
Photo No. 28.	Graco Infant W/ Base Unbelted, Middle Seat Track, Handle Up	E-9
Photo No. 29.	Graco Infant W/ Base Unbelted, Rearward Seat Track, Handle Up	E-9
Photo No. 30.	Graco Infant W/ Base Fwd Facing Unbelted, Forward Seat Track, Handle Up	E-9
Photo No. 31.	Graco Infant W/ Base Fwd Facing Unbelted, Middle Seat Track, Handle Up	E-9
Photo No. 32.	Graco Infant W/ Base Fwd Facing Unbelted, Rearward Seat Track, Handle Up	E-10
Photo No. 33.	Graco Infant W/O Base With Belt, Forward Seat Track, Handle Up	E-10

	<u>Page #</u>
Photo No. 34. Graco Infant W/O Base With Belt, Middle Seat Track, Handle Up	E-10
Photo No. 35. Graco Infant W/O Base With Belt, Rearward Seat Track, Handle Down	E-10
Photo No. 36. Graco Infant W/O Base Unbelted, Forward Seat Track, Handle Up	E-11
Photo No. 37. Graco Infant W/O Base Unbelted, Middle Seat Track, Handle Up	E-11
Photo No. 38. Graco Infant W/O Base Unbelted, Rearward Seat Track, Handle Down	E-11
Photo No. 39. Graco Infant W/O Base Fwd Facing Unbelted, Forward Seat Track, Handle Up	E-11
Photo No. 40. Graco Infant W/O Base Fwd Facing Unbelted, Middle Seat Track, Handle Up	E-12
Photo No. 41. Graco Infant W/O Base Fwd Facing Unbelted, Rearward Seat Track, Handle Up	E-12
Photo No. 42. Unbelted 5 th Percentile Female Reactivation, Middle Seat Track	E-12
Photo No. 43. Britax Roundabout 161 Fwd Facing With Belt, Forward Seat Track	E-13
Photo No. 44. Britax Roundabout 161 Fwd Facing With Belt, Middle Seat Track	E-13
Photo No. 45. Britax Roundabout 161 Fwd Facing With Belt, Rearward Seat Track	E-13
Photo No. 46. Britax Roundabout 161 Fwd Facing Unbelted, Forward Seat Track	E-13
Photo No. 47. Britax Roundabout 161 Fwd Facing Unbelted, Middle Seat Track	E-14
Photo No. 48. Britax Roundabout 161 Fwd Facing Unbelted, Rearward Seat Track	E-14
Photo No. 49. Britax Roundabout 161 Rear Facing With Belt, Forward Seat Track	E-14
Photo No. 50. Britax Roundabout 161 Rear Facing With Belt, Middle Seat Track	E-14
Photo No. 51. Britax Roundabout 161 Rear Facing With Belt, Rearward Seat Track	E-15
Photo No. 52. Britax Roundabout 161 Rear Facing Unbelted, Forward Seat Track	E-15
Photo No. 53. Britax Roundabout 161 Rear Facing Unbelted, Middle Seat Track	E-15
Photo No. 54. Britax Roundabout 161 Rear Facing Unbelted, Rearward Seat Track	E-15
Photo No. 55. Unbelted 5 th Percentile Female Reactivation, Rearward Seat Track	E-16
Photo No. 56. Century Encore Fwd Facing With Belt, Forward Seat Track	E-17
Photo No. 57. Century Encore Fwd Facing With Belt, Middle Seat Track	E-17
Photo No. 58. Century Encore Fwd Facing With Belt, Rearward Seat Track	E-17
Photo No. 59. Century Encore Fwd Facing Unbelted, Forward Seat Track	E-17
Photo No. 60. Century Encore Fwd Facing Unbelted, Middle Seat Track	E-18
Photo No. 61. Century Encore Fwd Facing Unbelted, Rearward Seat Track	E-18
Photo No. 62. Century Encore Rear Facing With Belt, Forward Seat Track	E-18
Photo No. 63. Century Encore Rear Facing With Belt, Middle Seat Track	E-18
Photo No. 64. Century Encore Rear Facing With Belt, Rearward Seat Track	E-19
Photo No. 65. Century Encore Rear Facing Unbelted, Forward Seat Track	E-19
Photo No. 66. Century Encore Rear Facing Unbelted, Middle Seat Track	E-19
Photo No. 67. Century Encore Rear Facing Unbelted, Rearward Seat Track	E-19
Photo No. 68. Unbelted 5 th Percentile Female Reactivation, Middle Seat Track	E-20

	<u>Page #</u>
Photo No. 69. Evenflo Medallion 254 Rear Facing With Belt, Forward Seat Track	E-21
Photo No. 70. Evenflo Medallion 254 Rear Facing With Belt, Middle Seat Track	E-21
Photo No. 71. Evenflo Medallion 254 Rear Facing With Belt, Rearward Seat Track	E-21
Photo No. 72. Evenflo Medallion 254 Rear Facing Unbelted, Forward Seat Track	E-21
Photo No. 73. Evenflo Medallion 254 Rear Facing Unbelted, Middle Seat Track	E-22
Photo No. 74. Evenflo Medallion 254 Rear Facing Unbelted, Rearward Seat Track	E-22
Photo No. 75. Evenflo Medallion 254 Fwd Facing With Belt, Forward Seat Track	E-22
Photo No. 76. Evenflo Medallion 254 Fwd Facing With Belt, Middle Seat Track	E-22
Photo No. 77. Evenflo Medallion 254 Fwd Facing With Belt, Rearward Seat Track	E-23
Photo No. 78. Evenflo Medallion 254 Fwd Facing Unbelted, Forward Seat Track	E-23
Photo No. 79. Evenflo Medallion 254 Fwd Facing Unbelted, Middle Seat Track	E-23
Photo No. 80. Evenflo Medallion 254 Fwd Facing Unbelted, Rearward Seat Track	E-23
Photo No. 81. Unbelted 5 th Percentile Female Reactivation, Forward Seat Track	E-24
Photo No. 82. 3-Year-Old Fwd Facing Britax Roundabout Belted, Forward Seat Track	E-25
Photo No. 83. 3-Year-Old Fwd Facing Britax Roundabout Belted, Middle Seat Track	E-25
Photo No. 84. 3-Year-Old Fwd Facing Britax Roundabout Belted, Rearward Seat Track	E-25
Photo No. 85. Unbelted 5 th Percentile Female Reactivation, Rearward Seat Track	E-25
Photo No. 86. 3-Year-Old Fwd Facing Century Encore Belted, Forward Seat Track	E-26
Photo No. 87. 3-Year-Old Fwd Facing Century Encore Belted, Middle Seat Track	E-26
Photo No. 88. 3-Year-Old Fwd Facing Century Encore Belted, Rearward Seat Track	E-26
Photo No. 89. Unbelted 5 th Percentile Female Reactivation, Middle Seat Track	E-26
Photo No. 90. 3-Year-Old Fwd Facing Evenflo Medallion Belted, Forward Seat Track	E-27
Photo No. 91. 3-Year-Old Fwd Facing Evenflo Medallion Belted, Middle Seat Track	E-27
Photo No. 92. 3-Year-Old Fwd Facing Evenflo Medallion Belted, Rearward Seat Track	E-27
Photo No. 93. Unbelted 5 th Percentile Female Reactivation, Forward Seat Track	E-27
Photo No. 94. 3-Year-Old Century Next Step Belted, Forward Seat Track	E-28
Photo No. 95. 3-Year-Old Century Next Step Belted, Middle Seat Track	E-28
Photo No. 96. 3-Year-Old Century Next Step Belted, Rearward Seat Track	E-28
Photo No. 97. 3-Year-Old Century Next Step Cinched With Harness, Forward Seat Track	E-28
Photo No. 98. 3-Year-Old Century Next Step Cinched With Harness, Middle Seat Track	E-29
Photo No. 99. 3-Year-Old Century Next Step Cinched With Harness, Rearward Seat Track	E-29
Photo No. 100. Unbelted 5 th Percentile Female Reactivation, Rearward Seat Track	E-29
Photo No. 101. 3-Year-Old Cosco High Back Booster Belted, Forward Seat Track	E-30
Photo No. 102. 3-Year-Old Cosco High Back Booster Belted, Middle Seat Track	E-30
Photo No. 103. 3-Year-Old Cosco High Back Booster Belted, Rearward Seat Track	E-30

Photo No. 104.	3-Year-Old Cosco High Back Booster Cinched With Harness, Forward Seat Track	E-30
Photo No. 104.	3-Year-Old Cosco High Back Booster Cinched With Harness, Middle Seat Track	E-31
Photo No. 105.	3-Year-Old Cosco High Back Booster Cinched With Harness, Rearward Seat Track	E-31
Photo No. 106.	Unbelted 5 th Percentile Female Reactivation, Middle Seat Track	E-31
Photo No. 107.	6-Year-Old Century Next Step Belted, Forward Seat Track	E-32
Photo No. 108.	6-Year-Old Century Next Strap Belted, Middle Seat Track	E-32
Photo No. 109.	6-Year-Old Century Next Step Belted, Rearward Seat Track	E-32
Photo No. 110.	Unbelted 5 th Percentile Female Reactivation, Rearward Seat Track	E-32
Photo No. 111.	6-Year-Old Cosco High Back Booster Belted, Forward Seat Track	E-33
Photo No. 112.	6-Year-Old Cosco High Back Booster Belted, Middle Seat Track	E-33
Photo No. 113.	6-Year-Old Cosco High Back Booster Belted, Rearward Seat Track	E-33
Photo No. 114.	Unbelted 5 th Percentile Female Reactivation, Rearward Seat Track	E-33
Photo No. 115.	6-Year-Old Evenflo Right Fit Belted, Forward Seat Track	E-34
Photo No. 116.	6-Year-Old Evenflo Right Fit Belted, Middle Seat Track	E-34
Photo No. 117.	6-Year-Old Evenflo Right Fit Belted, Rearward Seat Track	E-34
Photo No. 118.	Unbelted 5 th Percentile Female Reactivation, Middle Seat Track	E-34
Photo No. 119.	3-Year-Old Unbelted, Forward Seat Track, Position 1	E-35
Photo No. 120.	3-Year-Old Unbelted, Forward Seat Track, Position 2	E-35
Photo No. 121.	3-Year-Old Unbelted, Forward Seat Track, Position 3	E-35
Photo No. 122.	3-Year-Old Unbelted, Forward Seat Track, Position 4	E-35
Photo No. 123.	3-Year-Old Unbelted, Forward Seat Track, Position 5	E-36
Photo No. 124.	3-Year-Old Unbelted, Forward Seat Track, Position 6	E-36
Photo No. 125.	3-Year-Old Unbelted, Forward Seat Track, Position 7	E-36
Photo No. 126.	3-Year-Old Unbelted, Middle Seat Track, Position 1	E-36
Photo No. 127.	3-Year-Old Unbelted, Middle Seat Track, Position 2	E-37
Photo No. 128.	3-Year-Old Unbelted, Middle Seat Track, Position 3	E-37
Photo No. 129.	3-Year-Old Unbelted, Middle Seat Track, Position 4	E-37
Photo No. 130.	3-Year-Old Unbelted, Middle Seat Track, Position 5	E-37
Photo No. 131.	3-Year-Old Unbelted, Middle Seat Track, Position 6	E-38
Photo No. 132.	3-Year-Old Unbelted, Middle Seat Track, Position 7	E-38
Photo No. 133.	3-Year-Old Unbelted, Rearward Seat Track, Position 1	E-38
Photo No. 134.	3-Year-Old Unbelted, Rearward Seat Track, Position 2	E-38
Photo No. 135.	3-Year-Old Unbelted, Rearward Seat Track, Position 3	E-39
Photo No. 136.	3-Year-Old Unbelted, Rearward Seat Track, Position 4	E-39
Photo No. 137.	3-Year-Old Unbelted, Rearward Seat Track, Position 5	E-39

	<u>Page #</u>
Photo No. 138. 3-Year-Old Unbelted, Rearward Seat Track, Position 6	E-39
Photo No. 139. 3-Year-Old Unbelted, Rearward Seat Track, Position 7	E-40
Photo No. 140. Unbelted 5 th Percentile Female Reactivation, Middle Seat Track	E-40
Photo No. 141. 6-Year-Old Unbelted, Forward Seat Track, Position 1	E-41
Photo No. 142. 6-Year-Old Unbelted, Forward Seat Track, Position 2	E-41
Photo No. 143. 6-Year-Old Unbelted, Forward Seat Track, Position 3	E-41
Photo No. 144. 6-Year-Old Unbelted, Forward Seat Track, Position 4	E-41
Photo No. 145. 6-Year-Old Unbelted, Forward Seat Track, Position 4, View 2	E-42
Photo No. 146. 6-Year-Old Unbelted, Middle Seat Track, Position 1	E-42
Photo No. 147. 6-Year-Old Unbelted, Middle Seat Track, Position 2	E-42
Photo No. 148. 6-Year-Old Unbelted, Middle Seat Track, Position 3	E-42
Photo No. 149. 6-Year-Old Unbelted, Middle Seat Track, Position 4	E-43
Photo No. 150. 6-Year-Old Unbelted, Middle Seat Track, Position 4, View 2	E-43
Photo No. 151. 6-Year-Old Unbelted, Rearward Seat Track, Position 1	E-43
Photo No. 152. 6-Year-Old Unbelted, Rearward Seat Track, Position 2	E-43
Photo No. 153. 6-Year-Old Unbelted, Rearward Seat Track, Position 3	E-44
Photo No. 154. 6-Year-Old Unbelted, Rearward Seat Track, Position 4	E-44
Photo No. 155. 6-Year-Old Unbelted, Rearward Seat Track, Position 4, View 2	E-44
Photo No. 156. Unbelted 5 th Percentile Female Reactivation, Middle Seat Track	E-44

E-1



Cosco Dream Ride Car Bed With Belt, Middle Seat Track



Cosco Dream Ride Car Bed With Belt, Rearward Seat Track



Unbelted 5th Percentile Female Reactivation,
Rearward Seat Track

DOT/NHTSA 208 Suppression Test – 2006 Pontiac G6 (C60104)

12 Month

Section B

Rear Facing CRS

E-2



Britax Handle With Care 191 With Belt, Forward Seat Track, Handle Down



Britax Handle With Care 191 With Belt, Middle Seat Track, Handle Down



Britax Handle With Care 191 With Belt, Rearward Seat Track, Handle Down



Britax Handle With Care 191 Unbuckled, Forward Seat Track, Handle Down

E-3



Britax Handle With Care 191 Unbelted, Middle Seat Track, Handle Down



Britax Handle With Care 191 Unbelted, Rearward Seat Track, Handle Down



Britax Handle With Care 191 Fwd Facing Unbelted, Forward Seat Track, Handle Down



Britax Handle With Care 191 Fwd Facing Unbelted, Middle Seat Track, Handle Down



Britax Handle With Care 191 Fwd Facing Unbelted,
Rearward Seat Track, Handle Down



Unbelted 5th Percentile Female Reactivation,
Rearward Seat Track

E-5



Evenflo First Choice 204 With Belt, Forward Seat Track,
Handle Up



Evenflo First Choice 204 With Belt, Middle Seat Track,
Handle Up



Evenflo First Choice 204 With Belt, Rearward Seat Track,
Handle Down



Evenflo First Choice 204 Unbelted, Forward Seat Track,
Handle Up

E-6



Evenflo First Choice 204 Unbelted, Middle Seat Track, Handle Up



Evenflo First Choice 204 Unbelted, Rearward Seat Track, Handle Down



Evenflo First Choice 204 Fwd Facing Unbelted, Forward Seat Track, Handle Up



Evenflo First Choice 204 Fwd Facing Unbelted, Middle Seat Track, Handle Up



Evenflo First Choice 204 Fwd Facing Unbelted,
Rearward Seat Track, Handle Up



Unbelted 5th Percentile Female Reactivation,
Forward Seat Track



Graco Infant W/ Base With Belt, Forward Seat Track, Handle Up



Graco Infant W/ Base With Belt, Middle Seat Track, Handle Down



Graco Infant W/ Base With Belt, Rearward Seat Track, Handle Down



Graco Infant W/ Base Unbelted, Forward Seat Track, Handle Up

E-9



Graco Infant W/ Base Unbelted, Middle Seat Track, Handle Up



Graco Infant W/ Base Unbelted, Rearward Seat Track, Handle Up



Graco Infant W/ Base Fwd Facing Unbelted, Forward Seat Track, Handle Up



Graco Infant W/ Base Fwd Facing Unbelted, Middle Seat Track, Handle Up

E-10



Graco Infant W/ Base Fwd Facing Unbelted,
Rearward Seat Track, Handle Up

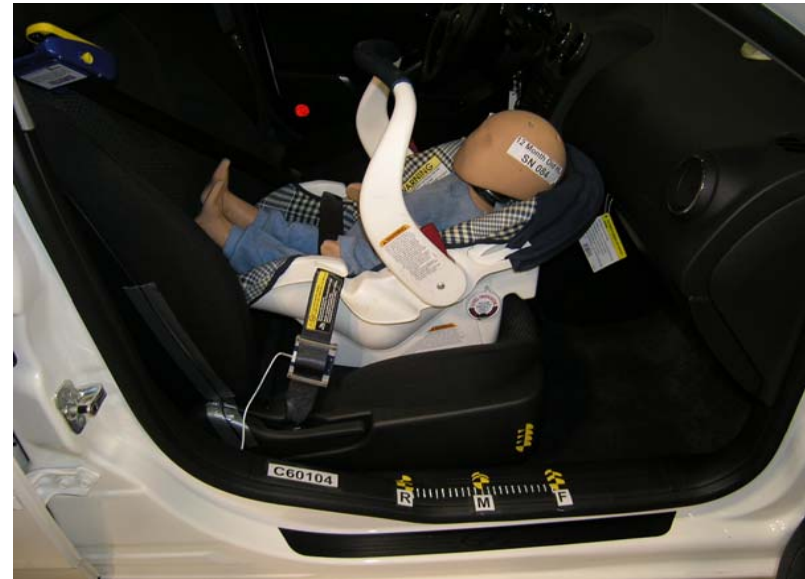

Graco Infant W/O Base With Belt,
Forward Seat Track, Handle Up



Graco Infant W/O Base With Belt,
Middle Seat Track, Handle Up



Graco Infant W/O Base With Belt,
Rearward Seat Track, Handle Down

DOT/NHTSA 208 Suppression Test – 2006 Pontiac G6 (C60104)

12 Month

Section B

Rear Facing CRS

E-11



Graco Infant W/O Base Unbelted,
Forward Seat Track, Handle Up



Graco Infant W/O Base Unbelted,
Middle Seat Track, Handle Up



Graco Infant W/O Base Unbelted,
Rearward Seat Track, Handle Down



Graco Infant W/O Base Fwd Facing Unbelted,
Forward Seat Track, Handle Up



Graco Infant W/O Base Fwd Facing Unbelted,
Middle Seat Track, Handle Up



Graco Infant W/O Base Fwd Facing Unbelted,
Rearward Seat Track, Handle Up



Unbelted 5th Percentile Female Reactivation,
Middle Seat Track

E-13



Britax Roundabout 161 Fwd Facing With Belt,
Forward Seat Track



Britax Roundabout 161 Fwd Facing With Belt,
Middle Seat Track



Britax Roundabout 161 Fwd Facing With Belt,
Rearward Seat Track



Britax Roundabout 161 Fwd Facing Unbelted,
Forward Seat Track

E-14



Britax Roundabout 161 Fwd Facing Unbelted,
Middle Seat Track



Britax Roundabout 161 Fwd Facing Unbelted,
Rearward Seat Track



Britax Roundabout 161 Rear Facing With Belt,
Forward Seat Track



Britax Roundabout 161 Rear Facing With Belt,
Middle Seat Track

E-15



Britax Roundabout 161 Rear Facing With Belt,
Rearward Seat Track



Britax Roundabout 161 Rear Facing Unbelted,
Forward Seat Track



Britax Roundabout 161 Rear Facing Unbelted,
Middle Seat Track



Britax Roundabout 161 Rear Facing Unbelted,
Rearward Seat Track



Unbelted 5th Percentile Female Reactivation,
Rearward Seat Track

E-17



Century Encore Fwd Facing With Belt,
Forward Seat Track



Century Encore Fwd Facing With Belt,
Middle Seat Track



Century Encore Fwd Facing With Belt,
Rearward Seat Track



Century Encore Fwd Facing Unbelted,
Forward Seat Track

E-18



Century Encore Fwd Facing Unbelted,
Middle Seat Track



Century Encore Fwd Facing Unbelted,
Rearward Seat Track



Century Encore Rear Facing With Belt,
Forward Seat Track



Century Encore Rear Facing With Belt,
Middle Seat Track

E-19



Century Encore Rear Facing With Belt,
Rearward Seat Track



Century Encore Rear Facing Unbelted,
Forward Seat Track



Century Encore Rear Facing Unbelted,
Middle Seat Track



Century Encore Rear Facing Unbelted,
Rearward Seat Track



Unbelted 5th Percentile Female Reactivation,
Middle Seat Track

E-21



Evenflo Medallion 254 Rear Facing With Belt,
Forward Seat Track



Evenflo Medallion 254 Rear Facing With Belt,
Middle Seat Track



Evenflo Medallion 254 Rear Facing With Belt,
Rearward Seat Track



Evenflo Medallion 254 Rear Facing Unbelted,
Forward Seat Track

E-22



Evenflo Medallion 254 Rear Facing Unbelted,
Middle Seat Track



Evenflo Medallion 254 Rear Facing Unbelted,
Rearward Seat Track



Evenflo Medallion 254 Fwd Facing With Belt,
Forward Seat Track



Evenflo Medallion 254 Fwd Facing With Belt,
Middle Seat Track

E-23



Evenflo Medallion 254 Fwd Facing With Belt,
Rearward Seat Track



Evenflo Medallion 254 Fwd Facing Unbelted,
Forward Seat Track



Evenflo Medallion 254 Fwd Facing Unbelted,
Middle Seat Track



Evenflo Medallion 254 Fwd Facing Unbelted,
Rearward Seat Track



Unbelted 5th Percentile Female Reactivation,
Forward Seat Track

DOT/NHTSA 208 Suppression Test – 2006 Pontiac G6 (C60104)

3 Year Old

Section C

Forward Facing Convertible CRS

E-25



3-Year-Old Fwd Facing Britax Roundabout Belted, Forward Seat Track



3-Year-Old Fwd Facing Britax Roundabout Belted, Middle Seat Track



3-Year-Old Fwd Facing Britax Roundabout Belted, Rearward Seat Track



Unbelted 5th Percentile Female Reactivation, Rearward Seat Track

E-26



3-Year-Old Fwd Facing Century Encore Belted,
Forward Seat Track



3-Year-Old Fwd Facing Century Encore Belted,
Middle Seat Track



3-Year-Old Fwd Facing Century Encore Belted,
Rearward Seat Track



Unbelted 5th Percentile Female Reactivation,
Middle Seat Track

E-27



3-Year-Old Fwd Facing Evenflo Medallion Belted,
Forward Seat Track



3-Year-Old Fwd Facing Evenflo Medallion Belted,
Middle Seat Track



3-Year-Old Fwd Facing Evenflo Medallion Belted,
Rearward Seat Track



Unbelted 5th Percentile Female Reactivation,
Forward Seat Track

DOT/NHTSA 208 Suppression Test – 2006 Pontiac G6 (C60104)

3 Year Old

Section D

Forward Facing Toddler

Belt Positioning Booster Seat



3-Year-Old Century Next Step Belted, Forward Seat Track



3-Year-Old Century Next Step Belted, Middle Seat Track



3-Year-Old Century Next Step Belted,
Rearward Seat Track



3-Year-Old Century Next Step Cinched With Harness,
Forward Seat Track

DOT/NHTSA 208 Suppression Test – 2006 Pontiac G6 (C60104)

3 Year Old

Section D

Forward Facing Toddler

Belt Positioning Booster Seat



3-Year-Old Century Next Step Cinched With Harness,
Middle Seat Track



3-Year-Old Century Next Step Cinched With Harness,
Rearward Seat Track



Unbelted 5th Percentile Female Reactivation,
Rearward Seat Track

DOT/NHTSA 208 Suppression Test – 2006 Pontiac G6 (C60104)

3 Year Old

Section D

Forward Facing Toddler

Belt Positioning Booster Seat

E-30



3-Year-Old Cosco High Back Booster Belted, Forward Seat Track



3-Year-Old Cosco High Back Booster Belted, Middle Seat Track



3-Year-Old Cosco High Back Booster Belted, Rearward Seat Track



3-Year-Old Cosco High Back Booster Cinched With Harness, Forward Seat Track

DOT/NHTSA 208 Suppression Test – 2006 Pontiac G6 (C60104)

3 Year Old

Section D

Forward Facing Toddler

Belt Positioning Booster Seat

E-31



3-Year-Old Cosco High Back Booster Cinched With Harness, Middle Seat Track



3-Year-Old Cosco High Back Booster Cinched With Harness, Rearward Seat Track



Unbelted 5th Percentile Female Reactivation, Middle Seat Track

DOT/NHTSA 208 Suppression Test – 2006 Pontiac G6 (C60104)

6 Year Old

Section D

Forward Facing Toddler

Belt Positioning Booster Seat



6-Year-Old Century Next Step Belted, Forward Seat Track



6-Year-Old Century Next Step Belted, Middle Seat Track



6-Year-Old Century Next Step Belted, Rearward Seat Track



Unbelted 5th Percentile Female Reactivation,
Rearward Seat Track

DOT/NHTSA 208 Suppression Test – 2006 Pontiac G6 (C60104)

6 Year Old

Section D

Forward Facing Toddler

Belt Positioning Booster Seat

E-33



6-Year-Old Cosco High Back Booster Belted,
Forward Seat Track



6-Year-Old Cosco High Back Booster Belted,
Middle Seat Track



6-Year-Old Cosco High Back Booster Belted,
Rearward Seat Track



Unbelted 5th Percentile Female Reactivation,
Rearward Seat Track

DOT/NHTSA 208 Suppression Test – 2006 Pontiac G6 (C60104)

6 Year Old

Section D

Forward Facing Toddler

Belt Positioning Booster Seat



6-Year-Old Evenflo Right Fit Belted, Forward Seat Track



6-Year-Old Evenflo Right Fit Belted, Middle Seat Track



6-Year-Old Evenflo Right Fit Belted, Rearward Seat Track



Unbelted 5th Percentile Female Reactivation,
Middle Seat Track

DOT/NHTSA 208 Suppression Test – 2006 Pontiac G6 (C60104)
3 Year Old

No CRS

E-35



3-Year-Old Unbelted, Forward Seat Track, Position 1



3-Year-Old Unbelted, Forward Seat Track, Position 2



3-Year-Old Unbelted, Forward Seat Track, Position 3



3-Year-Old Unbelted, Forward Seat Track, Position 4

DOT/NHTSA 208 Suppression Test – 2006 Pontiac G6 (C60104)
3 Year Old

No CRS

E-36



3-Year-Old Unbelted, Forward Seat Track, Position 5



3-Year-Old Unbelted, Forward Seat Track, Position 6



3-Year-Old Unbelted, Forward Seat Track, Position 7



3-Year-Old Unbelted, Middle Seat Track, Position 1

E-37



3-Year-Old Unbelted, Middle Seat Track, Position 2



3-Year-Old Unbelted, Middle Seat Track, Position 3



3-Year-Old Unbelted, Middle Seat Track, Position 4



3-Year-Old Unbelted, Middle Seat Track, Position 5



3-Year-Old Unbelted, Middle Seat Track, Position 6



3-Year-Old Unbelted, Middle Seat Track, Position 7



3-Year-Old Unbelted, Rearward Seat Track, Position 1



3-Year-Old Unbelted, Rearward Seat Track, Position 2



3-Year-Old Unbelted, Rearward Seat Track, Position 3



3-Year-Old Unbelted, Rearward Seat Track, Position 4



3-Year-Old Unbelted, Rearward Seat Track, Position 5



3-Year-Old Unbelted, Rearward Seat Track, Position 6

DOT/NHTSA 208 Suppression Test – 2006 Pontiac G6 (C60104)
3 Year Old

No CRS



3-Year-Old Unbelted, Rearward Seat Track, Position 7



Unbelted 5th Percentile Female Reactivation, Middle Seat Track

E-40

E-41



6-Year-Old Unbelted, Forward Seat Track, Position 1



6-Year-Old Unbelted, Forward Seat Track, Position 2



6-Year-Old Unbelted, Forward Seat Track, Position 3



6-Year-Old Unbelted, Forward Seat Track, Position 4

E-42



6-Year-Old Unbelted, Forward Seat Track, Position 4, View 2



6-Year-Old Unbelted, Middle Seat Track, Position 1



6-Year-Old Unbelted, Middle Seat Track, Position 2



6-Year-Old Unbelted, Middle Seat Track, Position 3

E-43



6-Year-Old Unbelted, Middle Seat Track, Position 4



6-Year-Old Unbelted, Middle Seat Track, Position 4, View 2



6-Year-Old Unbelted, Rearward Seat Track, Position 1



6-Year-Old Unbelted, Rearward Seat Track, Position 2

E-44



6-Year-Old Unbelted, Rearward Seat Track, Position 3



6-Year-Old Unbelted, Rearward Seat Track, Position 4



6-Year-Old Unbelted, Rearward Seat Track, Position 4, View 2



Unbelted 5th Percentile Female Reactivation,
Middle Seat Track

APPENDIX F
INSTRUMENTATION CALIBRATION

INSTRUMENTS FOR DRIVER DUMMY NO. 507

	SERIAL NO.	MANUFACTURER	CALIBRATION DATE
Head X	P49526	Endevco	04/04/06
Head Y	P49473	Endevco	04/04/06
Head Z	P49472	Endevco	04/04/06
Neck Load Cell	1703	Denton	06/05/06
Chest X	ET21315	Entran	05/31/06
Chest Y	ET21183	Entran	05/31/06
Chest Z	ET21159	Entran	05/31/06
Chest Displacement	507	Servo	08/11/06
Left Femur Load Cell	1360	Denton	06/08/06
Right Femur Load Cell	1359	Denton	06/08/06

INSTRUMENTS FOR PASSENGER DUMMY NO. 511

	SERIAL NO.	MANUFACTURER	CALIBRATION DATE
Head X	P49475	Endevco	04/04/06
Head Y	P49477	Endevco	04/04/06
Head Z	P49476	Endevco	04/04/06
Neck Load Cell	376	Denton	05/17/06
Chest X	P49478	Endevco	04/04/06
Chest Y	P49470	Endevco	04/04/06
Chest Z	P49506	Endevco	04/04/06
Chest Displacement	511	Servo	04/11/06
Left Femur Load Cell	1362	Denton	04/10/06
Right Femur Load Cell	1361	Denton	04/10/06

INSTRUMENTS FOR LOW RISK 5TH FEMALE DUMMY NO. 505 (P1)

	SERIAL NO.	MANUFACTURER	CALIBRATION DATE
Head X	A07-J05	Entran	04/11/06
Head Y	G22-L04	Entran	04/26/06
Head Z	J23-M09	Entran	04/26/06
Neck Load Cell	252	Denton	07/17/06
Chest X	J13709	Endevco	05/24/06
Chest Y	J17709	Endevco	05/24/06
Chest Z	J13541	Endevco	05/24/06
Chest Displacement	505	Servo	08/03/06
Left Femur Load Cell	84	Denton	07/14/06
Right Femur Load Cell	83	Denton	07/14/06

INSTRUMENTS FOR LOW RISK 5TH FEMALE DUMMY NO. 510 (P2)

	SERIAL NO.	MANUFACTURER	CALIBRATION DATE
Head X	P49471	Endevco	04/04/06
Head Y	P49480	Endevco	04/04/06
Head Z	P49468	Endevco	04/04/06
Neck Load Cell	606	Denton	06/06/06
Chest X	J23-M06	Entran	04/04/06
Chest Y	J23-M07	Entran	04/04/06
Chest Z	J23-M03	Entran	04/04/06
Chest Displacement	510	Servo	02/08/06
Left Femur Load Cell	1362	Denton	04/10/06
Right Femur Load Cell	1361	Denton	04/10/06

VEHICLE INSTRUMENTS

	SERIAL NO.	MANUFACTURER	CALIBRATION DATE
Left Rear Seat Crossmember X	C09-Y13	Entran	03/07/06
Right Rear Seat Crossmember X	C04-L15	Entran	03/07/06
Top of Engine X	J22033	Endevco	04/04/06
Bottom of Engine X	AGM47	Endevco	07/18/06
Left Brake Caliper X	J13642	Endevco	07/18/06
Right Brake Caliper X	AMRR4	Endevco	04/04/06
Instrument Panel X	J14-J16	Entran	04/04/06
Trunk Z	H06-L31	Entran	06/21/06

APPENDIX G
NOTICE OF TEST FAILURE

LABORATORY NOTICE OF APPARENT TEST FAILURE TO OVSC

FMVSS NO. 208 TEST DATE: June 12, 2006

LABORATORY: MGA Research Corporation

CONTRACT NO.: DTNH22-03-D-11002 DELV. ORDER NO.: #11

LABORATORY PROJECT ENGINEER'S NAME: Jeff Lewandowski

TEST SPECIMEN DESCRIPTION: 2006 Pontiac G6 Passenger Car

VEHICLE NHTSA NO.: C60104 VIN: 1G2ZF55B264278160

MFR: General Motors Corporation

APPARENT TEST FAILURE DESCRIPTION: TP208-13, Data Sheet 8, Step 19 The left, center, and right rear belt would not lock at the minimum length.

FMVSS REQUIREMENT, PARAGRAPH S S7.1.1.5(c)(7) :
The difference between the measurements recorded under S7.1.1.5(c)(6) and (4) shall not exceed 2 inches.

NOTIFICATION TO NHTSA (COTR): Charles Case

DATE: 6-12-2006 BY: Jeff Lewandowski

REMARKS: See the attached photograph of the certification label.



Vehicle certification label