

**RAPPORT D'ESSAI - TEST REPORT
COLLISION FRONTALE DE RECHERCHE
RESEARCH FRONTAL IMPACT**

VÉHICULE D'ESSAI / TEST VEHICLE FORD FREESTYLE 2005 TC # 05-226
--

**ESSAIS DE RECHERCHE CONJOINTS TC/NHTSA SUR LES
SACS GONFLABLES FRONTAUX
JOINT TC/NHTSA FRONTAL AIRBAGS RESEARCH TESTS**

Préparé par :
PMG TECHNOLOGIES
CENTRE D'ESSAIS ET DE RECHERCHE
100, rue du Landais
Blainville (Québec) J7C 5C9

N° de contrat : **05-5001**
Rapport N°: **RR05-240**

Pour :
TRANSPORTS CANADA
SÉCURITÉ ET SÛRETÉ
Programmes de sécurité routière
Recherche et essais de véhicules
Ottawa (Ontario)

Prepared by :
PMG TECHNOLOGIES
TEST AND RESEARCH CENTRE
100, rue du Landais
Blainville (Quebec) J7C 5C9

Contract N° : **05-5001**
Report N° : **RR05-240**

For :
TRANSPORT CANADA
SAFETY AND SECURITY
Research Engineering and
Vehicle Testing
Ottawa (Ontario)

Les résultats des essais figurant dans ce compte-rendu ne représentent pas une décision officielle du Ministère des Transports quant à l'acceptation de la performance sécuritaire, de la consommation de carburant ou de la conformité d'un véhicule ou des composantes d'un véhicule aux normes de sécurité et d'antipollution. Le Ministère des Transports ne certifie, n'approuve ou n'endosse aucun produit de véhicule automobile.

The test results presented herein do not, in themselves, represent an official determination by the Department of Transport with fuel consumption or compliance with safety and emission standards of any motor vehicle or motor vehicle component. The Department of Transport does not certify, approve or endorse any motor vehicle product.

Date de collision Crash date	2005-03-30	Véhicule Vehicle	FORD FREESTYLE 2005	T.C. N° T.C.No	05-226
---------------------------------	-------------------	---------------------	----------------------------	-------------------	---------------

VÉHICULE D'ESSAI - TEST VEHICLE

Fabricant - Manufacturer FORD MOTOR CO.	Type de carrosserie - Body Style Hayon 5P / 5D Hatchback	Marque, modèle, Année - Make, model, Year FORD FREESTYLE 2005
Classe de véhicule - Class of vehicle VTUM / MPV	Boîte de vitesse - Transmission Type Auto. avant / Auto. Front wheel	Moteur - Engine V6 trans. avant / V6 trans. front
Date de fabrication - Date of Manufacture 01/05	Cylindres - Cylinders 3.0 Lit.	N° d'ident. du véhicule - Vehicle Ident. No. 1FMDK011X5GA33584
Lecture de l'odomètre - Odometer Reading 46 km	Nombre de places assises désignées Number of Designated Seating Positions 6	Numéro d'ident. PMG - PMG Ident. Number UN5-251
PNBV - GVWR 2440 kg	PNBE (Avant) - GAWR (Front) 1224 kg	PNBE (Arrière) - GAWR (Rear) 1270 kg



CONFIGURATION D'ESSAI - TEST CONFIGURATION

Type d'essai - Test type Véh. vs barrière - Veh. vs barrier	Vitesse d'impact- Impact velocity Prévu / Intended : 56.0 km/h Obtenu / Obtained : 56.4 km/h		Angle d'impact Impact angle 0 °	Masse du véhicule d'essai Test vehicle mass 2033.0 kg
Description et position du mannequin (conducteur) Dummy description and position (driver) Description Hybrid III (5 %)	Position ** 0 mm	Description et position du mannequin (passager avant) Dummy description and position (front passenger) Description Hybrid III (5 %)	Position ** 0 mm	
Description et position du mannequin (passager arrière gauche) Dummy description and position (left rear passenger) Description N/A	Position ** N/A	Description et position du mannequin (passager arrière droit) Dummy description and position (right rear passenger) Description Hybrid III (5 %)	Position ** N/A	

RÉSULTATS GÉNÉRAUX - GENERAL RESULTS

Déploiement des sacs gonflables - Airbags deployment Coussins frontaux - Frontal airbags		Déploiement des sacs gonflables - Airbags deployment Coussins latéraux - Lateral airbags	
Conducteur / Driver	Passager / Passenger	Conducteur / Driver	Passager / Passenger
Déployé / Deployed 19.1ms	Déployé / Deployed 20.4ms	N/A 0.0	N/A 0.0
Rétracteurs de ceintures-prétensionneurs Seat belts retractors-pretensioners		Limiteur de charge des ceintures de sécurité Seat belts load limiter	
Conducteur / Driver	Passager / Passenger	Conducteur / Driver	Passager / Passenger
Déployé / Deployed	Déployé / Deployed	Non-équipé / Not equipped	Non-équipé / Not equipped

**Essai réalisé selon la procédure de PMG : Collision frontale de recherche, version 3, révision 10 avril 2000.
Test performed according to PMG procedure: Research frontal impact, version 3, revised april 10, 2000.**

Préparé par : Prepared by : 	Digitally signed by Pierre Beauchamp Date: 2005.09.14	Approuvé par : Approved by :
Vérifié par : Verified by : 	Digitally signed by Linda Allard Date: 2005.09.14	Accepté par : Accepted by :

- * Tel qu'observé avec l'application d'une charge de 12V après l'essai.
- * As observed by a 12V application after the test.
- ** Référence : 0 est la position la plus avancée. / ** Reference : 0 is the foremost position.

Date de collision Crash date	2005-03-30	Véhicule Vehicle	FORD FREESTYLE 2005	T.C. N° T.C.No	05-226
---------------------------------	-------------------	---------------------	----------------------------	-------------------	---------------

DONNÉES DU VÉHICULE D'ESSAI / TEST VEHICLE DATA

Capacité du véhicule - Vehicle Capacity 521 kg	Masse des bagages - Cargo Load 101 kg	Type de sièges - Type of seats		Types de dossiers - Type of seat back			
			Avt - Frt	Arr - Rr		Avt - Frt	Arr - Rr
Nombre d'occupants (places assises désignées) Number of Occupants (Designated Seating Positions)		Banquette Bench			Dossier ajustable Adjustable Seat Back	X	X
Avant - Front 2 Arrière - Rear 2+2 Total 6		Baquet Bucket	X	X	Dossier non-ajustable Non-adjustable Seat Back		
Volume de carburant pour l'essai Fuel system test volume 65.40 l	Pression à froid - Cold Tire Pressure			Dimension - Size			
	Avant - Front 220 kPa	Arrière - Rear 235 kPa	Secours - Spare 415 kPa	P215/65R17			

PREMIÈRE PESÉE : VÉHICULE TEL QUE LIVRÉ (AVEC LIQUIDES AU MAXIMUM)

FIRST WEIGHT : VEHICLE AS RECEIVED (WITH MAXIMUM FLUIDS)

Avant gauche - Left front 515.0 kg	Avant droit - Right front 511.8 kg	Masse avant totale - Total front weight 1026.8 kg
Arrière gauche - Left rear 393.5 kg	Arrière droit - Right rear 390.3 kg	Masse arrière totale - Total rear weight 783.8 kg
Masse totale côté gauche - Total left side weight 908.5 kg	Masse totale côté droit - Total right side weight 902.1 kg	Masse totale - Total weight 1810.6 kg

TROISIÈME PESÉE : VÉHICULE PRÊT POUR L'ESSAI

THIRD WEIGHT : VEHICLE READY FOR TEST

Avant gauche - Left front 545.4 kg	Avant droit - Right front 561.6 kg	Masse avant totale - Total front weight 1107.0 kg
Arrière gauche - Left rear 462.6 kg	Arrière droit - Right rear 463.4 kg	Masse arrière totale - Total rear weight 926.0 kg
Masse totale côté gauche - Total left side weight 1008.0 kg	Masse totale côté droit - Total right side weight 1025.0 kg	Masse totale - Total weight 2033.0 kg

ATTITUDE DU VÉHICULE / VEHICLE ATTITUDE

		Attitude tel que livré Attitude on delivery	Attitude tel que testé Attitude as tested
1	Roue avant gauche* Left front wheel*	782 mm	772 mm
2	Roue avant droite* Front right wheel*	786 mm	772 mm
3	Roue arrière droite* Rear right wheel*	797 mm	772 mm
4	Roue arrière gauche* Rear left wheel*	790 mm	669 mm

* Mesures prises aux puits de roues. // *Measurements taken at wheel openings.

Vue de plan / Plan view

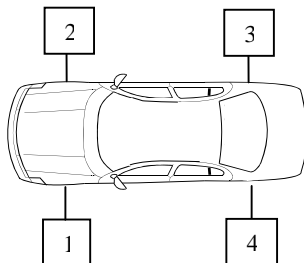

Vue de côté / Side view

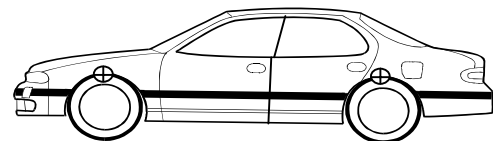

⊕ Points de mesure / Measurement points

Date de collision Crash date	2005-03-30	Véhicule Vehicle	FORD FREESTYLE 2005	T.C. N° T.C.No	05-226
---------------------------------	-------------------	---------------------	----------------------------	-------------------	---------------

**EMPLACEMENT DES ACCÉLÉROMÈTRES
ACCELEROMETER LOCATIONS**

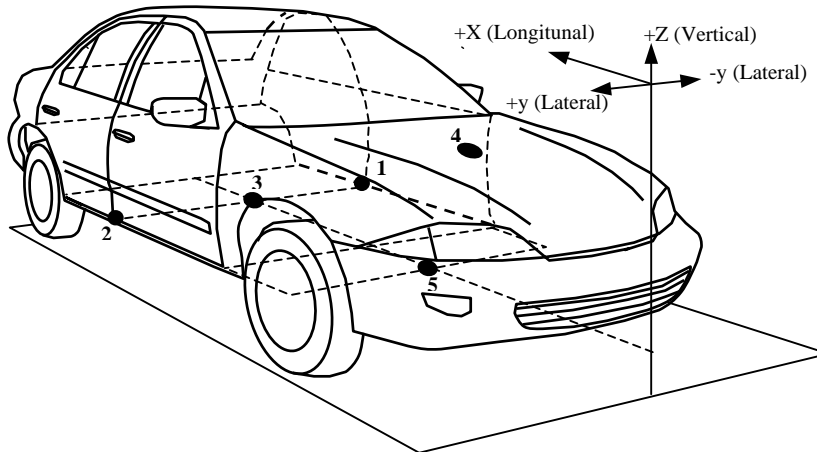

Point de référence : Centre transversal du véhicule, au point le plus avancé, au niveau du sol. Selon SAE J182a.
Reference point : Transversal center of the vehicle, at the foremost point and at ground level. As per SAE J182a.

EMPLACEMENT LOCATION	DESCRIPTIONS	COORDONNÉES / COORDINATES (mm)		
		X	Y	Z
#1	Seuil de la porte gauche @ pilier "B" Left door sill @ pillar "B"	2635	-614	329
#2	Seuil de la porte droite @ pilier "B" Right door sill @ pillar "B"	2679	611	327
#3	Centre de gravité Centre of gravity	2700	0	454
#4	Le dessus du moteur Top of engine	-	-	-
#5	Le dessous du moteur Bottom of engine	-	-	-

Date de collision Crash date	2005-03-30	Véhicule Vehicle	FORD FREESTYLE 2005	T.C. N° T.C.No	05-226
---------------------------------	-------------------	---------------------	----------------------------	-------------------	---------------

MESURES NHTSA / NHTSA MEASUREMENTS

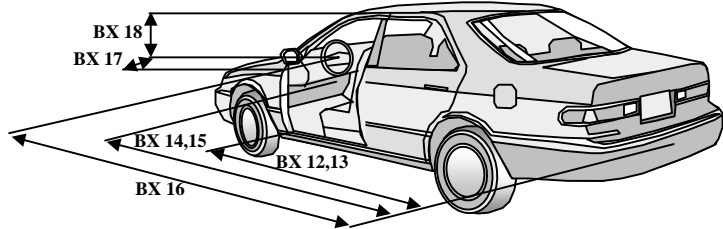
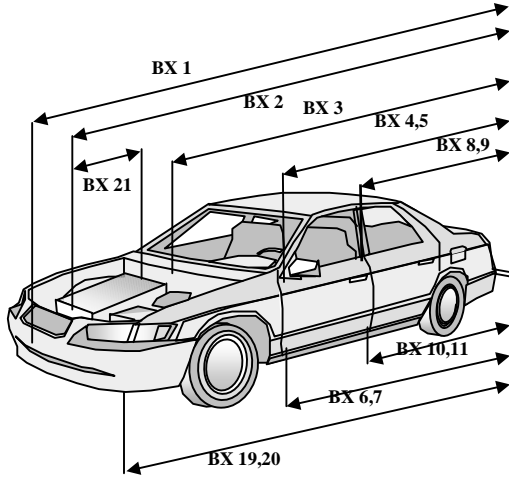

- 1 - Longueur totale du véhicule
Total length of vehicle
- 2 - Surface arrière à l'avant du bloc moteur
Rear surface at front of engine block
- 3 - Surface arrière à la cloison pare-feu
Rear surface at fire-wall
- 4 - Surface arrière à la partie supérieure avant porte avant droite
Rear surface of front superior part of right front door
- 5 - Surface arrière à la partie supérieure avant porte avant gauche
Rear surface of front superior part of left front door
- 6 - Surface arrière à la partie inférieure avant porte avant droite
Rear surface of front inferior part of right front door
- 7 - Surface arrière à la partie inférieure avant porte avant gauche
Rear surface of front inferior part of left front door
- 8 - Surface arrière à la partie supérieure arrière porte avant droite
Rear surface of rear superior part of right rear door
- 9 - Surface arrière à la partie supérieure arrière porte avant gauche
Rear surface of rear superior part of left rear door
- 10 - Surface arrière à la partie inférieure arrière porte avant droite
Rear surface of rear inferior part of right rear door
- 11 - Surface arrière à la partie inférieure arrière porte avant gauche
Rear surface of rear inferior part of left rear door
- 12 - Surface arrière à la partie inférieure du pilier "A" droit
Rear surface of rear inferior part of right pillar "A"
- 13 - Surface arrière à la partie inférieure du pilier "A" gauche
Rear surface of rear inferior part of left pillar "A"
- 14 - Surface arrière à la cloison pare-feu côté droit
Rear surface of right side of fire-wall
- 15 - Surface arrière à la cloison pare-feu côté gauche
Rear surface of left side of fire-wall
- 16 - Surface arrière à la colonne de direction
Rear surface of steering column
- 17 - Centre de la colonne de direction au pilier "A"
Centre of steering column to pillar "A"
- 18 - Centre de la colonne de direction au toit
Centre of steering column to roof
- 19 - Surface arrière du véhicule au coin droit du pare-choc avant
Rear surface of vehicle to right corner of front bumper
- 20 - Surface arrière du véhicule au coin gauche du pare-choc avant
Rear surface of vehicle to left corner of front bumper
- 21 - Longueur du bloc moteur
Length of engine block

	BX*	AX**	ΔX		BX*	AX**	ΔX
1	5075	4558	517	12	3431	3417	14
2	4535	4269	266	13	3431	3414	17
3	3894	3790	104	14	3620	3540	80
4	3481	3471	10	15	3774	3690	84
5	3460	3476	-16	16	3042	3081	-39
6	3479	3469	10	17	434	430	4
7	3482	3471	11	18	495	517	-22
8	2415	2406	9	19	5028	4540	488
9	2413	2401	12	20	5025	4442	583
10	2441	2432	9	21	405	415	-10
11	2440	2430	10				

Mesures en mm / Measurements in mm

* BX : Mesures du véhicule avant-essai. / Pre-test vehicle measurements data.

** AX : Mesures du véhicule après-essai. / Post-test vehicle measurements data.

REMARQUES / COMMENTS : Aucune / None.

Date de collision Crash date	2005-03-30	Véhicule Vehicle	FORD FREESTYLE 2005	T.C. N° T.C.No	05-226
---------------------------------	-------------------	---------------------	----------------------------	-------------------	---------------

MESURES DES DPD / DPD'S MEASUREMENTS

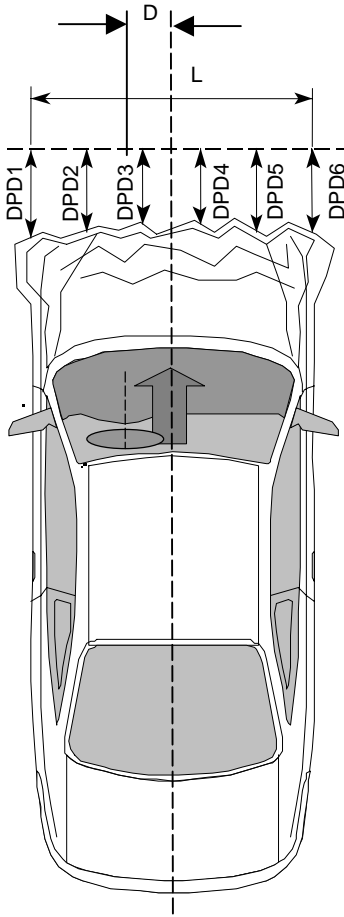

- DPD 1:
- DPD 2:
- DPD 3:
- DPD 4:
- DPD 5:
- DPD 6:
- MESURE L:
- MEASUREMENT L:
- MESURE D:
- MEASUREMENT D:

AVANT ESSAI PRE-TEST	APRÈS ESSAI POST-TEST	Δx
263	722	-459
66	578	-512
11	525	-514
10	510	-500
64	494	-430
245	698	-453
	1600	
	0	

Mesures en mm / Measurements in mm

L : Longueur de la région endommagée
Length of damaged region

D : Distance du centre de déformation à la ligne de centre du véhicule
Midpoint of damage to Vehicle Longitudinal Centerline

REMARQUES / COMMENTS : Aucune / None.

Date de collision Crash date	2005-03-30	Véhicule Vehicle	FORD FREESTYLE 2005	T.C. N° T.C.No	05-226
---------------------------------	-------------------	---------------------	----------------------------	-------------------	---------------

MESURES DE VÉHICULE
VEHICLE MEASUREMENTS

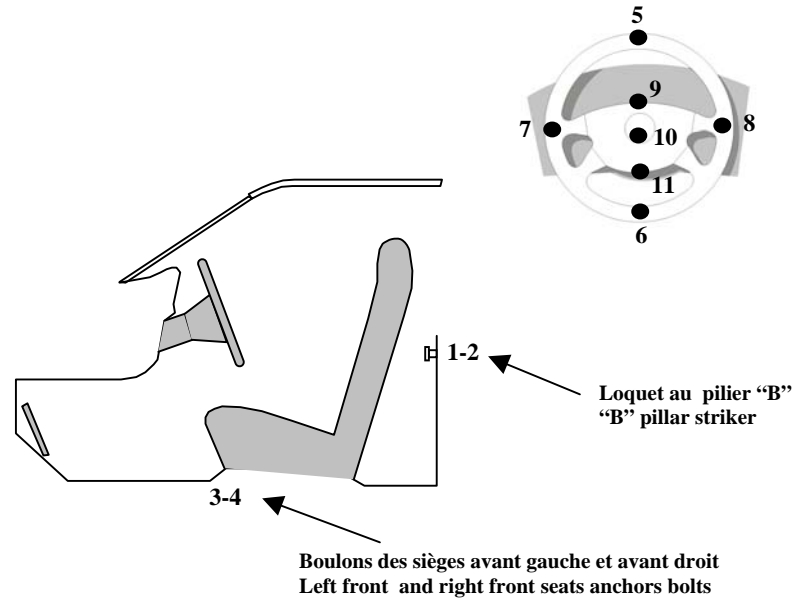
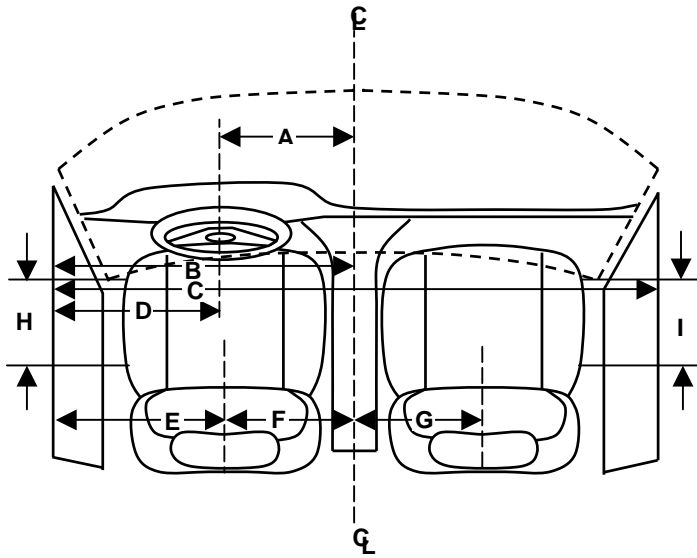

Code	Description	mm
A	Centre du volant à la ligne de centre du véhicule Steering wheel center to center line of vehicle	373
B	Seuil de fenêtre à la ligne de centre du véhicule Window edge to center line of the vehicle	874
C	Fenêtre à fenêtre Window to window	1747
D	Centre du volant au seuil de la fenêtre Steering wheel center to window edge	501
E	Seuil de la fenêtre au centre du siège (conducteur) Window edge to seat midline (driver)	495
F	Centre du siège à la ligne de centre du véhicule (conducteur) Seat midline to center line of vehicle (driver)	379
G	Centre du siège à la ligne de centre du véhicule (passager) Seat midline to center line of vehicle (passenger)	381
H	Course du siège (conducteur) Seat travel (driver)	242
I	Course du siège (passager) Seat travel (passenger)	244
J	Ajustement du volant Steering wheel adjustment	39
K	Ajustement de la ceinture baudrier Upper torso belt adjustment	94

Code	Description	X(mm)	Y(mm)	Z(mm)
1	Loquet au pilier "B" (conducteur) "B" pillar striker (driver)	2571	-817	764
2	Loquet au pilier "B" (passager) "B" pillar striker (passenger)	2572	815	765
3	Boulon siège avant, extérieur (conducteur) Front seat bolt, outboard (driver)	2059	-582	366
4	Boulon siège avant, extérieur (passager) Front seat bolt, outboard (passenger)	2060	582	365
5	Jante du volant, centre haut Steering wheel rim, top centre	1940	-373	1196
6	Jante du volant, centre bas Steering wheel rim, bottom centre	2095	-373	849
7	Jante du volant, centre gauche Steering wheel rim, left centre	2024	-562	1021
8	Jante du volant, centre droit Steering wheel rim, right centre	2017	-183	1021
9	Moyeu du volant, centre haut Steering wheel hub, top centre	1995	-372	1055
10	Moyeu du volant, centre Steering wheel hub, centre	2046	-373	990
11	Moyeu du volant, centre bas Steering wheel hub, bottom centre	2067	-373	926
12	Centre du volant Center of steering wheel	2033	-373	1022

Point de référence : Centre transversal du véhicule, au point le plus avancé, au niveau du sol. Selon SAE J182a.
Reference point : Transversal center of the vehicle, at the foremost point and at ground level. As per SAE J182a.

Remarques - Comments: Aucune / None.

Date de collision Crash date	2005-03-30	Véhicule Vehicle	FORD FREESTYLE 2005	T.C. N° T.C.No	05-226
---------------------------------	-------------------	---------------------	----------------------------	-------------------	---------------

MESURES DE VÉHICULE (SIÈGE ARRIÈRE)
VEHICLE MEASUREMENTS (REAR SEAT)

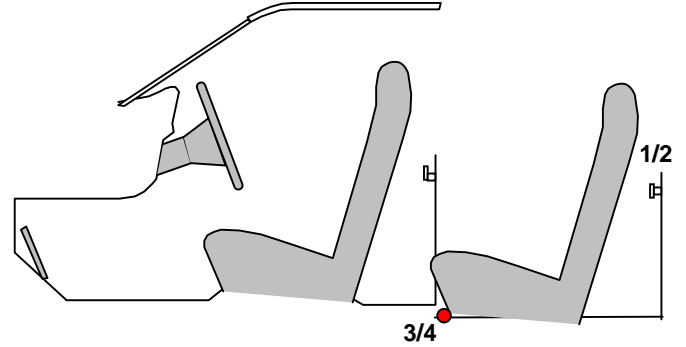
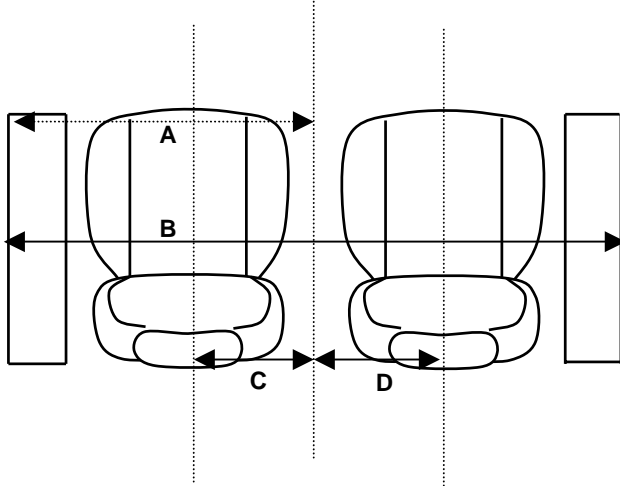

Code	Description	mm
A	Seuil de fenêtre à la ligne de centre du véhicule Window edge to center line of the vehicle	866
B	Fenêtre à fenêtre Window to window	1731
C	Centre du siège à la ligne de centre du véhicule (passager gauche) Seat midline to center line of vehicle (left passenger)	-
D	Centre du siège à la ligne de centre du véhicule (passager droit) Seat midline to center line of vehicle (right passenger)	397

Code	Description	X(mm)	Y(mm)	Z(mm)
1	Loquet au pilier "B" (conducteur) "B" pillar striker (driver)	-	-	-
2	Loquet au pilier "B" (passager) "B" pillar striker (passenger)	3665	821	933
3	Boulon siège avant, extérieur (conducteur) Front seat bolt, outboard (driver)	-	-	-
4	Boulon siège avant, extérieur (passager) Front seat bolt, outboard (passenger)	-	-	-

Point de référence : Centre transversal du véhicule, au point le plus avancé, au niveau du sol. Selon SAE J182a.
Referene point : Transversal center of the vehicle, at the foremost point and at ground level. As per SAE J182a.

Remarques - Comments: Aucune / None.

Date de collision Crash date	2005-03-30	Véhicule Vehicle	FORD FREESTYLE 2005	T.C. N° T.C.No	05-226
---------------------------------	-------------------	---------------------	----------------------------	-------------------	---------------

POSITIONNEMENT DES MANNEQUINS / MEASUREMENTS OF DUMMY POSITIONS

		<u>MESURES / MEASUREMENTS :</u>					
Conducteur/Driver :	Hybrid III (5 %)	Toutes les mesures sont en mm / All measurements are in mm					
Angle du pelvis - Pelvic angle :	20.2°	Conducteur / Driver			Passager / Passenger		
Angle transversal - Transversal angle :	0.4°	Ajustement du siège : Seat adjustment :			Ajustement du siège : Seat adjustment :		
Angle de la tête - Head angle :	0.0°	Électrique / Electrical			Micro-crans / Micro notches		
Seuil de porte - Door sill :	0.0°	Angle du dossier : Seat back angle :			Angle du dossier : Seat back angle :		
Mouvement du lacet / Yaw movement :	2 mm	10.0 °			10.0 °		
Position de la rail du siège / Seat track position * :	0 mm	X	Y	Z	X	Y	Z
Passager avant/Front Passenger:	Hybrid III (5 %)	2351	-445	1236	2337	458	1227
Angle du pelvis - Pelvic angle :	19.5°	2204	-542	673	2200	549	658
Angle transversal - Transversal angle :	0.3°	1870	-513	726	1869	515	740
Angle de la tête - Head angle :	0.5°						
Seuil de porte - Door sill :	0.0°						
Mouvement du lacet / Yaw movement :	2 mm						
Position de la rail du siège / Seat track position * :	0 mm						
Cible de tête / Head target :							
Point-H / H-Point :							
Rotule / Knee joint :							

Remarques – Comments : Aucune / None.

* **Référence : 0 est la position la plus avancée.**

* **Reference : 0 is the foremost position.**

Selon la procédure de positionnement de mannequin 5^e percentile Hybrid III, 49 CFR 552, 571, 585 and 595, Docket No. NHTSA 00-7013; Notice 1, RIN 2127-AG70, Federal Motor Vehicle Safety Standards, Occupant Crash Protection (Paragraphe S16.3).

As per procedure for placement of a 5th percentile Hybrid III 49 CFR 552, 571, 585 and 595, Docket No. NHTSA 00-7013; Notice 1, RIN 2127-AG70, Federal Motor Vehicle Safety Standards, Occupant Crash Protection (Section S16.3).

Point de référence : Centre transversal du véhicule, au point le plus avancé, au niveau du sol. Selon SAE J182a.

Reference point : Transversal center of the vehicle, at the foremost point and at ground level. As per SAE J182a.

Date de collision Crash date	2005-03-30	Véhicule Vehicle	FORD FREESTYLE 2005	T.C. N° T.C.No	05-226
---------------------------------	-------------------	---------------------	----------------------------	-------------------	---------------

POSITIONNEMENT DES MANNEQUINS / MEASUREMENTS OF DUMMY POSITIONS

		<u>MESURES / MEASUREMENTS :</u>					
Passager arrière gauche : Rear left passenger :	N/A	Toutes les mesures sont en mm / All measurements are in mm					
Angle du pelvis - Pelvic angle :	N/A	Passager arrière gauche Rear left passenger			Passager arrière droit Rear right passenger		
Angle transversal - Transversal angle :	N/A	Ajustement du siège : Seat adjustment :			Ajustement du siège : Seat adjustment :		
Angle de la tête - Head angle :	N/A	N/A			N/A		
Mouvement du lacet / Yaw movement :	N/A	Ajustement du dossier : Seat back adjustment :			Ajustement du dossier : Seat back adjustment :		
Passager arrière droit : Rear right passenger :	Hybrid III (5 %)	N/A			N/A		
Angle du pelvis - Pelvic angle :	19.8°	X	Y	Z	X	Y	Z
Angle transversal - Transversal angle :	0.3°						
Angle de la tête - Head angle :	1.6°						
Mouvement du lacet / Yaw movement :	0.0°						
Cible de tête / Head target :		-	-	-	3395	471	1268
Point-H / H-Point :		-	-	-	3252	548	702
Rotule / Knee joint :		-	-	-	2914	523	723

Remarques – Comments : Aucune / None.

Selon la procédure de positionnement de mannequin 5^e percentile Hybrid III, 49 CFR 552, 571, 585 and 595, Docket No. NHTSA 00-7013; Notice 1, RIN 2127-AG70, Federal Motor Vehicle Safety Standards, Occupant Crash Protection (Paragraphe S16.3).

As per procedure for placement of a 5th percentile Hybrid III 49 CFR 552, 571, 585 and 595, Docket No. NHTSA 00-7013; Notice 1, RIN 2127-AG70, Federal Motor Vehicle Safety Standards, Occupant Crash Protection (Section S16.3).

Point de référence : Centre transversal du véhicule, au point le plus avancé, au niveau du sol. Selon SAE J182a.
Reference point : Transversal center of the vehicle, at the foremost point and at ground level. As per SAE J182a.

Date de collision Crash date	2005-03-30	Véhicule Vehicle	FORD FREESTYLE 2005	T.C. N° T.C.No	05-226
---------------------------------	------------	---------------------	---------------------	-------------------	--------

COTES DE LOCALISATION DES MANNEQUINS
DUMMY LOCATION DATA

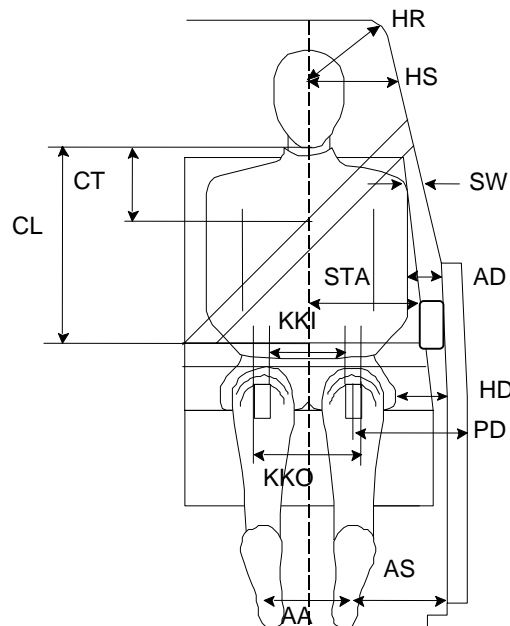
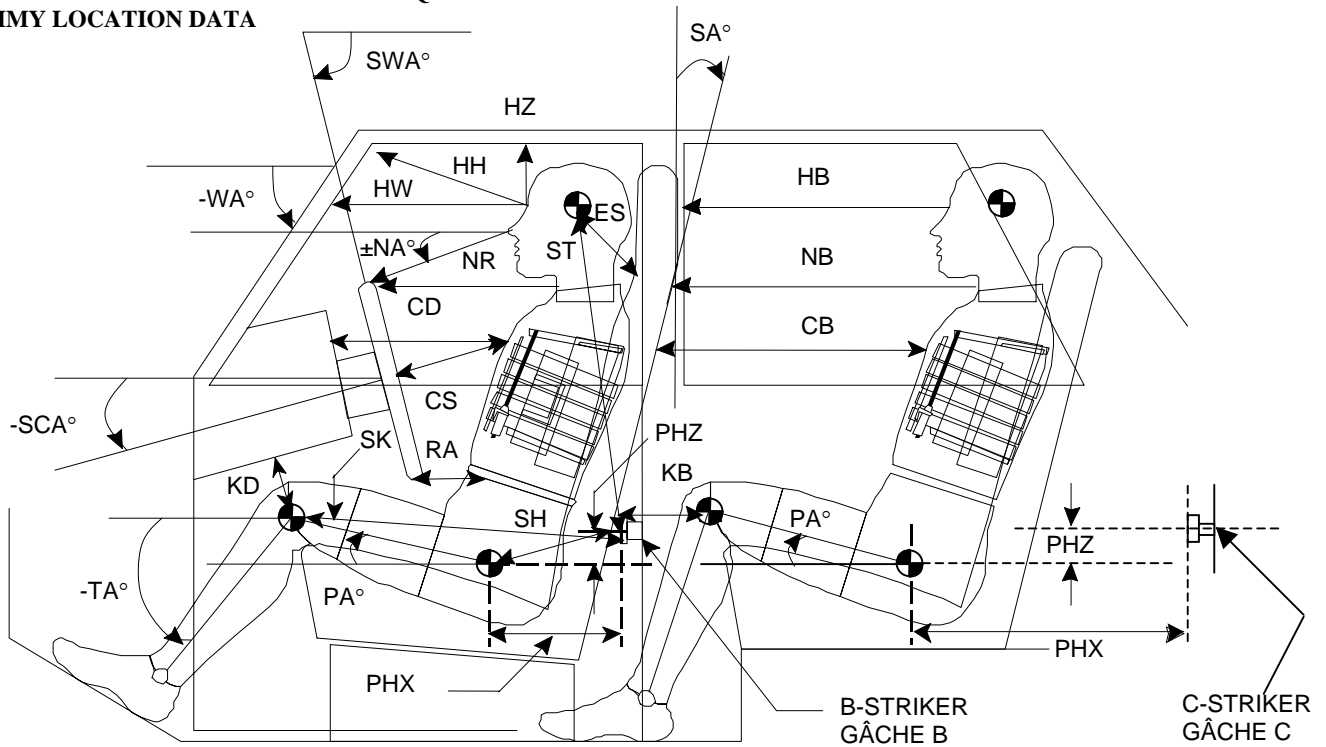

référence
reference :

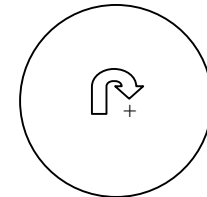

Date de collision Crash date	2005-03-30	Véhicule Vehicle	FORD FREESTYLE 2005	T.C. N° T.C.No	05-226
---------------------------------	-------------------	---------------------	----------------------------	-------------------	---------------

COTES DE LOCALISATION DES MANNEQUINS (suite)

DUMMY LOCATION DATA (continued)

(Mesures prises en mm / Measurements taken in mm)

DESCRIPTION	CODE	CONDUCTEUR DRIVER	PASSAGER Av. F. PASSENGER	PASSAGER Arr.G. L.R. PASSENGER	PASSAGER Arr.D. R.R. PASSENGER
De cheville à cheville (boulon extérieur) Ankle to ankle (exterior bolt)	AA	280	255		250
Genou à genou (plaque) Intérieur / Interior Centre / Center Knee to knee (plate) Extérieur / Extérieur	KKI	120	95		95
	KKC	190	165		165
	KKO	260	235		235
De la cheville jusqu'au seuil de porte (horizontalement) Ankle to door sill (horizontal)	AS	210	153		190
Centre du genou au tableau de bord ou siège horizontalement (minimum) Knees centre to dash or seat back horizontal (minimum)	KDL	5	25		360
	KDR	25	32		355
Sternum au tableau de bord (horizontalement) Chest to dash (horizontal)	CD		340		
Milieu du sternum au centre du moyeu du volant ou siège avant Mid sternum to steering hub center or front seat	CS/CB	205			690
Milieu du front jusqu'au pare-brise (horizontalement) Mid forehead to windshield (horizontal)	HW	675	685		655
Milieu du front jusqu'au haut du pare-brise Mid forehead to windshield header	HH	330	352		700
Nez à la jante du volant de direction (haut) ou siège avant Nose to steering wheel rim (top) or front seat	NR/HB	280			
Milieu du front jusqu'au début du toit Mid forehead to edge roof	HR	301	307		290
Haut de l'oreille au haut du siège avant Ear top to front seat top	ES	245	251		220
Menton au haut de la ceinture sous-abdominale (verticalement) Chin to lap belt upper edge (vertical)	CL	374	372		370
Menton au haut de la ceinture baudrier (verticalement) Chin to thorax belt upper edge (vertical)	CT	124	125		125
Milieu du front à la fenêtre latérale (horizontalement) Mid forehead to side window (horizontal)	HS	395	395		345
La rotule à la porte (horizontalement) Patella to door (horizontal)	PD	210	210		210
Du point-H à la porte (horizontalement) H-point to door (horizontal)	HD	245	233		175
Du milieu du bras à la porte (horizontalement) Mid upper arm to door (horizontal)	AD	145	166		163
Cou jusqu'au volant ou tableau de bord (horizontalement) ou siège avant Neck to steering wheel or dash board (horizontal) or front seat	NB	374	488		730
Épaule à la fenêtre de côté Shoulder to side window	SW	182	172		163
Abdomen à l'appui-bras Abdomen to armrest	STA	160	157		175
Milieu du front au toit (verticalement) Mid forehead to roof (vertical)	HZ	207	217		360
Tête au loquet (plan (x,z)) Striker to head ((x,z) plan)	ST	521	518		440
Abdomen à la jante du volant de direction (bas) Steering wheel rim to abdomen (bottom)	RA	96			
Genou au loquet (plan (x,z)) Striker to knee ((x,z) plan)	SK	702	703		790
Point-H au loquet (plan (x,z)) Striker to H-Point ((x,z) plan)	SH	378	387		470
Point-H au loquet en X (horizontalement) Striker to H-Point in X (horizontal)	PHX	367	372		420
Point-H au loquet en Z (verticalement) Striker to H-Point in Z (vertical)	PHZ	91	107		240

Date de collision Crash date	2005-03-30	Véhicule Vehicle	FORD FREESTYLE 2005	T.C. N° T.C.No	05-226
---------------------------------	-------------------	---------------------	----------------------------	-------------------	---------------

COTES DE LOCALISATION DES MANNEQUINS (suite)

DUMMY LOCATION DATA (continued)

(Mesures prises en deg. / Measurements taken in deg.)

DESCRIPTION	CODE	CONDUCTEUR DRIVER	PASSAGER Av. F. PASSENGER	PASSAGER Arr.G. L.R. PASSENGER	PASSAGER Arr.D. R.R. PASSENGER
Angle du volant Steering wheel angle	+SWA	64.9°			
Angle du pare-brise Windshield angle	-WA	-30.5°			
Angle de la colonne de direction Steering column angle	-SCA	-25.0°			
Angle du tibia gauche Left tibial angle	-TA	-23.4°	-17.9°		-16.3°
Angle du tibia droit Right tibial angle	-TA	-16.5°	-16.7°		-15.7°
Angle pelvis Pelvic angle	+PA	20.2°	19.5°		19.8°
Angle du nez à la jante de direction (haut) Nose to steering wheel rim (top) angle	±NA	-4.0°			
Angle du dossier Seat back angle	+SA	10.0°	10.0°		16.5°
Angle ST (horizontalement) ST angle (horizontal)	+ST-A	65.0°	63.0°		
Angle SK (horizontalement) SK angle (horizontal)	±SK-A	-3.1°	-2.0°		
Angle SH (horizontalement) SH angle (horizontal)	-SH-A	-13.9°	-16.0°		

Date de collision Crash date	2005-03-30	Véhicule Vehicle	FORD FREESTYLE 2005	T.C. N° T.C.No	05-226
---------------------------------	-------------------	---------------------	----------------------------	-------------------	---------------

**MESURES DE MANNEQUIN DAE
TEST DUMMY MEASUREMENTS**

CONDUCTEUR / DRIVER

Description et emplacement du Mannequin
ATD description and location :

DESCRIPTION	X(mm)	Y(mm)	Z(mm)
Centre de gravité de la tête, extérieur - Head CG, outboard	2351	-445	1236
Base du nez - Glabella (root of nose)	2261	-379	1250
Menton - Chin (bottom)	2261	-379	1139
Jonction menton et cou - Chin / neck junction	2326	-379	1163
Thorax au niveau des côtes supérieures - Chest at upper rib level	2240	-384	981
Thorax au niveau des côtes inférieures - Chest at lower rib level	2211	-385	874
Boulon supérieur avant de l'épaule, ext. - Shoulder bolt, top front outboard	2374	-537	1010
Boulon supérieur avant de l'épaule, int. - Shoulder bolt, top front inboard	2369	-223	1011
Boulon du coude, extérieur - Elbow bolt, outboard	2218	-628	891
Boulon du coude, intérieur - Elbow bolt, inboard	2213	-104	920
Boulon du poignet, extérieur - Wrist bolt, outboard	2056	-596	1031
Boulon du poignet, intérieur - Wrist bolt, inboard	2052	-152	1063
Point d'articulation de la hanche, extérieur - Hip point, outboard	2291	-500	711
Boulon du genou gauche, extérieur - Knee bolt, left leg, outboard	1870	-514	724
Boulon de la cheville gauche, extérieur - Ankle bolt, left leg , outboard	1717	-450	424
Point du talon gauche - Heel point, left leg	1772	-448	307
Plante du pied gauche vs plancher - Ball of foot at toeboard contact, left leg	1642	-485	339
Boulon du genou droit, intérieur - Knee bolt, right leg , inboard	1868	-322	728
Boulon de la cheville droite, intérieur - Ankle bolt, right leg , inboard	1727	-248	431
Point du talon droit - Heel point, right leg	1751	-260	305
Plante du pied droit vs plancher - Ball of foot at toeboard contact, right leg	1629	-270	376

Remarques – Comments : Aucune / None.

Date de collision Crash date	2005-03-30	Véhicule Vehicle	FORD FREESTYLE 2005	T.C. N° T.C.No	05-226
---------------------------------	-------------------	---------------------	----------------------------	-------------------	---------------

**MESURES DE MANNEQUIN DAE
TEST DUMMY MEASUREMENTS**

PASSAGER / PASSENGER

Description et emplacement du Mannequin
ATD description and location:

DESCRIPTION	X(mm)	Y(mm)	Z(mm)
Centre de gravité de la tête, extérieur - Head CG, outboard	2337	458	1227
Base du nez - Glabella (root of nose)	2251	390	1239
Menton - Chin (bottom)	2246	390	1135
Jonction menton et cou - Chin / neck junction	2320	390	1160
Thorax au niveau des côtes supérieures - Chest at upper rib level	2223	384	940
Thorax au niveau des côtes inférieures - Chest at lower rib level	2192	382	828
Boulon supérieur avant de l'épaule, ext. - Shoulder bolt, top front outboard	2355	542	993
Boulon supérieur avant de l'épaule, int. - Shoulder bolt, top front inboard	2359	229	996
Boulon du coude, extérieur - Elbow bolt, outboard	2295	598	783
Boulon du coude, intérieur - Elbow bolt, inboard	2302	186	791
Boulon du poignet, extérieur - Wrist bolt, outboard	2085	547	756
Boulon du poignet, intérieur - Wrist bolt, inboard	2093	224	749
Point d'articulation de la hanche, extérieur - Hip point, outboard	2284	508	704
Boulon du genou gauche, intérieur - Knee bolt, left leg, inboard	1872	347	736
Boulon de la cheville gauche, intérieur - Ankle bolt, left leg, inboard	1736	312	427
Point du talon gauche - Heel point, left leg	1803	305	313
Plante du pied gauche vs plancher - Ball of foot at toeboard contact, left leg	1668	348	336
Boulon du genou droit, extérieur - Knee bolt, right leg, outboard	1869	514	741
Boulon de la cheville droite, extérieur - Ankle bolt, right leg, outboard	1740	507	425
Point du talon droit - Heel point, right leg	1808	509	321
Plante du pied droit vs plancher - Ball of foot at toeboard contact, right leg	1674	561	345

Remarques – Comments : Aucune / None.

Date de collision Crash date	2005-03-30	Véhicule Vehicle	FORD FREESTYLE 2005	T.C. N° T.C.No	05-226
---------------------------------	-------------------	---------------------	----------------------------	-------------------	---------------

**MESURES DE MANNEQUIN DAE
TEST DUMMY MEASUREMENTS**

PASSAGER ARRIÈRE DROIT / RIGHT REAR PASSENGER

Description et emplacement du Mannequin
ATD description and location:

DESCRIPTION	X(mm)	Y(mm)	Z(mm)
Centre de gravité de la tête, extérieur - Head CG, outboard	3395	471	1268
Base du nez - Glabella (root of nose)	3307	409	1271
Menton - Chin (bottom)	3302	409	1164
Jonction menton et cou - Chin / neck junction	3365	409	1180
Thorax au niveau des côtes supérieures - Chest at upper rib level	3283	400	1008
Thorax au niveau des côtes inférieures - Chest at lower rib level	3253	395	900
Boulon supérieur avant de l'épaule, ext. - Shoulder bolt, top front outboard	3413	552	1024
Boulon supérieur avant de l'épaule, int. - Shoulder bolt, top front inboard	3410	246	1027
Boulon du coude, extérieur - Elbow bolt, outboard	3363	618	811
Boulon du coude, intérieur - Elbow bolt, inboard	3384	206	813
Boulon du poignet, extérieur - Wrist bolt, outboard	3149	569	776
Boulon du poignet, intérieur - Wrist bolt, inboard	3174	223	769
Point d'articulation de la hanche, extérieur - Hip point, outboard	3339	518	744
Boulon du genou gauche, intérieur - Knee bolt, left leg, inboard	2914	343	717
Boulon de la cheville gauche, intérieur - Ankle bolt, left leg, inboard	2786	298	453
Point du talon gauche - Heel point, left leg	2887	319	311
Plante du pied gauche vs plancher - Ball of foot at toeboard contact, left leg	2749	342	311
Boulon du genou droit, extérieur - Knee bolt, right leg, outboard	2913	519	720
Boulon de la cheville droite, extérieur - Ankle bolt, right leg, outboard	2781	478	462
Point du talon droit - Heel point, right leg	2884	466	326
Plante du pied droit vs plancher - Ball of foot at toeboard contact, right leg	2750	521	313

Remarques – Comments : Aucune / None.

Date de collision Crash date	2005-03-30	Véhicule Vehicle	FORD FREESTYLE 2005	T.C. N° T.C.No	05-226
---------------------------------	-------------------	---------------------	----------------------------	-------------------	---------------

MESURES PLANCHER / FOOTWELL MEASUREMENTS

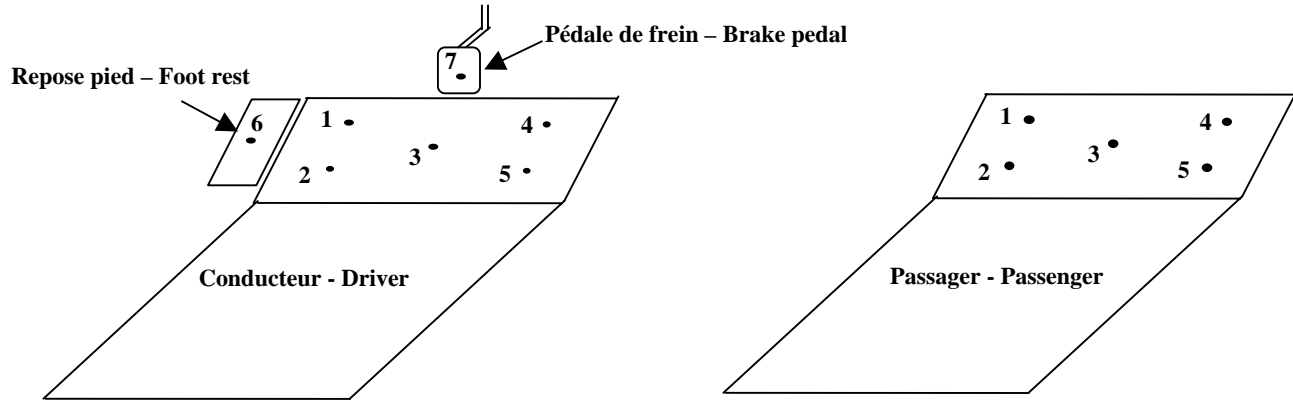

N° Cible		AVANT ESSAI	APRÈS ESSAI	
Target No.		PRE-TEST	POST-TEST	Δ mm
1	x	1432	1454	-22
	y	-425	-414	-11
	z	406	454	-48
2	x	1543	1546	-3
	y	-436	-429	-7
	z	318	345	-27
3	x	1479	1491	-12
	y	-342	-332	-10
	z	373	406	-33
4	x	1451	1455	-4
	y	-234	-227	-7
	z	374	407	-33
5	x	1596	1596	0
	y	-216	-210	-6
	z	332	356	-24
6	x	1575	1592	-17
	y	-549	-546	-3
	z	389	406	-17
7	x	1572	1632	-60
	y	-360	-343	-17
	z	483	506	-23

N° Cible		AVANT ESSAI	APRÈS ESSAI	
Target No.		PRE-TEST	POST-TEST	Δ mm
1	x	1398	1423	-25
	y			
	z			
2	x	1491	1497	-6
	y			
	z			
3	x	1459	1456	3
	y			
	z			
4	x	1398	1450	-52
	y	366	354	12
	z	447	491	-44
5	x	1485	1490	-5
	y	416	409	7
	z	368	392	-24

Date de collision Crash date	2005-03-30	Véhicule Vehicle	FORD FREESTYLE 2005	T.C. N° T.C.No	05-226
---------------------------------	------------	---------------------	---------------------	-------------------	--------

PÉNÉTRATION DE L'HABITACLE DU CONDUCTEUR (Distances en mm)
DRIVER COMPARTMENT INTRUSION (Distances in mm)

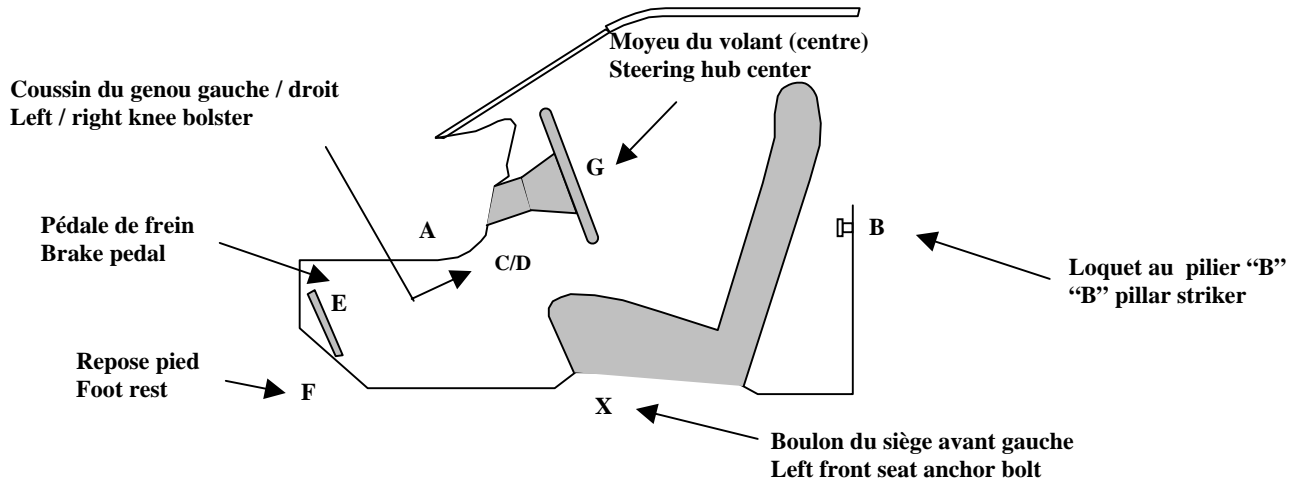

Habitacle du conducteur
Driver's compartment

	DESCRIPTION	Avant essai / Pre-test			Après essai / Post-test		
		X	Y	Z	X	Y	Z
A	Ouverture de porte Door opening	1734	-862	1097	1747	-872	1097
B	Loquet au pilier "B" "B" pillar striker	2571	-817	764	2576	-816	765
C	Coussin du genou gauche Left knee bolster	1820	-458	764	1842	-453	754
D	Coussin du genou droit Right knee bolster	1818	-263	779	1845	-259	783
E	Pédale de frein Break pedal	1572	-360	483	1632	-343	506
F	Repose pied Foot rest	1575	-549	389	1592	-546	406
G	Moyeu du volant (centre) Steering hub (center)	2046	-373	990	1994	-381	1002
X	Boulon du siège avant gauche Left front seat anchor bolt	2059	-582	366	2058	-578	372

APPENDICE / APPENDIX A

**PHOTOGRAPHIES DE L'ESSAI
TEST PHOTOGRAPHS**

Date de collision Crash date	2005-03-30	Véhicule Vehicle	FORD FREESTYLE 2005	T.C. N° T.C.No	05-226
---------------------------------	------------	---------------------	---------------------	-------------------	--------

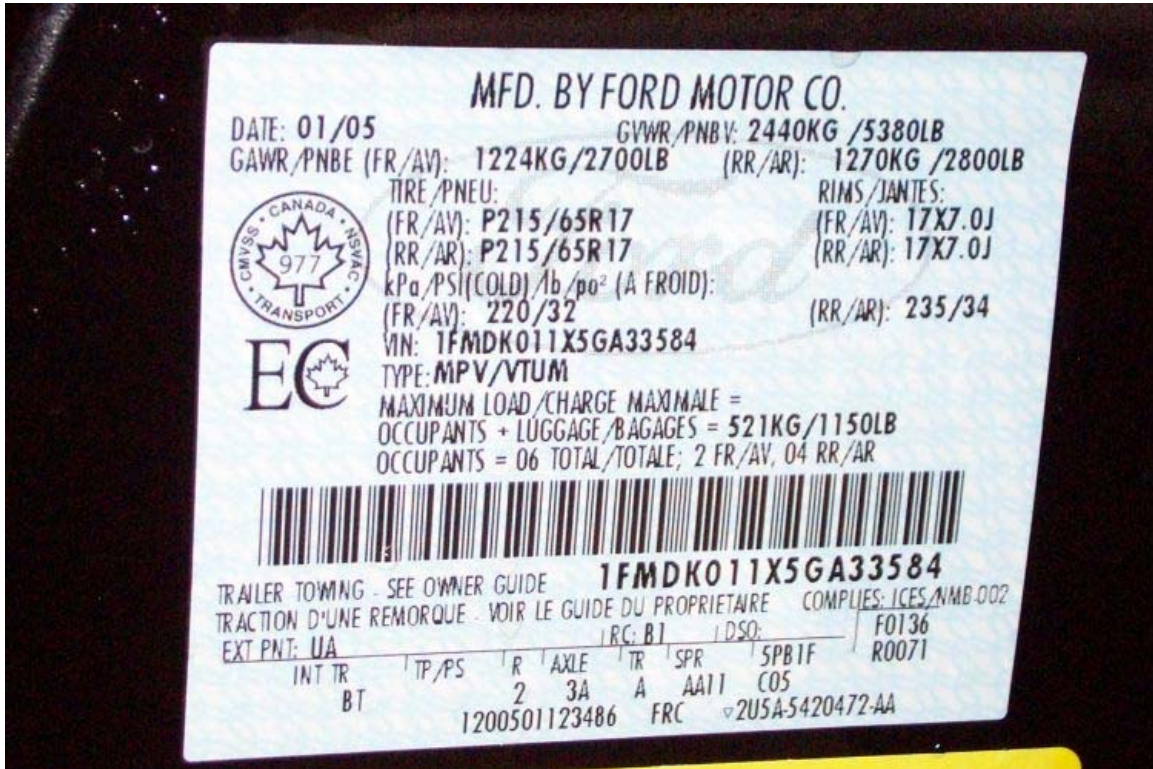

1. Étiquette de déclaration de conformité du véhicule d'essai.
Statement of compliance label of the test vehicle.

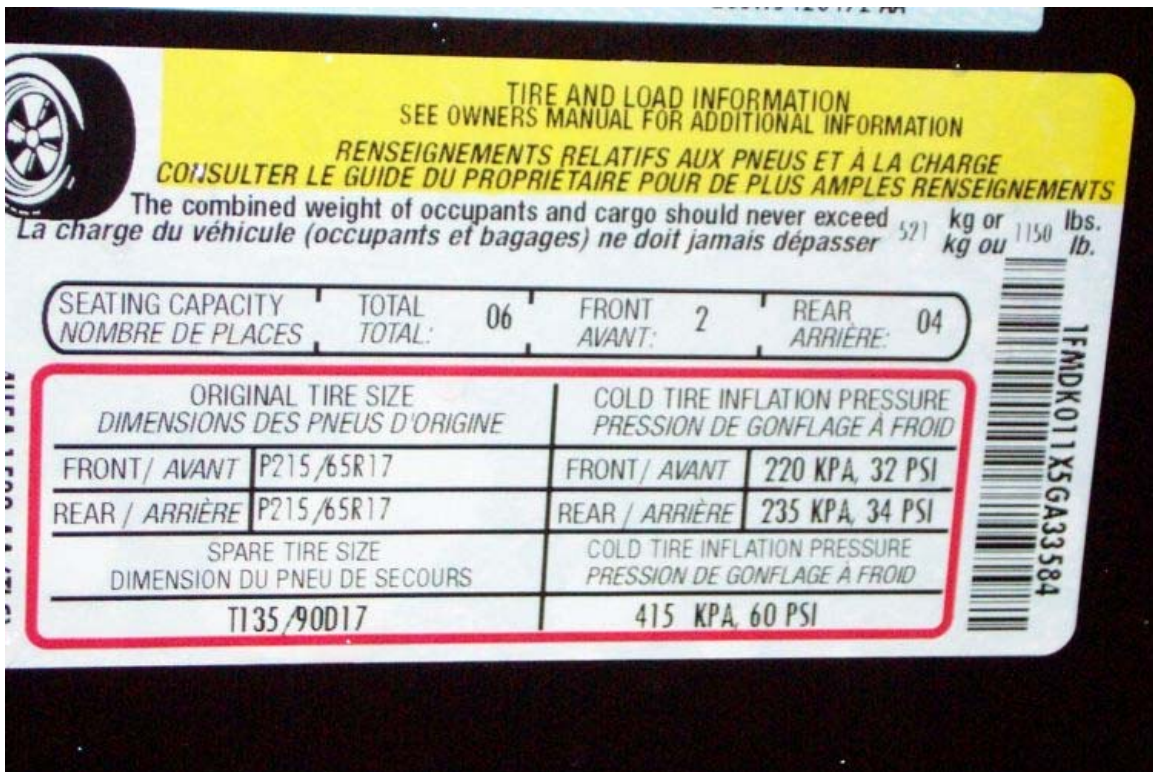

2. Étiquette d'information des pneus.
Tire information label.

Date de collision Crash date	2005-03-30	Véhicule Vehicle	FORD FREESTYLE 2005	T.C. N° T.C.No	05-226
---------------------------------	-------------------	---------------------	----------------------------	-------------------	---------------



**3. Vue ¾ avant du véhicule d'essai.
¾ front view of the test vehicle.**



**4. Vue ¾ arrière du véhicule d'essai.
¾ rear view of the test vehicle.**

Date de collision Crash date	2005-03-30	Véhicule Vehicle	FORD FREESTYLE 2005	T.C. N° T.C.No	05-226
---------------------------------	------------	---------------------	---------------------	-------------------	--------



5. Vue générale côté gauche du véhicule d'essai, avant essai.
Left side view of the test vehicle, pre-test.



6. Vue générale côté gauche du véhicule d'essai, après essai.
Left side view of the test vehicle, post-test.

Date de collision Crash date	2005-03-30	Véhicule Vehicle	FORD FREESTYLE 2005	T.C. N° T.C.No	05-226
---------------------------------	-------------------	---------------------	----------------------------	-------------------	---------------



**7. Vue arrière du véhicule d'essai, avant essai.
Rear view of the test vehicle, pre-test.**



**8. Vue arrière du véhicule d'essai, après essai.
Rear view of the test vehicle, post-test.**

Date de collision Crash date	2005-03-30	Véhicule Vehicle	FORD FREESTYLE 2005	T.C. N° T.C.No	05-226
---------------------------------	------------	---------------------	---------------------	-------------------	--------



9. Vue générale côté droit du véhicule d'essai, avant essai.
General right side view of the test vehicle, pre-test.



10. Vue générale côté droit du véhicule d'essai, après essai.
General right side view of the test vehicle, post-test.

Date de collision Crash date	2005-03-30	Véhicule Vehicle	FORD FREESTYLE 2005	T.C. N° T.C.No	05-226
---------------------------------	------------	---------------------	---------------------	-------------------	--------



11. Vue avant du véhicule d'essai, avant essai.
Front view of the test vehicle, pre-test.



12. Vue avant du véhicule d'essai, après essai.
Front view of the test vehicle, post-test.

Date de collision Crash date	2005-03-30	Véhicule Vehicle	FORD FREESTYLE 2005	T.C. N° T.C.No	05-226
---------------------------------	-------------------	---------------------	----------------------------	-------------------	---------------



**13. Vue de plan du véhicule d'essai, avant essai.
Over view of the test vehicle, pre-test.**



**14. Vue de plan du véhicule d'essai, après essai.
Over view of the test vehicle, post-test.**

Date de collision Crash date	2005-03-30	Véhicule Vehicle	FORD FREESTYLE 2005	T.C. N° T.C.No	05-226
---------------------------------	------------	---------------------	---------------------	-------------------	--------



15. Vue de plan du devant du véhicule d’essai, avant essai.
Over view of the front part of the test vehicle, pre-test.



16. Vue de plan du devant du véhicule d’essai, après essai.
Over view of the front part of the test vehicle, post-test.

Date de collision Crash date	2005-03-30	Véhicule Vehicle	FORD FREESTYLE 2005	T.C. N° T.C.No	05-226
---------------------------------	------------	---------------------	---------------------	-------------------	--------



17. Vue côté gauche de l'avant du véhicule d'essai, avant essai.
Left side view of front of test vehicle, pre-test.



18. Vue côté gauche de l'avant du véhicule d'essai, après essai.
Left side view of front of test vehicle, post-test.

Date de collision Crash date	2005-03-30	Véhicule Vehicle	FORD FREESTYLE 2005	T.C. N° T.C.No	05-226
---------------------------------	------------	---------------------	---------------------	-------------------	--------



19. Vue côté droit de l'avant du véhicule d'essai, avant essai.
Right side view of front of test vehicle, pre-test.



20. Vue côté droit de l'avant du véhicule d'essai, après essai.
Right side view of front of test vehicle, post-test.

Date de collision Crash date	2005-03-30	Véhicule Vehicle	FORD FREESTYLE 2005	T.C. N° T.C.No	05-226
---------------------------------	-------------------	---------------------	----------------------------	-------------------	---------------



**21. Vue du compartiment moteur du véhicule d'essai, avant essai.
Engine compartment view of the vehicle, pre-test.**



**22. Vue du compartiment moteur du véhicule d'essai, après essai.
Engine compartment view of the vehicle, post-test.**

Date de collision Crash date	2005-03-30	Véhicule Vehicle	FORD FREESTYLE 2005	T.C. N° T.C.No	05-226
---------------------------------	-------------------	---------------------	----------------------------	-------------------	---------------

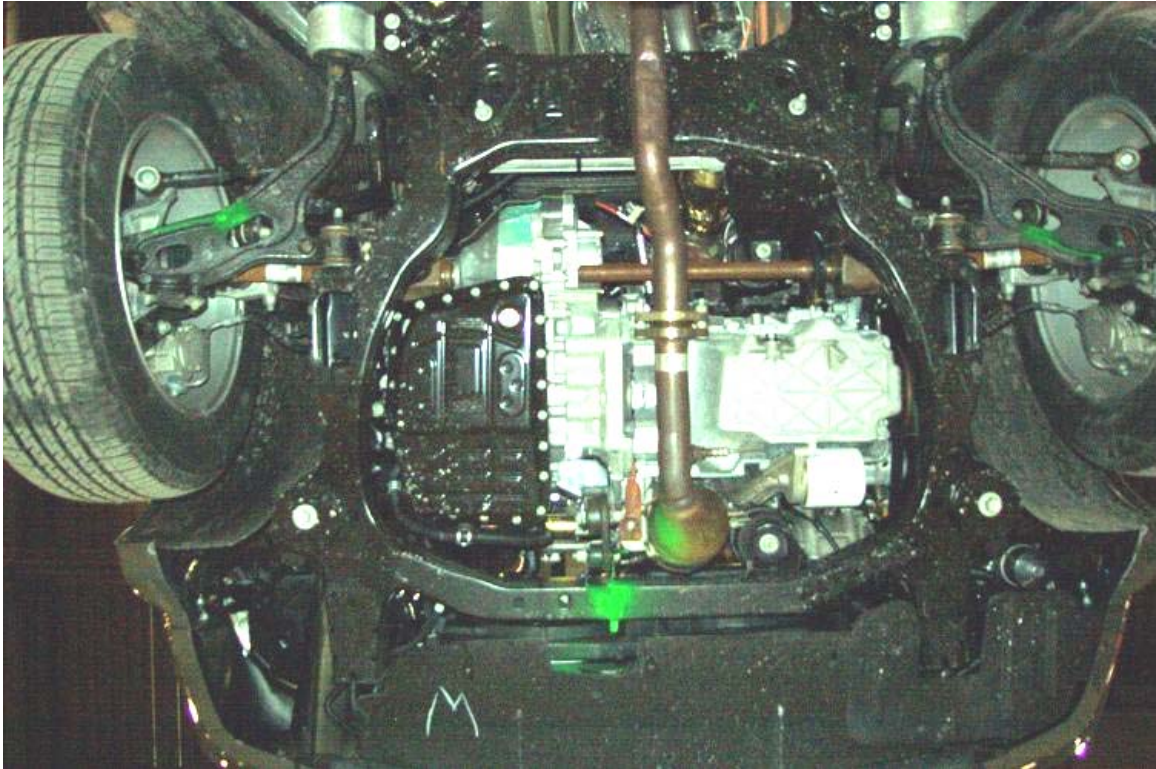

**23. Vue du dessous du compartiment moteur, avant essai.
Under view of the engine compartment , pre-test.**



**24. Vue du dessous du compartiment moteur, après essai.
Under view of the engine compartment , post-test.**

Date de collision Crash date	2005-03-30	Véhicule Vehicle	FORD FREESTYLE 2005	T.C. N° T.C.No	05-226
---------------------------------	------------	---------------------	---------------------	-------------------	--------



25. Position du conducteur, avant essai.
Driver's position, pre-test.



26. Position du conducteur, après essai.
Driver's position, post-test.

Date de collision Crash date	2005-03-30	Véhicule Vehicle	FORD FREESTYLE 2005	T.C. N° T.C.No	05-226
---------------------------------	------------	---------------------	---------------------	-------------------	--------



27. Point de contact de tête du conducteur, après essai.
Driver's head contact point, post-test.



28. Point de contact de tête du conducteur, après essai.
Driver's head contact point, post-test.

Date de collision Crash date	2005-03-30	Véhicule Vehicle	FORD FREESTYLE 2005	T.C. N° T.C.No	05-226
---------------------------------	-------------------	---------------------	----------------------------	-------------------	---------------



**29. Point de contact des genoux du conducteur, après essai.
Driver's knees contact point, post-test.**



**30. Contact du volant sur l'abdomen du conducteur, après essai.
Steering wheel's contact point with driver's abdomen.**

Date de collision Crash date	2005-03-30	Véhicule Vehicle	FORD FREESTYLE 2005	T.C. N° T.C.No	05-226
---------------------------------	-------------------	---------------------	----------------------------	-------------------	---------------



**31. Position du passager, avant essai.
Passenger's position, pre-test.**



**32. Position du passager, après essai.
Passenger's position, post-test.**

Date de collision Crash date	2005-03-30	Véhicule Vehicle	FORD FREESTYLE 2005	T.C. N° T.C.No	05-226
---------------------------------	-------------------	---------------------	----------------------------	-------------------	---------------



**33. Point de contact de tête du passager, après essai.
Passenger's head contact point, post-test.**



**34. Point de contact de tête du passager, après essai.
Passenger's head contact point, post-test.**

Date de collision Crash date	2005-03-30	Véhicule Vehicle	FORD FREESTYLE 2005	T.C. N° T.C.No	05-226
---------------------------------	-------------------	---------------------	----------------------------	-------------------	---------------



**35. Point de contact des genoux du passager, après essai.
Passenger's knees contact point, post-test.**

Date de collision Crash date	2005-03-30	Véhicule Vehicle	FORD FREESTYLE 2005	T.C. N° T.C.No	05-226
---------------------------------	-------------------	---------------------	----------------------------	-------------------	---------------



**36. Position du passager arrière droit, avant essai.
Rear right passenger's position, pre-test.**



**37. Position du passager arrière droit, après essai.
Rear right passenger's position, post-test.**

Date de collision Crash date	2005-03-30	Véhicule Vehicle	FORD FREESTYLE 2005	T.C. N° T.C.No	05-226
---------------------------------	-------------------	---------------------	----------------------------	-------------------	---------------



38. Affichage du lecteur de vitesse.
Speed trap reading.

APPENDICE / APPENDIX B

**DONNÉES GRAPHIQUES
GRAPHICAL DATA**



Nom du client
Client Name **TRANSPORT CANADA**

Type de véhicule
Type of Vehicle **FORD FREESTYLE 2005**

Numéro de TC
Tc Number **TC05-226**

Vitesse
Speed **56 km/h**

Numéro de contrat
Contract No **05-5001**

Acquisition de données selon
Data Acquisition according to **SAE J211/1 MAR 95**

Date de l'essai
Test date **2005-03-30**

Titre du projet
Project Title **COLLISION DE RECHERCHE**
COLLISION FRONTALE
RESEARCH COLLISION TEST
FRONTAL CRASH

MANNEQUIN / DUMMY

Position 1	Position 2	Position 3
HF		HF
Position 4	Position 5	Position 6
		HF
Position 7	Position 8	Position 9

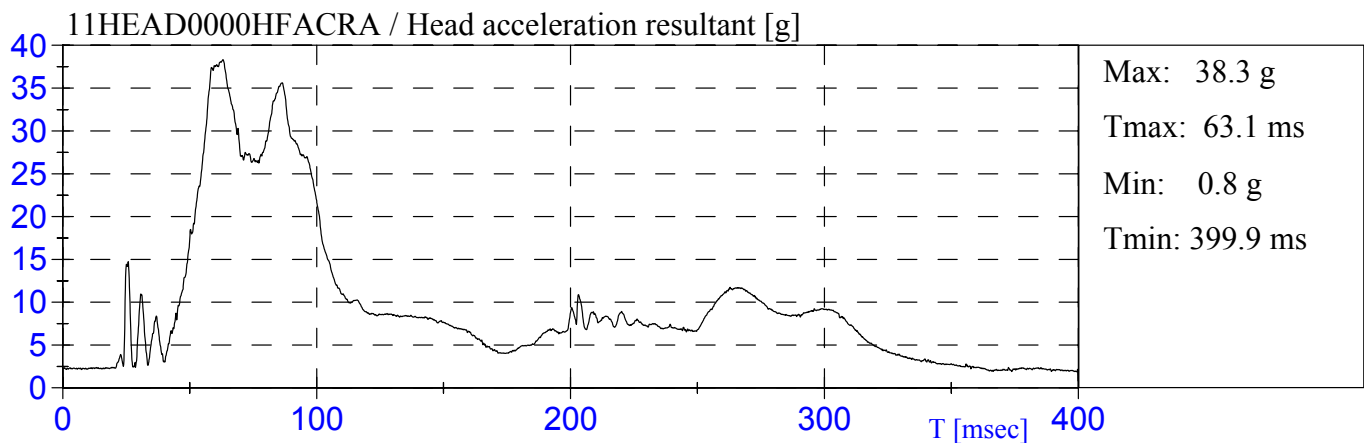
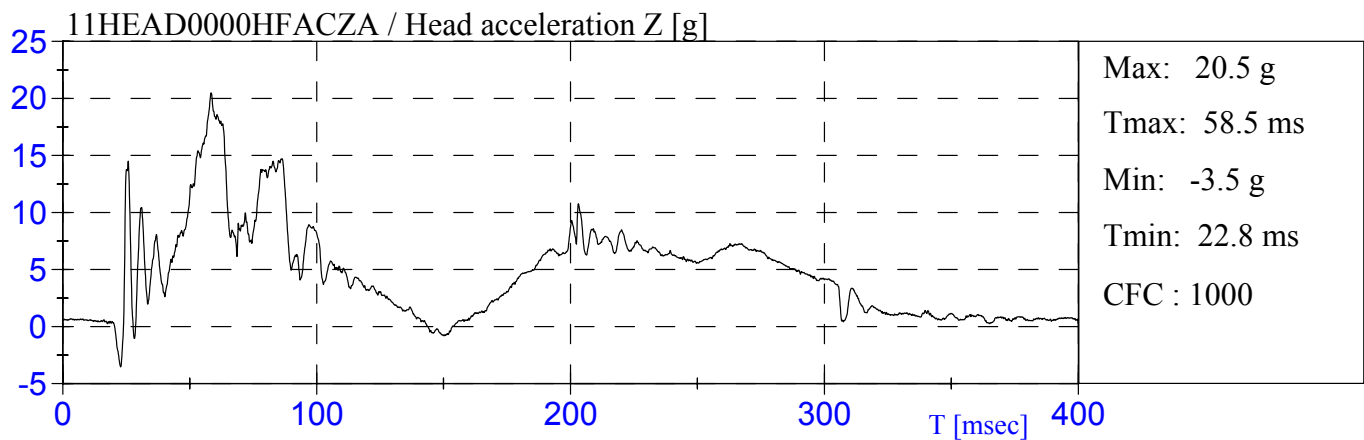
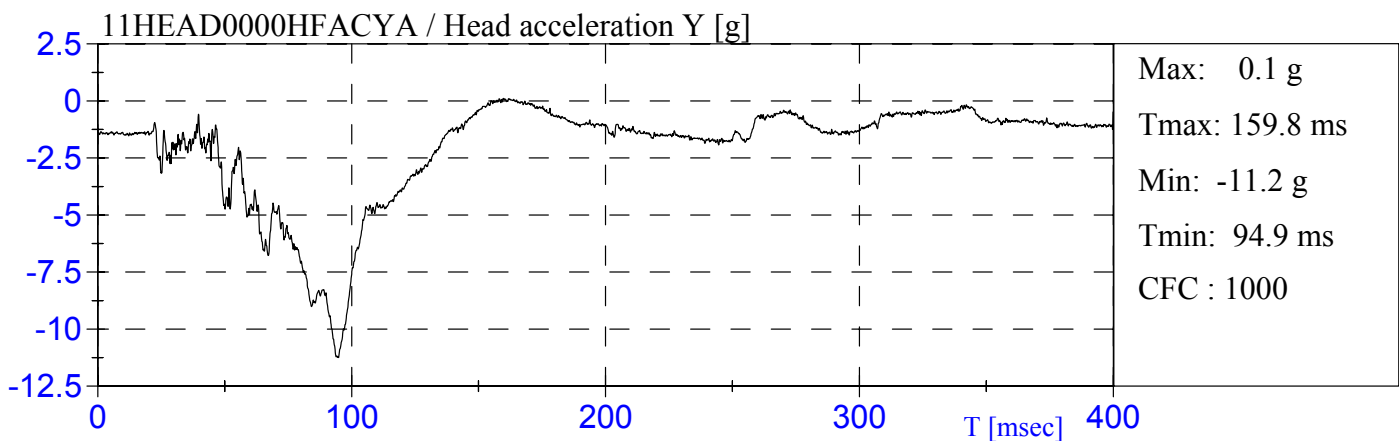
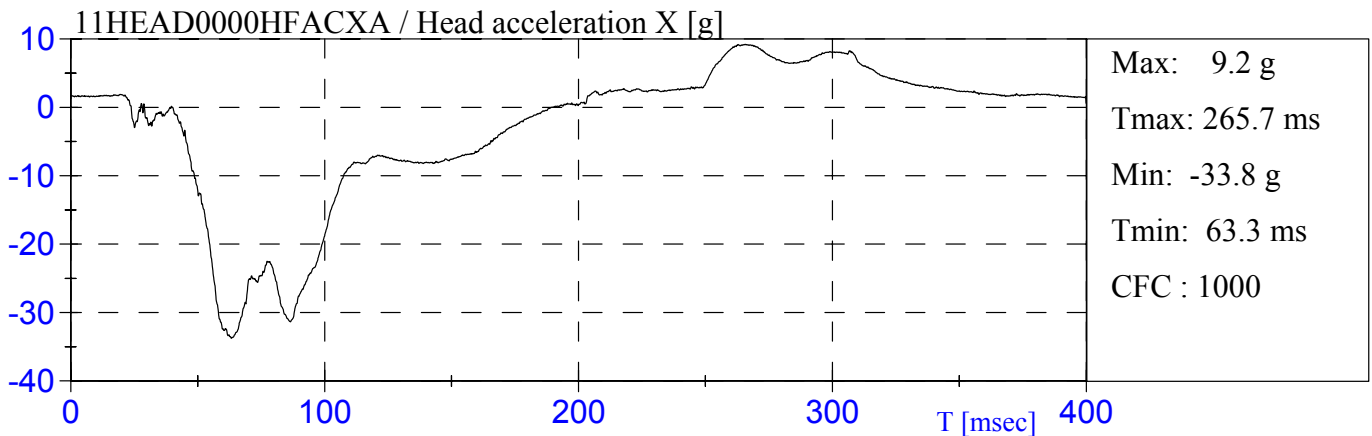

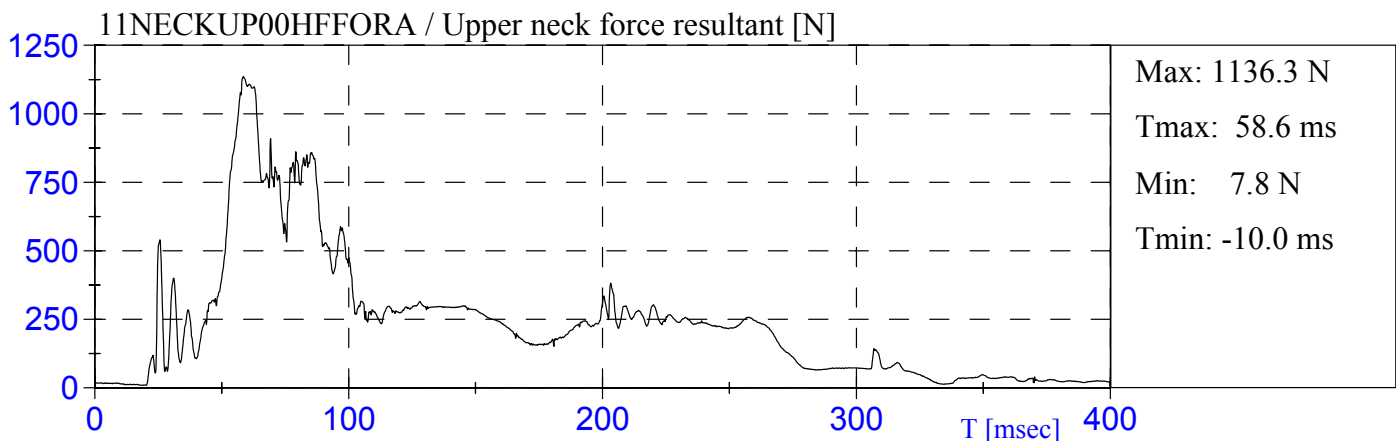
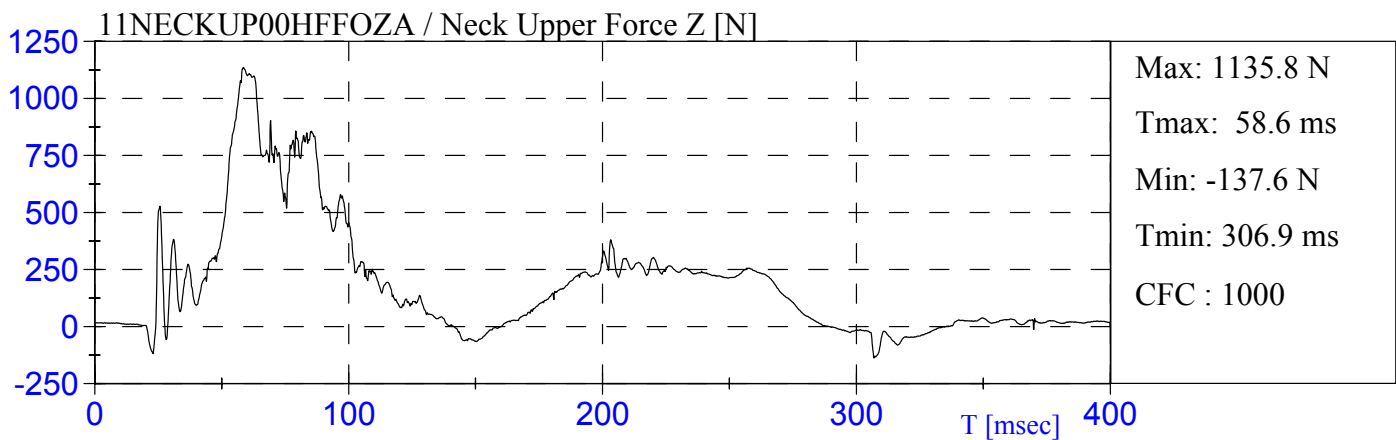
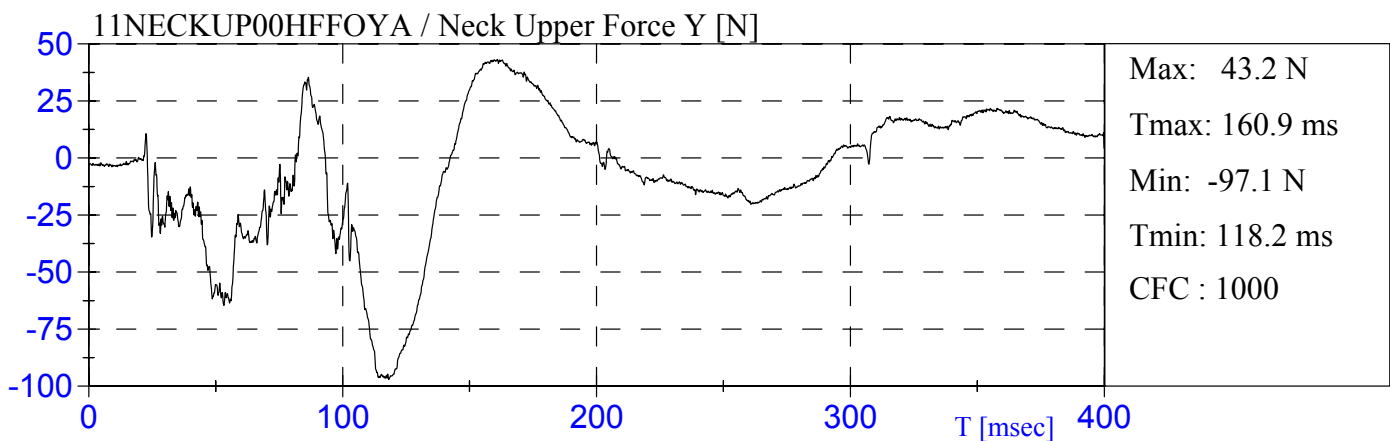
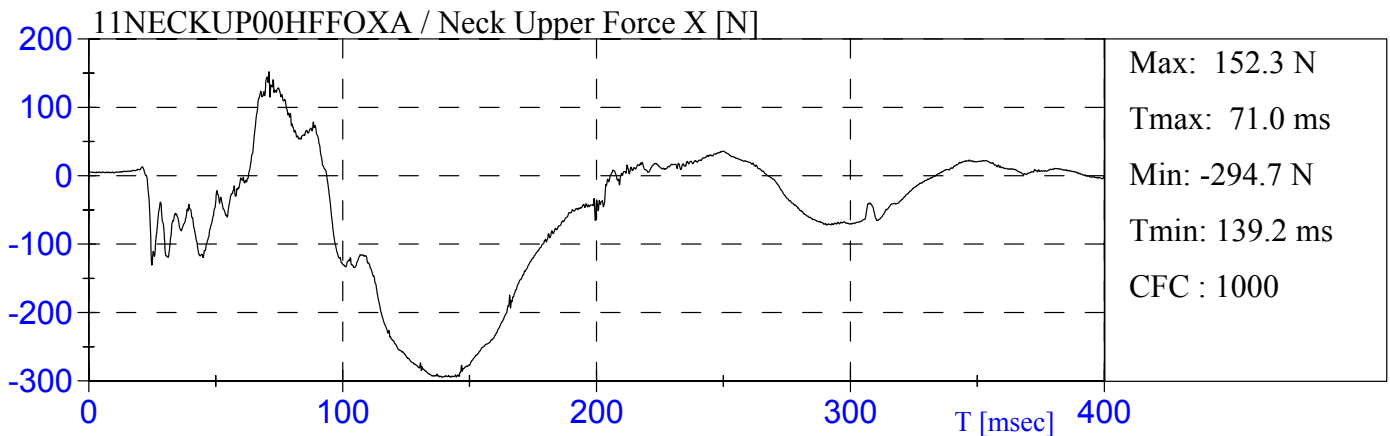

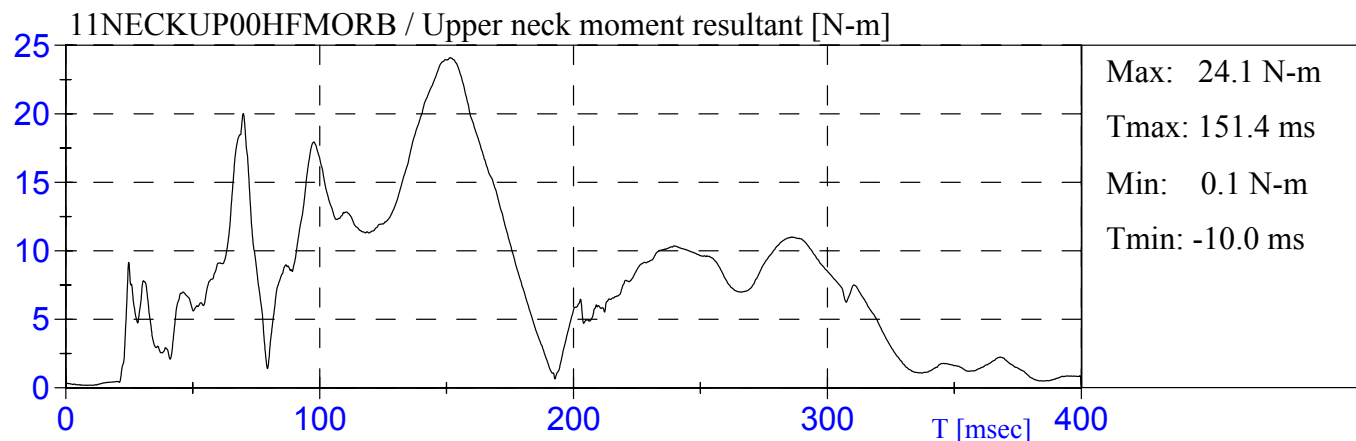
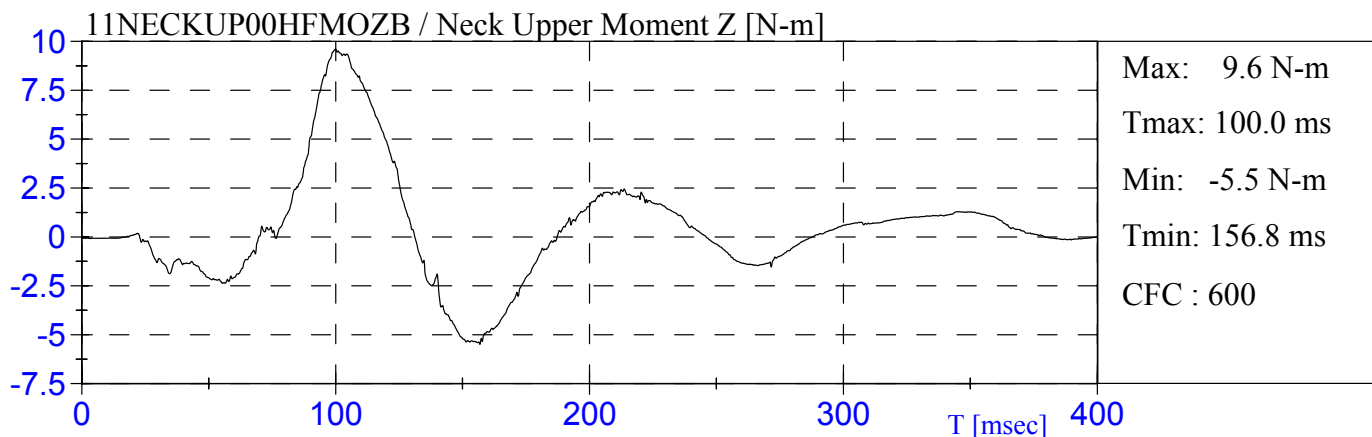
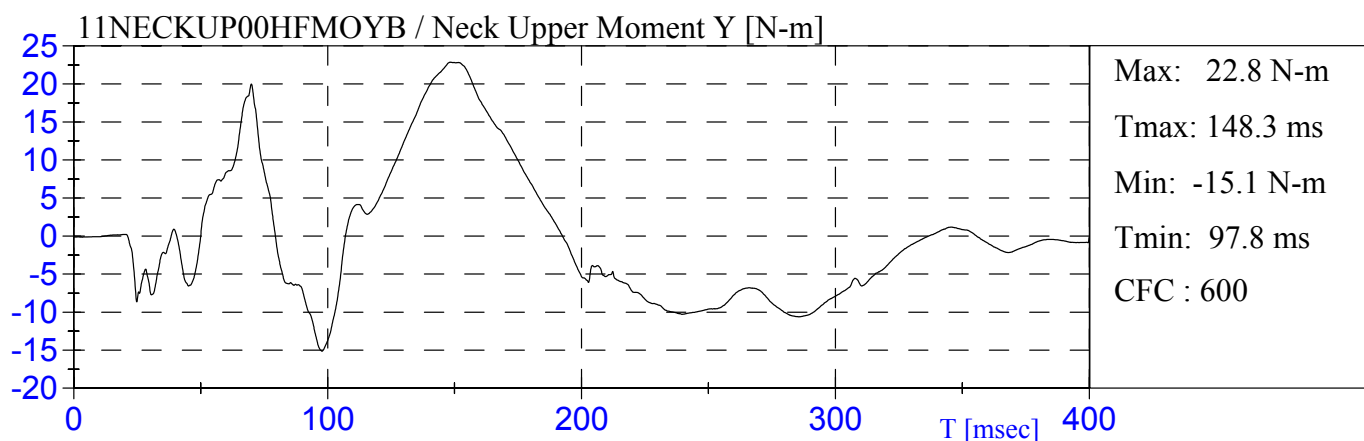
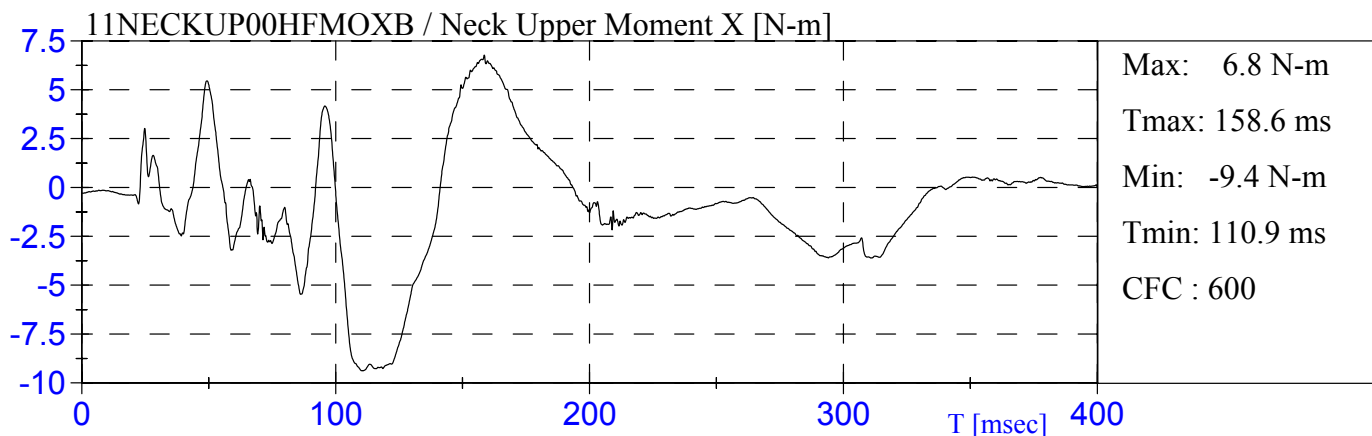

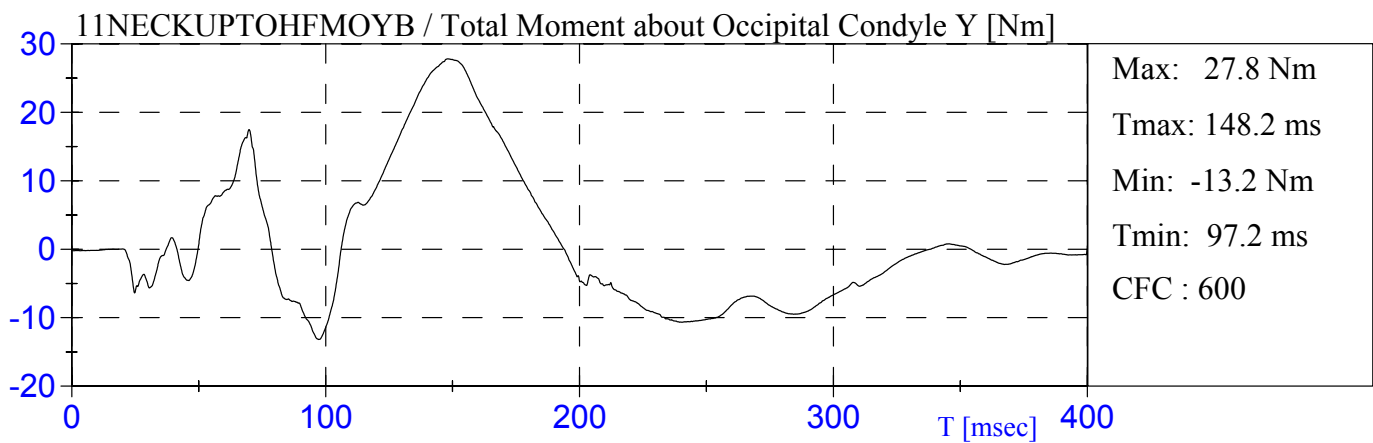
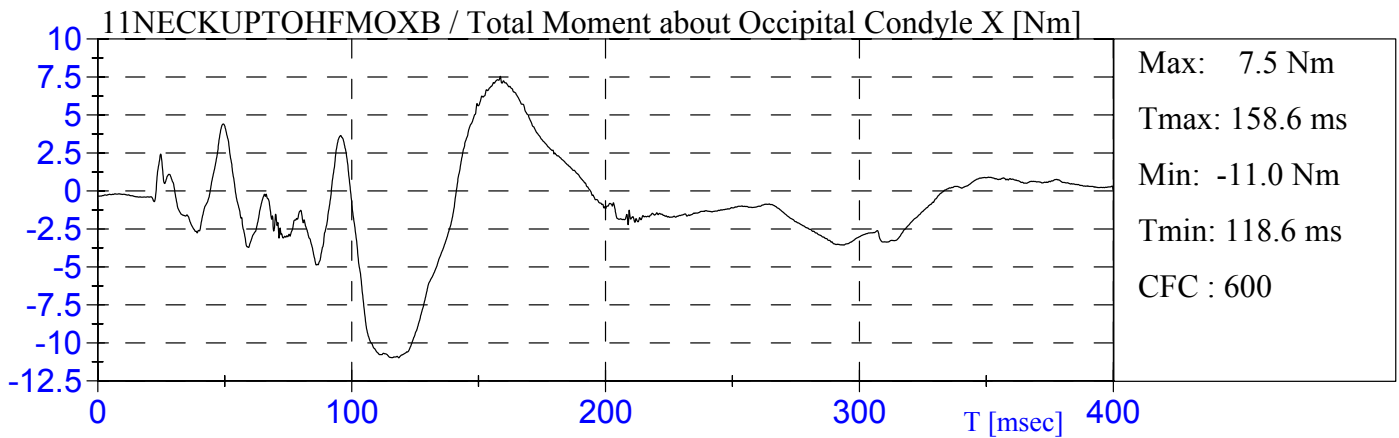

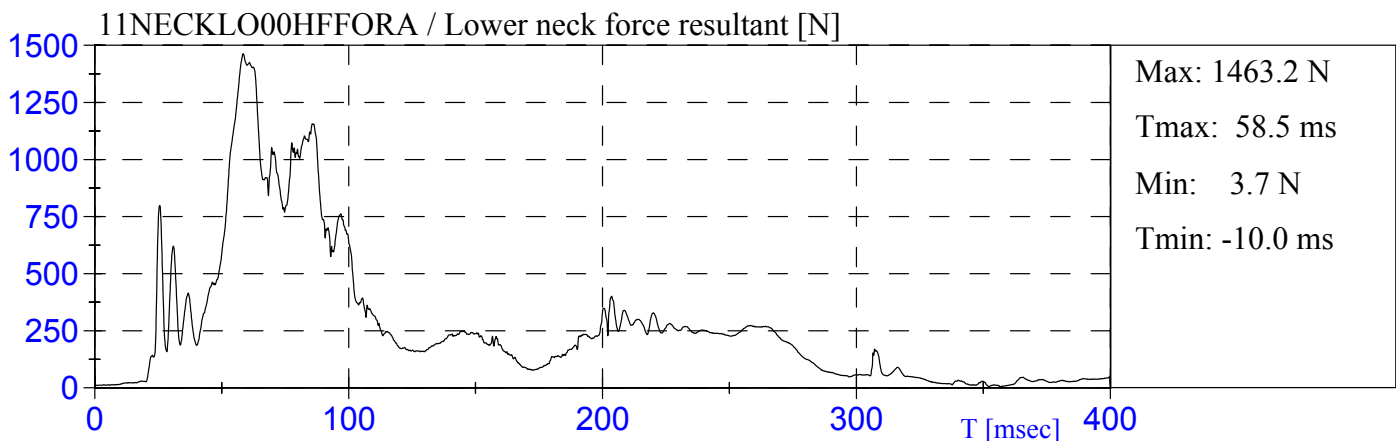
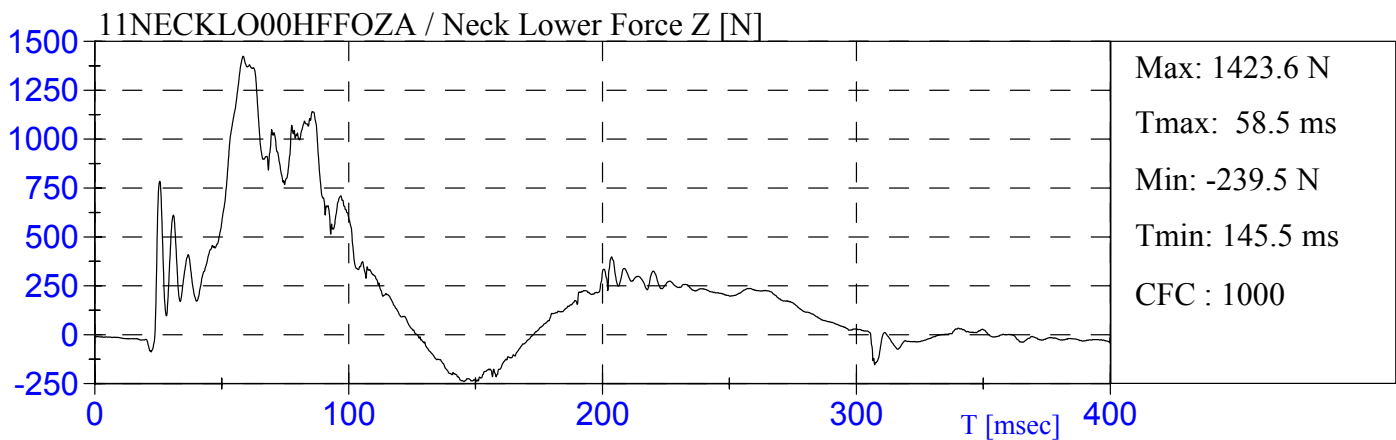
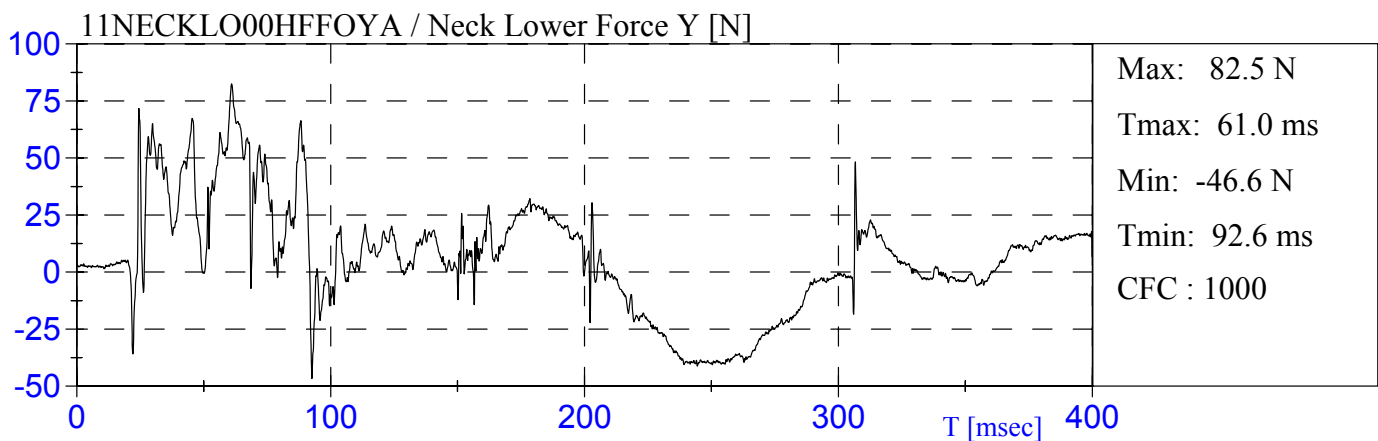
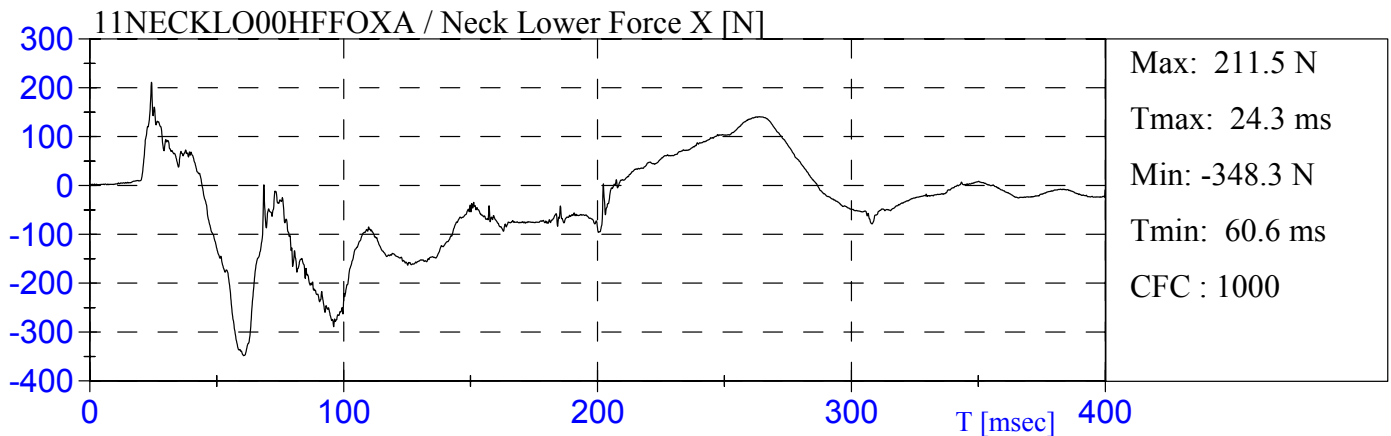

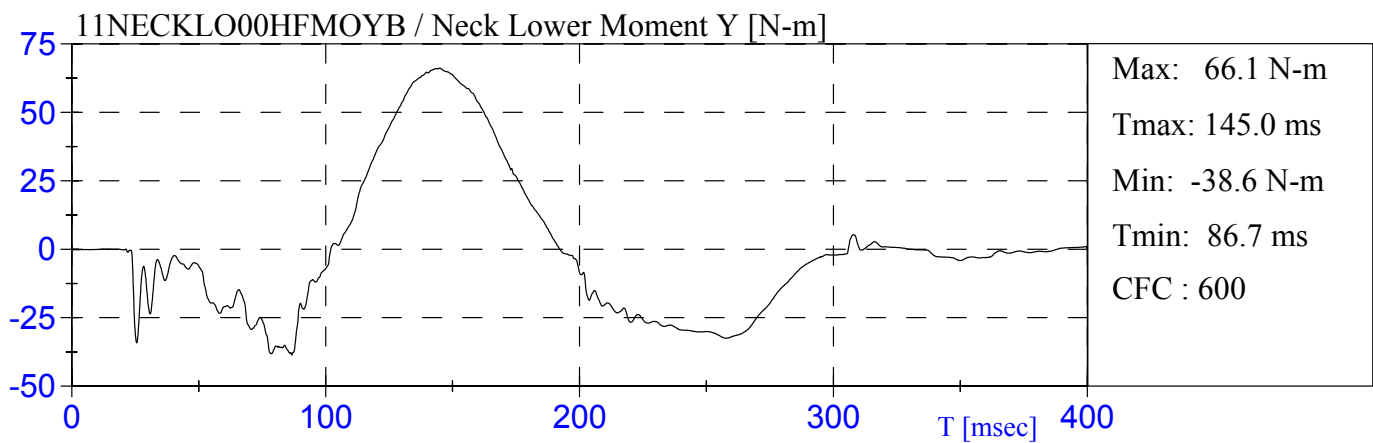
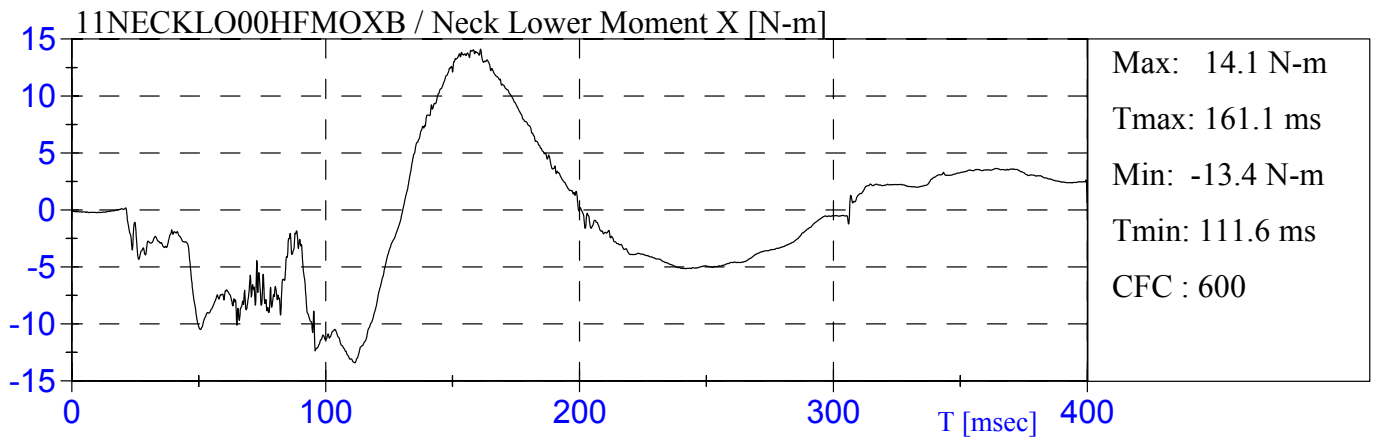

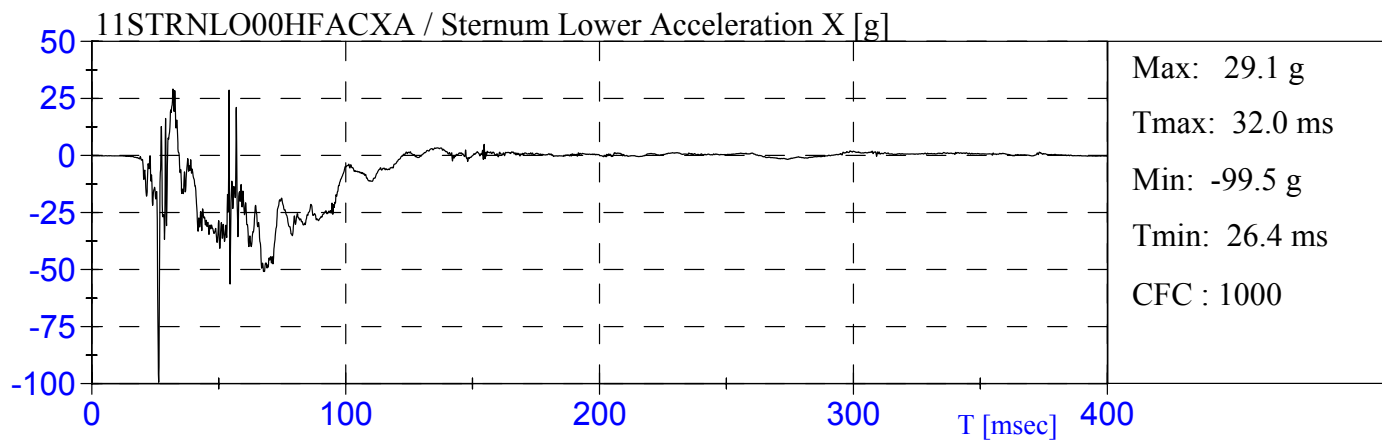
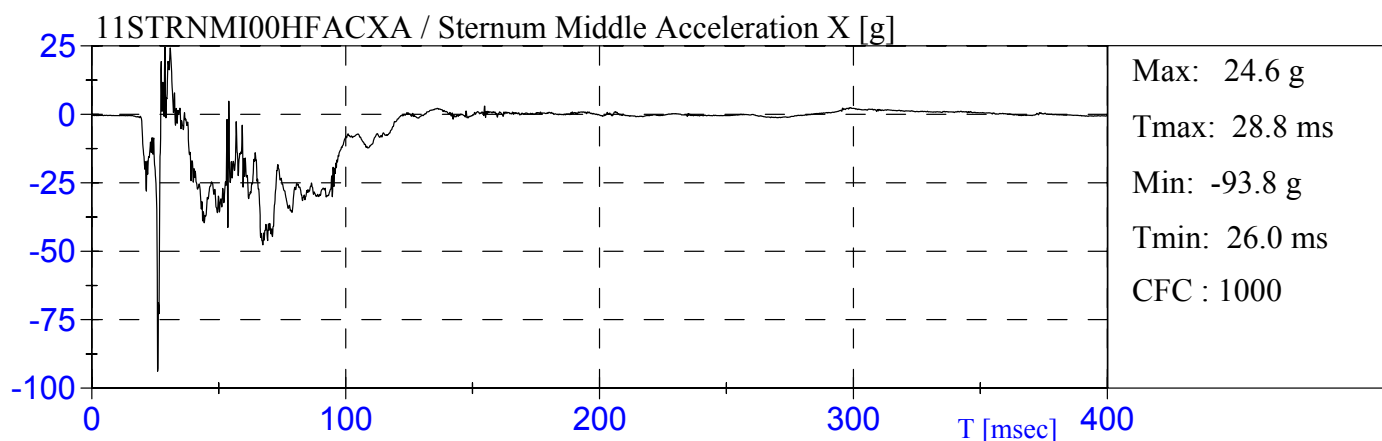
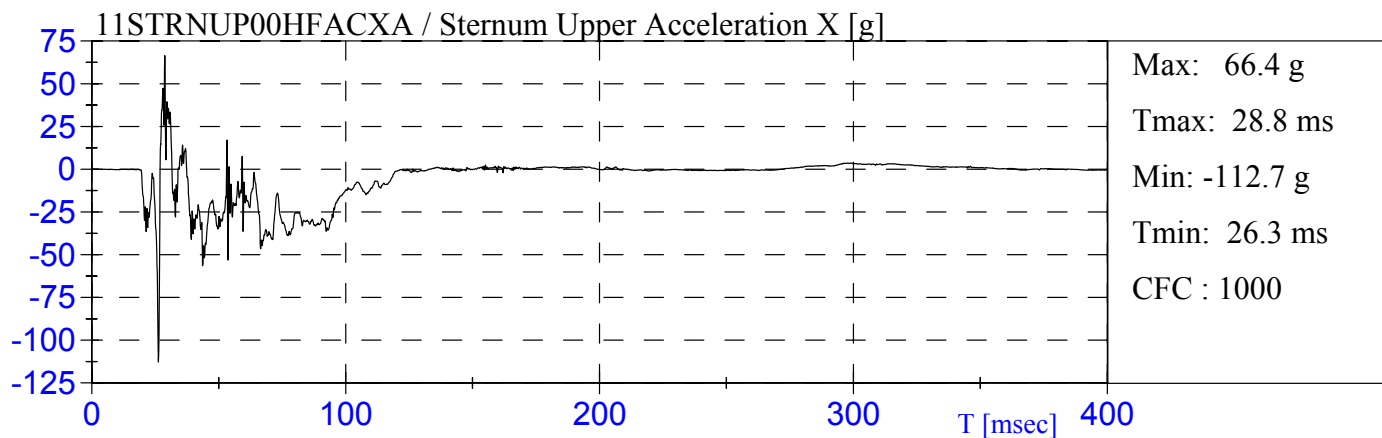

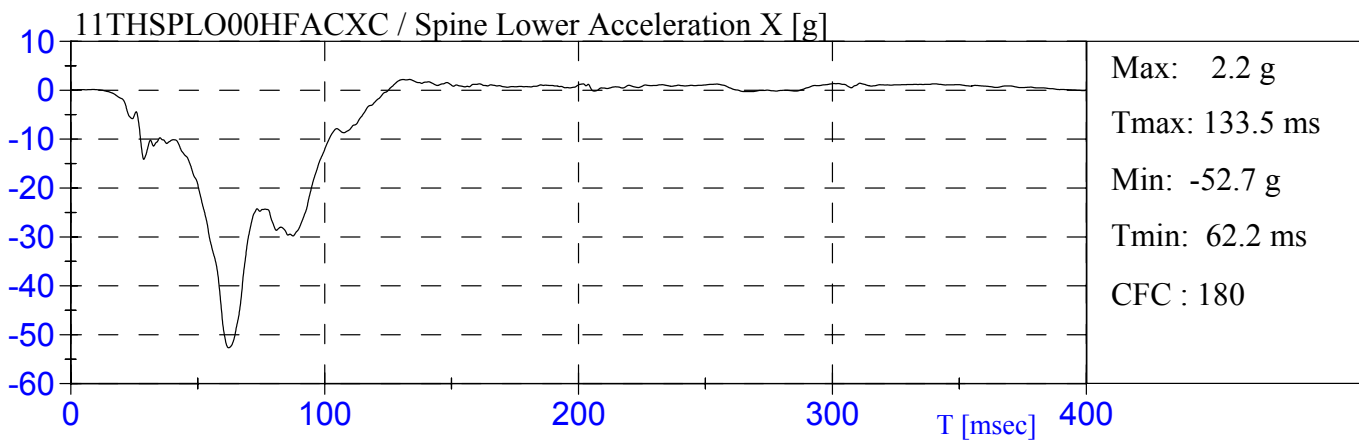
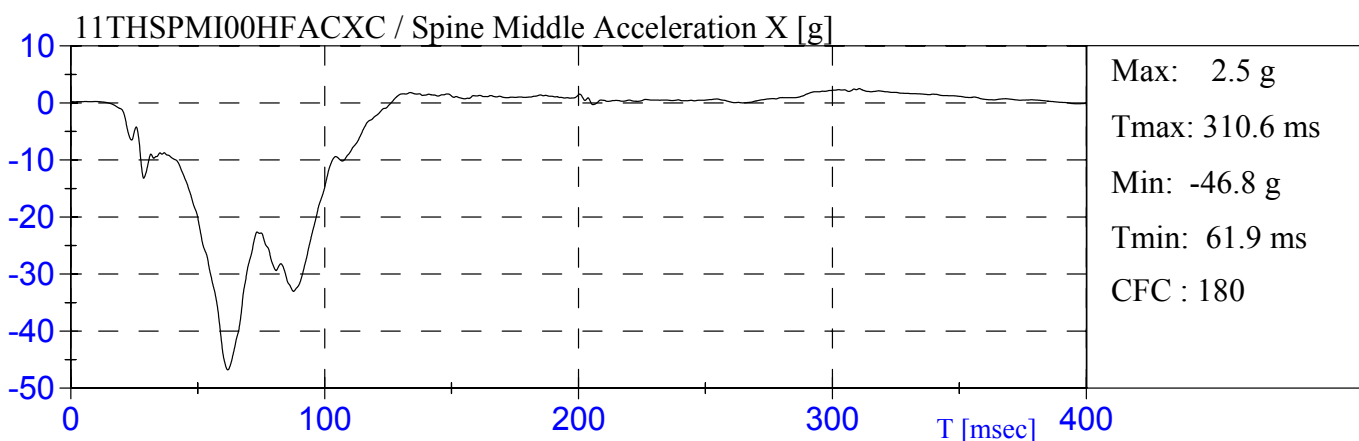
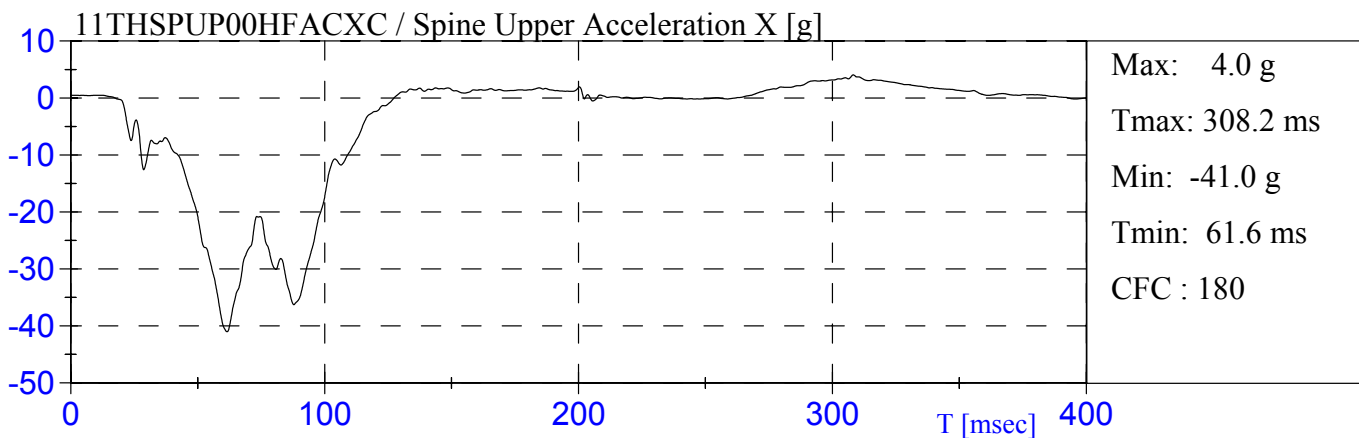

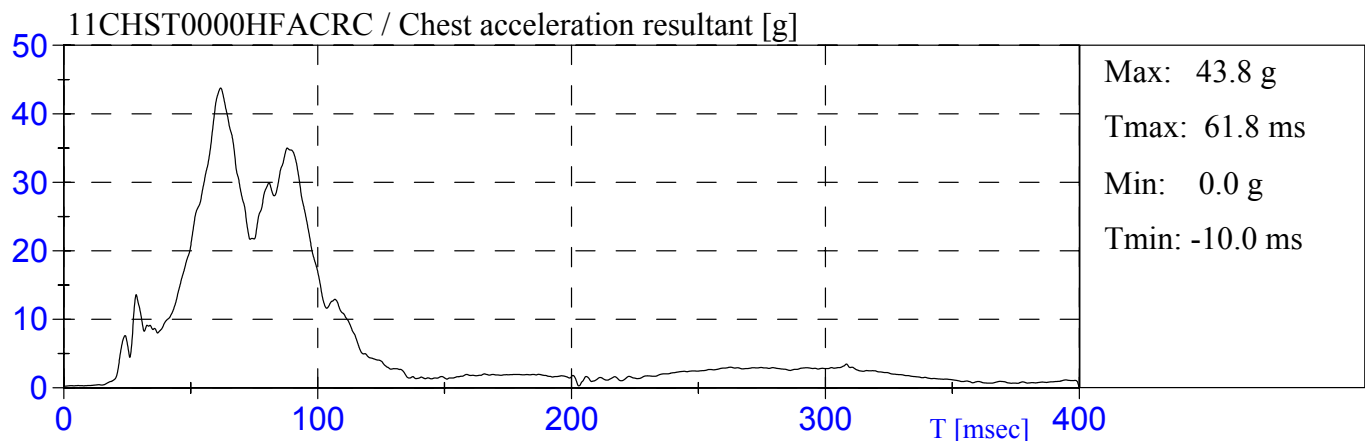
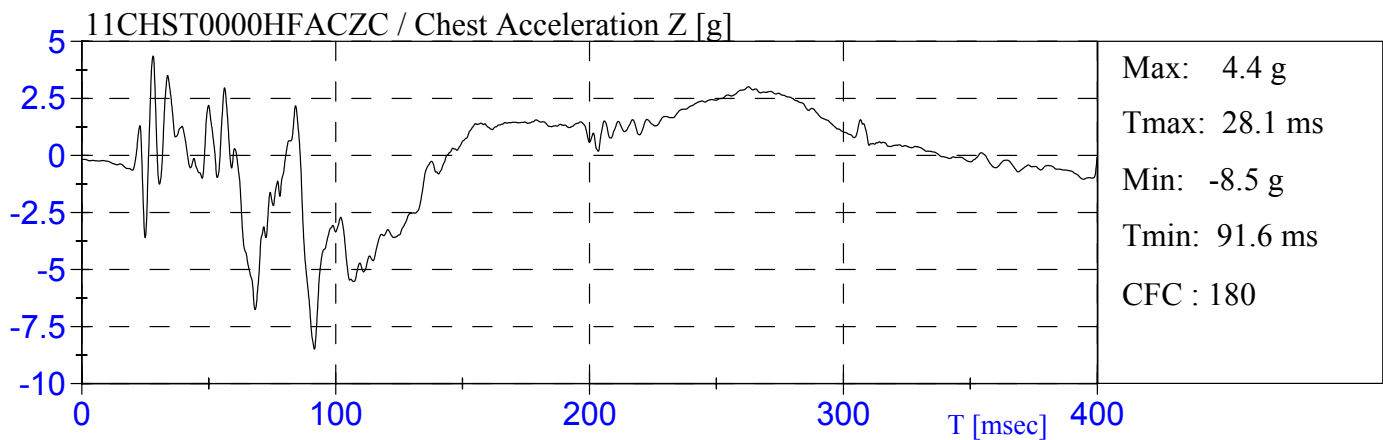
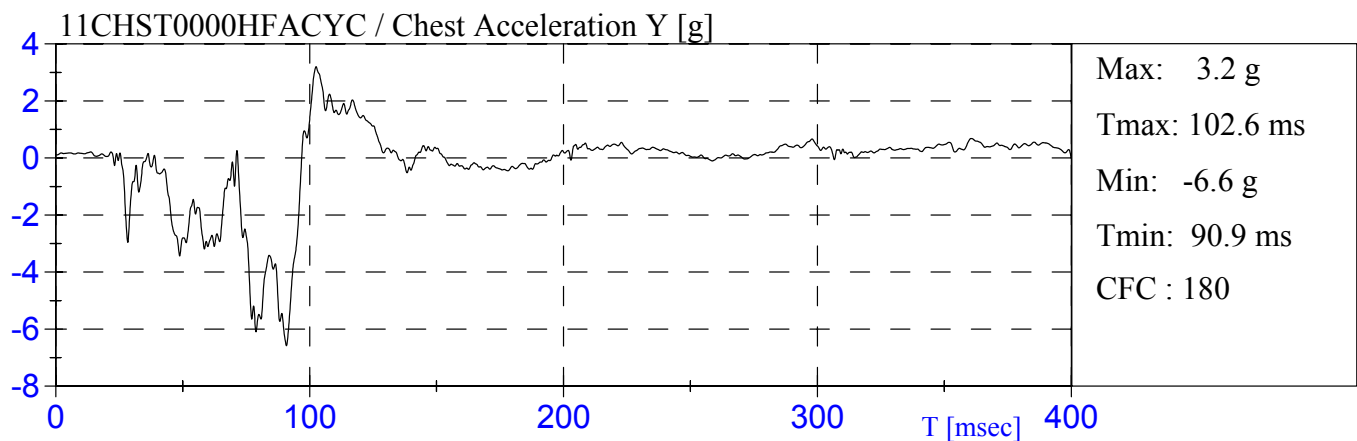
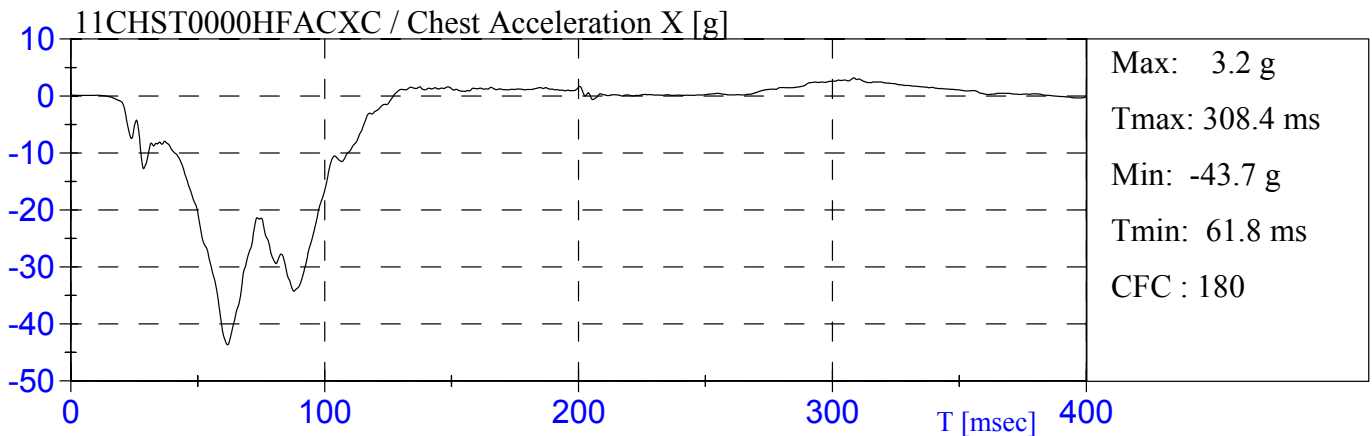

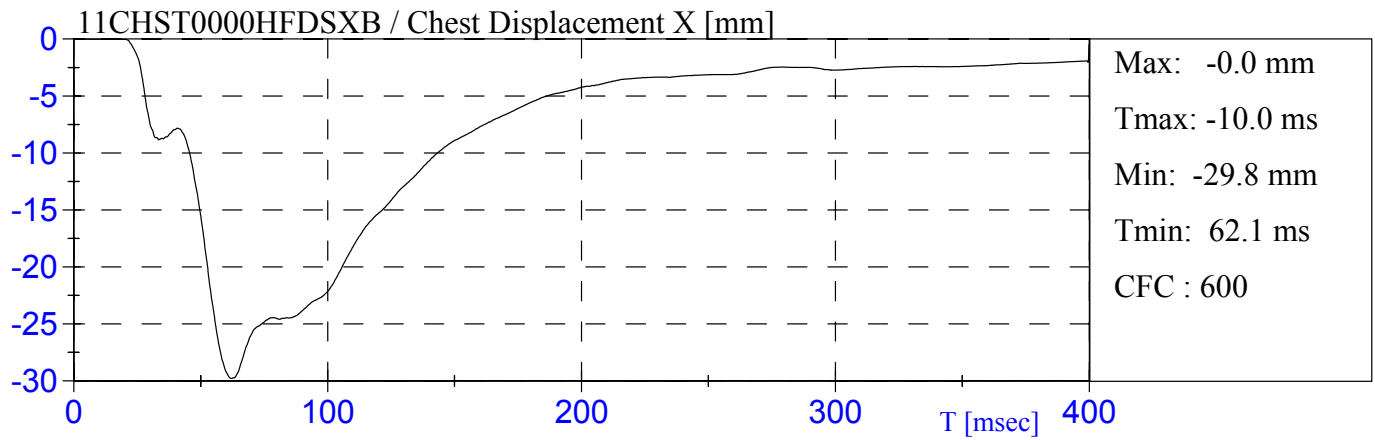

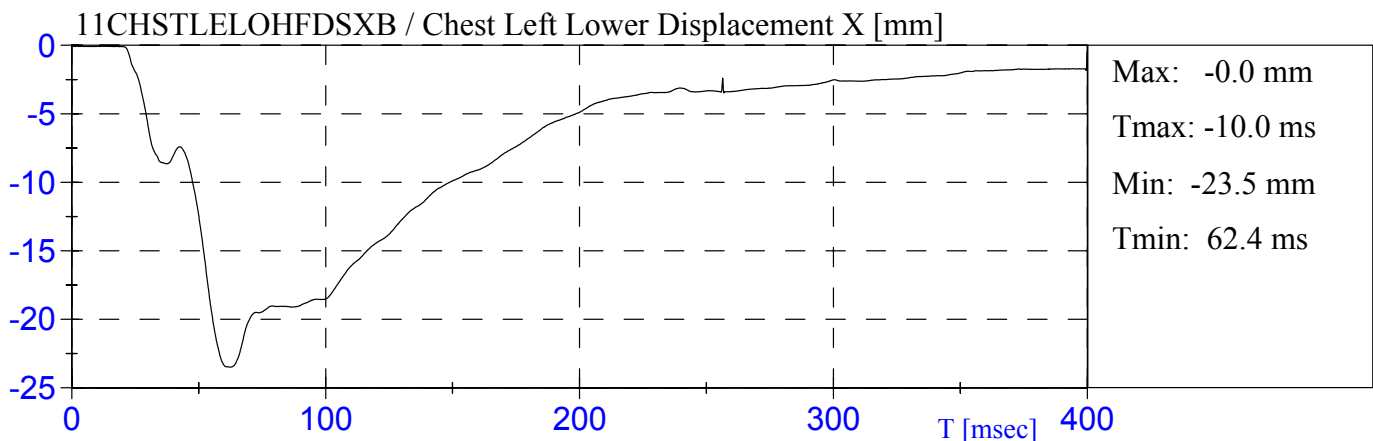
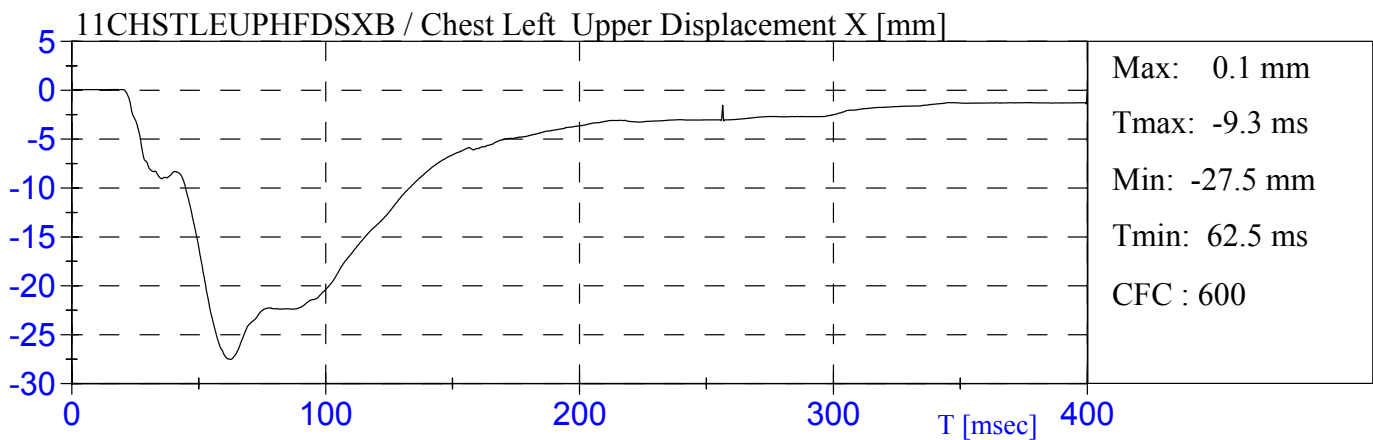
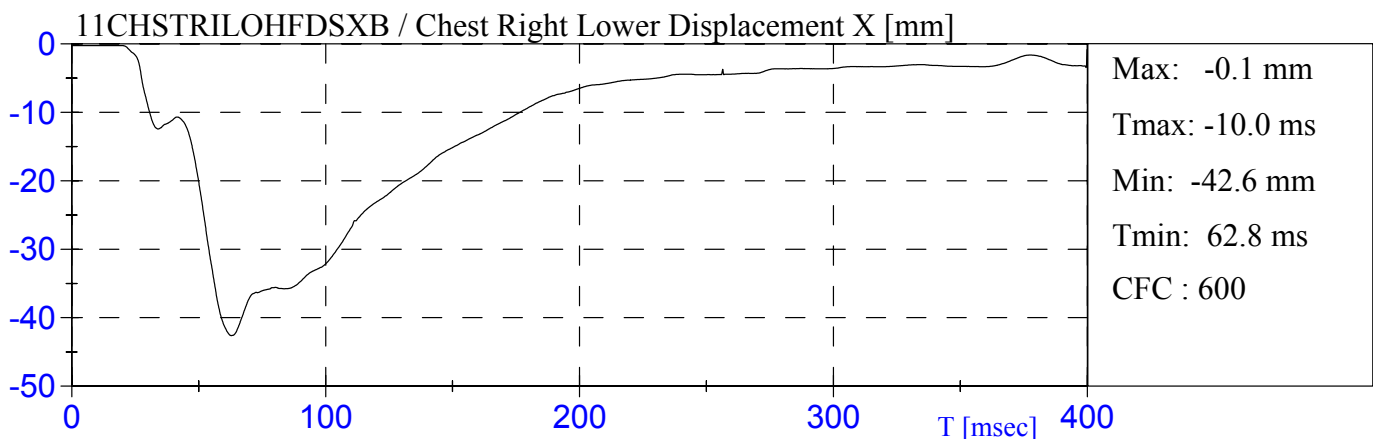
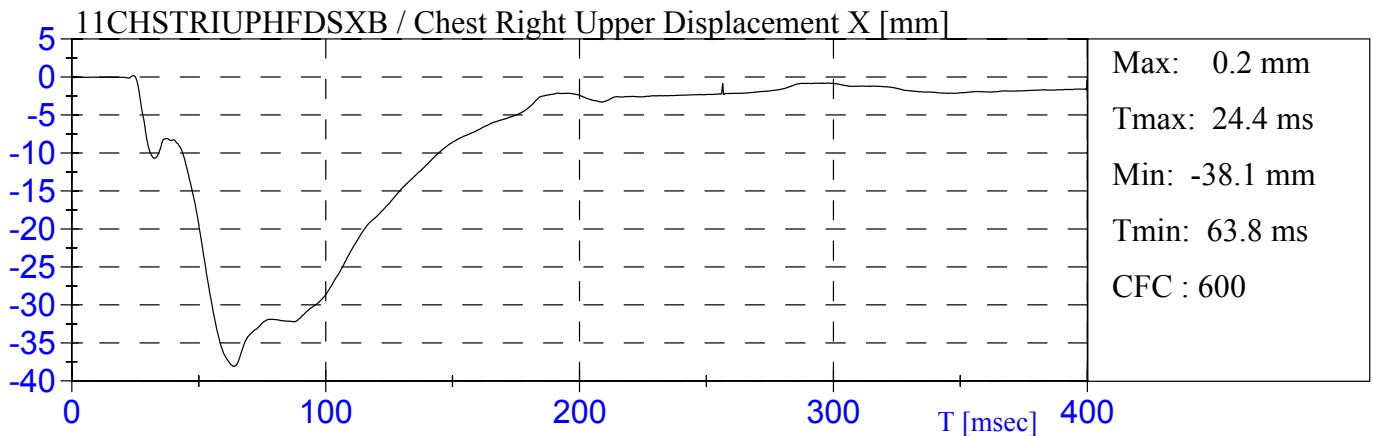

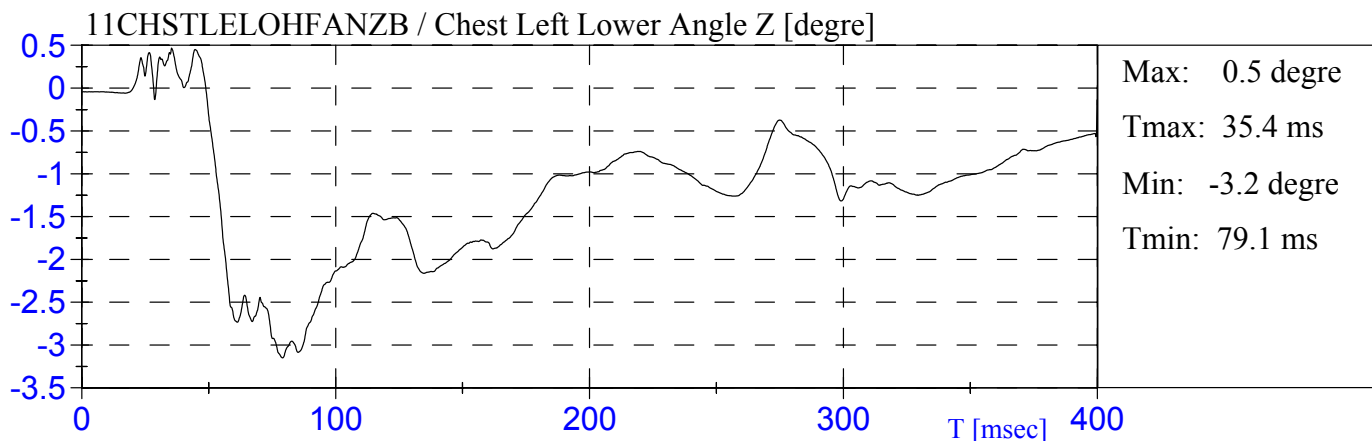
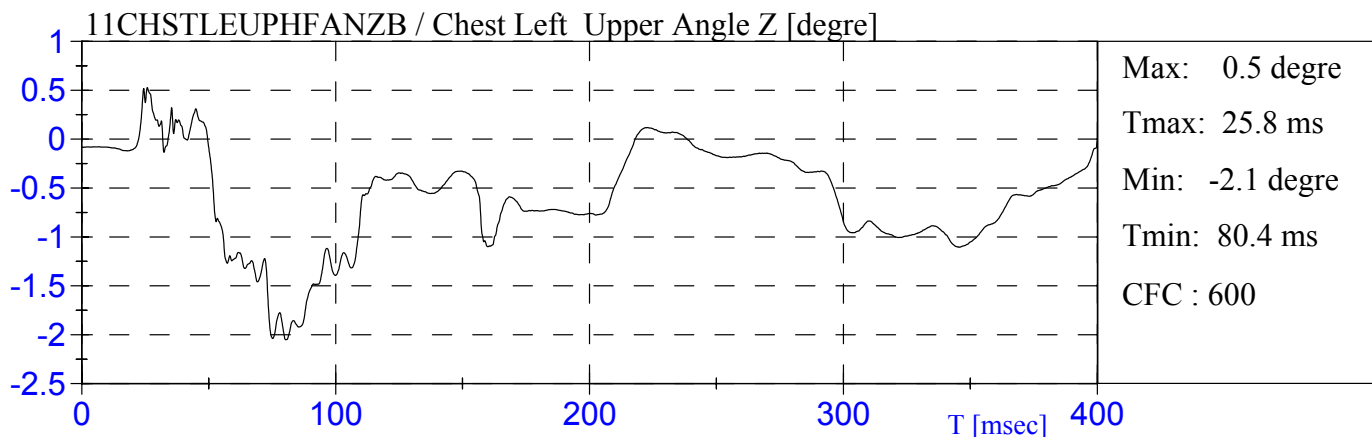
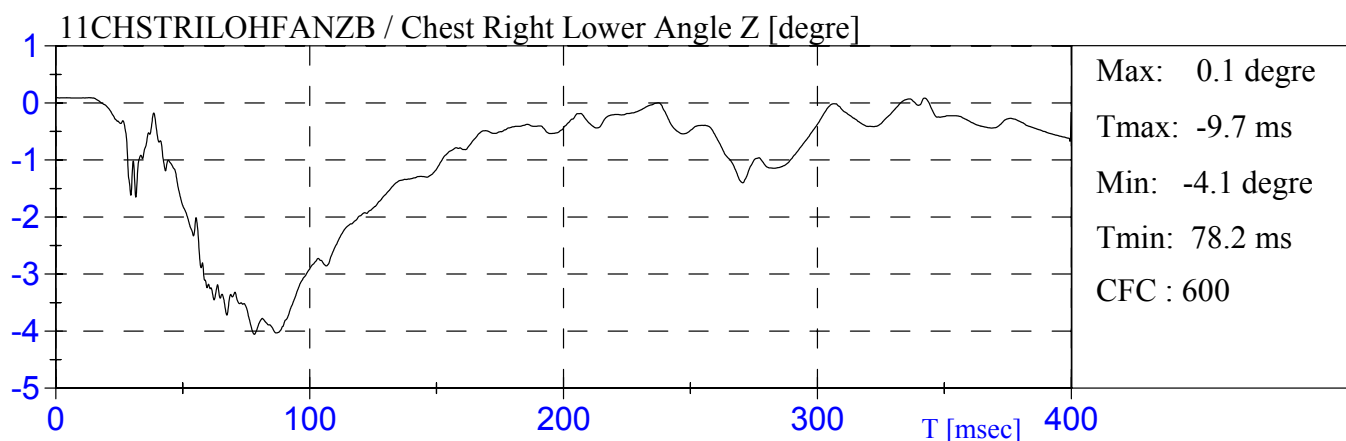
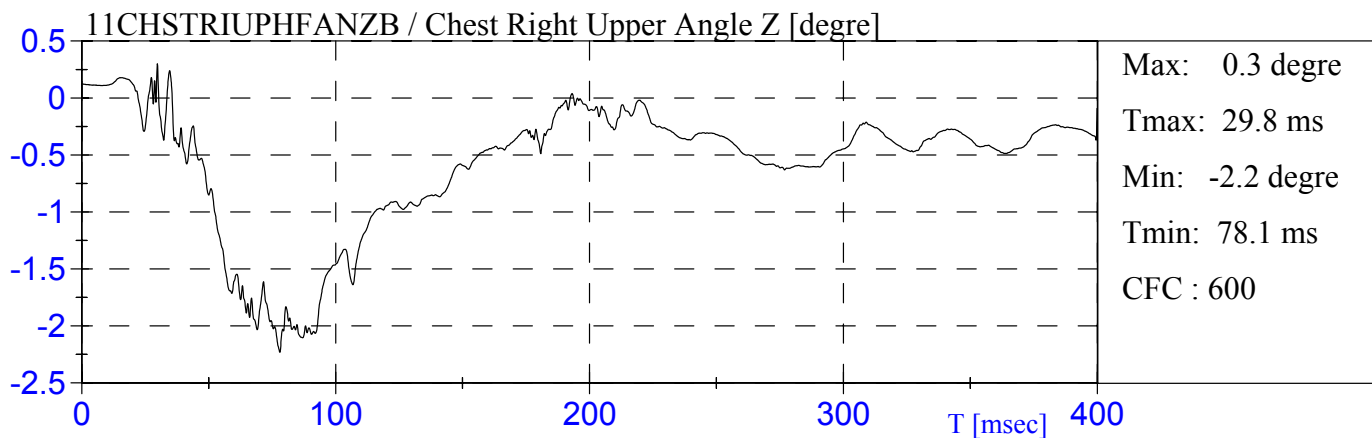

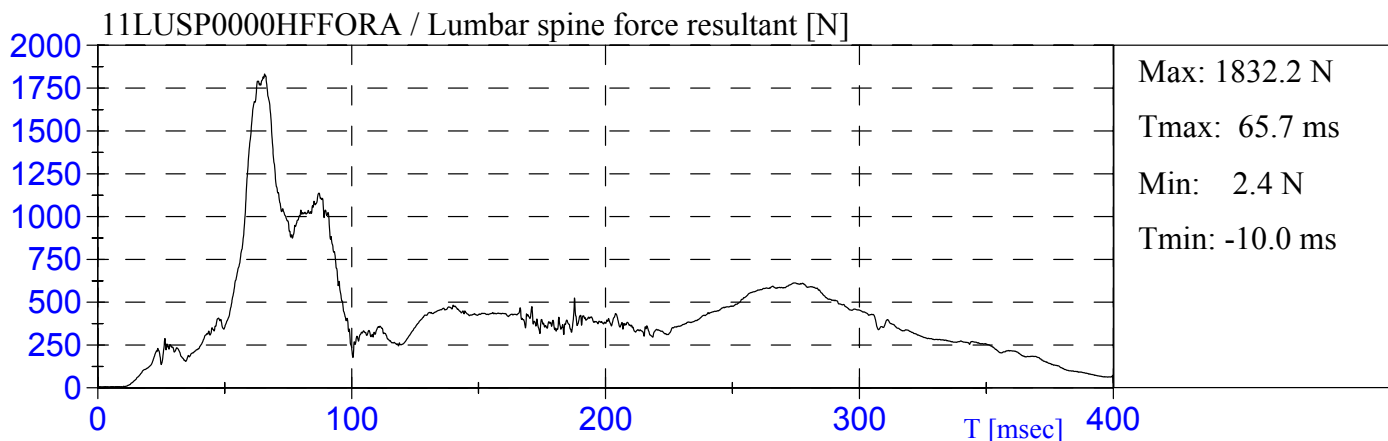
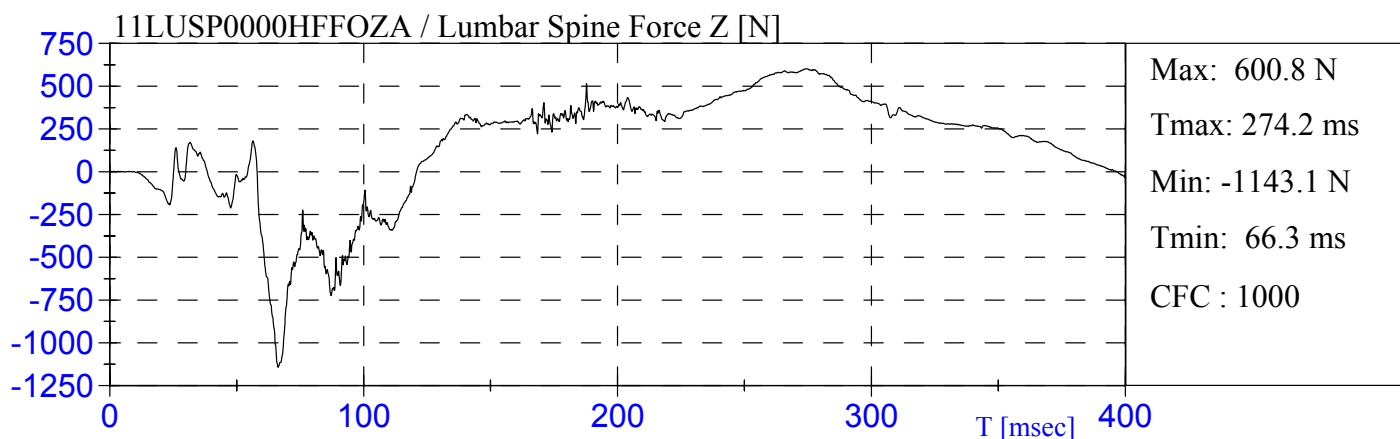
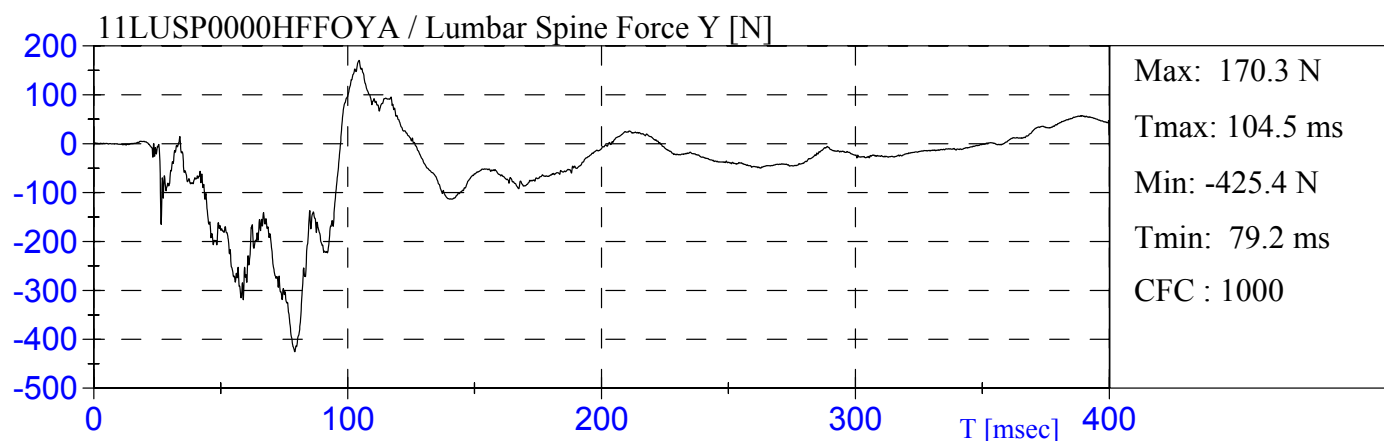
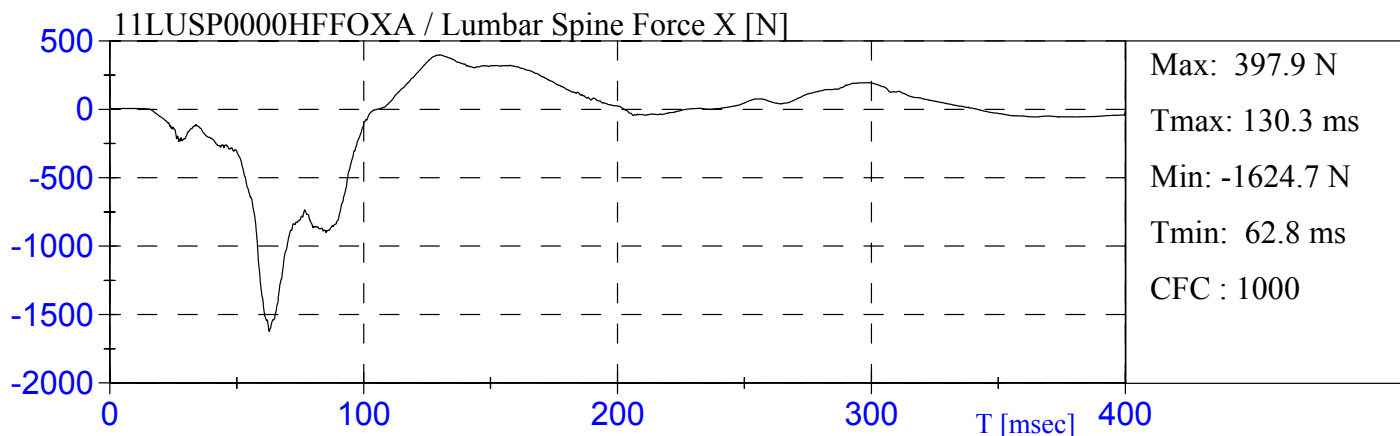

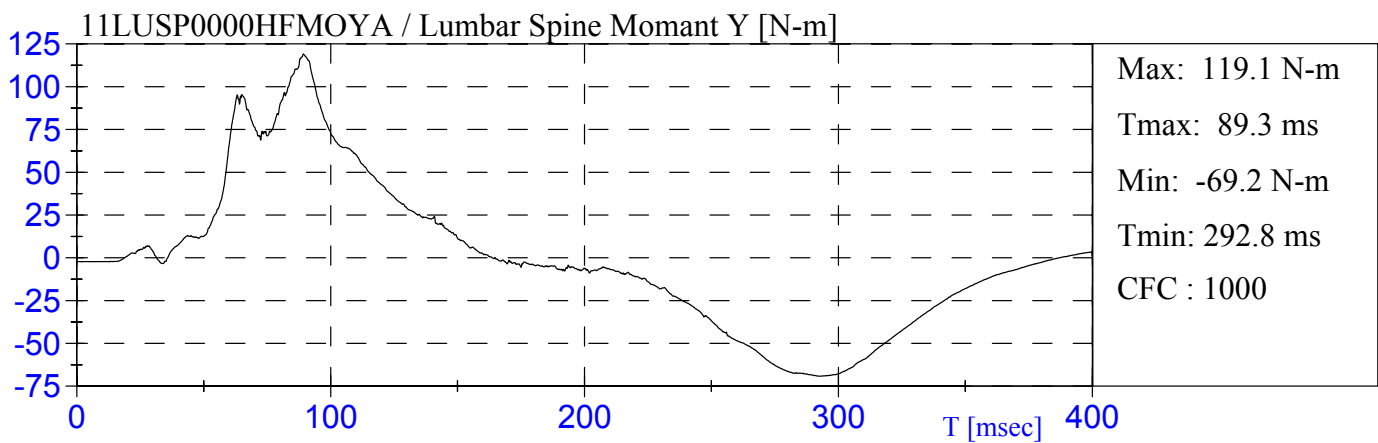
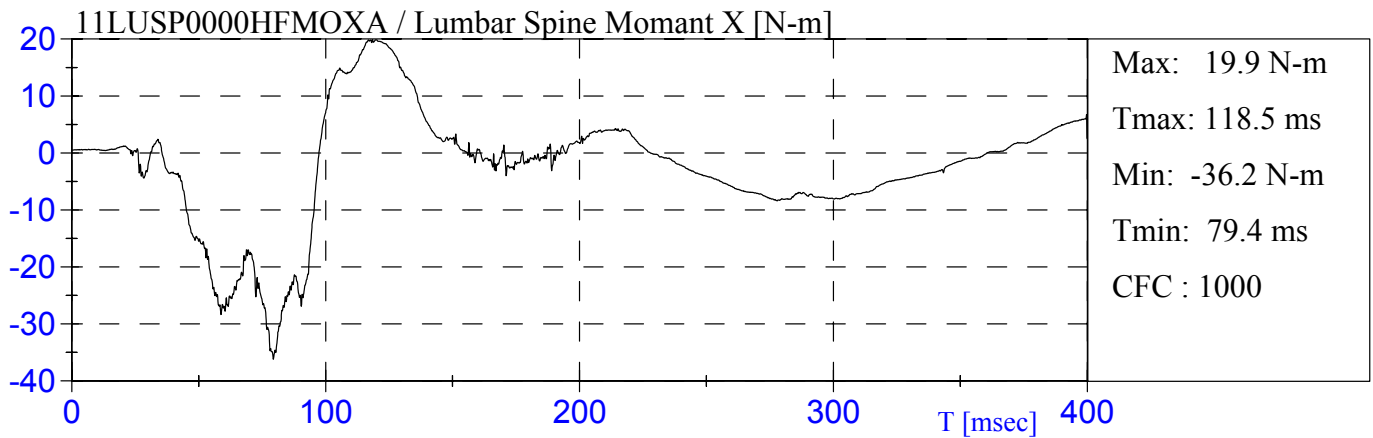

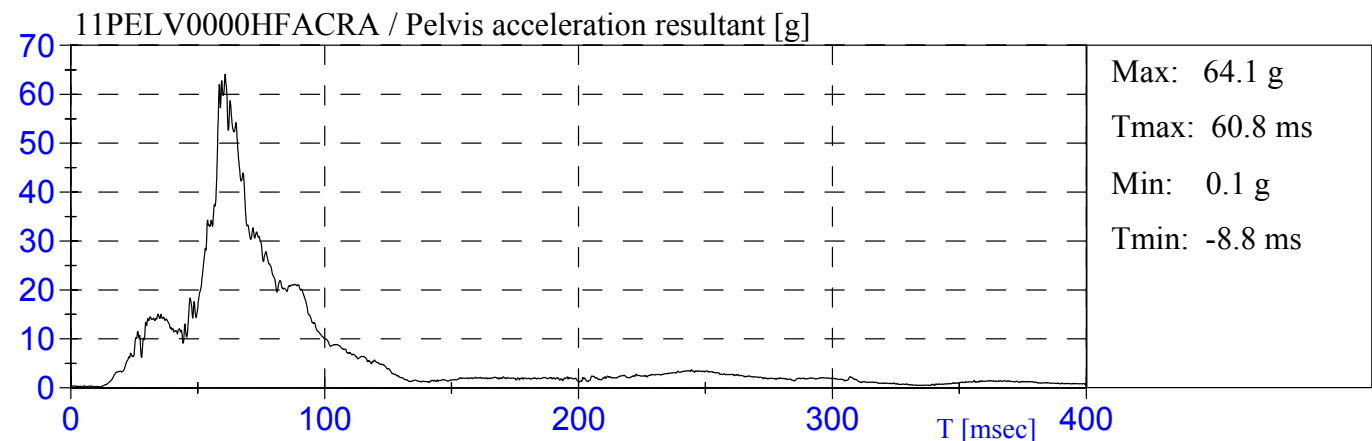
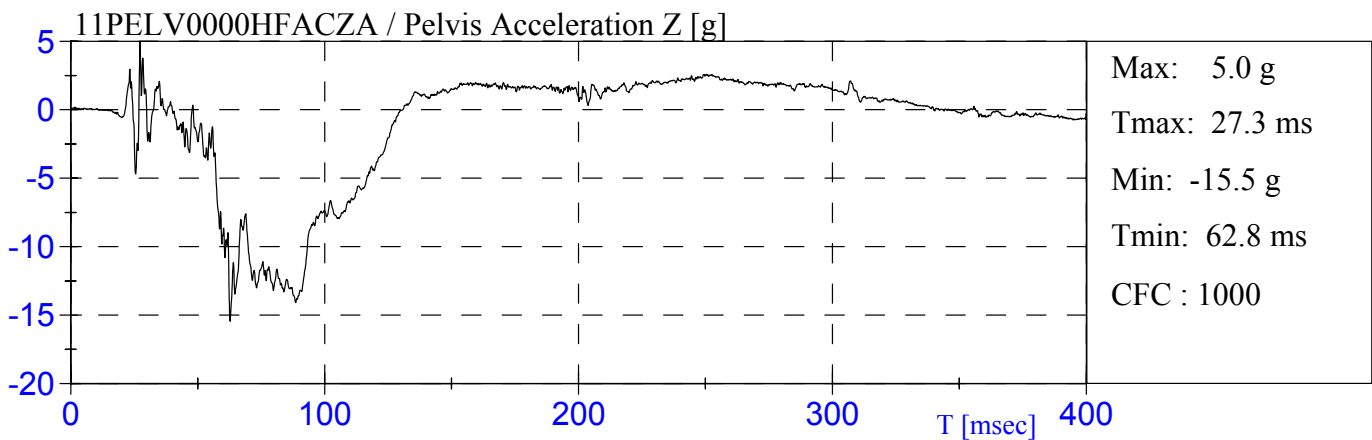
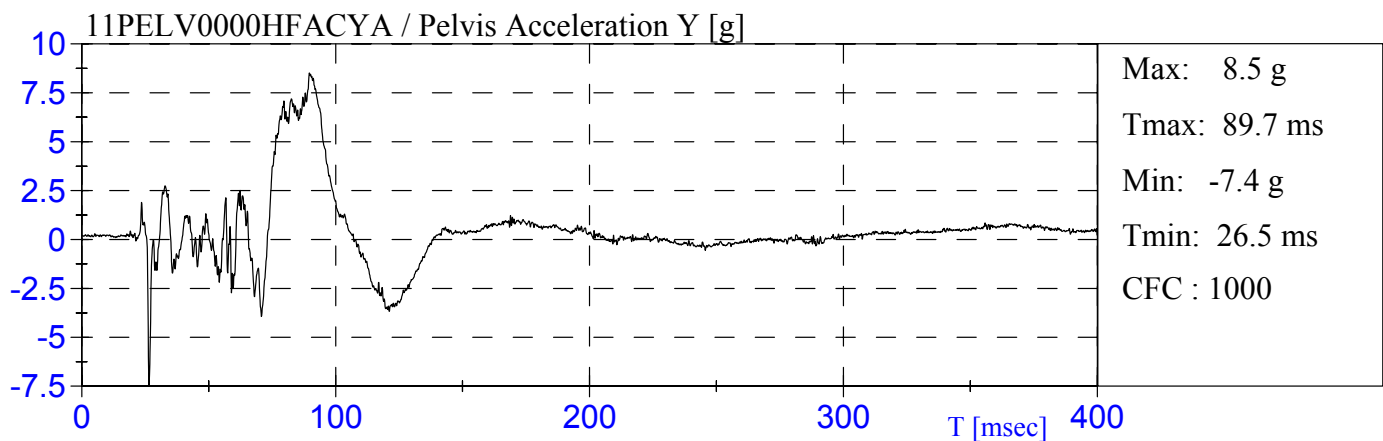
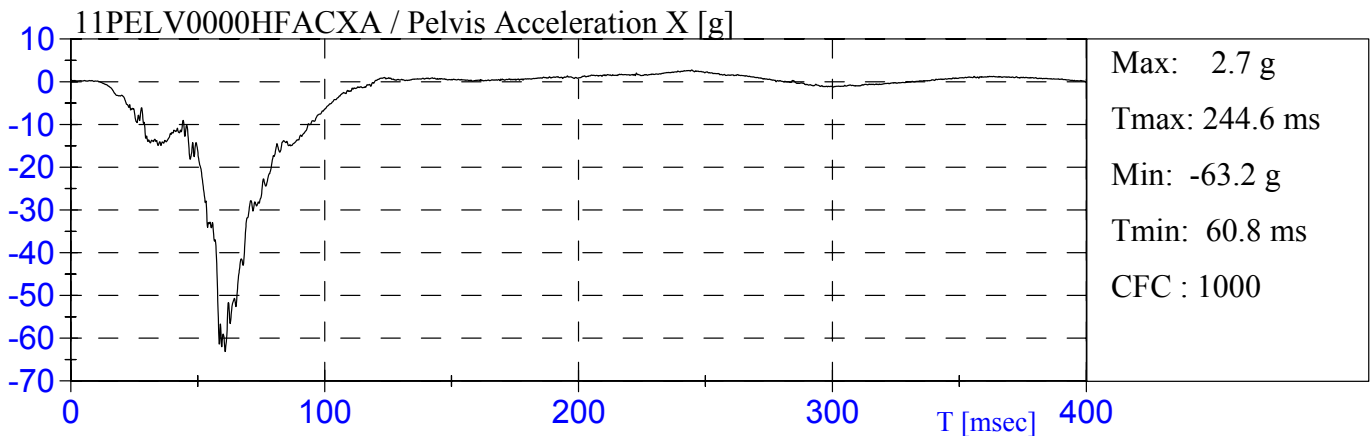

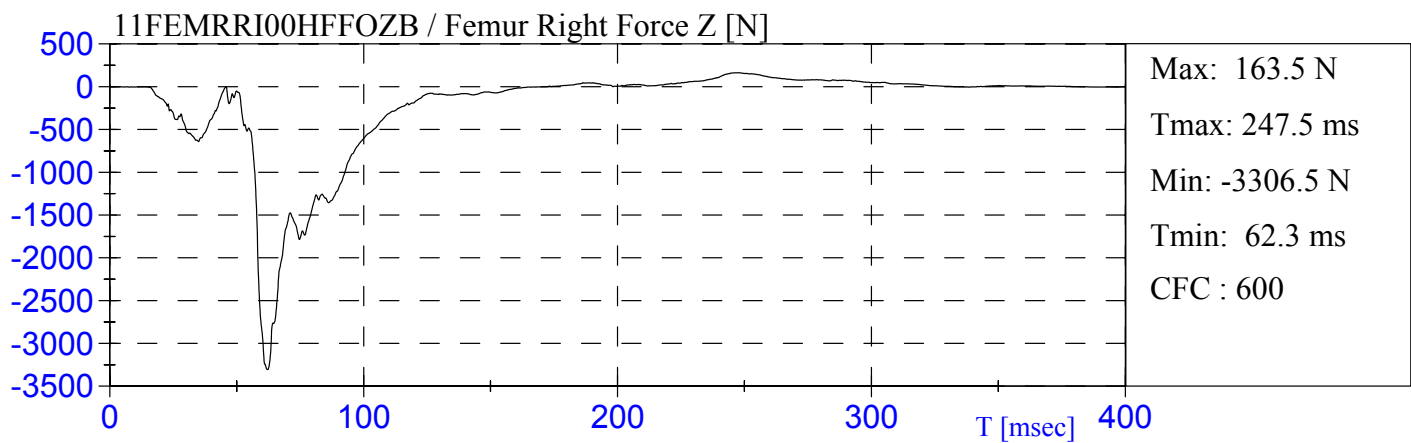
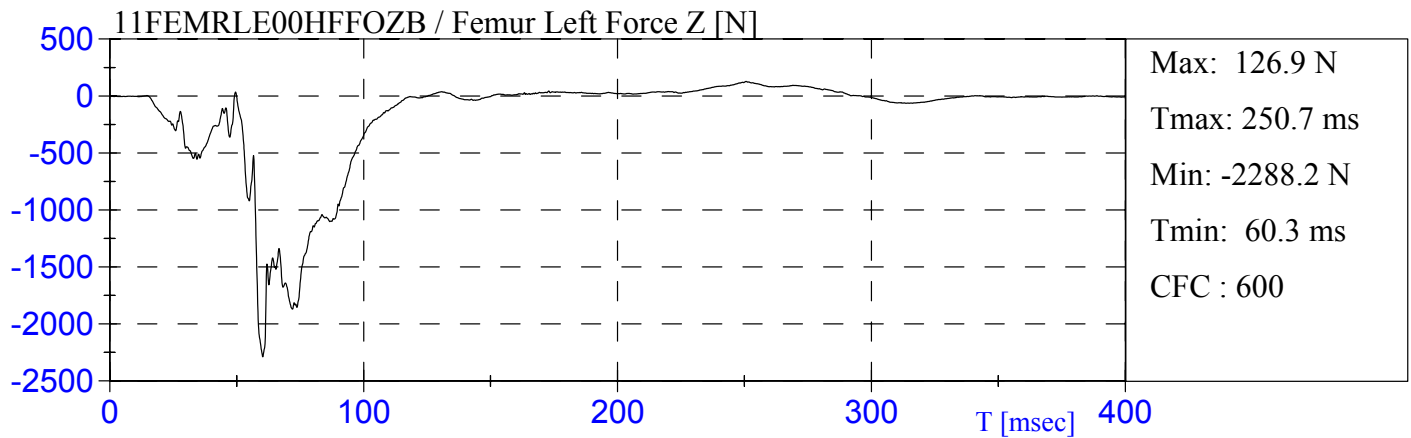

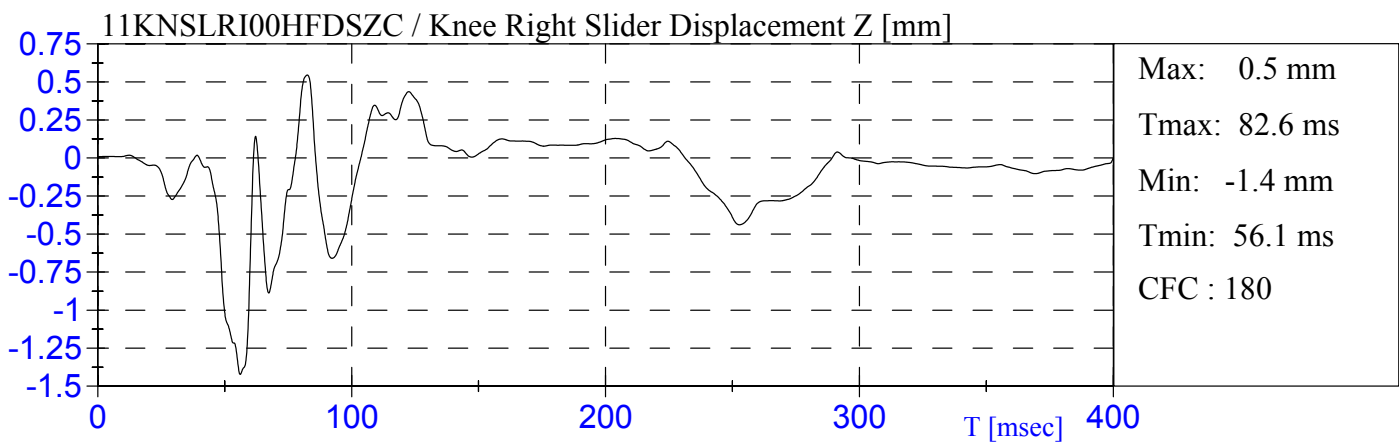
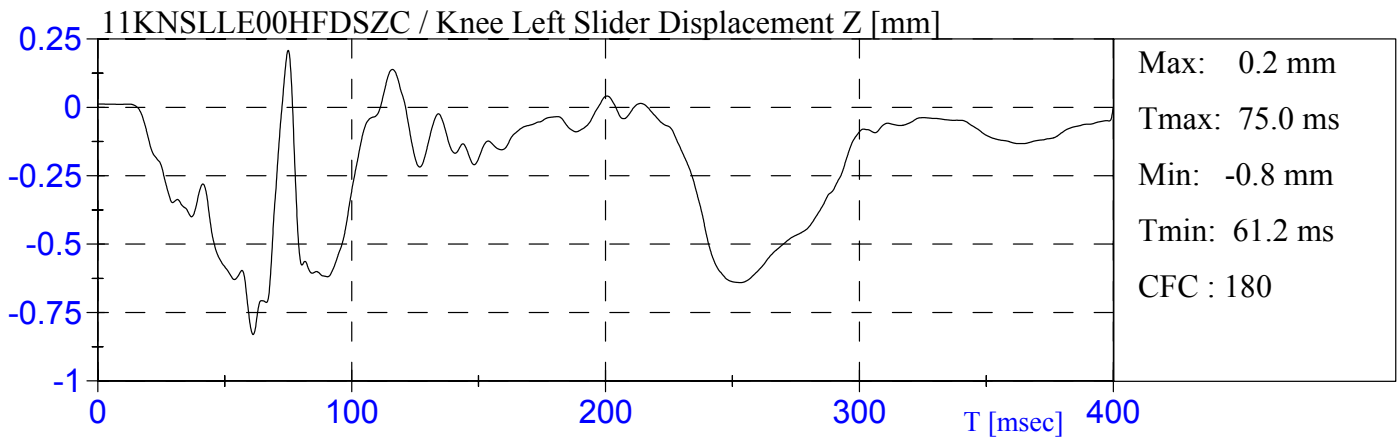

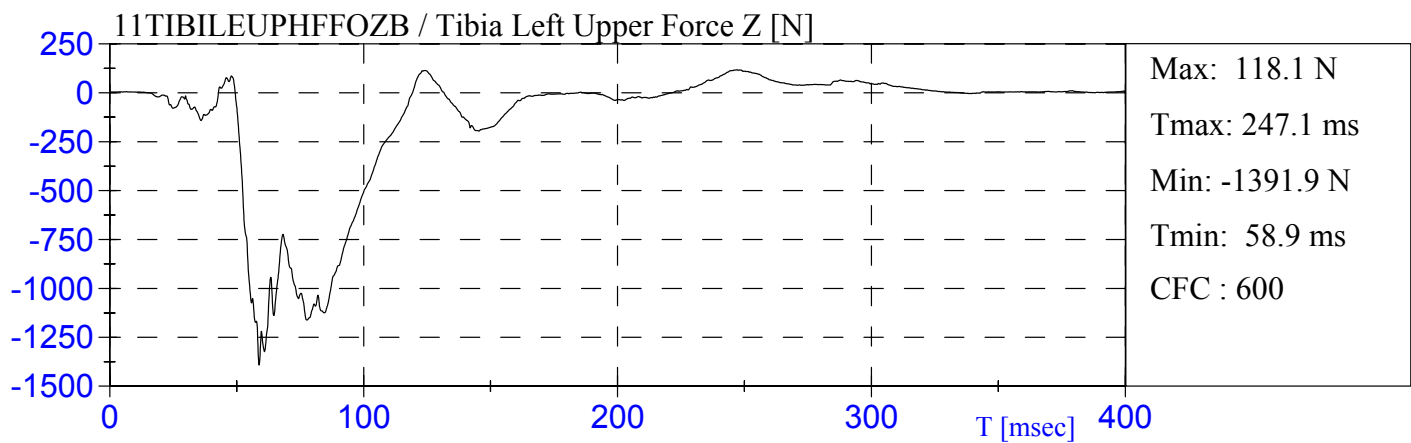
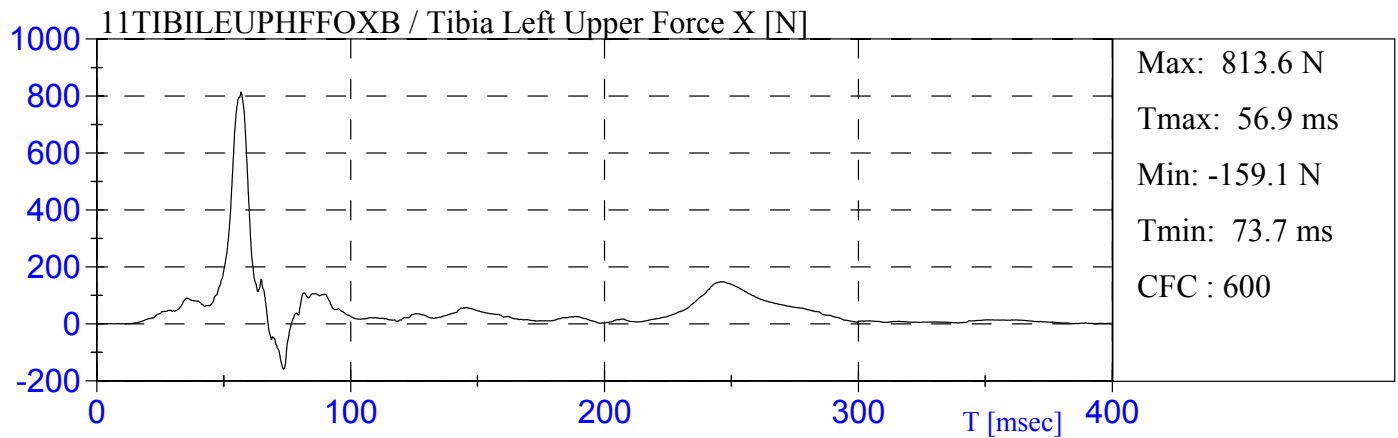

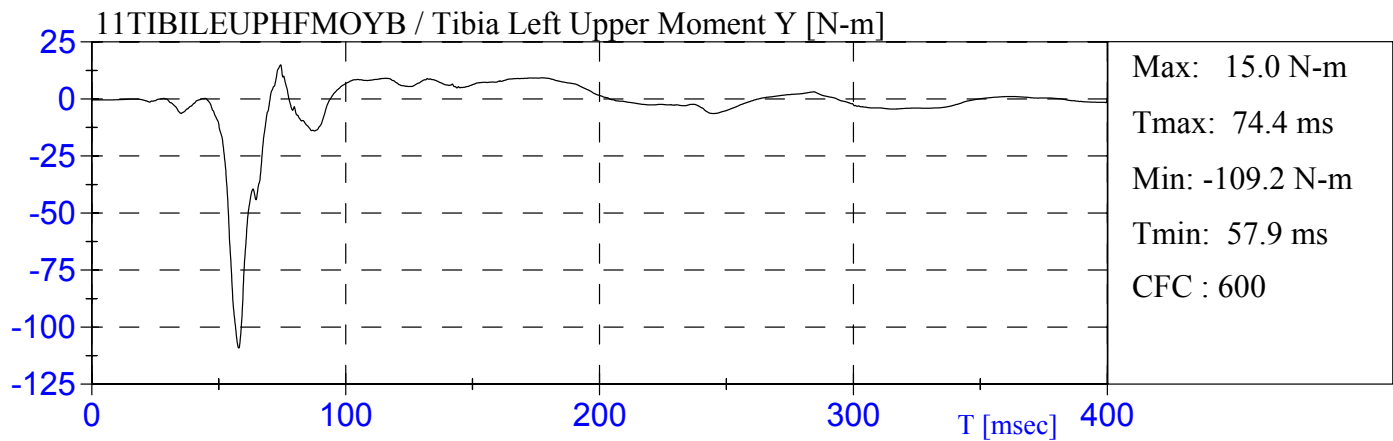
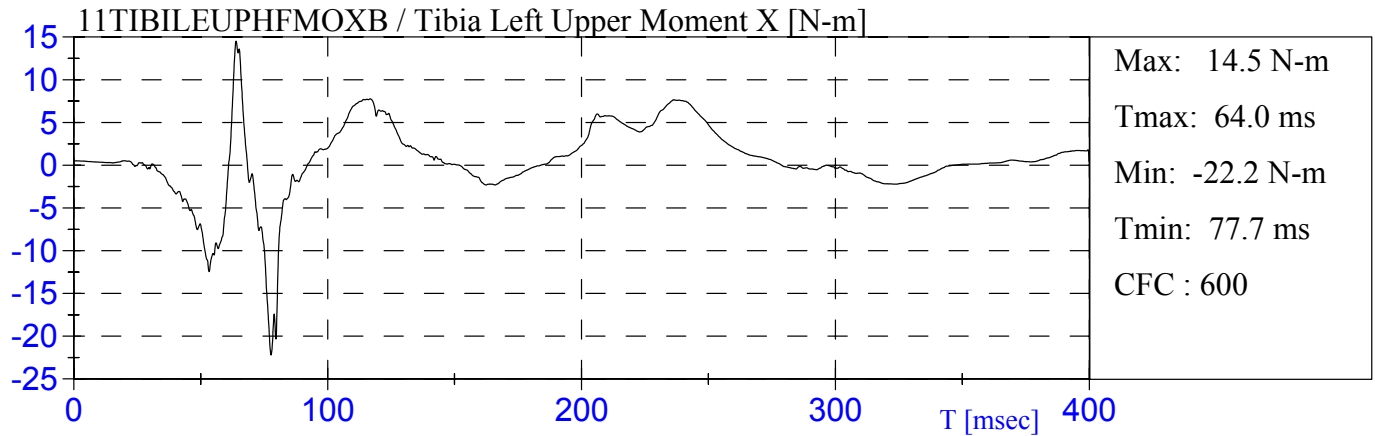

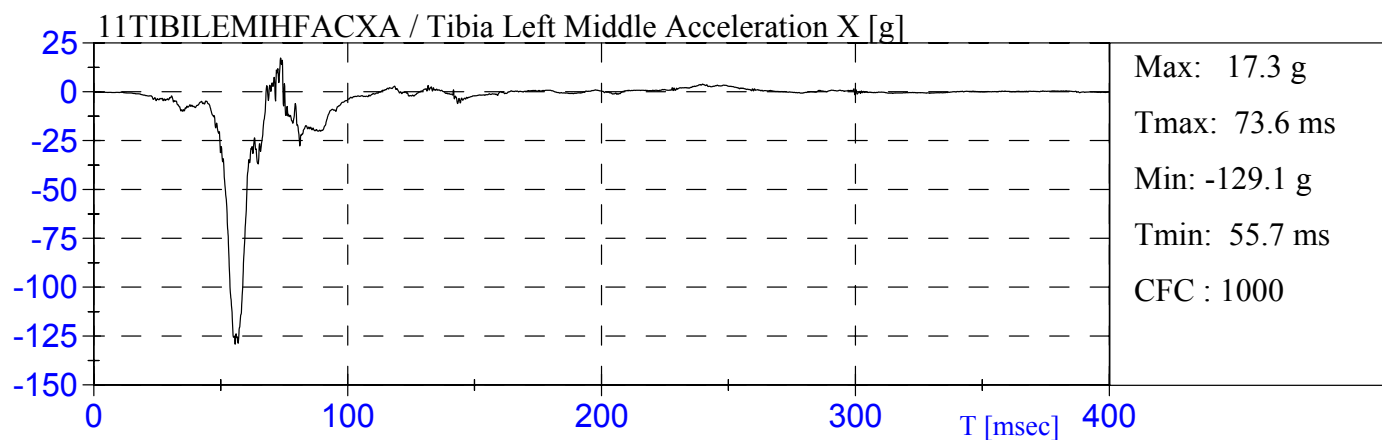

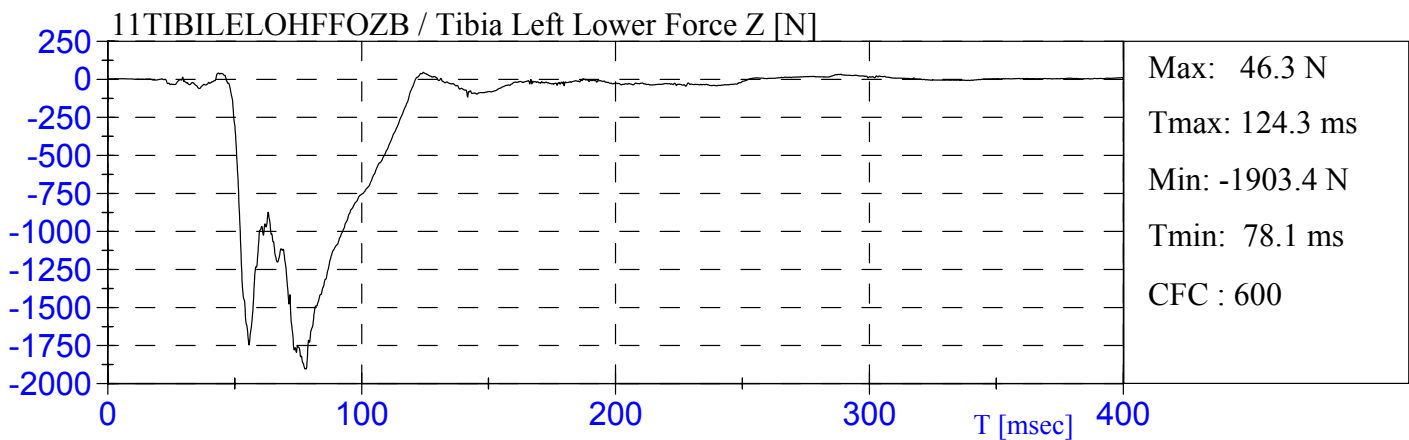
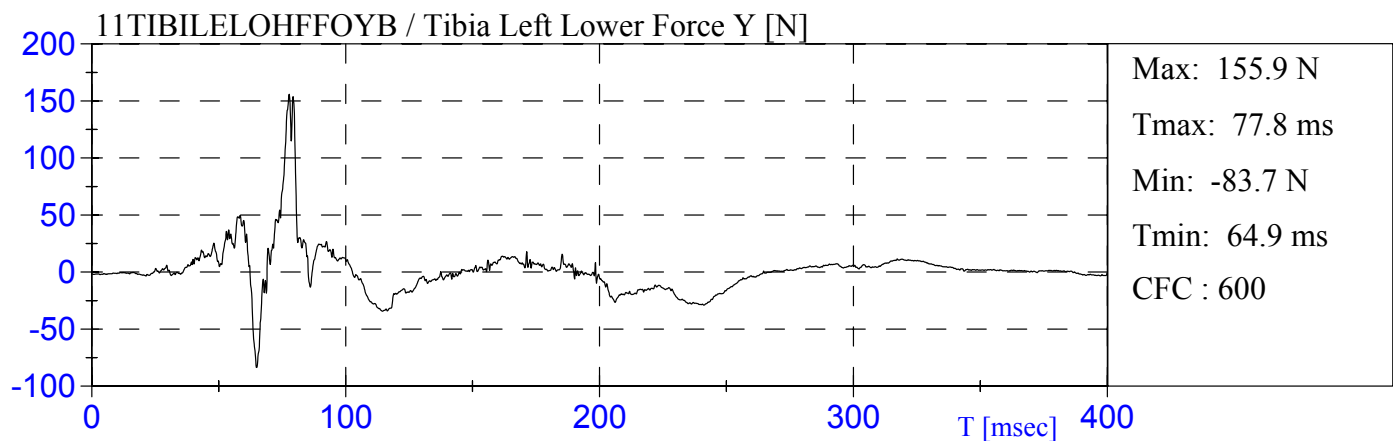
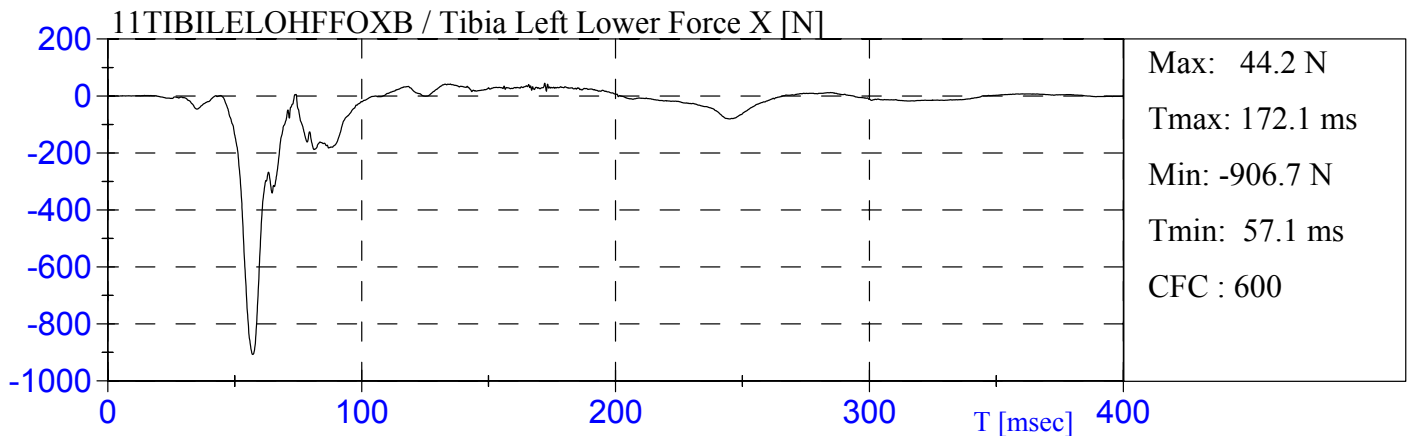

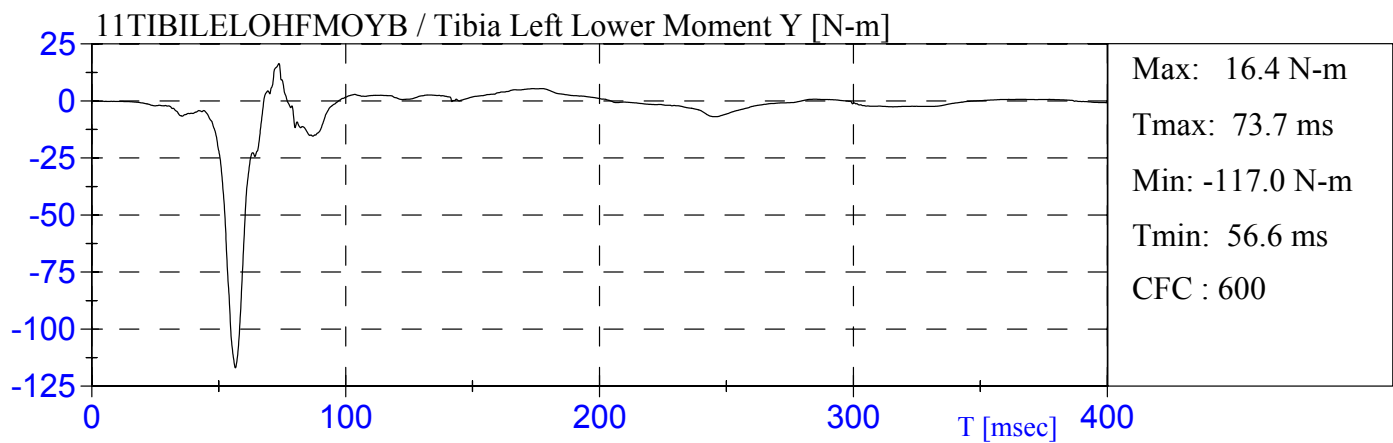
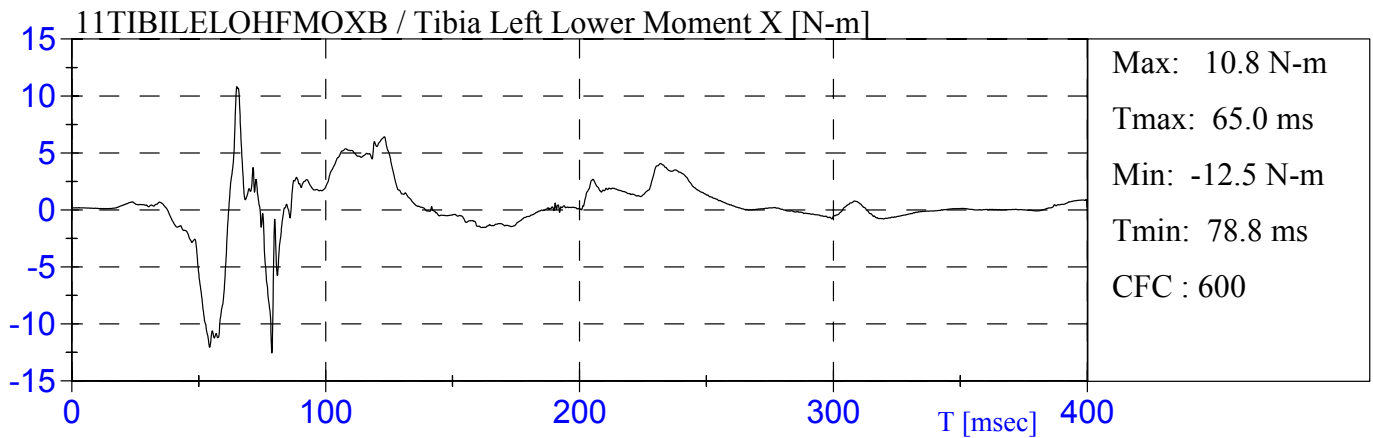

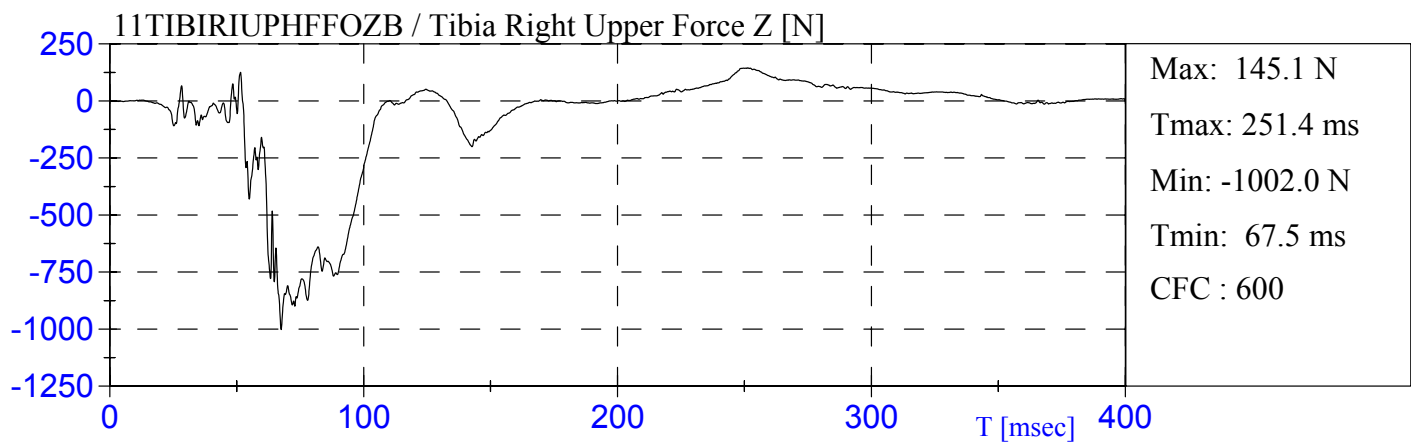
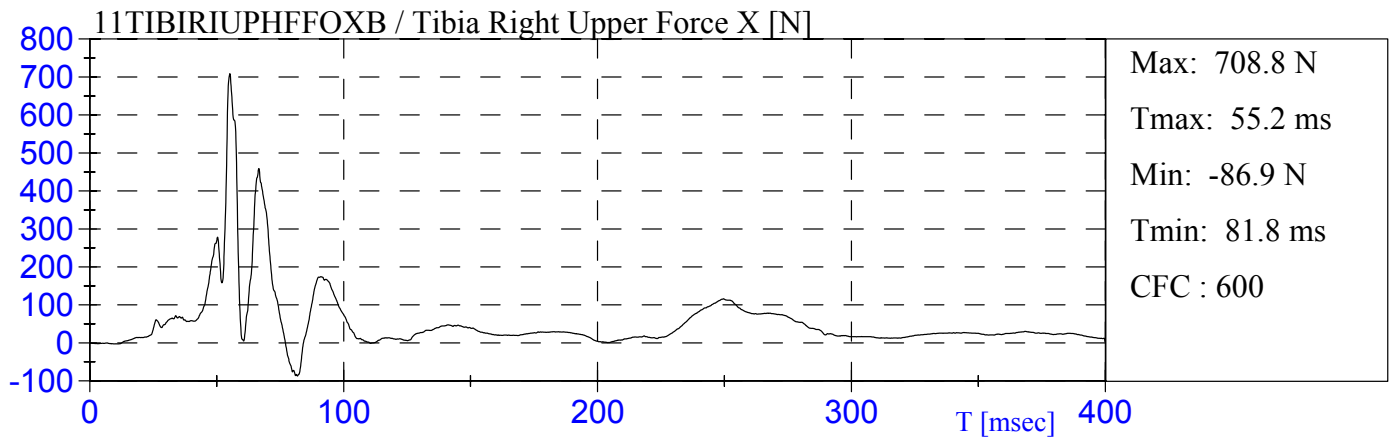

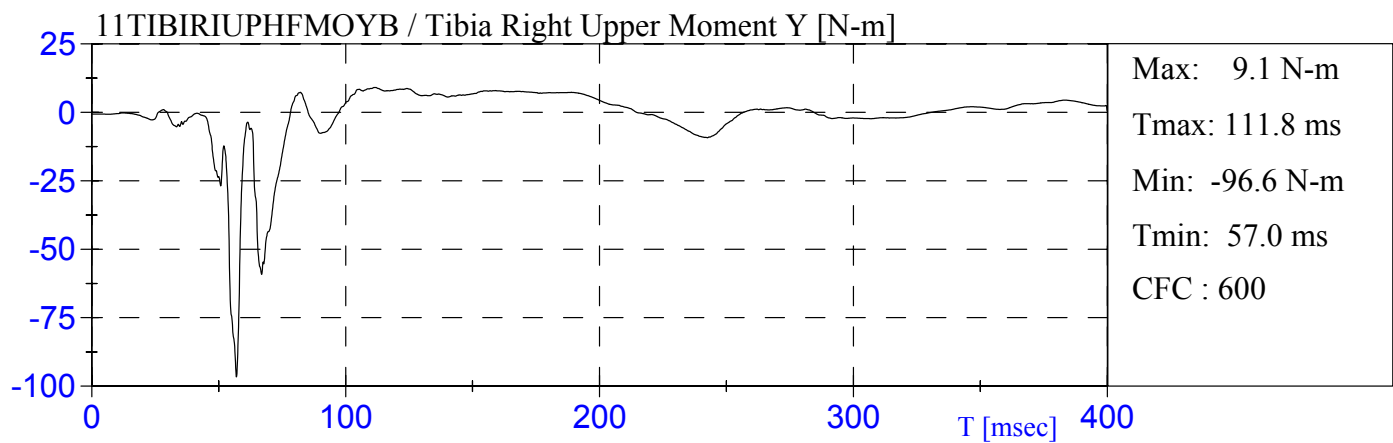
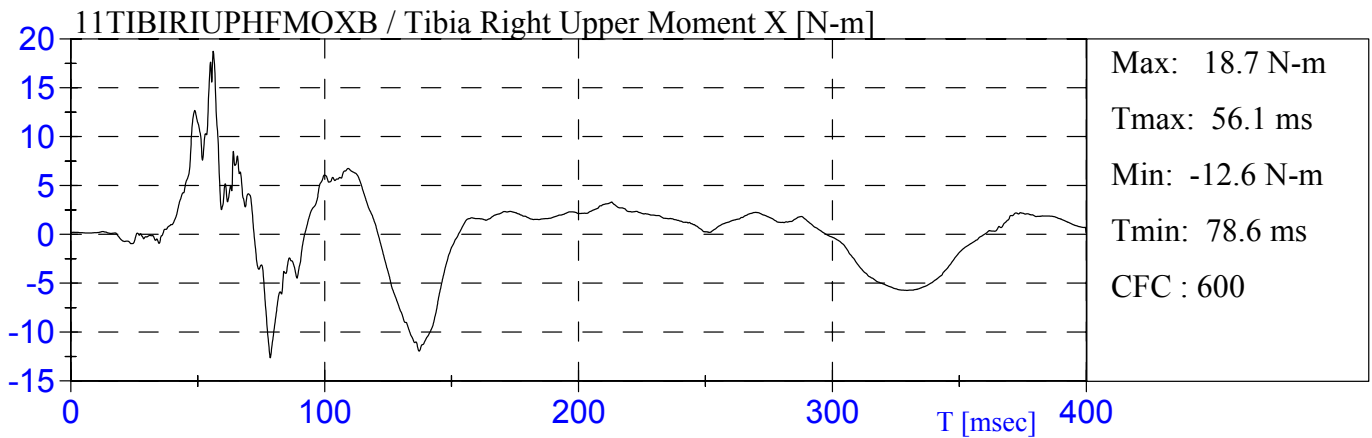

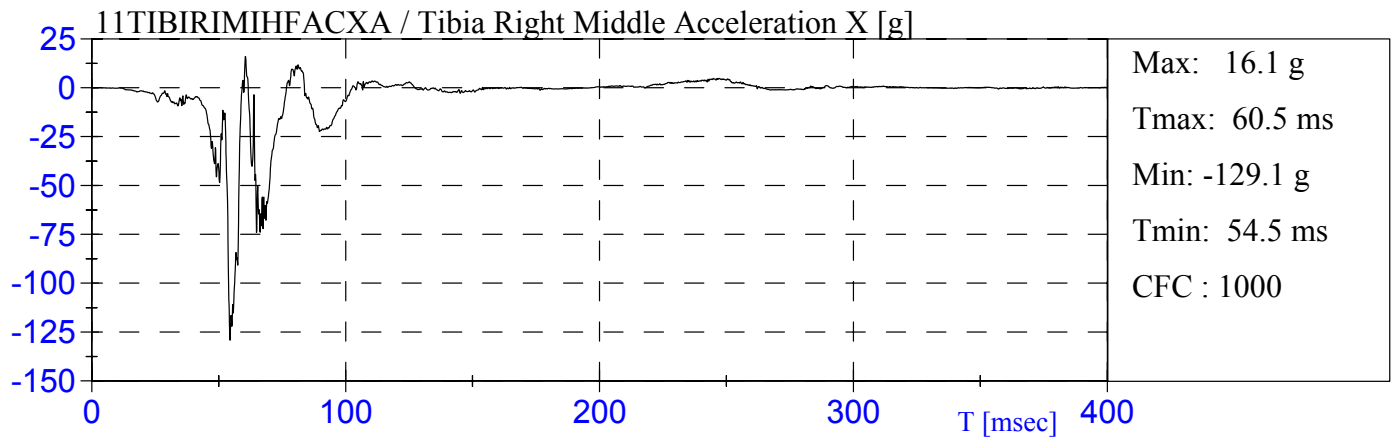

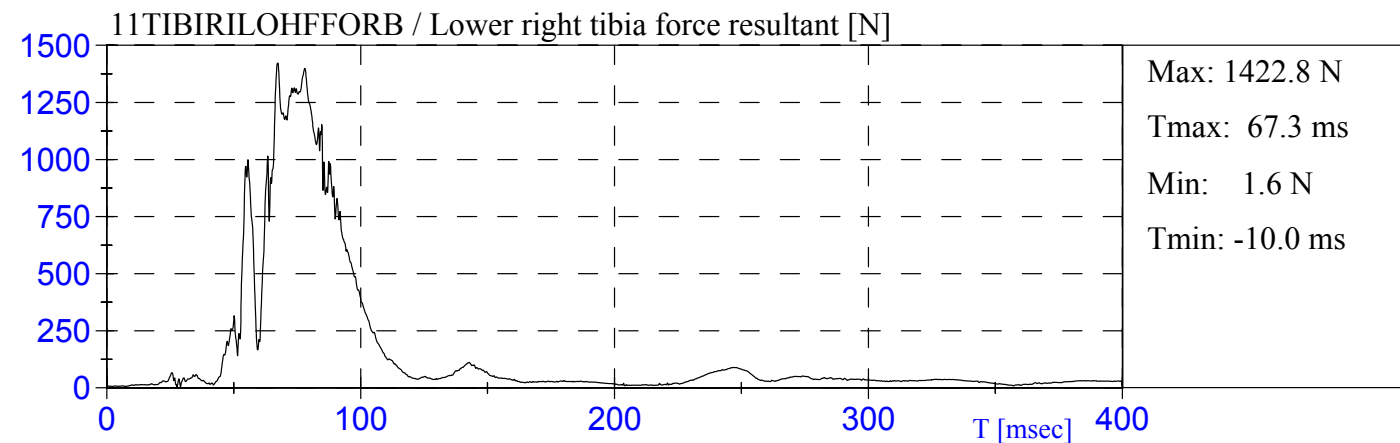
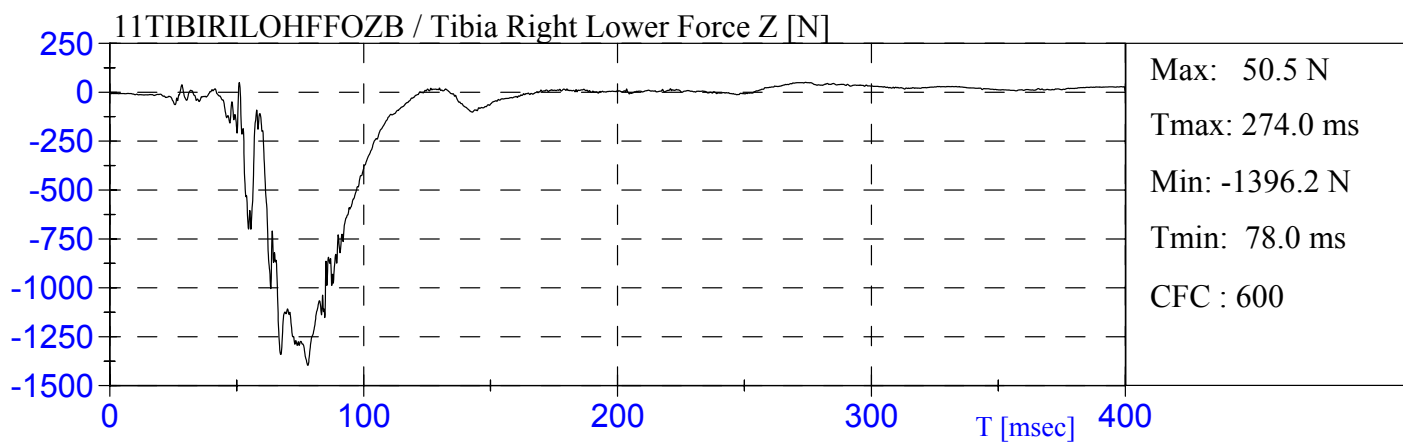
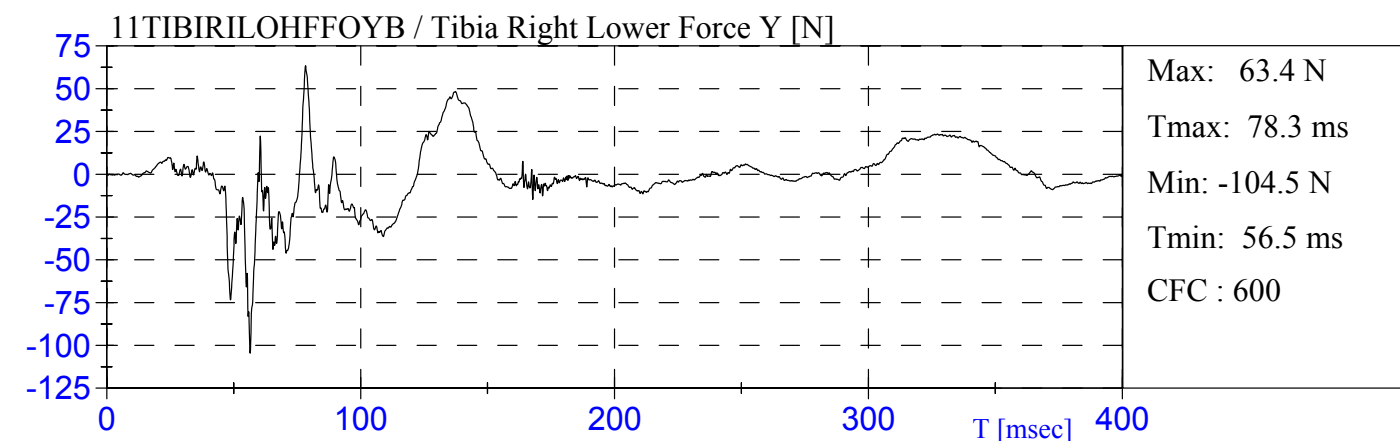
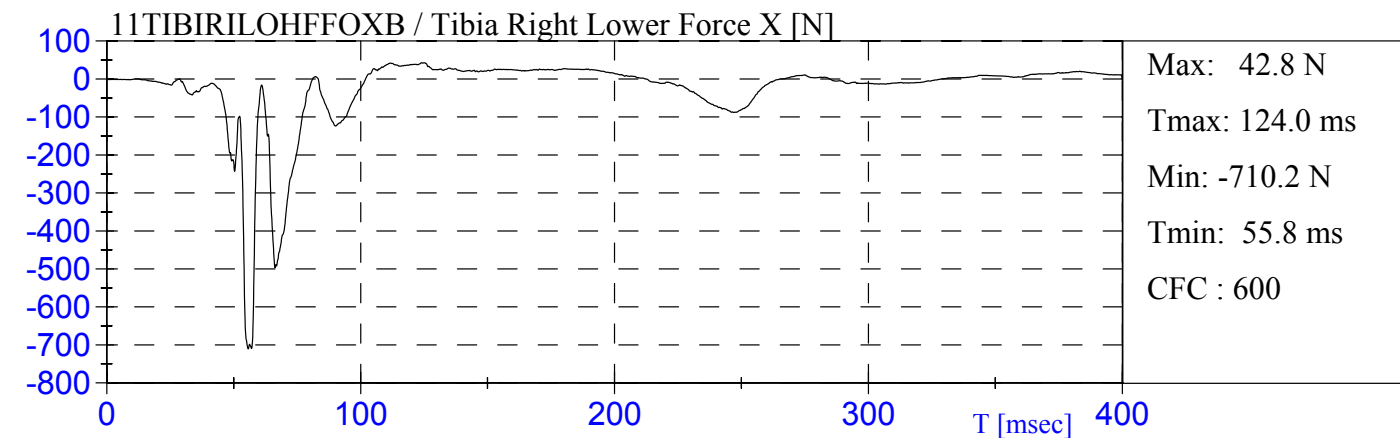

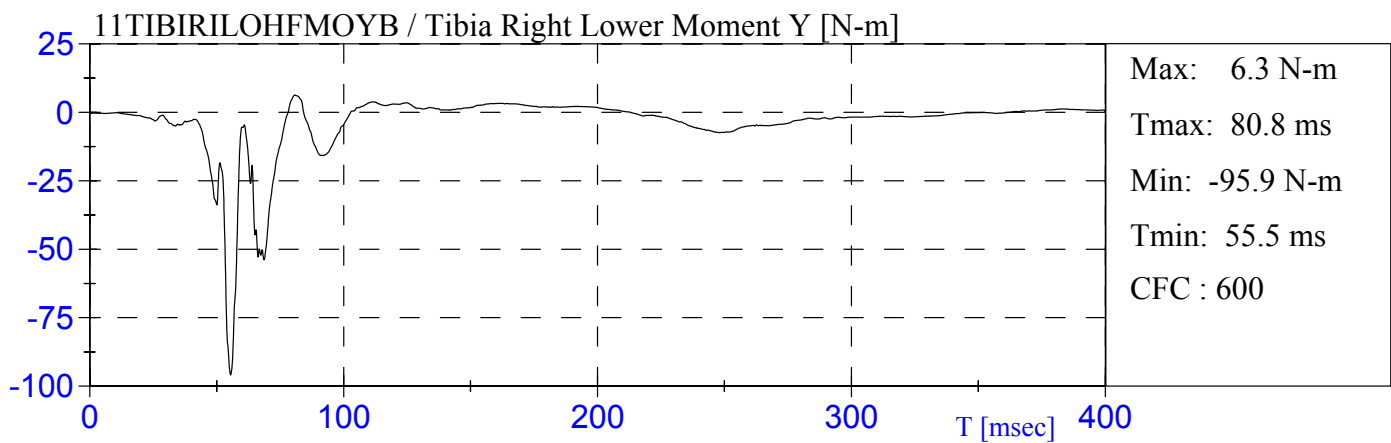
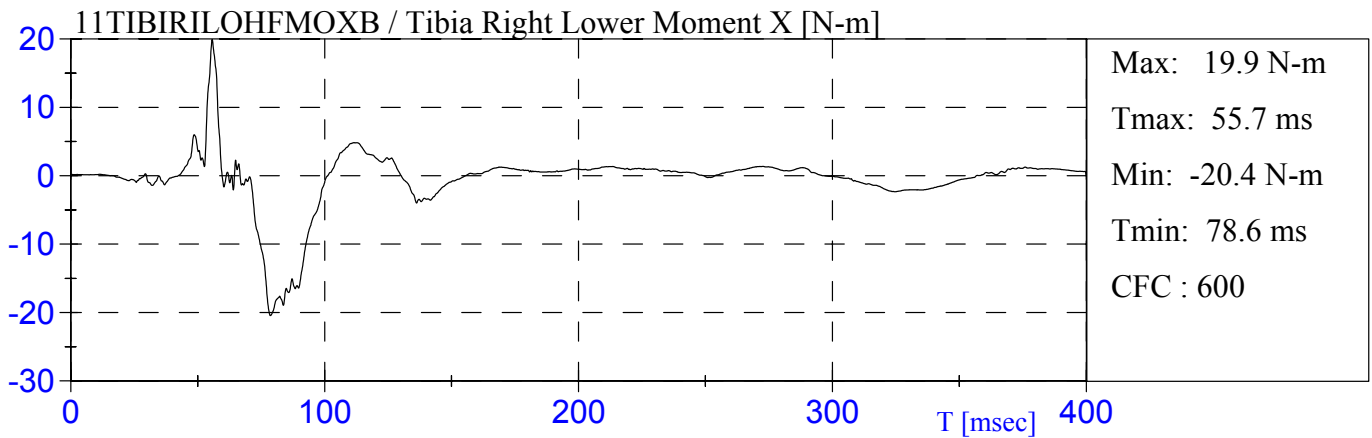

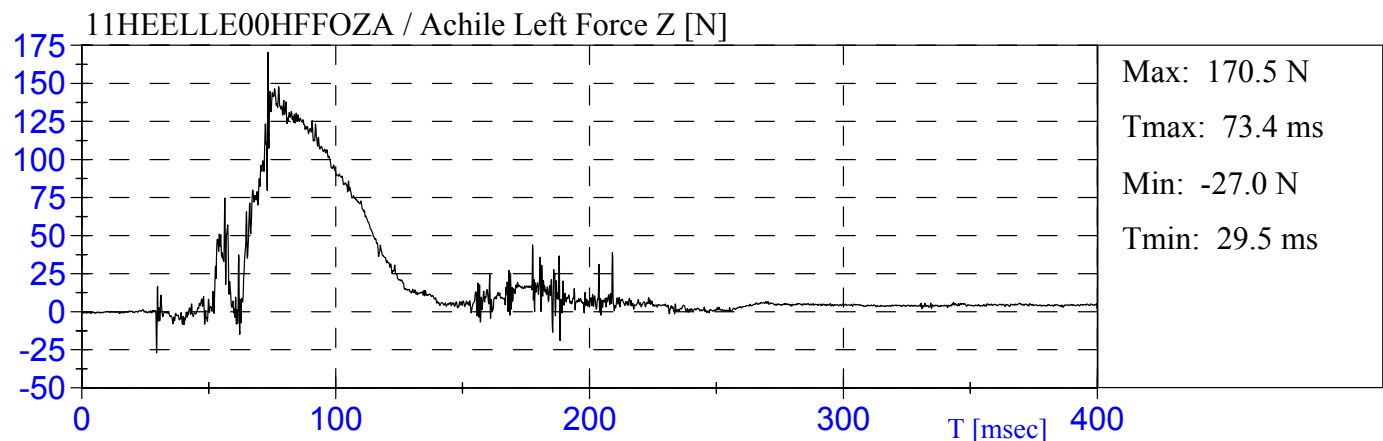
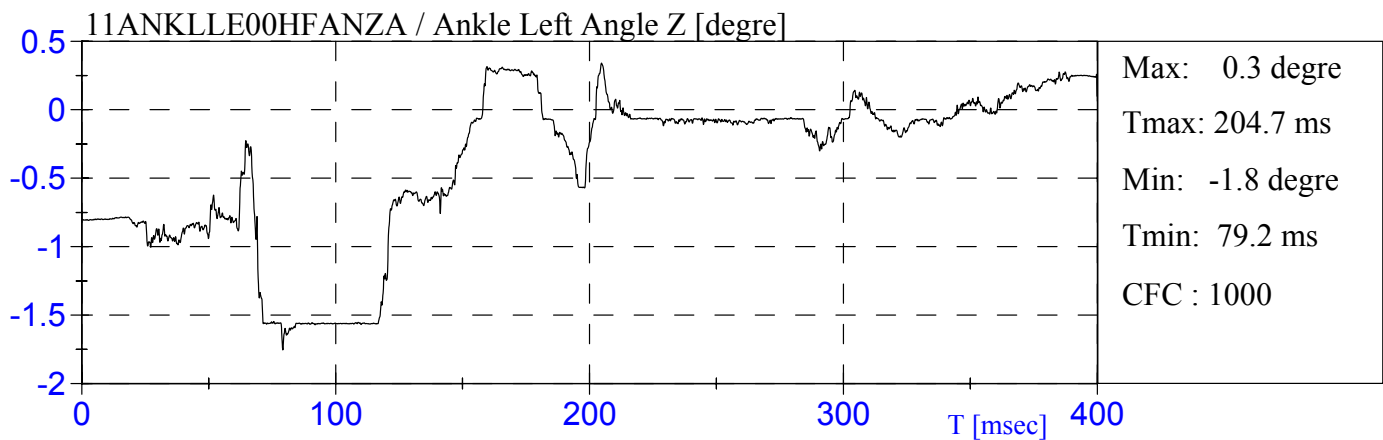
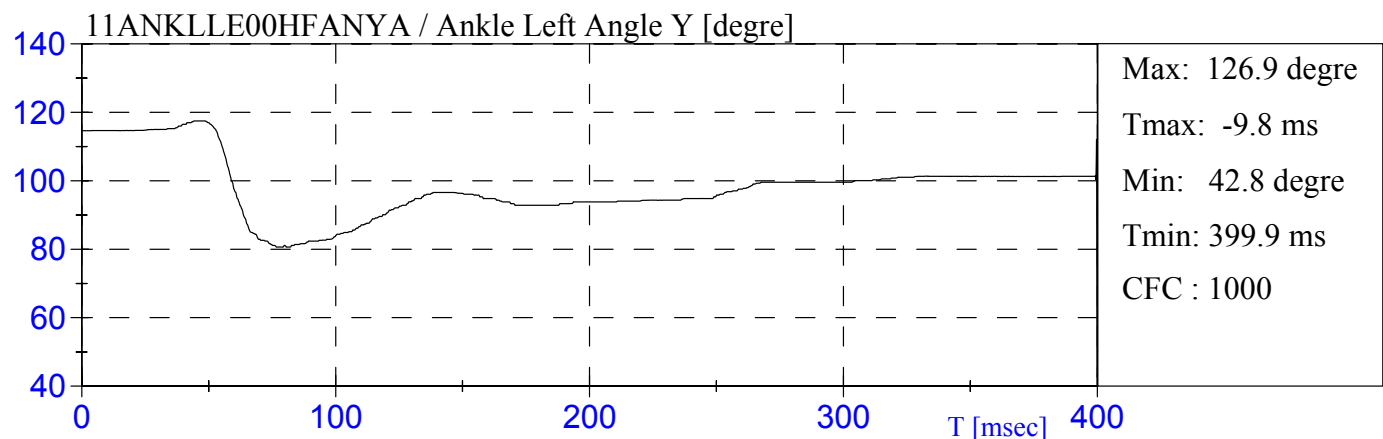
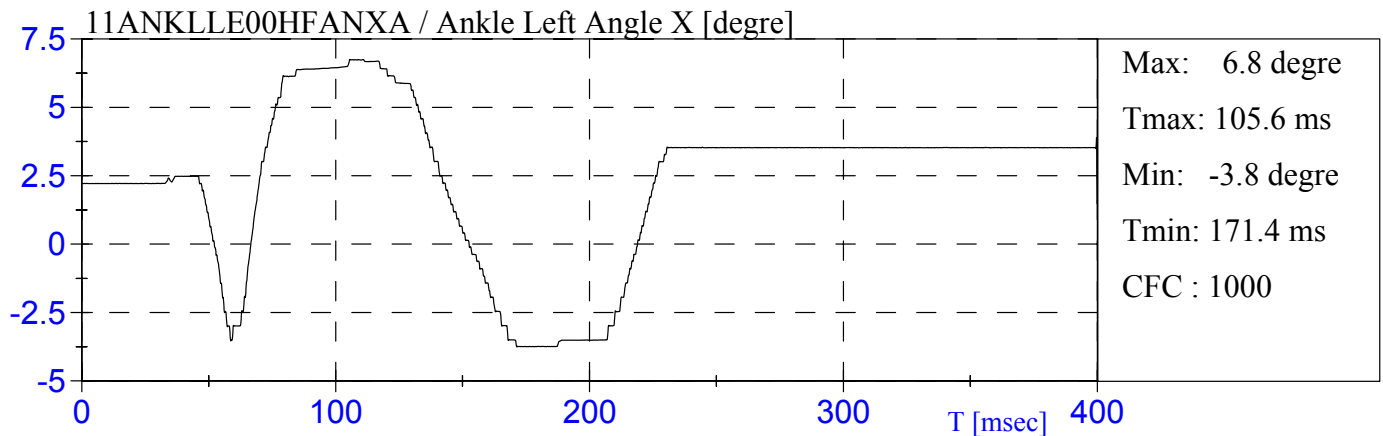

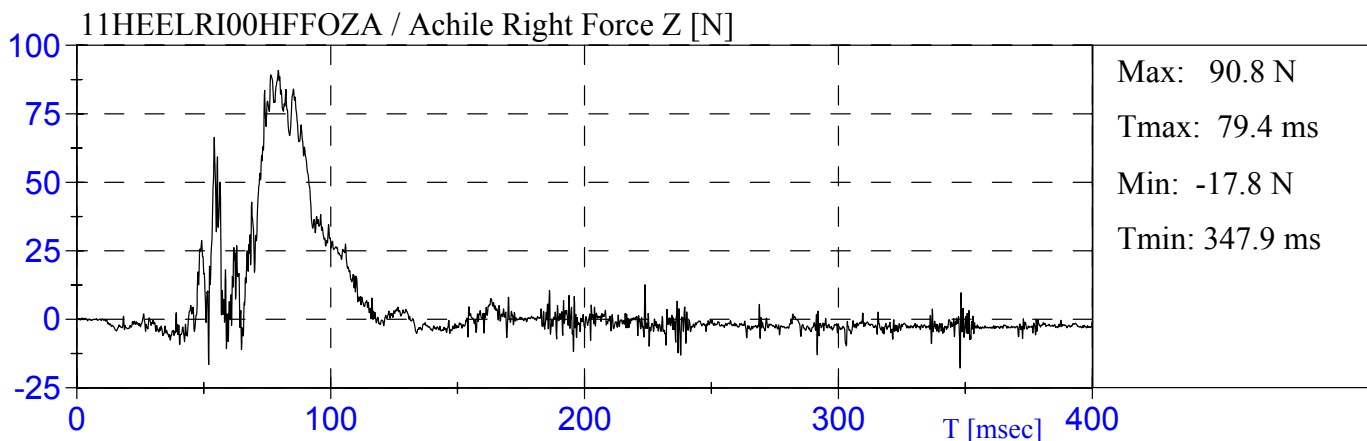
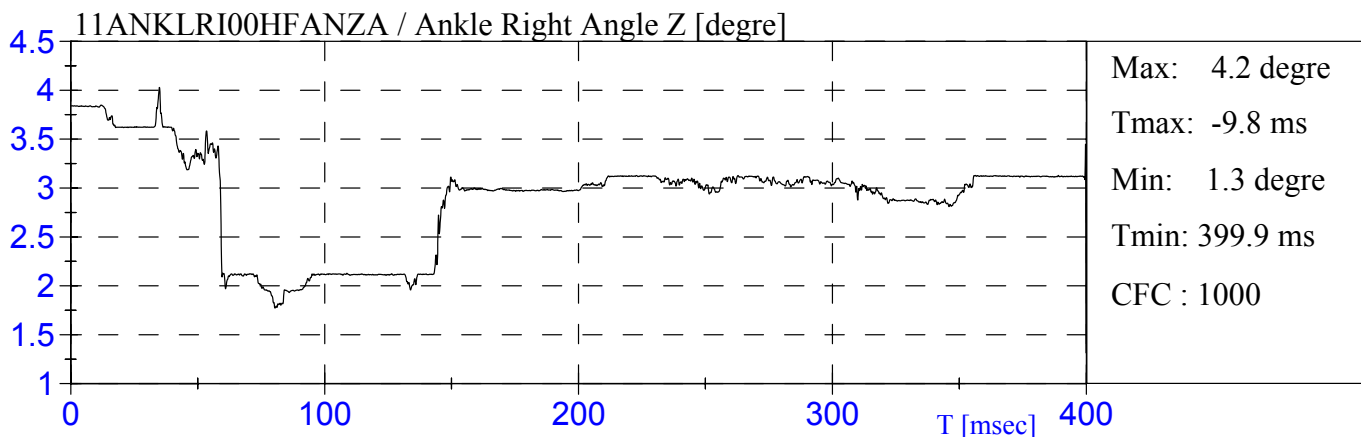
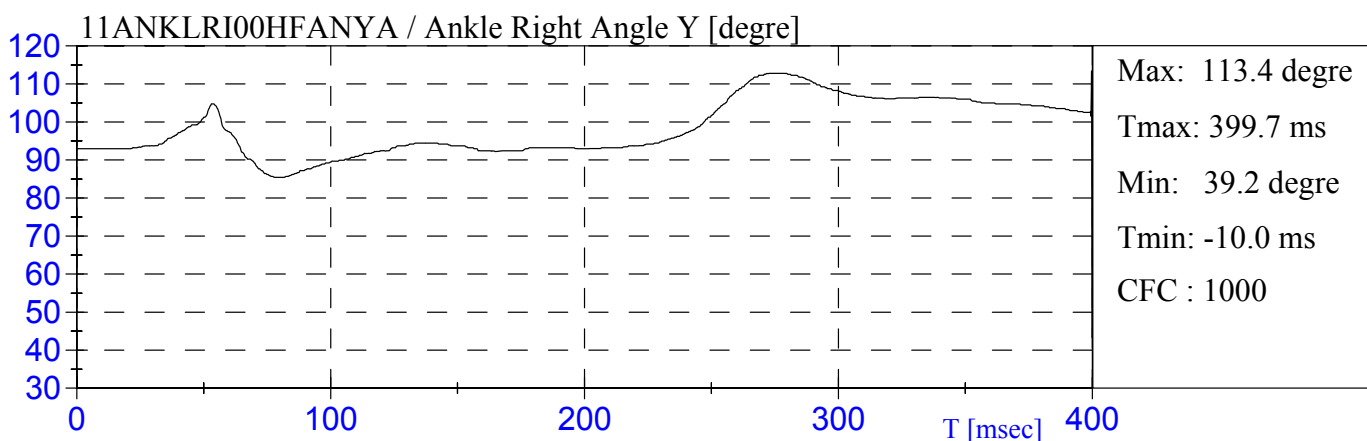
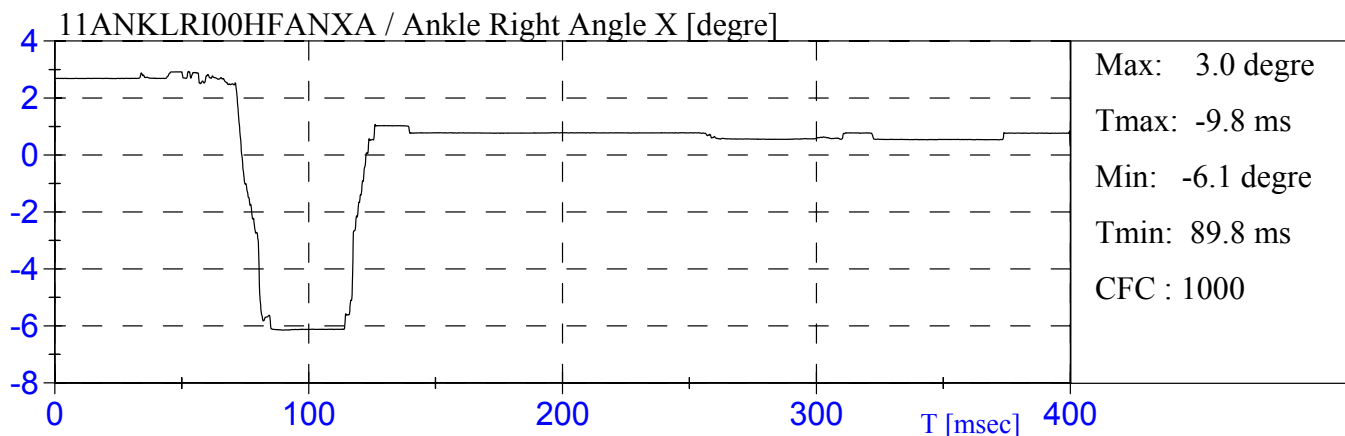

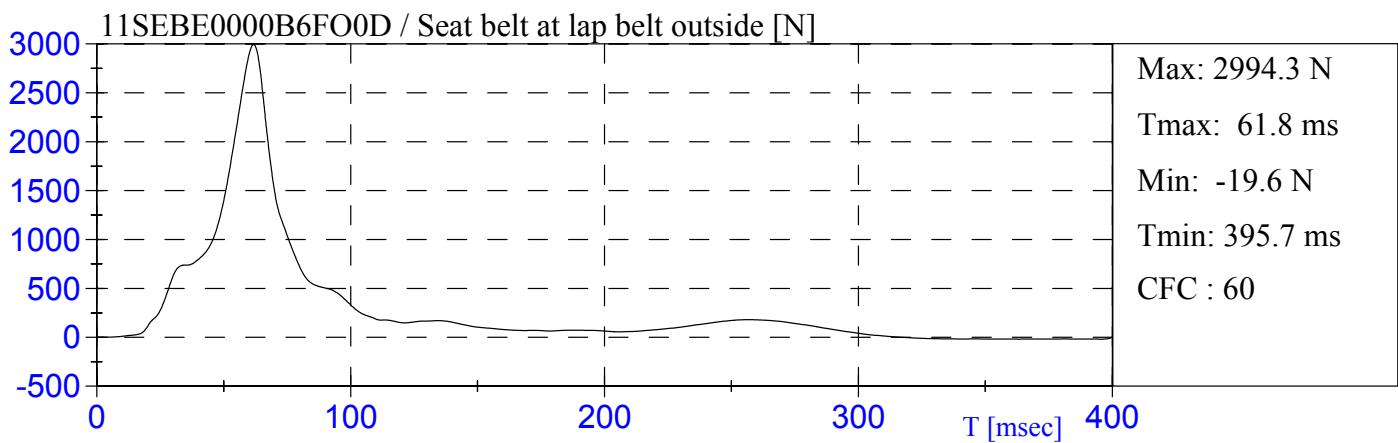
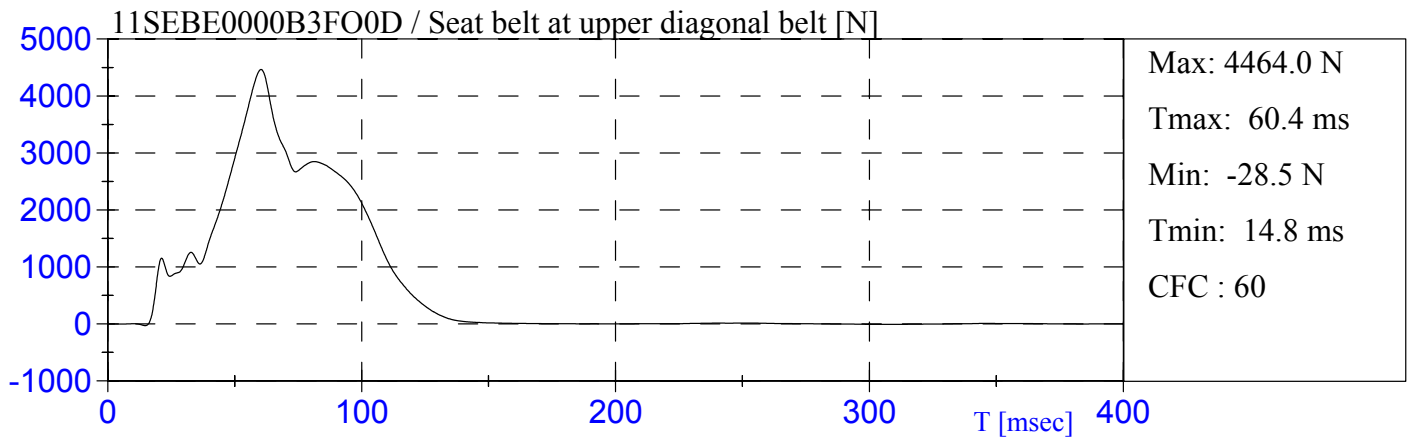

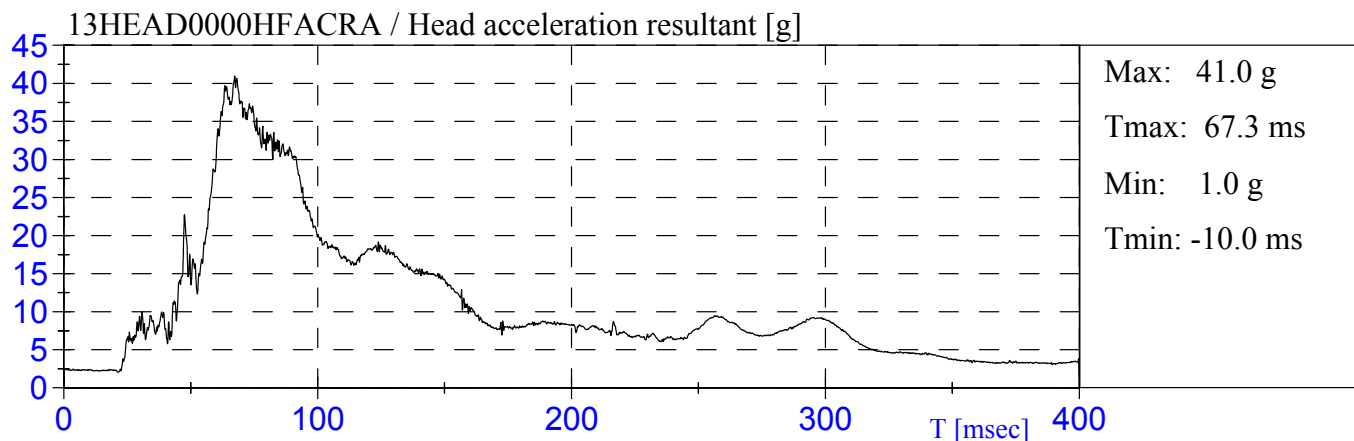
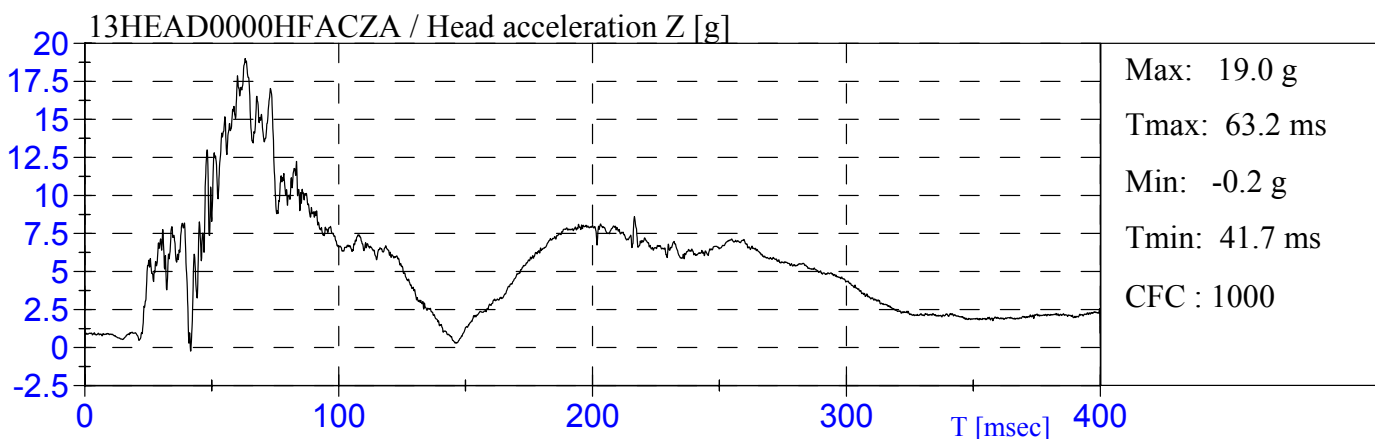
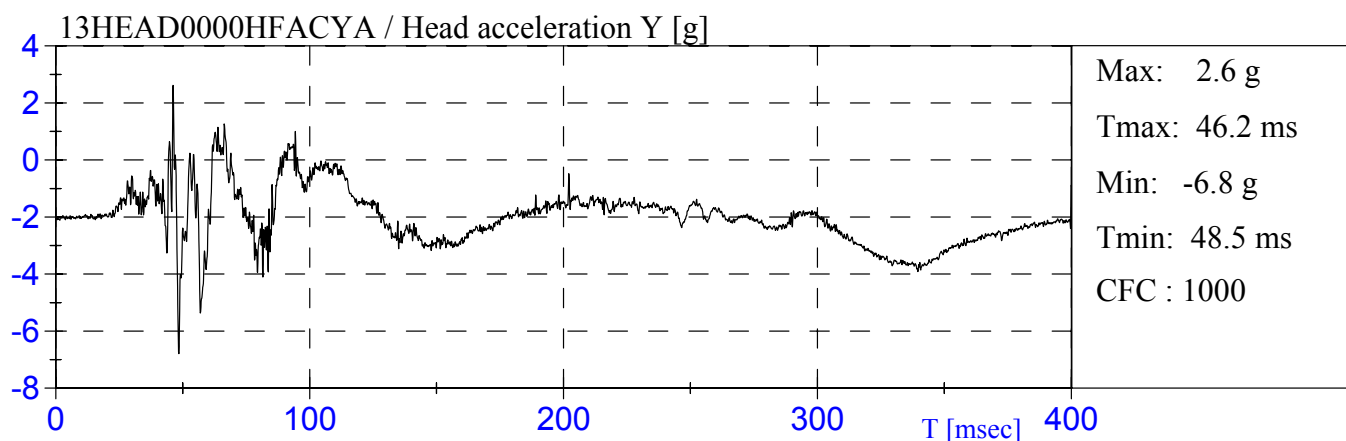
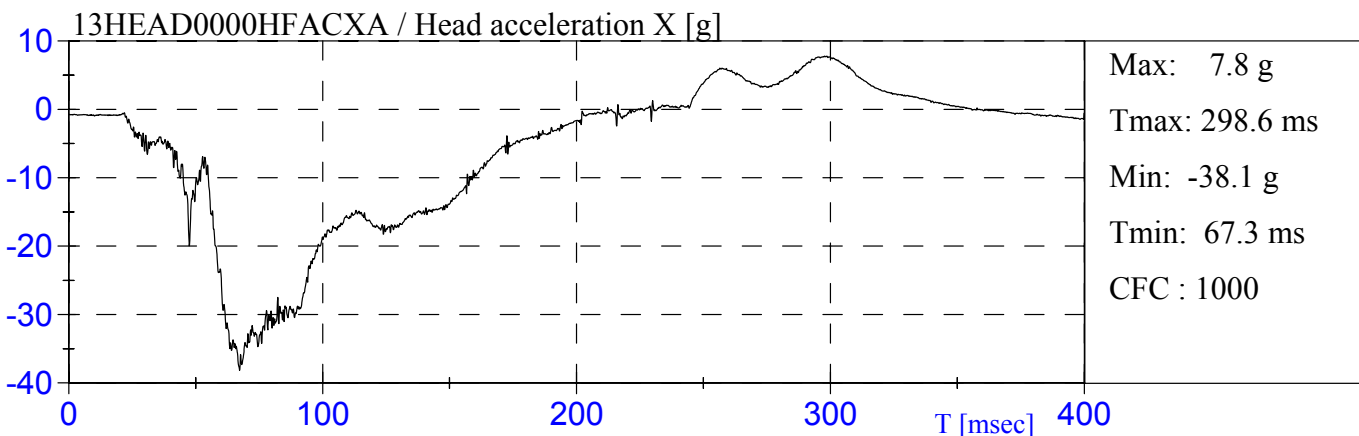

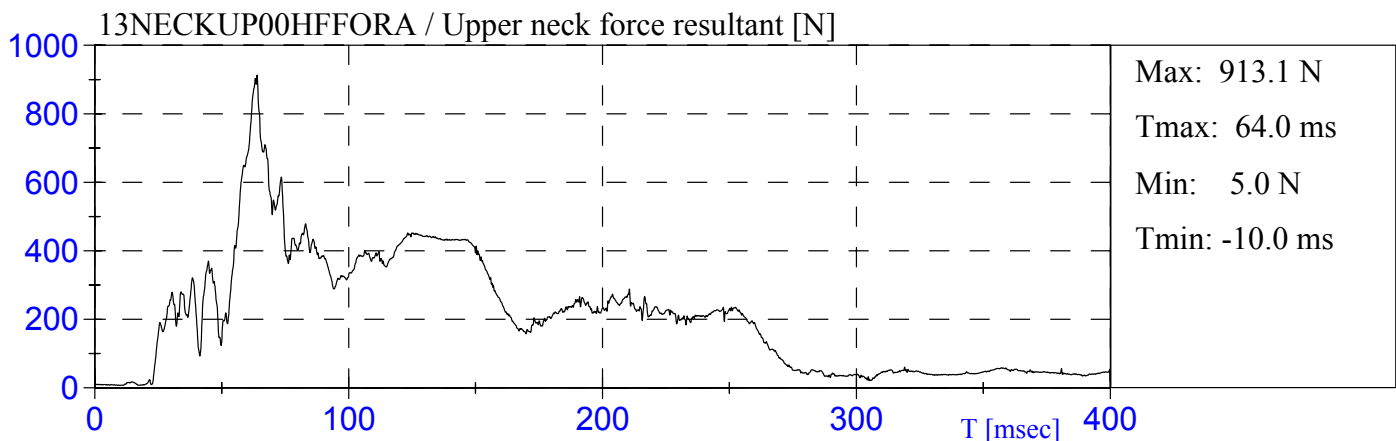
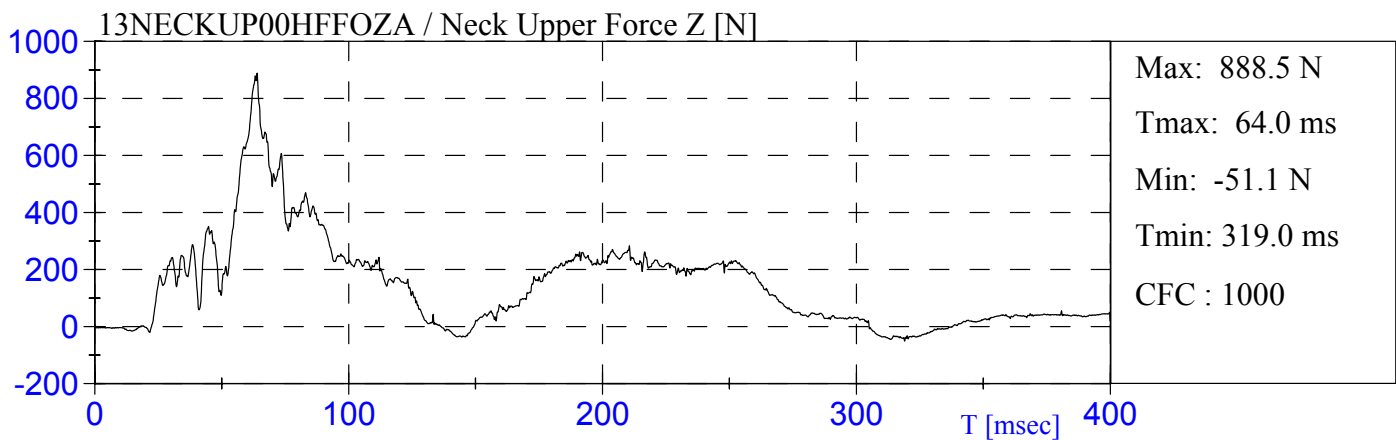
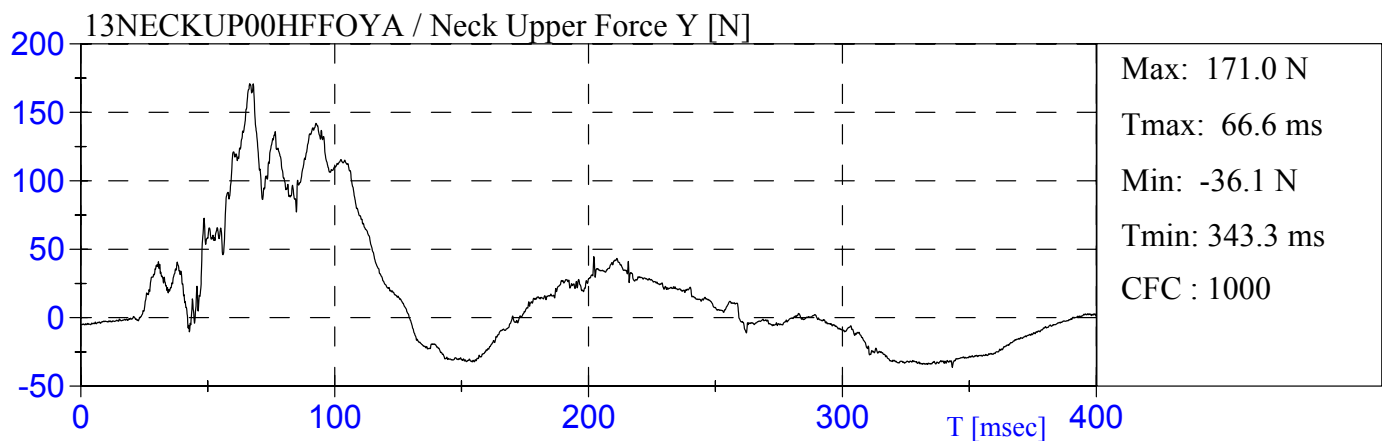
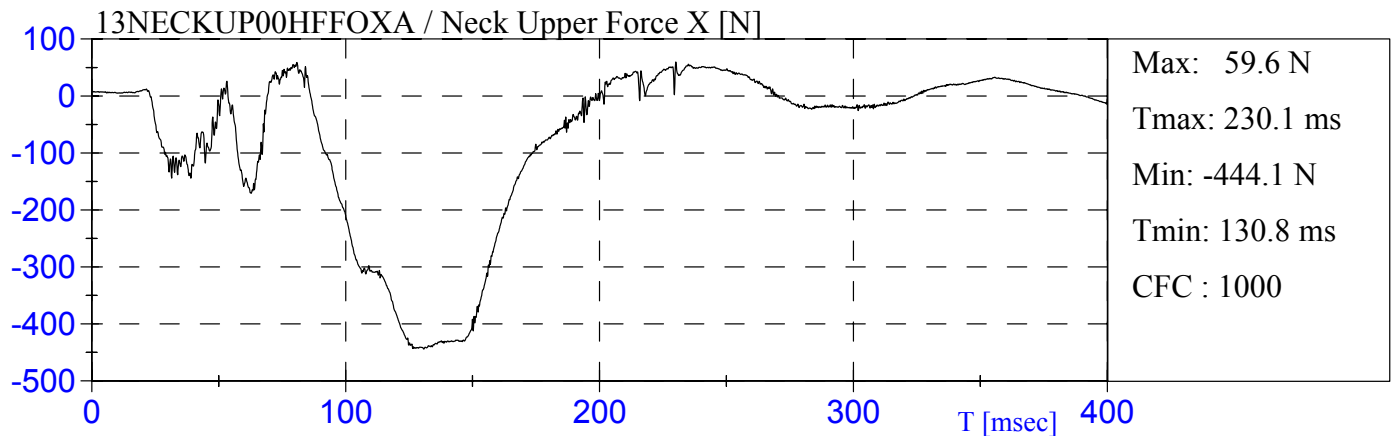

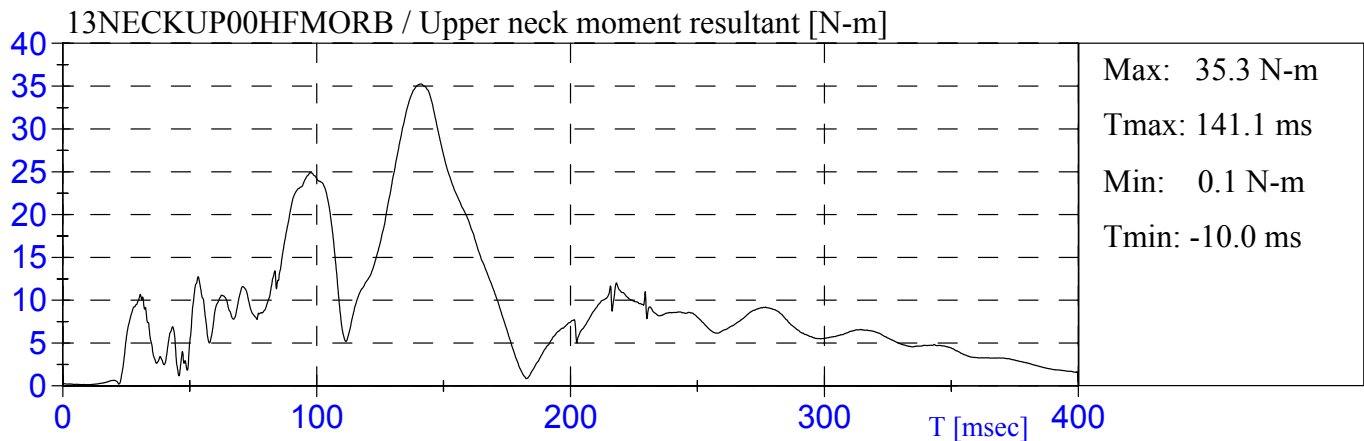
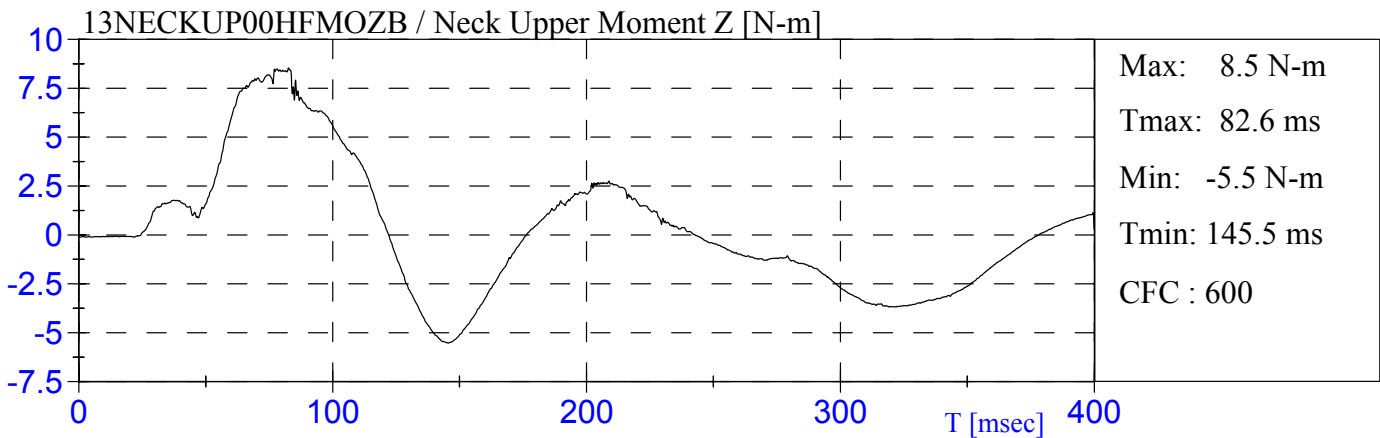
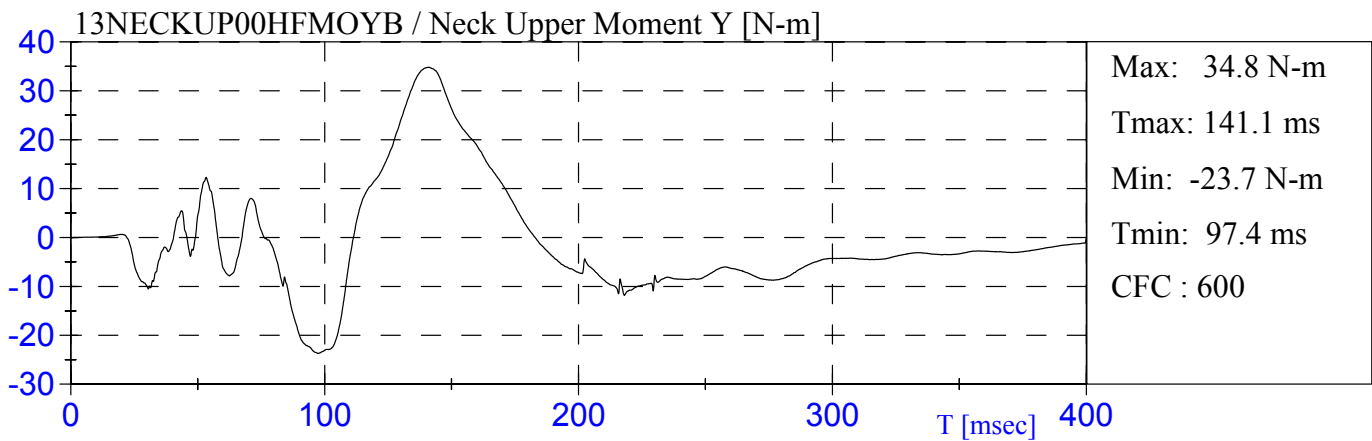
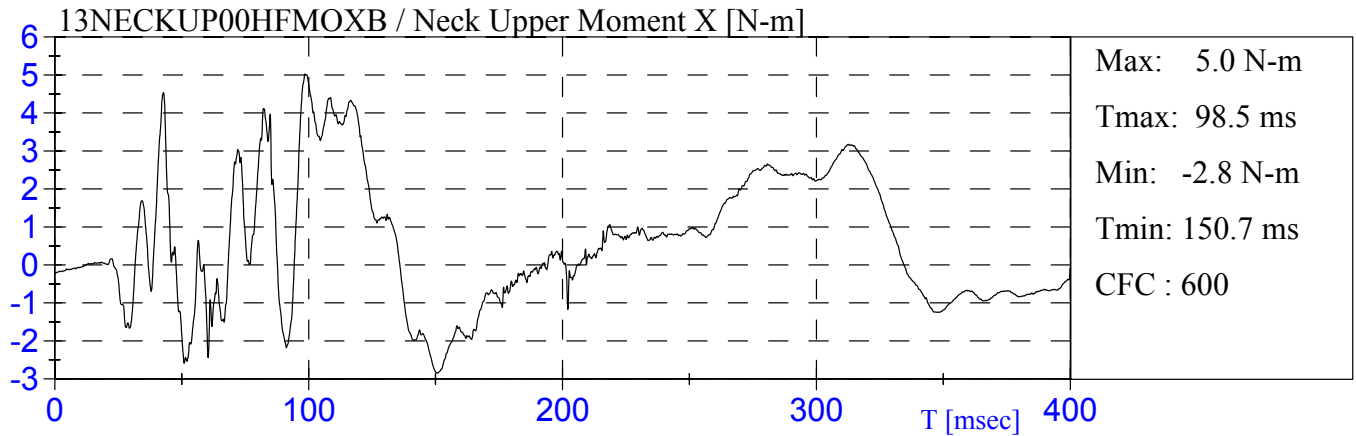

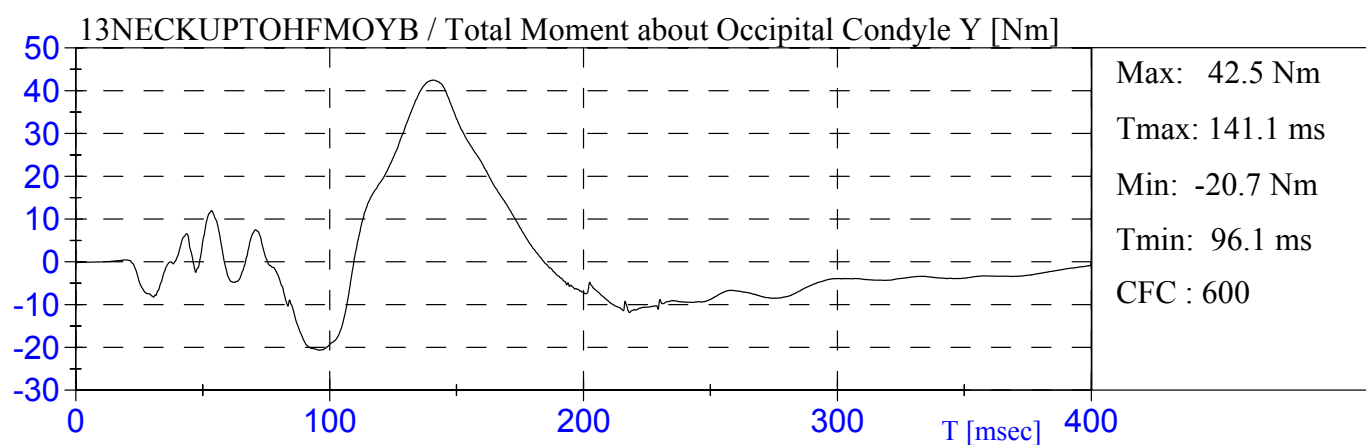
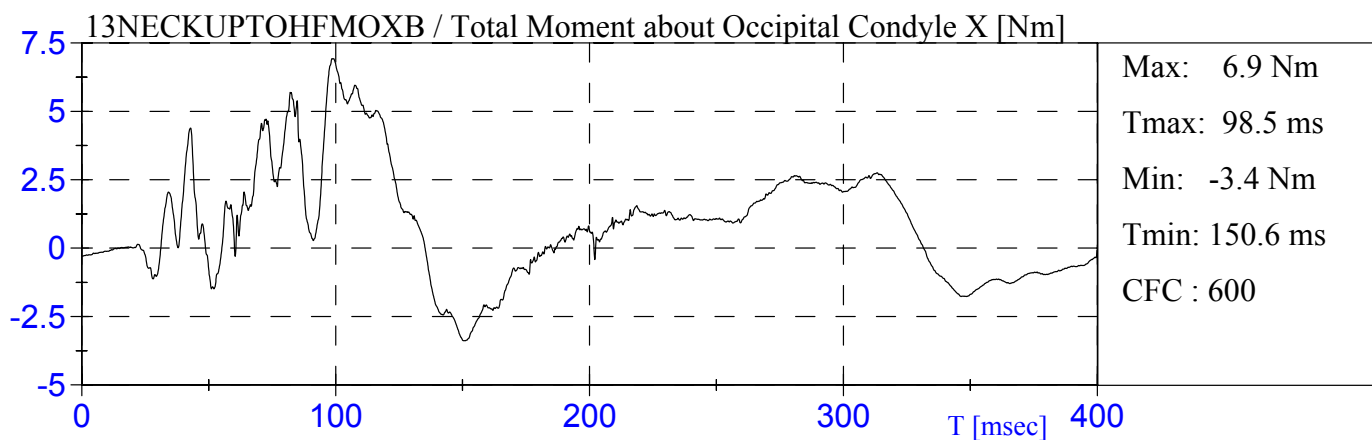

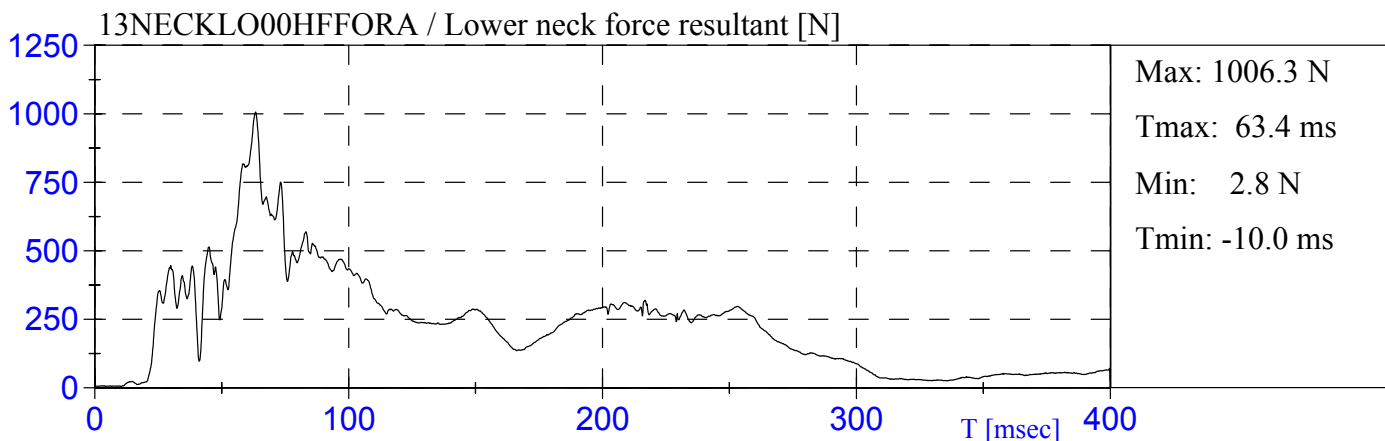
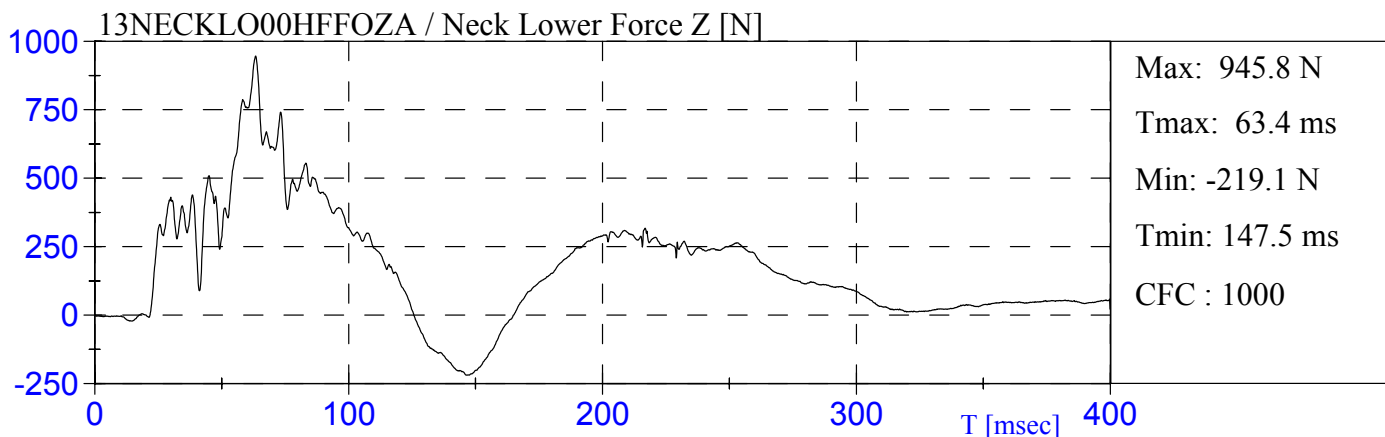
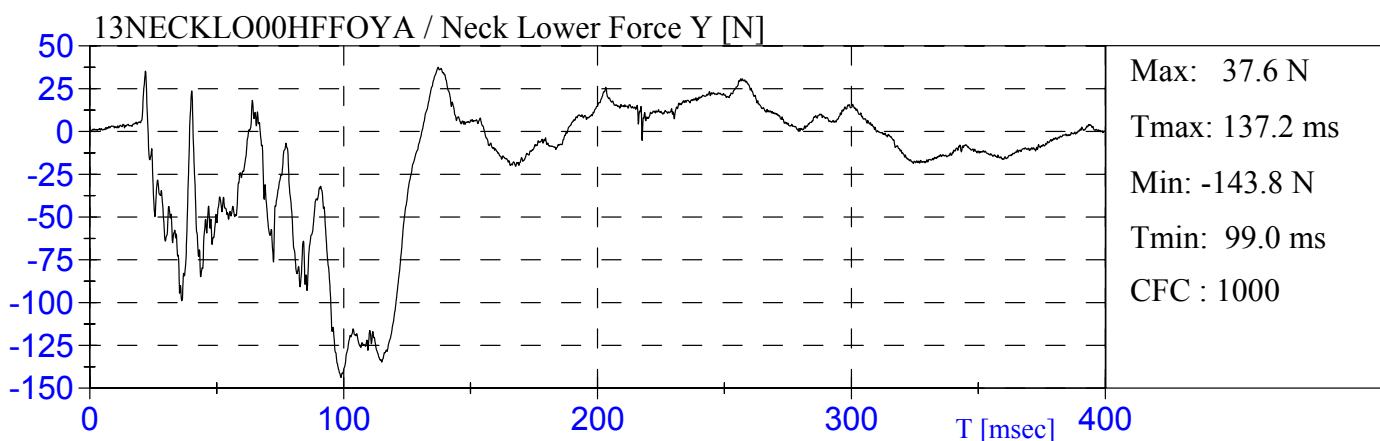
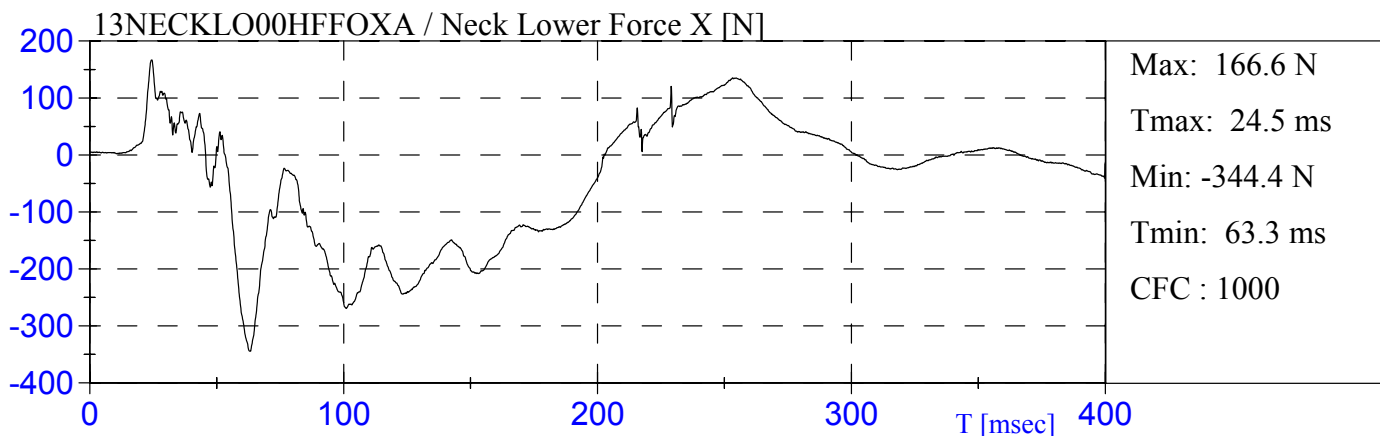

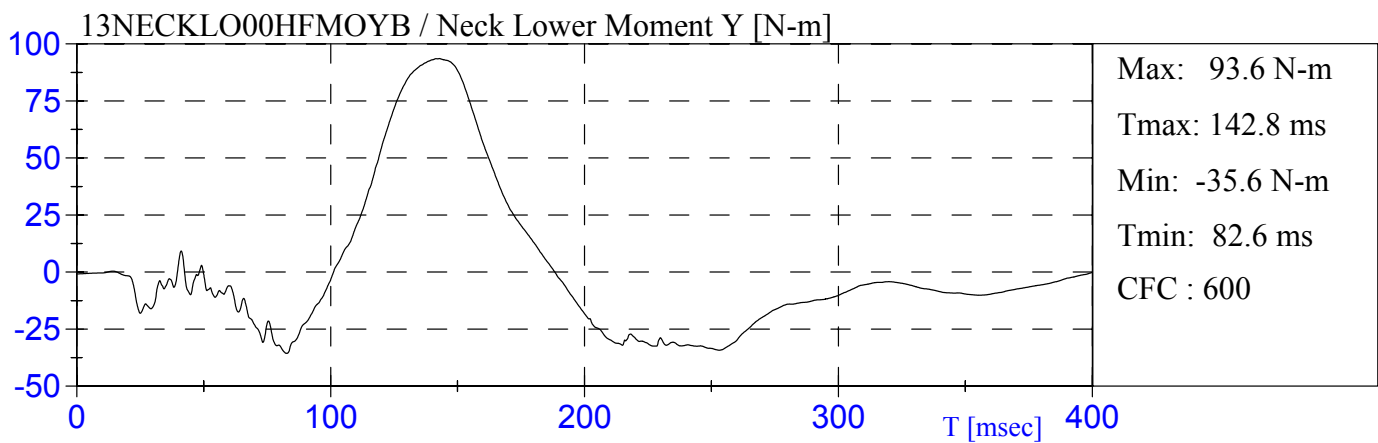
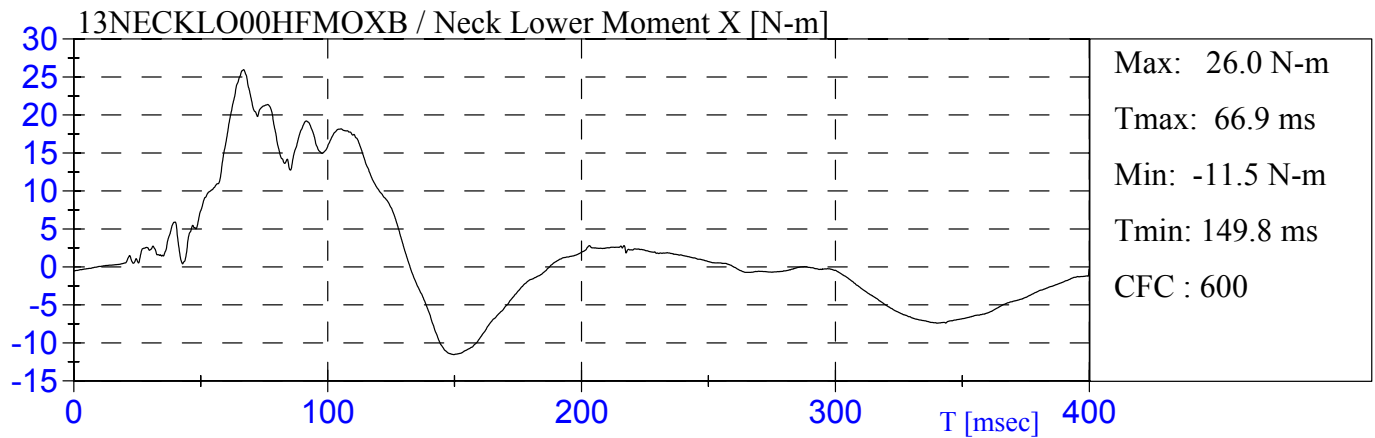

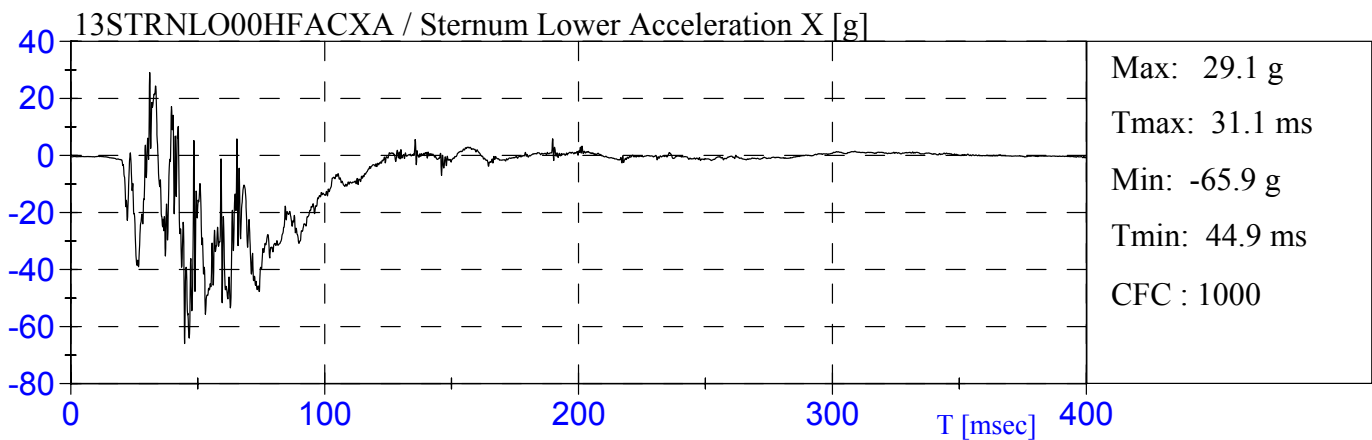
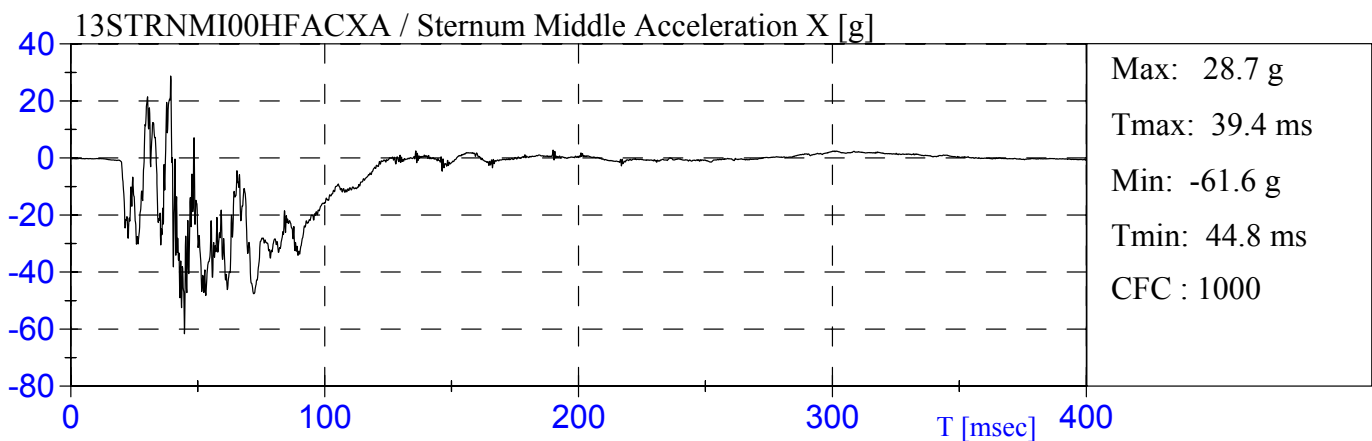
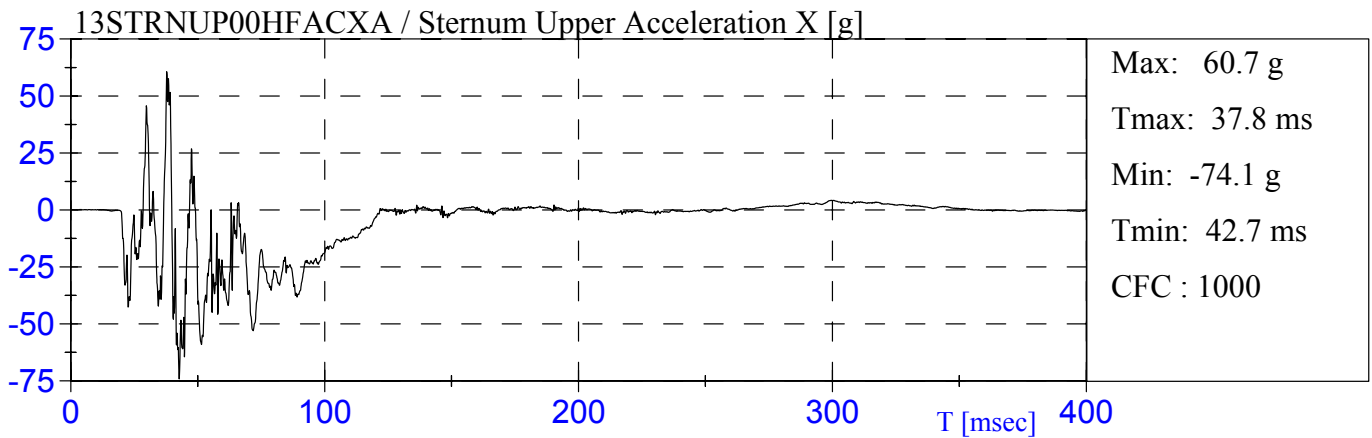

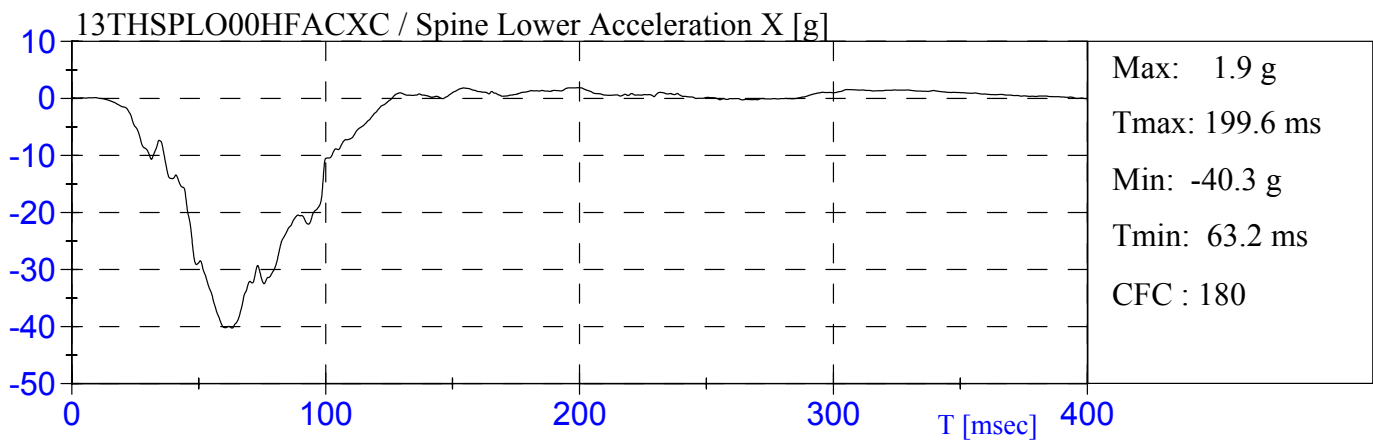
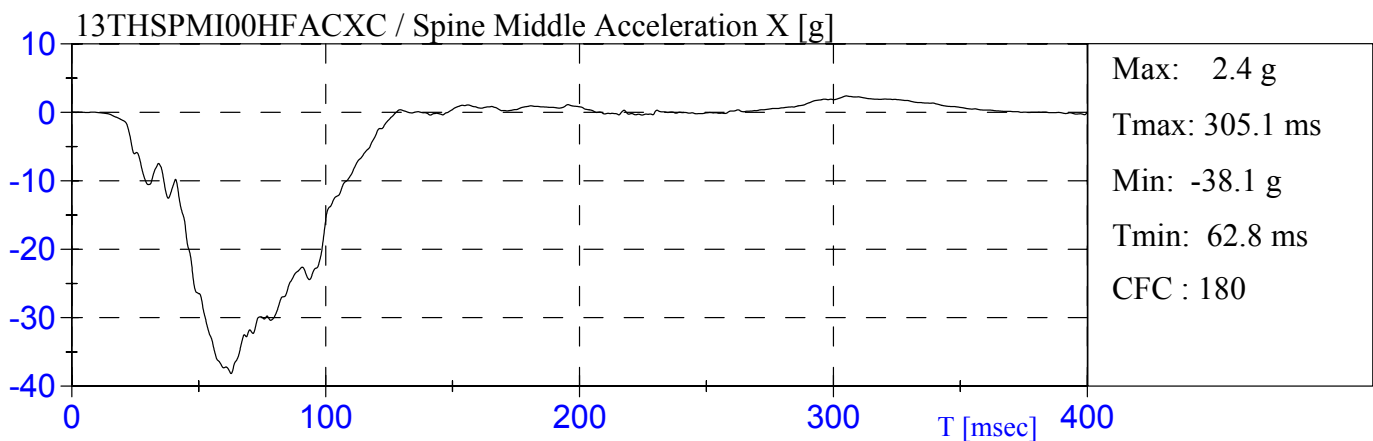
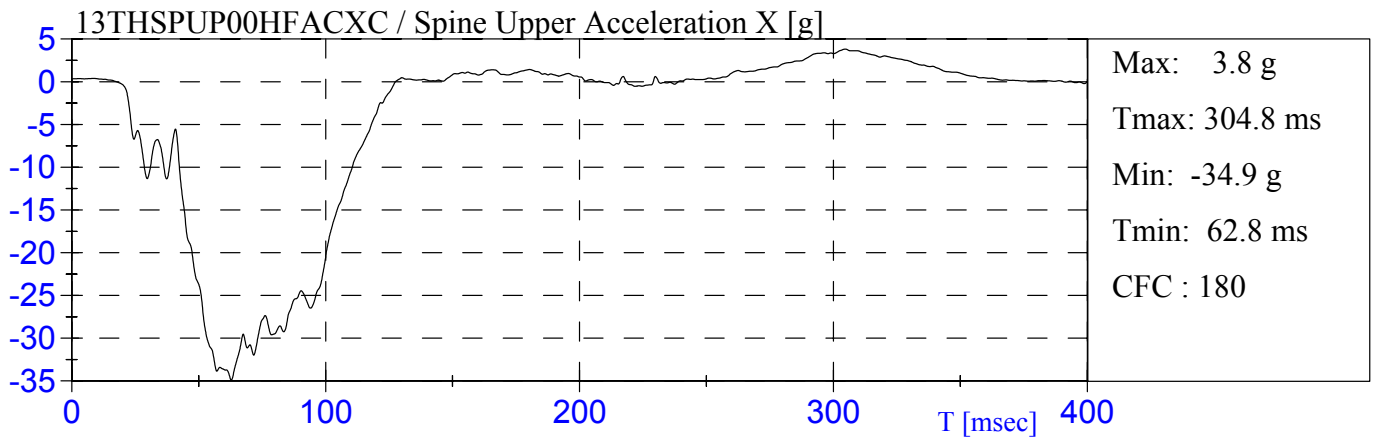

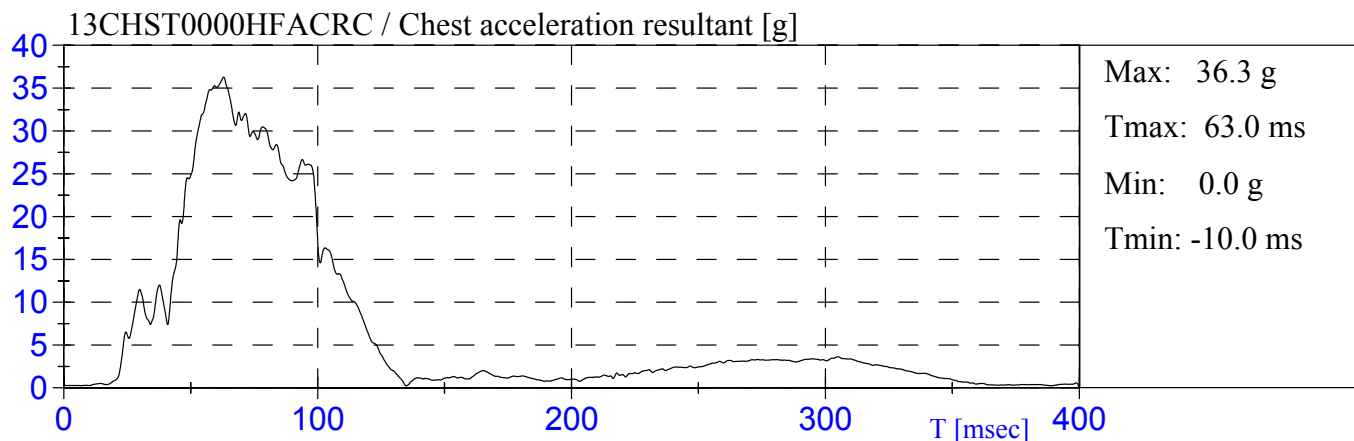
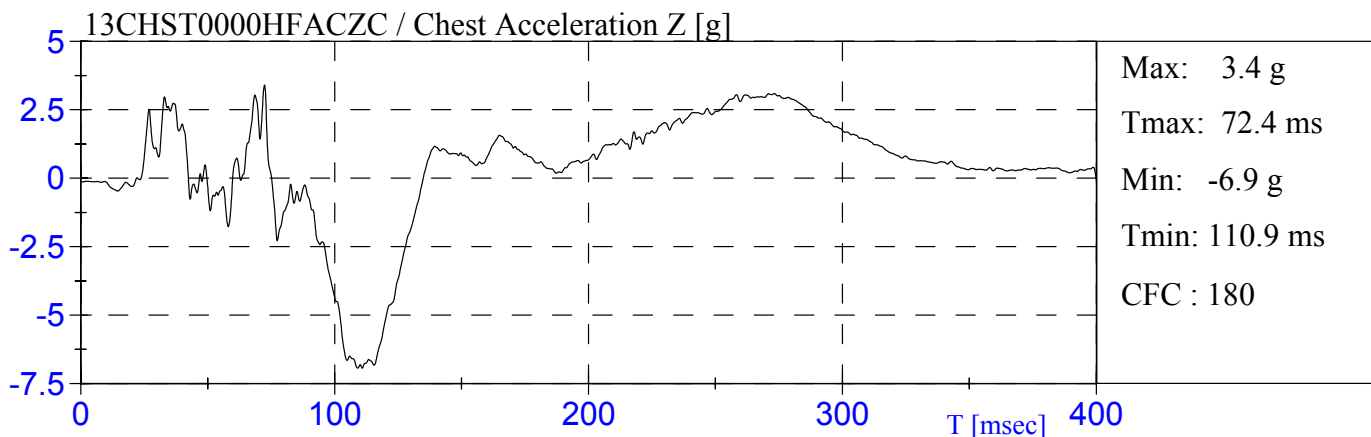
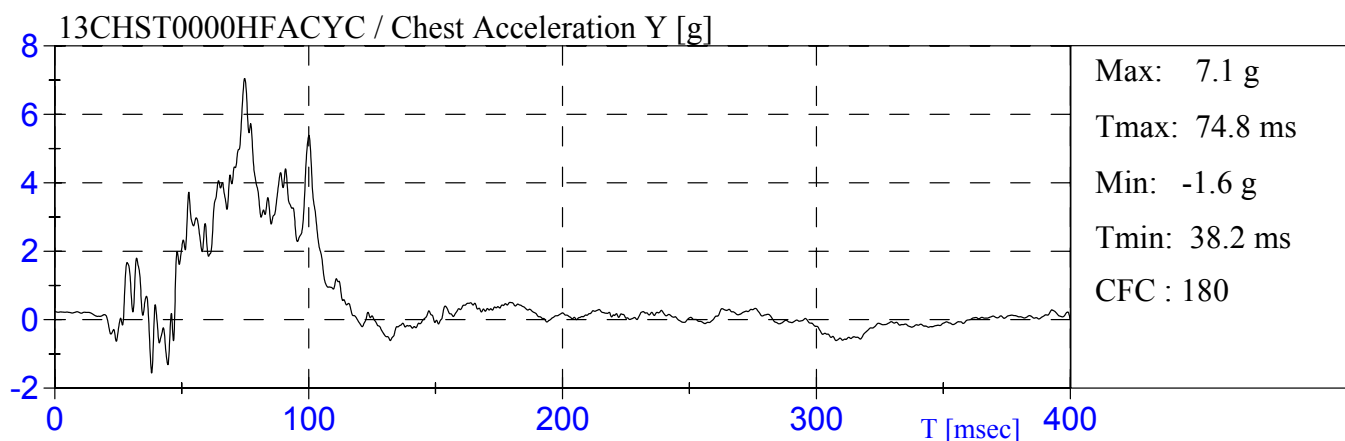
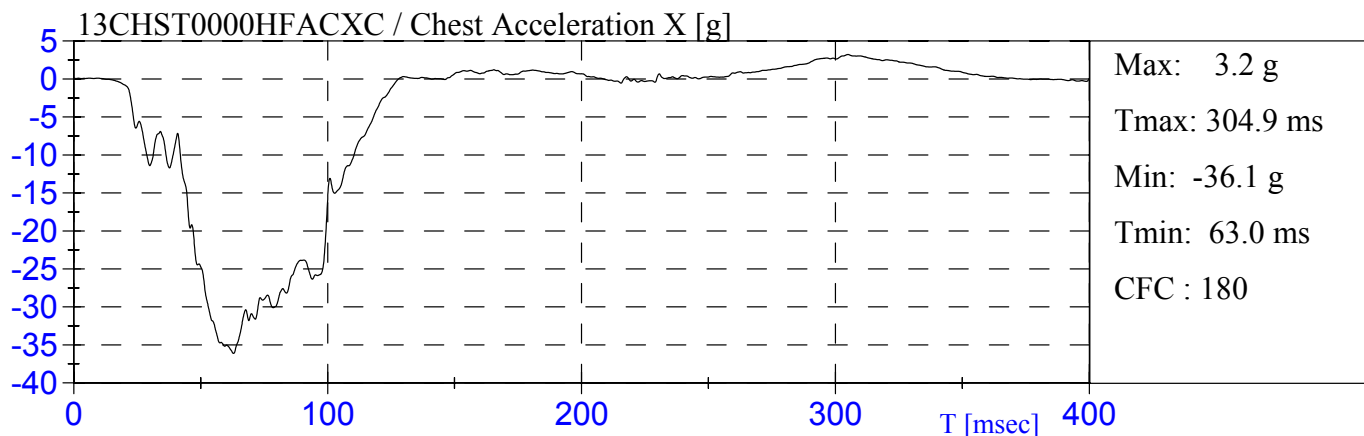

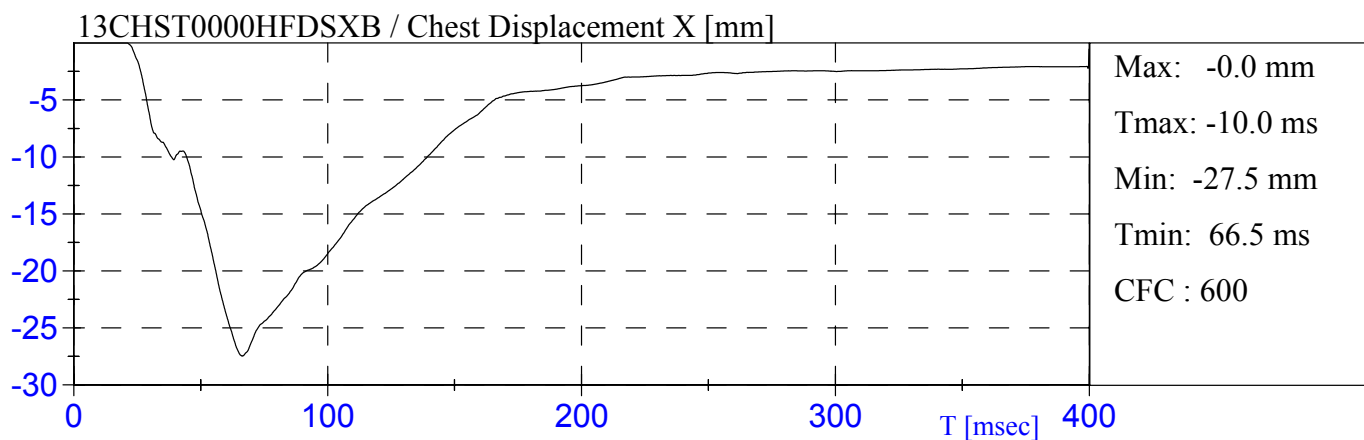

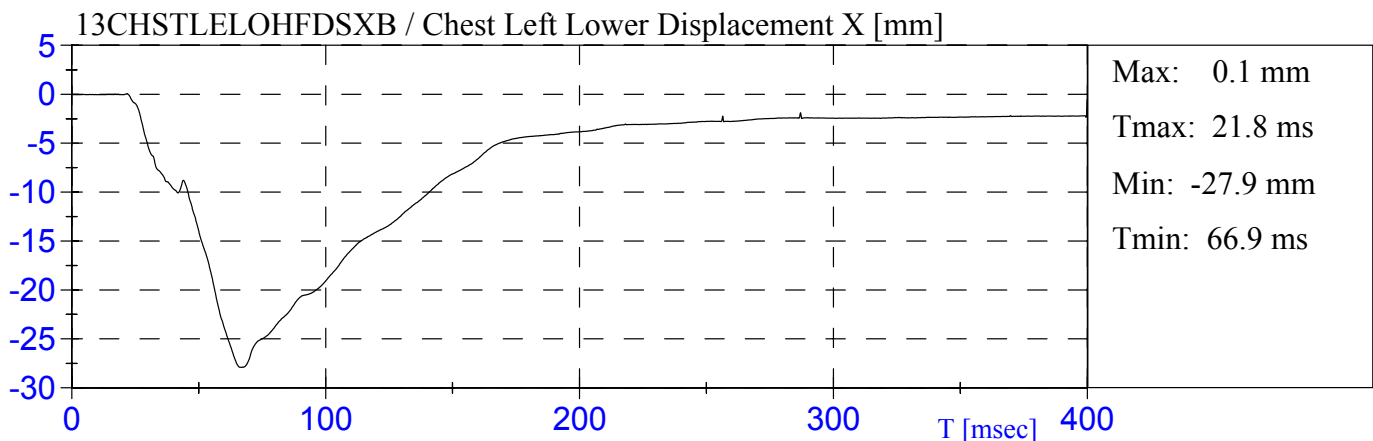
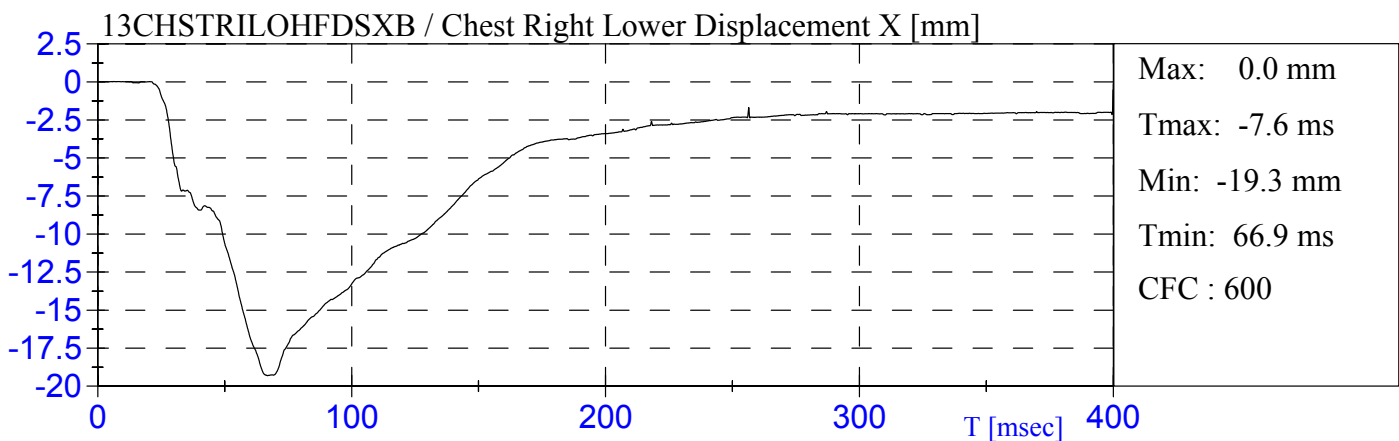
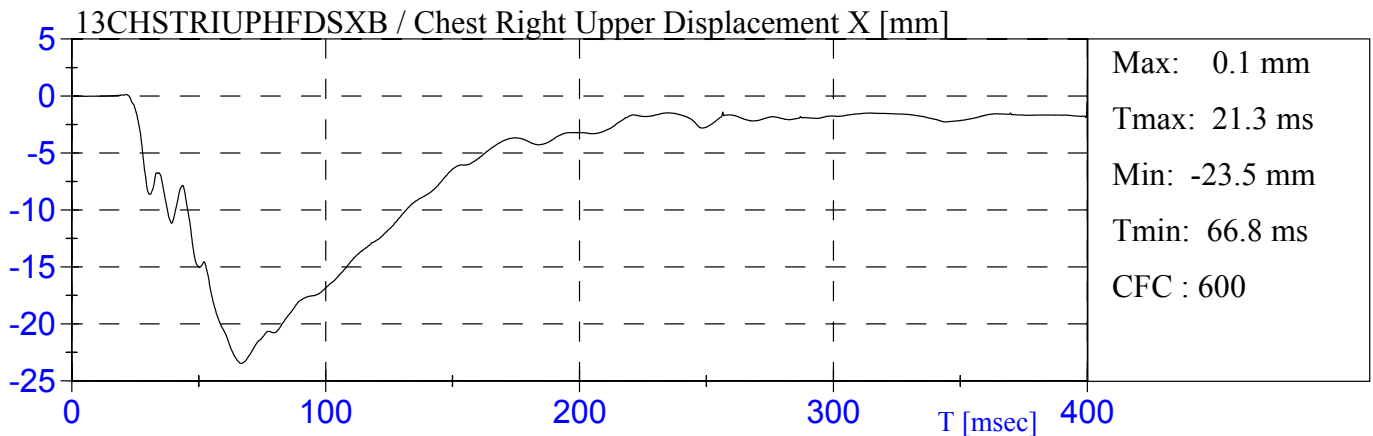

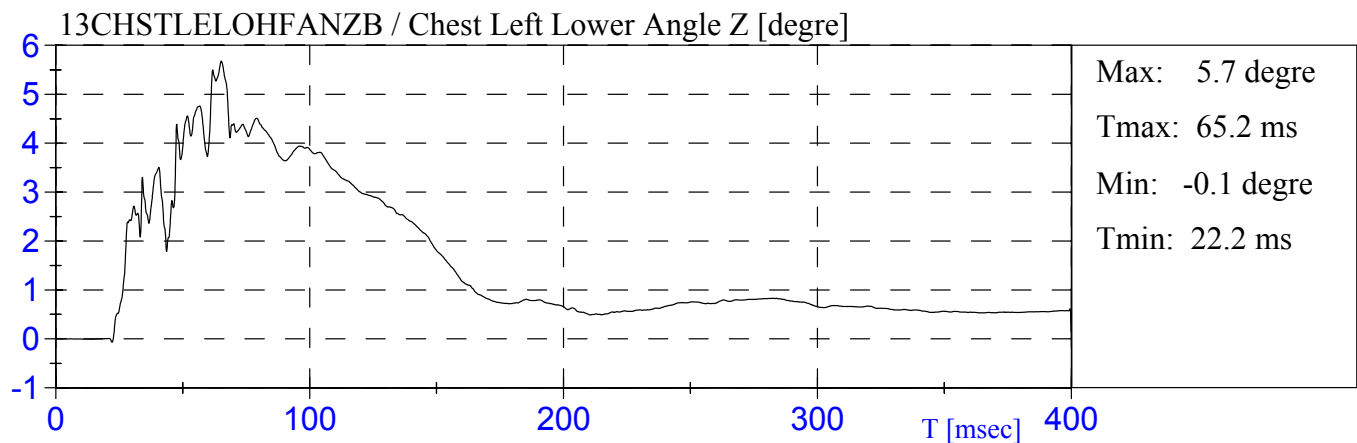
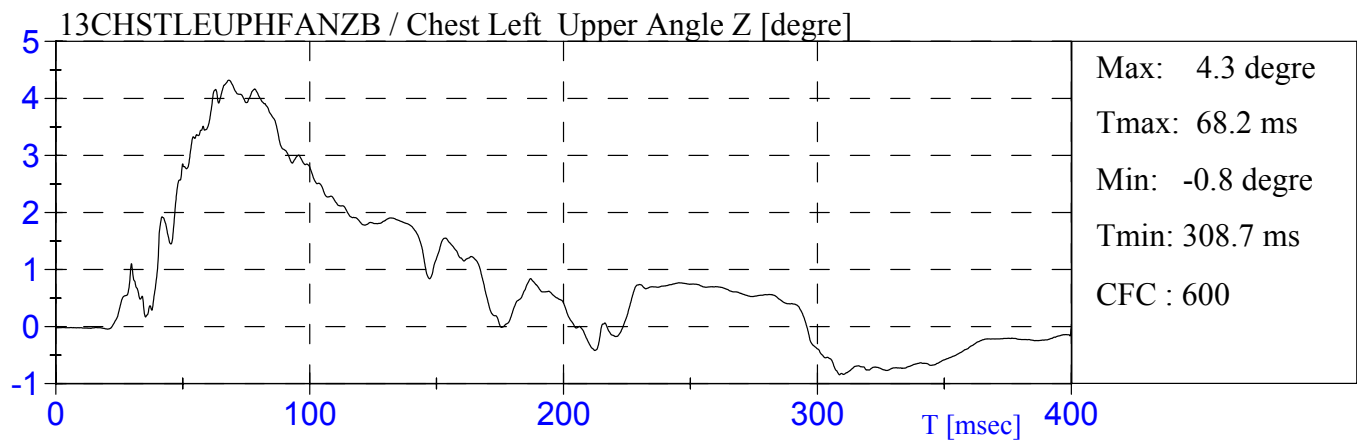
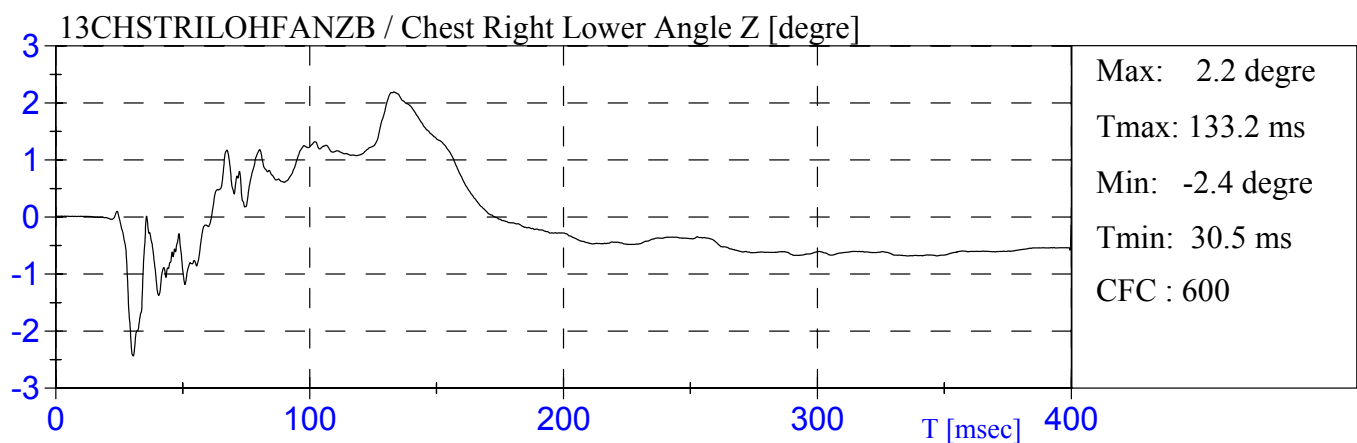
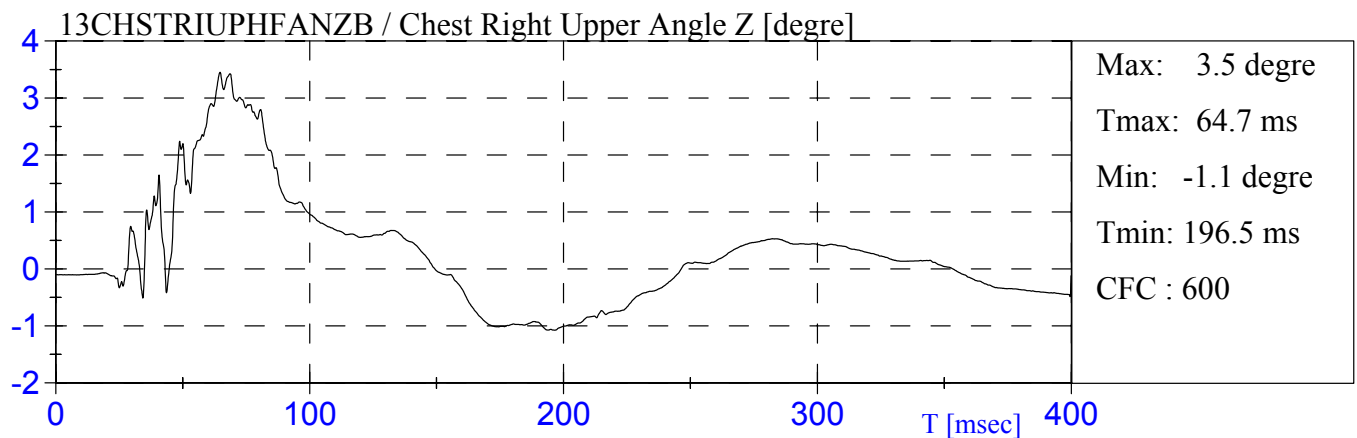

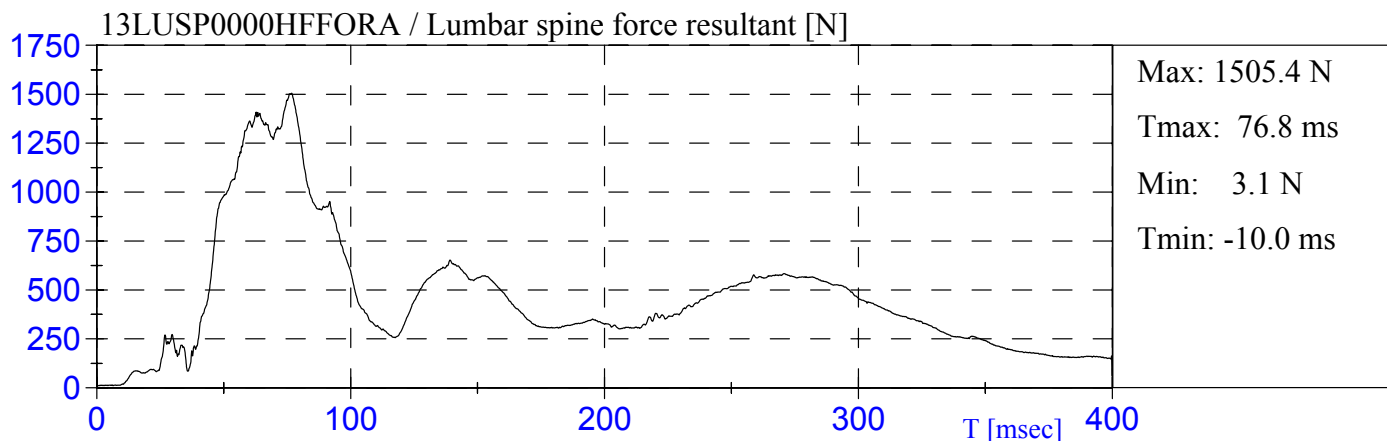
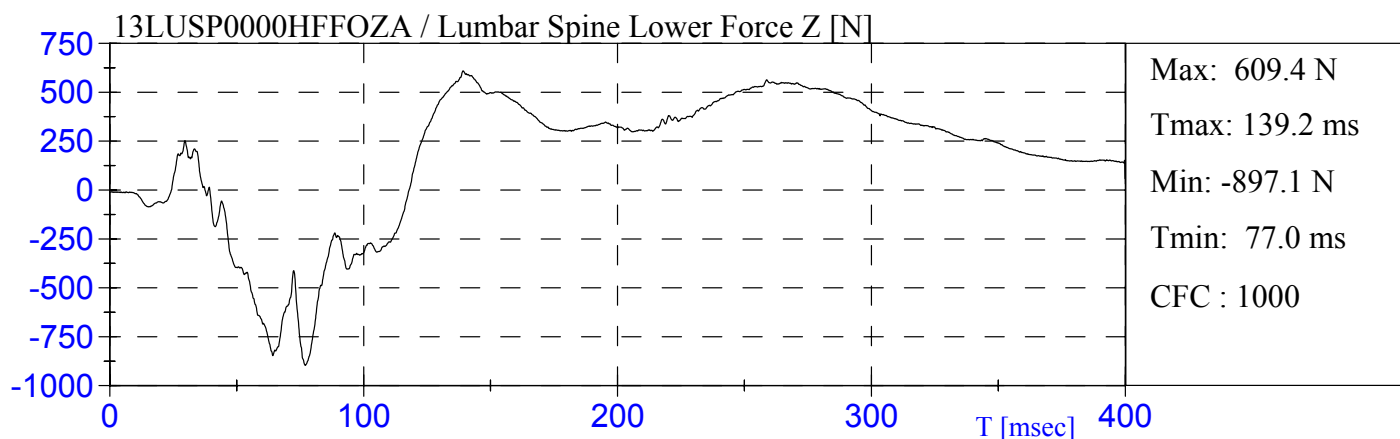
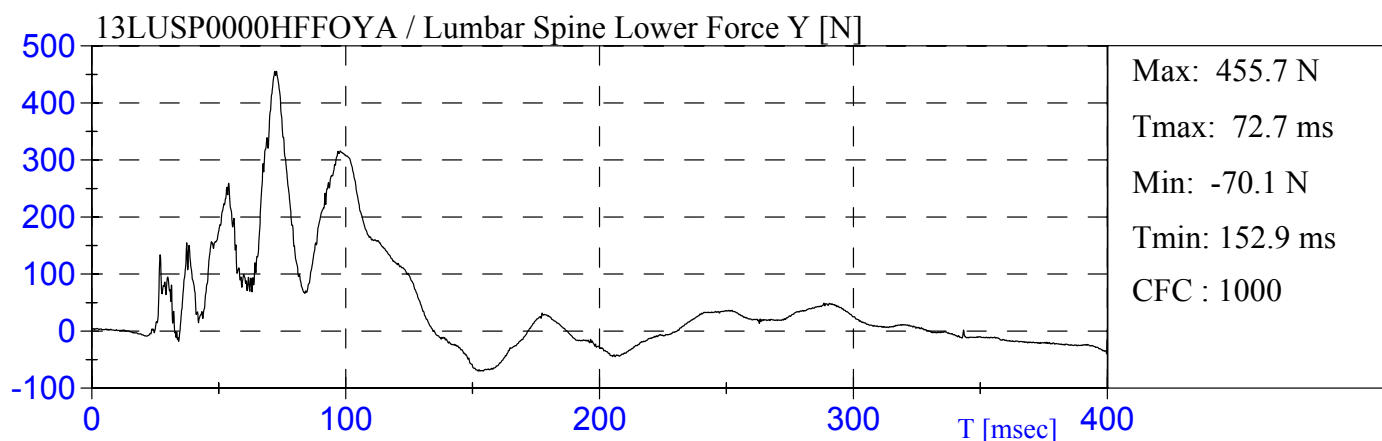
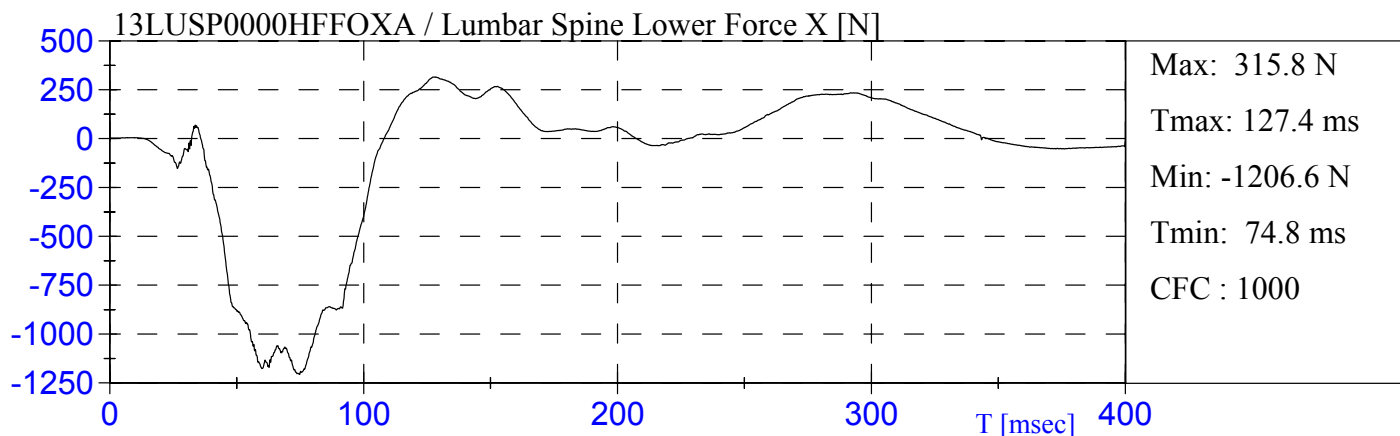

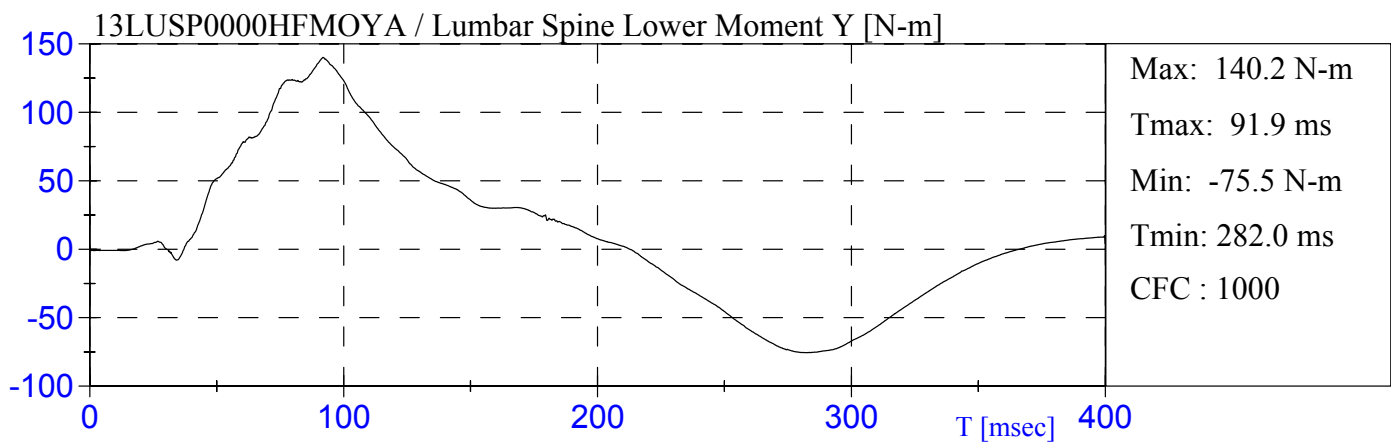
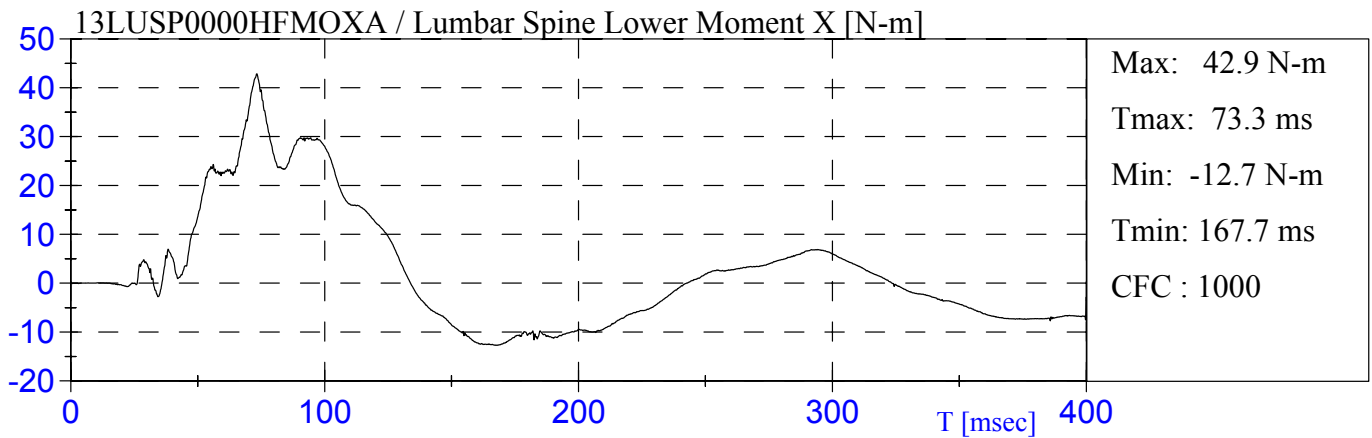

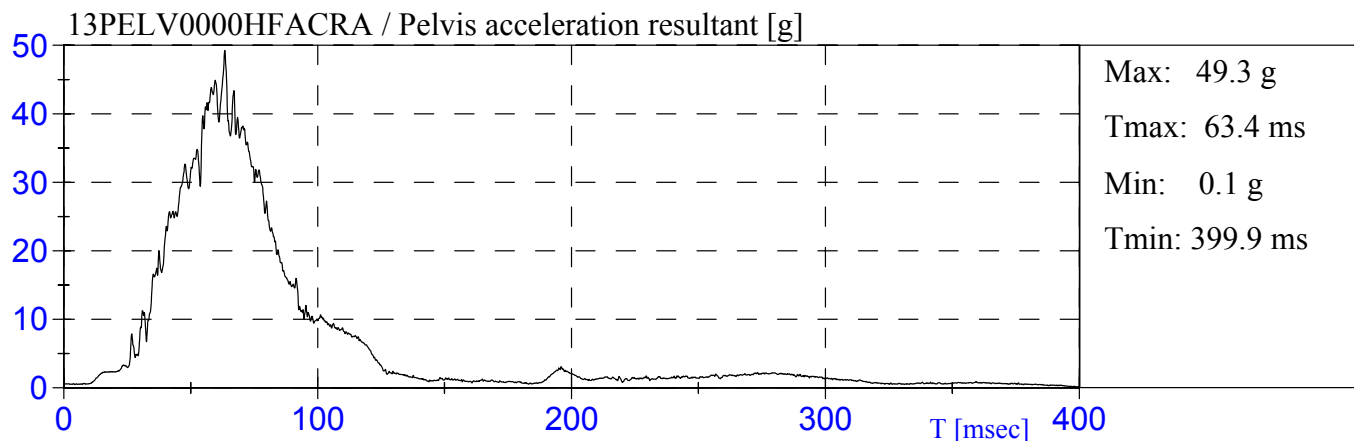
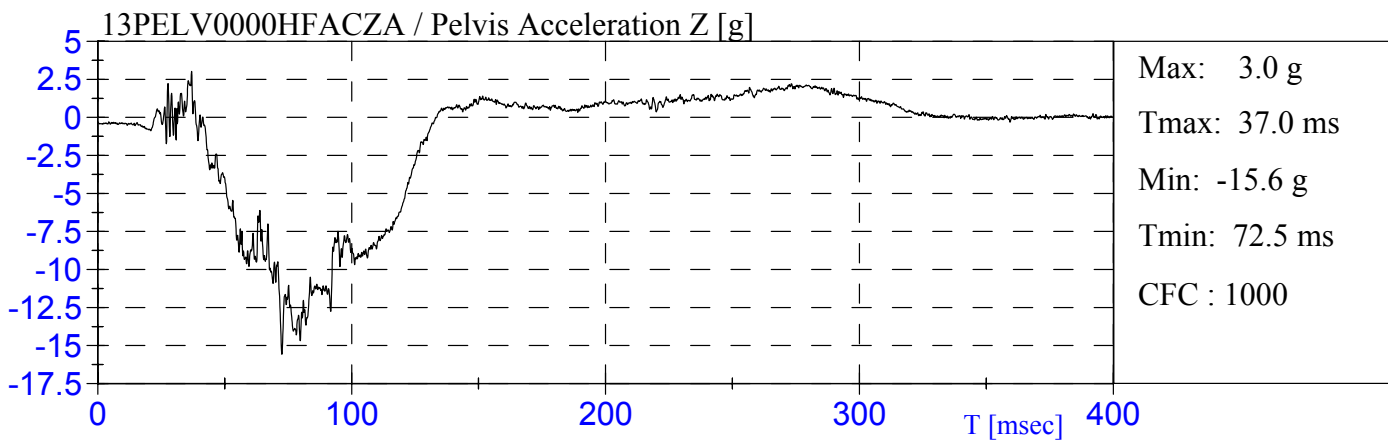
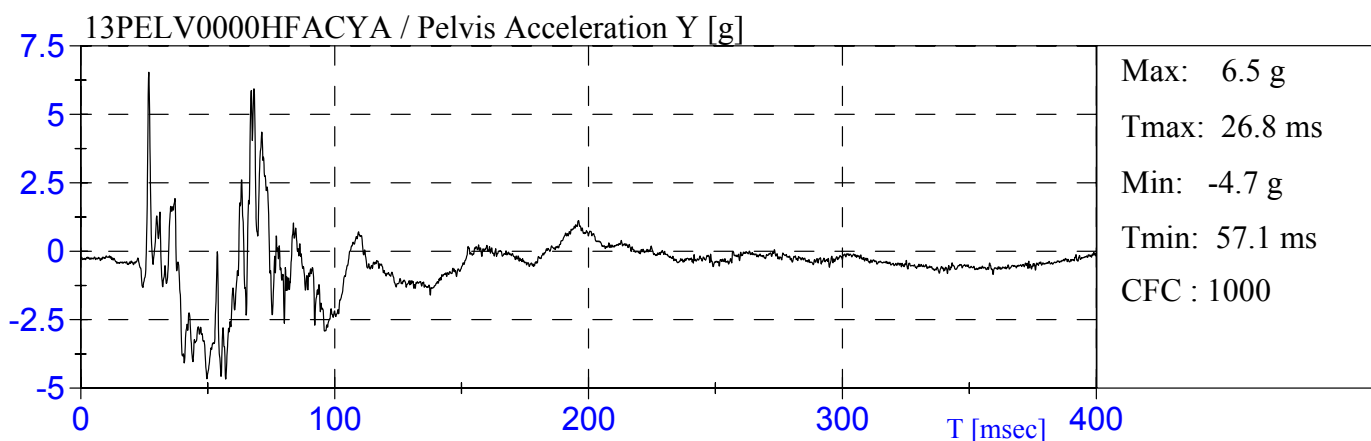
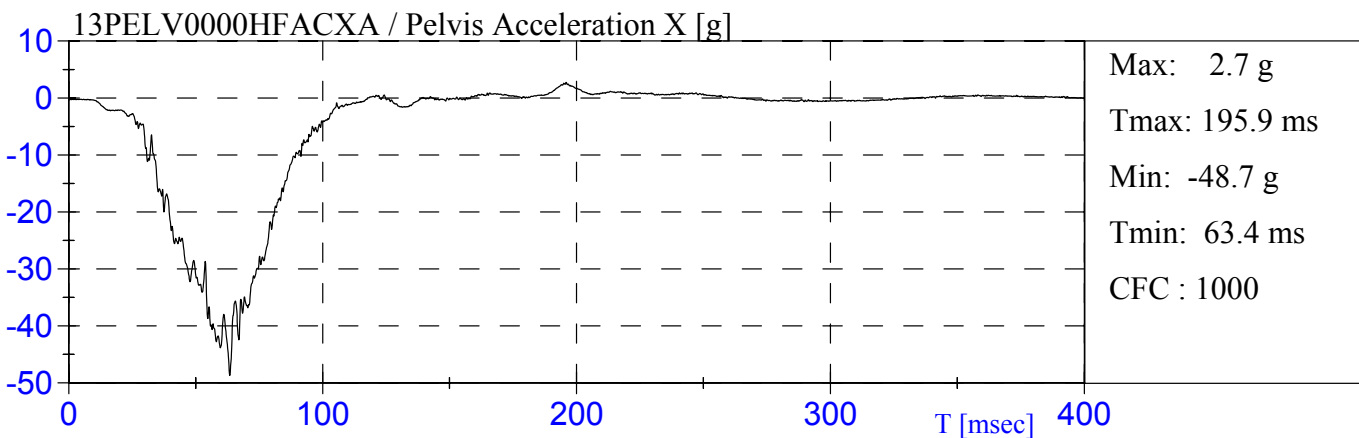

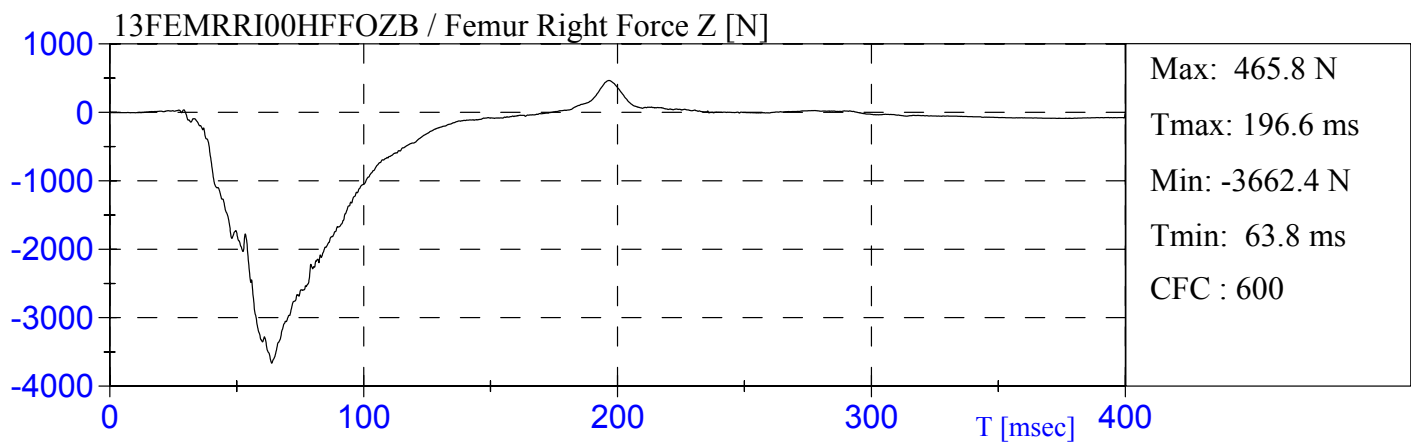
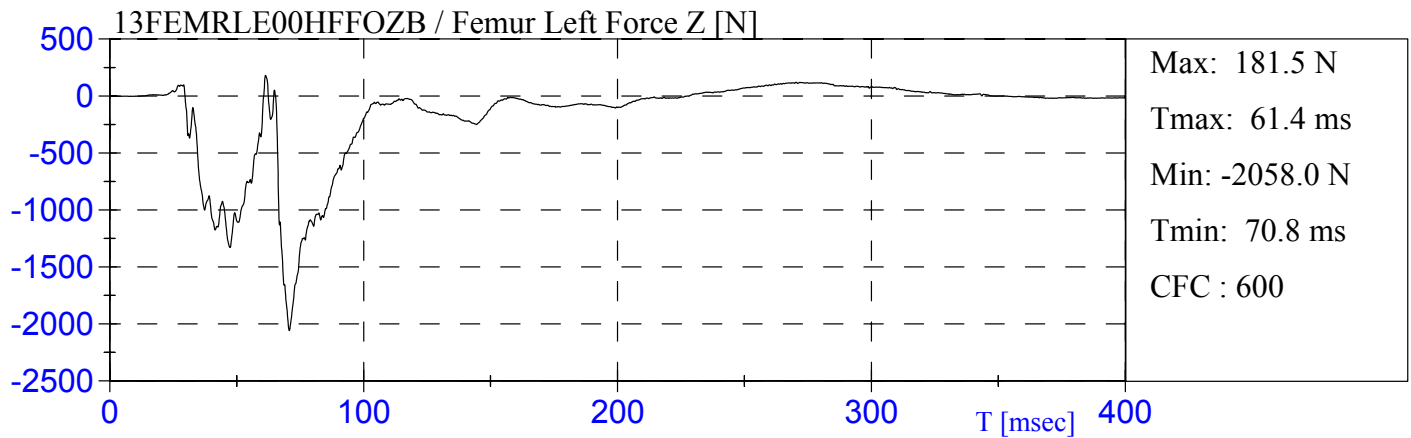

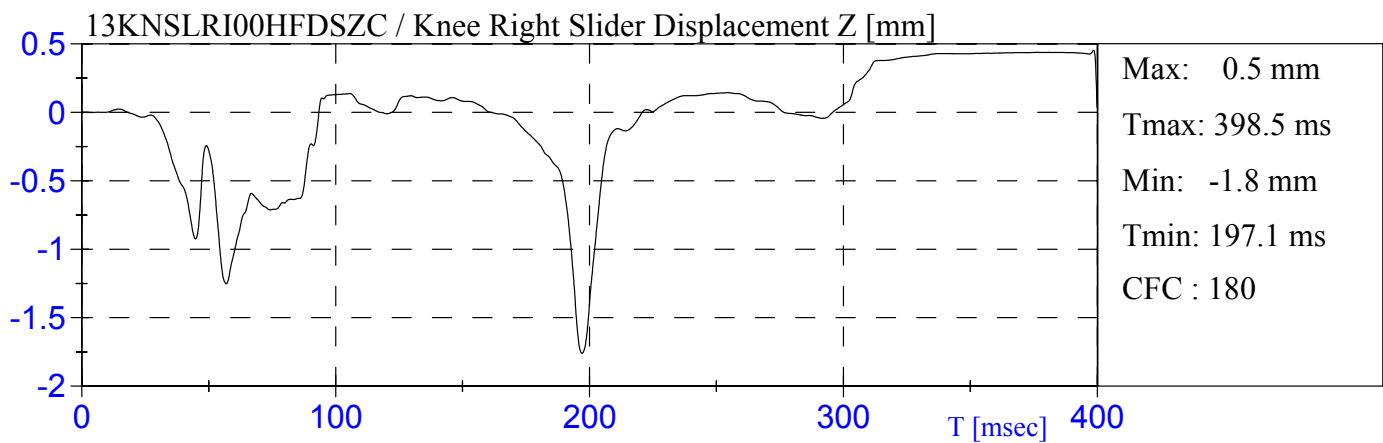
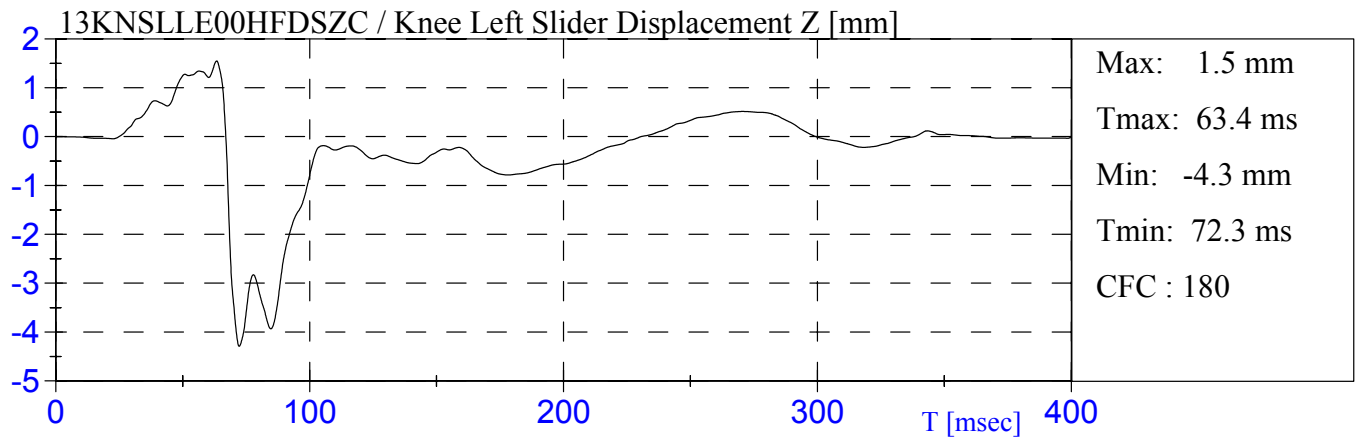

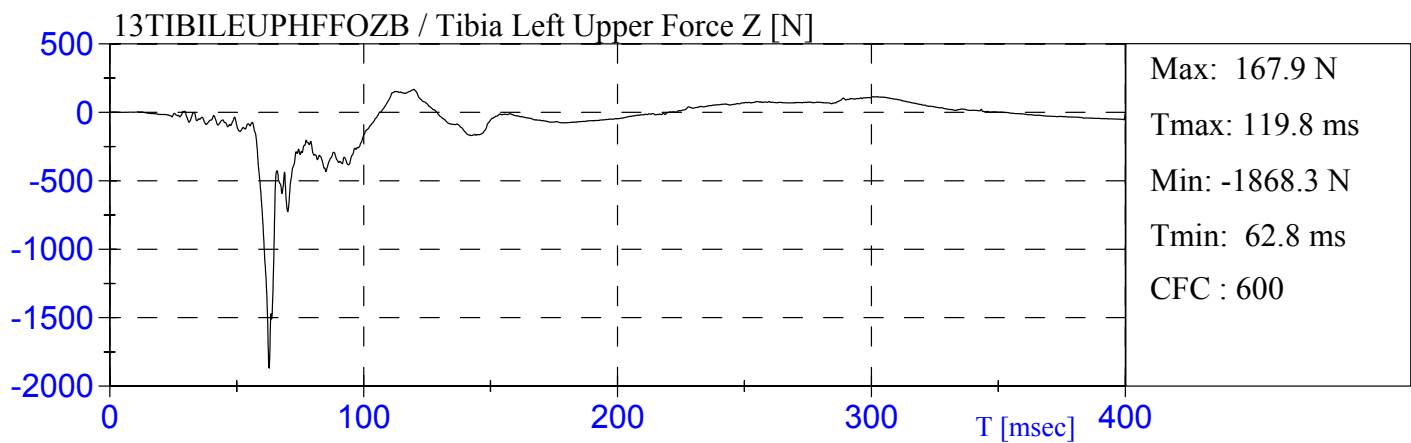
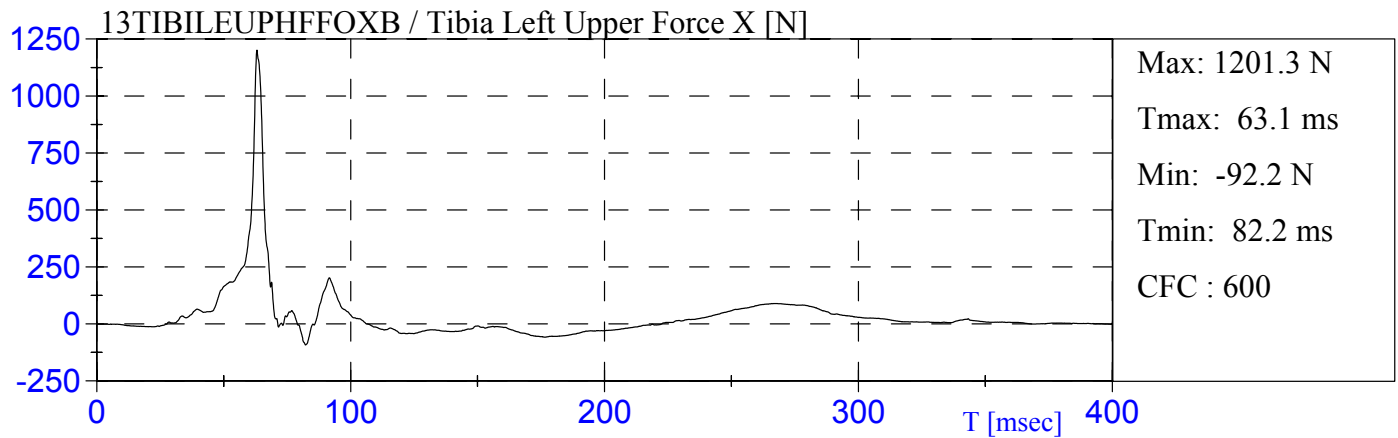

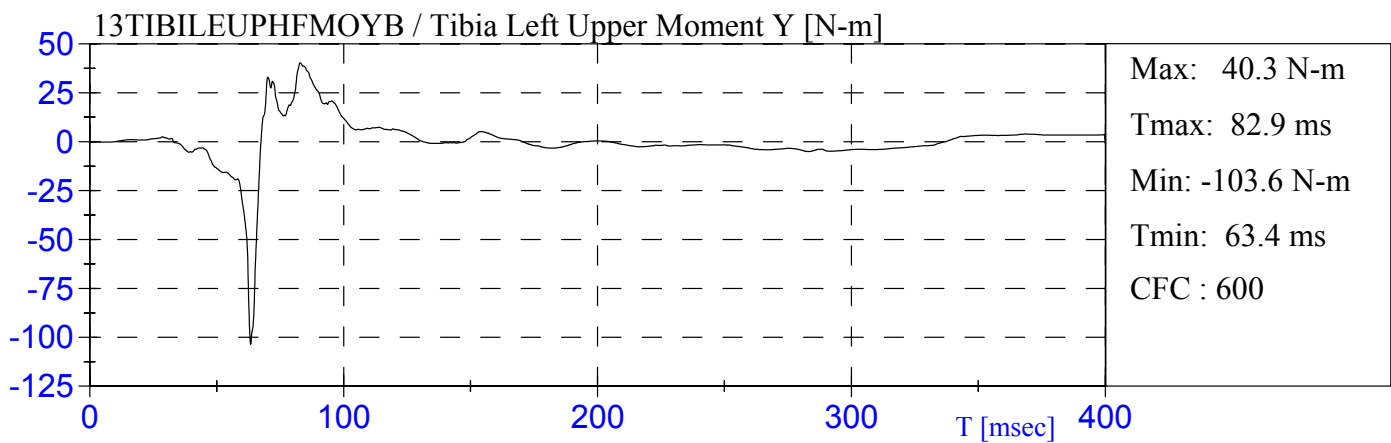
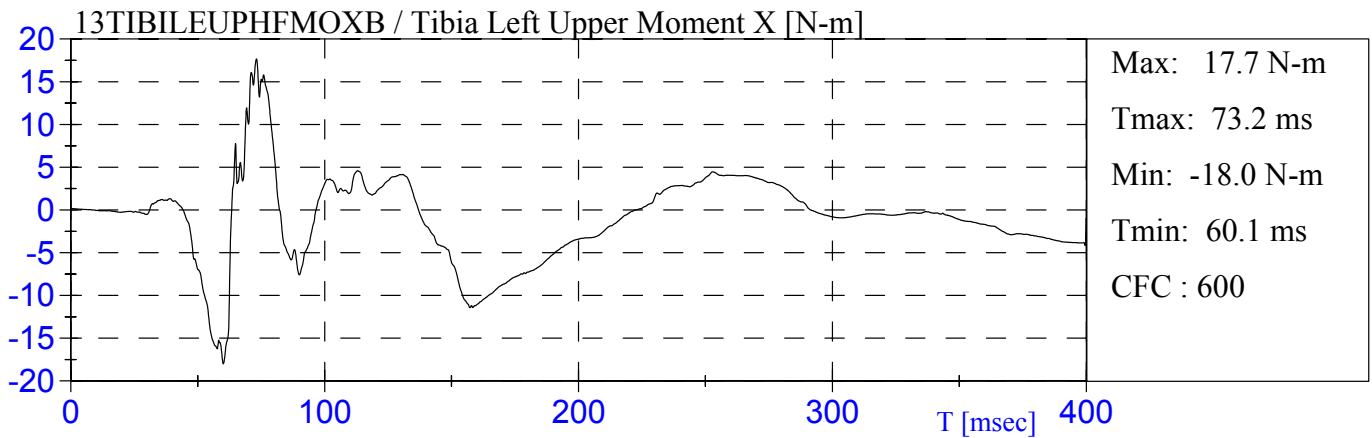

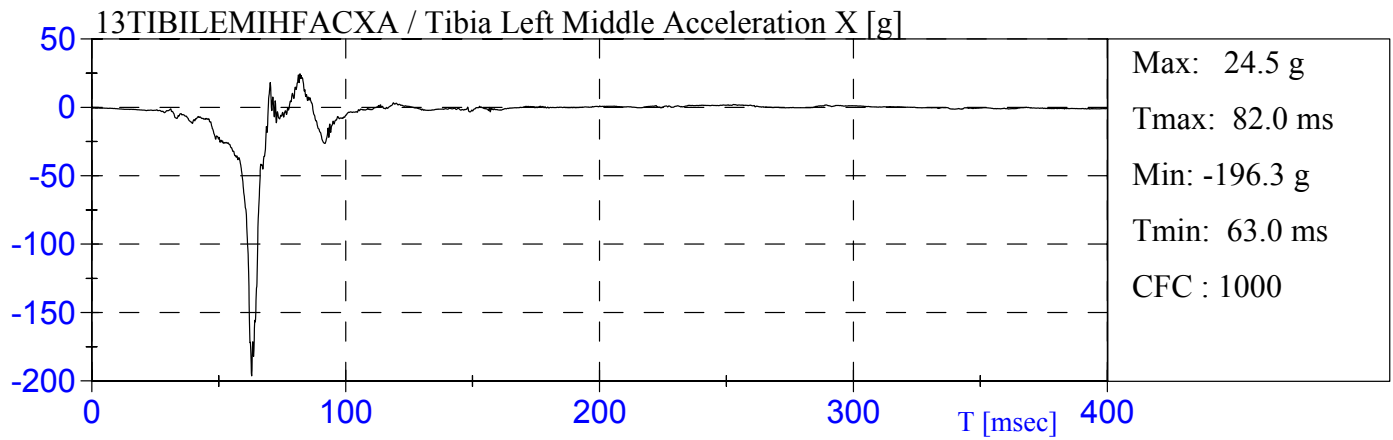

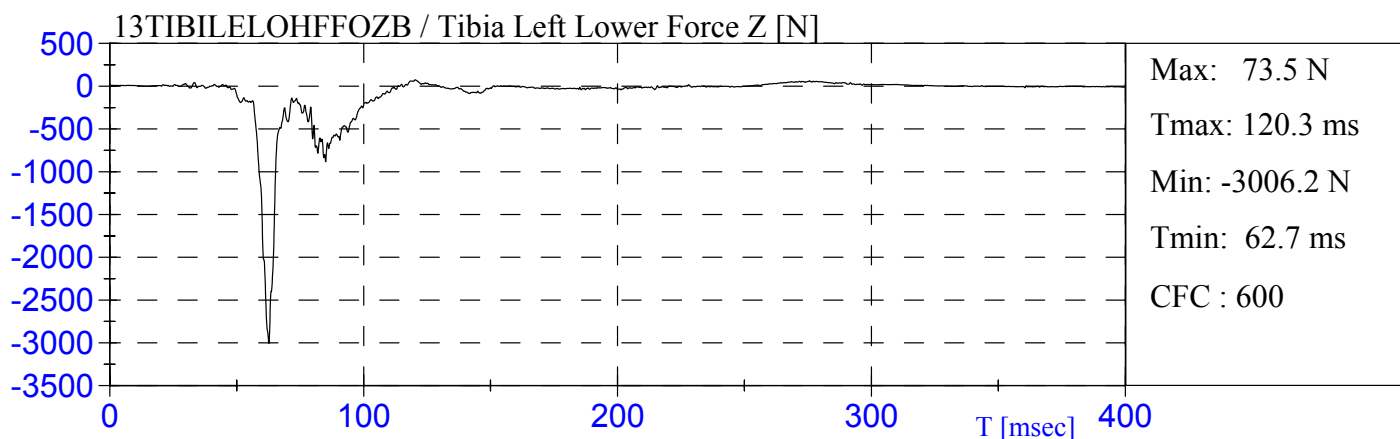
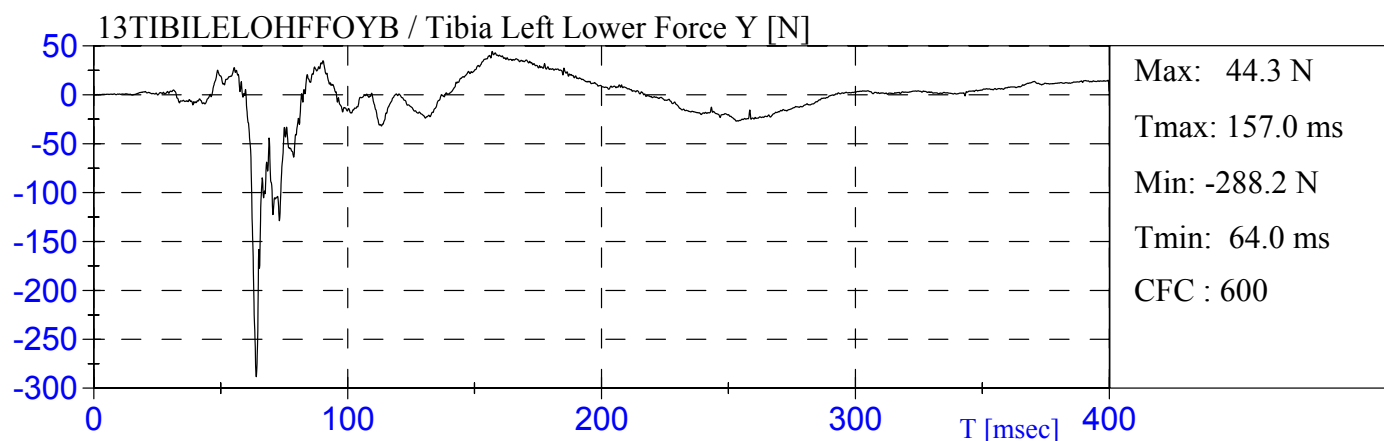
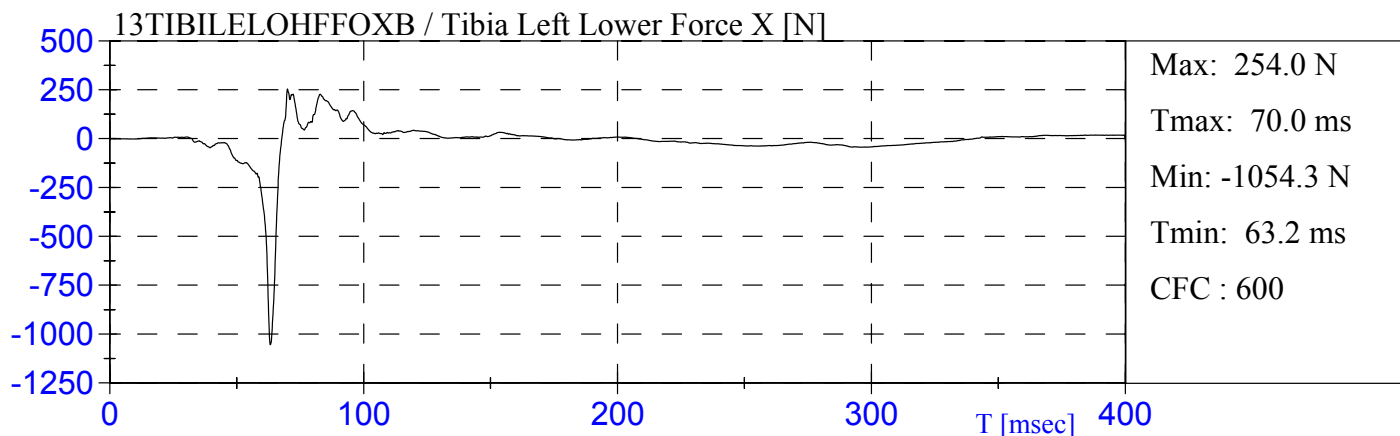

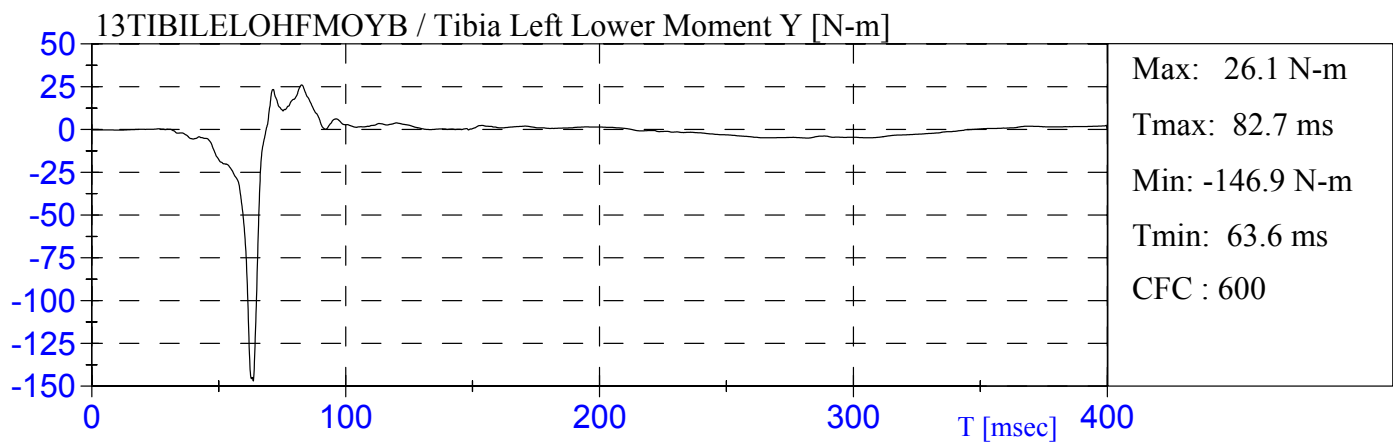
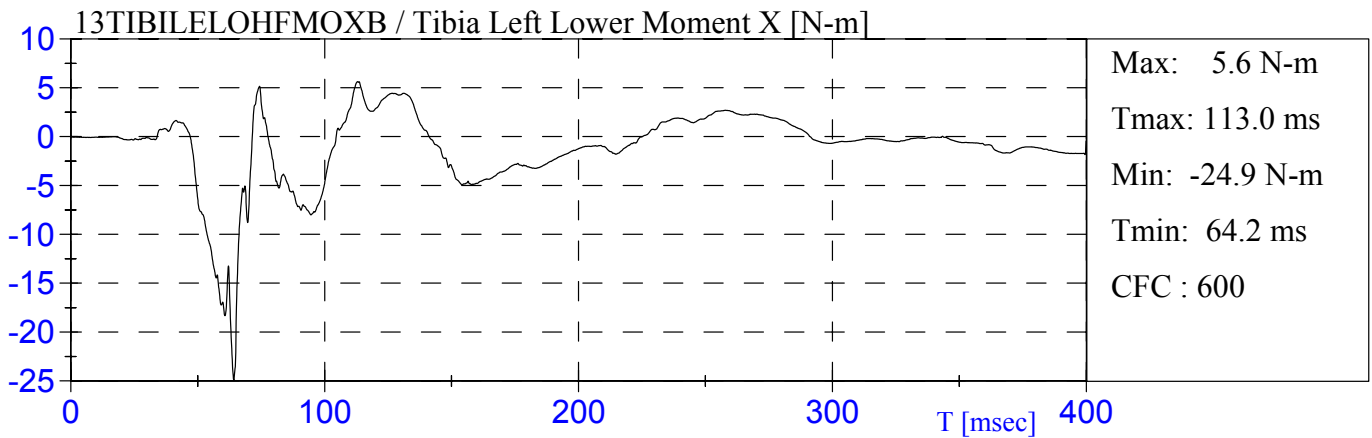

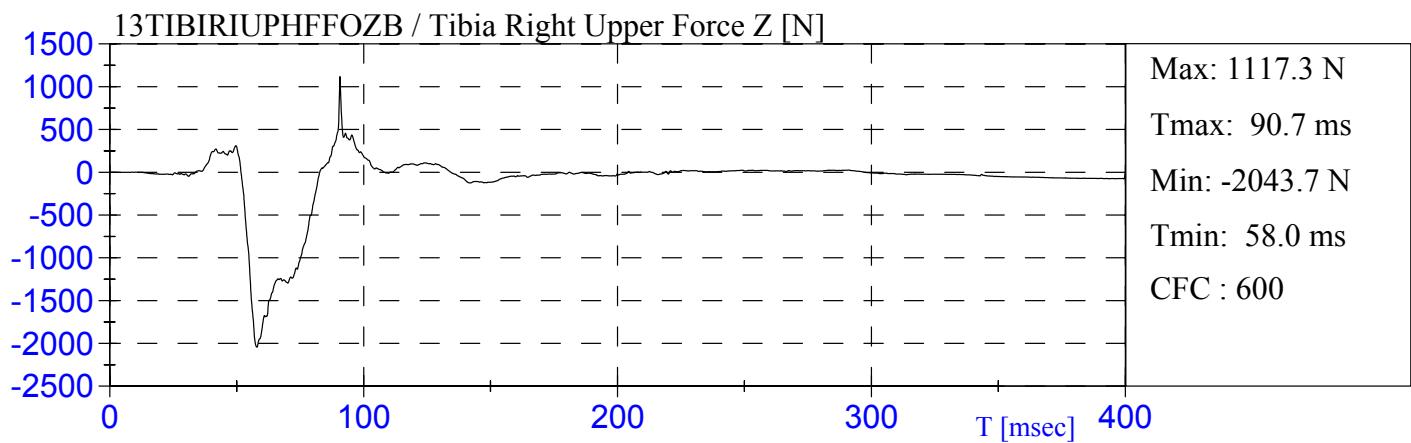
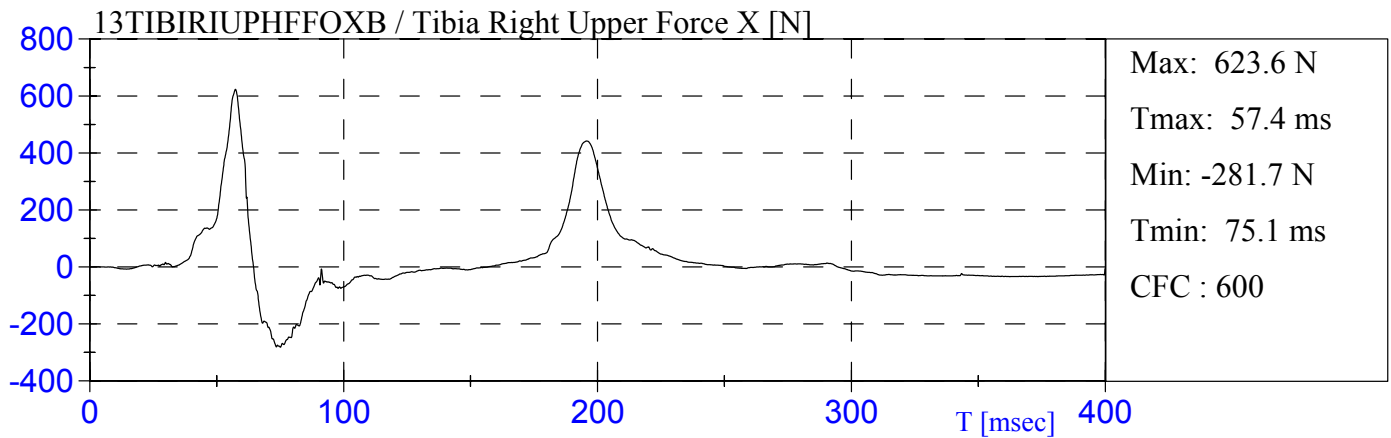

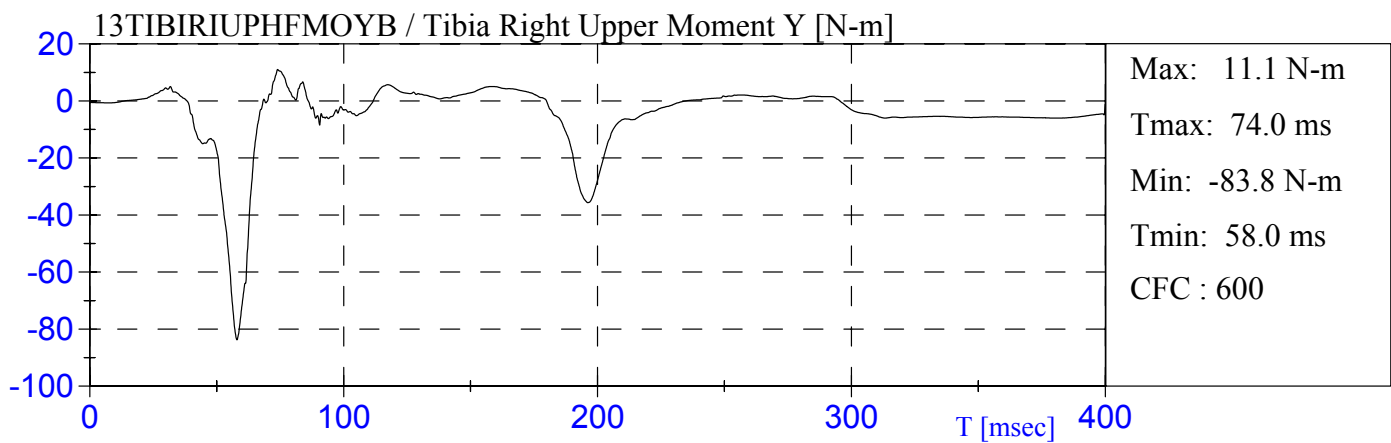
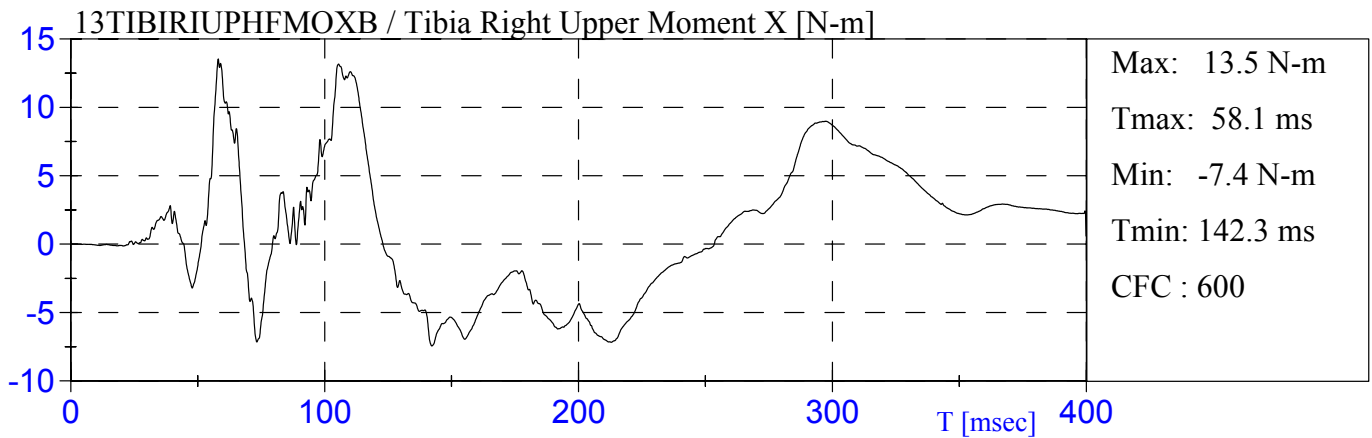

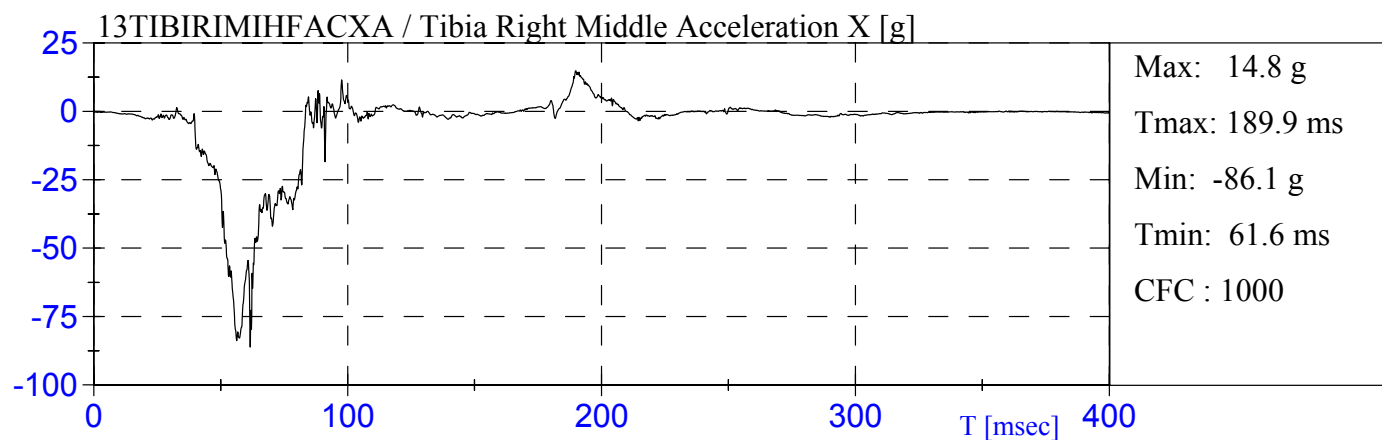

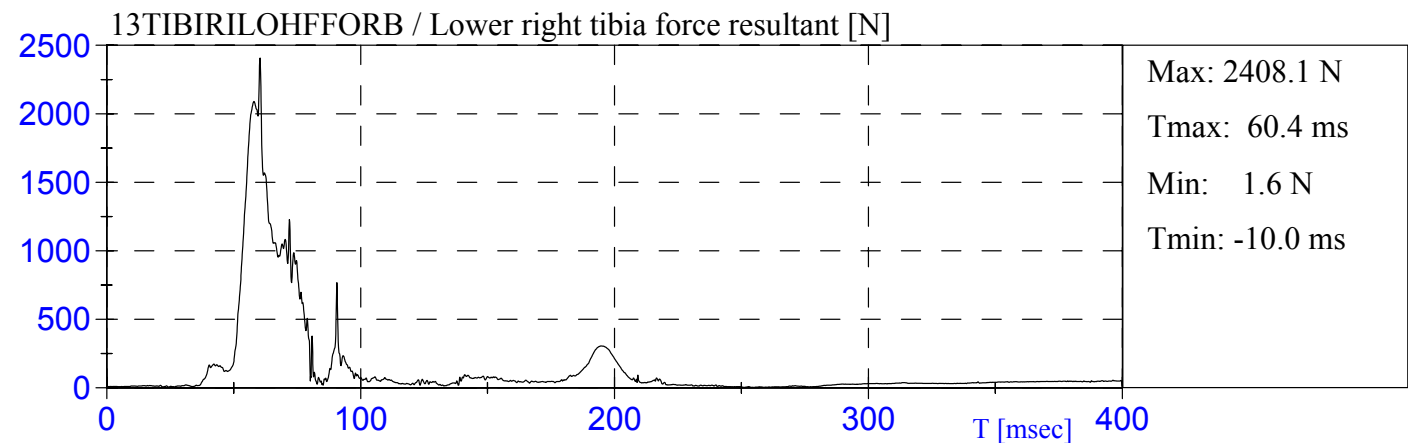
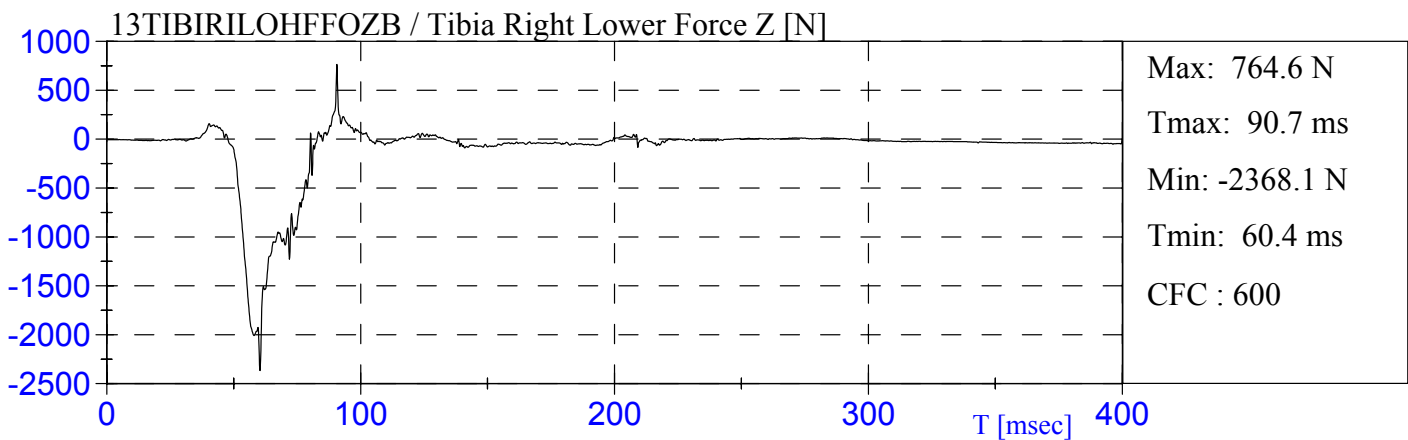
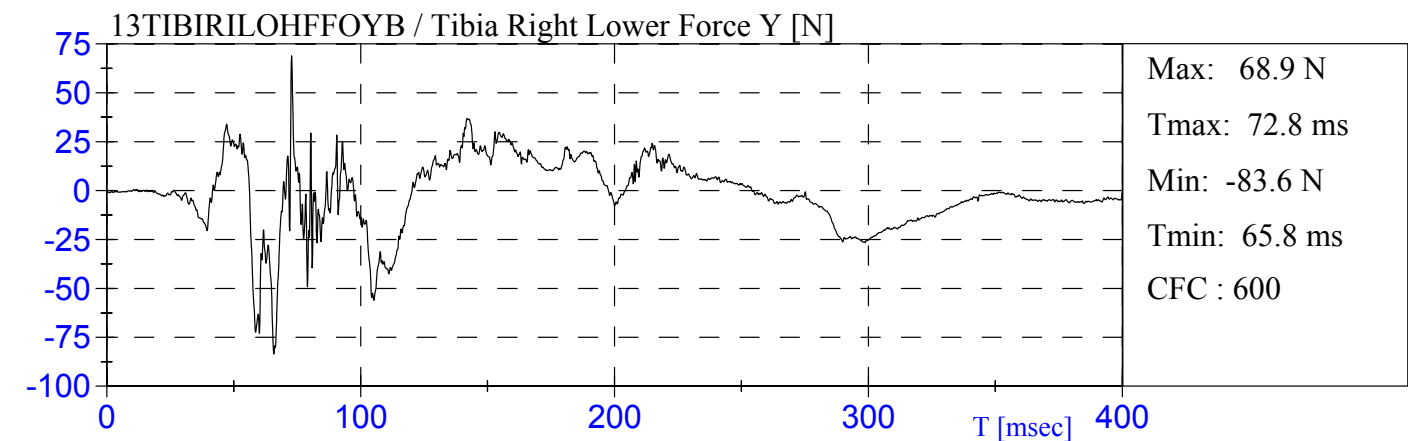
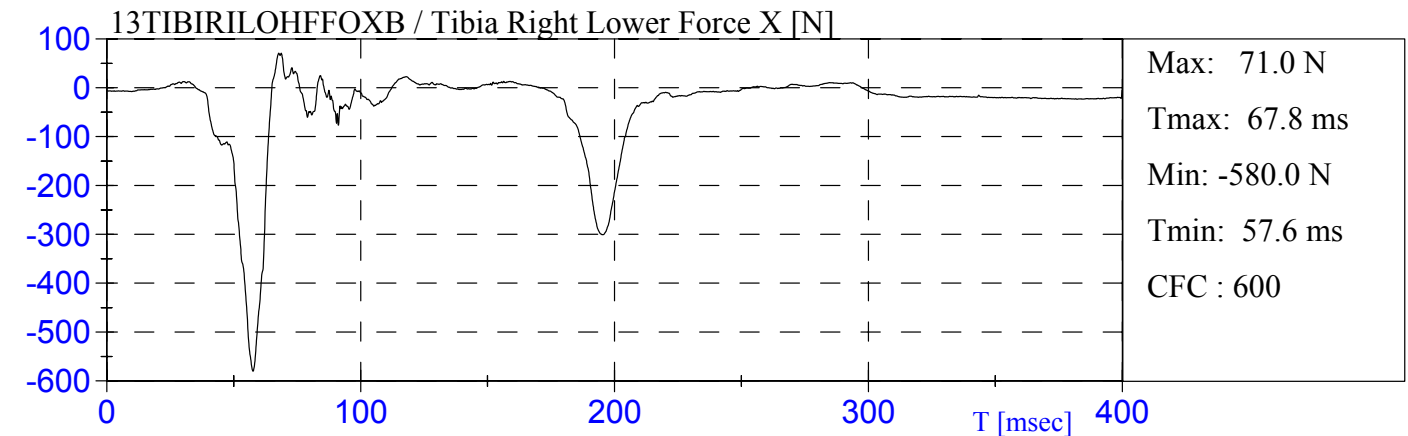

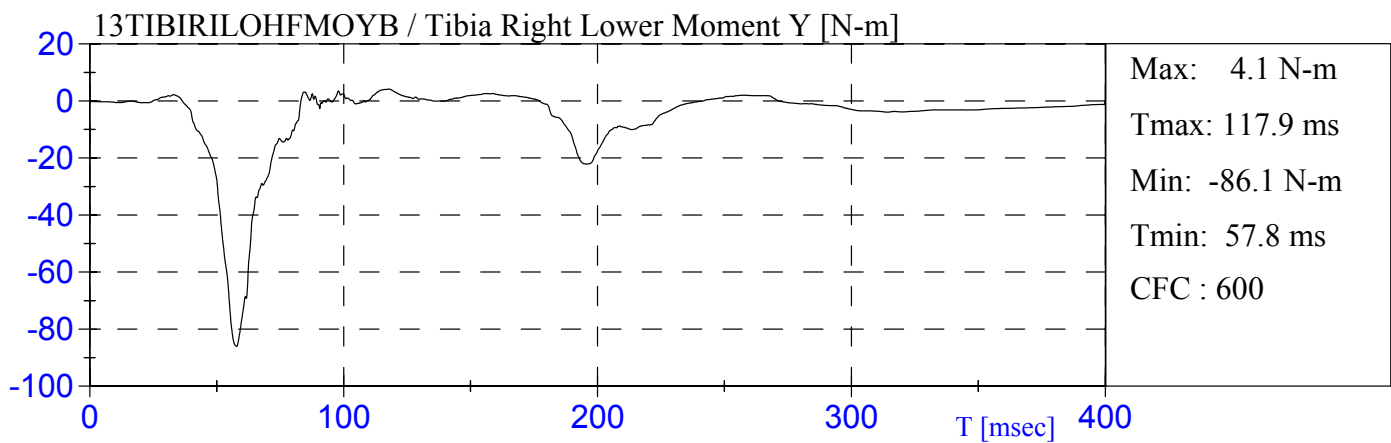
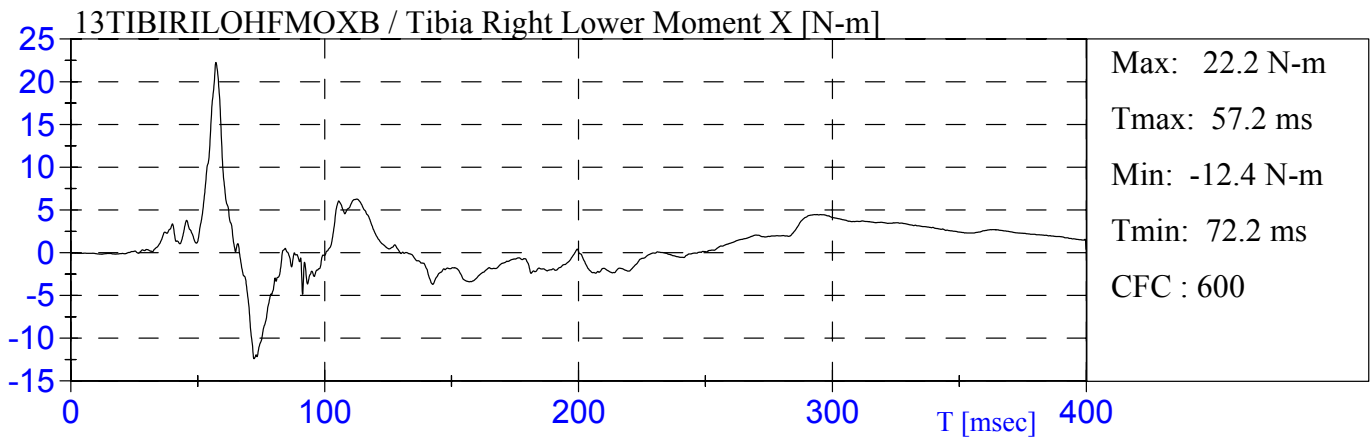

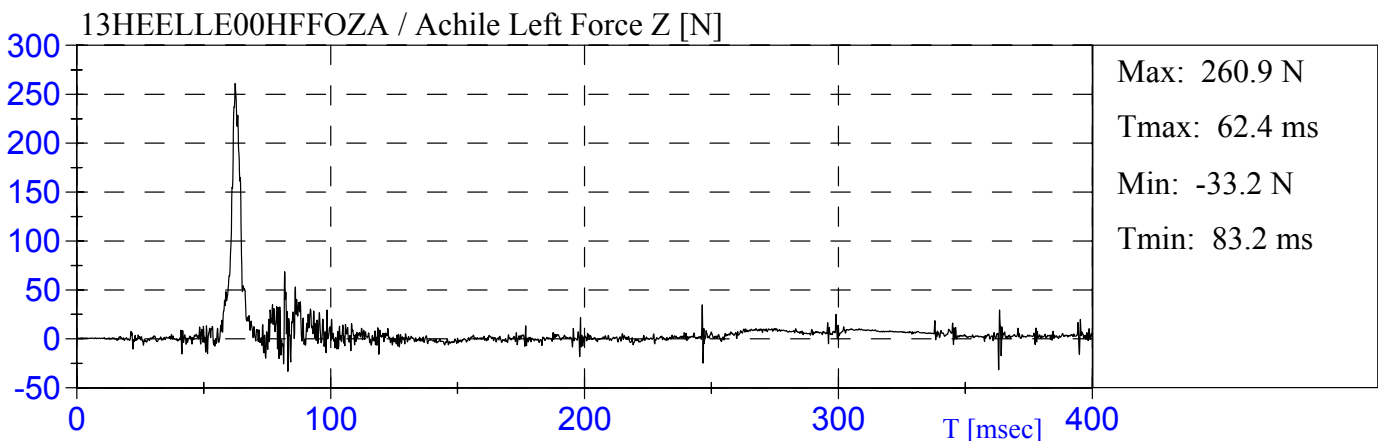
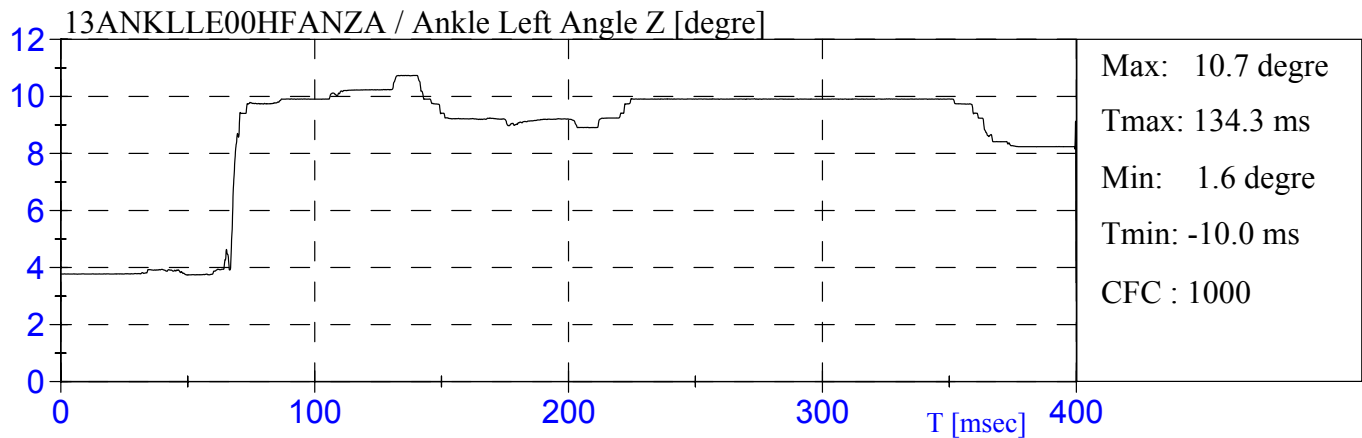
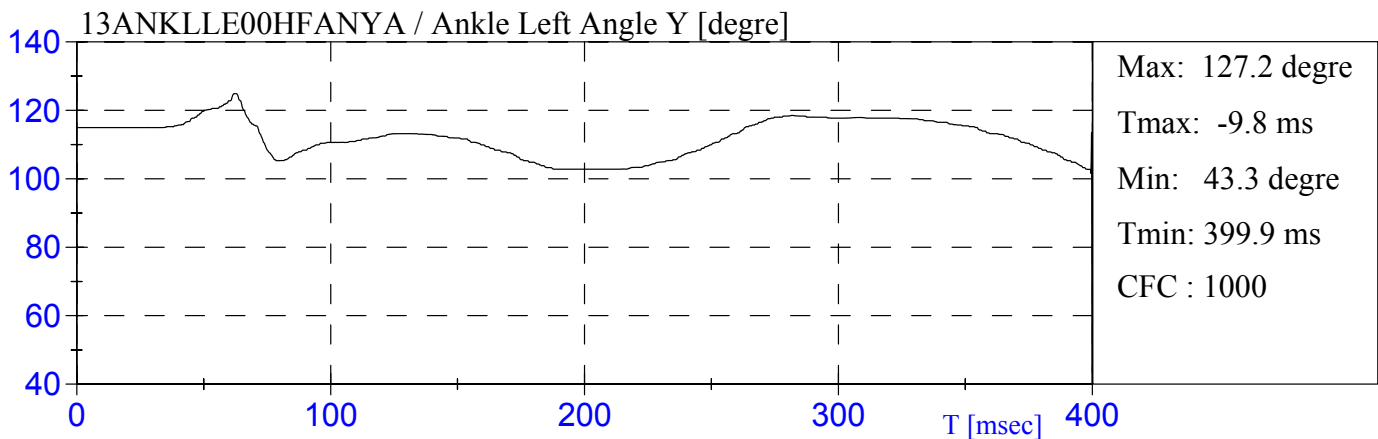
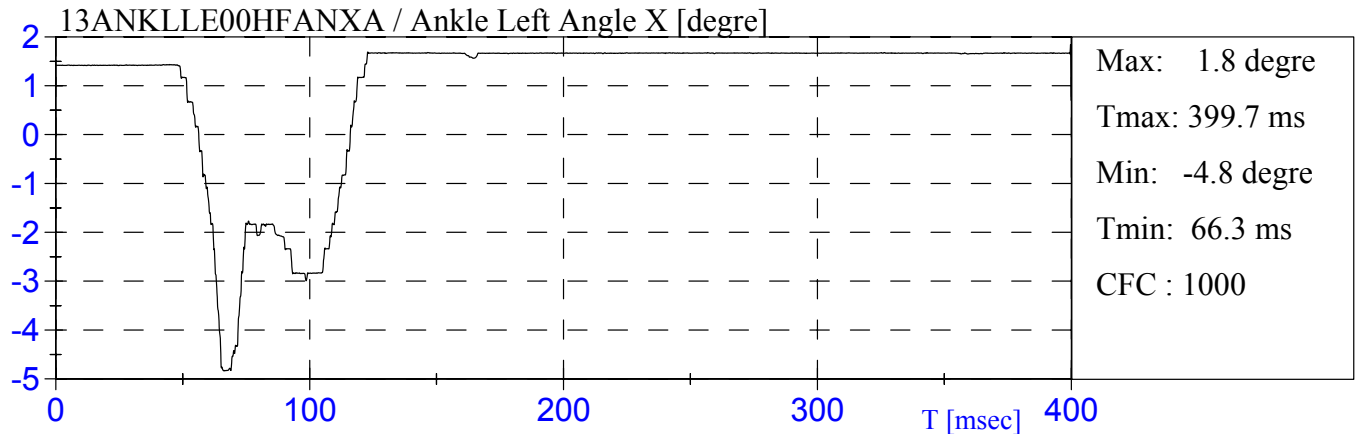

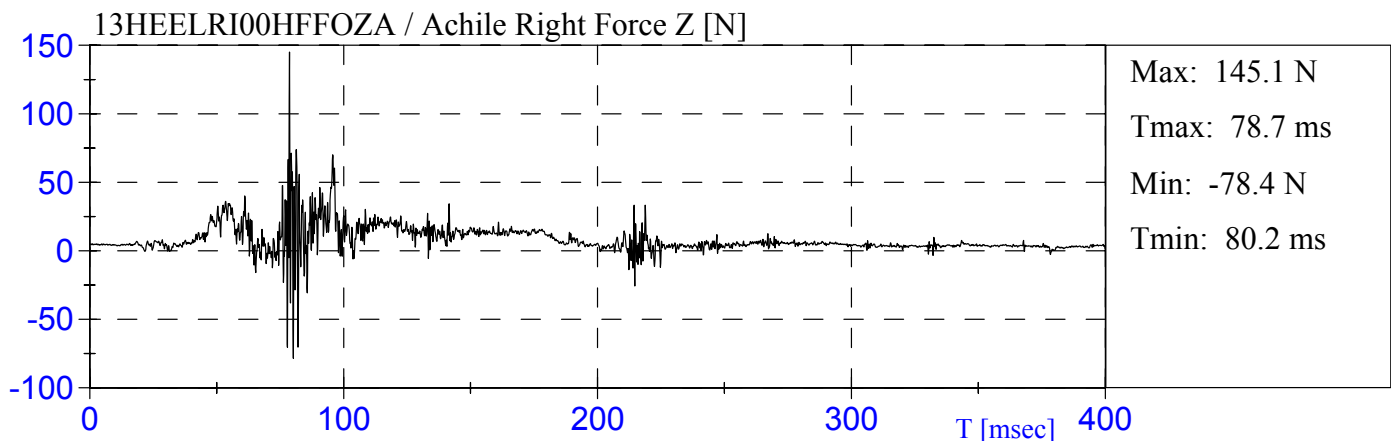
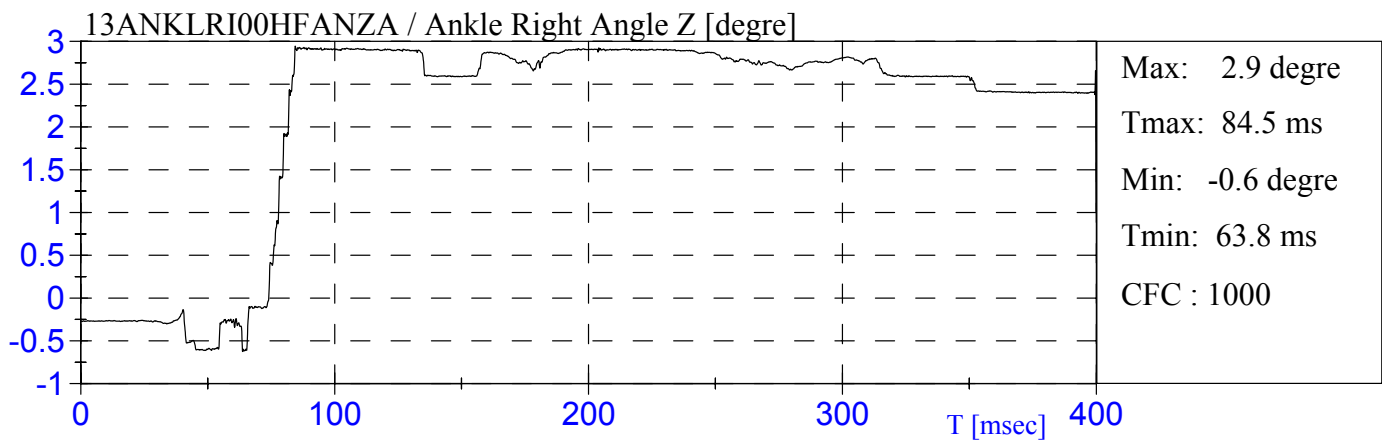
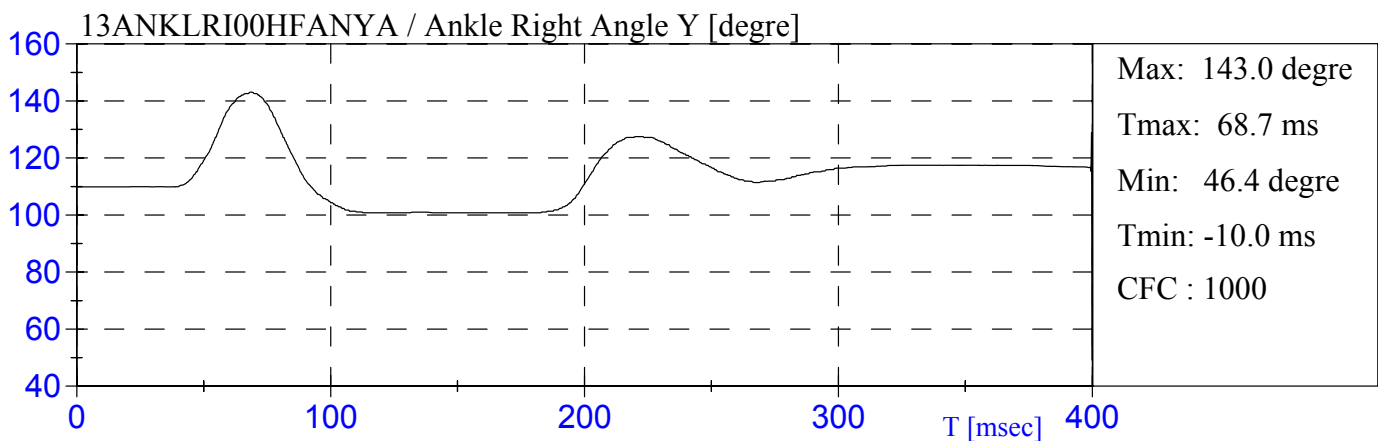
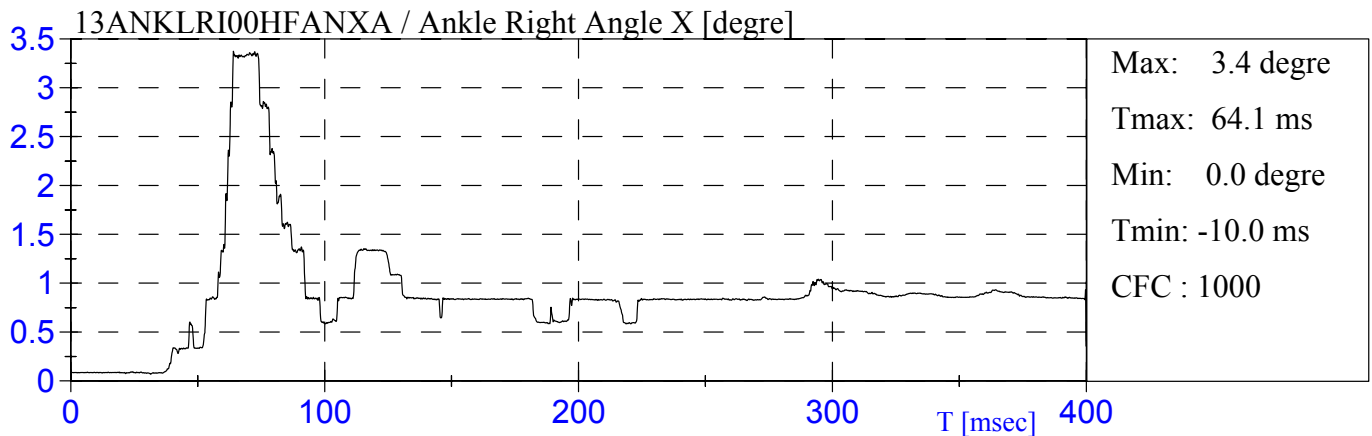

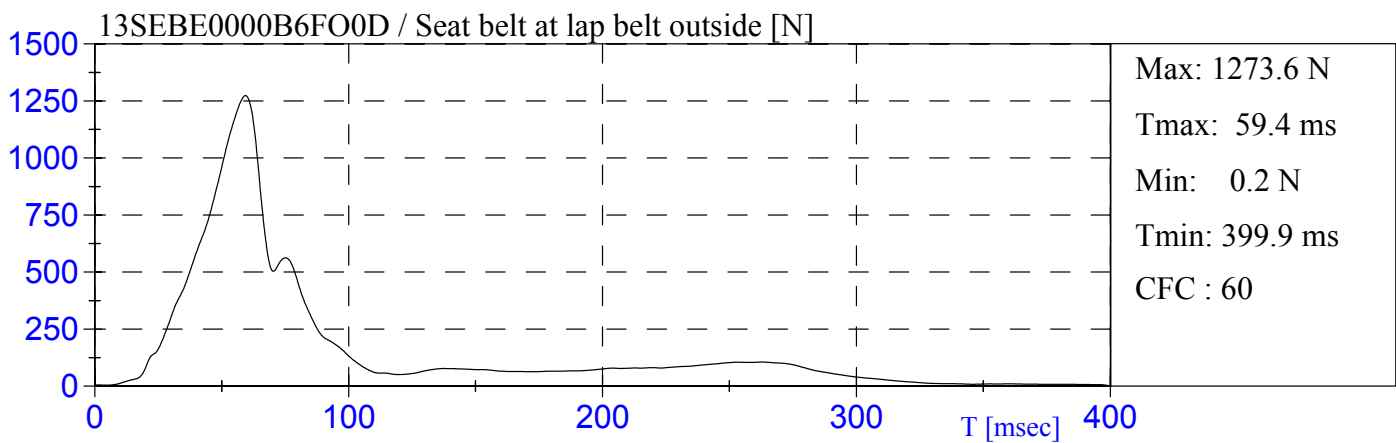
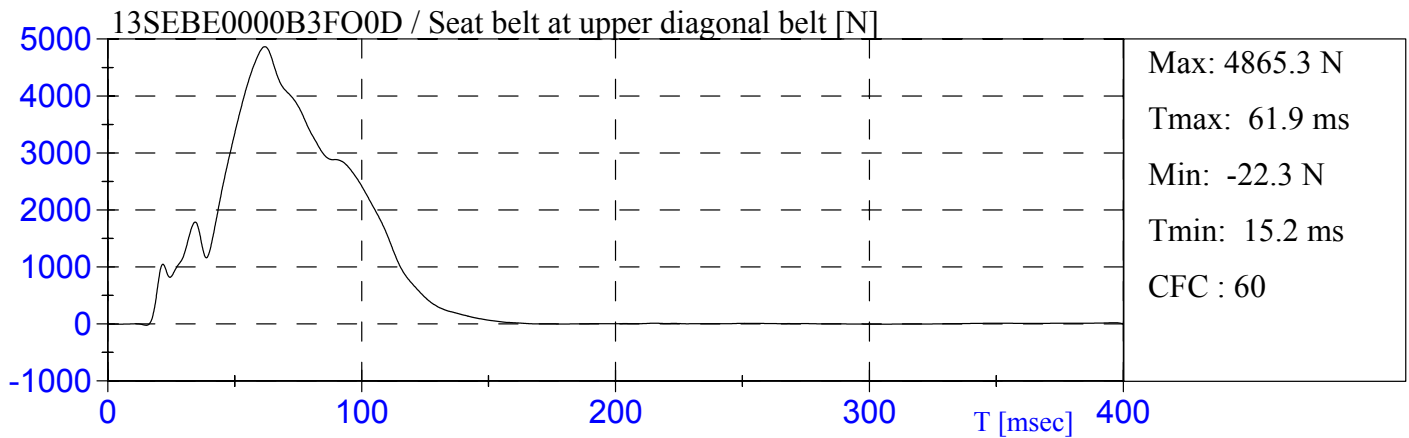

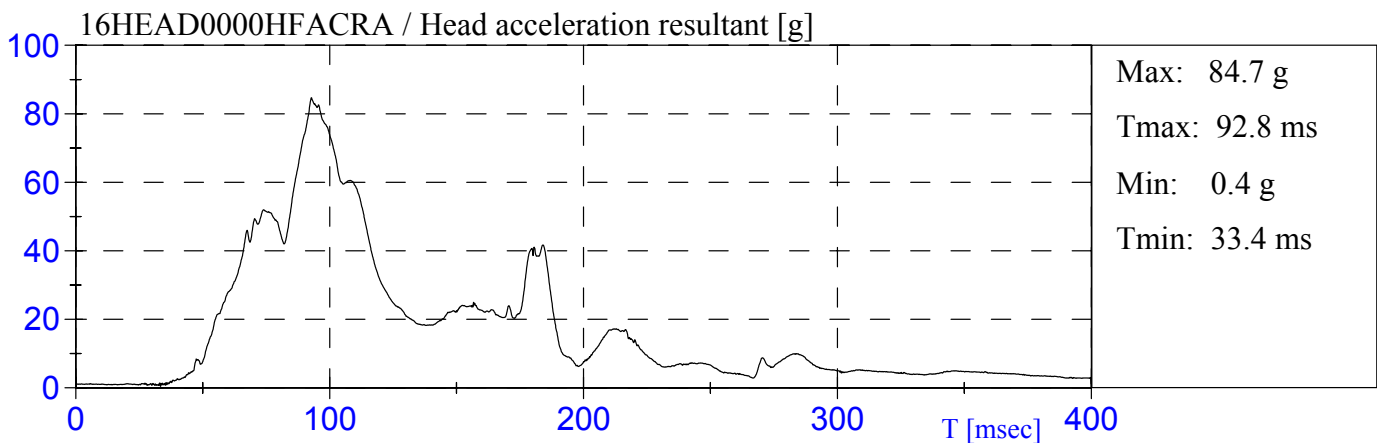
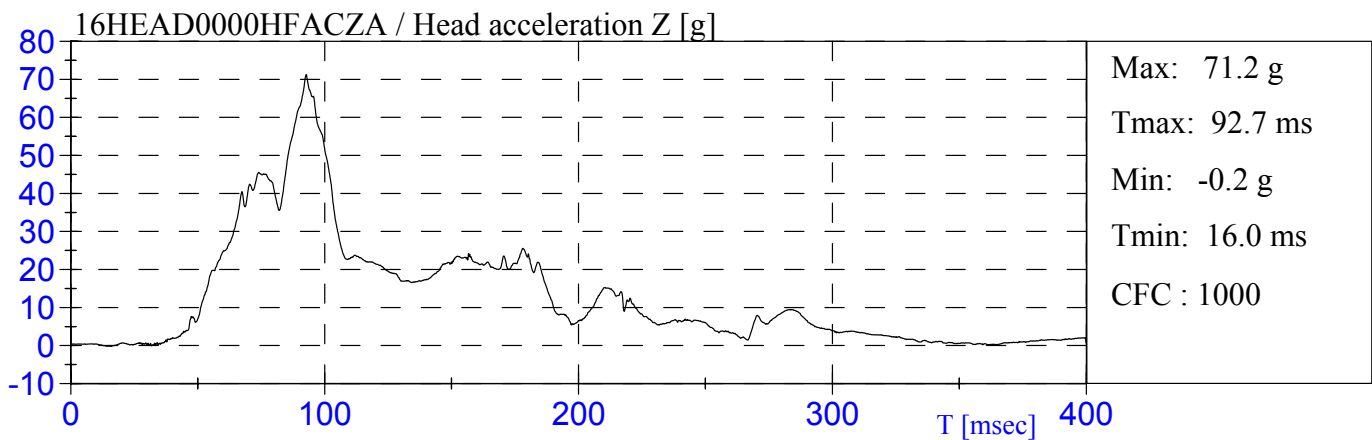
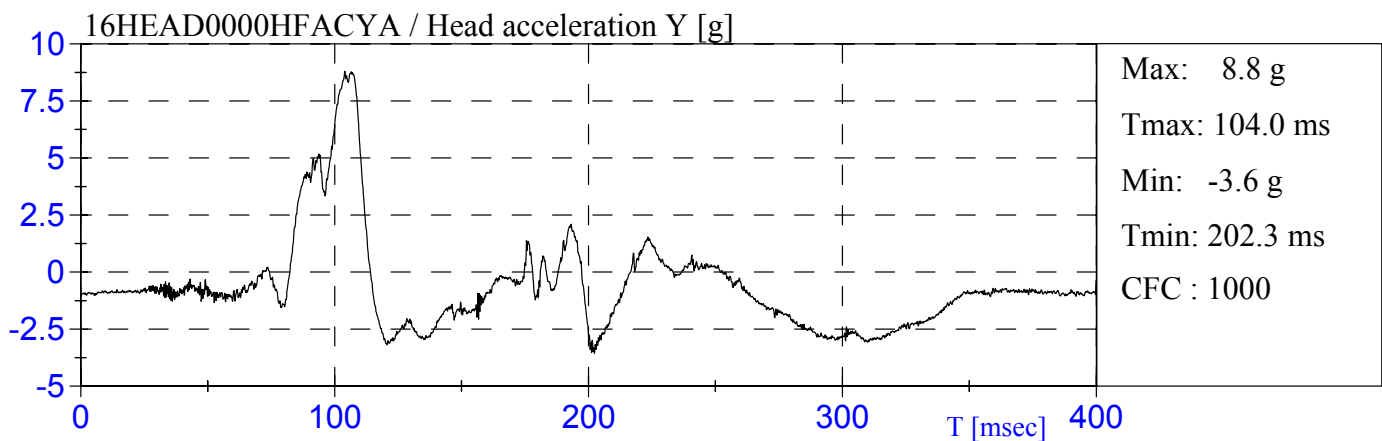
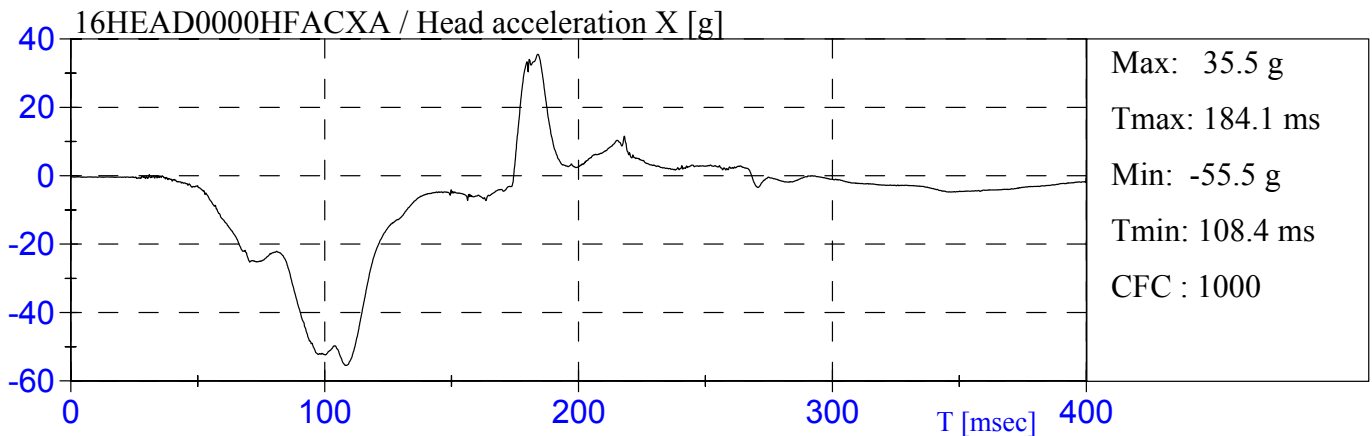

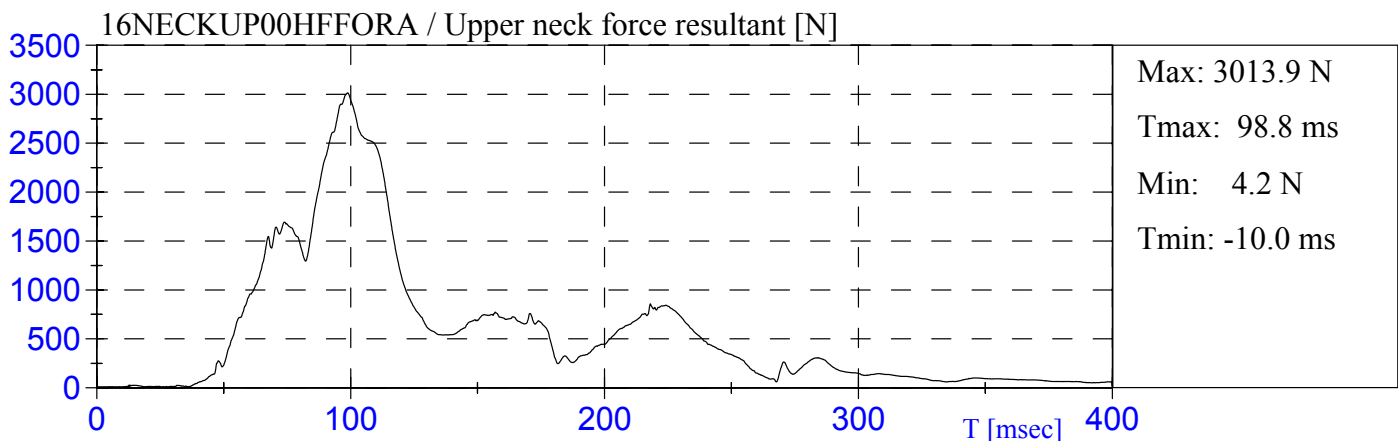
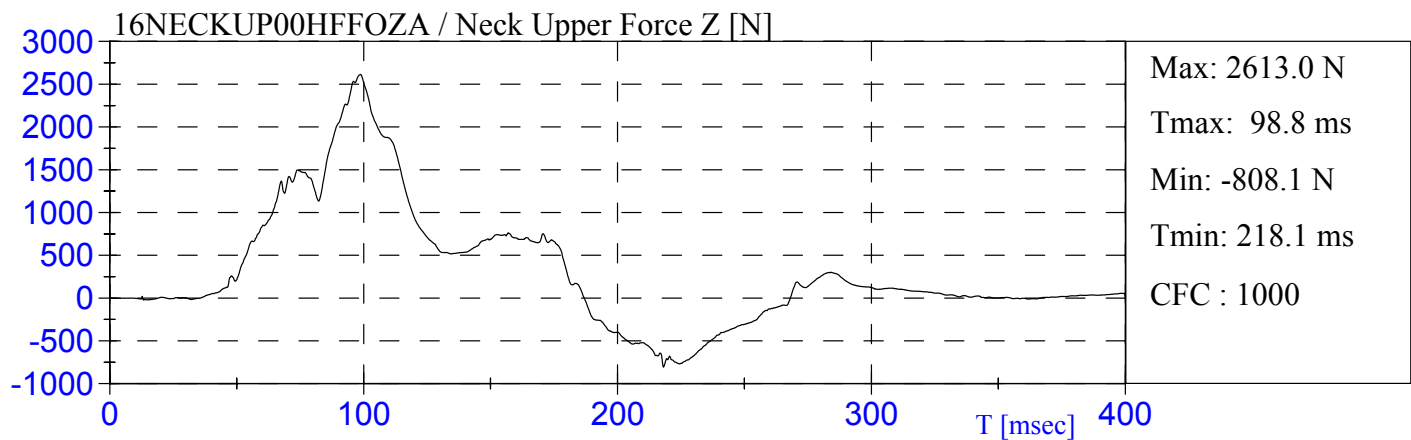
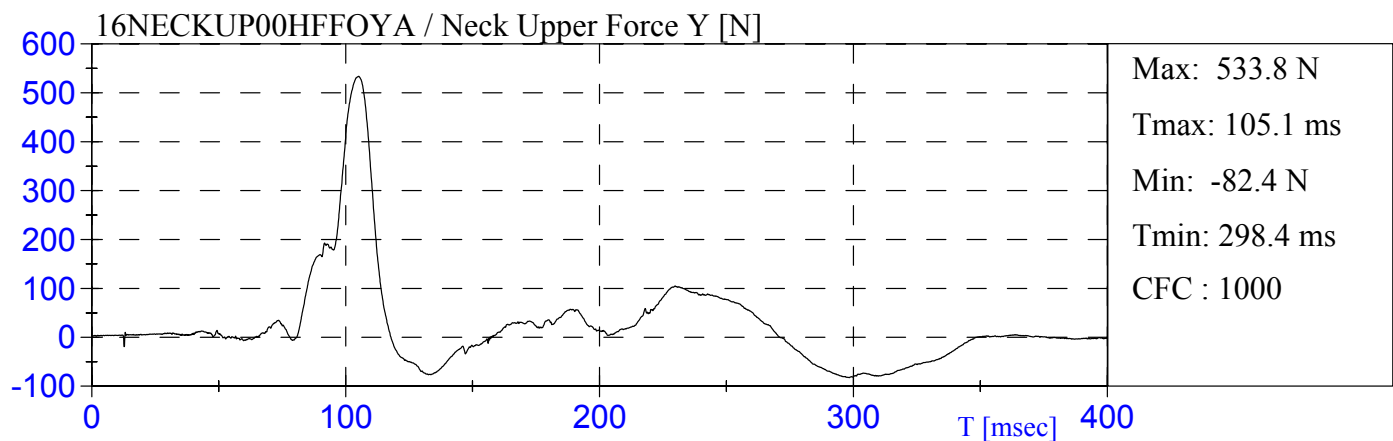
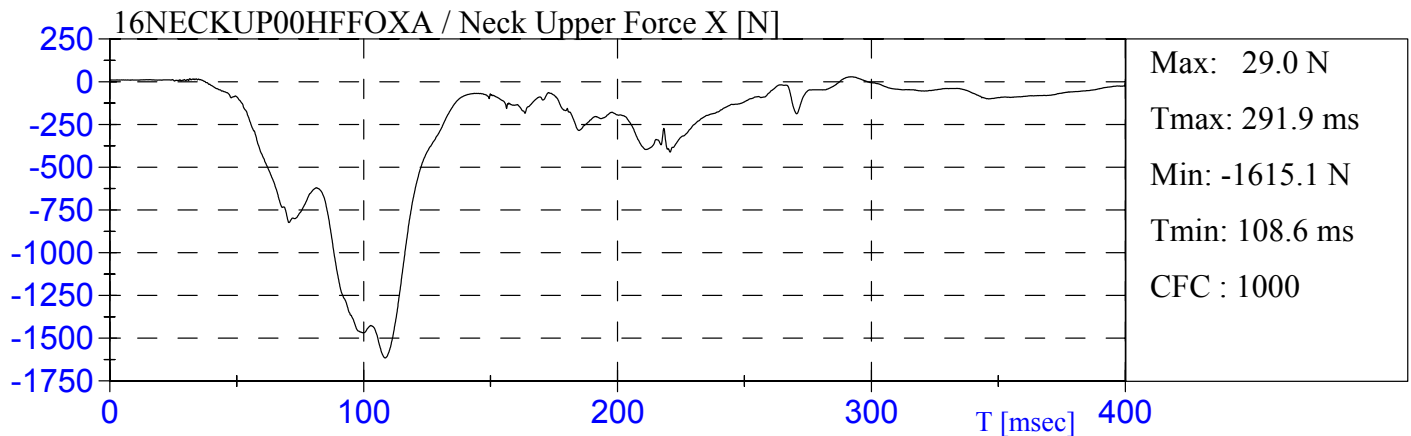

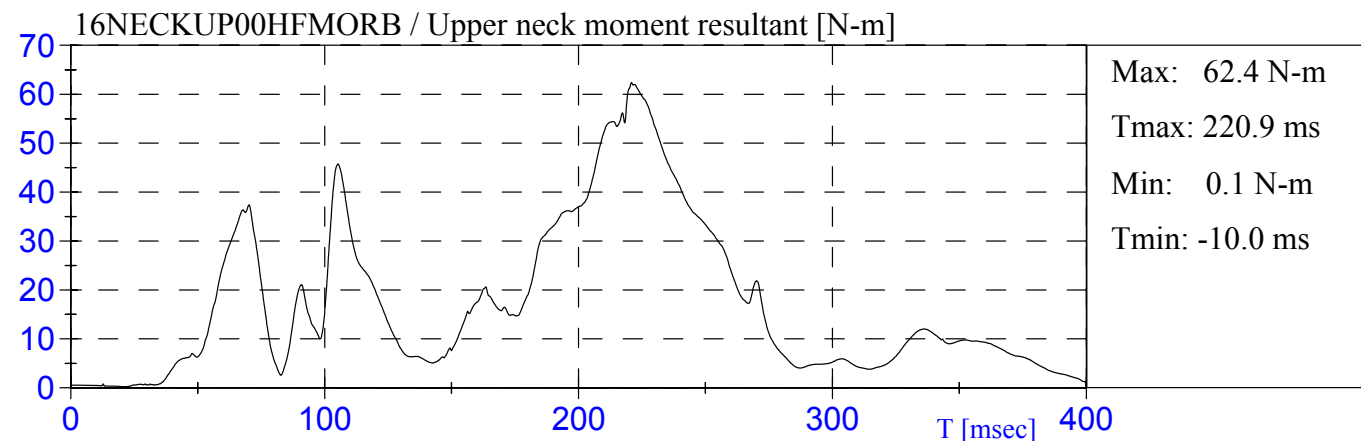
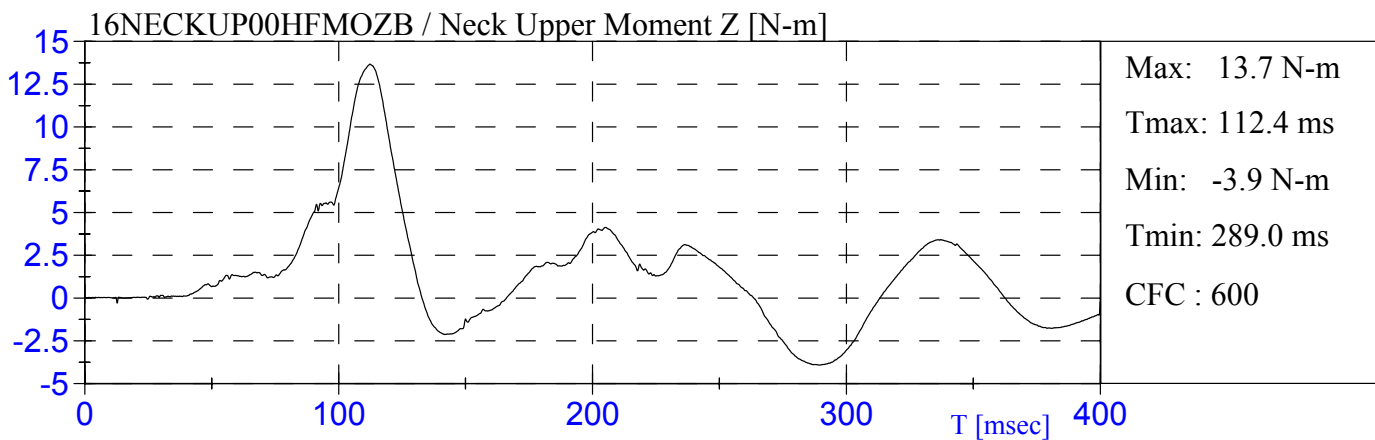
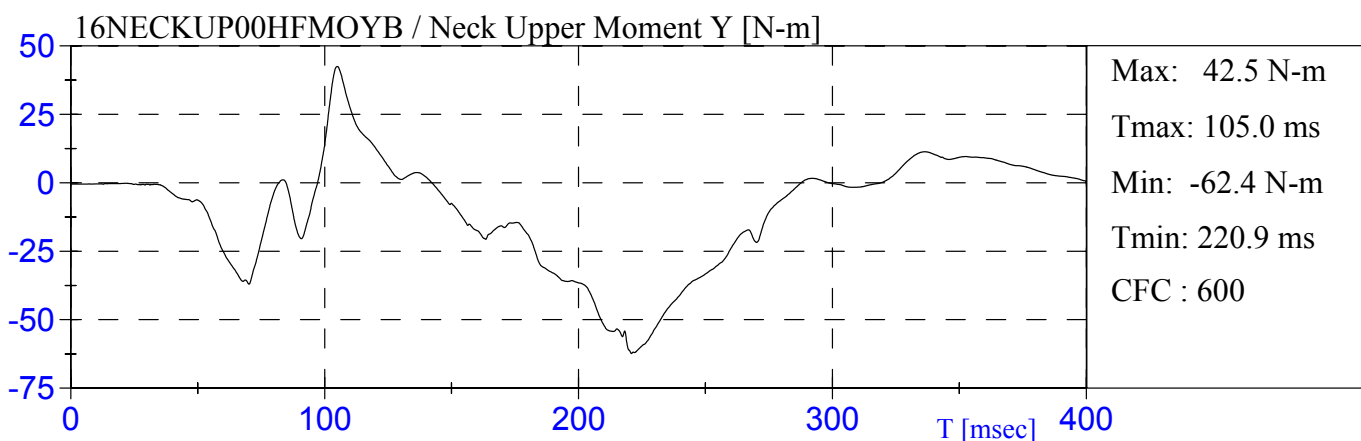
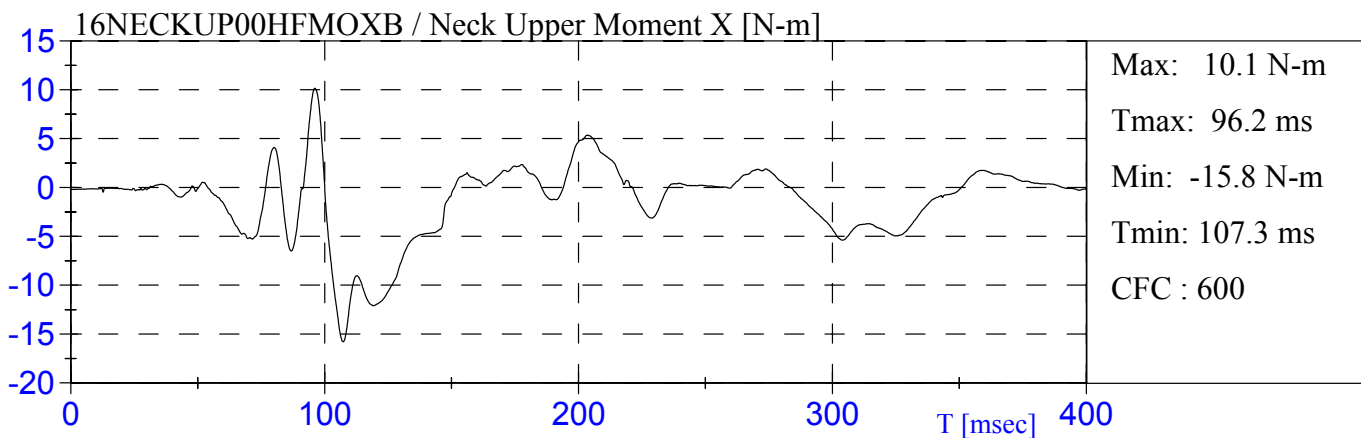

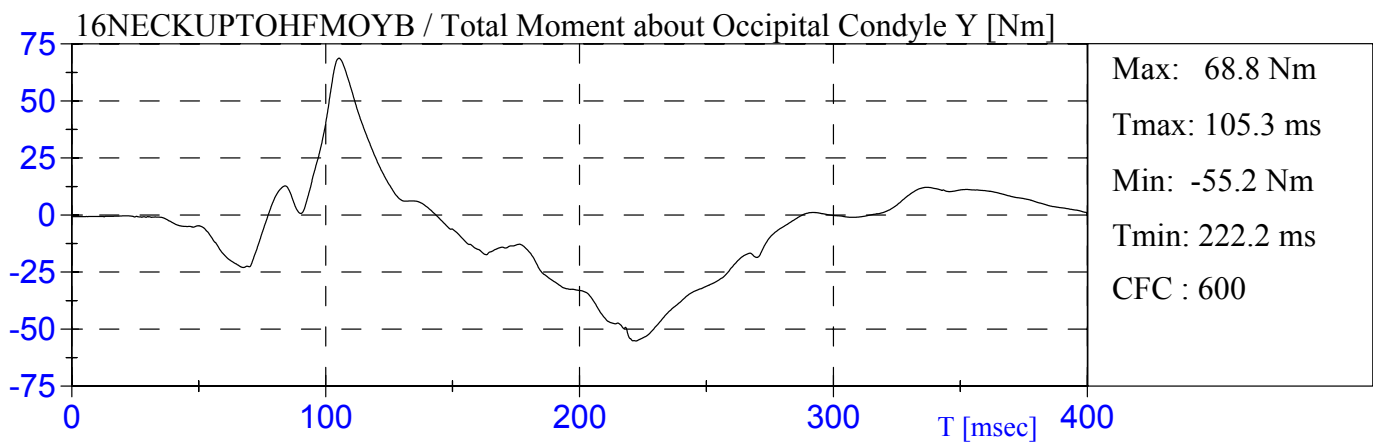
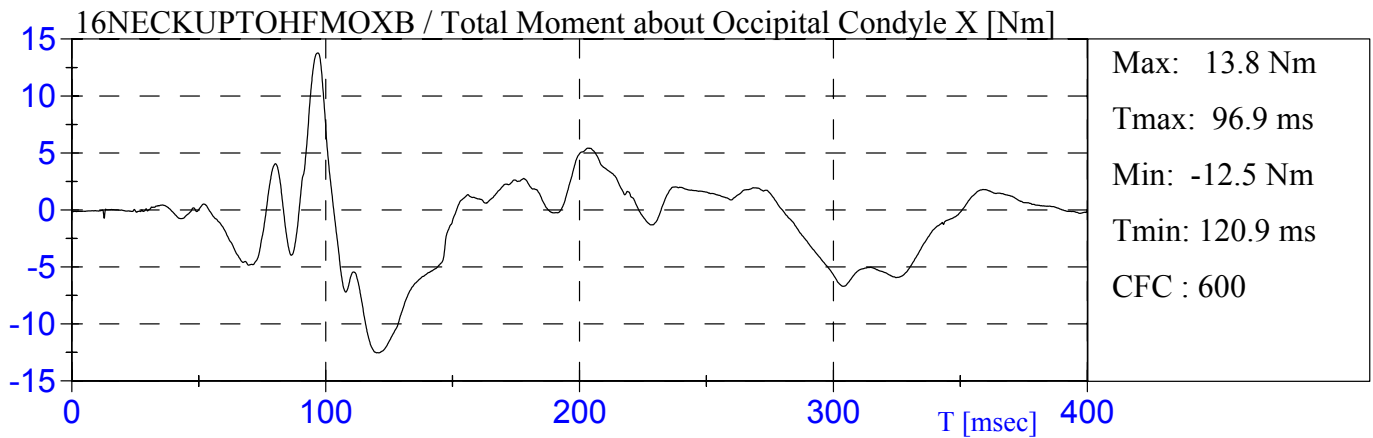

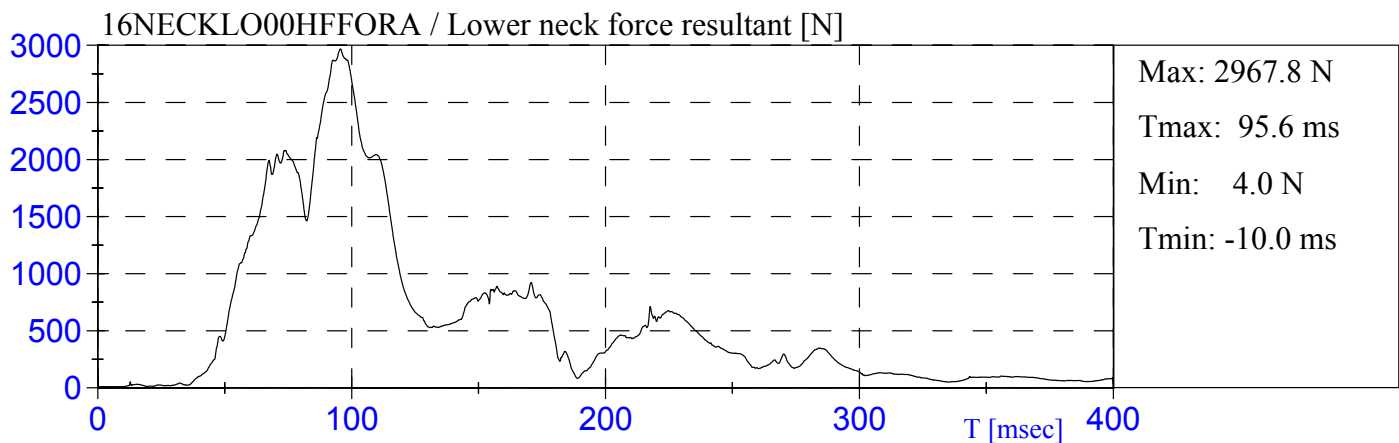
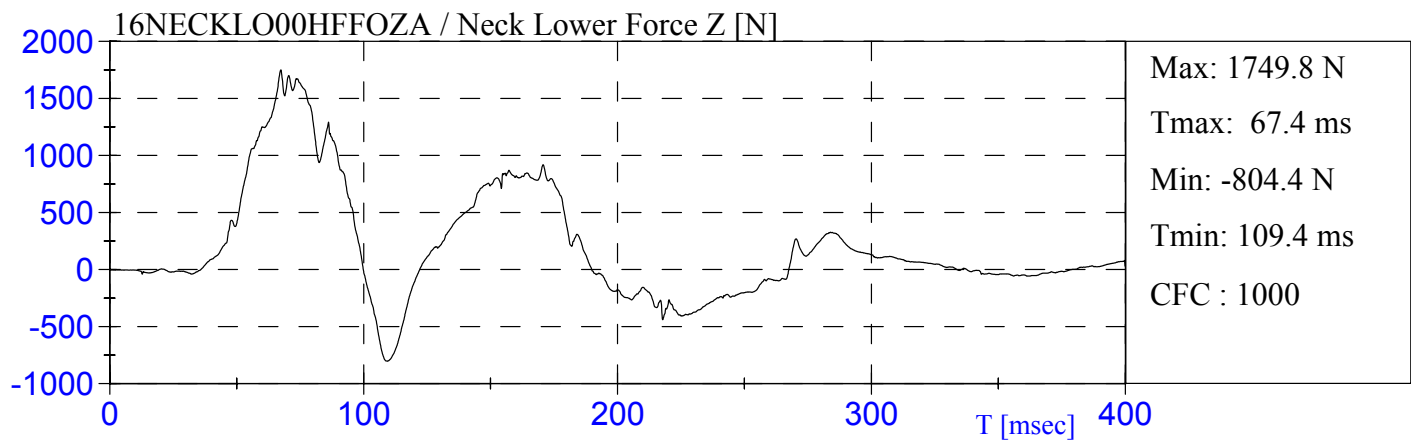
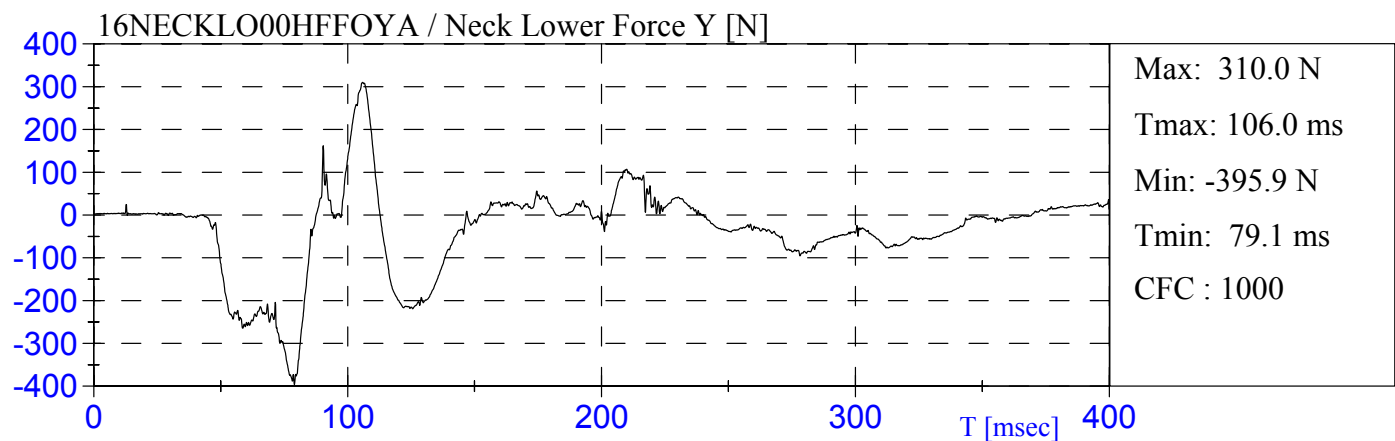
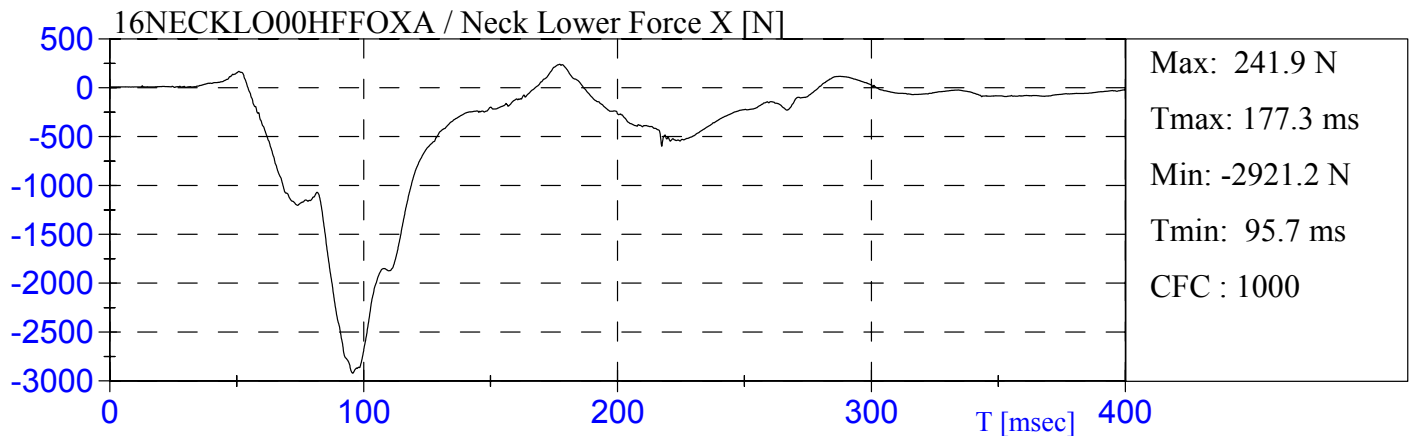

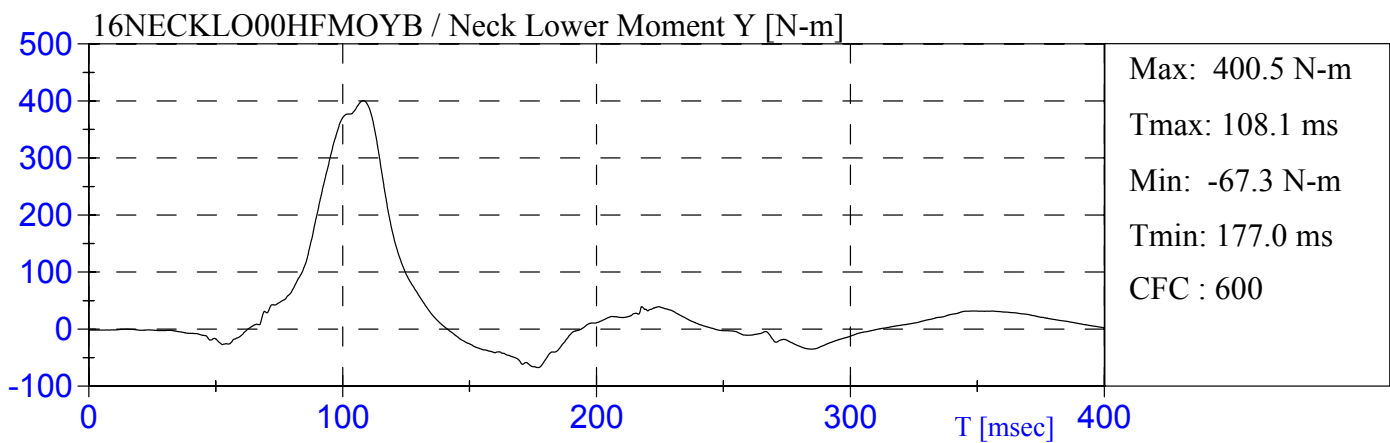
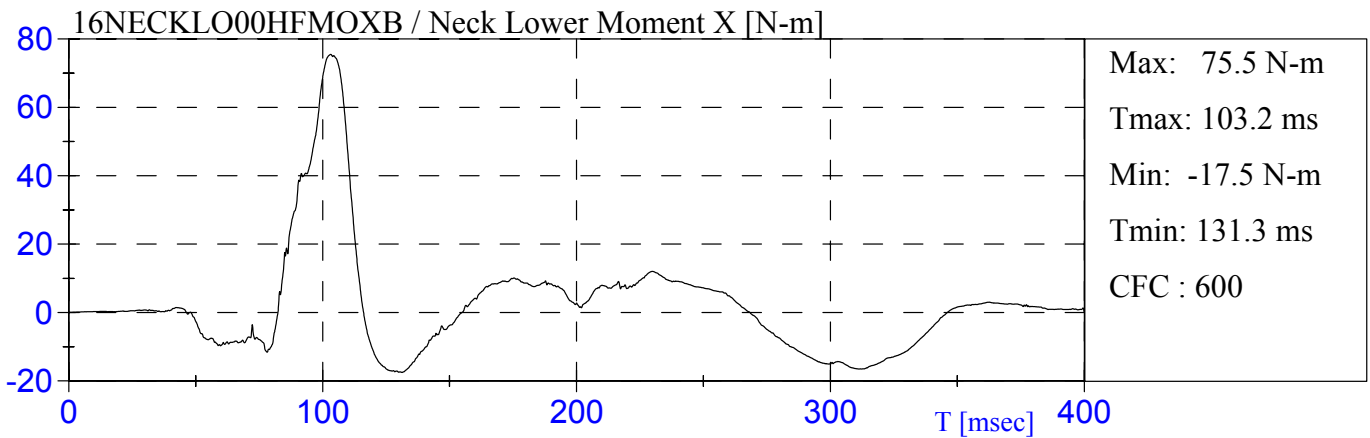

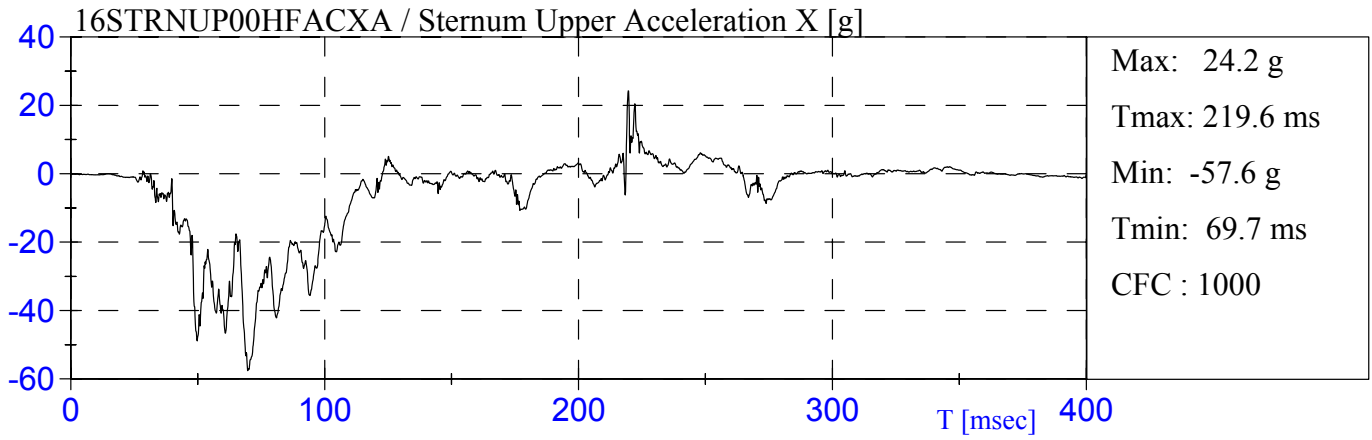

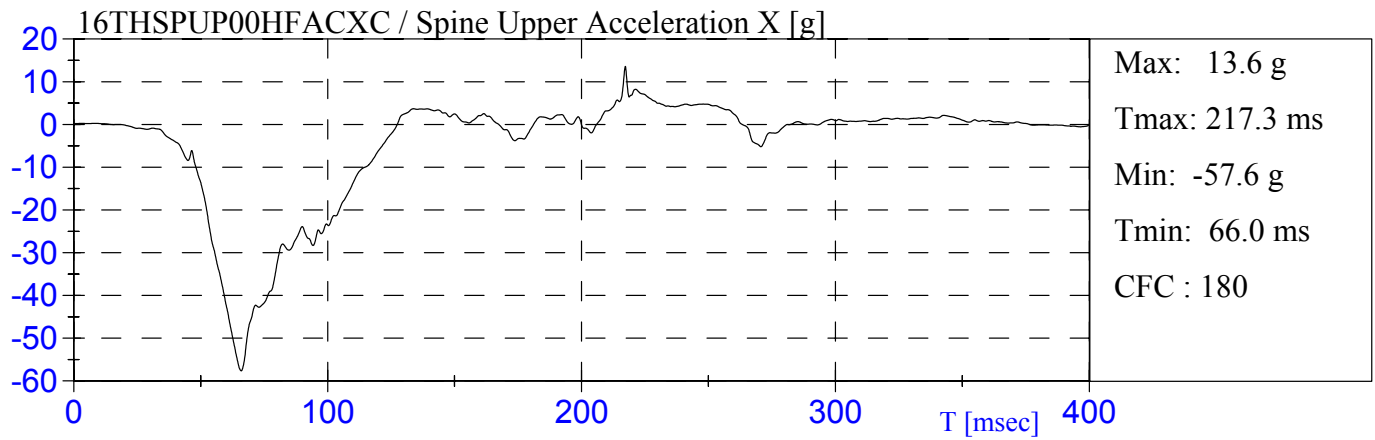

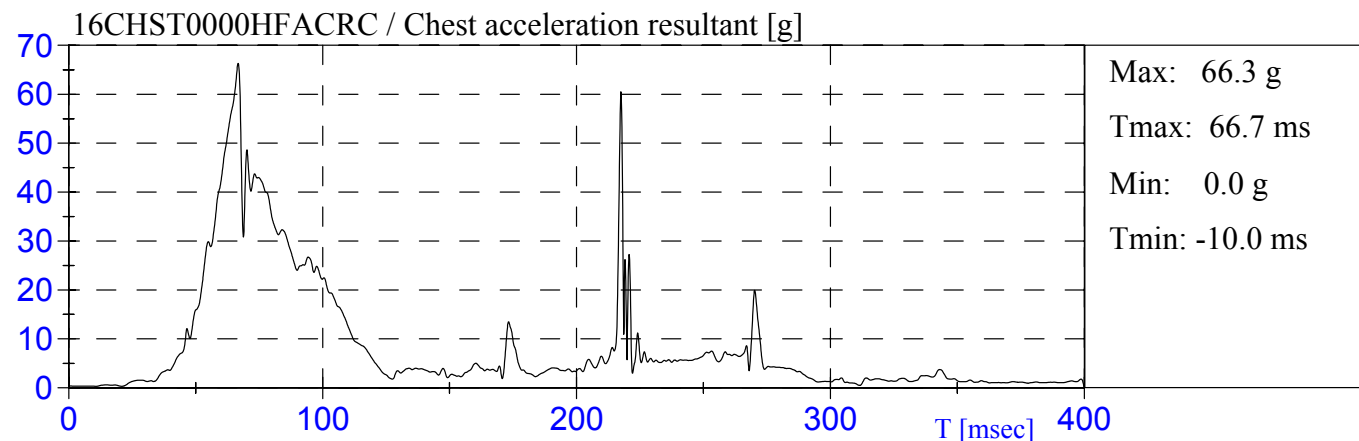
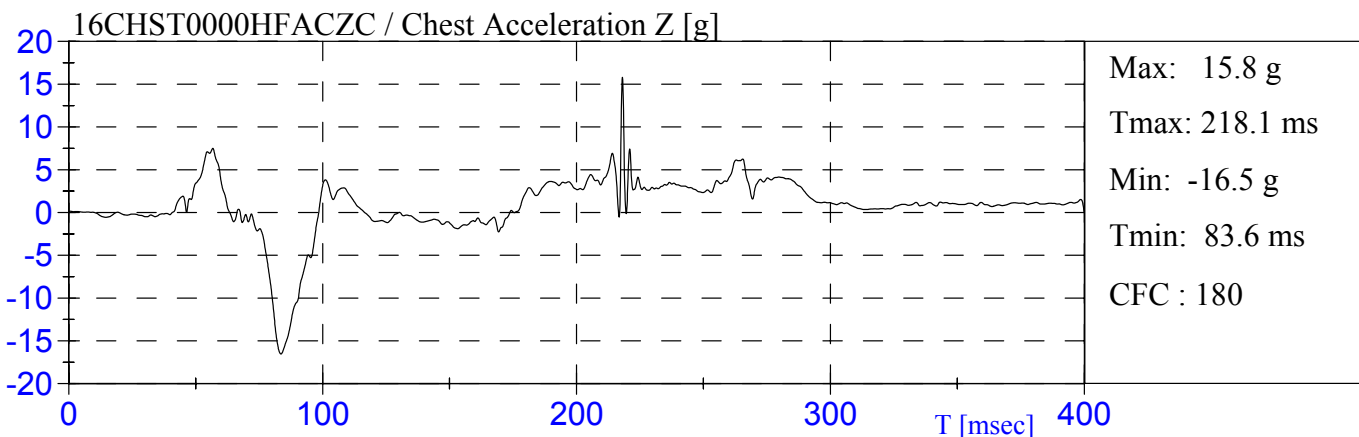
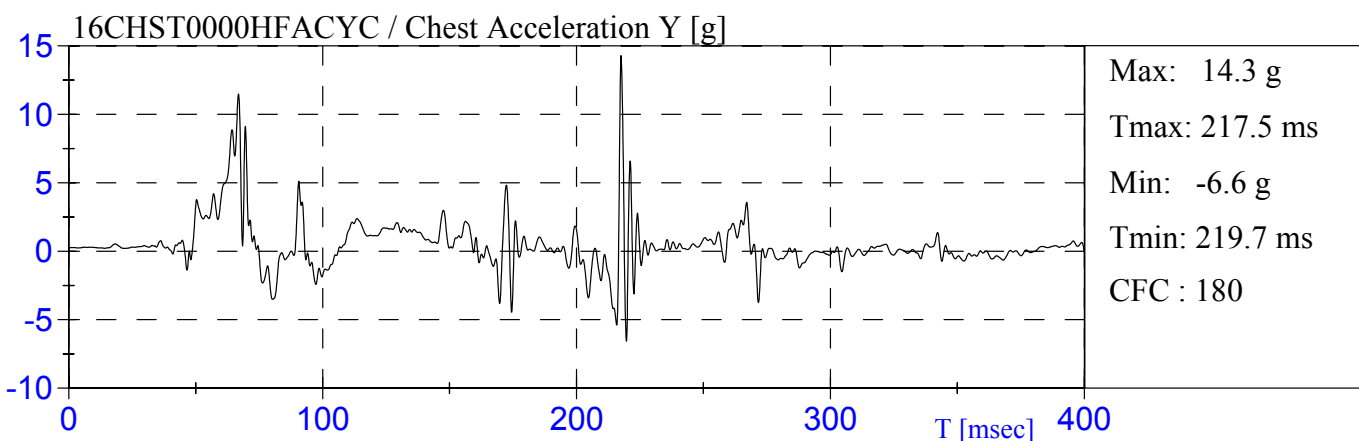
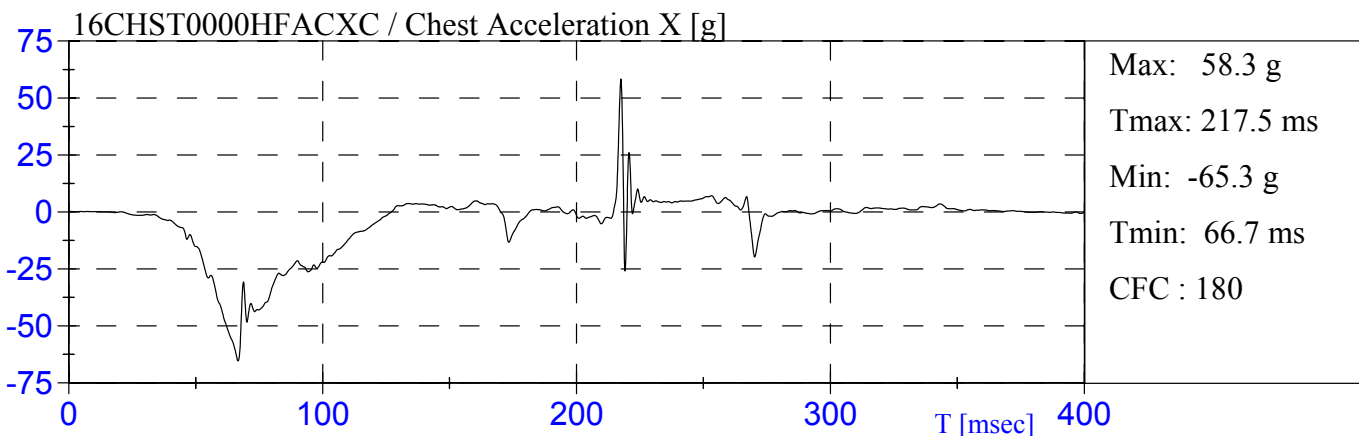

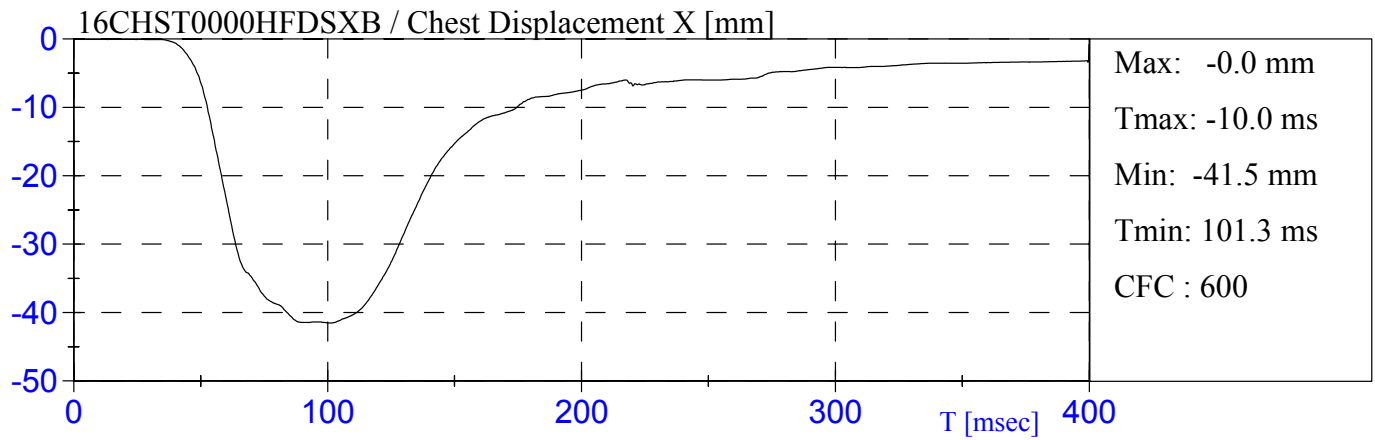

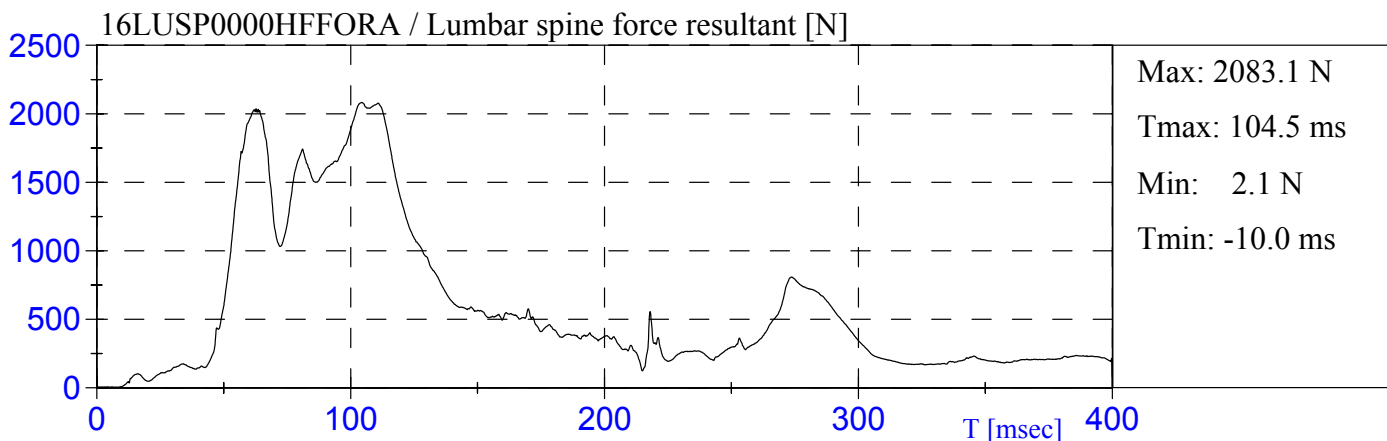
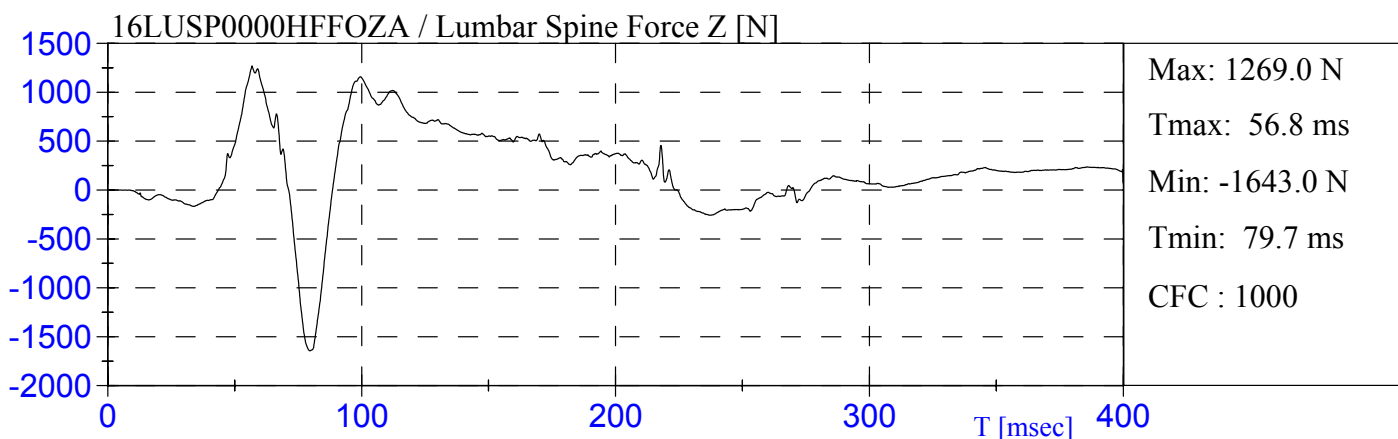
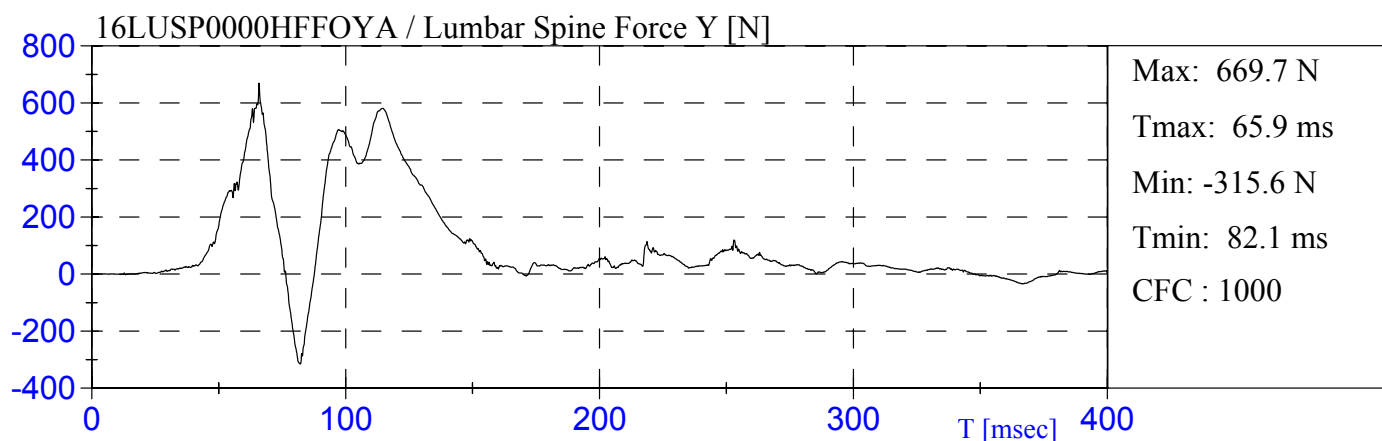
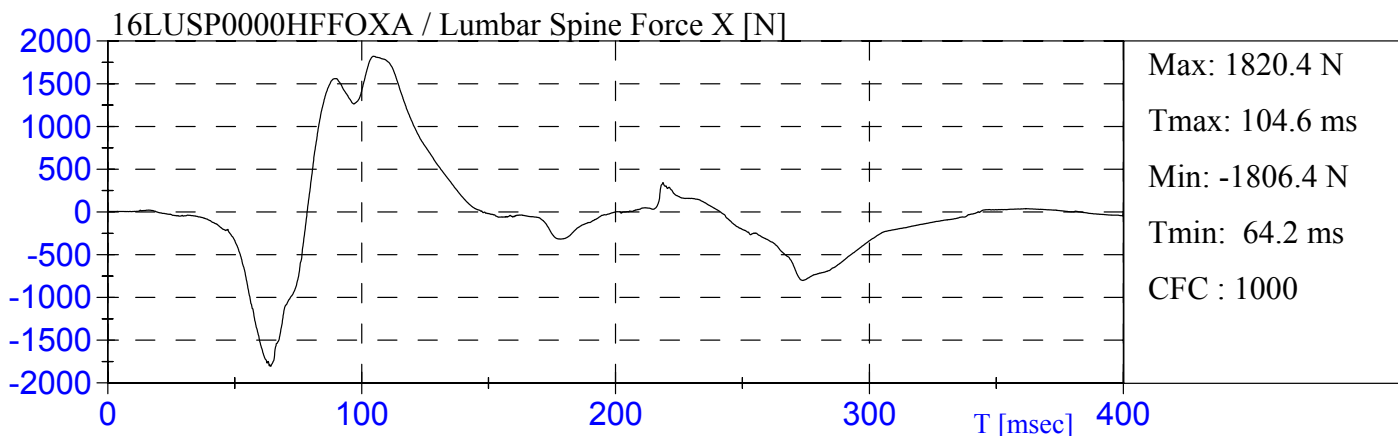

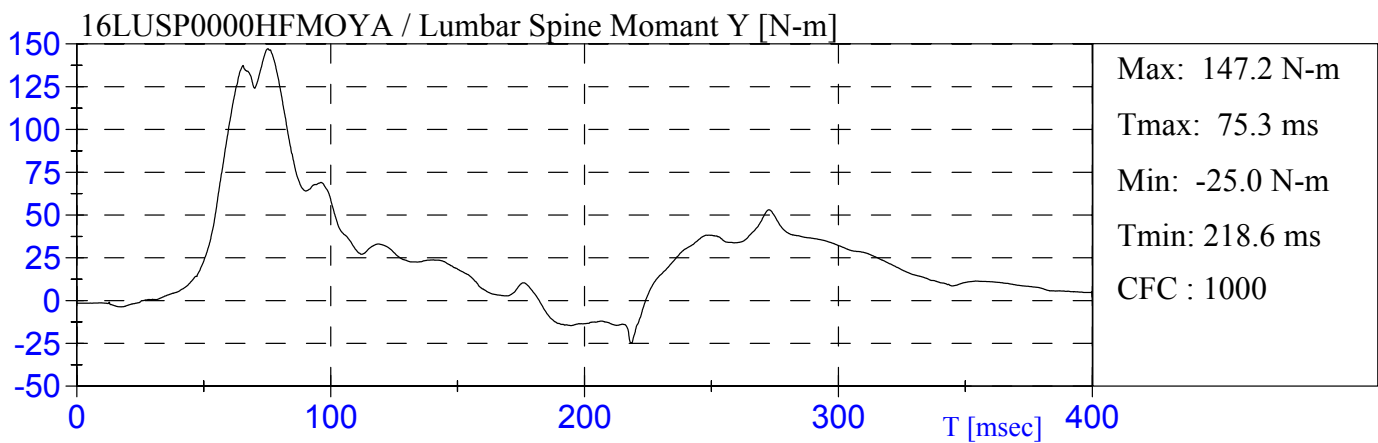
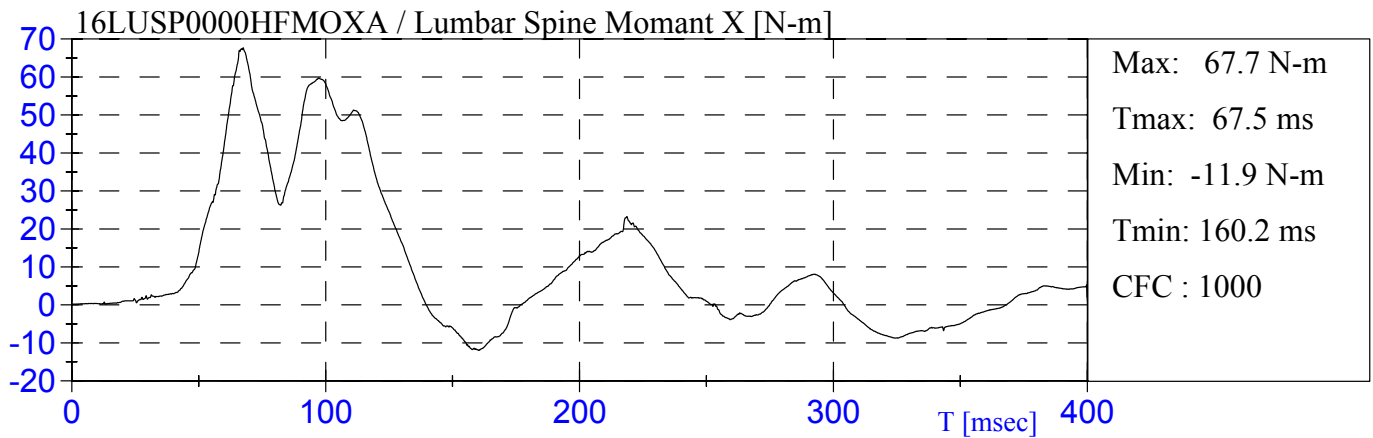

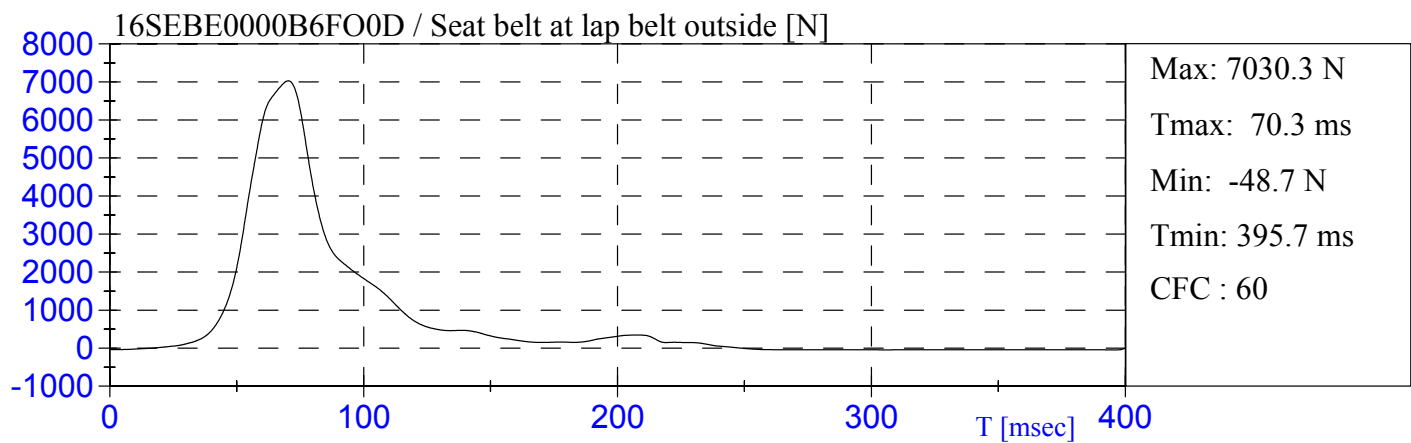
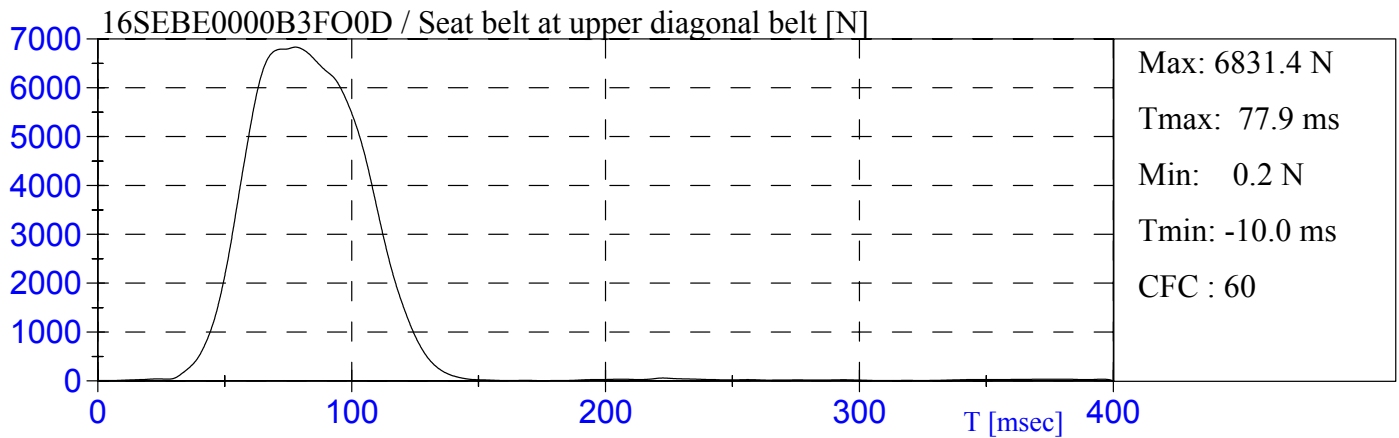

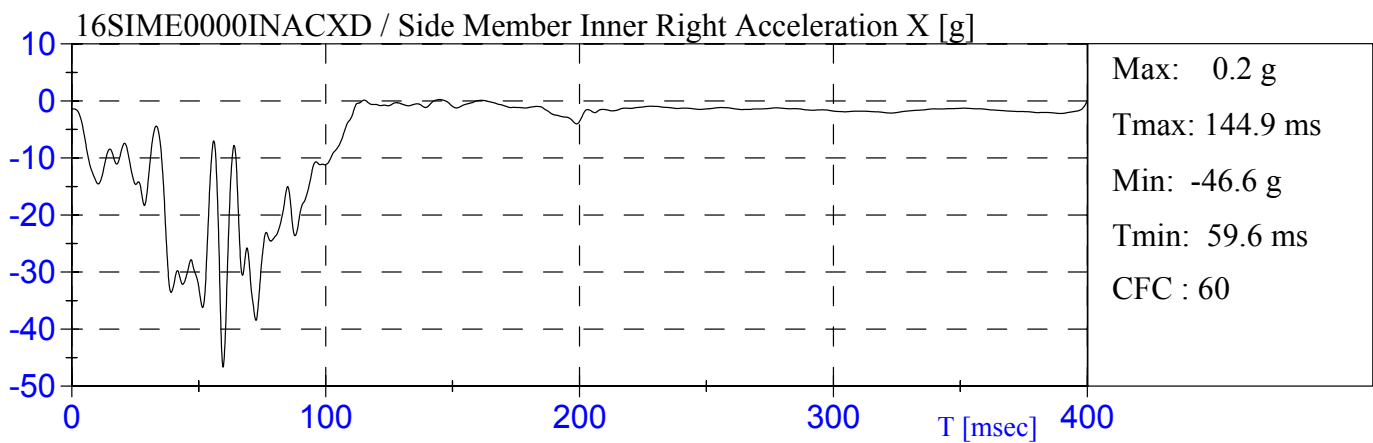
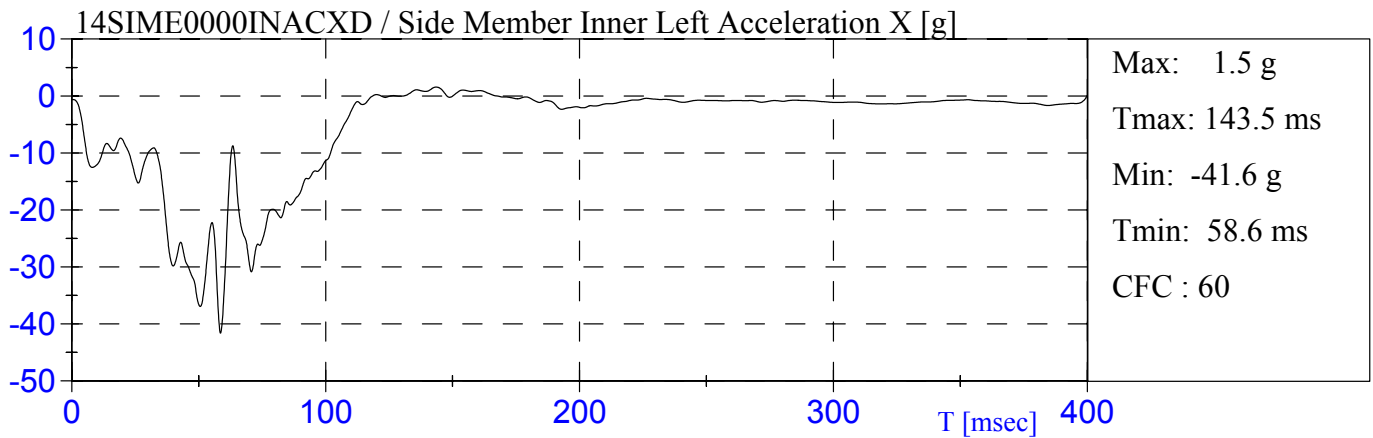

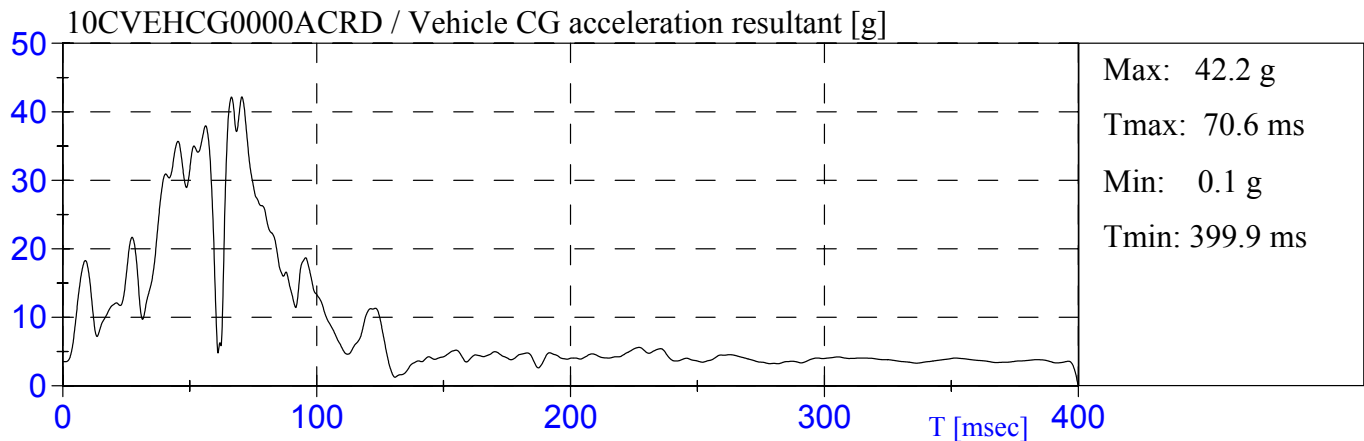
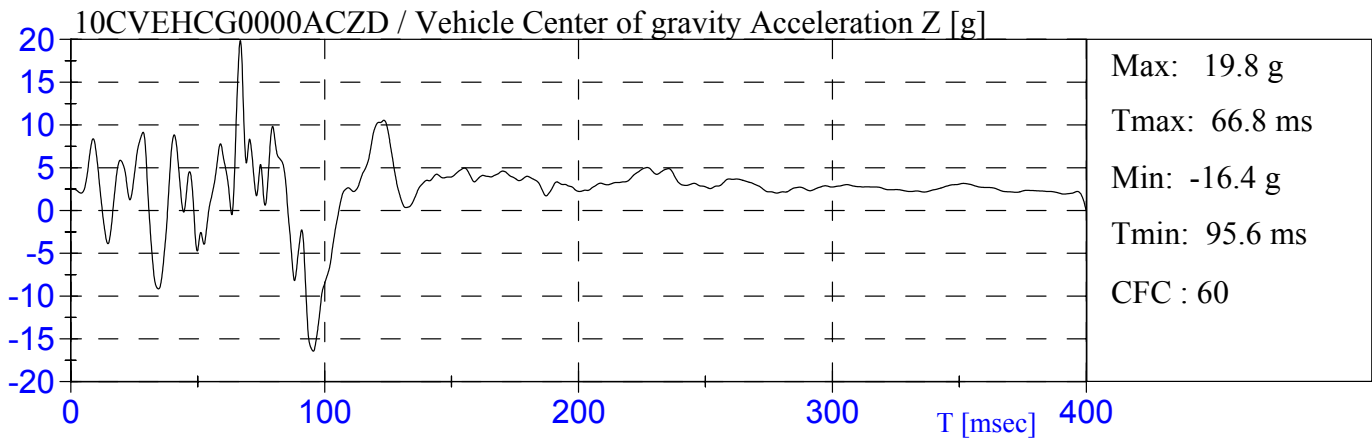
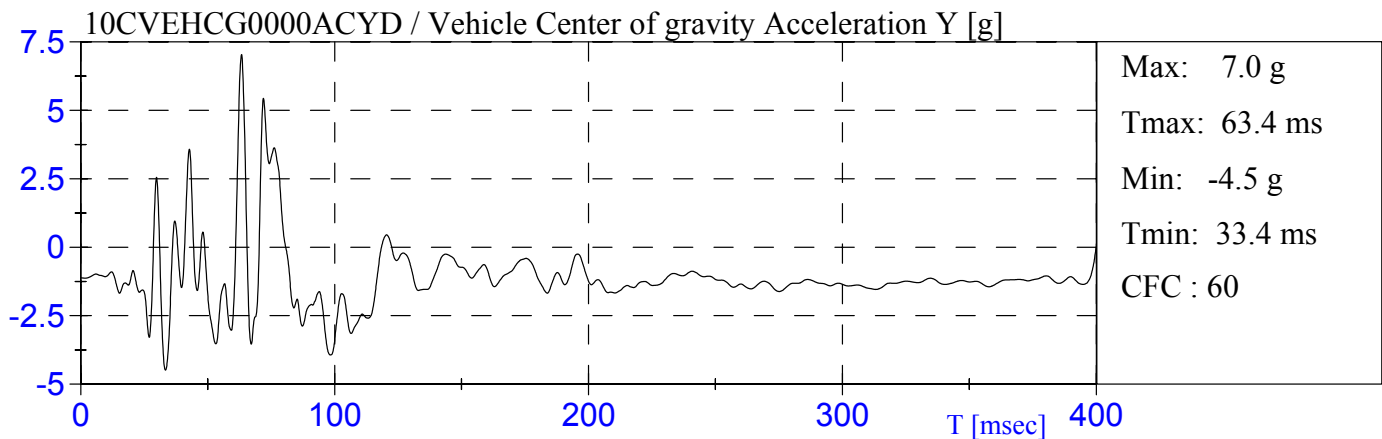
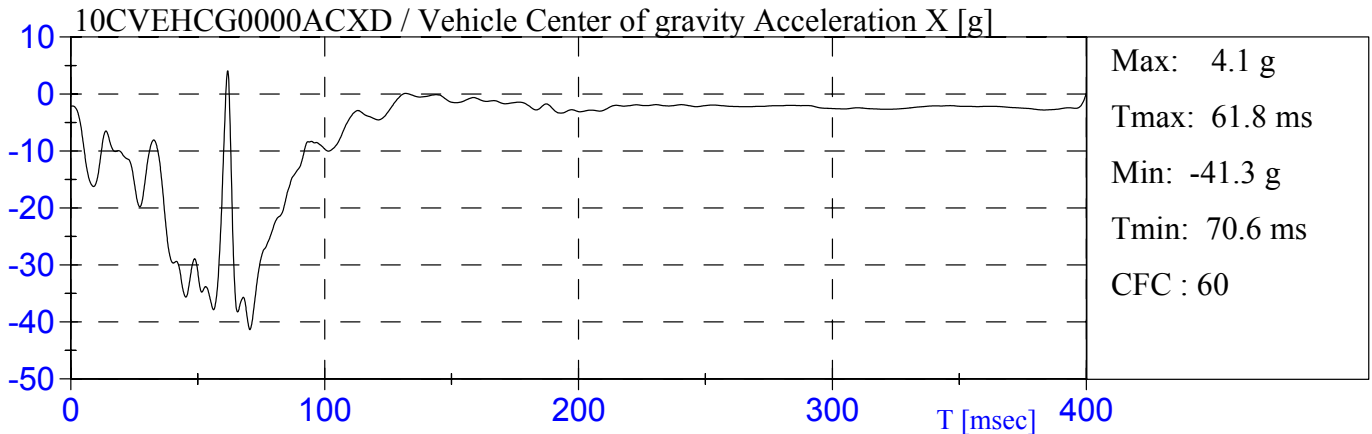

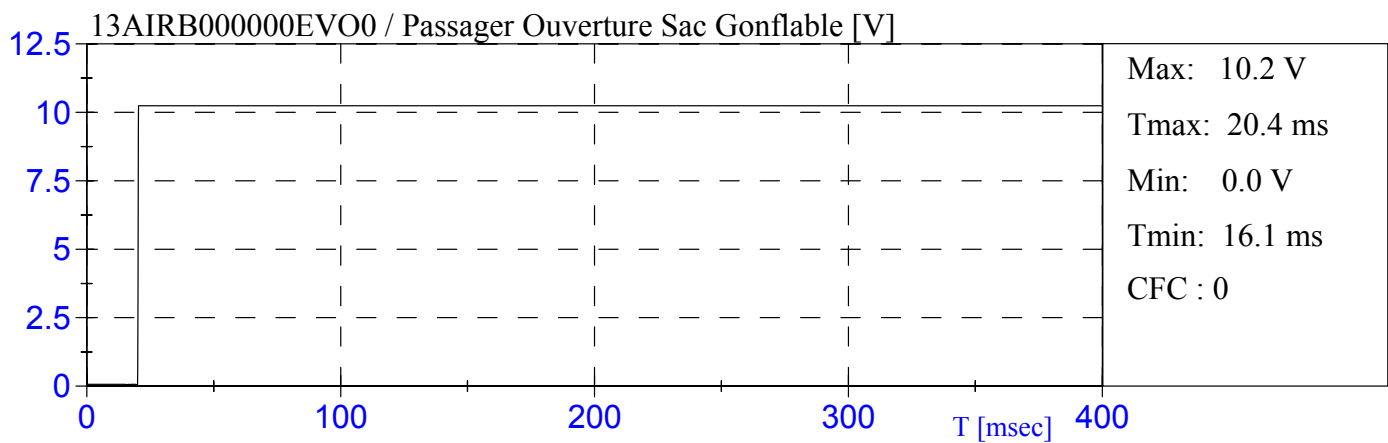
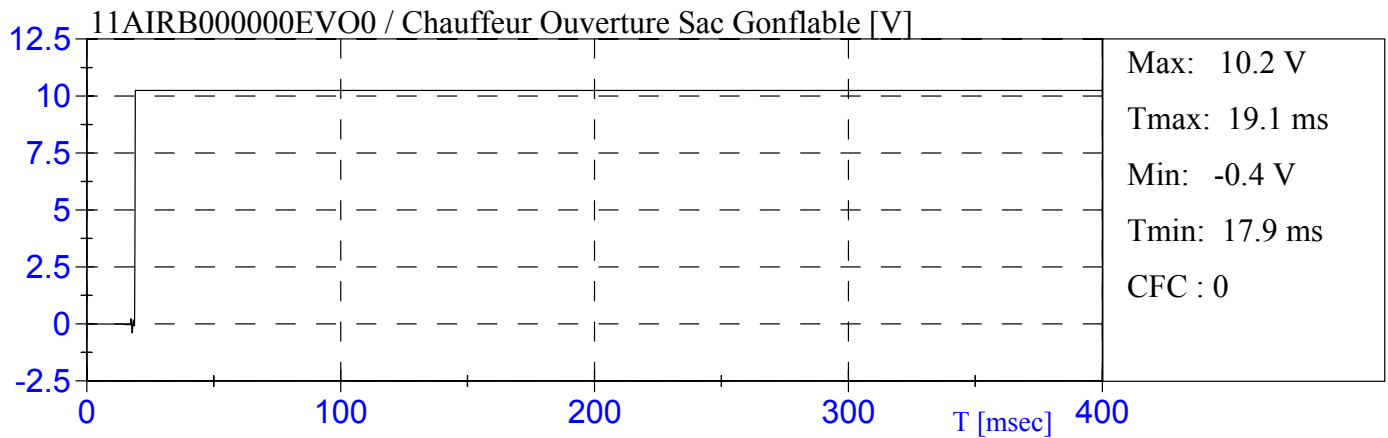

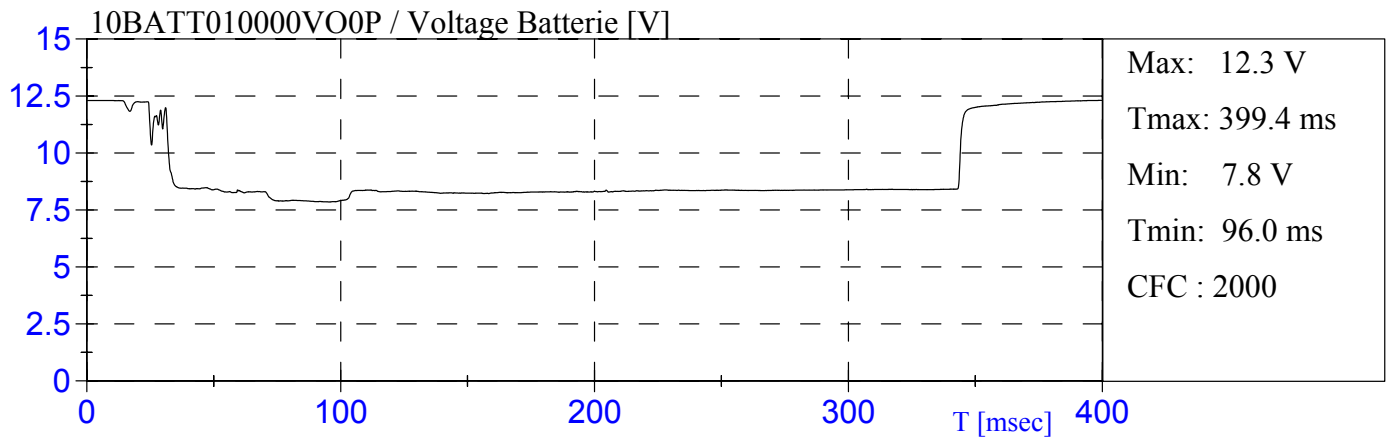

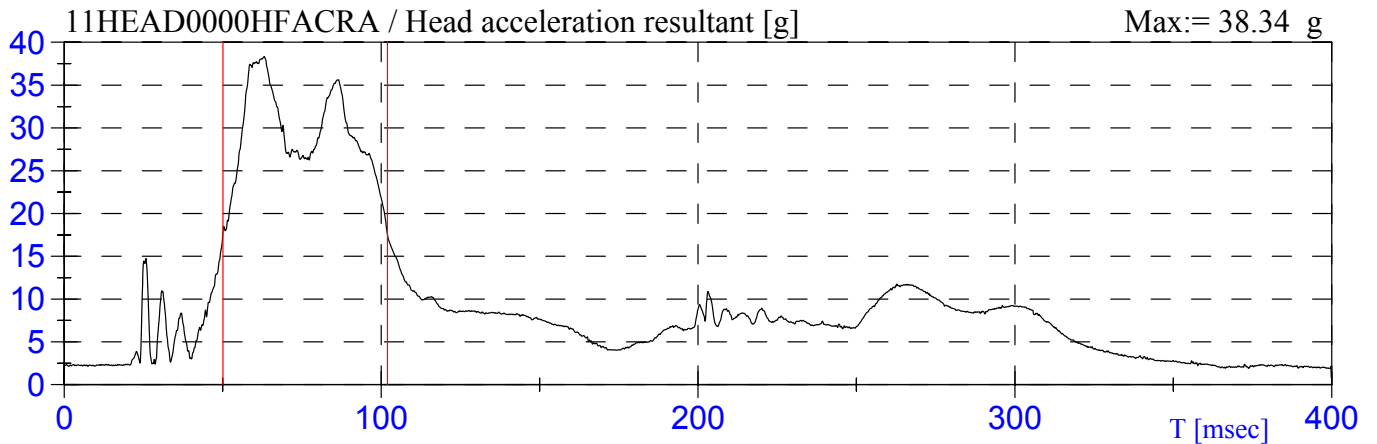

HEAD INJURY CRITERIA (HIC) *

CRITÈRE DE BLESSURE DE LA TÊTE

HIC:= 241	HIC(36ms):= 203	HIC(15ms):= 103
T1:= 50.1 ms	T1:= 55.8 ms	T1:= 55.2 ms
T2:= 102.0 ms	T2:= 91.8 ms	T2:= 70.2 ms

* Selon / According To: SAE J1727 96-08

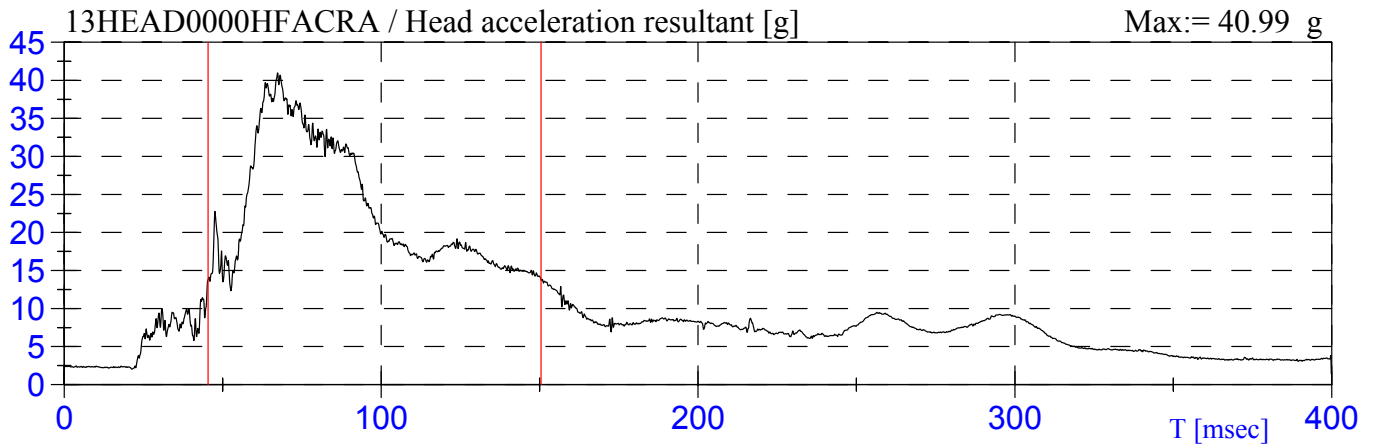

HEAD INJURY CRITERIA (HIC) *
CRITÈRE DE BLESSURE DE LA TÊTE

HIC:= 267	HIC(36ms):= 236	HIC(15ms):= 127
T1:= 45.4 ms	T1:= 58.2 ms	T1:= 61.4 ms
T2:= 150.5 ms	T2:= 94.2 ms	T2:= 76.4 ms

* Selon / According To: SAE J1727 96-08

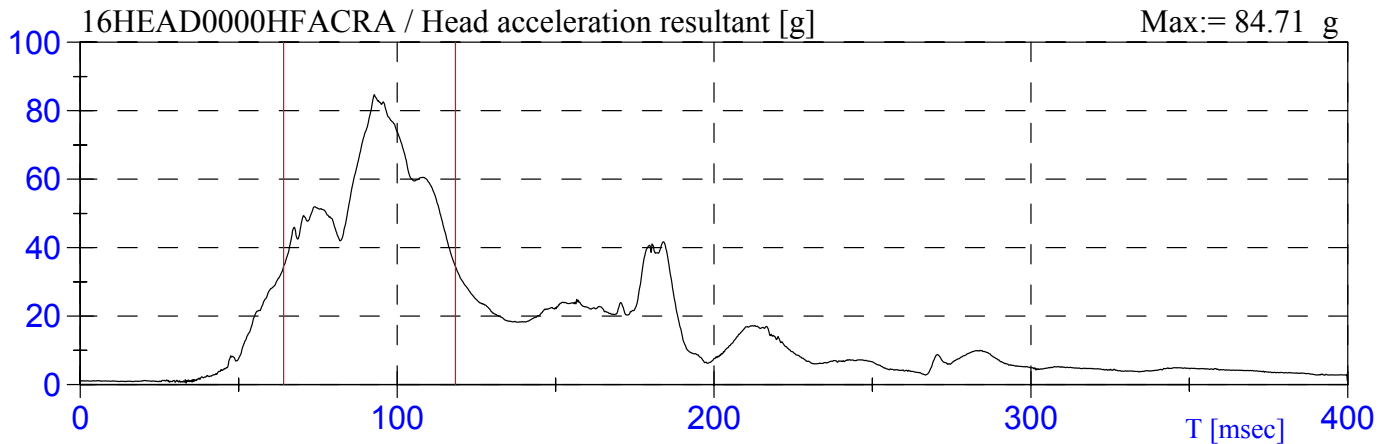

HEAD INJURY CRITERIA (HIC) *
CRITÈRE DE BLESSURE DE LA TÊTE

HIC:= 1363	HIC(36ms):= 1169	HIC(15ms):= 767
T1:= 64.2 ms	T1:= 77.5 ms	T1:= 87.8 ms
T2:= 118.4 ms	T2:= 113.5 ms	T2:= 102.8 ms

* Selon / According To: SAE J1727 96-08



Neck Injury Criteria: 11NIJCIP000000YX

$$N_{ij}^* = 0.33$$

Valeurs critiques
Criticals Values

N _{tf}	N _{te}	N _{cf}	N _{ce}	Tc	4287
				Cc	3880
0.32	0.33	0.20	0.14	Fc	155
				Ec	67

* Selon / According To: Federal Register 5/2000



Neck Injury Criteria: 13NIJCIP000000YX

$$N_{ij}^* = 0.37$$

Valeurs critiques
Criticals Values

N _{tf}	N _{te}	N _{cf}	N _{ce}	Tc	4287
				Cc	3880
0.26	0.37	0.28	0.08	Fc	155
				Ec	67

* Selon / According To: Federal Register 5/2000



Neck Injury Criteria: 16NIJCIP000000YX

$$N_{ij}^* = 1.02$$

Valeurs critiques
Criticals Values

N _{tf}	N _{te}	N _{cf}	N _{ce}	Tc	4287
				Cc	3880
0.92	0.66	0.07	1.02	Fc	155
				Ec	67

* Selon / According To: Federal Register 5/2000

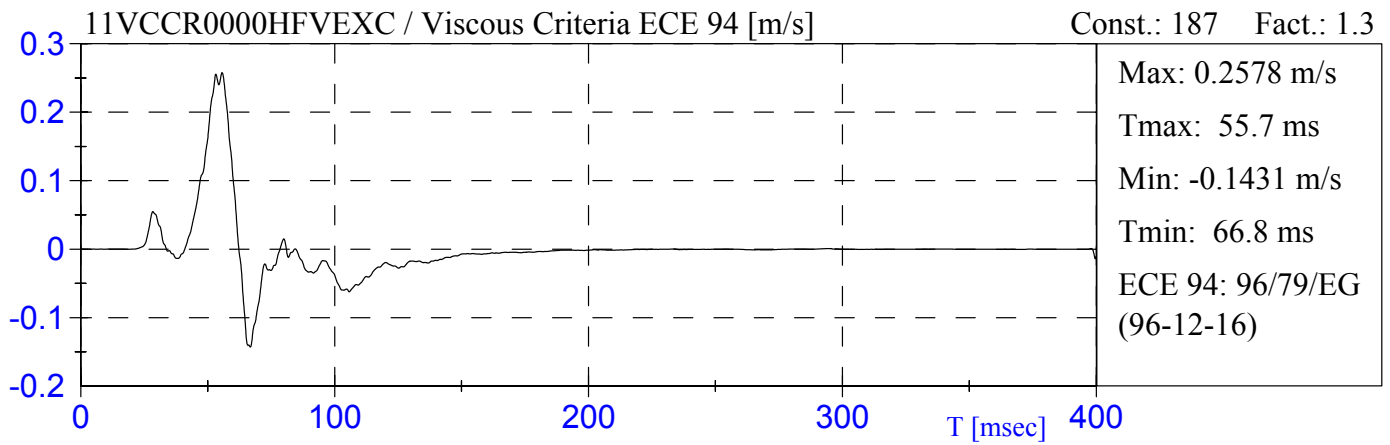
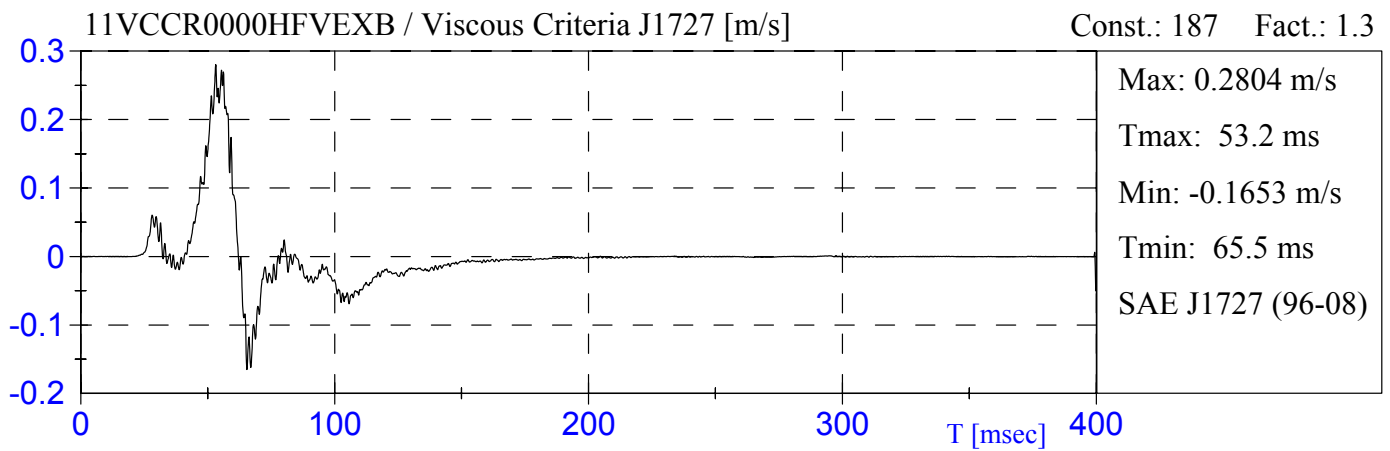
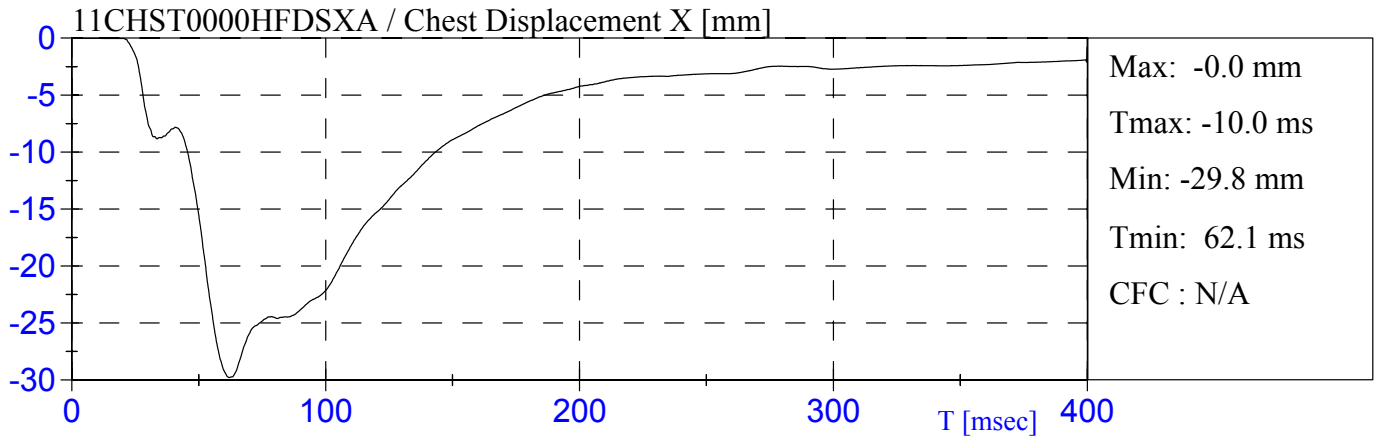

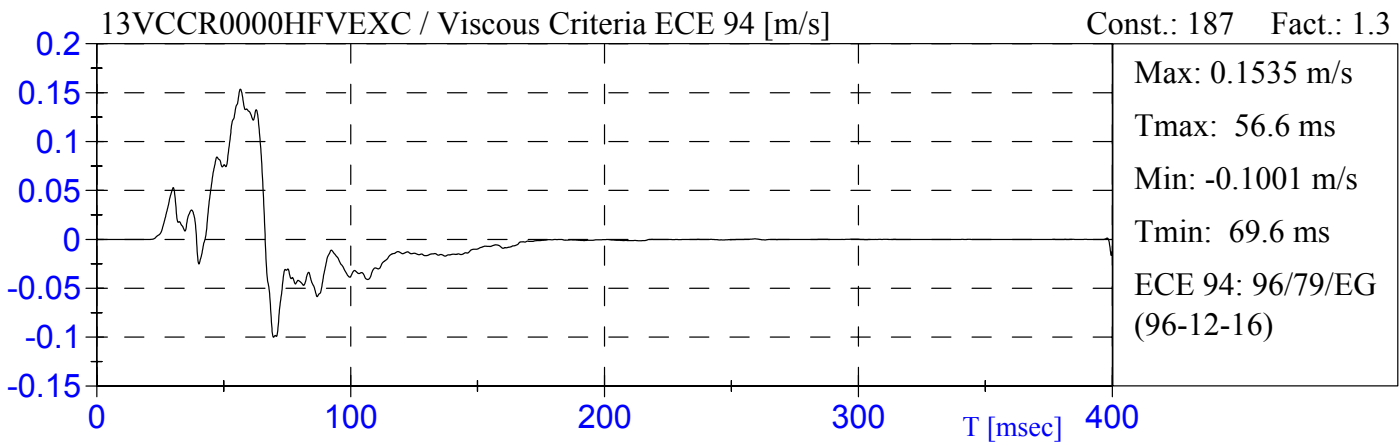
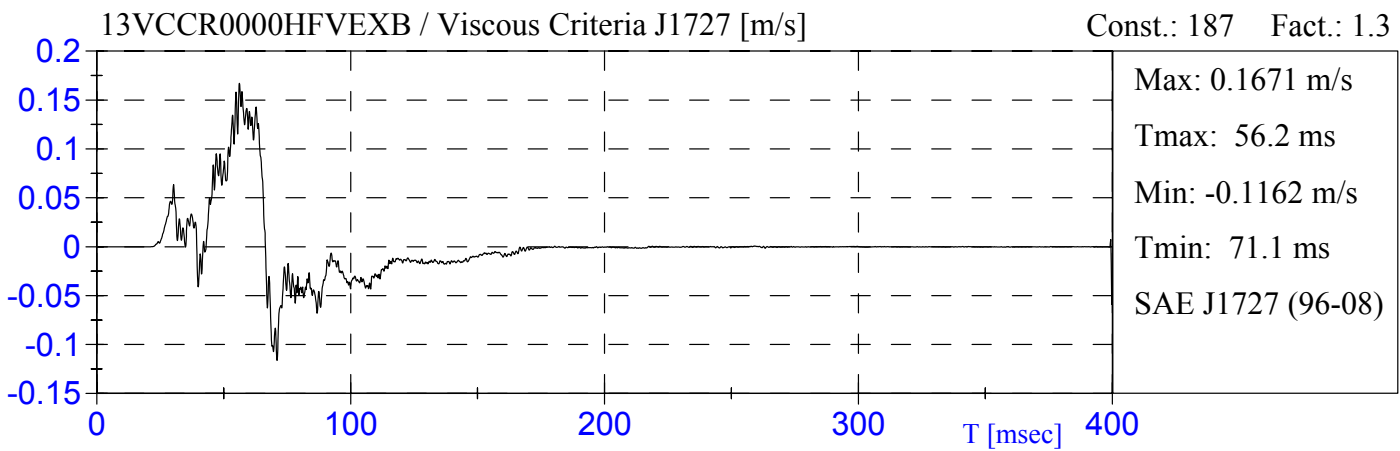
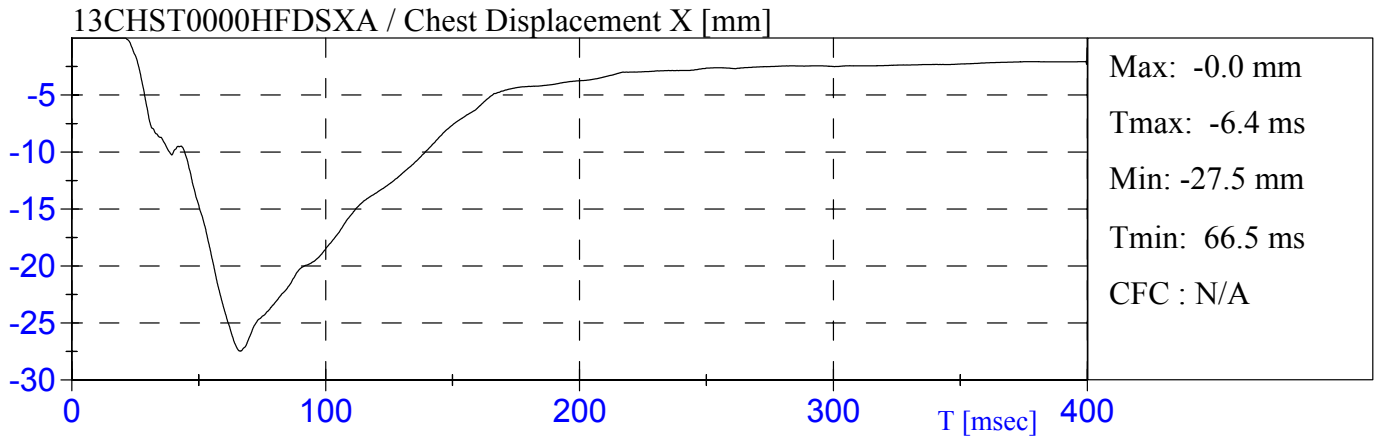

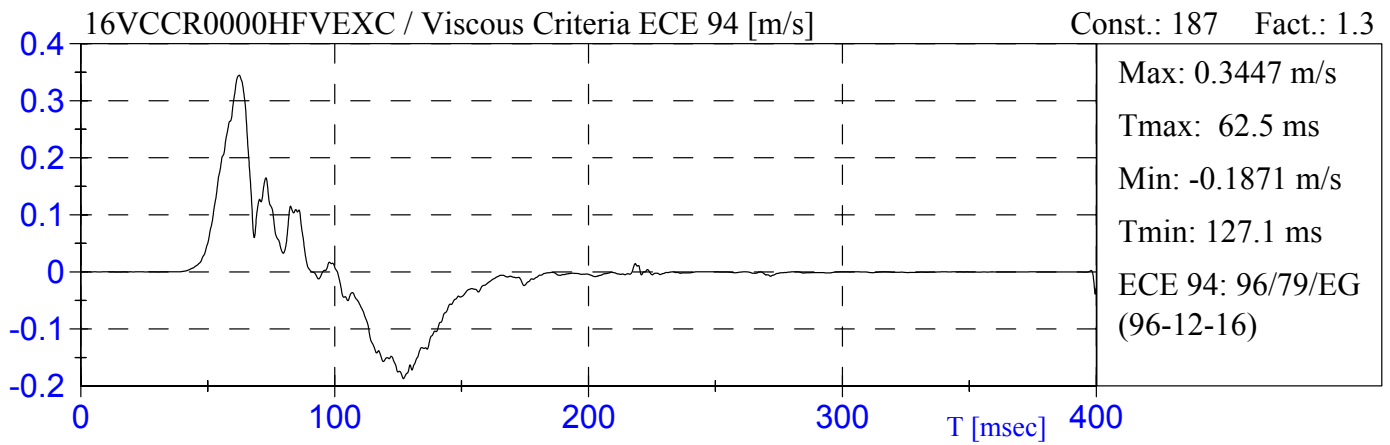
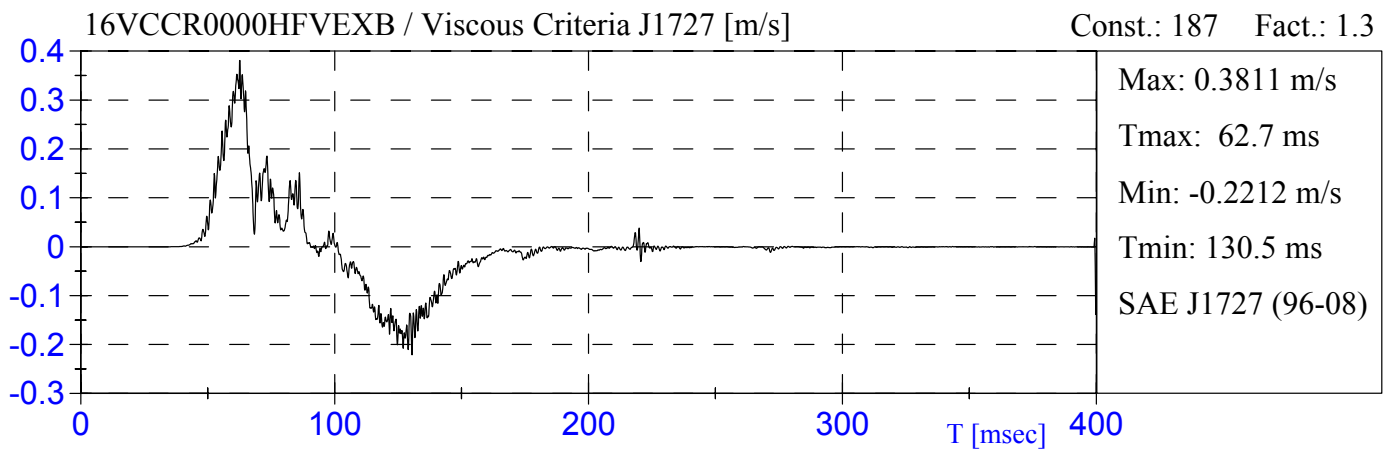
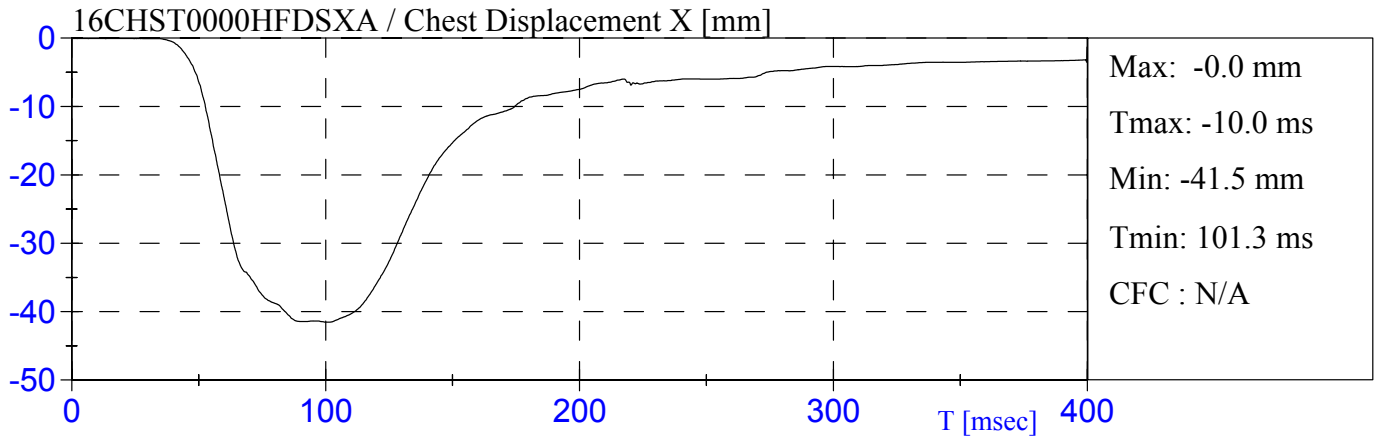

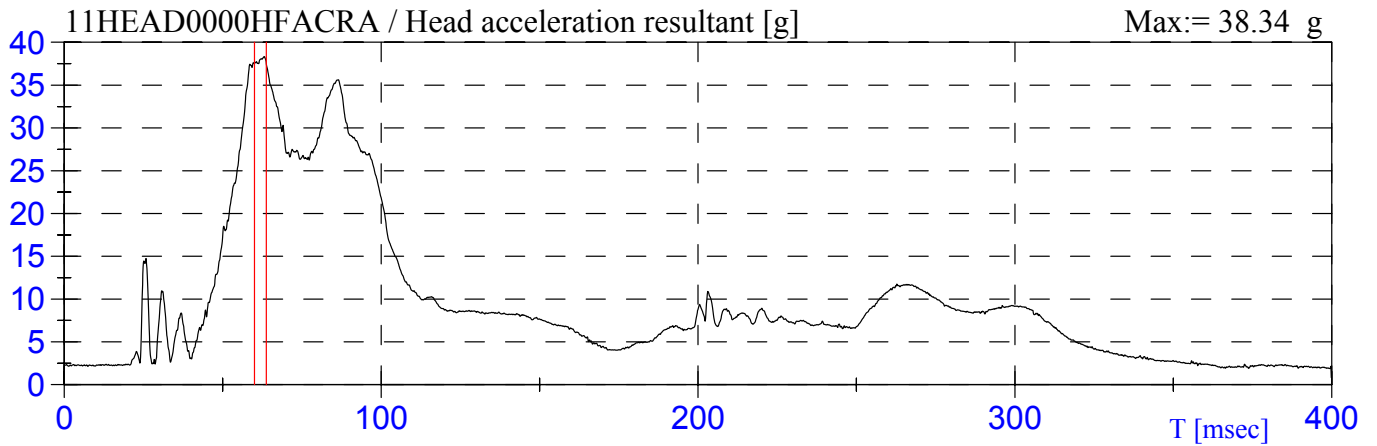

CLIP 3ms *

Acc. := 37.52 g	T1:= 60.0 ms	T2:= 63.8 ms
-----------------	--------------	--------------

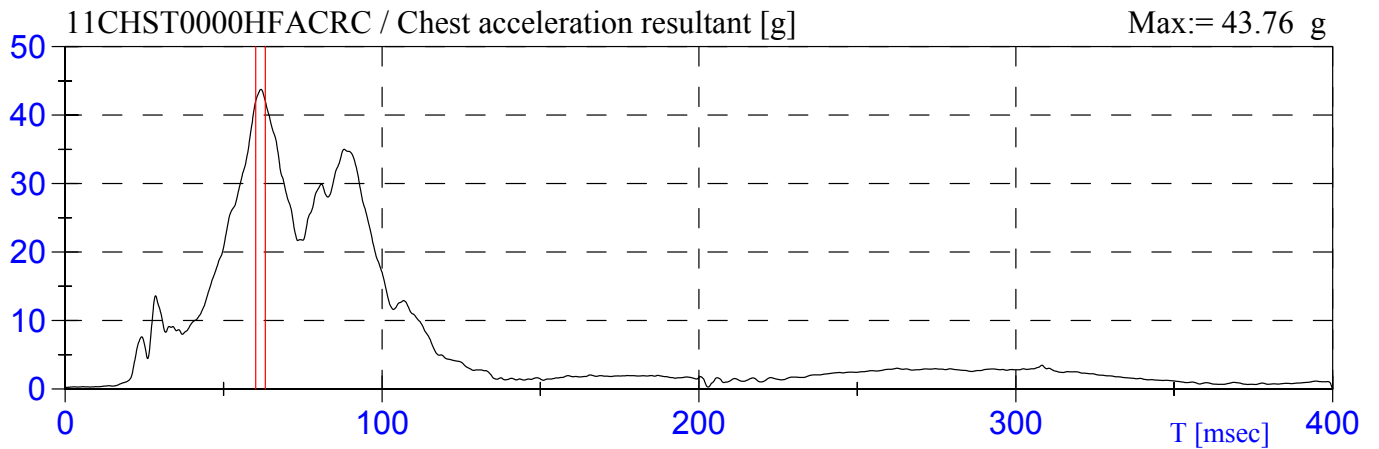

CLIP 3ms *

Acc. := 42.06 g	T1:= 60.2 ms	T2:= 63.2 ms
-----------------	--------------	--------------

* Selon / According To: NHTSA CLIP VERSION 2.1 5/95

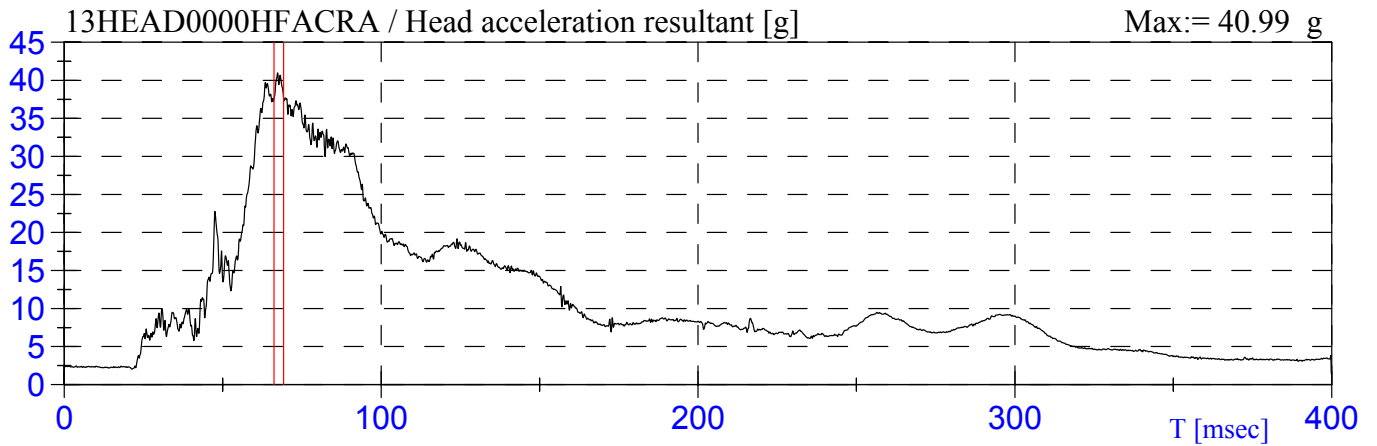

CLIP 3ms *

Acc. := 37.66 g	T1:= 66.2 ms	T2:= 69.2 ms
-----------------	--------------	--------------

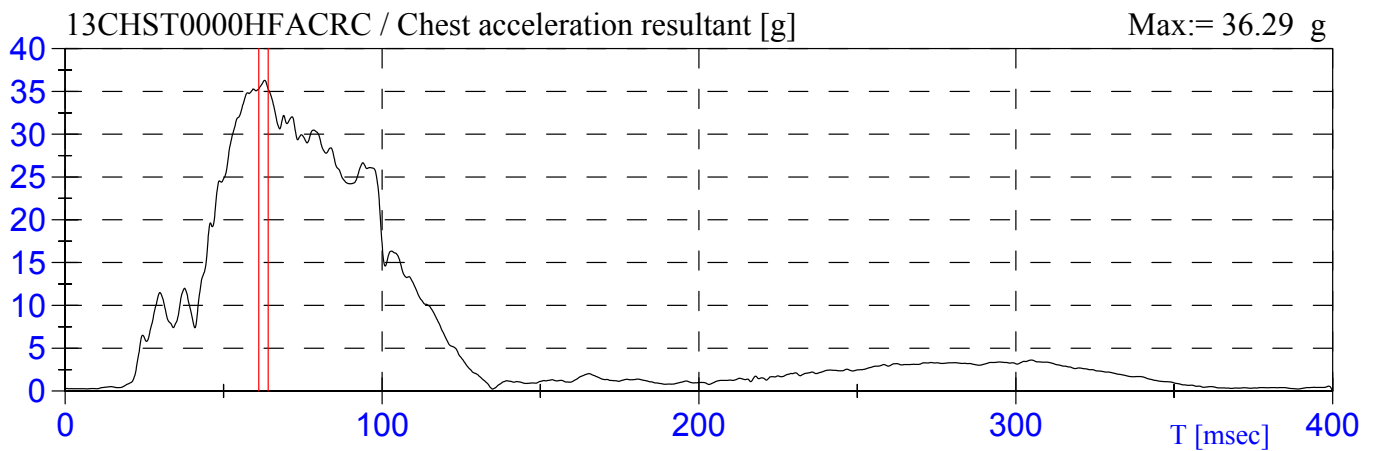

CLIP 3ms *

Acc. := 35.30 g	T1:= 61.1 ms	T2:= 64.1 ms
-----------------	--------------	--------------

* Selon / According To: NHTSA CLIP VERSION 2.1 5/95

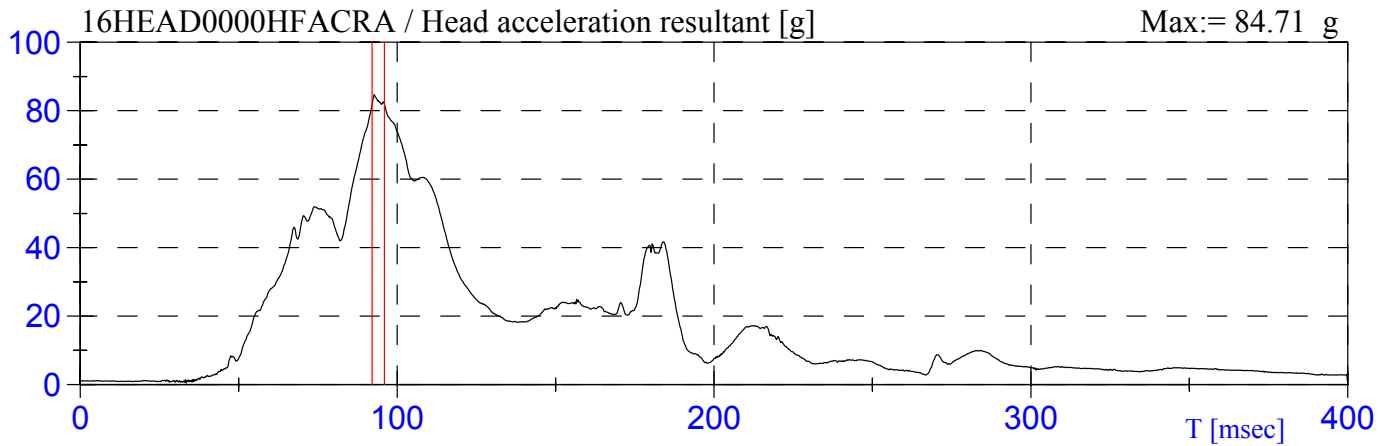

CLIP 3ms *

Acc. := 81.86 g	T1:= 92.1 ms	T2:= 96.0 ms
-----------------	--------------	--------------

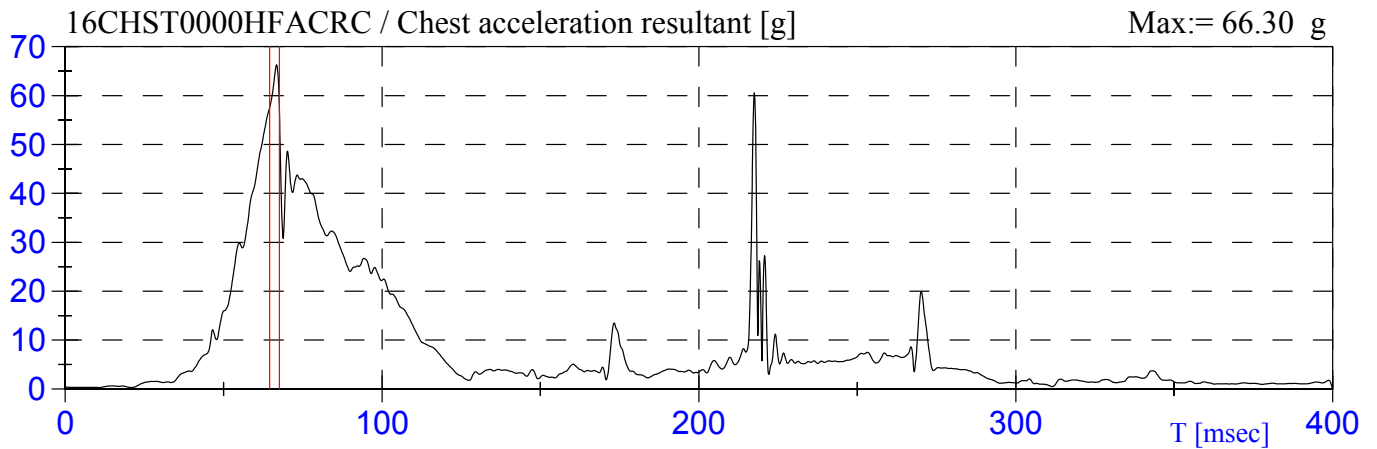

CLIP 3ms *

Acc. := 57.65 g	T1:= 64.6 ms	T2:= 67.6 ms
-----------------	--------------	--------------

* Selon / According To: NHTSA CLIP VERSION 2.1 5/95

APPENDICE /APPENDIX C

**DONNÉES DES TEMPÉRATURES
TEMPERATURE DATA**

Temperature TC05-226

