

**RAPPORT D'ESSAI - TEST REPORT  
COLLISION FRONTALE DE RECHERCHE  
RESEARCH FRONTAL IMPACT**

<b>VÉHICULE D'ESSAI / TEST VEHICLE FORD FREESTAR 2005 TC # 05-210</b>
---

**ESSAIS DE RECHERCHE CONJOINTS TC/NHTSA SUR LES  
SACS GONFLABLES FRONTAUX  
JOINT TC/NHTSA FRONTAL AIRBAGS RESEARCH TESTS**

Préparé par :  
PMG TECHNOLOGIES  
CENTRE D'ESSAIS ET DE RECHERCHE  
100, rue du Landais  
Blainville (Québec) J7C 5C9

N° de contrat : **05-6008**  
Rapport N°: **RR05-212**

Pour :  
TRANSPORTS CANADA  
SÉCURITÉ ET SÛRETÉ  
Programmes de sécurité routière  
Recherche et essais de véhicules  
Ottawa (Ontario)

Prepared by :  
PMG TECHNOLOGIES  
TEST AND RESEARCH CENTRE  
100, rue du Landais  
Blainville (Quebec) J7C 5C9

Contract N° : **05-6008**  
Report N° : **RR05-212**

For :  
TRANSPORT CANADA  
SAFETY AND SECURITY  
Research Engineering and  
Vehicle Testing  
Ottawa (Ontario)

Les résultats des essais figurant dans ce compte-rendu ne représentent pas une décision officielle du Ministère des Transports quant à l'acceptation de la performance sécuritaire, de la consommation de carburant ou de la conformité d'un véhicule ou des composantes d'un véhicule aux normes de sécurité et d'antipollution. Le Ministère des Transports ne certifie, n'approuve ou n'endosse aucun produit de véhicule automobile.

The test results presented herein do not, in themselves, represent an official determination by the Department of Transport with fuel consumption or compliance with safety and emission standards of any motor vehicle or motor vehicle component. The Department of Transport does not certify, approve or endorse any motor vehicle product.

Date de collision Crash date	<b>2005-02-28</b>	Véhicule Vehicle	<b>FORD FREESTAR 2005</b>	T.C. N° T.C.No	<b>05-210</b>
---------------------------------	-------------------	---------------------	---------------------------	-------------------	---------------

**VÉHICULE D'ESSAI - TEST VEHICLE**

Fabricant - Manufacturer <b>FORD MOTOR CO.</b>	Type de carrosserie - Body Style <b>Fourgonnette / Minivan</b>	Marque, modèle, Année - Make, model, Year <b>FORD FREESTAR 2005</b>
Classe de véhicule - Class of vehicle <b>VTUM / MPV</b>	Boîte de vitesse - Transmission Type <b>Auto. avant / Auto. Front wheel</b>	Moteur - Engine <b>V6 trans. avant / V6 trans. front</b>
Date de fabrication - Date of Manufacture <b>08/04</b>	Cylindres - Cylinders <b>4.2 Lit.</b>	N° d'ident. du véhicule - Vehicle Ident. No. <b>2FMZA50225BA08170</b>
Lecture de l'odomètre - Odometer Reading <b>19 km</b>	Nombre de places assises désignées Number of Designated Seating Positions <b>7</b>	Numéro d'ident. PMG - PMG Ident. Number <b>UN5-185</b>
PNBV - GVWR <b>2576 kg</b>	PNBE (Avant) - GAWR (Front) <b>1326 kg</b>	PNBE (Arrière) - GAWR (Rear) <b>1258 kg</b>

**CONFIGURATION D'ESSAI - TEST CONFIGURATION**

Type d'essai - Test type <b>Véh. vs barrière - Veh. vs barrier</b>	Vitesse d'impact- Impact velocity		Angle d'impact Impact angle <b>0 °</b>	Masse du véhicule d'essai Test vehicle mass <b>2259.2 kg</b>
	Prévu / Intended : <b>56.0 km/h</b>	Obtenu / Obtained : <b>56.0 km/h</b>		
Description et position du mannequin (conducteur) Dummy description and position (driver) Description <b>Hybrid III (5 %)</b>	Position ** <b>- mm</b>	Description et position du mannequin (passager avant) Dummy description and position (front passenger) Description <b>Hybrid III (5 %)</b>	Position ** <b>- mm</b>	
Description et position du mannequin (passager arrière gauche) Dummy description and position (left rear passenger) Description <b>Hybrid III (6 ans / 6 years old)</b>	Position ** <b>N/A</b>	Description et position du mannequin (passager arrière droit) Dummy description and position (right rear passenger) Description <b>Hybrid III (6 ans / 6 years old)</b>	Position ** <b>N/A</b>	
Description et position du mannequin (passager arrière centre, 3 <sup>e</sup> rangée) Dummy description and position (centre rear passenger, 3 <sup>rd</sup> row) Description <b>Hybrid III (3 ans / 3 years old)</b>	Position ** <b>N/A</b>	Description et position du mannequin (passager arrière droit, 3 <sup>e</sup> rangée) Dummy description and position (right rear passenger, 3 <sup>rd</sup> row) Description <b>N/A</b>	Position ** <b>N/A</b>	

**RÉSULTATS GÉNÉRAUX - GENERAL RESULTS**

Déploiement des sacs gonflables - Airbags deployment Coussins frontaux - Frontal airbags		Déploiement des sacs gonflables - Airbags deployment Coussins latéraux - Lateral airbags	
Conducteur / Driver	Passager / Passenger	Conducteur / Driver	Passager / Passenger
<b>Déployé / Deployed</b> <b>21.2ms</b>	<b>Déployé / Deployed</b> <b>19.1ms</b>	<b>N/A</b>	<b>0.0</b>
Rétracteurs de ceintures-prétensionneurs Seat belts retractors-pretensioners		Limiteur de charge des ceintures de sécurité Seat belts load limiter	
Conducteur / Driver	Passager / Passenger	Conducteur / Driver	Passager / Passenger
<b>Non-équipé / Not equipped</b>	<b>Non-équipé / Not equipped</b>	<b>Non-équipé / Not equipped</b>	<b>Non-équipé / Not equipped</b>

**Essai réalisé selon la procédure de PMG : Collision frontale de recherche, version 3, révision 10 avril 2000.  
Test performed according to PMG procedure: Research frontal impact, version 3, revised april 10, 2000.**

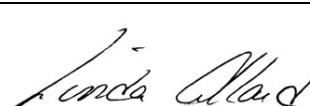
Préparé par : Prepared by : 	Digitally signed by Pierre Beauchamp Date: 2005.09.14	Approuvé par : Approved by :
Vérifié par : Verified by : 	Digitally signed by Linda Allard Date: 2005.09.14	Accepté par : Accepted by :

\* Tel qu'observé avec l'application d'une charge de 12V après l'essai.  
\* As observed by a 12V application after the test.

Date de collision Crash date	<b>2005-02-28</b>	Véhicule Vehicle	<b>FORD FREESTAR 2005</b>	T.C. N° T.C.No	<b>05-210</b>
---------------------------------	-------------------	---------------------	---------------------------	-------------------	---------------

**\*\* Référence : 0 est la position la plus avancée. / \*\* Reference : 0 is the foremost position.**

**DONNÉES DU VÉHICULE D'ESSAI / TEST VEHICLE DATA**

/3

Capacité du véhicule - Vehicle Capacity <b>544 kg</b>	Masse des bagages - Cargo Load <b>54 kg</b>	Type de sièges - Type of seats		Types de dossiers - Type of seat back			
			Avt - Frt	Arr - Rr		Avt - Frt	Arr - Rr
Nombre d'occupants (places assises désignées) Number of Occupants (Designated Seating Positions)		Banquette Bench		<b>X</b>	Dossier ajustable Adjustable Seat Back	<b>X</b>	
Avant - Front <b>2</b> Arrière - Rear <b>2+3</b> Total <b>7</b>		Baquet Bucket	<b>X</b>		Dossier non-ajustable Non-adjustable Seat Back		<b>X</b>
Volume de carburant pour l'essai Fuel system test volume <b>89.50 l</b>	Pression à froid - Cold Tire Pressure			Dimension - Size <b>P225/60R16</b>			
	Avant - Front <b>240 kPa</b>	Arrière - Rear <b>240 kPa</b>	Secours - Spare <b>415 kPa</b>				

**PREMIÈRE PESÉE : VÉHICULE TEL QUE LIVRÉ (AVEC LIQUIDES AU MAXIMUM)**

**FIRST WEIGHT : VEHICLE AS RECEIVED (WITH MAXIMUM FLUIDS)**

Avant gauche - Left front <b>595.0 kg</b>	Avant droit - Right front <b>564.2 kg</b>	Masse avant totale - Total front weight <b>1159.2 kg</b>
Arrière gauche - Left rear <b>376.7 kg</b>	Arrière droit - Right rear <b>400.0 kg</b>	Masse arrière totale - Total rear weight <b>776.7 kg</b>
Masse totale côté gauche - Total left side weight <b>971.7 kg</b>	Masse totale côté droit - Total right side weight <b>964.2 kg</b>	Masse totale - Total weight <b>1935.9 kg</b>

**TROISIÈME PESÉE : VÉHICULE PRÊT POUR L'ESSAI**

**THIRD WEIGHT : VEHICLE READY FOR TEST**

Avant gauche - Left front <b>619.3 kg</b>	Avant droit - Right front <b>605.0 kg</b>	Masse avant totale - Total front weight <b>1224.3 kg</b>
Arrière gauche - Left rear <b>502.5 kg</b>	Arrière droit - Right rear <b>532.4 kg</b>	Masse arrière totale - Total rear weight <b>1034.9 kg</b>
Masse totale côté gauche - Total left side weight <b>1121.8 kg</b>	Masse totale côté droit - Total right side weight <b>1137.4 kg</b>	Masse totale - Total weight <b>2259.2 kg</b>

**ATTITUDE DU VÉHICULE / VEHICLE ATTITUDE**

		Attitude tel que livré Attitude on delivery	Attitude tel que testé Attitude as tested
<b>1</b>	Roue avant gauche* Left front wheel*	<b>740 mm</b>	<b>740 mm</b>
<b>2</b>	Roue avant droite* Front right wheel*	<b>740 mm</b>	<b>733 mm</b>
<b>3</b>	Roue arrière droite* Rear right wheel*	<b>765 mm</b>	<b>714 mm</b>
<b>4</b>	Roue arrière gauche* Rear left wheel*	<b>765 mm</b>	<b>720 mm</b>

\* Mesures prises aux puits de roues. // \*Measurements taken at wheel openings.

**Vue de plan / Plan view**

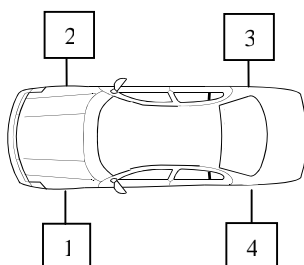

**Vue de côté / Side view**

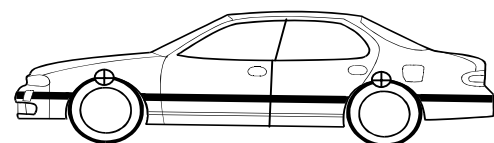

⊕ Points de mesure / Measurement points

Date de collision Crash date	<b>2005-02-28</b>	Véhicule Vehicle	<b>FORD FREESTAR 2005</b>	T.C. N° T.C.No	<b>05-210</b>
---------------------------------	-------------------	---------------------	---------------------------	-------------------	---------------

**EMPLACEMENT DES ACCÉLÉROMÈTRES  
ACCELEROMETER LOCATIONS**

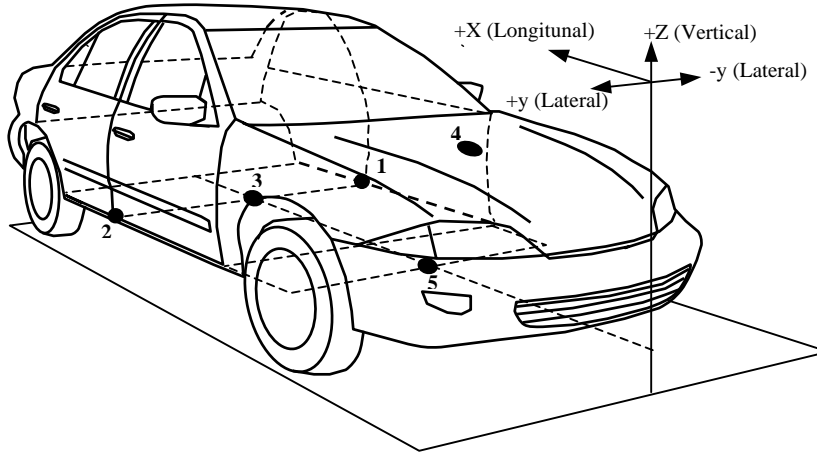

**Point de référence :** Centre transversal du véhicule, au point le plus avancé, au niveau du sol. Selon SAE J182a.  
**Reference point :** Transversal center of the vehicle, at the foremost point and at ground level. As per SAE J182a.

EMPLACEMENT LOCATION	DESCRIPTIONS	COORDONNÉES / COORDINATES (mm)		
		X	Y	Z
#1	Seuil de la porte gauche @ pilier "B" Left door sill @ pillar "B"	2534	-538	392
#2	Seuil de la porte droite @ pilier "B" Right door sill @ pillar "B"	2572	525	390
#3	Centre de gravité Centre of gravity	2522	49	380
#4	Le dessus du moteur Top of engine	-	-	-
#5	Le dessous du moteur Bottom of engine	-	-	-

Date de collision Crash date	<b>2005-02-28</b>	Véhicule Vehicle	<b>FORD FREESTAR 2005</b>	T.C. N° T.C.No	<b>05-210</b>
---------------------------------	-------------------	---------------------	---------------------------	-------------------	---------------

MESURES NHTSA / NHTSA MEASUREMENTS

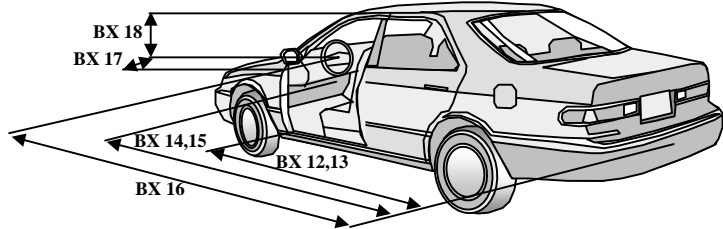
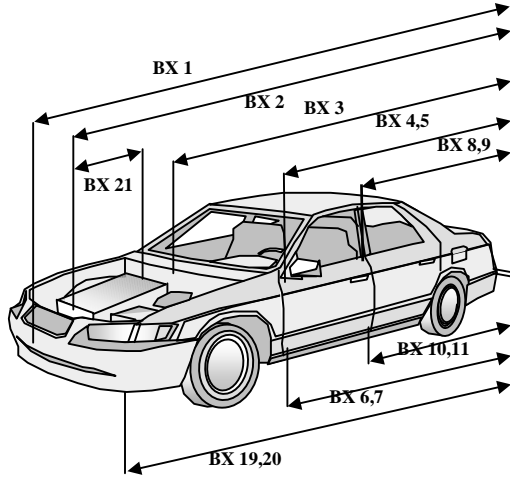

- 1 - Longueur totale du véhicule  
Total length of vehicle
- 2 - Surface arrière à l'avant du bloc moteur  
Rear surface at front of engine block
- 3 - Surface arrière à la cloison pare-feu  
Rear surface at fire-wall
- 4 - Surface arrière à la partie supérieure avant porte avant droite  
Rear surface of front superior part of right front door
- 5 - Surface arrière à la partie supérieure avant porte avant gauche  
Rear surface of front superior part of left front door
- 6 - Surface arrière à la partie inférieure avant porte avant droite  
Rear surface of front inferior part of right front door
- 7 - Surface arrière à la partie inférieure avant porte avant gauche  
Rear surface of front inferior part of left front door
- 8 - Surface arrière à la partie supérieure arrière porte avant droite  
Rear surface of rear superior part of right rear door
- 9 - Surface arrière à la partie supérieure arrière porte avant gauche  
Rear surface of rear superior part of left rear door
- 10 - Surface arrière à la partie inférieure arrière porte avant droite  
Rear surface of rear inferior part of right rear door
- 11 - Surface arrière à la partie inférieure arrière porte avant gauche  
Rear surface of rear inferior part of left rear door
- 12 - Surface arrière à la partie inférieure du pilier "A" droit  
Rear surface of rear inferior part of right pillar "A"
- 13 - Surface arrière à la partie inférieure du pilier "A" gauche  
Rear surface of rear inferior part of left pillar "A"
- 14 - Surface arrière à la cloison pare-feu côté droit  
Rear surface of right side of fire-wall
- 15 - Surface arrière à la cloison pare-feu côté gauche  
Rear surface of left side of fire-wall
- 16 - Surface arrière à la colonne de direction  
Rear surface of steering column
- 17 - Centre de la colonne de direction au pilier "A"  
Centre of steering column to pillar "A"
- 18 - Centre de la colonne de direction au toit  
Centre of steering column to roof
- 19 - Surface arrière du véhicule au coin droit du pare-choc avant  
Rear surface of vehicle to right corner of front bumper
- 20 - Surface arrière du véhicule au coin gauche du pare-choc avant  
Rear surface of vehicle to left corner of front bumper
- 21 - Longueur du bloc moteur  
Length of engine block

	BX*	AX**	ΔX		BX*	AX**	ΔX
1	5105	4591	514	12	3612	3594	18
2	4493	4203	290	13	3622	3612	10
3	4181	4162	19	14	3720	3653	67
4	3655	3641	14	15	3839	3803	36
5	3660	3651	9	16	3141	3160	-19
6	3567	3570	-3	17	421	401	20
7	3566	3570	-4	18	510	530	-20
8	2494	2481	13	19	5040	4522	518
9	2490	2482	8	20	5050	4567	483
10	2535	2539	-4	21	313	290	23
11	2536	2541	-5				

Mesures en mm / Measurements in mm

\* BX : Mesures du véhicule avant-essai. / Pre-test vehicle measurements data.

\*\* AX : Mesures du véhicule après-essai. / Post-test vehicle measurements data.

REMARQUES / COMMENTS : Aucune / None.

Date de collision Crash date	<b>2005-02-28</b>	Véhicule Vehicle	<b>FORD FREESTAR 2005</b>	T.C. N° T.C.No	<b>05-210</b>
---------------------------------	-------------------	---------------------	---------------------------	-------------------	---------------

MESURES DES DPD / DPD'S MEASUREMENTS

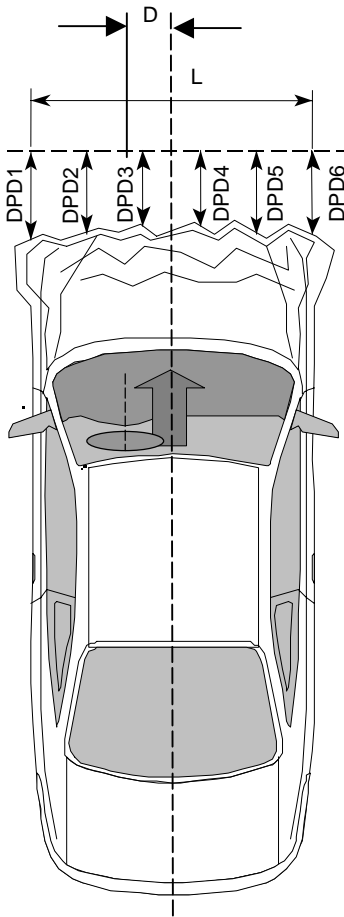

- DPD 1:
- DPD 2:
- DPD 3:
- DPD 4:
- DPD 5:
- DPD 6:
- MESURE L:
- MEASUREMENT L:
- MESURE D:
- MEASUREMENT D:

AVANT ESSAI PRE-TEST	APRÈS ESSAI POST-TEST	$\Delta x$
208	545	-337
42	546	-504
9	508	-499
8	513	-505
42	554	-512
213	553	-340
	1600	
	0	

Mesures en mm / Measurements in mm

L : Longueur de la région endommagée  
Length of damaged region

D : Distance du centre de déformation à la ligne de centre du véhicule  
Midpoint of damage to Vehicle Longitudinal Centerline

REMARQUES / COMMENTS : Aucune / None.

Date de collision Crash date	<b>2005-02-28</b>	Véhicule Vehicle	<b>FORD FREESTAR 2005</b>	T.C. N° T.C.No	<b>05-210</b>
---------------------------------	-------------------	---------------------	---------------------------	-------------------	---------------

MESURES DE VÉHICULE  
VEHICLE MEASUREMENTS

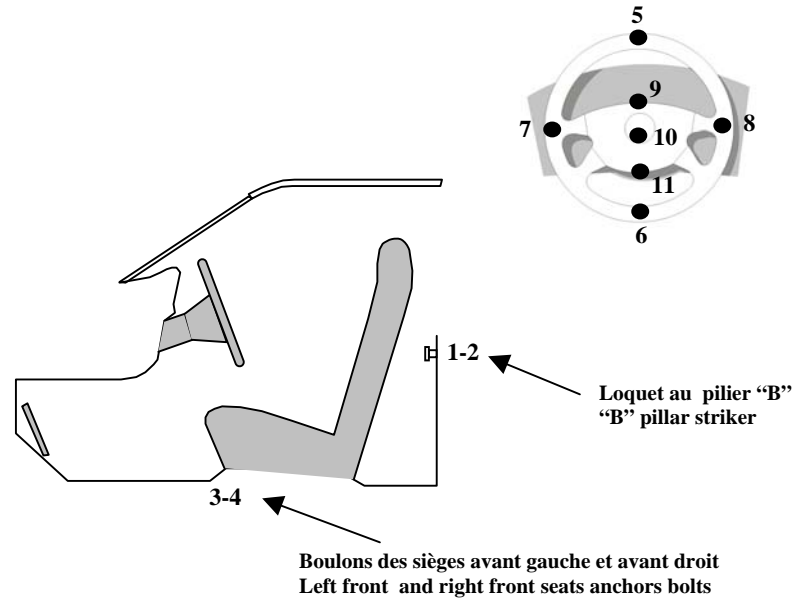
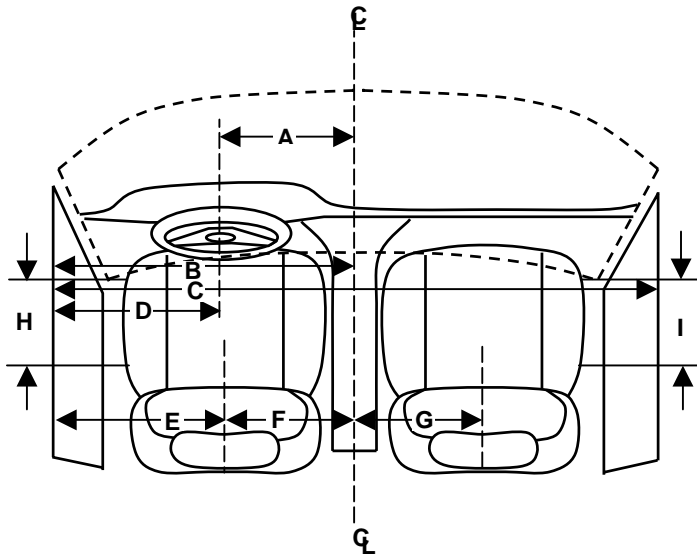

Code	Description	mm
A	Centre du volant à la ligne de centre du véhicule Steering wheel center to center line of vehicle	<b>411</b>
B	Seuil de fenêtre à la ligne de centre du véhicule Window edge to center line of the vehicle	<b>902</b>
C	Fenêtre à fenêtre Window to window	<b>1800</b>
D	Centre du volant au seuil de la fenêtre Steering wheel center to window edge	<b>491</b>
E	Seuil de la fenêtre au centre du siège (conducteur) Window edge to seat midline (driver)	<b>488</b>
F	Centre du siège à la ligne de centre du véhicule (conducteur) Seat midline to center line of vehicle (driver)	<b>414</b>
G	Centre du siège à la ligne de centre du véhicule (passager) Seat midline to center line of vehicle (passenger)	<b>422</b>
H	Course du siège (conducteur) Seat travel (driver)	<b>180</b>
I	Course du siège (passager) Seat travel (passenger)	<b>162</b>
J	Ajustement du volant Steering wheel adjustment	<b>44</b>
K	Ajustement de la ceinture baudrier Upper torso belt adjustment	<b>47</b>

Code	Description	X(mm)	Y(mm)	Z(mm)
1	Loquet au pilier "B" (conducteur) "B" pillar striker (driver)	<b>2501</b>	<b>-836</b>	<b>745</b>
2	Loquet au pilier "B" (passager) "B" pillar striker (passenger)	<b>2500</b>	<b>835</b>	<b>744</b>
3	Boulon siège avant, extérieur (conducteur) Front seat bolt, outboard (driver)	<b>2103</b>	<b>-592</b>	<b>349</b>
4	Boulon siège avant, extérieur (passager) Front seat bolt, outboard (passenger)	<b>2108</b>	<b>602</b>	<b>346</b>
5	Jante du volant, centre haut Steering wheel rim, top centre	<b>1875</b>	<b>-412</b>	<b>1233</b>
6	Jante du volant, centre bas Steering wheel rim, bottom centre	<b>2014</b>	<b>-412</b>	<b>878</b>
7	Jante du volant, centre gauche Steering wheel rim, left centre	<b>1944</b>	<b>-602</b>	<b>1056</b>
8	Jante du volant, centre droit Steering wheel rim, right centre	<b>1946</b>	<b>-222</b>	<b>1056</b>
9	Moyeu du volant, centre haut Steering wheel hub, top centre	<b>1921</b>	<b>-413</b>	<b>1105</b>
10	Moyeu du volant, centre Steering wheel hub, centre	<b>1974</b>	<b>-412</b>	<b>1034</b>
11	Moyeu du volant, centre bas Steering wheel hub, bottom centre	<b>1992</b>	<b>-412</b>	<b>964</b>
12	Centre du volant Center of steering wheel	<b>1964</b>	<b>-411</b>	<b>1055</b>

Point de référence : Centre transversal du véhicule, au point le plus avancé, au niveau du sol. Selon SAE J182a.  
Reference point : Transversal center of the vehicle, at the foremost point and at ground level. As per SAE J182a.

Remarques - Comments: Aucune / None.

Date de collision Crash date	<b>2005-02-28</b>	Véhicule Vehicle	<b>FORD FREESTAR 2005</b>	T.C. N° T.C.No	<b>05-210</b>
---------------------------------	-------------------	---------------------	---------------------------	-------------------	---------------

**POINTS DE MESURES DES CEINTURES DE SÉCURITÉ EN UTILISANT L'APPAREIL (BTD)  
PASSENGER CAR BELT FIT MEASUREMENTS USING THE BELT DEPLOYMENT TEST DEVICE (BTD)**

Type de siège / Seat type:      baquet / bucket       banquette / bench       banquette 60-40 / bench 60-40

Type de ceinture / Belt system:      3 points       passive       active       automatique / automatic       motorisée / motorised

Localisation du siège / Seat location:      Av-G / F-L       Av-D / F-R       Arr-G / R-L       Arr-D / R-R

Espacement du genou gauche / Left knee spacing:      106 mm      Espacement du genou droit / Right knee spacing:      105 mm

Essai no: / Trial no:		1	2	3
Angle du dossier BTD Back pan angle		24.5 deg.	25.0 deg.	24.3 deg.
Angle de la cuvette BTD Seat pan angle		14.4 deg.	14.7 deg.	15.2 deg.
Angle du pied Foot angle	gauche / left	99 deg.	104 deg.	106 deg.
	droit / right	122 deg.	122 deg.	122 deg.
Angle du genou Knee angle	gauche / left	113 deg.	112 deg.	111 deg.
	droit / right	110 deg.	110 deg.	109 deg.
Mesure sous-abdominale Lap belt score	gauche / left	49 mm / 0 mm	48 mm / 0 mm	46 mm / 0 mm
	droit / right	36 mm / 0 mm	35 mm / 0 mm	36 mm / 0 mm
Ceinture en contact Belt in contact	gauche / left	Oui/Yes	Oui/Yes	Oui/Yes
	droit / right	Oui/Yes	Oui/Yes	Oui/Yes
Mesure ceinture baudrier Upper torso belt score	Sternum	188 mm / - *	186 mm / - *	180 mm / - *
	Clavicule	122 mm / 1 mm	120 mm / 1 mm	117 mm / 10 mm
Ceinture en contact Belt in contact	Clavicule	Oui/Yes	Oui/Yes	Oui/Yes

Mesure / Score	Jeu / Slack
----------------	-------------

\* Mesure ceinture baudrier (jeu sternum) : (-) signifie un jeu causé par l'appareil BTD. Impossible à éliminer.  
\* Upper torso belt score (sternum slack) : (-) means a slack impossible to eliminate due to BTD machine.

**Remarques – Comments : Aucune / None.**

**Selon le manuel d'opérations pour mesures géométriques des ceintures de sécurité, ébauche, Transports Canada, janvier 1993.  
As per the operational manual for the belt deployment test device, draft, Transport Canada, January 1993.**

Date de collision Crash date	<b>2005-02-28</b>	Véhicule Vehicle	<b>FORD FREESTAR 2005</b>	T.C. N° T.C.No	<b>05-210</b>
---------------------------------	-------------------	---------------------	---------------------------	-------------------	---------------

**POINTS DE MESURES DES CEINTURES DE SÉCURITÉ EN UTILISANT L'APPAREIL (BTD)  
PASSENGER CAR BELT FIT MEASUREMENTS USING THE BELT DEPLOYMENT TEST DEVICE (BTD)**

Type de siège  
Seat type

baquet / bucket       banquette / bench       banquette 60-40 / bench 60-40

Type de ceinture  
Belt system

3 points       passive       active       automatique / automatic       motorisée / motorised

Localisation du siège  
Seat location

Av-G / F-L       Av-D / F-R       Arr-G / R-L       Arr-D / R-R

Espacement du genou gauche  
Left knee spacing

104 mm

Espacement du genou droit  
Right knee spacing

105 mm

Essai no: / Trial no:		1	2	3
Angle du dossier BTD Back pan angle		24.8 deg.	25.3 deg.	25.3 deg.
Angle de la cuvette BTD Seat pan angle		14.9 deg.	15.6 deg.	15.5 deg.
Angle du pied Foot angle	gauche / left	110 deg.	111 deg.	110 deg.
	droit / right	112 deg.	112 deg.	113 deg.
Angle du genou Knee angle	gauche / left	112 deg.	109 deg.	110 deg.
	droit / right	112 deg.	111 deg.	110 deg.
Mesure sous-abdominale Lap belt score	gauche / left	36 mm / 0 mm	36 mm / 0 mm	36 mm / 0 mm
	droit / right	46 mm / 0 mm	46 mm / 0 mm	46 mm / 0 mm
Ceinture en contact Belt in contact	gauche / left	Oui/Yes	Oui/Yes	Oui/Yes
	droit / right	Oui/Yes	Oui/Yes	Oui/Yes
Mesure ceinture baudrier Upper torso belt score	Sternum	174 mm / - *	173 mm / - *	171 mm / - *
	Clavicule	111 mm / 0 mm	110 mm / 0 mm	110 mm / 0 mm
Ceinture en contact Belt in contact	Clavicule	Oui/Yes	Oui/Yes	Oui/Yes

Mesure Score	/	Jeu Slack
-----------------	---	--------------

\* Mesure ceinture baudrier (jeu sternum) : (-) signifie un jeu causé par l'appareil BTD. Impossible à éliminer.  
\* Upper torso belt score (sternum slack) : (-) means a slack impossible to eliminate due to BTD machine.

**Remarques - Comments:** Aucune / None.

**Selon le manuel d'opérations pour mesures géométriques des ceintures de sécurité, ébauche, Transports Canada, janvier 1993.**

**As per the operational manual for the belt deployment test device, draft, Transport Canada, January 1993.**

Date de collision Crash date	<b>2005-02-28</b>	Véhicule Vehicle	<b>FORD FREESTAR 2005</b>	T.C. N° T.C.No	<b>05-210</b>
---------------------------------	-------------------	---------------------	---------------------------	-------------------	---------------

**POSITIONNEMENT DES MANNEQUINS / MEASUREMENTS OF DUMMY POSITIONS**

		<b>MESURES / MEASUREMENTS :</b>					
Conducteur/Driver : <b>Hybrid III (5 %)</b>		Toutes les mesures sont en mm / All measurements are in mm					
Angle du pelvis - Pelvic angle : <b>19.5°</b>		Conducteur / Driver			Passager / Passenger		
Angle transversal - Transversal angle : <b>-0.2°</b>		Ajustement du siège : Seat adjustment :			Ajustement du siège : Seat adjustment :		
Angle de la tête - Head angle : <b>0.0°</b>		<b>1 de 19 crans/notches</b>			<b>1 de 19 crans/notches</b>		
Seuil de porte - Door sill : <b>0.0°</b>		Angle du dossier : Seat back angle :			Angle du dossier : Seat back angle :		
Mouvement du lacet / Yaw movement : <b>2 mm</b>		N/A			N/A		
Position de la rail du siège / Seat track position * : <b>2275 mm</b>		X	Y	Z	X	Y	Z
Passager avant/Front Passenger: <b>Hybrid III (5 %)</b>		<b>2350</b>	<b>-479</b>	<b>1266</b>	<b>2335</b>	<b>494</b>	<b>1264</b>
Angle du pelvis - Pelvic angle : <b>19.7°</b>		<b>2191</b>	<b>-577</b>	<b>706</b>	<b>2198</b>	<b>584</b>	<b>701</b>
Angle transversal - Transversal angle : <b>-0.2°</b>		<b>1861</b>	<b>-530</b>	<b>800</b>	<b>1868</b>	<b>534</b>	<b>794</b>
Angle de la tête - Head angle : <b>0.0°</b>							
Seuil de porte - Door sill : <b>0.0°</b>							
Mouvement du lacet / Yaw movement : <b>3 mm</b>							
Position de la rail du siège / Seat track position * : <b>2278 mm</b>							
Cible de tête / Head target :							
Point-H / H-Point :							
Rotule / Knee joint :							

**Remarques – Comments :** **Aucune / None.**

\* **Référence : 0 est la position la plus avancée.**

\* **Reference : 0 is the foremost position.**

**Selon la procédure de positionnement de mannequin 5<sup>e</sup> percentile Hybrid III, 49 CFR 552, 571, 585 and 595, Docket No. NHTSA 00-7013; Notice 1, RIN 2127-AG70, Federal Motor Vehicle Safety Standards, Occupant Crash Protection (Paragraphe S16.3).**

**As per procedure for placement of a 5<sup>th</sup> percentile Hybrid III 49 CFR 552, 571, 585 and 595, Docket No. NHTSA 00-7013; Notice 1, RIN 2127-AG70, Federal Motor Vehicle Safety Standards, Occupant Crash Protection (Section S16.3).**

**Point de référence : Centre transversal du véhicule, au point le plus avancé, au niveau du sol. Selon SAE J182a.**

**Reference point : Transversal center of the vehicle, at the foremost point and at ground level. As per SAE J182a.**

Date de collision Crash date	<b>2005-02-28</b>	Véhicule Vehicle	<b>FORD FREESTAR 2005</b>	T.C. N° T.C.No	<b>05-210</b>
---------------------------------	-------------------	---------------------	---------------------------	-------------------	---------------

**POSITIONNEMENT DES MANNEQUINS / MEASUREMENTS OF DUMMY POSITIONS**

		<u>MESURES / MEASUREMENTS :</u>					
Passager arrière gauche : Rear left passenger :	<b>Hybrid III (6 ans / 6 years old)</b>	Toutes les mesures sont en mm / All measurements are in mm					
Angle du pelvis - Pelvic angle :	N/A	Passager arrière gauche Rear left passenger			Passager arrière droit Rear right passenger		
Angle transversal - Transversal angle :	N/A	Ajustement du siège : Seat adjustment :			Ajustement du siège : Seat adjustment :		
Angle de la tête - Head angle :	N/A	N/A			N/A		
Mouvement du lacet / Yaw movement :	N/A	Ajustement du dossier : Seat back adjustment :			Ajustement du dossier : Seat back adjustment :		
Passager arrière droit : Rear right passenger :	<b>Hybrid III (6 ans / 6 years old)</b>	N/A			N/A		
Angle du pelvis - Pelvic angle :	N/A	X	Y	Z	X	Y	Z
Angle transversal - Transversal angle :	N/A						
Angle de la tête - Head angle :	N/A						
Mouvement du lacet / Yaw movement :	N/A						
Cible de tête / Head target :		<b>2350</b>	<b>-479</b>	<b>1266</b>	<b>2335</b>	<b>494</b>	<b>1264</b>

**Point de référence :** Centre transversal du véhicule, au point le plus avancé, au niveau du sol. Selon SAE J182a.  
**Reference point :** Transversal center of the vehicle, at the foremost point and at ground level. As per SAE J182a.

<b>Passager arrière gauche : Rear left passenger :</b>	<b>Hybrid III (6 ans / 6 years old)</b>	
	<b>Méthodes d'attaches : Attachment methods:</b>	<b>Siège / Seat : ancrage sup. et système d'ancrage univ. / with tether and latch Enfant / Child : ceinture boudrier gauche / left shoulder belt</b>
	<b>Manufacturier du siège : Seat manufacturer :</b>	<b>Cenutury Brevera Contour</b>
	<b>Modèle du siège : Seat model :</b>	<b>44875LBLECA</b>
	<b>No. de série du siège : Seat serial number :</b>	<b>N/A</b>
	<b>Date de fabrication du siège : Seat fabrication date :</b>	<b>3/25/2003</b>

<b>Passager arrière droit : Rear right passenger :</b>	<b>Hybrid III (6 ans / 6 years old)</b>	
	<b>Méthodes d'attaches : Attachment methods:</b>	<b>Siège / Seat : ceinture boudrier droit / right shoulder belt Enfant / Child : ceinture boudrier droit / right shoulder belt</b>
	<b>Manufacturier du siège : Seat manufacturer :</b>	<b>Graco Turbo Booster</b>
	<b>Modèle du siège : Seat model :</b>	<b>8495STOCA</b>
	<b>No. de série du siège : Seat serial number :</b>	<b>N/A</b>
	<b>Date de fabrication du siège : Seat fabrication date :</b>	<b>7/8/2003</b>

Date de collision Crash date	<b>2005-02-28</b>	Véhicule Vehicle	<b>FORD FREESTAR 2005</b>	T.C. N° T.C.No	<b>05-210</b>
---------------------------------	-------------------	---------------------	---------------------------	-------------------	---------------

**POSITIONNEMENT DES MANNEQUINS / MEASUREMENTS OF DUMMY POSITIONS**

	<b>MESURES / MEASUREMENTS :</b>					
Passager arrière centre, 3 <sup>e</sup> rangée : Rear centre passenger, 3 <sup>rd</sup> row :	<b>Hybrid III (3 ans / 3 years old)</b>					
Toutes les mesures sont en mm / All measurements are in mm						
Angle du pelvis - Pelvic angle :	N/A			Passager arrière centre, 3 <sup>e</sup> rangée Rear centre passenger, 3 <sup>rd</sup> row	Passager arrière droit, 3 <sup>e</sup> rangée Rear right passenger, 3 <sup>rd</sup> row	
Angle transversal - Transversal angle :	N/A			Ajustement du siège : Seat adjustment :		
Angle de la tête - Head angle :	N/A			N/A		
Mouvement du lacet / Yaw movement :	N/A			Ajustement du dossier : Seat back adjustment :		
Passager arrière droit, 3 <sup>e</sup> rangée : Rear right passenger, 3 <sup>rd</sup> row :	N/A			N/A		
Angle du pelvis - Pelvic angle :	N/A			X	Y	Z
Angle transversal - Transversal angle :	N/A			X	Y	Z
Angle de la tête - Head angle :	N/A			X	Y	Z
Mouvement du lacet / Yaw movement :	N/A			X	Y	Z
Cible de tête / Head target :	<b>4101</b>	<b>-64</b>	<b>1138</b>	-	-	-

**Point de référence :** Centre transversal du véhicule, au point le plus avancé, au niveau du sol. Selon SAE J182a.  
**Reference point :** Transversal center of the vehicle, at the foremost point and at ground level. As per SAE J182a.

<b>Passager arrière centre : Rear centre passenger :</b>	<b>Hybrid III (3 ans / 3 years old)</b>	
<b>Méthodes d'attaches : Attachment methods:</b>	<b>Siège / Seat : ancrage sup. et ceinture d'auto / with tether and car belt Enfant / Child : harnais / harness</b>	
<b>Manufacturier du siège : Seat manufacturer :</b>	<b>3rd row Graco Treasured Cargo</b>	
<b>Modèle du siège : Seat model :</b>	<b>8486HMPCA</b>	
<b>No. de série du siège : Seat serial number :</b>	<b>N/A</b>	
<b>Date de fabrication du siège : Seat fabrication date :</b>	<b>10/11/2004</b>	

Date de collision Crash date	2005-02-28	Véhicule Vehicle	FORD FREESTAR 2005	T.C. N° T.C.No	05-210
---------------------------------	------------	---------------------	--------------------	-------------------	--------

COTES DE LOCALISATION DES MANNEQUINS  
DUMMY LOCATION DATA

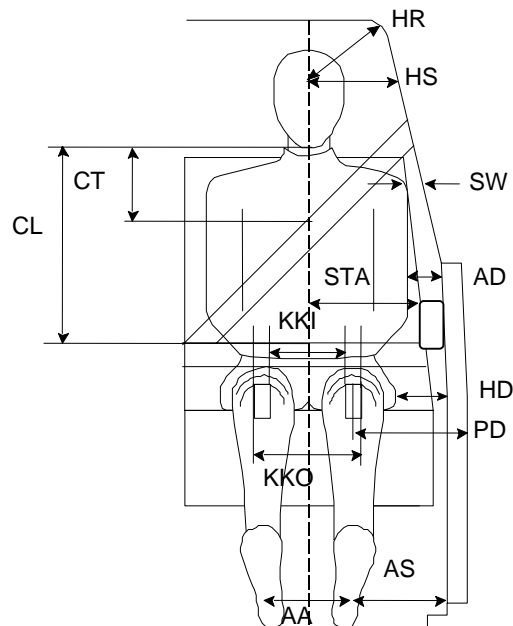
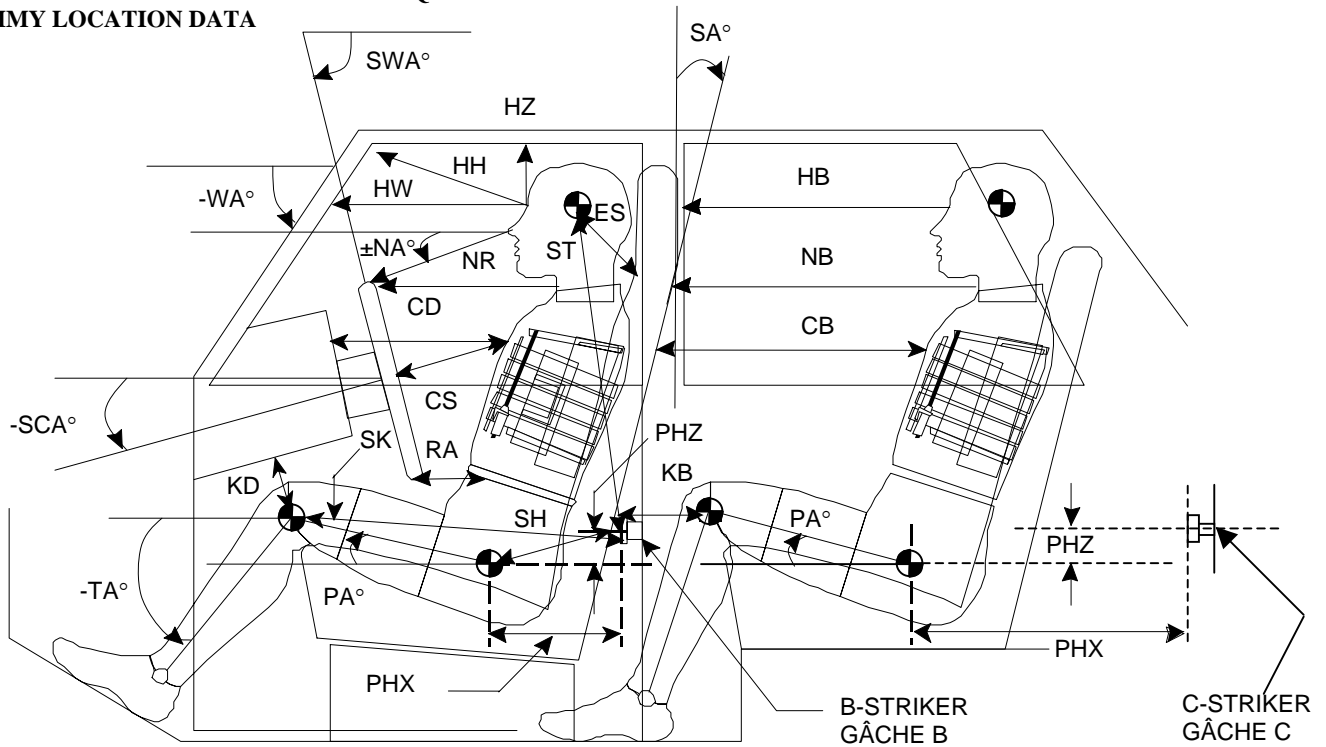

référence  
reference :

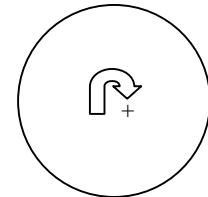

Date de collision Crash date	<b>2005-02-28</b>	Véhicule Vehicle	<b>FORD FREESTAR 2005</b>	T.C. N° T.C.No	<b>05-210</b>
---------------------------------	-------------------	---------------------	---------------------------	-------------------	---------------

**COTES DE LOCALISATION DES MANNEQUINS (suite)**

**DUMMY LOCATION DATA (continued)**

**(Mesures prises en mm / Measurements taken in mm)**

DESCRIPTION	CODE	CONDUCTEUR DRIVER	PASSAGER Av. F. PASSENGER	PASSAGER Arr.G. L.R. PASSENGER	PASSAGER Arr.D. R.R. PASSENGER
De cheville à cheville (boulon extérieur) Ankle to ankle (exterior bolt)	AA	<b>300</b>	<b>245</b>		
Genou à genou (plaque) Intérieur / Interior Centre / Center Knee to knee (plate) Extérieur / Extérieur	KKI	<b>90</b>	<b>90</b>		
	KKC	<b>160</b>	<b>160</b>		
	KKO	<b>230</b>	<b>230</b>		
De la cheville jusqu'au seuil de porte (horizontalement) Ankle to door sill (horizontal)	AS	<b>150</b>	<b>150</b>		
Centre du genou au tableau de bord ou siège horizontalement (minimum) Knees centre to dash or seat back horizontal (minimum)	KDL	<b>45</b>	<b>80</b>		
	KDR	<b>80</b>	<b>80</b>		
Sternum au tableau de bord (horizontalement) Chest to dash (horizontal)	CD		<b>435</b>		
Milieu du sternum au centre du moyeu du volant ou siège avant Mid sternum to steering hub center or front seat	CS/CB	<b>270</b>			
Milieu du front jusqu'au pare-brise (horizontalement) Mid forehead to windshield (horizontal)	HW	<b>763</b>	<b>738</b>		
Milieu du front jusqu'au haut du pare-brise Mid forehead to windshield header	HH	<b>423</b>	<b>398</b>		
Nez à la jante du volant de direction (haut) ou siège avant Nose to steering wheel rim (top) or front seat	NR/HB	<b>345</b>			
Milieu du front jusqu'au début du toit Mid forehead to edge roof	HR	<b>295</b>	<b>295</b>		
Haut de l'oreille au haut du siège avant Ear top to front seat top	ES	<b>255</b>	<b>285</b>		
Menton au haut de la ceinture sous-abdominale (verticalement) Chin to lap belt upper edge (vertical)	CL	<b>360</b>	<b>345</b>		
Menton au haut de la ceinture baudrier (verticalement) Chin to thorax belt upper edge (vertical)	CT	<b>165</b>	<b>165</b>		
Milieu du front à la fenêtre latérale (horizontalement) Mid forehead to side window (horizontal)	HS	<b>355</b>	<b>338</b>		
La rotule à la porte (horizontalement) Patella to door (horizontal)	PD	<b>213</b>	<b>208</b>		
Du point-H à la porte (horizontalement) H-point to door (horizontal)	HD	<b>216</b>	<b>213</b>		
Du milieu du bras à la porte (horizontalement) Mid upper arm to door (horizontal)	AD	<b>142</b>	<b>133</b>		
Cou jusqu'au volant ou tableau de bord (horizontalement) ou siège avant Neck to steering wheel or dash board (horizontal) or front seat	NB	<b>440</b>	<b>580</b>		
Épaulé à la fenêtre de côté Shoulder to side window	SW	<b>193</b>	<b>180</b>		
Abdomen à l'appui-bras Abdomen to armrest	STA	<b>165</b>	<b>155</b>		
Milieu du front au toit (verticalement) Mid forehead to roof (vertical)	HZ	<b>280</b>	<b>265</b>		
Tête au loquet (plan (x,z)) Striker to head ( (x,z) plan)	ST	<b>542</b>	<b>546</b>		
Abdomen à la jante du volant de direction (bas) Steering wheel rim to abdomen (bottom)	RA	<b>160</b>			
Genou au loquet (plan (x,z)) Striker to knee ( (x,z) plan)	SK	<b>642</b>	<b>634</b>		
Point-H au loquet (plan (x,z)) Striker to H-Point ( (x,z) plan)	SH	<b>312</b>	<b>305</b>		
Point-H au loquet en X (horizontalement) Striker to H-Point in X (horizontal)	PHX	<b>310</b>	<b>302</b>		
Point-H au loquet en Z (verticalement) Striker to H-Point in Z (vertical)	PHZ	<b>39</b>	<b>43</b>		

Date de collision Crash date	<b>2005-02-28</b>	Véhicule Vehicle	<b>FORD FREESTAR 2005</b>	T.C. N° T.C.No	<b>05-210</b>
---------------------------------	-------------------	---------------------	---------------------------	-------------------	---------------

**COTES DE LOCALISATION DES MANNEQUINS (suite)  
DUMMY LOCATION DATA (continued)**

**(Mesures prises en deg. / Measurements taken in deg.)**

DESCRIPTION	CODE	CONDUCTEUR DRIVER	PASSAGER Av. F. PASSENGER	PASSAGER Arr.G. L.R. PASSENGER	PASSAGER Arr.D. R.R. PASSENGER
Angle du volant Steering wheel angle	+SWA	<b>68.2°</b>			
Angle du pare-brise Windshield angle	-WA	<b>-29.1°</b>			
Angle de la colonne de direction Steering column angle	-SCA	<b>-20.4°</b>			
Angle du tibia gauche Left tibial angle	-TA	<b>-20.0°</b>	<b>-22.8°</b>		
Angle du tibia droit Right tibial angle	-TA	<b>-23.8°</b>	<b>-20.4°</b>		
Angle pelvis Pelvic angle	+PA	<b>19.5°</b>	<b>19.7°</b>		
Angle du nez à la jante de direction (haut) Nose to steering wheel rim (top) angle	±NA	<b>-21.0°</b>			
Angle du dossier Seat back angle	+SA	-	-		
Angle ST (horizontalement) ST angle (horizontal)	+ST-A	<b>73.8°</b>	<b>72.4°</b>		
Angle SK (horizontalement) SK angle (horizontal)	±SK-A	<b>4.9°</b>	<b>4.5°</b>		
Angle SH (horizontalement) SH angle (horizontal)	-SH-A	<b>-7.2°</b>	<b>-8.1°</b>		

Date de collision Crash date	<b>2005-02-28</b>	Véhicule Vehicle	<b>FORD FREESTAR 2005</b>	T.C. N° T.C.No	<b>05-210</b>
---------------------------------	-------------------	---------------------	---------------------------	-------------------	---------------

**MESURES DE MANNEQUIN DAE  
TEST DUMMY MEASUREMENTS**

**CONDUCTEUR / DRIVER**

Description et emplacement du Mannequin  
ATD description and location :

DESCRIPTION	X(mm)	Y(mm)	Z(mm)
Centre de gravité de la tête, extérieur - Head CG, outboard	2350	-479	1266
Base du nez - Glabella (root of nose)	2261	-415	1283
Menton - Chin (bottom)	2256	-416	1174
Jonction menton et cou - Chin / neck junction	2323	-416	1186
Thorax au niveau des côtes supérieures - Chest at upper rib level	2232	-419	1014
Thorax au niveau des côtes inférieures - Chest at lower rib level	2200	-417	908
Boulon supérieur avant de l'épaule, ext. - Shoulder bolt, top front outboard	2381	-571	1045
Boulon supérieur avant de l'épaule, int. - Shoulder bolt, top front inboard	2374	-255	1046
Boulon du coude, extérieur - Elbow bolt, outboard	2200	-689	1005
Boulon du coude, intérieur - Elbow bolt, inboard	2193	-136	986
Boulon du poignet, extérieur - Wrist bolt, outboard	2002	-633	1067
Boulon du poignet, intérieur - Wrist bolt, inboard	1997	-188	1066
Point d'articulation de la hanche, extérieur - Hip point, outboard	2277	-533	748
Boulon du genou gauche, extérieur - Knee bolt, left leg, outboard	1862	-530	801
Boulon de la cheville gauche, extérieur - Ankle bolt, left leg , outboard	1712	-520	491
Point du talon gauche - Heel point, left leg	1772	-535	376
Plante du pied gauche vs plancher - Ball of foot at toeboard contact, left leg	1642	-563	415
Boulon du genou droit, intérieur - Knee bolt, right leg , inboard	1864	-361	768
Boulon de la cheville droite, intérieur - Ankle bolt, right leg , inboard	1657	-284	506
Point du talon droit - Heel point, right leg	1688	-282	382
Plante du pied droit vs plancher - Ball of foot at toeboard contact, right leg	1570	-307	445

**Remarques – Comments : Aucune / None.**

Date de collision Crash date	<b>2005-02-28</b>	Véhicule Vehicle	<b>FORD FREESTAR 2005</b>	T.C. N° T.C.No	<b>05-210</b>
---------------------------------	-------------------	---------------------	---------------------------	-------------------	---------------

**MESURES DE MANNEQUIN DAE  
TEST DUMMY MEASUREMENTS**

**PASSAGER / PASSENGER**

Description et emplacement du Mannequin  
ATD description and location:

DESCRIPTION	X(mm)	Y(mm)	Z(mm)
Centre de gravité de la tête, extérieur - Head CG, outboard	2335	494	1264
Base du nez - Glabella (root of nose)	2248	426	1276
Menton - Chin (bottom)	2243	426	1173
Jonction menton et cou - Chin / neck junction	2312	426	1197
Thorax au niveau des côtes supérieures - Chest at upper rib level	2221	419	975
Thorax au niveau des côtes inférieures - Chest at lower rib level	2189	418	864
Boulon supérieur avant de l'épaule, ext. - Shoulder bolt, top front outboard	2355	578	1027
Boulon supérieur avant de l'épaule, int. - Shoulder bolt, top front inboard	2357	267	1034
Boulon du coude, extérieur - Elbow bolt, outboard	2303	637	817
Boulon du coude, intérieur - Elbow bolt, inboard	2298	208	834
Boulon du poignet, extérieur - Wrist bolt, outboard	2095	588	779
Boulon du poignet, intérieur - Wrist bolt, inboard	2090	261	796
Point d'articulation de la hanche, extérieur - Hip point, outboard	2283	544	742
Boulon du genou gauche, intérieur - Knee bolt, left leg, inboard	1869	383	787
Boulon de la cheville gauche, intérieur - Ankle bolt, left leg, inboard	1686	324	503
Point du talon gauche - Heel point, left leg	1717	322	388
Plante du pied gauche vs plancher - Ball of foot at toeboard contact, left leg	1615	353	426
Boulon du genou droit, extérieur - Knee bolt, right leg, outboard	1869	533	794
Boulon de la cheville droite, extérieur - Ankle bolt, right leg, outboard	1703	506	490
Point du talon droit - Heel point, right leg	1771	507	391
Plante du pied droit vs plancher - Ball of foot at toeboard contact, right leg	1639	550	418

**Remarques – Comments : Aucune / None.**

Date de collision Crash date	<b>2005-02-28</b>	Véhicule Vehicle	<b>FORD FREESTAR 2005</b>	T.C. N° T.C.No	<b>05-210</b>
---------------------------------	-------------------	---------------------	---------------------------	-------------------	---------------

MESURES PLANCHER / FOOTWELL MEASUREMENTS

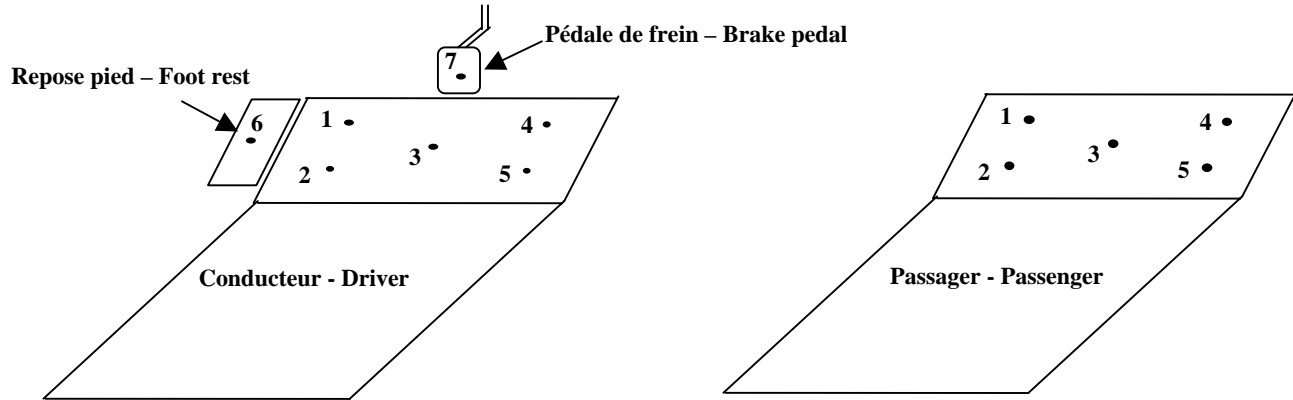

N° Cible		AVANT ESSAI	APRÈS ESSAI	
Target No.		PRE-TEST	POST-TEST	$\Delta$ mm
1	x	1356	1373	-17
	y	-431	-421	-10
	z	465	509	-44
2	x	1518	1525	-7
	y	-467	-461	-6
	z	398	425	-27
3	x	1375	1446	-71
	y	-250	-334	84
	z	457	462	-5
4	x	1530	1391	139
	y	-227	-241	14
	z	388	496	-108
5	x	1436	1537	-101
	y	-341	-220	-121
	z	431	410	21
6	x	1467	1482	-15
	y	-610	-598	-12
	z	500	534	-34
7	x	1502	1555	-53
	y	-386	-377	-9
	z	549	610	-61

N° Cible		AVANT ESSAI	APRÈS ESSAI	
Target No.		PRE-TEST	POST-TEST	$\Delta$ mm
1	x	1339	1415	-76
	y			
	z			
2	x	1508	1520	-12
	y			
	z			
3	x	1415	1471	-56
	y			
	z			
4	x	1324	1393	-69
	y	511	515	-4
	z	562	636	-74
5	x	1478	1493	-15
	y	504	512	-8
	z	427	460	-33

Date de collision Crash date	2005-02-28	Véhicule Vehicle	FORD FREESTAR 2005	T.C. N° T.C.No	05-210
---------------------------------	------------	---------------------	--------------------	-------------------	--------

**PÉNÉTRATION DE L'HABITACLE DU CONDUCTEUR (Distances en mm)**  
**DRIVER COMPARTMENT INTRUSION (Distances in mm)**

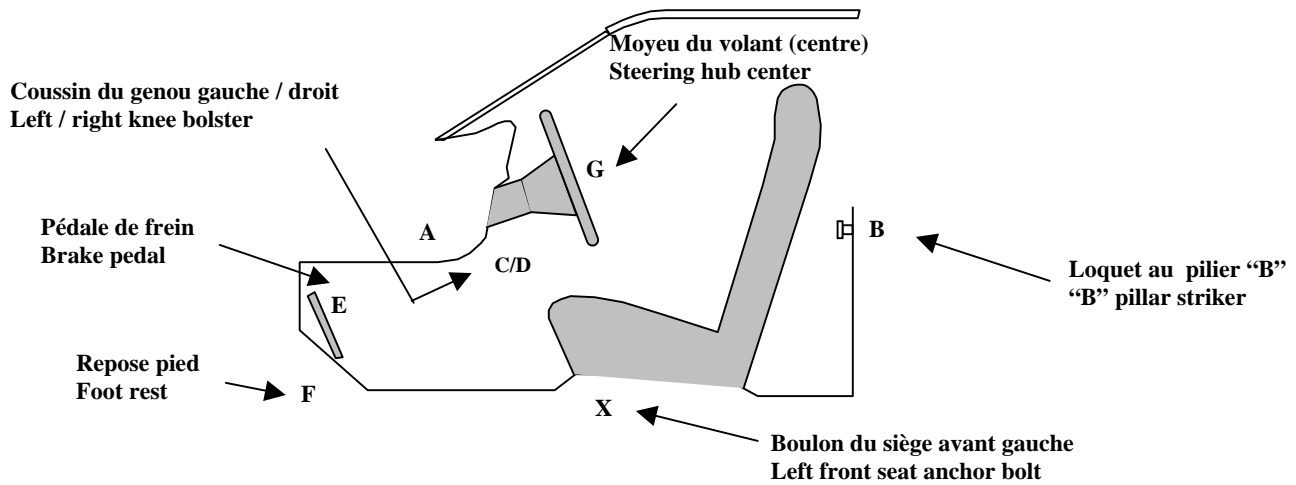

Habitacle du conducteur  
Driver's compartment

	DESCRIPTION	Avant essai / Pre-test			Après essai / Post-test		
		X	Y	Z	X	Y	Z
A	Ouverture de porte Door opening	1640	-869	1080	1652	-861	1101
B	Loquet au pilier "B" "B" pillar striker	2501	-836	745	2505	-835	745
C	Coussin du genou gauche Left knee bolster	-	-	-	-	-	-
D	Coussin du genou droit Right knee bolster	-	-	-	-	-	-
E	Pédale de frein Break pedal	1502	-386	549	1555	-377	610
F	Repose pied Foot rest	1467	-610	500	1482	-598	534
G	Moyeu du volant (centre) Steering hub (center)	1974	-412	1034	1957	-421	1079
X	Boulon du siège avant gauche Left front seat anchor bolt	2103	-592	349	2112	-589	344

**APPENDICE / APPENDIX A**

**PHOTOGRAPHIES DE L'ESSAI  
TEST PHOTOGRAPHS**

Date de collision Crash date	2005-02-28	Véhicule Vehicle	FORD FREESTAR 2005	T.C. N° T.C.No	05-210
---------------------------------	------------	---------------------	--------------------	-------------------	--------

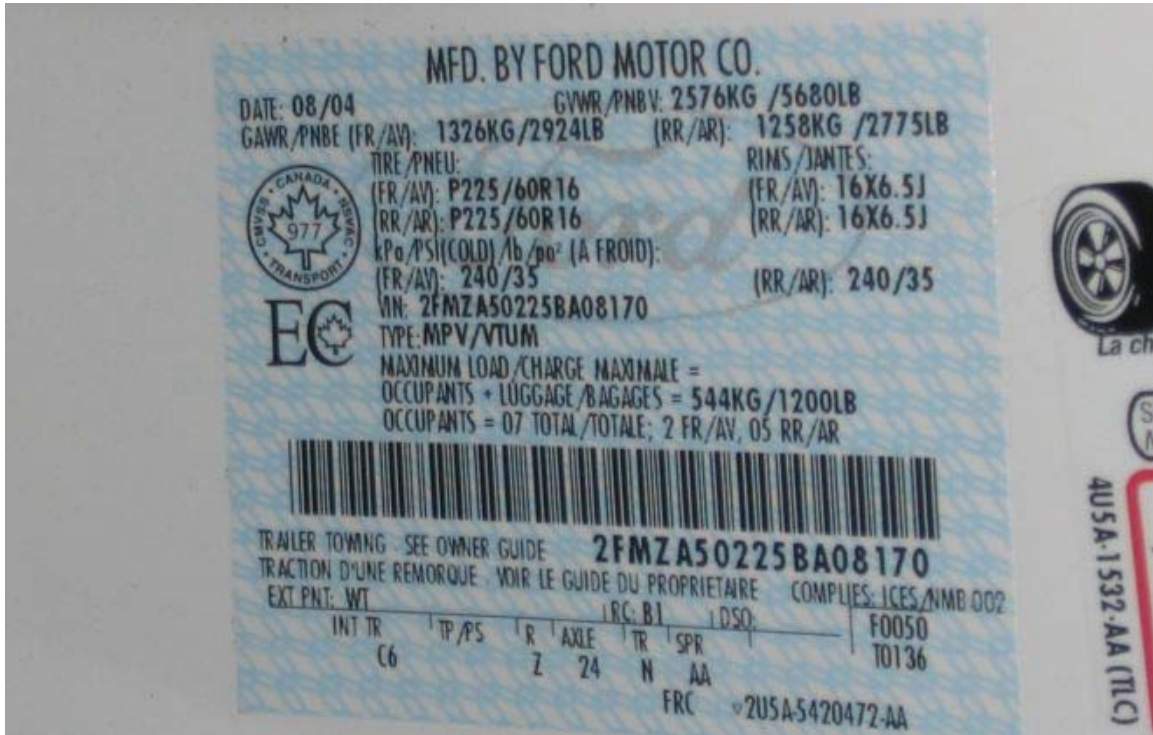

1. Étiquette de déclaration de conformité du véhicule d'essai.  
Statement of compliance label of the test vehicle.

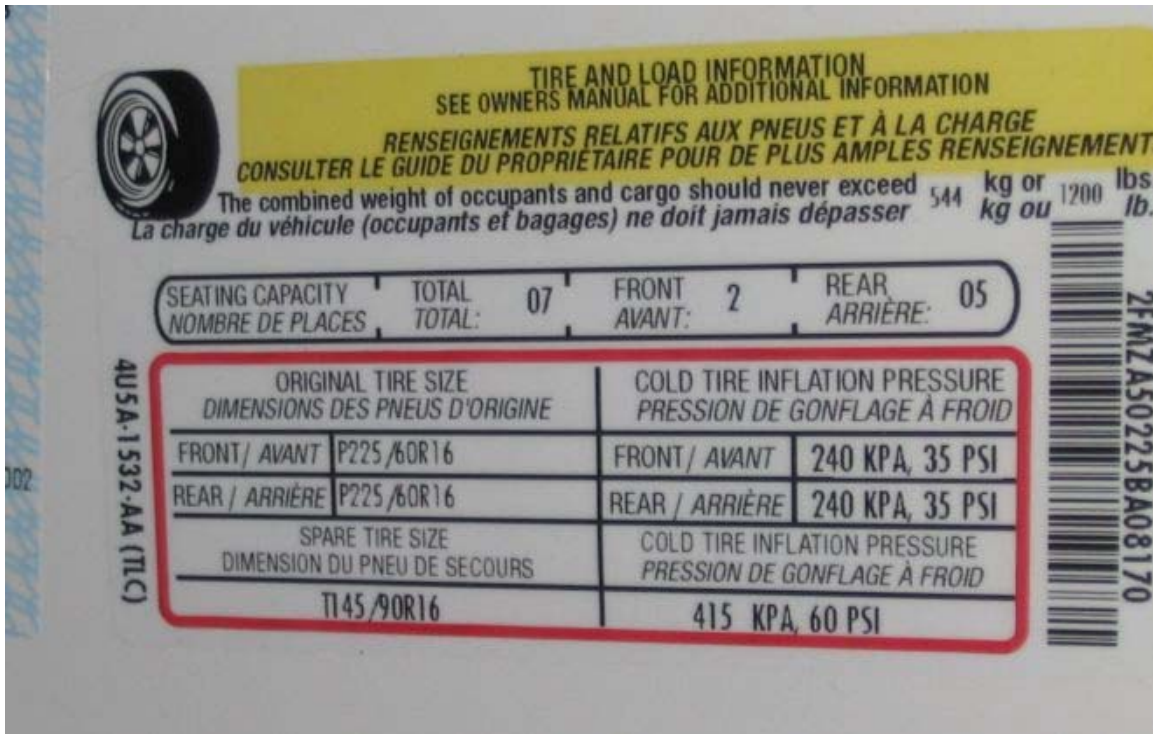

2. Étiquette d'information des pneus.  
Tire information label.

Date de collision Crash date	<b>2005-02-28</b>	Véhicule Vehicle	<b>FORD FREESTAR 2005</b>	T.C. N° T.C.No	<b>05-210</b>
---------------------------------	-------------------	---------------------	---------------------------	-------------------	---------------



**3. Vue  $\frac{3}{4}$  avant du véhicule d'essai.  
 $\frac{3}{4}$  front view of the test vehicle.**



**4. Vue  $\frac{3}{4}$  arrière du véhicule d'essai.  
 $\frac{3}{4}$  rear view of the test vehicle.**

Date de collision Crash date	<b>2005-02-28</b>	Véhicule Vehicle	<b>FORD FREESTAR 2005</b>	T.C. N° T.C.No	<b>05-210</b>
---------------------------------	-------------------	---------------------	---------------------------	-------------------	---------------



5. Vue générale côté gauche du véhicule d'essai, avant essai.  
Left side view of the test vehicle, pre-test.



6. Vue générale côté gauche du véhicule d'essai, après essai.  
Left side view of the test vehicle, post-test.

Date de collision Crash date	<b>2005-02-28</b>	Véhicule Vehicle	<b>FORD FREESTAR 2005</b>	T.C. N° T.C.No	<b>05-210</b>
---------------------------------	-------------------	---------------------	---------------------------	-------------------	---------------



7. Vue arrière du véhicule d'essai, avant essai.  
Rear view of the test vehicle, pre-test.



8. Vue arrière du véhicule d'essai, après essai.  
Rear view of the test vehicle, post-test.

Date de collision Crash date	2005-02-28	Véhicule Vehicle	FORD FREESTAR 2005	T.C. N° T.C.No	05-210
---------------------------------	------------	---------------------	--------------------	-------------------	--------



9. Vue générale côté droit du véhicule d'essai, avant essai.  
General right side view of the test vehicle, pre-test.



10. Vue générale côté droit du véhicule d'essai, après essai.  
General right side view of the test vehicle, post-test.

Date de collision Crash date	2005-02-28	Véhicule Vehicle	FORD FREESTAR 2005	T.C. N° T.C.No	05-210
---------------------------------	------------	---------------------	--------------------	-------------------	--------



11. Vue avant du véhicule d'essai, avant essai.  
Front view of the test vehicle, pre-test.



12. Vue avant du véhicule d'essai, après essai.  
Front view of the test vehicle, post-test.

Date de collision Crash date	<b>2005-02-28</b>	Véhicule Vehicle	<b>FORD FREESTAR 2005</b>	T.C. N° T.C.No	<b>05-210</b>
---------------------------------	-------------------	---------------------	---------------------------	-------------------	---------------



**13. Vue de plan du véhicule d'essai, avant essai.  
Over view of the test vehicle, pre-test.**



**14. Vue de plan du véhicule d'essai, après essai.  
Over view of the test vehicle, post-test.**

Date de collision Crash date	2005-02-28	Véhicule Vehicle	FORD FREESTAR 2005	T.C. N° T.C.No	05-210
---------------------------------	------------	---------------------	--------------------	-------------------	--------



15. Vue de plan du devant du véhicule d'essai, avant essai.  
Over view of the front part of the test vehicle, pre-test.



16. Vue de plan du devant du véhicule d'essai, après essai.  
Over view of the front part of the test vehicle, post-test.

Date de collision Crash date	2005-02-28	Véhicule Vehicle	FORD FREESTAR 2005	T.C. N° T.C.No	05-210
---------------------------------	------------	---------------------	--------------------	-------------------	--------



17. Vue côté gauche de l'avant du véhicule d'essai, avant essai.  
Left side view of front of test vehicle, pre-test.



18. Vue côté gauche de l'avant du véhicule d'essai, après essai.  
Left side view of front of test vehicle, post-test.

Date de collision Crash date	2005-02-28	Véhicule Vehicle	FORD FREESTAR 2005	T.C. N° T.C.No	05-210
---------------------------------	------------	---------------------	--------------------	-------------------	--------



19. Vue côté droit de l'avant du véhicule d'essai, avant essai.  
Right side view of front of test vehicle, pre-test.



20. Vue côté droit de l'avant du véhicule d'essai, après essai.  
Right side view of front of test vehicle, post-test.

Date de collision Crash date	<b>2005-02-28</b>	Véhicule Vehicle	<b>FORD FREESTAR 2005</b>	T.C. N° T.C.No	<b>05-210</b>
---------------------------------	-------------------	---------------------	---------------------------	-------------------	---------------



**21. Vue du compartiment moteur du véhicule d'essai, avant essai.  
Engine compartment view of the vehicle, pre-test.**



**22. Vue du compartiment moteur du véhicule d'essai, après essai.  
Engine compartment view of the vehicle, post-test.**

Date de collision Crash date	<b>2005-02-28</b>	Véhicule Vehicle	<b>FORD FREESTAR 2005</b>	T.C. N° T.C.No	<b>05-210</b>
---------------------------------	-------------------	---------------------	---------------------------	-------------------	---------------



**23. Vue du dessous du compartiment moteur, avant essai.  
Under view of the engine compartment , pre-test.**



**24. Vue du dessous du compartiment moteur, après essai.  
Under view of the engine compartment , post-test.**

Date de collision Crash date	<b>2005-02-28</b>	Véhicule Vehicle	<b>FORD FREESTAR 2005</b>	T.C. N° T.C.No	<b>05-210</b>
---------------------------------	-------------------	---------------------	---------------------------	-------------------	---------------



**25. Position du conducteur, avant essai.  
Driver's position, pre-test.**



**26. Position du conducteur, après essai.  
Driver's position, post-test.**

Date de collision Crash date	<b>2005-02-28</b>	Véhicule Vehicle	<b>FORD FREESTAR 2005</b>	T.C. N° T.C.No	<b>05-210</b>
---------------------------------	-------------------	---------------------	---------------------------	-------------------	---------------



**27. Point de contact de tête du conducteur, après essai.  
Driver's head contact point, post-test.**



**28. Point de contact de tête du conducteur, après essai.  
Driver's head contact point, post-test.**

Date de collision Crash date	<b>2005-02-28</b>	Véhicule Vehicle	<b>FORD FREESTAR 2005</b>	T.C. N° T.C.No	<b>05-210</b>
---------------------------------	-------------------	---------------------	---------------------------	-------------------	---------------



**29. Point de contact des genoux du conducteur, après essai.  
Driver's knees contact point, post-test.**



**30. Contact du volant sur l'abdomen du conducteur, après essai.  
Steering wheel's contact point with driver's abdomen.**

Date de collision Crash date	<b>2005-02-28</b>	Véhicule Vehicle	<b>FORD FREESTAR 2005</b>	T.C. N° T.C.No	<b>05-210</b>
---------------------------------	-------------------	---------------------	---------------------------	-------------------	---------------



**31. Position du passager, avant essai.  
Passenger's position, pre-test.**



**32. Position du passager, après essai.  
Passenger's position, post-test.**

Date de collision Crash date	<b>2005-02-28</b>	Véhicule Vehicle	<b>FORD FREESTAR 2005</b>	T.C. N° T.C.No	<b>05-210</b>
---------------------------------	-------------------	---------------------	---------------------------	-------------------	---------------



**33. Point de contact de tête du passager, après essai.  
Passenger's head contact point, post-test.**



**34. Point de contact de tête du passager, après essai.  
Passenger's head contact point, post-test.**

Date de collision Crash date	<b>2005-02-28</b>	Véhicule Vehicle	<b>FORD FREESTAR 2005</b>	T.C. N° T.C.No	<b>05-210</b>
---------------------------------	-------------------	---------------------	---------------------------	-------------------	---------------



**35. Point de contact des genoux du passager, après essai.  
Passenger's knees contact point, post-test.**

Date de collision Crash date	<b>2005-02-28</b>	Véhicule Vehicle	<b>FORD FREESTAR 2005</b>	T.C. N° T.C.No	<b>05-210</b>
---------------------------------	-------------------	---------------------	---------------------------	-------------------	---------------



**36. Position du passager arrière droit, avant essai.  
Rear right passenger's position, pre-test.**



**37. Position du passager arrière droit, après essai.  
Rear right passenger's position, post-test.**

Date de collision Crash date	<b>2005-02-28</b>	Véhicule Vehicle	<b>FORD FREESTAR 2005</b>	T.C. N° T.C.No	<b>05-210</b>
---------------------------------	-------------------	---------------------	---------------------------	-------------------	---------------



**38. Position du passager arrière gauche, avant essai.  
Rear left passenger's position, pre-test.**



**39. Position du passager arrière gauche, après essai.  
Rear left passenger's position, post-test.**

Date de collision Crash date	<b>2005-02-28</b>	Véhicule Vehicle	<b>FORD FREESTAR 2005</b>	T.C. N° T.C.No	<b>05-210</b>
---------------------------------	-------------------	---------------------	---------------------------	-------------------	---------------



**40. Position du passager arrière centre, 3<sup>e</sup> rangée, avant essai.  
Rear centre passenger's position, 3<sup>rd</sup> row, pre-test.**



**41. Position du passager arrière centre, 3<sup>e</sup> rangée, après essai.  
Rear centre passenger's position, 3<sup>rd</sup> row, post-test.**

Date de collision Crash date	2005-02-28	Véhicule Vehicle	FORD FREESTAR 2005	T.C. N° T.C.No	05-210
---------------------------------	------------	---------------------	--------------------	-------------------	--------



42. Affichage du lecteur de vitesse.  
Speed trap reading.

**APPENDICE / APPENDIX B**

**DONNÉES GRAPHIQUES  
GRAPHICAL DATA**



**Nom du client**  
**Client Name** **TRANSPORT CANADA**

**Type de véhicule**  
**Type of Vehicle** **FORD FREESTAR 2005**

**Numéro de TC**  
**Tc Number** **TC05-210**

**Numéro de contrat**  
**Contract No** **05-5001**

**Acquisition de données selon**  
**Data Acquisition according to** **SAE J211/1 MAR 95**

**Date de l'essai**  
**Test date** **2005-02-28**

**Titre du projet**  
**Project Title** **COLLISION DE RECHERCHE**  
**COLLISION FRONTALE**  
**RESEARCH COLLISION TEST**  
**FRONTAL CRASH**

**MANNEQUIN / DUMMY**

Position 1	Position 2	Position 3
<b>HF</b>		<b>HF</b>

Position 4	Position 5	Position 6
<b>Y7</b>		<b>Y7</b>

Position 7	Position 8	Position 9
	<b>Y6</b>	

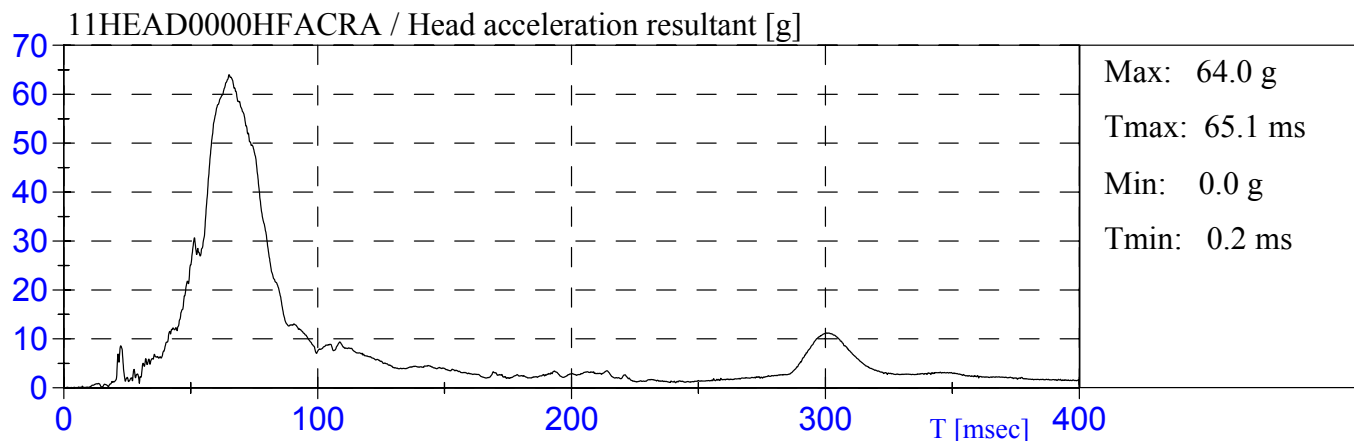
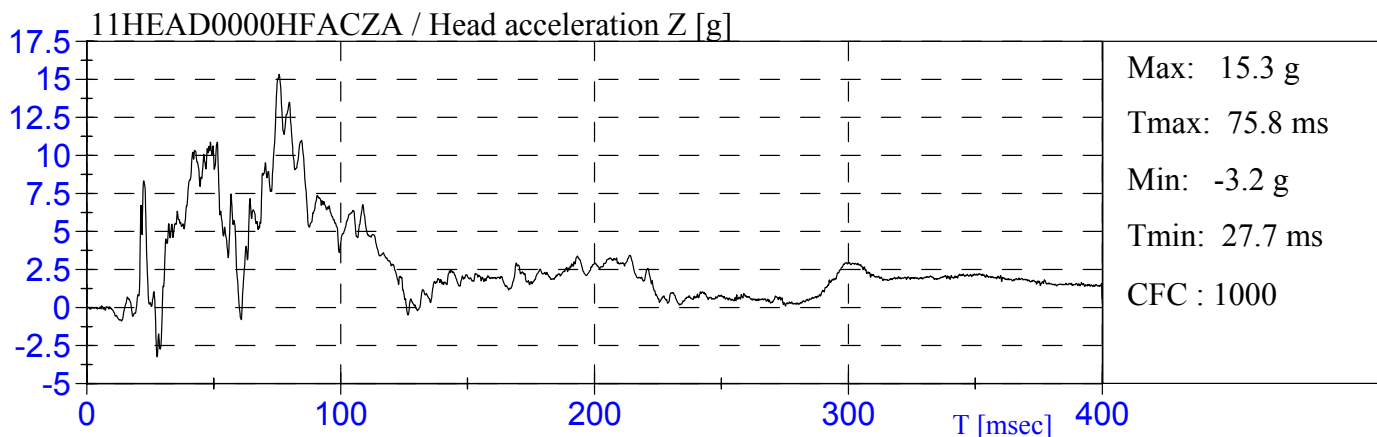
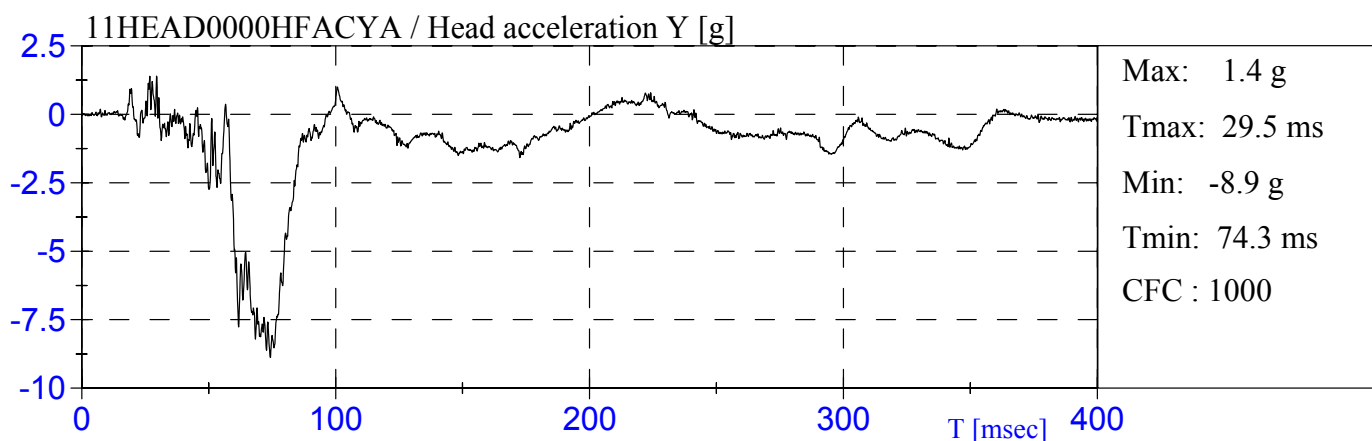
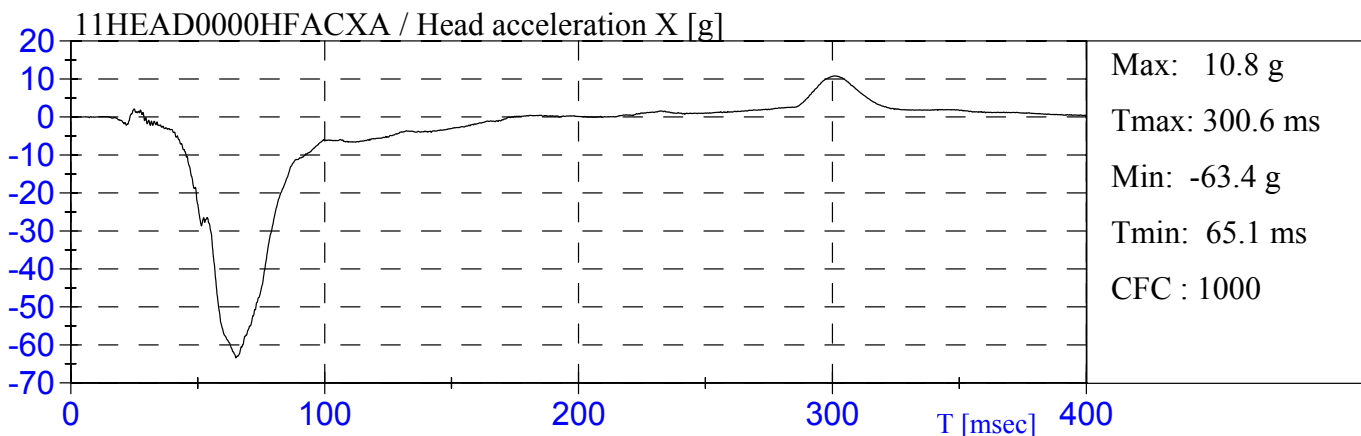

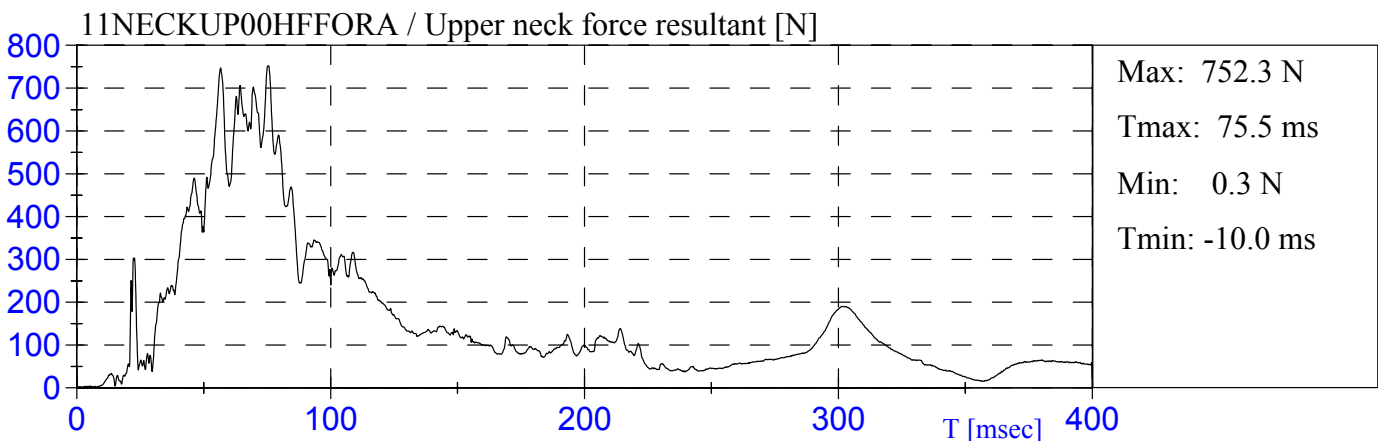
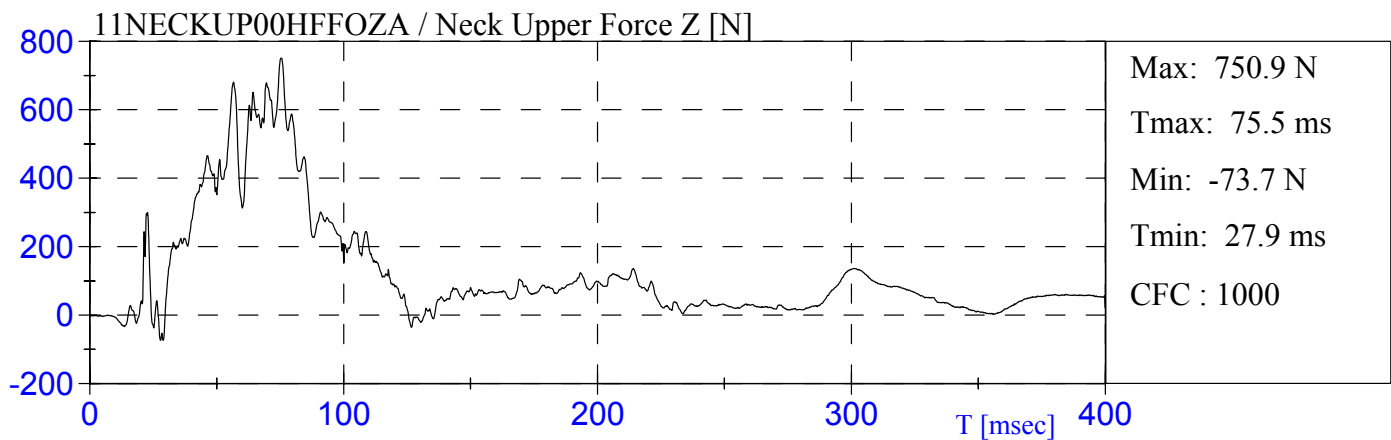
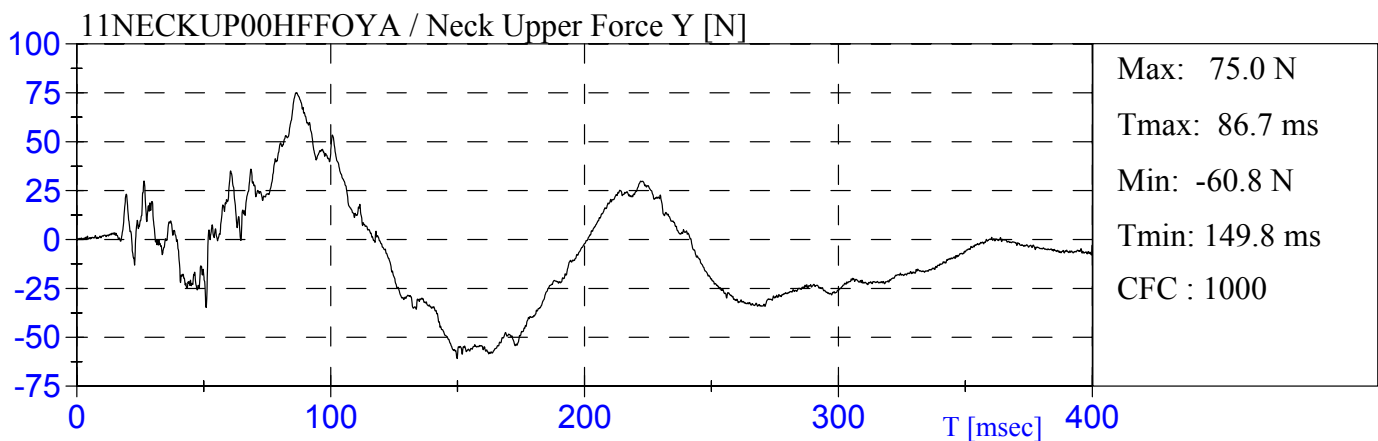
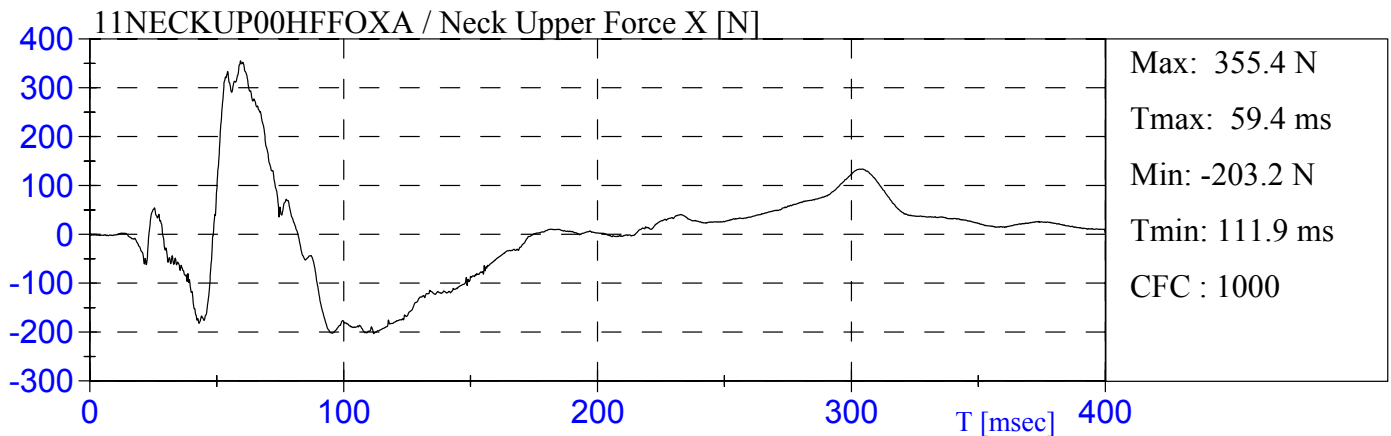

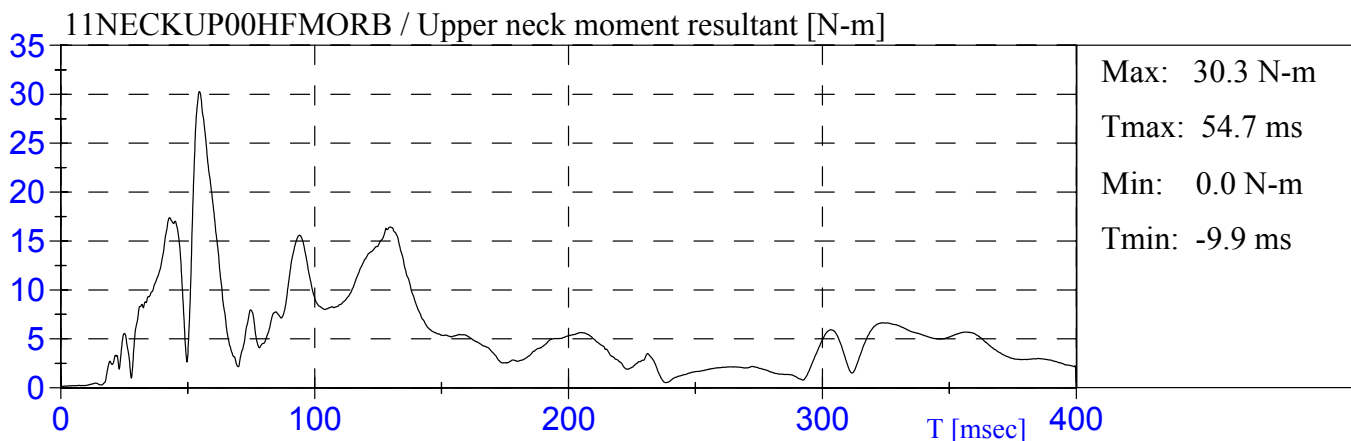
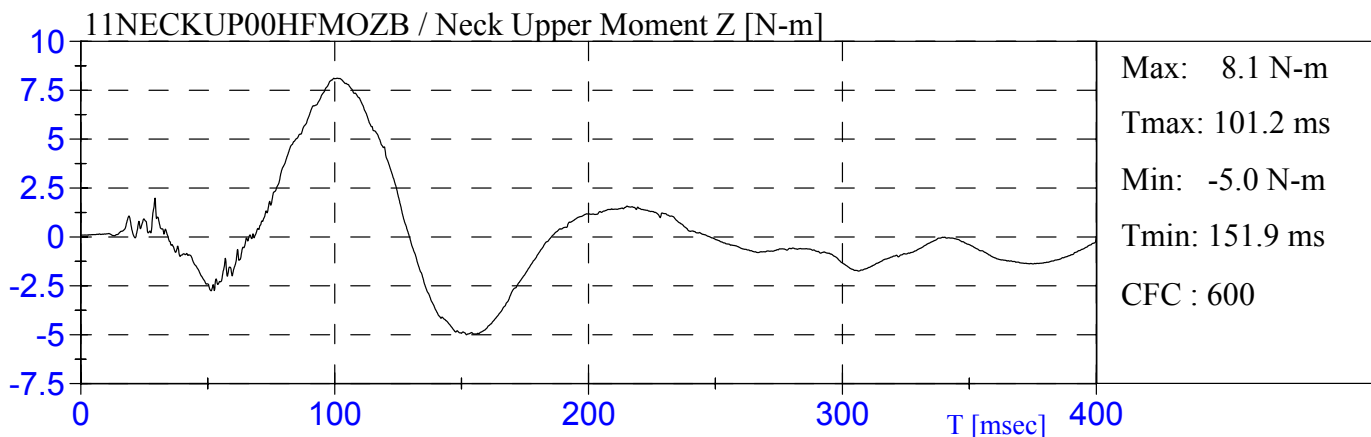
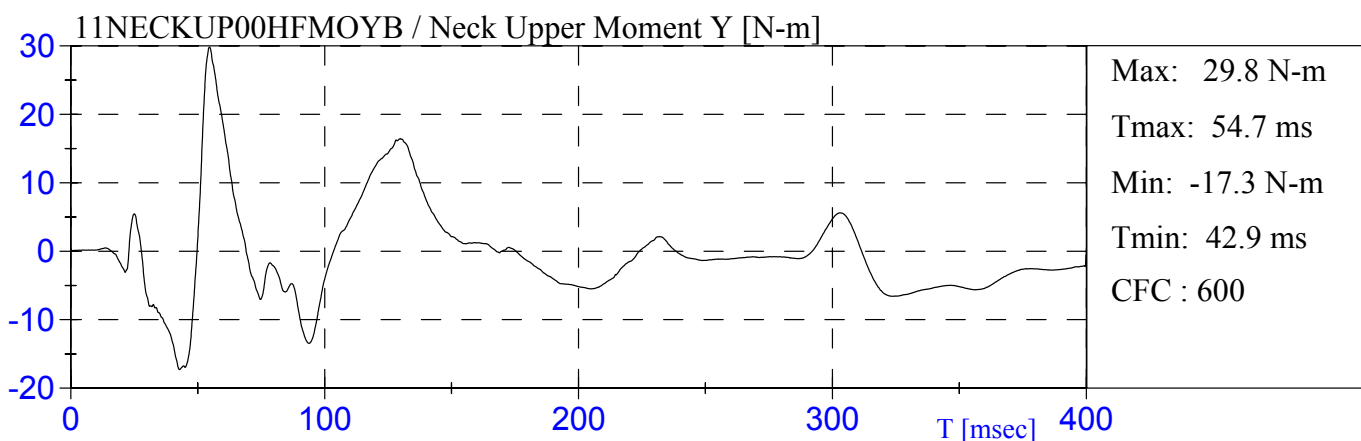
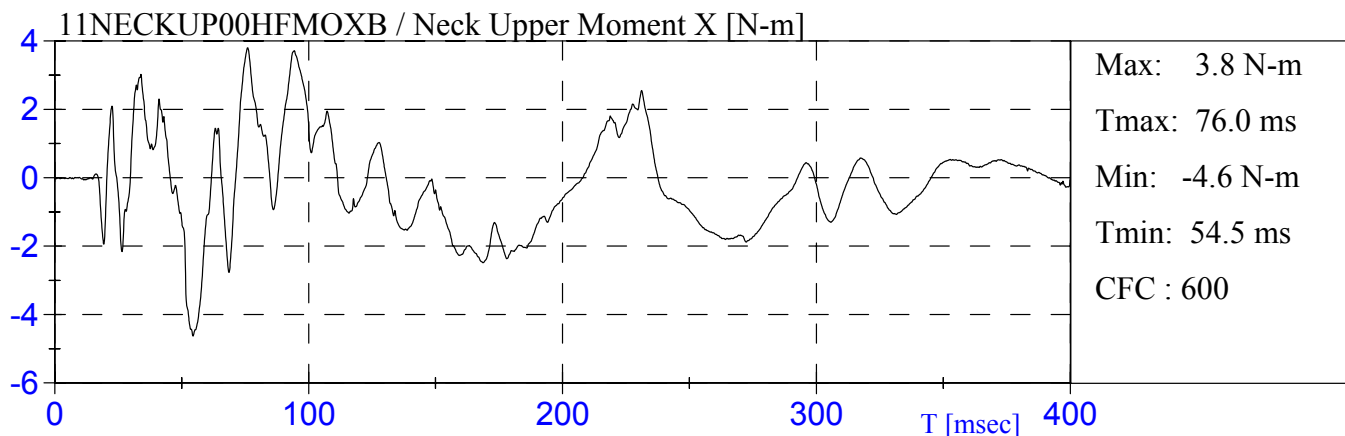

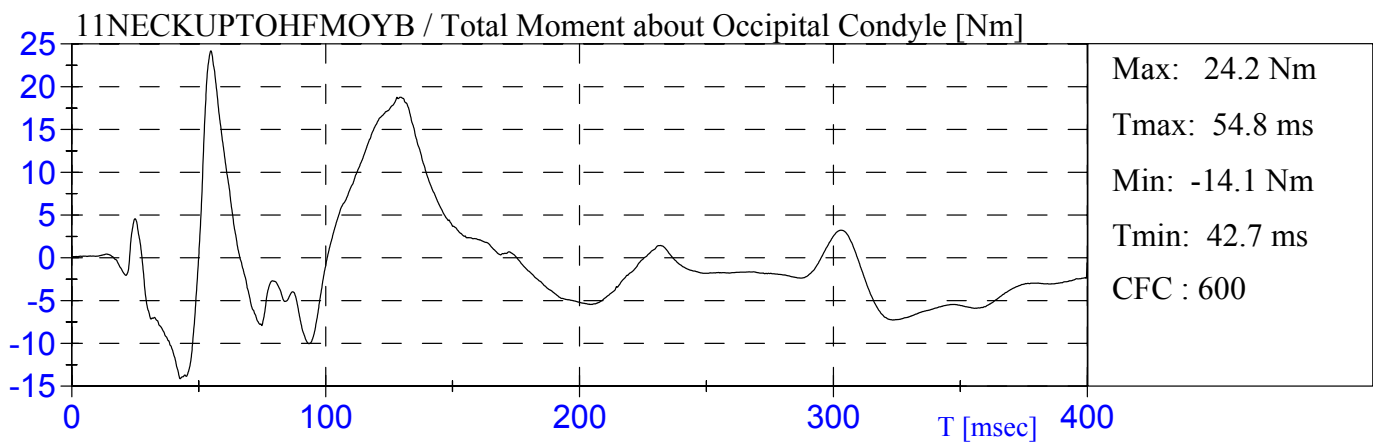
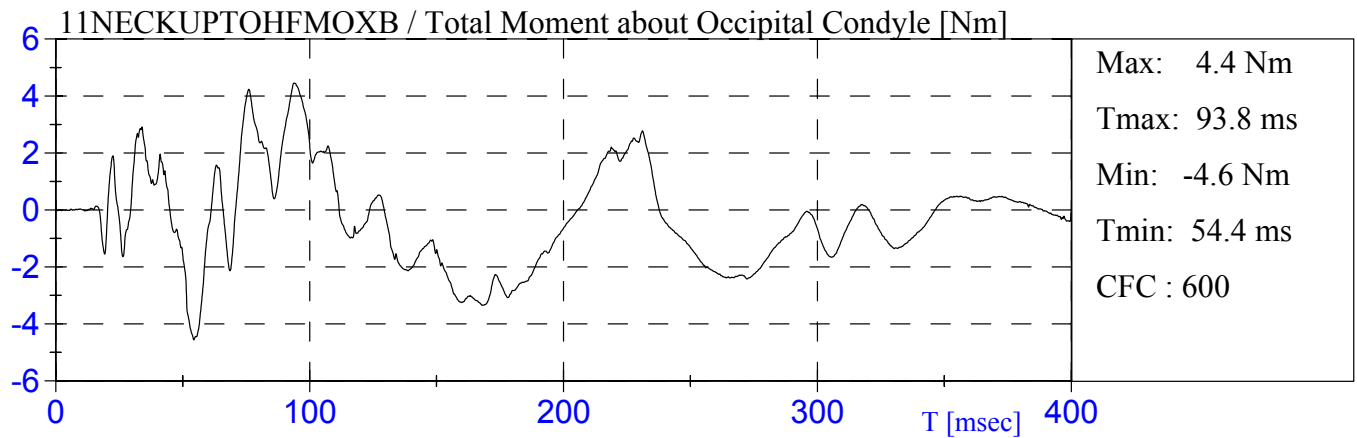

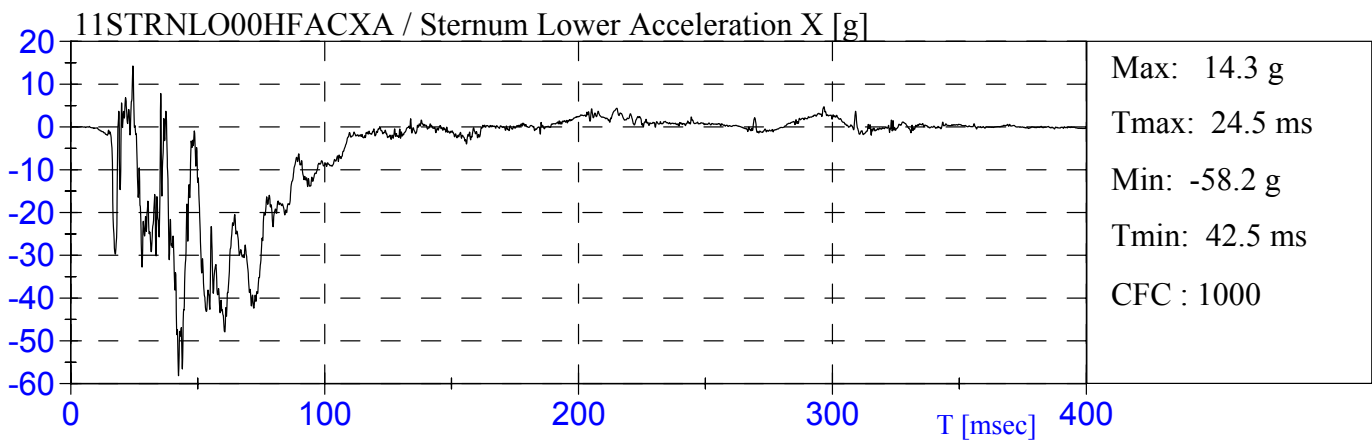
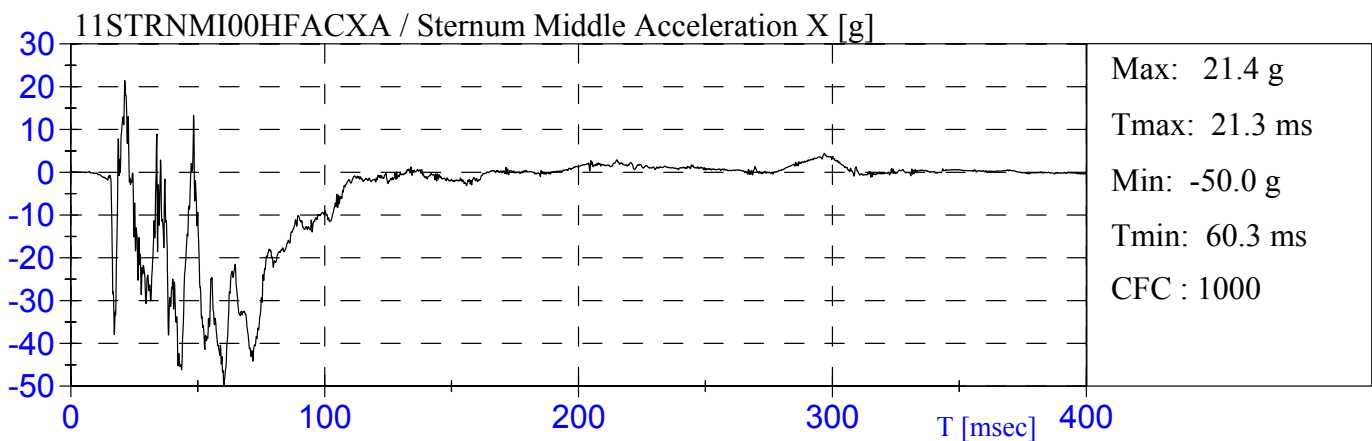
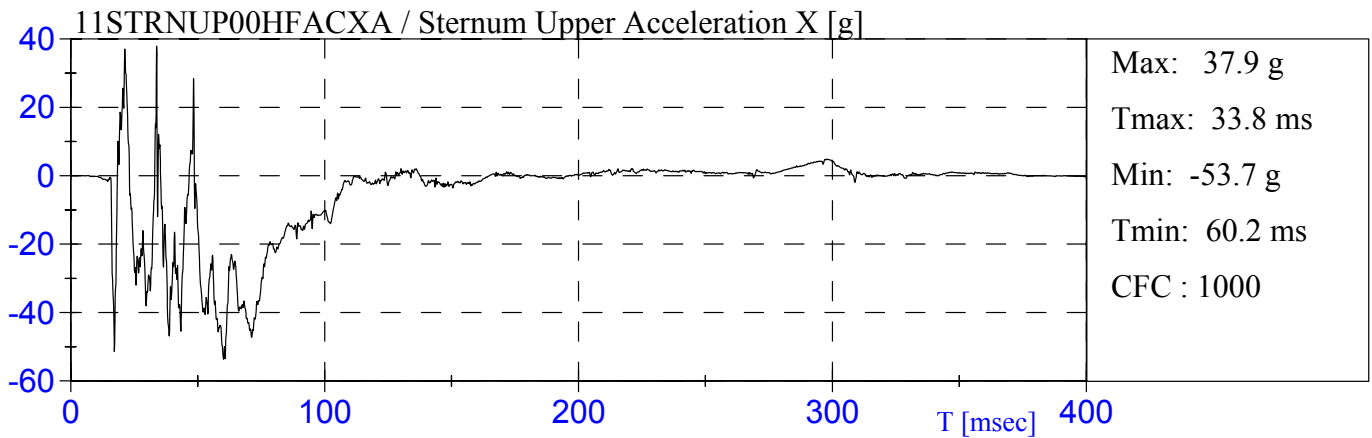

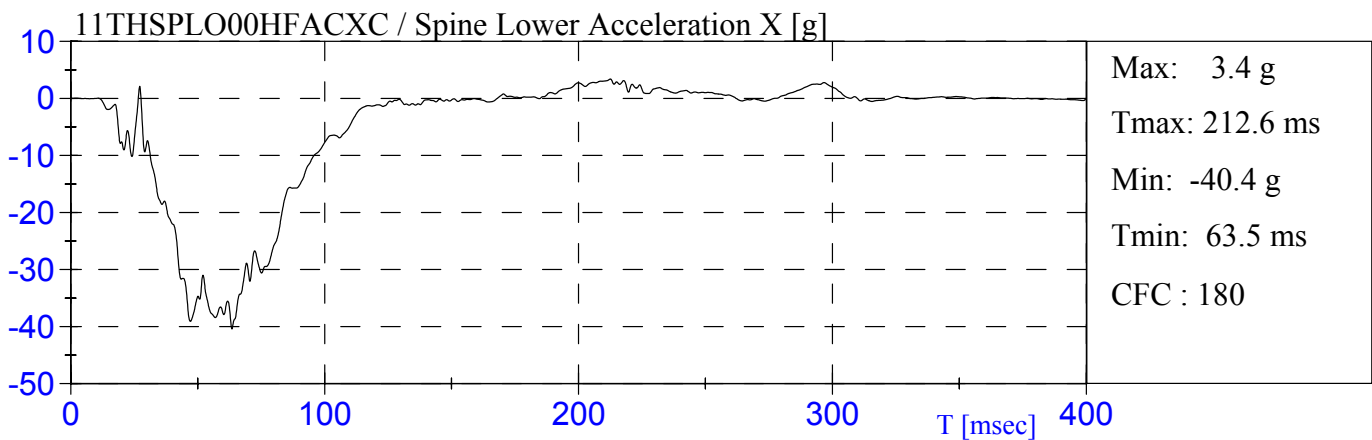
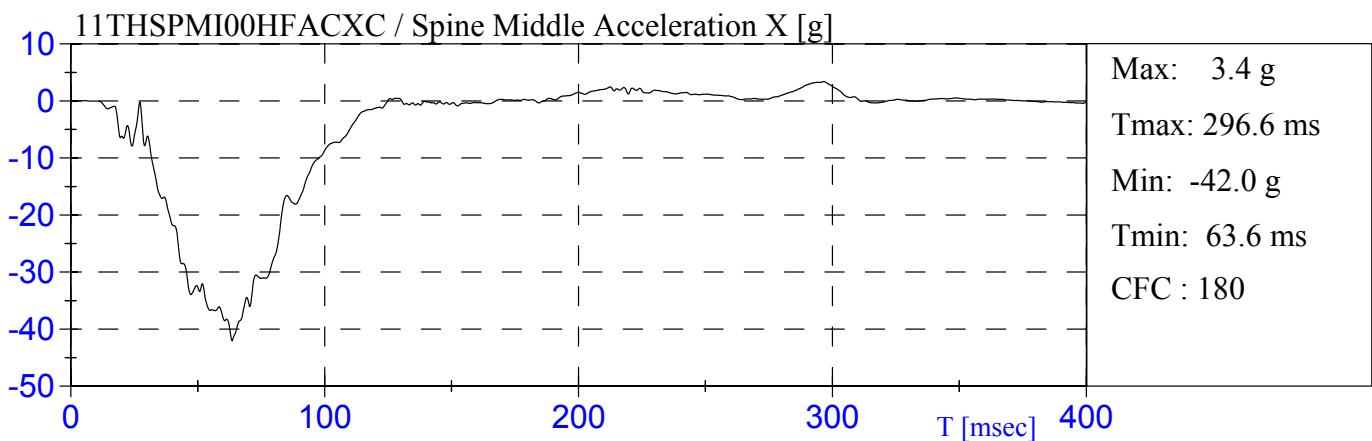
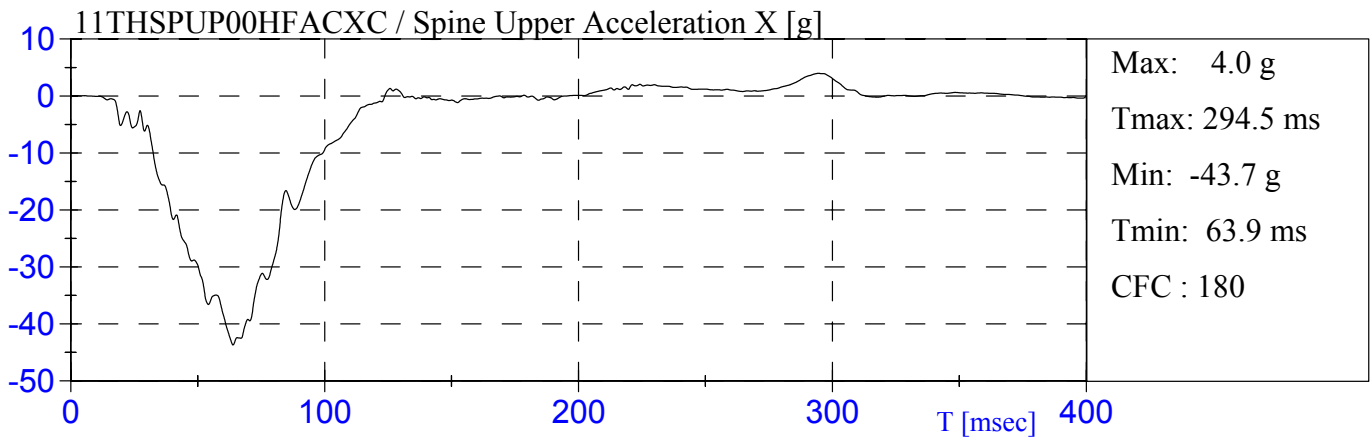

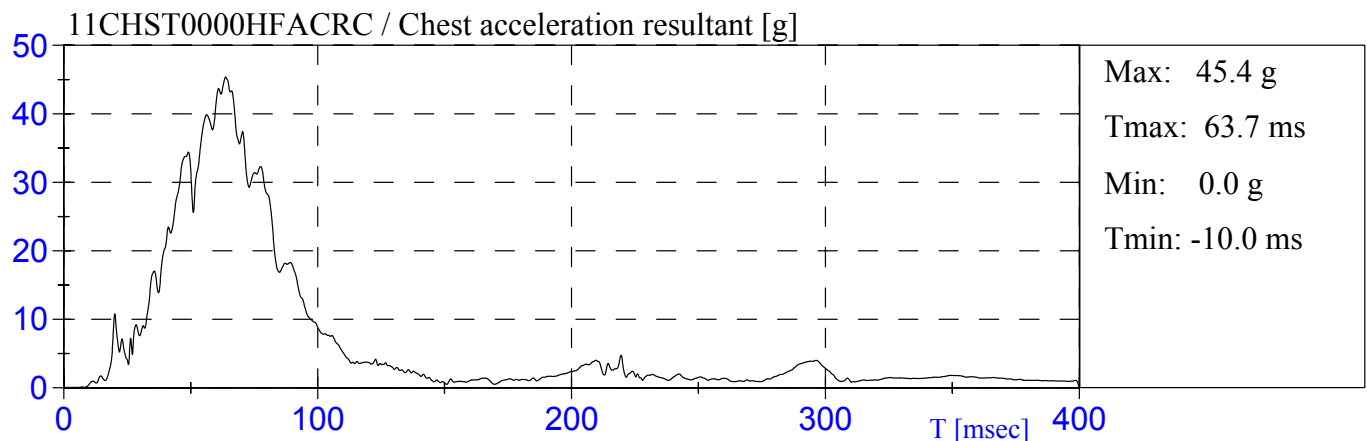
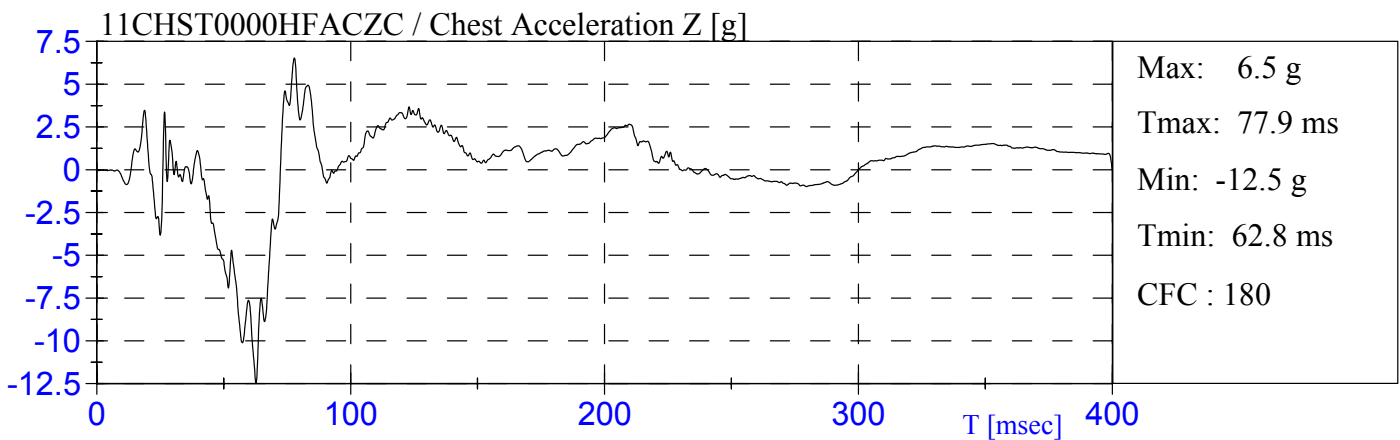
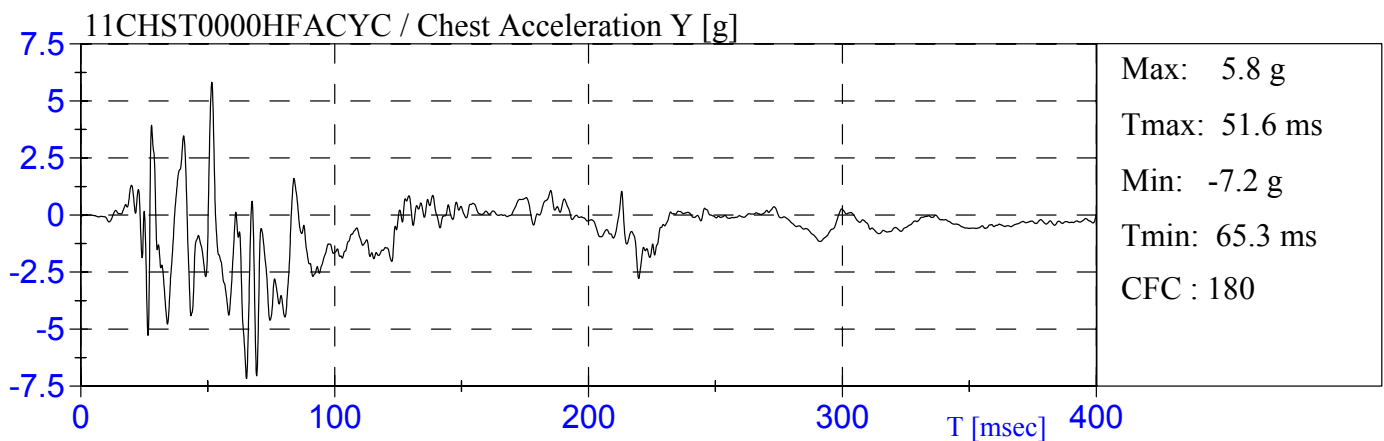
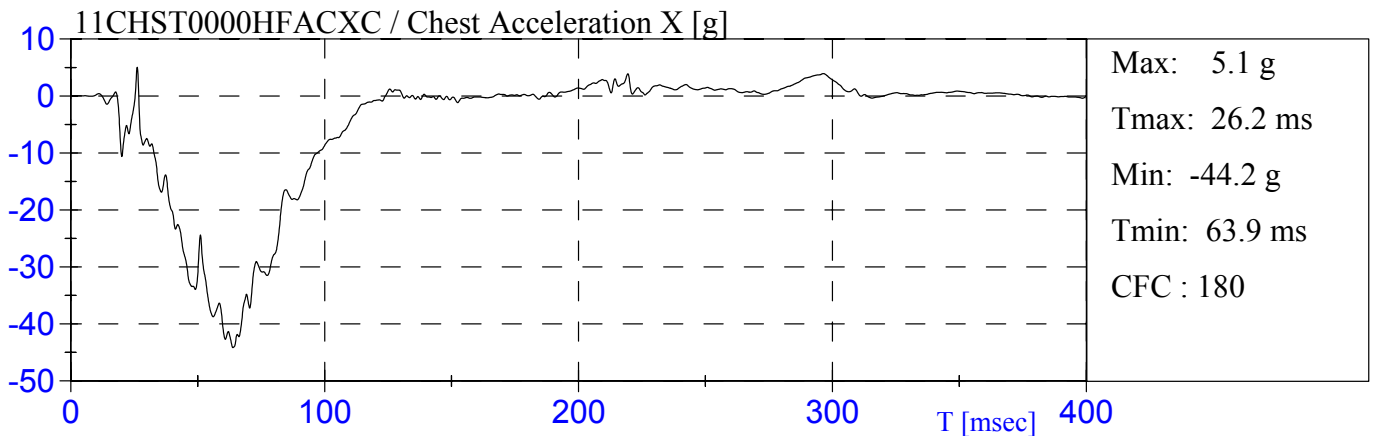

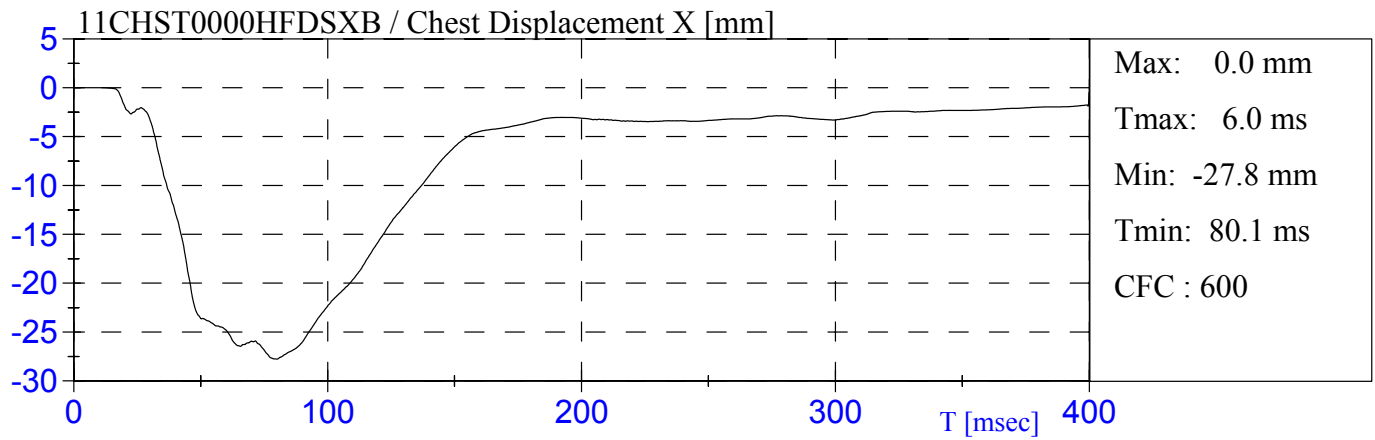

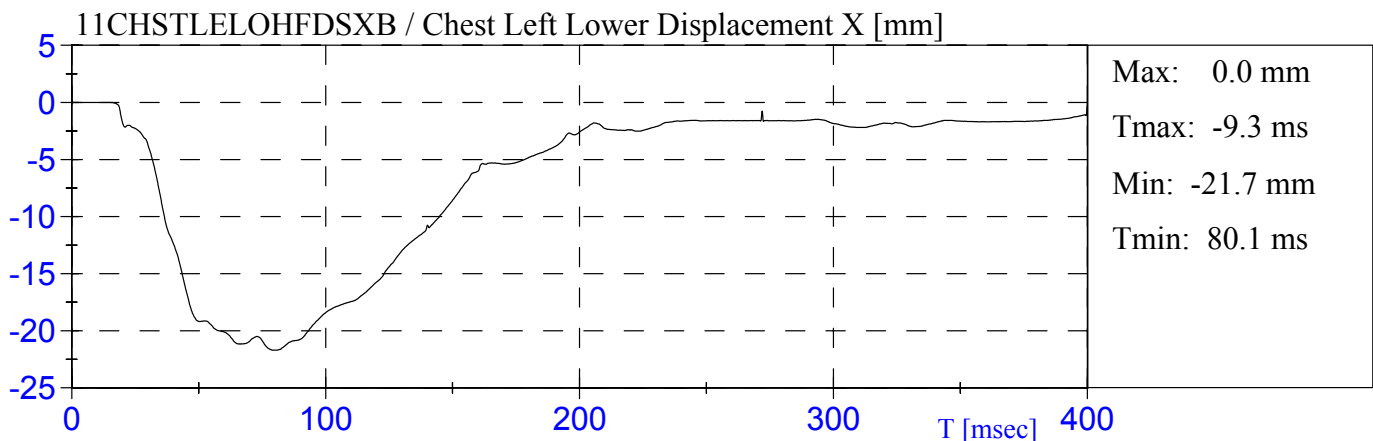
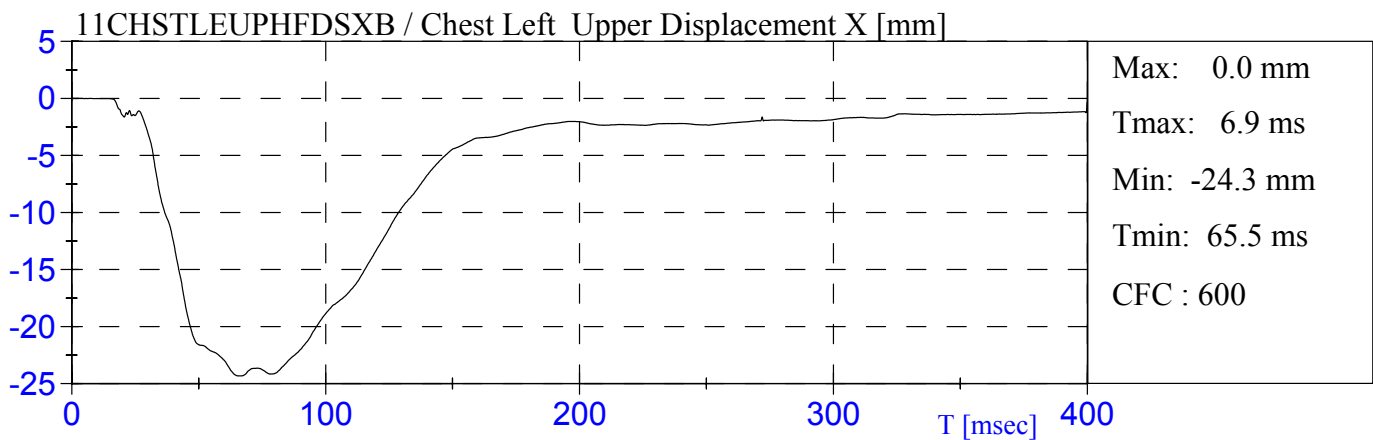
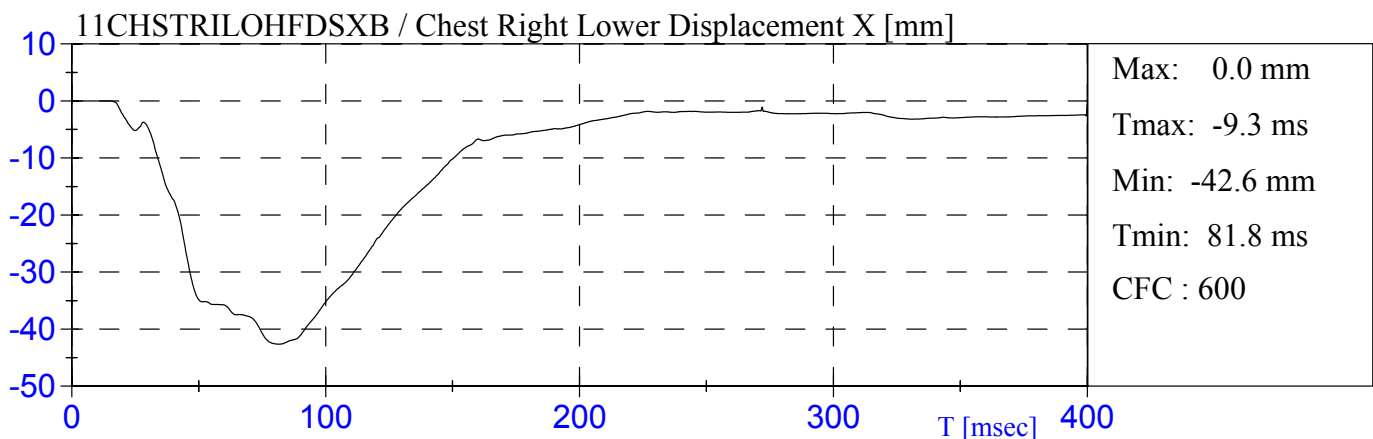
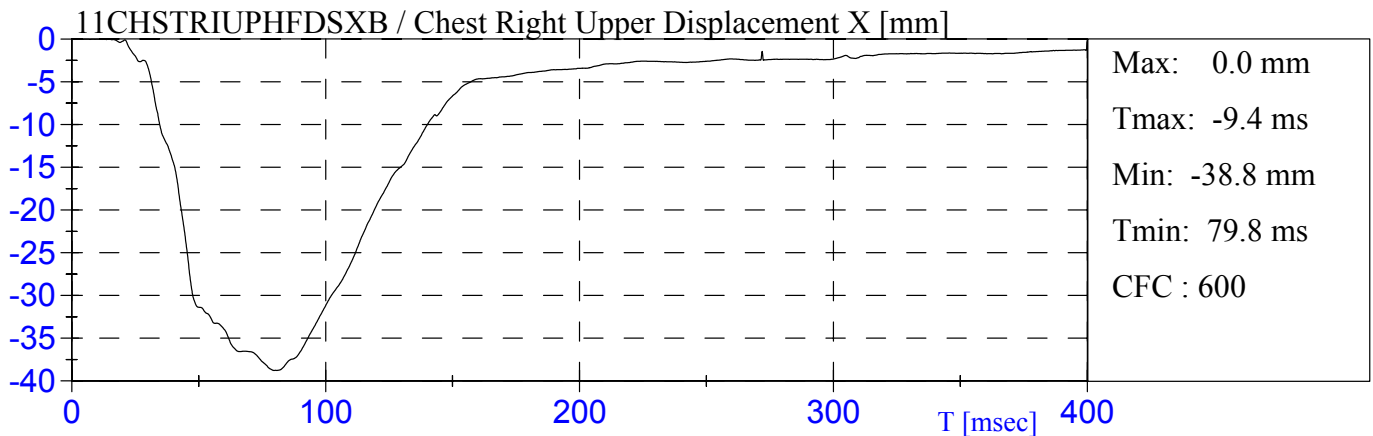

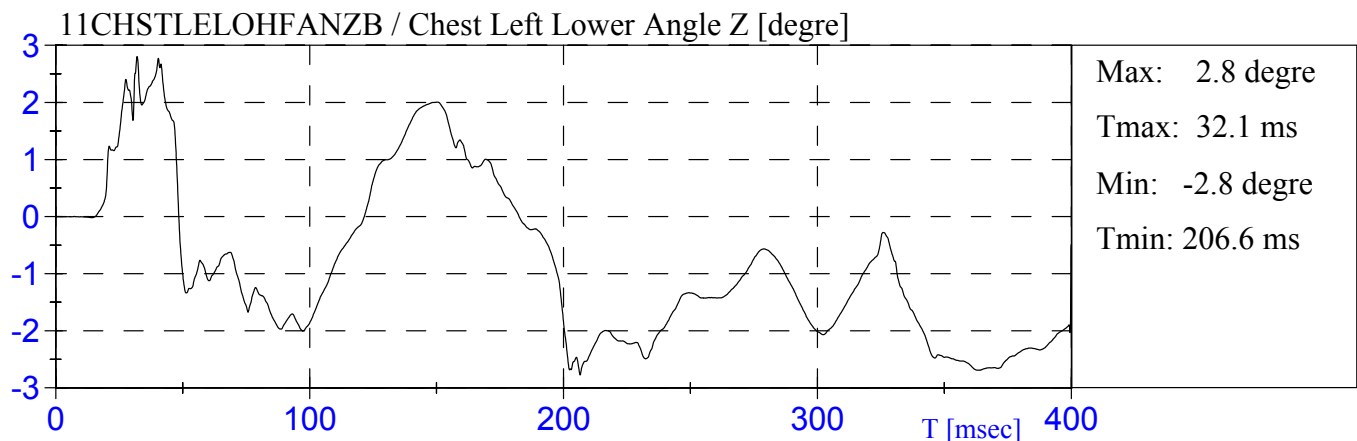
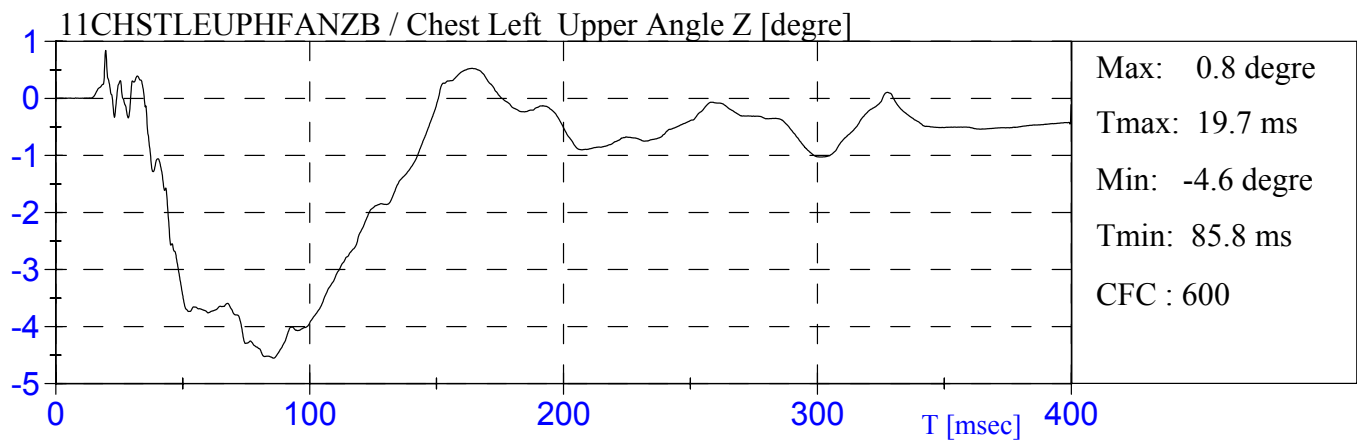
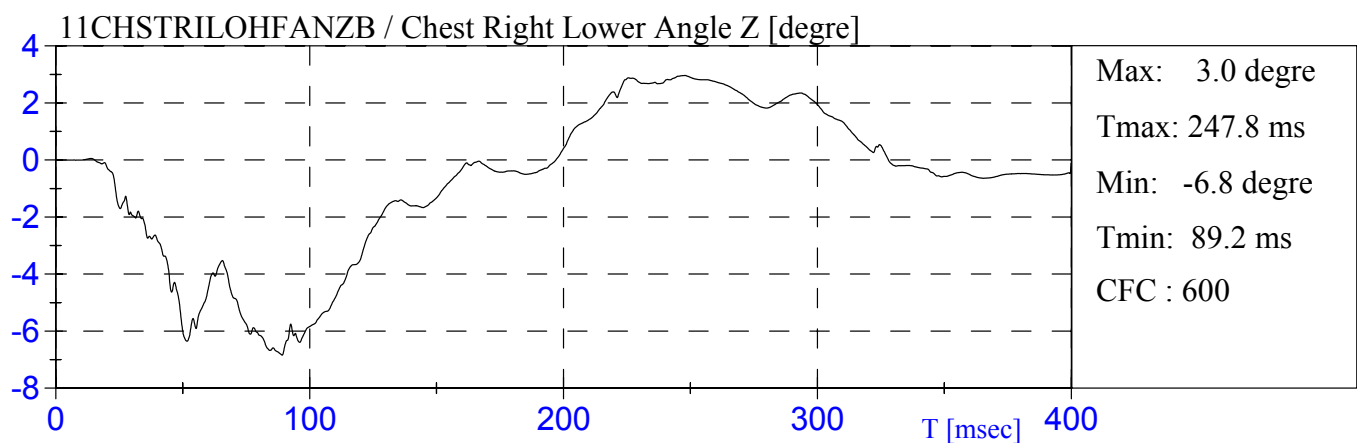
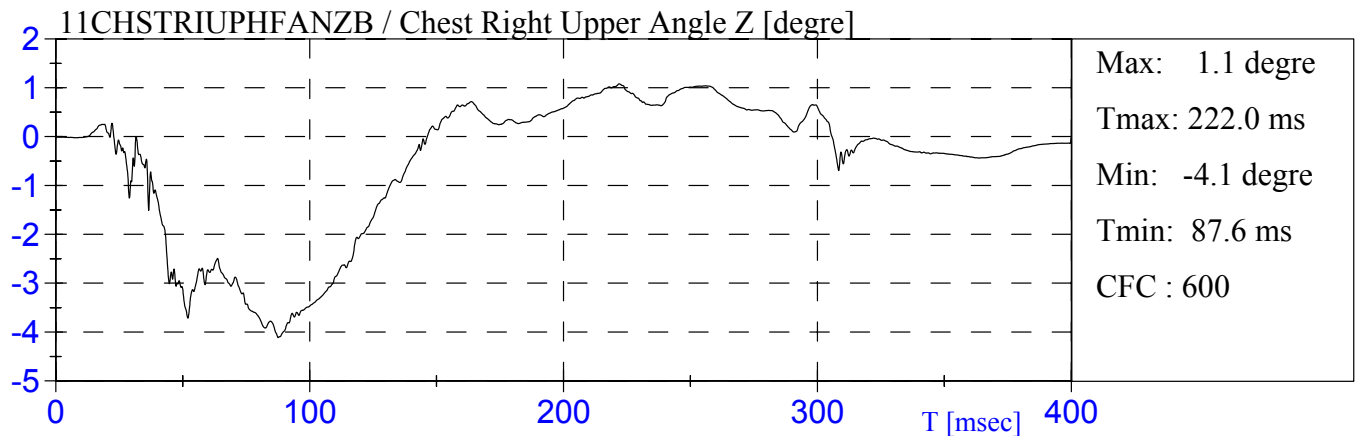

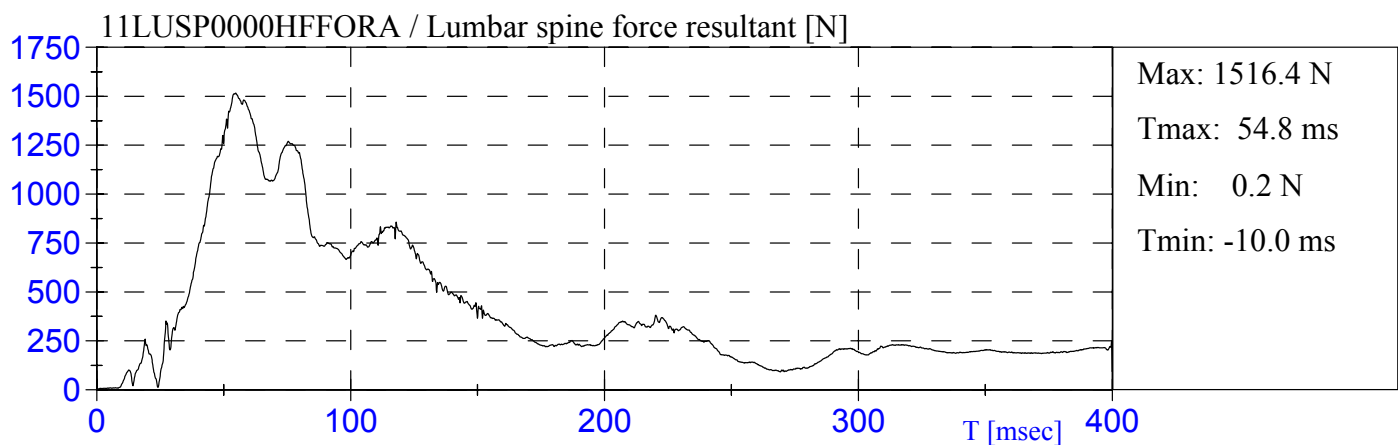
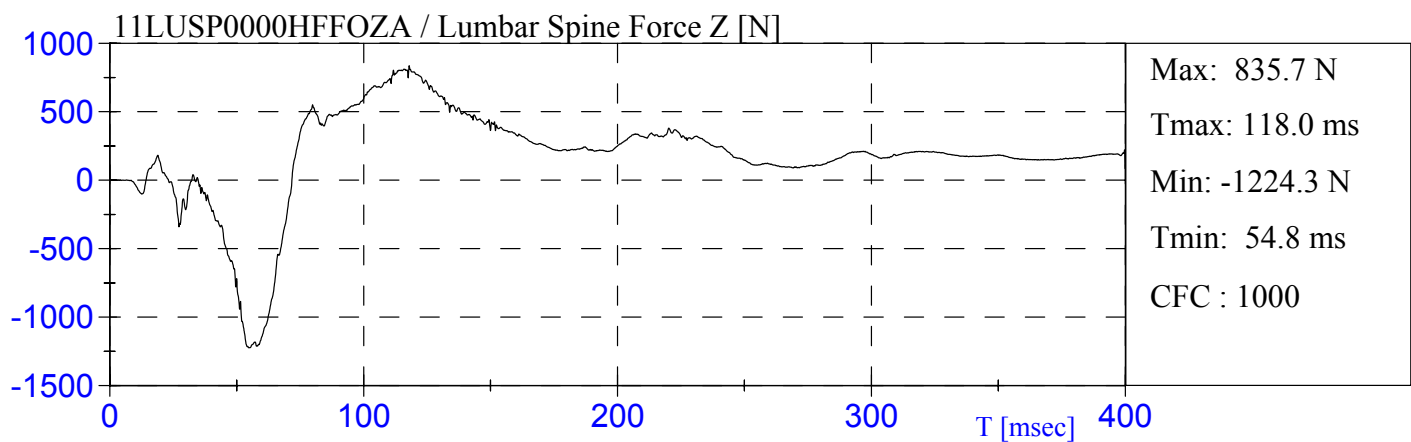
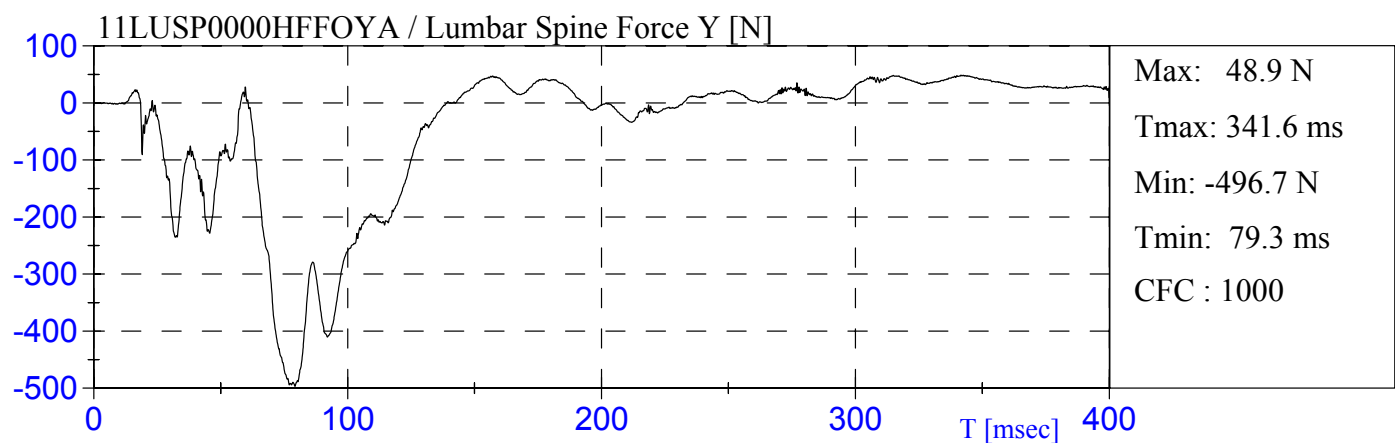
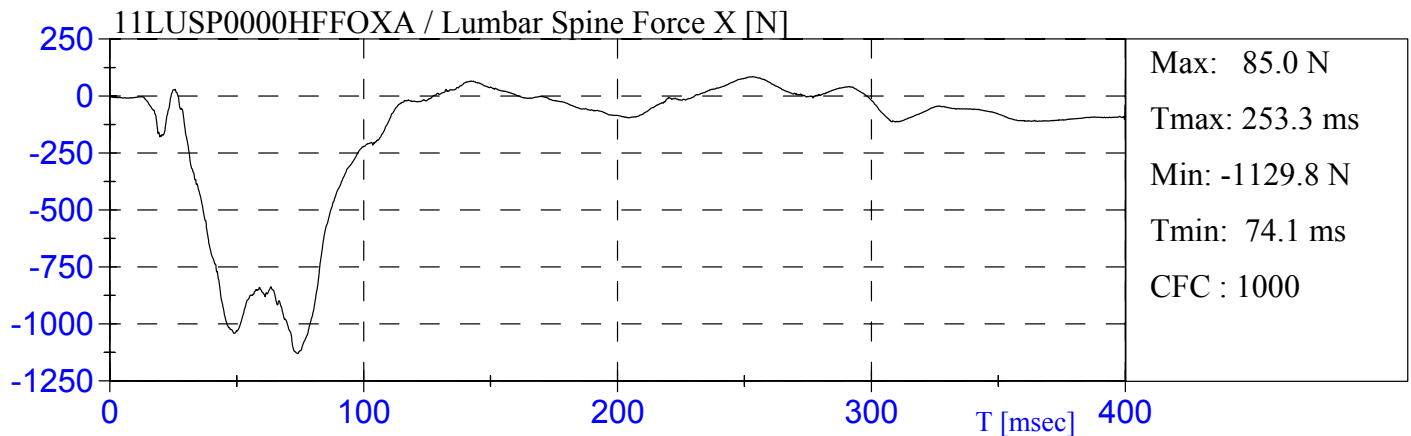

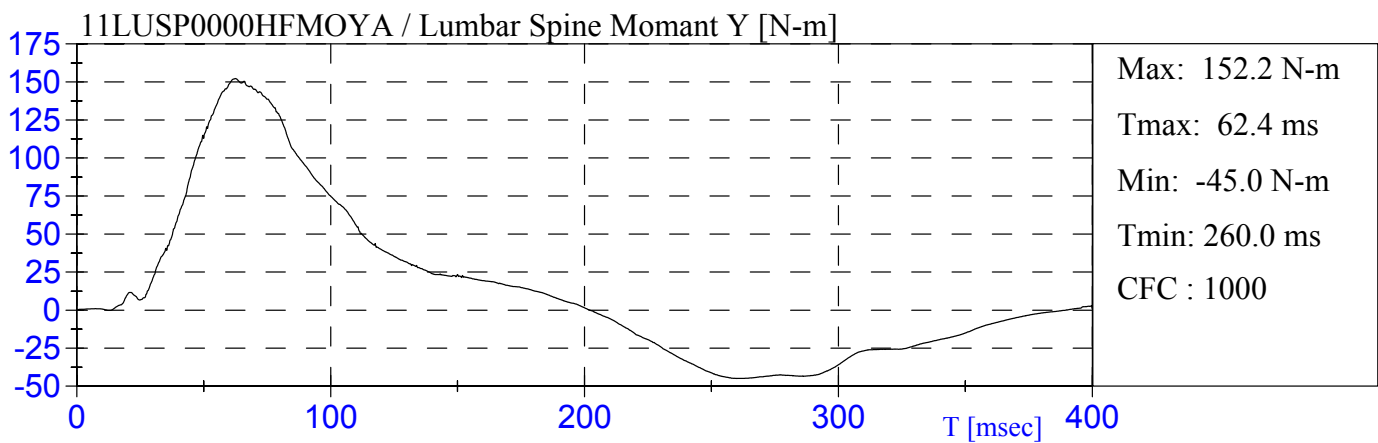
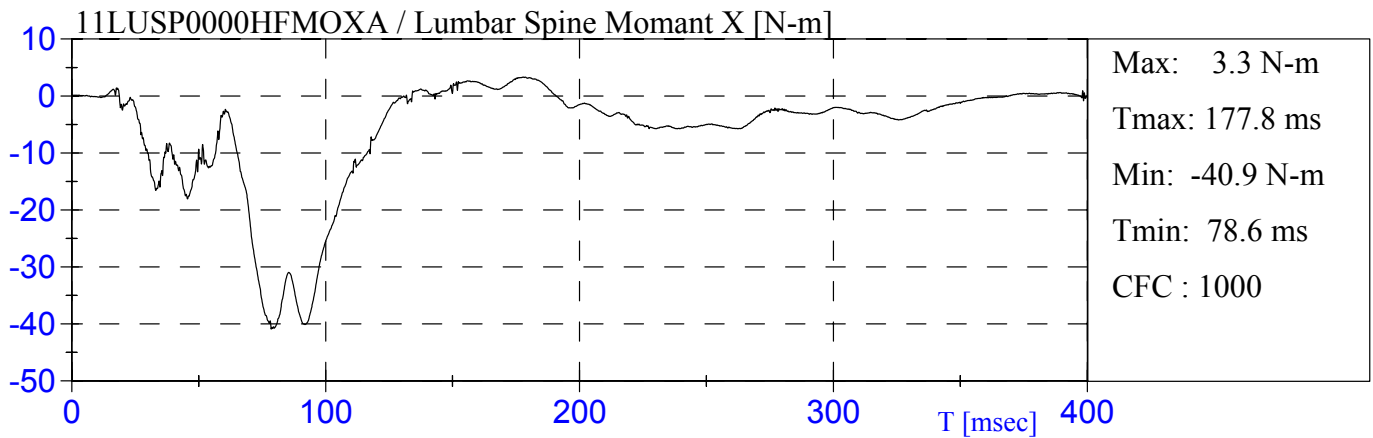

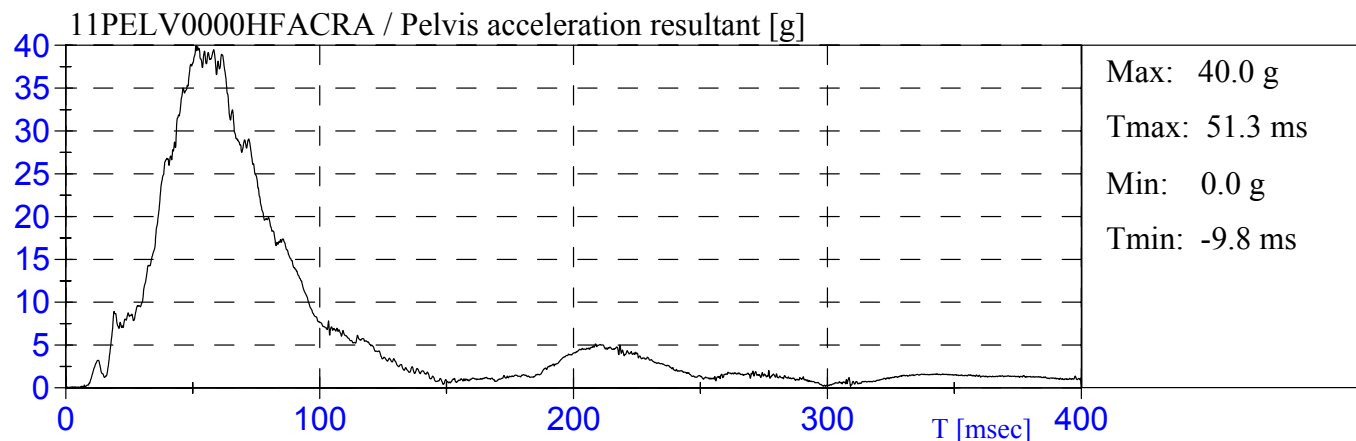
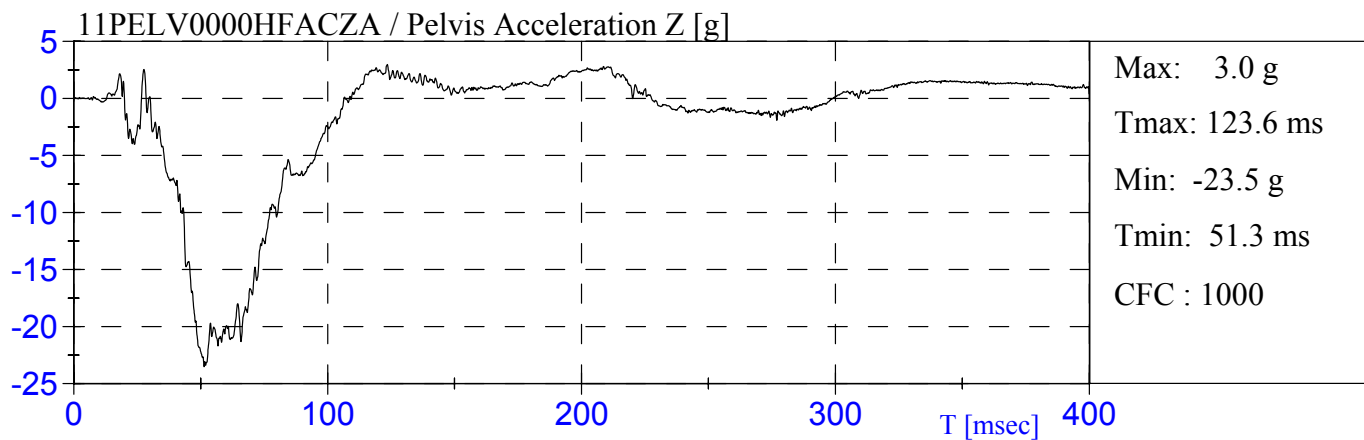
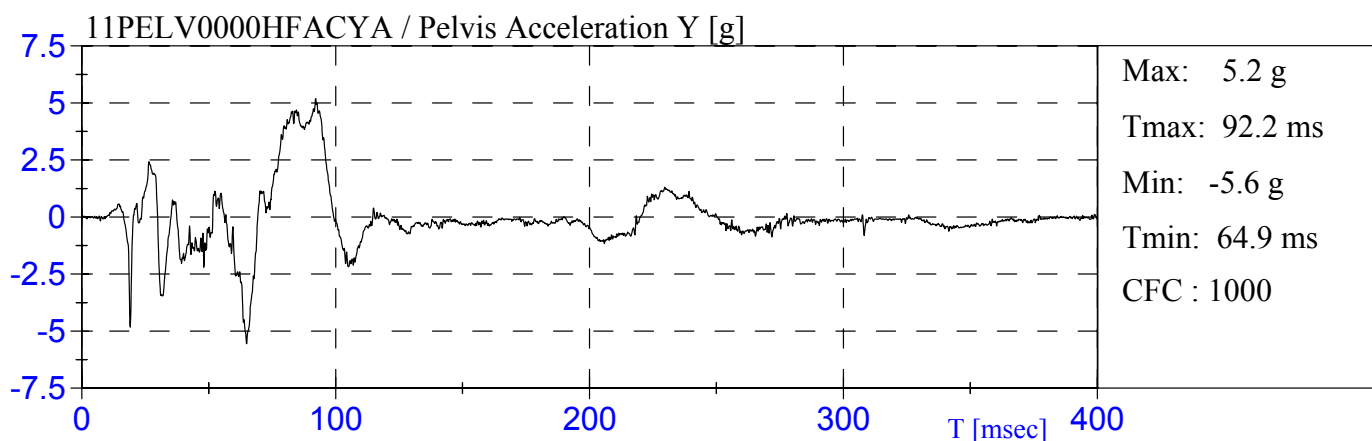
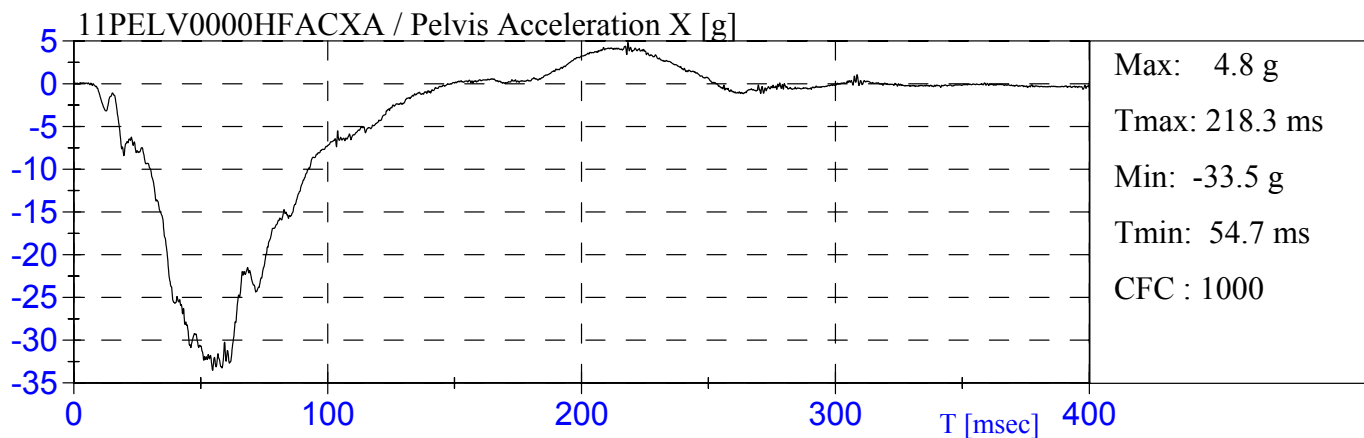

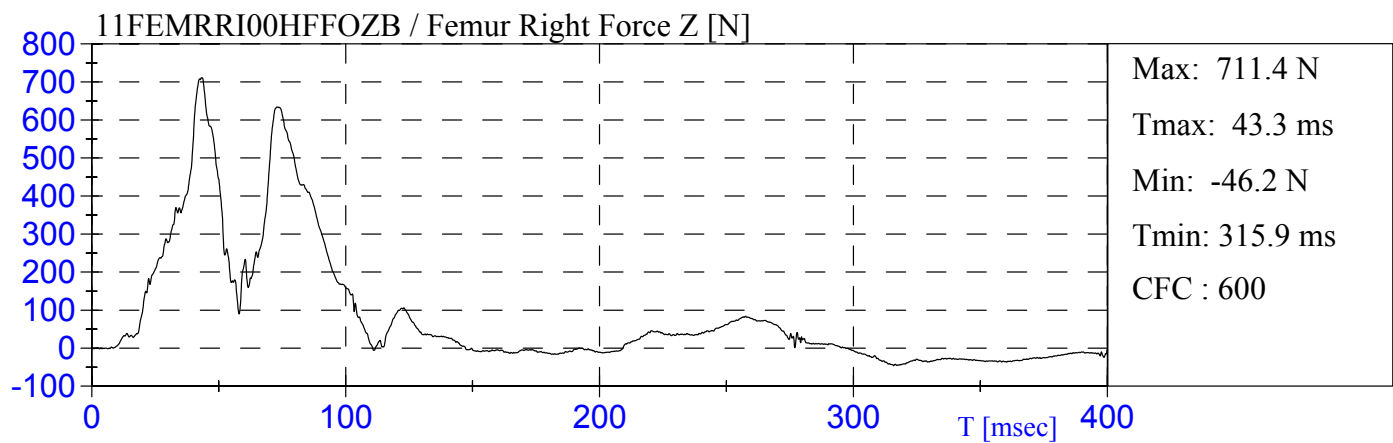
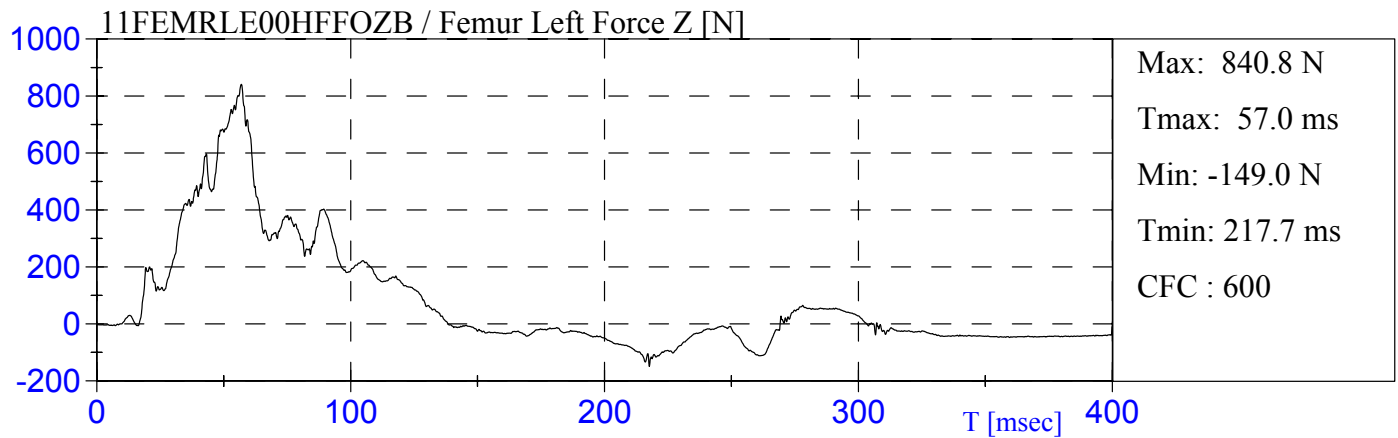

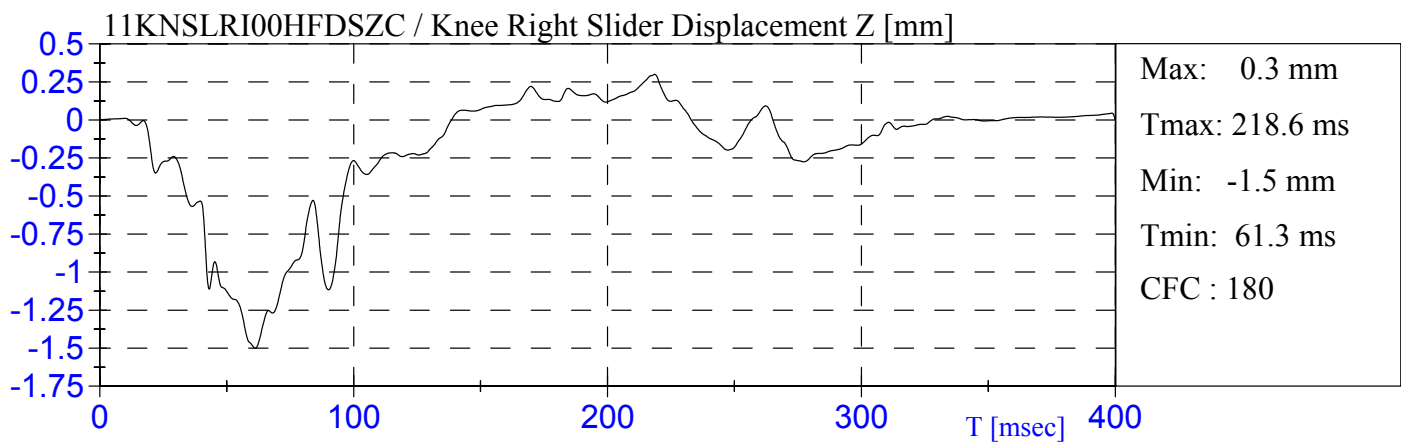
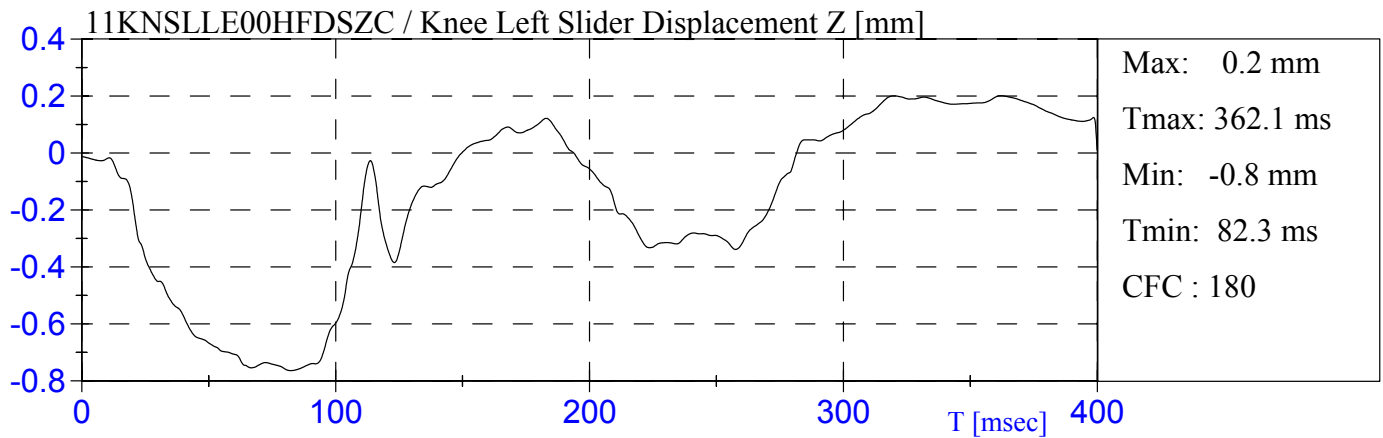

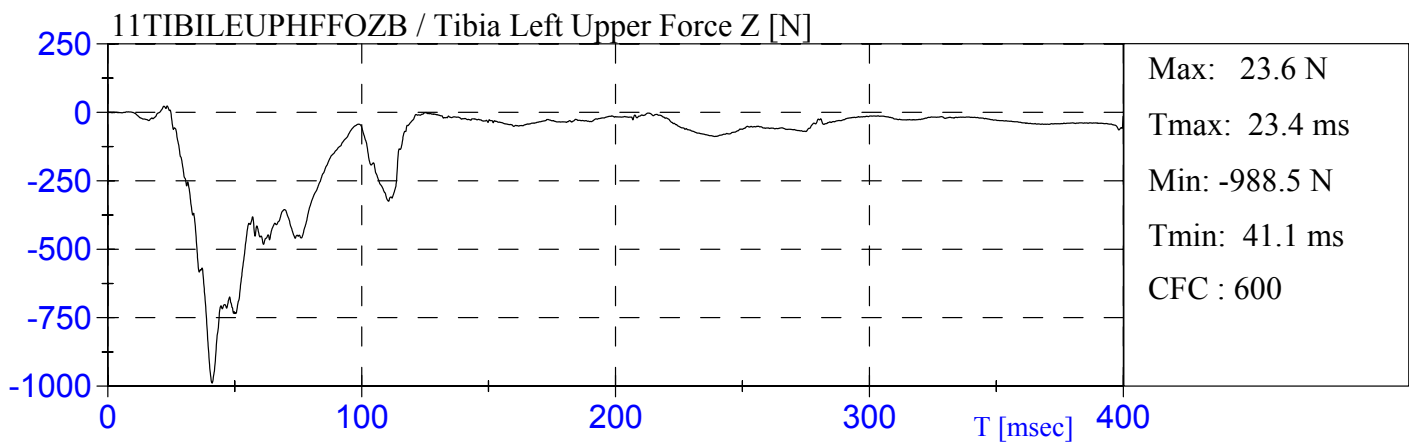
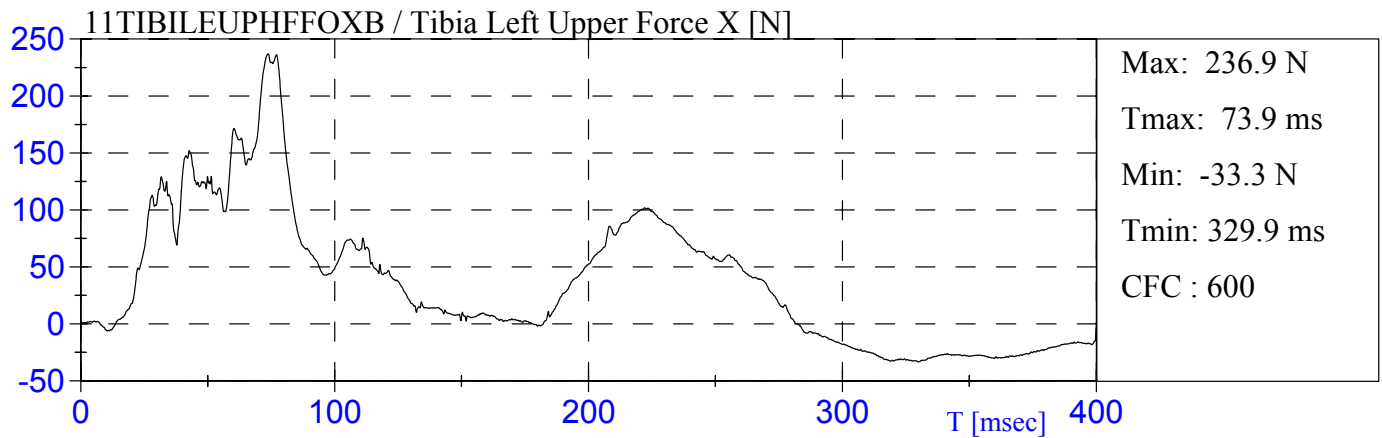

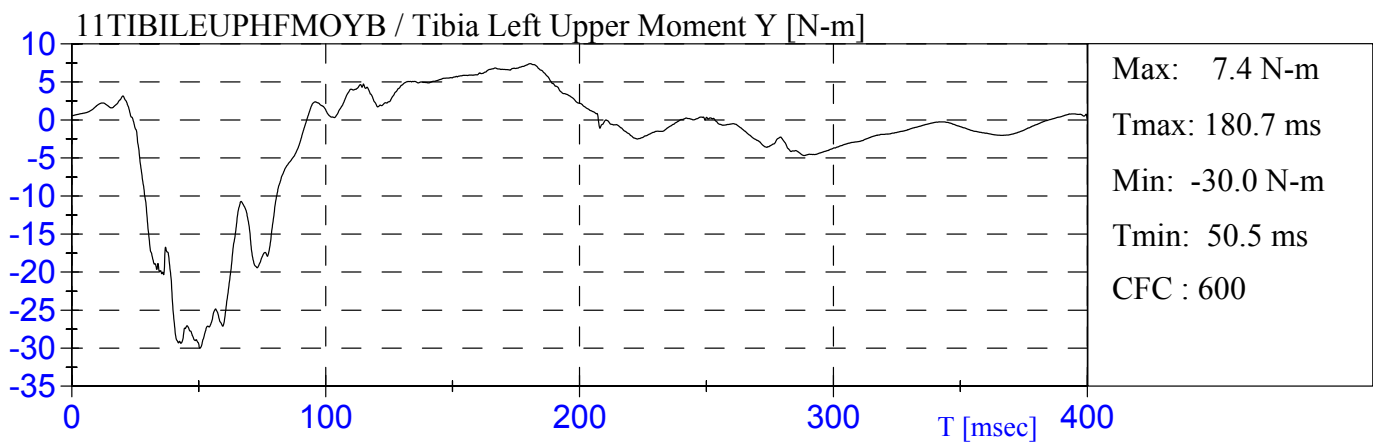
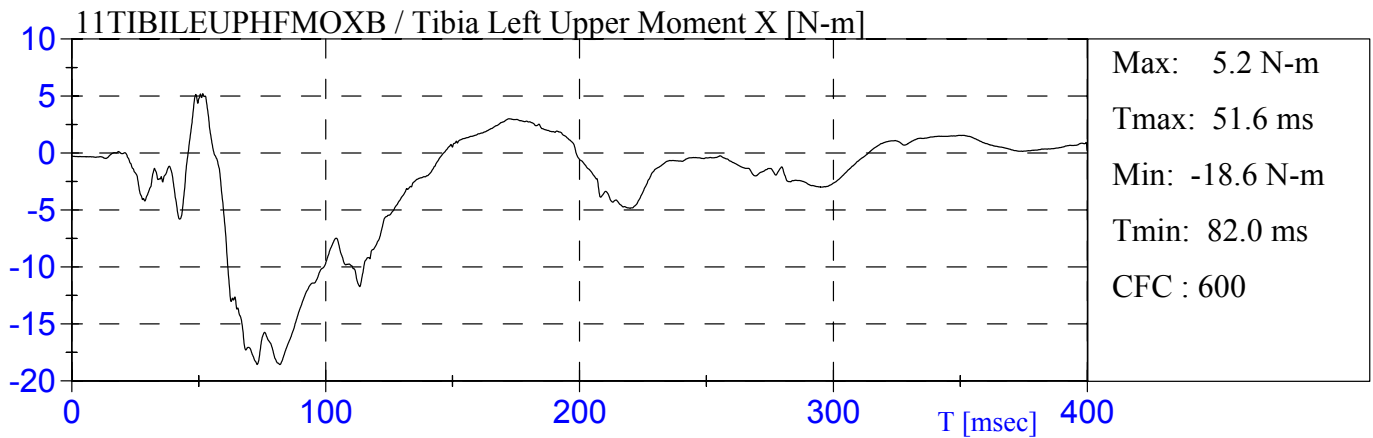

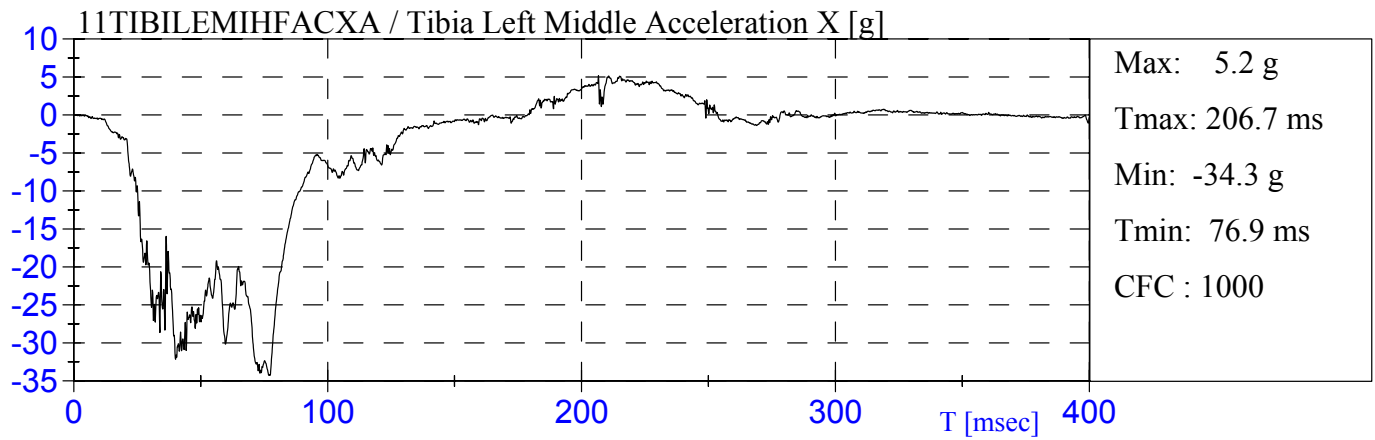

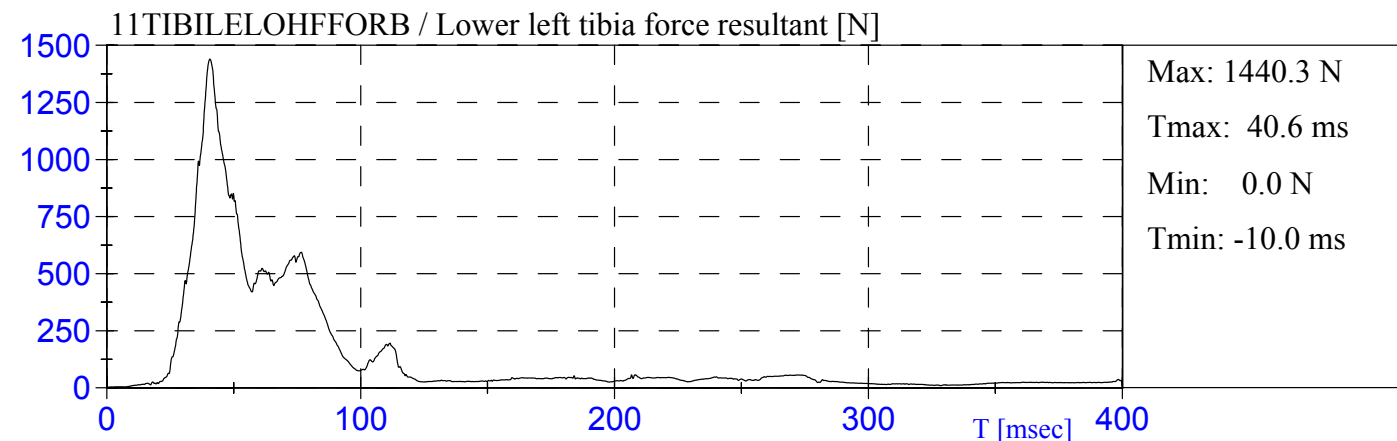
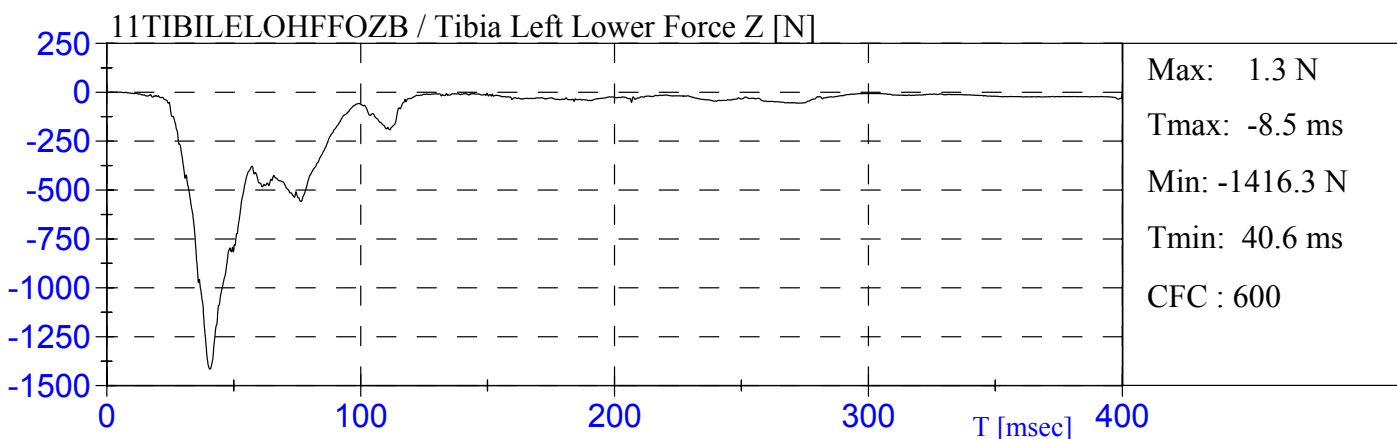
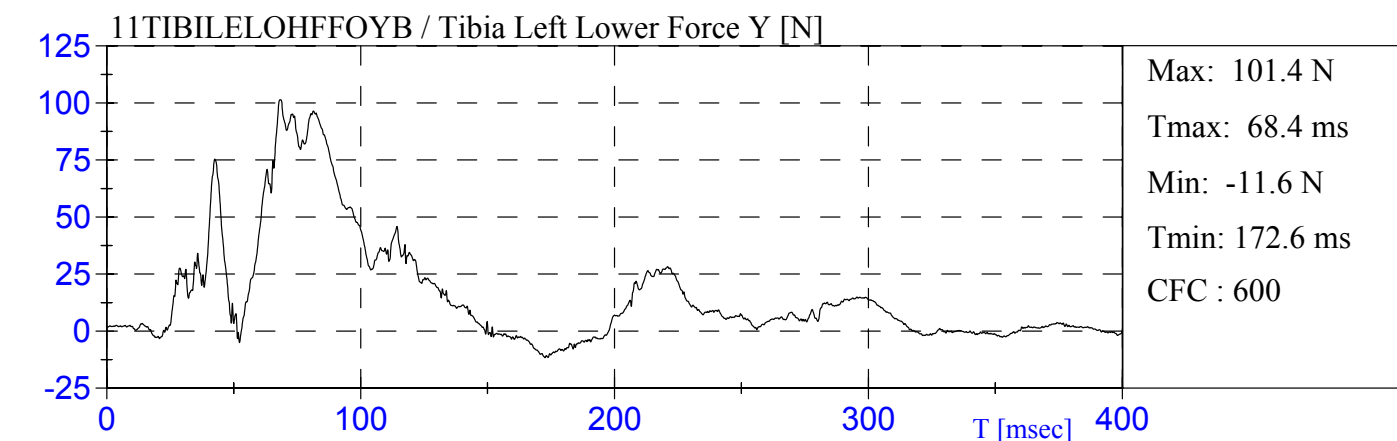
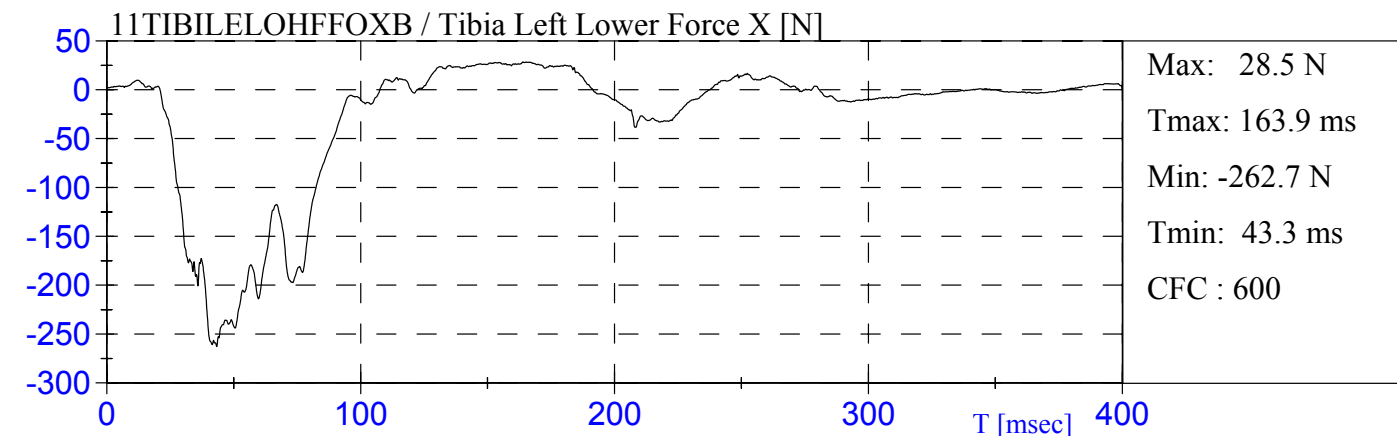

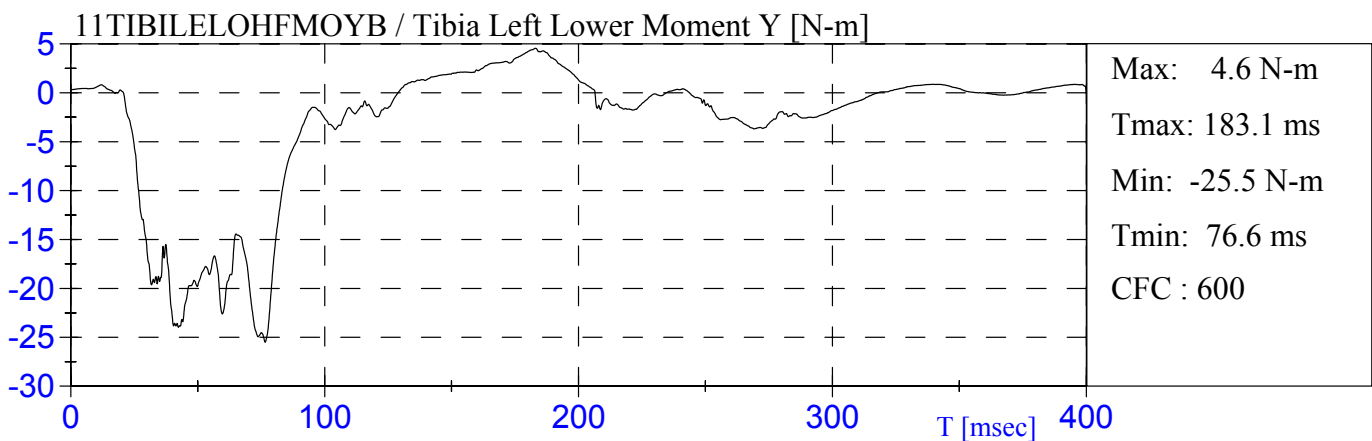
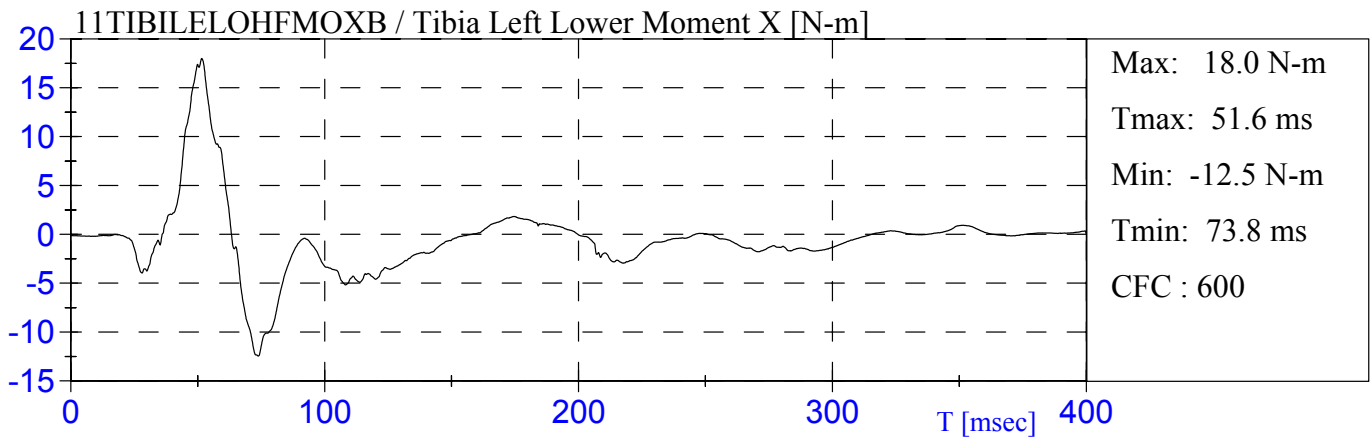

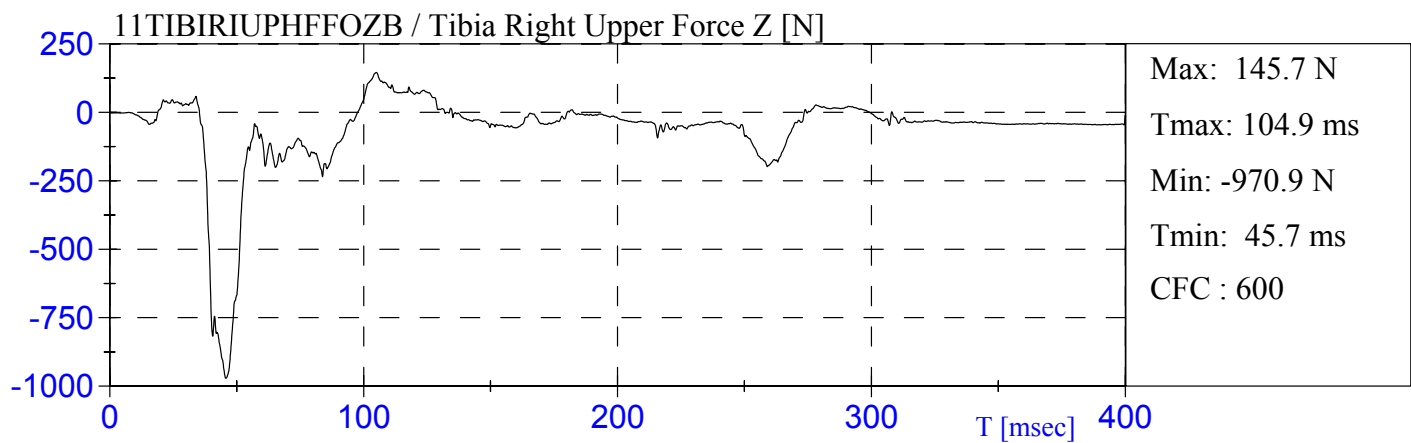
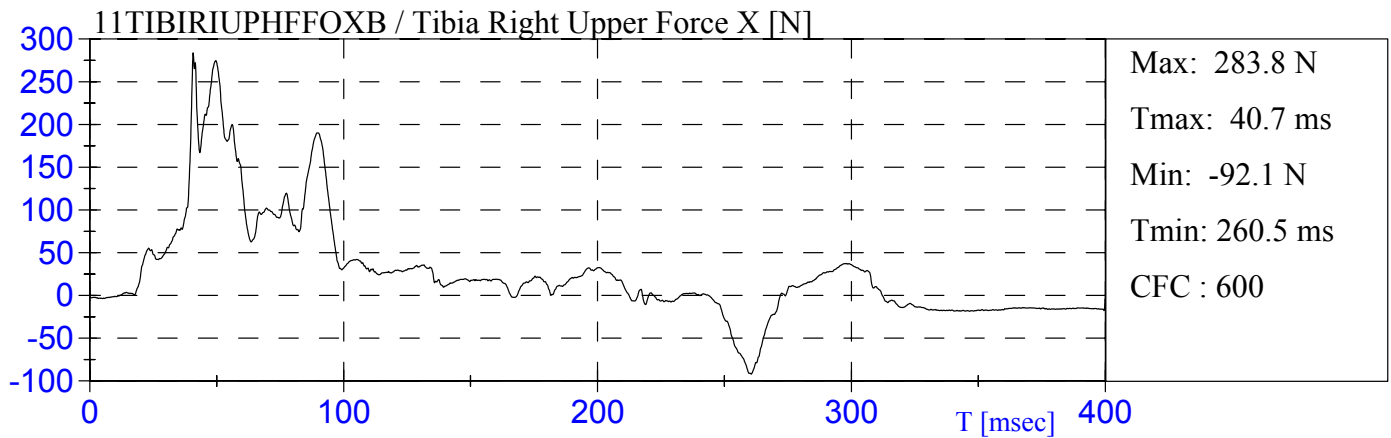

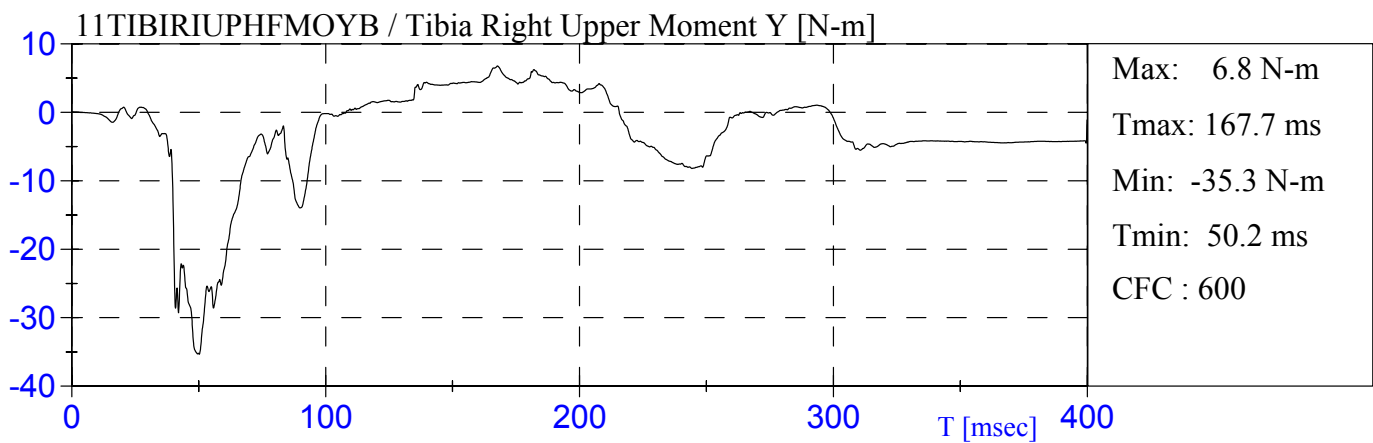
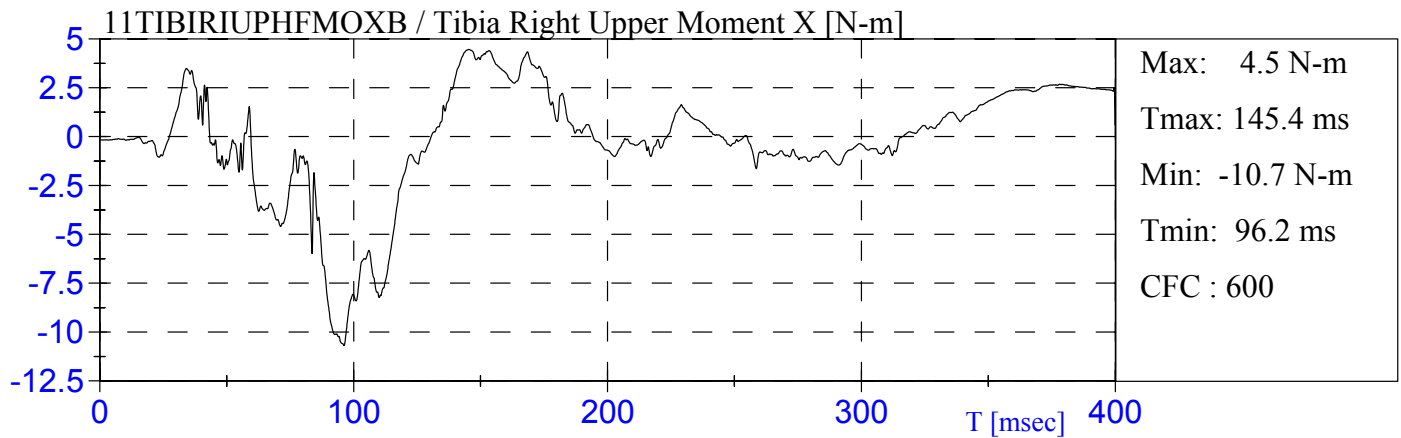

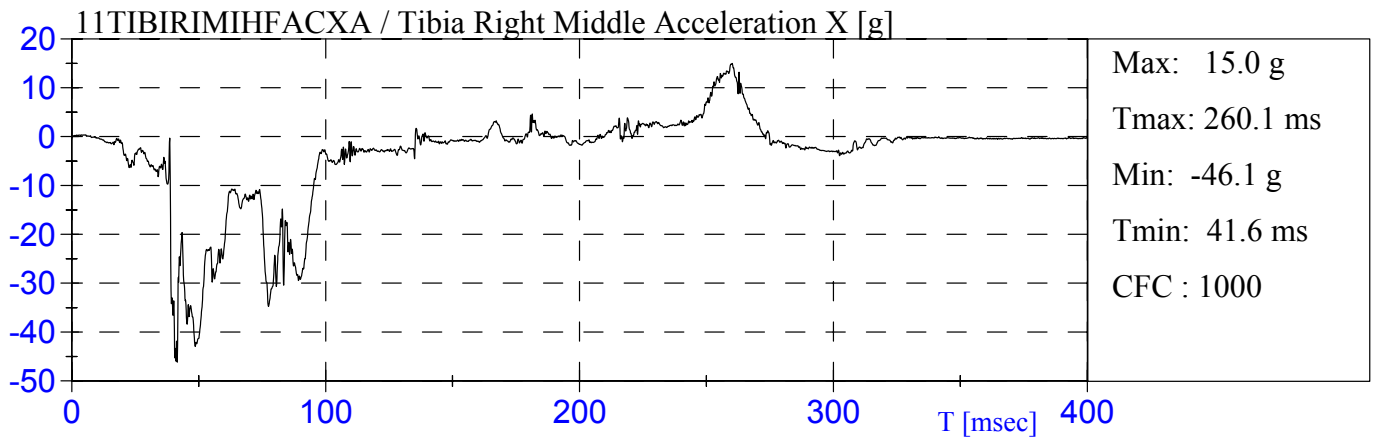

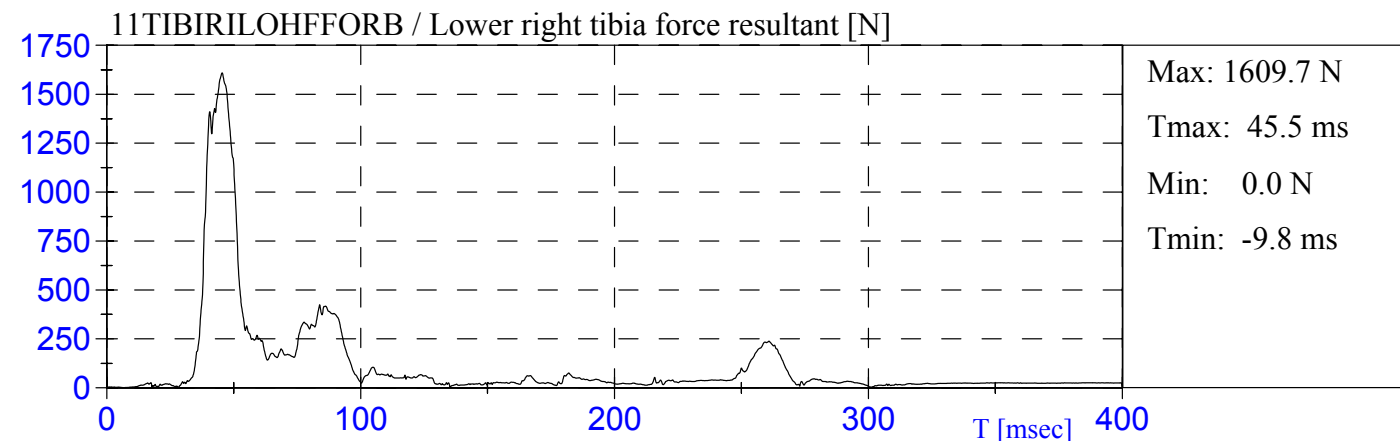
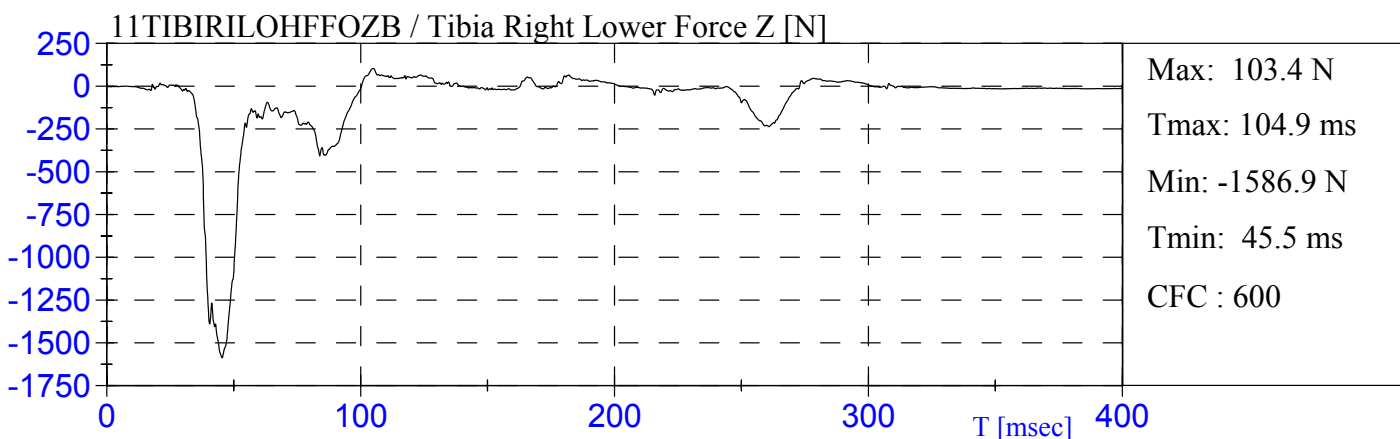
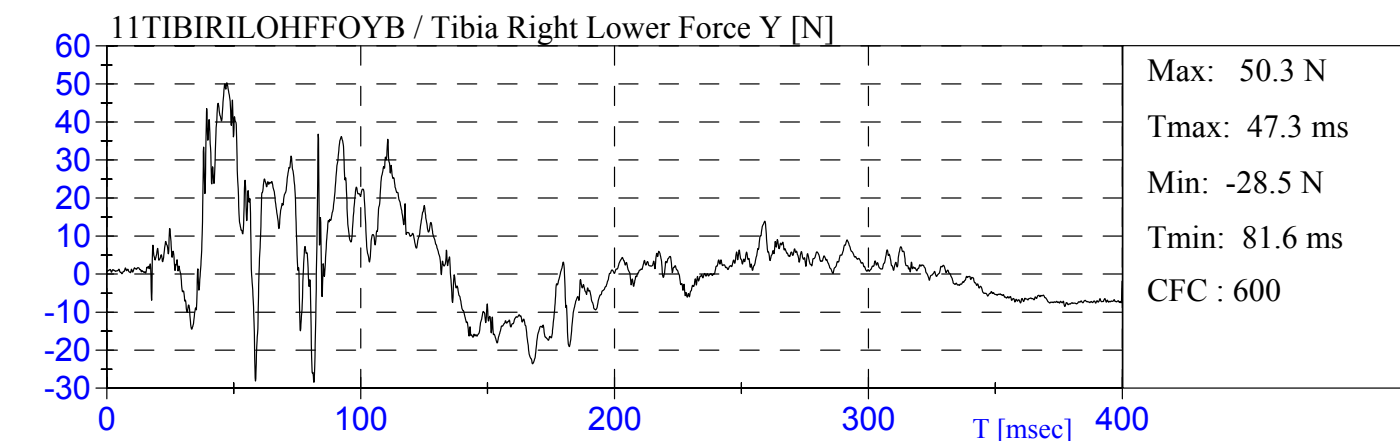
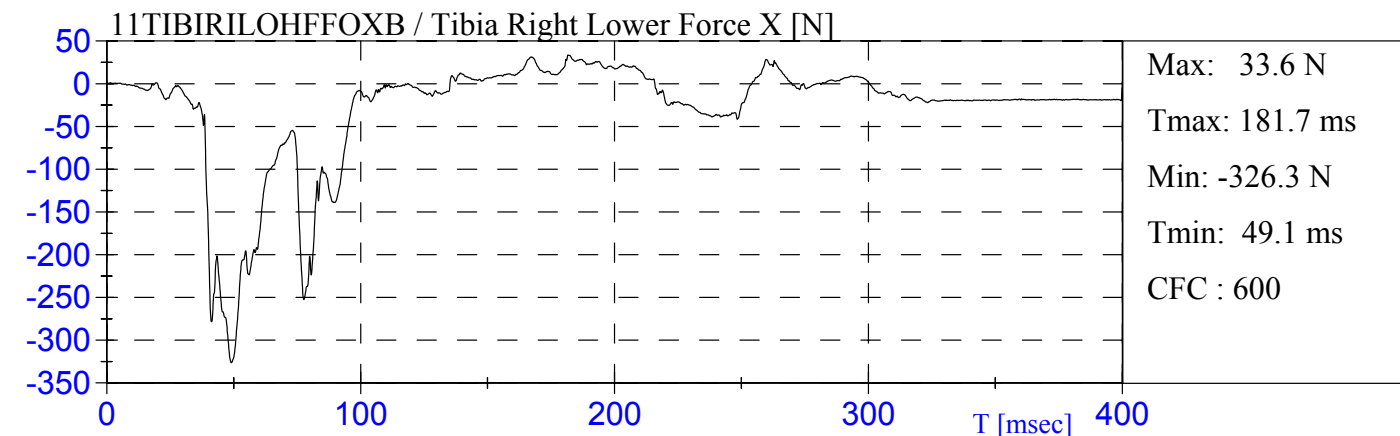

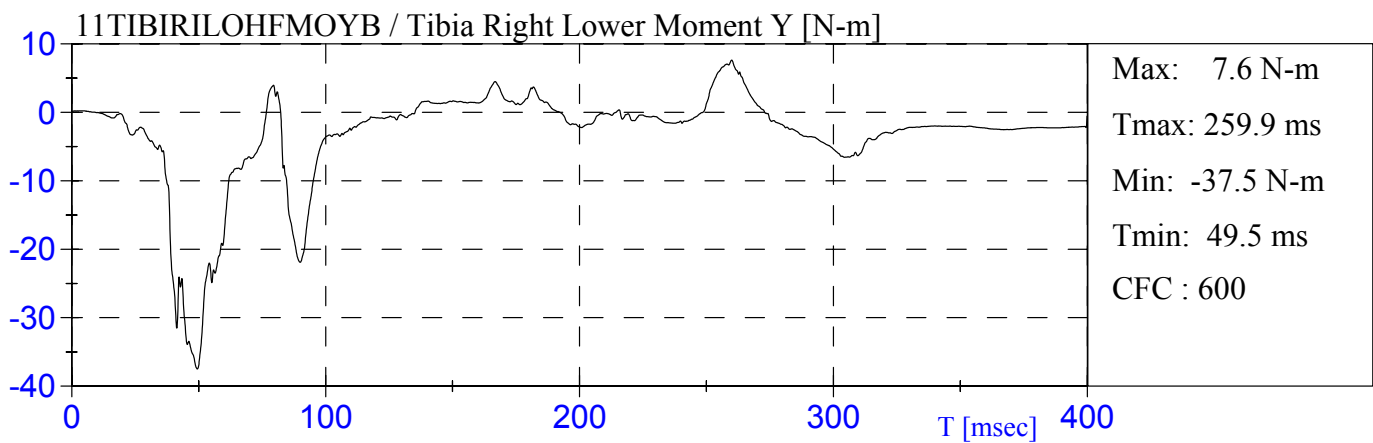
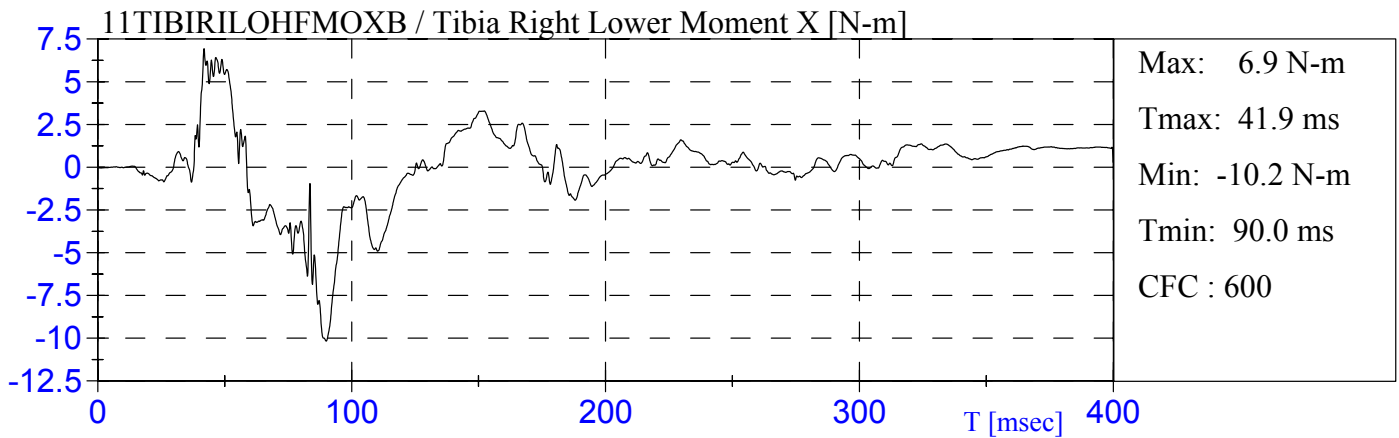

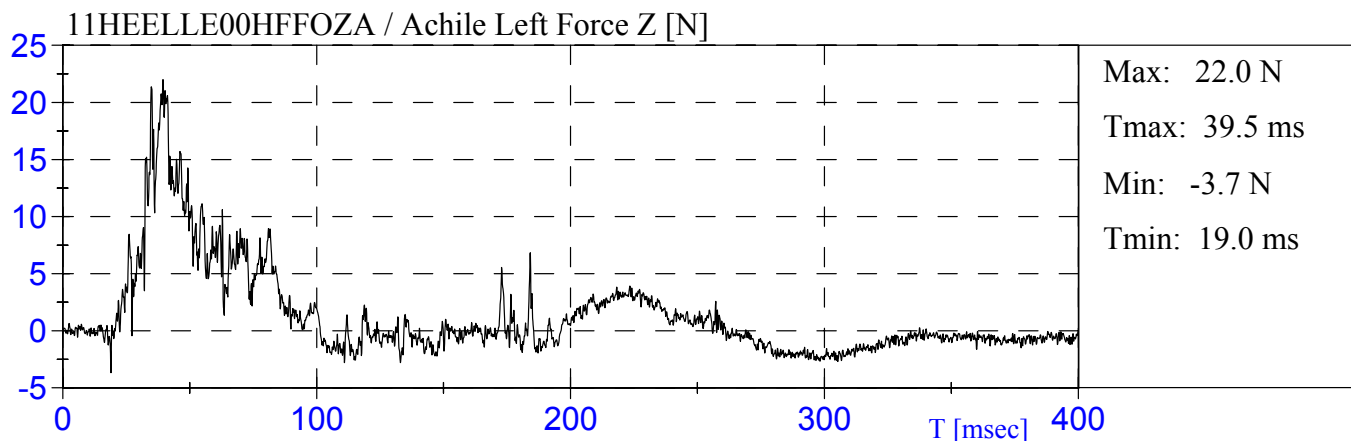
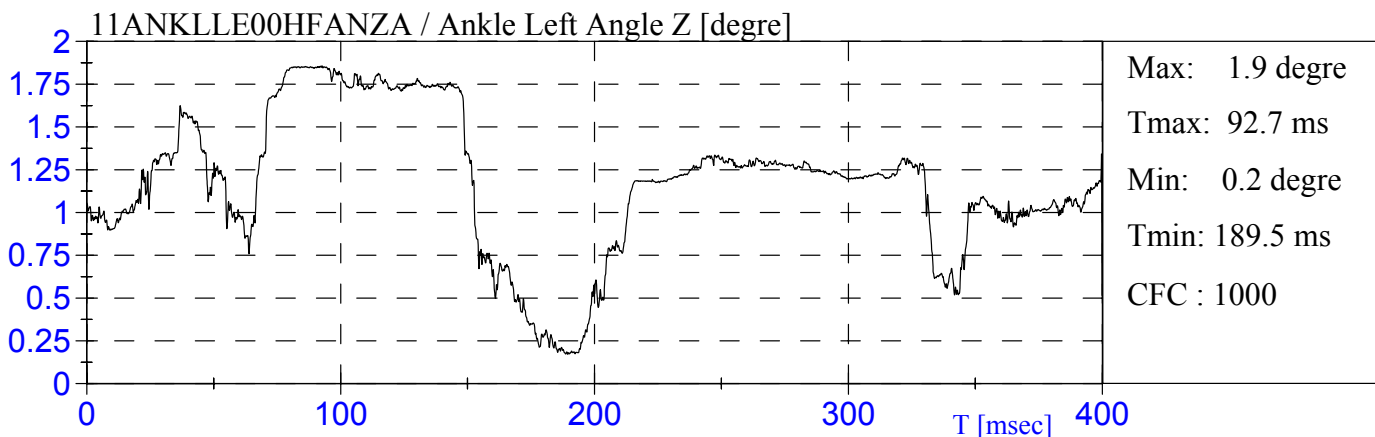
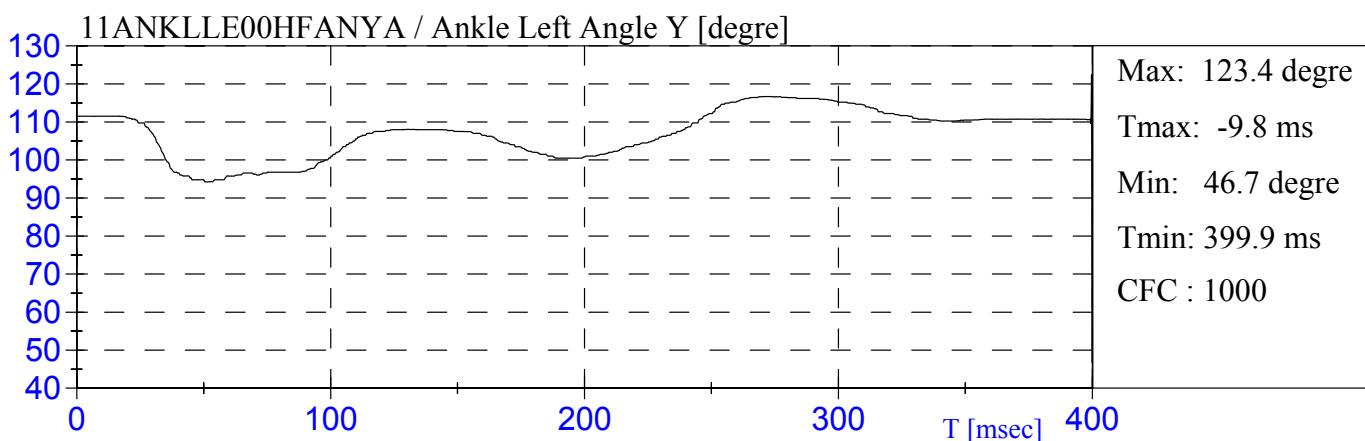
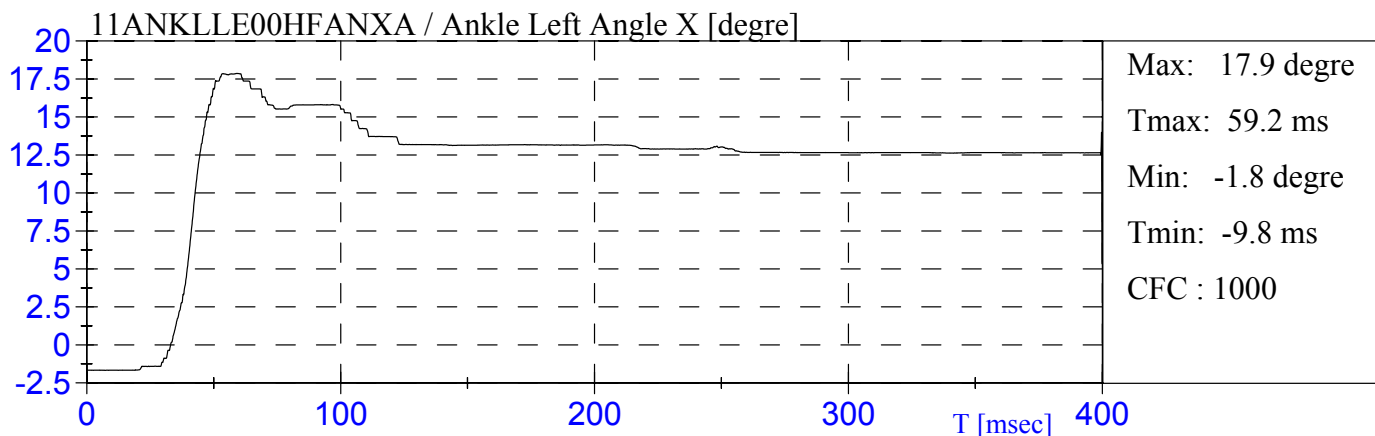

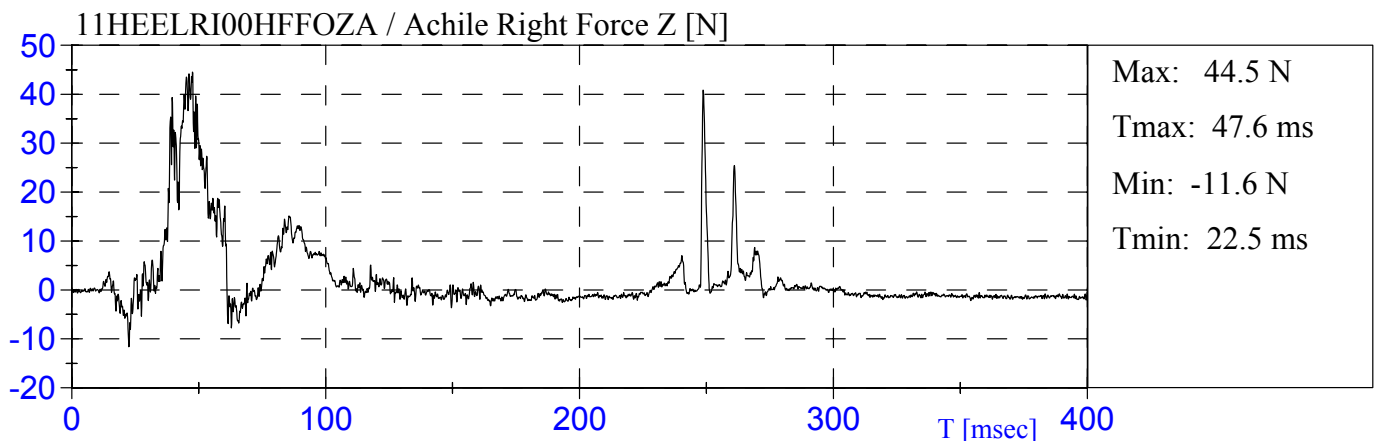
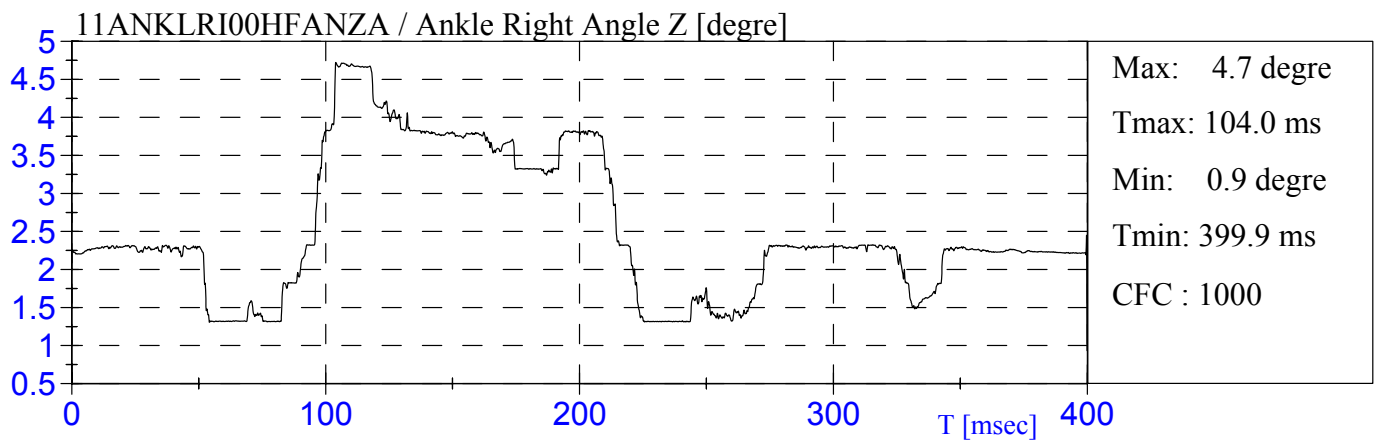
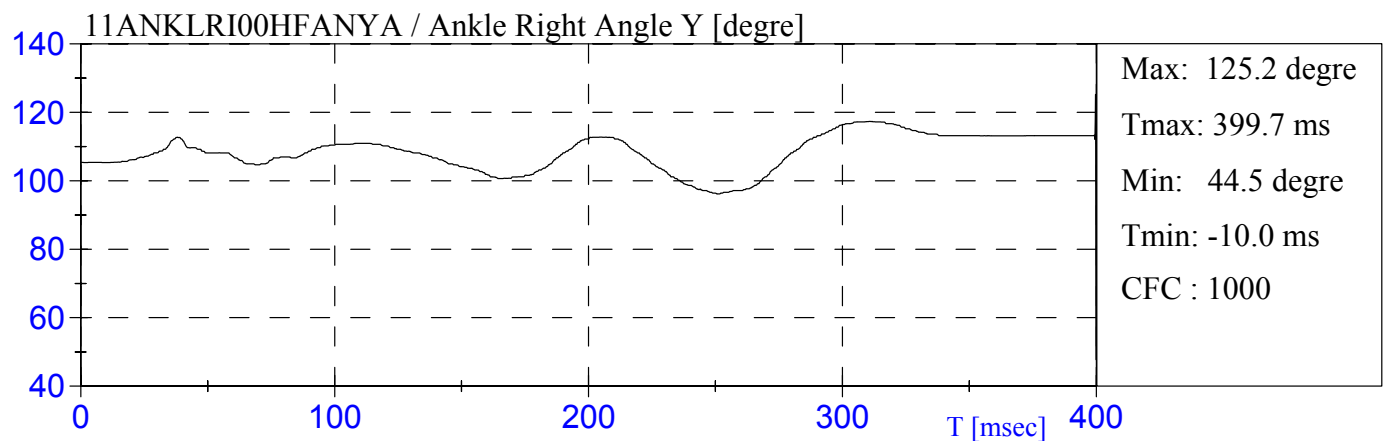
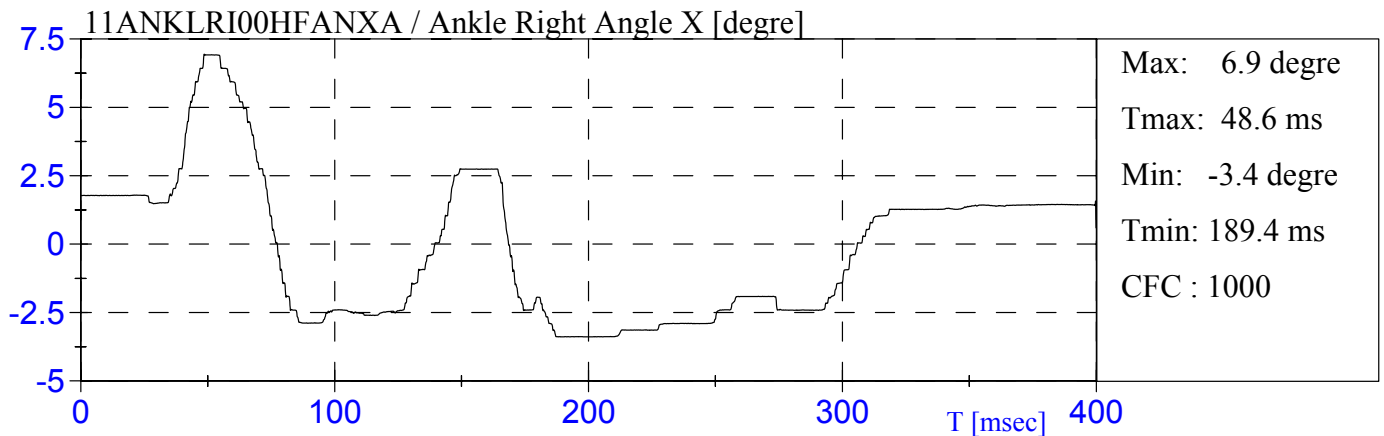

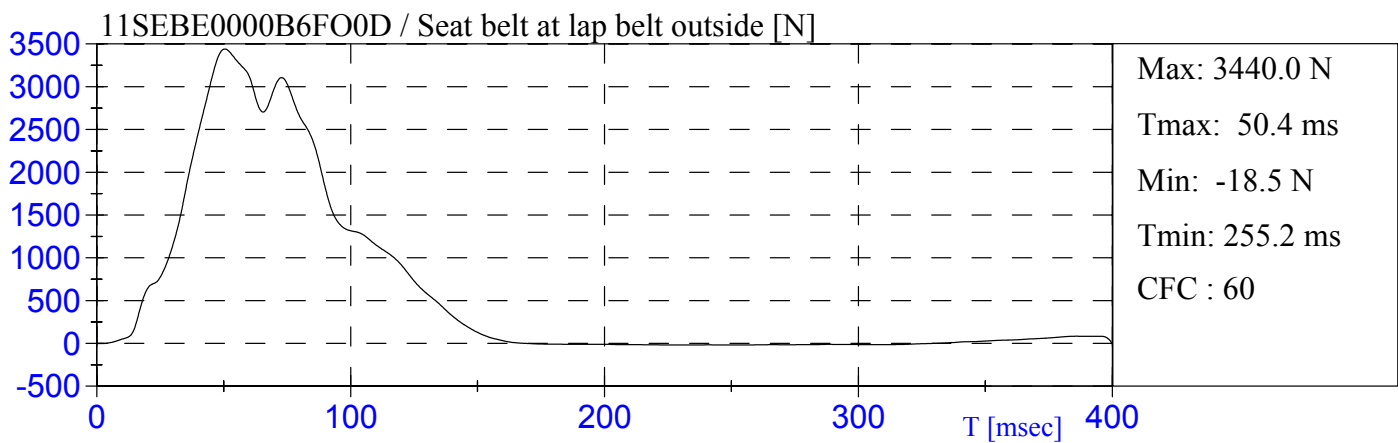
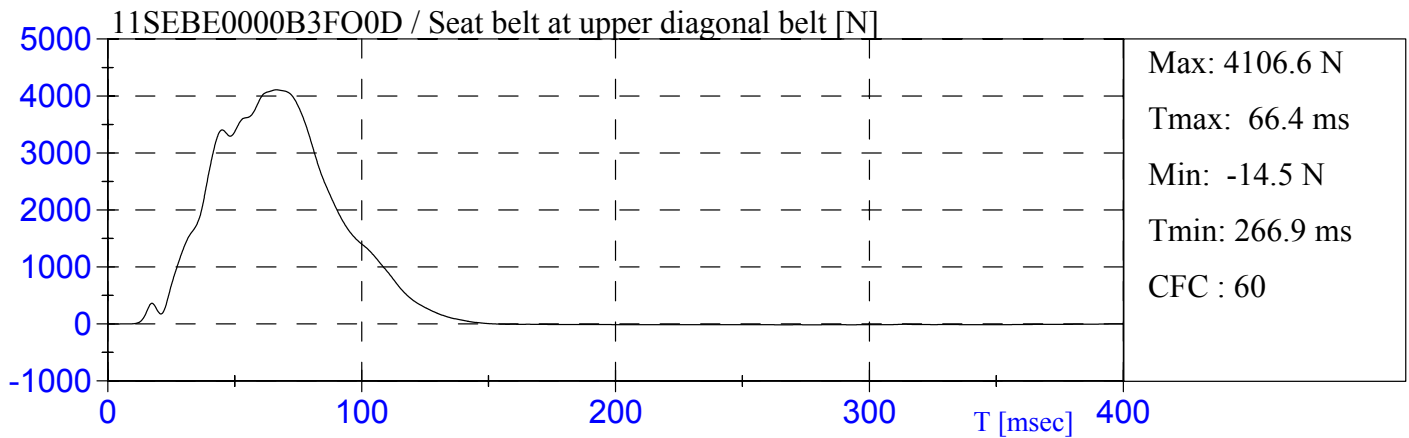

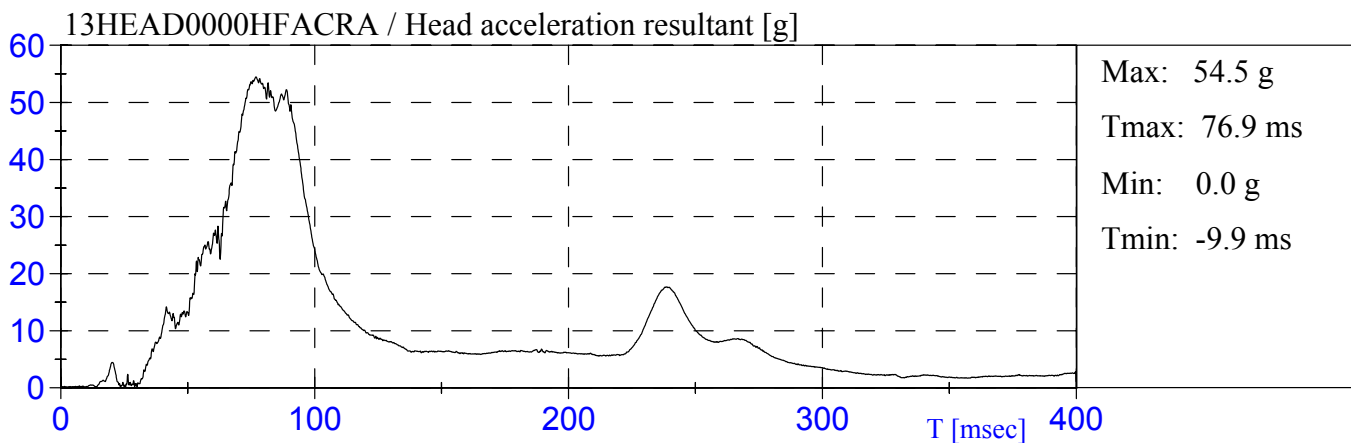
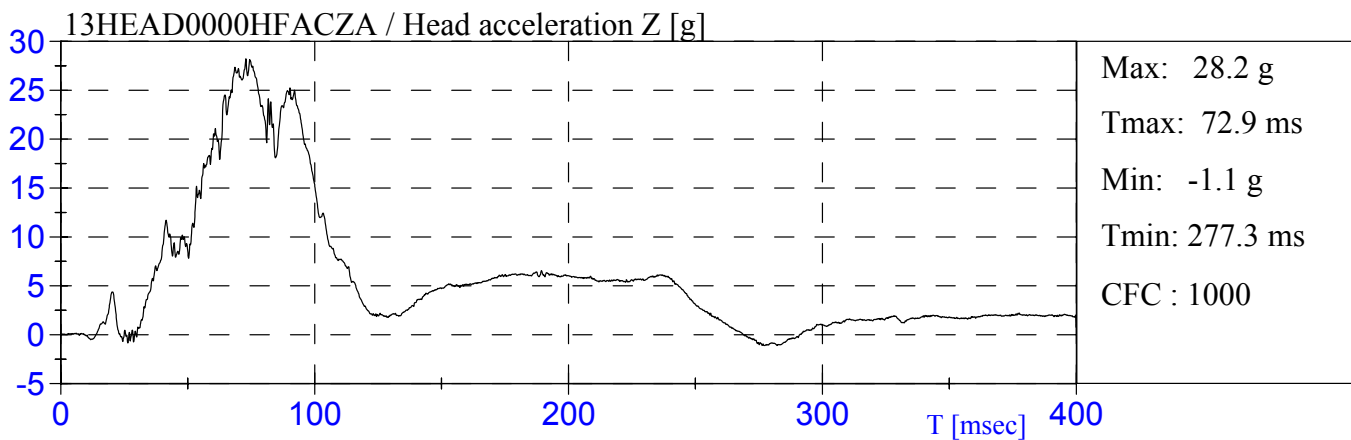
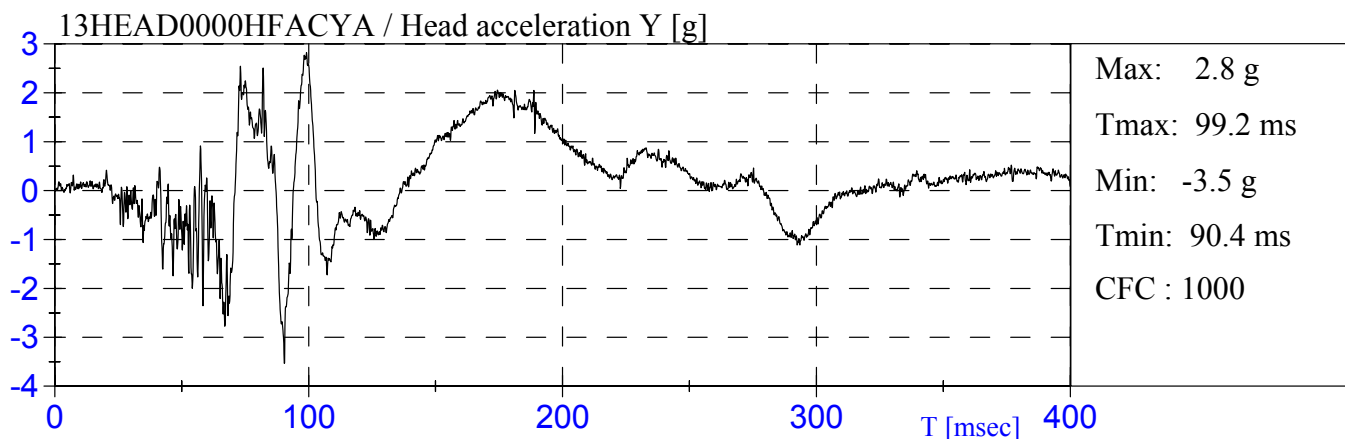
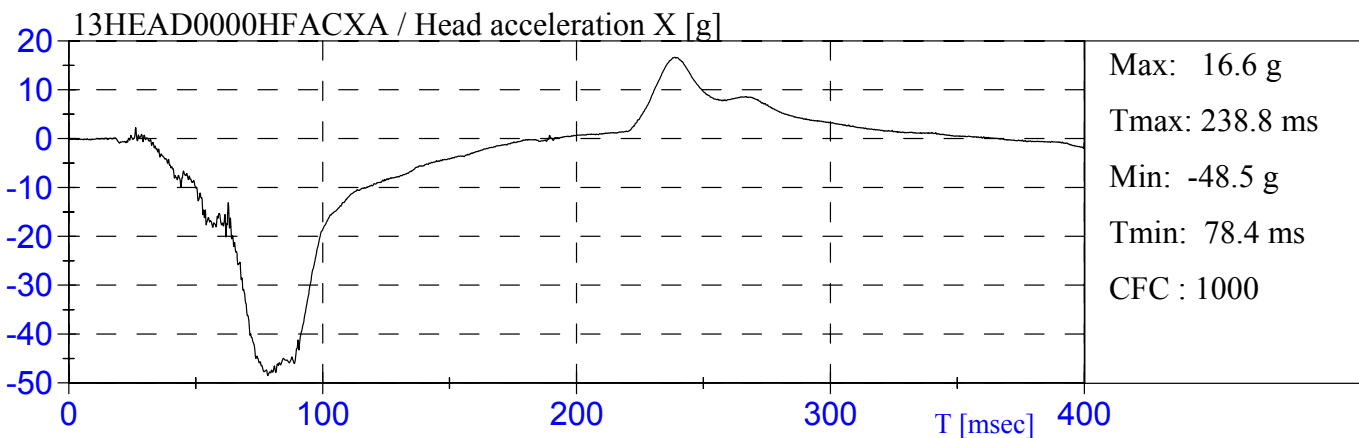

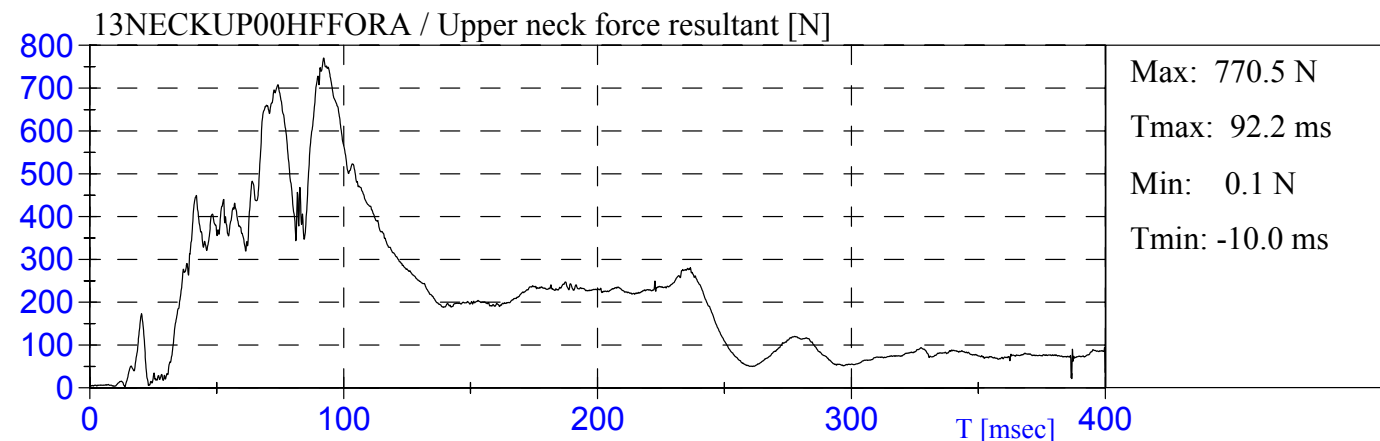
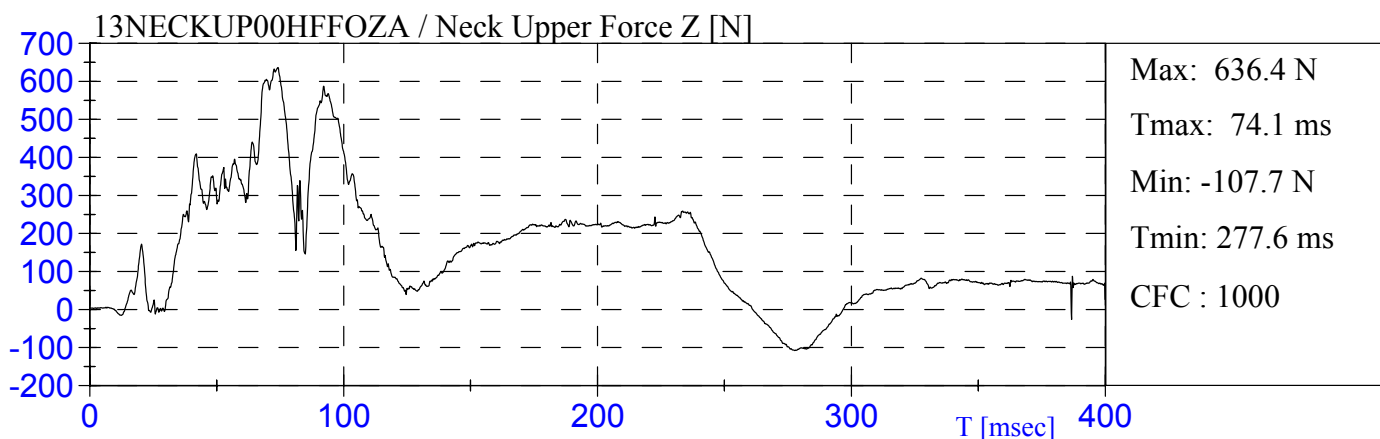
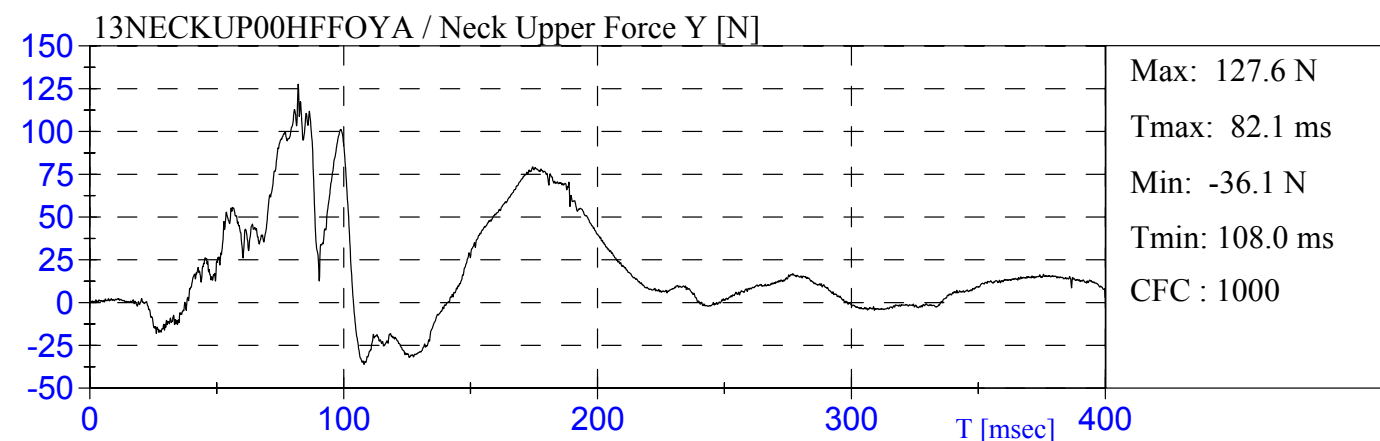
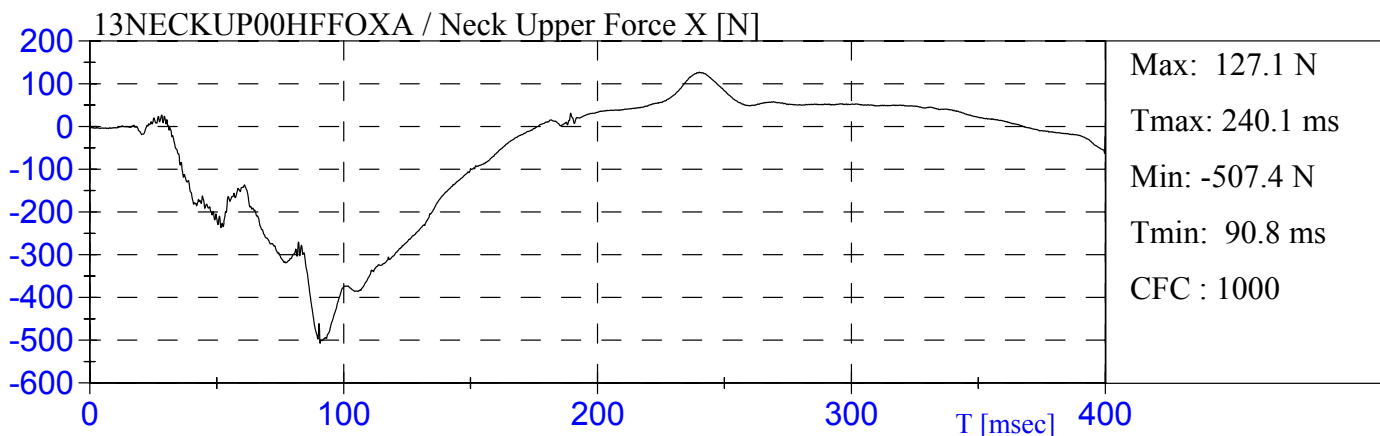

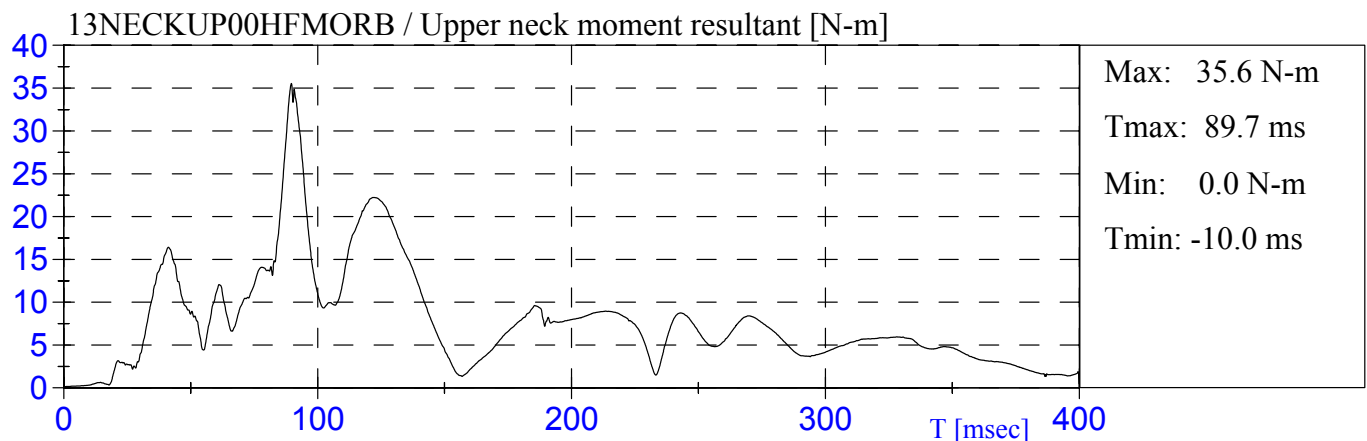
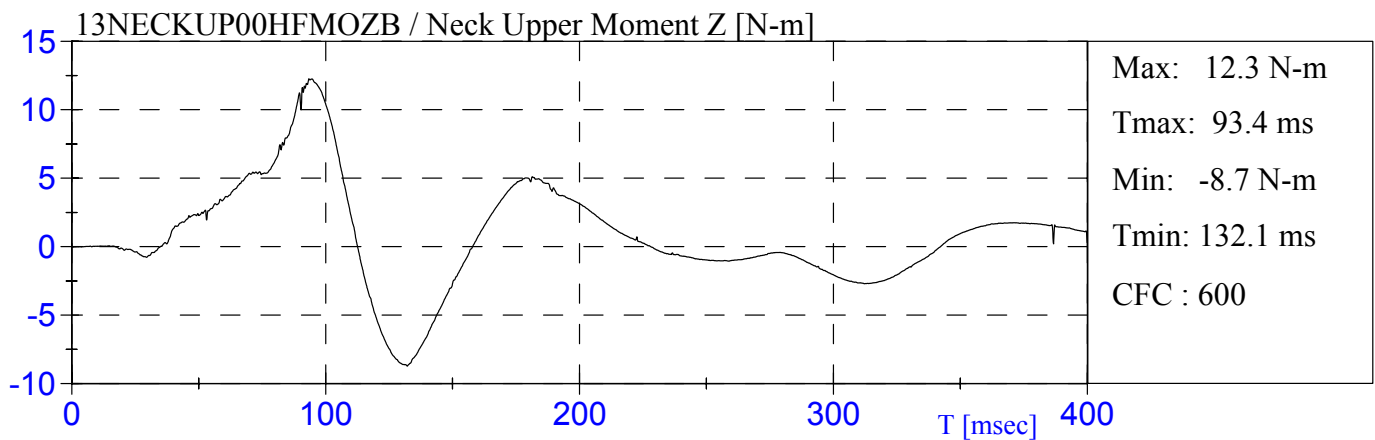
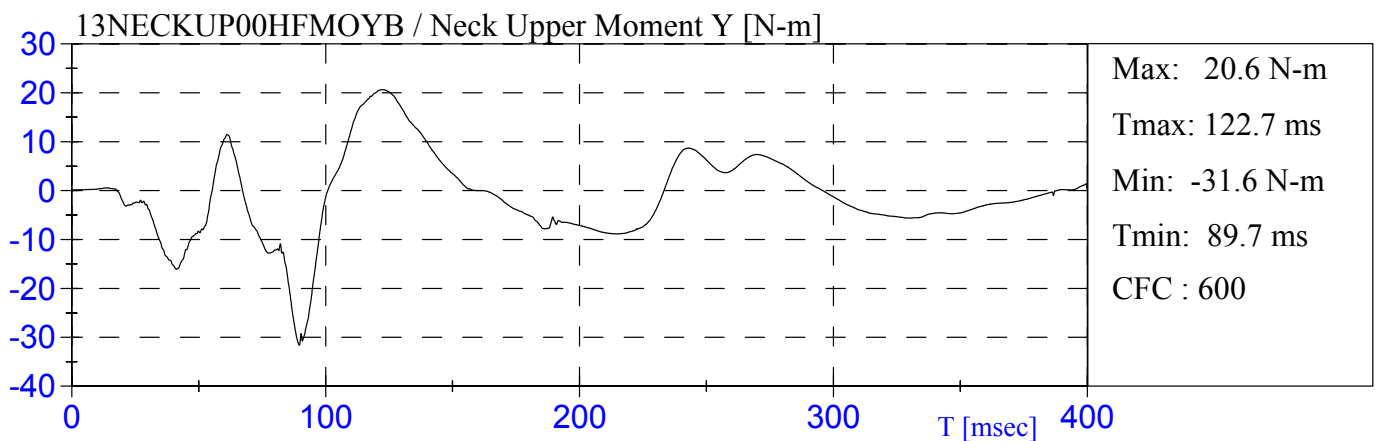
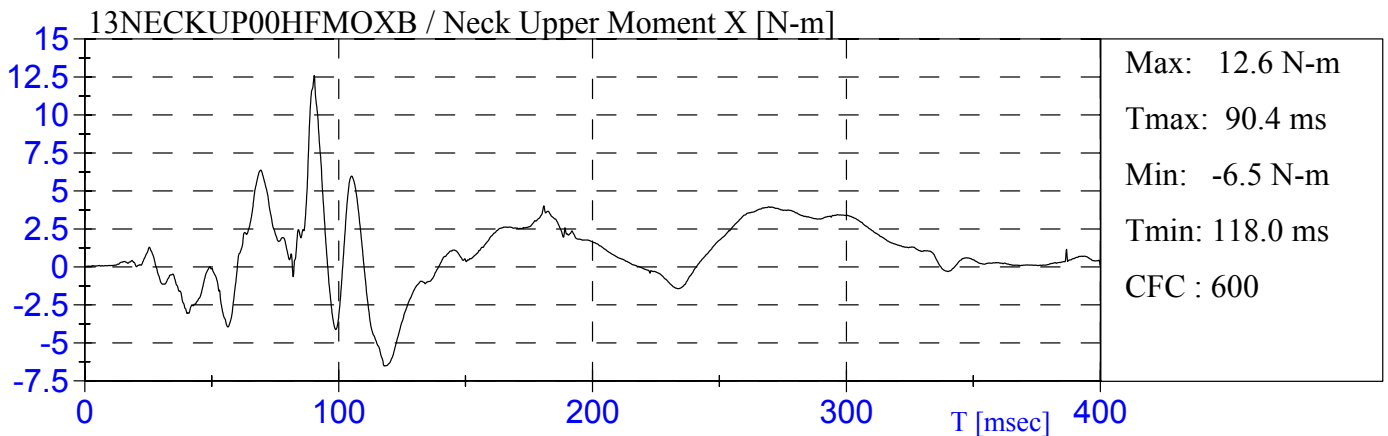

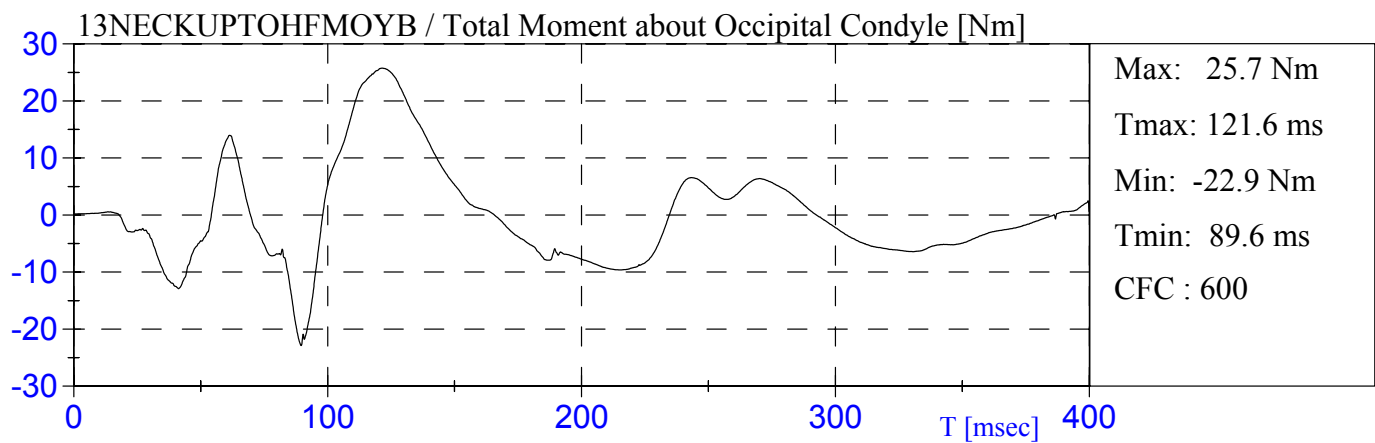
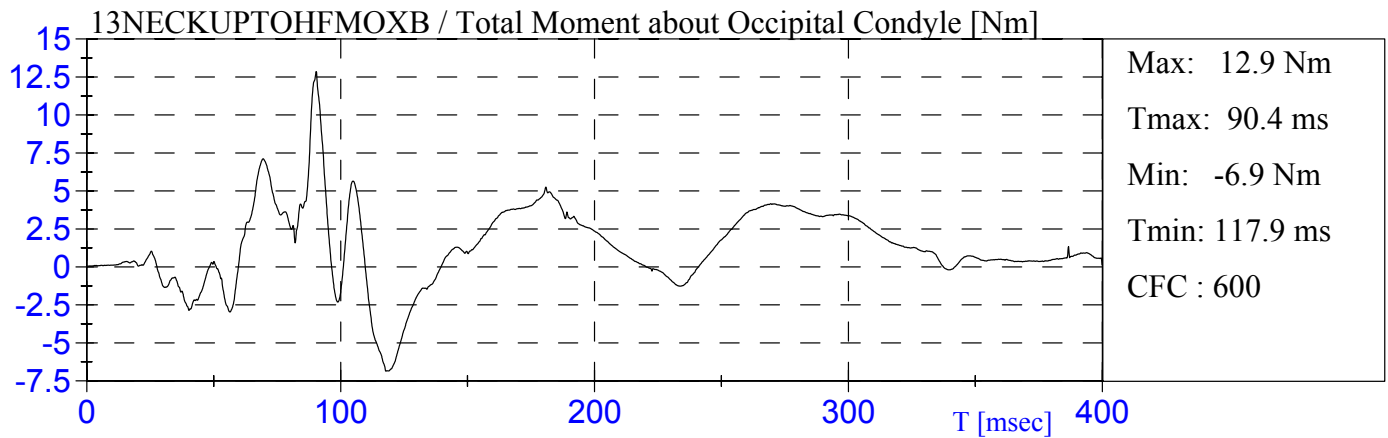

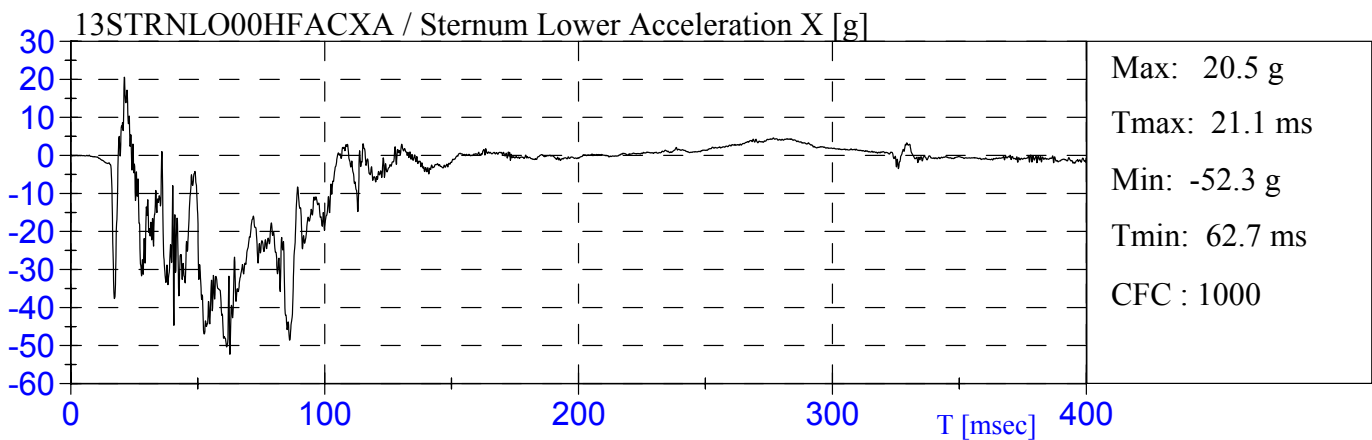
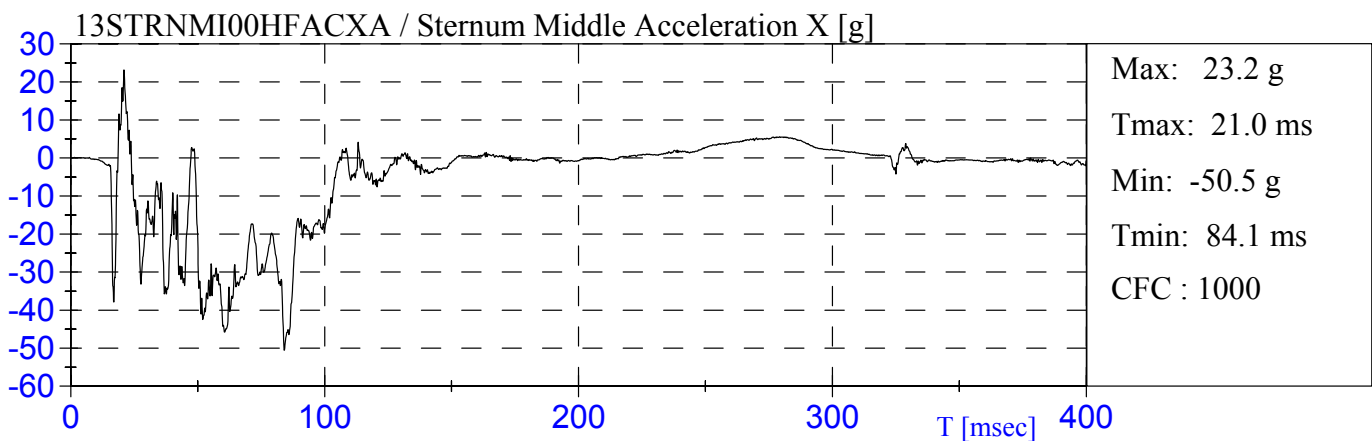
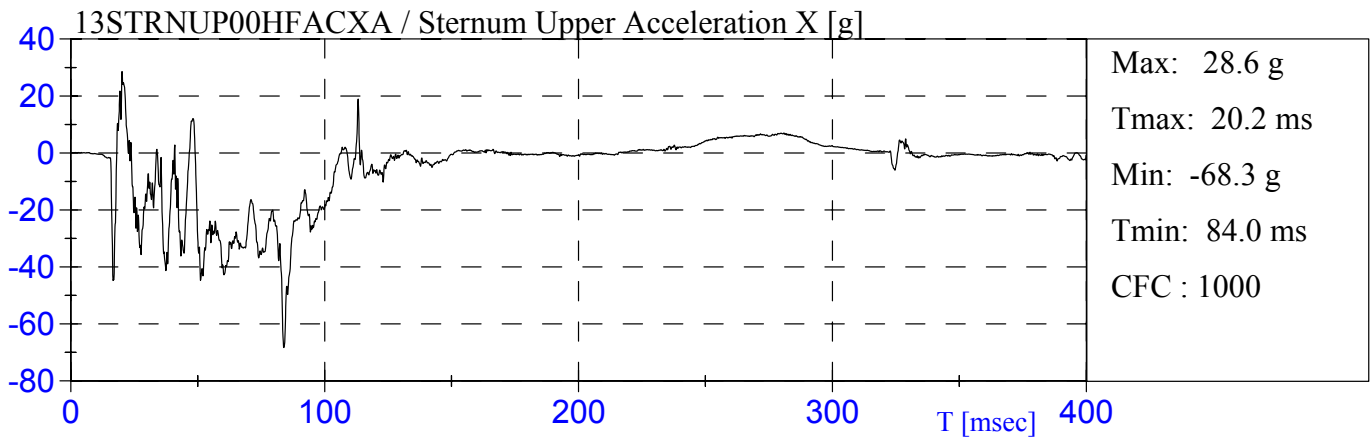

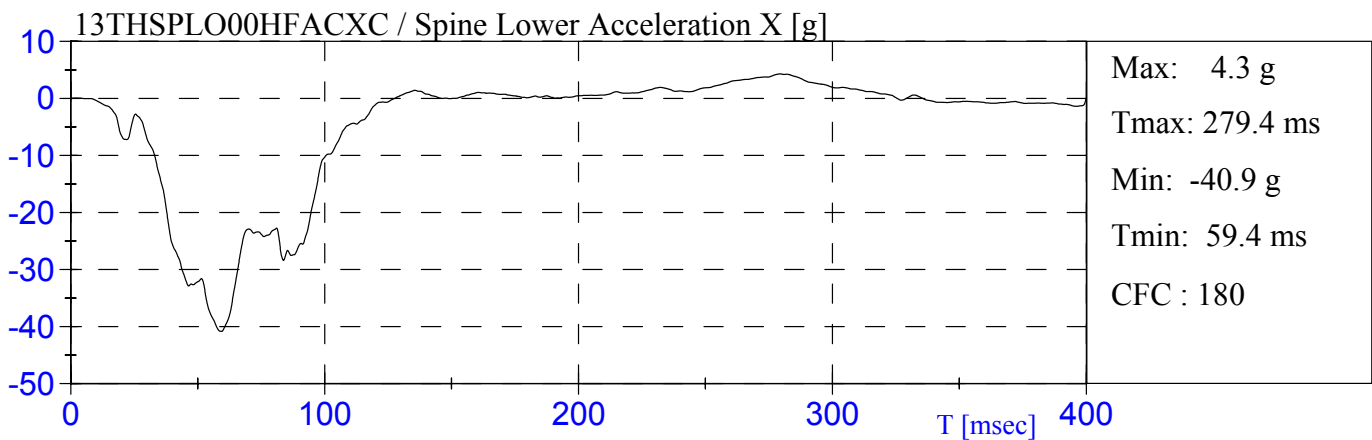
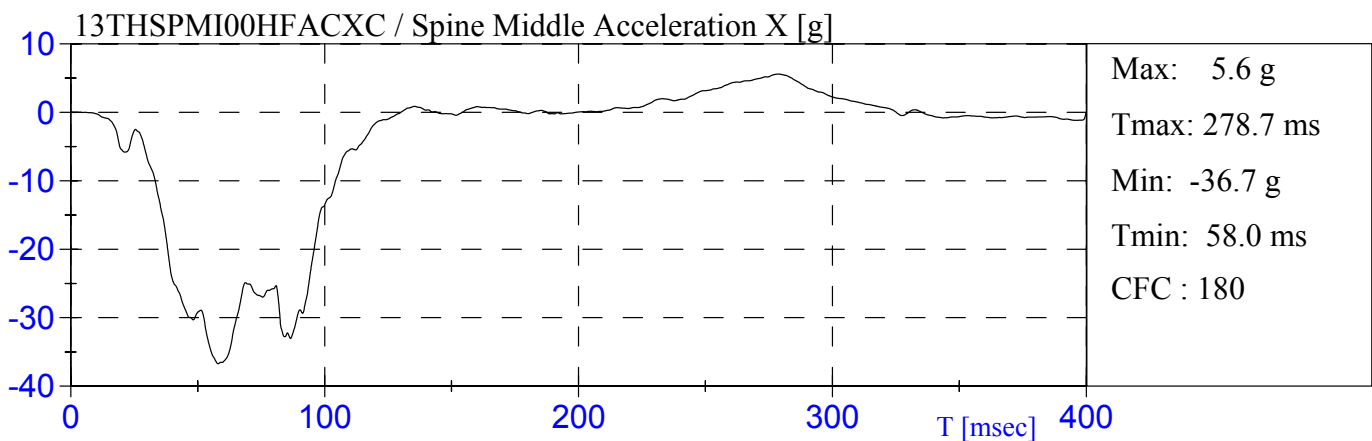
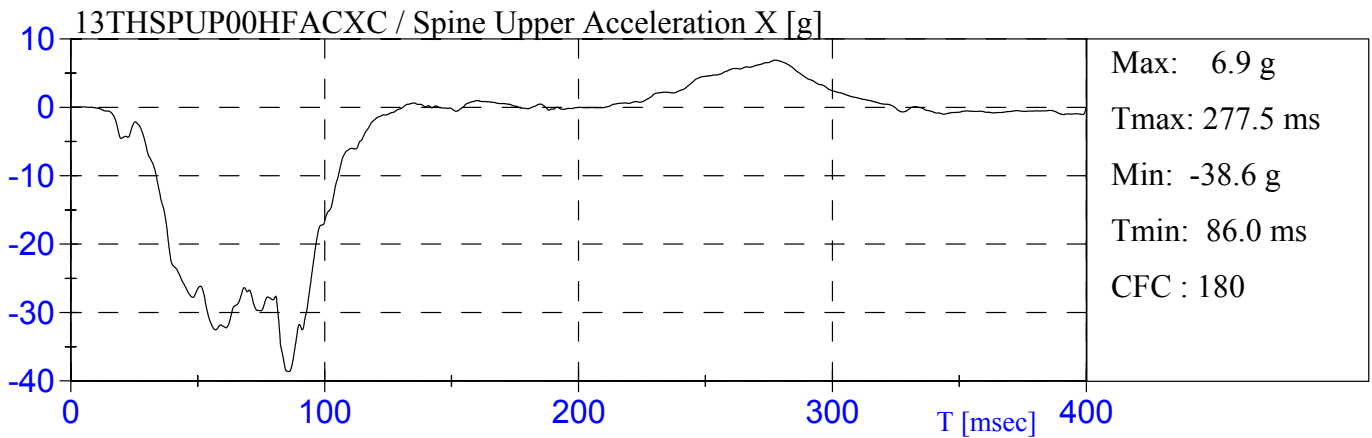

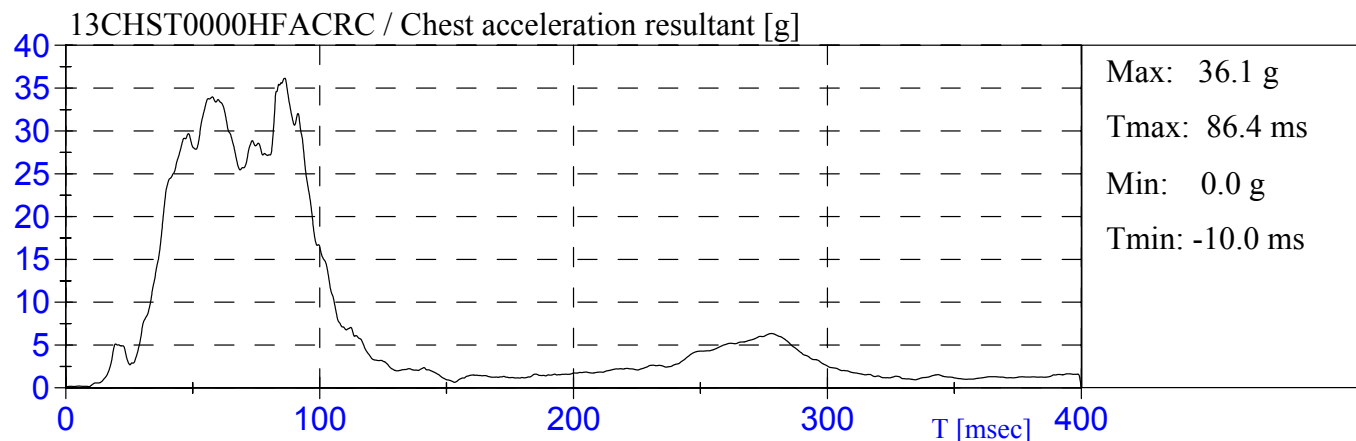
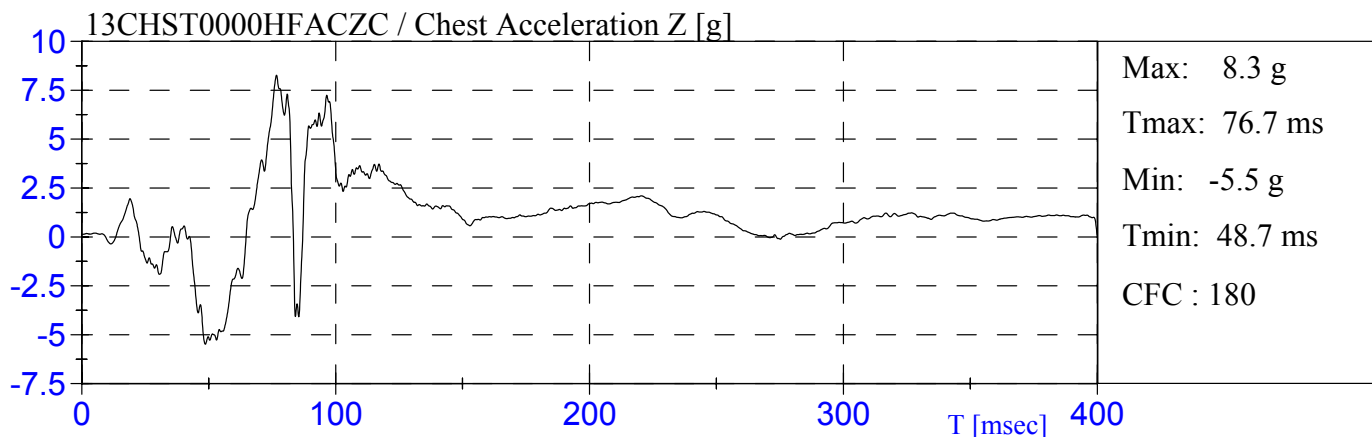
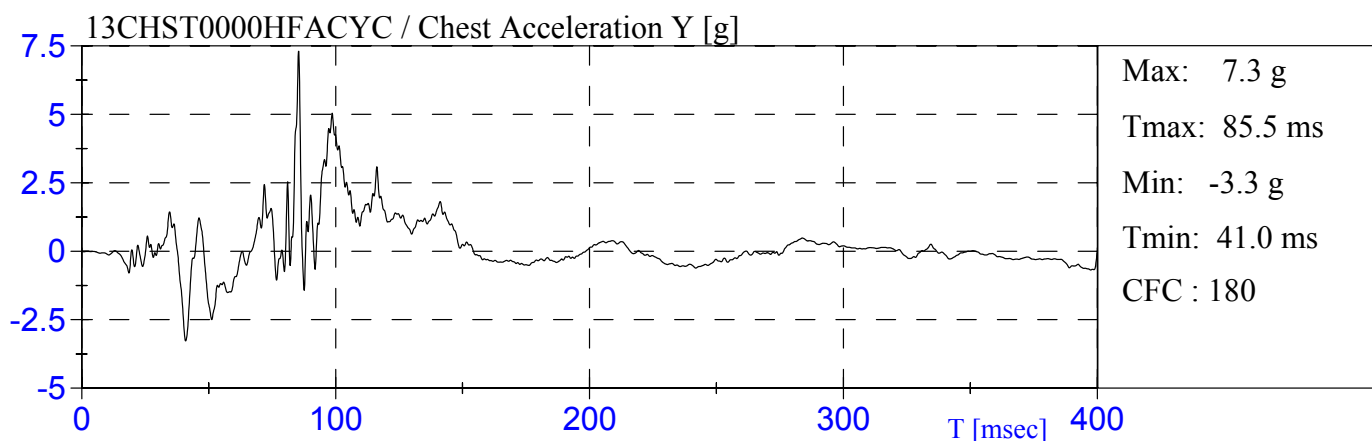
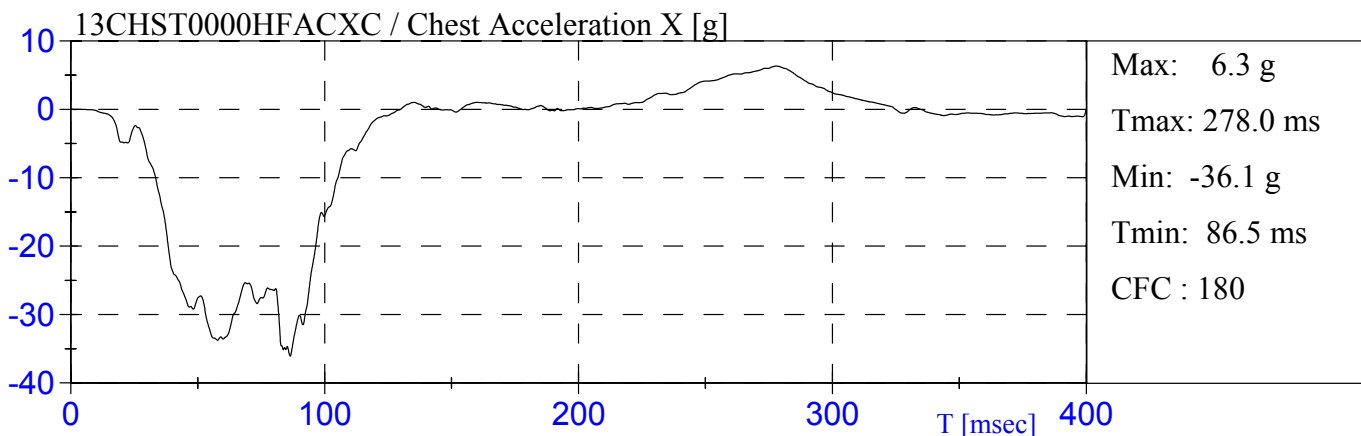

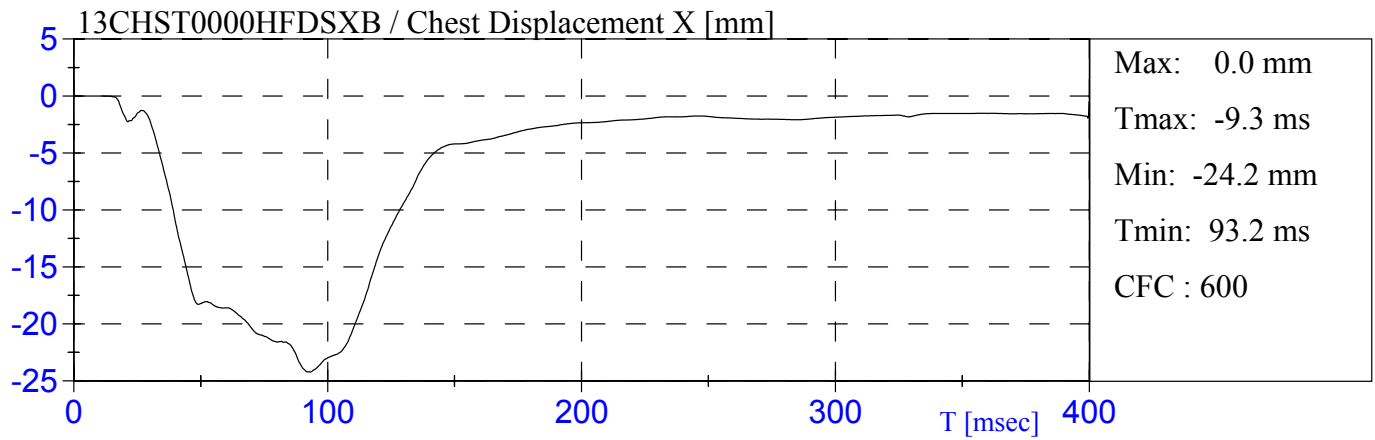

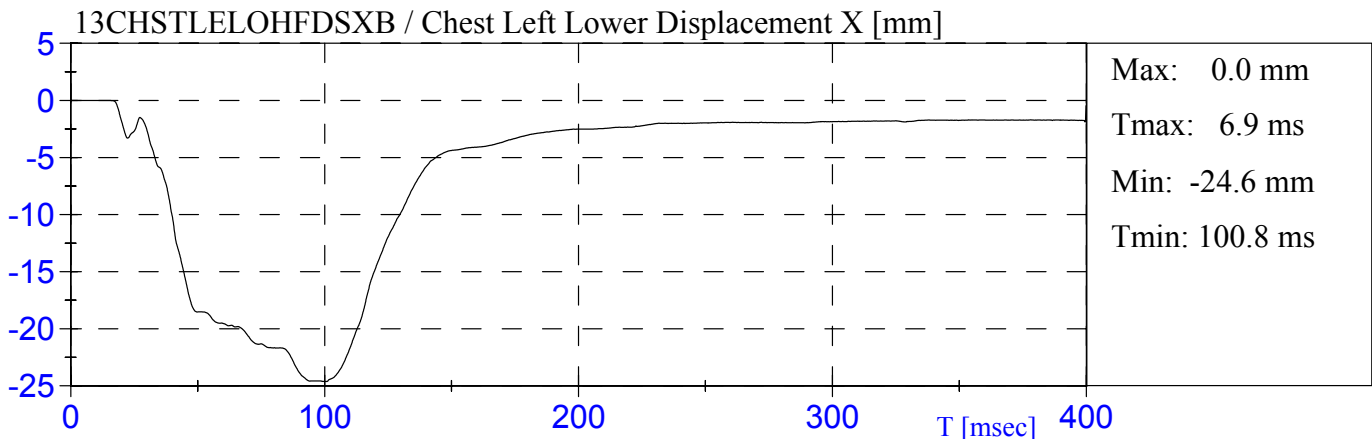
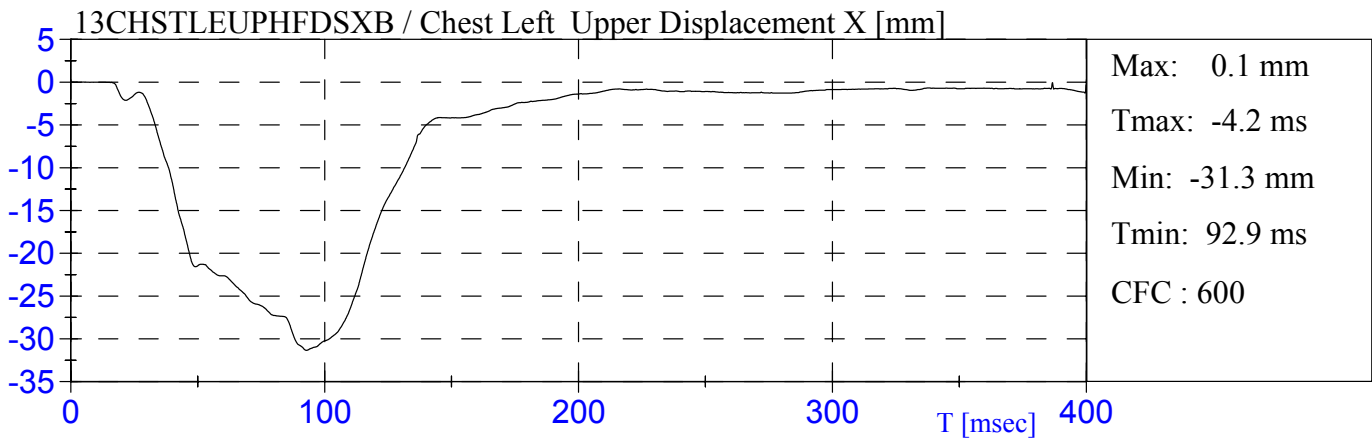
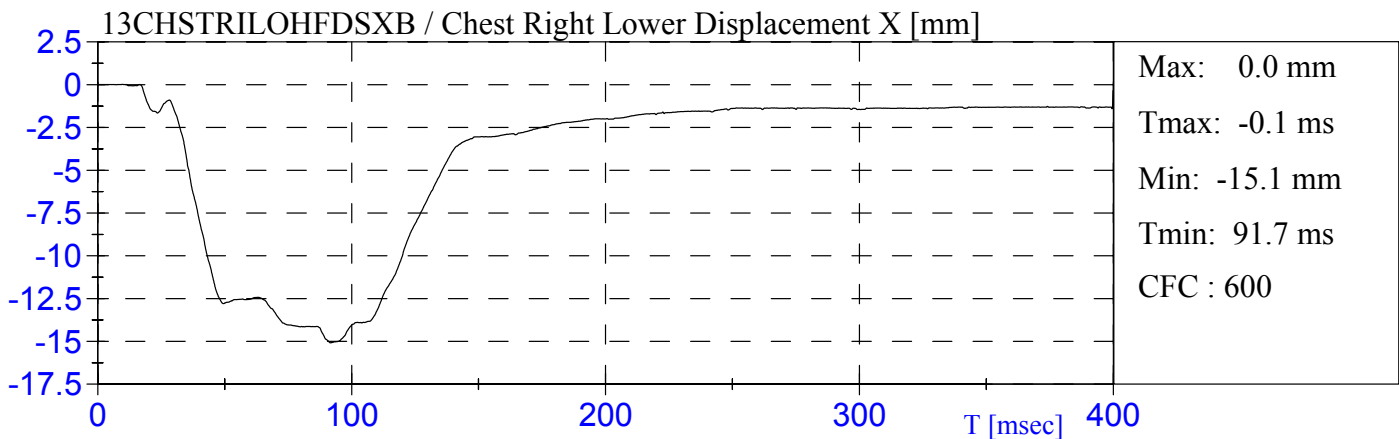
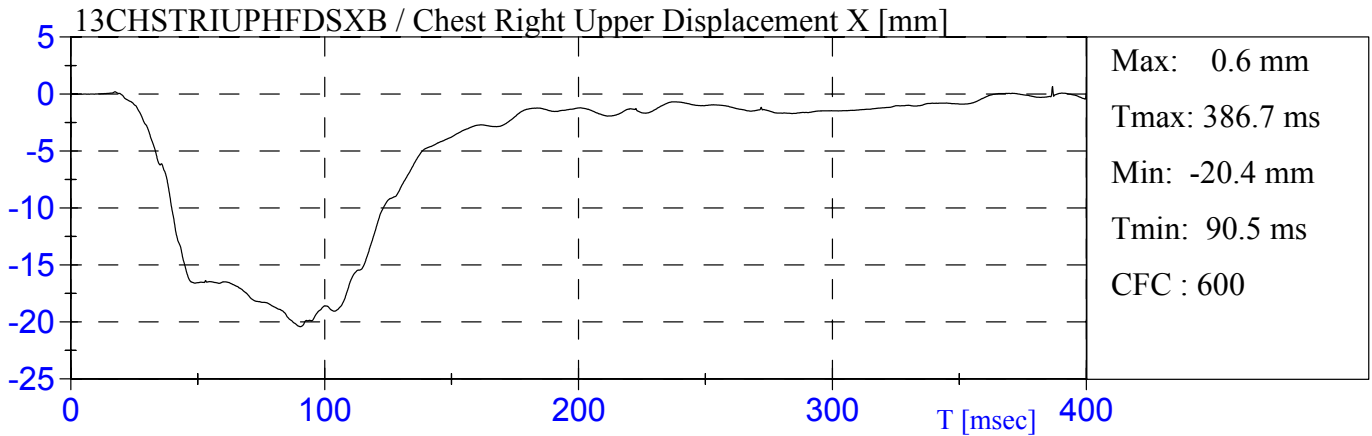

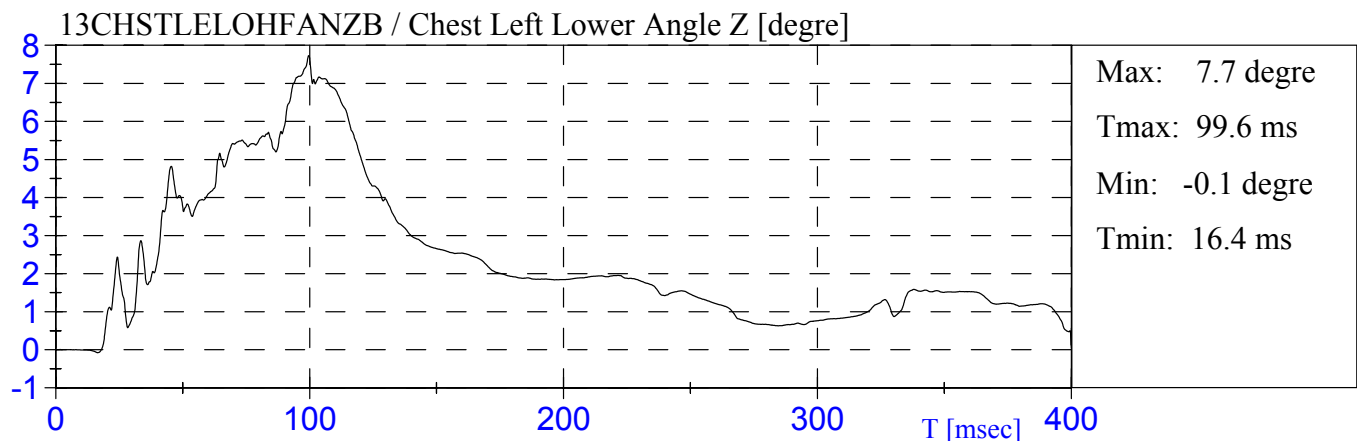
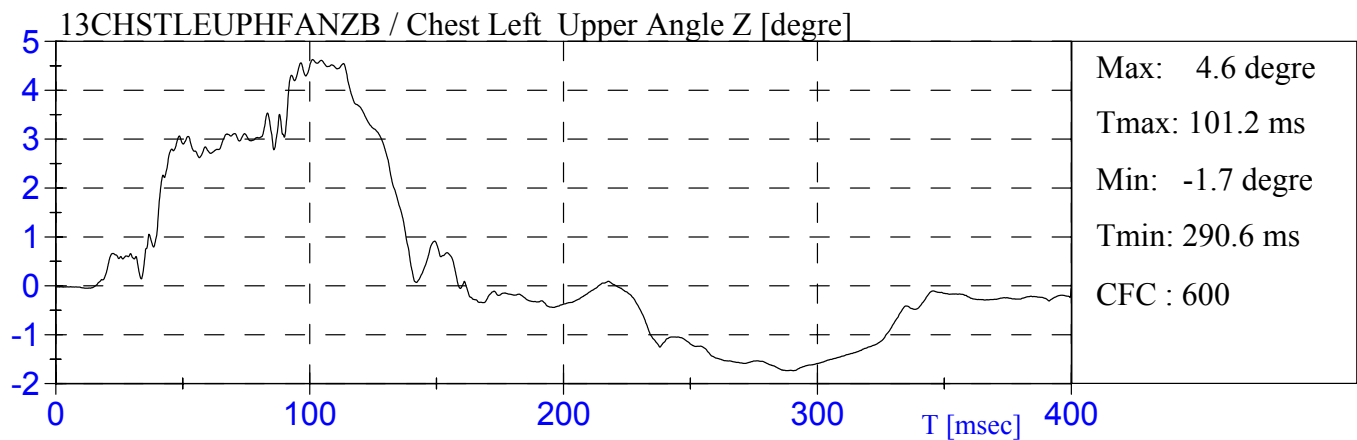
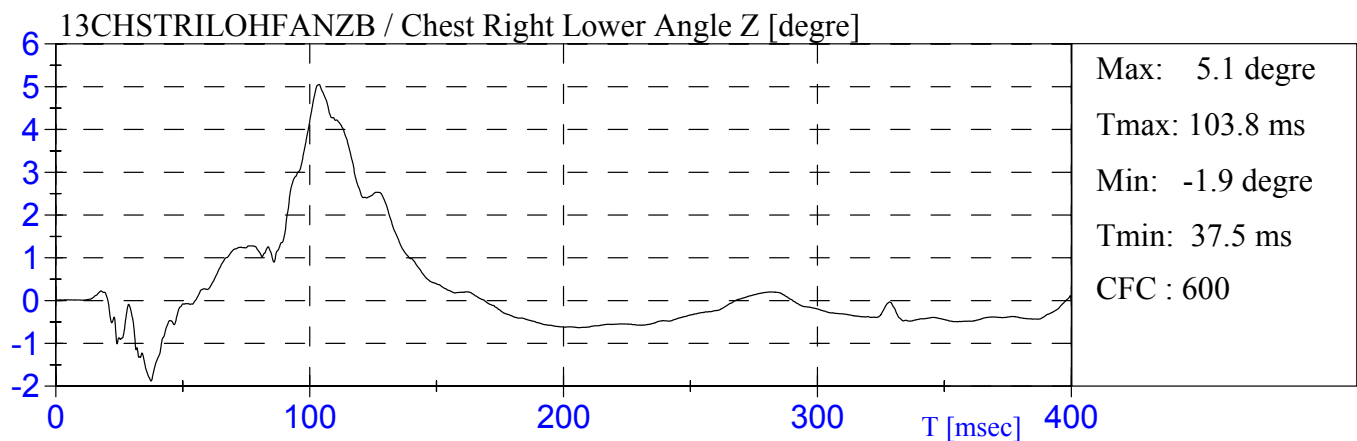
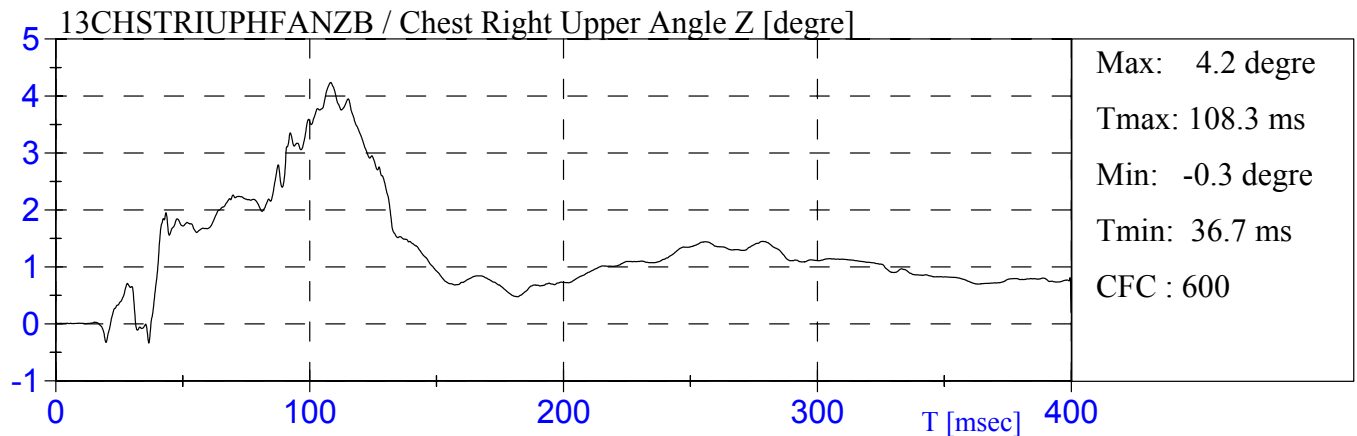

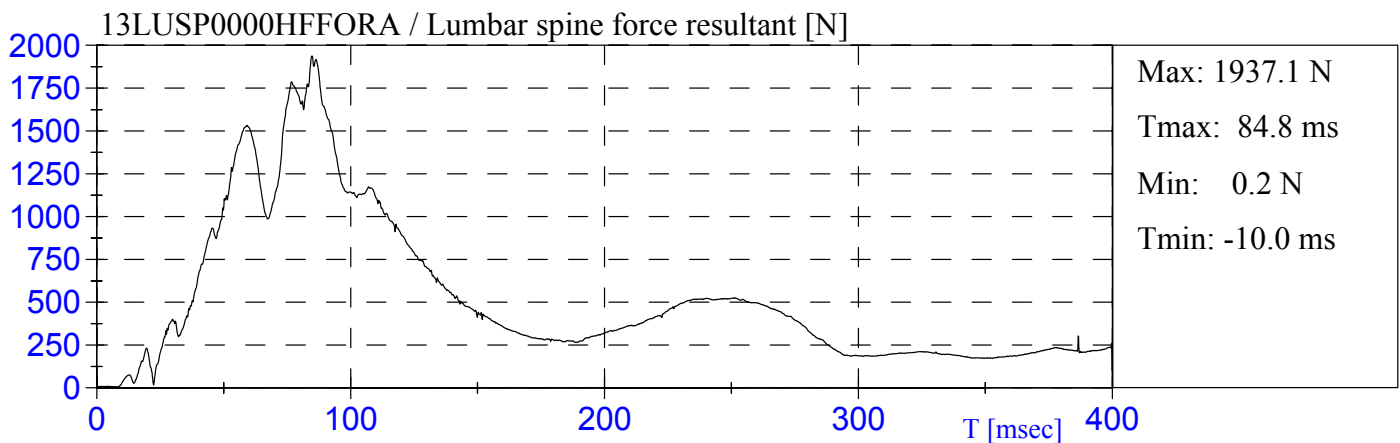
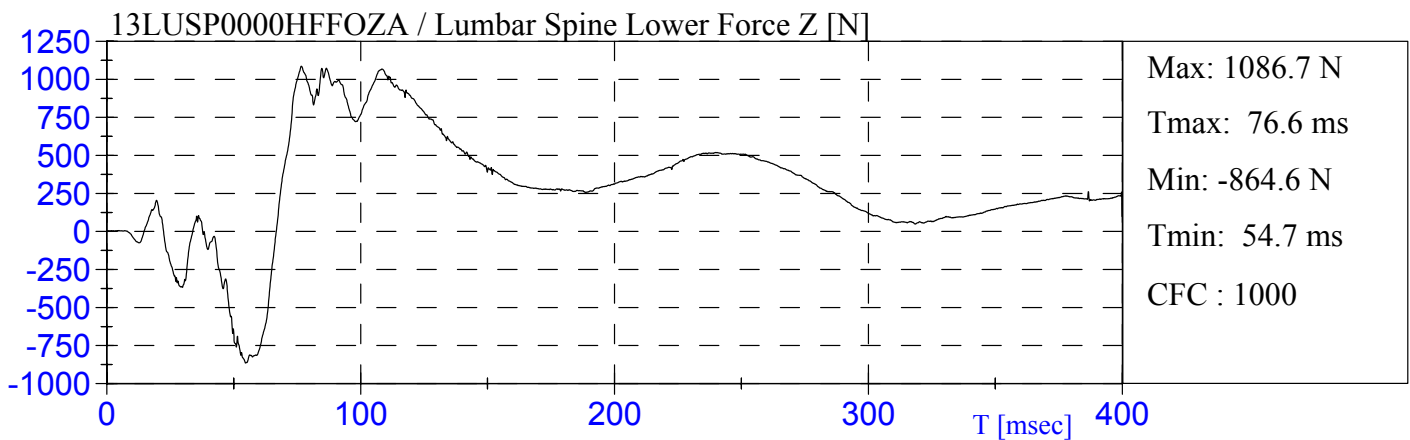
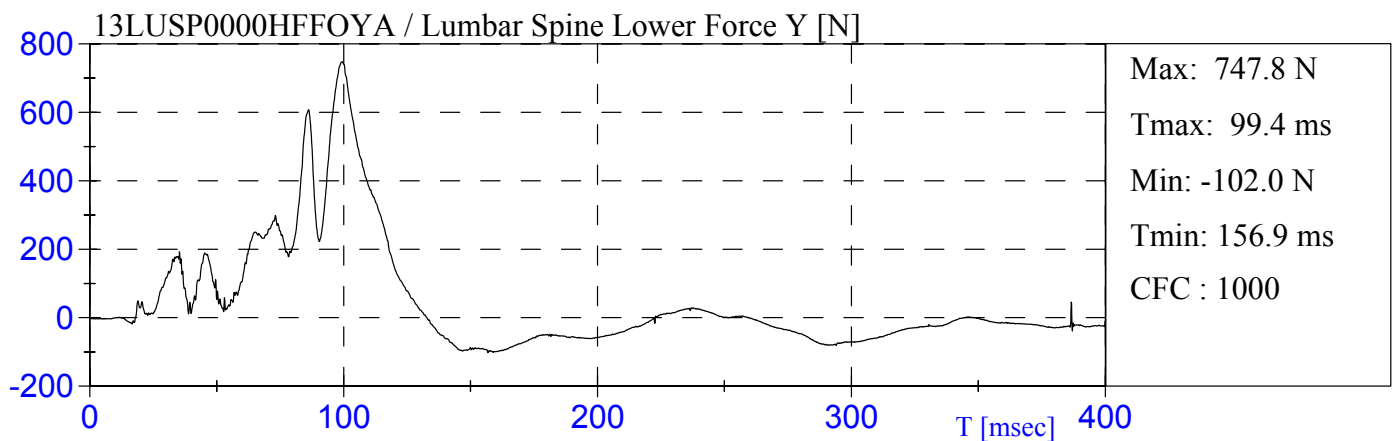
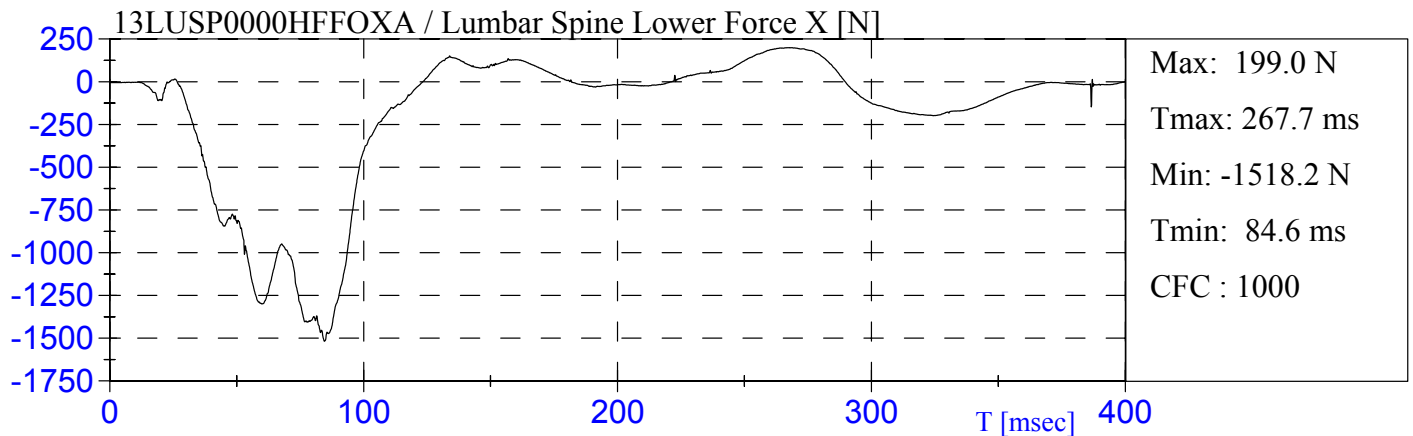

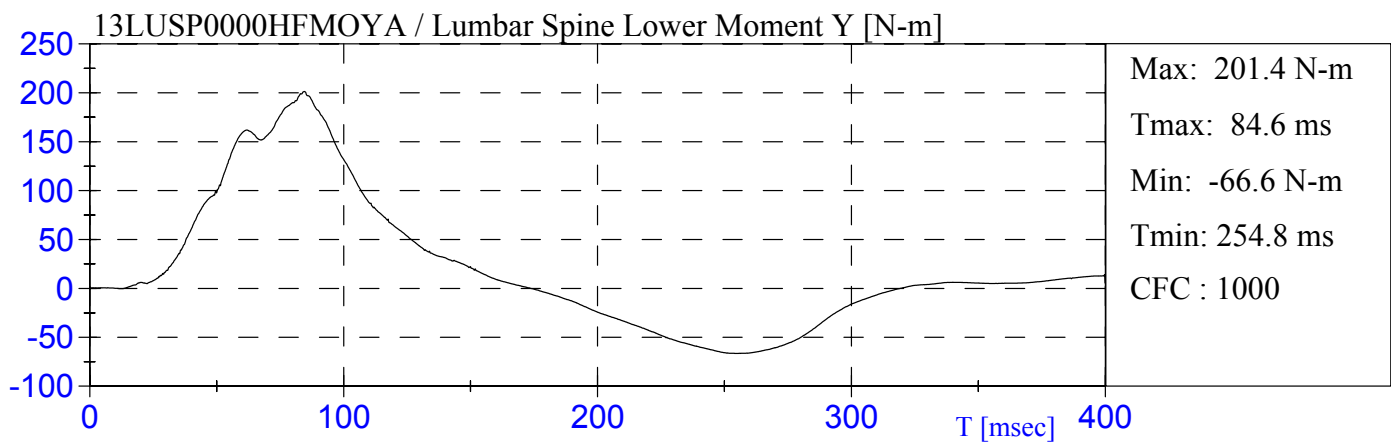
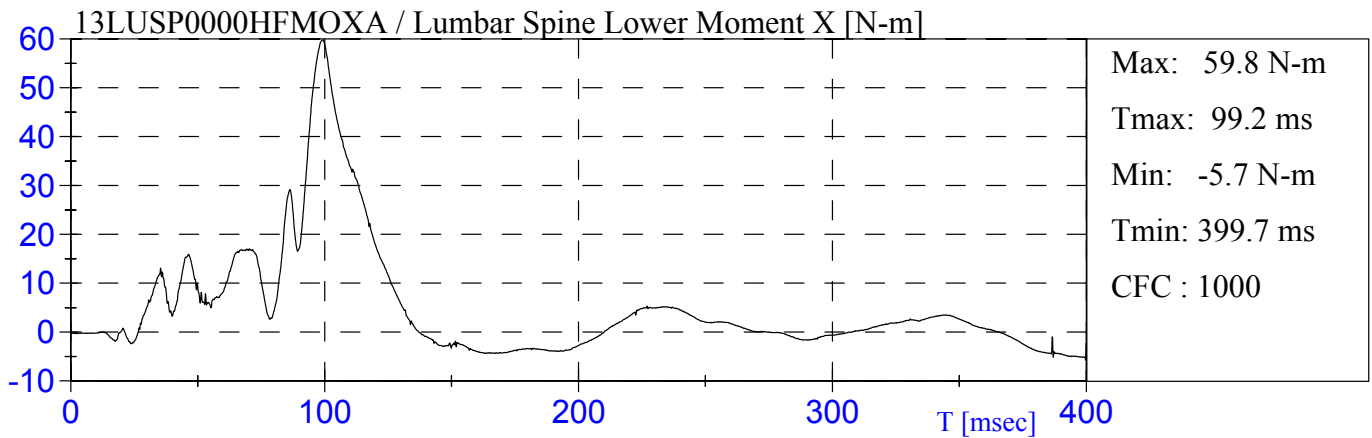

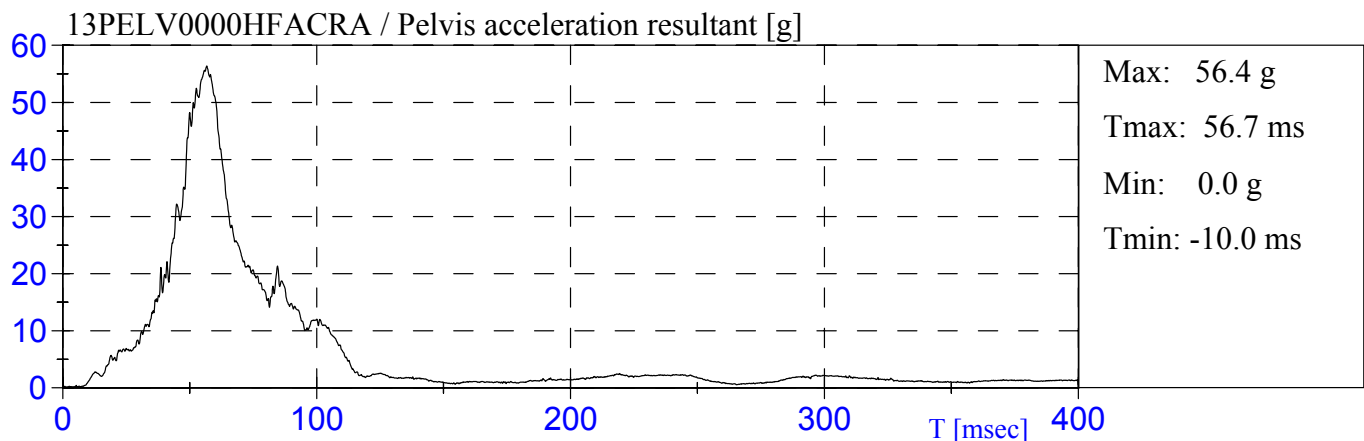
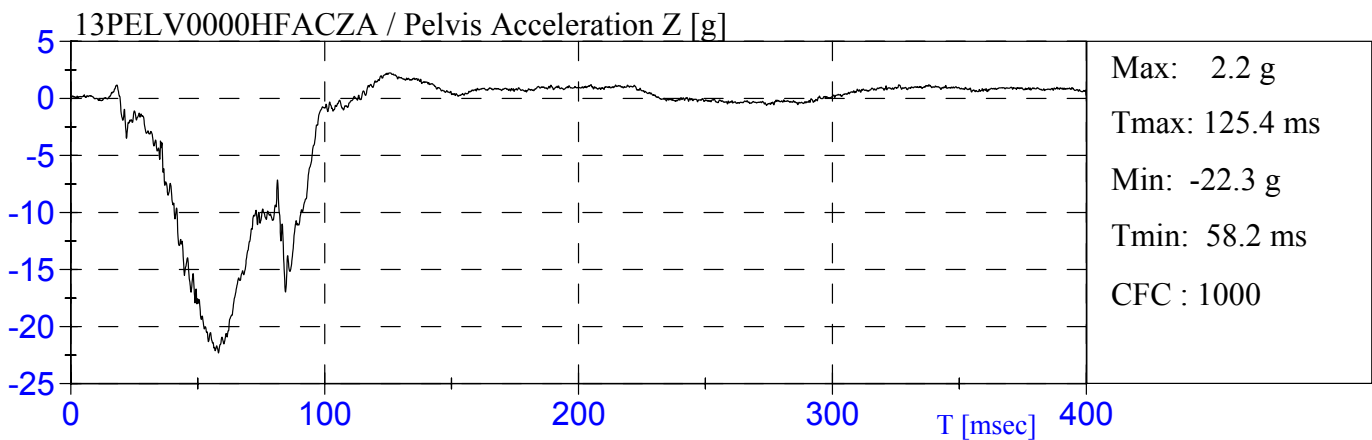
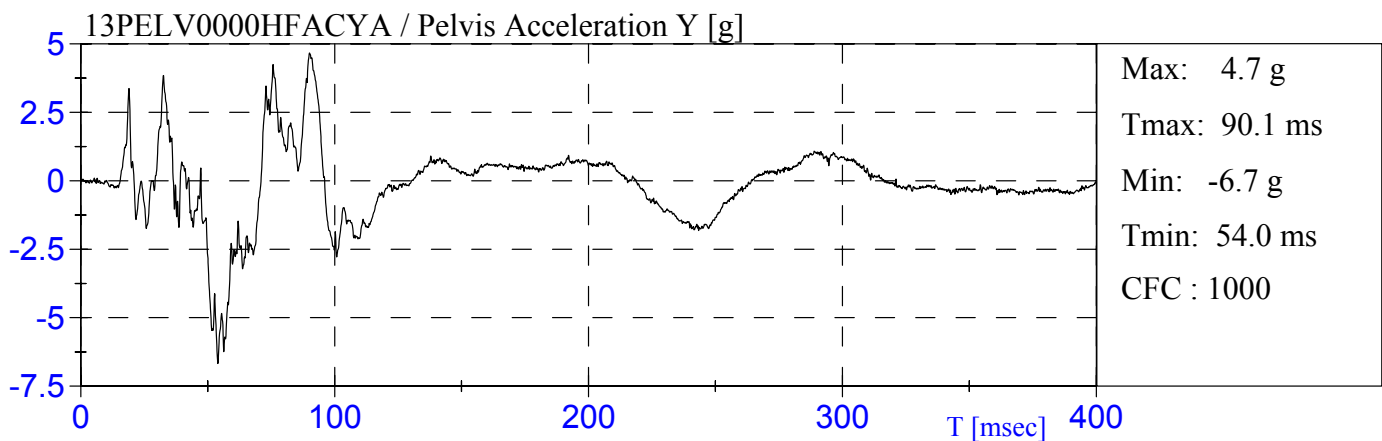
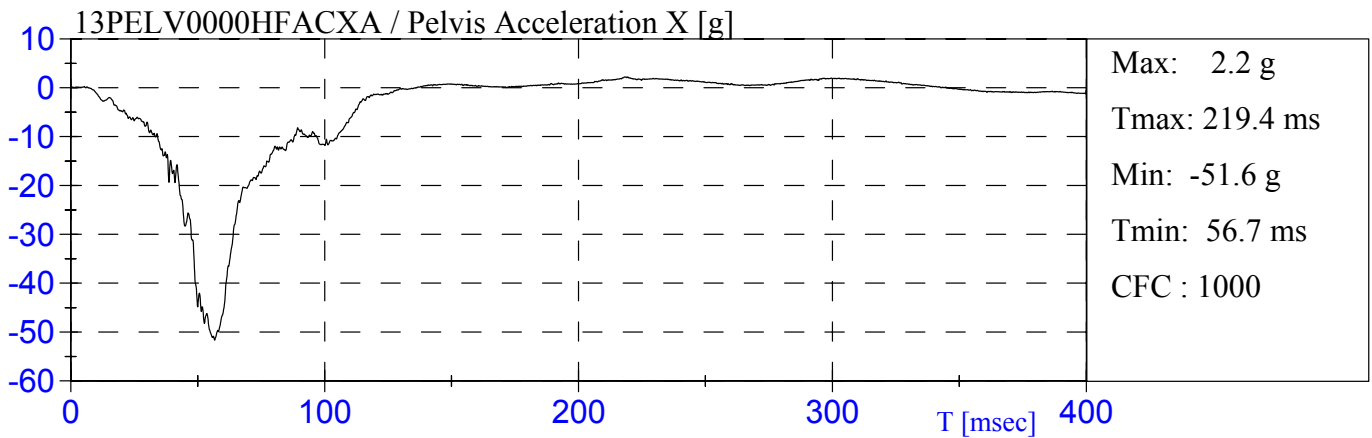

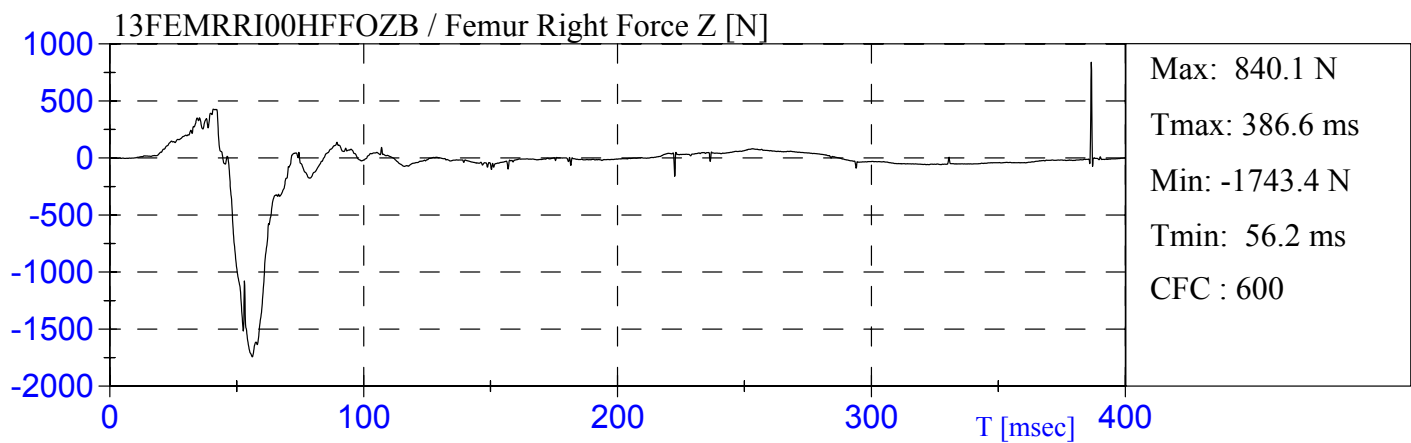
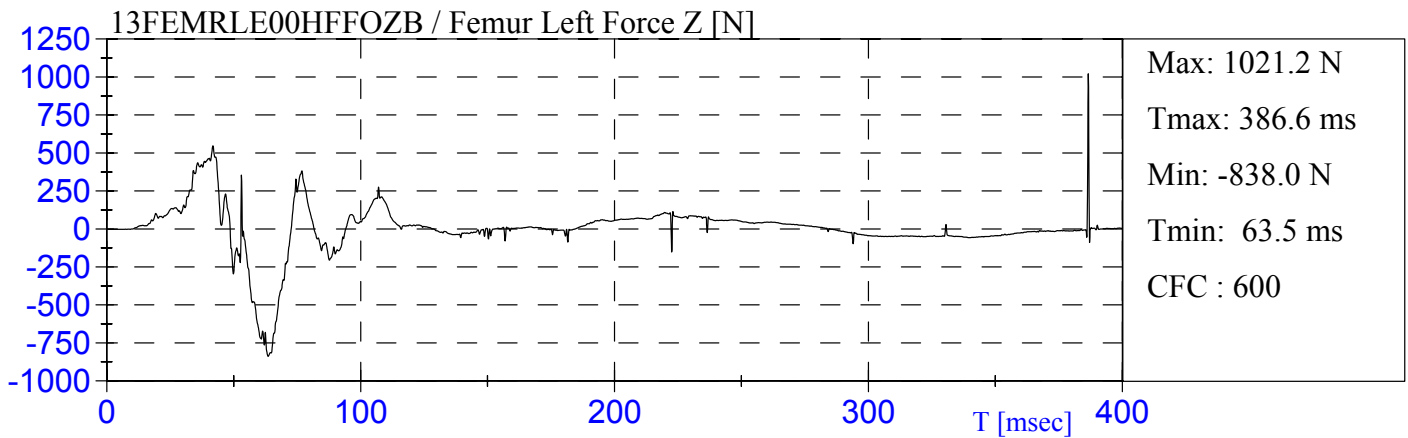

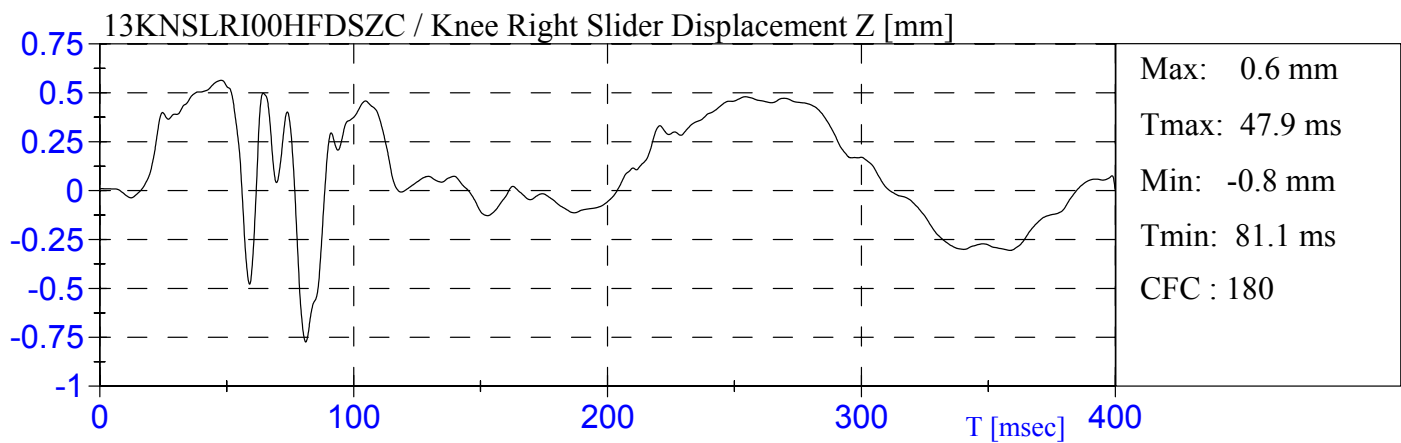
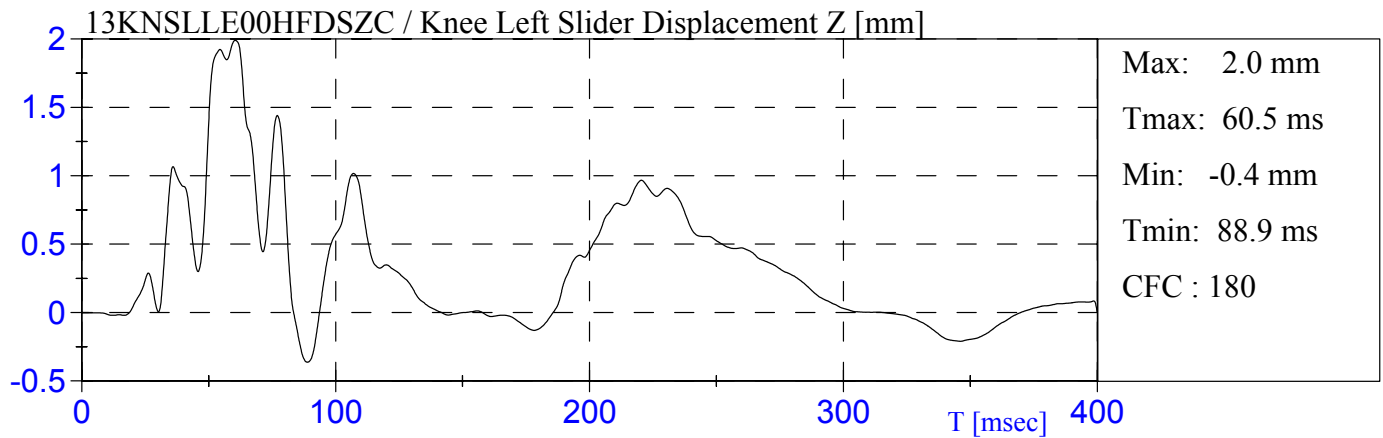

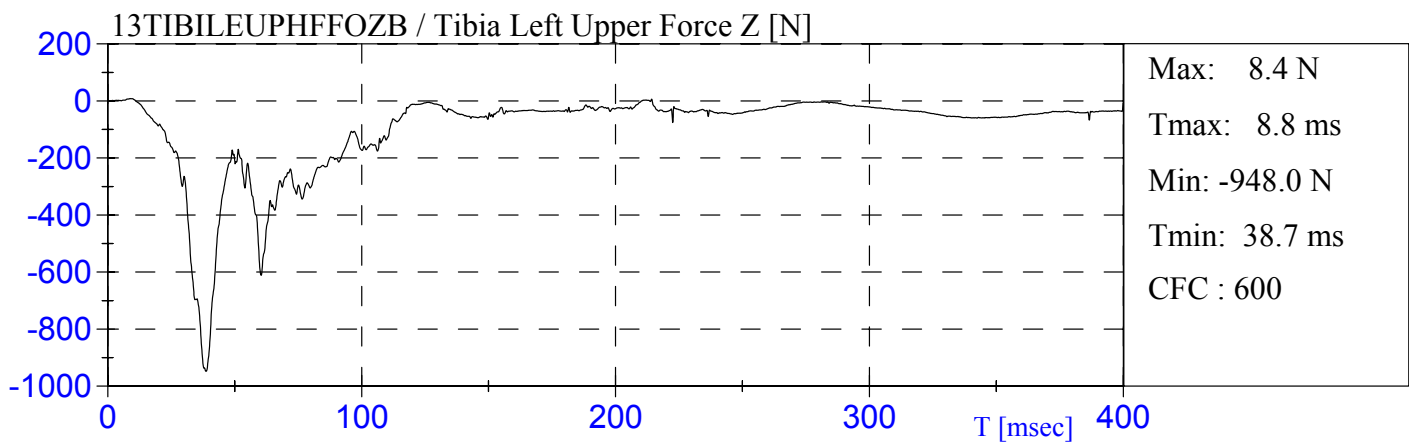
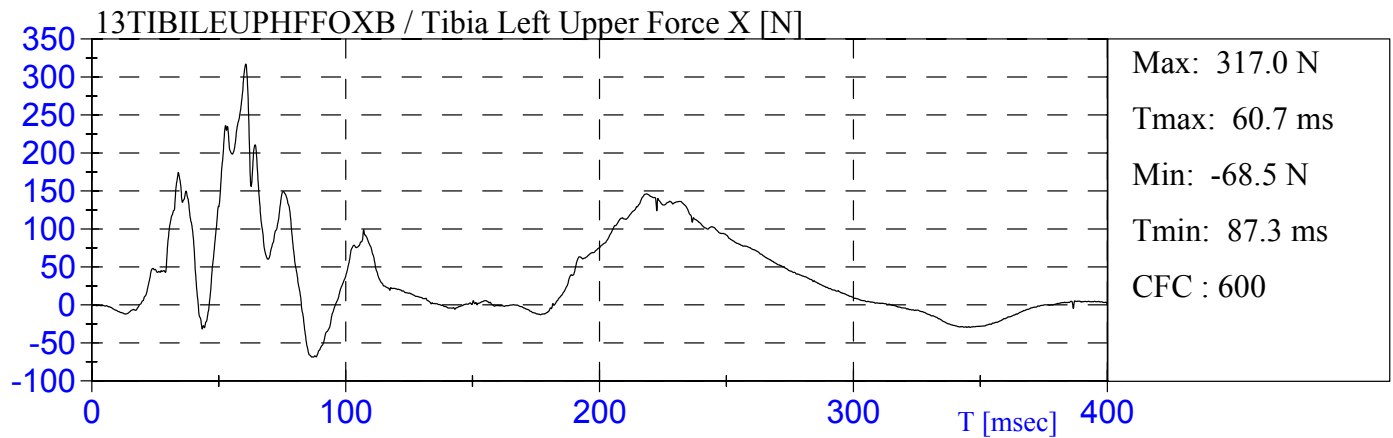

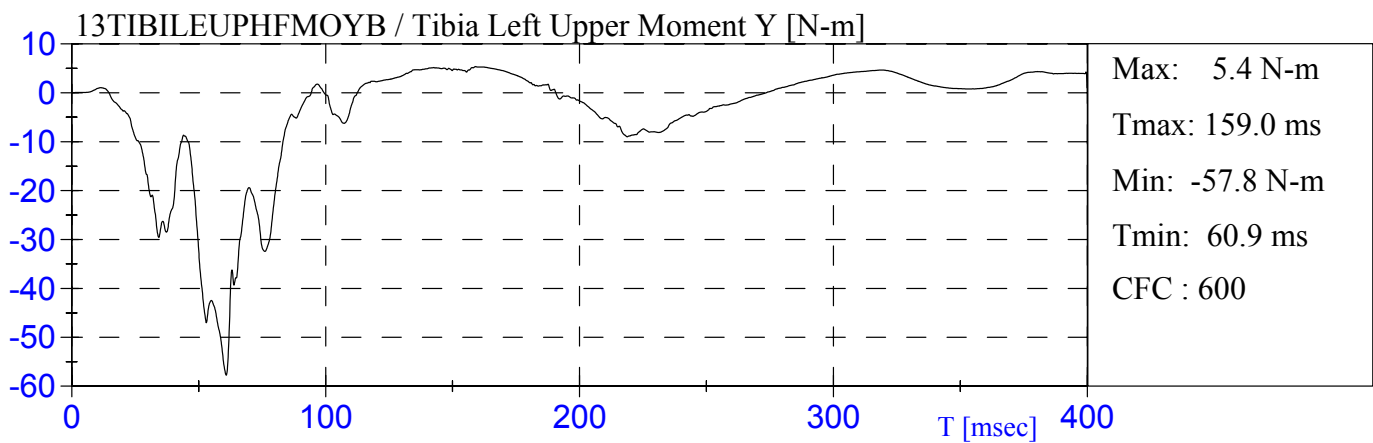
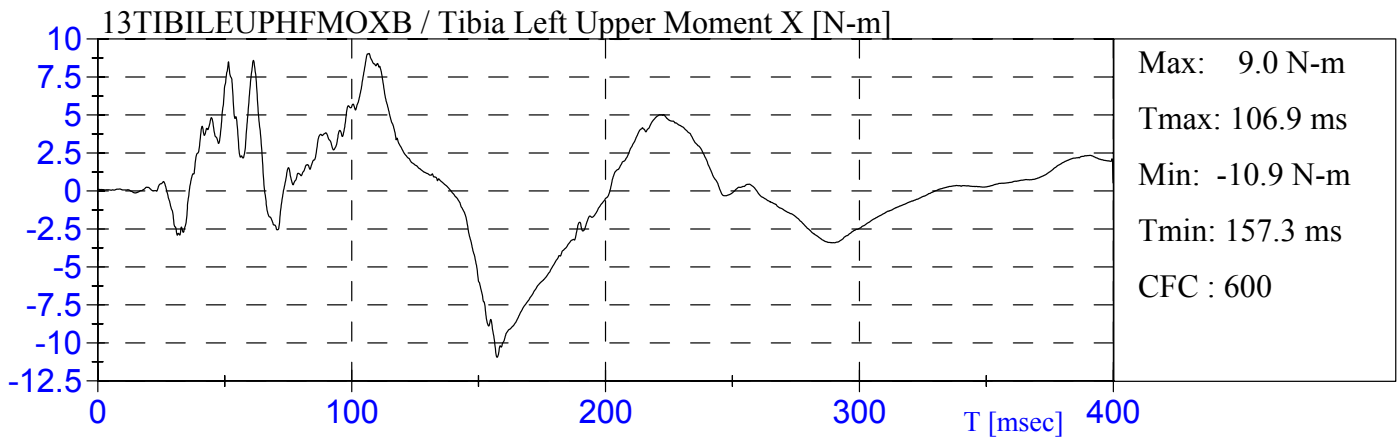

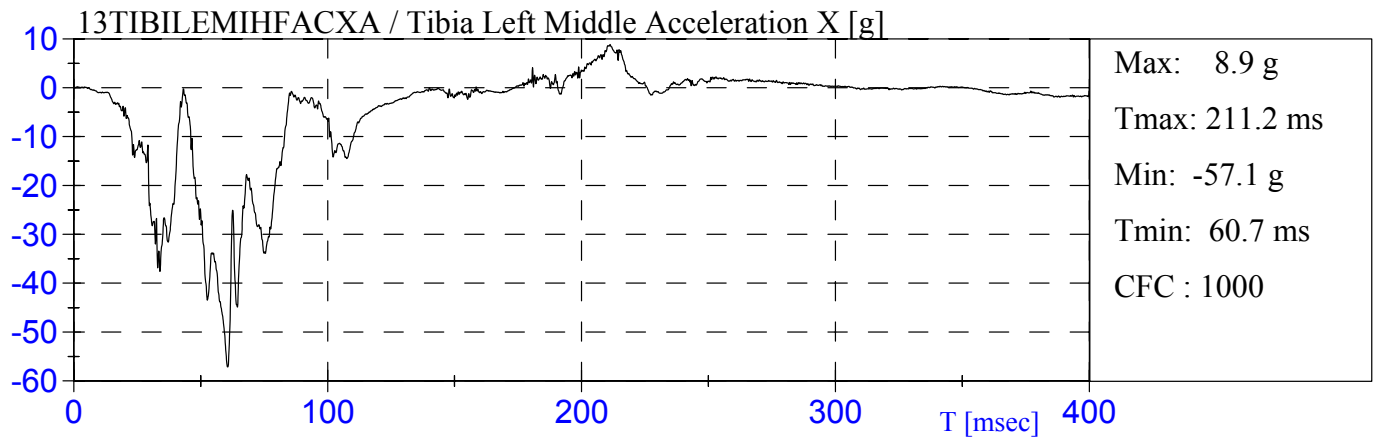

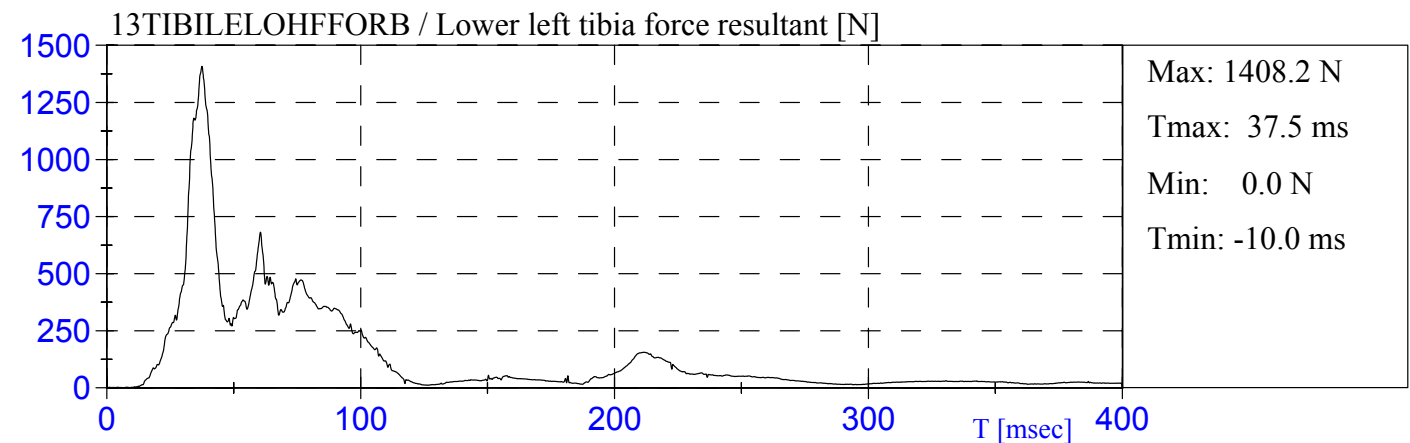
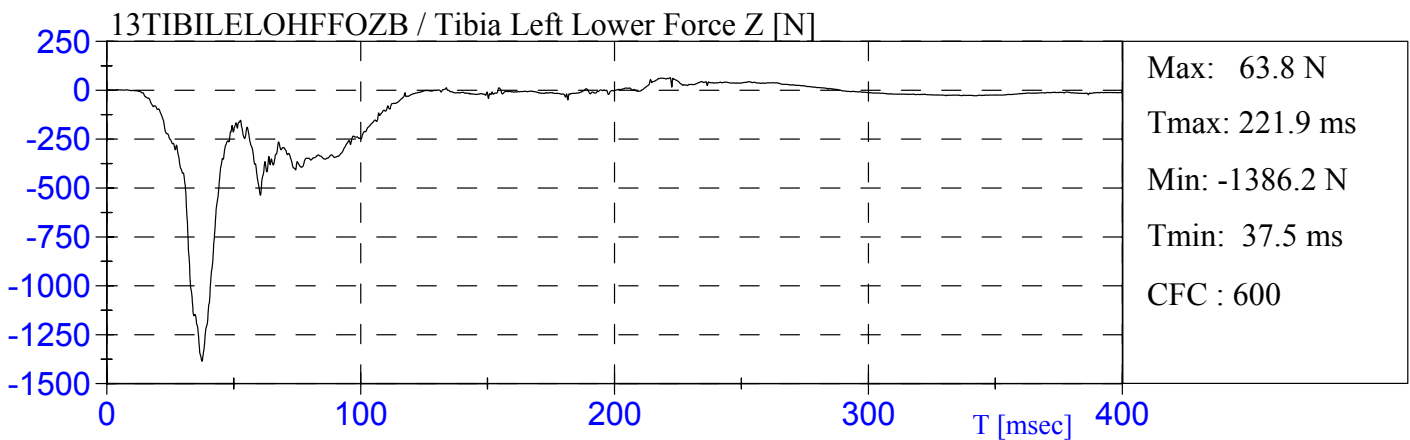
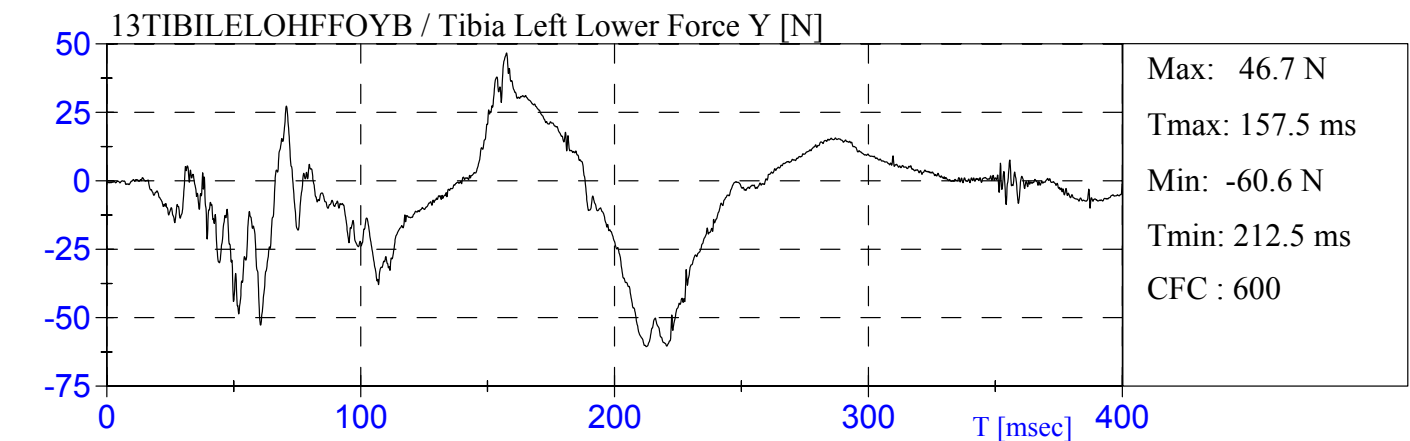
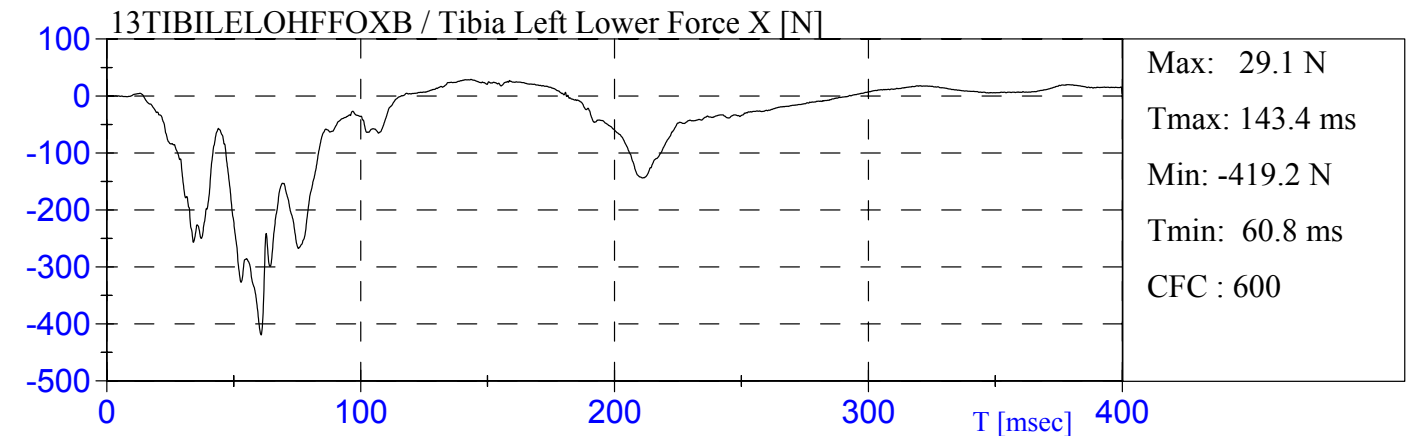

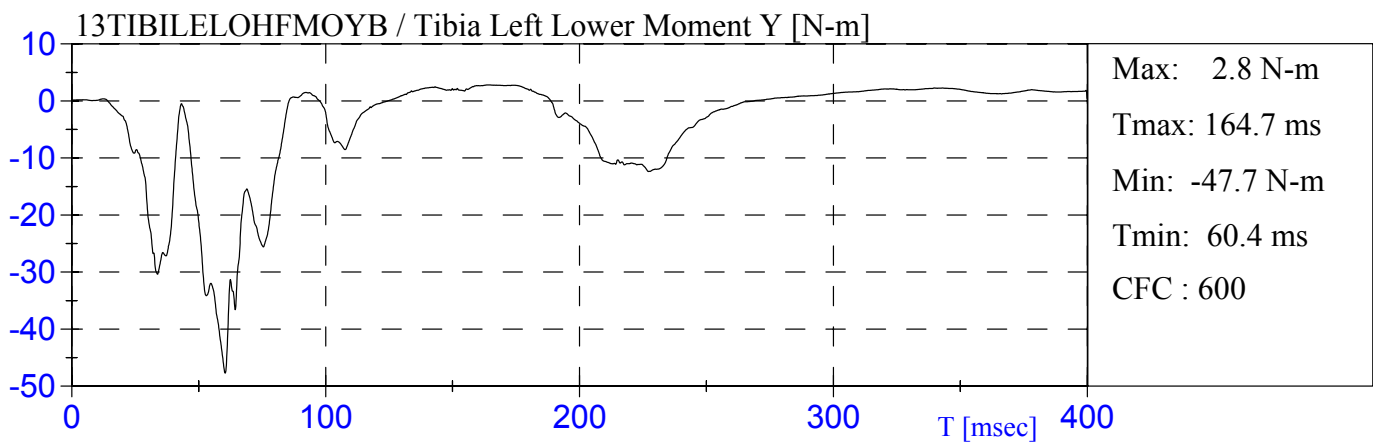
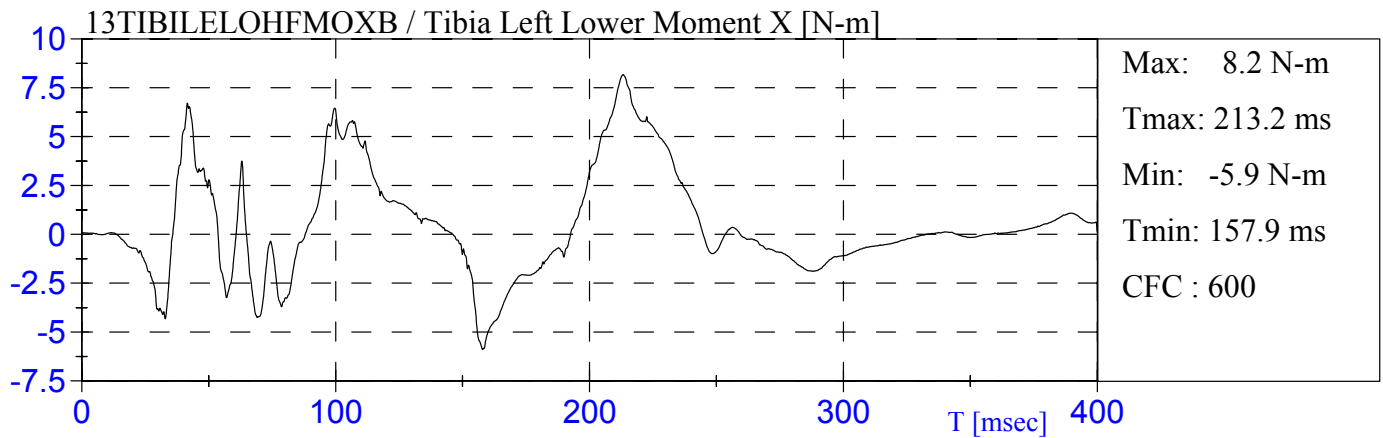

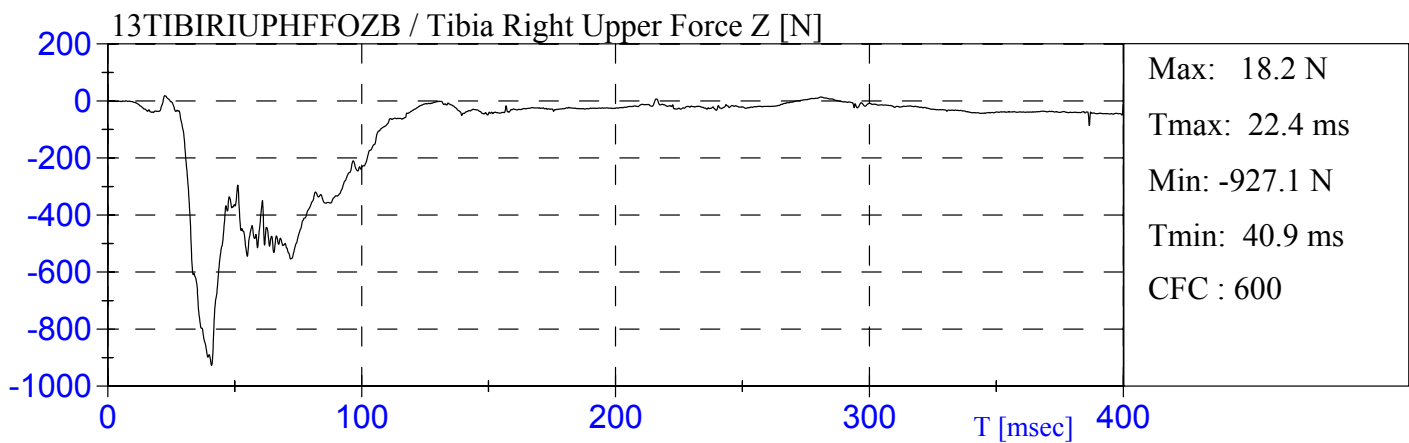
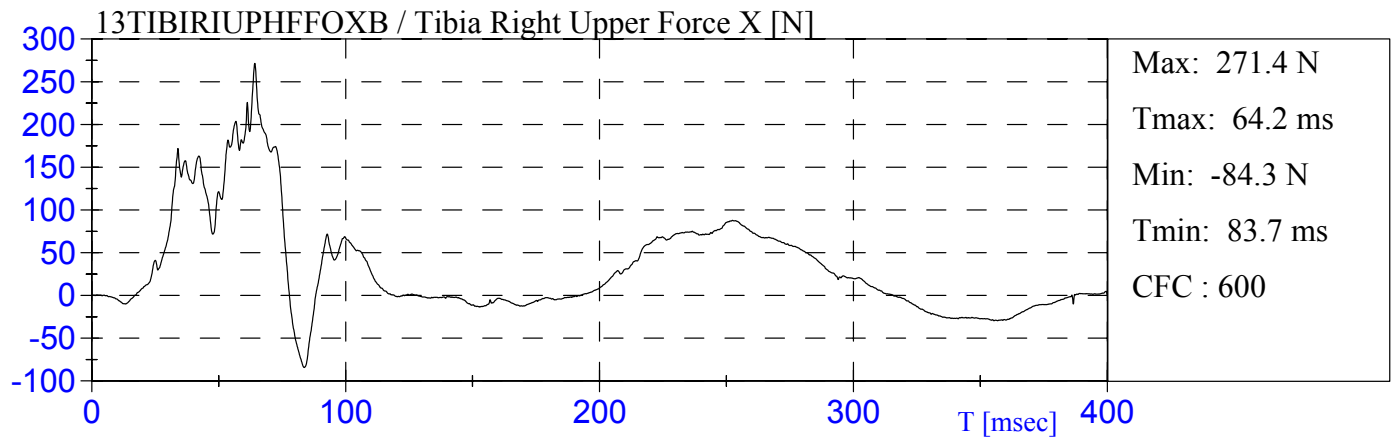

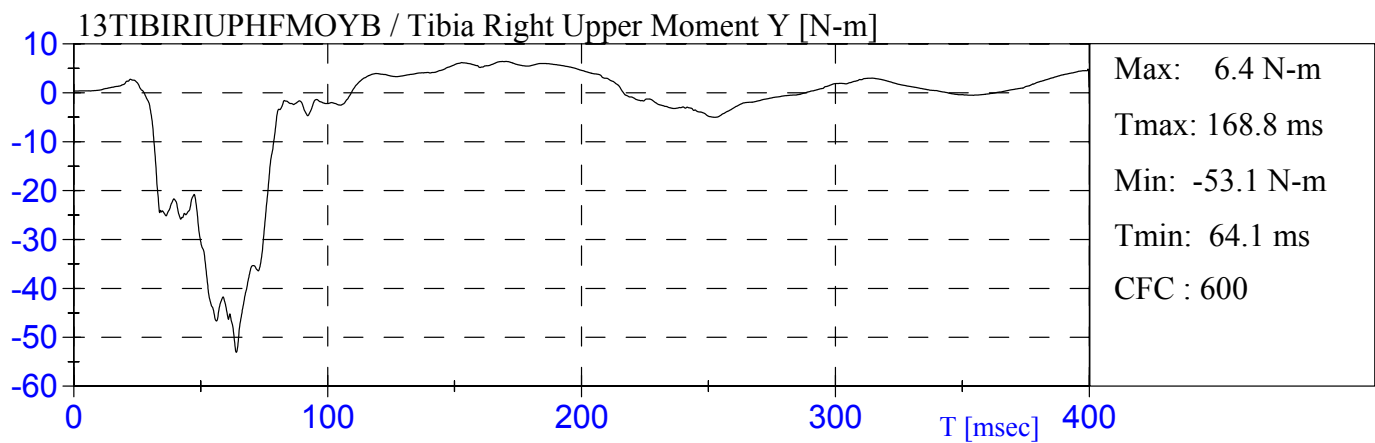
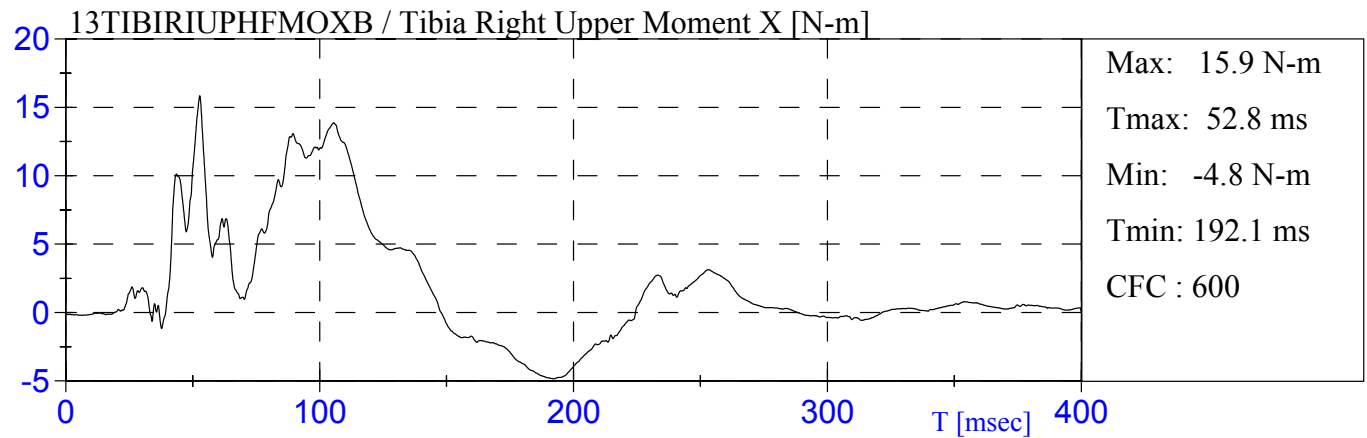

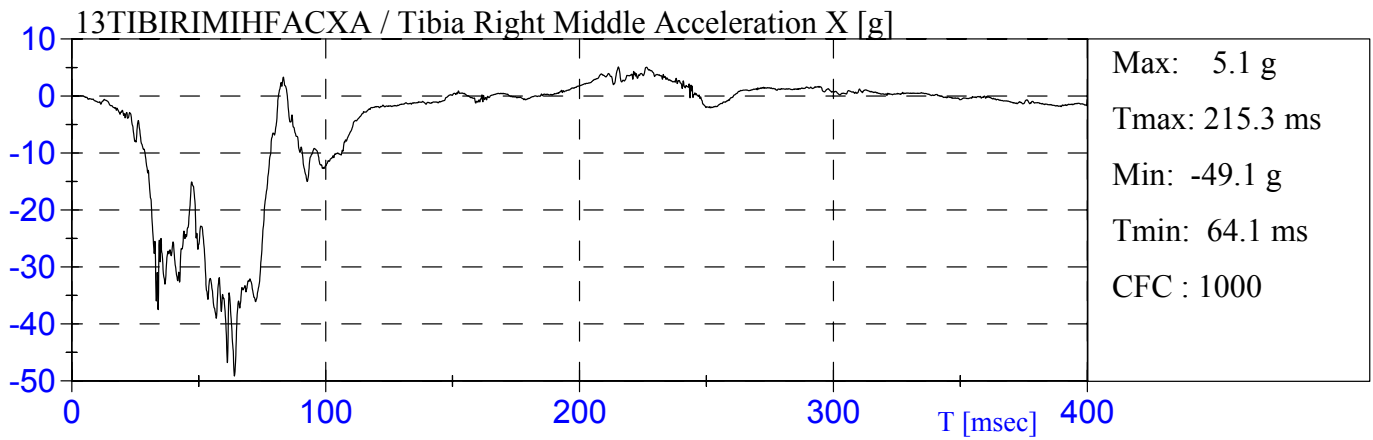

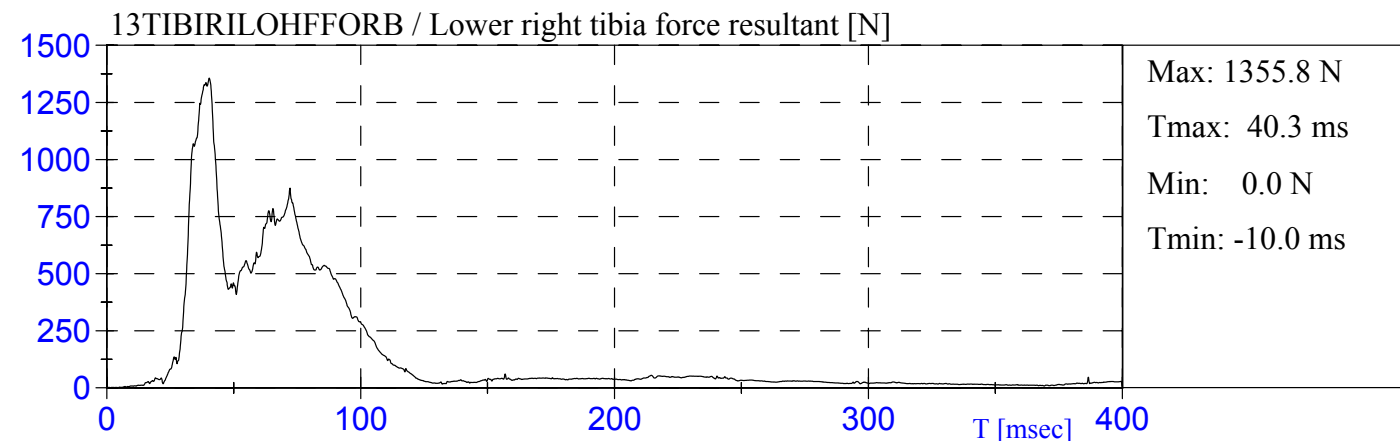
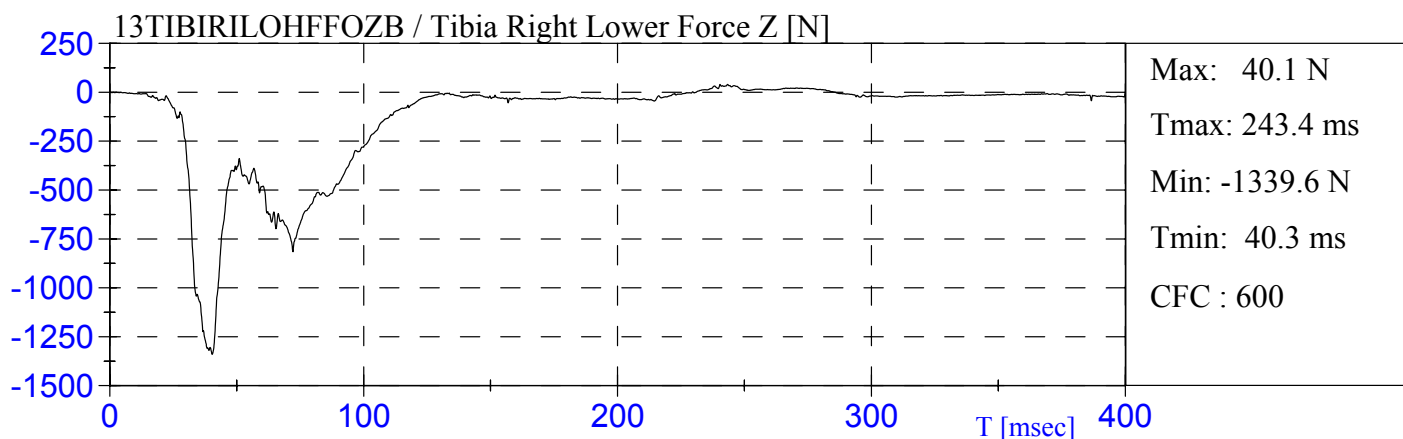
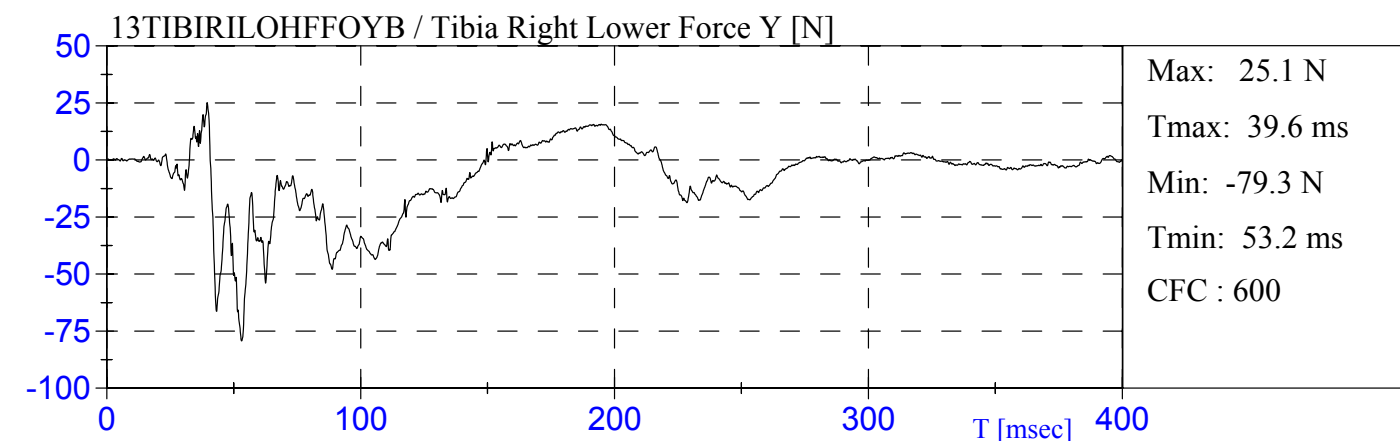
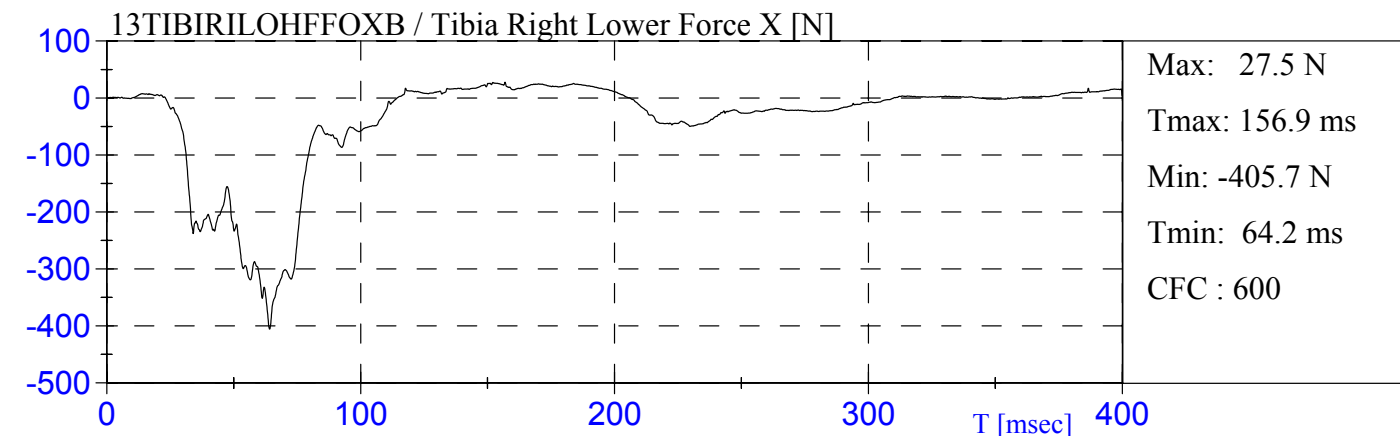

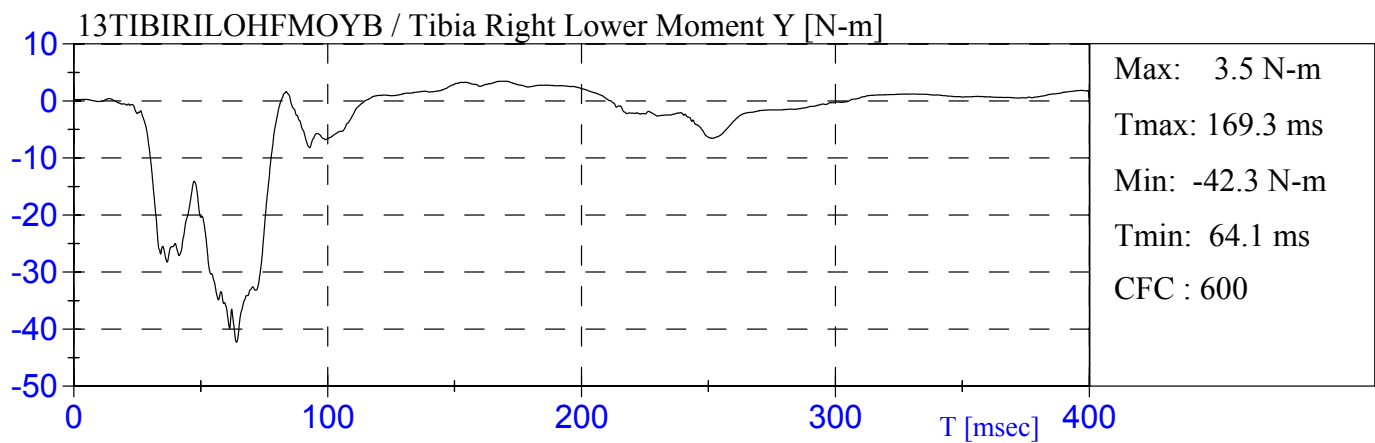
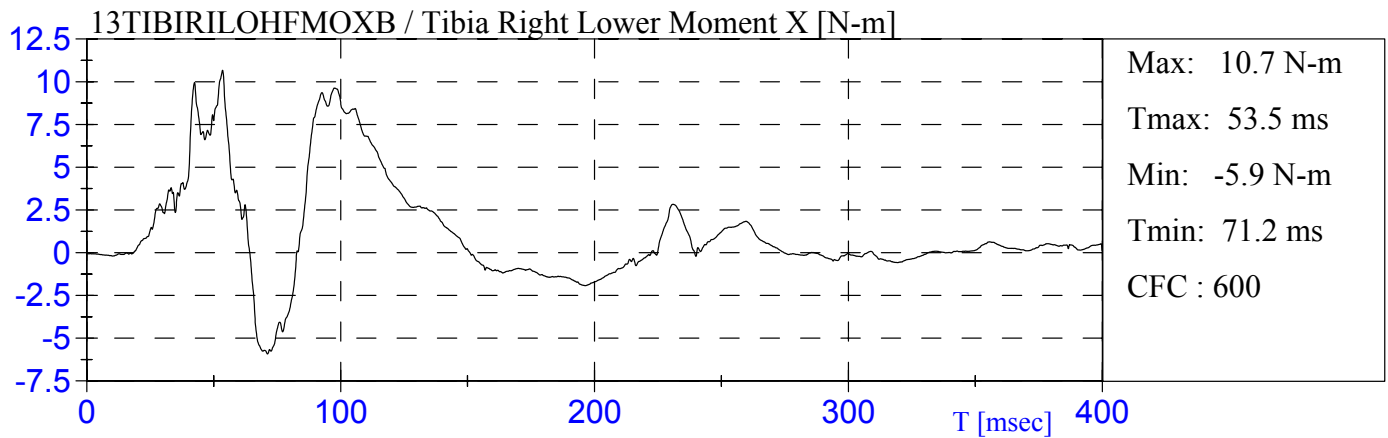

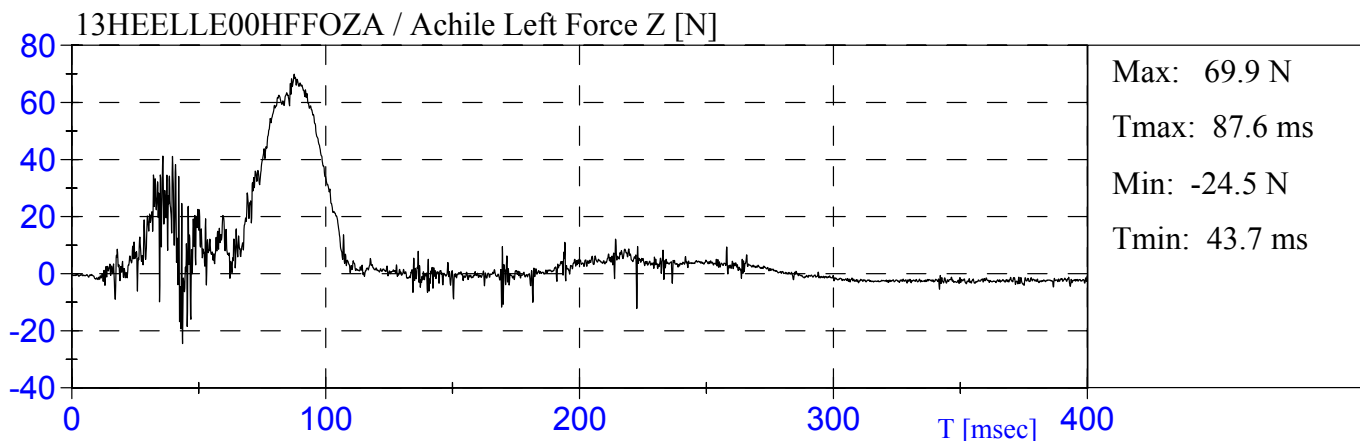
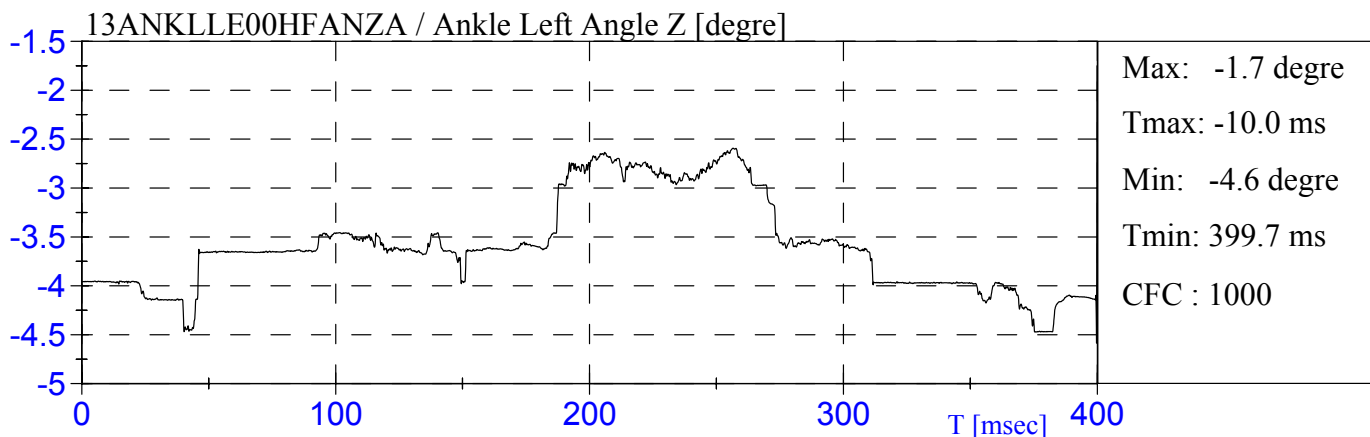
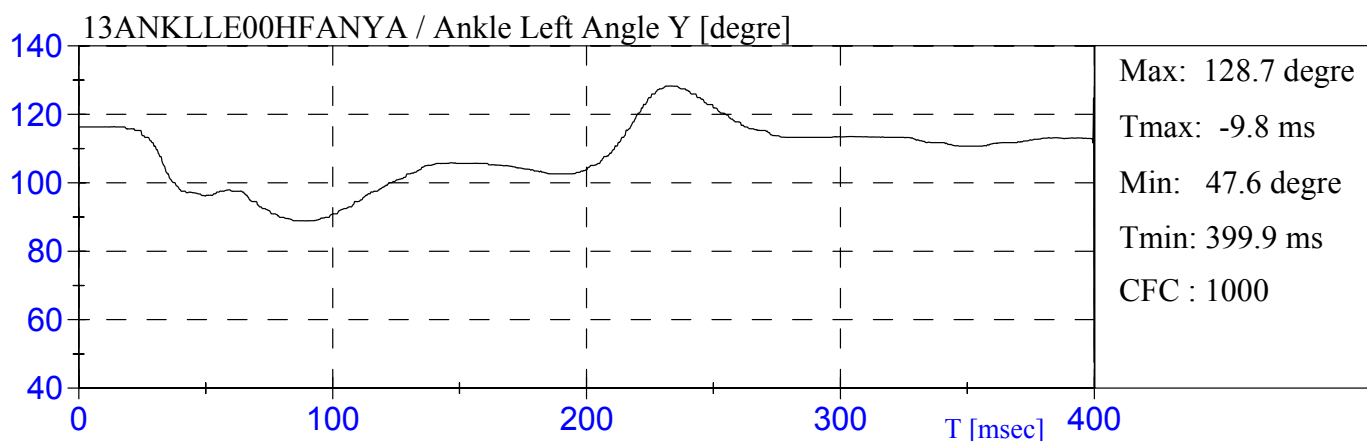
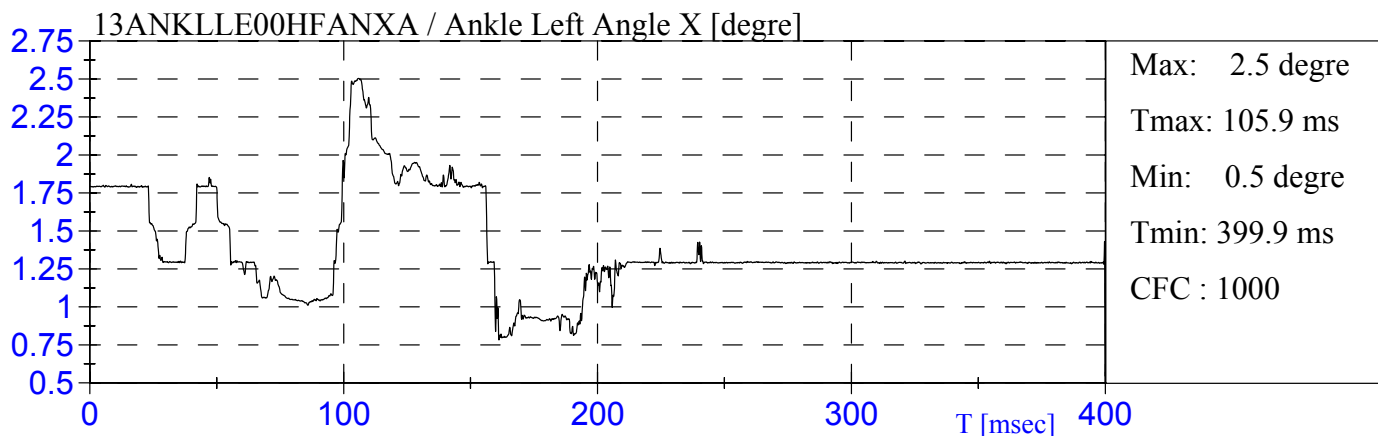

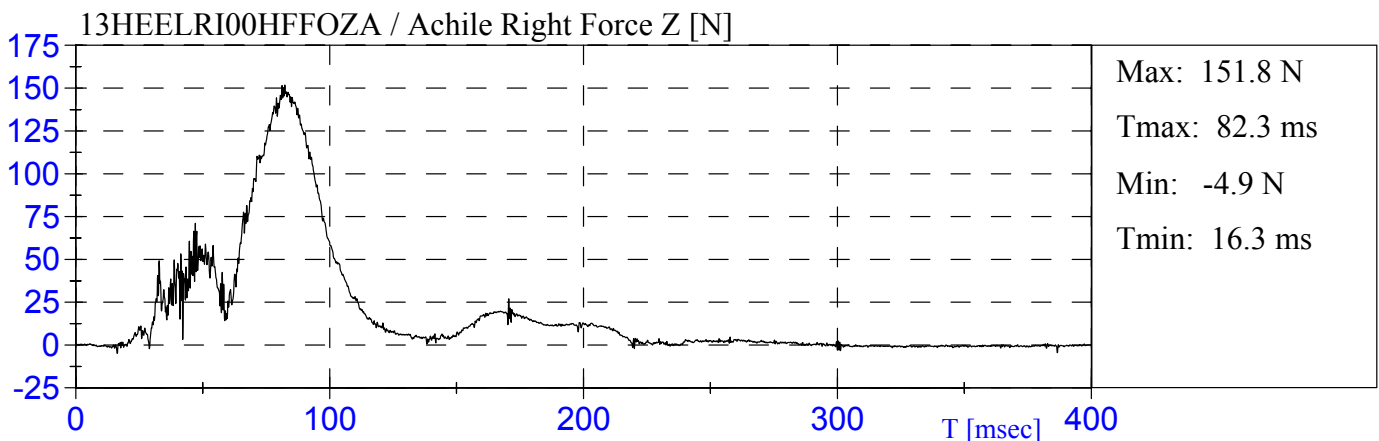
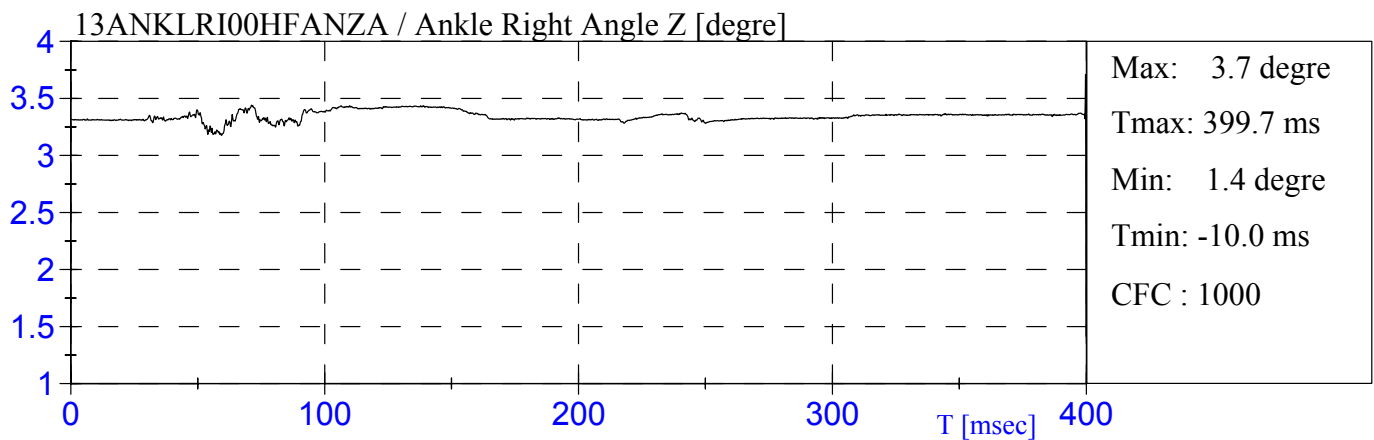
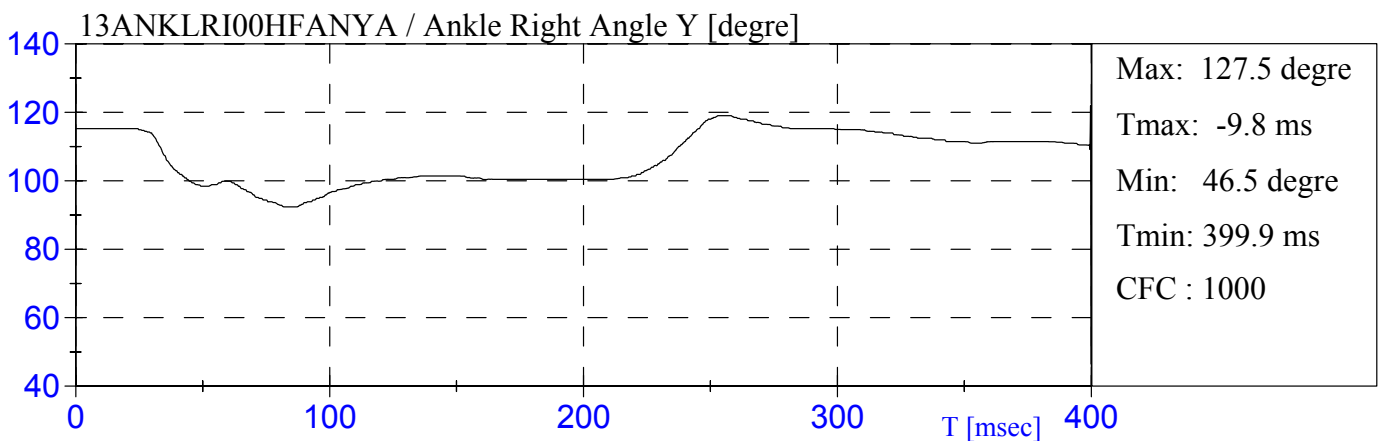
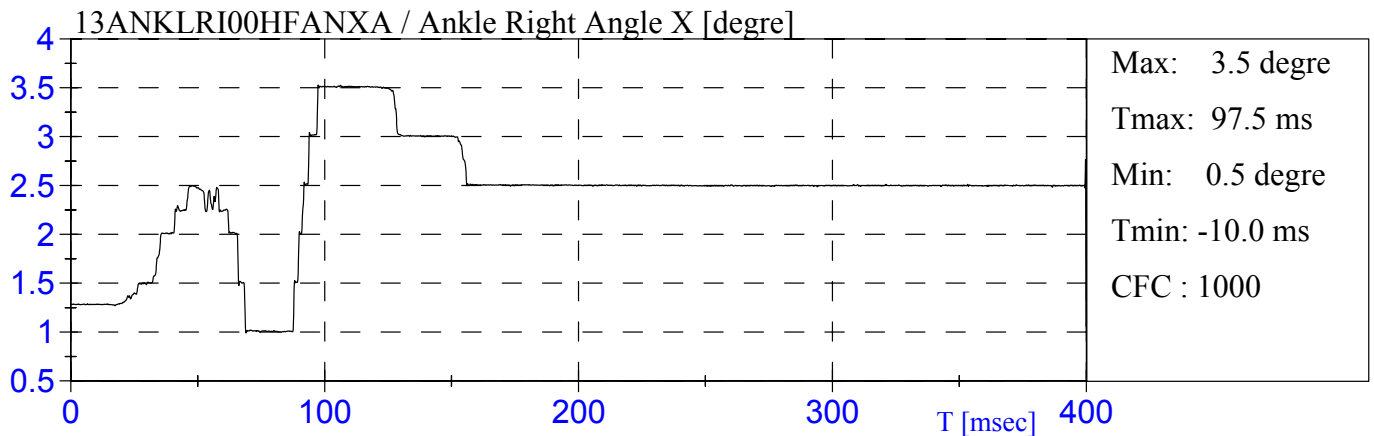

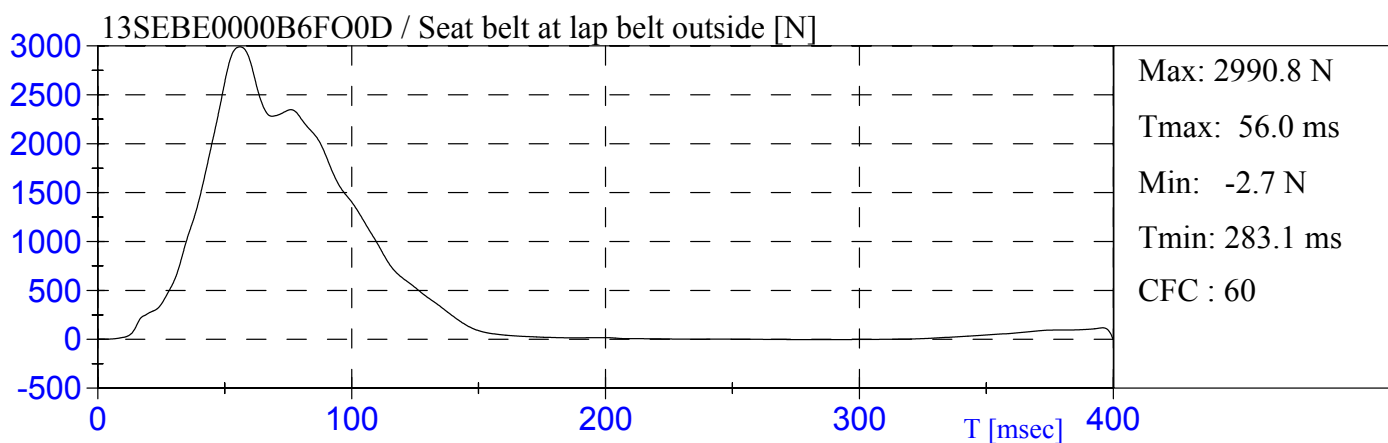
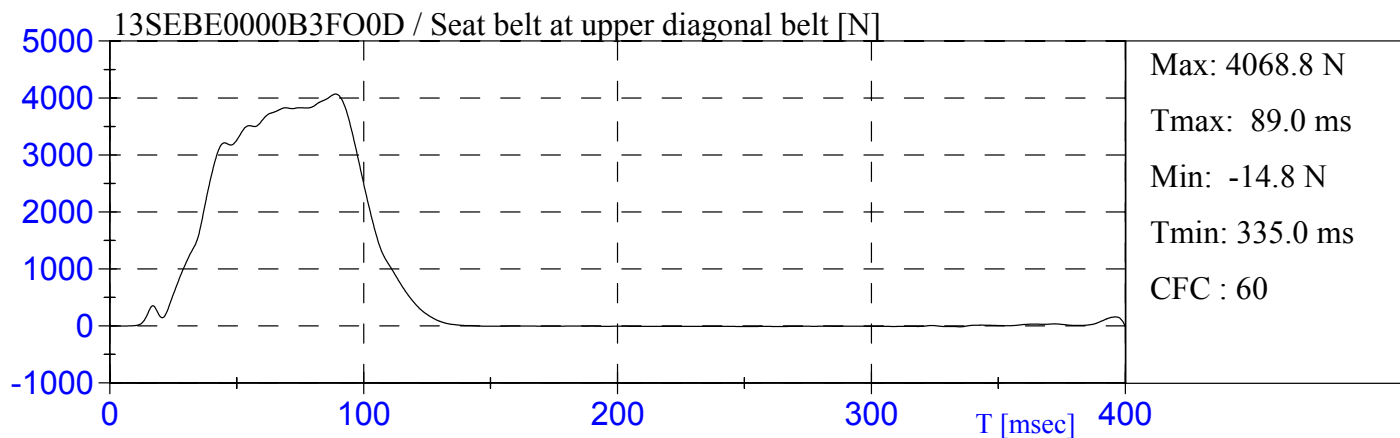

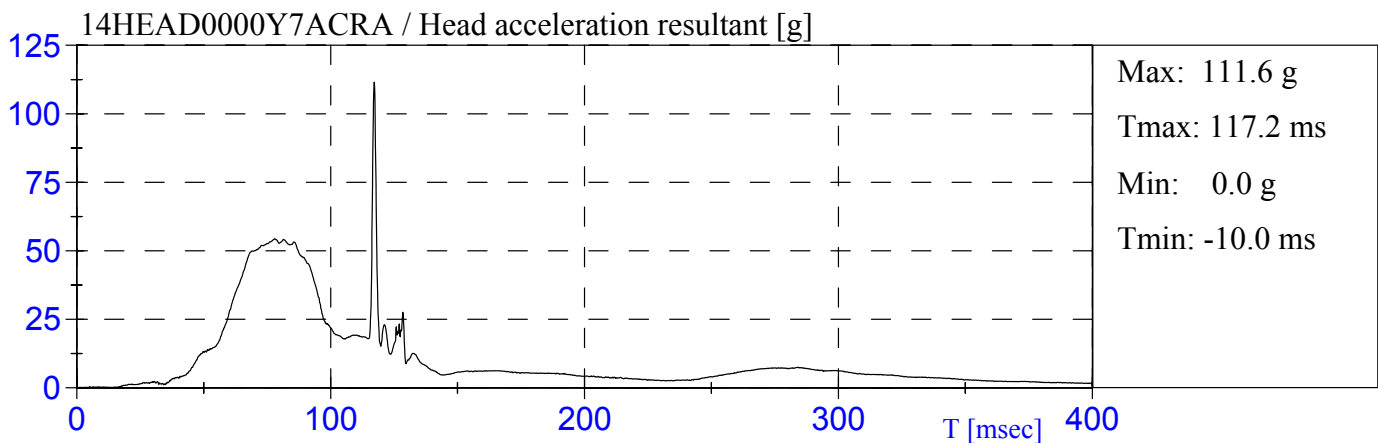
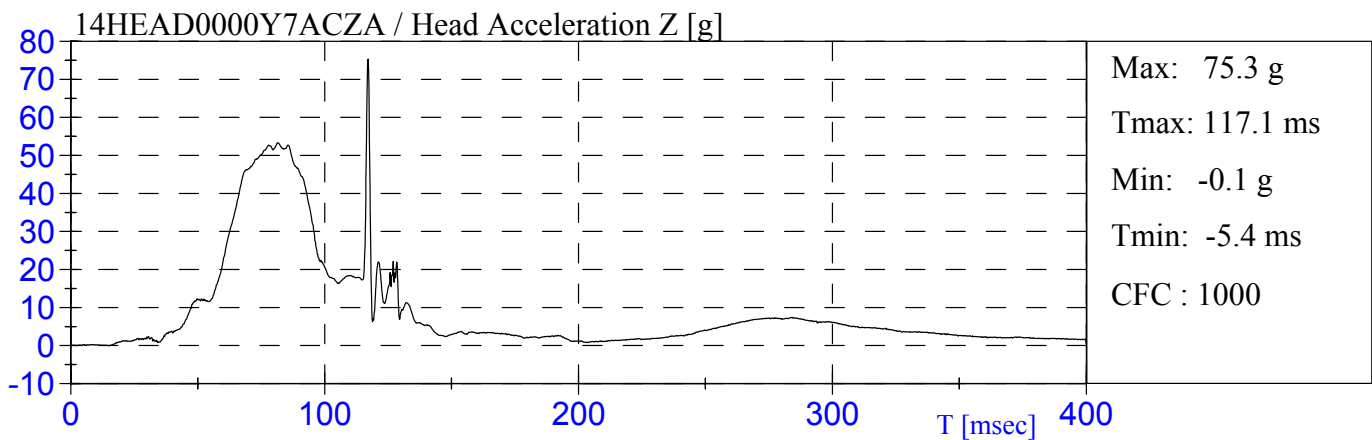
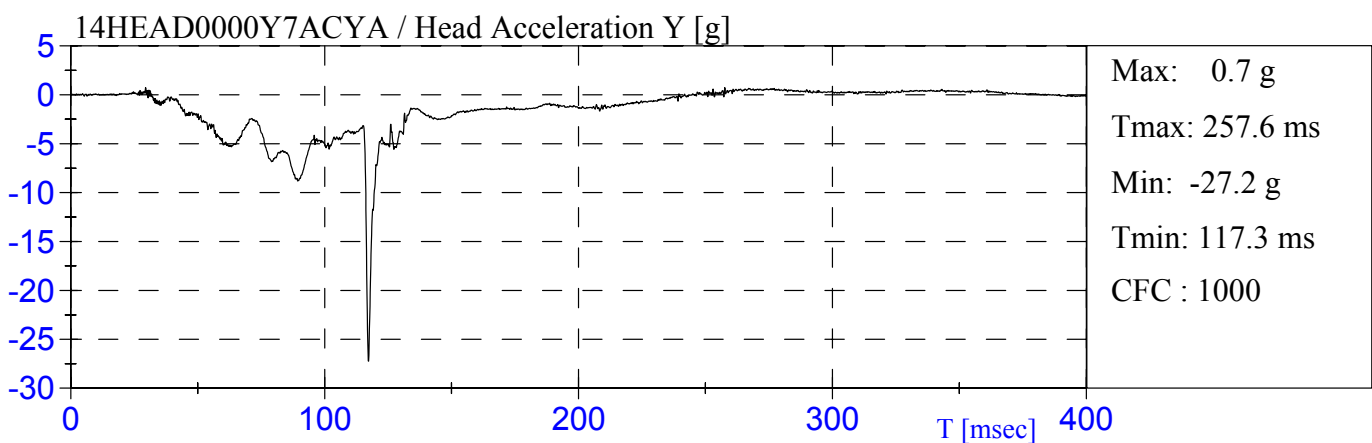
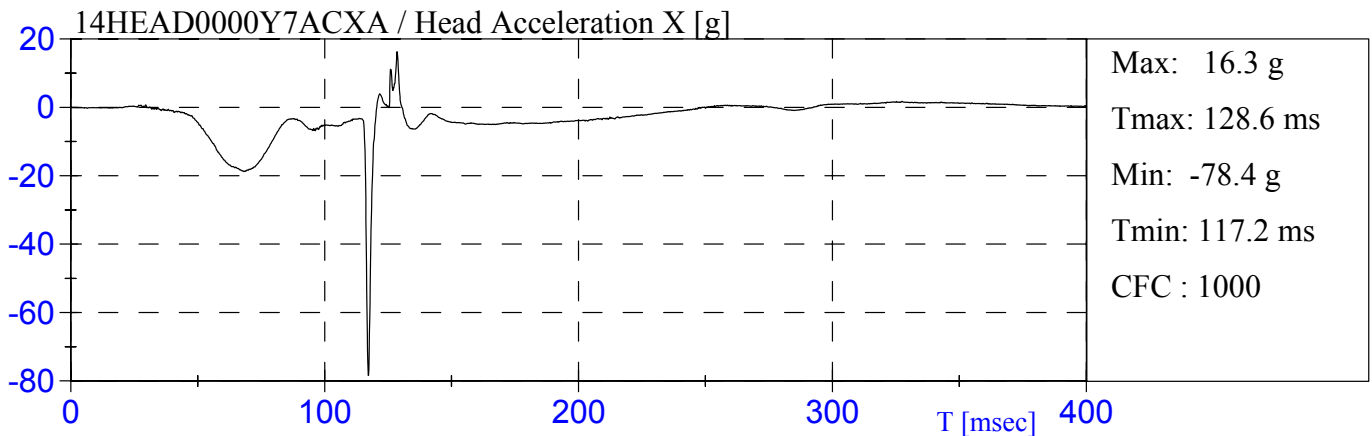

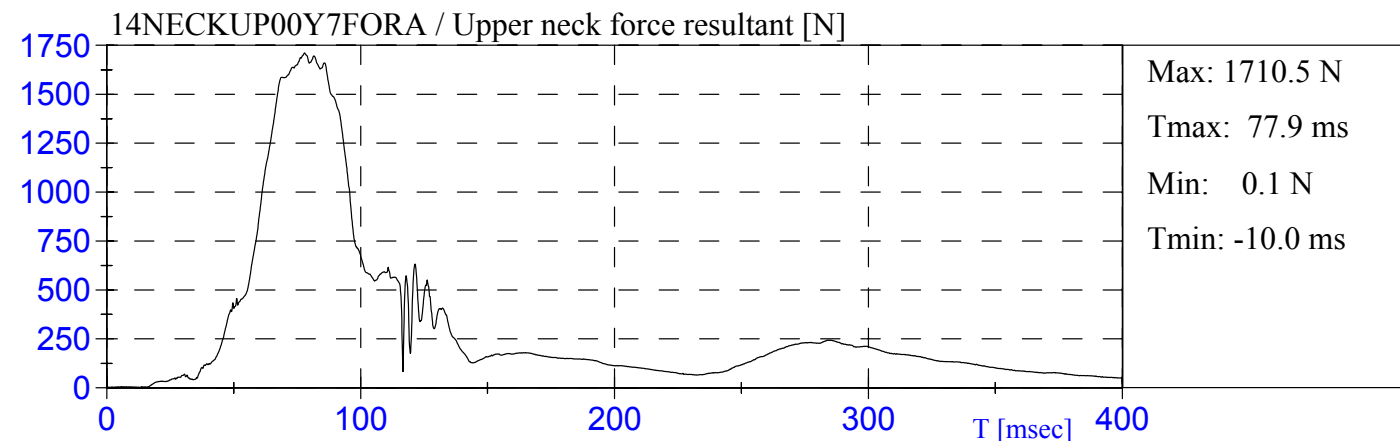
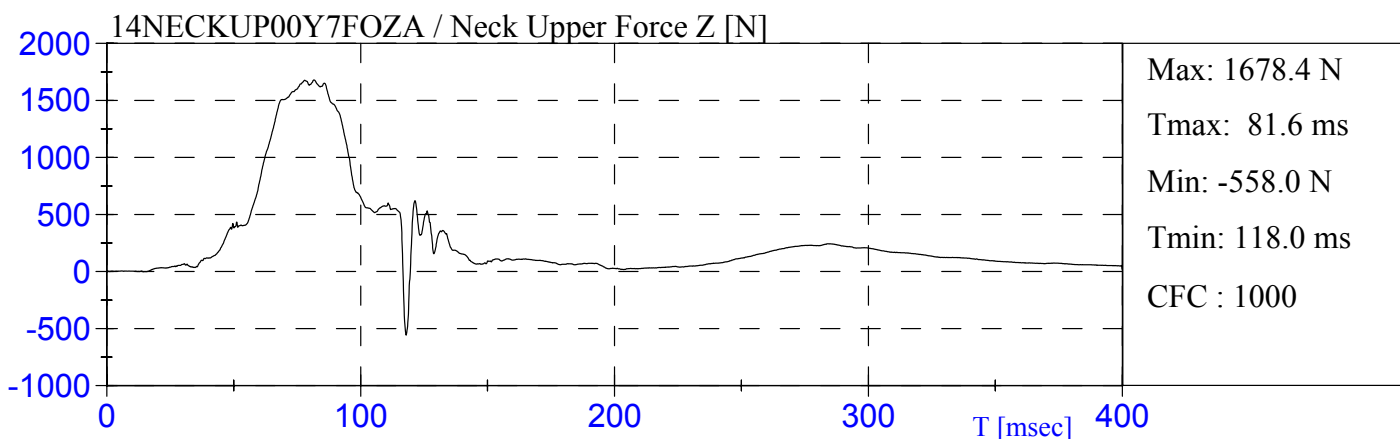
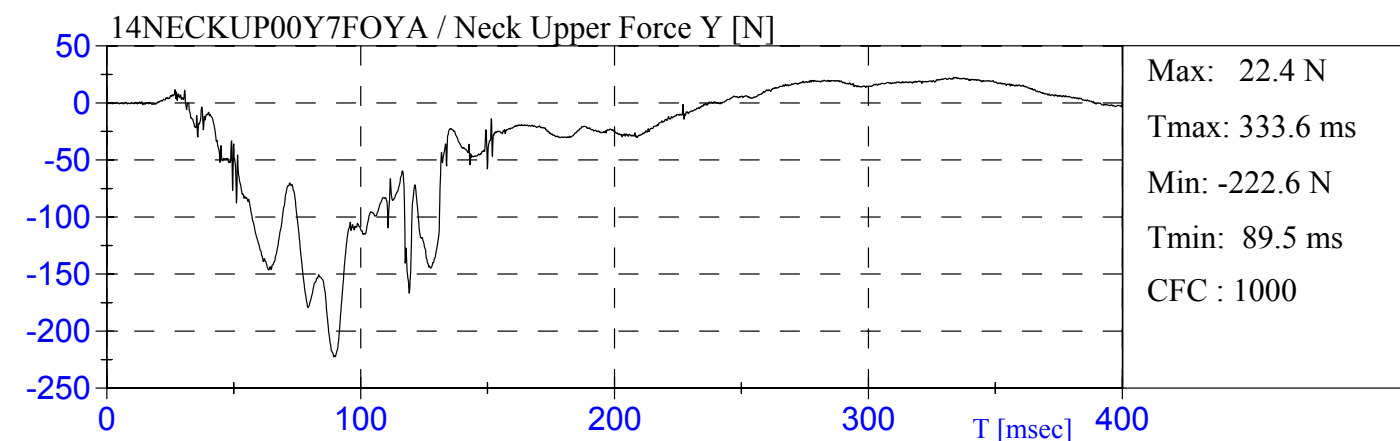
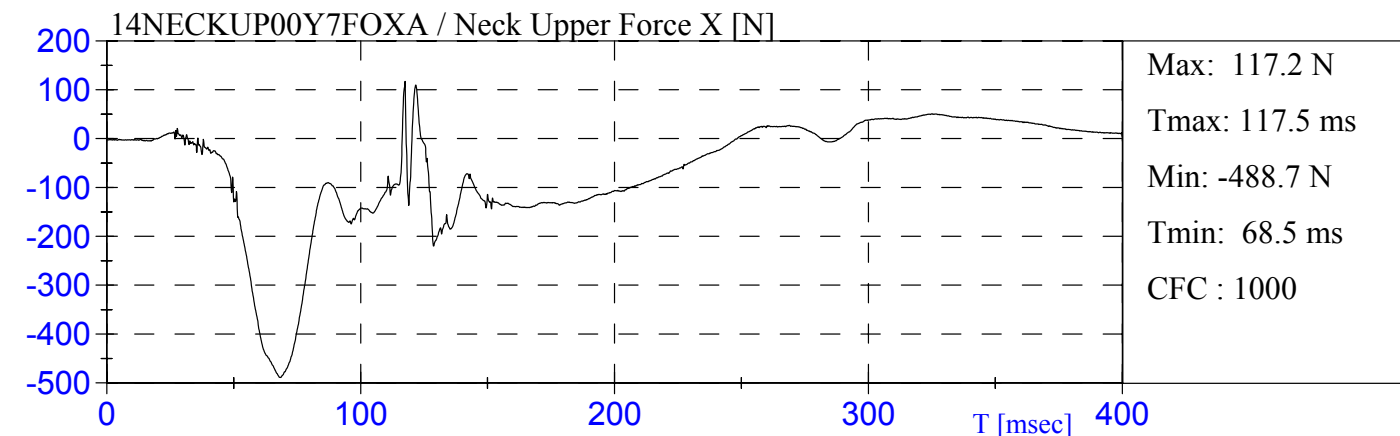

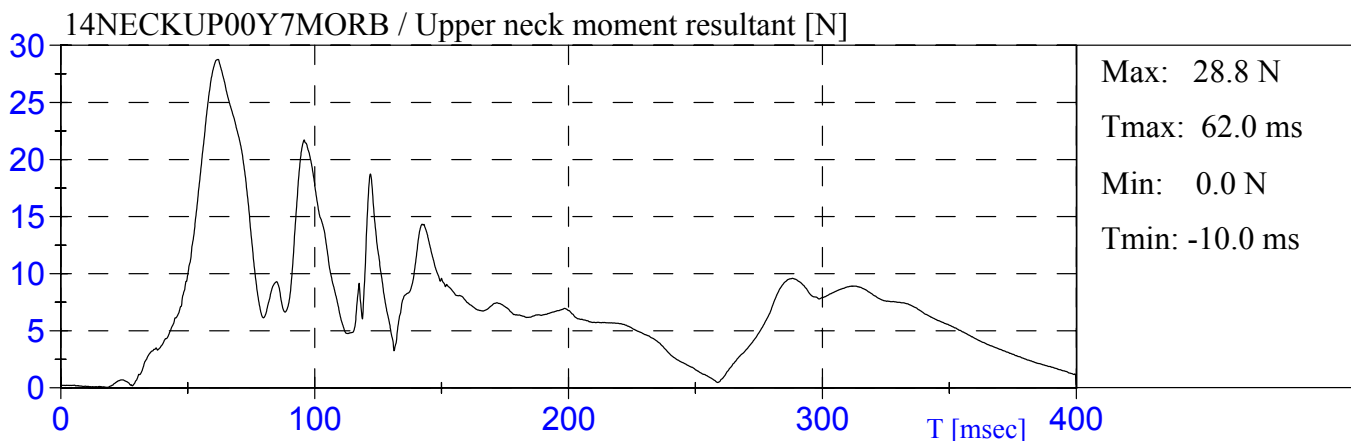
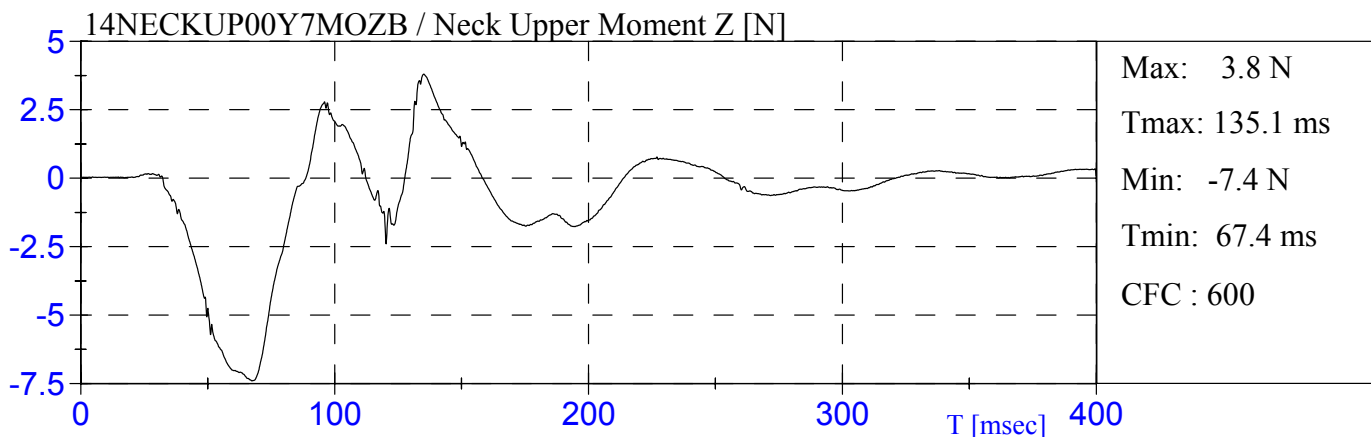
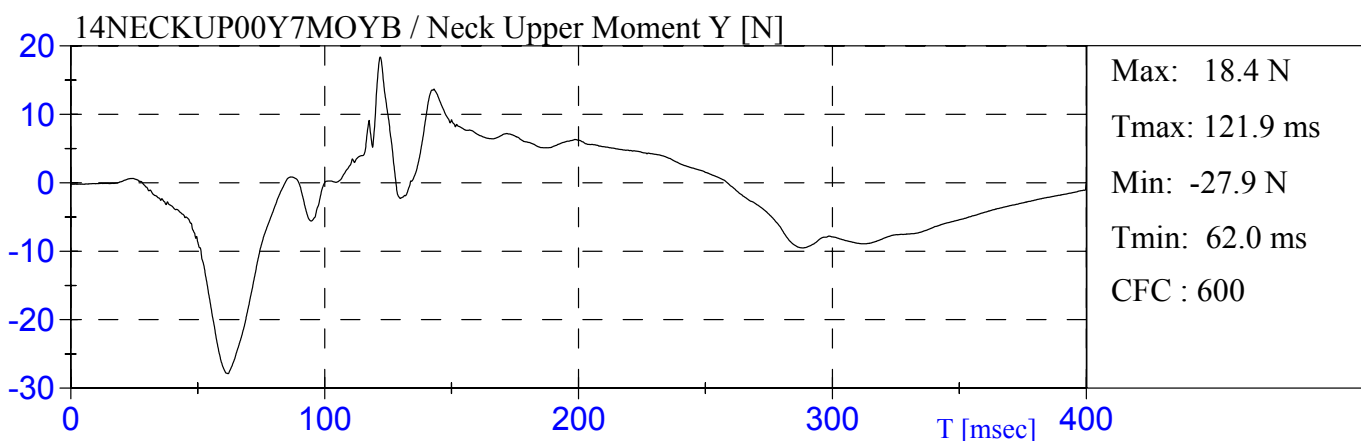
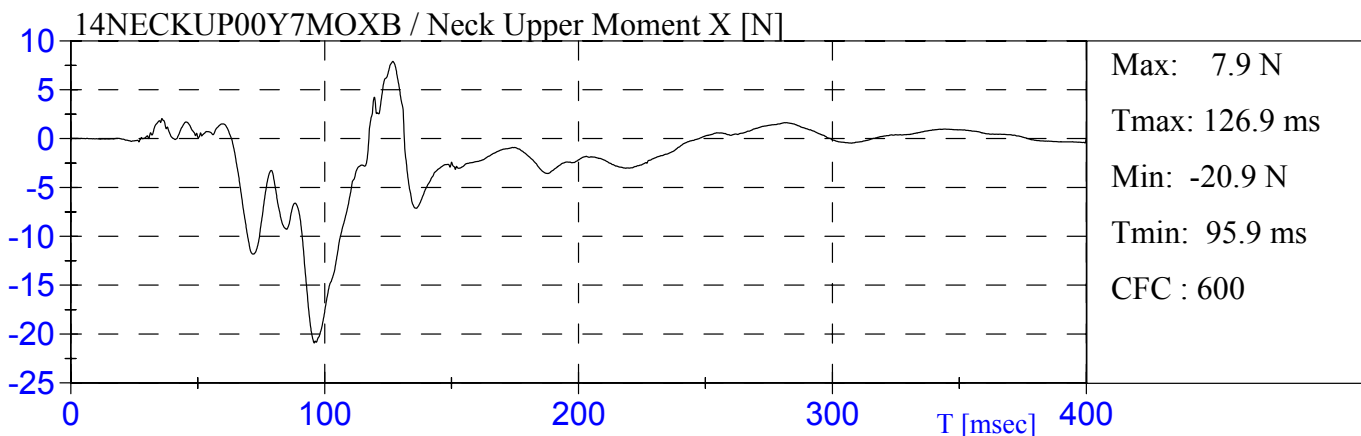

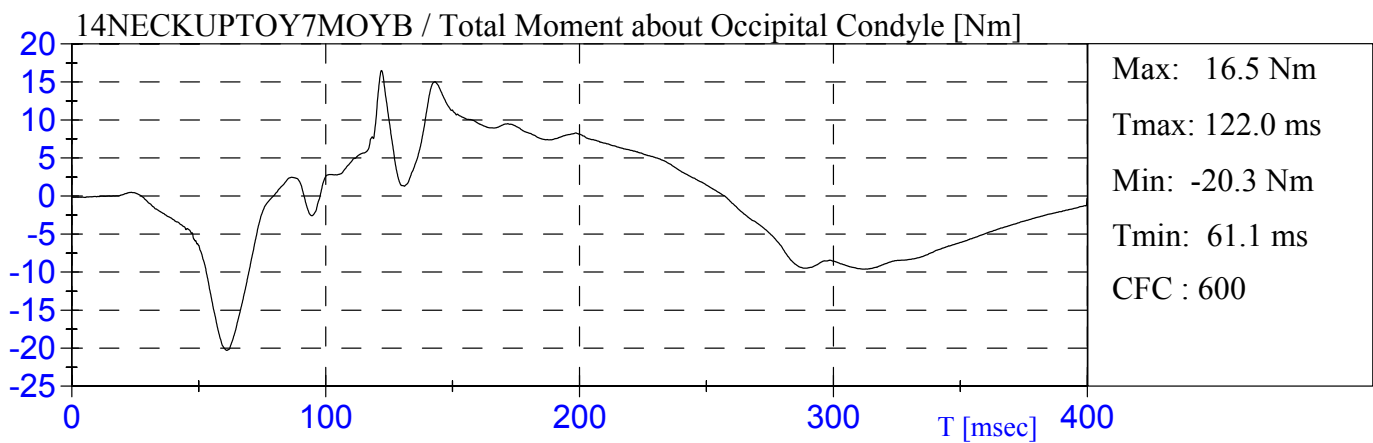
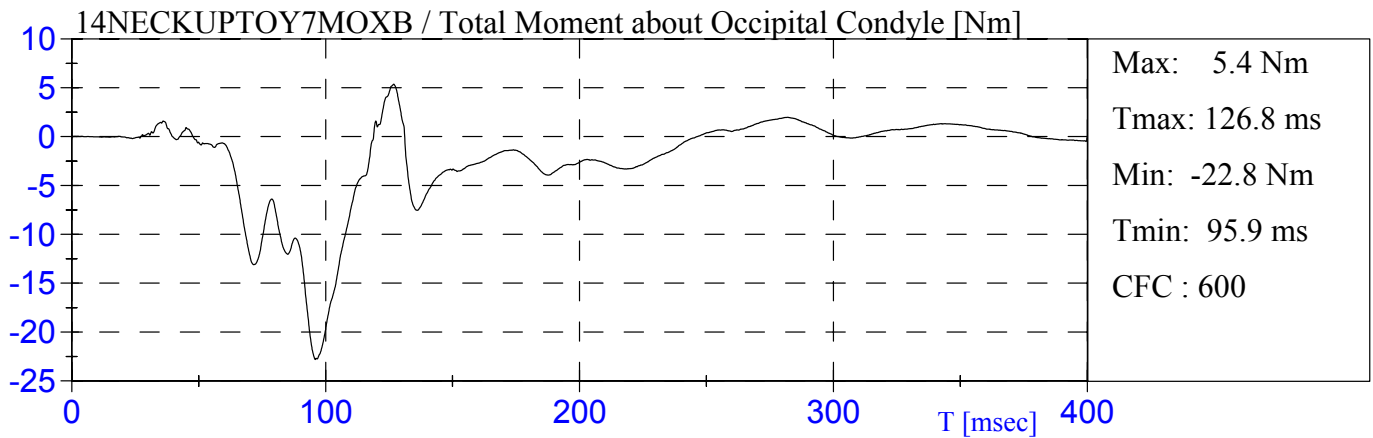

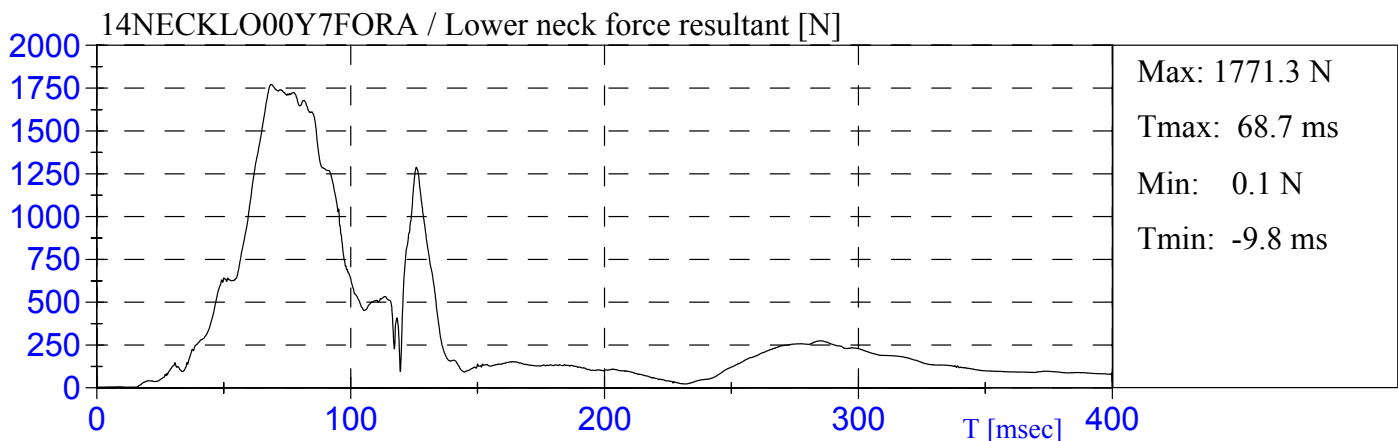
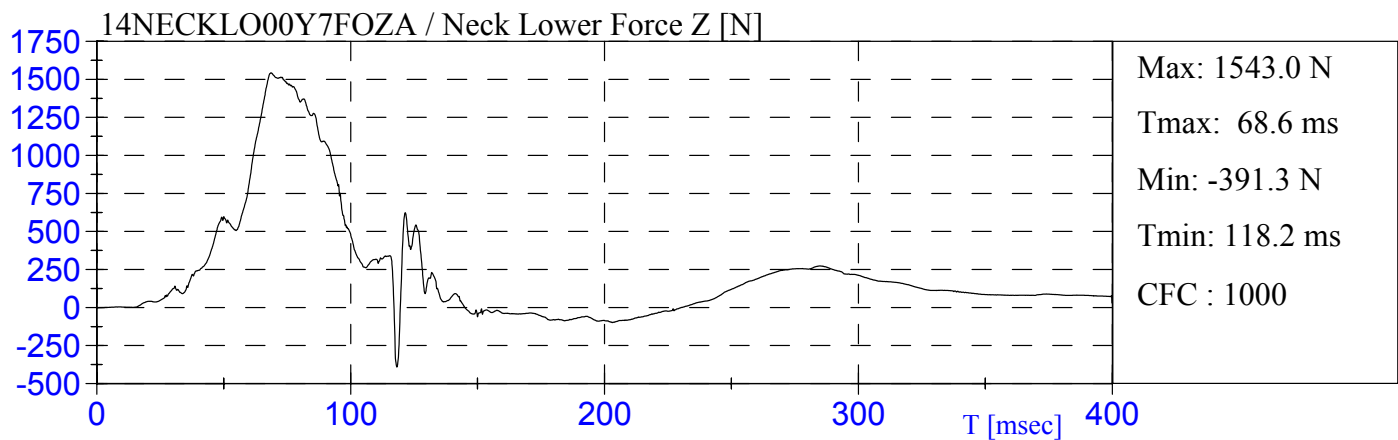
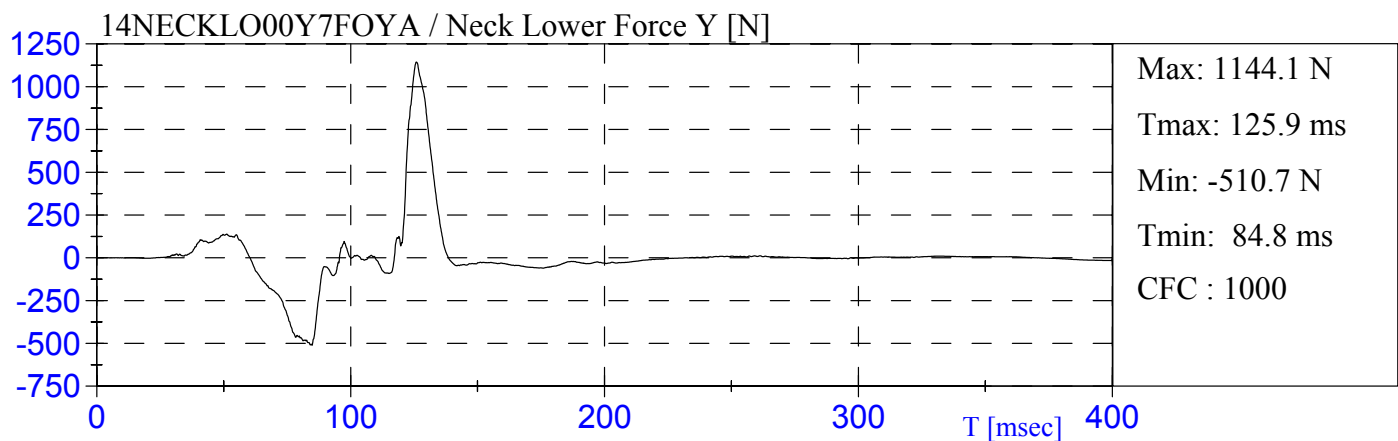
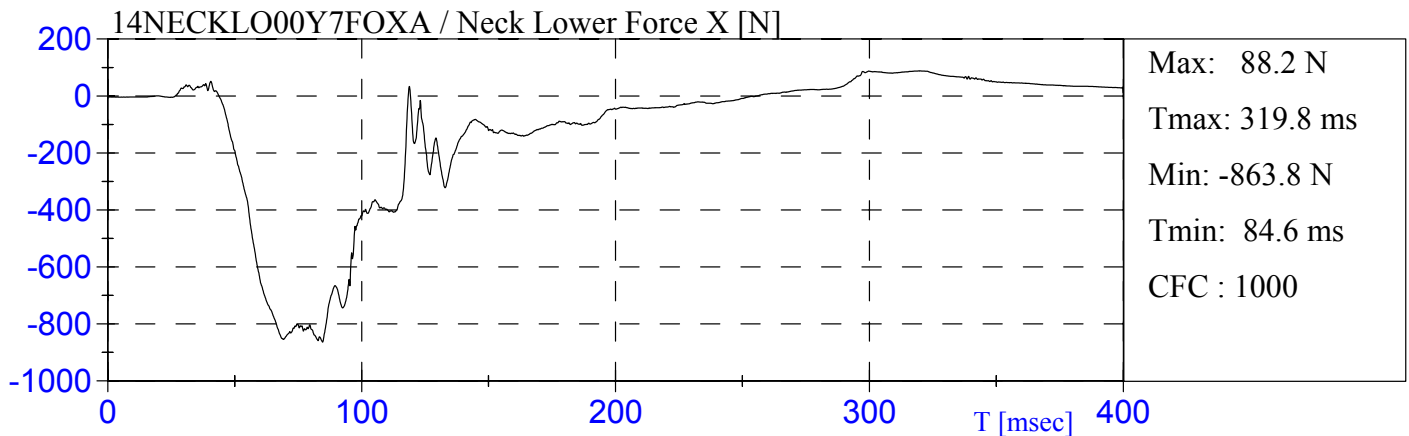

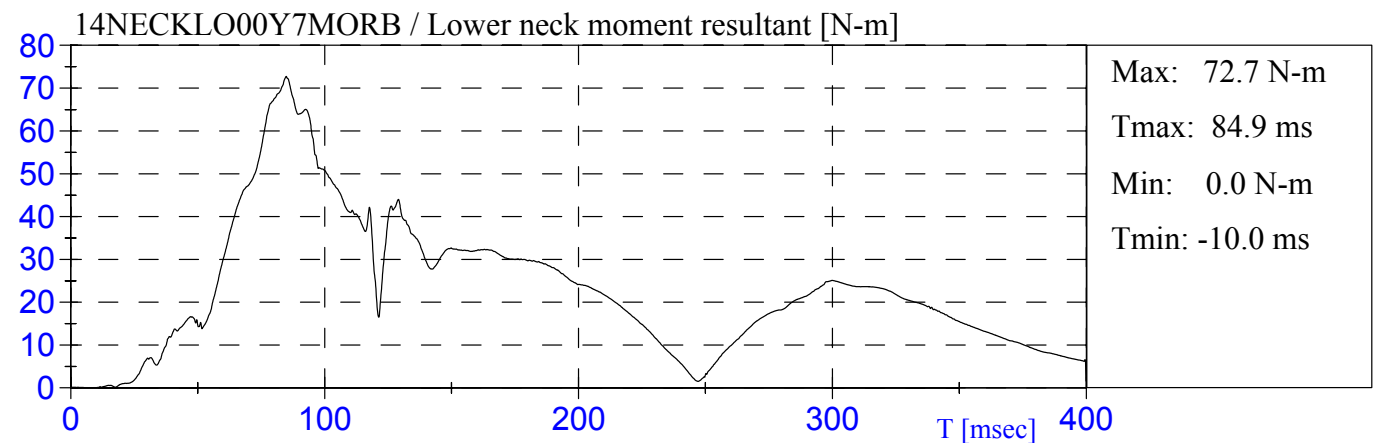
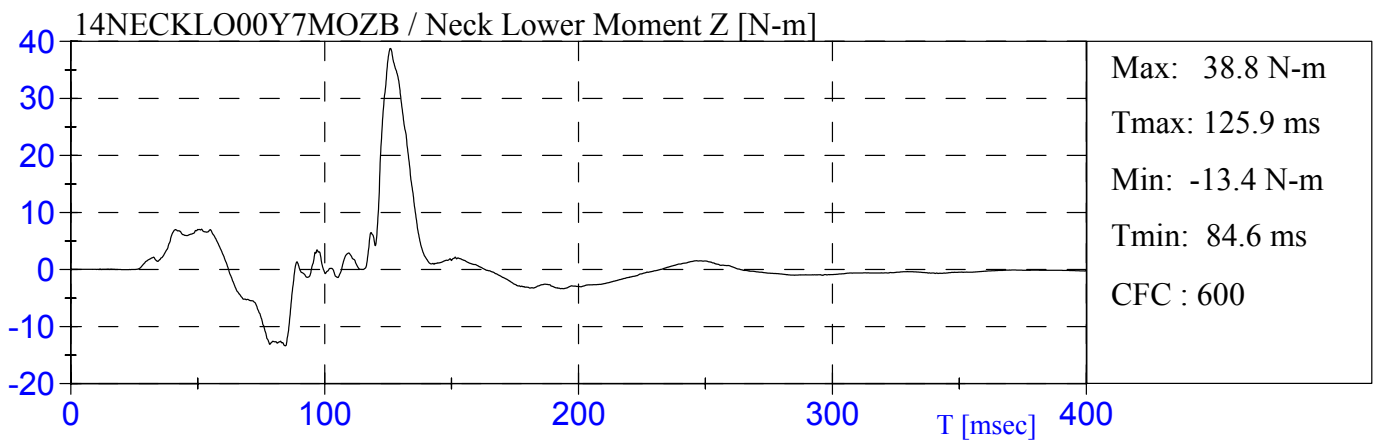
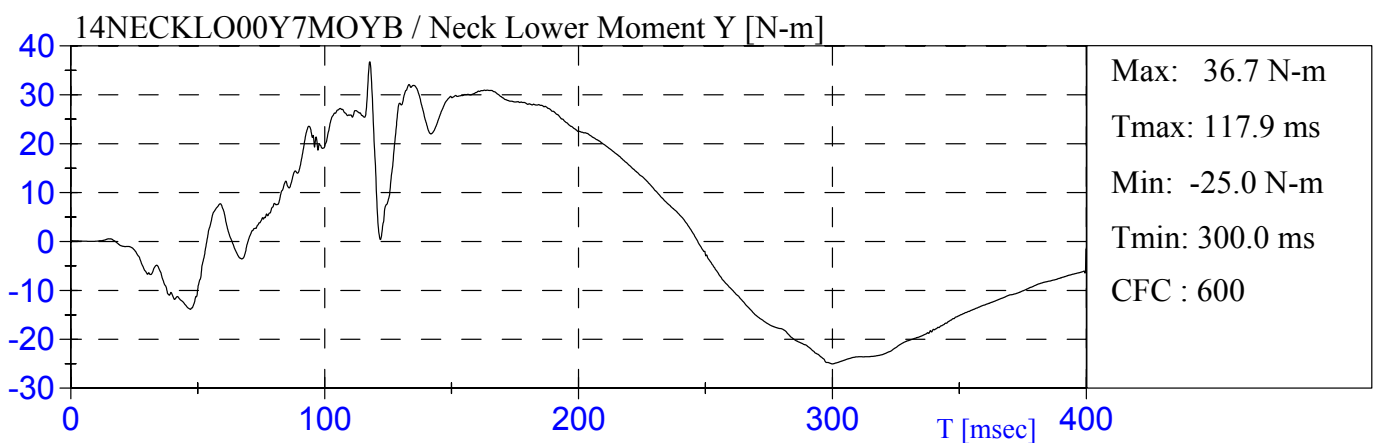
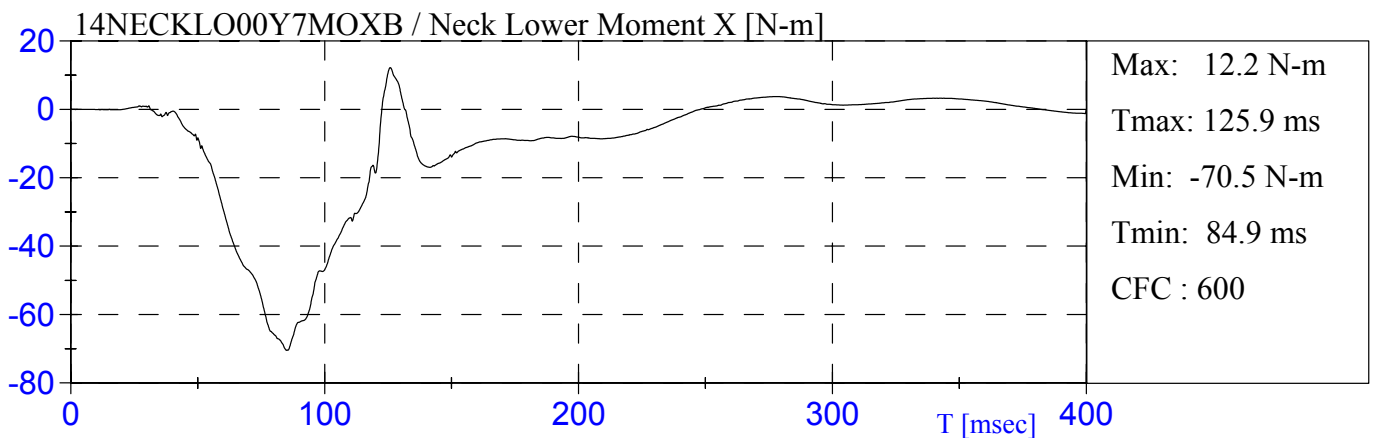

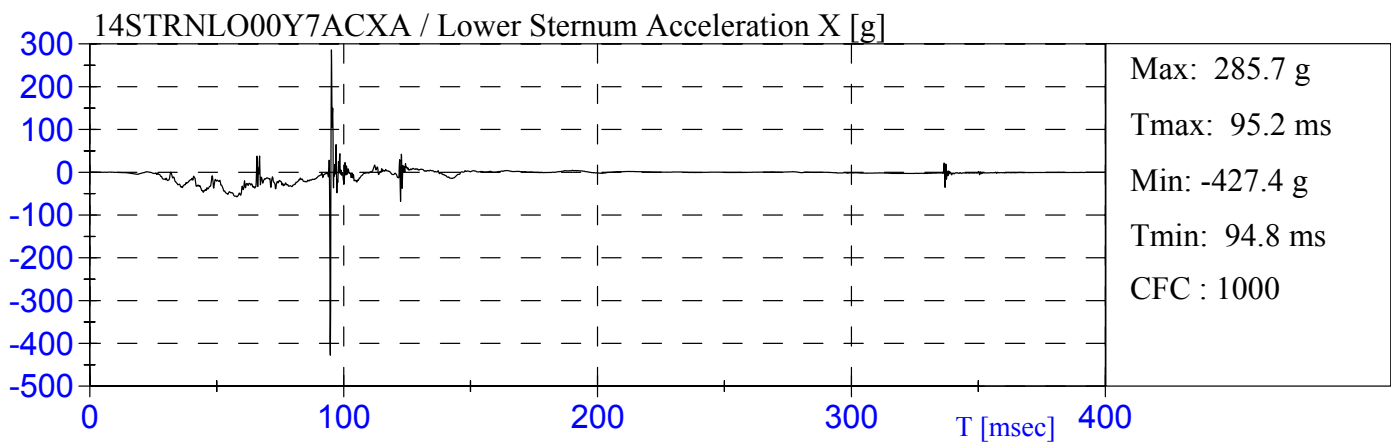
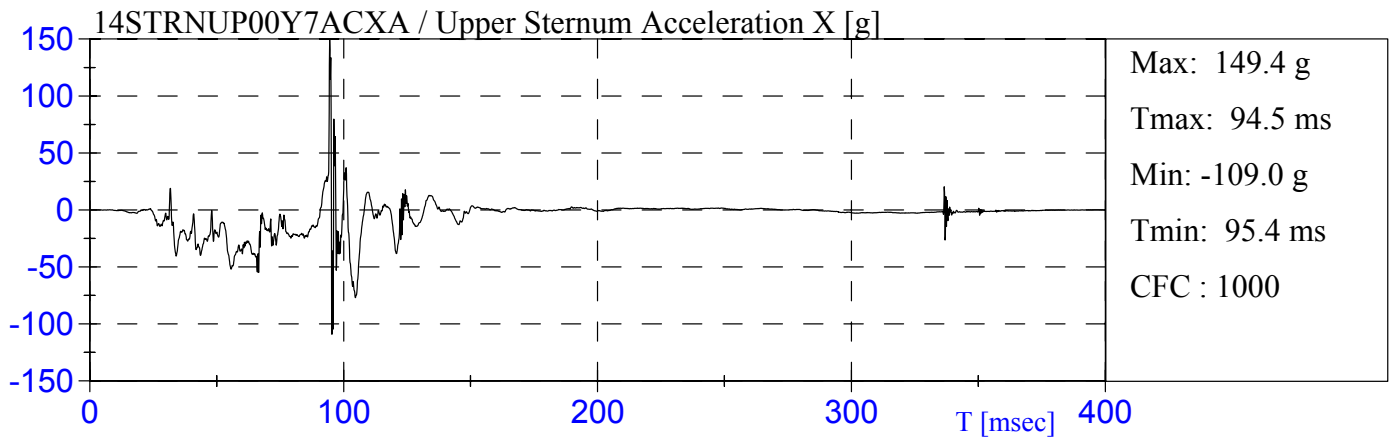

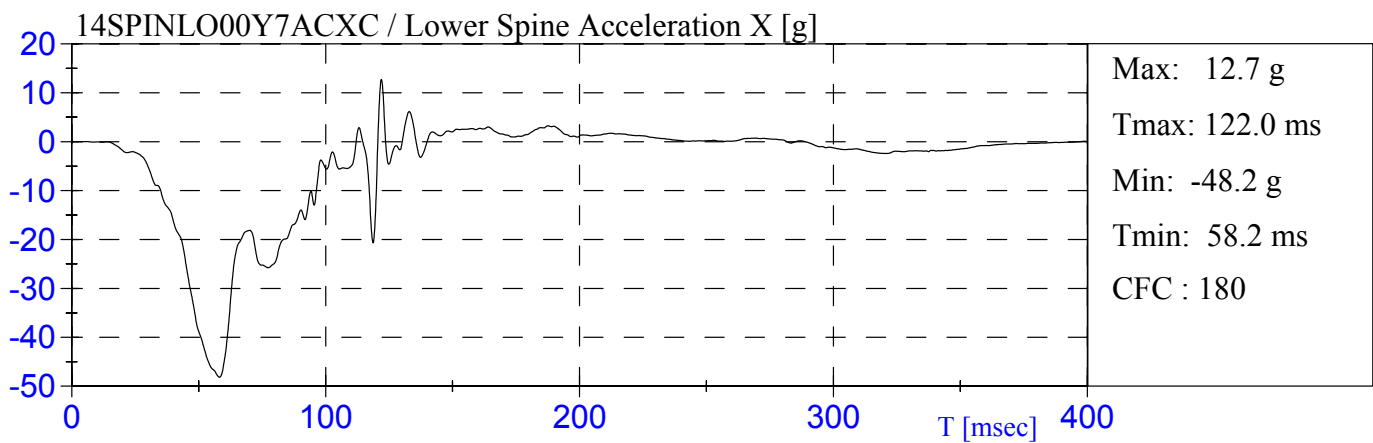
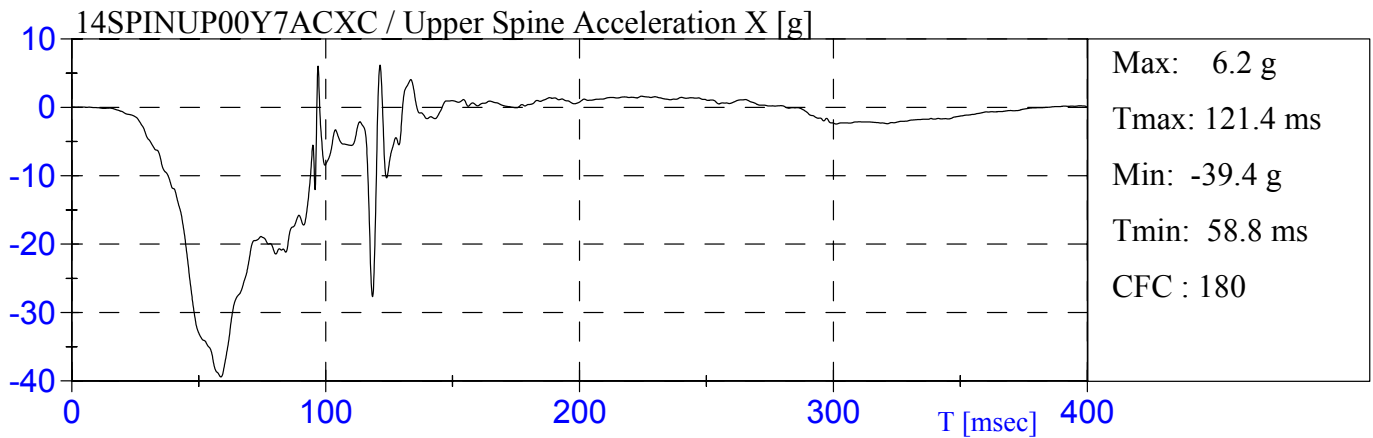

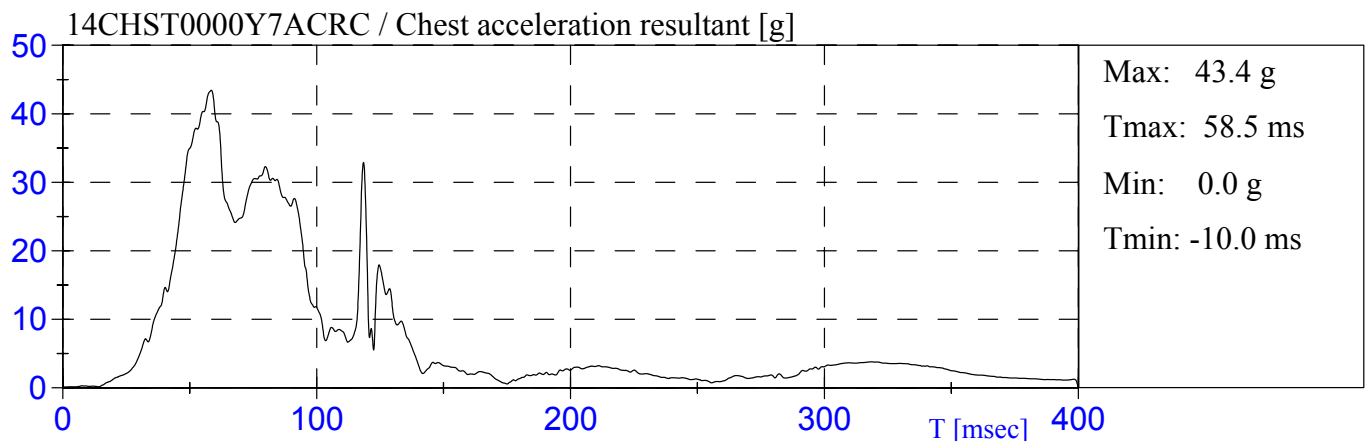
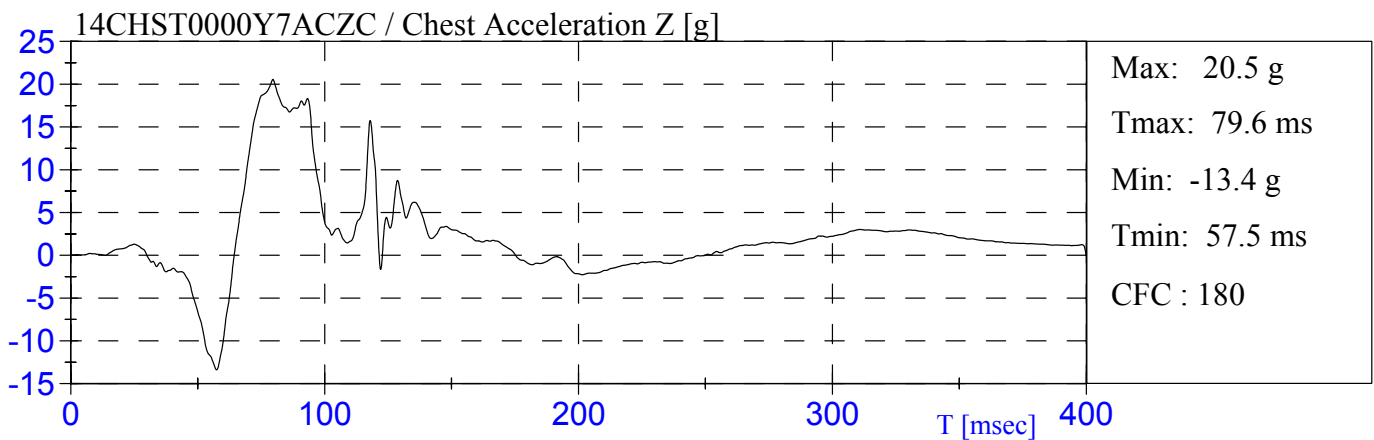
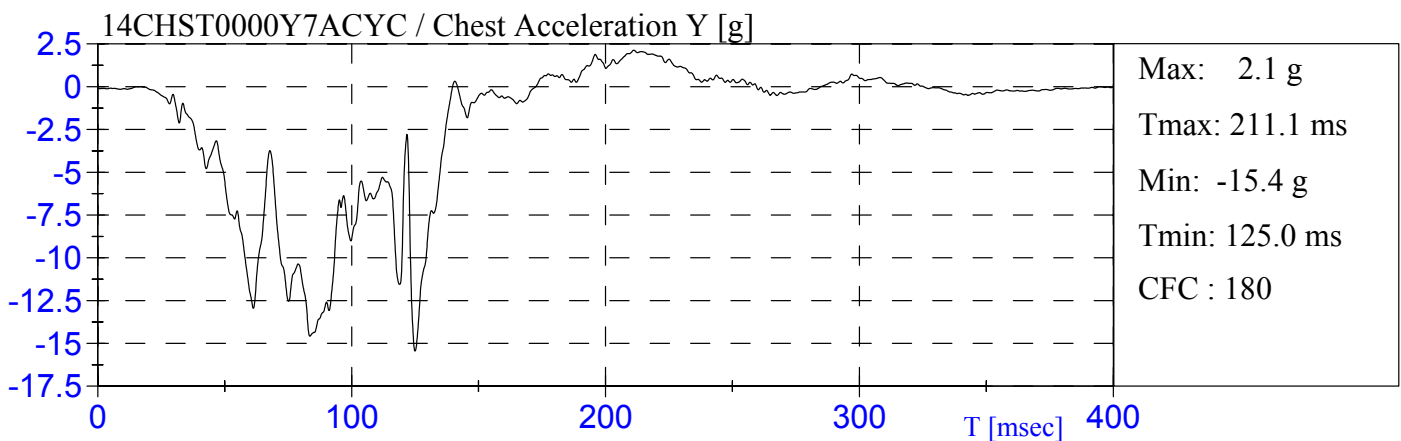
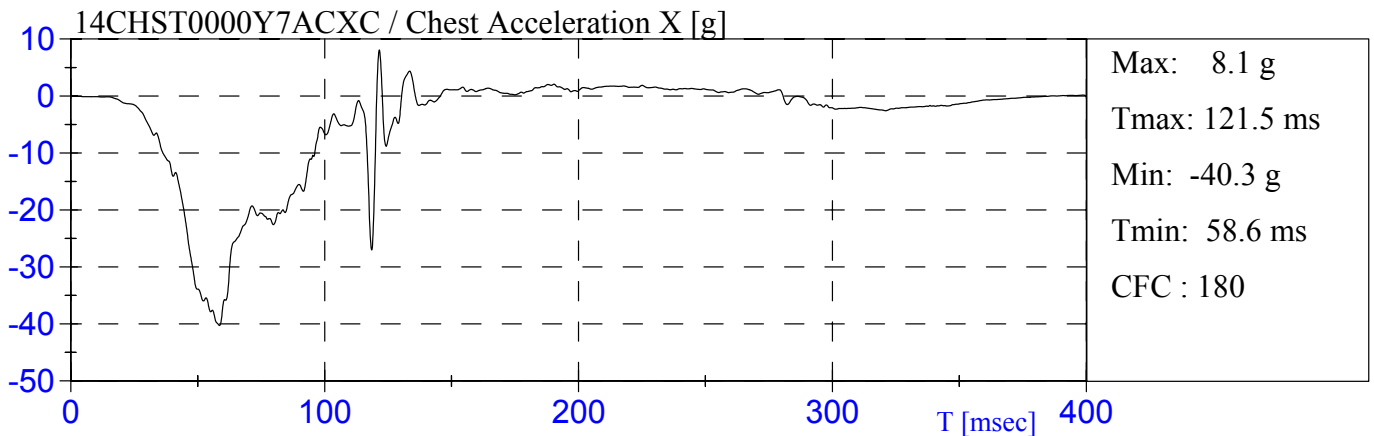

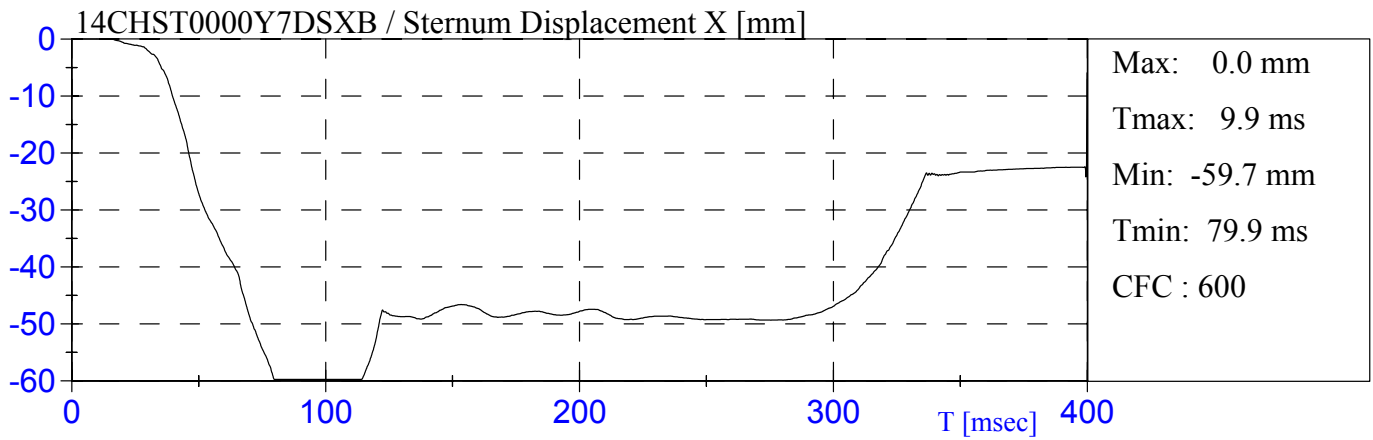

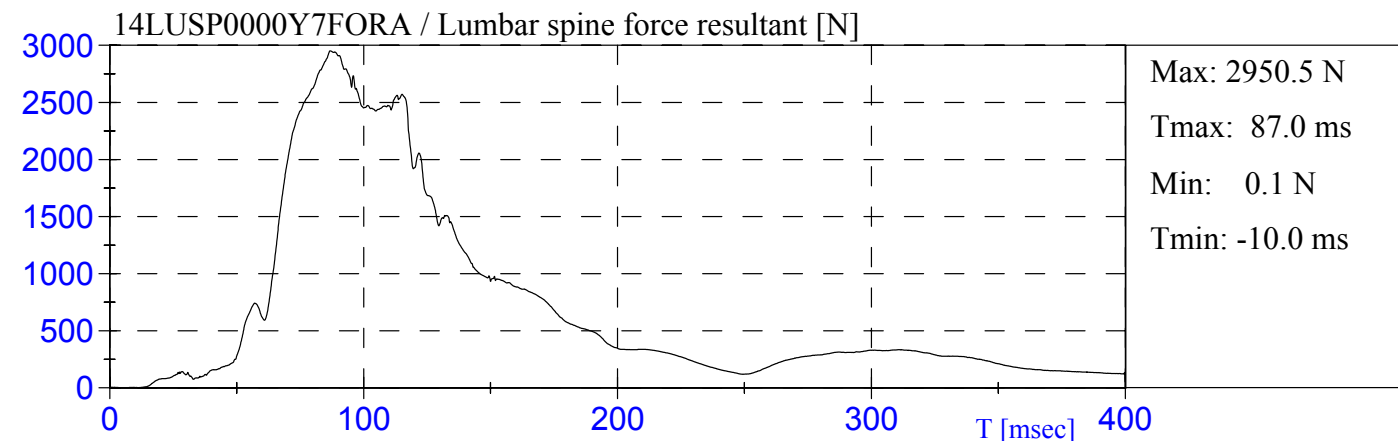
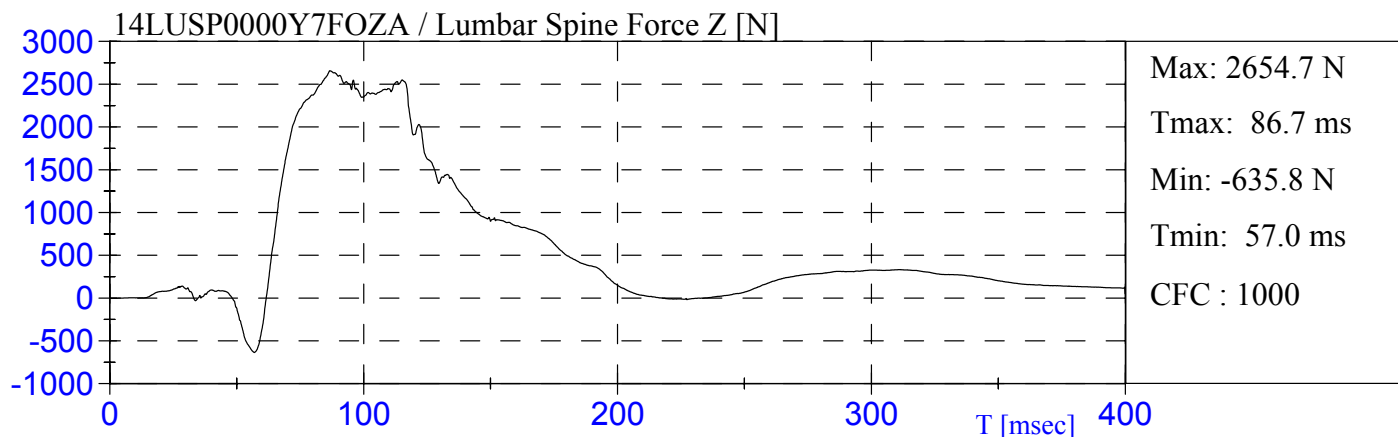
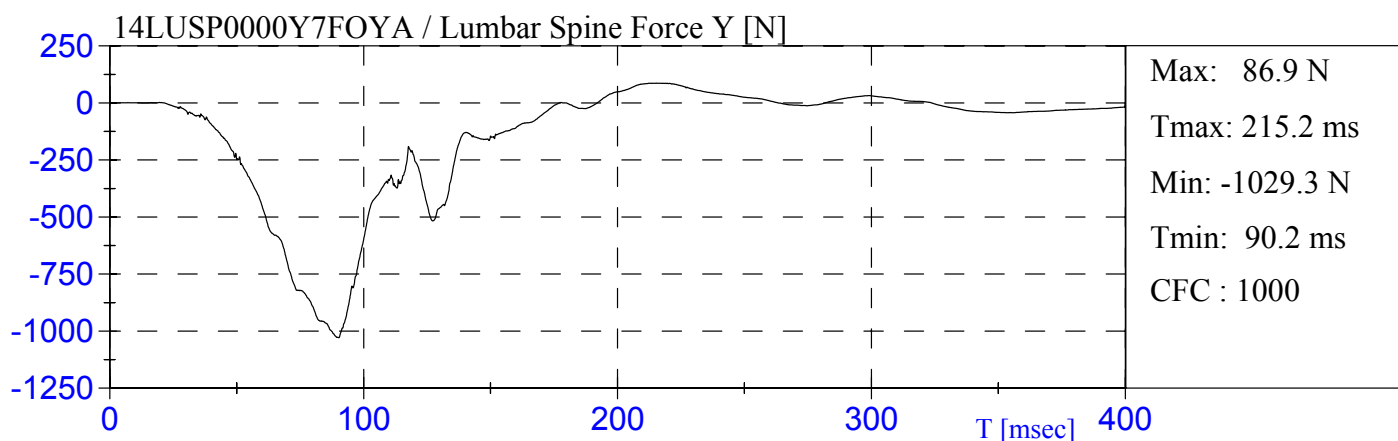
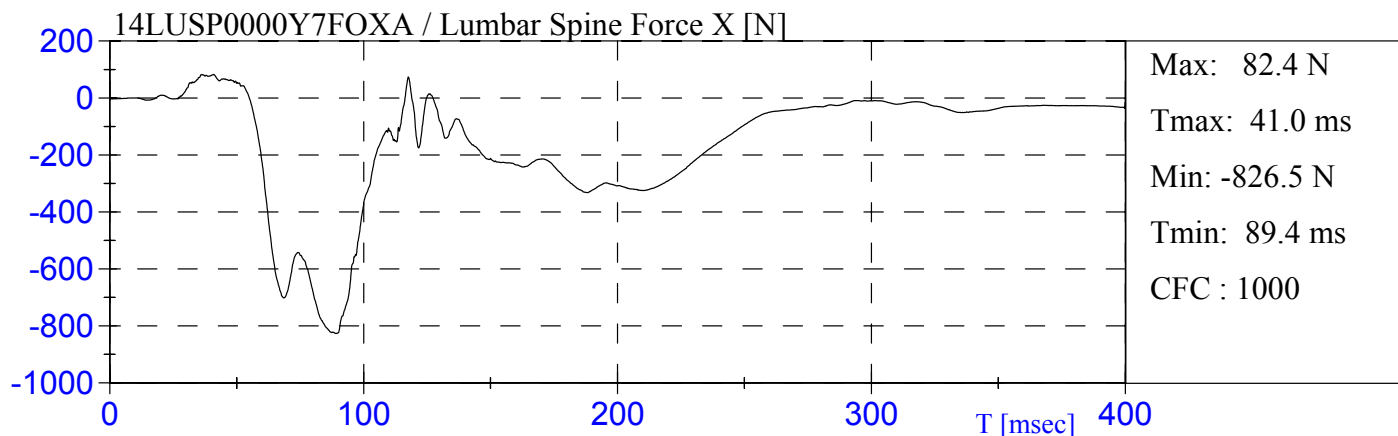

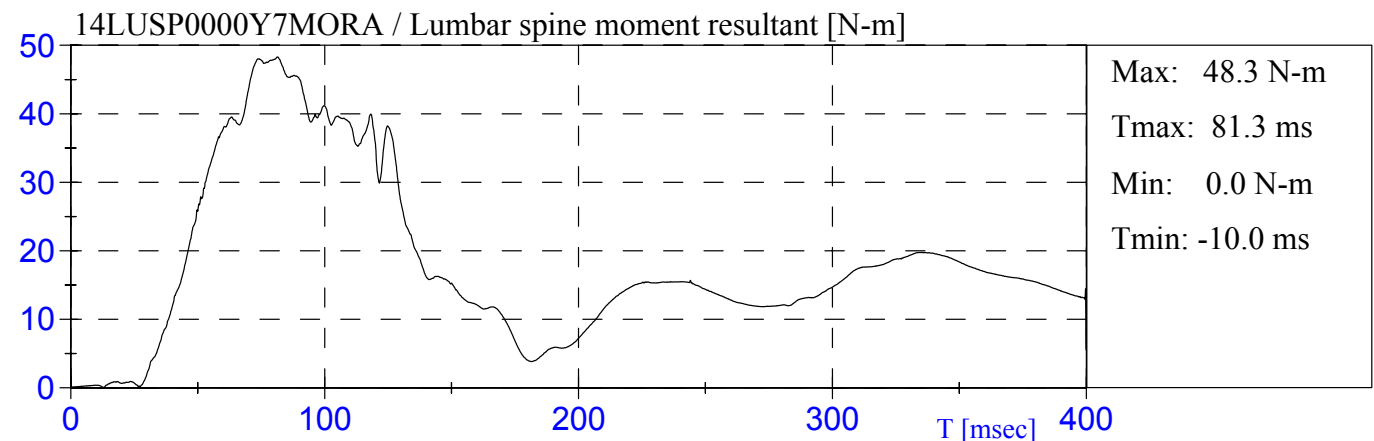
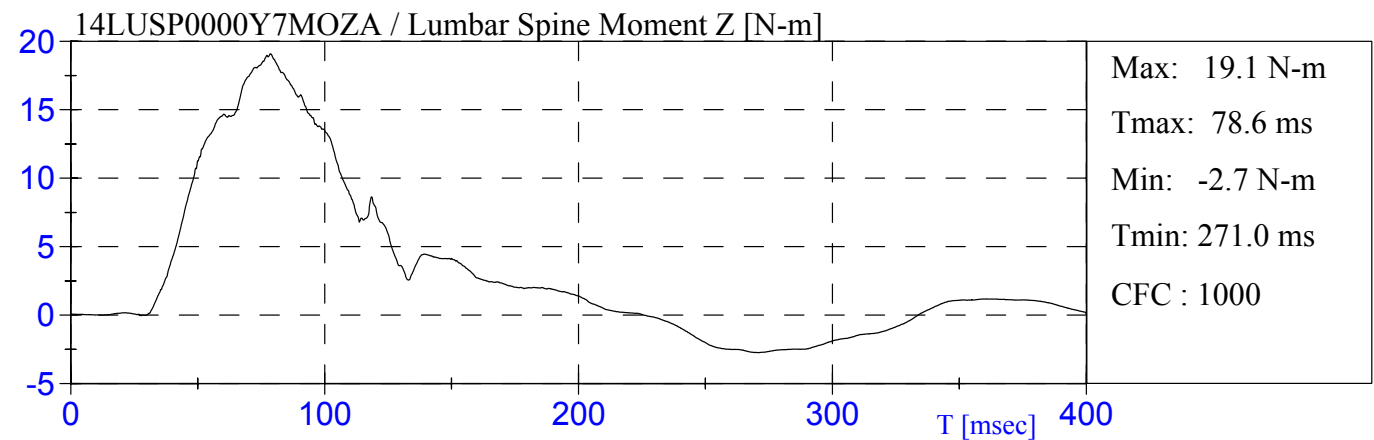
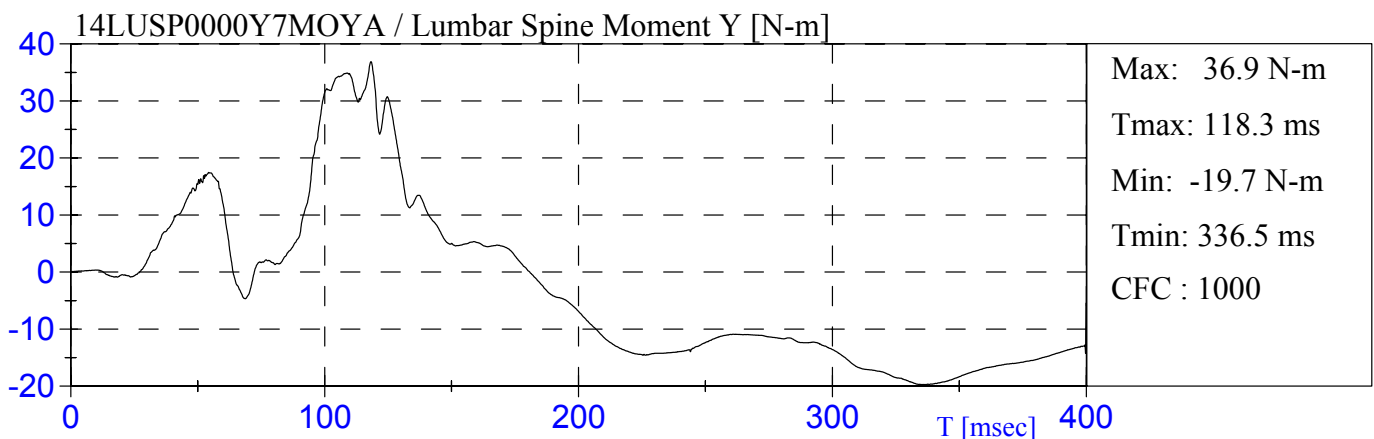
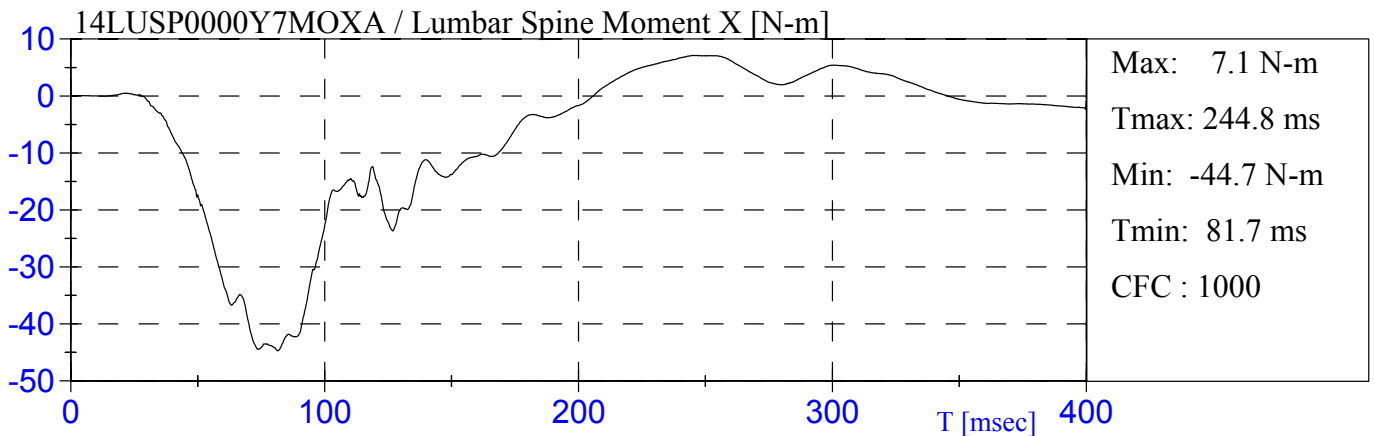

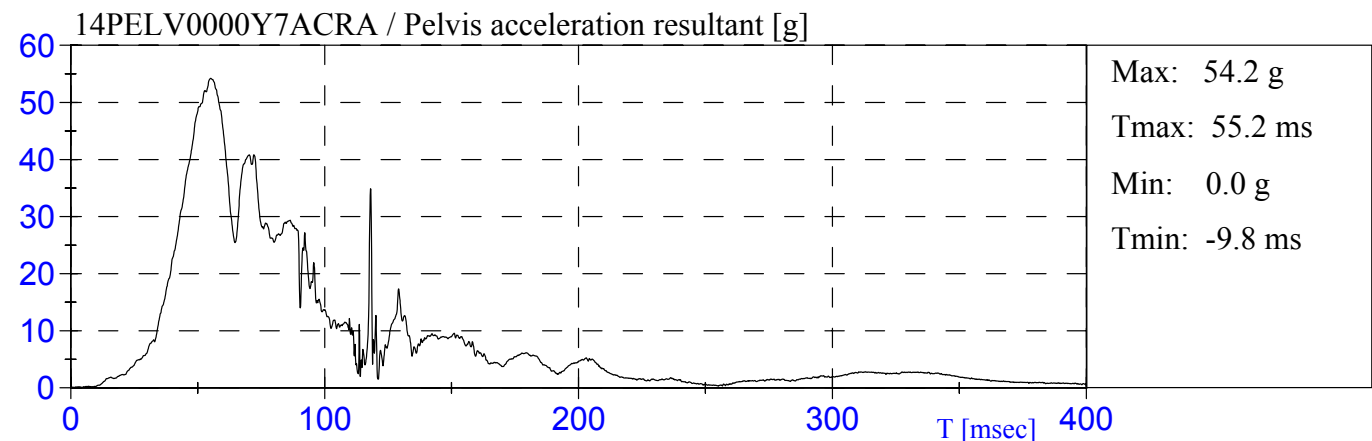
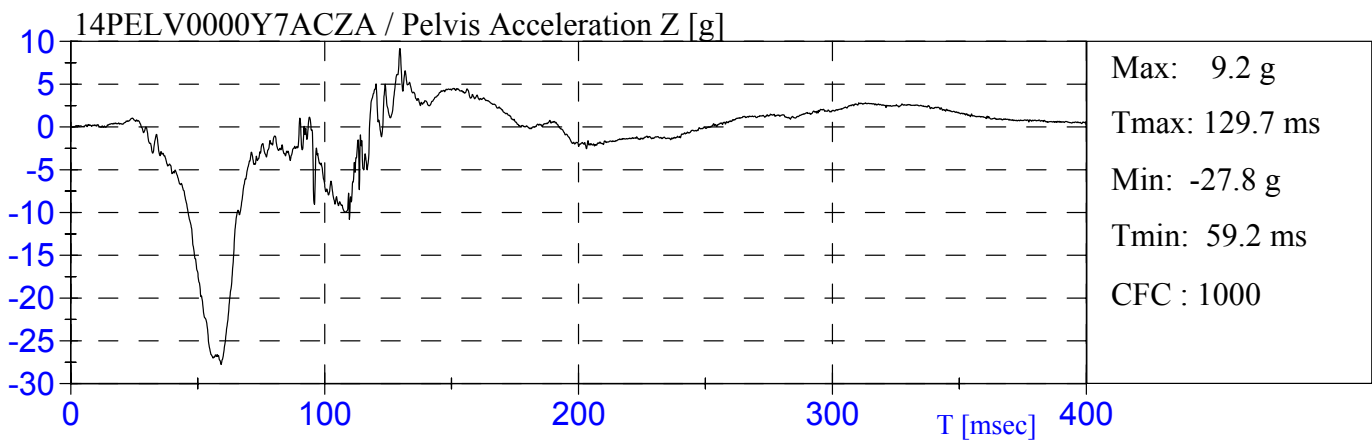
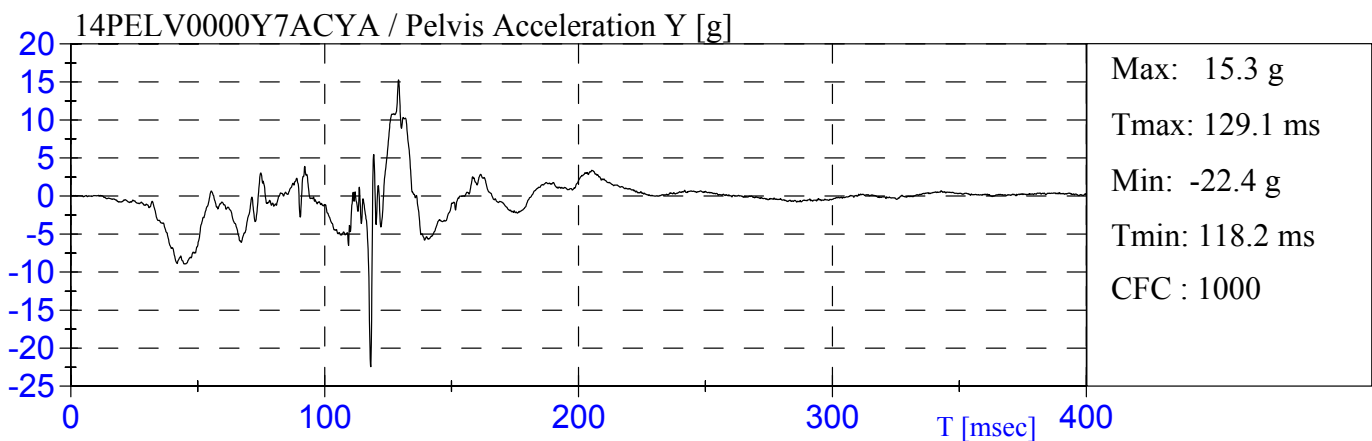
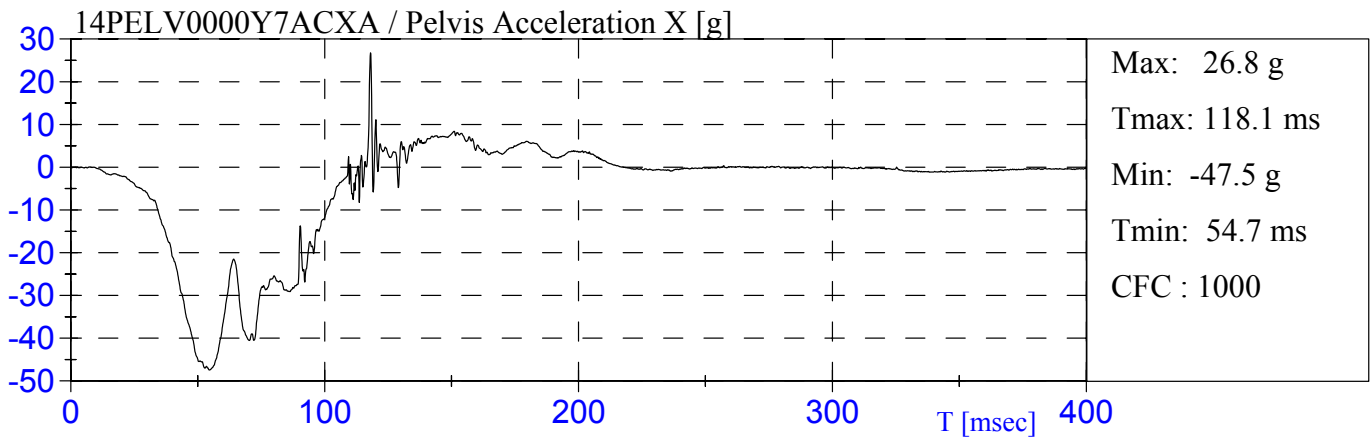

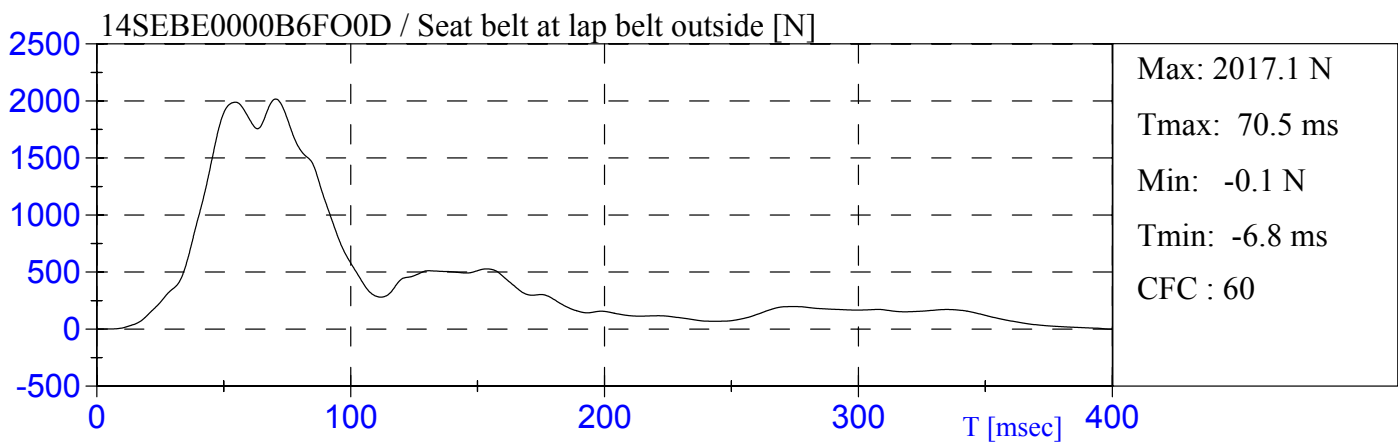
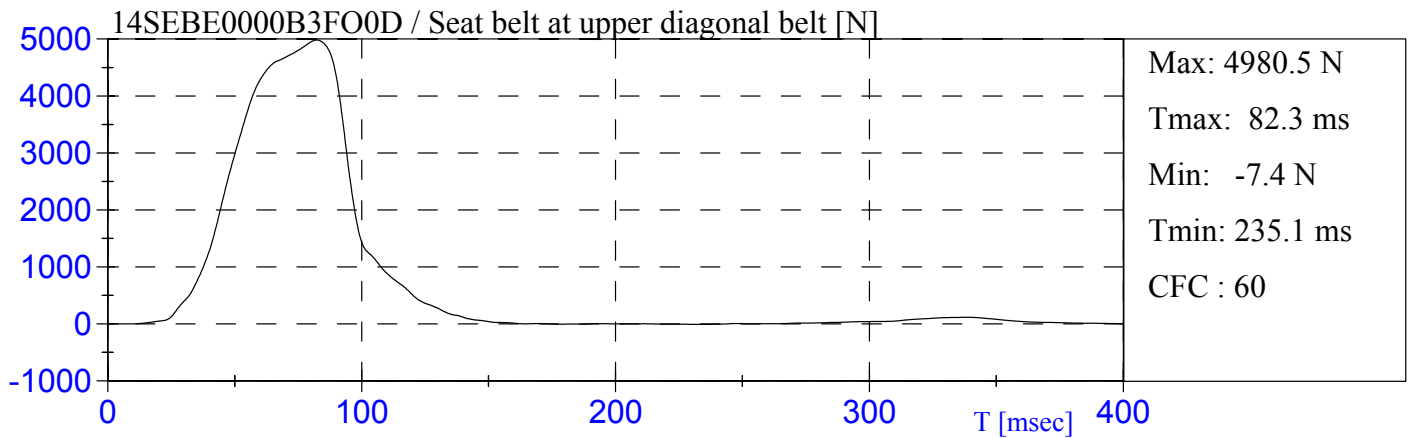

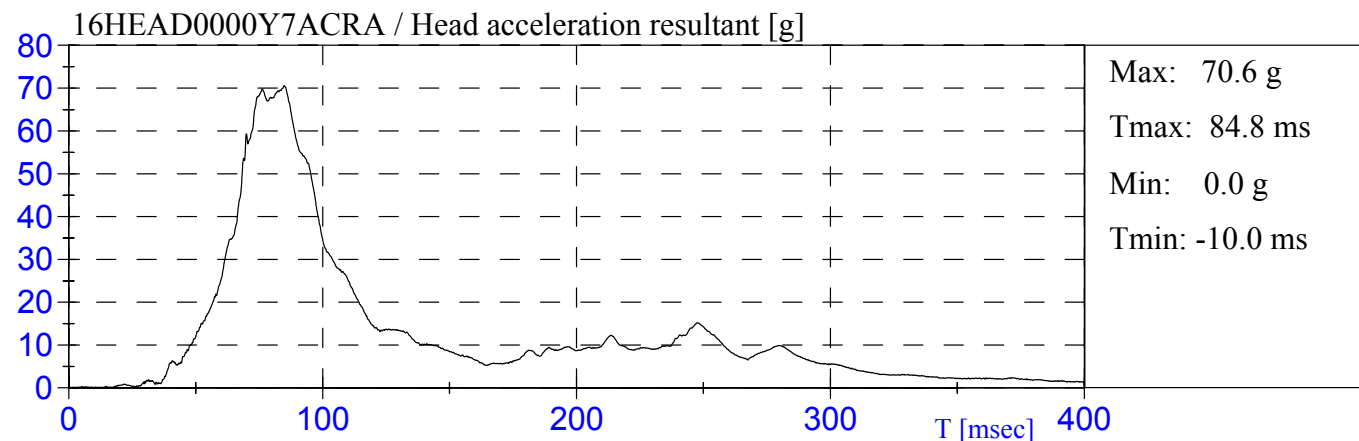
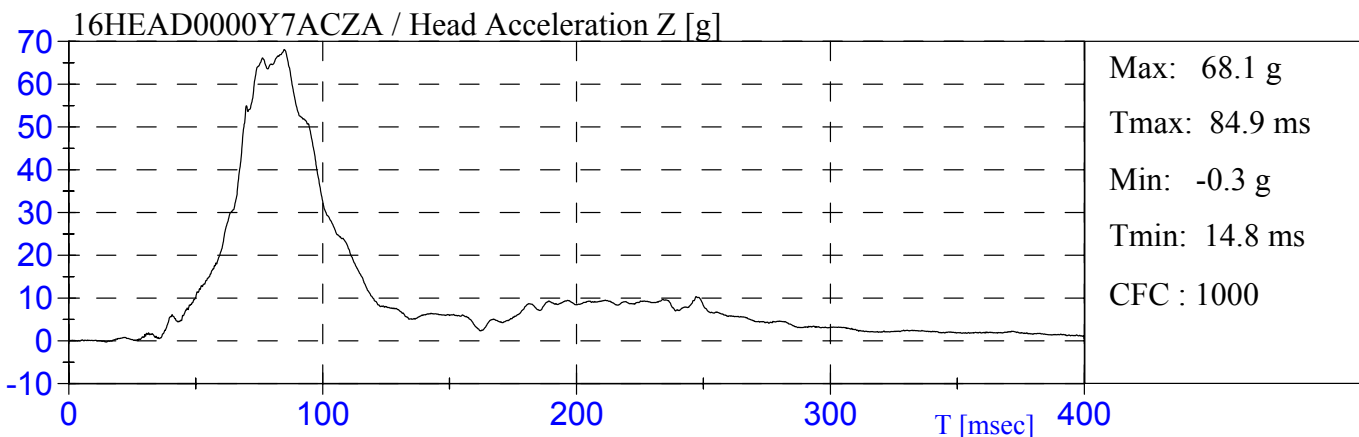
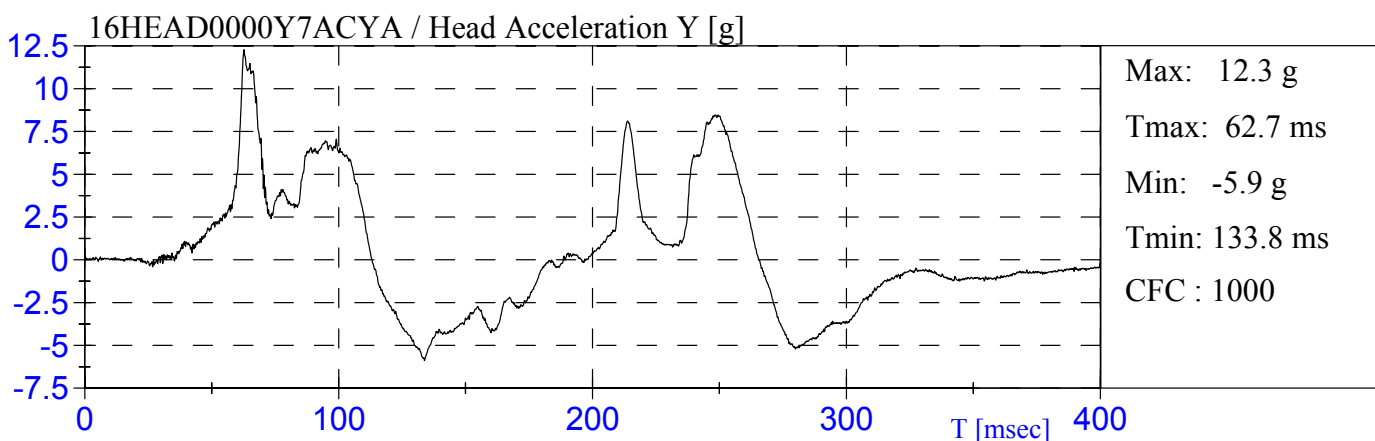
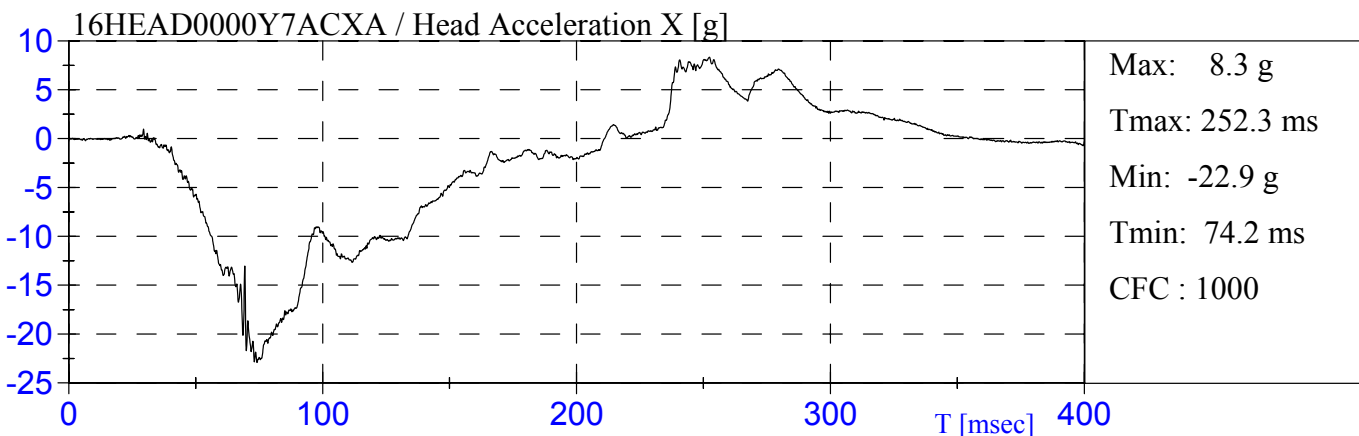

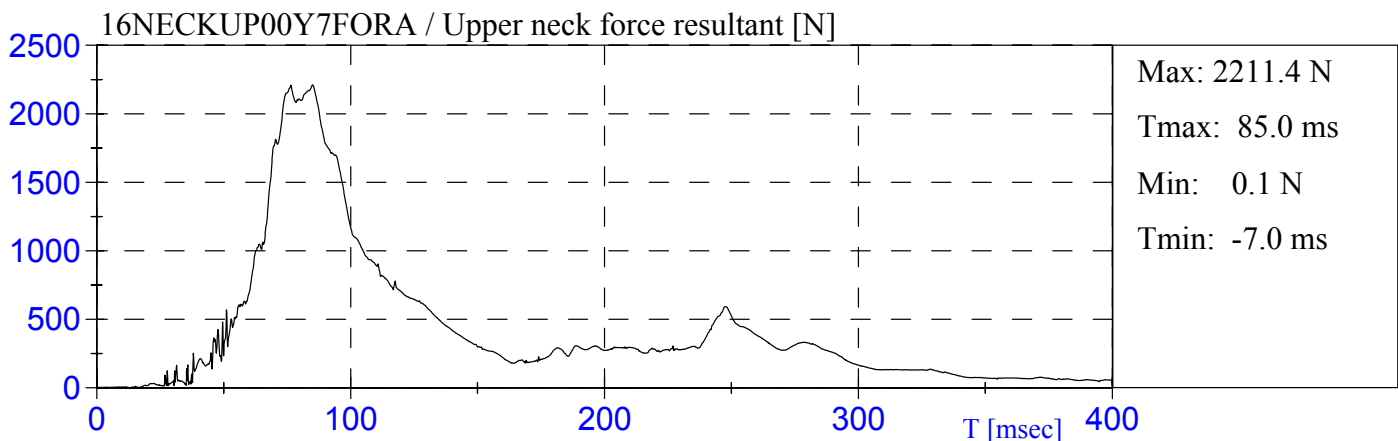
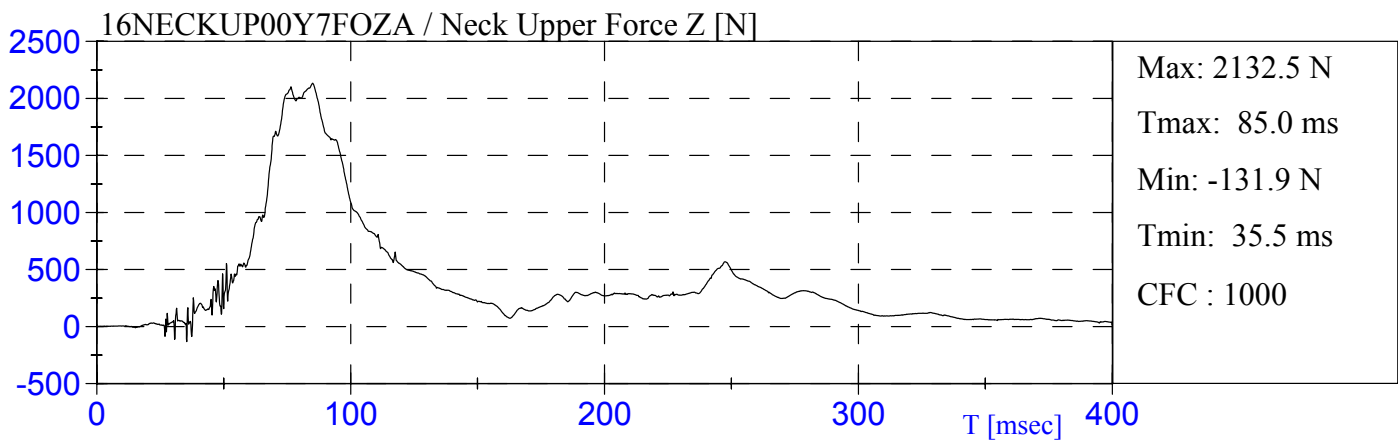
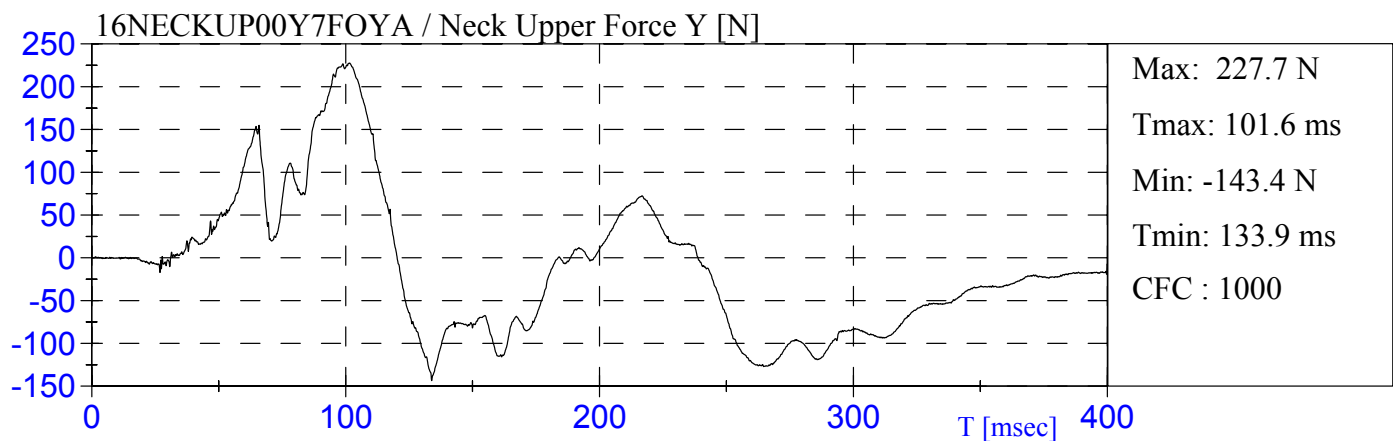
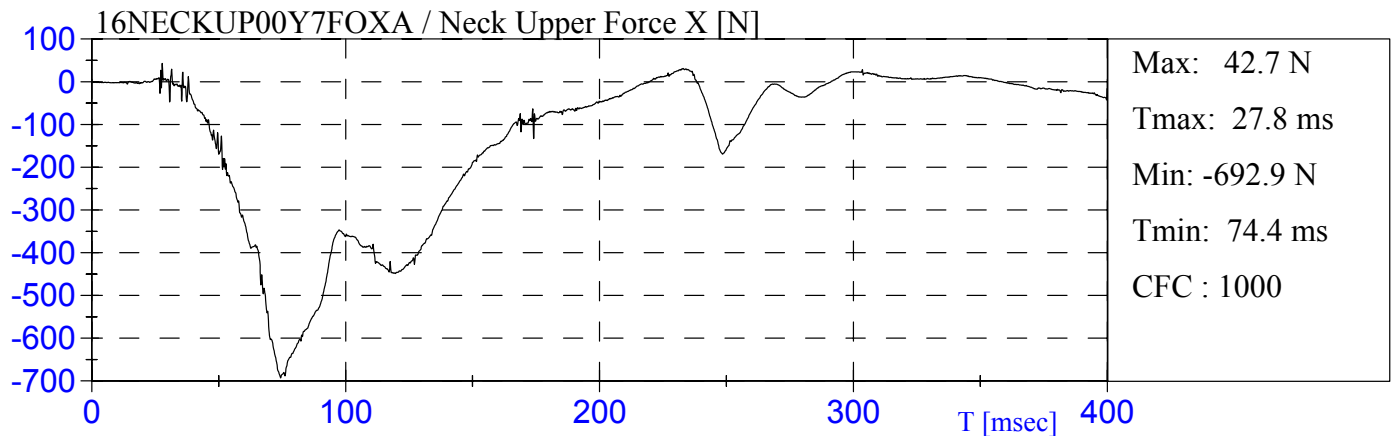

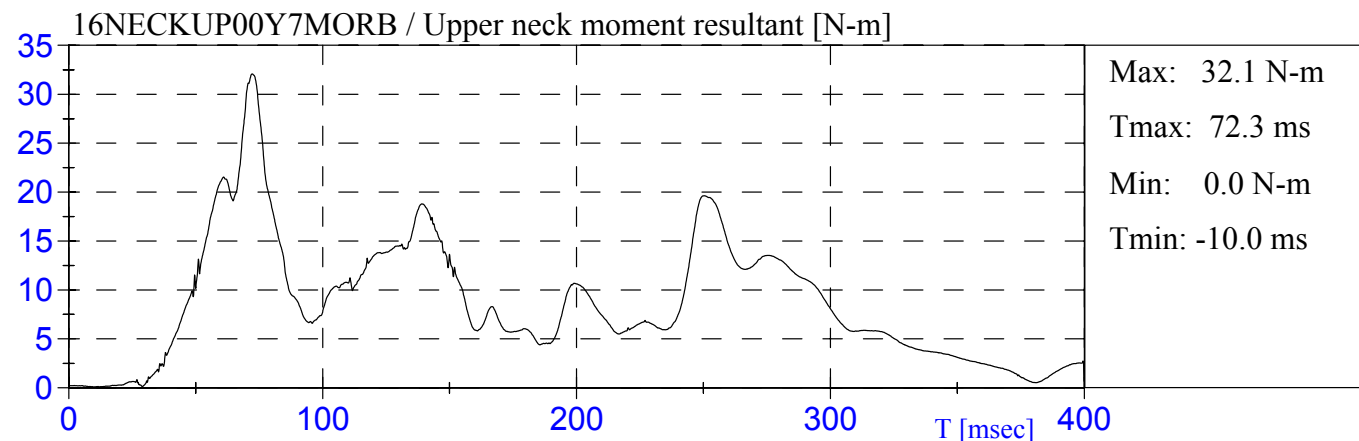
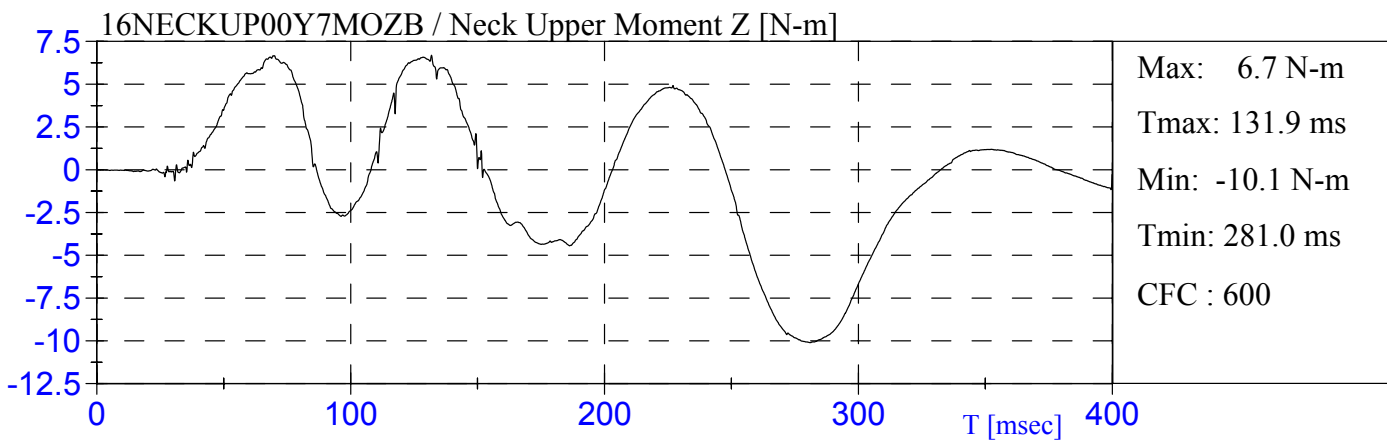
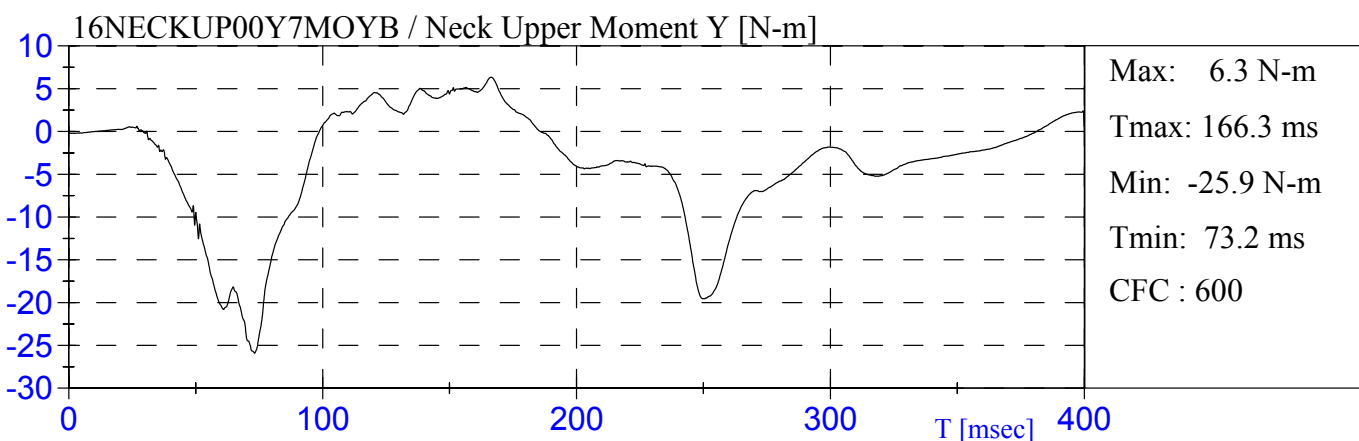
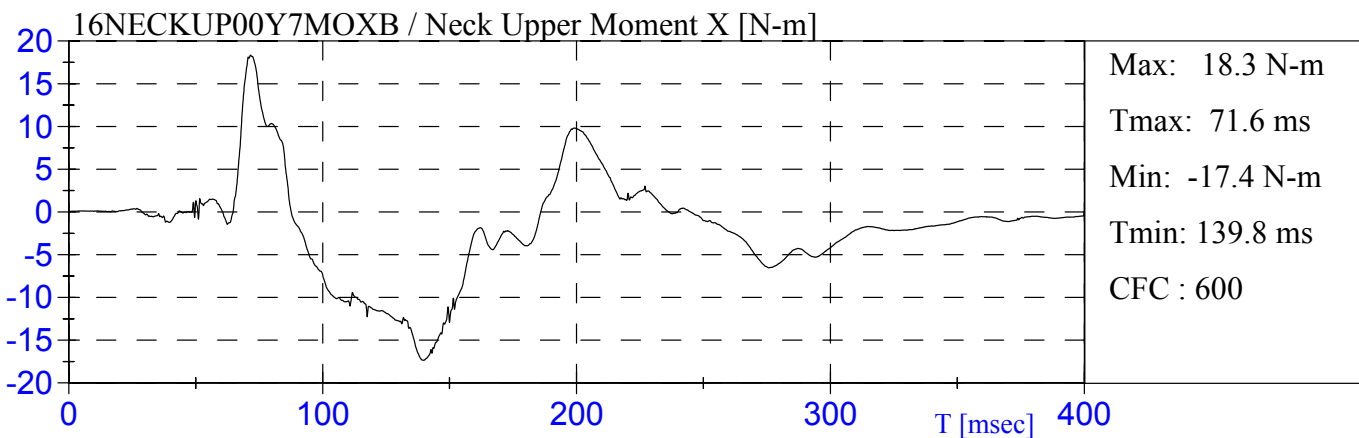

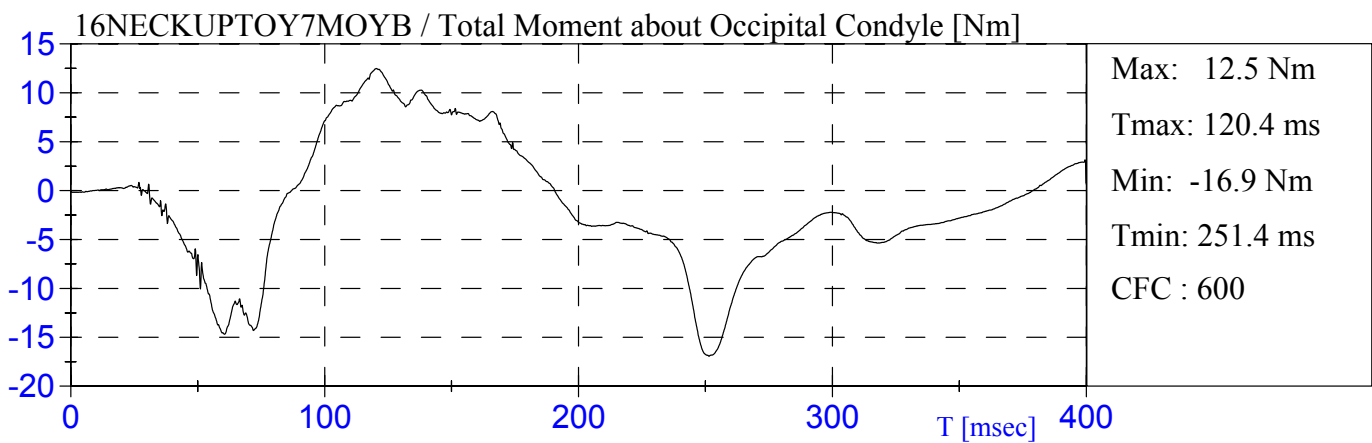
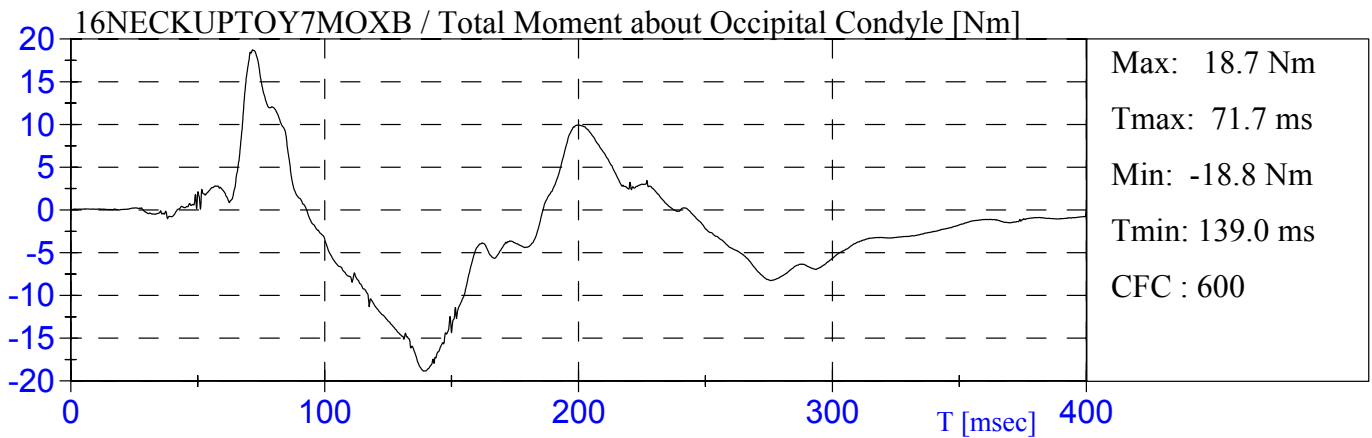

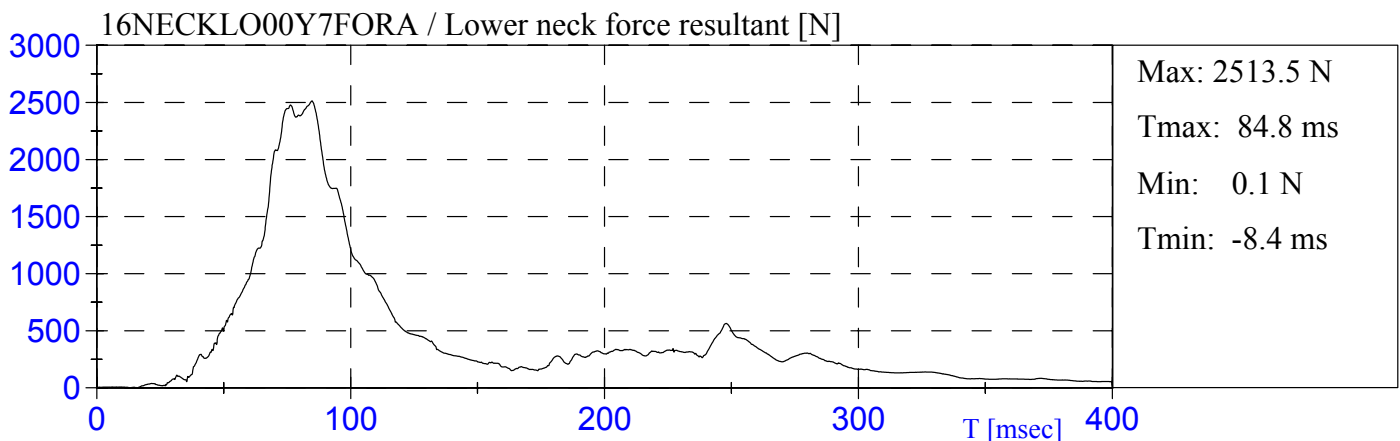
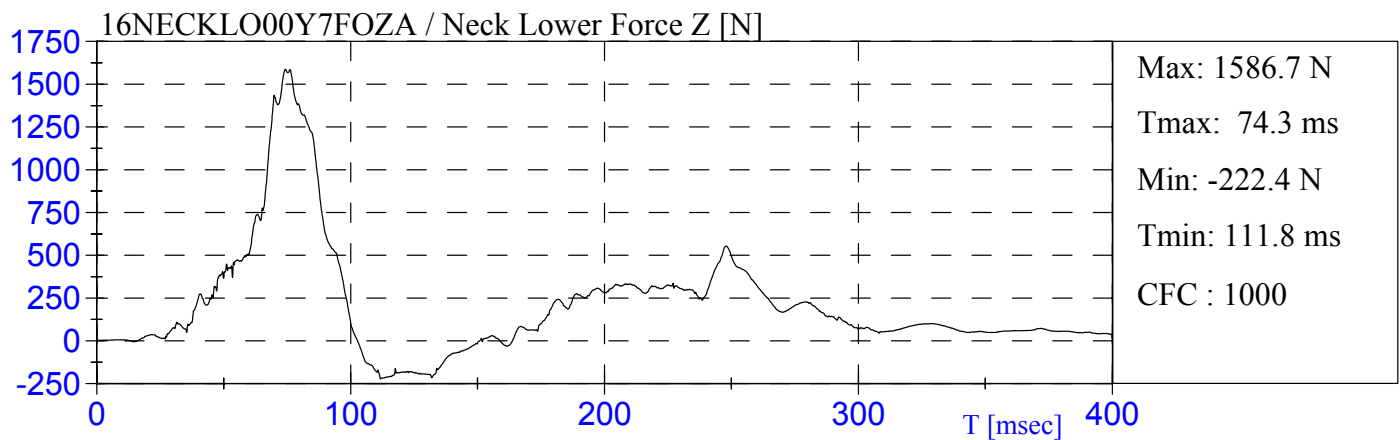
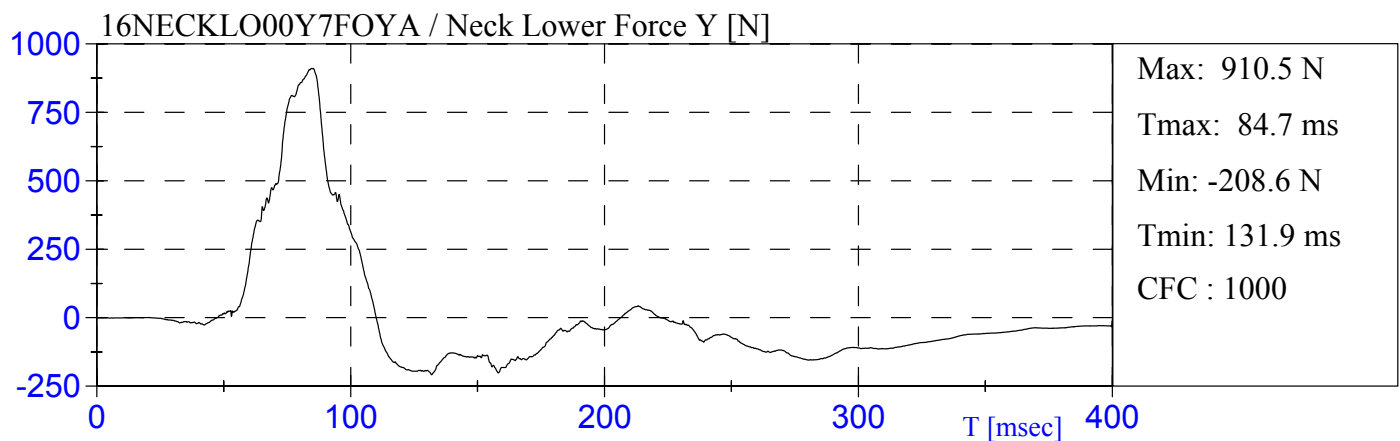
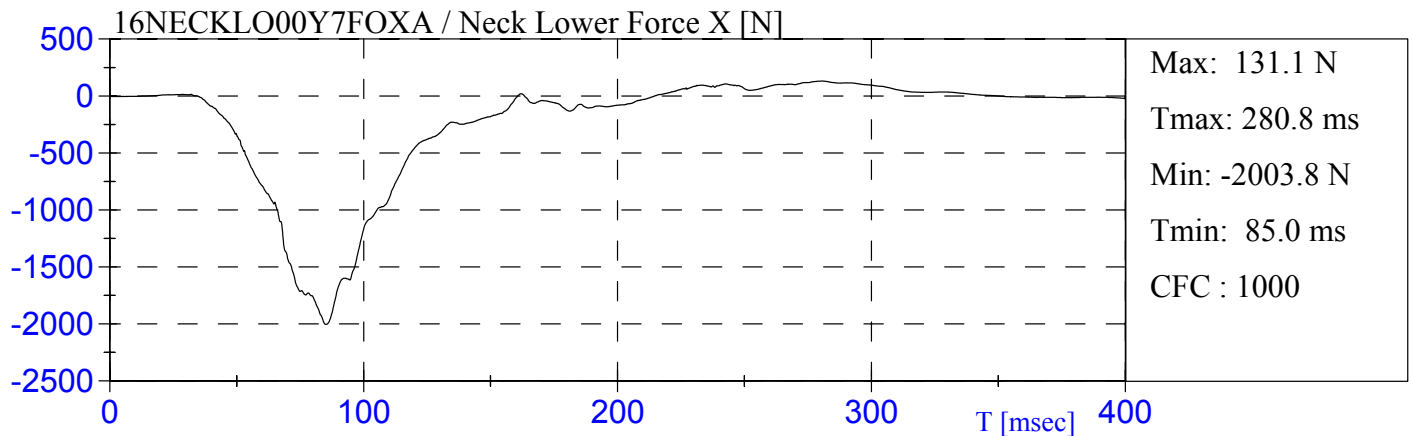

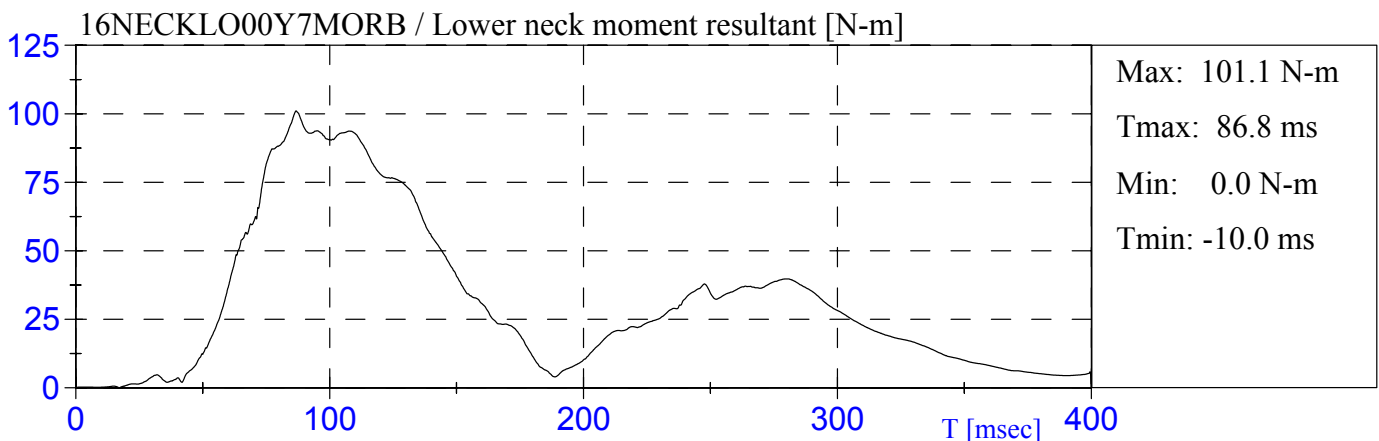
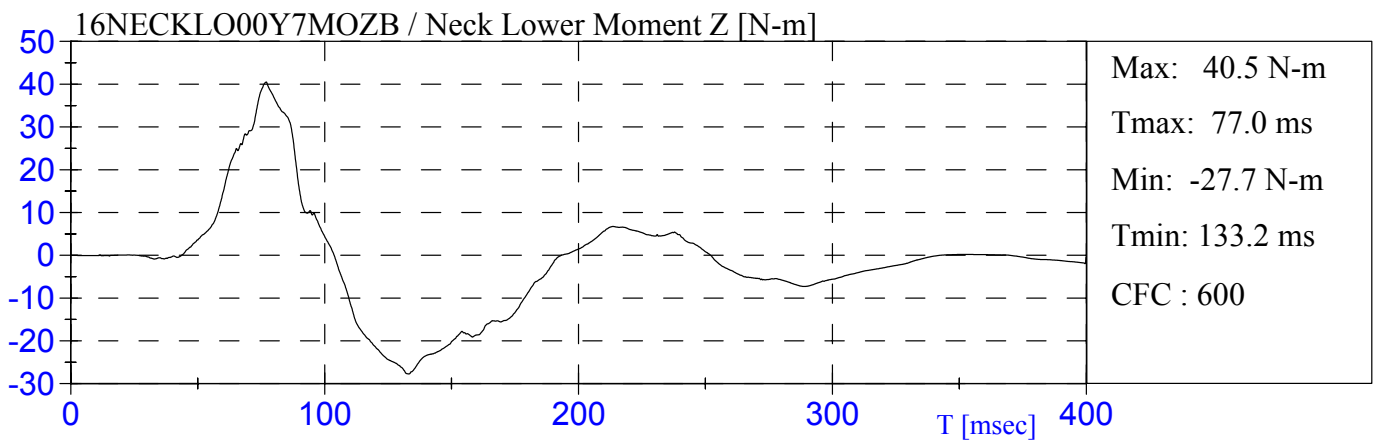
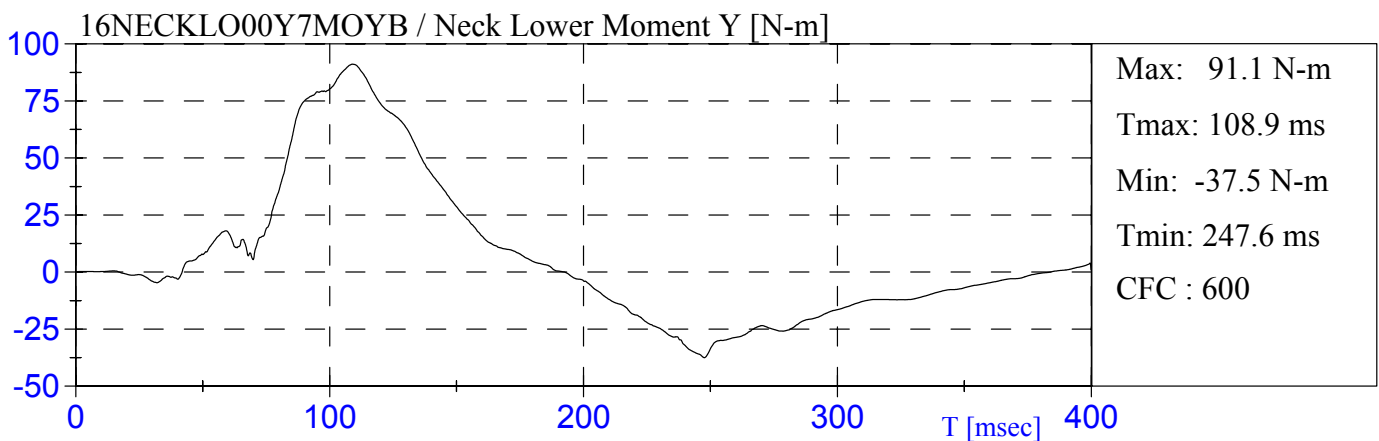
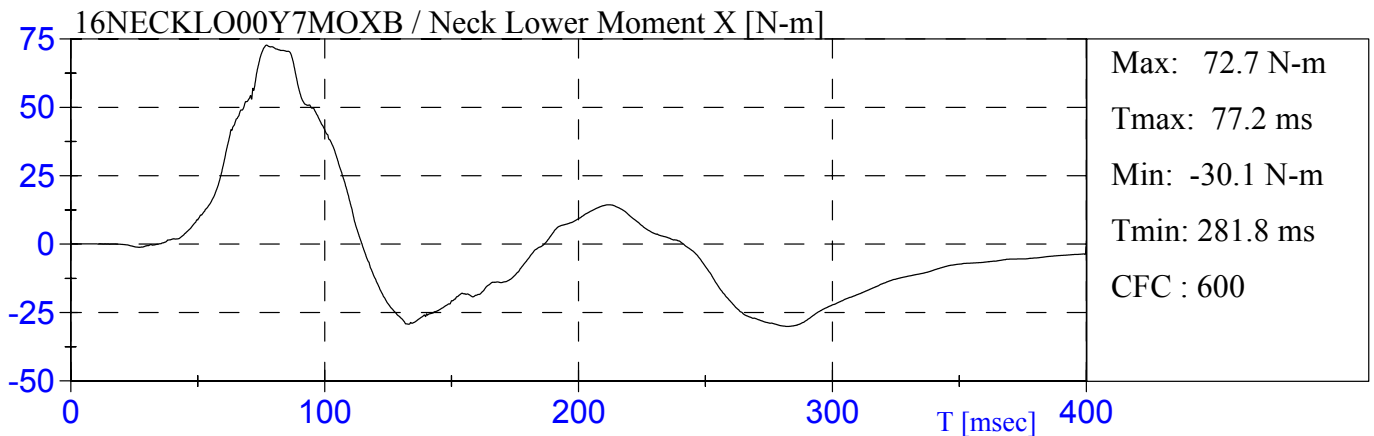

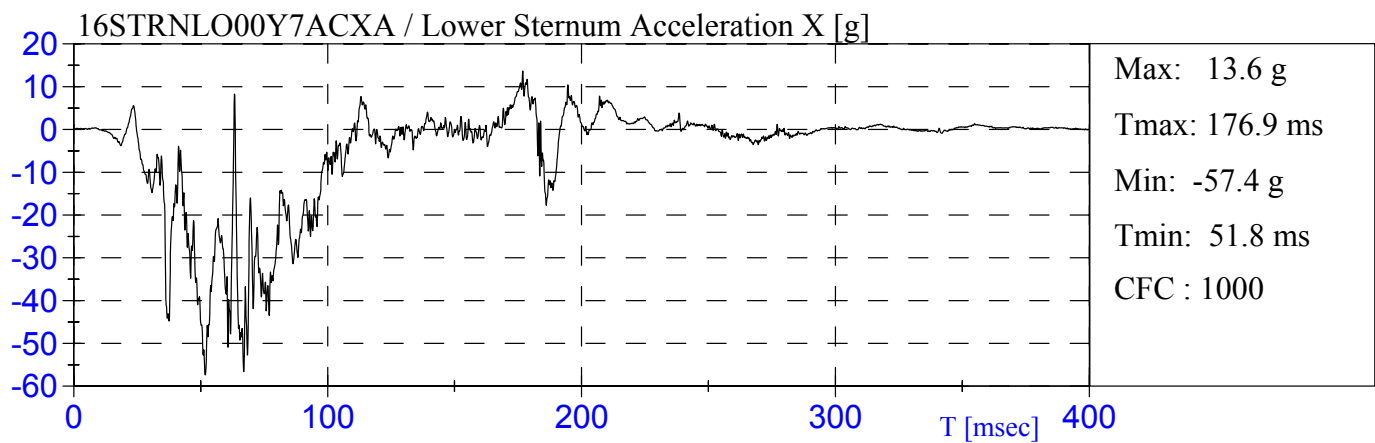
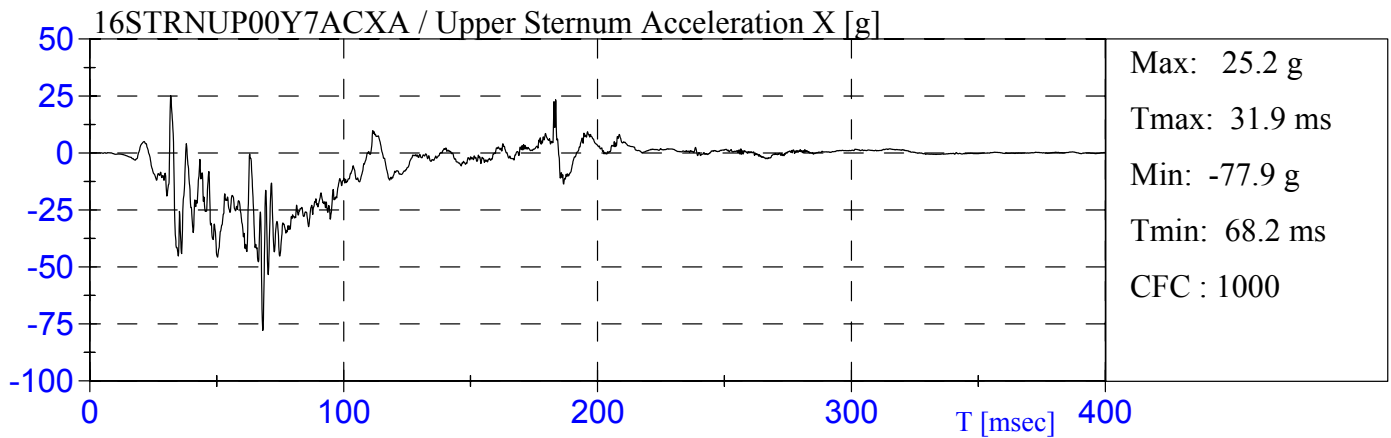

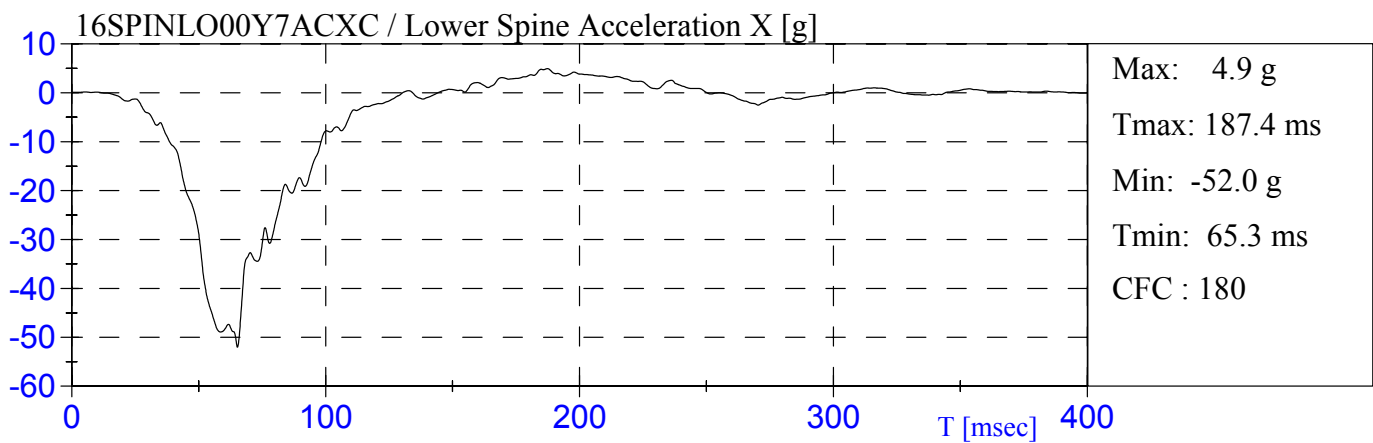
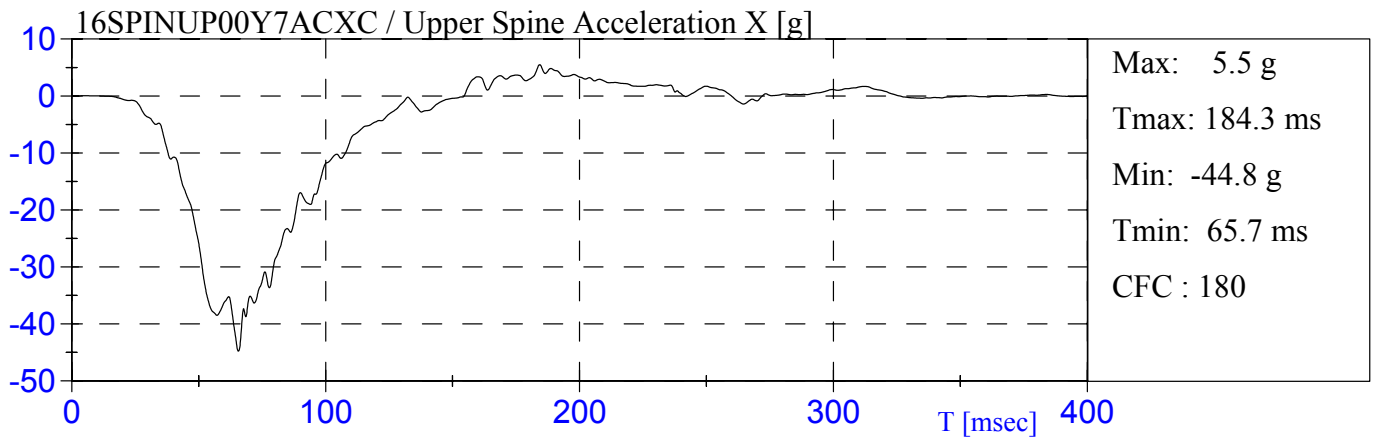

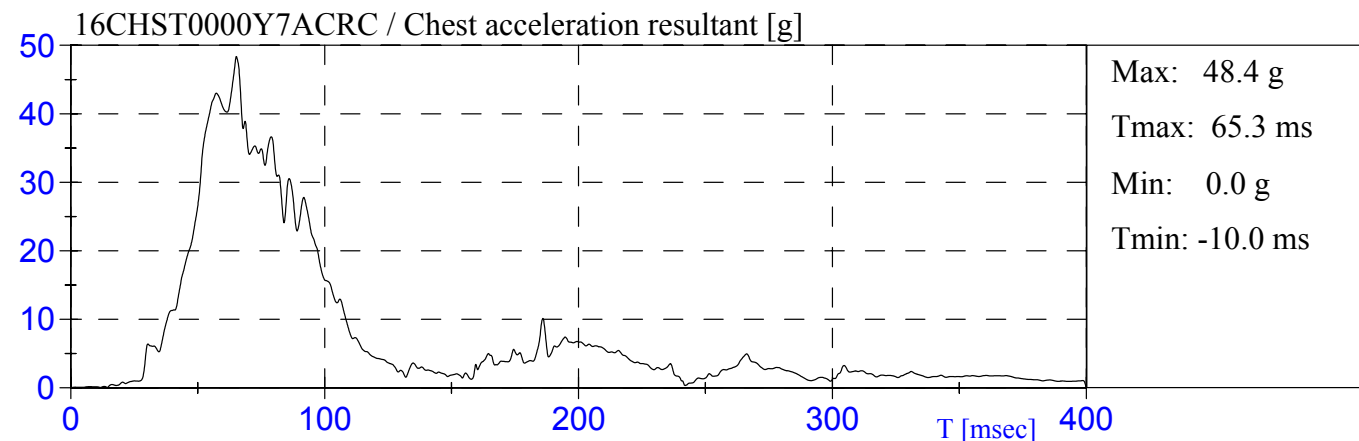
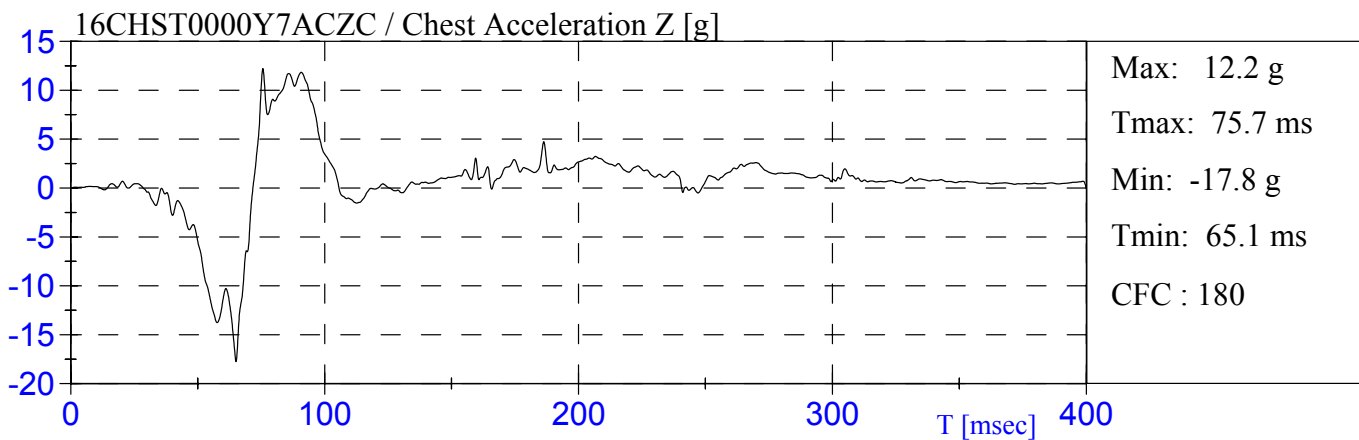
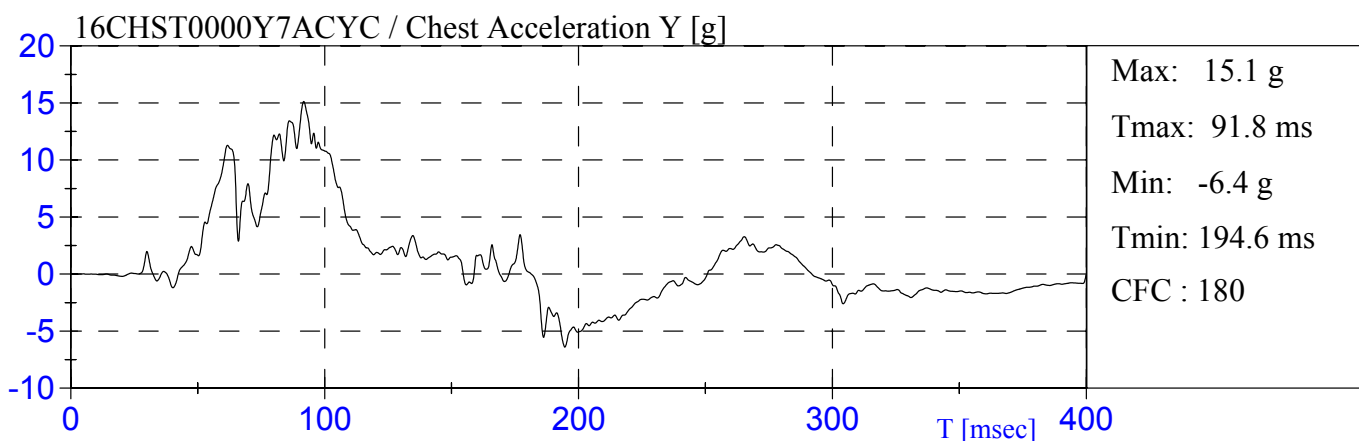
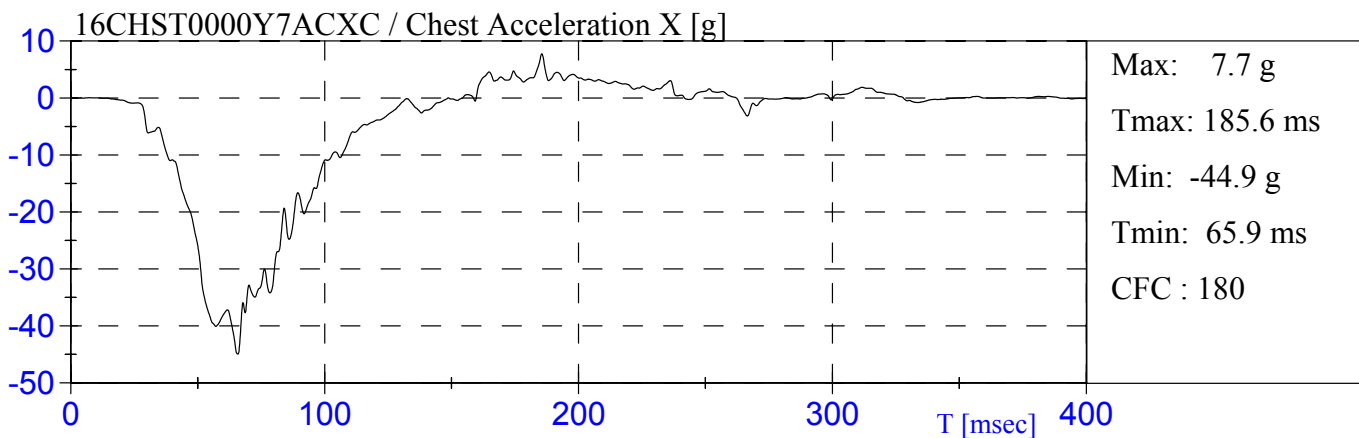

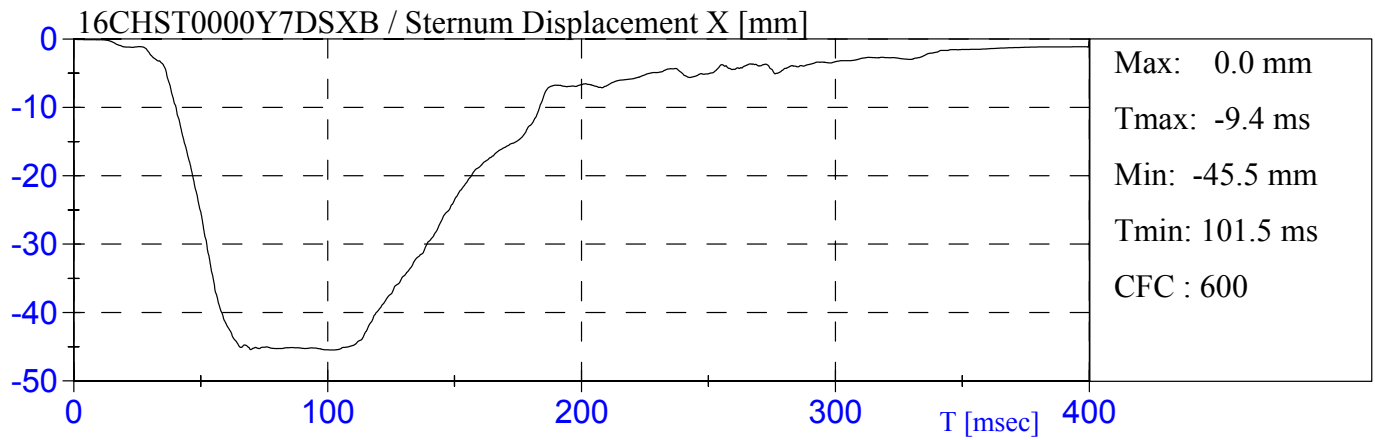

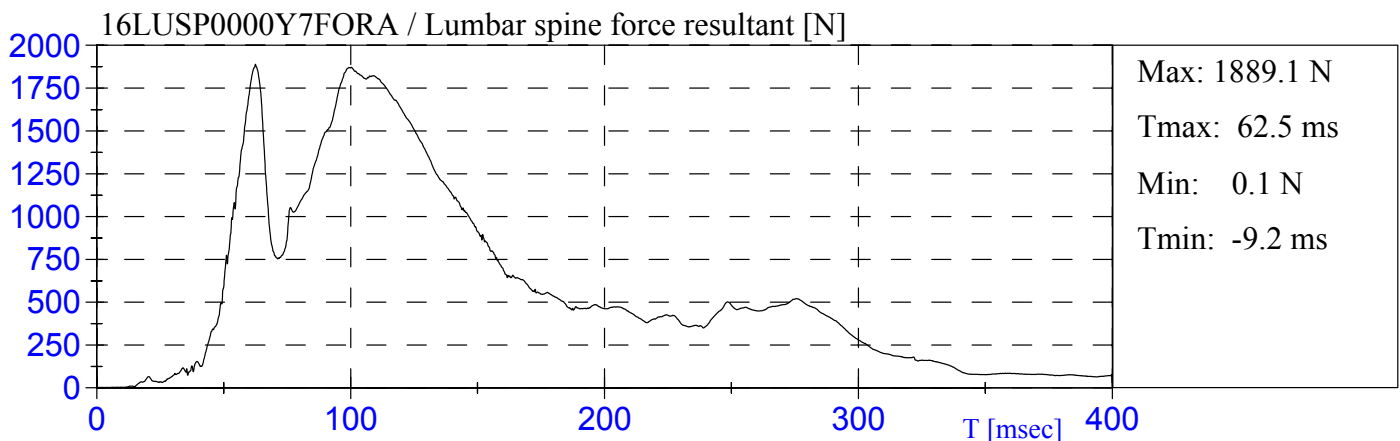
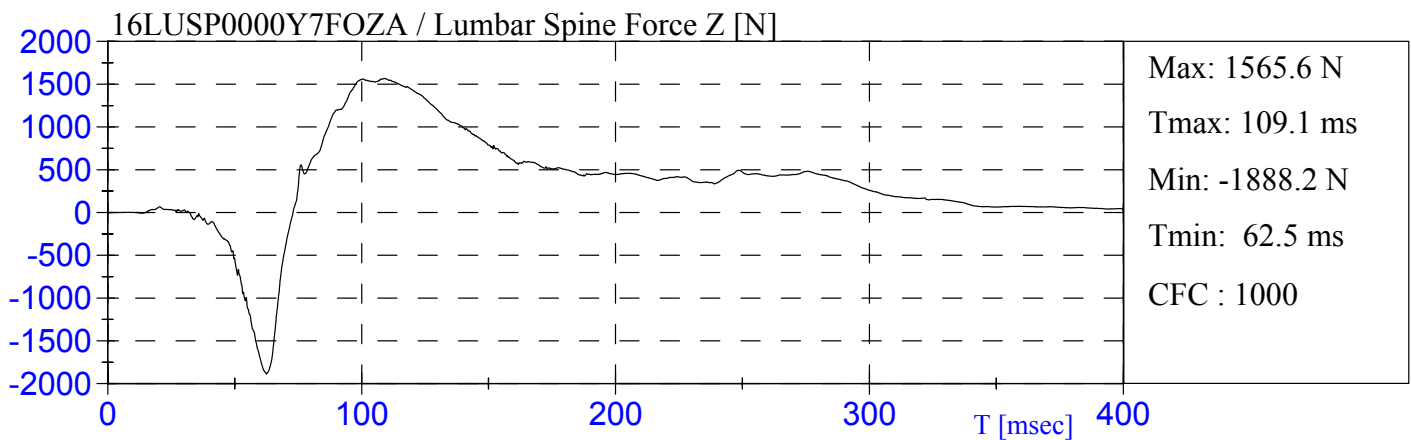
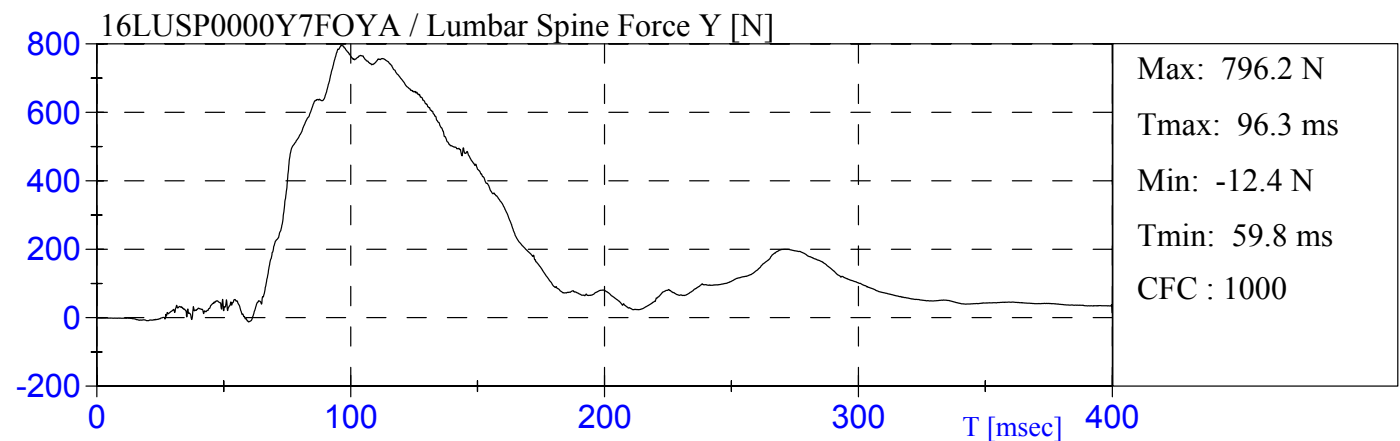
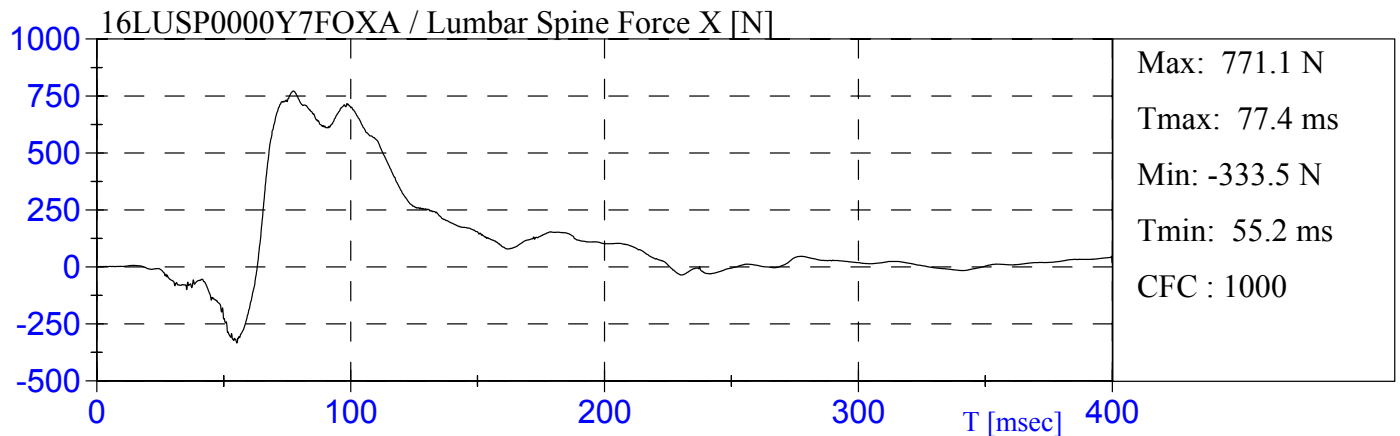

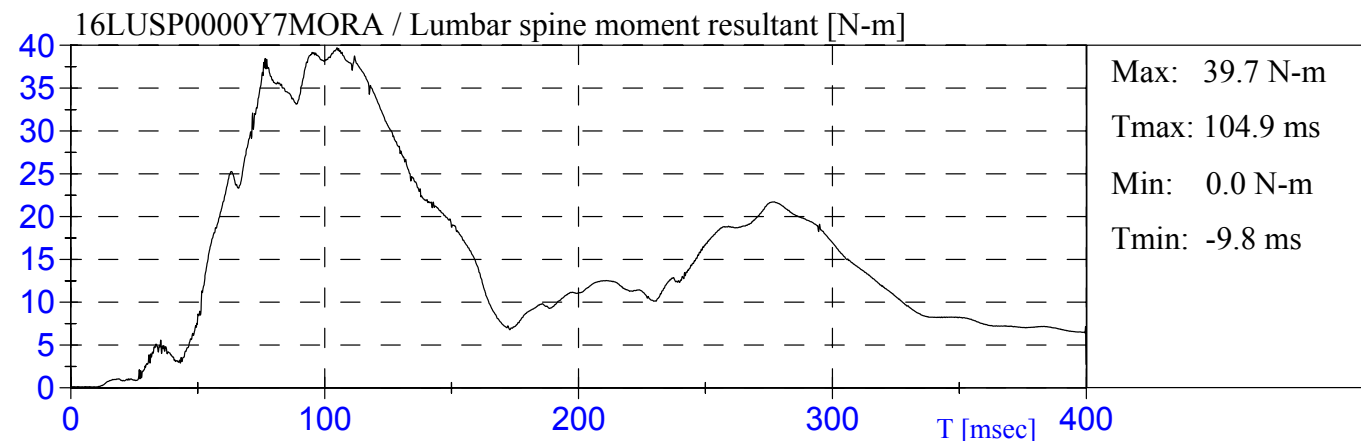
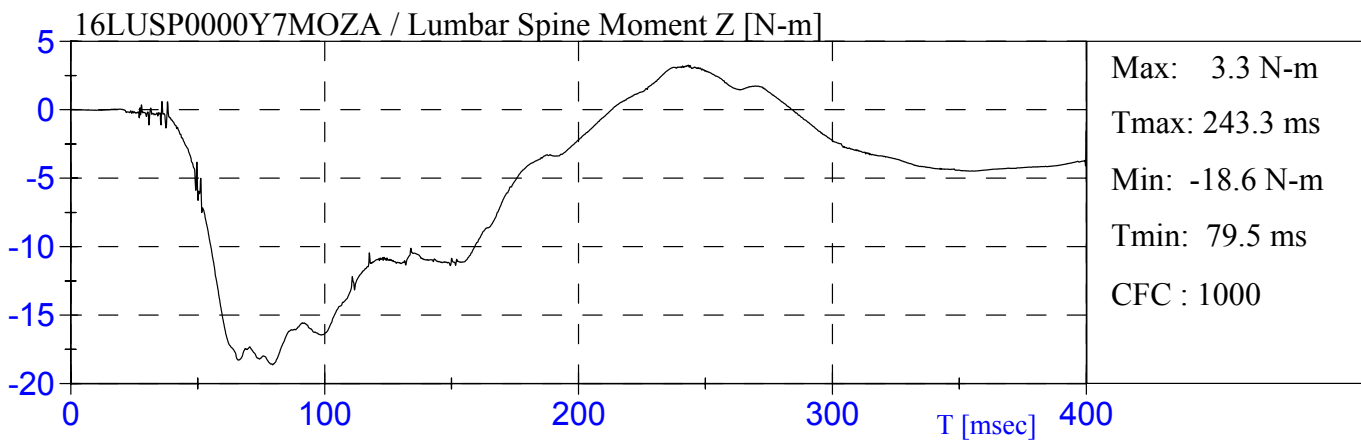
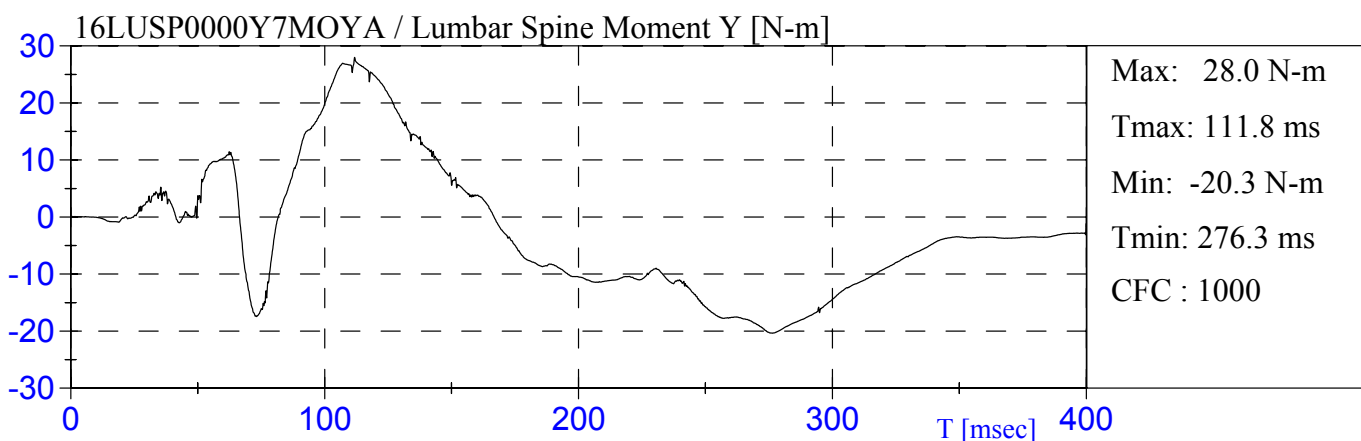
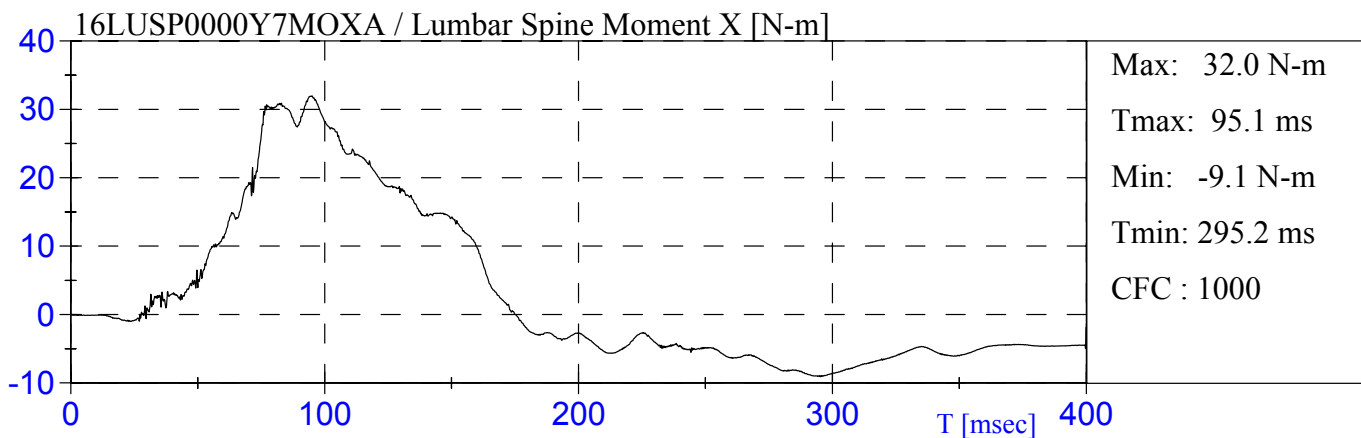

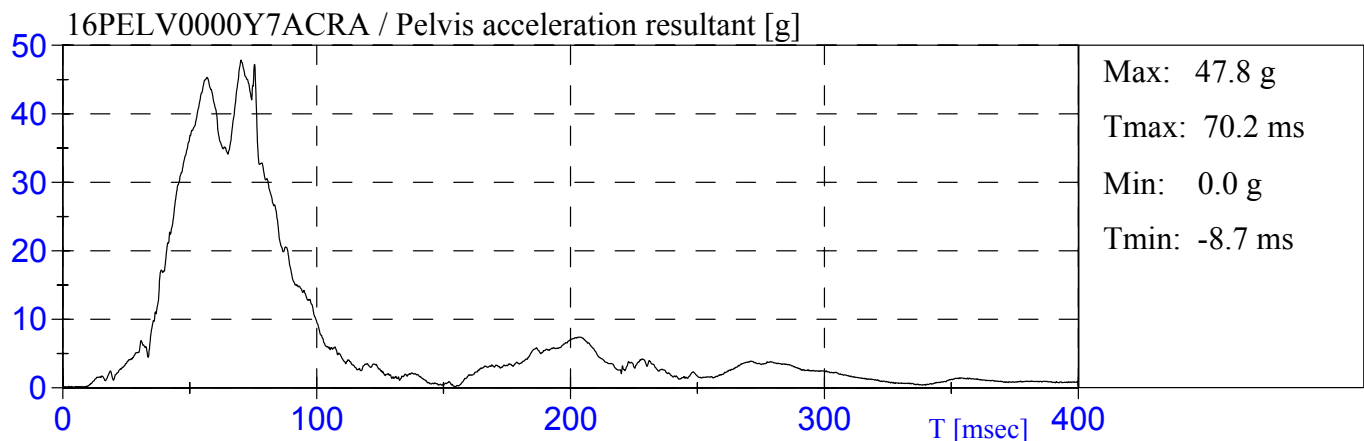
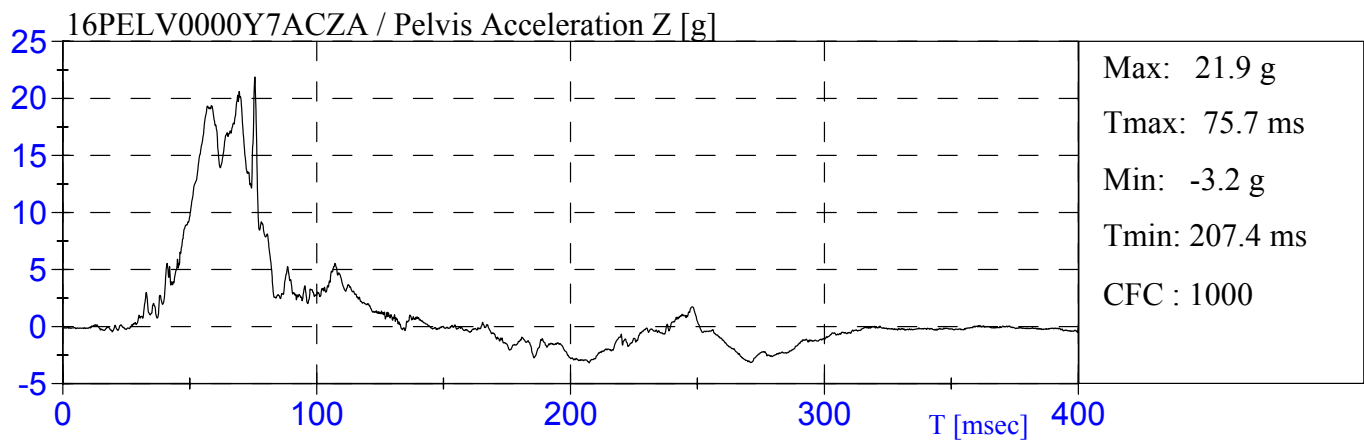
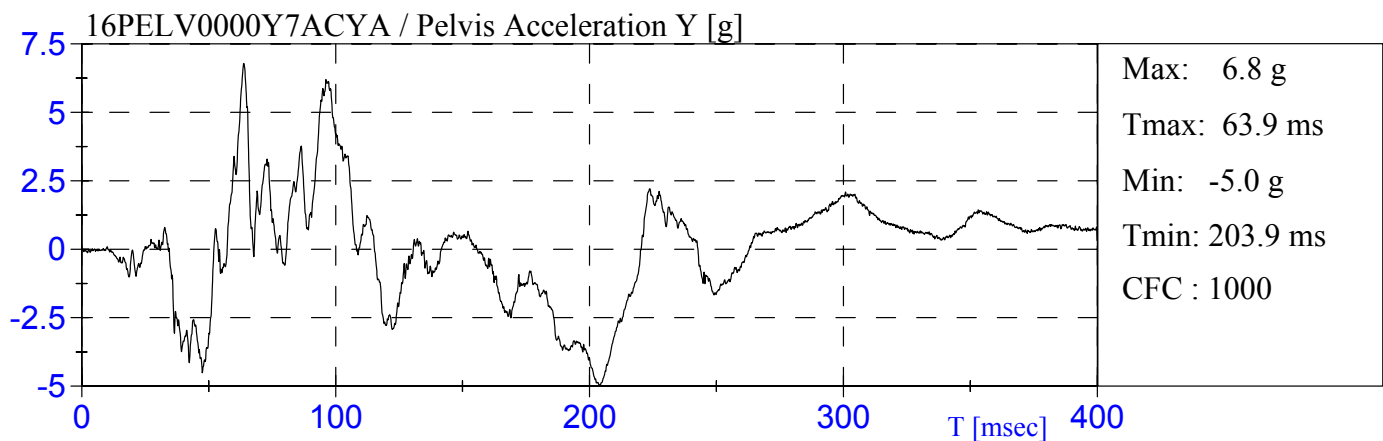
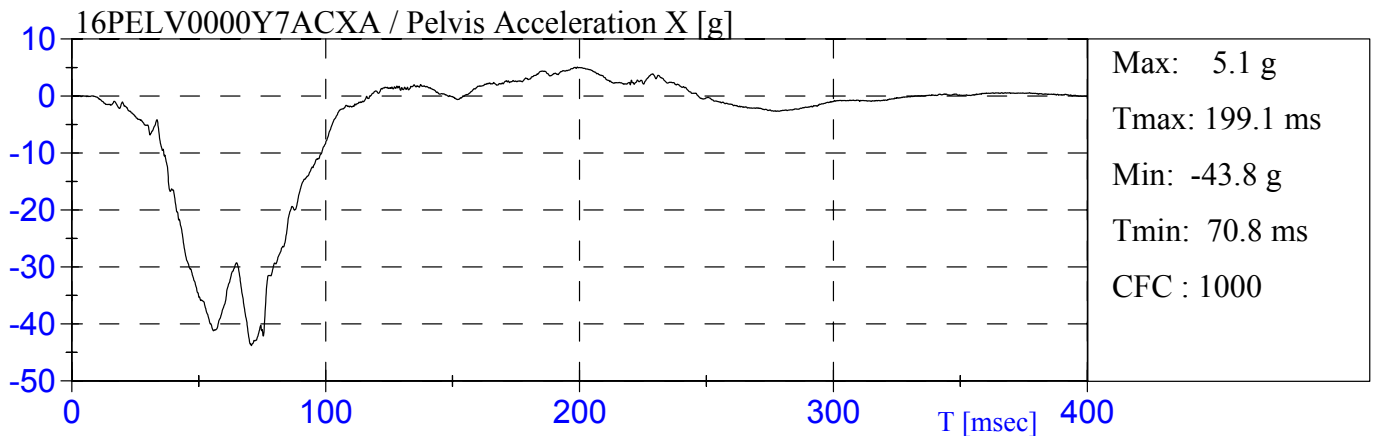

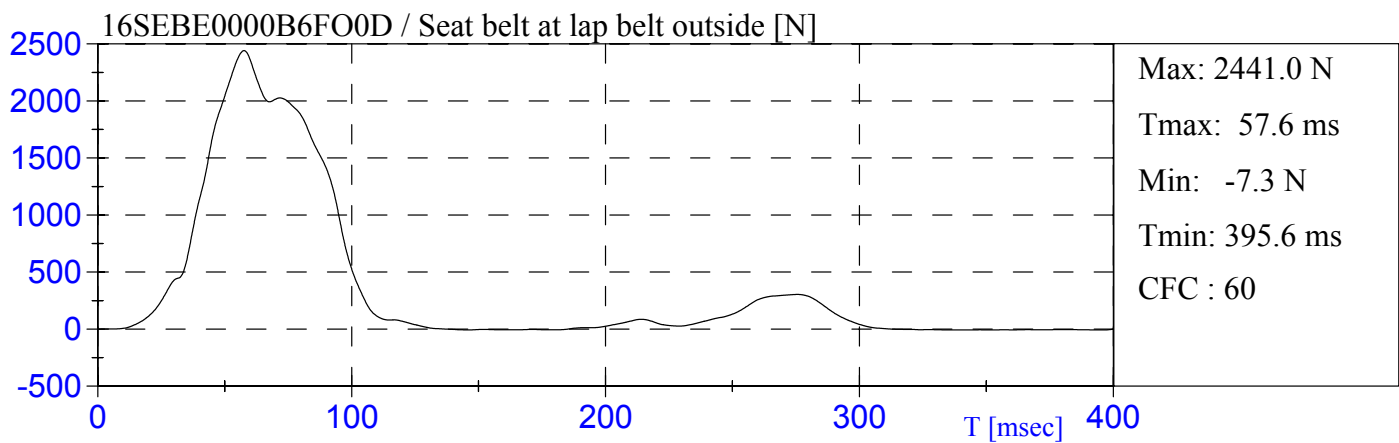
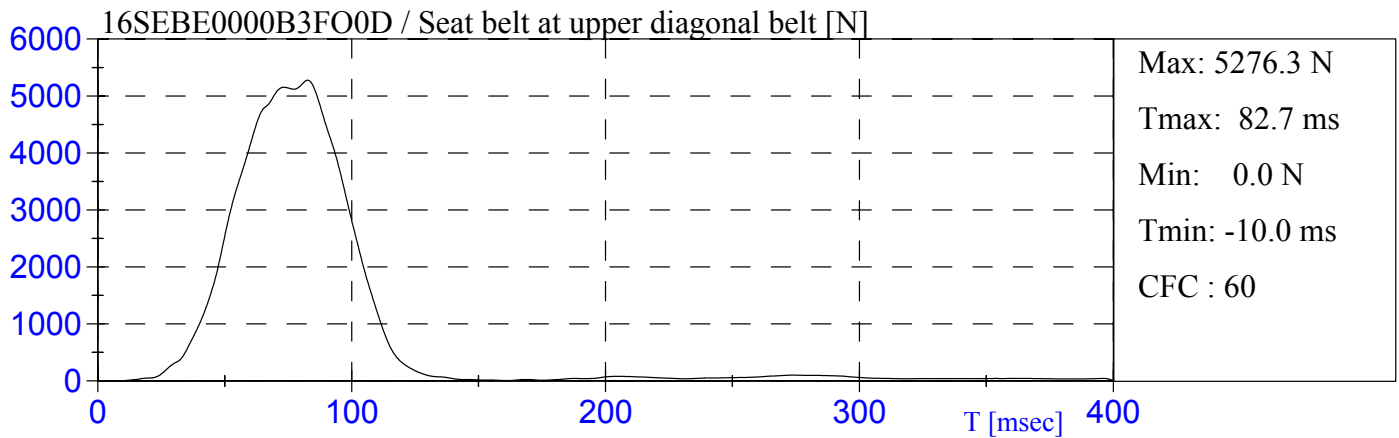

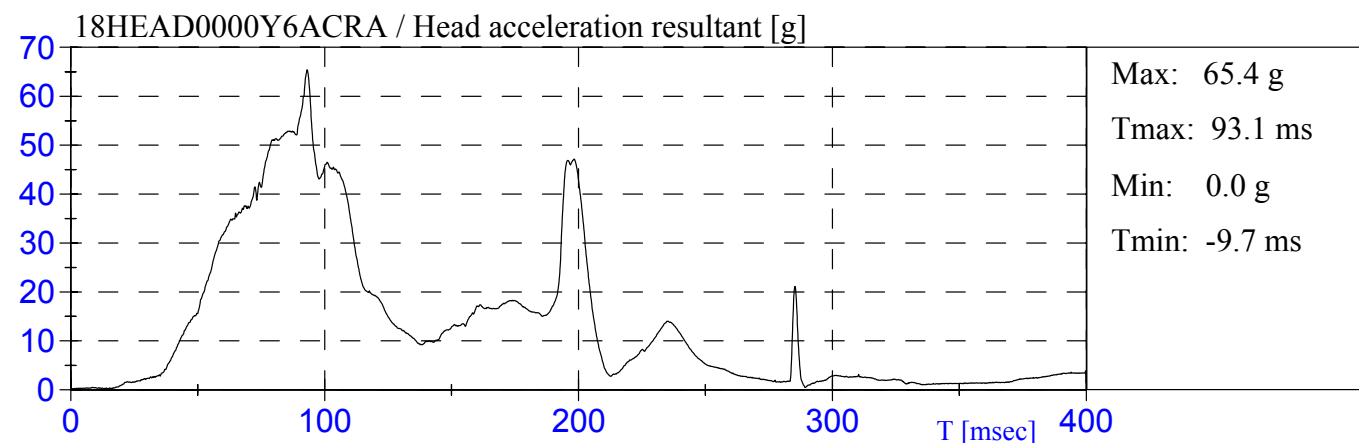
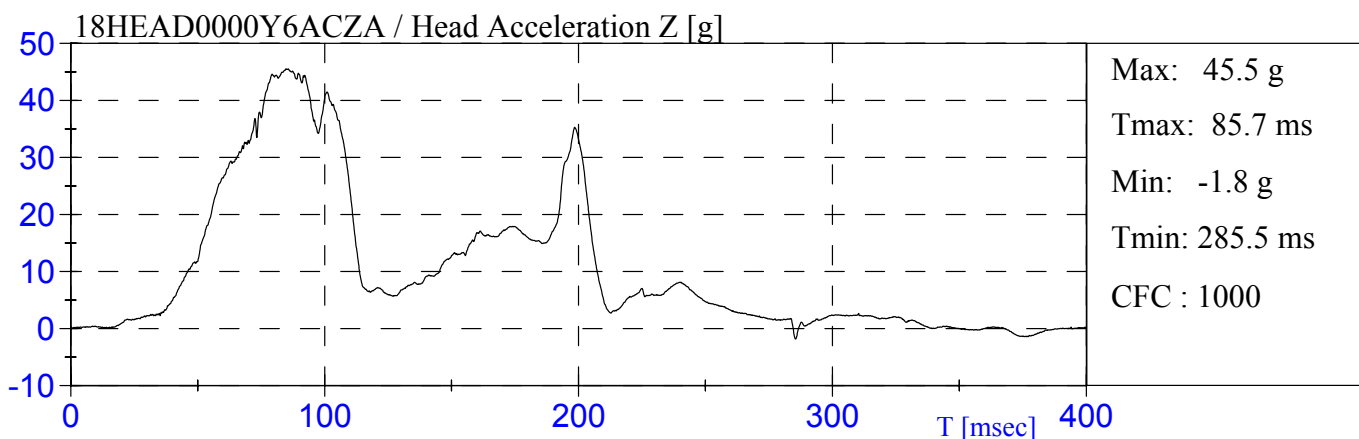
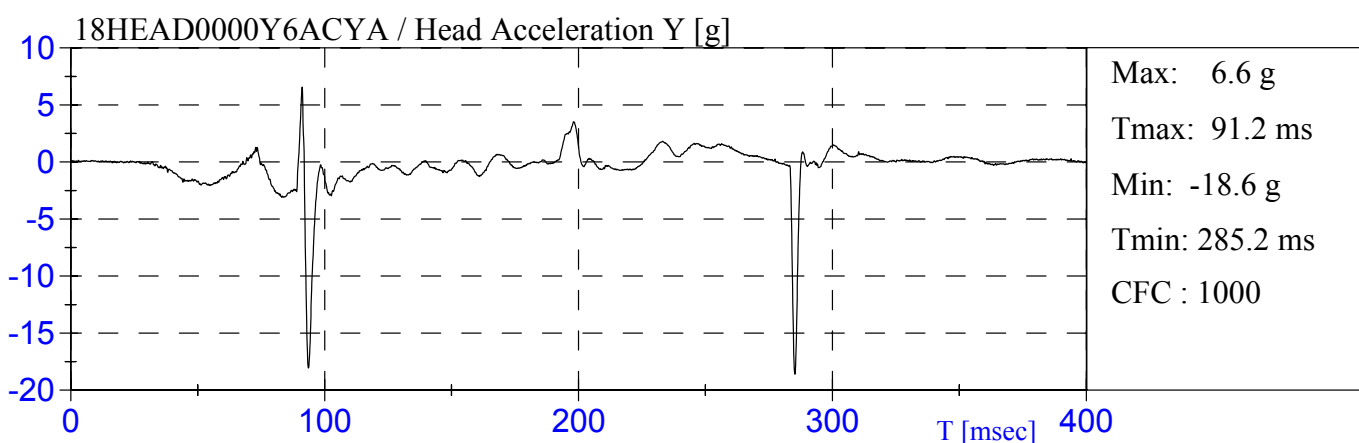
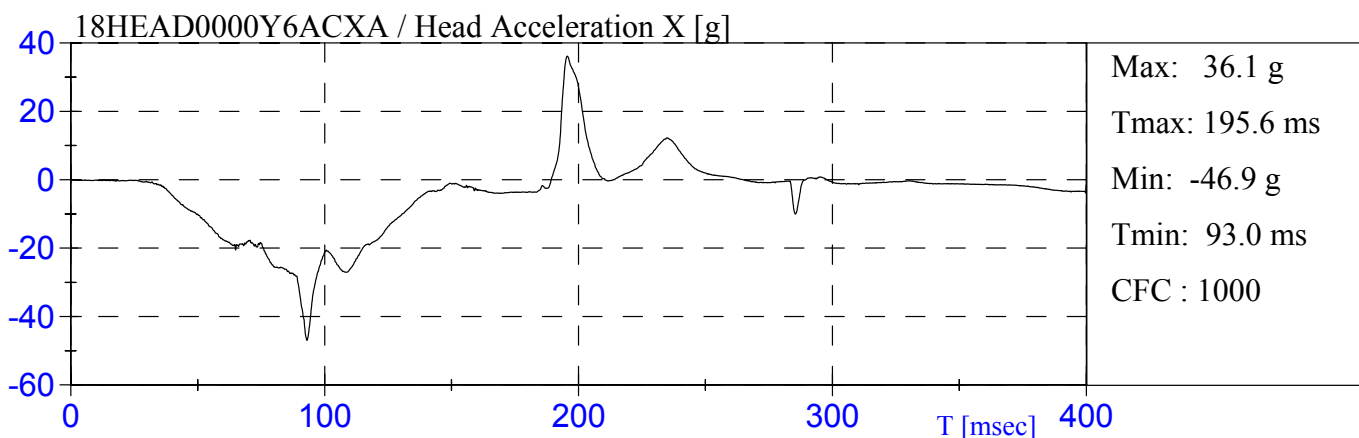

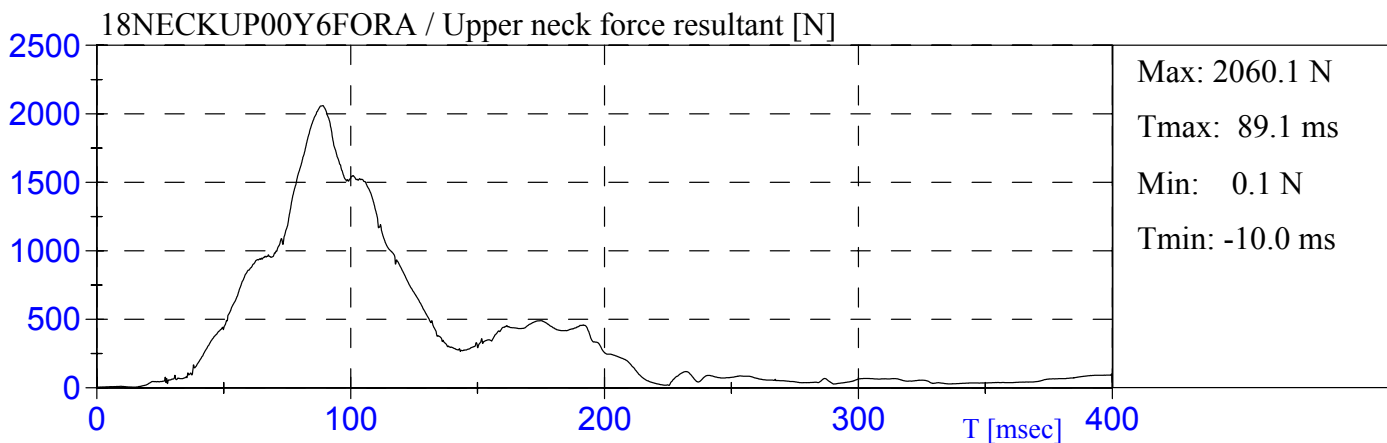
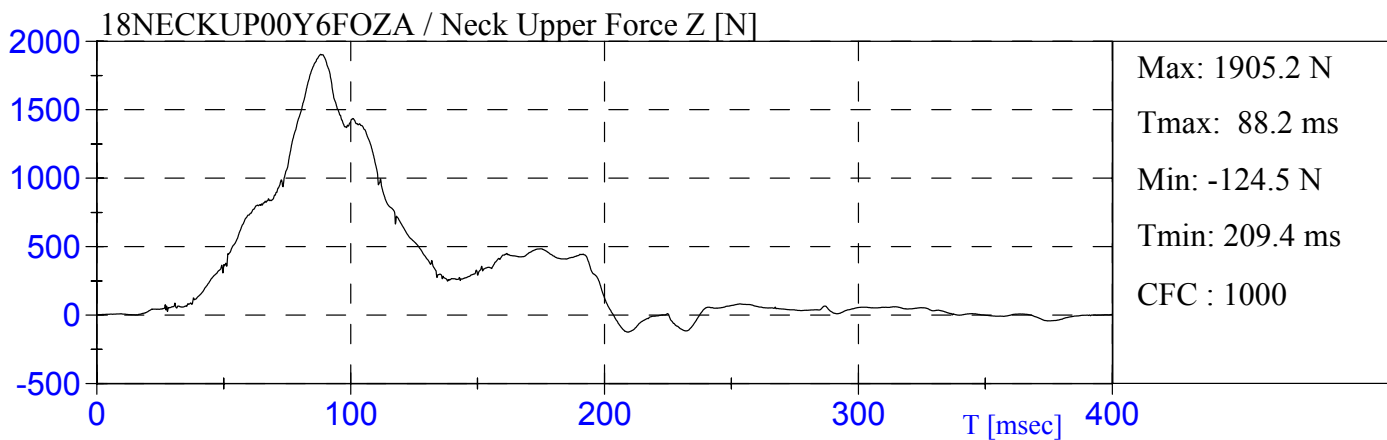
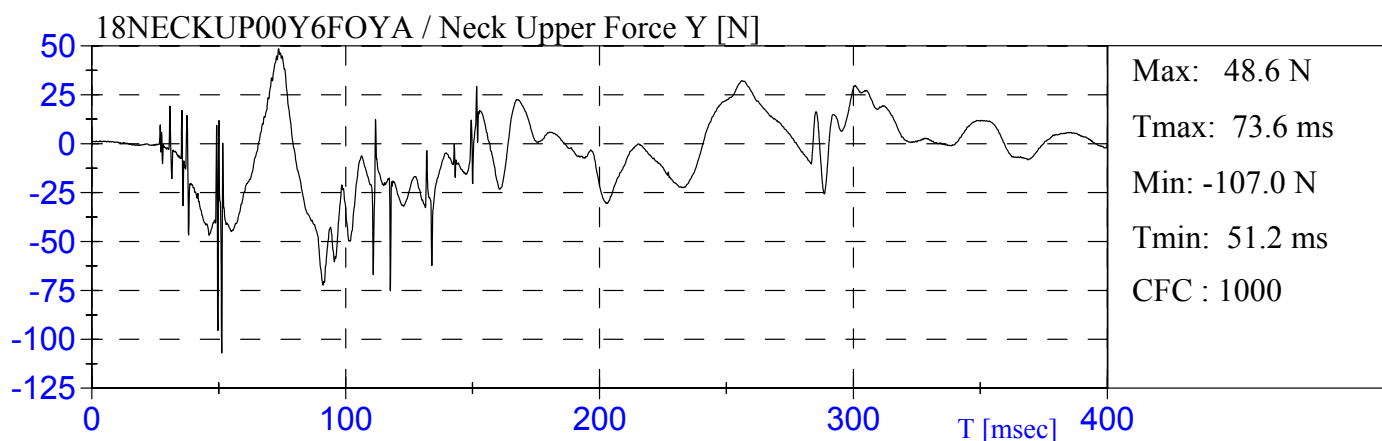
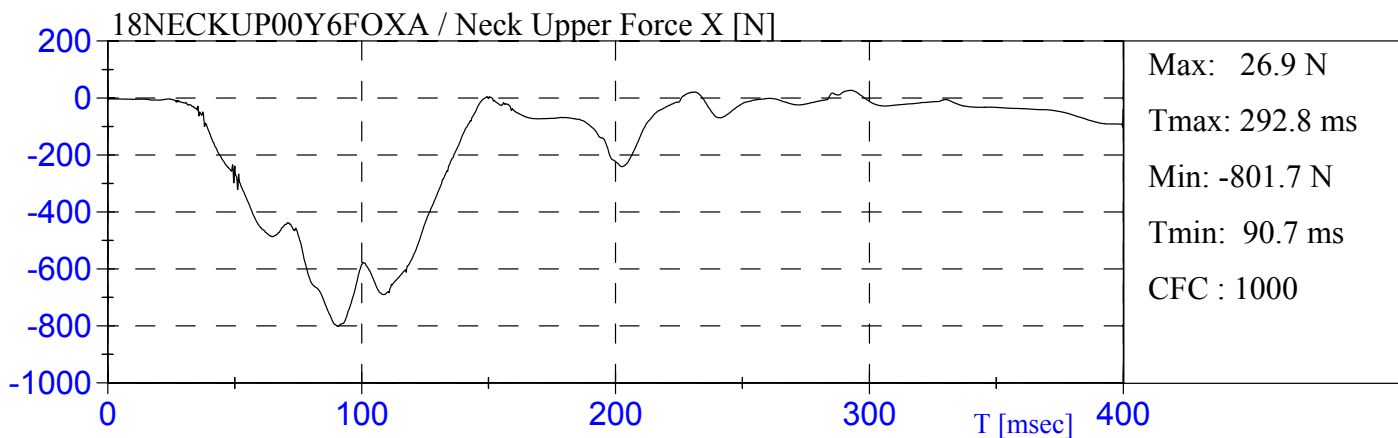

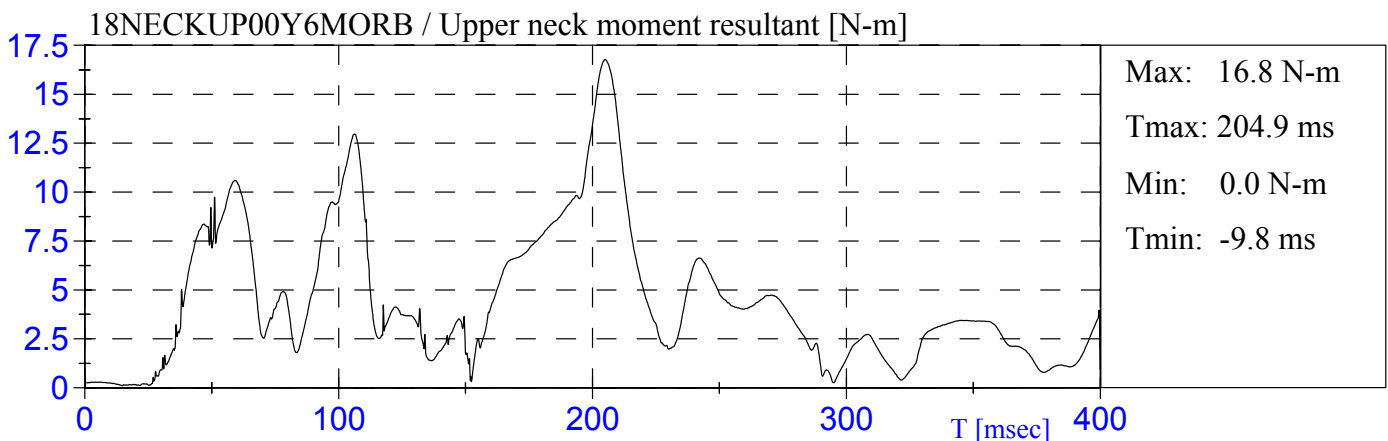
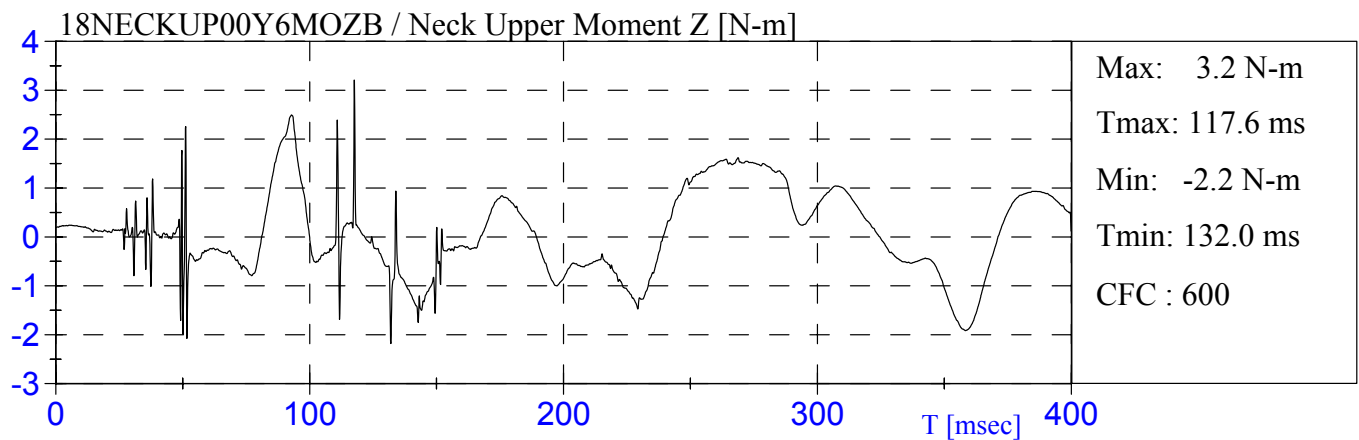
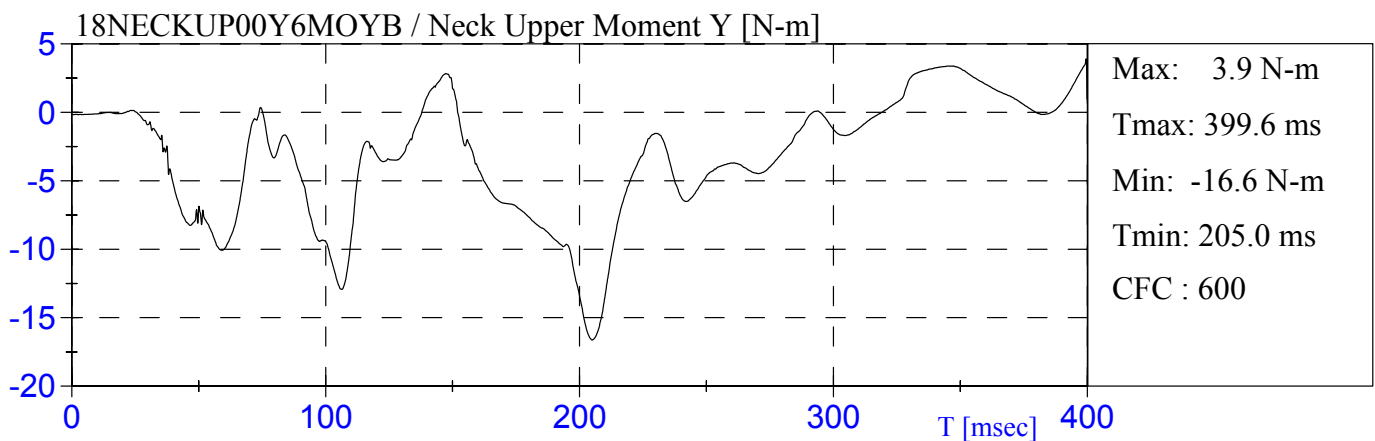
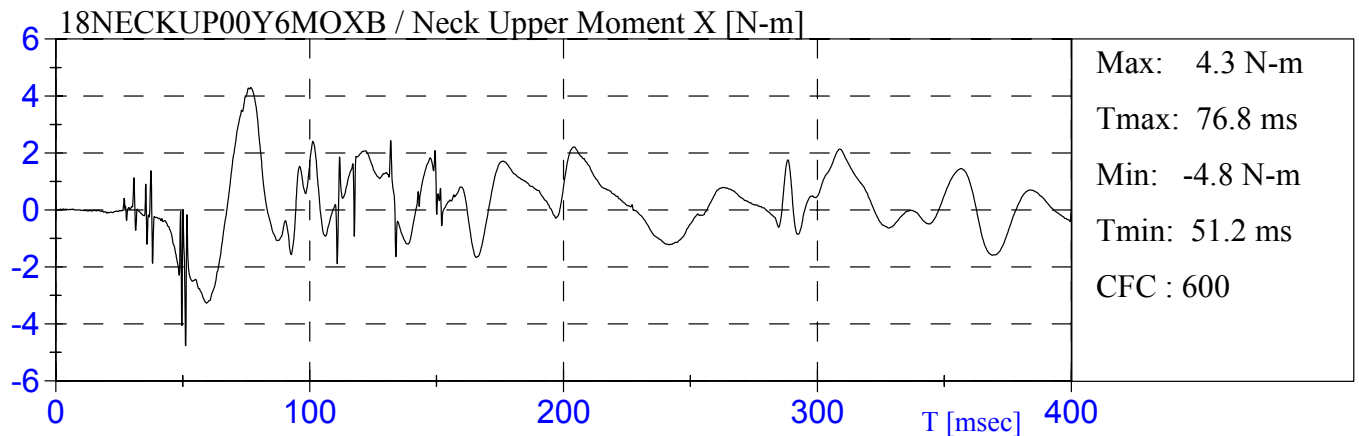

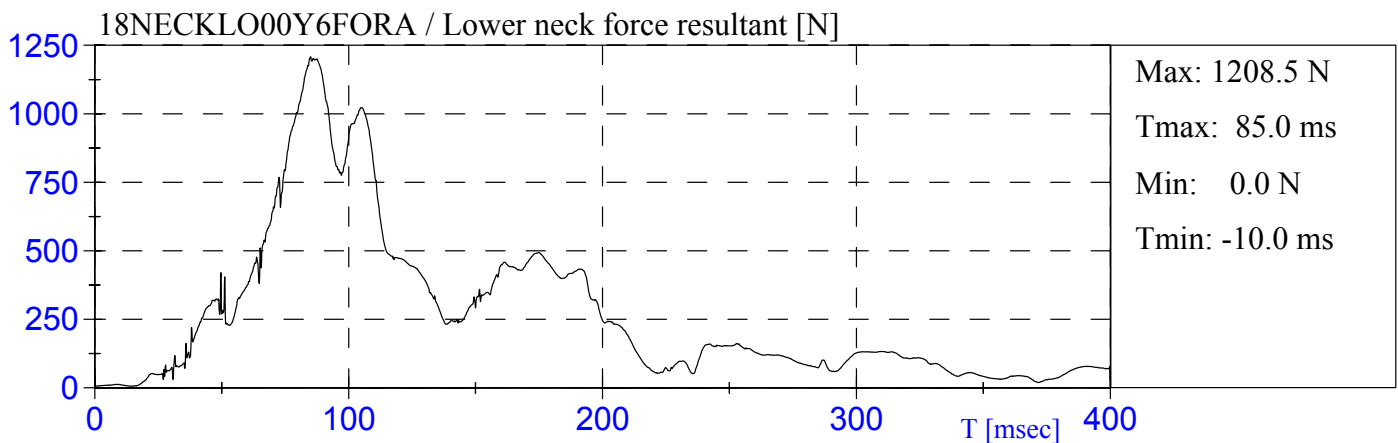
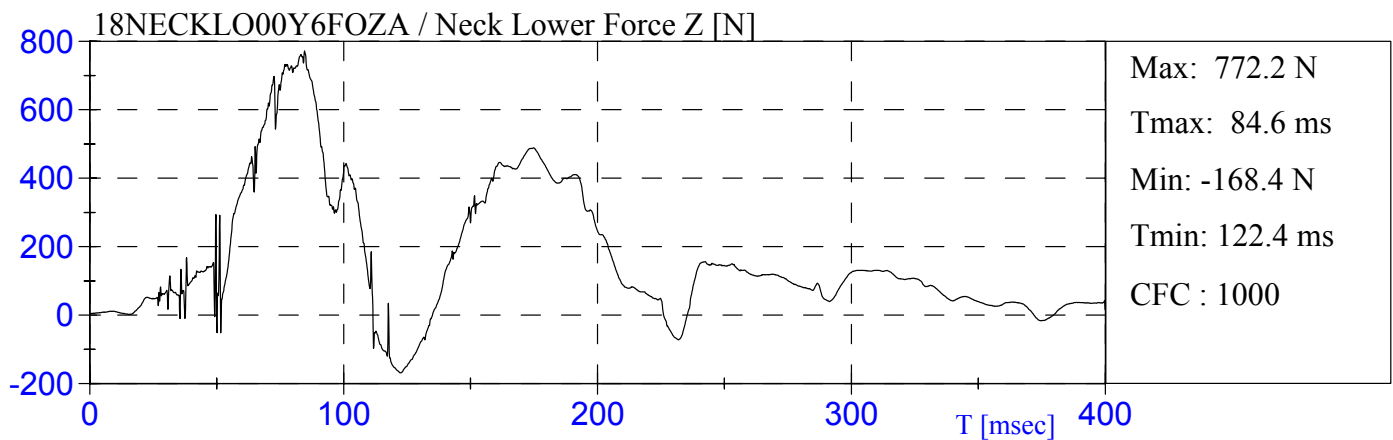
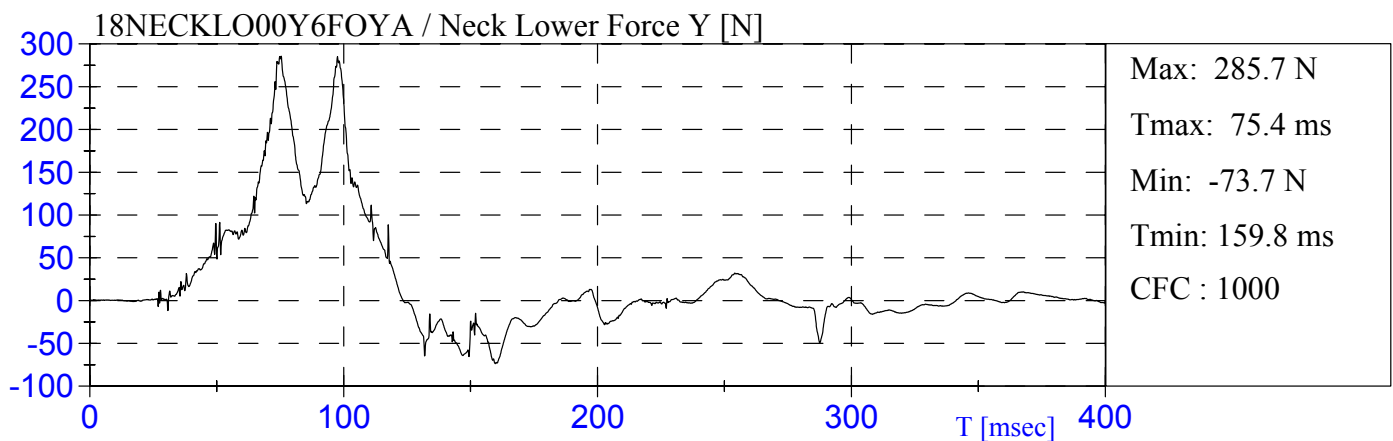
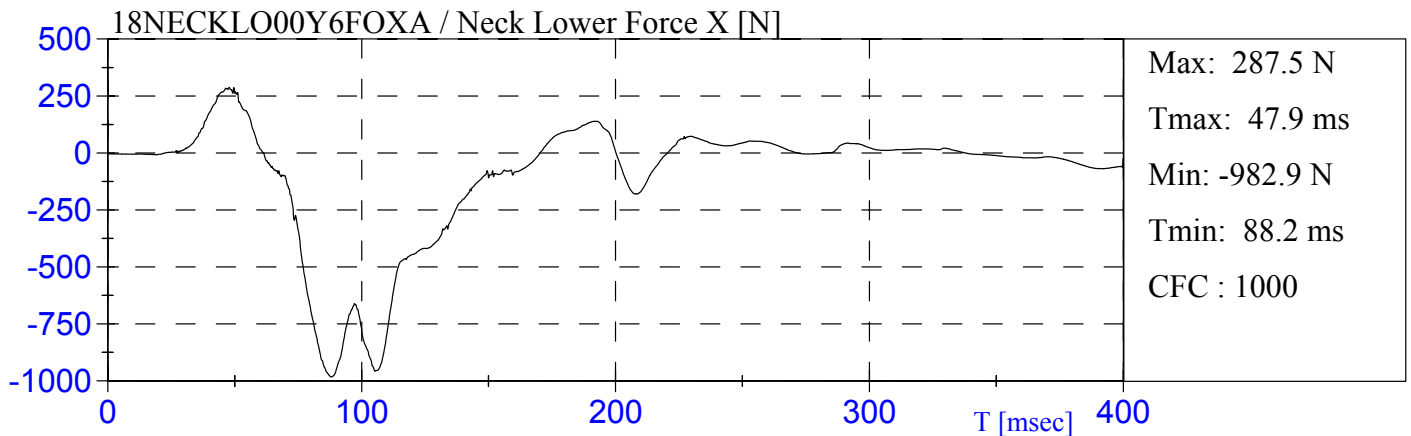

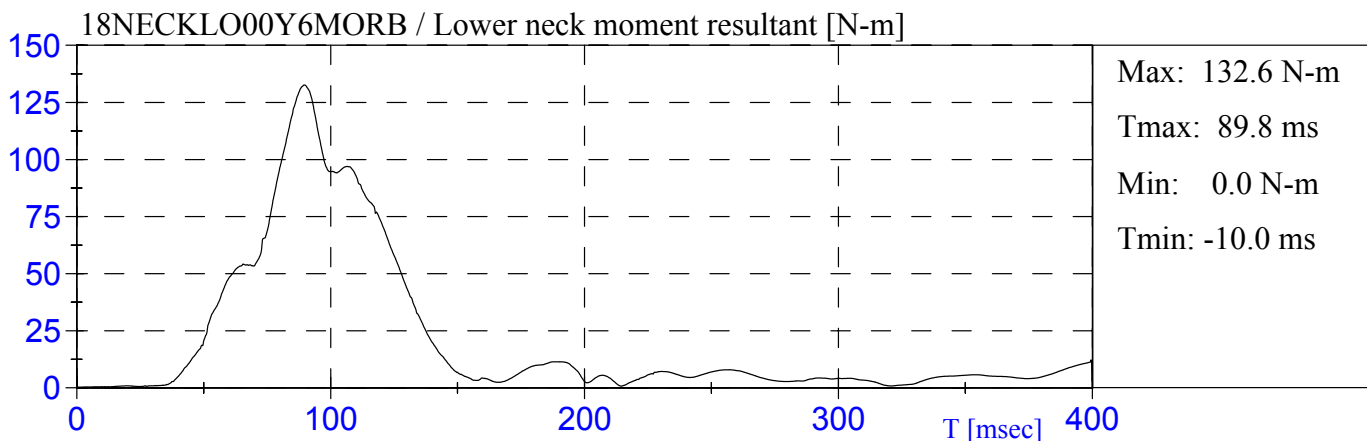
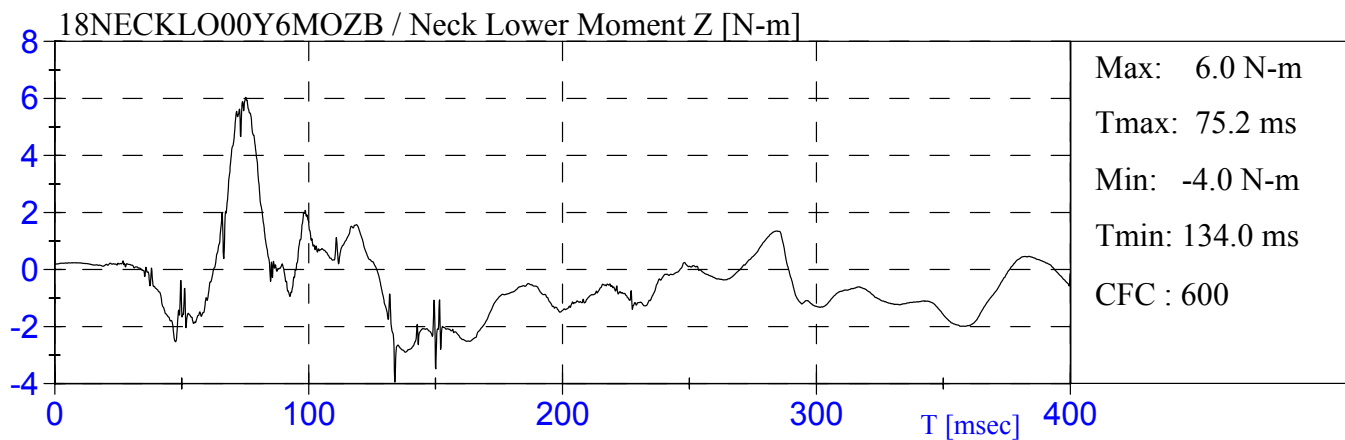
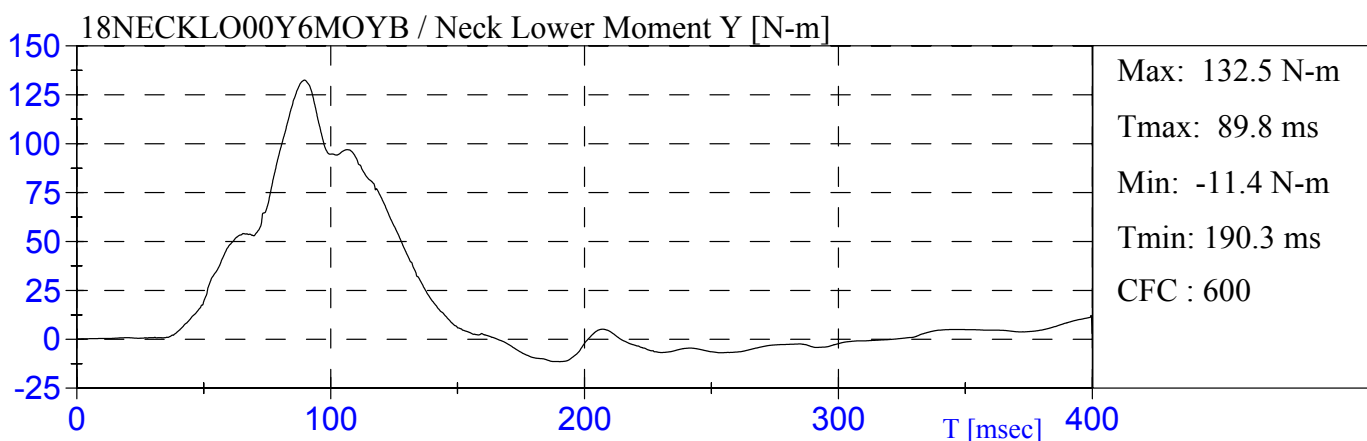
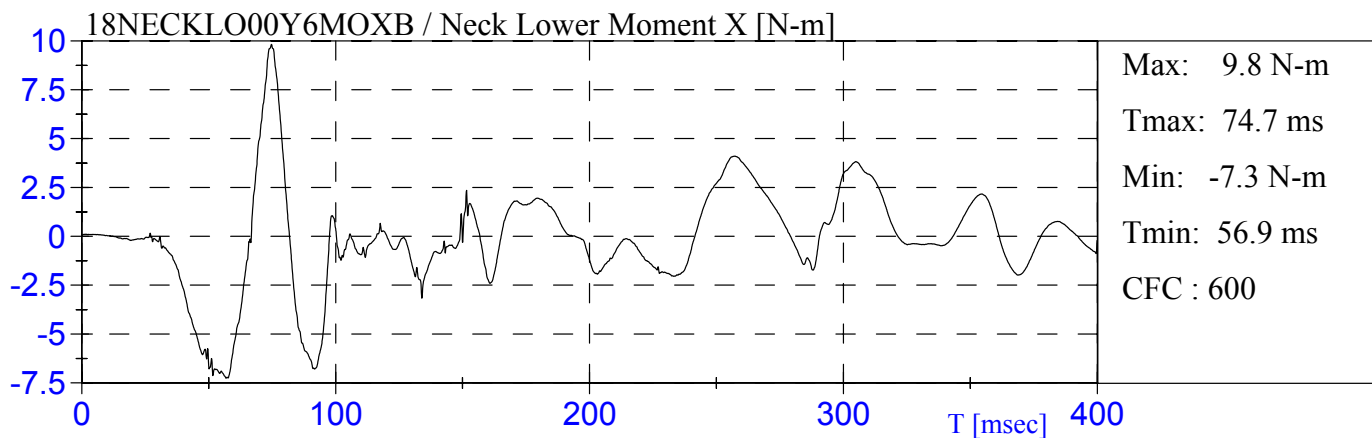

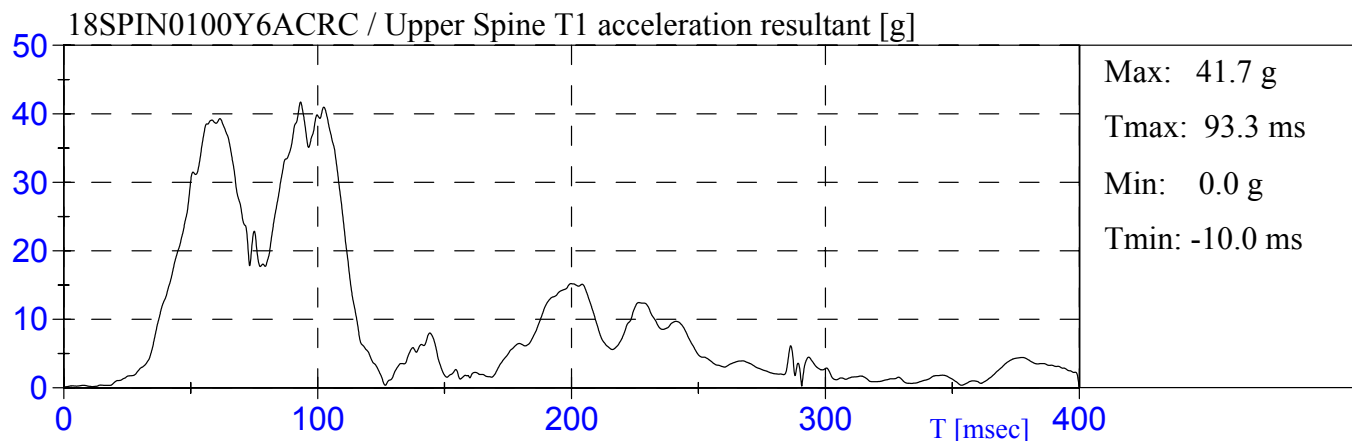
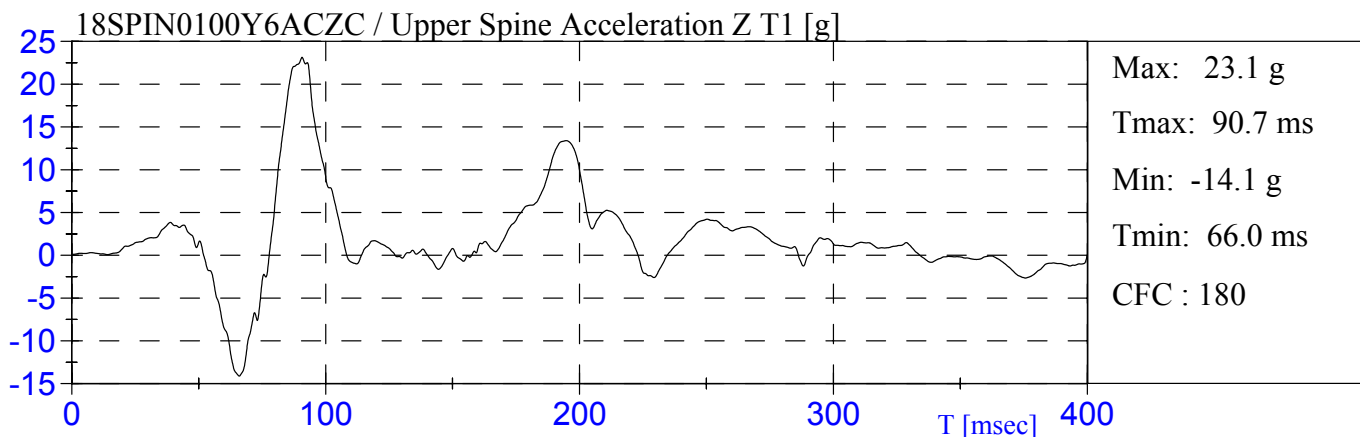
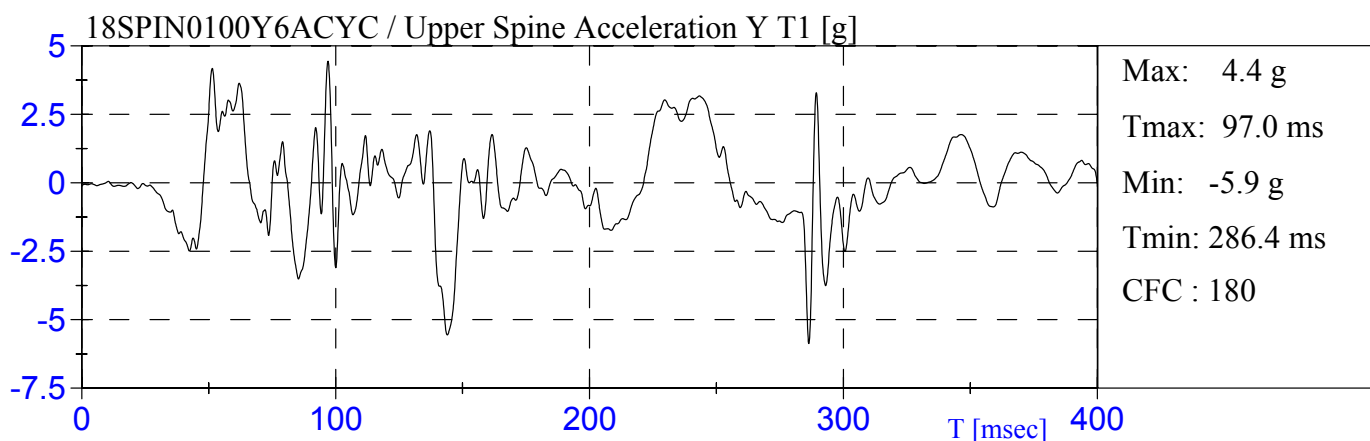
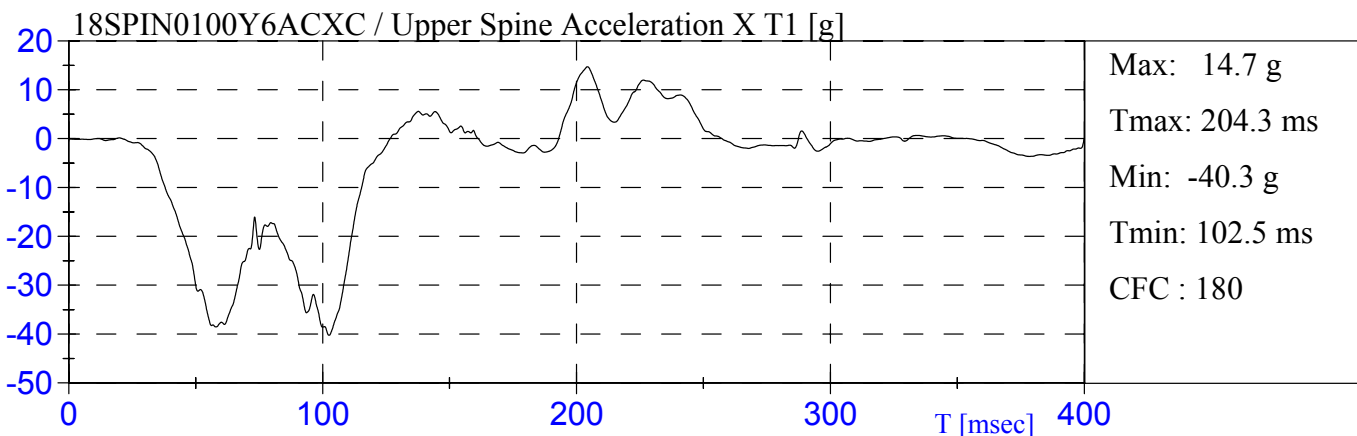

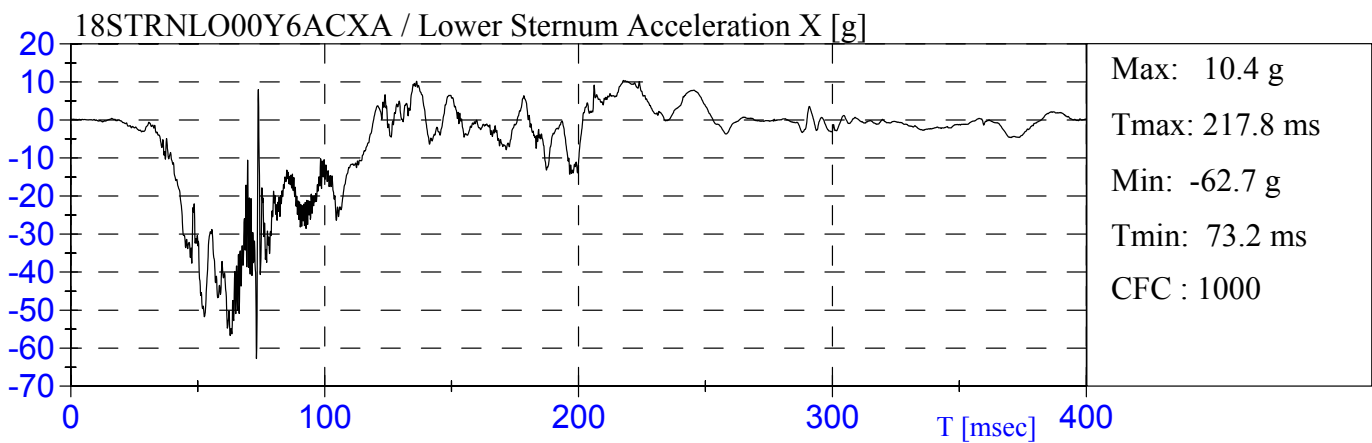
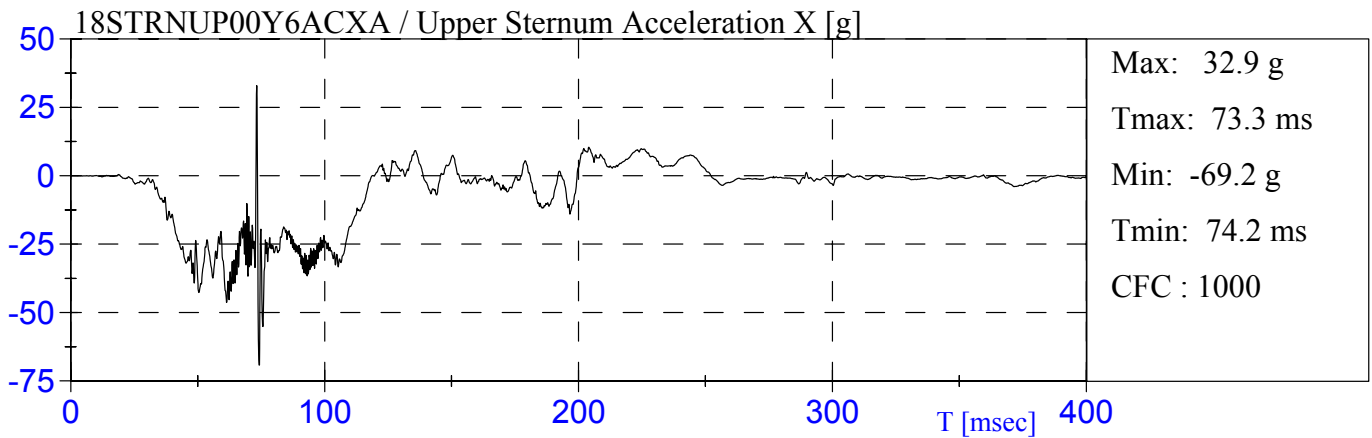

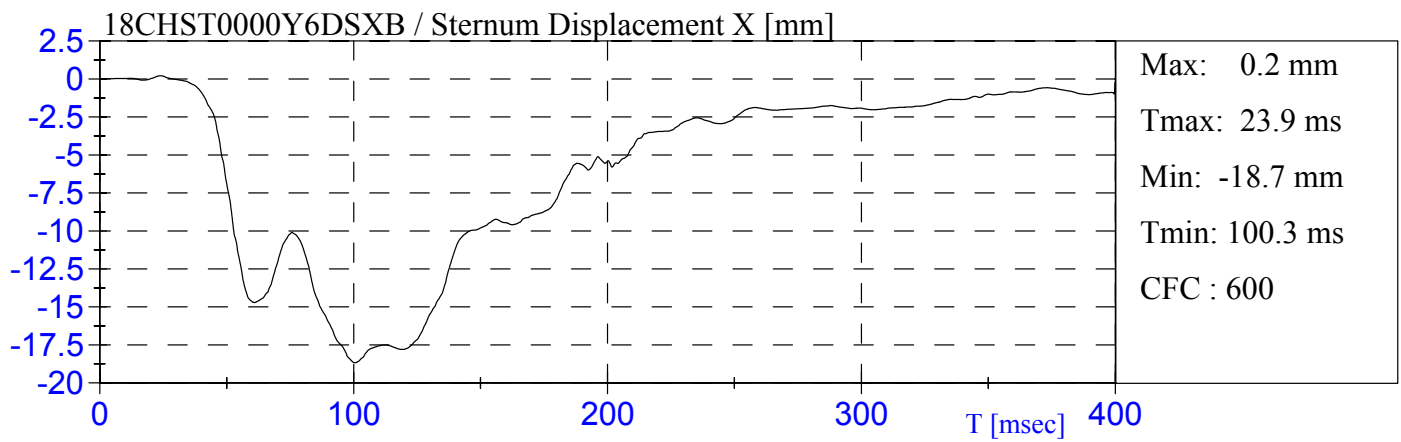

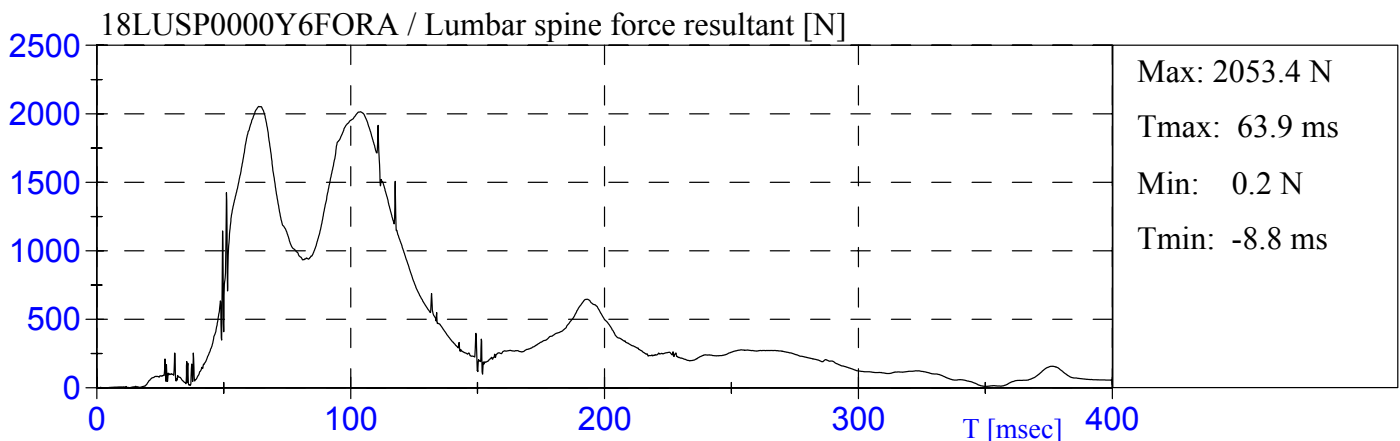
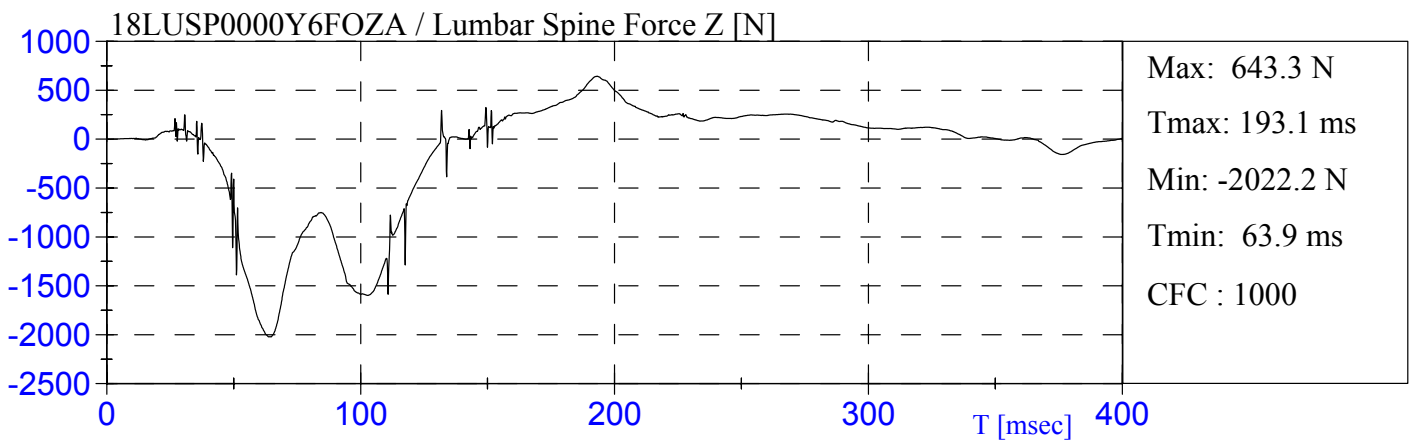
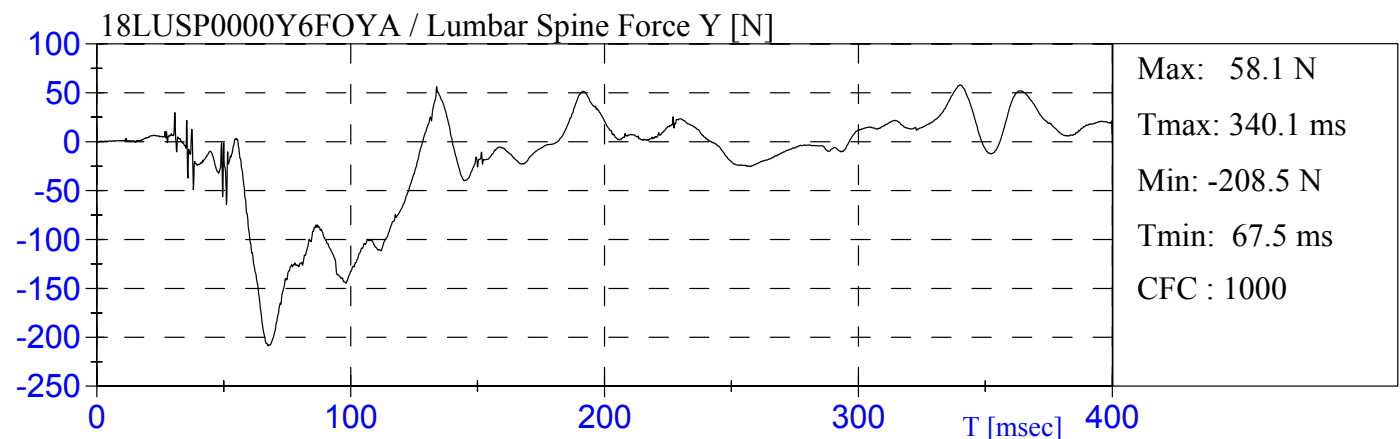
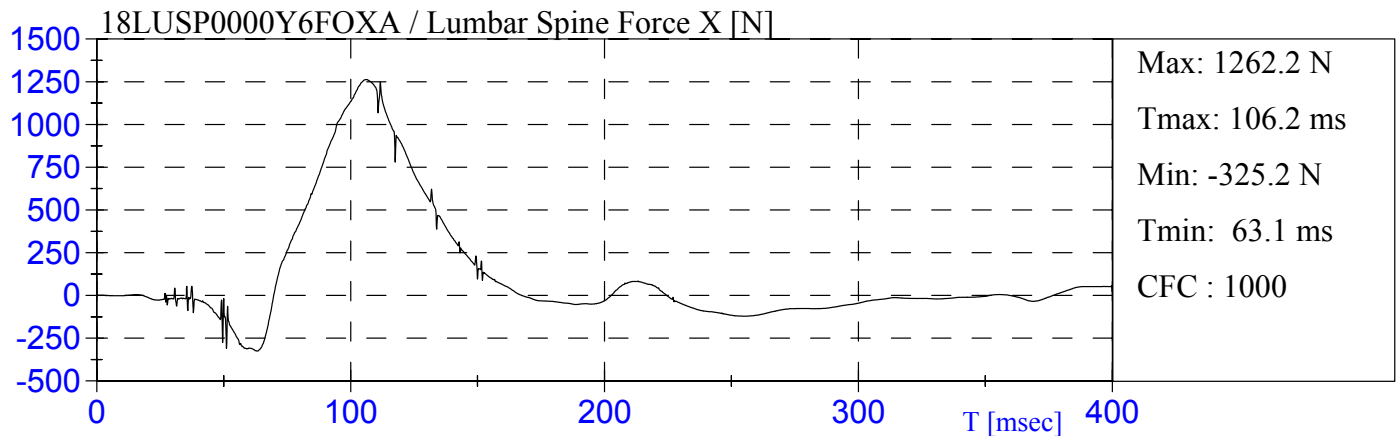

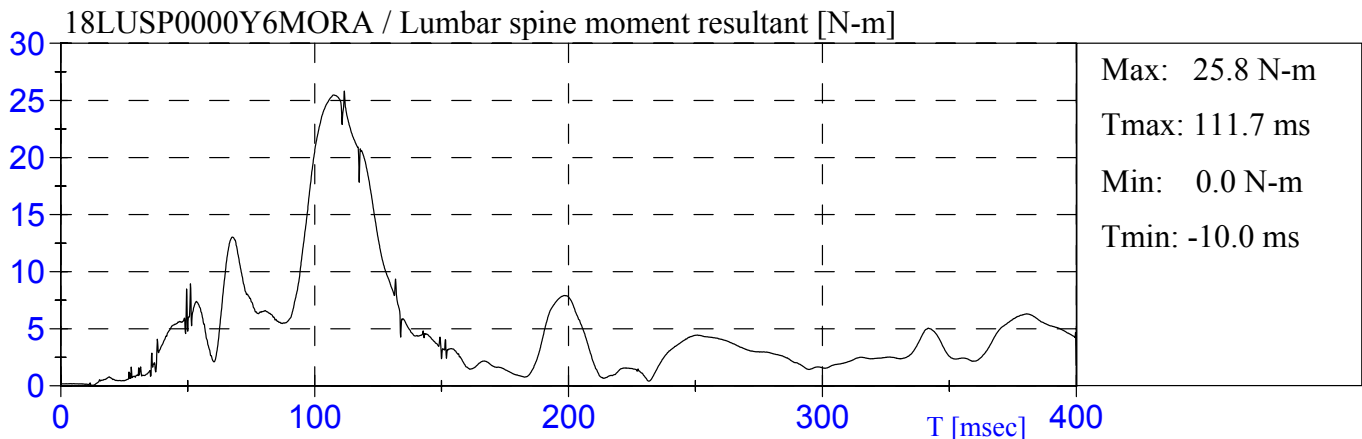
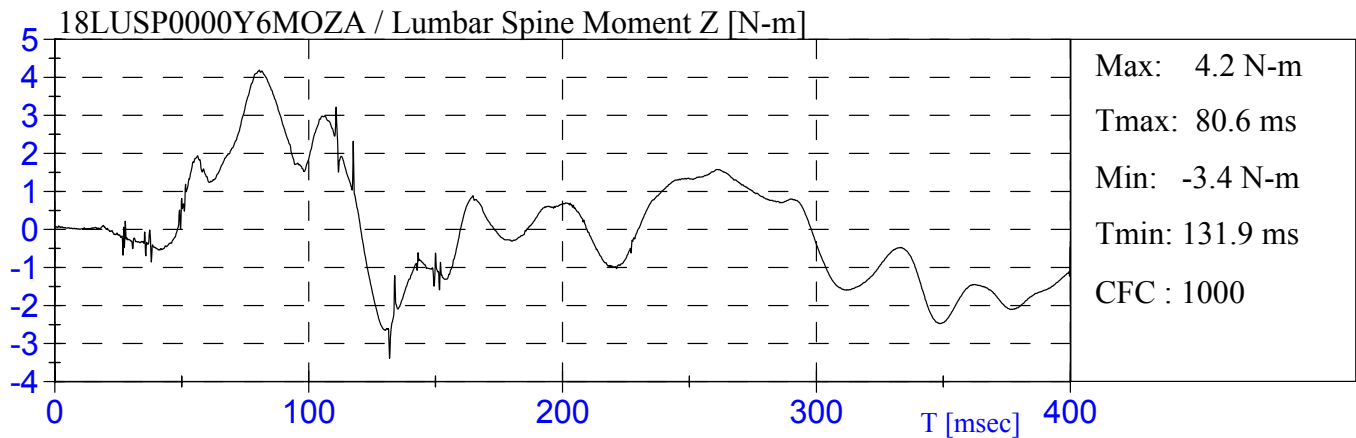
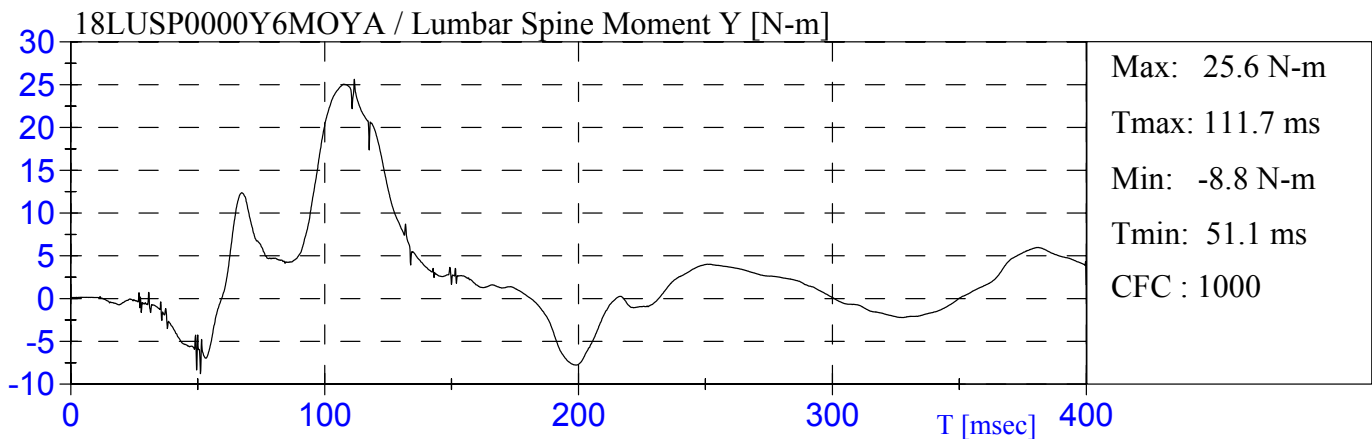
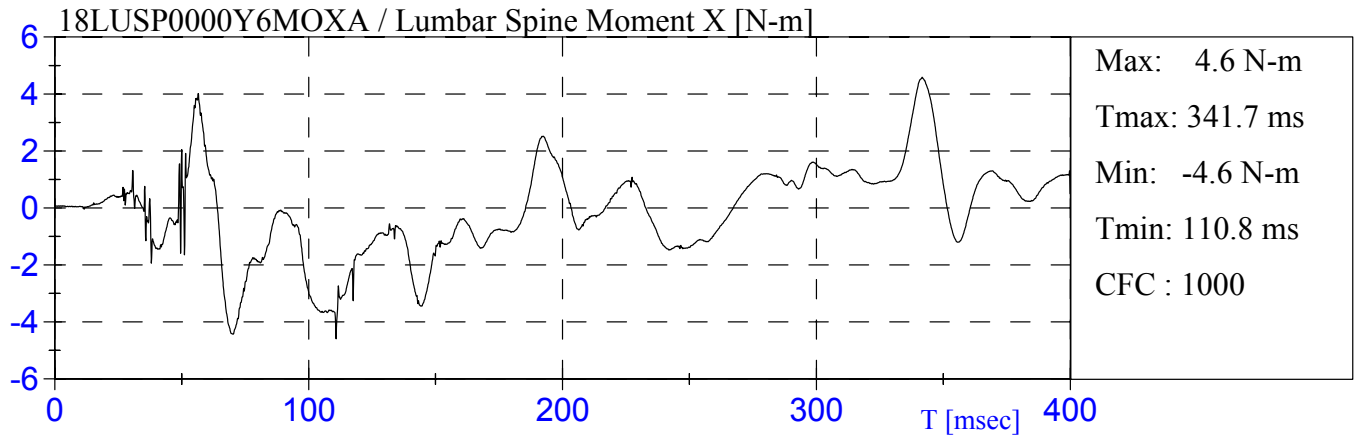

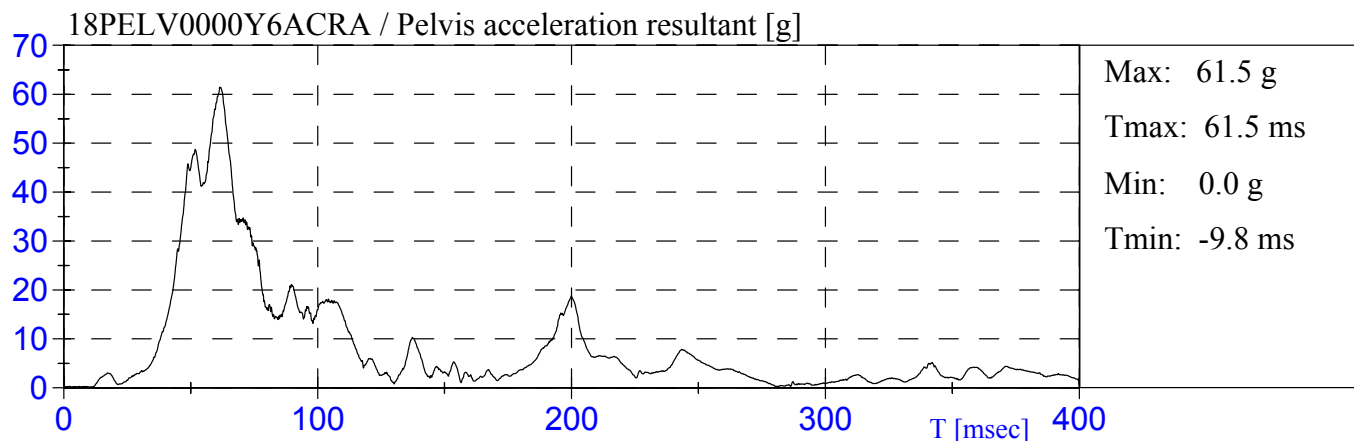
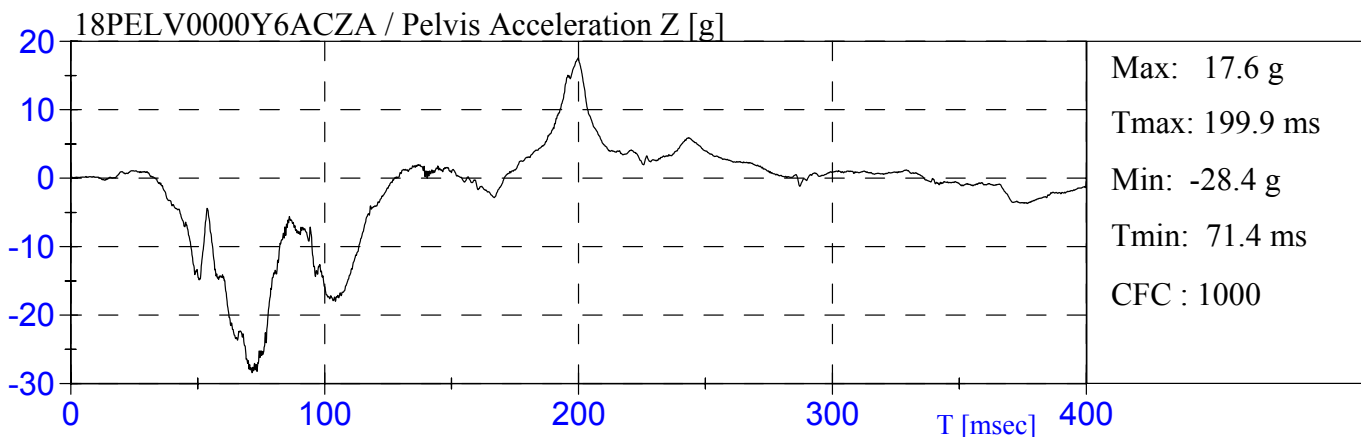
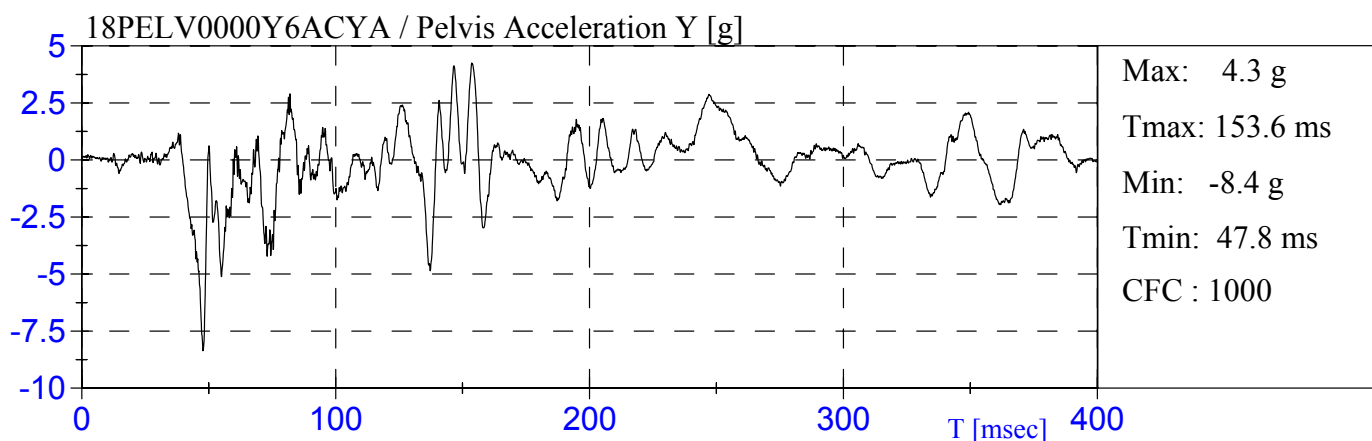
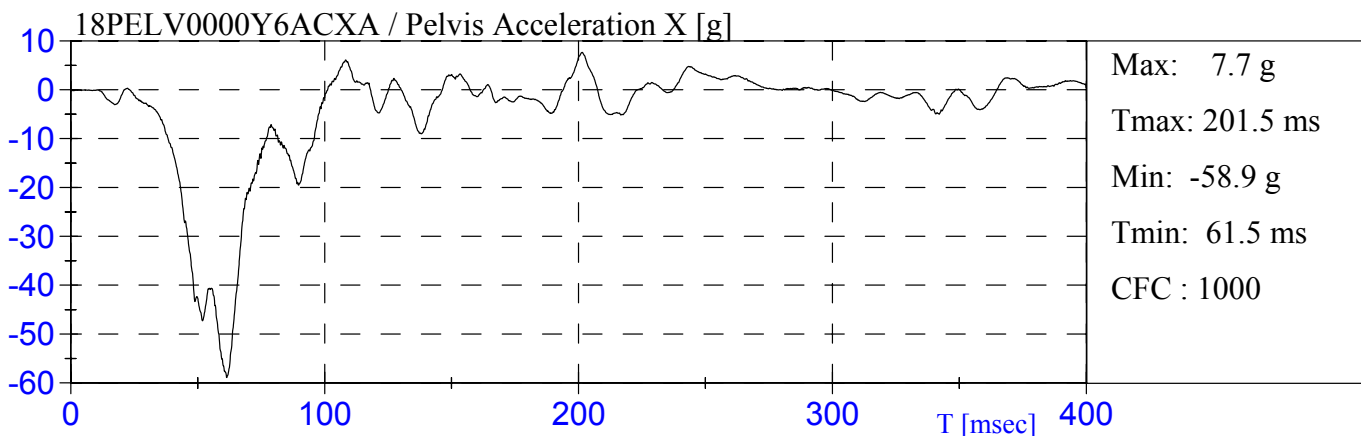

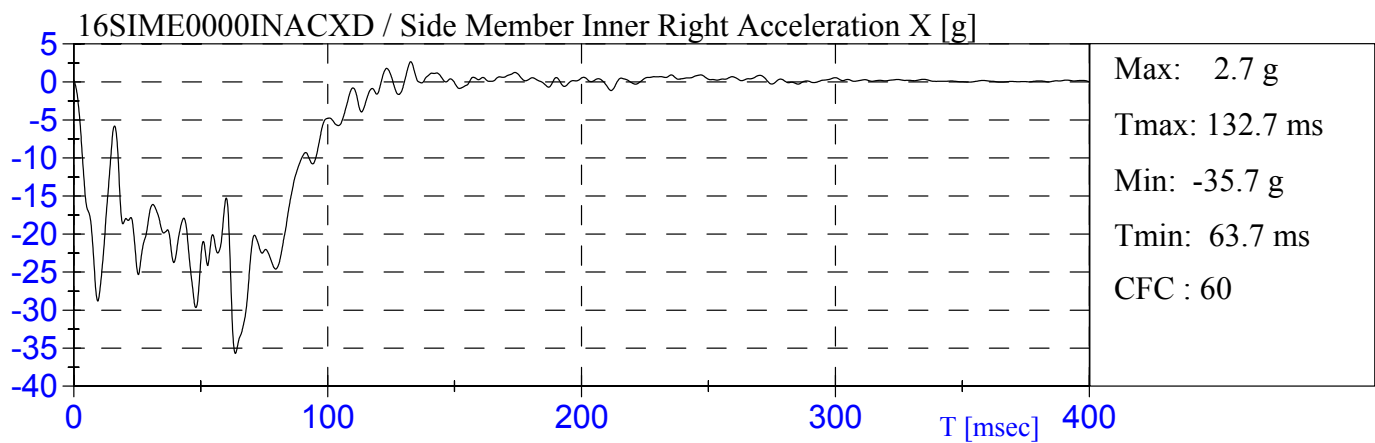
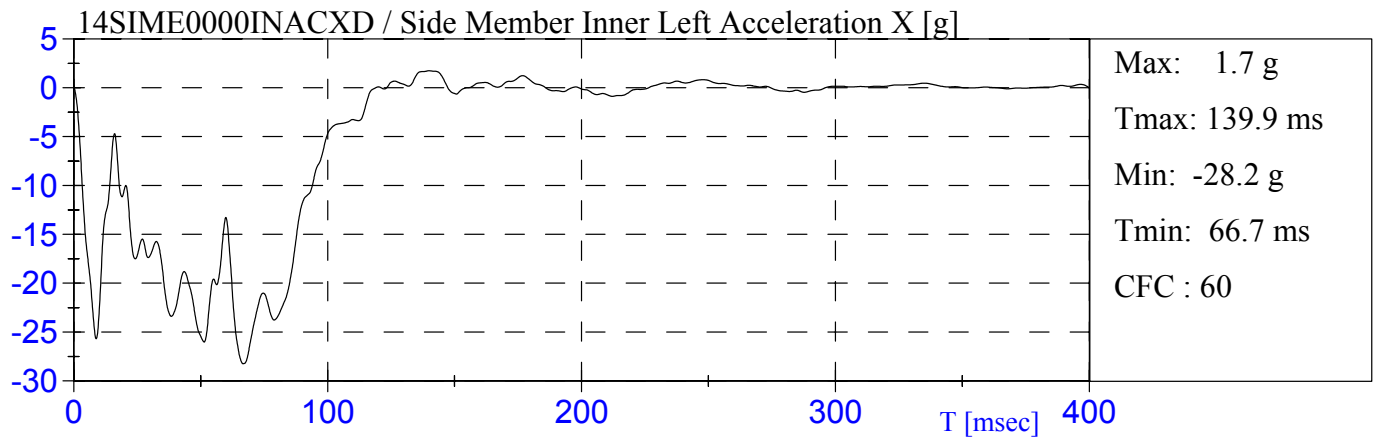

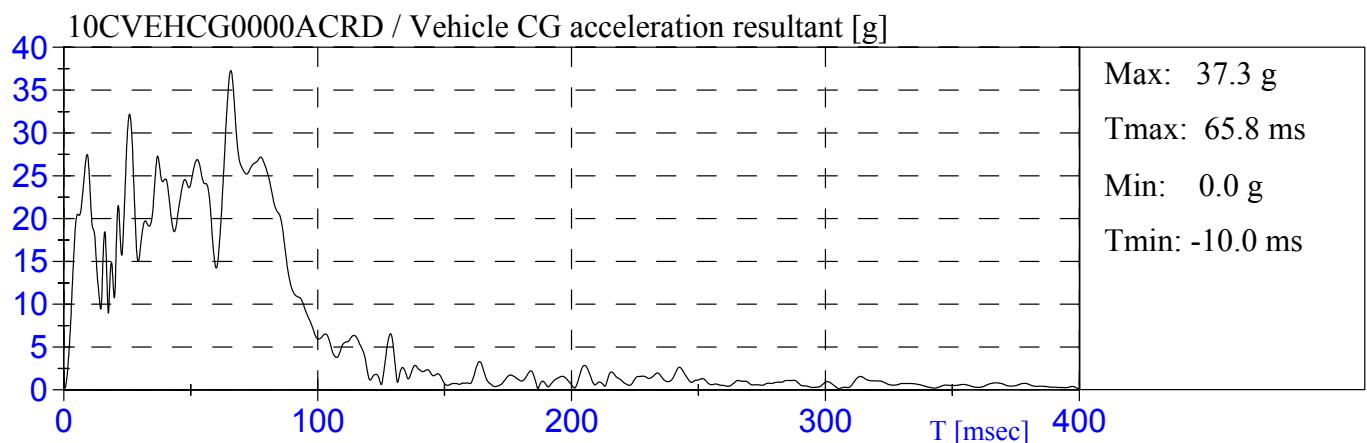
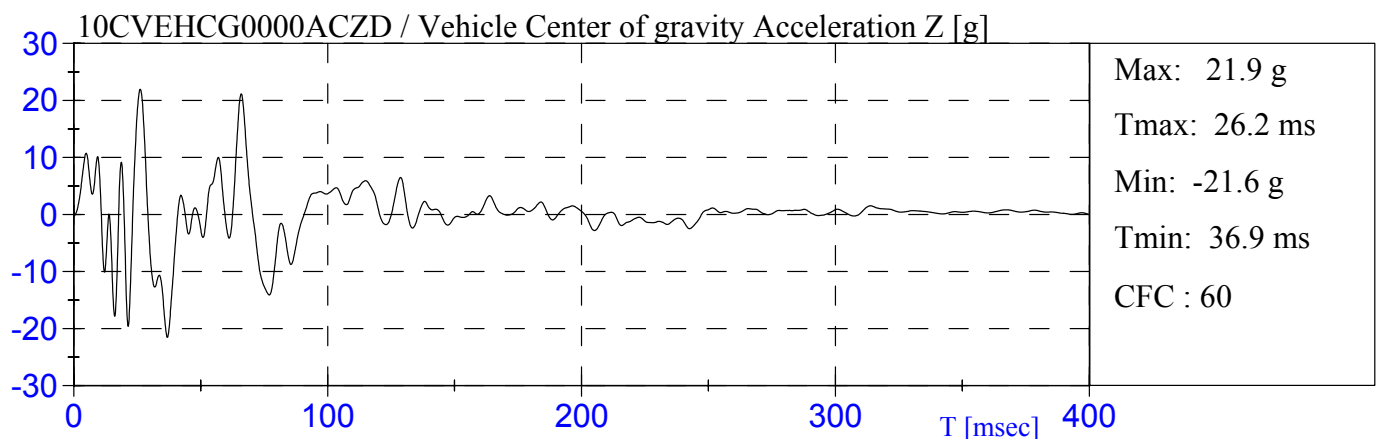
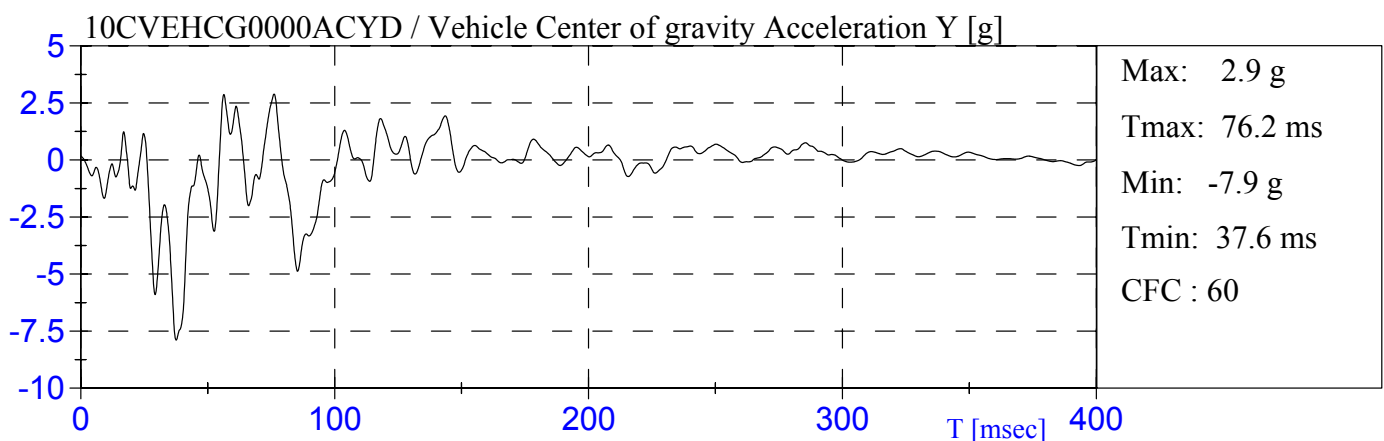
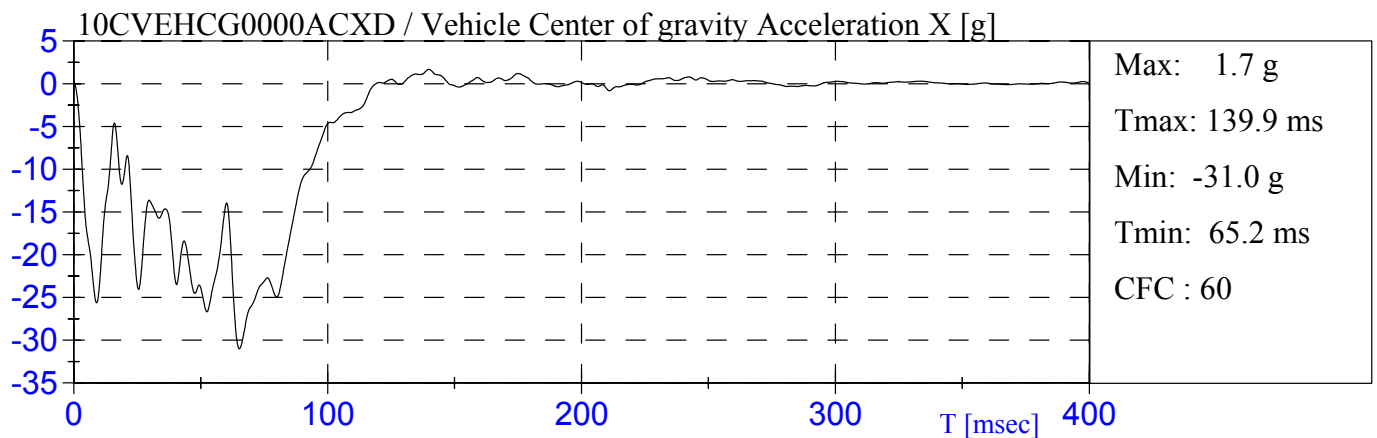

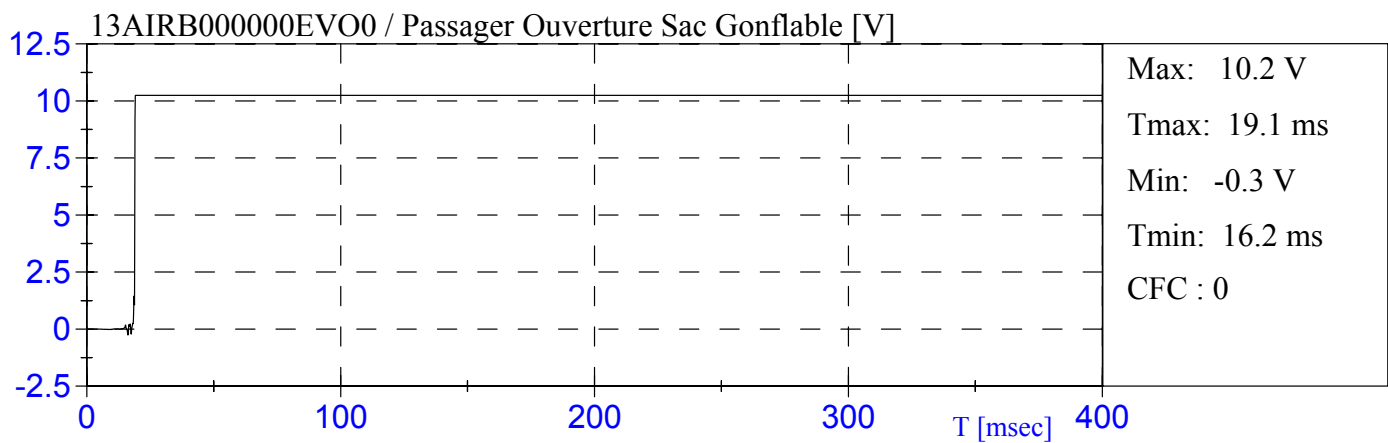
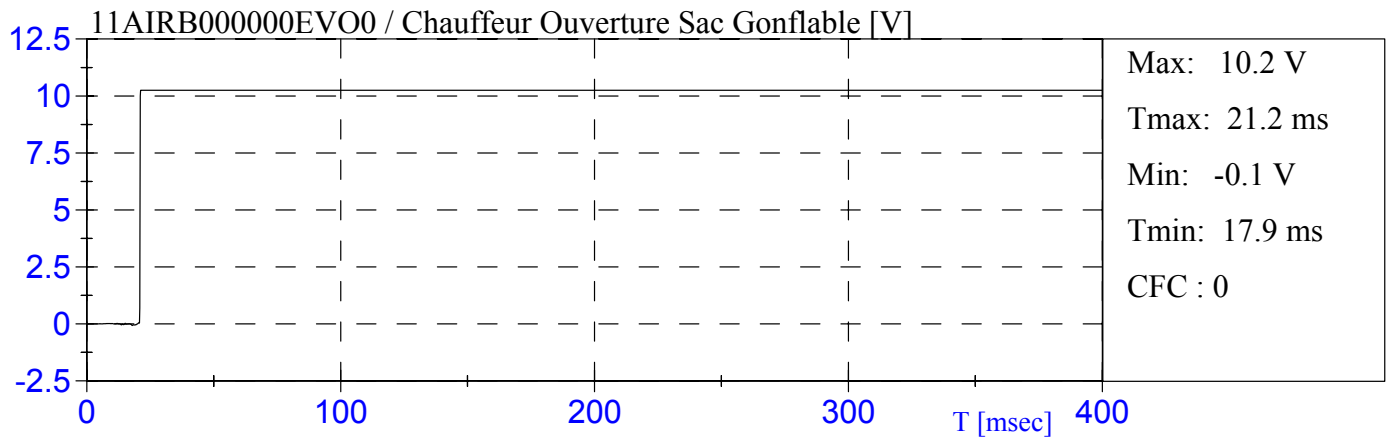

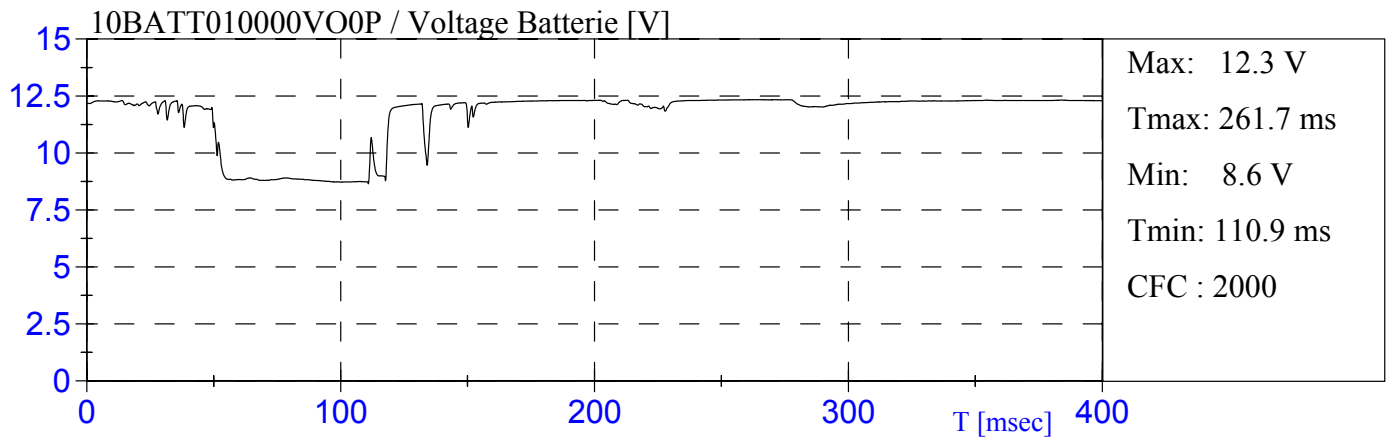

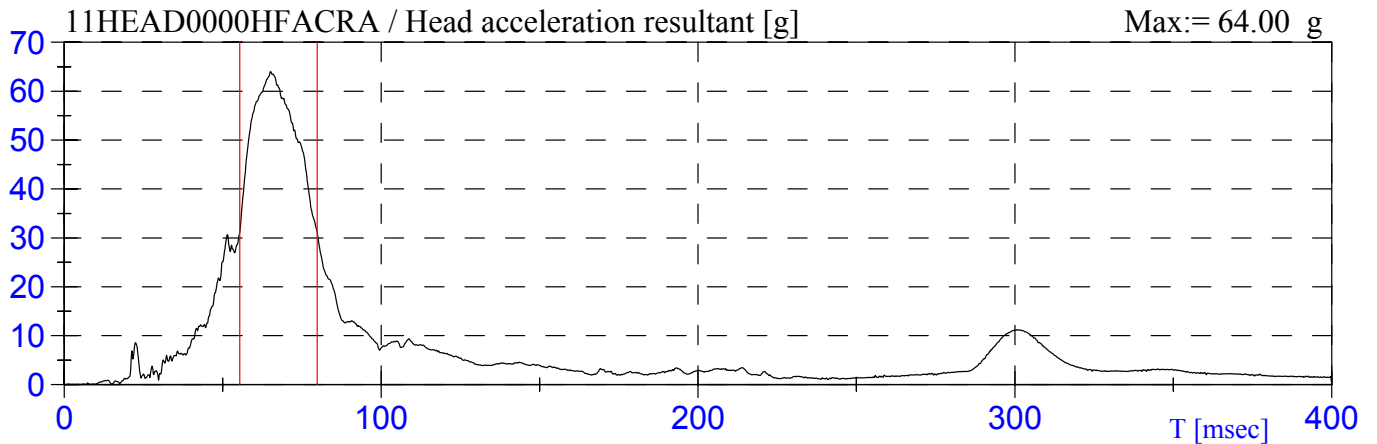

**HEAD INJURY CRITERIA (HIC) \***  
**CRITÈRE DE BLESSURE DE LA TÊTE**

HIC:= 475	HIC(36ms):= 475	HIC(15ms):= 390
T1:= 55.4 ms	T1:= 55.4 ms	T1:= 58.2 ms
T2:= 79.8 ms	T2:= 79.8 ms	T2:= 73.2 ms

\* Selon / According To: SAE J1727 96-08

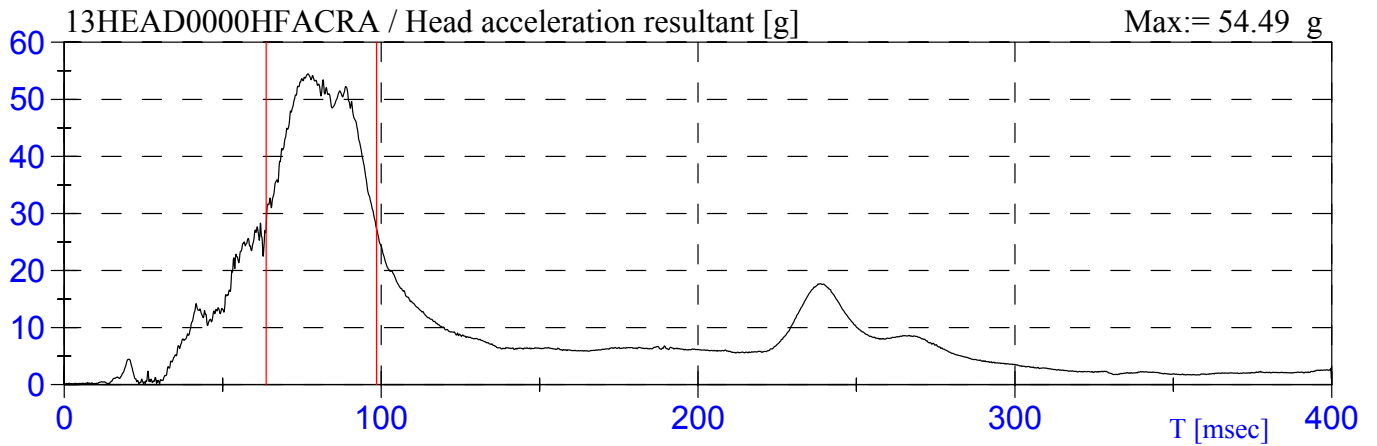

HEAD INJURY CRITERIA (HIC) \*  
CRITÈRE DE BLESSURE DE LA TÊTE

HIC:= 486	HIC(36ms):= 486	HIC(15ms):= 292
T1:= 63.7 ms	T1:= 63.7 ms	T1:= 73.4 ms
T2:= 98.6 ms	T2:= 98.6 ms	T2:= 88.4 ms

\* Selon / According To: SAE J1727 96-08

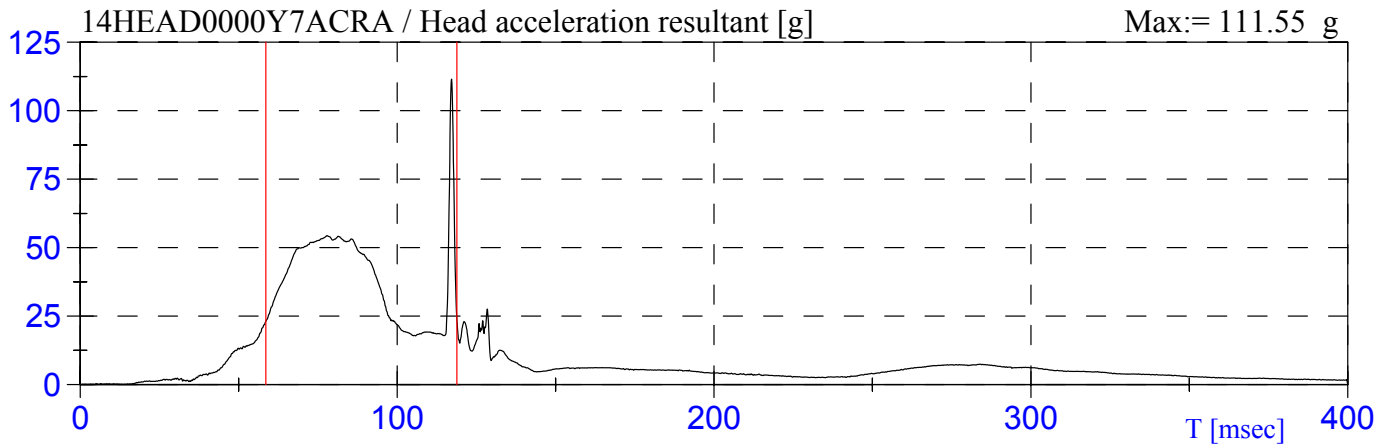

**HEAD INJURY CRITERIA (HIC) \***  
**CRITÈRE DE BLESSURE DE LA TÊTE**

HIC:= 558	HIC(36ms):= 539	HIC(15ms):= 305
T1:= 58.6 ms	T1:= 60.4 ms	T1:= 71.8 ms
T2:= 118.9 ms	T2:= 96.4 ms	T2:= 86.8 ms

\* Selon / According To: SAE J1727 96-08

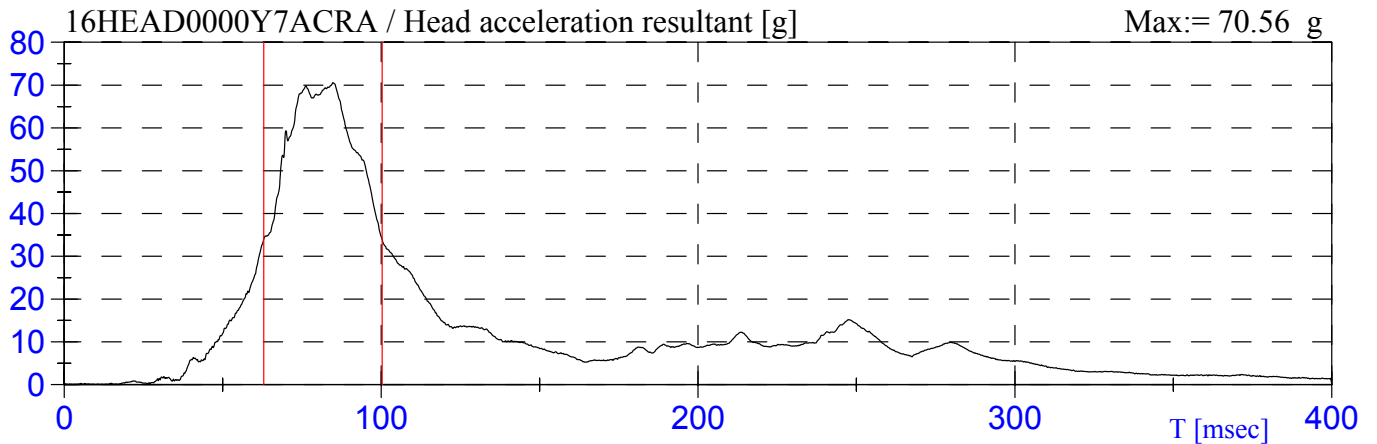

**HEAD INJURY CRITERIA (HIC) \***  
**CRITÈRE DE BLESSURE DE LA TÊTE**

HIC:= 900	HIC(36ms):= 899	HIC(15ms):= 575
T1:= 63.0 ms	T1:= 64.0 ms	T1:= 72.9 ms
T2:= 100.3 ms	T2:= 100.0 ms	T2:= 87.9 ms

\* Selon / According To: SAE J1727 96-08

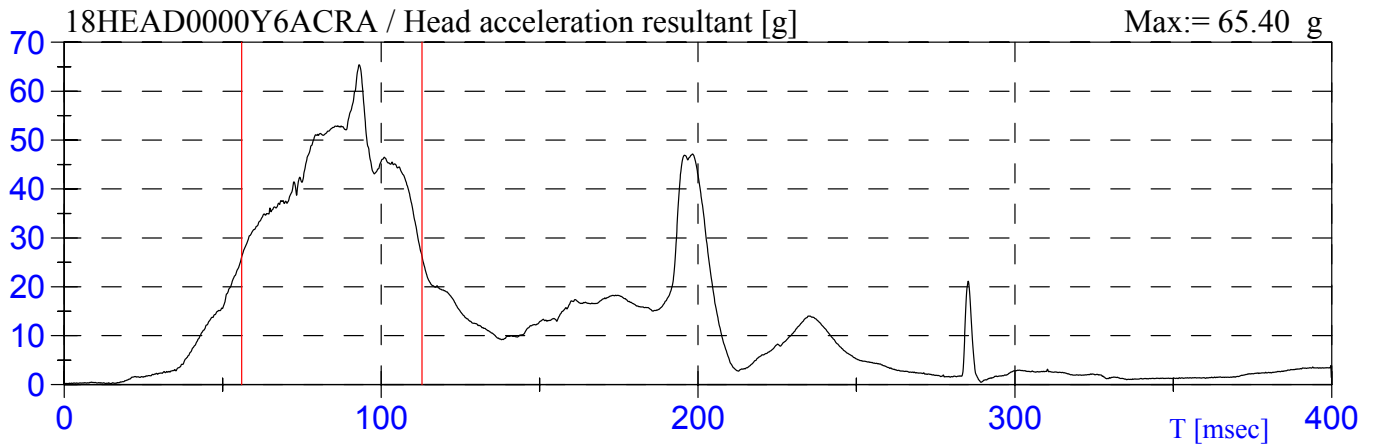

**HEAD INJURY CRITERIA (HIC) \***  
**CRITÈRE DE BLESSURE DE LA TÊTE**

HIC:= 716	HIC(36ms):= 610	HIC(15ms):= 335
T1:= 56.0 ms	T1:= 72.2 ms	T1:= 80.3 ms
T2:= 112.9 ms	T2:= 108.2 ms	T2:= 95.3 ms

\* Selon / According To: SAE J1727 96-08



Neck Injury Criteria: 11NIJCIP000000YX

$$N_{ij}^* = 0.30$$

Valeurs critiques  
Criticals Values

N <sub>tf</sub>	N <sub>te</sub>	N <sub>cf</sub>	N <sub>ce</sub>	Tc	4287
				Cc	3880
0.30	0.30	0.13	0.09	Fc	155
				Ec	67

\* Selon / According To: Federal Register 5/2000



Neck Injury Criteria: 13NIJCIP000000YX

$$N_{ij}^* = 0.46$$

Valeurs critiques  
Criticals Values

N <sub>tf</sub>	N <sub>te</sub>	N <sub>cf</sub>	N <sub>ce</sub>	Tc	4287
				Cc	3880
0.20	0.46	0.06	0.05	Fc	155
				Ec	67

\* Selon / According To: Federal Register 5/2000

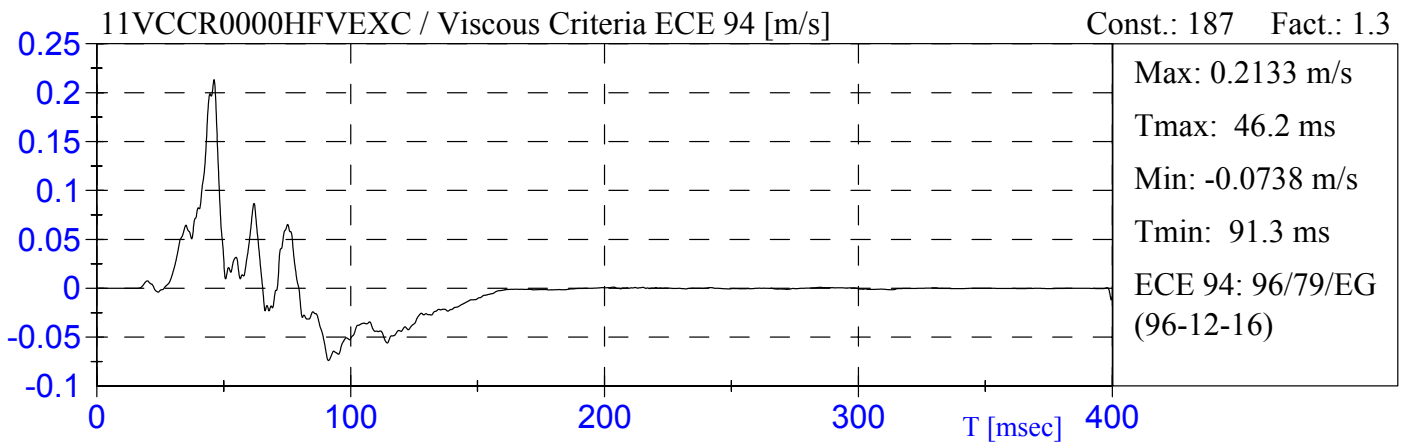
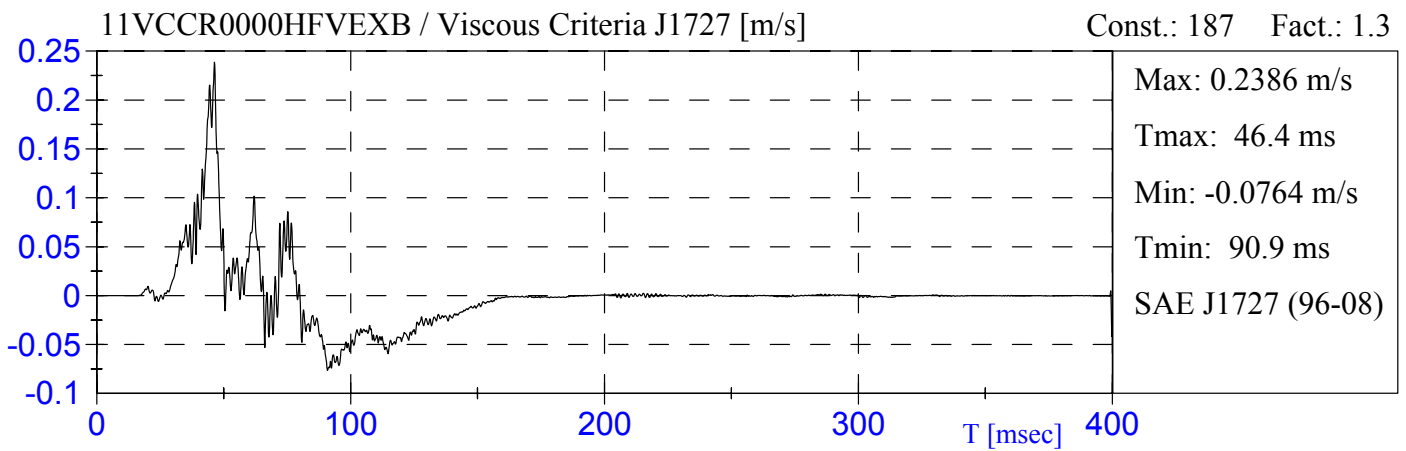
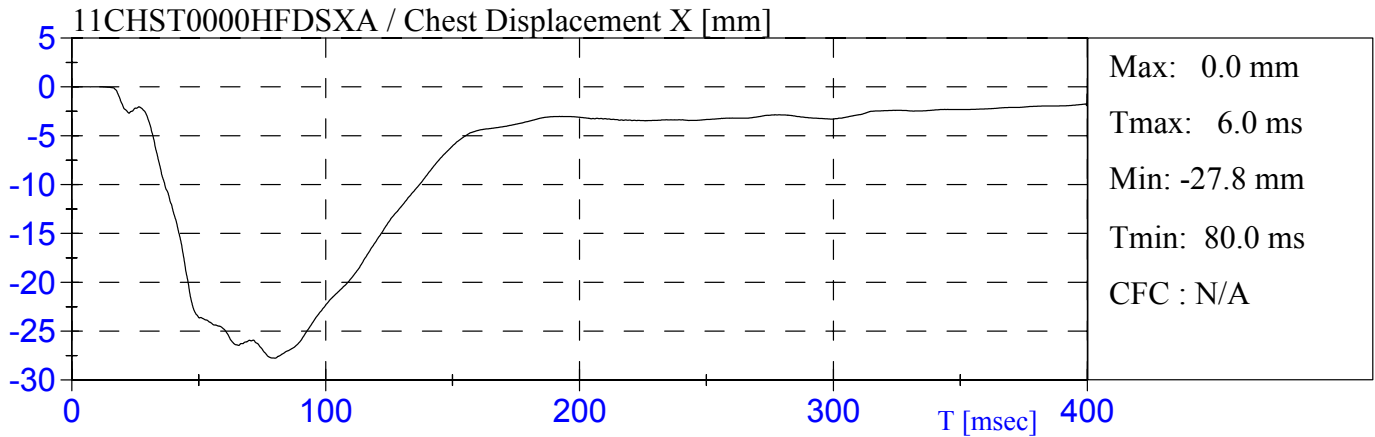

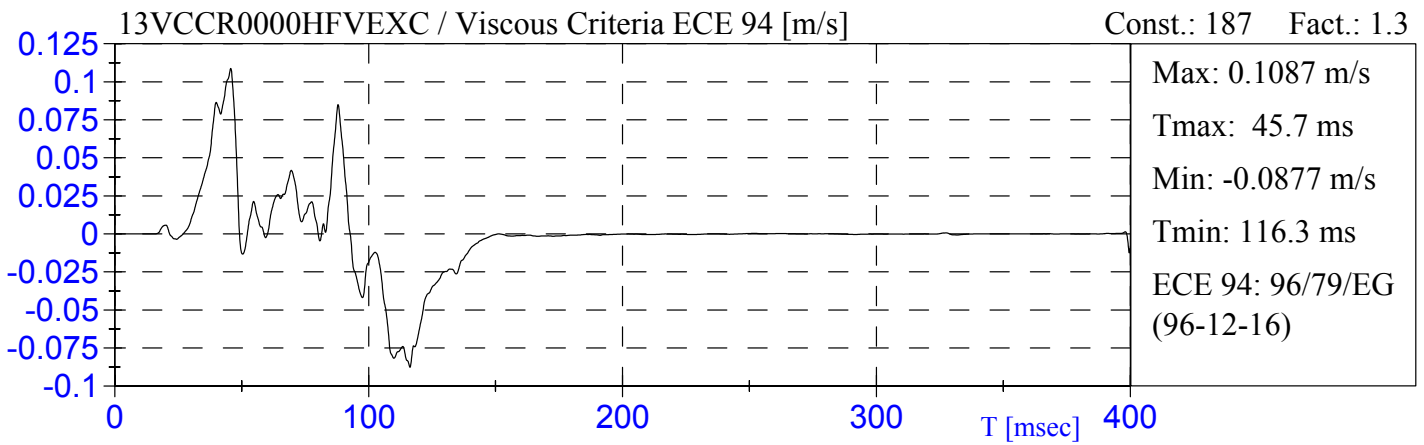
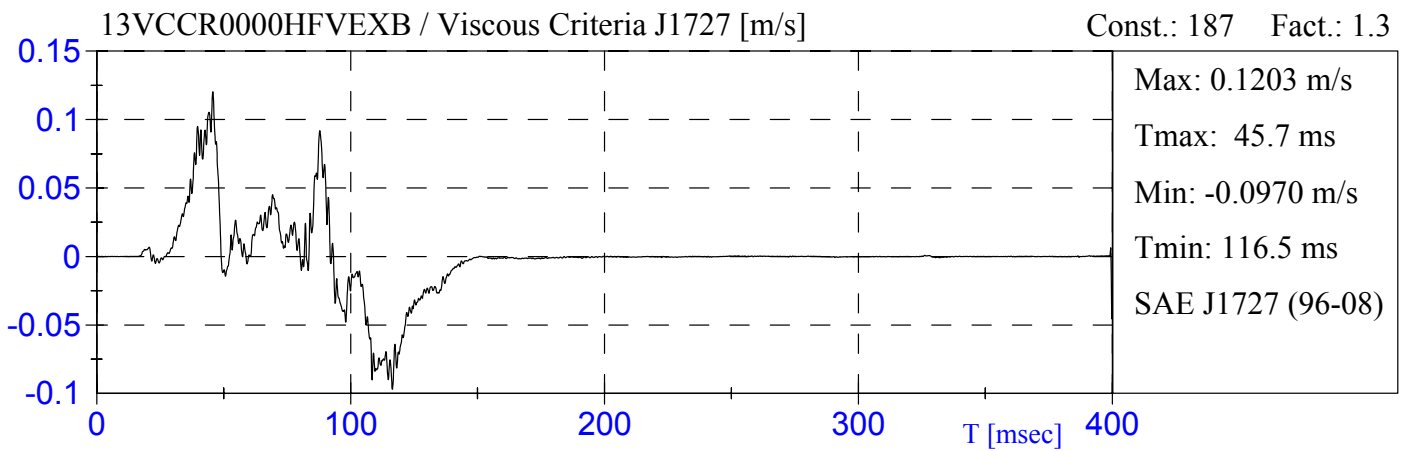
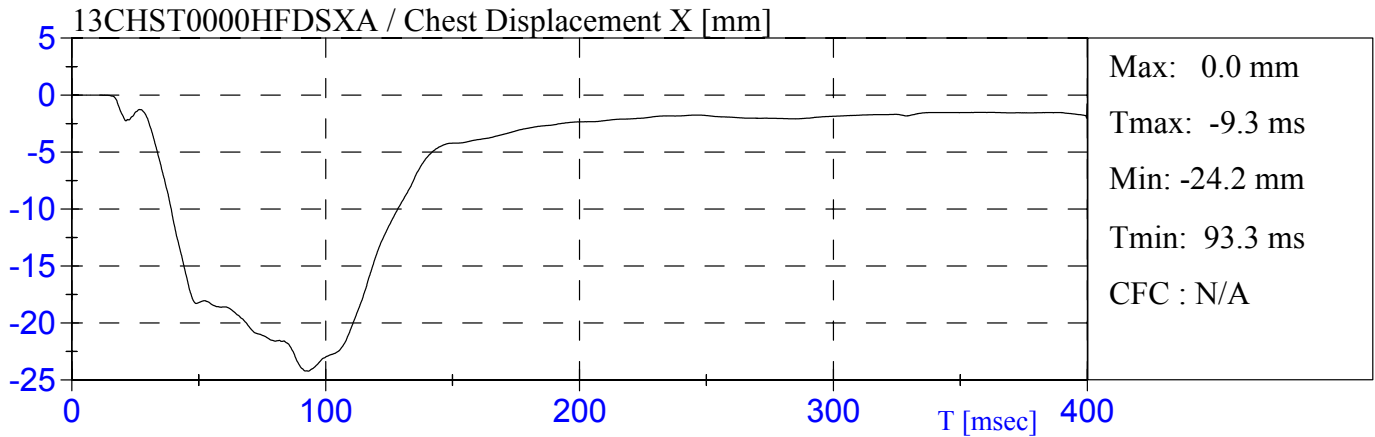

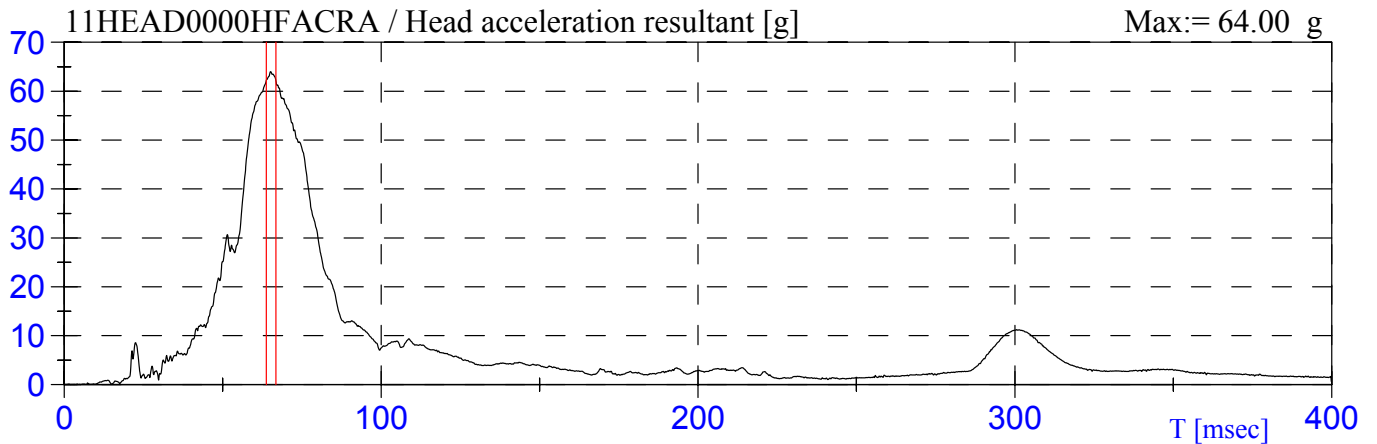

### CLIP 3ms \*

Acc. := 62.21 g	T1:= 63.8 ms	T2:= 66.8 ms
-----------------	--------------	--------------

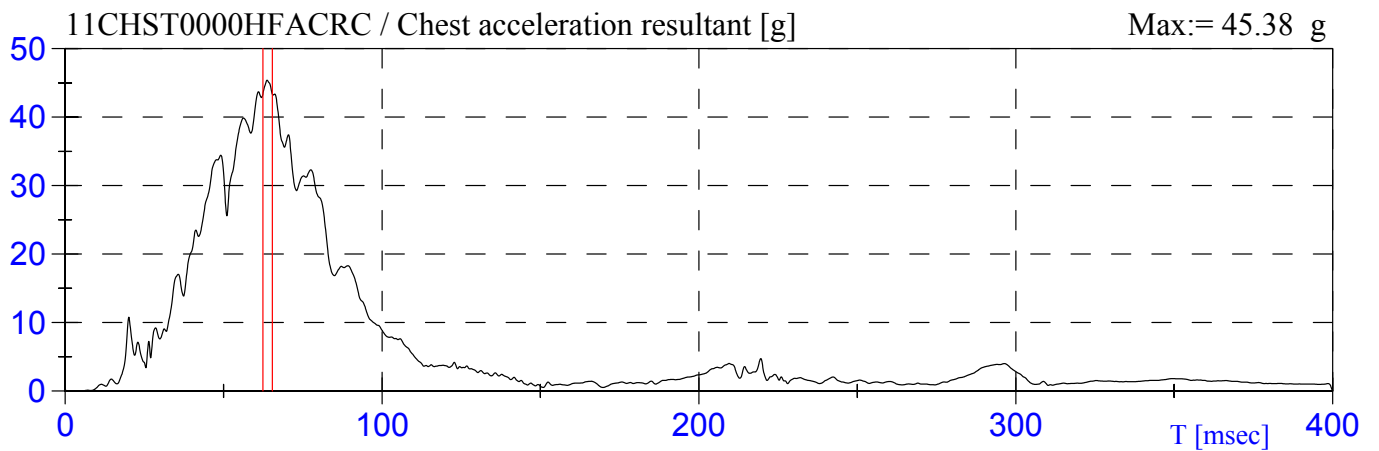

### CLIP 3ms \*

Acc. := 43.34 g	T1:= 62.4 ms	T2:= 65.4 ms
-----------------	--------------	--------------

\* Selon / According To: NHTSA CLIP VERSION 2.1 5/95

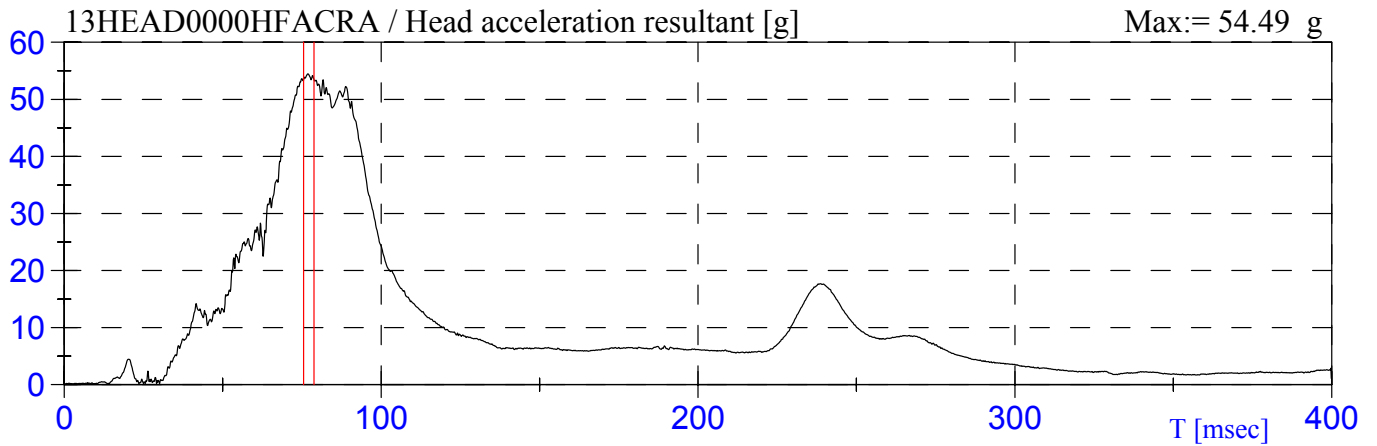

### CLIP 3ms \*

Acc. := 53.43 g	T1:= 75.5 ms	T2:= 78.8 ms
-----------------	--------------	--------------

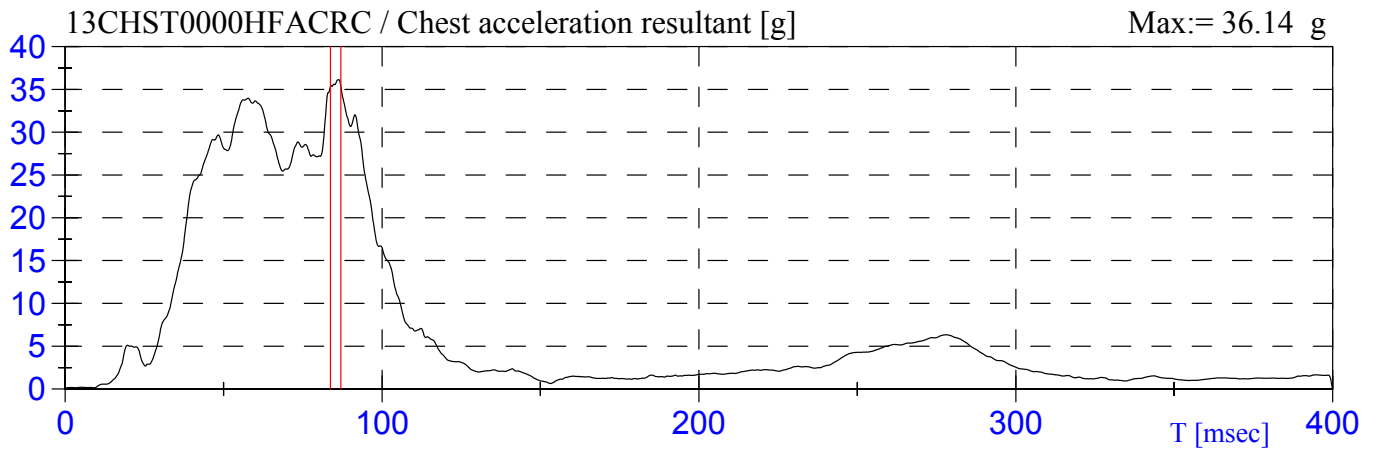

### CLIP 3ms \*

Acc. := 35.36 g	T1:= 83.7 ms	T2:= 87.0 ms
-----------------	--------------	--------------

\* Selon / According To: NHTSA CLIP VERSION 2.1 5/95

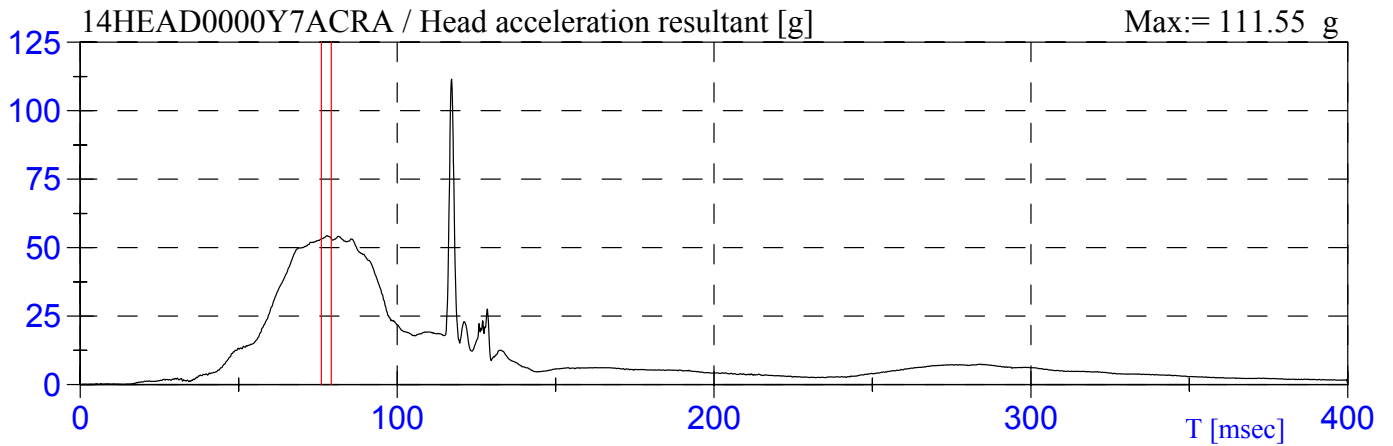

### CLIP 3ms \*

Acc. := 53.30 g	T1:= 76.1 ms	T2:= 79.2 ms
-----------------	--------------	--------------

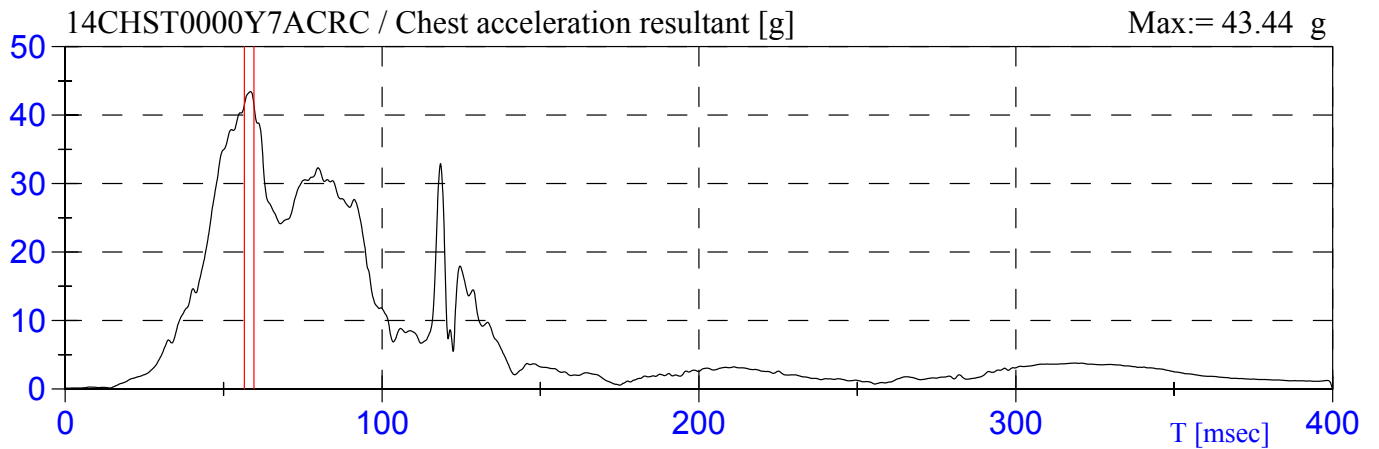

### CLIP 3ms \*

Acc. := 41.56 g	T1:= 56.6 ms	T2:= 59.6 ms
-----------------	--------------	--------------

\* Selon / According To: NHTSA CLIP VERSION 2.1 5/95

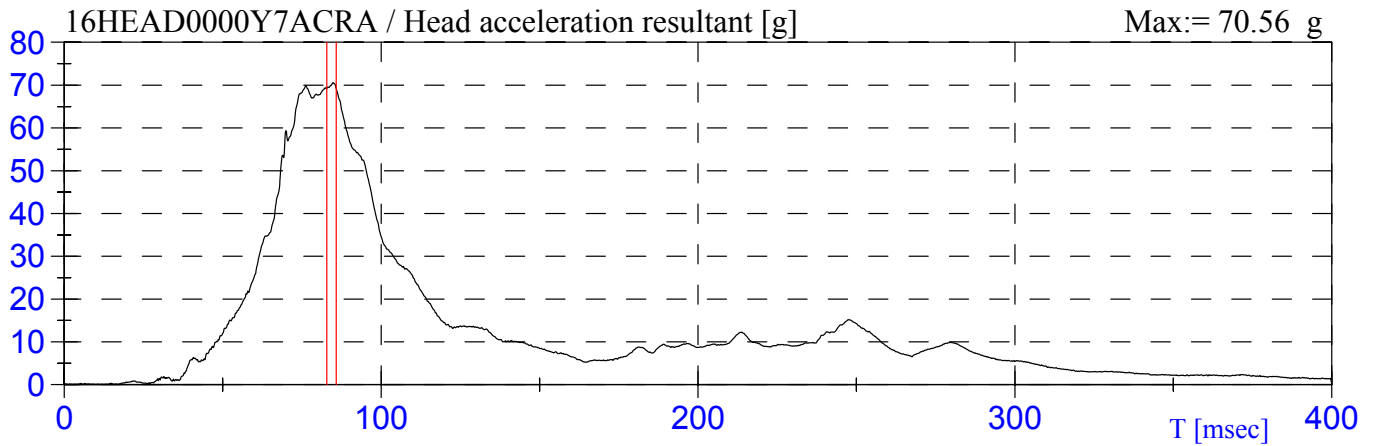

### CLIP 3ms \*

Acc. := 69.21 g	T1:= 82.8 ms	T2:= 85.8 ms
-----------------	--------------	--------------

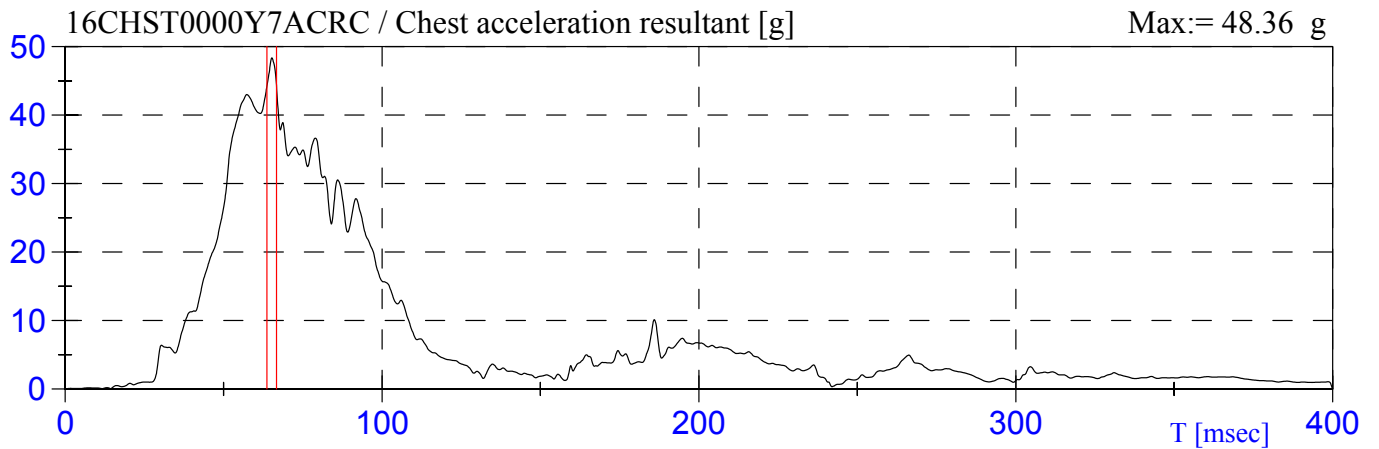

### CLIP 3ms \*

Acc. := 44.27 g	T1:= 63.7 ms	T2:= 66.7 ms
-----------------	--------------	--------------

\* Selon / According To: NHTSA CLIP VERSION 2.1 5/95



## COMMENTAIRES / COMMENTS

14CHST0000Y7DSXB: N'est pas valide.  
Is not valid.

**APPENDICE /APPENDIX C**

**DONNÉES DES TEMPÉRATURES  
TEMPERATURE DATA**

# Temperature TC05-210

