

REPORT NUMBER TR-P25125-01-NC

**NEW CAR ASSESSMENT PROGRAM
SIDE IMPACT TEST**

**HONDA MFG. OF ALABAMA, LLC
2006 HONDA ODYSSEY
5-DOOR MPV**

NHTSA NUMBER: H65302

**Prepared By:
KARCO ENGINEERING, LLC
9270 HOLLY ROAD
ADELANTO, CALIFORNIA 92301**



SEPTEMBER 23, 2005

FINAL REPORT

**PREPARED FOR:
U.S. DEPARTMENT OF TRANSPORTATION
NATIONAL HIGHWAY TRAFFIC SAFETY ADMINISTRATION
OFFICE OF CRASHWORTHINESS STANDARDS
RULEMAKING
MAIL CODE: NVS-111
400 SEVENTH STREET, SW, ROOM 5311
WASHINGTON, D.C. 20590**

This final test report was prepared for the U.S. Department of Transportation, National Highway Traffic Safety Administration, in response to Contract Number DTNH22-03-D-32005.

This publication is distributed by the U.S. Department of Transportation, National Highway Traffic Safety Administration, in the interest of information exchange. The opinions, findings and conclusions expressed in this publication are those of the author(s) and not necessarily those of the Department of Transportation or the National Highway Traffic Safety Administration. The United States Government assumes no liability for its contents or use thereof. If trade or manufacturers' names or products are mentioned it is only because they are considered essential to the object of the publication and should not be construed as an endorsement. The United States Government does not endorse products or manufacturers.

Prepared by: _____
Mr. Matt Ivory, Project Engineer
KARCO Engineering, LLC

Date: September 23, 2005

Reviewed by: _____
Mr. Michael Dunlap, Quality Assurance Manager
KARCO Engineering, LLC

Date: September 23, 2005

Approved by: _____
Mr. Frank D. Richardson, Program Manager
KARCO Engineering, LLC

Date: September 23, 2005

FINAL REPORT ACCEPTED BY:

Manager, Side Impact NCAP

Date of Acceptance

Technical Report Documentation Page

4. Title and Subtitle Final Report of Side Impact New Car Assessment Program Testing of a 2006 Honda Odyssey 5-Door MPV NHTSA No. H65302		5. Report Date September 23, 2005	
7. Authors Mr. Matt Ivory, Project Engineer, Karco Mr. Frank Richardson, Project Manager, Karco		6. Performing Organization Code KAR	
9. Performing Organization Name and Address Karco Engineering, LLC 9270 Holly Rd. Adelanto, CA, 92301		8. Performing Organization Report No. TR-P25125-01-NC	
12. Sponsoring Agency Name and Address U. S. Department of Transportation National Highway Traffic Safety Administration Rulemaking Office of Crashworthiness Standards Mail Code NVS-111 400 Seventh Street, SW, Room 5311 Washington, D.C 20590		10. Work Unit No. 11. Contract or Grant No. DTNH22-03-D-32005	
15. Supplementary Notes 16. Abstract A 55/28 km/h 90 deg. Moving Deformable Barrier Side Impact NCAP Test was conducted on the subject 2006 Honda Odyssey 5-Door MPV in accordance with the specifications of the Office of Crash Worthiness Standards Test Procedures for the generation of consumer information on vehicle side crash protection. The test was conducted at KARCO Engineering,LLC laboratories in Adelanto, California, on September 8, 2005. The impact velocity of the Moving Deformable Barrier was 62.38 km/h, and the outside ambient temperature at the struck (driver's) side of the vehicle was 33.3 deg C. The target vehicle's maximum post-test static crush was 298 mm located at level 3. The test vehicle's occupant performance data is as follows:		13. Type of Report and Period Covered Final Test Report 14. Sponsoring Agency Code DOT/NHTSA/NRM/OCS	
17. Key Words New Car Assessment Program (NCAP) Side Impact Moving Deformable Barrier (MDB) Side Impact Dummy (SID/HIII)		18. Distribution Statement Copies of this report are available from: National Highway Traffic Safety Admin. NHTSA Technical Reference Division 400 Seventh St., SW, Room 5108 Washington, DC 20590	
19. Security Classification of this report UNCLASSIFIED	20. Security Classification of this page UNCLASSIFIED	21. No. of Pages 88	22. Price

Form DOT F1700.7 (8-72)

TABLE OF CONTENTS

Section		Page
1	Purpose and Test Procedure	1
2	Summary of Side Impact Test	2
3	Occupant and Vehicle Information Sheets	4

Data Sheet No.		Page
1	General Test and Vehicle Parameter Data	5
2	Test Vehicle Summary of Results	10
3	Moving Deformable Barrier (MDB) Summary of Results	11
4	Post-Test Observations	12
5	Vehicle Pre-Test and Post-Test Measurements	13
6	SID/HIII Longitudinal Clearance Dimensions	14
7	SID/HIII Lateral Clearance Dimensions	15
8	Vehicle Side Measurements	16
9	Vehicle Exterior Crush Profiles	17
10	Vehicle Damage Profile Distances	19
11	Deformable Barrier Honeycomb Face Static Crush	20
12	Vehicle Accelerometer Locations	21
13	MDB Accelerometer Locations	23
14	High Speed Camera Locations and Data	24
15	FMVSS 301 Fuel System Integrity Post-Impact Data	25
16	FMVSS 301 Static Rollover Data	26

Appendix		
A	Photographs	A
B	SID/HIII, Vehicle and MDB Response Data	B
C	SID/HIII Configuration and Performance Verification Data	C

SECTION 1

PURPOSE AND TEST PROCEDURE

1.1 PURPOSE

This Side Impact NCAP test is conducted as part of the FY' 2006 test program sponsored by the National Highway Traffic Safety Administration (NHTSA), under contract No. DTNH22-03-D-32005. The purpose of this test is to generate comparative side impact data on a 2006 Honda Odyssey 5-Door MPV manufactured by Honda Mfg. of Alabama, LLC.

1.2 TEST PROCEDURE

The side impact test was conducted in accordance with the current National Highway Traffic Safety Administration (NHTSA), Office of Crashworthiness Standards (OCS), laboratory test procedure NCAP Side Impact Testing, dated November 2002. The procedures for receiving, inspection, testing, and reporting of test results are described in the test procedures and are not repeated in this report.

SECTION 2
SUMMARY OF SIDE IMPACT TEST

2.1 SUMMARY OF SIDE IMPACT NCAP TEST

A model year 2006 Honda Odyssey 5-Door MPV was impacted on the left (driver's) side by a Moving Deformable Barrier (MDB) which was moving forward in a 27° crabbed position to the tow road guidance system at a velocity of 62.38 km/h. The specified impact velocity range is from 61.14 to 62.75 km/h. The test (target) vehicle was stationary and positioned 63° to the line of forward motion. The weight of the vehicle as tested was 2267 kg and the test weight of the MDB was 1361 kg. The test was conducted at KARCO Engineering, LLC in Adelanto, California, on September 8, 2005.

Two (2) real-time cameras and ten (10) high-speed cameras were used to document the impact event. Camera locations and pertinent camera information is documented in the data sheets. Pre- and post-test photographs of the vehicle and SID/HIIIs can be found in Appendix A. Two 50th percentile adult male Side Impact Dummies, Hybrid III (SID/HIIIs) were placed in the driver's and left rear passenger designated seating positions according to the test procedure. Each SID/HIII is instrumented with contact switches on the pelvis, thorax and six-axis neck load cells, and fourteen accelerometers in the following locations:

- Left Upper Rib (LUR) uni-axial accelerometer (Y-axis primary and redundant)
- Left Lower Rib (LLR) uni-axial accelerometer (Y-axis primary and redundant)
- Lower Thoracic Spine (T12) uni-axial accelerometer (Y-axis primary and redundant)
- Pelvic (PEV) section uni-axial accelerometer (Y-axis primary and redundant)
- Head Center of Gravity (CG) tri-axial accelerometers (X, Y, and Z axes primary and redundant)

SUPPLEMENTAL RESTRAINT INFORMATION

Restraint Type	Left Front Driver		Left Rear (Passenger)	
	Installed	Deployed	Installed	Deployed
Front Airbag	Yes	No	No	
Side Torso Airbag	Yes	Yes	No	
Head Airbag	No		No	
Curtain Airbag	Yes	Yes	Yes	Yes

SECTION 2...(CONTINUED)

The test vehicle was instrumented with thirteen (13) structural accelerometers and the MDB was instrumented with five (5) accelerometers and one (1) contact switch on the right bumper to compare left side to right side bumper impact timing. All data channels were recorded with the fully self contained on-board Data Acquisition System (DAS). The data was digitally sampled at 10,000 samples per second and processed per Appendix V of the Test Procedure.

2.2 GENERAL COMMENTS

The driver and passenger doors remained closed and latched during impact. The test vehicle sustained a maximum static crush of 298 mm at level 3, 1350 mm rearward of the left vertical impact point. The driver SID/Hybrid III, Serial No. 274 and the passenger SID/Hybrid III, Serial No. 275 were calibrated prior to this test. The SID/Hybrid III injury criteria is summarized as follows:

Measurement	Units	Driver	Passenger
Thoracic Trauma Index (TTI)	G's	44.0	43.0
Peak Pelvic G's (PEV)	G's	39.8	76.9

Additional data plots for this test are available in the research and development section of the NHTSA website. The website can be found at www.NHTSA.dot.gov.

Tests summaries and post-test observations are presented in Section 3. Appendix A contains the still photograph prints. Appendix B contains the driver and passenger SID/HIIIs response data traces. Appendix C contains the SID Configuration and performance verification data.

SECTION 3
OCCUPANT AND VEHICLE INFORMATION SHEETS

Test Vehicle: 2006 Honda Odyssey 5-Door MPV
 Test Program: 55/28 km/h Side Impact NCAP

NHTSA No.: H65302
 Test Date: 9/8/05

CONVERSION FACTORS USED IN THIS REPORT*

Quantity	Typical Application	Std Units	Metric Unit	Multiply By
Mass	Vehicle Weight	lb	kg	0.4536
Linear Velocity	Impact Velocity	mile/h	km/h	1.609
Length or Distance	Measurements	in	mm	25.4
Volume	Fuel Systems	gal	liter	3.785
Volume	Small Fluids	oz	mL	29.573
Pressure	Tire Pressures	lbf/in ²	kPa	7.0
Volume	Liquid	gal	liter	3.785
Temperature	General Use	°F	°C	$=(t_f - 32)/1.8$
Force	Dynamic Forces	lbf	N	4.448
Moment	Torque	lbf/ft	Nm	1.355

* Based on the Recommended Practice in SAE J916, May 85

DATA SHEET NO. 1

GENERAL TEST AND VEHICLE PARAMETER DATA

Test Vehicle: 2006 Honda Odyssey 5-Door MPV

NHTSA No.: H65302

Test Program: 55/28 km/h Side Impact NCAP

Test Date: 9/8/05

TEST VEHICLE INFORMATION AND OPTIONS

NHTSA No.	H65302
Make	Honda
Model	Odyssey
Body Style	5-Door MPV
Vin No.	5FNRL38416B001692
Color	Blue
Delivery Date	8/31/2005
Odometer	79.0
Dealer	Valley-Hi Honda
Transmission	4-Speed Automatic
Final Drive	Front
Type/No. Cyl.	V-6
Engine Disp. (L)	3.5
Engine Placement	Transverse
Roof Rack	No
Sunroof/T-Top	No
Tinted Glass	No
Traction Control	No
Power Brakes	Yes
Front Disc	Yes
Rear Disc	No

Anti-Lock Brakes	No
All Wheel Drive	No
Power Steering	Yes
Driver Front Airbag	Yes
Driver Side Torso Airbag	Yes
Driver Side Head Airbag	No
Driver Curtain/Airbag	Yes
Rear Pass. Airbag	No
Rear Pass. Side Airbag	No
Rear Pass. Head Airbag	No
Rear Pass. Curtain/Airbag	Yes
Pre-Tensioners	Yes
Load Limiters	Yes
Bucket Seats	Yes
Air Cond.	Yes
AM/FM Cassette	Yes
Tilt Steering	Yes
Automatic Door Locks	Yes
Power Windows	No
Power Seats	No
Other	No

Does Owners Manual provide instructions to turn off automatic door locks.

Yes

DATA FROM CERTIFICATION LABEL

Manufactured By	Honda Mfg. Of Alabama, LLC
Date of Manufacture	08/05

GVWR (kg)	2700
GAWR Front (kg)	1285
GAWR Rear (kg)	1450

VEHICLE SEATING AND CAPACITY WEIGHT INFORMATION

Measured Parameter	Front	Rear	Third	Total
Type of Seats	Bucket	Bucket	Bench	
Number of Occupants	2	3	3	8
Capacity Weight (VCW) (kg)				630
Cargo Weight (RCLW) (kg)				85

DATA SHEET NO. 1...(CONTINUED)

GENERAL TEST AND VEHICLE PARAMETER DATA

Test Vehicle: 2006 Honda Odyssey 5-Door MPV

NHTSA No.: H65302

Test Program: 55/28 km/h Side Impact NCAP

Test Date: 9/8/05

TIRE INFORMATION

Measured Parameter	Front	Rear
Max. Tire Pressure (kpa)	230	240
Cold Pressure (kpa)	230	240
Recommended Tire Size	235/65R16	235/65R16
Tire Size on Vehicle	235/65R16	235/65R16
Tire Manufacturer	Michelin	Michelin
Treadwear	500	500
Traction	A	A
Temperature Grades	B	B
Tire Plies Sidewall	2 Polyester	2 Polyester
Tire Plies Body	2-Polyester,2 Polymaide,2 Steel	2-Polyester,2 Polymaide,2 Steel
Load Index/Speed Symbol	103T	103T
Tire Material	Polyester, Polymaide, Steel	Polyester, Polymaide, Steel
DOT Safety Code Right	AP46-CPXX-3105	AP46-CPXX-3105
DOT Safety Code Left	AP46-CPXX-3005	AP46-CPXX-3005

Collect year, make, model, VIN, items circled in red, and tire manufacturer and tire name.

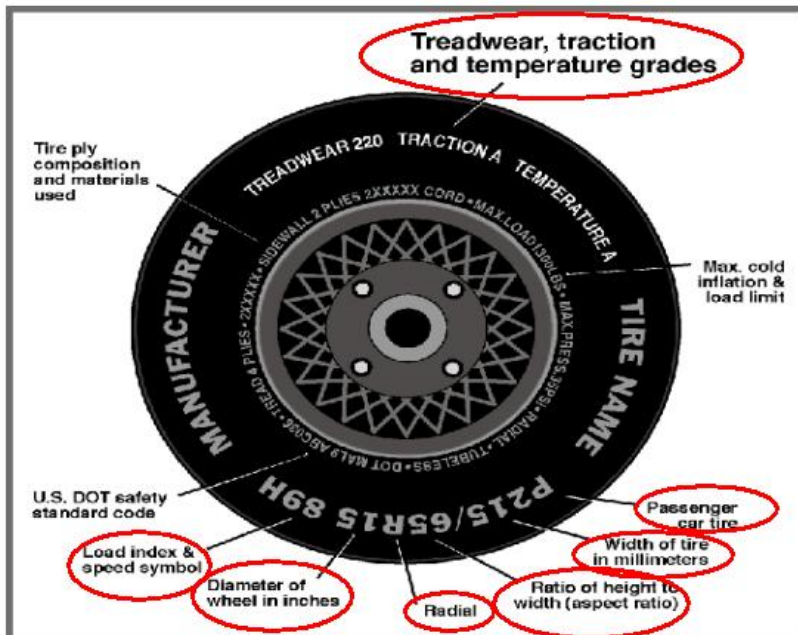

DATA SHEET NO. 1...(CONTINUED)

GENERAL TEST AND VEHICLE PARAMETER DATA

Test Vehicle: 2006 Honda Odyssey 5-Door MPV

NHTSA No.: H65302

Test Program: 55/28 km/h Side Impact NCAP

Test Date: 9/8/05

TEST VEHICLE WEIGHTS

	Units	As Delivered Weights (UVW)			As Tested Weights (ATW)		
		Front Axle	Rear Axle	Total	Front Axle	Rear Axle	Total
Left	kg	568	465		640	541	
Right	kg	551	445		590	496	
Ratio	%	55.1	44.9		54.3	45.7	
Totals	kg	1119	910	2029	1230	1037	2267

TARGET TEST WEIGHT CALCULATION

Measured Parameter	Units	Value
Total Delivered Weight (UVW)	kg	2029
Weight of 2 P572 ATD's	kg	161
Rated Cargo/Luggage Wt. (RCLW)	kg	85
Calculated Vehicle Target Wt. (TVTWT)	kg	2275

TEST VEHICLE ATTITUDE AND CG

	Units	LF	RF	LR	RR	CG (aft of front axle)
As Delivered	mm	744	745	744	754	1347
As Tested	mm	732	743	726	737	1373
Fully Loaded	mm	732	743	712	732	

GENERAL TEST VEHICLE DATA

Measurement Description	Units	Value
Test Vehicle Wheel Base	mm	3002
Total Vehicle Length at Left Side	mm	3558
Total Vehicle Length at Centerline	mm	5108
Total Vehicle Length at Right Side	mm	3558
Weight of Ballast In Cargo Area	kg	16
Amount of Stoddard Solvent in Fuel Tank	liters	73.9

TEST VEHICLE VERTICAL IMPACT LINE DATA

Measurement Description	Units	Value
Test Vehicle Wheel Base	mm	3002
Target Impact Point Aft of Front Axle	mm	1656
Actual Impact Point Aft of Front Axle	mm	1656

DATA SHEET NO. 1...(CONTINUED)

GENERAL TEST AND VEHICLE PARAMETER DATA

Test Vehicle: 2006 Honda Odyssey 5-Door MPV
 Test Program: 55/28 km/h Side Impact NCAP

NHTSA No.: H65302
 Test Date: 9/8/05

NOMINAL DESIGN RIDING POSITION

The driver and passenger seat backs are positioned to the manufacturer's designated angle. The procedure is as follows: Seat back angle was measured at the headrest using a digital inclinometer.

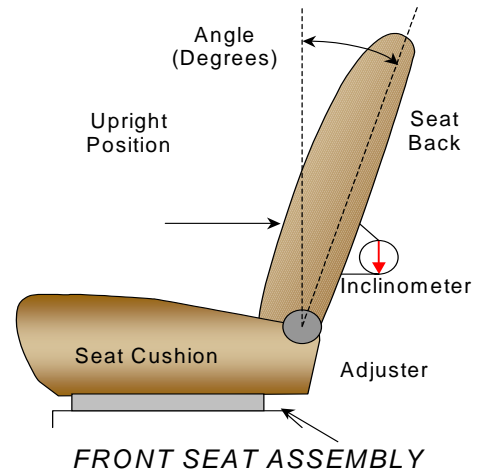

SEAT BACK ANGLES

	Deg.
Driver Seat Back Angle	15.5
Rear Seat Back Angle	20.0

SEAT FORE/AFT POSITIONS

The total seat travel was measured from forward most position to rearmost position, irrespective of vertical seat height in those positions. The seat was set at the longitudinal mid position with vertical adjustment at the lowest position obtainable for both the driver and passenger.

SEAT FORE/AFT POSITIONING

	Total Fore/Aft Travel	Placed in Position #
Driver Seat	230mm	115mm
Rear Seat	17	9

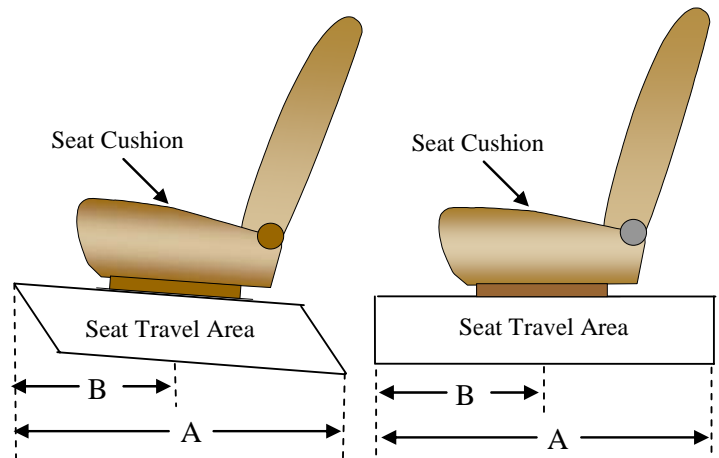

SEAT BELT UPPER ANCHORAGE

Position number one (1) is the uppermost position

SEAT BELT UPPER ANCHORAGE

	Total # of Positions	Placed in Position #
Driver Seat	4	2
Rear Seat	4	2

DATA SHEET NO. 1...(CONTINUED)

GENERAL TEST AND VEHICLE PARAMETER DATA

Test Vehicle: 2006 Honda Odyssey 5-Door MPV
 Test Program: 55/28 km/h Side Impact NCAP

NHTSA No.: H65302
 Test Date: 9/8/05

FUEL TANK CAPACITY

	Liters
Usable Capacity of "Standard Tank"	79.5
Usable Capacity of "Optional" Tank	
Usable Capacity used for FMVSS 301	73.1 to 74.7
Actual Amount of Solvent used	73.9

The test vehicle is equipped with an electric fuel pump. The fuel pump will operate for approximately three (3) seconds with the ignition in the "ON" position, after which the fuel pump automatically shuts off. The fuel filler door is located on the left rear fender.

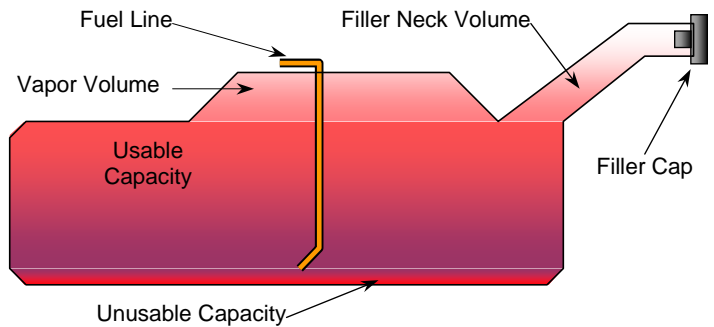

VEHICLE FUEL TANK ASSEMBLY

STEERING COLUMN ADJUSTMENT

Steering wheel and column adjustments are made so that the steering wheel hub is at the geometric center of the locus it describes when moved through its full range of motion. An aluminum plate is placed across the rim of the steering wheel, an inclinometer is placed on the plate and the angle is measured.

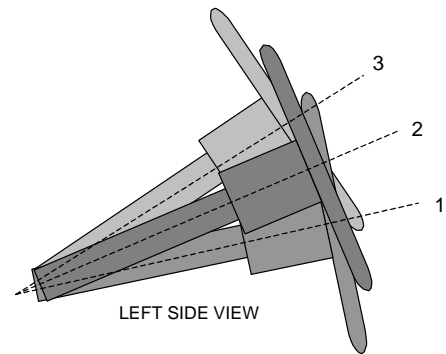

STEERING COLUMN ASSEMBLY

STEERING COLUMN POSITIONS

	Degrees	Fore/Aft Position (mm)
Lowermost position No. 1	23.4	
Geometric center position No. 2	26.5	
Uppermost position No. 3	29.5	

DATA SHEET NO. 2**TEST VEHICLE SUMMARY OF RESULTS**Test Vehicle: 2006 Honda Odyssey 5-Door MPVNHTSA No.: H65302Test Program: 55/28 km/h Side Impact NCAPTest Date: 9/8/05**TEST VEHICLE WEIGHTS**

	Units	As Delivered Weights (UVW)			As Tested Weights (ATW)		
		Front Axle	Rear Axle	Total	Front Axle	Rear Axle	Total
Left	kg	568	465		640	541	
Right	kg	551	445		590	496	
Ratio	%	55.1	44.9		54.3	45.7	
Totals	kg	1119	910	2029	1230	1037	2267

MAXIMUM EXTERIOR STATIC CRUSH

Level	Measured Parameter	Units	Maximum Crush	Above Ground
Level 1	Sill Top Height	mm	42	222
Level 2	Occupant H-Point	mm	275	726
Level 3	Mid Door	mm	298	659
Level 4	Window Sill	mm	178	1019
Level 5	Window top	mm	76	1642
N/A	Maximum Penetration	mm	298	

INSTRUMENTATION

Driver SID/Hybrid III Accelerometers	20
Passenger SID/Hybrid III Accelerometers	20
Vehicle Structure Accelerometers	26
MDB Accelerometers	5
Total No. of Contact Switches	5
Total	76

CAMERA COVERAGE

High Speed, Vehicle On-Board	3
High Speed, Off-Board	5
High Speed, MDB On-Board	2
Real Time, Panning	2
Total	12

DATA SHEET NO. 3

MOVING DEFORMABLE BARRIER (MDB) SUMMARY OF RESULTS

Test Vehicle: 2006 Honda Odyssey 5-Door MPV

NHTSA No.: H65302

Test Program: 55/28 km/h Side Impact NCAP

Test Date: 9/8/05

MDB SPECIFICATIONS (mm)

Measurement Description	Length
Overall Width of Framework Carriage	1252
Overall Length including Honeycomb Face	4115
Wheel Base of Framework Carriage	2590
C.G. location aft of Front Axle	1127

MDB WEIGHTS

	Units	Front Axle	Rear Axle	Total
Left	kg	384	308	
Right	kg	385	284	
Ratio	%	56.5	43.5	
Totals	kg	769	592	1361

SPEED AND IMPACT DATA

Measured Parameter	Units	Requirement	Value
Trap No. 1 Velocity (Primary)	km/h	61.1 to 62.7	62.38
Trap No. 2 Velocity (Redundant)	km/h	61.1 to 62.7	62.40
MDB CL to Target Vehicle CL	degrees	88.5 to 91.5	89.5

MAXIMUM STATIC CRUSH OF HONEYCOMB FACE (mm)

Vertical Location			From Centerline		Max. Crush
Row	Description	Height	Distance	Direction	
A	Center of Bumper	432	800	Right	240
B	Top of Bumper	533	800	Left	128
C	Mid Level	686	800	Right	96
D	Top of Stack	813	800	Right	126

MDB INSTRUMENTATION AND CAMERAS

Accelerometers	5
Contact Switches	1
High Speed Cameras	2

DATA SHEET NO. 4

POST-TEST OBSERVATIONS

Test Vehicle: 2006 Honda Odyssey 5-Door MPV

NHTSA No.: H65302

Test Program: 55/28 km/h Side Impact NCAP

Test Date: 9/8/05

TEST DUMMY INFORMATION AND CONTACT POINTS

Description	Front Seat SID/Hybrid III	Rear Seat SID/Hybrid III
Dummy Type / Serial No.	P572F, SID/NO. 274	P572F, SID/NO. 275
Head Contact	Curtain Airbag	Curtain Airbag
Upper Torso Contact	Side Airbag	Curtain Airbag/Door Panel
Lower Torso Contact	Side Airbag/Door Panel	Door Panel
Left Knee Contact	None	Door Panel
Right Knee Contact	None	None

POST-TEST DOOR OPENING AND SEAT TRACK INFORMATION

Description	Front	Rear
Left Side Door Opening	Door remained closed and latched, jammed	Door remained closed and latched, jammed
Right Side Door Opening	Remained closed and latched, operational	Remained closed and latched, operational
Seat Movement (mm)	None	None
Seat Back Failure	None	None

POST-TEST STRUCTURAL OBSERVATIONS

Critical Areas of Performance	Observations and Conclusions
Pillar Performance	No separation
Sill Separation	None
Windshield Damage	None
Window Damage	Driver and passenger front windows broken
Other Notable Effects	None

SUPPLEMENTAL RESTRAINT SYSTEM INFORMATION

Restraint Type	Left Front (Driver) Occupant Location 01		Left Rear (Passenger) Occupant Location 04	
	Installed	Operation	Installed	Operation
Front Airbag	Yes	No	No	
Side Torso Airbag	Yes	Yes	No	
Head Airbag	No		No	
Curtain Airbag	Yes	Yes	Yes	
Seat Belt Pretensioner	Yes			
Seat Belt Load Limiter	Yes			

MDB LEFT EDGE IMPACT POINT DATA

Measured Parameter	Units	Requirement	Value
Horizontal Offset	mm	+/- 50	-15(left)
Vertical Offset	mm	+/- 20	0

DATA SHEET NO. 5

VEHICLE PRE-TEST AND POST-TEST MEASUREMENTS

Test Vehicle: 2006 Honda Odyssey 5-Door MPV

NHTSA No.: H65302

Test Program: 55/28 km/h Side Impact NCAP

Test Date: 9/8/05

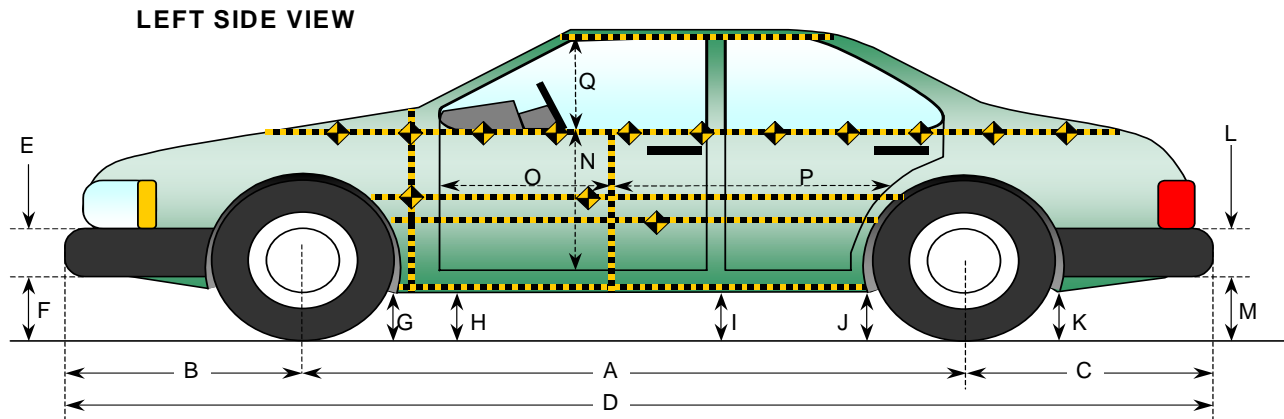

VEHICLE PRE AND POST TEST MEASUREMENT INFORMATION

Code	Measurement Description	Pre-Test	Post-Test	Difference
A	Wheelbase	3002	3000	-2
B	Front Axle to FSOV	928	920	-8
C	Rear Axle to RSOV	1170	1150	-20
D	Total Length at Centerline	5108	5101	-7
E	Front Bumper Thickness	460	460	0
F	Front Bumper Bottom to Ground	170	200	30
G	Sill Height at Front Wheel Well	173	193	20
H	Sill Height at Front Door Leading Edge	175	201	26
I	Sill Height at "B" Pillar	190	238	48
J1	Sill Height at Rear Wheel Well	184	204	20
J2	Pinch Weld Height at Rear Wheel Well	189	243	54
K	Sill Height aft of Rear Wheel Well	266	290	24
L	Rear Bumper Thickness	240	240	0
M	Rear Bumper Bottom to Ground	336	361	25
N	Sill Height to Window Bottom Sill	828	726	-102
O	Front Door Leading Edge to Impact CL	887	790	-97
P	Rear Door Trailing Edge to Impact CL	1255	1183	-72
Q	Front Window Opening	535	508	-27
R	Right Side Length	3558	3560	2
S	Left Side Length	3558	3545	-13
T	Vehicle Width at "B" Post	1950	1780	-170

DATA SHEET NO. 6

SID/HIII LONGITUDINAL CLEARANCE DIMENSIONS

Test Vehicle: 2006 Honda Odyssey 5-Door MPV

NHTSA No.: H65302

Test Program: 55/28 km/h Side Impact NCAP

Test Date: 9/8/05

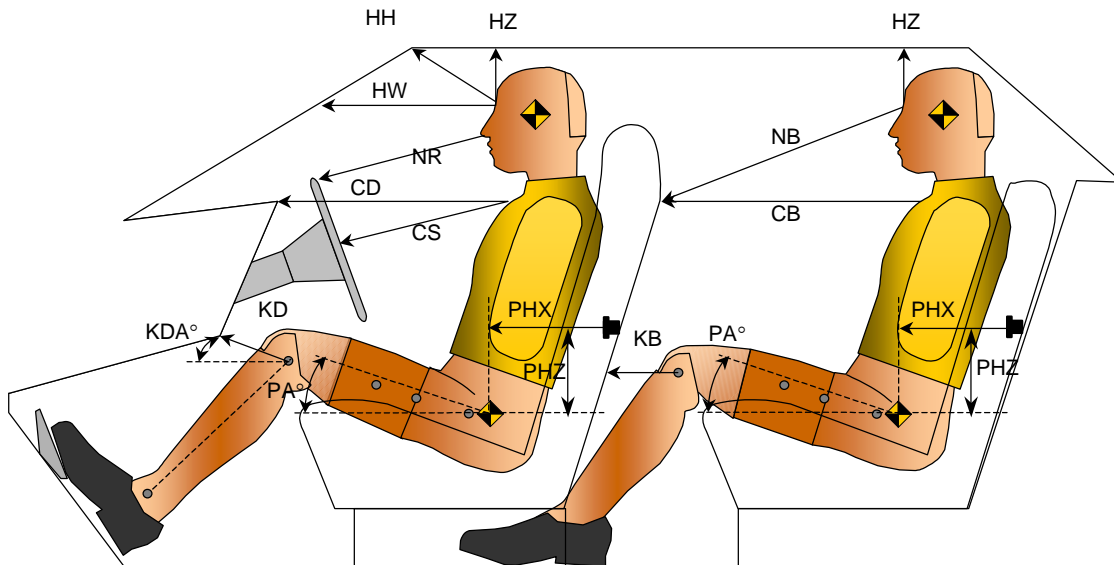

LONGITUDINAL CLEARANCE DIMENSION INFORMATION

Driver Code	Pass. Code	Measurement Description	Driver		Passenger	
			Length(mm)	Angle	Length(mm)	Angle
HH		Head to Header	450	14.9		
HW		Head to Windshield	685			
HZ	HZ	Head to Roof	222	90.0	232	90.0
NR	NB	Nose to Rim/Nose to Seat Back	495	15.5	610	20.0
CD	CB	Chest to Dash or Seat Back	610		575	
CS		Chest to Steering Wheel	320			
KDL	KBL	Left Knee to Dash or Seat Back	130	31.0	240	
KDR	KBR	Right Knee to Dash or Seat Back	130		240	
PA	PA	Pelvic Angle		23.0		23.0
PHX	PHX	H-Point to Striker (X-Axis)	285		340	
PHZ	PHZ	H-Point to Striker (Z-Axis)	74		54	

DATA SHEET NO. 7

SID/HIII LATERAL CLEARANCE DIMENSIONS

Test Vehicle: 2006 Honda Odyssey 5-Door MPV

NHTSA No.: H65302

Test Program: 55/28 km/h Side Impact NCAP

Test Date: 9/8/05

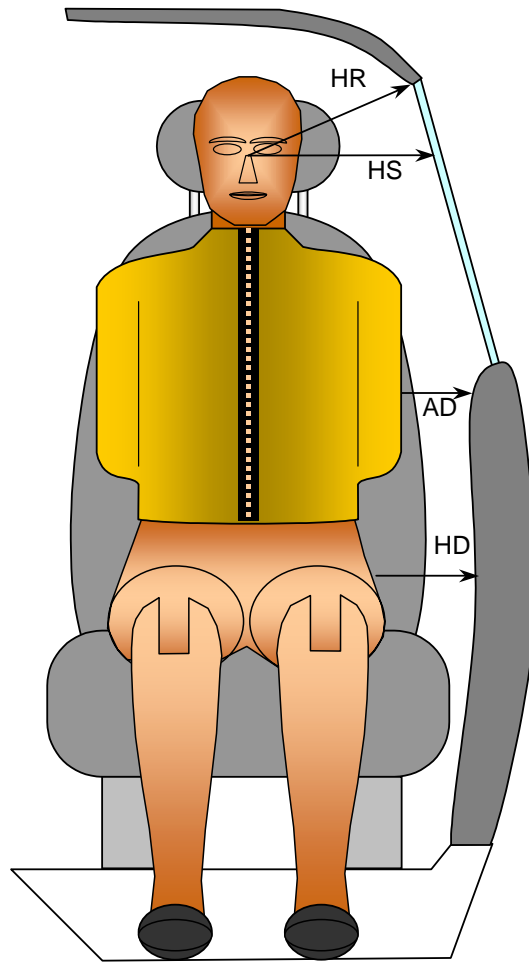

FRONT VIEW OF DUMMY

LATERAL CLEARANCE DIMENSION INFORMATION

Code	Measurement Description	Units	Driver	Passenger
HR	Head to Side Header	mm	255	210
HS	Head to Side Window	mm	340	320
AD	Arm to Door	mm	345	135
HD	H-Point to Door	mm	235	200

DATA SHEET NO. 8

VEHICLE SIDE MEASUREMENTS

Test Vehicle: 2006 Honda Odyssey 5-Door MPV

NHTSA No.: H65302

Test Program: 55/28 km/h Side Impact NCAP

Test Date: 9/8/05

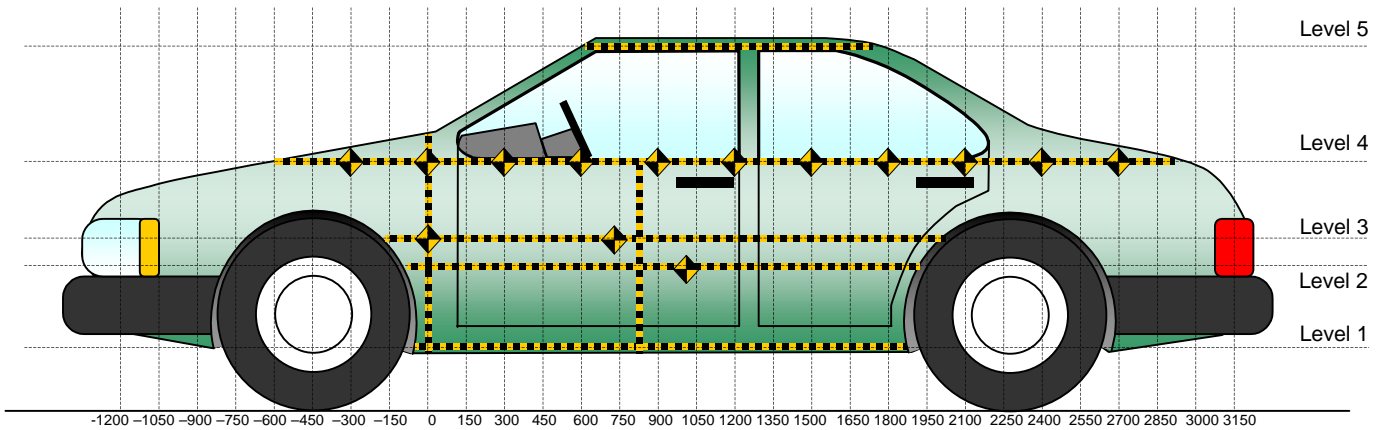

All Measurements Shown in mm

LEFT SIDE VIEW

Measurements are taken with vehicle in the as tested condition.
 Measurements taken 900 mm right of impact reference.
 All measurements below in mm.

Level	Measurement Description	Height Above Ground
1	Sill Top	222
2	Occupant H-Point	726
3	Mid Door	659
4	Window Sill	1019
5	Window Top	1642

DATA SHEET NO. 9

VEHICLE EXTERIOR CRUSH PROFILES

Test Vehicle: 2006 Honda Odyssey 5-Door MPV

NHTSA No.: H65302

Test Program: 55/28 km/h Side Impact NCAP

Test Date: 9/8/05

	Pre-Test					Post-Test					Difference				
	1	2	3	4	5	1	2	3	4	5	1	2	3	4	5
-900															
-750															
-600															
-450															
-300		16	13	101			26	56	121			10	43	20	
-150		16	26	86			26	46	108			10	20	22	
0	61	21	28	81		60	127	110	114		-1	106	82	33	
150	59	21	26	81		66	241	236	150		7	220	210	69	
300	56	20	23	76	401	71	246	253	176	416	15	226	230	100	15
450	55	16	21	76	386	78	249	271	203	386	23	233	250	127	0
600	53	14	21	71	351	86	246	278	240	366	33	232	257	169	15
750	50	14	18	70	351	89	246	278	231	366	39	232	260	161	15
900	49	13	18	65	323	91	249	265	233	320	42	236	247	168	-3
1050	50	13	16	63	321	86	271	288	241	274	36	258	272	178	-47
1200	50	15	18	61	325	77	288	310	232	273	27	273	292	171	-52
1350	50	16	18	61	325	71	291	316	193	206	21	275	298	132	-119
1500	52	17	20	61	328	69	285	313	193	161	17	268	293	132	-167
1650	50	18	21	60	328	63	288	301	194	361	13	270	280	134	33
1800	49	20	21	60	329	60	261	191	179	346	11	241	170	119	17
1950		18	22	60	326		86	126	81	381		68	104	21	55
2100		16	20	61	325		43	70	106	401		27	50	45	76
2250		8	12	62			46	44	104			38	32	42	
2400			8	62				43	106				35	44	
2550			8	74				46	105				38	31	
2700			13	74				46	125				33	51	
2850			33	79				51	106				18	27	
3000			36	79				58	138				22	59	

Measurements are taken from fixed reference 1000mm from vehicle CL.

DATA SHEET NO. 10...(CONTINUED)
VEHICLE EXTERIOR CRUSH PROFILES

Test Vehicle: 2006 Honda Odyssey 5-Door MPV
 Test Program: 55/28 km/h Side Impact NCAP

NHTSA No.: H65302
 Test Date: 9/8/05

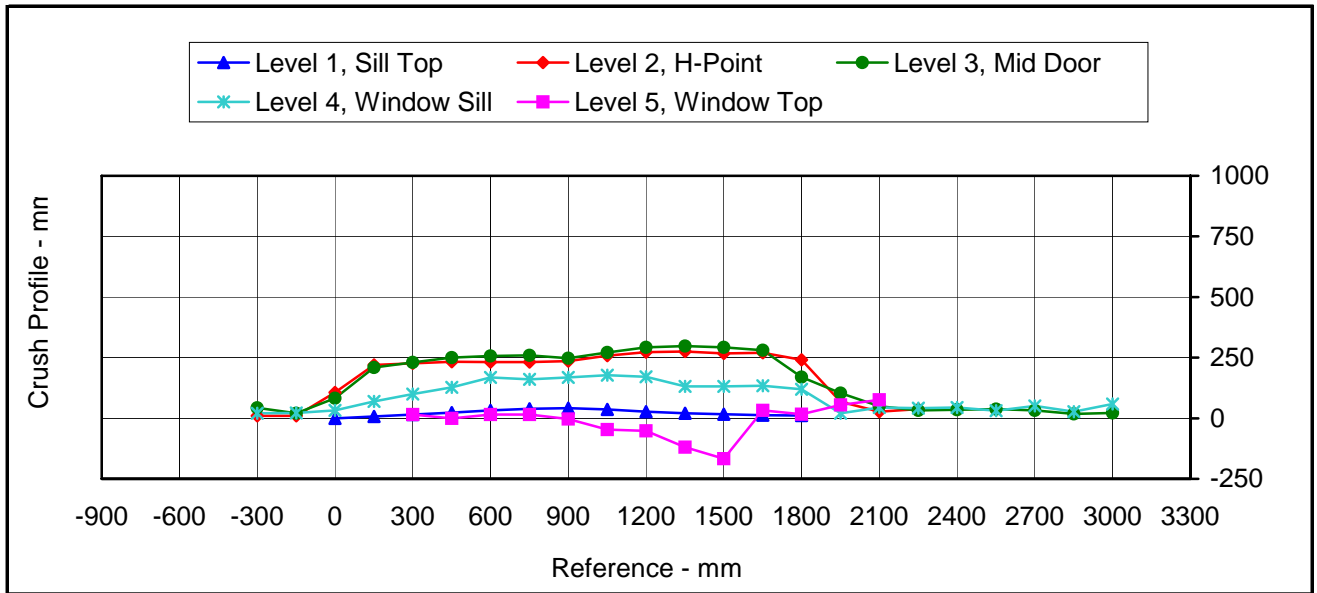

	Units	Level 1	Level 2	Level 3	Level 4	Level 5
Maximum Crush	mm	42	275	298	178	76
Distance from Impact	mm	900	1350	1350	1050	2100

DATA SHEET NO. 10

VEHICLE DAMAGE PROFILE DISTANCES

Test Vehicle: 2006 Honda Odyssey 5-Door MPV

NHTSA No.: H65302

Test Program: 55/28 km/h Side Impact NCAP

Test Date: 9/8/05

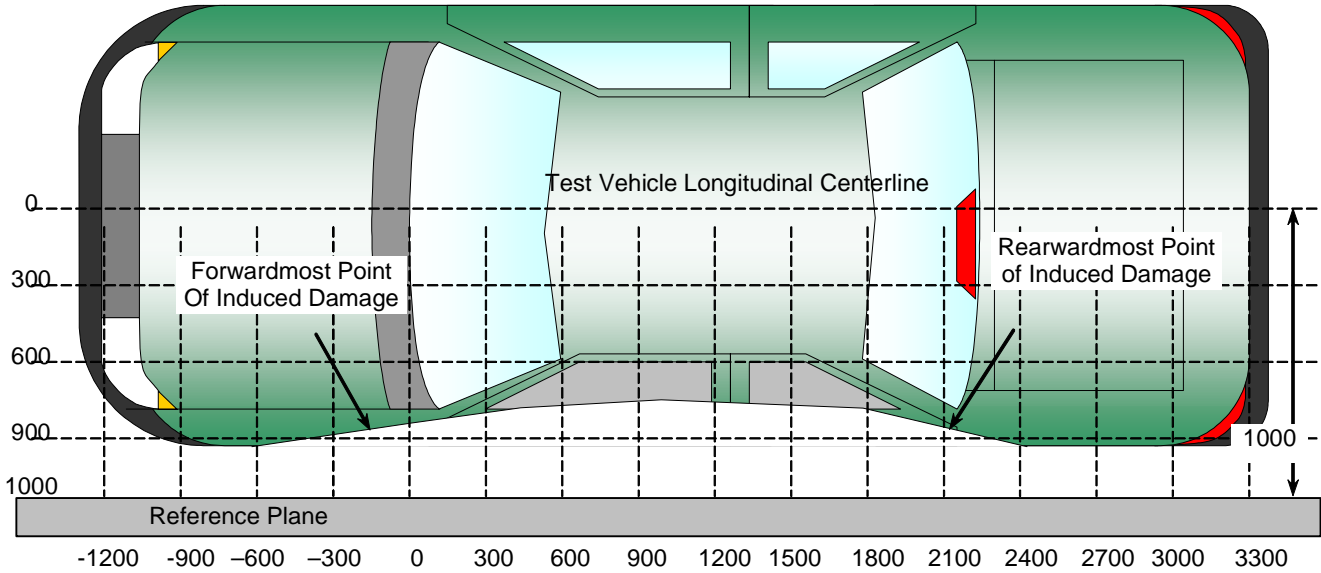

All Dimensions Shown in millimeters

TOP VIEW

DAMAGE PROFILE DISTANCES

DPD	Distance From Impact Point in mm	Level	Pre-Test (mm)	Post-Test (mm)	Max. Static Crush (mm)
1	-150	4	86	108	22
2	300	3	23	253	230
3	750	3	18	278	260
4	1200	3	18	310	292
5	1650	3	21	301	280
6	2100	5	325	401	76

DATA SHEET NO. 11

DEFORMABLE BARRIER HONEYCOMB FACE STATIC CRUSH

Test Vehicle: 2006 Honda Odyssey 5-Door MPV
 Test Program: 55/28 km/h Side Impact NCAP

NHTSA No.: H65302
 Test Date: 9/8/05

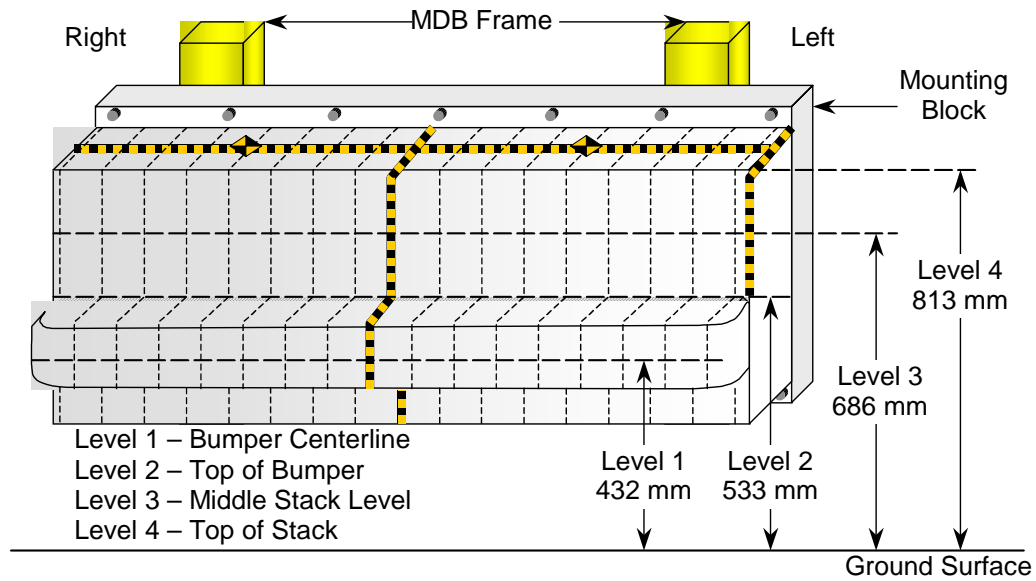

DEFORMABLE BARRIER STATIC CRUSH

Stack Level	Distance Right of Center								C/L	Distance Left of Center							
	800	700	600	500	400	300	200	100		100	200	300	400	500	600	700	800
1	195	175	176	180	179	186	183	187	193	199	208	210	212	210	218	230	240
2	128	119	116	116	115	110	102	96	91	86	85	85	81	79	78	79	88
3	96	76	57	46	40	41	46	47	41	29	24	23	28	36	51	71	96
4	116	86	58	36	31	22	23	33	33	28	26	31	39	56	76	99	126

All Dimensions in mm

DATA SHEET NO. 12

VEHICLE ACCELEROMETER LOCATIONS

Test Vehicle: 2006 Honda Odyssey 5-Door MPV

NHTSA No.: H65302

Test Program: 55/28 km/h Side Impact NCAP

Test Date: 9/8/05

LEFT SIDE VIEW

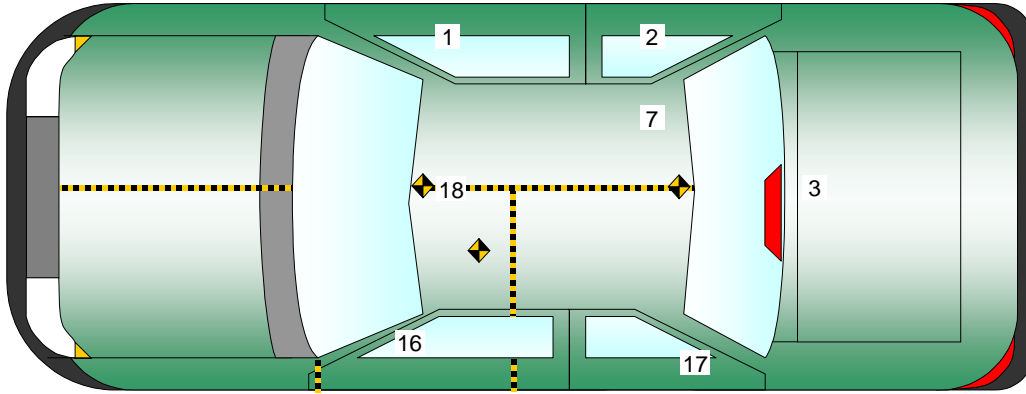
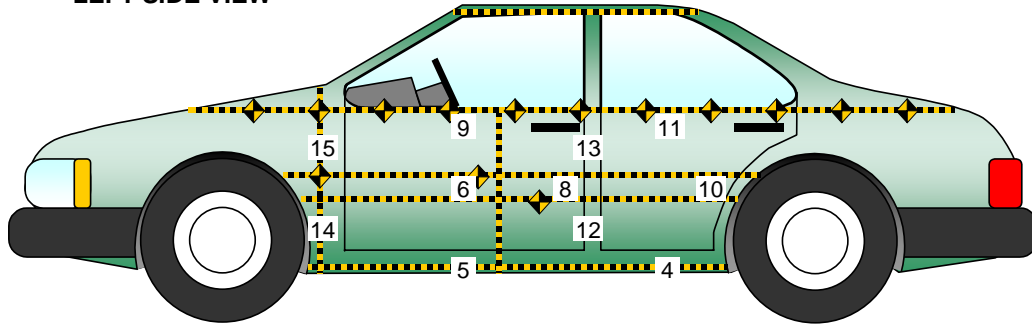

No.	Location
1	Right Sill at Front Seat
2	Right Sill at Rear Seat
3	Rear Floorpan Above Axle
4	Left Sill at Rear Door
5	Left Sill at Front Door
6	Left Front Door Centerline
7	Right Rear Occupant Compartment
8	Left Front Door Mid-Rear
9	Left Front Door Upper Centerline

No.	Location
10	Left Rear Door Mid-Rear
11	Left Rear Door Upper Centerline
12	Left Lower B-Post
13	Left Middle B-Post
14	Left Lower A-Post
15	Left Middle A-Post
16	Front Seat Track
17	Rear Seat Track or Structure
18	Vehicle CG

DATA SHEET NO. 12...(CONTINUED)
VEHICLE ACCELEROMETER LOCATIONS

Test Vehicle: 2006 Honda Odyssey 5-Door MPV
 Test Program: 55/28 km/h Side Impact NCAP

NHTSA No.: H65302
 Test Date: 9/8/05

VEHICLE ACCELEROMETER PRE-TEST LOCATIONS

Loc. No.	Accelerometer Location	Measurements (mm)		
		X	Y	Z
1	Right Sill at Front Seat	3130	820	310
2	Right Sill at Rear Seat	2210	780	370
3	Rear Floorpan Above Axle	590	25	225
4	Left Sill at Rear Door	1895	-875	210
5	Left Sill at Front Door	3150	875	190
6	Front Door Centerline			
7	Rt. Rear Occ. Compartment	2730	480	330
8	Front Door Mid-Rear			
9	Front Door Upper Centerline			
10	Rear Door Mid-Rear			
11	Rear Door Upper Centerline			
12	B-Post Lower	2650	-780	600
13	B-Post Middle	2650	-780	810
14	A-Post Lower	3585	-845	460
15	A-Post Middle	3585	-845	725
16	Front Seat Track	3135	-680	550
17	Rear Seat Structure	2185	-220	535
18	Vehicle CG	3460	240	280

Reference Planes: X=From Rear Surface of Vehicle, Y=Vehicle Centerline, Z=Ground Plane

1.) Not installed per manufacturer's request

DATA SHEET NO. 13
MDB ACCELEROMETER LOCATIONS

Test Vehicle: 2006 Honda Odyssey 5-Door MPV
Test Program: 55/28 km/h Side Impact NCAP

NHTSA No.: H65302
Test Date: 9/8/05

MDB ACCELEROMETER LOCATIONS

Loc. No.	Accelerometer Locations	Measurements (mm)		
		X	Y	Z
1	MDB CG	-1195	0	430
2	MDB Rear	-2642	-593	608

Reference Points: X - MDB Front Axle
Y - MDB Centerline
Z - Ground Plane

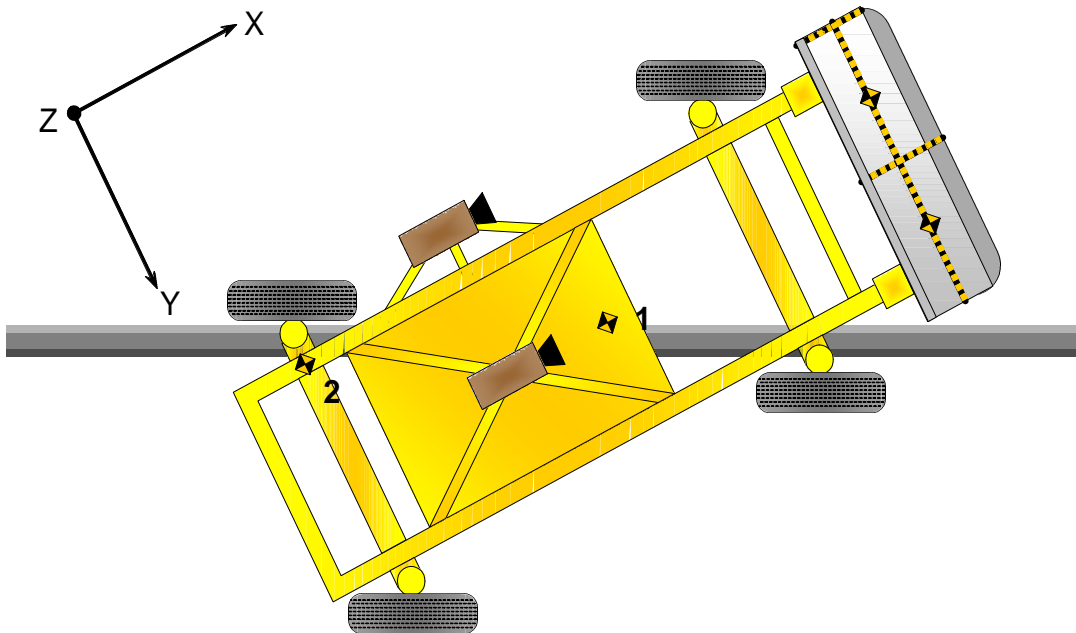

DATA SHEET NO. 14

HIGH SPEED CAMERA LOCATIONS AND DATA

Test Vehicle: 2006 Honda Odyssey 5-Door MPV

NHTSA No.: H65302

Test Program: 55/28 km/h Side Impact NCAP

Test Date: 9/8/05

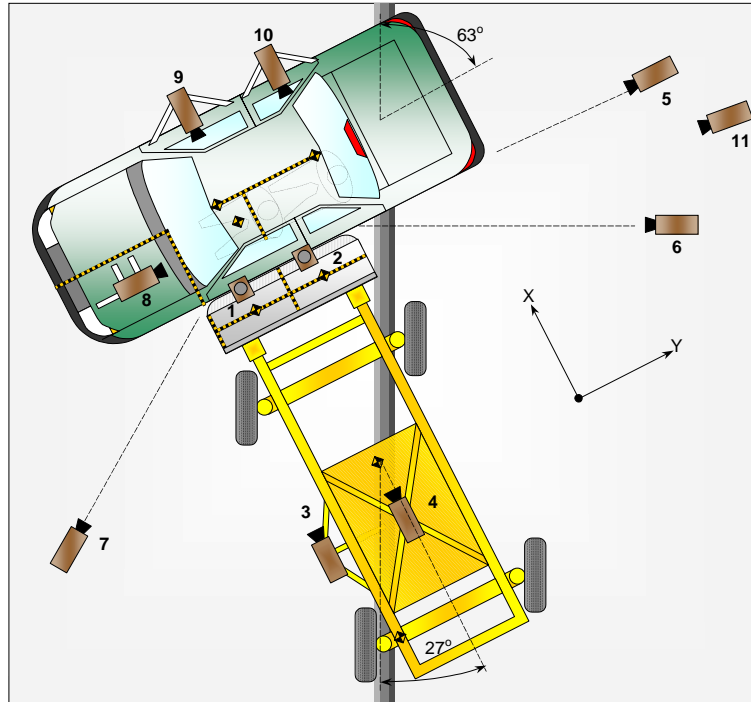

No.	Camera View	Location (mm)			Angle (deg.)	Lens (mm)	Film Speed (fps)
		X	Y	Z			
Doc	Real Time Digital	3658	22860	-1730	-5	N/A	30
1	Overhead Overall	1220	2286	-5485	-90	14	1000
2	Overhead Close Up	609	1675	-5485	-90	25	1000
3	Left Impact Point (MDB)	-1860	-16	-980	-7	25	1000
4	Side Overall (MDB)	-3440	840	-1680	-11	12.5	1000
5	Rear	228	15545	-1371	-1	50	1000
6	Left Rear (MDB)	-1770	1750	-1010	-1	25	1000
7	Left Front	-2665	-3550	-1475	-10	13	1000
8	Driver Front (O.B.)	390	-990	-1490	-20	35	1000
9	Driver Side (O.B.)	1835	663	-1175	-2	20	1000
10	Passenger Side (O.B.)	1815	1520	-1235	-2	20	1000
11	Additional Real Time Digital	-2600	-4700	-1473	-1	N/A	30

X = Barrier Face Y = Monorail Centerline Z = Ground DNR = Did Not Run NTM = No Timing Marks

DATA SHEET NO. 15

FMVSS 301 FUEL SYSTEM INTEGRITY POST-IMPACT DATA

Test Vehicle: 2006 Honda Odyssey 5-Door MPV NHTSA No.: H65302
Test Program: 55/28 km/h Side Impact NCAP Test Date: 9/8/05

Test Time: 1:18 PM Temperature: 33.3 Deg. C.

Stoddard Solvent Spillage Measurements

- A. From impact until vehicle motion ceases: 0.0 oz.
(Maximum Allowable = 1 ounce)
- B. For the 5 minute period after motion ceases: 0.0 oz.
(Maximum Allowable = 5 ounces)
- C. For the following 25 minutes: 0.0 oz.
(Maximum Allowable = 1 oz./minute)
- D. Spillage Details: No leakage occurred

DATA SHEET NO. 16
FMVSS 301 STATIC ROLLOVER DATA

Test Vehicle: 2006 Honda Odyssey 5-Door MPV
 Test Program: 55/28 km/h Side Impact NCAP

NHTSA No.: H65302
 Test Date: 9/8/05

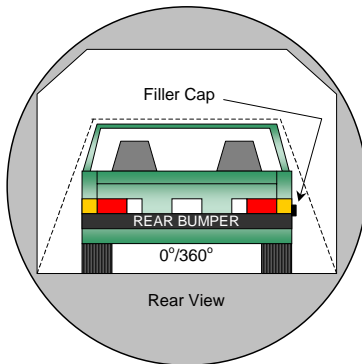

0° to 90°

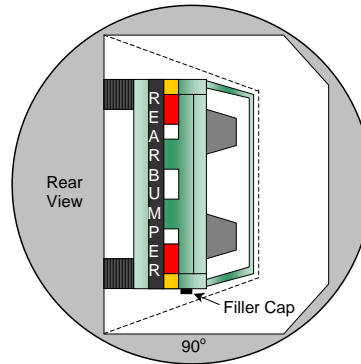

90° to 180°

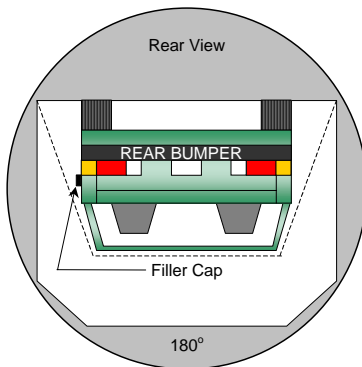
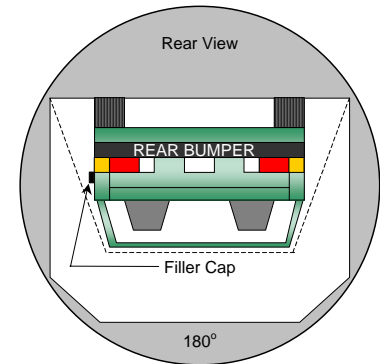

180° to 270°

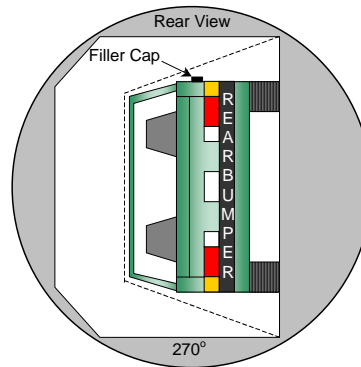

270° to 360°

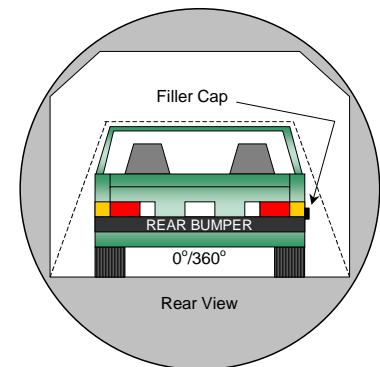

1. The specified fixture rollover rate for each 90° of rotation is 60 to 120 seconds.
 2. The position hold time at each position is 300 seconds (minimum).
 3. Details of Stoddard Solvent spillage locations.
- No solvent leakage occurred during static rollover testing.

FMVSS 301 STATIC ROLLOVER DATA

Test Vehicle: 2006 Honda Odyssey 5-Door MPV

NHTSA No.: H65302

Test Program: 55/28 km/h Side Impact NCAP

Test Date: 9/8/05

SOLVENT COLLECTION TIME TABLE IN SECONDS

Test Phase	Rotation Time	Hold Time	Total Time
0° to 90°	84	300	384
90° to 180°	77	300	377
180° to 270°	78	300	378
270° to 360°	79	300	379

FMVSS 301 SPILLAGE TABLE REQUIREMENT (oz.)

First 5 Minutes	5.0
Sixth Minute	1.0
Seventh Minute	1.0
Eighth Minute	1.0

Test Phase	First 5 Minutes	Sixth Minute	Seventh Minute	Eighth Minute
0° to 90°	0	0	0	0
90° to 180°	0	0	0	0
180° to 270°	0	0	0	0
270° to 360°	0	0	0	0

SOLVENT SPILLAGE LOCATION TABLE

Test Phase	Spillage Location
0° to 90°	None
90° to 180°	None
180° to 270°	None
270° to 360°	None

**APPENDIX A
PHOTOGRAPHS**

LIST OF PHOTOGRAPHS

Figure		Page
A-1	Left Front $\frac{3}{4}$ View, as Received	A-1
A-2	Right Rear $\frac{3}{4}$ View, as Received	A-2
A-3	Manufacturer's Label	A-3
A-4	Tire Placard	A-4
A-5	Pre-Test Front View	A-5
A-6	Post-Test Front View	A-6
A-7	Pre-Test Left Front $\frac{3}{4}$ View	A-7
A-8	Post-Test Left Front $\frac{3}{4}$ View	A-8
A-9	Pre-Test Left Side View	A-9
A-10	Post-Test Left Side View	A-10
A-11	Pre-Test Left Rear $\frac{3}{4}$ View	A-11
A-12	Post-Test Left Rear $\frac{3}{4}$ View	A-12
A-13	Pre-Test Rear View	A-13
A-14	Post-Test Rear View	A-14
A-15	Pre-Test Right Rear $\frac{3}{4}$ View	A-15
A-16	Post-Test Right Rear $\frac{3}{4}$ View	A-16
A-17	Pre-Test Right Side View	A-17
A-18	Post-Test Right Side View	A-18
A-19	Pre-Test Right Front $\frac{3}{4}$ View	A-19
A-20	Post-Test Right Front $\frac{3}{4}$ View	A-20
A-21	Pre-Test Overhead View	A-21
A-22	Post-Test Overhead View	A-22
A-23	Pre-Test Overhead Close-up View	A-23
A-24	Post-Test Overhead Close-up View	A-24
A-25	Pre-Test Left Impact Point	A-25
A-26	Post-Test Left Impact Point	A-26
A-27	Pre-Test Front $\frac{3}{4}$ View of Left Side Doors	A-27
A-28	Post-Test Front $\frac{3}{4}$ View of Left Side Doors	A-28
A-29	Pre-Test Rear $\frac{3}{4}$ View of Left Side Doors	A-29
A-30	Post-Test Rear $\frac{3}{4}$ View of Left Side Doors	A-30
A-31	Pre-Test Left Front Door	A-31
A-32	Post-Test Left Front Door	A-32
A-33	Pre-Test Left Rear Door	A-33
A-34	Post-Test Left Rear Door	A-34

LIST OF PHOTOGRAPHS...(CONTINUED)

Figure		Page
A-35	Pre-Test Driver Dummy (Door Open)	A-35
A-36	Pre-Test Driver Dummy (Through Window)	A-36
A-37	Post-Test Driver Dummy (Through Window)	A-37
A-38	Pre-Test Driver Dummy Clearance from Door	A-38
A-39	Post-Test Driver Dummy Clearance from Door	A-39
A-40	Pre-Test Driver Dummy Right Side View	A-40
A-41	Post-Test Driver Dummy Right Side View	A-41
A-42	Pre-Test Front Door Panel (Interior)	A-42
A-43	Post-Test Front Door Panel (Interior)	A-43
A-44	Pre-Test Passenger Dummy Left Side (Door Open)	A-44
A-45	Pre-Test Passenger Dummy Left Side (Through Window)	A-45
A-46	Post-Test Passenger Dummy Left Side (Through Window)	A-46
A-47	Pre-Test Passenger Dummy Clearance from Door	A-47
A-48	Post-Test Passenger Dummy Clearance from Door	A-48
A-49	Pre-Test Passenger Dummy Right Side View	A-49
A-50	Post-Test Passenger Dummy Right Side View	A-50
A-51	Pre-Test Rear Door Panel (Interior)	A-51
A-52	Post-Test Rear Door Panel (Interior)	A-52
A-53	Pre-Test Front View of Deformable Barrier	A-53
A-54	Post-Test Front View of Deformable Barrier	A-54
A-55	Pre-Test Top View of Deformable Barrier	A-55
A-56	Post-Test Top View of Deformable Barrier	A-56
A-57	Pre-Test Right Side View of Deformable Barrier	A-57
A-58	Post-Test Right Side View of Deformable Barrier	A-58
A-59	Pre-Test Left Side View of Deformable Barrier	A-59
A-60	Post-Test Left Side View of Deformable Barrier	A-60
A-61	Vehicle on Rollover Device (0°)	A-61
A-62	Vehicle on Rollover Device (90°)	A-62
A-63	Vehicle on Rollover Device (180°)	A-63
A-64	Vehicle on Rollover Device (270°)	A-64
A-65	Vehicle Impact	A-65
A-66	Post-Test Passenger Door	A-66



A-1

TR-P25125-01-NC

Figure A-1: Left Front $\frac{3}{4}$ View, as Received



Figure A-2: Right Rear $\frac{3}{4}$ View, as Received

MFD. BY HONDA MFG. OF ALABAMA, LLC 8/'05
GVWR 2700KG (5952LBS) TIRE SIZE RIM SIZE
GAWR F 1285KG (2833LBS) 235/65R16 103T 16X7J
GAWR R 1450KG (3197LBS) 235/65R16 103T 16X7J

THIS VEHICLE CONFORMS TO ALL APPLICABLE FEDE -
RAL MOTOR VEHICLE SAFETY AND THEFT PREVENTION
STANDARDS IN EFFECT ON THE DATE OF MANUFACTURE
SHOWN ABOVE. V.I.N.: 5FNRL38416B001692 TYPE:MPV



SHJ 6 AJ5 - B530M - B - B

Figure A-3: Manufacturer's Label



TIRE AND LOADING INFORMATION

SEATING CAPACITY: TOTAL 8 : FRONT 2 : SECOND 3 : THIRD 3

The combined weight of occupants and cargo should never exceed 630kg or 1388lbs.

TIRE	SIZE	COLD TIRE PRESSURE	SEE OWNER'S MANUAL FOR ADDITIONAL INFORMATION
FRONT	235/65R16 103T	230KPA, 33PSI	
REAR		240KPA, 35PSI	
SPARE	T135/80D17 103M	420KPA, 60PSI	

JA3

Figure A-4: Tire Placard



Figure A-5: Pre-Test Front View



Figure A-6: Post-Test Front View



Figure A-7: Pre-Test Left Front ¾ View



Figure A-8: Post-Test Left Front $\frac{3}{4}$ View



Figure A-9: Pre-Test Left Side View



Figure A-10: Post-Test Left Side View



Figure A-11: Pre-Test Left Rear 3/4 View



Figure A-12: Post-Test Left Rear $\frac{3}{4}$ View



A-13

TR-P25125-01-NC

Figure A-13: Pre-Test Rear View



Figure A-14: Post-Test Rear View



Figure A-15: Pre-Test Right Rear ¾ View



Figure A-16: Post-Test Right Rear 3/4 View



Figure A-17: Pre-Test Right Side View



Figure A-18: Post-Test Right Side View



A-19

TR-P25125-01-NC

Figure A-19: Pre-Test Right Front 3/4 View



Figure A-20: Post-Test Right Front $\frac{3}{4}$ View



Figure A-21: Pre-Test Overhead View



Figure A-22: Post-Test Overhead View



H65302
55/28 km/h 90°
SIDE IMPACT
09/08/05
2006 HONDA
ODYSSEY (5dr MPV)
KARC
Engineering

Figure A-23: Pre-Test Overhead Close-up View



Figure A-24: Post-Test Overhead Close-up View



Figure A-25: Pre-Test Left Impact Point

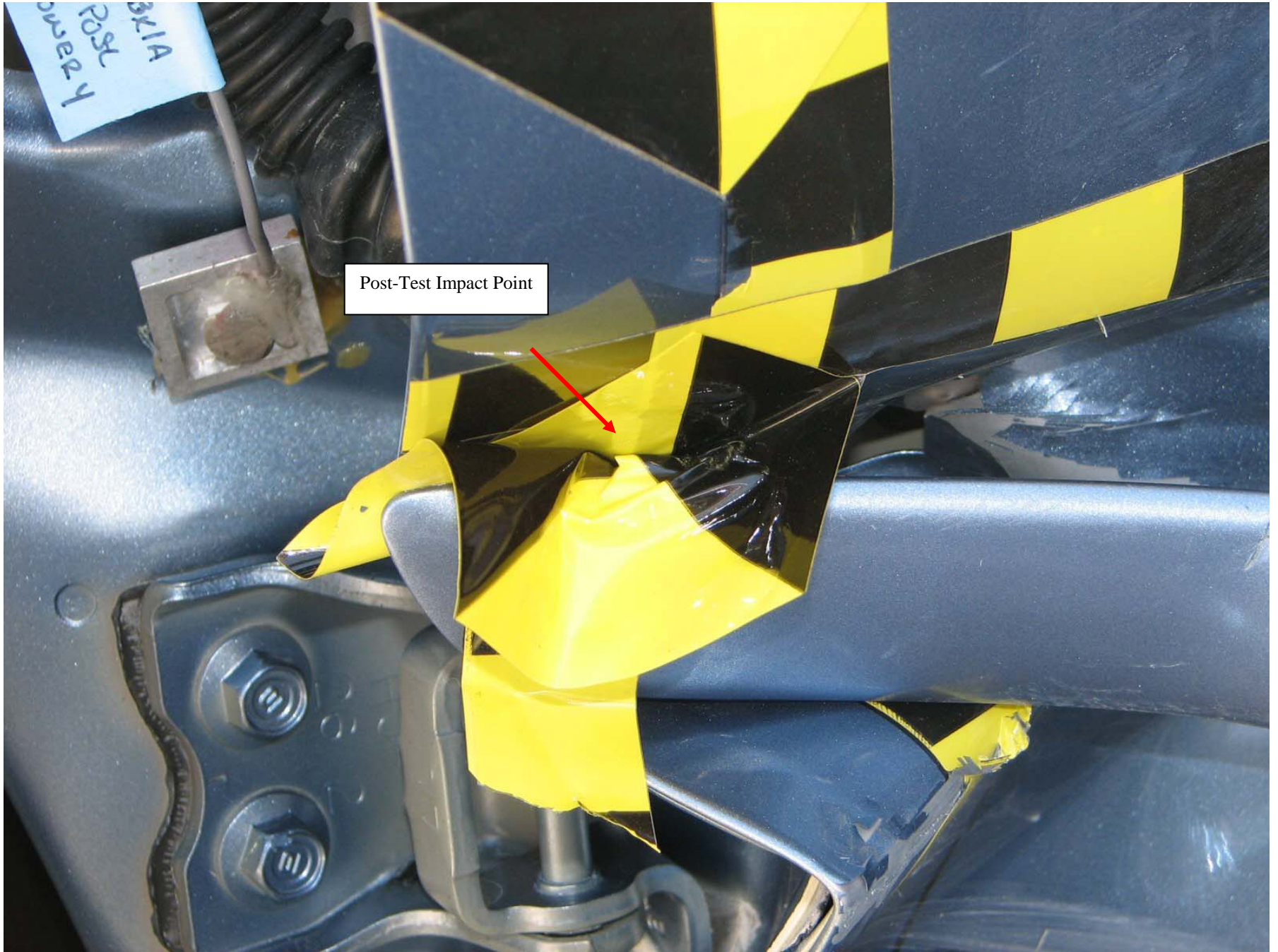

Post-Test Impact Point

Figure A-26: Post-Test Left Impact Point



Figure A-27: Pre-Test Front $\frac{3}{4}$ View of Left Side Doors



Figure A-28: Post-Test Front ¾ View of Left Side Doors



Figure A-29: Pre-Test Rear ¾ View of Left Side Doors



Figure A-30: Post-Test Rear ¾ View of Left Side Doors



Figure A-31: Pre-Test Left Front Door



Figure A-32: Post-Test Left Front Door



Figure A-33: Pre-Test Left Rear Door



Figure A-34: Post-Test Left Rear Door



Figure A-35: Pre-Test Driver Dummy (Door Open)



Figure A-36: Pre-Test Driver Dummy (Through Window)



Figure A-37: Post-Test Driver Dummy (Through Window)



Figure A-38: Pre-Test Driver Dummy Clearance From Door

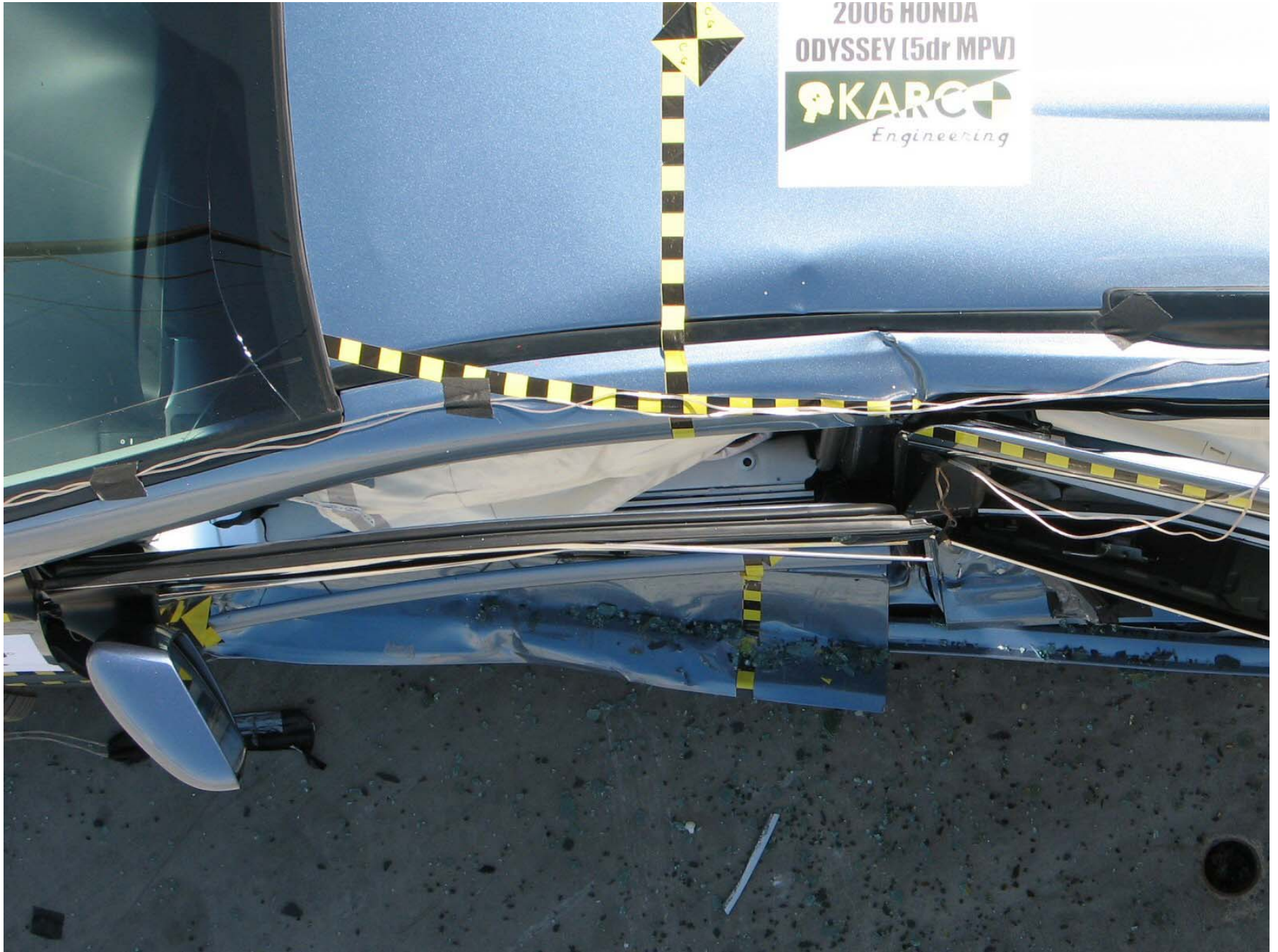

Figure A-39: Post-Test Driver Dummy Clearance From Door



Figure A-40: Pre-Test Driver Dummy Right Side View



Figure A-41: Post-Test Driver Dummy Right Side View



Figure A-42: Pre-Test Front Door Panel (Interior)



Figure A-43: Post-Test Front Door Panel (Interior)

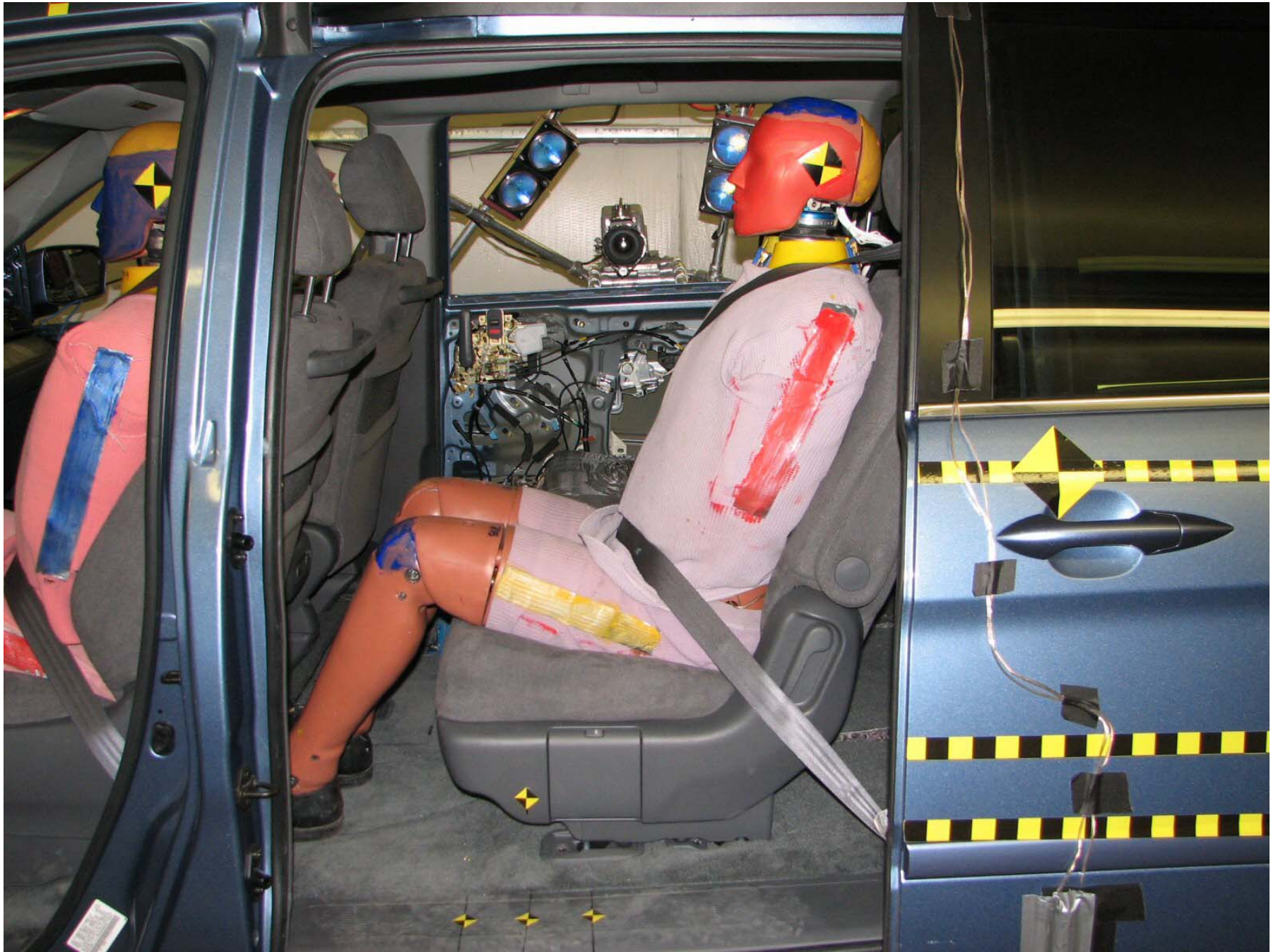

Figure A-44: Pre-Test Passenger Dummy Left Side (Door Open)



Figure A-45: Pre-Test Passenger Dummy Left Side (Through Window)



Figure A-46: Post-Test Passenger Dummy Left Side (Through Window)



Figure A-47: Pre-Test Passenger Dummy Clearance From Door



Figure A-48: Post-Test Passenger Dummy Clearance From Door



Figure A-49: Pre-Test Passenger Dummy Right Side View



Figure A-50: Post-Test Passenger Dummy Right Side View



Figure A-51: Pre-Test Rear Door Panel (Interior)



Figure A-52: Post-Test Rear Door Panel (Interior)



Figure A-53: Pre-Test Front View of Deformable Barrier



A-54

TR-P25125-01-NC

Figure A-54: Post-Test Front View of Deformable Barrier

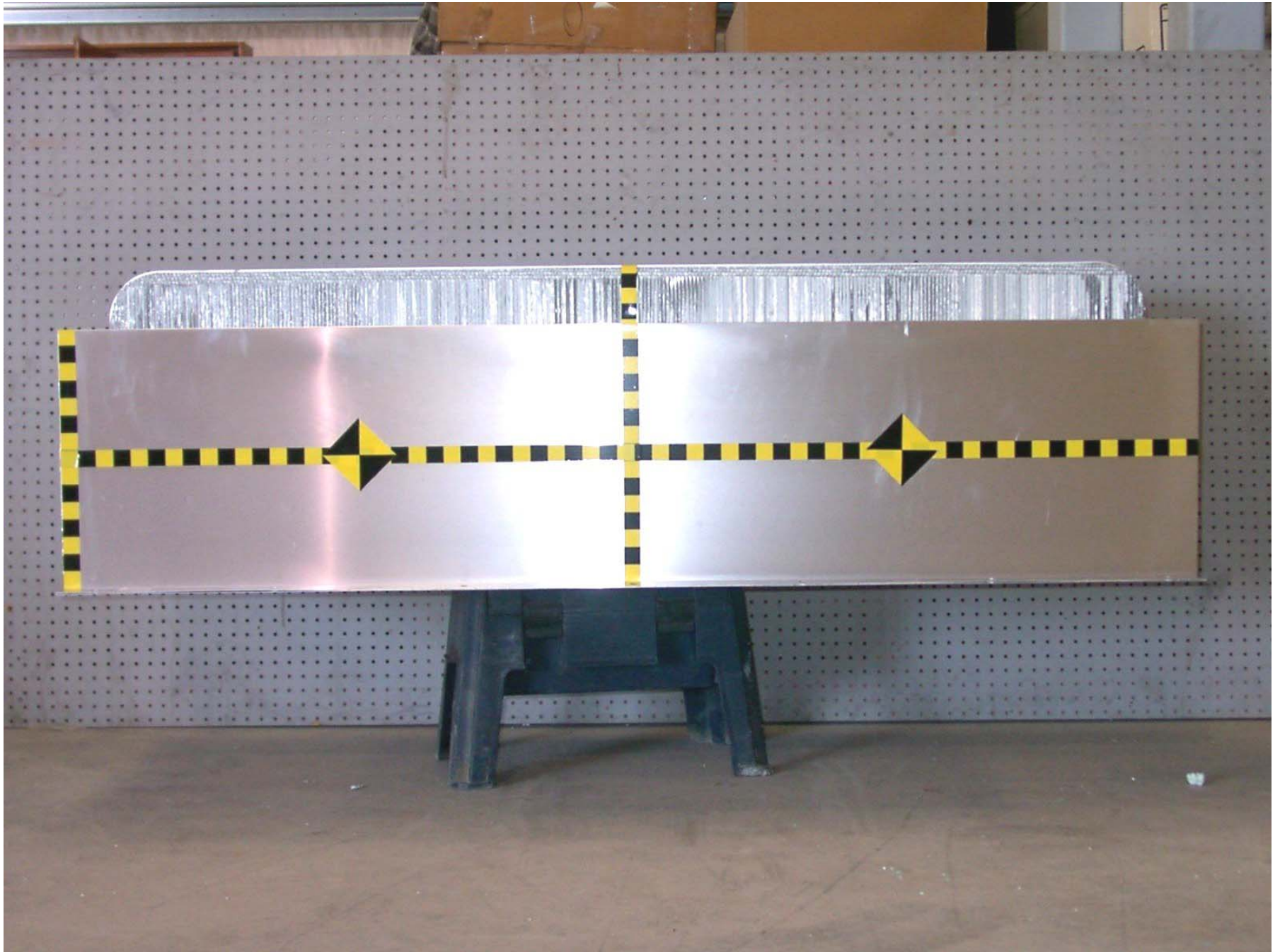

A-55

TR-P25125-01-NC

Figure A-55: Pre-Test Top View of Deformable Barrier



Figure A-56: Post-Test Top View of Deformable Barrier



Figure A-57: Pre-Test Right Side View of Deformable Barrier



Figure A-58: Post-Test Right Side View of Deformable Barrier

A-59

TR-P25125-01-NC



Figure A-59: Pre-Test Left Side View of Deformable Barrier

A-60

TR-P25125-01-NC

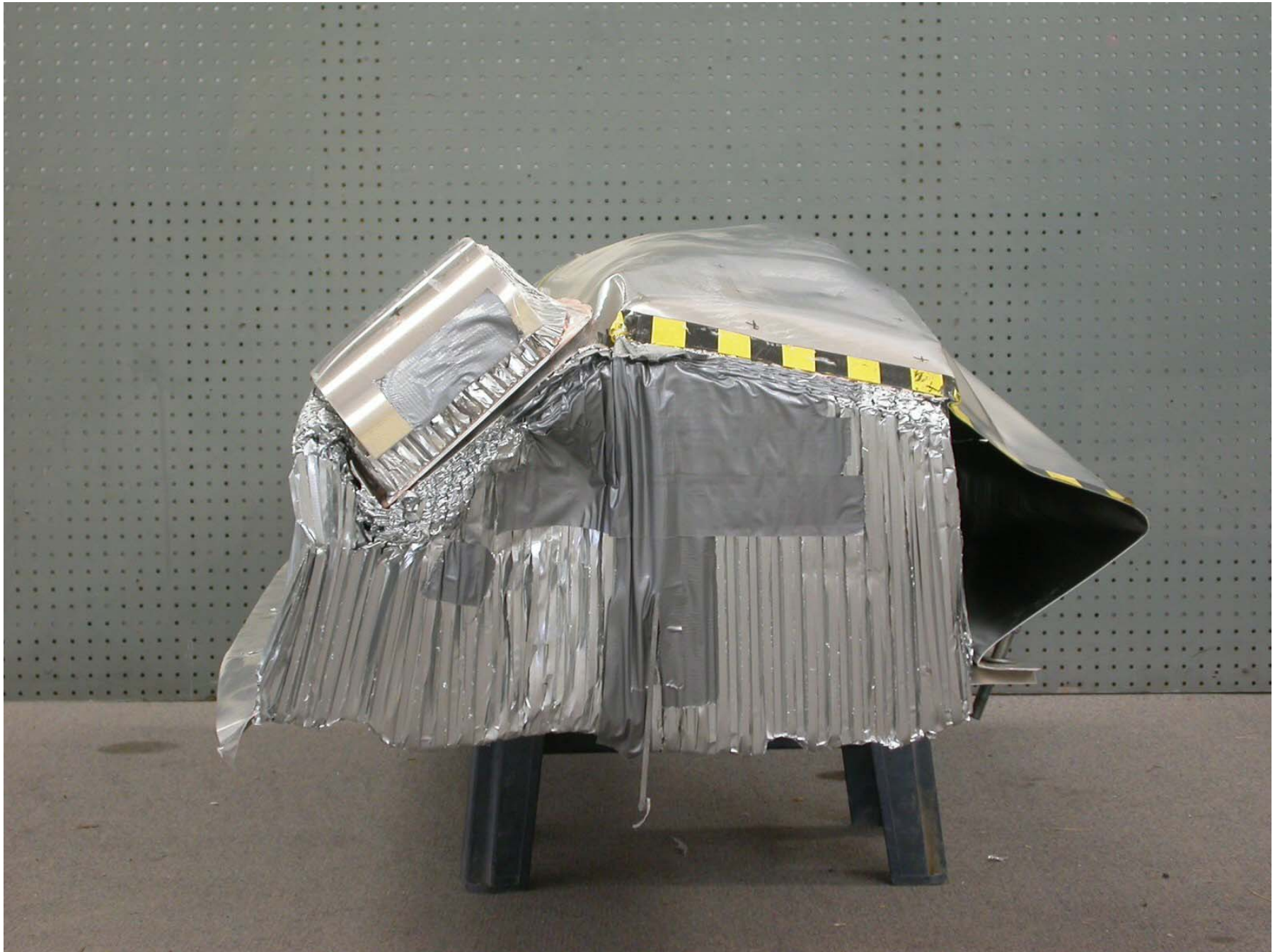

Figure A-60: Post-Test Left Side View of Deformable Barrier



Figure A-61: Vehicle on Rollover Device (0°)



Figure A-62: Vehicle on Rollover Device (90°)



Figure A-63: Vehicle on Rollover Device (180°)

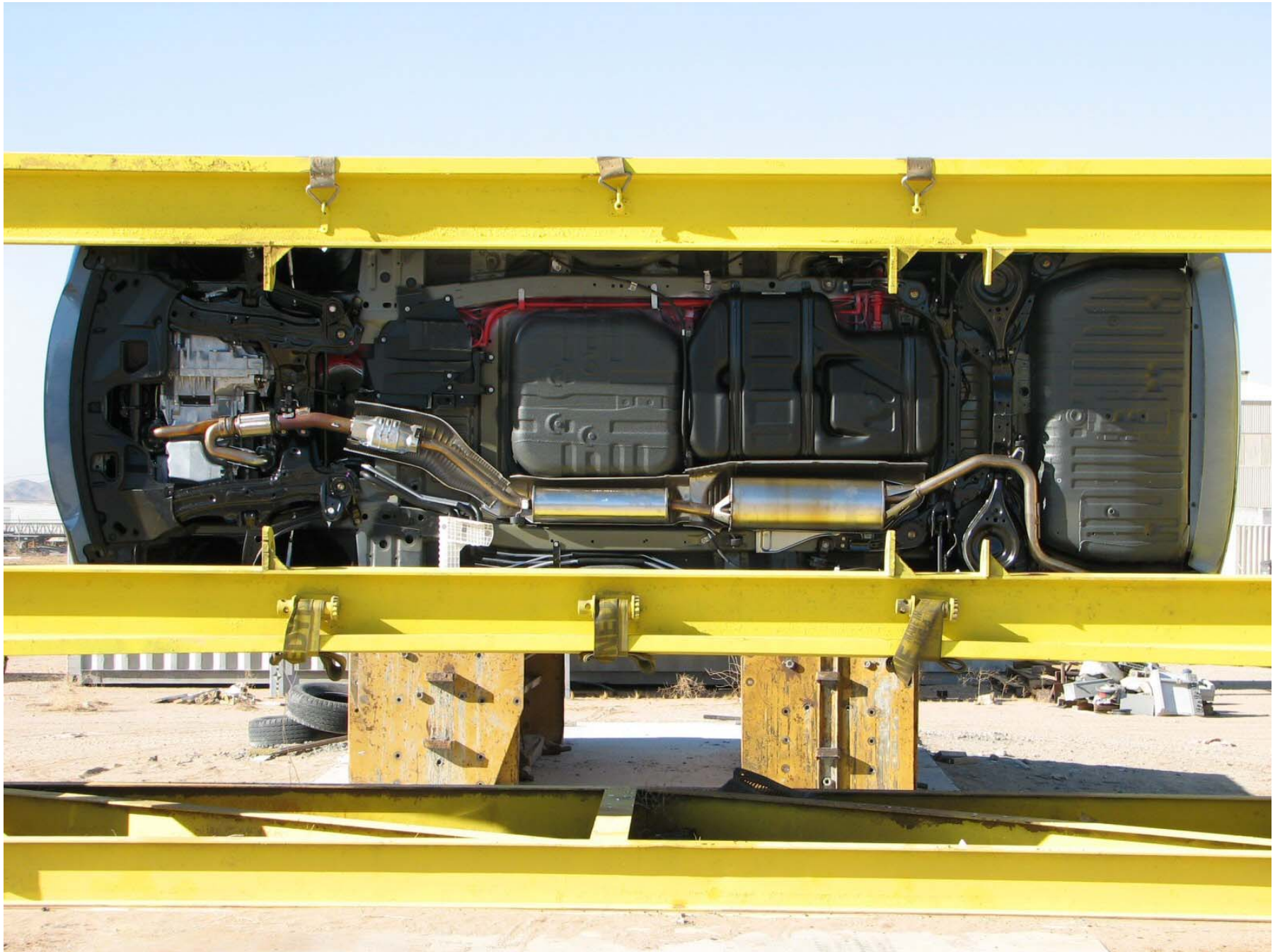

Figure A-64: Vehicle on Rollover Device (270°)



Figure A-66: Post-Test Passenger Door Side View

APPENDIX B
SID/HIII, VEHICLE AND MDB RESPONSE DATA

LIST OF DATA PLOTS

<u>Data Plot</u>		<u>Page</u>
B-1	Driver Upper Rib Primary Y	B-1
	Driver Lower Rib Primary Y	B-1
	Driver Lower Spine Primary Y	B-1
	Driver Pelvis Primary Y	B-1
B-2	Passenger Upper Rib Primary Y	B-2
	Passenger Lower Rib Primary Y	B-2
	Passenger Lower Spine Primary Y	B-2
	Passenger Pelvis Primary Y	B-2

The following additional data plots for this test can be obtained from the research and development section of the NHTSA website. The website can be found at www.NHTSA.dot.gov

LIST OF DATA PLOTS...(CONTINUED)

Driver Head X Primary
Driver Head Y Primary
Driver Head Z Primary
Driver Head Resultant Primary
Driver Head Primary X Velocity
Driver Head Primary Y Velocity
Driver Head Primary Z Velocity
Driver Head X Redundant
Driver Head Y Redundant
Driver Head Z Redundant
Driver Head Resultant Redundant
Driver Head Redundant X Velocity
Driver Head Redundant Y Velocity
Driver Head Redundant Z Velocity
Driver Upper Neck Force X
Driver Upper Neck Force Y
Driver Upper Neck Force Z
Driver Upper Neck Force Resultant
Driver Upper Neck Moment X
Driver Upper Neck Moment Y
Driver Upper Neck Moment Z
Driver Upper Neck Moment Resultant
Driver Upper Rib Primary Y Velocity
Driver Lower Rib Primary Y Velocity
Driver Lower Spine Primary Y Velocity
Driver Pelvis Primary Y Velocity
Driver Upper Rib Redundant Y
Driver Lower Rib Redundant Y
Driver Lower Spine Redundant Y
Driver Pelvis Redundant Y

LIST OF DATA PLOTS...(CONTINUED)

Driver Upper Rib Redundant Y Velocity
Driver Lower Rib Redundant Y Velocity
Driver Lower Spine Redundant Y Velocity
Driver Pelvis Redundant Y Velocity
Driver Thorax Contact
Driver Pelvis Contact
Passenger Head X Primary
Passenger Head Y Primary
Passenger Head Z Primary
Passenger Head Resultant Primary
Passenger Head Primary X Velocity
Passenger Head Primary Y Velocity
Passenger Head Primary Z Velocity
Passenger Head X Redundant
Passenger Head Y Redundant
Passenger Head Z Redundant
Passenger Head Resultant Redundant
Passenger Head Redundant X Velocity
Passenger Head Redundant Y Velocity
Passenger Head Redundant Z Velocity
Passenger Upper Neck Force X
Passenger Upper Neck Force Y
Passenger Upper Neck Force Z
Passenger Upper Neck Force Resultant
Passenger Upper Neck Moment X
Passenger Upper Neck Moment Y
Passenger Upper Neck Moment Z
Passenger Upper Neck Moment Resultant

LIST OF DATA PLOTS...(CONTINUED)

Passenger Upper Rib Primary Y Velocity
Passenger Lower Rib Primary Y Velocity
Passenger Lower Spine Primary Y Velocity
Passenger Pelvis Primary Y Velocity
Passenger Upper Rib Redundant Y
Passenger Lower Rib Redundant Y
Passenger Lower Spine Redundant Y
Passenger Pelvis Redundant Y
Passenger Upper Rib Redundant Y Velocity
Passenger Lower Rib Redundant Y Velocity
Passenger Lower Spine Redundant Y Velocity
Passenger Pelvis Redundant Y Velocity
Passenger Thorax Contact
Passenger Pelvis Contact
Vehicle Right Sill at Front Seat X
Vehicle Right Sill at Front Seat Y
Vehicle Right Sill at Front Seat Z
Vehicle Right Sill Front Seat Resultant
Vehicle Right Sill at Front Seat X Velocity
Vehicle Right Sill at Front Seat Y Velocity
Vehicle Right Sill at Front Seat Z Velocity
Vehicle Right Sill at Rear Seat X
Vehicle Right Sill at Rear Seat Y
Vehicle Right Sill at Rear Seat Z
Vehicle Right Sill Rear Seat Resultant
Vehicle Right Sill at Rear Seat X Velocity
Vehicle Right Sill at Rear Seat Y Velocity
Vehicle Right Sill at Rear Seat Z Velocity
Vehicle Rear Floor Above Axle X
Vehicle Rear Floor Above Axle Y
Vehicle Rear Floor Above Axle Z
Vehicle Rear Floor Above Axle Resultant
Vehicle Rear Floor Above Axle X Velocity
Vehicle Rear Floor Above Axle Y Velocity
Vehicle Rear Floor Above Axle Z Velocity

LIST OF DATA PLOTS...(CONTINUED)

Vehicle Left Sill at Rear Door Y
Vehicle Left Sill at Front Door Y
Vehicle Left Sill at Rear Door Y Velocity
Vehicle Left Sill at Front Door Y Velocity
Vehicle Left Front Door C/L Y
Vehicle Right Rear Occupant Compartment
Vehicle Left Front Door Mid Rear Y
Vehicle Left Front Door Upper CL Y
Vehicle Left Front Door CL Y Velocity
Vehicle Right Rear Occupant Compartment Y Velocity
Vehicle Left Front Door Mid Rear Y Velocity
Vehicle Left Rear Door Upper CL Y Velocity
Vehicle Left Rear Door Mid Rear Y
Vehicle Left Rear Door Upper C/L Y
Vehicle Left Rear Door Mid Rear Y Velocity
Vehicle Left Rear Door Upper CL Y Velocity
Vehicle B-Post Lower Y
Vehicle B-Post Middle Y
Vehicle B-Post Lower Y Velocity
Vehicle B-Post Middle Y Velocity
Vehicle A-Post Lower Y
Vehicle A-Post Middle Y
Vehicle A-Post Lower Y Velocity
Vehicle A-Post Middle Y Velocity
Vehicle Left Front Seat Track
Vehicle Rear Seat Structure
Vehicle Left Front Seat Track Y Velocity
Vehicle Rear Seat Structure Y Velocity
Vehicle CG X
Vehicle CG Y
Vehicle CG Z
Vehicle CG Resultant
Vehicle CG X Velocity
Vehicle CG Y Velocity
Vehicle CG Z Velocity

LIST OF DATA PLOTS...(CONTINUED)

Driver Upper Rib Primary Y
Driver Lower Rib Primary Y
Driver Lower Spine Primary Y
Driver Pelvis Primary Y
Driver Upper Rib Redundant Y
Driver Lower Rib Redundant Y
Driver Lower Spine Redundant Y
Driver Pelvis Redundant Y
Passenger Upper Rib Primary Y
Passenger Lower Rib Primary Y
Passenger Lower Spine Primary Y
Passenger Pelvis Primary Y
Passenger Upper Rib Redundant Y
Passenger Lower Rib Redundant Y
Passenger Lower Spine Redundant Y
Passenger Pelvis Redundant Y
MDB CG X
MDB CG Y
MDB CG Z
MDB CG Resultant
MDB CG X Velocity
MDB CG Y Velocity
MDB CG Z Velocity
MDB Rear X
MDB Rear Y
MDB Rear X Velocity
MDB Rear Y Velocity
MDB Right Bumper Contact

Test Vehicle: 2006 Honda Odyssey 5-Door MPV
 Test Program: 55/28 km/h Side Impact NCAP

Test Date: 9/8/05
 NHTSA No.: H65302

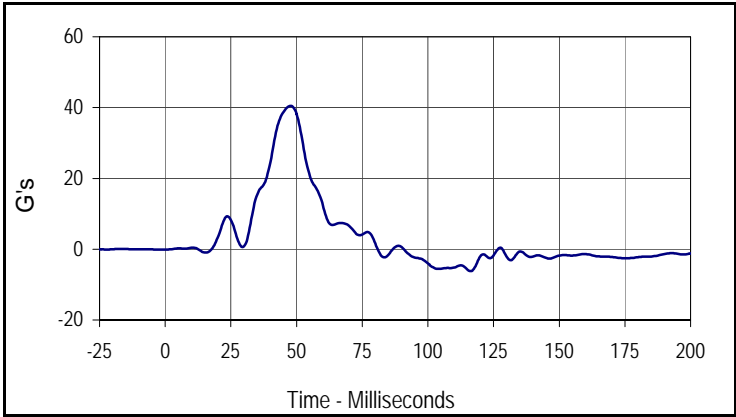

Curve Description			
Driver Upper Rib Primary Y			
CURNO	Type	SAE Class	Units
001	FIR	FIR100	G's
Max	Time	Min	Time
40.5	47.5	-6.2	116.3

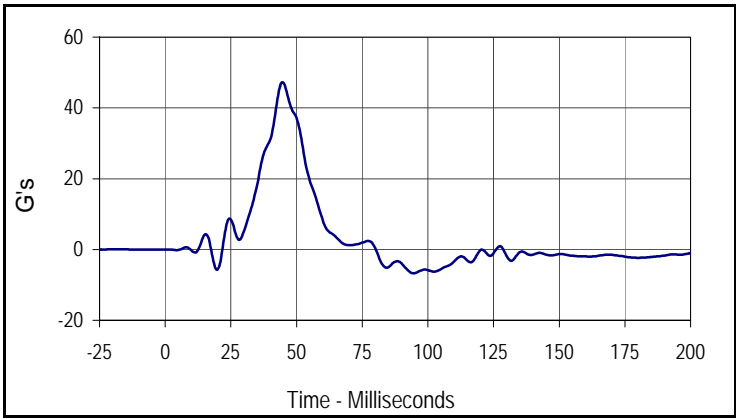

Curve Description			
Driver Lower Rib Primary Y			
CURNO	Type	SAE Class	Units
002	FIR	FIR100	G's
Max	Time	Min	Time
47.1	44.4	-6.7	94.4

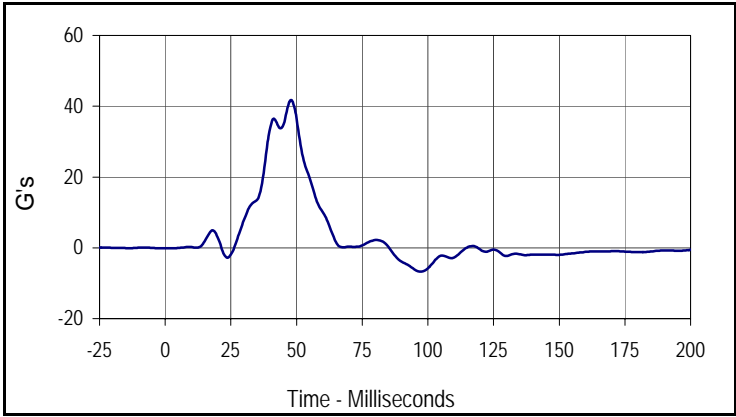

Curve Description			
Driver Lower Spine Primary Y			
CURNO	Type	SAE Class	Units
003	FIR	FIR100	G's
Max	Time	Min	Time
41.7	48.1	-6.7	97.5

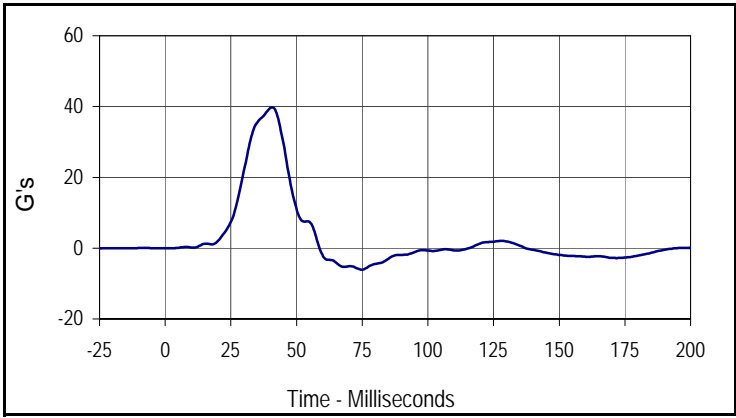

Curve Description			
Driver Pelvis Primary Y			
CURNO	Type	SAE Class	Units
004	FIR	FIR100	G's
Max	Time	Min	Time
39.8	40.6	-6.1	75.0

Test Vehicle: 2006 Honda Odyssey 5-Door MPV
 Test Program: 55/28 km/h Side Impact NCAP

Test Date: 9/8/05
 NHTSA No.: H65302

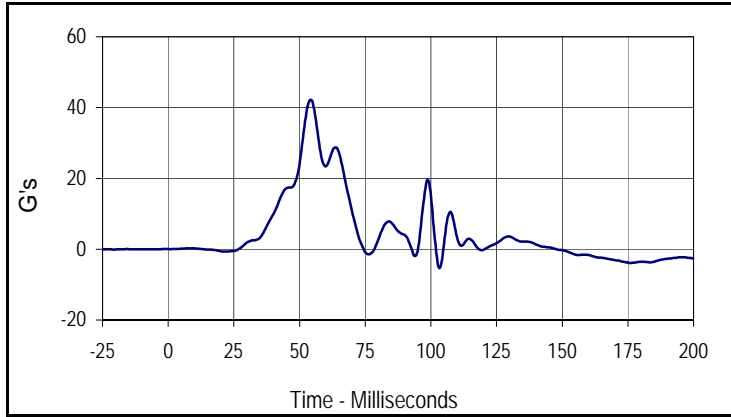

Curve Description			
Passenger Upper Rib Primary Y			
CURNO	Type	SAE Class	Units
005	FIR	FIR100	G's
Max	Time	Min	Time
42.2	54.4	-5.4	103.1

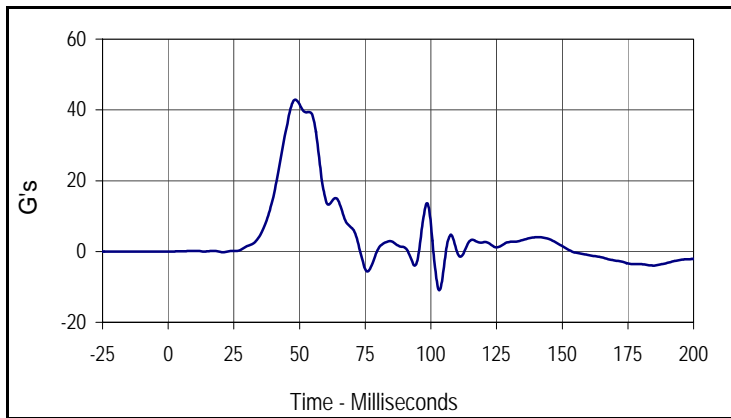

Curve Description			
Passenger Lower Rib Primary Y			
CURNO	Type	SAE Class	Units
006	FIR	FIR100	G's
Max	Time	Min	Time
42.8	48.1	-11.0	103.1

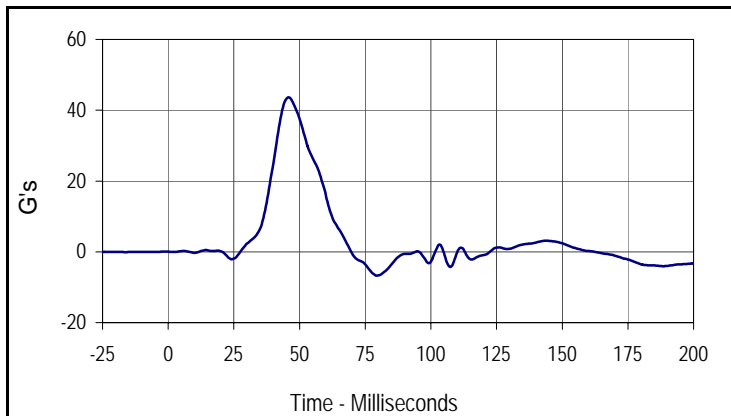

Curve Description			
Passenger Lower Spine Primary Y			
CURNO	Type	SAE Class	Units
007	FIR	FIR100	G's
Max	Time	Min	Time
43.7	45.6	-6.7	79.4

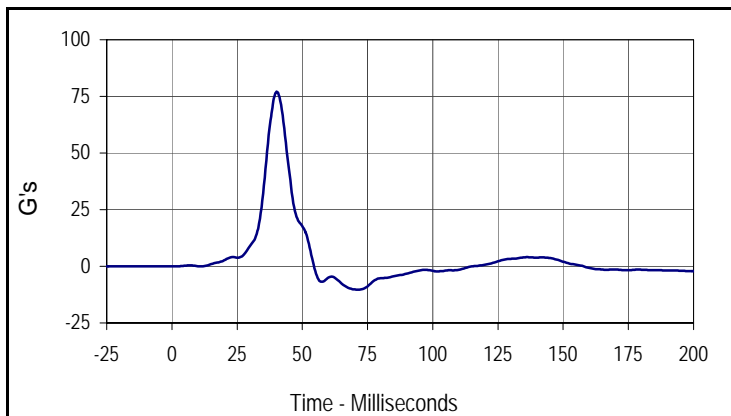

Curve Description			
Passenger Pelvis Primary Y			
CURNO	Type	SAE Class	Units
008	FIR	FIR100	G's
Max	Time	Min	Time
76.9	40.0	-10.3	71.3

APPENDIX C
SID/HIII CONFIGURATION AND PERFORMANCE VERIFICATION DATA

APPENDIX C
PRE-TEST SID / HIII CONFIGURATION AND PERFORMANCE VERIFICATION DATA

Test Program: SID / HIII External Measurements

Test Date: 9/7/05

ATD Serial No.: 274

Test I.D.: N/A



Tested Parameter	Units	Specification	Result	Pass/Fail
Laboratory Temperature	°C	18.9 to 25.6	21.1	Pass
Laboratory Relative Humidity	%	10 to 70	30	Pass
SH- Seated Height	mm	889 to 909	901	Pass
HP- Hip Point Height	mm	99 (reference)	99	Pass
RH- Rib Height	mm	502 to 520	507	Pass
KH- Knee Pivot From Back Line	mm	511 to 526	519	Pass
KV- Knee Pivot From Floor	mm	490 to 505	495	Pass
HW- Hip Width	mm	356 to 391	362	Pass
Overall Test Results				Pass

Test Program: SID / HIII Thorax Lateral Impact
 ATD Serial No.: 274

Test Date: 9/705
 Test I.D.: TH08C



Tested Parameter	Units	Specification	Result	Pass/Fail
Laboratory Temperature	°C	18.9 to 25.6	21.1	Pass
Laboratory Relative Humidity	%	10 to 70	30	Pass
Probe Velocity	m/s	4.21 to 4.33	4.25	Pass
Upper Rib Acceleration	G's	37.0 to 46.0	40.4	Pass
Lower Rib Acceleration	G's	37.0 to 46.0	40.2	Pass
Thoracic Spine Acceleration	G's	15.0 to 22.0	19.5	Pass
Overall Test Results			Pass	

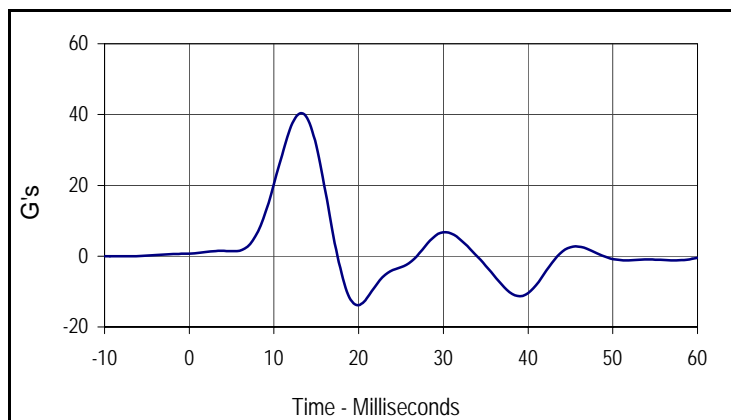

Curve Description			
Upper Rib Primary			
CURNO	Type	SAE Class	Units
001	FIL	FIR100	G's
Max	Time	Min	Time
40.4	13.1	-13.8	20.0

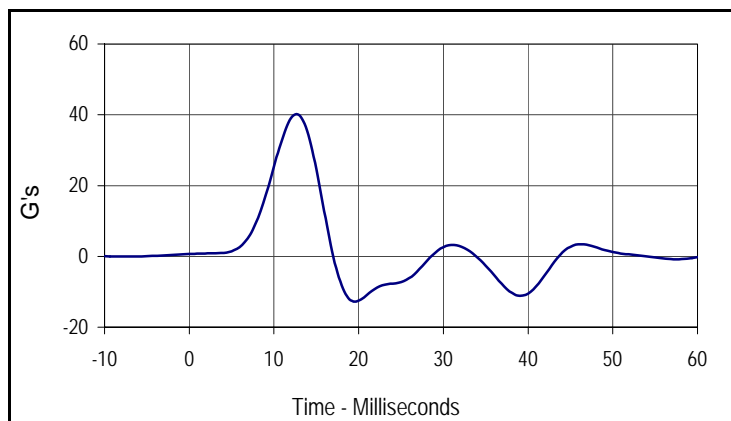

Curve Description			
Lower Rib Primary			
CURNO	Type	SAE Class	Units
002	FIL	FIR100	G's
Max	Time	Min	Time
40.2	12.5	-12.7	19.4

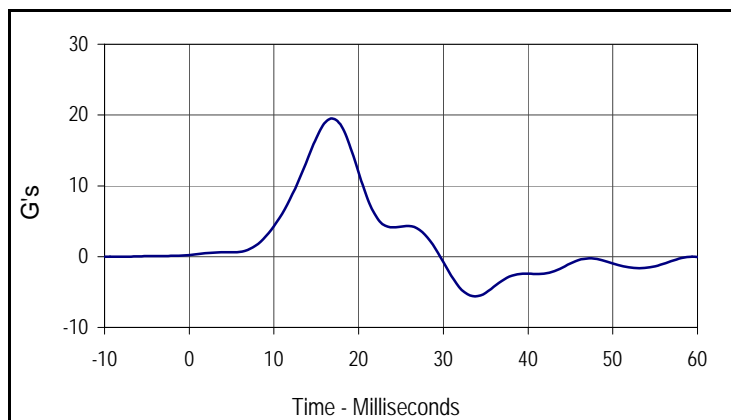

Curve Description			
Lower Spine Primary			
CURNO	Type	SAE Class	Units
003	FIL	FIR100	G's
Max	Time	Min	Time
19.5	16.9	-5.6	33.8

Test Program: SID / HIII Pelvis Lateral Impact
 ATD Serial No.: 274

Test Date: 9/7/05
 Test I.D.: PI08C



Tested Parameter	Units	Specification	Result	Pass/Fail
Laboratory Temperature	°C	18.9 to 25.6	21.1	Pass
Laboratory Relative Humidity	%	10 to 70	30	Pass
Probe Velocity	m/s	4.21 to 4.33	4.27	Pass
Peak Pelvis Acceleration	G's	40.0 to 60.0	43.6	Pass
Acceleration Time Above 20 G's	Msec.	3.0 to 7.0	6.88	Pass
Overall Test Results				Pass

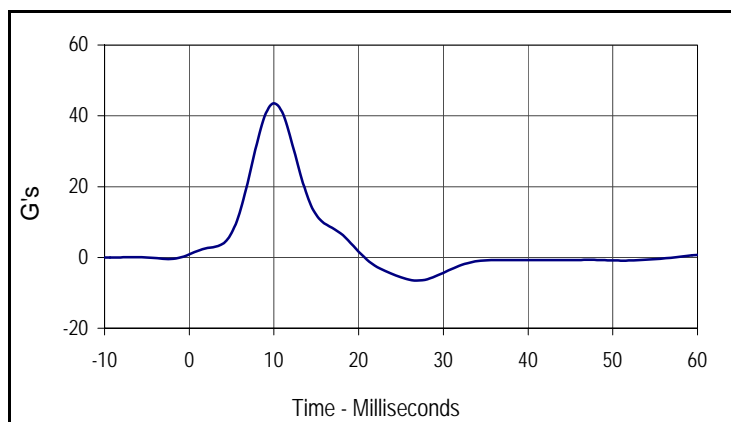

Curve Description			
Pelvis Primary Y			
CURNO	Type	SAE Class	Units
001	FIL	FIR100	G's
Max	Time	Min	Time
43.6	10.0	-6.5	26.9

Test Program: SID / HIII Head Drop Lateral Impact Test
 ATD Serial No.: 274

Test Date: 9/7/05
 Test I.D.: HD08C



Tested Parameter	Units	Specification	Result	Pass/Fail
Laboratory Temperature	°C	18.9 to 25.6	21.1	Pass
Laboratory Relative Humidity	%	10 to 70	30	Pass
Peak Resultant Acceleration	G's	120.0 to 150.0	148.8	Pass
Peak Longitudinal Acceleration	G's	≤15.0	5.8	Pass
Is Acceleration Unimodal?	Yes/No	Yes	Yes	Pass
Oscillations After Main Pulse	%	<15	2.8	Pass
Overall Test Results				Pass

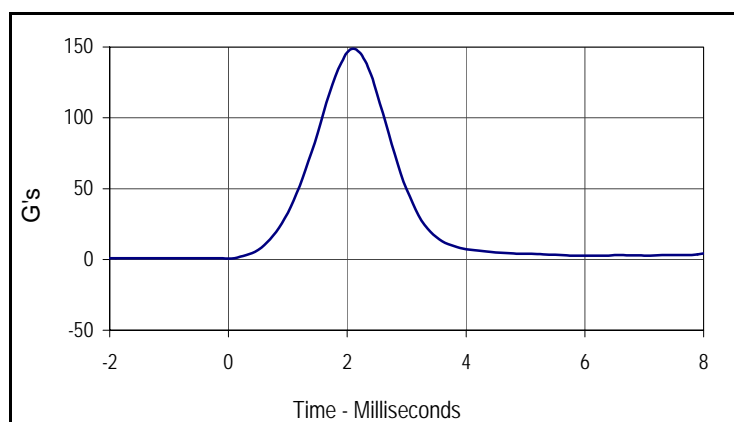

Curve Description			
Head Resultant			
CURNO	Type	SAE Class	Units
001	RES	1000	G's
Max	Time	Min	Time
148.8	2.1	0.6	0.0

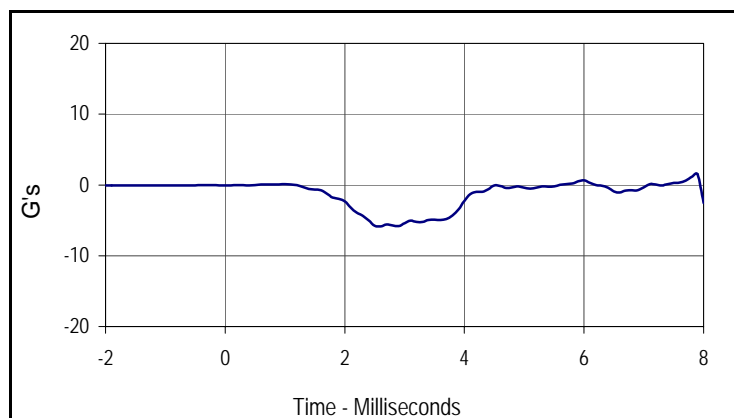

Curve Description			
Head X			
CURNO	Type	SAE Class	Units
002	FIL	1000	G's
Max	Time	Min	Time
0.6	6.0	-5.8	2.6

Test Program: SID / HIII Neck Pendulum Lateral Test
 ATD Serial No.: 274

Test Date: 9/7/05
 Test I.D.: NB09H



Tested Parameter	Units	Specification	Result	Pass/Fail	
Laboratory Temperature	°C	20.6 to 22.2	21.1	Pass	
Laboratory Relative Humidity	%	10 to 70	30	Pass	
Pendulum Velocity	m/sec	6.89 to 7.13	6.94	Pass	
Pendulum Deceleration	10 Msec.	m/sec	1.96 to 2.55	2.00	Pass
	20 Msec.	m/sec	4.12 to 5.10	4.25	Pass
	30 Msec.	m/sec	5.73 to 7.01	6.38	Pass
	40 to 70	m/sec	6.27 to 7.64	7.48	Pass
"D" Plane Rotation	Max	Degrees	66.0 to 82.0	78.5	Pass
Max Rotation Time After Peak Moment	Msec.	2.0 to 16.0	8.6	Pass	
Rotation Time From Peak to Zero Angle	Msec.	58.0 to 67.0	60.4	Pass	
Moment About Occipital Condyle	Nm	73.0 to 88.0	85.4	Pass	
Positive Moment Decay, Time To 0 Nm	Msec.	49.0 to 64.0	49.7	Pass	
Overall Test Results				Pass	

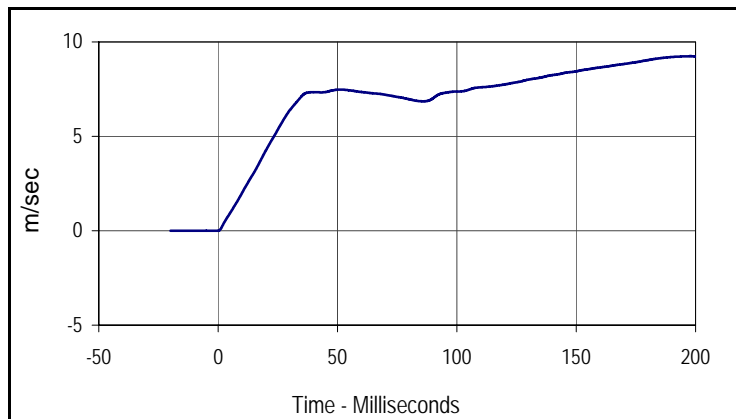

Curve Description			
Pendulum Velocity			
CURNO	Type	SAE Class	Units
001	FIL	180	m/sec
Max	Time	Min	Time
9.2	197.9	0.0	-0.3

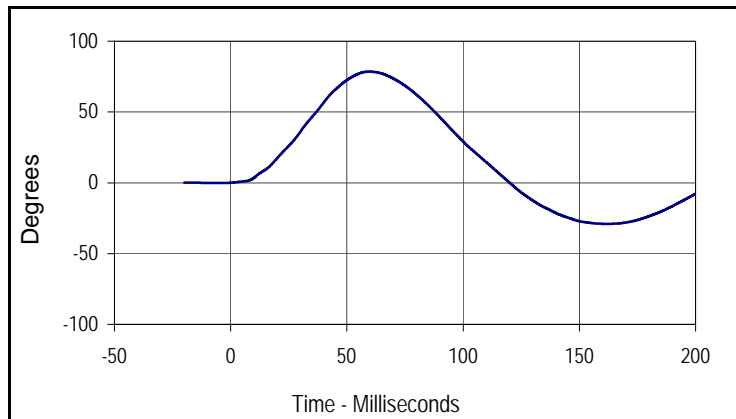

Curve Description			
"D" Plane Rotation			
CURNO	Type	SAE Class	Units
003	FIL	60	Degrees
Max	Time	Min	Time
78.5	59.7	-29.0	161.4

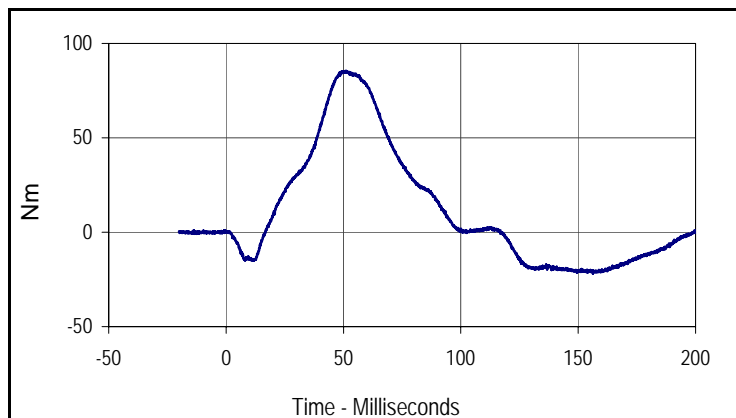

Curve Description			
Moment About Occipital Condyle			
CURNO	Type	SAE Class	Units
004	FIL	60	Nm
Max	Time	Min	Time
85.4	51.1	-21.9	156.3

Test Program: SID / HIII External Measurements

Test Date: 9/7/05

ATD Serial No.: 275

Test I.D.: N/A



Tested Parameter	Units	Specification	Result	Pass/Fail
Laboratory Temperature	°C	18.9 to 25.6	21.1	Pass
Laboratory Relative Humidity	%	10 to 70	30	Pass
SH- Seated Height	mm	889 to 909	905	Pass
HP- Hip Point Height	mm	99 (reference)	99	Pass
RH- Rib Height	mm	502 to 520	505	Pass
KH- Knee Pivot From Back Line	mm	511 to 526	518	Pass
KV- Knee Pivot From Floor	mm	490 to 505	500	Pass
HW- Hip Width	mm	356 to 391	368	Pass
Overall Test Results				Pass

Test Program: SID / HIII Thorax Lateral Impact
 ATD Serial No.: 275

Test Date: 9/7/05
 Test I.D.: TH08D



Tested Parameter	Units	Specification	Result	Pass/Fail
Laboratory Temperature	°C	18.9 to 25.6	21.1	Pass
Laboratory Relative Humidity	%	10 to 70	30	Pass
Probe Velocity	m/s	4.21 to 4.33	4.24	Pass
Upper Rib Acceleration	G's	37.0 to 46.0	41.2	Pass
Lower Rib Acceleration	G's	37.0 to 46.0	41.1	Pass
Thoracic Spine Acceleration	G's	15.0 to 22.0	19.8	Pass
Overall Test Results			Pass	

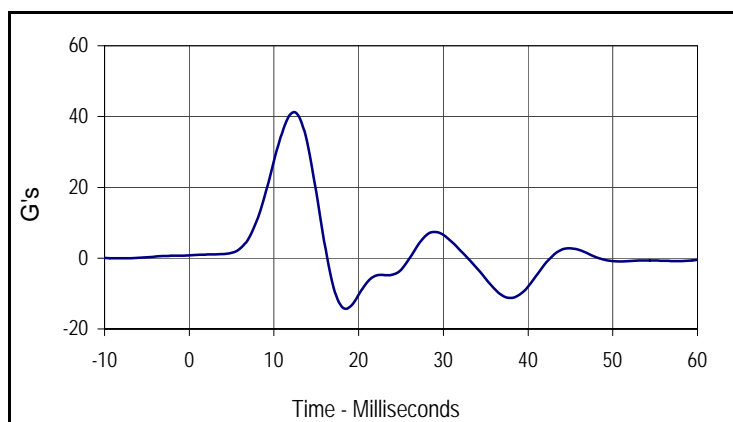

Curve Description			
Upper Rib Primary			
CURNO	Type	SAE Class	Units
001	FIL	FIR100	G's
Max	Time	Min	Time
41.2	12.5	-14.2	18.8

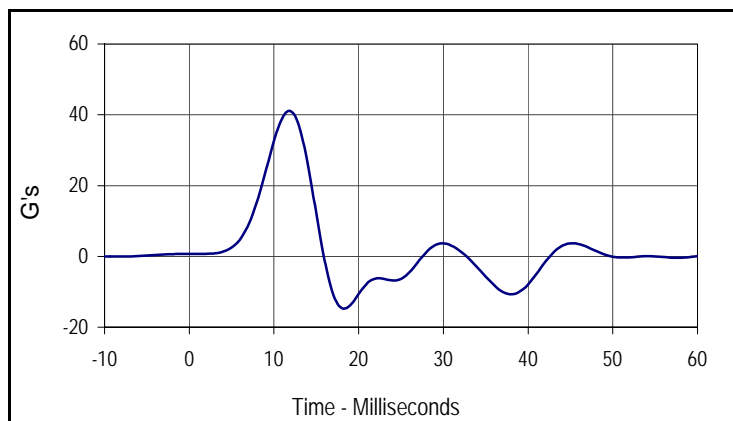

Curve Description			
Lower Rib Primary			
CURNO	Type	SAE Class	Units
002	FIL	FIR100	G's
Max	Time	Min	Time
41.1	11.9	-14.7	18.1

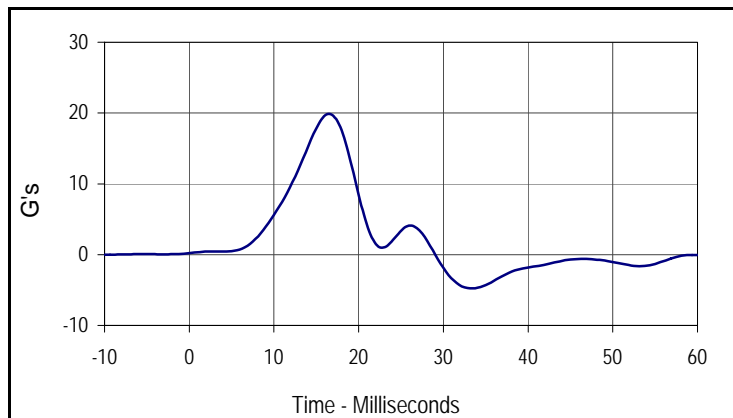

Curve Description			
Lower Spine Primary			
CURNO	Type	SAE Class	Units
003	FIL	FIR100	G's
Max	Time	Min	Time
19.8	16.3	-4.8	33.1

Test Program: SID / HIII Pelvis Lateral Impact
 ATD Serial No.: 275

Test Date: 9/7/05
 Test I.D.: PI08D



Tested Parameter	Units	Specification	Result	Pass/Fail
Laboratory Temperature	°C	18.9 to 25.6	21.1	Pass
Laboratory Relative Humidity	%	10 to 70	30	Pass
Probe Velocity	m/s	4.21 to 4.33	4.29	Pass
Peak Pelvis Acceleration	G's	40.0 to 60.0	42.8	Pass
Acceleration Time Above 20 G's	Msec.	3.0 to 7.0	5.63	Pass
Overall Test Results				Pass

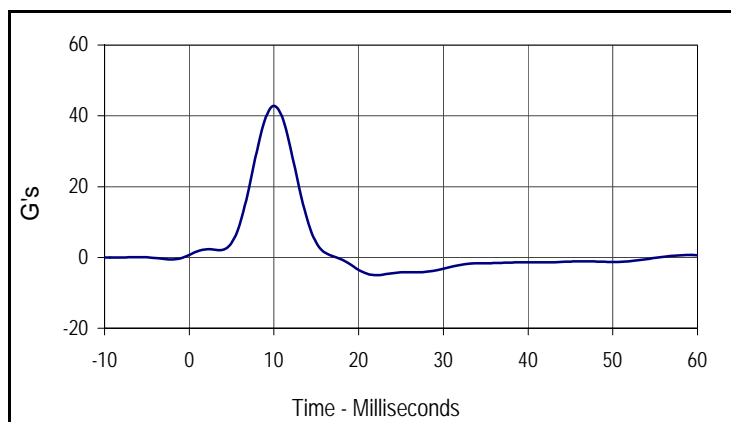

Curve Description			
Pelvis Primary Y			
CURNO	Type	SAE Class	Units
001	FIL	FIR100	G's
Max	Time	Min	Time
42.8	10.0	-5.0	21.9

Test Program: SID / HIII Head Drop Lateral Impact Test
 ATD Serial No.: 275

Test Date: 9/7/05
 Test I.D.: HD08D



Tested Parameter	Units	Specification	Result	Pass/Fail
Laboratory Temperature	°C	18.9 to 25.6	21.1	Pass
Laboratory Relative Humidity	%	10 to 70	30	Pass
Peak Resultant Acceleration	G's	120.0 to 150.0	147.6	Pass
Peak Longitudinal Acceleration	G's	≤15.0	5.3	Pass
Is Acceleration Unimodal?	Yes/No	Yes	Yes	Pass
Oscillations After Main Pulse	%	<15	2.4	Pass
Overall Test Results				Pass

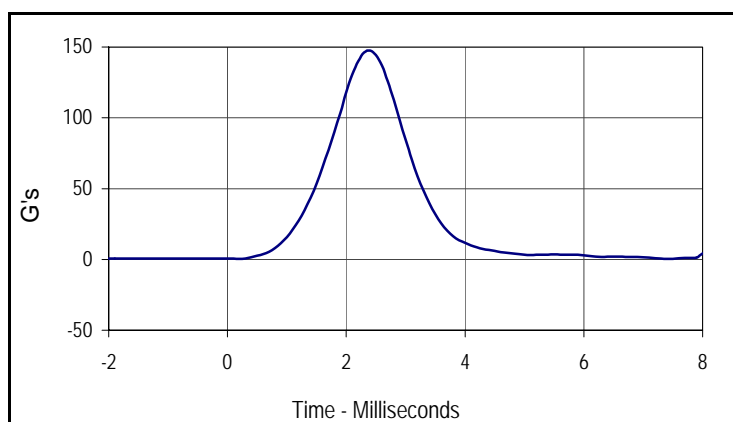

Curve Description			
Head Resultant			
CURNO	Type	SAE Class	Units
001	RES	1000	G's
Max	Time	Min	Time
147.6	2.4	0.5	0.2

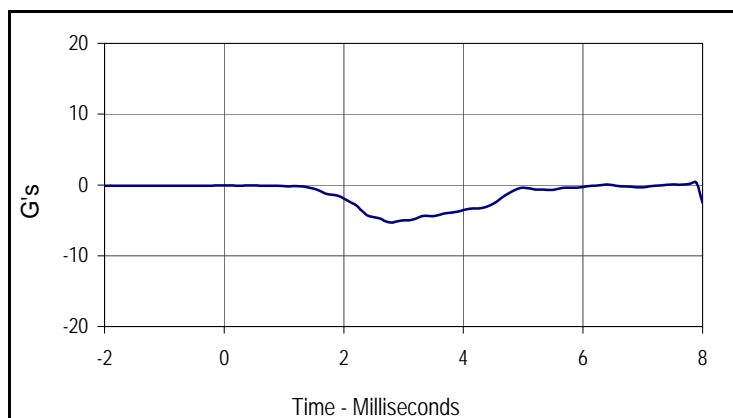

Curve Description			
Head X			
CURNO	Type	SAE Class	Units
002	FIL	1000	G's
Max	Time	Min	Time
-0.1	0.5	-5.3	2.8

Test Program: SID / HIII Neck Pendulum Lateral Test
 ATD Serial No.: 275

Test Date: 9/7/05
 Test I.D.: NB09J



Tested Parameter	Units	Specification	Result	Pass/Fail	
Laboratory Temperature	°C	20.6 to 22.2	21.1	Pass	
Laboratory Relative Humidity	%	10 to 70	30	Pass	
Pendulum Velocity	m/sec	6.89 to 7.13	6.93	Pass	
Pendulum Deceleration	10 Msec.	m/sec	1.96 to 2.55	2.20	Pass
	20 Msec.	m/sec	4.12 to 5.10	4.48	Pass
	30 Msec.	m/sec	5.73 to 7.01	6.49	Pass
	40 to 70	m/sec	6.27 to 7.64	7.54	Pass
"D" Plane Rotation	Max	Degrees	66.0 to 82.0	77.5	Pass
Max Rotation Time After Peak Moment	Msec.	2.0 to 16.0	9.4	Pass	
Rotation Time From Peak to Zero Angle	Msec.	58.0 to 67.0	59.4	Pass	
Moment About Occipital Condyle	Nm	73.0 to 88.0	75.8	Pass	
Positive Moment Decay, Time To 0 Nm	Msec.	49.0 to 64.0	50.4	Pass	
Overall Test Results				Pass	

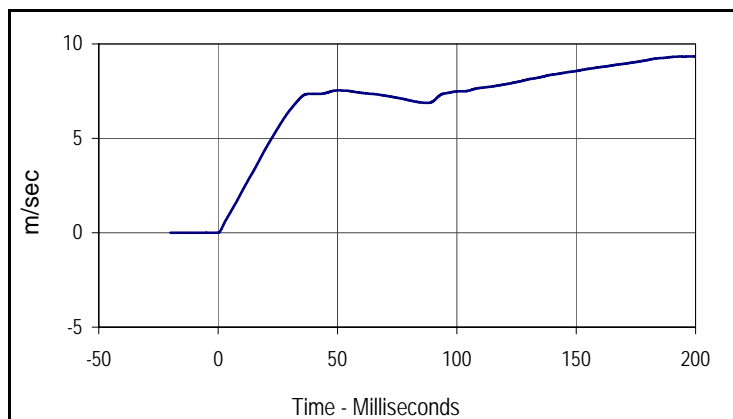

Curve Description			
Pendulum Velocity			
CURNO	Type	SAE Class	Units
001	FIL	180	m/sec
Max	Time	Min	Time
9.3	198.8	0.0	-0.5

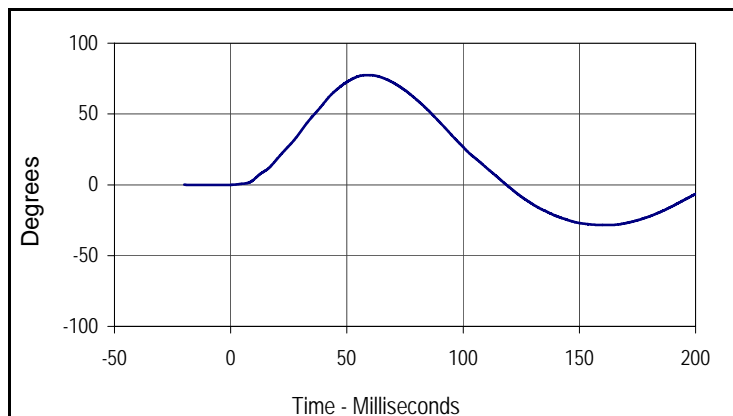

Curve Description			
"D" Plane Rotation			
CURNO	Type	SAE Class	Units
003	FIL	60	Degrees
Max	Time	Min	Time
77.5	59.2	-28.4	161.2

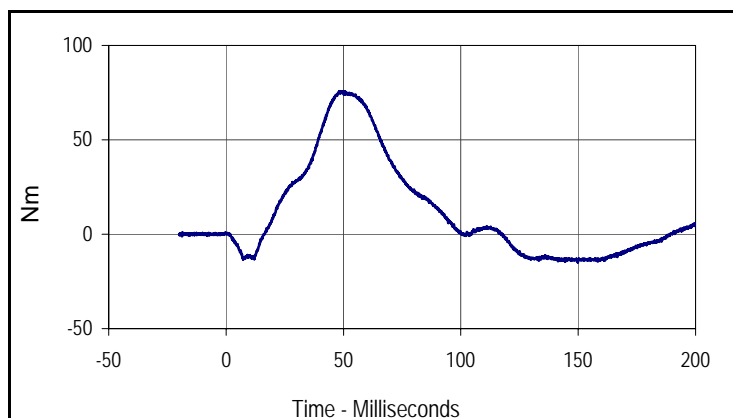

Curve Description			
Moment About Occipital Condyle			
CURNO	Type	SAE Class	Units
004	FIL	60	Nm
Max	Time	Min	Time
75.8	49.8	-14.9	149.8

APPENDIX C
POST-TEST SID / HIII CONFIGURATION AND PERFORMANCE VERIFICATION DATA

Test Program: SID / HIII External Measurements

Test Date: 9/14/05

ATD Serial No.: 274

Test I.D.: N/A



Tested Parameter	Units	Specification	Result	Pass/Fail
Laboratory Temperature	°C	18.9 to 25.6	21.1	Pass
Laboratory Relative Humidity	%	10 to 70	30	Pass
SH- Seated Height	mm	889 to 909	900	Pass
HP- Hip Point Height	mm	99 (reference)	99	Pass
RH- Rib Height	mm	502 to 520	510	Pass
KH- Knee Pivot From Back Line	mm	511 to 526	515	Pass
KV- Knee Pivot From Floor	mm	490 to 505	495	Pass
HW- Hip Width	mm	356 to 391	366	Pass
Overall Test Results				Pass

Test Program: SID / HIII Thorax Lateral Impact
 ATD Serial No.: 274

Test Date: 9/12/05
 Test I.D.: TH09M



Tested Parameter	Units	Specification	Result	Pass/Fail
Laboratory Temperature	°C	18.9 to 25.6	21.1	Pass
Laboratory Relative Humidity	%	10 to 70	30	Pass
Probe Velocity	m/s	4.21 to 4.33	4.30	Pass
Upper Rib Acceleration	G's	37.0 to 46.0	39.0	Pass
Lower Rib Acceleration	G's	37.0 to 46.0	38.8	Pass
Thoracic Spine Acceleration	G's	15.0 to 22.0	18.8	Pass
Overall Test Results			Pass	

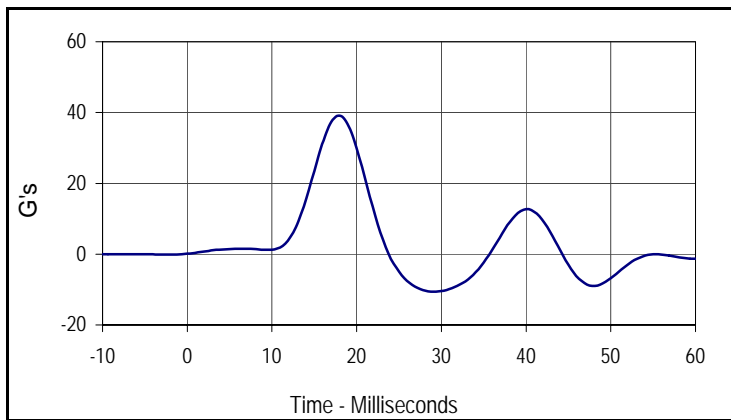

Curve Description			
Upper Rib Primary Y			
CURNO	Type	SAE Class	Units
001	FIL	FIR100	G's
Max	Time	Min	Time
39.0	18.1	-10.6	29.4

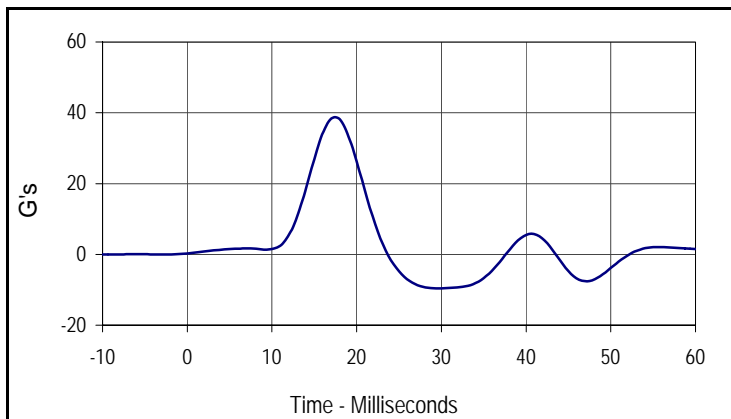

Curve Description			
Lower Rib Primary Y			
CURNO	Type	SAE Class	Units
002	FIL	FIR100	G's
Max	Time	Min	Time
38.8	17.5	-9.6	29.4

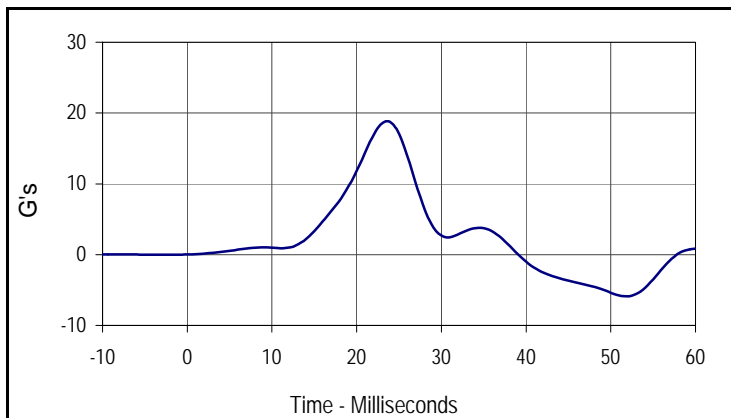

Curve Description			
Lower Spine Primary Y			
CURNO	Type	SAE Class	Units
003	FIL	FIR100	G's
Max	Time	Min	Time
18.8	23.8	-5.9	51.9

Test Program: SID / HIII Pelvis Lateral Impact
 ATD Serial No.: 274

Test Date: 9/12/05
 Test I.D.: PL09M



Tested Parameter	Units	Specification	Result	Pass/Fail
Laboratory Temperature	°C	18.9 to 25.6	21.1	Pass
Laboratory Relative Humidity	%	10 to 70	30	Pass
Probe Velocity	m/s	4.21 to 4.33	4.25	Pass
Peak Pelvis Acceleration	G's	40.0 to 60.0	52.7	Pass
Acceleration Time Above 20 G's	Msec.	3.0 to 7.0	6.25	Pass
Overall Test Results				Pass

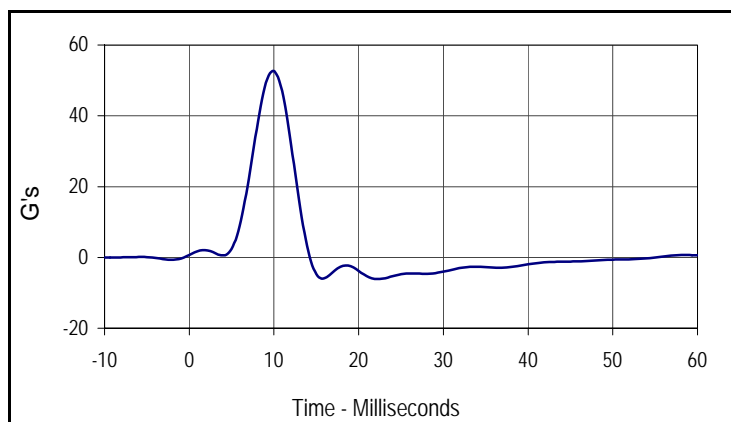

Curve Description			
Pelvis Primary Y			
CURNO	Type	SAE Class	Units
001	FIL	FIR100	G's
Max	Time	Min	Time
52.7	10.0	-6.1	22.5

Test Program: SID / HIII Head Drop Lateral Impact Test
 ATD Serial No.: 274

Test Date: 9/13/05
 Test I.D.: HD09M



Tested Parameter	Units	Specification	Result	Pass/Fail
Laboratory Temperature	°C	18.9 to 25.6	21.1	Pass
Laboratory Relative Humidity	%	10 to 70	30	Pass
Peak Resultant Acceleration	G's	120.0 to 150.0	145.9	Pass
Peak Longitudinal Acceleration	G's	≤15.0	8.2	Pass
Is Acceleration Unimodal?	Yes/No	Yes	Yes	Pass
Oscillations After Main Pulse	%	<15	3.4	Pass
Overall Test Results				Pass

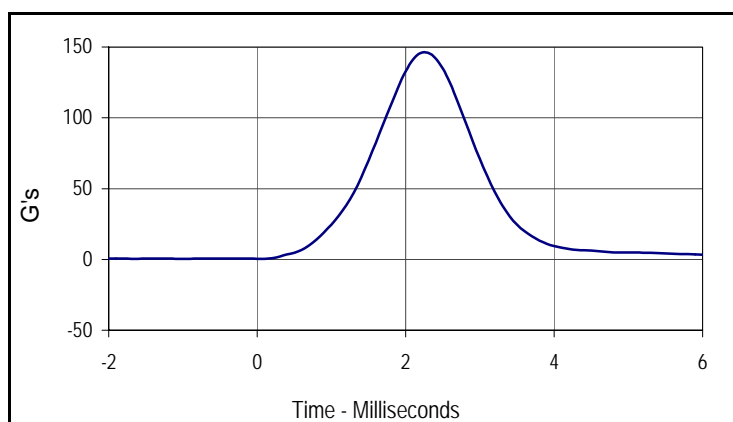

Curve Description			
Head Resultant			
CURNO	Type	SAE Class	Units
001	RES	1000	G's
Max	Time	Min	Time
145.9	2.3	0.4	0.1

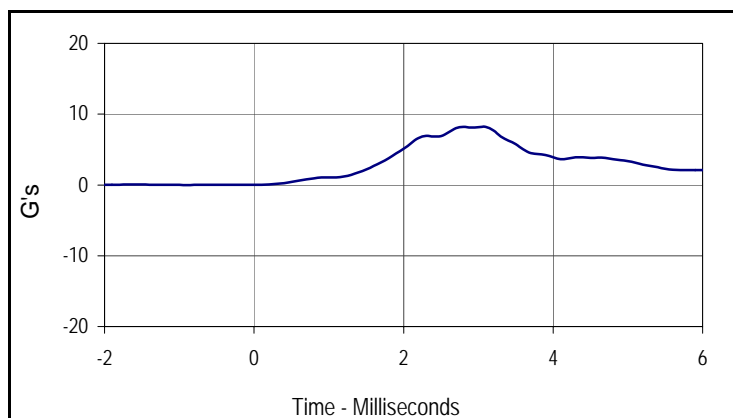

Curve Description			
Head X			
CURNO	Type	SAE Class	Units
002	FIL	1000	G's
Max	Time	Min	Time
8.2	3.1	0.0	-0.9

Test Program: SID / HIII Neck Pendulum Lateral Test
 ATD Serial No.: 274

Test Date: 9/13/05
 Test I.D.: NB10X



Tested Parameter	Units	Specification	Result	Pass/Fail	
Laboratory Temperature	°C	20.6 to 22.2	21.1	Pass	
Laboratory Relative Humidity	%	10 to 70	30	Pass	
Pendulum Velocity	m/sec	6.89 to 7.13	6.94	Pass	
Pendulum Deceleration	10 Msec.	m/sec	1.96 to 2.55	2.01	Pass
	20 Msec.	m/sec	4.12 to 5.10	4.19	Pass
	30 Msec.	m/sec	5.73 to 7.01	6.10	Pass
	40 to 70	m/sec	6.27 to 7.64	7.56	Pass
"D" Plane Rotation	Max	Degrees	66.0 to 82.0	75.2	Pass
Max Rotation Time After Peak Moment	Msec.	2.0 to 16.0	9.6	Pass	
Rotation Time From Peak to Zero Angle	Msec.	58.0 to 67.0	58.8	Pass	
Moment About Occipital Condyle	Nm	73.0 to 88.0	84.5	Pass	
Positive Moment Decay, Time To 0 Nm	Msec.	49.0 to 64.0	50.0	Pass	
Overall Test Results				Pass	

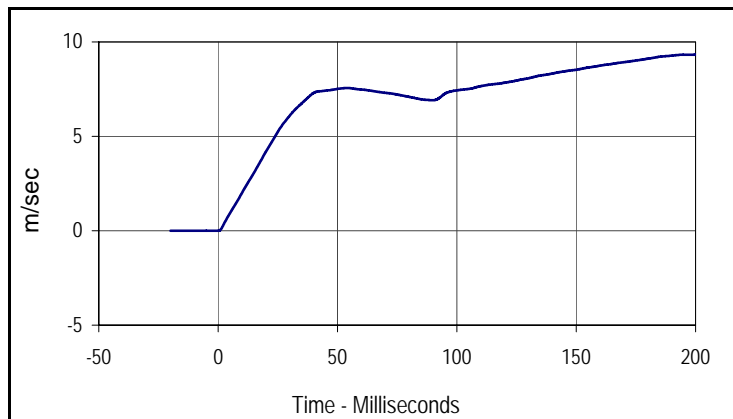

Curve Description			
Pendulum Velocity			
CURNO	Type	SAE Class	Units
001	FIL	180	m/sec
Max	Time	Min	Time
9.3	200.0	0.0	-0.1

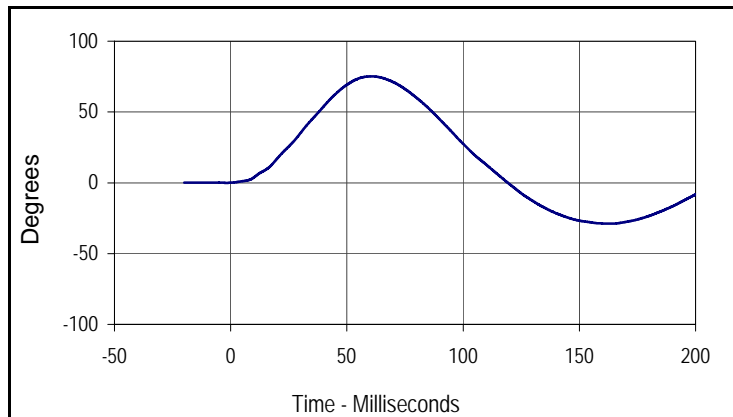

Curve Description			
"D" Plane Rotation			
CURNO	Type	SAE Class	Units
003	FIL	60	Degrees
Max	Time	Min	Time
75.2	60.5	-28.9	163.8

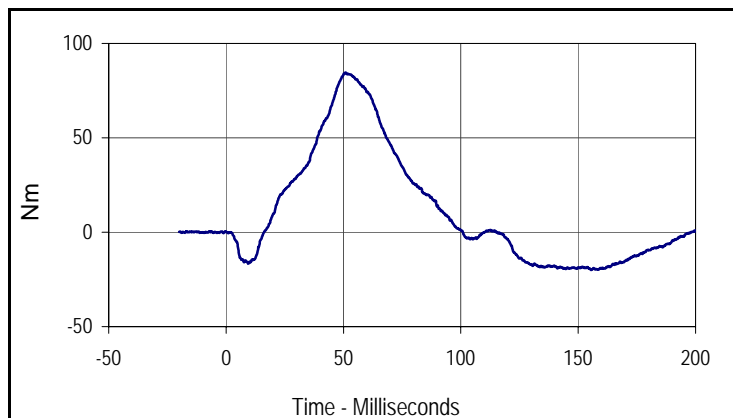

Curve Description			
Moment About Occipital Condyle			
CURNO	Type	SAE Class	Units
004	FIL	600	Nm
Max	Time	Min	Time
84.5	50.9	-20.0	155.5

Test Program: SID / HIII External Measurements

Test Date: 9/14/05

ATD Serial No.: 275

Test I.D.: N/A



Tested Parameter	Units	Specification	Result	Pass/Fail
Laboratory Temperature	°C	18.9 to 25.6	21.1	Pass
Laboratory Relative Humidity	%	10 to 70	30	Pass
SH- Seated Height	mm	889 to 909	895	Pass
HP- Hip Point Height	mm	99 (reference)	99	Pass
RH- Rib Height	mm	502 to 520	505	Pass
KH- Knee Pivot From Back Line	mm	511 to 526	513	Pass
KV- Knee Pivot From Floor	mm	490 to 505	495	Pass
HW- Hip Width	mm	356 to 391	381	Pass
Overall Test Results				Pass

Test Program: SID / HIII Thorax Lateral Impact
 ATD Serial No.: 275

Test Date: 9/12/05
 Test I.D.: TH09N



Tested Parameter	Units	Specification	Result	Pass/Fail
Laboratory Temperature	°C	18.9 to 25.6	21.1	Pass
Laboratory Relative Humidity	%	10 to 70	30	Pass
Probe Velocity	m/s	4.21 to 4.33	4.25	Pass
Upper Rib Acceleration	G's	37.0 to 46.0	41.8	Pass
Lower Rib Acceleration	G's	37.0 to 46.0	38.9	Pass
Thoracic Spine Acceleration	G's	15.0 to 22.0	17.8	Pass
Overall Test Results			Pass	

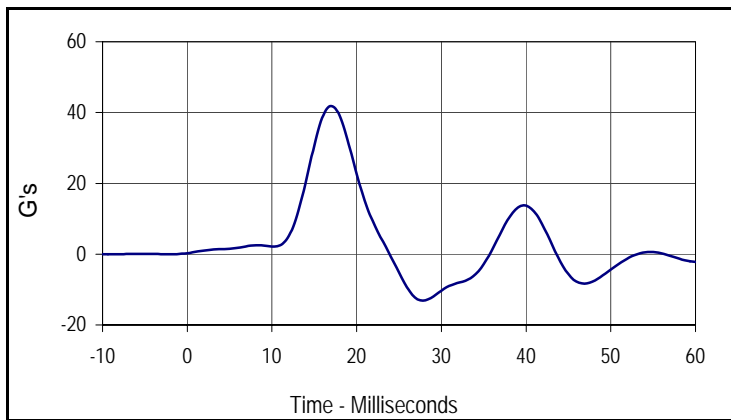

Curve Description			
Upper Rib Primary Y			
CURNO	Type	SAE Class	Units
001	FIL	FIR100	G's
Max	Time	Min	Time
41.8	16.9	-13.1	28.1

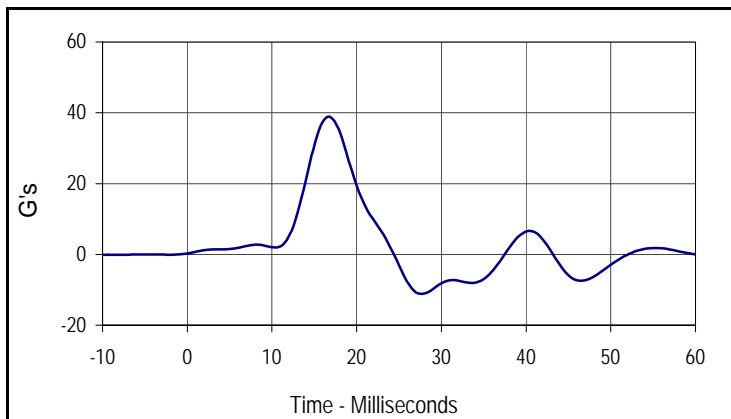

Curve Description			
Lower Rib Primary Y			
CURNO	Type	SAE Class	Units
002	FIL	FIR100	G's
Max	Time	Min	Time
38.9	16.9	-11.2	27.5

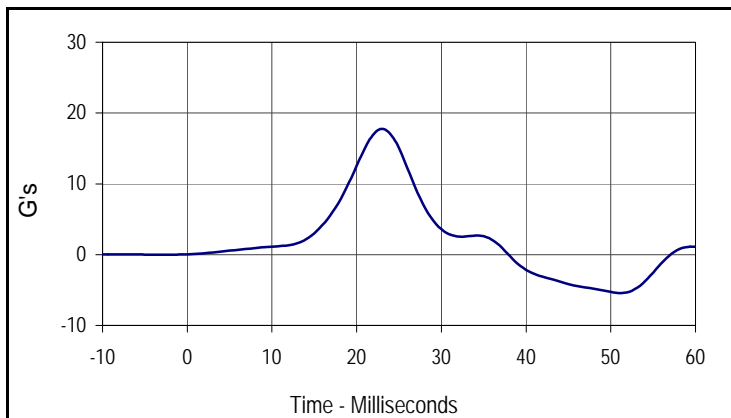

Curve Description			
Lower Spine Primary Y			
CURNO	Type	SAE Class	Units
003	FIL	FIR100	G's
Max	Time	Min	Time
17.8	23.1	-5.4	51.3

Test Program: SID / HIII Pelvis Lateral Impact
 ATD Serial No.: 275

Test Date: 9/12/05
 Test I.D.: PL09N



Tested Parameter	Units	Specification	Result	Pass/Fail
Laboratory Temperature	°C	18.9 to 25.6	21.1	Pass
Laboratory Relative Humidity	%	10 to 70	30	Pass
Probe Velocity	m/s	4.21 to 4.33	4.28	Pass
Peak Pelvis Acceleration	G's	40.0 to 60.0	46.0	Pass
Acceleration Time Above 20 G's	Msec.	3.0 to 7.0	6.25	Pass
Overall Test Results				Pass

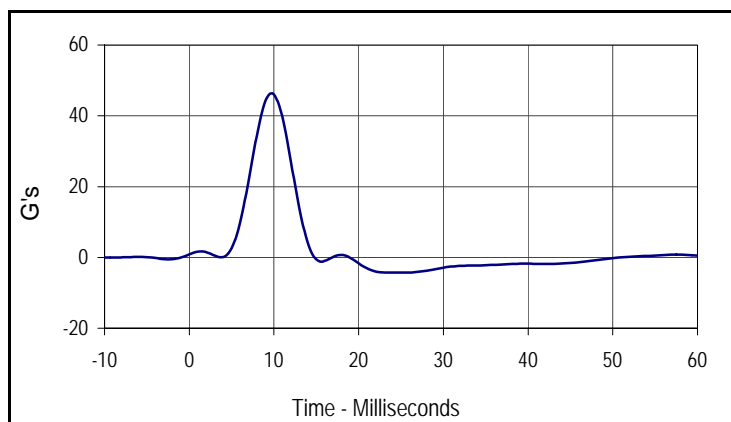

Curve Description			
Pelvis Primary Y			
CURNO	Type	SAE Class	Units
001	FIL	FIR100	G's
Max	Time	Min	Time
46.0	10.0	-4.3	25.6

Test Program: SID / HIII Head Drop Lateral Impact Test
 ATD Serial No.: 275

Test Date: 9/13/05
 Test I.D.: HD09N



Tested Parameter	Units	Specification	Result	Pass/Fail
Laboratory Temperature	°C	18.9 to 25.6	21.1	Pass
Laboratory Relative Humidity	%	10 to 70	30	Pass
Peak Resultant Acceleration	G's	120.0 to 150.0	125.8	Pass
Peak Longitudinal Acceleration	G's	≤15.0	4.5	Pass
Is Acceleration Unimodal?	Yes/No	Yes	Yes	Pass
Oscillations After Main Pulse	%	<15	3.5	Pass
Overall Test Results				Pass

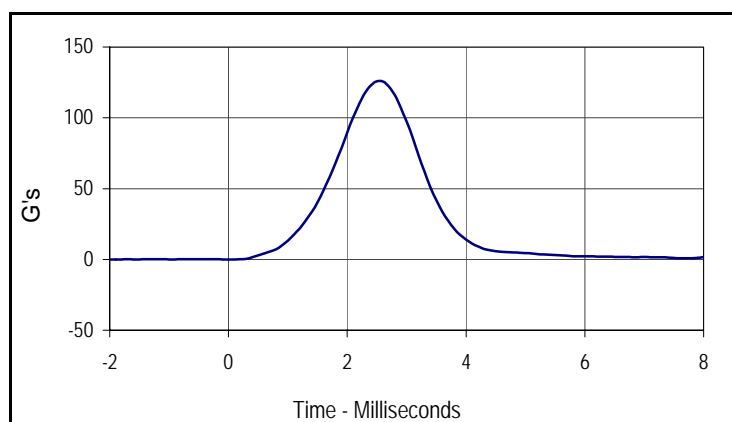

Curve Description			
Head Resultant			
CURNO	Type	SAE Class	Units
001	RES	1000	G's
Max	Time	Min	Time
125.8	2.5	0.0	0.0

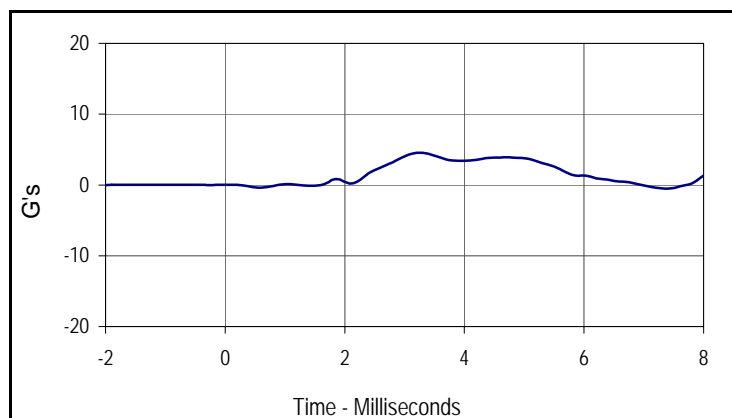

Curve Description			
Head X			
CURNO	Type	SAE Class	Units
002	FIL	1000	G's
Max	Time	Min	Time
4.5	3.3	-0.4	0.6

Test Program: SID / HIII Neck Pendulum Lateral Test
 ATD Serial No.: 275

Test Date: 9/13/05
 Test I.D.: NB09Z



Tested Parameter	Units	Specification	Result	Pass/Fail	
Laboratory Temperature	°C	20.6 to 22.2	21.1	Pass	
Laboratory Relative Humidity	%	10 to 70	30	Pass	
Pendulum Velocity	m/sec	6.89 to 7.13	7.01	Pass	
Pendulum Deceleration	10 Msec.	m/sec	1.96 to 2.55	2.04	Pass
	20 Msec.	m/sec	4.12 to 5.10	4.17	Pass
	30 Msec.	m/sec	5.73 to 7.01	6.16	Pass
	40 to 70	m/sec	6.27 to 7.64	7.55	Pass
"D" Plane Rotation	Max	Degrees	66.0 to 82.0	77.7	Pass
Max Rotation Time After Peak Moment	Msec.	2.0 to 16.0	8.2	Pass	
Rotation Time From Peak to Zero Angle	Msec.	58.0 to 67.0	60.0	Pass	
Moment About Occipital Condyle	Nm	73.0 to 88.0	85.4	Pass	
Positive Moment Decay, Time To 0 Nm	Msec.	49.0 to 64.0	50.0	Pass	
Overall Test Results				Pass	

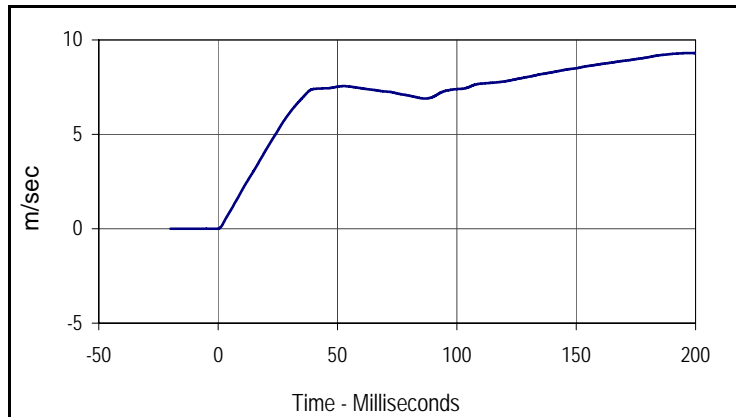

Curve Description			
Pendulum Velocity			
CURNO	Type	SAE Class	Units
001	FIL	180	m/sec
Max	Time	Min	Time
9.3	200.0	0.0	-0.4

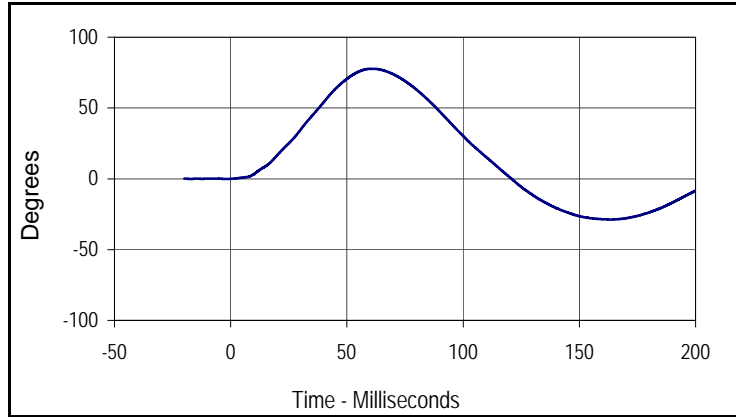

Curve Description			
"D" Plane Rotation			
CURNO	Type	SAE Class	Units
003	FIL	60	Degrees
Max	Time	Min	Time
77.7	60.9	-28.7	163.5

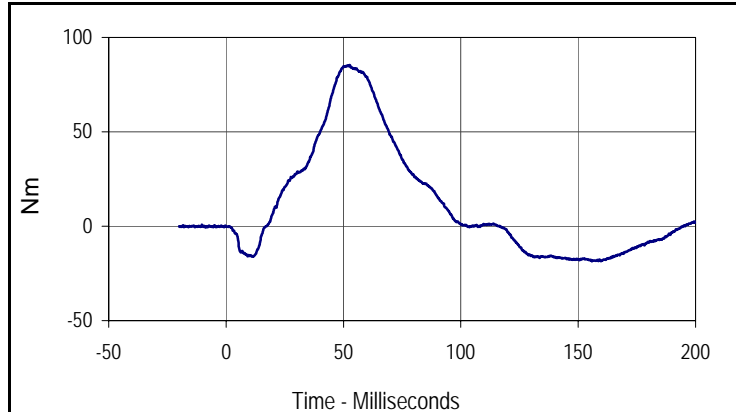

Curve Description			
Moment About Occipital Condyle			
CURNO	Type	SAE Class	Units
004	FIL	600	Nm
Max	Time	Min	Time
85.4	52.7	-18.5	159.7