

REPORT NUMBER: CAL-06-02

**NEW CAR ASSESSMENT PROGRAM (NCAP)  
FRONTAL BARRIER IMPACT TEST**

HYUNDAI MOTOR COMPANY  
2006 HYUNDAI SONATA  
FOUR-DOOR SEDAN

NHTSA NUMBER: M60506

CALSPAN TEST NUMBER: 8642-NCAP-62

CALSPAN CORPORATION  
TRANSPORTATION SCIENCES CENTER  
P.O. BOX 400  
BUFFALO, NEW YORK 14225

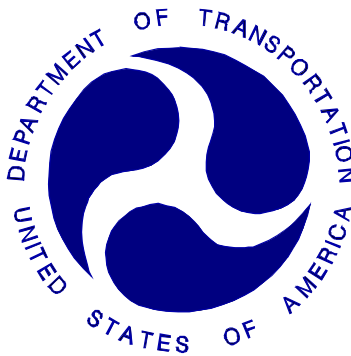

August 25, 2005

FINAL REPORT

PREPARED FOR:

U. S. DEPARTMENT OF TRANSPORTATION  
National Highway Traffic Safety Administration  
Rulemaking  
Office of Crashworthiness Standards  
Mail Code: NVS-111  
400 Seventh Street, SW, Room No. 5313  
Washington, DC 20590

This publication is distributed by the U. S. Department of Transportation, National Highway Traffic Safety Administration, in the interest of information exchange. The opinions, findings and conclusions expressed in this publication are those of the author(s) and not necessarily those of the Department of Transportation or the National Highway Traffic Safety Administration. The United States Government assumes no liability for its contents or use thereof. If trade or manufacturers' names or products are mentioned, it is only because they are considered essential to the object of the publication and should not be construed as an endorsement. The United States Government does not endorse products or manufacturers.

Prepared by:

---

Patrick G. MacDiarmid, Jr., Project Engineer

Approved by:

---

David J. Travale, Program Manager  
Transportation Science Center

Approval Date:

---

**TECHNICAL REPORT STANDARD TITLE PAGE**

1. Report No. CAL-06-02		2. Government Accession No.		3. Recipient's Catalog No.	
4. Title and Subtitle Final Report of NEW CAR ASSESSMENT PROGRAM (NCAP) Testing of a 2006 Hyundai Sonata Four-Door Sedan NHTSA No. M60506				5. Report Date August 25, 2005	
				6. Performing Organization Code CAL	
7. Author(s) David J. Travale, Program Manager Patrick G. MacDiarmid, Jr., Project Engineer				8. Performing Organization Report No. 8642-NCAP-62	
9. Performing Organization Name and Address Calspan Corporation 4455 Genesee Street Buffalo, New York 14225				10. Work Unit No.	
				11. Contract or Grant No. DTNH22-01-D-32005	
12. Sponsoring Agency Name and Address U.S. Department of Transportation National Highway Traffic Safety Administration Office of Crashworthiness Standards Mail Code: NVS-111 400 Seventh, SW, Room 5313 Washington, D.C. 20590				13. Type of Report and Period Covered Final Report August - September, 2005	
				14. Sponsoring Agency Code NVS-111	
15. Supplementary Notes					
16. Abstract  A frontal load cell barrier test of a 2006 Hyundai Sonata Four-Door Sedan was performed at Calspan Corporation's crash test facility in Buffalo, New York, on August 25, 2005. The impact velocity was 56.65 kph and the temperature at the barrier face was 21 °C. The maximum post-test vehicle crush was 431 mm. The test vehicle was equipped with 3-point restraint systems with shoulder belt pretensioners and force limiters, knee bolsters, head restraints and airbags at both the driver and right outboard passenger seating positions. With respect to FMVSS 208 "Occupant Crash Protection - Injury Criteria" both the driver and passenger appeared to comply with head, chest, and femur requirements. The occupant injury criteria summary is as follows:					
<b>Measurement Description</b>		<b>Units</b>	<b>Threshold</b>	<b>Driver (142)</b>	<b>Passenger (150)</b>
<b>Head Injury Criteria (HIC - 36 ms)</b>		-	1000	267.5	277.8
<b>Maximum Thorax Acceleration (3 ms Clip)</b>		g's	60 g's	42.5	38.5
<b>Chest Displacement</b>		mm	-76 mm	-42.3	-31.5
<b>Left Femur Force</b>		Newtons	-10000 N	-3238.6	-2032.7
<b>Right Femur Force</b>		Newtons	-10000 N	-3413.6	-1181.9
17. Key Words 56 kph Frontal Barrier Impact test New Car Assessment Program (NCAP)				18. Distribution Statement Copies of this report are available from: NHTSA Technical Reference Division National Highway Traffic Safety Admin. 400 Seventh St., SW, Room 5111 Washington, DC 20590	
19. Security Classif. (of this report) UNCLASSIFIED		20. Security Classif. (of this page) UNCLASSIFIED		21. No. of Pages 102	22. Price

Form DOT F1700.7 (8-69)

## TABLE OF CONTENTS

<u>Section</u>		<u>Page No.</u>
1	PURPOSE AND SUMMARY OF NCAP TEST	1-1
2	OCCUPANT AND VEHICLE INFORMATION	2-1
<u>Data Sheet</u>	<u>Description</u>	
1.	CRASH TEST SUMMARY	2-1
2.	GENERAL TEST AND VEHICLE PARAMETER DATA	2-2
3.	TEST VEHICLE TIRE INFORMATION	2-4
4.	TEST VEHICLE INFORMATION	2-5
5.	DUMMY POSITIONING IN VEHICLE	2-7
6.	SEAT BELT POSITIONING DATA	2-9
7.	VEHICLE ACCELEROMETER LOCATION AND DATA SUMMARY	2-10
8.	SUMMARY OF FMVSS 212 and FMVSS 219 (Partial) DATA	2-11
9.	SUMMARY OF FMVSS NO. 301 DATA	2-12
10.	VEHICLE MEASUREMENTS	2-13
11.	HIGH-SPEED CAMERA LOCATIONS	2-16
12.	VEHICLE REFERENCE PHOTO TARGET LOCATIONS	2-18
13.	VEHICLE INTRUSION MEASUREMENTS	2-19
14.	LOAD CELL LOCATIONS ON FIXED BARRIER	2-23
15.	ACCIDENT INVESTIGATION DIVISION DATA	2-24
16.	VEHICLE AND DUMMY TEMPERATURE STABILIZATION CHART	2-25
APPENDIX A	PHOTOGRAPHS	A-1
APPENDIX B	VEHICLE, LOAD CELL BARRIER AND DUMMY RESPONSE DATA	B-1
APPENDIX C	PART 572E DUMMY CONFIGURATION AND PERFORMANCE VERIFICATION TESTS	C-1
APPENDIX D	DUMMY, VEHICLE AND LABORATORY INSTRUMENT CALIBRATION	D-1
APPENDIX E	VEHICLE INTERIOR INTRUSION MEASUREMENTS	E-1

## SECTION 1

### PURPOSE AND SUMMARY OF TEST

#### 1.1 PURPOSE

This 56.65 kph frontal barrier impact test is part of the Vehicle Barrier Impact Testing Program sponsored by the National Highway Traffic Safety Administration (NHTSA) under Contract No. DTNH22-01-D-32005. The purpose of this test was to obtain vehicle crashworthiness and occupant restraint system performance data for an impact speed in excess of the current 48.3 kph requirements.

The 56.65 kph frontal barrier impact test was conducted in accordance with the Office of Crashworthiness Standards Laboratory Indicant Test procedure.

#### 1.2 TEST PROCEDURE

This 56.65 kph frontal barrier impact test was conducted in accordance with the Office of Crashworthiness Standards (OCS) New Car Assessment Program (NCAP) Laboratory Indicant Test Procedure, dated December 1999. Data was obtained indicant of FMVSS 208, "Occupant Crash Protection"; FMVSS 212, "Windshield Retention"; FMVSS 219, "Windshield Zone Intrusion (Partial)"; and FMVSS 301 "Fuel System Integrity" performance. Procedures for receiving, inspection testing and reporting of test results are described in the test procedures and are not repeated in this report.

One real-time camera and 16 high-speed cameras were used to document the frontal barrier impact event. Camera locations and other pertinent camera information can be found in this report.

Two Part 572E, 50th percentile male anthropomorphic test devices (ATDs), were placed in the driver and right-front passenger seating positions according to dummy placement instructions specified in the Laboratory Indicant Test Procedure.

Both ATDs were fully instrumented with nine accelerometer array heads, chest and pelvis triaxial accelerometers, chest displacement potentiometers, upper neck transducers, right/left femur load cells, and lower leg instrumentation. Seat belt load cells were also on the driver's and passenger's lap and shoulder belts to measure dummy torso and pelvic section loading. The driver (position 1) ATD (Serial No. 142) and the right-front passenger (position 2) ATD (Serial No.150) were used in one test previous to this test where they did not exceed FMVSS 208 head, chest and femur requirements. Certification details, along with instrumentation calibration data, are found in Appendix C.

The vehicle, occupant, camera and measurement data are presented in Section 2. Appendix A contains the still photograph prints. The 142 channels of data were recorded on an on-board data acquisition system. Appendix B contains the vehicle, load cell barrier and dummy response data traces. Appendix C contains the dummy calibration data and Appendix D contains the transducer calibration dates.

### 1.3 SUMMARY OF FRONTAL BARRIER IMPACT TEST

A load cell barrier consisting of 36 load cells was impacted by a 2006 Hyundai Sonata Four-Door Sedan at a velocity of 56.65 kph. The test was performed at Calspan on August 25, 2005. Pre- and post-test photographs of the vehicle and dummies can be found in Appendix A.

The occupant data is summarized below.

<b>ATD</b>	<b>HIC</b>	<b>T<sub>1</sub></b>	<b>T<sub>2</sub></b>	<b>Clip (g)</b>	<b>T<sub>1</sub></b>	<b>T<sub>2</sub></b>	<b>Chest Disp. (mm)</b>	<b>Left Femur (N)</b>	<b>Right Femur (N)</b>
<b>Driver</b>	267.5	50.1	86.1	42.5	56.0	59.0	-42.3	-3238.6	-3413.6
<b>Passenger</b>	277.8	62.1	98.1	38.5	57.0	60.0	-31.5	-2032.7	-1181.9

The test data can be found on the NHTSA website at [www.nhtsa.dot.gov](http://www.nhtsa.dot.gov)

### TEST NOTES

#### Data Comments

87 V1P2 TBRL Fz Data Spike at 40 ms  
88 V1P2 TBRL Mx Transducer Failed  
92 V1P2 FTLF Az Questionable Data

**SECTION 2  
OCCUPANT AND VEHICLE INFORMATION**

**DATA SHEET NO. 1  
CRASH TEST SUMMARY**

Vehicle NHTSA No.:           M60506           Test Mode:           56.3 kph Frontal Barrier            
 Test Date:           August 25, 2005           Time:           12:04           Temperature:           21           °C  
 Vehicle Make/Model/Body Style:           2006 Hyundai Sonata Four-Door Sedan            
 Vehicle Test Weight:           1710.0           kg Impact Velocity:           56.65           kph (55.5 – 57.1 kph)  
 Vehicle/Barrier Impact Angle:           0           ° Max Static Crush:           431           mm

**ATD INFORMATION AND VISIBLE CONTACT POINTS**

	DRIVER	PASSENGER
ATD Type:	Part 572E	Part 572E
Restraint System:	Seatbelt with shoulder pretensioner and force limiter, head restraint, airbag, knee bolster	Seatbelt with shoulder pretensioner and force limiter, head restraint, airbag, knee bolster
Head Contact:	The face to the center of the airbag and the back of the head to the center of the head restraint	The face to the right of center of the airbag and the back and the top of head to the head liner
Abdomen Contact:	None	None
Chest Contact:	Chest to the airbag	Chest to the airbag
Left Knee Contact:	Knee Bolster	Knee Bolster
Right Knee Contact:	Knee Bolster	Knee Bolster

**DOOR OPENING, SEAT TRACK AND GLAZING INFORMATION**

Description	Driver Side	Passenger Side
Door Lock Status	Locked	Locked
Front Door Opening	Closed, latched and operable without tools	Closed, latched and operable without tools
Rear Door Opening	Closed, latched and operable without tools	Closed, latched and operable without tools
Hatch/Other Door Opening	N/A	N/A
Front Seat Track Shift (mm)	0	0
Front Seat Back Failure	None	None
Glazing Damage	None	

**VEHICLE REBOUND FROM BARRIER**

Measured Parameter	Left Side (mm)	Center (mm)	Right Side (mm)	Average (mm)
Value	745	592	577	638

**BELT LENGTH DATA**

Measurement Description	Units	Driver	Passenger
Shoulder belt length as measured on ATD	mm	870	880
Lap belt length as measured on ATD	mm	900	885
Belt length from trim panel exit to bolt hole anchor point for continuous webbing systems	mm	1770	1765

DATA SHEET NO. 2  
GENERAL TEST AND VEHICLE PARAMETER DATA

TEST VEHICLE INFORMATION:

Year/Make/Model/Body Style: 2006 Hyundai Sonata Four-Door Sedan

NHTSA No. : M60506 ; VIN: KMHET46CX6A078130 ; Color: Black

Engine Data: 4 cylinders; - CID; 2.4 Liters; - cc

Placement: - Longitudinal or In-Line; X Transverse or Lateral

Transmission Data: 5 speeds; - Manual; X Automatic; X Overdrive

Final Drive: - Rear Wheel Drive; X Front Wheel Drive; - Four Wheel Drive

AUTOMATIC DOOR LOCKS:

Is test vehicle equipped with Automatic Door Locks (ADLs)? X Yes; - No;

Does vehicle owner's manual describe how to deactivate ADLs? - Yes; X No; - N/A

DEALER AND DELIVERY INFORMATION:

Date Received: 7-26-2005 ; Odometer Reading 121 km

Selling Dealer: Northtown Hyundai

Dealer Address: 3675 Sheridan Drive Amherst, NY 14226

TEST VEHICLE OPTIONS:

X AC; X Power Steering; X Power Brakes; X Power Locks; - Power Seats

X ABS; X Tilt Wheel; X Stability Control X Traction Control X Anti-Theft

SAFETY BELT FEATURES:

Driver: X Pretensioner (Shoulder); X Load Limiter; X Adjustable Anchorage

Passenger: X Pretensioner (Shoulder); X Load Limiter; X Adjustable Anchorage

AIRBAG FEATURES:

Position	Frontal	Knee Bolster	Side Torso	Side Head/Torso Combination	Side Curtain
Driver:	Yes	No	Yes	No	Yes
Passenger:	Yes	No	Yes	No	Yes
Rear Passenger:	No	N/A	No	No	Yes

DATA FROM VEHICLE'S CERTIFICATION LABEL:

Vehicle Manufactured by: Hyundai Motor Company

Date of Manufacture APR/22/2005

GVWR: 1950 kg; GAWR: 1140 kg FRONT; 970 kg REAR

VEHICLE CAPACITY DATA:

Type of Front Seats: - Bench; X Bucket; - Split Bench

Number of Occupants: 2 Front; 3 Rear; 5 Total

Vehicle Capacity Weight (VCW) = 390 kg

No. of Occupants x 68.04 kg = 340.2 kg

Rated Cargo/Luggage Weight (RCLW) = 49.8 kg

DATA SHEET NO. 2  
GENERAL TEST AND VEHICLE PARAMETER DATA ( cont. )

WEIGHT OF TEST VEHICLE AS RECEIVED FROM DEALER (with maximum fluids)= UDW:

	Left Side (kg)	Right Side (kg)	Ratio (%)	Total (kg)
<b>Front =</b>	458.0	463.0	60.9	921.0
<b>Rear =</b>	303.0	289.0	39.1	592.0
<b>Total Delivered Weight (UDW) =</b>				1513.0

CALCULATION OF VEHICLE'S TARGET TEST WEIGHT:

Total Delivered Weight (UDW) =	1513.0	kg
Rated Cargo/Luggage Weight (RCLW) =	49.8	kg
Weight of 2 p.572 Dummies @ 76 each =	152	kg
<b>TARGET TEST WEIGHT =</b>	<b>1714.8</b>	<b>kg</b>

WEIGHT OF TEST VEHICLE WITH TWO DUMMIES AND 45.0 KG OF CARGO WEIGHT:

	Left Side (kg)	Right Side (kg)	Ratio (%)	Total (kg)
<b>Front =</b>	490.5	493.5	57.5	984.0
<b>Rear =</b>	366.5	359.5	42.5	726.0
<b>Total Vehicle Test Weight (ATW) =</b>				1710.0

Weight of Ballast Secured in Vehicle Trunk Area<sup>1</sup> = 0 kg

Vehicle Components Removed for Weight Reduction: Rear Seat Cushion, Spare Tire, Side View Mirrors, Jack, Rear Head Restraints

VEHICLE ATTITUDE (all dimension in millimeters):

	Left Front	Right Front	Left Rear	Right Rear	CG <sup>2</sup>
AS DELIVERED:	728	733	731	735	1067.0
FULLY LOADED:	716	721	699	706	-
AS TESTED:	720	728	699	707	1157.8

Vehicle's Wheel Base: 2727 mm

<sup>1</sup>Ballast weight does not include the weight of instrumentation, on-board cameras and data acquisition system

<sup>2</sup>Rearward of the front axle centerline.

DATA SHEET NO. 3  
TEST VEHICLE TIRE INFORMATION

Vehicle Year/Make/Model/Body Style: 2006 Hyundai Sonata Four-Door Sedan

NHTSA Test No.: M60506 Test Date: August 25, 2005

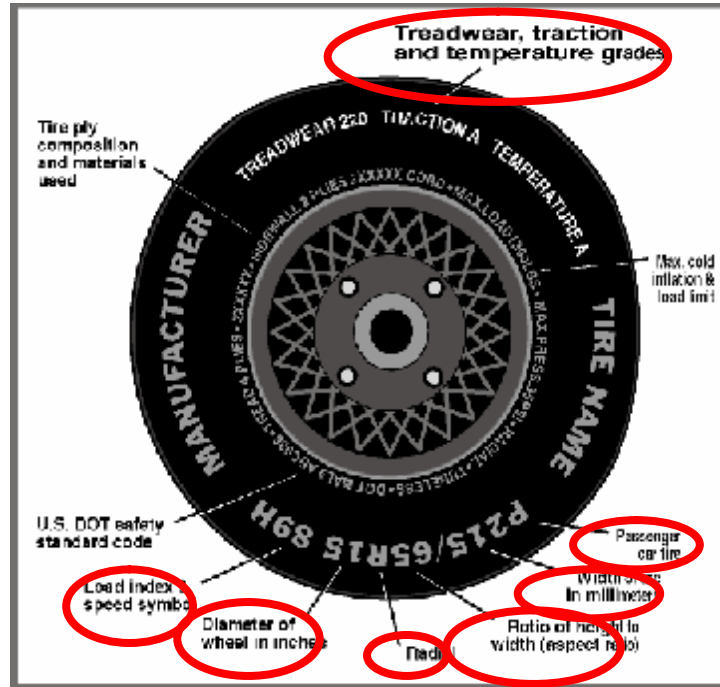

Measured Parameter	Front	Rear
Maximum Tire Pressure (from sidewall - kPa)	300	300
Cold Pressure (from tire placard - kPa)*	210	210
Recommended Tire Size (from tire placard)	P215/60R16	P215/60R16
Tire size on Vehicle	P215/60R16	P215/60R16
Tire Manufacturer	Michelin	Michelin
Tire Name	Energy MXV4	Energy MXV4
Tire Type	P	P
Tire Width (mm)	215	215
Ratio of Height to Width (aspect ratio)	60	60
Radial	R	R
Wheel Diameter	16	16
Load Index & Speed Symbol	94V	94V
Treadwear	440	440
Traction Grade	A	A
Temperature Grade	A	A

\*Tire pressure used for test

DATA SHEET NO. 4  
TEST VEHICLE INFORMATION

VEHICLE IDENTIFICATION:

Model Year : 2006    Vehicle Model: Hyundai Sonata    Body Style : Four-Door Sedan

1. NOMINAL DESIGN RIDING POSITION:  
for adjustable driver and passenger seat backs.  
Please describe how to position the inclinometer to measure the seat back angle. Include description of the location of the adjustment latch detent, if applicable.

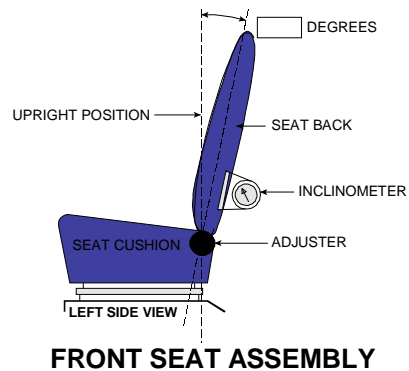

Seat back angle for driver's seat: 15°

Measurement instructions: Recline seat to 11<sup>th</sup> step from initial lock position

Seat back angle for passenger's seat: 15°

Measurement instructions: The same as the driver's seat.

2. SEAT FORE AND AFT POSITIONING:

Positioning of the driver's seat: There are 0 – 24 detents and 254 mm of travel. The seat was placed in detent 12.

Positioning of the passenger's seat: There are 0 – 24 detents and 240 mm of travel. The seat was placed in detent 12.

3. FUEL TANK CAPACITY DATA:

3.1 A. "Usable Capacity" of the standard equipment fuel tank is 67 liters

B. "Usable Capacity" of the optional equipment fuel tank is - liters

C. "Usable Capacity" of the vehicle(s) used for certification testing to requirements of FMVSS 301 = 61.6 to 63.0 liters

3.2 Actual Amount of Stoddard solvent added to vehicle for test = 61.7 liters

3.3 One-Third of Useable Capacity = 22.3 liters

3.4 Is vehicle equipped with electric fuel pump? Yes- X ; No- -

If YES, explain the vehicle operating conditions under which the fuel pump will pump fuel.

When the key is turned to the 'ON' position in order to pressurize the fuel system and while the engine is running.

DATA SHEET NO. 4  
TEST VEHICLE INFORMATION (cont.)

4. STEERING COLUMN ADJUSTMENTS:

Steering wheel and column adjustments are made so that the steering wheel hub is at the geometric center of the locus it describes when it is moved through its full range of driving positions. If the tested vehicle has any of these adjustments, does your company use any specific procedures to determine the geometric center.

Operational Instructions: There are 0 to 6 detents. The column was placed in detent 3. The  
test column angle was 24°.

5. SEAT BELT UPPER ANCHORAGE:

Nominal design riding position: The detents are numbered from 0 to 3 with 0 being uppermost. The  
d-ring was placed in detent 1.

6. AUTOMATIC DOOR LOCKS: Is test vehicle equipped with ADLs?  X  Yes;  -  No;

Does vehicle owner's manual describe how to deactivate ADLs?  -  Yes;  X  No;  -  N/A

Comments: The manual explains that only the dealer can disable this feature – page 1-7.  
\_\_\_\_\_  
\_\_\_\_\_  
\_\_\_\_\_

DATA SHEET NO. 5

FRONT SEAT DUMMY POSITIONING MEASUREMENTS IN VEHICLE

DUMMY MEASUREMENT FOR FRONT SEAT PASSENGERS

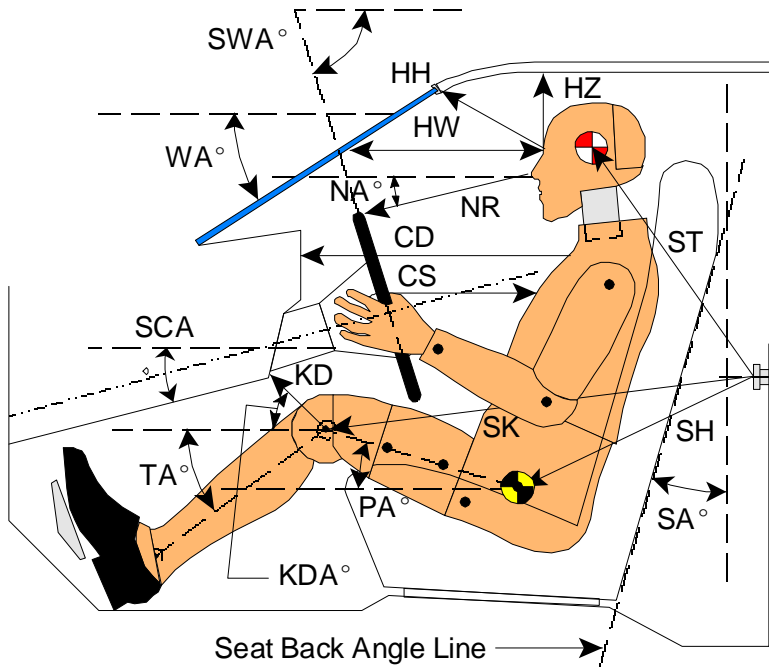

- AD - Arm to Door
- HD - H-Point to Door
- HR - Head to Side Header
- HS - Head to Side Window
- KK - Knee to Knee
- AA - Ankle to Ankle
- SHY- Striker to H-Point (Y Direction)

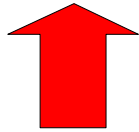

- CD - Chest to Dash
- CS - Steering Wheel to Chest
- HH - Head to Header
- HW - Head to Windshield
- HZ - Head to Roof
- KDA - Knee to Dash Angle
- KDL- Left Knee to Dash
- KDR - Right Knee to Dash
- NA - Nose to Rim Angle
- NR - Nose to Rim
- PA - Pelvic Angle
- RA - Rim to Abdomen
- SA - Seat Back Angle
- SCA - Steering Column Angle
- SH - Striker to H-Point
- SK - Striker to Knee
- ST - Striker to Head
- SWA- Steering Wheel Angle
- TA - Tibial Angle
- WA - Windshield Angle

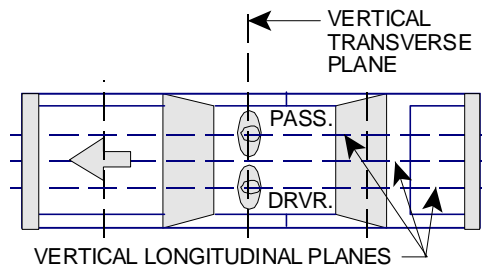
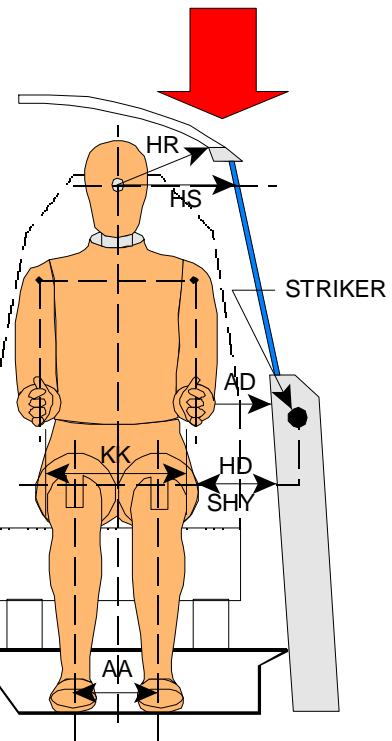

DATA SHEET NO. 5  
FRONT SEAT DUMMY POSITIONING MEASUREMENTS IN VEHICLE (cont.)

	DRIVER (Serial #142)			PASS. (Serial #150)		
WA <sup>o</sup>	26.2 deg.			N/A		
SWA <sup>o</sup>	66 deg.			N/A		
SCA <sup>o</sup>	24 deg.			N/A		
SA <sup>o</sup>	15 deg.			15 deg.		
HZ	169			161		
HH	305			305		
HW	532			516		
HR	185			170		
NR	400	Angle	15 deg.	N/A		
CD	518			545		
CS	297			N/A		
RA	193			N/A		
KDL	173	Angle (KDA)	28 deg.	124		
KDR	137			169	Angle (KDA)	30 deg.
PA <sup>o</sup>	22.6 deg.			22.2 deg.		
TA <sup>o</sup>	41.7 deg.			40.4 deg.		
KK	337			277		
AA	383			252		
ST	430	Angle	13.2 deg.	445	Angle	12 deg.
SK	648	Angle	105 deg.	655	Angle	106 deg.
SH	335	Angle	108 deg.	330	Angle	130 deg.
SHY	240			240		
HS	308			308		
HD	166			160		
AD	112			120		

Dimensions in millimeters

DATA SHEET NO. 6  
SEAT BELT POSITIONING DATA

**SEAT BELT POSITIONING DATA**

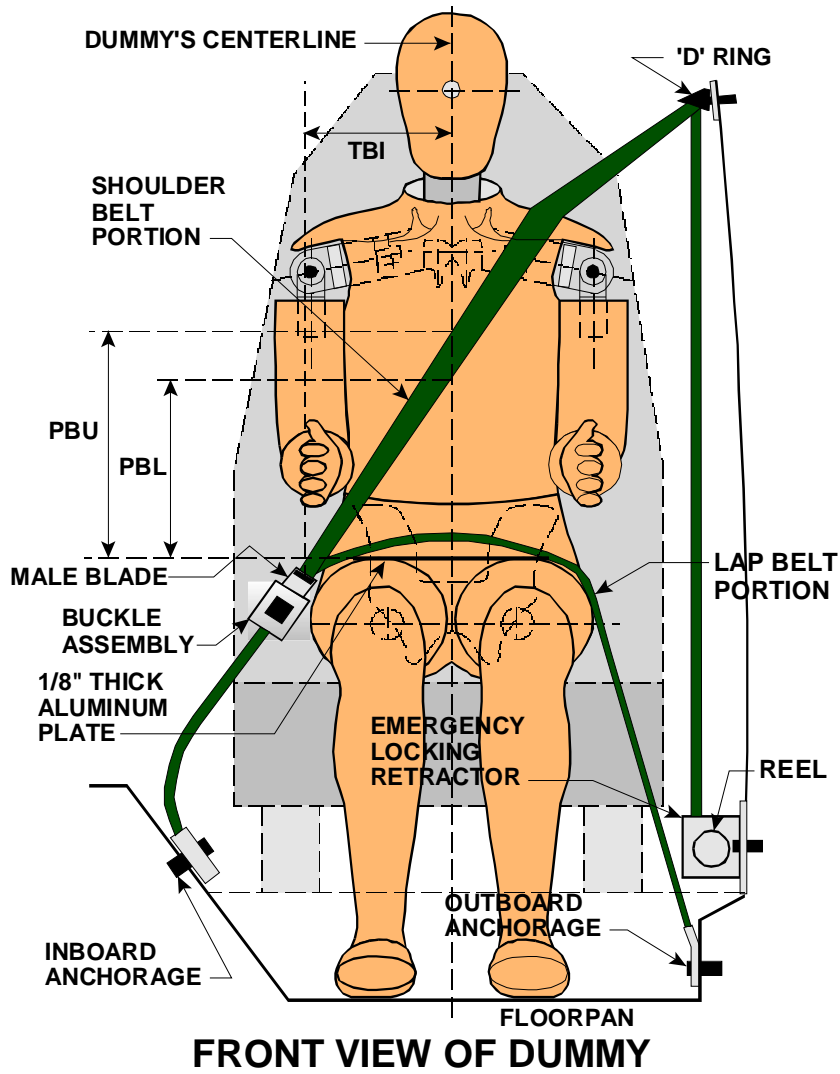

	DRIVER DUMMY (mm)	PASSENGER DUMMY (mm)
PBU -- Top surface of alum. plate to upper edge	345	345
PBL-- Top surface of alum. plate to belt lower edge	255	255
LAP BELT TENSION	10 N	10 N
SHOULDER BELT TENSION	Retractor	Retractor

DATA SHEET NO. 7  
VEHICLE ACCELEROMETER LOCATIONS AND DATA SUMMARY

**VEHICLE ACCELEROMETER LOCATION  
AND DATA SUMMARY**

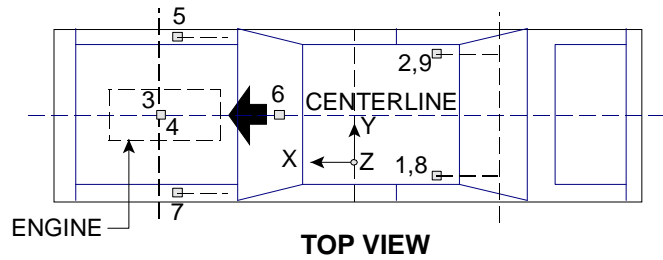

REAR SEAT CUSHION  
ASSY. FRONT ATTACHMENT  
BRACKET SUPPORT

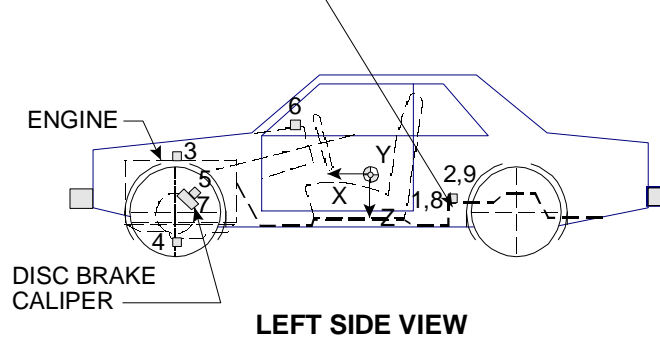

No.	LOCATION	PRE-TEST LENGTH (mm)		
		X	Y	Z
1	Left Rear Seat Cross Member X	1960	645	272
2	Right Rear Seat Cross Member X	1949	-646	272
3	Top of Engine Block	3893	-36	759
4	Bottom of Engine	4155	50	324
5	Disc Brake Caliper @ Right Side	3838	-737	454
6	Instrument Panel	3038	0	913
7	Disc Brake Caliper @Left Side	3837	737	454
8	Left Rear Seat Cross Member Z	1960	645	272
9	Right Rear Seat Cross Member Z	1949	-646	272

X – From rear surface of vehicle (+ forward)  
Y – From vehicle centerline (+ right)  
Z – From ground plane (+ up)

DATA SHEET NO.8  
SUMMARY OF FMVSS 212 and FMVSS 219 (Partial) DATA

DETAILS OF WINDSHIELD MOUNTING SUCH AS RETENTION METHOD, TRIM TYPE, ETC.:

Windshield is bonded in place and covered with a 18 mm molding.

FMVSS 212 REQUIREMENTS:

The Post-Test periphery retention amount must be at least 75% of the Pre-Test periphery measurement for vehicles NOT equipped with automatic restraints, and 50% for each side of the windshield for vehicles equipped with automatic restraint systems for front occupants,

Temperature of windshield molding during test: 21°C.

FMVSS 212 TEST DATA

	WINDSHIELD PERIPHERY		% OF RETENTION
	PRE-TEST (mm)	POST-TEST (mm)	
RIGHT SIDE	2215.0	2215.0	100.0%
LEFT SIDE	2215.0	2215.0	100.0%
TOTAL	4430	4430	100.0%

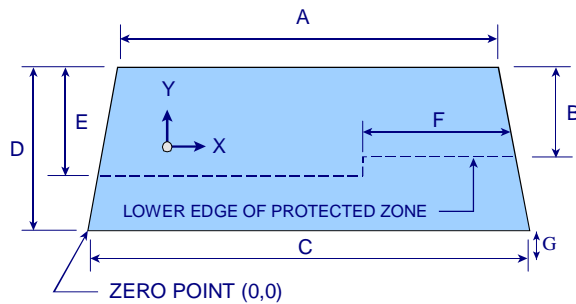

DIMENSIONS (mm)	
A	1180
B	515
C	1530
D	860
E	540
F	545
G	18

FRONT VIEW OF WINDSHIELD

FAILURE DETAILS: None

DETAILS OF WINDSHIELD GLASS PENETRATION GREATER THAN 6 mm: None

	COORDINATES	
	X	Y
1.	-	-
2.	-	-
3.	-	-
4.	-	-



**DATA SHEET NO. 10**  
**TEST VEHICLE MEASUREMENTS**

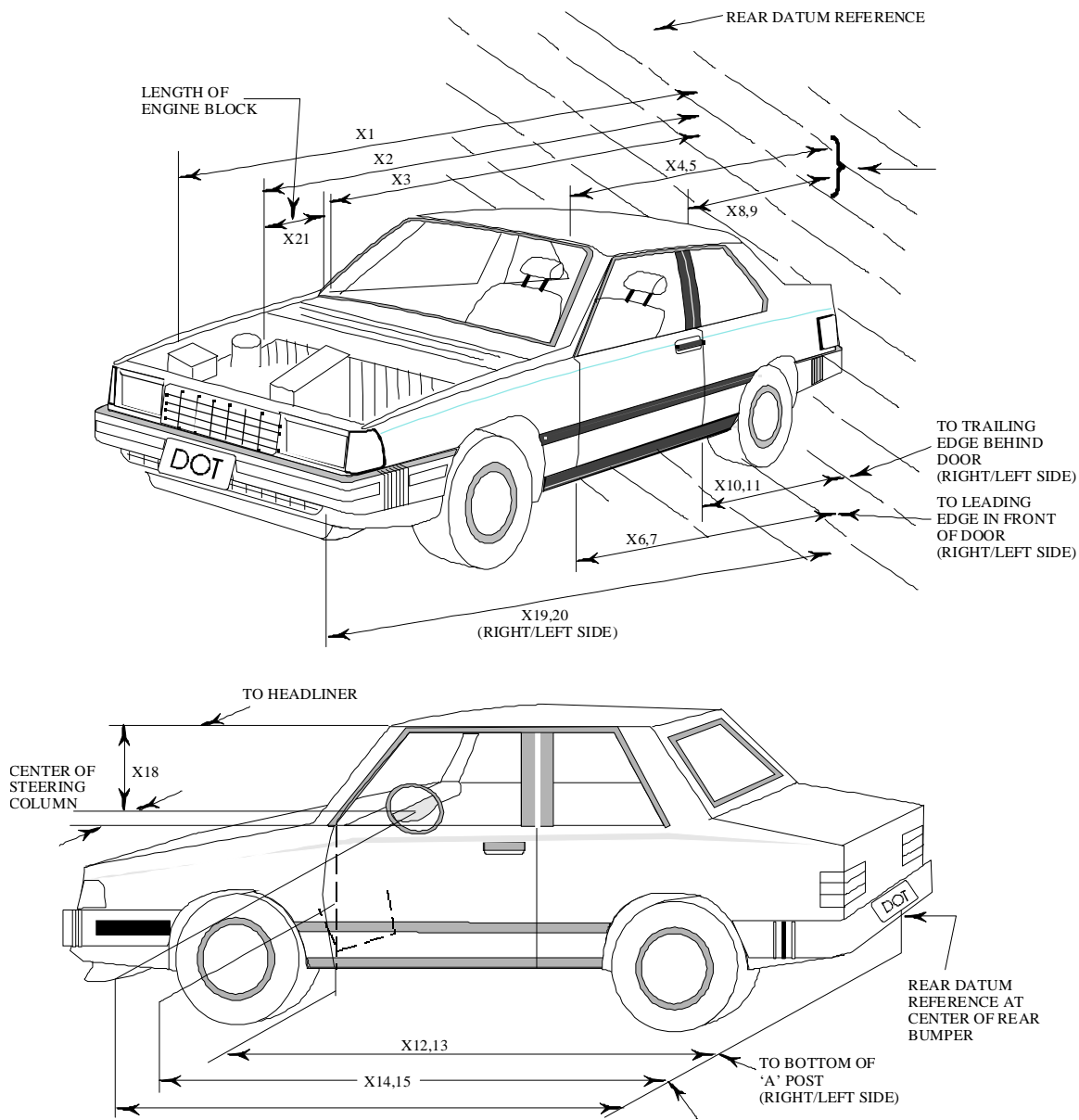



DATA SHEET NO.10  
VEHICLE MEASUREMENTS (cont.)

NHTSA TEST No.: M60506 TEST DATE: August 25, 2005  
VEHICLE MAKE/MODEL: 2006 Hyundai Sonata Four-Door Sedan

TARGET VEHICLE STRUCTURAL MEASUREMENTS

	Elements	Pre-Test (mm)
1	Total length	4801
2	Total Width	1832
3	Bumper Top Height	-
4	Bumper Bottom Height	-
5	Longitudinal Member Top Height	-
6	Distance Between Longitudinal Members	-
7	Longitudinal Member Width	-
8	Engine top height	810
9	Engine bottom height	-
10	Engine and gearbox width	-
11	Front bumper-engine distance	475
12	Front shock absorber fixing height	-
13	Bonnet leading edge height	-
14	Front shock absorber fixing width	-
15	Front bumper – front axle distance	963
16	Front axle – a pillar distance	564
17	A-pillar – B pillar distance	989
18	B-pillar – rear axle distance	2163
19	B-pillar – C Pillar distance	-
20	Roof sill bottom height	-
21	Roof sill top height	-
22	Floor sill bottom height	-
23	Floor sill top height	-

DATA SHEET NO.11  
HIGH-SPEED CAMERA LOCATIONS

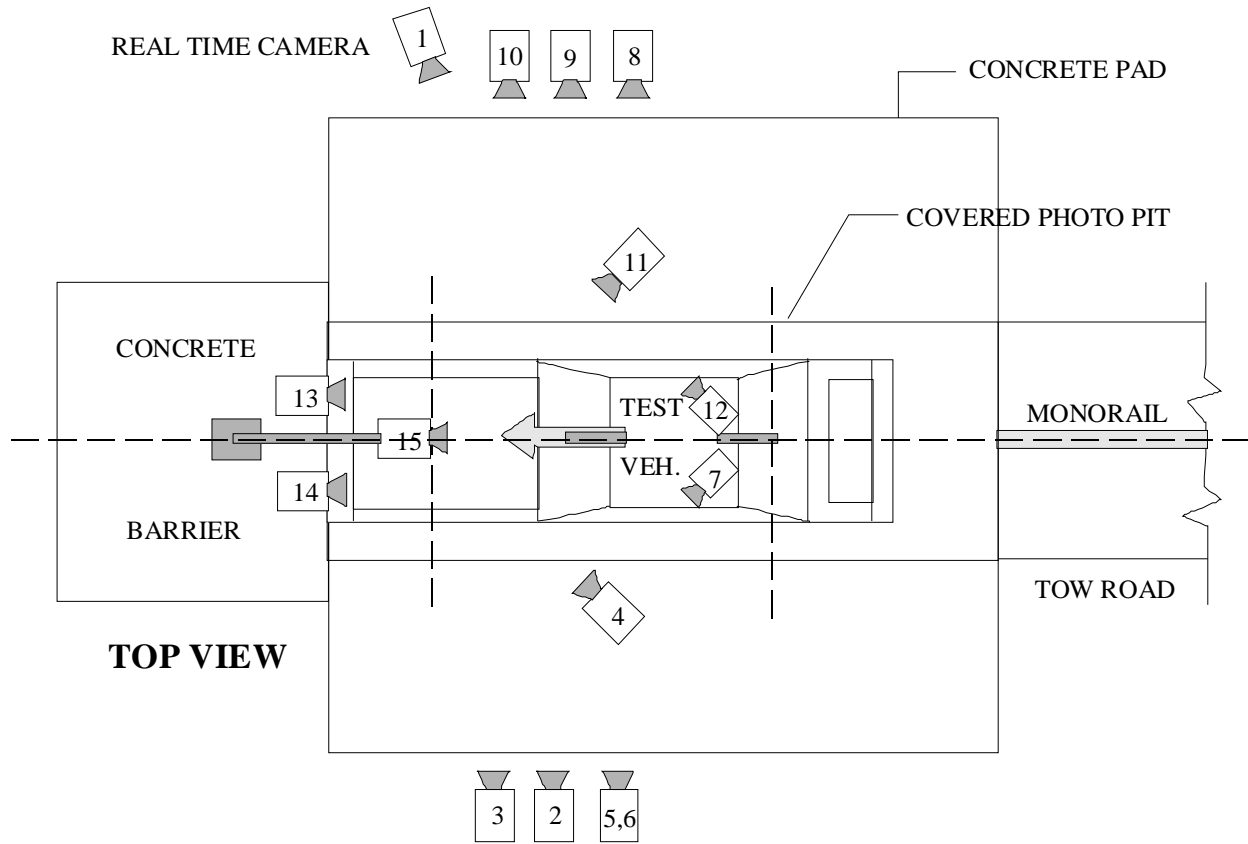

CAMERA FRAME RATES:  
#1 - 24 FPS  
All Others - 1000 fps

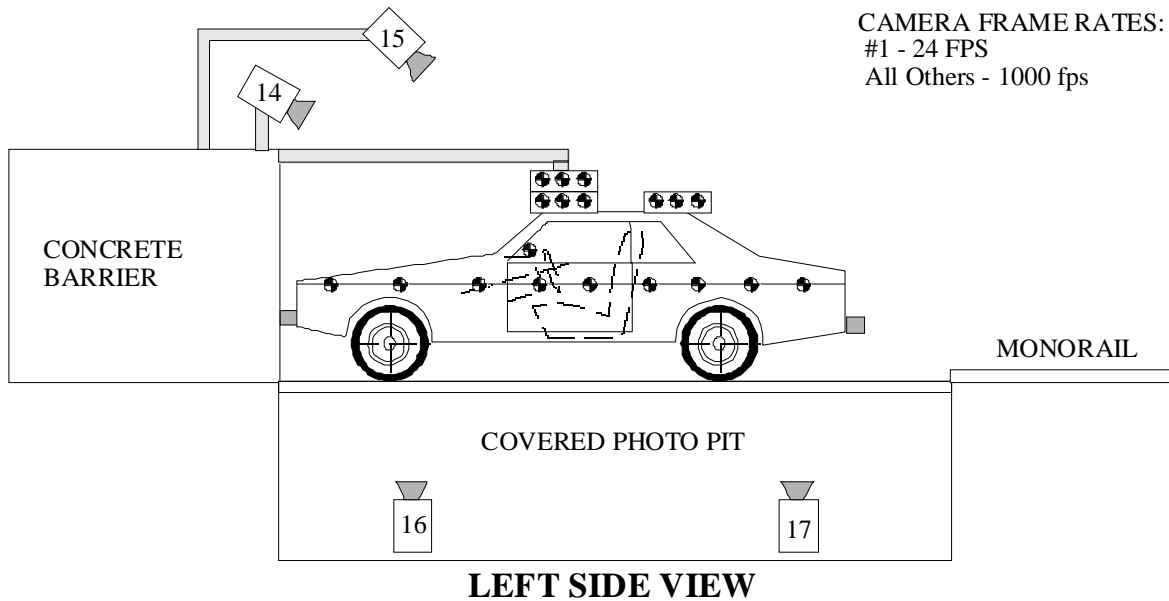

DATA SHEET NO.11  
HIGH-SPEED CAMERA LOCATIONS (cont.)

NHTSA Test No.:         M60506         Vehicle:         2006 Hyundai Sonata Four-Door Sedan        

CAMERA NO.	VIEW	CAMERA POSITIONS (mm)*			ANGLE (deg)**	FILM PLANE TO HEAD TARGET	LENS (mm)	SPEED (fps)
		X	Y	Z				
1	Real-Time Camera	-	-	-	-	-	-	30
2	Overall Left Side	1622	6096	1080	-2	1431	28	1000
3	Left Side View	957	9266	1091	-4	766	50	1000
4	Driver and Interior View	2891	6096	2052	-10	-	28-70	500
5	Steering Column (Bottom)	2011	6096	1177	-4	1820	25	1000
6	Steering Column (Top)	2011	6096	1777	-9	1820	25	1000
7	Left CRS Lateral View	-	-	-	-	-	-	500
8	Overall Right Side	1049	6096	1126	-2	1354	28	500
9	Right Side View	1322	9258	1248	-5	1627	50	1000
10	Right Passenger View	1949	6706	1380	-1	2254	35	1000
11	Passenger and Interior View	1039	6706	2003	-11	-	35	500
12	Right CRS Lateral View	-	-	-	-	-	-	500
13	Passenger Front View	620	-92	1987	-35	-	13	500
14	Driver Front View	620	-92	1987	-38	-	13	500
15	Windshield View	0	-530	3374	-44	-		500
16	Pit View of Engine	0	615	-3048	90	-	13	500
17	Pit View of Fuel Tank	0	3128	-3048	90	-	13	500

\*X = film plane to monorail centerline      \*\* = referenced to horizontal plane

Y = film plane to impact location      N.T. indicates No Timing

Z = film plane to ground

DATA SHEET NO. 12  
VEHICLE REFERENCE PHOTO TARGET LOCATIONS

NHTSA Test No.:           M60506           Vehicle:           2006 Hyundai Sonata Four-Door Sedan          

(Dimensions in millimeters)

A	381
B	496
C	1225
D	2124
E	317
F	1571
G	914
H	912
I	108
J	1419
K	1020
L	1448
M	320
N	106
O	914
P	911
Q	1447
R	1020
S	1424

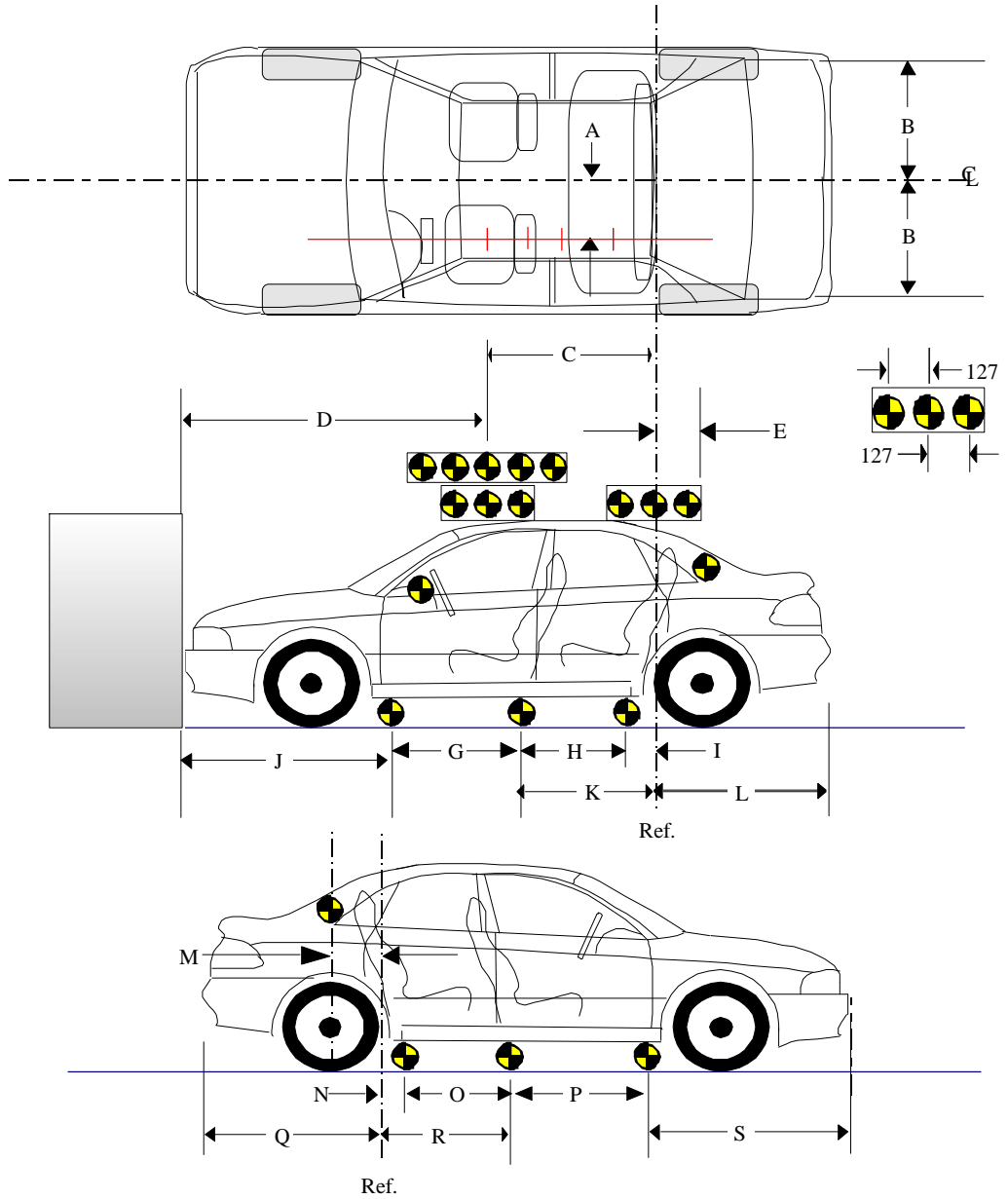

DATA SHEET NO. 13  
VEHICLE INTRUSION MEASUREMENTS

NHTSA Test No.:           M60506           Vehicle:           2006 Hyundai Sonata Four-Door Sedan          

DOOR OPENING WIDTH AND WHEELBASE MEASUREMENTS

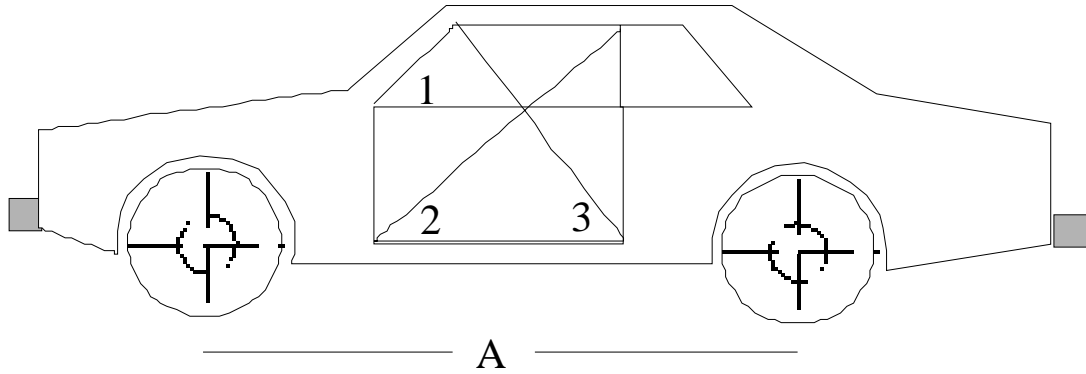

UNITS (mm)	LEFT			RIGHT		
MEASUREMENT	1	2	3	1	2	3
BEFORE TEST	989	1468	978	987	1464	984
AFTER TEST	988	1470	980	985	1465	986
DIFFERENCE	1	-2	-2	2	-1	-2

UNITS (mm)	A = WHEELBASE LEFT	A = WHEELBASE RIGHT
BEFORE TEST	2726	2727
AFTER TEST	2666	2651
DIFFERENCE	60	76

DATA SHEET NO.13  
VEHICLE INTRUSION MEASUREMENTS (cont)

NHTSA Test No.:           M60506           Vehicle:           2006 Hyundai Sonata Four-Door Sedan          

STATIC FOOTWELL DEFORMATION

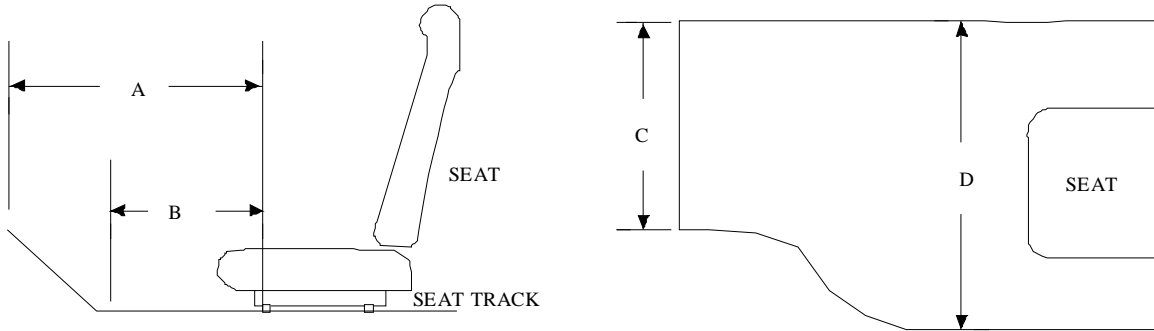

DRIVER

Measurement	Pre-Test	Post-Test	Difference
A	3524	3478	46
B	3343	3326	17
C	498	491	7
D	488	460	28

PASSENGER

Measurement	Pre-Test	Post-Test	Difference
A	3544	3513	31
B	3323	3318	5
C	466	468	-2
D	477	454	23

Units = mm

DATA SHEET NO.13  
VEHICLE INTRUSION MEASUREMENTS (cont.)

NHTSA Test No.:           M60506           Vehicle:           2006 Hyundai Sonata Four-Door Sedan          

STATIC PASSENGER COMPARTMENT INTRUSION

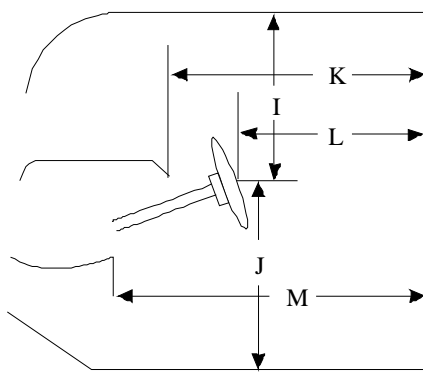

DRIVER'S SIDE

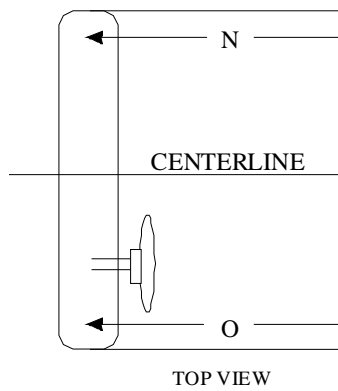

TOP VIEW

MEASUREMENTS  
FROM C-PILLAR  
BELT ANCHORAGE

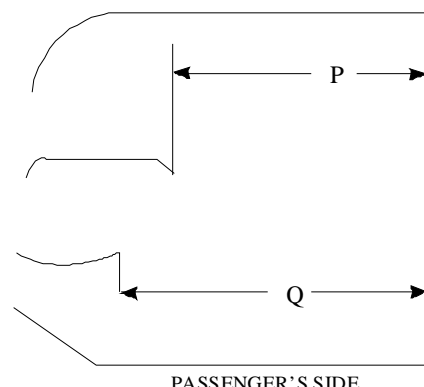

PASSENGER'S SIDE

Measurement	Pre-Test	Post-Test	Difference
I	418	409	9
J	654	658	-4
K	760	758	2
L	551	579	-28
M	813	798	15
N	751	747	4
O	750	748	2
P = K (PASS.)	793	790	3
Q = M (PASS.)	855	841	14

Units = mm

DATA SHEET NO.13  
VEHICLE INTRUSION MEASUREMENTS (cont.)

NHTSA Test No.:         M60506         Vehicle:         2006 Hyundai Sonata Four-Door Sedan        

FLOORBOARD DEFORMATION

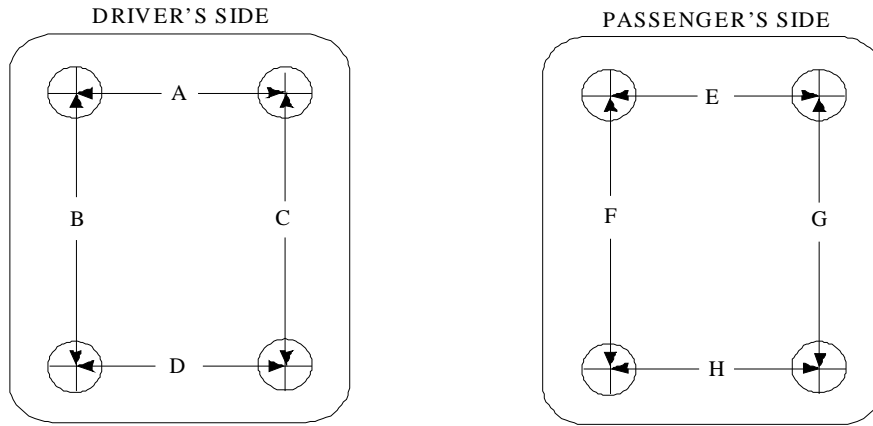

TOP VIEW THROUGH FLOOR PAN

Measurement	Pre-Test	Post-Test	Difference
A	498	491	7
B	470	471	0
C	361	358	3
D	488	460	28
E	466	468	-1
F	345	343	2
G	369	361	8
H	477	454	23

Units = mm

DATA SHEET NO.14  
LOAD CELL LOCATIONS ON FIXED BARRIER

36 Load Cells  
4 Rows  
9 Columns

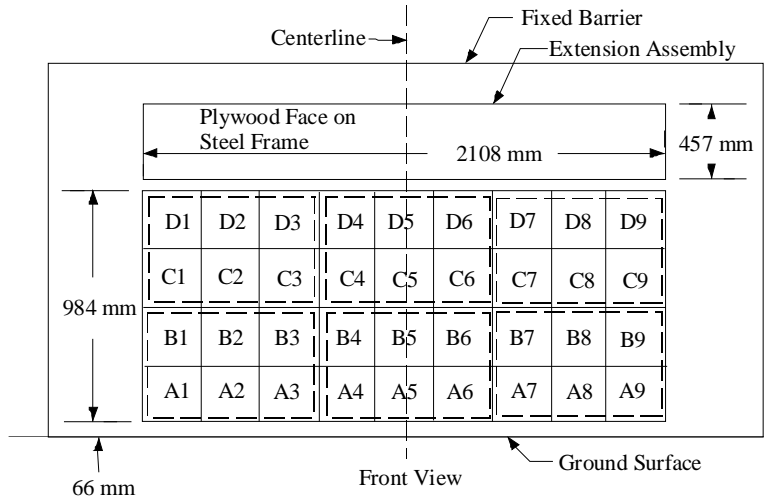

Momentum Plot

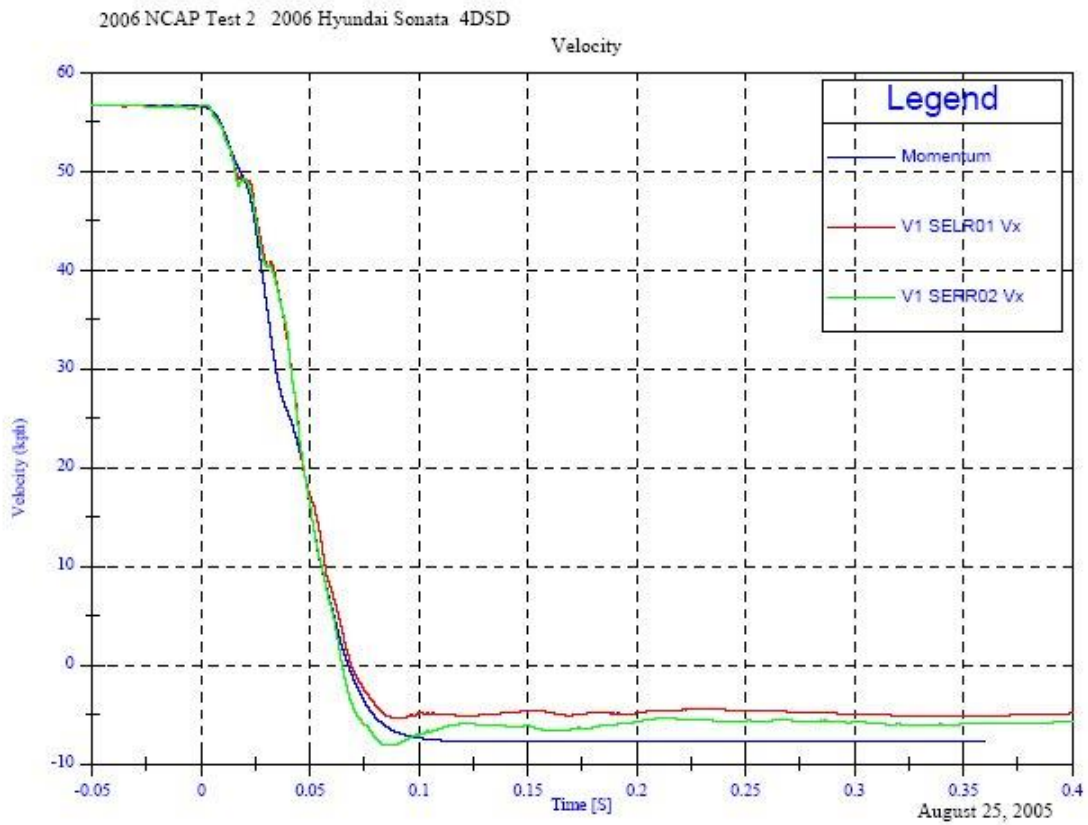

DATA SHEET NO. 15  
ACCIDENT INVESTIGATION DIVISION DATA

FOR FRONTAL BARRIER IMPACT

Vehicle Make/Model/Body Style: Hyundai Sonata Four-Door Sedan

NHTSA Test No.: M60506 VIN: KMHET46CX6A078130

Model Year: 2006 Build Date: APR/22/2005 Test Date: August 25, 2005

Vehicle Size Category: Large Car Test Weight: 1710.0 kg

Vehicle Wheelbase: 2727 mm; Front Overhang: 964 mm; Overall Width: 1832 mm

Collision Deformation Classification (CDC) Code: 12FDEW2

Crush Depth Dimensions

	PRE (mm)	POST (mm)	DIFF (mm)
C1 =	4601	4310	291
C2 =	4737	4312	425
C3 =	4793	4401	392
C4 =	4793	4422	371
C5 =	4736	4393	343
C6 =	4599	4270	329

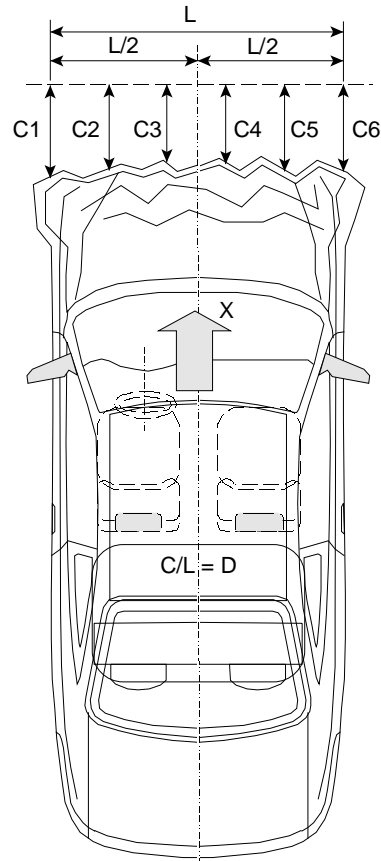

Midpoint of Damage: D = Vehicle Centerline (Longitudinal)

Length of Damaged Region:

L1=	<u>1452</u>	mm
L2=	<u>726.0</u>	mm
L5=	<u>290.4</u>	mm

DATA SHEET NO.16  
VEHICLE AND DUMMY TEMPERATURE STABILIZATION CHART

NHTSA Test No.:           M60506           Vehicle:           2006 Hyundai Sonata Four-Door Sedan          

**2006 Hyundai Sonata M60506 Environmental Conditions**

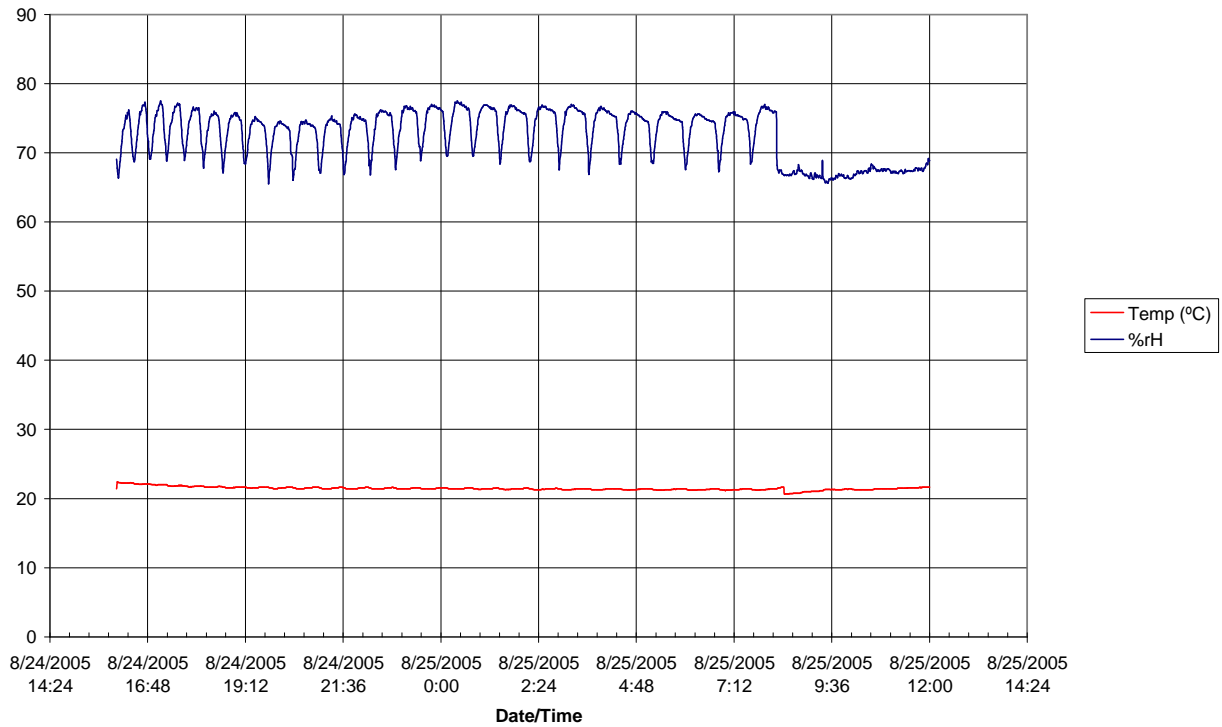

**APPENDIX A**  
**PHOTOGRAPHS**

## TABLE OF PHOTOGRAPHS

<u>Figure</u>	<u>Title</u>	<u>Page</u>
A-1	Load Cell Locations	A-4
A-2	Vehicle Certification Placard	A-5
A-3	Tire Placard	A-5
A-4	Right Front, As Received	A-6
A-5	Left Rear, As Received	A-6
A-6	Pre-Test Front View	A-7
A-7	Post-Test Front View	A-7
A-8	Pre-Test Left Side View	A-8
A-9	Post-Test Left Side View	A-8
A-10	Pre-Test Right Side View	A-9
A-11	Post-Test Right Side View	A-9
A-12	Pre-Test Right Front Three-Quarter View	A-10
A-13	Post-Test Right Front Three-Quarter View	A-10
A-14	Pre-Test Left Rear Three-Quarter View	A-11
A-15	Post-Test Left Rear Three-Quarter View	A-11
A-16	Left Rear Three-Quarter View Of Doors After Impact	A-12
A-17	Right Rear Three-Quarter View Of Doors After Impact	A-12
A-18	Pre-Test Windshield View	A-13
A-19	Post-Test Windshield View	A-13
A-20	Pre-Test Engine Compartment View	A-14
A-21	Post-Test Engine Compartment View	A-14
A-22	Pre-Test Fuel Cap View	A-15
A-23	Post-Test Fuel Cap View	A-15
A-24	Pre-Test Front Underbody View	A-16
A-25	Post-Test Front Underbody View	A-16
A-26	Pre-Test Mid Underbody View	A-17
A-27	Post-Test Mid Underbody View	A-17
A-28	Pre-Test Rear Underbody View	A-18
A-29	Post-Test Rear Underbody View	A-18
A-30	Pre-Test Driver Head Location	A-19
A-31	Post-Test Driver Head Location	A-19
A-32	Pre-Test Driver Position View	A-20
A-33	Post-Test Driver Position View	A-20
A-34	Pre-Test Driver And Interior View	A-21
A-35	Post-Test Driver And Interior View	A-21
A-36	Pre-Test Driver Feet View	A-22
A-37	Post-Test Driver Feet View	A-22
A-38	Pre-Test Driver Knee Bolster View	A-23
A-39	Post-Test Driver Knee Bolster View	A-23
A-40	Pre-Test Driver Floor Pan View	A-24
A-41	Post-Test Driver Floor Pan View	A-24
A-42	Post-Test Driver Head View	A-25
A-43	Post-Test Driver Contact To Airbag	A-25

TABLE OF PHOTOGRAPHS (CONTINUED)

<u>Figure</u>	<u>Title</u>	<u>Page</u>
A-44	Pre-Test Passenger Head Location	A-26
A-45	Post-Test Passenger Head Location	A-26
A-46	Pre-Test Passenger Position View	A-27
A-47	Post-Test Passenger Position View	A-27
A-48	Pre-Test Passenger And Interior View	A-28
A-49	Post-Test Passenger And Interior View	A-28
A-50	Pre-Test Passenger Feet View	A-29
A-51	Post-Test Passenger Feet View	A-29
A-52	Pre-Test Passenger Knee Bolster View	A-30
A-53	Post-Test Passenger Knee Bolster View	A-30
A-54	Pre-Test Passenger Floor Pan View	A-31
A-55	Post-Test Passenger Floor Pan View	A-31
A-56	Post-Test Passenger Head View	A-32
A-57	Post-Test Passenger Contact To Airbag	A-32
A-58	Rollover View - 90°	A-33
A-59	Rollover View - 180°	A-33
A-60	Rollover View - 270°	A-34
A-61	Rollover View - 360°	A-34
A-62	Impact View	A-35



**Figure A-1: Load Cell Locations**



**Figure A-2: Vehicle Certification Placard**



**Figure A-3: Vehicle Tire Placard**



**Figure A-4: Right Front, As Received**



**Figure A-5: Left Rear, As Received**



**Figure A-6: Pre-Test Front View**



**Figure A-7: Post-Test Front View**



**Figure A-8: Pre-Test Left Side View**



**Figure A-9: Post-Test Left Side View**



**Figure A-10: Pre-Test Right Side View**



**Figure A-11: Post-Test Right Side View**



**Figure A-12: Pre-Test Right Front Three-Quarter View**



**Figure A-13: Post-Test Right Front Three-Quarter View**



**Figure A-14: Pre-Test Left Rear Three-Quarter View**



**Figure A-15: Post-Test Left Rear Three-Quarter View**



**Figure A-16: Left Rear Three-Quarter View of Doors After Impact**



**Figure A-17: Right Rear Three-Quarter View of Doors After Impact**



**Figure A-18: Pre-Test Windshield View**



**Figure A-19: Post-Test Windshield View**



**Figure A-20: Pre-Test Engine Compartment View**



**Figure A-21: Post-Test Engine Compartment View**



**Figure A-22: Pre-Test Fuel Cap View**



**Figure A-23: Post-Test Fuel Cap View**



**Figure A-24: Pre-Test Front Underbody View**



**Figure A-25: Post-Test Front Underbody View**



**Figure A-26: Pre-Test Mid Underbody View**



**Figure A-27: Post-Test Mid Underbody View**



**Figure A-28: Pre-Test Rear Underbody View**



**Figure A-29: Post-Test Rear Underbody View**



**Figure A-30: Pre-Test Driver Head Location**



**Figure A-31: Post-Test Driver Head Location**



Figure A-32: Pre-Test Driver Position View



Figure A-33: Post-Test Driver Position View



**Figure A-34: Pre-Test Driver and Interior View**



**Figure A-35: Post-Test Driver and Interior View**



**Figure A-36: Pre-Test Driver Feet View**



**Figure A-37: Post-Test Driver Feet View**



**Figure A-38: Pre-Test Driver Knee Bolster View**



**Figure A-39: Post-Test Driver Knee Bolster View**



**Figure A-40: Pre-Test Driver Floor Pan View**



**Figure A-41: Post-Test Driver Floor Pan View**



**Figure A-42: Post-Test Driver Head View**



**Figure A-43: Post-Test Driver Contact to Airbag**



**Figure A-44: Pre-Test Passenger Head Location**



**Figure A-45: Post-Test Passenger Head Location**



Figure A-46: Pre-Test Passenger Position View



Figure A-47: Post-Test Passenger Position View



**Figure A-48: Pre-Test Passenger and Interior View**



**Figure A-49: Post-Test Passenger and Interior View**



**Figure A-50: Pre-Test Passenger Feet View**



**Figure A-51: Post-Test Passenger Feet View**



**Figure A-52: Pre-Test Passenger Knee Bolster View**



**Figure A-53: Post-Test Passenger Knee Bolster View**



**Figure A-54: Pre-Test Passenger Floor Pan View**



**Figure A-55: Post-Test Passenger Floor Pan View**



**Figure A-56: Post-Test Passenger Head View**



**Figure A-57: Post-Test Passenger Contact to Airbag**



**Figure A-58: Rollover View - 90°**



**Figure A-59: Rollover View - 180°**



**Figure A-60: Rollover View - 270°**



**Figure A-61: Rollover View - 360°**



**Figure A-62: Impact View**

**APPENDIX B**

**DUMMY, VEHICLE AND LOAD CELL BARRIER RESPONSE DATA**

**Hybrid III Dummy Sign Conventions  
Load Cells and Special Transducers**

<b>Transducer</b>	<b>SAE Sign Convention (positive unless noted)</b>
Upper Neck Load Cell	Fx    Head rearward Fy    Head left Fz    Neck in tension Mx    Left ear to left shoulder My    Chin to chest (flexion) Mz    Chin to left shoulder (look left)
Chest Displacement Potentiometer	Compression is negative
Pelvic Load Cell (Lower Lumbar)	Fx    Chest rearward Fy    Chest left Fz    Spine in tension
Femur Load Cell	Compression is negative
Upper Tibia Load Cell (right and left leg)	Mx    Support tibia at ends, load left side center My    Support tibia at ends, load front (shin) center
Lower Tibia Load Cell (right and left leg)	Fz    Tibia in tension Mx    Support tibia at ends, load left side center My    Support tibia at ends, load front (shin) center

## DATA CHANNEL FILTER CLASS SUMMARY

NHTSA TEST NO.

<b>DATA TYPE</b>	<b>SAE FILTER CLASS (Hz)</b>
Dummy Head Accelerations	1000
Dummy Chest Accelerations	180
Dummy Chest Displacements	600
Dummy Femur Forces	600
Dummy Belt Loads	60
Dummy Belt Displacements	180
Dummy Neck Forces	1000
Dummy Neck Moments	600
Vehicle Accelerations	60
Vehicle Velocity Integrations	180
Vehicle Displacement Integrations	180
Load Cell Barrier Forces	60

### Table of Data Plots

<b>PLOT</b>	<b>PLOT NAME[UNITS, CHANNEL FILTER CLASS]</b>	<b>PAGE</b>
1	V1P1 Head CG x [g, CFC_1000]	B-8
2	V1P1 Head CG y [g, CFC_1000]	B-8
3	V1P1 Head CG z [g, CFC_1000]	B-8
4	V1P1 Head CG Resultant [g, CFC_1000]	B-8
5	V1P1 Chest x [g, CFC_180]	B-9
6	V1P1 Chest y [g, CFC_180]	B-9
7	V1P1 Chest z [g, CFC_180]	B-9
8	V1P1 Chest Resultant [g, CFC_180]	B-9
9	V1P1 Left Femur z [N, CFC_600]	B-10
10	V1P1 Right Femur z [N, CFC_600]	B-10
11	V1P2 Head CG x [g, CFC_1000]	B-11
12	V1P2 Head CG y [g, CFC_1000]	B-11
13	V1P2 Head CG z [g, CFC_1000]	B-11
14	V1P2 Head CG Resultant [g, CFC_1000]	B-11
15	V1P2 Chest x [g, CFC_180]	B-12
16	V1P2 Chest y [g, CFC_180]	B-12
17	V1P2 Chest z [g, CFC_180]	B-12
18	V1P2 Chest Resultant [g, CFC_180]	B-12
19	V1P2 Left Femur z [N, CFC_600]	B-13
20	V1P2 Right Femur z [N, CFC_600]	B-13

The following dummy, vehicle and load cell response data can be found in the research and development section of the NHTSA website at: [www.nhtsa.dot.gov](http://www.nhtsa.dot.gov)

V1P1Head 9 Array X Arm Ay  
V1P1Head 9 Array X Arm Az  
V1P1Head 9 Array Y Arm Ax  
V1P1Head 9 Array Y Arm Az  
V1P1Head 9 Array Z Arm Ax  
V1P1Head 9 Array Z Arm Ay  
V1P1Head CG Red x  
V1P1Head CG Red y  
V1P1Head CG Red z  
V1P1Head CG Red Resultant  
V1P1Upper Neck Fx  
V1P1Upper Neck Fy  
V1P1Upper Neck Fz  
V1P1Upper Neck F Resultant  
V1P1Upper Neck Mx  
V1P1Upper Neck My  
V1P1Upper Neck Mz  
V1P1Upper Neck M Resultant  
V1P1Chest Red x  
V1P1Chest Red y  
V1P1Chest Red z  
V1P1Chest Red Resultant  
V1P1 Chest Compression x  
V1P1Pelvic x  
V1P1Pelvic y  
V1P1Pelvic z  
V1P1Pelvic Resultant  
V1P1Left Upper Tibia Mx  
V1P1Left Upper Tibia My  
V1P1Left Lower Tibia Fz  
V1P1Left Lower Tibia Mx  
V1P1Left Lower Tibia My  
V1P1Left Upper Tibia Mx  
V1P1Left Upper Tibia My  
V1P1Left Lower Tibia Fz  
V1P1Left Lower Tibia Mx  
V1P1Left Lower Tibia My  
V1P1Right Upper Tibia Fz  
V1P1Right Upper Tibia Mx  
V1P1 Right Upper Tibia My  
V1P1Right Lower Tibia Mx  
V1P1Right Lower Tibia My  
V1P1 Left Foot Aft x  
V1P1 Left Foot Aft z  
V1P1 Left Foot Fore z  
V1P1 Right Foot Aft x  
V1P1 Right Foot Aft z [  
V1P1 Right Foot Fore z  
V1P1 Lap Belt  
V1P1 Shoulder Belt

V1P2 Head 9 Array X Arm Ay  
V1P2 Head 9 Array X Arm Az  
V1P2 Head 9 Array Y Arm Ax  
V1P2 Head 9 Array Y Arm Az  
V1P2 Head 9 Array Z Arm Ax  
V1P2 Head 9 Array Z Arm Ay  
V1P2 Head CG Red x  
V1P2 Head CG Red y  
V1P2 Head CG Red z  
V1P2 Head CG Red Resultant  
V1P2 Upper Neck Fx  
V1P2 Upper Neck Fy  
V1P2 Upper Neck Fz  
V1P2 Upper Neck F Resultant  
V1P2 Upper Neck Mx  
V1P2 Upper Neck My  
V1P2 Upper Neck Mz  
V1P2 Upper Neck M Resultant  
V1P2 Chest Red x  
V1P2 Chest Red y  
V1P2 Chest Red z  
V1P2 Chest Red Resultant  
V1P2 Chest Compression x  
V1P2 Pelvic x  
V1P2 Pelvic y  
V1P2 Pelvic z  
V1P2 Pelvic Resultant  
V1P2 Left Upper Tibia Fz  
V1P2 Left Upper Tibia Mx  
V1P2 Left Upper Tibia My  
V1P2 Left Lower Tibia Mx  
V1P2 Left Lower Tibia My  
V1P2 Left Upper Tibia Mx  
V1P2 Left Upper Tibia My  
V1P2 Left Lower Tibia Fz  
V1P2 Left Lower Tibia Mx  
V1P2 Left Lower Tibia My  
V1P2 Right Upper Tibia Mx  
V1P2 Right Upper Tibia My  
V1P2 Right Lower Tibia Fz  
V1P2 Right Lower Tibia Mx  
V1P2 Right Lower Tibia My  
V1P2 Left Foot Aft x  
V1P2 Left Foot Aft z  
V1P2 Left Foot Fore z  
V1P2 Right Foot Aft x  
V1P2 Right Foot Aft z  
V1P2 Right Foot Fore z  
V1P2 Lap Belt  
V1P2 Shoulder Belt

V1 Left Rear #1x  
V1 Right Rear #2x  
V1 Engine Top #3x  
V1 Engine Bottom #4x  
V1 Right Caliper #5x  
V1 Instrument Panel #6x  
V1 Left Caliper #7x  
V1 Left Rear #8z  
V1 Right Rear #9z  
Barrier Load Cell A1 Fx  
Barrier Load Cell A2 Fx  
Barrier Load Cell A3 Fx  
Barrier Load Cell A4 Fx  
Barrier Load Cell A5 Fx  
Barrier Load Cell A6 Fx  
Barrier Load Cell A7 Fx  
Barrier Load Cell A8 Fx  
Barrier Load Cell A9 Fx  
Barrier Load Cell B1 Fx  
Barrier Load Cell B2 Fx  
Barrier Load Cell B3 Fx  
Barrier Load Cell B4 Fx  
Barrier Load Cell B5 Fx  
Barrier Load Cell B6 Fx  
Barrier Load Cell B7 Fx  
Barrier Load Cell B8 Fx  
Barrier Load Cell B9 Fx  
Barrier Load Cell C1 Fx  
Barrier Load Cell C2 Fx  
Barrier Load Cell C3 Fx  
Barrier Load Cell C4 Fx  
Barrier Load Cell C5 Fx  
Barrier Load Cell C6 Fx  
Barrier Load Cell C7 Fx  
Barrier Load Cell C8 Fx  
Barrier Load Cell C9 Fx  
Barrier Load Cell D1 Fx  
Barrier Load Cell D2 Fx  
Barrier Load Cell D3 Fx  
Barrier Load Cell D4 Fx  
Barrier Load Cell D5 Fx  
Barrier Load Cell D6 Fx  
Barrier Load Cell D7 Fx  
Barrier Load Cell D8 Fx  
Barrier Load Cell D9 Fx

# 2006 NCAP Test 2 2006 Hyundai Sonata 4DSD M60506 - August 25, 2005

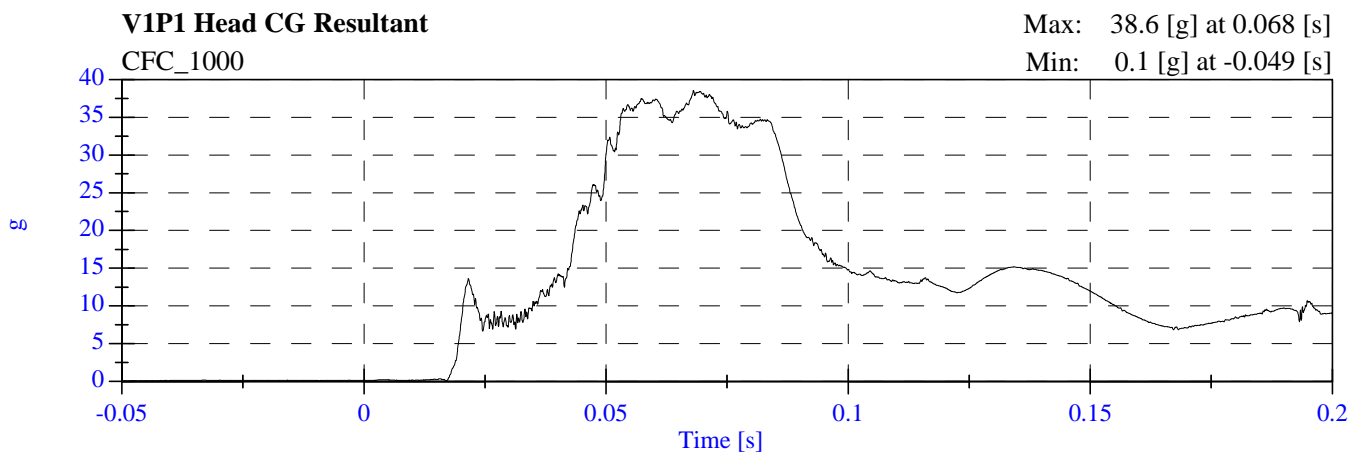
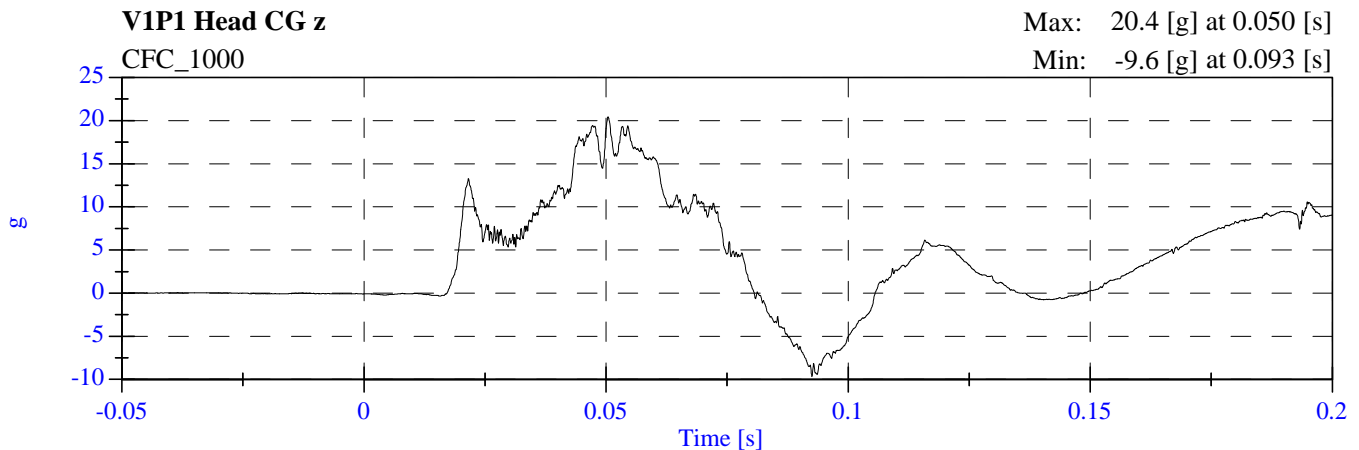
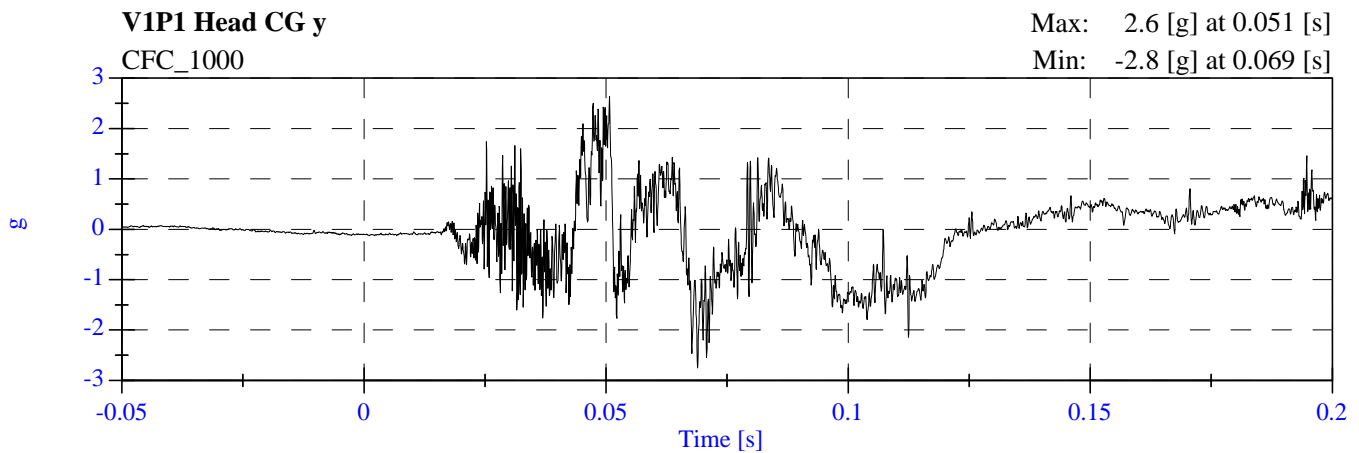
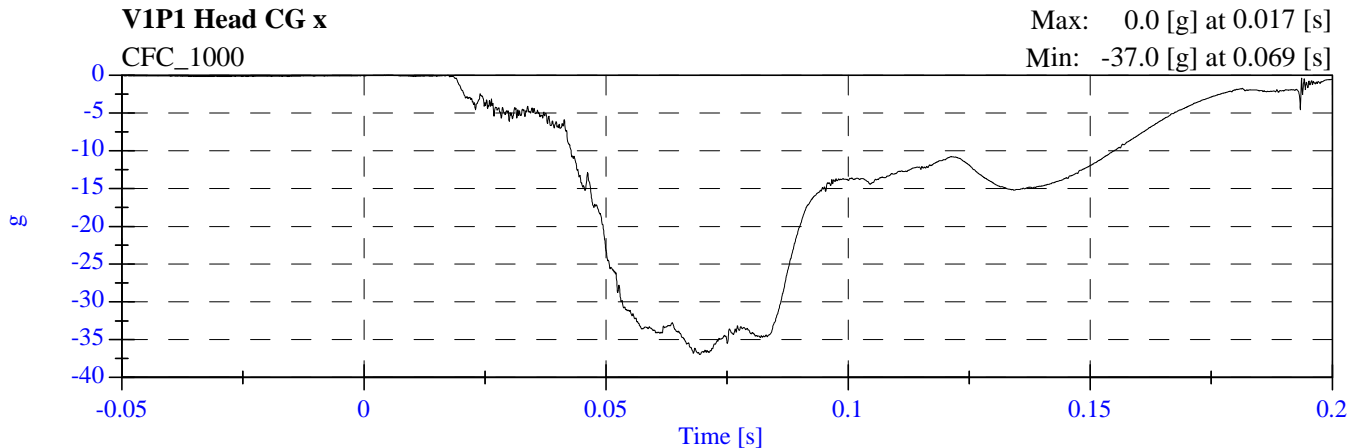

# 2006 NCAP Test 2 2006 Hyundai Sonata 4DSD M60506 - August 25, 2005

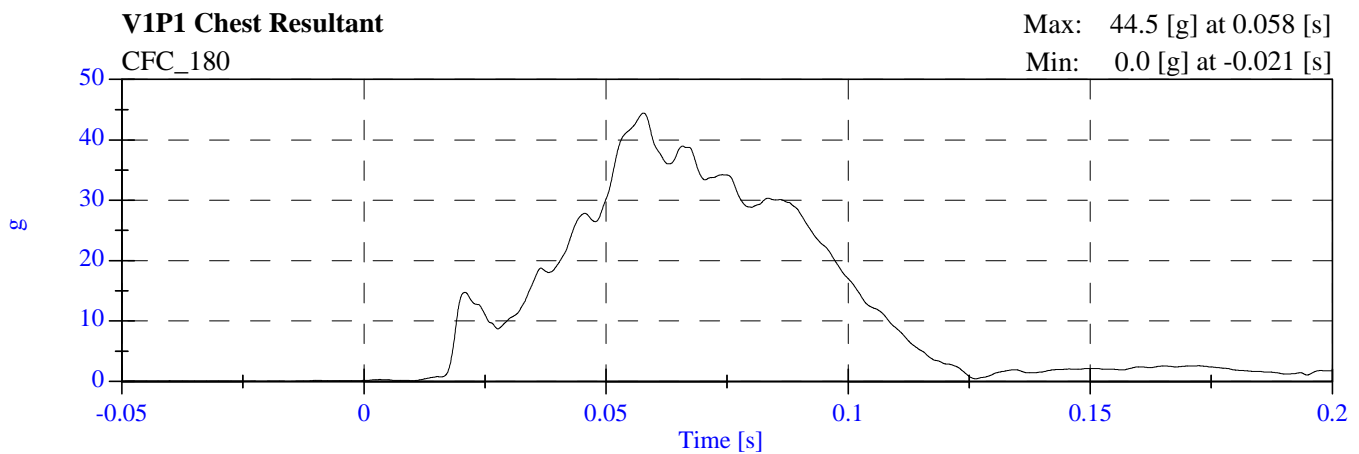
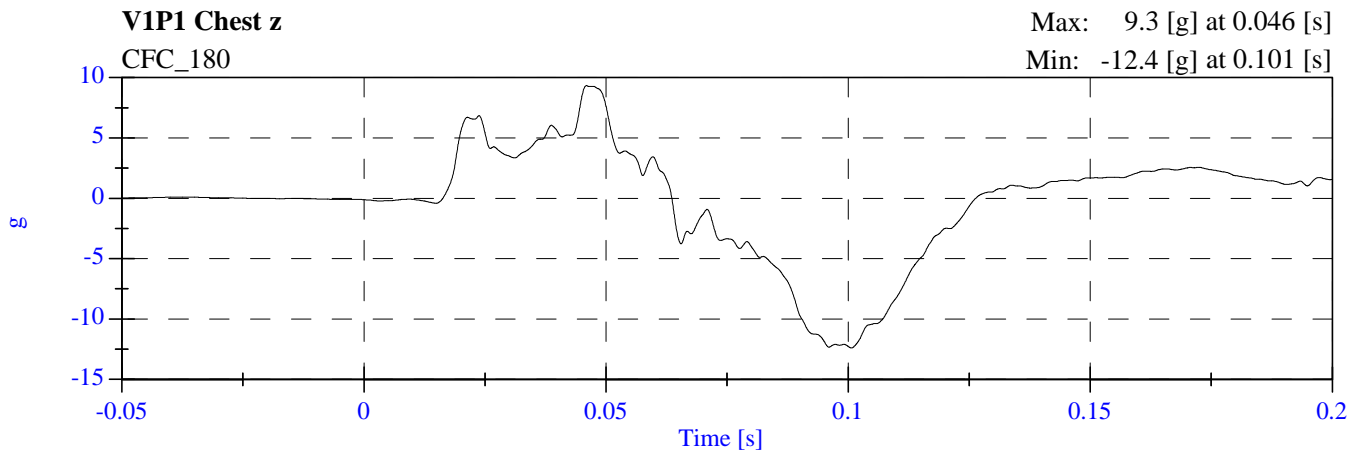
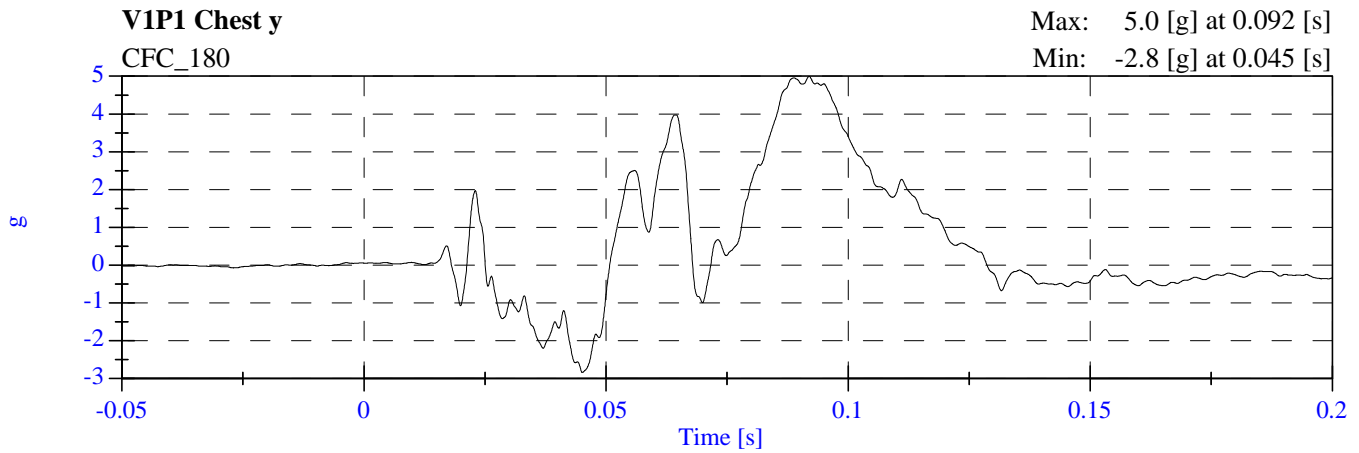
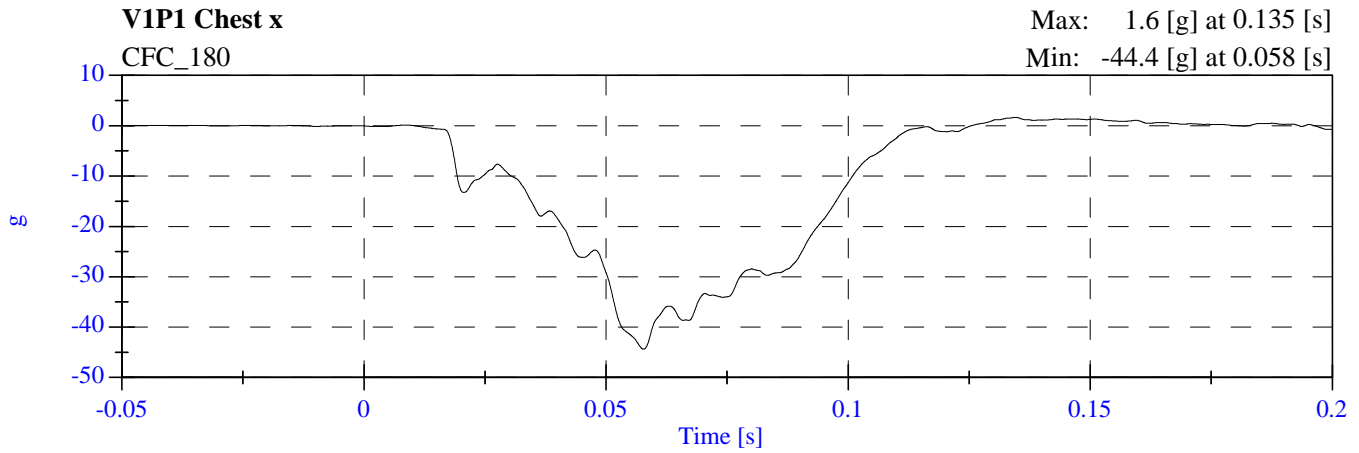

**2006 NCAP Test 2 2006 Hyundai Sonata 4DSD  
M60506 - August 25, 2005**

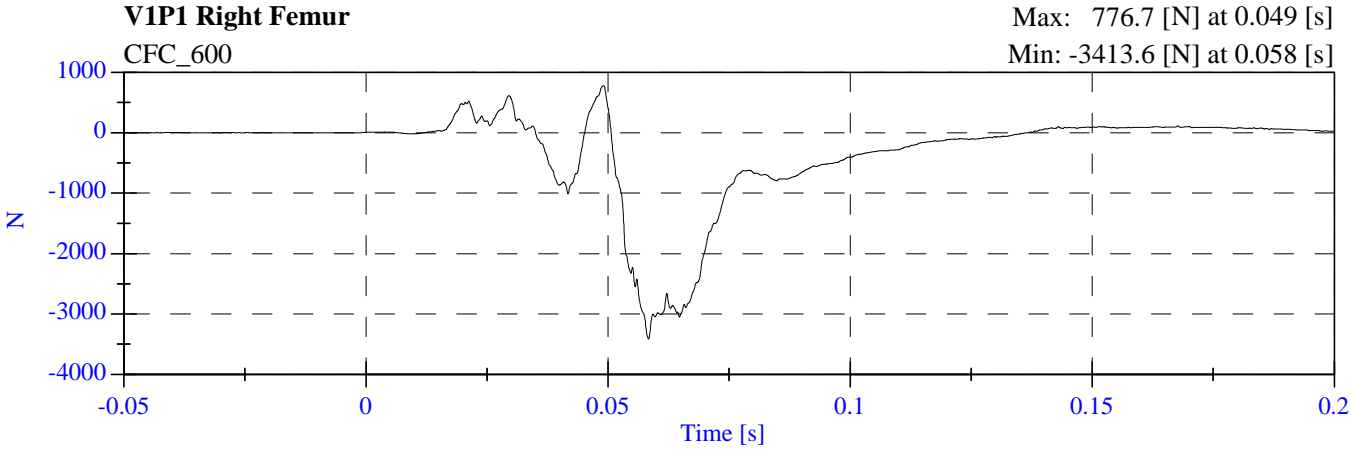
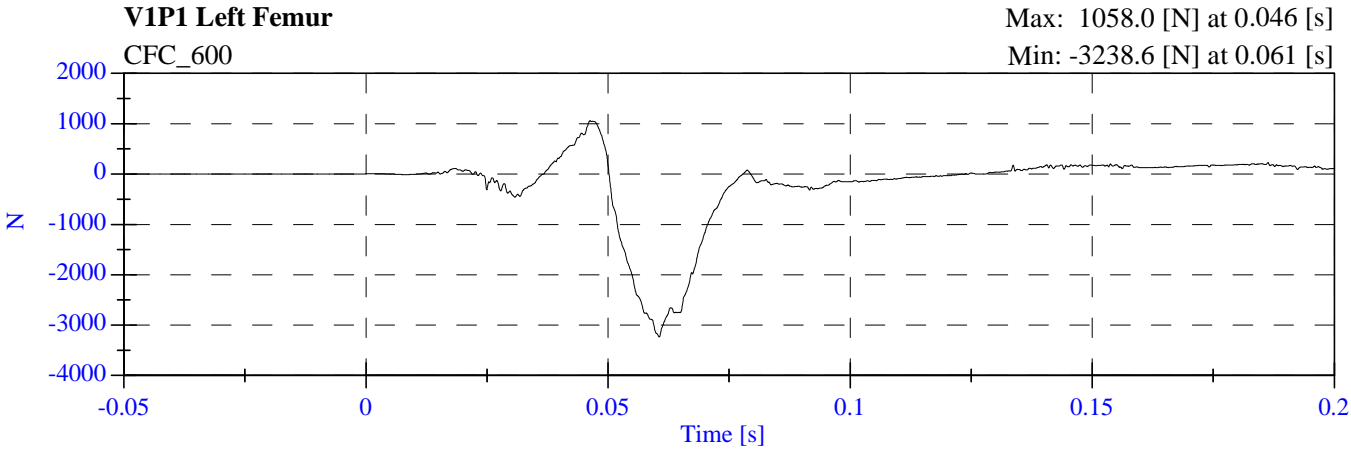

# 2006 NCAP Test 2 2006 Hyundai Sonata 4DSD M60506 - August 25, 2005

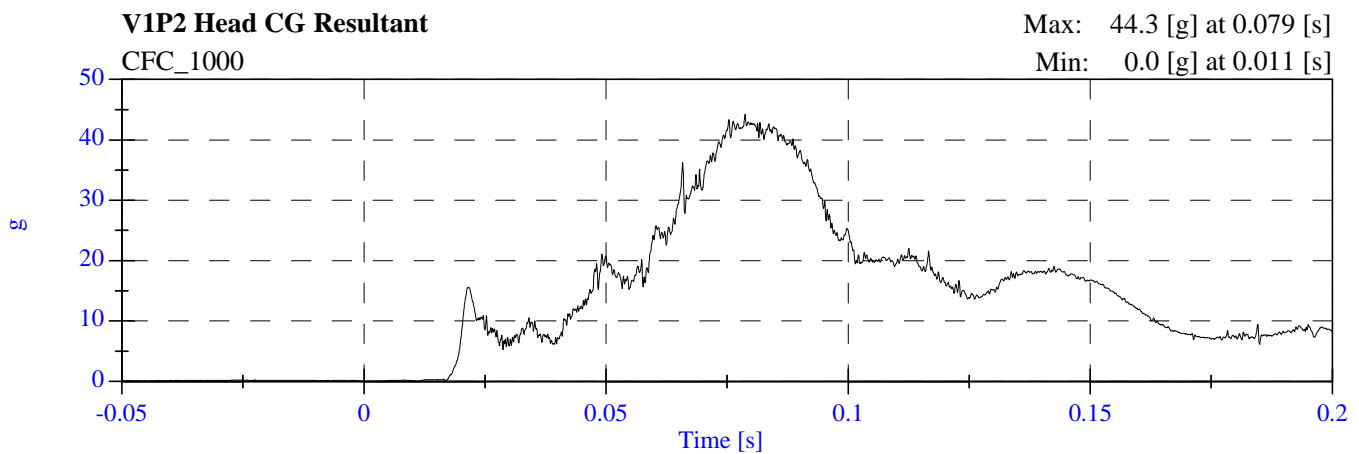
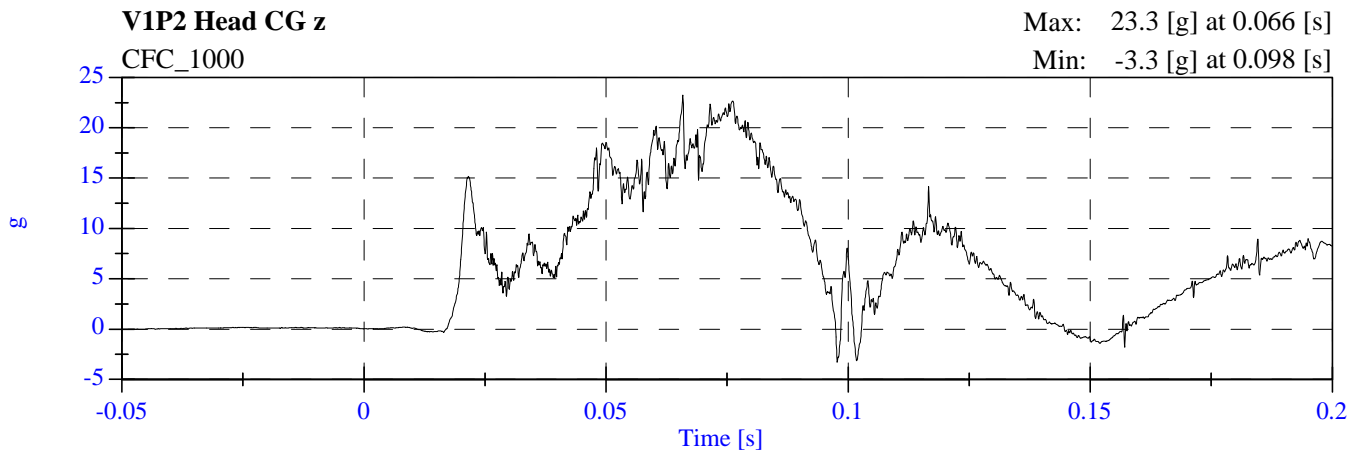
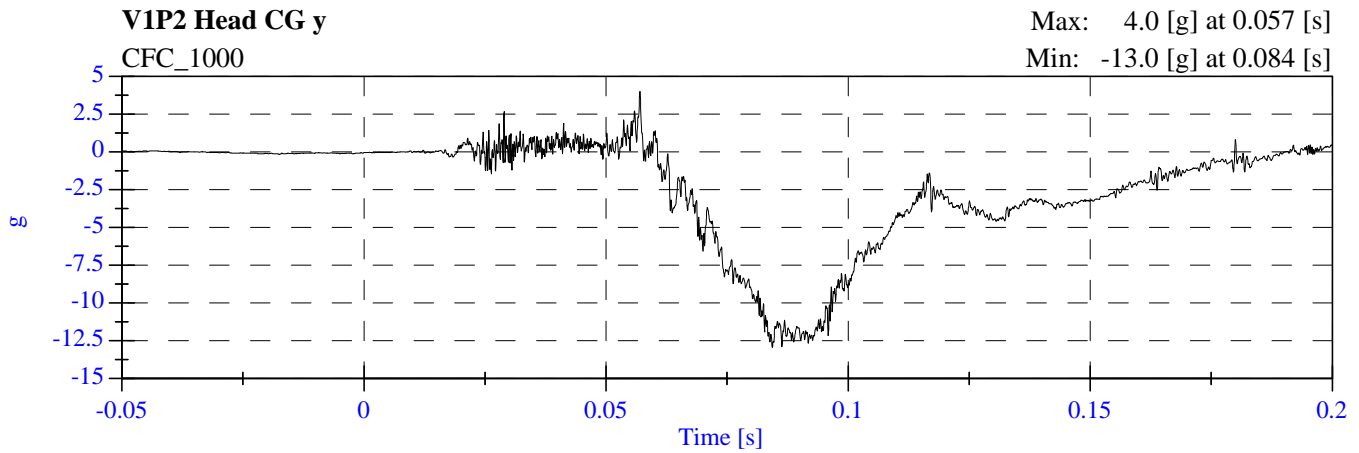
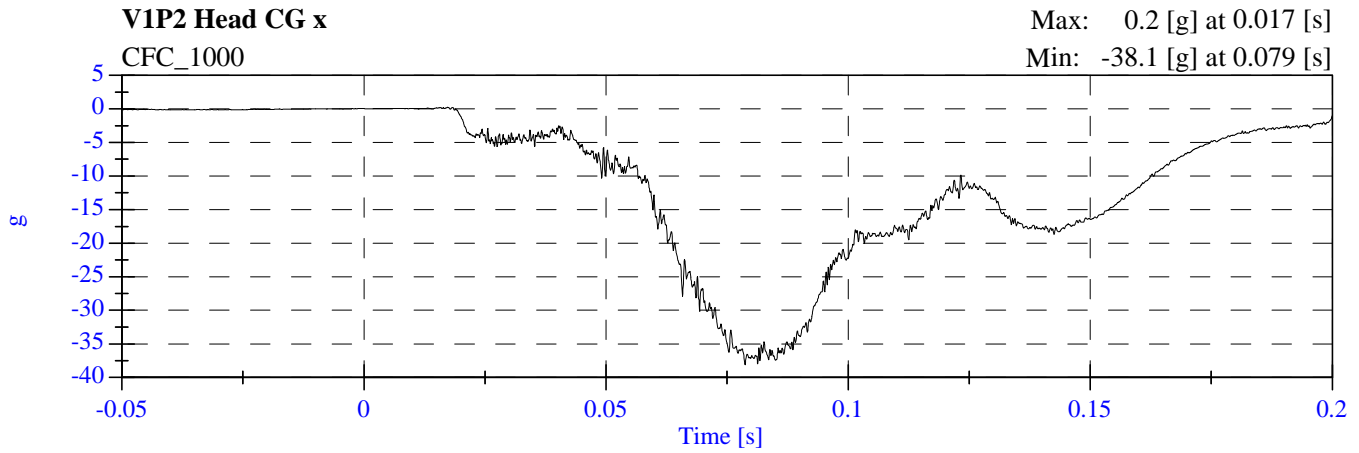

# 2006 NCAP Test 2 2006 Hyundai Sonata 4DSD M60506 - August 25, 2005

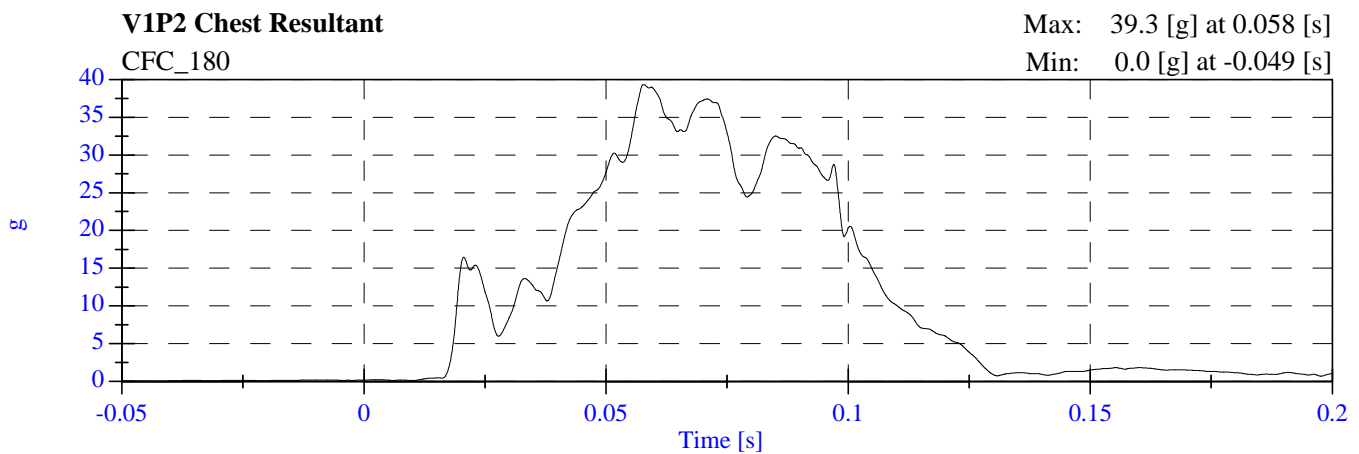
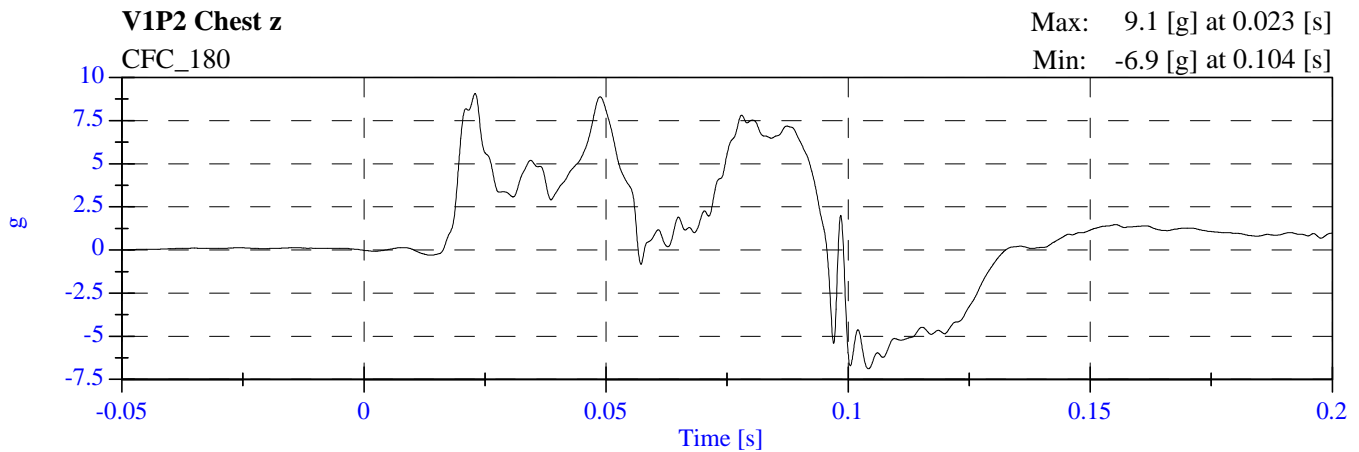
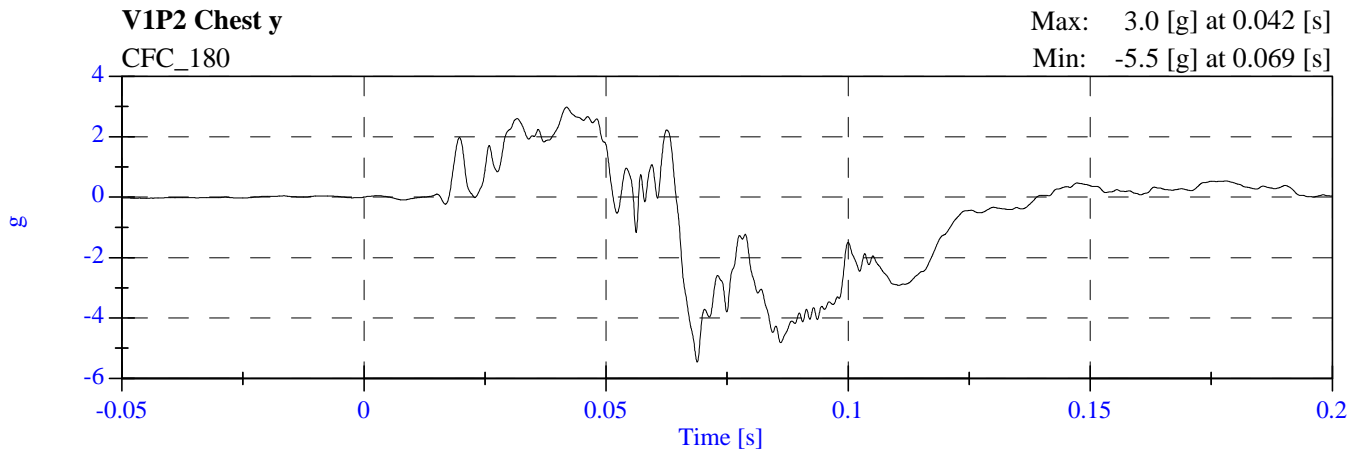
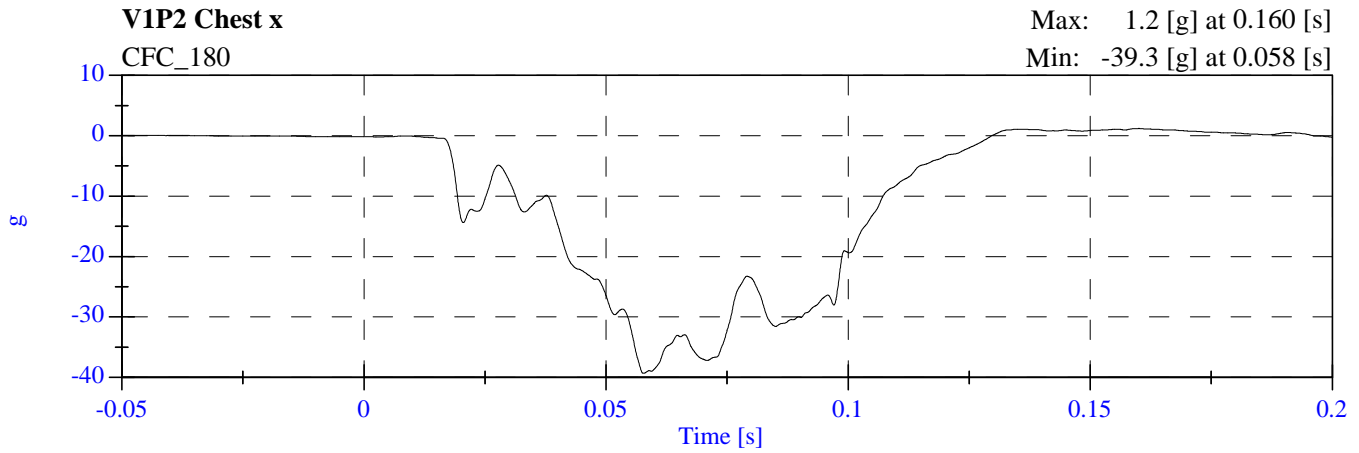

# 2006 NCAP Test 2 2006 Hyundai Sonata 4DSD M60506 - August 25, 2005

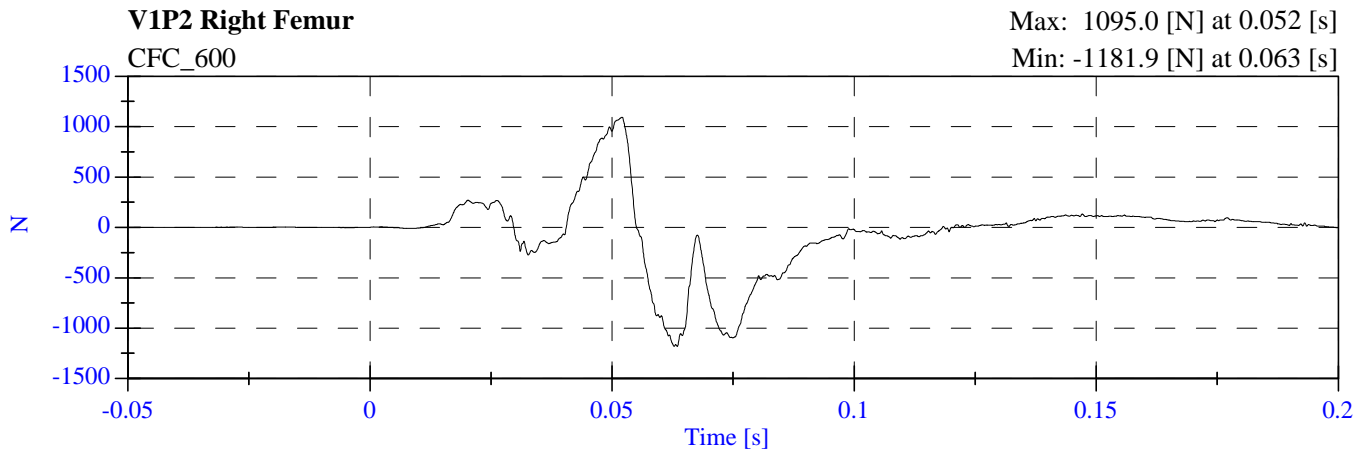
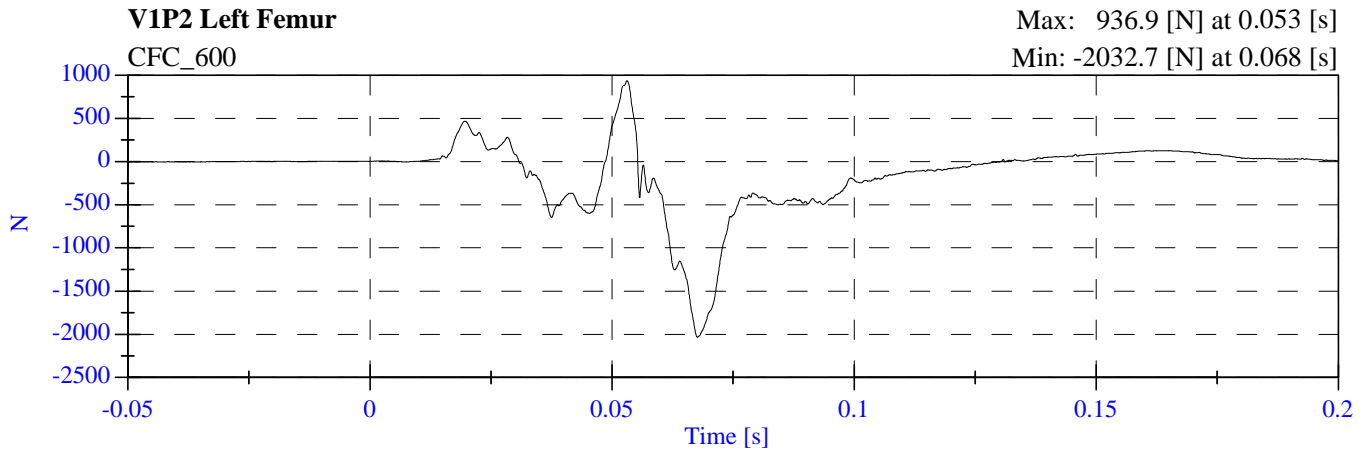

## **APPENDIX C**

### **PART 572B/E DUMMY CONFIGURATION AND PERFORMANCE VERIFICATION DATA SHEETS**

Appendix C contains the results from certification tests performed on the 50th percentile male anthropomorphic test devices utilized for this crash test. The results indicate that the dummies meet all of the performance requirements of the six standard tests as specified in 49 CFR Part 572, Federal Register, Volume 42, No. 25, dated February 7, 1977.

The tests were conducted at the Dummy Certification Test Facility of Calspan. A summary of the test results, and Part 572 specifications are included in this Appendix.

Dummy serial numbers and certification dates are:

<u>Position No./Location</u>	<u>Serial No.</u>	<u>Completion Date</u>
#1/Driver	142	August 3, 2005
#2/Right Front Passenger	150	August 3, 2005

#### Electronic Test Equipment

The complement of signal conditioning, recording and display equipment, in conjunction with dummy certification testing, can be found in New Car Assessment and Standards Indicant Testing Final Report No. 6525-V-1.

# EXTERNAL DIMENSIONS SPECIFICATIONS

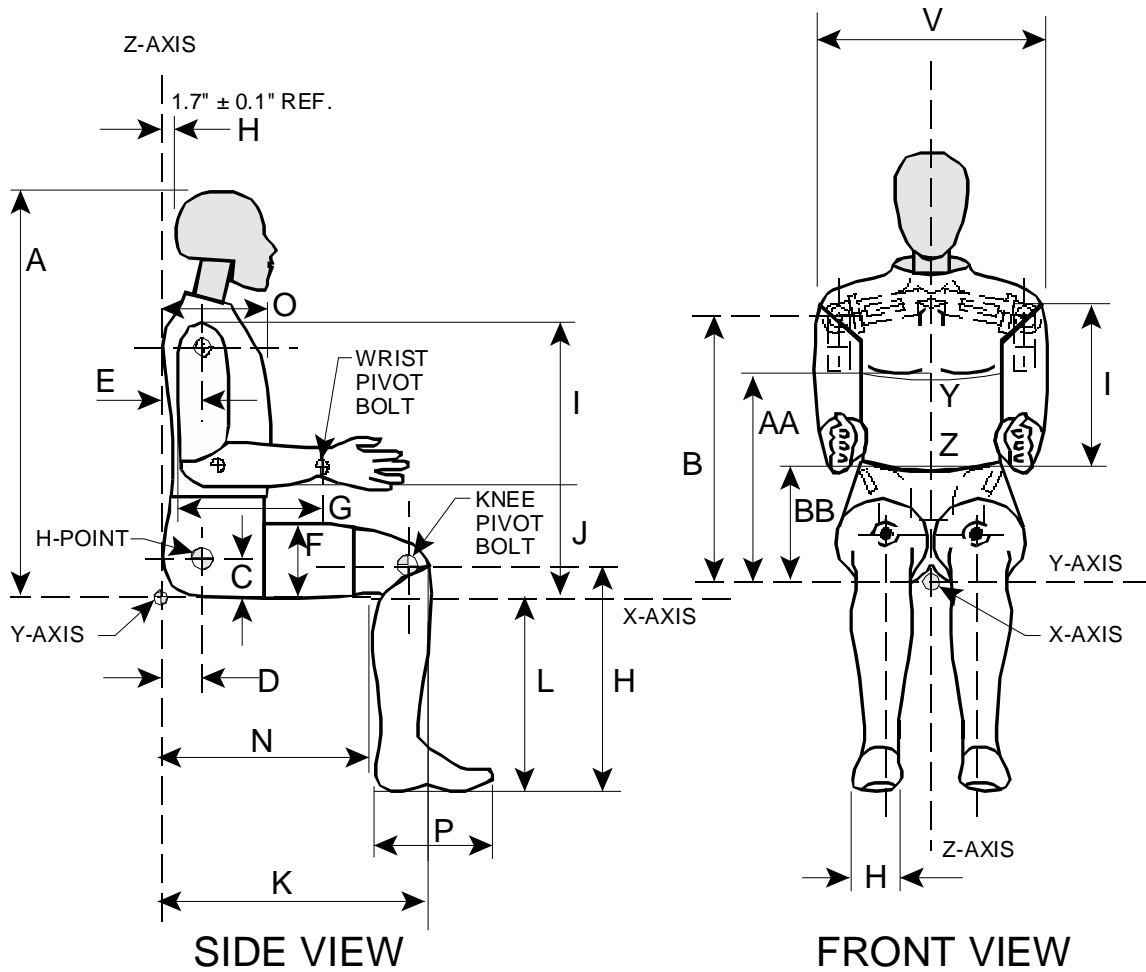

NOTE: Figure is referenced to the erect seated position. The curved lumbar does not allow the Hybrid III to be positioned in a perfect erect attitude. (REF: S572.31(A)(6))

PART 572E  
HEAD DROP TEST

Dummy Serial Number 142  
Sequential Test Number 1.2  
Date August 1, 2005  
Workfile 142H1 08-01-05

TEST PARAMETER	SPECIFICATION	TEST RESULTS
Temperature	18.9 – 25.6 Deg C	21.1
Relative Humidity	10% - 70%	30.00
Peak Resultant Acceleration	225-275 G's	262.25
Peak Lateral Acceleration	15 G's Max	1.85
Is Acceleration Curve Unimodal?	YES	YES

Remarks:

Laboratory Technician:

B. Swiecicki

PART 572E  
NECK FLEXION TEST

Dummy Serial Number	142	
Sequential Test Number	1.2	
Date	August 2, 2005	6 Axis Neck Transducer
Workfile	142 NF1 08-02-05	

TEST PARAMETER	SPECIFICATION	TEST RESULTS
Temperature	20.6 – 22.2 Deg C	21.11
Relative Humidity	10% - 70%	36.00
Impact Velocity	6.89 – 7.13 m/s	6.99
Pendulum Deceleration	10 ms	22.50 - 27.50 G's
	20 ms	17.60 - 22.60 G's
	30 ms	12.50 - 18.50 G's
Max Pendulum G's Above 30 ms	29 G's Max	15.57
Deceleration - Time Curve Decay Time to 5 G's	34 - 42 ms	39.20
D Plane Rotation	Max	64 - 78 Deg
	Time	57 - 64 ms
Moment About Occipital Condyle	Max	88.13 – 108.47 N-m
	Time	47 - 58 ms
Rotation Angle - Time Curve Decay Time to Zero	113 - 128 ms	117.90
Positive Moment - Time Curve Decay Time to Zero	97 - 107 ms	100.00

Remarks:

Laboratory Technician:

B. Swiecicki

---

PART 572E  
NECK EXTENSION TEST

Dummy Serial Number	142	
Sequential Test Number	1.2	
Date	August 2, 2005	6 Axis Neck Transducer
Workfile	142 NE 08-02-05	

TEST PARAMETER	SPECIFICATION	TEST RESULTS
Temperature	20.6 – 22.2 Deg C	21.11
Relative Humidity	10% - 70%	36.00
Impact Velocity	5.94 – 6.19 m/s	6.02
Pendulum Deceleration	10 ms	17.20 - 21.20 G's
	20 ms	14.00 - 19.00 G's
	30 ms	11.00 - 16.00 G's
Max Pendulum G's Above 30 ms	22 G's Max	14.37
Deceleration - Time Curve Decay Time to 5 G's	38 - 46 ms	43.40
D Plane Rotation	Max	81 - 106 Deg
	Time	72 - 82 ms
Moment About Occipital Condyle	Max	-79.99 - -52.88 N-m
	Time	65 - 79 ms
Rotation Angle - Time Curve Decay Time to Zero	147 - 174 ms	158.10
Positive Moment - Time Curve Decay Time to Zero	120 - 148 ms	141.70

Remarks:

Laboratory Technician:

B. Swiecicki

---

PART 572E  
THORAX IMPACT TEST

Dummy Serial Number 142  
Sequential Test Number 1.2  
Date August 2, 2005  
Workfile 142T 08-02-05

TEST PARAMETER	SPECIFICATION	TEST RESULTS
Temperature	20.6 – 22.2 Deg C	21.1
Relative Humidity	10% - 70%	35.00
Pendulum Velocity	6.58 – 6.83 m/s	6.69
Maximum Deflection	64.52 – 72.64 mm	65.46
Maximum Resistive Force	5159.9 – 5893.9 N	5495.01
Internal Hysteresis	69 - 85 %	76.09

Remarks:

Laboratory Technician:

\_\_\_\_\_ B. Swiecicki

PART 572E  
KNEE IMPACT TEST

Dummy Serial Number            142  
 Sequential Test Number        1.2  
 Date                                    August 2, 2005  
 Workfile                              142LF/RF 08-02-05

TEST PARAMETER	SPECIFICATION	TEST RESULTS
<b>LEFT KNEE</b>		
Temperature	18.9 – 25.6 Deg C	21.11
Relative Humidity	10% - 70%	35.00
Probe Velocity	2.07 – 2.13 m/s	2.13
Peak Knee Impact Force	4715.1 – 5782.7 N	5384.96
<b>RIGHT KNEE</b>		
Temperature	18.9 – 25.6 Deg C	21.11
Relative Humidity	10% - 70%	35.00
Probe Velocity	2.07 – 2.13 m/s	2.13
Peak Knee Impact Force	4715.1 – 5782.7 N	5209.31

Remarks:

Laboratory Technician:

B. Swiecicki

---

PART 572E  
EXTERNAL DIMENSIONS

Dummy Serial Number            142  
 Sequential Test Number        1.2  
 Date                                    August 3, 2005

TEST PARAMETER		SPECIFICATION	TEST RESULTS
Temperature			70
Relative Humidity			35
Location for Chest Circumference	AA	16.9 - 17.1 in	17.0
Location for Waist Circumference	BB	8.9 - 9.1 in	9.0
Total Sitting Height	A	34.6 - 35.0 in	35.0
Shoulder Pivot Height	B	19.9 - 20.5 in	20.4
H-Point Height	C	3.3 - 3.5 in	3.5
H-Point from Backline	D	5.3 - 5.5 in	5.3
Shoulder Pivot from Backline	E	3.3 - 3.7 in	3.7
Thigh Clearance	F	5.5 - 6.1 in	6.0
Back of Elbow to Wrist Pivot	G	11.4 - 12.0 in	11.5
Skull Cap to Backline	H	1.6 - 1.8 in	1.7
Shoulder - Elbow Length	I	13.0 - 13.6 in	13.5
Elbow Rest Height	J	7.5 - 8.3 in	8.25
Buttock Knee Length	K	22.8 - 23.8 in	23.5
Popliteal Height	L	16.9 - 17.9 in	17.75
Knee Pivot Height	M	19.1 - 19.7 in	19.25
Buttock Popliteal Length	N	17.8 - 18.8 in	18.75
Chest Depth	O	8.4 - 9.0 in	9.0
Foot Length	P	9.9 - 10.5 in	10.25
Shoulder Breadth	V	16.6 - 17.2 in	16.9
Foot Breadth	W	3.6 - 4.2 in	4.0
Chest Circumference (With Jacket)	Y	38.2 - 39.4 in	38.75
Waist Circumference	Z	32.9 - 34.1 in	33.0

Remarks:

Laboratory Technician:

B. Swiecicki

---

PART 572E  
HEAD DROP TEST

Dummy Serial Number           150  
Sequential Test Number        1.2  
Date                               July 27, 2005  
Workfile                         150H1 07-27-05

TEST PARAMETER	SPECIFICATION	TEST RESULTS
Temperature	18.9 – 25.6 Deg C	21.1
Relative Humidity	10% - 70%	28.00
Peak Resultant Acceleration	225-275 G's	261.91
Peak Lateral Acceleration	15 G's Max	1.40
Is Acceleration Curve Unimodal?	YES	YES

Remarks:

Laboratory Technician:

B. Swiecicki

PART 572E  
NECK FLEXION TEST

Dummy Serial Number	150	
Sequential Test Number	1.2	
Date	August 2, 2005	6 Axis Neck Transducer
Workfile	150NF1 08-02-05	

TEST PARAMETER	SPECIFICATION	TEST RESULTS
Temperature	20.6 – 22.2 Deg C	21.11
Relative Humidity	10% - 70%	35.00
Impact Velocity	6.89 – 7.13 m/s	7.00
Pendulum Deceleration	10 ms 22.50 - 27.50 G's	22.90
	20 ms 17.60 - 22.60 G's	22.09
	30 ms 12.50 - 18.50 G's	14.68
Max Pendulum G's Above 30 ms	29 G's Max	14.68
Deceleration - Time Curve Decay Time to 5 G's	34 - 42 ms	42.00
D Plane Rotation	Max 64 - 78 Deg	69.37
	Time 57 - 64 ms	59.20
Moment About Occipital Condyle	Max 88.13 – 108.47 N-m	94.41
	Time 47 - 58 ms	54.90
Rotation Angle - Time Curve Decay Time to Zero	113 - 128 ms	117.70
Positive Moment - Time Curve Decay Time to Zero	97 - 107 ms	100.40

Remarks:

Laboratory Technician:

B. Swiecicki

---

PART 572E  
NECK EXTENSION TEST

Dummy Serial Number	150	
Sequential Test Number	1.2	
Date	August 2, 2005	6 Axis Neck Transducer
Workfile	150NE 08-02-05	

TEST PARAMETER		SPECIFICATION	TEST RESULTS
Temperature		20.6 – 22.2 Deg C	21.11
Relative Humidity		10% - 70%	35.00
Impact Velocity		5.94 – 6.19 m/s	6.00
Pendulum Deceleration	10 ms	17.20 - 21.20 G's	19.39
	20 ms	14.00 - 19.00 G's	18.85
	30 ms	11.00 - 16.00 G's	14.91
Max Pendulum G's Above 30 ms		22 G's Max	14.91
Deceleration - Time Curve Decay Time to 5 G's		38 - 46 ms	38.00
D Plane Rotation	Max	81 - 106 Deg	94.22
	Time	72 - 82 ms	72.80
Moment About Occipital Condyle	Max	-79.99 - -52.88 N-m	-72.41
	Time	65 - 79 ms	68.90
Rotation Angle - Time Curve Decay Time to Zero		147 - 174 ms	153.40
Positive Moment - Time Curve Decay Time to Zero		120 - 148 ms	135.00

Remarks:

Laboratory Technician:

B. Swiecicki

---

PART 572E  
THORAX IMPACT TEST

Dummy Serial Number 150  
Sequential Test Number 1.2  
Date August 3, 2005  
Workfile 150T 08-02-05

TEST PARAMETER	SPECIFICATION	TEST RESULTS
Temperature	20.6 – 22.2 Deg C	21.1
Relative Humidity	10% - 70%	35.00
Pendulum Velocity	6.58 – 6.83 m/s	6.71
Maximum Deflection	64.52 – 72.64 mm	65.00
Maximum Resistive Force	5159.9 – 5893.9 N	5542.36
Internal Hysteresis	69 - 85 %	75.09

Remarks:

Laboratory Technician:

\_\_\_\_\_ B. Swiecicki

PART 572E  
KNEE IMPACT TEST

Dummy Serial Number            150  
 Sequential Test Number        1.2  
 Date                                    August 2, 2005  
 Workfile                              150LF/RF 08-02-05

TEST PARAMETER	SPECIFICATION	TEST RESULTS
<b>LEFT KNEE</b>		
Temperature	18.9 – 25.6 Deg C	21.1
Relative Humidity	10% - 70%	35.00
Probe Velocity	2.07 – 2.13 m/s	2.13
Peak Knee Impact Force	4715.1 – 5782.7 N	5205.9
<b>RIGHT KNEE</b>		
Temperature	18.9 – 25.6 Deg C	21.1
Relative Humidity	10% - 70%	35.00
Probe Velocity	2.07 – 2.13 m/s	2.13
Peak Knee Impact Force	4715.1 – 5782.7 N	5281.41

Remarks:

Laboratory Technician:

\_\_\_\_\_ B. Swiecicki

PART 572E  
EXTERNAL DIMENSIONS

Dummy Serial Number           150  
Sequential Test Number        1.2  
Date                                August 3, 2005

TEST PARAMETER		SPECIFICATION	TEST RESULTS
Temperature			70.0
Relative Humidity			35.0
Location for Chest Circumference	AA	16.9 - 17.1 in	17.0
Location for Waist Circumference	BB	8.9 - 9.1 in	9.0
Total Sitting Height	A	34.6 - 35.0 in	34.8
Shoulder Pivot Height	B	19.9 - 20.5 in	20.1
H-Point Height	C	3.3 - 3.5 in	3.4
H-Point from Backline	D	5.3 - 5.5 in	5.5
Shoulder Pivot from Backline	E	3.3 - 3.7 in	3.7
Thigh Clearance	F	5.5 - 6.1 in	6.0
Back of Elbow to Wrist Pivot	G	11.4 - 12.0 in	11.5
Skull Cap to Backline	H	1.6 - 1.8 in	1.7
Shoulder - Elbow Length	I	13.0 - 13.6 in	13.2
Elbow Rest Height	J	7.5 - 8.3 in	8.1
Buttock Knee Length	K	22.8 - 23.8 in	23.5
Popliteal Height	L	16.9 - 17.9 in	17.8
Knee Pivot Height	M	19.1 - 19.7 in	19.5
Buttock Popliteal Length	N	17.8 - 18.8 in	18.4
Chest Depth	O	8.4 - 9.0 in	9.0
Foot Length	P	9.9 - 10.5 in	10.2
Shoulder Breadth	V	16.6 - 17.2 in	16.9
Foot Breadth	W	3.6 - 4.2 in	4.0
Chest Circumference (With Jacket)	Y	38.2 - 39.4 in	39.0
Waist Circumference	Z	32.9 - 34.1 in	34.0

Remarks:

Laboratory Technician:

B. Swiecicki

---

## **APPENDIX D**

### **DUMMY, VEHICLE AND LABORATORY INSTRUMENT CALIBRATION**

INSTRUMENT CALIBRATION FOR DRIVER DUMMY  
(Six Month Calibration Minimum)

DRIVER DUMMY (S/N 142)		Manufacturer	Serial #	Calibration	
				Last	Next
Head 9 Array	X Arm Y	ENDEVCO	AC-J35933	14-Jul-05	12-Jan-06
	X Arm Z	ENDEVCO	AC-J36038	13-Jul-05	11-Jan-06
	Y Arm X	ENDEVCO	AC-J36605	14-Jul-05	12-Jan-06
	Y Arm Z	ENDEVCO	AC-J21907	13-Jul-05	11-Jan-06
	Z Arm X	ENDEVCO	AC-J19843	13-Jul-05	11-Jan-06
	Z Arm Y	ENDEVCO	AC-AJ507	13-Jul-05	11-Jan-06
Head	X	ENDEVCO	AC-J14189	13-Jul-05	11-Jan-06
	Y	ENDEVCO	AC-J20125	13-Jul-05	11-Jan-06
	Z	ENDEVCO	AC-J36744	14-Jul-05	12-Jan-06
Head	X (R)	ENDEVCO	AC-J21989	14-Jul-05	12-Jan-06
	Y (R)	ENDEVCO	AC-J35921	13-Jul-05	11-Jan-06
	Z (R)	ENDEVCO	AC-ACCY2	13-Jul-05	11-Jan-06
Neck Load Cell	X	DENTON	LC-297Fx	13-Jul-05	11-Jan-06
	Y	DENTON	LC-297Fy	13-Jul-05	11-Jan-06
	Z	DENTON	LC-297Fz	13-Jul-05	11-Jan-06
Neck Moment	X	DENTON	LC-297Mx	13-Jul-05	11-Jan-06
	Y	DENTON	LC-297My	13-Jul-05	11-Jan-06
	Z	DENTON	LC-297Mz	13-Jul-05	11-Jan-06
Chest	X	ENDEVCO	AC-AC9F9	13-Jul-05	11-Jan-06
	Y	ENDEVCO	AC-P16194	14-Jul-05	12-Jan-06
	Z	ENDEVCO	AC-J14688	13-Jul-05	11-Jan-06
Chest	X (R)	ENDEVCO	AC-AAK48	13-Jul-05	11-Jan-06
	Y (R)	ENDEVCO	AC-AAKB1	14-Jul-05	12-Jan-06
	Z (R)	ENDEVCO	AC-J27517	14-Jul-05	12-Jan-06
Chest Deflection	X	SERVO	DS-142	28-Jun-05	27-Dec-05
Pelvic	X	ENDEVCO	AC-AJ5R0	18-Jul-05	16-Jan-06
	Y	ENDEVCO	AC-J22036	14-Jul-05	12-Jan-06
	Z	ENDEVCO	AC-J17649	13-Jul-05	11-Jan-06

INSTRUMENT CALIBRATION FOR DRIVER DUMMY  
(Six Month Calibration Minimum)

DRIVER DUMMY (S/N 142)	Manufacturer	Serial #	Calibration		
			Last	Next	
Left Femur Load Cell Fz	DENTON	LC-729	20-Dec-04	20-Jun-05	
Right Femur Load Cell Fz	GSE	LC-631	16-Dec-04	16-Jun-05	
Left Upper Tibia	Mx	DENTON	LC-266Mx	24-Jun-05	23-Dec-05
	My	DENTON	LC-266My	24-Jun-05	23-Dec-05
Left Lower Tibia	Fz	DENTON	LC-179Fz	22-Jun-05	21-Dec-05
	Mx	DENTON	LC-179Mx	22-Jun-05	21-Dec-05
	My	DENTON	LC-179My	22-Jun-05	21-Dec-05
Right Lower Tibia	Mx	DENTON	LC-265Mx	28-Jun-05	27-Dec-05
	My	DENTON	LC-265My	28-Jun-05	27-Dec-05
Right Upper Tibia	Fz	DENTON	LC-178Fz	28-Jun-05	27-Dec-05
	Mx	DENTON	LC-178Mx	28-Jun-05	27-Dec-05
	My	DENTON	LC-178My	28-Jun-05	27-Dec-05
Left Foot Rear	X	ENTRAN	AC-02I02I05-F06	15-Jul-05	13-Jan-06
	Z	ENTRAN	AC-01G18-F14	15-Jul-05	13-Jan-06
Left Foot Front	Z	ENTRAN	AC-99H30-Z13	18-Jul-05	16-Jan-06
Right Foot Rear	X	ENTRAN	AC-02I20I16-A13	15-Jul-05	13-Jan-06
	Z	ENTRAN	AC-03D03D16-F01	15-Jul-05	13-Jan-06
Right Foot Front	Z	ENTRAN	AC-00L20-A15	15-Jul-05	13-Jan-06
Lap Belt Load Cell	First Technology	LC-159	01-Oct-04	01-Apr-05	
Shoulder Belt Load Cell	First Technology	LC-175	01-Oct-04	01-Apr-05	

INSTRUMENT CALIBRATION FOR PASSENGER DUMMY  
(Six Month Calibration Minimum)

PASSENGER DUMMY (S/N 150)	Manufacturer	Serial #	Calibration		
			Last	Next	
Head 9 Array	X Arm Y	ENDEVCO	AC-J27470	13-Jul-05	11-Jan-06
	X Arm Z	ENDEVCO	AC-J36741	13-Jul-05	11-Jan-06
	Y Arm X	ENDEVCO	AC-J20027	14-Jul-05	12-Jan-06
	Y Arm Z	ENDEVCO	AC-J21988	15-Jul-05	13-Jan-06
	Z Arm X	ENDEVCO	AC-AAKC6	13-Jul-05	11-Jan-06
	Z Arm Y	ENDEVCO	AC-AAKD0	13-Jul-05	11-Jan-06
Head	X	ENDEVCO	AC-J20061	13-Jul-05	11-Jan-06
	Y	ENDEVCO	AC-AJ4F8	13-Jul-05	11-Jan-06
	Z	ENDEVCO	AC-AHRW5	14-Jul-05	12-Jan-06
Head	X (R)	ENDEVCO	AC-AJ7Y4	13-Jul-05	11-Jan-06
	Y (R)	ENDEVCO	AC-AJ454	13-Jul-05	11-Jan-06
	Z (R)	ENDEVCO	AC-J19563	13-Jul-05	11-Jan-06
Neck Load Cell	X	DENTON	LC-157Fx	14-Jul-05	12-Jan-06
	Y	DENTON	LC-157Fy	14-Jul-05	12-Jan-06
	Z	DENTON	LC-157Fz	14-Jul-05	12-Jan-06
Neck Moment	X	DENTON	LC-157Mx	14-Jul-05	12-Jan-06
	Y	DENTON	LC-157My	14-Jul-05	12-Jan-06
	Z	DENTON	LC-157Mz	14-Jul-05	12-Jan-06
Chest	X	ENDEVCO	AC-J20580	14-Jul-05	12-Jan-06
	Y	ENDEVCO	AC-J20018	13-Jul-05	11-Jan-06
	Z	ENDEVCO	AC-J20569	14-Jul-05	12-Jan-06
Chest	X (R)	ENDEVCO	AC-J21963	14-Jul-05	12-Jan-06
	Y (R)	ENDEVCO	AC-P16755	14-Jul-05	12-Jan-06
	Z (R)	ENDEVCO	AC-J14667	14-Jul-05	12-Jan-06
Chest Deflection	X	SERVO	DS-150	23-Jun-05	22-Dec-05
Pelvic	X	ENDEVCO	AC-J34378	13-Jul-05	11-Jan-06
	Y	ENDEVCO	AC-J23757	14-Jul-05	12-Jan-06
	Z	ENDEVCO	AC-J27513	14-Jul-05	12-Jan-06

INSTRUMENT CALIBRATION FOR PASSENGER DUMMY  
(Six Month Calibration Minimum)

PASSENGER DUMMY (S/N 150)	Manufacturer	Serial #	Calibration		
			Last	Next	
Left Femur Load Cell	Fz	DENTON	LC-261	02-Jul-05	31-Dec-05
Right Femur Load Cell	Fz	DENTON	LC-264	02-Jul-05	31-Dec-05
Left Lower Tibia	Mx	DENTON	LC-263Mx	29-Jun-05	28-Dec-05
	My	DENTON	LC-263My	29-Jun-05	28-Dec-05
Left Upper Tibia	Fz	DENTON	LC-174Fz	28-Jun-05	27-Dec-05
	Mx	DENTON	LC-174Mx	28-Jun-05	27-Dec-05
	My	DENTON	LC-174My	28-Jun-05	27-Dec-05
Right Upper Tibia	Mx	DENTON	LC-274Mx	02-Jul-05	31-Dec-05
	My	DENTON	LC-274My	02-Jul-05	31-Dec-05
Right Lower Tibia	Fz	DENTON	LC-185Fz	03-May-05	01-Nov-05
	Mx	DENTON	LC-185Mx	28-Jun-05	27-Dec-05
	My	DENTON	LC-185My	28-Jun-05	27-Dec-05
Left Foot Rear	X	ENDEVCO	AC-J19223	14-Jul-05	12-Jan-06
	Z	ENDEVCO	AC-J20083	14-Jul-05	12-Jan-06
Left Foot Front	Z	ENTRAN	AC-04J04J07-M02	14-Jul-05	12-Jan-06
Right Foot Rear	X	ENDEVCO	AC-J27496	13-Jul-05	11-Jan-06
	Z	ENDEVCO	AC-J35747	13-Jul-05	11-Jan-06
Right Foot Front	Z	ENDEVCO	AC-J36723	13-Jul-05	11-Jan-06
Lap Belt Load Cell		First Technology	LC-173	01-Oct-04	01-Apr-05
Shoulder Belt Load Cell		First Technology	LC-178	01-Oct-04	01-Apr-05

INSTRUMENT CALIBRATION FOR VEHICLE ACCELEROMETERS  
(Six Month Calibration Minimum)

	Manufacturer	Serial #	Calibration	
			Last	Next
Left Seat Rear Crossmember X	ICS	AC-FGP50	28-Feb-05	29-Aug-05
Right Rear Seat Crossmember X	GS SENSORS	AC-9440-032	28-Feb-05	29-Aug-05
Top of Engine	ICS	AC-FGP22	28-Feb-05	29-Aug-05
Bottom of Engine	ICS	AC-9026-042	16-Mar-05	14-Sep-05
Right Disc Brake Caliper	ICS	AC-FGP39	22-Mar-05	20-Sep-05
Instrument Panel	ICS	AC-FGP41	22-Mar-05	20-Sep-05
Left Disc Brake Caliper	ICS	AC-FGP34	23-Mar-05	21-Sep-05
Left Seat Rear Crossmember Z	GS SENSORS	AC-9440-017	28-Feb-05	29-Aug-05
Right Seat Rear Crossmember Z	ICS	AC-FGP26	28-Feb-05	29-Aug-05

## **APPENDIX E**

### **VEHICLE INTERIOR INTRUSION MEASUREMENTS**

## TOE-PAN INTRUSION

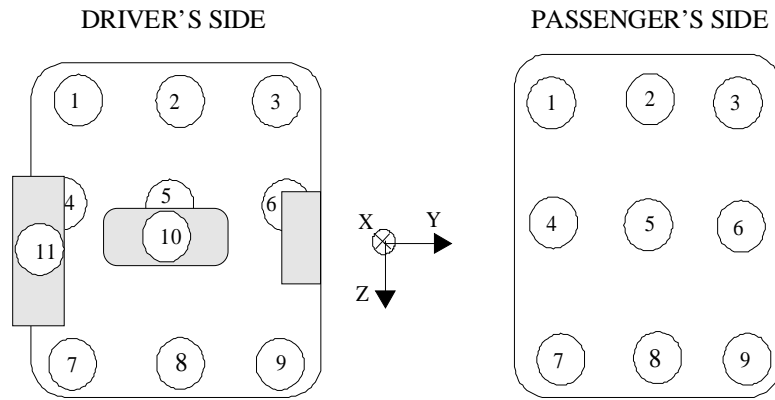

### Driver Side Toe-pan Measurements

Toe-pan Location	X Deformation (mm)			Z Deformation (mm)		
	Pre-Test	Post-Test	Difference	Pre-Test	Post-Test	Difference
1	3521	3478	43	474	504	-30
2	3524	3478	46	455	495	-40
3	3524	3473	51	456	493	-37
4	3438	3413	25	373	394	-21
5	3436	3400	36	369	399	-30
6	3439	3404	35	373	401	-28
7	3339	3332	7	296	299	-3
8	3343	3326	17	300	304	-4
9	3341	3323	18	302	313	-11
10	3353	3399	-46	479	475	4
11	3403	3382	21	418	429	-11

### Passenger Side Toe-pan Measurements

Toe-pan Location	X Deformation (mm)			Z Deformation (mm)		
	Pre-Test	Post-Test	Difference	Pre-Test	Post-Test	Difference
1	3547	3500	47	481	517	-36
2	3544	3513	31	474	509	-35
3	3515	3479	36	515	536	-21
4	3434	3413	21	382	408	-26
5	3436	3416	20	383	408	-25
6	3447	3432	15	390	410	-20
7	3326	3316	10	304	311	-7
8	3323	3318	5	303	304	-1
9	3338	3336	2	305	308	-3

Reference: SAE: X = Rear Bumper (Positive: forward); Z = Ground (Positive: up)