

REPORT NUMBER TR-P25064-01-NC

**NEW CAR ASSESSMENT PROGRAM
FRONTAL BARRIER IMPACT TEST**

**AMERICAN HONDA MOTOR COMPANY, INC
2006 HONDA RIDGELINE RTS
4-DOOR TRUCK**

NHTSA NUMBER: H65300

**PREPARED BY:
KARCO ENGINEERING, LLC
9270 HOLLY ROAD
ADELANTO, CALIFORNIA 92301**



APRIL 14, 2005

FINAL REPORT

**PREPARED FOR:
U.S. DEPARTMENT OF TRANSPORTATION
NATIONAL HIGHWAY TRAFFIC SAFETY ADMINISTRATION
RULEMAKING
OFFICE OF CRASHWORTHINESS STANDARDS
MAIL CODE: NVS-111
400 SEVENTH STREET, SW, ROOM 5311
WASHINGTON, D.C. 20590**

This final test report was prepared for the U.S. Department of Transportation, National Highway Traffic Safety Administration, in response to Contract Number DTNH22-01-D-02005.

This publication is distributed by the U.S. Department of Transportation, National Highway Traffic Safety Administration, in the interest of information exchange. The opinions, findings and conclusions expressed in this publication are those of the author(s) and not necessarily those of the Department of Transportation or the National Highway Traffic Safety Administration. The United States Government assumes no liability for its contents or use thereof. If trade or manufacturers' names or products are mentioned, it is only because they are considered essential to the object of the publication and should not be construed as an endorsement. The United States Government does not endorse products or manufacturers.

Prepared by: _____
Mr. Biren J. Patel, Project Engineer
KARCO Engineering, LLC

Date: 4/27/05

Reviewed by: _____
Mr. Michael L. Dunlap, Quality Assurance Manager
KARCO Engineering, LLC

Date: 4/27/05

Approved by: _____
Mr. Frank D. Richardson, Program Manager
KARCO Engineering, LLC

Date: 4/27/05

FINAL REPORT ACCEPTED BY:

Manager, New Car Assessment Program

Date of Acceptance

COTR, NCAP Frontal Impact Program

Date of Acceptance

Technical Report Documentation Page

1. Report No. TR-P25064-01-NC		2. Government Accession No.		3. Recipients Catalog No.	
4. Title and Subtitle Final Report of New Car Assessment Program 2006 Honda Ridgeline RTS 4-Door Truck NHTSA No. H65300				5. Report Date April 14, 2005	
				6. Performing Organization Code KAR	
7. Authors Mr. Biren J. Patel, Project Engineer, Karco Mr. Frank Richardson, Program Manager, Karco				8. Performing Organization Report No. TR-P25064-01-NC	
9. Performing Organization Name and Address Karco Engineering, LLC 9270 Holly Rd. Adelanto, CA, 92301				10. Work Unit No.	
				11. Contract or Grant No. DTNH22-01-D-02005	
12. Sponsoring Agency Name and Address U. S. Department of Transportation National Highway Traffic Safety Administration Rulemaking Office of Crashworthiness Standards Mail Code NPS-111 400 Seventh Street, SW, Room 5311 Washington, D.C 20590				13. Type of Report and Period Covered Final Test Report Option Year 4	
				14. Sponsoring Agency Code DOT/NHTSA/NRM/OCS	
15. Supplementary Notes					
16. Abstract A 35 mph (56.3 km/h) frontal barrier impact was conducted on a 2006 Honda Ridgeline RTS 4-Door Truck at Karco Engineering, LLC on April 14, 2005. This test was conducted to obtain data indicant of FMVSS 208, 212, 219 (partial), 301, and footwell intrusion performance. The impact velocity was 55.87 km/h. The ambient temperature at the barrier face at the time of impact was 20.6 degrees Celsius. The vehicle's maximum post-test static crush was 555 mm at center of the vehicle. The test vehicle is equipped with 3 point continous seat belts and second generation supplemental airbags in both front outboard seating positions. With respect to FMVSS 208 "Occupant Crash Protection", the occupant injury criteria summary is as follows:					
Measurement Description		Units	Threshold	Driver ATD	Passenger ATD
Head Injury Criteria (HIC ₃₆)			1000	244.1	272.3
Max. Chest Accel. (3 msec Clip)		G's	60	33.3	35.8
Left Femur Force		Newtons	10008	-3997.9	-4264.8
Right Femur Force		Newtons	10008	-2701.4	-3338.8
17. Key Words 56.3 km/h NCAP Frontal Barrier Impact Test New Car Assessment Program (NCAP) 2006 Honda Ridgeline RTS 4-Door Truck NHTSA No. H65300				18. Distribution of Statement Copies of this report available from: NHTSA Technical Reference Division National Highway Traffic Safety Admin. 400 Seventh St., SW, Room 5108 Washington, D.C. 20590	
19. Security Classification (this report) Unclassified		20. Security Classification (this page) Unclassified		21. No. of Pages 191	22. Price

Form DOT F1700.7 (8-72)

TABLE OF CONTENTS

Section	Description	Page
1	Purpose and Summary of Test H65300	1
2	Occupant and Vehicle Information/Data Sheets	3

Data Sheet	Description	Page
1	Crash Test Summary	4
2	General Test and Vehicle Parameter Data	5
3	Post-Test Impact Data	8
4	Test Vehicle Information	9
5	Dummy Positioning in Vehicle	11
6	Seat Belt Positioning Data	13
7	Vehicle Accelerometer Location and Data Summary	14
8	Hybrid III ATD Injury Criteria and Sensor Data	15
9	Seat Belt Assessment Test Data	18
10	Summary of FMVSS 212 Data	19
11	Windshield Zone Intrusion FMVSS 219 Data (Partial)	20
12	FMVSS 301 Fuel System Integrity Post Impact Data	21
13	FMVSS 301 Static Rollover Data	22
14	Vehicle Measurements	24
15	Camera Locations	27
16	Photographic Reference Target Locations	28
17	Vehicle Intrusion Measurements	29
18	Fixed Barrier Load Cell Locations	33
19	Post-Test Air Bag Data	34
20	Accident Investigation Division Data	35
21	Dummy/Vehicle Temperature Stabilization	36

Appendix	Description	Appendix
A	Photographs	A
B	Data Plots	B
C	Load Cell Barrier Data Plots	C
D	Instrumentation Data Channel Assignments	D
E	Dummy Calibration Data	E
F	Child Restraint System	F

SECTION 1

PURPOSE AND SUMMARY OF TEST H65300

1.1 PURPOSE

This 35 mph (56.3 km/h) frontal barrier impact test is part of the New Car Assessment Program (NCAP) sponsored by the National Highway Traffic Safety Administration (NHTSA) under Contract No. DTNH22-01-D-02005. The purpose of this test was to obtain vehicle crashworthiness and occupant restraint system performance data for an impact speed in excess of the current 30 mph (48.3 km/h) requirements.

This 56.3 km/h frontal barrier impact test was conducted in accordance with the Office of Crashworthiness Standards (OCS) New Car Assessment Program (NCAP) Laboratory Indicant Test Procedure, dated December 1999. Data was obtained indicant of FMVSS 208, "Occupant Crash Protection"; FMVSS 212, "Windshield Retention"; FMVSS 219, "Windshield Zone Intrusion (Partial)"; and FMVSS 301, "Fuel System Integrity" performance. Procedures for receiving, inspection testing and reporting of test results are described in the test procedures and are not repeated in this report.

1.2 SUMMARY

A load cell barrier consisting of 36 load cells was impacted by a 2006 Honda Ridgeline RTS 4-Door Truck at a velocity of 55.87 km/h (34.72 mph). The test was performed at Karco Engineering, LLC on April 14, 2005.

Three (3) real-time video and fourteen (14) high-speed cameras were used to document the frontal barrier impact event. Camera locations and other pertinent camera information can be found in data sheet number 15 (Page Number 27) of this report.

Two Part 572E, 50th percentile male anthropomorphic test devices (ATDs), were placed in the driver and right-front passenger seating positions according to dummy placement instructions specified in the Laboratory Indicant Test Procedure.

Both ATDs were fully instrumented with head (primary and redundant), chest (primary and redundant) and pelvic tri-axial accelerometers, chest displacement potentiometers, six-axis upper neck transducers, right/left femur load cells, and lower leg instrumentation. Seat belt load cells were also placed on the driver and passenger's lap and shoulder belts to measure dummy torso and pelvic section loading. Shoulder belt spool-off was also measured for the driver and passenger dummies. The driver (position 1) ATD (Serial No. 035) and the right-front passenger (position 2) ATD (Serial No. 034) were calibrated two tests prior to this test.

Ninety seven (97) channels of data were recorded using an on-board data acquisition system. Appendix A contains Pre and Post-Test Photographs, Appendix B contains the vehicle and dummy response data traces. Appendix C contains Load Cell Barrier information. Appendix D contains the Instrumentation Data Channel assignments. Appendix E contains the Dummy Calibration data. Appendix F contains the Child Restraint data.

There was 100 percent windshield retention and no intrusion into the protected zone of the windshield during the impact event. There was no Stoddard solvent leakage after the event or during any phase of the static rollover.

The maximum static crush of the vehicle was 555 mm and both the driver and passenger side doors remained closed during the impact and were operable after the impact. During impact the driver and passenger seat back covers broke off of the seats.

The driver's visible contact points were as follows: The driver ATD's head, chest and abdomen contacted the airbag. Both knees contacted the knee bolster.

The passenger's visible contact points were as follows: The passenger ATD's head, chest and abdomen contacted the airbag. Both knees contacted the glove box.

Occupant injury data is contained in the table below.

OCCUPANT DATA SUMMARY

ATD Position	HIC ₃₆	Clip (g)	Chest Def. (mm)	Left Femur (N)	Right Femur (N)	Belt Spool (mm)
Driver	244.1	33.3	-23.4	-3997.9	-2701.4	109.5
Passenger	272.3	35.8	-18.5	-4264.8	-3338.8	117.4

**SECTION 2
OCCUPANT AND VEHICLE INFORMATION/DATA SHEETS**

Test Vehicle: 2006 Honda Ridgeline RTS 4-Door Truck

NHTSA No.: H65300

Test Program: 2005 NHTSA 35mph NCAP

Test Date: 4/14/05

CONVERSION FACTORS USED IN THIS REPORT*

Quantity	Typical Application	Std Units	Metric Unit	Multiply By
Mass	Vehicle Weight	lb	kg	0.4536
Linear Velocity	Impact Velocity	mile/h	km/h	1.609
Length or Distance	Measurements	in	mm	25.4
Volume	Fuel Systems	gal	liter	3.785
Volume	Small Fluids	oz	mL	29.573
Pressure	Tire Pressures	lbf/in ²	kPa	7.0
Volume	Liquid	gal	liter	3.785
Temperature	General Use	°F	°C	=(tf -32)/1.8
Force	Dynamic Forces	lbf	N	4.448
Moment	Torque	lbf/ft	Nm	1.355

* Based on the Recommended Practice in SAE J916, May 85

**DATA SHEET NO. 1
CRASH TEST SUMMARY**

Test Vehicle: 2006 Honda Ridgeline RTS 4-Door Truck

NHTSA No.: H65300

Test Program: 2005 NHTSA 35mph NCAP

Test Date: 4/14/05

PRIMARY IMPACT DATA

Measured Parameter	Units	Value
Velocity at Impact	km/h	55.87
Test Weight	kg	2301
Impact Angle	degrees	0
Average Rebound	mm	720
Maximum Static Crush	mm	555

DOOR OPENING AND SEAT TRACK INFORMATION

Description	Driver	Passenger
Front Door opening	Remained closed, opened w/o tools	Remained closed, opened w/o tools
Rear Door Opening	Remained closed, opened w/o tools	Remained closed, opened w/o tools
Seat Track Shift (mm)	0	0
Seat Back Failure	No	No

TEST DUMMY INFORMATION

Description	Driver	Passenger
Dummy Type/ Serial No.	50% Male Hybrid III No. 035	50% Male Hybrid III No. 034
Head Contact	Airbag	Airbag
Chest Contact	Airbag	Airbag
Abdomen Contact	Airbag	Airbag
Left Knee Contact	Knee Bolster	Glove Box
Right Knee Contact	Knee Bolster	Glove Box

16mm MOVIE COVERAGE

Description	Standard	Additional
High Speed	14	0
Real Time	1	2
Total	15	2

DATA CHANNELS

Driver ATD Sensors	40
Passenger ATD Sensors	40
Belt Assessment Sensors	8
Vehicle Structure Accelerometers	9
Rigid Barrier Load Cells	36
Total	133

DATA SHEET NO. 2

GENERAL TEST AND VEHICLE PARAMETER DATA

Test Vehicle: 2006 Honda Ridgeline RTS 4-Door Truck

NHTSA No.: H65300

Test Program: 2005 NHTSA 35mph NCAP

Test Date: 4/14/05

TEST VEHICLE INFORMATION AND OPTIONS

NHTSA No.	H65300
Make	Honda
Model	Ridgeline RTS
Body Style	4-Door Truck
Vin No.	2HJYK16416H506367
Color	Silver
Delivery Date	3/22/2005
Odometer (mi)	46
Dealer	Rock Honda of Fontana
Transmission	4-Speed Automatic
Final Drive	Four Wheel Drive
Type/No. Cyl.	V6
Engine Disp. (L)	3.5
Engine Placement	Transverse
Roof Rack	No
Sunroof/T-Top	No
Tinted Glass	Yes
Traction Control	Yes
Power Brakes	Yes
Front Disc	Yes
Rear Disc	Yes

Anti-Lock Brakes	Yes
All Wheel Drive	No
Power Steering	Yes
Driver Front Airbag	Yes
Driver Side Airbag	Yes
Driver Head Airbag	No
Driver Curtain Airbag	Yes
Pass. Airbag	Yes
Pass. Side Airbag	Yes
Pass. Head Airbag	No
Pass. Curtain Airbag	Yes
Pre-Tensioners	Yes
Load Limiters	Yes
Bucket Seats	Yes
Air Cond.	Yes
AM/FM Cassette	Yes
Tilt Steering	Yes
Automatic Door Locks	Yes
Power Windows	Yes
Power Seats	Yes
Other	

Does Owners Manual provide instructions to turn off automatic door locks?

Yes

DATA FROM CERTIFICATION LABEL

Manufactured By	Honda of Canada
Date of Manufacture	Mar-04

GVWR (kg)	2745
GAWR Front (kg)	1410
GAWR Rear (kg)	1475

VEHICLE SEATING AND CAPACITY WEIGHT INFORMATION

Measured Parameter	Front	Rear	Third	Total
Type of Seats	Bucket	Split Bench		
Number of Occupants	2	3		5
Capacity Weight (VCW) (kg)				690
Cargo Weight (RCLW) (kg)				136

GENERAL TEST AND VEHICLE PARAMETER DATA

Test Vehicle: 2006 Honda Ridgeline RTS 4-Door Truck

NHTSA No.: H65300

Test Program: 2005 NHTSA 35mph NCAP

Test Date: 4/14/05

Collect year, make, model, VIN, items circled in red, and tire manufacturer and tire name.

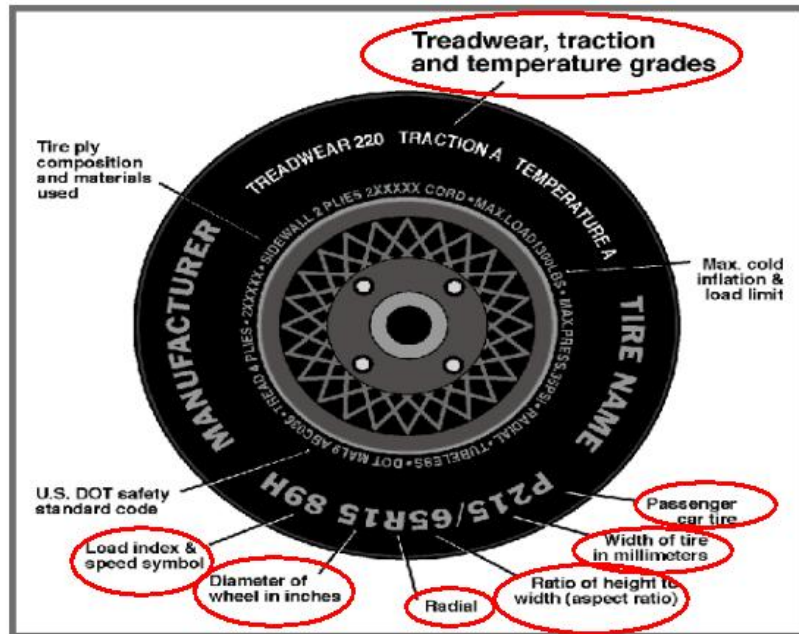

TIRE INFORMATION

Measured Parameter	Front	Rear
Max. Tire Pressure (kpa)	300	300
Cold Pressure (kpa)	220	220
Recommended Tire Size	P245/65R17	P245/65R17
Tire Size on Vehicle	P245/65R17	P245/65R17
Tire Manufacturer	Michelin	Michelin
Treadwear	440	440
Traction	A	A
Temperature Grades	B	B
Tire Plies Sidewall	1 Polyester	1 Polyester
Tire Plies Body	2 Polyester + 2 Steel + 1 Polymaide	2 Polyester + 2 Steel + 1 Polymaide
Load Index/Speed Symbol	105S	105S
Tire Material	Polyester + Steel + Polymaide + Rubber	Polyester + Steel + Polymaide + Rubber
DOT Safety Code Right	M3KT-MMJK-0705	M3KT-MMJK-0705
DOT Safety Code Left	M3KT-MMJK-0705	M3KT-MMJK-0705

GENERAL TEST AND VEHICLE PARAMETER DATA

Test Vehicle: 2006 Honda Ridgeline RTS 4-Door Truck

NHTSA No.: H65300

Test Program: 2005 NHTSA 35mph NCAP

Test Date: 4/14/05

TEST VEHICLE WEIGHTS

	Units	As Delivered Weights (UVW)			As Tested Weights (ATW)		
		Front Axle	Rear Axle	Total	Front Axle	Rear Axle	Total
Left	kg	606	426	1032	663	496	1159
Right	kg	572	415	987	637	505	1142
Ratio	%	58.4	41.6	100%	56.5	43.5	100%
Totals	kg	1178	841	2019	1300	1001	2301

TARGET TEST WEIGHT CALCULATION

Measured Parameter	Units	Value
Total Delivered Weight (UVW)	kg	2019
Weight of 2 P572 ATD's	kg	152
Rated Cargo/Luggage Wt. (RCLW)	kg	136
Calculated Vehicle Target Wt. (TVTW)	kg	2307

TEST VEHICLE ATTITUDE AND CG

	Units	LF	RF	LR	RR	CG (aft of front axle)
As Delivered	mm	833	832	863	866	1291
As Tested	mm	812	815	842	845	1348

Vehicle Wheelbase (mm) 3100

Weight of Ballast Secured in Cargo Area (kg) 0

Vehicle Components Removed Spare Tire, Tail Gate, Muffler

* Ballast weight does not include cameras, instrumentation and brake abort system.

FUEL SYSTEM DATA

Fuel System Capacity From Owners Manual (L) 83.3

Usable Capacity Furnished by COTR (L) N/A

Actual Test Volume with Entire Fuel System Filled (L) 68.1

1/3 of Usable Capacity (L) 27.8

Test Fluid Type: Stoddard Solvent N/A

Kinematic Viscosity: as per ASTM Standard D484-71 Purple

Is Vehicle Fuel Pump Electric or Mechanical? Electric

If Electric, Does Pump Operate with Ignition Switch "On" & Engine "OFF" Yes

Fuel System Particulars: None

**DATA SHEET NO. 3
POST-TEST IMPACT DATA**

Test Vehicle: 2006 Honda Ridgeline RTS 4-Door Truck

NHTSA No.: H65300

Test Program: 2005 NHTSA 35mph NCAP

Test Date: 4/14/05

SPEED TRAP DATA

Measured Parameter	Units	Requirement	Value
Trap No.1 Velocity (Primary)	km/h	55.51 to 57.12	55.87
Trap No. 1 Entry Distance	mm	<1524	1524
Trap No.1 Exit Distance	mm	<1524	305
Trap No.2 Velocity (Redun.)	km/h	55.51 to 57.12	55.85
Trap No.2 Entry Distance	mm	<1524	1524
Trap No.2 Exit Distance	mm	<1524	305

VEHICLE STATIC CRUSH

Measured Parameter	Units	Pre-Test	Post-Test	Difference
Left Side	mm	4974	4650	-324
Center	mm	5214	4686	-528
Right Side	mm	4981	4666	-315

VEHICLE REBOUND FROM BARRIER

Measured Parameter	Units	Value
Left Side	mm	794
Center	mm	695
Right Side	mm	670
Average	mm	720

DATA SHEET NO. 4
TEST VEHICLE INFORMATION

Test Vehicle: 2006 Honda Ridgeline RTS 4-Door Truck

NHTSA No.: H65300

Test Program: 2005 NHTSA 35mph NCAP

Test Date: 4/14/05

NOMINAL DESIGN RIDING POSITION

The driver and passenger seat backs are positioned to the manufacturers designated angle. The procedure is as follows: Seat back angle was measured at the headrest using a digital inclinometer. Seat back angle at forward-most locking position or forward stop defined as first position.

SEAT BACK ANGLES

	Angle (Deg.)	Placed in Position #
Driver w/seated Dummy	13.2	7th Detent
Passenger w/seated Dummy	11.1	7th Detent

* Placed in the Manufacturer's nominal design position using detents provided.

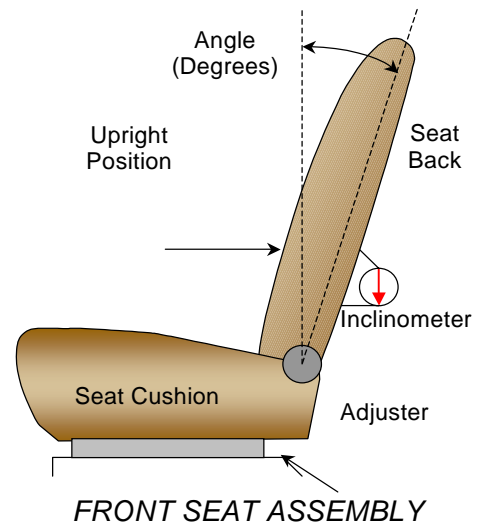

SEAT FORE/AFT POSITIONS

The total seat travel was measured from forward most position to rearmost position, irrespective of vertical seat height in those positions. The seat was set at the longitudinal mid position with vertical adjustment at the lowest position obtainable for both the driver and passenger.

SEAT FORE/AFT POSITIONING

	Total Fore/Aft Travel	Placed in Position #
Driver	235 mm	118 mm
Passenger	22 Detents	11th Detent

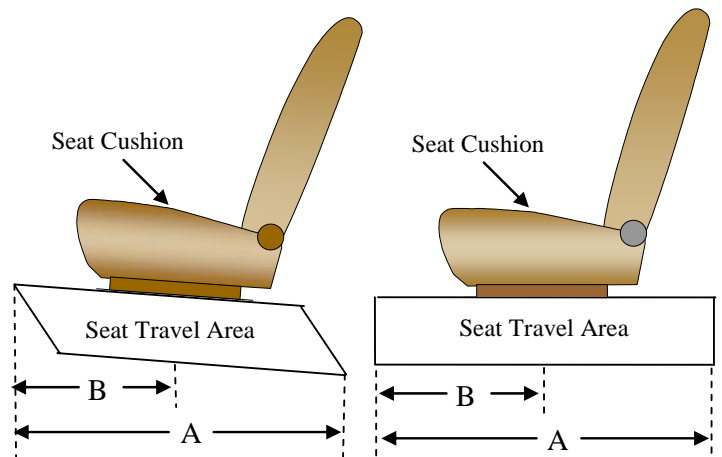

SEAT BELT UPPER ANCHORAGE

Position number one (1) is the uppermost position.

SEAT BELT UPPER ANCHORAGE

	Total # of Positions	Placed in Position #
Driver	4	1
Passenger	4	1

DATA SHEET NO. 4...(CONTINUED)
TEST VEHICLE INFORMATION

Test Vehicle: 2006 Honda Ridgeline RTS 4-Door Truck

NHTSA No.: H65300

Test Program: 2005 NHTSA 35mph NCAP

Test Date: 4/14/05

FUEL TANK CAPACITY

	Liters
Usable Capacity of "Standard Tank"	83.3
Usable Capacity of "Optional" Tank	
Usable Capacity used for FMVSS 301	76.6 to 78.3
Actual Amount of Solvent used	68.1
1/3 of Usable Capacity	27.8

The test vehicle is equipped with an electric fuel pump. The fuel pump operates for approximately two seconds after the ignition is placed in the "ON" position, after which the fuel pump automatically shuts off. The fuel filler door is located on the left rear fender. The standard fuel tank occupies the area under the rear seat.

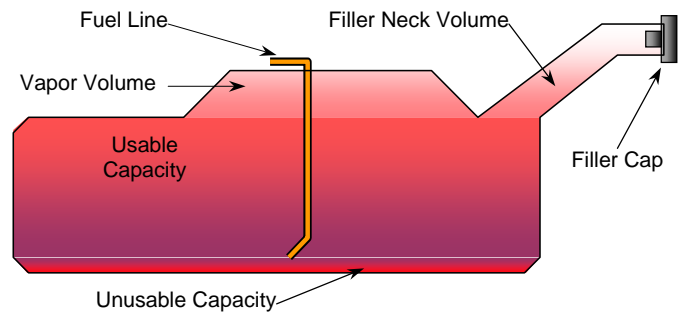

VEHICLE FUEL TANK ASSEMBLY

STEERING COLUMN ADJUSTMENT

Steering wheel and column adjustments are made so that the steering wheel hub is at the geometric center of the locus it describes when moved through its full range of motion. An aluminum plate is placed across the rim of the steering wheel, an inclinometer is placed on the plate and the angle is measured.

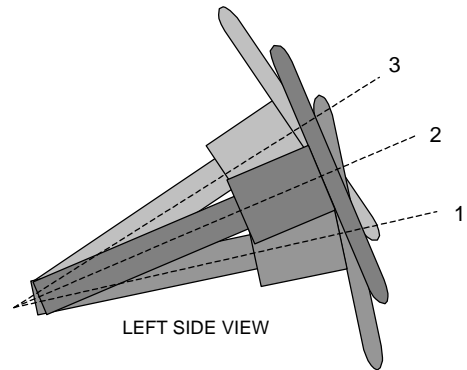

STEERING COLUMN ASSEMBLY

STEERING COLUMN POSITIONS

	Fore/Aft Positon (mm)	Degrees
Lowermost positon No. 1		26.4
Geometric center position No. 2		26.8*
Uppermost position No. 3		30.0

* Placed in the manufacturer's nominal design position.

DATA SHEET NO. 5
DUMMY POSITIONING IN VEHICLE

Test Vehicle: 2006 Honda Ridgeline RTS 4-Door Truck

NHTSA No.: H65300

Test Program: 2005 NHTSA 35mph NCAP

Test Date: 4/14/05

TEST DUMMY POSITION MEASUREMENTS

Code	Measurement Description	Driver		Passenger	
		Length (mm)	Angle (deg)	Length (mm)	Angle (deg)
WA	Windshield Angle		67.0		
SWA	Steering Wheel Angle		63.2		
SCA	Steering Column Angle		26.8		
SA	Seat Back Angle		13.5		11.1
HZ	Head to Roof (Z)	240	90.0	230	90.0
HH	Head to Header	427		445	
HW	Head to Windshield	654		695	
HR	Head to Side Header (Y)	357		296	
NR	Nose to Rim	398	9.7		
CD	Chest to Dash	568		630	
CS	Chest to Steering Hub	305			
RA	Rim to Abdomen	173			
KDL	Left Knee to Dash	120	10.7	120	
KDR	Right Knee to Dash	110		110	21.9
PA	Pelvic Angle		24.0		21.9
TA	Tibia Angle		57.0		49.6
KK	Knee to Knee (Y)	360		270	
SK	Striker to Knee	600	2.0	255	20.5
ST	Striker to Head	560	80.0	560	88.0
SH	Striker to H-Point	240	27.0	245	28.6
SHY	Striker to H-Point (Y)	270		255	
HS	Head to Side Window	442		390	
HD	H-Point to Door (Y)	158		140	
AD	Arm to Door (Y)	130		60	

DATA SHEET NO. 5...(CONTINUED)
DUMMY POSITIONING IN VEHICLE

Test Vehicle: 2006 Honda Ridgeline RTS 4-Door Truck

NHTSA No.: H65300

Test Program: 2005 NHTSA 35mph NCAP

Test Date: 4/14/05

DUMMY MEASUREMENTS FOR FRONT SEAT OCCUPANTS

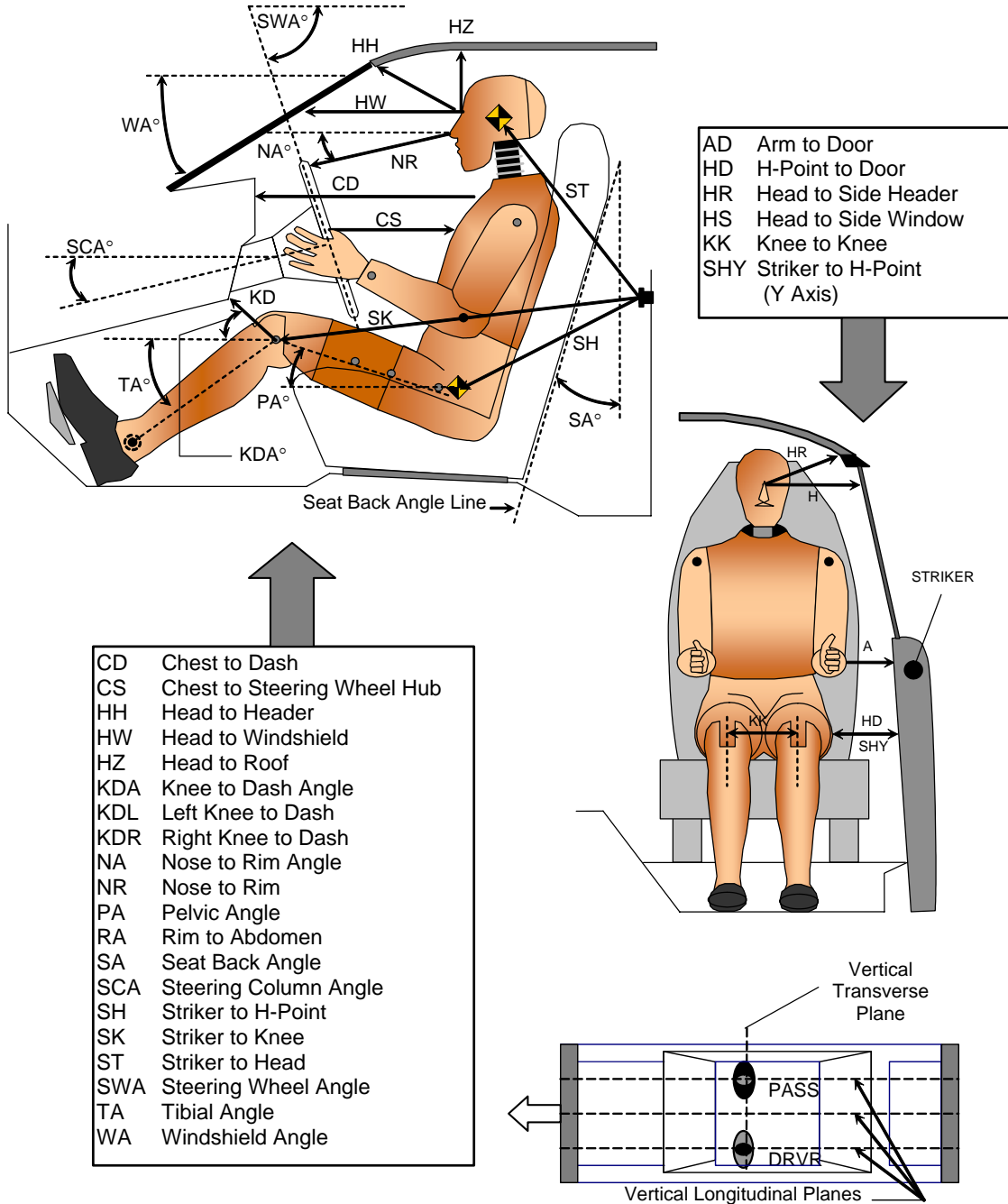

DATA SHEET NO. 6
SEAT BELT POSITIONING DATA

Test Vehicle: 2006 Honda Ridgeline RTS 4-Door Truck

NHTSA No.: H65300

Test Program: 2005 NHTSA 35mph NCAP

Test Date: 4/14/05

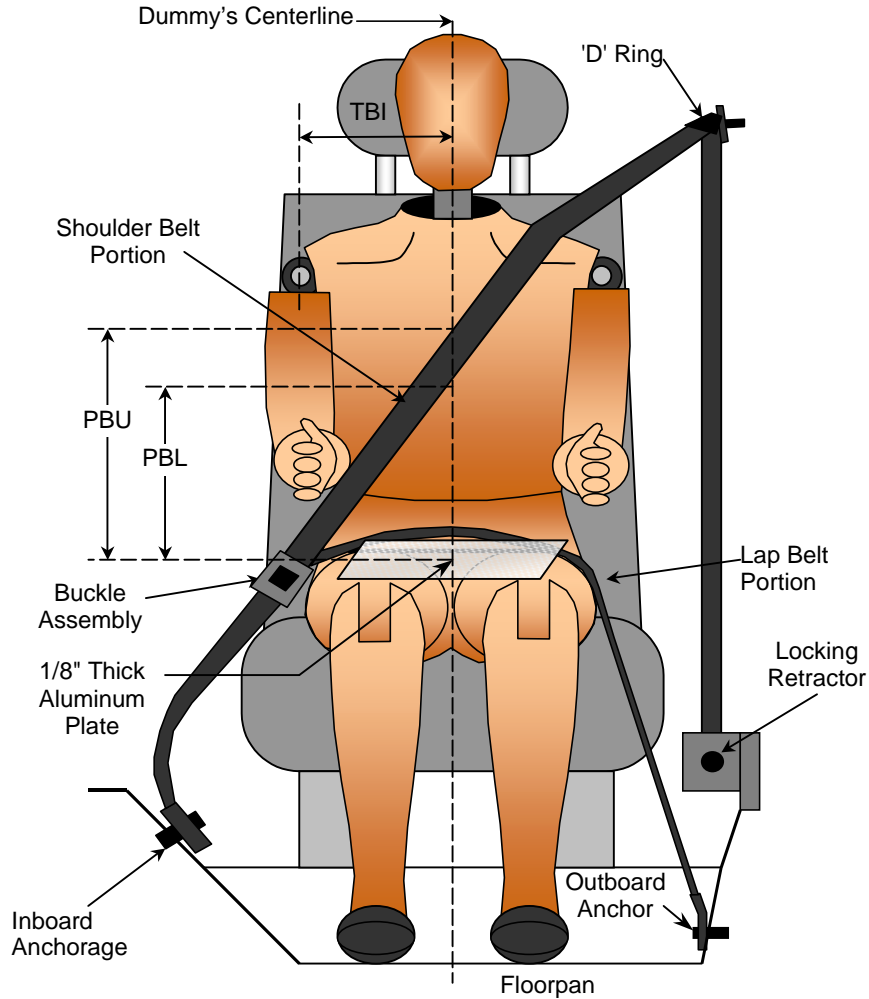

SEAT BELT POSITIONING MEASUREMENTS

Measured Parameter	Units	Driver	Passenger
TBI -Dummy C/L to Lap/Shoulder Belt Intersect	mm	220	220
PBU - Top Surface of reference to belt upper edge	mm	310	345
PBL - Top Surface of reference to belt lower edge	mm	240	250
Lap Belt Tension	Newtons	10	10
Shoulder Belt Tension		Retractor	Retractor

DATA SHEET NO. 7 - VEHICLE ACCELEROMETER LOCATION AND DATA SUMMARY

Test Vehicle: 2006 Honda Ridgeline RTS 4-Door Truck

NHTSA No.: H65300

Test Program: 2005 NHTSA 35mph NCAP

Test Date: 4/14/05

VEHICLE ACCELEROMETER PEAK DATA AND PRE-TEST LOCATIONS

No.	Accelerometer Location	Measurements (mm)			Peak Values				
		X	Y	Z	Units	Max	Time	Min	Time
1	Left Rear X-Member	2370	-775	450	G's	2.7	154.3	-34.8	42.5
2	Right Rear X-Member	2370	775	450	G's	2.7	154.0	-35.6	58.7
3	Engine Top	4680	112	930	G's	50.3	57.5	-213.5	29.2
4	Engine Bottom	4500	175	220	G's	32.1	43.3	-116.8	28.0
5	Left Brake Caliper	4440	-790	380	G's	79.7	62.8	-150.5	43.8
6	Right Brake Caliper	4440	790	380	G's	19.4	24.6	-76.3	43.6
7	Instrument Panel	3640	-25	1250	G's	1.6	140.0	-46.3	20.9
8	Left Rear X-Member (Z-Axis)	2310	-775	450	G's	10.4	10.1	-10.3	86.8
9	Right Rear X-Member (Z-Axis)	2310	775	450	G's	12.4	70.3	-13.3	87.5

Reference Planes: X=From Rear Surface of Vehicle, Y=Vehicle Centerline, Z=Ground Plane

1.) Channel failed at 45.5 msec.

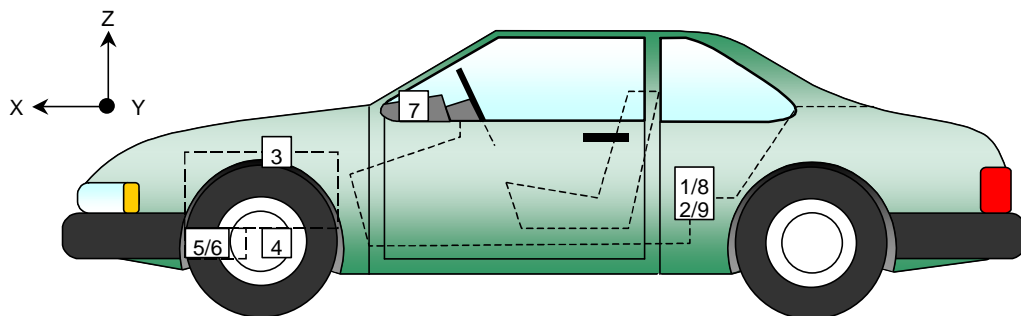
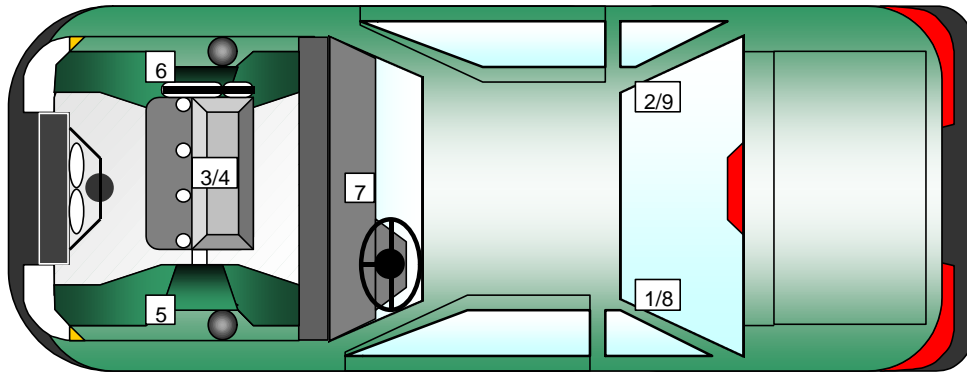

DATA SHEET NO. 8 - HYBRID III ATD INJURY CRITERIA AND SENSOR DATA

Test Vehicle: 2006 Honda Ridgeline RTS 4-Door Truck

NHTSA No.: H65300

Test Program: 2005 NHTSA 35mph NCAP

Test Date: 4/14/05

HEAD PRIMARY PEAK ACCELERATIONS

Location	Axis	Units	Driver				Passenger			
			Max	Time	Min	Time	Max	Time	Min	Time
Head CG	X	G's	0.0	192.6	-41.1	73.0	0.3	13.3	-42.1	87.6
Head CG	Y	G's	5.7	87.7	-7.3	86.9	2.3	51.1	-11.5	86.3
Head CG	Z	G's	12.8	48.2	-6.2	94.8	26.8	87.6	-0.9	35.7
Head CG Resultant	N/A	G's	41.5	73.0			50.0	87.6		

CHEST PRIMARY PEAK ACCELERATIONS

Location	Axis	Units	Driver				Passenger			
			Max	Time	Min	Time	Max	Time	Min	Time
Chest CG	X	G's	3.1	150.7	-33.1	84.3	1.1	160.6	-38.7	87.7
Chest CG	Y	G's	4.0	82.0	-1.9	111.8	3.6	45.0	-4.0	92.5
Chest CG	Z	G's	6.3	23.7	-5.5	66.5	5.0	53.4	-10.5	85.4
Chest CG Resultant	N/A	G's	33.4	84.4			40.1	87.7		

FEMUR PEAK FORCES

Location	Axis	Units	Driver				Passenger			
			Max	Time	Min	Time	Max	Time	Min	Time
Left Femur	Z	Newtons	207.8	33.7	-3997.9	52.6	231.5	22.6	-4264.8	54.1
Right Femur	Z	Newtons	299.4	32.0	-2701.4	56.0	153.3	26.7	-3338.8	52.5

SEAT BELT SENSOR PEAK VALUES

Location	Axis	Units	Driver				Passenger			
			Max	Time	Min	Time	Max	Time	Min	Time
Shoulder Belt Pullout	N/A	MM	47.7	109.5	-20.4	39.9	221.6	117.4	-21.0	37.6
Shoulder Belt Stretch	N/A	MM/CM	0.0	0.0	0.0	0.0	0.0	0.0	0.0	0.0
Lap Belt Force	N/A	Newtons	3550.1	48.4	-1.7	0.2	3369.4	51.9	-28.6	195.2
Shoulder Belt Force	N/A	Newtons	5511.9	86.2	-26.5	10.3	4646.2	45.6	-27.2	191.2

1.) Not used with pre-tensioners

PRIMARY HEAD INJURY CRITERIA (HIC36)

Location	Driver				Passenger			
	HIC	T ¹	T ²	Avg G	HIC	T ¹	T ²	Avg G
Head CG Primary	244.1	52.6	88.6	34.1	272.3	69.1	105.1	35.6

PRIMARY CHEST CLIP (3MSEC)

Location	Driver			Passenger		
	CLIP	T ¹	T ²	CLIP	T ¹	T ²
Chest CG Primary	33.3	83.0	86.0	35.8	86.2	89.2

DATA SHEET NO. 8...(CONTINUED)

Test Vehicle: 2006 Honda Ridgeline RTS 4-Door Truck

NHTSA No.: H65300

Test Program: 2005 NHTSA 35mph NCAP

Test Date: 4/14/05

PELVIC PEAK ACCELERATIONS

Location	Axis	Units	Driver				Passenger			
			Max	Time	Min	Time	Max	Time	Min	Time
Pelvis	X	G's	4.1	184.7	-37.9	52.5	1.8	200.0	-45.8	53.0
Pelvis	Y	G's	4.5	107.7	-9.1	60.3	4.0	46.2	-10.3	90.5
Pelvis	Z	G's	2.8	199.3	-22.4	83.9	1.5	26.4	-16.2	76.3
Pelvis Resultant	N/A	G's	41.4	52.5			47.8	53.0		

UPPER NECK PEAK FORCES AND MOMENTS

Location	Axis	Units	Driver				Passenger			
			Max	Time	Min	Time	Max	Time	Min	Time
Neck Force	X	Newtons	558.9	87.7	-357.5	146.5	533.3	87.6	-389.0	149.4
Neck Force	Y	Newtons	106.0	93.2	-131.4	47.5	128.4	50.2	-175.1	153.1
Neck Force	Z	Newtons	957.6	77.9	-70.4	159.1	690.5	73.7	-58.0	156.3
Neck Force Resultant	N/A	Newtons	1012.4	77.9			726.6	87.6		
Neck Moment	X	Nm	6.0	103.8	-18.6	73.0	23.5	102.2	-9.5	142.9
Neck Moment	Y	Nm	57.9	61.0	-34.7	102.3	30.1	152.5	-21.1	104.6
Neck Moment	Z	Nm	15.8	105.9	-10.5	166.6	15.8	101.7	-9.4	160.3
Neck Moment Resultant	N/A	Nm	59.0	61.0			34.8	102.8		

FOOT PEAK ACCELERATIONS

Location	Axis	Units	Driver				Passenger			
			Max	Time	Min	Time	Max	Time	Min	Time
Left Foot Aft	X	G's	4.7	31.1	-36.9	64.8	70.7	58.9	-152.0	46.6
Left Foot Aft	Z	G's	1.5	193.6	-28.3	39.5	12.7	68.6	-44.3	53.1
Left Foot Fore	Z	G's	13.5	19.4	-82.5	39.5	57.4	68.9	-89.4	58.4
Right Foot Aft	X	G's	27.9	77.9	-70.7	55.6	23.7	72.7	-74.1	62.5
Right Foot Aft	Z	G's	9.5	72.0	-73.2	48.3	6.8	86.7	-28.5	49.5
Right Foot Fore	Z	G's	33.1	34.0	-119.8	50.1	24.8	86.2	-52.8	66.2

UPPER AND LOWER TIBIA PEAK FORCES AND MOMENTS

Location	Axis	Units	Driver				Passenger			
			Max	Time	Min	Time	Max	Time	Min	Time
Left Upper Moment	X	Nm	46.1	71.6	-29.8	93.9	6.6	46.8	-32.3	55.7
Left Upper Moment	Y	Nm	11.9	198.6	-66.5	48.5	34.9	51.5	-15.1	61.0
Right Upper Moment	X	Nm	65.4	56.3	-15.8	78.8	26.2	65.4	-30.8	81.2
Right Upper Moment	Y	Nm	20.2	199.4	-56.0	41.8	117.8	64.5	-21.9	24.7
Left Lower Moment	X	Nm	18.2	66.5	-47.1	91.1	10.0	47.0	-20.6	55.3
Left Lower Moment	Y	Nm	8.2	32.8	-33.6	64.0	33.4	74.0	-44.7	49.9
Left Lower Force	Z	Newtons	74.9	148.4	-1106.1	42.5	54.6	141.5	-2479.4	46.9
Right Lower Moment	X	Nm	23.2	56.1	-38.9	77.8	15.4	64.9	-24.0	94.3
Right Lower Moment	Y	Nm	88.0	78.6	-21.3	39.5	55.6	73.7	-10.1	24.1
Right Lower Force	Z	Newtons	83.7	140.5	-3031.5	48.2	58.2	175.5	-1922.2	75.5

DATA SHEET NO. 8...(CONTINUED)

Test Vehicle: 2006 Honda Ridgeline RTS 4-Door Truck

NHTSA No.: H65300

Test Program: 2005 NHTSA 35mph NCAP

Test Date: 4/14/05

CHEST PEAK DEFLECTIONS

Location	Axis	Units	Driver				Passenger			
			Max	Time	Min	Time	Max	Time	Min	Time
Chest	X	MM	0.0	7.0	-23.4	68.2	0.0	7.0	-18.5	88.2

HEAD REDUNDANT PEAK ACCELERATIONS

Location	Axis	Units	Driver				Passenger			
			Max	Time	Min	Time	Max	Time	Min	Time
Head CG	X	G's	-0.1	199.8	-40.7	72.2	1.0	14.1	-41.1	87.6
Head CG	Y	G's	5.9	87.7	-7.3	86.5	2.5	46.7	-11.3	86.4
Head CG	Z	G's	12.3	48.2	-6.6	95.2	27.1	87.7	-0.9	35.7
Head CG Resultant	N/A	G's	41.2	72.2			49.2	87.6		

CHEST REDUNDANT PEAK ACCELERATIONS

Location	Axis	Units	Driver				Passenger			
			Max	Time	Min	Time	Max	Time	Min	Time
Chest CG	X	G's	2.9	150.6	-32.9	84.3	1.2	150.8	-38.1	87.7
Chest CG	Y	G's	4.2	82.0	-1.9	120.6	3.5	45.0	-3.9	90.8
Chest CG	Z	G's	0.0	0.0	0.0	0.0	4.8	53.5	-10.7	87.7
Chest CG Resultant	N/A	G's	33.2	84.3			39.6	87.7		

1.) Driver channel failed, no data

REDUNDANT HEAD INJURY CRITERIA (HIC36)

Location	Driver				Passenger			
	HIC	T ¹	T ²	Avg G	HIC	T ¹	T ²	Avg G
Head CG Redundant	241.9	52.6	88.6	33.9	269.2	69.2	105.2	35.4

REDUNDANT CHEST CLIP (3MSEC)

Location	Driver			Passenger		
	CLIP	T ¹	T ²	CLIP	T ¹	T ²
Chest CG Redundant	32.9	83.0	86.0	35.7	86.0	89.0

1.) Driver chest Z channel failed, no data

**DATA SHEET NO. 9
SEAT BELT ASSESSMENT TEST DATA**

Test Vehicle: 2006 Honda Ridgeline RTS 4-Door Truck

NHTSA No.: H65300

Test Program: 2005 NHTSA 35mph NCAP

Test Date: 4/14/05

SEAT BELT POSITIONING MEASUREMENTS

Measurement Description	Units	Driver	Passenger
TBI -Dummy C/L to Lap/Shoulder Belt Intersect	mm	220	220
PBU - Top Surface of reference to belt upper edge	mm	310	345
PBL - Top Surface of reference to belt lower edge	mm	240	250
Lap Belt Tension	Newtons	10	10
Shoulder Belt Tension		Retractor	Retractor

SEAT BELT POSITIONING MEASUREMENTS

Measurement Description	Units	Driver	Passenger
Retractor Reel to "D" ring	mm	790	790
Shoulder Belt length as measured on ATD	mm	890	870
Lap Belt length as measured on ATD	mm	850	810
Remainder of belt on reel	mm	680	630
Total belt length for continuous webbing systems	mm	3210	3100

SHOULDER BELT SPOOL-OFF DATA

Measurement Description	Units	Driver	Passenger
As determined mechanically	mm	15.0	160.0
As determined electronically	mm	109.5	117.4

BELT STRETCH DATA

Measurement Description	Units	Driver	Passenger
Electronically between belt load cell and "D" ring	mm/cm	*	*
Mechanically	mm/cm		

* Not used with shoulder belt pre-tensioner systems.

DATA SHEET NO. 10
SUMMARY OF FMVSS 212 DATA

Test Vehicle: 2006 Honda Ridgeline RTS 4-Door Truck

NHTSA No.: H65300

Test Program: 2005 NHTSA 35mph NCAP

Test Date: 4/14/05

Windshield Mounting Details: Windshield glass is secured to the vehicle frame with a rubber type adhesive. No molding covers the windshield periphery at any point.

The standard requires that the post-test retention measurement be a minimum of 75 percent of the pretest total periphery measurement for vehicles not equipped with occupant passive restraints and 50 percent for each side of the windshield for vehicles that are equipped with occupant passive restraints.

Temperature of windshield molding during test: 21.1 °C

WINDSHIELD PERIPHERY MEASUREMENTS

Measurement	Pre-Test(mm)	Post-Test(mm)	% of Retention
Left Side	2252	2252	100
Right Side	2252	2252	100
Total	4504	4504	100

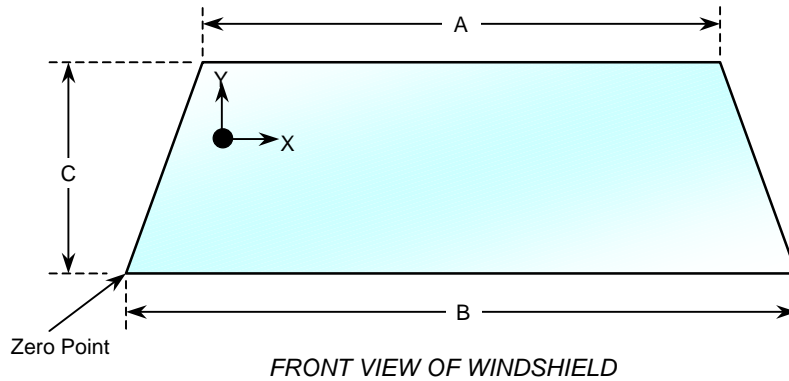

WINDSHIELD DIMENSIONS

Item	Units	Segment Length	Molding Width
A	mm	1375	15
B	mm	1619	15
C-Left	mm	755	15
C-Right	mm	755	10

DATA SHEET NO. 11
WINDSHIELD ZONE INTRUSION FMVSS 219 DATA (PARTIAL)

Test Vehicle: 2006 Honda Ridgeline RTS 4-Door Truck

NHTSA No.: H65300

Test Program: 2005 NHTSA 35mph NCAP

Test Date: 4/14/05

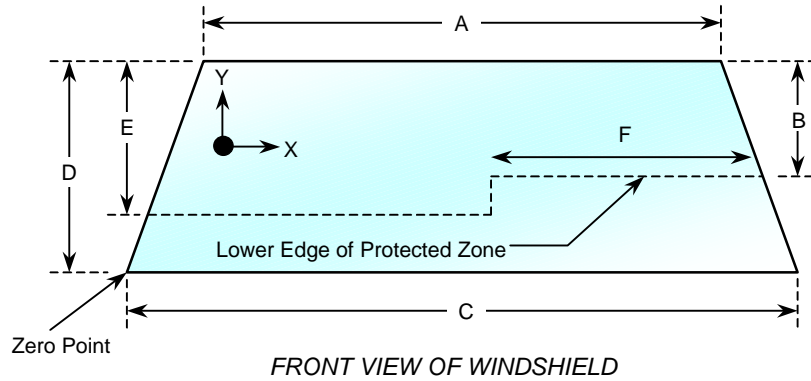

**WINDSHIELD AND
PROTECTED ZONE**

Item	Units	Value
A	mm	1375
B	mm	332
C	mm	1619
D	mm	755
E	mm	436
F	mm	381

AREA OF PROTECTED ZONE FAILURES

- A. Provide coordinates of the area that the protected zone was penetrated more than 0.25 in. by a vehicle component other than one that is normally in contact with the windshield.

X	Y

- B. Provide coordinates of the area beneath the protected zone that the inner surface of the windshield was penetrated by a vehicle component.

X	Y

DATA SHEET NO. 12
FMVSS 301 FUEL SYSTEM INTEGRITY POST IMPACT DATA

Test Vehicle: 2006 Honda Ridgeline RTS 4-Door Truck NHTSA No.: H65300

Test Program: 2005 NHTSA 35mph NCAP Test Date: 4/14/05

Test Time: 1:58 PM

Temperature: 20.6 Deg. C.

STODDARD SOLVENT SPILLAGE MEASUREMENTS

- A. From impact until vehicle motion ceases: 0.0 oz.
(Maximum Allowable = 1 ounce)
- B. For the 5-minute period after motion ceases: 0.0 oz.
(Maximum Allowable = 5 ounces)
- C. For the following 25 minutes: 0.0 oz.
(Maximum Allowable = 1 oz./minute)
- D. Spillage Location Details: No leakage occurred

DATA SHEET NO. 13
FMVSS 301 STATIC ROLLOVER DATA

Test Vehicle: 2006 Honda Ridgeline RTS 4-Door Truck

NHTSA No.: H65300

Test Program: 2005 NHTSA 35mph NCAP

Test Date: 4/14/05

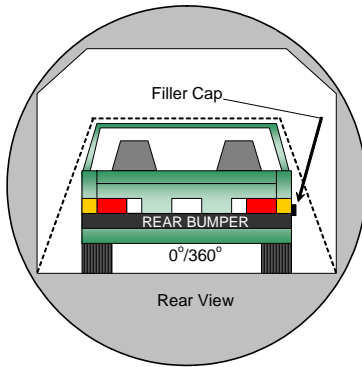

0° to 90°

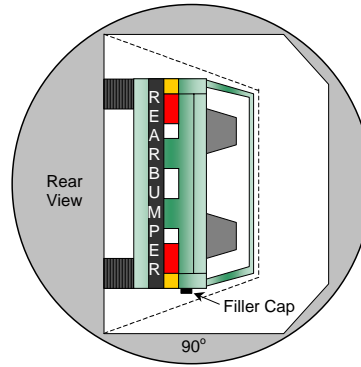

90° to 180°

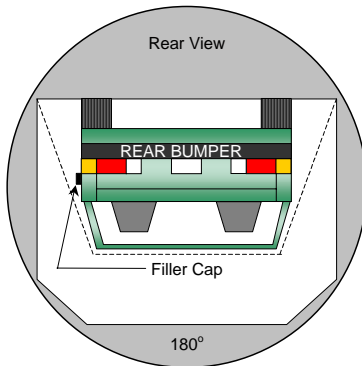
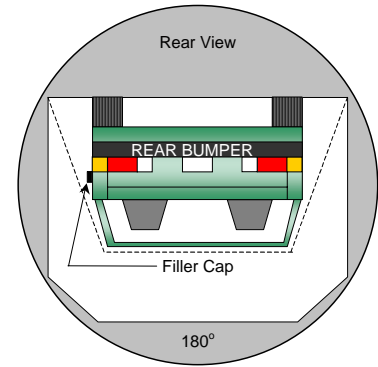

180° to 270°

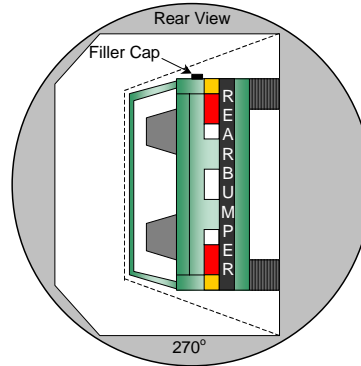

270° to 360°

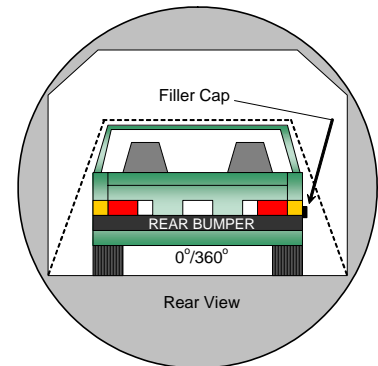

1. The specified fixture rollover rate for each 90° of rotation is 60 to 120 seconds.
2. The position hold time at each position is 300 seconds (minimum).
3. No solvent leakage occurred during rollover.

DATA SHEET NO. 13...(CONTINUED)
FMVSS 301 STATIC ROLLOVER DATA

Test Vehicle: 2006 Honda Ridgeline RTS 4-Door Truck

NHTSA No.: H65300

Test Program: 2005 NHTSA 35mph NCAP

Test Date: 4/14/05

SOLVENT COLLECTION TIME TABLE IN SECONDS

Test Phase	Rotation Time	Hold Time	Total Time
0° to 90°	85	300	385
90° to 180°	78	300	378
180° to 270°	76	300	376
270° to 360°	79	300	379

FMVSS 301 SPILLAGE TABLE REQUIREMENT (oz.)

First 5 Minutes	5
Sixth Minute	1
Seventh Minute	1
Eighth Minute	1

ACTUAL TEST VEHICLE SOLVENT SPILLAGE TABLE (oz.)

Test Phase	First 5 Minutes	Sixth Minute	Seventh Minute	Eighth Minute
0° to 90°	0	0	0	0
90° to 180°	0	0	0	0
180° to 270°	0	0	0	0
270° to 360°	0	0	0	0

SOLVENT SPILLAGE LOCATION TABLE

Test Phase	Spillage Location
0° to 90°	None
90° to 180°	None
180° to 270°	None
270° to 360°	None

DATA SHEET NO. 14
VEHICLE MEASUREMENTS

Test Vehicle: 2006 Honda Ridgeline RTS 4-Door Truck

NHTSA No.: H65300

Test Program: 2005 NHTSA 35mph NCAP

Test Date: 4/14/05

VEHICLE MEASUREMENT TABLE

No.	Measurement Description	Units	Pre-Test	Post-Test	Diff.
1	Total length of vehicle at centerline	mm	5241	4686	-555
2	RSOV to front of engine	mm	4791	4306	-485
3	RSOV to firewall centerline	mm	4336	4296	-40
4	RSOV to leading edge of right door	mm	3745	3752	7
5	RSOV to leading edge of left door	mm	3822	3819	-3
6	RSOV to lower leading edge of right door	mm	3823	3828	5
7	RSOV to lower leading edge of left door	mm	3748	3744	-4
8	RSOV to upper trailing edge of right door	mm	2760	2775	15
9	RSOV to upper trailing edge of left door	mm	2760	2761	1
10	RSOV to lower trailing edge of right door	mm	2772	2765	-7
11	RSOV to lower trailing edge of left door	mm	2769	2765	-4
12	RSOV to bottom of right 'A' pillar	mm	3758	3767	9
13	RSOV to bottom of left 'A' pillar	mm	3765	3759	-6
14	RSOV to firewall on right side	mm	4351	4307	-44
15	RSOV to firewall on left side	mm	4331	4327	-4
16	RSOV to steering column	mm	3351	3421	70
17	Center of steering column to left 'A' pillar	mm	435	420	-15
18	Center of steering column to headlining	mm	475	445	-30
19	RSOV to right side of front bumper	mm	4981	4666	-315
20	RSOV to left side of front bumper	mm	4974	4650	-324
21	Length of engine block	mm	490	490	0
RD	RSOV to right side of dash panel	mm	3603	3609	6
CD	RSOV to center of dash panel	mm	3620	3605	-15
LD	RSOV to left side of dash panel	mm	3598	3572	-26

DATA SHEET NO. 14...(CONTINUED)
VEHICLE STRUCTURAL MEASUREMENTS

Test Vehicle: 2006 Honda Ridgeline RTS 4-Door Truck

NHTSA No.: H65300

Test Program: 2005 NHTSA 35mph NCAP

Test Date: 4/14/05

VEHICLE STRUCTURAL MEASUREMENT TABLE

No.	Measurement Description	Units	Pre-Test	Post-Test	Diff.
1	Total length	mm	5241	4686	-555
2	Total width	mm	1942	1947	5
3	Bumper top height	mm	725	845	120
4	Bumper bottom height	mm	349	315	-34
5	Longitudinal member top height	mm	530	716	186
6	Longitudinal member bottom height	mm	405	591	186
7	Distance between longitudinal members	mm	960	995	35
8	Longitudinal member width	mm	130	126	-4
9	Engine top height	mm	985	994	9
10	Engine bottom height	mm	212	203	-9
11	Engine and gear box width	mm	800	800	0
12	Front bumper to engine distance	mm	455	370	-85
13	Front shock absorber fixing width	mm	1040	1070	30
14	Bonnet leading edge height	mm	1026	1080	54
15	Front shock absorber fixing width	mm	1260	1245	-15
16	Front bumper to front axle distance	mm	970	485	-485
17	Front axle to 'A' pillar distance	mm	465	470	5
18	'A' pillar to 'B' pillar distance	mm	1050	1042	-8
19	'B' pillar to rear axle distance	mm	1585	1580	-5
20	'B' pillar to 'C' pillar distance	mm	1010	1010	0
21	Roof sill bottom height	mm	1612	1605	-7
22	Roof sill top height	mm	1717	1715	-2
23	Floor sill bottom height	mm	355	351	-4
24	Floor sill top height	mm	480	476	-4

DATA SHEET NO. 14...(CONTINUED)
VEHICLE MEASUREMENTS

Test Vehicle: 2006 Honda Ridgeline RTS 4-Door Truck

NHTSA No.: H65300

Test Program: 2005 NHTSA 35mph NCAP

Test Date: 4/14/05

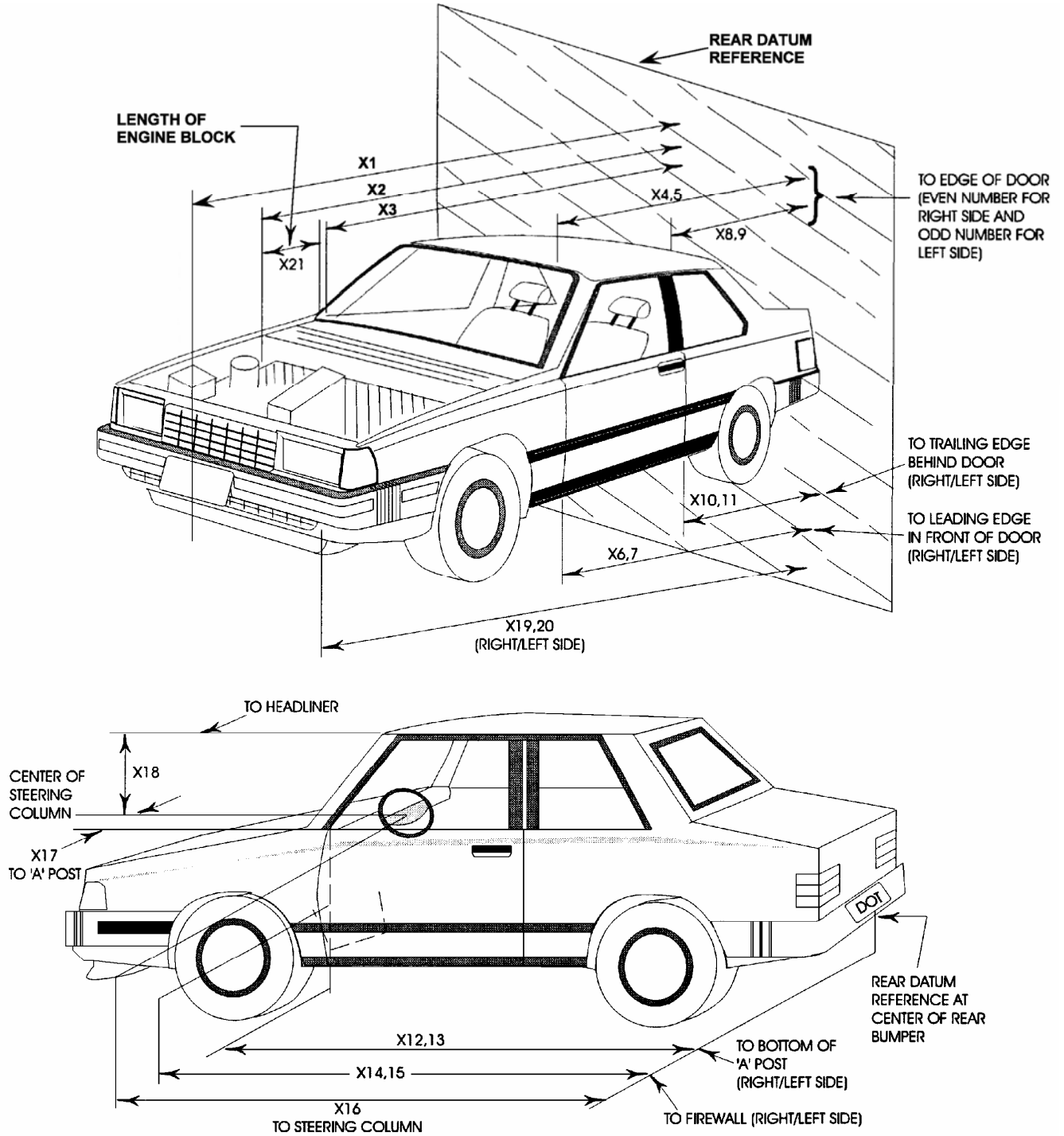

**DATA SHEET NO. 15
CAMERA LOCATIONS**

Test Vehicle: 2006 Honda Ridgeline RTS 4-Door Truck

NHTSA No.: H65300

Test Program: 2005 NHTSA 35mph NCAP

Test Date: 4/14/05

VEHICLE CAMERA MEASUREMENT TABLE

No.	Camera View	Location (mm)			Angle (deg.)	Film Plane to Head (mm)	Lens (mm)	Speed (fps)
		X	Y	Z				
1	Real Time Camera (Panning)	0	-6096	-1651	-10		Zoom	30
2	Overall Left Side	-2489	-8280	-1143	-4	7738	24	1000
3	Left Side View	-1677	-7620	-1329	-4	7094	50	1000
4	Driver and Interior View	-6477	-10185	-4748	-13	10980	80	990
5	Steering Column (Bottom)	-2134	-8230	-2997	-16	7812	19	980
6	Steering Column (Top)	-2134	-8230	-3404	-20	7898	19	1005
7	Overall Right Side	-2083	8230	-1270	-6	7682	13	1025
8	Right Side View	-1677	7316	-1422	-4	6813	50	DNR
9	Passenger and Interior View	-6781	9144	-2997	-9	9802	65	1010
10	Right Side View	-1829	7316	-1422	-4	6777	28	1000
11	Windshield	-610	0	-5944	-90		13	1025
12	Driver Front View	610	-432	-2667	-40		13	1095
13	Passenger Front View	610	432	-2667	-40		13	1045
14	View of Engine	-914	0	1499	90		6	1005
15	View of Fuel Tank	-2438	0	1499	90		6	865

ADDITIONAL CAMERAS

1	Left Side Overall Real Time Camera	-1219	-8585	-1372	0	8102	Zoom	30
2	Right Side Overall Real Time Camera	-1067	7976	-991	0	7540	Zoom	30

X = Barrier Face Y = Monorail Centerline Z = Ground DNR = Did Not Run NTM = No Timing Marks

DATA SHEET NO. 16
PHOTOGRAPHIC REFERENCE TARGET LOCATIONS

Test Vehicle: 2006 Honda Ridgeline RTS 4-Door Truck

NHTSA No.: H65300

Test Program: 2005 NHTSA 35mph NCAP

Test Date: 4/14/05

All Dimensions in (mm)	
Item	Value
A	360
B	1942
C	2040
D	605
E	2570
F	150
G	1730
H	1705
I	1550
J	990
K	990
L	1720
M	1705
N	1720
O	990
P	990
Q	1550

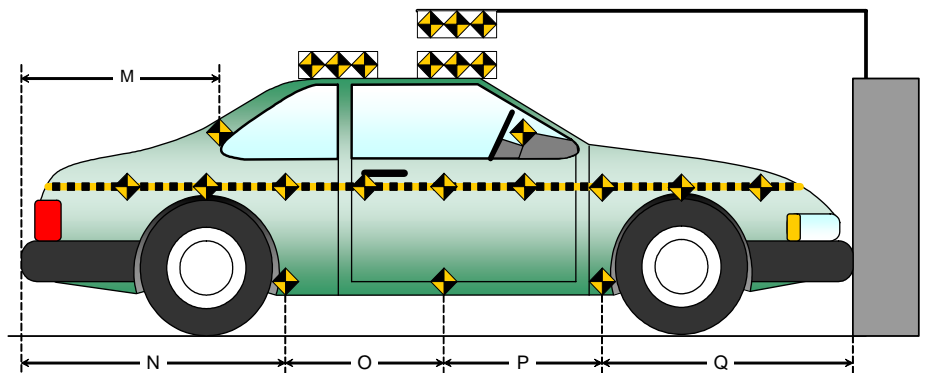
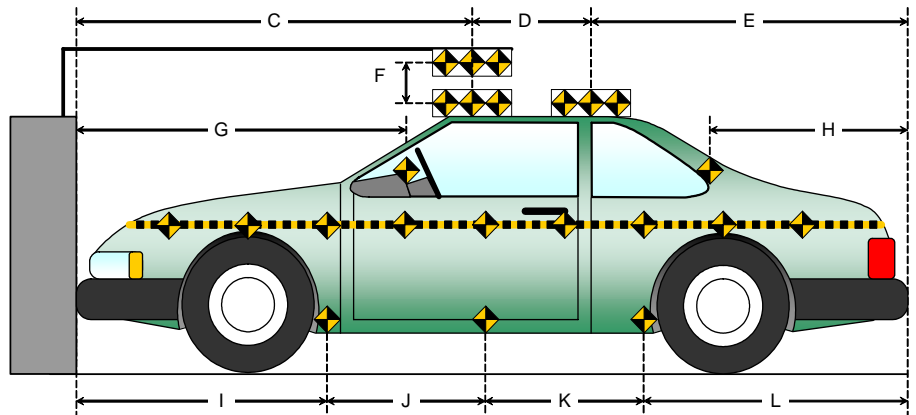
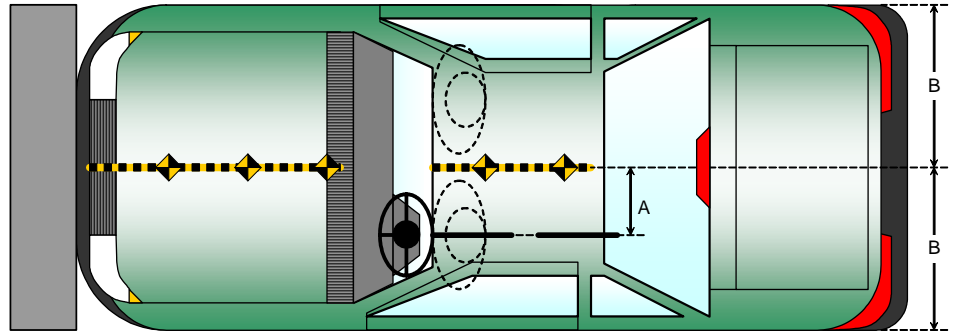

DATA SHEET NO. 17
VEHICLE INTRUSION MEASUREMENTS

Test Vehicle: 2006 Honda Ridgeline RTS 4-Door Truck

NHTSA No.: H65300

Test Program: 2005 NHTSA 35mph NCAP

Test Date: 4/14/05

DOOR OPENING WIDTH TABLE

Item	Description	Units	Pre-Test	Post-Test	Diff.
A	Left Side Upper	mm	966	966	0
B	Left Side Lower	mm	896	897	1
D	Right Side Upper	mm	967	963	-4
E	Right Side Lower	mm	886	888	2

WHEELBASE MEASUREMENT TABLE

Item	Description	Units	Pre-Test	Post-Test	Diff.
C	Left Side Wheel Base	mm	3100	3035	-65
F	Right Side Wheel Base	mm	3100	2975	-125

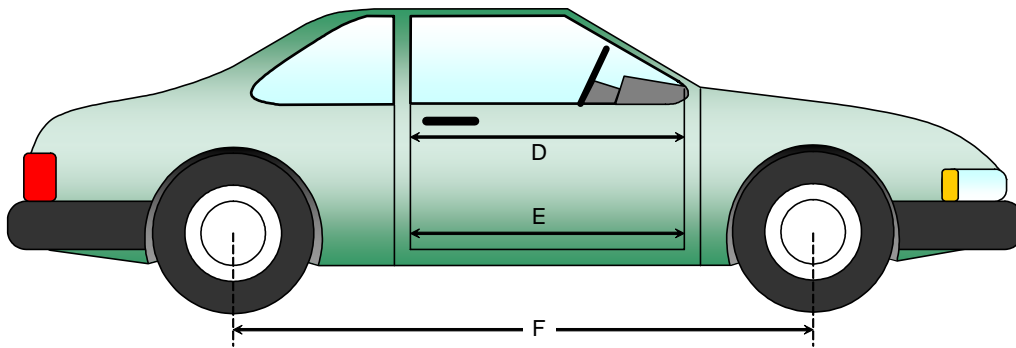
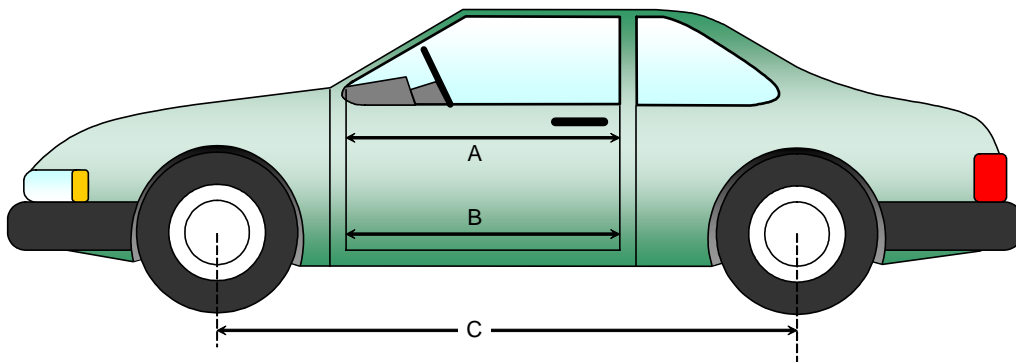

DATA SHEET NO. 17...(CONTINUED)
VEHICLE INTRUSION MEASUREMENTS

Test Vehicle: 2006 Honda Ridgeline RTS 4-Door Truck

NHTSA No.: H65300

Test Program: 2005 NHTSA 35mph NCAP

Test Date: 4/14/05

DRIVER COMPARTMENT INTRUSION TABLE

Item	Description	Units	Pre-Test	Post-Test	Diff.
AB	Door Opening (Inside window jam)	mm	966	966	0
CX	Left Knee Bolster to X	mm	225	242	17
DX	Right Knee Bolster to X	mm	270	245	-25
EX	Brake Pedal to X	mm	571	524	-47
FX	Foot Rest to X	mm	551	501	-50
GX	Center of Steering Wheel Hub to X	mm	90	92	2

X = Left Front Seat Outboard Anchor Bolt Head

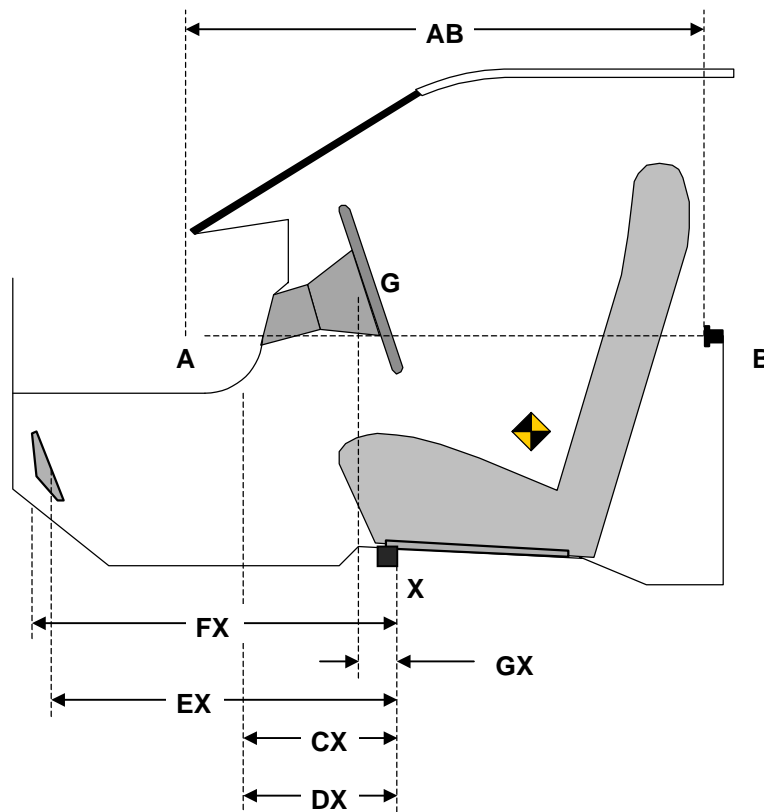

DATA SHEET NO. 17...(CONTINUED)
VEHICLE INTRUSION MEASUREMENTS

Test Vehicle: 2006 Honda Ridgeline RTS 4-Door Truck

NHTSA No.: H65300

Test Program: 2005 NHTSA 35mph NCAP

Test Date: 4/14/05

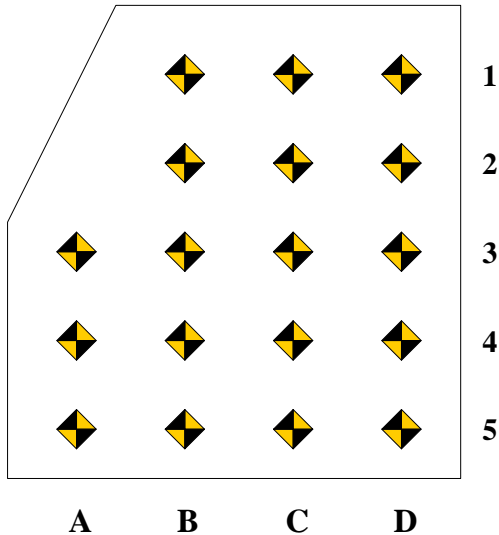

Measurement reference point for X and Z-axis is the forward outboard seat mounting bolt.

Columns A through D are evenly spaced.

Rows 1 and 2 are on the toe kick portion of the floor pan. Rows 3, 4 and 5 are located on the most level portion of the floor pan.

Row 3 will be at the intersection of the toe kick and the level sections of the floor pan.

DRIVER FLOOR PAN X-AXIS

	Pre-Test				Post-Test				Difference			
	A	B	C	D	A	B	C	D	A	B	C	D
1		651	643	651		607	615	642		-44	-28	-9
2		566	563	561		542	560	558		-24	-3	-3
3	462	453	449	442	471	470	469	463	8	17	20	21
4	369	361	353	350	379	382	378	378	10	21	25	28
5	270	262	249	243	280	277	279	277	10	15	30	33

DRIVER FLOOR PAN Z-AXIS

	Pre-Test				Post-Test				Difference			
	A	B	C	D	A	B	C	D	A	B	C	D
1		-43	-36	14		-21	-11	22		22	25	8
2		8	11	22		56	52	64		48	42	42
3	8	19	13	19	63	72	65	61	54	53	52	42
4	7	18	13	23	62	77	71	95	54	59	57	72
5	7	18	13	18	61	76	76	95	54	58	63	77

DATA SHEET NO. 17...(CONTINUED)
VEHICLE INTRUSION MEASUREMENTS

Test Vehicle: 2006 Honda Ridgeline RTS 4-Door Truck

NHTSA No.: H65300

Test Program: 2005 NHTSA 35mph NCAP

Test Date: 4/14/05

Measurement reference point for X and Z axis is the forward outboard seat mounting bolt.

Columns A through D are evenly spaced.

Rows 1 and 2 are on the toe kick portion of the floor pan. Rows 3, 4 and 5 are located on the most level portion of the floor pan.

Row 3 will be at the intersection of the toe kick and the level sections of the floor pan.

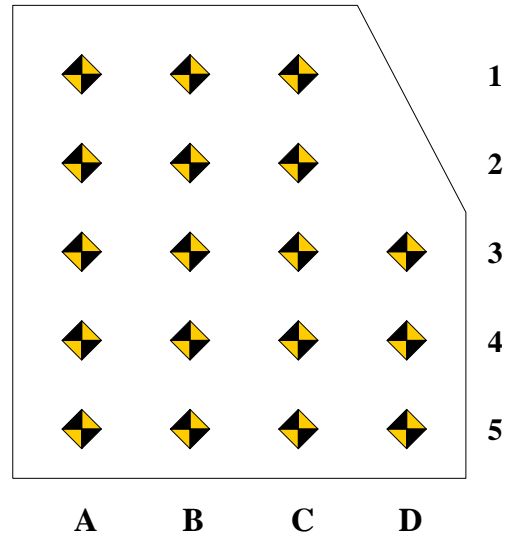

PASSENGER FLOOR PAN X-AXIS

	Pre-Test				Post-Test				Difference			
	A	B	C	D	A	B	C	D	A	B	C	D
1	769	753	748		600	621	679		-169	-132	-69	
2	710	683	680		636	633	622		-74	-54	-58	
3	613	602	599	592	568	562	558	567	-45	-40	-41	-25
4	498	495	497	493	454	466	478	495	-44	-29	-19	2
5	395	394	392	390	351	369	380	390	-44	-25	-12	0

PASSENGER FLOOR PAN Z-AXIS

	Pre-Test				Post-Test				Difference			
	A	B	C	D	A	B	C	D	A	B	C	D
1	-78	-109	-118		-78	-99	-93		0	10	25	
2	-22	-52	-61		-3	-10	-36		19	42	25	
3	11	-5	-9	-17	61	52	37	34	50	57	46	51
4	12	7	16	14	72	70	70	74	60	63	54	60
5	14	5	14	22	94	76	88	85	80	71	74	63

DATA SHEET NO. 18
FIXED BARRIER LOAD CELL LOCATIONS

Test Vehicle: 2006 Honda Ridgeline RTS 4-Door Truck

NHTSA No.: H65300

Test Program: 2005 NHTSA 35mph NCAP

Test Date: 4/14/05

36 Load Cell Rigid Barrier (NHTSA Standard)
Load Cell Locations on Fixed Barrier

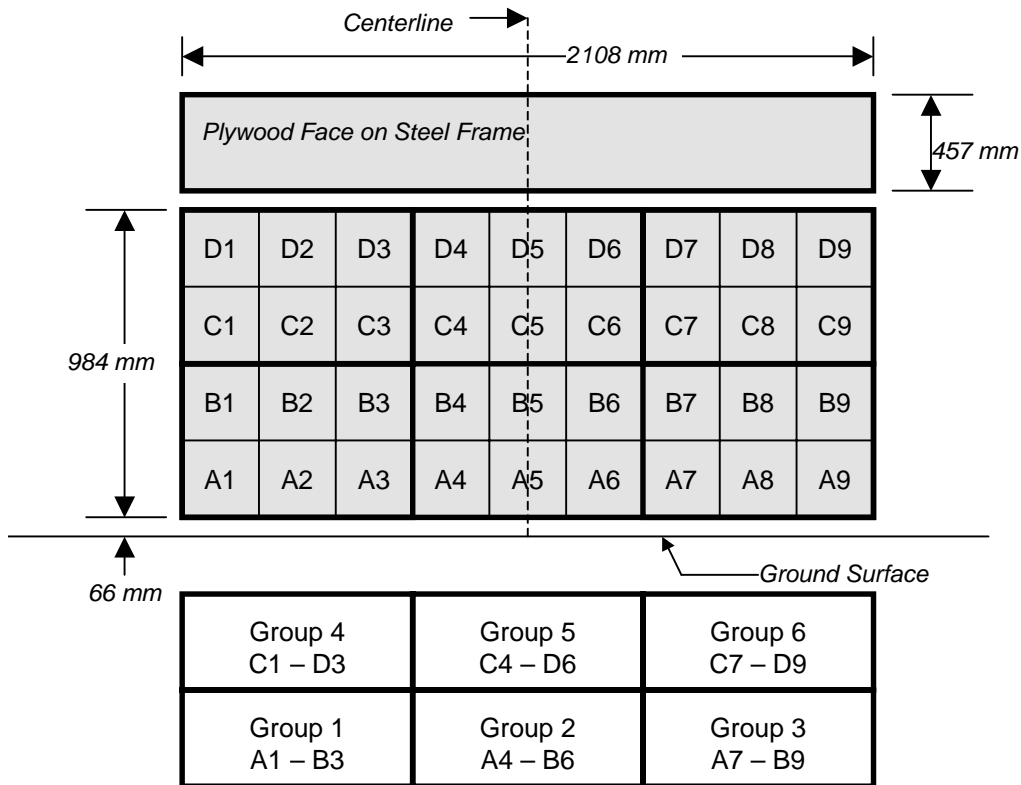

6 Groups of 6 Load Cells Each

The Data is presented in Appendix C with the following requirements:

- 1.) Data from 36 individual load cells
- 2.) Sum data from 6 groupings shown above (6 cells/group)
- 3.) Total or sum of all 36 individual load cells
- 4.) Sum of all 36 individual load cells vs. vehicle dynamic crush

**DATA SHEET NO. 19
POST-TEST AIRBAG DATA**

Test Vehicle: 2006 Honda Ridgeline RTS 4-Door Truck

NHTSA No.: H65300

Test Program: 2005 NHTSA 35mph NCAP

Test Date: 4/14/05

POST-TEST AIRBAG DATA

	DRIVER	PASSENGER
No. of vent holes	2	2
Size of vent (mm ²)	711	2844
Total vent area (mm ²)	1422	5688

Deflated Airbag Length and Width Dimensions or, If Round, Diameter (mm)		
Length		600
Width		700
Depth or Diameter	550	520

Tethering Information		
Is the airbag tethered?	Yes	No
Record length of tether (mm)	290	

Airbag Manufacturing Information		
Manufacturer	Takata	Takata
Part No.	2405667	*
Gas Generator	JGUS0272818	*

* Part number and gas generator labels were burned due to airbag deployment.

Sketch the airbag showing the location of the vent holes, how the bag is tethered, and where the bag is tethered. Also describe how the tethers are attached to the bag and the steering wheel:

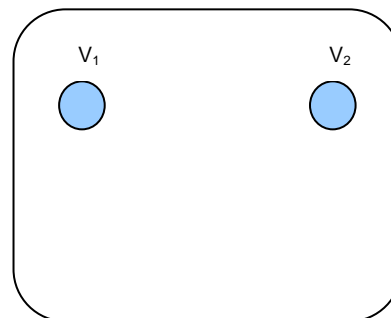
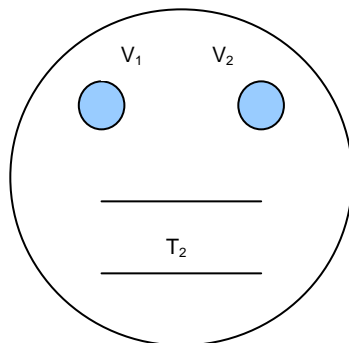

DATA SHEET NO. 20
ACCIDENT INVESTIGATION DIVISION DATA

Test Vehicle: 2006 Honda Ridgeline RTS 4-Door Truck

NHTSA No.: H65300

Test Program: 2005 NHTSA 35mph NCAP

Test Date: 4/14/05

VEHICLE INFORMATION

VIN: 2HJYK16416H506367

Wheelbase (mm): 3100

Vehicle Size Category: 4-Door Truck

Test Weight (kg): 2301

ACCELEROMETER DATA

Accelerometer Location: Left Rear Sill

Cal. Procedure/Interval: 6 months / drop test

Integration Algorithm: NHTSA Standard

Linearity: Good

Impact Velocity (km/h): 55.87

Velocity Change (km/h): 66.38

Time of Separation (msec): 81.0

CRUSH PROFILE

Collision Deformation Classification: 12FDEW6

Maximum Damage: Vehicle Centerline

Damage Region Length (mm): 1680

Impact Mode: Full Frontal

No.	Measurement Description	Units	Pre-Test	Post-Test	Difference
C1	Crush zone 1 at left side	mm	267	591	-324
C2	Crush zone 2 on left side	mm	45	585	-540
C3	Crush zone 3 on left side	mm	5	557	-552
C4	Crush zone 4 on right side	mm	5	560	-555
C5	Crush zone 5 on right side	mm	45	595	-550
C6	Crush zone 6 at right side	mm	260	575	-315

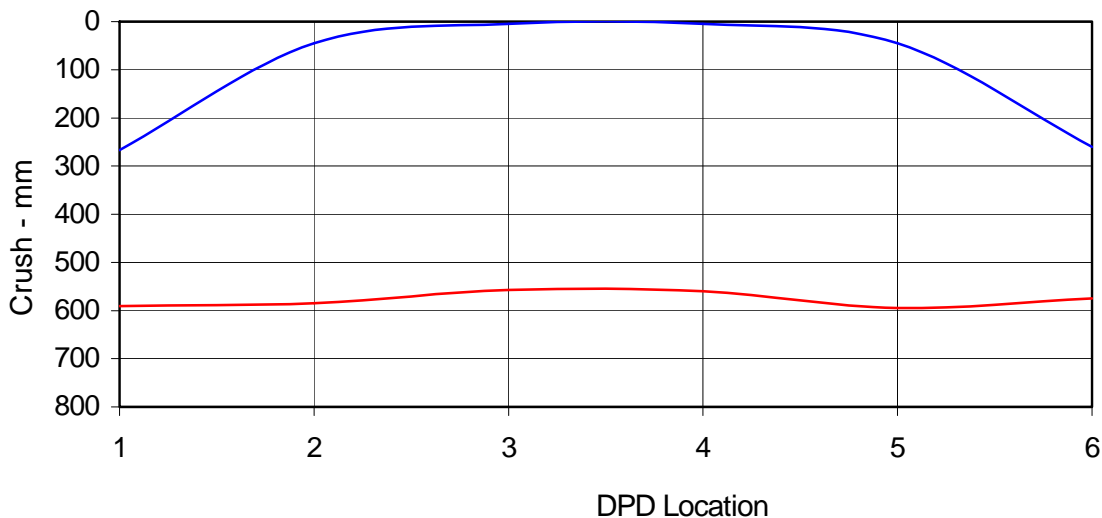

DATA SHEET NO. 21
DUMMY/VEHICLE TEMPERATURE STABILIZATION

Test Vehicle: 2006 Honda Ridgeline RTS 4-Door Truck

NHTSA No.: H65300

Test Program: 2005 NHTSA 35mph NCAP

Test Date: 4/14/05

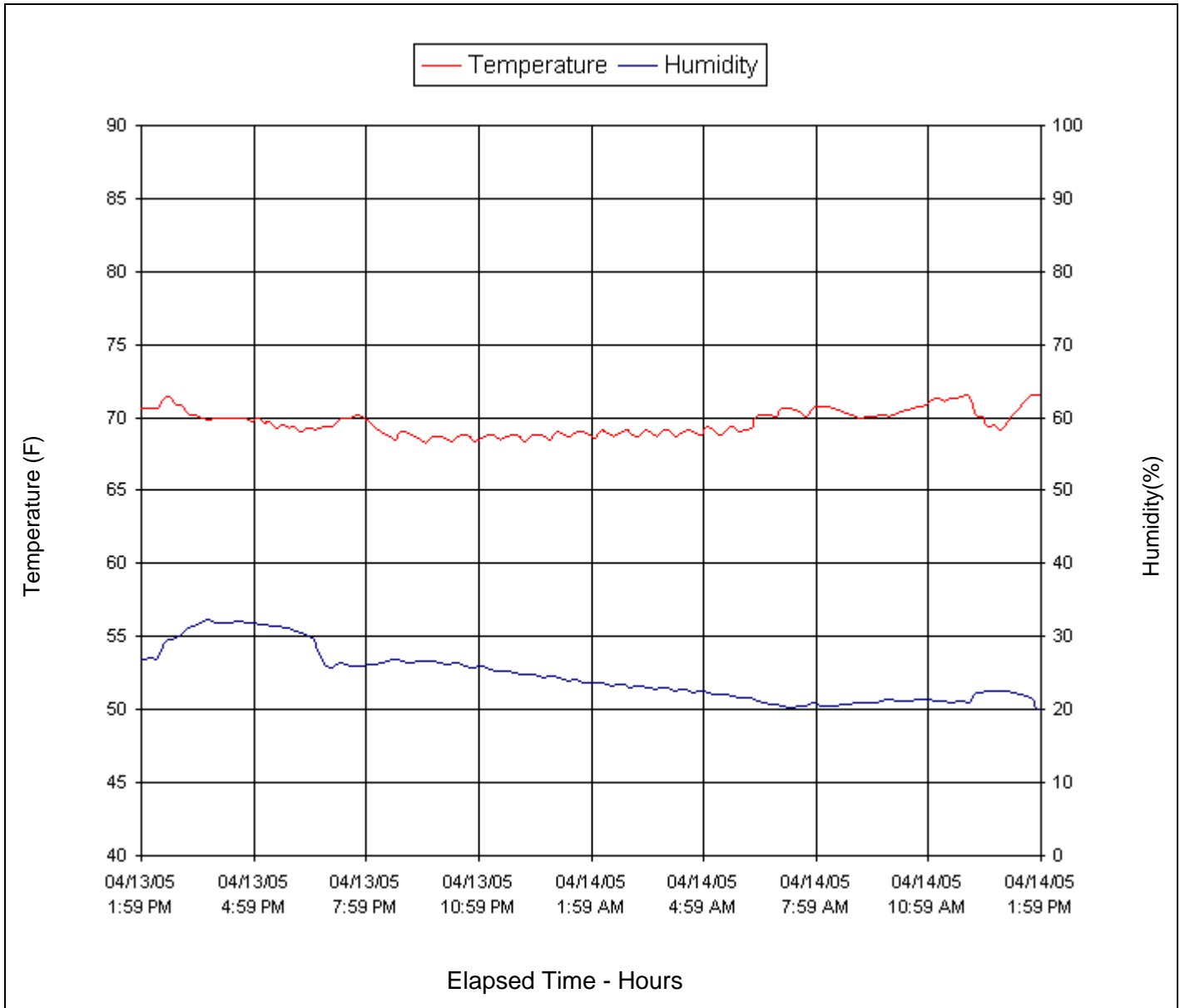

APPENDIX A
PHOTOGRAPHS

LIST OF PHOTOGRAPHS

Figure		Page
1	Load Cell Location	A-1
2	Manufacturer's Label	A-2
3	Tire Placard	A-3
4	Right Front $\frac{3}{4}$ View, As Received	A-4
5	Left Rear $\frac{3}{4}$ View, As Received	A-5
6	Pre-Test Front View	A-6
7	Post-Test Front View (Vehicle Moved)	A-7
8	Pre-Test Left Side View	A-8
9	Post-Test Left Side View	A-9
10	Pre-Test Right Side View	A-10
11	Post-Test Right Side View	A-11
12	Pre-Test Right Front $\frac{3}{4}$ View	A-12
13	Post-Test Right Front $\frac{3}{4}$ View (Vehicle Moved)	A-13
14	Pre-Test Left Rear $\frac{3}{4}$ View	A-14
15	Post-Test Left Rear $\frac{3}{4}$ View	A-15
16	Post-Test Left Side $\frac{3}{4}$ View of Doors After Impact	A-16
17	Post-Test Right Side $\frac{3}{4}$ View of Doors After Impact	A-17
18	Pre-Test Windshield	A-18
19	Post-Test Windshield	A-19
20	Pre-Test Engine Compartment (Vehicle Moved)	A-20
21	Post-Test Engine Compartment (Vehicle Moved)	A-21
22	Pre-Test Fuel Cap	A-22
23	Post-Test Fuel Cap	A-23
24	Pre-Test Front Underbody	A-24
25	Post-Test Front Underbody	A-25
26	Pre-Test Mid Underbody	A-26
27	Post-Test Mid Underbody	A-27
28	Pre-Test Rear Underbody	A-28
29	Post-Test Rear Underbody	A-29
30	Pre-Test Driver Dummy Front View (Head Position)	A-30
31	Post-Test Driver Dummy Front View (Head Position)	A-31
32	Pre-Test Driver Dummy (Through Window)	A-32
33	Post-Test Driver Dummy (Through Window)	A-33
34	Pre-Test Driver Dummy (Door Open)	A-34

LIST OF PHOTOGRAPHS...(CONTINUED)

Figure		Page
35	Post-Test Driver Dummy (Door Open)	A-35
36	Pre-Test Driver Dummy Feet	A-36
37	Post-Test Driver Dummy Feet	A-37
38	Pre-Test Driver Side Knee Bolster	A-38
39	Post-Test Driver Side Knee Bolster	A-39
40	Pre-Test Driver Side Floor Pan	A-40
41	Post-Test Driver Side Floor Pan	A-41
42	Post-Test Driver Dummy Head	A-42
43	Post-Test Driver Dummy Airbag Contact	A-43
44	Pre-Test Passenger Dummy Front View (Head Position)	A-44
45	Post-Test Passenger Dummy Front View (Head Position)	A-45
46	Pre-Test Passenger Dummy (Through Window)	A-46
47	Post-Test Passenger Dummy (Through Window)	A-47
48	Pre-Test Passenger Dummy (Door Open)	A-48
49	Post-Test Passenger Dummy (Door Open)	A-49
50	Pre-Test Passenger Dummy Feet	A-50
51	Post-Test Passenger Dummy Feet	A-51
52	Pre-Test Passenger Side Glove Box	A-52
53	Post-Test Passenger Side Glove Box	A-53
54	Pre-Test Passenger Side Floor Pan	A-54
55	Post-Test Passenger Side Floor Pan	A-55
56	Post-Test Passenger Dummy Head	A-56
57	Post-Test Passenger Dummy Airbag Contact	A-57
58	Vehicle on Rollover Device at (0°)	A-58
59	Vehicle on Rollover Device (90°)	A-59
60	Vehicle on Rollover Device (180°)	A-60
61	Vehicle on Rollover Device (270°)	A-61
62	Vehicle Impact	A-62
63	Driver Seat, Seat Back Cover	A-63
64	Driver Seat, Seat Back	A-64
65	Passenger Seat, Seat Back Cover	A-65
66	Passenger Seat, Seat Back	A-66

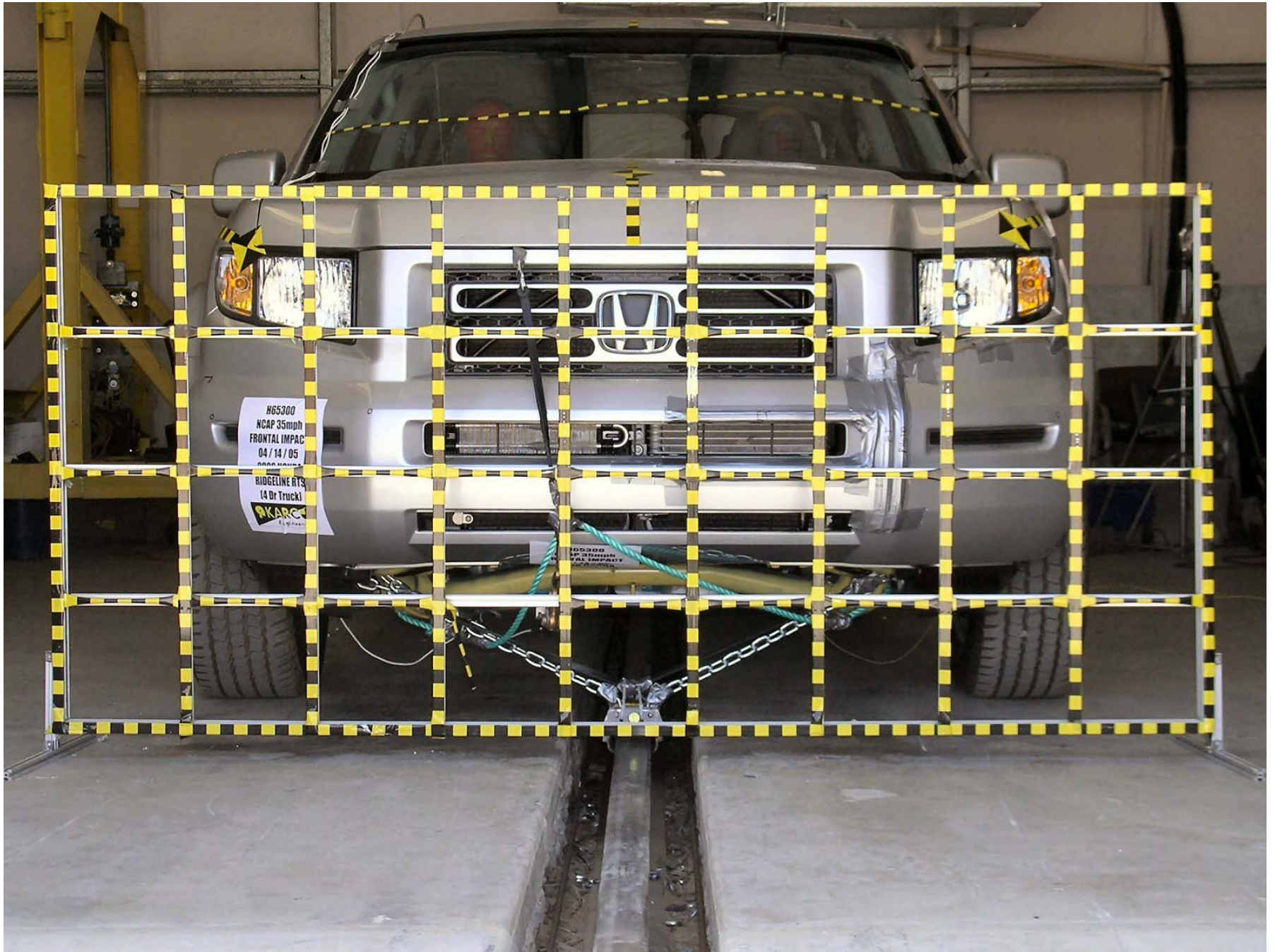

Figure A-1: Load Cell Location

This Space Intentionally Left Blank

MFD. IN CANADA BY HONDA OF CANADA MFG.,
A DIVISION OF HONDA CANADA INC. 03/05
GVWR 2745KG (6050LBS) TIRE SIZE RIM SIZE
GAWR F 1410KG (3105LBS) P245/65R17 105S 17X7.5J
GAWR R 1475KG (3245LBS) P245/65R17 105S 17X7.5J
THIS VEHICLE CONFORMS TO ALL APPLICABLE
FEDERAL MOTOR VEHICLE SAFETY
AND THEFT PREVENTION STANDARDS IN EFFECT
ON THE DATE OF MANUFACTURE SHOWN ABOVE.
V.I.N.: 2HJYK16416H506367 TYPE: TRUCK



Figure A-2: Manufacturer's Label



TIRE AND LOADING INFORMATION

SEATING CAPACITY : TOTAL 5 : FRONT 2 : REAR 3

The combined weight of occupants and cargo should never exceed 690kg or 1530lbs

ORIGINAL TIRE SIZE	COLD TIRE INFLATION PRESSURE		SEE OWNER'S MANUAL FOR ADDITIONAL INFORMATION
P245/65R17 105S	FRONT	220kPa, 32PSI	
	REAR	220kPa, 32PSI	
COMPACT SPARE TIRE	COLD TIRE INFLATION PRESSURE		
T165/90R17 105M	420kPa, 60PSI		

SJCA0

Figure A-3: Tire Placard



Figure A-4: Right Front $\frac{3}{4}$ View, As Received



A-5

TR-P25064-01-NC

Figure A-5: Left Rear ¾ View, as Received



Figure A-6: Pre-Test Front View

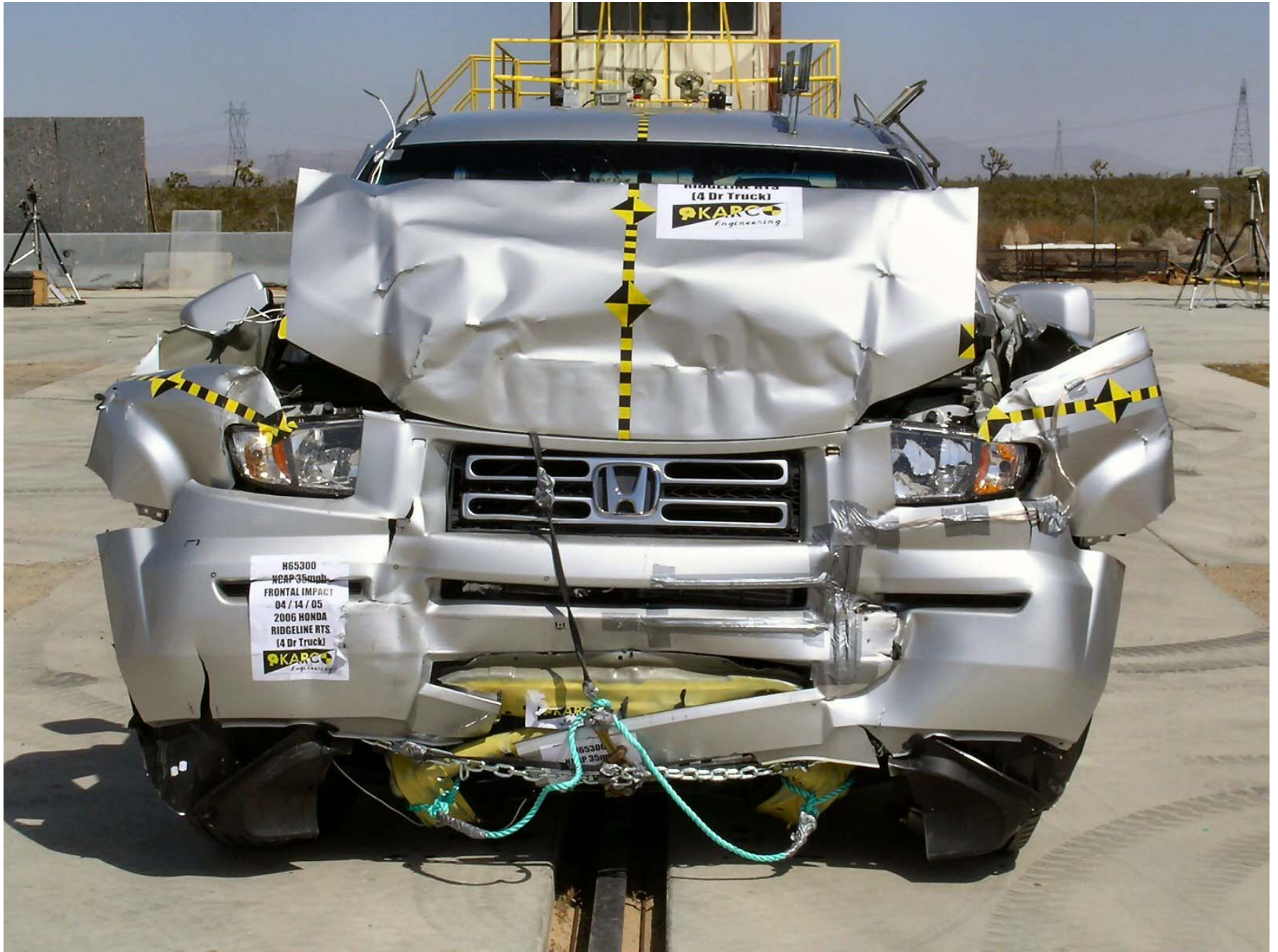

Figure A-7: Post-Test Front View (Vehicle Moved)



Figure A-8: Pre-Test Left Side View



Figure A-9: Post-Test Left Side View



Figure A-10: Pre-Test Right Side View



Figure A-11: Post-Test Right Side View



Figure A-12: Pre-Test Right Front 3/4 View



Figure A-13: Post-Test Right Front ¾ View (Vehicle Moved)



Figure A-14: Pre-Test Left Rear ¾ View



Figure A-15: Post-Test Left Rear $\frac{3}{4}$ View



Figure A-16: Post-Test Left Side ¾ View of Doors After Impact



Figure A-17: Post-Test Right Side $\frac{3}{4}$ View of Doors After Impact

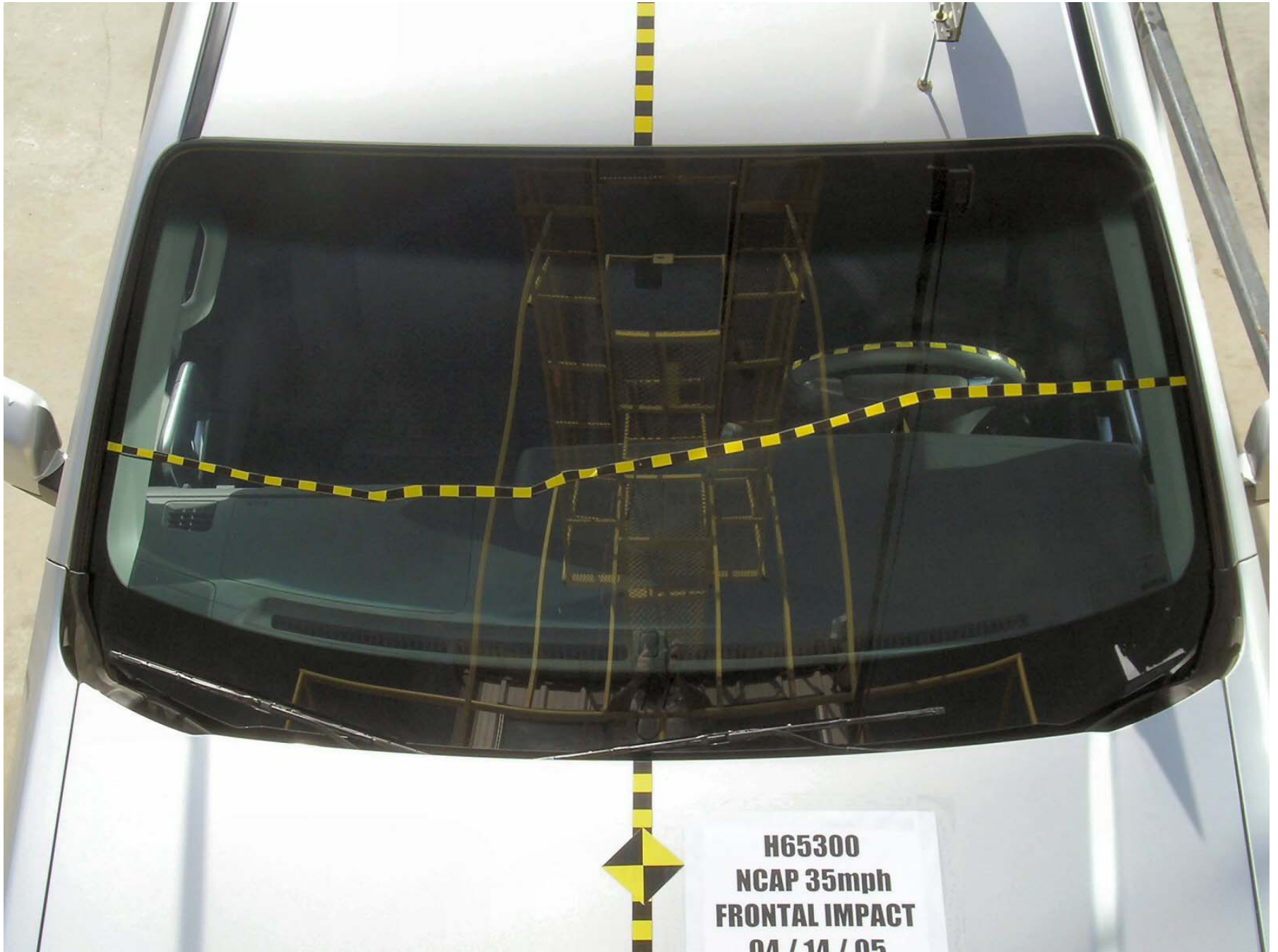

Figure A-18: Pre-Test Windshield



Figure A-19: Post-Test Windshield



A-20

TR-P25064-01-NC

Figure A-20: Pre-Test Engine Compartment

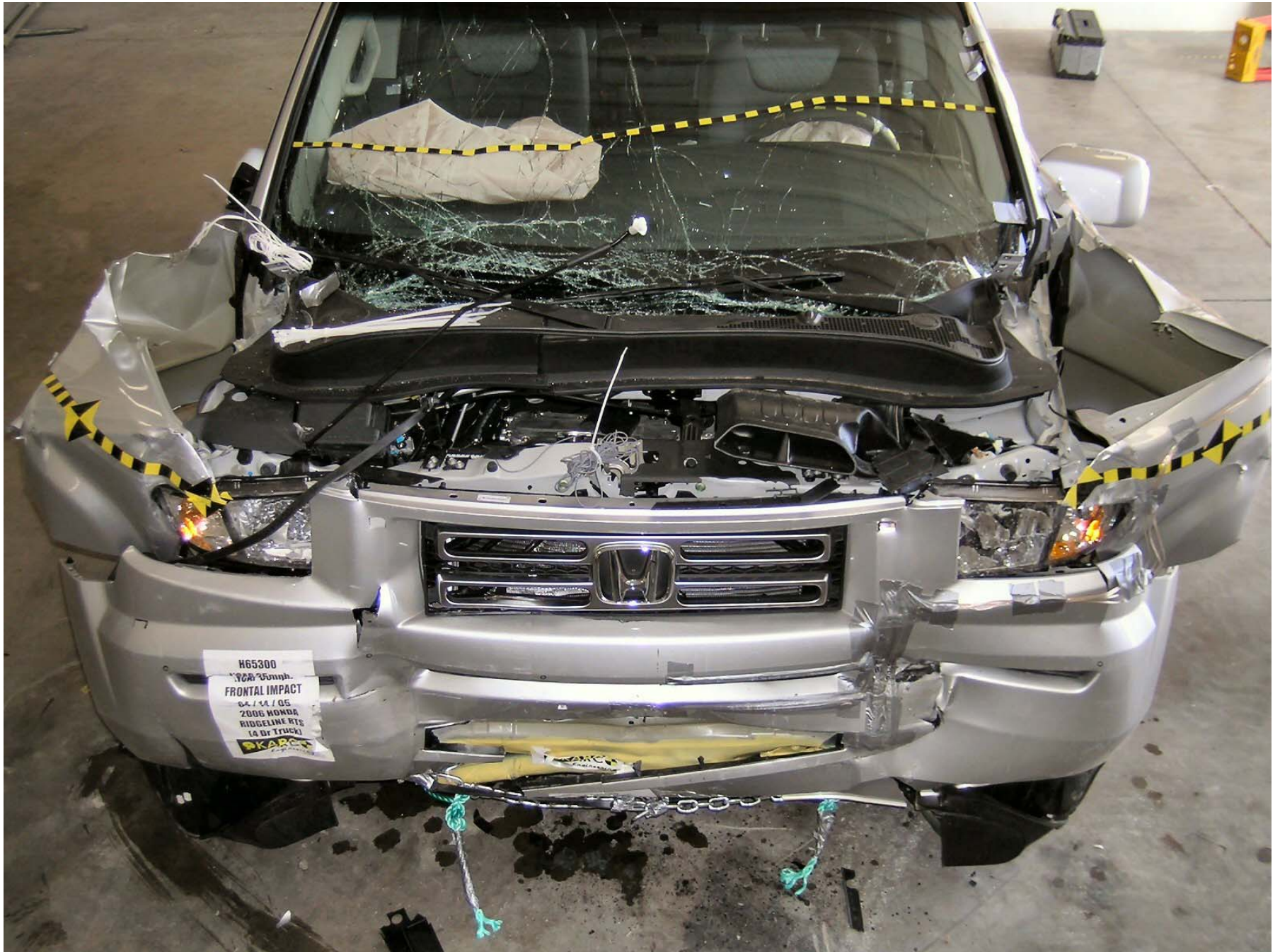

Figure A-21: Post-Test Engine Compartment (Vehicle Moved)



Figure A-22: Pre-Test Fuel Cap



Figure A-23: Post-Test Fuel Cap

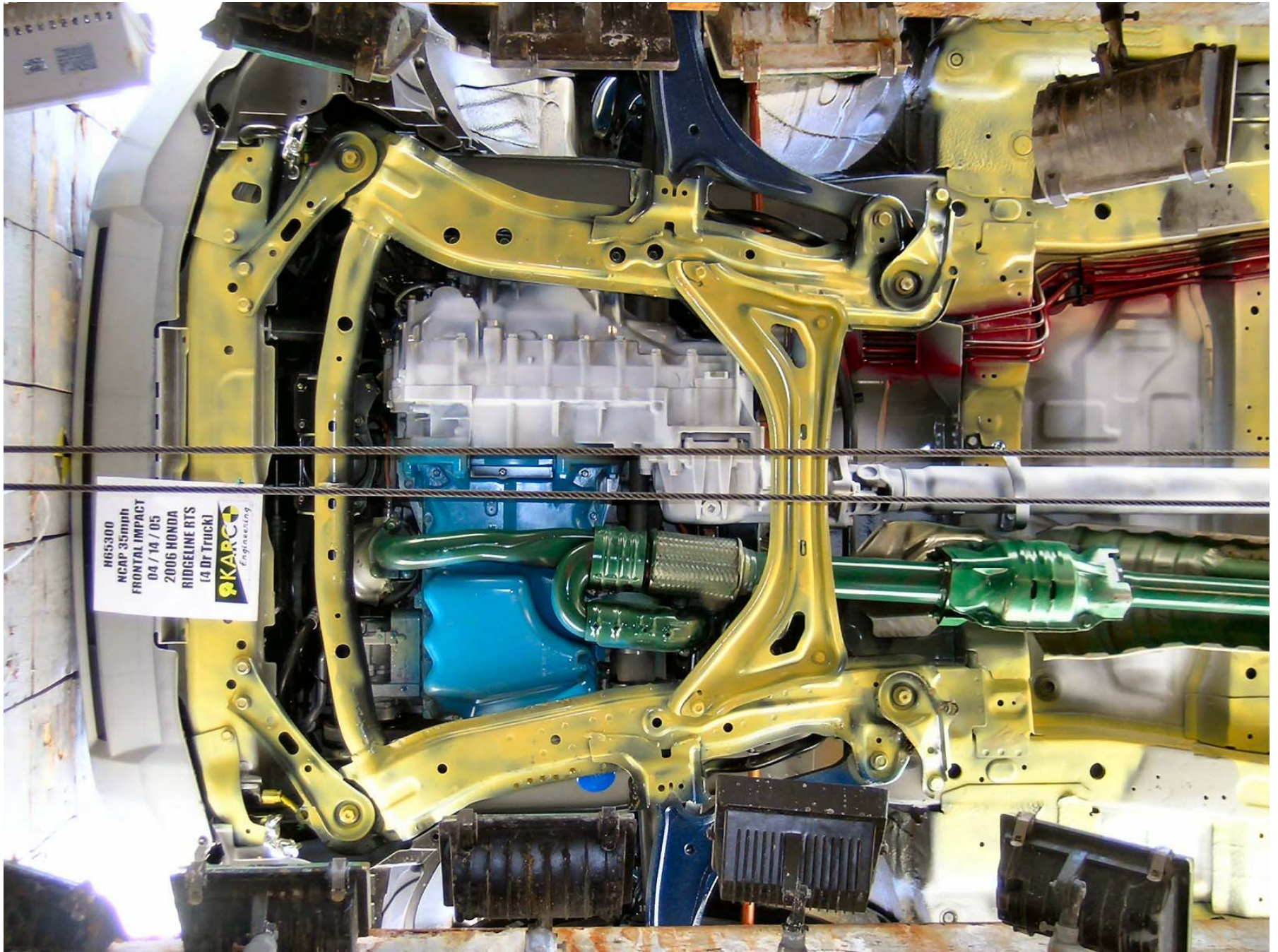

H65300
NCAP 35mph
FRONTAL IMPACT
04 / 14 / 05
2006 HONDA
RIDGELINE RTS
14 Dr Truck

PKARCO
Engineering

Figure A-24: Pre-Test Front Underbody

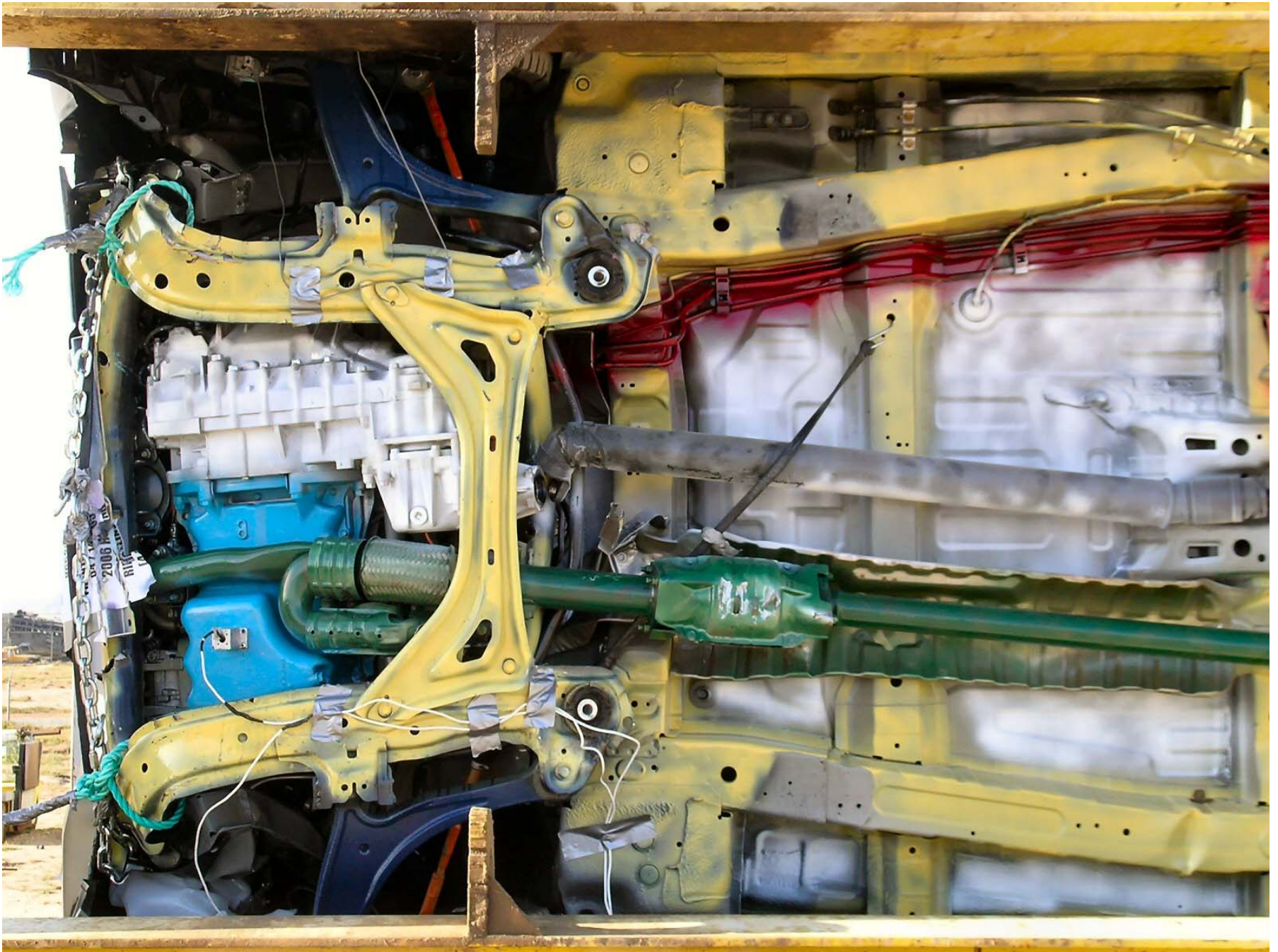

Figure A-25: Post-Test Front Underbody

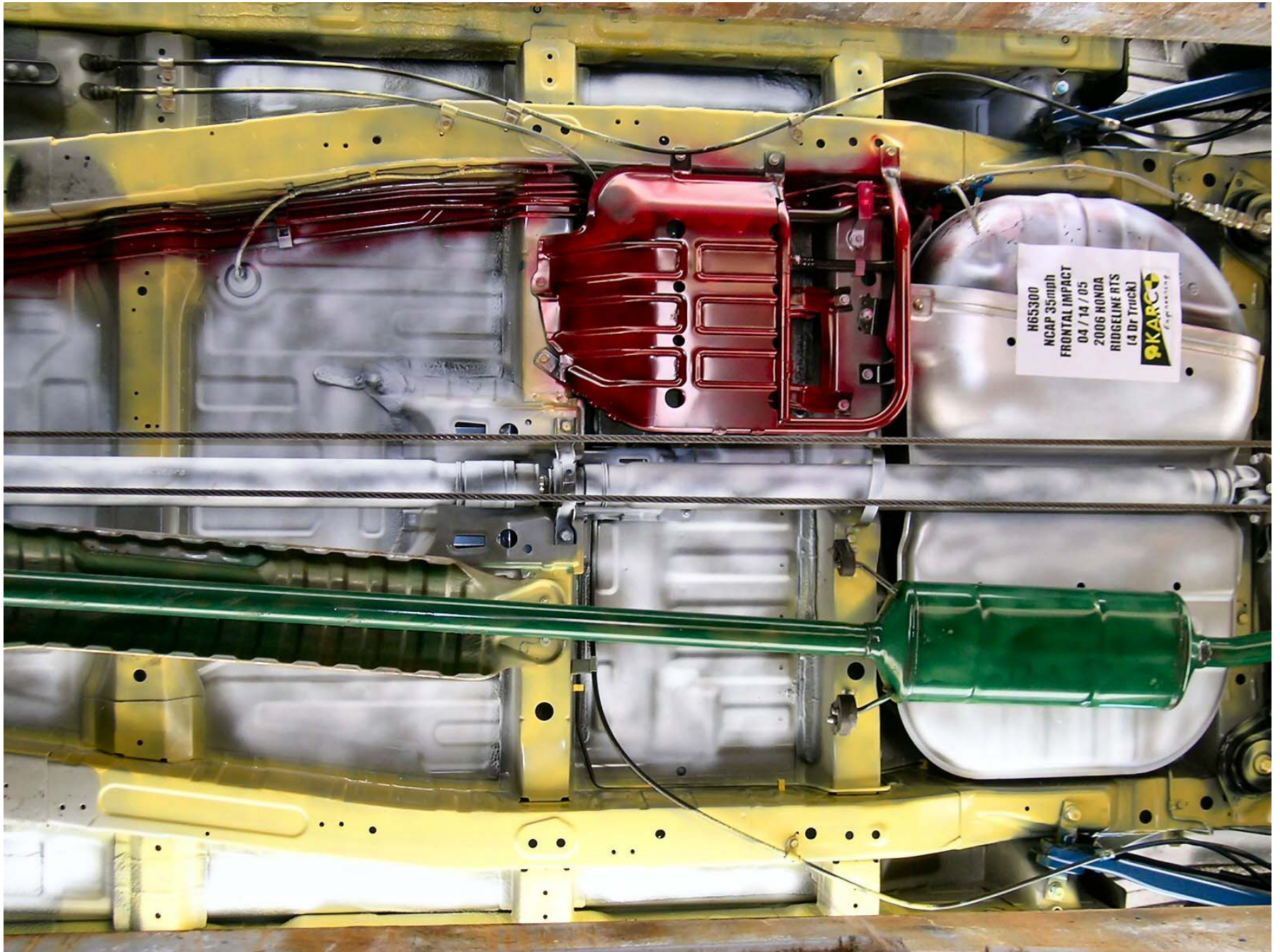

Figure A-26: Pre-Test Mid Underbody

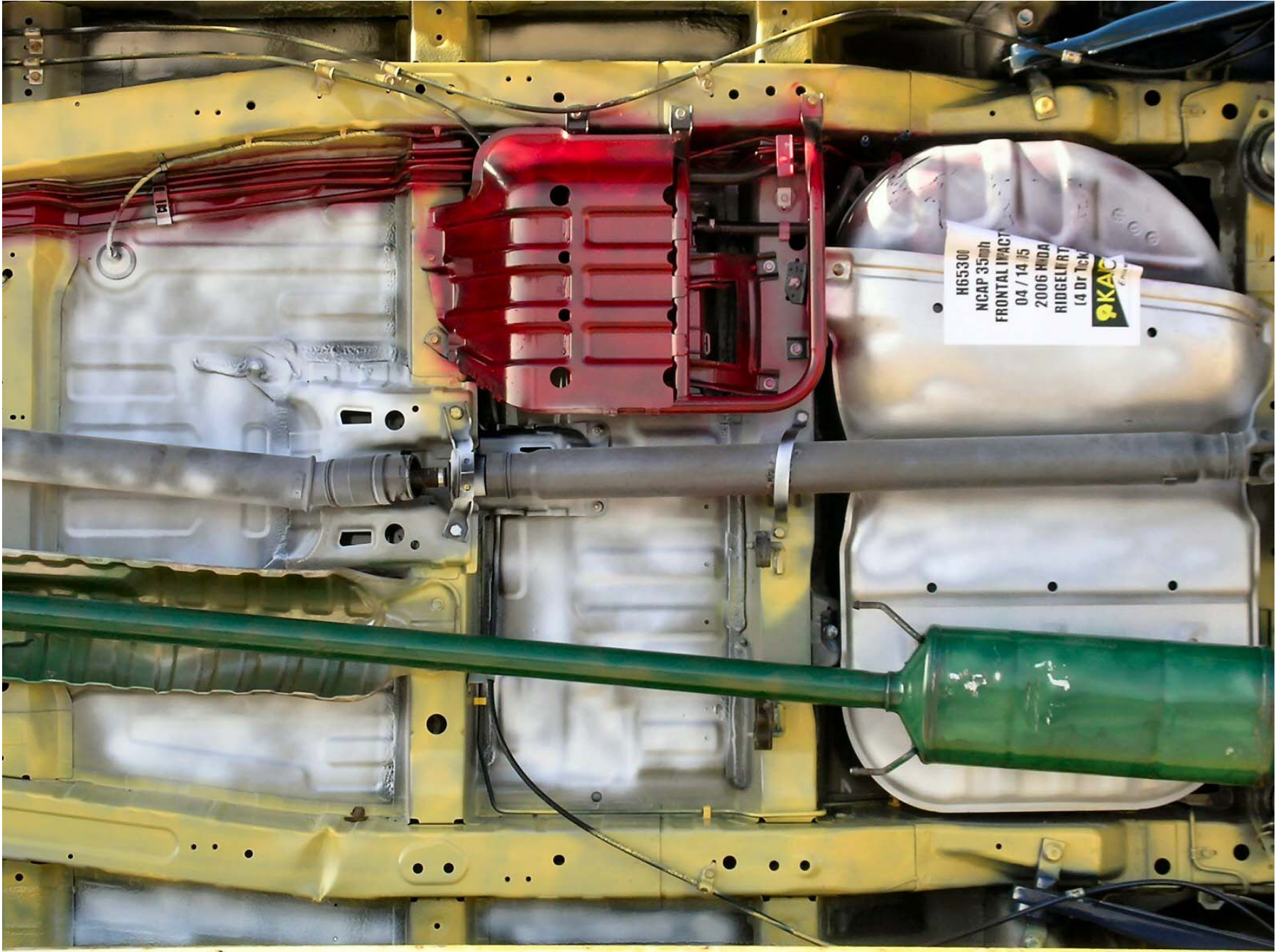
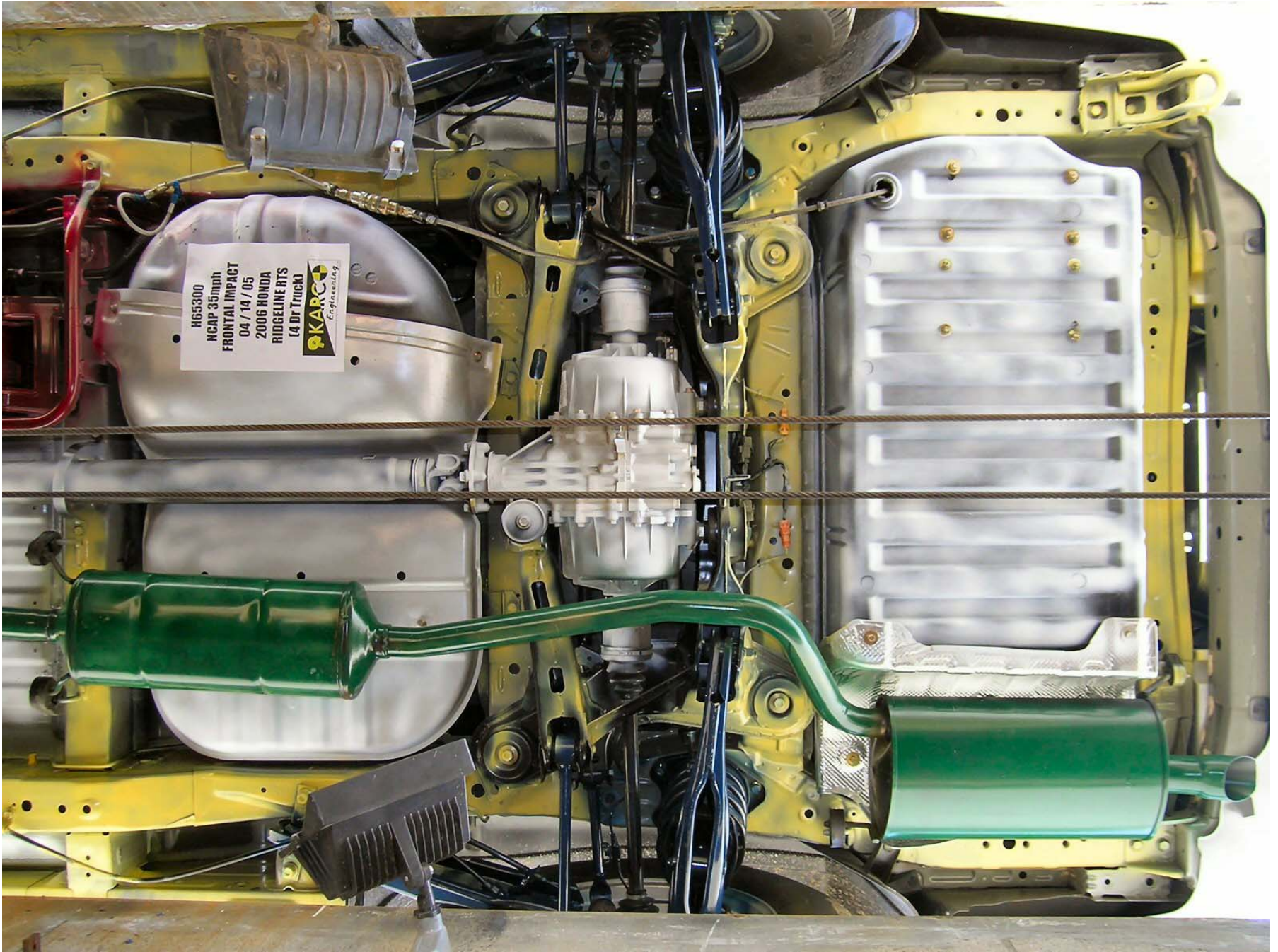
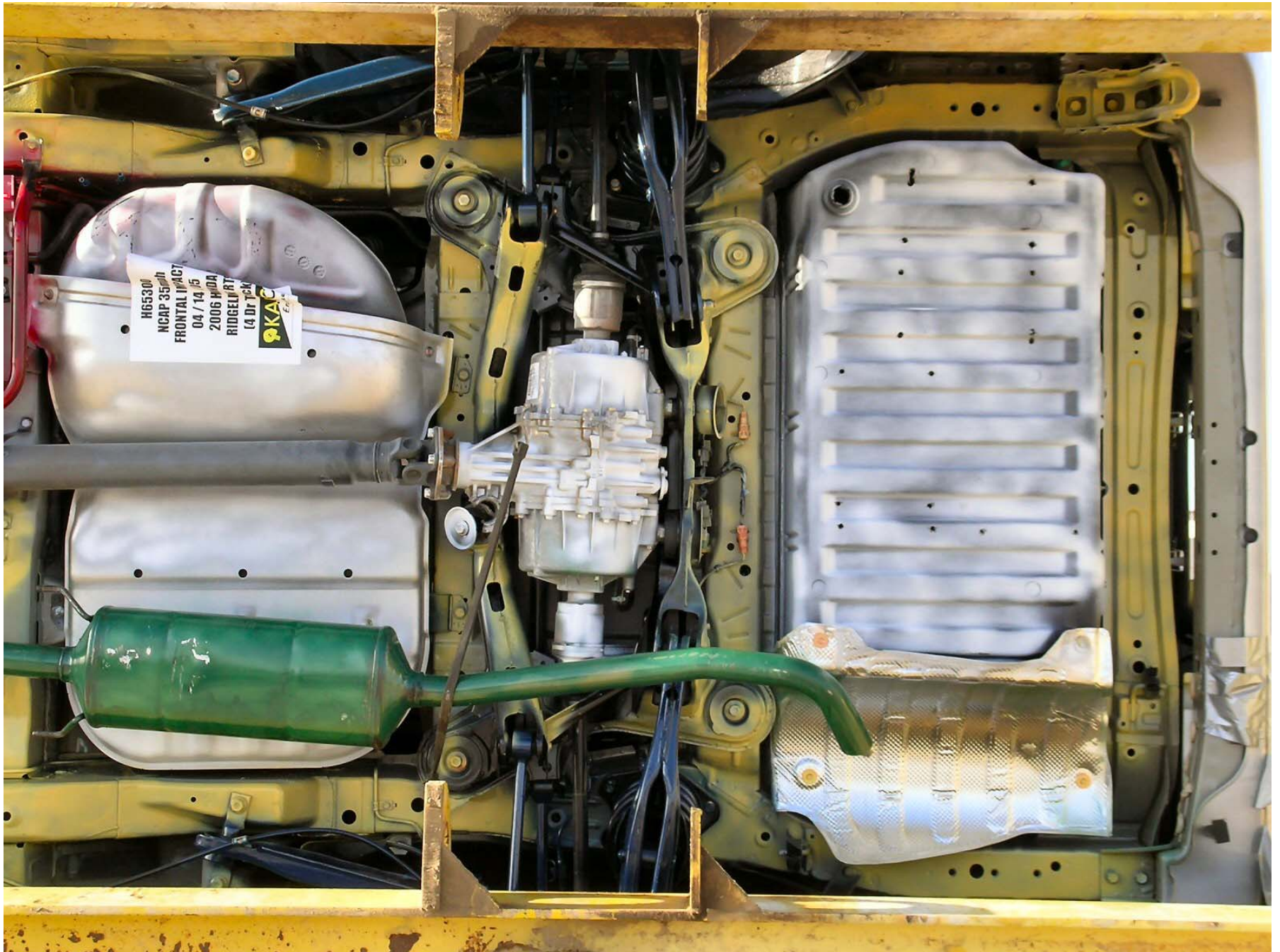

Figure A-27: Post-Test Mid Underbody



H65300
NCAP 35mph
FRONTAL IMPACT
04 / 14 / 05
2006 HONDA
RIDGELINE RTS
14 Dr Truck
KARCO
Engineering

Figure A-28: Pre-Test Rear Underbody



H65300
NCAP 35mph
FRONTAL IMPACT
04 / 14 / 15
2006 HIDA
RIDGELIFT
14 DR TRK
KAC

Figure A-29: Post-Test Rear Underbody



Figure A-30: Pre-Test Driver Dummy Front View (Head Position)

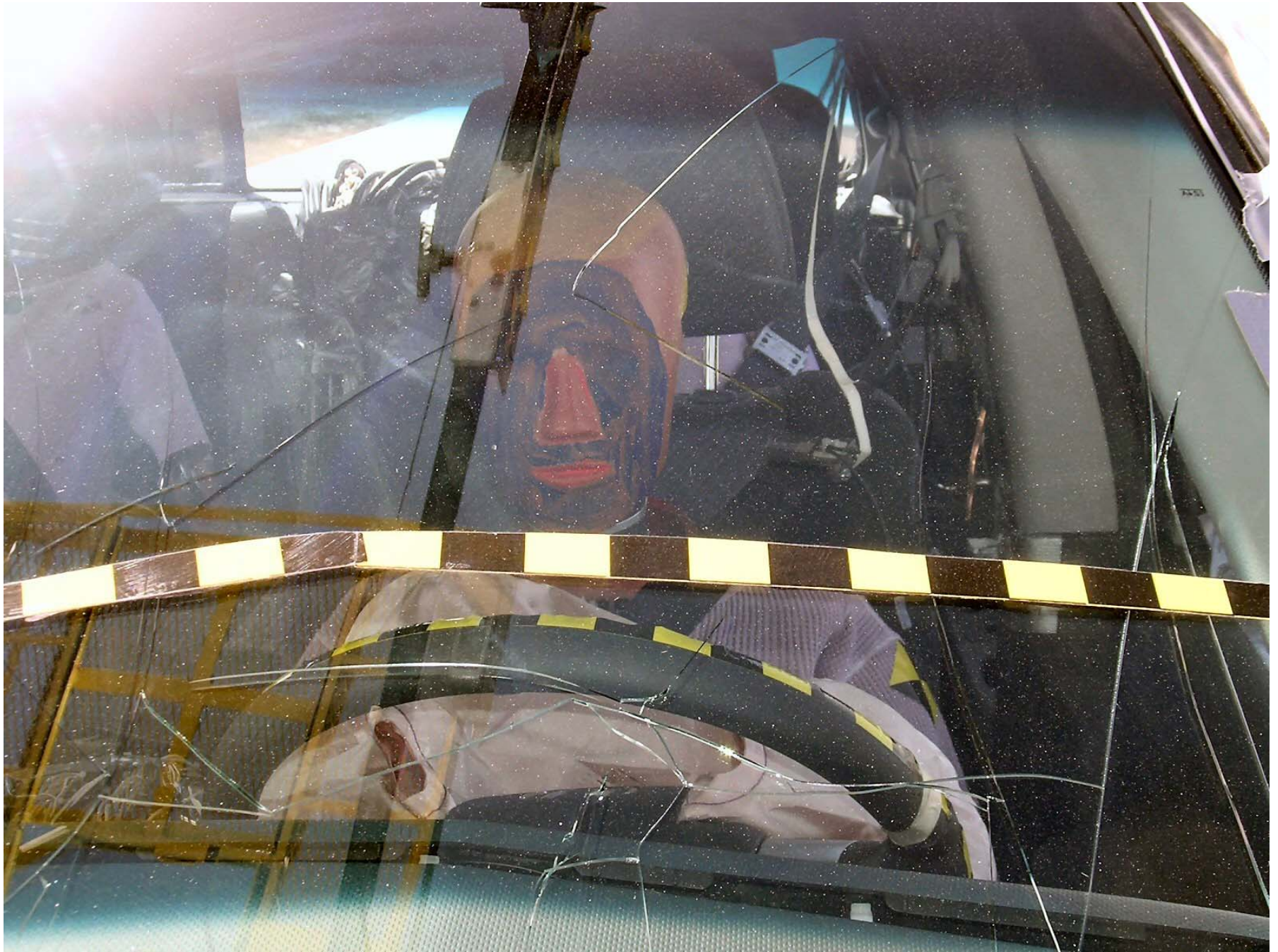

Figure A-31: Post-Test Driver Dummy Front View (Head Position)



Figure A-32: Pre-Test Driver Dummy (Through Window)



Figure A-33: Post-Test Driver Dummy (Through Window)



Figure A-34: Pre-Test Driver Dummy (Door Open)



Figure A-35: Post-Test Driver Dummy (Door Open)



Figure A-36: Pre-Test Driver Dummy Feet



Figure A-37: Post-Test Driver Dummy Feet



Figure A-38: Pre-Test Driver Side Knee Bolster



Figure A-39: Post-Test Driver Side Knee Bolster



Figure A-40: Pre-Test Driver Side Floor Pan



Figure A-41: Post-Test Driver Side Floor Pan



Figure A-42: Post-Test Driver Dummy Head



Figure A-43: Post-Test Driver Dummy Airbag Contact



Figure A-44: Pre-Test Passenger Dummy Front View (Head Position)



Figure A-45: Post-Test Passenger Dummy Front View (Head Position)



Figure A-46: Pre-Test Passenger Dummy (Through Window)



Figure A-47: Post-Test Passenger Dummy (Through Window)



Figure A-48: Pre-Test Passenger Dummy (Door Open)



Figure A-49: Post-Test Passenger Dummy (Door Open)

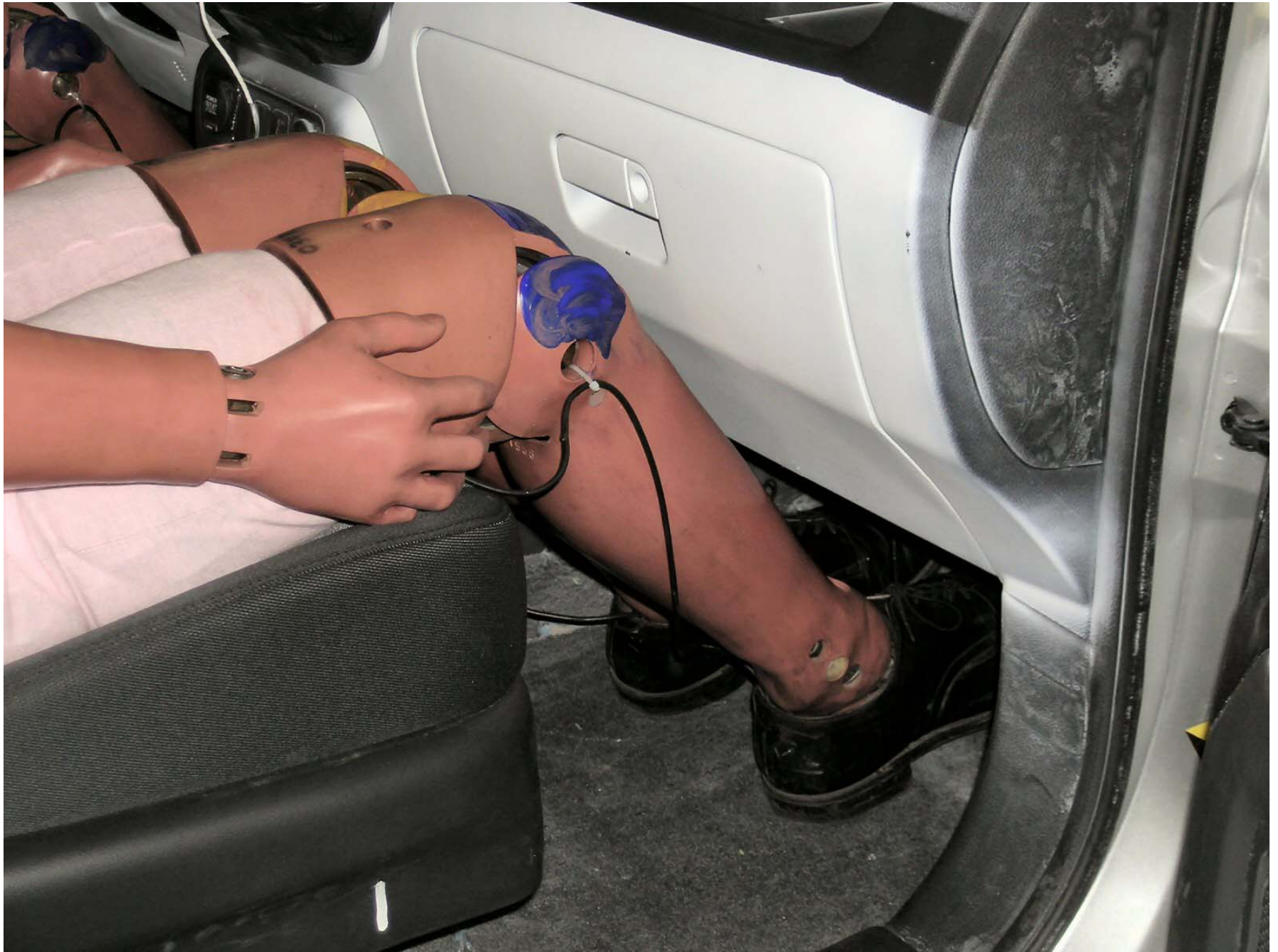

Figure A-50: Pre-Test Passenger Dummy Feet



Figure A-51: Post-Test Passenger Dummy Feet



Figure A-52: Pre-Test Passenger Side Glove Box



Figure A-53: Post-Test Passenger Side Glove Box



Figure A-54: Pre-Test Passenger Side Floor Pan



Figure A-55: Post-Test Passenger Side Floor Pan



Figure A-56: Post-Test Passenger Dummy Head



Figure A-57: Post-Test Passenger Dummy Airbag Contact

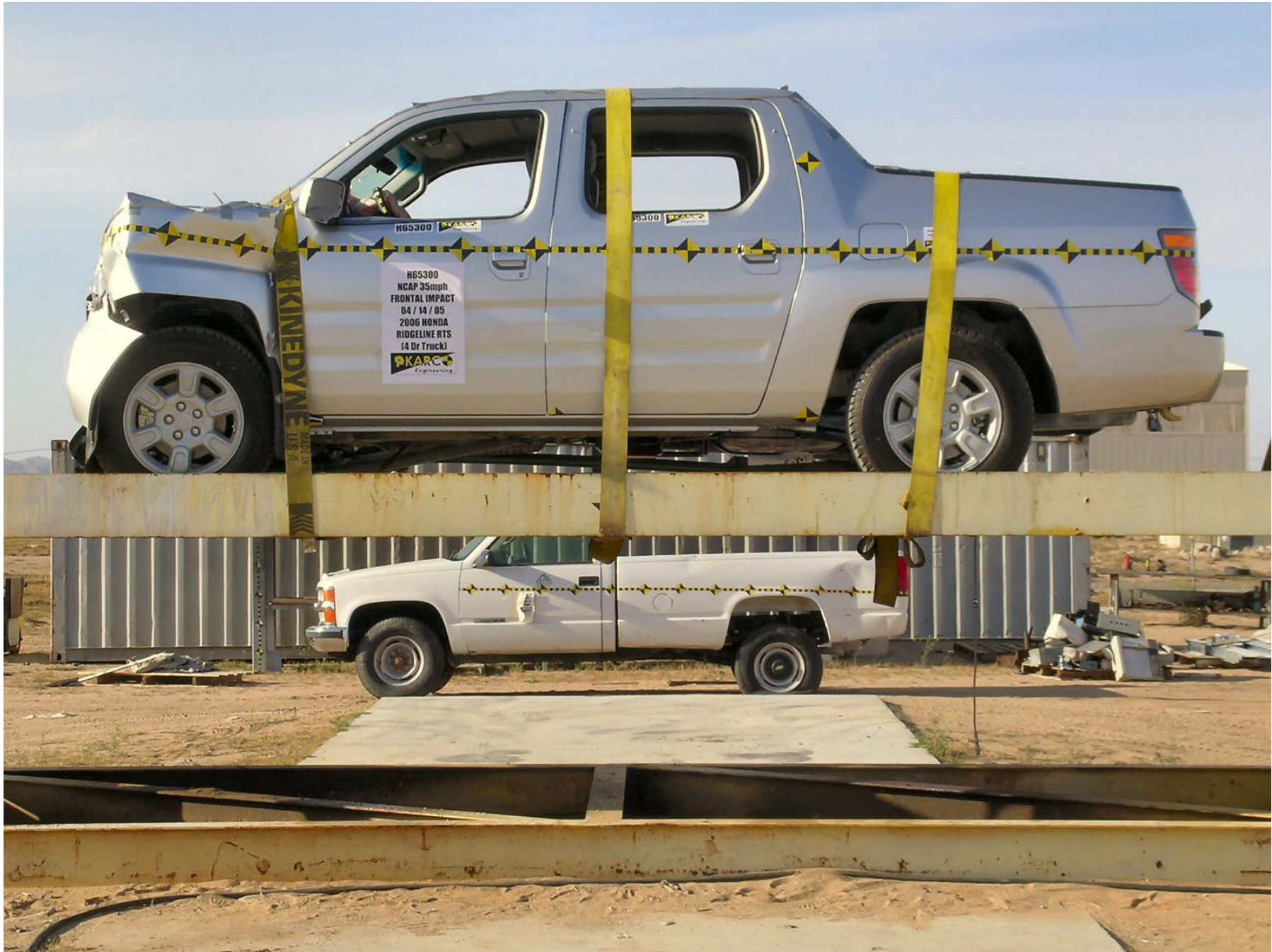

Figure A-58: Vehicle on Rollover Device (0°)



Figure A-59: Vehicle on Rollover Device (90°)



Figure A-60: Vehicle on Rollover Device (180°)

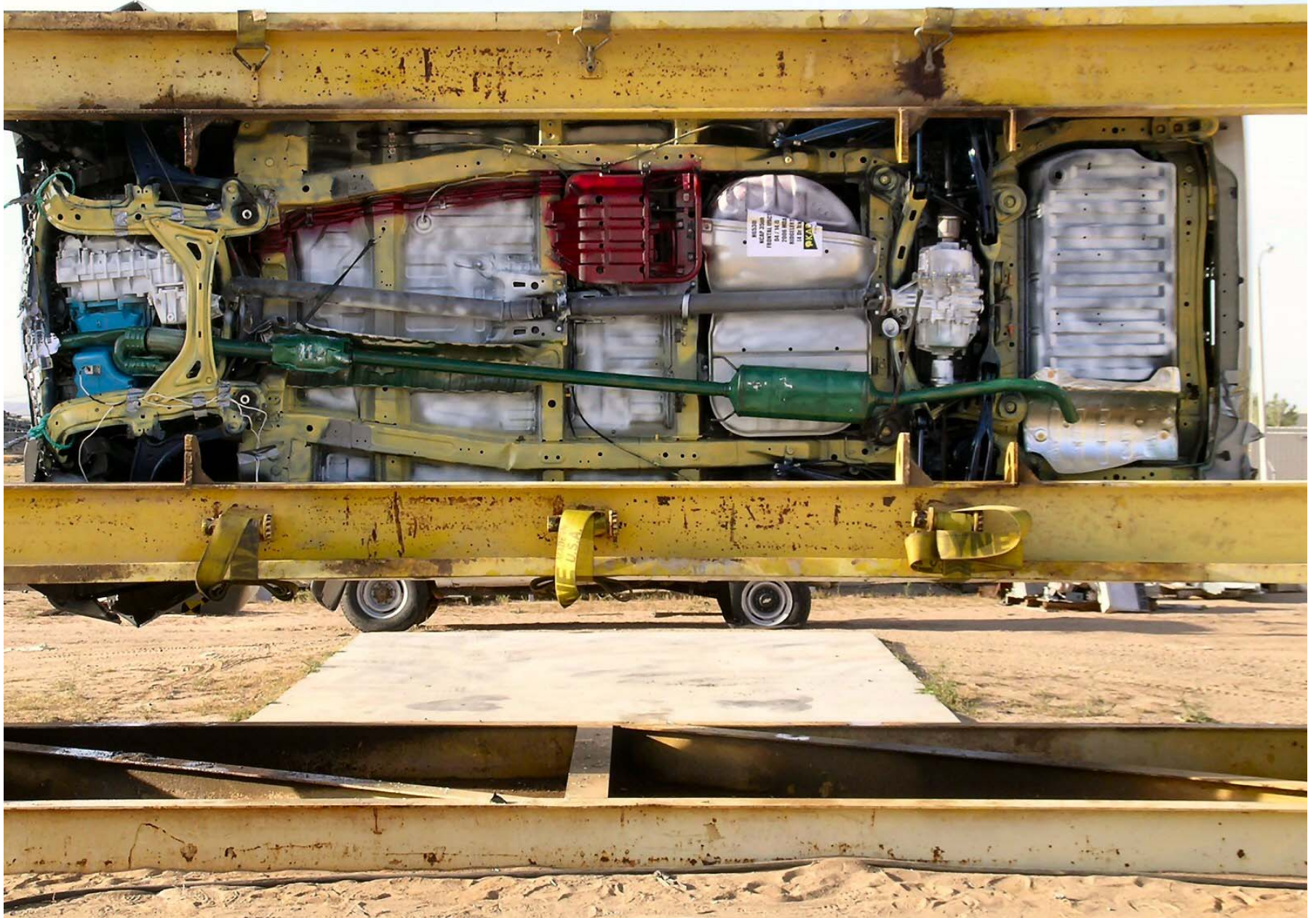

Figure A-61: Vehicle on Rollover Device (270°)

A-61

TR-P25064-01-NC



Figure A-62: Vehicle Impact



Figure A-63: Driver Seat, Seat Back Cover



Figure A-64: Driver Seat, Seat Back

A-65

TR-P25064-01-NC



Figure A-65: Passenger Seat, Seat Back Cover



Figure A-66: Passenger Seat, Seat Back

APPENDIX B

DATA PLOTS

LIST OF DATA PLOTS

Data Plot	Page	
B-1	Driver Head Primary X	B-1
	Driver Head Primary Y	B-1
	Driver Head Primary Z	B-1
	Driver Head Resultant Primary	B-1
B-2	Driver Head Primary X Velocity	B-2
	Driver Head Primary X Displacement	B-2
B-3	Driver Head Redundant X	B-3
	Driver Head Redundant Y	B-3
	Driver Head Redundant Z	B-3
	Driver Head Resultant Redundant	B-3
B-4	Driver Head Redundant X Velocity	B-4
	Driver Head Redundant X Displacement	B-4
B-5	Driver Upper Neck Force X	B-5
	Driver Upper Neck Force Y	B-5
	Driver Upper Neck Force Z	B-5
	Driver Upper Neck Force Resultant	B-5
B-6	Driver Upper Neck Moment X	B-6
	Driver Upper Neck Moment Y	B-6
	Driver Upper Neck Moment Z	B-6
	Driver Upper Neck Moment Resultant	B-6
B-7	Driver Chest Primary X	B-7
	Driver Chest Primary Y	B-7
	Driver Chest Primary Z	B-7
	Driver Chest Resultant Primary	B-7
B-8	Driver Chest Primary X Velocity	B-8
	Driver Chest Primary X Displacement	B-8
B-9	Driver Chest Redundant X	B-9
	Driver Chest Redundant Y	B-9
	Driver Chest Redundant Z	B-9
	Driver Chest Resultant Redundant	B-9
B-10	Driver Chest Redundant X Velocity	B-10
	Driver Chest Redundant X Displacement	B-10
B-11	Driver Chest Deflection	B-11

LIST OF DATA PLOTS...(CONTINUED)

Data Plot	Page	
B-12	Driver Pelvis X	B-12
	Driver Pelvis Y	B-12
	Driver Pelvis Z	B-12
	Driver Pelvis Resultant	B-12
B-13	Driver Pelvis X Velocity	B-13
	Driver Pelvis X Displacement	B-13
B-14	Driver Left Femur Force	B-14
	Driver Right Femur Force	B-14
B-15	Driver Left Upper Tibia Moment X	B-15
	Driver Left Upper Tibia Moment Y	B-15
	Driver Right Upper Tibia Moment X	B-15
	Driver Right Upper Tibia Moment Y	B-15
B-16	Driver Left Lower Tibia Moment X	B-16
	Driver Left Lower Tibia Moment Y	B-16
	Driver Left Lower Tibia Force Z	B-16
B-17	Driver Right Lower Tibia Moment X	B-17
	Driver Right Lower Tibia Moment Y	B-17
	Driver Right Lower Tibia Force Z	B-17
B-18	Driver Left Foot Aft X	B-18
	Driver Left Foot Aft Z	B-18
	Driver Left Foot Fore Z	B-18
B-19	Driver Right Foot Aft X	B-19
	Driver Right Foot Aft Z	B-19
	Driver Right Foot Fore Z	B-19
B-20	Driver Lap Belt Force	B-20
	Driver Shoulder Belt Force	B-20
	Driver Shoulder Belt Pullout	B-20
	Driver Shoulder Belt Elongation	B-20
B-21	Passenger Head Primary X	B-21
	Passenger Head Primary Y	B-21
	Passenger Head Primary Z	B-21
	Passenger Head Resultant Primary	B-21
B-22	Passenger Head Primary X Velocity	B-22
	Passenger Head Primary X Displacement	B-22

LIST OF DATA PLOTS...(CONTINUED)

Data Plot	Page	
B-23	Passenger Head Redundant X	B-23
	Passenger Head Redundant Y	B-23
	Passenger Head Redundant Z	B-23
	Passenger Head Resultant Redundant	B-23
B-24	Passenger Head Redundant X Velocity	B-24
	Passenger Head Redundant X Displacement	B-24
B-25	Passenger Upper Neck Force X	B-25
	Passenger Upper Neck Force Y	B-25
	Passenger Upper Neck Force Z	B-25
	Passenger Upper Neck Force Resultant	B-25
B-26	Passenger Upper Neck Moment X	B-26
	Passenger Upper Neck Moment Y	B-26
	Passenger Upper Neck Moment Z	B-26
	Passenger Upper Neck Moment Resultant	B-26
B-27	Passenger Chest Primary X	B-27
	Passenger Chest Primary Y	B-27
	Passenger Chest Primary Z	B-27
	Passenger Chest Resultant Primary	B-27
B-28	Passenger Chest Primary X Velocity	B-28
	Passenger Chest Primary X Displacement	B-28
B-29	Passenger Chest Redundant X	B-29
	Passenger Chest Redundant Y	B-29
	Passenger Chest Redundant Z	B-29
	Passenger Chest Resultant Redundant	B-29
B-30	Passenger Chest Redundant X Velocity	B-30
	Passenger Chest Redundant X Displacement	B-30
B-31	Passenger Chest Deflection	B-31
B-32	Passenger Pelvis X	B-32
	Passenger Pelvis Y	B-32
	Passenger Pelvis Z	B-32
	Passenger Pelvis Resultant	B-32
B-33	Passenger Pelvis X Velocity	B-33
	Passenger Pelvis X Displacement	B-33

LIST OF DATA PLOTS...(CONTINUED)

Data Plot		Page
B-34	Passenger Left Femur Force	B-34
	Passenger Right Femur Force	B-34
B-35	Passenger Left Upper Tibia Moment X	B-35
	Passenger Left Upper Tibia Moment Y	B-35
	Passenger Right Upper Tibia Moment X	B-35
	Passenger Right Upper Tibia Moment Y	B-35
B-36	Passenger Left Lower Tibia Moment X	B-36
	Passenger Left Lower Tibia Moment Y	B-36
	Passenger Left Lower Tibia Force Z	B-36
B-37	Passenger Right Lower Tibia Moment X	B-37
	Passenger Right Lower Tibia Moment Y	B-37
	Passenger Right Lower Tibia Force Z	B-37
B-38	Passenger Left Foot Aft X	B-38
	Passenger Left Foot Aft Z	B-38
	Passenger Left Foot Fore Z	B-38
B-39	Passenger Right Foot Aft X	B-39
	Passenger Right Foot Aft Z	B-39
	Passenger Right Foot Fore Z	B-39
B-40	Passenger Lap Belt Force	B-40
	Passenger Shoulder Belt Force	B-40
	Passenger Shoulder Belt Pullout	B-40
	Passenger Shoulder Belt Elongation	B-40
B-41	Vehicle Left Rear X	B-41
	Vehicle Left Rear X Velocity	B-41
	Vehicle Left Rear X Displacement	B-41
B-42	Vehicle Right Rear X	B-42
	Vehicle Right Rear X Velocity	B-42
	Vehicle Right Rear X Displacement	B-42
B-43	Vehicle Engine Top X	B-43
	Vehicle Engine Top X Velocity	B-43
	Vehicle Engine Top X Displacement	B-43
B-44	Vehicle Engine Bottom X	B-44
	Vehicle Engine Bottom X Velocity	B-44
	Vehicle Engine Bottom X Displacement	B-44

LIST OF DATA PLOTS...(CONTINUED)

<u>Data Plot</u>		<u>Page</u>
B-45	Vehicle Left Brake Caliper X	B-45
	Vehicle Left Brake Caliper X Velocity	B-45
	Vehicle Left Brake Caliper X Displacement	B-45
B-46	Vehicle Right Brake Caliper X	B-46
	Vehicle Right Brake Caliper X Velocity	B-46
	Vehicle Right Brake Caliper X Displacement	B-46
B-47	Vehicle Instrument Panel X	B-47
	Vehicle Instrument Panel X Velocity	B-47
	Vehicle Instrument Panel X Displacement	B-47
B-48	Vehicle Left Rear Z	B-48
	Vehicle Left Rear Z Velocity	B-48
	Vehicle Left Rear Z Displacement	B-48
B-49	Vehicle Right Rear Z	B-49
	Vehicle Right Rear Z Velocity	B-49
	Vehicle Right Rear Z Displacement	B-49

Test Vehicle: 2006 Honda Ridgeline RTS 4-Door Truck
 Test Program: 2005 NHTSA 35mph NCAP

Test Date: 4/14/05
 NHTSA No.: H65300

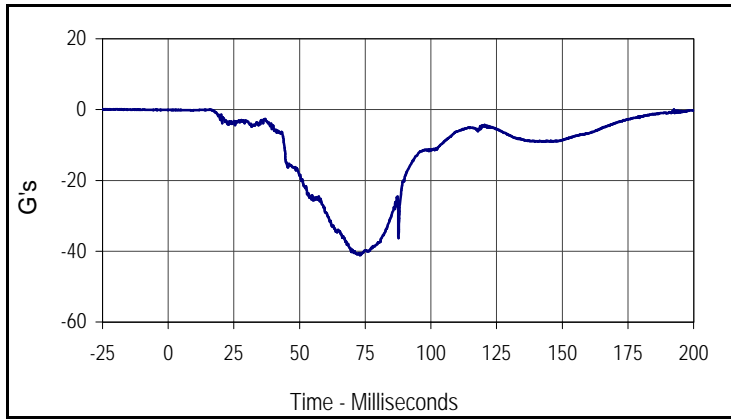

Curve Description			
Driver Head Primary X			
CURNO	Type	SAE Class	Units
001	FIL	1000	G's
Max	Time	Min	Time
0.0	192.6	-41.1	73.0

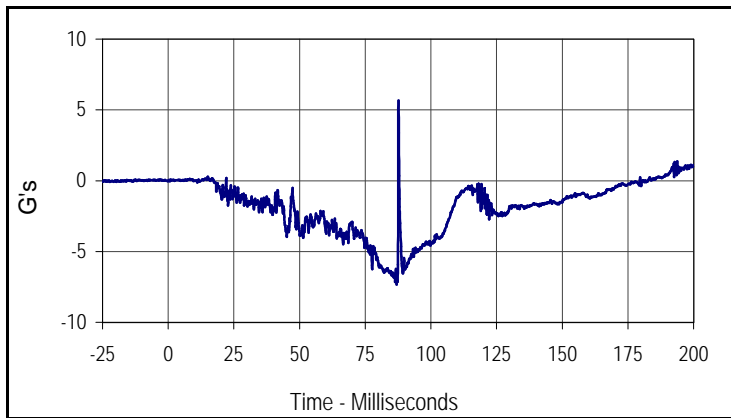

Curve Description			
Driver Head Primary Y			
CURNO	Type	SAE Class	Units
002	FIL	1000	G's
Max	Time	Min	Time
5.7	87.7	-7.3	86.9

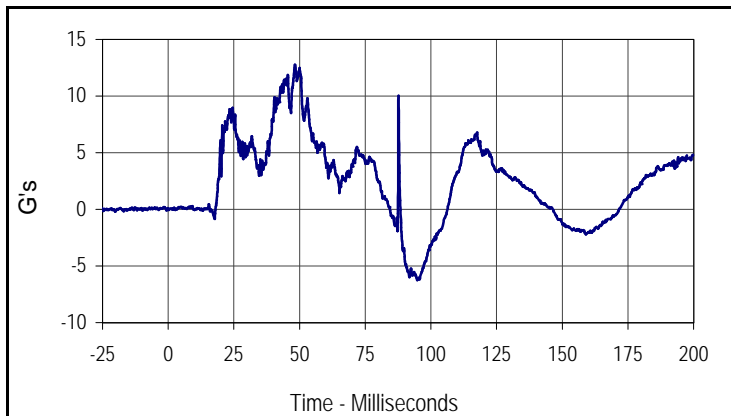

Curve Description			
Driver Head Primary Z			
CURNO	Type	SAE Class	Units
003	FIL	1000	G's
Max	Time	Min	Time
12.8	48.2	-6.2	94.8

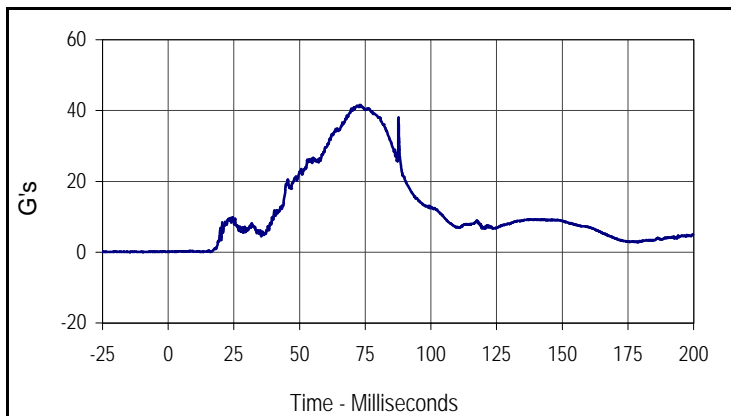

Curve Description			
Driver Head Resultant Primary			
CURNO	Type	SAE Class	Units
001	RES	1000	G's
Max	Time	Min	Time
41.5	73.0	0.0	12.4

Test Vehicle: 2006 Honda Ridgeline RTS 4-Door Truck
 Test Program: 2005 NHTSA 35mph NCAP

Test Date: 4/14/05
 NHTSA No.: H65300

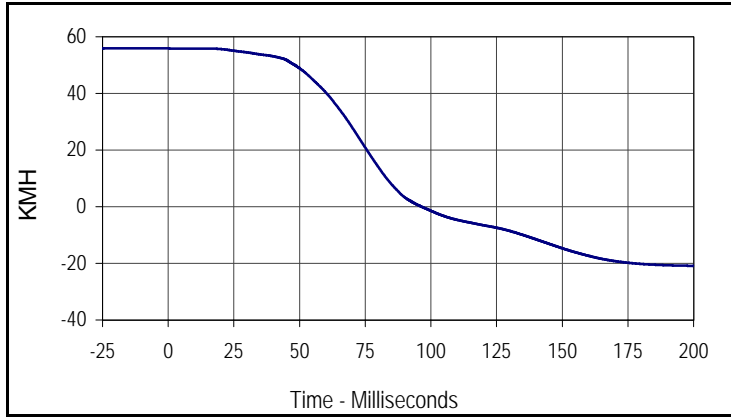

Curve Description			
Driver Head Primary X Velocity			
CURNO	Type	SAE Class	Units
001	IN1	180	KMH
Max	Time	Min	Time
55.9	0.0	-20.9	200.0

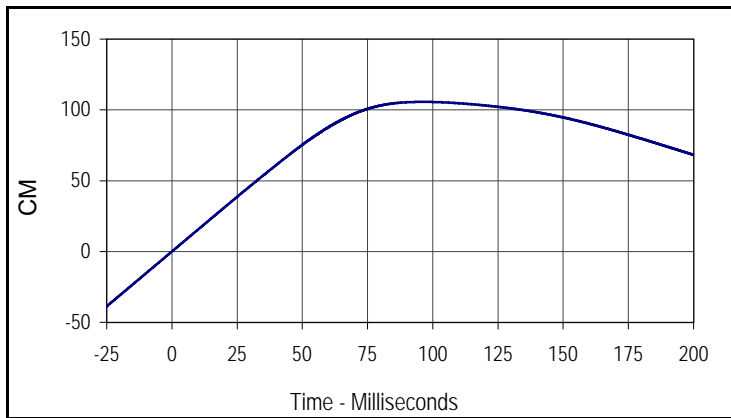

Curve Description			
Driver Head Primary X Displacement			
CURNO	Type	SAE Class	Units
001	IN2	180	CM
Max	Time	Min	Time
105.7	96.4	0.0	0.0

Test Vehicle: 2006 Honda Ridgeline RTS 4-Door Truck
 Test Program: 2005 NHTSA 35mph NCAP

Test Date: 4/14/05
 NHTSA No.: H65300

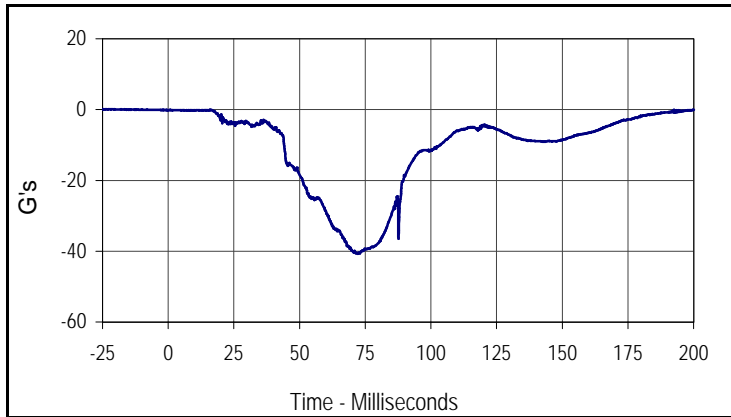

Curve Description			
Driver Head Redundant X			
CURNO	Type	SAE Class	Units
004	FIL	1000	G's
Max	Time	Min	Time
-0.1	199.8	-40.7	72.2

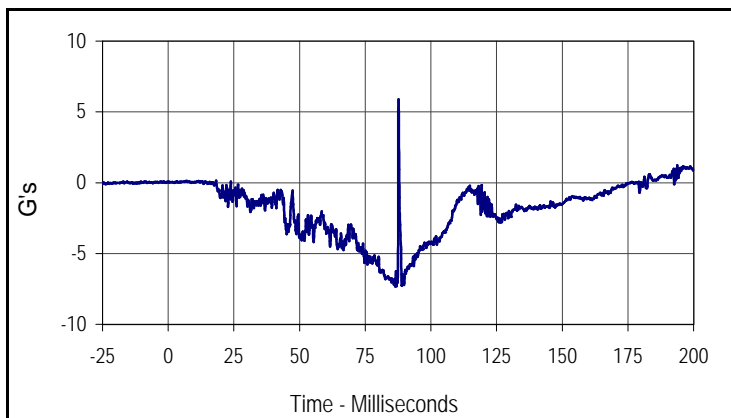

Curve Description			
Driver Head Redundant Y			
CURNO	Type	SAE Class	Units
005	FIL	1000	G's
Max	Time	Min	Time
5.9	87.7	-7.3	86.5

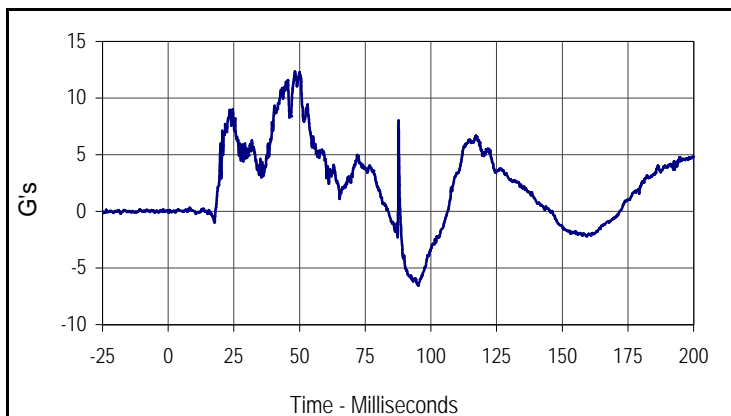

Curve Description			
Driver Head Redundant Z			
CURNO	Type	SAE Class	Units
006	FIL	1000	G's
Max	Time	Min	Time
12.3	48.2	-6.6	95.2

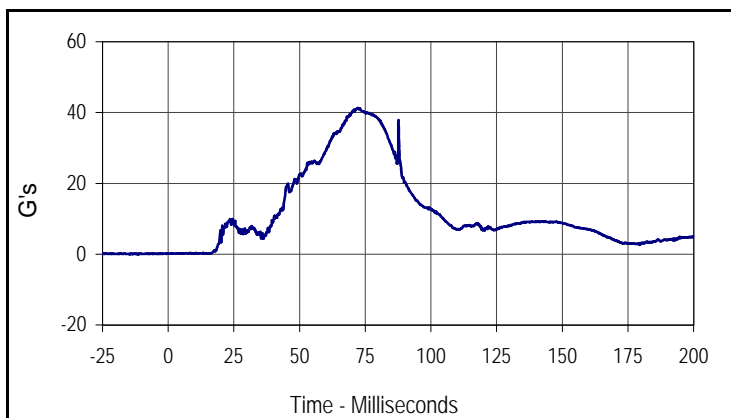

Curve Description			
Driver Head Resultant Redundant			
CURNO	Type	SAE Class	Units
004	RES	1000	G's
Max	Time	Min	Time
41.2	72.2	0.1	0.8

Test Vehicle: 2006 Honda Ridgeline RTS 4-Door Truck
 Test Program: 2005 NHTSA 35mph NCAP

Test Date: 4/14/05
 NHTSA No.: H65300

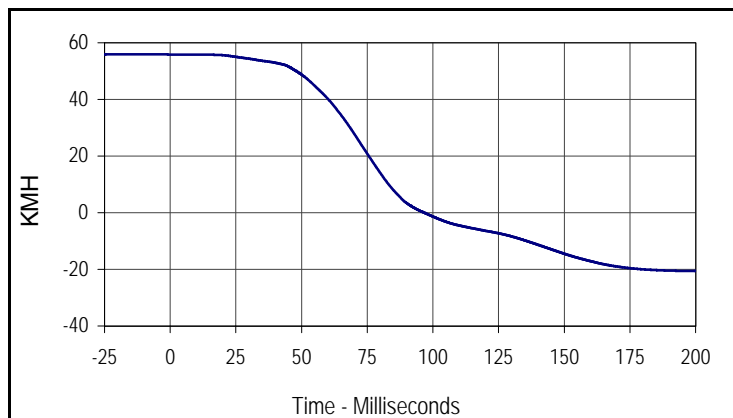

Curve Description			
Driver Head Redundant X Velocity			
CURNO	Type	SAE Class	Units
004	IN1	180	KMH
Max	Time	Min	Time
55.9	0.0	-20.6	200.0

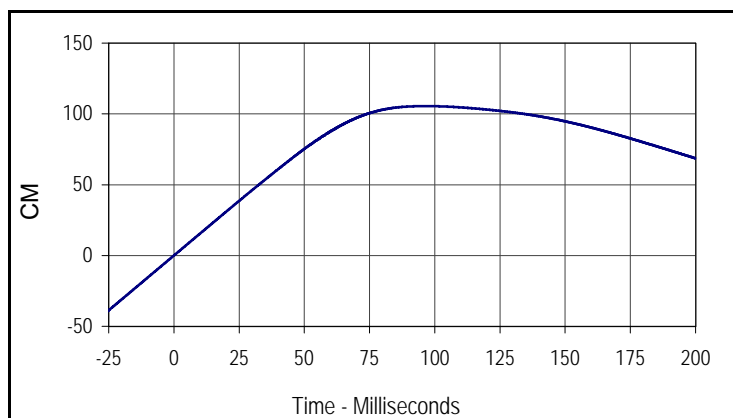

Curve Description			
Driver Head Redundant X Displacement			
CURNO	Type	SAE Class	Units
004	IN2	180	CM
Max	Time	Min	Time
105.5	96.7	0.0	0.0

Test Vehicle: 2006 Honda Ridgeline RTS 4-Door Truck
 Test Program: 2005 NHTSA 35mph NCAP

Test Date: 4/14/05
 NHTSA No.: H65300

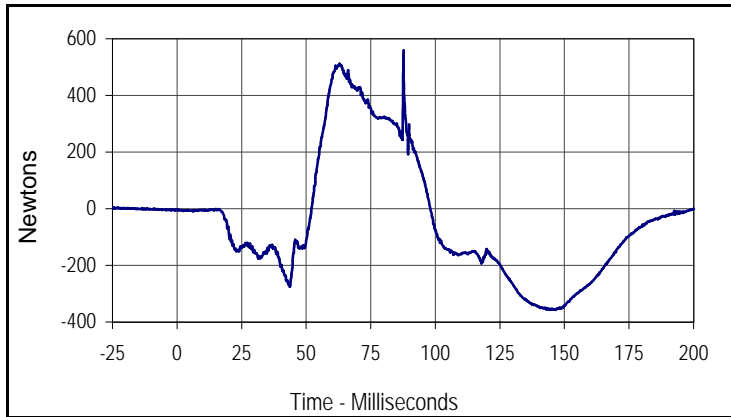

Curve Description			
Driver Upper Neck Force X			
CURNO	Type	SAE Class	Units
007	FIL	1000	Newtons
Max	Time	Min	Time
558.9	87.7	-357.5	146.5

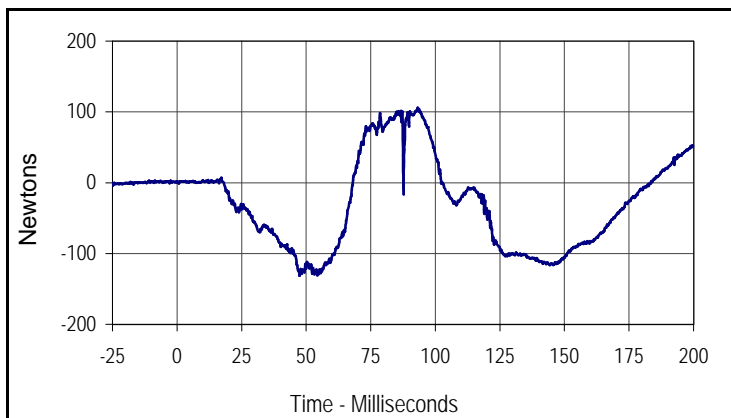

Curve Description			
Driver Upper Neck Force Y			
CURNO	Type	SAE Class	Units
008	FIL	1000	Newtons
Max	Time	Min	Time
106.0	93.2	-131.4	47.5

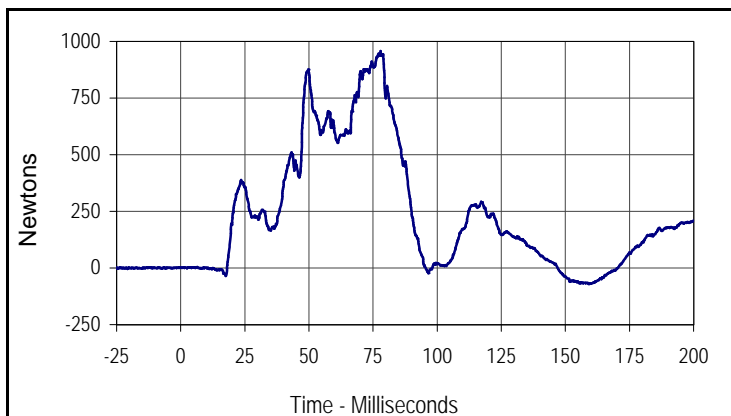

Curve Description			
Driver Upper Neck Force Z			
CURNO	Type	SAE Class	Units
009	FIL	1000	Newtons
Max	Time	Min	Time
957.6	77.9	-70.4	159.1

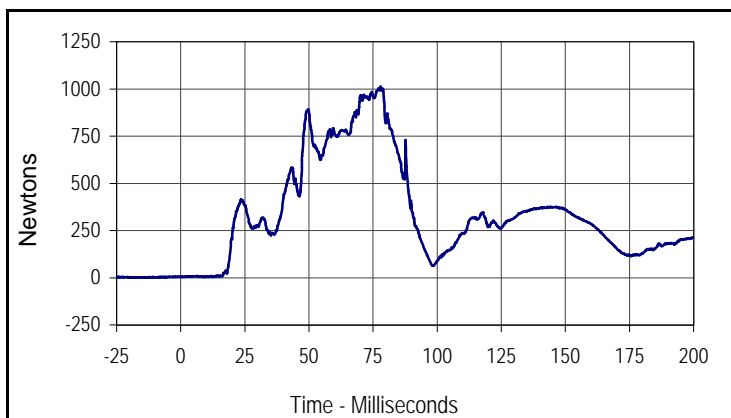

Curve Description			
Driver Upper Neck Force Res.			
CURNO	Type	SAE Class	Units
007	RES	1000	Newtons
Max	Time	Min	Time
1012.4	77.9	3.6	12.4

Test Vehicle: 2006 Honda Ridgeline RTS 4-Door Truck
 Test Program: 2005 NHTSA 35mph NCAP

Test Date: 4/14/05
 NHTSA No.: H65300

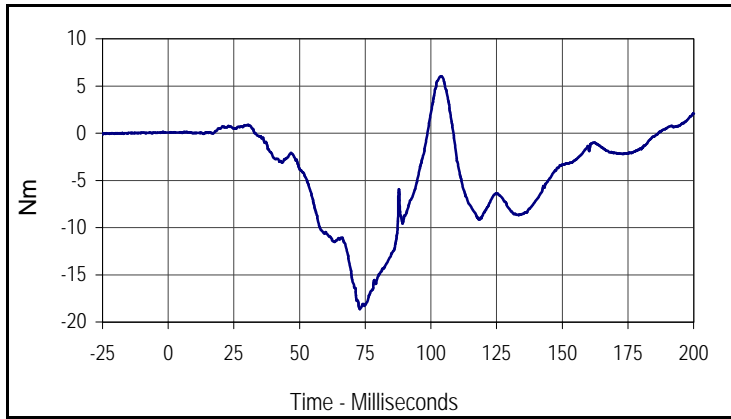

Curve Description			
Driver Upper Neck Moment X			
CURNO	Type	SAE Class	Units
010	FIL	600	Nm
Max	Time	Min	Time
6.0	103.8	-18.6	73.0

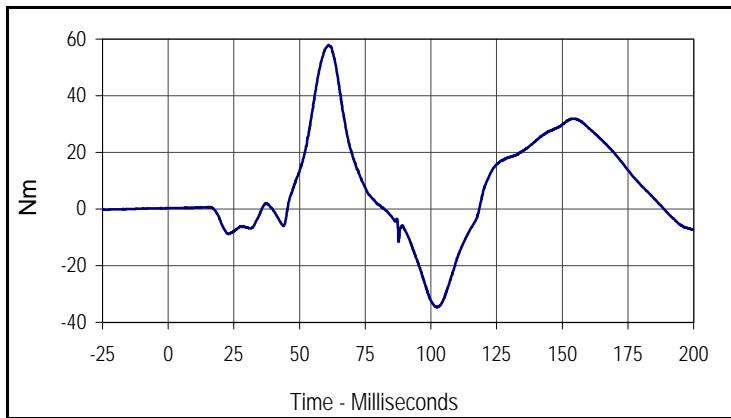

Curve Description			
Driver Upper Neck Moment Y			
CURNO	Type	SAE Class	Units
011	FIL	600	Nm
Max	Time	Min	Time
57.9	61.0	-34.7	102.3

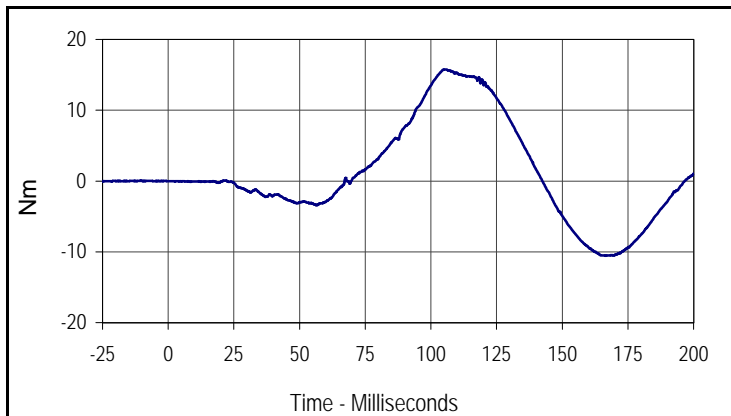

Curve Description			
Driver Upper Neck Moment Z			
CURNO	Type	SAE Class	Units
012	FIL	600	Nm
Max	Time	Min	Time
15.8	105.9	-10.5	166.6

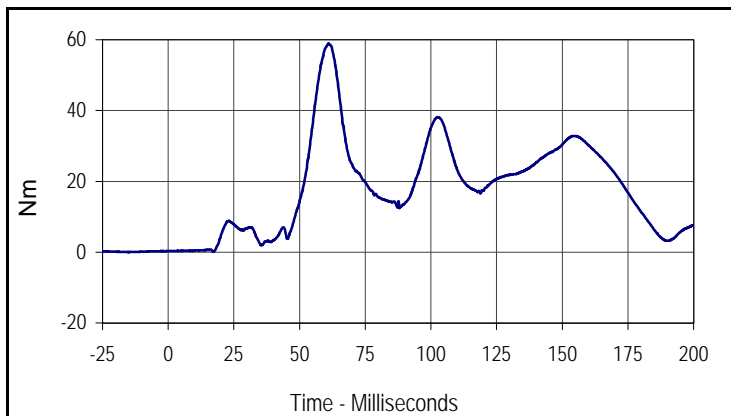

Curve Description			
Driver Upper Neck Moment Res.			
CURNO	Type	SAE Class	Units
010	RES	600	Nm
Max	Time	Min	Time
59.0	61.0	0.0	17.3

Test Vehicle: 2006 Honda Ridgeline RTS 4-Door Truck
 Test Program: 2005 NHTSA 35mph NCAP

Test Date: 4/14/05
 NHTSA No.: H65300

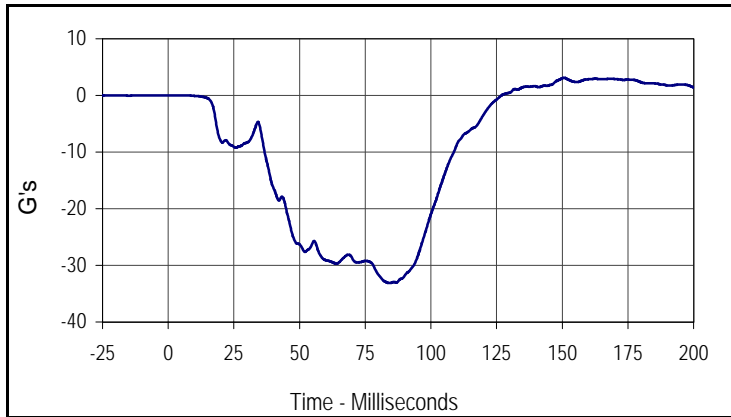

Curve Description			
Driver Chest Primary X			
CURNO	Type	SAE Class	Units
013	FIL	180	G's
Max	Time	Min	Time
3.1	150.7	-33.1	84.3

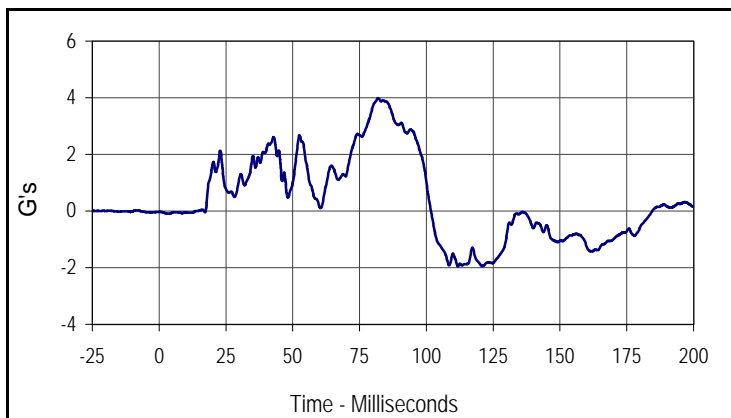

Curve Description			
Driver Chest Primary Y			
CURNO	Type	SAE Class	Units
014	FIL	180	G's
Max	Time	Min	Time
4.0	82.0	-1.9	111.8

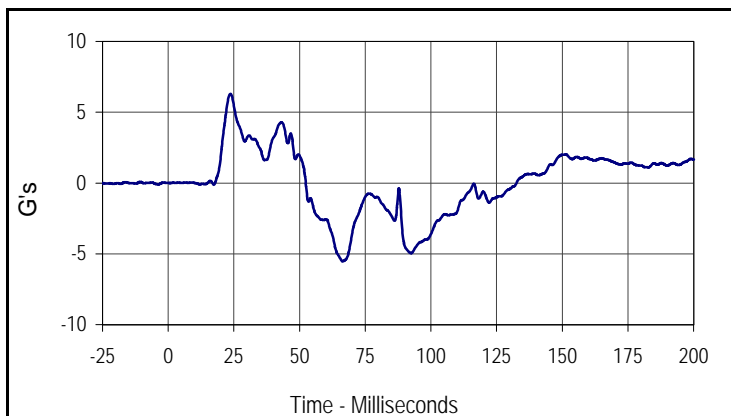

Curve Description			
Driver Chest Primary Z			
CURNO	Type	SAE Class	Units
015	FIL	180	G's
Max	Time	Min	Time
6.3	23.7	-5.5	66.5

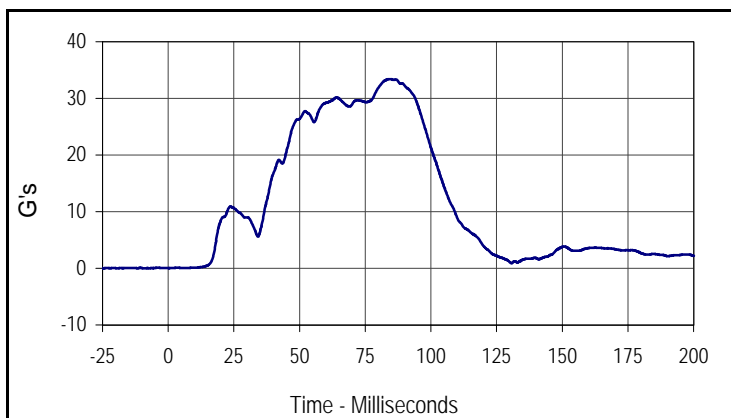

Curve Description			
Driver Chest Resultant Primary			
CURNO	Type	SAE Class	Units
013	RES	180	G's
Max	Time	Min	Time
33.4	84.4	0.0	0.3

Test Vehicle: 2006 Honda Ridgeline RTS 4-Door Truck
 Test Program: 2005 NHTSA 35mph NCAP

Test Date: 4/14/05
 NHTSA No.: H65300

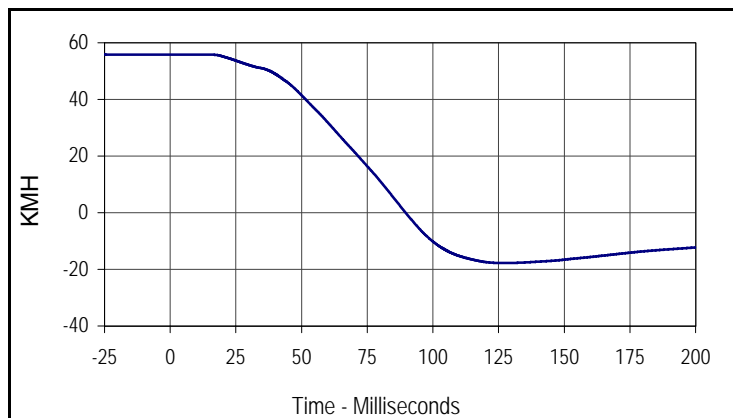

Curve Description			
Driver Chest Primary X Velocity			
CURNO	Type	SAE Class	Units
013	IN1	180	KMH
Max	Time	Min	Time
55.9	3.4	-17.8	126.9

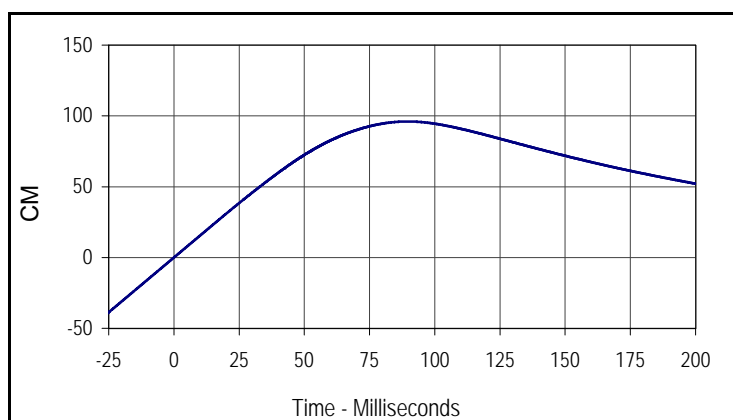

Curve Description			
Driver Chest Primary X Displacement			
CURNO	Type	SAE Class	Units
013	IN2	180	CM
Max	Time	Min	Time
96.1	89.6	0.0	0.0

Test Vehicle: 2006 Honda Ridgeline RTS 4-Door Truck
 Test Program: 2005 NHTSA 35mph NCAP

Test Date: 4/14/05
 NHTSA No.: H65300

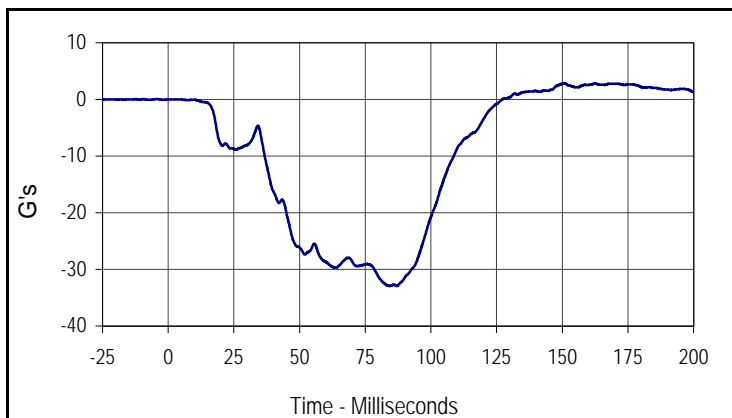

Curve Description			
Driver Chest Redundant X			
CURNO	Type	SAE Class	Units
016	FIL	180	G's
Max	Time	Min	Time
2.9	150.6	-32.9	84.3

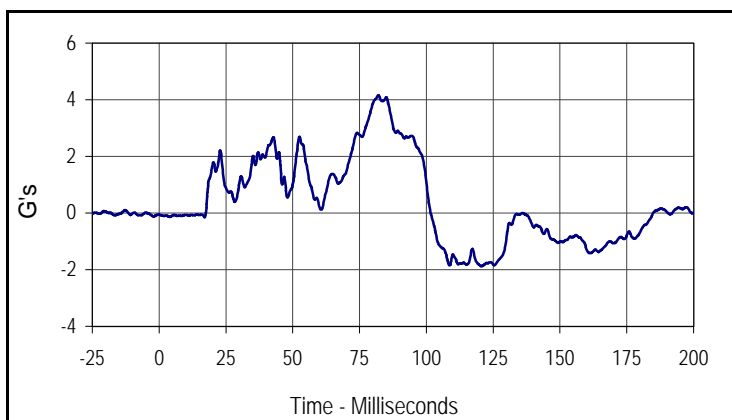

Curve Description			
Driver Chest Redundant Y			
CURNO	Type	SAE Class	Units
017	FIL	180	G's
Max	Time	Min	Time
4.2	82.0	-1.9	120.6

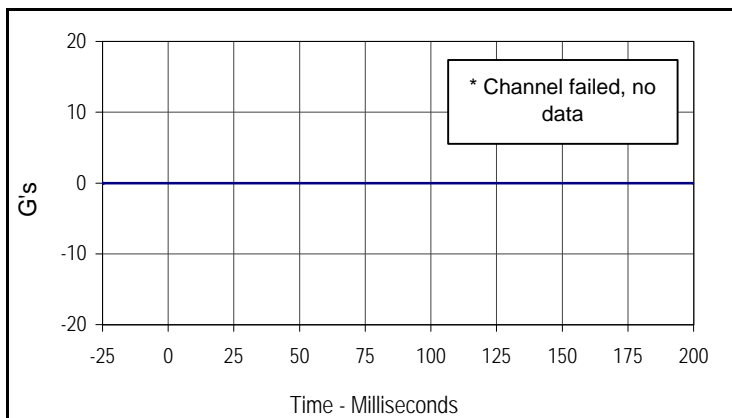

Curve Description			
Driver Chest Redundant Z			
CURNO	Type	SAE Class	Units
018	FIL	180	G's
Max	Time	Min	Time
0.0	0.0	0.0	0.0

* Channel failed, no data

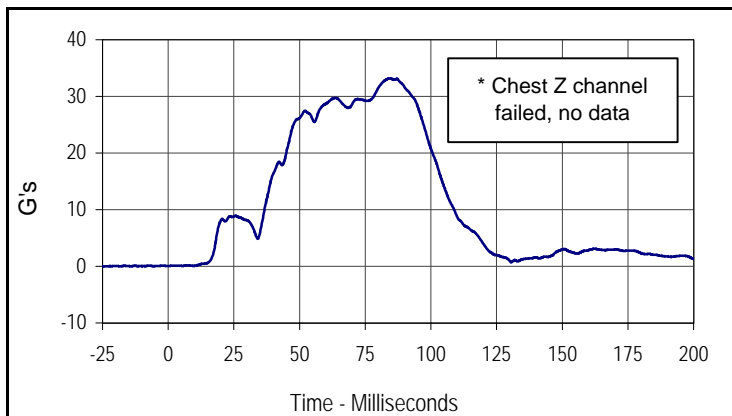

Curve Description			
Driver Chest Resultant Redundant			
CURNO	Type	SAE Class	Units
016	RES	180	G's
Max	Time	Min	Time
33.2	84.3	0.1	0.0

* Chest Z channel failed, no data

Test Vehicle: 2006 Honda Ridgeline RTS 4-Door Truck
 Test Program: 2005 NHTSA 35mph NCAP

Test Date: 4/14/05
 NHTSA No.: H65300

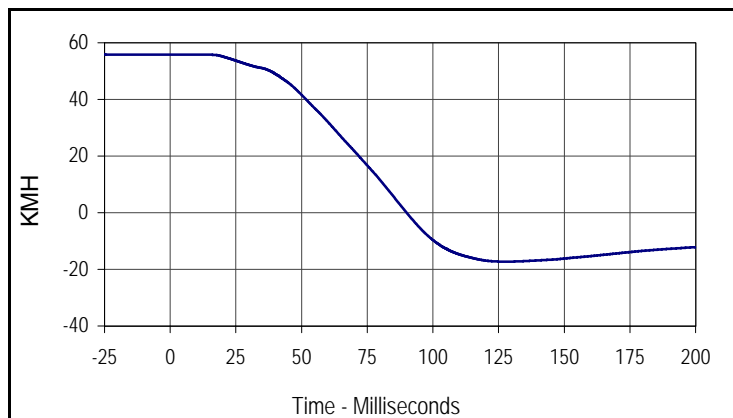

Curve Description			
Driver Chest Redundant X Velocity			
CURNO	Type	SAE Class	Units
016	IN1	180	KMH
Max	Time	Min	Time
55.9	0.0	-17.3	127.2

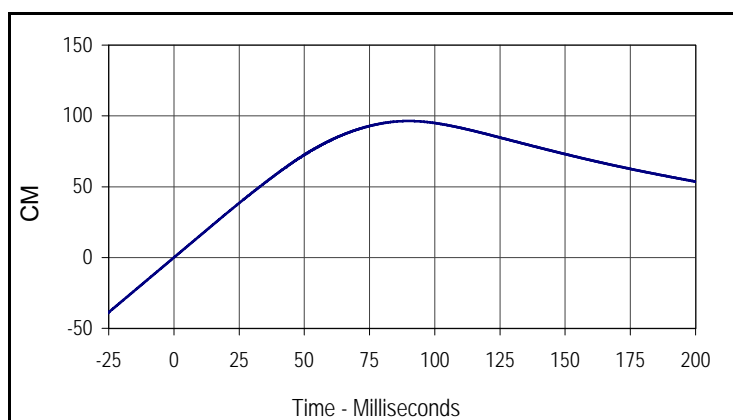

Curve Description			
Driver Chest Redundant X Displacement			
CURNO	Type	SAE Class	Units
016	IN2	180	CM
Max	Time	Min	Time
96.4	90.0	0.0	0.0

Test Vehicle: 2006 Honda Ridgeline RTS 4-Door Truck
 Test Program: 2005 NHTSA 35mph NCAP

Test Date: 4/14/05
 NHTSA No.: H65300

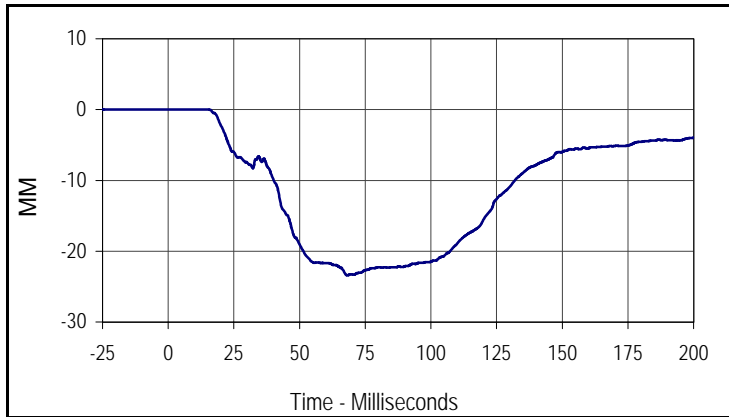

Curve Description			
Driver Chest Deflection			
CURNO	Type	SAE Class	Units
019	FIL	600	MM
Max	Time	Min	Time
0.0	7.0	-23.4	68.2

Test Vehicle: 2006 Honda Ridgeline RTS 4-Door Truck
 Test Program: 2005 NHTSA 35mph NCAP

Test Date: 4/14/05
 NHTSA No.: H65300

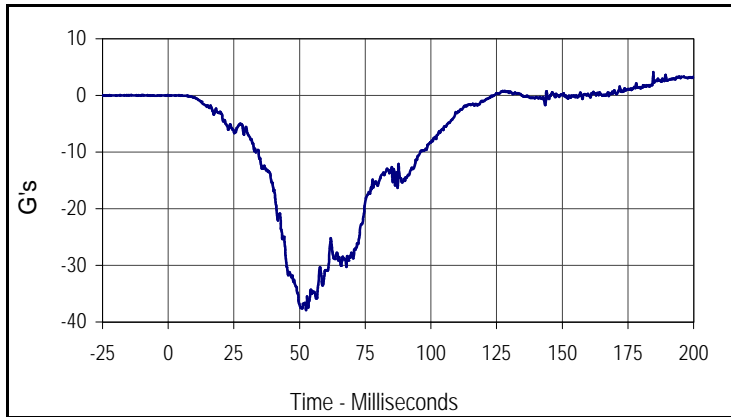

Curve Description			
Driver Pelvis X			
CURNO	Type	SAE Class	Units
020	FIL	1000	G's
Max	Time	Min	Time
4.1	184.7	-37.9	52.5

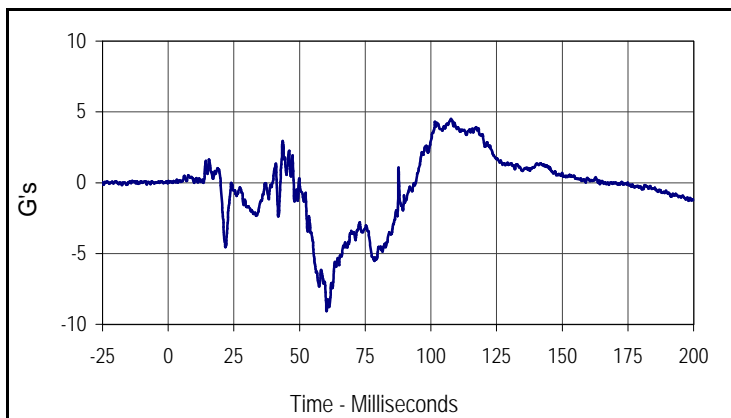

Curve Description			
Driver Pelvis Y			
CURNO	Type	SAE Class	Units
021	FIL	1000	G's
Max	Time	Min	Time
4.5	107.7	-9.1	60.3

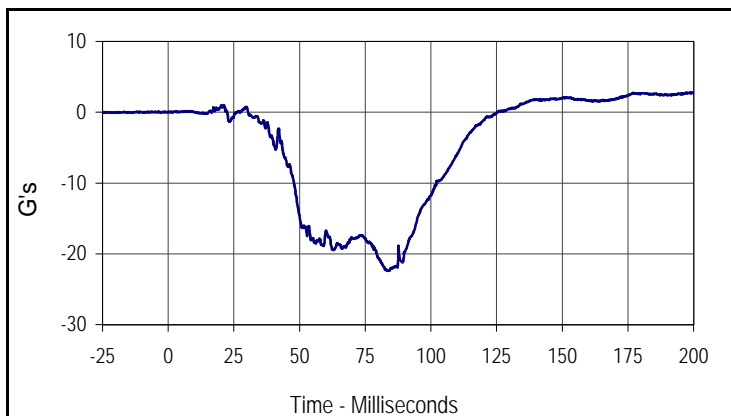

Curve Description			
Driver Pelvis Z			
CURNO	Type	SAE Class	Units
022	FIL	1000	G's
Max	Time	Min	Time
2.8	199.3	-22.4	83.9

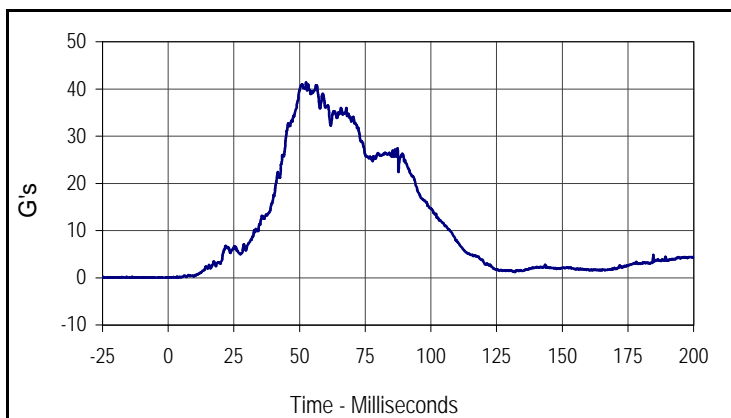

Curve Description			
Driver Pelvis Resultant			
CURNO	Type	SAE Class	Units
020	RES	1000	G's
Max	Time	Min	Time
41.4	52.5	0.0	3.7

Test Vehicle: 2006 Honda Ridgeline RTS 4-Door Truck
 Test Program: 2005 NHTSA 35mph NCAP

Test Date: 4/14/05
 NHTSA No.: H65300

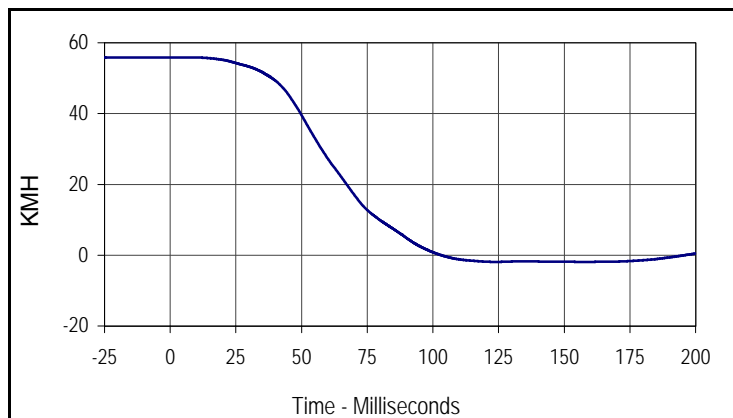

Curve Description			
Driver Pelvis X Velocity			
CURNO	Type	SAE Class	Units
020	IN1	180	KMH
Max	Time	Min	Time
55.9	0.0	-1.9	123.9

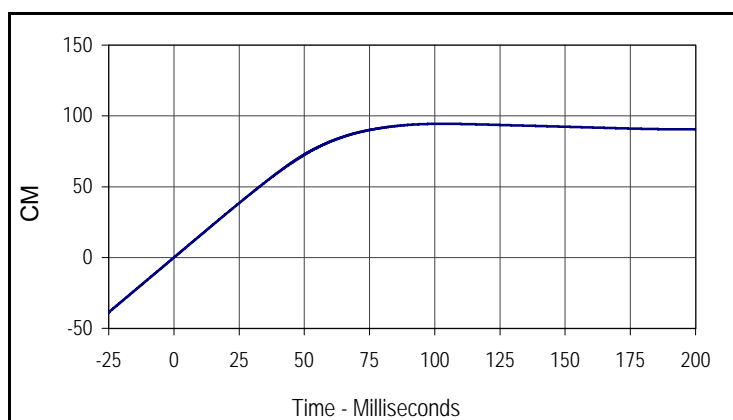

Curve Description			
Driver Pelvis X Displacement			
CURNO	Type	SAE Class	Units
020	IN2	180	CM
Max	Time	Min	Time
94.4	103.1	0.0	0.0

Test Vehicle: 2006 Honda Ridgeline RTS 4-Door Truck
 Test Program: 2005 NHTSA 35mph NCAP

Test Date: 4/14/05
 NHTSA No.: H65300

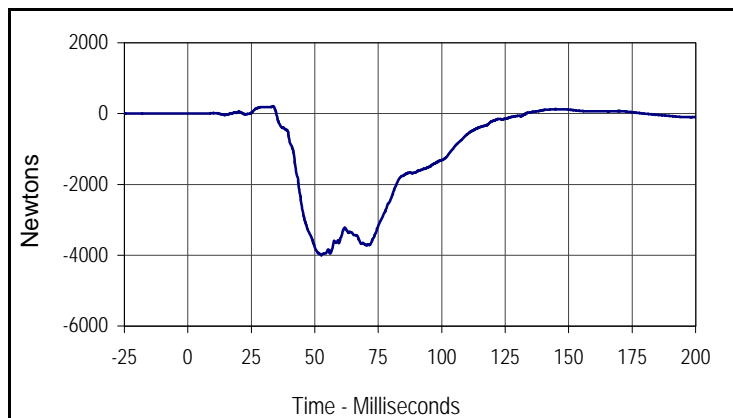

Curve Description			
Driver Left Femur Force			
CURNO	Type	SAE Class	Units
023	FIL	600	Newtons
Max	Time	Min	Time
207.8	33.7	-3997.9	52.6

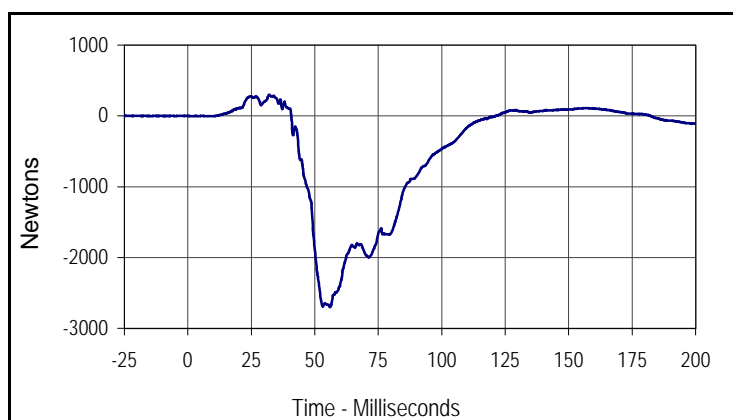

Curve Description			
Driver Right Femur Force			
CURNO	Type	SAE Class	Units
024	FIL	600	Newtons
Max	Time	Min	Time
299.4	32.0	-2701.4	56.0

Test Vehicle: 2006 Honda Ridgeline RTS 4-Door Truck
 Test Program: 2005 NHTSA 35mph NCAP

Test Date: 4/14/05
 NHTSA No.: H65300

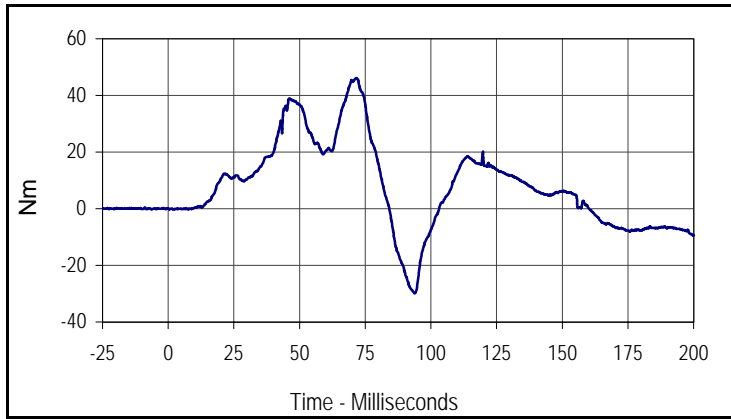

Curve Description			
Driver Left Upper Tibia Moment X			
CURNO	Type	SAE Class	Units
025	FIL	600	Nm
Max	Time	Min	Time
46.1	71.6	-29.8	93.9

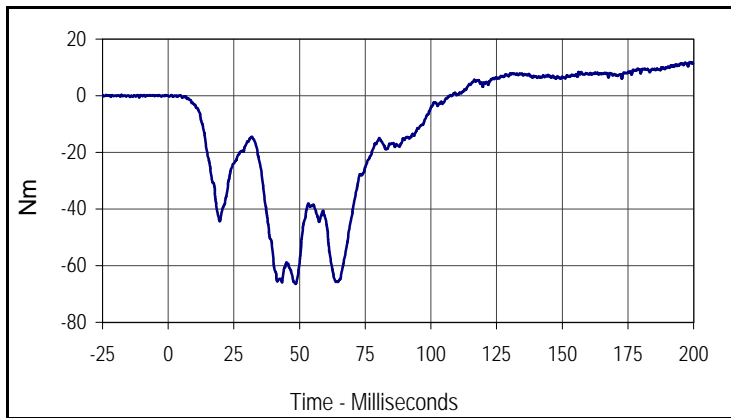

Curve Description			
Driver Left Upper Tibia Moment Y			
CURNO	Type	SAE Class	Units
026	FIL	600	Nm
Max	Time	Min	Time
11.9	198.6	-66.5	48.5

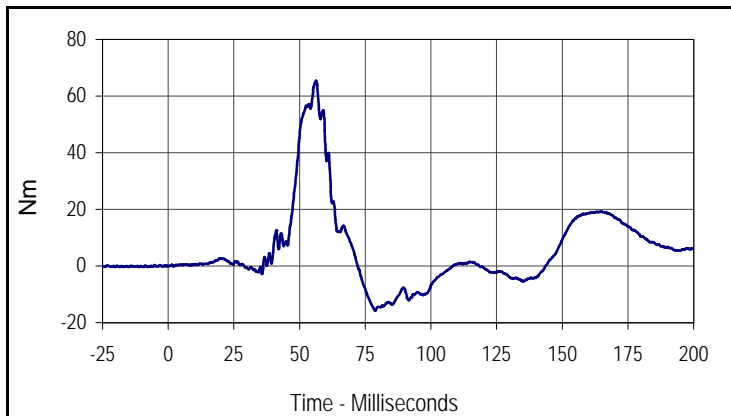

Curve Description			
Driver Right Upper Tibia Moment X			
CURNO	Type	SAE Class	Units
027	FIL	600	Nm
Max	Time	Min	Time
65.4	56.3	-15.8	78.8

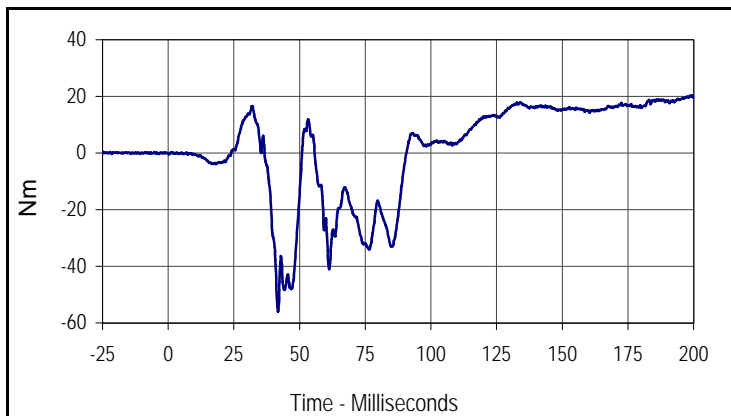

Curve Description			
Driver Right Upper Tibia Moment Y			
CURNO	Type	SAE Class	Units
028	FIL	600	Nm
Max	Time	Min	Time
20.2	199.4	-56.0	41.8

Test Vehicle: 2006 Honda Ridgeline RTS 4-Door Truck
 Test Program: 2005 NHTSA 35mph NCAP

Test Date: 4/14/05
 NHTSA No.: H65300

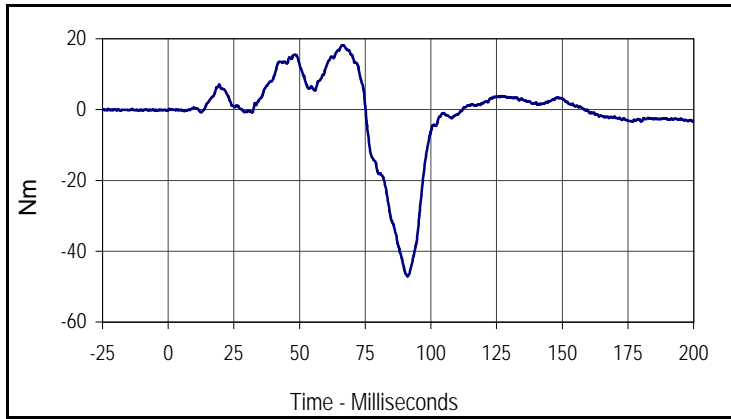

Curve Description			
Driver Left Lower Tibia Moment X			
CURNO	Type	SAE Class	Units
029	FIL	600	Nm
Max	Time	Min	Time
18.2	66.5	-47.1	91.1

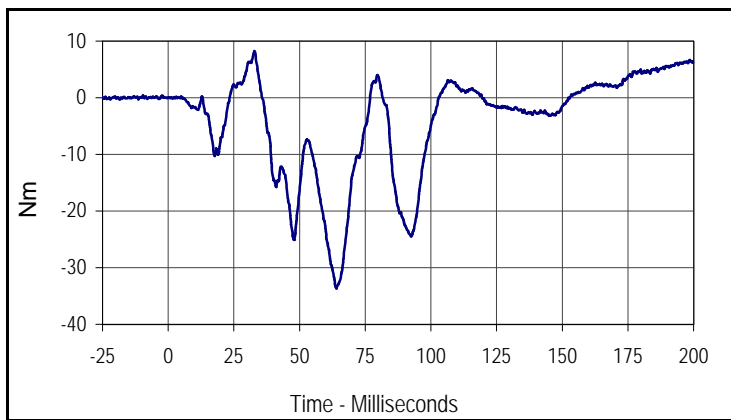

Curve Description			
Driver Left Lower Tibia Moment Y			
CURNO	Type	SAE Class	Units
030	FIL	600	Nm
Max	Time	Min	Time
8.2	32.8	-33.6	64.0

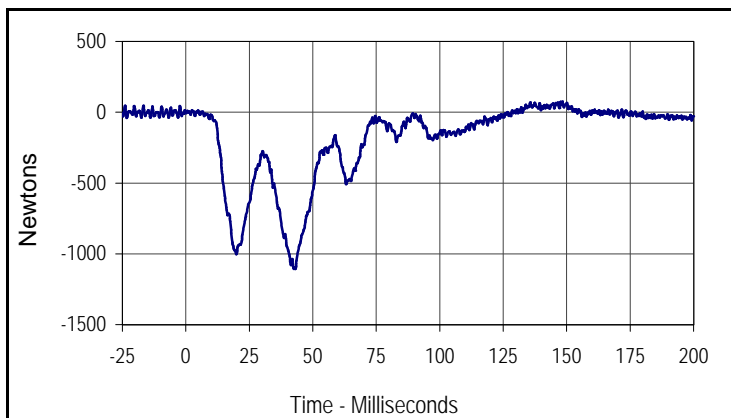

Curve Description			
Driver Left Lower Tibia Force Z			
CURNO	Type	SAE Class	Units
031	FIL	600	Newtons
Max	Time	Min	Time
74.9	148.4	-1106.1	42.5

Test Vehicle: 2006 Honda Ridgeline RTS 4-Door Truck
 Test Program: 2005 NHTSA 35mph NCAP

Test Date: 4/14/05
 NHTSA No.: H65300

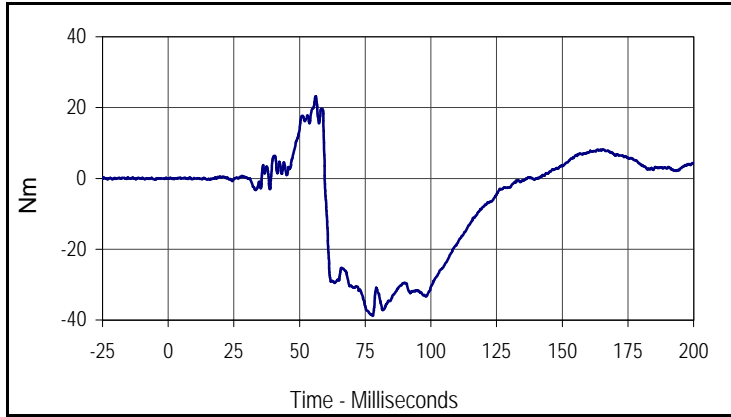

Curve Description			
Driver Right Lower Tibia Moment X			
CURNO	Type	SAE Class	Units
032	FIL	600	Nm
Max	Time	Min	Time
23.2	56.1	-38.9	77.8

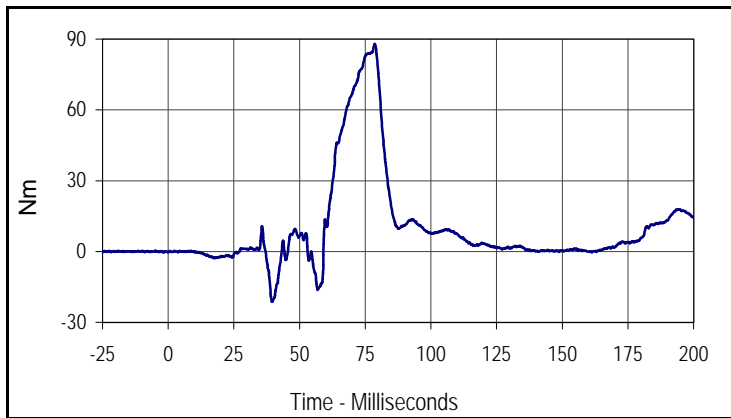

Curve Description			
Driver Right Lower Tibia Moment Y			
CURNO	Type	SAE Class	Units
033	FIL	600	Nm
Max	Time	Min	Time
88.0	78.6	-21.3	39.5

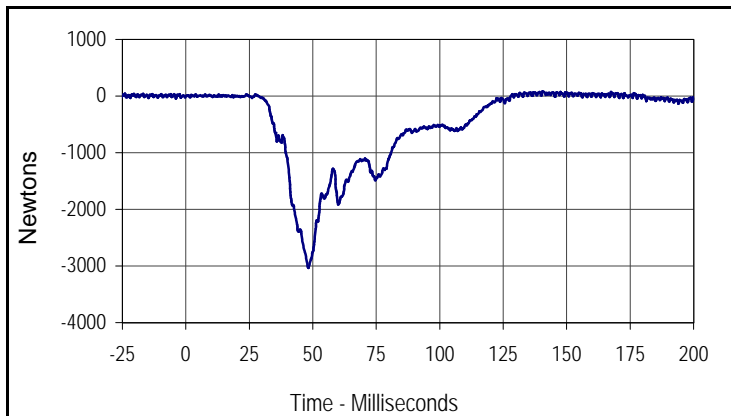

Curve Description			
Driver Right Lower Tibia Force Z			
CURNO	Type	SAE Class	Units
034	FIL	600	Newtons
Max	Time	Min	Time
83.7	140.5	-3031.5	48.2

Test Vehicle: 2006 Honda Ridgeline RTS 4-Door Truck
 Test Program: 2005 NHTSA 35mph NCAP

Test Date: 4/14/05
 NHTSA No.: H65300

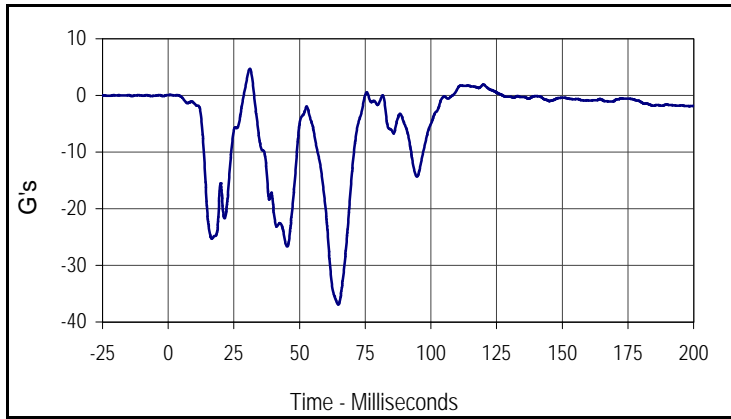

Curve Description			
Driver Left Foot Aft X			
CURNO	Type	SAE Class	Units
035	FIL	180	G's
Max	Time	Min	Time
4.7	31.1	-36.9	64.8

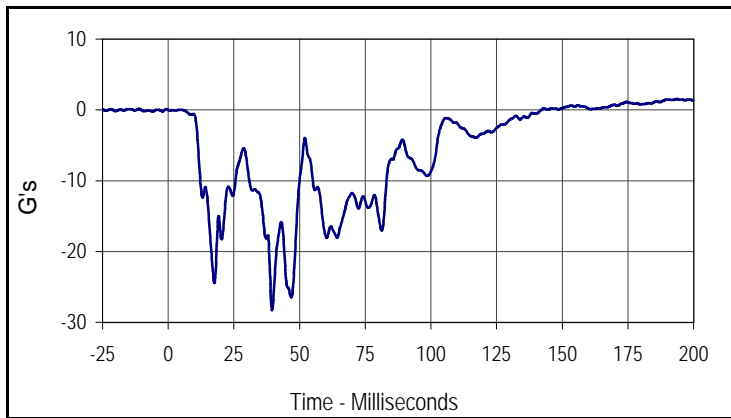

Curve Description			
Driver Left Foot Aft Z			
CURNO	Type	SAE Class	Units
036	FIL	180	G's
Max	Time	Min	Time
1.5	193.6	-28.3	39.5

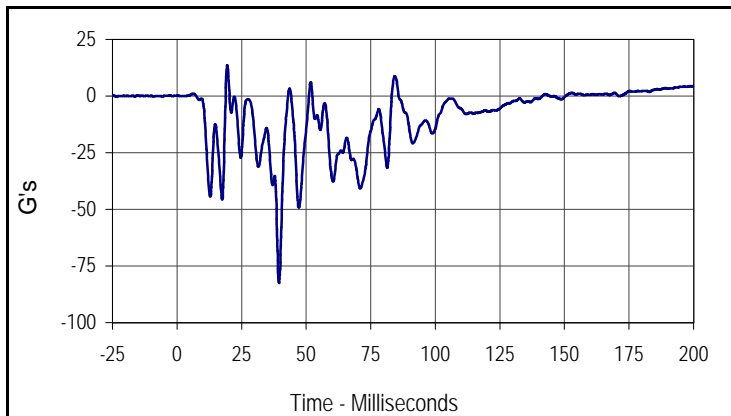

Curve Description			
Driver Left Foot Fore Z			
CURNO	Type	SAE Class	Units
037	FIL	180	G's
Max	Time	Min	Time
13.5	19.4	-82.5	39.5

Test Vehicle: 2006 Honda Ridgeline RTS 4-Door Truck
 Test Program: 2005 NHTSA 35mph NCAP

Test Date: 4/14/05
 NHTSA No.: H65300

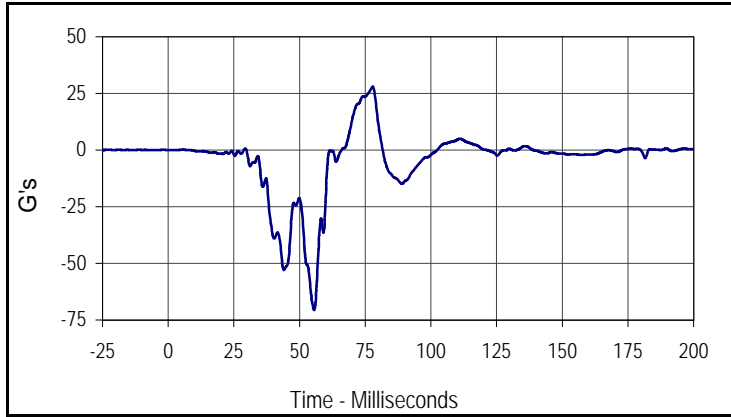

Curve Description			
Driver Right Foot Aft X			
CURNO	Type	SAE Class	Units
038	FIL	180	G's
Max	Time	Min	Time
27.9	77.9	-70.7	55.6

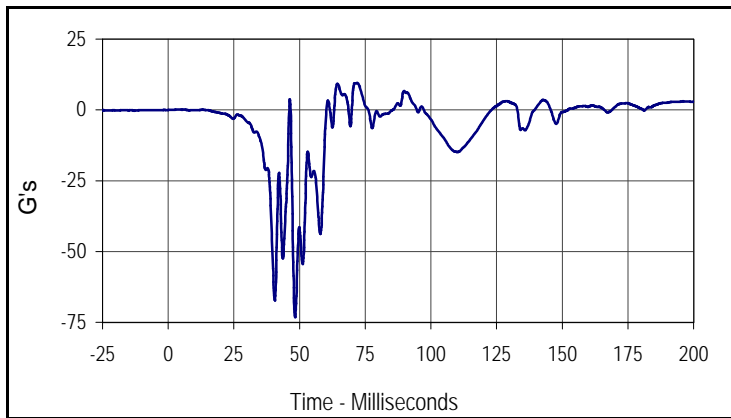

Curve Description			
Driver Right Foot Aft Z			
CURNO	Type	SAE Class	Units
039	FIL	180	G's
Max	Time	Min	Time
9.5	72.0	-73.2	48.3

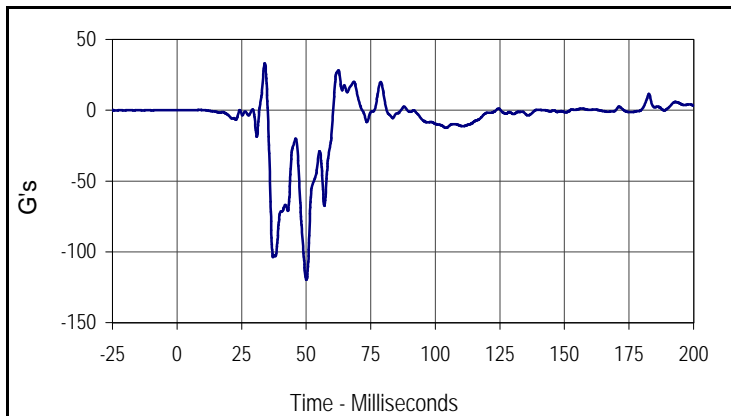

Curve Description			
Driver Right Foot Fore Z			
CURNO	Type	SAE Class	Units
040	FIL	180	G's
Max	Time	Min	Time
33.1	34.0	-119.8	50.1

Test Vehicle: 2006 Honda Ridgeline RTS 4-Door Truck
 Test Program: 2005 NHTSA 35mph NCAP

Test Date: 4/14/05
 NHTSA No.: H65300

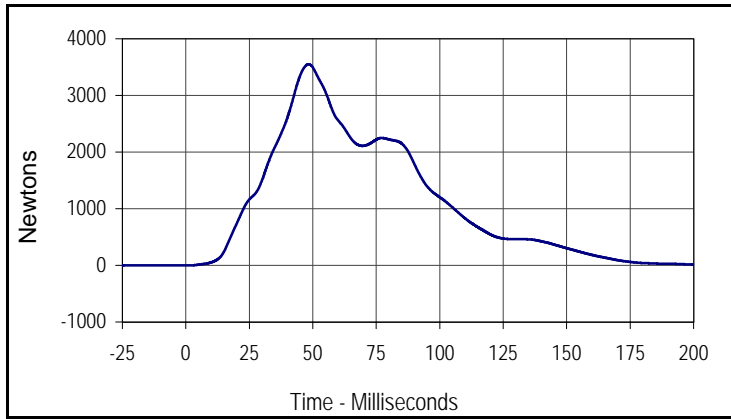

Curve Description			
Driver Lap Belt Force			
CURNO	Type	SAE Class	Units
041	FIL	60	Newtons
Max	Time	Min	Time
3550.1	48.4	-1.7	0.2

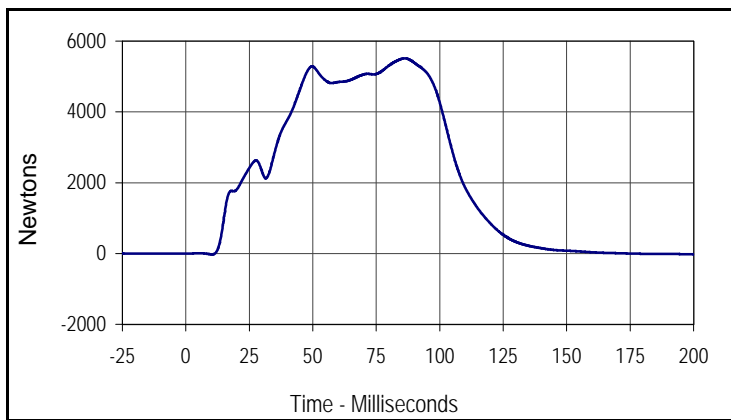

Curve Description			
Driver Shoulder Belt Force			
CURNO	Type	SAE Class	Units
042	FIL	60	Newtons
Max	Time	Min	Time
5511.9	86.2	-26.5	10.3

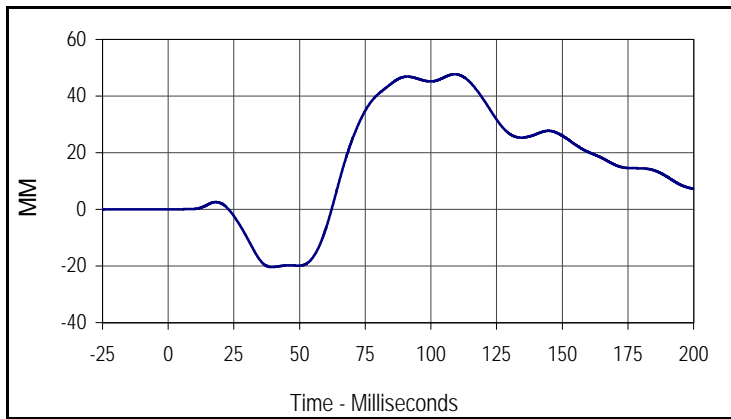

Curve Description			
Driver Shoulder Belt Pullout			
CURNO	Type	SAE Class	Units
043	FIL	60	MM
Max	Time	Min	Time
47.7	109.5	-20.4	39.9

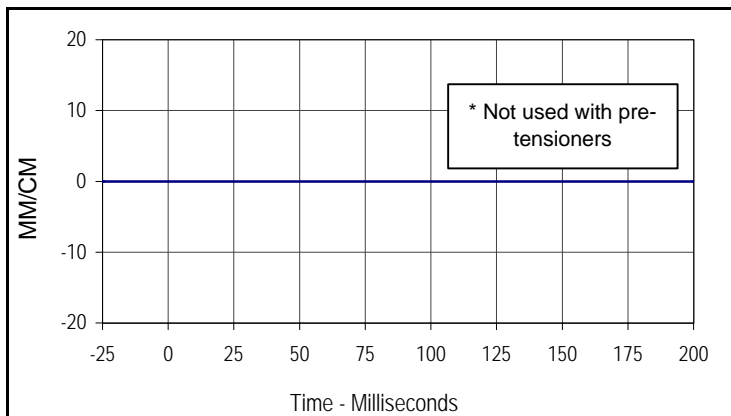

Curve Description			
Driver Shoulder Belt Elongation			
CURNO	Type	SAE Class	Units
044	FIL	60	MM/CM
Max	Time	Min	Time
0.0	0.0	0.0	0.0

* Not used with pre-tensioners

Test Vehicle: 2006 Honda Ridgeline RTS 4-Door Truck
 Test Program: 2005 NHTSA 35mph NCAP

Test Date: 4/14/05
 NHTSA No.: H65300

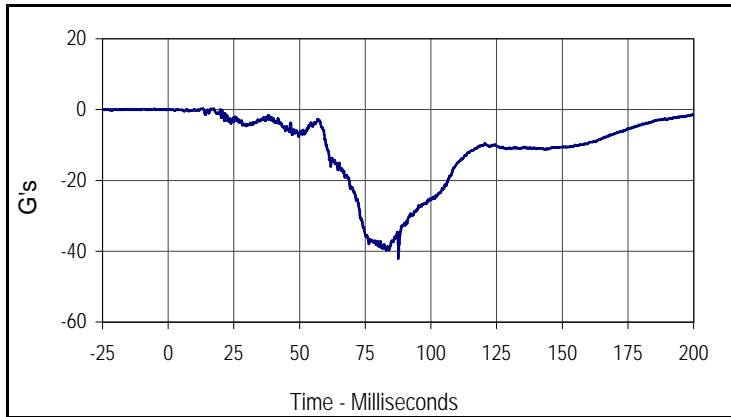

Curve Description			
Passenger Head Primary X			
CURNO	Type	SAE Class	Units
045	FIL	1000	G's
Max	Time	Min	Time
0.3	13.3	-42.1	87.6

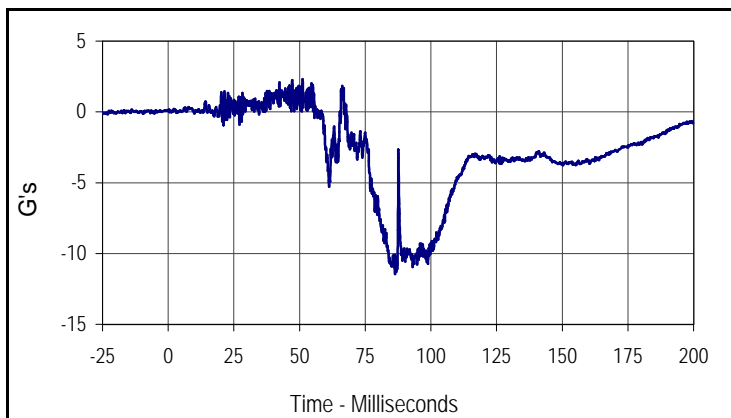

Curve Description			
Passenger Head Primary Y			
CURNO	Type	SAE Class	Units
046	FIL	1000	G's
Max	Time	Min	Time
2.3	51.1	-11.5	86.3

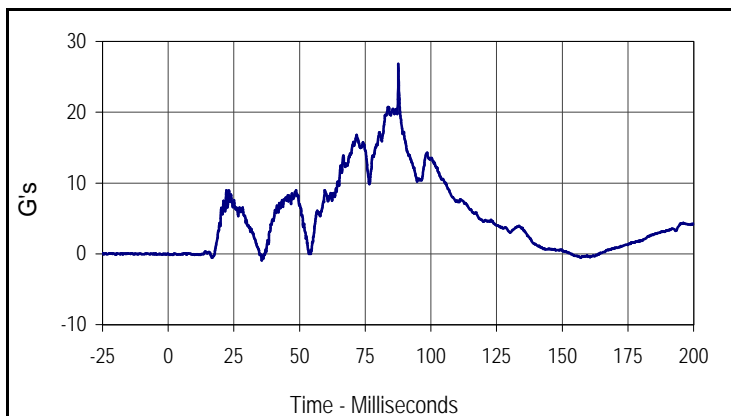

Curve Description			
Passenger Head Primary Z			
CURNO	Type	SAE Class	Units
047	FIL	1000	G's
Max	Time	Min	Time
26.8	87.6	-0.9	35.7

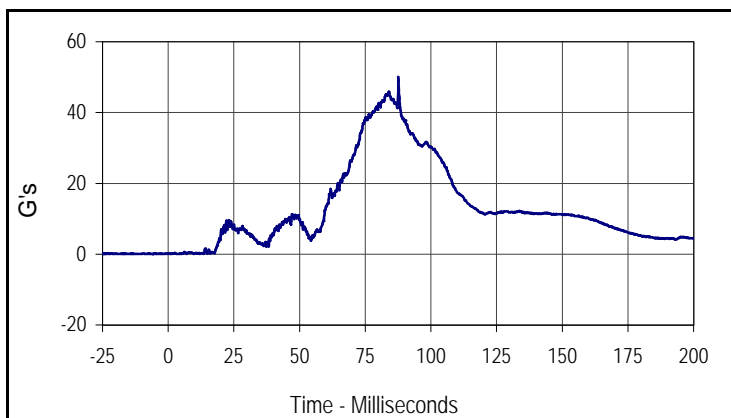

Curve Description			
Passenger Head Resultant Primary			
CURNO	Type	SAE Class	Units
045	RES	1000	G's
Max	Time	Min	Time
50.0	87.6	0.1	4.1

Test Vehicle: 2006 Honda Ridgeline RTS 4-Door Truck
 Test Program: 2005 NHTSA 35mph NCAP

Test Date: 4/14/05
 NHTSA No.: H65300

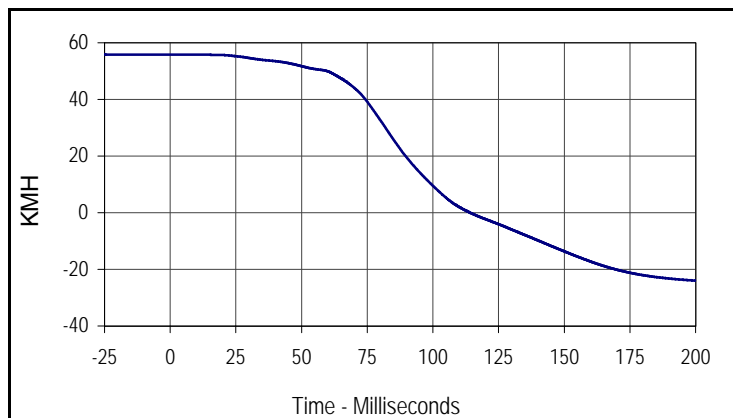

Curve Description			
Passenger Head Primary X Velocity			
CURNO	Type	SAE Class	Units
045	IN1	180	KMH
Max	Time	Min	Time
55.9	0.0	-24.0	200.0

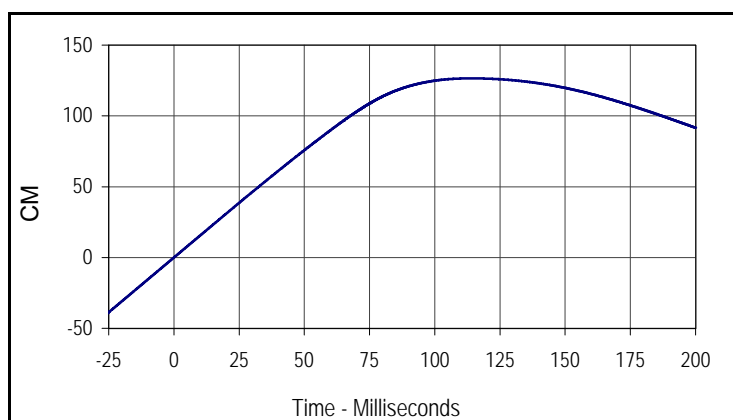

Curve Description			
Passenger Head Primary X Displacement			
CURNO	Type	SAE Class	Units
045	IN2	180	CM
Max	Time	Min	Time
126.5	114.2	0.0	0.0

Test Vehicle: 2006 Honda Ridgeline RTS 4-Door Truck
 Test Program: 2005 NHTSA 35mph NCAP

Test Date: 4/14/05
 NHTSA No.: H65300

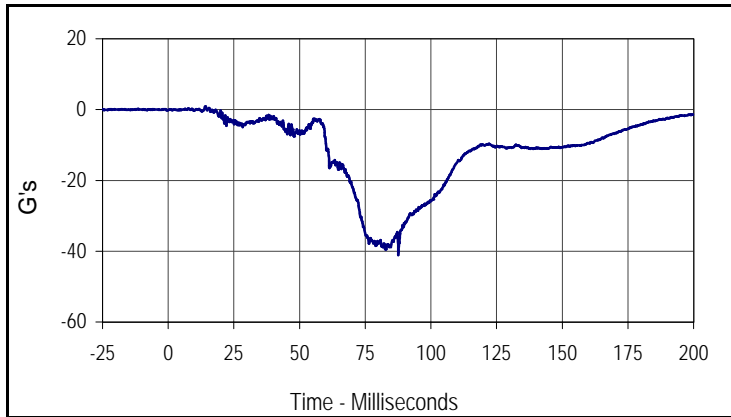

Curve Description			
Passenger Head Redundant X			
CURNO	Type	SAE Class	Units
048	FIL	1000	G's
Max	Time	Min	Time
1.0	14.1	-41.1	87.6

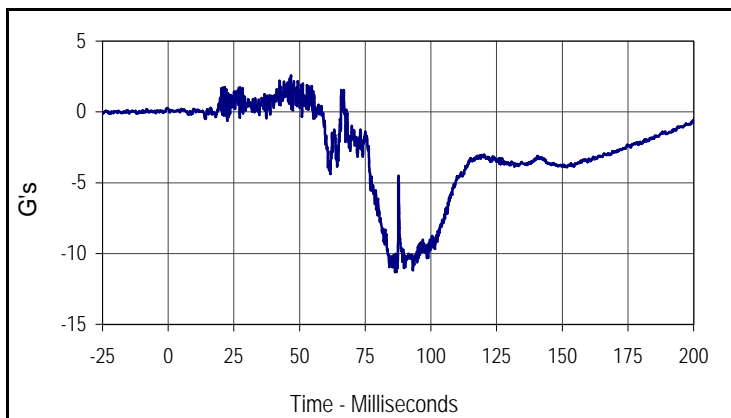

Curve Description			
Passenger Head Redundant Y			
CURNO	Type	SAE Class	Units
049	FIL	1000	G's
Max	Time	Min	Time
2.5	46.7	-11.3	86.4

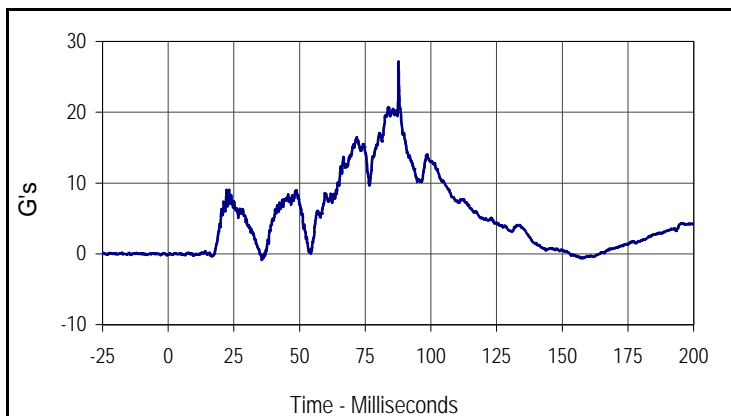

Curve Description			
Passenger Head Redundant Z			
CURNO	Type	SAE Class	Units
050	FIL	1000	G's
Max	Time	Min	Time
27.1	87.7	-0.9	35.7

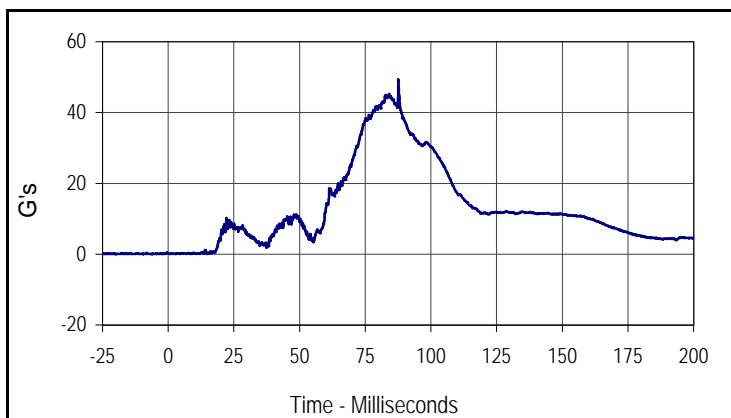

Curve Description			
Passenger Head Resultant Redundant			
CURNO	Type	SAE Class	Units
048	RES	1000	G's
Max	Time	Min	Time
49.2	87.6	0.0	4.4

Test Vehicle: 2006 Honda Ridgeline RTS 4-Door Truck
 Test Program: 2005 NHTSA 35mph NCAP

Test Date: 4/14/05
 NHTSA No.: H65300

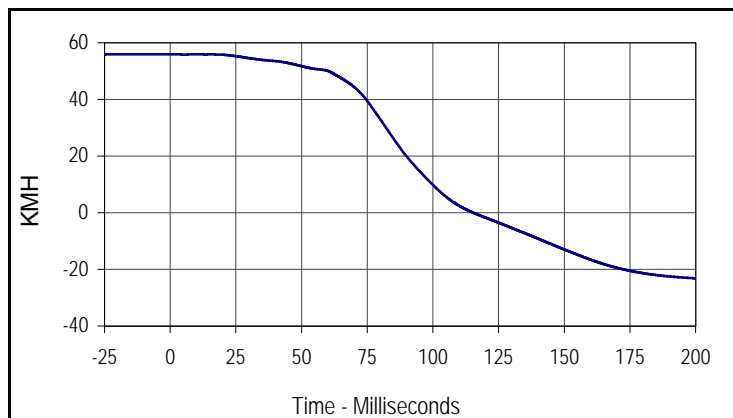

Curve Description			
Passenger Head Redundant X Velocity			
CURNO	Type	SAE Class	Units
048	IN1	180	KMH
Max	Time	Min	Time
55.9	15.7	-23.2	200.0

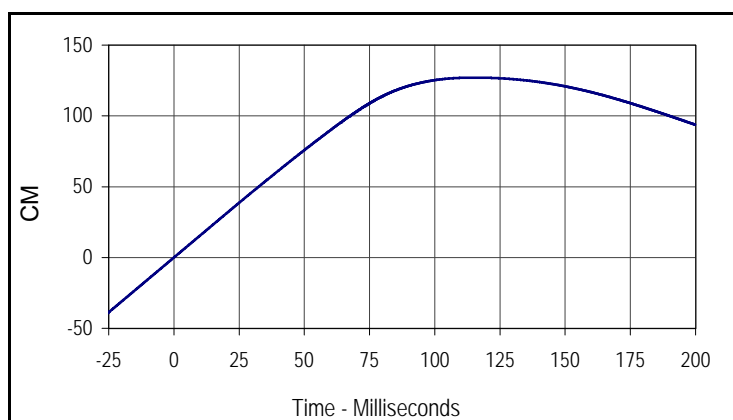

Curve Description			
Passenger Head Redundant X Displacement			
CURNO	Type	SAE Class	Units
048	IN2	180	CM
Max	Time	Min	Time
127.0	115.3	0.0	0.0

Test Vehicle: 2006 Honda Ridgeline RTS 4-Door Truck
 Test Program: 2005 NHTSA 35mph NCAP

Test Date: 4/14/05
 NHTSA No.: H65300

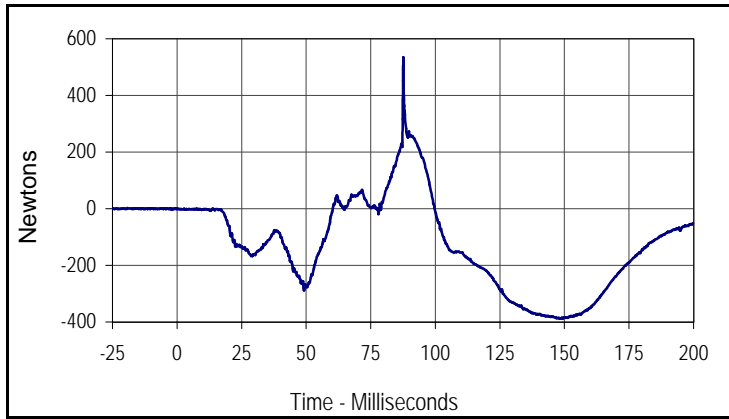

Curve Description			
Passenger Upper Neck Force X			
CURNO	Type	SAE Class	Units
051	FIL	1000	Newtons
Max	Time	Min	Time
533.3	87.6	-389.0	149.4

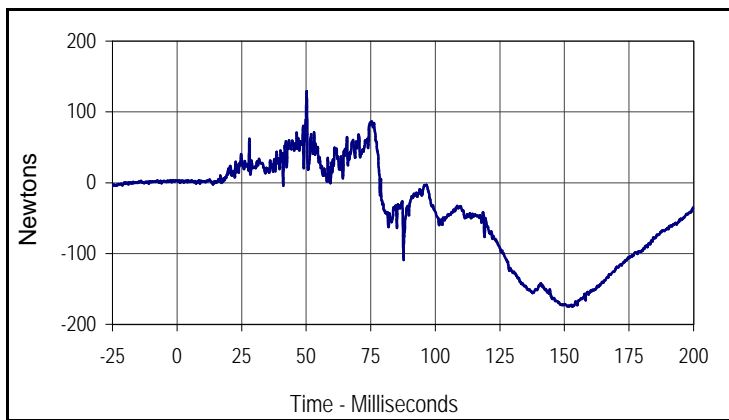

Curve Description			
Passenger Upper Neck Force Y			
CURNO	Type	SAE Class	Units
052	FIL	1000	Newtons
Max	Time	Min	Time
128.4	50.2	-175.1	153.1

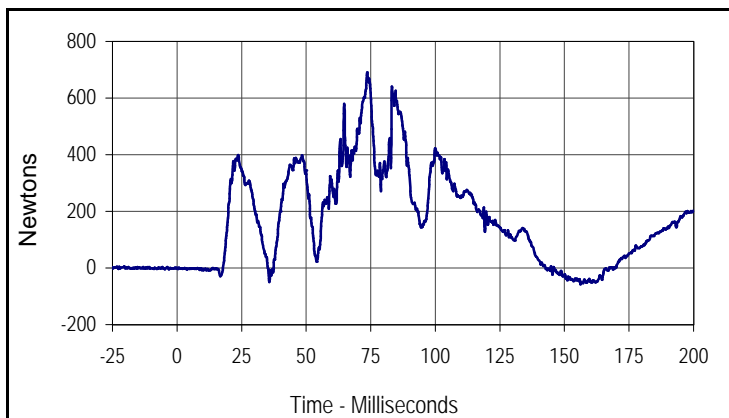

Curve Description			
Passenger Upper Neck Force Z			
CURNO	Type	SAE Class	Units
053	FIL	1000	Newtons
Max	Time	Min	Time
690.5	73.7	-58.0	156.3

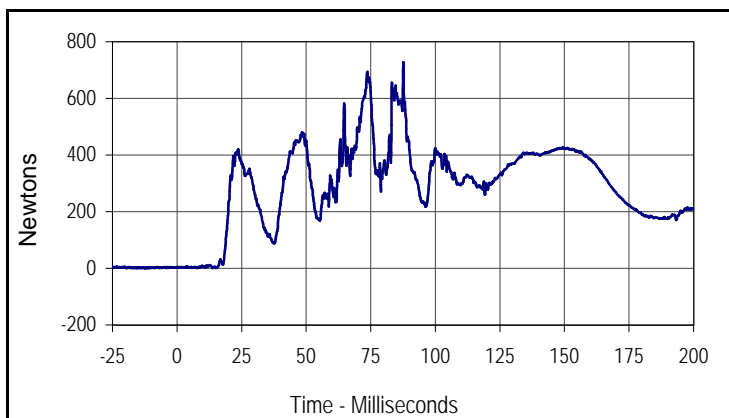

Curve Description			
Passenger Upper Neck Force Res.			
CURNO	Type	SAE Class	Units
051	RES	1000	Newtons
Max	Time	Min	Time
726.6	87.6	0.7	13.7

Test Vehicle: 2006 Honda Ridgeline RTS 4-Door Truck
 Test Program: 2005 NHTSA 35mph NCAP

Test Date: 4/14/05
 NHTSA No.: H65300

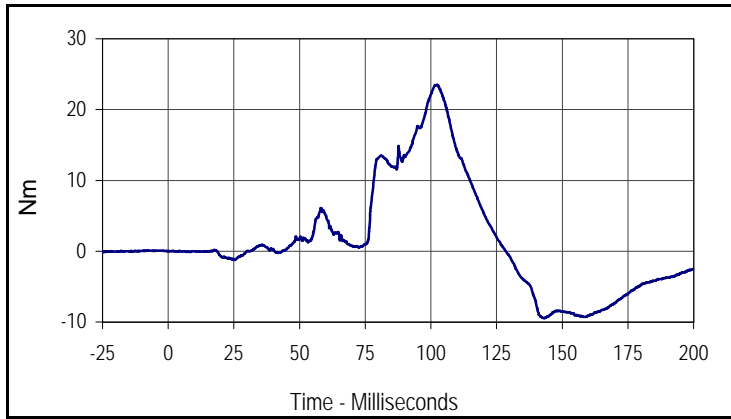

Curve Description			
Passenger Upper Neck Moment X			
CURNO	Type	SAE Class	Units
054	FIL	600	Nm
Max	Time	Min	Time
23.5	102.2	-9.5	142.9

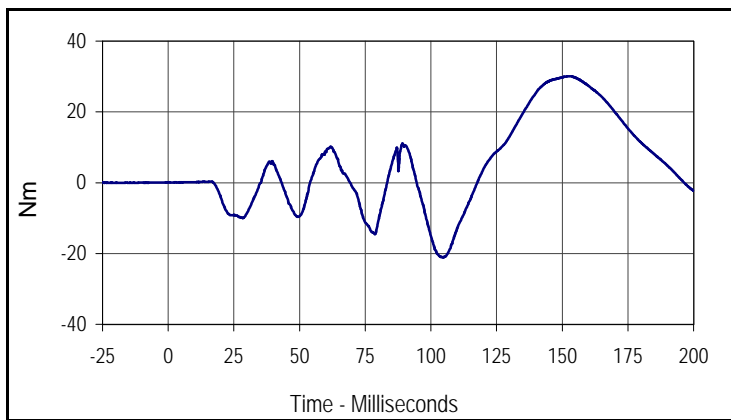

Curve Description			
Passenger Upper Neck Moment Y			
CURNO	Type	SAE Class	Units
055	FIL	600	Nm
Max	Time	Min	Time
30.1	152.5	-21.1	104.6

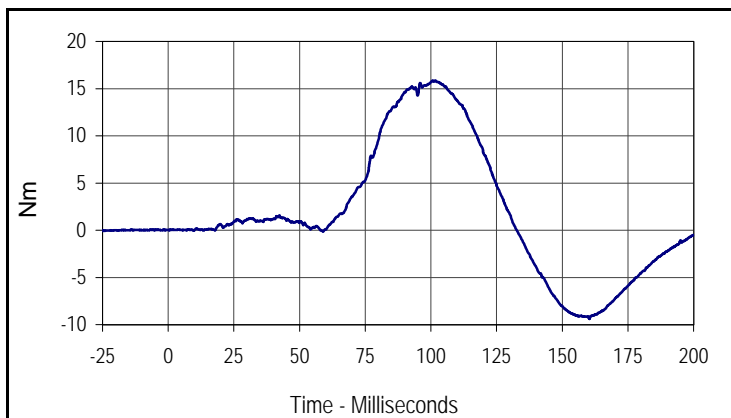

Curve Description			
Passenger Upper Neck Moment Z			
CURNO	Type	SAE Class	Units
056	FIL	600	Nm
Max	Time	Min	Time
15.8	101.7	-9.4	160.3

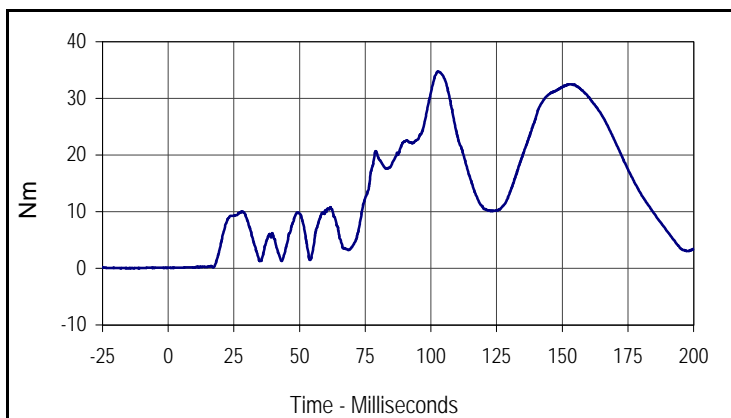

Curve Description			
Passenger Upper Neck Moment Res.			
CURNO	Type	SAE Class	Units
054	RES	600	Nm
Max	Time	Min	Time
34.8	102.8	0.0	1.2

Test Vehicle: 2006 Honda Ridgeline RTS 4-Door Truck
 Test Program: 2005 NHTSA 35mph NCAP

Test Date: 4/14/05
 NHTSA No.: H65300

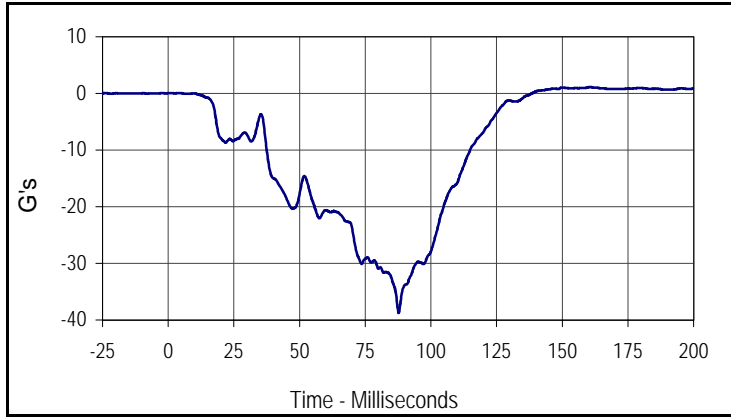

Curve Description			
Passenger Chest Primary X			
CURNO	Type	SAE Class	Units
057	FIL	180	G's
Max	Time	Min	Time
1.1	160.6	-38.7	87.7

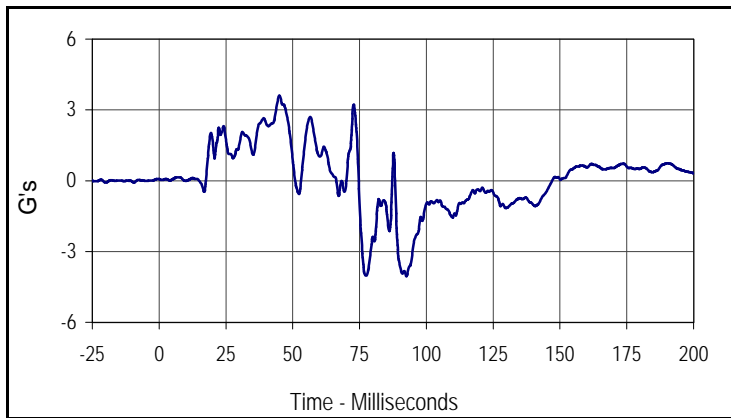

Curve Description			
Passenger Chest Primary Y			
CURNO	Type	SAE Class	Units
058	FIL	180	G's
Max	Time	Min	Time
3.6	45.0	-4.0	92.5

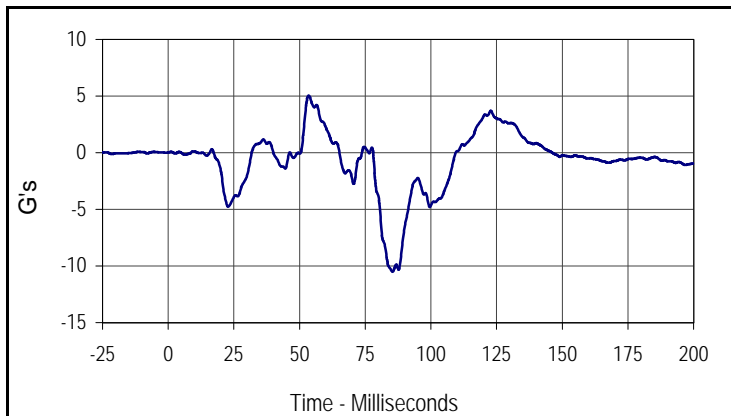

Curve Description			
Passenger Chest Primary Z			
CURNO	Type	SAE Class	Units
059	FIL	180	G's
Max	Time	Min	Time
5.0	53.4	-10.5	85.4

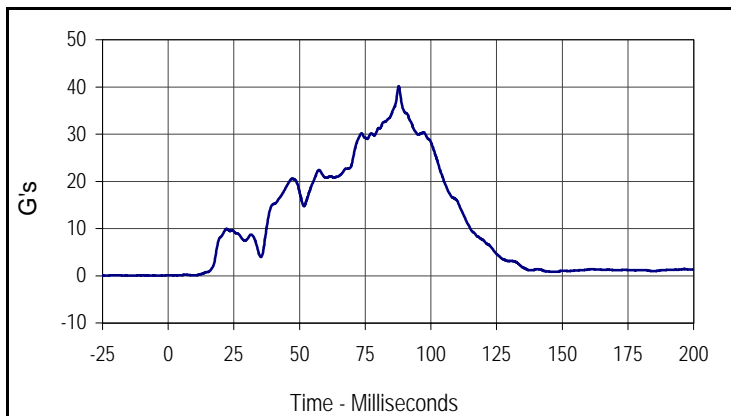

Curve Description			
Passenger Chest Resultant Primary			
CURNO	Type	SAE Class	Units
057	RES	180	G's
Max	Time	Min	Time
40.1	87.7	0.1	3.3

Test Vehicle: 2006 Honda Ridgeline RTS 4-Door Truck
 Test Program: 2005 NHTSA 35mph NCAP

Test Date: 4/14/05
 NHTSA No.: H65300

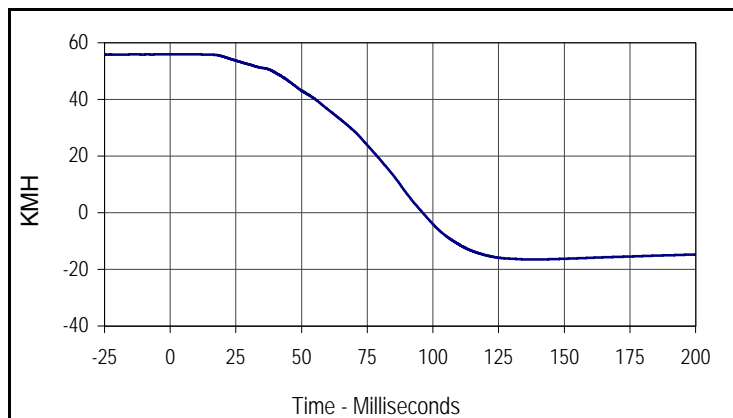

Curve Description			
Passenger Chest Primary X Velocity			
CURNO	Type	SAE Class	Units
057	IN1	180	KMH
Max	Time	Min	Time
55.9	5.5	-16.5	138.3

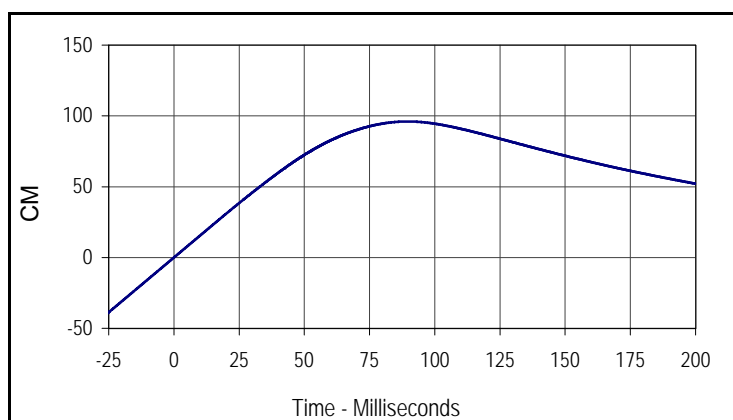

Curve Description			
Passenger Chest Primary X Displacement			
CURNO	Type	SAE Class	Units
057	IN2	180	CM
Max	Time	Min	Time
96.1	89.6	0.0	0.0

Test Vehicle: 2006 Honda Ridgeline RTS 4-Door Truck
 Test Program: 2005 NHTSA 35mph NCAP

Test Date: 4/14/05
 NHTSA No.: H65300

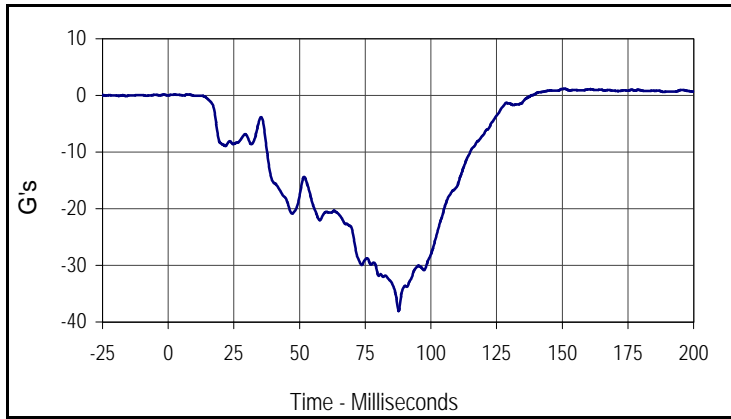

Curve Description			
Passenger Chest Redundant X			
CURNO	Type	SAE Class	Units
060	FIL	180	G's
Max	Time	Min	Time
1.2	150.8	-38.1	87.7

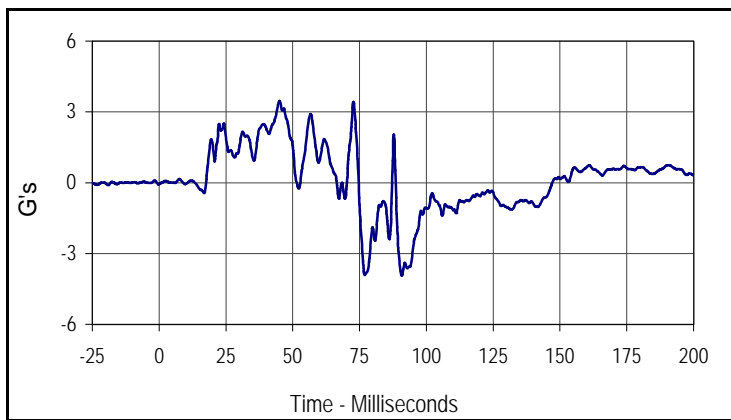

Curve Description			
Passenger Chest Redundant Y			
CURNO	Type	SAE Class	Units
061	FIL	180	G's
Max	Time	Min	Time
3.5	45.0	-3.9	90.8

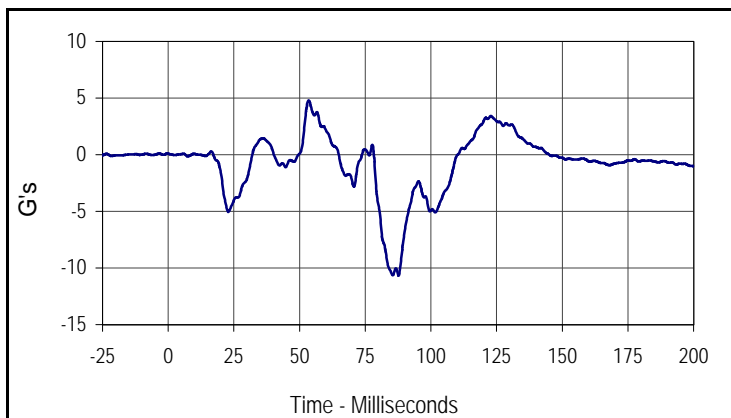

Curve Description			
Passenger Chest Redundant Z			
CURNO	Type	SAE Class	Units
062	FIL	180	G's
Max	Time	Min	Time
4.8	53.5	-10.7	87.7

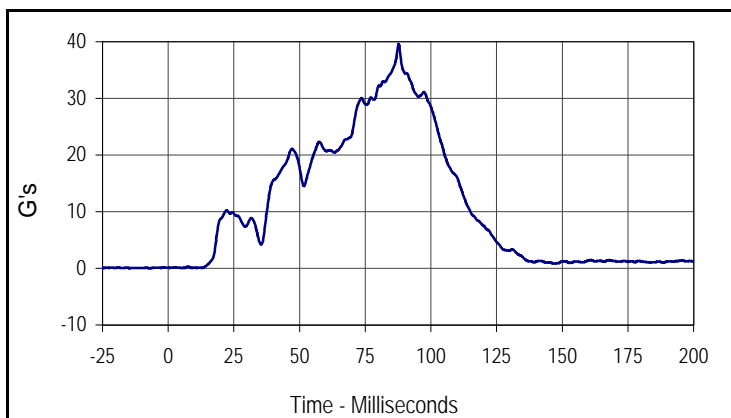

Curve Description			
Passenger Chest Resultant Redundant			
CURNO	Type	SAE Class	Units
060	RES	180	G's
Max	Time	Min	Time
39.6	87.7	0.0	9.1

Test Vehicle: 2006 Honda Ridgeline RTS 4-Door Truck
 Test Program: 2005 NHTSA 35mph NCAP

Test Date: 4/14/05
 NHTSA No.: H65300

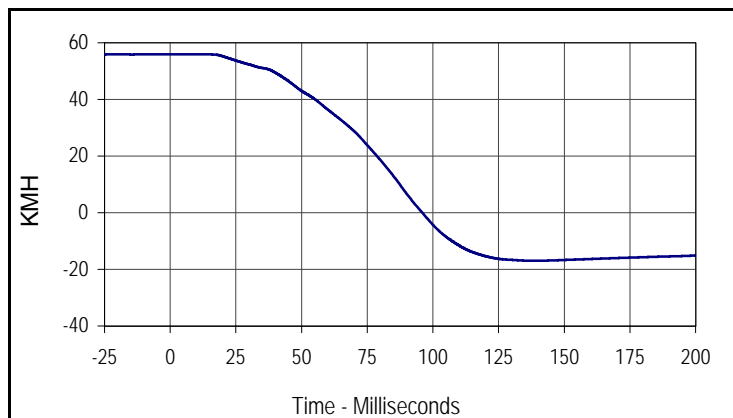

Curve Description			
Passenger Chest Redundant X Velocity			
CURNO	Type	SAE Class	Units
060	IN1	180	KMH
Max	Time	Min	Time
55.9	9.3	-17.0	138.3

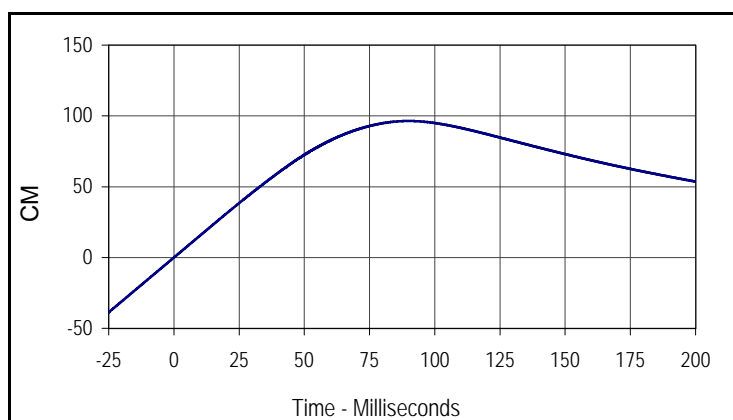

Curve Description			
Passenger Chest Redundant X Displacement			
CURNO	Type	SAE Class	Units
060	IN2	180	CM
Max	Time	Min	Time
96.4	90.0	0.0	0.0

Test Vehicle: 2006 Honda Ridgeline RTS 4-Door Truck
 Test Program: 2005 NHTSA 35mph NCAP

Test Date: 4/14/05
 NHTSA No.: H65300

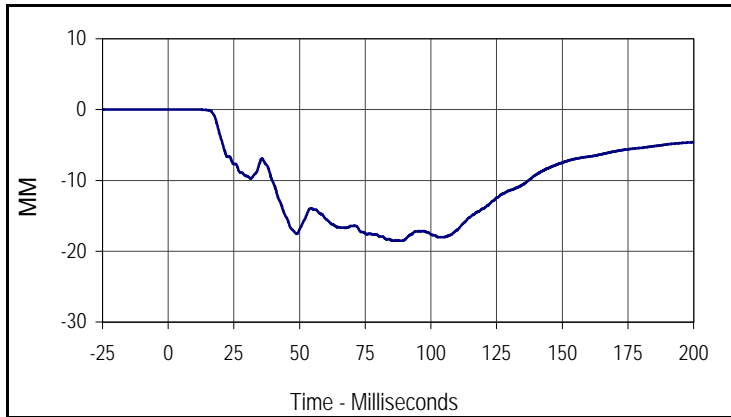

Curve Description			
Passenger Chest Deflection			
CURNO	Type	SAE Class	Units
063	FIL	600	MM
Max	Time	Min	Time
0.0	7.0	-18.5	88.2

Test Vehicle: 2006 Honda Ridgeline RTS 4-Door Truck
 Test Program: 2005 NHTSA 35mph NCAP

Test Date: 4/14/05
 NHTSA No.: H65300

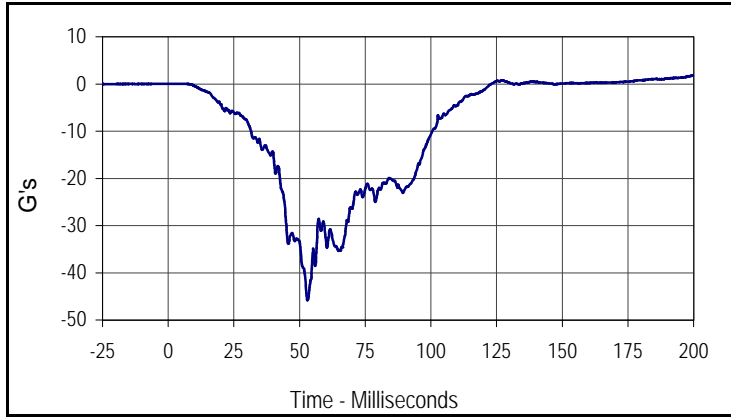

Curve Description			
Passenger Pelvis X			
CURNO	Type	SAE Class	Units
064	FIL	1000	G's
Max	Time	Min	Time
1.8	200.0	-45.8	53.0

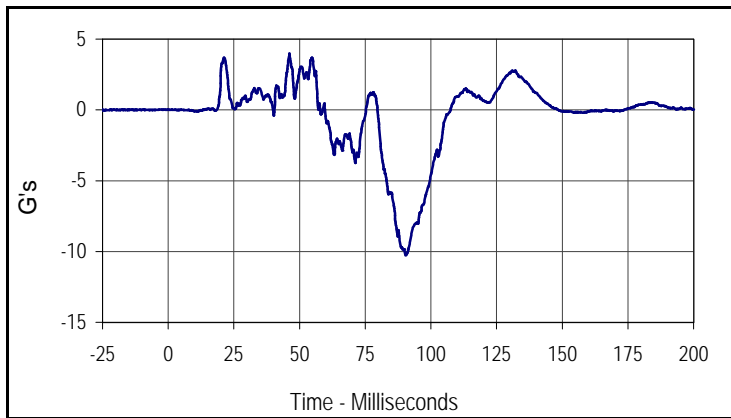

Curve Description			
Passenger Pelvis Y			
CURNO	Type	SAE Class	Units
065	FIL	1000	G's
Max	Time	Min	Time
4.0	46.2	-10.3	90.5

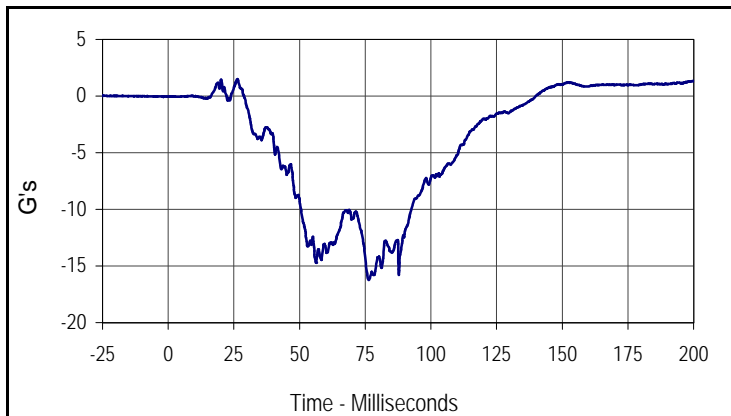

Curve Description			
Passenger Pelvis Z			
CURNO	Type	SAE Class	Units
066	FIL	1000	G's
Max	Time	Min	Time
1.5	26.4	-16.2	76.3

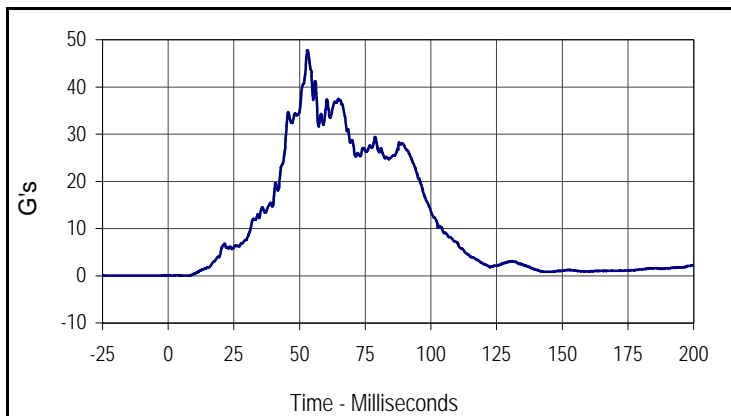

Curve Description			
Passenger Pelvis Resultant			
CURNO	Type	SAE Class	Units
064	RES	1000	G's
Max	Time	Min	Time
47.8	53.0	0.0	7.7

Test Vehicle: 2006 Honda Ridgeline RTS 4-Door Truck
 Test Program: 2005 NHTSA 35mph NCAP

Test Date: 4/14/05
 NHTSA No.: H65300

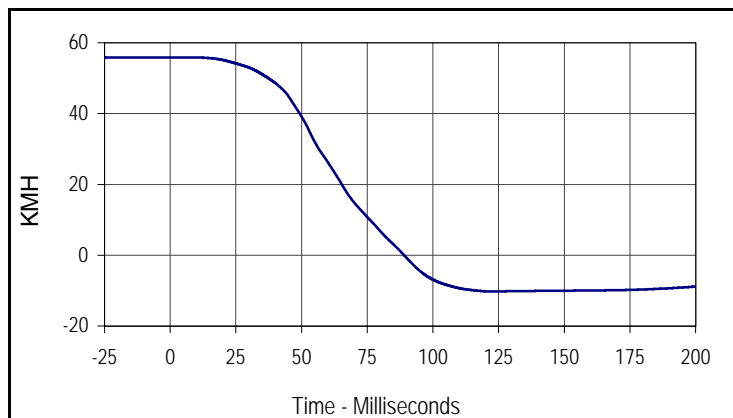

Curve Description			
Passenger Pelvis X Velocity			
CURNO	Type	SAE Class	Units
064	IN1	180	KMH
Max	Time	Min	Time
55.9	7.5	-10.3	122.9

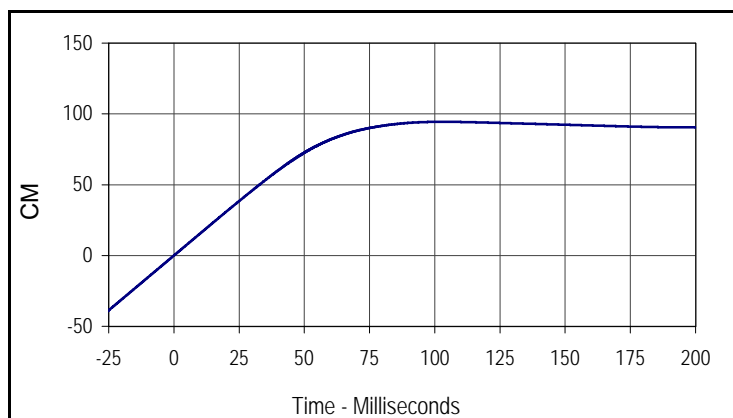

Curve Description			
Passenger Pelvis X Displacement			
CURNO	Type	SAE Class	Units
064	IN2	180	CM
Max	Time	Min	Time
94.4	103.1	0.0	0.0

Test Vehicle: 2006 Honda Ridgeline RTS 4-Door Truck
 Test Program: 2005 NHTSA 35mph NCAP

Test Date: 4/14/05
 NHTSA No.: H65300

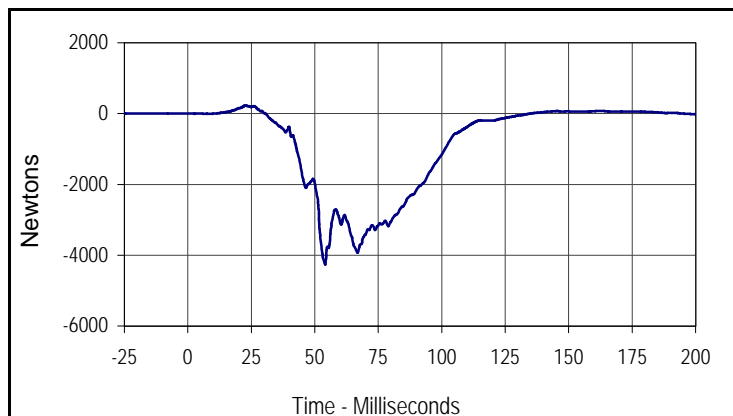

Curve Description			
Passenger Left Femur Force			
CURNO	Type	SAE Class	Units
067	FIL	600	Newtons
Max	Time	Min	Time
231.5	22.6	-4264.8	54.1

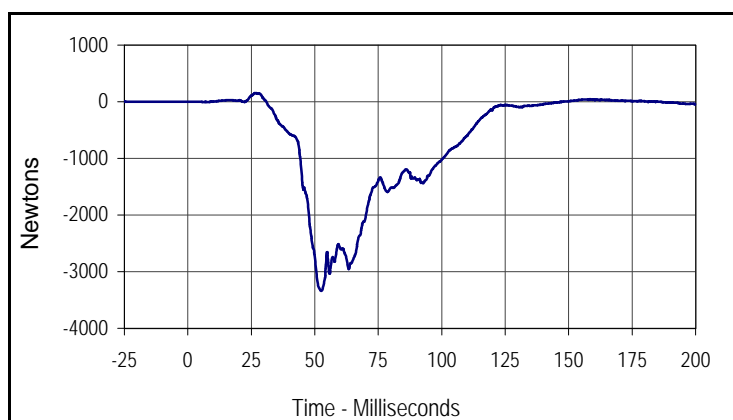

Curve Description			
Passenger Right Femur Force			
CURNO	Type	SAE Class	Units
068	FIL	600	Newtons
Max	Time	Min	Time
153.3	26.7	-3338.8	52.5

Test Vehicle: 2006 Honda Ridgeline RTS 4-Door Truck
 Test Program: 2005 NHTSA 35mph NCAP

Test Date: 4/14/05
 NHTSA No.: H65300

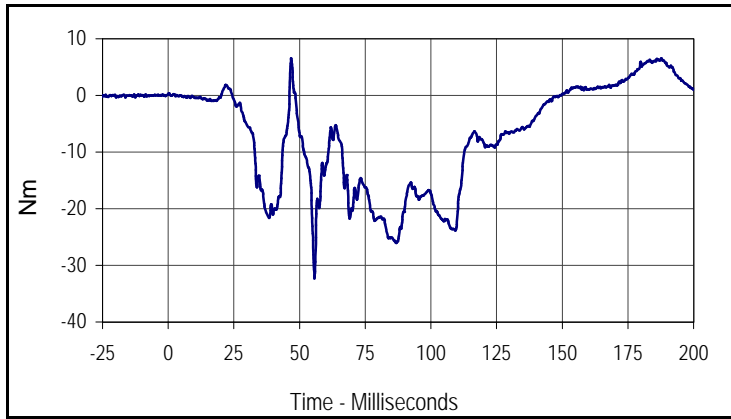

Curve Description			
Passenger Left Upper Tibia Moment X			
CURNO	Type	SAE Class	Units
069	FIL	600	Nm
Max	Time	Min	Time
6.6	46.8	-32.3	55.7

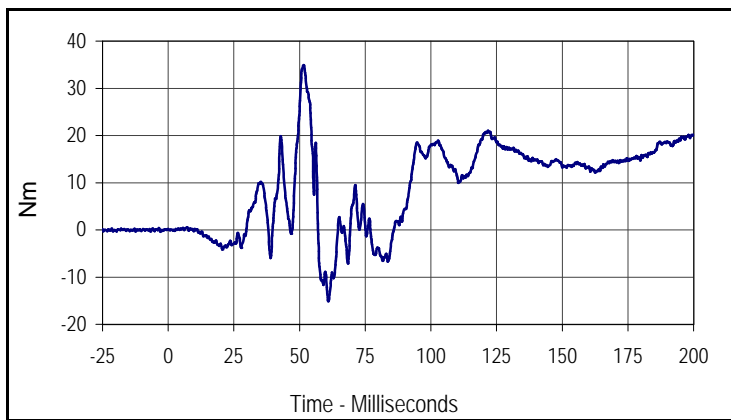

Curve Description			
Passenger Left Upper Tibia Moment Y			
CURNO	Type	SAE Class	Units
070	FIL	600	Nm
Max	Time	Min	Time
34.9	51.5	-15.1	61.0

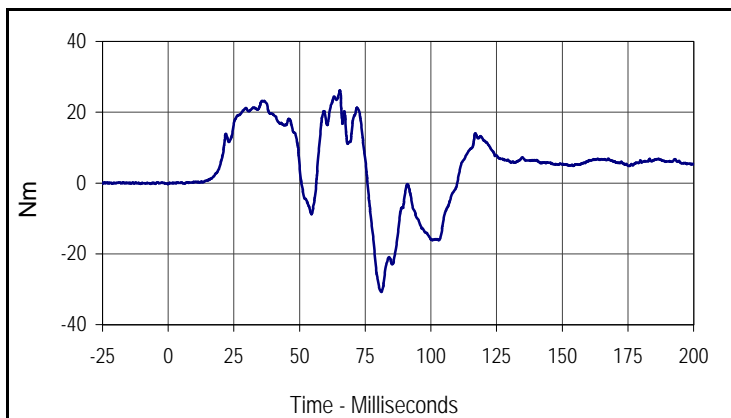

Curve Description			
Passenger Right Upper Tibia Moment X			
CURNO	Type	SAE Class	Units
071	FIL	600	Nm
Max	Time	Min	Time
26.2	65.4	-30.8	81.2

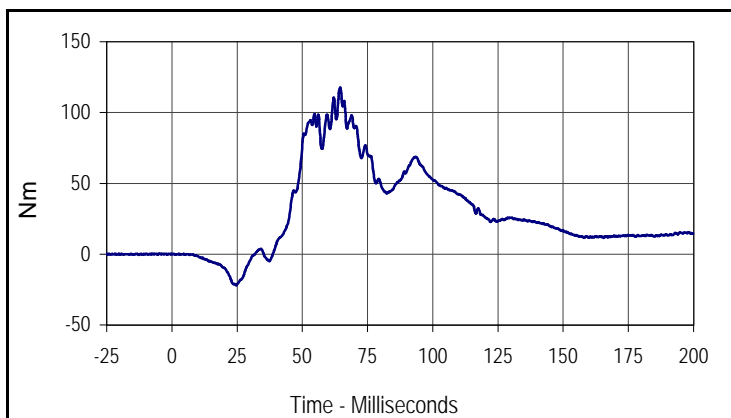

Curve Description			
Passenger Right Upper Tibia Moment Y			
CURNO	Type	SAE Class	Units
072	FIL	600	Nm
Max	Time	Min	Time
117.8	64.5	-21.9	24.7

Test Vehicle: 2006 Honda Ridgeline RTS 4-Door Truck
 Test Program: 2005 NHTSA 35mph NCAP

Test Date: 4/14/05
 NHTSA No.: H65300

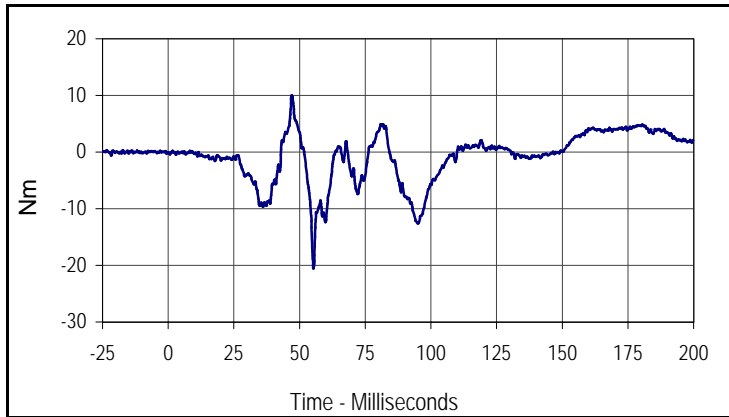

Curve Description			
Passenger Left Lower Tibia Moment X			
CURNO	Type	SAE Class	Units
073	FIL	600	Nm
Max	Time	Min	Time
10.0	47.0	-20.6	55.3

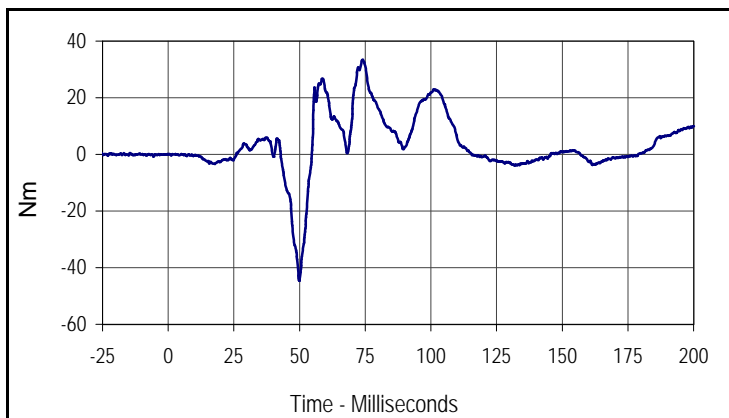

Curve Description			
Passenger Left Lower Tibia Moment Y			
CURNO	Type	SAE Class	Units
074	FIL	600	Nm
Max	Time	Min	Time
33.4	74.0	-44.7	49.9

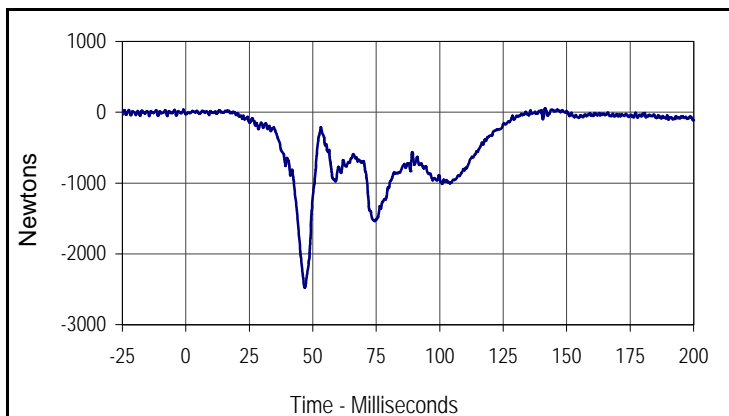

Curve Description			
Passenger Left Lower Tibia Force Z			
CURNO	Type	SAE Class	Units
075	FIL	600	Newtons
Max	Time	Min	Time
54.6	141.5	-2479.4	46.9

Test Vehicle: 2006 Honda Ridgeline RTS 4-Door Truck
 Test Program: 2005 NHTSA 35mph NCAP

Test Date: 4/14/05
 NHTSA No.: H65300

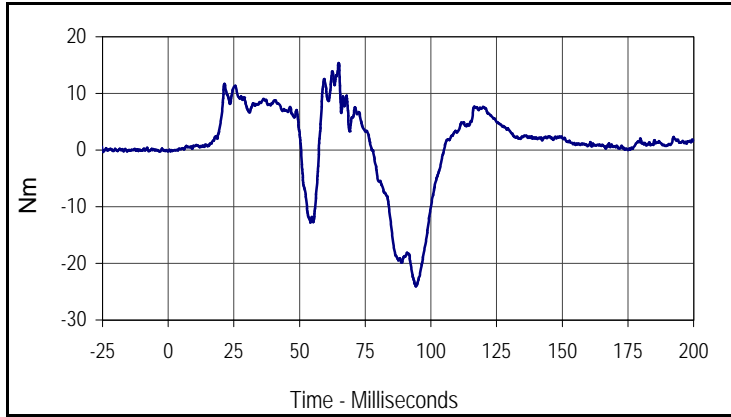

Curve Description			
Passenger Right Lower Tibia Moment X			
CURNO	Type	SAE Class	Units
076	FIL	600	Nm
Max	Time	Min	Time
15.4	64.9	-24.0	94.3

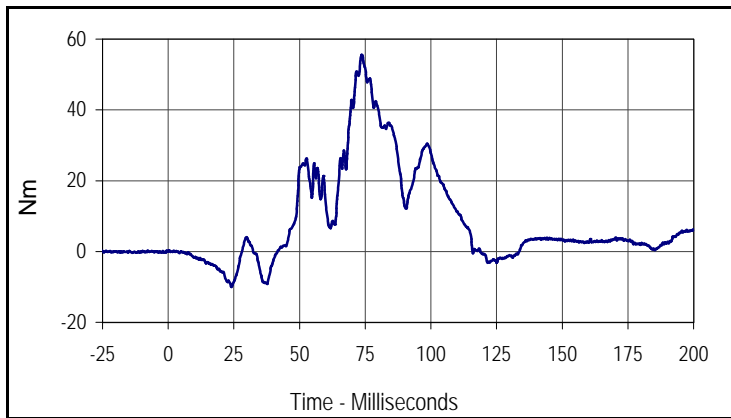

Curve Description			
Passenger Right Lower Tibia Moment Y			
CURNO	Type	SAE Class	Units
077	FIL	600	Nm
Max	Time	Min	Time
55.6	73.7	-10.1	24.1

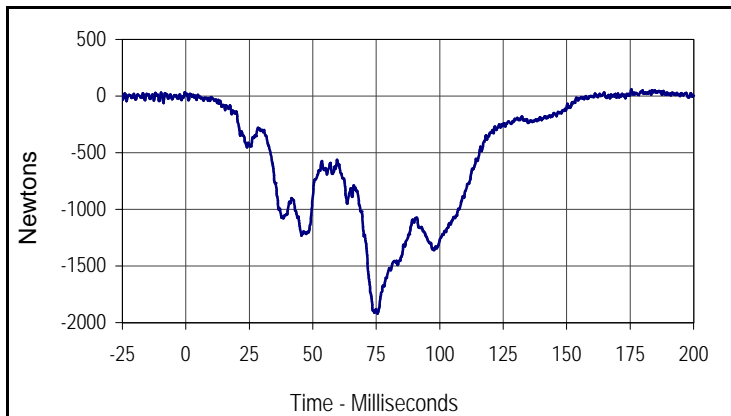

Curve Description			
Passenger Right lower Tibia Force Z			
CURNO	Type	SAE Class	Units
078	FIL	600	Newtons
Max	Time	Min	Time
58.2	175.5	-1922.2	75.5

Test Vehicle: 2006 Honda Ridgeline RTS 4-Door Truck
 Test Program: 2005 NHTSA 35mph NCAP

Test Date: 4/14/05
 NHTSA No.: H65300

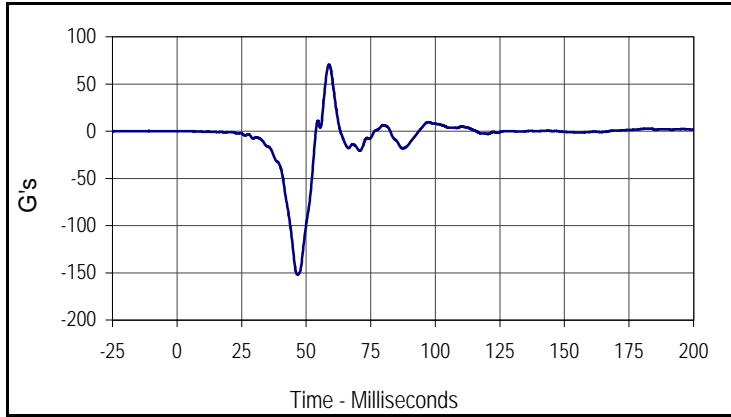

Curve Description			
Passenger Left Foot Aft X			
CURNO	Type	SAE Class	Units
079	FIL	180	G's
Max	Time	Min	Time
70.7	58.9	-152.0	46.6

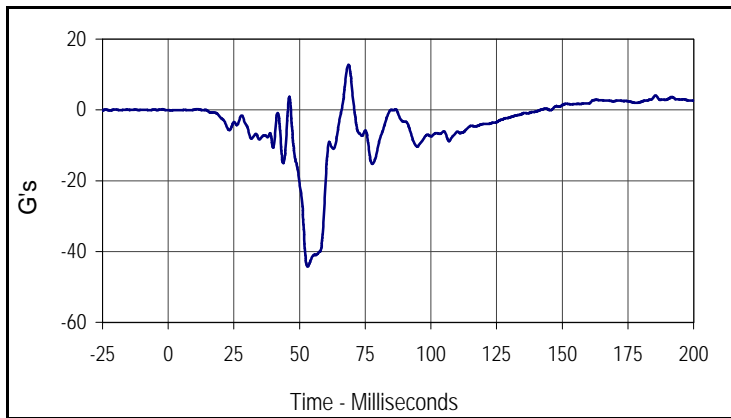

Curve Description			
Passenger Left Foot Aft Z			
CURNO	Type	SAE Class	Units
080	FIL	180	G's
Max	Time	Min	Time
12.7	68.6	-44.3	53.1

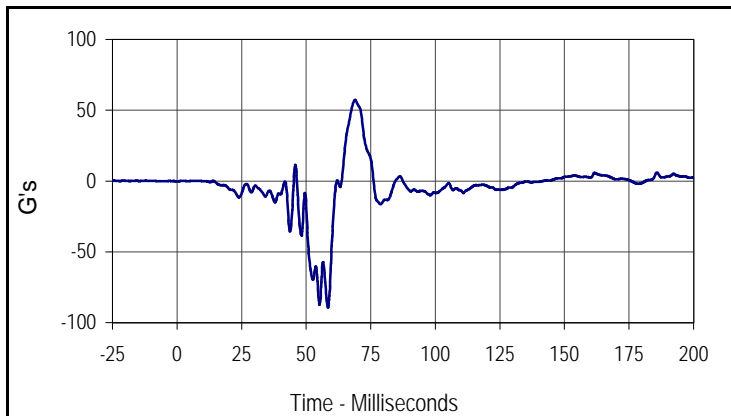

Curve Description			
Passenger Left Foot Fore Z			
CURNO	Type	SAE Class	Units
081	FIL	180	G's
Max	Time	Min	Time
57.4	68.9	-89.4	58.4

Test Vehicle: 2006 Honda Ridgeline RTS 4-Door Truck
 Test Program: 2005 NHTSA 35mph NCAP

Test Date: 4/14/05
 NHTSA No.: H65300

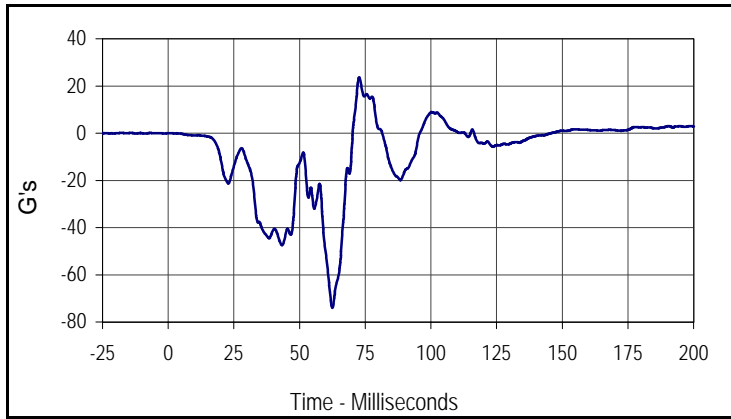

Curve Description			
Passenger Right Foot Aft X			
CURNO	Type	SAE Class	Units
082	FIL	180	G's
Max	Time	Min	Time
23.7	72.7	-74.1	62.5

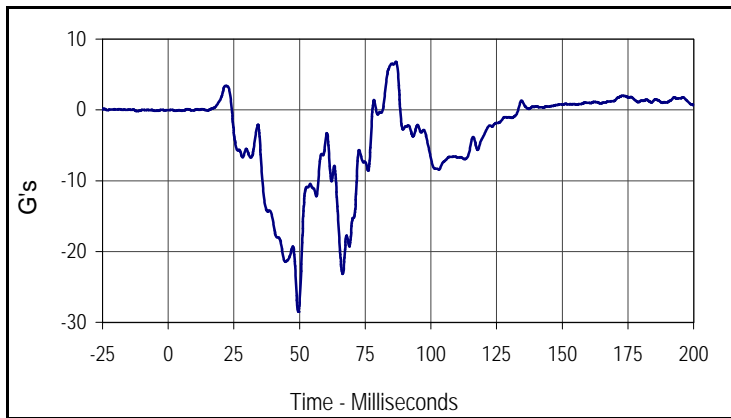

Curve Description			
Passenger Right Foot Aft Z			
CURNO	Type	SAE Class	Units
083	FIL	180	G's
Max	Time	Min	Time
6.8	86.7	-28.5	49.5

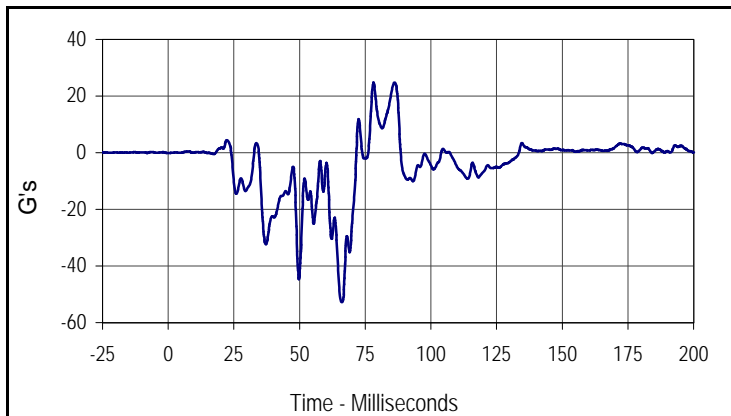

Curve Description			
Passenger Right Foot Fore Z			
CURNO	Type	SAE Class	Units
084	FIL	180	G's
Max	Time	Min	Time
24.8	86.2	-52.8	66.2

Test Vehicle: 2006 Honda Ridgeline RTS 4-Door Truck
 Test Program: 2005 NHTSA 35mph NCAP

Test Date: 4/14/05
 NHTSA No.: H65300

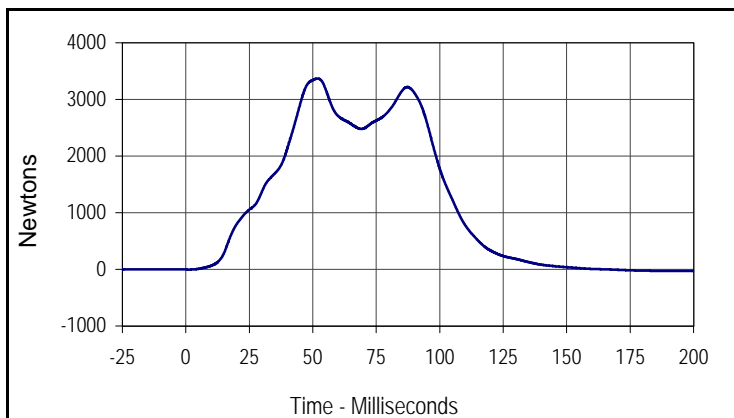

Curve Description			
Passenger Lap Belt Force			
CURNO	Type	SAE Class	Units
085	FIL	60	Newtons
Max	Time	Min	Time
3369.4	51.9	-28.6	195.2

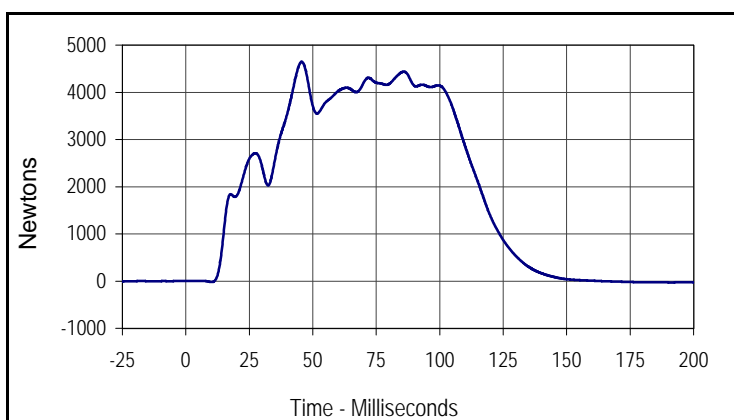

Curve Description			
Passenger Shoulder Belt Force			
CURNO	Type	SAE Class	Units
086	FIL	60	Newtons
Max	Time	Min	Time
4646.2	45.6	-27.2	191.2

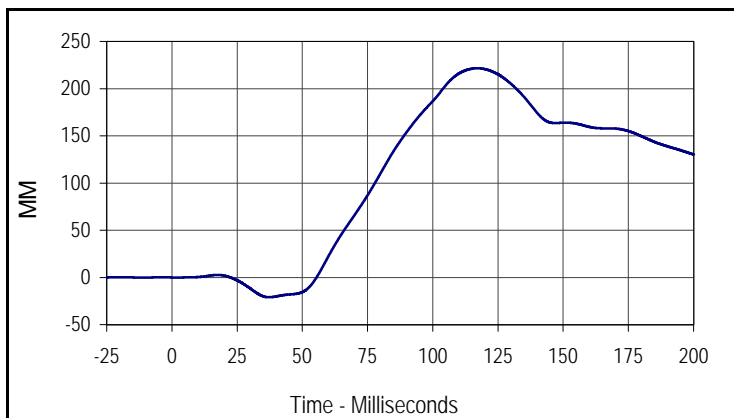

Curve Description			
Passenger Shoulder Belt Pullout			
CURNO	Type	SAE Class	Units
087	FIL	60	MM
Max	Time	Min	Time
221.6	117.4	-21.0	37.6

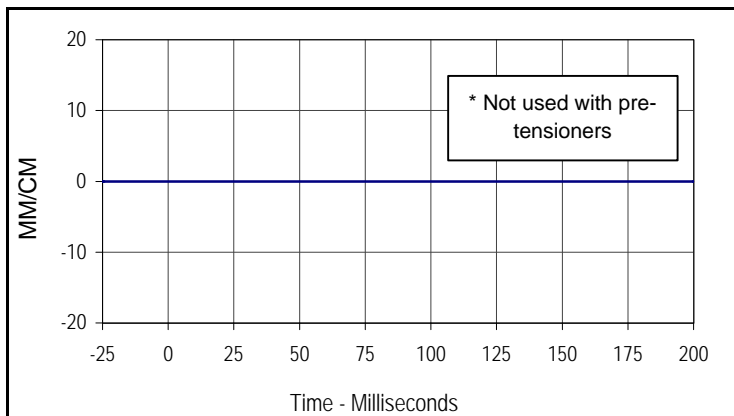

Curve Description			
Passenger Shoulder Belt Elongation			
CURNO	Type	SAE Class	Units
088	FIL	60	MM/CM
Max	Time	Min	Time
0.0	0.0	0.0	0.0

* Not used with pre-tensioners

Test Vehicle: 2006 Honda Ridgeline RTS 4-Door Truck
 Test Program: 2005 NHTSA 35mph NCAP

Test Date: 4/14/05
 NHTSA No.: H65300

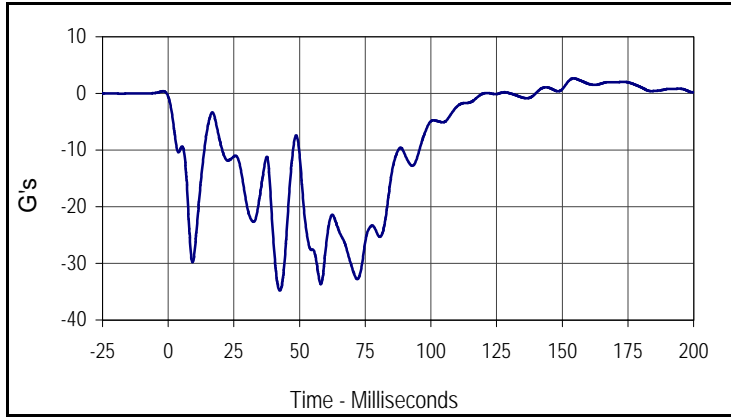

Curve Description			
Vehicle Left Rear X			
CURNO	Type	SAE Class	Units
089	FIL	60	G's
Max	Time	Min	Time
2.7	154.3	-34.8	42.5

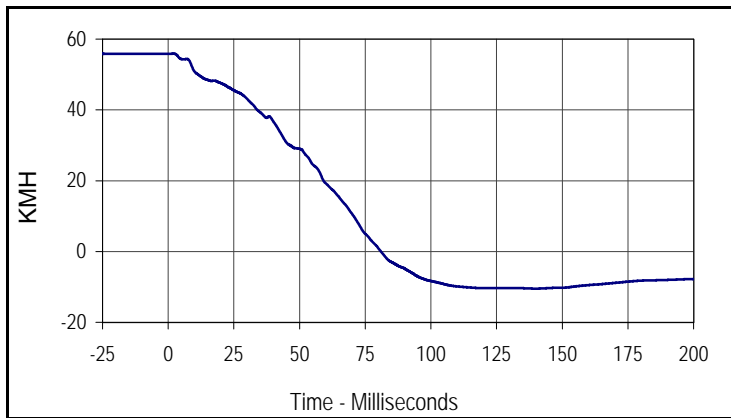

Curve Description			
Vehicle Left Rear X Velocity			
CURNO	Type	SAE Class	Units
089	IN1	180	KMH
Max	Time	Min	Time
55.9	1.9	-10.5	139.9

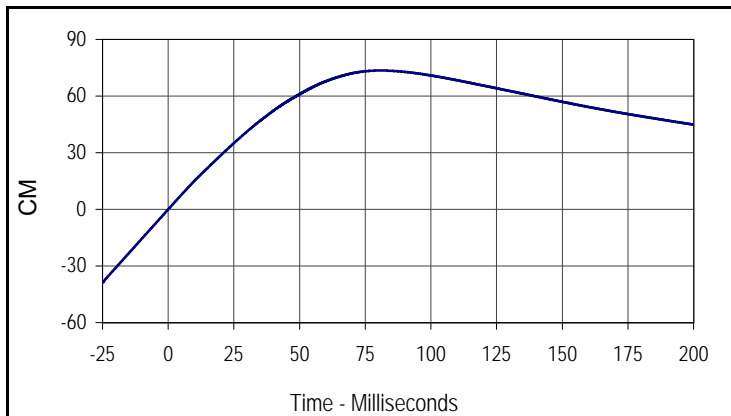

Curve Description			
Vehicle Left Rear X Displacement			
CURNO	Type	SAE Class	Units
089	IN2	180	CM
Max	Time	Min	Time
73.5	81.0	0.0	0.0

Test Vehicle: 2006 Honda Ridgeline RTS 4-Door Truck
 Test Program: 2005 NHTSA 35mph NCAP

Test Date: 4/14/05
 NHTSA No.: H65300

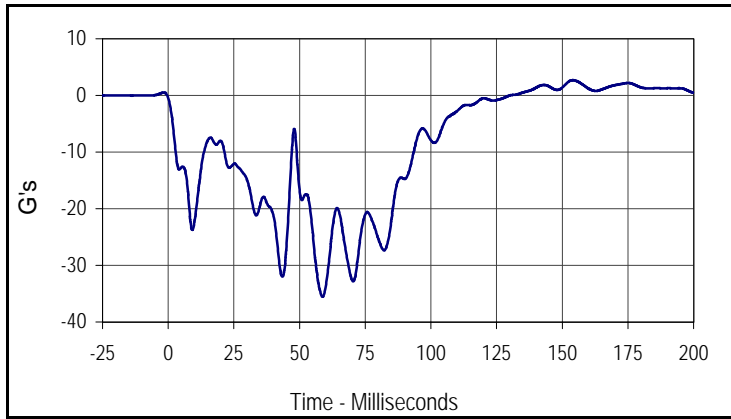

Curve Description			
Vehicle Right Rear X			
CURNO	Type	SAE Class	Units
090	FIL	60	G's
Max	Time	Min	Time
2.7	154.0	-35.6	58.7

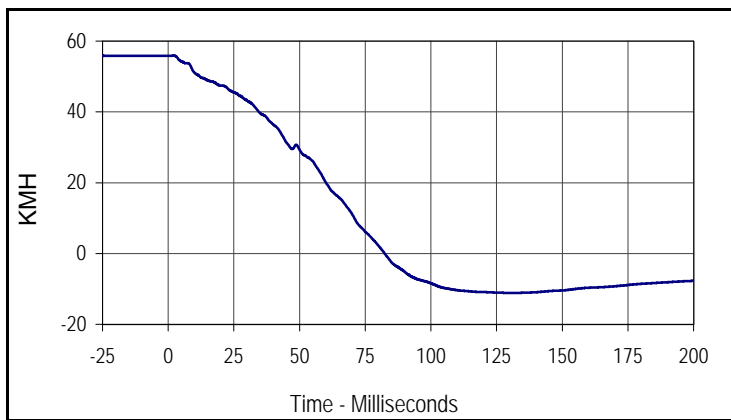

Curve Description			
Vehicle Right Rear X Velocity			
CURNO	Type	SAE Class	Units
090	IN1	180	KMH
Max	Time	Min	Time
55.9	2.1	-11.1	129.6

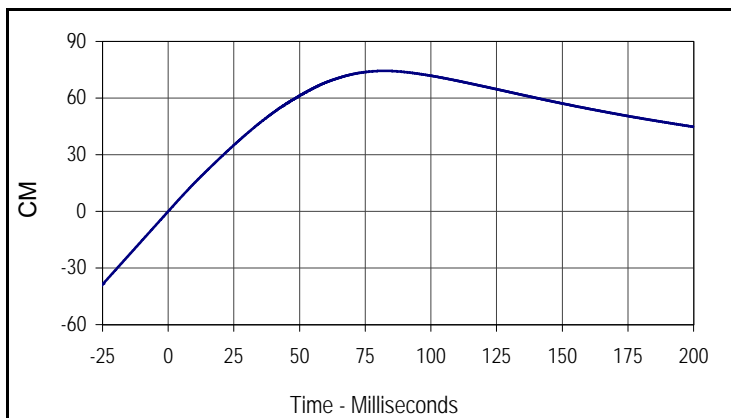

Curve Description			
Vehicle Right Rear X Displacement			
CURNO	Type	SAE Class	Units
090	IN2	180	CM
Max	Time	Min	Time
74.4	82.4	0.0	0.0

Test Vehicle: 2006 Honda Ridgeline RTS 4-Door Truck
 Test Program: 2005 NHTSA 35mph NCAP

Test Date: 4/14/05
 NHTSA No.: H65300

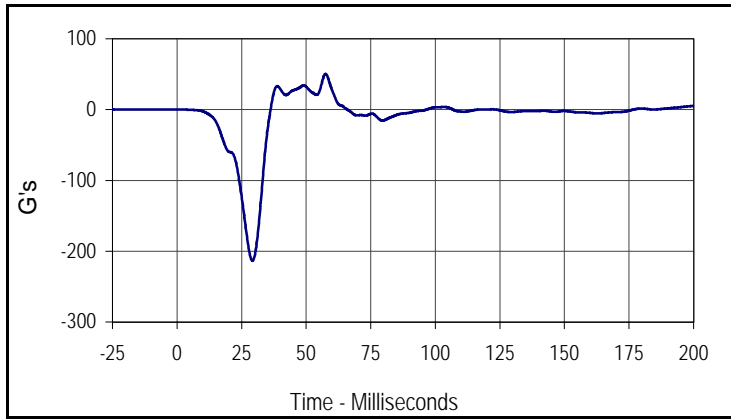

Curve Description			
Vehicle Engine Top X			
CURNO	Type	SAE Class	Units
091	FIL	60	G's
Max	Time	Min	Time
50.3	57.5	-213.5	29.2

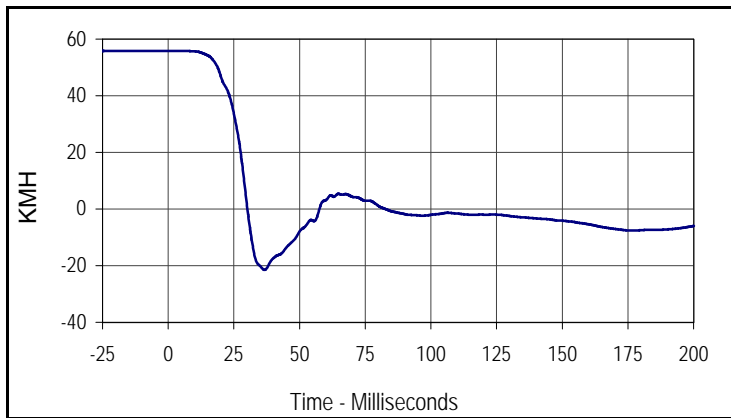

Curve Description			
Vehicle Engine Top X Velocity			
CURNO	Type	SAE Class	Units
091	IN1	180	KMH
Max	Time	Min	Time
55.9	0.4	-21.5	36.7

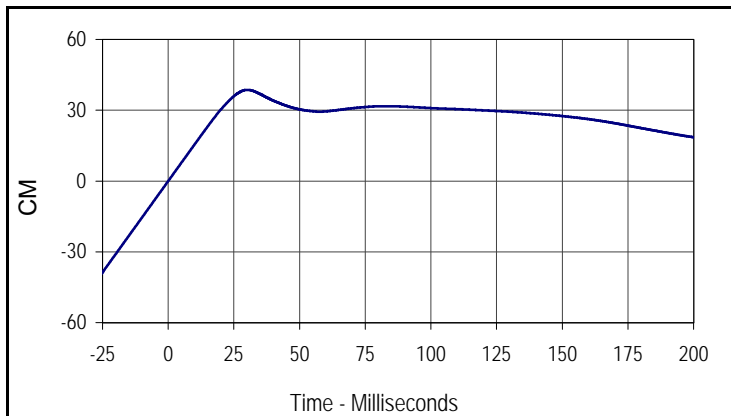

Curve Description			
Vehicle Engine Top X Displacement			
CURNO	Type	SAE Class	Units
091	IN2	180	CM
Max	Time	Min	Time
38.6	30.1	0.0	0.0

Test Vehicle: 2006 Honda Ridgeline RTS 4-Door Truck
 Test Program: 2005 NHTSA 35mph NCAP

Test Date: 4/14/05
 NHTSA No.: H65300

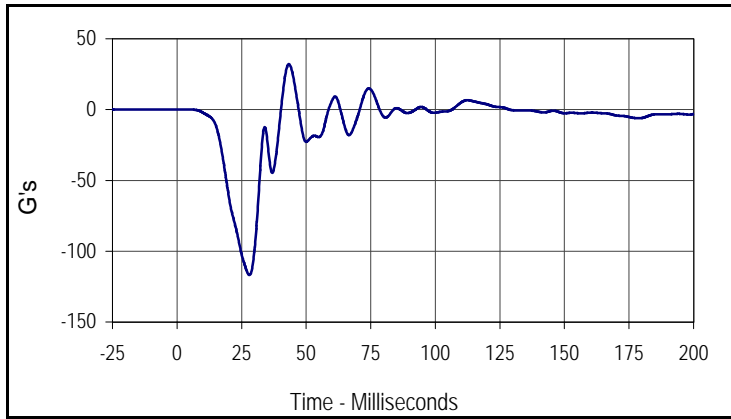

Curve Description			
Vehicle Engine Bottom X			
CURNO	Type	SAE Class	Units
092	FIL	60	G's
Max	Time	Min	Time
32.1	43.3	-116.8	28.0

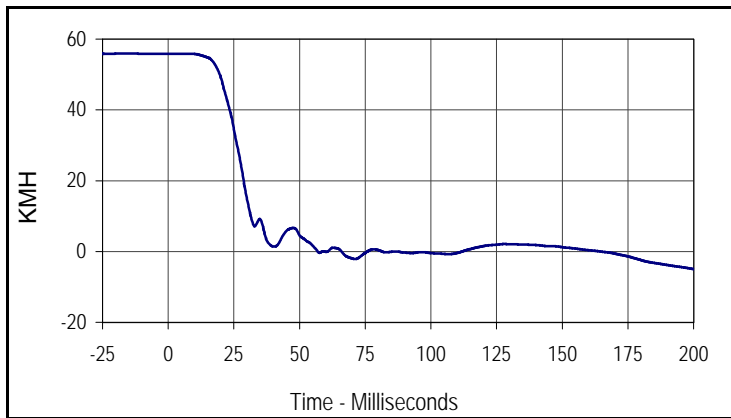

Curve Description			
Vehicle Engine Bottom X Velocity			
CURNO	Type	SAE Class	Units
092	IN1	180	KMH
Max	Time	Min	Time
55.9	5.2	-5.0	200.0

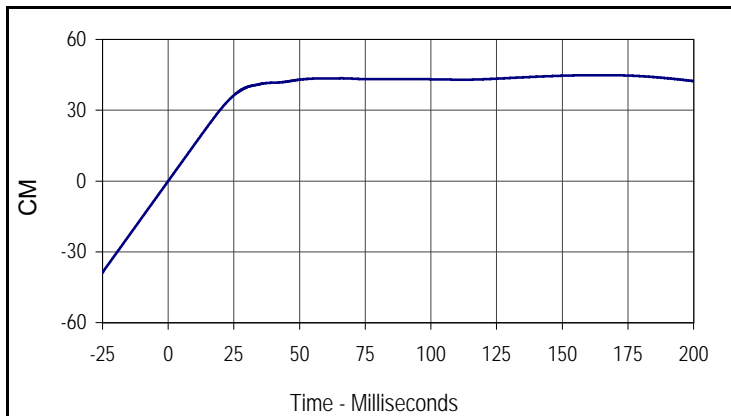

Curve Description			
Vehicle Engine Bottom X Displacement			
CURNO	Type	SAE Class	Units
092	IN2	180	CM
Max	Time	Min	Time
44.9	164.6	0.0	0.0

Test Vehicle: 2006 Honda Ridgeline RTS 4-Door Truck
 Test Program: 2005 NHTSA 35mph NCAP

Test Date: 4/14/05
 NHTSA No.: H65300

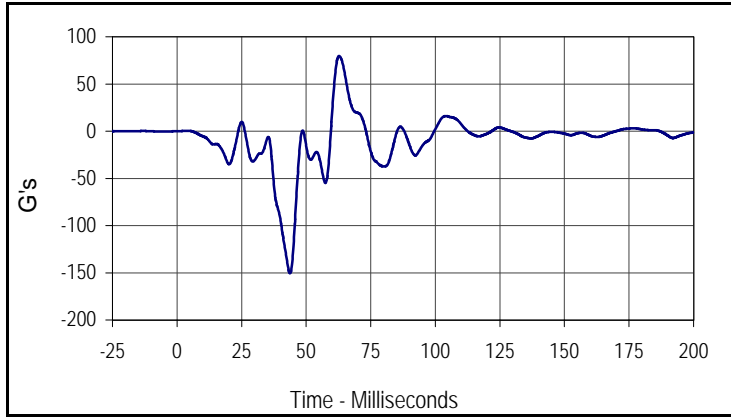

Curve Description			
Vehicle Left Brake Caliper X			
CURNO	Type	SAE Class	Units
093	FIL	60	G's
Max	Time	Min	Time
79.7	62.8	-150.5	43.8

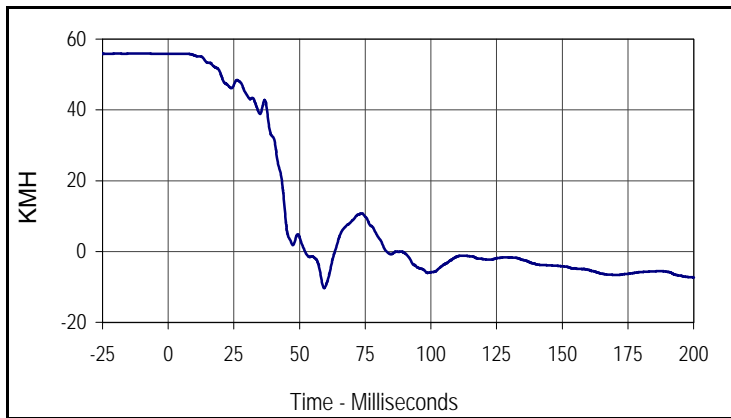

Curve Description			
Vehicle Left Brake Caliper X Velocity			
CURNO	Type	SAE Class	Units
093	IN1	180	KMH
Max	Time	Min	Time
55.9	6.2	-10.3	59.4

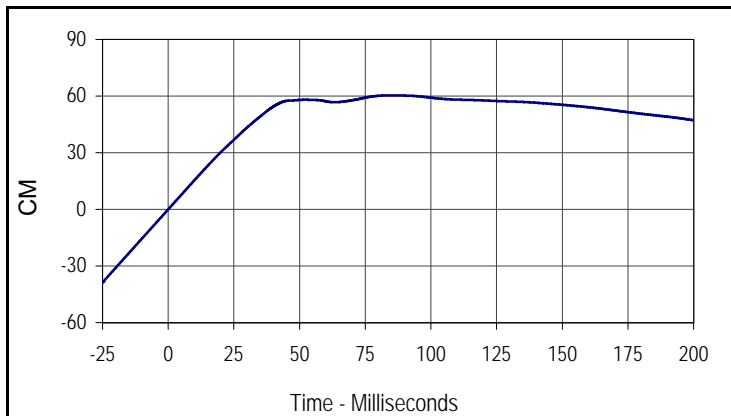

Curve Description			
Vehicle Left Brake Caliper X Displacement			
CURNO	Type	SAE Class	Units
093	IN2	180	CM
Max	Time	Min	Time
60.3	83.1	0.0	0.0

Test Vehicle: 2006 Honda Ridgeline RTS 4-Door Truck
 Test Program: 2005 NHTSA 35mph NCAP

Test Date: 4/14/05
 NHTSA No.: H65300

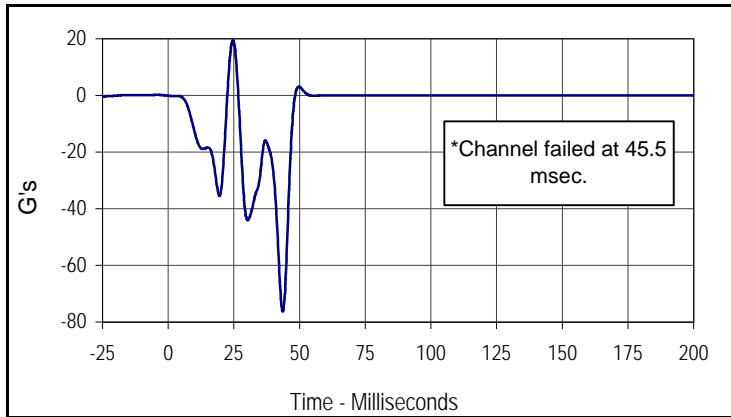

Curve Description			
Vehicle Right Brake Caliper X			
CURNO	Type	SAE Class	Units
094	FIL	60	G's
Max	Time	Min	Time
19.4	24.6	-76.3	43.6

*Channel failed at 45.5 msec.

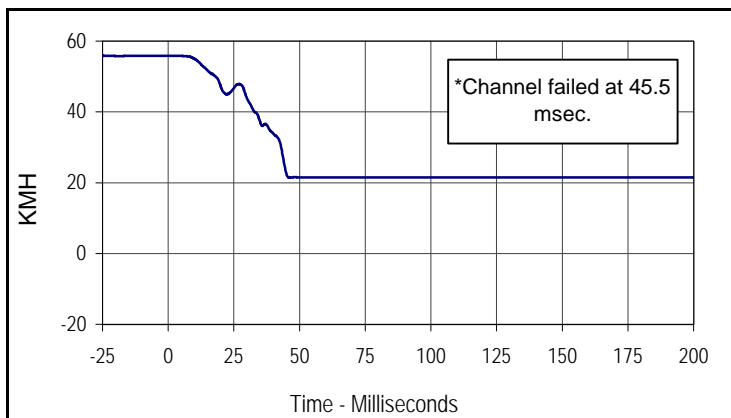

Curve Description			
Vehicle Right Brake Caliper X Velocity			
CURNO	Type	SAE Class	Units
094	IN1	180	KMH
Max	Time	Min	Time
55.9	0.0	21.4	46.1

*Channel failed at 45.5 msec.

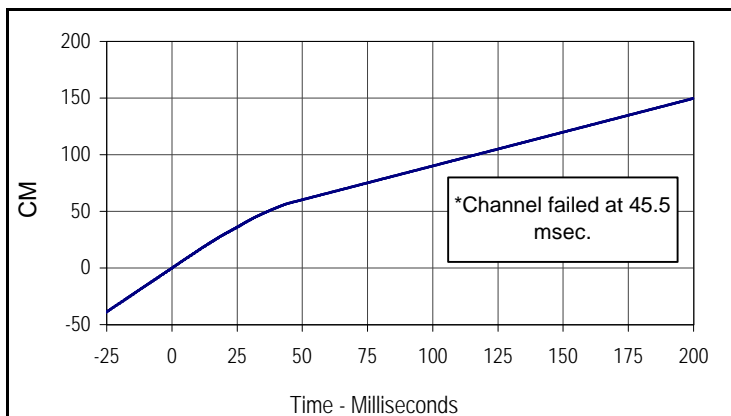

Curve Description			
Vehicle Right Brake Caliper X Displacement			
CURNO	Type	SAE Class	Units
094	IN2	180	CM
Max	Time	Min	Time
149.7	200.0	0.0	0.0

*Channel failed at 45.5 msec.

Test Vehicle: 2006 Honda Ridgeline RTS 4-Door Truck
 Test Program: 2005 NHTSA 35mph NCAP

Test Date: 4/14/05
 NHTSA No.: H65300

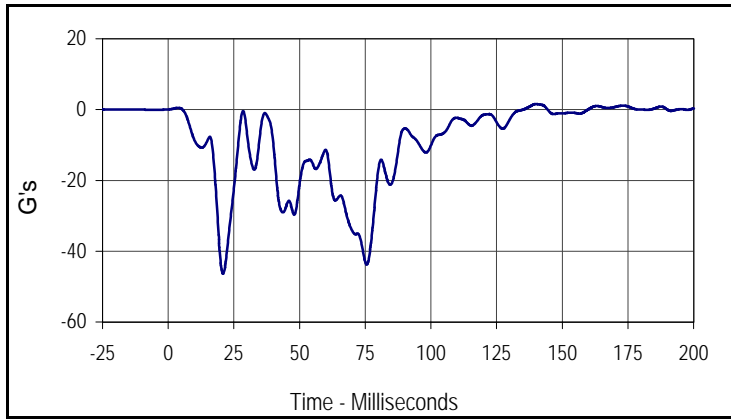

Curve Description			
Vehicle Instrument Panel X			
CURNO	Type	SAE Class	Units
095	FIL	60	G's
Max	Time	Min	Time
1.6	140.0	-46.3	20.9

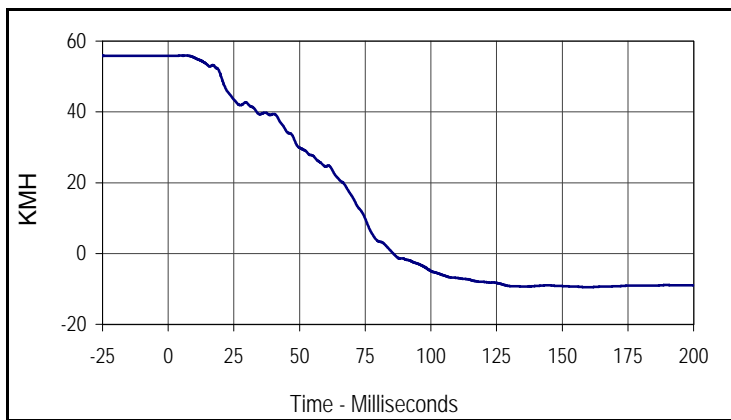

Curve Description			
Vehicle Instrument Panel X Velocity			
CURNO	Type	SAE Class	Units
095	IN1	180	KMH
Max	Time	Min	Time
55.9	6.9	-9.5	159.0

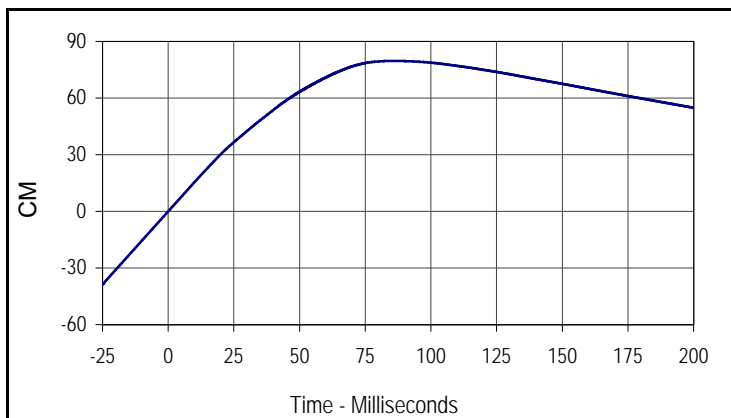

Curve Description			
Vehicle Instrument Panel X Displacement			
CURNO	Type	SAE Class	Units
095	IN2	180	CM
Max	Time	Min	Time
79.7	85.7	0.0	0.0

Test Vehicle: 2006 Honda Ridgeline RTS 4-Door Truck
 Test Program: 2005 NHTSA 35mph NCAP

Test Date: 4/14/05
 NHTSA No.: H65300

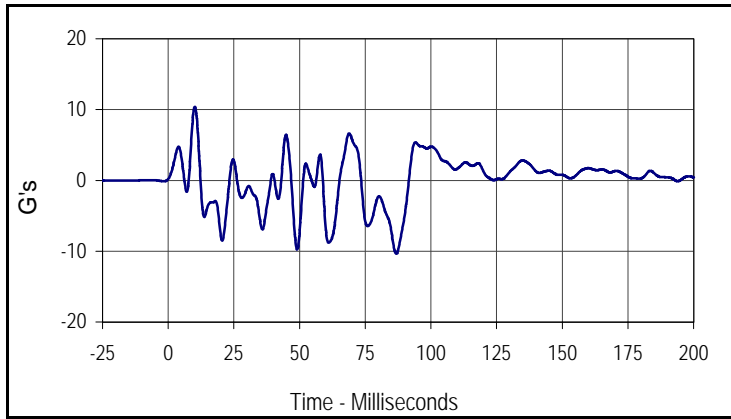

Curve Description			
Vehicle Left Rear Z			
CURNO	Type	SAE Class	Units
096	FIL	60	G's
Max	Time	Min	Time
10.4	10.1	-10.3	86.8

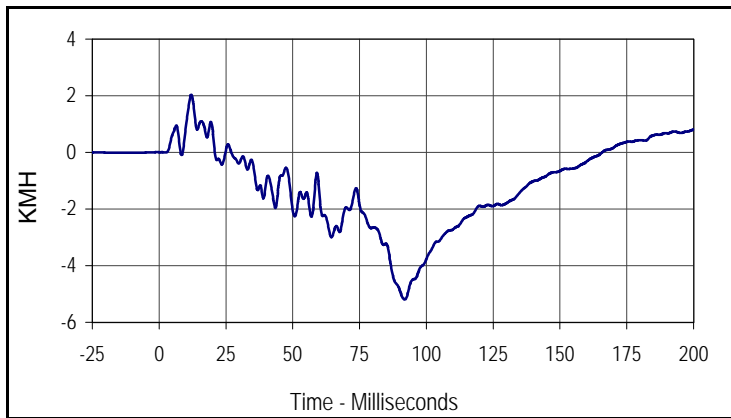

Curve Description			
Vehicle Left Rear Z Velocity			
CURNO	Type	SAE Class	Units
096	IN1	180	KMH
Max	Time	Min	Time
2.0	12.0	-5.2	91.9

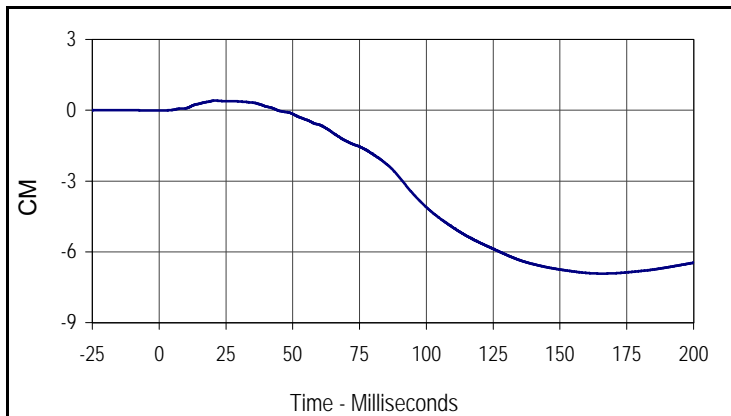

Curve Description			
Vehicle Left Rear Z Displacement			
CURNO	Type	SAE Class	Units
096	IN2	180	CM
Max	Time	Min	Time
0.4	20.9	-6.9	165.8

Test Vehicle: 2006 Honda Ridgeline RTS 4-Door Truck
 Test Program: 2005 NHTSA 35mph NCAP

Test Date: 4/14/05
 NHTSA No.: H65300

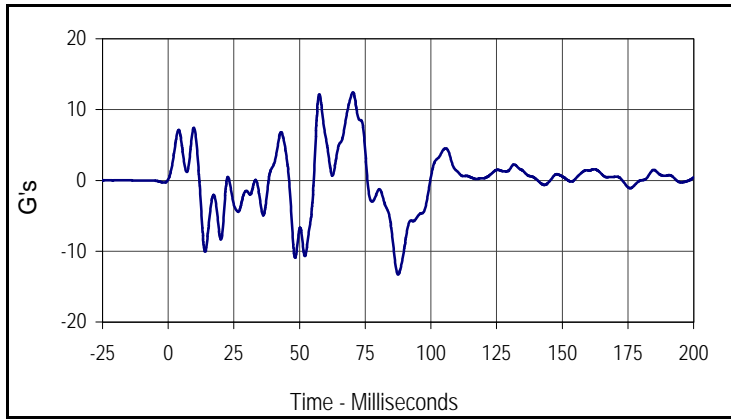

Curve Description			
Vehicle Right Rear Z			
CURNO	Type	SAE Class	Units
097	FIL	60	G's
Max	Time	Min	Time
12.4	70.3	-13.3	87.5

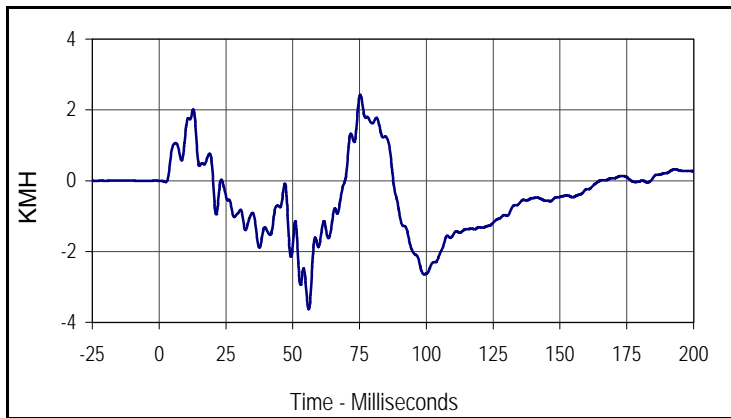

Curve Description			
Vehicle Right Rear Z Velocity			
CURNO	Type	SAE Class	Units
097	IN1	180	KMH
Max	Time	Min	Time
2.4	75.3	-3.6	56.0

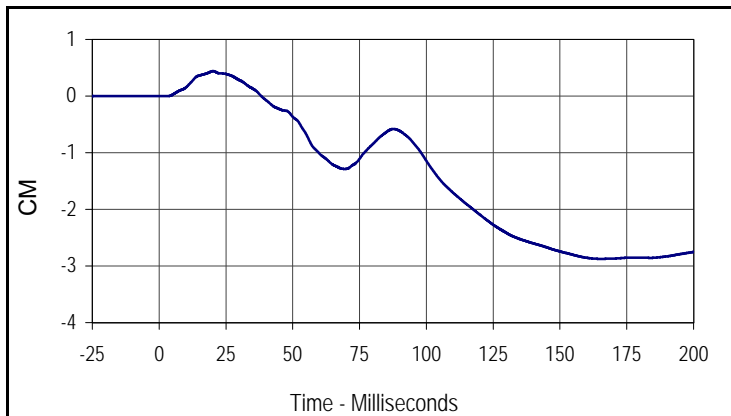

Curve Description			
Vehicle Right Rear Z Displacement			
CURNO	Type	SAE Class	Units
097	IN2	180	CM
Max	Time	Min	Time
0.4	20.2	-2.9	164.9

APPENDIX C

LOAD CELL BARRIER DATA PLOTS

Test Vehicle: 2006 Honda Ridgeline RTS 4-Door Truck
 Test Program: 2005 NHTSA 35mph NCAP

Test Date: 4/14/05
 NHTSA No.: H65300

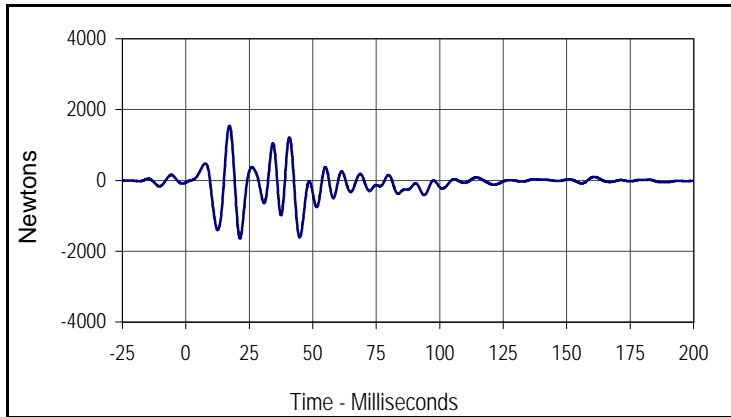

Curve Description			
Barrier Force A1			
CURNO	Type	SAE Class	Units
098	FIL	60	Newtons
Max	Time	Min	Time
1543.6	17.2	-1641.6	21.3

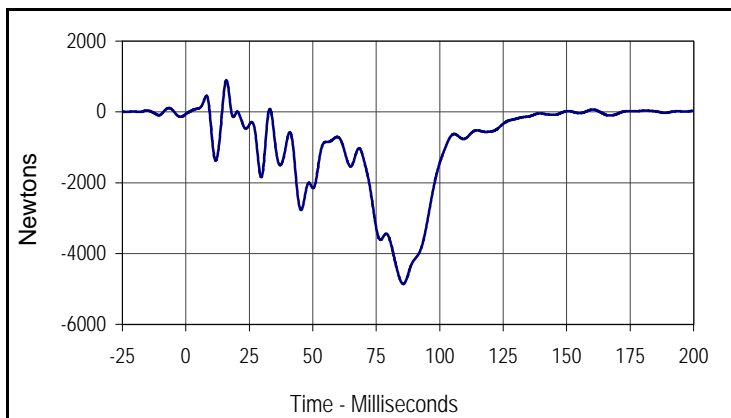

Curve Description			
Barrier Force B1			
CURNO	Type	SAE Class	Units
107	FIL	60	Newtons
Max	Time	Min	Time
895.3	15.9	-4859.9	85.6

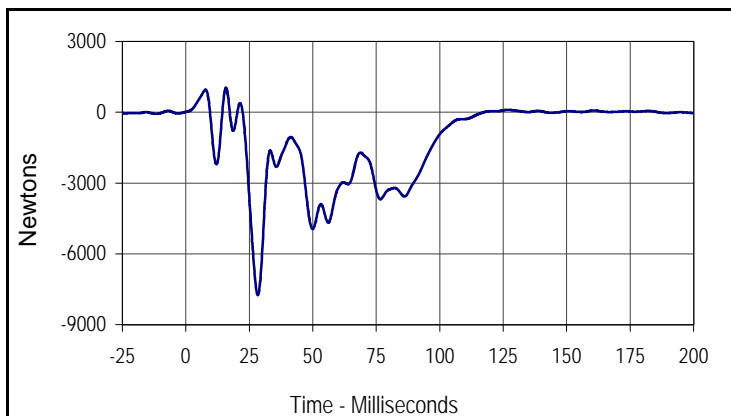

Curve Description			
Barrier Force C1			
CURNO	Type	SAE Class	Units
116	FIL	60	Newtons
Max	Time	Min	Time
1036.2	15.8	-7749.0	28.3

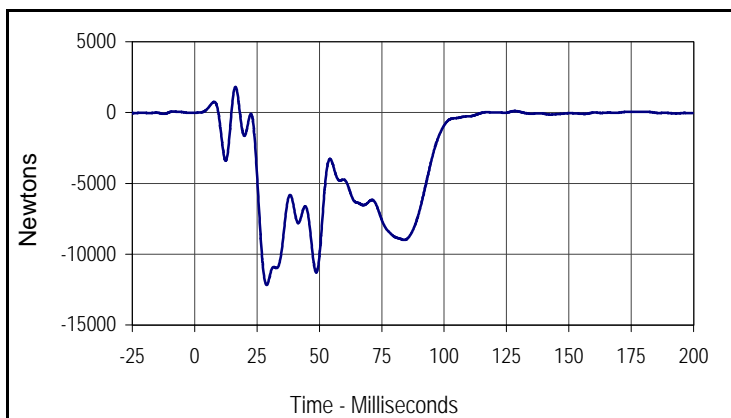

Curve Description			
Barrier Force D1			
CURNO	Type	SAE Class	Units
125	FIL	60	Newtons
Max	Time	Min	Time
1810.1	16.3	-12175.1	28.8

Test Vehicle: 2006 Honda Ridgeline RTS 4-Door Truck
 Test Program: 2005 NHTSA 35mph NCAP

Test Date: 4/14/05
 NHTSA No.: H65300

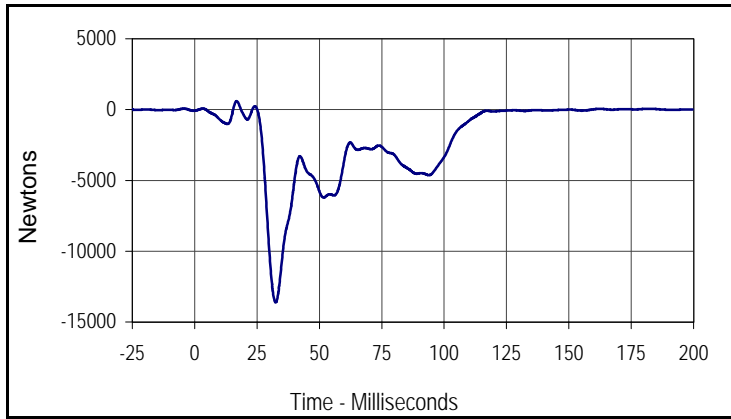

Curve Description			
Barrier Force A2			
CURNO	Type	SAE Class	Units
099	FIL	60	Newtons
Max	Time	Min	Time
597.8	16.8	-13616.4	32.5

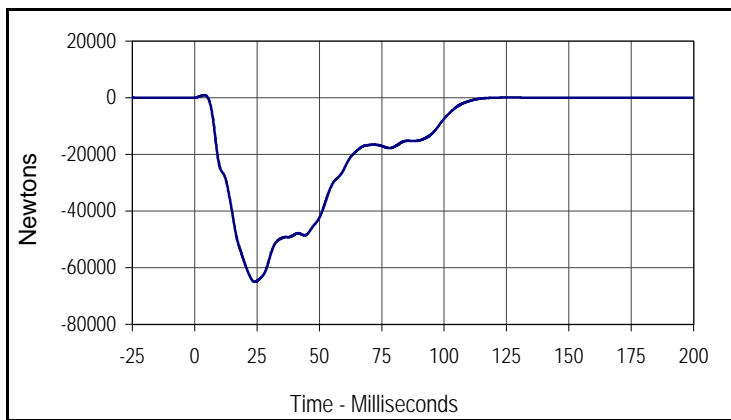

Curve Description			
Barrier Force B2			
CURNO	Type	SAE Class	Units
108	FIL	60	Newtons
Max	Time	Min	Time
930.2	3.9	-65015.8	24.1

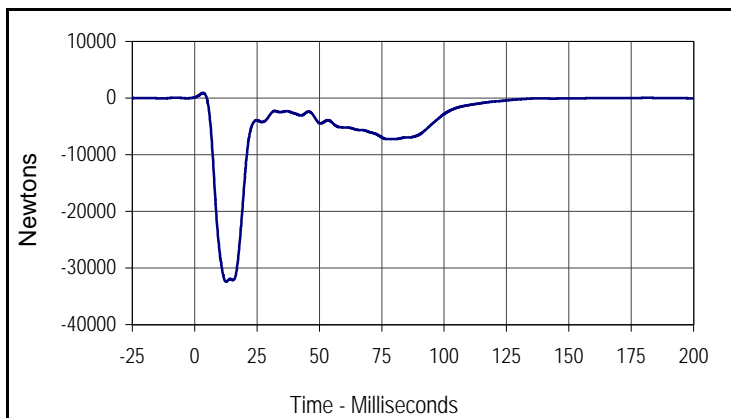

Curve Description			
Barrier Force C2			
CURNO	Type	SAE Class	Units
117	FIL	60	Newtons
Max	Time	Min	Time
902.2	3.4	-32447.1	12.6

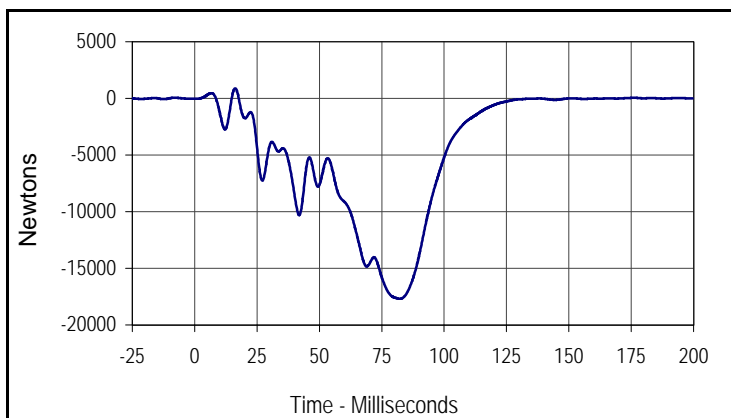

Curve Description			
Barrier Force D2			
CURNO	Type	SAE Class	Units
126	FIL	60	Newtons
Max	Time	Min	Time
889.3	16.2	-17687.0	82.3

Test Vehicle: 2006 Honda Ridgeline RTS 4-Door Truck
 Test Program: 2005 NHTSA 35mph NCAP

Test Date: 4/14/05
 NHTSA No.: H65300

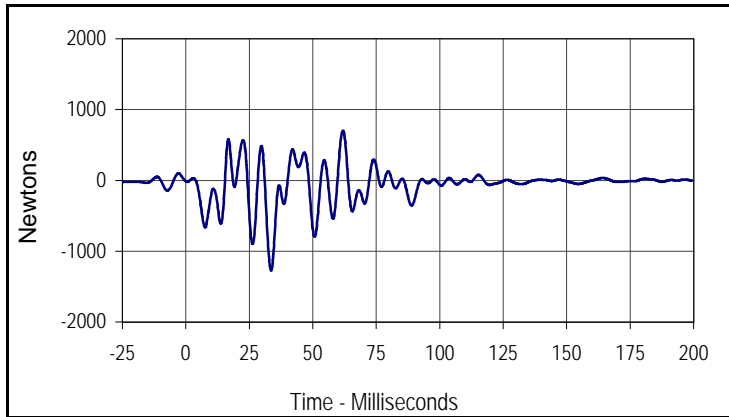

Curve Description			
Barrier Force A3			
CURNO	Type	SAE Class	Units
100	FIL	60	Newtons
Max	Time	Min	Time
702.4	61.9	-1276.9	33.6

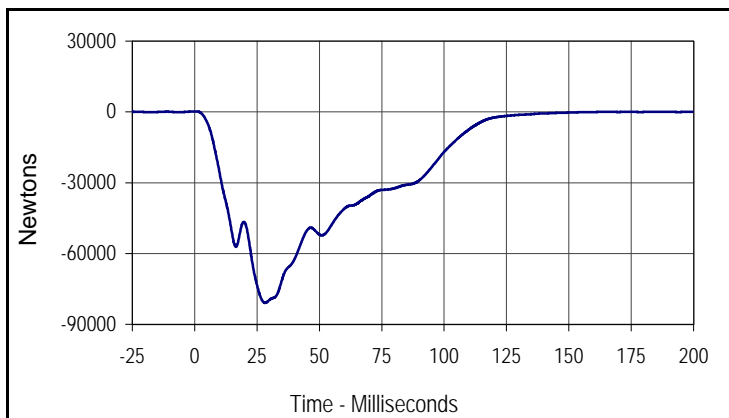

Curve Description			
Barrier Force B3			
CURNO	Type	SAE Class	Units
109	FIL	60	Newtons
Max	Time	Min	Time
233.1	0.3	-80874.6	28.2

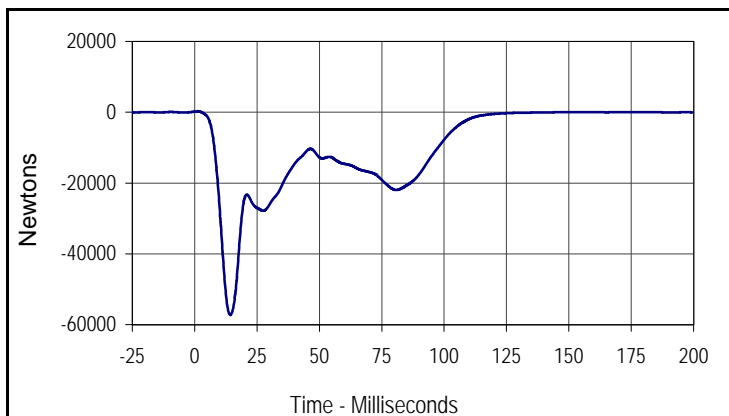

Curve Description			
Barrier Force C3			
CURNO	Type	SAE Class	Units
118	FIL	60	Newtons
Max	Time	Min	Time
252.3	1.2	-57256.7	14.3

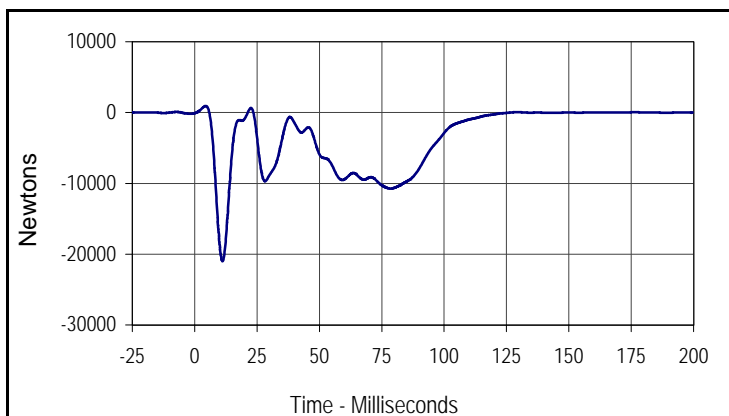

Curve Description			
Barrier Force D3			
CURNO	Type	SAE Class	Units
127	FIL	60	Newtons
Max	Time	Min	Time
927.3	4.4	-20992.2	11.2

Test Vehicle: 2006 Honda Ridgeline RTS 4-Door Truck
 Test Program: 2005 NHTSA 35mph NCAP

Test Date: 4/14/05
 NHTSA No.: H65300

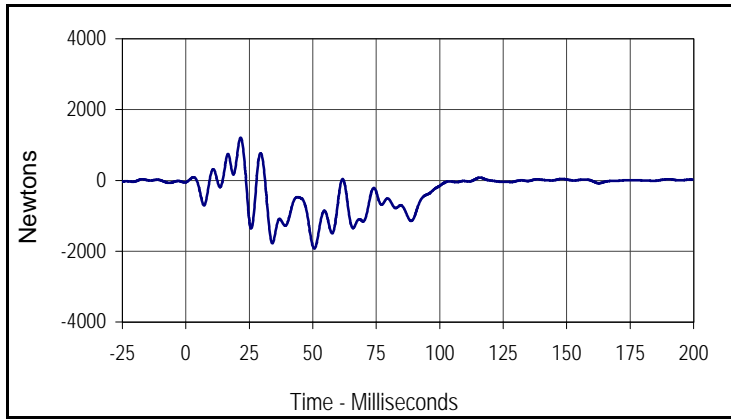

Curve Description			
Barrier Force A4			
CURNO	Type	SAE Class	Units
101	FIL	60	Newtons
Max	Time	Min	Time
1210.4	21.6	-1925.1	50.6

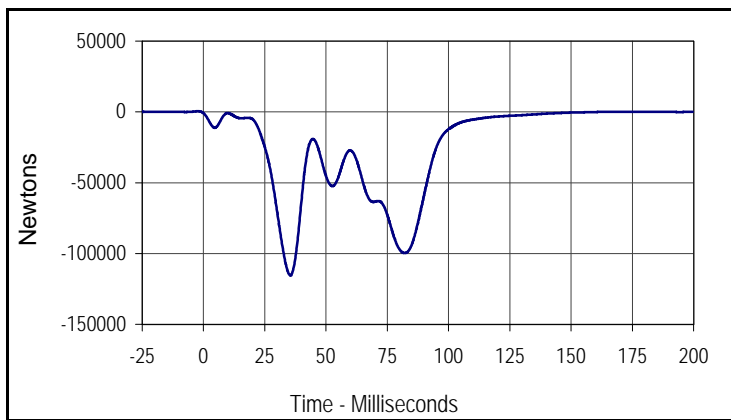

Curve Description			
Barrier Force B4			
CURNO	Type	SAE Class	Units
110	FIL	60	Newtons
Max	Time	Min	Time
49.7	176.7	-115324.0	35.4

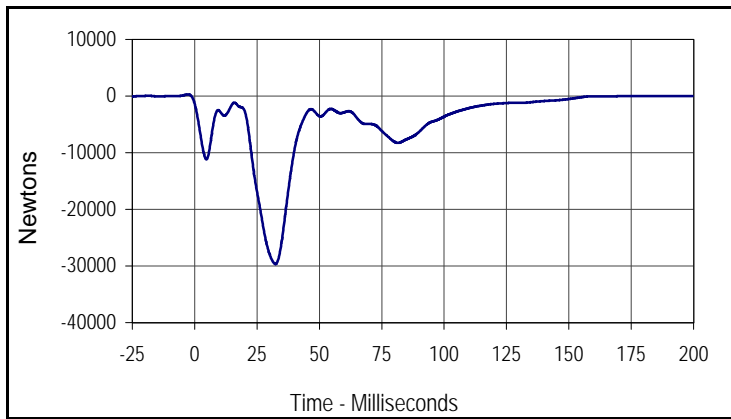

Curve Description			
Barrier Force C4			
CURNO	Type	SAE Class	Units
119	FIL	60	Newtons
Max	Time	Min	Time
22.4	174.8	-29635.1	32.3

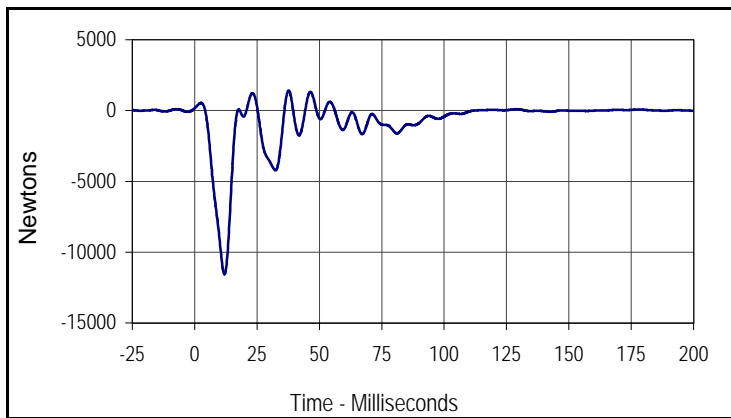

Curve Description			
Barrier Force D4			
CURNO	Type	SAE Class	Units
128	FIL	60	Newtons
Max	Time	Min	Time
1407.3	37.6	-11556.1	11.9

Test Vehicle: 2006 Honda Ridgeline RTS 4-Door Truck
 Test Program: 2005 NHTSA 35mph NCAP

Test Date: 4/14/05
 NHTSA No.: H65300

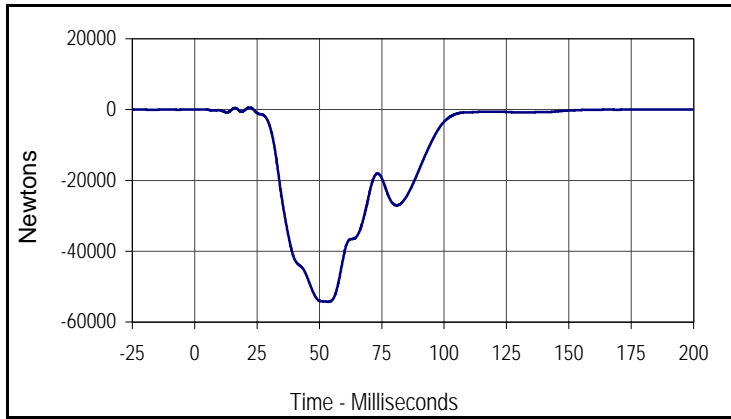

Curve Description			
Barrier Force A5			
CURNO	Type	SAE Class	Units
102	FIL	60	Newtons
Max	Time	Min	Time
595.3	22.0	-54276.0	53.4

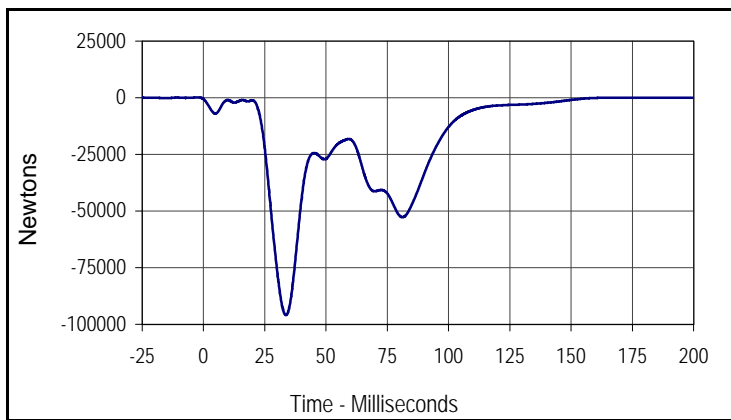

Curve Description			
Barrier Force B5			
CURNO	Type	SAE Class	Units
111	FIL	60	Newtons
Max	Time	Min	Time
23.6	199.5	-95971.6	33.6

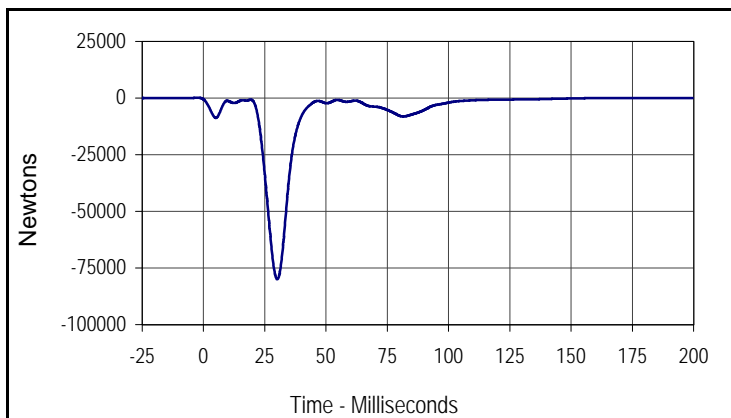

Curve Description			
Barrier Force C5			
CURNO	Type	SAE Class	Units
120	FIL	60	Newtons
Max	Time	Min	Time
30.5	177.5	-80005.0	30.1

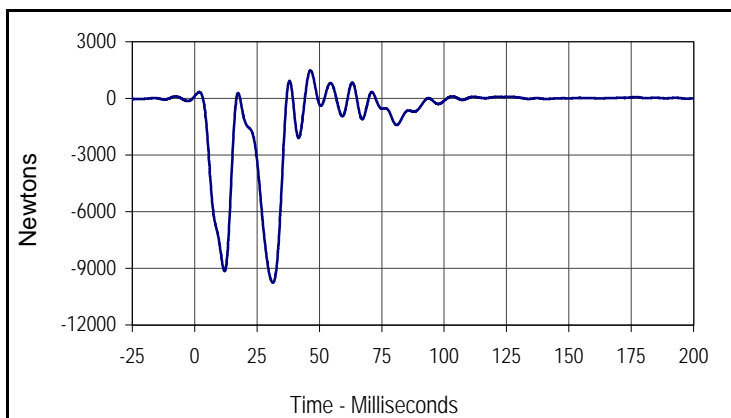

Curve Description			
Barrier Force D5			
CURNO	Type	SAE Class	Units
129	FIL	60	Newtons
Max	Time	Min	Time
1483.0	46.4	-9761.9	31.4

Test Vehicle: 2006 Honda Ridgeline RTS 4-Door Truck
 Test Program: 2005 NHTSA 35mph NCAP

Test Date: 4/14/05
 NHTSA No.: H65300

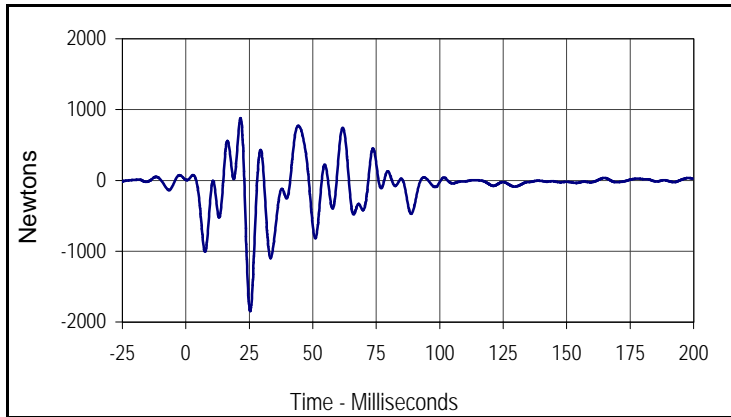

Curve Description			
Barrier Force A6			
CURNO	Type	SAE Class	Units
103	FIL	60	Newtons
Max	Time	Min	Time
877.2	21.5	-1847.8	25.4

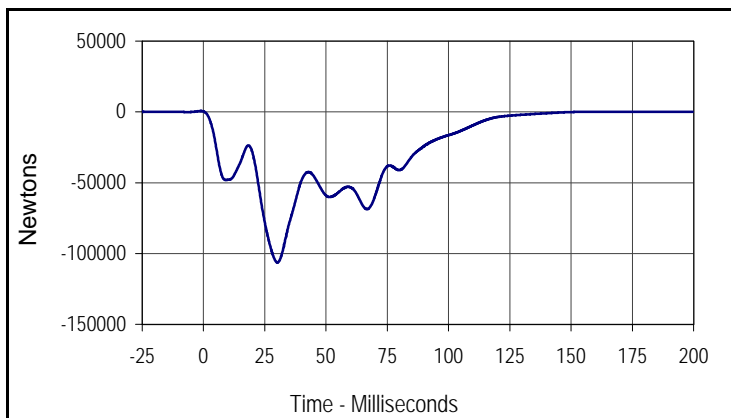

Curve Description			
Barrier Force B6			
CURNO	Type	SAE Class	Units
112	FIL	60	Newtons
Max	Time	Min	Time
369.6	0.0	-106338.1	30.2

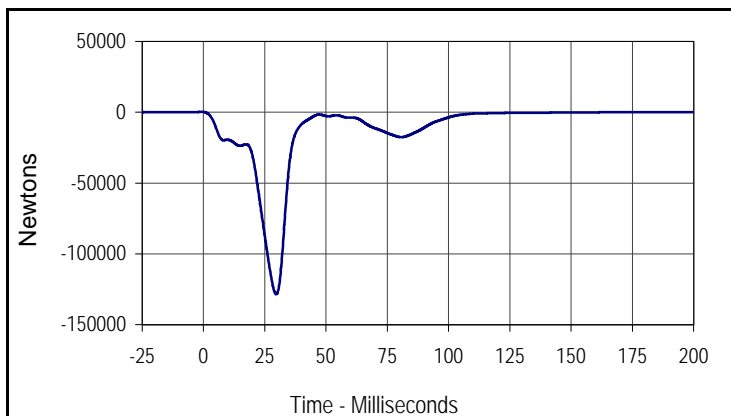

Curve Description			
Barrier Force C6			
CURNO	Type	SAE Class	Units
121	FIL	60	Newtons
Max	Time	Min	Time
199.4	0.0	-128633.0	29.7

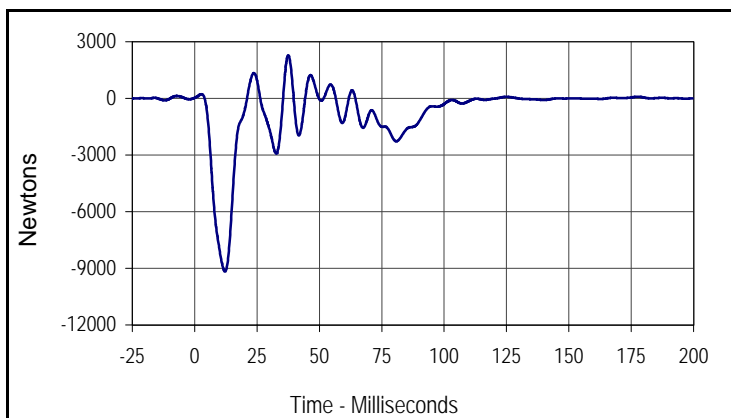

Curve Description			
Barrier Force D6			
CURNO	Type	SAE Class	Units
130	FIL	60	Newtons
Max	Time	Min	Time
2266.1	37.5	-9177.3	12.2

Test Vehicle: 2006 Honda Ridgeline RTS 4-Door Truck
 Test Program: 2005 NHTSA 35mph NCAP

Test Date: 4/14/05
 NHTSA No.: H65300

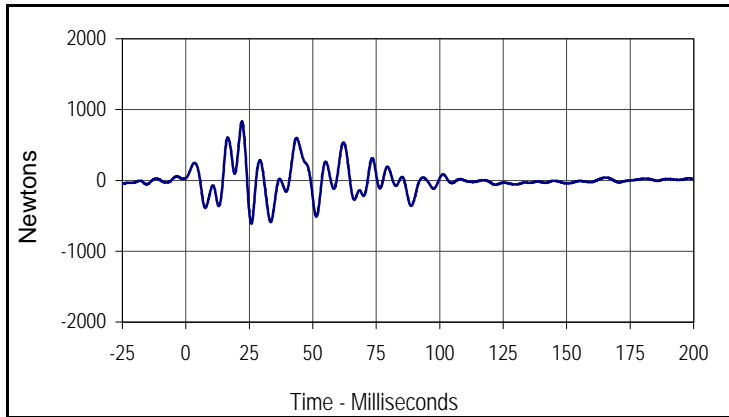

Curve Description			
Barrier Force A7			
CURNO	Type	SAE Class	Units
104	FIL	60	Newtons
Max	Time	Min	Time
833.1	22.1	-609.0	25.8

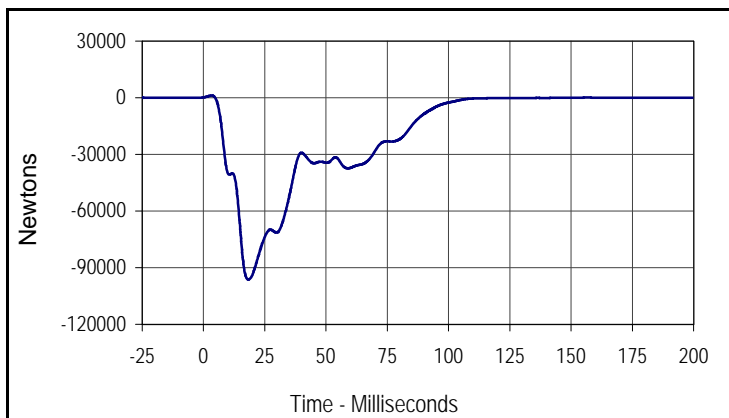

Curve Description			
Barrier Force B7			
CURNO	Type	SAE Class	Units
113	FIL	60	Newtons
Max	Time	Min	Time
1176.5	3.3	-96264.1	18.3



Curve Description			
Barrier Force C7			
CURNO	Type	SAE Class	Units
122	FIL	60	Newtons
Max	Time	Min	Time
832.3	2.8	-66074.0	13.5

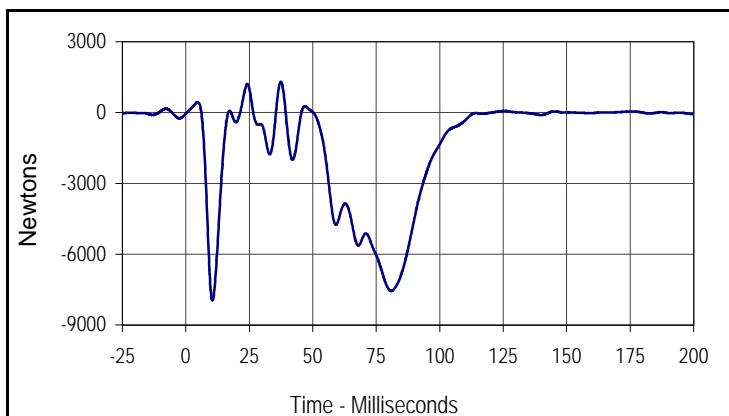

Curve Description			
Barrier Force D7			
CURNO	Type	SAE Class	Units
131	FIL	60	Newtons
Max	Time	Min	Time
1304.1	37.4	-7954.7	10.5

Test Vehicle: 2006 Honda Ridgeline RTS 4-Door Truck
 Test Program: 2005 NHTSA 35mph NCAP

Test Date: 4/14/05
 NHTSA No.: H65300

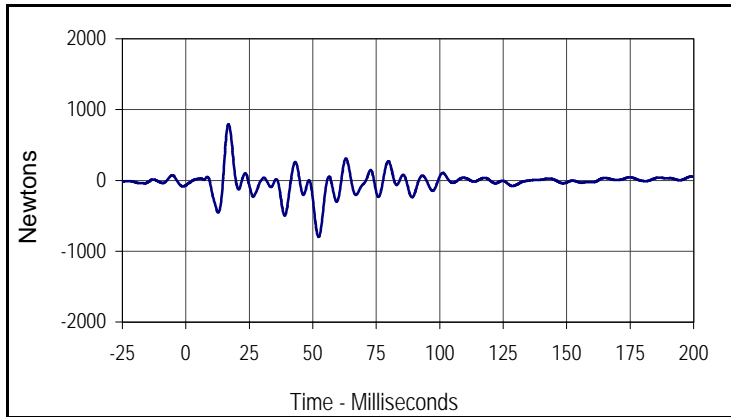

Curve Description			
Barrier Force A8			
CURNO	Type	SAE Class	Units
105	FIL	60	Newtons
Max	Time	Min	Time
791.0	16.8	-796.3	52.3

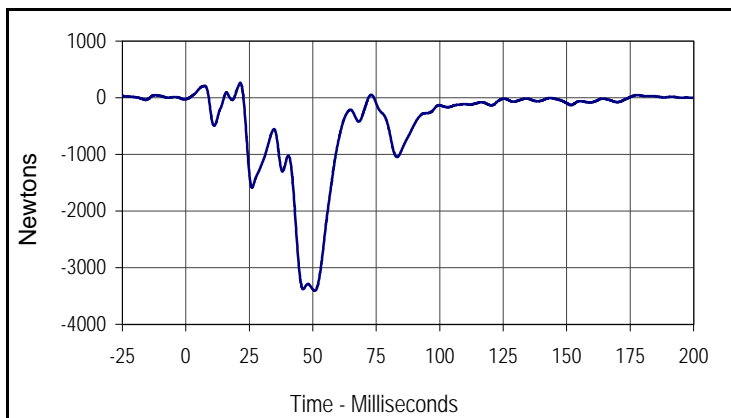

Curve Description			
Barrier Force B8			
CURNO	Type	SAE Class	Units
114	FIL	60	Newtons
Max	Time	Min	Time
263.1	21.4	-3407.7	50.8

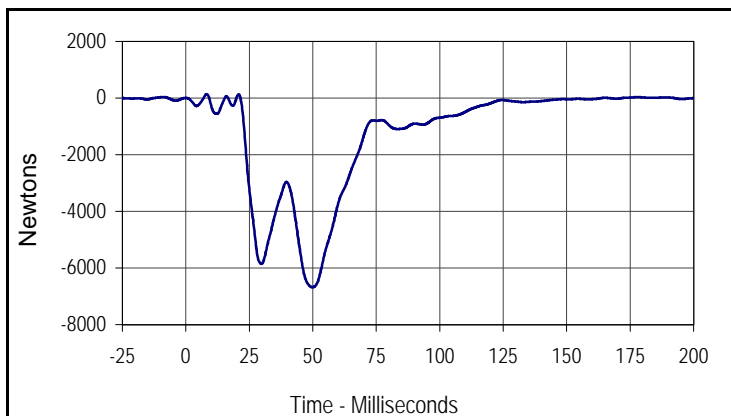

Curve Description			
Barrier Force C8			
CURNO	Type	SAE Class	Units
123	FIL	60	Newtons
Max	Time	Min	Time
140.8	8.2	-6680.2	49.9

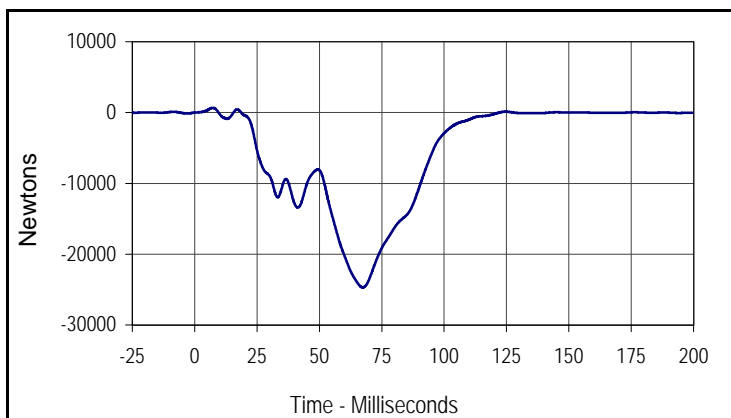

Curve Description			
Barrier Force D8			
CURNO	Type	SAE Class	Units
132	FIL	60	Newtons
Max	Time	Min	Time
653.7	7.2	-24693.9	67.4

Test Vehicle: 2006 Honda Ridgeline RTS 4-Door Truck
 Test Program: 2005 NHTSA 35mph NCAP

Test Date: 4/14/05
 NHTSA No.: H65300

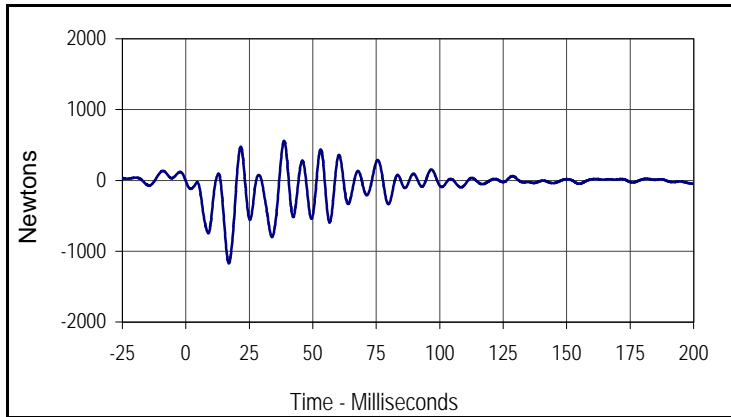

Curve Description			
Barrier Force A9			
CURNO	Type	SAE Class	Units
106	FIL	60	Newtons
Max	Time	Min	Time
558.1	38.7	-1174.0	17.0

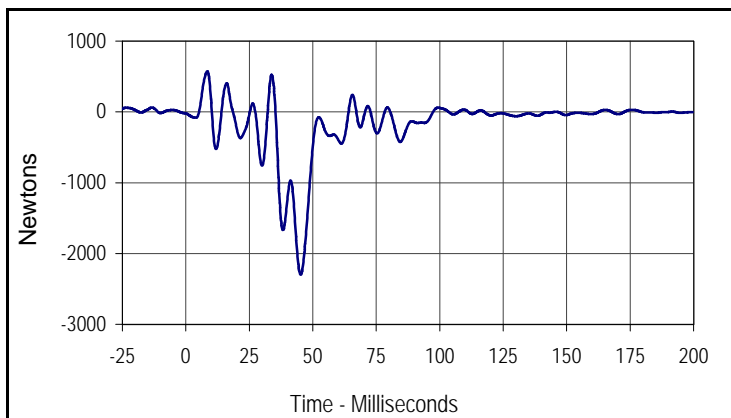

Curve Description			
Barrier Force B9			
CURNO	Type	SAE Class	Units
115	FIL	60	Newtons
Max	Time	Min	Time
572.5	8.4	-2298.1	45.2

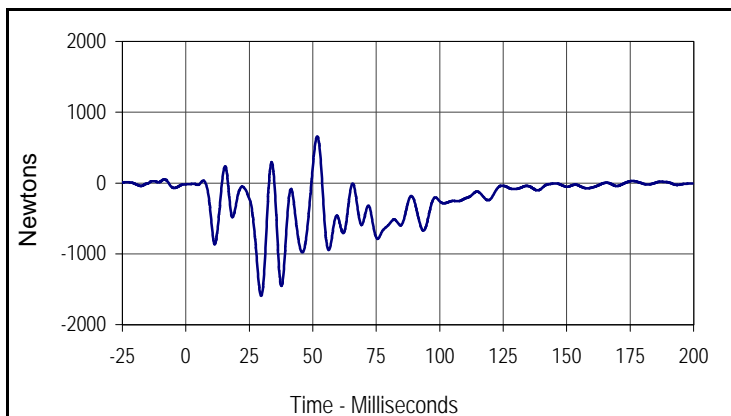

Curve Description			
Barrier Force C9			
CURNO	Type	SAE Class	Units
124	FIL	60	Newtons
Max	Time	Min	Time
657.9	51.7	-1591.7	29.7

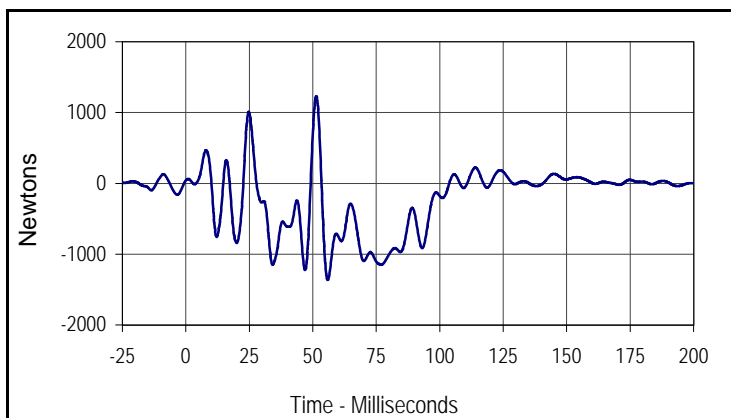

Curve Description			
Barrier Force D9			
CURNO	Type	SAE Class	Units
133	FIL	60	Newtons
Max	Time	Min	Time
1233.4	51.4	-1361.3	55.9

Test Vehicle: 2006 Honda Ridgeline RTS 4-Door Truck
 Test Program: 2005 NHTSA 35mph NCAP

Test Date: 4/14/05
 NHTSA No.: H65300

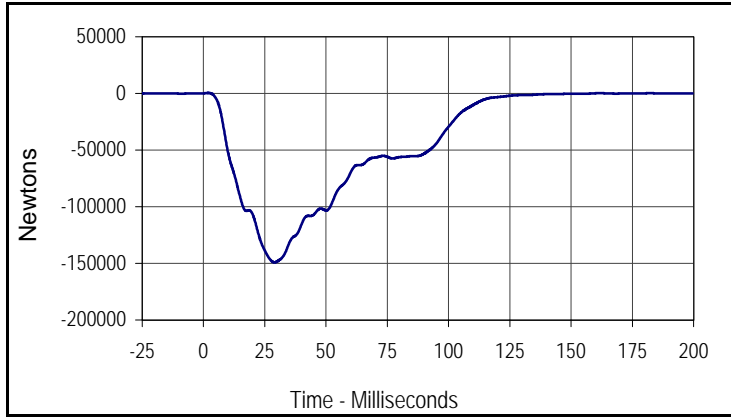

Curve Description			
Barrier Force Sum Group 1			
CURNO	Type	SAE Class	Units
001	SUM	60	Newtons
Max	Time	Min	Time
434.3	1.9	-149104.6	29.0

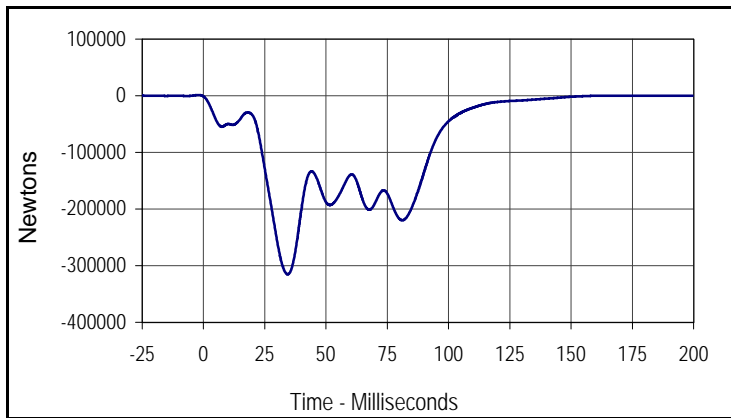

Curve Description			
Barrier Force Sum Group 2			
CURNO	Type	SAE Class	Units
002	SUM	60	Newtons
Max	Time	Min	Time
91.8	177.4	-315256.9	34.4

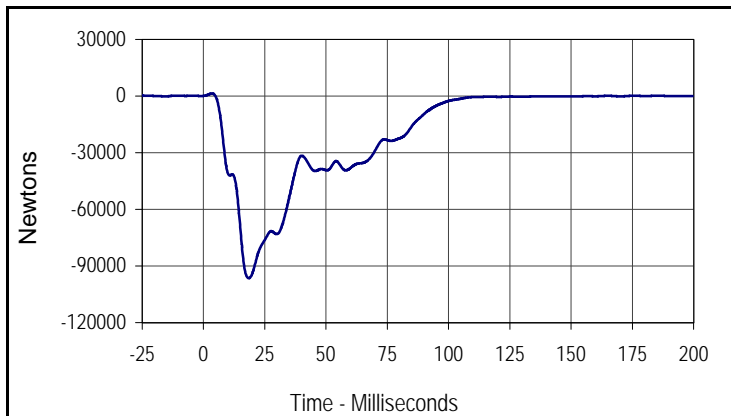

Curve Description			
Barrier Force Sum Group 3			
CURNO	Type	SAE Class	Units
003	SUM	60	Newtons
Max	Time	Min	Time
1343.8	3.5	-96455.1	18.5

Test Vehicle: 2006 Honda Ridgeline RTS 4-Door Truck
 Test Program: 2005 NHTSA 35mph NCAP

Test Date: 4/14/05
 NHTSA No.: H65300

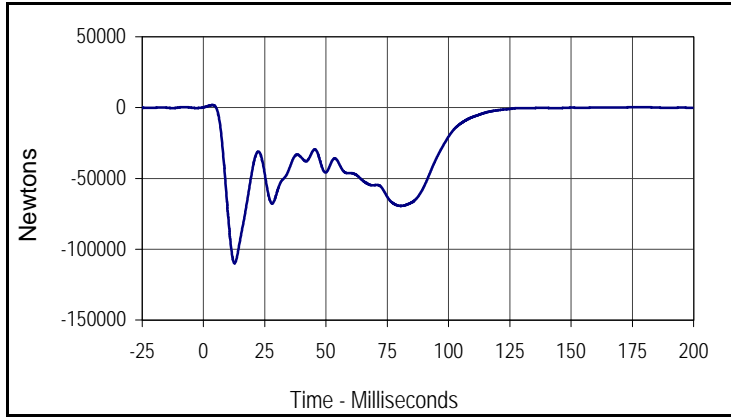

Curve Description			
Barrier Force Sum Group 4			
CURNO	Type	SAE Class	Units
004	SUM	60	Newtons
Max	Time	Min	Time
1803.3	3.7	-109889.0	12.7

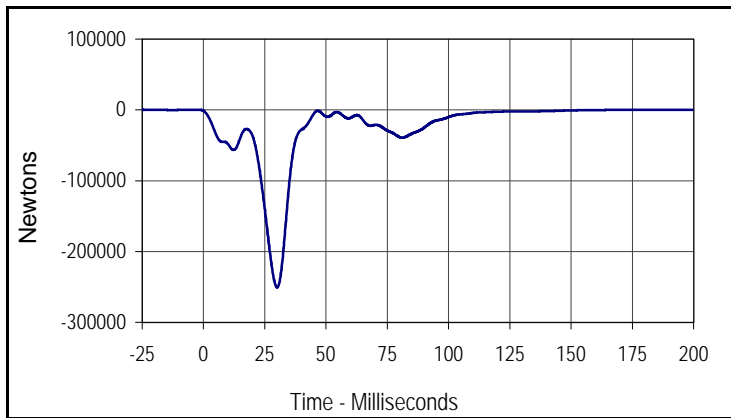

Curve Description			
Barrier Force Sum Group 5			
CURNO	Type	SAE Class	Units
005	SUM	60	Newtons
Max	Time	Min	Time
315.4	177.5	-250642.9	30.0

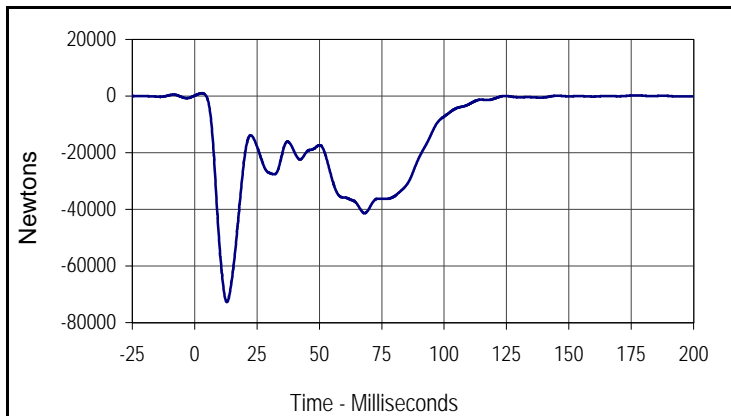

Curve Description			
Barrier Force Sum Group 6			
CURNO	Type	SAE Class	Units
006	SUM	60	Newtons
Max	Time	Min	Time
991.0	2.9	-72758.0	12.9

Test Vehicle: 2006 Honda Ridgeline RTS 4-Door Truck
 Test Program: 2005 NHTSA 35mph NCAP

Test Date: 4/14/05
 NHTSA No.: H65300

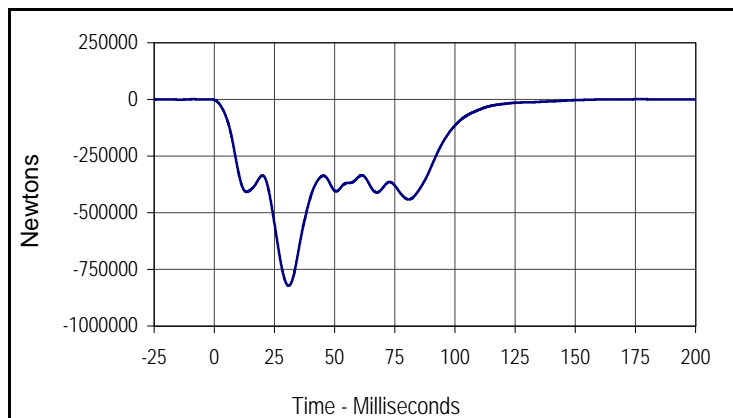

Curve Description			
Barrier Force Total Sum			
CURNO	Type	SAE Class	Units
007	SUM	60	Newtons
Max	Time	Min	Time
957.3	177.2	-822576.0	30.9

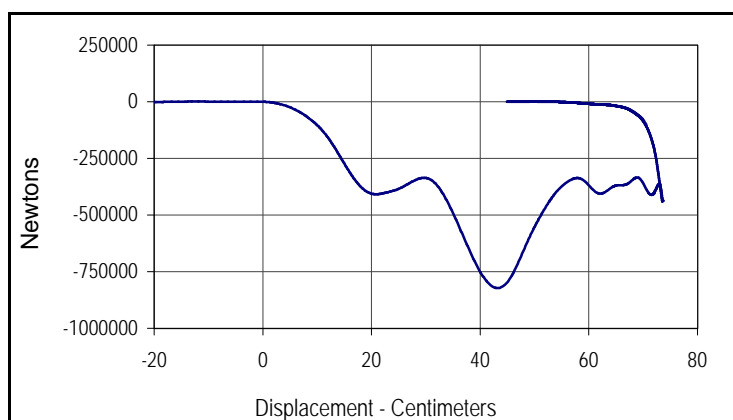

Curve Description			
Barrier Force Total Sum vs. Displ.			
CURNO	Type	SAE Class	Units
001	XVY	60	Newtons
Max	CM	Min	CM
957.3	50.0	-822576.0	42.3

BARRIER LOAD CELL SUMMARY DATA

Test Vehicle: 2006 Honda Ridgeline RTS 4-Door Truck

NHTSA No.: H65300

Test Program: 2005 NHTSA 35mph NCAP

Test Date: 4/14/05

Location	Units	Max	Time	Min	Time
Barrier Force A1	Newtons	1543.6	17.2	-1641.6	21.3
Barrier Force A2	Newtons	597.8	16.8	-13616.4	32.5
Barrier Force A3	Newtons	702.4	61.9	-1276.9	33.6
Barrier Force A4	Newtons	1210.4	21.6	-1925.1	50.6
Barrier Force A5	Newtons	595.3	22.0	-54276.0	53.4
Barrier Force A6	Newtons	877.2	21.5	-1847.8	25.4
Barrier Force A7	Newtons	833.1	22.1	-609.0	25.8
Barrier Force A8	Newtons	791.0	16.8	-796.3	52.3
Barrier Force A9	Newtons	558.1	38.7	-1174.0	17.0
Barrier Force B1	Newtons	895.3	15.9	-4859.9	85.6
Barrier Force B2	Newtons	930.2	3.9	-65015.8	24.1
Barrier Force B3	Newtons	233.1	0.3	-80874.6	28.2
Barrier Force B4	Newtons	49.7	176.7	-115324.0	35.4
Barrier Force B5	Newtons	23.6	199.5	-95971.6	33.6
Barrier Force B6	Newtons	369.6	0.0	-106338.1	30.2
Barrier Force B7	Newtons	1176.5	3.3	-96264.1	18.3
Barrier Force B8	Newtons	263.1	21.4	-3407.7	50.8
Barrier Force B9	Newtons	572.5	8.4	-2298.1	45.2
Barrier Force C1	Newtons	1036.2	15.8	-7749.0	28.3
Barrier Force C2	Newtons	902.2	3.4	-32447.1	12.6
Barrier Force C3	Newtons	252.3	1.2	-57256.7	14.3
Barrier Force C4	Newtons	22.4	174.8	-29635.1	32.3
Barrier Force C5	Newtons	30.5	177.5	-80005.0	30.1
Barrier Force C6	Newtons	199.4	0.0	-128633.0	29.7
Barrier Force C7	Newtons	832.3	2.8	-66074.0	13.5
Barrier Force C8	Newtons	140.8	8.2	-6680.2	49.9
Barrier Force C9	Newtons	657.9	51.7	-1591.7	29.7
Barrier Force D1	Newtons	1810.1	16.3	-12175.1	28.8
Barrier Force D2	Newtons	889.3	16.2	-17687.0	82.3
Barrier Force D3	Newtons	927.3	4.4	-20992.2	11.2
Barrier Force D4	Newtons	1407.3	37.6	-11556.1	11.9
Barrier Force D5	Newtons	1483.0	46.4	-9761.9	31.4
Barrier Force D6	Newtons	2266.1	37.5	-9177.3	12.2
Barrier Force D7	Newtons	1304.1	37.4	-7954.7	10.5
Barrier Force D8	Newtons	653.7	7.2	-24693.9	67.4
Barrier Force D9	Newtons	1233.4	51.4	-1361.3	55.9
Barrier Force Sum Group 1	Newtons	434.3	1.9	-149104.6	29.0
Barrier Force Sum Group 2	Newtons	91.8	177.4	-315256.9	34.4
Barrier Force Sum Group 3	Newtons	1343.8	3.5	-96455.1	18.5
Barrier Force Sum Group 4	Newtons	1803.3	3.7	-109889.0	12.7
Barrier Force Sum Group 5	Newtons	315.4	177.5	-250642.9	30.0
Barrier Force Sum Group 6	Newtons	991.0	2.9	-72758.0	12.9
Barrier Force Total Sum	Newtons	957.3	177.2	-822576.0	30.9

APPENDIX D

INSTRUMENTATION DATA CHANNEL ASSIGNMENTS

**2005 NHTSA 35mph NCAP
Instrumentation Data Channel Assignments
Driver A.T.D. Serial Number 35
4/14/05
2006 Honda Ridgeline RTS 4-Door Truck**

CH.	LOCATION	AXIS	IDENT. NO.	DESCRIPTION	MFR	MODEL	UNITS
1	HEAD, PRIMARY	X	GPAC027	Accel., 1/2 bridge	Endevco	7264-2000	G
2	HEAD, PRIMARY	Y	GPAC002	Accel., 1/2 bridge	Endevco	7264-2000	G
3	HEAD, PRIMARY	Z	GPAC003	Accel., 1/2 bridge	Endevco	7264-2000	G
4	HEAD, REDUNDANT	X	GPAC032	Accel., 1/2 bridge	Endevco	7264-2000	G
5	HEAD, REDUNDANT	Y	GPAC021	Accel., 1/2 bridge	Endevco	7264-2000	G
6	HEAD, REDUNDANT	Z	GPAC026	Accel., 1/2 bridge	Endevco	7264-2000	G
7	NECK FORCE	X	GPUN01FX	Load cell, six axis neck	R. A. Denton	1716A	N
8	NECK FORCE	Y	GPUN01FY	Load cell, six axis neck	R. A. Denton	1716A	N
9	NECK FORCE	Z	GPUN01FZ	Load cell, six axis neck	R. A. Denton	1716A	N
10	NECK MOMENT	X	GPUN01MX	Load cell, six axis neck	R. A. Denton	1716A	Nm
11	NECK MOMENT	Y	GPUN01MY	Load cell, six axis neck	R. A. Denton	1716A	Nm
12	NECK MOMENT	Z	GPUN01MZ	Load cell, six axis neck	R. A. Denton	1716A	Nm
13	CHEST, PRIMARY	X	GPAC005	Accel., 1/2 bridge	Endevco	7264-2000	G
14	CHEST, PRIMARY	Y	GPAC011	Accel., 1/2 bridge	Endevco	7264-2000	G
15	CHEST, PRIMARY	Z	GPAC010	Accel., 1/2 bridge	Endevco	7264-2000	G
16	CHEST, REDUNDANT	X	GPAC034	Accel., 1/2 bridge	Endevco	7264-2000	G
17	CHEST, REDUNDANT	Y	GPAC023	Accel., 1/2 bridge	Endevco	7264-2000	G
18	CHEST, REDUNDANT	Z	GPAC020	Accel., 1/2 bridge	Endevco	7264-2000	G
19	CHEST DEFLECTION	X	GPCP002	Rotary Pot Chest	Servo	14CBI	MM
20	PELVIS, PRIMARY	X	GPAC025	Accel., 1/2 bridge	Endevco	7264-2000	G
21	PELVIS, PRIMARY	Y	GPAC022	Accel., 1/2 bridge	Endevco	7264-2000	G
22	PELVIS, PRIMARY	Z	GPAC019	Accel., 1/2 bridge	Endevco	7264-2000	G
23	LEFT FEMUR FORCE	Z	KEFF003	Load cell, Femur	R.A. Denton	2121	N
24	RIGHT FEMUR FORCE	Z	KEFF004	Load cell, Femur	R.A. Denton	2121	N

**2005 NHTSA 35mph NCAP
Instrumentation Data Channel Assignments
Driver A.T.D. Serial Number 35
4/14/05
2006 Honda Ridgeline RTS 4-Door Truck**

CH.	LOCATION	AXIS	IDENT. NO.	DESCRIPTION	MFR	MODEL	UNITS
25	UP. TIBIA LEFT MOM.	X	GPUT09MX	2 ch., Upper tibia gage	R. A. Denton	1583	Nm
26	UP. TIBIA LEFT MOM.	Y	GPUT09MY	2 ch., Upper tibia gage	R. A. Denton	1583	Nm
27	UP. TIBIA RIGHT MOM.	X	GPUT09MX	2 ch., Upper tibia gage	R. A. Denton	1583	Nm
28	UP. TIBIA RIGHT MOM.	Y	GPUT09MY	2 ch., Upper tibia gage	R. A. Denton	1583	Nm
29	LWR. TIBIA LEFT MOM.	X	GPLT09MX	3 ch., lower tibia gage	R. A. Denton	3093	Nm
30	LWR. TIBIA LEFT MOM.	Y	GPLT09MY	3 ch., lower tibia gage	R. A. Denton	3093	Nm
31	LWR. TIBIA LEFT FORCE	Z	GPLT09FZ	3 ch., lower tibia gage	R. A. Denton	3093	N
32	LWR. TIBIA RIGHT MOM.	X	GPLT09MX	3 ch., lower tibia gage	R. A. Denton	3093	Nm
33	LWR. TIBIA RIGHT MOM.	Y	GPLT09MY	3 ch., lower tibia gage	R. A. Denton	3093	Nm
34	LWR. TIBIA RIGHT FORCE	Z	GPLT09FZ	3 ch., lower tibia gage	R. A. Denton	3093	N
35	FOOT LEFT, AFT	X	KEIC002X	Accel., Foot Triax	I.C. Sensor	3031-500	G
36	FOOT LEFT, AFT	Z	KEIC002Y	Accel., Foot Triax	I.C. Sensor	3031-500	G
37	FOOT LEFT, FORE	Z	KEIC002Z	Accel., Foot Triax	I.C. Sensor	3031-500	G
38	FOOT RIGHT, AFT	X	KEIC001X	Accel., Foot Triax	I.C. Sensor	3031-500	G
39	FOOT RIGHT, AFT	Z	KEIC001Y	Accel., Foot Triax	I.C. Sensor	3031-500	G
40	FOOT RIGHT, FORE	Z	KEIC001Z	Accel., Foot Triax	I.C. Sensor	3031-500	G
41	LAP BELT FORCE	X	BL134	Load cell, Seat belt	FGP	FN4060	N
42	SHOULDER BELT FORCE	X	BL135	Load cell, Seat belt	FGP	FN4060	N
43	SHOULDER BELT SPOOL	X	KEPP001	Pullout pot	Celesco	PTX101-0030	MM
44	SHOULDER BELT ELONG.	X	KEEP001	Linear pot., belt stretch	E.T.I.	LCP8-10 10K	MM/CM

**2005 NHTSA 35mph NCAP
Instrumentation Data Channel Assignments
Passenger A.T.D. Serial Number 34
4/14/05
2006 Honda Ridgeline RTS 4-Door Truck**

CH.	LOCATION	AXIS	IDENT. NO.	DESCRIPTION	MFR	MODEL	UNITS
45	HEAD, PRIMARY	X	KEAC039	Accel., 1/2 bridge	Endevco	7264-2000	G
46	HEAD, PRIMARY	Y	KEAC038	Accel., 1/2 bridge	Endevco	7264-2000	G
47	HEAD, PRIMARY	Z	KEAC027	Accel., 1/2 bridge	Endevco	7264-2000	G
48	HEAD, REDUNDANT	X	KEAC031	Accel., 1/2 bridge	Endevco	7264-2000	G
49	HEAD, REDUNDANT	Y	KEAC032	Accel., 1/2 bridge	Endevco	7264-2000	G
50	HEAD, REDUNDANT	Z	KEAC026	Accel., 1/2 bridge	Endevco	7264-2000	G
51	NECK FORCE	X	GPUN02FX	Load cell, six axis neck	R. A. Denton	1716A	N
52	NECK FORCE	Y	GPUN02FY	Load cell, six axis neck	R. A. Denton	1716A	N
53	NECK FORCE	Z	GPUN02FZ	Load cell, six axis neck	R. A. Denton	1716A	N
54	NECK MOMENT	X	GPUN02MX	Load cell, six axis neck	R. A. Denton	1716A	Nm
55	NECK MOMENT	Y	GPUN02MY	Load cell, six axis neck	R. A. Denton	1716A	Nm
56	NECK MOMENT	Z	GPUN02MZ	Load cell, six axis neck	R. A. Denton	1716A	Nm
57	CHEST, PRIMARY	X	GPAC031	Accel., 1/2 bridge	Endevco	7264-2000	G
58	CHEST, PRIMARY	Y	GPAC024	Accel., 1/2 bridge	Endevco	7264-2000	G
59	CHEST, PRIMARY	Z	GPAC029	Accel., 1/2 bridge	Endevco	7264-2000	G
60	CHEST, REDUNDANT	X	KEAC023	Accel., 1/2 bridge	Endevco	7264-200	G
61	CHEST, REDUNDANT	Y	KEAC022	Accel., 1/2 bridge	Endevco	7264-200	G
62	CHEST, REDUNDANT	Z	KEAC024	Accel., 1/2 bridge	Endevco	7264-200	G
63	CHEST DEFLECTION	X	GPCP001	Rotary Pot Chest	Servo	14CBI	MM
64	PELVIS, PRIMARY	X	KEAC019	Accel., 1/2 bridge	Endevco	7264-200	G
65	PELVIS, PRIMARY	Y	KEAC020	Accel., 1/2 bridge	Endevco	7264-200	G
66	PELVIS, PRIMARY	Z	KEAC021	Accel., 1/2 bridge	Endevco	7264-200	G
67	LEFT FEMUR FORCE	Z	KEFF001	Load cell, Femur	R.A. Denton	2121	N
68	RIGHT FEMUR FORCE	Z	KEFF002	Load cell, Femur	R.A. Denton	2121	N

**2005 NHTSA 35mph NCAP
Instrumentation Data Channel Assignments
Passenger A.T.D. Serial Number 34
4/14/05
2006 Honda Ridgeline RTS 4-Door Truck**

CH.	LOCATION	AXIS	IDENT. NO.	DESCRIPTION	MFR	MODEL	UNITS
69	UP. TIBIA LEFT MOM.	X	GPUT09MX	2 ch., Upper tibia gage	R. A. Denton	1583	Nm
70	UP. TIBIA LEFT MOM.	Y	GPUT09MY	2 ch., Upper tibia gage	R. A. Denton	1583	Nm
71	UP. TIBIA RIGHT MOM.	X	GPUT09MX	2 ch., Upper tibia gage	R. A. Denton	1583	Nm
72	UP. TIBIA RIGHT MOM.	Y	GPUT09MY	2 ch., Upper tibia gage	R. A. Denton	1583	Nm
73	LWR. TIBIA LEFT MOM.	X	GPLT09MX	3 ch., lower tibia gage	R. A. Denton	3093	Nm
74	LWR. TIBIA LEFT MOM.	Y	GPLT09MY	3 ch., lower tibia gage	R. A. Denton	3093	Nm
75	LWR. TIBIA LEFT FORCE	Z	GPLT09FZ	3 ch., lower tibia gage	R. A. Denton	3093	N
76	LWR. TIBIA RIGHT MOM.	X	GPLT09MX	3 ch., lower tibia gage	R. A. Denton	3093	Nm
77	LWR. TIBIA RIGHT MOM.	Y	GPLT09MY	3 ch., lower tibia gage	R. A. Denton	3093	Nm
78	LWR. TIBIA RIGHT FORCE	Z	GPLT09FZ	3 ch., lower tibia gage	R. A. Denton	3093	N
79	FOOT LEFT, AFT	X	KEIC003X	Accel., Foot Triax	I.C. Sensor	3031-500	G
80	FOOT LEFT, AFT	Z	KEIC003Y	Accel., Foot Triax	I.C. Sensor	3031-500	G
81	FOOT LEFT, FORE	Z	KEIC003Z	Accel., Foot Triax	I.C. Sensor	3031-500	G
82	FOOT RIGHT, AFT	X	KEIC004X	Accel., Foot Triax	I.C. Sensor	3031-500	G
83	FOOT RIGHT, AFT	Z	KEIC004Y	Accel., Foot Triax	I.C. Sensor	3031-500	G
84	FOOT RIGHT, FORE	Z	KEIC004Z	Accel., Foot Triax	I.C. Sensor	3031-500	G
85	LAP BELT FORCE	X	BL168	Load cell, Seat belt	First Tech	IF-964	N
86	SHOULDER BELT FORCE	X	BL169	Load cell, Seat belt	First Tech	IF-964	N
87	SHOULDER BELT SPOOL	X	KEPP001	Pullout pot	Celesco	PTX101-0030	MM
88	SHOULDER BELT ELONG.	X	KEEP001	Linear pot., belt stretch	E.T.I.	LCP8-10 10K	MM/CM

**2005 NHTSA 35mph NCAP
Instrumentation Data Channel Assignments
Vehicle Accelerometers
4/14/05
2006 Honda Ridgeline RTS 4-Door Truck**

CH.	LOCATION	AXIS	IDENT. NO.	DESCRIPTION	MFR	MODEL	UNITS
89	LEFT REAR	X	KEVA002	Accel., Pre-Amp	I.C.S/Karco	3031-500	G
90	RIGHT REAR	X	KEVA006	Accel., Vehicle block	I.C. Sensor	3031-200	G
91	ENGINE TOP	X	KEVA009	Accel., Vehicle block	I.C. Sensor	3031-500	G
92	ENGINE BOTTOM	X	KEVA007	Accel., Vehicle block	I.C. Sensor	3031-500	G
93	LEFT BRAKE CALIPER	X	KEVA008	Accel., Vehicle block	I.C. Sensor	3031-500	G
94	RIGHT BRAKE CALIPER	X	KEVA012	Accel., Vehicle block	I.C. Sensor	3031-500	G
95	INSTRUMENT PANEL	X	KEVA011	Accel., Vehicle block	I.C. Sensor	3031-200	G
96	LEFT REAR	Z	KEVA001	Accel., Vehicle block	I.C. Sensor	3031-500	G
97	RIGHT REAR	Z	KEVA010	Accel., Vehicle block	I.C. Sensor	3031-200	G

**2005 NHTSA 35mph NCAP
Instrumentation Data Channel Assignments
Rigid Load Cell Barrier
4/14/05
2006 Honda Ridgeline RTS 4-Door Truck**

CH.	LOCATION	AXIS	IDENT. NO.	DESCRIPTION	MFR	MODEL	UNITS
98	BARRIER FORCE A1	X	BARRIER	Load Cell, LCB	Interface	1220-FS	N
99	BARRIER FORCE A2	X	BARRIER	Load Cell, LCB	Interface	1220-FS	N
100	BARRIER FORCE A3	X	BARRIER	Load Cell, LCB	Interface	1220-FS	N
101	BARRIER FORCE A4	X	BARRIER	Load Cell, LCB	Interface	1220-FS	N
102	BARRIER FORCE A5	X	BARRIER	Load Cell, LCB	Interface	1220-FS	N
103	BARRIER FORCE A6	X	BARRIER	Load Cell, LCB	Interface	1220-FS	N
104	BARRIER FORCE A7	X	BARRIER	Load Cell, LCB	Interface	1220-FS	N
105	BARRIER FORCE A8	X	BARRIER	Load Cell, LCB	Interface	1220-FS	N
106	BARRIER FORCE A9	X	BARRIER	Load Cell, LCB	Interface	1220-FS	N
107	BARRIER FORCE B1	X	BARRIER	Load Cell, LCB	Interface	1220-FS	N
108	BARRIER FORCE B2	X	BARRIER	Load Cell, LCB	Interface	1220-FS	N
109	BARRIER FORCE B3	X	BARRIER	Load Cell, LCB	Interface	1220-FS	N
110	BARRIER FORCE B4	X	BARRIER	Load Cell, LCB	Interface	1220-FS	N
111	BARRIER FORCE B5	X	BARRIER	Load Cell, LCB	Interface	1220-FS	N
112	BARRIER FORCE B6	X	BARRIER	Load Cell, LCB	Interface	1220-FS	N
113	BARRIER FORCE B7	X	BARRIER	Load Cell, LCB	Interface	1220-FS	N
114	BARRIER FORCE B8	X	BARRIER	Load Cell, LCB	Interface	1220-FS	N
115	BARRIER FORCE B9	X	BARRIER	Load Cell, LCB	Interface	1220-FS	N

**2005 NHTSA 35mph NCAP
Instrumentation Data Channel Assignments
Rigid Load Cell Barrier
4/14/05
2006 Honda Ridgeline RTS 4-Door Truck**

CH.	LOCATION	AXIS	IDENT. NO.	DESCRIPTION	MFR	MODEL	UNITS
116	BARRIER FORCE C1	X	BARRIER	Load Cell, LCB	Interface	1220-FS	N
117	BARRIER FORCE C2	X	BARRIER	Load Cell, LCB	Interface	1220-FS	N
118	BARRIER FORCE C3	X	BARRIER	Load Cell, LCB	Interface	1220-FS	N
119	BARRIER FORCE C4	X	BARRIER	Load Cell, LCB	Interface	1220-FS	N
120	BARRIER FORCE C5	X	BARRIER	Load Cell, LCB	Interface	1220-FS	N
121	BARRIER FORCE C6	X	BARRIER	Load Cell, LCB	Interface	1220-FS	N
122	BARRIER FORCE C7	X	BARRIER	Load Cell, LCB	Interface	1220-FS	N
123	BARRIER FORCE C8	X	BARRIER	Load Cell, LCB	Interface	1220-FS	N
124	BARRIER FORCE C9	X	BARRIER	Load Cell, LCB	Interface	1220-FS	N
125	BARRIER FORCE D1	X	BARRIER	Load Cell, LCB	Interface	1220-FS	N
126	BARRIER FORCE D2	X	BARRIER	Load Cell, LCB	Interface	1220-FS	N
127	BARRIER FORCE D3	X	BARRIER	Load Cell, LCB	Interface	1220-FS	N
128	BARRIER FORCE D4	X	BARRIER	Load Cell, LCB	Interface	1220-FS	N
129	BARRIER FORCE D5	X	BARRIER	Load Cell, LCB	Interface	1220-FS	N
130	BARRIER FORCE D6	X	BARRIER	Load Cell, LCB	Interface	1220-FS	N
131	BARRIER FORCE D7	X	BARRIER	Load Cell, LCB	Interface	1220-FS	N
132	BARRIER FORCE D8	X	BARRIER	Load Cell, LCB	Interface	1220-FS	N
133	BARRIER FORCE D9	X	BARRIER	Load Cell, LCB	Interface	1220-FS	N

APPENDIX E
DUMMY CALIBRATION DATA

Test Program: Hybrid III 50th Percentile Male Head Drop Test

Test Date: 3/28/05

ATD Serial No.: 034

Test I.D.: HD03G



Tested Parameter	Units	Specification	Result	Pass/Fail
Laboratory Temperature	°C	18.9 to 25.6	21.1	Pass
Laboratory Relative Humidity	%	10 to 70	30	Pass
Peak Resultant Acceleration	G's	225.0 to 275.0	234.0	Pass
Peak Lateral Acceleration	G's	≤15.0	6.2	Pass
Is Acceleration Unimodal?	Yes/No	Yes	Yes	Pass
Overall Test Results			Pass	

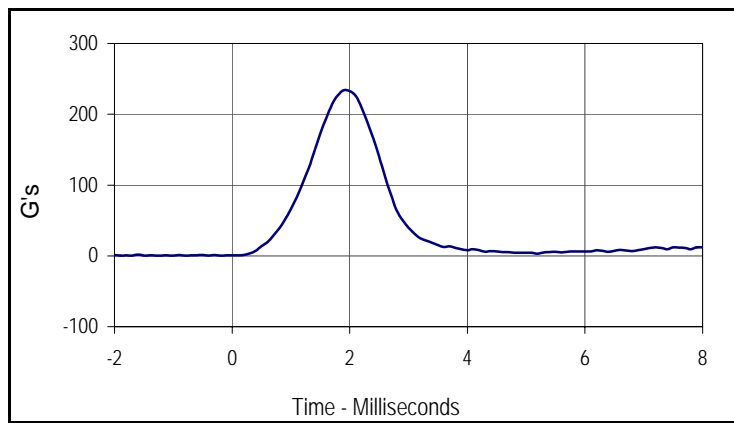

Curve Description			
Head Resultant			
CURNO	Type	SAE Class	Units
001	RES	1000	G's
Max	Time	Min	Time
234.0	1.9	0.3	-1.9

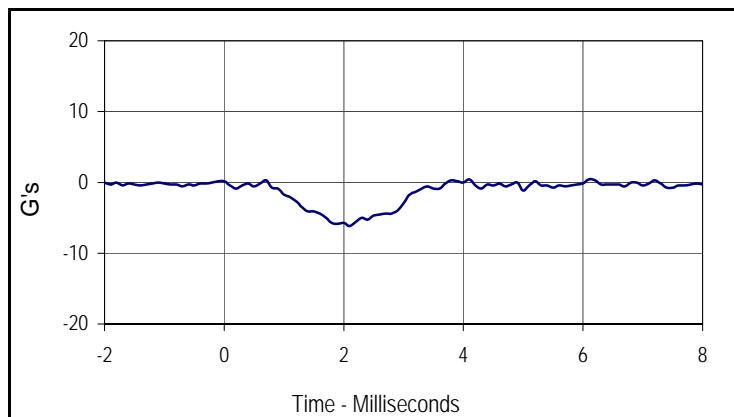

Curve Description			
Head Y			
CURNO	Type	SAE Class	Units
002	FIL	1000	G's
Max	Time	Min	Time
0.4	4.1	-6.2	2.1

Test Program: Hybrid III 50th Percentile Male Thorax Impact Test

Test Date: 3/29/05

ATD Serial No.: 034

Test I.D.: CH03H



Tested Parameter	Units	Specification	Result	Pass/Fail
Laboratory Temperature	°C	20.6 to 22.2	21.1	Pass
Laboratory Relative Humidity	%	10 to 70	30	Pass
Probe Velocity	m/s	6.58 to 6.82	6.74	Pass
Peak Probe Force	Newtons	5159 to 5893	5445	Pass
Peak Sternum Displacement	CM	6.35 to 7.26	6.43	Pass
Internal Hysteresis	%	69 to 85	73.3	Pass
Overall Test Results				Pass

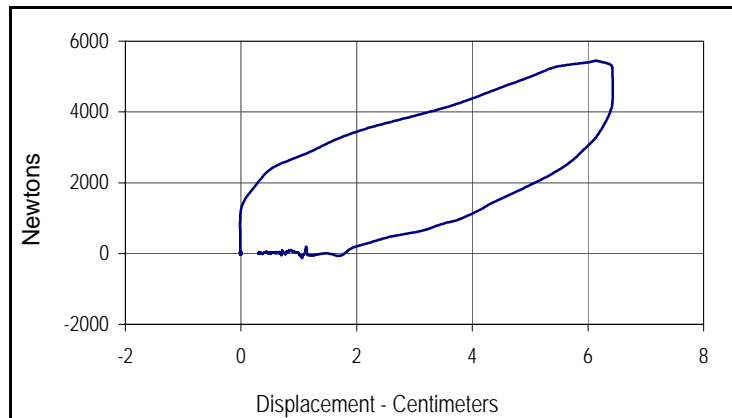

Curve Description			
Probe Force vs. Chest Deflection			
CURNO	Type	SAE Class	Hysteresis
001	FIL	180	73.3
Peak Probe Force		Peak Chest Deflection	
5445		6.43	

Test Program: Hybrid III 50th Percentile Male Neck Flexion Test

Test Date: 3/29/05

ATD Serial No.: 034

Test I.D.: NF03J



Tested Parameter	Units	Specification	Result	Pass/Fail	
Laboratory Temperature	°C	20.6 to 22.2	21.1	Pass	
Laboratory Relative Humidity	%	10 to 70	30	Pass	
Pendulum Velocity	m/s	6.89 to 7.13	7.11	Pass	
Pendulum Deceleration	10 Msec.	G's	22.5 to 27.5	22.7	Pass
	20 Msec.	G's	17.6 to 22.6	20.1	Pass
	30 Msec.	G's	12.5 to 18.5	16.9	Pass
Peak Pendulum Decel. after 30 Msec.	G's	≤ 29.0	16.9	Pass	
Deceleration Decay, Time to Cross 5 G's	Msec.	34.0 to 42.0	40.7	Pass	
Maximum "D" Plane Rotation	Max	Degrees	64.0 to 78.0	70.4	Pass
	Time	Msec.	57.0 to 64.0	63.5	Pass
"D" Plane Rotation Decay, Time To Zero Crossing	Msec.	113.0 to 128.0	125.5	Pass	
Moment About Occ. Condyle	Max	Nm	84.1 to 108.5	91.7	Pass
	Time	Msec.	47.0 to 58.0	57.1	Pass
Positive Moment Decay, Time To Zero Crossing	Msec.	97.0 to 107.0	103.8	Pass	
Overall Test Results				Pass	

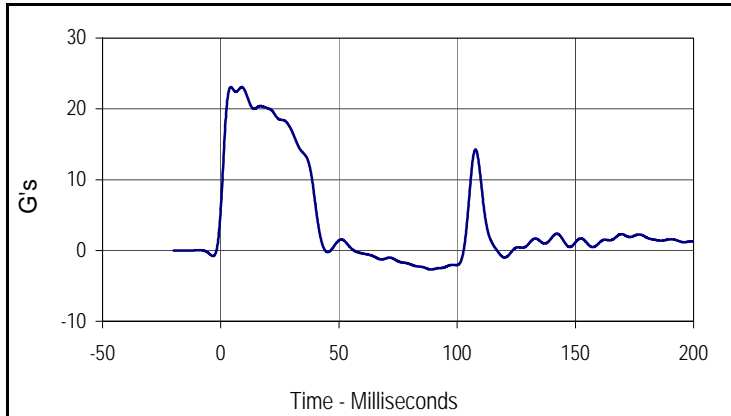

Curve Description			
Pendulum Deceleration			
CURNO	Type	SAE Class	Units
001	FIL	60	G's
Max	Time	Min	Time
23.1	4.2	-2.7	88.9

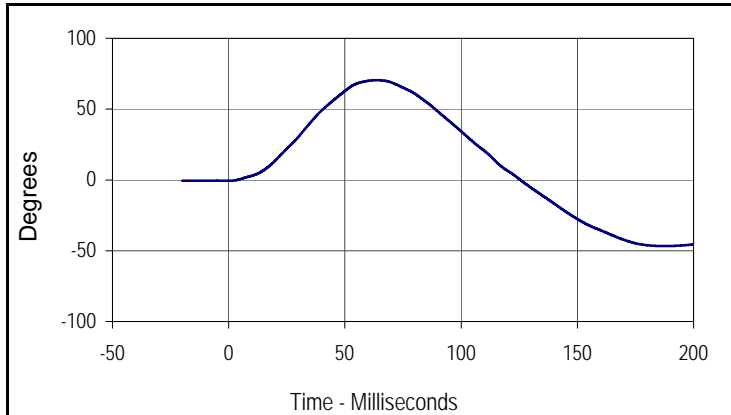

Curve Description			
"D" Plane Rotation			
CURNO	Type	SAE Class	Units
003	FIL	60	Degrees
Max	Time	Min	Time
70.4	63.5	-46.7	187.5

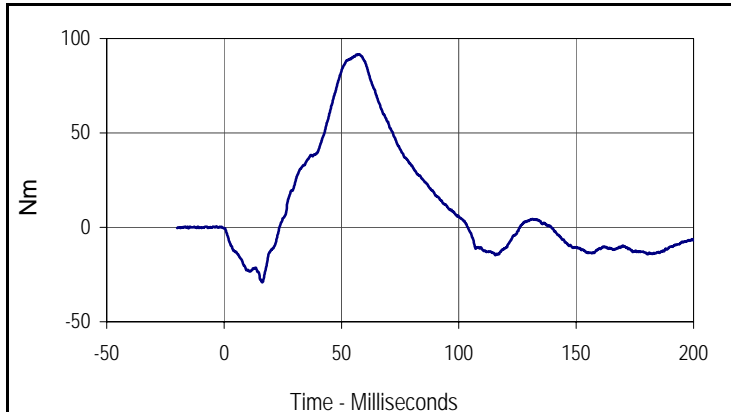

Curve Description			
Moment About Occipital Condyle			
CURNO	Type	SAE Class	Units
004	FIL	600	Nm
Max	Time	Min	Time
91.7	57.1	-29.1	16.3



Tested Parameter	Units	Specification	Result	Pass/Fail	
Laboratory Temperature	°C	20.6 to 22.2	21.1	Pass	
Laboratory Relative Humidity	%	10 to 70	30	Pass	
Pendulum Velocity	m/s	5.94 to 6.19	6.08	Pass	
Pendulum Deceleration	10 Msec.	G's	17.2 to 21.2	17.9	Pass
	20 Msec.	G's	14.0 to 19.0	17.3	Pass
	30 Msec.	G's	11.0 to 16.0	15.0	Pass
Peak Pendulum Decel. after 30 Msec.	G's	≤ 22.0	15.0	Pass	
Deceleration Decay, Time to Cross 5 G's	Msec.	38.0 to 46.0	40.0	Pass	
Maximum "D" Plane Rotation	Max	Degrees	81.0 to 106.0	93.3	Pass
	Time	Msec.	72.0 to 82.0	75.7	Pass
"D" Plane Rotation Decay, Time To Zero Crossing	Msec.	147.0 to 174.0	155	Pass	
Moment About Occ. Condyle	Max	Nm	-52.9 to- 79.9	-55.3	Pass
	Time	Msec.	65.0 to 79.0	65.1	Pass
Positive Moment Decay, Time To Zero Crossing	Msec.	120.0 to 148.0	146.4	Pass	
Overall Test Results				Pass	

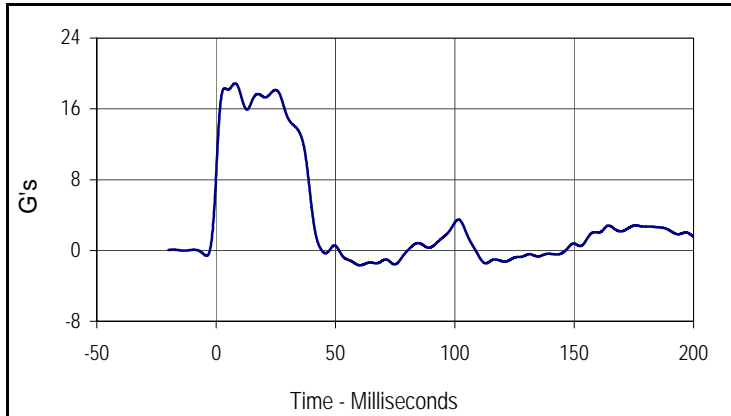

Curve Description			
Pendulum Deceleration			
CURNO	Type	SAE Class	Units
001	FIL	60	G's
Max	Time	Min	Time
18.9	8.0	-1.7	60.3

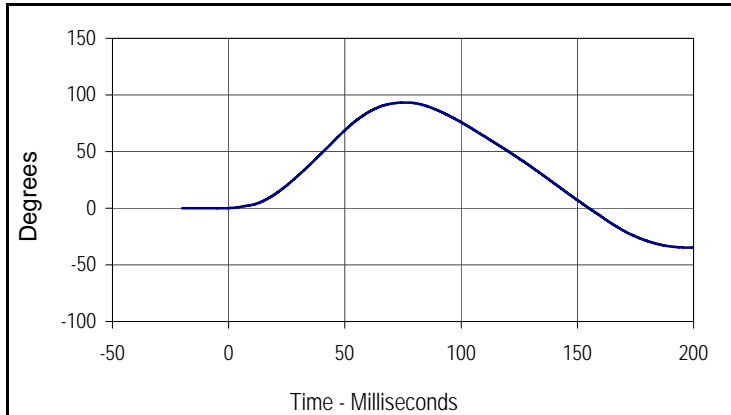

Curve Description			
"D" Plane Rotation			
CURNO	Type	SAE Class	Units
003	FIL	60	Degrees
Max	Time	Min	Time
93.3	75.7	-34.7	198.1

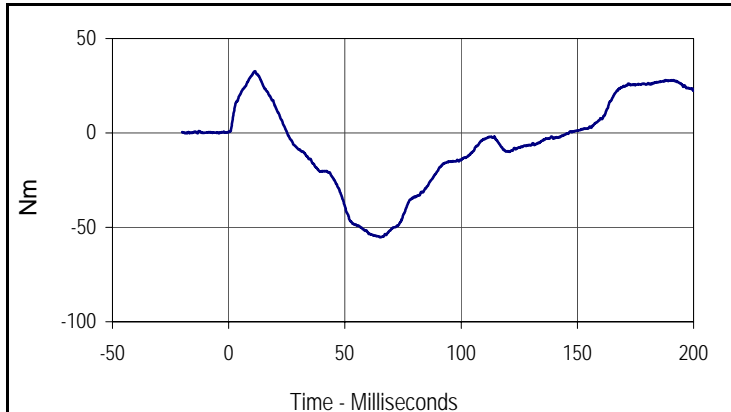

Curve Description			
Moment About Occipital Condyle			
CURNO	Type	SAE Class	Units
004	FIL	600	Nm
Max	Time	Min	Time
32.7	11.4	-55.3	65.1

Test Program: Hybrid III 50th Percentile Male Knee Impact Test

Test Date: 3/29/05

ATD Serial No.: 034

Test I.D.: LK03G , RK03G



Left Knee

Tested Parameter	Units	Specification	Result	Pass/Fail
Laboratory Temperature	°C	18.9 to 25.6	21.1	Pass
Laboratory Relative Humidity	%	10 to 70	30	Pass
Pendulum Velocity at T=0	m/sec	2.07 to 2.13	2.10	Pass
Peak Probe Force	Newtons	4715 to 5782	5216	Pass
Overall Test Results				Pass

Right Knee

Pendulum Velocity at T=0	m/sec	2.07 to 2.13	2.13	Pass
Peak Probe Force	Newtons	4715 to 5782	5406	Pass
Overall Test Results				Pass

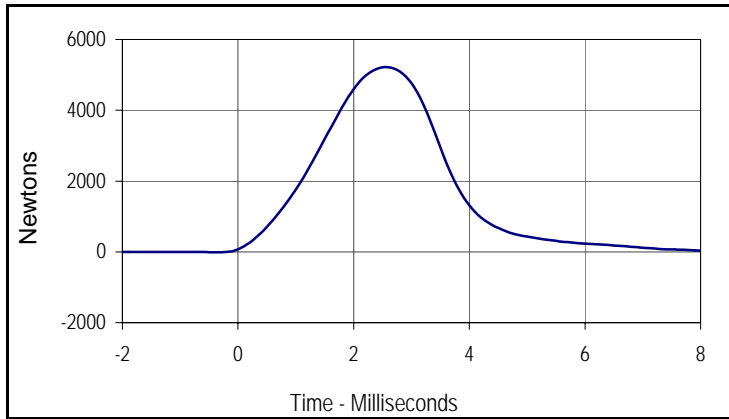

Curve Description			
Left Knee Probe Force			
CURNO	Type	SAE Class	Units
001	FIL	600	Newtons
Max	Time	Min	Time
5216.4	2.6	-27.4	9.2

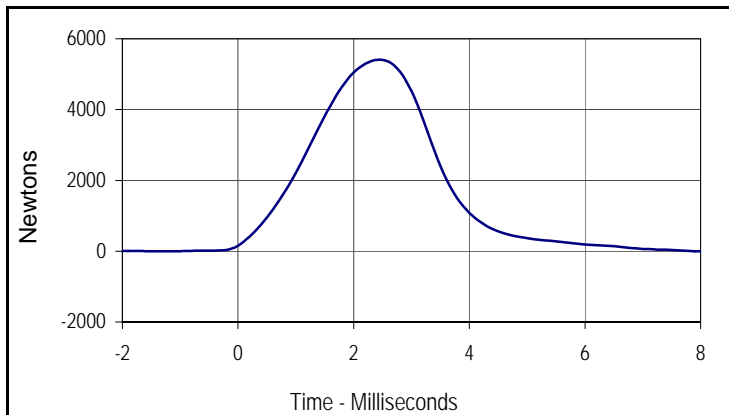

Curve Description			
Right Knee Probe Force			
CURNO	Type	SAE Class	Units
002	FIL	600	Newtons
Max	Time	Min	Time
5406.5	2.4	-31.1	8.7

Test Program: Hybrid III 50th Percentile Male External Measurements Test Date: 3/30/05
 ATD Serial No.: 034 Test I.D.: N/A



Tested Parameter	Units	Specification	Result	Pass/Fail
Laboratory Temperature	°C	20.6 to 22.2	21.1	Pass
Laboratory Relative Humidity	%	10 to 70	30	Pass
A - Total sitting height	mm	879 to 889	885	Pass
B - Shoulder pivot height	mm	505 to 521	510	Pass
C - "H" point height	mm	84 to 89	85	Pass
D - "H" point from seat back	mm	135 to 140	139	Pass
E - Shoulder pivot from back	mm	84 to 94	90	Pass
F - Thigh clearance	mm	140 to 155	143	Pass
G - Elbow back to wrist pivot	mm	290 to 305	295	Pass
H - Skull cap to back line	mm	41 to 46	44	Pass
I - Shoulder to elbow length	mm	330 to 345	340	Pass
J - Elbow rest height	mm	190 to 211	200	Pass
K - Buttock to knee length	mm	579 to 604	600	Pass
L - Popliteal length	mm	429 to 455	435	Pass
M - Knee pivot height	mm	485 to 500	490	Pass
N - Buttock popliteal length	mm	452 to 477	470	Pass
O - Chest depth	mm	213 to 229	221	Pass
P - Foot length	mm	251 to 267	260	Pass
V - Shoulder breadth	mm	422 to 437	430	Pass
W - Foot breadth	mm	91 to 107	105	Pass
Y - Chest circumference	mm	970 to 1001	985	Pass
Z - Waist circumference	mm	836 to 866	850	Pass
AA - Location for chest circumference	mm	429 to 434	430	Pass
BB - Location for waist circumference	mm	226 to 231	228	Pass
Overall Test Results				Pass

Test Program: Hybrid III 50th Percentile Male Head Drop Test

Test Date: 3/28/05

ATD Serial No.: 035

Test I.D.: HD03H



Tested Parameter	Units	Specification	Result	Pass/Fail
Laboratory Temperature	°C	18.9 to 25.6	21.1	Pass
Laboratory Relative Humidity	%	10 to 70	30	Pass
Peak Resultant Acceleration	G's	225.0 to 275.0	230.3	Pass
Peak Lateral Acceleration	G's	≤15.0	3.6	Pass
Is Acceleration Unimodal?	Yes/No	Yes	Yes	Pass
Overall Test Results				Pass

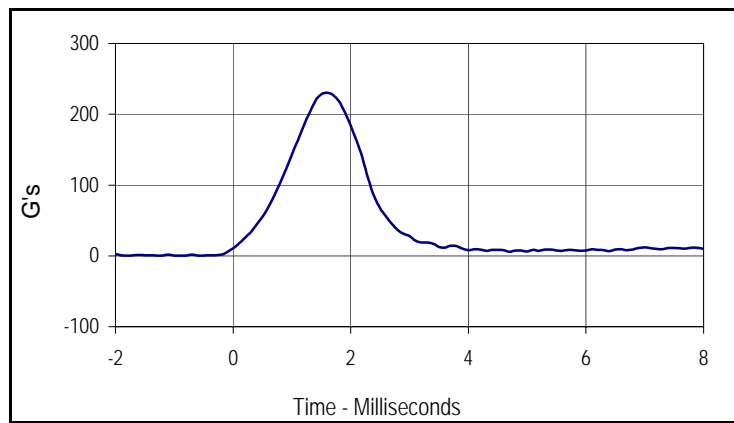

Curve Description			
Head Resultant			
CURNO	Type	SAE Class	Units
001	RES	1000	G's
Max	Time	Min	Time
230.3	1.6	0.3	-0.9

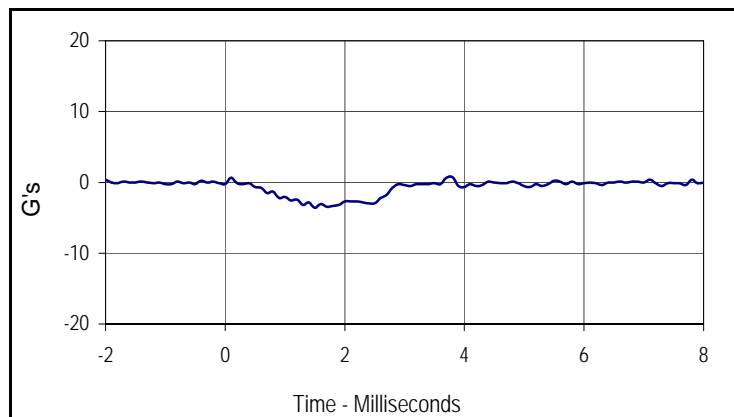

Curve Description			
Head Y			
CURNO	Type	SAE Class	Units
002	FIL	1000	G's
Max	Time	Min	Time
0.8	3.8	-3.6	1.5

Test Program: Hybrid III 50th Percentile Male Thorax Impact Test

Test Date: 3/29/05

ATD Serial No.: 035

Test I.D.: CH03I



Tested Parameter	Units	Specification	Result	Pass/Fail
Laboratory Temperature	°C	20.6 to 22.2	21.1	Pass
Laboratory Relative Humidity	%	10 to 70	30	Pass
Probe Velocity	m/s	6.58 to 6.82	6.64	Pass
Peak Probe Force	Newtons	5159 to 5893	5425	Pass
Peak Sternum Displacement	CM	6.35 to 7.26	6.78	Pass
Internal Hysteresis	%	69 to 85	73.9	Pass
Overall Test Results				Pass

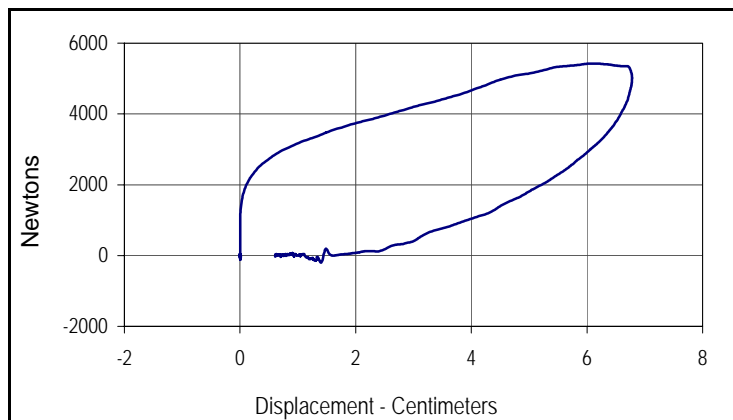

Curve Description			
Probe Force vs. Chest Deflection			
CURNO	Type	SAE Class	Hysteresis
001	FIL	180	73.9
Peak Probe Force		Peak Chest Deflection	
5425		6.78	

Test Program: Hybrid III 50th Percentile Male Neck Flexion Test

Test Date: 3/29/05

ATD Serial No.: 035

Test I.D.: NF03K



Tested Parameter	Units	Specification	Result	Pass/Fail	
Laboratory Temperature	°C	20.6 to 22.2	21.1	Pass	
Laboratory Relative Humidity	%	10 to 70	30	Pass	
Pendulum Velocity	m/s	6.89 to 7.13	7.06	Pass	
Pendulum Deceleration	10 Msec.	G's	22.5 to 27.5	23.3	Pass
	20 Msec.	G's	17.6 to 22.6	19.5	Pass
	30 Msec.	G's	12.5 to 18.5	15.9	Pass
Peak Pendulum Decel. after 30 Msec.	G's	≤ 29.0	15.9	Pass	
Deceleration Decay, Time to Cross 5 G's	Msec.	34.0 to 42.0	41.2	Pass	
Maximum "D" Plane Rotation	Max	Degrees	64.0 to 78.0	66.5	Pass
	Time	Msec.	57.0 to 64.0	63.3	Pass
"D" Plane Rotation Decay, Time To Zero Crossing	Msec.	113.0 to 128.0	124	Pass	
Moment About Occ. Condyle	Max	Nm	84.1 to 108.5	88.6	Pass
	Time	Msec.	47.0 to 58.0	56.8	Pass
Positive Moment Decay, Time To Zero Crossing	Msec.	97.0 to 107.0	101.4	Pass	
Overall Test Results				Pass	

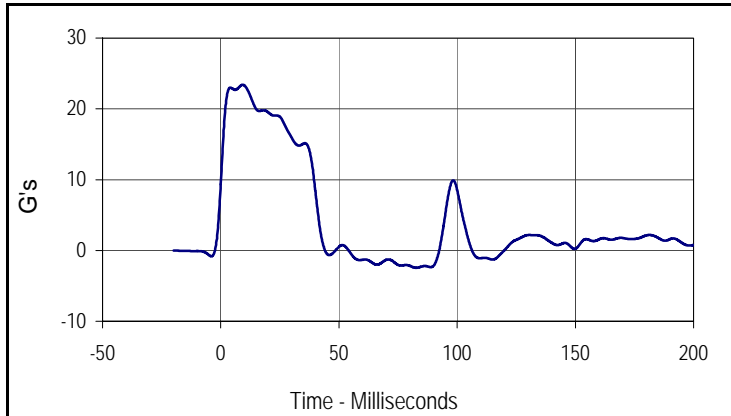

Curve Description			
Pendulum Deceleration			
CURNO	Type	SAE Class	Units
001	FIL	60	G's
Max	Time	Min	Time
23.4	9.3	-2.4	82.7

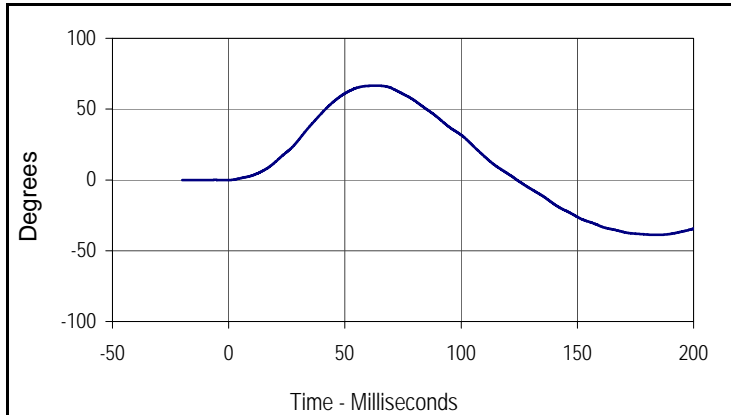

Curve Description			
"D" Plane Rotation			
CURNO	Type	SAE Class	Units
003	FIL	60	Degrees
Max	Time	Min	Time
66.5	63.3	-38.8	184.3

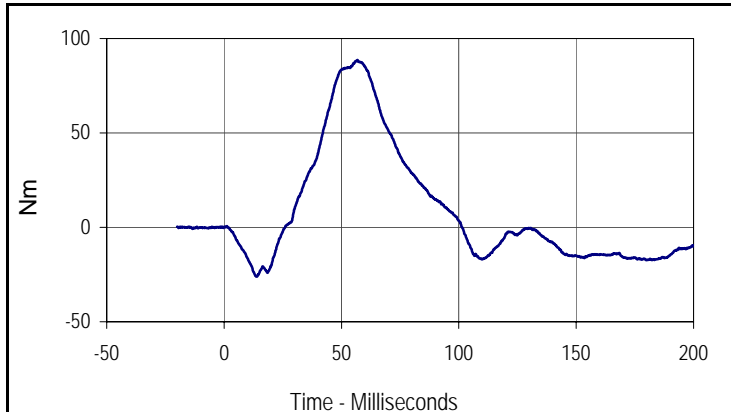

Curve Description			
Moment About Occipital Condyle			
CURNO	Type	SAE Class	Units
004	FIL	600	Nm
Max	Time	Min	Time
88.6	56.8	-26.1	13.9



Tested Parameter	Units	Specification	Result	Pass/Fail	
Laboratory Temperature	°C	20.6 to 22.2	21.1	Pass	
Laboratory Relative Humidity	%	10 to 70	30	Pass	
Pendulum Velocity	m/s	5.94 to 6.19	6.13	Pass	
Pendulum Deceleration	10 Msec.	G's	17.2 to 21.2	17.3	Pass
	20 Msec.	G's	14.0 to 19.0	16.7	Pass
	30 Msec.	G's	11.0 to 16.0	13.8	Pass
Peak Pendulum Decel. after 30 Msec.	G's	≤ 22.0	13.8	Pass	
Deceleration Decay, Time to Cross 5 G's	Msec.	38.0 to 46.0	42.8	Pass	
Maximum "D" Plane Rotation	Max	Degrees	81.0 to 106.0	96.3	Pass
	Time	Msec.	72.0 to 82.0	78.1	Pass
"D" Plane Rotation Decay, Time To Zero Crossing	Msec.	147.0 to 174.0	158	Pass	
Moment About Occ. Condyle	Max	Nm	-52.9 to- 79.9	-63.9	Pass
	Time	Msec.	65.0 to 79.0	66.4	Pass
Positive Moment Decay, Time To Zero Crossing	Msec.	120.0 to 148.0	143.6	Pass	
Overall Test Results				Pass	

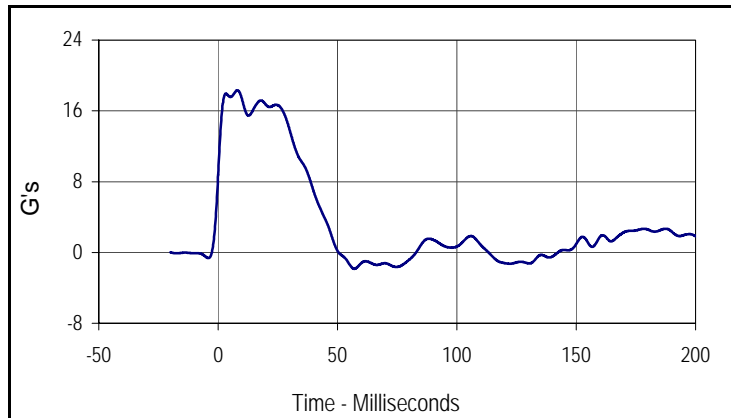

Curve Description			
Pendulum Deceleration			
CURNO	Type	SAE Class	Units
001	FIL	60	G's
Max	Time	Min	Time
18.3	8.1	-1.8	57.0

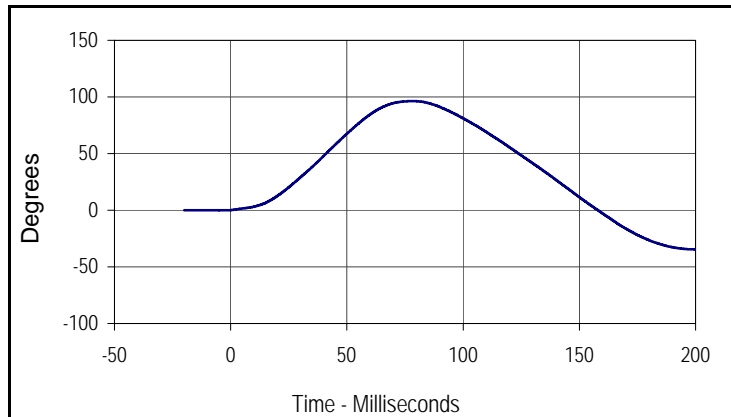

Curve Description			
"D" Plane Rotation			
CURNO	Type	SAE Class	Units
003	FIL	60	Degrees
Max	Time	Min	Time
96.3	78.1	-34.6	200.0

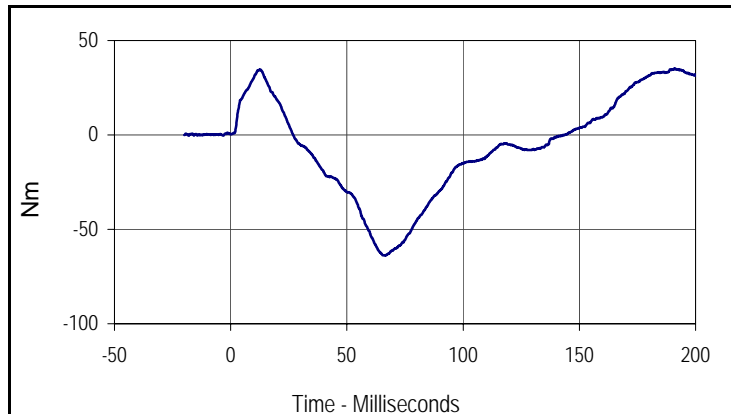

Curve Description			
Moment About Occipital Condyle			
CURNO	Type	SAE Class	Units
004	FIL	600	Nm
Max	Time	Min	Time
35.2	191.2	-63.9	66.4

Test Program: Hybrid III 50th Percentile Male Knee Impact Test

Test Date: 3/29/05

ATD Serial No.: 035

Test I.D.: LK03I , RK03I



Left Knee

Tested Parameter	Units	Specification	Result	Pass/Fail
Laboratory Temperature	°C	18.9 to 25.6	21.1	Pass
Laboratory Relative Humidity	%	10 to 70	30	Pass
Pendulum Velocity at T=0	m/sec	2.07 to 2.13	2.09	Pass
Peak Probe Force	Newtons	4715 to 5782	5507	Pass
Overall Test Results				Pass

Right Knee

Pendulum Velocity at T=0	m/sec	2.07 to 2.13	2.10	Pass
Peak Probe Force	Newtons	4715 to 5782	5265	Pass
Overall Test Results				Pass



Curve Description			
Left Knee Probe Force			
CURNO	Type	SAE Class	Units
001	FIL	600	Newtons
Max	Time	Min	Time
5506.9	2.5	-28.5	9.4



Curve Description			
Right Knee Probe Force			
CURNO	Type	SAE Class	Units
002	FIL	600	Newtons
Max	Time	Min	Time
5264.9	2.5	-19.4	9.2

Test Program: Hybrid III 50th Percentile Male External Measurements Test Date: 3/30/05
 ATD Serial No.: 035 Test I.D.: N/A



Tested Parameter	Units	Specification	Result	Pass/Fail
Laboratory Temperature	°C	20.6 to 22.2	21.1	Pass
Laboratory Relative Humidity	%	10 to 70	30	Pass
A - Total sitting height	mm	879 to 889	884	Pass
B - Shoulder pivot height	mm	505 to 521	511	Pass
C - "H" point height	mm	84 to 89	85	Pass
D - "H" point from seat back	mm	135 to 140	139	Pass
E - Shoulder pivot from back	mm	84 to 94	86	Pass
F - Thigh clearance	mm	140 to 155	150	Pass
G - Elbow back to wrist pivot	mm	290 to 305	300	Pass
H - Skull cap to back line	mm	41 to 46	44	Pass
I - Shoulder to elbow length	mm	330 to 345	335	Pass
J - Elbow rest height	mm	190 to 211	205	Pass
K - Buttock to knee length	mm	579 to 604	600	Pass
L - Popliteal length	mm	429 to 455	450	Pass
M - Knee pivot height	mm	485 to 500	489	Pass
N - Buttock popliteal length	mm	452 to 477	475	Pass
O - Chest depth	mm	213 to 229	225	Pass
P - Foot length	mm	251 to 267	255	Pass
V - Shoulder breadth	mm	422 to 437	435	Pass
W - Foot breadth	mm	91 to 107	102	Pass
Y - Chest circumference	mm	970 to 1001	985	Pass
Z - Waist circumference	mm	836 to 866	850	Pass
AA - Location for chest circumference	mm	429 to 434	431	Pass
BB - Location for waist circumference	mm	226 to 231	230	Pass
Overall Test Results				Pass

APPENDIX F
CHILD RESTRAINT SYSTEM

REPORT NUMBER TR-P25064-01-NC

**NEW CAR ASSESSMENT PROGRAM
FRONTAL BARRIER IMPACT TEST**

**AMERICAN HONDA MOTOR COMPANY, INC
2006 HONDA RIDGELINE RTS
4-DOOR TRUCK**

NHTSA NUMBER: H65300

**PREPARED BY:
KARCO ENGINEERING, LLC
9270 HOLLY ROAD
ADELANTO, CALIFORNIA 92301**



APRIL 14, 2005

FINAL REPORT

**PREPARED FOR:
U.S. DEPARTMENT OF TRANSPORTATION
NATIONAL HIGHWAY TRAFFIC SAFETY ADMINISTRATION
RULEMAKING
OFFICE OF CRASHWORTHINESS STANDARDS
MAIL CODE: NVS-111
400 SEVENTH STREET, SW, ROOM 5311
WASHINGTON, D.C. 20590**

This final test report was prepared for the U.S. Department of Transportation, National Highway Traffic Safety Administration, in response to Contract Number DTNH22-01-D-02005.

This publication is distributed by the U.S. Department of Transportation, National Highway Traffic Safety Administration, in the interest of information exchange. The opinions, findings and conclusions expressed in this publication are those of the author(s) and not necessarily those of the Department of Transportation or the National Highway Traffic Safety Administration. The United States Government assumes no liability for its contents or use thereof. If trade or manufacturers' names or products are mentioned, it is only because they are considered essential to the object of the publication and should not be construed as an endorsement. The United States Government does not endorse products or manufacturers.

Prepared by: _____
Mr. Biren J. Patel, Project Engineer
KARCO Engineering, LLC

Date: 4/27/05

Reviewed by: _____
Mr. Michael L. Dunlap, Quality Assurance Manager
KARCO Engineering, LLC

Date: 4/27/05

Approved by: _____
Mr. Frank D. Richardson, Program Manager
KARCO Engineering, LLC

Date: 4/27/05

FINAL REPORT ACCEPTED BY:

Manager, New Car Assessment Program

Date of Acceptance

COTR, NCAP Frontal Impact Program

Date of Acceptance

Technical Report Documentation Page

1. Report No. TR-P25064-01-NC		2. Government Accession No.		3. Recipients Catalog No.	
4. Title and Subtitle Final Report of a Graco Hi-Back TurboBooster CRS Final Report of a Graco Hi-Back TurboBooster CRS NHTSA NO. H65300				5. Report Date April 14, 2005	
				6. Performing Organization Code KAR	
7. Authors Mr. Biren J. Patel, Project Engineer, Karco Mr. Frank Richardson, Program Manager, Karco				8. Performing Organization Report No. TR-P25064-01-NC	
9. Performing Organization Name and Address Karco Engineering, LLC 9270 Holly Rd. Adelanto, CA, 92301				10. Work Unit No.	
				11. Contract or Grant No. DTNH22-01-D-02005	
12. Sponsoring Agency Name and Address U. S. Department of Transportation National Highway Traffic Safety Administration Rulemaking Office of Crashworthiness Standards Mail Code NPS-111 400 Seventh Street, SW, Room 5311 Washington, D.C 20590				13. Type of Report and Period Covered Final Test Report Option Year 4	
				14. Sponsoring Agency Code DOT/NHTSA/NRM/OCS	
15. Supplementary Notes					
16. Abstract A frontal test was conducted on the subject CRS's Graco Hi-Back TurboBoosters in conjunction with frontal NCAP testing on a 2006 Honda Ridgeline RTS 4-Door Truck and in accordance with the specifications of the Office of Crashworthiness Standards Test Procedure for the determination of CRS crashworthiness. This test was conducted at Karco Engineering, LLC on April 14, 2005					
Measurement Description		Units		Left Rear	Right Rear
Head Injury Criteria (HIC) 36				989.4	910.7
Head Injury Criteria (HIC) 15				555.1	499.0
3 msec. Chest Clip		G's		33.3	35.1
Peak Chest Deflection		mm		-51.8	-35.6
17. Key Words 56.3 km/h NCAP Frontal Barrier Impact Test New Car Assessment Program (NCAP) Final Report of a Graco Hi-Back TurboBooster CRS Final Report of a Graco Hi-Back TurboBooster CRS				18. Distribution of Statement Copies of this report available from: NHTSA Technical Reference Division National Highway Traffic Safety Admin. 400 Seventh St., SW, Room 5108 Washington, D.C. 20590	
19. Security Classification (this report) Unclassified		20. Security Classification (this page) Unclassified		21. No. of Pages 45	22. Price

Form DOT F1700.7 (8-72)

TABLE OF CONTENTS

<u>Section</u>	<u>Description</u>	<u>Page</u>
F-1	Purpose and Summary of Test H65300	F1-1 to F1-10
F-2	Photographs	F2-1 to F2-36
F-3	Child Dummy Response and CRS Data Traces	F3-1 to F3-27
F-4	Instrumentation Data Channel Assignments	F4-1 to F4-4
F-5	Child Dummy Calibration Information	F5-1 to F5-13

<u>Data Sheet</u>	<u>Description</u>	<u>Page</u>
1	Crash Test Summary	F1-2
2	CRS Parameter Data	F1-3
3	Child Dummy Positioning in Vehicle	F1-4
4	Child Hybrid III ATD Injury Criteria and Sensor Data	F1-6
5	CRS Performance Data	F1-9
6	CRS Camera Data	F1-10

SECTION F-1

PURPOSE AND SUMMARY OF TEST H65300

The purpose of this test is to obtain CRS performance data during an NCAP (35mph) frontal impact test.

The 55.87 km/h NCAP frontal impact test was conducted in accordance with the Office of Crashworthiness Standards (OCS) NCAP Laboratory Test Procedure.

SUMMARY

Two ten year old child Hybrid III dummies (P3 and P4) were instrumented with head, chest, and pelvic tri-axial accelerometers, a chest displacement potentiometer, six-axis upper neck, lumbar, clavicle, ASIS and femur load cells. In addition, a tri-axial accelerometer was installed on the CRS and the CRS seat back. Seat belt load cells were placed on the shoulder and lap belts. Shoulder belt spool-out and elongation were also measured.

The right rear (Serial No. 009) child dummy was calibrated prior to this test and left rear (Serial No. 011) child dummy was calibrated two tests prior to this test. Child dummy calibration information is found in Section F-5.

CHILD DUMMY VALUES

Location	HIC 36 Values	HIC 15 Values	3 Msec. Chest Clip	Peak Chest Deflection
Right Rear Child (10 Yr.)	910.7	499	35.1	-35.6
Left Rear Child (10Yr.)	989.4	555.1	33.3	-51.8

**DATA SHEET NO.1
CRASH TEST SUMMARY**

Test Vehicle: 2006 Honda Ridgeline RTS 4-Door Truck

NHTSA No.: H65300

Test Program: 2005 NHTSA 35mph NCAP

Test Date: 4/14/05

CHILD RESTRAINT SYSTEM INFORMATION

Description	Position #3 CRS	Position #4 CRS
Manufacturer	Graco Children's Products, Inc.	Graco Children's Products, Inc.
Model Name	TurboBooster	TurboBooster
Serial No.	JJ 0125050185197	JJ 0125050185260
Type	Hi-Back TurboBooster	Hi-Back TurboBooster
Forward/Rearward	Forward	Forward

VISIBLE DUMMY CONTACT POINTS

Description	Position #3 CRS	Position #4 CRS
Head Contact	Chin to Chest, C-Pillar, Roof	Chin to Chest, Roof Rail
Chest Contact	None	None
Abdomen Contact	None	None
Left Knee Contact	None	None
Right Knee Contact	None	None
Left Toe Contact	Front Passenger Seat Back	Driver Seat Back
Right Toe Contact	Front Passenger Seat Back	Driver Seat Back

POST-TEST DOOR OPENINGS

Description	Position #3 CRS	Position #4 CRS
Front Door	Remained closed/latched, opened w/o tools	Remained closed/latched, opened w/o tools
Rear Door	Remained closed/latched, opened w/o tools	Remained closed/latched, opened w/o tools
Hatch/Other Door		

POST-TEST SEAT DATA

Location	Seat Movement (mm)	Seat Back Failure
Left Rear	0	No
Right Rear	0	No

CAMERA COVERAGE

Description	Standard	Additional
High Speed	2	2
Real Time	0	0
Total	2	2

DATA CHANNELS

Child Sensors	64
Belt Sensors	8
CRS Sensors	9
Total	81

DATA SHEET NO.2
CRS PARAMETER DATA

Test Vehicle: 2006 Honda Ridgeline RTS 4-Door Truck

NHTSA No.: H65300

Test Program: 2005 NHTSA 35mph NCAP

Test Date: 4/14/05

RETAINING CLIP INFORMATION

Description	Position #3 CRS	Position #4 CRS
Ret. Clip Movement		

CHILD HARNESS STRETCH

Description	Position #3 CRS	Position #4 CRS
Harness Stretch		

TEST VEHICLE WEIGHTS

	Units	As Delivered Weights (UVW)			As Tested Weights (ATW)		
		Front Axle	Rear Axle	Total	Front Axle	Rear Axle	Total
Left	kg	606	426	1032	663	496	1159
Right	kg	572	415	987	637	505	1142
Ratio	%	58.4	41.6	100	56.5	43.5	100
Totals	kg	1178	841	2019	1300	1001	2301

TARGET TEST WEIGHT CALCULATION

Measured Parameter	Units	Value
Total Delivered Weight (UVW)	kg	2019
Weight of 2 P572 ATD's	kg	152
Rated Cargo/Luggage Wt. (RCLW)	kg	136
Calculated Vehicle Target Wt. (TVTWTW)	kg	2307

DATA SHEET NO.3
CHILD DUMMY POSITIONING IN VEHICLE

Test Vehicle: 2006 Honda Ridgeline RTS 4-Door Truck

NHTSA No.: H65300

Test Program: 2005 NHTSA 35mph NCAP

Test Date: 4/14/05

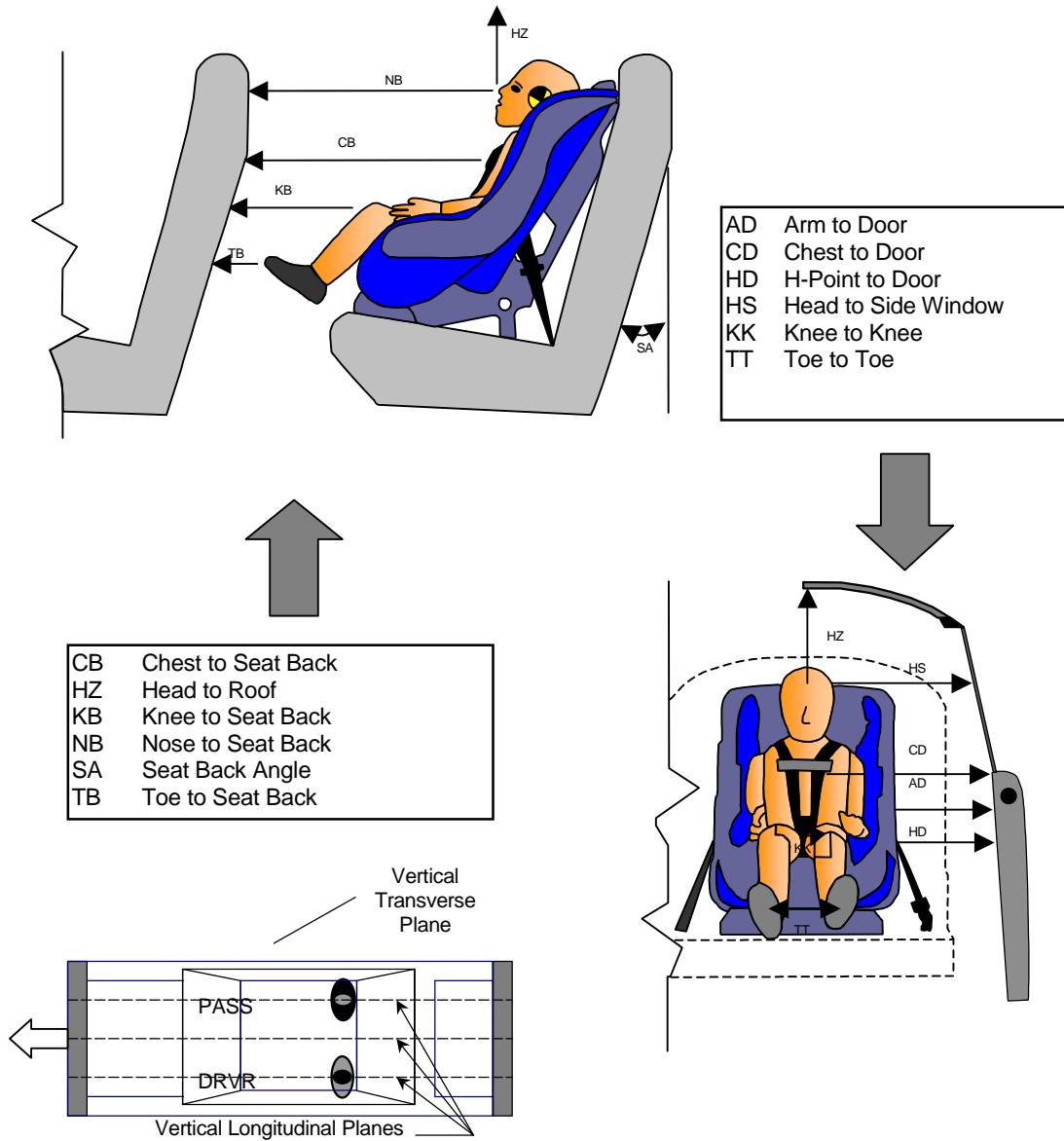

DUMMY MEASUREMENTS FOR REAR SEAT OCCUPANTS

DATA SHEET NO.3
CHILD DUMMY POSITIONING IN VEHICLE...(CONTINUED)

Test Vehicle: 2006 Honda Ridgeline RTS 4-Door Truck

NHTSA No.: H65300

Test Program: 2005 NHTSA 35mph NCAP

Test Date: 4/14/05

CHILD DUMMY POSITION MEASUREMENTS

Code	Measurement	Units	P3 CRS Serial No. 009			P4 CRS Serial No. 011		
			Pre-Test	Post-Test	Diff.	Pre-Test	Post-Test	Diff.
SA	Seat Back Angle	deg.	22.6	22.3	-0.3	22.6	22.3	-0.3
HZ	Head to Roof (Z)	mm	235	250	15	240	250	10
CD	Chest to Door	mm	470	502	32	480	496	16
KK	Knee to Knee (Y)	mm	160	142	-18	172	165	-7
HS	Head to Side Window	mm	398	436	38	375	426	51
HD	H-Point to Door (Y)	mm	162	168	6	165	205	40
AD	Arm to Door	mm	211	178	-33	203	192	-11
NB	Nose to Seat Back	mm	575	605	30	567	574	7
CB	Chest to Seat Back	mm	522	598	76	520	578	58
FF	Foot to Foot	mm	150	190	40	180	180	0
KB-Left	Knee to Seat Back	mm	270	400	130	275	375	100
KB-Right	Knee to Seat Back	mm	280	410	130	275	390	115
TB-Left	Toe to Seat Back	mm	270	220	-50	150	280	130
TB-Right	Toe to Seat Back	mm	270	220	-50	150	250	100

DATA SHEET NO. 4 - CHILD HYBRID III ATD INJURY CRITERIA AND SENSOR DATA

Test Vehicle: 2006 Honda Ridgeline RTS 4-Door Truck

NHTSA No.: H65300

Test Program: 2005 NHTSA 35mph NCAP

Test Date: 4/14/05

HEAD PRIMARY PEAK ACCELERATIONS

Location	Axis	Units	Left Rear (10 Yr.)				Right Rear (10 Yr.)			
			Max	Time	Min	Time	Max	Time	Min	Time
Head CG	X	G's	0.4	23.1	-36.4	103.3	0.6	22.7	-34.9	117.2
Head CG	Y	G's	4.0	58.5	-2.1	133.3	9.8	114.0	-1.7	139.4
Head CG	Z	G's	64.8	93.7	-0.3	13.4	61.6	90.7	-0.2	8.5
Head CG Resultant	N/A	G's	71.8	94.7			67.0	91.3		

PRIMARY HEAD INJURY CRITERIA (HIC)

Location	Left Rear (10 Yr.)				Right Rear (10 Yr.)			
	HIC	T ¹	T ²	Avg G	HIC	T ¹	T ²	Avg G
Head CG (HIC36)	989.4	71.8	107.8	59.6	910.7	71.3	107.3	57.7
Head CG (HIC15)	555.1	86.2	101.2	67.2	499.0	88.2	103.2	64.4

CHEST PRIMARY PEAK ACCELERATIONS

Location	Axis	Units	Left Rear (10 Yr.)				Right Rear (10 Yr.)			
			Max	Time	Min	Time	Max	Time	Min	Time
Chest CG	X	G's	1.8	188.4	-31.2	79.9	2.2	163.8	-33.4	88.4
Chest CG	Y	G's	3.0	132.9	-15.9	93.5	11.4	102.0	-2.2	72.3
Chest CG	Z	G's	11.7	83.9	-5.0	68.3	13.2	82.2	-10.2	59.1
Chest CG Resultant	N/A	G's	34.6	79.7			35.4	88.4		

PRIMARY CHEST CLIP (3MSEC)

Location	Left Rear (10 Yr.)			Right Rear (10 Yr.)		
	CLIP	T ¹	T ²	CLIP	T ¹	T ²
Chest CG	33.3	78.7	81.7	35.1	86.5	89.5

CHEST PEAK DEFLECTIONS

Location	Axis	Units	Left Rear (10 Yr.)				Right Rear (10 Yr.)			
			Max	Time	Min	Time	Max	Time	Min	Time
Chest	X	MM	11.1	199.3	-51.8	90.4	0.0	7.0	-35.6	101.4

PELVIC PEAK ACCELERATIONS

Location	Axis	Units	Left Rear (10 Yr.)				Right Rear (10 Yr.)			
			Max	Time	Min	Time	Max	Time	Min	Time
Pelvis	X	G's	6.2	183.7	-33.7	76.8	4.5	199.9	-40.2	77.4
Pelvis	Y	G's	12.5	91.1	-8.0	47.7	3.9	36.4	-10.1	69.5
Pelvis	Z	G's	3.4	117.4	-26.4	74.4	2.5	118.1	-23.0	60.4
Pelvis Resultant	N/A	G's	42.6	76.8			43.0	77.3		

DATA SHEET NO. 4...(CONTINUED)

Test Vehicle: 2006 Honda Ridgeline RTS 4-Door Truck

NHTSA No.: H65300

Test Program: 2005 NHTSA 35mph NCAP

Test Date: 4/14/05

UPPER NECK PEAK FORCES AND MOMENTS

Location	Axis	Units	Left Rear (10 Yr.)				Right Rear (10 Yr.)			
			Max	Time	Min	Time	Max	Time	Min	Time
Neck Force	X	Newtons	10.4	27.4	-1076.9	109.4	87.3	18.1	-1022.5	97.1
Neck Force	Y	Newtons	31.5	153.2	-297.5	109.3	329.2	113.8	-102.0	141.9
Neck Force	Z	Newtons	2407.3	95.8	-33.3	31.6	2211.9	91.4	-57.9	0.2
Neck Force Resultant	N/A	Newtons	2576.1	95.8			2414.5	96.8		
Neck Moment	X	Nm	11.8	138.9	-5.8	78.0	6.0	80.0	-11.0	121.8
Neck Moment	Y	Nm	4.3	149.7	-34.1	71.0	25.3	112.9	-34.0	71.7
Neck Moment	Z	Nm	0.5	22.7	-6.4	76.6	6.0	85.5	-0.7	34.2
Neck Moment Resultant	N/A	Nm	34.5	71.0			34.3	71.7		

FEMUR PEAK FORCES AND MOMENTS

Location	Axis	Units	Left Rear (10 Yr.)				Right Rear (10 Yr.)			
			Max	Time	Min	Time	Max	Time	Min	Time
Left Femur Force	Z	Newtons	1554.4	65.6	-32.4	153.4	2385.4	71.0	-120.8	180.9
Right Femur Force	Z	Newtons	1881.0	68.8	-2.5	5.4	1719.5	68.9	-40.5	146.4

LUMBAR PEAK FORCES AND MOMENTS

Location	Axis	Units	Left Rear (10 Yr.)				Right Rear (10 Yr.)			
			Max	Time	Min	Time	Max	Time	Min	Time
Lumbar Force	X	Newtons	880.0	103.9	-602.2	49.1	1407.9	104.8	-373.2	48.1
Lumbar Force	Y	Newtons	52.8	182.1	-1895.9	89.8	1151.5	94.0	-117.0	199.1
Lumbar Force	Z	Newtons	1590.3	105.4	-801.2	56.2	923.5	117.8	-1168.8	62.9
Lumbar Force Resultant	N/A	Newtons	2322.0	100.4			1900.9	103.8		
Lumbar Moment	X	Nm	10.6	182.2	-188.7	87.9	120.6	92.3	-24.4	167.0
Lumbar Moment	Y	Nm	49.5	49.3	-30.0	199.6	54.6	91.9	-21.9	70.8
Lumbar Moment	Z	Nm	47.3	87.6	0.3	0.1	3.0	199.7	-54.2	89.3
Lumbar Moment Res.	N/A	Nm	199.3	88.0			141.3	92.1		

CLAVICLE PEAK FORCES

Location	Axis	Units	Left Rear (10 Yr.)				Right Rear (10 Yr.)			
			Max	Time	Min	Time	Max	Time	Min	Time
Left Clavicle Force	X	Newtons	2148.4	92.7	-6.8	199.6	104.9	101.4	-366.4	87.2
Left Clavicle Force	Z	Newtons	240.6	50.2	-132.7	92.7	178.8	87.7	-134.1	108.5
Right Clavicle Force	X	Newtons	82.3	131.3	-110.9	90.2	3798.2	94.5	-6.3	198.9
Right Clavicle Force	Z	Newtons	22.5	37.1	-140.2	120.7	1244.9	87.7	-137.4	135.5

DATA SHEET NO. 4...(CONTINUED)

Test Vehicle: 2006 Honda Ridgeline RTS 4-Door Truck

NHTSA No.: H65300

Test Program: 2005 NHTSA 35mph NCAP

Test Date: 4/14/05

UPPER AND LOWER ASIS PEAK FORCES

Location	Axis	Units	Left Rear (10 Yr.)				Right Rear (10 Yr.)			
			Max	Time	Min	Time	Max	Time	Min	Time
Left Upper ASIS Force	X	Newtons	48.6	145.8	-93.8	65.8	372.3	77.1	-638.2	102.5
Left Lower ASIS Force	Z	Newtons	299.2	84.0	-0.7	0.5	842.2	101.2	-13.0	4.7
Right Upper ASIS Force	X	Newtons	548.4	68.6	-771.5	102.1	86.5	69.2	-50.1	30.3
Right Lower ASIS Force	Z	Newtons	1557.5	94.0	-1.0	10.0	475.7	82.2	-18.2	13.0

CRS ACCELEROMETER PEAK VALUES

Location	Axis	Units	Left Rear (10 Yr.)				Right Rear (10 Yr.)			
			Max	Time	Min	Time	Max	Time	Min	Time
CRS	X	G's	10.1	179.2	-40.5	64.2	7.1	104.9	-43.9	64.0
CRS	Y	G's	12.8	88.5	-3.2	184.2	3.6	174.1	-8.9	83.9
CRS	Z	G's	10.7	56.2	-13.9	61.9	12.0	178.5	-16.6	91.4
CRS Resultant	N/A	G's	42.5	62.9			44.8	64.0		
CRS Seat Back	X	G's	84.8	174.6	-41.0	85.3	45.5	167.3	-46.8	87.6
CRS Seat Back	Y	G's	20.5	84.2	-15.4	79.8	18.9	93.2	-12.6	54.9
CRS Seat Back	Z	G's	23.5	100.4	-14.3	167.2	19.3	77.3	-11.3	54.6
CRS Seat Back Resultant	N/A	G's	86.3	174.6			48.7	87.7		

CHILD SEAT BELT SENSOR PEAK VALUES

Location	Axis	Units	Left Rear (10 Yr.)				Right Rear (10 Yr.)			
			Max	Time	Min	Time	Max	Time	Min	Time
Lap Belt Force	N/A	Newtons	1935.4	77.1	-3.0	8.3	4890.7	89.7	-6.1	200.0
Shoulder Belt Force	N/A	Newtons	7995.9	92.8	-13.5	189.8	3731.4	77.4	5.7	0.0
Shoulder Belt Pullout	N/A	MM	144.6	101.6	-0.1	12.8	136.0	104.0	0.0	1.2
Shoulder Belt Elongation	N/A	MM/CM	0.0	0.0	0.0	0.0	0.0	0.0	0.0	0.0

1.) Not installed

DATA SHEET NO.5
CRS PERFORMANCE DATA

Test Vehicle: 2006 Honda Ridgeline RTS 4-Door Truck

NHTSA No.: H65300

Test Program: 2005 NHTSA 35mph NCAP

Test Date: 4/14/05

CRS PERFORMANCE DATA

Location	P3 CRS Serial No. 009		P4 CRS Serial No. 011	
	Damage	Post-Test	Damage	Post-Test
Upper Tether Strap				
Upper Tether Buckle				
Upper Tether Hook				
Veh. Upper Tether Anchor				
Lower Anchor Strap				
Lower Anchor Buckle				
Lower Anchor Hooks				
Veh. Lower CRS Anchors				
5-Point Harness Connections				
Cracks on CRS	No	None	No	None
Fabric Tears on CRS	No	None	No	None
Vehicle Seat Structure	No	None	No	None
Vehicle Seat Fabric Tears	No	None	No	None

DATA SHEET NO.6
CRS CAMERA DATA

Test Vehicle: 2006 Honda Ridgeline RTS 4-Door Truck

NHTSA No.: H65300

Test Program: 2005 NHTSA 35mph NCAP

Test Date: 4/14/05

CAMERA LOCATIONS

No.	Camera View	Location(mm)			Angle (Deg.)	Film Plane to Head	Lens (mm)	Speed (fps)
		X	Y	Z				
1	Left Rear Dummy Onboard	-2690	787	-1470	-10	704	13	1000
2	Right Rear Dummy Onboard	-2690	-787	-1470	-10	704	12	1000

ADDITIONAL CAMERAS

1	Left Rear Dummy Onboard	-2710	790	-1475	-10	915	8.5	1000
2	Right Rear Dummy Onboard	-2700	-790	-1475	-10	915	8.5	1000

X = Barrier Face Y = Monorail Centerline Z = Ground DNR = Did Not Run NTM = No Time Marks

SECTION F-2
PHOTOGRAPHS

LIST OF PHOTOGRAPHS

Figure		Page
1	Close-up, Position 3 CRS Label	F-1
2	Pre-Test Frontal View of Position 3 CRS	F-2
3	Post-Test Frontal View of Position 3 CRS	F-3
4	Pre-Test Rear View of Position 3 CRS	F-4
5	Post-Test Rear View of Position 3 CRS	F-5
6	Pre-Test Left Side View of Position 3 CRS	F-6
7	Post-Test Left Side View of Position 3 CRS	F-7
8	Pre-Test Right Side View of Position 3 CRS	F-8
9	Post-Test Right Side View of Position 3 CRS	F-9
10	Pre-Test Position 3 Front View (Head Position)	F-10
11	Post-Test Position 3 Front View (Head Position)	F-11
12	Pre-Test Position 3 Front View (Seat Belt Position)	F-12
13	Post-Test Position 3 Front View (Seat Belt Position)	F-13
14	Pre-Test Position 3 Right Side View	F-14
15	Post-Test Position 3 Right Side View	F-15
16	Pre-Test Position 3 Left Side View	F-16
17	Post-Test Position 3 Left Side View	F-17
18	Post-Test Position 3 Dummy Feet	F-18
19	Close-up, Position 4 CRS Label	F-19
20	Pre-Test Frontal View of Position 4 CRS	F-20
21	Pre-Test Front View of Position 4 CRS	F-21
22	Pre-Test Rear View of Position 4 CRS	F-22
23	Post-Test Rear View of Position 4 CRS	F-23
24	Pre-Test Left Side View of Position 4 CRS	F-24
25	Post-Test Left Side View of Position 4 CRS	F-25
26	Pre-Test Right Side View of Position 4 CRS	F-26
27	Post-Test Right Side View of Position 4 CRS	F-27
28	Pre-Test Position 4 Front View (Head Position)	F-28
29	Post-Test Position 4 Front View (Head Position)	F-29
30	Pre-Test Position 4 Front View (Seat Belt Position)	F-30
31	Post-Test Position 4 Front View (Seat Belt Position)	F-31
32	Pre-Test Position 4 Left Side View	F-32
33	Post-Test Position 4 Left Side View	F-33
34	Pre-Test Position 4 Right Side View	F-34
35	Post-Test Position 4 Right Side View	F-35
36	Post-Test Position 4 Dummy Feet	F-36

Extón, PA 19341 EE.UU. o llame al 1-800-343-4100.
Para información sobre retiradas, llame a la línea de información s
seguridad automotriz del gobierno de EE.UU. al 1-800-424-9393
(202-366-0123 en el Distrito de Columbia). LAP

MODEL 8674ATH NAME: TurboBooster
SERIAL JJ 0125050185197
Manufactured in 012505
GRACO CHILDREN'S PRODUCTS, INC.
EXTON, PA 19341 1-888-224-6549
Made in China

LAPZ0004B

Figure F2-1: Close-up, Position 3 CRS Label

This Space Intentionally Left Blank



Figure F2-2: Pre-Test Frontal View of Position 3 CRS



Figure F2-3: Post-Test Frontal View of Position 3 CRS



Figure F2-4: Pre-Test Rear View of Position 3 CRS



Figure F2-5: Post-Test Rear View of Position 3 CRS



Figure F2-6: Pre-Test Left Side View of Position 3 CRS



Figure F2-7: Post-Test Left Side View of Position 3 CRS



Figure F2-8: Pre-Test Right Side View of Position 3 CRS



Figure F2-9: Post-Test Right Side View of Position 3 CRS



Figure F2-10: Pre-Test Position 3 Front View (Head Position)



Figure F2-11: Post-Test Position 3 Front View (Head Position)



Figure F2-12: Pre-Test Position 3 Front View (Seat Belt Position)



Figure F2-13: Post-Test Position 3 Front View (Seat Belt Position)



Figure F2-14: Pre-Test Position 3 Right Side View



Figure F2-15: Post-Test Position 3 Right Side View



Figure F2-16: Pre-Test Position 3 Left Side View

**Photograph Not
Available**



F2-18

TR-P25064-01-NC

Figure F2-18: Post-Test Position 3 Dummy Feet

Los asientos infantiles podrán quedar sujetos a retiradas por razones de seguridad. Debe registrar este asiento para recibir información sobre retiradas. Envíe su nombre, dirección y el número de modelo y la fabricación del asiento a Graco Children's Products Inc., 150 Oaklawn, Exton, PA 19341 EE.UU. o llame al 1-800-345-4109. Para información sobre retiradas, llame a la línea de información sobre seguridad automotriz del gobierno de EE.UU. al 1-800-424-9393 (202-366-0123 en el Distrito de Columbia).

LAP

MODEL 8674ATH NAME: TurboBooster
SERIAL JJ 0125050185260
Manufactured in 012505
GRACO CHILDREN'S PRODUCTS, INC.
EXTON, PA 19341 1-888-224-6549
Made in China

LAPZ0004B

F2-19

TR-P25064-01-NC

Figure F2-19: Close-up, Position 4 CRS Label



Figure F2-20: Pre-Test Frontal View of Position 4 CRS



Figure F2-21: Post-Test Frontal View of Position 4 CRS



Figure F2-22: Pre-Test Rear View of Position 4 CRS



Figure F2-23: Post-Test Rear View of Position 4 CRS



Figure F2-24: Pre-Test Left Side View of Position 4 CRS



Figure F2-25: Post-Test Left Side View of Position 4 CRS



Figure F2-26: Pre-Test Right Side View of Position 4 CRS



Figure F2-27: Post-Test Right Side View of Position 4 CRS



Figure F2-28: Pre-Test Position 4 Front View (Head Position)



Figure F2-29: Post-Test Position 4 Front View (Head Position)



Figure F2-30: Pre-Test Position 4 Front View (Seat Belt Position)



Figure F2-31: Post-Test Position 4 Front View (Seat Belt Position)



Figure F2-32: Pre-Test Position 4 Left Side View



Figure F2-33: Post-Test Position 4 Left Side View



Figure F2-34: Pre-Test Position 4 Right Side View



Figure F2-35: Post-Test Position 4 Right Side View



Figure F2-36: Post-Test Position 4 Dummy Feet

SECTION F-3

CHILD DUMMY RESPONSE AND CRS DATA TRACES

LIST OF DATA PLOTS

<u>Data Plot</u>	<u>Page</u>	
F3-1	Left Rear (10 Yr.) Head X	F3-1
	Left Rear (10 Yr.) Head Y	F3-1
	Left Rear (10 Yr.) Head Z	F3-1
	Left Rear (10 Yr.) Head Resultant	F3-1
F3-2	Left Rear (10 Yr.) Upper Neck Force X	F3-2
	Left Rear (10 Yr.) Upper Neck Force Y	F3-2
	Left Rear (10 Yr.) Upper Neck Force Z	F3-2
	Left Rear (10 Yr.) Upper Neck Force Resultant	F3-2
F3-3	Left Rear (10 Yr.) Upper Neck Moment X	F3-3
	Left Rear (10 Yr.) Upper Neck Moment Y	F3-3
	Left Rear (10 Yr.) Upper Neck Moment Z	F3-3
	Left Rear (10 Yr.) Upper Neck Moment Resultant	F3-3
F3-4	Left Rear (10 Yr.) Chest X	F3-4
	Left Rear (10 Yr.) Chest Y	F3-4
	Left Rear (10 Yr.) Chest Z	F3-4
	Left Rear (10 Yr.) Chest Resultant	F3-4
F3-5	Left Rear (10 Yr.) Chest Deflection	F3-5
F3-6	Left Rear (10 Yr.) Pelvis X	F3-6
	Left Rear (10 Yr.) Pelvis Y	F3-6
	Left Rear (10 Yr.) Pelvis Z	F3-6
	Left Rear (10 Yr.) Pelvis Resultant	F3-6
F3-7	Left Rear (10 Yr.) Left Femur Force	F3-7
	Left Rear (10 Yr.) Right Femur Force	F3-7
F3-8	Left Rear (10 Yr.) Lumbar Force X	F3-8
	Left Rear (10 Yr.) Lumbar Force Y	F3-8
	Left Rear (10 Yr.) Lumbar Force Z	F3-8
	Left Rear (10 Yr.) Lumbar Force Resultant	F3-8
F3-9	Left Rear (10 Yr.) Lumbar Moment X	F3-9
	Left Rear (10 Yr.) Lumbar Moment Y	F3-9
	Left Rear (10 Yr.) Lumbar Moment Z	F3-9
	Left Rear (10 Yr.) Lumbar Moment Resultant	F3-9
F3-10	Left Rear (10 Yr.) Left Clavicle Force X	F3-10
	Left Rear (10 Yr.) Left Clavicle Force Z	F3-10
	Left Rear (10 Yr.) Right Clavicle Force X	F3-10
	Left Rear (10 Yr.) Right Clavicle Force Z	F3-10

LIST OF DATA PLOTS...(CONTINUED)

<u>Data Plot</u>	<u>Page</u>	
F3-11	Left Rear (10 Yr.) Left Upper ASIS Force	F3-11
	Left Rear (10 Yr.) Left Lower ASIS Force	F3-11
	Left Rear (10 Yr.) Right Upper ASIS Force	F3-11
	Left Rear (10 Yr.) Right Lower ASIS Force	F3-11
F3-12	Left Rear (10 Yr.) Lap Belt Force	F3-12
	Left Rear (10 Yr.) Shoulder Belt Force	F3-12
	Left Rear (10 Yr.) Shoulder Belt Pullout	F3-12
	Left Rear (10 Yr.) Shoulder Belt Elongation	F3-12
F3-13	Left Rear (10 Yr.) CRS X	F3-13
	Left Rear (10 Yr.) CRS Y	F3-13
	Left Rear (10 Yr.) CRS Z	F3-13
	Left Rear (10 Yr.) CRS Resultant	F3-13
F3-14	Left Rear (10 Yr.) CRS Seat Back X	F3-14
	Left Rear (10 Yr.) CRS Seat Back Y	F3-14
	Left Rear (10 Yr.) CRS Seat Back Z	F3-14
	Left Rear (10 Yr.) CRS Seat Back Resultant	F3-14
F3-15	Right Rear (10 Yr.) Head X	F3-15
	Right Rear (10 Yr.) Head Y	F3-15
	Right Rear (10 Yr.) Head Z	F3-15
	Right Rear (10 Yr.) Head Resultant	F3-15
F3-16	Right Rear (10 Yr.) Upper Neck Force X	F3-16
	Right Rear (10 Yr.) Upper Neck Force Y	F3-16
	Right Rear (10 Yr.) Upper Neck Force Z	F3-16
	Right Rear (10 Yr.) Upper Neck Force Resultant	F3-16
F3-17	Right Rear (10 Yr.) Upper Neck Moment X	F3-17
	Right Rear (10 Yr.) Upper Neck Moment Y	F3-17
	Right Rear (10 Yr.) Upper Neck Moment Z	F3-17
	Right Rear (10 Yr.) Upper Neck Moment Resultant	F3-17
F3-18	Right Rear (10 Yr.) Chest X	F3-18
	Right Rear (10 Yr.) Chest Y	F3-18
	Right Rear (10 Yr.) Chest Z	F3-18
	Right Rear (10 Yr.) Chest Resultant	F3-18
F3-19	Right Rear (10 Yr.) Chest Deflection	F3-19
F3-20	Right Rear (10 Yr.) Pelvis X	F3-20
	Right Rear (10 Yr.) Pelvis Y	F3-20
	Right Rear (10 Yr.) Pelvis Z	F3-20

LIST OF DATA PLOTS...(CONTINUED)

<u>Data Plot</u>		<u>Page</u>
	Right Rear (10 Yr.) Pelvis Resultant	F3-20
F3-21	Right Rear (10 Yr.) Left Femur Force	F3-21
	Right Rear (10 Yr.) Right Femur Force	F3-21
F3-22	Right Rear (10 Yr.) Lumbar Force X	F3-22
	Right Rear (10 Yr.) Lumbar Force Y	F3-22
	Right Rear (10 Yr.) Lumbar Force Z	F3-22
	Right Rear (10 Yr.) Lumbar Force Resultant	F3-22
F3-23	Right Rear (10 Yr.) Lumbar Moment X	F3-23
	Right Rear (10 Yr.) Lumbar Moment Y	F3-23
	Right Rear (10 Yr.) Lumbar Moment Z	F3-23
	Right Rear (10 Yr.) Lumbar Moment Resultant	F3-23
F3-24	Right Rear (10 Yr.) Left Clavicle Force X	F3-24
	Right Rear (10 Yr.) Left Clavicle Force Z	F3-24
	Right Rear (10 Yr.) Right Clavicle Force X	F3-24
	Right Rear (10 Yr.) Right Clavicle Force Z	F3-24
F3-25	Right Rear (10 Yr.) Left Upper ASIS Force	F3-25
	Right Rear (10 Yr.) Left Lower ASIS Force	F3-25
	Right Rear (10 Yr.) Right Upper ASIS Force	F3-25
	Right Rear (10 Yr.) Right Lower ASIS Force	F3-25
F3-26	Right Rear (10 Yr.) Lap Belt Force	F3-26
	Right Rear (10 Yr.) Shoulder Belt Force	F3-26
	Right Rear (10 Yr.) Shoulder Belt Pullout	F3-26
	Right Rear (10 Yr.) Shoulder Belt Elongation	F3-26
F3-27	Right Rear (10 Yr.) CRS X	F3-27
	Right Rear (10 Yr.) CRS Y	F3-27
	Right Rear (10 Yr.) CRS Z	F3-27
	Right Rear (10 Yr.) CRS Resultant	F3-27

Test Vehicle: 2006 Honda Ridgeline RTS 4-Door Truck
 Test Program: 2005 NHTSA 35mph NCAP

Test Date: 4/14/05
 NHTSA No.: H65300

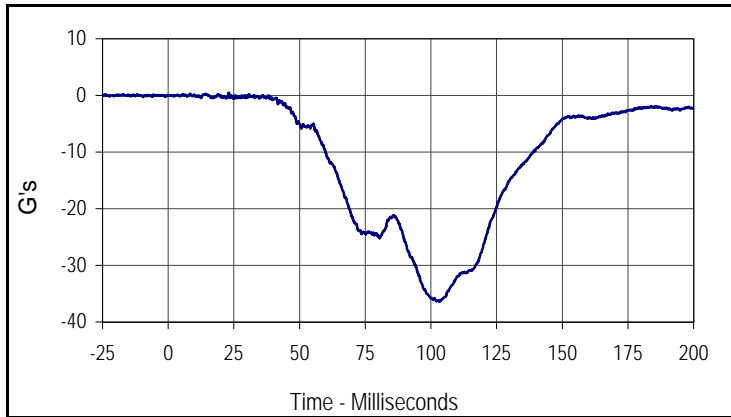

Curve Description			
Left Rear (10 Yr.) Head X			
CURNO	Type	SAE Class	Units
134	FIL	1000	G's
Max	Time	Min	Time
0.4	23.1	-36.4	103.3

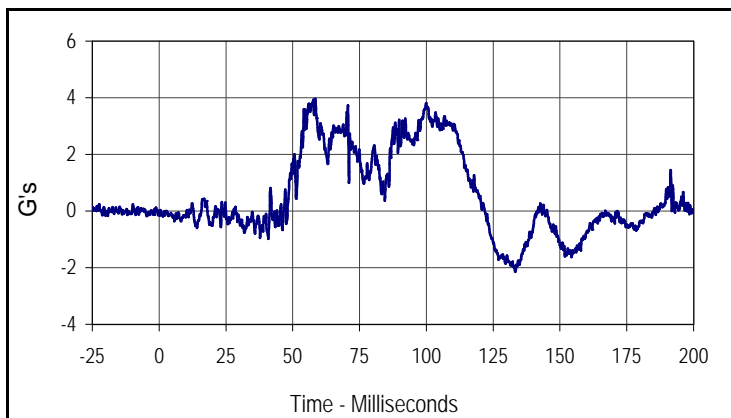

Curve Description			
Left Rear (10 Yr.) Head Y			
CURNO	Type	SAE Class	Units
135	FIL	1000	G's
Max	Time	Min	Time
4.0	58.5	-2.1	133.3

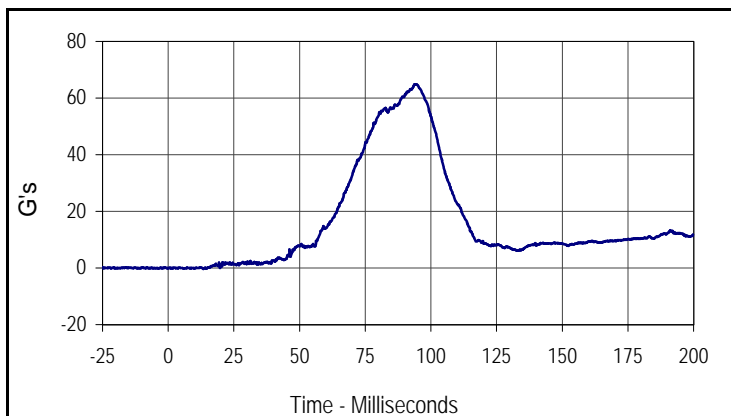

Curve Description			
Left Rear (10 Yr.) Head Z			
CURNO	Type	SAE Class	Units
136	FIL	1000	G's
Max	Time	Min	Time
64.8	93.7	-0.3	13.4

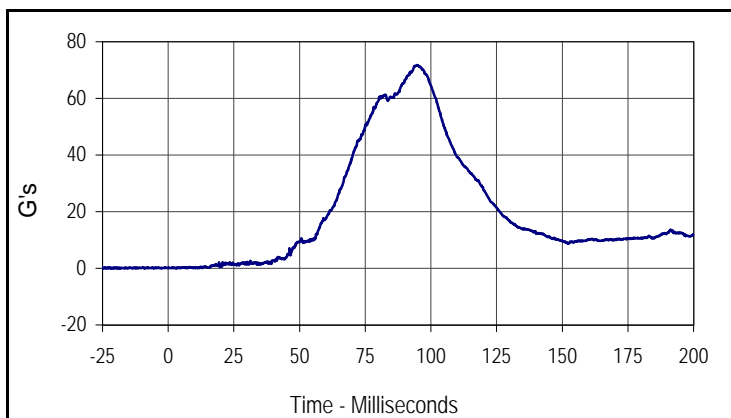

Curve Description			
Left Rear (10 Yr.) Head Resultant			
CURNO	Type	SAE Class	Units
134	RES	1000	G's
Max	Time	Min	Time
71.8	94.7	0.0	3.0

Test Vehicle: 2006 Honda Ridgeline RTS 4-Door Truck
 Test Program: 2005 NHTSA 35mph NCAP

Test Date: 4/14/05
 NHTSA No.: H65300

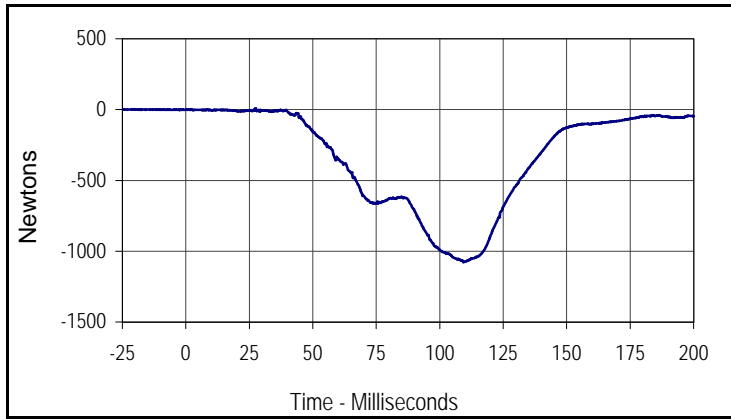

Curve Description			
Left Rear (10 Yr.) Upper Neck Force X			
CURNO	Type	SAE Class	Units
137	FIL	1000	Newtons
Max	Time	Min	Time
10.4	27.4	-1076.9	109.4

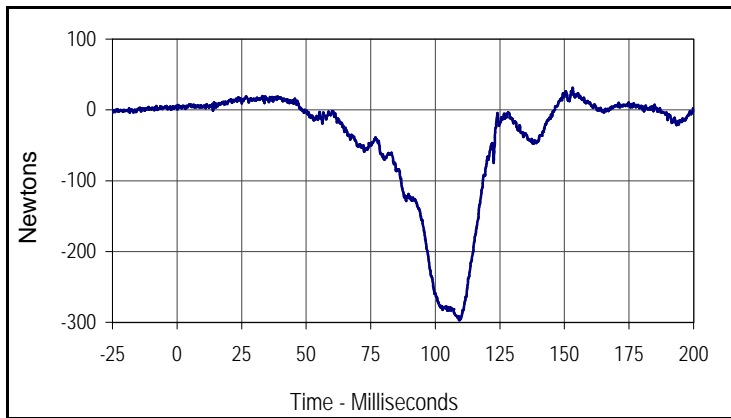

Curve Description			
Left Rear (10 Yr.) Upper Neck Force Y			
CURNO	Type	SAE Class	Units
138	FIL	1000	Newtons
Max	Time	Min	Time
31.5	153.2	-297.5	109.3

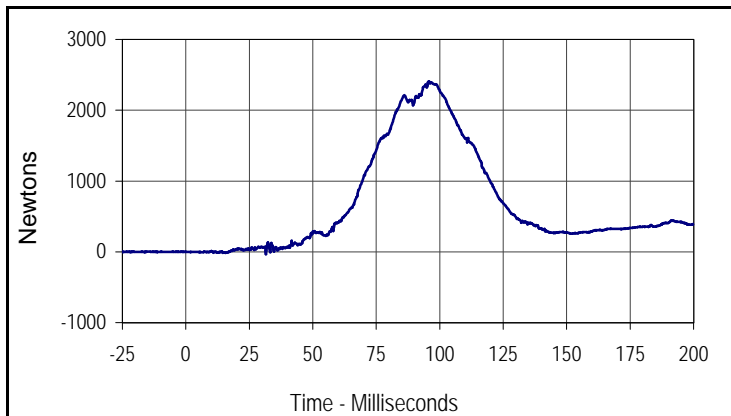

Curve Description			
Left Rear (10 Yr.) Upper Neck Force Z			
CURNO	Type	SAE Class	Units
139	FIL	1000	Newtons
Max	Time	Min	Time
2407.3	95.8	-33.3	31.6

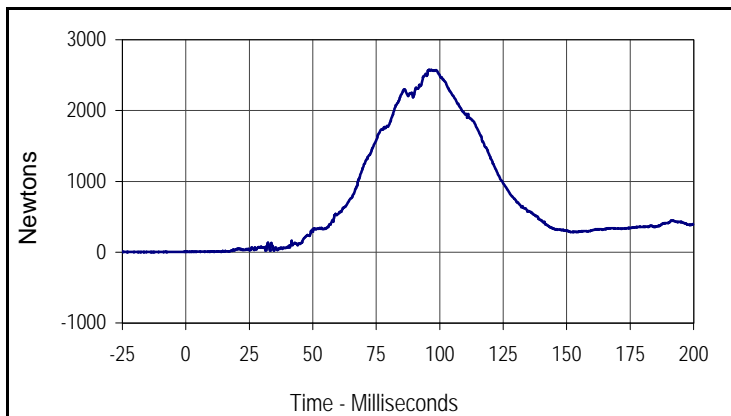

Curve Description			
Left Rear (10 Yr.) Upper Neck Force Res.			
CURNO	Type	SAE Class	Units
137	RES	1000	Newtons
Max	Time	Min	Time
2576.1	95.8	2.0	0.2

Test Vehicle: 2006 Honda Ridgeline RTS 4-Door Truck
 Test Program: 2005 NHTSA 35mph NCAP

Test Date: 4/14/05
 NHTSA No.: H65300

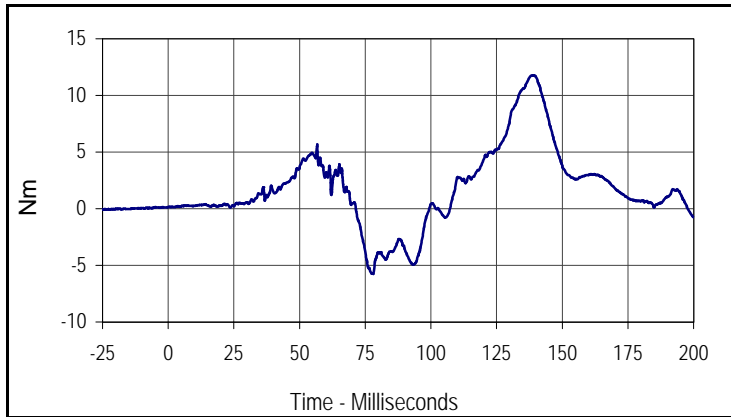

Curve Description			
Left Rear (10 Yr.) Upper Neck Moment X			
CURNO	Type	SAE Class	Units
140	FIL	600	Nm
Max	Time	Min	Time
11.8	138.9	-5.8	78.0

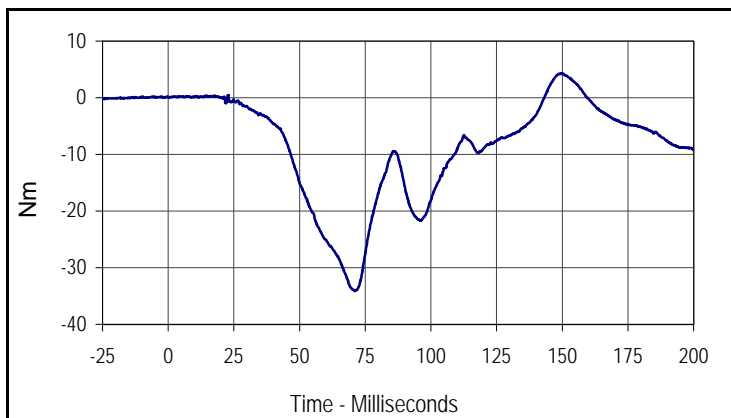

Curve Description			
Left Rear (10 Yr.) Upper Neck Moment Y			
CURNO	Type	SAE Class	Units
141	FIL	600	Nm
Max	Time	Min	Time
4.3	149.7	-34.1	71.0

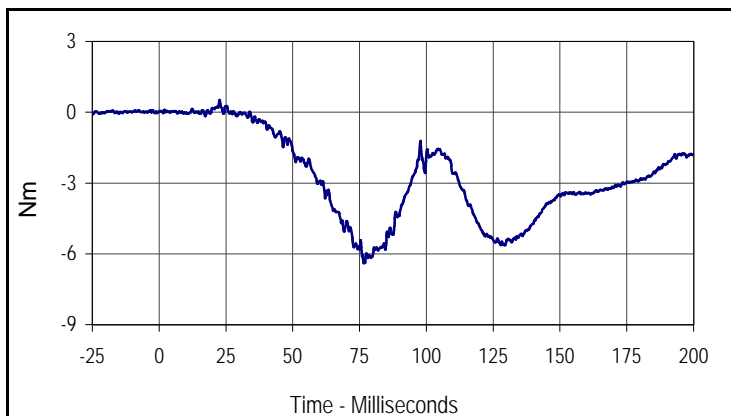

Curve Description			
Left Rear (10 Yr.) Upper Neck Moment Z			
CURNO	Type	SAE Class	Units
142	FIL	600	Nm
Max	Time	Min	Time
0.5	22.7	-6.4	76.6

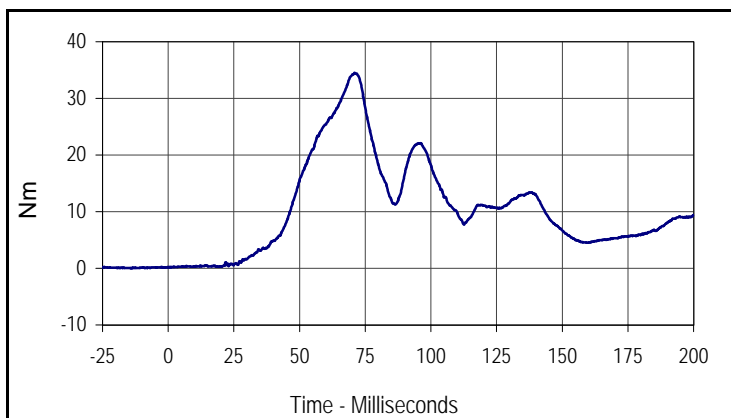

Curve Description			
Left Rear (10 Yr.) Upper Neck Moment Res.			
CURNO	Type	SAE Class	Units
140	RES	600	Nm
Max	Time	Min	Time
34.5	71.0	0.2	1.1

Test Vehicle: 2006 Honda Ridgeline RTS 4-Door Truck
 Test Program: 2005 NHTSA 35mph NCAP

Test Date: 4/14/05
 NHTSA No.: H65300

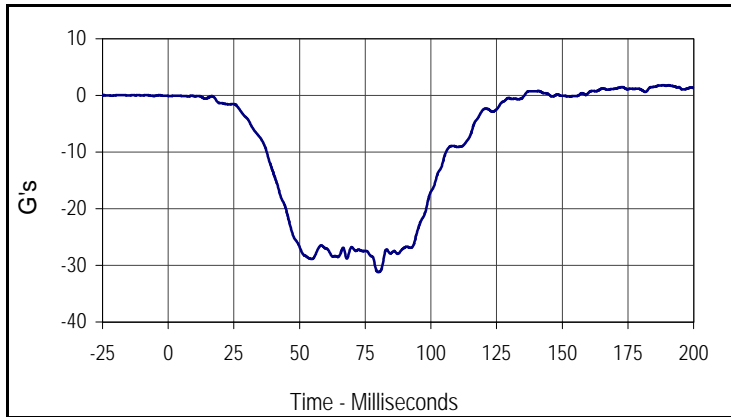

Curve Description			
Left Rear (10 Yr.) Chest X			
CURNO	Type	SAE Class	Units
143	FIL	180	G's
Max	Time	Min	Time
1.8	188.4	-31.2	79.9

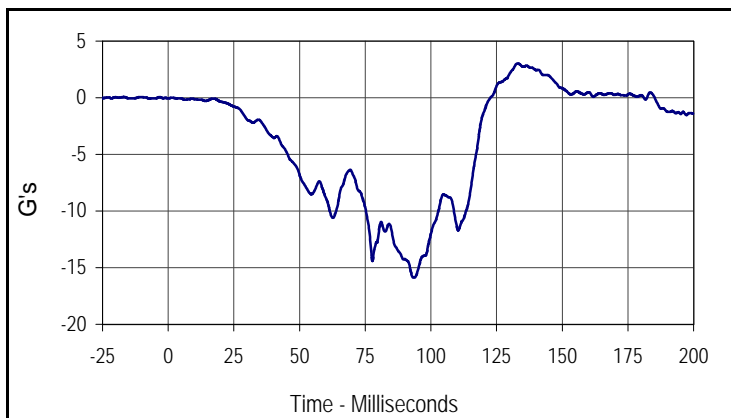

Curve Description			
Left Rear (10 Yr.) Chest Y			
CURNO	Type	SAE Class	Units
144	FIL	180	G's
Max	Time	Min	Time
3.0	132.9	-15.9	93.5

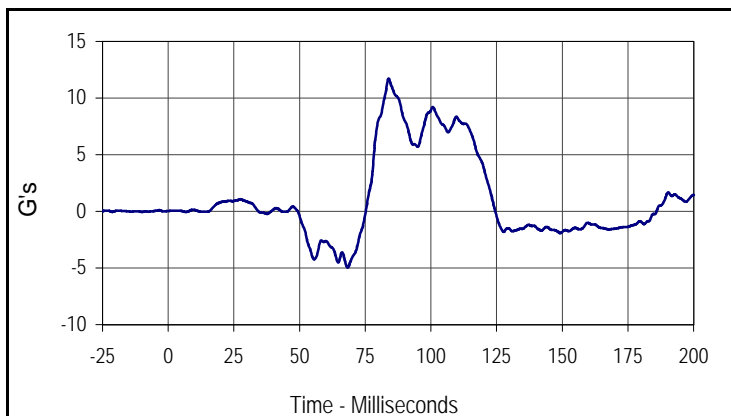

Curve Description			
Left Rear (10 Yr.) Chest Z			
CURNO	Type	SAE Class	Units
145	FIL	180	G's
Max	Time	Min	Time
11.7	83.9	-5.0	68.3

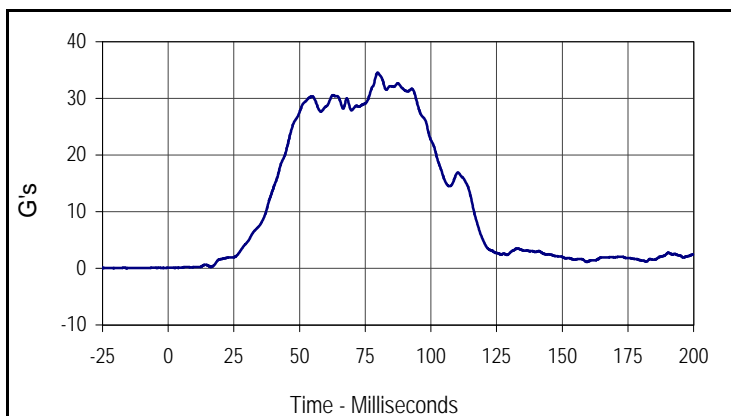

Curve Description			
Left Rear (10 Yr.) Chest Resultant			
CURNO	Type	SAE Class	Units
143	RES	180	G's
Max	Time	Min	Time
34.6	79.7	0.1	2.6

Test Vehicle: 2006 Honda Ridgeline RTS 4-Door Truck
 Test Program: 2005 NHTSA 35mph NCAP

Test Date: 4/14/05
 NHTSA No.: H65300

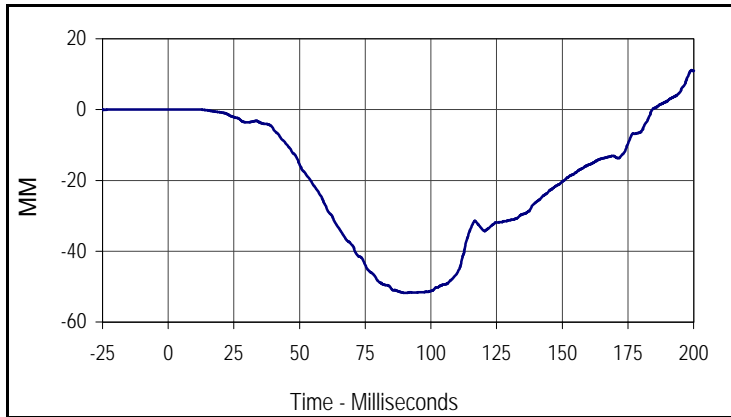

Curve Description			
Left Rear (10 Yr.) Chest Deflection			
CURNO	Type	SAE Class	Units
146	FIL	600	MM
Max	Time	Min	Time
11.1	199.3	-51.8	90.4

Test Vehicle: 2006 Honda Ridgeline RTS 4-Door Truck
 Test Program: 2005 NHTSA 35mph NCAP

Test Date: 4/14/05
 NHTSA No.: H65300

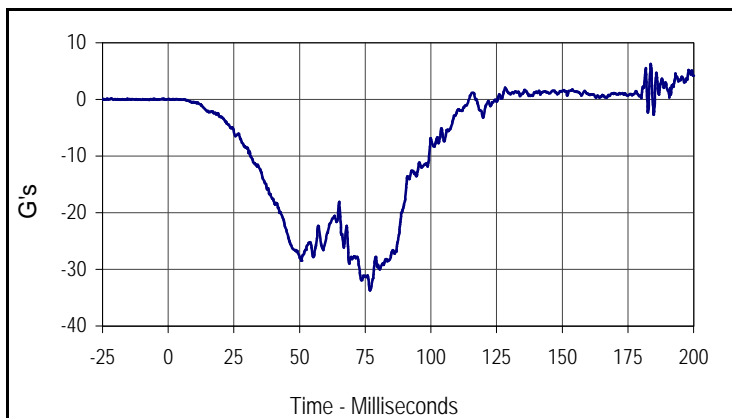

Curve Description			
Left Rear (10 Yr.) Pelvis X			
CURNO	Type	SAE Class	Units
147	FIL	1000	G's
Max	Time	Min	Time
6.2	183.7	-33.7	76.8

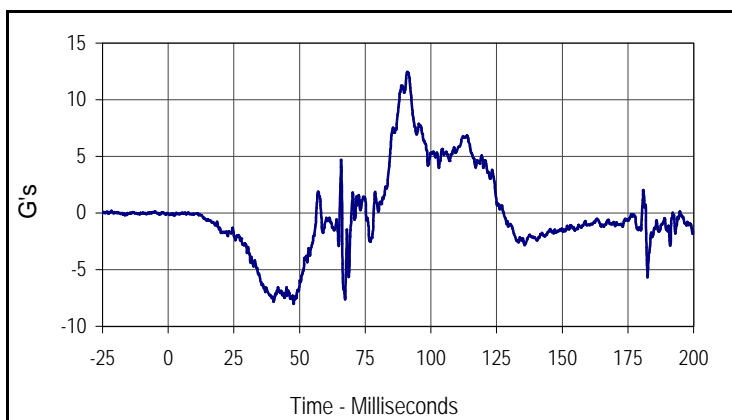

Curve Description			
Left Rear (10 Yr.) Pelvis Y			
CURNO	Type	SAE Class	Units
148	FIL	1000	G's
Max	Time	Min	Time
12.5	91.1	-8.0	47.7

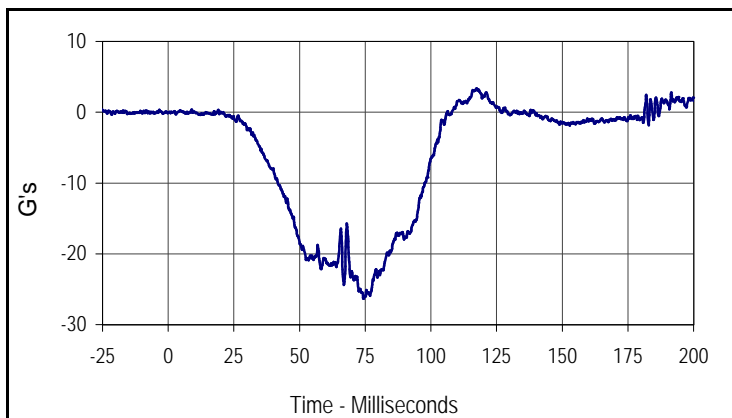

Curve Description			
Left Rear (10 Yr.) Pelvis Z			
CURNO	Type	SAE Class	Units
149	FIL	1000	G's
Max	Time	Min	Time
3.4	117.4	-26.4	74.4

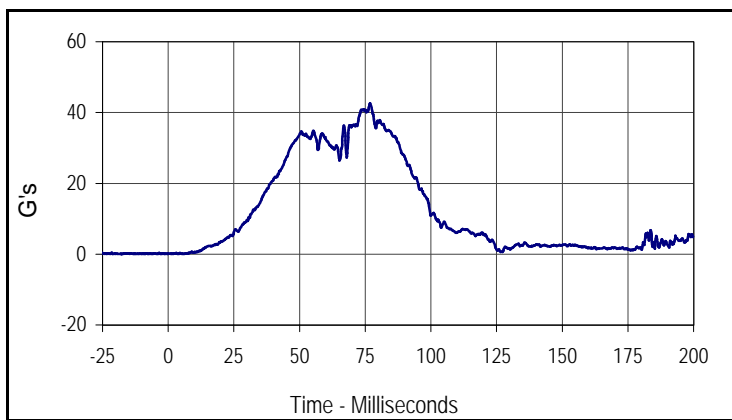

Curve Description			
Left Rear (10 Yr.) Pelvis Resultant			
CURNO	Type	SAE Class	Units
147	RES	1000	G's
Max	Time	Min	Time
42.6	76.8	0.0	5.9

Test Vehicle: 2006 Honda Ridgeline RTS 4-Door Truck
 Test Program: 2005 NHTSA 35mph NCAP

Test Date: 4/14/05
 NHTSA No.: H65300

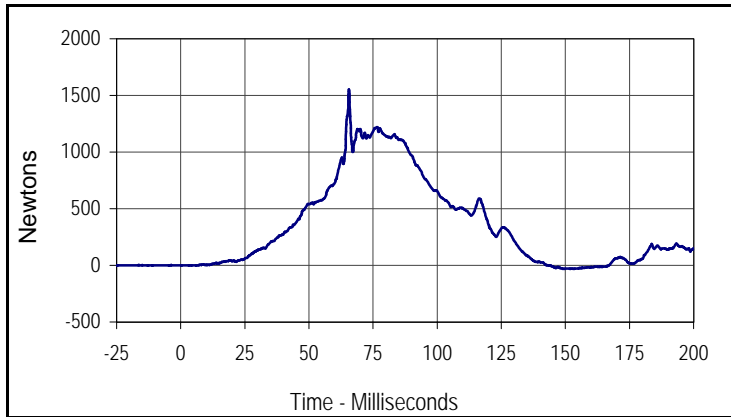

Curve Description			
Left Rear (10 Yr.) Left Femur Force			
CURNO	Type	SAE Class	Units
150	FIL	600	Newtons
Max	Time	Min	Time
1554.4	65.6	-32.4	153.4

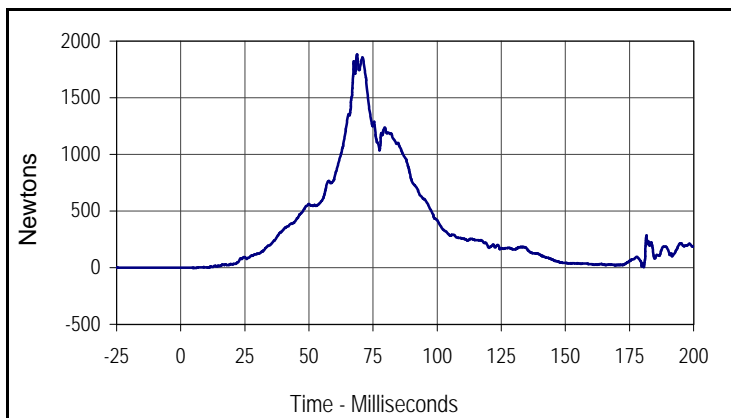

Curve Description			
Left Rear (10 Yr.) Right Femur Force			
CURNO	Type	SAE Class	Units
151	FIL	600	Newtons
Max	Time	Min	Time
1881.0	68.8	-2.5	5.4

Test Vehicle: 2006 Honda Ridgeline RTS 4-Door Truck
 Test Program: 2005 NHTSA 35mph NCAP

Test Date: 4/14/05
 NHTSA No.: H65300

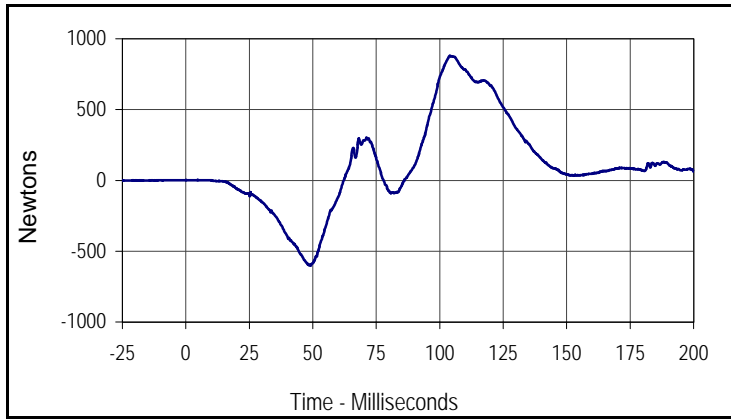

Curve Description			
Left Rear (10 Yr.) Lumbar Force X			
CURNO	Type	SAE Class	Units
152	FIL	1000	Newtons
Max	Time	Min	Time
880.0	103.9	-602.2	49.1

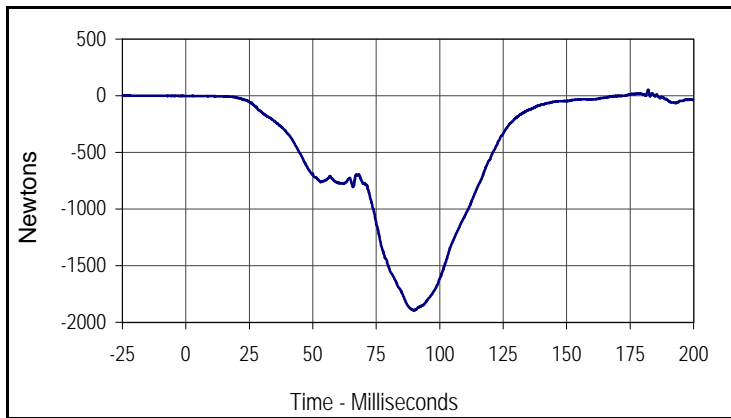

Curve Description			
Left Rear (10 Yr.) Lumbar Force Y			
CURNO	Type	SAE Class	Units
153	FIL	1000	Newtons
Max	Time	Min	Time
52.8	182.1	-1895.9	89.8

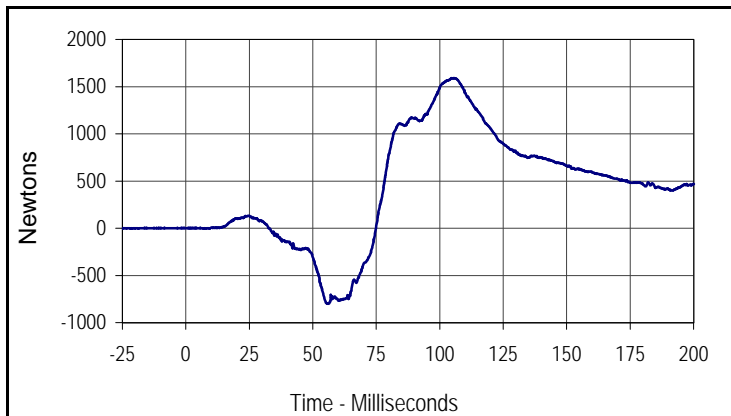

Curve Description			
Left Rear (10 Yr.) Lumbar Force Z			
CURNO	Type	SAE Class	Units
154	FIL	1000	Newtons
Max	Time	Min	Time
1590.3	105.4	-801.2	56.2

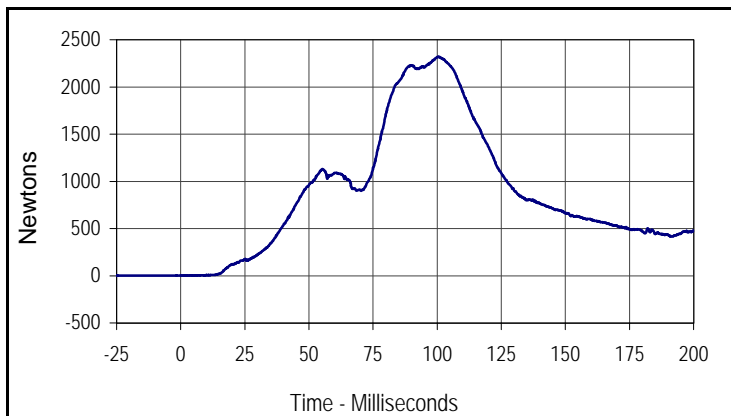

Curve Description			
Left Rear (10 Yr.) Lumbar Force Resultant			
CURNO	Type	SAE Class	Units
152	RES	1000	Newtons
Max	Time	Min	Time
2322.0	100.4	2.0	0.4

Test Vehicle: 2006 Honda Ridgeline RTS 4-Door Truck
 Test Program: 2005 NHTSA 35mph NCAP

Test Date: 4/14/05
 NHTSA No.: H65300

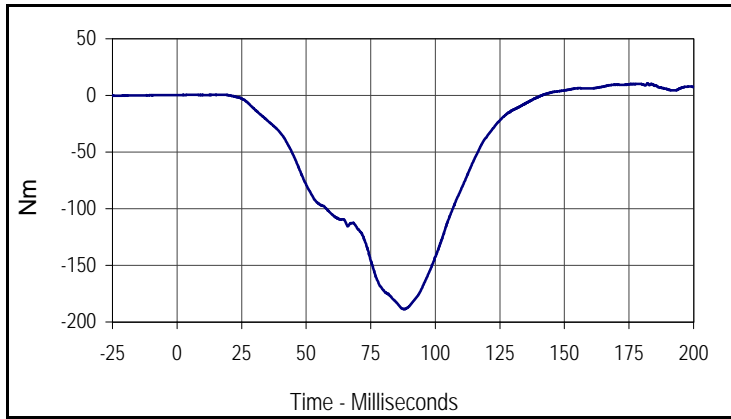

Curve Description			
Left Rear (10 Yr.) Lumbar Moment X			
CURNO	Type	SAE Class	Units
155	FIL	1000	Nm
Max	Time	Min	Time
10.6	182.2	-188.7	87.9

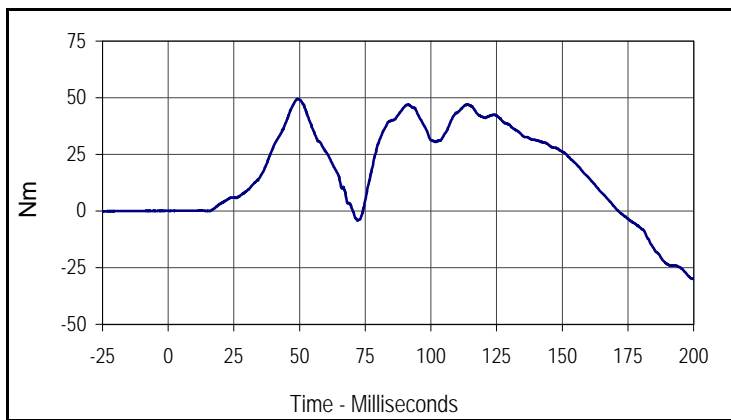

Curve Description			
Left Rear (10 Yr.) Lumbar Moment Y			
CURNO	Type	SAE Class	Units
156	FIL	1000	Nm
Max	Time	Min	Time
49.5	49.3	-30.0	199.6

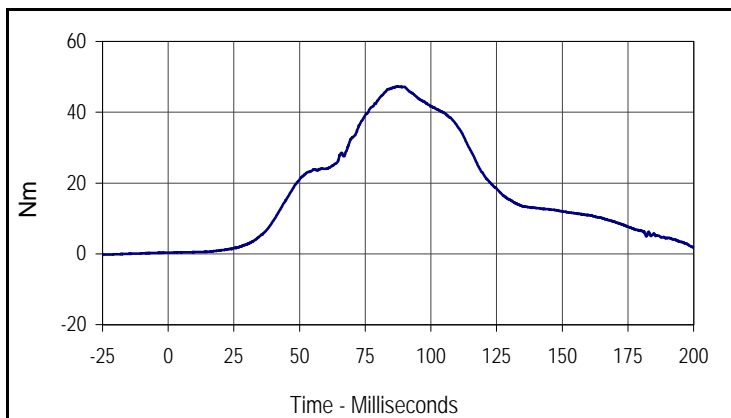

Curve Description			
Left Rear (10 Yr.) Lumbar Moment Z			
CURNO	Type	SAE Class	Units
157	FIL	1000	Nm
Max	Time	Min	Time
47.3	87.6	0.3	0.1

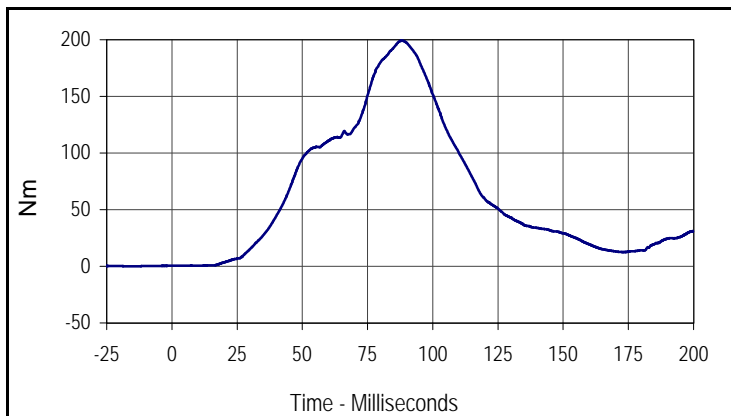

Curve Description			
Left Rear (10 Yr.) Lumbar Moment Resultant			
CURNO	Type	SAE Class	Units
155	RES	1000	Nm
Max	Time	Min	Time
199.3	88.0	0.5	0.6

Test Vehicle: 2006 Honda Ridgeline RTS 4-Door Truck
 Test Program: 2005 NHTSA 35mph NCAP

Test Date: 4/14/05
 NHTSA No.: H65300

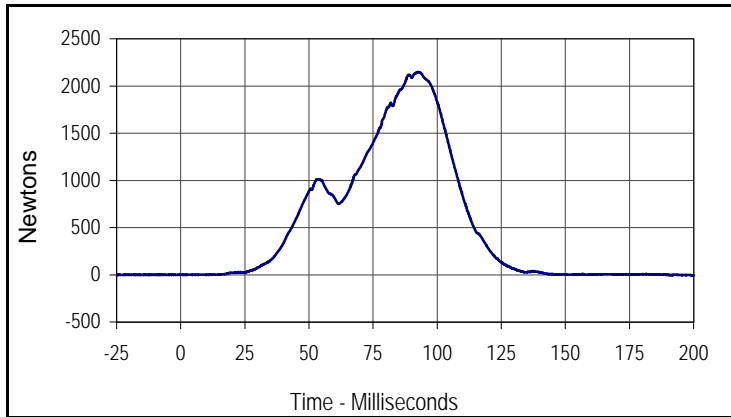

Curve Description			
Left Rear (10 Yr.) Left Clavicle Force X			
CURNO	Type	SAE Class	Units
158	FIL	1000	Newtons
Max	Time	Min	Time
2148.4	92.7	-6.8	199.6

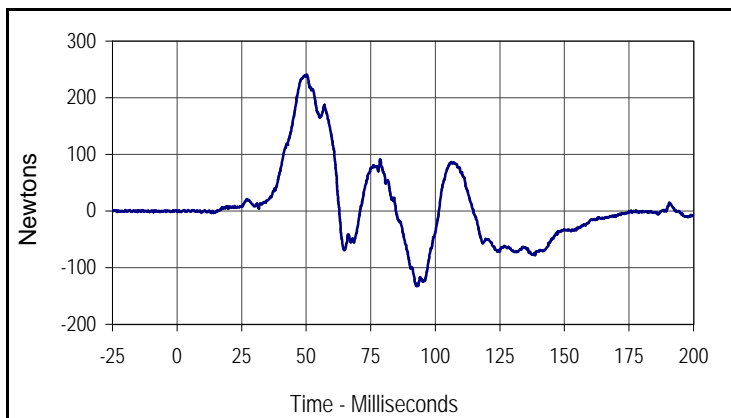

Curve Description			
Left Rear (10 Yr.) Left Clavicle Force Z			
CURNO	Type	SAE Class	Units
159	FIL	1000	Newtons
Max	Time	Min	Time
240.6	50.2	-132.7	92.7

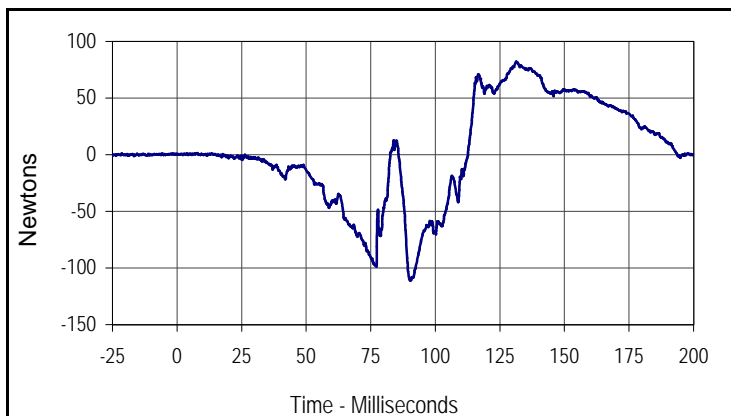

Curve Description			
Left Rear (10 Yr.) Right Clavicle Force X			
CURNO	Type	SAE Class	Units
160	FIL	1000	Newtons
Max	Time	Min	Time
82.3	131.3	-110.9	90.2

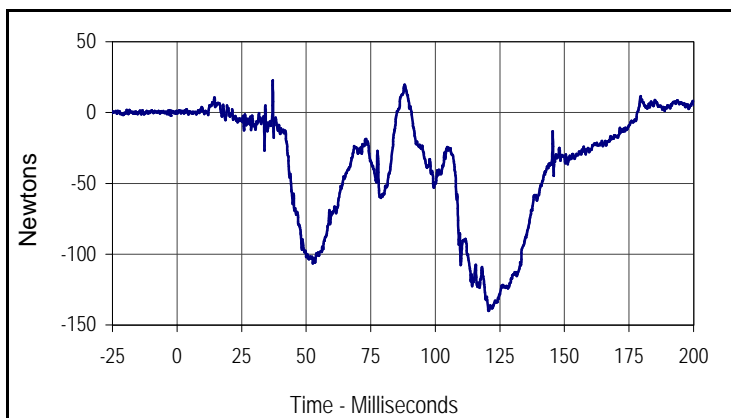

Curve Description			
Left Rear (10 Yr.) Right Clavicle Force Z			
CURNO	Type	SAE Class	Units
161	FIL	1000	Newtons
Max	Time	Min	Time
22.5	37.1	-140.2	120.7

Test Vehicle: 2006 Honda Ridgeline RTS 4-Door Truck
 Test Program: 2005 NHTSA 35mph NCAP

Test Date: 4/14/05
 NHTSA No.: H65300

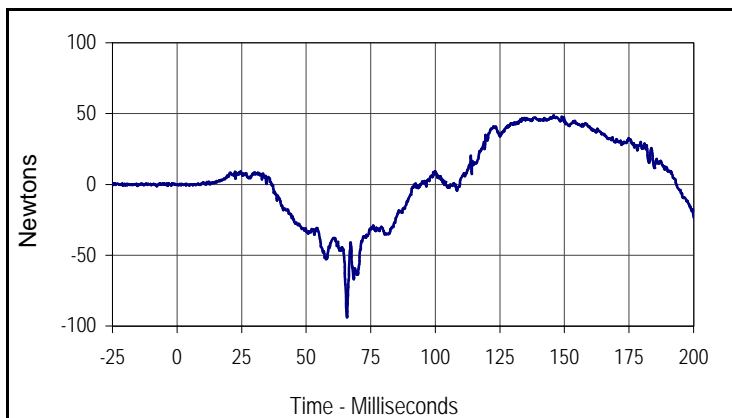

Curve Description			
Left Rear (10 Yr.) Left Upper ASIS Force			
CURNO	Type	SAE Class	Units
162	FIL	1000	Newtons
Max	Time	Min	Time
48.6	145.8	-93.8	65.8

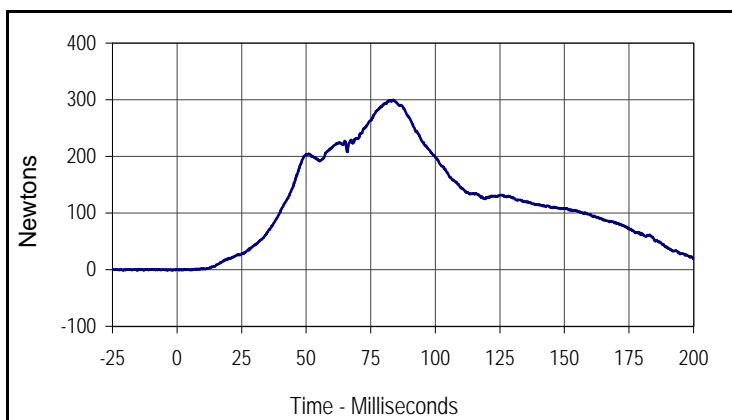

Curve Description			
Left Rear (10 Yr.) Left Lower ASIS Force			
CURNO	Type	SAE Class	Units
163	FIL	1000	Newtons
Max	Time	Min	Time
299.2	84.0	-0.7	0.5

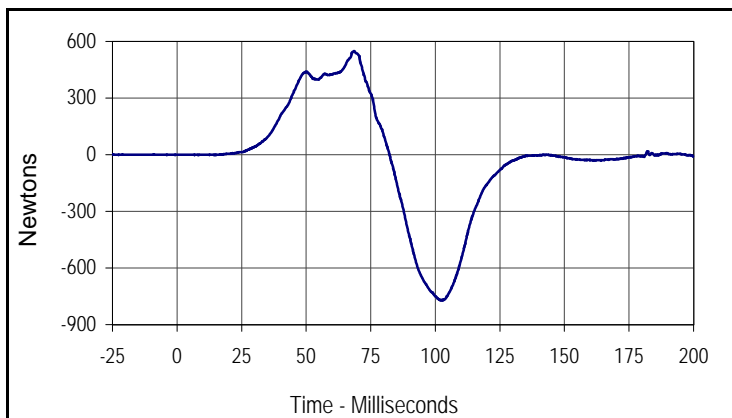

Curve Description			
Left Rear (10 Yr.) Right Upper ASIS Force			
CURNO	Type	SAE Class	Units
164	FIL	1000	Newtons
Max	Time	Min	Time
548.4	68.6	-771.5	102.1

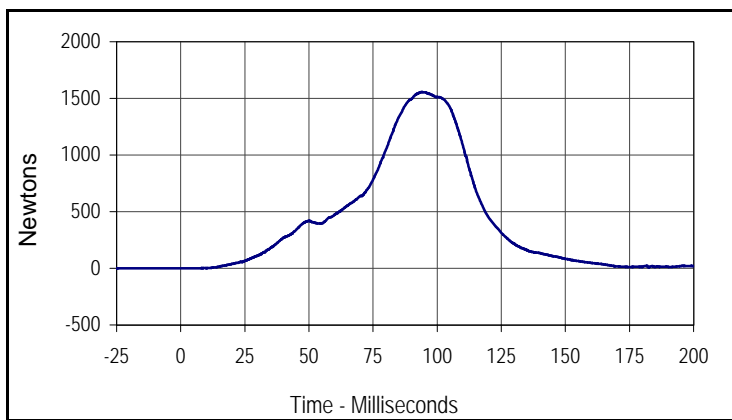

Curve Description			
Left Rear (10 Yr.) Right Lower ASIS Force			
CURNO	Type	SAE Class	Units
165	FIL	1000	Newtons
Max	Time	Min	Time
1557.5	94.0	-1.0	10.0

Test Vehicle: 2006 Honda Ridgeline RTS 4-Door Truck
 Test Program: 2005 NHTSA 35mph NCAP

Test Date: 4/14/05
 NHTSA No.: H65300

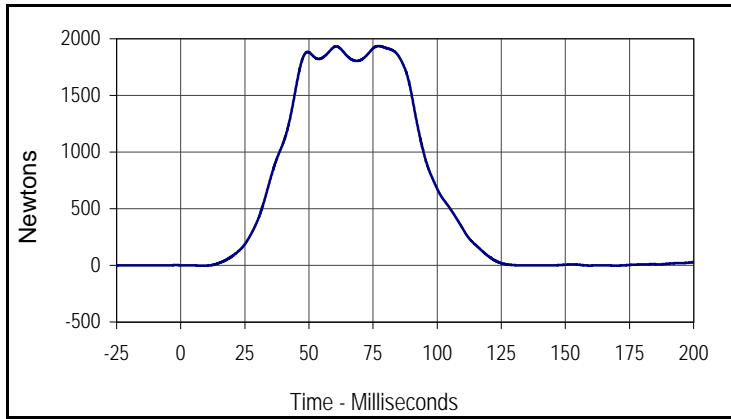

Curve Description			
Left Rear (10 Yr.) Lap Belt Force			
CURNO	Type	SAE Class	Units
166	FIL	60	Newtons
Max	Time	Min	Time
1935.4	77.1	-3.0	8.3

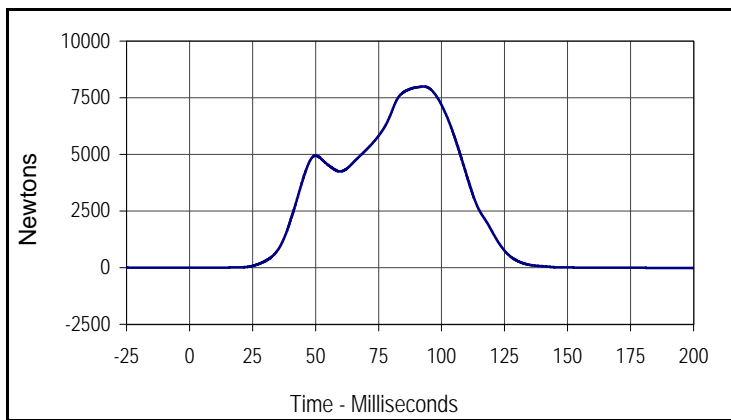

Curve Description			
Left Rear (10 Yr.) Shoulder Belt Force			
CURNO	Type	SAE Class	Units
167	FIL	60	Newtons
Max	Time	Min	Time
7995.9	92.8	-13.5	189.8

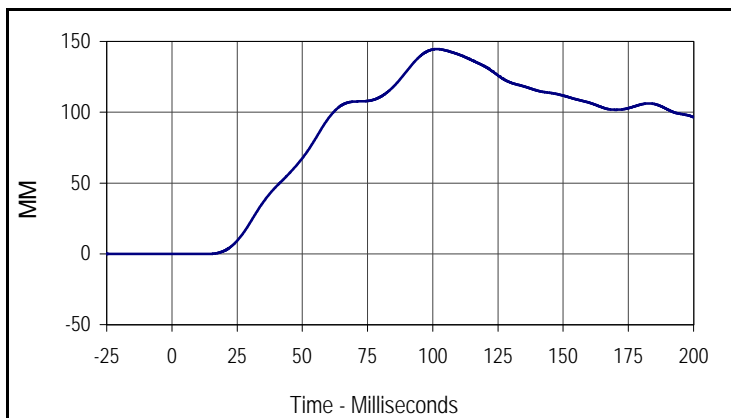

Curve Description			
Left Rear (10 Yr.) Shoulder Belt Pullout (10Yr.)			
CURNO	Type	SAE Class	Units
168	FIL	60	MM
Max	Time	Min	Time
144.6	101.6	-0.1	12.8

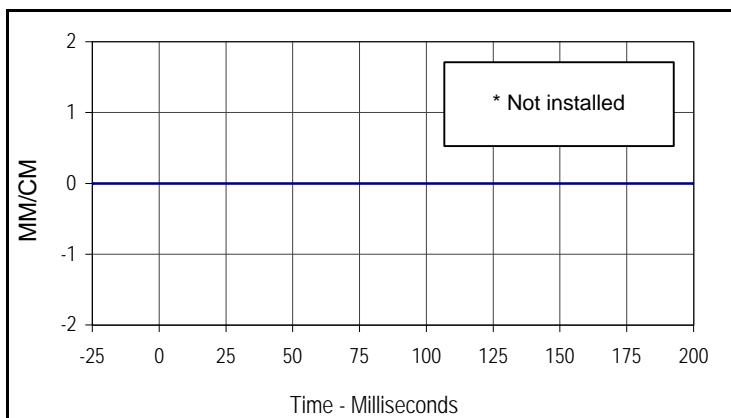

Curve Description			
Left Rear (10 Yr.) Shoulder Belt Elongation			
CURNO	Type	SAE Class	Units
169	FIL	60	MM/CM
Max	Time	Min	Time
0.00	0.0	0.00	0.0

* Not installed

Test Vehicle: 2006 Honda Ridgeline RTS 4-Door Truck
 Test Program: 2005 NHTSA 35mph NCAP

Test Date: 4/14/05
 NHTSA No.: H65300

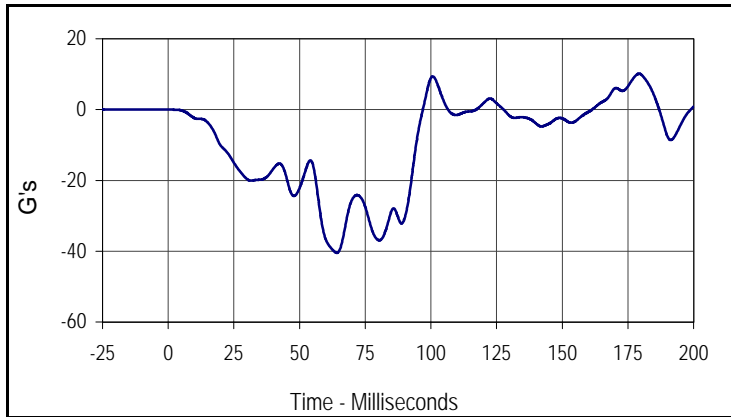

Curve Description			
Left Rear (10 Yr.) CRS X			
CURNO	Type	SAE Class	Units
170	FIL	60	G's
Max	Time	Min	Time
10.1	179.2	-40.5	64.2

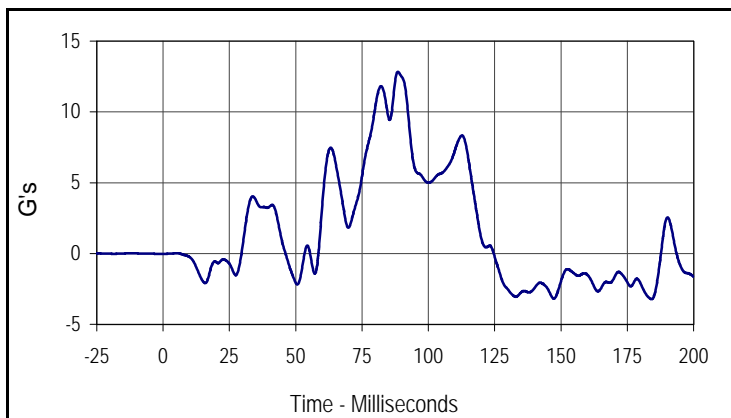

Curve Description			
Left Rear (10 Yr.) CRS Y			
CURNO	Type	SAE Class	Units
171	FIL	60	G's
Max	Time	Min	Time
12.8	88.5	-3.2	184.2

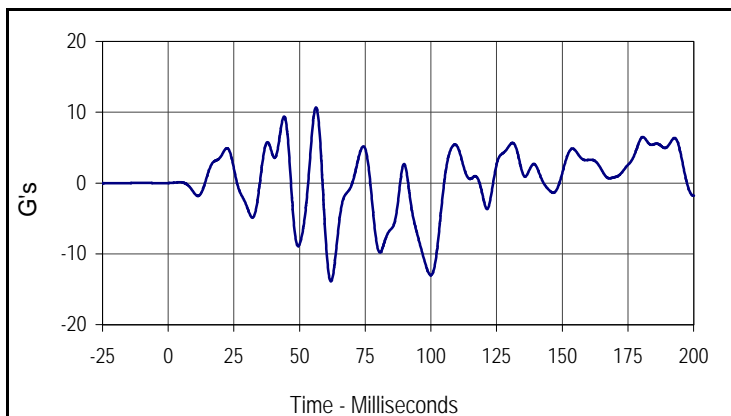

Curve Description			
Left Rear (10 Yr.) CRS Z			
CURNO	Type	SAE Class	Units
172	FIL	60	G's
Max	Time	Min	Time
10.7	56.2	-13.9	61.9

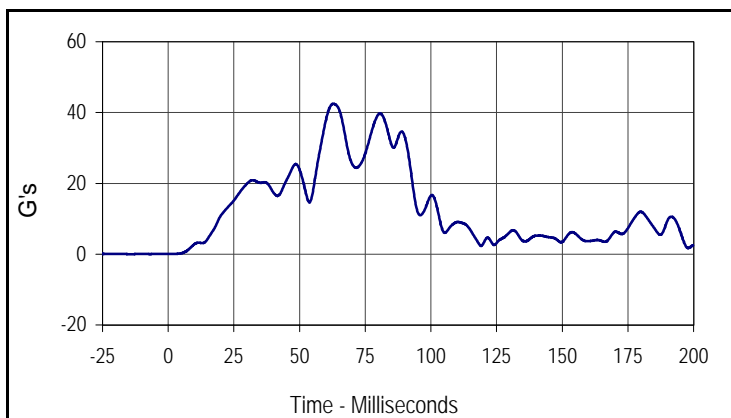

Curve Description			
Left Rear (10 Yr.) CRS Resultant			
CURNO	Type	SAE Class	Units
170	RES	60	G's
Max	Time	Min	Time
42.5	62.9	0.0	0.3

Test Vehicle: 2006 Honda Ridgeline RTS 4-Door Truck
 Test Program: 2005 NHTSA 35mph NCAP

Test Date: 4/14/05
 NHTSA No.: H65300

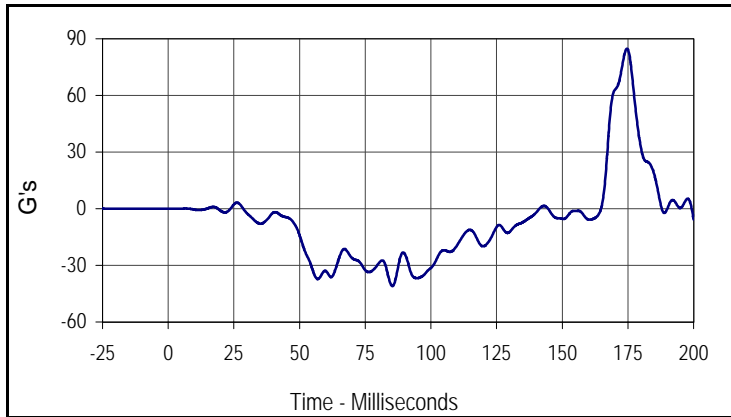

Curve Description			
Left Rear (10 Yr.) CRS Seat Back X			
CURNO	Type	SAE Class	Units
173	FIL	60	G's
Max	Time	Min	Time
84.8	174.6	-41.0	85.3

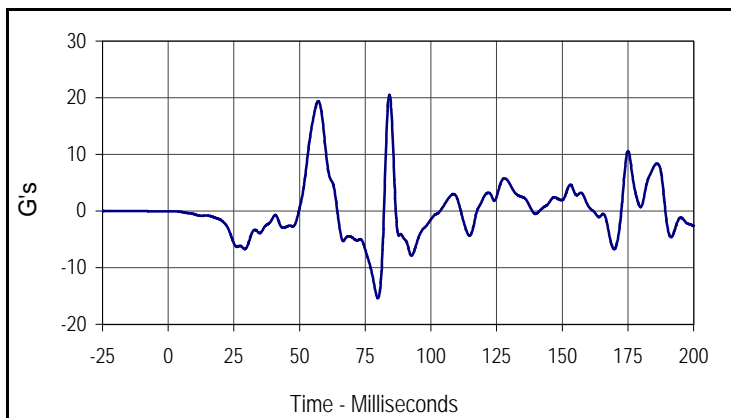

Curve Description			
Left Rear (10 Yr.) CRS Seat Back Y			
CURNO	Type	SAE Class	Units
174	FIL	60	G's
Max	Time	Min	Time
20.5	84.2	-15.4	79.8

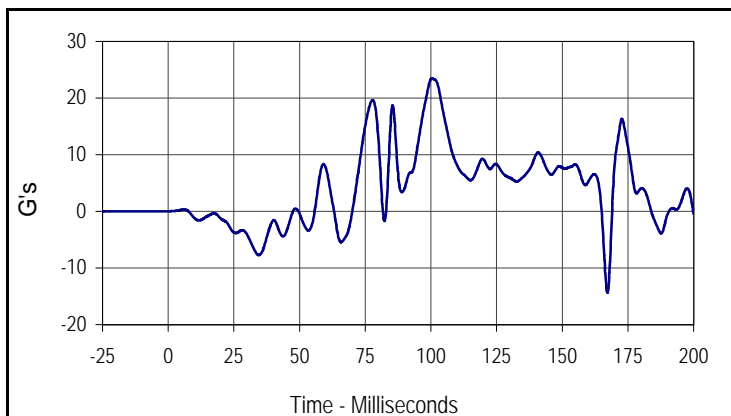

Curve Description			
Left Rear (10 Yr.) CRS Seat Back Z			
CURNO	Type	SAE Class	Units
175	FIL	60	G's
Max	Time	Min	Time
23.5	100.4	-14.3	167.2

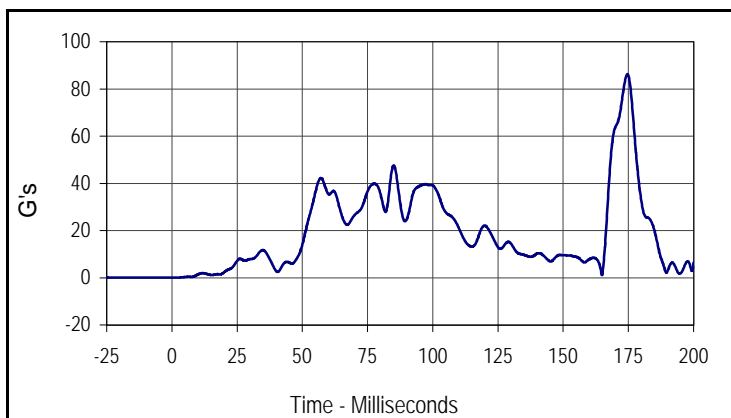

Curve Description			
Left Rear (10 Yr.) CRS Seat Back Resultant			
CURNO	Type	SAE Class	Units
173	RES	60	G's
Max	Time	Min	Time
86.3	174.6	0.1	1.3

Test Vehicle: 2006 Honda Ridgeline RTS 4-Door Truck
 Test Program: 2005 NHTSA 35mph NCAP

Test Date: 4/14/05
 NHTSA No.: H65300

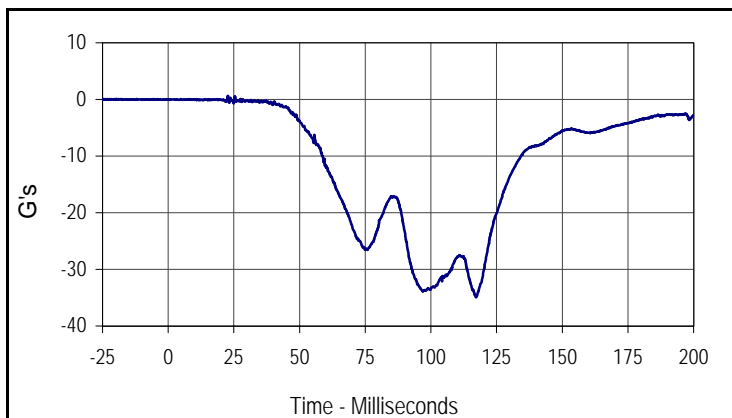

Curve Description			
Right Rear (10 Yr.) Head X			
CURNO	Type	SAE Class	Units
176	FIL	1000	G's
Max	Time	Min	Time
0.6	22.7	-34.9	117.2

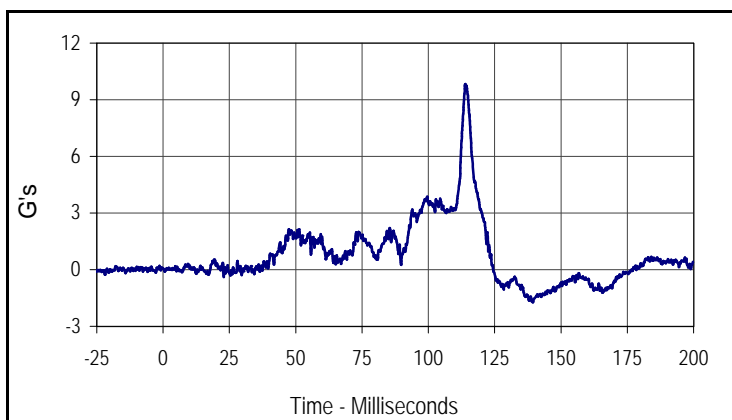

Curve Description			
Right Rear (10 Yr.) Head Y			
CURNO	Type	SAE Class	Units
177	FIL	1000	G's
Max	Time	Min	Time
9.8	114.0	-1.7	139.4

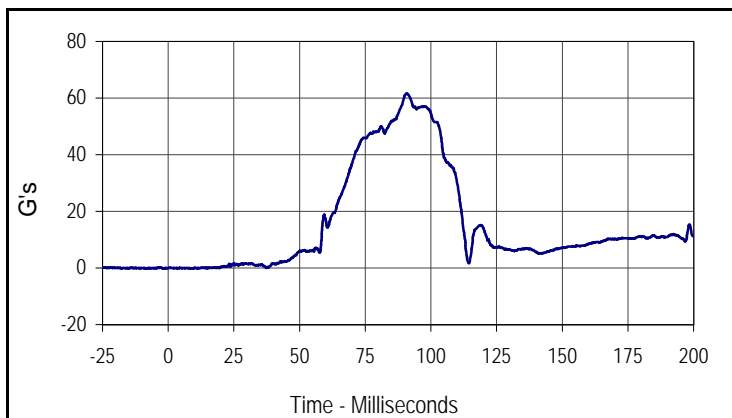

Curve Description			
Right Rear (10 Yr.) Head Z			
CURNO	Type	SAE Class	Units
178	FIL	1000	G's
Max	Time	Min	Time
61.6	90.7	-0.2	8.5

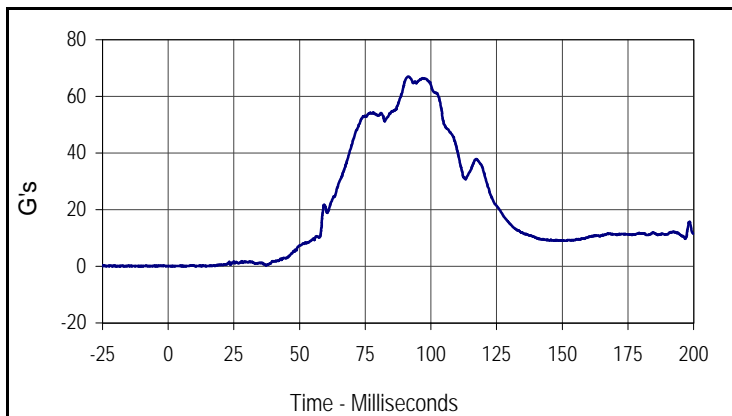

Curve Description			
Right Rear (10 Yr.) Head Resultant			
CURNO	Type	SAE Class	Units
176	RES	1000	G's
Max	Time	Min	Time
67.0	91.3	0.0	6.0

Test Vehicle: 2006 Honda Ridgeline RTS 4-Door Truck
 Test Program: 2005 NHTSA 35mph NCAP

Test Date: 4/14/05
 NHTSA No.: H65300

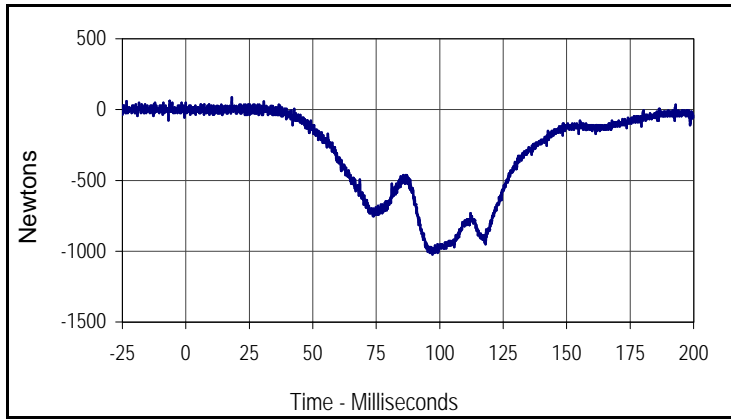

Curve Description			
Right Rear (10 Yr.) Upper Neck Force X			
CURNO	Type	SAE Class	Units
179	FIL	1000	Newtons
Max	Time	Min	Time
87.3	18.1	-1022.5	97.1

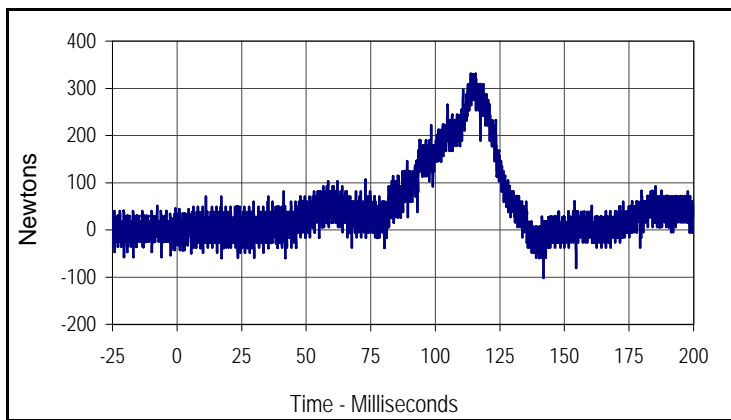

Curve Description			
Right Rear (10 Yr.) Upper Neck Force Y			
CURNO	Type	SAE Class	Units
180	FIL	1000	Newtons
Max	Time	Min	Time
329.2	113.8	-102.0	141.9

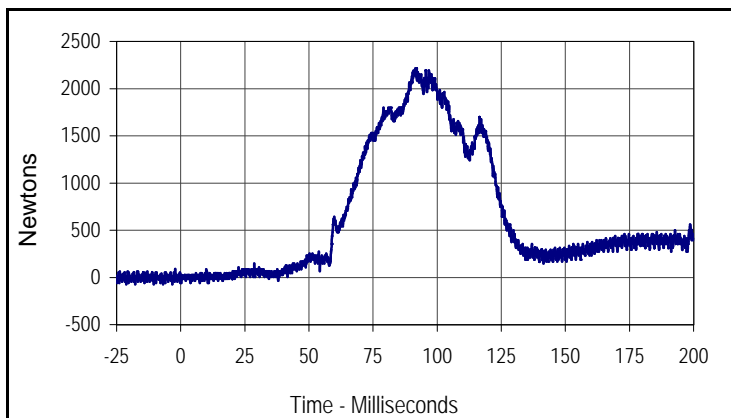

Curve Description			
Right Rear (10 Yr.) Upper Neck Force Z			
CURNO	Type	SAE Class	Units
181	FIL	1000	Newtons
Max	Time	Min	Time
2211.9	91.4	-57.9	0.2

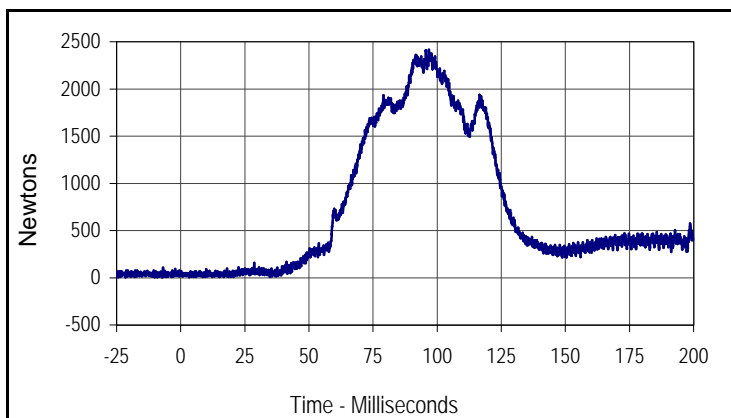

Curve Description			
Right Rear (10 Yr.) Upper Neck Force Resultant			
CURNO	Type	SAE Class	Units
179	RES	1000	Newtons
Max	Time	Min	Time
2414.5	96.8	5.8	3.3

Test Vehicle: 2006 Honda Ridgeline RTS 4-Door Truck
 Test Program: 2005 NHTSA 35mph NCAP

Test Date: 4/14/05
 NHTSA No.: H65300

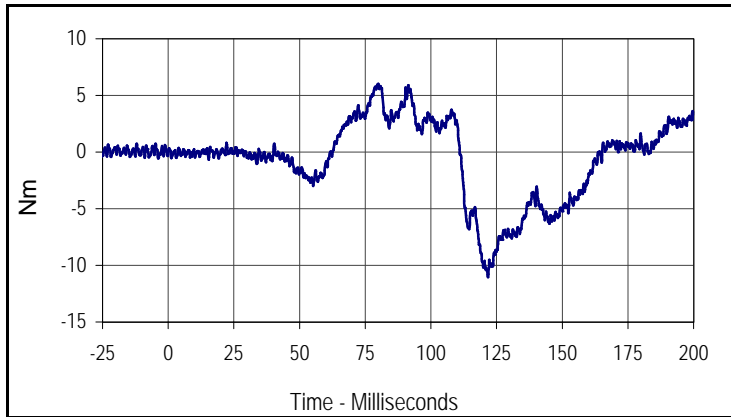

Curve Description			
Right Rear (10 Yr.) Upper Neck Moment X			
CURNO	Type	SAE Class	Units
182	FIL	600	Nm
Max	Time	Min	Time
6.0	80.0	-11.0	121.8

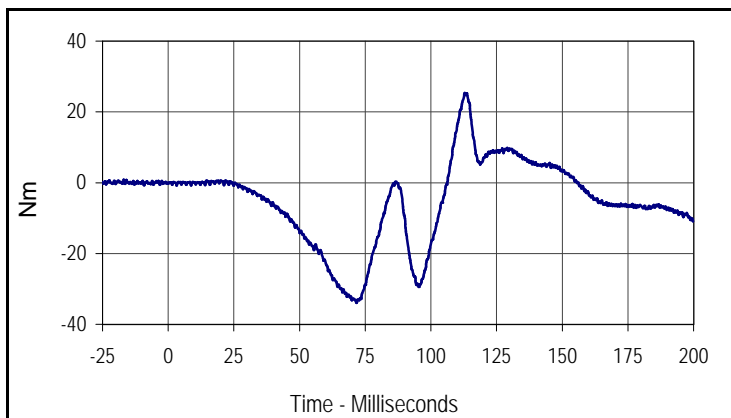

Curve Description			
Right Rear (10 Yr.) Upper Neck Moment Y			
CURNO	Type	SAE Class	Units
183	FIL	600	Nm
Max	Time	Min	Time
25.3	112.9	-34.0	71.7

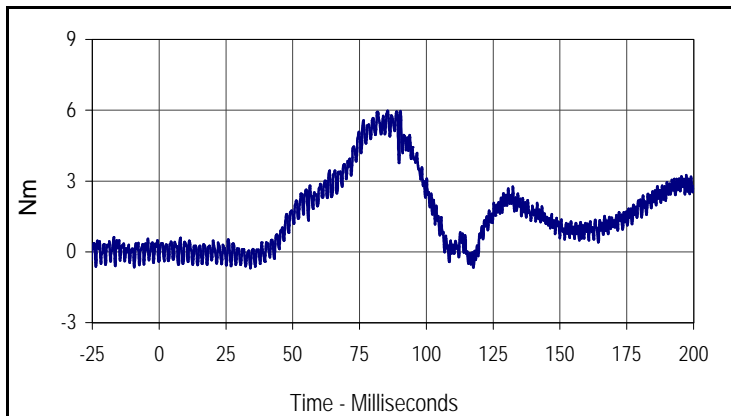

Curve Description			
Right Rear (10 Yr.) Upper Neck Moment Z			
CURNO	Type	SAE Class	Units
184	FIL	600	Nm
Max	Time	Min	Time
6.0	85.5	-0.7	34.2

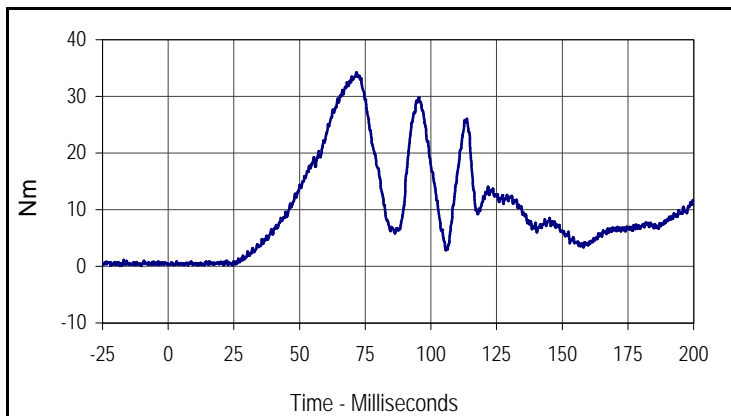

Curve Description			
Right Rear (10 Yr.) Upper Neck Moment Resultant			
CURNO	Type	SAE Class	Units
182	RES	600	Nm
Max	Time	Min	Time
34.3	71.7	0.1	24.4

Test Vehicle: 2006 Honda Ridgeline RTS 4-Door Truck
 Test Program: 2005 NHTSA 35mph NCAP

Test Date: 4/14/05
 NHTSA No.: H65300

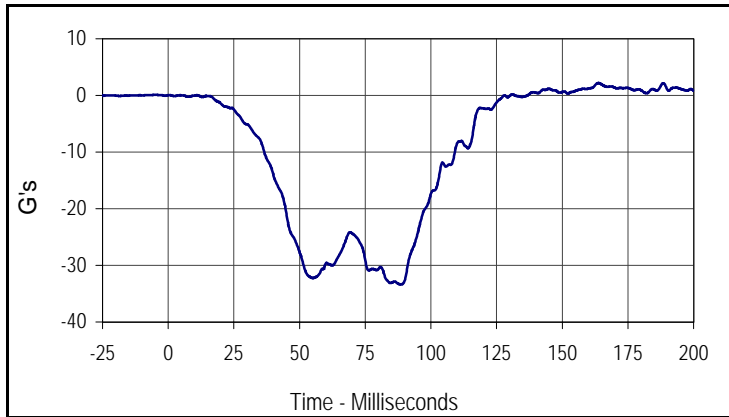

Curve Description			
Right Rear (10 Yr.) Chest X			
CURNO	Type	SAE Class	Units
185	FIL	180	G's
Max	Time	Min	Time
2.2	163.8	-33.4	88.4

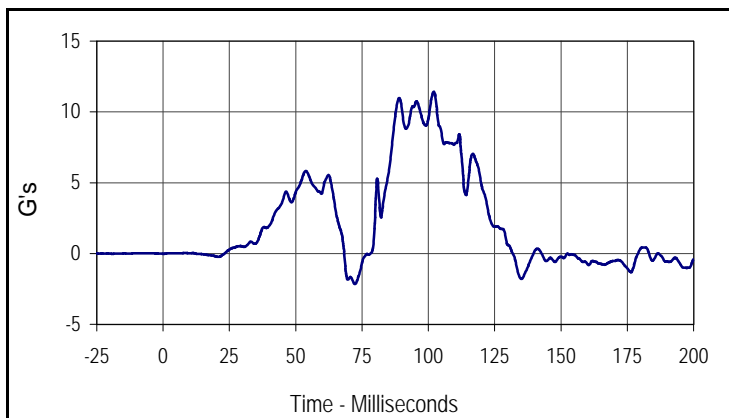

Curve Description			
Right Rear (10 Yr.) Chest Y			
CURNO	Type	SAE Class	Units
186	FIL	180	G's
Max	Time	Min	Time
11.4	102.0	-2.2	72.3

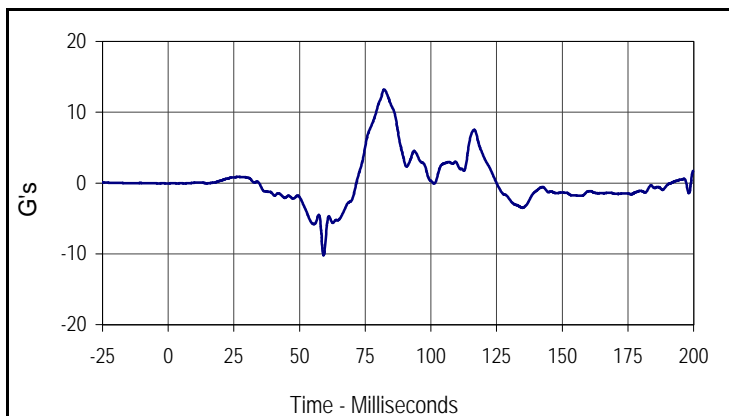

Curve Description			
Right Rear (10 Yr.) Chest Z			
CURNO	Type	SAE Class	Units
187	FIL	180	G's
Max	Time	Min	Time
13.2	82.2	-10.2	59.1

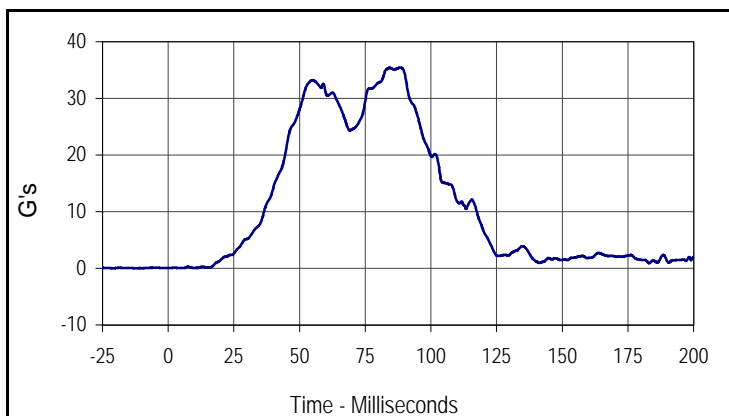

Curve Description			
Right Rear (10 Yr.) Chest Resultant			
CURNO	Type	SAE Class	Units
185	RES	180	G's
Max	Time	Min	Time
35.4	88.4	0.0	5.2

Test Vehicle: 2006 Honda Ridgeline RTS 4-Door Truck
 Test Program: 2005 NHTSA 35mph NCAP

Test Date: 4/14/05
 NHTSA No.: H65300

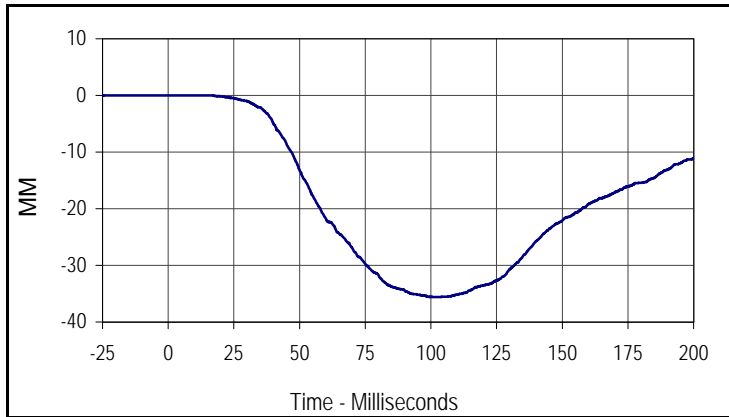

Curve Description			
Right Rear (10 Yr.) Chest Deflection			
CURNO	Type	SAE Class	Units
188	FIL	600	MM
Max	Time	Min	Time
0.0	7.0	-35.6	101.4

Test Vehicle: 2006 Honda Ridgeline RTS 4-Door Truck
 Test Program: 2005 NHTSA 35mph NCAP

Test Date: 4/14/05
 NHTSA No.: H65300

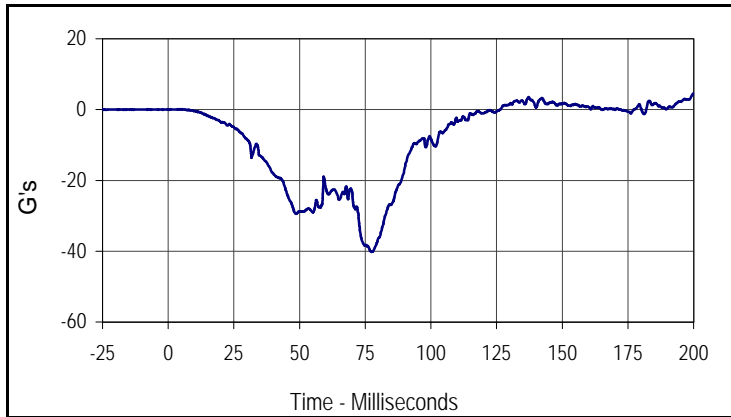

Curve Description			
Right Rear (10 Yr.) Pelvis X			
CURNO	Type	SAE Class	Units
189	FIL	1000	G's
Max	Time	Min	Time
4.5	199.9	-40.2	77.4

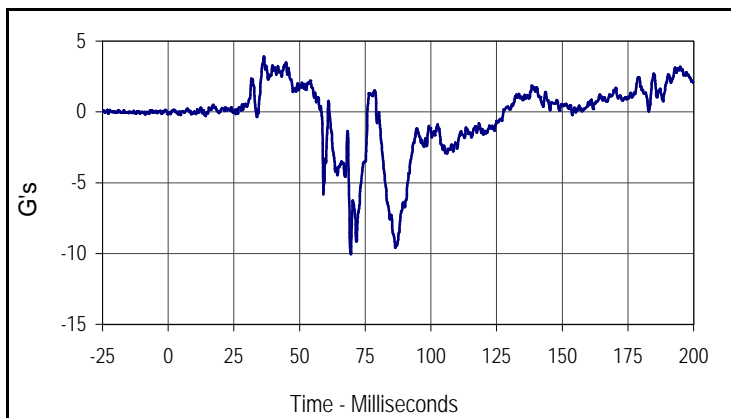

Curve Description			
Right Rear (10 Yr.) Pelvis Y			
CURNO	Type	SAE Class	Units
190	FIL	1000	G's
Max	Time	Min	Time
3.9	36.4	-10.1	69.5

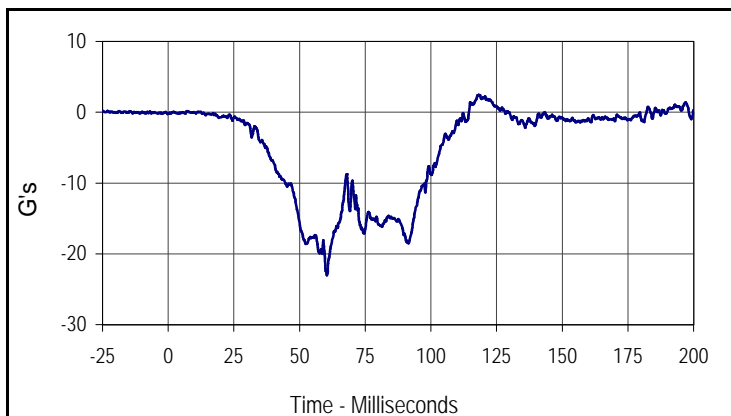

Curve Description			
Right Rear (10 Yr.) Pelvis Z			
CURNO	Type	SAE Class	Units
191	FIL	1000	G's
Max	Time	Min	Time
2.5	118.1	-23.0	60.4

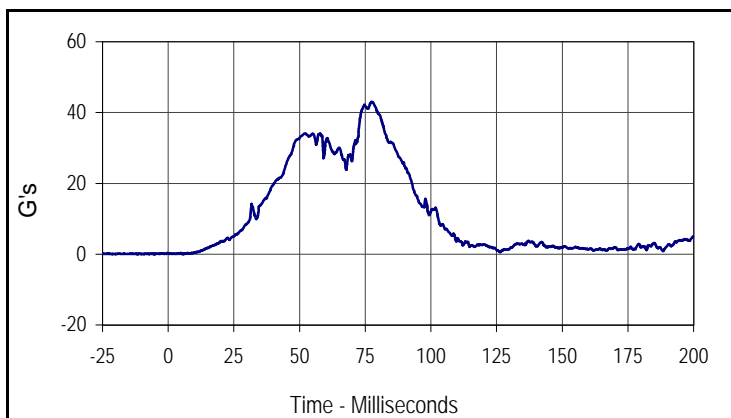

Curve Description			
Right Rear (10 Yr.) Pelvis Resultant			
CURNO	Type	SAE Class	Units
189	RES	1000	G's
Max	Time	Min	Time
43.0	77.3	0.0	5.7

Test Vehicle: 2006 Honda Ridgeline RTS 4-Door Truck
 Test Program: 2005 NHTSA 35mph NCAP

Test Date: 4/14/05
 NHTSA No.: H65300

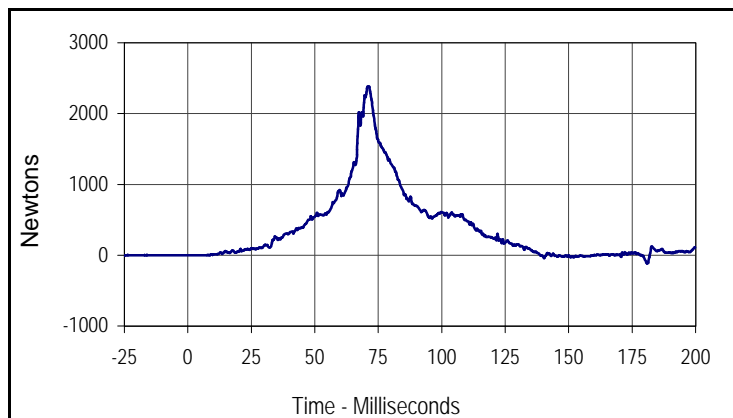

Curve Description			
Right Rear (10 Yr.) Left Femur Force			
CURNO	Type	SAE Class	Units
192	FIL	600	Newtons
Max	Time	Min	Time
2385.4	71.0	-120.8	180.9

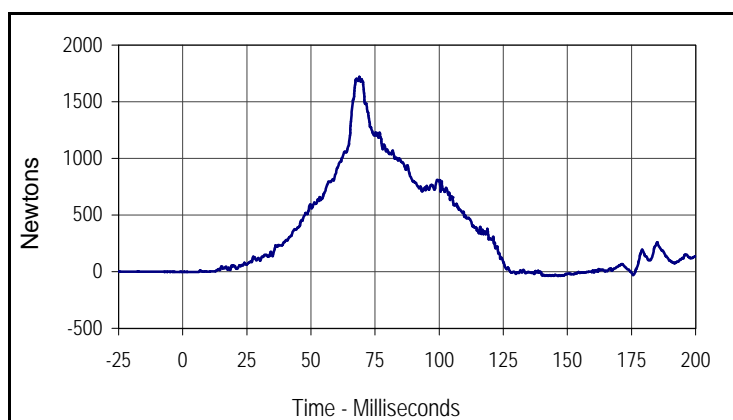

Curve Description			
Right Rear (10 Yr.) Right Femur Force			
CURNO	Type	SAE Class	Units
193	FIL	600	Newtons
Max	Time	Min	Time
1719.5	68.9	-40.5	146.4

Test Vehicle: 2006 Honda Ridgeline RTS 4-Door Truck
 Test Program: 2005 NHTSA 35mph NCAP

Test Date: 4/14/05
 NHTSA No.: H65300

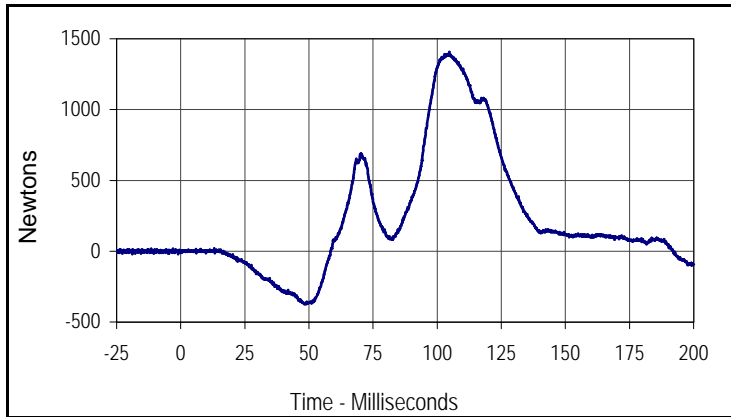

Curve Description			
Right Rear (10 Yr.) Lumbar Force X			
CURNO	Type	SAE Class	Units
194	FIL	1000	Newtons
Max	Time	Min	Time
1407.9	104.8	-373.2	48.1

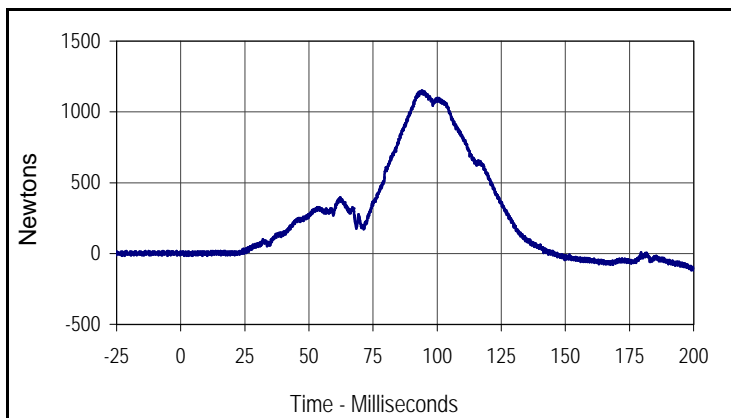

Curve Description			
Right Rear (10 Yr.) Lumbar Force Y			
CURNO	Type	SAE Class	Units
195	FIL	1000	Newtons
Max	Time	Min	Time
1151.5	94.0	-117.0	199.1

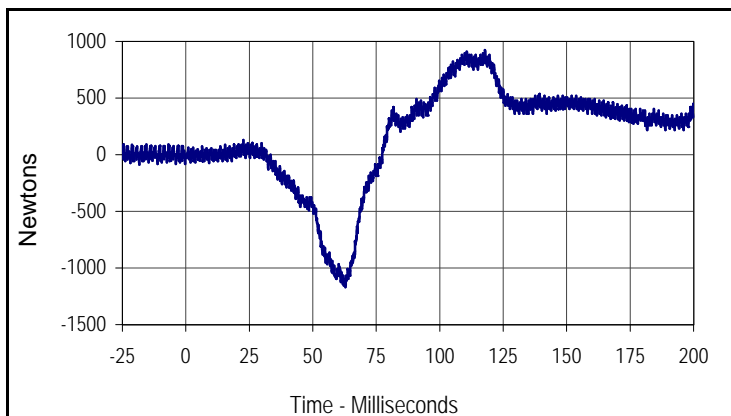

Curve Description			
Right Rear (10 Yr.) Lumbar Force Z			
CURNO	Type	SAE Class	Units
196	FIL	1000	Newtons
Max	Time	Min	Time
923.5	117.8	-1168.8	62.9

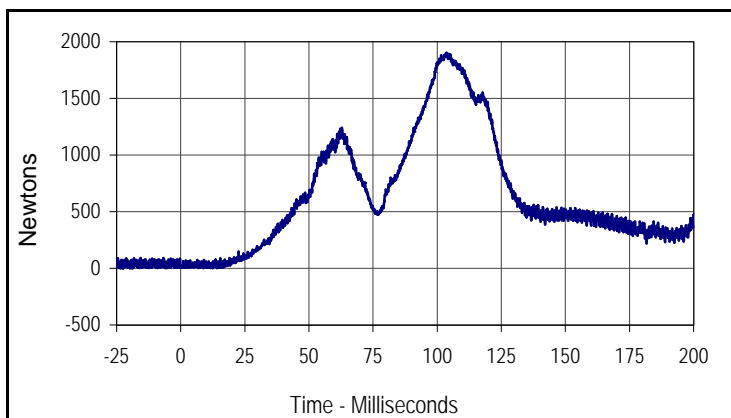

Curve Description			
Right Rear (10 Yr.) Lumbar Force Resultant			
CURNO	Type	SAE Class	Units
194	RES	1000	Newtons
Max	Time	Min	Time
1900.9	103.8	2.0	6.9

Test Vehicle: 2006 Honda Ridgeline RTS 4-Door Truck
 Test Program: 2005 NHTSA 35mph NCAP

Test Date: 4/14/05
 NHTSA No.: H65300

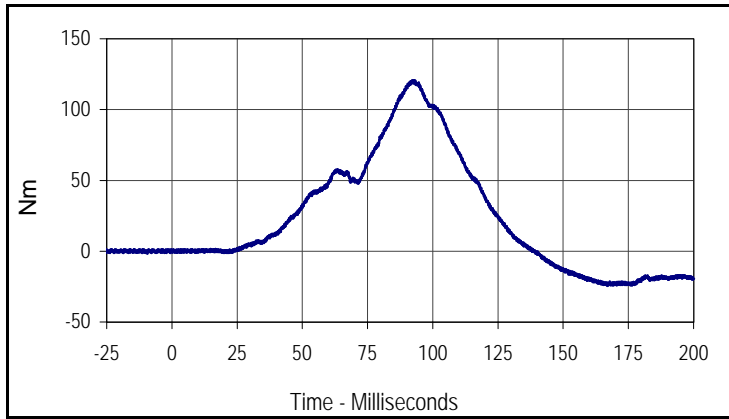

Curve Description			
Right Rear (10 Yr.) Lumbar Moment X			
CURNO	Type	SAE Class	Units
197	FIL	1000	Nm
Max	Time	Min	Time
120.6	92.3	-24.4	167.0

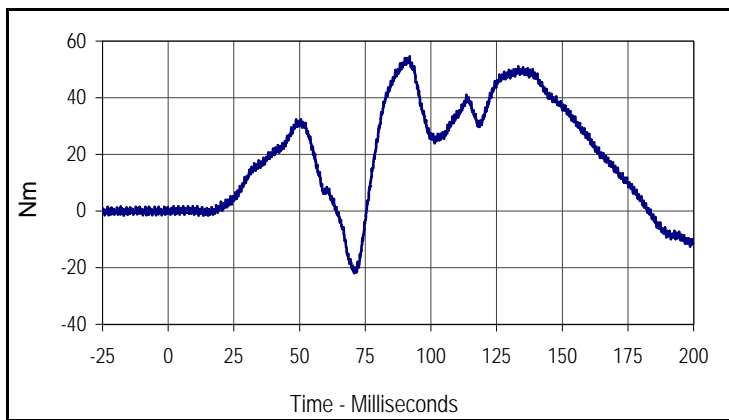

Curve Description			
Right Rear (10 Yr.) Lumbar Moment Y			
CURNO	Type	SAE Class	Units
198	FIL	1000	Nm
Max	Time	Min	Time
54.6	91.9	-21.9	70.8

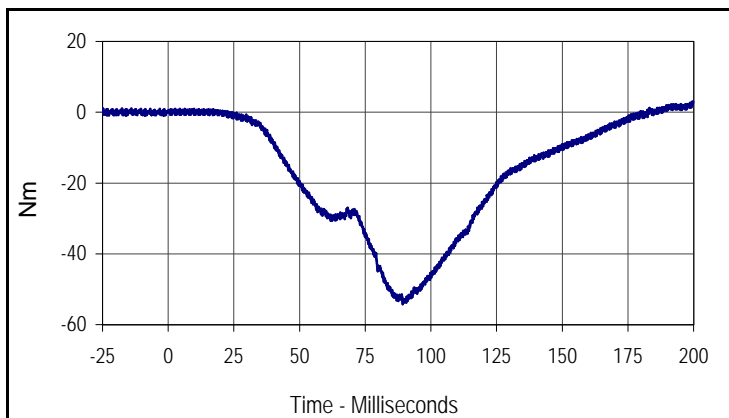

Curve Description			
Right Rear (10 Yr.) Lumbar Moment Z			
CURNO	Type	SAE Class	Units
199	FIL	1000	Nm
Max	Time	Min	Time
3.0	199.7	-54.2	89.3

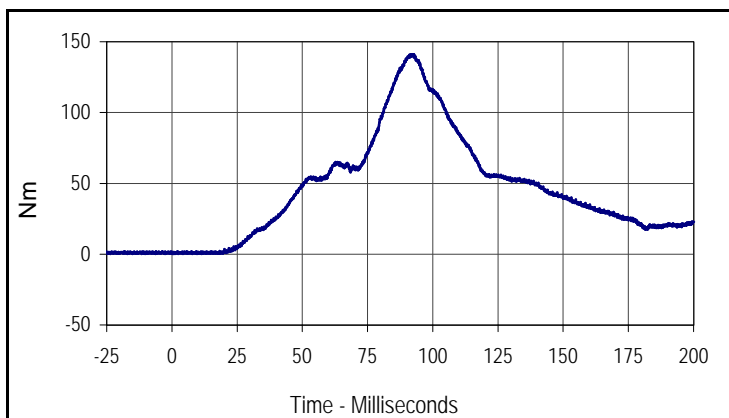

Curve Description			
Right Rear (10 Yr.) Lumbar Moment Resultant			
CURNO	Type	SAE Class	Units
197	RES	1000	Nm
Max	Time	Min	Time
141.3	92.1	0.1	4.2

Test Vehicle: 2006 Honda Ridgeline RTS 4-Door Truck
 Test Program: 2005 NHTSA 35mph NCAP

Test Date: 4/14/05
 NHTSA No.: H65300

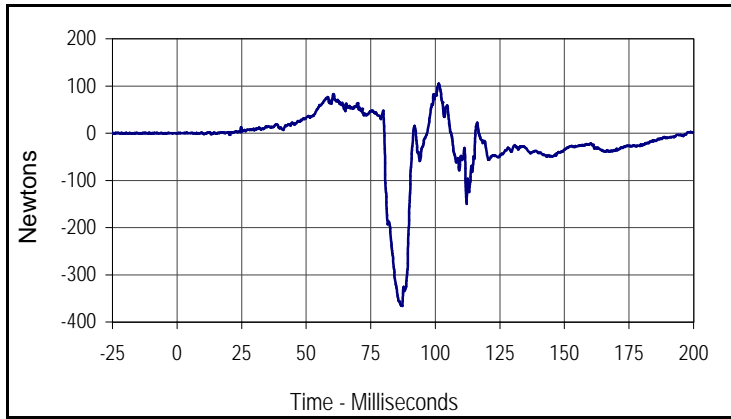

Curve Description			
Right Rear (10 Yr.) Left Clavicle Force X			
CURNO	Type	SAE Class	Units
200	FIL	1000	Newtons
Max	Time	Min	Time
104.9	101.4	-366.4	87.2

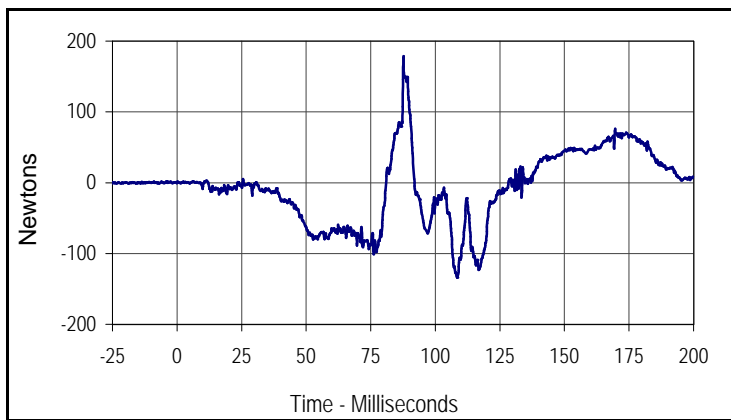

Curve Description			
Right Rear (10 Yr.) Left Clavicle Force Z			
CURNO	Type	SAE Class	Units
201	FIL	1000	Newtons
Max	Time	Min	Time
178.8	87.7	-134.1	108.5

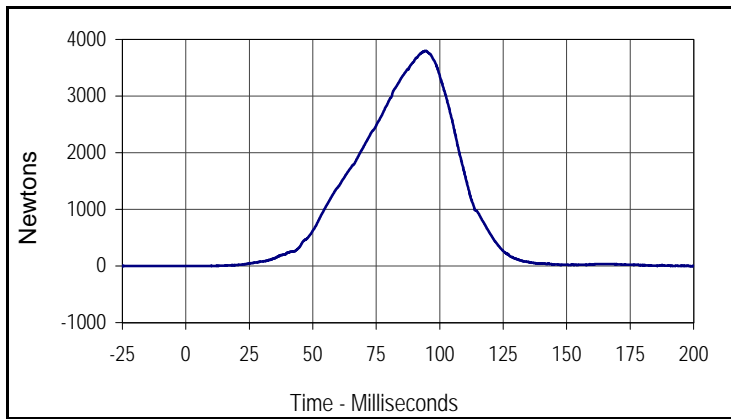

Curve Description			
Right Rear (10 Yr.) Right Clavicle Force X			
CURNO	Type	SAE Class	Units
202	FIL	1000	Newtons
Max	Time	Min	Time
3798.2	94.5	-6.3	198.9

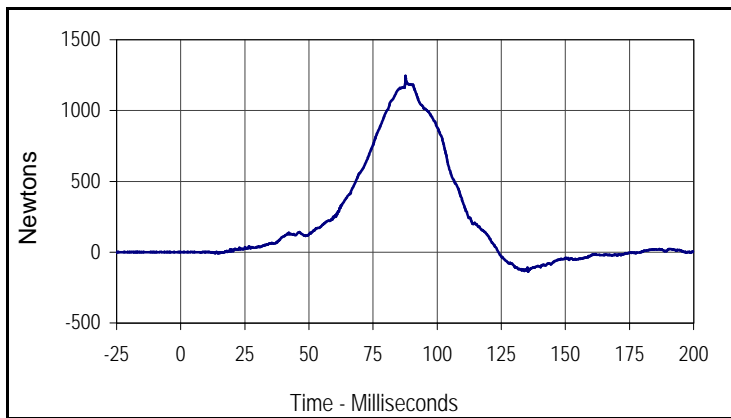

Curve Description			
Right Rear (10 Yr.) Right Clavicle Force Z			
CURNO	Type	SAE Class	Units
203	FIL	1000	Newtons
Max	Time	Min	Time
1244.92	87.7	-137.41	135.5

Test Vehicle: 2006 Honda Ridgeline RTS 4-Door Truck
 Test Program: 2005 NHTSA 35mph NCAP

Test Date: 4/14/05
 NHTSA No.: H65300

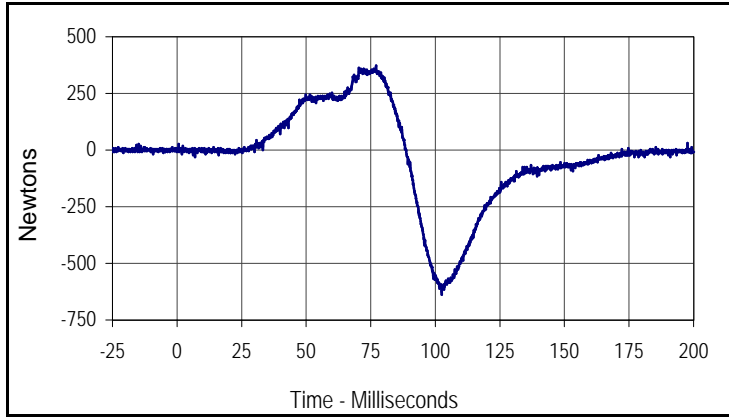

Curve Description			
Right Rear (10 Yr.) Left Upper ASIS Force			
CURNO	Type	SAE Class	Units
204	FIL	1000	Newtons
Max	Time	Min	Time
372.3	77.1	-638.2	102.5

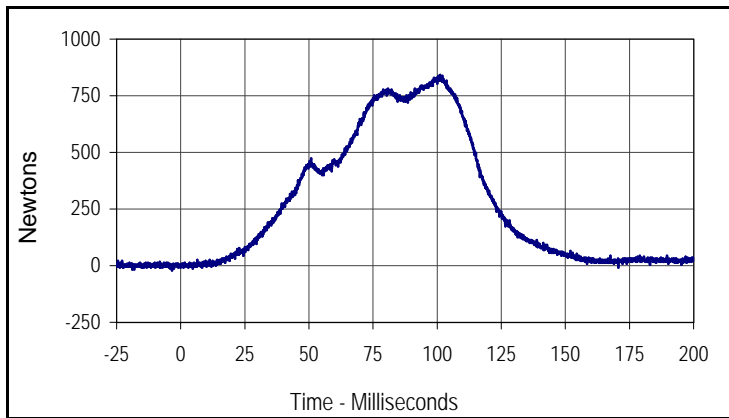

Curve Description			
Right Rear (10 Yr.) Left Lower ASIS Force			
CURNO	Type	SAE Class	Units
205	FIL	1000	Newtons
Max	Time	Min	Time
842.2	101.2	-13.0	4.7

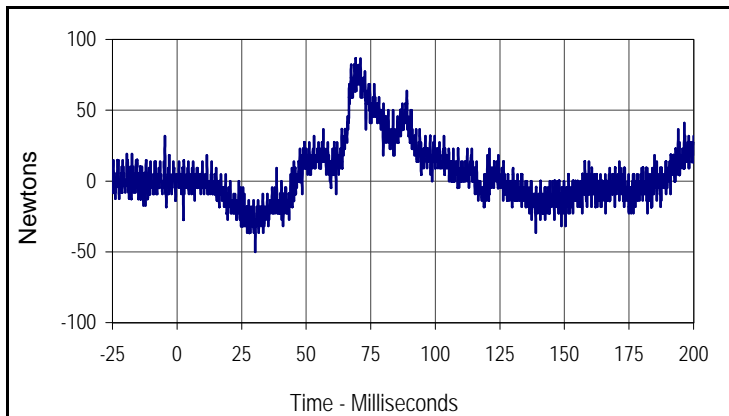

Curve Description			
Right Rear (10 Yr.) Right Upper ASIS Force			
CURNO	Type	SAE Class	Units
206	FIL	1000	Newtons
Max	Time	Min	Time
86.5	69.2	-50.1	30.3

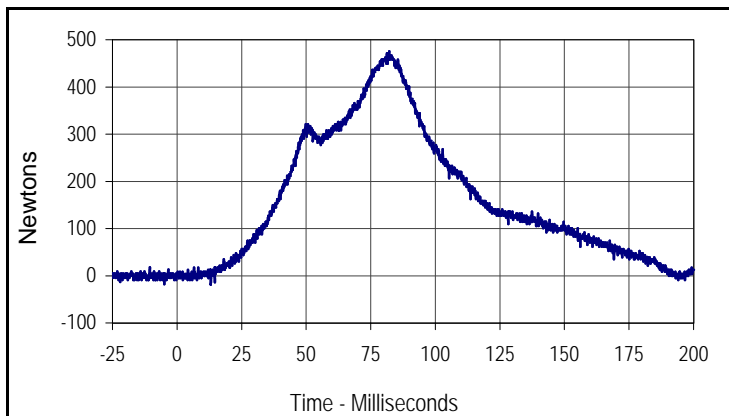

Curve Description			
Right Rear (10 Yr.) Right Lower ASIS Force			
CURNO	Type	SAE Class	Units
207	FIL	1000	Newtons
Max	Time	Min	Time
475.7	82.2	-18.2	13.0

Test Vehicle: 2006 Honda Ridgeline RTS 4-Door Truck
 Test Program: 2005 NHTSA 35mph NCAP

Test Date: 4/14/05
 NHTSA No.: H65300

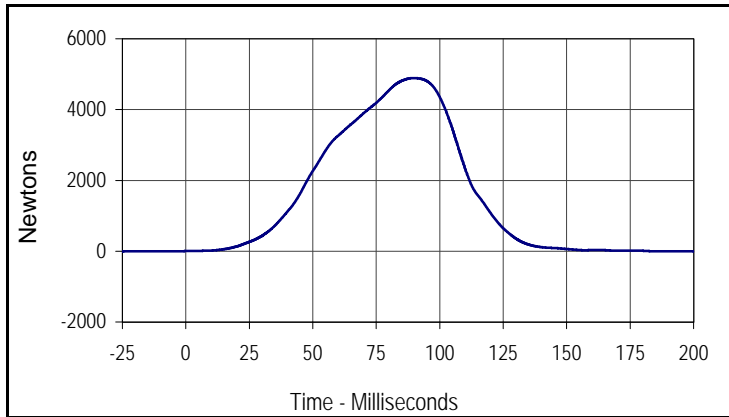

Curve Description			
Right Rear (10 Yr.) Lap Belt Force			
CURNO	Type	SAE Class	Units
208	FIL	60	Newtons
Max	Time	Min	Time
4890.7	89.7	-6.1	200.0

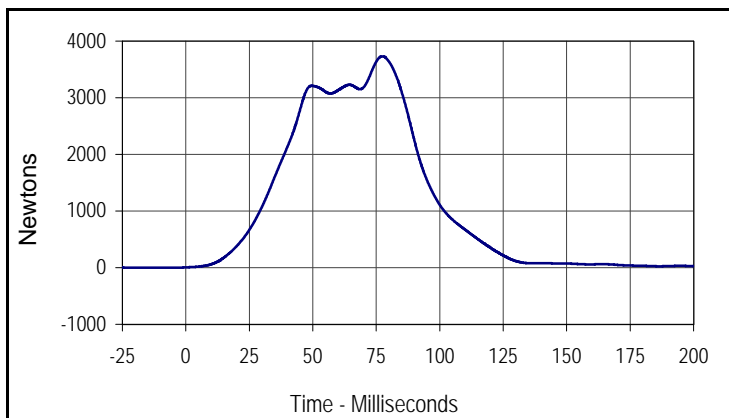

Curve Description			
Right Rear (10 Yr.) Shoulder Belt Force			
CURNO	Type	SAE Class	Units
209	FIL	60	Newtons
Max	Time	Min	Time
3731.4	77.4	5.7	0.0

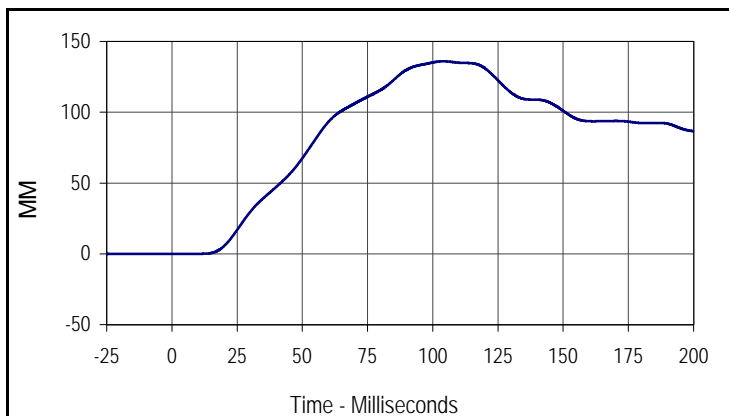

Curve Description			
Right Rear (10 Yr.) Shoulder Belt Pullout (10 yr)			
CURNO	Type	SAE Class	Units
210	FIL	60	MM
Max	Time	Min	Time
136.0	104.0	0.0	1.2

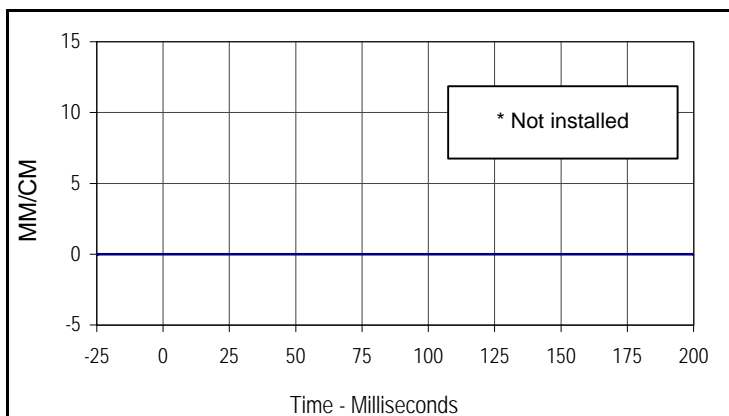

Curve Description			
Right Rear (10 Yr.) Shoulder Belt Elongation			
CURNO	Type	SAE Class	Units
211	FIL	60	MM/CM
Max	Time	Min	Time
0.0	0.0	0.0	0.0

* Not installed

Test Vehicle: 2006 Honda Ridgeline RTS 4-Door Truck
 Test Program: 2005 NHTSA 35mph NCAP

Test Date: 4/14/05
 NHTSA No.: H65300

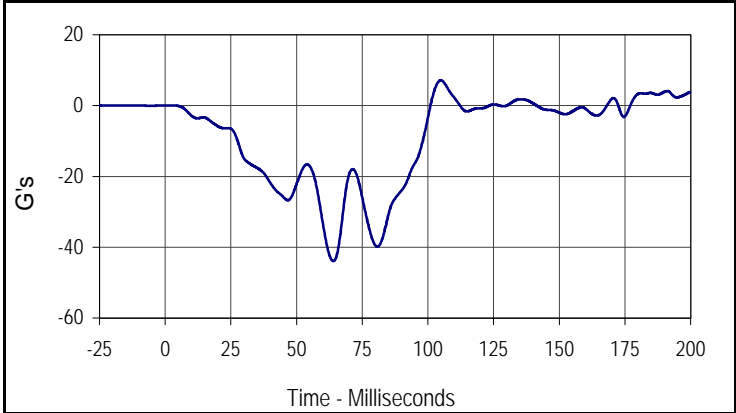

Curve Description			
Right Rear (10 Yr.) CRS X			
CURNO	Type	SAE Class	Units
212	FIL	60	G's
Max	Time	Min	Time
7.1	104.9	-43.9	64.0

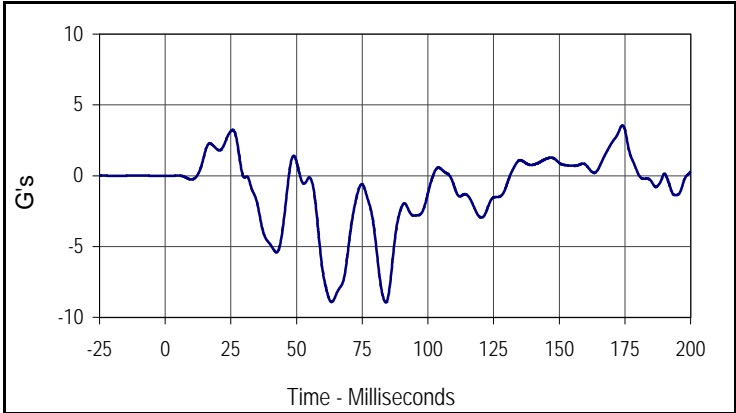

Curve Description			
Right Rear (10 Yr.) CRS Y			
CURNO	Type	SAE Class	Units
213	FIL	60	G's
Max	Time	Min	Time
3.6	174.1	-8.9	83.9

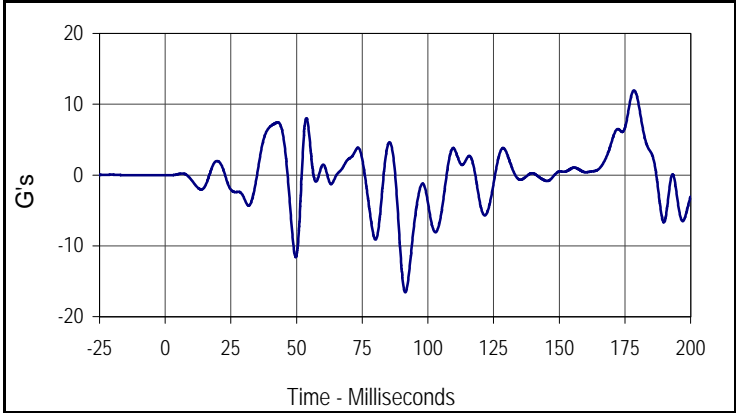

Curve Description			
Right Rear (10 Yr.) CRS Z			
CURNO	Type	SAE Class	Units
214	FIL	60	G's
Max	Time	Min	Time
12.0	178.5	-16.6	91.4

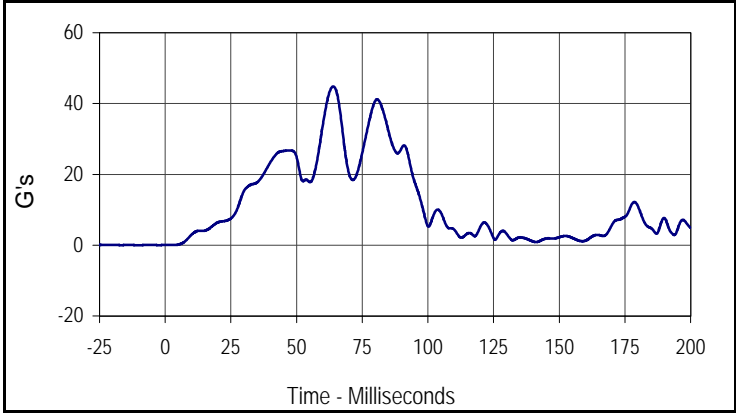

Curve Description			
Right Rear (10 Yr.) CRS Resultant			
CURNO	Type	SAE Class	Units
212	RES	60	G's
Max	Time	Min	Time
44.8	64.0	0.0	3.7

Test Vehicle: 2006 Honda Ridgeline RTS 4-Door Truck
 Test Program: 2005 NHTSA 35mph NCAP

Test Date: 4/14/05
 NHTSA No.: H65300

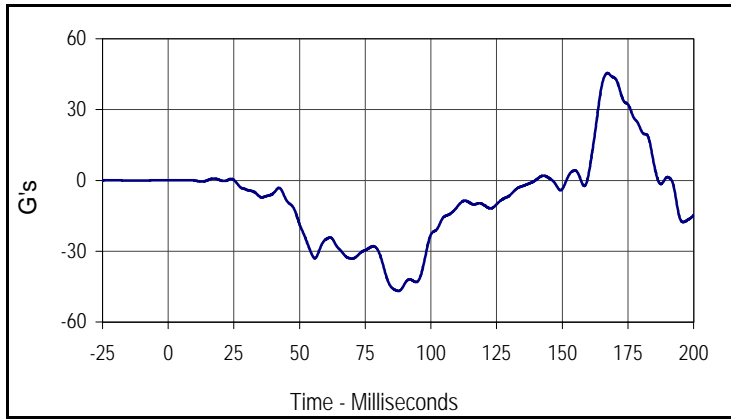

Curve Description			
Right Rear (10 Yr.) CRS Seat Back X			
CURNO	Type	SAE Class	Units
215	FIL	60	G's
Max	Time	Min	Time
45.5	167.3	-46.8	87.6

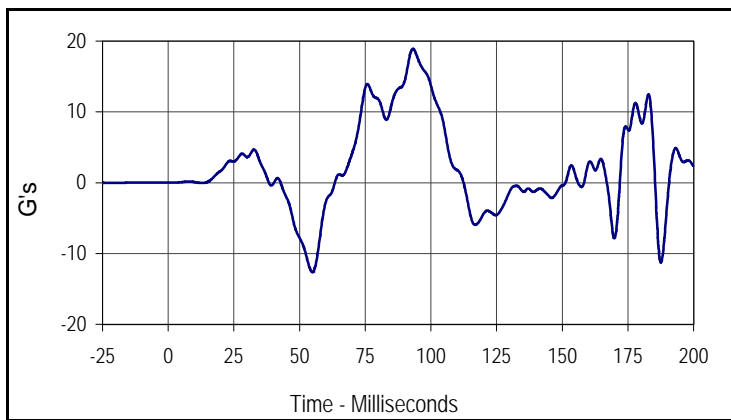

Curve Description			
Right Rear (10 Yr.) CRS Seat Back Y			
CURNO	Type	SAE Class	Units
216	FIL	60	G's
Max	Time	Min	Time
18.9	93.2	-12.6	54.9

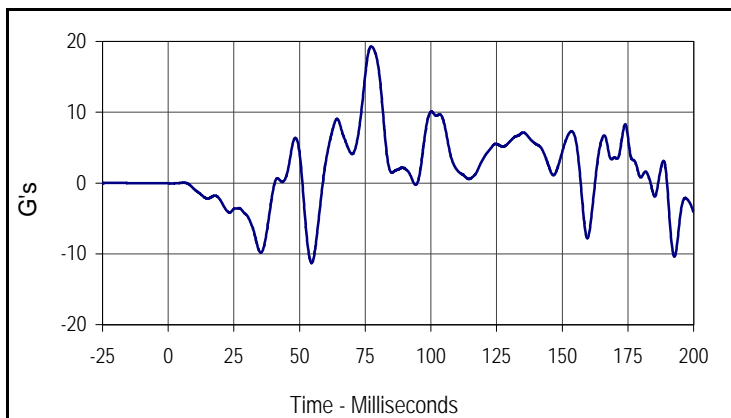

Curve Description			
Right Rear (10 Yr.) CRS Seat Back Z			
CURNO	Type	SAE Class	Units
217	FIL	60	G's
Max	Time	Min	Time
19.3	77.3	-11.3	54.6

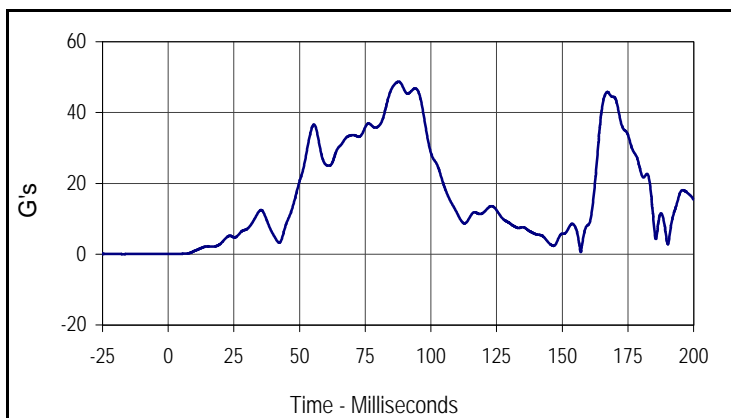

Curve Description			
Right Rear (10 Yr.) CRS Seat Back Resultant			
CURNO	Type	SAE Class	Units
215	RES	60	G's
Max	Time	Min	Time
48.7	87.7	0.0	3.5

SECTION F-4

INSTRUMENTATION DATA CHANNEL ASSIGNMENTS

**2005 NHTSA 35mph NCAP
Instrumentation Data Channel Assignments
Left Rear Child A.T.D. Serial Number 011 (10 Yr.)
4/14/05
2006 Honda Ridgeline RTS 4-Door Truck**

CH.	LOCATION	AXIS	IDENT. NO.	DESCRIPTION	MFR	MODEL	UNITS
134	HEAD CG	X	GPAC047	Accel.,1/2 bridge	Endevco	7264-2000	G
135	HEAD CG	Y	GPAC048	Accel.,1/2 bridge	Endevco	7264-2000	G
136	HEAD CG	Z	GPAC049	Accel.,1/2 bridge	Endevco	7264-2000	G
137	UPPER NECK FORCE	X	10UNFX	Load cell, six axis neck	R. A. Denton	IF-234	N
138	UPPER NECK FORCE	Y	10UNFY	Load cell, six axis neck	R. A. Denton	IF-234	N
139	UPPER NECK FORCE	Z	10UNFZ	Load cell, six axis neck	R. A. Denton	IF-234	N
140	UPPER NECK MOMENT	X	10UNMX	Load cell, six axis neck	R. A. Denton	IF-234	Nm
141	UPPER NECK MOMENT	Y	10UNMY	Load cell, six axis neck	R. A. Denton	IF-234	Nm
142	UPPER NECK MOMENT	Z	10UNMZ	Load cell, six axis neck	R. A. Denton	IF-234	Nm
143	CHEST CG	X	2116-A01	Accel., Full Bridge	Entran	2000JF	G
144	CHEST CG	Y	2116-A06	Accel., Full Bridge	Entran	2000JF	G
145	CHEST CG	Z	2116-A07	Accel., Full Bridge	Entran	2000JF	G
146	CHEST DEFLECTION	X	10CP	Rotary Pot Chest	Servo	14CBI	MM
147	PELVIS	X	2116-N07	Accel., Full Bridge	Entran	2000JF	G
148	PELVIS	Y	2116-A03	Accel., Full Bridge	Entran	2000JF	G
149	PELVIS	Z	2116-A17	Accel., Full Bridge	Entran	2000JF	G
150	LEFT FEMUR FORCE	Z	KEFF001	Load cell, Femur	R.A. Denton	2090	N
151	RIGHT FEMUR FORCE	Z	KEFF002	Load cell, Femur	R.A. Denton	2090	N
152	LUMBAR FORCE	X	LUMFX	Load cell, Lumbar	R.A. Denton	2431	N
153	LUMBAR FORCE	Y	LUMFY	Load cell, Lumbar	R.A. Denton	2431	N
154	LUMBAR FORCE	Z	LUMFZ	Load cell, Lumbar	R.A. Denton	2431	N
155	LUMBAR MOMENT	X	LUMMX	Load cell, Lumbar	R.A. Denton	2431	Nm
156	LUMBAR MOMENT	Y	LUMMY	Load cell, Lumbar	R.A. Denton	2431	Nm
157	LUMBAR MOMENT	Z	LUMMZ	Load cell, Lumbar	R.A. Denton	2431	Nm

E4-1

TR-P25064-01-NC

**2005 NHTSA 35mph NCAP
Instrumentation Data Channel Assignments
Left Rear Child A.T.D. Serial Number 011 (10 Yr.)
4/14/05
2006 Honda Ridgeline RTS 4-Door Truck**

CH.	LOCATION	AXIS	IDENT. NO.	DESCRIPTION	MFR	MODEL	UNITS
158	LEFT CLAVICLE FORCE	X	CLFX	Load cell, Clavicle	R.A. Denton	5400J	N
159	LEFT CLAVICLE FORCE	Z	CLFY	Load cell, Clavicle	R.A. Denton	5400J	N
160	RIGHT CLAVICLE FORCE	X	CLRFX	Load cell, Clavicle	R.A. Denton	5410J	N
161	RIGHT CLAVICLE FORCE	Z	CLRFZ	Load cell, Clavicle	R.A. Denton	5410J	N
162	LEFT ASIS UPPER	X	10LUASIS	Load cell, ASIS	R.A. Denton	3475	N
163	LEFT ASIS LOWER	X	10LLASIS	Load cell, ASIS	R.A. Denton	3475	N
164	RIGHT ASIS UPPER	X	10RUASIS	Load cell, ASIS	R.A. Denton	3476	N
165	RIGHT ASIS LOWER	X	10RLASIS	Load cell, ASIS	R.A. Denton	3476	N
166	LAP BELT FORCE	X	BL168	Load cell, Seat belt	First Tech	IF-964	N
167	SHOULDER BELT FORCE	X	BL169	Load cell, Seat belt	First Tech	IF-964	N
168	SHOULDER BELT SPOOL	X	KEPP001	Pullout pot	Celesco	PTX101-0030	MM
169	SHOULDER BELT ELONG.	X	KEEP001	Linear pot., belt stretch	E.T.I.	LCP8-10 10K	MM/CM
170	CRS	X	KETX1A	Accel.,1/2 bridge	Endevco	7264-200	G
171	CRS	Y	KETX1B	Accel.,1/2 bridge	Endevco	7264-200	G
172	CRS	Z	KETX1C	Accel.,1/2 bridge	Endevco	7264-200	G
173	CRS SEAT BACK	X	KETX6A	Accel.,1/2 bridge	Endevco	7264-200	G
174	CRS SEAT BACK	Y	KETX6B	Accel.,1/2 bridge	Endevco	7264-200	G
175	CRS SEAT BACK	Z	KETX6C	Accel.,1/2 bridge	Endevco	7264-200	G

F4-2

TR-P25064-01-NC

**2005 NHTSA 35mph NCAP
Instrumentation Data Channel Assignments
Right Rear Child A.T.D. Serial Number 009 (10 Yr.)
4/14/05
2006 Honda Ridgeline RTS 4-Door Truck**

CH.	LOCATION	AXIS	IDENT. NO.	DESCRIPTION	MFR	MODEL	UNITS
176	HEAD CG	X	09HDX	Accel.,1/2 bridge	Endevco	7264-2000	G
177	HEAD CG	Y	09HDY	Accel.,1/2 bridge	Endevco	7264-2000	G
178	HEAD CG	Z	09HDZ	Accel.,1/2 bridge	Endevco	7264-2000	G
179	UPPER NECK FORCE	X	09UNFX	Load cell, six axis neck	R. A. Denton	IF-234	N
180	UPPER NECK FORCE	Y	09UNFY	Load cell, six axis neck	R. A. Denton	IF-234	N
181	UPPER NECK FORCE	Z	09UNFZ	Load cell, six axis neck	R. A. Denton	IF-234	N
182	UPPER NECK MOMENT	X	09UNMX	Load cell, six axis neck	R. A. Denton	IF-234	Nm
183	UPPER NECK MOMENT	Y	09UNMY	Load cell, six axis neck	R. A. Denton	IF-234	Nm
184	UPPER NECK MOMENT	Z	09UNMZ	Load cell, six axis neck	R. A. Denton	IF-234	Nm
185	CHEST CG	X	09CHX	Accel., Full Bridge	Entran	2000JF	G
186	CHEST CG	Y	09CHY	Accel., Full Bridge	Entran	2000JF	G
187	CHEST CG	Z	09CHZ	Accel., Full Bridge	Entran	2000JF	G
188	CHEST DEFLECTION	X	09CHP	Rotary Pot Chest	Servo	14CBI	MM
189	PELVIS	X	09PELX	Accel., Full Bridge	Entran	2000JF	G
190	PELVIS	Y	09PELY	Accel., Full Bridge	Entran	2000JF	G
191	PELVIS	Z	09PELZ	Accel., Full Bridge	Entran	2000JF	G
192	LEFT FEMUR FORCE	Z	09LFEM	Load cell, Femur	R.A. Denton	2090	N
193	RIGHT FEMUR FORCE	Z	09RFEM	Load cell, Femur	R.A. Denton	2090	N
194	LUMBAR FORCE	X	09LUMFX	Load cell, Lumbar	R.A. Denton	2431	N
195	LUMBAR FORCE	Y	09LUMFY	Load cell, Lumbar	R.A. Denton	2431	N
196	LUMBAR FORCE	Z	09LUMFZ	Load cell, Lumbar	R.A. Denton	2431	N
197	LUMBAR MOMENT	X	09LUMMX	Load cell, Lumbar	R.A. Denton	2431	Nm
198	LUMBAR MOMENT	Y	09LUMMY	Load cell, Lumbar	R.A. Denton	2431	Nm
199	LUMBAR MOMENT	Z	09LUMMZ	Load cell, Lumbar	R.A. Denton	2431	Nm

**2005 NHTSA 35mph NCAP
Instrumentation Data Channel Assignments
Right Rear Child A.T.D. Serial Number 009 (10 Yr.)
4/14/05
2006 Honda Ridgeline RTS 4-Door Truck**

CH.	LOCATION	AXIS	IDENT. NO.	DESCRIPTION	MFR	MODEL	UNITS
200	LEFT CLAVICLE FORCE	X	09CLFX	Load cell, Clavicle	R.A. Denton	5400J	N
201	LEFT CLAVICLE FORCE	Z	09CLFY	Load cell, Clavicle	R.A. Denton	5400J	N
202	RIGHT CLAVICLE FORCE	X	09CLRFX	Load cell, Clavicle	R.A. Denton	5410J	N
203	RIGHT CLAVICLE FORCE	Z	09CLRFZ	Load cell, Clavicle	R.A. Denton	5410J	N
204	LEFT ASIS UPPER	X	09LUASIS	Load cell, ASIS	R.A. Denton	3475	N
205	LEFT ASIS LOWER	X	09LLASIS	Load cell, ASIS	R.A. Denton	3475	N
206	RIGHT ASIS UPPER	X	09RUASIS	Load cell, ASIS	R.A. Denton	3476	N
207	RIGHT ASIS LOWER	X	09RLASIS	Load cell, ASIS	R.A. Denton	3476	N
208	LAP BELT FORCE	X	BL176	Load cell, Seat belt	First Tech	IF-964	N
209	SHOULDER BELT FORCE	X	BL179	Load cell, Seat belt	First Tech	IF-964	N
210	SHOULDER BELT SPOOL	X	KEPP002	Pullout pot	Celesco	PTX101-0030	MM
211	SHOULDER BELT ELONG.	X	KEEP002	Linear pot., belt stretch	E.T.I.	LCP8-10 10K	MM/CM
212	CRS	X	KETX4A	Accel.,1/2 bridge	Endevco	7264-200	G
213	CRS	Y	KETX4B	Accel.,1/2 bridge	Endevco	7264-200	G
214	CRS	Z	KETX4C	Accel.,1/2 bridge	Endevco	7264-200	G
215	CRS SEAT BACK	X	KETX5A	Accel.,1/2 bridge	Endevco	7264-200	G
216	CRS SEAT BACK	Y	KETX5B	Accel.,1/2 bridge	Endevco	7264-200	G
217	CRS SEAT BACK	Z	KETX5C	Accel.,1/2 bridge	Endevco	7264-200	G

SECTION F-5

CHILD DUMMY CALIBRATION INFORMATION

Test Program: Hybrid III 10 Yr Old Head Drop Test
 ATD Serial No.: 009

Test Date: 3/30/05
 Test I.D.: HD03M



Tested Parameter	Units	Specification	Result	Pass/Fail
Laboratory Temperature	°C	18.9 to 25.6	21.1	Pass
Laboratory Relative Humidity	%	10 to 70	30	Pass
Peak Resultant Acceleration	G's	250.0 to 300.0	278.5	Pass
Peak Lateral Acceleration	G's	≤15.0	8.5	Pass
Is Acceleration Unimodal?	Yes/No	Yes	Yes	Pass
Oscillations After Main Pulse	%	<10	1.4	Pass
Overall Test Results				Pass

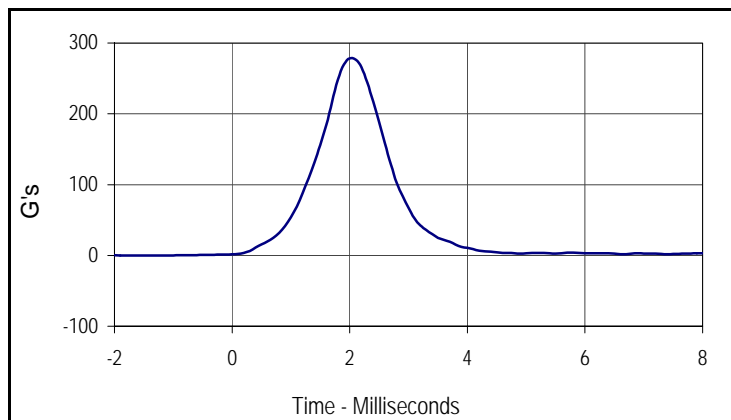

Curve Description			
Head Resultant			
CURNO	Type	SAE Class	Units
001	RES	1000	G's
Max	Time	Min	Time
278.5	2.0	0.0	-1.2

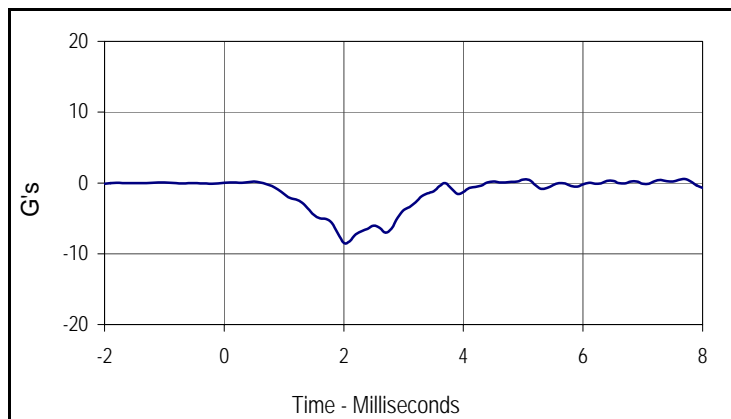

Curve Description			
Head Y			
CURNO	Type	SAE Class	Units
002	FIL	1000	G's
Max	Time	Min	Time
0.5	5.0	-8.5	2.0

Test Program: Hybrid III 10 Yr Old Thorax Impact Test
 ATD Serial No.: 009

Test Date: 3/30/05
 Test I.D.: CH03J



Tested Parameter	Units	Specification	Result	Pass/Fail
Laboratory Temperature	°C	20.6 to 22.2	21.1	Pass
Laboratory Relative Humidity	%	10 to 70	30	Pass
Probe Velocity	m/s	5.88 to 6.12	6.10	Pass
Peak Chest Deflection	MM	40.5 to 48.5	43.1	Pass
Peak Force Between 40.5 and 48.5 MM	Newtons	1830 to 2330	1846	Pass
Peak Force Between 20 and 40.5 MM	Newtons	≤2330	1841	Pass
Internal Hysteresis	%	69 to 85	81.5	Pass
Overall Test Results			Pass	Pass

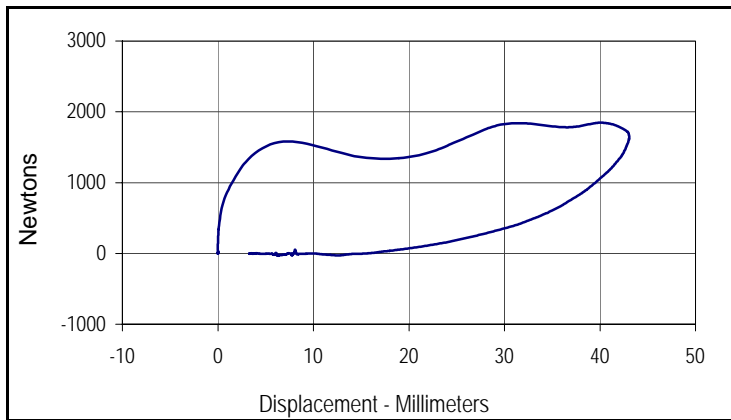

Curve Description			
Probe Force vs. Chest Deflection			
CURNO	Type	SAE Class	Hysteresis
003	FIL	180	81.5
Peak Probe Force		Peak Chest Deflection	
1846.1		43.1	

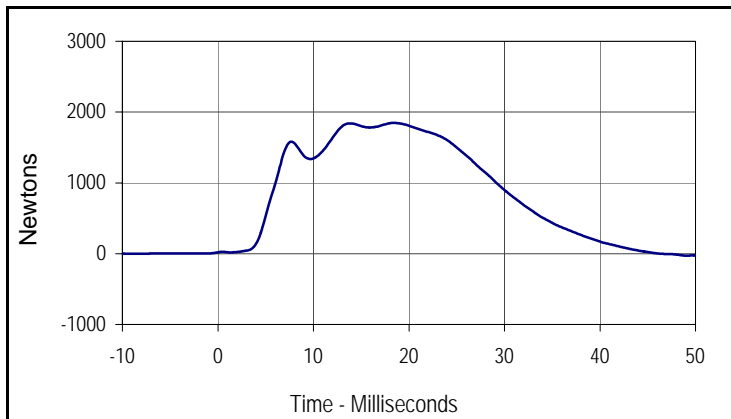

Curve Description			
Probe Force			
CURNO	Type	SAE Class	Units
002	FIL	180	Newtons
Max	Time	Min	Time
1846.1	18.4	-31.9	81.8

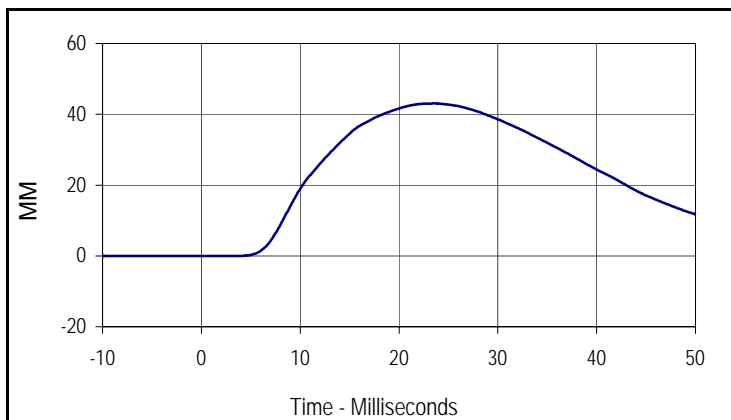

Curve Description			
Chest Deflection			
CURNO	Type	SAE Class	Units
001	FIL	180	MM
Max	Time	Min	Time
43.1	23.5	0.0	3.6

Test Program: Hybrid III 10 Yr Old Neck Flexion Test
 ATD Serial No.: 009

Test Date: 3/29/05
 Test I.D.: NF03K



Tested Parameter	Units	Specification	Result	Pass/Fail	
Laboratory Temperature	°C	20.6 to 22.2	21.1	Pass	
Laboratory Relative Humidity	%	10 to 70	30	Pass	
Pendulum Velocity	m/s	5.98 to 6.22	6.14	Pass	
Pendulum Deceleration	10 Msec.	m/s	1.64 to 2.04	1.95	Pass
	20 Msec.	m/s	3.04 to 4.04	3.88	Pass
	30 Msec.	m/s	4.45 to 5.65	4.69	Pass
"D" Plane Rotation	Max	Degrees	74.0 to 88.0	84.7	Pass
Peak Moment in Rotation	Max	Nm	50.0 to 62.0	52.6	Pass
Positive Moment Decay, Time To 10 Nm	Msec.		85.0 to 105.0	90.8	Pass
Overall Test Results				Pass	

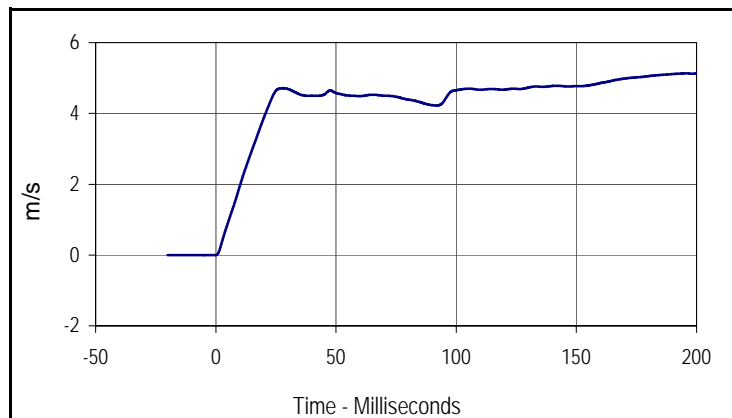

Curve Description			
Pendulum Velocity			
CURNO	Type	SAE Class	Units
001	FIL	180	m/s
Max	Time	Min	Time
5.1	195.5	0.0	-0.2

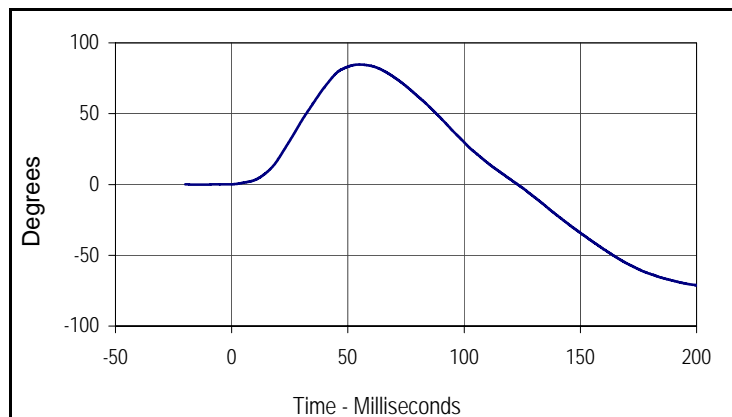

Curve Description			
"D" Plane Rotation			
CURNO	Type	SAE Class	Units
003	FIL	60	Degrees
Max	Time	Min	Time
84.7	54.9	-71.1	200.0

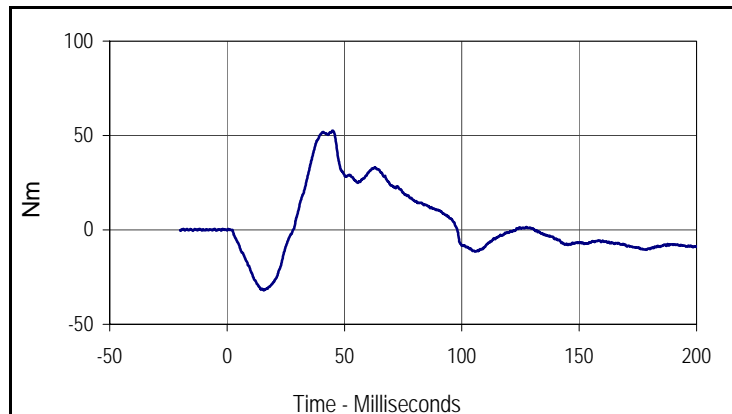

Curve Description			
Moment About Occipital Condyle			
CURNO	Type	SAE Class	Units
002	FIL	600	Nm
Max	Time	Min	Time
52.6	44.9	-32.0	15.7

Test Program: Hybrid III 10 Yr Old Neck Extension Test
 ATD Serial No.: 009

Test Date: 3/29/05
 Test I.D.: NE03U



Tested Parameter	Units	Specification	Result	Pass/Fail	
Laboratory Temperature	°C	20.6 to 22.2	21.1	Pass	
Laboratory Relative Humidity	%	10 to 70	30	Pass	
Pendulum Velocity	m/s	4.91 to 5.15	4.97	Pass	
Pendulum Deceleration	10 Msec.	m/s	1.59 to 1.89	1.63	Pass
	20 Msec.	m/s	2.88 to 3.68	3.40	Pass
	30 Msec.	m/s	4.20 to 5.20	5.08	Pass
"D" Plane Rotation	Max	Degrees	99.0 to 114.0	113.8	Pass
Peak Moment in Rotation	Max	Nm	-35.0 to -47.0	-45.2	Pass
Positive Moment Decay, Time To 10 Nm	Msec.		100.0 to 120.0	104.0	Pass
Overall Test Results				Pass	

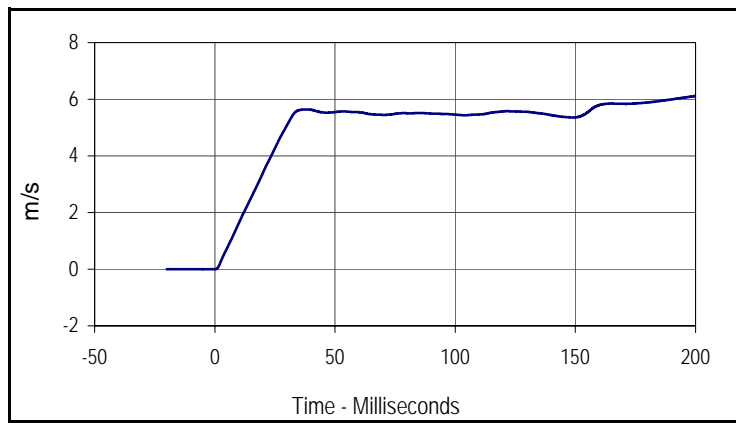

Curve Description			
Pendulum Velocity			
CURNO	Type	SAE Class	Units
001	FIL	180	m/s
Max	Time	Min	Time
6.1	200.0	0.0	0.0

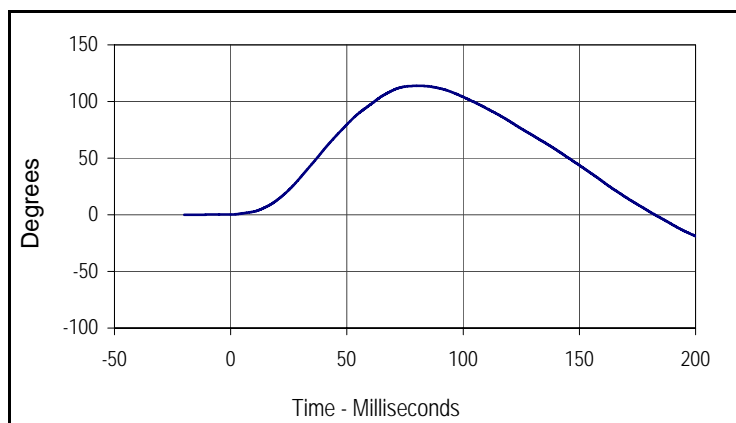

Curve Description			
"D" Plane Rotation			
CURNO	Type	SAE Class	Units
003	FIL	60	Degrees
Max	Time	Min	Time
113.8	80.7	-18.8	200.0

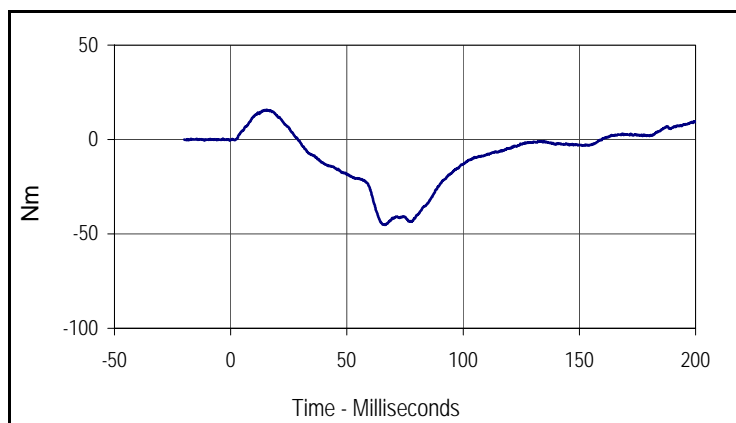

Curve Description			
Moment About Occipital Condyle			
CURNO	Type	SAE Class	Units
002	FIL	600	Nm
Max	Time	Min	Time
15.7	15.4	-45.2	66.3

Test Program: Hybrid III 10 Yr Old Knee Impact Test
 ATD Serial No.: 009

Test Date: 3/28/05
 Test I.D.: LK03K , RK03K



Left Knee

Tested Parameter	Units	Specification	Result	Pass/Fail
Laboratory Temperature	°C	18.9 to 25.6	21.1	Pass
Laboratory Relative Humidity	%	10 to 70	30	Pass
Pendulum Velocity at T=0	m/sec	2.07 to 2.13	2.09	Pass
Peak Probe Force	Newtons	2560 to 3140	3100	Pass
Overall Test Results				Pass

Right Knee

Pendulum Velocity at T=0	m/sec	2.07 to 2.13	2.10	Pass
Peak Probe Force	Newtons	2560 to 3140	2966	Pass
Overall Test Results				Pass



Curve Description			
Left Knee Probe Force			
CURNO	Type	SAE Class	Units
001	FIL	600	Newtons
Max	Time	Min	Time
3100.4	2.0	-27.5	6.9

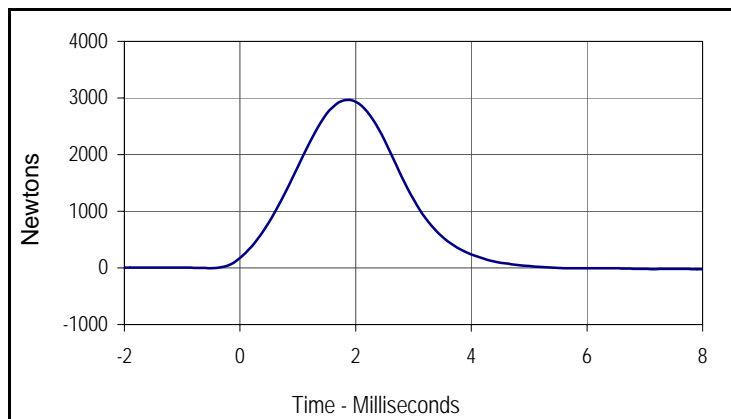

Curve Description			
Right Knee Probe Force			
CURNO	Type	SAE Class	Units
002	FIL	600	Newtons
Max	Time	Min	Time
2966.3	1.9	-26.3	8.5

Test Program: Hybrid III 10 Yr Old External Measurements

Test Date: 3/30/05

ATD Serial No.: 009

Test I.D.: N/A



Tested Parameter	Units	Specification	Result	Pass/Fail
Laboratory Temperature	°C	20.6 to 22.2	21.1	Pass
Laboratory Relative Humidity	%	10 to 70	30	Pass
A - Total sitting height	mm	710 to 737	725	Pass
B - Shoulder pivot height	mm	385 to 405	400	Pass
C - "H" point height	mm	78 to 88	85	Pass
D - "H" point from backline	mm	133 to 143	138	Pass
E - Shoulder pivot from back	mm	80 to 90	85	Pass
F - Thigh clearance	mm	105 to 121	115	Pass
G - Elbow back to wrist pivot	mm	227 to 243	236	Pass
H - Skull cap to back line	mm	46 to 51	49	Pass
I - Shoulder to elbow length	mm	269 to 285	276	Pass
J - Elbow rest height	mm	137 to 158	145	Pass
K - Buttock to knee length	mm	464 to 484	475	Pass
L - Popliteal length	mm	321 to 342	340	Pass
M - Knee pivot height	mm	370 to 389	380	Pass
N - Buttock popliteal length	mm	367 to 387	370	Pass
O - Chest depth without jacket	mm	158 to 173	165	Pass
P - Foot length	mm	188 to 203	195	Pass
R - Buttock to knee pivot length	mm	414 to 434	425	Pass
S - Head breadth	mm	137 to 147	145	Pass
T - Head depth	mm	178 to 188	182	Pass
U - Hip breadth	mm	257 to 272	265	Pass
V - Shoulder breadth	mm	307 to 323	315	Pass
W - Foot breadth	mm	69 to 84	74	Pass
X - Head circumference	mm	528 to 549	540	Pass
Y - Chest circumference with jacket	mm	691 to 716	701	Pass
Z - Waist circumference	mm	696 to 721	710	Pass
AA - Location for chest circumference	mm	338 to 348	340	Pass
Overall Test Results				Pass

Test Program: Hybrid III 10 Yr Old Head Drop Test
 ATD Serial No.: 011

Test Date: 3/30/05
 Test I.D.: HD03N



Tested Parameter	Units	Specification	Result	Pass/Fail
Laboratory Temperature	°C	18.9 to 25.6	21.1	Pass
Laboratory Relative Humidity	%	10 to 70	30	Pass
Peak Resultant Acceleration	G's	250.0 to 300.0	280.4	Pass
Peak Lateral Acceleration	G's	≤15.0	8.2	Pass
Is Acceleration Unimodal?	Yes/No	Yes	Yes	Pass
Oscillations After Main Pulse	%	<10	0.9	Pass
Overall Test Results				Pass

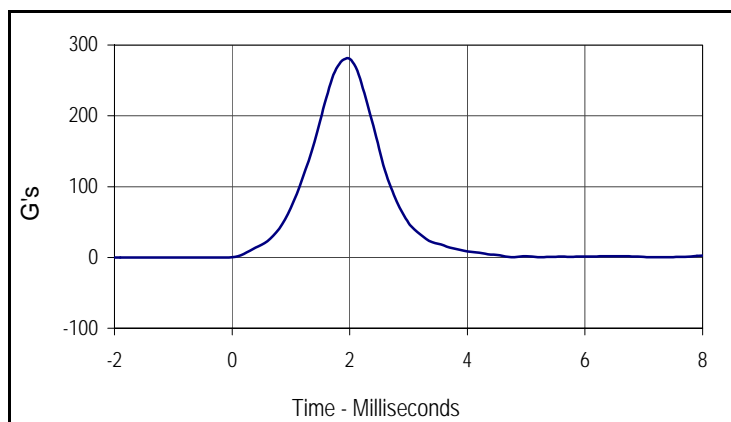

Curve Description			
Head Resultant			
CURNO	Type	SAE Class	Units
001	RES	1000	G's
Max	Time	Min	Time
280.4	2.0	0.0	-0.5

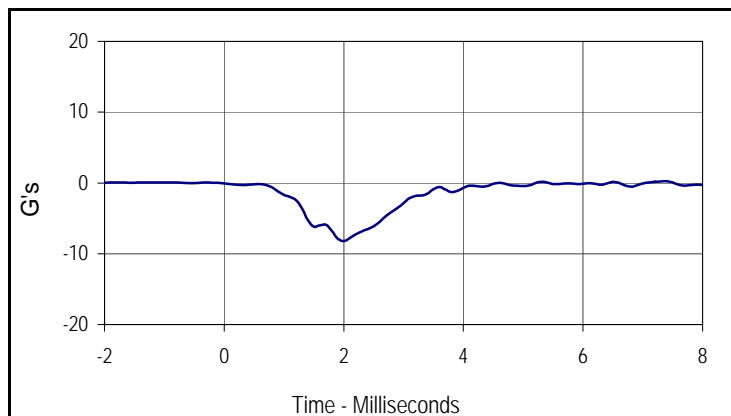

Curve Description			
Head Y			
CURNO	Type	SAE Class	Units
002	FIL	1000	G's
Max	Time	Min	Time
0.2	5.3	-8.2	2.0

Test Program: Hybrid III 10 Yr Old Thorax Impact Test
 ATD Serial No.: 011

Test Date: 3/30/05
 Test I.D.: CH03K



Tested Parameter	Units	Specification	Result	Pass/Fail
Laboratory Temperature	°C	20.6 to 22.2	21.1	Pass
Laboratory Relative Humidity	%	10 to 70	30	Pass
Probe Velocity	m/s	5.88 to 6.12	5.96	Pass
Peak Chest Deflection	MM	40.5 to 48.5	46.5	Pass
Peak Force Between 40.5 and 48.5 MM	Newtons	1830 to 2330	2117	Pass
Peak Force Between 20 and 40.5 MM	Newtons	≤2330	2096	Pass
Internal Hysteresis	%	69 to 85	81.4	Pass
Overall Test Results				Pass

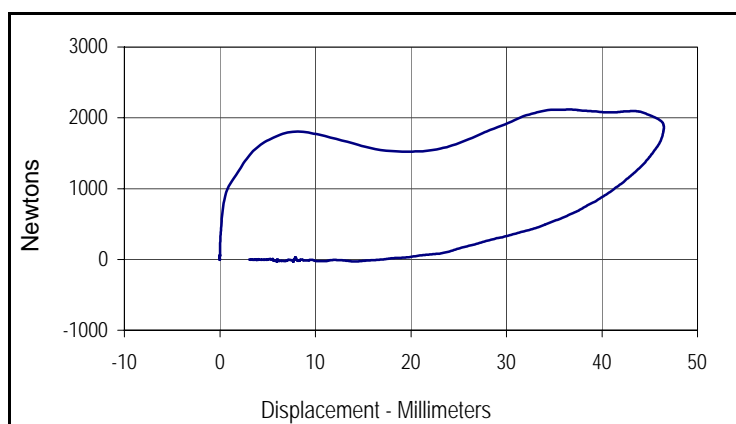

Curve Description			
Probe Force vs. Chest Deflection			
CURNO	Type	SAE Class	Hysteresis
003	FIL	180	81.4
Peak Probe Force		Peak Chest Deflection	
2116.8		46.5	

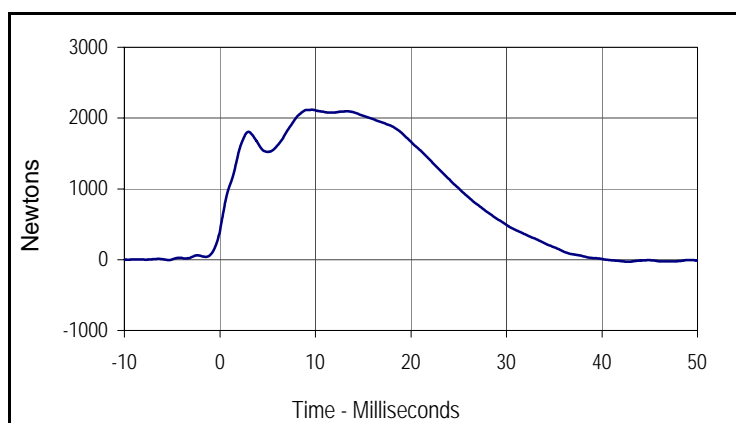

Curve Description			
Probe Force			
CURNO	Type	SAE Class	Units
002	FIL	180	Newtons
Max	Time	Min	Time
2116.8	9.7	-34.0	85.1

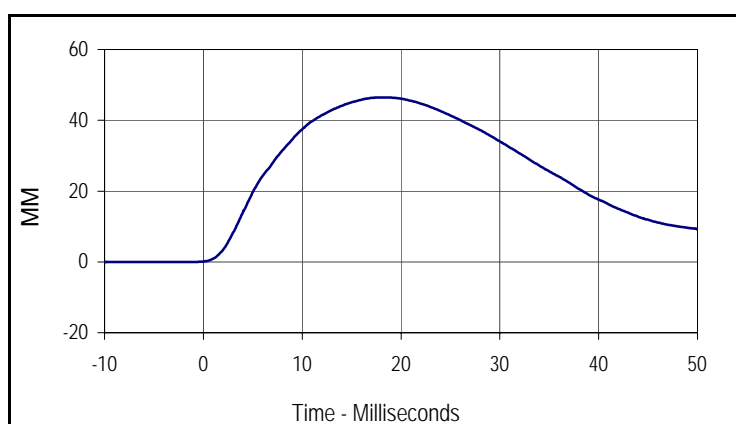

Curve Description			
Chest Deflection			
CURNO	Type	SAE Class	Units
001	FIL	180	MM
Max	Time	Min	Time
46.5	18.2	0.0	-7.1

Test Program: Hybrid III 10 Yr Old Neck Flexion Test
 ATD Serial No.: 011

Test Date: 3/29/05
 Test I.D.: NF03M



Tested Parameter	Units	Specification	Result	Pass/Fail	
Laboratory Temperature	°C	20.6 to 22.2	21.1	Pass	
Laboratory Relative Humidity	%	10 to 70	30	Pass	
Pendulum Velocity	m/s	5.98 to 6.22	6.08	Pass	
Pendulum Deceleration	10 Msec.	m/s	1.64 to 2.04	1.64	Pass
	20 Msec.	m/s	3.04 to 4.04	3.78	Pass
	30 Msec.	m/s	4.45 to 5.65	5.56	Pass
"D" Plane Rotation	Max	Degrees	74.0 to 88.0	87.5	Pass
Peak Moment in Rotation	Max	Nm	50.0 to 62.0	54.8	Pass
Positive Moment Decay, Time To 10 Nm	Msec.		85.0 to 105.0	95.0	Pass
Overall Test Results				Pass	

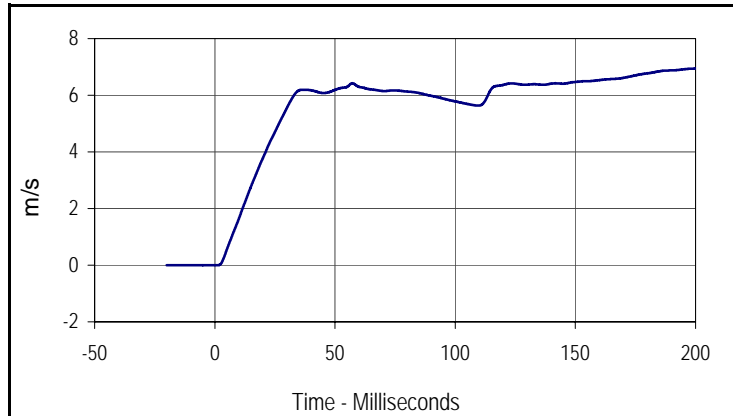

Curve Description			
Pendulum Velocity			
CURNO	Type	SAE Class	Units
001	FIL	180	m/s
Max	Time	Min	Time
6.9	200.0	0.0	1.2

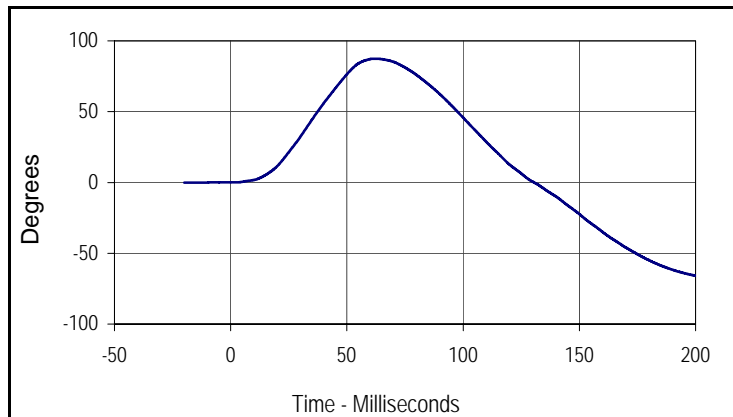

Curve Description			
"D" Plane Rotation			
CURNO	Type	SAE Class	Units
003	FIL	60	Degrees
Max	Time	Min	Time
87.5	62.1	-65.9	200.0

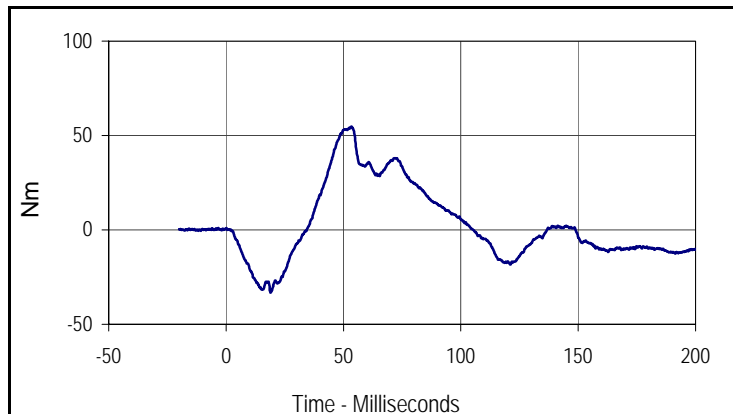

Curve Description			
Moment About Occipital Condyle			
CURNO	Type	SAE Class	Units
002	FIL	600	Nm
Max	Time	Min	Time
54.8	53.3	-33.2	19.0

Test Program: Hybrid III 10 Yr Old Neck Extension Test
 ATD Serial No.: 011

Test Date: 3/29/05
 Test I.D.: NE03V



Tested Parameter	Units	Specification	Result	Pass/Fail	
Laboratory Temperature	°C	20.6 to 22.2	21.1	Pass	
Laboratory Relative Humidity	%	10 to 70	30	Pass	
Pendulum Velocity	m/s	4.91 to 5.15	5.07	Pass	
Pendulum Deceleration	10 Msec.	m/s	1.59 to 1.89	1.62	Pass
	20 Msec.	m/s	2.88 to 3.68	3.29	Pass
	30 Msec.	m/s	4.20 to 5.20	4.85	Pass
"D" Plane Rotation	Max	Degrees	99.0 to 114.0	113.6	Pass
Peak Moment in Rotation	Max	Nm	-35.0 to -47.0	-45.8	Pass
Positive Moment Decay, Time To 10 Nm	Msec.		100.0 to 120.0	104.3	Pass
Overall Test Results				Pass	

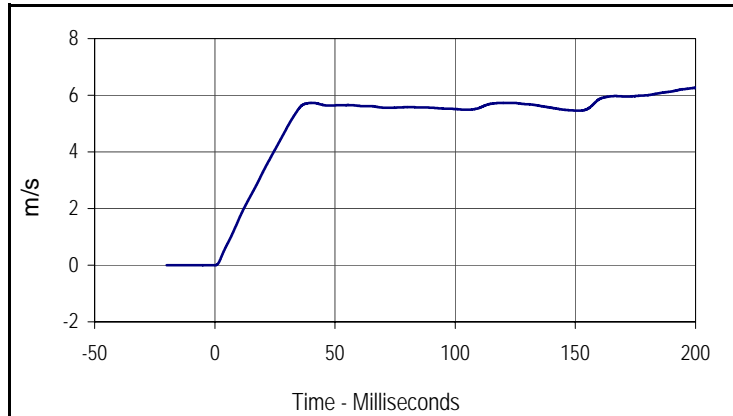

Curve Description			
Pendulum Velocity			
CURNO	Type	SAE Class	Units
001	FIL	180	m/s
Max	Time	Min	Time
6.3	200.0	0.0	0.0

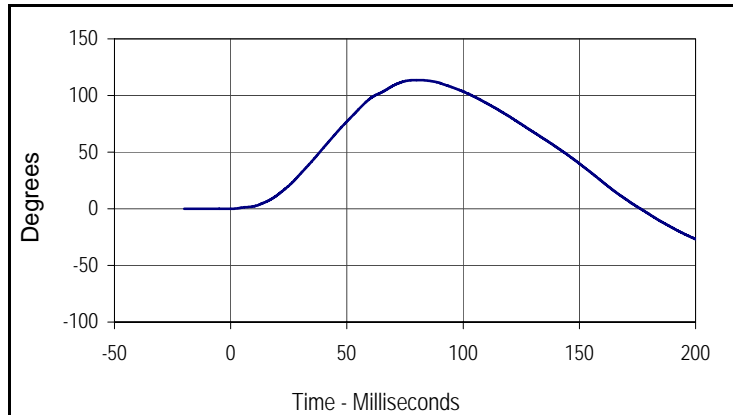

Curve Description			
"D" Plane Rotation			
CURNO	Type	SAE Class	Units
003	FIL	60	Degrees
Max	Time	Min	Time
113.6	80.1	-26.8	200.0

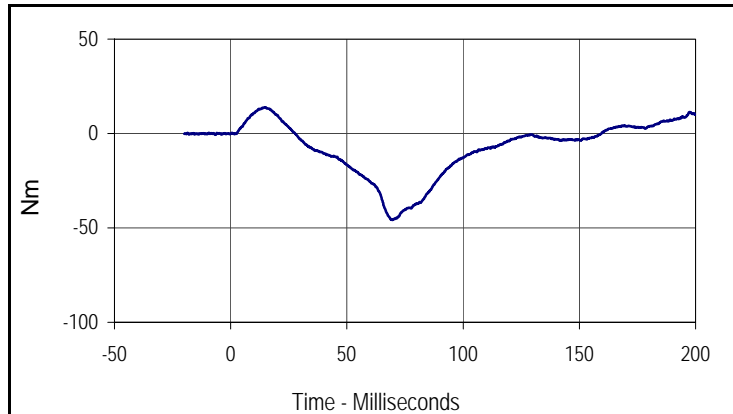

Curve Description			
Moment About Occipital Condyle			
CURNO	Type	SAE Class	Units
002	FIL	600	Nm
Max	Time	Min	Time
13.8	15.1	-45.8	69.6

Test Program: Hybrid III 10 Yr Old Knee Impact Test
 ATD Serial No.: 011

Test Date: 3/28/05
 Test I.D.: LK03M , RK03M



Left Knee

Tested Parameter	Units	Specification	Result	Pass/Fail
Laboratory Temperature	°C	18.9 to 25.6	21.1	Pass
Laboratory Relative Humidity	%	10 to 70	30	Pass
Pendulum Velocity at T=0	m/sec	2.07 to 2.13	2.11	Pass
Peak Probe Force	Newtons	2560 to 3140	3067	Pass
Overall Test Results				Pass

Right Knee

Pendulum Velocity at T=0	m/sec	2.07 to 2.13	2.10	Pass
Peak Probe Force	Newtons	2560 to 3140	2907	Pass
Overall Test Results				Pass

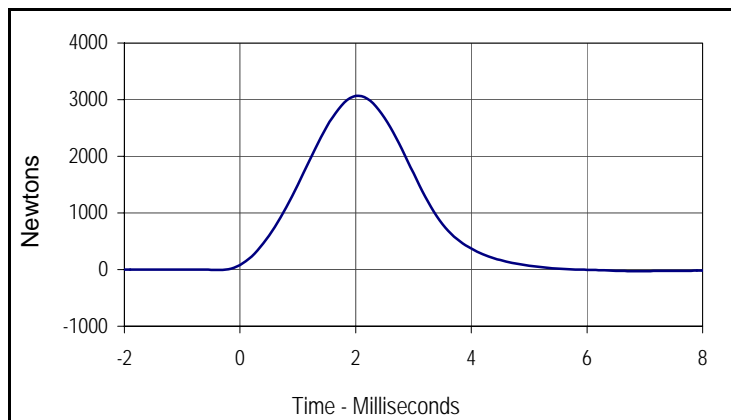

Curve Description			
Left Knee Probe Force			
CURNO	Type	SAE Class	Units
001	FIL	600	Newtons
Max	Time	Min	Time
3066.7	2.0	-27.2	6.9

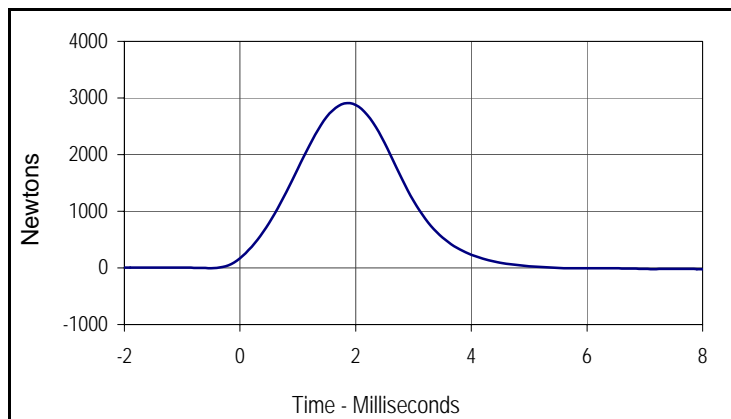

Curve Description			
Right Knee Probe Force			
CURNO	Type	SAE Class	Units
002	FIL	600	Newtons
Max	Time	Min	Time
2907.0	1.9	-25.8	8.5

Test Program: Hybrid III 10 Yr Old External Measurements

Test Date: 3/30/05

ATD Serial No.: 011

Test I.D.: N/A



Tested Parameter	Units	Specification	Result	Pass/Fail
Laboratory Temperature	°C	20.6 to 22.2	21.1	Pass
Laboratory Relative Humidity	%	10 to 70	30	Pass
A - Total sitting height	mm	710 to 737	725	Pass
B - Shoulder pivot height	mm	385 to 405	389	Pass
C - "H" point height	mm	78 to 88	81	Pass
D - "H" point from backline	mm	133 to 143	141	Pass
E - Shoulder pivot from back	mm	80 to 90	86	Pass
F - Thigh clearance	mm	105 to 121	120	Pass
G - Elbow back to wrist pivot	mm	227 to 243	231	Pass
H - Skull cap to back line	mm	46 to 51	48	Pass
I - Shoulder to elbow length	mm	269 to 285	284	Pass
J - Elbow rest height	mm	137 to 158	156	Pass
K - Buttock to knee length	mm	464 to 484	480	Pass
L - Popliteal length	mm	321 to 342	341	Pass
M - Knee pivot height	mm	370 to 389	380	Pass
N - Buttock popliteal length	mm	367 to 387	369	Pass
O - Chest depth without jacket	mm	158 to 173	170	Pass
P - Foot length	mm	188 to 203	200	Pass
R - Buttock to knee pivot length	mm	414 to 434	431	Pass
S - Head breadth	mm	137 to 147	145	Pass
T - Head depth	mm	178 to 188	185	Pass
U - Hip breadth	mm	257 to 272	268	Pass
V - Shoulder breadth	mm	307 to 323	311	Pass
W - Foot breadth	mm	69 to 84	81	Pass
X - Head circumference	mm	528 to 549	540	Pass
Y - Chest circumference with jacket	mm	691 to 716	700	Pass
Z - Waist circumference	mm	696 to 721	712	Pass
AA - Location for chest circumference	mm	338 to 348	340	Pass
Overall Test Results				Pass