

REPORT NUMBER: NCAPCHILD-MGA-2005-006

**NEW CAR ASSESSMENT PROGRAM
FRONTAL BARRIER IMPACT TEST**

**Evenflo Titan 5
Graco Turbo Booster**

NHTSA NUMBER: M50204

**PREPARED BY:
MGA RESEARCH CORPORATION
5000 WARREN ROAD
BURLINGTON, WI 53105**



Test Date: December 6, 2004

Final Report Date: January 21, 2005

FINAL REPORT

**PREPARED FOR:
U.S. DEPARTMENT OF TRANSPORTATION
NATIONAL HIGHWAY TRAFFIC SAFETY ADMINISTRATION
RULEMAKING
OFFICE OF CRASHWORTHINESS STANDARDS
400 SEVENTH STREET, SW, ROOM 5311
WASHINGTON, D.C. 20590**

This final test report was prepared for the U.S. Department of Transportation, National Highway Traffic Safety Administration, in response to Contract Number DTNH22-01-D-12005.

This publication is distributed by the U.S. Department of Transportation, National Highway Traffic Safety Administration, in the interest of information exchange. The opinions, findings and conclusions expressed in this publication are those of the author(s) and not necessarily those of the Department of Transportation or the National Highway Traffic Safety Administration. The United States Government assumes no liability for its contents or use thereof. If trade or manufacturers' names or products are mentioned it is only because they are considered essential to the object of the publication and should not be construed as an endorsement. The United States Government does not endorse products or manufacturers.

Prepared by: Shefalika Naik Date: 1/21/05
Shefalika Naik, Project Engineer

Reviewed by: David Winkelbauer Date: 1/21/05
David Winkelbauer, Facility Director

FINAL REPORT ACCEPTED BY:

Manager, New Car Assessment Program

Date of Acceptance

COTR, NCAP Frontal Impact Program

Date of Acceptance

Technical Report Documentation Page

1. Report No. NCAPCHILD-MGA-2005-006		2. Government Accession No.		3. Recipient's Catalog No.																	
4. Title and Subtitle Final Report of New Car Assessment Program Testing of Evenflo Titan 5 and Graco Turbo Booster Child Restraint Systems NHTSA No.: M50204		5. Report Date January 21, 2005		6. Performing Organization Code MGA																	
		7. Author(s) Shefalika Naik, Project Engineer		8. Performing Organization Report No. NCAPCHILD-MGA-2005-006																	
9. Performing Organization Name and Address MGA Research Corporation 5000 Warren Road Burlington, WI 53105		10. Work Unit No.		11. Contract or Grant No. DTNH22-01-D-12005																	
		12. Sponsoring Agency Name and Address U.S. Department of Transportation National Highway Traffic Safety Administration Rulemaking, Office of Crashworthiness Standards 400 Seventh Street, SW, Room 5311 Washington, D.C. 20590		13. Type of Report and Period Covered Final Report 12/06/04 to 1/21/05																	
				14. Sponsoring Agency Code NVS-111																	
15. Supplementary Notes																					
16. Abstract The subjects CRS Evenflo Titan 5 and Graco Turbo Booster were tested in conjunction with a Frontal NCAP test in support of research in accordance with the specifications of the Office of Crashworthiness Standards Test Procedure for the determination of CRS crashworthiness. This test was conducted at MGA Research Corporation in Burlington, Wisconsin on December 6, 2004, in conjunction with frontal NCAP.																					
<table border="1"> <thead> <tr> <th>Measurement Description</th> <th>Units</th> <th>Pos. 3 ATD</th> <th>Pos. 4 ATD</th> </tr> </thead> <tbody> <tr> <td>Head Injury Criteria (HIC36)</td> <td>N/A</td> <td>1051.7</td> <td>703.5</td> </tr> <tr> <td>Head Injury Criteria (HIC15)</td> <td>N/A</td> <td>530.9</td> <td>384.6</td> </tr> <tr> <td>Max. Thorax Accel. (3msec Clip)</td> <td>G's</td> <td>45.8</td> <td>67.0</td> </tr> </tbody> </table>						Measurement Description	Units	Pos. 3 ATD	Pos. 4 ATD	Head Injury Criteria (HIC36)	N/A	1051.7	703.5	Head Injury Criteria (HIC15)	N/A	530.9	384.6	Max. Thorax Accel. (3msec Clip)	G's	45.8	67.0
Measurement Description	Units	Pos. 3 ATD	Pos. 4 ATD																		
Head Injury Criteria (HIC36)	N/A	1051.7	703.5																		
Head Injury Criteria (HIC15)	N/A	530.9	384.6																		
Max. Thorax Accel. (3msec Clip)	G's	45.8	67.0																		
17. Key Words 56.3 km/h NCAP Frontal Barrier Impact Test New Car Assessment Program (NCAP) Evenflo Titan 5 Graco Turbo Booster NHTSA No: M50204			18. Distribution Statement Copies of this report are available from: National Highway Traffic Safety Admin., Technical Ref. Division, Room 5108 (NPO-230) 400 Seventh Street, S.W. Washington, D.C. 20590																		
19. Security Classif. (of this report) Unclassified		20. Security Classif. (of this page) Unclassified		21. No. of Pages 107	22. Price																

Form DOT F1700.7 (8-72)

TABLE OF CONTENTS

<u>Section</u>		<u>Page No</u>
1	Purpose and Summary of Test	1
2	Data Sheets	2
<u>Data Sheet No.</u>		
1	Crash Test Summary	2
2	CRS Parameter Data	3
3	Child Dummy Positioning in Vehicle	4
4	Child Dummy Injury Criteria Values	6
5	CRS Performance Data	9
6	CRS Camera Data	10
<u>Appendix</u>		
A	Photographs	A
B	Child Dummy Response Data Traces	B
C	Child Dummy Calibration Information	C
D	Test Equipment List and Calibration Information	D

SECTION 1

PURPOSE AND SUMMARY OF TEST

PURPOSE

The purpose of this test was to obtain CRS performance data in a frontal impact NCAP condition.

This 56.3 km/h frontal barrier impact test is part of the Vehicle Barrier Impact Testing Program sponsored by the National Highway Traffic Safety Administration (NHTSA) under contract number DTNH22-01-D-12005.

SUMMARY

Both child dummies were instrumented with head, chest, and pelvic triaxial accelerometers. In addition, both dummies had six upper axial neck force and moment sensors.

The right rear (Position 3) child dummy (S/N 42) and left rear (Position 4) child dummy (S/N 144) were calibrated previous to this test. Child dummy certification information is found in Appendix C.

The right rear child dummy's HIC36 was 1051.7; maximum chest deceleration over 3 msec was 45.8 g's. The left rear child dummy's HIC36 was 703.5. The maximum chest deceleration over 3 msec was 67.0 g's. Position 3 and Position 4 were forward facing. Position 3 used the vehicle LATCH and top tether for attachments. Position 4 (booster seat) used vehicle seat belts.

TEST NOTES

None

SECTION 2

DATA SHEET NO. 1 CRASH TEST SUMMARY

TEST DUMMY INFORMATION

Description	Position 3 CRS	Position 4 CRS
Dummy Type / Serial No.	HIII 3 Year Old / 42	HIII 6 Year Old / 144
Number of Data Channels	16	18
Restraint System	Evenflo Titan 5 (Forward Facing)	Graco Turbo Booster (Booster)

16 MM CAMERA COVERAGE

High Speed	16
Real Time	1
Total	17

POST TEST DOOR OPENING

Description	Driver	Passenger
Locked/Unlocked Doors	Doors were unlocked	Doors were unlocked
Front Door Opening	Door remained closed and latched; Door opened without tools	Door remained closed and latched; Door opened without tools
Rear Door Opening	Door remained closed and latched; Door opened without tools	Door remained closed and latched; Door opened without tools
Seat Track Shift (mm)	0	0
Seat Back Failure	None	None
Glazing Damage	The windshield cracked	

POST TEST SEAT DATA

Location	Seat Movement (mm)	Seat Back Failure
P1 (Left Front)	0	None
P2 (Right Front)	0	None
P3 (Right Rear)	0	None
P4 (Left Rear)	0	None

VISIBLE DUMMY CONTACT POINTS

Description	Position 3 CRS (S/N 42)	Position 4 CRS (S/N 144)
Head Contact	Back of head to CRS, Child Seat chest clip	Back of head to CRS, Vehicle seat belt
Upper Torso Contact	None	None
Lower Torso Contact	None	None
Left Foot Contact	Passenger seat back	Driver seat back
Right Foot Contact	Passenger seat back	Driver seat back

SECTION 2... (continued)

**DATA SHEET NO. 2
CRS PARAMETER DATA**

Child Restraint System (Position 3)	Evenflo Titan 5 (Forward Facing)
Child Restraint System (Position 4)	Graco Turbo Booster (Forward Facing)
NHTSA No.	M50204

TARGET TEST WEIGHT CALCULATION

Measured Parameter	Units	Value
Total Delivered Weight (UVW)	kg	1864.9
Weight of 2 P572E ATDs	kg	156.0
Rated Cargo/Luggage Weight (RCLW)	kg	113.4
Calculated Vehicle Target Weight (TVTW)	kg	2134.3

TEST VEHICLE WEIGHTS

	Units	As Tested (ATW) (Axle)		
		Front	Rear	Total
Left	kg	547.0	516.2	
Right	kg	543.4	523.0	
Ratio	%	51.2	48.8	
Totals	kg	1090.4	1039.2	2129.6

As tested weight of vehicle includes two 50th percentile ATDs, one 3 year old with CRS, one 6 year old with CRS, cargo, equipment and instrumentation.

CHEST CLIP DISPLACEMENT

	Units	Left	Right
Right Child Dummy	mm	66	72
Left Child Dummy	mm		

SECTION 2... (continued)
DATA SHEET NO. 3
CHILD DUMMY POSITIONING IN VEHICLE

Child Restraint System (Position 3)	Evenflo Titan 5 (Forward Facing)
NHTSA No.	M50204

Dummy Measurements for CRS Passengers

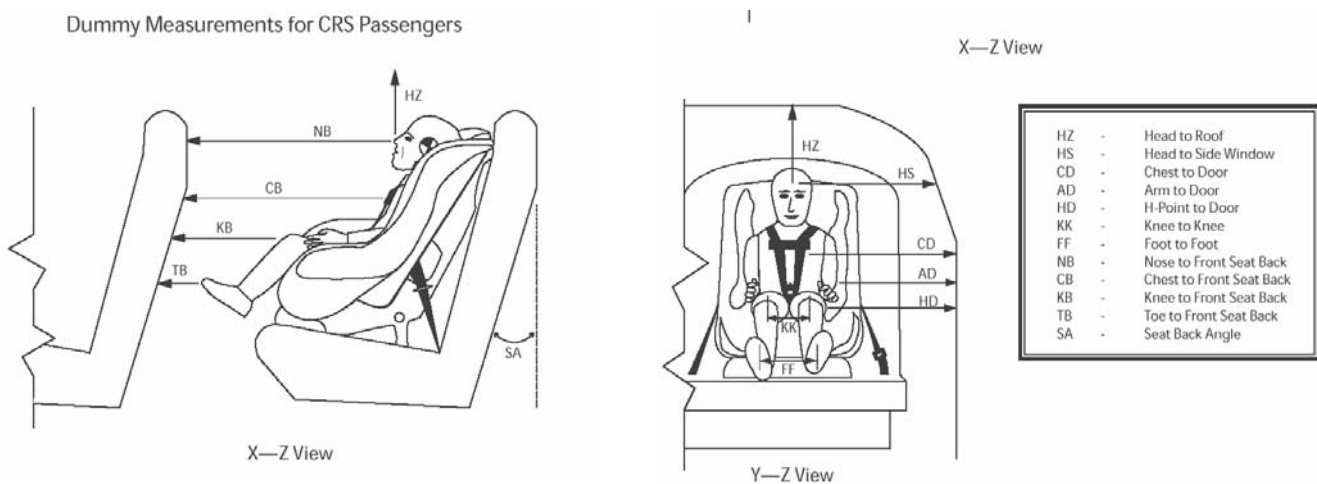

Measurement	Pre-Test (mm)	Post-Test (mm)
	P3 CRS (42)	P3 CRS (42)
SA (deg)	20.0	20.0
HS	391	401
CD	333	341
AD	212	219
HD	273	281
HZ	402	387
NB	588	576
CB	564	571
KK	161	178
FF	110	259
KB - LEFT	360	380
KB - RIGHT	348	407
TB - LEFT	110	101
TB - RIGHT	112	92

All dimensions in mm (unless noted)
P3 – Right Rear Passenger (Forward Facing)

SECTION 2... (continued)
DATA SHEET NO. 3
CHILD DUMMY POSITIONING IN VEHICLE

Child Restraint System (Position 4)	Graco Turbo Booster(Forward Facing)
NHTSA No.	M50204

Dummy Measurements for CRS Passengers

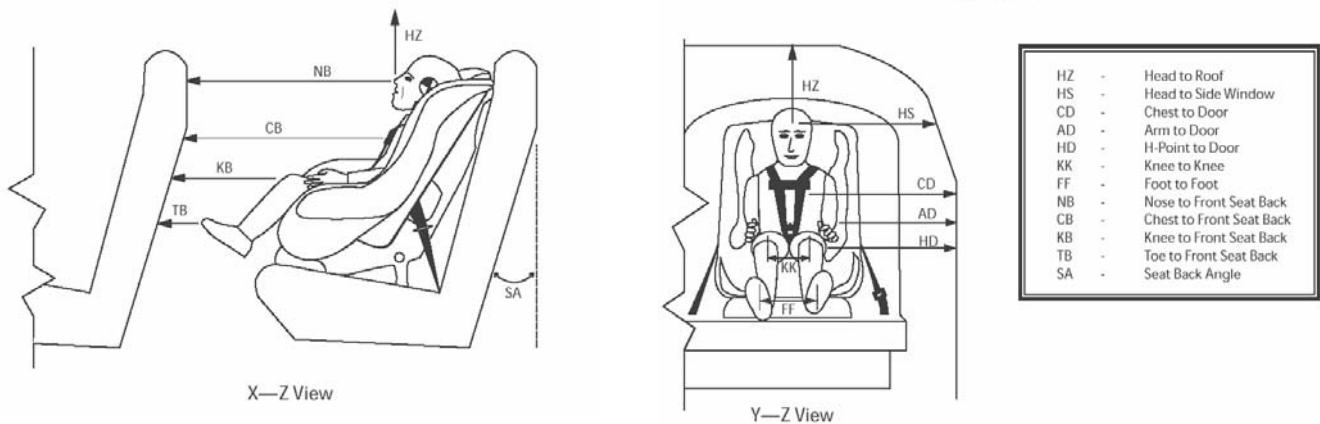

Measurement	Pre-Test (mm)	Post-Test (mm)
	P4 CRS (144)	P4 CRS (144)
SA (deg)	20.0	20.0
HS	359	406
CD	346	342
AD	217	58
HD	204	206
HZ	342	333
NB	565	562
CB	535	552
KK	159	136
FF	101	60
KB - LEFT	328	370
KB - RIGHT	331	345
TB - LEFT	117	108
TB - RIGHT	117	140

All dimensions in mm (unless noted)
P4 – Left Rear Passenger (Forward facing)

**DATA SHEET NO. 4
CHILD DUMMY INJURY CRITERIA VALUES**

Child Restraint System (Position 3)	Evenflo Titan 5
Child Restraint System (Position 4)	Graco Turbo Booster
NHTSA No.	M50204

HEAD PEAK ACCELERATIONS

Location	Axis	Units	Position 3				Position 4			
			Max	Time	Min	Time	Max	Time	Min	Time
Head CG	X	G's	131.4	182	-49.3	100	15.6	239	-22.7	70
Head CG	Y	G's	3.4	106	-19.5	100	2.6	123	-9.5	181
Head CG	Z	G's	66.9	85	-5.2	37	57.7	66	-0.8	27
Resultant	N/A	G's	142.4	182			61.4	66		

UPPER NECK PEAK FORCES AND MOMENTS

Location	Axis	Units	Position 3				Position 4			
			Max	Time	Min	Time	Max	Time	Min	Time
Neck Force	X	N	26	231	-910	112	52	226	-611	67
Neck Force	Y	N	89	111	-72	181	48	-139	-245	81
Neck Force	Z	N	2049	99	-374	224	1803	66	-16.7	21
Resultant	N/A	N	2177	99			1903	66		
Neck Moment	X	N•m	3.1	131	-5.7	106	10.2	128	-15.5	72
Neck Moment	Y	N•m	3.3	147	-13.8	114	17.0	103	-26.9	56
Neck Moment	Z	N•m	2.0	62	-2.6	83	5.9	101	-4.8	130
Resultant	N/A	N•m	14.1	106			27.1	56		

CHEST PRIMARY PEAK ACCELERATIONS

Location	Axis	Units	Position 3				Position 4			
			Max	Time	Min	Time	Max	Time	Min	Time
Chest CG	X	G's	19.1	224	-40.7	68	3.6	280	-63.1	58
Chest CG	Y	G's	6.6	103	-3.1	160	10.1	59	-8.6	71
Chest CG	Z	G's	19.1	185	-23.8	69	26.6	61	-4.2	250
Resultant	N/A	G's	47.3	68			67.6	58		

CHEST PEAK DISPLACEMENTS

Location	Axis	Units	Position 3				Position 4			
			Max	Time	Min	Time	Max	Time	Min	Time
Chest	X	mm			-18.3	115			-32.1	68

SECTION 2... (continued)
DATA SHEET NO. 4... (continued)
CHILD DUMMY INJURY CRITERIA VALUES

Child Restraint System (Position 3)	Evenflo Titan 5
Child Restraint System (Position 4)	Graco Turbo Booster
NHTSA No.	M50204

TETHER FORCE

Location	Axis	Units	Position 3				Position 4			
			Max	Time	Min	Time	Max	Time	Min	Time
Right Tether Force	N/A	N	1174	90						

PELVIC PEAK ACCELERATIONS

Location	Axis	Units	Position 3				Position 4			
			Max	Time	Min	Time	Max	Time	Min	Time
Pelvis	X	G's	20.2	243	-58.3	65	6.2	195	-63.7	56
Pelvis	Y	G's	8.5	78	-7.5	64	12.4	62	-5.1	52
Pelvis	Z	G's	26.4	185	-27.2	80	5.5	251	-20.4	55
Resultant	N/A	G's	62.4	65			66.3	55		

FEMUR FORCES

Location	Axis	Units	Position 3				Position 4			
			Max	Time	Min	Time	Max	Time	Min	Time
Left Femur	N/A	N					1405	61	-65	152
Right Femur	N/A	N					1172	61	-77	-189

BELT FORCES

Location	Axis	Units	Position 3				Position 4			
			Max	Time	Min	Time	Max	Time	Min	Time
Shoulder Belt	N/A	N					6400	64		
Lap Belt	N/A	N					4286	59		

SECTION 2... (continued)
DATA SHEET NO. 4... (continued)
CHILD DUMMY INJURY CRITERIA VALUES

Child Restraint System (Position 3)	Evenflo Titan 5
Child Restraint System (Position 4)	Graco Turbo Booster
NHTSA No.	M50204

HEAD INJURY CRITERIA (HIC36)

Location	HIC	T ¹ (msec)	T ² (msec)	Average Acceleration (G's)
Position 3 - Right	1051.7	74.4	110.4	61.1
Position 4 – Left	703.5	57.4	93.4	52.0

HIC is as defined in FMVSS 208. The maximum time interval from t1 to t2 is 36 milliseconds.

HEAD INJURY CRITERIA (HIC15)

Location	HIC	T ¹ (msec)	T ² (msec)	Average Acceleration (G's)
Position 3 - Right	530.9	80.0	95.0	66.0
Position 4 – Left	384.6	64.0	79.0	58.0

HIC is as defined in FMVSS 208. The maximum time interval from t1 to t2 is 15 milliseconds.

CLIP SUMMARY

Location	CLIP	T ¹ (msec)	T ² (msec)
Position 3 - Right	45.8	66.4	69.4
Position 4 – Left	67.0	57.0	60.0

The maximum chest resultant acceleration is defined as the maximum acceleration, which exceeds 0.003 seconds in duration.

SECTION 2... (continued)

**DATA SHEET NO. 5
CRS PERFORMANCE DATA**

Child Restraint System (Position 3)	Evenflo Titan 5 (Forward Facing)
Child Restraint System (Position 4)	Graco Turbo Booster(Forward Facing)
NHTSA No.	M50204

POSITION 3 CRS POST-TEST INSPECTION

Location	Damage	Remarks
Upper Tether Strap	None	
Upper Tether Buckle	None	
Upper Tether Hook	None	
Vehicle Upper Tether Anchor	None	
Lower Anchor Strap	None	
Lower Anchor Buckle	None	
Lower Anchor Hooks	None	
Vehicle Lower CRS Anchors	None	
Five Point Harness Connections	None	
Cracks on CRS	None	
Fabric Tears on CRS	None	
Vehicle Seat Structure	None	
Vehicle Seat Fabric Tears	None	
Child Dummy	None	

POSITION 4 CRS POST-TEST INSPECTION

Location	Damage	Remarks
Upper Tether Strap	None	
Upper Tether Buckle	None	
Upper Tether Hook	None	
Vehicle Upper Tether Anchor	None	
Lower Anchor Strap	None	
Lower Anchor Buckle	None	
Lower Anchor Hooks	None	
Vehicle Lower CRS Anchors	None	
Five Point Harness Connections	None	
Cracks on CRS	None	
Fabric Tears on CRS	None	
Vehicle Seat Structure	None	
Vehicle Seat Fabric Tears	None	
Child Dummy	None	

SECTION 2... (continued)

DATA SHEET NO. 6
CRS CAMERA DATA

Child Restraint System (Position 3)	Evenflo Titan 5 (Forward Facing)
Child Restraint System (Position 4)	Graco Turbo Booster (Forward Facing)
NHTSA No.	M50204

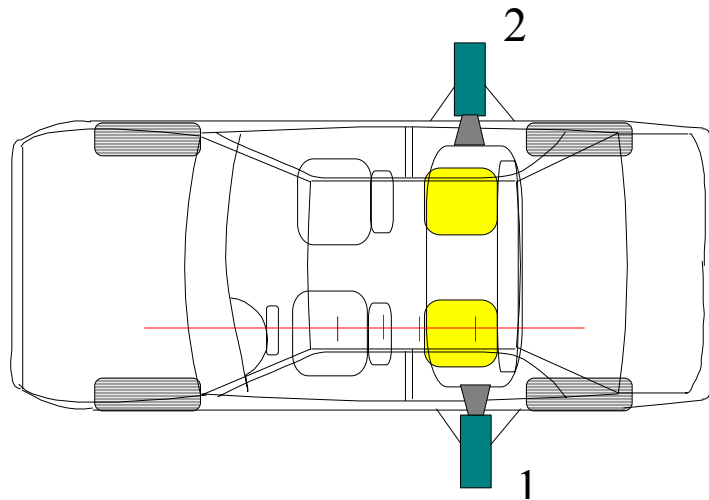

No.	Camera View	Location (mm) *			Angle (deg)	Lens (mm)	Speed (fps)
		X	Y	Z			
1	Left Side CRS Lateral View					13	1000
2	Right Side CRS Lateral View					10	1000

*COORDINATES:

- +X = forward of impact plane
- +Y = right of monorail centerline
- +Z = above ground level

APPENDIX A
PHOTOGRAPHS

TABLE OF PHOTOGRAPHS

		<u>Page No.</u>
Photo No. 1.	Close-up View of Position 3 CRS Label	A-1
Photo No. 2.	Pre-Test Front View of Position 3 CRS	A-2
Photo No. 3.	Post-Test Front View of Position 3 CRS	A-3
Photo No. 4.	Pre-Test Rear View of Position 3 CRS	A-4
Photo No. 5.	Post-Test Rear View of Position 3 CRS	A-5
Photo No. 6.	Pre-Test Left Side View of Position 3 CRS	A-6
Photo No. 7.	Post-Test Left Side View of Position 3 CRS	A-7
Photo No. 8.	Pre-Test Right Side View of Position 3 CRS	A-8
Photo No. 9.	Post-Test Right Side View of Position 3 CRS	A-9
Photo No. 10.	Close-up View of Position 4 CRS Label	A-10
Photo No. 11.	Pre-Test Front View of Position 4 CRS	A-11
Photo No. 12.	Post-Test Front View of Position 4 CRS	A-12
Photo No. 13.	Pre-Test Rear View of Position 4 CRS	A-13
Photo No. 14.	Post-Test Rear View of Position 4 CRS	A-14
Photo No. 15.	Pre-Test Left Side View of Position 4 CRS	A-15
Photo No. 16.	Post-Test Left Side View of Position 4 CRS	A-16
Photo No. 17.	Pre-Test Right Side View of Position 4 CRS	A-17
Photo No. 18.	Post-Test Right Side View of Position 4 CRS	A-18
Photo No. 19.	Pre-Test Position 3 Left Side View	A-19
Photo No. 20.	Post-Test Position 3 Left Side View	A-20
Photo No. 21.	Pre-Test Position 4 Left Side View	A-21
Photo No. 22.	Post-Test Position 4 Left Side View	A-22
Photo No. 23.	Pre-Test Position 3 Right Side View	A-23
Photo No. 24.	Post-Test Position 3 Right Side View	A-24
Photo No. 25.	Pre-Test Position 4 Right Side View	A-25
Photo No. 26.	Post-Test Position 4 Right Side View	A-26
Photo No. 27.	Pre-Test Position 3 Rear View	A-27

		<u>Page No.</u>
Photo No. 28.	Post-Test Position 3 Foot Contact	A-28
Photo No. 29.	Post-Test Position 4 Foot Contact	A-29
Photo No. 30.	Post-Test Position 3 Head Contact	A-30
Photo No. 31.	Post-Test Position 4 Head Contact	A-31

A-1.



Close-up View of Position 3 CRS Label

A-2.



Pre-Test Front View of Position 3 CRS

A-3.



Post-Test Front View of Position 3 CRS

A-4.



Pre-Test Rear View of Position 3 CRS

A-5.



Post-Test Rear View of Position 3 CRS

A-6.



Pre-Test Left Side View of Position 3 CRS

A-7.



Post-Test Left Side View of Position 3 CRS

A-8.



Pre-Test Right Side View of Position 3 CRS

A-9.



Post-Test Right Side View of Position 3 CRS

...entre 40 y 57 pulgadas...
 ...debe encontrarse del lado de la parte...
 ...del asiento del vehículo/apoyacabeza...
CONSULTE EL MANUAL DEL PROPIETARIO PARA OBTENER LAS INSTRUCCIONES COMPLETAS.

Este sistema de seguridad infantil cumple con todas las normas federales de seguridad para automóviles aplicables. Este asiento está certificado para su uso en automóviles. Este asiento no está certificado para su uso en aeronaves.

Los asientos infantiles podrán quedar sujetos a retiradas por razones de seguridad. Debe registrar este asiento para recibir información sobre retiradas. Envíe su nombre, dirección y el número de modelo y la fecha de fabricación del asiento a Graco Children's Products Inc., 150 Oaklands Blvd., Exton, PA 19341 EE.UU. o llame al 1-800-345-4109. Para información sobre retiradas, llame a la línea de información sobre seguridad automotriz del gobierno de EE.UU. al 1-800-424-9393 (202-366-0123 en el Distrito de Columbia).

LAPB0095A

MODEL 8495STO NAME: TurboBooster
 SERIAL JJ 0329040425878
 Manufactured in 032904
 GRACO CHILDREN'S PRODUCTS, INC.
 EXTON, PA 19341 1-888-224-6549
 Made in China

LAP70004B

Close-up View of Position 4 CRS Label

A-11.



Pre-Test Front View of Position 4 CRS

A-12.



Post-Test Front View of Position 4 CRS

A-13.



Pre-Test Rear View of Position 4 CRS

A-14.



Post-Test Rear View of Position 4 CRS

A-15.



Pre-Test Left Side View of Position 4 CRS



Post-Test Left Side View of Position 4 CRS



Pre-Test Right Side View of Position 4 CRS

A-18.



Post-Test Right Side View of Position 4 CRS



Pre-Test Position 3 Left Side View



Post-Test Position 3 Left Side View

A-21.



Pre-Test Position 4 Left Side View



Post-Test Position 4 Left Side View

A-23.



Pre-Test Position 3 Right Side View

A-24.



Post-Test Position 3 Right Side View



Pre-Test Position 4 Right Side View

A-26.



Post-Test Position 4 Right Side View

A-27.



Pre-Test Position 3 Rear View



Post-Test Position 3 Foot Contact



Post-Test Position 4 Foot Contact

A-30.



Post-Test Position 3 Head Contact



Post-Test Position 4 Head Contact

APPENDIX B
CHILD DUMMY RESPONSE DATA TRACES

TABLE OF DATA PLOTS

		<u>Page No.</u>
Figure No. 1.	LRP Child Head X Acceleration vs. Time	B-1
Figure No. 2.	LRP Child Head Y Acceleration vs. Time	B-1
Figure No. 3.	LRP Child Head Z Acceleration vs. Time	B-1
Figure No. 4.	LRP Child Head Resultant Acceleration vs. Time	B-1
Figure No. 5.	LRP Child Head X Velocity vs. Time	B-2
Figure No. 6.	LRP Child Head Y Velocity vs. Time	B-2
Figure No. 7.	LRP Child Head Z Velocity vs. Time	B-2
Figure No. 8.	LRP Child Upper Neck Force X vs. Time	B-3
Figure No. 9.	LRP Child Upper Neck Force Y vs. Time	B-3
Figure No. 10.	LRP Child Upper Neck Force Z vs. Time	B-3
Figure No. 11.	LRP Child Upper Neck Force Resultant vs. Time	B-3
Figure No. 12.	LRP Child Upper Neck Moment X vs. Time	B-4
Figure No. 13.	LRP Child Upper Neck Moment Y vs. Time	B-4
Figure No. 14.	LRP Child Upper Neck Moment Z vs. Time	B-4
Figure No. 15.	LRP Child Upper Neck Moment Resultant vs. Time	B-4
Figure No. 16.	LRP Child Chest X Acceleration vs. Time	B-5
Figure No. 17.	LRP Child Chest Y Acceleration vs. Time	B-5
Figure No. 18.	LRP Child Chest Z Acceleration vs. Time	B-5
Figure No. 19.	LRP Child Chest Resultant Acceleration vs. Time	B-5
Figure No. 20.	LRP Child Chest X Velocity vs. Time	B-6
Figure No. 21.	LRP Child Chest Y Velocity vs. Time	B-6
Figure No. 22.	LRP Child Chest Z Velocity vs. Time	B-6
Figure No. 23.	LRP Child Chest Displacement vs. Time	B-6
Figure No. 24.	LRP Child Pelvis X Acceleration vs. Time	B-7
Figure No. 25.	LRP Child Pelvis Y Acceleration vs. Time	B-7
Figure No. 26.	LRP Child Pelvis Z Acceleration vs. Time	B-7
Figure No. 27.	LRP Child Pelvis Resultant Acceleration vs. Time	B-7
Figure No. 28.	LRP Child Pelvis X Velocity vs. Time	B-8
Figure No. 29.	LRP Child Pelvis Y Velocity vs. Time	B-8

		<u>Page No.</u>
Figure No. 30.	LRP Child Pelvis Z Velocity vs. Time	B-8
Figure No. 31.	LRP Child Right Femur Force vs. Time	B-9
Figure No. 32.	LRP Child Left Femur Force vs. Time	B-9
Figure No. 33.	LRP Child Shoulder Belt Force vs. Time	B-9
Figure No. 34.	LRP Child Lap Belt Force vs. Time	B-9
Figure No. 35.	RRP Child Head X Acceleration vs. Time	B-10
Figure No. 36.	RRP Child Head Y Acceleration vs. Time	B-10
Figure No. 37.	RRP Child Head Z Acceleration vs. Time	B-10
Figure No. 38.	RRP Child Head Resultant Acceleration vs. Time	B-10
Figure No. 39.	RRP Child Head X Velocity vs. Time	B-11
Figure No. 40.	RRP Child Head Y Velocity vs. Time	B-11
Figure No. 41.	RRP Child Head Z Velocity vs. Time	B-11
Figure No. 42.	RRP Child Upper Neck Force X vs. Time	B-12
Figure No. 43.	RRP Child Upper Neck Force Y vs. Time	B-12
Figure No. 44.	RRP Child Upper Neck Force Z vs. Time	B-12
Figure No. 45.	RRP Child Upper Neck Force Resultant vs. Time	B-12
Figure No. 46.	RRP Child Upper Neck Moment X vs. Time	B-13
Figure No. 47.	RRP Child Upper Neck Moment Y vs. Time	B-13
Figure No. 48.	RRP Child Upper Neck Moment Z vs. Time	B-13
Figure No. 49.	RRP Child Upper Neck Moment Resultant vs. Time	B-13
Figure No. 50.	RRP Child Chest X Acceleration vs. Time	B-14
Figure No. 51.	RRP Child Chest Y Acceleration vs. Time	B-14
Figure No. 52.	RRP Child Chest Z Acceleration vs. Time	B-14
Figure No. 53.	RRP Child Chest Resultant Acceleration vs. Time	B-14
Figure No. 54.	RRP Child Chest X Velocity vs. Time	B-15
Figure No. 55.	RRP Child Chest Y Velocity vs. Time	B-15
Figure No. 56.	RRP Child Chest Z Velocity vs. Time	B-15
Figure No. 57.	RRP Child Chest Displacement vs. Time	B-15
Figure No. 58.	RRP Child Pelvis X Acceleration vs. Time	B-16
Figure No. 59.	RRP Child Pelvis Y Acceleration vs. Time	B-16

		<u>Page No.</u>
Figure No. 60.	RRP Child Pelvis Z Acceleration vs. Time	B-16
Figure No. 61.	RRP Child Pelvis Resultant Acceleration vs. Time	B-16
Figure No. 62.	RRP Child Pelvis X Velocity vs. Time	B-17
Figure No. 63.	RRP Child Pelvis Y Velocity vs. Time	B-17
Figure No. 64.	RRP Child Pelvis Z Velocity vs. Time	B-17
Figure No. 65.	RRP Tether Force vs. Time	B-17
Figure No. 66.	Left Rear Seat Back X Acceleration vs. Time	B-18
Figure No. 67.	Left Rear Seat Back Y Acceleration vs. Time	B-18
Figure No. 68.	Left Rear Seat Back Z Acceleration vs. Time	B-18
Figure No. 69.	Left Rear Seat Back Resultant Acceleration vs. Time	B-18
Figure No. 70.	Left Rear Seat Back X Velocity vs. Time	B-19
Figure No. 71.	Left Rear Seat Back Y Velocity vs. Time	B-19
Figure No. 72.	Left Rear Seat Back Z Velocity vs. Time	B-19
Figure No. 73.	RRP Child Seat X Acceleration vs. Time	B-20
Figure No. 74.	RRP Child Seat Y Acceleration vs. Time	B-20
Figure No. 75.	RRP Child Seat Z Acceleration vs. Time	B-20
Figure No. 76.	RRP Child Seat Resultant Acceleration vs. Time	B-20
Figure No. 77.	RRP Child Seat X Velocity vs. Time	B-21
Figure No. 78.	RRP Child Seat Y Velocity vs. Time	B-21
Figure No. 79.	RRP Child Seat Z Velocity vs. Time	B-21
Figure No. 80.	LRP Child Seat X Acceleration vs. Time	B-22
Figure No. 81.	LRP Child Seat Y Acceleration vs. Time	B-22
Figure No. 82.	LRP Child Seat Z Acceleration vs. Time	B-22
Figure No. 83.	LRP Child Seat Resultant Acceleration vs. Time	B-22
Figure No. 84.	LRP Child Seat X Velocity vs. Time	B-23
Figure No. 85.	LRP Child Seat Y Velocity vs. Time	B-23
Figure No. 86.	LRP Child Seat Z Velocity vs. Time	B-23

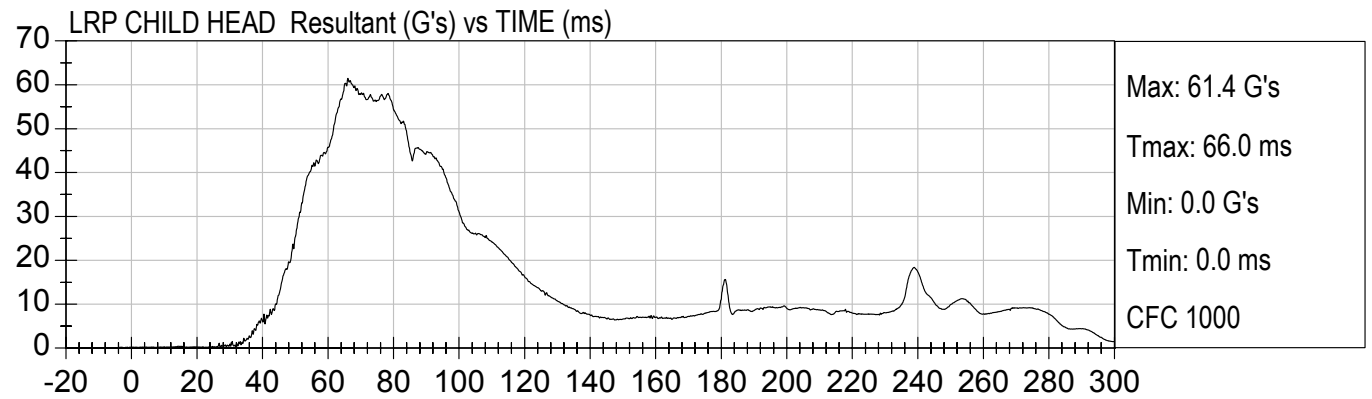
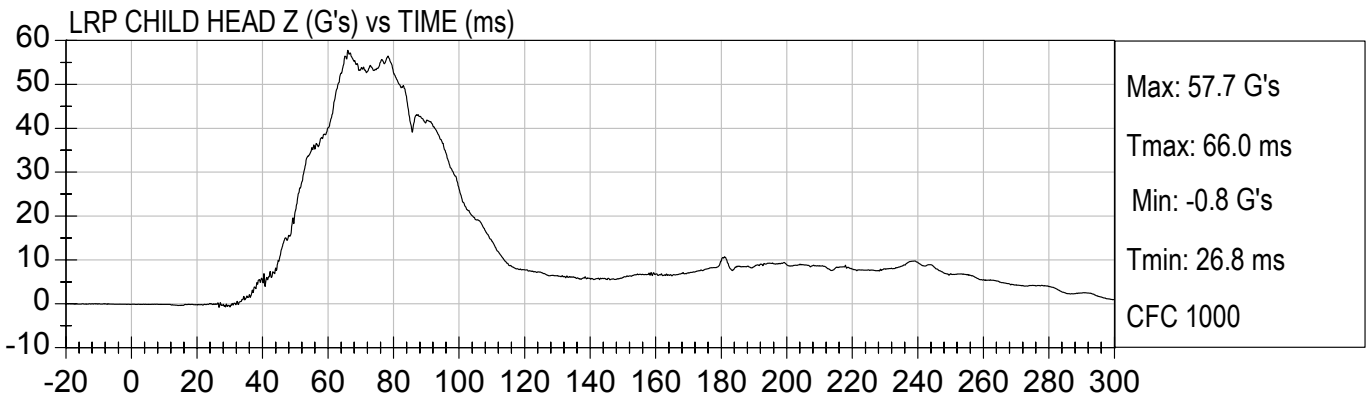
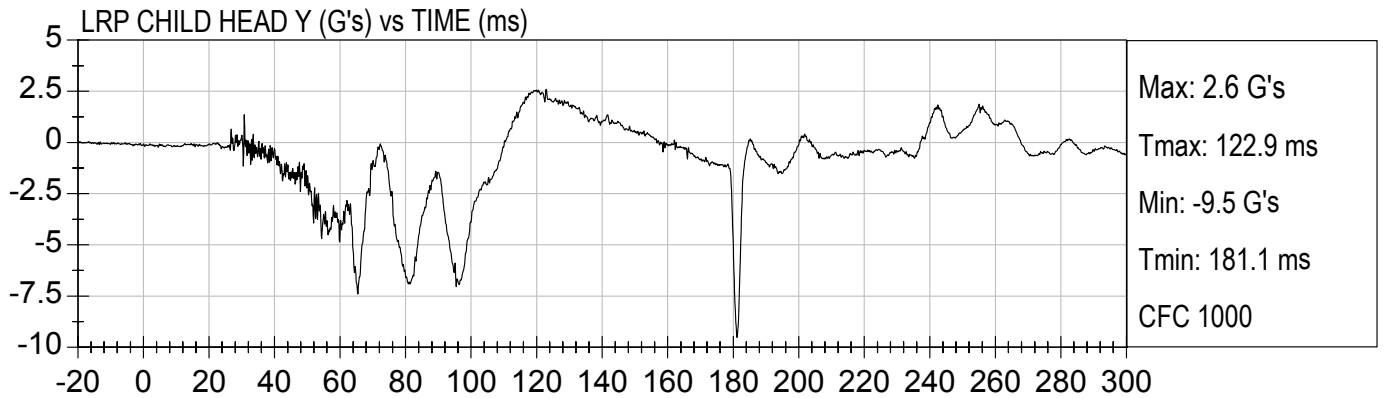
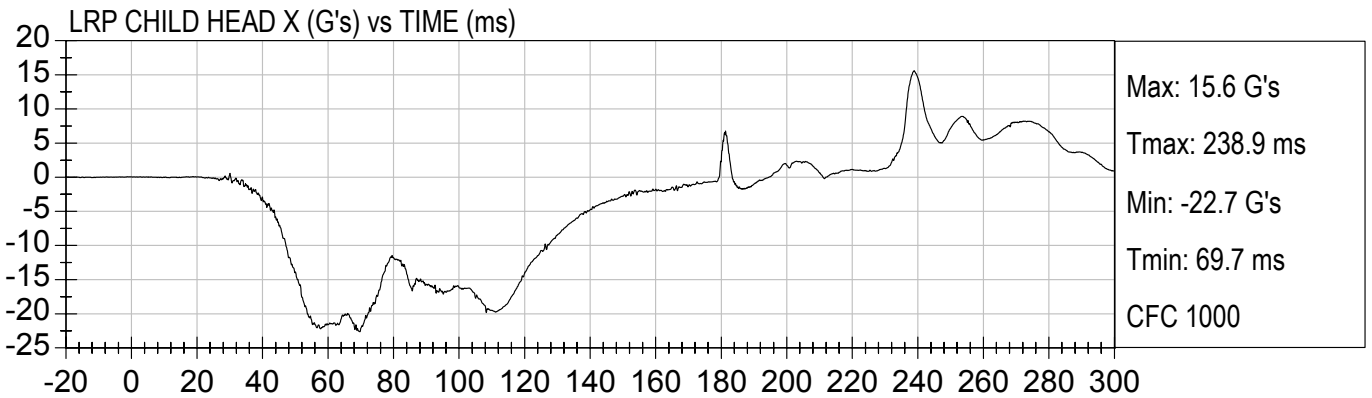

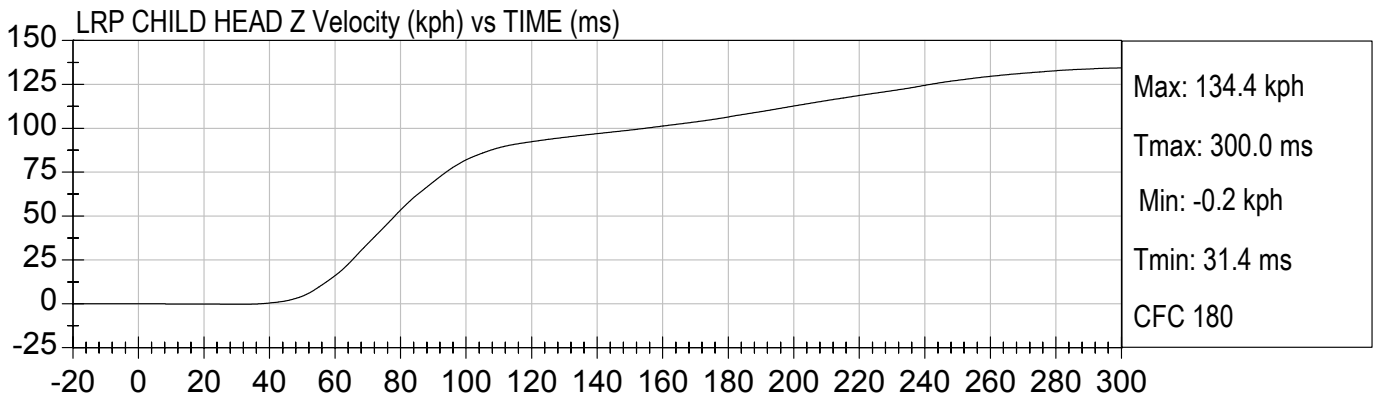
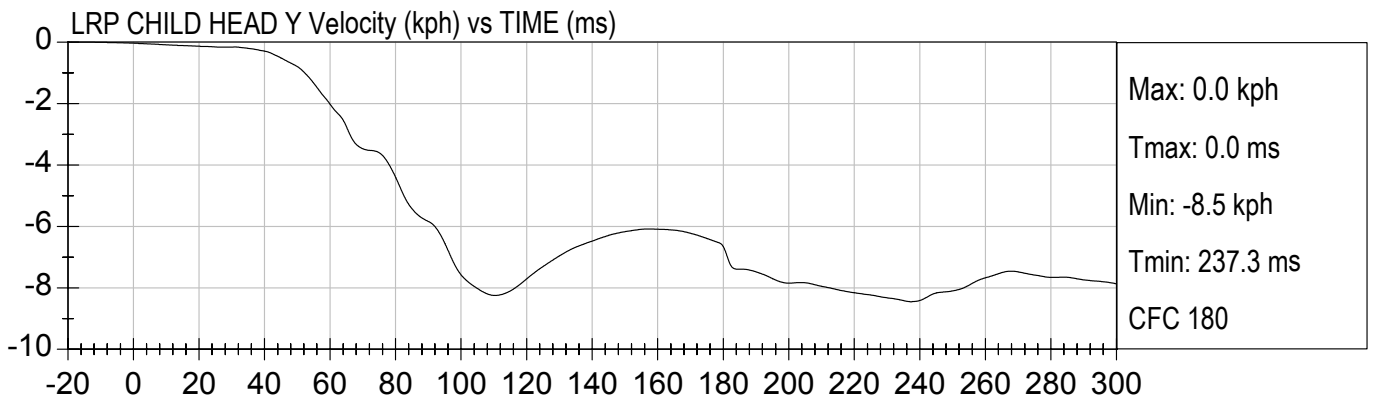
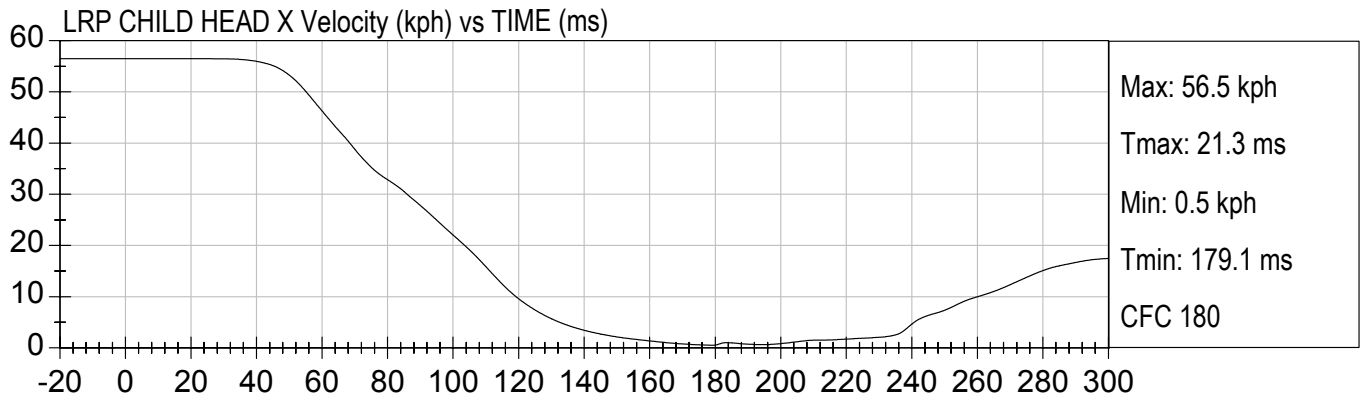

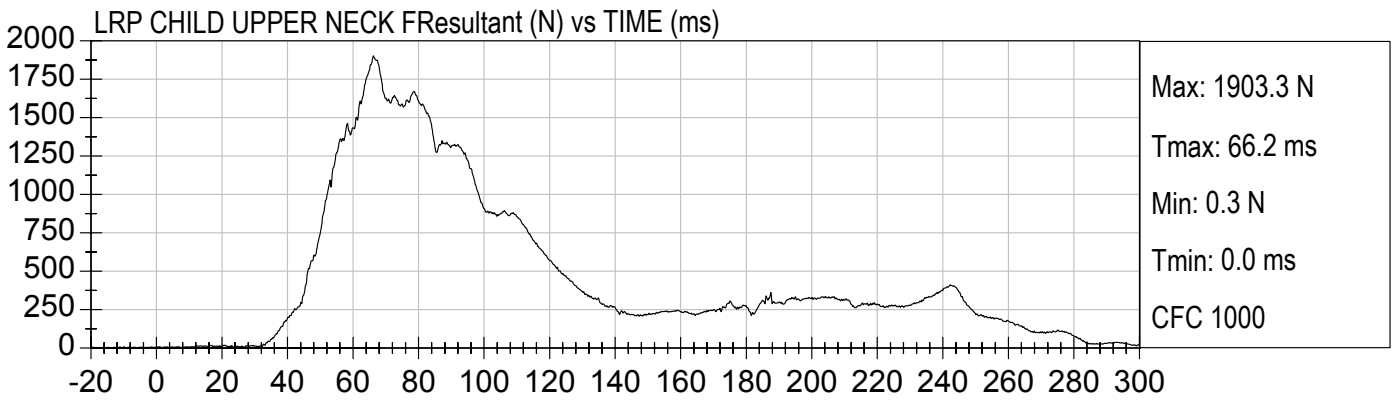
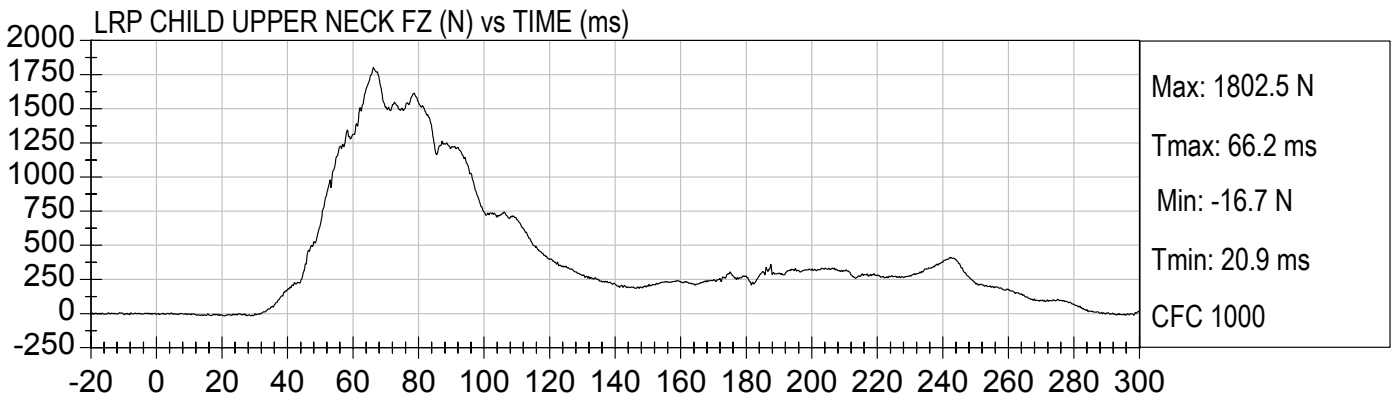
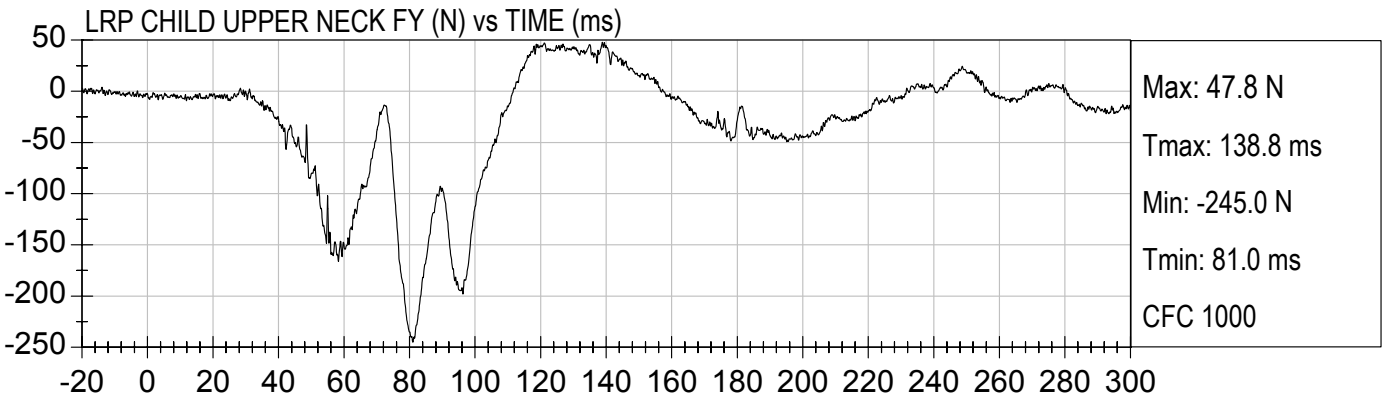
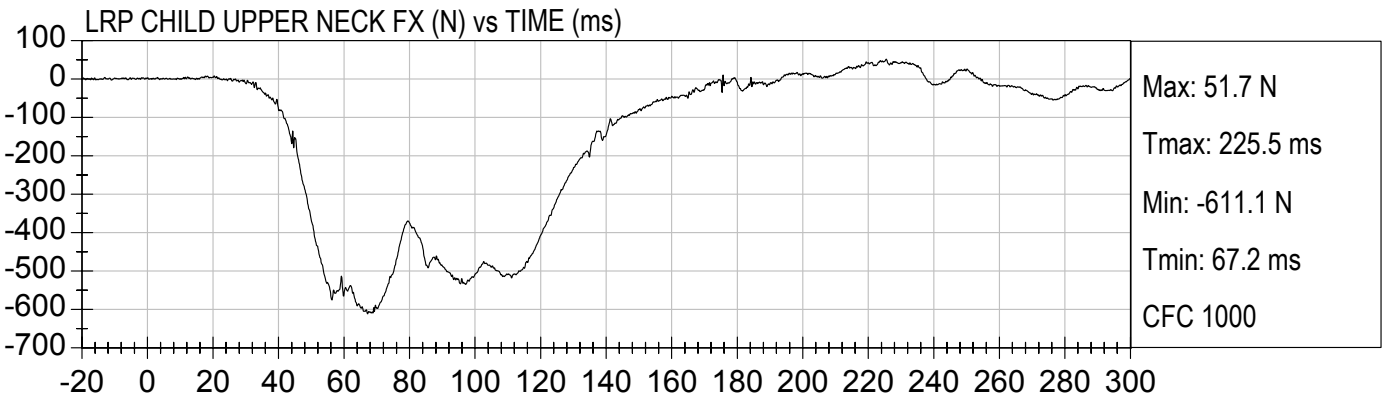

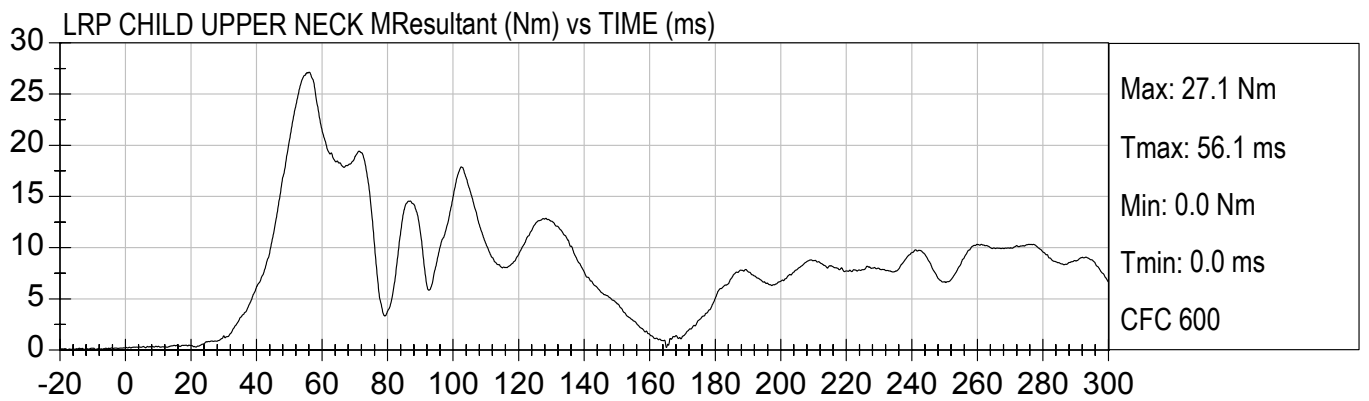
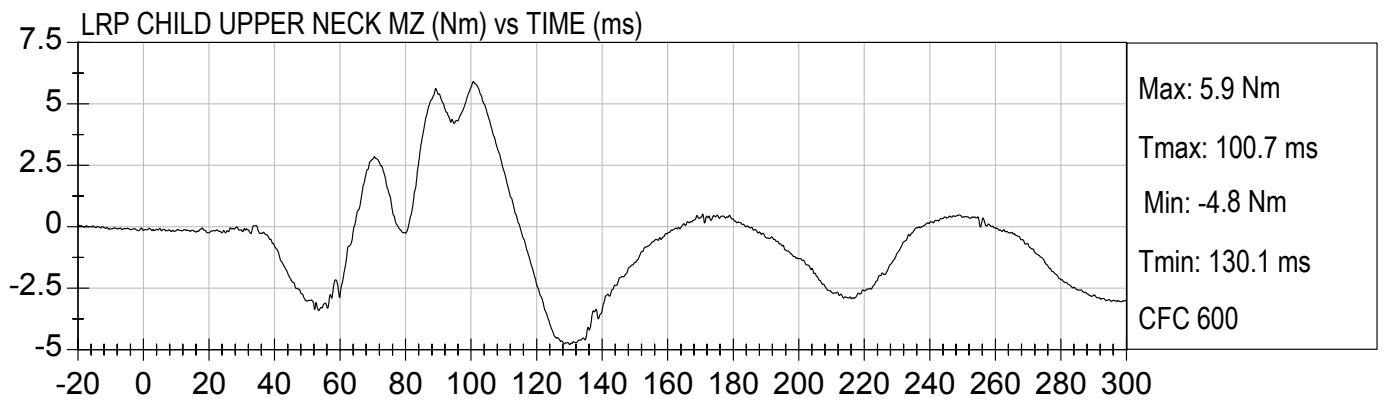
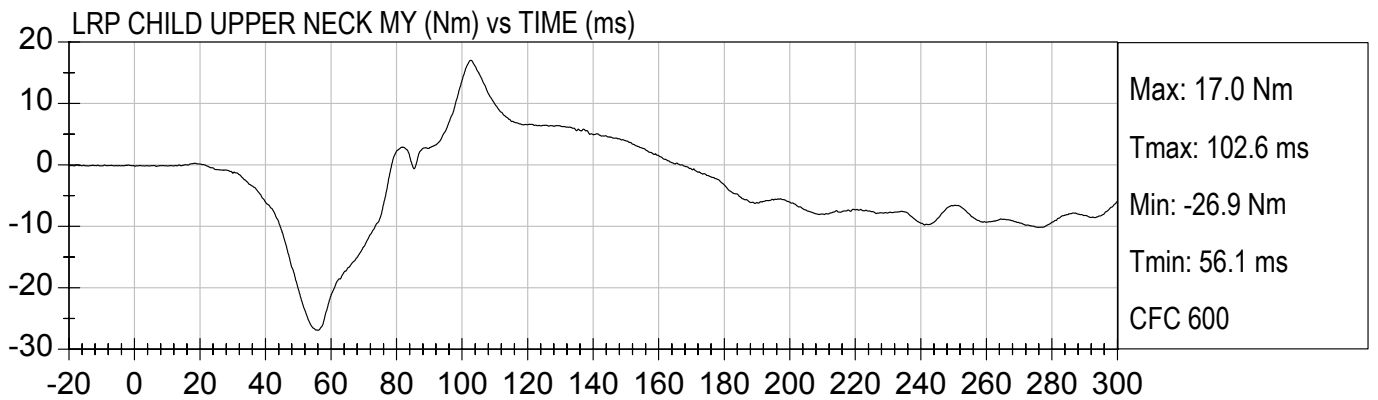
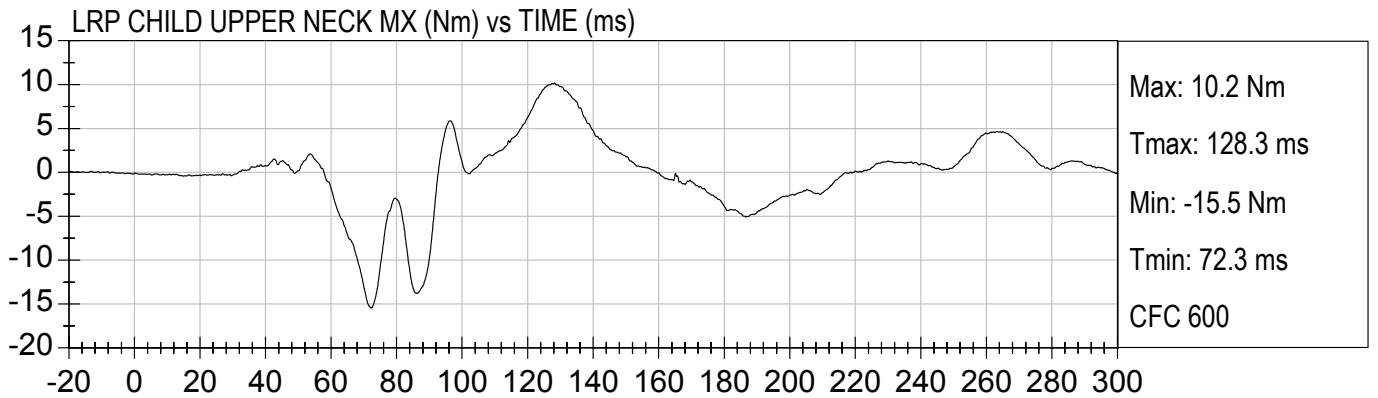

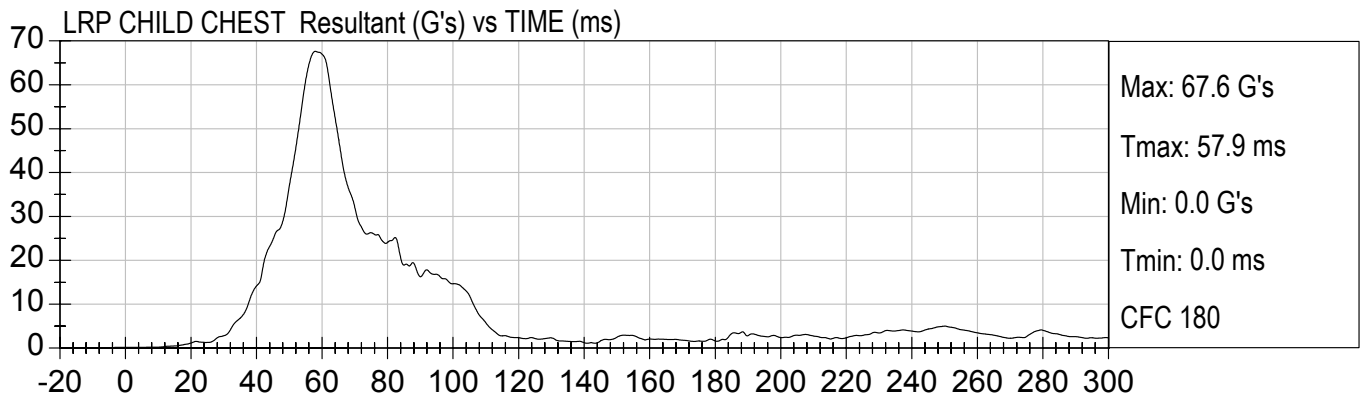
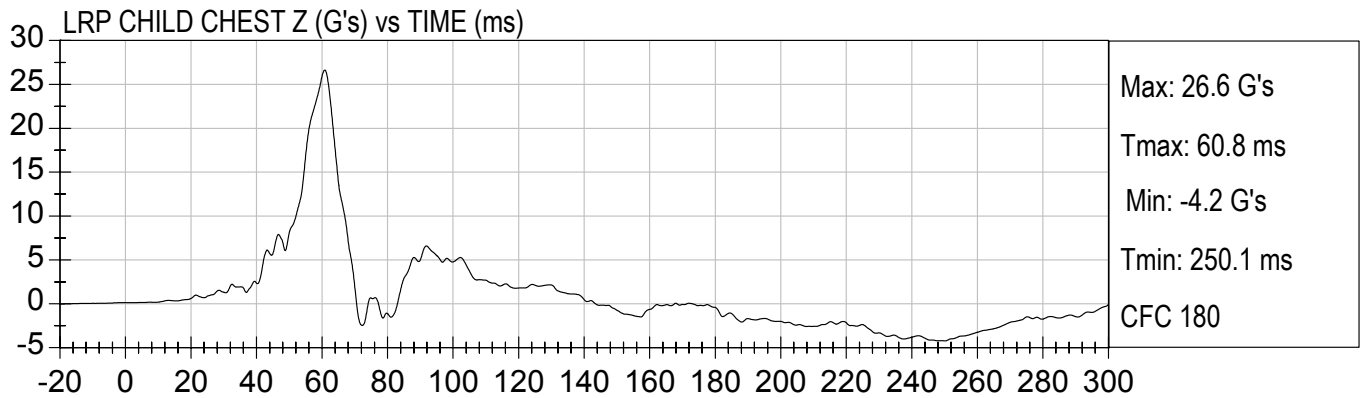
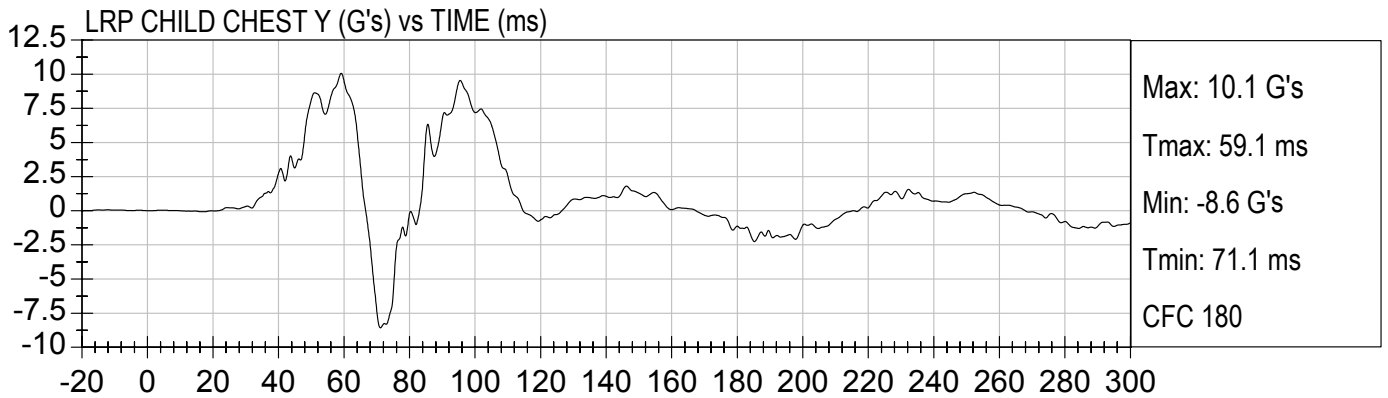
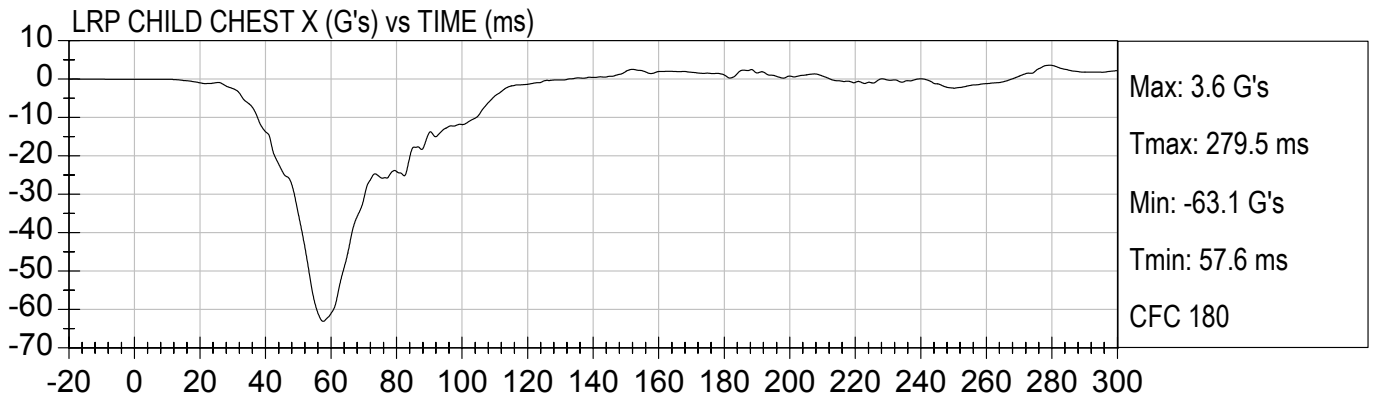

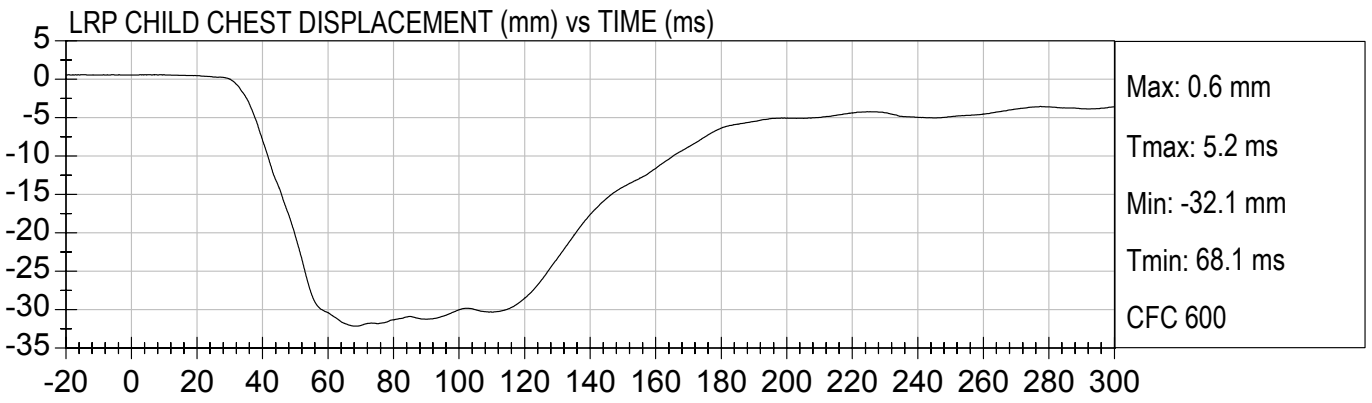
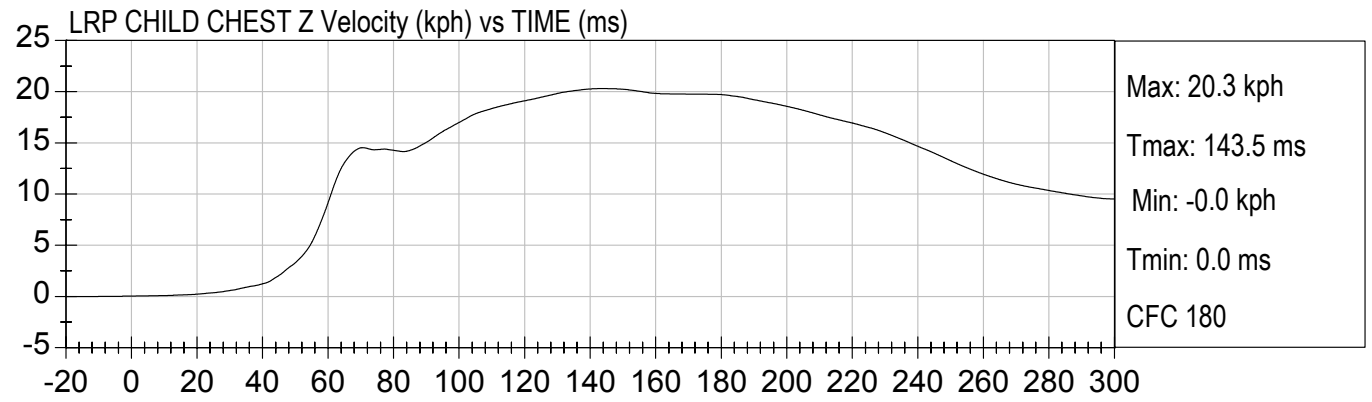
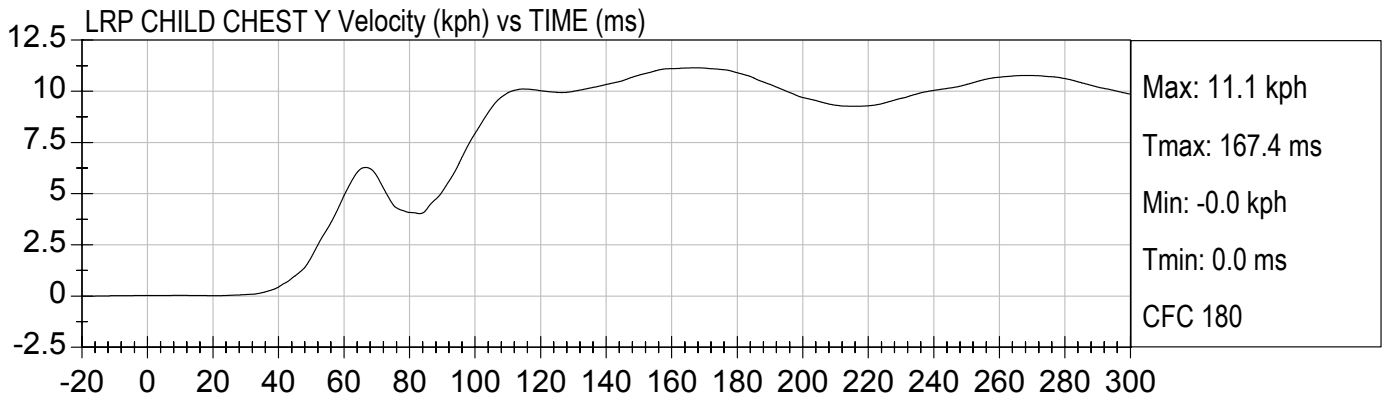
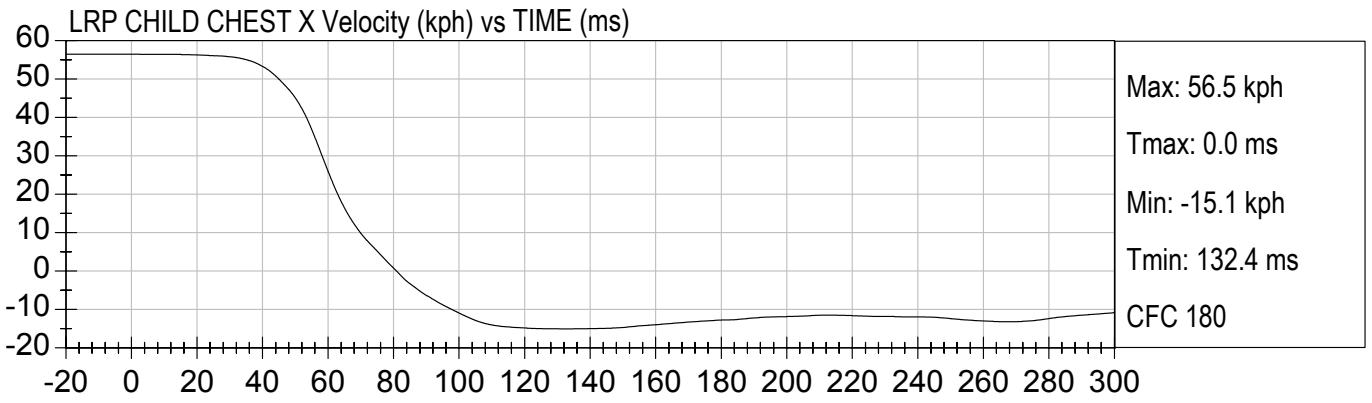

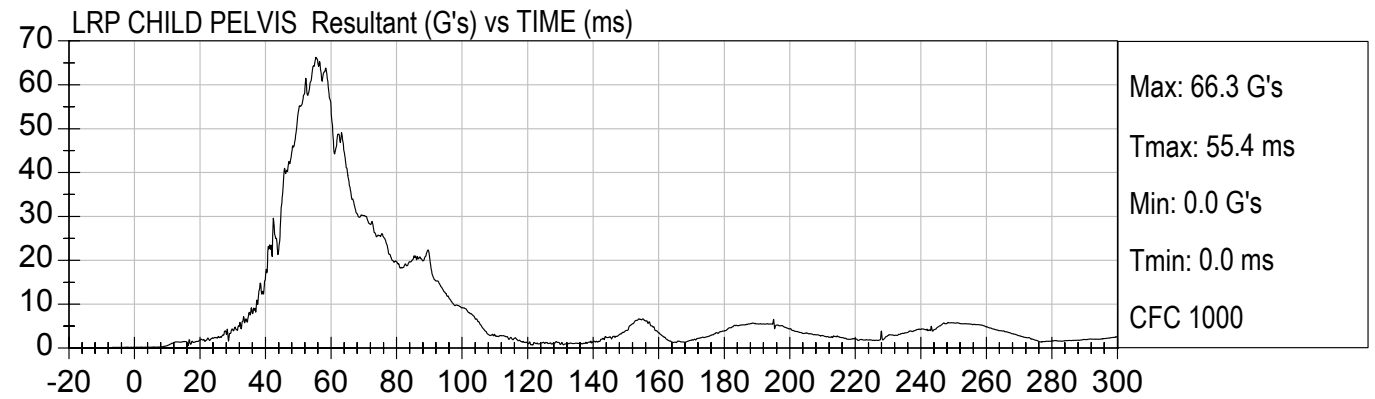
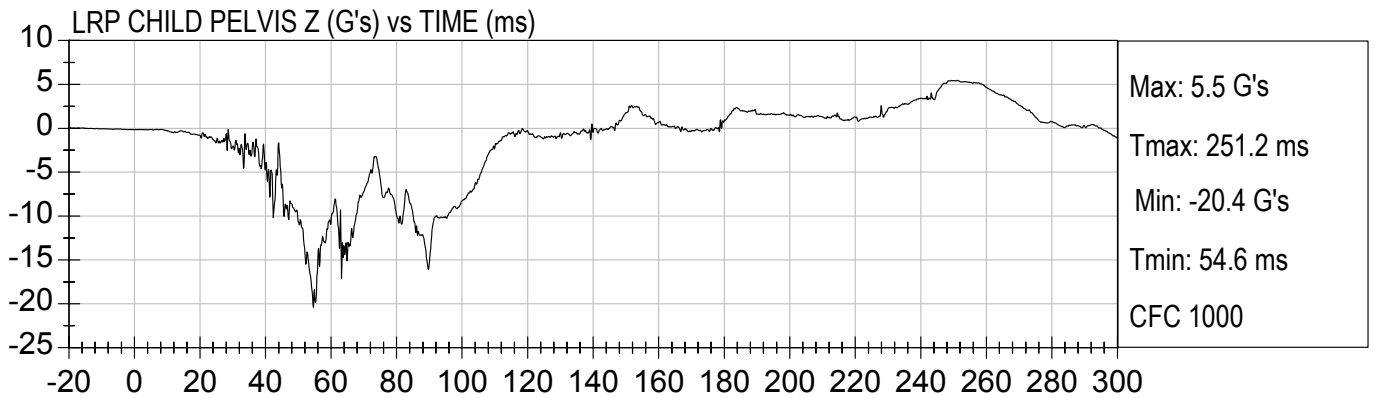
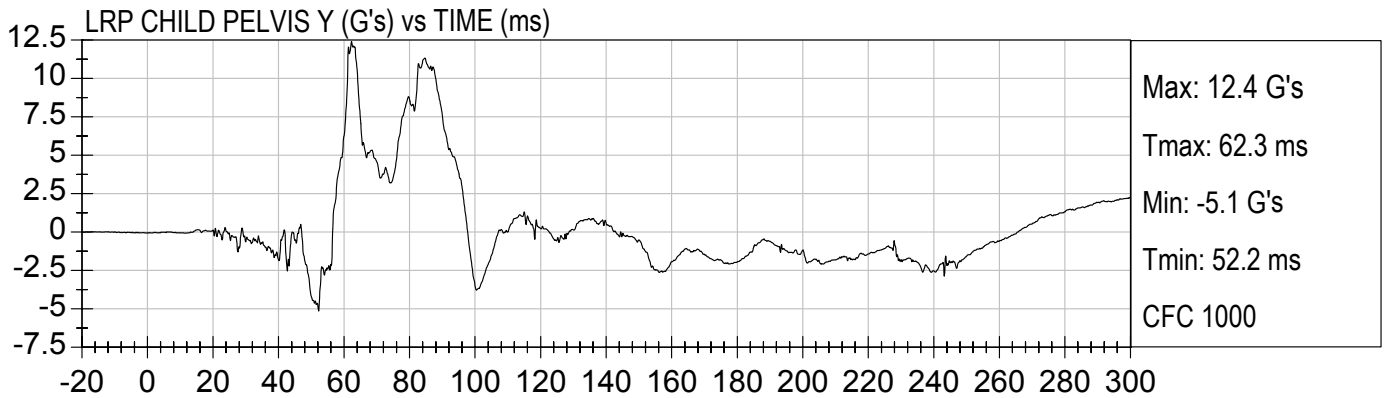
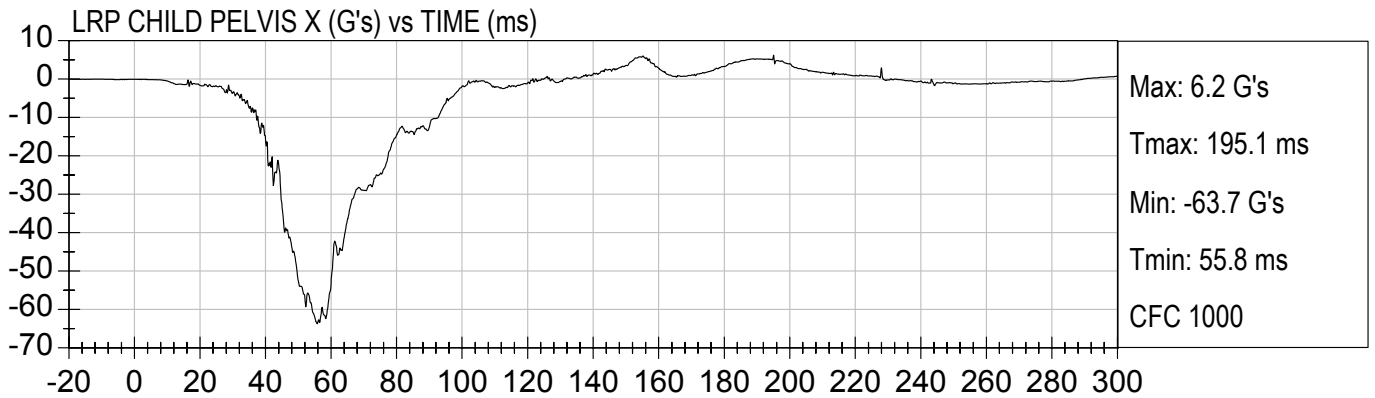

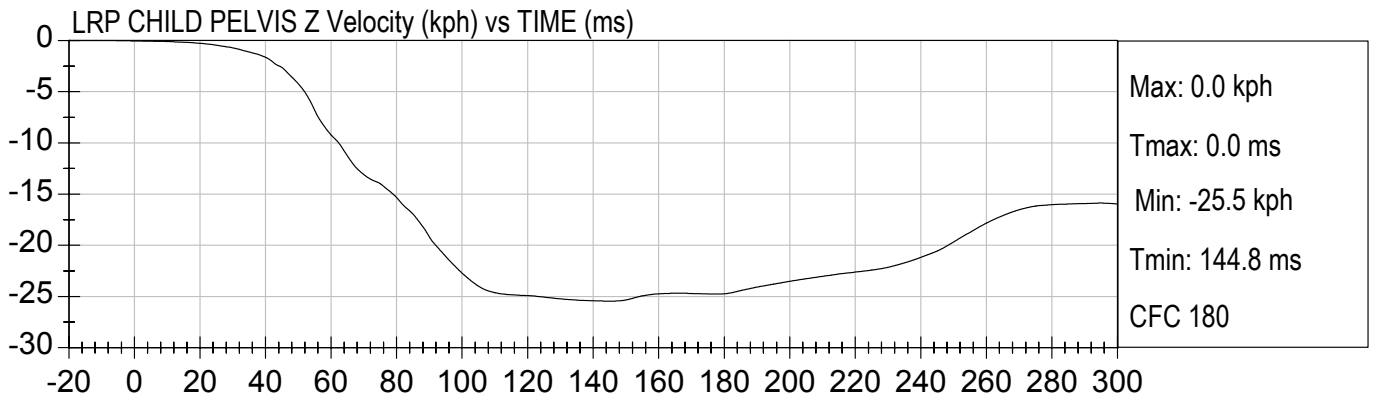
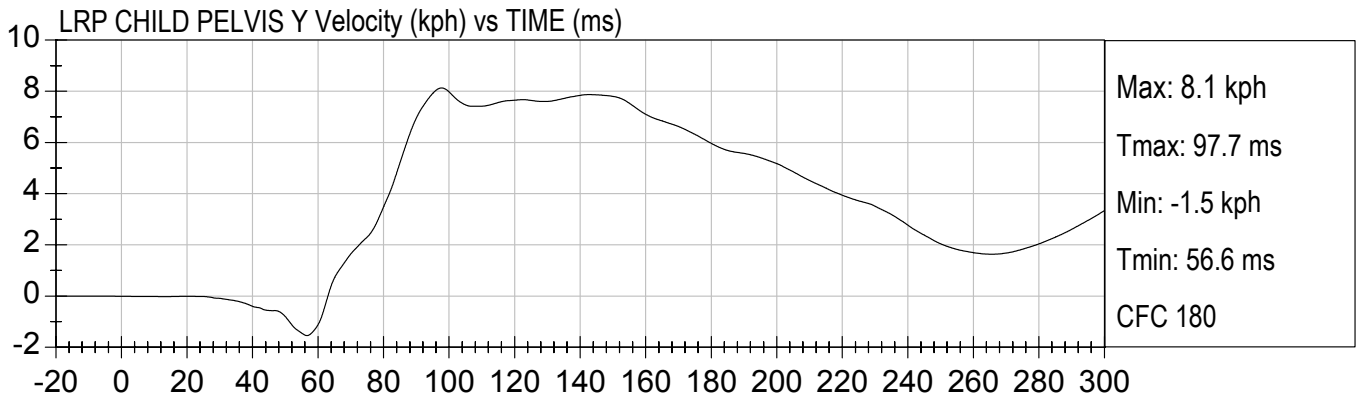
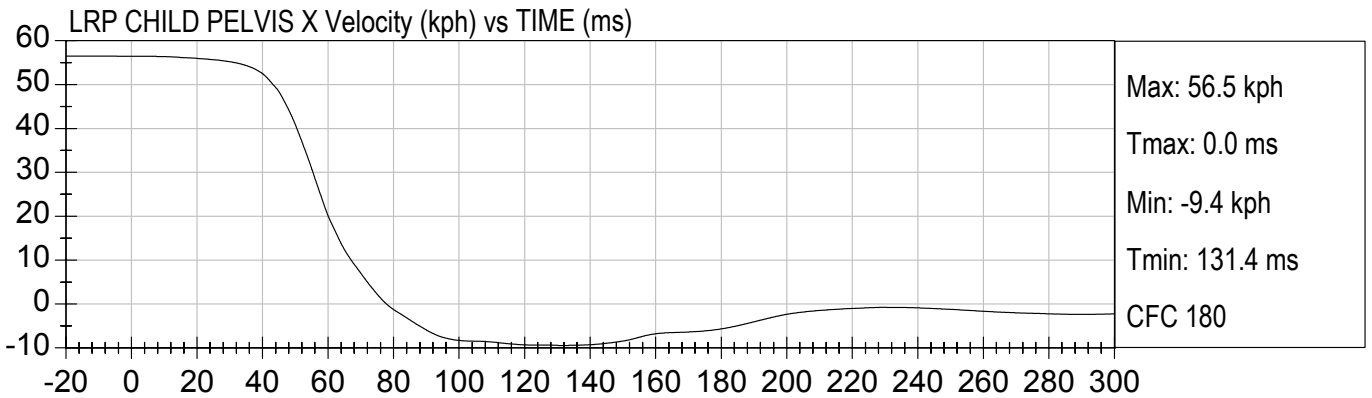



LRP CHILD RIGHT FEMUR (N) vs TIME (ms)

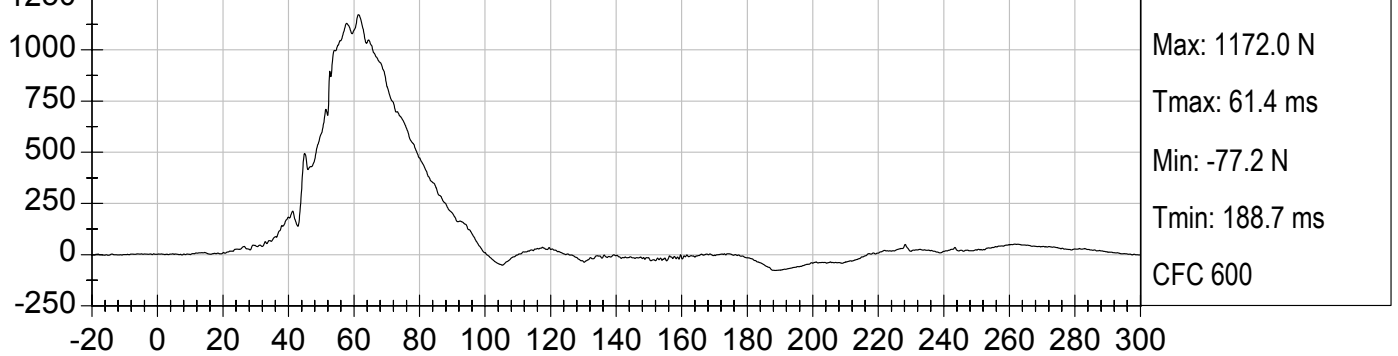

LRP CHILD LEFT FEMUR (N) vs TIME (ms)

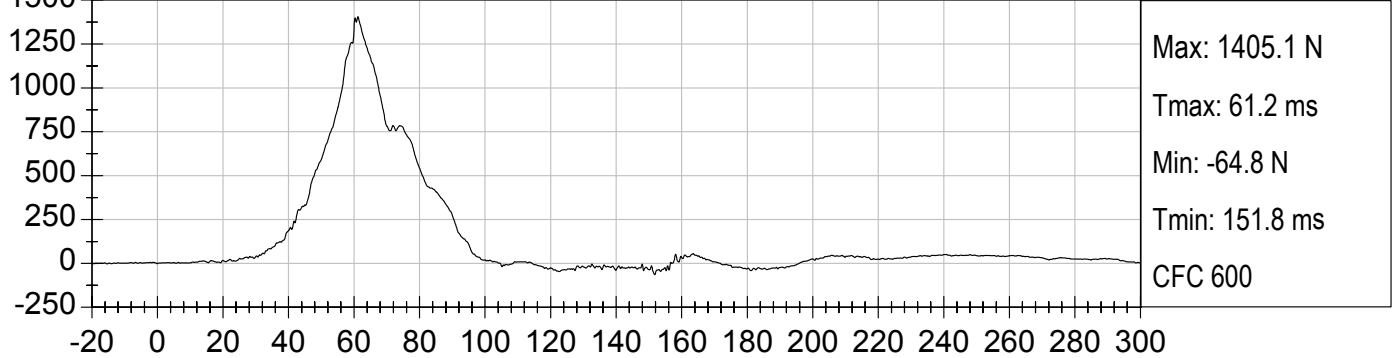

LRP CHILD SHOULDER BELT (N) vs TIME (ms)

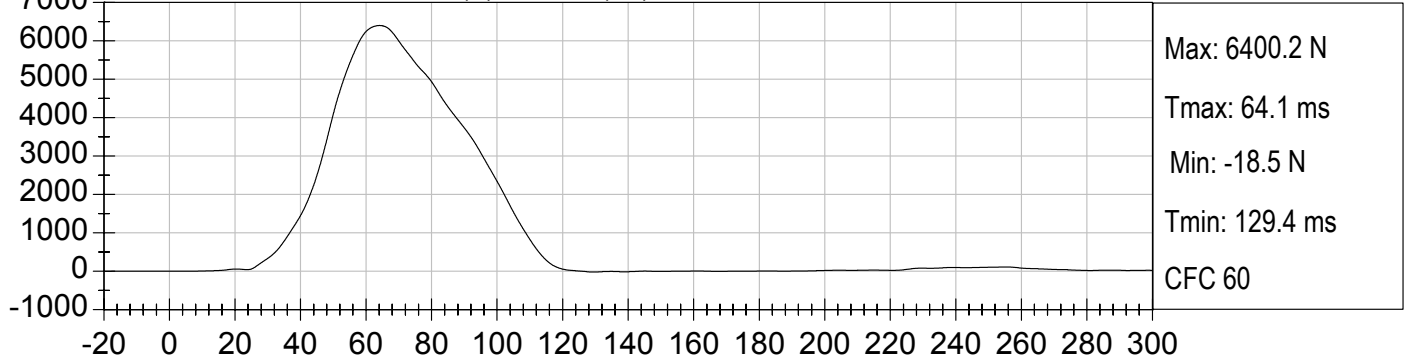

LRP CHILD LAP BELT (N) vs TIME (ms)

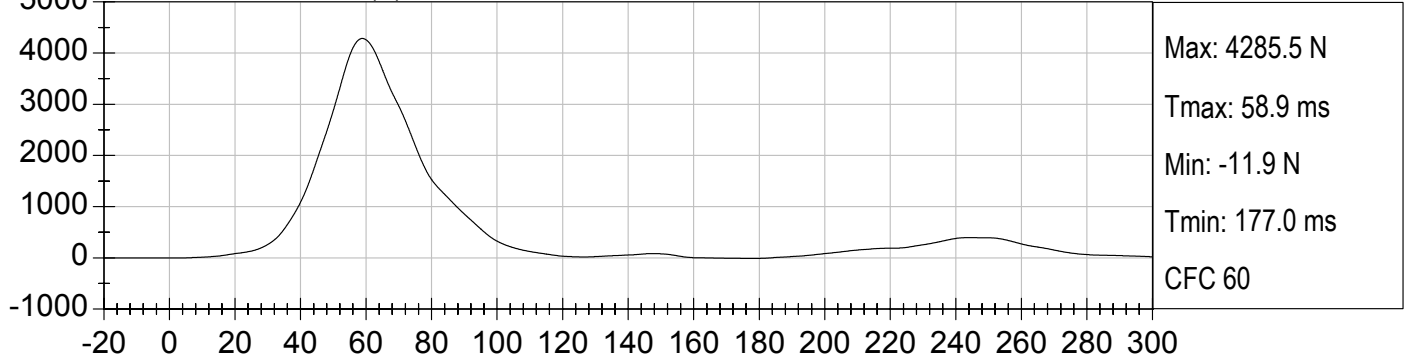

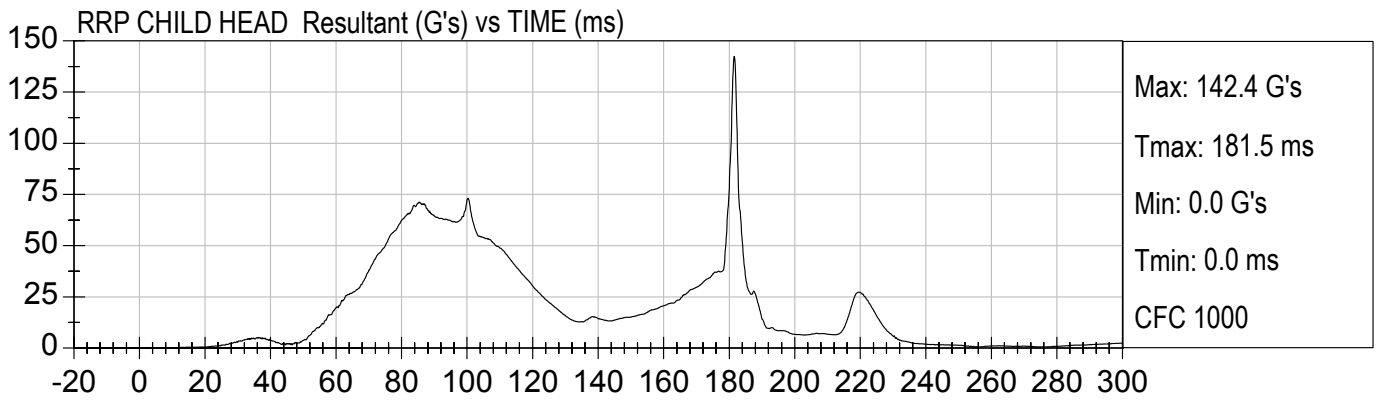
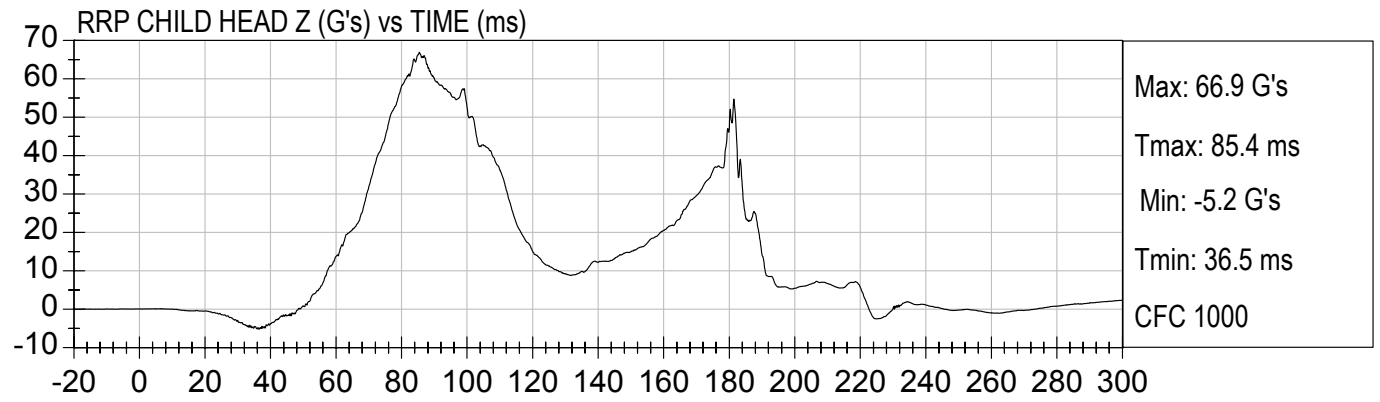
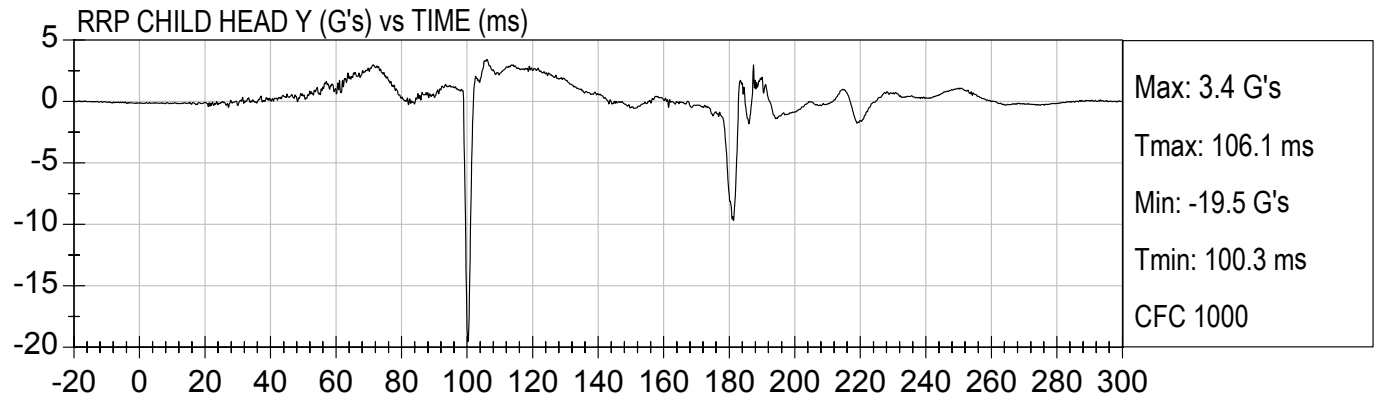
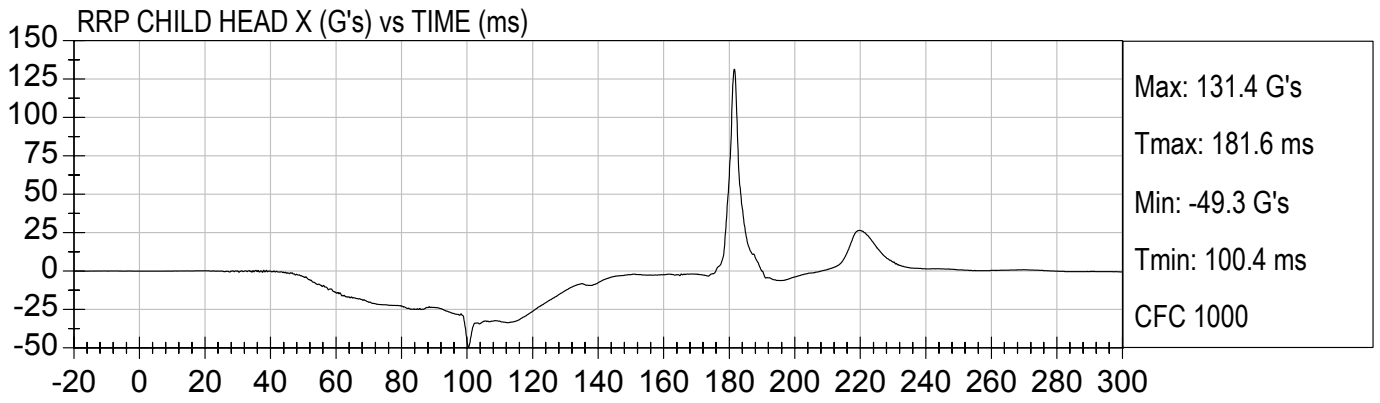

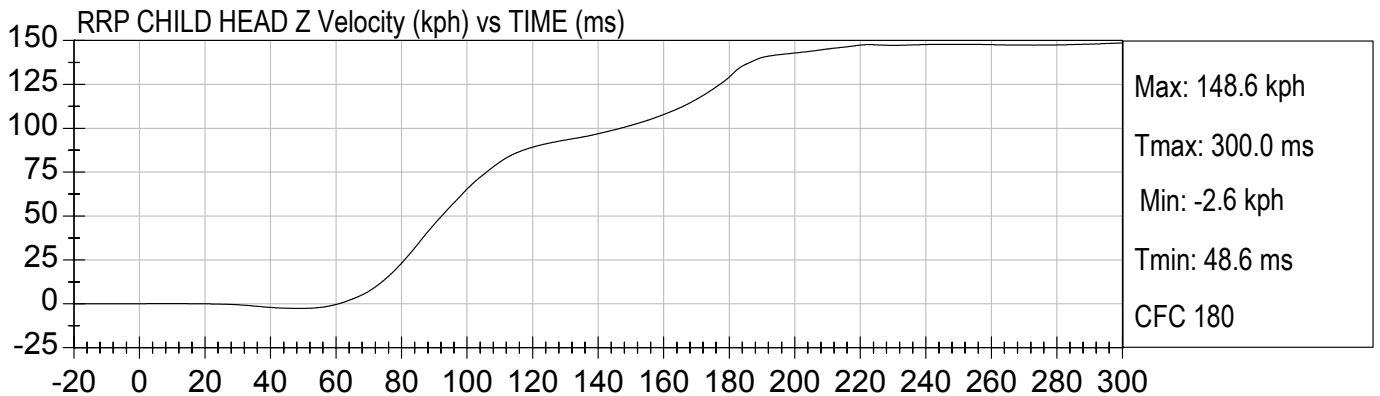
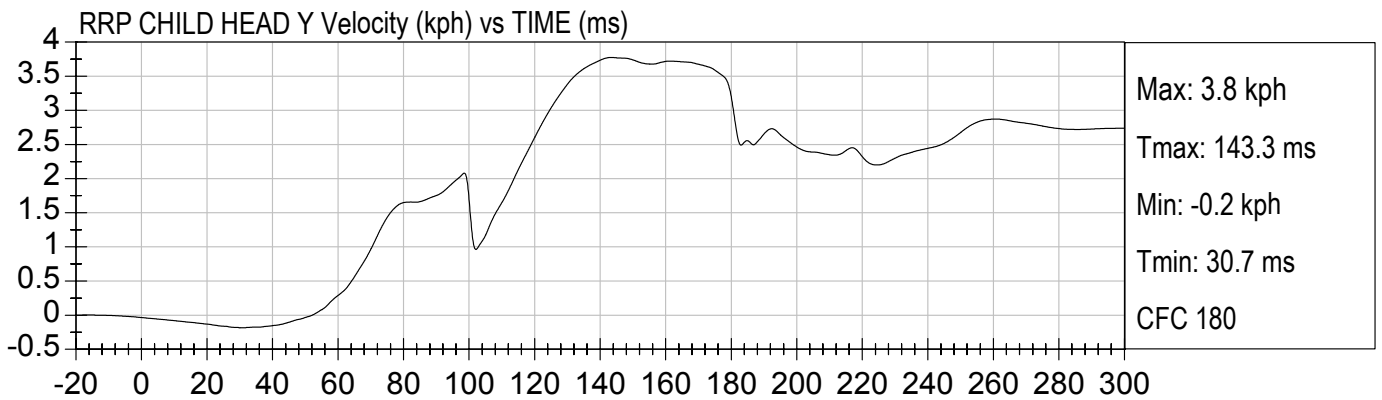
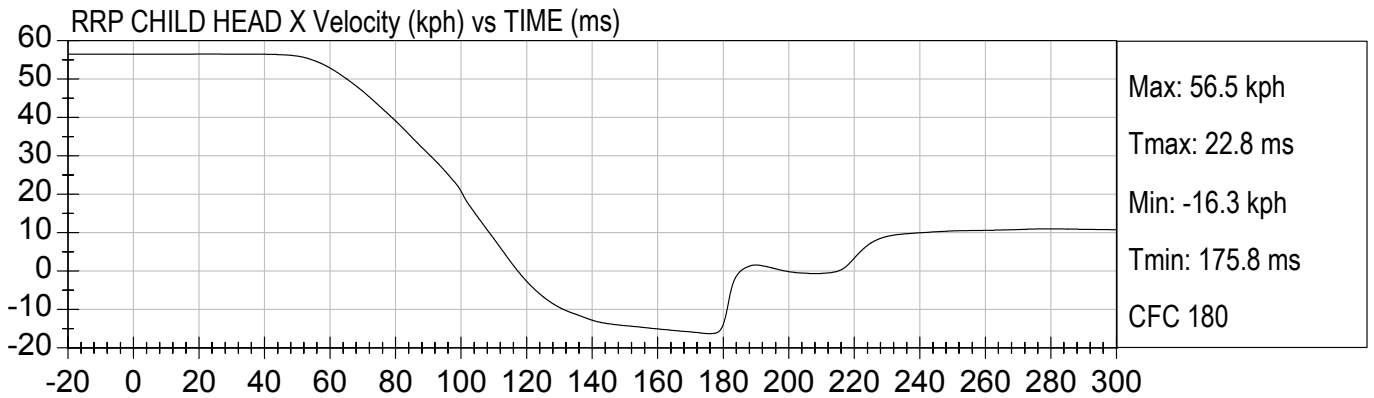

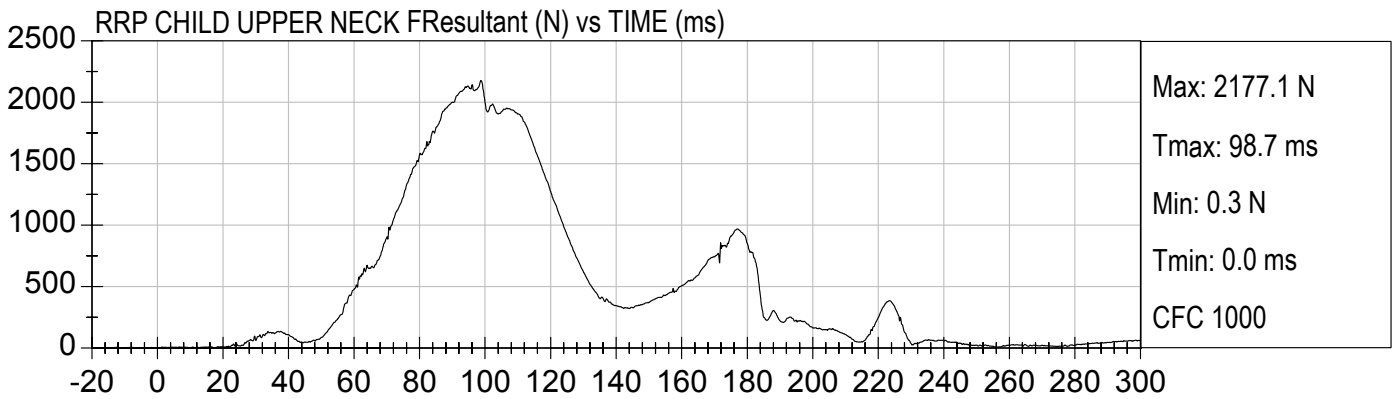
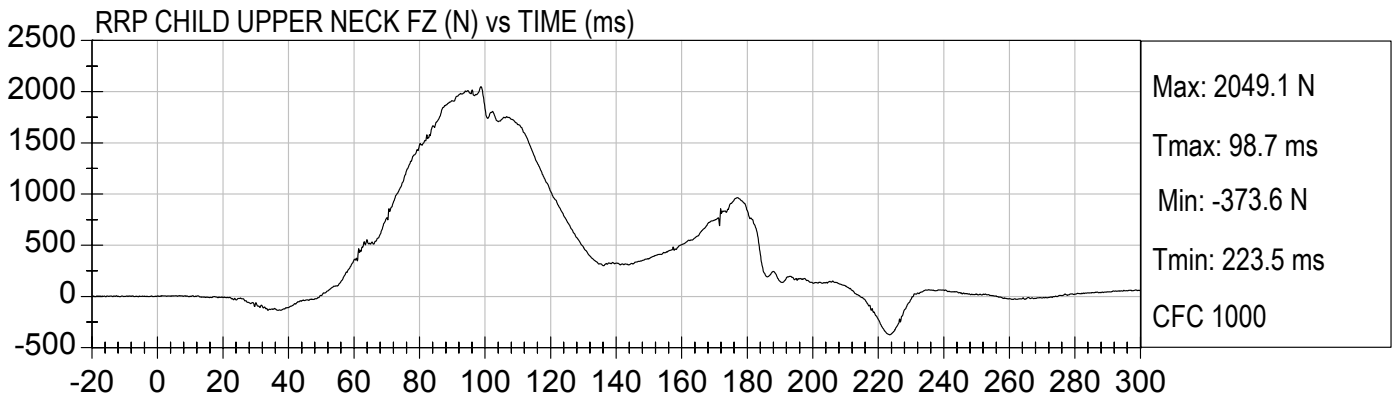
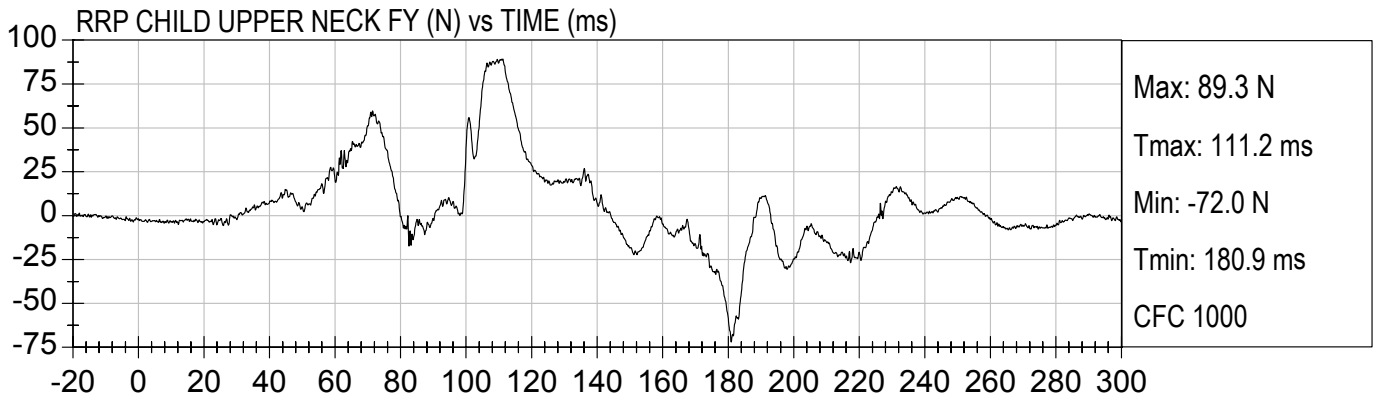
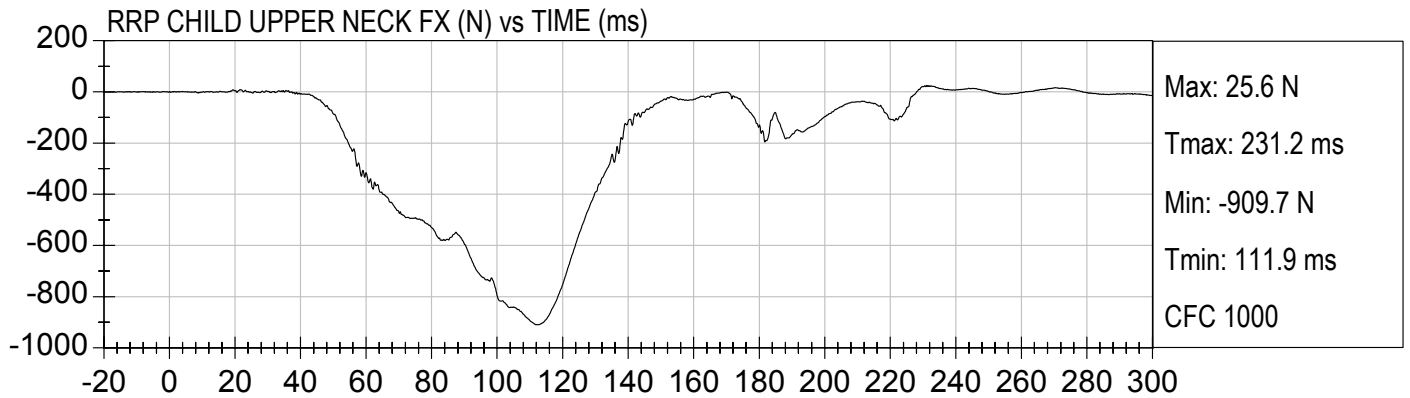



RRP CHILD UPPER NECK MX (Nm) vs TIME (ms)

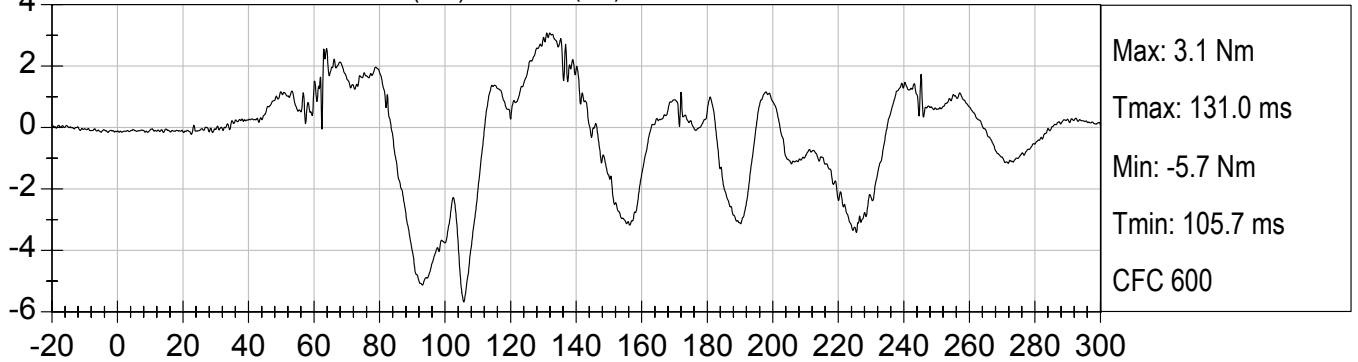

RRP CHILD UPPER NECK MY (Nm) vs TIME (ms)

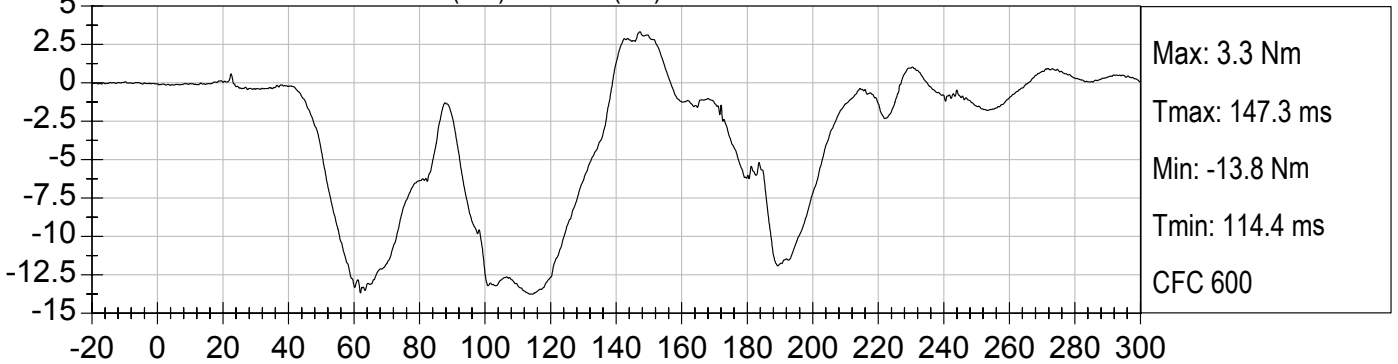

RRP CHILD UPPER NECK MZ (Nm) vs TIME (ms)

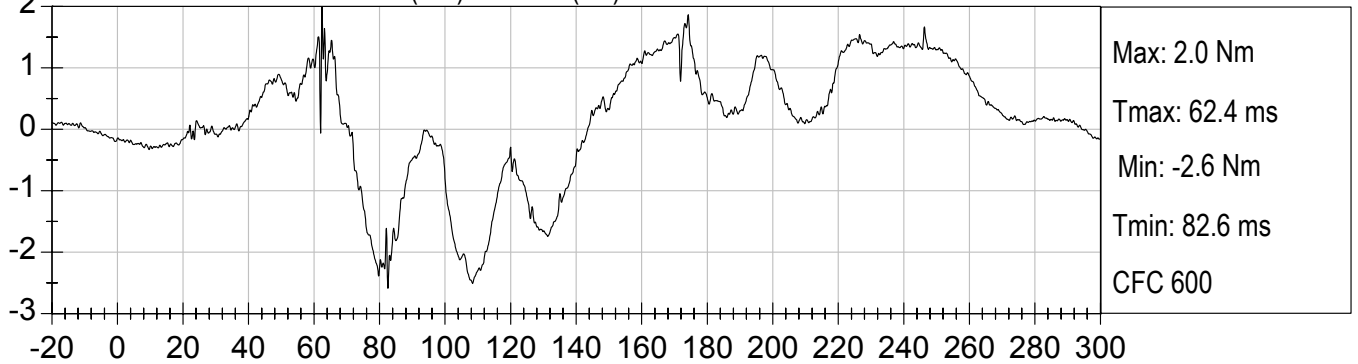

RRP CHILD UPPER NECK MResultant (Nm) vs TIME (ms)

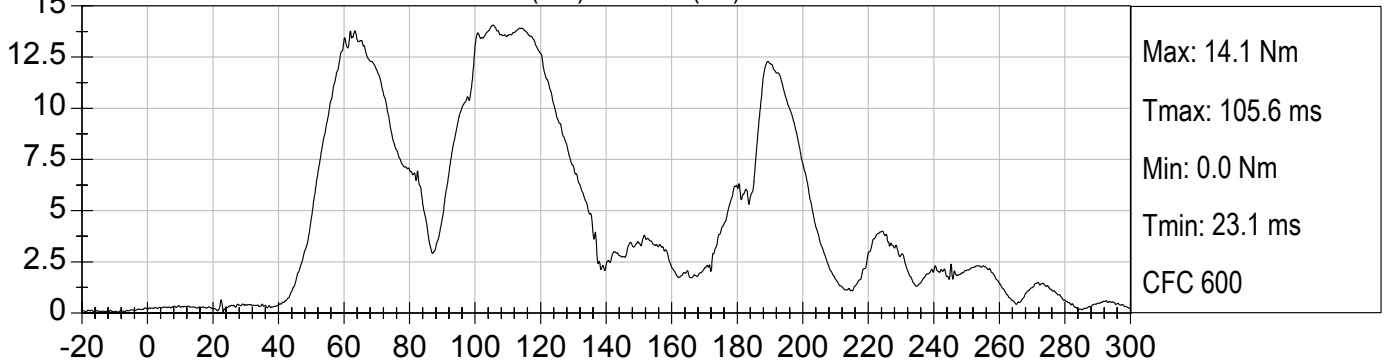

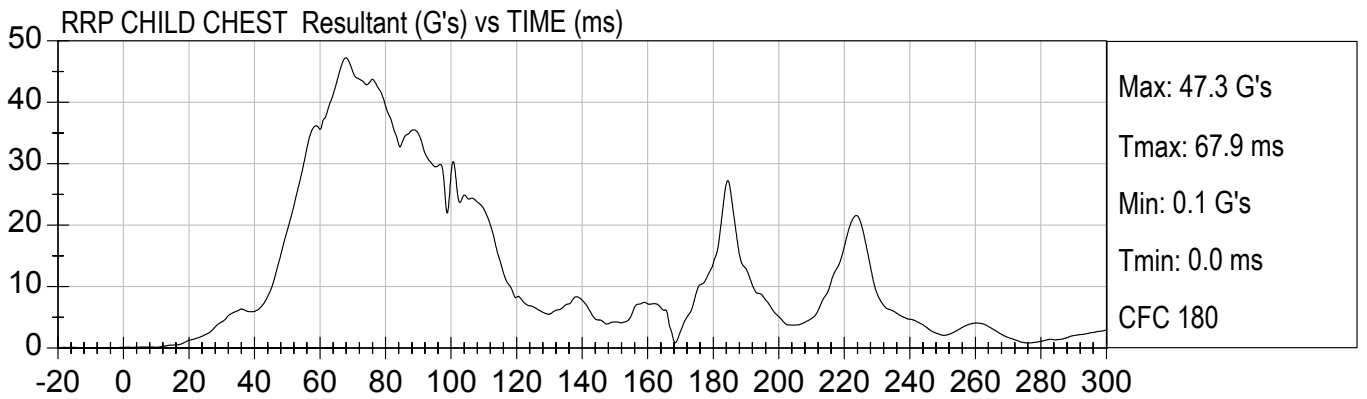
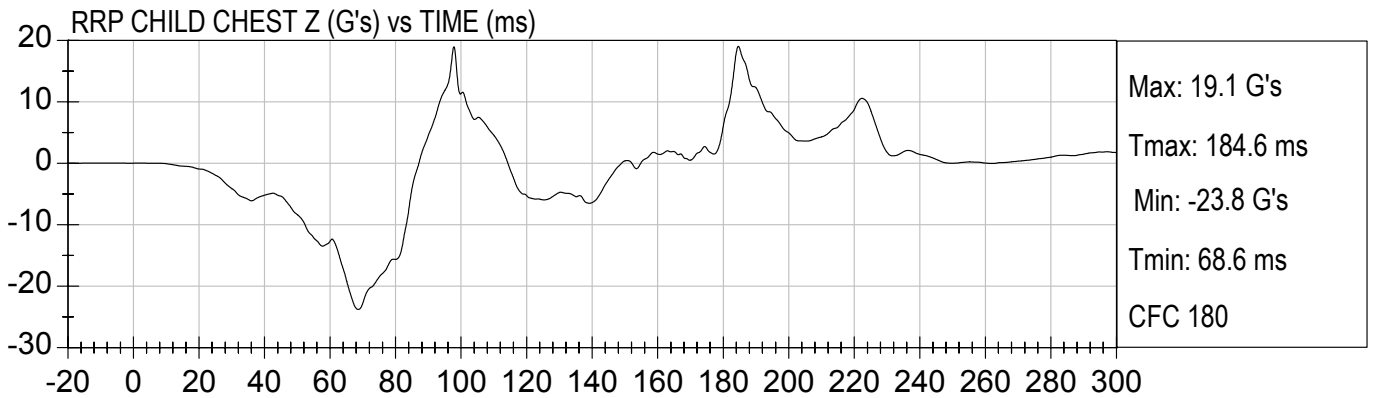
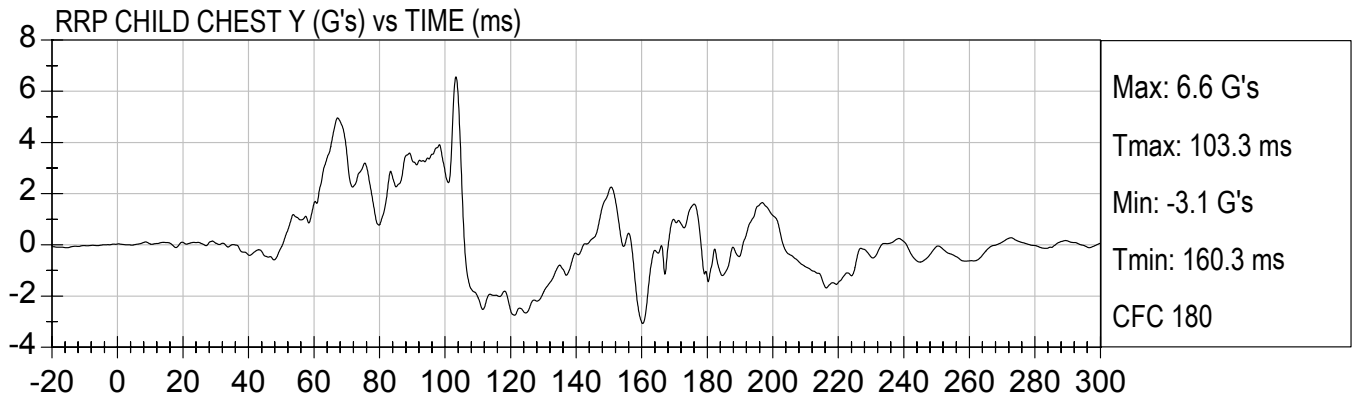
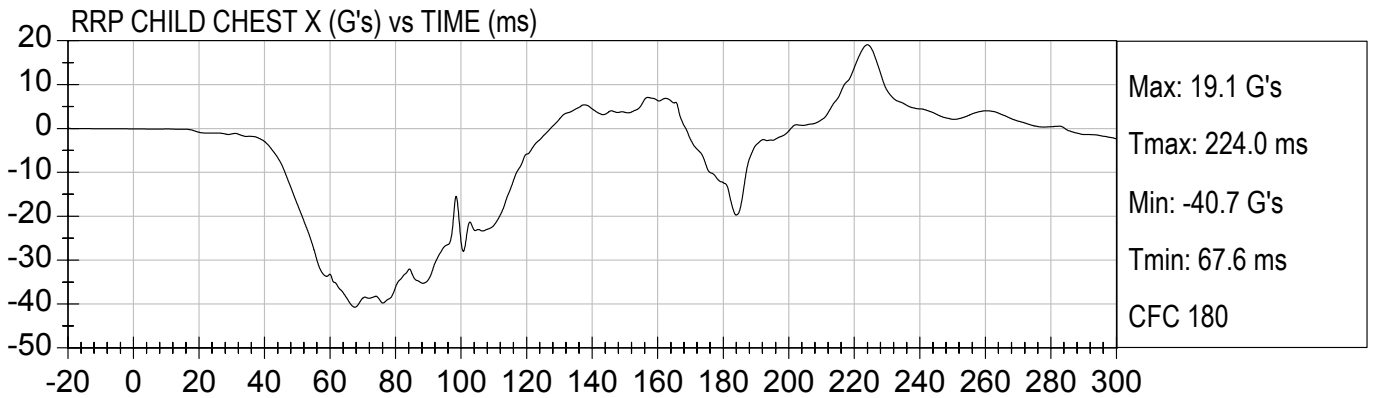

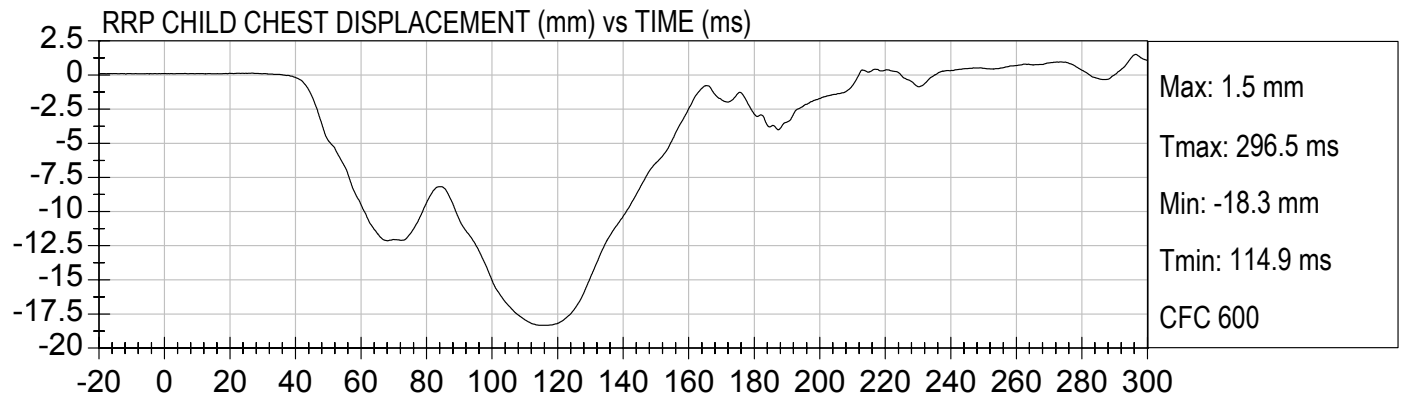
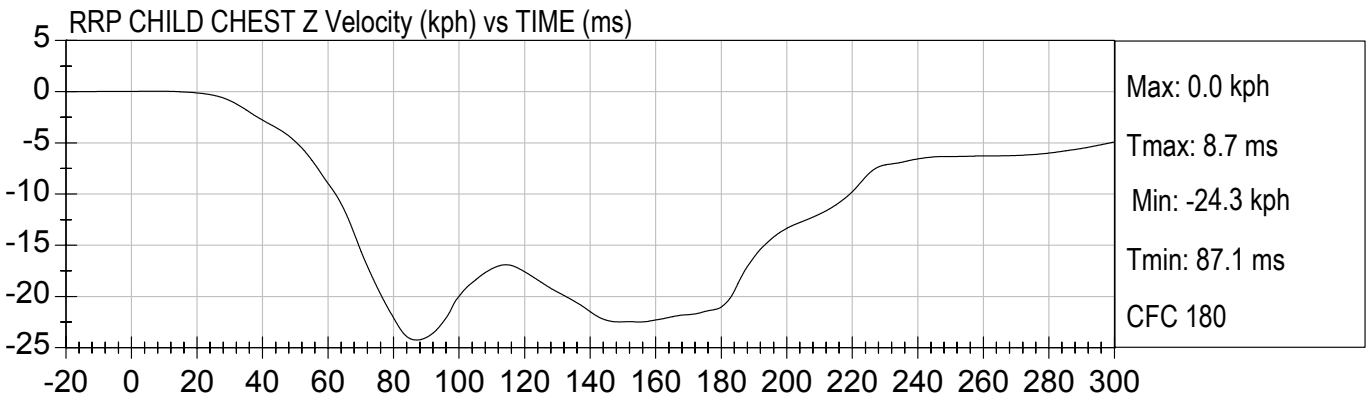
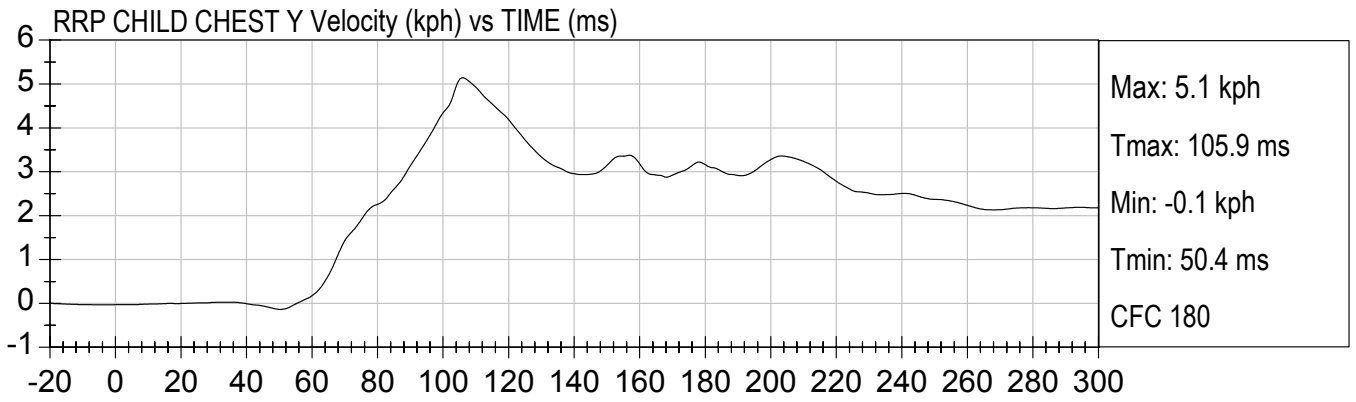
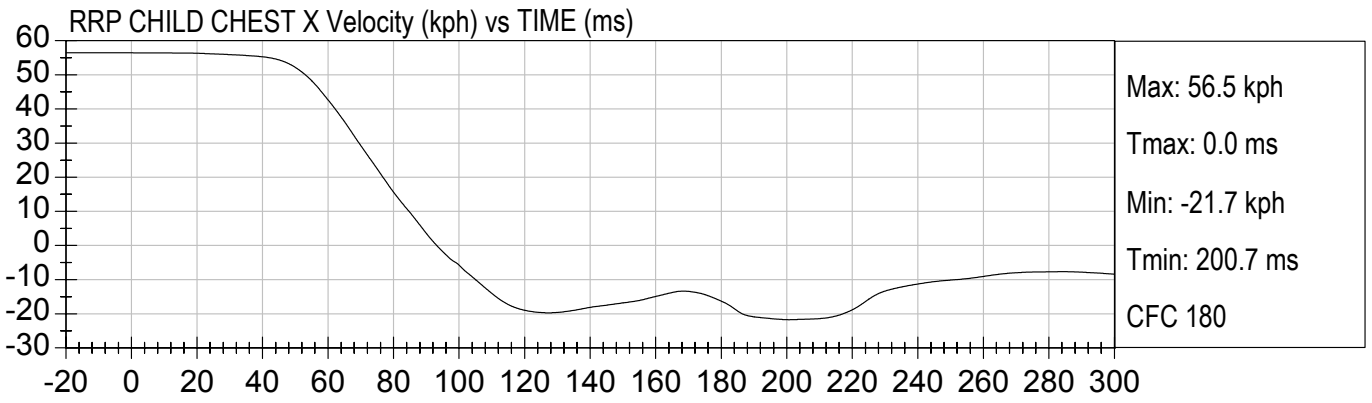

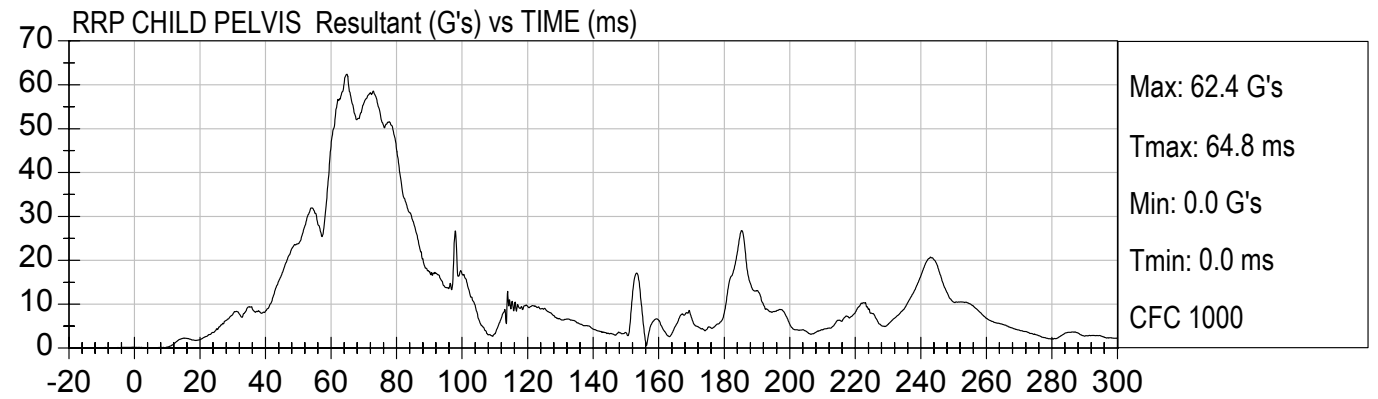
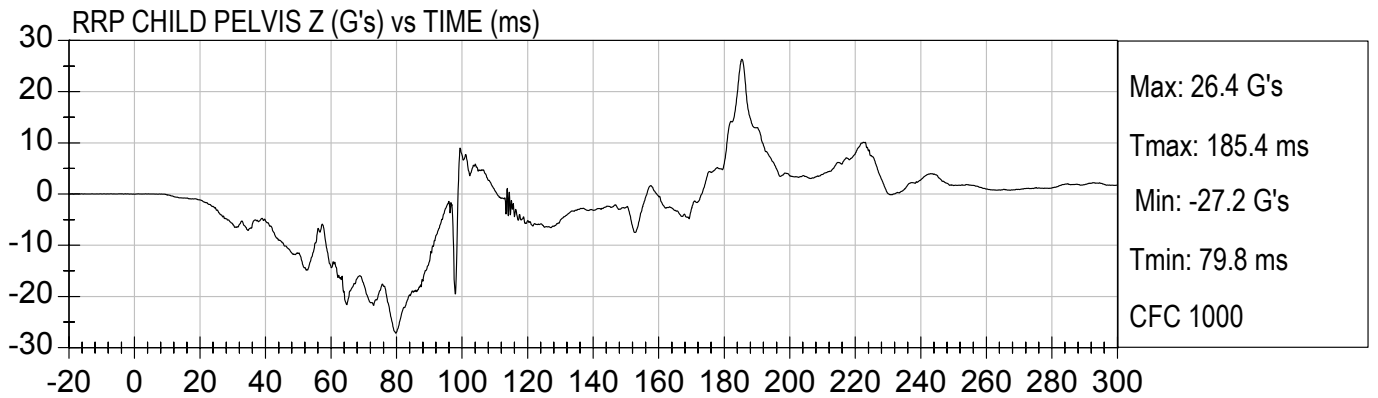
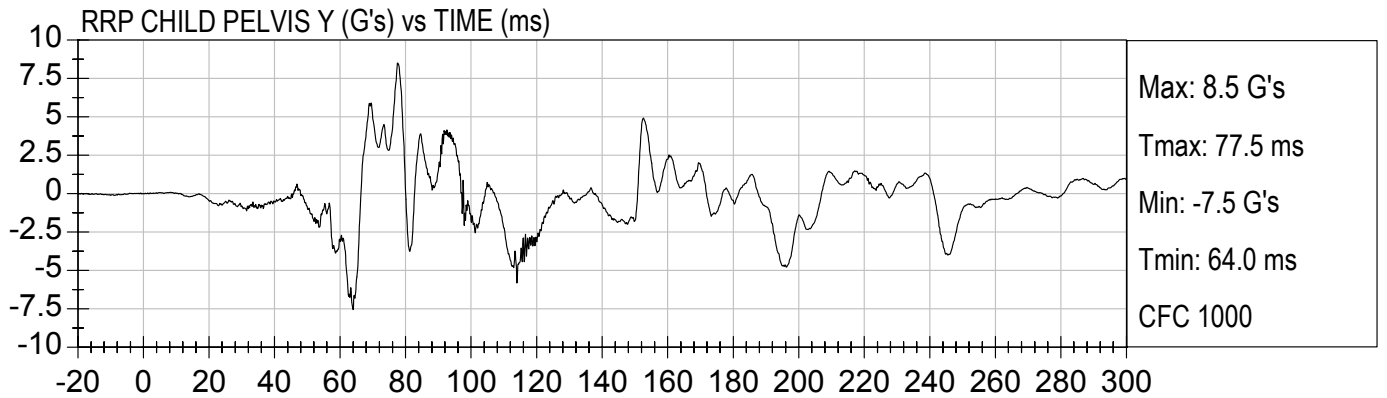
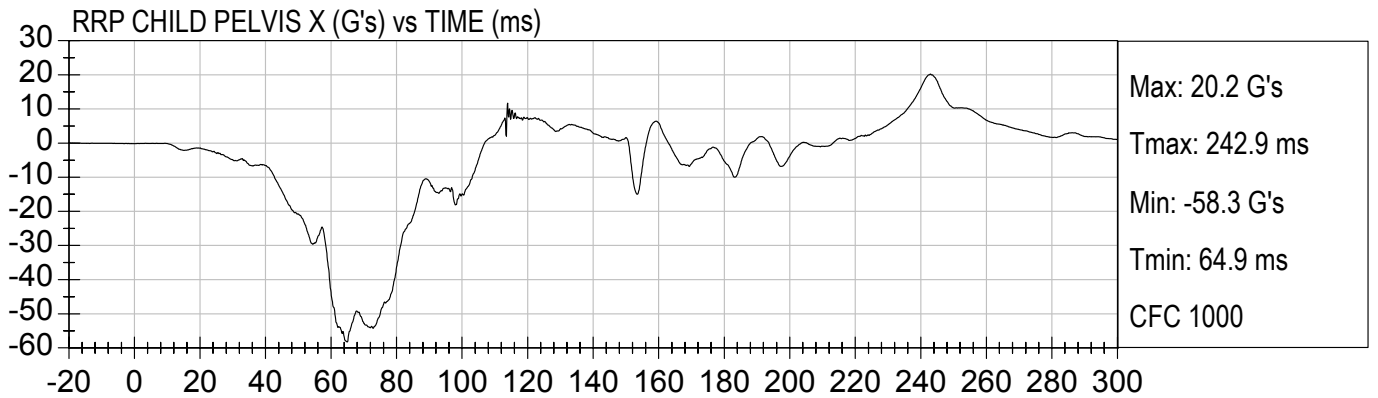

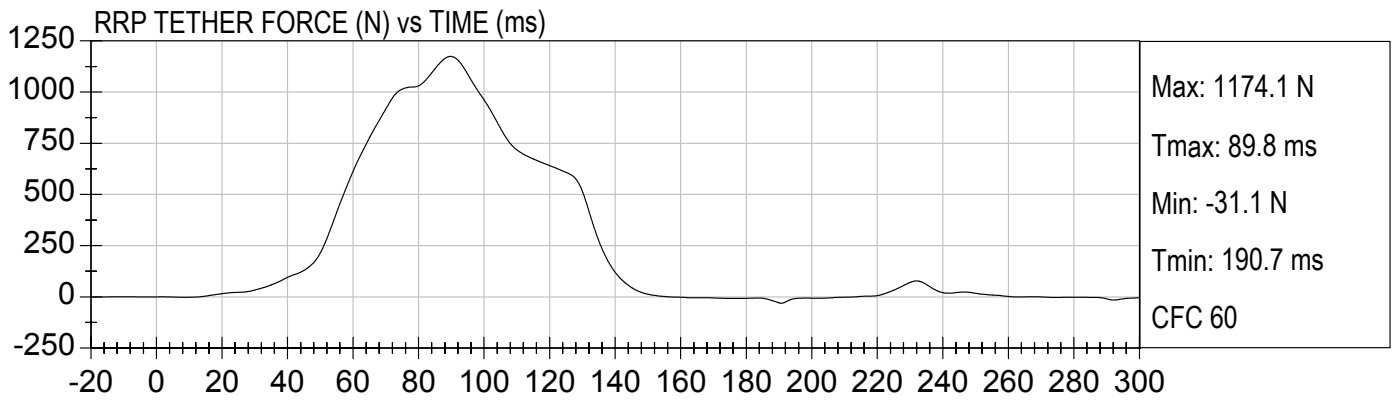
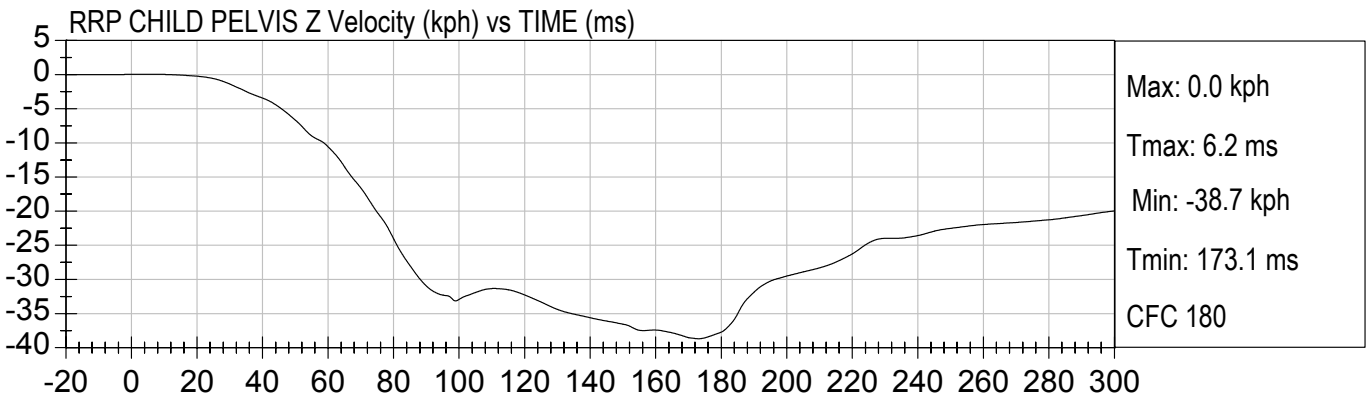
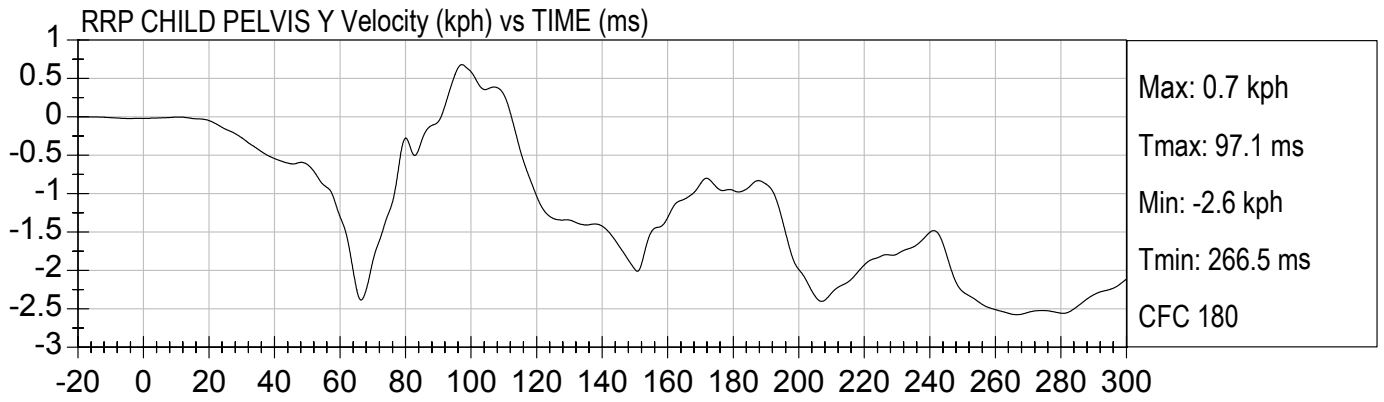
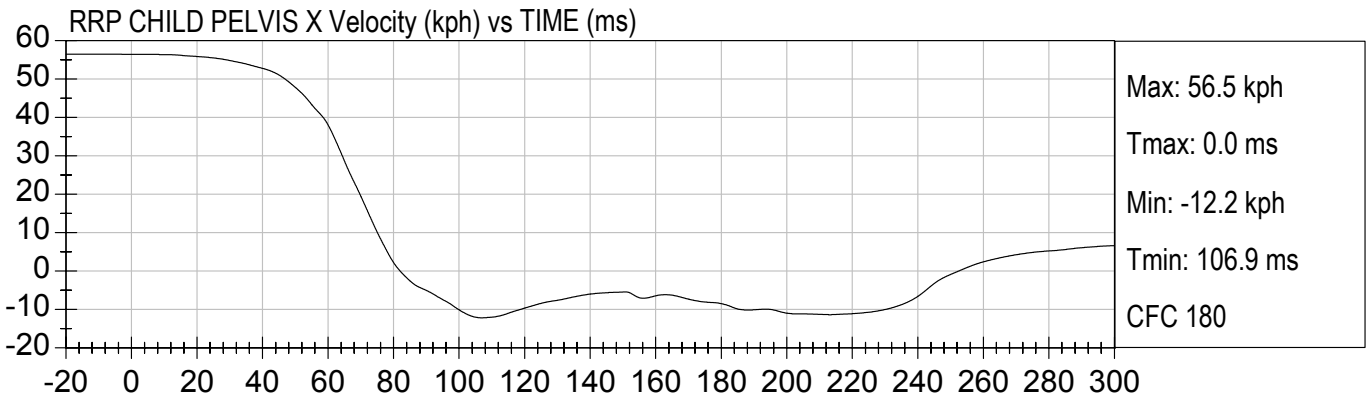

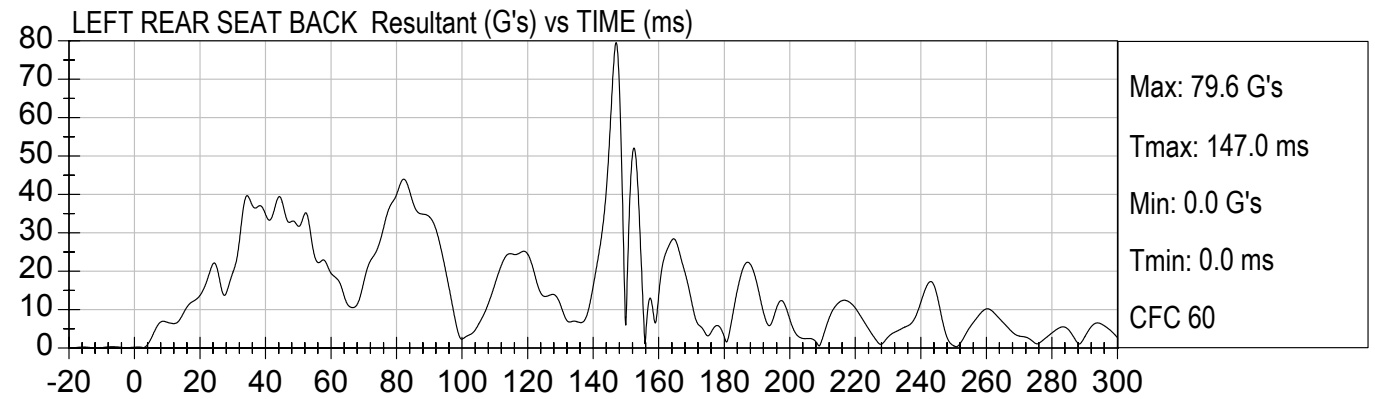
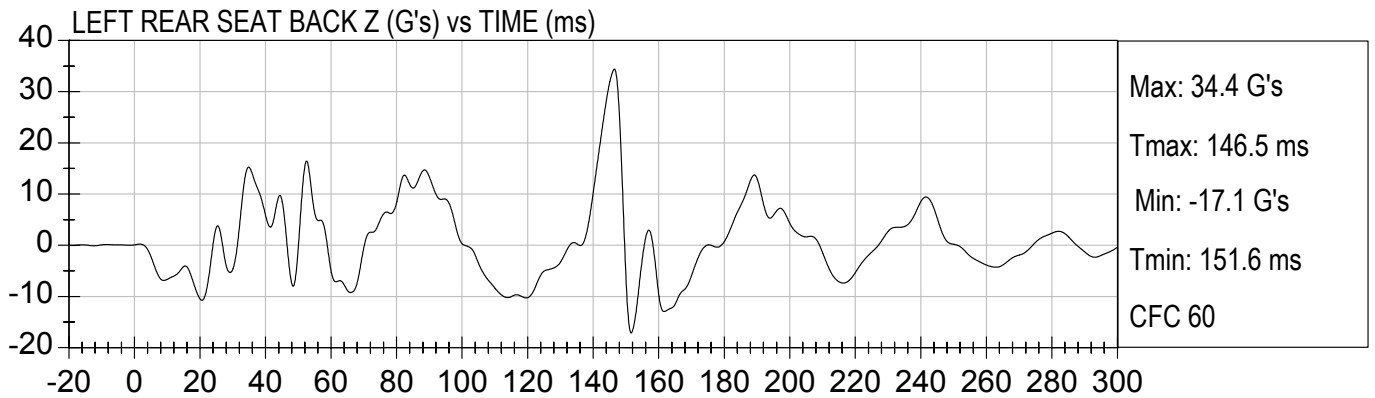
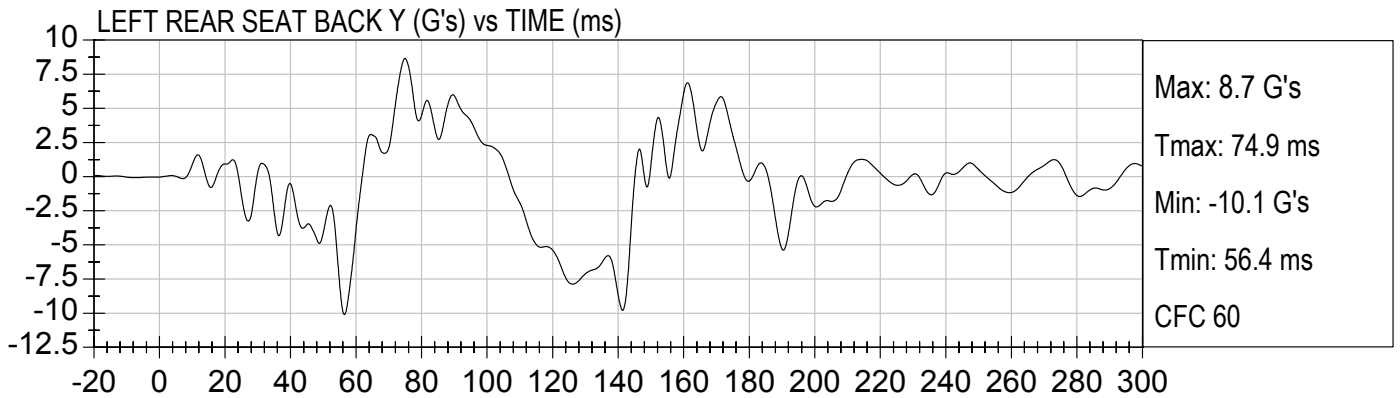
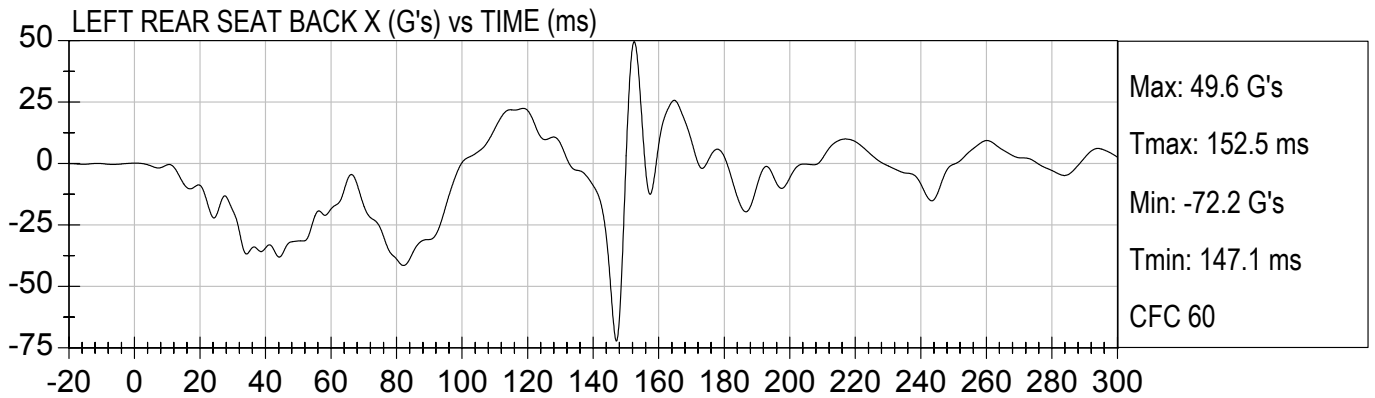

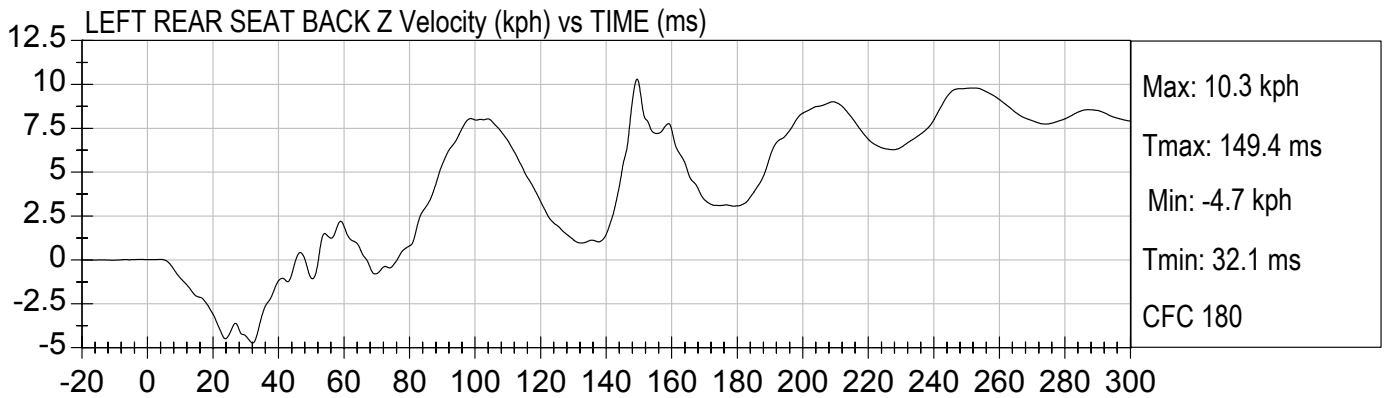
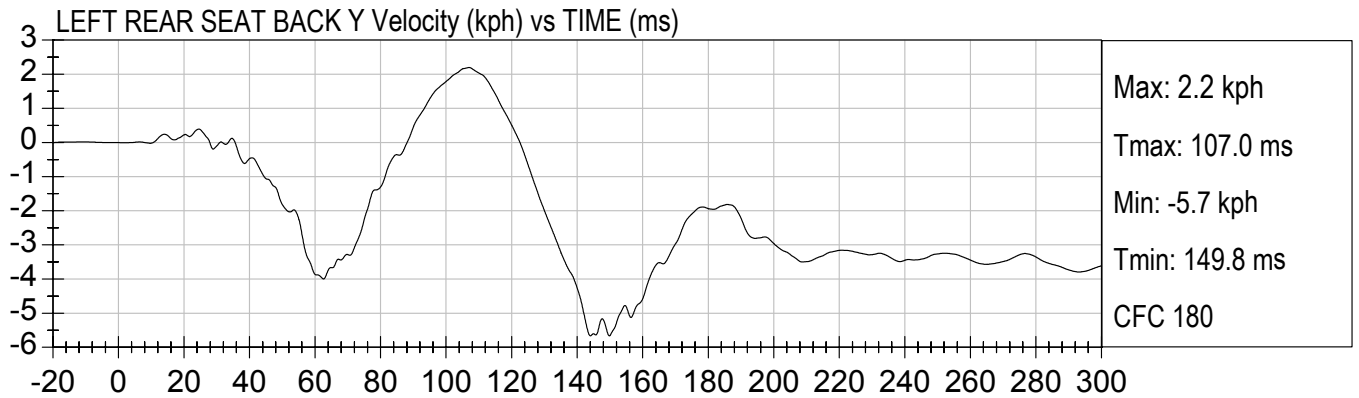
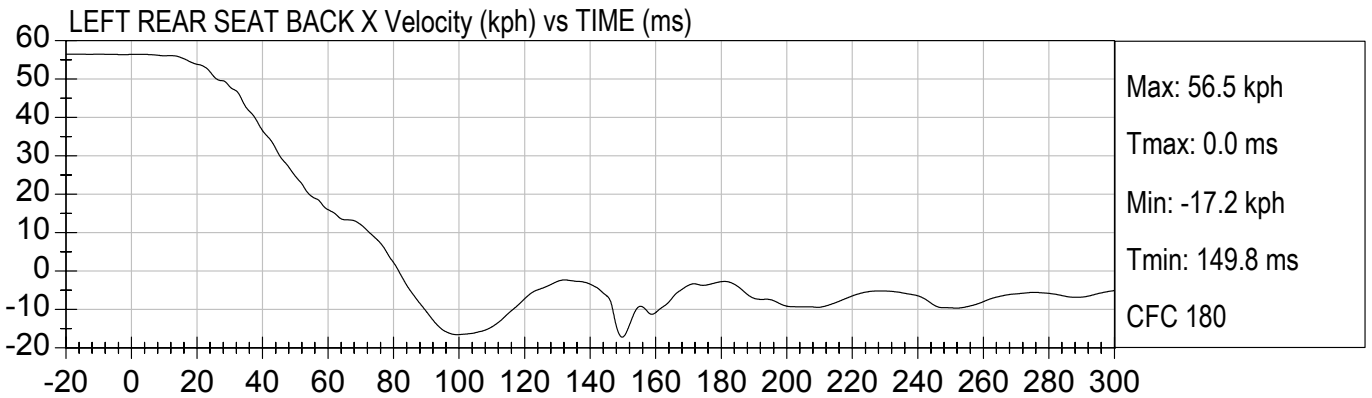

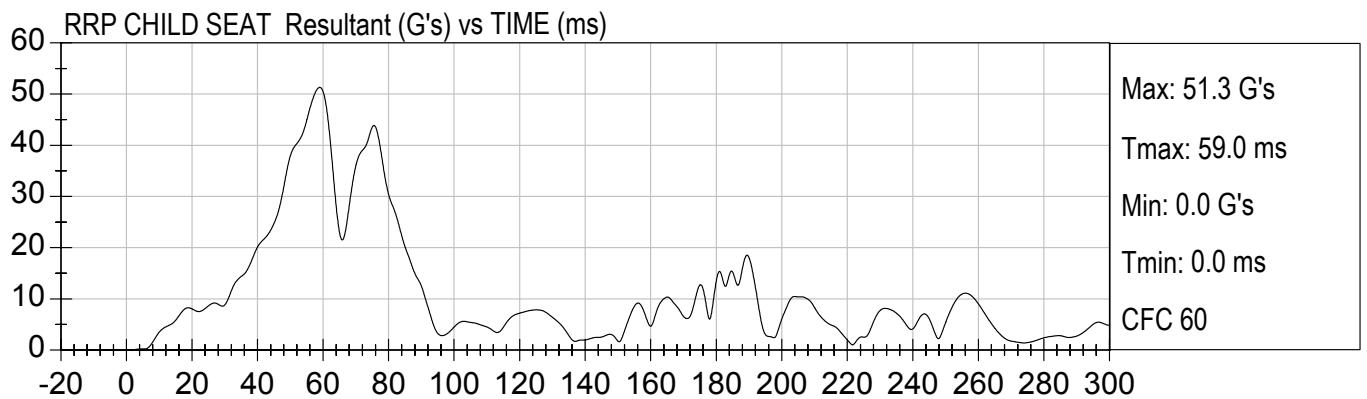
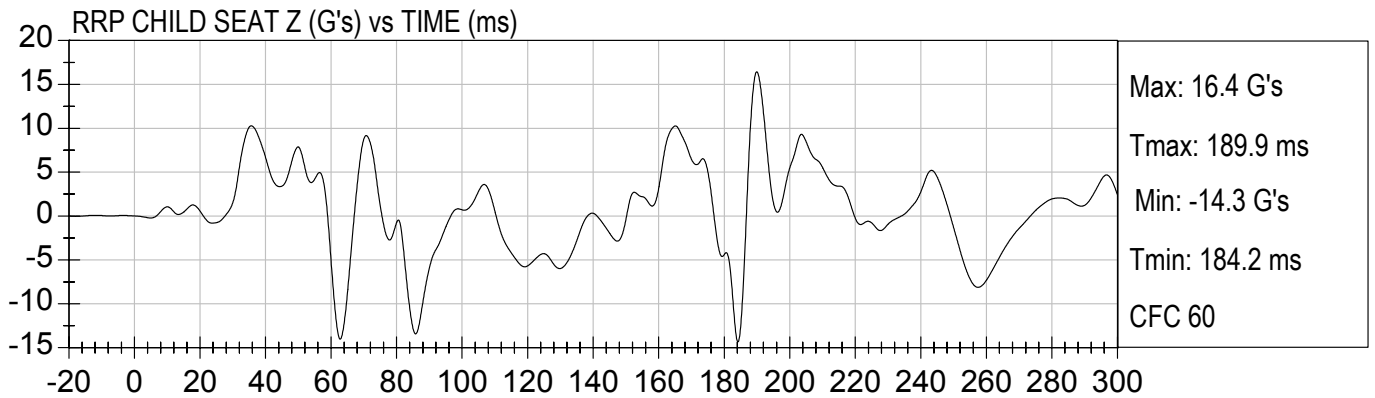
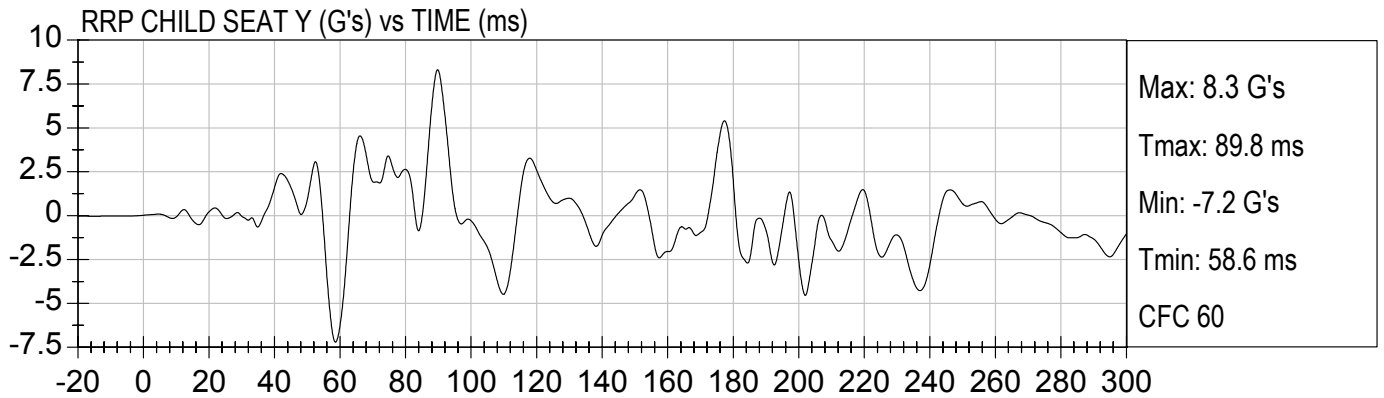
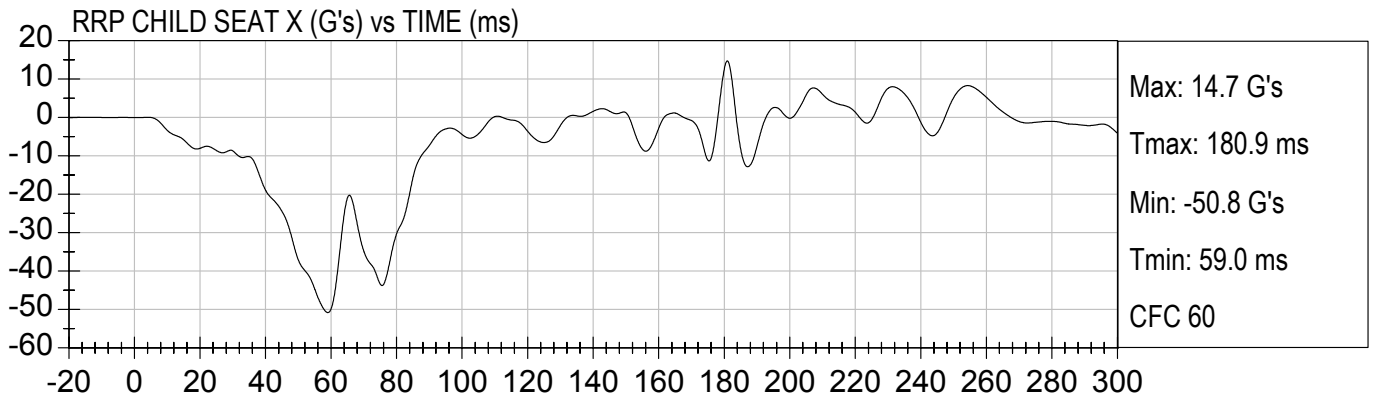

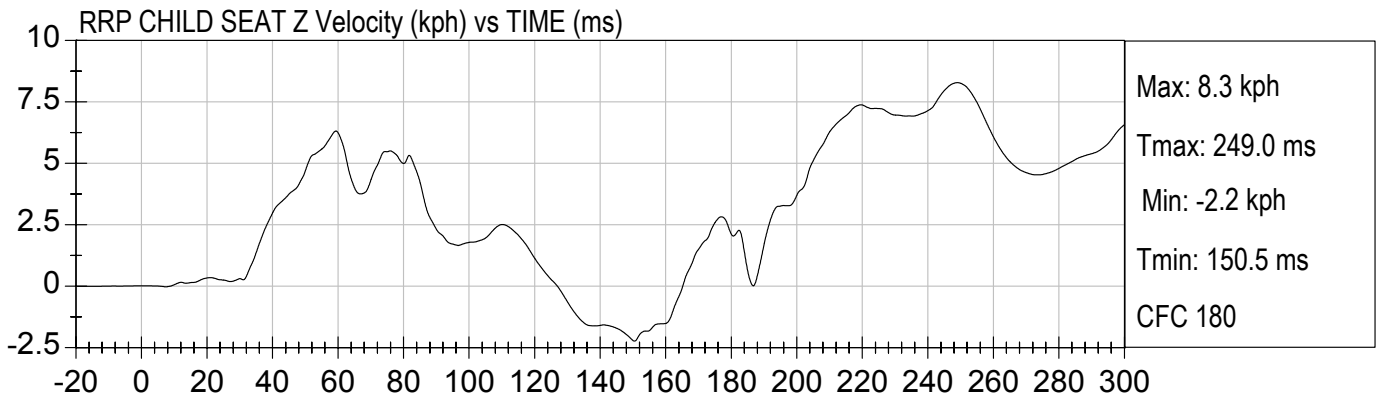
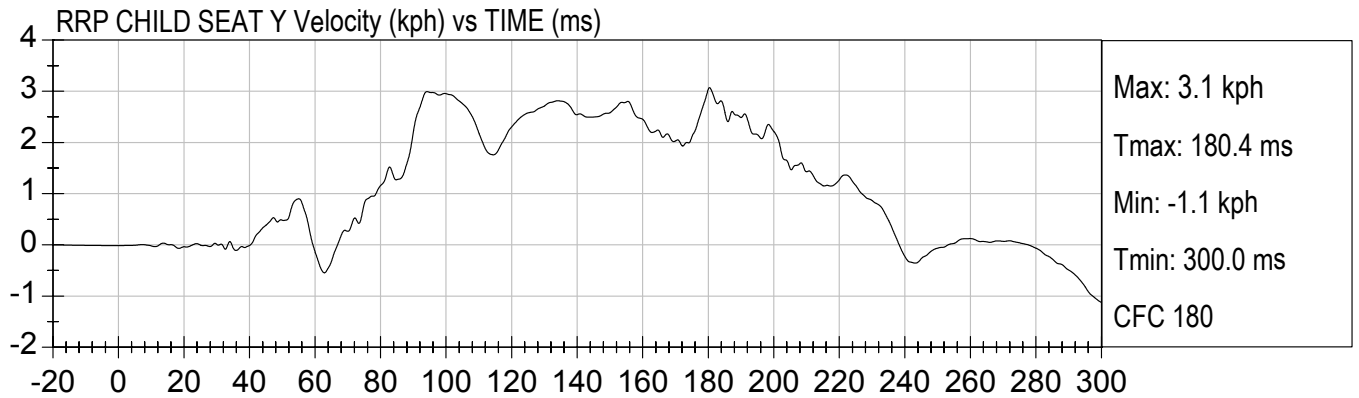
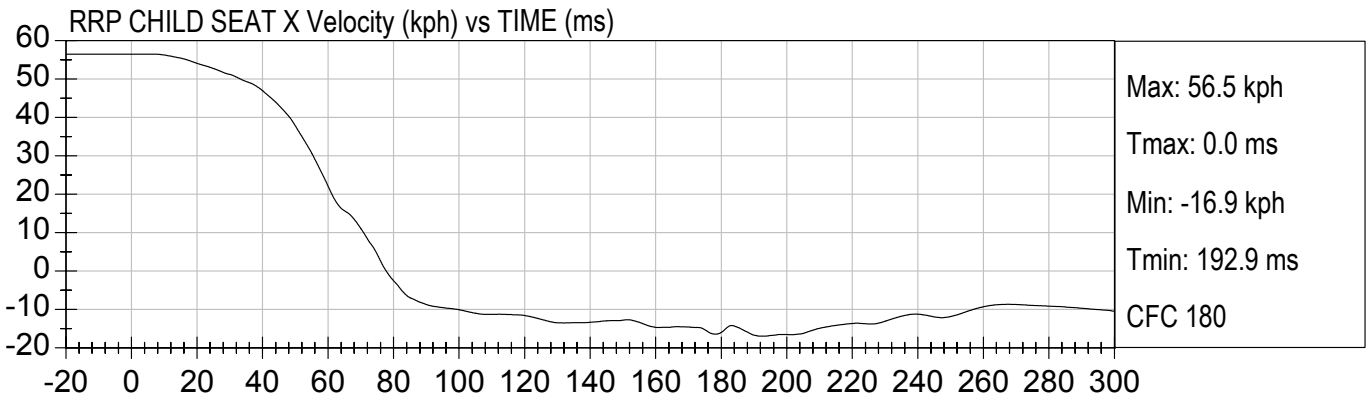

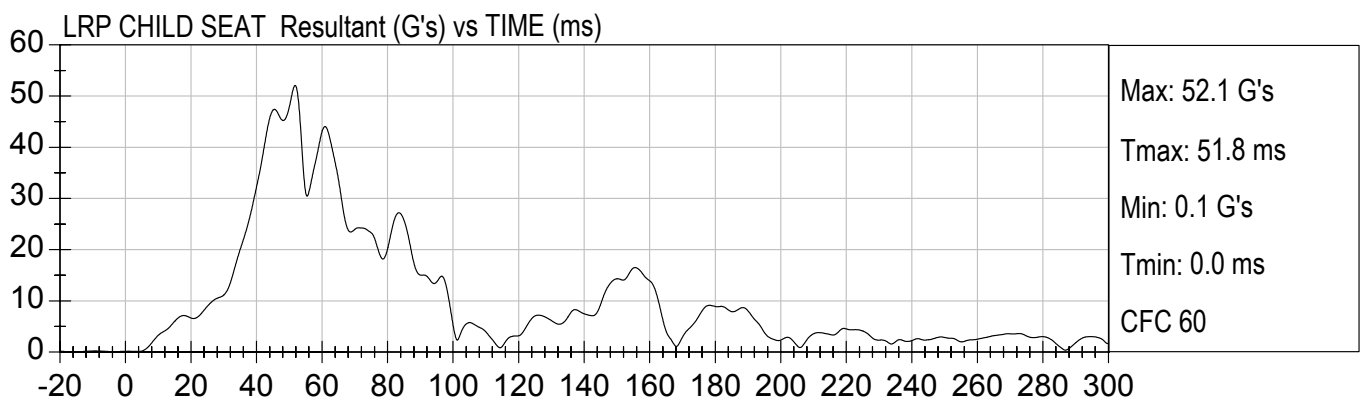
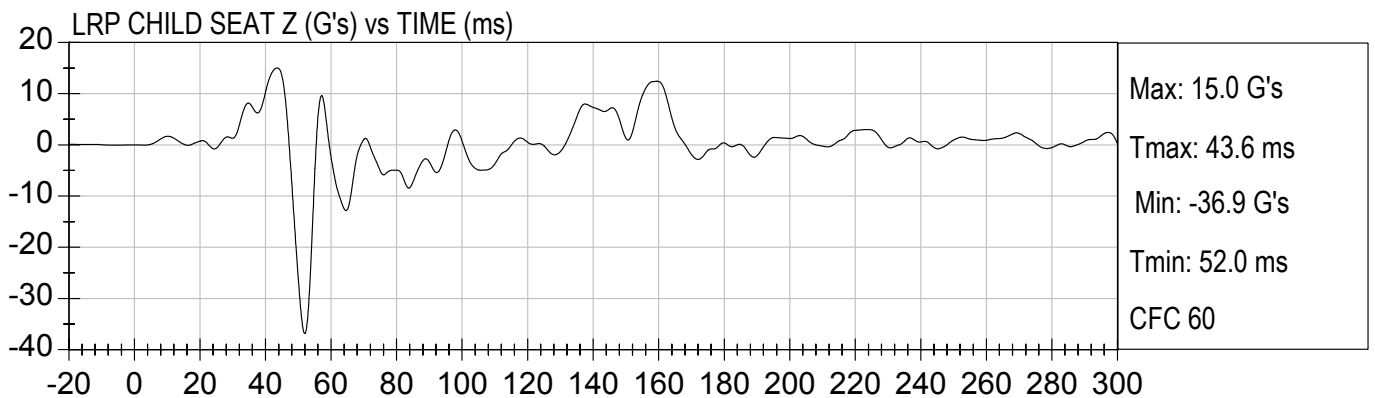
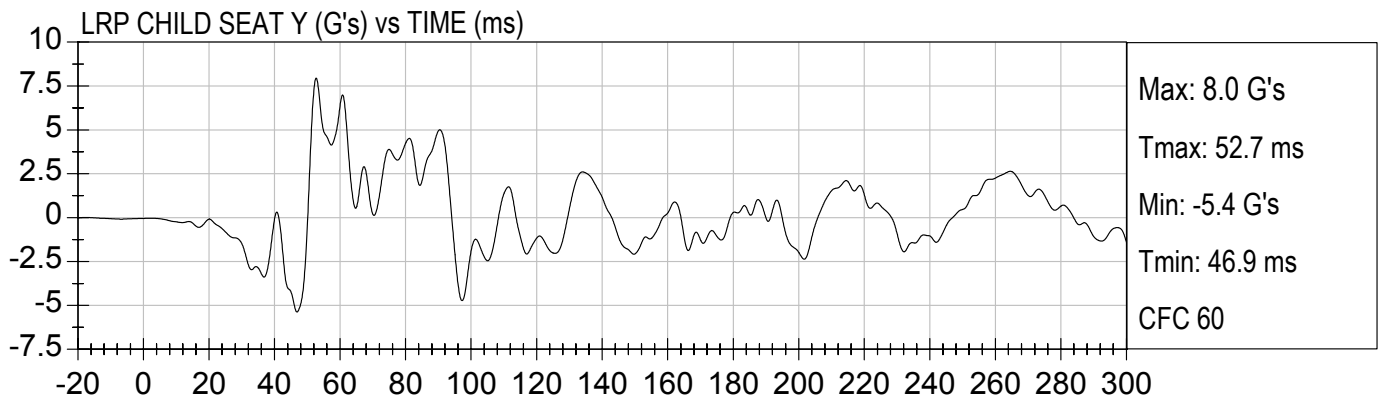
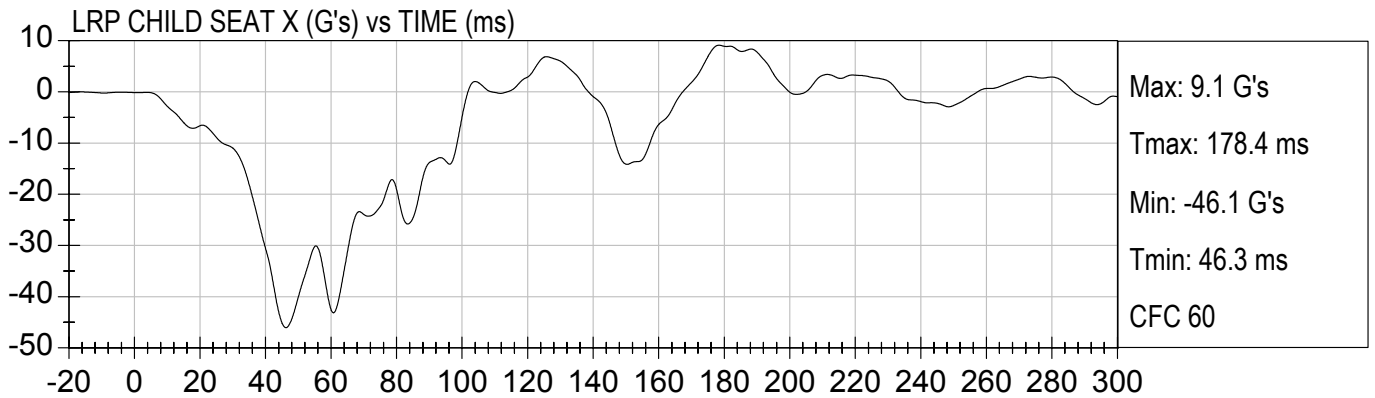

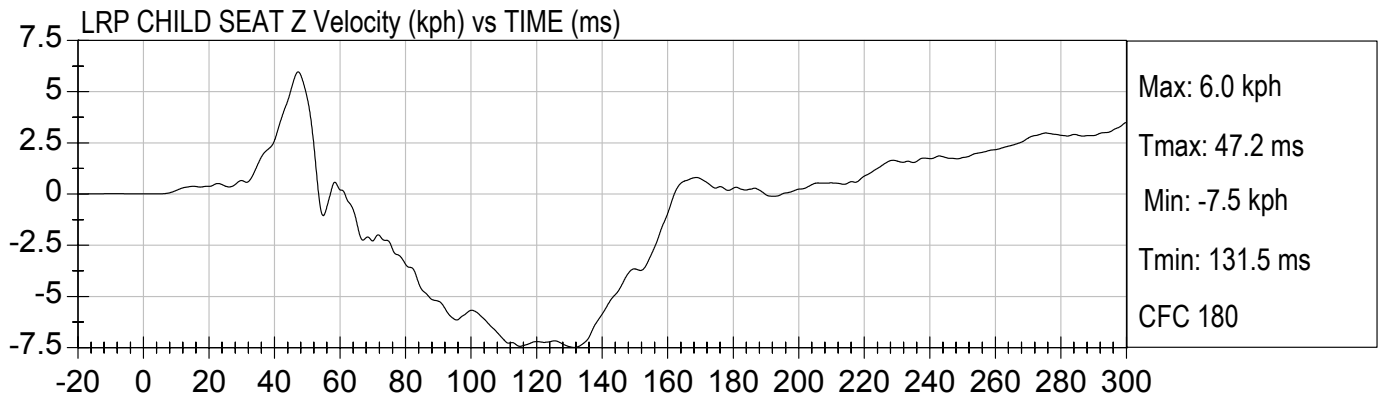
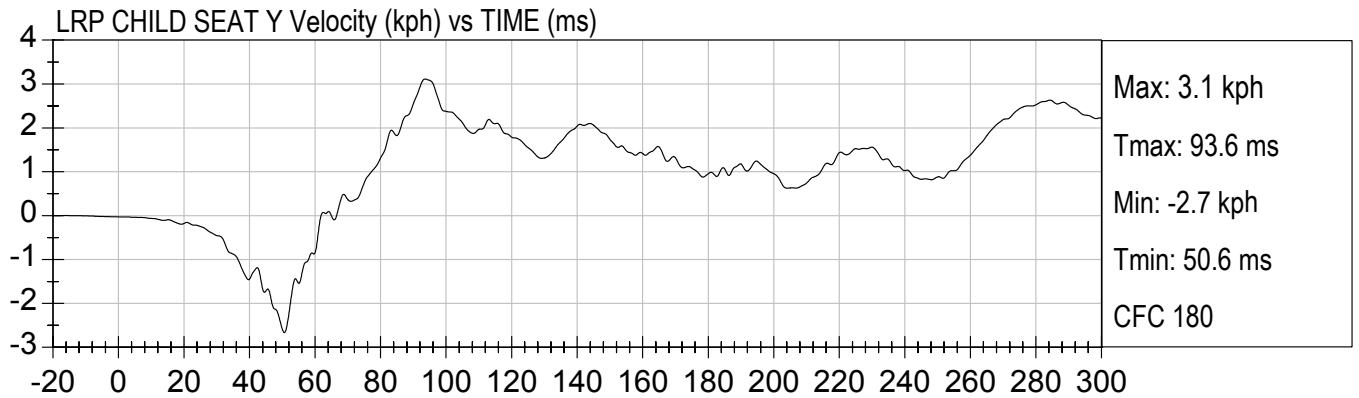
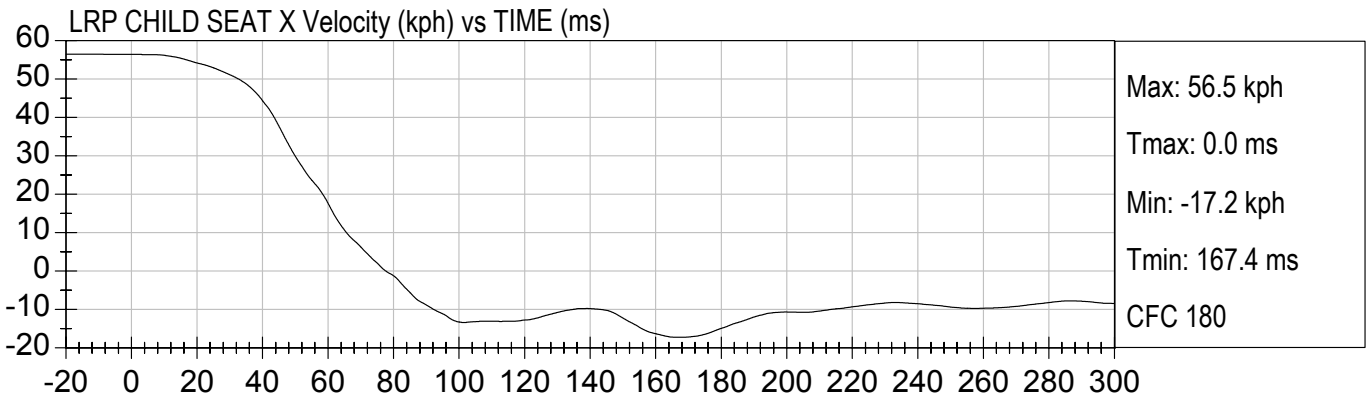

APPENDIX C
CHILD DUMMY CALIBRATION INFORMATION

**Transportation Research
Center Inc.**

ATD Calibration Report

for

VRTC

**HIII 6 Year Old Serial No. 144
Calibration No. 05**



Transportation Research Center Inc.
P.O. Box B-67
10820 St. Rt. 347
East Liberty, OH 43319-0367

Transportation Research Center Inc.
572N HIII 6 Year Old Dummy
External Dimensions
Serial No. 144 Calibration No. 05

Test Parameter	Dimension	Specification	Results	Pass
Total Sitting Height	A	622.3 - 647.7 mm	643 mm	Yes
Shoulder Pivot Height	B	348.0 - 363.2 mm	358 mm	Yes
Hip Pivot Height	C	63.5 - 73.7 mm	73 mm	Yes
Hip Pivot from Backline	D	88.9 - 99.1 mm	98 mm	Yes
Shoulder Pivot from Backline	E	53.3 - 63.5 mm	57 mm	Yes
Thigh Clearance	F	88.9 - 104.1 mm	95 mm	Yes
Back of Elbow to Wrist Pivot	G	182.9 - 198.1 mm	189 mm	Yes
Head Back to Backline	H	17.8 - 22.8 mm	22 mm	Yes
Shoulder to Elbow Length	I	215.9 - 231.1 mm	225 mm	Yes
Elbow Rest Height	J	157.4 - 177.8 mm	172 mm	Yes
Buttock to Knee Length	K	370.8 - 391.2 mm	375 mm	Yes
Popliteal Height	L	269.2 - 289.6 mm	276 mm	Yes
Knee to Floor Height	M	307.4 - 322.6 mm	313 mm	Yes
Buttock Popliteal Height	N	320.0 - 340.4 mm	332 mm	Yes
Chest Depth without Jacket	O	129.6 - 144.8 mm	138 mm	Yes
Foot Length	P	170.2 - 184.6 mm	175 mm	Yes
Buttock to Knee Pivot Length	R	342.9 - 363.2 mm	354 mm	Yes
Head Breadth	S	137.1 - 147.3 mm	139 mm	Yes
Head Depth	T	167.6 - 177.8 mm	170 mm	Yes
Hip Breadth	U	208.3 - 223.5 mm	215 mm	Yes
Shoulder Breadth	V	259.1 - 274.3 mm	270 mm	Yes
Foot Breadth	W	62.3 - 77.5 mm	66 mm	Yes
Head Circumference	X	510.5 - 530.9 mm	519 mm	Yes
Chest Circumference with Jacket	Y	596.9 - 622.3 mm	613 mm	Yes
Waist Circumference	Z	558.8 - 584.2 mm	571 mm	Yes
Reference Location for Chest Circumference	AA	325.1 - 335.3 mm	330 mm	Yes
Reference Location for Waist Circumference	BB	153.7 - 163.9 mm	158 mm	Yes

Technician



Approved





Transportation Research Center Inc.

572N Head Drop Test

HIII 6 Year Old Serial No. 144 Calibration No. 05 - 3

Test Date 07/23/2004

Test Parameter	Specification	Test Results	Pass
Temperature	18.9 - 25.6 °C	21.9 °C	Yes
Relative Humidity	10 - 70 %	51 %	Yes
Peak Resultant Acceleration	245 - 300 g	299.8 g	Yes
Peak Lateral Acceleration	15 g Max	4.9 g	Yes
Is Acceleration Curve Unimodal?	Yes	Yes	Yes

Test meets specifications.

Comments:

Technician

Approved

07.23.2004 16:03:07 614



Transportation Research Center Inc.

572N Head Drop Test

HIII 6 Year Old Serial No. 144 Calibration No. 05 - 3

Test Date 07/23/2004

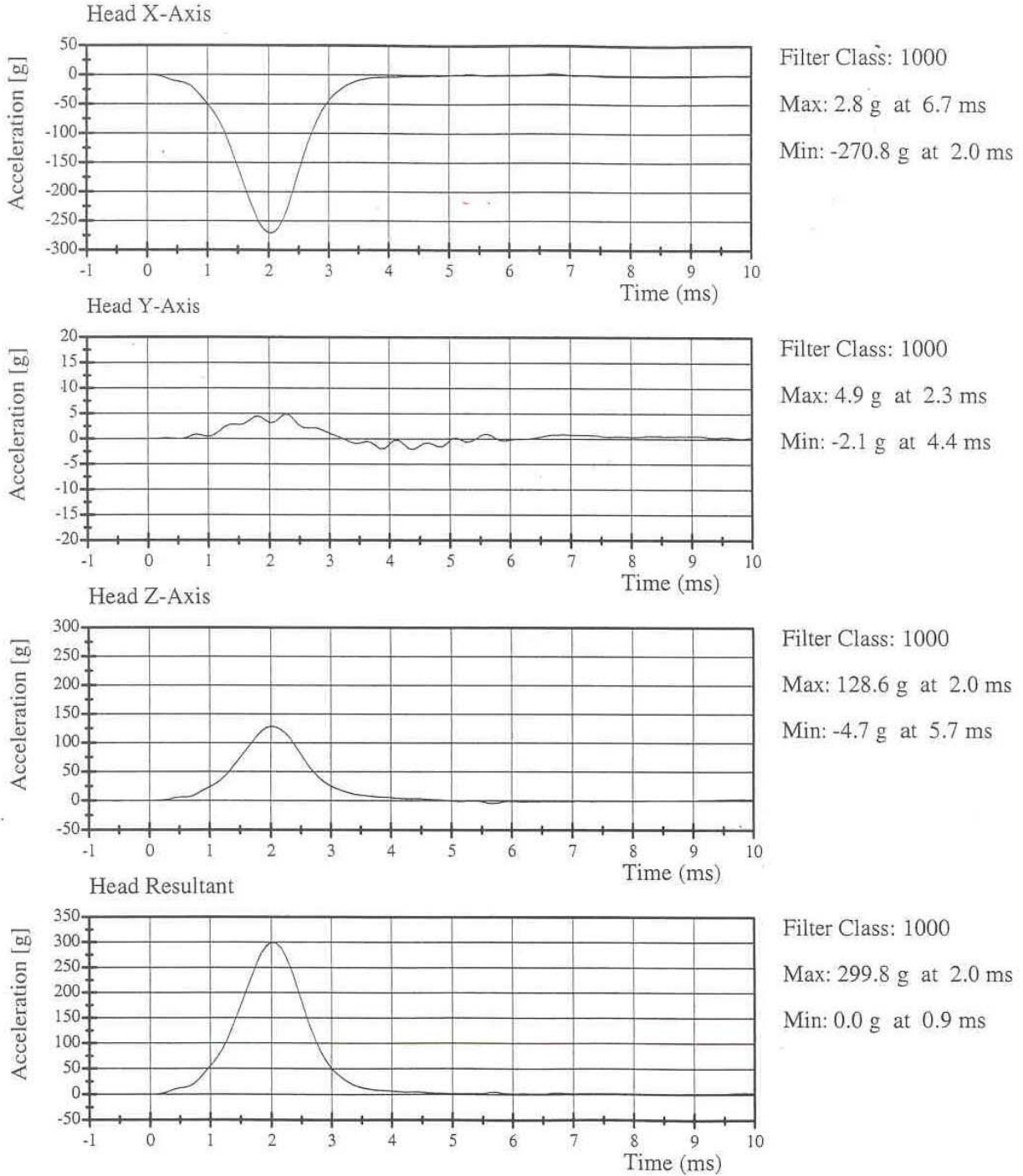

07.23.2004 16:03:09 614



Transportation Research Center Inc.

572N Neck Flexion Test - 6 Channel Transducer

HIII 6 Year Old Serial No. 144 Calibration No. 05 - 3

Test Date 07/26/2004

Test Parameter	Specification	Test Results	Pass
Temperature	20.6 - 22.2 °C	21.9 °C	Yes
Relative Humidity	10 - 70 %	58 %	Yes
Impact Velocity	4.83 - 5.07 m/s	5.04 m/s	Yes
Integrated Pendulum Velocity			
10 ms	1.20 - 1.60 m/s	1.56 m/s	Yes
20 ms	2.40 - 3.40 m/s	3.00 m/s	Yes
30 ms	3.80 - 5.00 m/s	4.35 m/s	Yes
Peak D Plane Rotation	74 - 92 °	75.9 °	Yes
Peak Moment About Occipital Condyles (During time interval rotation is within specified corridors)	27.0 - 33.0 N·m	30.69 N·m	Yes
Positive Moment Decay Time To 5 N·m	103 - 123 ms	111.36 ms	Yes

Test meets specifications.

Comments:

Technician



Approved



07.26.2004 12:55:37 713



Transportation Research Center Inc.

572N Neck Flexion Test

HIII 6 Year Old Serial No. 144 Calibration No. 05 - 3

Test Date 07/26/2004

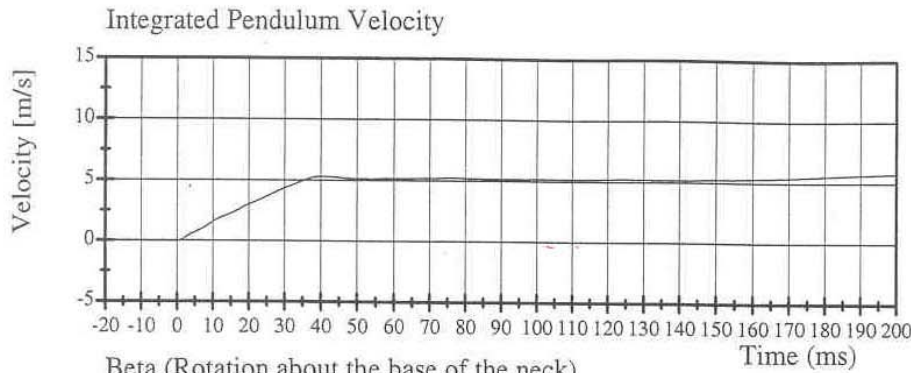

Filter Class: 180

Max: 6.3 m/s at 282.9 ms

Min: -0.0 m/s at -0.1 ms

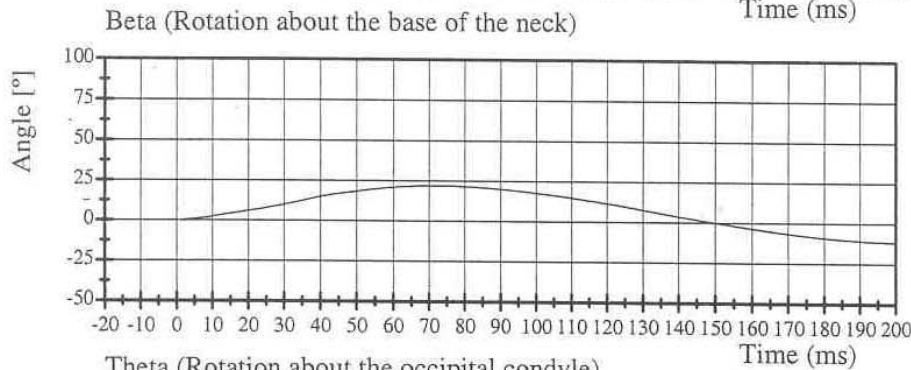

Filter Class: 60

Max: 22.1 ° at 71.1 ms

Min: -12.2 ° at 210.6 ms

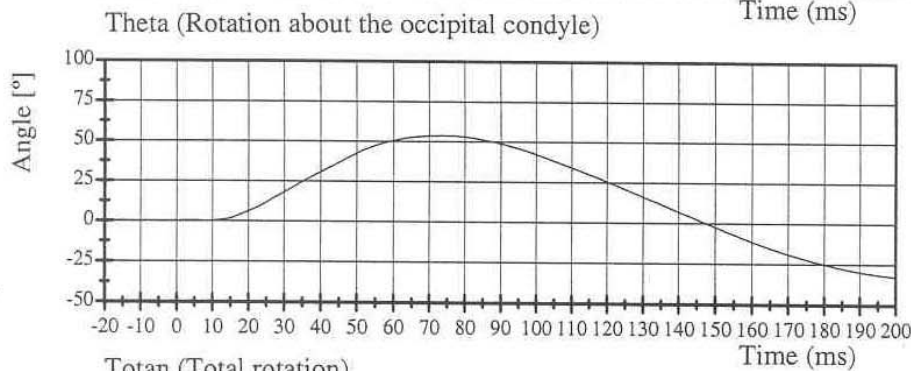

Filter Class: 60

Max: 53.8 ° at 73.7 ms

Min: -33.9 ° at 213.2 ms

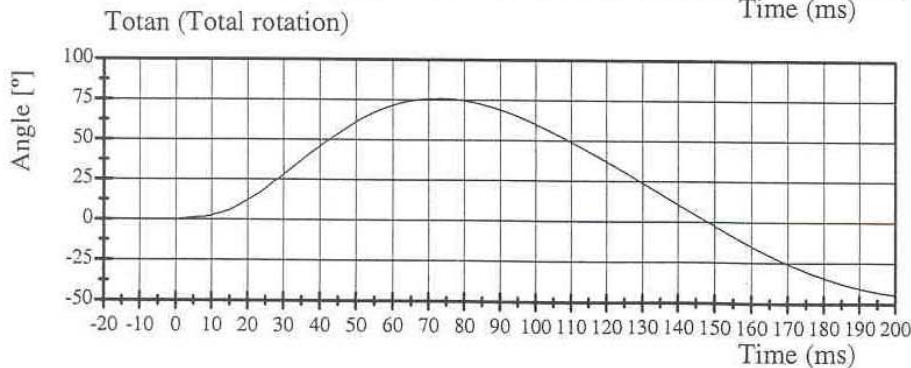

Filter Class: 60

Max: 75.9 ° at 73.4 ms

Min: -46.0 ° at 212.6 ms

07.26.2004 12:55:38 713



Transportation Research Center Inc.

572N Neck Flexion Test

HIII 6 Year Old Serial No. 144 Calibration No. 05 - 3

Test Date 07/26/2004

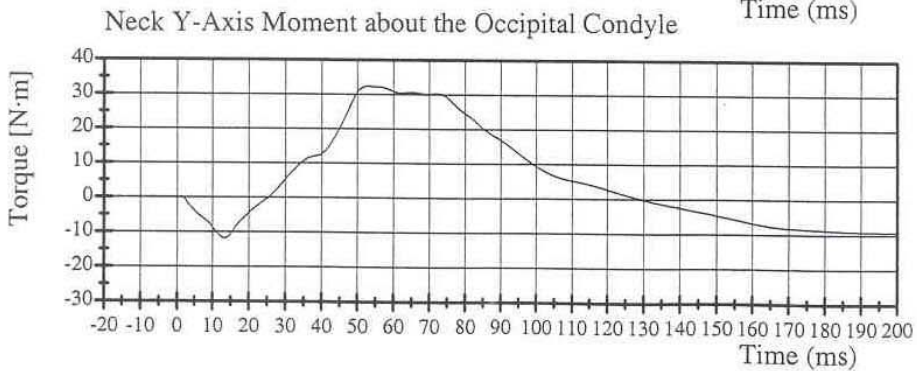
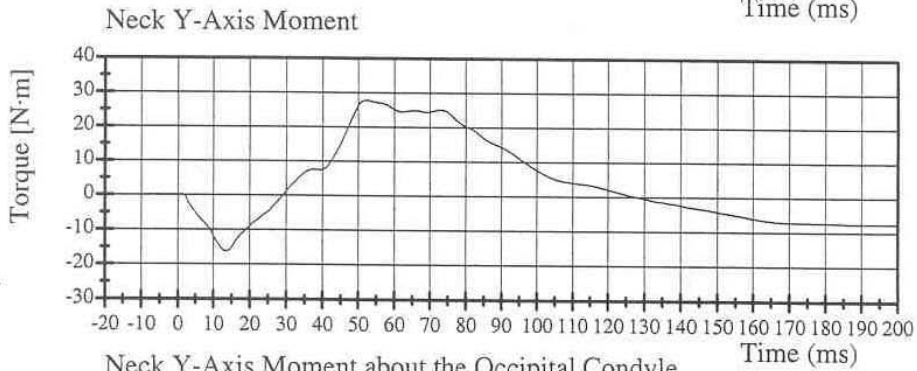
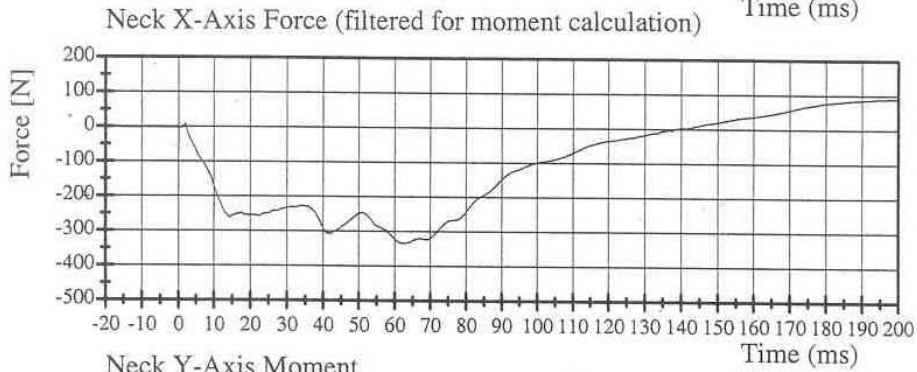
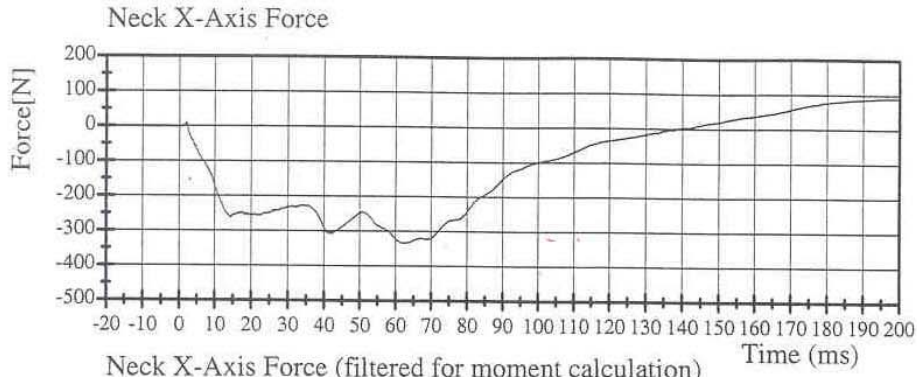

07.26.2004 12:55:39 713



Transportation Research Center Inc.

572N Neck Extension Test - 6 Channel Transducer

HIII 6 Year Old Serial No. 144 Calibration No. 05 - 5

Test Date 07/26/2004

Test Parameter	Specification	Test Results	Pass
Temperature	20.6 - 22.2 °C	22.0 °C	Yes
Relative Humidity	10 - 70 %	57 %	Yes
Impact Velocity	4.18 - 4.42 m/s	4.41 m/s	Yes
Integrated Pendulum Velocity			
10 ms	1.00 - 1.40 m/s	1.26 m/s	Yes
20 ms	2.20 - 3.00 m/s	2.36 m/s	Yes
30 ms	3.20 - 4.20 m/s	3.48 m/s	Yes
Peak D Plane Rotation	85 - 103 °	90.0 °	Yes
Peak Moment About Occipital Condyles (During time interval rotation is within specified corridors)	-24.0 - (-19.0) N·m	-22.81 N·m	Yes
Negative Moment Decay Time To -5 N·m	123 - 147 ms	134.16 ms	Yes

Test meets specifications.

Comments:

Technician



Approved

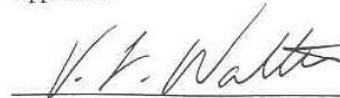

07.26.2004 16:15:00 829



Transportation Research Center Inc.

572N Neck Extension Test

HIII 6 Year Old Serial No. 144 Calibration No. 05 - 5

Test Date 07/26/2004

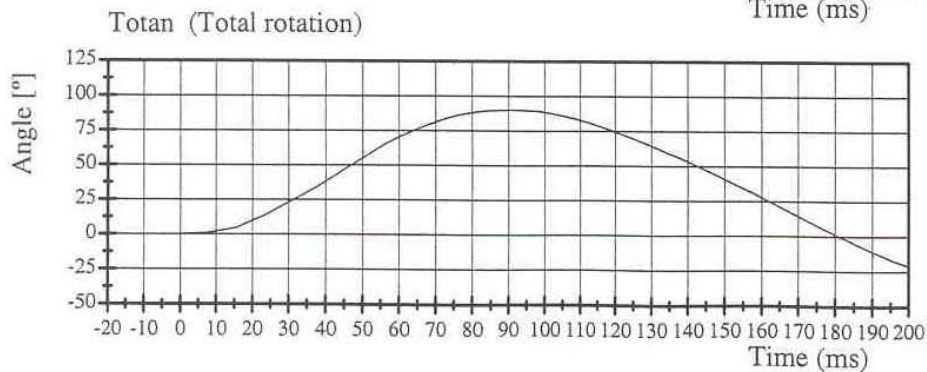
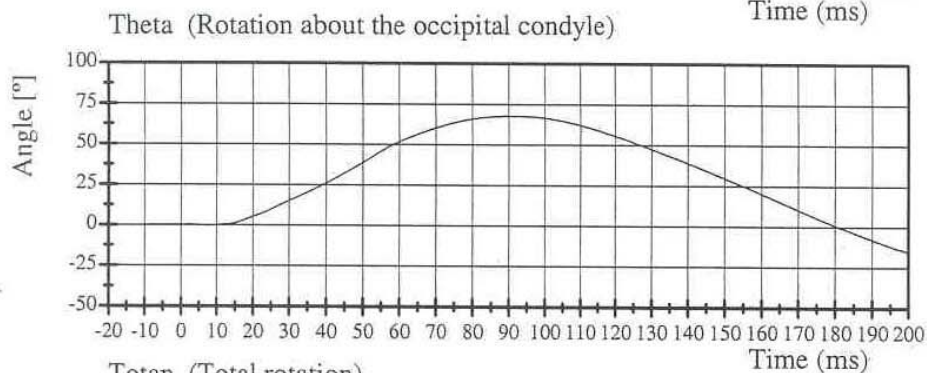
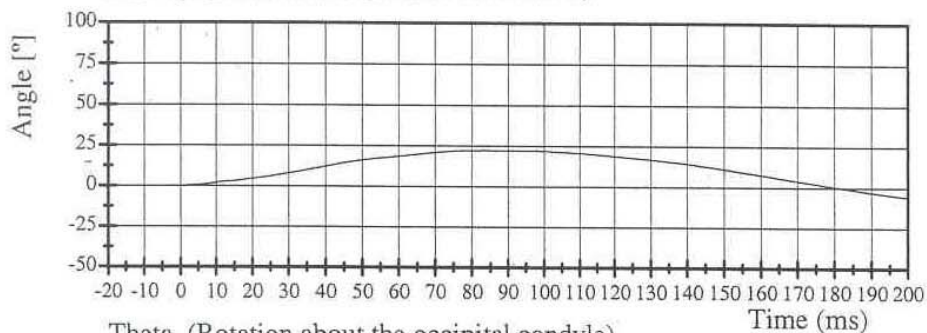
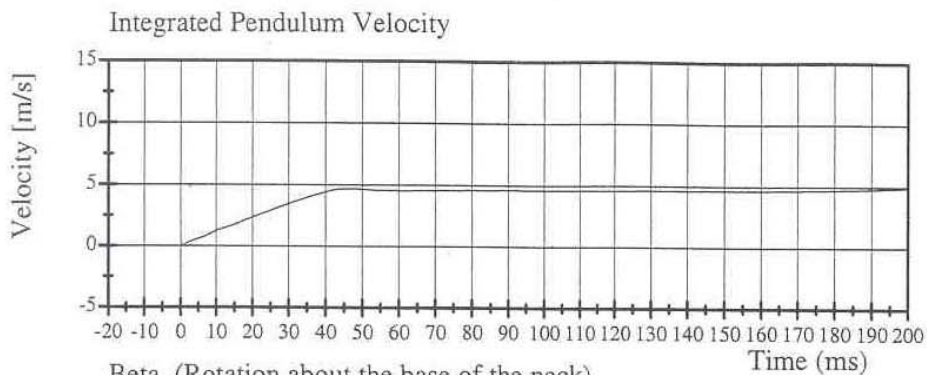

07.26.2004 16:15:01 829



Transportation Research Center Inc.

572N Neck Extension Test

HIII 6 Year Old Serial No. 144 Calibration No. 05 - 5

Test Date 07/26/2004

Neck X-Axis Force

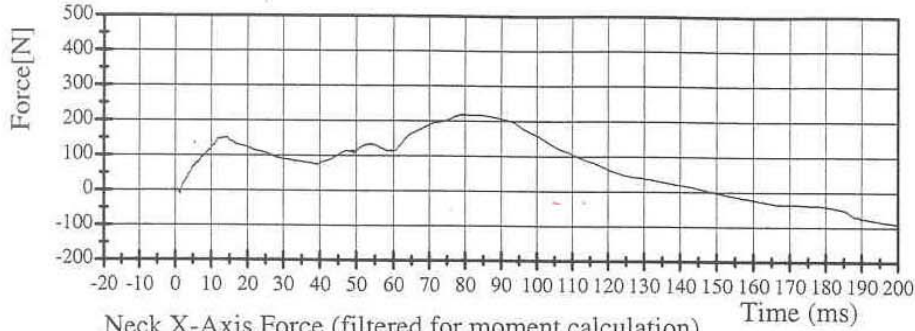

Filter Class: 1000

Max: 219.2 N at 79.5 ms

Min: -112.8 N at 221.4 ms

Neck X-Axis Force (filtered for moment calculation)

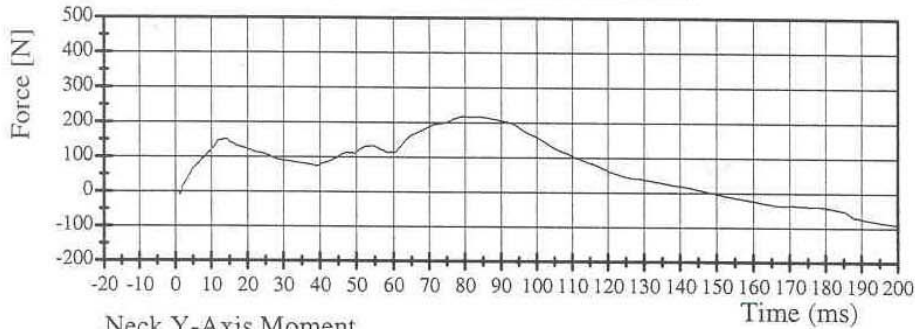

Filter Class: 600

Max: 218.6 N at 79.5 ms

Min: -112.3 N at 221.4 ms

Neck Y-Axis Moment

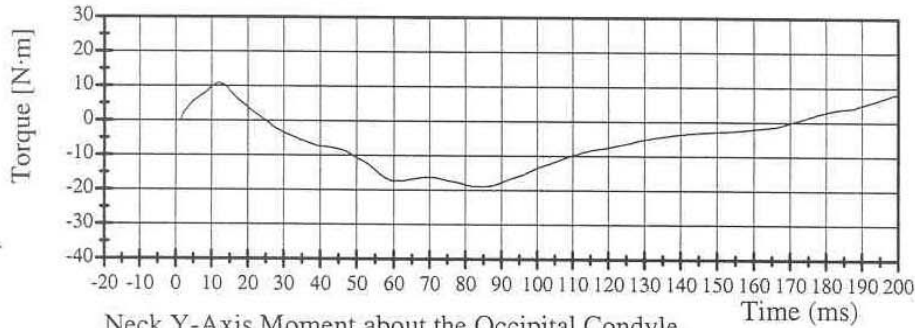

Filter Class: 600

Max: 11.3 N·m at 225.0 ms

Min: -18.9 N·m at 83.9 ms

Neck Y-Axis Moment about the Occipital Condyle

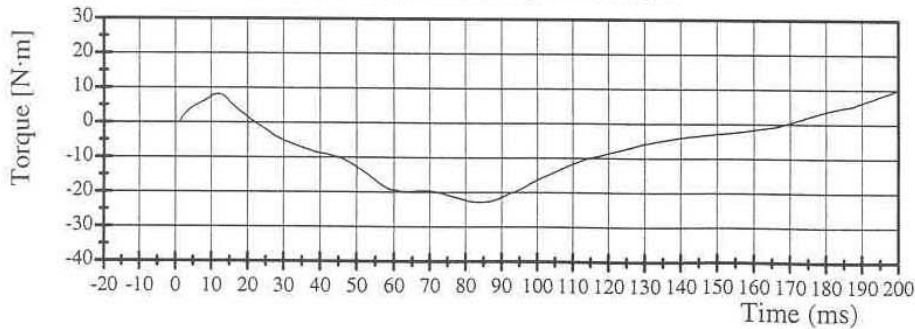

Filter Class: 600

Max: 13.2 N·m at 222.5 ms

Min: -22.8 N·m at 83.9 ms

07.26.2004 16:15:02 829



Transportation Research Center Inc.

572N Thorax Test

HIII 6 Year Old Serial No. 144 Calibration No. 05 - 2

Test Date 07/29/2004

Test Parameter	Specification	Test Results	Pass
Temperature	20.6 - 22.2 °C	21.4 °C	Yes
Relative Humidity	10 - 70 %	52 %	Yes
Pendulum Velocity	6.59 - 6.83 m/s	6.61 m/s	Yes
Maximum Chest Deflection	-46.0 - (-38.0) mm	-46.0 mm	Yes
Peak Impact Probe Force Within Compression Corridor	1150 - 1380 N	1212 N	Yes
Internal Hysteresis	65 - 85 %	73 %	Yes
Maximum Force Between 12.5 mm & 38 mm Of Deflection	<= 1500	1222	Yes

Test meets specifications.

Comments:

Technician



Approved



07.29.2004 07:28:15 958



Transportation Research Center Inc.

572N Thorax Test

HIII 6 Year Old Serial No. 144 Calibration No. 05 - 2

Test Date 07/29/2004

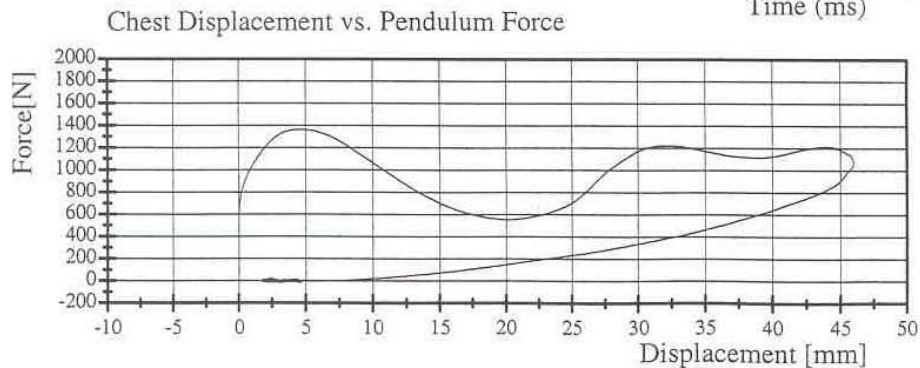
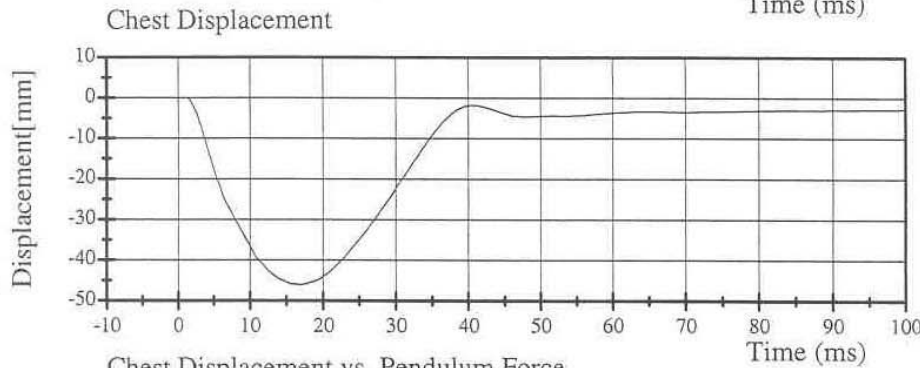
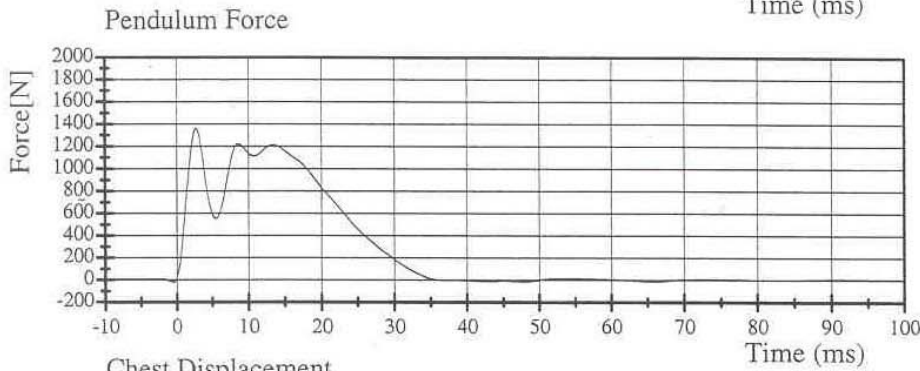
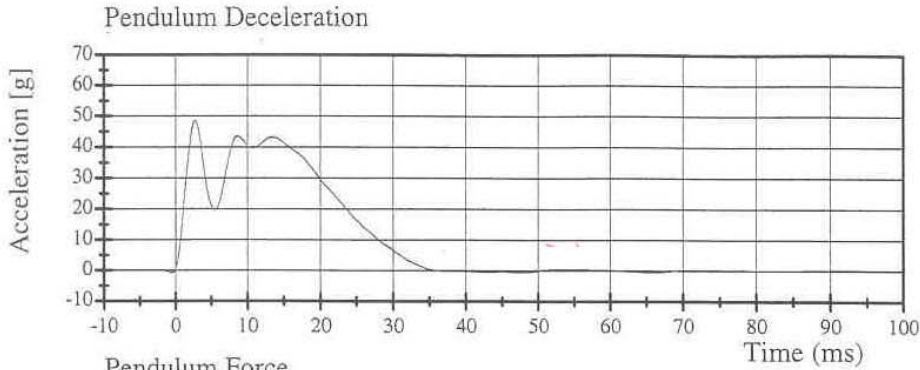

07.29.2004 07:28:16 958



TRANSPORTATION RESEARCH CENTER INC.

TORSO FLEXION TEST

HYBRID III SIX-YEAR-OLD

CAL DATE: 29-Jul-04

TRC, INC. TEST NO: 144C05TF2 572 N SN144 TORSO FLEX CAL 05

TEST PARAMETER	SPECIFICATION	TEST RESULTS
TEMPERATURE	20.6 – 22.2 DEG. C	21.3 DEG. C
RELATIVE HUMIDITY	10 – 70 %	49 %
INITIAL ANGLE OF UNSUPPORTTED DUMMY	<= 22 DEG. REFERENCED TO VERTICAL	21.1 DEG.
MAXIMUM FORCE AT 45 DEG. DURING 10 SECOND PERIOD	147 – 200 N	160.9 N
RETURN ANGLE		24.6 DEG.
DIFFERENCE BETWEEN RETURN ANGLE & INTIAL ANGLE	+/- 8 DEG. OF INTIAL ANGLE	3.5 DEG.
RATE	0.5° - 1.5°/sec	1.03 °/sec

TEST MEETS SPECIFICATIONS

TECHNICIAN



Transportation Research Center Inc.

572N Left Knee Test

HIII 6 Year Old Serial No. 144 Calibration No. 05 - 1

Test Date 07/23/2004

Test Parameter	Specification	Test Results	Pass
Temperature	18.9 - 25.6 °C	21.9 °C	Yes
Relative Humidity	10 - 70 %	49 %	Yes
Pendulum Velocity	2.07 - 2.13 m/s	2.10 m/s	Yes
Maximum Pendulum Force	2000 - 3000 N	2444 N	Yes

Test meets specifications.

Comments:

Technician



Approved



07.23.2004 15:10:43 1688



Transportation Research Center Inc.

572N Left Knee Test

HIII 6 Year Old Serial No. 144 Calibration No. 05 - 1

Test Date 07/23/2004

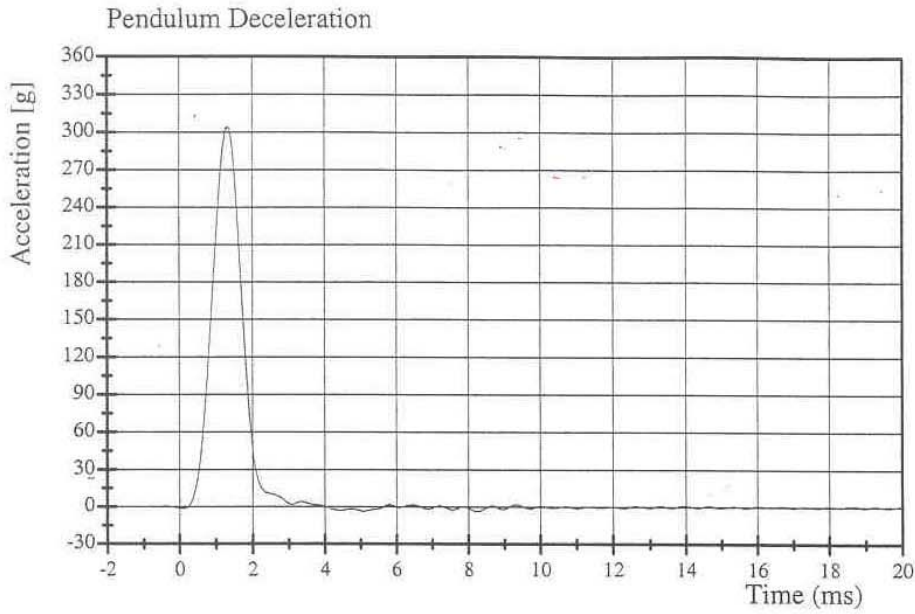

Filter Class: 600

Max: 303.9 g at 1.4 ms

Min: -3.7 g at 8.2 ms

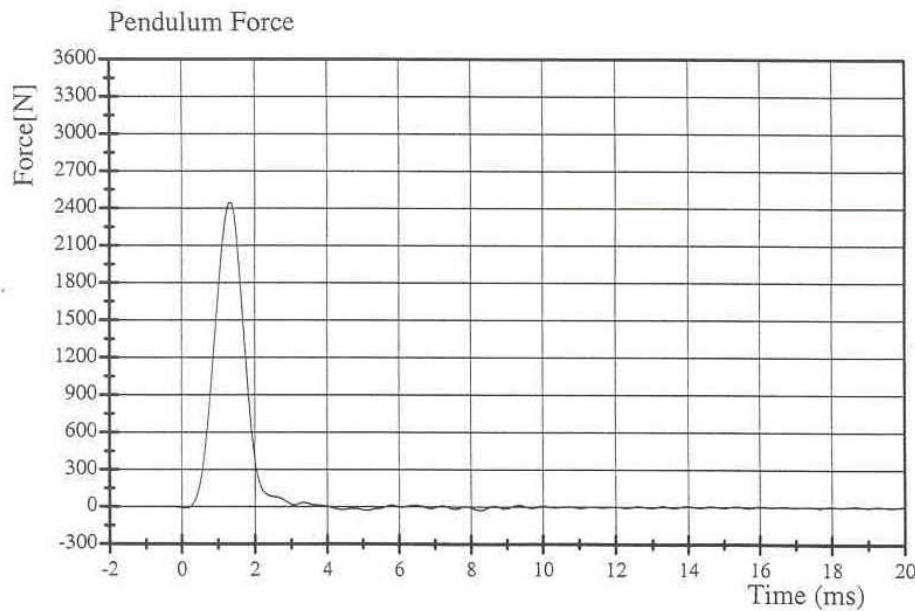

Filter Class: 600

Max: 2444.2 N at 1.4 ms

Min: -30.0 N at 8.2 ms

07.23.2004 15:10:44 1688



Transportation Research Center Inc.

572N Right Knee Test

HIII 6 Year Old Serial No. 144 Calibration No. 05 - 1

Test Date 07/23/2004

Test Parameter	Specification	Test Results	Pass
Temperature	18.9 - 25.6 °C	21.8 °C	Yes
Relative Humidity	10 - 70 %	49 %	Yes
Pendulum Velocity	2.07 - 2.13 m/s	2.11 m/s	Yes
Maximum Pendulum Force	2000 - 3000 N	2293 N	Yes

Test meets specifications.

Comments:

Technician

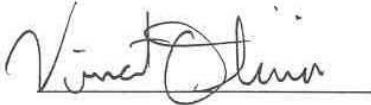

Approved



07.23.2004 14:58:07 1683



Transportation Research Center Inc.

572N Right Knee Test

HIII 6 Year Old Serial No. 144 Calibration No. 05 - 1

Test Date 07/23/2004

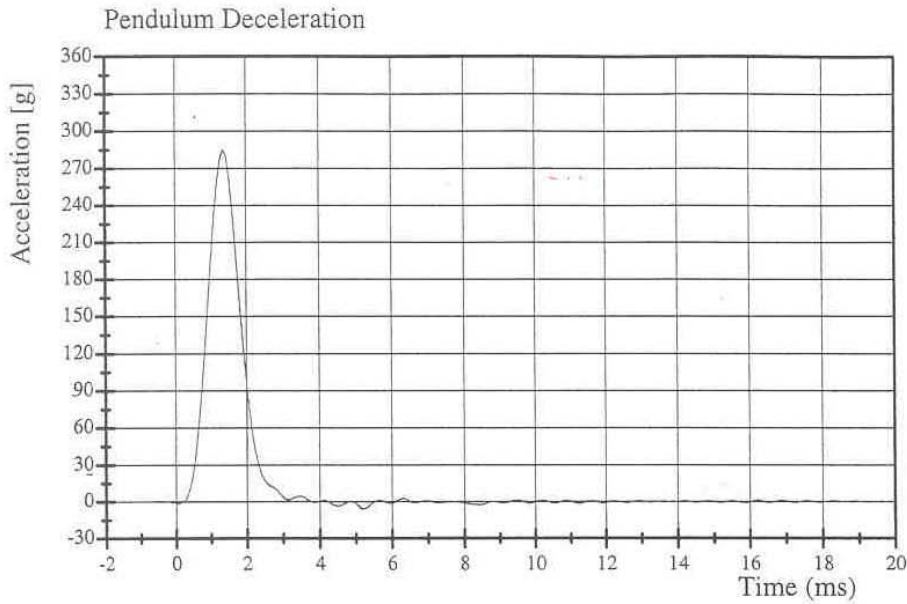

Filter Class: 600

Max: 285.2 g at 1.4 ms

Min: -6.0 g at 5.2 ms

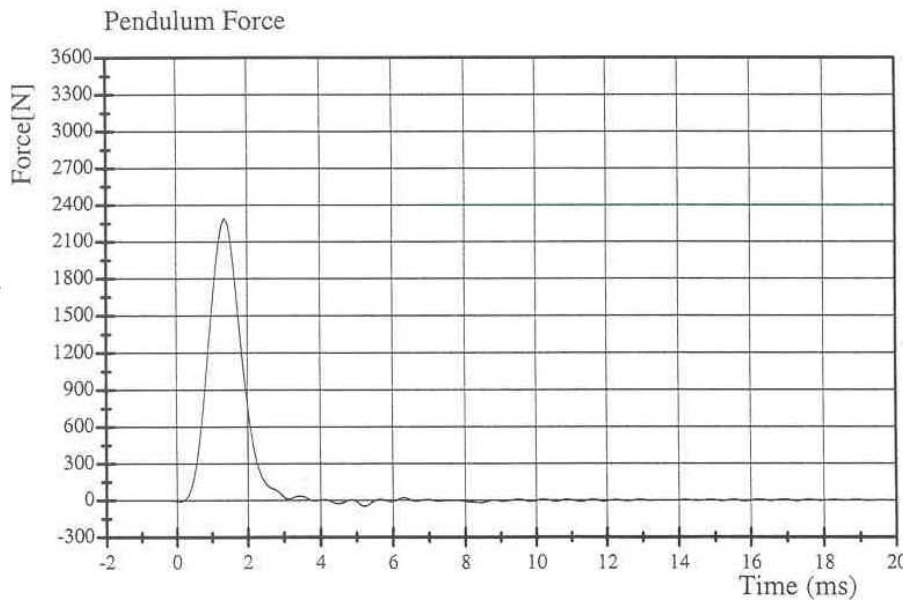

Filter Class: 600

Max: 2293.4 N at 1.4 ms

Min: -48.0 N at 5.2 ms

07.23.2004 14:58:08 1683



Hybrid III Calibration Data Sheet
3 Year Old
Head Drop Calibration

ATD Serial No: 042

Test I.D.: D041811

Tested Parameter	Units	Specification	Result	Pass/Fail
Laboratory Temperature	deg C	18.9 to 25.5	21.7	Pass
Laboratory Relative Humidity	%	10 to 70	46	Pass
Peak Resultant Acceleration	G's	250.0 to 280.0	268.4	Pass
Peak Lateral Acceleration	G's	<= +/- 15.0	-11.5	Pass
Is Acceleration Unimodal?	Yes/No	< 10% Peak	Yes	Pass
Overall Test Results				Pass

Jessica Hall
 Laboratory Technician

08/06/2004
 Test Date

David Winkelbauer
 Approved By



Test Description: Head Drop

Test Date: 08/06/2004

Component: D041811

Speed: 0 ft/s, 0.00 m/s

HEAD RESULTANT (G's) vs TIME (ms)

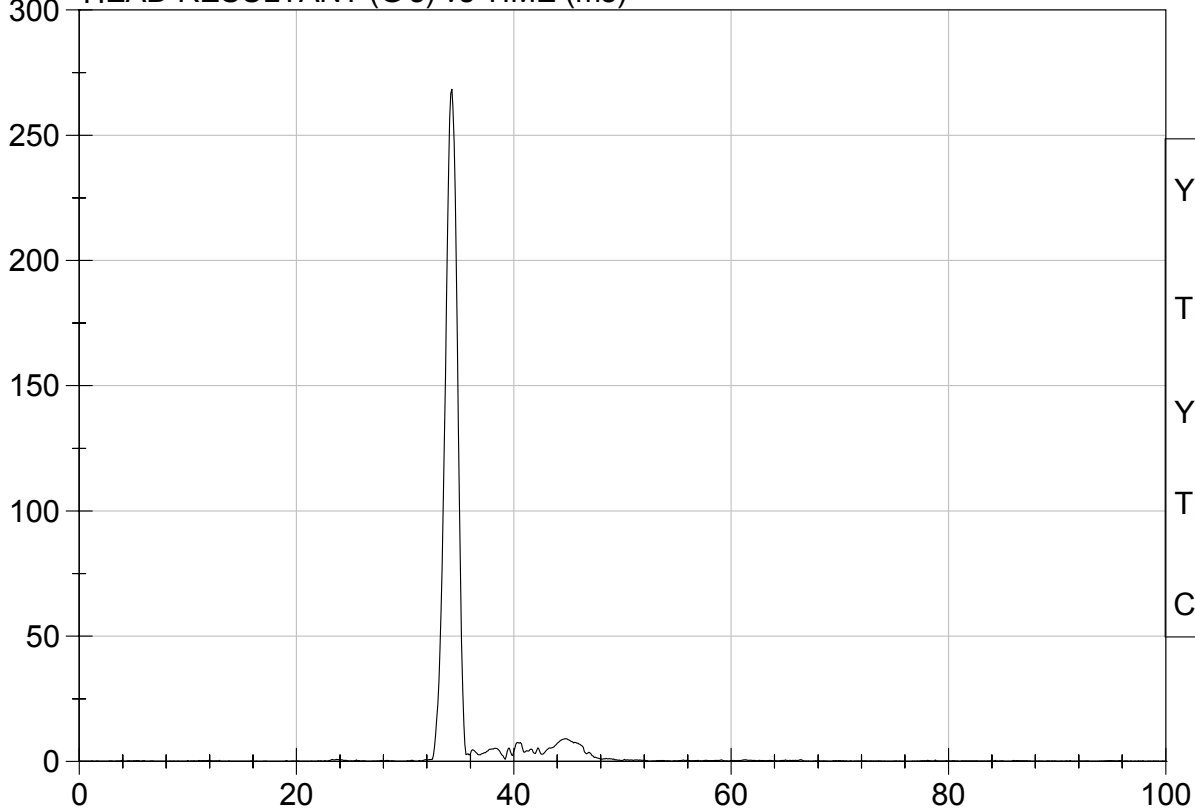

YMax: 268.4 G
Tmax: 34.3 ms
YMin: 0.1 G
Tmin: 0.1 ms
CFC 1000

HEAD Y (G's) vs TIME (ms)

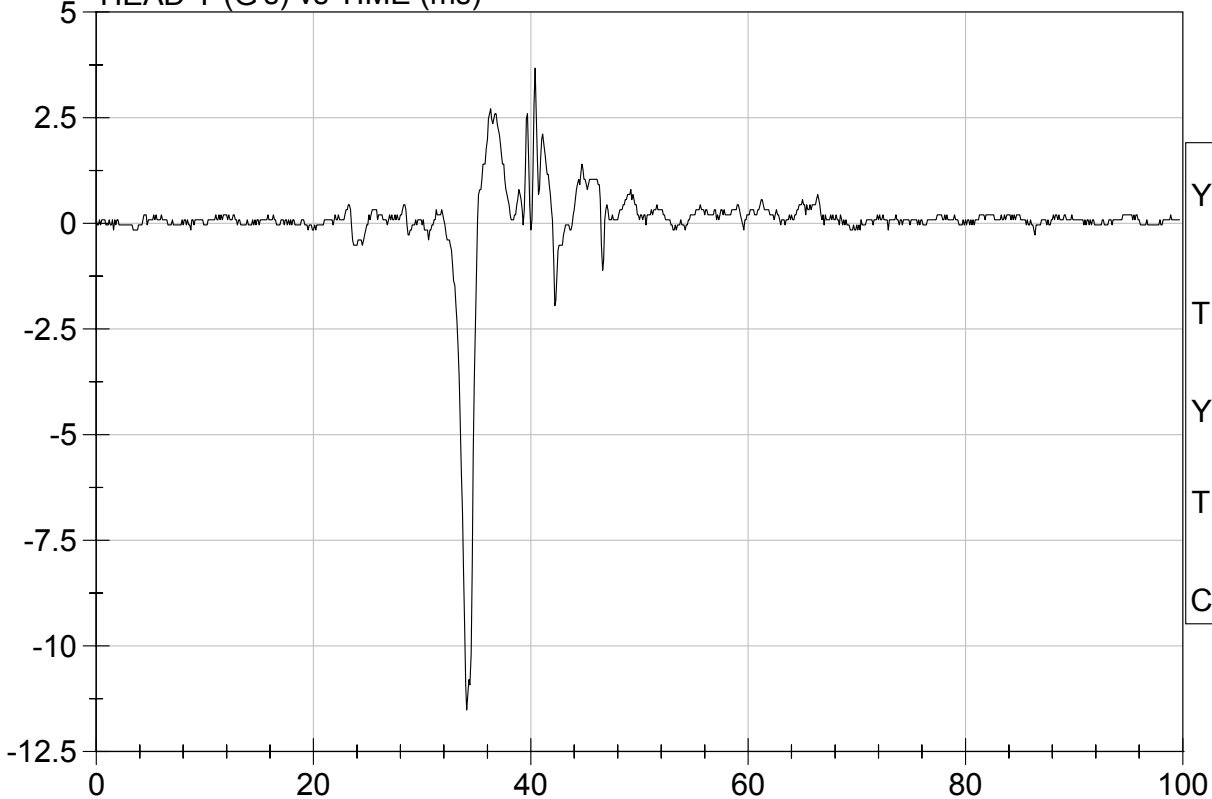

YMax: 3.7 G
Tmax: 40.4 ms
YMin: -11.5 G
Tmin: 34.1 ms
CFC 1000

Hybrid III Calibration Data Sheet
3 Year Old
Neck Flexion Test

ATD Serial No: 042

Test I.D: D041812

Tested Parameter	Units	Specification	Result	Pass/Fail	
Laboratory Temperature	deg C	20.6 to 22.2	21.8	Pass	
Laboratory Relative Humidity	%	10 to 70	46	Pass	
Pendulum Speed	m/s	5.4 to 5.6	5.5	Pass	
Pendulum Deceleration	10 msec	m/s	2.0 - 2.7	2.3	Pass
	15 msec	m/s	3.0 - 4.0	3.3	Pass
	20 msec	m/s	4.0 - 5.1	4.5	Pass
D Plane Rotation	deg	70 - 82	81	Pass	
Peak Moment within Deflection Corridor	Nm	42.0 - 53.0	43.8	Pass	
Positive Moment - Time Curve Decay to 10 Nm	msec	60.0 - 80.0	71.5	Pass	
Overall Test Results				Pass	

Jessica Hall
 Laboratory Technician

08/06/2004
 Test Date

David Winkelbauer
 Approved By



Test Description: Neck Flexion

Test Date: 08/06/2004

Component: D041812

Speed: 17.98 ft/sec, 5.48 m/sec

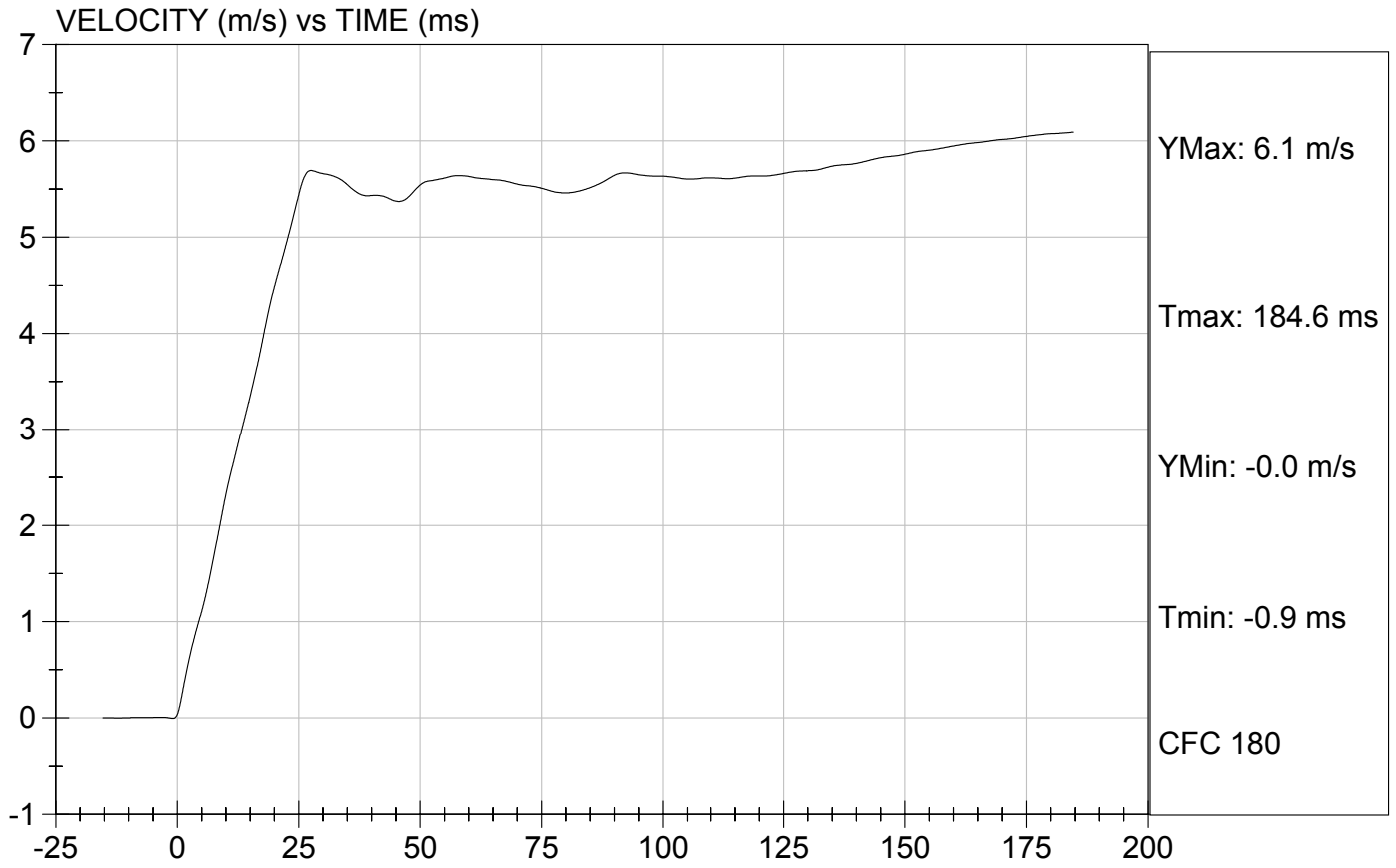



Test Description: Neck Flexion

Test Date: 08/06/2004

Component: D041812

Speed: 17.98 ft/s, 5.48 m/s

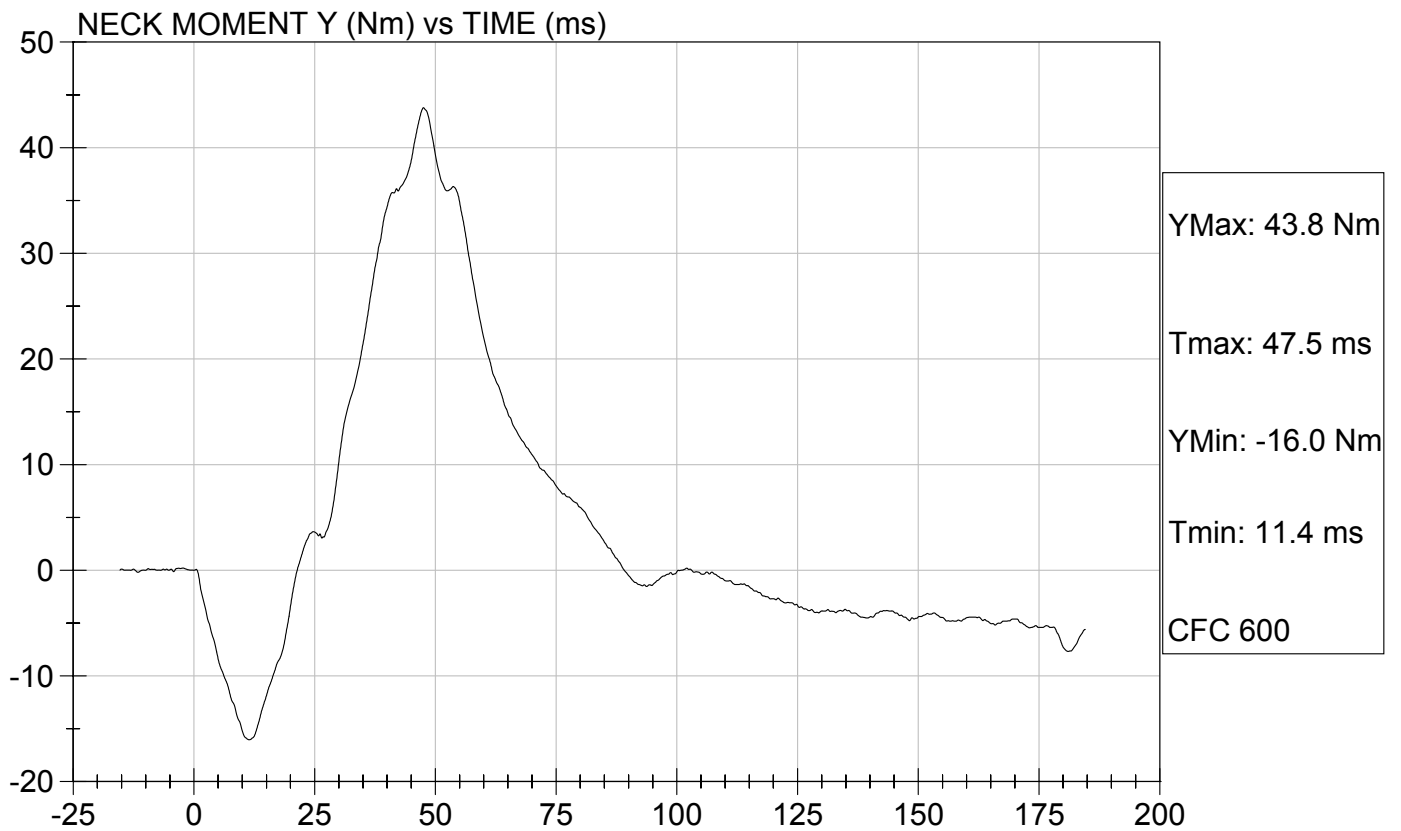
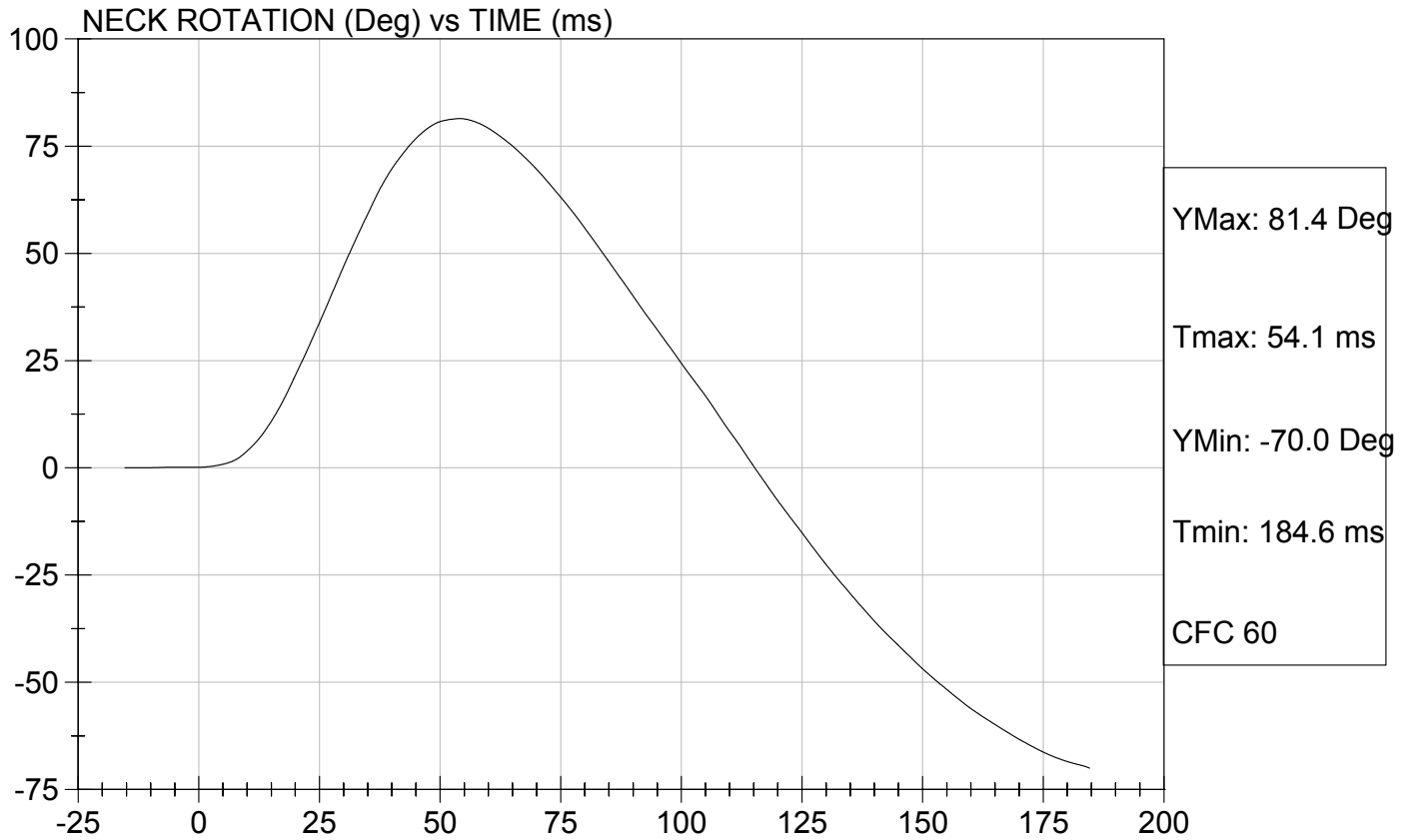

Hybrid III Calibration Data Sheet
3 Year Old
Neck Extension Test

ATD Serial No: 042

Test I.D: D041813

Tested Parameter	Units	Specification	Result	Pass/Fail	
Laboratory Temperature	deg C	20.6 to 22.2	21.9	Pass	
Laboratory Relative Humidity	%	10 to 70	44	Pass	
Pendulum Speed	m/s	3.55 to 3.75	3.75	Pass	
Pendulum Deceleration	6 msec	m/s	1.0 - 1.4	1.3	Pass
	10 msec	m/s	1.9 - 2.5	2.2	Pass
	14 msec	m/s	2.8 - 3.5	2.9	Pass
D Plane Rotation	deg	83 - 93	85	Pass	
Peak Moment within Deflection Corridor	Nm	-53.3 - -43.7	-45.9	Pass	
Negative Moment - Time Curve Decay to -10 Nm	msec	60.0 - 80.0	69.1	Pass	
Overall Test Results				Pass	

Jessica Hall
 Laboratory Technician

08/06/2004
 Test Date

David Winkelbauer
 Approved By



Test Description: Neck Extension Test Date: 08/06/2004

Component: D041813

Speed: 12.29 ft/sec, 3.75 m/sec

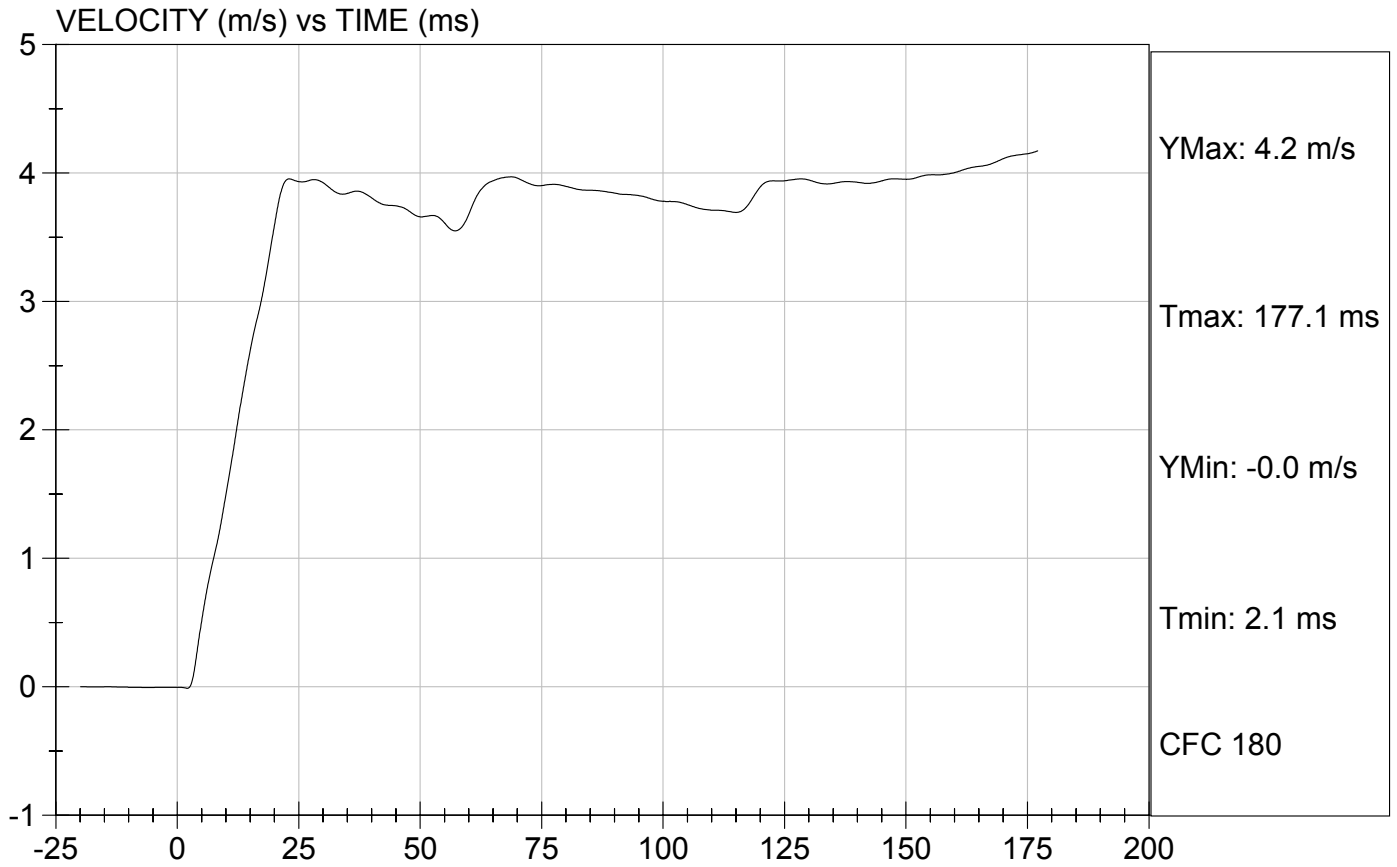



Test Description: Neck Extension

Test Date: 08/06/2004

Component: D041813

Speed: 12.29 ft/s, 3.75 m/s

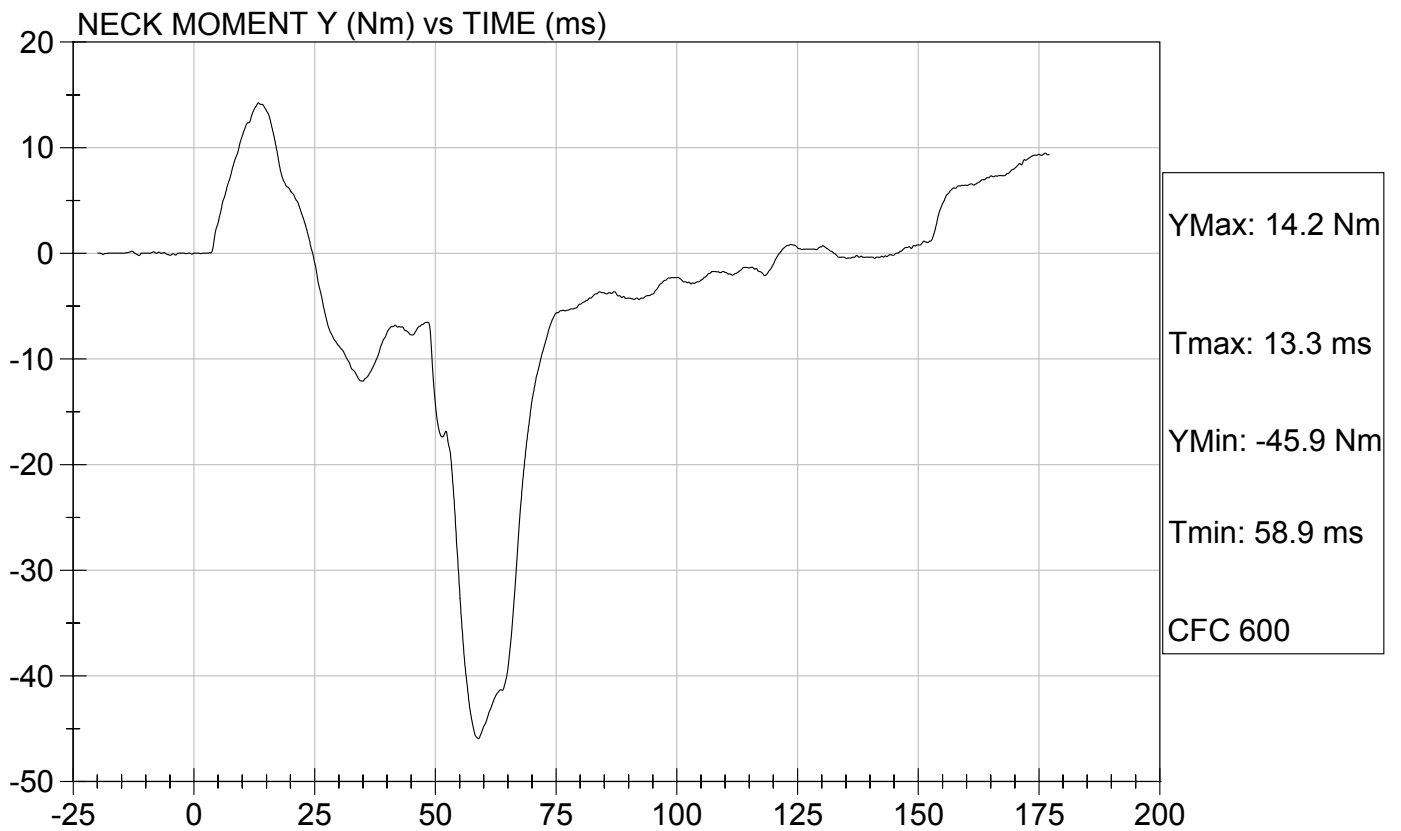
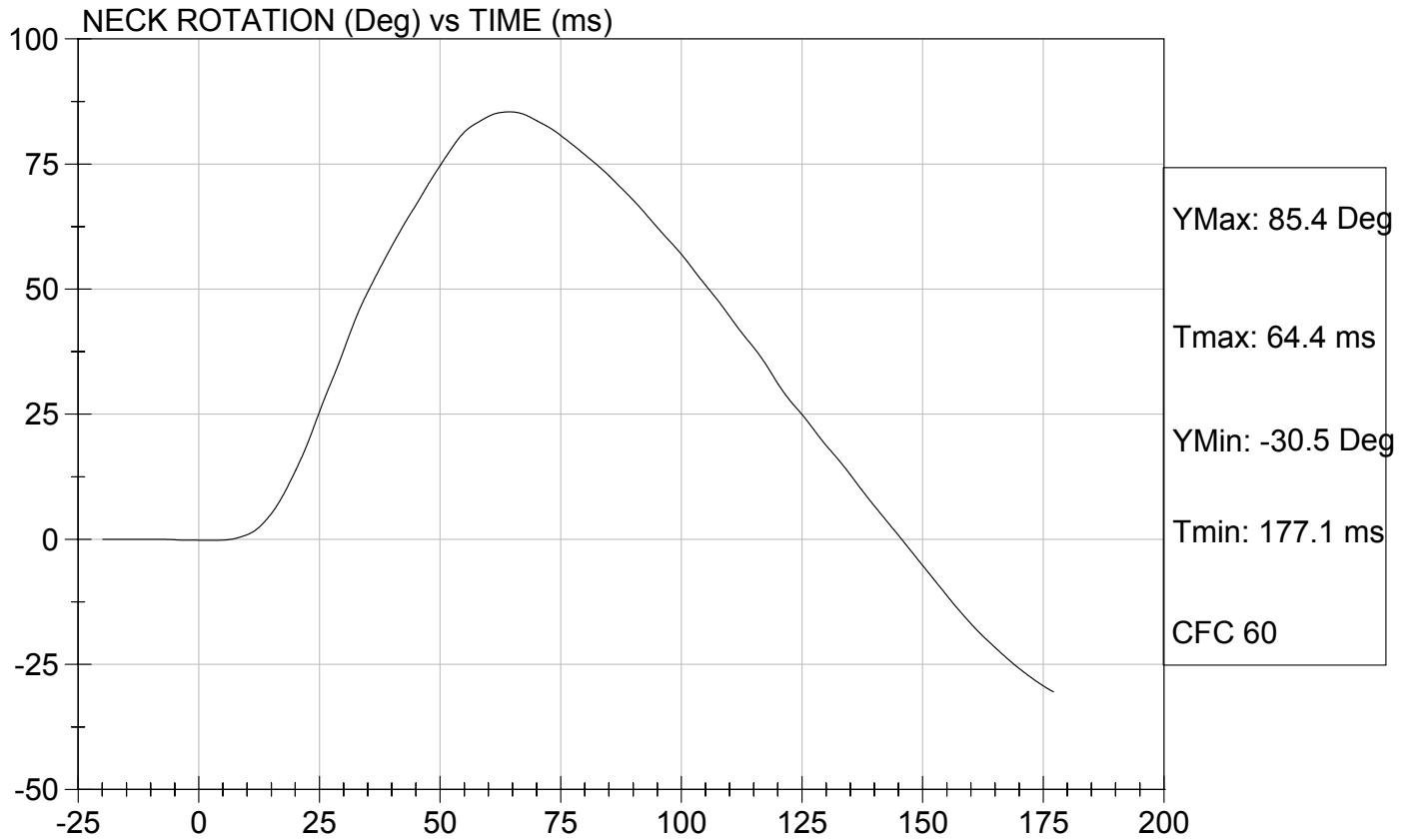

Hybrid III Calibration Data Sheet
3 Year Old
Thorax Impact Test

ATD Serial No: 042

Test I.D.: D041814

Tested Parameter	Units	Specification	Result	Pass/Fail
Laboratory Temperature	deg C	20.6 to 22.2	21.1	Pass
Laboratory Relative Humidity	%	10 to 70	43	Pass
Probe Velocity	m/s	5.9 to 6.1	5.9	Pass
Peak Deflection	mm	32 - 38	37	Pass
Peak Force w/in Deflection Corridor	kN	0.68 - 0.81	0.74	Pass
Internal Hysteresis	%	65 to 85	69	Pass
Max Force 12.5 mm - 32 mm Deflection	kN	Max 0.86	0.48	Pass
Overall Test Results				Pass

Jessica Hall
 Laboratory Technician

08/06/2004
 Test Date

David Winkelbauer
 Approved By



Test Description: Thorax Impact

Test Date: 08/06/2004

Component: D041814

Speed: 19.42 ft/sec, 5.92 m/sec

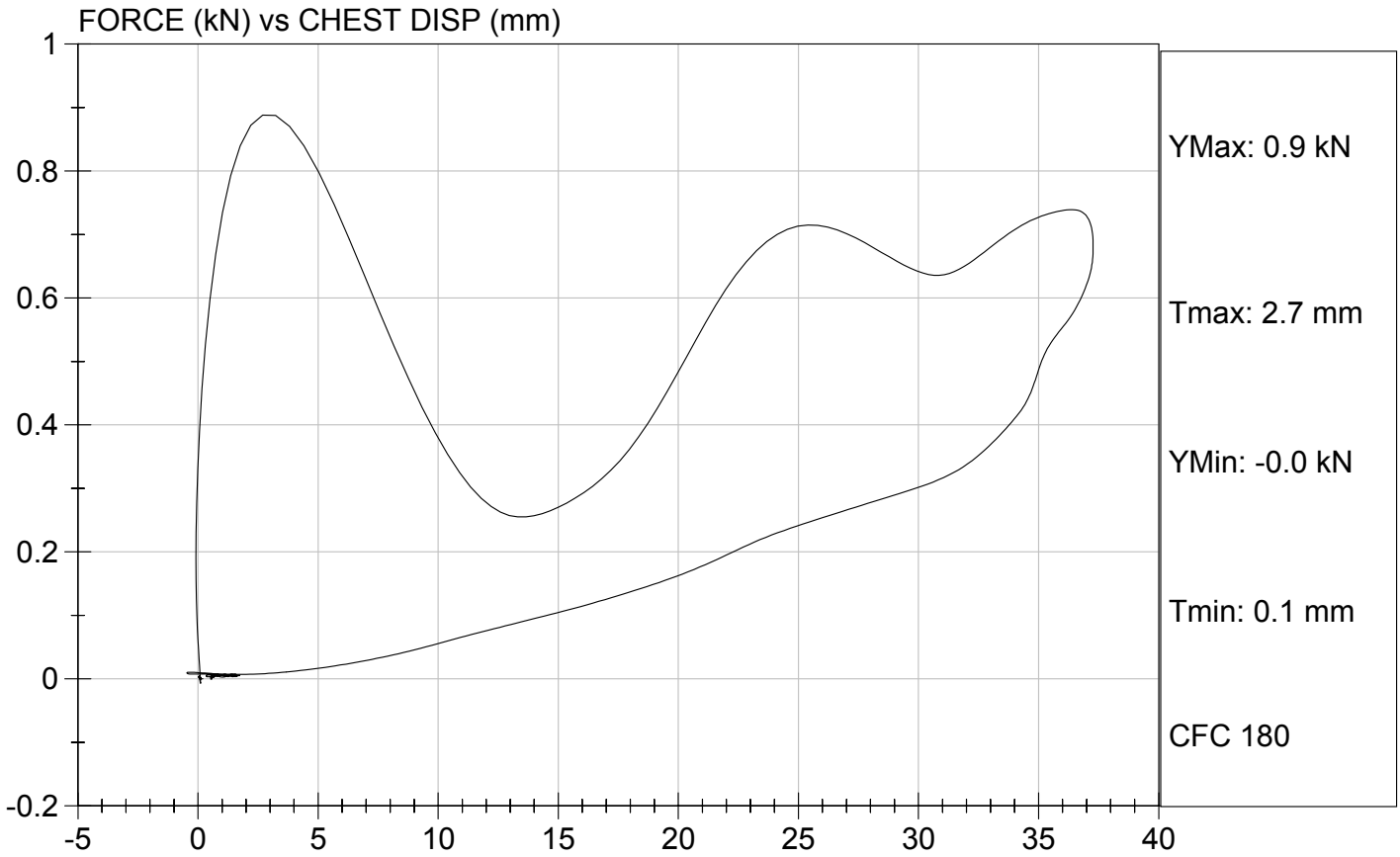

Hybrid III Calibration Data Sheet
3 Year Old
Torso Lumbar Flexion

ATD Serial No: 042

Test I.D.: D041817

Tested Parameter	Units	Specification	Result	Pass/Fail
Laboratory Temperature	deg C	18.9 to 25.6	21.0	Pass
Laboratory Relative Humidity	%	10 to 70	42	Pass
Force At 45 deg.	N	130 - 180	172	Pass
Initial Angle	deg	0 - 15	4	Pass
Return Angle	deg	0 - 10	4	Pass
Overall Test Results				Pass

Jessica Hall
 Laboratory Technician

08/06/2004
 Test Date

David Winkelbauer
 Approved By

APPENDIX D

TEST EQUIPMENT LIST AND CALIBRATION INFORMATION

INSTRUMENTS FOR LRP CHILD DUMMY S/N: 144

	SERIAL NO.	MANUFACTURER	CALIBRATION DATE
Head X	AH0B0	Endevco	7/23/04
Head Y	ALE80	Endevco	7/23/04
Head Z	AP1H2	Endevco	7/23/04
Upper Neck Load Cell	1626	FTSS	7/20/04
Chest X	P22203	Endevco	11/12/04
Chest Y	L20-B14	Entran	11/12/04
Chest Z	AJ621	Endevco	11/12/04
Chest Deflection Gauge	144	Servo	8/09/04
Pelvis X	J13653	Endevco	9/15/04
Pelvis Y	J13649	Endevco	9/15/04
Pelvis Z	J13713	Endevco	9/15/04
Shoulder Belt	199	Denton	6/08/04
Lap Belt	198	Denton	6/08/04
Right Femur	126	Denton	7/21/04
Left Femur	125	Denton	7/21/04

INSTRUMENTS FOR RRP CHILD DUMMY S/N: 042

	SERIAL NO.	MANUFACTURER	CALIBRATION DATE
Head X	B05-J12	Entran	9/15/04
Head Y	B05-J19	Entran	9/15/04
Head Z	A27-Z11	Entran	9/15/04
Upper Neck Load Cell	208	FTSS	5/13/04
Chest X	A27-Z23	Entran	9/15/04
Chest Y	A27-Z24	Entran	9/15/04
Chest Z	A27-Z13	Entran	9/15/04
Chest Deflection Gauge	042	Servo	8/06/04
Pelvis X	A27-Z19	Entran	9/15/04
Pelvis Y	A27-Z07	Entran	9/15/04
Pelvis Z	A27-Z16	Entran	9/15/04
RRP Tether Force	172	FTSS	8/18/04

INSTRUMENTS FOR VEHICLE AND CHILD SEAT

	SERIAL NO.	MANUFACTURER	CALIBRATION DATE
Left Rear Seat Back X	K18-J06	Entran	12/02/04
Left Rear Seat Back Y	C12-M13	Entran	12/02/04
Left Rear Seat Back Z	K18-J03	Entran	12/02/04
LRP Child Seat X	L17-D29	Entran	12/02/04
LRP Child Seat Y	K18-D17	Entran	12/02/04
LRP Child Seat Z	K18-D25	Entran	12/02/04
RRP Child Seat X	L17-D26	Entran	12/02/04
RRP Child Seat Y	L17-D02	Entran	12/02/04
RRP Child Seat Z	K11-Z14	Entran	12/02/04