

**REPORT NUMBER TR-P25001-04-NC**

**NEW CAR ASSESSMENT PROGRAM  
FRONTAL BARRIER IMPACT TEST**

**TOYOTA MOTOR CORPORATION  
2005 TOYOTA TUNDRA  
2-DOOR TRUCK**

**NHTSA NUMBER: M55111**

**PREPARED BY:  
KARCO ENGINEERING, LLC  
9270 HOLLY ROAD  
ADELANTO, CALIFORNIA 92301**



**OCTOBER 5, 2004**

**FINAL REPORT**

**PREPARED FOR:  
U.S. DEPARTMENT OF TRANSPORTATION  
NATIONAL HIGHWAY TRAFFIC SAFETY ADMINISTRATION  
RULEMAKING  
OFFICE OF CRASHWORTHINESS STANDARDS  
MAIL CODE: NVS-111  
400 SEVENTH STREET, SW, ROOM 5311  
WASHINGTON, D.C. 20590**

This final test report was prepared for the U.S. Department of Transportation, National Highway Traffic Safety Administration, in response to Contract Number DTNH22-01-D-02005.

This publication is distributed by the U.S. Department of Transportation, National Highway Traffic Safety Administration, in the interest of information exchange. The opinions, findings and conclusions expressed in this publication are those of the author(s) and not necessarily those of the Department of Transportation or the National Highway Traffic Safety Administration. The United States Government assumes no liability for its contents or use thereof. If trade or manufacturers' names or products are mentioned, it is only because they are considered essential to the object of the publication and should not be construed as an endorsement. The United States Government does not endorse products or manufacturers.

Prepared by: \_\_\_\_\_  
Mr. Biren J. Patel, Project Engineer  
KARCO Engineering, LLC

Date: 10/5/04

Reviewed by: \_\_\_\_\_  
Mr. Michael L. Dunlap, Quality Assurance Manager  
KARCO Engineering, LLC

Date: 10/5/04

Approved by: \_\_\_\_\_  
Mr. Frank D. Richardson, Program Manager  
KARCO Engineering, LLC

Date: 10/5/04

FINAL REPORT ACCEPTED BY:

\_\_\_\_\_  
Manager, New Car Assessment Program

\_\_\_\_\_  
Date of Acceptance

\_\_\_\_\_  
COTR, NCAP Frontal Impact Program

\_\_\_\_\_  
Date of Acceptance

**Technical Report Documentation Page**

<b>1. Report No.</b> TR-P25001-04-NC		<b>2. Government Accession No.</b>		<b>3. Recipients Catalog No.</b>	
<b>4. Title and Subtitle</b> Final Report of New Car Assessment Program 2005 Toyota Tundra 2-Door Truck NHTSA No. M55111				<b>5. Report Date</b> October 5, 2004	
				<b>6. Performing Organization Code</b>	
<b>7. Authors</b> Mr. Biren J. Patel, Project Engineer, Karco Mr. Frank Richardson, Program Manager, Karco				<b>8. Performing Organization Report No.</b> TR-P25001-04-NC	
<b>9. Performing Organization Name and Address</b> Karco Engineering, LLC 9270 Holly Rd. Adelanto, CA, 92301				<b>10. Work Unit No.</b>	
				<b>11. Contract or Grant No.</b> DTNH22-01-D-02005	
<b>12. Sponsoring Agency Name and Address</b> U. S. Department of Transportation National Highway Traffic Safety Administration Rulemaking Office of Crashworthiness Standards Mail Code NPS-111 400 Seventh Street, SW, Room 5311 Washington, D.C 20590				<b>13. Type of Report and Period Covered</b> Final Test Report Option Year 3	
				<b>14. Sponsoring Agency Code</b> DOT/NHTSA/NRMOCS	
<b>15. Supplementary Notes</b>					
<b>16. Abstract</b>  A 35 mph (56.3 km/h) frontal barrier impact was conducted on a 2005 Toyota Tundra 2-Door Truck at Karco Engineering, LLC on October 5, 2004. This test was conducted to obtain data indicant of FMVSS 208, 212, 219 (partial), 301, and footwell intrusion performance. The impact velocity was 56.35 km/h. The ambient temperature at the barrier face at the time of impact was 28.3 degrees Celcius. The vehicle's maximum post test static crush is 545 mm at center of the vehicle. The test vehicle is equipped with a 3-point continuous belt system and second generation supplemental airbags in both front outboard seating positions. With respect to FMVSS 208 "Occupant Crash Protection", the occupant injury criteria summary is as follows:					
<b>Measurement Description</b>		<b>Units</b>	<b>Threshold</b>	<b>Driver ATD</b>	<b>Passenger ATD</b>
Head Injury Criteria (HIC <sub>36</sub> )		N/A	1000	614.8	413.4
Max. Chest Accel. (3 msec Clip)		G's	60	46.1	44.0
Left Femur Force		Newtons	10008	-4818.5	-3612.1
Right Femur Force		Newtons	10008	-2677.4	-2185.0
<b>17. Key Words</b> 56.2 km/h NCAP Frontal Barrier Impact Test New Car Assessment Program (NCAP) 2005 Toyota Tundra 2-Door Truck NHTSA No. M55111				<b>18. Distribution of Statement</b> Copies of this report available from NHTSA Technical Reference Division National Highway Traffic Safety Administration 400 Seventh St., SW, Room 5108 Washington, D.C. 20590	
<b>19. Security Classification (this report)</b> Unclassified		<b>20. Security Classification (this page)</b> Unclassified		<b>21. No. of Pages</b> 191	<b>22. Price</b>

Form DOT F1700.7 (8-72)

TABLE OF CONTENTS

Section	Description	Page
1	Purpose and Summary of Test M55111	1
2	Occupant and Vehicle Information/Data Sheets	3

Data Sheet	Description	Page
1	Crash Test Summary	4
2	General Test and Vehicle Parameter Data	5
3	Post Test Impact Data	8
4	Test Vehicle Information	9
5	Dummy Positioning in Vehicle	11
6	Seatbelt Positioning Data	13
7	Vehicle Accelerometer Location and Data Summary	14
8	Hybrid III ATD Injury Criteria and Sensor Data	15
9	Seatbelt Assessment Test Data	18
10	Summary of FMVSS 212 Data	19
11	Windshield Zone Intrusion FMVSS 219 Data (Partial)	20
12	FMVSS 301 Fuel System Integrity Post Impact Data	21
13	FMVSS 301 Static Rollover Data	22
14	Vehicle Measurements	24
15	Camera Locations	27
16	Photographic Reference Target Locations	28
17	Vehicle Intrusion Measurements	29
18	Fixed Barrier Load Cell Locations	33
19	Post-Test Air Bag Data	34
21	Accident Investigation Division Data	35
22	Dummy/Vehicle Temperature Stabilization	36

Appendix	Description	Appendix
A	Photographs	A
B	Data Plots	B
C	Load Cell Barrier Data Plots	C
D	Instrumentation Data Channel Assignments	D
E	Dummy Calibration Data	E
F	NAAH Data	F

## SECTION 1

### PURPOSE AND SUMMARY OF TEST M55111

#### 1.1 PURPOSE

This 35 mph (56.3 km/h) frontal barrier impact test is part of the New Car Assessment Program (NCAP) sponsored by the National Highway Traffic Safety Administration (NHTSA) under Contract No. DTNH22-01-D-02005. The purpose of this test was to obtain vehicle crashworthiness and occupant restraint system performance data for an impact speed in excess of the current 30 mph (48.3 km/h) requirements.

This 56.3 km/h frontal barrier impact test was conducted in accordance with the Office of Crashworthiness Standards (OCS) New Car Assessment Program (NCAP) Laboratory Indicant Test Procedure, dated December 1999. Data was obtained indicant of FMVSS 208 "Occupant Crash Protection"; FMVSS 212, "Windshield Retention"; FMVSS 219, "Windshield Zone Intrusion (Partial)"; and FMVSS 301 "Fuel System Integrity" performance. Procedures for receiving, inspection testing and reporting of test results are described in the test procedures and are not repeated in this report.

#### 1.2 SUMMARY

A load cell barrier consisting of 36 load cells was impacted by a 2005 Toyota Tundra 2-Door Truck at a velocity of 56.35 km/h. The test was performed at Karco Engineering, LLC on October 5, 2004.

Two (2) real-time, five (5) high-speed digital video and fourteen (14) high-speed film cameras were used to document the frontal barrier impact event. Camera locations and other pertinent camera information can be found in data sheet number 15 (page number: 27) of this report.

Two Part 572E, 50<sup>th</sup> percentile male anthropomorphic test devices (ATDs), were placed in the driver and right-front passenger seating positions according to dummy placement instructions specified in the Laboratory Indicant Test Procedure.

Both ATDs were fully instrumented with head (primary and redundant), chest (primary and redundant) and pelvic triaxial accelerometers, chest displacement potentiometers, six-axis upper neck transducers, right/left femur load cells, and lower leg instrumentation. Seat belt load cells were also placed on the driver's and passenger's lap and shoulder belts to measure dummy torso and pelvic section loading. Also, shoulder belt spool-off was measured for the driver and passenger dummies. The driver (position 1) ATD (Serial No. 035) and the right-front passenger (position 2) ATD (Serial No. 034) were calibrated prior to this test.

One hundred and seven (107) channels of data were recorded using an on-board data acquisition system. Appendix A contains Pre and Post-Test Photographs, Appendix B contains the vehicle and dummy response data traces. Appendix C contains Load Cell Barrier information. Appendix D contains the Instrumentation Data Channel assignments. Appendix E contains the Dummy Calibration data and Appendix F contains the NAAH data.

There was 100 percent windshield retention and no intrusion into the protected zone of the windshield during the impact event. There was no Stoddard solvent leakage after the event or during any phase of the static rollover.

The maximum static crush of the vehicle was 545 mm and both the driver and the passenger side doors remained closed during the impact event and were operable after the impact.

The driver's visible contact points were as follows: The driver ATD head contacted the airbag and on rebound the head contacted the B-pillar, its chest and abdomen contacted the airbag, both knees contacted the knee bolster.

The passenger's visible contact points were as follows: The passenger ATD head contacted the airbag, its chest and abdomen contacted the airbag and both knees contacted the glove box.

Occupant injury data is contained in table below.

**OCCUPANT DATA SUMMARY**

ATD Position	HIC	Clip (g)	Chest Disp. (mm)	Left Femur (N)	Right Femur (N)	Belt Spool (mm)
Driver	614.8	46.1	-25.7	-4818.5	-2677.4	174.7
Passenger	413.4	44.0	-26.9	-3612.1	-2185.0	202.2

**SECTION 2  
OCCUPANT AND VEHICLE INFORMATION/DATA SHEETS**

Test Vehicle: 2005 Toyota Tundra 2-Door Truck

NHTSA No.: M55111

Test Program: 2005 NHTSA 35mph NCAP

Test Date: 10/5/04

**CONVERSION FACTORS USED IN THIS REPORT\***

Quantity	Typical Application	Std Units	Metric Unit	Multiply By
Mass	Vehicle Weight	lb	kg	0.4536
Linear Velocity	Impact Velocity	mile/h	km/h	1.609
Length or Distance	Measurements	in	mm	25.4
Volume	Fuel Systems	gal	liter	3.785
Volume	Small Fluids	oz	mL	29.573
Pressure	Tire Pressures	lbf/in <sup>2</sup>	kPa	7.0
Volume	Liquid	gal	liter	3.785
Temperature	General Use	°F	°C	=(tf -32)/1.8
Force	Dynamic Forces	lbf	N	4.448
Moment	Torque	lbf/ft	Nm	1.355

\* Based on the Recommended Practice in SAE J916, May 85

**DATA SHEET NO. 1  
CRASH TEST SUMMARY**

Test Vehicle: 2005 Toyota Tundra 2-Door Truck

NHTSA No.: M55111

Test Program: 2005 NHTSA 35mph NCAP

Test Date: 10/5/04

**PRIMARY IMPACT DATA**

Measured Parameter	Units	Value
Velocity at Impact	km/h	56.35
Test Weight	kg	2079
Impact Angle	degrees	0
Average Rebound	mm	967
Maximum Static Crush	mm	545

**DOOR OPENING AND SEAT TRACK INFORMATION**

Description	Driver	Passenger
Front Door opening	Remained closed, opened w/o tools	Remained closed, opened w/o tools
Rear Door Opening		
Seat Track Shift (mm)	0	0
Seat Back Failure	No	No

**TEST DUMMY INFORMATION**

Description	Driver	Passenger
Dummy Type/ Serial No.	50% Male Hybrid III No. 35	50% Male Hybrid III No. 34
Head Contact	Airbag, Head Rest, B-Pillar	Airbag, Head Rest
Chest Contact	Airbag	Airbag
Abdomen Contact	Airbag	Airbag
Left Knee Contact	Knee Bolster	Glove Box
Right Knee Contact	Knee Bolster	Glove Box

**16mm MOVIE COVERAGE**

High Speed	19
Real Time	2
Total	21

**DATA CHANNELS**

Driver ATD Sensors	46
Passenger ATD Sensors	46
Belt Assessment Sensors	8
Vehicle Structure Accelerometers	9
Rigid Barrier Load Cells	36
Total	145

**DATA SHEET NO. 2  
GENERAL TEST AND VEHICLE PARAMETER DATA**

Test Vehicle: 2005 Toyota Tundra 2-Door Truck

NHTSA No.: M55111

Test Program: 2005 NHTSA 35mph NCAP

Test Date: 10/5/04

**TEST VEHICLE INFORMATION AND OPTIONS**

NHTSA No.	M55111
Make	Toyota
Model	Tundra
Body Style	2-Door Regular Cab
Vin No.	5TBJU32135S442753
Color	White
Delivery Date	9/13/04
Odometer	59
Dealer	Sierra Toyota
Transmission	5-Speed Automatic
Final Drive	Rear
Type/No. Cyl.	V6
Engine Disp. (L)	4.0
Engine Placement	Longitudinal
Roof Rack	No
Sunroof/T-Top	No
Tinted Glass	No
Traction Control	No
Power Brakes	Yes
Front Disc	Yes
Rear Disc	No

Anti-Lock Brakes	Yes
All Wheel Drive	No
Power Steering	Yes
Driver Front Airbag	Yes
Driver Side Airbag	No
Driver Head Airbag	No
Driver Curtain Airbag	No
Pass. Airbag	Yes
Pass. Side Airbag	No
Pass. Head Airbag	No
Pass. Curtain Airbag	No
Pre-Tensioners	Yes
Load Limiters	Yes
Bucket Seats	No
Air Cond.	Yes
AM/FM Cassette	Yes
Tilt Steering	Yes
Automatic Door Locks	No
Power Windows	No
Power Seats	No
Tire Pressure Monitoring System	Yes

Does Owners Manual provide instructions to turn off automatic door locks.

N/A

**DATA FROM CERTIFICATION LABEL**

Manufactured By	Toyota Motor Manufacturing
Date of Manufacture	Aug-04

GWR (kg)	2495
GAWR Front (kg)	1588
GAWR Rear (kg)	1615

**VEHICLE SEATING AND CAPACITY WEIGHT INFORMATION**

Measured Parameter	Front	Rear	Third	Total
Type of Seats	Bench	Bench	None	
Number of Occupants	3	0	0	3
Capacity Weight (VCW) (kg)				637
Cargo Weight (RCLW) (kg)				136

**DATA SHEET NO. 2...(CONTINUED)**  
**GENERAL TEST AND VEHICLE PARAMETER DATA**

Test Vehicle: 2005 Toyota Tundra 2-Door Truck

NHTSA No.: M55111

Test Program: 2005 NHTSA 35mph NCAP

Test Date: 10/5/04

Collect year, make, model, VIN, items circled in red, and tire manufacturer and tire name.

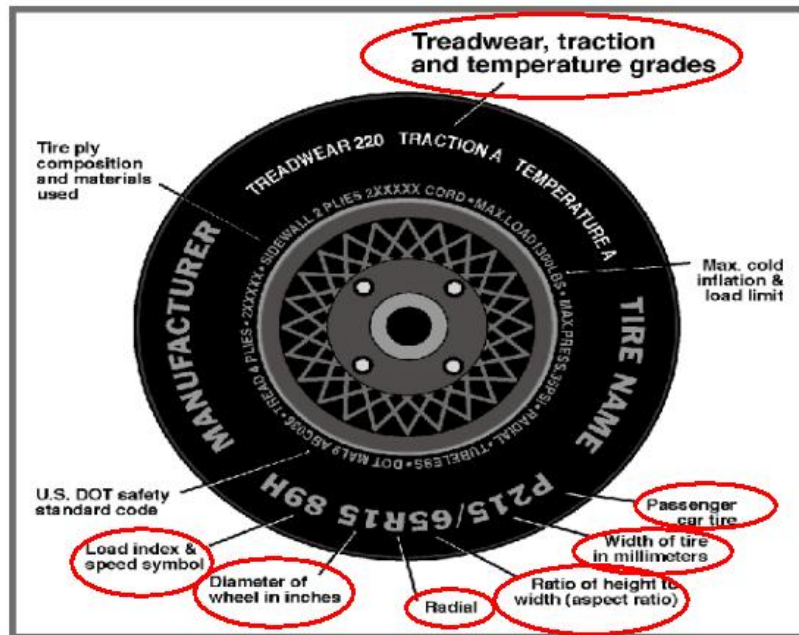

**TIRE INFORMATION**

Measured Parameter	Front	Rear
Max. Tire Pressure (kpa)	308	308
Cold Pressure (kpa)	200	245
Recommended Tire Size	P245/70R16	P245/70R16
Tire Size on Vehicle	P245/70R16	P245/70R16
Tire Manufacturer	Bridgestone	Bridgestone
Treadwear	180	180
Traction	B	B
Temperature Grades	B	B
Tire Plies Sidewall	2 Polyester	2 Polyester
Tire Plies Body	N/A	N/A
Load Index/Speed Symbol	106S	106S
Tire Material	2 Steel + 2 Polyester + 1 Nylon	2 Steel + 2 Polyester + 1 Nylon
DOT Safety Code Right	DOT 7X9L PDE 3004	DOT 7X9L PDE 3004
DOT Safety Code Left	DOT 7X9L PDE 3004	DOT 7X9L PDE 3004

**DATA SHEET NO. 2...(CONTINUED)**  
**GENERAL TEST AND VEHICLE PARAMETER DATA**

Test Vehicle: 2005 Toyota Tundra 2-Door Truck

NHTSA No.: M55111

Test Program: 2005 NHTSA 35mph NCAP

Test Date: 10/5/04

**TEST VEHICLE WEIGHTS**

	Units	As Delivered Weights (UWV)			As Tested Weights (ATW)		
		Front Axle	Rear Axle	Total	Front Axle	Rear Axle	Total
Left	kg	536	386		576	491	
Right	kg	488	388		541	472	
Ratio	%	56.9	43.1		53.7	46.3	
Totals	kg	1024	775	1799	1117	963	2079

**TARGET TEST WEIGHT CALCULATION**

Measured Parameter	Units	Value
Total Delivered Weight (UWV)	kg	1799
Weight of 2 P572 ATD's	kg	152
Rated Cargo/Luggage Wt. (RCLW)	kg	136
Calculated Vehicle Target Wt. (TVTWT)	kg	2087

**TEST VEHICLE ATTITUDE AND CG**

	Units	LF	RF	LR	RR	CG (aft of front axle)
As Delivered	mm	863	883	923	925	1411
As Tested	mm	850	855	890	890	1517

Vehicle Wheel Base (mm) 3276

Weight of Ballast Secured in cargo area (kg) 34.5

Vehicle Components Removed N/A

\* Ballast weight does not include cameras, instrumentation and brake abort system.

**FUEL SYSTEM DATA**

Fuel System Capacity From Owners Manual (L) 99.93

Usable Capacity Furnished by COTR (L) 75.71

Actual Test Volume with entire fuel System Filled (L) 92.93

1/3 of Usable Capacity (L)

Test Fluid Type: Stoddard Solvent

Kinematic Viscosity: as per ASTM Standard D484-71 Purple

Is Vehicle Fuel Pump Electric or Mechanical? Electric

If electric, does pump operate with ignition switch "On" & engine "OFF" Yes

Fuel System Particulars: None

**DATA SHEET NO. 3  
POST TEST IMPACT DATA**

Test Vehicle: 2005 Toyota Tundra 2-Door Truck

NHTSA No.: M55111

Test Program: 2005 NHTSA 35mph NCAP

Test Date: 10/5/04

**SPEED TRAP DATA**

Measured Parameter	Units	Requirement	Value
Trap No.1 Velocity (Primary)	km/h	55.51 to 57.12	56.35
Trap No. 1 Entry Distance	mm	<1524	1524
Trap No.1 Exit Distance	mm	<1524	305
Trap No.2 Velocity (Redun.)	km/h	55.51 to 57.12	56.28
Trap No.2 Entry Distance	mm	<1524	1524
Trap No.2 Exit Distance	mm	<1524	305

**VEHICLE STATIC CRUSH**

Measured Parameter	Units	Pre-Test	Post-Test	Difference
Left Side	mm	5399	5045	-354
Center	mm	5550	5005	-545
Right Side	mm	5390	5023	-367

**VEHICLE REBOUND FROM BARRIER**

Measured Parameter	Units	Value
Left Side	mm	980
Center	mm	990
Right Side	mm	930
Average	mm	967

**DATA SHEET NO. 4  
TEST VEHICLE INFORMATION**

Test Vehicle: 2005 Toyota Tundra 2-Door Truck

NHTSA No.: M55111

Test Program: 2005 NHTSA 35mph NCAP

Test Date: 10/5/04

**NOMINAL DESIGN RIDING POSITION**

The driver and passenger seat backs are positioned to the manufacturers designated angle. The procedure is as follows: Seat back angle was measured at the headrest using a digital inclinometer.

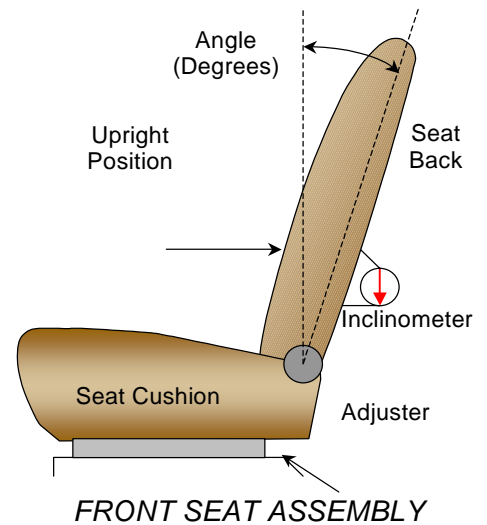

**SEAT BACK ANGLES**

	Deg.
Driver w/seated Dummy	6.3
Passenger w/seated Dummy	6.3

**SEAT FORE/AFT POSITIONS**

The first or forward most position is counted as number one (1). The fore/aft position is set aft of the middle position for both the driver and passenger.

**SEAT FORE/AFT POSITIONING**

	Total Fore/Aft Travel	Placed in Position #
Driver	16 Detents	8th Detent
Passenger	16 Detents	8th Detent

**SEAT BELT UPPER ANCHORAGE**

Position number one (1) is the uppermost position.

**SEAT BELT UPPER ANCHORAGE**

	Total # of Positions	Placed in Position #
Driver	5	2
Passenger	5	2

**DATA SHEET NO. 4...(CONTINUED)**  
**TEST VEHICLE INFORMATION**

Test Vehicle: 2005 Toyota Tundra 2-Door Truck

NHTSA No.: M55111

Test Program: 2005 NHTSA 35mph NCAP

Test Date: 10/5/04

**FUEL TANK CAPACITY**

	Liters
Usable Capacity of "Standard Tank"	99.93
Usable Capacity of "Optional" Tank	N/A
Usable Capacity used for FMVSS 301	91.91 to 93.92
Actual Amount of Solvent used	92.93
1/3 of Usable Capacity	

The test vehicle is equipped with an electric fuel pump. The fuel pump operates for approximately two seconds after the ignition is placed in the "ON" position, after which the fuel pump automatically shuts off. The fuel filler door is located on the right rear fender. The standard fuel tank occupies the area under the rear seat.

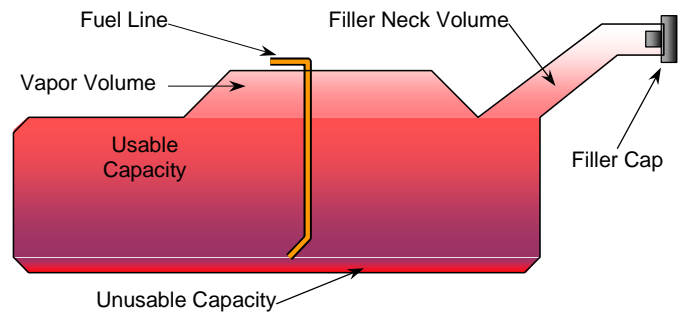

VEHICLE FUEL TANK ASSEMBLY

**STEERING COLUMN ADJUSTMENT**

Steering wheel and column adjustments are made so that the steering wheel hub is at the geometric center of the locus it describes when moved through its full range of motion. An aluminum plate is placed across the rim of the steering wheel, an inclinometer is placed on the plate and the angle is measured.

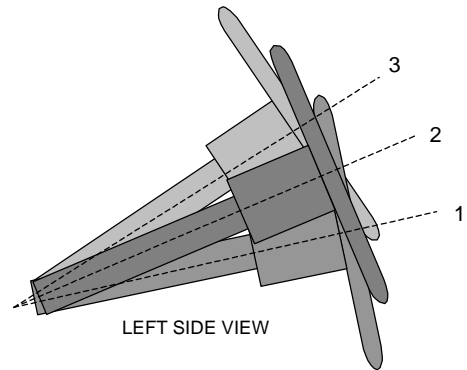

STEERING COLUMN ASSEMBLY

**STEERING COLUMN POSITIONS**

	Fore/Aft Positon (mm)	Degrees
Lowermost positon No. 1	N/A	N/A
Geometric center position No. 2	N/A	25.7
Uppermost position No. 3	N/A	N/A

**DATA SHEET NO. 5**  
**DUMMY POSITIONING IN VEHICLE**

Test Vehicle: 2005 Toyota Tundra 2-Door Truck

NHTSA No.: M55111

Test Program: 2005 NHTSA 35mph NCAP

Test Date: 10/5/04

**TEST DUMMY POSITION MEASUREMENTS**

Code	Measurement Description	Driver		Passenger	
		Length (mm)	Angle (deg)	Length (mm)	Angle (deg)
WA	Windshield Angle		50.7		
SWA	Steering Wheel Angle		64.3		
SCA	Steering Column Angle		25.7		
SA	Seat Back Angle		6.3		6.3
HZ	Head to Roof (Z)	190	90.0	210	90.0
HH	Head to Header	370		405	
HW	Head to Windshield	530		570	
HR	Head to Side Header (Y)	245		265	
NR	Nose to Rim	390	19.5		
CD	Chest to Dash	530		630	
CS	Chest to Steering Hub	260			
RA	Rim to Abdomen	190			
KDL	Left Knee to Dash	200	10.3	150	
KDR	Right Knee to Dash	280		145	15.1
PA	Pelvic Angle		20.0		24.0
TA	Tibia Angle		39.8		48.0
KK	Knee to Knee (Y)	285		270	
SK	Striker to Knee	740	4.2	760	1.1
ST	Striker to Head	600	66.2	580	64.4
SH	Striker to H-Point	370	20.6	386	18.2
SHY	Striker to H-Point (Y)	245		265	
HS	Head to Side Window	305		340	
HD	H-Point to Door (Y)	165		180	
AD	Arm to Door (Y)	100		70	

**DATA SHEET NO. 5...(CONTINUED)**  
**DUMMY POSITIONING IN VEHICLE**

Test Vehicle: 2005 Toyota Tundra 2-Door Truck

NHTSA No.: M55111

Test Program: 2005 NHTSA 35mph NCAP

Test Date: 10/5/04

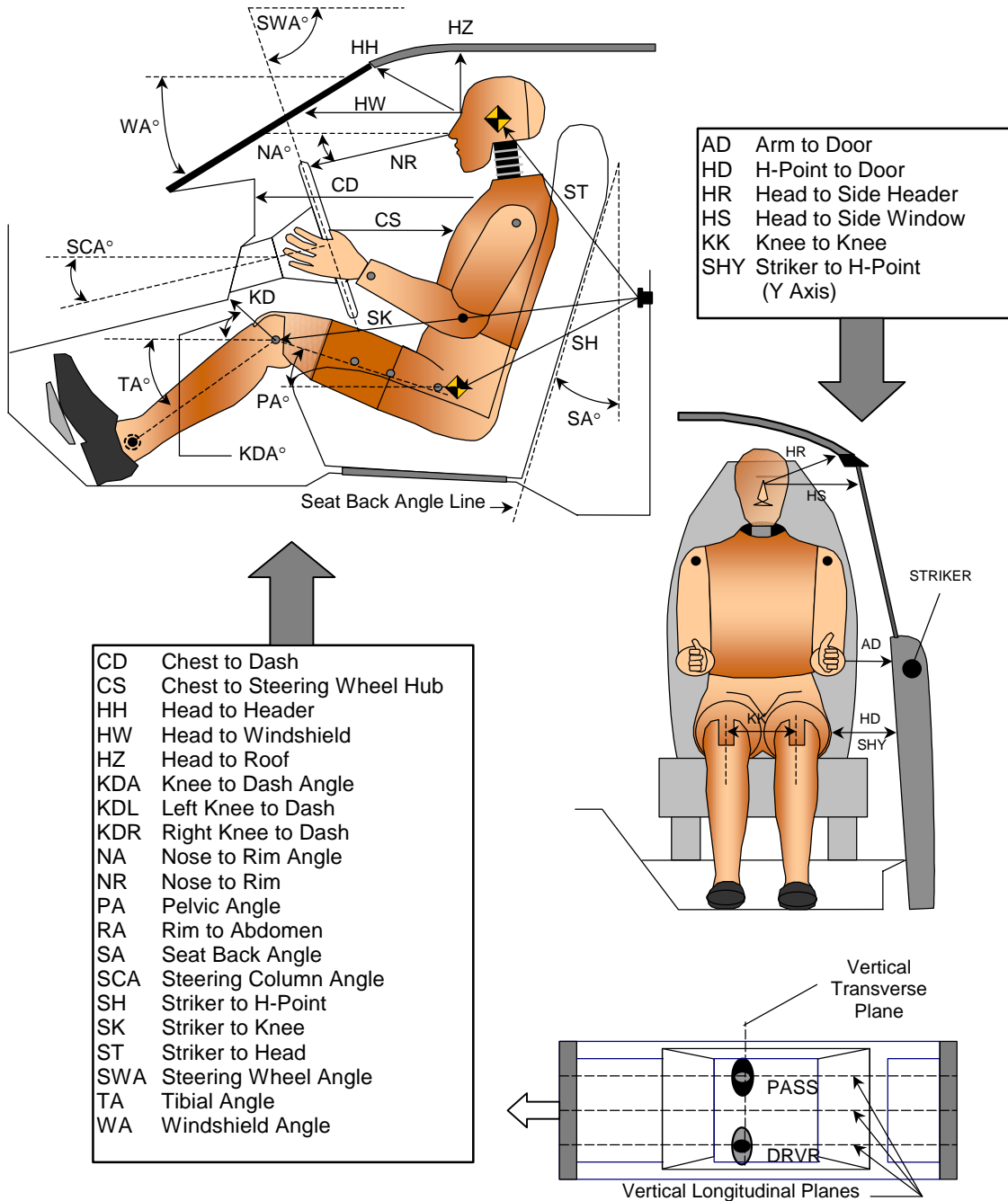

**DUMMY MEASUREMENTS FOR FRONT SEAT OCCUPANTS**

**DATA SHEET NO. 6**  
**SEAT BELT POSITIONING DATA**

Test Vehicle: 2005 Toyota Tundra 2-Door Truck

NHTSA No.: M55111

Test Program: 2005 NHTSA 35mph NCAP

Test Date: 10/5/04

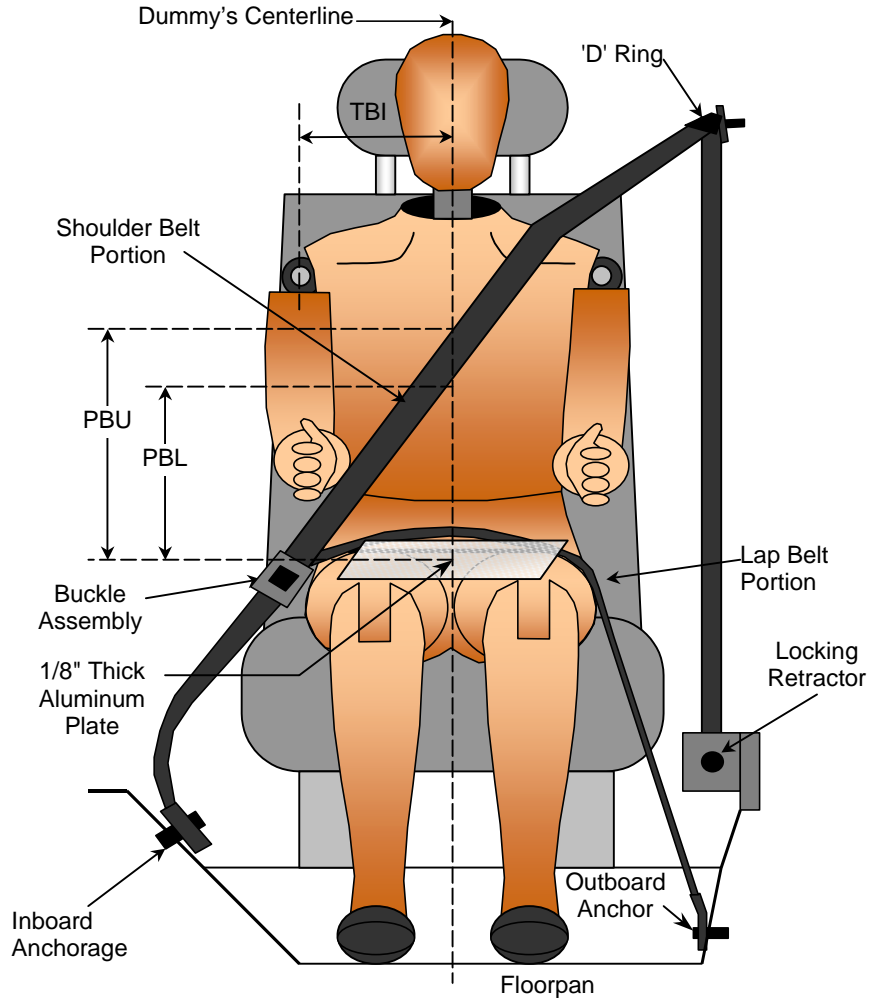

**SEAT BELT POSITIONING MEASUREMENTS**

Measured Parameter	Units	Driver	Passenger
TBI -Dummy C/L to Lap/Shoulder Belt Intersect	mm	210	220
PBU - Top Surface of reference to belt upper edge	mm	335	300
PBL - Top Surface of reference to belt lower edge	mm	260	220
Lap Belt Tension	Newtons	10	10
Shoulder Belt Tension	N/A	Retractor	Retractor

# DATA SHEET NO. 7 - VEHICLE ACCELEROMETER LOCATION AND DATA SUMMARY

Test Vehicle: 2005 Toyota Tundra 2-Door Truck

NHTSA No.: M55111

Test Program: 2005 NHTSA 35mph NCAP

Test Date: 10/5/04

## VEHICLE ACCELEROMETER PEAK DATA AND PRE-TEST LOCATIONS

No.	Accelerometer Location	Measurements (mm)			Peak Values				
		X	Y	Z	Units	Max	Time	Min	Time
1	Left Rear X-Member	3225	-790	530	G's	3.1	128.9	-47.6	20.7
2	Right Rear X-Member	3225	790	530	G's	2.7	153.0	-44.1	20.4
3	Engine Top	4560	-160	1050	G's	40.2	47.8	-129.0	36.0
4	Engine Bottom	4770	0	380	G's	27.9	47.0	-111.9	38.9
5	Left Brake Caliper	4760	-710	300	G's	52.7	65.7	-94.4	40.2
6	Right Brake Caliper	4760	710	300	G's	58.0	63.2	-128.2	46.6
7	Instrument Panel	3850	0	1310	G's	7.7	121.0	-58.6	34.5
8	Left Rear X-Member (Z-Axis)	3275	-790	530	G's	14.9	50.2	-8.2	24.7
9	Right Rear X-Member (Z-Axis)	3275	790	530	G's	12.4	43.1	-9.2	25.4

Reference Planes: X=From Rear Surface of Vehicle, Y=Vehicle Centerline, Z=Ground Plane

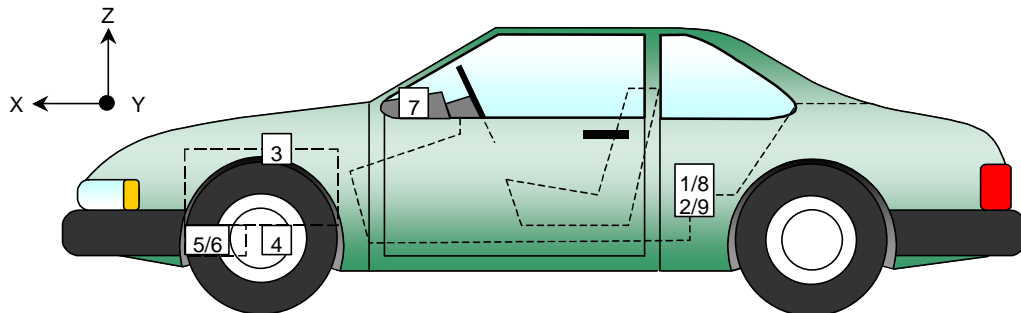
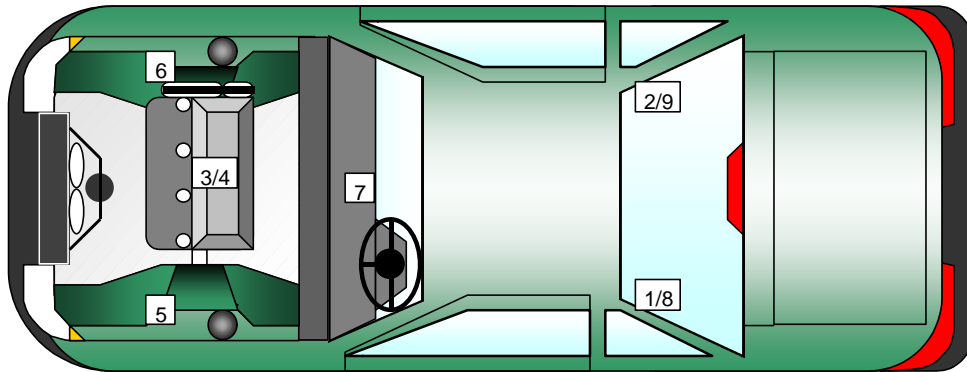

**DATA SHEET NO. 8 - HYBRID III ATD INJURY CRITERIA AND SENSOR DATA**

Test Vehicle: 2005 Toyota Tundra 2-Door Truck

NHTSA No.: M55111

Test Program: 2005 NHTSA 35mph NCAP

Test Date: 10/5/04

**HEAD PRIMARY PEAK ACCELERATIONS**

Location	Axis	Units	Driver				Passenger			
			Max	Time	Min	Time	Max	Time	Min	Time
Head CG	X	G's	10.5	199.7	-66.8	72.5	2.8	200.0	-49.8	75.1
Head CG	Y	G's	3.0	137.6	-7.5	55.8	2.9	35.2	-12.8	87.7
Head CG	Z	G's	25.1	56.0	-12.2	90.3	23.2	64.7	-1.4	17.4
Head CG Resultant	N/A	G's	67.0	72.5			52.6	75.1		

**CHEST PRIMARY PEAK ACCELERATIONS**

Location	Axis	Units	Driver				Passenger			
			Max	Time	Min	Time	Max	Time	Min	Time
Chest CG	X	G's	6.3	179.9	-46.3	59.5	1.9	153.0	-44.4	61.2
Chest CG	Y	G's	6.4	75.0	-4.5	43.7	6.4	50.2	-9.5	79.9
Chest CG	Z	G's	14.9	46.5	-8.1	97.4	7.0	43.1	-10.8	83.0
Chest CG Resultant	N/A	G's	46.9	59.3			44.5	61.4		

**FEMUR PEAK FORCES**

Location	Axis	Units	Driver				Passenger			
			Max	Time	Min	Time	Max	Time	Min	Time
Left Femur	Z	Newtons	1038.3	47.4	-4818.5	51.7	422.9	40.3	-3612.1	51.2
Right Femur	Z	Newtons	1151.6	70.9	-2677.4	60.0	673.4	39.5	-2185.0	58.4

**SEAT BELT SENSOR PEAK VALUES**

Location	Axis	Units	Driver				Passenger			
			Max	Time	Min	Time	Max	Time	Min	Time
Shoulder Belt Pullout	N/A	MM	174.7	88.4	-20.8	42.3	202.2	96.8	-12.5	43.6
Shoulder Belt Stretch	N/A	MM/CM	0.0	0.0	0.0	0.0	0.00	0.0	0.00	0.0
Lap Belt Force	N/A	Newtons	7747.4	60.9	-6.9	144.0	8735.9	55.5	-1.7	163.5
Shoulder Belt Force	N/A	Newtons	6023.4	54.9	-29.8	10.3	5798.2	55.6	-27.9	150.2

1.) Not used with pre-tensioners

**PRIMARY HEAD INJURY CRITERIA (HIC36)**

Location	Driver				Passenger			
	HIC	T <sup>1</sup>	T <sup>2</sup>	Avg G	HIC	T <sup>1</sup>	T <sup>2</sup>	Avg G
Head CG Primary	614.8	54.4	88.2	50.5	413.4	57.4	93.4	42.0

**PRIMARY CHEST CLIP (3MSEC)**

Location	Driver			Passenger		
	CLIP	T <sup>1</sup>	T <sup>2</sup>	CLIP	T <sup>1</sup>	T <sup>2</sup>
Chest CG Primary	46.1	58.5	61.5	44.0	59.3	62.3

**DATA SHEET NO. 8...(CONTINUED)**

Test Vehicle: 2005 Toyota Tundra 2-Door Truck

NHTSA No.: M55111

Test Program: 2005 NHTSA 35mph NCAP

Test Date: 10/5/04

**PELVIC PEAK ACCELERATIONS**

Location	Axis	Units	Driver				Passenger			
			Max	Time	Min	Time	Max	Time	Min	Time
Pelvis	X	G's	4.6	118.9	-65.9	52.0	4.4	91.9	-56.7	54.6
Pelvis	Y	G's	10.9	71.6	-10.1	58.1	6.5	46.6	-15.2	72.7
Pelvis	Z	G's	5.3	39.9	-26.8	60.5	0.9	169.7	-33.4	61.7
Pelvis Resultant	N/A	G's	68.2	52.0			62.9	61.2		

**UPPER NECK PEAK FORCES AND MOMENTS**

Location	Axis	Units	Driver				Passenger			
			Max	Time	Min	Time	Max	Time	Min	Time
Neck Force	X	Newtons	318.1	70.7	-445.1	44.7	33.2	200.0	-445.9	119.2
Neck Force	Y	Newtons	75.2	125.1	-120.5	82.4	211.1	77.6	-224.0	119.2
Neck Force	Z	Newtons	1920.9	69.4	-188.8	100.2	915.3	46.6	-124.5	17.6
Neck Force Resultant	N/A	Newtons	1946.6	69.4			1004.9	46.6		
Neck Moment	X	N•m	8.1	187.3	-9.3	61.6	38.5	85.9	-13.4	124.8
Neck Moment	Y	N•m	31.6	62.5	-22.1	86.9	28.6	126.9	-28.3	87.1
Neck Moment	Z	N•m	4.7	200.0	-4.9	105.9	14.8	93.9	-7.6	146.8
Neck Moment Resultant	N/A	N•m	32.9	62.3			49.4	86.5		

**FOOT PEAK ACCELERATIONS**

Location	Axis	Units	Driver				Passenger			
			Max	Time	Min	Time	Max	Time	Min	Time
Left Foot Aft	X	G's	29.4	48.3	-90.4	40.3	21.3	61.5	-124.2	38.1
Left Foot Aft	Z	G's	1.6	156.4	-99.0	39.7	9.4	66.7	-81.9	51.1
Left Foot Fore	Z	G's	58.5	38.4	-142.3	43.2	84.7	54.4	-271.9	51.0
Right Foot Aft	X	G's	36.5	60.9	-113.2	48.4	16.8	56.9	-145.2	45.8
Right Foot Aft	Z	G's	74.6	59.4	-84.6	41.9	4.7	68.8	-72.2	46.2
Right Foot Fore	Z	G's	65.8	61.2	-274.8	38.4	32.4	43.9	-83.5	46.6

**UPPER AND LOWER TIBIA PEAK FORCES AND MOMENTS**

Location	Axis	Units	Driver				Passenger			
			Max	Time	Min	Time	Max	Time	Min	Time
Left Upper Moment	X	N•m	40.5	51.8	-61.4	44.1	32.5	79.1	-14.1	35.1
Left Upper Moment	Y	N•m	13.4	171.2	-107.1	53.1	14.4	167.1	-143.1	52.6
Right Upper Moment	X	N•m	55.8	63.2	-72.9	52.3	28.4	46.7	-29.2	71.6
Right Upper Moment	Y	N•m	15.0	28.4	-124.4	43.6	23.0	134.9	-95.3	50.6
Left Lower Moment	X	N•m	89.7	45.5	-36.6	41.0	8.6	43.2	-36.8	73.6
Left Lower Moment	Y	N•m	21.6	73.9	-34.8	41.9	32.5	76.7	-65.7	52.2
Left Lower Force	Z	Newtons	123.5	150.8	-3653.5	39.6	246.8	159.7	-2653.3	45.3
Right Lower Moment	X	N•m	68.0	61.0	-30.0	51.7	15.0	44.8	-58.3	48.4
Right Lower Moment	Y	N•m	39.4	61.7	-68.9	49.7	27.7	69.9	-48.5	47.3
Right Lower Force	Z	Newtons	105.7	132.4	-2957.3	40.6	177.3	144.7	-2648.3	48.0

**DATA SHEET NO. 8...(CONTINUED)**

Test Vehicle: 2005 Toyota Tundra 2-Door Truck

NHTSA No.: M55111

Test Program: 2005 NHTSA 35mph NCAP

Test Date: 10/5/04

**CHEST PEAK DISPLACEMENTS**

Location	Axis	Units	Driver				Passenger			
			Max	Time	Min	Time	Max	Time	Min	Time
Chest CG	X	MM	0.0	4.7	-25.7	64.1	0.0	14.0	-26.9	77.8

**HEAD REDUNDANT PEAK ACCELERATIONS**

Location	Axis	Units	Driver				Passenger			
			Max	Time	Min	Time	Max	Time	Min	Time
Head CG	X	G's	10.6	199.9	-67.0	72.6	3.3	16.6	-50.3	74.9
Head CG	Y	G's	3.6	23.8	-6.4	55.3	2.8	46.3	-13.4	88.0
Head CG	Z	G's	25.1	55.9	-12.6	89.1	22.9	64.7	-1.7	17.3
Head CG Resultant	N/A	G's	67.3	72.5			52.9	74.9		

**CHEST REDUNDANT PEAK ACCELERATIONS**

Location	Axis	Units	Driver				Passenger			
			Max	Time	Min	Time	Max	Time	Min	Time
Chest CG	X	G's	6.3	180.8	-46.5	59.5	1.9	153.0	-44.6	61.1
Chest CG	Y	G's	6.2	75.0	-4.5	44.7	6.8	50.2	-9.4	79.9
Chest CG	Z	G's	14.6	46.5	-8.0	97.4	7.0	43.1	-10.6	83.0
Chest CG Resultant	N/A	G's	47.1	59.4			44.7	61.4		

**REDUNDANT HEAD INJURY CRITERIA (HIC36)**

Location	Driver				Passenger			
	HIC	T <sup>1</sup>	T <sup>2</sup>	Avg G	HIC	T <sup>1</sup>	T <sup>2</sup>	Avg G
Head CG Redundant	622.4	54.4	88.3	50.7	408.3	57.3	93.3	41.8

**REDUNDANT CHEST CLIP (3MSEC)**

Location	Driver			Passenger		
	CLIP	T <sup>1</sup>	T <sup>2</sup>	CLIP	T <sup>1</sup>	T <sup>2</sup>
Chest CG Redundant	45.7	58.4	61.4	44.2	59.4	62.4

**DATA SHEET NO. 9**  
**SEATBELT ASSESSMENT TEST DATA**

Test Vehicle: 2005 Toyota Tundra 2-Door Truck

NHTSA No.: M55111

Test Program: 2005 NHTSA 35mph NCAP

Test Date: 10/5/04

**SEAT BELT POSITIONING MEASUREMENTS**

Measurement Description	Units	Driver	Passenger
TBI -Dummy C/L to Lap/Shoulder Belt Intersect	mm	210	220
PBU - Top Surface of reference to belt upper edge	mm	335	300
PBL - Top Surface of reference to belt lower edge	mm	260	220
Lap Belt Tension	Newtons	10	10
Shoulder Belt Tension	N/A	Retractor	Retractor

**SEAT BELT POSITIONING MEASUREMENTS**

Measurement Description	Units	Driver	Passenger
Retractor Reel to "D" ring	mm	720	720
Shoulder Belt length as measured on ATD	mm	950	950
Lap Belt length as measured on ATD	mm	900	980
Remainder of belt on reel	mm	845	780
Total belt length for continuous webbing systems	mm	3415	3430

**SHOULDER BELT SPOOL-OFF DATA**

Measurement Description	Units	Driver	Passenger
As determined mechanically	mm	135.0	150.0
As determined electronically	mm	174.7	202.2

**BELT STRETCH DATA**

Measurement Description	Units	Driver	Passenger
Electronically between belt load cell and "D" ring	mm/cm	*	*
Mechanically	mm/cm	N/A	N/A

\* Not used with shoulder belt pre-tensioner systems

**DATA SHEET NO. 10**  
**SUMMARY OF FMVSS 212 DATA**

Test Vehicle: 2005 Toyota Tundra 2-Door Truck

NHTSA No.: M55111

Test Program: 2005 NHTSA 35mph NCAP

Test Date: 10/5/04

Windshield Mounting Details: Windshield glass is secured to the vehicle frame with a rubber type adhesive. No molding covers the windshield periphery at any point.

The standard requires that the posttest retention measurement be a minimum of 75 percent of the pretest total periphery measurement for vehicles not equipped with occupant passive restraints and 50 percent for each side of the windshield for vehicles that are equipped with occupant passive restraints.

Temperature of windshield molding during test: 28.3 °C

**WINDSHIELD PERIPHERY MEASUREMENTS**

Measurement	Pre-Test(mm)	Post-Test(mm)	% of Retention
Left Side	2072	2072	100
Right Side	2072	2072	100
Total	4143	4143	100

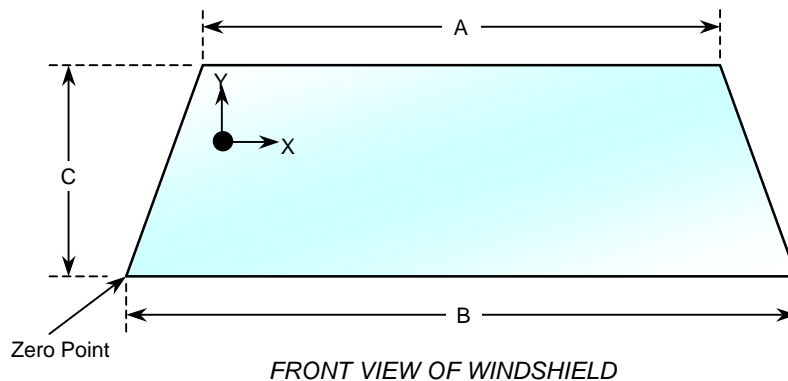

**WINDSHIELD DIMENSIONS**

Item	Units	Segment Length	Molding Width
A	mm	1283	18
B	mm	1580	14
C-Left	mm	640	18
C-Right	mm	640	18

**DATA SHEET NO. 11**  
**WINDSHIELD ZONE INTRUSION FMVSS 219 DATA (PARTIAL)**

Test Vehicle: 2005 Toyota Tundra 2-Door Truck

NHTSA No.: M55111

Test Program: 2005 NHTSA 35mph NCAP

Test Date: 10/5/04

**WINDSHIELD AND  
PROTECTED ZONE**

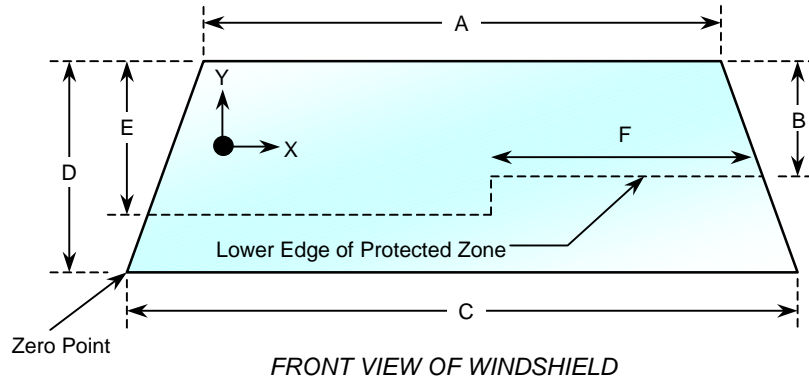

Item	Units	Value
A	mm	1283
B	mm	372
C	mm	1580
D	mm	640
E	mm	384
F	mm	620

**AREA OF PROTECTED ZONE FAILURES**

- A. Provide coordinates of the area that the protected zone was penetrated more than 0.25 in. by a vehicle component other than one that is normally in contact with the windshield.

X	Y
N/A	N/A
N/A	N/A
N/A	N/A
N/A	N/A

- B. Provide coordinates of the area beneath the protected zone that the inner surface of the windshield was penetrated by a vehicle component.

X	Y
N/A	N/A
N/A	N/A
N/A	N/A
N/A	N/A

**DATA SHEET NO. 12**  
**FMVSS 301 FUEL SYSTEM INTEGRITY POST IMPACT DATA**

Test Vehicle: 2005 Toyota Tundra 2-Door Truck NHTSA No.: M55111  
Test Program: 2005 NHTSA 35mph NCAP Test Date: 10/5/04  
Test Time: 11:44 AM Temperature: 28.3 Deg. C.

**STODDARD SOLVENT SPILLAGE MEASUREMENTS**

- A. From impact until vehicle motion ceases: 0.0 oz.  
(Maximum Allowable = 1 ounce)
- B. For the 5-minute period after motion ceases: 0.0 oz.  
(Maximum Allowable = 5 ounces)
- C. For the following 25 minutes: 0.0 oz.  
(Maximum Allowable = 1 oz./minute)
- D. Spillage Location Details: No leakage occurred

**DATA SHEET NO. 13**  
**FMVSS 301 STATIC ROLLOVER DATA**

Test Vehicle: 2005 Toyota Tundra 2-Door Truck

NHTSA No.: M55111

Test Program: 2005 NHTSA 35mph NCAP

Test Date: 10/5/04

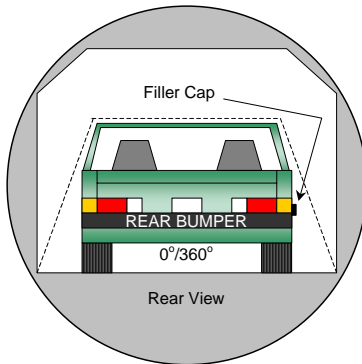

**0° to 90°**

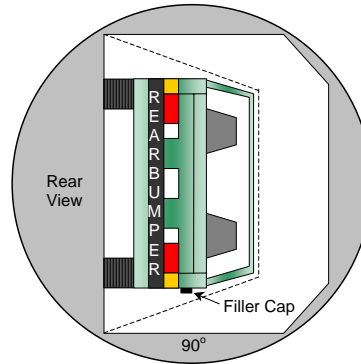

**90° to 180°**

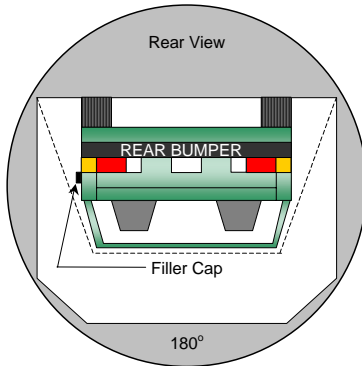
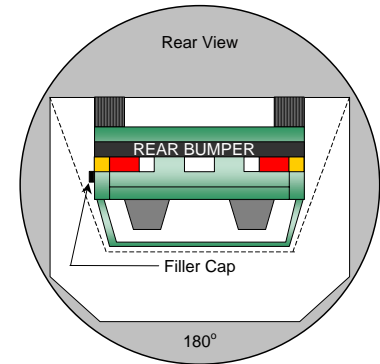

**180° to 270°**

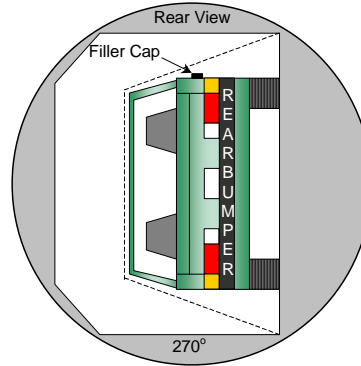

**270° to 360°**

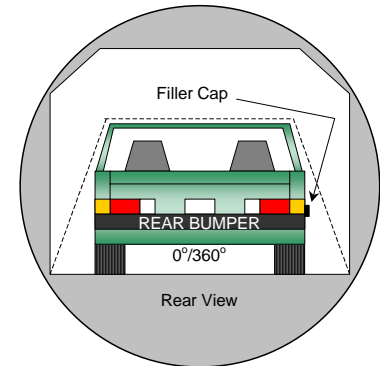

1. The specified fixture rollover rate for each 90° of rotation is 60 to 120 seconds.
2. The position hold time at each position is 300 seconds (minimum).
3. No solvent leakage occurred during rollover.

**DATA SHEET NO. 13...(CONTINUED)**  
**FMVSS 301 STATIC ROLLOVER DATA**

Test Vehicle: 2005 Toyota Tundra 2-Door Truck

NHTSA No.: M55111

Test Program: 2005 NHTSA 35mph NCAP

Test Date: 10/5/04

**SOLVENT COLLECTION TIME TABLE IN SECONDS**

Test Phase	Rotation Time	Hold Time	Total Time
0° to 90°	84	300	384
90° to 180°	84	300	384
180° to 270°	75	300	375
270° to 360°	77	300	377

**FMVSS 301 SPILLAGE TABLE REQUIREMENT (oz.)**

First 5 Minutes	5
Sixth Minute	1
Seventh Minute	1
Eighth Minute	1

**ACTUAL TEST VEHICLE SOLVENT SPILLAGE TABLE (oz.)**

Test Phase	First 5 Minutes	Sixth Minute	Seventh Minute	Eighth Minute
0° to 90°	0	0	0	0
90° to 180°	0	0	0	0
180° to 270°	0	0	0	0
270° to 360°	0	0	0	0

**SOLVENT SPILLAGE LOCATION TABLE**

Test Phase	Spillage Location
0° to 90°	None
90° to 180°	None
180° to 270°	None
270° to 360°	None

**DATA SHEET NO. 14**  
**VEHICLE MEASUREMENTS**

Test Vehicle: 2005 Toyota Tundra 2-Door Truck

NHTSA No.: M55111

Test Program: 2005 NHTSA 35mph NCAP

Test Date: 10/5/04

**VEHICLE MEASUREMENT TABLE**

No.	Measurement Description	Units	Pre-Test	Post-Test	Diff.
1	Total length of vehicle at centerline	mm	5550	5005	-545
2	RSOV to front of engine	mm	5035	4860	-175
3	RSOV to firewall centerline	mm	4335	4310	-25
4	RSOV to leading edge of right door	mm	4060	4077	17
5	RSOV to leading edge of left door	mm	4068	4114	46
6	RSOV to lower leading edge of right door	mm	4030	4015	-15
7	RSOV to lower leading edge of left door	mm	4034	4030	-4
8	RSOV to upper trailing edge of right door	mm	2916	2928	12
9	RSOV to upper trailing edge of left door	mm	2924	2946	22
10	RSOV to lower trailing edge of right door	mm	2897	2886	-11
11	RSOV to lower trailing edge of left door	mm	2906	2902	-4
12	RSOV to bottom of right 'A' pillar	mm	4034	4028	-6
13	RSOV to bottom of left 'A' pillar	mm	3937	4054	117
14	RSOV to firewall on right side	mm	4335	4350	15
15	RSOV to firewall on left side	mm	4335	4355	20
16	RSOV to steering column	mm	3640	3642	2
17	Center of steering column to left 'A' pillar	mm	350	350	0
18	Center of steering column to headlining	mm	440	450	10
19	RSOV to right side of front bumper	mm	5390	5023	-367
20	RSOV to left side of front bumper	mm	5399	5045	-354
21	Length of engine block	mm	700	700	0
RD	RSOV to right side of dash panel	mm	3839	3858	19
CD	RSOV to center of dash panel	mm	3820	3858	38
LD	RSOV to left side of dash panel	mm	3869	3893	24

All measurements are in millimeters

**DATA SHEET NO. 14...(CONTINUED)**  
**VEHICLE STRUCTURAL MEASUREMENTS**

Test Vehicle: 2005 Toyota Tundra 2-Door Truck

NHTSA No.: M55111

Test Program: 2005 NHTSA 35mph NCAP

Test Date: 10/5/04

**VEHICLE STRUCTURAL MEASUREMENT TABLE**

No.	Measurement Description	Units	Pre-Test	Post-Test	Diff.
1	Total length	mm	5550	5005	-545
2	Total width	mm	1866	1870	4
3	Bumper top height	mm	785	795	10
4	Bumper bottom height	mm	396	375	-21
5	Longitudinal member top height	mm	560	600	40
6	Longitudinal member bottom height	mm	450	476	26
7	Distance between longitudinal members	mm	810	860	50
8	Longitudinal member width	mm	50	75	25
9	Engine top height	mm	1165	1160	-5
10	Engine bottom height	mm	369	286	-83
11	Engine and gear box width	mm	700	700	0
12	Front bumper to engine distance	mm	500	250	-250
13	Front shock absorber fixing width	mm	800	766	-34
14	Bonnet leading edge height	mm	1070	1150	80
15	Front shock absorber fixing width	mm	1160	1220	60
16	Front bumper to front axle distance	mm	940	520	-420
17	Front axle to 'A' pillar distance	mm	596	500	-96
18	'A' pillar to 'B' pillar distance	mm	1200	1200	0
19	'B' pillar to rear axle distance	mm	1575	1584	9
20	'B' pillar to 'C' pillar distance	mm	N/A	N/A	N/A
21	Roof sill bottom height	mm	1660	1565	-95
22	Roof sill top height	mm	1775	1722	-53
23	Floor sill bottom height	mm	444	395	-49
24	Floor sill top height	mm	534	480	-54

All measurements are in millimeters

**DATA SHEET NO. 14...(CONTINUED)**  
**VEHICLE MEASUREMENTS**

Test Vehicle: 2005 Toyota Tundra 2-Door Truck

NHTSA No.: M55111

Test Program: 2005 NHTSA 35mph NCAP

Test Date: 10/5/04

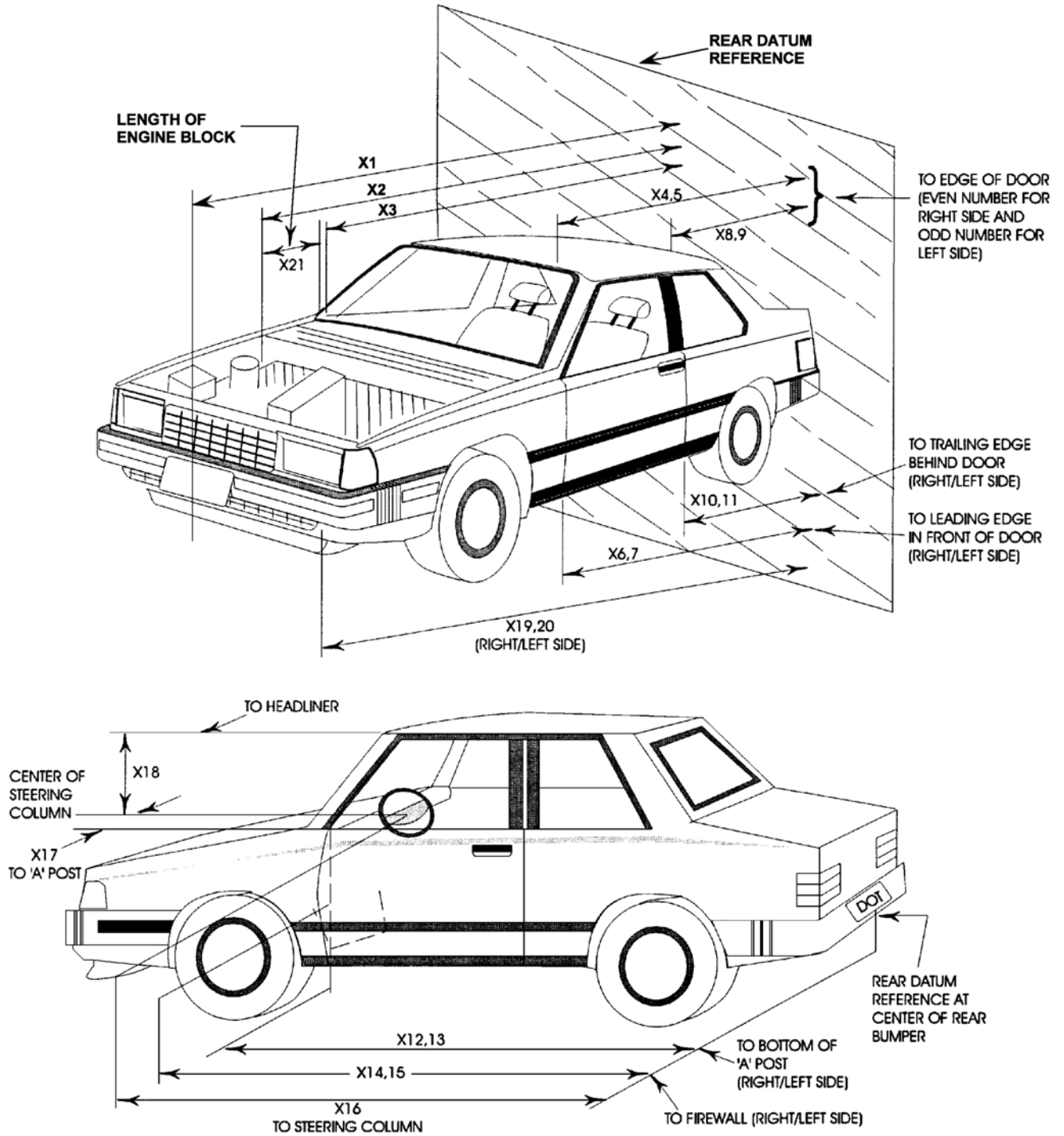

**DATA SHEET NO. 15  
CAMERA LOCATIONS**

Test Vehicle: 2005 Toyota Tundra 2-Door Truck

NHTSA No.: M55111

Test Program: 2005 NHTSA 35mph NCAP

Test Date: 10/5/04

**VEHICLE CAMERA MEASUREMENT TABLE**

No.	Camera View	Location (mm)			Angle (deg.)	Film Plane to Head	Lens (mm)	Speed (fps)
		X	Y	Z				
1	Real Time Camera (Panning)	-12192	-6096	-1651	-10	N/A	Zoom	30
1C	Real Time Camera (Still)	-1067	7976	-991	0	7714.7	Zoom	30
2	Overall Left Side	-2489	-8280	-1143	-4	7873.2	13	NTM*
2B	Overall Left Side	-1883	-7671	-1143	-2	7291.5	10	1000
3	Left Side View	-1677	-7773	-1270	-4	7406.0	50	1000
3B	Left Side View	-2134	-8230	-1449	-4	7820.0	35	935
4	Driver and Interior View	-5257	-10897	-4648	-13	11254.6	75	1005
4B	Driver and Interior View	-5360	-10846	-4648	-13	11232.6	Zoom	1000
5	Steering Column (Bottom)	-2134	-8230	-2997	-16	7942.9	19	1020
6	Steering Column (Top)	-2134	-8230	-3404	-20	8023.9	19	1010
7	Overall Right Side	-2083	8230	-1270	-6	7828.0	13	1005
8	Right Side View	-1577	10871	-1575	-4	10491.7	105	1000
9	Passenger and Interior View	-6781	9144	-2997	-9	9817.6	50	1005
9B	Passenger and Interior View	-6477	9068	-2946	-9	9613.3	Zoom	1000
10	Right Side View	-1883	8230	-1575	-4	7834.3	28	990
10B	Right Side View	-1883	8230	-1575	-4	7834.3	28	995
11	Windshield View	-610	0	-5944	-90	N/A	13	1010
12	Driver Front View	610	-432	-2667	-40	N/A	13	1030
13	Passenger Front View	610	432	-2667	-40	N/A	13	655
14	Pit View of Engine	-914	0	1499	90	N/A	9	1070
19	Pit View of Fuel Tank	-2438	0	1499	90	N/A	6	825

X = Barrier Face Y = Monorail Centerline Z = Ground DNR = Did Not Run NTM = No Timing Marks

**DATA SHEET NO. 16**  
**PHOTOGRAPHIC REFERENCE TARGET LOCATIONS**

Test Vehicle: 2005 Toyota Tundra 2-Door Truck

NHTSA No.: M55111

Test Program: 2005 NHTSA 35mph NCAP

Test Date: 10/5/04

All Dimensions in (mm)	
Item	Value
A	440
B	933
C	1990
D	600
E	2900
F	150
G	1750
H	N/A
I	1465
J	1116
K	1116
L	1850
M	N/A
N	1845
O	1115
P	1115
Q	1450

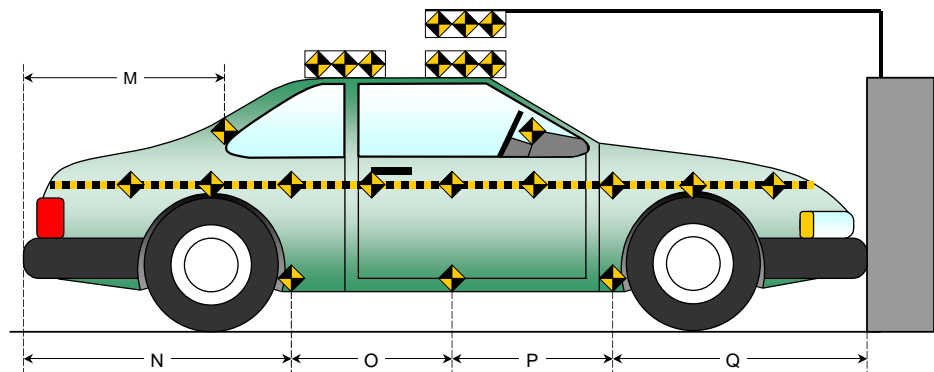
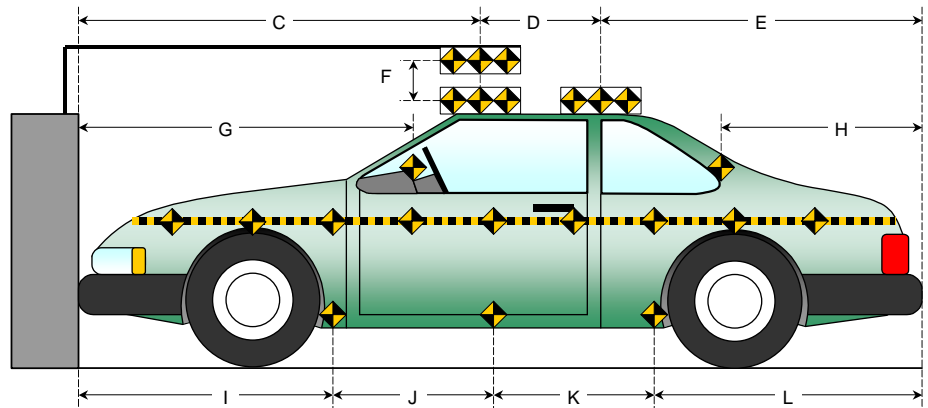
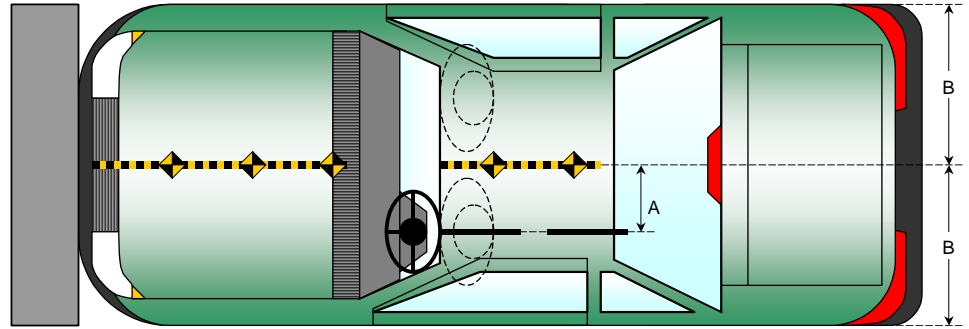

**DATA SHEET NO. 17**  
**VEHICLE INTRUSION MEASUREMENTS**

Test Vehicle: 2005 Toyota Tundra 2-Door Truck

NHTSA No.: M55111

Test Program: 2005 NHTSA 35mph NCAP

Test Date: 10/5/04

**DOOR OPENING WIDTH TABLE**

Item	Description	Units	Pre-Test	Post-Test	Diff.
A	Left Side Upper	mm	1080	1081	1
B	Left Side Lower	mm	1065	1081	16
D	Right Side Upper	mm	1085	1081	-4
E	Right Side Lower	mm	1070	1071	1

**WHEELBASE MEASUREMENT TABLE**

Item	Description	Units	Pre-Test	Post-Test	Diff.
C	Left Side Wheel Base	mm	3276	3250	-26
F	Right Side Wheel Base	mm	3276	3185	-91

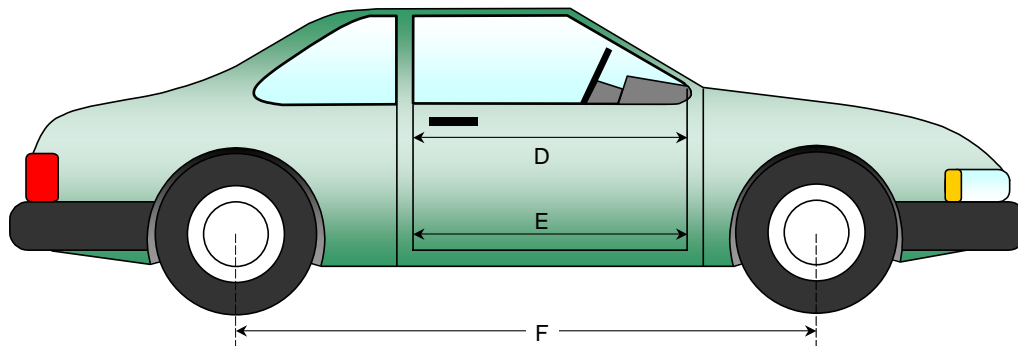
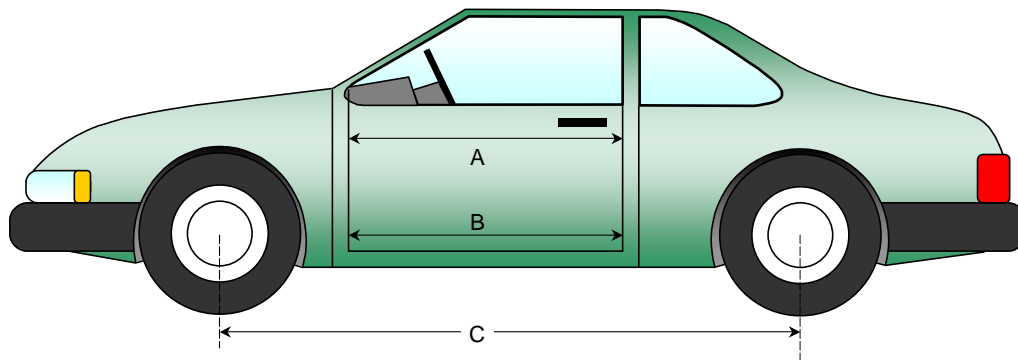

**DATA SHEET NO. 17...(CONTINUED)**  
**VEHICLE INTRUSION MEASUREMENTS**

Test Vehicle: 2005 Toyota Tundra 2-Door Truck

NHTSA No.: M55111

Test Program: 2005 NHTSA 35mph NCAP

Test Date: 10/5/04

**DRIVER COMPARTMENT INTRUSION TABLE**

Item	Description	Units	Pre-Test	Post-Test	Diff.
AB	Door Opening (Inside window jam)	mm	1075	1071	-4
CX	Left Knee Bolster to X	mm	260	345	85
DX	Right Knee Bolster to X	mm	245	345	100
EX	Brake Pedal to X	mm	530	540	10
FX	Foot Rest to X	mm	570	520	-50
GX	Center of Steering Wheel Hub to X	mm	55	60	5

X = Left Front Seat Outboard Anchor Bolt Head

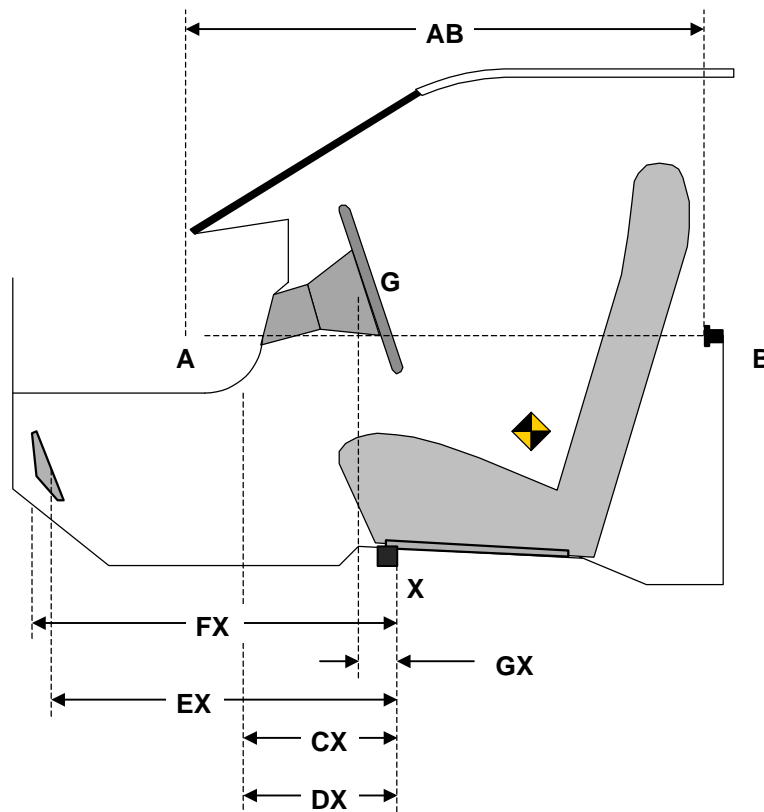

**DATA SHEET NO. 17...(CONTINUED)**  
**VEHICLE INTRUSION MEASUREMENTS**

Test Vehicle: 2005 Toyota Tundra 2-Door Truck

NHTSA No.: M55111

Test Program: 2005 NHTSA 35mph NCAP

Test Date: 10/5/04

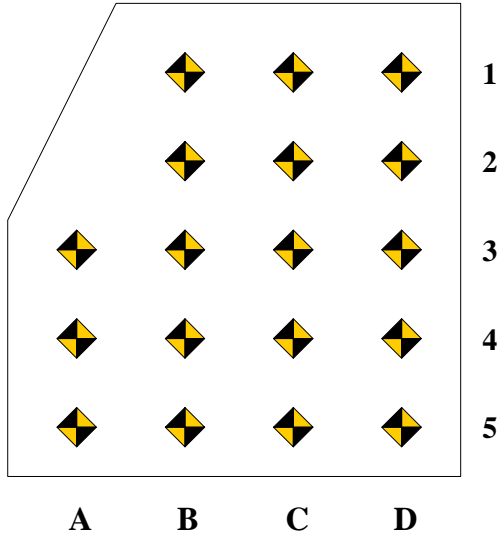

Measurement reference point for X and Z-axis is the forward outboard seat mounting bolt.

Columns A through D are evenly spaced.

Rows 1 and 2 are on the toe kick portion of the floor pan. Rows 3, 4 and 5 are located on the most level portion of the floor pan.

Row 3 will be at the intersection of the toe kick and the level sections of the floor pan.

**DRIVER FLOOR PAN X-AXIS**

	Pre-Test				Post-Test				Difference			
	A	B	C	D	A	B	C	D	A	B	C	D
1		694	691	697		699	691	691		5	0	-6
2		649	640	633		650	639	622		1	-1	-11
3	565	554	548	539	553	558	555	555	-12	4	7	16
4	464	453	445	434	459	457	452	448	-5	4	7	14
5	366	356	349	337	361	357	354	351	-5	1	5	14

**DRIVER FLOOR PAN Z-AXIS**

	Pre-Test				Post-Test				Difference			
	A	B	C	D	A	B	C	D	A	B	C	D
1		-65	-61	-55		-64	-67	-77		1	-6	-22
2		7	16	17		8	-2	-13		1	-18	-30
3	56	7	46	45	57	8	44	41	1	1	-2	-4
4	63	43	48	55	70	44	46	45	7	1	-2	-10
5	55	47	50	50	58	47	46	38	3	0	-4	-12

**DATA SHEET NO. 17...(CONTINUED)**  
**VEHICLE INTRUSION MEASUREMENTS**

Test Vehicle: 2005 Toyota Tundra 2-Door Truck

NHTSA No.: M55111

Test Program: 2005 NHTSA 35mph NCAP

Test Date: 10/5/04

Measurement reference point for X and Z axis is the forward outboard seat mounting bolt.

Columns A through D are evenly spaced.

Rows 1 and 2 are on the toe kick portion of the floor pan. Rows 3, 4 and 5 are located on the most level portion of the floor pan.

Row 3 will be at the intersection of the toe kick and the level sections of the floor pan.

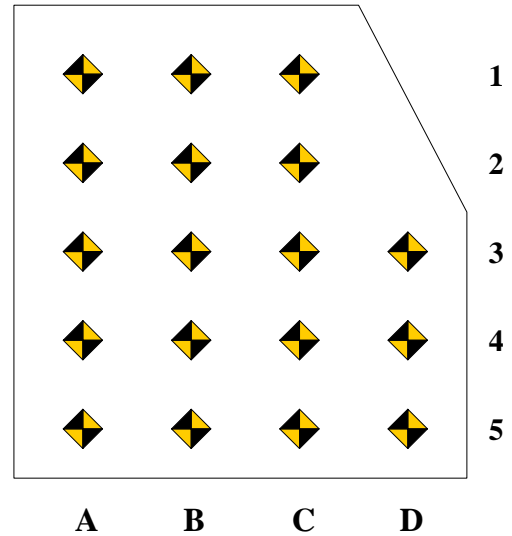

**PASSENGER FLOOR PAN X-AXIS**

	Pre-Test				Post-Test				Difference			
	A	B	C	D	A	B	C	D	A	B	C	D
1	732	724	719		687	688	698		-45	-36	-20	
2	664	658	652		616	623	630		-48	-36	-22	
3	570	564	560	557	539	540	544	548	-31	-24	-16	-9
4	462	460	455	454	433	438	440	447	-30	-22	-15	-7
5	365	359	351	349	336	337	335	339	-28	-22	-16	-9

**PASSENGER FLOOR PAN Z-AXIS**

	Pre-Test				Post-Test				Difference			
	A	B	C	D	A	B	C	D	A	B	C	D
1	-70	-67	-65		-70	-71	-61		0	-4	4	
2	4	10	13		2	6	14		-2	-4	1	
3	36	38	42	43	45	49	54	55	9	11	11	12
4	44	47	43	40	47	55	52	49	3	7	9	8
5	42	44	45	45	39	46	49	50	-2	1	5	6

**DATA SHEET NO. 18**  
**FIXED BARRIER LOAD CELL LOCATIONS**

Test Vehicle: 2005 Toyota Tundra 2-Door Truck

NHTSA No.: M55111

Test Program: 2005 NHTSA 35mph NCAP

Test Date: 10/5/04

**36 Load Cell Rigid Barrier (NHTSA Standard)**  
**Load Cell Locations on Fixed Barrier**

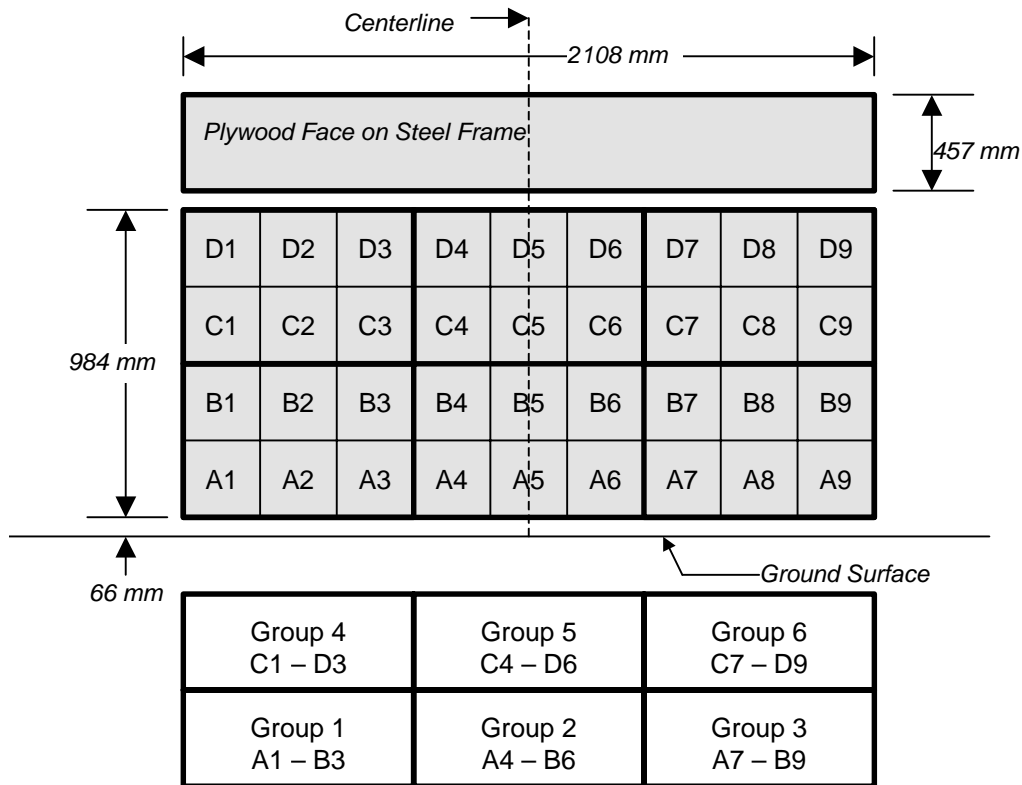

6 Groups of 6 Load Cells Each

The Data is presented in Appendix C with the following requirements:

- 1.) Data from 36 individual load cells
- 2.) Sum data from 6 groupings shown above (6 cells/group)
- 3.) Total or sum of all 36 individual load cells
- 4.) Sum of all 36 individual load cells vs. vehicle dynamic crush

**DATA SHEET NO. 19  
POST-TEST AIRBAG DATA**

Test Vehicle: 2005 Toyota Tundra 2-Door Truck

NHTSA No.: M55111

Test Program: 2005 NHTSA 35mph NCAP

Test Date: 10/5/04

**POST-TEST AIRBAG DATA**

	DRIVER	PASSENGER
No. of vent holes	2	2
Size of vent (mm <sup>2</sup> )	500	3883.3
Total vent area (mm <sup>2</sup> )	1000	7766.6

<b>Deflated Airbag Length and Width Dimensions or, If Round, Diameter (mm)</b>		
Length	N/A	420
Width	N/A	700
Depth or Diameter	580	480

<b>Tethering Information</b>		
Is the airbag tethered?	Yes	NO
Record length of tether (mm)	230	N/A

<b>Airbag Manufacturing Information</b>		
Manufacturer	*	*
Part No.	GA120 06080 060804013249	No Information Found
Gas Generator	TGCR8A3EB0G	No Information Found

\* Manufacturers label was burned due to air bag explosion.

Sketch the airbag showing the location of the vent holes, how the bag is tethered, and where the bag is tethered. Also describe how the tethers are attached to the bag and the steering wheel:

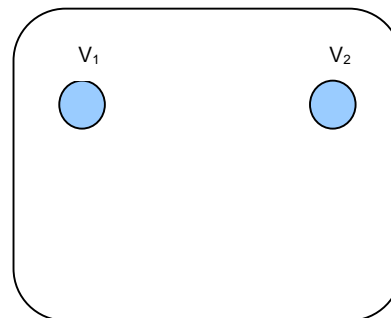
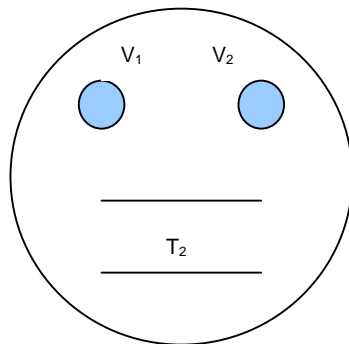

**DATA SHEET NO. 20**  
**ACCIDENT INVESTIGATION DIVISION DATA**

Test Vehicle: 2005 Toyota Tundra 2-Door Truck NHTSA No.: M55111  
 Test Program: 2005 NHTSA 35mph NCAP Test Date: 10/5/04

**VEHICLE INFORMATION**

VIN: 5TBJU32135S442753 Wheel base (mm): 3276  
 Vehicle Size Category: 2-Door Regular Cab Test Weight (kg): 2079

**ACCELEROMETER DATA**

Accelerometer Location: Left rear cross member  
 Cal. Procedure/Interval: 6 months / drop test  
 Integration Algorithm: NHTSA Standard Linearity: Good  
 Impact Velocity (km/h): 56.35  
 Velocity Change (km/h): 62.35 Time of Separation (msec): 75.4

**CRUSH PROFILE**

Collision Deformation Classification: 12FDEW6 Midpoint of Damage: Vehicle Centerline  
 Damage Region Length (mm): 1534 Impact Mode: Full Frontal

No.	Measurement Description	Units	Pre-Test	Post-Test	Difference
C1	Crush zone 1 at left side	mm	151	505	-354
C2	Crush zone 2 on left side	mm	65	540	-475
C3	Crush zone 3 on left side	mm	28	525	-497
C4	Crush zone 4 on right side	mm	31	527	-496
C5	Crush zone 5 on right side	mm	71	553	-482
C6	Crush zone 6 at right side	mm	160	527	-367

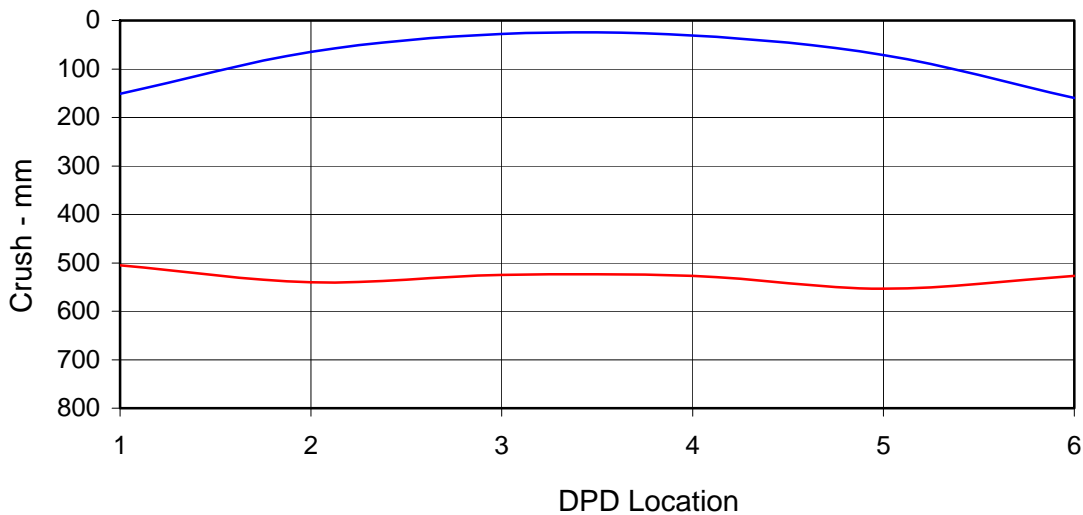

**DATA SHEET NO. 21**  
**DUMMY/VEHICLE TEMPERATURE STABILIZATION**

Test Vehicle: 2005 Toyota Tundra 2-Door Truck

NHTSA No.: M55111

Test Program: 2005 NHTSA 35mph NCAP

Test Date: 10/5/04

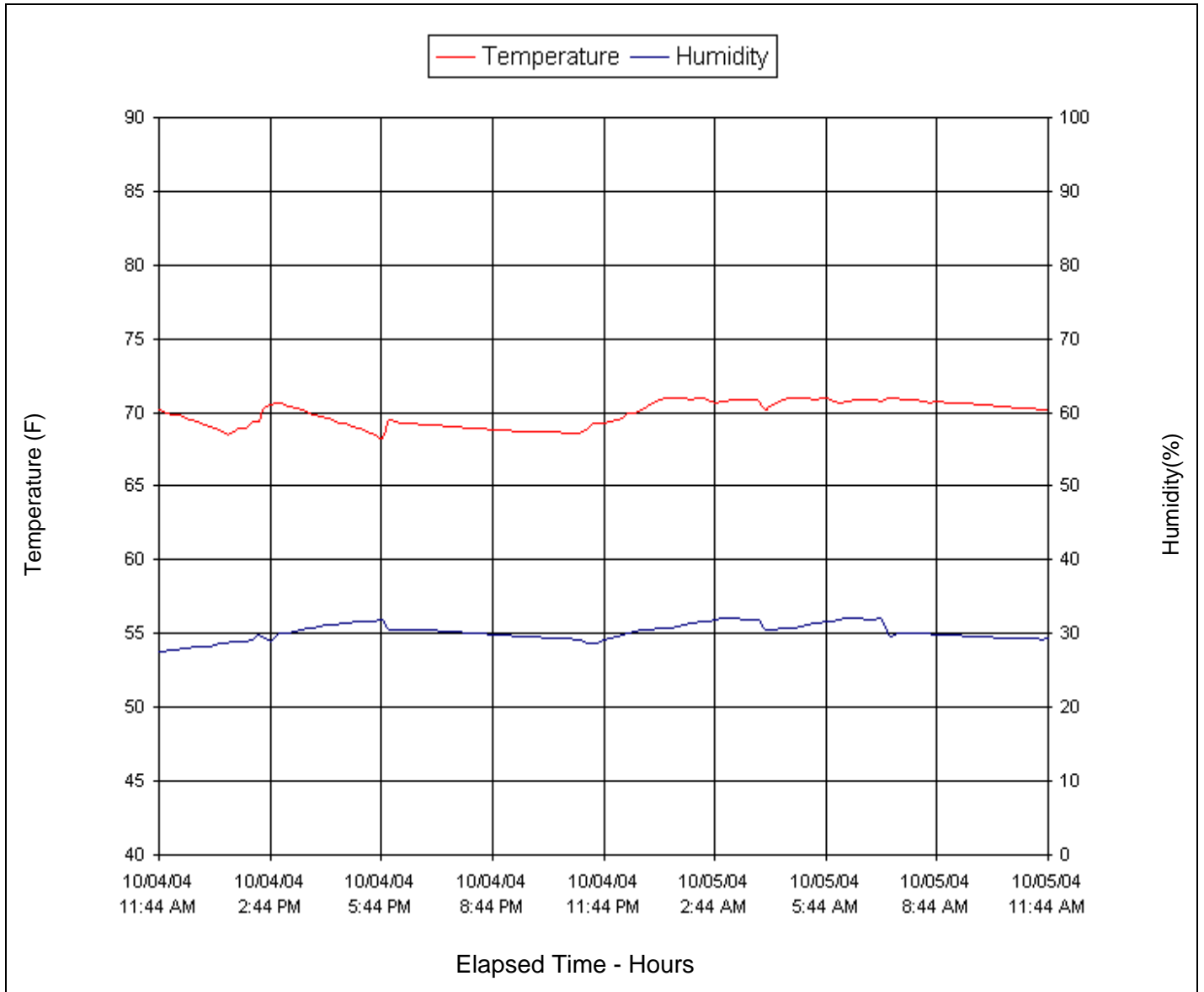

**APPENDIX A**  
**PHOTOGRAPHS**

## LIST OF PHOTOGRAPHS

Figure		Page
1	Load Cell Location	A-1
2	Vehicle Certification Label	A-2
3	Vehicle Tire Label	A-3
4	Right Front $\frac{3}{4}$ View, As Received	A-4
5	Left Rear $\frac{3}{4}$ View, As Received	A-5
6	Pre-Test Front View	A-6
7	Post-Test Front View (Vehicle Moved)	A-7
8	Pre-Test Left Side View	A-8
9	Post-Test Left Side View	A-9
10	Pre-Test Right Side View	A-10
11	Post-Test Right Side View	A-11
12	Pre-Test Right Front $\frac{3}{4}$ View	A-12
13	Post-Test Right Front $\frac{3}{4}$ View (Vehicle Moved)	A-13
14	Pre-Test Left Rear $\frac{3}{4}$ View	A-14
15	Post-Test Left Rear $\frac{3}{4}$ View	A-15
16	Left Rear $\frac{3}{4}$ View of Doors After Impact	A-16
17	Right Rear $\frac{3}{4}$ View of Doors After Impact	A-17
18	Pre-Test Windshield View	A-18
19	Post-Test Windshield View	A-19
20	Pre-Test Engine Compartment	A-20
21	Post-Test Engine Compartment (Vehicle Moved)	A-21
22	Pre-Test Fuel Cap	A-22
23	Post-Test Fuel Cap	A-23
24	Pre-Test Front Underbody View	A-24
25	Post-Test Front Underbody View	A-25
26	Pre-Test Mid Underbody View	A-26
27	Post-Test Mid Underbody View	A-27
28	Pre-Test Rear Underbody View	A-28
29	Post-Test Rear Underbody View	A-29
30	Pre-Test Driver Dummy Front View (Head Position)	A-30
31	Post-Test Driver Dummy Front View (Head Position)	A-31
32	Pre-Test Driver Dummy Through Window	A-32
33	Post-Test Driver Dummy Through Window	A-33
34	Pre-Test Driver Dummy Door Open	A-34
35	Post-Test Driver Dummy Door Open	A-35

LIST OF PHOTOGRAPHS...(Continued)

Figure		Page
36	Pre-Test Driver Dummy Feet	A-36
37	Post-Test Driver Dummy Feet	A-37
38	Pre-Test Driver Side Knee Bolster	A-38
39	Post-Test Driver Side Knee Bolster	A-39
40	Pre-Test Driver Side Floor Pan	A-40
41	Post-Test Driver Side Floor Pan	A-41
42	Post-Test Driver Dummy Head	A-42
43	Post-Test Driver Dummy Contact to Air Bag	A-43
44	Pre-Test Passenger Dummy Front View (Head Position)	A-44
45	Post-Test Passenger Dummy Front View (Head Position)	A-45
46	Pre-Test Passenger Dummy Through Window	A-46
47	Post-Test Passenger Dummy Through Window	A-47
48	Pre-Test Passenger Dummy Door Open	A-48
49	Post-Test Passenger Dummy Door Open	A-49
50	Pre-Test Passenger Dummy Feet	A-50
51	Post-Test Passenger Dummy Feet	A-51
52	Pre-Test Passenger Side Glove Box	A-52
53	Post-Test Passenger Side Glove Box	A-53
54	Pre-Test Passenger Side Floor Pan	A-54
55	Post-Test Passenger Side Floor Pan	A-55
56	Post-Test Passenger Dummy Head	A-56
57	Post-Test Passenger Dummy Contact to Air Bag	A-57
58	Vehicle on Rollover Device at 0°	A-58
59	Vehicle on Rollover Device 90°	A-59
60	Vehicle on Rollover Device 180°	A-60
61	Vehicle on Rollover Device 270°	A-61
62	Vehicle During Impact	A-62



Figure A-1: Load Cell Location

MFD. BY: TOYOTA MOTOR MANUFACTURING, INDIANA, INC. 08/04  
GVWR: 2495KG (5500LB)  
GAWR: FRT. 1588KG (3500LB) WITH P245/70R16 TIRES,  
16X7JJ RIMS, AT 200KPA (29PSI) COLD.  
RR. 1615KG (3560LB) WITH P245/70R16 TIRES,  
16X7JJ RIMS, AT 240KPA (35PSI) COLD.  
THIS VEHICLE CONFORMS TO ALL APPLICABLE FEDERAL MOTOR  
VEHICLE SAFETY AND THEFT PREVENTION STANDARDS IN EFFECT ON  
THE DATE OF MANUFACTURE SHOWN ABOVE.  
5TBJU32135S442753 TRUCK



C/TR: 056/FN43 GSK30L-TRBDKA  
A/TM: A06A/A750E MADE IN U.S.A. 531 A

A-2

TR-P25001-04-NC

Figure A-2: Vehicle Certification Label



**TIRE AND LOADING INFORMATION**  
**SEE OWNER'S MANUAL FOR ADDITIONAL INFORMATION**  
**RENSEIGNEMENTS RELATIFS AUX PNEUS ET À LA CHARGE DU VÉHICULE**  
**CONSULTER LE GUIDE DU PROPRIÉTAIRE POUR DE PLUS AMPLES RENSEIGNEMENTS**

SEATING CAPACITY	TOTAL	FRONT	REAR
NOMBRE DE PLACES	TOTAL: 3	AVANT: 3	ARRIERE: 0

The combined weight of occupants and cargo should never exceed 638KG OR 1405LBS  
 La charge du véhicule (occupants et baggages) ne doit jamais dépasser 638KG OR 1405LBS

ORIGINAL TIRE SIZE DIMENSIONS DES PNEUS D'ORIGINE		COLD TIRE INFLATION PRESSURE PRESSION DE GONFLAGE A FROID	
FRONT/AVANT	P245/70R16	FRONT/AVANT	200 kPa, 29 PSI
REAR/ARRIERE	P245/70R16	REAR/ARRIERE	240 kPa, 35 PSI
COMPACT SIZE SPARE TIRE DIMENSIONS DU PNEU SECOURS COMPACT		COLD TIRE INFLATION PRESSURE PRESSION DE GONFLAGE A FROID	
..		.. kPa, .. PSI	

**16B31**



16B3112991

Figure A-3: Vehicle Tire Label



Figure A-4: Right Front 3/4 View, As Received



A-5

TR-P25001-04-NC

Figure A-5: Left Rear  $\frac{3}{4}$  View, as Received



Figure A-6: Pre-Test Front View

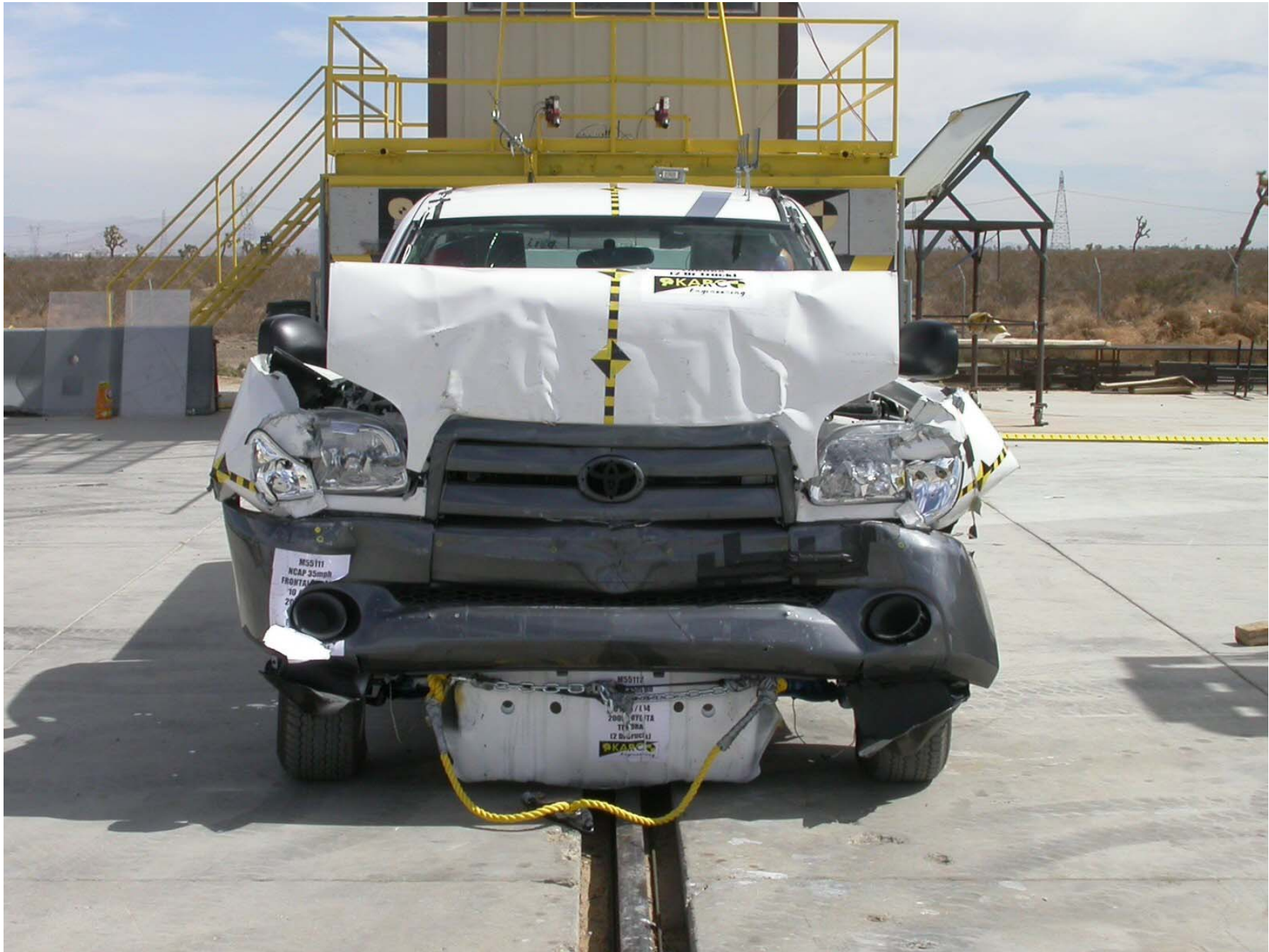

Figure A-7: Post-Test Front View (Vehicle Moved)



Figure A-8: Pre-Test Left Side View



Figure A-9: Post-Test Left Side View



Figure A-10: Pre-Test Right Side View



A-11

TR-P25001-04-NC

Figure A-11: Post-Test Right Side View



Figure A-12: Pre-Test Right Front ¾ View



Figure A-13: Post-Test Right Front 3/4 View



Figure A-14: Pre-Test Left Rear ¾ View



Figure A-15: Post-Test Left Rear ¾ View



Figure A-16: Left Rear  $\frac{3}{4}$  View of Doors After Impact



Figure A-17: Right Rear ¾ View of Doors After Impact

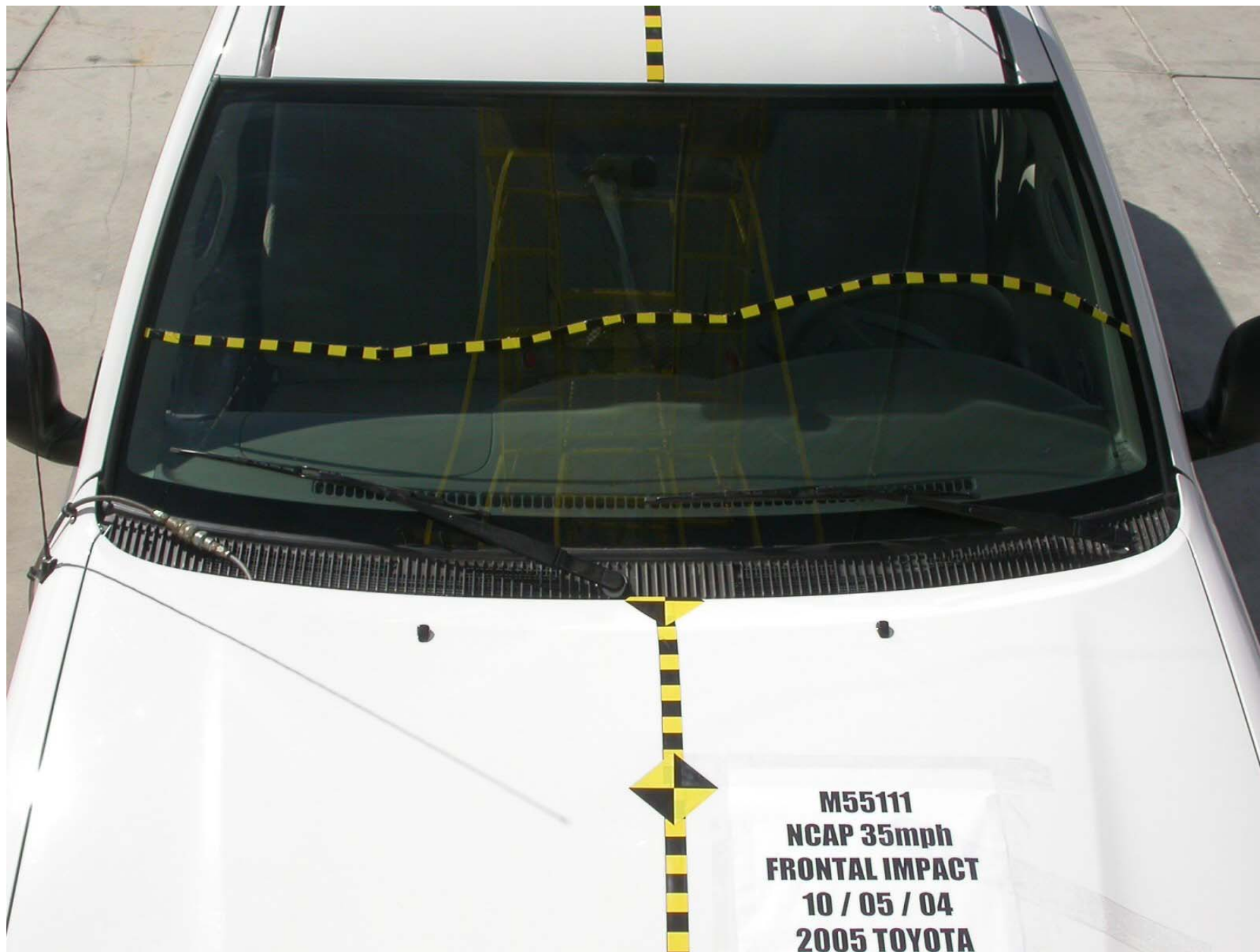

A-18

TR-P25001-04-NC

Figure A-18: Pre-Test Windshield View



A-19

TR-P25001-04-NC

Figure A-19: Post-Test Windshield View



Figure A-20: Pre-Test Engine Compartment



Figure A-21: Post-Test Engine Compartment (Vehicle Moved)



Figure A-22: Pre-Test Fuel Cap



Figure A-23: Post-Test Fuel Cap

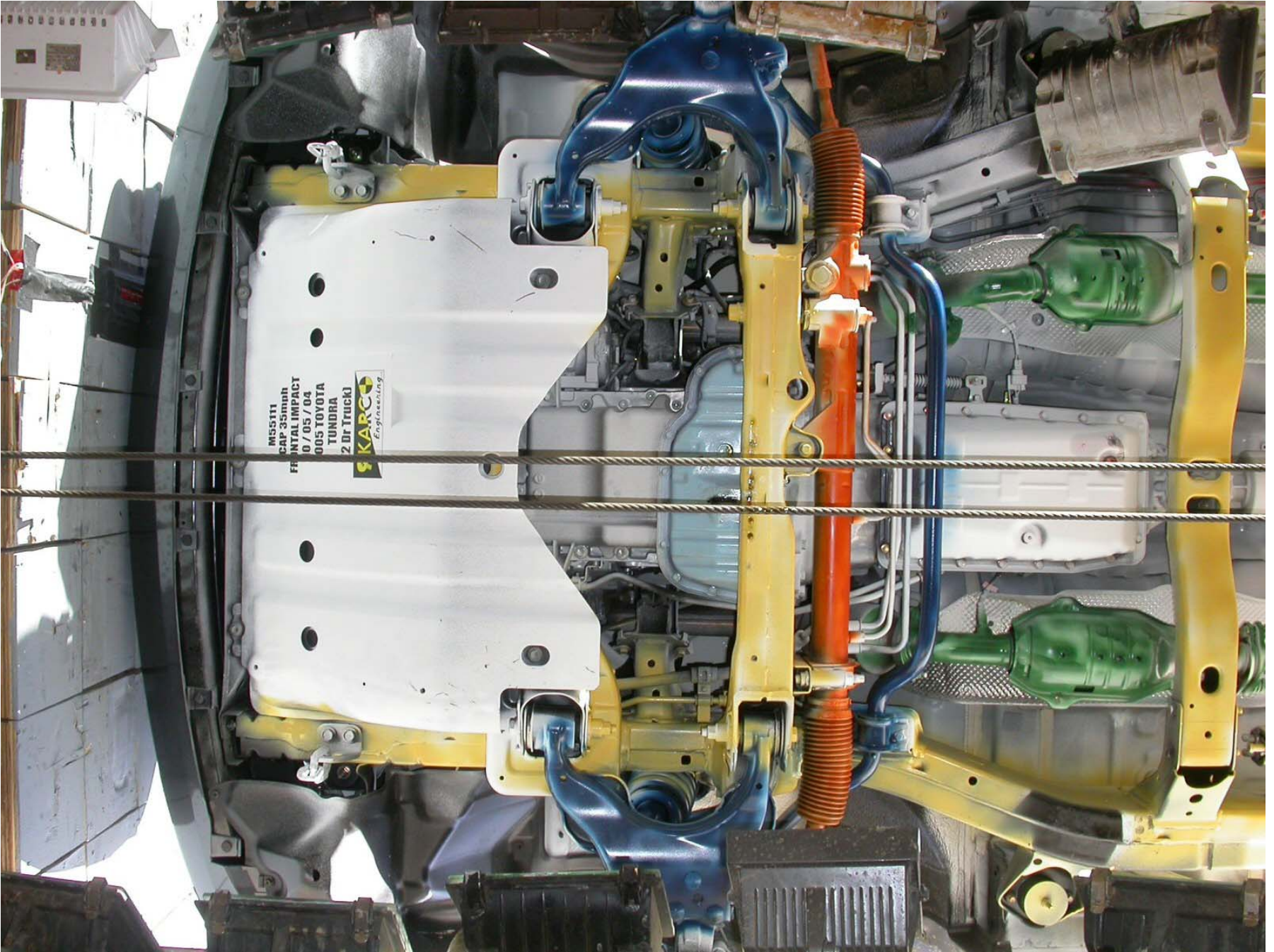

Figure A-24: Pre-Test Front Underbody View

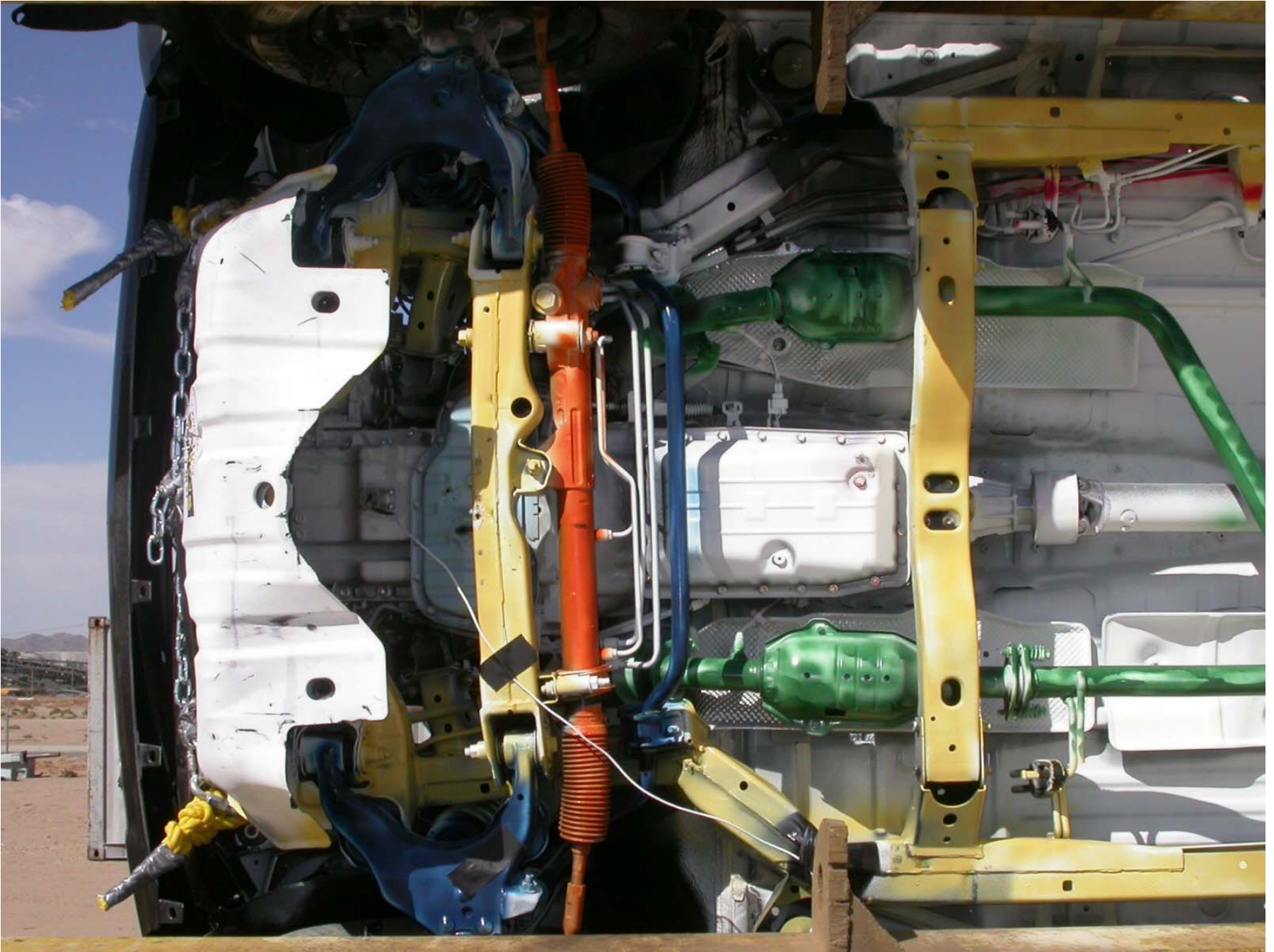

Figure A-25: Post-Test Front Underbody View

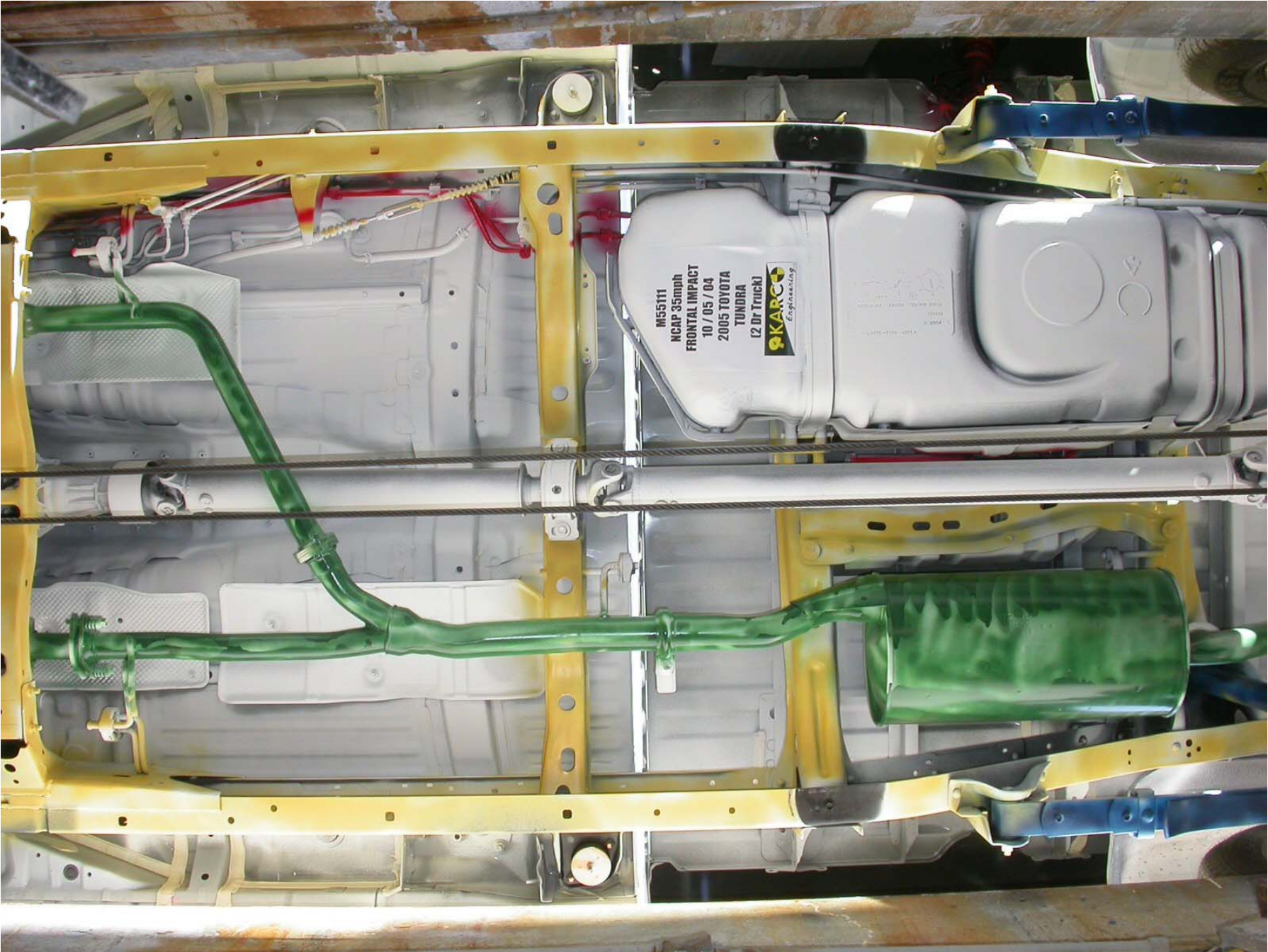

Figure A-26: Pre-Test Mid Underbody View



Figure A-27: Post-Test Mid Underbody View

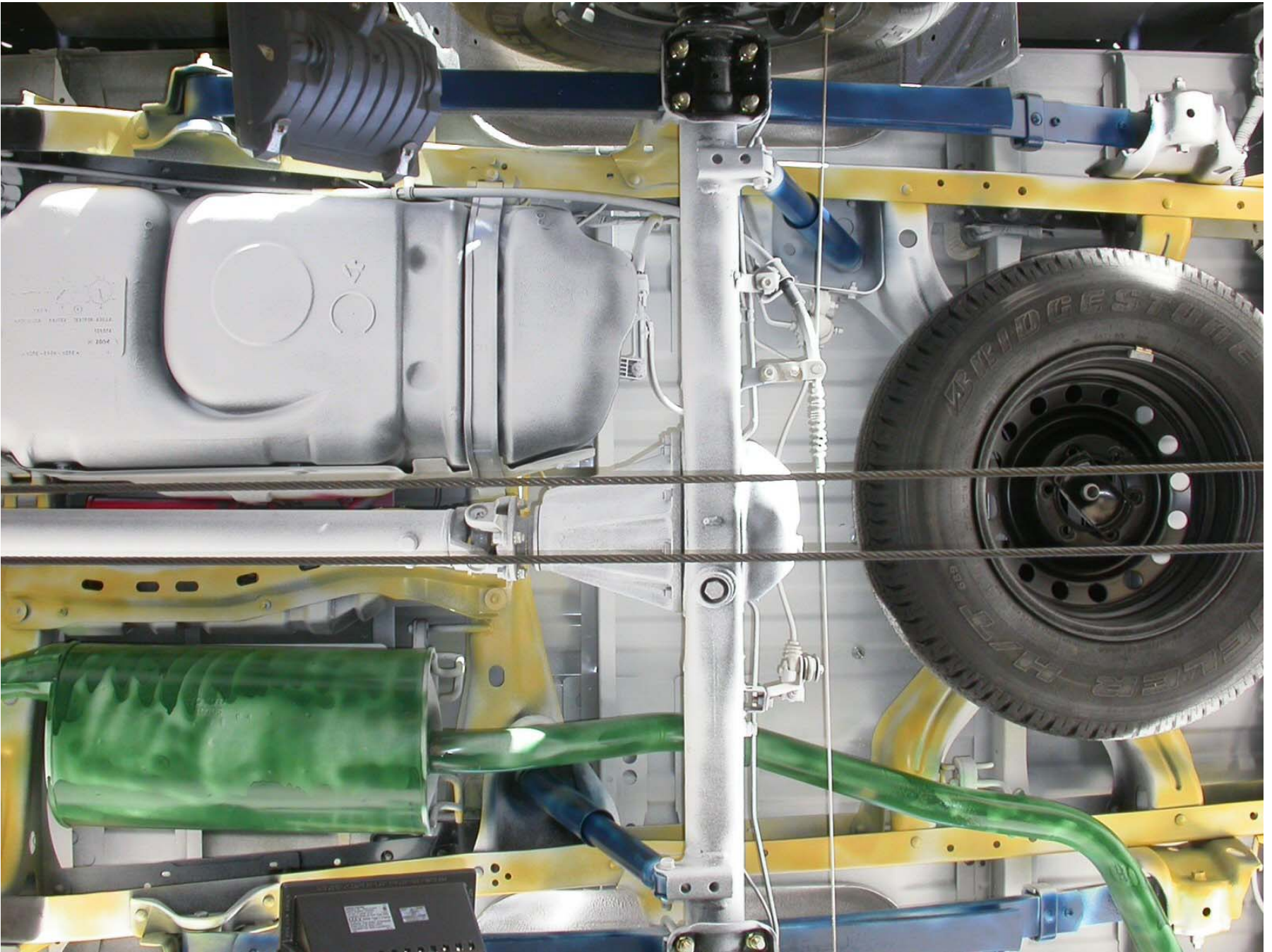

Figure A-28: Pre-Test Rear Underbody View

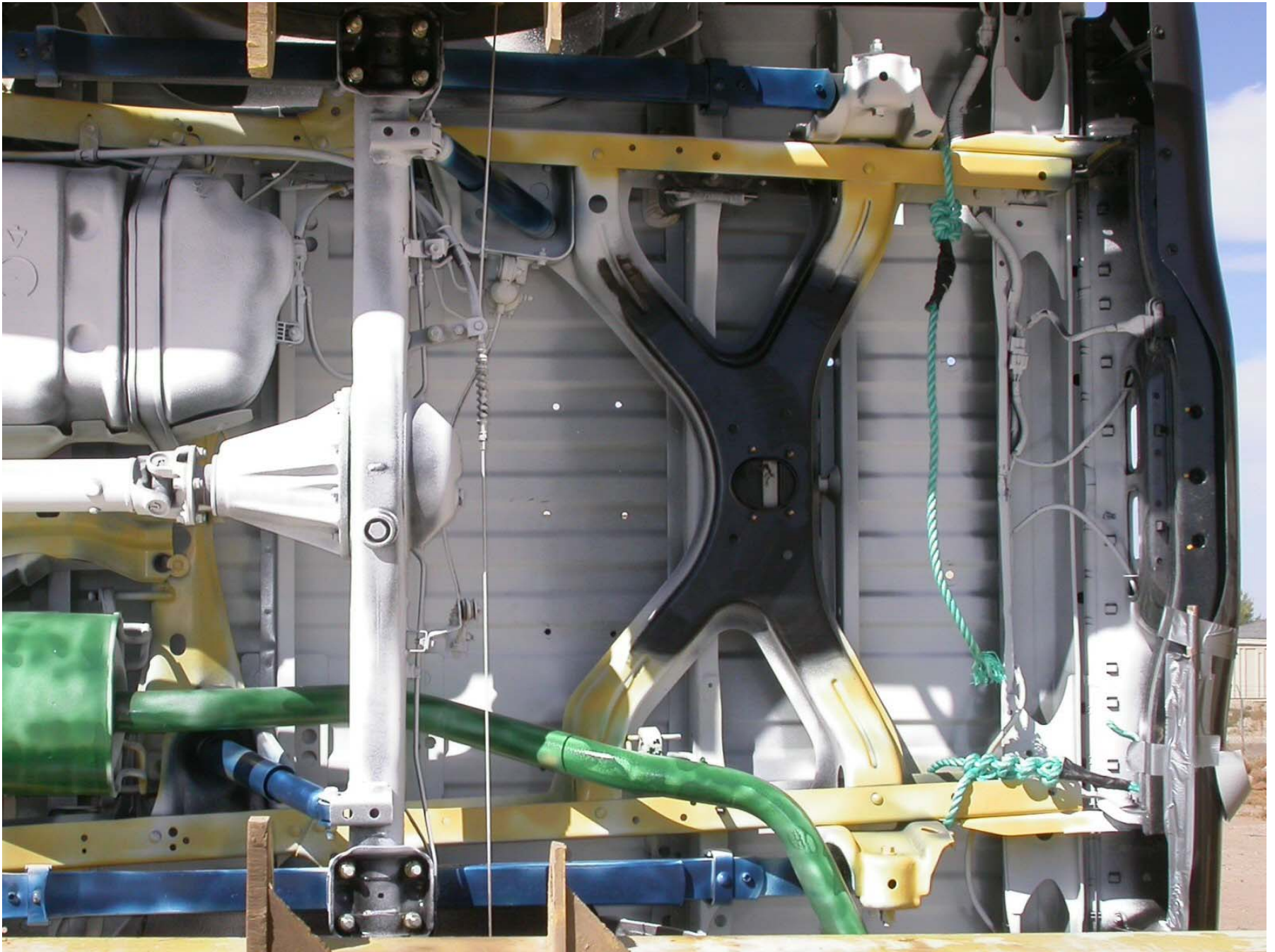

Figure A-29: Post-Test Rear Underbody View



Figure A-30: Pre-Test Driver Dummy Front View (Head Position)



Figure A-31: Post-Test Driver Dummy Front View (Head Position)



Figure A-32: Pre-Test Driver Dummy Through Window



A-33

TR-P25001-04-NC

Figure A-33: Post-Test Driver Dummy Through Window



Figure A-34: Pre-Test Driver Dummy Door Open



Figure A-35: Post-Test Driver Dummy Door Open



Figure A-36: Pre-Test Driver Dummy Feet



Figure A-37: Post-Test Driver Dummy Feet



Figure A-38: Pre-Test Driver Side Knee Bolster



Figure A-39: Post-Test Driver Side Knee Bolster



Figure A-40: Pre-Test Driver Side Floor Pan



Figure A-41: Post-Test Driver Side Floor Pan



Figure A-42: Post-Test Driver Dummy Head



Figure A-43: Post-Test Driver Dummy Contact to Air Bag



Figure A-44: Pre-Test Passenger Dummy Front View (Head Position)



Figure A-45: Post-Test Passenger Dummy Front View (Head Position)



Figure A-46: Pre-Test Passenger Dummy Through Window



A-47

TR-P25001-04-NC

Figure A-47: Post-Test Passenger Dummy Through Window



Figure A-48: Pre-Test Passenger Dummy Door Open



Figure A-49: Post-Test Passenger Dummy Door Open



Figure A-50: Pre-Test Passenger Dummy Feet



Figure A-51: Post-Test Passenger Dummy Feet



Figure A-52: Pre-Test Passenger Side Glove Box



Figure A-53: Post-Test Passenger Side Glove Box



Figure A-54: Pre-Test Passenger Side Floor Pan



Figure A-55: Post-Test Passenger Side Floor Pan



Figure A-56: Post-Test Passenger Dummy Head



Figure A-57: Post-Test Passenger Dummy Contact to Air Bag



A-58

TR-P25001-04-NC

Figure A-58: Vehicle on Rollover Device at 0°



A-59

TR-P25001-04-NC

Figure A-59: Vehicle on Rollover Device at 90°

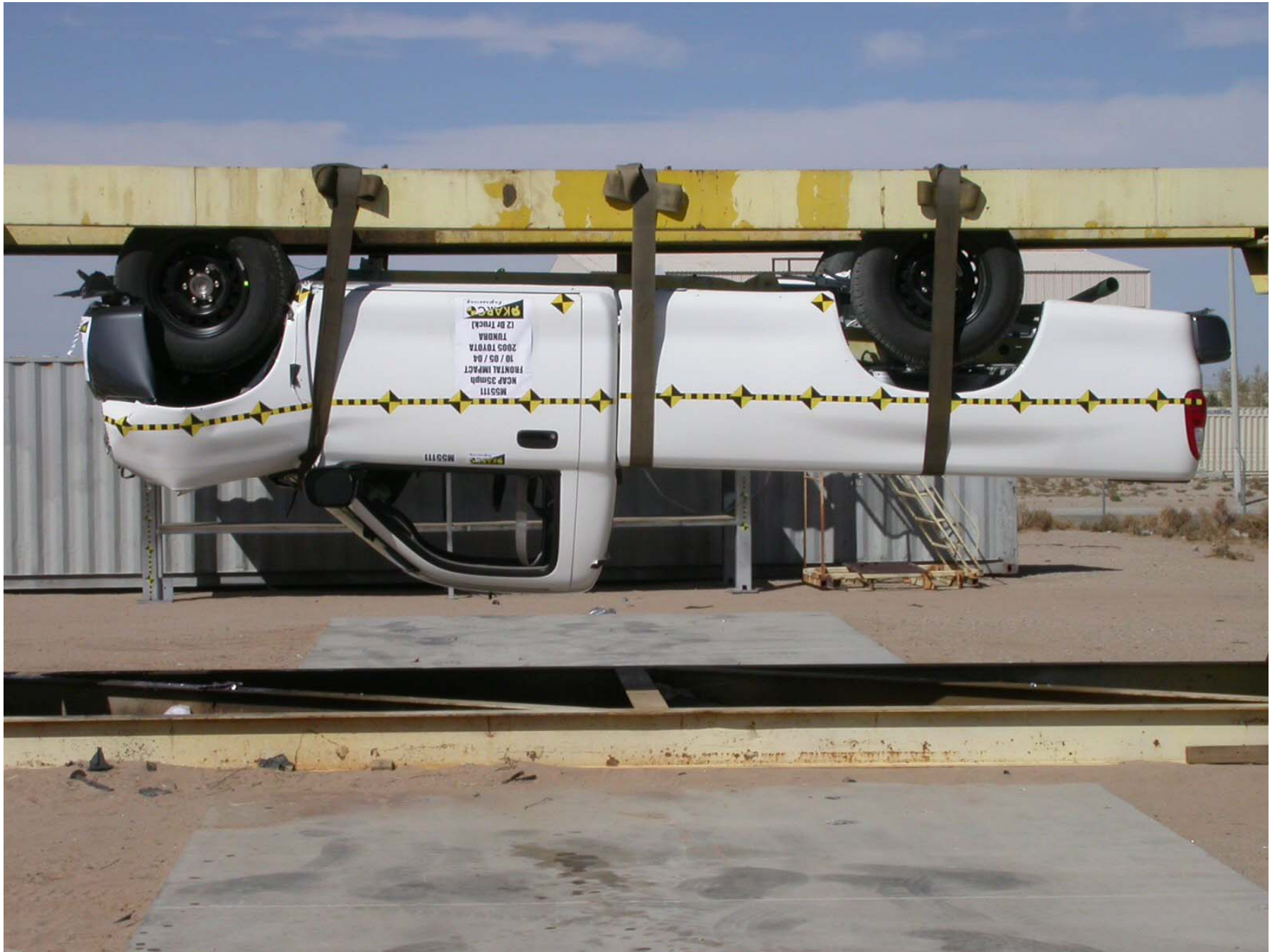

Figure A-60: Vehicle on Rollover Device at 180°



A-61

TR-P25001-04-NC

Figure A-61: Vehicle on Rollover Device at 270°



Figure A-62: Vehicle During Impact

**APPENDIX B**

**DATA PLOTS**

LIST OF DATA PLOTS

Data Plot	Page	
B-1	Driver Head Primary X	B-1
	Driver Head Primary Y	B-1
	Driver Head Primary Z	B-1
	Driver Head Resultant Primary	B-1
B-2	Driver Head Primary X Velocity	B-2
	Driver Head Primary X Displacement	B-2
B-3	Driver Head Redundant X	B-3
	Driver Head Redundant Y	B-3
	Driver Head Redundant Z	B-3
	Driver Head Resultant Redundant	B-3
B-4	Driver Head Redundant X Velocity	B-4
	Driver Head Redundant X Displacement	B-4
B-5	Driver Upper Neck Force X	B-5
	Driver Upper Neck Force Y	B-5
	Driver Upper Neck Force Z	B-5
	Driver Upper Neck Force Resultant	B-5
B-6	Driver Upper Neck Moment X	B-6
	Driver Upper Neck Moment Y	B-6
	Driver Upper Neck Moment Z	B-6
	Driver Upper Neck Moment Resultant	B-6
B-7	Driver Chest Primary X	B-7
	Driver Chest Primary Y	B-7
	Driver Chest Primary Z	B-7
	Driver Chest Resultant Primary	B-7
B-8	Driver Chest Primary X Velocity	B-8
	Driver Chest Primary X Displacement	B-8
B-9	Driver Chest Redundant X	B-9
	Driver Chest Redundant Y	B-9
	Driver Chest Redundant Z	B-9
	Driver Chest Resultant Redundant	B-9
B-10	Driver Chest Redundant X Velocity	B-10
	Driver Chest Redundant X Displacement	B-10
B-11	Driver Chest Displacement	B-11

LIST OF DATA PLOTS...(Continued)

Data Plot	Page	
B-12	Driver Pelvis X	B-12
	Driver Pelvis Y	B-12
	Driver Pelvis Z	B-12
	Driver Pelvis Resultant	B-12
B-13	Driver Pelvis X Velocity	B-13
	Driver Pelvis X Displacement	B-13
B-14	Driver Left Femur Force	B-14
	Driver Right Femur Force	B-14
B-15	Driver Left Upper Tibia Moment X	B-15
	Driver Left Upper Tibia Moment Y	B-15
	Driver Right Upper Tibia Moment X	B-15
	Driver Right Upper Tibia Moment Y	B-15
B-16	Driver Left Lower Tibia Moment X	B-16
	Driver Left Lower Tibia Moment Y	B-16
	Driver Left Lower Tibia Force Z	B-16
B-17	Driver Right Lower Tibia Moment X	B-17
	Driver Right Lower Tibia Moment Y	B-17
	Driver Right Lower Tibia Force Z	B-17
B-18	Driver Left Foot Aft X	B-18
	Driver Left Foot Aft Z	B-18
	Driver Left Foot Fore Z	B-18
B-19	Driver Right Foot Aft X	B-19
	Driver Right Foot Aft Z	B-19
	Driver Right Foot Fore Z	B-19
B-20	Driver Lap Belt Force	B-20
	Driver Shoulder Belt Force	B-20
	Driver Shoulder Belt Pullout	B-20
	Driver Shoulder Belt Elongation	B-20
B-21	Passenger Head Primary X	B-21
	Passenger Head Primary Y	B-21
	Passenger Head Primary Z	B-21
	Passenger Head Resultant Primary	B-21
B-22	Passenger Head Primary X Velocity	B-22
	Passenger Head Primary X Displacement	B-22

LIST OF DATA PLOTS...(Continued)

Data Plot	Page	
B-23	Passenger Head Redundant X	B-23
	Passenger Head Redundant Y	B-23
	Passenger Head Redundant Z	B-23
	Passenger Head Resultant Redundant	B-23
B-24	Passenger Head Redundant X Velocity	B-24
	Passenger Head Redundant X Displacement	B-24
B-25	Passenger Upper Neck Force X	B-25
	Passenger Upper Neck Force Y	B-25
	Passenger Upper Neck Force Z	B-25
	Passenger Upper Neck Force Resultant	B-25
B-26	Passenger Upper Neck Moment X	B-26
	Passenger Upper Neck Moment Y	B-26
	Passenger Upper Neck Moment Z	B-26
	Passenger Upper Neck Moment Resultant	B-26
B-27	Passenger Chest Primary X	B-27
	Passenger Chest Primary Y	B-27
	Passenger Chest Primary Z	B-27
	Passenger Chest Resultant Primary	B-27
B-28	Passenger Chest Primary X Velocity	B-28
	Passenger Chest Primary X Displacement	B-28
B-29	Passenger Chest Redundant X	B-29
	Passenger Chest Redundant Y	B-29
	Passenger Chest Redundant Z	B-29
	Passenger Chest Resultant Redundant	B-29
B-30	Passenger Chest Redundant X Velocity	B-30
	Passenger Chest Redundant X Displacement	B-30
B-31	Passenger Chest Displacement	B-31
B-32	Passenger Pelvis X	B-32
	Passenger Pelvis Y	B-32
	Passenger Pelvis Z	B-32
	Passenger Pelvis Resultant	B-32
B-33	Passenger Pelvis X Velocity	B-33
	Passenger Pelvis X Displacement	B-33

## LIST OF DATA PLOTS...(Continued)

Data Plot	Page	
B-34	Passenger Left Femur Force	B-34
	Passenger Right Femur Force	B-34
B-35	Passenger Left Upper Tibia Moment X	B-35
	Passenger Left Upper Tibia Moment Y	B-35
	Passenger Right Upper Tibia Moment X	B-35
	Passenger Right Upper Tibia Moment Y	B-35
B-36	Passenger Left Lower Tibia Moment X	B-36
	Passenger Left Lower Tibia Moment Y	B-36
	Passenger Left Lower Tibia Force Z	B-36
B-37	Passenger Right Lower Tibia Moment X	B-37
	Passenger Right Lower Tibia Moment Y	B-37
	Passenger Right Lower Tibia Force Z	B-37
B-38	Passenger Left Foot Aft X	B-38
	Passenger Left Foot Aft Z	B-38
	Passenger Left Foot Fore Z	B-38
B-39	Passenger Right Foot Aft X	B-39
	Passenger Right Foot Aft Z	B-39
	Passenger Right Foot Fore Z	B-39
B-40	Passenger Lap Belt Force	B-40
	Passenger Shoulder Belt Force	B-40
	Passenger Shoulder Belt Pullout	B-40
	Passenger Shoulder Belt Elongation	B-40
B-41	Vehicle Left Rear X	B-41
	Vehicle Left Rear X Velocity	B-41
	Vehicle Left Rear X Displacement	B-41
B-42	Vehicle Right Rear X	B-42
	Vehicle Right Rear X Velocity	B-42
	Vehicle Right Rear X Displacement	B-42
B-43	Vehicle Engine Top X	B-43
	Vehicle Engine Top X Velocity	B-43
	Vehicle Engine Top X Displacement	B-43
B-44	Vehicle Engine Bottom X	B-44
	Vehicle Engine Bottom X Velocity	B-44
	Vehicle Engine Bottom X Displacement	B-44

LIST OF DATA PLOTS...(Continued)

<u>Data Plot</u>	<u>Page</u>	
B-45	Vehicle Left Brake Caliper X	B-45
	Vehicle Left Brake Caliper X Velocity	B-45
	Vehicle Left Brake Caliper X Displacement	B-45
B-46	Vehicle Right Brake Caliper X	B-46
	Vehicle Right Brake Caliper X Velocity	B-46
	Vehicle Right Brake Caliper X Displacement	B-46
B-47	Vehicle Instrument Panel X	B-47
	Vehicle Instrument Panel X Velocity	B-47
	Vehicle Instrument Panel X Displacement	B-47
B-48	Vehicle Left Rear Z	B-48
	Vehicle Left Rear Z Velocity	B-48
	Vehicle Left Rear Z Displacement	B-48
B-49	Vehicle Right Rear Z	B-49
	Vehicle Right Rear Z Velocity	B-49
	Vehicle Right Rear Z Displacement	B-49

Test Vehicle: 2005 Toyota Tundra 2-Door Truck  
 Test Program: 2005 NHTSA 35mph NCAP

Test Date: 10/5/04  
 NHTSA No.: M55111

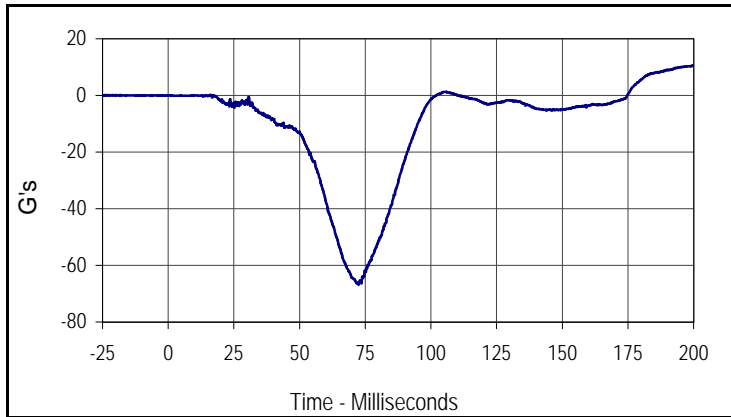

Curve Description			
Driver Head Primary X			
CURNO	Type	SAE Class	Units
001	FIL	1000	G's
Max	Time	Min	Time
10.5	199.7	-66.8	72.5

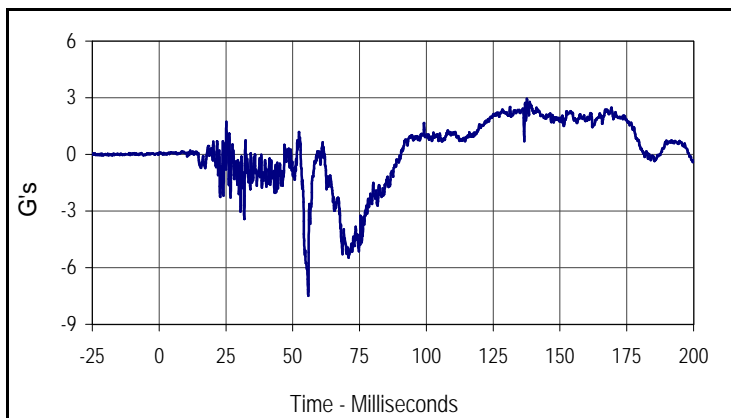

Curve Description			
Driver Head Primary Y			
CURNO	Type	SAE Class	Units
002	FIL	1000	G's
Max	Time	Min	Time
3.0	137.6	-7.5	55.8

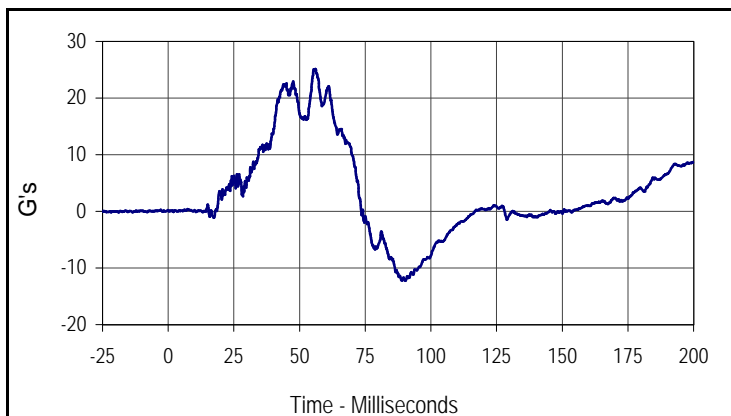

Curve Description			
Driver Head Primary Z			
CURNO	Type	SAE Class	Units
003	FIL	1000	G's
Max	Time	Min	Time
25.1	56.0	-12.2	90.3

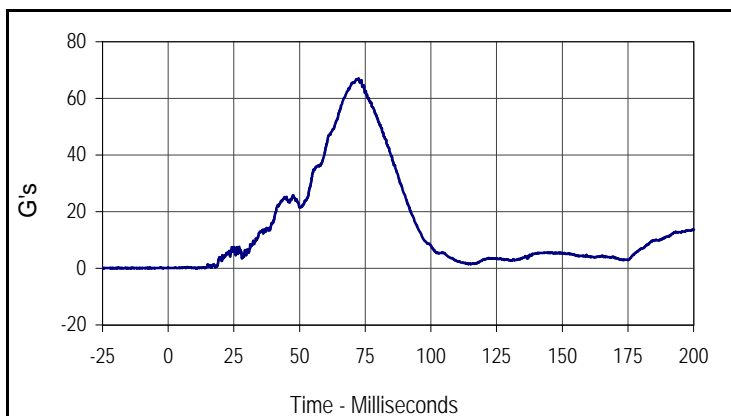

Curve Description			
Driver Head Resultant Primary			
CURNO	Type	SAE Class	Units
001	RES	1000	G's
Max	Time	Min	Time
67.0	72.5	0.0	11.1

Test Vehicle: 2005 Toyota Tundra 2-Door Truck  
 Test Program: 2005 NHTSA 35mph NCAP

Test Date: 10/5/04  
 NHTSA No.: M55111

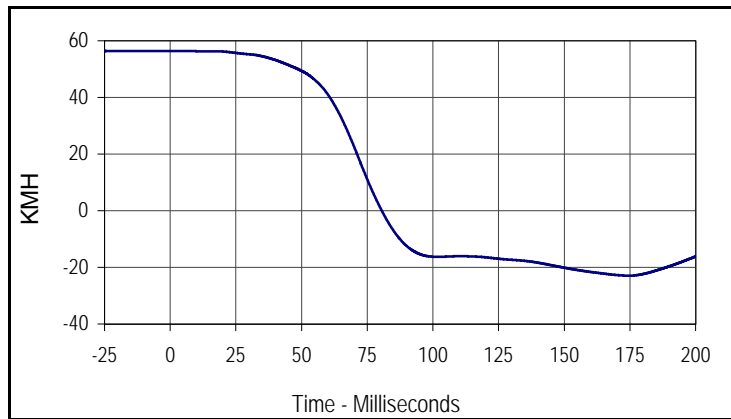

Curve Description			
Driver Head Primary X Velocity			
CURNO	Type	SAE Class	Units
001	IN1	180	KMH
Max	Time	Min	Time
56.4	0.0	-23.0	174.8

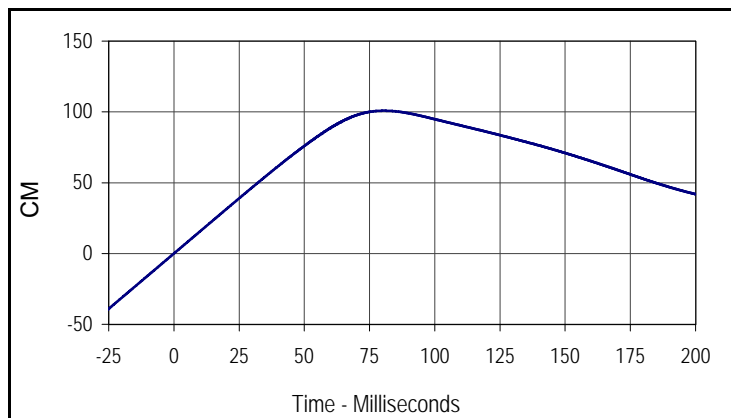

Curve Description			
Driver Head Primary X Displacement			
CURNO	Type	SAE Class	Units
001	IN2	180	CM
Max	Time	Min	Time
100.9	80.5	0.0	0.0

Test Vehicle: 2005 Toyota Tundra 2-Door Truck  
 Test Program: 2005 NHTSA 35mph NCAP

Test Date: 10/5/04  
 NHTSA No.: M55111

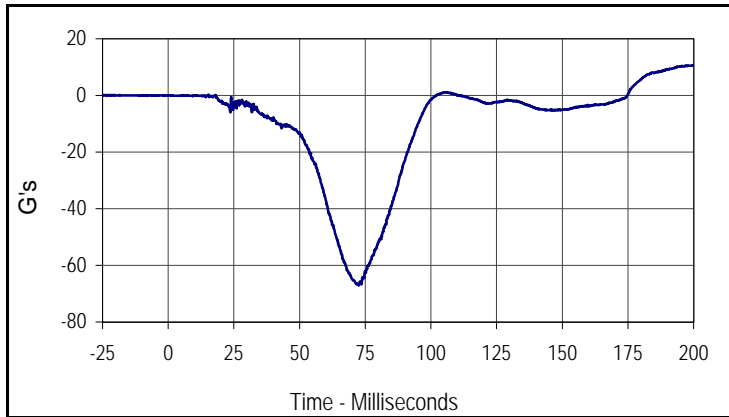

Curve Description			
Driver Head Redundant X			
CURNO	Type	SAE Class	Units
004	FIL	1000	G's
Max	Time	Min	Time
10.6	199.9	-67.0	72.6

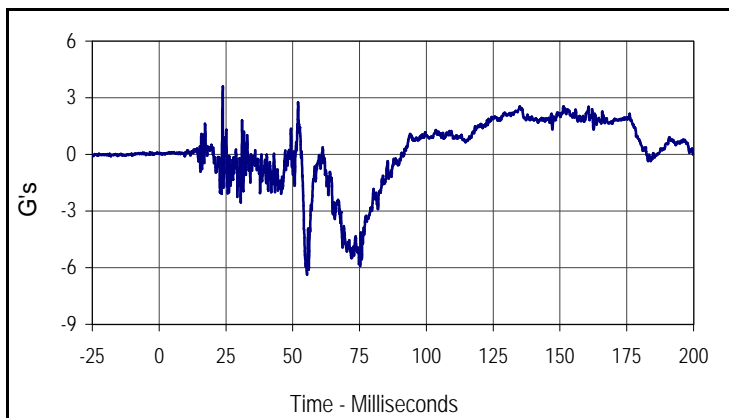

Curve Description			
Driver Head Redundant Y			
CURNO	Type	SAE Class	Units
005	FIL	1000	G's
Max	Time	Min	Time
3.6	23.8	-6.4	55.3

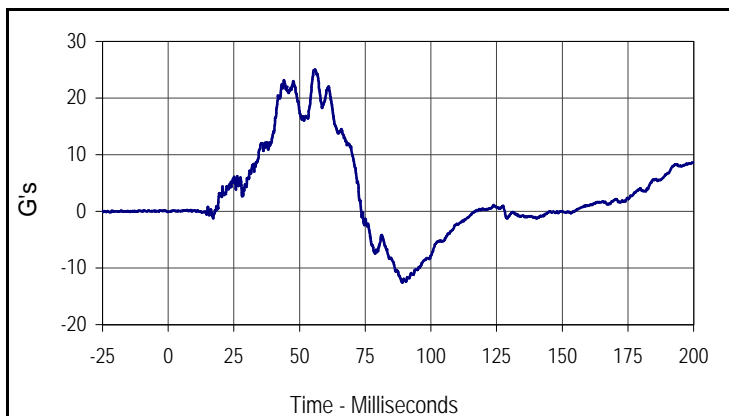

Curve Description			
Driver Head Redundant Z			
CURNO	Type	SAE Class	Units
006	FIL	1000	G's
Max	Time	Min	Time
25.1	55.9	-12.6	89.1

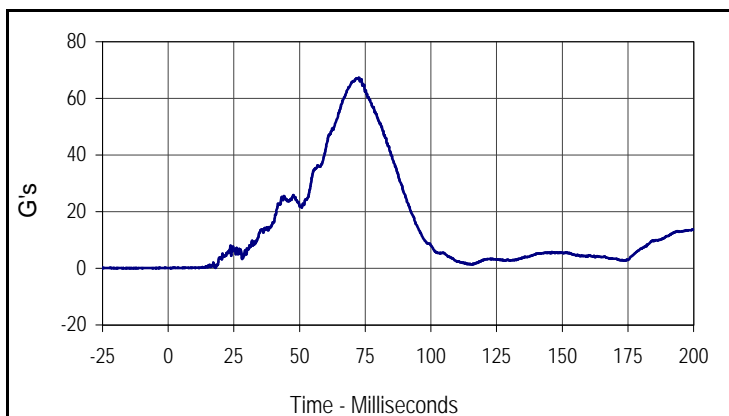

Curve Description			
Driver Head Resultant Redundant			
CURNO	Type	SAE Class	Units
004	RES	1000	G's
Max	Time	Min	Time
67.3	72.5	0.0	0.9

Test Vehicle: 2005 Toyota Tundra 2-Door Truck  
 Test Program: 2005 NHTSA 35mph NCAP

Test Date: 10/5/04  
 NHTSA No.: M55111

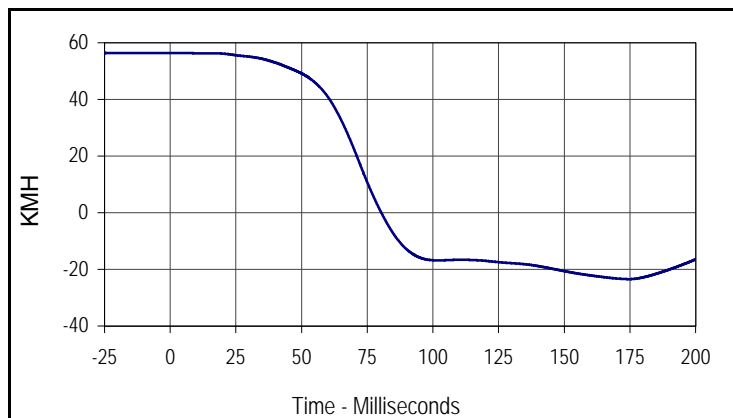

Curve Description			
Driver Head Redundant X Velocity			
CURNO	Type	SAE Class	Units
004	IN1	180	KMH
Max	Time	Min	Time
56.4	0.0	-23.5	174.7

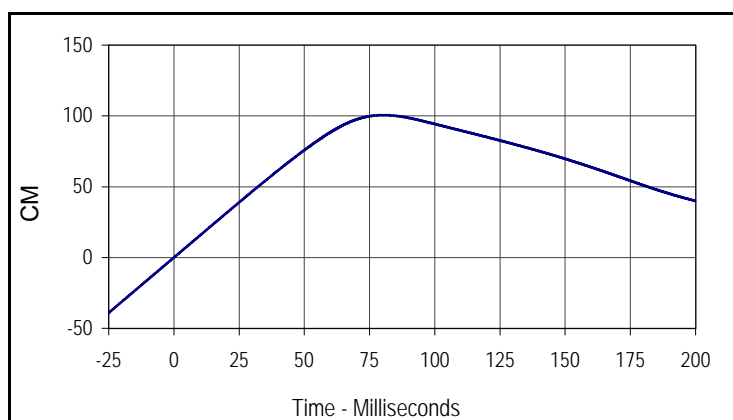

Curve Description			
Driver Head Redundant X Displacement			
CURNO	Type	SAE Class	Units
004	IN2	180	CM
Max	Time	Min	Time
100.5	80.4	0.0	0.0

Test Vehicle: 2005 Toyota Tundra 2-Door Truck  
 Test Program: 2005 NHTSA 35mph NCAP

Test Date: 10/5/04  
 NHTSA No.: M55111

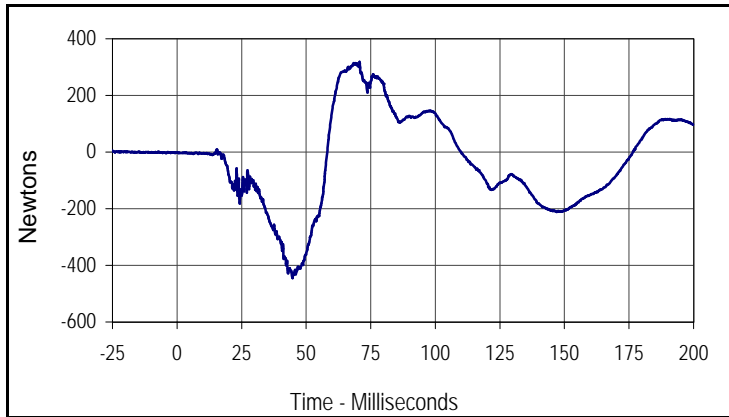

Curve Description			
Driver Upper Neck Force X			
CURNO	Type	SAE Class	Units
007	FIL	1000	Newtons
Max	Time	Min	Time
318.1	70.7	-445.1	44.7

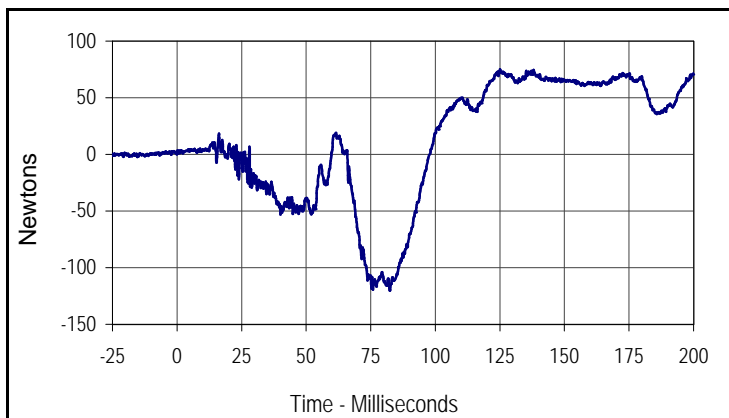

Curve Description			
Driver Upper Neck Force Y			
CURNO	Type	SAE Class	Units
008	FIL	1000	Newtons
Max	Time	Min	Time
75.2	125.1	-120.5	82.4

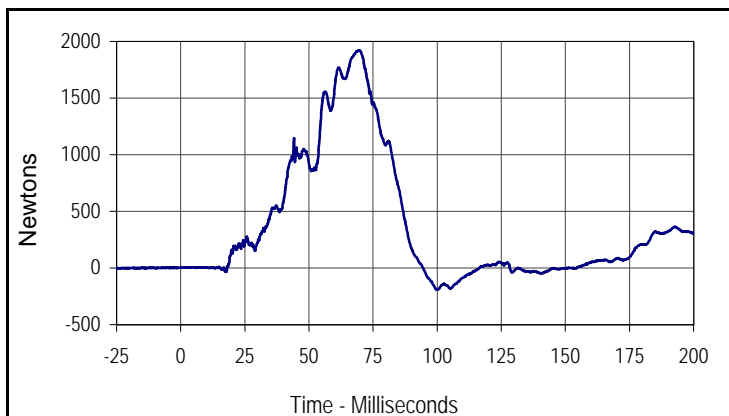

Curve Description			
Driver Upper Neck Force Z			
CURNO	Type	SAE Class	Units
009	FIL	1000	Newtons
Max	Time	Min	Time
1920.9	69.4	-188.8	100.2

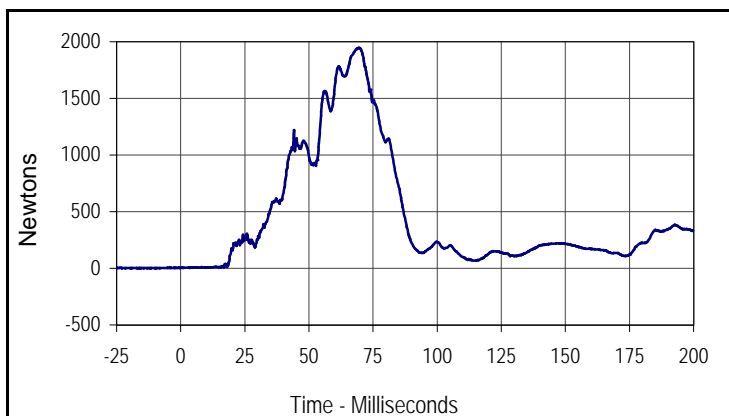

Curve Description			
Driver Upper Neck Force Res.			
CURNO	Type	SAE Class	Units
007	RES	1000	Newtons
Max	Time	Min	Time
1946.6	69.4	2.9	0.0

Test Vehicle: 2005 Toyota Tundra 2-Door Truck  
 Test Program: 2005 NHTSA 35mph NCAP

Test Date: 10/5/04  
 NHTSA No.: M55111

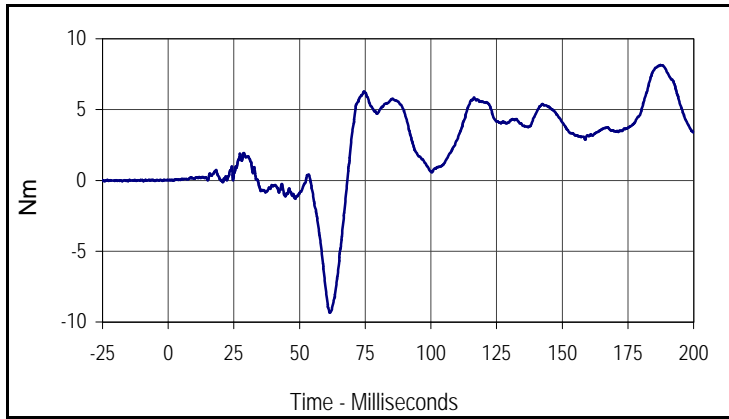

Curve Description			
Driver Upper Neck Moment X			
CURNO	Type	SAE Class	Units
010	FIL	600	Nm
Max	Time	Min	Time
8.1	187.3	-9.3	61.6

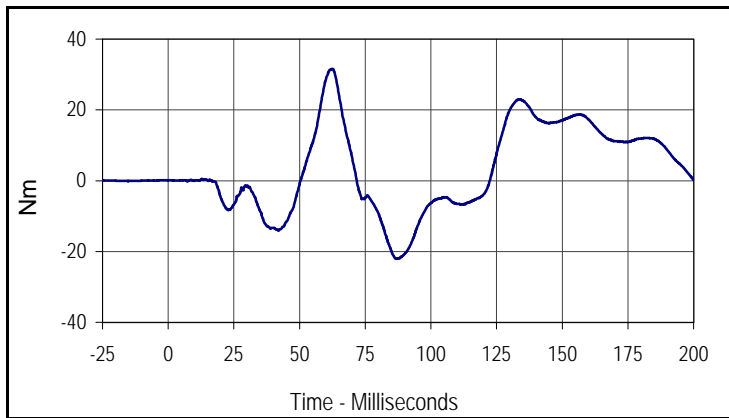

Curve Description			
Driver Upper Neck Moment Y			
CURNO	Type	SAE Class	Units
011	FIL	600	Nm
Max	Time	Min	Time
31.6	62.5	-22.1	86.9

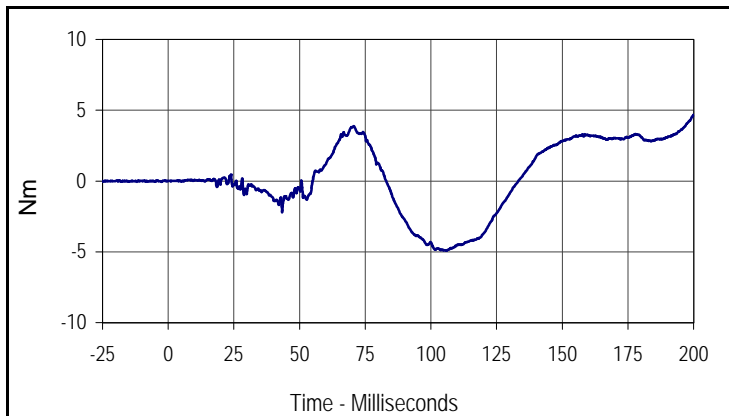

Curve Description			
Driver Upper Neck Moment Z			
CURNO	Type	SAE Class	Units
012	FIL	600	Nm
Max	Time	Min	Time
4.7	200.0	-4.9	105.9

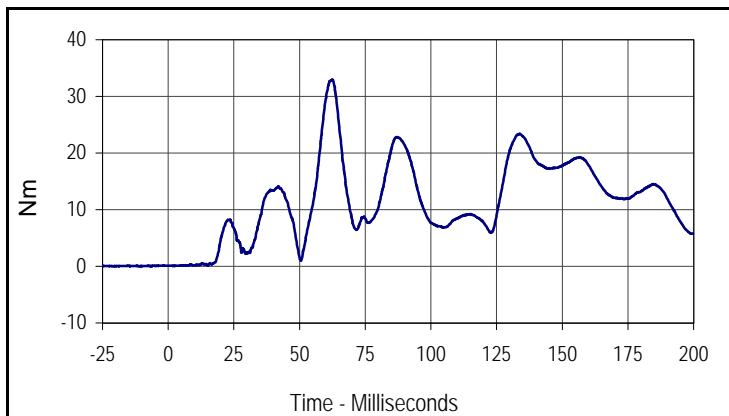

Curve Description			
Driver Upper Neck Moment Res.			
CURNO	Type	SAE Class	Units
010	RES	600	Nm
Max	Time	Min	Time
32.9	62.3	0.1	1.8

Test Vehicle: 2005 Toyota Tundra 2-Door Truck  
 Test Program: 2005 NHTSA 35mph NCAP

Test Date: 10/5/04  
 NHTSA No.: M55111

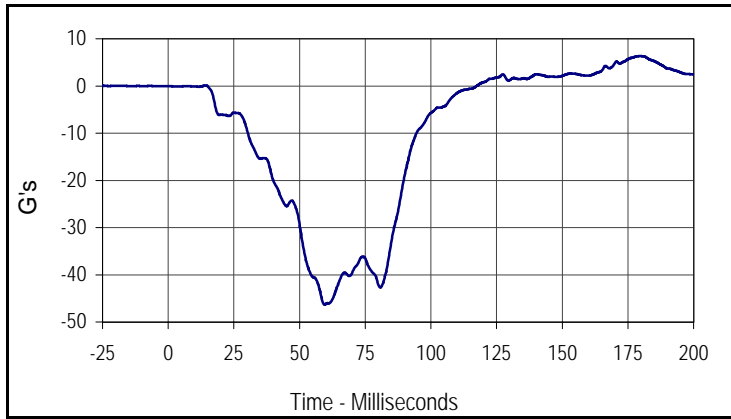

Curve Description			
Driver Chest Primary X			
CURNO	Type	SAE Class	Units
013	FIL	180	G's
Max	Time	Min	Time
6.3	179.9	-46.3	59.5

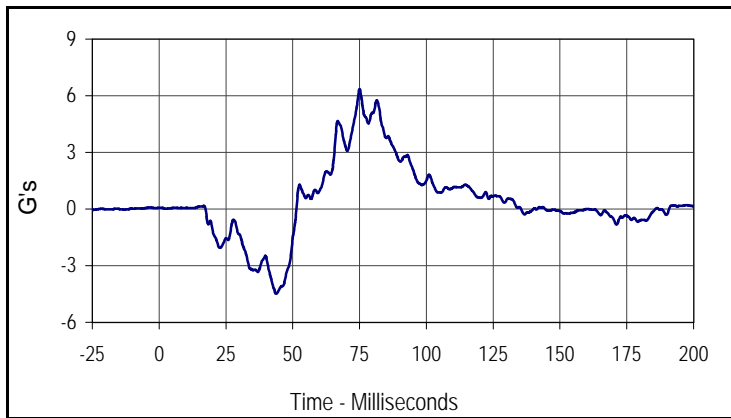

Curve Description			
Driver Chest Primary Y			
CURNO	Type	SAE Class	Units
014	FIL	180	G's
Max	Time	Min	Time
6.4	75.0	-4.5	43.7

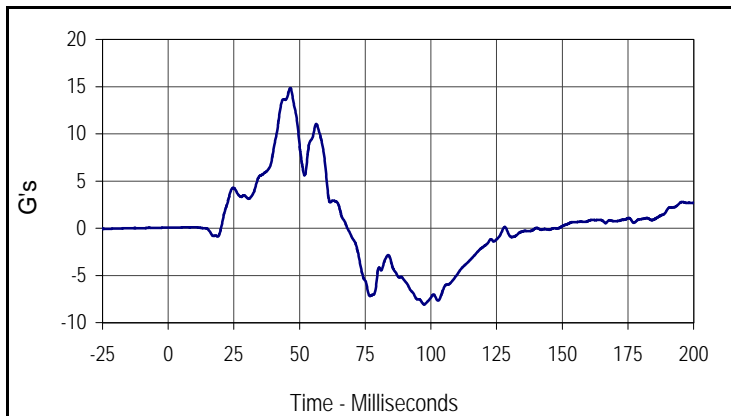

Curve Description			
Driver Chest Primary Z			
CURNO	Type	SAE Class	Units
015	FIL	180	G's
Max	Time	Min	Time
14.9	46.5	-8.1	97.4

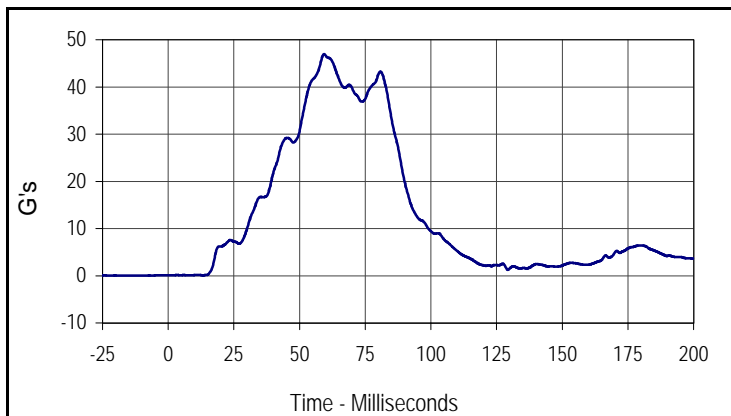

Curve Description			
Driver Chest Resultant Primary			
CURNO	Type	SAE Class	Units
013	RES	180	G's
Max	Time	Min	Time
46.9	59.3	0.1	13.3

Test Vehicle: 2005 Toyota Tundra 2-Door Truck  
 Test Program: 2005 NHTSA 35mph NCAP

Test Date: 10/5/04  
 NHTSA No.: M55111

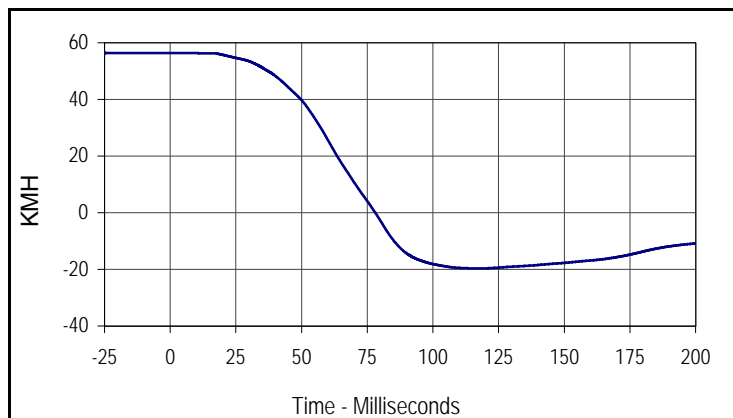

Curve Description			
Driver Chest Primary X Velocity			
CURNO	Type	SAE Class	Units
013	IN1	180	KMH
Max	Time	Min	Time
56.4	0.0	-19.7	117.4

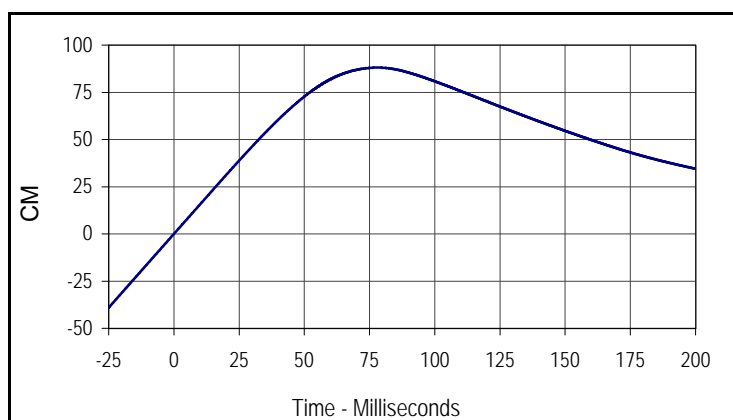

Curve Description			
Driver Chest Primary X Displacement			
CURNO	Type	SAE Class	Units
013	IN2	180	CM
Max	Time	Min	Time
88.1	78.0	0.0	0.0

Test Vehicle: 2005 Toyota Tundra 2-Door Truck  
 Test Program: 2005 NHTSA 35mph NCAP

Test Date: 10/5/04  
 NHTSA No.: M55111

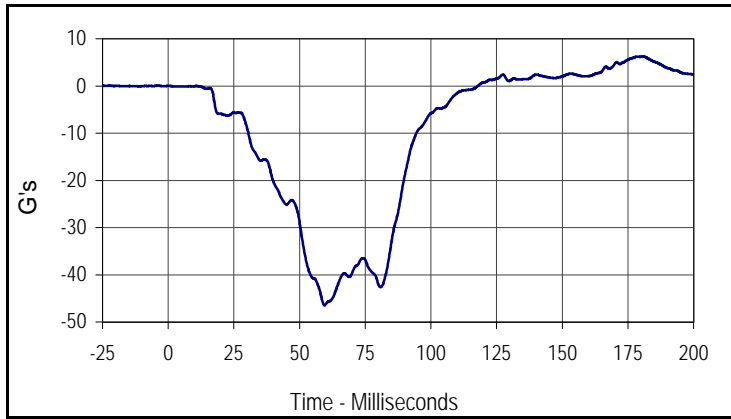

Curve Description			
Driver Chest Redundant X			
CURNO	Type	SAE Class	Units
016	FIL	180	G's
Max	Time	Min	Time
6.3	180.8	-46.5	59.5

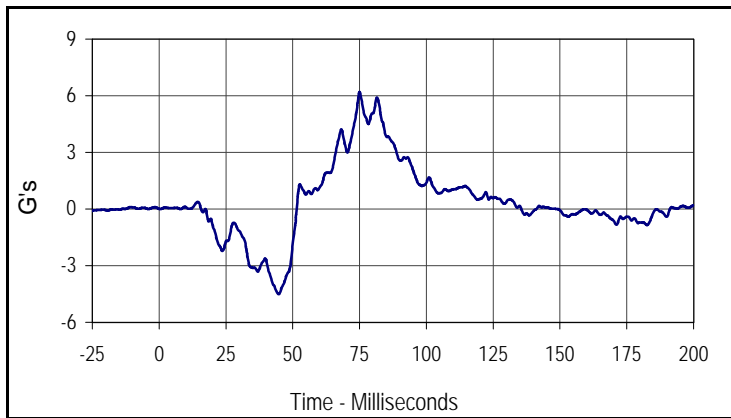

Curve Description			
Driver Chest Redundant Y			
CURNO	Type	SAE Class	Units
017	FIL	180	G's
Max	Time	Min	Time
6.2	75.0	-4.5	44.7

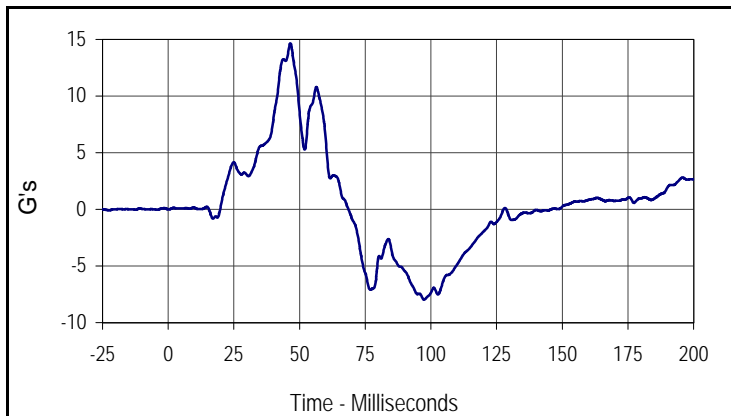

Curve Description			
Driver Chest Redundant Z			
CURNO	Type	SAE Class	Units
018	FIL	180	G's
Max	Time	Min	Time
14.6	46.5	-8.0	97.4

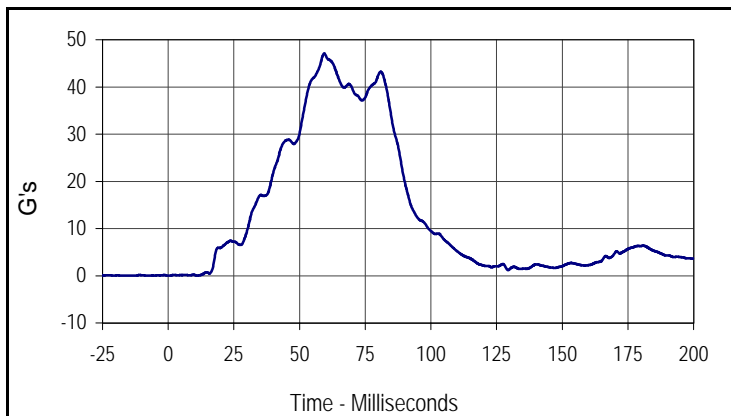

Curve Description			
Driver Chest Resultant Redundant			
CURNO	Type	SAE Class	Units
016	RES	180	G's
Max	Time	Min	Time
47.1	59.4	0.0	0.7

Test Vehicle: 2005 Toyota Tundra 2-Door Truck  
 Test Program: 2005 NHTSA 35mph NCAP

Test Date: 10/5/04  
 NHTSA No.: M55111

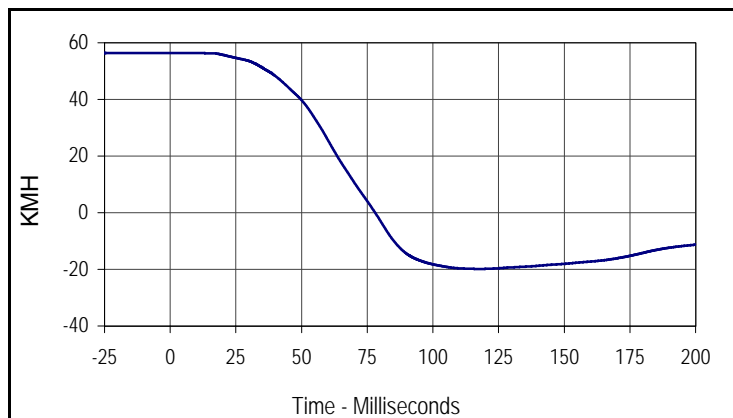

Curve Description			
Driver Chest Redundant X Velocity			
CURNO	Type	SAE Class	Units
016	IN1	180	KMH
Max	Time	Min	Time
56.4	0.9	-19.9	117.8

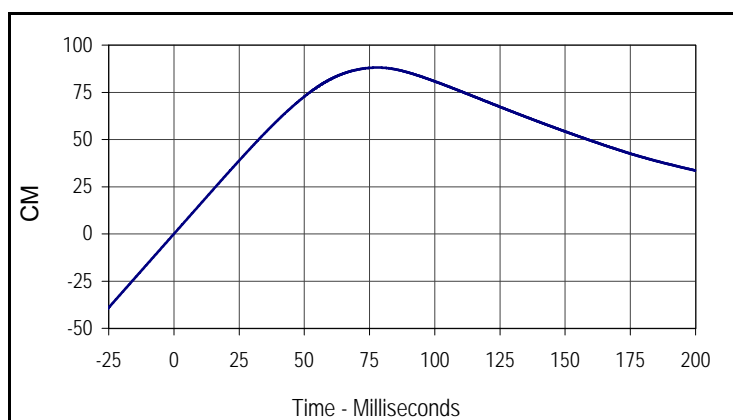

Curve Description			
Driver Chest Redundant X Displacement			
CURNO	Type	SAE Class	Units
016	IN2	180	CM
Max	Time	Min	Time
88.1	78.0	0.0	0.0

Test Vehicle: 2005 Toyota Tundra 2-Door Truck  
 Test Program: 2005 NHTSA 35mph NCAP

Test Date: 10/5/04  
 NHTSA No.: M55111

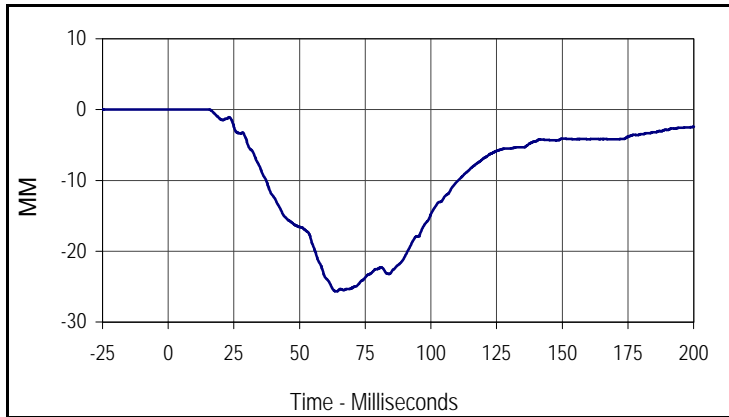

Curve Description			
Driver Chest Displacement			
CURNO	Type	SAE Class	Units
019	FIL	600	MM
Max	Time	Min	Time
0.0	4.7	-25.7	64.1

Test Vehicle: 2005 Toyota Tundra 2-Door Truck  
 Test Program: 2005 NHTSA 35mph NCAP

Test Date: 10/5/04  
 NHTSA No.: M55111

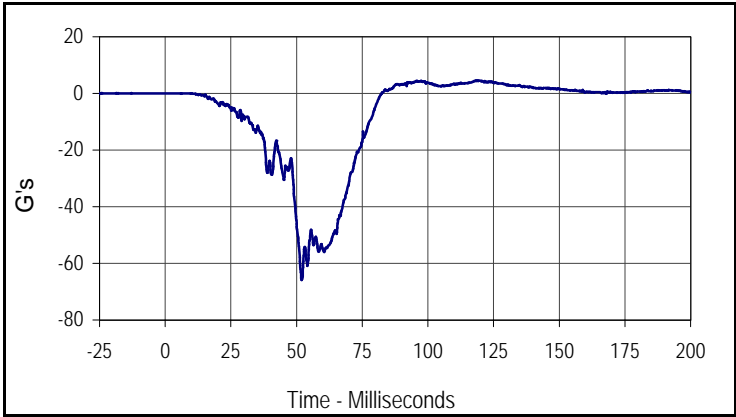

Curve Description			
Driver Pelvis X			
CURNO	Type	SAE Class	Units
020	FIL	1000	G's
Max	Time	Min	Time
4.6	118.9	-65.9	52.0

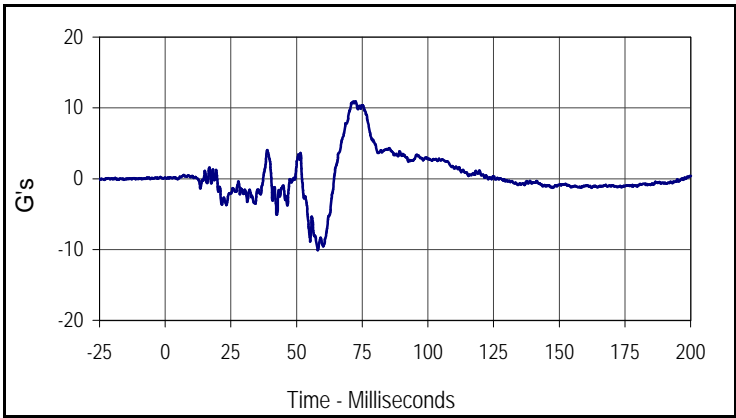

Curve Description			
Driver Pelvis Y			
CURNO	Type	SAE Class	Units
021	FIL	1000	G's
Max	Time	Min	Time
10.9	71.6	-10.1	58.1

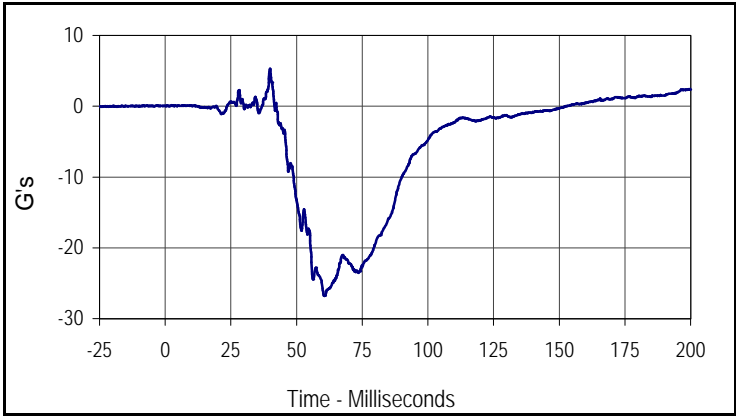

Curve Description			
Driver Pelvis Z			
CURNO	Type	SAE Class	Units
022	FIL	1000	G's
Max	Time	Min	Time
5.3	39.9	-26.8	60.5

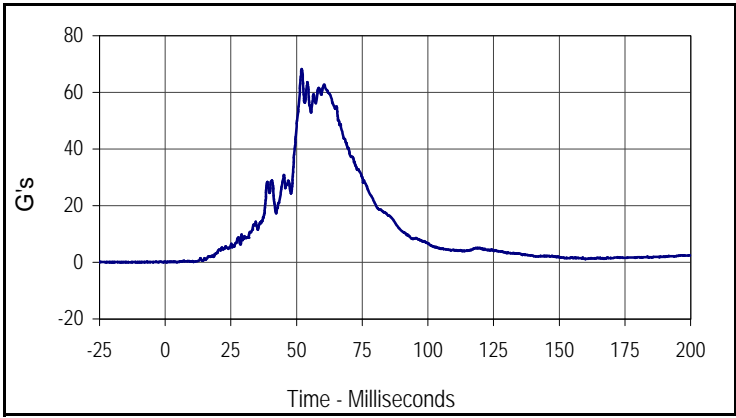

Curve Description			
Driver Pelvis Resultant			
CURNO	Type	SAE Class	Units
020	RES	1000	G's
Max	Time	Min	Time
68.2	52.0	0.0	4.5

Test Vehicle: 2005 Toyota Tundra 2-Door Truck  
 Test Program: 2005 NHTSA 35mph NCAP

Test Date: 10/5/04  
 NHTSA No.: M55111

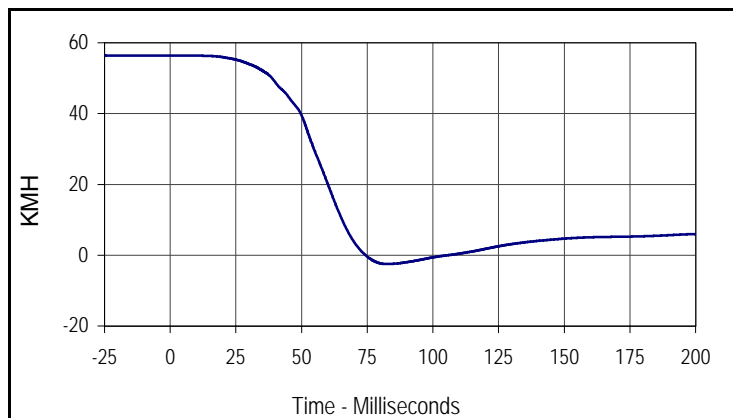

Curve Description			
Driver Pelvis X Velocity			
CURNO	Type	SAE Class	Units
020	IN1	180	KMH
Max	Time	Min	Time
56.4	0.0	-2.5	82.4

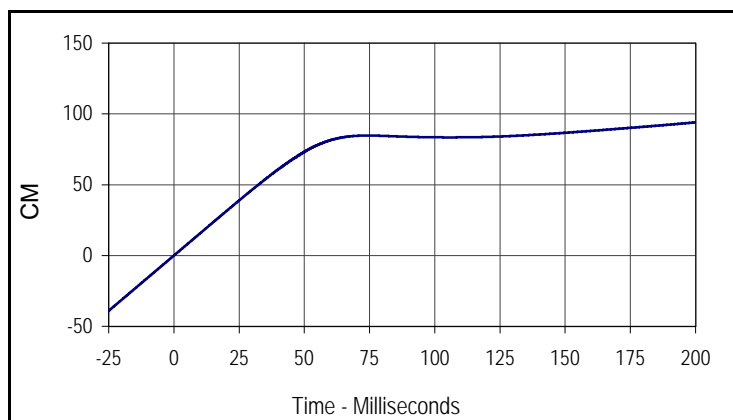

Curve Description			
Driver Pelvis X Displacement			
CURNO	Type	SAE Class	Units
020	IN2	180	CM
Max	Time	Min	Time
94.0	200.0	0.0	0.0

Test Vehicle: 2005 Toyota Tundra 2-Door Truck  
 Test Program: 2005 NHTSA 35mph NCAP

Test Date: 10/5/04  
 NHTSA No.: M55111

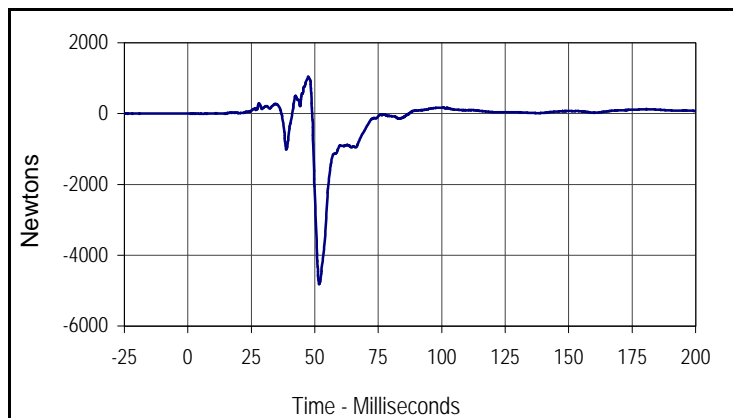

Curve Description			
Driver Left Femur Force			
CURNO	Type	SAE Class	Units
023	FIL	600	Newtons
Max	Time	Min	Time
1038.3	47.4	-4818.5	51.7

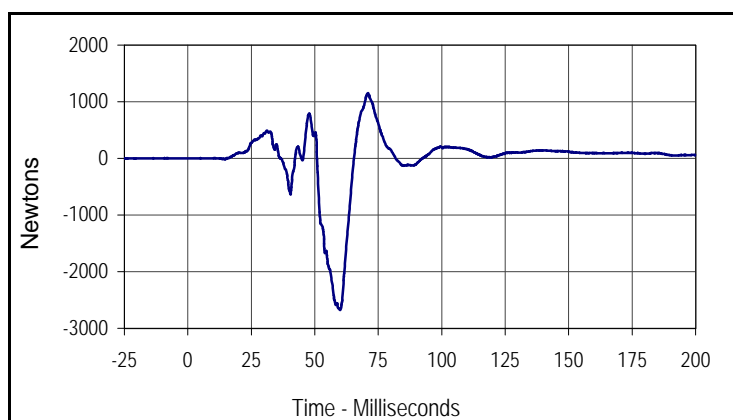

Curve Description			
Driver Right Femur Force			
CURNO	Type	SAE Class	Units
024	FIL	600	Newtons
Max	Time	Min	Time
1151.6	70.9	-2677.4	60.0

Test Vehicle: 2005 Toyota Tundra 2-Door Truck  
 Test Program: 2005 NHTSA 35mph NCAP

Test Date: 10/5/04  
 NHTSA No.: M55111

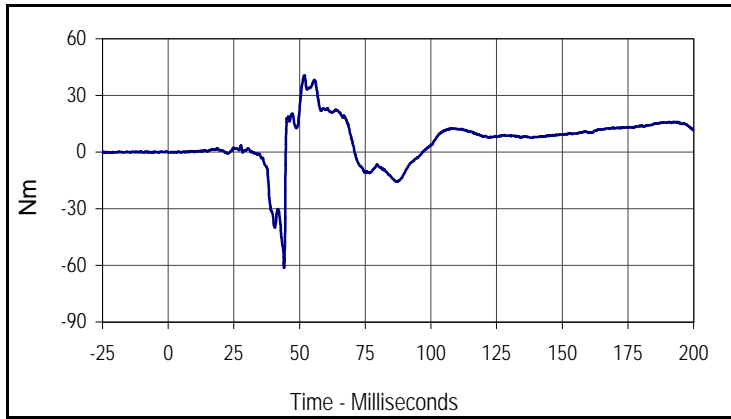

Curve Description			
Driver Left Upper Tibia Moment X			
CURNO	Type	SAE Class	Units
025	FIL	600	Nm
Max	Time	Min	Time
40.5	51.8	-61.4	44.1

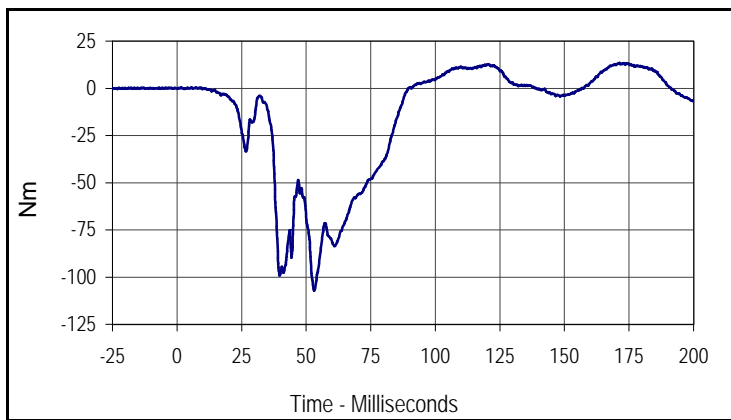

Curve Description			
Driver Left Upper Tibia Moment Y			
CURNO	Type	SAE Class	Units
026	FIL	600	Nm
Max	Time	Min	Time
13.4	171.2	-107.1	53.1

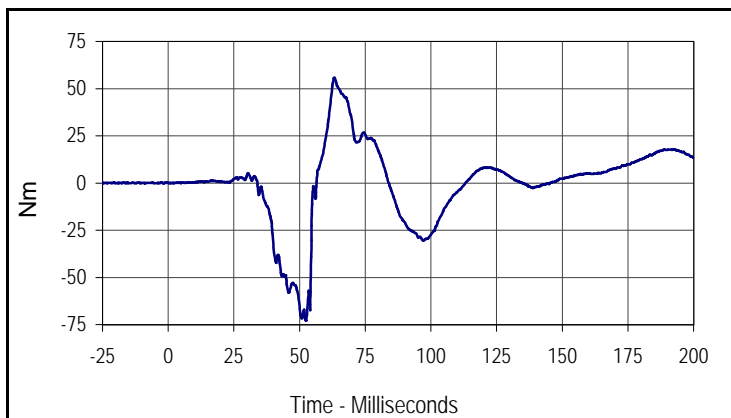

Curve Description			
Driver Right Upper Tibia Moment X			
CURNO	Type	SAE Class	Units
027	FIL	600	Nm
Max	Time	Min	Time
55.8	63.2	-72.9	52.3

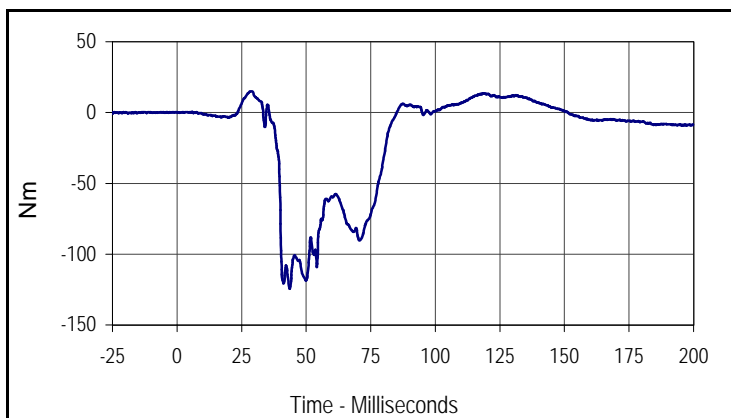

Curve Description			
Driver Right Upper Tibia Moment Y			
CURNO	Type	SAE Class	Units
028	FIL	600	Nm
Max	Time	Min	Time
15.0	28.4	-124.4	43.6

Test Vehicle: 2005 Toyota Tundra 2-Door Truck  
 Test Program: 2005 NHTSA 35mph NCAP

Test Date: 10/5/04  
 NHTSA No.: M55111

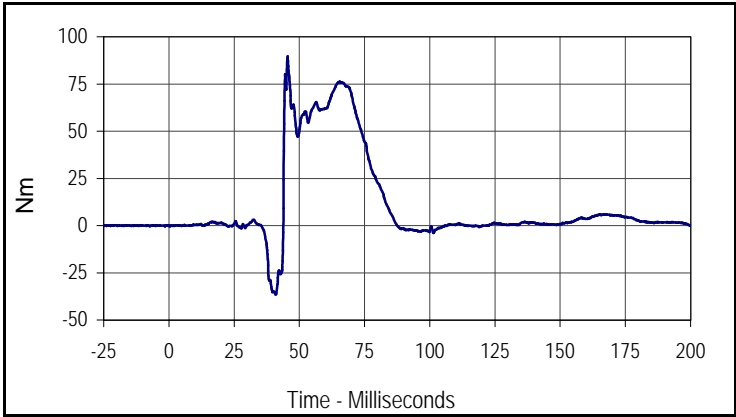

Curve Description			
Driver Left Lower Tibia Moment X			
CURNO	Type	SAE Class	Units
029	FIL	600	Nm
Max	Time	Min	Time
89.7	45.5	-36.6	41.0

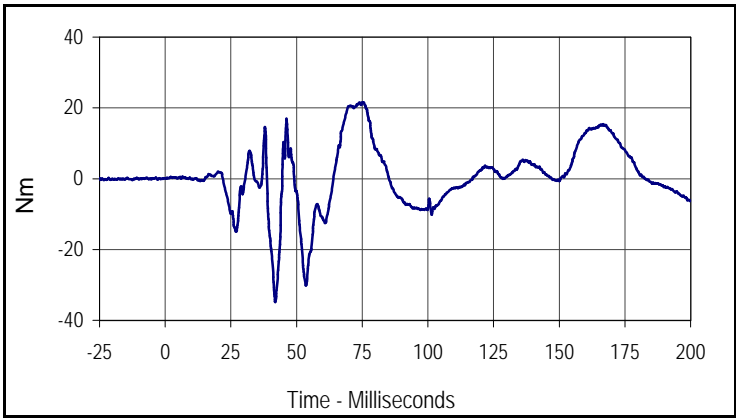

Curve Description			
Driver Left Lower Tibia Moment Y			
CURNO	Type	SAE Class	Units
030	FIL	600	Nm
Max	Time	Min	Time
21.6	73.9	-34.8	41.9

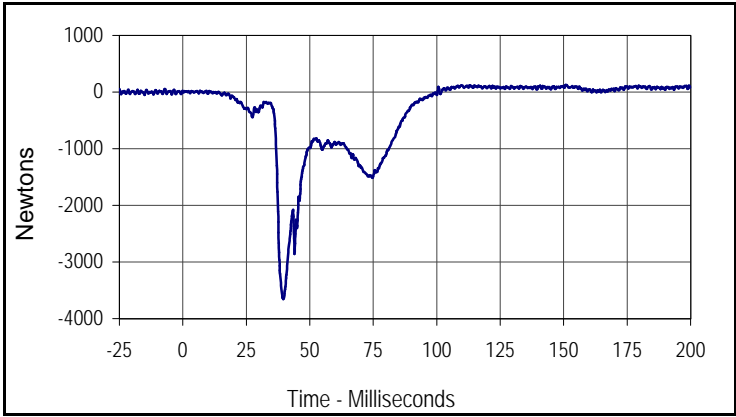

Curve Description			
Driver Left Lower Tibia Force Z			
CURNO	Type	SAE Class	Units
031	FIL	600	Newtons
Max	Time	Min	Time
123.5	150.8	-3653.5	39.6

Test Vehicle: 2005 Toyota Tundra 2-Door Truck  
 Test Program: 2005 NHTSA 35mph NCAP

Test Date: 10/5/04  
 NHTSA No.: M55111

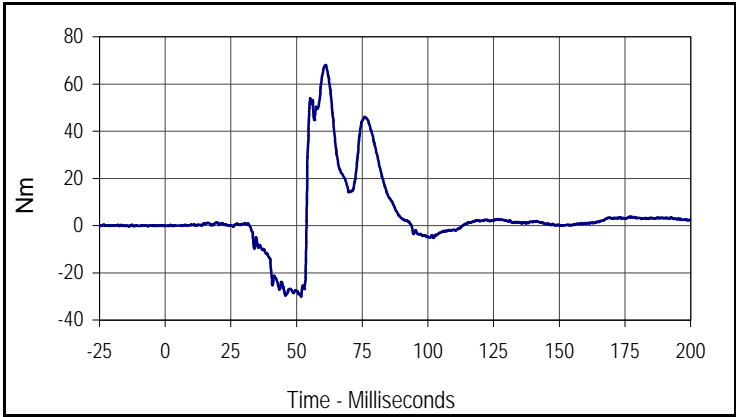

Curve Description			
Driver Right Lower Tibia Moment X			
CURNO	Type	SAE Class	Units
032	FIL	600	Nm
Max	Time	Min	Time
68.0	61.0	-30.0	51.7

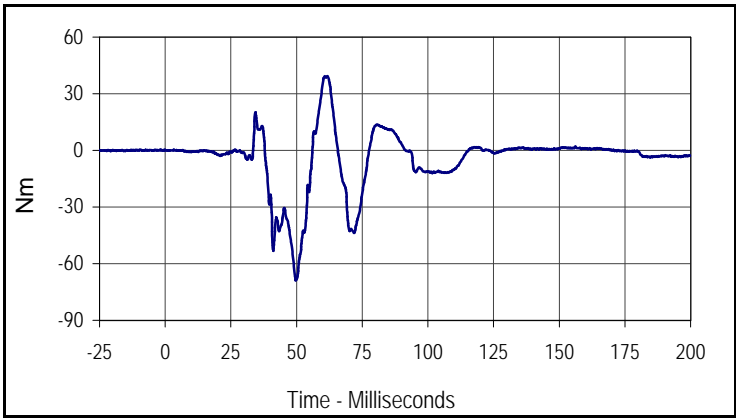

Curve Description			
Driver Right Lower Tibia Moment Y			
CURNO	Type	SAE Class	Units
033	FIL	600	Nm
Max	Time	Min	Time
39.4	61.7	-68.9	49.7

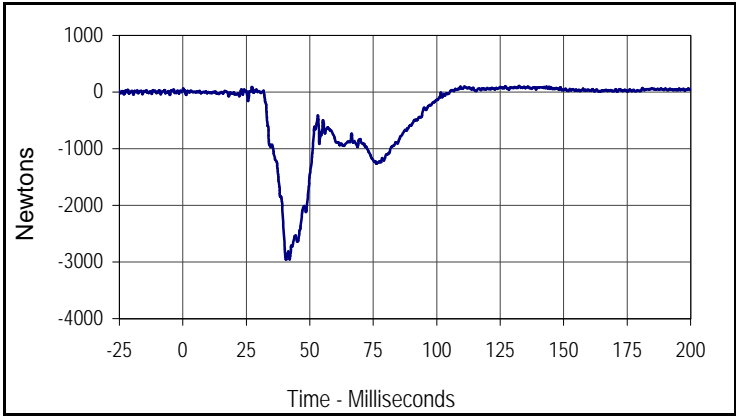

Curve Description			
Driver Right Lower Tibia Force Z			
CURNO	Type	SAE Class	Units
034	FIL	600	Newtons
Max	Time	Min	Time
105.7	132.4	-2957.3	40.6

Test Vehicle: 2005 Toyota Tundra 2-Door Truck  
 Test Program: 2005 NHTSA 35mph NCAP

Test Date: 10/5/04  
 NHTSA No.: M55111

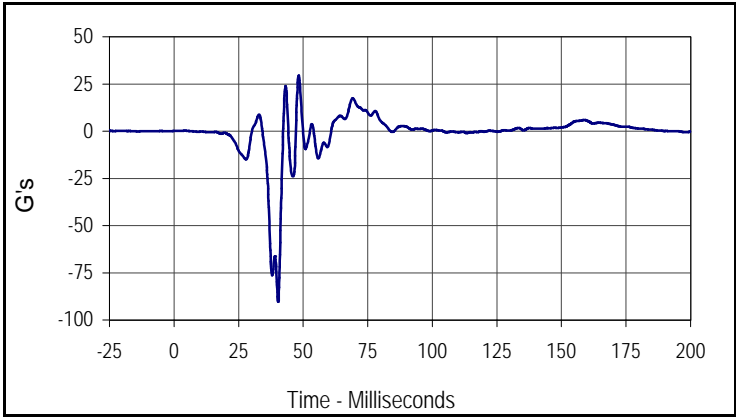

Curve Description			
Driver Left Foot Aft X			
CURNO	Type	SAE Class	Units
035	FIL	180	G's
Max	Time	Min	Time
29.4	48.3	-90.4	40.3

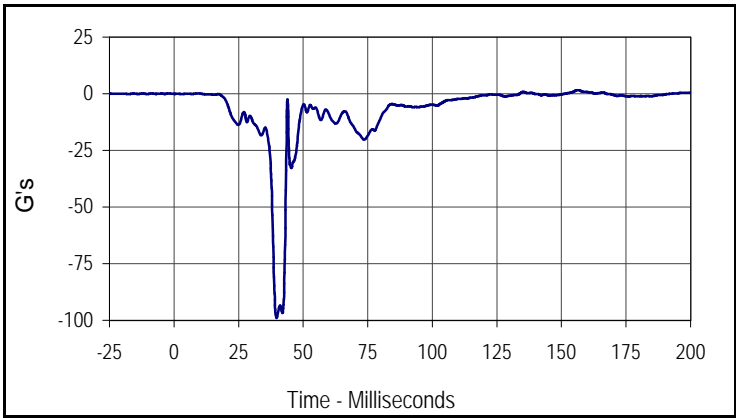

Curve Description			
Driver Left Foot Aft Z			
CURNO	Type	SAE Class	Units
036	FIL	180	G's
Max	Time	Min	Time
1.6	156.4	-99.0	39.7

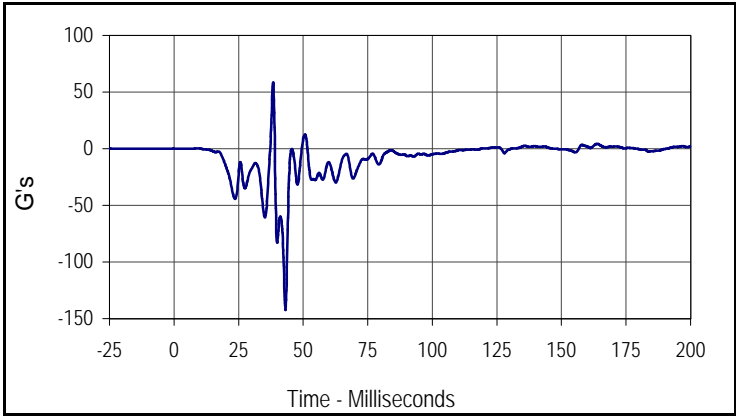

Curve Description			
Driver Left Foot Fore Z			
CURNO	Type	SAE Class	Units
037	FIL	180	G's
Max	Time	Min	Time
58.5	38.4	-142.3	43.2

Test Vehicle: 2005 Toyota Tundra 2-Door Truck  
 Test Program: 2005 NHTSA 35mph NCAP

Test Date: 10/5/04  
 NHTSA No.: M55111

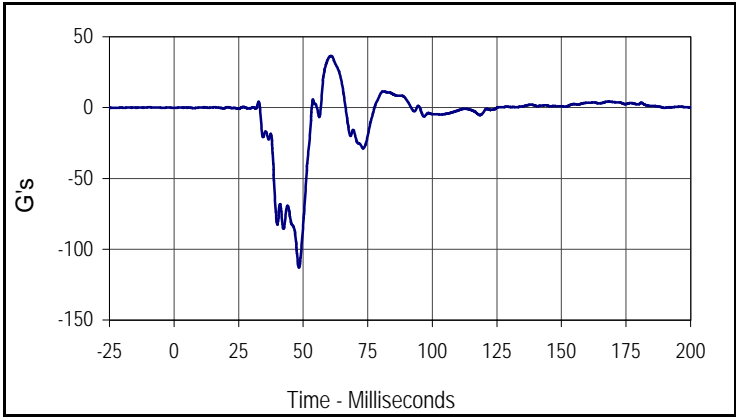

Curve Description			
Driver Right Foot Aft X			
CURNO	Type	SAE Class	Units
038	FIL	180	G's
Max	Time	Min	Time
36.5	60.9	-113.2	48.4

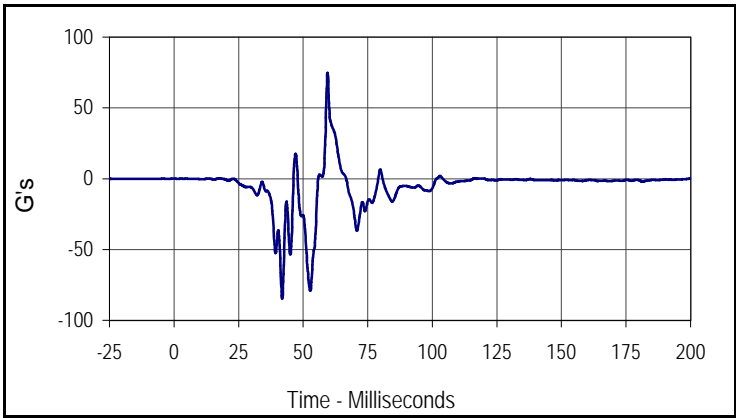

Curve Description			
Driver Right Foot Aft Z			
CURNO	Type	SAE Class	Units
039	FIL	180	G's
Max	Time	Min	Time
74.6	59.4	-84.6	41.9

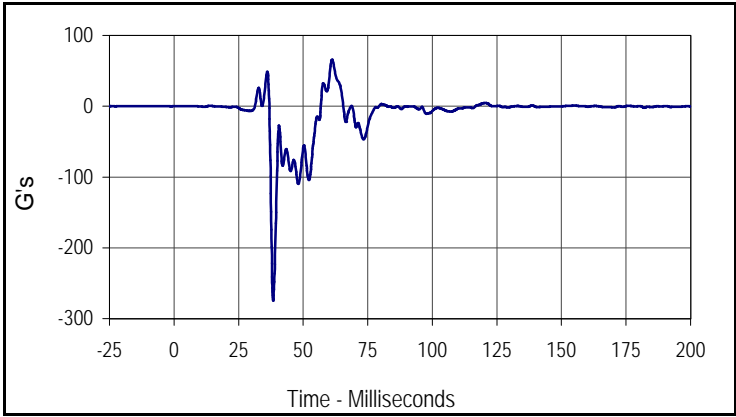

Curve Description			
Driver Right Foot Fore Z			
CURNO	Type	SAE Class	Units
040	FIL	180	G's
Max	Time	Min	Time
65.8	61.2	-274.8	38.4

Test Vehicle: 2005 Toyota Tundra 2-Door Truck  
 Test Program: 2005 NHTSA 35mph NCAP

Test Date: 10/5/04  
 NHTSA No.: M55111

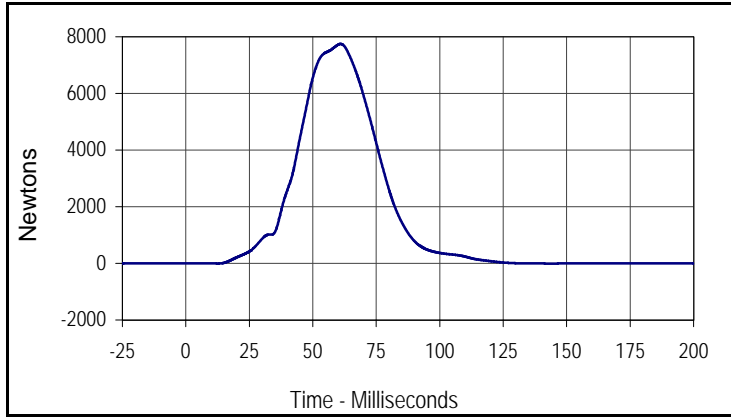

Curve Description			
Driver Lap Belt Force			
CURNO	Type	SAE Class	Units
041	FIL	60	Newtons
Max	Time	Min	Time
7747.4	60.9	-6.9	144.0

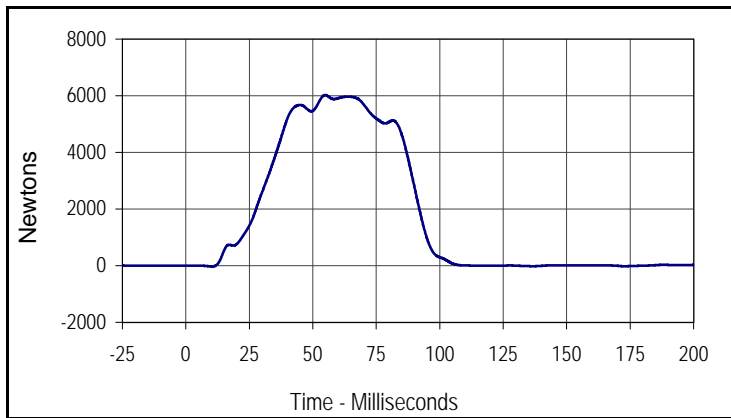

Curve Description			
Driver Shoulder Belt Force			
CURNO	Type	SAE Class	Units
042	FIL	60	Newtons
Max	Time	Min	Time
6023.4	54.9	-29.8	10.3

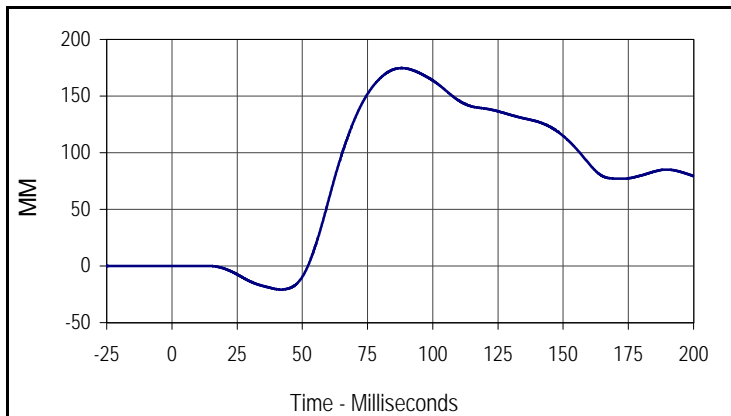

Curve Description			
Driver Shoulder Belt Pullout			
CURNO	Type	SAE Class	Units
043	FIL	60	MM
Max	Time	Min	Time
174.7	88.4	-20.8	42.3

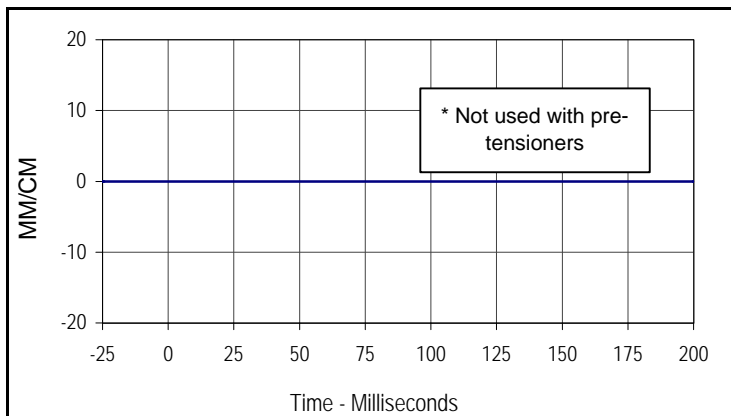

Curve Description			
Driver Shoulder Belt Elongation			
CURNO	Type	SAE Class	Units
044	FIL	60	MM/CM
Max	Time	Min	Time
0.0	0.0	0.0	0.0

\* Not used with pre-tensioners

Test Vehicle: 2005 Toyota Tundra 2-Door Truck  
 Test Program: 2005 NHTSA 35mph NCAP

Test Date: 10/5/04  
 NHTSA No.: M55111

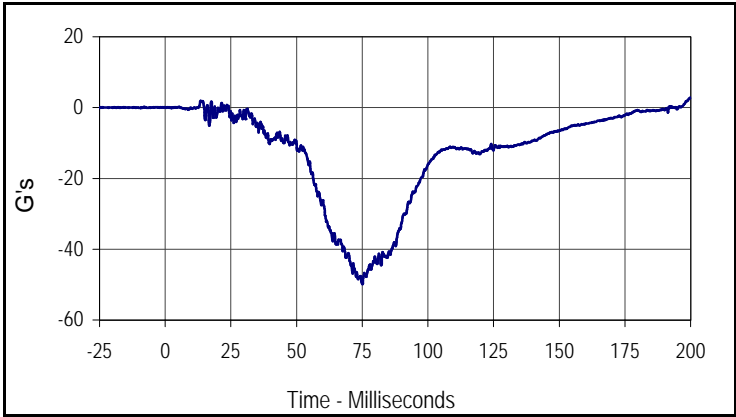

Curve Description			
Passenger Head Primary X			
CURNO	Type	SAE Class	Units
045	FIL	1000	G's
Max	Time	Min	Time
2.8	200.0	-49.8	75.1

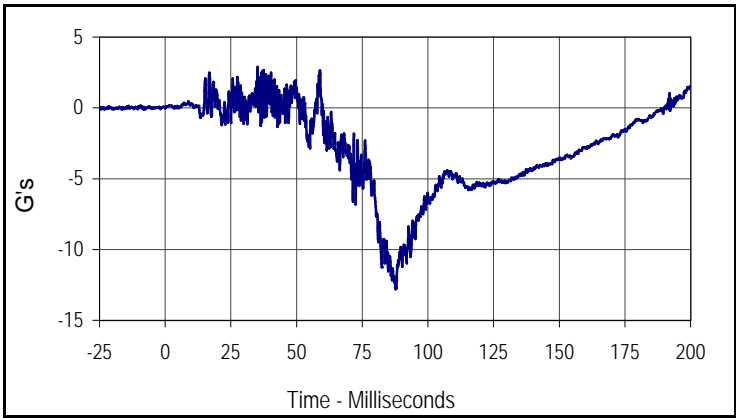

Curve Description			
Passenger Head Primary Y			
CURNO	Type	SAE Class	Units
046	FIL	1000	G's
Max	Time	Min	Time
2.9	35.2	-12.8	87.7

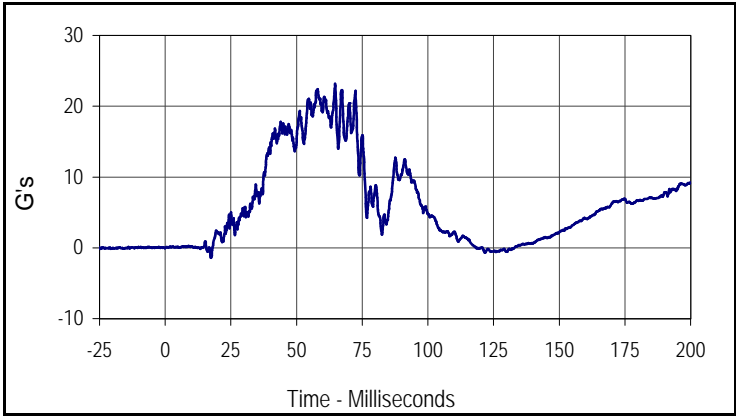

Curve Description			
Passenger Head Primary Z			
CURNO	Type	SAE Class	Units
047	FIL	1000	G's
Max	Time	Min	Time
23.2	64.7	-1.4	17.4

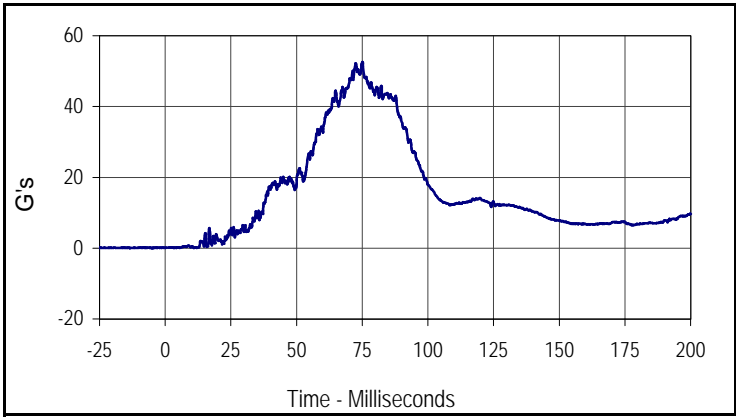

Curve Description			
Passenger Head Resultant Primary			
CURNO	Type	SAE Class	Units
045	RES	1000	G's
Max	Time	Min	Time
52.6	75.1	0.1	10.9

Test Vehicle: 2005 Toyota Tundra 2-Door Truck  
 Test Program: 2005 NHTSA 35mph NCAP

Test Date: 10/5/04  
 NHTSA No.: M55111

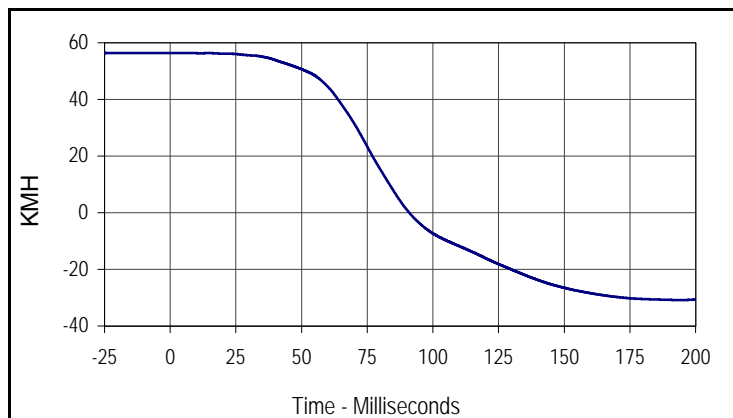

Curve Description			
Passenger Head Primary X Velocity			
CURNO	Type	SAE Class	Units
045	IN1	180	KMH
Max	Time	Min	Time
56.4	14.7	-30.8	195.5

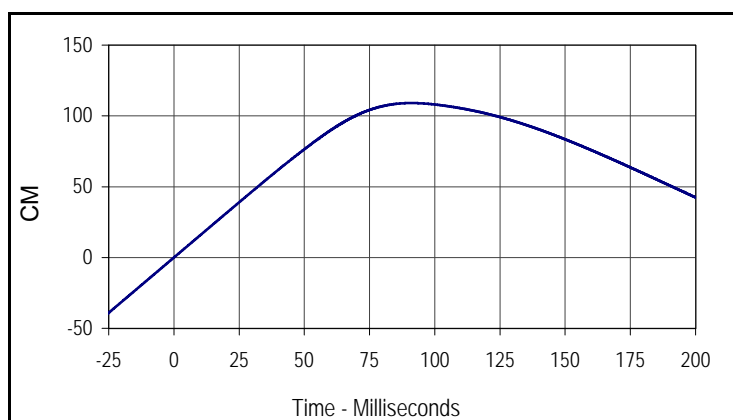

Curve Description			
Passenger Head Primary X Displacement			
CURNO	Type	SAE Class	Units
045	IN2	180	CM
Max	Time	Min	Time
109.1	91.0	0.0	0.0

Test Vehicle: 2005 Toyota Tundra 2-Door Truck  
 Test Program: 2005 NHTSA 35mph NCAP

Test Date: 10/5/04  
 NHTSA No.: M55111

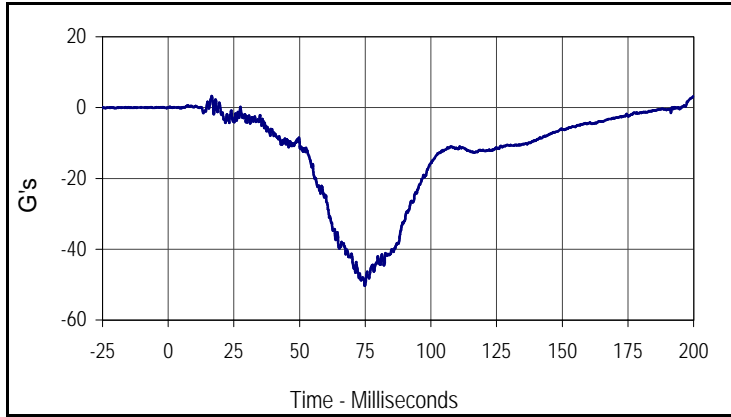

Curve Description			
Passenger Head Redundant X			
CURNO	Type	SAE Class	Units
048	FIL	1000	G's
Max	Time	Min	Time
3.3	16.6	-50.3	74.9

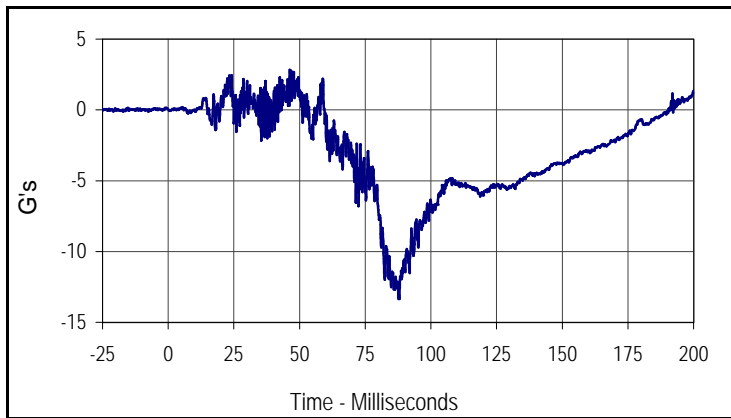

Curve Description			
Passenger Head Redundant Y			
CURNO	Type	SAE Class	Units
049	FIL	1000	G's
Max	Time	Min	Time
2.8	46.3	-13.4	88.0

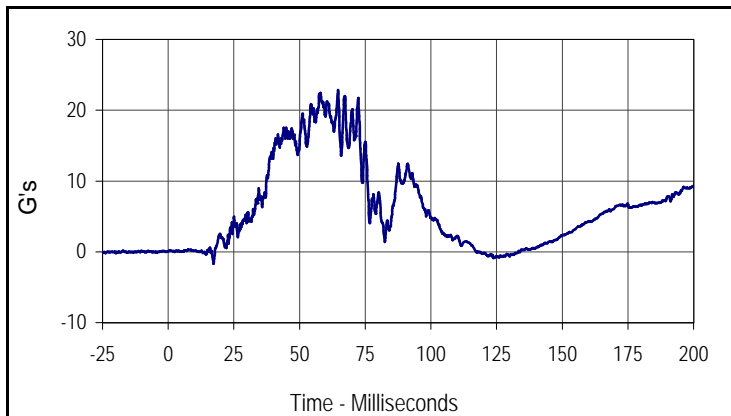

Curve Description			
Passenger Head Redundant Z			
CURNO	Type	SAE Class	Units
050	FIL	1000	G's
Max	Time	Min	Time
22.9	64.7	-1.7	17.3

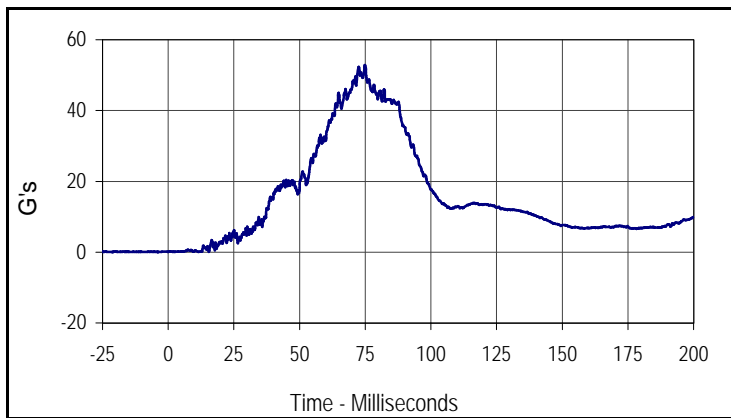

Curve Description			
Passenger Head Resultant Redundant			
CURNO	Type	SAE Class	Units
048	RES	1000	G's
Max	Time	Min	Time
52.9	74.9	0.0	2.6

Test Vehicle: 2005 Toyota Tundra 2-Door Truck  
 Test Program: 2005 NHTSA 35mph NCAP

Test Date: 10/5/04  
 NHTSA No.: M55111

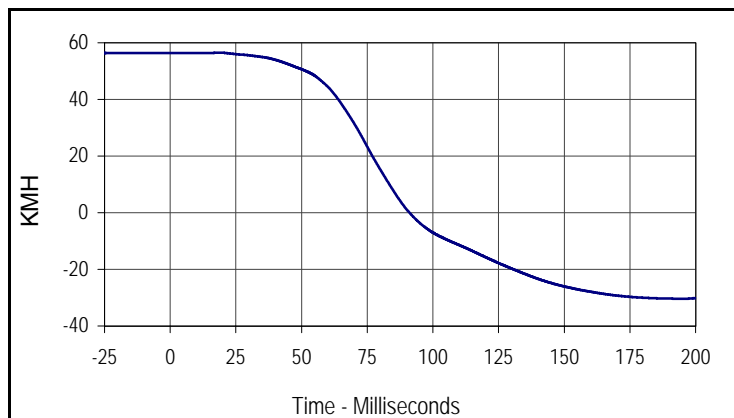

Curve Description			
Passenger Head Redundant X Velocity			
CURNO	Type	SAE Class	Units
048	IN1	180	KMH
Max	Time	Min	Time
56.5	19.6	-30.4	195.3

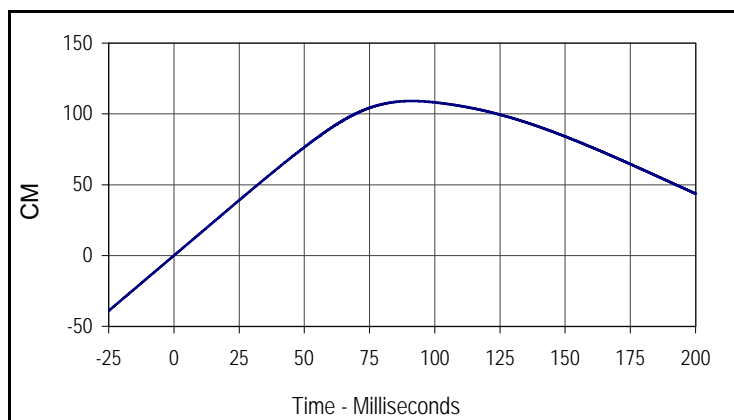

Curve Description			
Passenger Head Redundant X Displacement			
CURNO	Type	SAE Class	Units
048	IN2	180	CM
Max	Time	Min	Time
109.1	91.1	0.0	0.0

Test Vehicle: 2005 Toyota Tundra 2-Door Truck  
 Test Program: 2005 NHTSA 35mph NCAP

Test Date: 10/5/04  
 NHTSA No.: M55111

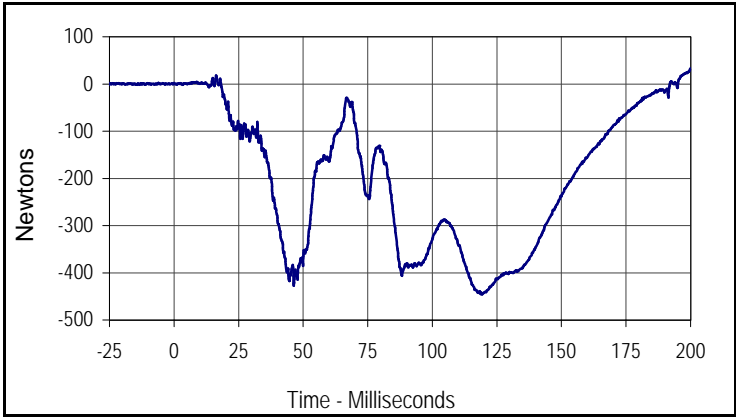

Curve Description			
Passenger Upper Neck Force X			
CURNO	Type	SAE Class	Units
051	FIL	1000	Newtons
Max	Time	Min	Time
33.2	200.0	-445.9	119.2

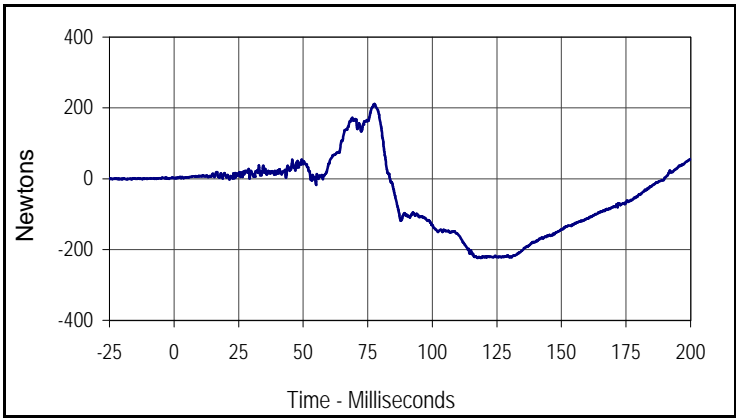

Curve Description			
Passenger Upper Neck Force Y			
CURNO	Type	SAE Class	Units
052	FIL	1000	Newtons
Max	Time	Min	Time
211.1	77.6	-224.0	119.2

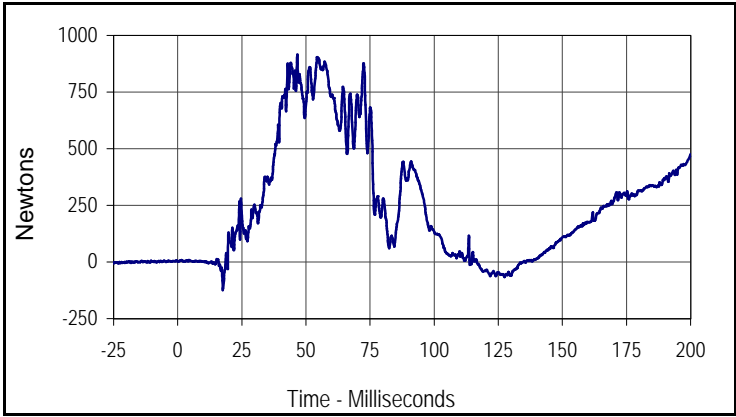

Curve Description			
Passenger Upper Neck Force Z			
CURNO	Type	SAE Class	Units
053	FIL	1000	Newtons
Max	Time	Min	Time
915.3	46.6	-124.5	17.6

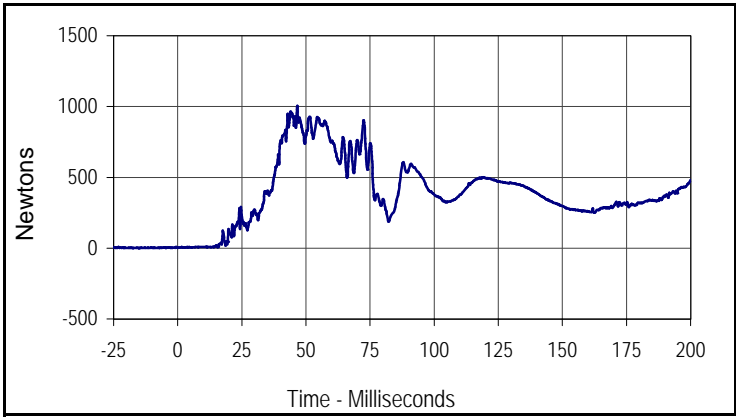

Curve Description			
Passenger Upper Neck Force Res.			
CURNO	Type	SAE Class	Units
051	RES	1000	Newtons
Max	Time	Min	Time
1004.9	46.6	2.5	0.1

Test Vehicle: 2005 Toyota Tundra 2-Door Truck  
 Test Program: 2005 NHTSA 35mph NCAP

Test Date: 10/5/04  
 NHTSA No.: M55111

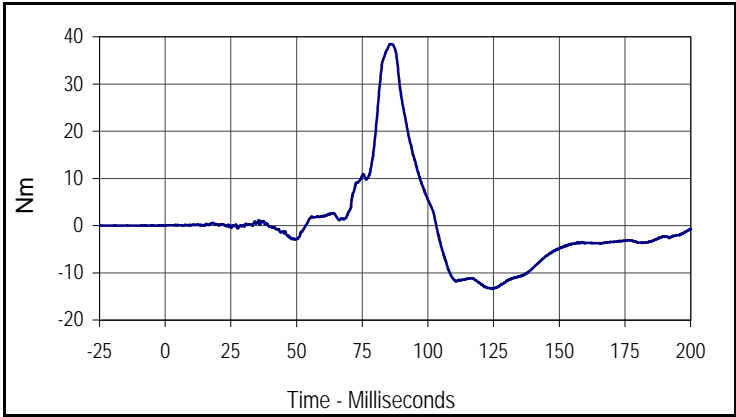

Curve Description			
Passenger Upper Neck Moment X			
CURNO	Type	SAE Class	Units
054	FIL	600	Nm
Max	Time	Min	Time
38.5	85.9	-13.4	124.8

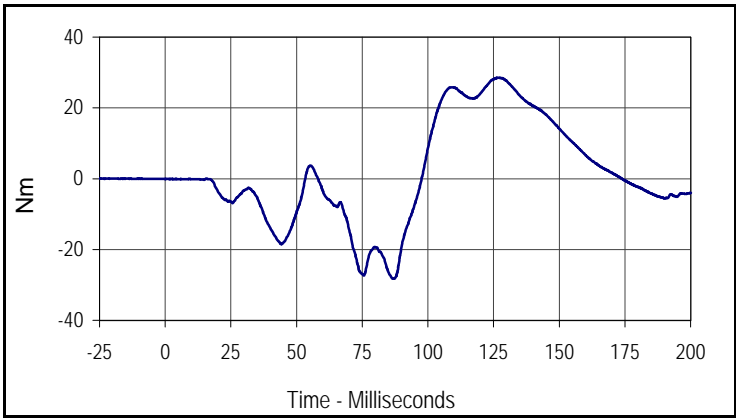

Curve Description			
Passenger Upper Neck Moment Y			
CURNO	Type	SAE Class	Units
055	FIL	600	Nm
Max	Time	Min	Time
28.6	126.9	-28.3	87.1

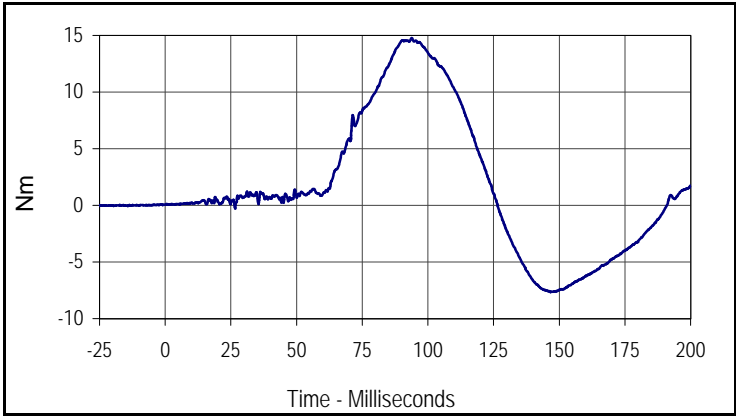

Curve Description			
Passenger Upper Neck Moment Z			
CURNO	Type	SAE Class	Units
056	FIL	600	Nm
Max	Time	Min	Time
14.8	93.9	-7.6	146.8

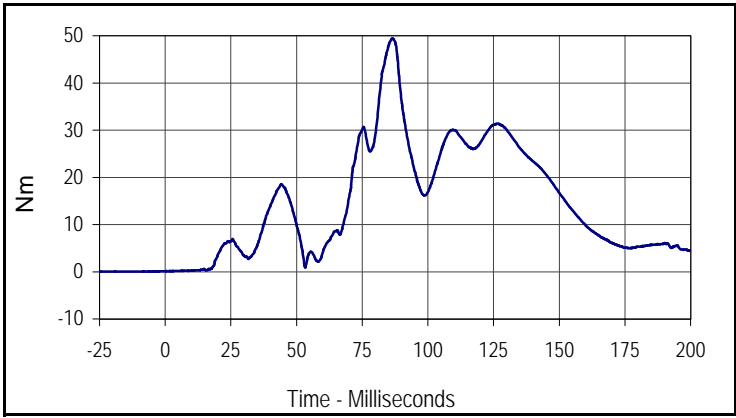

Curve Description			
Passenger Upper Neck Moment Res.			
CURNO	Type	SAE Class	Units
054	RES	600	Nm
Max	Time	Min	Time
49.4	86.5	0.1	0.0

Test Vehicle: 2005 Toyota Tundra 2-Door Truck  
 Test Program: 2005 NHTSA 35mph NCAP

Test Date: 10/5/04  
 NHTSA No.: M55111

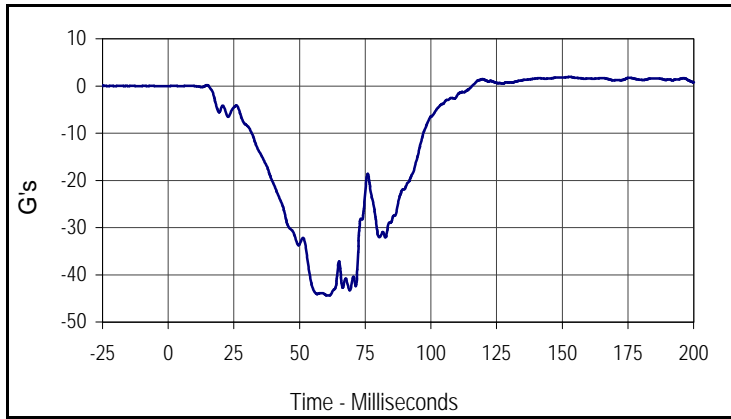

Curve Description			
Passenger Chest Primary X			
CURNO	Type	SAE Class	Units
057	FIL	180	G's
Max	Time	Min	Time
1.9	153.0	-44.4	61.2

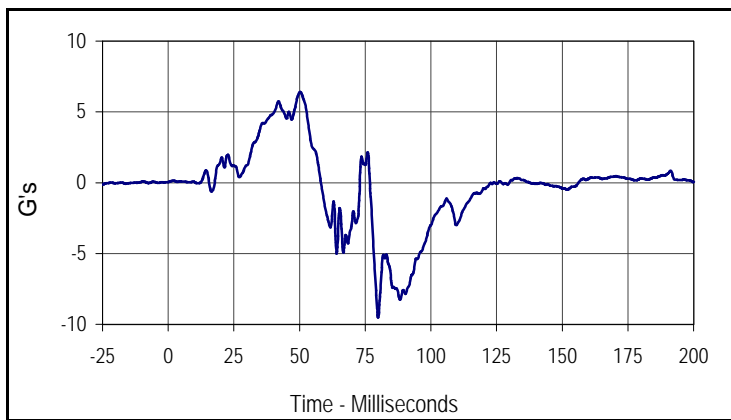

Curve Description			
Passenger Chest Primary Y			
CURNO	Type	SAE Class	Units
058	FIL	180	G's
Max	Time	Min	Time
6.4	50.2	-9.5	79.9

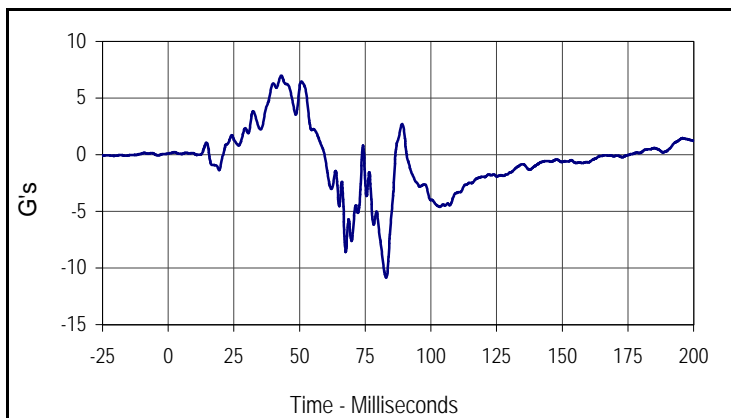

Curve Description			
Passenger Chest Primary Z			
CURNO	Type	SAE Class	Units
059	FIL	180	G's
Max	Time	Min	Time
7.0	43.1	-10.8	83.0

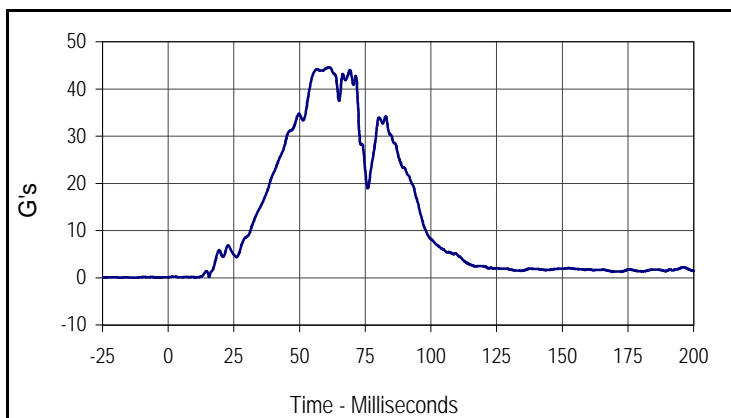

Curve Description			
Passenger Chest Resultant Primary			
CURNO	Type	SAE Class	Units
057	RES	180	G's
Max	Time	Min	Time
44.5	61.4	0.0	10.4

Test Vehicle: 2005 Toyota Tundra 2-Door Truck  
 Test Program: 2005 NHTSA 35mph NCAP

Test Date: 10/5/04  
 NHTSA No.: M55111

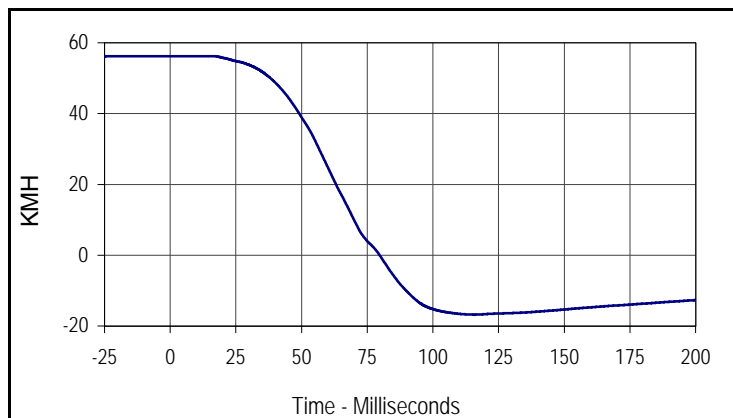

Curve Description			
Passenger Chest Primary X Velocity			
CURNO	Type	SAE Class	Units
057	IN1	180	KMH
Max	Time	Min	Time
56.2	10.0	-16.8	115.6

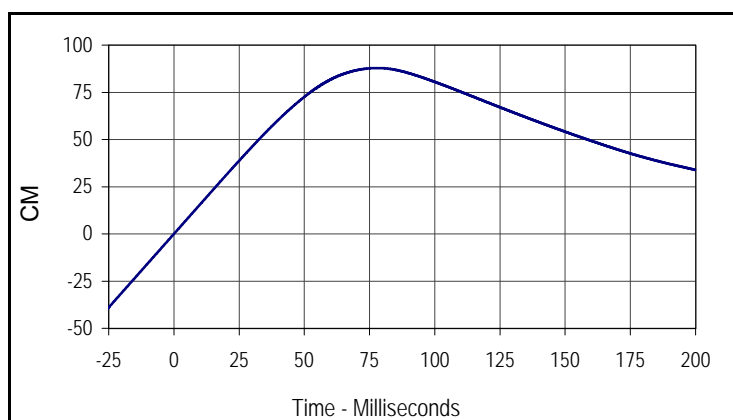

Curve Description			
Passenger Chest Primary X Displacement			
CURNO	Type	SAE Class	Units
057	IN2	180	CM
Max	Time	Min	Time
87.9	78.0	0.0	0.0

Test Vehicle: 2005 Toyota Tundra 2-Door Truck  
 Test Program: 2005 NHTSA 35mph NCAP

Test Date: 10/5/04  
 NHTSA No.: M55111

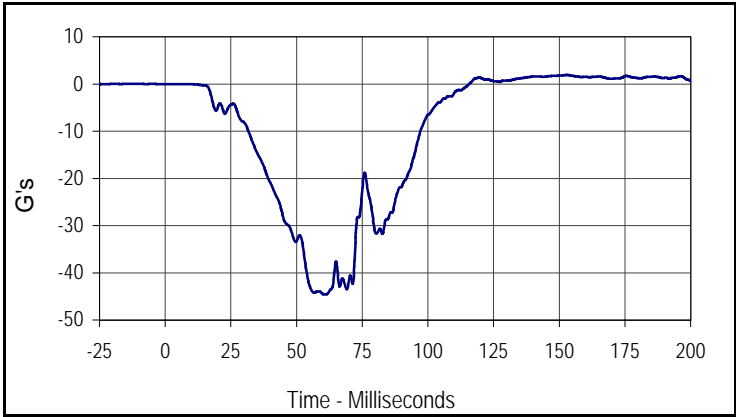

Curve Description			
Passenger Chest Redundant X			
CURNO	Type	SAE Class	Units
060	FIL	180	G's
Max	Time	Min	Time
1.9	153.0	-44.6	61.1

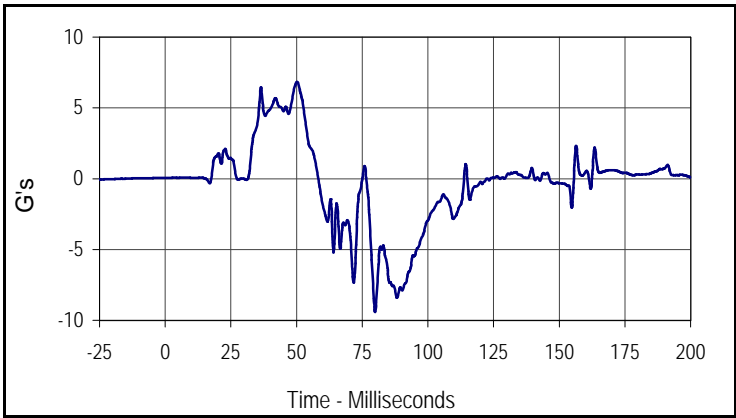

Curve Description			
Passenger Chest Redundant Y			
CURNO	Type	SAE Class	Units
061	FIL	180	G's
Max	Time	Min	Time
6.8	50.2	-9.4	79.9

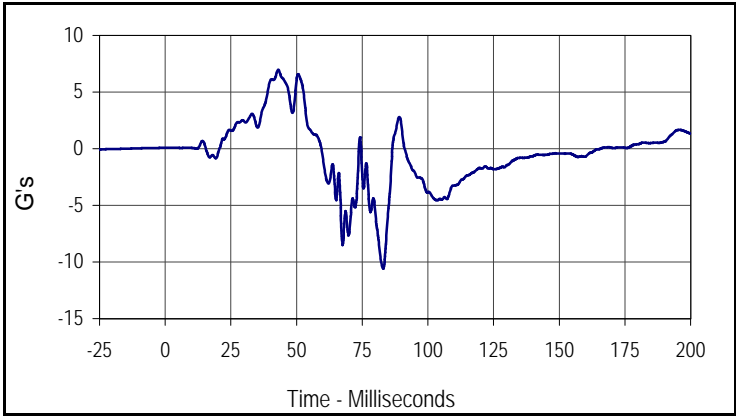

Curve Description			
Passenger Chest Redundant Z			
CURNO	Type	SAE Class	Units
062	FIL	180	G's
Max	Time	Min	Time
7.0	43.1	-10.6	83.0

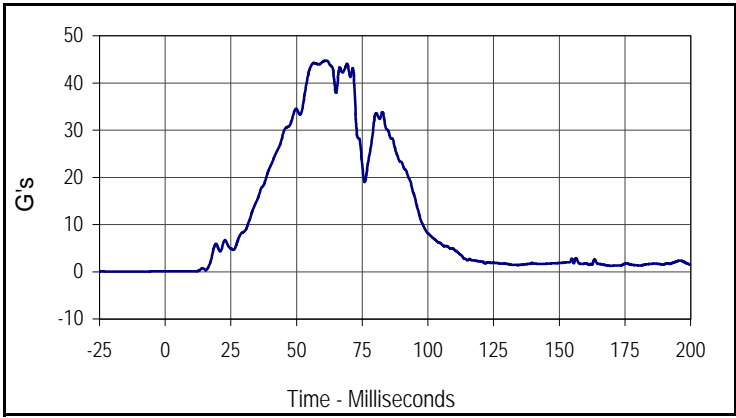

Curve Description			
Passenger Chest Resultant Redundant			
CURNO	Type	SAE Class	Units
060	RES	180	G's
Max	Time	Min	Time
44.7	61.4	0.1	0.0

Test Vehicle: 2005 Toyota Tundra 2-Door Truck  
 Test Program: 2005 NHTSA 35mph NCAP

Test Date: 10/5/04  
 NHTSA No.: M55111

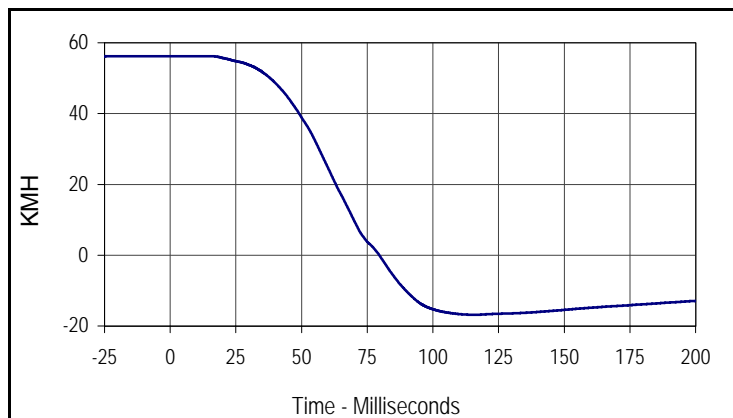

Curve Description			
Passenger Chest Redundant X Velocity			
CURNO	Type	SAE Class	Units
060	IN1	180	KMH
Max	Time	Min	Time
56.2	0.0	-16.9	115.7

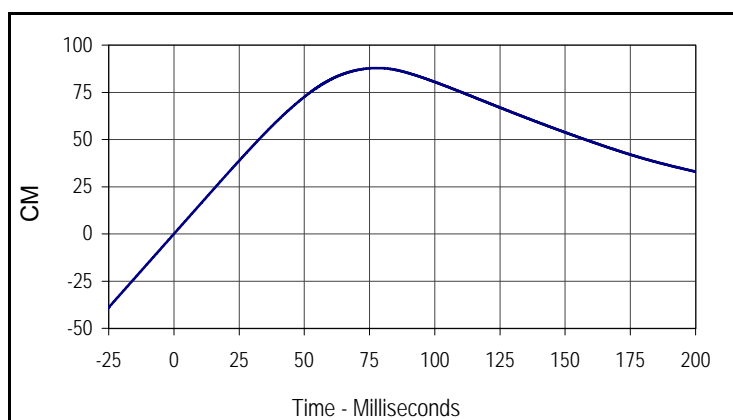

Curve Description			
Passenger Chest Redundant X Displacement			
CURNO	Type	SAE Class	Units
060	IN2	180	CM
Max	Time	Min	Time
87.9	77.9	0.0	0.0

Test Vehicle: 2005 Toyota Tundra 2-Door Truck  
 Test Program: 2005 NHTSA 35mph NCAP

Test Date: 10/5/04  
 NHTSA No.: M55111

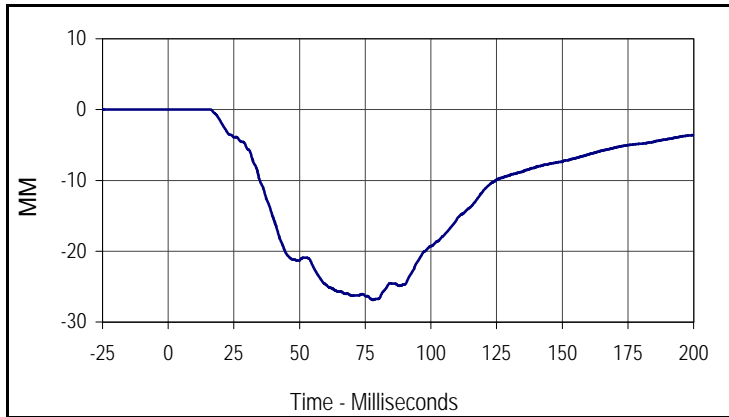

Curve Description			
Passenger Chest Displacement			
CURNO	Type	SAE Class	Units
063	FIL	600	MM
Max	Time	Min	Time
0.0	14.0	-26.9	77.8

Test Vehicle: 2005 Toyota Tundra 2-Door Truck  
 Test Program: 2005 NHTSA 35mph NCAP

Test Date: 10/5/04  
 NHTSA No.: M55111

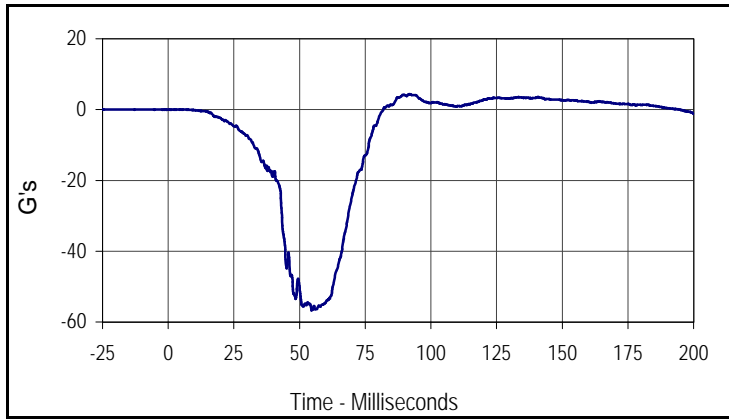

Curve Description			
Passenger Pelvis X			
CURNO	Type	SAE Class	Units
064	FIL	1000	G's
Max	Time	Min	Time
4.4	91.9	-56.7	54.6

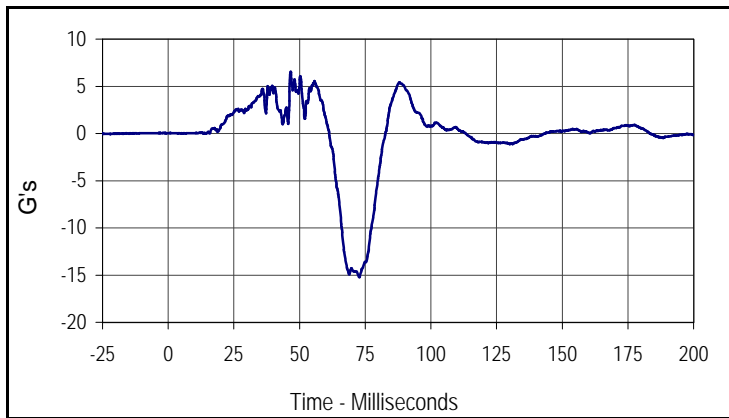

Curve Description			
Passenger Pelvis Y			
CURNO	Type	SAE Class	Units
065	FIL	1000	G's
Max	Time	Min	Time
6.5	46.6	-15.2	72.7

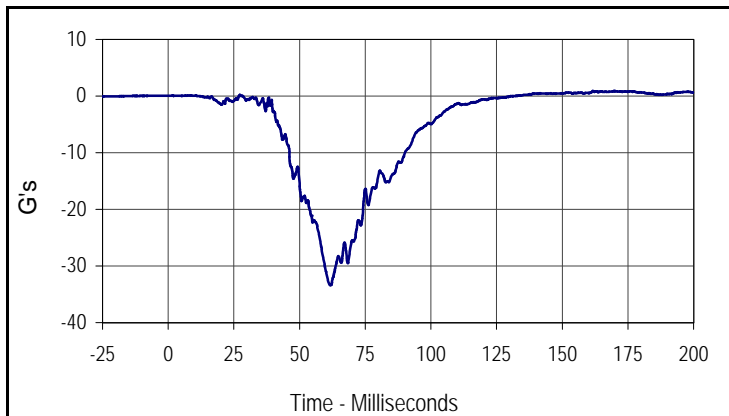

Curve Description			
Passenger Pelvis Z			
CURNO	Type	SAE Class	Units
066	FIL	1000	G's
Max	Time	Min	Time
0.9	169.7	-33.4	61.7

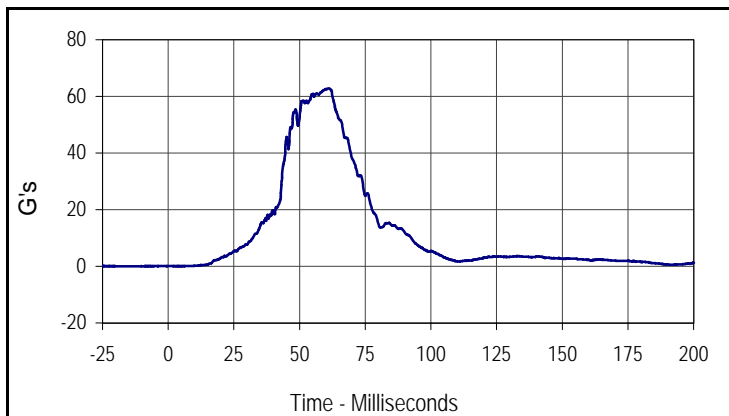

Curve Description			
Passenger Pelvis Resultant			
CURNO	Type	SAE Class	Units
064	RES	1000	G's
Max	Time	Min	Time
62.9	61.2	0.0	5.2

Test Vehicle: 2005 Toyota Tundra 2-Door Truck  
 Test Program: 2005 NHTSA 35mph NCAP

Test Date: 10/5/04  
 NHTSA No.: M55111

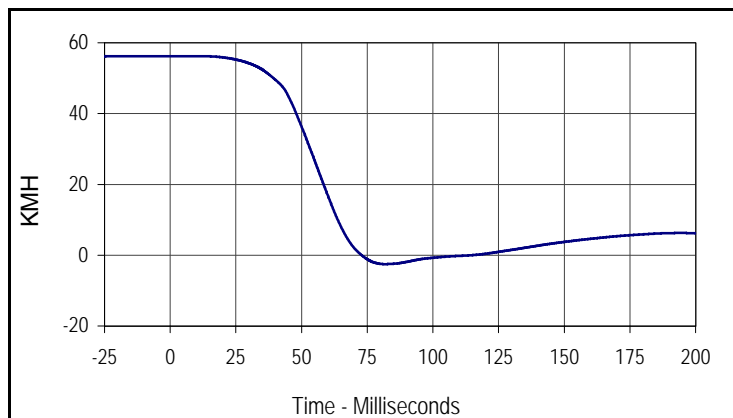

Curve Description			
Passenger Pelvis X Velocity			
CURNO	Type	SAE Class	Units
064	IN1	180	KMH
Max	Time	Min	Time
56.2	0.0	-2.5	81.8

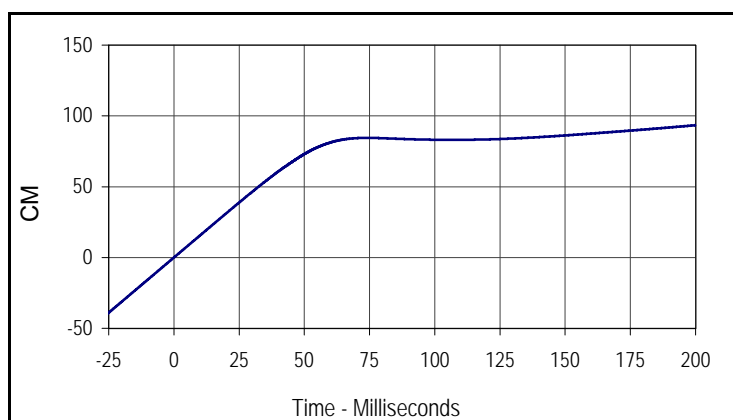

Curve Description			
Passenger Pelvis X Displacement			
CURNO	Type	SAE Class	Units
064	IN2	180	CM
Max	Time	Min	Time
93.4	200.0	0.0	0.0

Test Vehicle: 2005 Toyota Tundra 2-Door Truck  
 Test Program: 2005 NHTSA 35mph NCAP

Test Date: 10/5/04  
 NHTSA No.: M55111

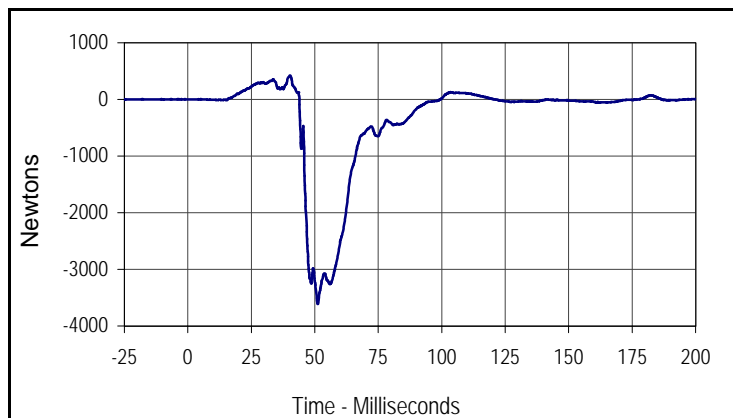

Curve Description			
Passenger Left Femur Force			
CURNO	Type	SAE Class	Units
067	FIL	600	Newtons
Max	Time	Min	Time
422.9	40.3	-3612.1	51.2

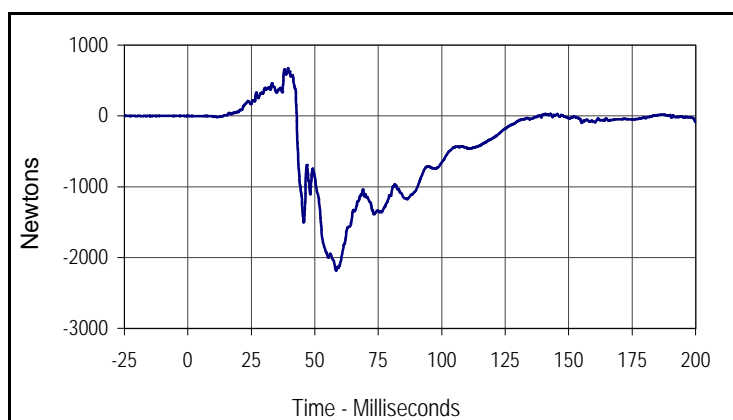

Curve Description			
Passenger Right Femur Force			
CURNO	Type	SAE Class	Units
068	FIL	600	Newtons
Max	Time	Min	Time
673.4	39.5	-2185.0	58.4

Test Vehicle: 2005 Toyota Tundra 2-Door Truck  
 Test Program: 2005 NHTSA 35mph NCAP

Test Date: 10/5/04  
 NHTSA No.: M55111

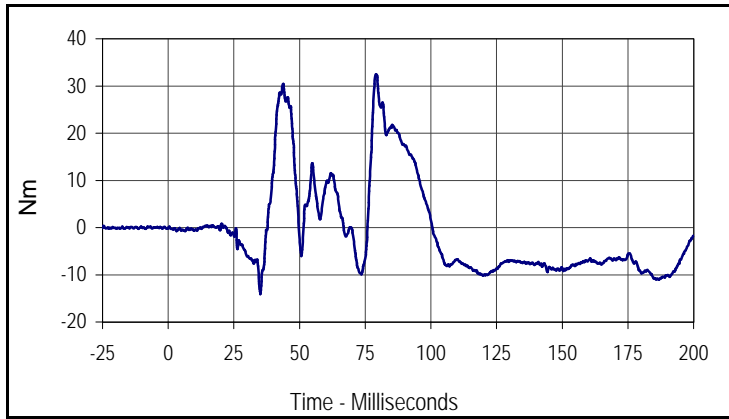

Curve Description			
Passenger Left Upper Tibia Moment X			
CURNO	Type	SAE Class	Units
069	FIL	600	Nm
Max	Time	Min	Time
32.5	79.1	-14.1	35.1

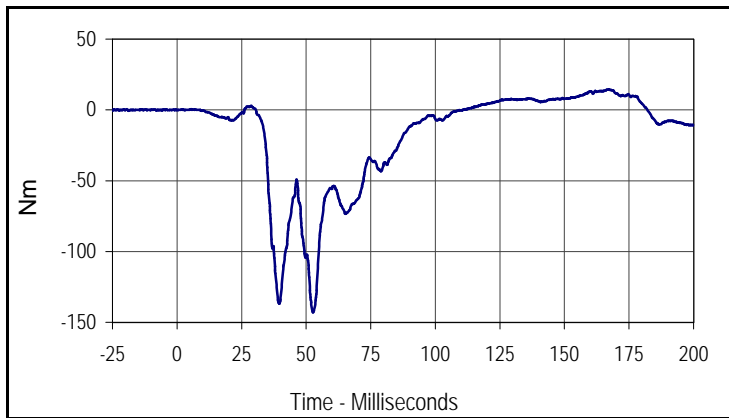

Curve Description			
Passenger Left Upper Tibia Moment Y			
CURNO	Type	SAE Class	Units
070	FIL	600	Nm
Max	Time	Min	Time
14.4	167.1	-143.1	52.6

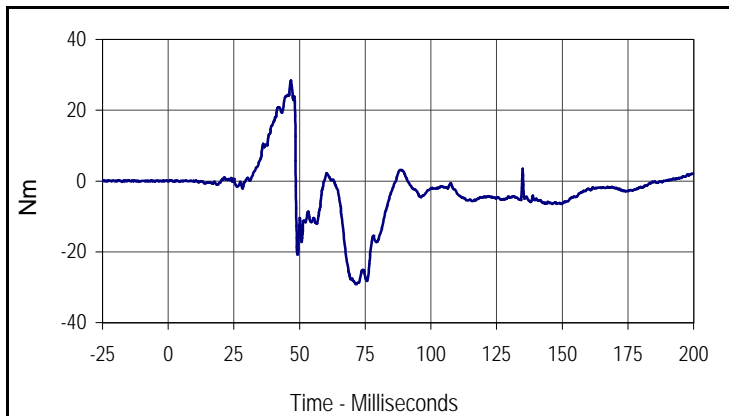

Curve Description			
Passenger Right Upper Tibia Moment X			
CURNO	Type	SAE Class	Units
071	FIL	600	Nm
Max	Time	Min	Time
28.4	46.7	-29.2	71.6

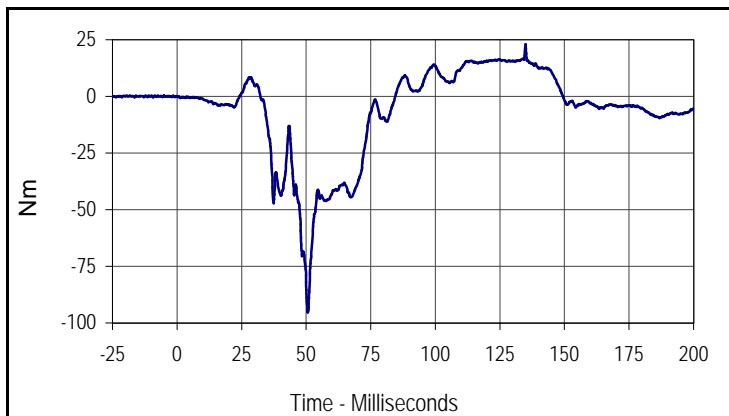

Curve Description			
Passenger Right Upper Tibia Moment Y			
CURNO	Type	SAE Class	Units
072	FIL	600	Nm
Max	Time	Min	Time
23.0	134.9	-95.3	50.6

Test Vehicle: 2005 Toyota Tundra 2-Door Truck  
 Test Program: 2005 NHTSA 35mph NCAP

Test Date: 10/5/04  
 NHTSA No.: M55111

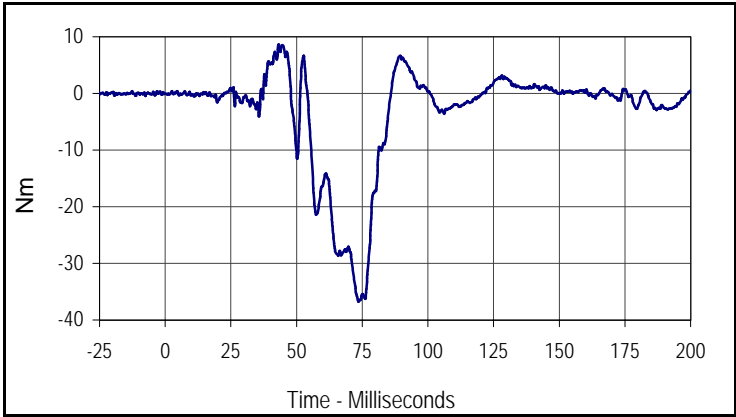

Curve Description			
Passenger Left Lower Tibia Moment X			
CURNO	Type	SAE Class	Units
073	FIL	600	Nm
Max	Time	Min	Time
8.6	43.2	-36.8	73.6

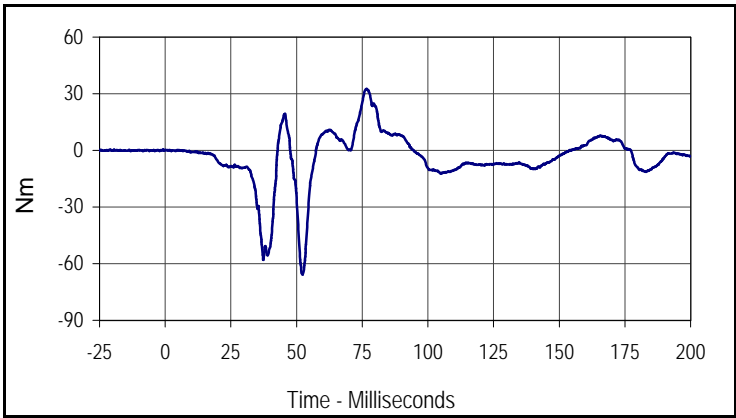

Curve Description			
Passenger Left Lower Tibia Moment Y			
CURNO	Type	SAE Class	Units
074	FIL	600	Nm
Max	Time	Min	Time
32.5	76.7	-65.7	52.2

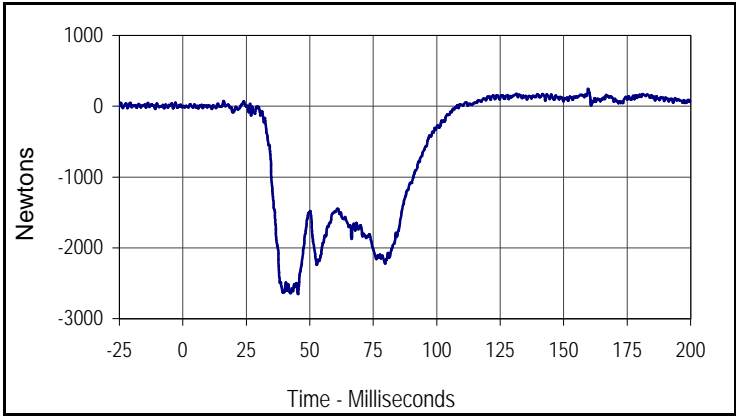

Curve Description			
Passenger Left Lower Tibia Force Z			
CURNO	Type	SAE Class	Units
075	FIL	600	Newtons
Max	Time	Min	Time
246.8	159.7	-2653.3	45.3

Test Vehicle: 2005 Toyota Tundra 2-Door Truck  
 Test Program: 2005 NHTSA 35mph NCAP

Test Date: 10/5/04  
 NHTSA No.: M55111

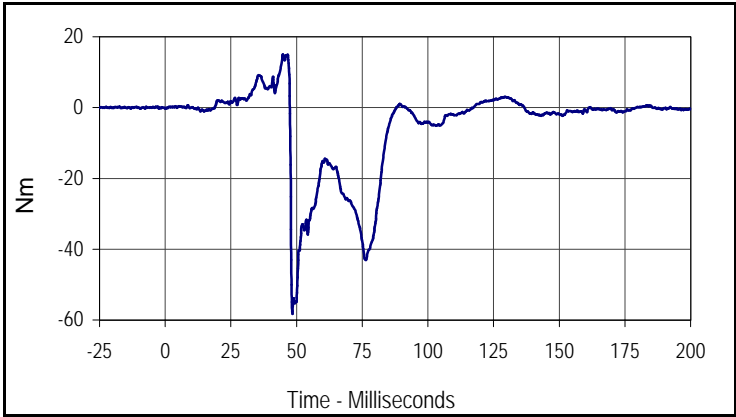

Curve Description			
Passenger Right Lower Tibia Moment X			
CURNO	Type	SAE Class	Units
076	FIL	600	Nm
Max	Time	Min	Time
15.0	44.8	-58.3	48.4

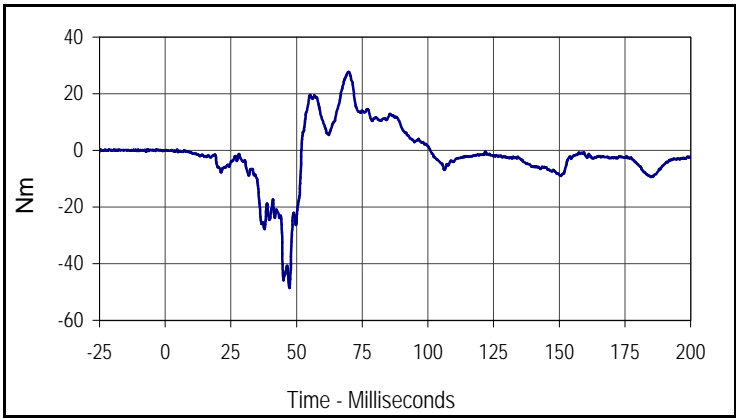

Curve Description			
Passenger Right Lower Tibia Moment Y			
CURNO	Type	SAE Class	Units
077	FIL	600	Nm
Max	Time	Min	Time
27.7	69.9	-48.5	47.3

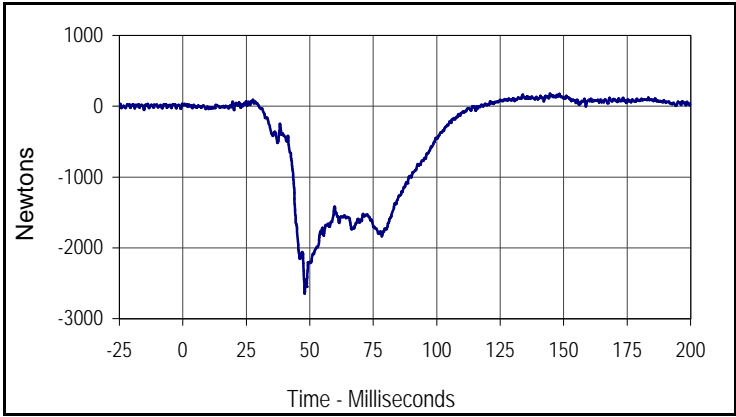

Curve Description			
Passenger Right lower Tibia Force Z			
CURNO	Type	SAE Class	Units
078	FIL	600	Newtons
Max	Time	Min	Time
177.3	144.7	-2648.3	48.0

Test Vehicle: 2005 Toyota Tundra 2-Door Truck  
 Test Program: 2005 NHTSA 35mph NCAP

Test Date: 10/5/04  
 NHTSA No.: M55111

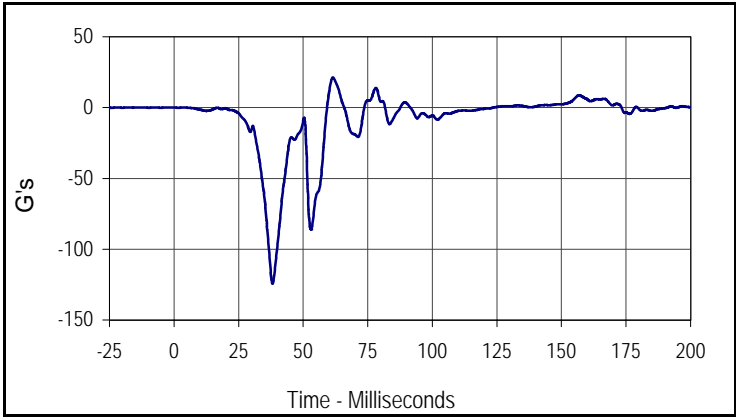

Curve Description			
Passenger Left Foot Aft X			
CURNO	Type	SAE Class	Units
079	FIL	180	G's
Max	Time	Min	Time
21.3	61.5	-124.2	38.1

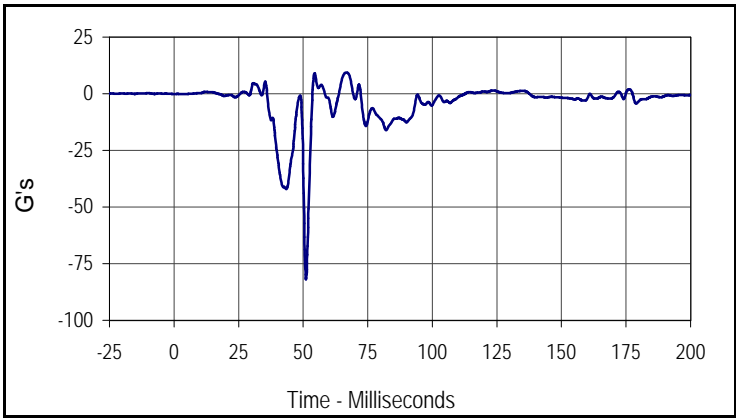

Curve Description			
Passenger Left Foot Aft Z			
CURNO	Type	SAE Class	Units
080	FIL	180	G's
Max	Time	Min	Time
9.4	66.7	-81.9	51.1

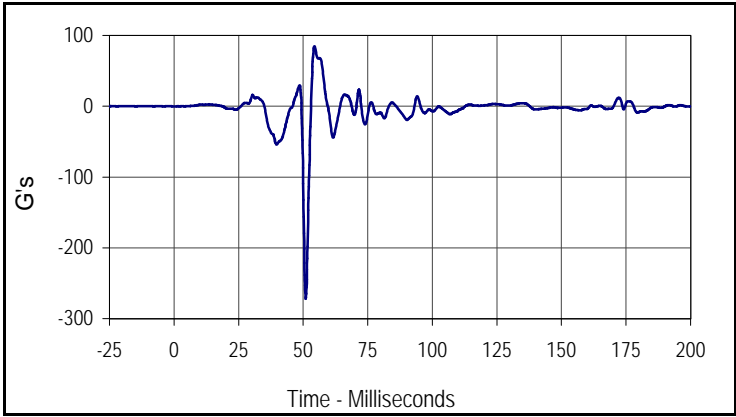

Curve Description			
Passenger Left Foot Fore Z			
CURNO	Type	SAE Class	Units
081	FIL	180	G's
Max	Time	Min	Time
84.7	54.4	-271.9	51.0

Test Vehicle: 2005 Toyota Tundra 2-Door Truck  
 Test Program: 2005 NHTSA 35mph NCAP

Test Date: 10/5/04  
 NHTSA No.: M55111

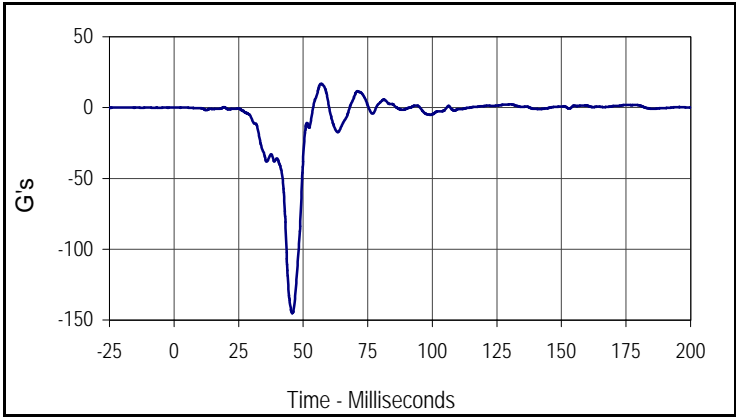

Curve Description			
Passenger Right Foot Aft X			
CURNO	Type	SAE Class	Units
082	FIL	180	G's
Max	Time	Min	Time
16.8	56.9	-145.2	45.8

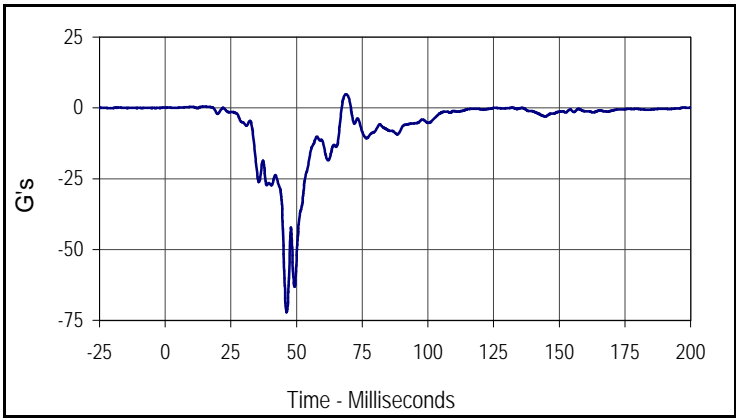

Curve Description			
Passenger Right Foot Aft Z			
CURNO	Type	SAE Class	Units
083	FIL	180	G's
Max	Time	Min	Time
4.7	68.8	-72.2	46.2

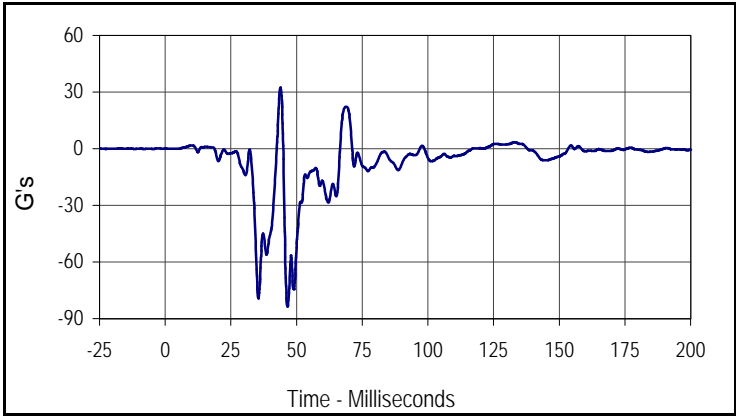

Curve Description			
Passenger Right Foot Fore Z			
CURNO	Type	SAE Class	Units
084	FIL	180	G's
Max	Time	Min	Time
32.4	43.9	-83.5	46.6

Test Vehicle: 2005 Toyota Tundra 2-Door Truck  
 Test Program: 2005 NHTSA 35mph NCAP

Test Date: 10/5/04  
 NHTSA No.: M55111

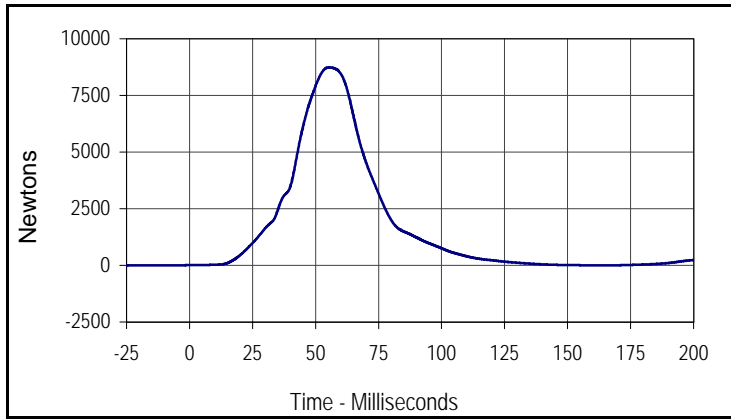

Curve Description			
Passenger Lap Belt Force			
CURNO	Type	SAE Class	Units
085	FIL	60	Newtons
Max	Time	Min	Time
8735.9	55.5	-1.7	163.5

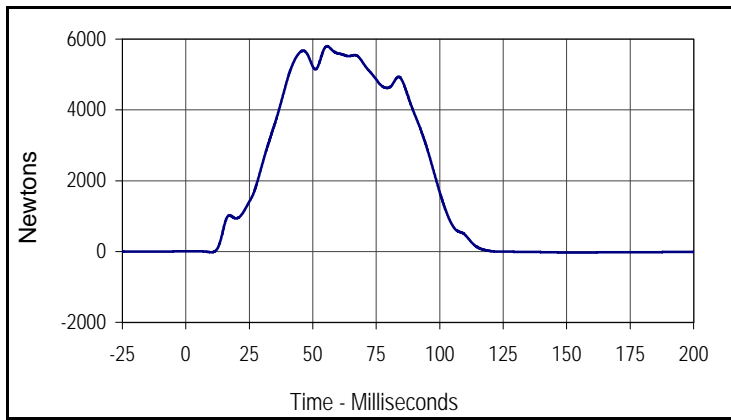

Curve Description			
Passenger Shoulder Belt Force			
CURNO	Type	SAE Class	Units
086	FIL	60	Newtons
Max	Time	Min	Time
5798.2	55.6	-27.9	150.2

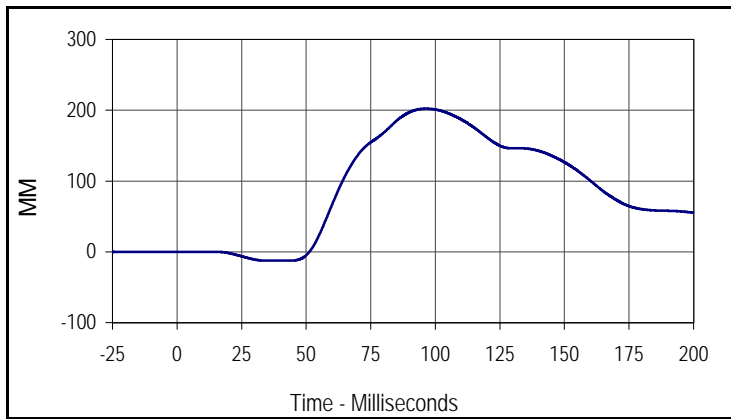

Curve Description			
Passenger Shoulder Belt Pullout			
CURNO	Type	SAE Class	Units
087	FIL	60	MM
Max	Time	Min	Time
202.2	96.8	-12.5	43.6

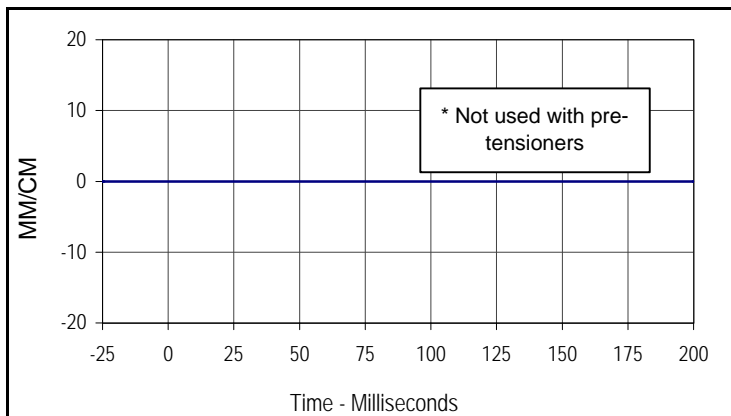

Curve Description			
Passenger Shoulder Belt Elongation			
CURNO	Type	SAE Class	Units
088	FIL	60	MM/CM
Max	Time	Min	Time
0.0	0.0	0.0	0.0

\* Not used with pre-tensioners

Test Vehicle: 2005 Toyota Tundra 2-Door Truck  
 Test Program: 2005 NHTSA 35mph NCAP

Test Date: 10/5/04  
 NHTSA No.: M55111

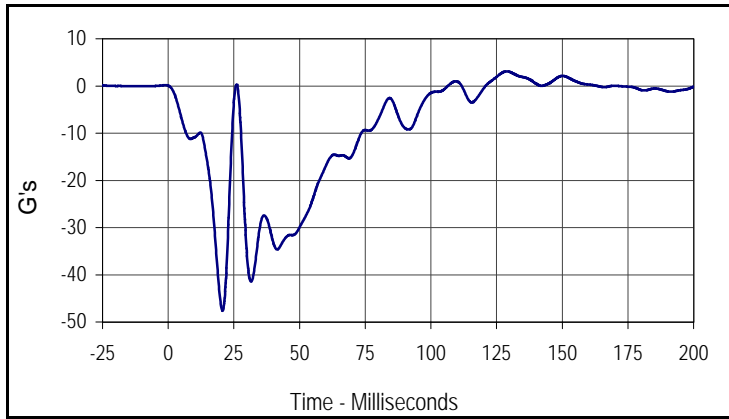

Curve Description			
Vehicle Left Rear X			
CURNO	Type	SAE Class	Units
089	FIL	60	G's
Max	Time	Min	Time
3.1	128.9	-47.6	20.7

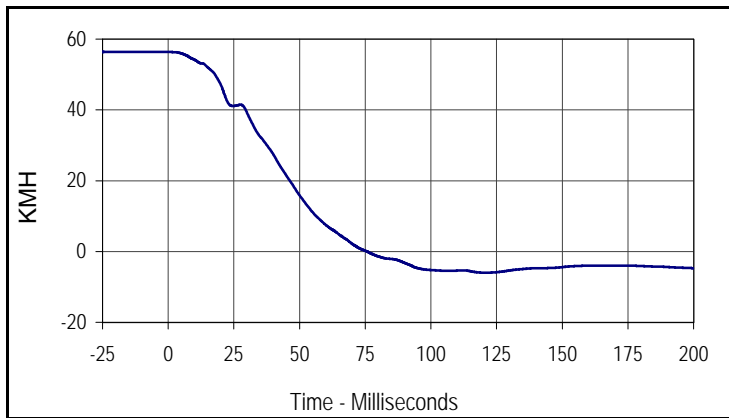

Curve Description			
Vehicle Left Rear X Velocity			
CURNO	Type	SAE Class	Units
089	IN1	180	KMH
Max	Time	Min	Time
56.3	0.0	-6.0	120.5

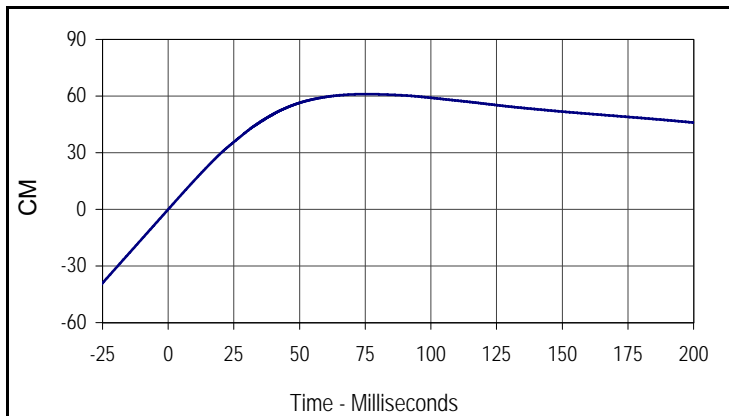

Curve Description			
Vehicle Left Rear X Displacement			
CURNO	Type	SAE Class	Units
089	IN2	180	CM
Max	Time	Min	Time
61.0	75.7	0.0	0.0

Test Vehicle: 2005 Toyota Tundra 2-Door Truck  
 Test Program: 2005 NHTSA 35mph NCAP

Test Date: 10/5/04  
 NHTSA No.: M55111

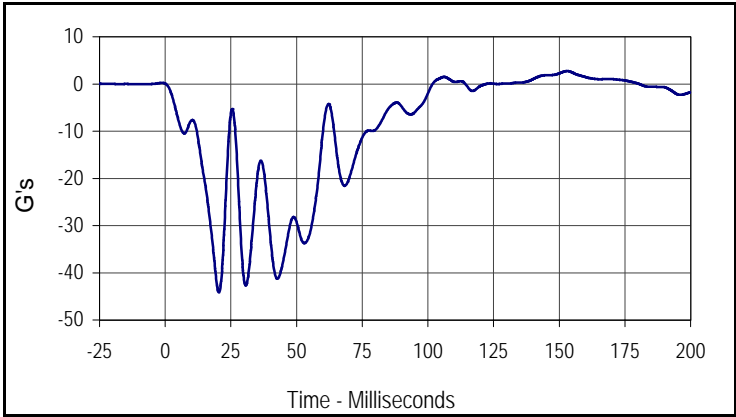

Curve Description			
Vehicle Right Rear X			
CURNO	Type	SAE Class	Units
090	FIL	60	G's
Max	Time	Min	Time
2.7	153.0	-44.1	20.4

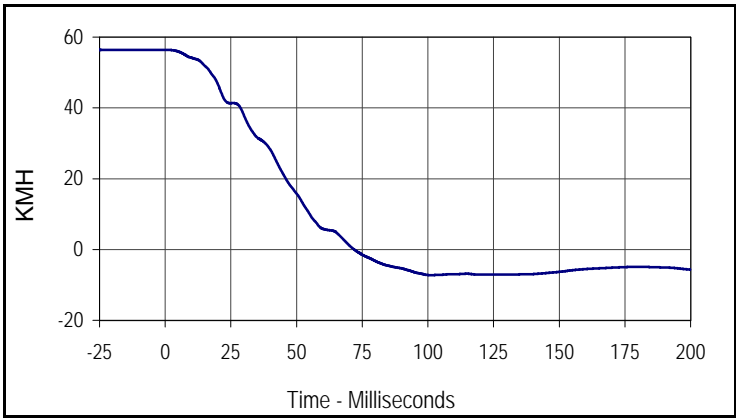

Curve Description			
Vehicle Right Rear X Velocity			
CURNO	Type	SAE Class	Units
090	IN1	180	KMH
Max	Time	Min	Time
56.4	1.0	-7.2	101.3

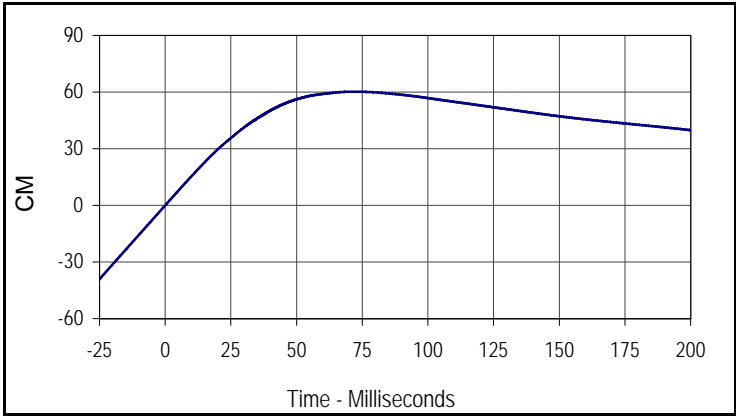

Curve Description			
Vehicle Right Rear X Displacement			
CURNO	Type	SAE Class	Units
090	IN2	180	CM
Max	Time	Min	Time
60.2	71.9	0.0	0.0

Test Vehicle: 2005 Toyota Tundra 2-Door Truck  
 Test Program: 2005 NHTSA 35mph NCAP

Test Date: 10/5/04  
 NHTSA No.: M55111

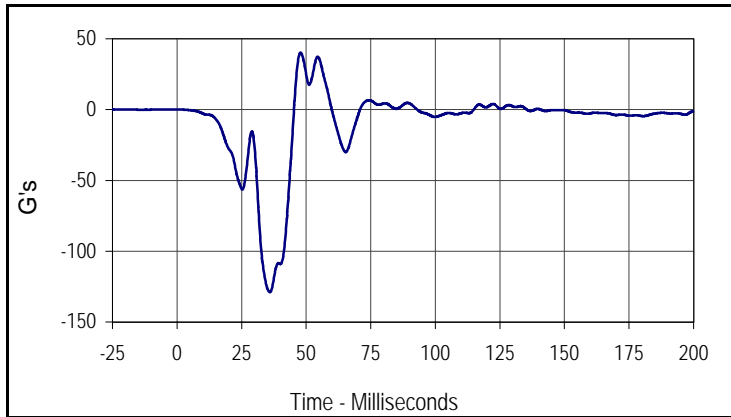

Curve Description			
Vehicle Engine Top X			
CURNO	Type	SAE Class	Units
091	FIL	60	G's
Max	Time	Min	Time
40.2	47.8	-129.0	36.0

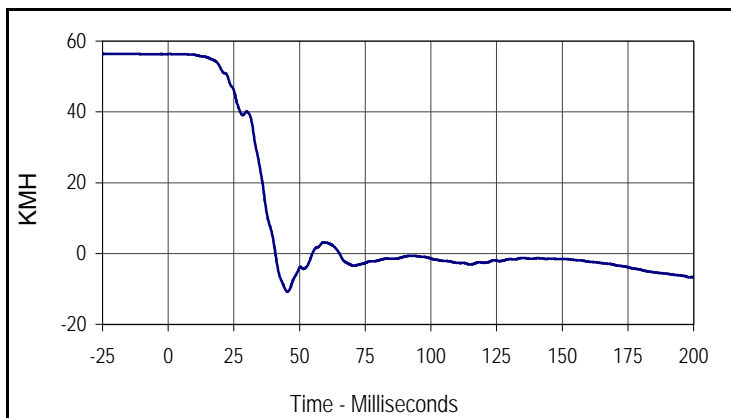

Curve Description			
Vehicle Engine Top X Velocity			
CURNO	Type	SAE Class	Units
091	IN1	180	KMH
Max	Time	Min	Time
56.3	0.5	-10.8	45.4

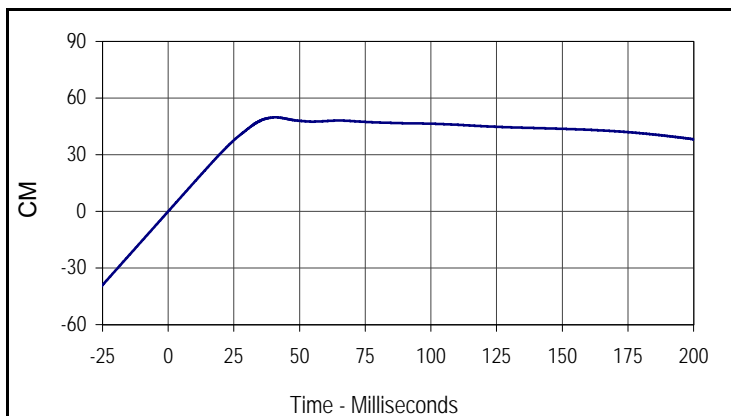

Curve Description			
Vehicle Engine Top X Displacement			
CURNO	Type	SAE Class	Units
091	IN2	180	CM
Max	Time	Min	Time
49.8	40.8	0.0	0.0

Test Vehicle: 2005 Toyota Tundra 2-Door Truck  
 Test Program: 2005 NHTSA 35mph NCAP

Test Date: 10/5/04  
 NHTSA No.: M55111

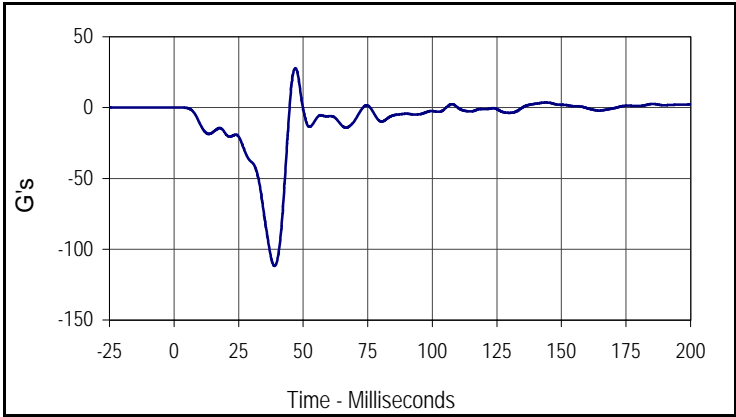

Curve Description			
Vehicle Engine Bottom X			
CURNO	Type	SAE Class	Units
092	FIL	60	G's
Max	Time	Min	Time
27.9	47.0	-111.9	38.9

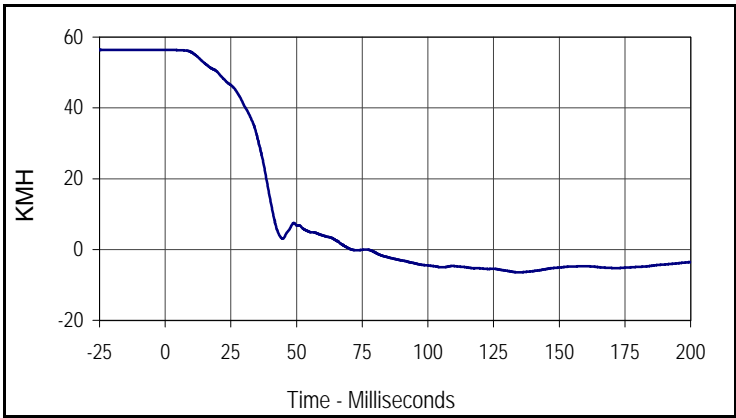

Curve Description			
Vehicle Engine Bottom X Velocity			
CURNO	Type	SAE Class	Units
092	IN1	180	KMH
Max	Time	Min	Time
56.4	0.0	-6.5	134.3

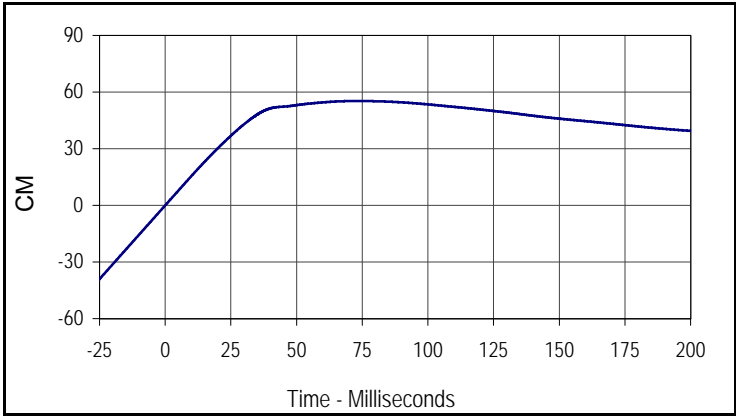

Curve Description			
Vehicle Engine Bottom X Displacement			
CURNO	Type	SAE Class	Units
092	IN2	180	CM
Max	Time	Min	Time
55.2	70.9	0.0	0.0

Test Vehicle: 2005 Toyota Tundra 2-Door Truck  
 Test Program: 2005 NHTSA 35mph NCAP

Test Date: 10/5/04  
 NHTSA No.: M55111

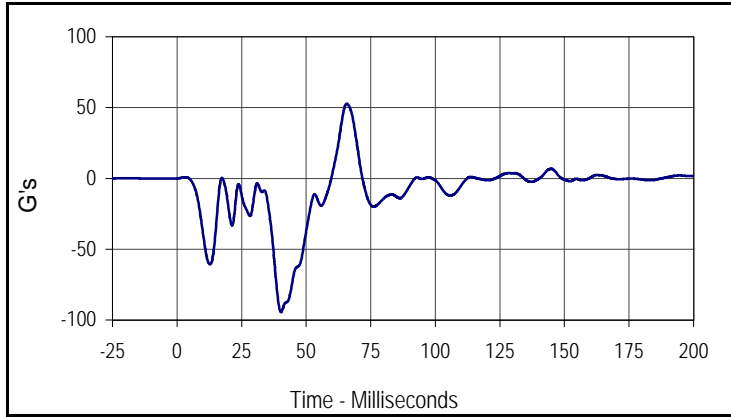

Curve Description			
Vehicle Left Brake Caliper X			
CURNO	Type	SAE Class	Units
093	FIL	60	G's
Max	Time	Min	Time
52.7	65.7	-94.4	40.2

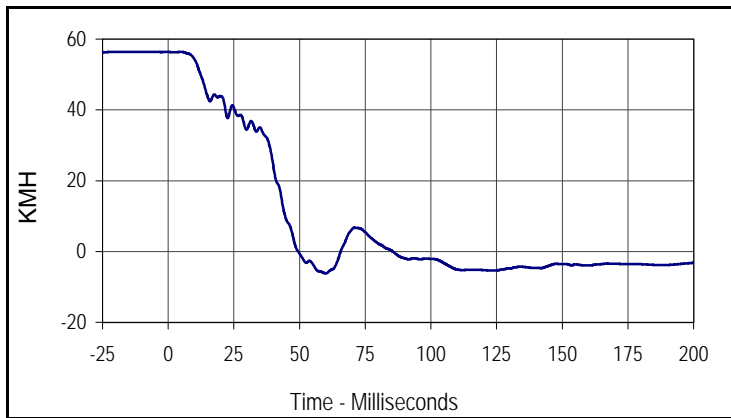

Curve Description			
Vehicle Left Brake Caliper X Velocity			
CURNO	Type	SAE Class	Units
093	IN1	180	KMH
Max	Time	Min	Time
56.4	5.0	-6.2	60.0

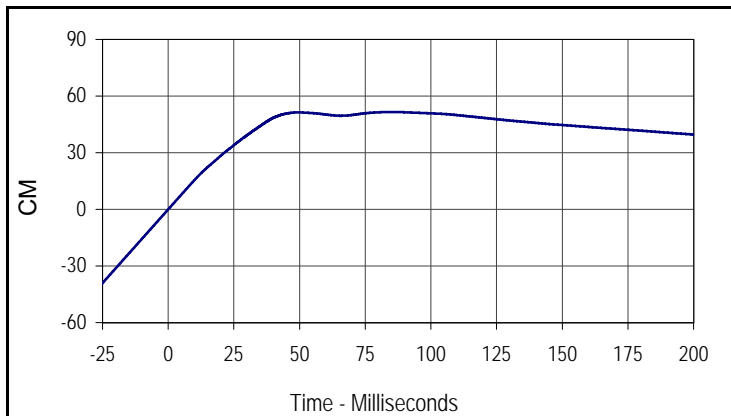

Curve Description			
Vehicle Left Brake Caliper X Displacement			
CURNO	Type	SAE Class	Units
093	IN2	180	CM
Max	Time	Min	Time
51.6	85.5	0.0	0.0

Test Vehicle: 2005 Toyota Tundra 2-Door Truck  
 Test Program: 2005 NHTSA 35mph NCAP

Test Date: 10/5/04  
 NHTSA No.: M55111

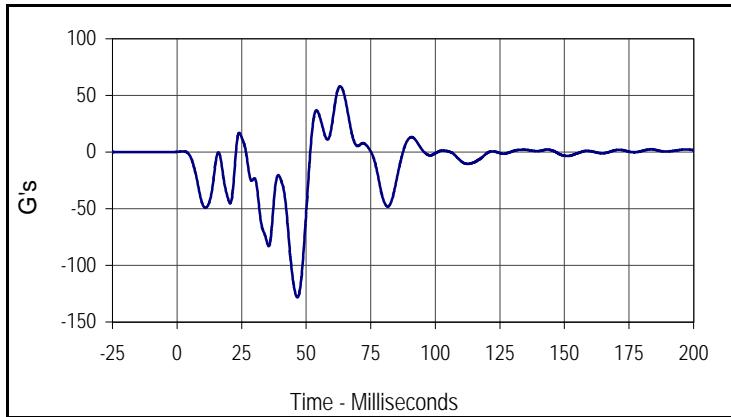

Curve Description			
Vehicle Right Brake Caliper X			
CURNO	Type	SAE Class	Units
094	FIL	60	G's
Max	Time	Min	Time
58.0	63.2	-128.2	46.6

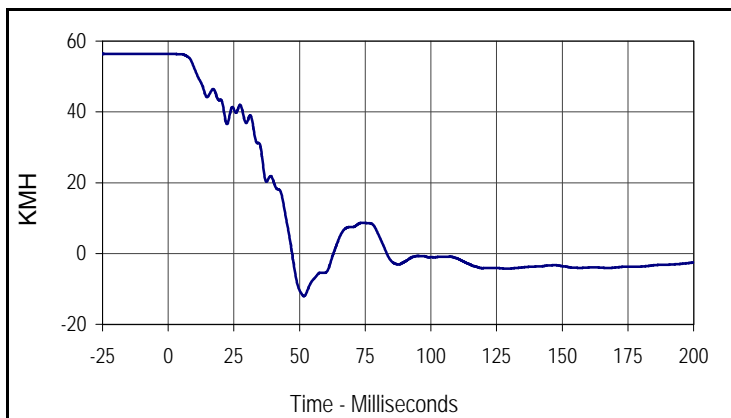

Curve Description			
Vehicle Right Brake Caliper X Velocity			
CURNO	Type	SAE Class	Units
094	IN1	180	KMH
Max	Time	Min	Time
56.4	0.0	-12.1	51.7

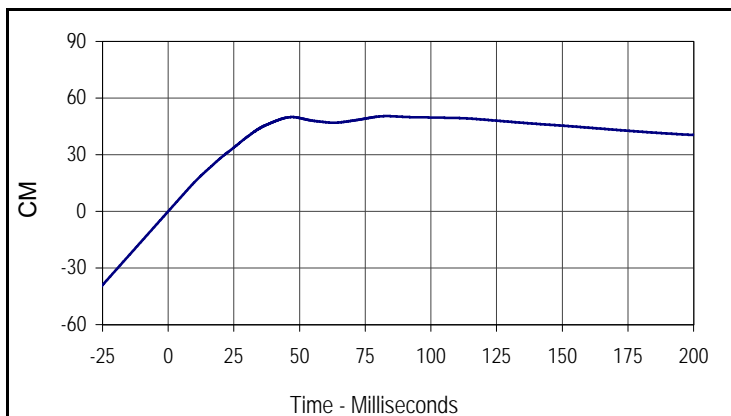

Curve Description			
Vehicle Right Brake Caliper X Displacement			
CURNO	Type	SAE Class	Units
094	IN2	180	CM
Max	Time	Min	Time
50.5	83.2	0.0	0.0

Test Vehicle: 2005 Toyota Tundra 2-Door Truck  
 Test Program: 2005 NHTSA 35mph NCAP

Test Date: 10/5/04  
 NHTSA No.: M55111

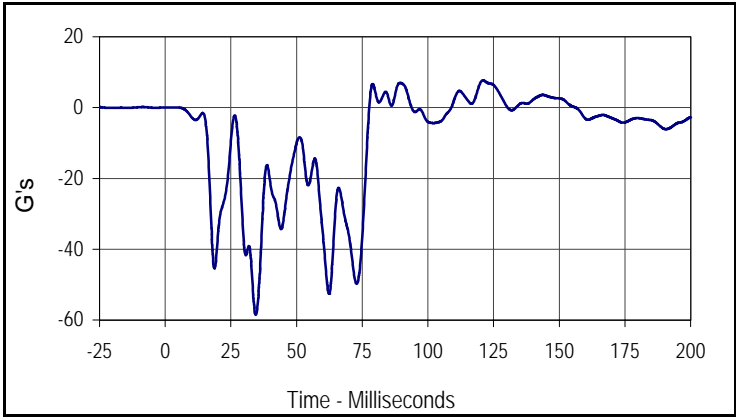

Curve Description			
Vehicle Instrument Panel X			
CURNO	Type	SAE Class	Units
095	FIL	60	G's
Max	Time	Min	Time
7.7	121.0	-58.6	34.5

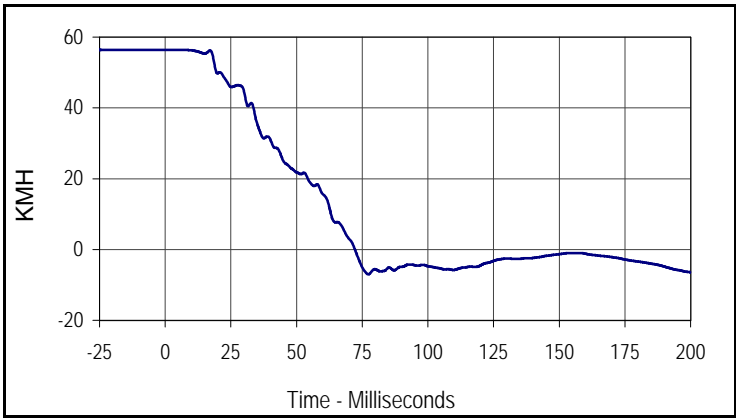

Curve Description			
Vehicle Instrument Panel X Velocity			
CURNO	Type	SAE Class	Units
095	IN1	180	KMH
Max	Time	Min	Time
56.4	1.2	-7.0	77.3

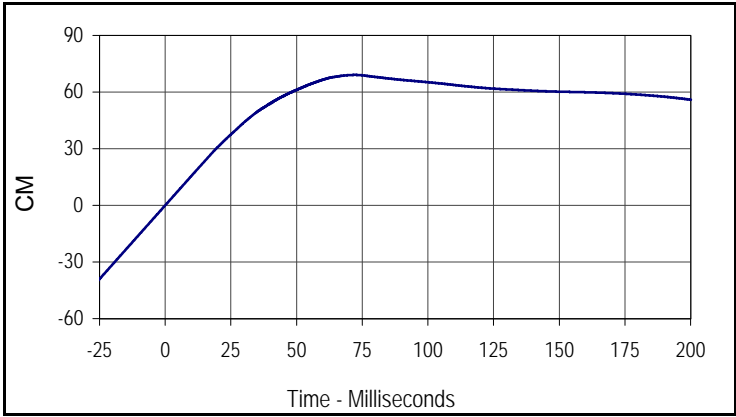

Curve Description			
Vehicle Instrument Panel X Displacement			
CURNO	Type	SAE Class	Units
095	IN2	180	CM
Max	Time	Min	Time
69.1	72.2	0.0	0.0

Test Vehicle: 2005 Toyota Tundra 2-Door Truck  
 Test Program: 2005 NHTSA 35mph NCAP

Test Date: 10/5/04  
 NHTSA No.: M55111

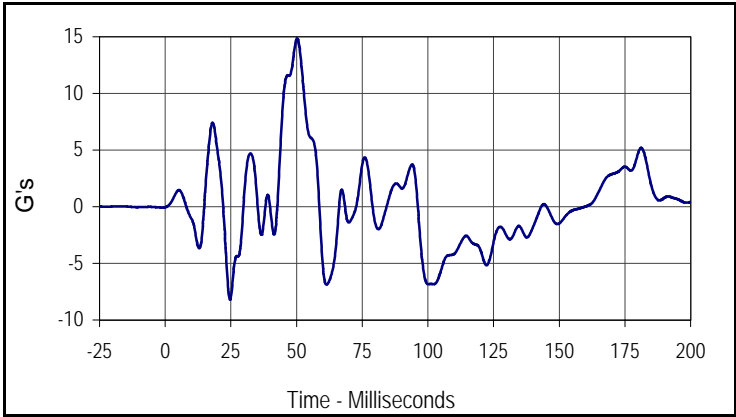

Curve Description			
Vehicle Left Rear Z			
CURNO	Type	SAE Class	Units
096	FIL	60	G's
Max	Time	Min	Time
14.9	50.2	-8.2	24.7

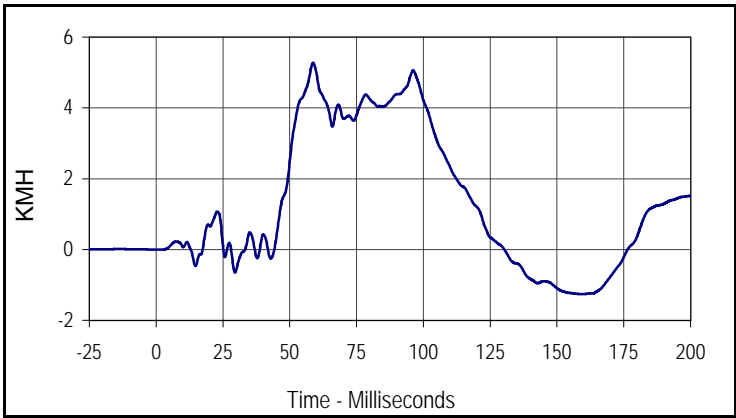

Curve Description			
Vehicle Left Rear Z Velocity			
CURNO	Type	SAE Class	Units
096	IN1	180	KMH
Max	Time	Min	Time
5.3	58.7	-1.3	159.2

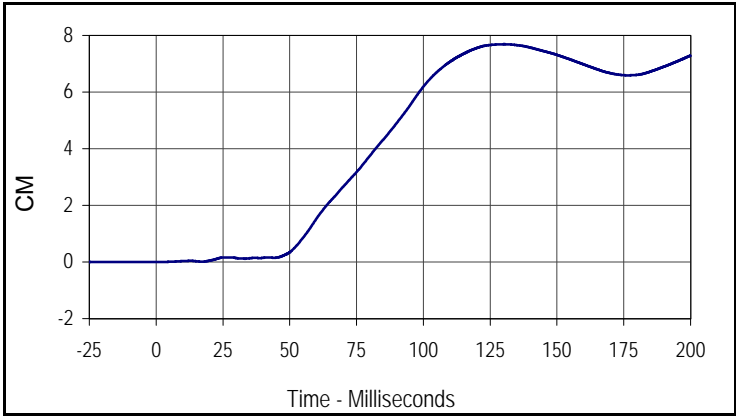

Curve Description			
Vehicle Left Rear Z Displacement			
CURNO	Type	SAE Class	Units
096	IN2	180	CM
Max	Time	Min	Time
7.7	130.3	0.0	2.7

Test Vehicle: 2005 Toyota Tundra 2-Door Truck  
 Test Program: 2005 NHTSA 35mph NCAP

Test Date: 10/5/04  
 NHTSA No.: M55111

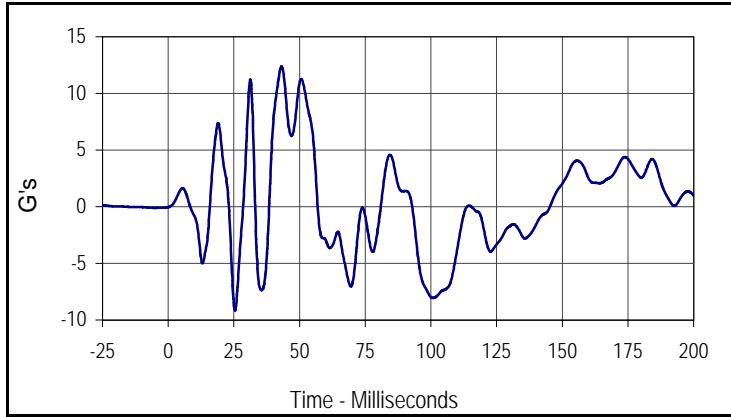

Curve Description			
Vehicle Right Rear Z			
CURNO	Type	SAE Class	Units
097	FIL	60	G's
Max	Time	Min	Time
12.4	43.1	-9.2	25.4

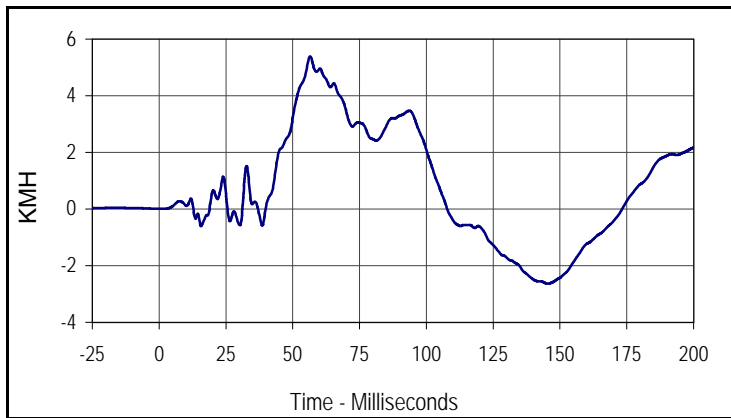

Curve Description			
Vehicle Right Rear Z Velocity			
CURNO	Type	SAE Class	Units
097	IN1	180	KMH
Max	Time	Min	Time
5.4	56.5	-2.6	145.5

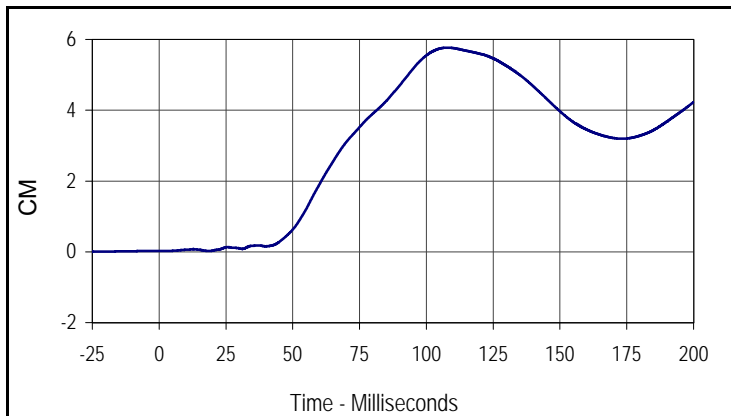

Curve Description			
Vehicle Right Rear Z Displacement			
CURNO	Type	SAE Class	Units
097	IN2	180	CM
Max	Time	Min	Time
5.8	107.8	0.0	18.9

**APPENDIX C**

**LOAD CELL BARRIER DATA PLOTS**

Test Vehicle: 2005 Toyota Tundra 2-Door Truck  
 Test Program: 2005 NHTSA 35mph NCAP

Test Date: 10/5/04  
 NHTSA No.: M55111

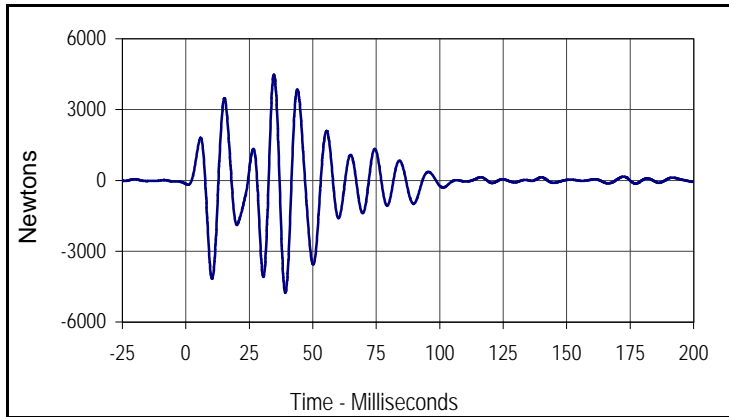

Curve Description			
Barrier Force A1			
CURNO	Type	SAE Class	Units
098	FIL	60	Newtons
Max	Time	Min	Time
4487.6	34.7	-4763.9	39.2

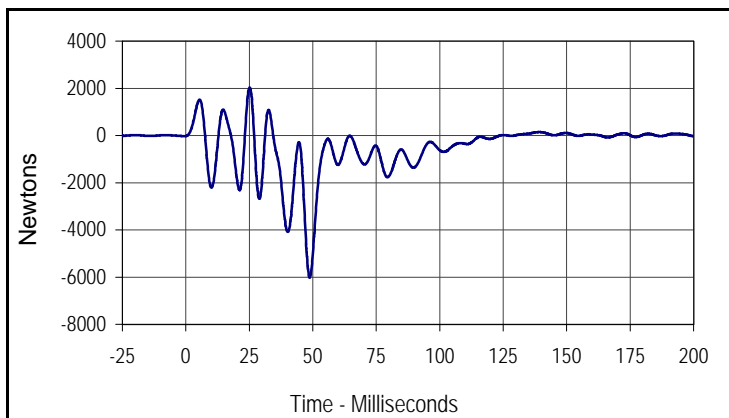

Curve Description			
Barrier Force B1			
CURNO	Type	SAE Class	Units
107	FIL	60	Newtons
Max	Time	Min	Time
2039.3	25.2	-6017.9	48.8

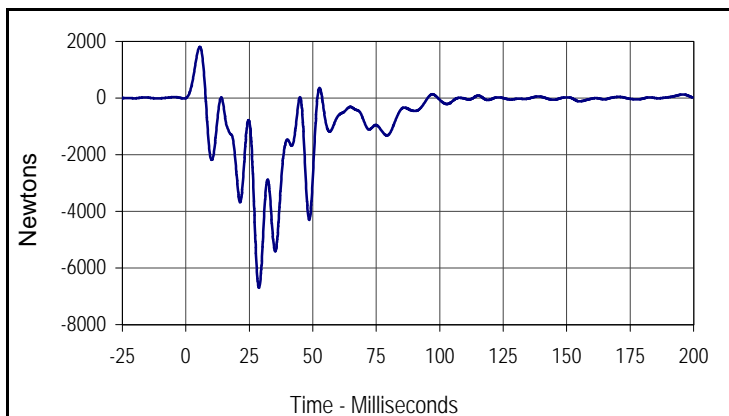

Curve Description			
Barrier Force C1			
CURNO	Type	SAE Class	Units
116	FIL	60	Newtons
Max	Time	Min	Time
1803.8	5.5	-6695.8	28.8

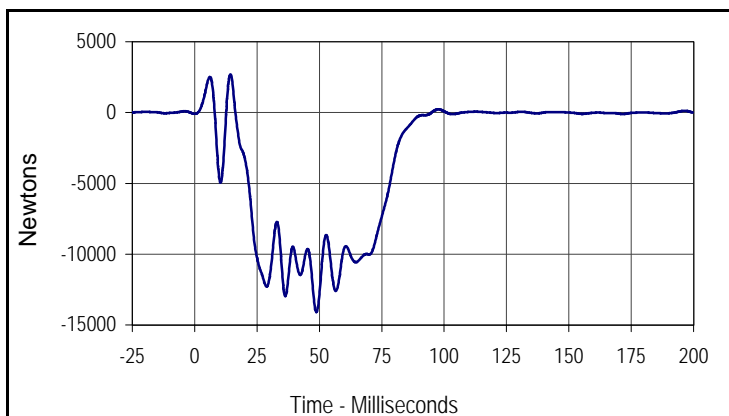

Curve Description			
Barrier Force D1			
CURNO	Type	SAE Class	Units
125	FIL	60	Newtons
Max	Time	Min	Time
2687.2	14.4	-14088.3	48.8

Test Vehicle: 2005 Toyota Tundra 2-Door Truck  
 Test Program: 2005 NHTSA 35mph NCAP

Test Date: 10/5/04  
 NHTSA No.: M55111

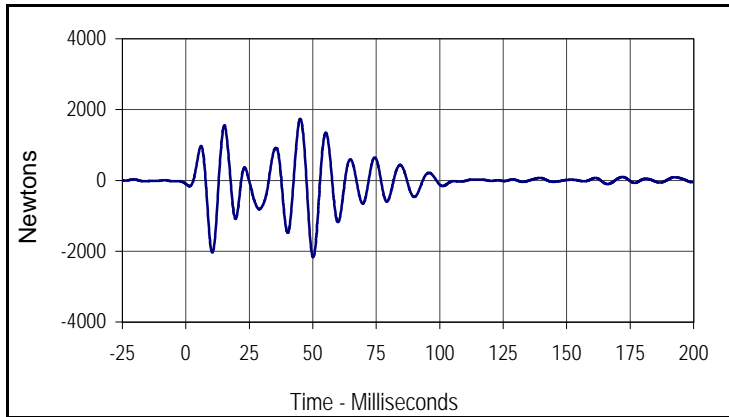

Curve Description			
Barrier Force A2			
CURNO	Type	SAE Class	Units
099	FIL	60	Newtons
Max	Time	Min	Time
1739.3	45.1	-2168.2	50.1

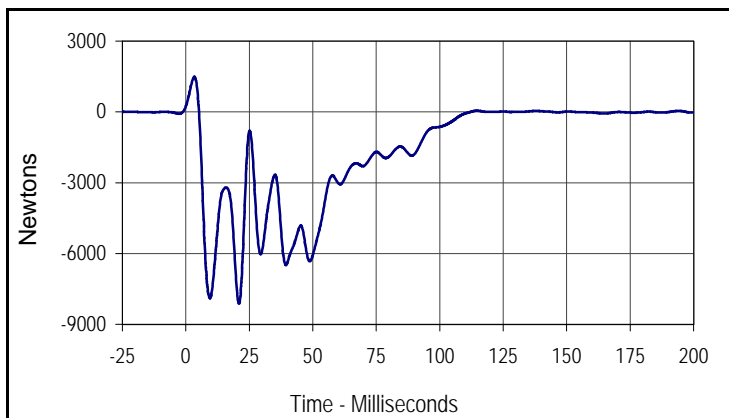

Curve Description			
Barrier Force B2			
CURNO	Type	SAE Class	Units
108	FIL	60	Newtons
Max	Time	Min	Time
1488.2	3.3	-8115.3	20.9

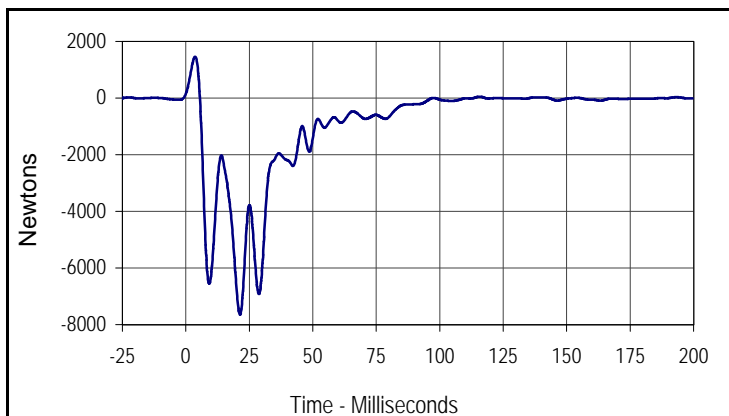

Curve Description			
Barrier Force C2			
CURNO	Type	SAE Class	Units
117	FIL	60	Newtons
Max	Time	Min	Time
1461.6	3.7	-7647.0	21.3

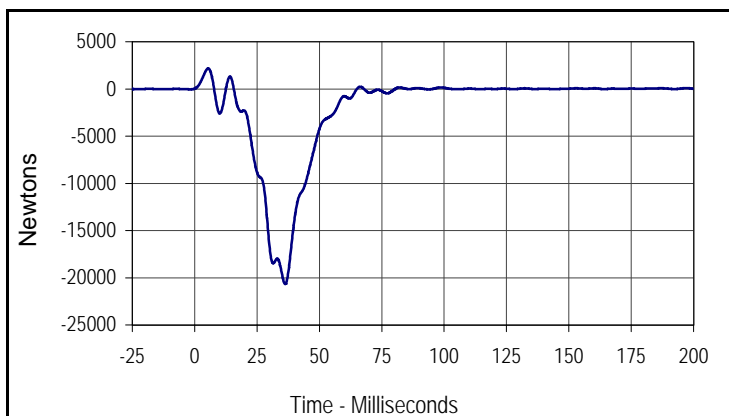

Curve Description			
Barrier Force D2			
CURNO	Type	SAE Class	Units
126	FIL	60	Newtons
Max	Time	Min	Time
2172.3	5.4	-20654.8	36.3

Test Vehicle: 2005 Toyota Tundra 2-Door Truck  
 Test Program: 2005 NHTSA 35mph NCAP

Test Date: 10/5/04  
 NHTSA No.: M55111

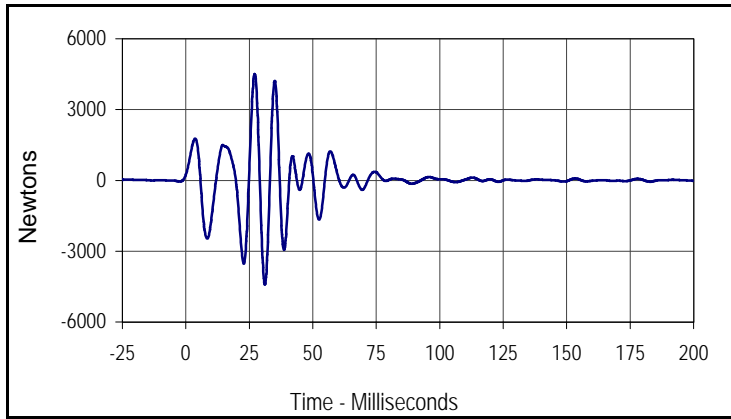

Curve Description			
Barrier Force A3			
CURNO	Type	SAE Class	Units
100	FIL	60	Newtons
Max	Time	Min	Time
4510.1	27.1	-4409.7	31.1

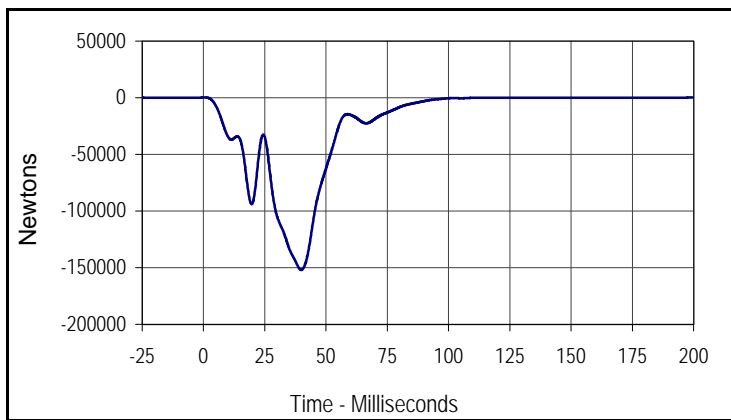

Curve Description			
Barrier Force B3			
CURNO	Type	SAE Class	Units
109	FIL	60	Newtons
Max	Time	Min	Time
195.7	0.5	-152052.2	39.9

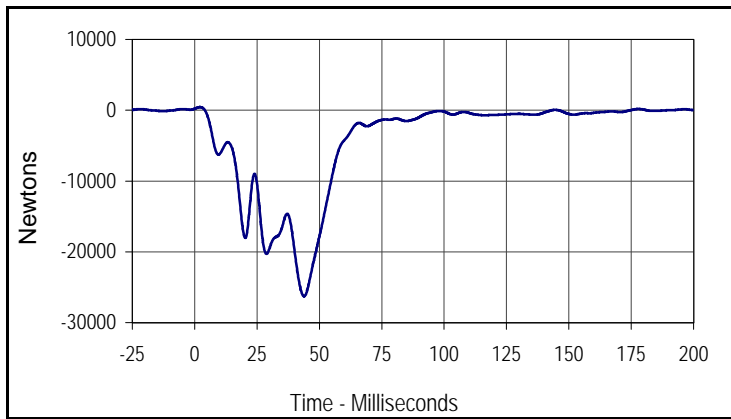

Curve Description			
Barrier Force C3			
CURNO	Type	SAE Class	Units
118	FIL	60	Newtons
Max	Time	Min	Time
442.6	2.1	-26277.3	43.8

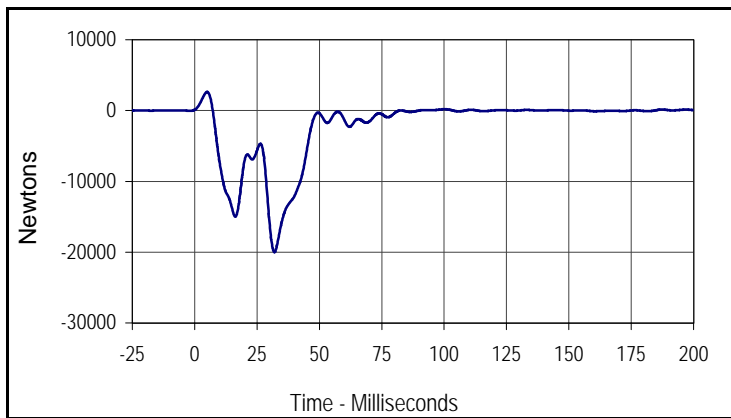

Curve Description			
Barrier Force D3			
CURNO	Type	SAE Class	Units
127	FIL	60	Newtons
Max	Time	Min	Time
2621.6	5.0	-20003.1	32.0

Test Vehicle: 2005 Toyota Tundra 2-Door Truck  
 Test Program: 2005 NHTSA 35mph NCAP

Test Date: 10/5/04  
 NHTSA No.: M55111

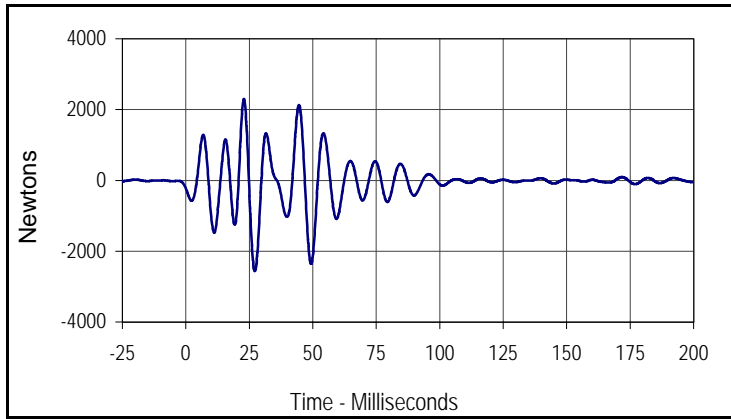

Curve Description			
Barrier Force A4			
CURNO	Type	SAE Class	Units
101	FIL	60	Newtons
Max	Time	Min	Time
2301.7	22.9	-2562.5	27.2

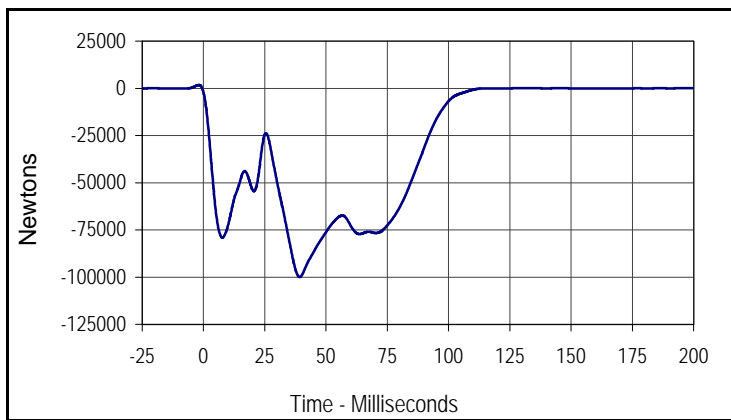

Curve Description			
Barrier Force B4			
CURNO	Type	SAE Class	Units
110	FIL	60	Newtons
Max	Time	Min	Time
108.6	196.3	-99949.5	39.2

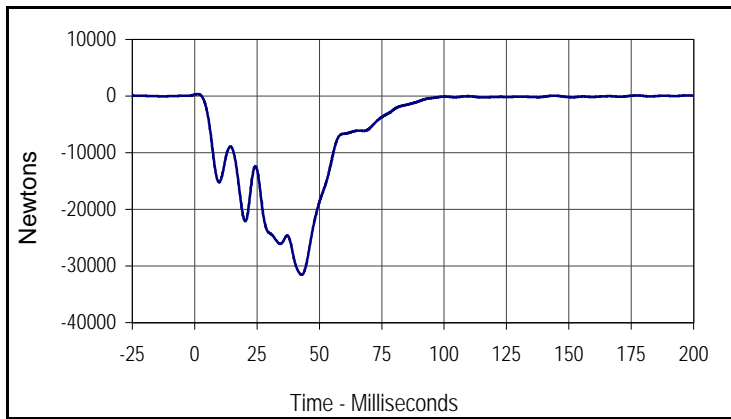

Curve Description			
Barrier Force C4			
CURNO	Type	SAE Class	Units
119	FIL	60	Newtons
Max	Time	Min	Time
360.9	1.3	-31536.9	42.9

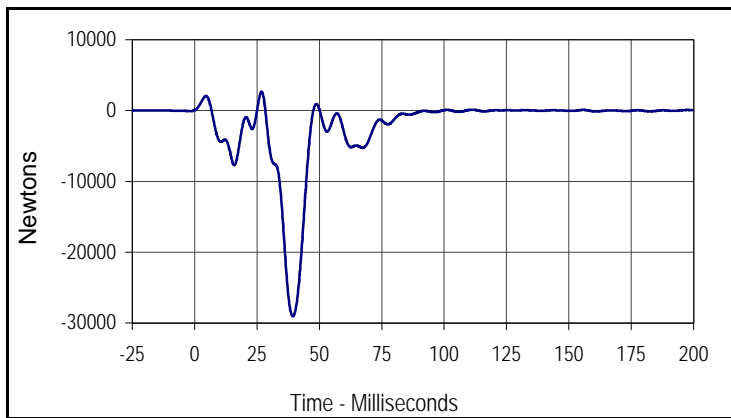

Curve Description			
Barrier Force D4			
CURNO	Type	SAE Class	Units
128	FIL	60	Newtons
Max	Time	Min	Time
2685.5	26.8	-29071.7	39.4

Test Vehicle: 2005 Toyota Tundra 2-Door Truck  
 Test Program: 2005 NHTSA 35mph NCAP

Test Date: 10/5/04  
 NHTSA No.: M55111

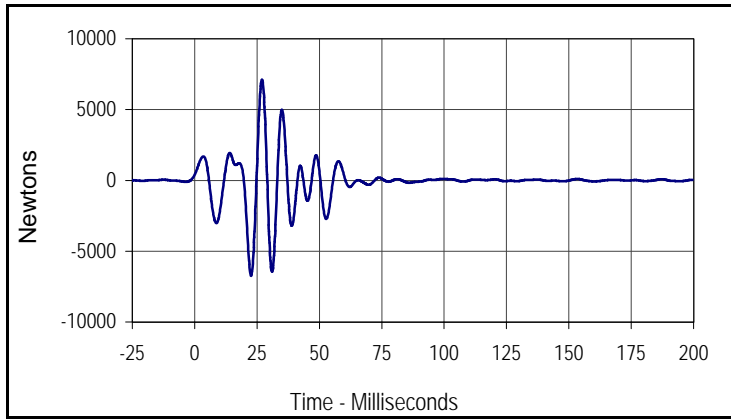

Curve Description			
Barrier Force A5			
CURNO	Type	SAE Class	Units
102	FIL	60	Newtons
Max	Time	Min	Time
7110.5	27.0	-6744.0	22.6

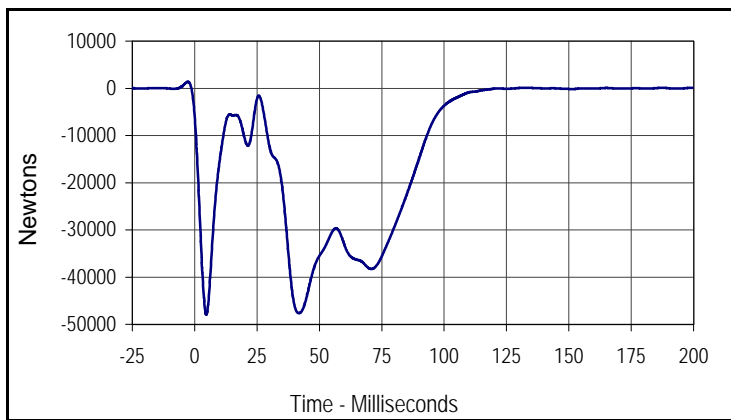

Curve Description			
Barrier Force B5			
CURNO	Type	SAE Class	Units
111	FIL	60	Newtons
Max	Time	Min	Time
128.0	132.3	-47961.5	4.6

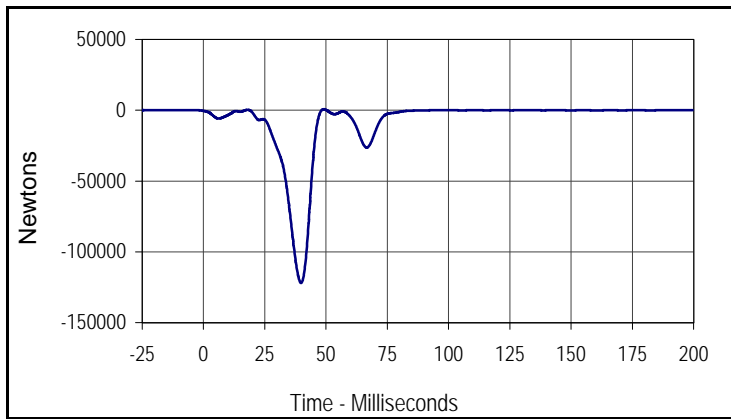

Curve Description			
Barrier Force C5			
CURNO	Type	SAE Class	Units
120	FIL	60	Newtons
Max	Time	Min	Time
630.0	49.1	-121901.2	39.8



Curve Description			
Barrier Force D5			
CURNO	Type	SAE Class	Units
129	FIL	60	Newtons
Max	Time	Min	Time
1940.0	48.8	-75624.9	39.8

Test Vehicle: 2005 Toyota Tundra 2-Door Truck  
 Test Program: 2005 NHTSA 35mph NCAP

Test Date: 10/5/04  
 NHTSA No.: M55111

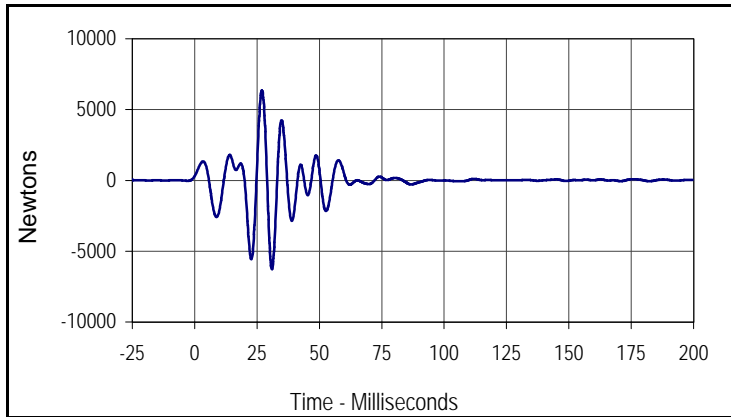

Curve Description			
Barrier Force A6			
CURNO	Type	SAE Class	Units
103	FIL	60	Newtons
Max	Time	Min	Time
6352.5	27.0	-6264.4	31.0

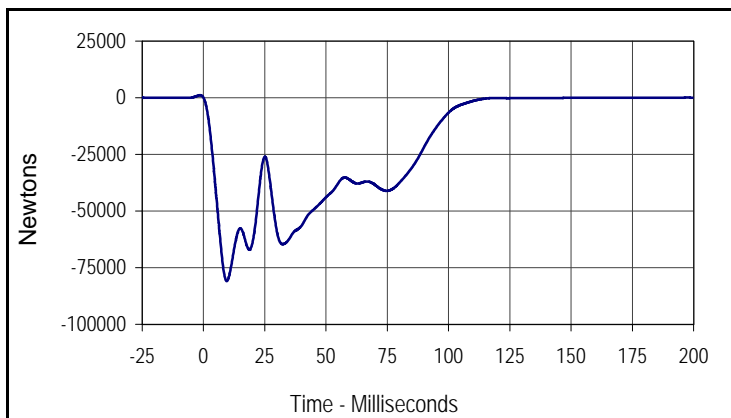

Curve Description			
Barrier Force B6			
CURNO	Type	SAE Class	Units
112	FIL	60	Newtons
Max	Time	Min	Time
78.5	197.5	-80920.7	9.5

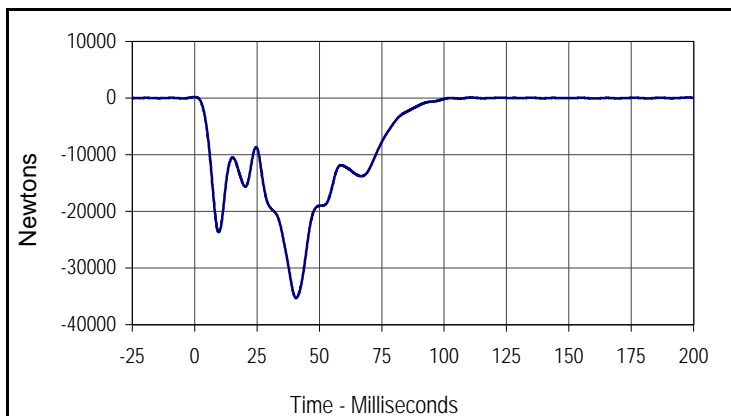

Curve Description			
Barrier Force C6			
CURNO	Type	SAE Class	Units
121	FIL	60	Newtons
Max	Time	Min	Time
194.2	0.1	-35297.6	40.7

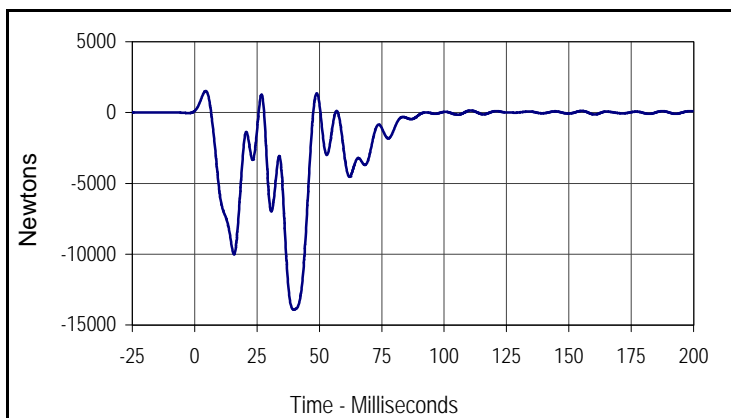

Curve Description			
Barrier Force D6			
CURNO	Type	SAE Class	Units
130	FIL	60	Newtons
Max	Time	Min	Time
1525.4	4.4	-13909.1	39.7

Test Vehicle: 2005 Toyota Tundra 2-Door Truck  
 Test Program: 2005 NHTSA 35mph NCAP

Test Date: 10/5/04  
 NHTSA No.: M55111

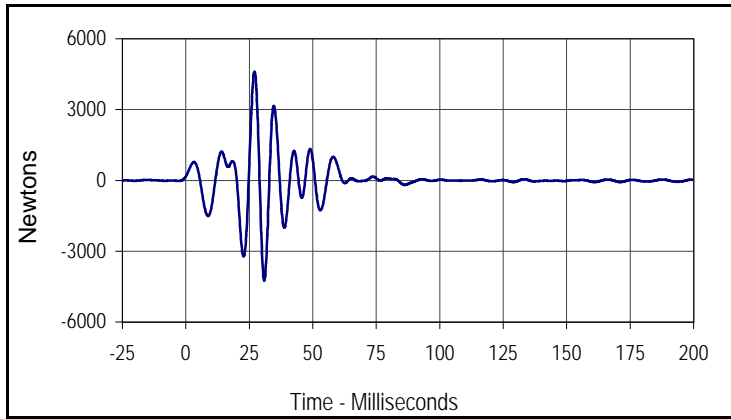

Curve Description			
Barrier Force A7			
CURNO	Type	SAE Class	Units
104	FIL	60	Newtons
Max	Time	Min	Time
4607.1	27.0	-4245.0	30.9

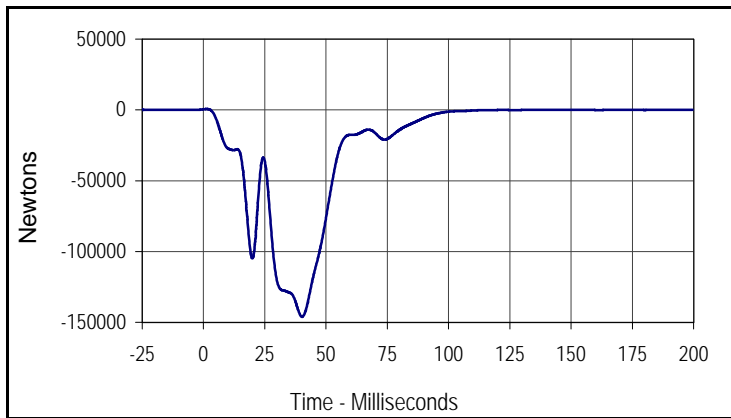

Curve Description			
Barrier Force B7			
CURNO	Type	SAE Class	Units
113	FIL	60	Newtons
Max	Time	Min	Time
646.9	1.3	-146061.0	40.2

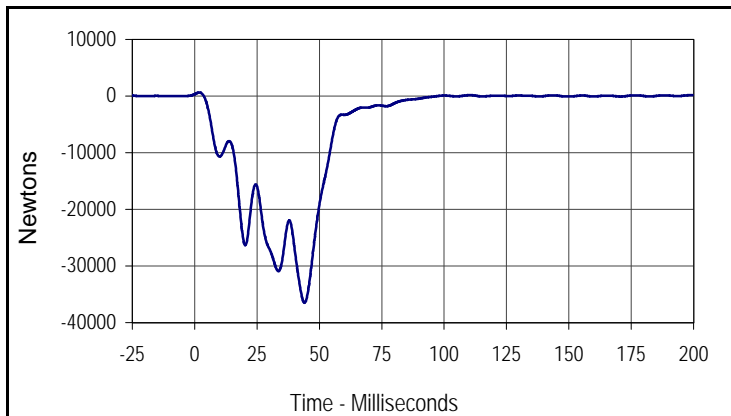

Curve Description			
Barrier Force C7			
CURNO	Type	SAE Class	Units
122	FIL	60	Newtons
Max	Time	Min	Time
631.2	1.9	-36476.0	44.0

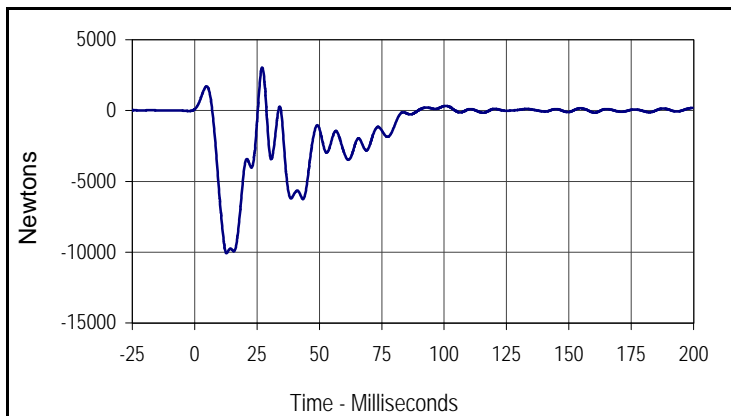

Curve Description			
Barrier Force D7			
CURNO	Type	SAE Class	Units
131	FIL	60	Newtons
Max	Time	Min	Time
3038.7	27.1	-10084.6	12.8

Test Vehicle: 2005 Toyota Tundra 2-Door Truck  
 Test Program: 2005 NHTSA 35mph NCAP

Test Date: 10/5/04  
 NHTSA No.: M55111

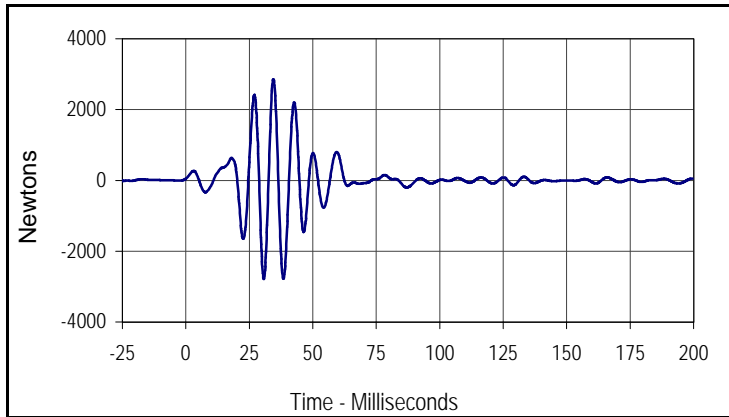

Curve Description			
Barrier Force A8			
CURNO	Type	SAE Class	Units
105	FIL	60	Newtons
Max	Time	Min	Time
2855.8	34.5	-2789.2	30.7

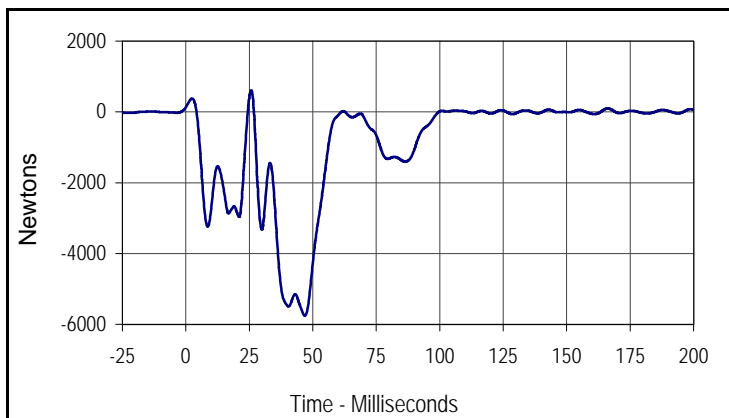

Curve Description			
Barrier Force B8			
CURNO	Type	SAE Class	Units
114	FIL	60	Newtons
Max	Time	Min	Time
608.8	25.7	-5754.4	46.9

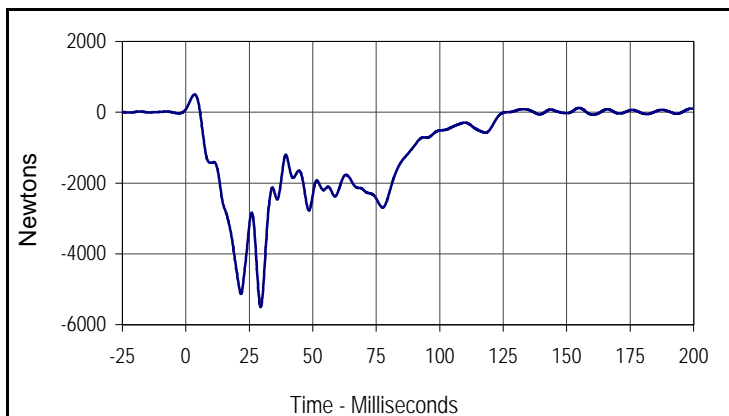

Curve Description			
Barrier Force C8			
CURNO	Type	SAE Class	Units
123	FIL	60	Newtons
Max	Time	Min	Time
499.0	3.4	-5506.6	29.5

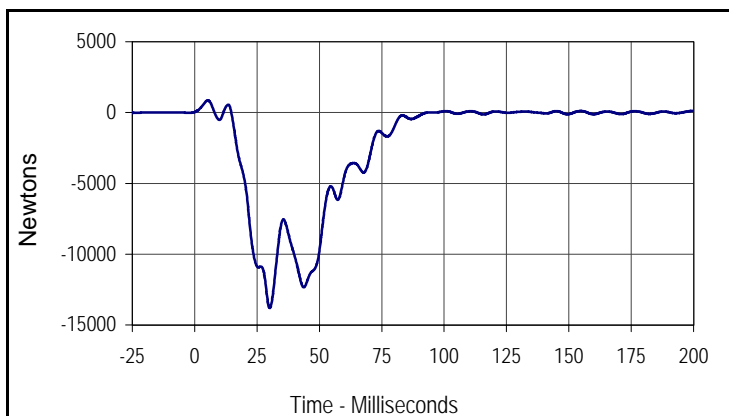

Curve Description			
Barrier Force D8			
CURNO	Type	SAE Class	Units
132	FIL	60	Newtons
Max	Time	Min	Time
864.1	5.3	-13793.6	30.1

Test Vehicle: 2005 Toyota Tundra 2-Door Truck  
 Test Program: 2005 NHTSA 35mph NCAP

Test Date: 10/5/04  
 NHTSA No.: M55111

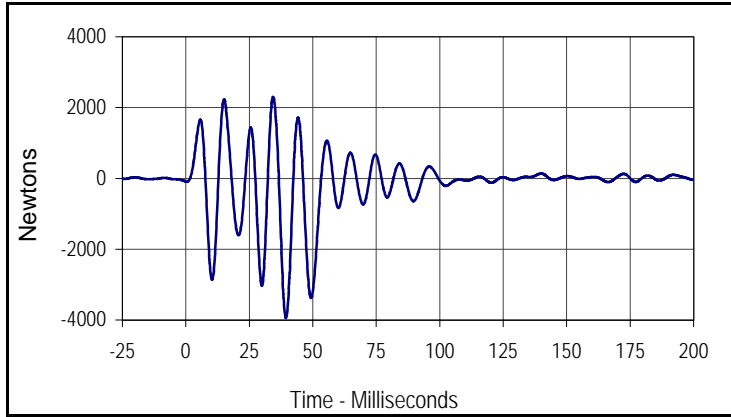

Curve Description			
Barrier Force A9			
CURNO	Type	SAE Class	Units
106	FIL	60	Newtons
Max	Time	Min	Time
2301.5	34.4	-3941.6	39.4

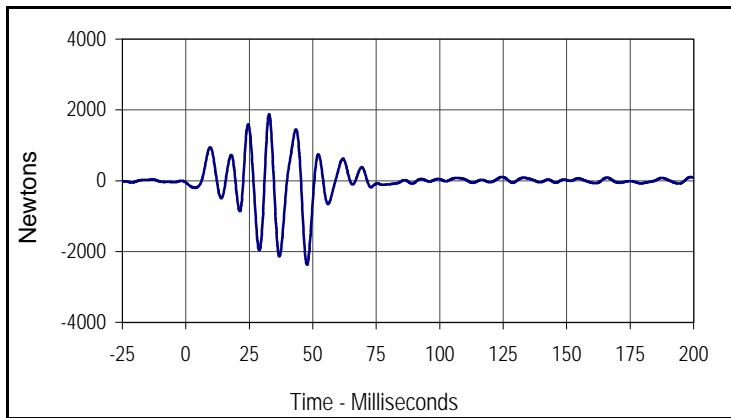

Curve Description			
Barrier Force B9			
CURNO	Type	SAE Class	Units
115	FIL	60	Newtons
Max	Time	Min	Time
1872.4	32.8	-2373.5	47.7

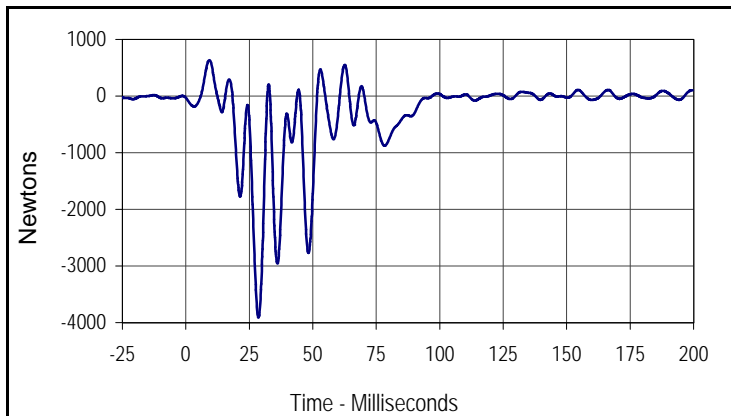

Curve Description			
Barrier Force C9			
CURNO	Type	SAE Class	Units
124	FIL	60	Newtons
Max	Time	Min	Time
634.5	9.3	-3910.0	28.6

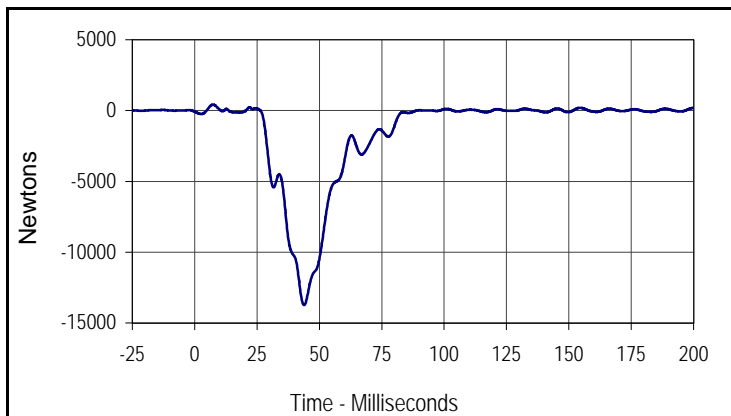

Curve Description			
Barrier Force D9			
CURNO	Type	SAE Class	Units
133	FIL	60	Newtons
Max	Time	Min	Time
418.3	7.4	-13742.2	43.8

Test Vehicle: 2005 Toyota Tundra 2-Door Truck  
 Test Program: 2005 NHTSA 35mph NCAP

Test Date: 10/5/04  
 NHTSA No.: M55111

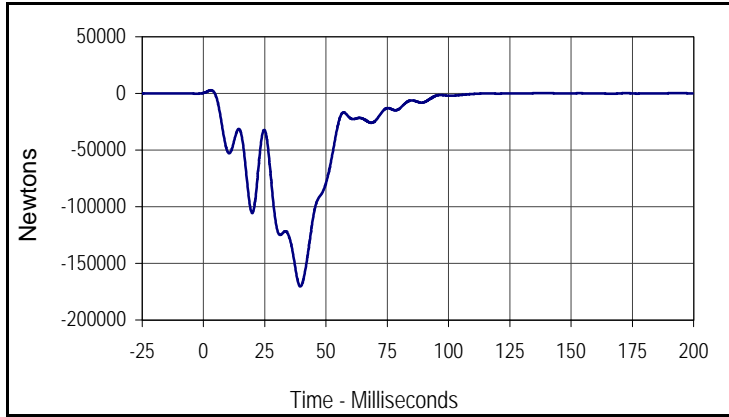

Curve Description			
Barrier Force Sum Group 1			
CURNO	Type	SAE Class	Units
001	SUM	60	Newtons
Max	Time	Min	Time
2752.6	3.1	-170475.6	39.5

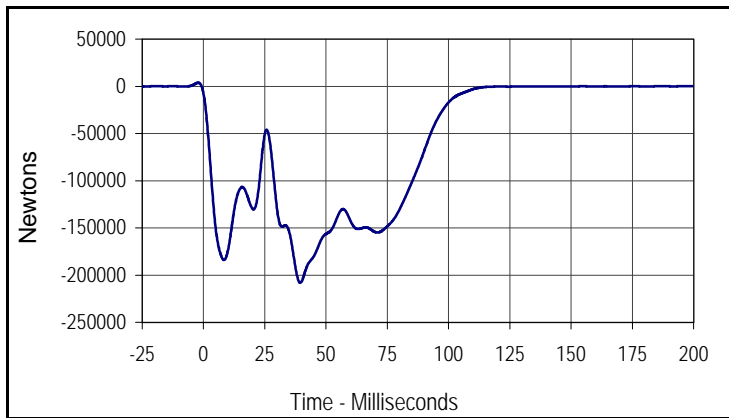

Curve Description			
Barrier Force Sum Group 2			
CURNO	Type	SAE Class	Units
002	SUM	60	Newtons
Max	Time	Min	Time
285.8	187.2	-208090.8	39.5

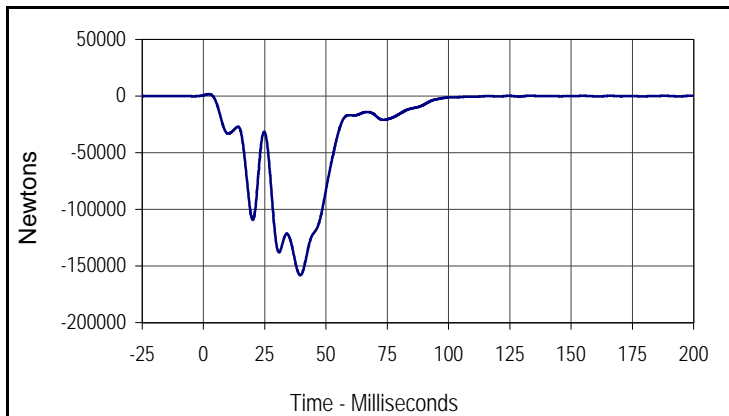

Curve Description			
Barrier Force Sum Group 3			
CURNO	Type	SAE Class	Units
003	SUM	60	Newtons
Max	Time	Min	Time
1678.9	2.3	-158244.4	39.5

Test Vehicle: 2005 Toyota Tundra 2-Door Truck  
 Test Program: 2005 NHTSA 35mph NCAP

Test Date: 10/5/04  
 NHTSA No.: M55111

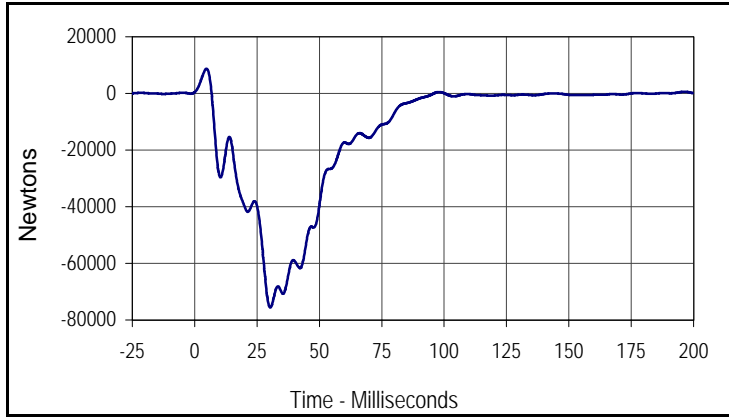

Curve Description			
Barrier Force Sum Group 4			
CURNO	Type	SAE Class	Units
004	SUM	60	Newtons
Max	Time	Min	Time
8740.9	4.7	-75601.0	30.3

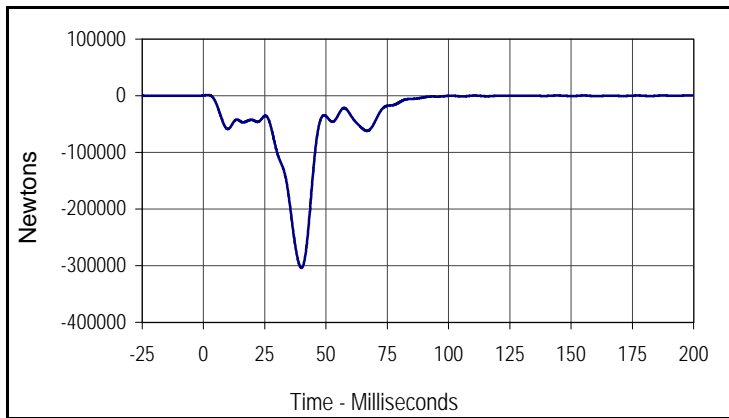

Curve Description			
Barrier Force Sum Group 5			
CURNO	Type	SAE Class	Units
005	SUM	60	Newtons
Max	Time	Min	Time
1375.0	1.8	-303981.8	40.0

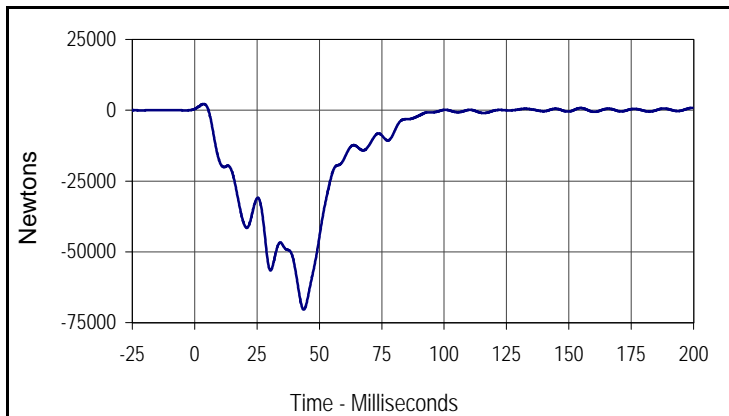

Curve Description			
Barrier Force Sum Group 6			
CURNO	Type	SAE Class	Units
006	SUM	60	Newtons
Max	Time	Min	Time
2187.0	3.6	-70415.4	43.7

Test Vehicle: 2005 Toyota Tundra 2-Door Truck  
 Test Program: 2005 NHTSA 35mph NCAP

Test Date: 10/5/04  
 NHTSA No.: M55111

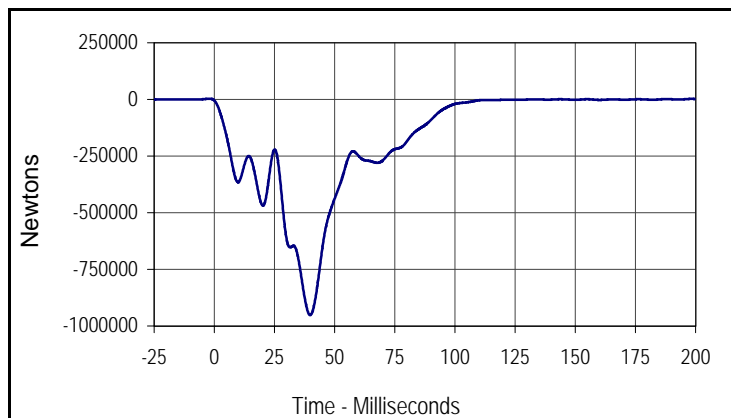

Curve Description			
Barrier Force Total Sum			
CURNO	Type	SAE Class	Units
007	SUM	60	Newtons
Max	Time	Min	Time
2340.8	198.2	-952152.2	39.8

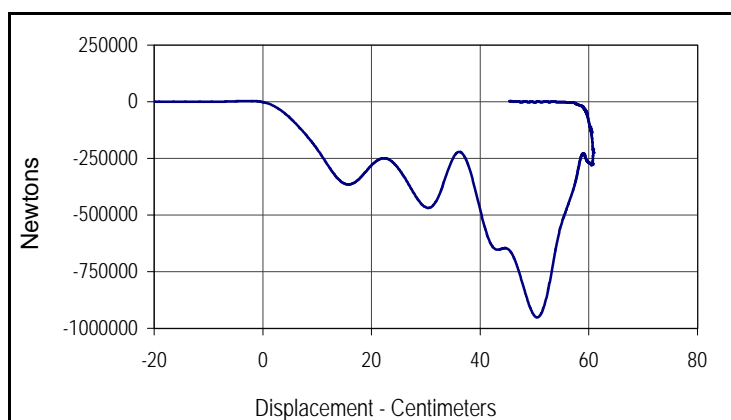

Curve Description			
Barrier Force Total Sum vs. Displ.			
CURNO	Type	SAE Class	Units
001	XVY	60	Newtons
Max	CM	Min	CM
2340.8	45.5	-952152.2	50.5

**APPENDIX D**

**INSTRUMENTATION DATA CHANNEL ASSIGNMENTS**

**2005 NHTSA 35mph NCAP  
Instrumentation Data Channel Assignments  
Driver A.T.D. Serial Number 35  
10/5/04  
2005 Toyota Tundra 2-Door Truck**

CH.	LOCATION	AXIS	IDENT. NO.	DESCRIPTION	MFR	MODEL	UNITS
1	HEAD, PRIMARY	X	GPAC027	Accel., 1/2 bridge	Endevco	7264-2000	G
2	HEAD, PRIMARY	Y	GPAC002	Accel., 1/2 bridge	Endevco	7264-2000	G
3	HEAD, PRIMARY	Z	GPAC003	Accel., 1/2 bridge	Endevco	7264-2000	G
4	HEAD, REDUNDANT	X	GPAC032	Accel., 1/2 bridge	Endevco	7264-2000	G
5	HEAD, REDUNDANT	Y	GPAC021	Accel., 1/2 bridge	Endevco	7264-2000	G
6	HEAD, REDUNDANT	Z	GPAC026	Accel., 1/2 bridge	Endevco	7264-2000	G
7	NECK FORCE	X	GPUN01FX	Load cell, six axis neck	R. A. Denton	1716A	N
8	NECK FORCE	Y	GPUN01FY	Load cell, six axis neck	R. A. Denton	1716A	N
9	NECK FORCE	Z	GPUN01FZ	Load cell, six axis neck	R. A. Denton	1716A	N
10	NECK MOMENT	X	GPUN01MX	Load cell, six axis neck	R. A. Denton	1716A	Nm
11	NECK MOMENT	Y	GPUN01MY	Load cell, six axis neck	R. A. Denton	1716A	Nm
12	NECK MOMENT	Z	GPUN01MZ	Load cell, six axis neck	R. A. Denton	1716A	Nm
13	CHEST, PRIMARY	X	GPAC005	Accel., 1/2 bridge	Endevco	7264-2000	G
14	CHEST, PRIMARY	Y	GPAC011	Accel., 1/2 bridge	Endevco	7264-2000	G
15	CHEST, PRIMARY	Z	GPAC010	Accel., 1/2 bridge	Endevco	7264-2000	G
16	CHEST, REDUNDANT	X	GPAC034	Accel., 1/2 bridge	Endevco	7264-2000	G
17	CHEST, REDUNDANT	Y	GPAC023	Accel., 1/2 bridge	Endevco	7264-2000	G
18	CHEST, REDUNDANT	Z	GPAC020	Accel., 1/2 bridge	Endevco	7264-2000	G
19	CHEST DISPLACEMENT	X	GPCP002	Rotary Pot Chest	Servo	14CBI	MM
20	PELVIS, PRIMARY	X	GPAC025	Accel., 1/2 bridge	Endevco	7264-2000	G
21	PELVIS, PRIMARY	Y	GPAC022	Accel., 1/2 bridge	Endevco	7264-2000	G
22	PELVIS, PRIMARY	Z	GPAC019	Accel., 1/2 bridge	Endevco	7264-2000	G
23	LEFT FEMUR FORCE	Z	KEFF003	Load cell, Femur	R.A. Denton	2121	N
24	RIGHT FEMUR FORCE	Z	KEFF004	Load cell, Femur	R.A. Denton	2121	N

D-1

TR-P25001-04-NC

**2005 NHTSA 35mph NCAP  
Instrumentation Data Channel Assignments  
Driver A.T.D. Serial Number 35  
10/5/04  
2005 Toyota Tundra 2-Door Truck**

CH.	LOCATION	AXIS	IDENT. NO.	DESCRIPTION	MFR	MODEL	UNITS
25	UP. TIBIA LEFT MOM.	X	GPUT09MX	2 ch., Upper tibia gage	R. A. Denton	1583	Nm
26	UP. TIBIA LEFT MOM.	Y	GPUT09MY	2 ch., Upper tibia gage	R. A. Denton	1583	Nm
27	UP. TIBIA RIGHT MOM.	X	GPUT09MX	2 ch., Upper tibia gage	R. A. Denton	1583	Nm
28	UP. TIBIA RIGHT MOM.	Y	GPUT09MY	2 ch., Upper tibia gage	R. A. Denton	1583	Nm
29	LWR. TIBIA LEFT MOM.	X	GPLT09MX	3 ch., lower tibia gage	R. A. Denton	3093	Nm
30	LWR. TIBIA LEFT MOM.	Y	GPLT09MY	3 ch., lower tibia gage	R. A. Denton	3093	Nm
31	LWR. TIBIA LEFT FORCE	Z	GPLT09FZ	3 ch., lower tibia gage	R. A. Denton	3093	N
32	LWR. TIBIA RIGHT MOM.	X	GPLT09MX	3 ch., lower tibia gage	R. A. Denton	3093	Nm
33	LWR. TIBIA RIGHT MOM.	Y	GPLT09MY	3 ch., lower tibia gage	R. A. Denton	3093	Nm
34	LWR. TIBIA RIGHT FORCE	Z	GPLT09FZ	3 ch., lower tibia gage	R. A. Denton	3093	N
35	FOOT LEFT, AFT	X	KEIC002X	Accel., Foot Triax	I.C. Sensor	3031-500	G
36	FOOT LEFT, AFT	Z	KEIC002Y	Accel., Foot Triax	I.C. Sensor	3031-500	G
37	FOOT LEFT, FORE	Z	KEIC002Z	Accel., Foot Triax	I.C. Sensor	3031-500	G
38	FOOT RIGHT, AFT	X	KEIC001X	Accel., Foot Triax	I.C. Sensor	3031-500	G
39	FOOT RIGHT, AFT	Z	KEIC001Y	Accel., Foot Triax	I.C. Sensor	3031-500	G
40	FOOT RIGHT, FORE	Z	KEIC001Z	Accel., Foot Triax	I.C. Sensor	3031-500	G
41	LAP BELT FORCE	X	BL134	Load cell, Seat belt	FGP	FN4060	N
42	SHOULDER BELT FORCE	X	BL135	Load cell, Seat belt	FGP	FN4060	N
43	SHOULDER BELT SPOOL	X	KEPP001	Pullout pot	Celesco	PTX101-0030	MM
44	SHOULDER BELT ELONG.	X	KEEP001	Linear pot., belt stretch	E.T.I.	LCP8-10 10K	MM/CM

D-2

TR-P25001-04-NC

**2005 NHTSA 35mph NCAP  
Instrumentation Data Channel Assignments  
Passenger A.T.D. Serial Number 34  
10/5/04  
2005 Toyota Tundra 2-Door Truck**

CH.	LOCATION	AXIS	IDENT. NO.	DESCRIPTION	MFR	MODEL	UNITS
45	HEAD, PRIMARY	X	KEAC039	Accel.,1/2 bridge	Endevco	7264-2000	G
46	HEAD, PRIMARY	Y	KEAC038	Accel.,1/2 bridge	Endevco	7264-2000	G
47	HEAD, PRIMARY	Z	KEAC027	Accel.,1/2 bridge	Endevco	7264-2000	G
48	HEAD, REDUNDANT	X	KEAC031	Accel.,1/2 bridge	Endevco	7264-2000	G
49	HEAD, REDUNDANT	Y	KEAC032	Accel.,1/2 bridge	Endevco	7264-2000	G
50	HEAD, REDUNDANT	Z	KEAC026	Accel.,1/2 bridge	Endevco	7264-2000	G
51	NECK FORCE	X	GPUN02FX	Load cell, six axis neck	R. A. Denton	1716A	N
52	NECK FORCE	Y	GPUN02FY	Load cell, six axis neck	R. A. Denton	1716A	N
53	NECK FORCE	Z	GPUN02FZ	Load cell, six axis neck	R. A. Denton	1716A	N
54	NECK MOMENT	X	GPUN02MX	Load cell, six axis neck	R. A. Denton	1716A	Nm
55	NECK MOMENT	Y	GPUN02MY	Load cell, six axis neck	R. A. Denton	1716A	Nm
56	NECK MOMENT	Z	GPUN02MZ	Load cell, six axis neck	R. A. Denton	1716A	Nm
57	CHEST, PRIMARY	X	GPAC031	Accel., 1/2 bridge	Endevco	7264-2000	G
58	CHEST, PRIMARY	Y	GPAC024	Accel., 1/2 bridge	Endevco	7264-2000	G
59	CHEST, PRIMARY	Z	GPAC029	Accel., 1/2 bridge	Endevco	7264-2000	G
60	CHEST, REDUNDANT	X	KEAC023	Accel.,1/2 bridge	Endevco	7264-200	G
61	CHEST, REDUNDANT	Y	KEAC022	Accel.,1/2 bridge	Endevco	7264-200	G
62	CHEST, REDUNDANT	Z	KEAC024	Accel.,1/2 bridge	Endevco	7264-200	G
63	CHEST DISPLACEMENT	X	GPCP001	Rotary Pot Chest	Servo	14CBI	MM
64	PELVIS, PRIMARY	X	KEAC019	Accel.,1/2 bridge	Endevco	7264-200	G
65	PELVIS, PRIMARY	Y	KEAC020	Accel.,1/2 bridge	Endevco	7264-200	G
66	PELVIS, PRIMARY	Z	KEAC021	Accel.,1/2 bridge	Endevco	7264-200	G
67	LEFT FEMUR FORCE	Z	KEFF001	Load cell, Femur	R.A. Denton	2121	N
68	RIGHT FEMUR FORCE	Z	KEFF002	Load cell, Femur	R.A. Denton	2121	N

**2005 NHTSA 35mph NCAP  
Instrumentation Data Channel Assignments  
Passenger A.T.D. Serial Number 34  
10/5/04  
2005 Toyota Tundra 2-Door Truck**

CH.	LOCATION	AXIS	IDENT. NO.	DESCRIPTION	MFR	MODEL	UNITS
69	UP. TIBIA LEFT MOM.	X	GPUT09MX	2 ch., Upper tibia gage	R. A. Denton	1583	Nm
70	UP. TIBIA LEFT MOM.	Y	GPUT09MY	2 ch., Upper tibia gage	R. A. Denton	1583	Nm
71	UP. TIBIA RIGHT MOM.	X	GPUT09MX	2 ch., Upper tibia gage	R. A. Denton	1583	Nm
72	UP. TIBIA RIGHT MOM.	Y	GPUT09MY	2 ch., Upper tibia gage	R. A. Denton	1583	Nm
73	LWR. TIBIA LEFT MOM.	X	GPLT09MX	3 ch., lower tibia gage	R. A. Denton	3093	Nm
74	LWR. TIBIA LEFT MOM.	Y	GPLT09MY	3 ch., lower tibia gage	R. A. Denton	3093	Nm
75	LWR. TIBIA LEFT FORCE	Z	GPLT09FZ	3 ch., lower tibia gage	R. A. Denton	3093	N
76	LWR. TIBIA RIGHT MOM.	X	GPLT09MX	3 ch., lower tibia gage	R. A. Denton	3093	Nm
77	LWR. TIBIA RIGHT MOM.	Y	GPLT09MY	3 ch., lower tibia gage	R. A. Denton	3093	Nm
78	LWR. TIBIA RIGHT FORCE	Z	GPLT09FZ	3 ch., lower tibia gage	R. A. Denton	3093	N
79	FOOT LEFT, AFT	X	KEIC003X	Accel., Foot Triax	I.C. Sensor	3031-500	G
80	FOOT LEFT, AFT	Z	KEIC003Y	Accel., Foot Triax	I.C. Sensor	3031-500	G
81	FOOT LEFT, FORE	Z	KEIC003Z	Accel., Foot Triax	I.C. Sensor	3031-500	G
82	FOOT RIGHT, AFT	X	KEIC004X	Accel., Foot Triax	I.C. Sensor	3031-500	G
83	FOOT RIGHT, AFT	Z	KEIC004Y	Accel., Foot Triax	I.C. Sensor	3031-500	G
84	FOOT RIGHT, FORE	Z	KEIC004Z	Accel., Foot Triax	I.C. Sensor	3031-500	G
85	LAP BELT FORCE	X	BL168	Load cell, Seat belt	First Tech	IF-964	N
86	SHOULDER BELT FORCE	X	BL169	Load cell, Seat belt	First Tech	IF-964	N
87	SHOULDER BELT SPOOL	X	KEPP001	Pullout pot	Celesco	PTX101-0030	MM
88	SHOULDER BELT ELONG.	X	KEEP001	Linear pot., belt stretch	E.T.I.	LCP8-10 10K	MM/CM

**2005 NHTSA 35mph NCAP  
Instrumentation Data Channel Assignments  
Vehicle Accelerometers  
10/5/04  
2005 Toyota Tundra 2-Door Truck**

CH.	LOCATION	AXIS	IDENT. NO.	DESCRIPTION	MFR	MODEL	UNITS
89	LEFT REAR	X	KEVA002	Accel., Pre-Amp	I.C.S/Karco	3031-500	G
90	RIGHT REAR	X	KEVA006	Accel., Vehicle block	I.C. Sensor	3031-200	G
91	ENGINE TOP	X	KEVA009	Accel., Vehicle block	I.C. Sensor	3031-500	G
92	ENGINE BOTTOM	X	KEVA007	Accel., Vehicle block	I.C. Sensor	3031-500	G
93	LEFT BRAKE CALIPER	X	KEVA008	Accel., Vehicle block	I.C. Sensor	3031-500	G
94	RIGHT BRAKE CALIPER	X	KEVA012	Accel., Vehicle block	I.C. Sensor	3031-500	G
95	INSTRUMENT PANEL	X	KEVA011	Accel., Vehicle block	I.C. Sensor	3031-200	G
96	LEFT REAR	Z	KEVA001	Accel., Vehicle block	I.C. Sensor	3031-500	G
97	RIGHT REAR	Z	KEVA010	Accel., Vehicle block	I.C. Sensor	3031-200	G

**2005 NHTSA 35mph NCAP  
Instrumentation Data Channel Assignments  
Rigid Load Cell Barrier  
10/5/04  
2005 Toyota Tundra 2-Door Truck**

CH.	LOCATION	AXIS	IDENT. NO.	DESCRIPTION	MFR	MODEL	UNITS
98	BARRIER FORCE A1	X	BARRIER	Load Cell, LCB	Interface	1220-FS	N
99	BARRIER FORCE A2	X	BARRIER	Load Cell, LCB	Interface	1220-FS	N
100	BARRIER FORCE A3	X	BARRIER	Load Cell, LCB	Interface	1220-FS	N
101	BARRIER FORCE A4	X	BARRIER	Load Cell, LCB	Interface	1220-FS	N
102	BARRIER FORCE A5	X	BARRIER	Load Cell, LCB	Interface	1220-FS	N
103	BARRIER FORCE A6	X	BARRIER	Load Cell, LCB	Interface	1220-FS	N
104	BARRIER FORCE A7	X	BARRIER	Load Cell, LCB	Interface	1220-FS	N
105	BARRIER FORCE A8	X	BARRIER	Load Cell, LCB	Interface	1220-FS	N
106	BARRIER FORCE A9	X	BARRIER	Load Cell, LCB	Interface	1220-FS	N
107	BARRIER FORCE B1	X	BARRIER	Load Cell, LCB	Interface	1220-FS	N
108	BARRIER FORCE B2	X	BARRIER	Load Cell, LCB	Interface	1220-FS	N
109	BARRIER FORCE B3	X	BARRIER	Load Cell, LCB	Interface	1220-FS	N
110	BARRIER FORCE B4	X	BARRIER	Load Cell, LCB	Interface	1220-FS	N
111	BARRIER FORCE B5	X	BARRIER	Load Cell, LCB	Interface	1220-FS	N
112	BARRIER FORCE B6	X	BARRIER	Load Cell, LCB	Interface	1220-FS	N
113	BARRIER FORCE B7	X	BARRIER	Load Cell, LCB	Interface	1220-FS	N
114	BARRIER FORCE B8	X	BARRIER	Load Cell, LCB	Interface	1220-FS	N
115	BARRIER FORCE B9	X	BARRIER	Load Cell, LCB	Interface	1220-FS	N

**2005 NHTSA 35mph NCAP  
Instrumentation Data Channel Assignments  
Rigid Load Cell Barrier  
10/5/04  
2005 Toyota Tundra 2-Door Truck**

CH.	LOCATION	AXIS	IDENT. NO.	DESCRIPTION	MFR	MODEL	UNITS
116	BARRIER FORCE C1	X	BARRIER	Load Cell, LCB	Interface	1220-FS	N
117	BARRIER FORCE C2	X	BARRIER	Load Cell, LCB	Interface	1220-FS	N
118	BARRIER FORCE C3	X	BARRIER	Load Cell, LCB	Interface	1220-FS	N
119	BARRIER FORCE C4	X	BARRIER	Load Cell, LCB	Interface	1220-FS	N
120	BARRIER FORCE C5	X	BARRIER	Load Cell, LCB	Interface	1220-FS	N
121	BARRIER FORCE C6	X	BARRIER	Load Cell, LCB	Interface	1220-FS	N
122	BARRIER FORCE C7	X	BARRIER	Load Cell, LCB	Interface	1220-FS	N
123	BARRIER FORCE C8	X	BARRIER	Load Cell, LCB	Interface	1220-FS	N
124	BARRIER FORCE C9	X	BARRIER	Load Cell, LCB	Interface	1220-FS	N
125	BARRIER FORCE D1	X	BARRIER	Load Cell, LCB	Interface	1220-FS	N
126	BARRIER FORCE D2	X	BARRIER	Load Cell, LCB	Interface	1220-FS	N
127	BARRIER FORCE D3	X	BARRIER	Load Cell, LCB	Interface	1220-FS	N
128	BARRIER FORCE D4	X	BARRIER	Load Cell, LCB	Interface	1220-FS	N
129	BARRIER FORCE D5	X	BARRIER	Load Cell, LCB	Interface	1220-FS	N
130	BARRIER FORCE D6	X	BARRIER	Load Cell, LCB	Interface	1220-FS	N
131	BARRIER FORCE D7	X	BARRIER	Load Cell, LCB	Interface	1220-FS	N
132	BARRIER FORCE D8	X	BARRIER	Load Cell, LCB	Interface	1220-FS	N
133	BARRIER FORCE D9	X	BARRIER	Load Cell, LCB	Interface	1220-FS	N

**2005 NHTSA 35mph NCAP  
Instrumentation Data Channel Assignments  
Nine Accelerometer Array Head  
10/5/04  
2005 Toyota Tundra 2-Door Truck**

CH.	LOCATION	AXIS	IDENT. NO.	DESCRIPTION	MFR	MODEL	UNITS
134	DRIVER X-ARM	Y	GPAC012	Accel., 1/2 bridge	Endevco	7264-2000	G
135	DRIVER X-ARM	Z	GPAC001	Accel., 1/2 bridge	Endevco	7264-2000	G
136	DRIVER Y-ARM	X	GPAC036	Accel., 1/2 bridge	Endevco	7264-2000	G
137	DRIVER Y-ARM	Z	GPAC014	Accel., 1/2 bridge	Endevco	7264-2000	G
138	DRIVER Z-ARM	X	GPAC030	Accel., 1/2 bridge	Endevco	7264-2000	G
139	DRIVER Z-ARM	Y	GPAC037	Accel., 1/2 bridge	Endevco	7264-2000	G
140	PASS. X-ARM	Y	GPAC016	Accel., 1/2 bridge	Endevco	7264-2000	G
141	PASS. X-ARM	Z	GPAC015	Accel., 1/2 bridge	Endevco	7264-2000	G
142	PASS. Y-ARM	X	GPAC004	Accel., 1/2 bridge	Endevco	7264-2000	G
143	PASS. Y-ARM	Z	GPAC018	Accel., 1/2 bridge	Endevco	7264-2000	G
144	PASS. Z-ARM	X	GPAC006	Accel., 1/2 bridge	Endevco	7264-2000	G
145	PASS. Z-ARM	Y	GPAC007	Accel., 1/2 bridge	Endevco	7264-2000	G

**APPENDIX E**  
**DUMMY CALIBRATION DATA**

Test Program: Hybrid III 50th Percentile Male Knee Impact Test

Test Date: 10/1/04

ATD Serial No.: 034

Test I.D.: LK11A , RK11A



**Left Knee**

Tested Parameter	Units	Specification	Result	Pass/Fail
Laboratory Temperature	°C	18.9 to 25.6	21.1	Pass
Laboratory Relative Humidity	%	10 to 70	30	Pass
Pendulum Velocity at T=0	m/sec	2.07 to 2.13	2.08	Pass
Peak Probe Force	Newtons	4715 to 5782	5149	Pass
Overall Test Results				Pass

**Right Knee**

Pendulum Velocity at T=0	m/sec	2.07 to 2.13	2.10	Pass
Peak Probe Force	Newtons	4715 to 5782	4968	Pass
Overall Test Results				Pass



Curve Description			
Left Knee Probe Force			
CURNO	Type	SAE Class	Units
001	FIL	600	Newtons
Max	Time	Min	Time
5149.0	2.6	-29.6	8.9

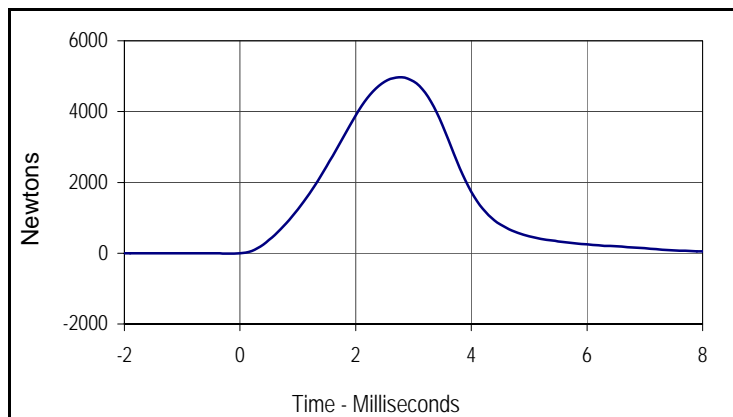

Curve Description			
Right Knee Probe Force			
CURNO	Type	SAE Class	Units
002	FIL	600	Newtons
Max	Time	Min	Time
4968.0	2.8	-26.0	9.4

Test Program: Hybrid III 50th Percentile Male Head Drop Test

Test Date: 10/1/04

ATD Serial No.: 034

Test I.D.: HD11A



Tested Parameter	Units	Specification	Result	Pass/Fail
Laboratory Temperature	°C	18.9 to 25.6	21.1	Pass
Laboratory Relative Humidity	%	10 to 70	30	Pass
Peak Resultant Acceleration	G's	225.0 to 275.0	258.6	Pass
Peak Lateral Acceleration	G's	≤15.0	5.3	Pass
Is Acceleration Unimodal?	Yes/No	Yes	Yes	Pass
Overall Test Results				Pass



Curve Description			
Head Resultant			
CURNO	Type	SAE Class	Units
001	RES	1000	G's
Max	Time	Min	Time
258.6	1.8	0.0	-1.5

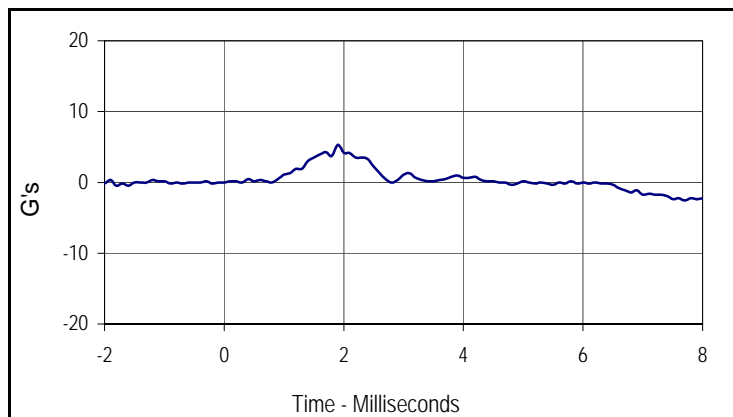

Curve Description			
Head Y			
CURNO	Type	SAE Class	Units
002	FIL	1000	G's
Max	Time	Min	Time
5.3	1.9	-0.5	-1.8

Test Program: Hybrid III 50th Percentile Male Thorax Impact Test

Test Date: 10/3/04

ATD Serial No.: 034

Test I.D.: CH11A



Tested Parameter	Units	Specification	Result	Pass/Fail
Laboratory Temperature	°C	20.6 to 22.2	21.1	Pass
Laboratory Relative Humidity	%	10 to 70	30	Pass
Probe Velocity	m/s	6.58 to 6.82	6.74	Pass
Peak Probe Force	Newtons	5159 to 5893	5419	Pass
Peak Sternum Displacement	CM	6.35 to 7.26	6.88	Pass
Internal Hysteresis	%	69 to 85	75.4	Pass
Overall Test Results				Pass

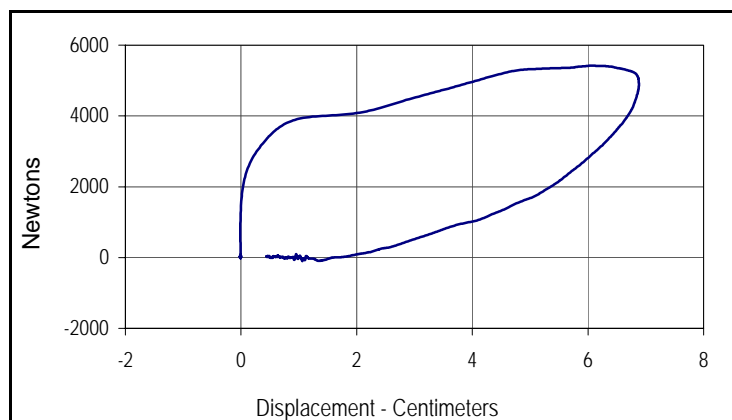

Curve Description			
Probe Force vs. Chest Displacement			
CURNO	Type	SAE Class	Hysteresis
001	FIL	1000	75.4
Peak Probe Force		Peak Chest Displ.	
5419		6.88	



Tested Parameter	Units	Specification	Result	Pass/Fail	
Laboratory Temperature	°C	20.6 to 22.2	21.1	Pass	
Laboratory Relative Humidity	%	10 to 70	30	Pass	
Pendulum Velocity	m/s	6.89 to 7.13	6.98	Pass	
Pendulum Deceleration	10 Msec.	G's	22.5 to 27.5	23.1	Pass
	20 Msec.	G's	17.6 to 22.6	19.3	Pass
	30 Msec.	G's	12.5 to 18.5	15.8	Pass
Peak Pendulum Decel. after 30 Msec.	G's	≤ 29.0	15.8	Pass	
Deceleration Decay, Time to Cross 5 G's	Msec.	34.0 to 42.0	41.2	Pass	
Maximum "D" Plane Rotation	Max	Degrees	64.0 to 78.0	67.2	Pass
	Time	Msec.	57.0 to 64.0	63.3	Pass
"D" Plane Rotation Decay, Time To Zero Crossing	Msec.	113.0 to 128.0	124	Pass	
Moment About Occ. Condyle	Max	Nm	84.1 to 108.5	88.0	Pass
	Time	Msec.	47.0 to 58.0	52.7	Pass
Positive Moment Decay, Time To Zero Crossing	Msec.	97.0 to 107.0	97.9	Pass	
<b>Overall Test Results</b>				<b>Pass</b>	

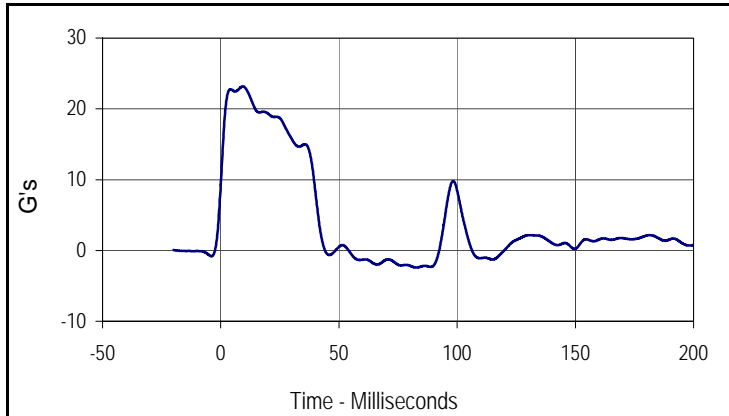

Curve Description			
Pendulum Deceleration			
CURNO	Type	SAE Class	Units
001	FIL	60	G's
Max	Time	Min	Time
23.2	9.3	-2.4	82.7

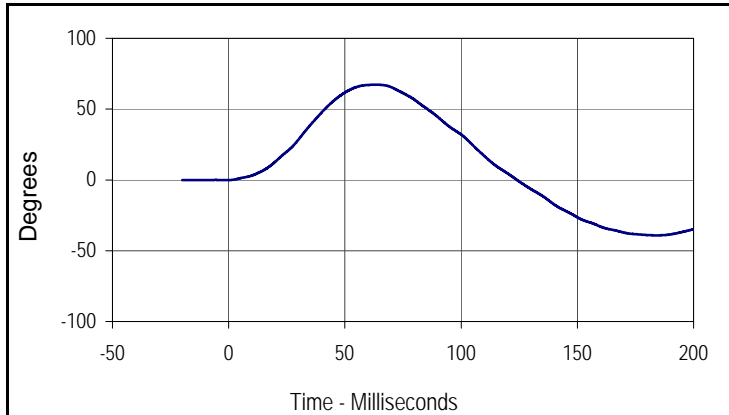

Curve Description			
"D" Plane Rotation			
CURNO	Type	SAE Class	Units
003	FIL	60	Degrees
Max	Time	Min	Time
67.2	63.3	-39.1	184.3

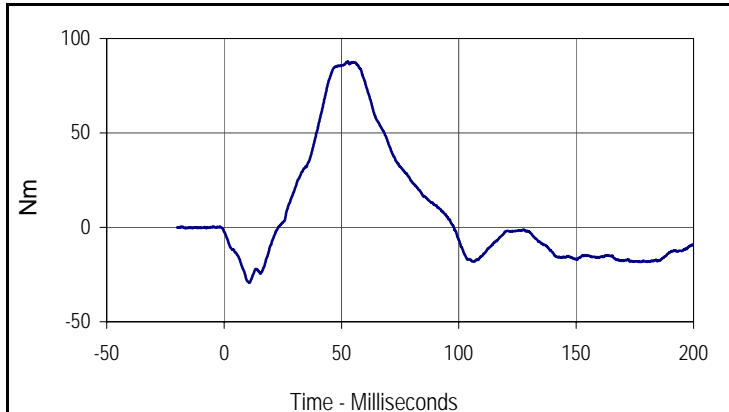

Curve Description			
Moment About Occipital Condyle			
CURNO	Type	SAE Class	Units
004	FIL	600	Nm
Max	Time	Min	Time
88.0	52.7	-29.4	10.8



Tested Parameter	Units	Specification	Result	Pass/Fail	
Laboratory Temperature	°C	20.6 to 22.2	21.1	Pass	
Laboratory Relative Humidity	%	10 to 70	30	Pass	
Pendulum Velocity	m/s	5.94 to 6.19	6.16	Pass	
Pendulum Deceleration	10 Msec.	G's	17.2 to 21.2	17.9	Pass
	20 Msec.	G's	14.0 to 19.0	17.3	Pass
	30 Msec.	G's	11.0 to 16.0	15.0	Pass
Peak Pendulum Decel. after 30 Msec.	G's	≤ 22.0	15.0	Pass	
Deceleration Decay, Time to Cross 5 G's	Msec.	38.0 to 46.0	40.0	Pass	
Maximum "D" Plane Rotation	Max	Degrees	81.0 to 106.0	92.7	Pass
	Time	Msec.	72.0 to 82.0	74.9	Pass
"D" Plane Rotation Decay, Time To Zero Crossing	Msec.	147.0 to 174.0	154.4	Pass	
Moment About Occ. Condyle	Max	Nm	-52.9 to- 79.9	-62.8	Pass
	Time	Msec.	65.0 to 79.0	66.2	Pass
Positive Moment Decay, Time To Zero Crossing	Msec.	120.0 to 148.0	137.4	Pass	
<b>Overall Test Results</b>				<b>Pass</b>	

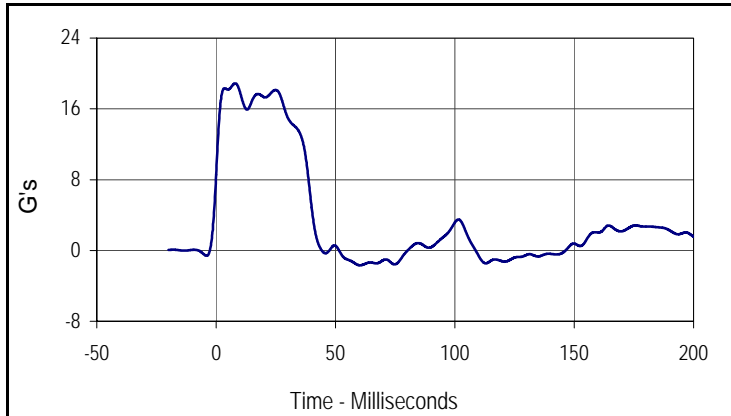

Curve Description			
Pendulum Deceleration			
CURNO	Type	SAE Class	Units
001	FIL	60	G's
Max	Time	Min	Time
18.9	8.0	-1.7	60.3

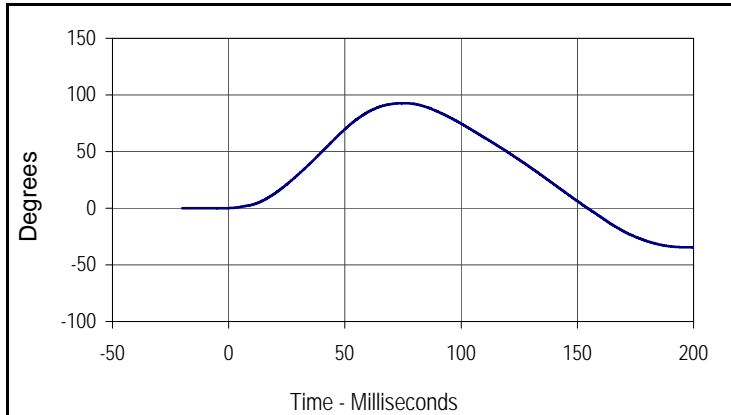

Curve Description			
"D" Plane Rotation			
CURNO	Type	SAE Class	Units
003	FIL	60	Degrees
Max	Time	Min	Time
92.7	74.9	-34.5	197.7

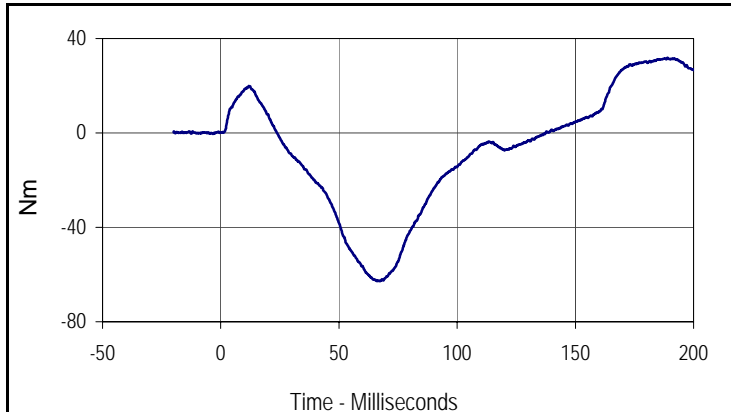

Curve Description			
Moment About Occipital Condyle			
CURNO	Type	SAE Class	Units
004	FIL	600	Nm
Max	Time	Min	Time
31.8	189.0	-62.8	66.2

Test Program: Hybrid III 50th Percentile Male External Measurements Test Date: 10/3/04  
 ATD Serial No.: 034 Test I.D.: N/A



Tested Parameter	Units	Specification	Result	Pass/Fail
Laboratory Temperature	°C	20.6 to 22.2	21.1	Pass
Laboratory Relative Humidity	%	10 to 70	30	Pass
A - Total sitting height	mm	879 to 889	886	Pass
B - Shoulder pivot height	mm	505 to 521	515	Pass
C - "H" point height	mm	84 to 89	86	Pass
D - "H" point from seat back	mm	135 to 140	137	Pass
E - Shoulder pivot from back	mm	84 to 94	90	Pass
F - Thigh clearance	mm	140 to 155	147	Pass
G - Elbow back to wrist pivot	mm	290 to 305	300	Pass
H - Skull cap to back line	mm	41 to 46	44	Pass
I - Shoulder to elbow length	mm	330 to 345	340	Pass
J - Elbow rest height	mm	190 to 211	200	Pass
K - Buttock to knee length	mm	579 to 604	600	Pass
L - Popliteal length	mm	429 to 455	445	Pass
M - Knee pivot height	mm	485 to 500	490	Pass
N - Buttock popliteal length	mm	452 to 477	470	Pass
O - Chest depth	mm	213 to 229	225	Pass
P - Foot length	mm	251 to 267	255	Pass
V - Shoulder breadth	mm	422 to 437	435	Pass
W - Foot breadth	mm	91 to 107	100	Pass
Y - Chest circumference	mm	970 to 1001	985	Pass
Z - Waist circumference	mm	836 to 866	845	Pass
AA - Location for chest circumference	mm	429 to 434	430	Pass
BB - Location for waist circumference	mm	226 to 231	228	Pass
Overall Test Results				Pass

Test Program: Hybrid III 50th Percentile Male Knee Impact Test

Test Date: 10/1/04

ATD Serial No.: 035

Test I.D.: LK11B , RK11B



**Left Knee**

Tested Parameter	Units	Specification	Result	Pass/Fail
Laboratory Temperature	°C	18.9 to 25.6	21.1	Pass
Laboratory Relative Humidity	%	10 to 70	30	Pass
Pendulum Velocity at T=0	m/sec	2.07 to 2.13	2.09	Pass
Peak Probe Force	Newtons	4715 to 5782	5542	Pass
Overall Test Results				Pass

**Right Knee**

Pendulum Velocity at T=0	m/sec	2.07 to 2.13	2.09	Pass
Peak Probe Force	Newtons	4715 to 5782	5399	Pass
Overall Test Results				Pass

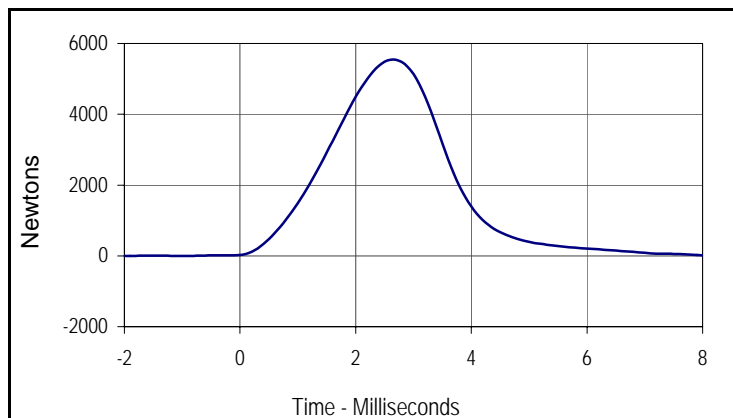

Curve Description			
Left Knee Probe Force			
CURNO	Type	SAE Class	Units
001	FIL	600	Newtons
Max	Time	Min	Time
5542.0	2.6	-20.4	9.3

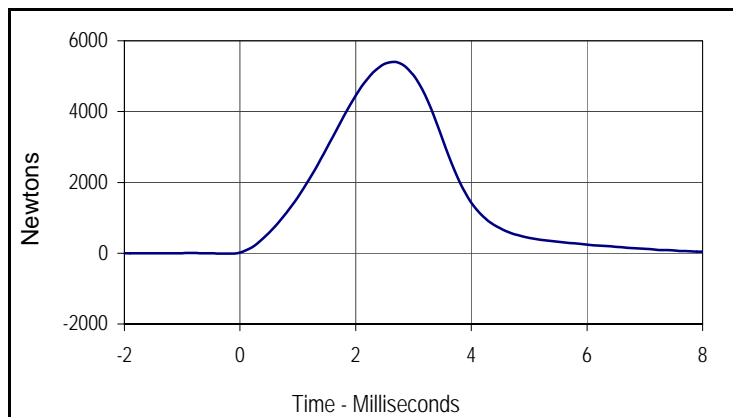

Curve Description			
Right Knee Probe Force			
CURNO	Type	SAE Class	Units
002	FIL	600	Newtons
Max	Time	Min	Time
5399.0	2.7	-27.9	9.6

Test Program: Hybrid III 50th Percentile Male Head Drop Test

Test Date: 10/1/04

ATD Serial No.: 035

Test I.D.: HD11B



Tested Parameter	Units	Specification	Result	Pass/Fail
Laboratory Temperature	°C	18.9 to 25.6	21.1	Pass
Laboratory Relative Humidity	%	10 to 70	30	Pass
Peak Resultant Acceleration	G's	225.0 to 275.0	238.7	Pass
Peak Lateral Acceleration	G's	≤15.0	4.9	Pass
Is Acceleration Unimodal?	Yes/No	Yes	Yes	Pass
Overall Test Results			Pass	

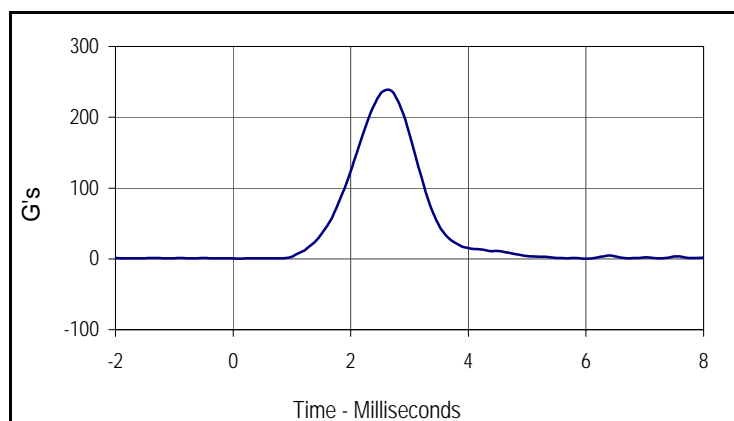

Curve Description			
Head Resultant			
CURNO	Type	SAE Class	Units
001	RES	1000	G's
Max	Time	Min	Time
238.7	2.6	0.4	0.1

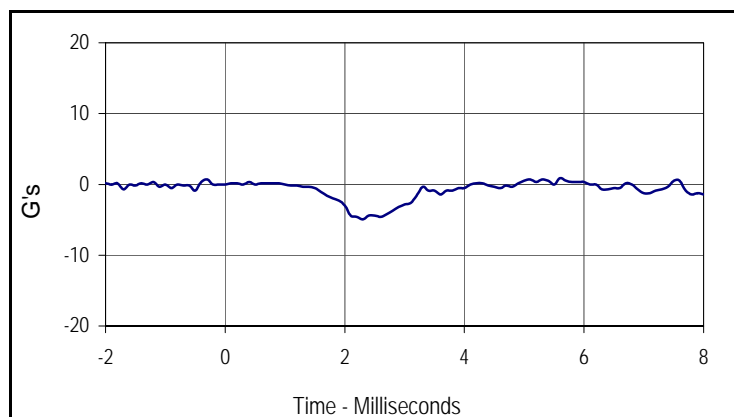

Curve Description			
Head Y			
CURNO	Type	SAE Class	Units
002	FIL	1000	G's
Max	Time	Min	Time
0.9	5.6	-4.9	2.3

Test Program: Hybrid III 50th Percentile Male Thorax Impact Test

Test Date: 10/3/04

ATD Serial No.: 035

Test I.D.: CH11B



Tested Parameter	Units	Specification	Result	Pass/Fail
Laboratory Temperature	°C	20.6 to 22.2	21.1	Pass
Laboratory Relative Humidity	%	10 to 70	30	Pass
Probe Velocity	m/s	6.58 to 6.82	6.61	Pass
Peak Probe Force	Newtons	5159 to 5893	5639	Pass
Peak Sternum Displacement	CM	6.35 to 7.26	7.13	Pass
Internal Hysteresis	%	69 to 85	76.3	Pass
Overall Test Results				Pass

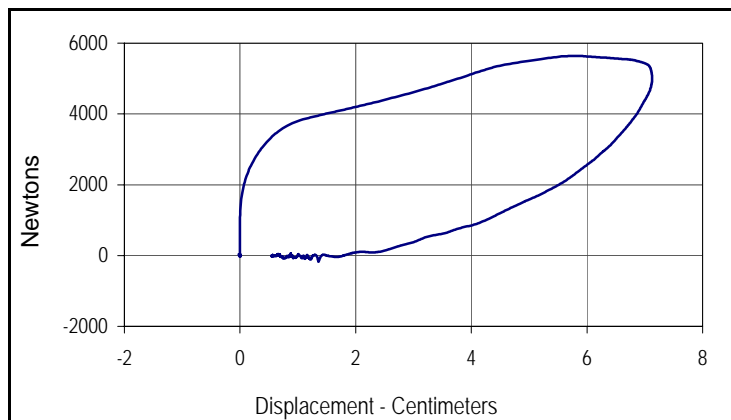

Curve Description			
Probe Force vs. Chest Displacement			
CURNO	Type	SAE Class	Hysteresis
001	FIL	1000	76.3
Peak Probe Force		Peak Chest Displ.	
5639		7.13	

Test Program: Hybrid III 50th Percentile Male Neck Flexion Test

Test Date: 11/2/04

ATD Serial No.: 035

Test I.D.: NF11B



Tested Parameter	Units	Specification	Result	Pass/Fail	
Laboratory Temperature	°C	20.6 to 22.2	21.1	Pass	
Laboratory Relative Humidity	%	10 to 70	30	Pass	
Pendulum Velocity	m/s	6.89 to 7.13	6.98	Pass	
Pendulum Deceleration	10 Msec.	G's	22.5 to 27.5	22.5	Pass
	20 Msec.	G's	17.6 to 22.6	20.4	Pass
	30 Msec.	G's	12.5 to 18.5	18.3	Pass
Peak Pendulum Decel. after 30 Msec.	G's	≤ 29.0	18.3	Pass	
Deceleration Decay, Time to Cross 5 G's	Msec.	34.0 to 42.0	39.3	Pass	
Maximum "D" Plane Rotation	Max	Degrees	64.0 to 78.0	69.1	Pass
	Time	Msec.	57.0 to 64.0	58.6	Pass
"D" Plane Rotation Decay, Time To Zero Crossing	Msec.	113.0 to 128.0	114	Pass	
Moment About Occ. Condyle	Max	Nm	84.1 to 108.5	89.1	Pass
	Time	Msec.	47.0 to 58.0	51.1	Pass
Positive Moment Decay, Time To Zero Crossing	Msec.	97.0 to 107.0	98.5	Pass	
<b>Overall Test Results</b>				<b>Pass</b>	

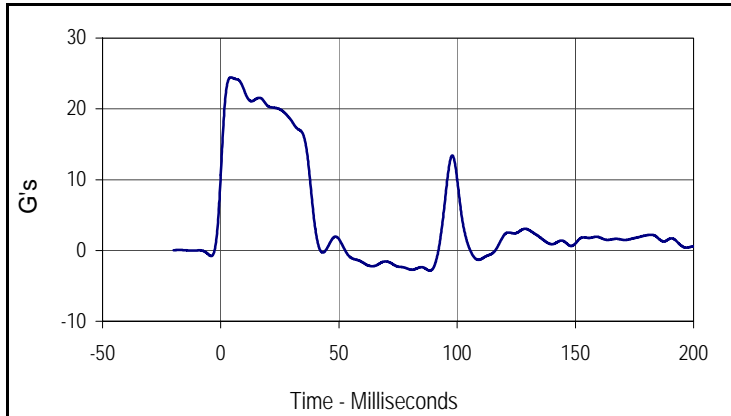

Curve Description			
Pendulum Deceleration			
CURNO	Type	SAE Class	Units
001	FIL	60	G's
Max	Time	Min	Time
24.5	4.3	-2.9	88.5

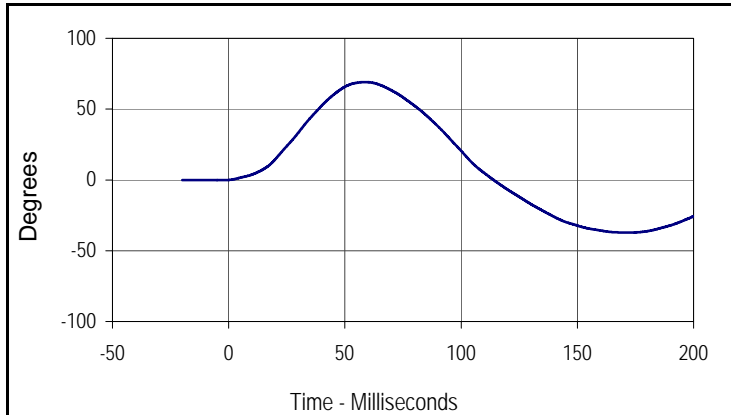

Curve Description			
"D" Plane Rotation			
CURNO	Type	SAE Class	Units
003	FIL	60	Degrees
Max	Time	Min	Time
69.1	58.6	-37.2	171.5

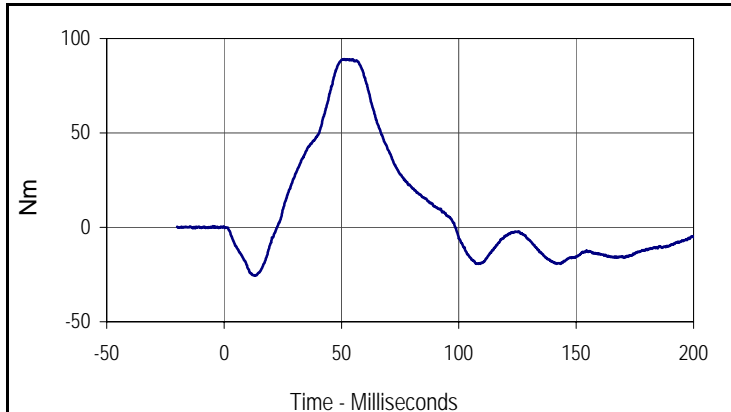

Curve Description			
Moment About Occipital Condyle			
CURNO	Type	SAE Class	Units
004	FIL	600	Nm
Max	Time	Min	Time
89.1	51.1	-25.6	12.9

Test Program: Hybrid III 50th Percentile Male Neck Extension Test

Test Date: 10/2/04

ATD Serial No.: 035

Test I.D.: NE11B



Tested Parameter	Units	Specification	Result	Pass/Fail	
Laboratory Temperature	°C	20.6 to 22.2	21.1	Pass	
Laboratory Relative Humidity	%	10 to 70	30	Pass	
Pendulum Velocity	m/s	5.94 to 6.19	6.02	Pass	
Pendulum Deceleration	10 Msec.	G's	17.2 to 21.2	17.2	Pass
	20 Msec.	G's	14.0 to 19.0	16.7	Pass
	30 Msec.	G's	11.0 to 16.0	13.7	Pass
Peak Pendulum Decel. after 30 Msec.	G's	≤ 22.0	13.7	Pass	
Deceleration Decay, Time to Cross 5 G's	Msec.	38.0 to 46.0	42.7	Pass	
Maximum "D" Plane Rotation	Max	Degrees	81.0 to 106.0	95.1	Pass
	Time	Msec.	72.0 to 82.0	77.7	Pass
"D" Plane Rotation Decay, Time To Zero Crossing	Msec.	147.0 to 174.0	157.8	Pass	
Moment About Occ. Condyle	Max	Nm	-52.9 to- 79.9	-65.1	Pass
	Time	Msec.	65.0 to 79.0	68.1	Pass
Positive Moment Decay, Time To Zero Crossing	Msec.	120.0 to 148.0	141.9	Pass	
<b>Overall Test Results</b>				<b>Pass</b>	

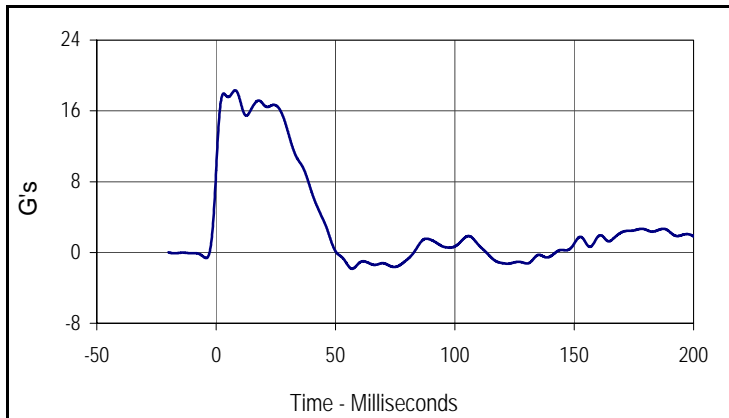

Curve Description			
Pendulum Deceleration			
CURNO	Type	SAE Class	Units
001	FIL	60	G's
Max	Time	Min	Time
18.3	8.0	-1.8	56.9

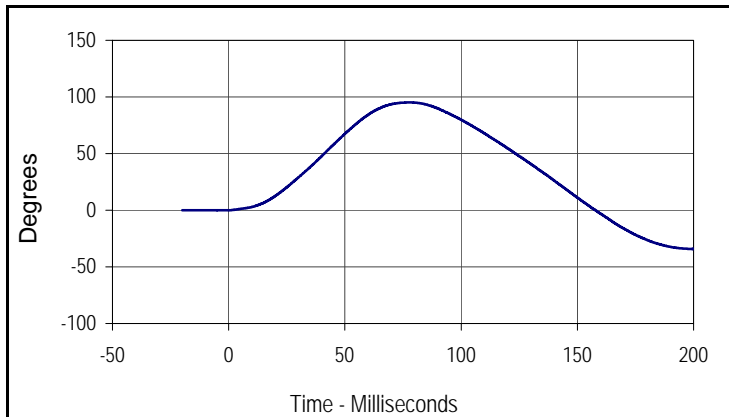

Curve Description			
"D" Plane Rotation			
CURNO	Type	SAE Class	Units
003	FIL	60	Degrees
Max	Time	Min	Time
95.1	77.7	-34.2	200.0

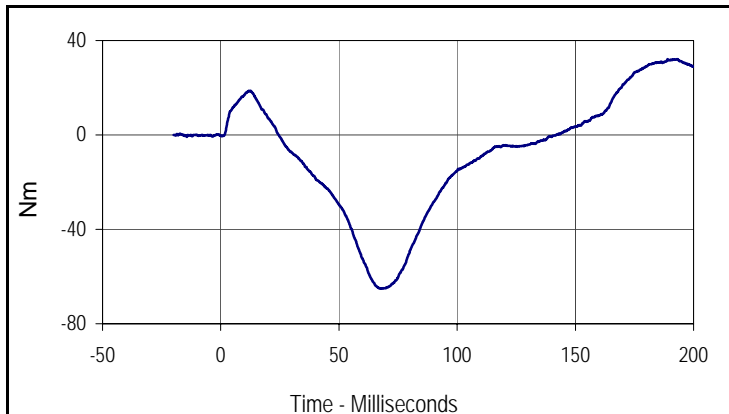

Curve Description			
Moment About Occipital Condyle			
CURNO	Type	SAE Class	Units
004	FIL	600	Nm
Max	Time	Min	Time
32.1	193.0	-65.1	68.1

Test Program: Hybrid III 50th Percentile Male External Measurements Test Date: 10/3/04  
 ATD Serial No.: 035 Test I.D.: N/A



Tested Parameter	Units	Specification	Result	Pass/Fail
Laboratory Temperature	°C	20.6 to 22.2	21.1	Pass
Laboratory Relative Humidity	%	10 to 70	30	Pass
A - Total sitting height	mm	879 to 889	880	Pass
B - Shoulder pivot height	mm	505 to 521	510	Pass
C - "H" point height	mm	84 to 89	87	Pass
D - "H" point from seat back	mm	135 to 140	138	Pass
E - Shoulder pivot from back	mm	84 to 94	86	Pass
F - Thigh clearance	mm	140 to 155	150	Pass
G - Elbow back to wrist pivot	mm	290 to 305	295	Pass
H - Skull cap to back line	mm	41 to 46	45	Pass
I - Shoulder to elbow length	mm	330 to 345	335	Pass
J - Elbow rest height	mm	190 to 211	210	Pass
K - Buttock to knee length	mm	579 to 604	595	Pass
L - Popliteal length	mm	429 to 455	450	Pass
M - Knee pivot height	mm	485 to 500	495	Pass
N - Buttock popliteal length	mm	452 to 477	465	Pass
O - Chest depth	mm	213 to 229	228	Pass
P - Foot length	mm	251 to 267	260	Pass
V - Shoulder breadth	mm	422 to 437	425	Pass
W - Foot breadth	mm	91 to 107	105	Pass
Y - Chest circumference	mm	970 to 1001	995	Pass
Z - Waist circumference	mm	836 to 866	860	Pass
AA - Location for chest circumference	mm	429 to 434	432	Pass
BB - Location for waist circumference	mm	226 to 231	230	Pass
Overall Test Results				Pass

**APPENDIX F**

**NAAH DATA**

Test Vehicle: 2005 Toyota Tundra 2-Door Truck  
 Test Program: 2005 NHTSA 35mph NCAP

Test Date: 10/5/04  
 NHTSA No.: M55111

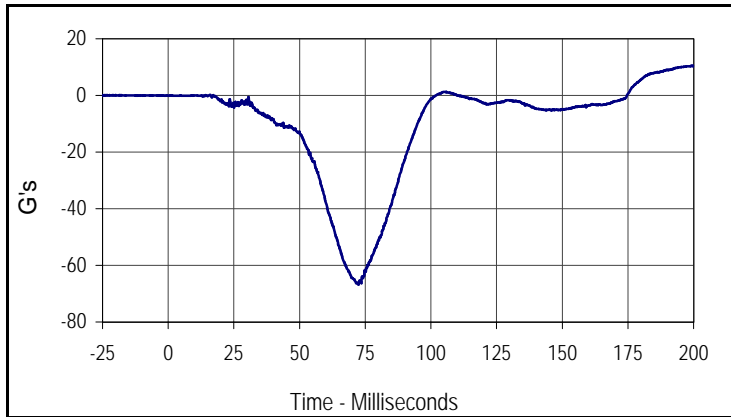

Curve Description			
Driver Head Primary X			
CURNO	Type	SAE Class	Units
001	FIL	1000	G's
Max	Time	Min	Time
10.5	199.6	-66.8	72.4

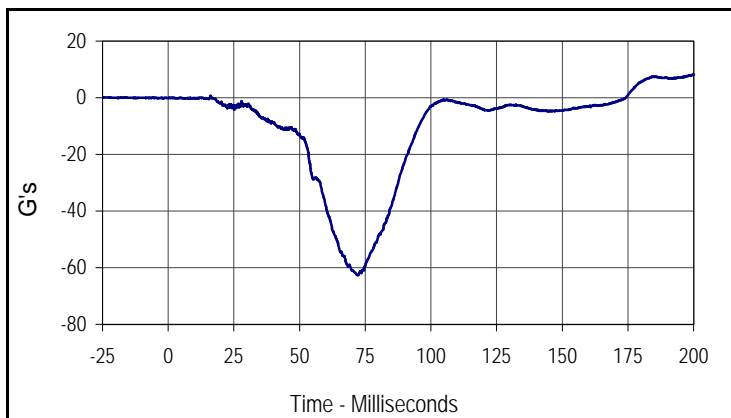

Curve Description			
Driver NAAH Yarm-X			
CURNO	Type	SAE Class	Units
136	FIL	1000	G's
Max	Time	Min	Time
8.2	200.0	-62.7	72.1

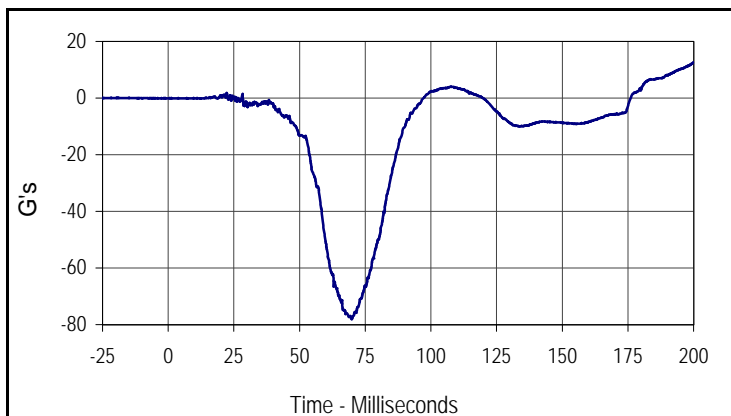

Curve Description			
Driver NAAH Zarm-X			
CURNO	Type	SAE Class	Units
138	FIL	1000	G's
Max	Time	Min	Time
12.7	200.0	-78.0	69.9

Test Vehicle: 2005 Toyota Tundra 2-Door Truck  
 Test Program: 2005 NHTSA 35mph NCAP

Test Date: 10/5/04  
 NHTSA No.: M55111

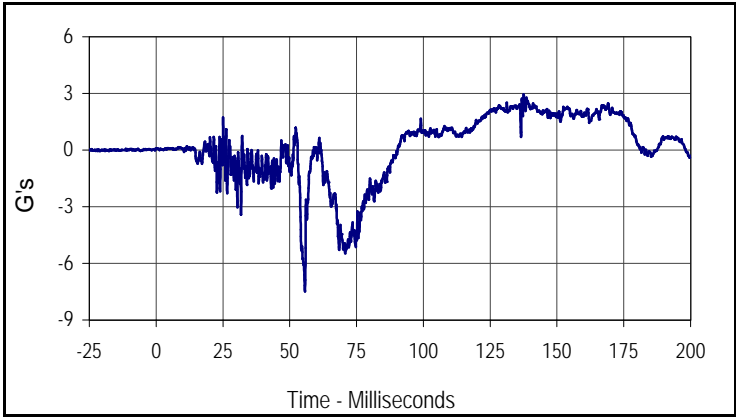

Curve Description			
Driver Head Primary Y			
CURNO	Type	SAE Class	Units
002	FIL	1000	G's
Max	Time	Min	Time
3.0	137.5	-7.5	55.7

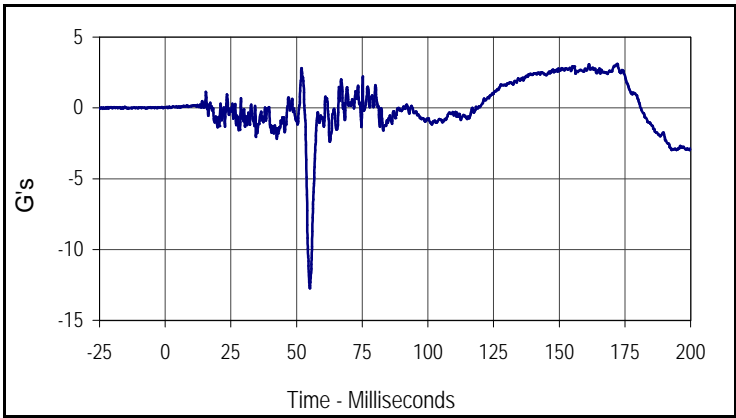

Curve Description			
Driver NAAH Xarm-Y			
CURNO	Type	SAE Class	Units
134	FIL	1000	G's
Max	Time	Min	Time
3.1	172.1	-12.7	55.0

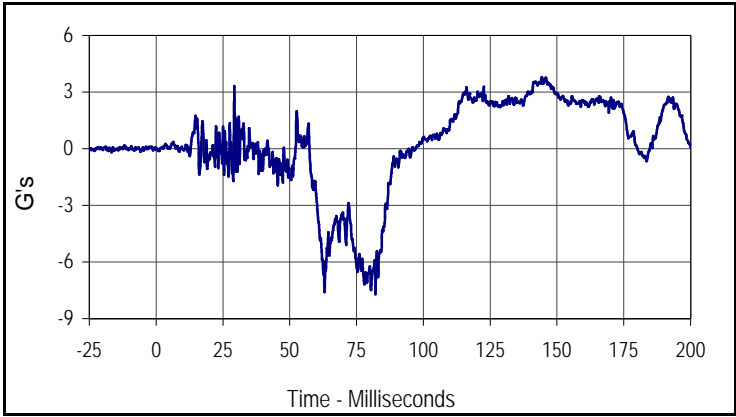

Curve Description			
Driver NAAH Zarm-Y			
CURNO	Type	SAE Class	Units
139	FIL	1000	G's
Max	Time	Min	Time
3.8	144.3	-7.7	82.1

Test Vehicle: 2005 Toyota Tundra 2-Door Truck  
 Test Program: 2005 NHTSA 35mph NCAP

Test Date: 10/5/04  
 NHTSA No.: M55111

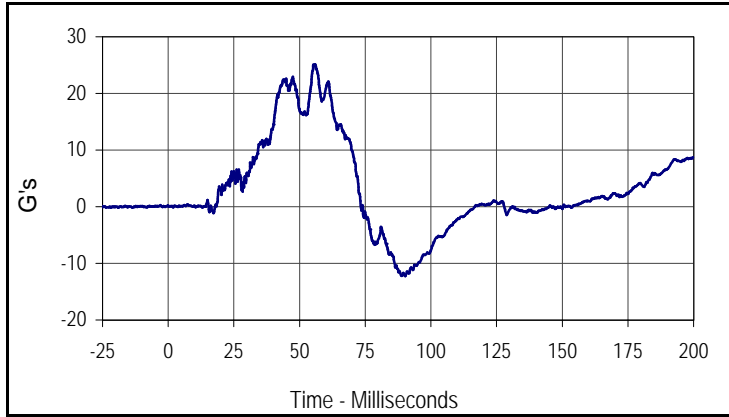

Curve Description			
Driver Head Primary Z			
CURNO	Type	SAE Class	Units
003	FIL	1000	G's
Max	Time	Min	Time
25.1	55.9	-12.2	90.2

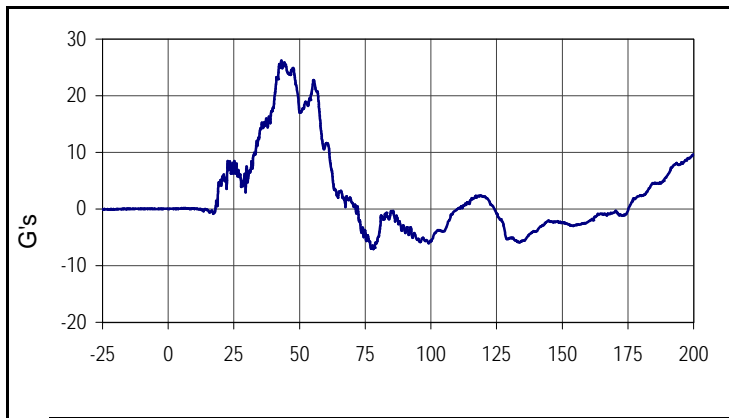

Curve Description			
Driver NAAH Xarm-Z			
CURNO	Type	SAE Class	Units
135	FIL	1000	G's
Max	Time	Min	Time
26.2	43.1	-7.1	78.2

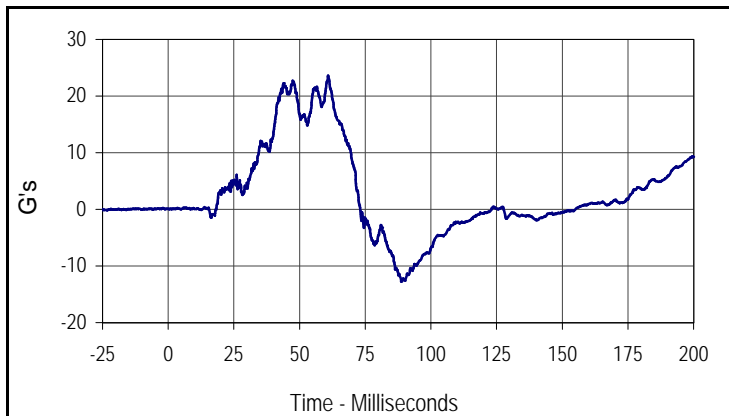

Curve Description			
Driver NAAH Yarm-Z			
CURNO	Type	SAE Class	Units
137	FIL	1000	G's
Max	Time	Min	Time
23.6	60.9	-12.8	88.8

Test Vehicle: 2005 Toyota Tundra 2-Door Truck  
 Test Program: 2005 NHTSA 35mph NCAP

Test Date: 10/5/04  
 NHTSA No.: M55111

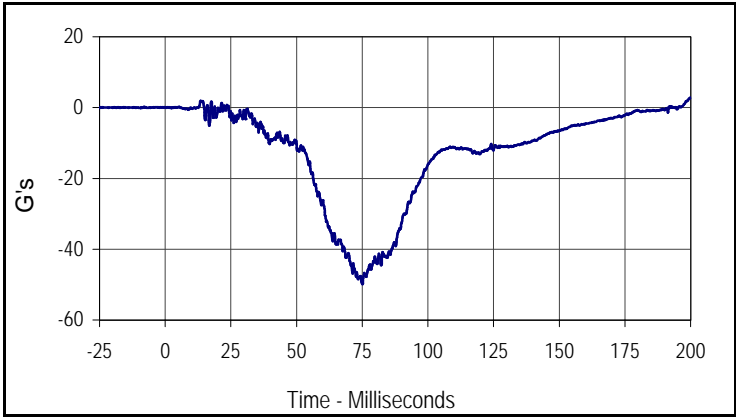

Curve Description			
Passenger Head Primary X			
CURNO	Type	SAE Class	Units
045	FIL	1000	G's
Max	Time	Min	Time
2.8	200.0	-49.8	75.1

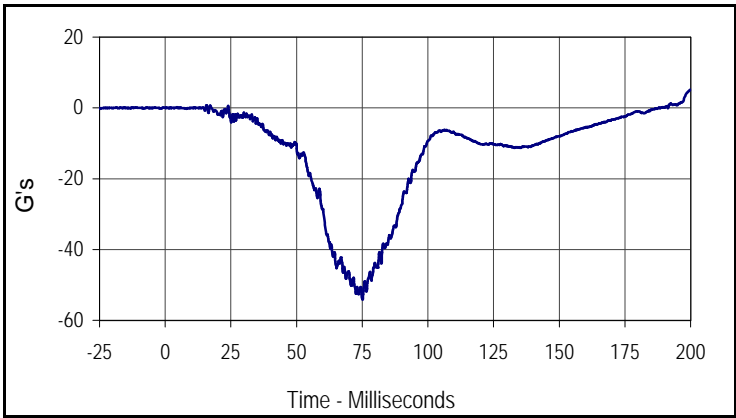

Curve Description			
Passenger NAAH Yarm-X			
CURNO	Type	SAE Class	Units
142	FIL	1000	G's
Max	Time	Min	Time
5.1	200.0	-54.1	75.1

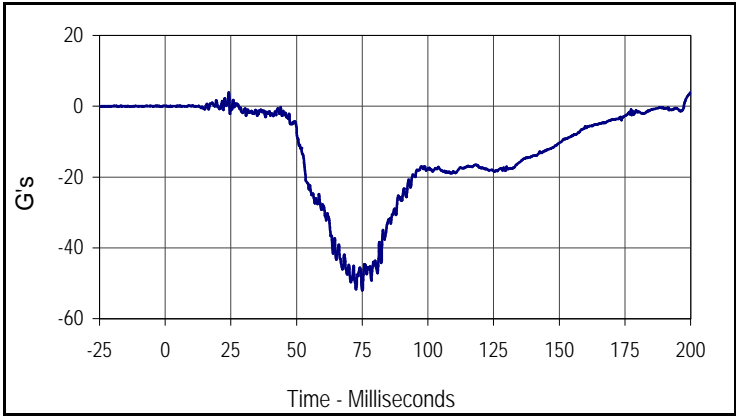

Curve Description			
Passenger NAAH Zarm-X			
CURNO	Type	SAE Class	Units
144	FIL	1000	G's
Max	Time	Min	Time
3.9	24.2	-52.0	75.0

Test Vehicle: 2005 Toyota Tundra 2-Door Truck  
 Test Program: 2005 NHTSA 35mph NCAP

Test Date: 10/5/04  
 NHTSA No.: M55111

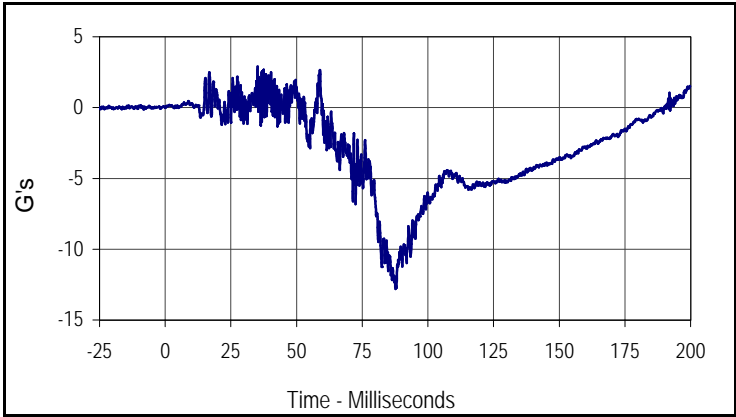

Curve Description			
Passenger Head Primary Y			
CURNO	Type	SAE Class	Units
046	FIL	1000	G's
Max	Time	Min	Time
2.9	35.2	-12.8	87.7

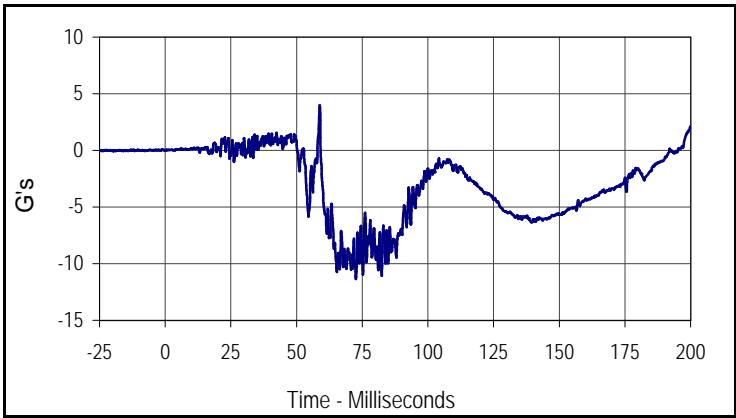

Curve Description			
Passenger NAAH Xarm-Y			
CURNO	Type	SAE Class	Units
140	FIL	1000	G's
Max	Time	Min	Time
4.0	58.8	-11.3	72.6

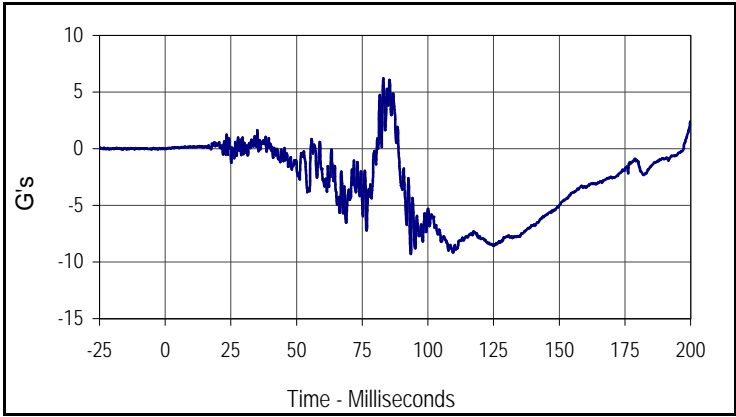

Curve Description			
Passenger NAAH Zarm-Y			
CURNO	Type	SAE Class	Units
145	FIL	1000	G's
Max	Time	Min	Time
6.2	83.0	-9.3	93.5

Test Vehicle: 2005 Toyota Tundra 2-Door Truck  
 Test Program: 2005 NHTSA 35mph NCAP

Test Date: 10/5/04  
 NHTSA No.: M55111

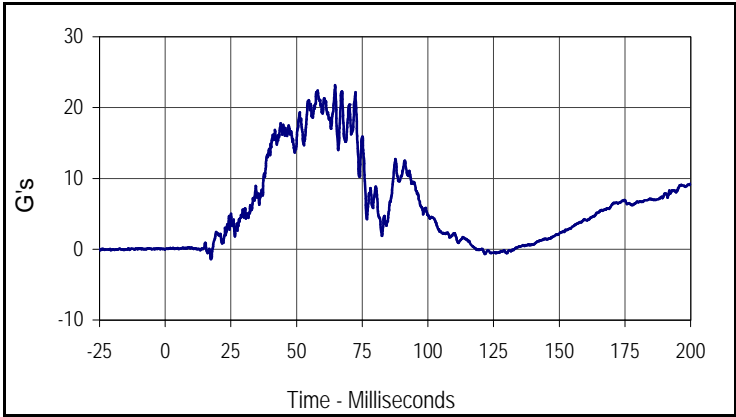

Curve Description			
Passenger Head Primary Z			
CURNO	Type	SAE Class	Units
047	FIL	1000	G's
Max	Time	Min	Time
23.2	64.7	-1.4	17.4

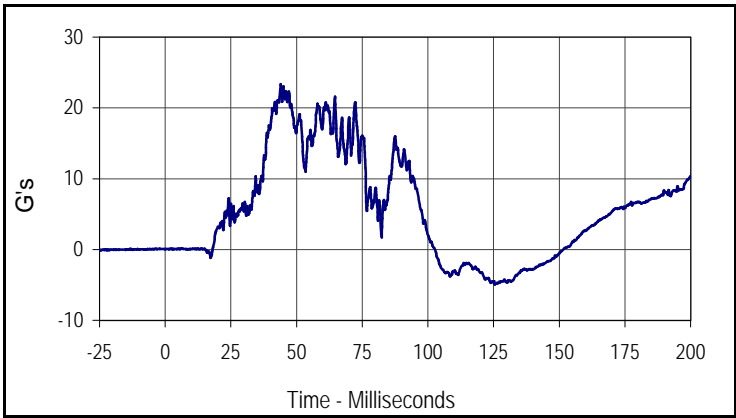

Curve Description			
Passenger NAAH Xarm-Z			
CURNO	Type	SAE Class	Units
141	FIL	1000	G's
Max	Time	Min	Time
23.4	44.0	-4.9	125.4

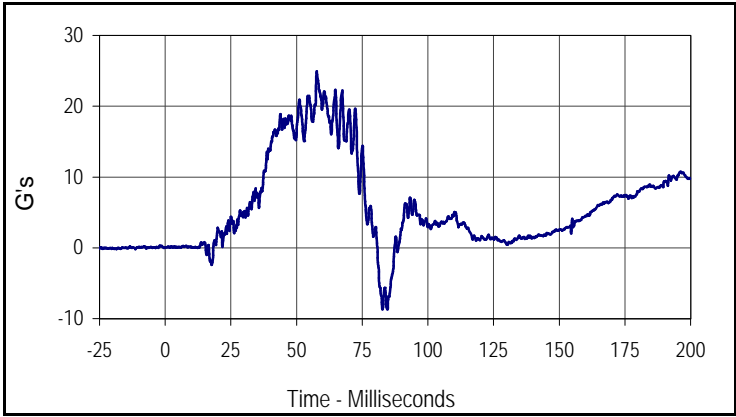

Curve Description			
Passenger NAAH Yarm-Z			
CURNO	Type	SAE Class	Units
143	FIL	1000	G's
Max	Time	Min	Time
24.9	57.7	-8.7	82.7