

**REPORT NUMBER TR-P25001-03-NC**

**NEW CAR ASSESSMENT PROGRAM  
FRONTAL BARRIER IMPACT TEST**

**TOYOTA MOTOR COPORATION  
2005 TOYOTA SCION TC 3-DOOR HATCHBACK**

**NHTSA NUMBER: M55110**

**PREPARED BY:  
KARCO ENGINEERING, LLC  
9270 HOLLY ROAD  
ADELANTO, CALIFORNIA 92301**

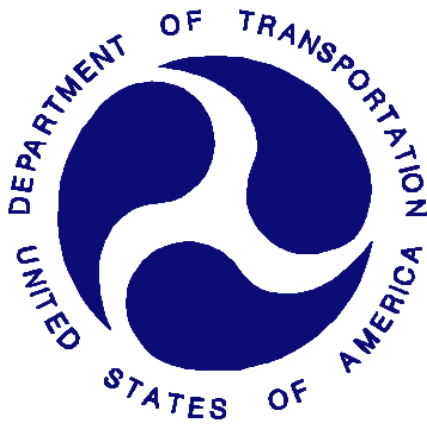

**SEPTEMBER 30, 2004**

**FINAL REPORT**

**PREPARED FOR:  
U.S. DEPARTMENT OF TRANSPORTATION  
NATIONAL HIGHWAY TRAFFIC SAFETY ADMINISTRATION  
RULEMAKING  
OFFICE OF CRASHWORTHINESS STANDARDS  
MAIL CODE: NVS-111  
400 SEVENTH STREET, SW, ROOM 5311  
WASHINGTON, D.C. 20590**

This final test report was prepared for the U.S. Department of Transportation, National Highway Traffic Safety Administration, in response to Contract Number DTNH22-01-D-02005.

This publication is distributed by the U.S. Department of Transportation, National Highway Traffic Safety Administration, in the interest of information exchange. The opinions, findings and conclusions expressed in this publication are those of the author(s) and not necessarily those of the Department of Transportation or the National Highway Traffic Safety Administration. The United States Government assumes no liability for its contents or use thereof. If trade or manufacturers' names or products are mentioned, it is only because they are considered essential to the object of the publication and should not be construed as an endorsement. The United States Government does not endorse products or manufacturers.

Prepared by: \_\_\_\_\_  
Mr. Yednesh Parnaik, Project Engineer  
KARCO Engineering, LLC

Date: October 13, 2004

Reviewed by: \_\_\_\_\_  
Mr. Michael L. Dunlap, Quality Assurance Manager  
KARCO Engineering, LLC

Date: October 13, 2004

Approved by: \_\_\_\_\_  
Mr. Frank D. Richardson, Program Manager  
KARCO Engineering, LLC

Date: October 13, 2004

FINAL REPORT ACCEPTED BY:

\_\_\_\_\_  
Manager, New Car Assessment Program

\_\_\_\_\_  
Date of Acceptance

\_\_\_\_\_  
COTR, NCAP Frontal Impact Program

\_\_\_\_\_  
Date of Acceptance

### Technical Report Documentation Page

<b>1. Report No.</b> TR-P25001-03-NC	<b>2. Government Accession No.</b>	<b>3. Recipients Catalog No.</b>																										
<b>4. Title and Subtitle</b> Final Report of New Car Assessment Program 2005 Toyota Scion TC 3-Door Hatchback NHTSA No. M55110		<b>5. Report Date</b> September 30, 2004																										
		<b>6. Performing Organization Code</b> KAR																										
<b>7. Authors</b> Mr. Yednesh Parnaik, Project Engineer, Karco Mr. Frank Richardson, Program Manager, Karco		<b>8. Performing Organization Report No.</b> TR-P25001-03-NC																										
<b>9. Performing Organization Name and Address</b> Karco Engineering, LLC 9270 Holly Rd. Adelanto, CA, 92301		<b>10. Work Unit No.</b>																										
		<b>11. Contract or Grant No.</b> DTNH22-01-D-02005																										
<b>12. Sponsoring Agency Name and Address</b> U. S. Department of Transportation National Highway Traffic Safety Administration Rulemaking Office of Crashworthiness Standards Mail Code NPS-111 400 Seventh Street, SW, Room 5311 Washington, D.C 20590		<b>13. Type of Report and Period Covered</b> Final Test Report Option Year 3																										
		<b>14. Sponsoring Agency Code</b> DOT/NHTSA/NRM/OCS																										
<b>15. Supplementary Notes</b>																												
<b>16. Abstract</b>  A 35 mph (56.3 km/h) frontal barrier impact was conducted on a 2005 Toyota Scion TC 3-Door Hatchback at Karco Engineering, LLC on September 30, 2004. This test was conducted to obtain data indicant of FMVSS 208, 212, 219 (partial), 301, and footwell intrusion performance. The impact velocity was 56.13 km/h. The ambient temperature at the barrier face at the time of impact was 27.2 degrees Celcius. The vehicle's maximum post test static crush is 456 mm at the center of the vehicle. The test vehicle is equipped with a 3-point continuous belt system and second generation supplemental airbags in both front outboard seating positions. With respect to FMVSS 208 "Occupant Crash Protection", the occupant injury criteria summary is as follows:																												
<table border="1" style="width: 100%; border-collapse: collapse;"> <thead> <tr> <th style="width: 35%;">Measurement Description</th> <th style="width: 15%;">Units</th> <th style="width: 15%;">Threshold</th> <th style="width: 15%;">Driver ATD</th> <th style="width: 20%;">Passenger ATD</th> </tr> </thead> <tbody> <tr> <td>Head Injury Criteria (HIC<sub>36</sub>)</td> <td>N/A</td> <td>1000</td> <td style="text-align: center;">283.1</td> <td style="text-align: center;">438.0</td> </tr> <tr> <td>Max. Chest Accel. (3 msec Clip)</td> <td>G's</td> <td>60</td> <td style="text-align: center;">39.7</td> <td style="text-align: center;">48.5</td> </tr> <tr> <td>Left Femur Force</td> <td>Newtons</td> <td>10008</td> <td style="text-align: center;">-1668.6</td> <td style="text-align: center;">-2962.5</td> </tr> <tr> <td>Right Femur Force</td> <td>Newtons</td> <td>10008</td> <td style="text-align: center;">-4488.4</td> <td style="text-align: center;">-1214.8</td> </tr> </tbody> </table>				Measurement Description	Units	Threshold	Driver ATD	Passenger ATD	Head Injury Criteria (HIC <sub>36</sub> )	N/A	1000	283.1	438.0	Max. Chest Accel. (3 msec Clip)	G's	60	39.7	48.5	Left Femur Force	Newtons	10008	-1668.6	-2962.5	Right Femur Force	Newtons	10008	-4488.4	-1214.8
Measurement Description	Units	Threshold	Driver ATD	Passenger ATD																								
Head Injury Criteria (HIC <sub>36</sub> )	N/A	1000	283.1	438.0																								
Max. Chest Accel. (3 msec Clip)	G's	60	39.7	48.5																								
Left Femur Force	Newtons	10008	-1668.6	-2962.5																								
Right Femur Force	Newtons	10008	-4488.4	-1214.8																								
<b>17. Key Words</b> 56.3 km/h NCAP Frontal Barrier Impact Test New Car Assessment Program (NCAP) 2005 Toyota Scion TC 3-Door Hatchback NHTSA No. M55110			<b>18. Distribution of Statement</b> Copies of this report available from: NHTSA Technical Reference Division National Highway Traffic Safety Adm 400 Seventh St., SW, Room 5108 Washington, D.C. 20590																									
<b>19. Security Classification (this report)</b> Unclassified	<b>20. Security Classification (this page)</b> Unclassified	<b>21. No. of Pages</b> 200	<b>22. Price</b>																									

TABLE OF CONTENTS

Section	Description	Page
1	Purpose and Summary of Test M55110	1
2	Occupant and Vehicle Information/Data Sheets	3

Data Sheet	Description	Page
1	Crash Test Summary	4
2	General Test and Vehicle Parameter Data	5
3	Post Test Impact Data	8
4	Test Vehicle Information	9
5	Dummy Positioning in Vehicle	11
6	Seatbelt Positioning Data	13
7	Vehicle Accelerometer Location and Data Summary	14
8	Hybrid III ATD Injury Criteria and Sensor Data	15
9	Seatbelt Assessment Test Data	18
10	Summary of FMVSS 212 Data	19
11	Windshield Zone Intrusion FMVSS 219 Data (Partial)	20
12	FMVSS 301 Fuel System Integrity Post Impact Data	21
13	FMVSS 301 Static Rollover Data	22
14	Vehicle Measurements	24
15	Camera Locations	27
16	Photographic Reference Target Locations	28
17	Vehicle Intrusion Measurements	29
18	Fixed Barrier Load Cell Locations	33
19	Post-Test Air Bag Data	34
20	Accident Investigation Division Data	35
21	Dummy/Vehicle Temperature Stabilization	36

Appendix	Description	Appendix
A	Photographs	A
B	Data Plots	B
C	Load Cell Barrier Data Plots	C
D	Instrumentation Data Channel Assignments	D
E	Dummy Calibration Data	E
F	Child Restrain Systems (CRS) Report	F
G	Nine Accelerometer Array Head Data	G

## SECTION 1

### PURPOSE AND SUMMARY OF TEST M55110

#### 1.1 PURPOSE

This 35 mph (56.3 km/h) frontal barrier impact test is part of the New Car Assessment Program (NCAP) sponsored by the National Highway Traffic Safety Administration (NHTSA) under Contract No. DTNH22-01-D-02005. The purpose of this test was to obtain vehicle crashworthiness and occupant restraint system performance data for an impact speed in excess of the current 30 mph (48.3 km/h) requirements.

This 56.3 km/h frontal barrier impact test was conducted in accordance with the Office of Crashworthiness Standards (OCS) New Car Assessment Program (NCAP) Laboratory Indicant Test Procedure, dated December 1999. Data was obtained indicant of FMVSS 208 "Occupant Crash Protection"; FMVSS 212, "Windshield Retention"; FMVSS 219, "Windshield Zone Intrusion (Partial)"; and FMVSS 301 "Fuel System Integrity" performance. Procedures for receiving, inspection testing and reporting of test results are described in the test procedures and are not repeated in this report.

#### 1.2 SUMMARY

A load cell barrier consisting of 36 load cells was impacted by a 2005 Toyota Scion TC 3-Door Hatchback at a velocity of 56.13 km/h. The test was performed at Karco Engineering, LLC on September 30, 2004.

Three (3) real-time, four (4) high-speed digital video and fifteen (15) high-speed film cameras were used to document the frontal barrier impact event. Camera locations and other pertinent camera information can be found in Data Sheet number 15 (page number: 27) of this report.

Two Part 572E, 50<sup>th</sup> percentile male anthropomorphic test devices (ATDs), were placed in the driver and right-front passenger seating positions according to dummy placement instructions specified in the Laboratory Indicant Test Procedure.

Both ATDs were fully instrumented with head (primary and redundant), chest (primary and redundant) and pelvic triaxial accelerometers, chest displacement potentiometers, six-axis upper neck transducers, right/left femur load cells, and lower leg instrumentation. Seat belt load cells were also placed on the driver's and passenger's lap and shoulder belts to measure dummy torso and pelvic section loading. Also, shoulder belt spool-off was measured for the driver and passenger dummy. The driver (position 1) ATD (Serial No. 34) and the right-front passenger (position 2) ATD (Serial No. 35) were calibrated two test prior to this test.

One hundred and nine (109) channels of data were recorded using an on-board data acquisition system. Appendix A contains Pre and Post-Test Photographs, Appendix B contains the vehicle and dummy response data traces. Appendix C contains Load Cell Barrier information. Appendix D contains the Instrumentation Data Channel assignments, Appendix E contains the Dummy Calibration data, Appendix F contains the Child Restraint System (CRS) report and Appendix G contains the Nine Accelerometer Array Head Data.

There was 100 percent windshield retention and no intrusion into the protected zone of the windshield during the impact event. There was no Stoddard solvent leakage after the event or during any phase of the static rollover.

The maximum static crush of the vehicle was 456 mm and both the driver and the passenger side doors remained closed during the impact event and were operable after the impact.

The driver's visible contact points were as follows: The driver ATD head contacted the airbag, its chest and abdomen contacted the airbag, both knees contacted the knee airbag. During rebound driver's head also contacted the headrest.

The passenger's visible contact points were as follows: The passenger ATD head contacted the airbag, its chest and abdomen contacted the airbag and both knees contacted the glove box. During rebound the passenger's head also contacted the headrest and side header.

Occupant injury data is contained in table below.

#### **OCCUPANT DATA SUMMARY**

ATD Position	HIC <sub>36</sub>	Clip (g)	Chest Disp. (mm)	Left Femur (N)	Right Femur (N)	Belt Spool (mm)
Driver	283.1	39.7	-19.1	-1668.6	-4488.4	136.5
Passenger	438.0	48.5	-20.6	-2962.5	-1214.8	90.6

**SECTION 2**  
**OCCUPANT AND VEHICLE INFORMATION/DATA SHEETS**

Test Vehicle: 2005 Toyota Scion TC 3-Door Hatchback

NHTSA No.: M55110

Test Program: 2005 NHTSA 35mph NCAP

Test Date: 9/30/04

**CONVERSION FACTORS USED IN THIS REPORT\***

Quantity	Typical Application	Std Units	Metric Unit	Multiply By
Mass	Vehicle Weight	lb	kg	0.4536
Linear Velocity	Impact Velocity	mile/h	km/h	1.609
Length or Distance	Measurements	in	mm	25.4
Volume	Fuel Systems	gal	liter	3.785
Volume	Small Fluids	oz	mL	29.573
Pressure	Tire Pressures	lbf/in <sup>2</sup>	kPa	7.0
Volume	Liquid	gal	liter	3.785
Temperature	General Use	°F	°C	$=(tf - 32)/1.8$
Force	Dynamic Forces	lbf	N	4.448
Moment	Torque	lbf/ft	Nm	1.355

\* Based on the Recommended Practice in SAE J916, May 85

**DATA SHEET NO. 1  
CRASH TEST SUMMARY**

Test Vehicle: 2005 Toyota Scion TC 3-Door Hatchback

NHTSA No.: M55110

Test Program: 2005 NHTSA 35mph NCAP

Test Date: 9/30/04

**PRIMARY IMPACT DATA**

Measured Parameter	Units	Value
Velocity at Impact	km/h	56.13
Test Weight	kg	1515
Impact Angle	degrees	0
Average Rebound	mm	2337
Maximum Static Crush	mm	456

**DOOR OPENING AND SEAT TRACK INFORMATION**

Description	Driver	Passenger
Front Door opening	Remained closed, opened w/o tools	Remained closed, opened w/o tools
Rear Door Opening	N/A	N/A
Seat Track Shift (mm)	0	0
Seat Back Failure	No	No

**TEST DUMMY INFORMATION**

Description	Driver	Passenger
Dummy Type/ Serial No.	50% Male Hybrid III No. 34	50% Male Hybrid III No. 35
Head Contact	Airbag, Headrest	Airbag, Headrest, Side header
Chest Contact	Airbag	Airbag
Abdomen Contact	Airbag	Airbag
Left Knee Contact	Knee Airbag	Glove Box
Right Knee Contact	Knee Airbag	Glove Box

**MOVIE COVERAGE**

High Speed	19
Real Time	3
Total	22

**DATA CHANNELS**

Driver ATD Sensors	46
Passenger ATD Sensors	46
Belt Assessment Sensors	8
Vehicle Structure Accelerometers	9
Rigid Barrier Load Cells	36
Total	145

**DATA SHEET NO. 2  
GENERAL TEST AND VEHICLE PARAMETER DATA**

Test Vehicle: 2005 Toyota Scion TC 3-Door Hatchback

NHTSA No.: M55110

Test Program: 2005 NHTSA 35mph NCAP

Test Date: 9/30/04

**TEST VEHICLE INFORMATION AND OPTIONS**

NHTSA No.	M55110	Anti-Lock Brakes	Yes
Make	Scion	All Wheel Drive	Yes
Model	Toyota TC	Power Steering	Yes
Body Style	3-Door Hatchback	Driver Front Airbag	Yes
Vin No.	JTKDE177550014651	Driver Side Airbag	No
Color	Light Blue	Driver Head Airbag	No
Delivery Date	9/10/2004	Driver Curtain Airbag	No
Odometer	145	Pass. Airbag	Yes
Dealer	Sierra Toyota	Pass. Side Airbag	No
Transmission	5 (manual)	Pass. Head Airbag	No
Final Drive	Front	Pass. Curtain Airbag	No
Type/No. Cyl.	4	Pre-Tensioners	Yes
Engine Disp. (L)	2.4	Load Limiters	Yes
Engine Placement	Transverse	Bucket Seats	Yes
Roof Rack	No	Air Cond.	Yes
Sunroof/T-Top	Yes	AM/FM Cassette	Yes
Tinted Glass	No	Tilt Steering	Yes
Traction Control	No	Automatic Door Locks	No
Power Brakes	Yes	Power Windows	No
Front Disc	Yes	Power Seats	No
Rear Disc	Yes	Other	None

Does Owners Manual provide instructions to turn off automatic door locks.

N/A

**DATA FROM CERTIFICATION LABEL**

Manufactured By	Toyota Motor Corporation	GVWR (kg)	1789
Date of Manufacture	Aug-04	GAWR Front (kg)	966
		GAWR Rear (kg)	832

**VEHICLE SEATING AND CAPACITY WEIGHT INFORMATION**

Measured Parameter	Front	Rear	Third	Total
Type of Seats	Bucket	N/A	N/A	
Number of Occupants	2	3	N/A	5
Capacity Weight (VCW) (kg)				392
Cargo Weight (RCLW) (kg)				52

**DATA SHEET NO. 2...(CONTINUED)**  
**GENERAL TEST AND VEHICLE PARAMETER DATA**

Test Vehicle: 2005 Toyota Scion TC 3-Door Hatchback

NHTSA No.: M55110

Test Program: 2005 NHTSA 35mph NCAP

Test Date: 9/30/04

Collect year, make, model, VIN, items circled in red, and tire manufacturer and tire name.

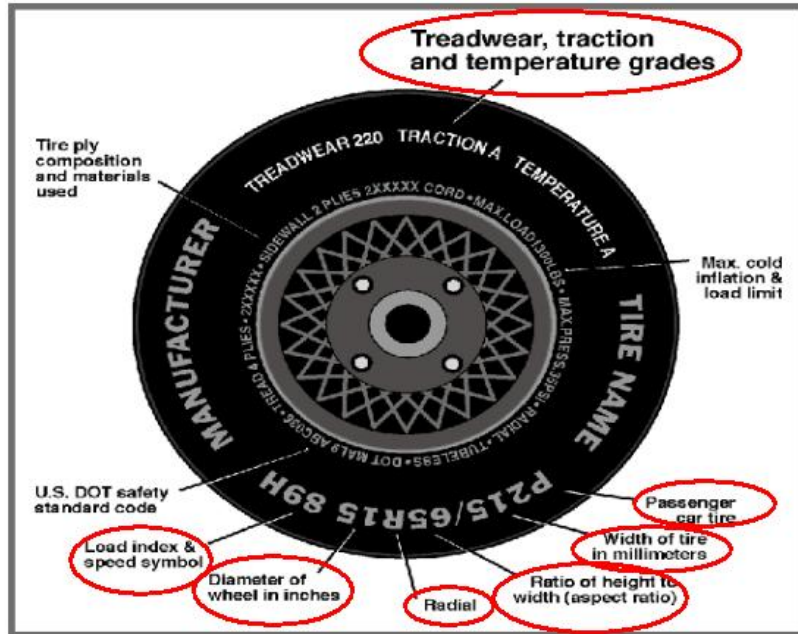

**TIRE INFORMATION**

Measured Parameter	Front	Rear
Max. Tire Pressure (kpa)	351	351
Cold Pressure (kpa)	220	200
Recommended Tire Size	215/45ZR17	215/45ZR17
Tire Size on Vehicle	215/45ZR17	215/45ZR17
Tire Manufacturer	Bridgestone	Bridgestone
Treadwear	160	160
Traction	A	A
Temperature Grades	A	A
Tire Plies Sidewall	2 Rayon	2 Rayon
Tire Plies Body	2 Steel + 1 Rayon + 1 Nylon	2 Steel + 1 Rayon + 1 Nylon
Load Index/Speed Symbol	RE 92	RE 92
Tire Material	Steel + Rayon + Nylon	Steel + Rayon + Nylon
DOT Safety Code Right	DOT-EJ-OK-JLE2504	DOT-EJ-OK-JLE2504
DOT Safety Code Left	DOT-EJ-OK-JLE2504	DOT-EJ-OK-JLE2504

**DATA SHEET NO. 2...(CONTINUED)**  
**GENERAL TEST AND VEHICLE PARAMETER DATA**

Test Vehicle: 2005 Toyota Scion TC 3-Door Hatchback NHTSA No.: M55110

Test Program: 2005 NHTSA 35mph NCAP Test Date: 9/30/04

**TEST VEHICLE WEIGHTS**

	Units	As Delivered Weights (UVW)			As Tested Weights (ATW)		
		Front Axle	Rear Axle	Total	Front Axle	Rear Axle	Total
Left	kg	402	261		433	327	
Right	kg	393	261		430	325	
Ratio	%	60.4	39.6		56.9	43.1	
Totals	kg	795	522	1317	863	652	1515

**TARGET TEST WEIGHT CALCULATION**

Measured Parameter	Units	Value
Total Delivered Weight (UVW)	kg	1317
Weight of 2 P572 ATD's	kg	152
Rated Cargo/Luggage Wt. (RCLW)	kg	52
Calculated Vehicle Target Wt. (TVTW)	kg	1521

**TEST VEHICLE ATTITUDE AND CG**

	Units	LF	RF	LR	RR	CG (aft of front axle)
As Delivered	mm	730	735	735	746	1070
As Tested	mm	710	715	705	710	1162

Vehicle Wheel Base (mm) 2700

Weight of Ballast Secured in cargo area (kg) 0

Vehicle Components Removed Rear bumper, hatch door, spare tire and tools

\* Ballast weight does not include cameras, instrumentation and brake abort system.

**FUEL SYSTEM DATA**

Fuel System Capacity From Owners Manual (L) 54.9

Usable Capacity Furnished by COTR (L) 50.5 to 51.6

Actual Test Volume with entire fuel System Filled (L) 18.2

Test Fluid Type: Stoddard Solvent

Kinematic Viscosity: as per ASTM Standard D484-71 Purple

Is Vehicle Fuel Pump Electric or Mechanical? Electric

If electric, does pump operate with ignition switch "On" & engine "OFF" Yes

Fuel System Particulars: None

**DATA SHEET NO. 3  
POST TEST IMPACT DATA**

Test Vehicle: 2005 Toyota Scion TC 3-Door Hatchback

NHTSA No.: M55110

Test Program: 2005 NHTSA 35mph NCAP

Test Date: 9/30/04

**SPEED TRAP DATA**

Measured Parameter	Units	Requirement	Value
Trap No.1 Velocity (Primary)	km/h	55.51 to 57.12	56.13
Trap No. 1 Entry Distance	mm	<1524	1524
Trap No.1 Exit Distance	mm	<1524	305
Trap No.2 Velocity (Redun.)	km/h	55.51 to 57.12	56.08
Trap No.2 Entry Distance	mm	<1524	1524
Trap No.2 Exit Distance	mm	<1524	305

**VEHICLE STATIC CRUSH**

Measured Parameter	Units	Pre-Test	Post-Test	Difference
Left Side	mm	4217	3907	-310
Center	mm	4407	3967	-440
Right Side	mm	4217	3907	-310

**VEHICLE REBOUND FROM BARRIER**

Measured Parameter	Units	Value
Left Side	mm	2360
Center	mm	2320
Right Side	mm	2330
Average	mm	2337

**DATA SHEET NO. 4  
TEST VEHICLE INFORMATION**

Test Vehicle: 2005 Toyota Scion TC 3-Door Hatchback

NHTSA No.: M55110

Test Program: 2005 NHTSA 35mph NCAP

Test Date: 9/30/04

**NOMINAL DESIGN RIDING POSITION**

The driver and passenger seat backs are positioned to the manufacturers designated angle. The procedure is as follows: Seat back angle was measured at the flat surface of the seat back using a digital inclinometer.

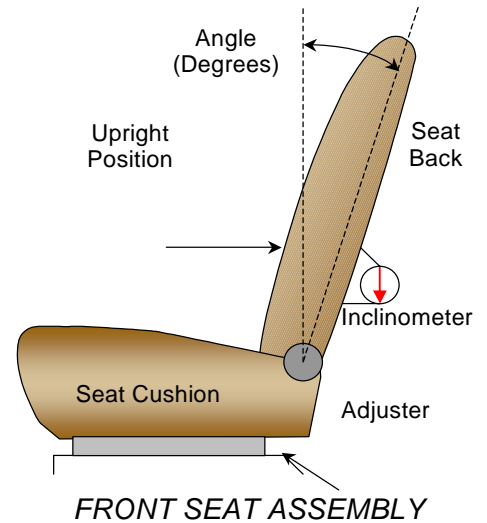

**SEAT BACK ANGLES**

	Deg.
Driver w/seated Dummy	21.7
Passenger w/seated Dummy	21.0

**SEAT FORE/AFT POSITIONS**

The first or forward most position is counted as number one (1). The fore/aft position is set aft of the middle position for both the driver and passenger.

**SEAT FORE/AFT POSITIONING**

	Total Fore/Aft Travel	Placed in Position #
Driver Seat	17	9
Passenger Seat	17	9

**SEAT BELT UPPER ANCHORAGE**

Position number one (1) is the uppermost position. No anchorage was present.

**SEAT BELT UPPER ANCHORAGE**

	Total # of Positions	Placed in Position #
Driver Seat	N/A	N/A
Passenger Seat	N/A	N/A

**DATA SHEET NO. 4...(CONTINUED)**  
**TEST VEHICLE INFORMATION**

Test Vehicle: 2005 Toyota Scion TC 3-Door Hatchback

NHTSA No.: M55110

Test Program: 2005 NHTSA 35mph NCAP

Test Date: 9/30/04

**FUEL TANK CAPACITY**

	Liters
Usable Capacity of "Standard Tank"	54.9
Usable Capacity of "Optional" Tank	N/A
Usable Capacity used for FMVSS 301	50.5 to 51.6
Actual Amount of Solvent used	N/A
1/3 of Usable Capacity	18.2

The test vehicle is equipped with an electric fuel pump. The fuel pump operates for approximately two seconds after the ignition is placed in the "ON" position, after which the fuel pump automatically shuts off. The fuel filler door is located on the right rear fender. The standard fuel tank occupies the area under the rear seat.

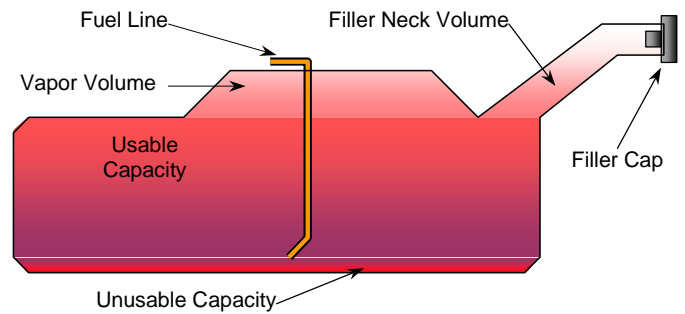

VEHICLE FUEL TANK ASSEMBLY

**STEERING COLUMN ADJUSTMENT**

Steering wheel and column adjustments are made so that the steering wheel hub is at the geometric center of the locus it describes when moved through its full range of motion. An aluminum plate is placed across the rim of the steering wheel, an inclinometer is placed on the plate and the angle is measured.

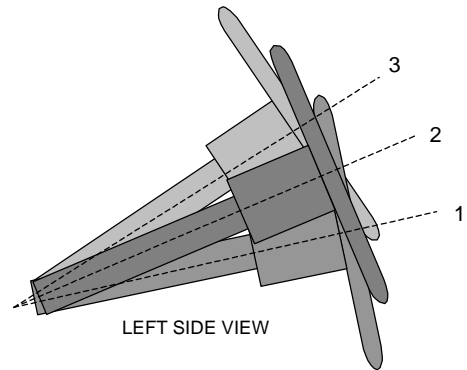

STEERING COLUMN ASSEMBLY

**STEERING COLUMN POSITIONS**

	Fore/Aft Positon (mm)	Degrees
Lowermost positon No. 1	N/A	17.3
Geometric center position No. 2	N/A	19.4
Uppermost position No. 3	N/A	21.5

**DATA SHEET NO. 5**  
**DUMMY POSITIONING IN VEHICLE**

Test Vehicle: 2005 Toyota Scion TC 3-Door Hatchback

NHTSA No.: M55110

Test Program: 2005 NHTSA 35mph NCAP

Test Date: 9/30/04

**TEST DUMMY POSITION MEASUREMENTS**

Code	Measurement Description	Driver		Passenger	
		Length (mm)	Angle (deg)	Length (mm)	Angle (deg)
WA	Windshield Angle		24.9		
SWA	Steering Wheel Angle		70.6		
SCA	Steering Column Angle		19.4		
SA	Seat Back Angle		21.7		21.0
HZ	Head to Roof (Z)	225	90.0	135	90.0
HH	Head to Header	360		335	
HW	Head to Windshield	700		705	
HR	Head to Side Header (Y)	270		225	
NR	Nose to Rim	380	10.4		
CD	Chest to Dash	510		610	
CS	Chest to Steering Hub	300			
RA	Rim to Abdomen	210			
KDL	Left Knee to Dash	190	11.1	150	
KDR	Right Knee to Dash	200		165	17.3
PA	Pelvic Angle		20.9		24.0
TA	Tibia Angle		46.3		37.8
KK	Knee to Knee (Y)	270		285	
SK	Striker to Knee	850	6.2	880	10.7
ST	Striker to Head	535	49.8	560	48.7
SH	Striker to H-Point	520	30.0	535	27.3
SHY	Striker to H-Point (Y)	260		250	
HS	Head to Side Window	390		235	
HD	H-Point to Door (Y)	140		145	
AD	Arm to Door (Y)	120		40	

**DATA SHEET NO. 5...(CONTINUED)**  
**DUMMY POSITIONING IN VEHICLE**

Test Vehicle: 2005 Toyota Scion TC 3-Door Hatchback

NHTSA No.: M55110

Test Program: 2005 NHTSA 35mph NCAP

Test Date: 9/30/04

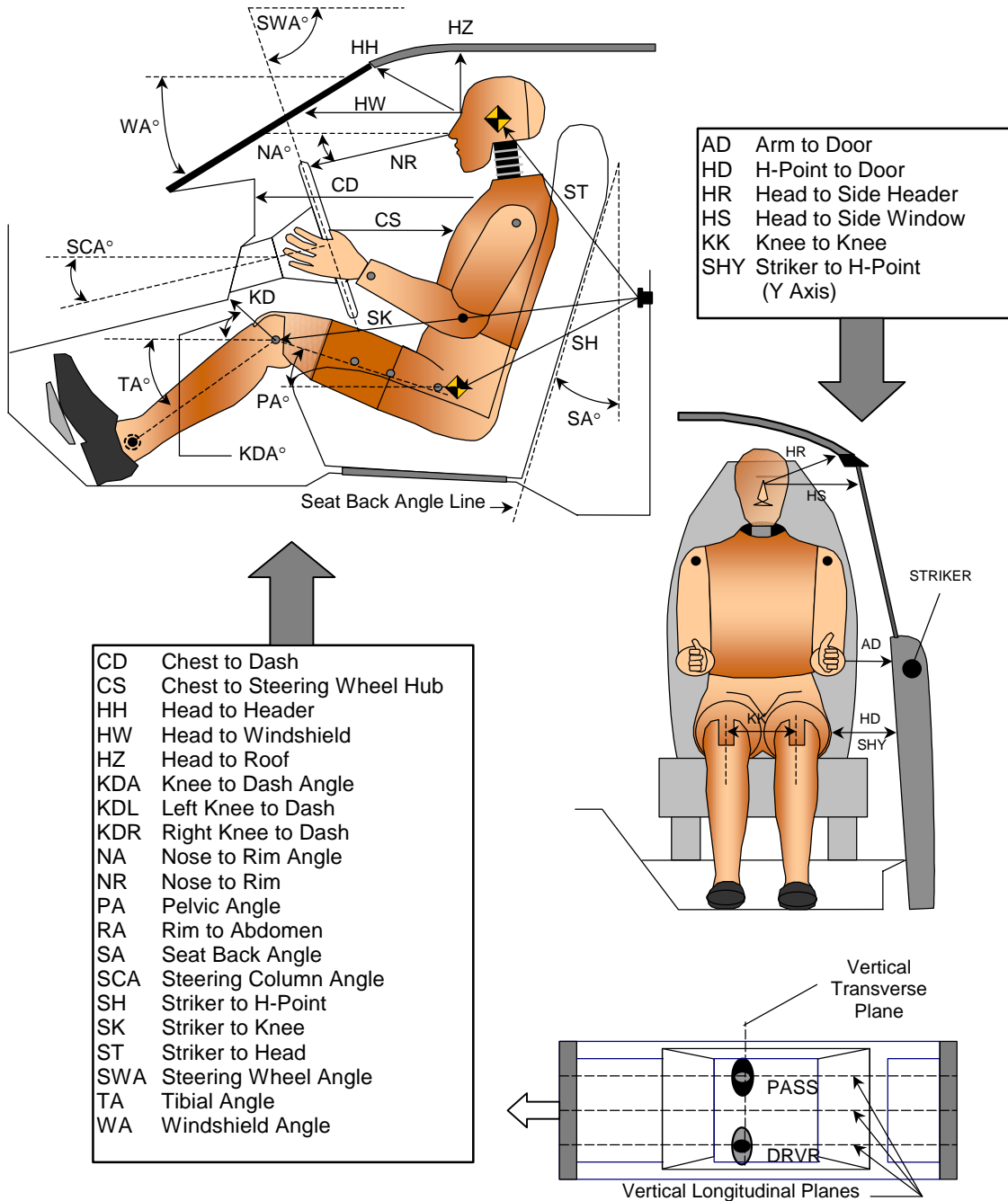

**DUMMY MEASUREMENTS FOR FRONT SEAT OCCUPANTS**

**DATA SHEET NO. 6**  
**SEAT BELT POSITIONING DATA**

Test Vehicle: 2005 Toyota Scion TC 3-Door Hatchback

NHTSA No.: M55110

Test Program: 2005 NHTSA 35mph NCAP

Test Date: 9/30/04

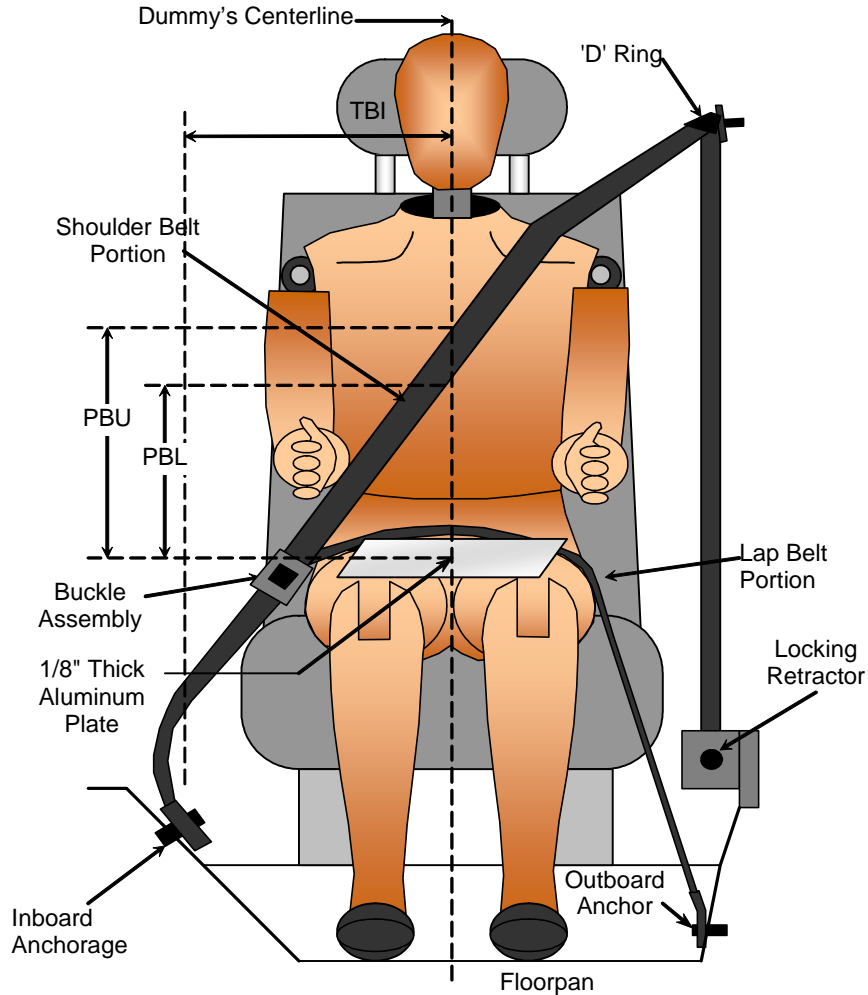

**SEAT BELT POSITIONING MEASUREMENTS**

Measured Parameter	Units	Driver	Passenger
TBI -Dummy C/L to Lap/Shoulder Belt Intersect	mm	280	210
PBU - Top Surface of reference to belt upper edge	mm	315	305
PBL - Top Surface of reference to belt lower edge	mm	250	220
Lap Belt Tension	Newtons	10	10
Shoulder Belt Tension	N/A	Retractor	Retractor

# DATA SHEET NO. 7 - VEHICLE ACCELEROMETER LOCATION AND DATA SUMMARY

Test Vehicle: 2005 Toyota Scion TC 3-Door Hatchback

NHTSA No.: M55110

Test Program: 2005 NHTSA 35mph NCAP

Test Date: 9/30/04

## VEHICLE ACCELEROMETER PEAK DATA AND PRE-TEST LOCATIONS

No.	Accelerometer Location	Measurements (mm)			Peak Values				
		X	Y	Z	Units	Max	Time	Min	Time
1	Left Rear X-Member	2050	-700	290	G's	1.0	120.7	-42.1	58.5
2	Right Rear X-Member	2050	700	290	G's	1.5	94.7	-44.1	58.9
3	Engine Top	3650	150	810	G's	21.4	45.1	-103.0	27.0 <sup>2</sup>
4	Engine Bottom	3740	260	130	G's	0.0	0.0	0.0	0.0 <sup>1</sup>
5	Left Brake Caliper	3640	-670	300	G's	21.3	57.8	-83.3	43.0
6	Right Brake Caliper	3640	670	300	G's	19.2	56.1	-88.4	37.1
7	Instrument Panel	2880	0	950	G's	0.0	0.0	0.0	0.0 <sup>1</sup>
8	Left Rear X-Member (Z-Axis)	1995	-700	290	G's	10.9	31.2	-6.5	26.4
9	Right Rear X-Member (Z-Axis)	1995	700	290	G's	15.6	36.1	-10.1	70.1

Reference Planes: X=From Rear Surface of Vehicle, Y=Vehicle Centerline, Z=Ground Plane

1.) Channels failed, no data

2.) Channel failed at 56.4 msec.

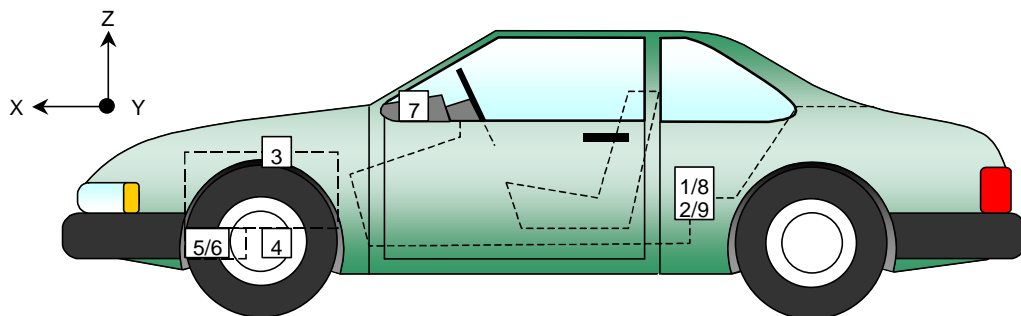
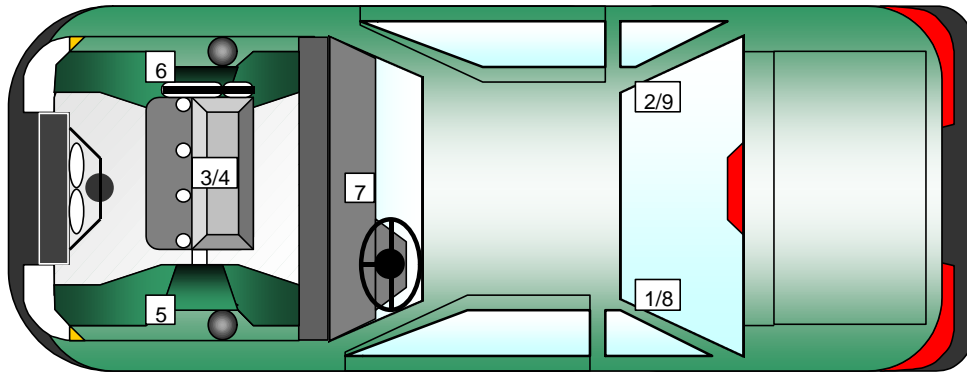

**DATA SHEET NO. 8 - HYBRID III ATD INJURY CRITERIA AND SENSOR DATA**

Test Vehicle: 2005 Toyota Scion TC 3-Door Hatchback

NHTSA No.: M55110

Test Program: 2005 NHTSA 35mph NCAP

Test Date: 9/30/04

**HEAD PRIMARY PEAK ACCELERATIONS**

Location	Axis	Units	Driver				Passenger			
			Max	Time	Min	Time	Max	Time	Min	Time
Head CG	X	G's	1.3	195.4	-43.8	73.3	2.2	200.0	-54.5	78.6
Head CG	Y	G's	2.2	154.0	-6.0	25.3	3.7	63.6	-7.5	95.7
Head CG	Z	G's	22.4	47.1	-7.0	87.8	28.8	49.5	-3.6	17.9
Head CG Resultant	N/A	G's	44.3	73.3			56.2	78.7		

**CHEST PRIMARY PEAK ACCELERATIONS**

Location	Axis	Units	Driver				Passenger			
			Max	Time	Min	Time	Max	Time	Min	Time
Chest CG	X	G's	2.1	131.1	-40.7	69.6	2.5	138.9	-44.6	67.1
Chest CG	Y	G's	3.7	98.0	-3.8	53.0	5.5	72.4	-12.7	76.9
Chest CG	Z	G's	11.9	47.3	-8.5	67.2	14.0	48.3	-27.1	73.7
Chest CG Resultant	N/A	G's	41.4	69.6			49.4	73.9		

**FEMUR PEAK FORCES**

Location	Axis	Units	Driver				Passenger			
			Max	Time	Min	Time	Max	Time	Min	Time
Left Femur	Z	Newtons	64.5	172.3	-1668.6	25.1	628.2	41.0	-2962.5	52.0
Right Femur	Z	Newtons	158.1	199.2	-4488.4	44.6	914.4	41.2	-1214.8	56.7

**SEAT BELT SENSOR PEAK VALUES**

Location	Axis	Units	Driver				Passenger			
			Max	Time	Min	Time	Max	Time	Min	Time
Shoulder Belt Pullout	N/A	MM	136.5	99.4	-29.4	55.9	90.6	90.6	-31.5	54.8
Shoulder Belt Stretch	N/A	MM/CM	0.0	0.0	0.0	0.0	0.00	0.0	0.00	0.0
Lap Belt Force	N/A	Newtons	5331.5	54.7	-18.7	114.6	8565.9	54.1	-29.9	109.5
Shoulder Belt Force	N/A	Newtons	6278.3	49.4	-54.8	10.7	7169.5	52.9	-48.6	120.2

1.) Not used with pre-tensioners

**PRIMARY HEAD INJURY CRITERIA (HIC36)**

Location	Driver				Passenger			
	HIC	T <sup>1</sup>	T <sup>2</sup>	Avg G	HIC	T <sup>1</sup>	T <sup>2</sup>	Avg G
Head CG Primary	283.1	51.0	87.0	36.1	438.0	53.4	89.4	43.0

**PRIMARY CHEST CLIP (3MSEC)**

Location	Driver			Passenger		
	CLIP	T <sup>1</sup>	T <sup>2</sup>	CLIP	T <sup>1</sup>	T <sup>2</sup>
Chest CG Primary	39.7	68.1	71.1	48.5	72.6	75.6

**DATA SHEET NO. 8...(CONTINUED)**

Test Vehicle: 2005 Toyota Scion TC 3-Door Hatchback

NHTSA No.: M55110

Test Program: 2005 NHTSA 35mph NCAP

Test Date: 9/30/04

**PELVIC PEAK ACCELERATIONS**

Location	Axis	Units	Driver				Passenger			
			Max	Time	Min	Time	Max	Time	Min	Time
Pelvis	X	G's	6.8	92.9	-49.8	44.9	11.7	89.3	-53.3	54.1
Pelvis	Y	G's	8.0	80.1	-8.8	44.0	4.0	52.1	-6.7	61.5
Pelvis	Z	G's	2.1	165.8	-31.8	68.0	1.9	199.4	-37.3	74.2
Pelvis Resultant	N/A	G's	56.5	63.3			58.5	58.7		

**UPPER NECK PEAK FORCES AND MOMENTS**

Location	Axis	Units	Driver				Passenger			
			Max	Time	Min	Time	Max	Time	Min	Time
Neck Force	X	Newtons	342.4	68.4	-406.1	133.2	58.9	200.0	-511.8	53.8
Neck Force	Y	Newtons	95.8	153.9	-87.1	96.2	61.2	190.8	-248.1	95.6
Neck Force	Z	Newtons	1483.6	46.0	-88.0	143.6	1287.4	54.8	-173.3	17.8
Neck Force Resultant	N/A	Newtons	1510.5	46.0			1383.2	54.8		
Neck Moment	X	N•m	6.2	162.0	-12.7	107.4	8.9	178.0	-12.3	119.3
Neck Moment	Y	N•m	34.0	140.8	-17.2	93.2	31.3	127.7	-37.0	78.6
Neck Moment	Z	N•m	6.8	61.5	-1.3	19.5	2.3	96.7	-5.9	66.0
Neck Moment Resultant	N/A	N•m	34.1	140.8			37.3	78.6		

**FOOT PEAK ACCELERATIONS**

Location	Axis	Units	Driver				Passenger			
			Max	Time	Min	Time	Max	Time	Min	Time
Left Foot Aft	X	G's	12.2	79.5	-40.7	41.3	24.2	73.8	-138.9	42.3
Left Foot Aft	Z	G's	2.9	108.6	-37.8	38.2	8.6	61.5	-49.5	45.5
Left Foot Fore	Z	G's	16.1	32.4	-55.7	38.0	30.0	52.2	-127.6	43.0
Right Foot Aft	X	G's	22.6	82.2	-159.0	45.1	21.2	86.7	-51.2	36.8
Right Foot Aft	Z	G's	7.3	55.2	-133.6	43.1	3.5	135.9	-54.3	26.6
Right Foot Fore	Z	G's	32.6	29.9	-249.8	42.8	15.4	103.5	-78.1	35.8

**UPPER AND LOWER TIBIA PEAK FORCES AND MOMENTS**

Location	Axis	Units	Driver				Passenger			
			Max	Time	Min	Time	Max	Time	Min	Time
Left Upper Moment	X	N•m	9.7	108.9	-47.1	70.2	68.5	44.7	-26.0	136.4
Left Upper Moment	Y	N•m	25.6	22.6	-49.3	17.8	14.6	107.1	-89.8	40.1
Right Upper Moment	X	N•m	19.5	118.9	-113.8	46.7	30.4	75.1	-24.7	117.1
Right Upper Moment	Y	N•m	49.0	24.5	-162.3	44.1	14.6	111.9	-80.8	69.9
Left Lower Moment	X	N•m	7.4	27.7	-10.2	72.7	38.0	44.3	-41.7	53.4
Left Lower Moment	Y	N•m	32.3	80.3	-9.6	63.7	34.9	54.0	-43.7	40.9
Left Lower Force	Z	Newtons	179.7	138.1	-2197.3	41.0	164.2	121.4	-2389.7	42.7
Right Lower Moment	X	N•m	9.1	50.1	-220.5	45.0	8.4	72.5	-13.5	82.9
Right Lower Moment	Y	N•m	39.5	45.3	-31.8	42.9	37.4	84.9	-33.8	38.1
Right Lower Force	Z	Newtons	102.9	114.6	-9419.1	44.9	214.7	130.9	-1846.9	31.9

**DATA SHEET NO. 8...(CONTINUED)**

Test Vehicle: 2005 Toyota Scion TC 3-Door Hatchback

NHTSA No.: M55110

Test Program: 2005 NHTSA 35mph NCAP

Test Date: 9/30/04

**CHEST PEAK DISPLACEMENTS**

Location	Axis	Units	Driver				Passenger			
			Max	Time	Min	Time	Max	Time	Min	Time
Chest CG	X	MM	0.0	4.6	-19.1	52.9	0.0	4.4	-20.6	65.3

**HEAD REDUNDANT PEAK ACCELERATIONS**

Location	Axis	Units	Driver				Passenger			
			Max	Time	Min	Time	Max	Time	Min	Time
Head CG	X	G's	1.8	195.3	-44.2	74.2	2.4	200.0	-54.8	78.6
Head CG	Y	G's	2.1	153.9	-5.5	85.1	3.7	59.4	-7.5	95.6
Head CG	Z	G's	22.2	47.0	-6.9	88.4	28.9	49.5	-3.9	17.8
Head CG Resultant	N/A	G's	44.6	74.2			56.5	78.6		

**CHEST REDUNDANT PEAK ACCELERATIONS**

Location	Axis	Units	Driver				Passenger			
			Max	Time	Min	Time	Max	Time	Min	Time
Chest CG	X	G's	2.2	131.4	-40.4	69.5	2.5	124.3	-45.0	67.1
Chest CG	Y	G's	3.6	97.6	-4.2	53.0	5.4	72.4	-12.9	76.9
Chest CG	Z	G's	12.0	47.2	-8.5	67.2	13.5	45.0	-26.9	73.7
Chest CG Resultant	N/A	G's	41.1	69.5			49.2	73.9		

**REDUNDANT HEAD INJURY CRITERIA (HIC36)**

Location	Driver				Passenger			
	HIC	T <sup>1</sup>	T <sup>2</sup>	Avg G	HIC	T <sup>1</sup>	T <sup>2</sup>	Avg G
Head CG Redundant	285.9	51.2	87.2	36.3	437.1	53.3	89.3	43.0

**REDUNDANT CHEST CLIP (3MSEC)**

Location	Driver			Passenger		
	CLIP	T <sup>1</sup>	T <sup>2</sup>	CLIP	T <sup>1</sup>	T <sup>2</sup>
Chest CG Redundant	39.5	68.1	71.1	48.4	72.5	75.5

**DATA SHEET NO. 9**  
**SEATBELT ASSESSMENT TEST DATA**

Test Vehicle: 2005 Toyota Scion TC 3-Door Hatchback

NHTSA No.: M55110

Test Program: 2005 NHTSA 35mph NCAP

Test Date: 9/30/04

**SEAT BELT POSITIONING MEASUREMENTS**

Measurement Description	Units	Driver	Passenger
Retractor Reel to "D" ring	mm	625	625
Shoulder Belt length as measured on ATD	mm	1030	1010
Lap Belt length as measured on ATD	mm	890	860
Remainder of belt on reel	mm	785	745
Total belt length for continuous webbing systems	mm	3330	3240

**SHOULDER BELT SPOOL-OFF DATA**

Measurement Description	Units	Driver	Passenger
As determined mechanically	mm	N/R	40
As determined electronically	mm	137	91

**BELT STRETCH DATA**

Measurement Description	Units	Driver	Passenger
Electronically between belt load cell and "D" ring	mm/cm	*	*
Mechanically	mm/cm	*	*

\* Not used with shoulder belt pre-tensioner systems

**DATA SHEET NO. 10**  
**SUMMARY OF FMVSS 212 DATA**

Test Vehicle: 2005 Toyota Scion TC 3-Door Hatchback

NHTSA No.: M55110

Test Program: 2005 NHTSA 35mph NCAP

Test Date: 9/30/04

Windshield Mounting Details: Windshield glass is secured to the vehicle frame with a rubber type adhesive. No molding covers the windshield periphery at any point.

The standard requires that the posttest retention measurement be a minimum of 75 percent of the pretest total periphery measurement for vehicles not equipped with occupant passive restraints and 50 percent for each side of the windshield for vehicles that are equipped with occupant passive restraints.

Temperature of windshield molding during test: 22.0 °C

**WINDSHIELD PERIPHERY MEASUREMENTS**

Measurement	Pre-Test(mm)	Post-Test(mm)	% of Retention
Left Side	2000	2000	100
Right Side	2000	2000	100
Total	4000	4000	100

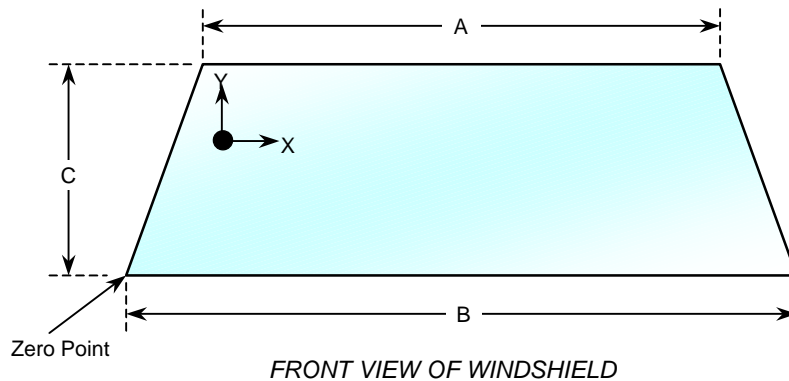

**WINDSHIELD DIMENSIONS**

Item	Units	Segment Length	Molding Width
A	mm	1210	30
B	mm	1410	12
C-Left	mm	690	17
C-Right	mm	690	17

**DATA SHEET NO. 11**  
**WINDSHIELD ZONE INTRUSION FMVSS 219 DATA (PARTIAL)**

Test Vehicle: 2005 Toyota Scion TC 3-Door Hatchback

NHTSA No.: M55110

Test Program: 2005 NHTSA 35mph NCAP

Test Date: 9/30/04

**WINDSHIELD AND  
PROTECTED ZONE**

Item	Units	Value
A	mm	1210
B	mm	520
C	mm	1410
D	mm	690
E	mm	515
F	mm	415

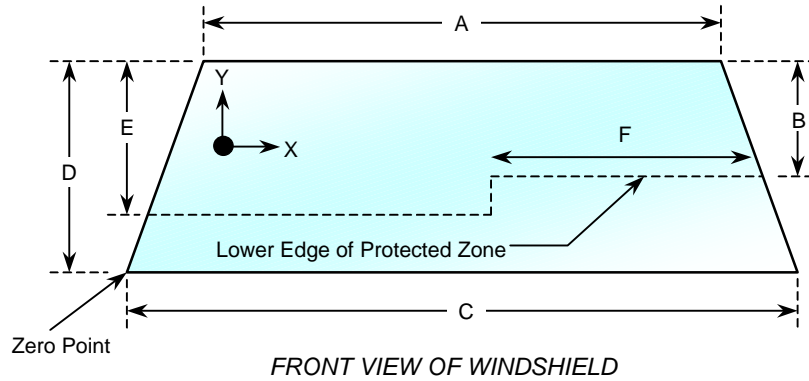

**AREA OF PROTECTED ZONE FAILURES**

- A. Provide coordinates of the area that the protected zone was penetrated more than 0.25 in. by a vehicle component other than one that is normally in contact with the windshield.

X	Y
N/A	N/A
N/A	N/A
N/A	N/A
N/A	N/A

- B. Provide coordinates of the area beneath the protected zone that the inner surface of the windshield was penetrated by a vehicle component.

X	Y
N/A	N/A
N/A	N/A
N/A	N/A
N/A	N/A

**DATA SHEET NO. 12**  
**FMVSS 301 FUEL SYSTEM INTEGRITY POST IMPACT DATA**

Test Vehicle: 2005 Toyota Scion TC 3-Door Hatchback NHTSA No.: M55110  
Test Program: 2005 NHTSA 35mph NCAP Test Date: 9/30/04  
Test Time: 2:39 PM Temperature: 27.2 Deg. C.

**STODDARD SOLVENT SPILLAGE MEASUREMENTS**

- A. From impact until vehicle motion ceases: 0.0 oz.  
(Maximum Allowable = 1 ounce)
- B. For the 5-minute period after motion ceases: 0.0 oz.  
(Maximum Allowable = 5 ounces)
- C. For the following 25 minutes: 0.0 oz.  
(Maximum Allowable = 1 oz./minute)
- D. Spillage Location Details: No leakage occurred

**DATA SHEET NO. 13**  
**FMVSS 301 STATIC ROLLOVER DATA**

Test Vehicle: 2005 Toyota Scion TC 3-Door Hatchback

NHTSA No.: M55110

Test Program: 2005 NHTSA 35mph NCAP

Test Date: 9/30/04

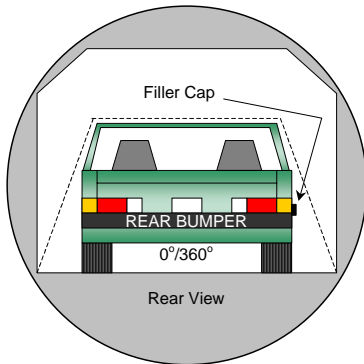

**0° to 90°**

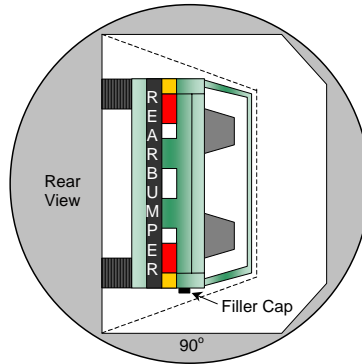

**90° to 180°**

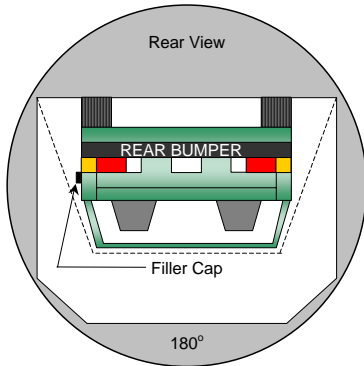
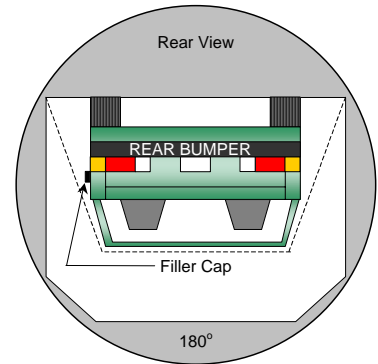

**180° to 270°**

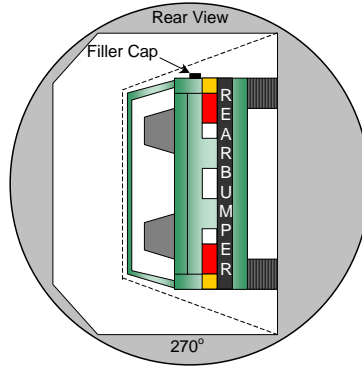

**270° to 360°**

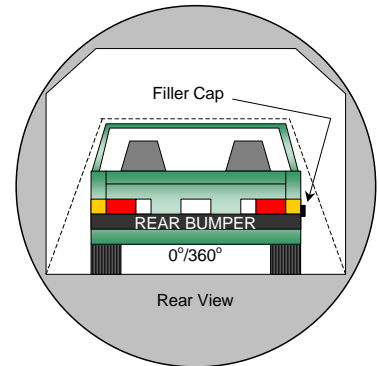

1. The specified fixture rollover rate for each 90° of rotation is 60 to 120 seconds.
2. The position hold time at each position is 300 seconds (minimum).
3. No solvent leakage occurred during rollover.

**DATA SHEET NO. 13...(CONTINUED)**  
**FMVSS 301 STATIC ROLLOVER DATA**

Test Vehicle: 2005 Toyota Scion TC 3-Door Hatchback

NHTSA No.: M55110

Test Program: 2005 NHTSA 35mph NCAP

Test Date: 9/30/04

**SOLVENT COLLECTION TIME TABLE IN SECONDS**

Test Phase	Rotation Time	Hold Time	Total Time
0° to 90°	81	300	381
90° to 180°	76	300	376
180° to 270°	79	300	379
270° to 360°	77	300	377

**FMVSS 301 SPILLAGE TABLE REQUIREMENT (oz.)**

First 5 Minutes	5
Sixth Minute	1
Seventh Minute	1
Eighth Minute	1

**ACTUAL TEST VEHICLE SOLVENT SPILLAGE TABLE (oz.)**

Test Phase	First 5 Minutes	Sixth Minute	Seventh Minute	Eighth Minute
0° to 90°	0	0	0	0
90° to 180°	0	0	0	0
180° to 270°	0	0	0	0
270° to 360°	0	0	0	0

**SOLVENT SPILLAGE LOCATION TABLE**

Test Phase	Spillage Location
0° to 90°	None
90° to 180°	None
180° to 270°	None
270° to 360°	None

**DATA SHEET NO. 14**  
**VEHICLE MEASUREMENTS**

Test Vehicle: 2005 Toyota Scion TC 3-Door Hatchback

NHTSA No.: M55110

Test Program: 2005 NHTSA 35mph NCAP

Test Date: 9/30/04

**VEHICLE MEASUREMENT TABLE**

No.	Measurement Description	Units	Pre-Test	Post-Test	Diff.
1	Total length of vehicle at centerline	mm	4407	3967	-440
2	RSOV to front of engine	mm	3740	3462	-278
3	RSOV to firewall centerline	mm	3492	3442	-50
4	RSOV to leading edge of right door	mm	3064	3064	0
5	RSOV to leading edge of left door	mm	3060	3066	6
6	RSOV to lower leading edge of right door	mm	2998	2986	-12
7	RSOV to lower leading edge of left door	mm	2994	2984	-10
8	RSOV to upper trailing edge of right door	mm	1743	1745	2
9	RSOV to upper trailing edge of left door	mm	1740	1746	6
10	RSOV to lower trailing edge of right door	mm	1824	1813	-11
11	RSOV to lower trailing edge of left door	mm	1820	1810	-10
12	RSOV to bottom of right 'A' pillar	mm	2989	2974	-15
13	RSOV to bottom of left 'A' pillar	mm	2981	2977	-4
14	RSOV to firewall on right side	mm	3592	3557	-35
15	RSOV to firewall on left side	mm	3592	3580	-12
16	RSOV to steering column	mm	2600	2625	25
17	Center of steering column to left 'A' pillar	mm	375	370	-5
18	Center of steering column to headlining	mm	430	450	20
19	RSOV to right side of front bumper	mm	4217	3907	-310
20	RSOV to left side of front bumper	mm	4217	3907	-310
21	Length of engine block	mm	420	420	0
RD	RSOV to right side of dash panel	mm	2809	2809	0
CD	RSOV to center of dash panel	mm	2818	2800	-18
LD	RSOV to left side of dash panel	mm	2809	2804	-5

All measurements are in millimeters

**DATA SHEET NO. 14...(CONTINUED)**  
**VEHICLE STRUCTURAL MEASUREMENTS**

Test Vehicle: 2005 Toyota Scion TC 3-Door Hatchback

NHTSA No.: M55110

Test Program: 2005 NHTSA 35mph NCAP

Test Date: 9/30/04

**VEHICLE STRUCTURAL MEASUREMENT TABLE**

No.	Measurement Description	Units	Pre-Test	Post-Test	Diff.
1	Total length	mm	4407	3967	-440
2	Total width	mm	1730	1735	5
3	Bumper top height	mm	600	620	20
4	Bumper bottom height	mm	178	180	2
5	Longitudinal member top height	mm	575	625	50
6	Longitudinal member bottom height	mm	457	515	58
7	Distance between longitudinal members	mm	900	920	20
8	Longitudinal member width	mm	85	85	0
9	Engine top height	mm	835	850	15
10	Engine bottom height	mm	163	223	60
11	Engine and gear box width	mm	800	800	0
12	Front bumper to engine distance	mm	668	530	-138
13	Front shock absorber fixing width	mm	850	830	-20
14	Bonnet leading edge height	mm	765	800	35
15	Front shock absorber fixing width	mm	1142	1130	-12
16	Front bumper to front axle distance	mm	845	430	-415
17	Front axle to 'A' pillar distance	mm	445	490	45
18	'A' pillar to 'B' pillar distance	mm	1340	1335	-5
19	'B' pillar to rear axle distance	mm	914	920	6
20	'B' pillar to 'C' pillar distance	mm	730	737	N/A
21	Roof sill bottom height	mm	1260	1245	-15
22	Roof sill top height	mm	1375	1365	-10
23	Floor sill bottom height	mm	185	170	-15
24	Floor sill top height	mm	340	340	0

All measurements are in millimeters

**DATA SHEET NO. 14...(CONTINUED)**  
**VEHICLE MEASUREMENTS**

Test Vehicle: 2005 Toyota Scion TC 3-Door Hatchback

NHTSA No.: M55110

Test Program: 2005 NHTSA 35mph NCAP

Test Date: 9/30/04

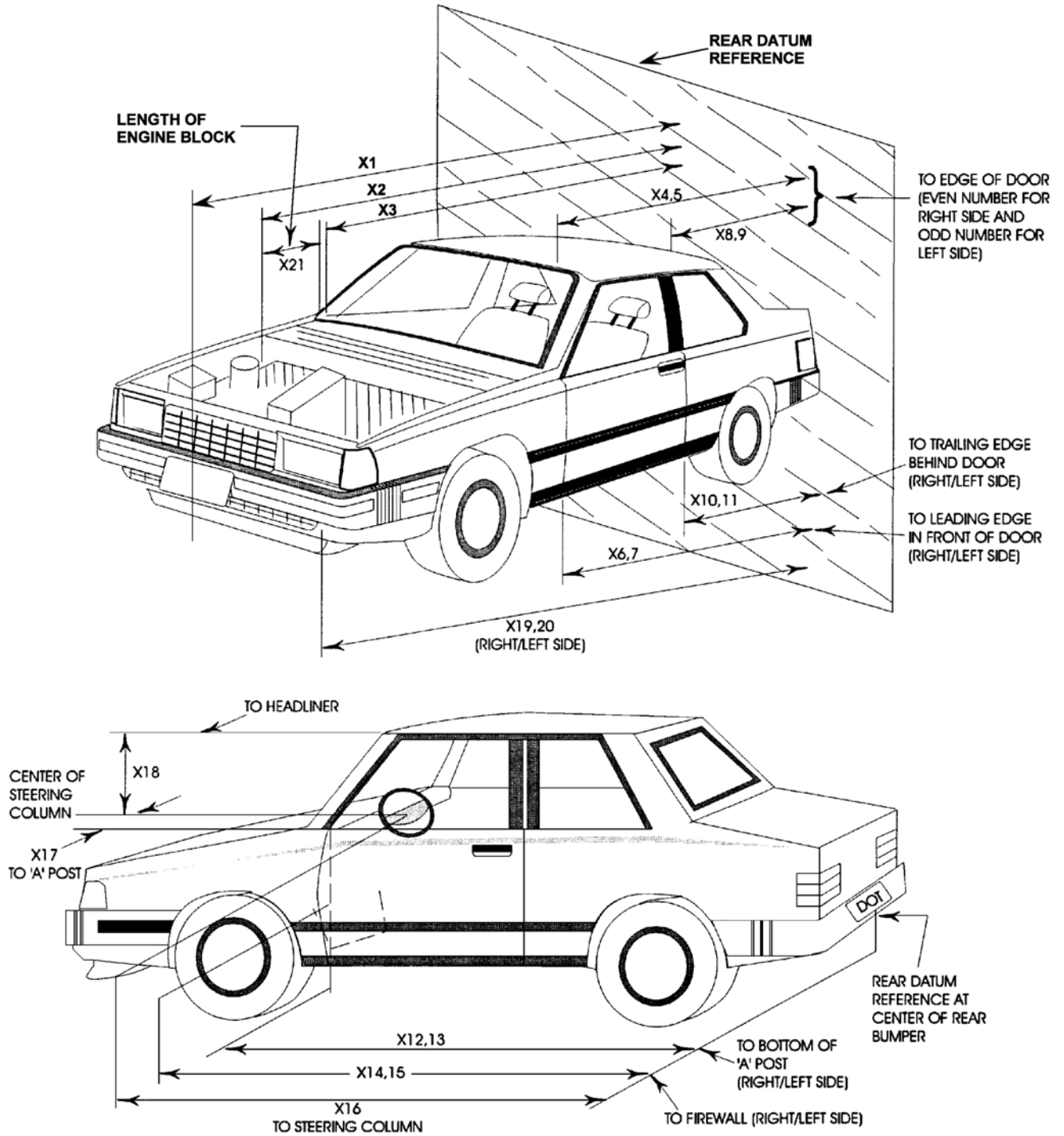

**DATA SHEET NO. 15  
CAMERA LOCATIONS**

Test Vehicle: 2005 Toyota Scion TC 3-Door Hatchback

NHTSA No.: M55110

Test Program: 2005 NHTSA 35mph NCAP

Test Date: 9/30/04

**VEHICLE CAMERA MEASUREMENT TABLE**

No.	Camera View	Location (mm)			Angle (deg.)	Film Plane to Head	Lens (mm)	Speed (fps)
		X	Y	Z				
1	Real Time Camera (Panning)	-12192	-6096	-1651	-10	N/A	Zoom	30
2	Real Time Camera (Still)	-1219	-8585	-1372	0	8547	Zoom	30
3	Real Time Camera (Still)	-1067	7976	-991	0	7883	Zoom	30
4	Overall Left Side	-2489	-8280	-1143	-4	8139	13	1005
5	Left Side View	-1677	-7773	-1270	-4	7702	50	1000
6	Left Side View	-2134	-8230	-1449	-4	8174.0	35	1015
7	Driver and Interior View	-5257	-10897	-4648	-13	12289	75	1020
8	Driver and Interior View	-5360	-10846	-4648	-13	12272	Zoom	1000
9	Steering Column (Bottom)	-2134	-8230	-2997	-16	8773	19	1020
10	Steering Column (Top)	-2134	-8230	-3404	-20	8968	19	1010
11	Overall Right Side	-2083	8230	-1270	-6	8122	13	1005
12	Right Side View	-1577	10871	-1575	-4	10767	105	1000
13	Right Side Passenger View	-1677	10871	-1575	-4	10762	80	970
14	Passenger and Interior View	-6481	9144	-2997	-9	10630	50	1000
15	Passenger and Interior View	-6477	9068	-2946	-9	10420	Zoom	1005
16	Right Side View	-2083	8230	-1575	-4	8215	28	1000
17	Right Side View	-1883	8230	-1575	-4	8220	28	1000
18	Windshield View	-610	0	-5944	-90	N/A	13	1005
19	Driver Front View	610	-432	-2667	-40	N/A	13	1055
20	Passenger Front View	610	432	-2667	-40	N/A	13	700
21	Pit View of Engine	-914	0	1499	90	N/A	9	1100
22	Pit View of Fuel Tank	-2438	0	1499	90	N/A	6	880

X = Barrier Face Y = Monorail Centerline Z = Ground DNR = Did Not Run NTM = No Timing Marks

**DATA SHEET NO. 16**  
**PHOTOGRAPHIC REFERENCE TARGET LOCATIONS**

Test Vehicle: 2005 Toyota Scion TC 3-Door Hatchback

NHTSA No.: M55110

Test Program: 2005 NHTSA 35mph NCAP

Test Date: 9/30/04

All Dimensions in (mm)	
Item	Value
A	N/A
B	865
C	N/A
D	N/A
E	N/A
F	N/A
G	1665
H	1012
I	1330
J	927
K	927
L	1221
M	1002
N	1225
O	930
P	930
Q	1330

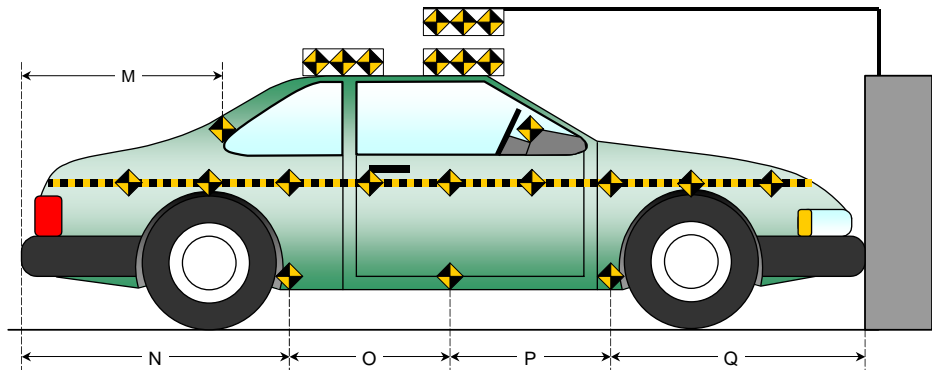
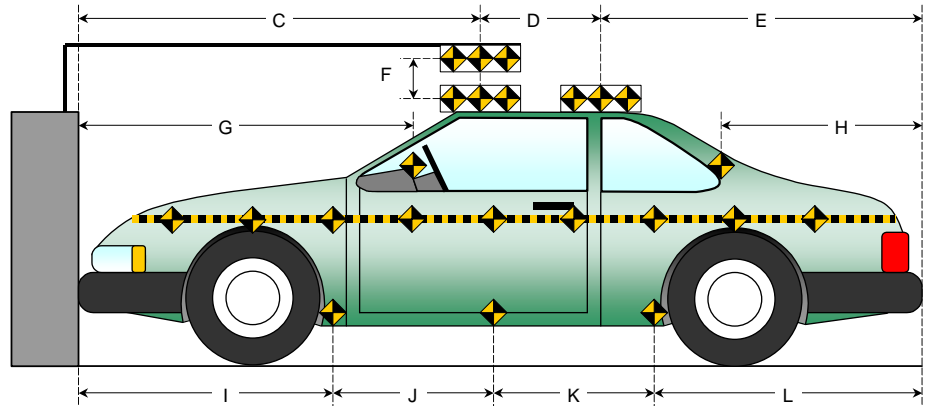
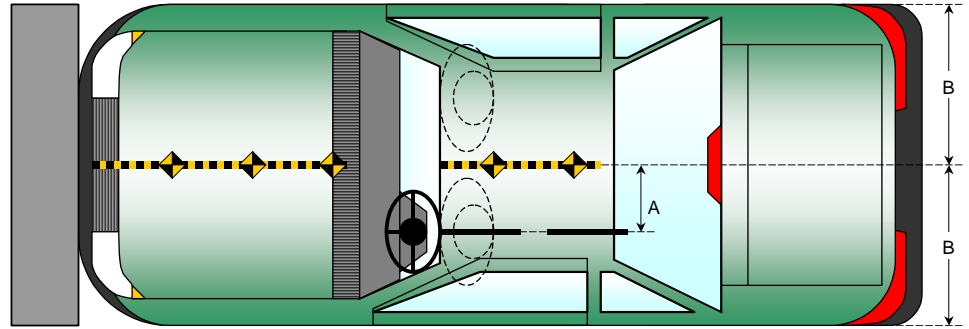

**DATA SHEET NO. 17**  
**VEHICLE INTRUSION MEASUREMENTS**

Test Vehicle: 2005 Toyota Scion TC 3-Door Hatchback

NHTSA No.: M55110

Test Program: 2005 NHTSA 35mph NCAP

Test Date: 9/30/04

**DOOR OPENING WIDTH TABLE**

Item	Description	Units	Pre-Test	Post-Test	Diff.
A	Left Side Upper	mm	1224	1224	0
B	Left Side Lower	mm	1144	1144	0
D	Right Side Upper	mm	1229	1224	-5
E	Right Side Lower	mm	1154	1149	-5

**WHEELBASE MEASUREMENT TABLE**

Item	Description	Units	Pre-Test	Post-Test	Diff.
C	Left Side Wheel Base	mm	2700	2705	5
F	Right Side Wheel Base	mm	2700	2635	-65

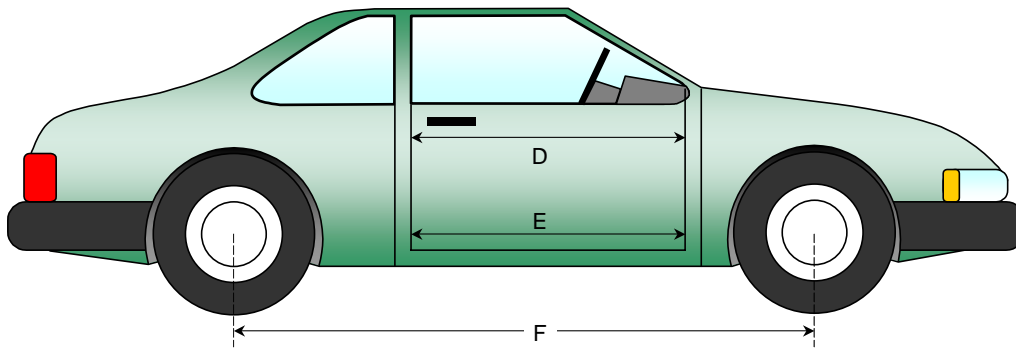
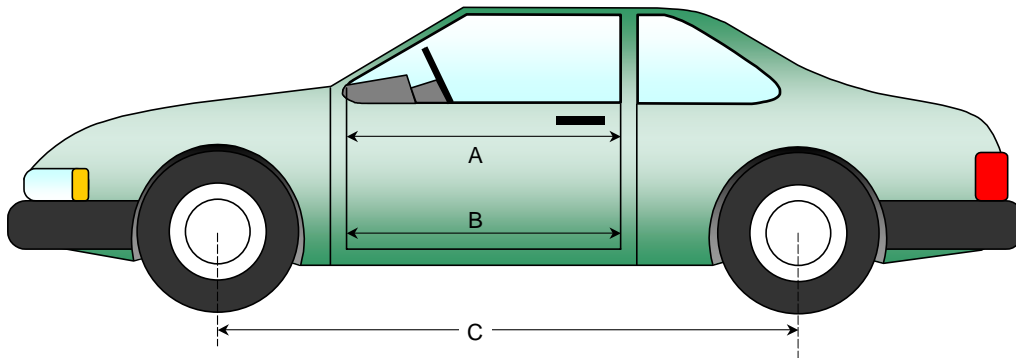

**DATA SHEET NO. 17...(CONTINUED)**  
**VEHICLE INTRUSION MEASUREMENTS**

Test Vehicle: 2005 Toyota Scion TC 3-Door Hatchback

NHTSA No.: M55110

Test Program: 2005 NHTSA 35mph NCAP

Test Date: 9/30/04

**DRIVER COMPARTMENT INTRUSION TABLE**

Item	Description	Units	Pre-Test	Post-Test	Diff.
AB	Door Opening (Inside window jam)	mm	1224	1224	0
CX	Left Knee Bolster to X	mm	280	385	105
DX	Right Knee Bolster to X	mm	270	330	60
EX	Brake Pedal to X	mm	554	544	-10
FX	Foot Rest to X	mm	559	589	30
GX	Center of Steering Wheel Hub to X	mm	30	85	55

X = Left Front Seat Outboard Anchor Bolt Head

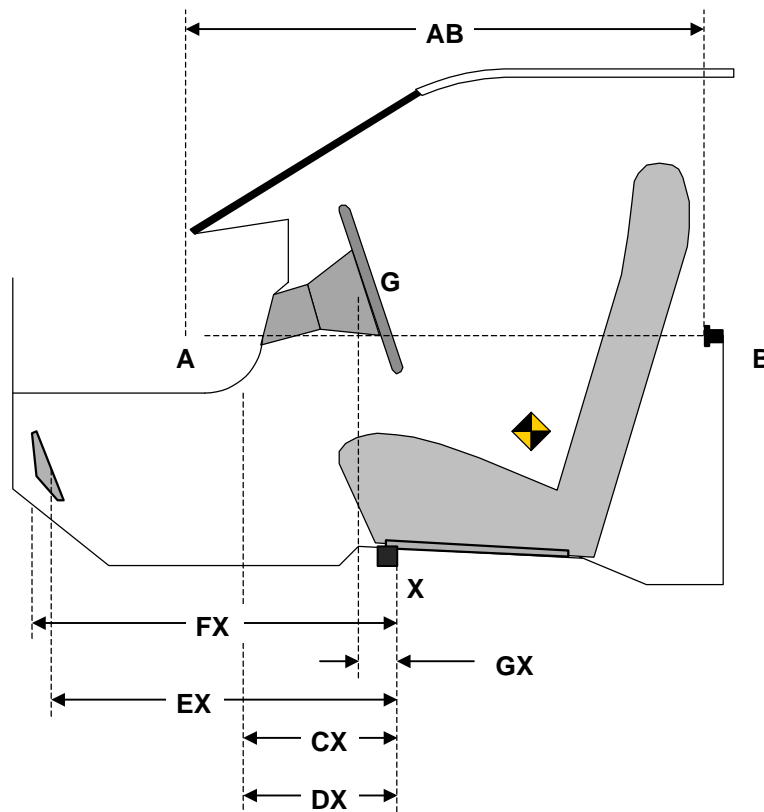

**DATA SHEET NO. 17...(CONTINUED)**  
**VEHICLE INTRUSION MEASUREMENTS**

Test Vehicle: 2005 Toyota Scion TC 3-Door Hatchback

NHTSA No.: M55110

Test Program: 2005 NHTSA 35mph NCAP

Test Date: 9/30/04

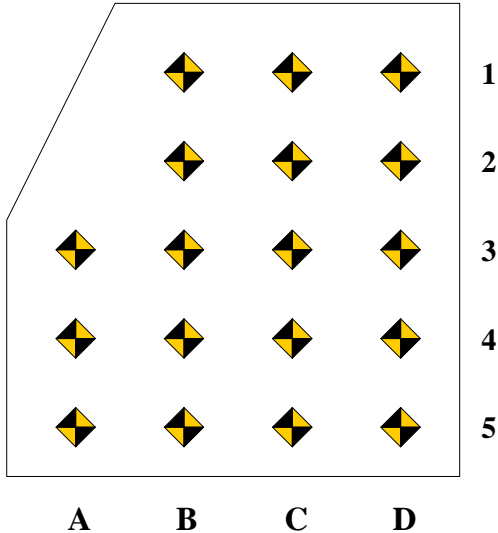

Measurement reference point for X and Z-axis is the forward outboard seat mounting bolt.

Columns A through D are evenly spaced.

Rows 1 and 2 are on the toe kick portion of the floor pan. Rows 3, 4 and 5 are located on the most level portion of the floor pan.

Row 3 will be at the intersection of the toe kick and the level sections of the floor pan.

**DRIVER FLOOR PAN X-AXIS**

	Pre-Test				Post-Test				Difference			
	A	B	C	D	A	B	C	D	A	B	C	D
1		670	675	671		646	646	647		-24	-30	-24
2		597	591	587		583	571	570		-14	-20	-17
3	520	509	505	497	510	509	508	508	-9	-1	4	11
4	413	407	402	396	408	415	408	408	-5	8	6	11
5	315	306	301	297	311	312	309	311	-4	5	8	14

**DRIVER FLOOR PAN Z-AXIS**

	Pre-Test				Post-Test				Difference			
	A	B	C	D	A	B	C	D	A	B	C	D
1		-57	-44	-47		-40	-31	-23		18	13	24
2		6	13	13		31	32	41		26	19	28
3	64	59	61	61	88	97	103	104	24	37	42	43
4	68	63.2	63	67	92	98	98	100	24	35	36	33
5	81	63.1	64	75	91	90	98	114	10.31	26	33	39

**DATA SHEET NO. 17...(CONTINUED)  
VEHICLE INTRUSION MEASUREMENTS**

Test Vehicle: 2005 Toyota Scion TC 3-Door Hatchback

NHTSA No.: M55110

Test Program: 2005 NHTSA 35mph NCAP

Test Date: 9/30/04

Measurement reference point for X and Z axis is the forward outboard seat mounting bolt.

Columns A through D are evenly spaced.

Rows 1 and 2 are on the toe kick portion of the floor pan. Rows 3, 4 and 5 are located on the most level portion of the floor pan.

Row 3 will be at the intersection of the toe kick and the level sections of the floor pan.

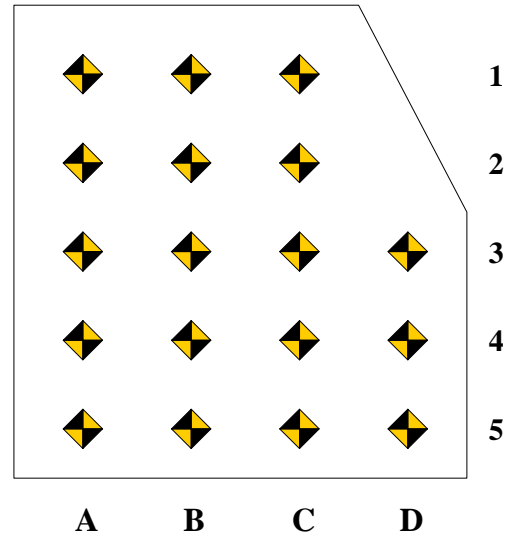

**PASSENGER FLOOR PAN X-AXIS**

	Pre-Test				Post-Test				Difference			
	A	B	C	D	A	B	C	D	A	B	C	D
1	680	679	673		628	636	633		-53	-43	-40	
2	605	598	597		565	565	570		-40	-33	-27	
3	516	511	508	507	507	502	496	498	-9	-9	-12	-10
4	414	411	409	410	403	402	400	402	-11	-10	-9	-8
5	315	312	307	307	303	300	300	300	-12	-12	-7	-7

**PASSENGER FLOOR PAN Z-AXIS**

	Pre-Test				Post-Test				Difference			
	A	B	C	D	A	B	C	D	A	B	C	D
1	-35	-41	-42		-48	-39	-42		-13	2	-1	
2	26	20	18		26	29	33		0	8	15	
3	62	63	63	63	87	89	90	86	26	26	27	23
4	76	68	66	66	101	94	89	83	25	26	23	17
5	85	73	67	85	103	90	85	97	18	18	17	12

**DATA SHEET NO. 18**  
**FIXED BARRIER LOAD CELL LOCATIONS**

Test Vehicle: 2005 Toyota Scion TC 3-Door Hatchback

NHTSA No.: M55110

Test Program: 2005 NHTSA 35mph NCAP

Test Date: 9/30/04

**36 Load Cell Rigid Barrier (NHTSA Standard)**  
**Load Cell Locations on Fixed Barrier**

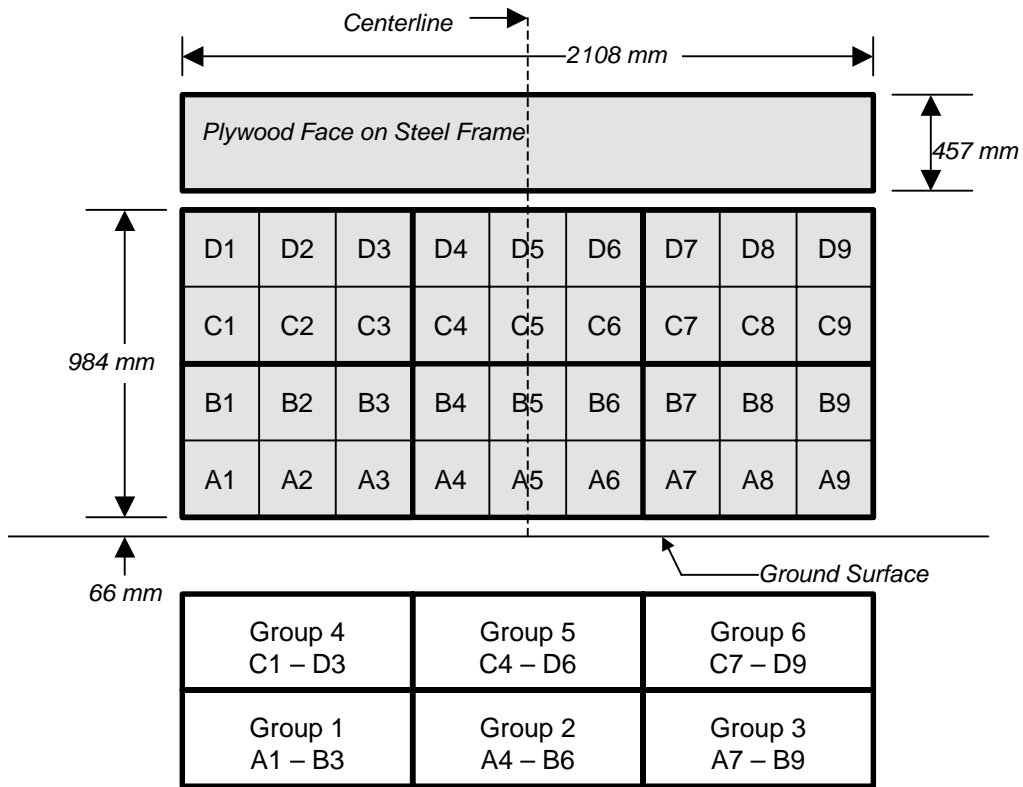

6 Groups of 6 Load Cells Each

The Data is presented in Appendix C with the following requirements:

- 1.) Data from 36 individual load cells
- 2.) Sum data from 6 groupings shown above (6 cells/group)
- 3.) Total or sum of all 36 individual load cells
- 4.) Sum of all 36 individual load cells vs. vehicle dynamic crush

**DATA SHEET NO. 19**  
**POST-TEST AIRBAG DATA**

Test Vehicle: 2005 Toyota Scion TC 3-Door Hatchback

NHTSA No.: M55110

Test Program: 2005 NHTSA 35mph NCAP

Test Date: 9/30/04

**POST-TEST AIRBAG DATA**

	DRIVER	PASSENGER
No. of vent holes	2	2
Size of vent holes (mm <sup>2</sup> )	1962	2826
Total vent area (mm <sup>2</sup> )	3925	5652

<b>Deflated Airbag Length and Width Dimensions or, If Round, Diameter (mm)</b>		
Length	N/A	730
Width	N/A	550
Depth or Diameter	590	650

<b>Tethering Information</b>		
Is the airbag tethered?	Yes	No
Record length of tether (mm)	340	N/A

<b>Airbag Manufacturing Information</b>		
Manufacturer	Daicel Safety Systems	Daicel Safety Systems
Part No.	GA120-00780 784010813	GA220-00750 5H413664
Gas Generator	Z21D4157915	Y12K434827

Sketch the airbag showing the location of the vent holes, how the bag is tethered, and where the bag is tethered. Also describe how the tethers are attached to the bag and the steering wheel:

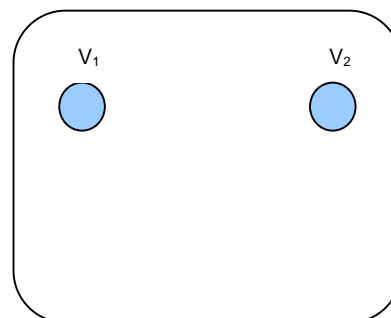
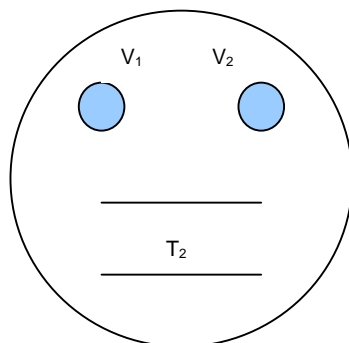

**DATA SHEET NO. 20**  
**ACCIDENT INVESTIGATION DIVISION DATA**

Test Vehicle: 2005 Toyota Scion TC 3-Door Hatchback NHTSA No.: M55110  
 Test Program: 2005 NHTSA 35mph NCAP Test Date: 9/30/04

**VEHICLE INFORMATION**

VIN: JTKDE177550014651 Wheel base (mm): 2700  
 Vehicle Size Category: 3-Door Hatchback Test Weight (kg): 1515

**ACCELEROMETER DATA**

Accelerometer Location: Left rear sill  
 Cal. Procedure/Interval: 6 months / drop test  
 Integration Algorithm: NHTSA Standard Linearity: Good  
 Impact Velocity (km/h): 56.13  
 Velocity Change (km/h): 64.28 Time of Separation (msec): 65.0

**CRUSH PROFILE**

Collision Deformation Classification: 12FDEW6 Midpoint of Damage: Vehicle Centerline  
 Damage Region Length (mm): 1315 Impact Mode: Full Frontal

No.	Measurement Description	Units	Pre-Test	Post-Test	Difference
C1	Crush zone 1 at left side	mm	190	500	-310
C2	Crush zone 2 on left side	mm	63	480	-417
C3	Crush zone 3 on left side	mm	34	475	-441
C4	Crush zone 4 on right side	mm	34	490	-456
C5	Crush zone 5 on right side	mm	63	510	-447
C6	Crush zone 6 at right side	mm	190	500	-310

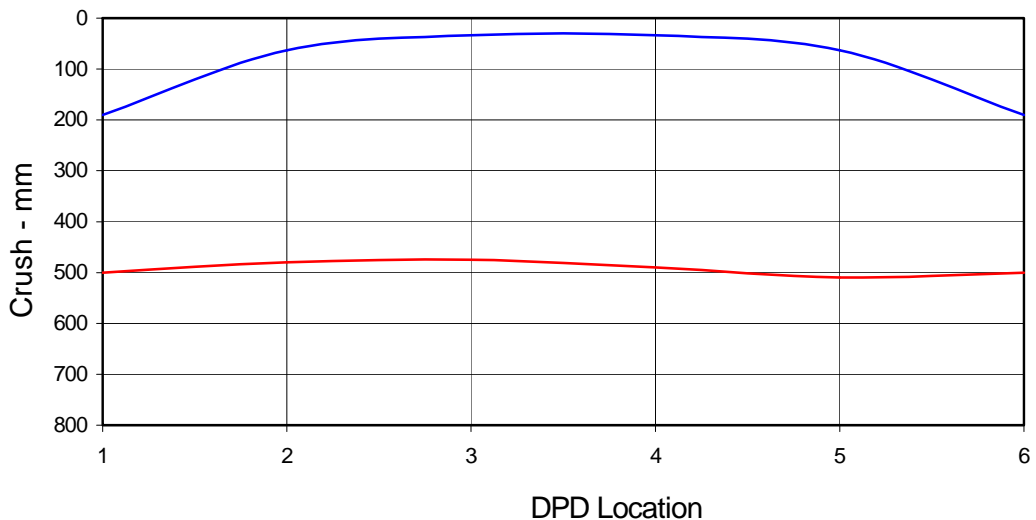

**DATA SHEET NO. 21**  
**DUMMY/VEHICLE TEMPERATURE STABILIZATION**

Test Vehicle: 2005 Toyota Scion TC 3-Door Hatchback

NHTSA No.: M55110

Test Program: 2005 NHTSA 35mph NCAP

Test Date: 9/30/04

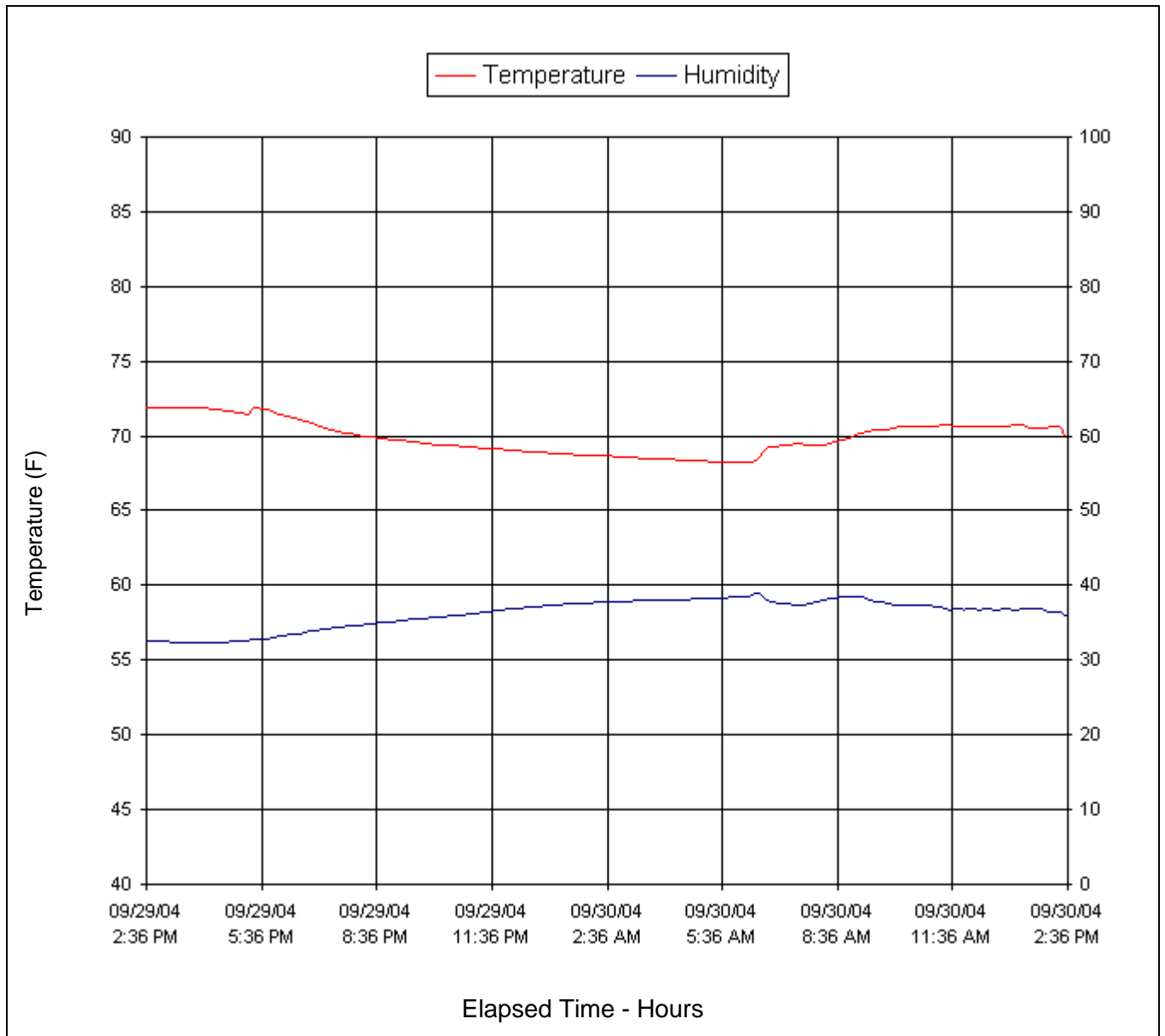

**APPENDIX A**  
**PHOTOGRAPHS**

## LIST OF PHOTOGRAPHS

Figure		Page
1	Load Cell Location	A-1
2	Vehicle Certification Label	A-2
3	Vehicle Tire Label	A-3
4	Right Front $\frac{3}{4}$ View, As Received	A-4
5	Left Rear $\frac{3}{4}$ View, As Received	A-5
6	Pre-Test Front View	A-6
7	Post-Test Front View (Vehicle Moved)	A-7
8	Pre-Test Left Side View	A-8
9	Post-Test Left Side View	A-9
10	Pre-Test Right Side View	A-10
11	Post-Test Right Side View	A-11
12	Pre-Test Right Front $\frac{3}{4}$ View	A-12
13	Post-Test Right Front $\frac{3}{4}$ View	A-13
14	Pre-Test Left Rear $\frac{3}{4}$ View	A-14
15	Post-Test Left Rear $\frac{3}{4}$ View	A-15
16	Left Rear $\frac{3}{4}$ View of Doors After Impact	A-16
17	Right Rear $\frac{3}{4}$ View of Doors After Impact	A-17
18	Pre-Test Windshield View	A-18
19	Post-Test Windshield View	A-19
20	Pre-Test Engine Compartment	A-20
21	Post-Test Engine Compartment (Vehicle Moved)	A-21
22	Pre-Test Fuel Cap	A-22
23	Post-Test Fuel Cap	A-23
24	Pre-Test Front Underbody View	A-24
25	Post-Test Front Underbody View	A-25
26	Pre-Test Mid Underbody View	A-26
27	Post-Test Mid Underbody View	A-27
28	Pre-Test Rear Underbody View	A-28
29	Post-Test Rear Underbody View	A-29
30	Pre-Test Driver Dummy Front View (Head Position)	A-30
31	Post-Test Driver Dummy Front View (Head Position)	A-31
32	Pre-Test Driver Dummy Through Window	A-32
33	Post-Test Driver Dummy Through Window	A-33
34	Pre-Test Driver Dummy (Door Open)	A-34

LIST OF PHOTOGRAPHS...(Continued)

Figure		Page
35	Post-Test Driver Dummy (Door Open)	A-35
36	Pre-Test Driver Dummy Feet	A-36
37	Post-Test Driver Dummy Feet	A-37
38	Pre-Test Driver Side Knee Bolster	A-38
39	Post-Test Driver Side Knee Bolster	A-39
40	Pre-Test Driver Side Floor Pan	A-40
41	Post-Test Driver Side Floor Pan	A-41
42	Post-Test Driver Dummy Head	A-42
43	Post-Test Driver Dummy Contact to Air Bag	A-43
44	Pre-Test Passenger Dummy Front View (Head Position)	A-44
45	Post-Test Passenger Dummy Front View (Head Position)	A-45
46	Pre-Test Passenger Dummy Through Window	A-46
47	Post-Test Passenger Dummy Through Window	A-47
48	Pre-Test Passenger Dummy (Door Open)	A-48
49	Post-Test Passenger Dummy (Door Open)	A-49
50	Pre-Test Passenger Dummy Feet	A-50
51	Post-Test Passenger Dummy Feet	A-51
52	Pre-Test Passenger Side Glove Box	A-52
53	Post-Test Passenger Side Glove Box	A-53
54	Pre-Test Passenger Side Floor Pan	A-54
55	Post-Test Passenger Side Floor Pan	A-55
56	Post-Test Passenger Dummy Head	A-56
57	Post-Test Passenger Dummy Contact to Air Bag	A-57
58	Vehicle on Rollover Device (0°)	A-58
59	Vehicle on Rollover Device (90°)	A-59
60	Vehicle on Rollover Device (180°)	A-60
61	Vehicle on Rollover Device (270°)	A-61

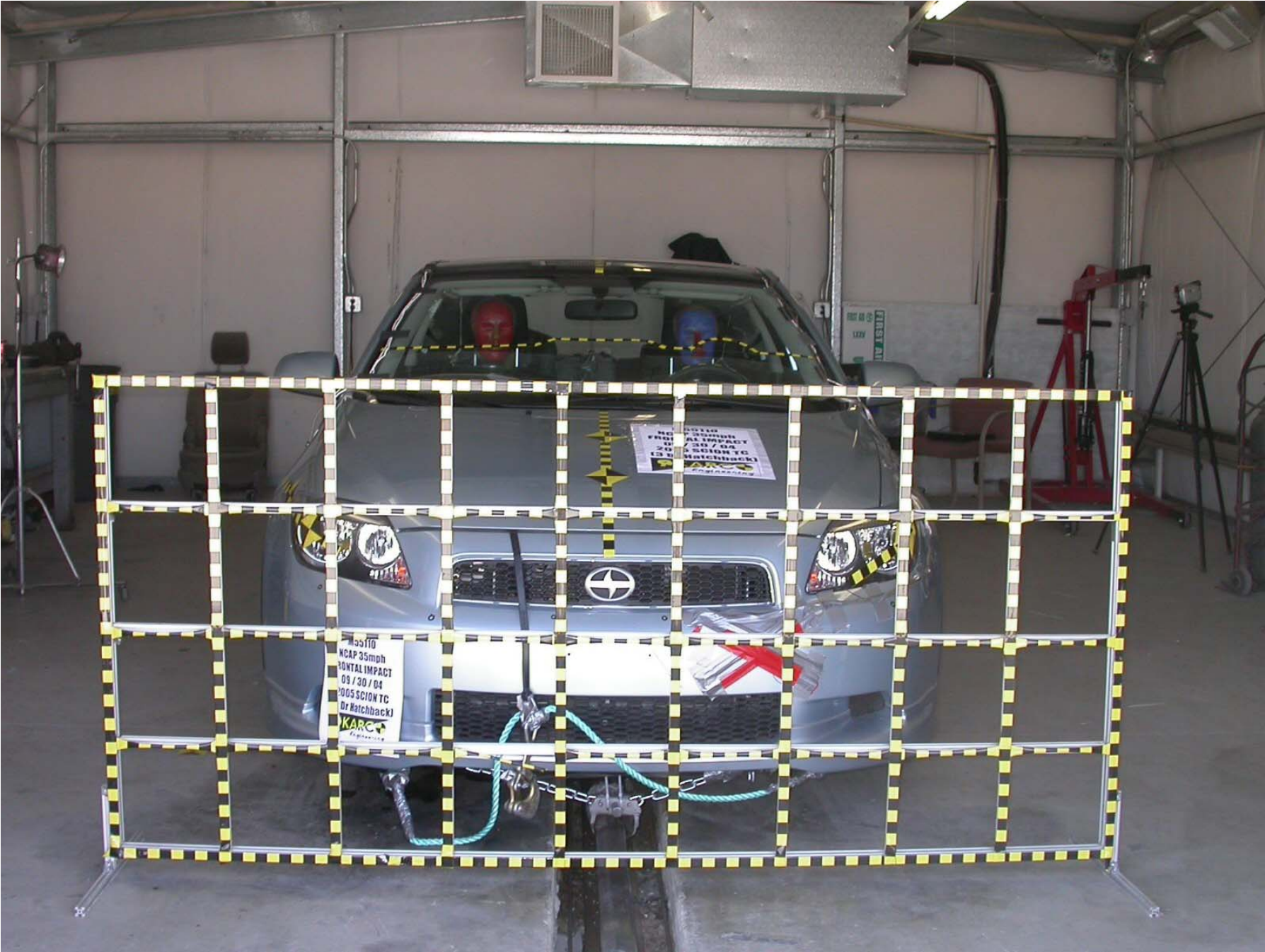

Figure A-1: Load Cell Location

**CHARGEMENT**

ARRIÈRE 3  
gement ne  
865 lb.

DE  
A FROID  
<Pa.32PSI  
Pa.29PSI  
AGE A FROID  
60PSI

**POUR DE PLUS  
AMPOLES INFOR-  
MATIONS, VOIR  
LE MANUEL DU  
PROPRIÉTAIRE.**

**M 4**

MFD. BY: TOYOTA MOTOR CORPORATION 08/04  
GVWR 3945LB GAWR FR 2130LB RR 1835LB  
THIS VEHICLE CONFORMS TO ALL APPLICABLE  
FEDERAL MOTOR VEHICLE SAFETY, BUMPER, AND  
THEFT PREVENTION STANDARDS IN EFFECT ON  
THE DATE OF MANUFACTURE SHOWN ABOVE.  
JTKDE177550014651 PASS CAR



C/TR: 8Q6/FA14 ANT10L-ALMGKA  
A/TM: -02A/E350\* MADE IN JAPAN 009 A

  
JTKDE177550014651  
009

Figure A-2: Vehicle Certification Label

**TIRE AND LOADING INFORMATION**

SEATING CAPACITY: TOTAL 5  
FRONT 2: REAR 3  
The combined weight of occupants and cargo should never exceed 392 kg or 865 lbs.

SEE OWNER'S  
MANUAL FOR  
ADDITIONAL  
INFORMATION.

21210

ORIGINAL TIRE SIZE	COLD TIRE INFLATION PRESSURE	
	215/45ZR17	FRONT
REAR		200kPa, 29PSI
COMPACT SPARE TIRE	COLD TIRE INFLATION PRESSURE	
T125/70D17	420kPa, 60PSI	

**INFORMATION SUR LES PNEUS ET LE CHARGEMENT**

NOMBRE DE PLACES ASSISES: TOTAL 5  
AVANT 2: ARRIÈRE 3  
Le poids total des occupants et du chargement ne doit jamais être supérieur à 392 kg ou 865 lb.

DIMENSION DES PNEUS D'ORIGINE	PRESSION DE GONFLAGE À FROID	
	215/45ZR17	AVANT
ARRIÈRE		200kPa, 29PSI
ROUE DE SECOURS COMPACTE	PRESSION DE GONFLAGE À FROID	
T125/70D17	420kPa, 60PSI	

POUR DE PLUS  
AMPOLES INFOR-  
MATIONS, VOIR  
LE MANUEL DU  
PROPRIÉTAIRE.

**M 4**



Figure A-3: Vehicle Tire Label



Figure A-4: Right Front  $\frac{3}{4}$  View, As Received



Figure A-5: Left Rear  $\frac{3}{4}$  View, as Received



Figure A-6: Pre-Test Front View

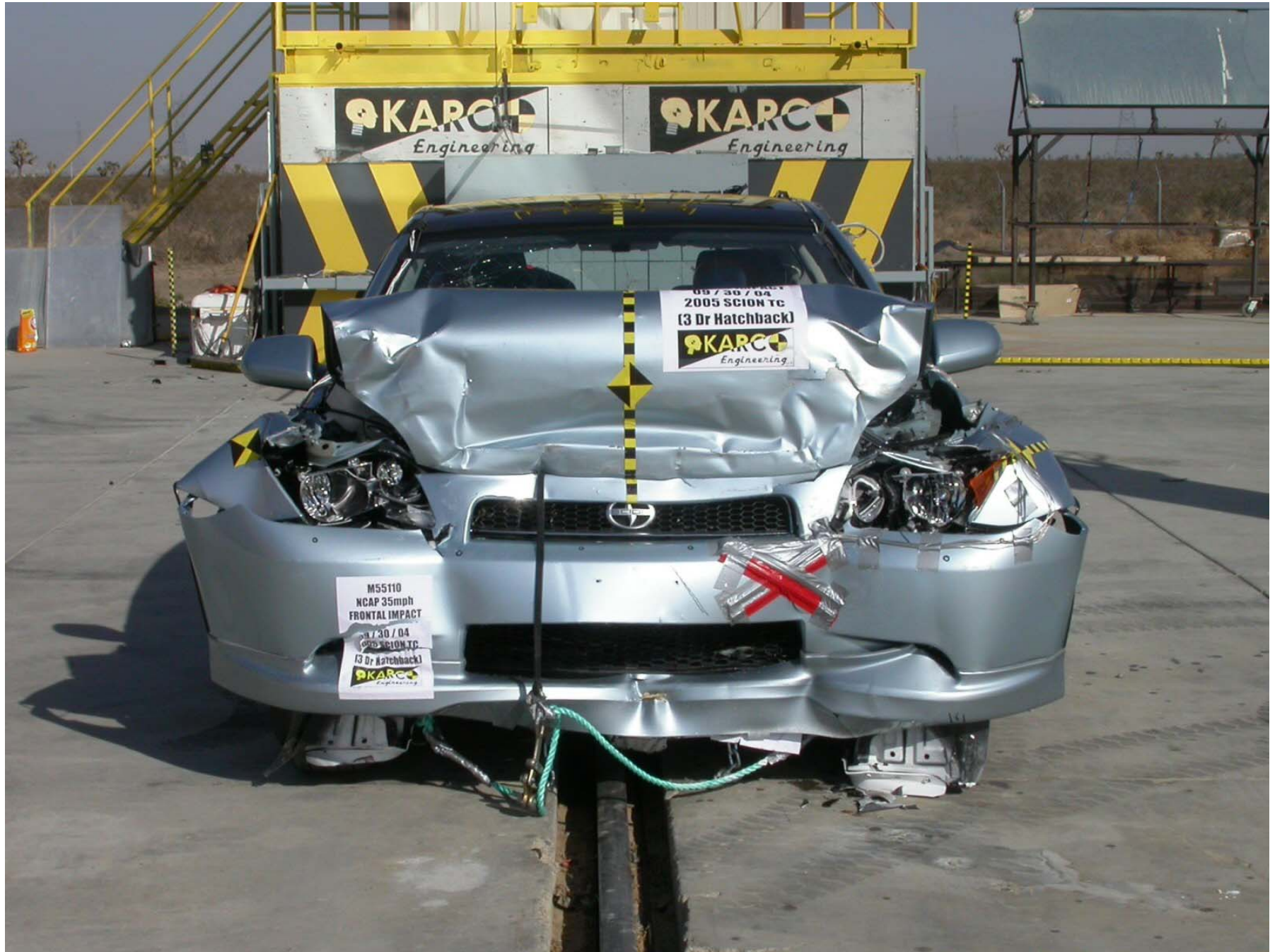

Figure A-7: Post-Test Front View (Vehicle Moved)



Figure A-8: Pre-Test Left Side View



Figure A-9: Post-Test Left Side View



Figure A-10: Pre-Test Right Side View



Figure A-11: Post-Test Right Side View



Figure A-12: Pre-Test Right Front 3/4 View



Figure A-13: Post-Test Right Front  $\frac{3}{4}$  View



A-14

TR-P25001-03-NC

Figure A-14: Pre-Test Left Rear  $\frac{3}{4}$  View



Figure A-15: Post-Test Left Rear ¾ View



Figure A-16: Left Rear  $\frac{3}{4}$  View of Doors After Impact



Figure A-17: Right Rear  $\frac{3}{4}$  View of Doors After Impact

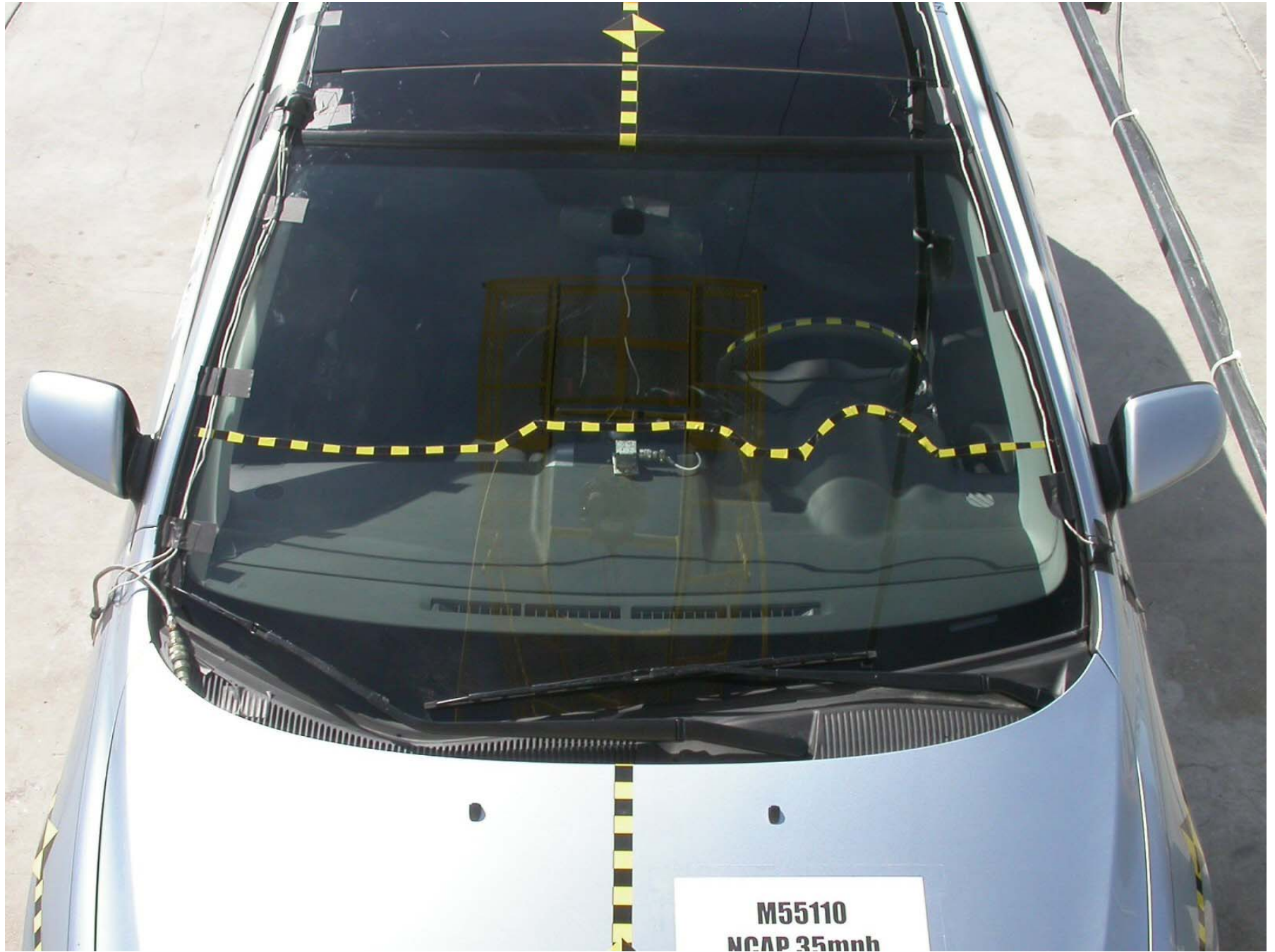

Figure A-18: Pre-Test Windshield



Figure A-19: Post-Test Windshield



Figure A-20: Pre-Test Engine Compartment



Figure A-21: Post-Test Engine Compartment (Vehicle Moved)



Figure A-22: Pre-Test Fuel Cap



Figure A-23: Post-Test Fuel Cap

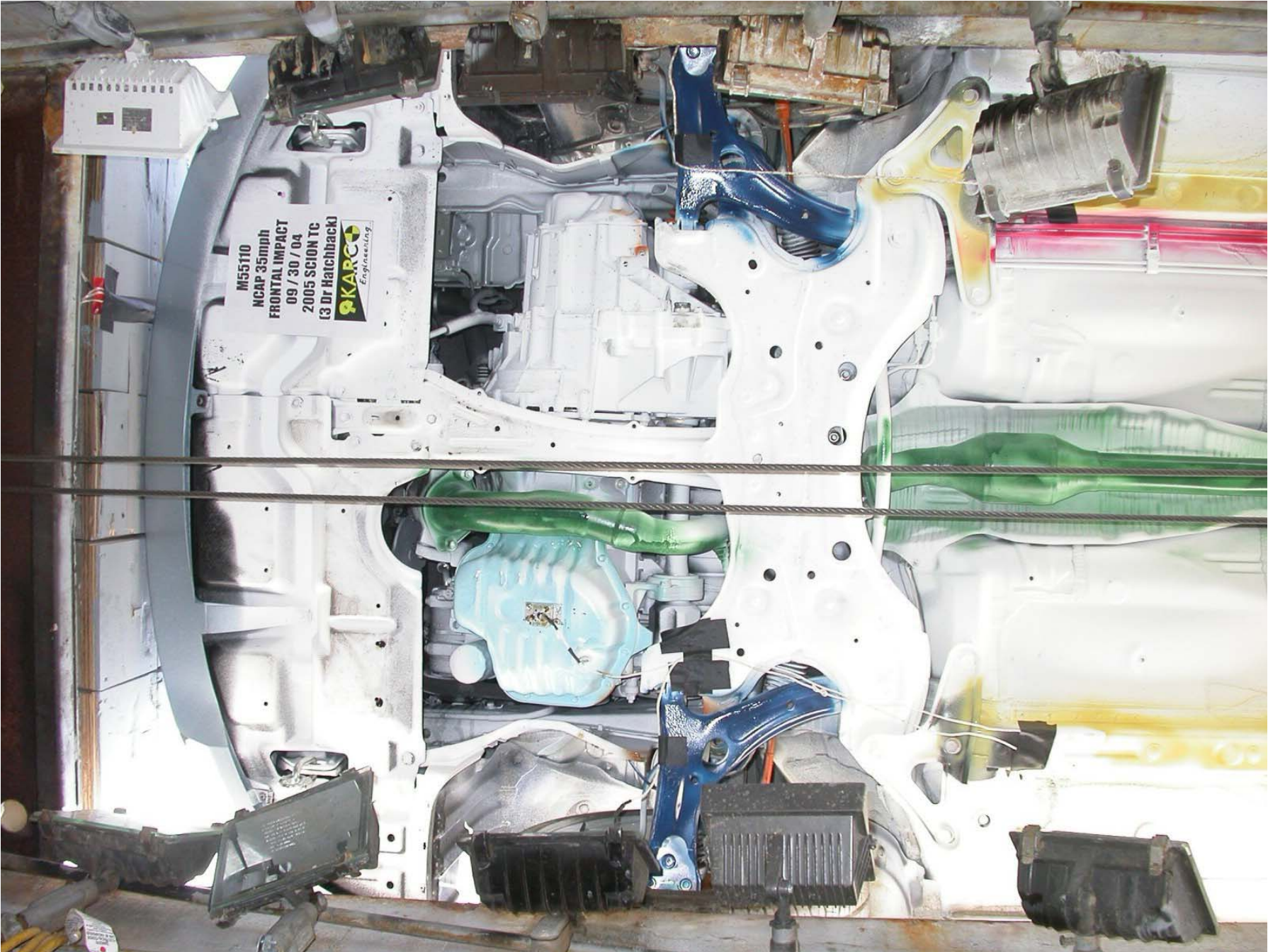

Figure A-24: Pre-Test Front Underbody



Figure A-25: Post-Test Front Underbody

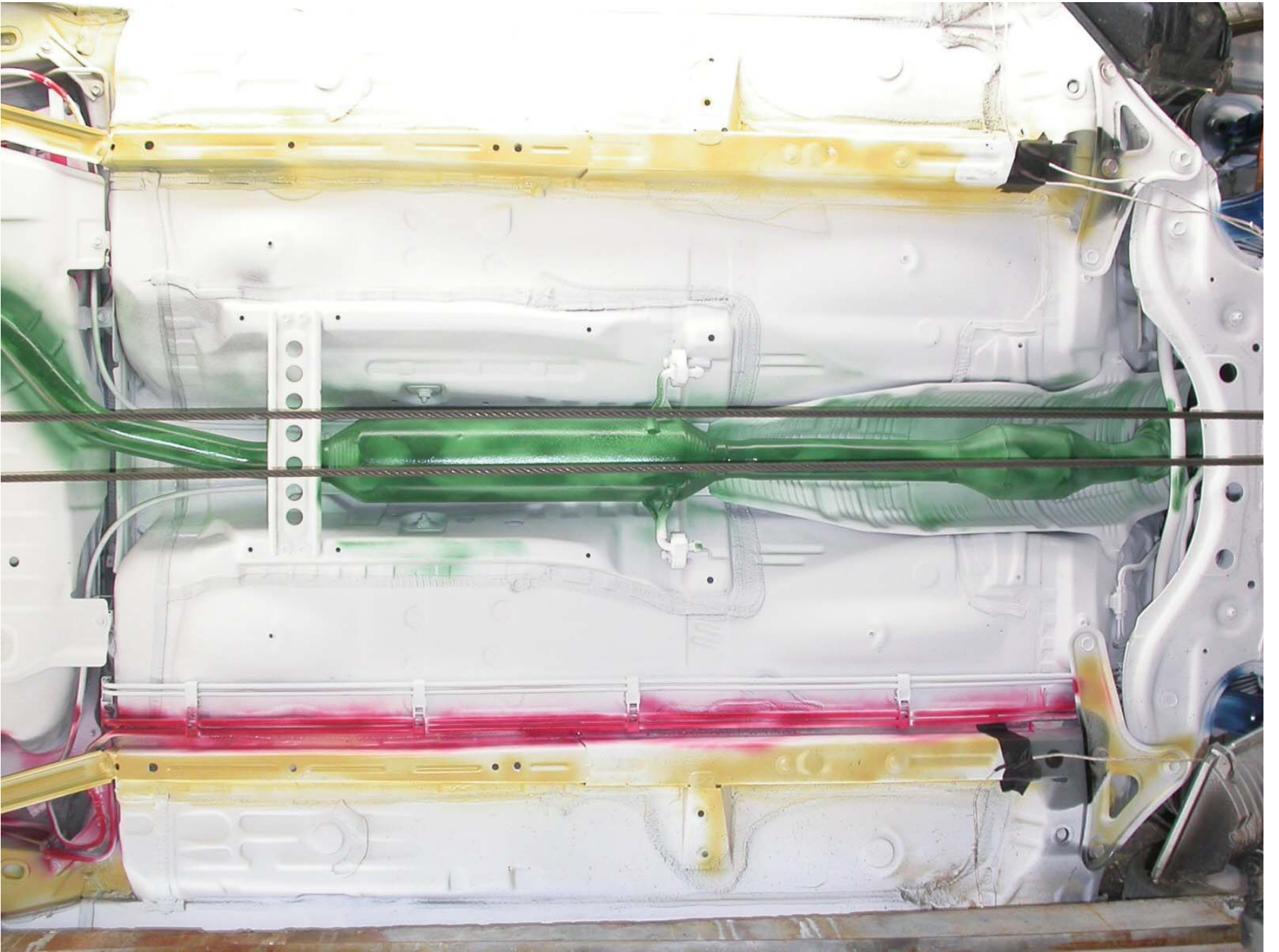

Figure A-26: Pre-Test Mid Underbody



Figure A-27: Post-Test Mid Underbody

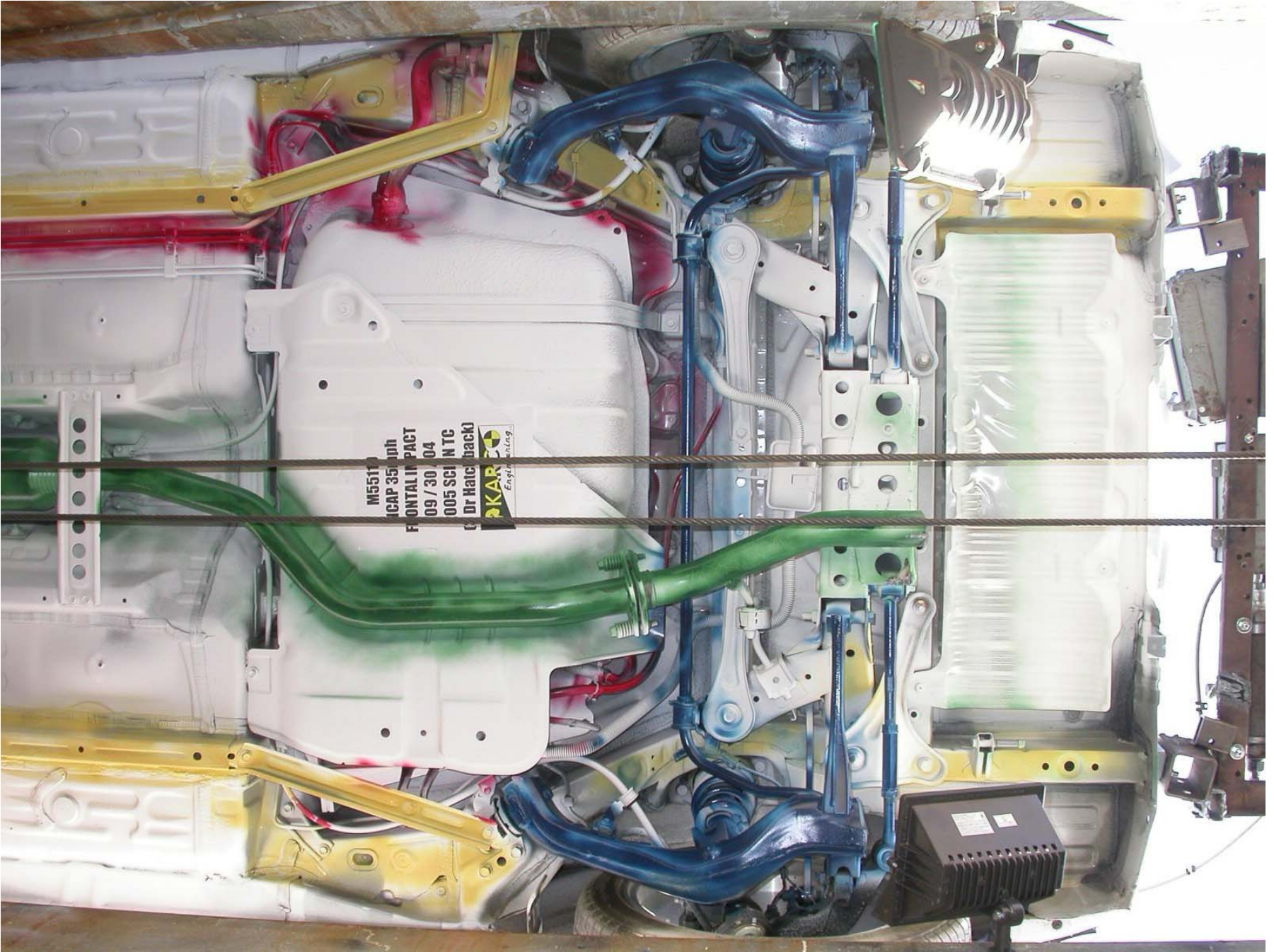

Figure A-28: Pre-Test Rear Underbody

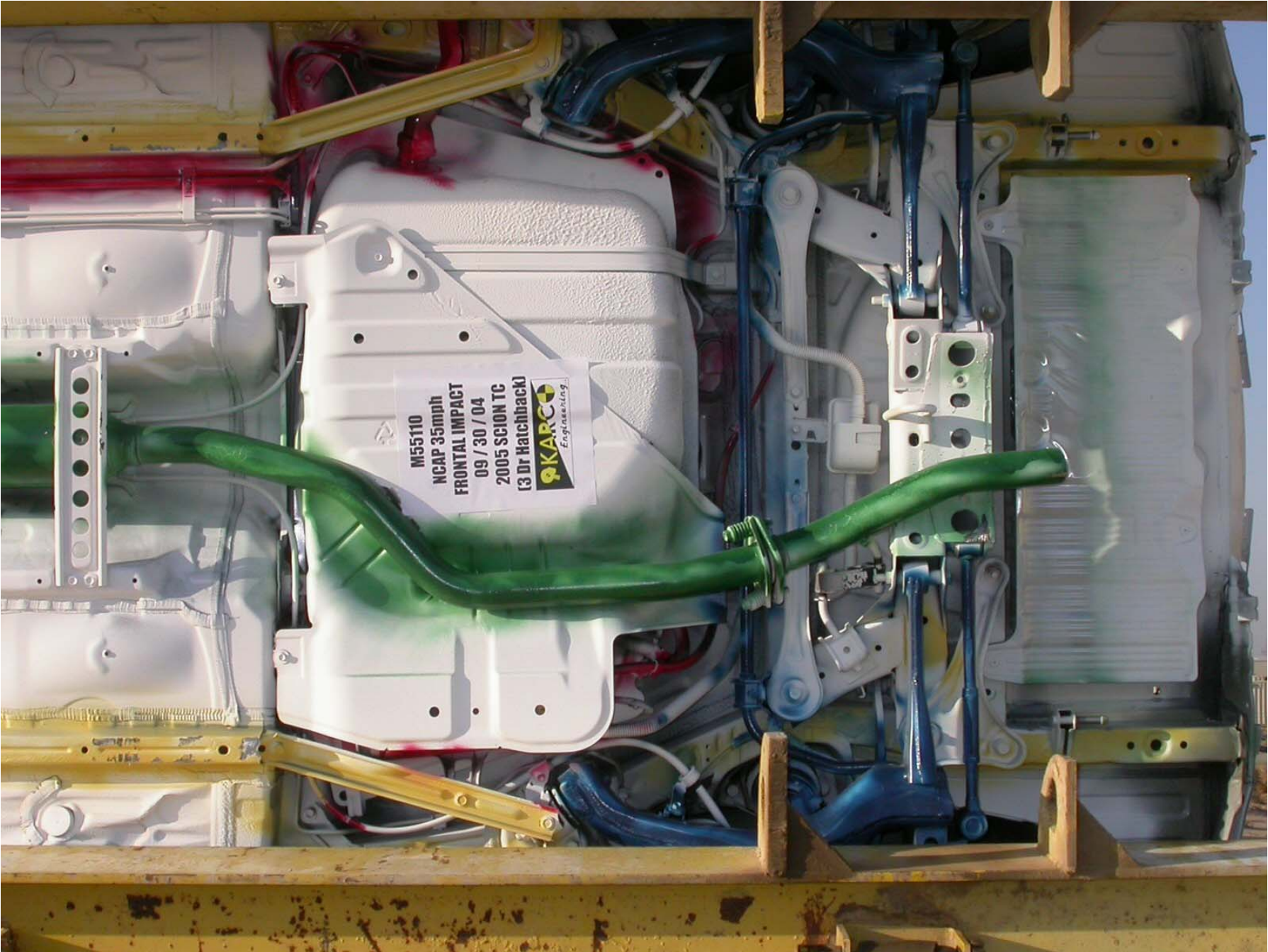

Figure A-29: Post-Test Rear Underbody



Figure A-30: Pre-Test Driver Dummy Head Position



Figure A-31: Post-Test Driver Dummy Head Position



Figure A-32: Pre-Test Driver Dummy Through Window



Figure A-33: Post-Test Driver Dummy Through Window



Figure A-34: Pre-Test Driver Dummy Position (Door Open)



Figure A-35: Post-Test Driver Dummy Position (Door Open)



A-36

TR-P25001-03-NC

Figure A-36: Pre-Test Driver Dummy Feet



Figure A-37: Post-Test Driver Dummy Feet



A-38

TR-P25001-03-NC

Figure A-38: Pre-Test Driver Side Knee Bolster



Figure A-39: Post-Test Driver Side Knee Bolster



Figure A-40: Pre-Test Driver Side Floor Pan



Figure A-41: Post-Test Driver Side Floor Pan



Figure A-42: Post-Test Driver Dummy Head



Figure A-43: Post-Test Driver Dummy Contact to Air Bag



Figure A-44: Pre-Test Passenger Dummy Head Position



Figure A-45: Post-Test Passenger Dummy Head Position



Figure A-46: Pre-Test Passenger Dummy Through Window



Figure A-47: Post-Test Passenger Dummy Through Window



Figure A-48: Pre-Test Passenger Dummy Position (Door Open)



Figure A-49: Post-Test Passenger Dummy Position (Door Open)



Figure A-50: Pre-Test Passenger Dummy Feet



Figure A-51: Post-Test Passenger Dummy Feet



Figure A-52: Pre-Test Passenger Side Glove Box



Figure A-53: Post-Test Passenger Side Glove Box



Figure A-54: Pre-Test Passenger Side Floor Pan



Figure A-55: Post-Test Passenger Side Floor Pan



Figure A-56: Post-Test Passenger Dummy Head



Figure A-57: Post-Test Passenger Dummy Contact to Air Bag



A-58

TR-P25001-03-NC

Figure A-58: Vehicle on Rollover Device at 0°



Figure A-59: Vehicle on Rollover Device at 90°



Figure A-60: Vehicle on Rollover Device at 180°



Figure A-61: Vehicle on Rollover Device at 270°

**APPENDIX B**

**DATA PLOTS**

## LIST OF DATA PLOTS

Data Plot	Page	
1	Driver Head Primary X	B-1
	Driver Head Primary Y	B-1
	Driver Head Primary Z	B-1
	Driver Head Resultant Primary	B-1
2	Driver Head Primary X Velocity	B-2
	Driver Head Primary X Displacement	B-2
3	Driver Head Redundant X	B-3
	Driver Head Redundant Y	B-3
	Driver Head Redundant Z	B-3
	Driver Head Resultant Redundant	B-3
4	Driver Head Redundant X Velocity	B-4
	Driver Head Redundant X Displacement	B-4
5	Driver Upper Neck Force X	B-5
	Driver Upper Neck Force Y	B-5
	Driver Upper Neck Force Z	B-5
	Driver Upper Neck Force Resultant	B-5
6	Driver Upper Neck Moment X	B-6
	Driver Upper Neck Moment Y	B-6
	Driver Upper Neck Moment Z	B-6
	Driver Upper Neck Moment Resultant	B-6
7	Driver Chest Primary X	B-7
	Driver Chest Primary Y	B-7
	Driver Chest Primary Z	B-7
	Driver Chest Resultant Primary	B-7
8	Driver Chest Primary X Velocity	B-8
	Driver Chest Primary X Displacement	B-8
9	Driver Chest Redundant X	B-9
	Driver Chest Redundant Y	B-9
	Driver Chest Redundant Z	B-9
	Driver Chest Resultant Redundant	B-9
10	Driver Chest Redundant X Velocity	B-10
	Driver Chest Redundant X Displacement	B-10
11	Driver Chest Displacement	B-11

LIST OF DATA PLOTS...(Continued)

Data Plot	Page	
12	Driver Pelvis X	B-12
	Driver Pelvis Y	B-12
	Driver Pelvis Z	B-12
	Driver Pelvis Resultant	B-12
13	Driver Pelvis X Velocity	B-13
	Driver Pelvis X Displacement	B-13
14	Driver Left Femur Force	B-14
	Driver Right Femur Force	B-14
15	Driver Left Upper Tibia Moment X	B-15
	Driver Left Upper Tibia Moment Y	B-15
	Driver Right Upper Tibia Moment X	B-15
	Driver Right Upper Tibia Moment Y	B-15
16	Driver Left Lower Tibia Moment X	B-16
	Driver Left Lower Tibia Moment Y	B-16
	Driver Left Lower Tibia Force Z	B-16
17	Driver Right Lower Tibia Moment X	B-17
	Driver Right Lower Tibia Moment Y	B-17
	Driver Right Lower Tibia Force Z	B-17
18	Driver Left Foot Aft X	B-18
	Driver Left Foot Aft Z	B-18
	Driver Left Foot Fore Z	B-18
19	Driver Right Foot Aft X	B-19
	Driver Right Foot Aft Z	B-19
	Driver Right Foot Fore Z	B-19
20	Driver Lap Belt Force	B-20
	Driver Shoulder Belt Force	B-20
	Driver Shoulder Belt Pullout	B-20
	Driver Shoulder Belt Elongation	B-20
21	Passenger Head Primary X	B-21
	Passenger Head Primary Y	B-21
	Passenger Head Primary Z	B-21
	Passenger Head Resultant Primary	B-21
22	Passenger Head Primary X Velocity	B-22
	Passenger Head Primary X Displacement	B-22

LIST OF DATA PLOTS...(Continued)

Data Plot	Page	
23	Passenger Head Redundant X	B-23
	Passenger Head Redundant Y	B-23
	Passenger Head Redundant Z	B-23
	Passenger Head Resultant Redundant	B-23
24	Passenger Head Redundant X Velocity	B-24
	Passenger Head Redundant X Displacement	B-24
25	Passenger Upper Neck Force X	B-25
	Passenger Upper Neck Force Y	B-25
	Passenger Upper Neck Force Z	B-25
	Passenger Upper Neck Force Resultant	B-25
26	Passenger Upper Neck Moment X	B-26
	Passenger Upper Neck Moment Y	B-26
	Passenger Upper Neck Moment Z	B-26
	Passenger Upper Neck Moment Resultant	B-26
27	Passenger Chest Primary X	B-27
	Passenger Chest Primary Y	B-27
	Passenger Chest Primary Z	B-27
	Passenger Chest Resultant Primary	B-27
28	Passenger Chest Primary X Velocity	B-28
	Passenger Chest Primary X Displacement	B-28
29	Passenger Chest Redundant X	B-29
	Passenger Chest Redundant Y	B-29
	Passenger Chest Redundant Z	B-29
	Passenger Chest Resultant Redundant	B-29
30	Passenger Chest Redundant X Velocity	B-30
	Passenger Chest Redundant X Displacement	B-30
31	Passenger Chest Displacement	B-31
32	Passenger Pelvis X	B-32
	Passenger Pelvis Y	B-32
	Passenger Pelvis Z	B-32
	Passenger Pelvis Resultant	B-32
33	Passenger Pelvis X Velocity	B-33
	Passenger Pelvis X Displacement	B-33

LIST OF DATA PLOTS...(Continued)

Data Plot	Page	
34	Passenger Left Femur Force	B-34
	Passenger Right Femur Force	B-34
35	Passenger Left Upper Tibia Moment X	B-35
	Passenger Left Upper Tibia Moment Y	B-35
	Passenger Right Upper Tibia Moment X	B-35
	Passenger Right Upper Tibia Moment Y	B-35
36	Passenger Left Lower Tibia Moment X	B-36
	Passenger Left Lower Tibia Moment Y	B-36
	Passenger Left Lower Tibia Force Z	B-36
37	Passenger Right Lower Tibia Moment X	B-37
	Passenger Right Lower Tibia Moment Y	B-37
	Passenger Right Lower Tibia Force Z	B-37
38	Passenger Left Foot Aft X	B-38
	Passenger Left Foot Aft Z	B-38
	Passenger Left Foot Fore Z	B-38
39	Passenger Right Foot Aft X	B-39
	Passenger Right Foot Aft Z	B-39
	Passenger Right Foot Fore Z	B-39
40	Passenger Lap Belt Force	B-40
	Passenger Shoulder Belt Force	B-40
	Passenger Shoulder Belt Pullout	B-40
	Passenger Shoulder Belt Elongation	B-40
41	Vehicle Left Rear X	B-41
	Vehicle Left Rear X Velocity	B-41
	Vehicle Left Rear X Displacement	B-41
42	Vehicle Right Rear X	B-42
	Vehicle Right Rear X Velocity	B-42
	Vehicle Right Rear X Displacement	B-42
43	Vehicle Engine Top X	B-43
	Vehicle Engine Top X Velocity	B-43
	Vehicle Engine Top X Displacement	B-43
44	Vehicle Engine Bottom X	B-44
	Vehicle Engine Bottom X Velocity	B-44
	Vehicle Engine Bottom X Displacement	B-44

LIST OF DATA PLOTS...(Continued)

Data Plot	Page	
45	Vehicle Left Brake Caliper X	B-45
	Vehicle Left Brake Caliper X Velocity	B-45
	Vehicle Left Brake Caliper X Displacement	B-45
46	Vehicle Right Brake X Caliper	B-46
	Vehicle Right Brake Caliper X Velocity	B-46
	Vehicle Right Brake Caliper X Displacement	B-46
47	Vehicle Instrument Panel X	B-47
	Vehicle Instrument Panel Velocity X	B-47
	Vehicle Instrument Panel Displacement X	B-47
48	Vehicle Left Rear Z	B-48
	Vehicle Left Rear Z Velocity	B-48
	Vehicle Left Rear Z Displacement	B-48
49	Vehicle Right Rear Z	B-49
	Vehicle Right Rear Z Velocity	B-49
	Vehicle Right Rear Z Displacement	B-49

Test Vehicle: 2005 Toyota Scion TC 3-Door Hatchback  
 Test Program: 2005 NHTSA 35mph NCAP

Test Date: 9/30/04  
 NHTSA No.: M55110

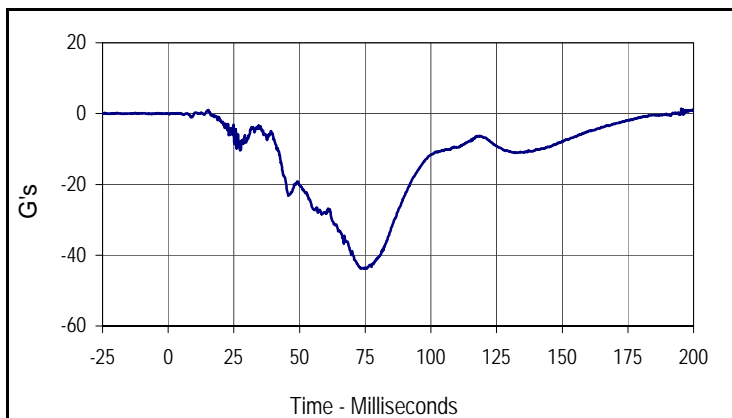

Curve Description			
Driver Head Primary X			
CURNO	Type	SAE Class	Units
001	FIL	1000	G's
Max	Time	Min	Time
1.3	195.4	-43.8	73.3

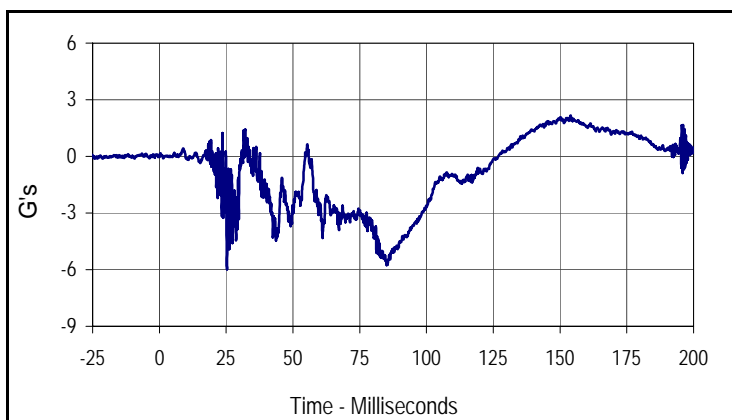

Curve Description			
Driver Head Primary Y			
CURNO	Type	SAE Class	Units
002	FIL	1000	G's
Max	Time	Min	Time
2.2	154.0	-6.0	25.3

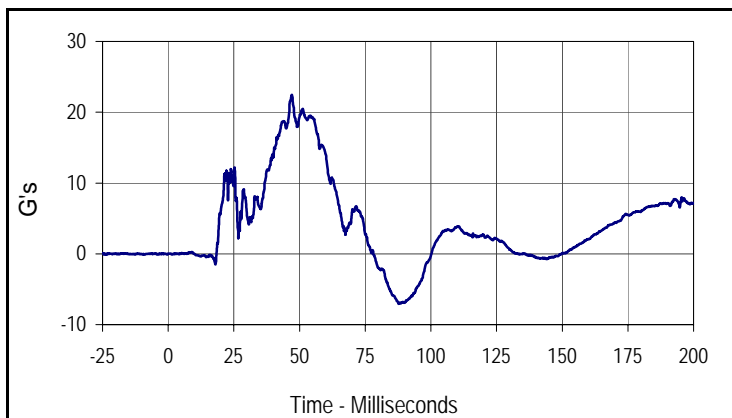

Curve Description			
Driver Head Primary Z			
CURNO	Type	SAE Class	Units
003	FIL	1000	G's
Max	Time	Min	Time
22.4	47.1	-7.0	87.8

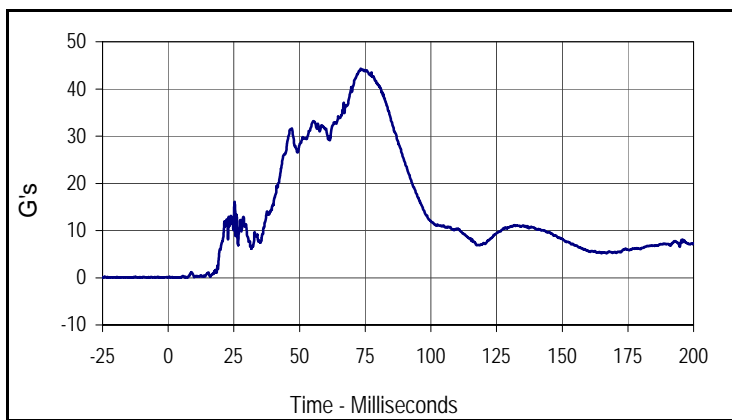

Curve Description			
Driver Head Resultant Primary			
CURNO	Type	SAE Class	Units
001	RES	1000	G's
Max	Time	Min	Time
44.3	73.3	0.0	1.9

Test Vehicle: 2005 Toyota Scion TC 3-Door Hatchback  
 Test Program: 2005 NHTSA 35mph NCAP

Test Date: 9/30/04  
 NHTSA No.: M55110

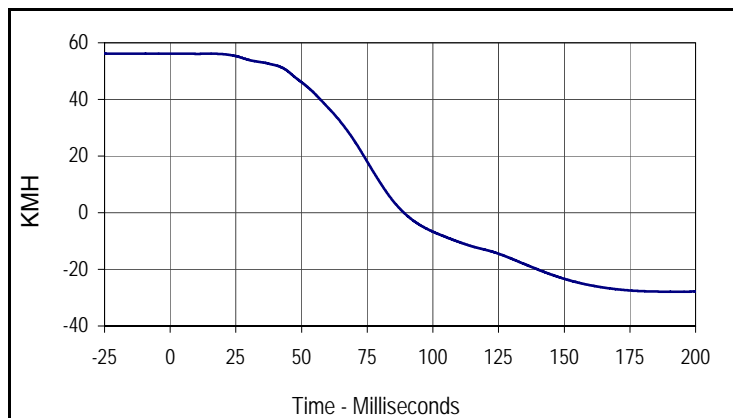

Curve Description			
Driver Head Primary X Velocity			
CURNO	Type	SAE Class	Units
001	IN1	180	KMH
Max	Time	Min	Time
56.2	4.7	-27.9	192.1

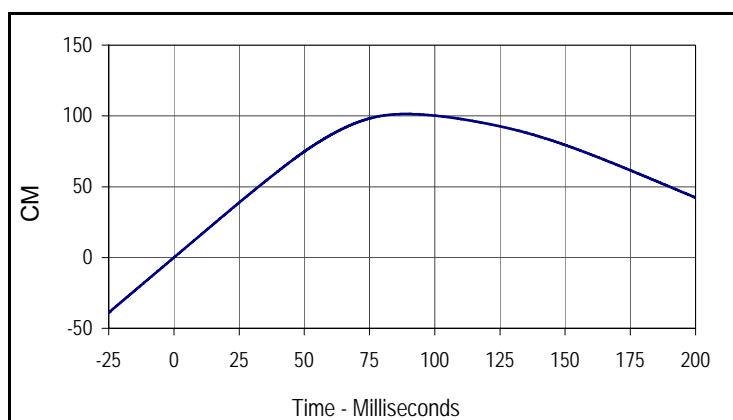

Curve Description			
Driver Head Primary X Displacement			
CURNO	Type	SAE Class	Units
001	IN2	180	CM
Max	Time	Min	Time
101.4	89.0	0.0	0.0

Test Vehicle: 2005 Toyota Scion TC 3-Door Hatchback  
 Test Program: 2005 NHTSA 35mph NCAP

Test Date: 9/30/04  
 NHTSA No.: M55110

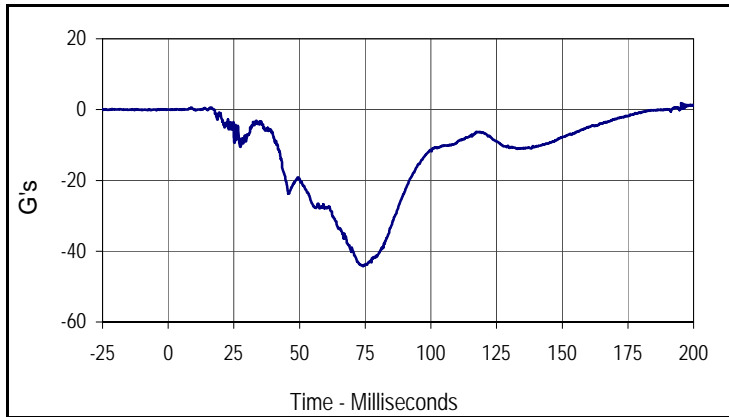

Curve Description			
Driver Head Redundant X			
CURNO	Type	SAE Class	Units
004	FIL	1000	G's
Max	Time	Min	Time
1.8	195.3	-44.2	74.2

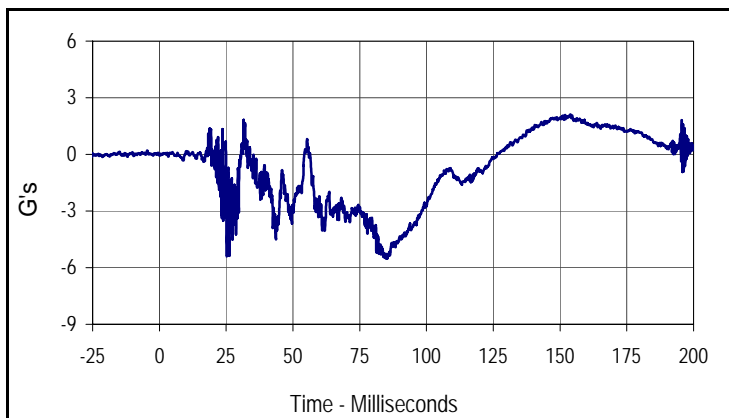

Curve Description			
Driver Head Redundant Y			
CURNO	Type	SAE Class	Units
005	FIL	1000	G's
Max	Time	Min	Time
2.1	153.9	-5.5	85.1

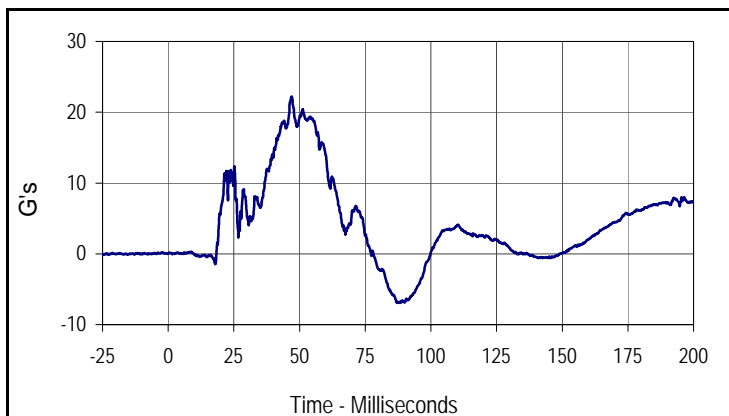

Curve Description			
Driver Head Redundant Z			
CURNO	Type	SAE Class	Units
006	FIL	1000	G's
Max	Time	Min	Time
22.2	47.0	-6.9	88.4

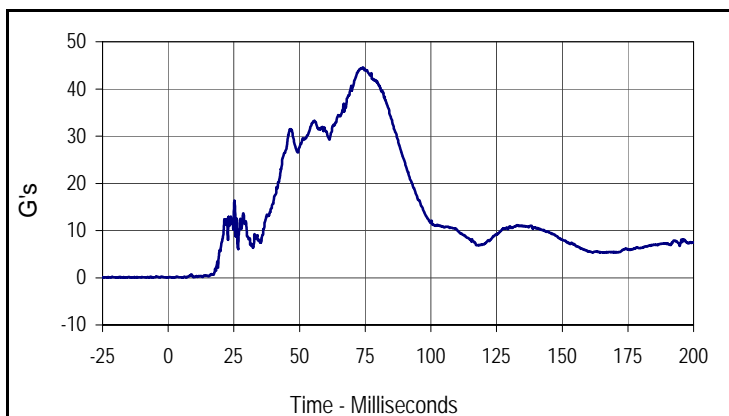

Curve Description			
Driver Head Resultant Redundant			
CURNO	Type	SAE Class	Units
004	RES	1000	G's
Max	Time	Min	Time
44.6	74.2	0.0	1.4

Test Vehicle: 2005 Toyota Scion TC 3-Door Hatchback  
 Test Program: 2005 NHTSA 35mph NCAP

Test Date: 9/30/04  
 NHTSA No.: M55110

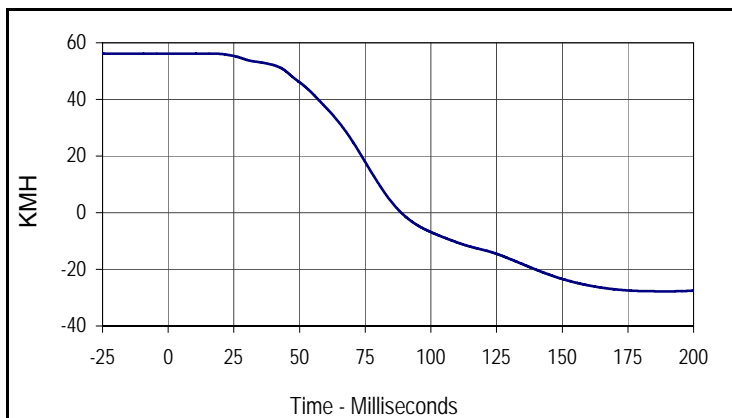

Curve Description			
Driver Head Redundant X Velocity			
CURNO	Type	SAE Class	Units
004	IN1	180	KMH
Max	Time	Min	Time
56.2	17.2	-27.8	191.7

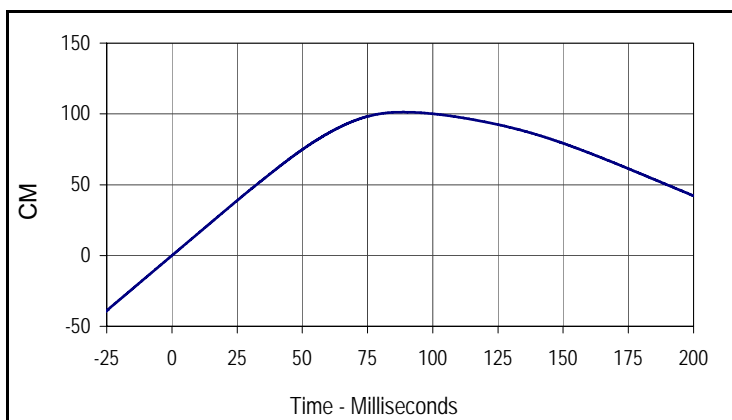

Curve Description			
Driver Head Redundant X Displacement			
CURNO	Type	SAE Class	Units
004	IN2	180	CM
Max	Time	Min	Time
101.3	88.7	0.0	0.0

Test Vehicle: 2005 Toyota Scion TC 3-Door Hatchback  
 Test Program: 2005 NHTSA 35mph NCAP

Test Date: 9/30/04  
 NHTSA No.: M55110

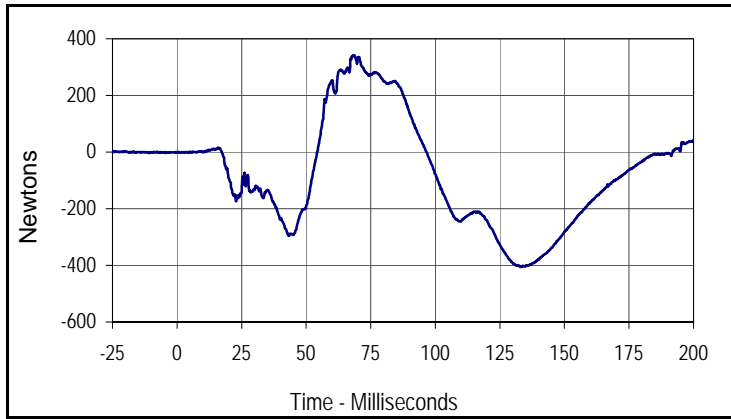

Curve Description			
Driver Upper Neck Force X			
CURNO	Type	SAE Class	Units
007	FIL	1000	Newtons
Max	Time	Min	Time
342.4	68.4	-406.1	133.2

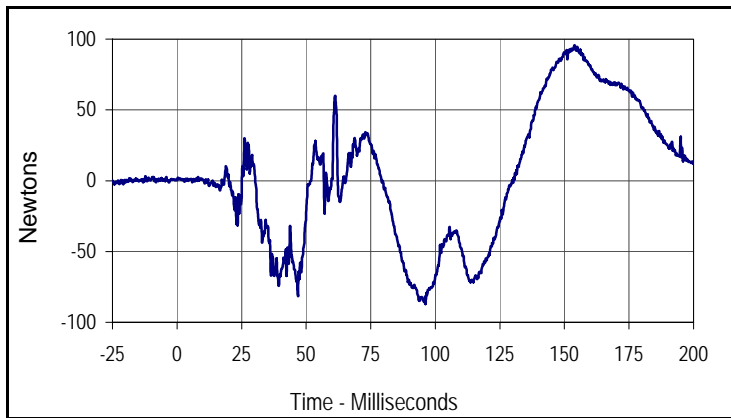

Curve Description			
Driver Upper Neck Force Y			
CURNO	Type	SAE Class	Units
008	FIL	1000	Newtons
Max	Time	Min	Time
95.8	153.9	-87.1	96.2

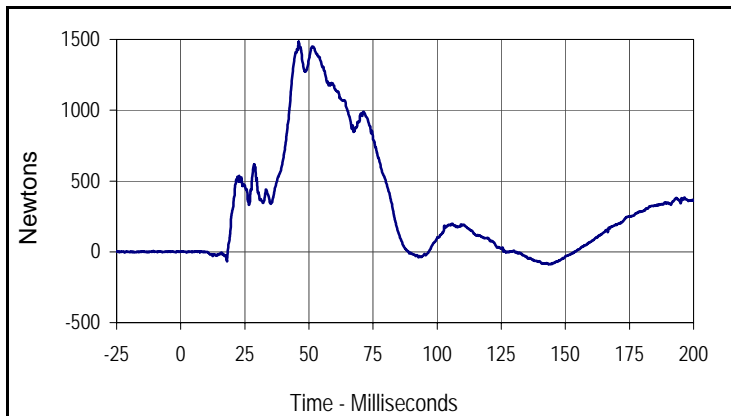

Curve Description			
Driver Upper Neck Force Z			
CURNO	Type	SAE Class	Units
009	FIL	1000	Newtons
Max	Time	Min	Time
1483.6	46.0	-88.0	143.6

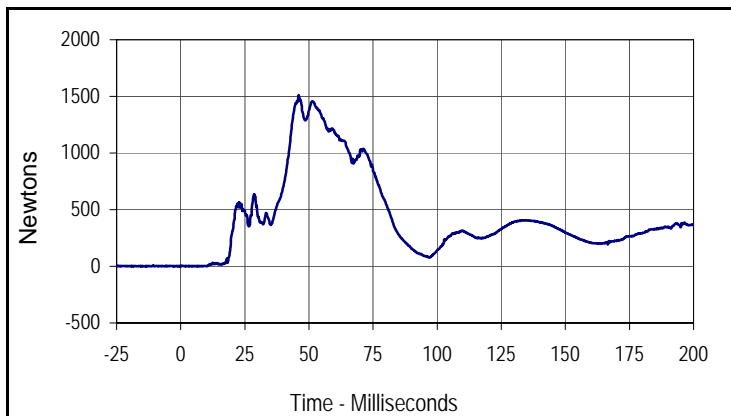

Curve Description			
Driver Upper Neck Force Res.			
CURNO	Type	SAE Class	Units
007	RES	1000	Newtons
Max	Time	Min	Time
1510.5	46.0	0.6	6.4

Test Vehicle: 2005 Toyota Scion TC 3-Door Hatchback  
 Test Program: 2005 NHTSA 35mph NCAP

Test Date: 9/30/04  
 NHTSA No.: M55110

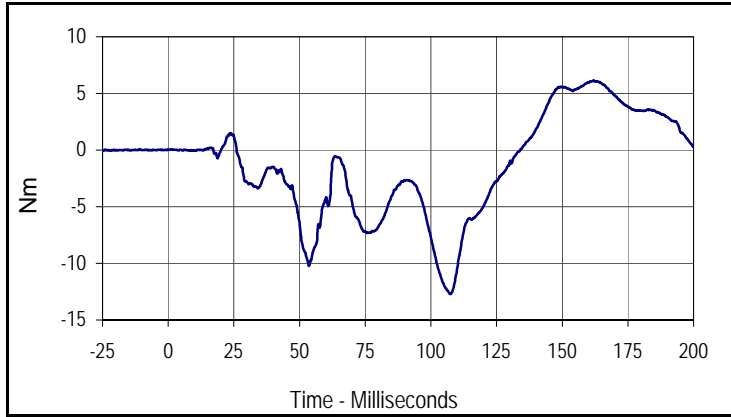

Curve Description			
Driver Upper Neck Moment X			
CURNO	Type	SAE Class	Units
010	FIL	600	Nm
Max	Time	Min	Time
6.2	162.0	-12.7	107.4

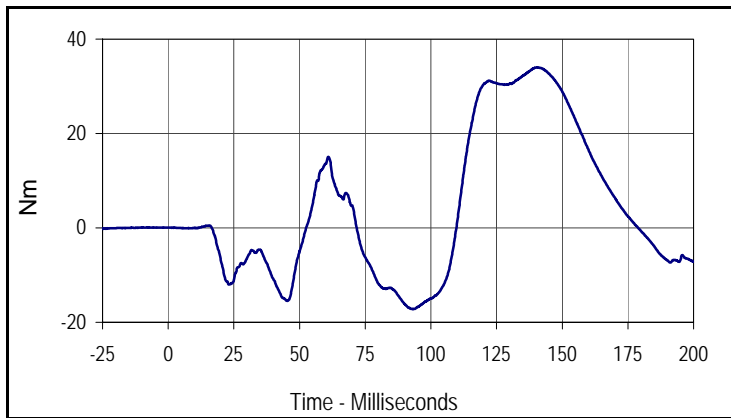

Curve Description			
Driver Upper Neck Moment Y			
CURNO	Type	SAE Class	Units
011	FIL	600	Nm
Max	Time	Min	Time
34.0	140.8	-17.2	93.2

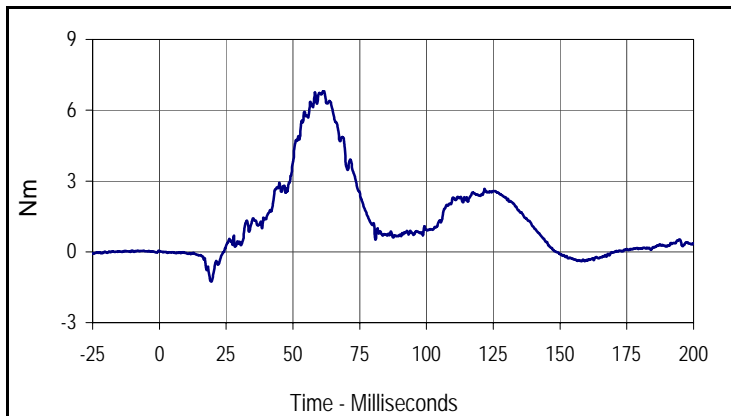

Curve Description			
Driver Upper Neck Moment Z			
CURNO	Type	SAE Class	Units
012	FIL	600	Nm
Max	Time	Min	Time
6.8	61.5	-1.3	19.5

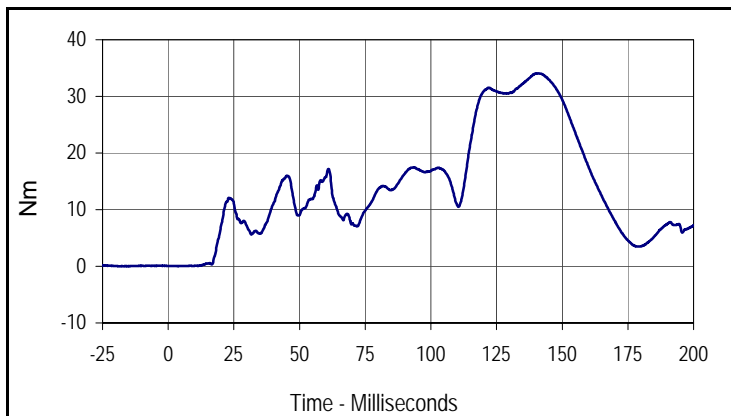

Curve Description			
Driver Upper Neck Moment Res.			
CURNO	Type	SAE Class	Units
010	RES	600	Nm
Max	Time	Min	Time
34.1	140.8	0.0	3.7

Test Vehicle: 2005 Toyota Scion TC 3-Door Hatchback  
 Test Program: 2005 NHTSA 35mph NCAP

Test Date: 9/30/04  
 NHTSA No.: M55110

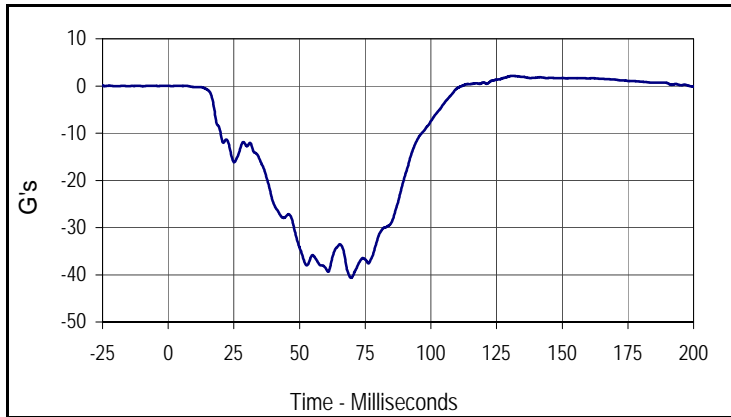

Curve Description			
Driver Chest Primary X			
CURNO	Type	SAE Class	Units
013	FIL	180	G's
Max	Time	Min	Time
2.1	131.1	-40.7	69.6

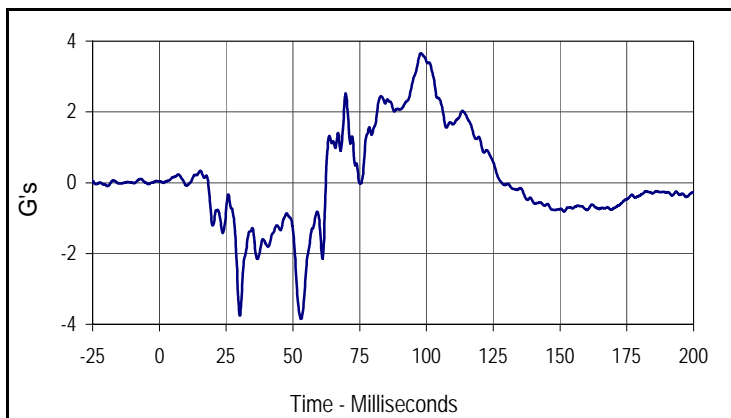

Curve Description			
Driver Chest Primary Y			
CURNO	Type	SAE Class	Units
014	FIL	180	G's
Max	Time	Min	Time
3.7	98.0	-3.8	53.0

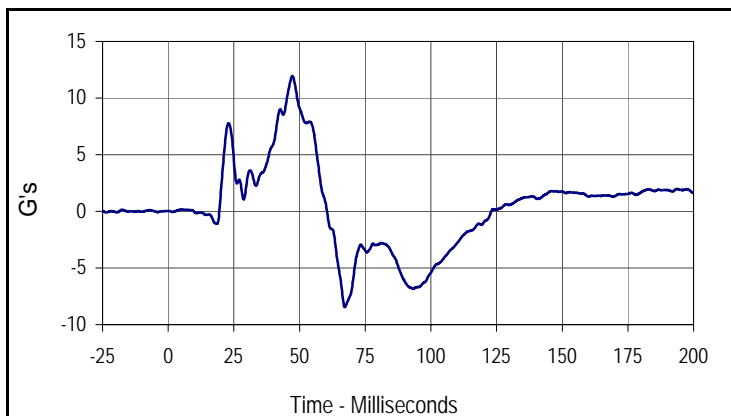

Curve Description			
Driver Chest Primary Z			
CURNO	Type	SAE Class	Units
015	FIL	180	G's
Max	Time	Min	Time
11.9	47.3	-8.5	67.2

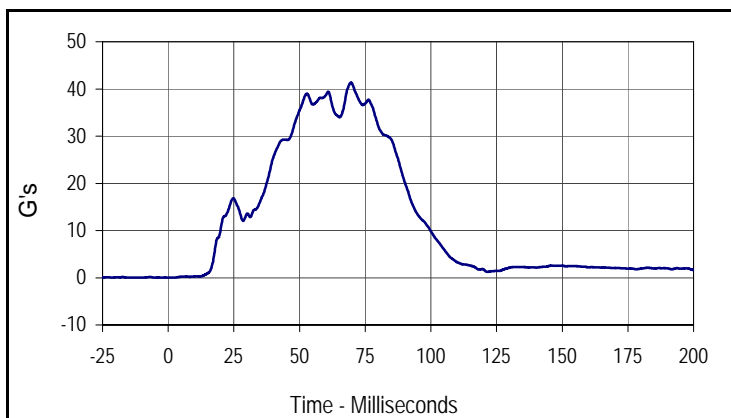

Curve Description			
Driver Chest Resultant Primary			
CURNO	Type	SAE Class	Units
013	RES	180	G's
Max	Time	Min	Time
41.4	69.6	0.0	1.0

Test Vehicle: 2005 Toyota Scion TC 3-Door Hatchback  
 Test Program: 2005 NHTSA 35mph NCAP

Test Date: 9/30/04  
 NHTSA No.: M55110

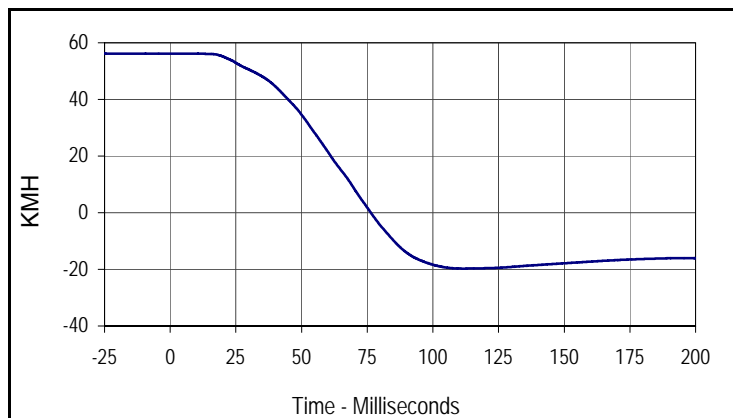

Curve Description			
Driver Chest Primary X Velocity			
CURNO	Type	SAE Class	Units
013	IN1	180	KMH
Max	Time	Min	Time
56.1	7.5	-19.7	111.8

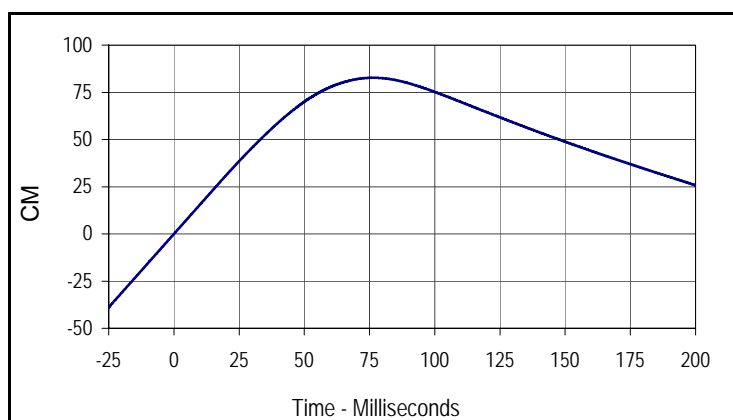

Curve Description			
Driver Chest Primary X Displacement			
CURNO	Type	SAE Class	Units
013	IN2	180	CM
Max	Time	Min	Time
82.7	76.4	0.0	0.0

Test Vehicle: 2005 Toyota Scion TC 3-Door Hatchback  
 Test Program: 2005 NHTSA 35mph NCAP

Test Date: 9/30/04  
 NHTSA No.: M55110

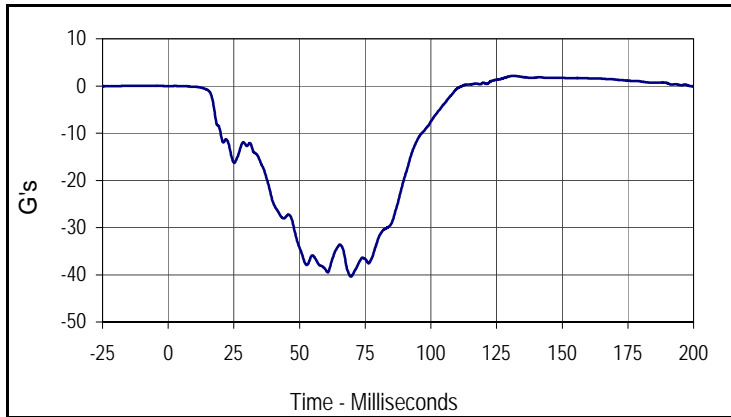

Curve Description			
Driver Chest Redundant X			
CURNO	Type	SAE Class	Units
016	FIL	180	G's
Max	Time	Min	Time
2.2	131.4	-40.4	69.5

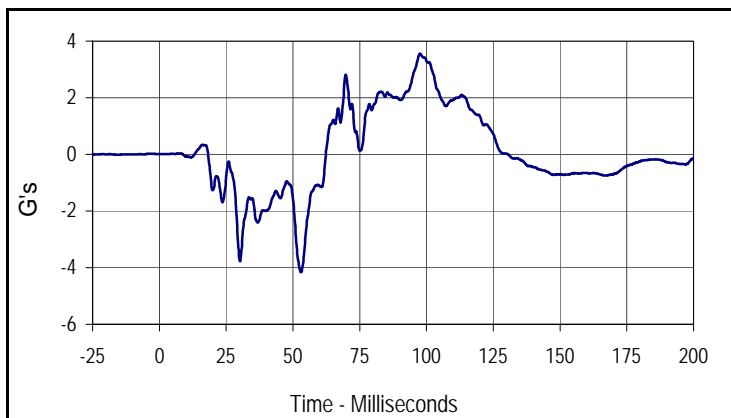

Curve Description			
Driver Chest Redundant Y			
CURNO	Type	SAE Class	Units
017	FIL	180	G's
Max	Time	Min	Time
3.6	97.6	-4.2	53.0

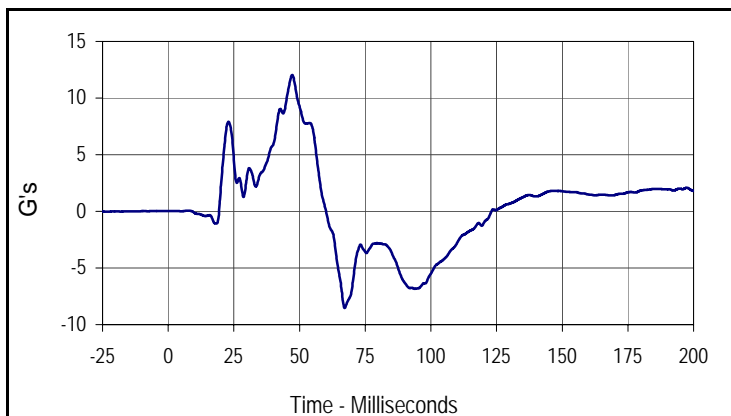

Curve Description			
Driver Chest Redundant Z			
CURNO	Type	SAE Class	Units
018	FIL	180	G's
Max	Time	Min	Time
12.0	47.2	-8.5	67.2

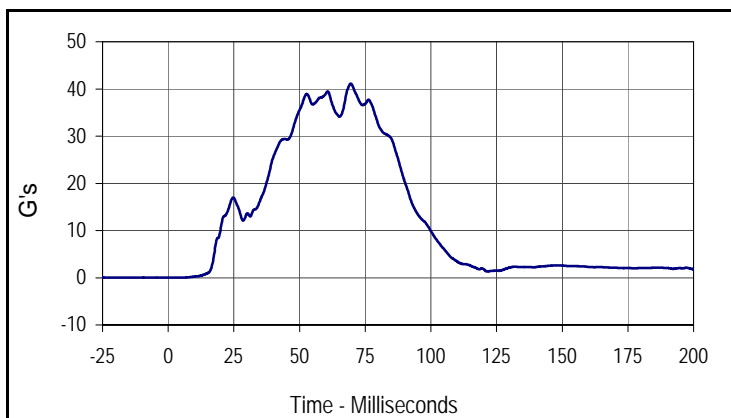

Curve Description			
Driver Chest Resultant Redundant			
CURNO	Type	SAE Class	Units
016	RES	180	G's
Max	Time	Min	Time
41.1	69.5	0.0	0.0

Test Vehicle: 2005 Toyota Scion TC 3-Door Hatchback  
 Test Program: 2005 NHTSA 35mph NCAP

Test Date: 9/30/04  
 NHTSA No.: M55110

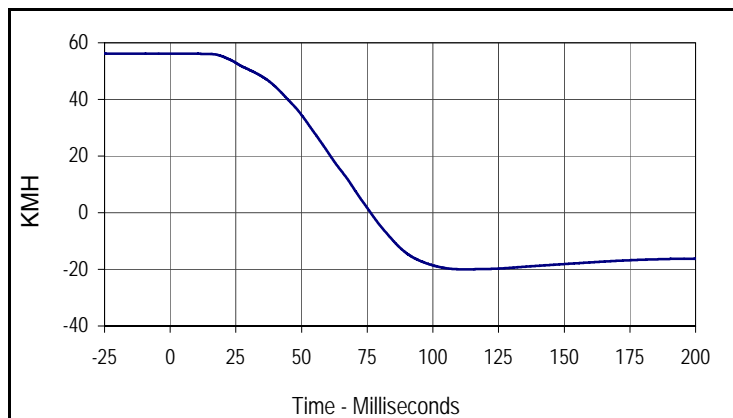

Curve Description			
Driver Chest Redundant X Velocity			
CURNO	Type	SAE Class	Units
016	IN1	180	KMH
Max	Time	Min	Time
56.1	0.0	-20.0	112.0

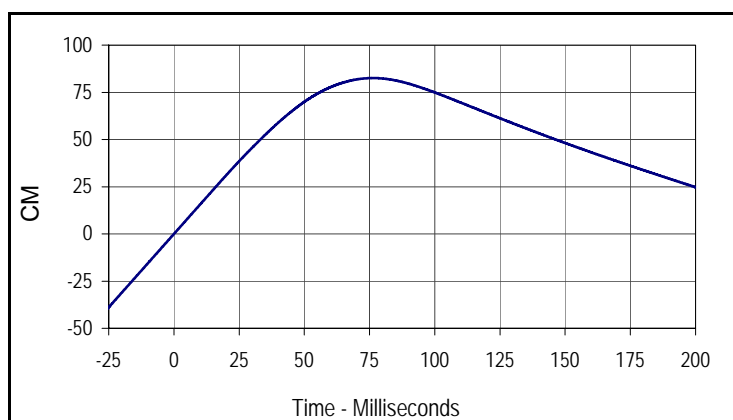

Curve Description			
Driver Chest Redundant X Displacement			
CURNO	Type	SAE Class	Units
016	IN2	180	CM
Max	Time	Min	Time
82.5	76.3	0.0	0.0

Test Vehicle: 2005 Toyota Scion TC 3-Door Hatchback  
 Test Program: 2005 NHTSA 35mph NCAP

Test Date: 9/30/04  
 NHTSA No.: M55110

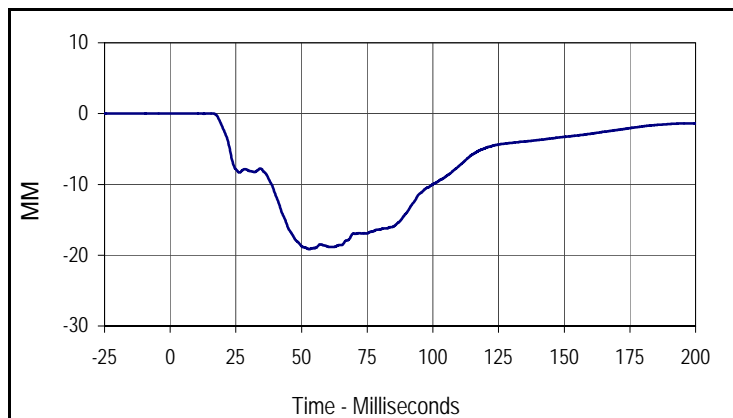

Curve Description			
Driver Chest Displacement			
CURNO	Type	SAE Class	Units
019	FIL	600	MM
Max	Time	Min	Time
0.0	4.6	-19.1	52.9

Test Vehicle: 2005 Toyota Scion TC 3-Door Hatchback  
 Test Program: 2005 NHTSA 35mph NCAP

Test Date: 9/30/04  
 NHTSA No.: M55110

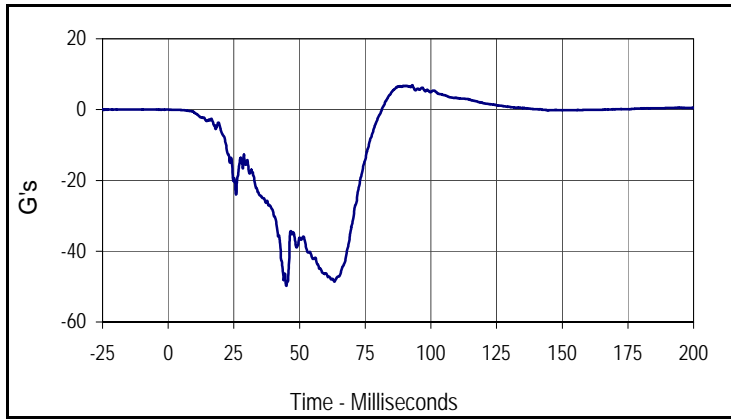

Curve Description			
Driver Pelvis X			
CURNO	Type	SAE Class	Units
020	FIL	1000	G's
Max	Time	Min	Time
6.8	92.9	-49.8	44.9

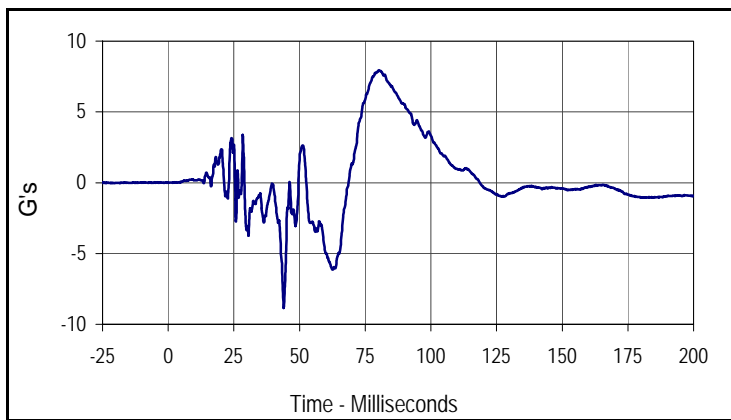

Curve Description			
Driver Pelvis Y			
CURNO	Type	SAE Class	Units
021	FIL	1000	G's
Max	Time	Min	Time
8.0	80.1	-8.8	44.0

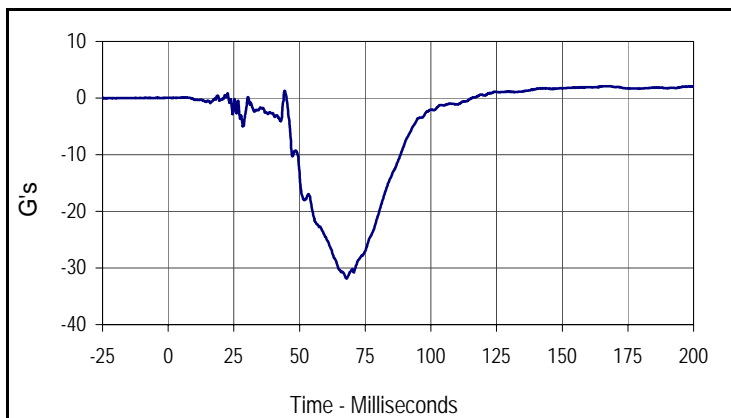

Curve Description			
Driver Pelvis Z			
CURNO	Type	SAE Class	Units
022	FIL	1000	G's
Max	Time	Min	Time
2.1	165.8	-31.8	68.0

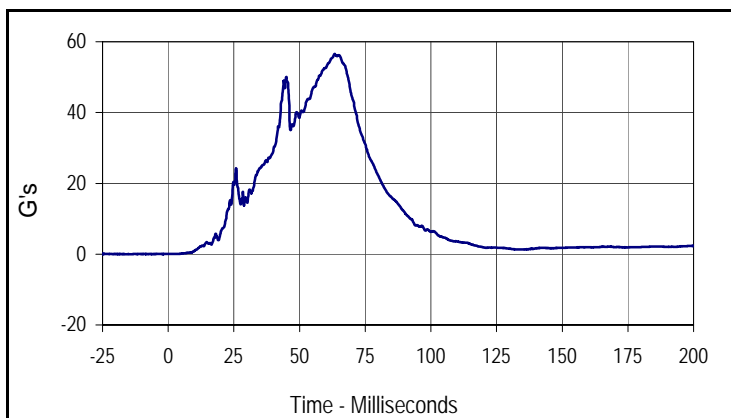

Curve Description			
Driver Pelvis Resultant			
CURNO	Type	SAE Class	Units
020	RES	1000	G's
Max	Time	Min	Time
56.5	63.3	0.0	1.4

Test Vehicle: 2005 Toyota Scion TC 3-Door Hatchback  
 Test Program: 2005 NHTSA 35mph NCAP

Test Date: 9/30/04  
 NHTSA No.: M55110

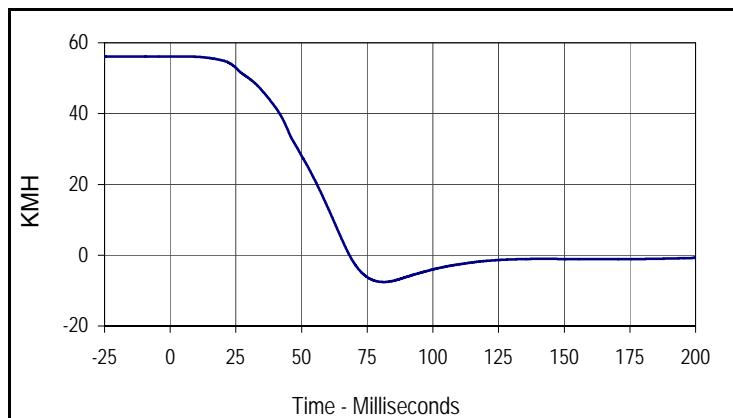

Curve Description			
Driver Pelvis X Velocity			
CURNO	Type	SAE Class	Units
020	IN1	180	KMH
Max	Time	Min	Time
56.1	0.0	-7.6	81.3

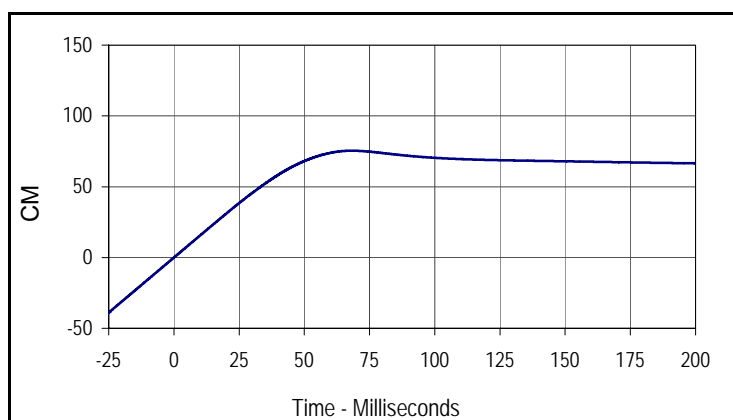

Curve Description			
Driver Pelvis X Displacement			
CURNO	Type	SAE Class	Units
020	IN2	180	CM
Max	Time	Min	Time
75.4	68.2	0.0	0.0

Test Vehicle: 2005 Toyota Scion TC 3-Door Hatchback  
 Test Program: 2005 NHTSA 35mph NCAP

Test Date: 9/30/04  
 NHTSA No.: M55110

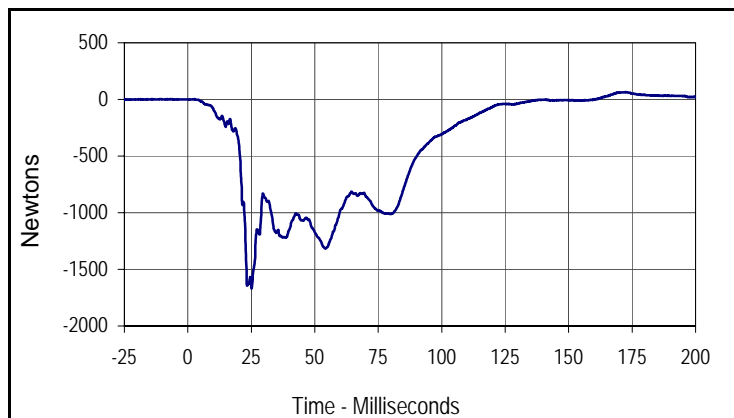

Curve Description			
Driver Left Femur Force			
CURNO	Type	SAE Class	Units
023	FIL	600	Newtons
Max	Time	Min	Time
64.5	172.3	-1668.6	25.1

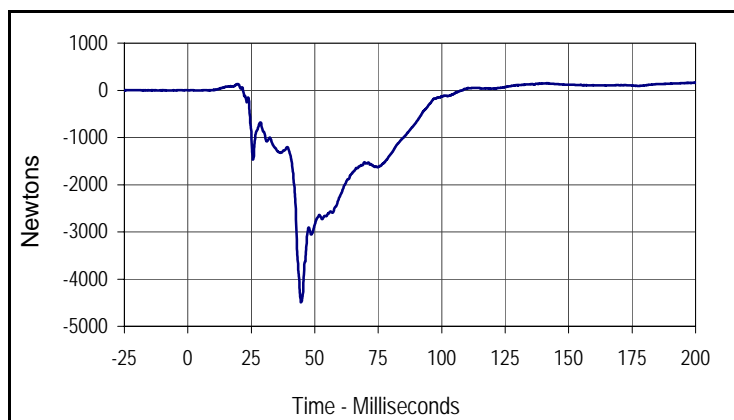

Curve Description			
Driver Right Femur Force			
CURNO	Type	SAE Class	Units
024	FIL	600	Newtons
Max	Time	Min	Time
158.1	199.2	-4488.4	44.6

Test Vehicle: 2005 Toyota Scion TC 3-Door Hatchback  
 Test Program: 2005 NHTSA 35mph NCAP

Test Date: 9/30/04  
 NHTSA No.: M55110

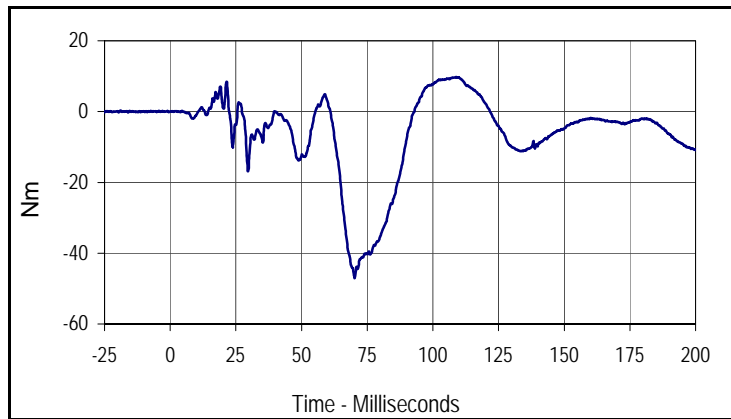

Curve Description			
Driver Left Upper Tibia Moment X			
CURNO	Type	SAE Class	Units
025	FIL	600	Nm
Max	Time	Min	Time
9.7	108.9	-47.1	70.2

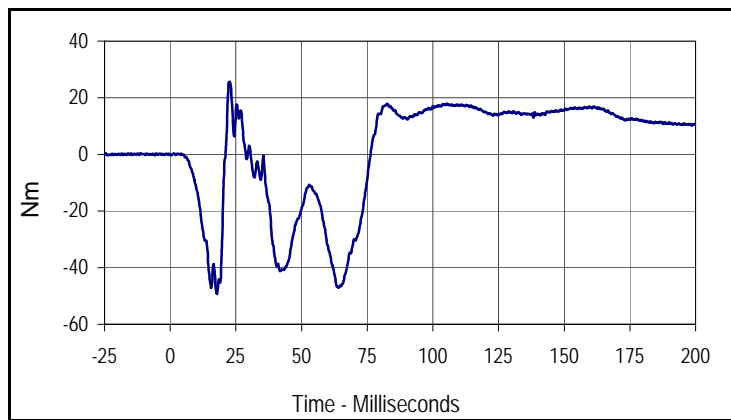

Curve Description			
Driver Left Upper Tibia Moment Y			
CURNO	Type	SAE Class	Units
026	FIL	600	Nm
Max	Time	Min	Time
25.6	22.6	-49.3	17.8

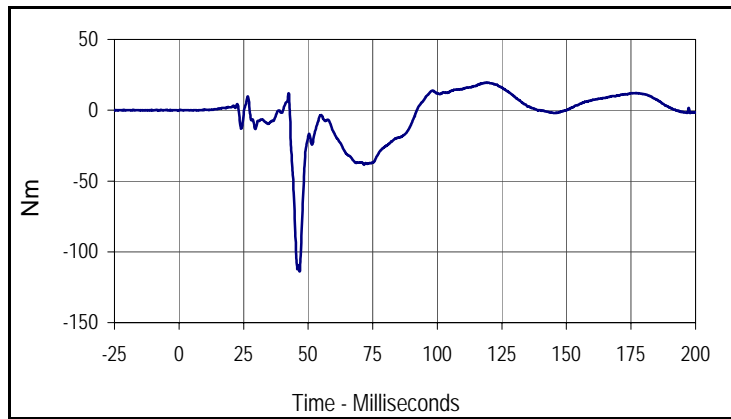

Curve Description			
Driver Right Upper Tibia Moment X			
CURNO	Type	SAE Class	Units
027	FIL	600	Nm
Max	Time	Min	Time
19.5	118.9	-113.8	46.7

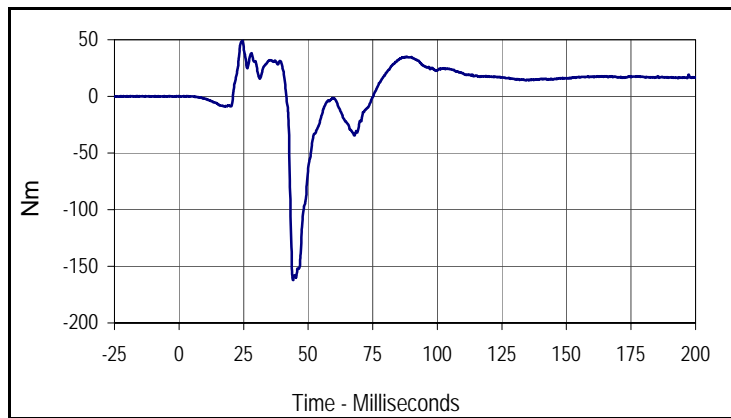

Curve Description			
Driver Right Upper Tibia Moment Y			
CURNO	Type	SAE Class	Units
028	FIL	600	Nm
Max	Time	Min	Time
49.0	24.5	-162.3	44.1

Test Vehicle: 2005 Toyota Scion TC 3-Door Hatchback  
 Test Program: 2005 NHTSA 35mph NCAP

Test Date: 9/30/04  
 NHTSA No.: M55110

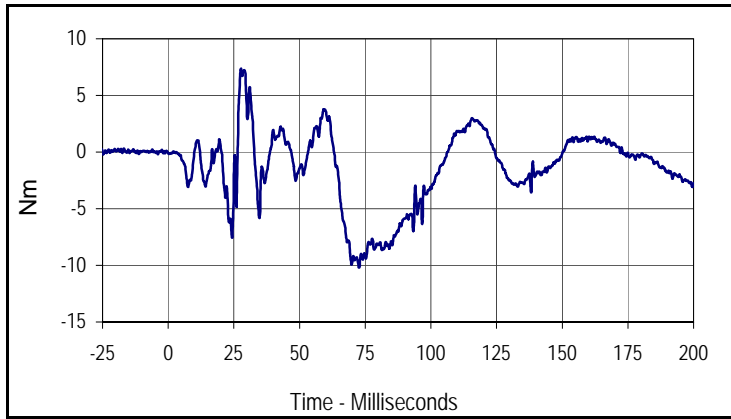

Curve Description			
Driver Left Lower Tibia Moment X			
CURNO	Type	SAE Class	Units
029	FIL	600	Nm
Max	Time	Min	Time
7.4	27.7	-10.2	72.7

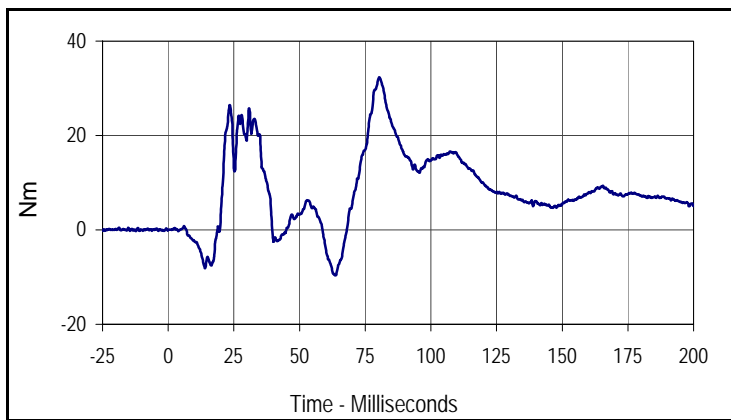

Curve Description			
Driver Left Lower Tibia Moment Y			
CURNO	Type	SAE Class	Units
030	FIL	600	Nm
Max	Time	Min	Time
32.3	80.3	-9.6	63.7

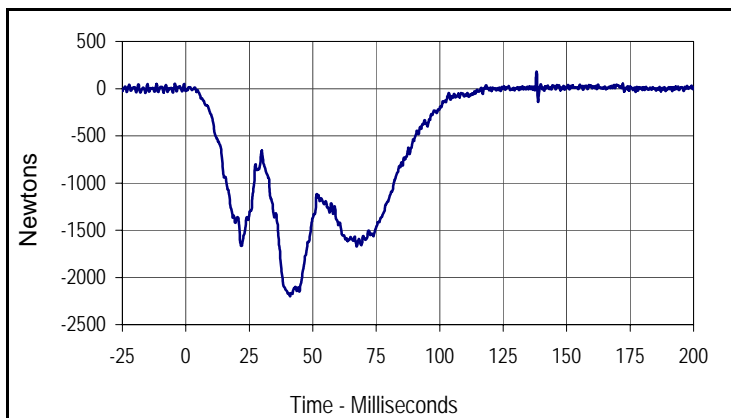

Curve Description			
Driver Left Lower Tibia Force Z			
CURNO	Type	SAE Class	Units
031	FIL	600	Newtons
Max	Time	Min	Time
179.7	138.1	-2197.3	41.0

Test Vehicle: 2005 Toyota Scion TC 3-Door Hatchback  
 Test Program: 2005 NHTSA 35mph NCAP

Test Date: 9/30/04  
 NHTSA No.: M55110

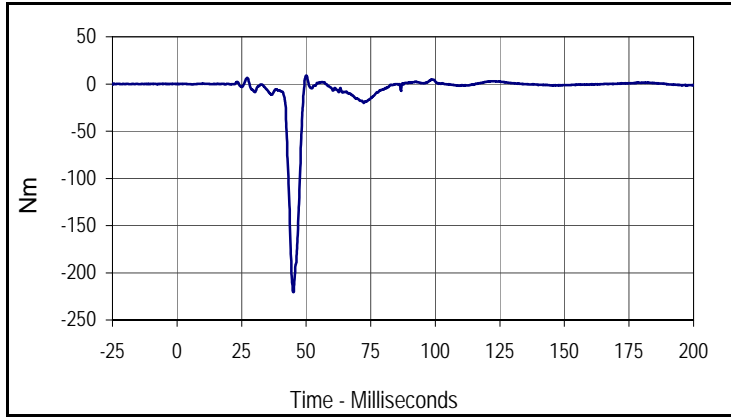

Curve Description			
Driver Right Lower Tibia Moment X			
CURNO	Type	SAE Class	Units
032	FIL	600	Nm
Max	Time	Min	Time
9.1	50.1	-220.5	45.0

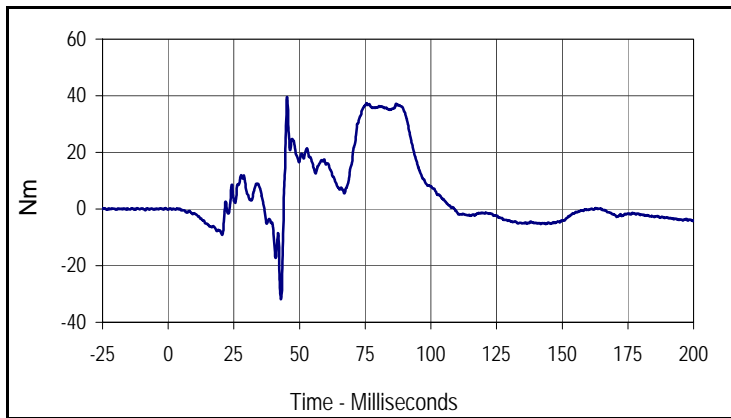

Curve Description			
Driver Right Lower Tibia Moment Y			
CURNO	Type	SAE Class	Units
033	FIL	600	Nm
Max	Time	Min	Time
39.5	45.3	-31.8	42.9

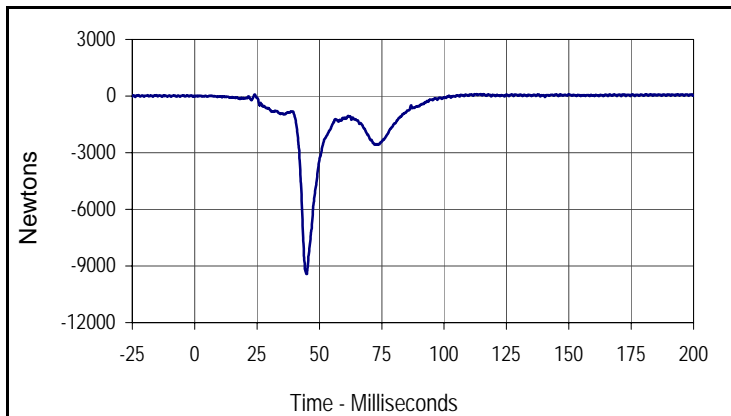

Curve Description			
Driver Right Lower Tibia Force Z			
CURNO	Type	SAE Class	Units
034	FIL	600	Newtons
Max	Time	Min	Time
102.9	114.6	-9419.1	44.9

Test Vehicle: 2005 Toyota Scion TC 3-Door Hatchback  
 Test Program: 2005 NHTSA 35mph NCAP

Test Date: 9/30/04  
 NHTSA No.: M55110

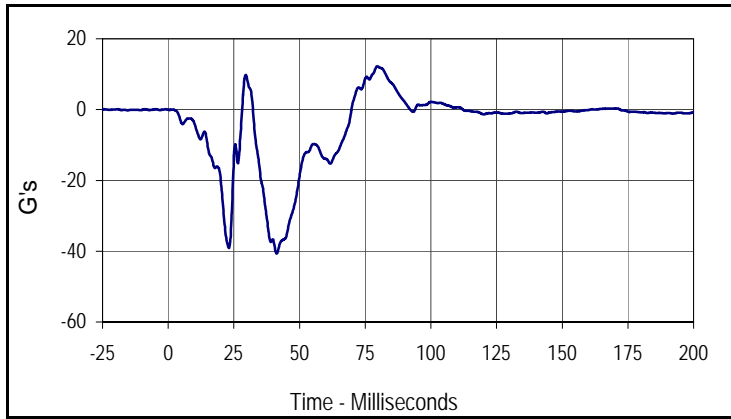

Curve Description			
Driver Left Foot Aft X			
CURNO	Type	SAE Class	Units
035	FIL	180	G's
Max	Time	Min	Time
12.2	79.5	-40.7	41.3

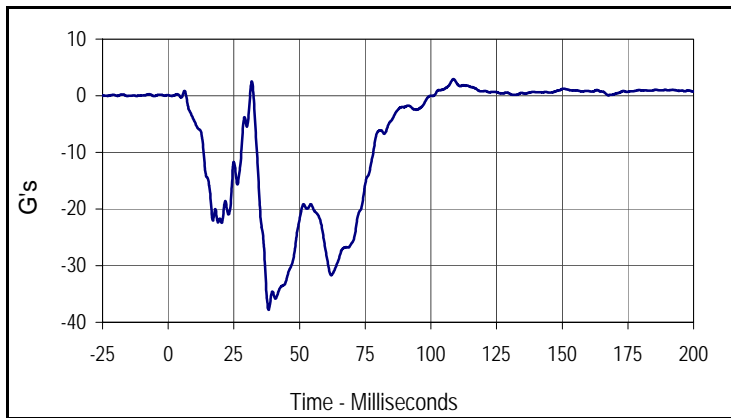

Curve Description			
Driver Left Foot Aft Z			
CURNO	Type	SAE Class	Units
036	FIL	180	G's
Max	Time	Min	Time
2.9	108.6	-37.8	38.2

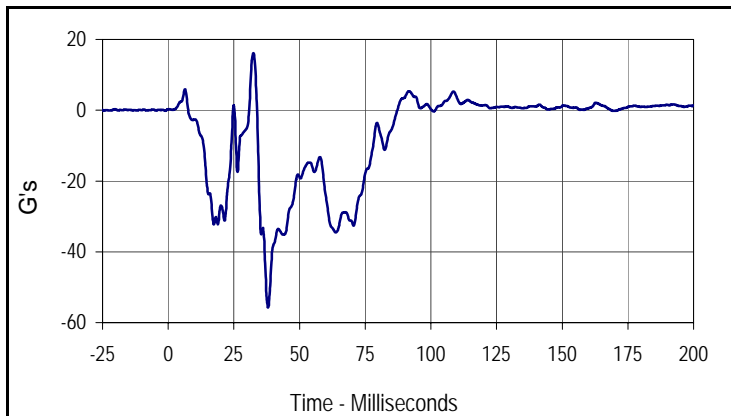

Curve Description			
Driver Left Foot Fore Z			
CURNO	Type	SAE Class	Units
037	FIL	180	G's
Max	Time	Min	Time
16.1	32.4	-55.7	38.0

Test Vehicle: 2005 Toyota Scion TC 3-Door Hatchback  
 Test Program: 2005 NHTSA 35mph NCAP

Test Date: 9/30/04  
 NHTSA No.: M55110

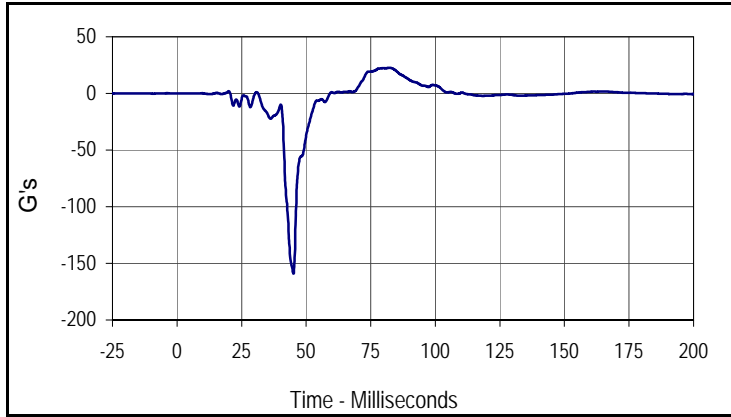

Curve Description			
Driver Right Foot Aft X			
CURNO	Type	SAE Class	Units
038	FIL	180	G's
Max	Time	Min	Time
22.6	82.2	-159.0	45.1

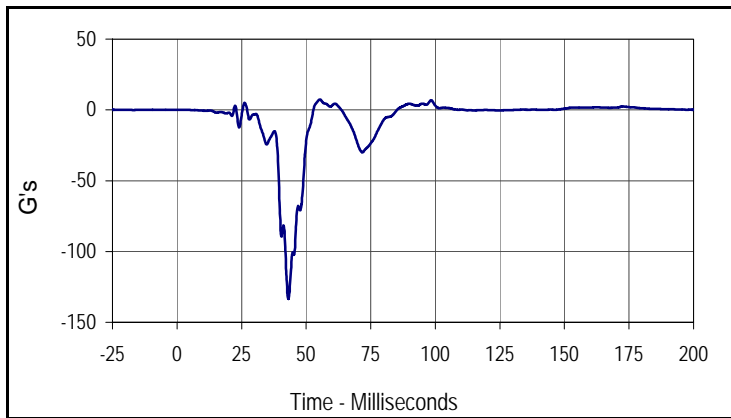

Curve Description			
Driver Right Foot Aft Z			
CURNO	Type	SAE Class	Units
039	FIL	180	G's
Max	Time	Min	Time
7.3	55.2	-133.6	43.1

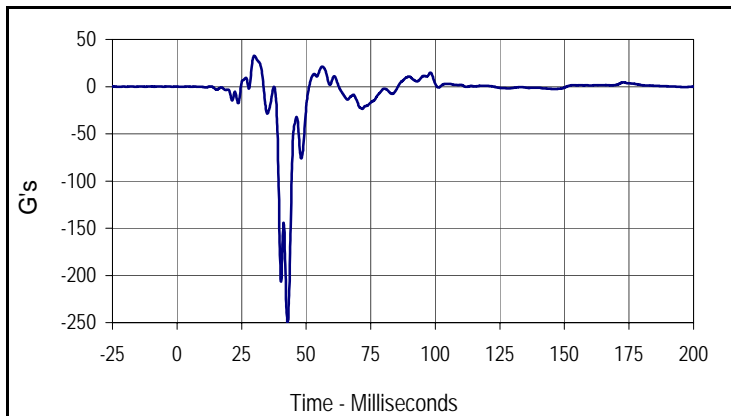

Curve Description			
Driver Right Foot Fore Z			
CURNO	Type	SAE Class	Units
040	FIL	180	G's
Max	Time	Min	Time
32.6	29.9	-249.8	42.8

Test Vehicle: 2005 Toyota Scion TC 3-Door Hatchback  
 Test Program: 2005 NHTSA 35mph NCAP

Test Date: 9/30/04  
 NHTSA No.: M55110

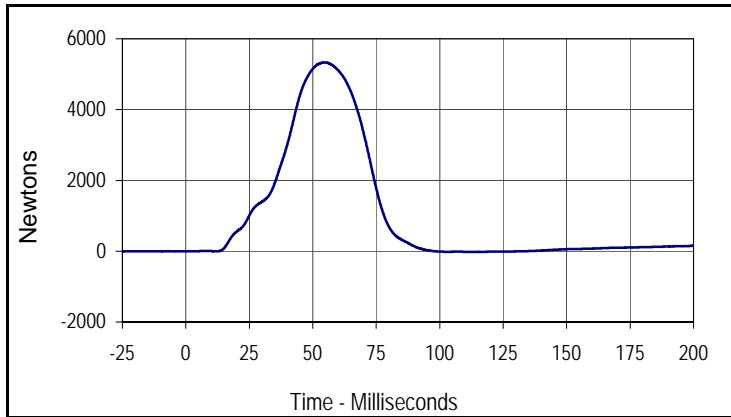

Curve Description			
Driver Lap Belt Force			
CURNO	Type	SAE Class	Units
041	FIL	60	Newtons
Max	Time	Min	Time
5331.5	54.7	-18.7	114.6

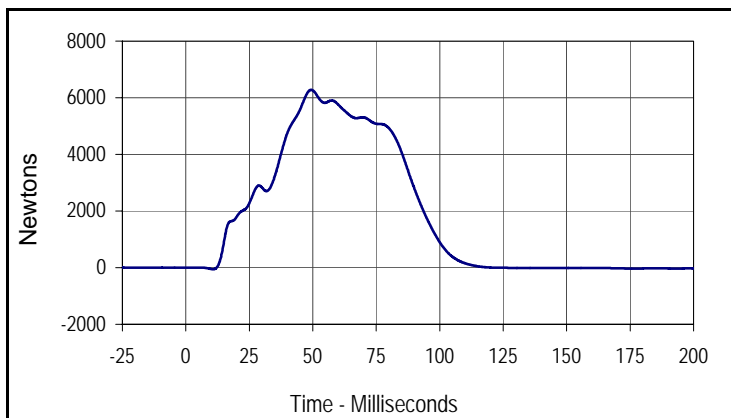

Curve Description			
Driver Shoulder Belt Force			
CURNO	Type	SAE Class	Units
042	FIL	60	Newtons
Max	Time	Min	Time
6278.3	49.4	-54.8	10.7

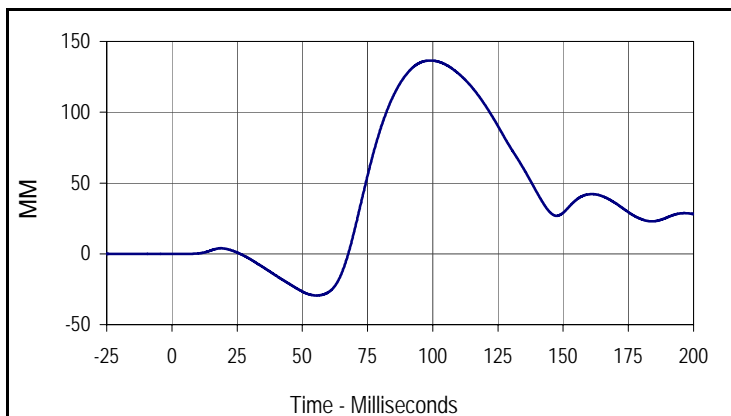

Curve Description			
Driver Shoulder Belt Pullout			
CURNO	Type	SAE Class	Units
043	FIL	60	MM
Max	Time	Min	Time
136.5	99.4	-29.4	55.9

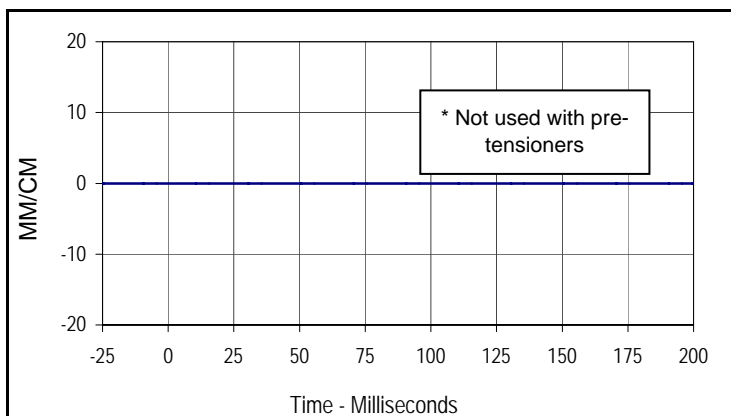

Curve Description			
Driver Shoulder Belt Elongation			
CURNO	Type	SAE Class	Units
044	FIL	60	MM/CM
Max	Time	Min	Time
0.0	0.0	0.0	0.0

\* Not used with pre-tensioners

Test Vehicle: 2005 Toyota Scion TC 3-Door Hatchback  
 Test Program: 2005 NHTSA 35mph NCAP

Test Date: 9/30/04  
 NHTSA No.: M55110



Curve Description			
Passenger Head Primary X			
CURNO	Type	SAE Class	Units
045	FIL	1000	G's
Max	Time	Min	Time
2.2	200.0	-54.5	78.6

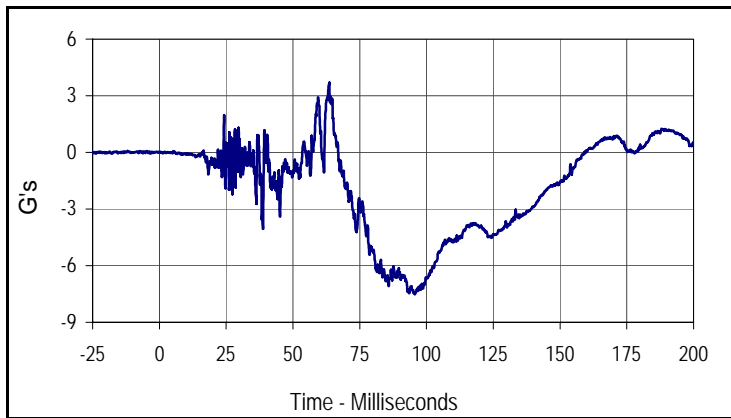

Curve Description			
Passenger Head Primary Y			
CURNO	Type	SAE Class	Units
046	FIL	1000	G's
Max	Time	Min	Time
3.7	63.6	-7.5	95.7

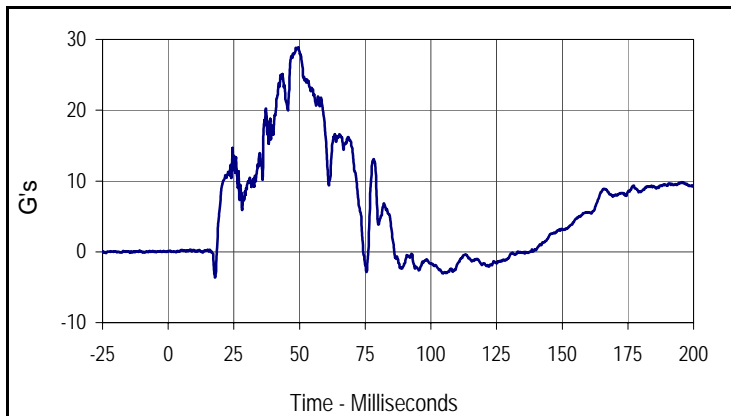

Curve Description			
Passenger Head Primary Z			
CURNO	Type	SAE Class	Units
047	FIL	1000	G's
Max	Time	Min	Time
28.8	49.5	-3.6	17.9

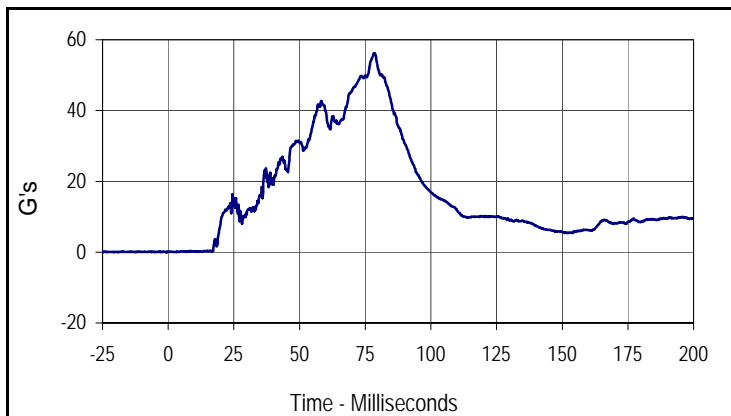

Curve Description			
Passenger Head Resultant Primary			
CURNO	Type	SAE Class	Units
045	RES	1000	G's
Max	Time	Min	Time
56.2	78.7	0.0	3.2

Test Vehicle: 2005 Toyota Scion TC 3-Door Hatchback  
 Test Program: 2005 NHTSA 35mph NCAP

Test Date: 9/30/04  
 NHTSA No.: M55110

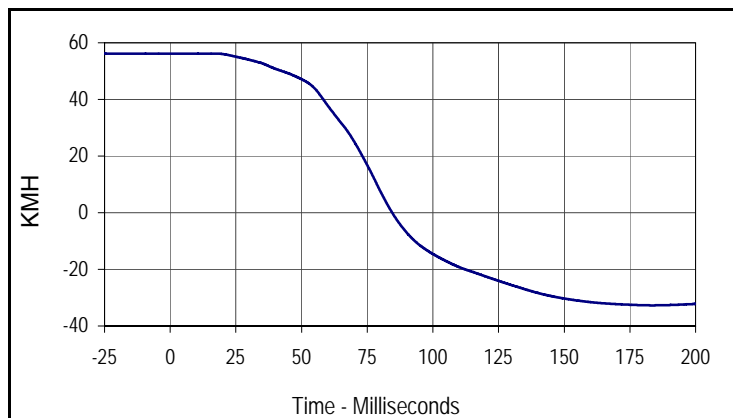

Curve Description			
Passenger Head Primary X Velocity			
CURNO	Type	SAE Class	Units
045	IN1	180	KMH
Max	Time	Min	Time
56.2	17.7	-32.7	183.5

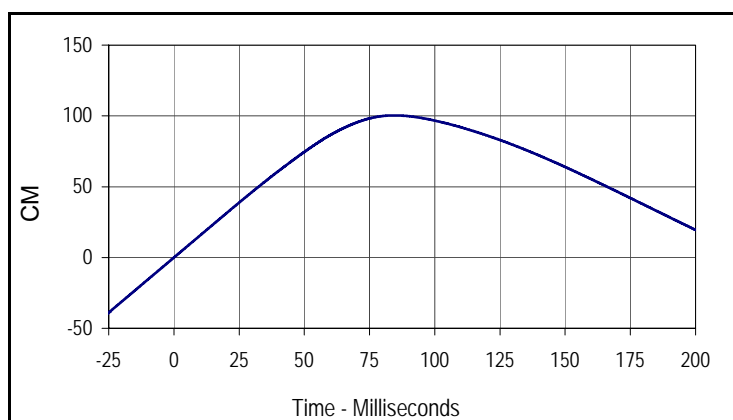

Curve Description			
Passenger Head Primary X Displacement			
CURNO	Type	SAE Class	Units
045	IN2	180	CM
Max	Time	Min	Time
100.4	84.5	0.0	0.0

Test Vehicle: 2005 Toyota Scion TC 3-Door Hatchback  
 Test Program: 2005 NHTSA 35mph NCAP

Test Date: 9/30/04  
 NHTSA No.: M55110

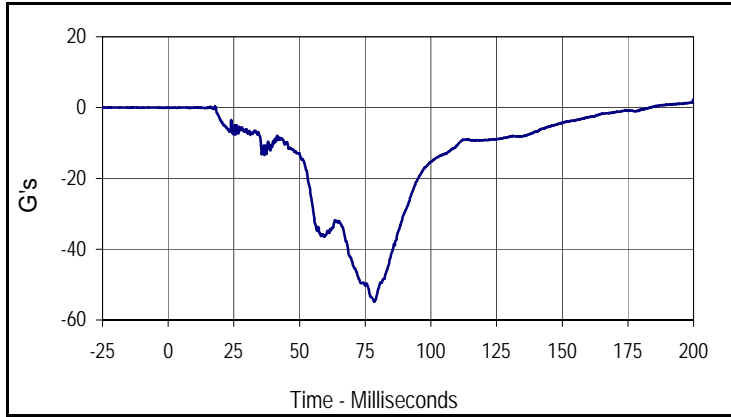

Curve Description			
Passenger Head Redundant X			
CURNO	Type	SAE Class	Units
048	FIL	1000	G's
Max	Time	Min	Time
2.4	200.0	-54.8	78.6

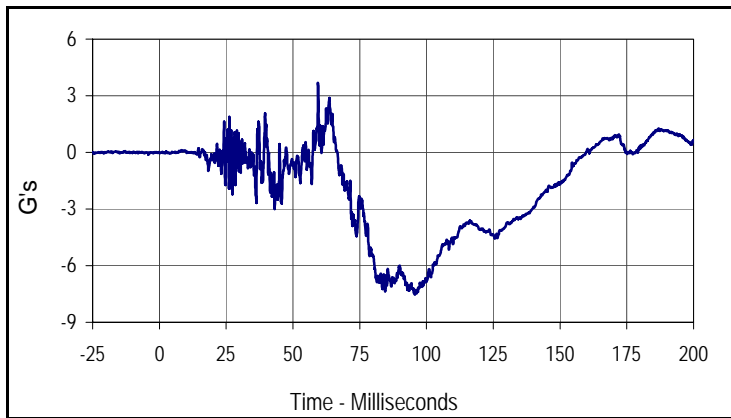

Curve Description			
Passenger Head Redundant Y			
CURNO	Type	SAE Class	Units
049	FIL	1000	G's
Max	Time	Min	Time
3.7	59.4	-7.5	95.6

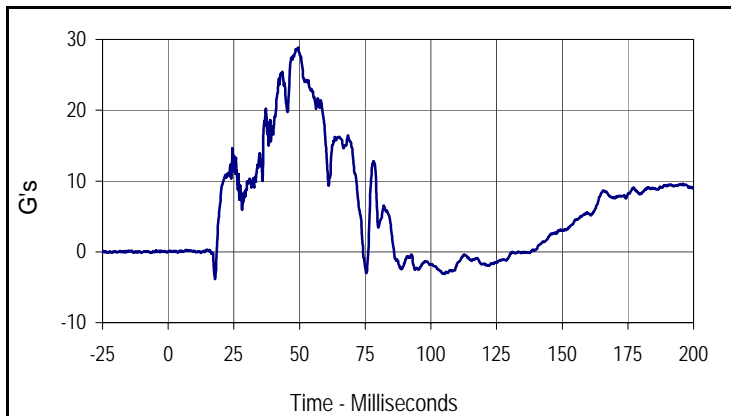

Curve Description			
Passenger Head Redundant Z			
CURNO	Type	SAE Class	Units
050	FIL	1000	G's
Max	Time	Min	Time
28.9	49.5	-3.9	17.8

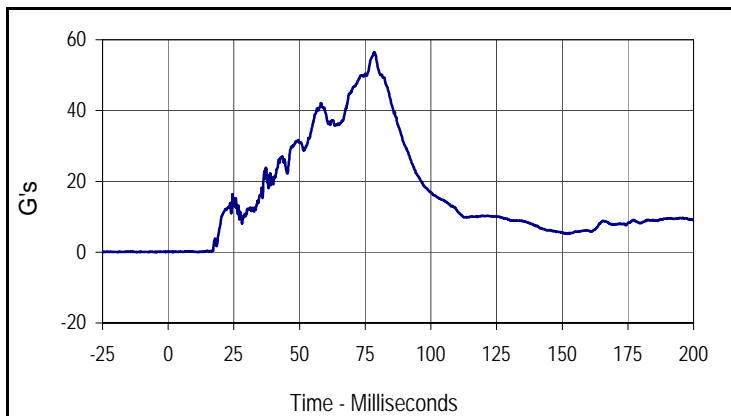

Curve Description			
Passenger Head Resultant Redundant			
CURNO	Type	SAE Class	Units
048	RES	1000	G's
Max	Time	Min	Time
56.5	78.6	0.0	11.3

Test Vehicle: 2005 Toyota Scion TC 3-Door Hatchback  
 Test Program: 2005 NHTSA 35mph NCAP

Test Date: 9/30/04  
 NHTSA No.: M55110

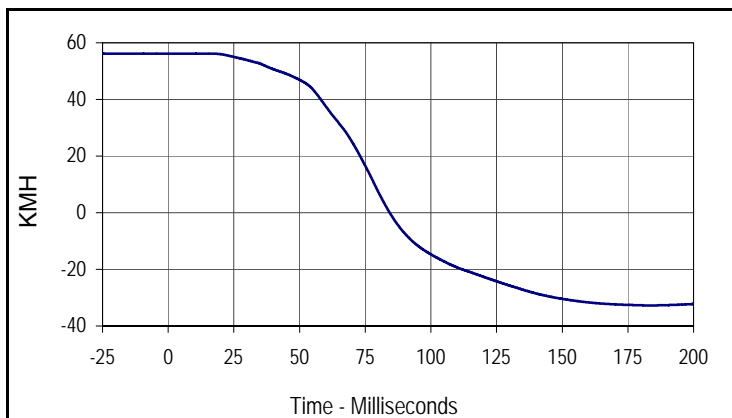

Curve Description			
Passenger Head Redundant X Velocity			
CURNO	Type	SAE Class	Units
048	IN1	180	KMH
Max	Time	Min	Time
56.1	0.0	-32.7	183.4

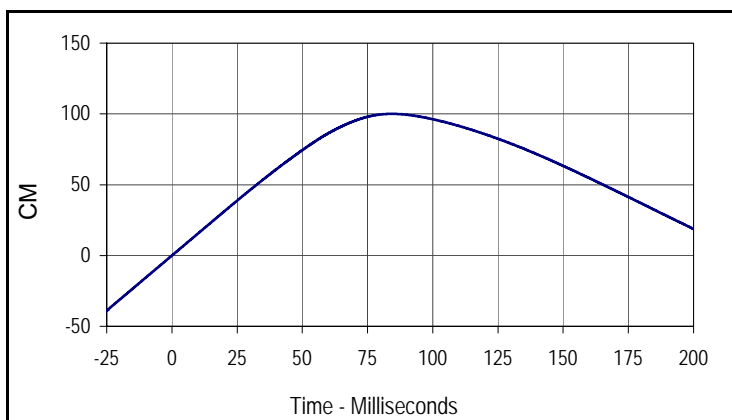

Curve Description			
Passenger Head Redundant X Displacement			
CURNO	Type	SAE Class	Units
048	IN2	180	CM
Max	Time	Min	Time
100.0	84.3	0.0	0.0

Test Vehicle: 2005 Toyota Scion TC 3-Door Hatchback  
 Test Program: 2005 NHTSA 35mph NCAP

Test Date: 9/30/04  
 NHTSA No.: M55110

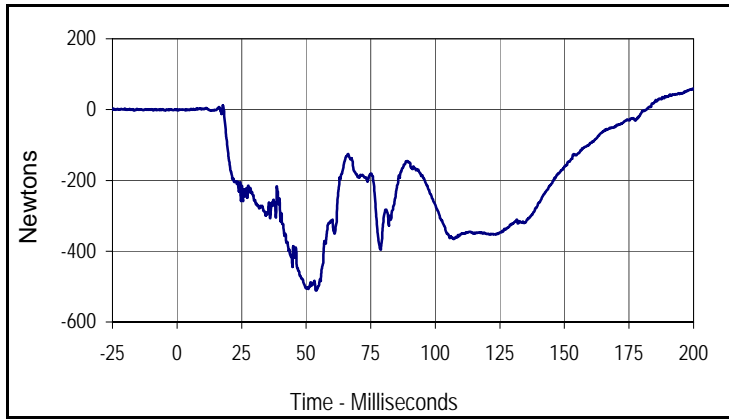

Curve Description			
Passenger Upper Neck Force X			
CURNO	Type	SAE Class	Units
051	FIL	1000	Newtons
Max	Time	Min	Time
58.9	200.0	-511.8	53.8

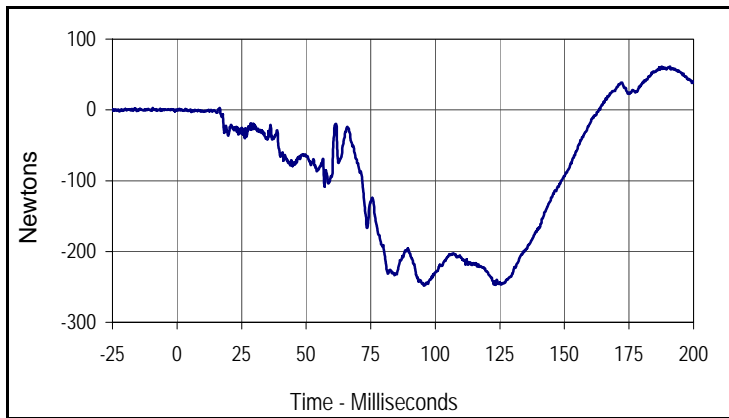

Curve Description			
Passenger Upper Neck Force Y			
CURNO	Type	SAE Class	Units
052	FIL	1000	Newtons
Max	Time	Min	Time
61.2	190.8	-248.1	95.6

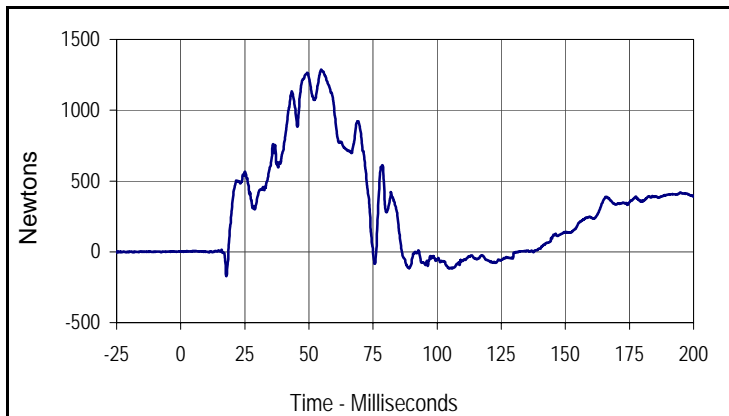

Curve Description			
Passenger Upper Neck Force Z			
CURNO	Type	SAE Class	Units
053	FIL	1000	Newtons
Max	Time	Min	Time
1287.4	54.8	-173.3	17.8

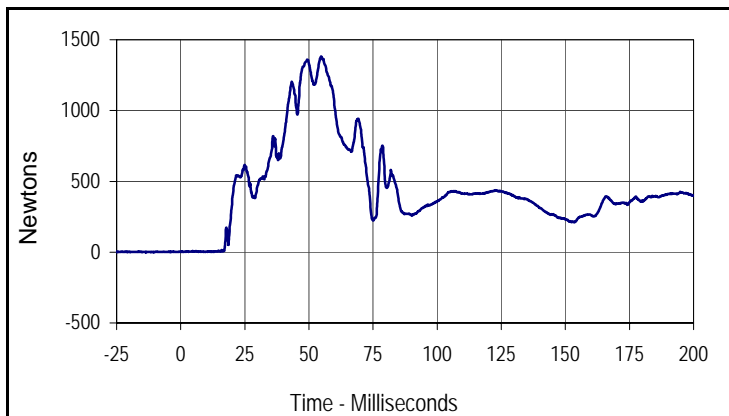

Curve Description			
Passenger Upper Neck Force Res.			
CURNO	Type	SAE Class	Units
051	RES	1000	Newtons
Max	Time	Min	Time
1383.2	54.8	0.6	12.1

Test Vehicle: 2005 Toyota Scion TC 3-Door Hatchback  
 Test Program: 2005 NHTSA 35mph NCAP

Test Date: 9/30/04  
 NHTSA No.: M55110

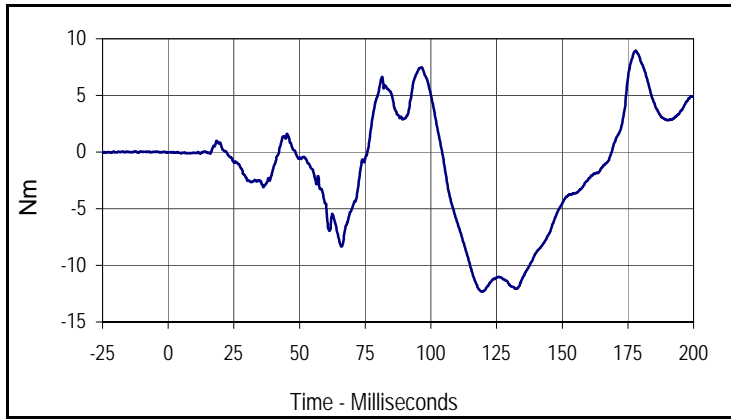

Curve Description			
Passenger Upper Neck Moment X			
CURNO	Type	SAE Class	Units
054	FIL	600	Nm
Max	Time	Min	Time
8.9	178.0	-12.3	119.3

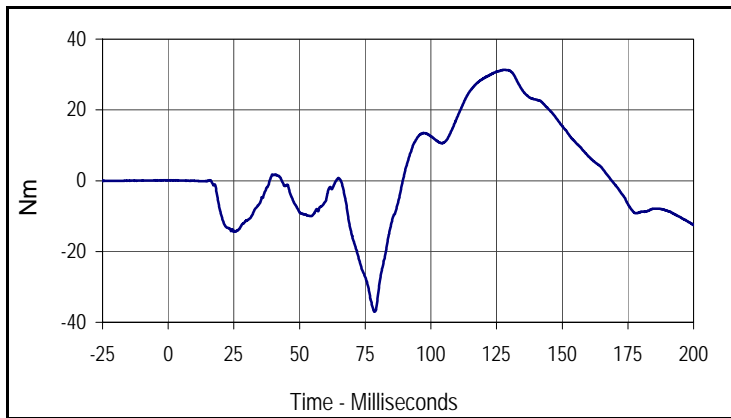

Curve Description			
Passenger Upper Neck Moment Y			
CURNO	Type	SAE Class	Units
055	FIL	600	Nm
Max	Time	Min	Time
31.3	127.7	-37.0	78.6

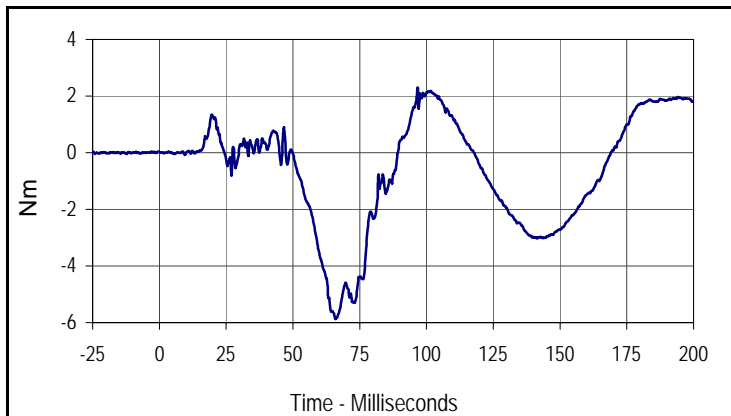

Curve Description			
Passenger Upper Neck Moment Z			
CURNO	Type	SAE Class	Units
056	FIL	600	Nm
Max	Time	Min	Time
2.3	96.7	-5.9	66.0

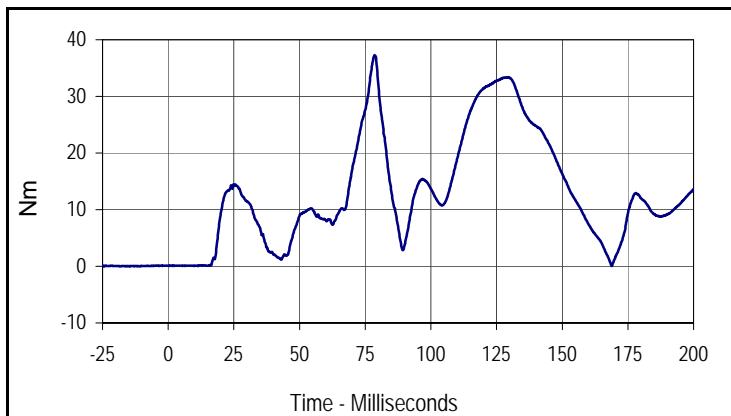

Curve Description			
Passenger Upper Neck Moment Res.			
CURNO	Type	SAE Class	Units
054	RES	600	Nm
Max	Time	Min	Time
37.3	78.6	0.1	11.3

Test Vehicle: 2005 Toyota Scion TC 3-Door Hatchback  
 Test Program: 2005 NHTSA 35mph NCAP

Test Date: 9/30/04  
 NHTSA No.: M55110

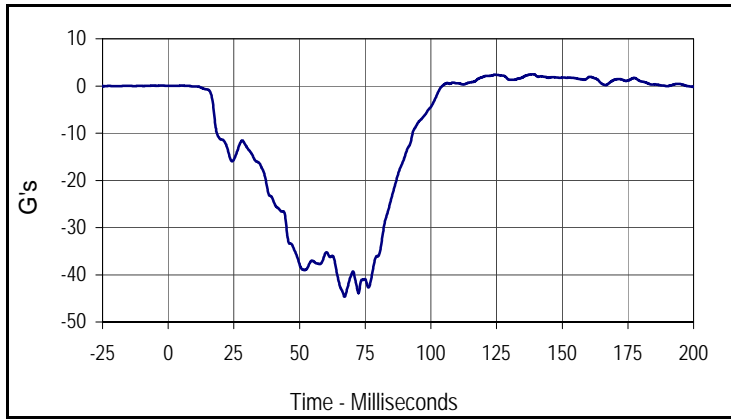

Curve Description			
Passenger Chest Primary X			
CURNO	Type	SAE Class	Units
057	FIL	180	G's
Max	Time	Min	Time
2.5	138.9	-44.6	67.1

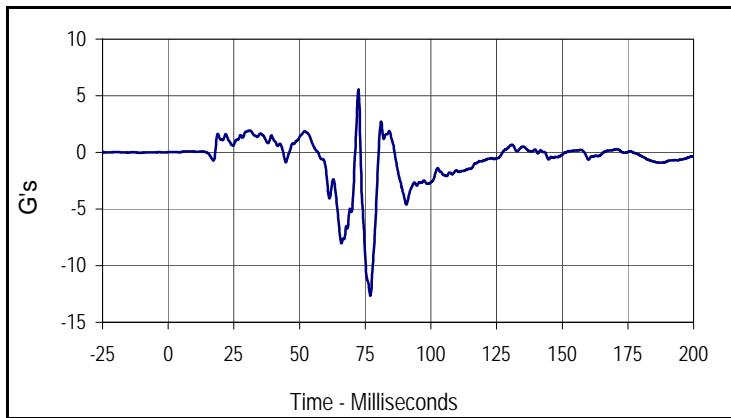

Curve Description			
Passenger Chest Primary Y			
CURNO	Type	SAE Class	Units
058	FIL	180	G's
Max	Time	Min	Time
5.5	72.4	-12.7	76.9

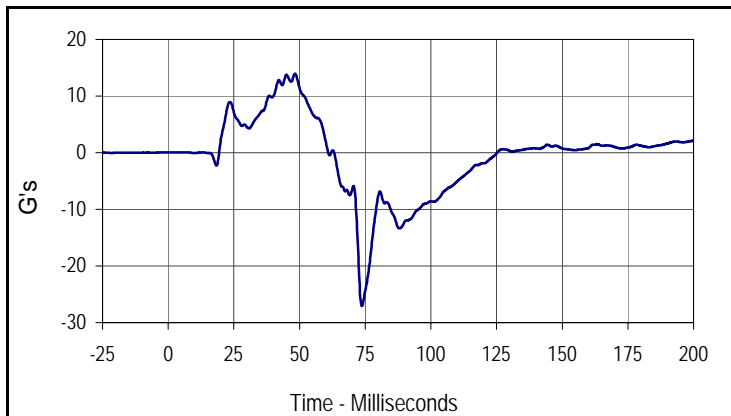

Curve Description			
Passenger Chest Primary Z			
CURNO	Type	SAE Class	Units
059	FIL	180	G's
Max	Time	Min	Time
14.0	48.3	-27.1	73.7

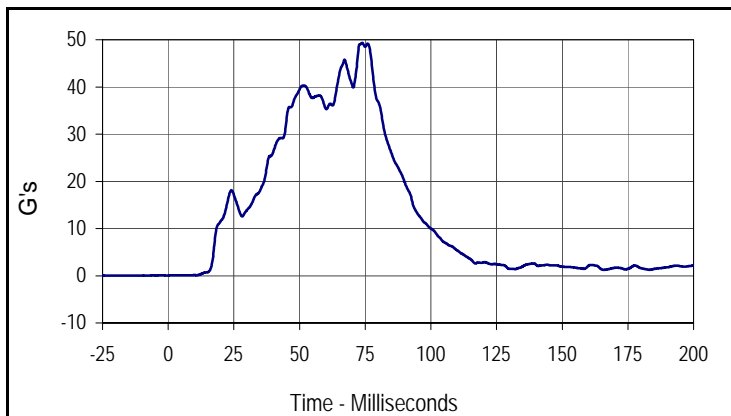

Curve Description			
Passenger Chest Resultant Primary			
CURNO	Type	SAE Class	Units
057	RES	180	G's
Max	Time	Min	Time
49.4	73.9	0.1	0.0

Test Vehicle: 2005 Toyota Scion TC 3-Door Hatchback  
 Test Program: 2005 NHTSA 35mph NCAP

Test Date: 9/30/04  
 NHTSA No.: M55110

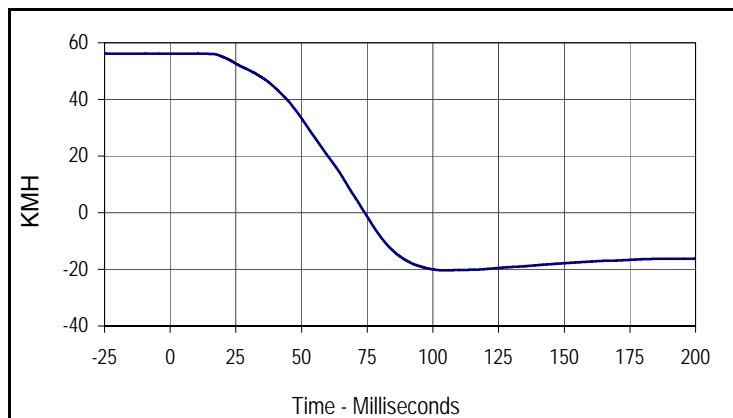

Curve Description			
Passenger Chest Primary X Velocity			
CURNO	Type	SAE Class	Units
057	IN1	180	KMH
Max	Time	Min	Time
56.2	8.1	-20.3	104.4

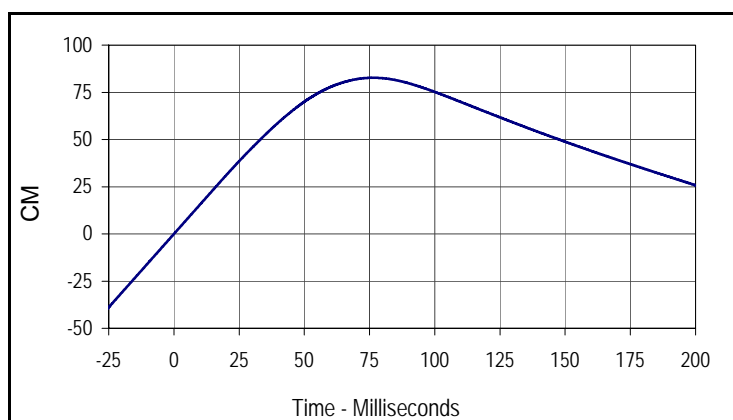

Curve Description			
Passenger Chest Primary X Displacement			
CURNO	Type	SAE Class	Units
057	IN2	180	CM
Max	Time	Min	Time
82.7	76.4	0.0	0.0

Test Vehicle: 2005 Toyota Scion TC 3-Door Hatchback  
 Test Program: 2005 NHTSA 35mph NCAP

Test Date: 9/30/04  
 NHTSA No.: M55110

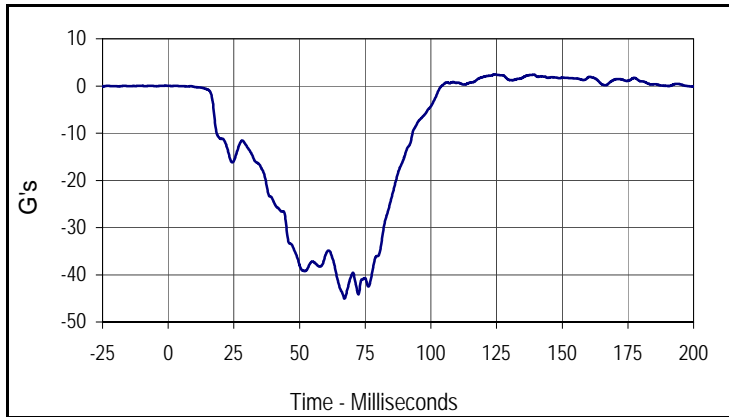

Curve Description			
Passenger Chest Redundant X			
CURNO	Type	SAE Class	Units
060	FIL	180	G's
Max	Time	Min	Time
2.5	124.3	-45.0	67.1

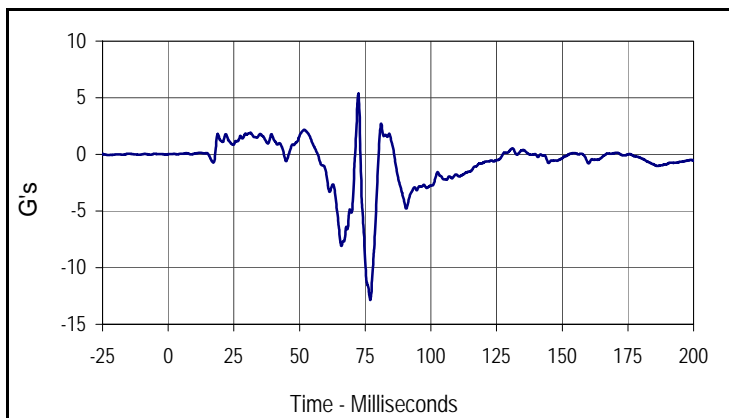

Curve Description			
Passenger Chest Redundant Y			
CURNO	Type	SAE Class	Units
061	FIL	180	G's
Max	Time	Min	Time
5.4	72.4	-12.9	76.9

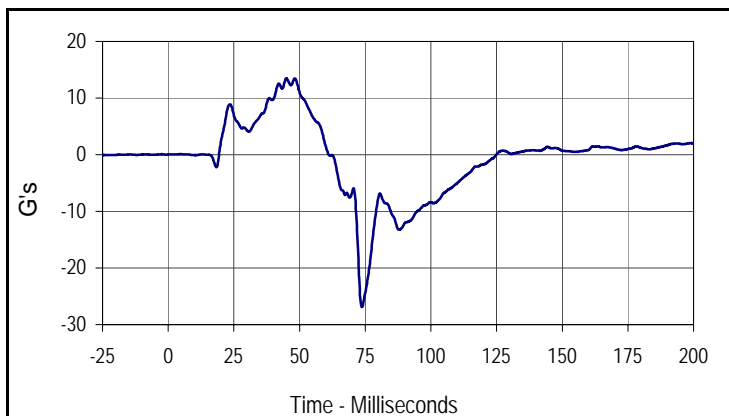

Curve Description			
Passenger Chest Redundant Z			
CURNO	Type	SAE Class	Units
062	FIL	180	G's
Max	Time	Min	Time
13.5	45.0	-26.9	73.7

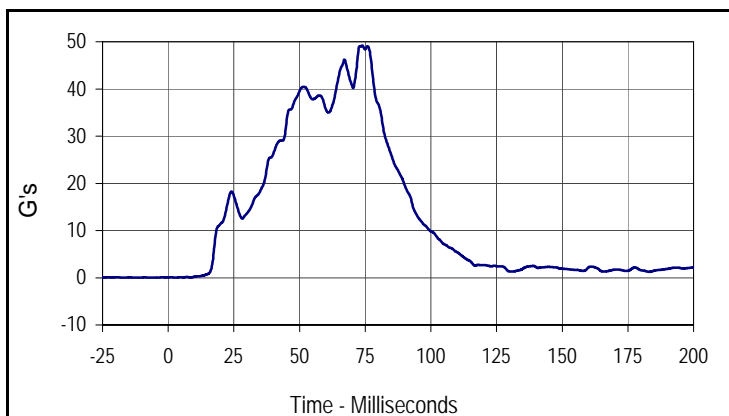

Curve Description			
Passenger Chest Resultant Redundant			
CURNO	Type	SAE Class	Units
060	RES	180	G's
Max	Time	Min	Time
49.2	73.9	0.1	3.5

Test Vehicle: 2005 Toyota Scion TC 3-Door Hatchback  
 Test Program: 2005 NHTSA 35mph NCAP

Test Date: 9/30/04  
 NHTSA No.: M55110

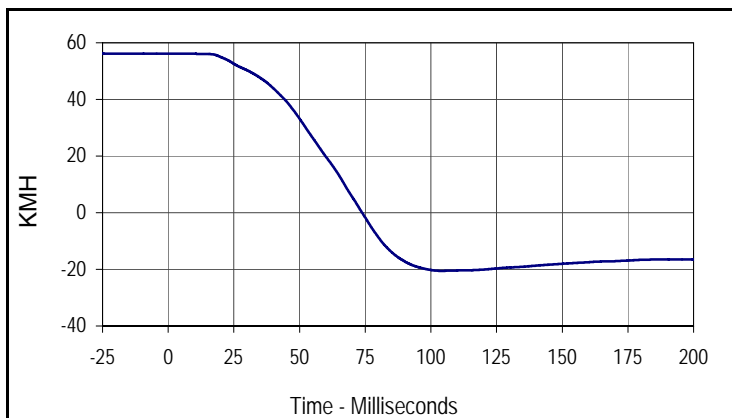

Curve Description			
Passenger Chest Redundant X Velocity			
CURNO	Type	SAE Class	Units
060	IN1	180	KMH
Max	Time	Min	Time
56.1	3.8	-20.5	104.1

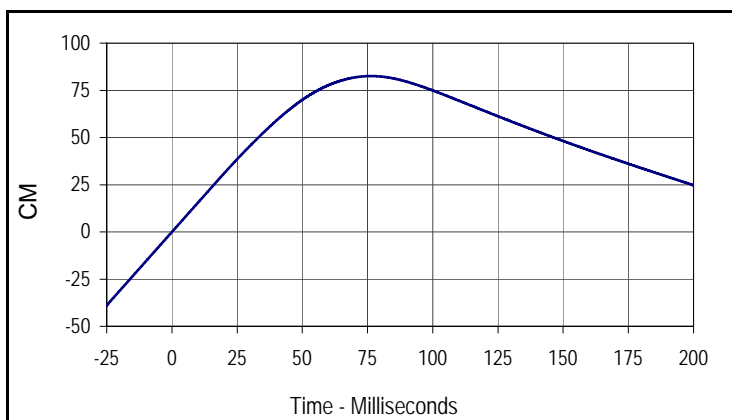

Curve Description			
Passenger Chest Redundant X Displacement			
CURNO	Type	SAE Class	Units
060	IN2	180	CM
Max	Time	Min	Time
82.5	76.3	0.0	0.0

Test Vehicle: 2005 Toyota Scion TC 3-Door Hatchback  
 Test Program: 2005 NHTSA 35mph NCAP

Test Date: 9/30/04  
 NHTSA No.: M55110

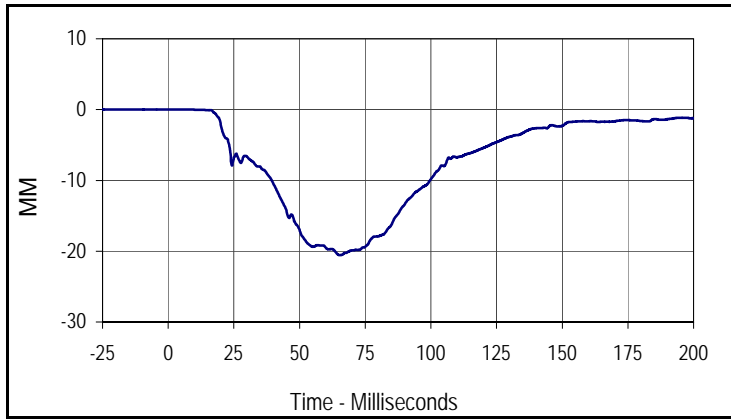

Curve Description			
Passenger Chest Displacement			
CURNO	Type	SAE Class	Units
063	FIL	600	MM
Max	Time	Min	Time
0.0	4.4	-20.6	65.3

Test Vehicle: 2005 Toyota Scion TC 3-Door Hatchback  
 Test Program: 2005 NHTSA 35mph NCAP

Test Date: 9/30/04  
 NHTSA No.: M55110

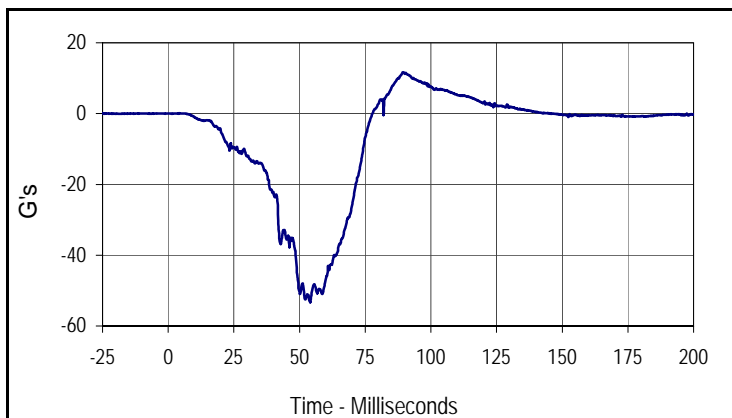

Curve Description			
Passenger Pelvis X			
CURNO	Type	SAE Class	Units
064	FIL	1000	G's
Max	Time	Min	Time
11.7	89.3	-53.3	54.1

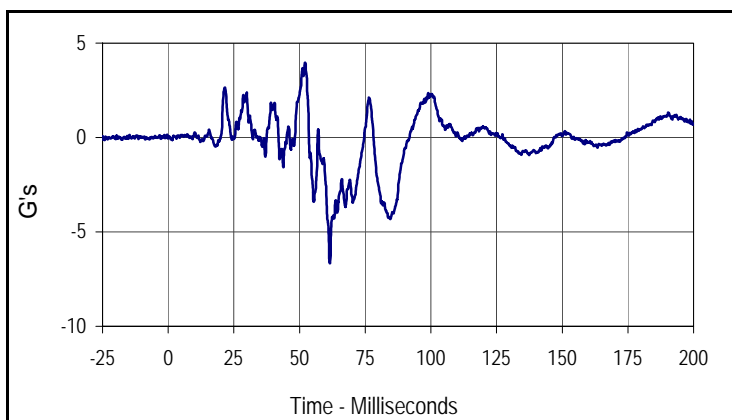

Curve Description			
Passenger Pelvis Y			
CURNO	Type	SAE Class	Units
065	FIL	1000	G's
Max	Time	Min	Time
4.0	52.1	-6.7	61.5

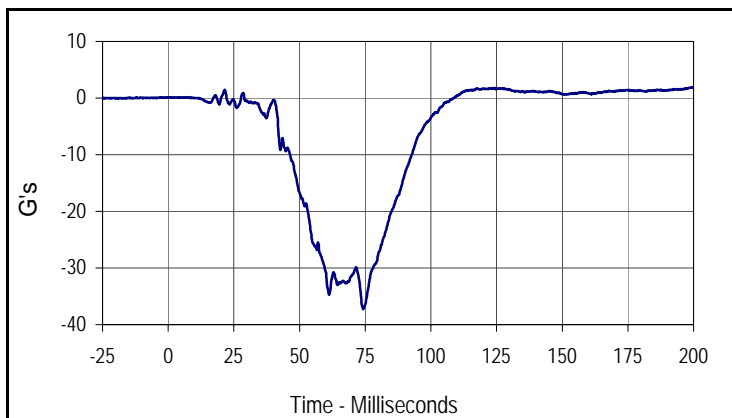

Curve Description			
Passenger Pelvis Z			
CURNO	Type	SAE Class	Units
066	FIL	1000	G's
Max	Time	Min	Time
1.9	199.4	-37.3	74.2

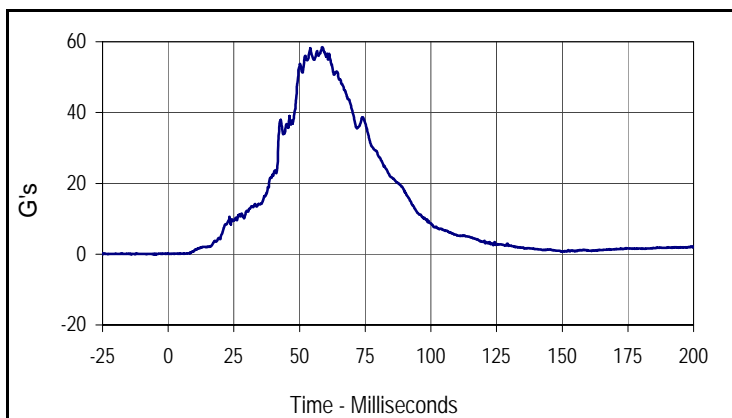

Curve Description			
Passenger Pelvis Resultant			
CURNO	Type	SAE Class	Units
064	RES	1000	G's
Max	Time	Min	Time
58.5	58.7	0.1	4.5

Test Vehicle: 2005 Toyota Scion TC 3-Door Hatchback  
 Test Program: 2005 NHTSA 35mph NCAP

Test Date: 9/30/04  
 NHTSA No.: M55110

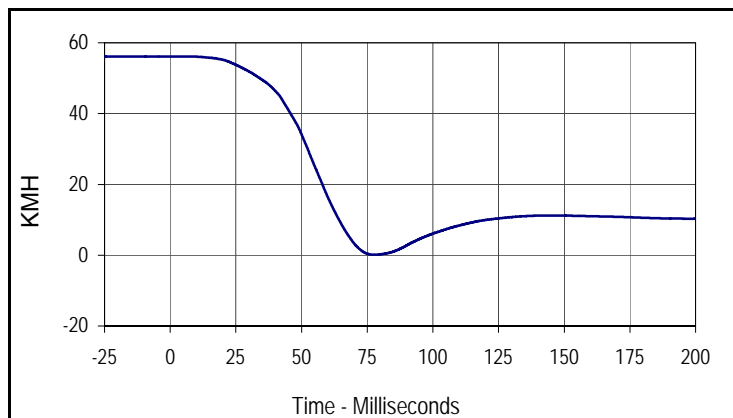

Curve Description			
Passenger Pelvis X Velocity			
CURNO	Type	SAE Class	Units
064	IN1	180	KMH
Max	Time	Min	Time
56.1	6.4	0.1	77.7

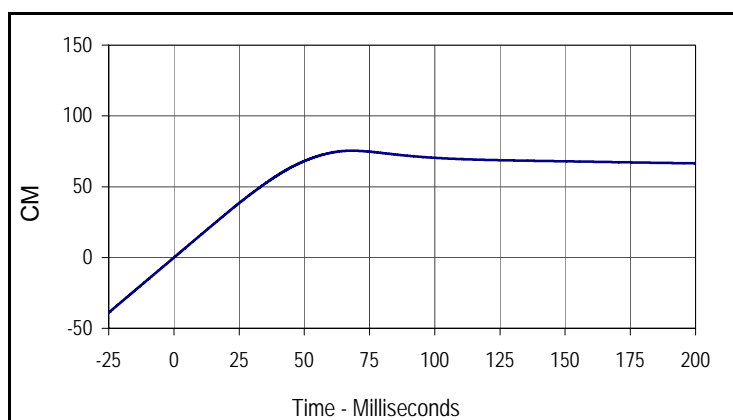

Curve Description			
Passenger Pelvis X Displacement			
CURNO	Type	SAE Class	Units
064	IN2	180	CM
Max	Time	Min	Time
75.4	68.2	0.0	0.0

Test Vehicle: 2005 Toyota Scion TC 3-Door Hatchback  
 Test Program: 2005 NHTSA 35mph NCAP

Test Date: 9/30/04  
 NHTSA No.: M55110

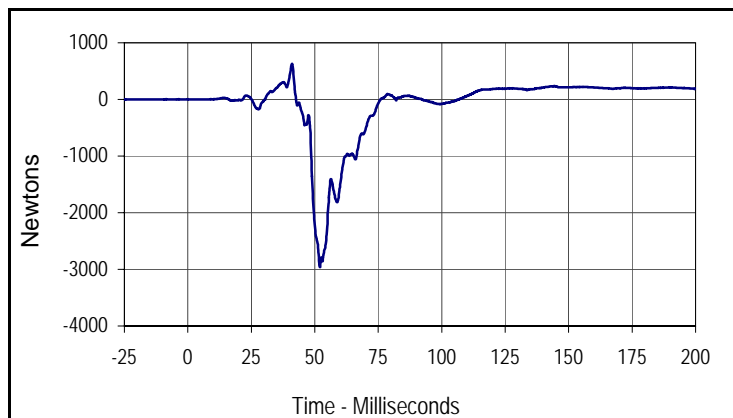

Curve Description			
Passenger Left Femur Force			
CURNO	Type	SAE Class	Units
067	FIL	600	Newtons
Max	Time	Min	Time
628.2	41.0	-2962.5	52.0

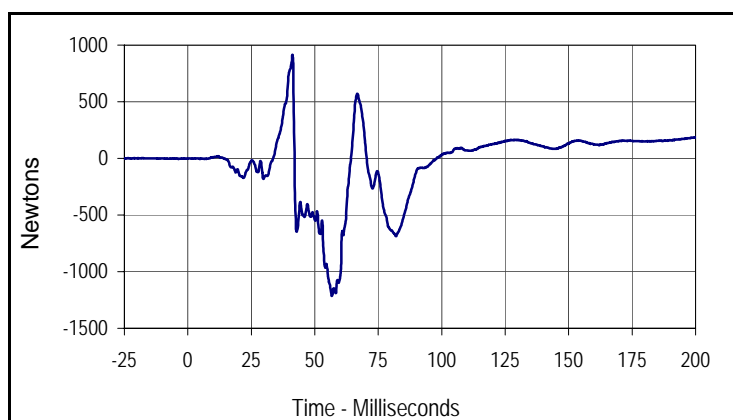

Curve Description			
Passenger Right Femur Force			
CURNO	Type	SAE Class	Units
068	FIL	600	Newtons
Max	Time	Min	Time
914.4	41.2	-1214.8	56.7

Test Vehicle: 2005 Toyota Scion TC 3-Door Hatchback  
 Test Program: 2005 NHTSA 35mph NCAP

Test Date: 9/30/04  
 NHTSA No.: M55110

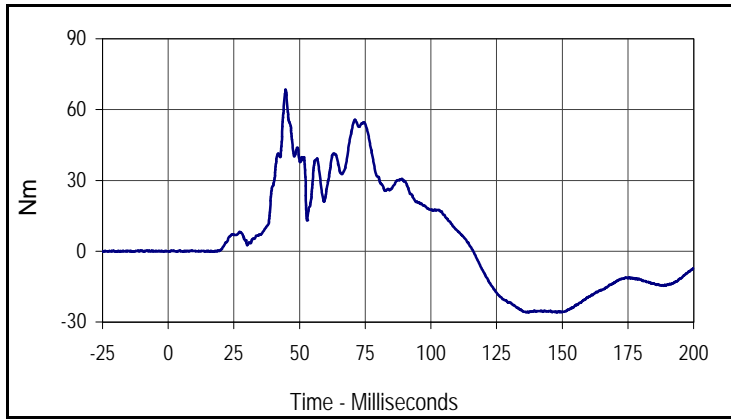

Curve Description			
Passenger Left Upper Tibia Moment X			
CURNO	Type	SAE Class	Units
069	FIL	600	Nm
Max	Time	Min	Time
68.5	44.7	-26.0	136.4

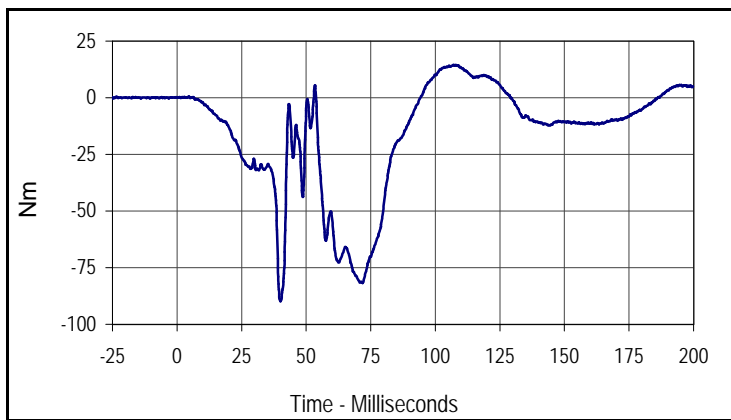

Curve Description			
Passenger Left Upper Tibia Moment Y			
CURNO	Type	SAE Class	Units
070	FIL	600	Nm
Max	Time	Min	Time
14.6	107.1	-89.8	40.1

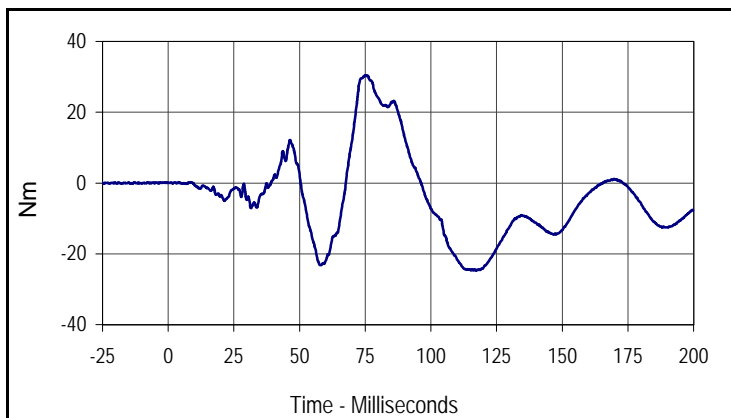

Curve Description			
Passenger Right Upper Tibia Moment X			
CURNO	Type	SAE Class	Units
071	FIL	600	Nm
Max	Time	Min	Time
30.4	75.1	-24.7	117.1

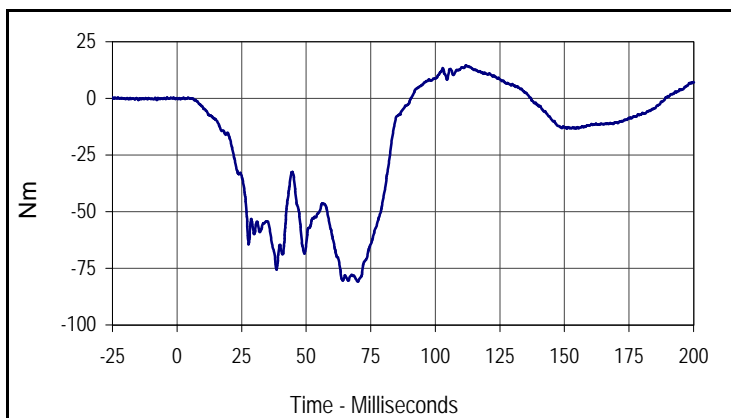

Curve Description			
Passenger Right Upper Tibia Moment Y			
CURNO	Type	SAE Class	Units
072	FIL	600	Nm
Max	Time	Min	Time
14.6	111.9	-80.8	69.9

Test Vehicle: 2005 Toyota Scion TC 3-Door Hatchback  
 Test Program: 2005 NHTSA 35mph NCAP

Test Date: 9/30/04  
 NHTSA No.: M55110

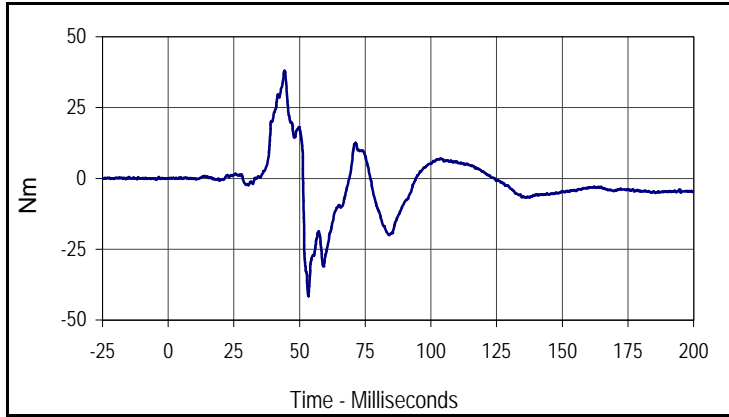

Curve Description			
Passenger Left Lower Tibia Moment X			
CURNO	Type	SAE Class	Units
073	FIL	600	Nm
Max	Time	Min	Time
38.0	44.3	-41.7	53.4

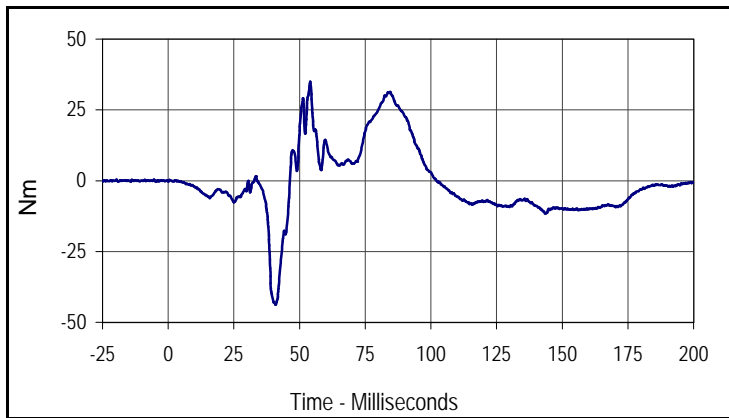

Curve Description			
Passenger Left Lower Tibia Moment Y			
CURNO	Type	SAE Class	Units
074	FIL	600	Nm
Max	Time	Min	Time
34.9	54.0	-43.7	40.9

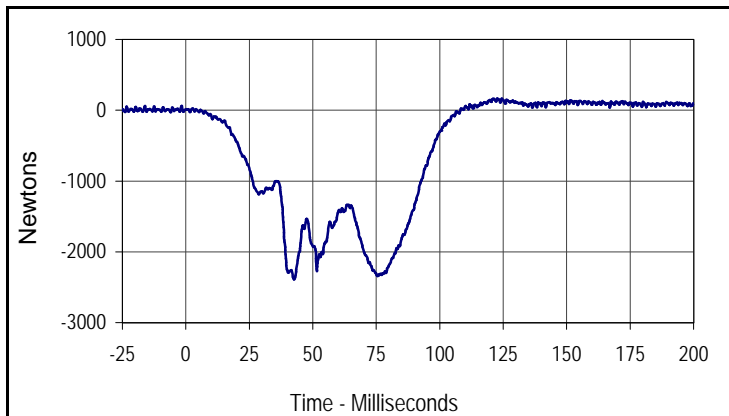

Curve Description			
Passenger Left Lower Tibia Force Z			
CURNO	Type	SAE Class	Units
075	FIL	600	Newtons
Max	Time	Min	Time
164.2	121.4	-2389.7	42.7

Test Vehicle: 2005 Toyota Scion TC 3-Door Hatchback  
 Test Program: 2005 NHTSA 35mph NCAP

Test Date: 9/30/04  
 NHTSA No.: M55110

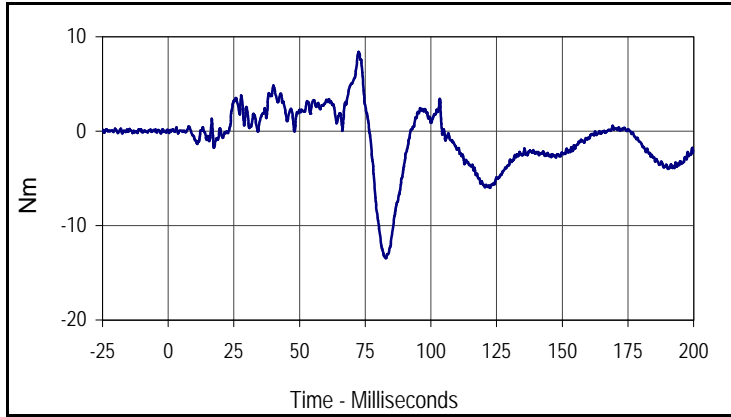

Curve Description			
Passenger Right Lower Tibia Moment X			
CURNO	Type	SAE Class	Units
076	FIL	600	Nm
Max	Time	Min	Time
8.4	72.5	-13.5	82.9

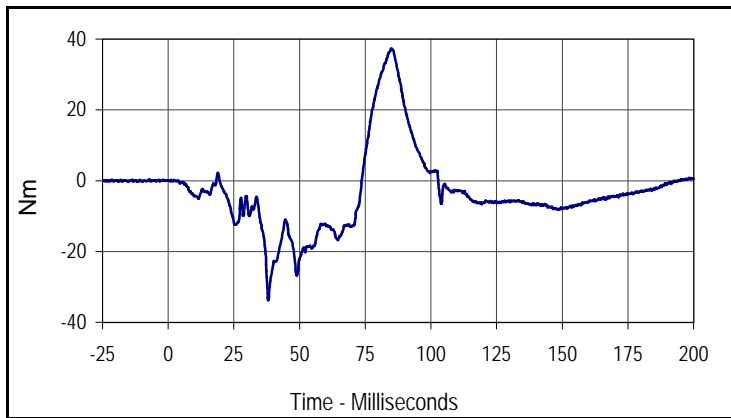

Curve Description			
Passenger Right Lower Tibia Moment Y			
CURNO	Type	SAE Class	Units
077	FIL	600	Nm
Max	Time	Min	Time
37.4	84.9	-33.8	31.9

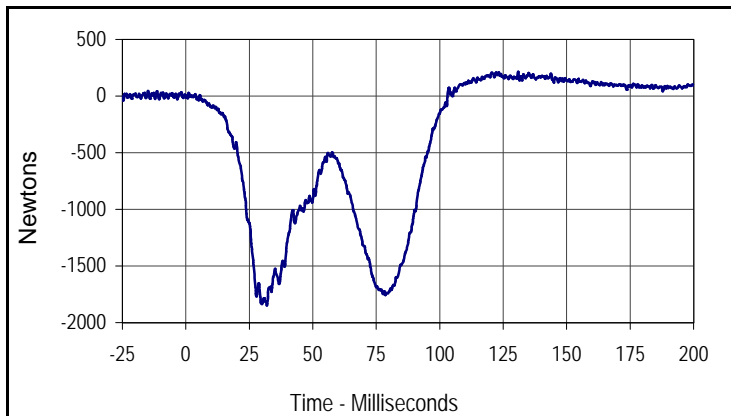

Curve Description			
Passenger Right lower Tibia Force Z			
CURNO	Type	SAE Class	Units
078	FIL	600	Newtons
Max	Time	Min	Time
214.7	130.9	-1846.9	31.9

Test Vehicle: 2005 Toyota Scion TC 3-Door Hatchback  
 Test Program: 2005 NHTSA 35mph NCAP

Test Date: 9/30/04  
 NHTSA No.: M55110

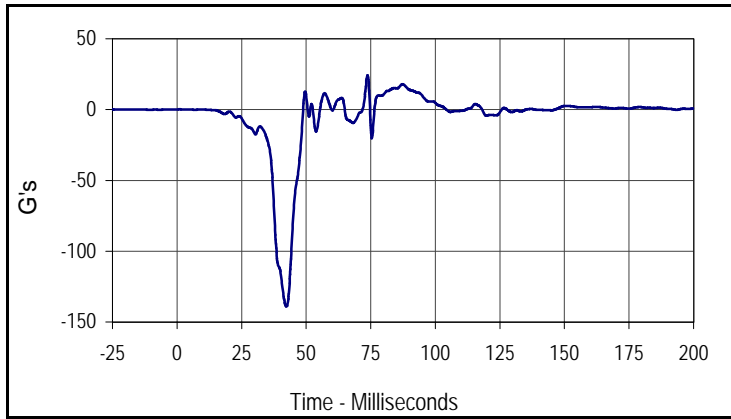

Curve Description			
Passenger Left Foot Aft X			
CURNO	Type	SAE Class	Units
079	FIL	180	G's
Max	Time	Min	Time
24.2	73.8	-138.9	42.3

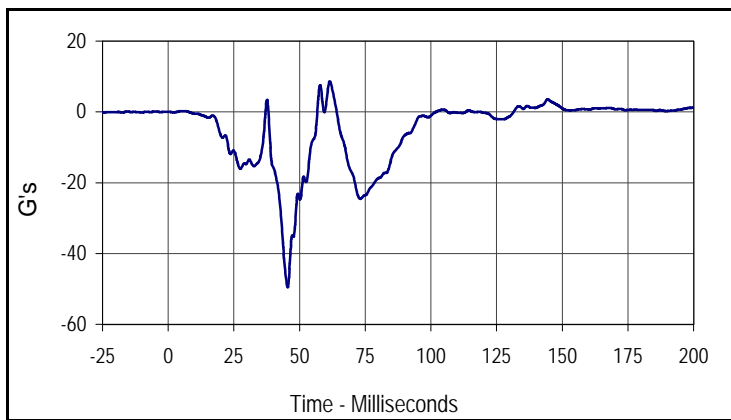

Curve Description			
Passenger Left Foot Aft Z			
CURNO	Type	SAE Class	Units
080	FIL	180	G's
Max	Time	Min	Time
8.6	61.5	-49.5	45.5

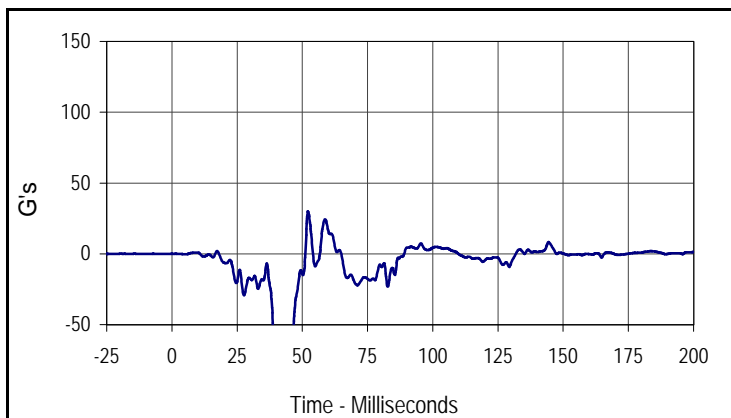

Curve Description			
Passenger Left Foot Fore Z			
CURNO	Type	SAE Class	Units
081	FIL	180	G's
Max	Time	Min	Time
30.0	52.2	-127.6	43.0

Test Vehicle: 2005 Toyota Scion TC 3-Door Hatchback  
 Test Program: 2005 NHTSA 35mph NCAP

Test Date: 9/30/04  
 NHTSA No.: M55110

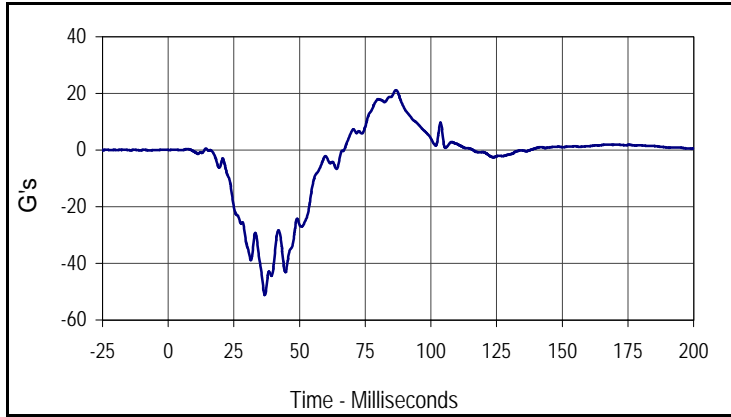

Curve Description			
Passenger Right Foot Aft X			
CURNO	Type	SAE Class	Units
082	FIL	180	G's
Max	Time	Min	Time
21.2	86.7	-51.2	36.8

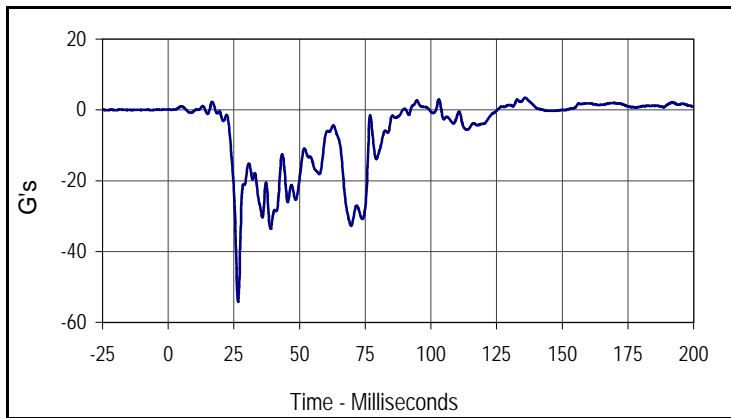

Curve Description			
Passenger Right Foot Aft Z			
CURNO	Type	SAE Class	Units
083	FIL	180	G's
Max	Time	Min	Time
3.5	135.9	-54.3	26.6

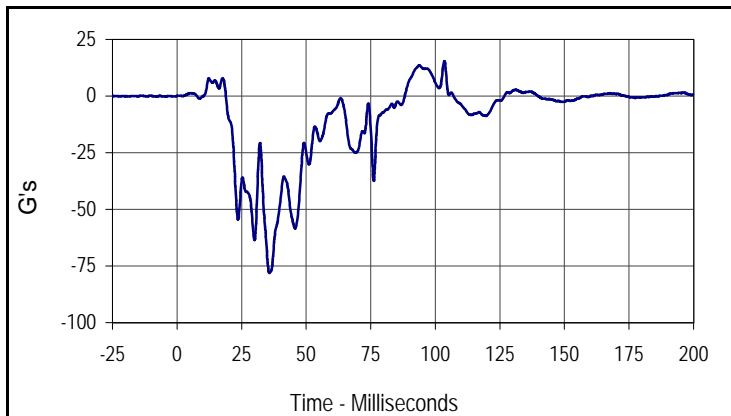

Curve Description			
Passenger Right Foot Fore Z			
CURNO	Type	SAE Class	Units
084	FIL	180	G's
Max	Time	Min	Time
15.4	103.5	-78.1	35.8

Test Vehicle: 2005 Toyota Scion TC 3-Door Hatchback  
 Test Program: 2005 NHTSA 35mph NCAP

Test Date: 9/30/04  
 NHTSA No.: M55110

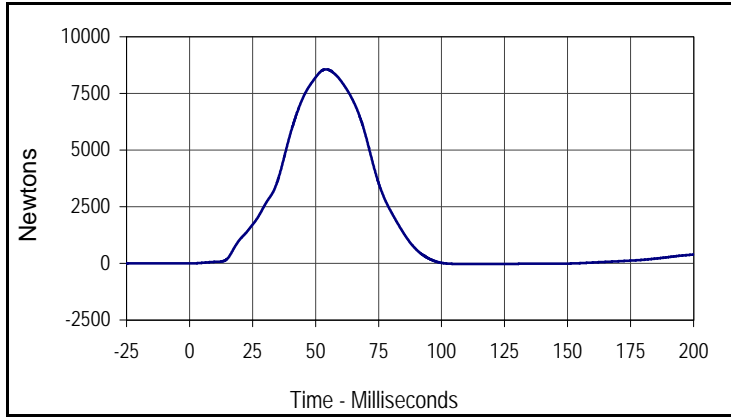

Curve Description			
Passenger Lap Belt Force			
CURNO	Type	SAE Class	Units
085	FIL	60	Newtons
Max	Time	Min	Time
8565.9	54.1	-29.9	109.5

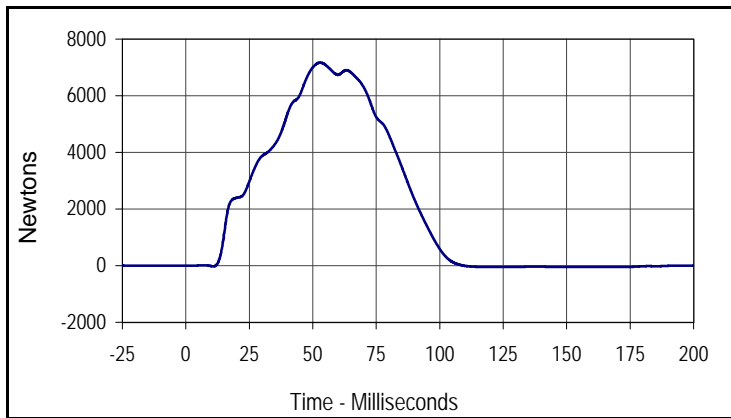

Curve Description			
Passenger Shoulder Belt Force			
CURNO	Type	SAE Class	Units
086	FIL	60	Newtons
Max	Time	Min	Time
7169.5	52.9	-48.6	120.2

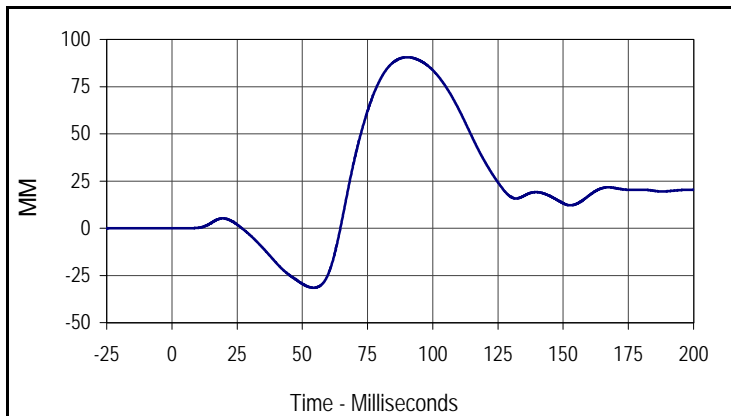

Curve Description			
Passenger Shoulder Belt Pullout			
CURNO	Type	SAE Class	Units
087	FIL	60	MM
Max	Time	Min	Time
90.6	90.6	-31.5	54.8

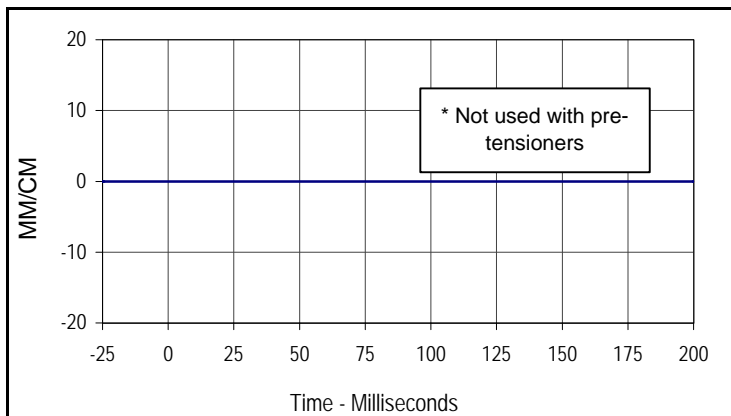

Curve Description			
Passenger Shoulder Belt Elongation			
CURNO	Type	SAE Class	Units
088	FIL	60	MM/CM
Max	Time	Min	Time
0.0	0.0	0.0	0.0

\* Not used with pre-tensioners

Test Vehicle: 2005 Toyota Scion TC 3-Door Hatchback  
 Test Program: 2005 NHTSA 35mph NCAP

Test Date: 9/30/04  
 NHTSA No.: M55110

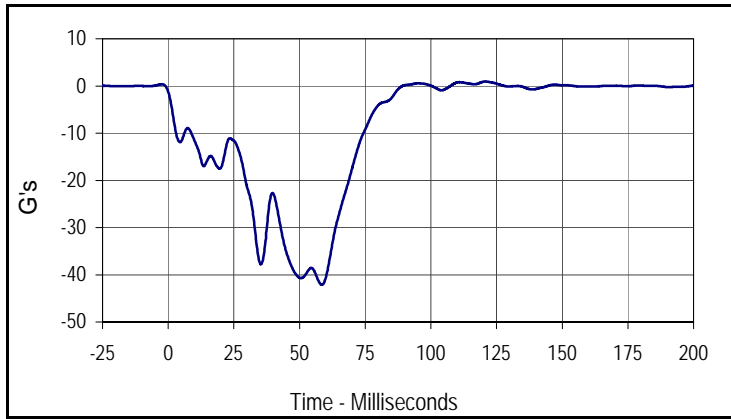

Curve Description			
Vehicle Left Rear X			
CURNO	Type	SAE Class	Units
089	FIL	60	G's
Max	Time	Min	Time
1.0	120.7	-42.1	58.5

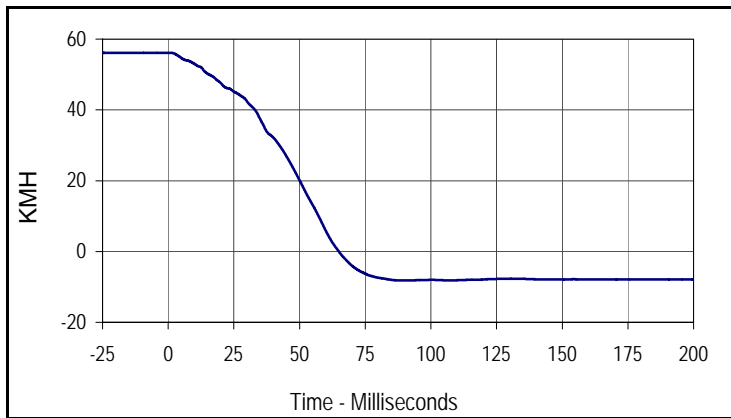

Curve Description			
Vehicle Left Rear X Velocity			
CURNO	Type	SAE Class	Units
089	IN1	180	KMH
Max	Time	Min	Time
56.1	0.6	-8.2	107.7

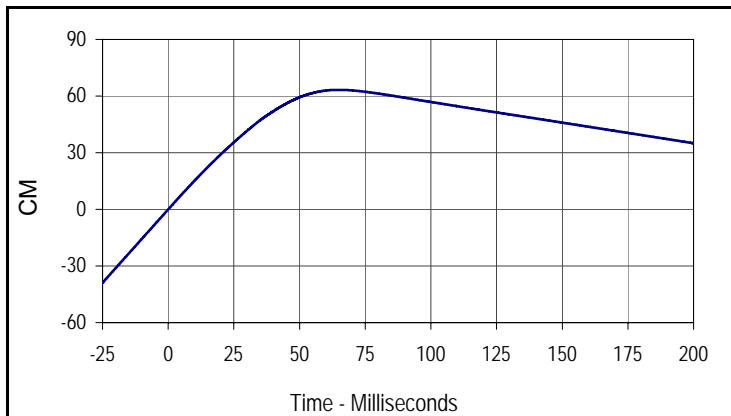

Curve Description			
Vehicle Left Rear X Displacement			
CURNO	Type	SAE Class	Units
089	IN2	180	CM
Max	Time	Min	Time
63.3	65.0	0.0	0.0

Test Vehicle: 2005 Toyota Scion TC 3-Door Hatchback  
 Test Program: 2005 NHTSA 35mph NCAP

Test Date: 9/30/04  
 NHTSA No.: M55110

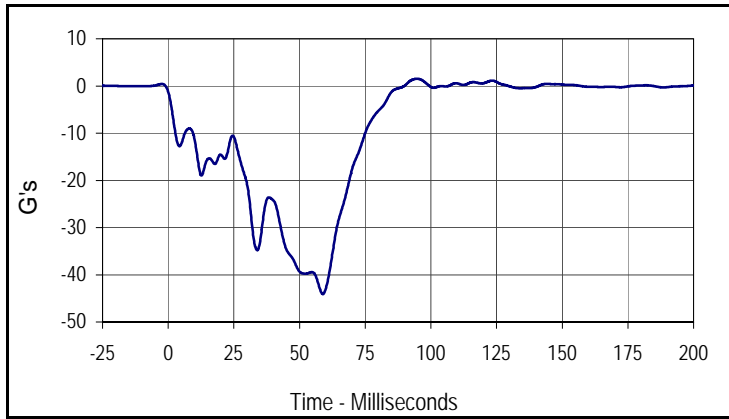

Curve Description			
Vehicle Right Rear X			
CURNO	Type	SAE Class	Units
090	FIL	60	G's
Max	Time	Min	Time
1.5	94.7	-44.1	58.9

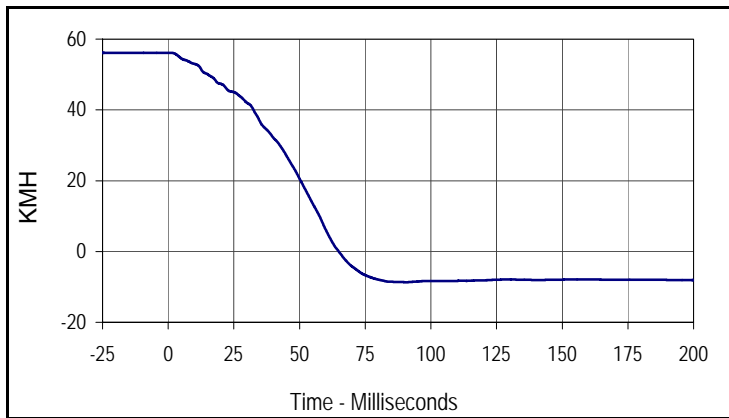

Curve Description			
Vehicle Right Rear X Velocity			
CURNO	Type	SAE Class	Units
090	IN1	180	KMH
Max	Time	Min	Time
56.1	0.5	-8.7	90.6

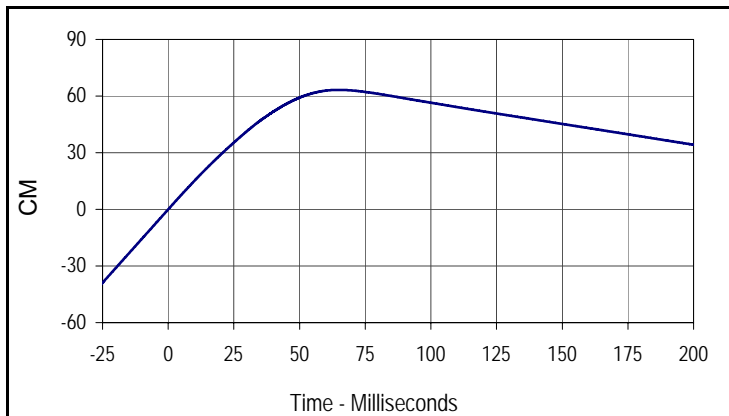

Curve Description			
Vehicle Right Rear X Displacement			
CURNO	Type	SAE Class	Units
090	IN2	180	CM
Max	Time	Min	Time
63.3	64.9	0.0	0.0

Test Vehicle: 2005 Toyota Scion TC 3-Door Hatchback  
 Test Program: 2005 NHTSA 35mph NCAP

Test Date: 9/30/04  
 NHTSA No.: M55110

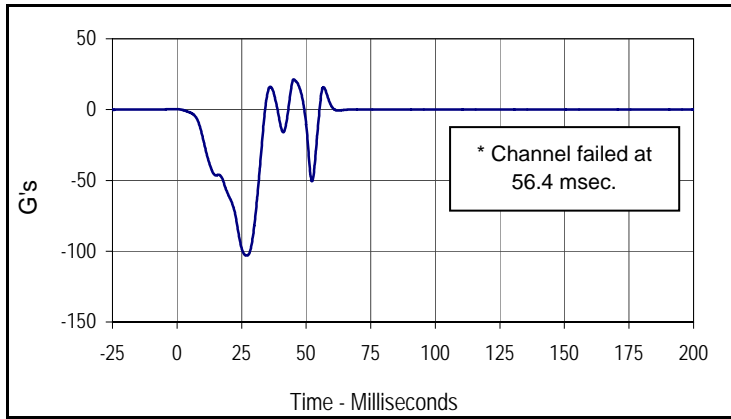

Curve Description			
Vehicle Engine Top			
CURNO	Type	SAE Class	Units
091	FIL	60	G's
Max	Time	Min	Time
21.4	45.1	-103.0	27.0

\* Channel failed at 56.4 msec.

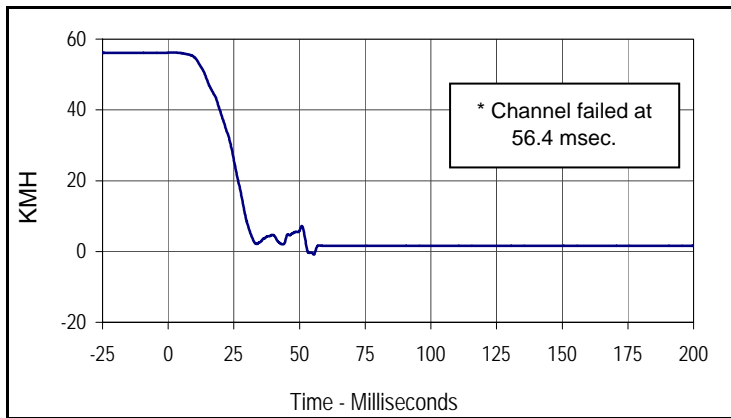

Curve Description			
Vehicle Engine Top X Velocity			
CURNO	Type	SAE Class	Units
091	IN1	180	KMH
Max	Time	Min	Time
56.2	2.5	-0.8	55.4

\* Channel failed at 56.4 msec.

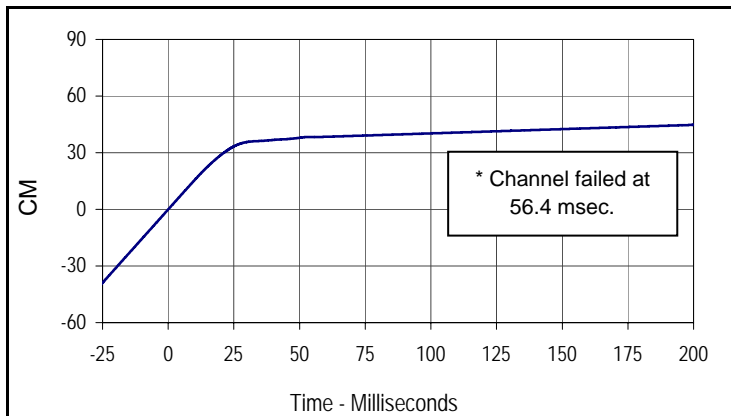

Curve Description			
Vehicle Engine Top X Displacement			
CURNO	Type	SAE Class	Units
091	IN2	180	CM
Max	Time	Min	Time
44.7	200.0	0.0	0.0

\* Channel failed at 56.4 msec.

Test Vehicle: 2005 Toyota Scion TC 3-Door Hatchback  
 Test Program: 2005 NHTSA 35mph NCAP

Test Date: 9/30/04  
 NHTSA No.: M55110

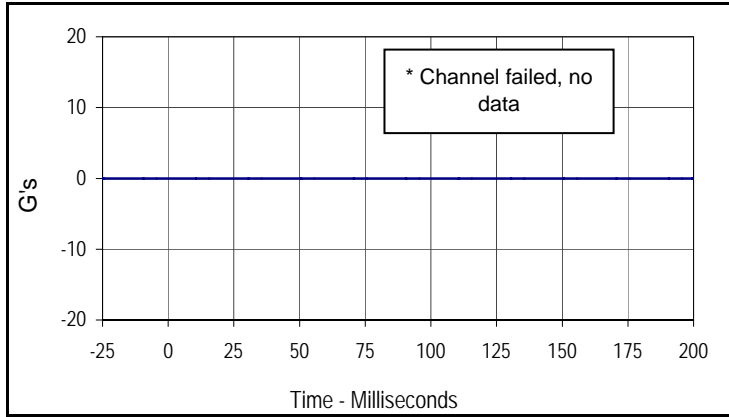

Curve Description			
Vehicle Engine Bottom			
CURNO	Type	SAE Class	Units
092	FIL	60	G's
Max	Time	Min	Time
0.0	0.0	0.0	0.0

\* Channel failed, no data

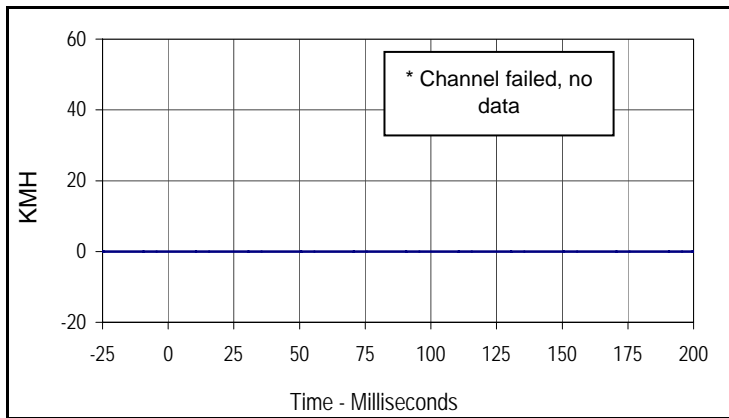

Curve Description			
Vehicle Engine Bottom X Velocity			
CURNO	Type	SAE Class	Units
092	IN1	180	KMH
Max	Time	Min	Time
0.0	0.0	0.0	0.0

\* Channel failed, no data

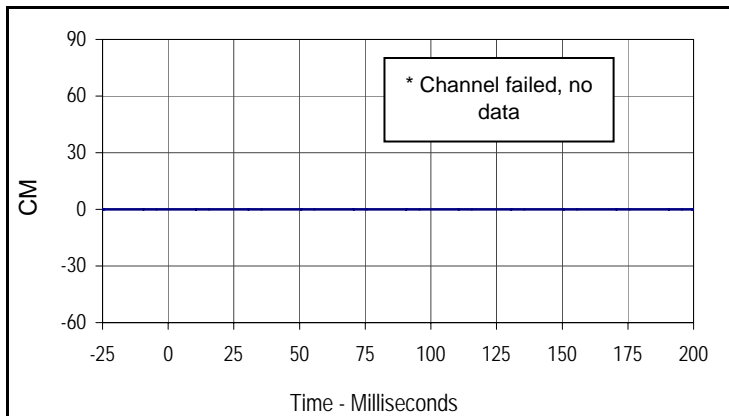

Curve Description			
Vehicle Engine Bottom X Displacement			
CURNO	Type	SAE Class	Units
092	IN2	180	CM
Max	Time	Min	Time
0.0	0.0	0.0	0.0

\* Channel failed, no data

Test Vehicle: 2005 Toyota Scion TC 3-Door Hatchback  
 Test Program: 2005 NHTSA 35mph NCAP

Test Date: 9/30/04  
 NHTSA No.: M55110

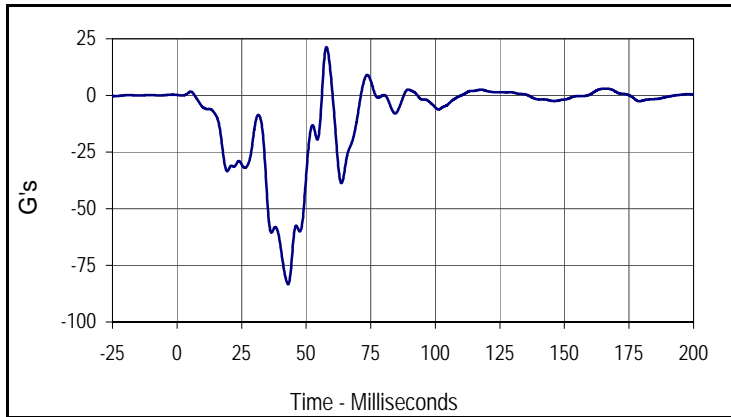

Curve Description			
Vehicle Left Brake Caliper X			
CURNO	Type	SAE Class	Units
093	FIL	60	G's
Max	Time	Min	Time
21.3	57.8	-83.3	43.0

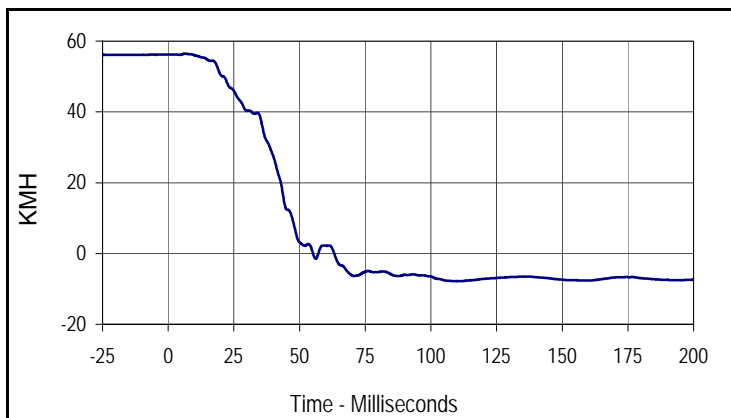

Curve Description			
Vehicle Left Brake Caliper X Velocity			
CURNO	Type	SAE Class	Units
093	IN1	180	KMH
Max	Time	Min	Time
56.5	6.5	-7.8	111.7

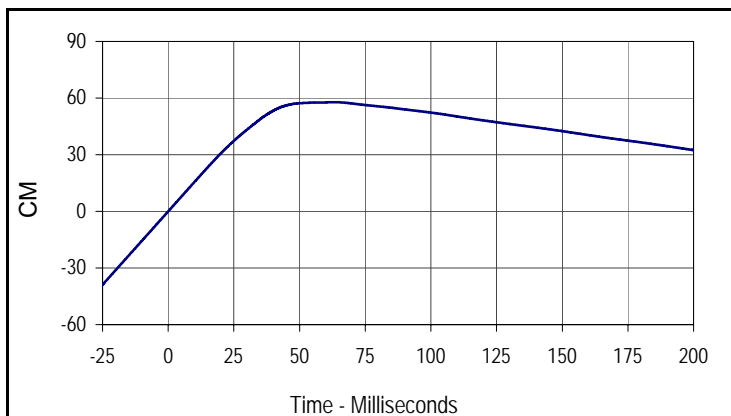

Curve Description			
Vehicle Left Brake Caliper X Displacement			
CURNO	Type	SAE Class	Units
093	IN2	180	CM
Max	Time	Min	Time
57.8	63.2	0.0	0.0

Test Vehicle: 2005 Toyota Scion TC 3-Door Hatchback  
 Test Program: 2005 NHTSA 35mph NCAP

Test Date: 9/30/04  
 NHTSA No.: M55110

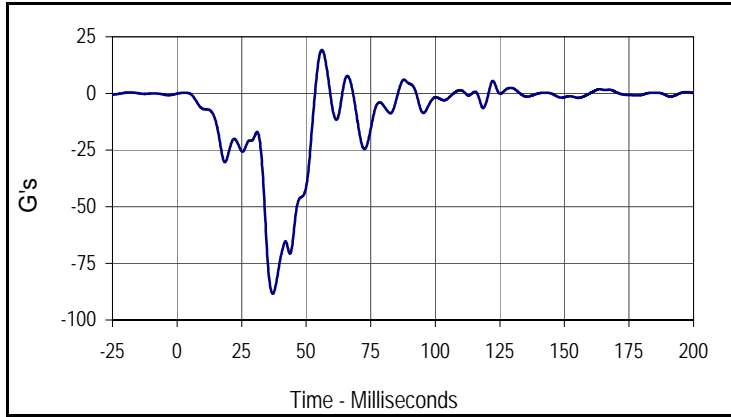

Curve Description			
Vehicle Right Brake Caliper X			
CURNO	Type	SAE Class	Units
094	FIL	60	G's
Max	Time	Min	Time
19.2	56.1	-88.4	37.1

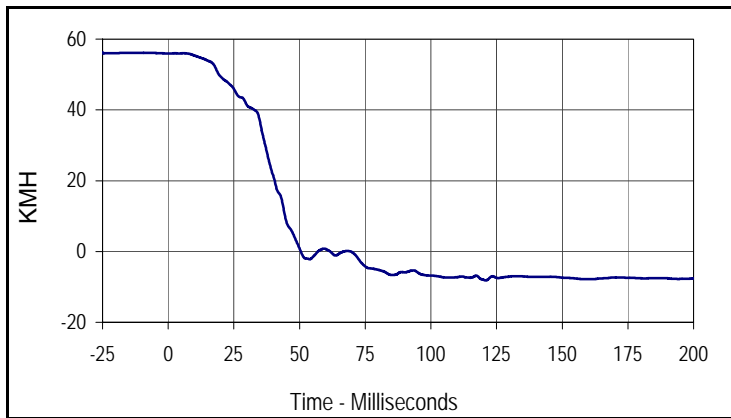

Curve Description			
Vehicle Right Brake Caliper X Velocity			
CURNO	Type	SAE Class	Units
094	IN1	180	KMH
Max	Time	Min	Time
56.0	5.8	-8.1	120.9

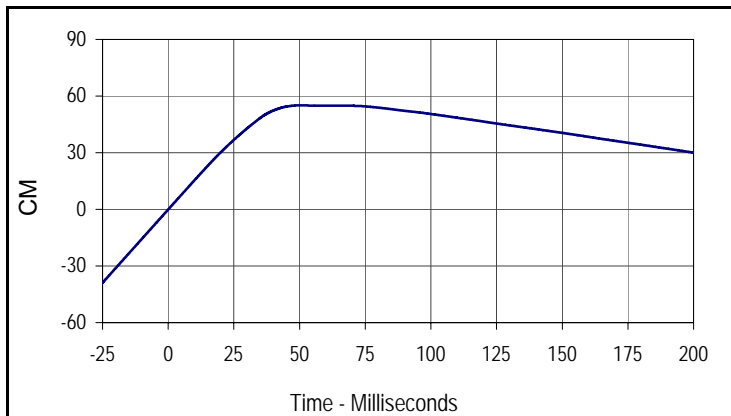

Curve Description			
Vehicle Right Brake Caliper X Displacement			
CURNO	Type	SAE Class	Units
094	IN2	180	CM
Max	Time	Min	Time
55.1	50.5	-0.1	0.0

Test Vehicle: 2005 Toyota Scion TC 3-Door Hatchback  
 Test Program: 2005 NHTSA 35mph NCAP

Test Date: 9/30/04  
 NHTSA No.: M55110

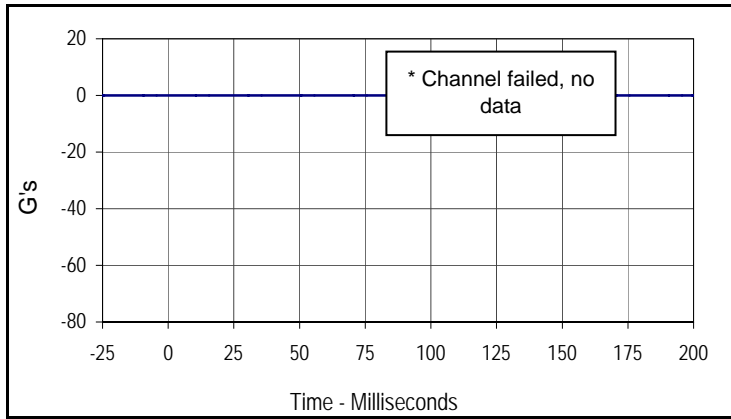

Curve Description			
Vehicle Instrument Panel			
CURNO	Type	SAE Class	Units
095	FIL	60	G's
Max	Time	Min	Time
0.0	0.0	0.0	0.0

\* Channel failed, no data

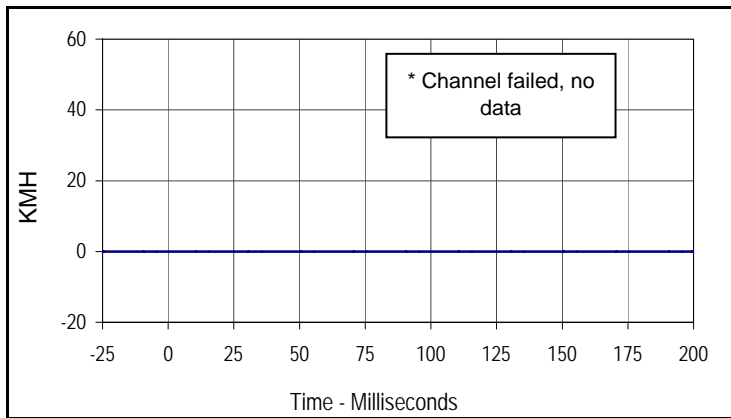

Curve Description			
Vehicle Instrument Panel X Velocity			
CURNO	Type	SAE Class	Units
095	IN1	180	KMH
Max	Time	Min	Time
0.0	0.0	0.0	0.0

\* Channel failed, no data

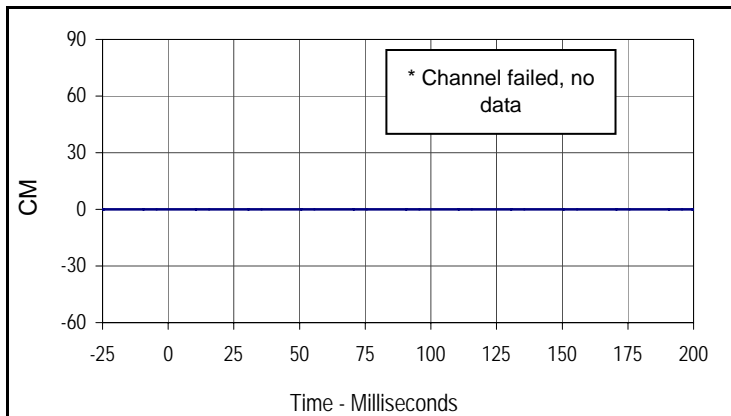

Curve Description			
Vehicle Instrument Panel X Displacement			
CURNO	Type	SAE Class	Units
095	IN2	180	CM
Max	Time	Min	Time
0.0	0.0	0.0	0.0

\* Channel failed, no data

Test Vehicle: 2005 Toyota Scion TC 3-Door Hatchback  
 Test Program: 2005 NHTSA 35mph NCAP

Test Date: 9/30/04  
 NHTSA No.: M55110

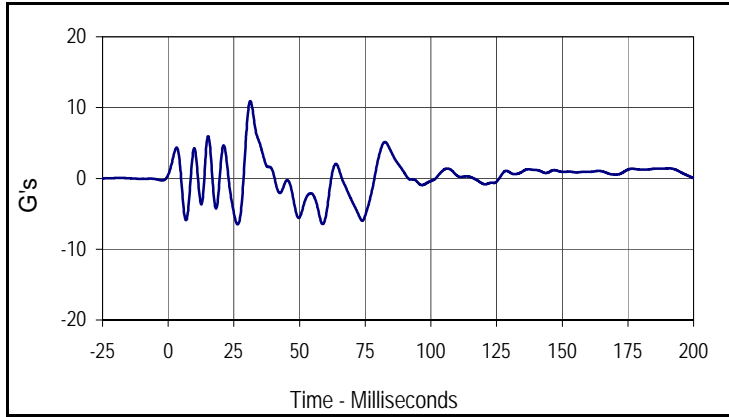

Curve Description			
Vehicle Left Rear Z			
CURNO	Type	SAE Class	Units
096	FIL	60	G's
Max	Time	Min	Time
10.9	31.2	-6.5	26.4

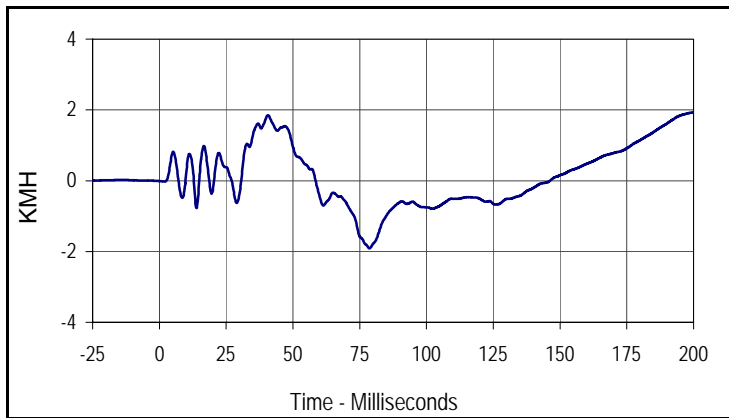

Curve Description			
Vehicle Left Rear Z Velocity			
CURNO	Type	SAE Class	Units
096	IN1	180	KMH
Max	Time	Min	Time
1.9	200.0	-1.9	78.7

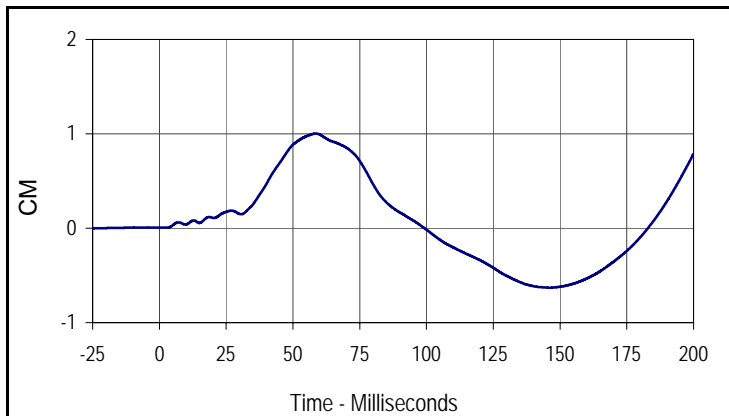

Curve Description			
Vehicle Left Rear Z Displacement			
CURNO	Type	SAE Class	Units
096	IN2	180	CM
Max	Time	Min	Time
1.0	58.5	-0.6	146.3

Test Vehicle: 2005 Toyota Scion TC 3-Door Hatchback  
 Test Program: 2005 NHTSA 35mph NCAP

Test Date: 9/30/04  
 NHTSA No.: M55110

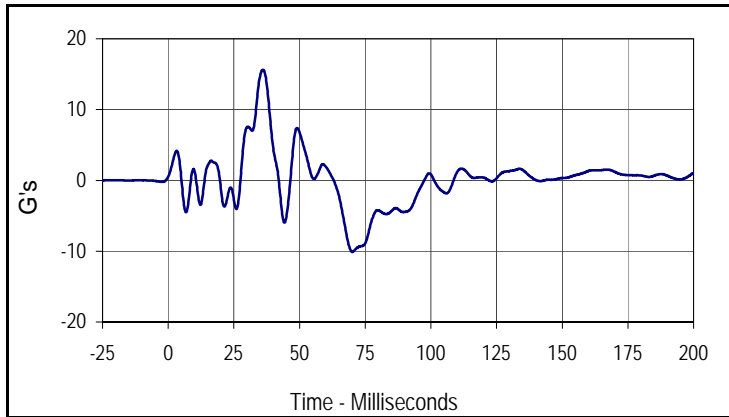

Curve Description			
Vehicle Right Rear Z			
CURNO	Type	SAE Class	Units
097	FIL	60	G's
Max	Time	Min	Time
15.6	36.1	-10.1	70.1

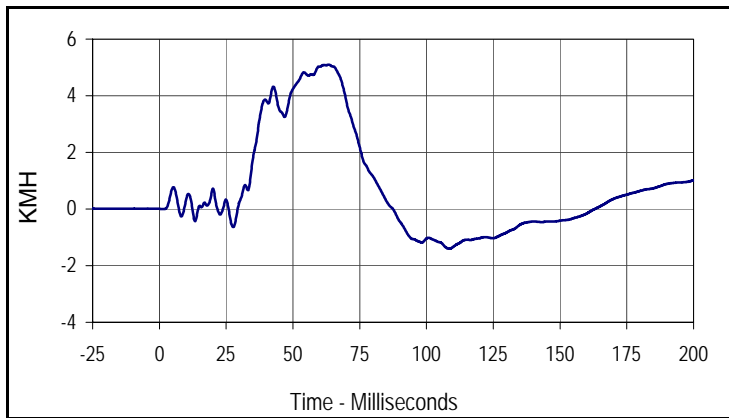

Curve Description			
Vehicle Right Rear Z Velocity			
CURNO	Type	SAE Class	Units
097	IN1	180	KMH
Max	Time	Min	Time
5.1	63.4	-1.4	108.5

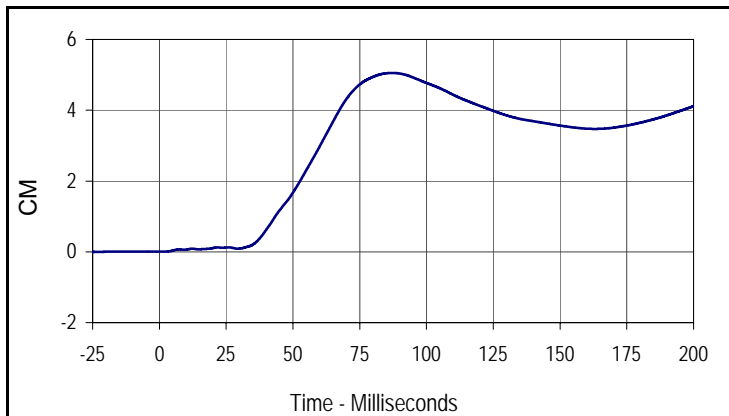

Curve Description			
Vehicle Right Rear Z Displacement			
CURNO	Type	SAE Class	Units
097	IN2	180	CM
Max	Time	Min	Time
5.1	87.4	0.0	0.0

**APPENDIX C**

**LOAD CELL BARRIER DATA PLOTS**

Test Vehicle: 2005 Toyota Scion TC 3-Door Hatchback  
 Test Program: 2005 NHTSA 35mph NCAP

Test Date: 9/30/04  
 NHTSA No.: M55110

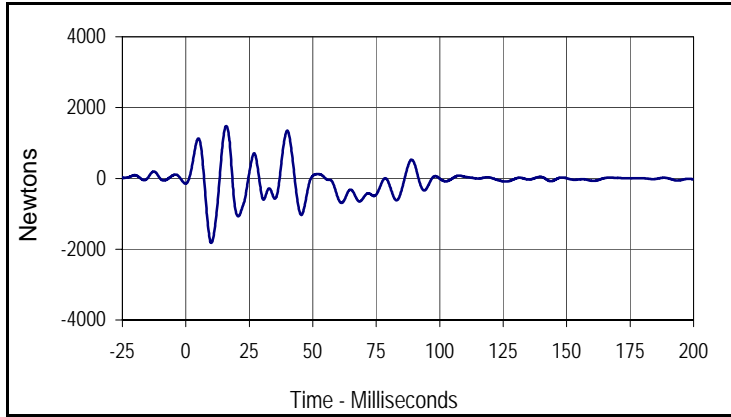

Curve Description			
Barrier Force A1			
CURNO	Type	SAE Class	Units
098	FIL	60	Newtons
Max	Time	Min	Time
1479.3	15.9	-1822.6	10.0

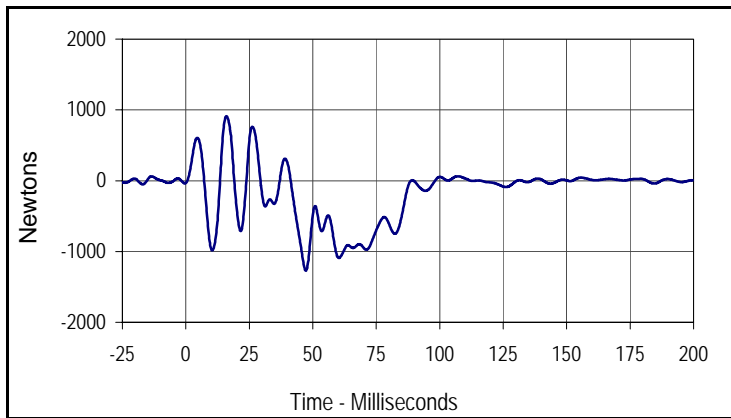

Curve Description			
Barrier Force B1			
CURNO	Type	SAE Class	Units
107	FIL	60	Newtons
Max	Time	Min	Time
910.4	16.0	-1270.1	47.3

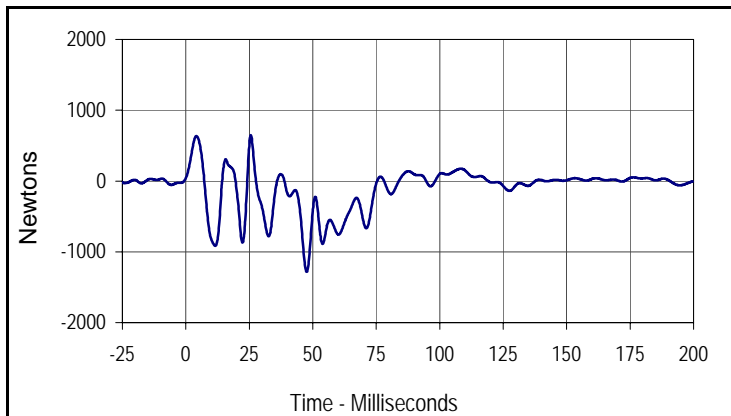

Curve Description			
Barrier Force C1			
CURNO	Type	SAE Class	Units
116	FIL	60	Newtons
Max	Time	Min	Time
649.0	25.6	-1283.3	47.6

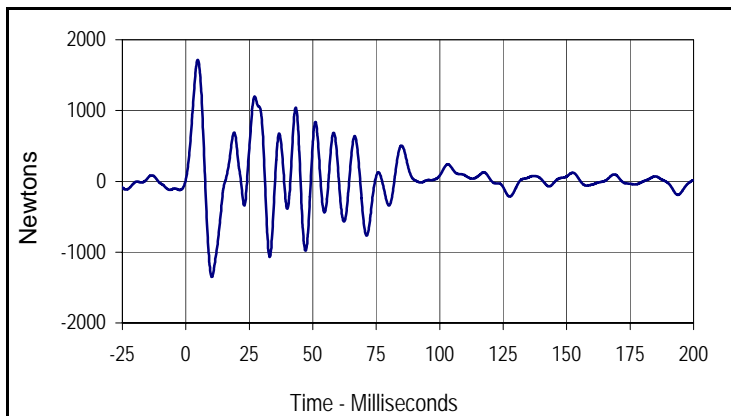

Curve Description			
Barrier Force D1			
CURNO	Type	SAE Class	Units
125	FIL	60	Newtons
Max	Time	Min	Time
1717.5	4.7	-1351.3	10.2

Test Vehicle: 2005 Toyota Scion TC 3-Door Hatchback  
 Test Program: 2005 NHTSA 35mph NCAP

Test Date: 9/30/04  
 NHTSA No.: M55110

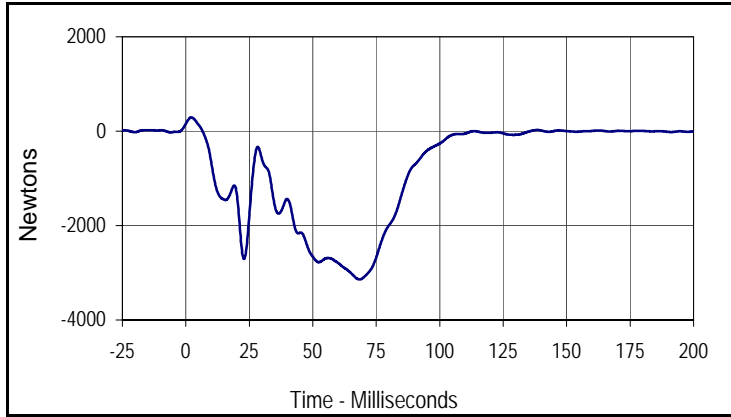

Curve Description			
Barrier Force A2			
CURNO	Type	SAE Class	Units
099	FIL	60	Newtons
Max	Time	Min	Time
292.0	2.1	-3142.3	68.4

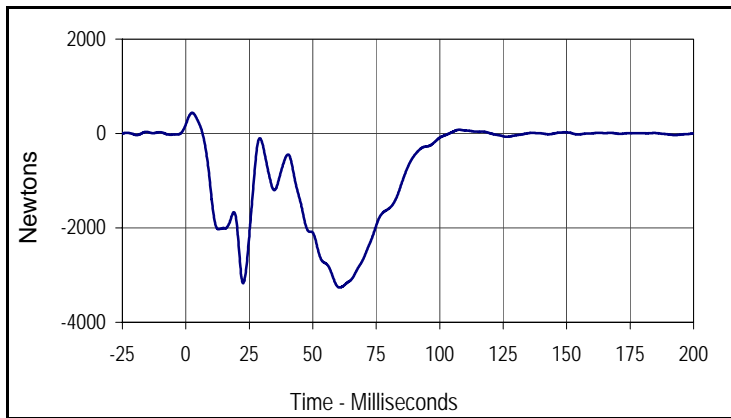

Curve Description			
Barrier Force B2			
CURNO	Type	SAE Class	Units
108	FIL	60	Newtons
Max	Time	Min	Time
439.2	2.5	-3263.0	60.6

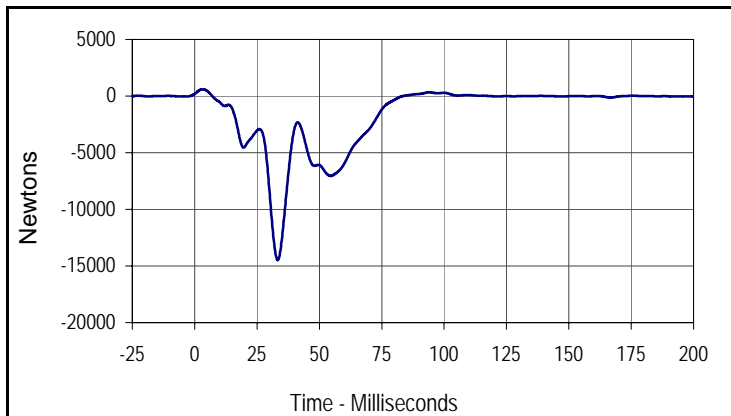

Curve Description			
Barrier Force C2			
CURNO	Type	SAE Class	Units
117	FIL	60	Newtons
Max	Time	Min	Time
596.7	3.1	-14477.7	33.3

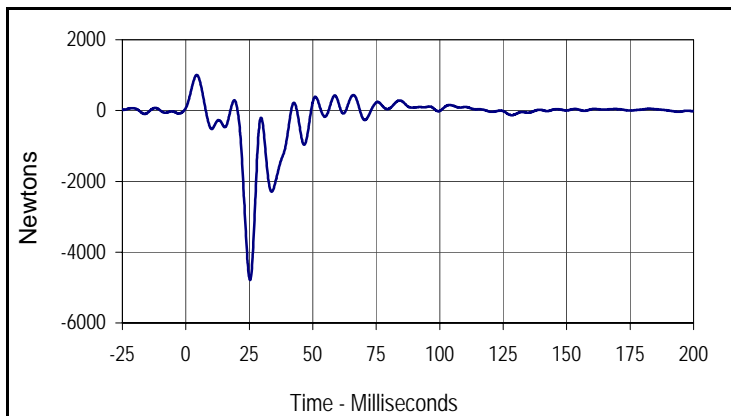

Curve Description			
Barrier Force D2			
CURNO	Type	SAE Class	Units
126	FIL	60	Newtons
Max	Time	Min	Time
1005.4	4.3	-4788.6	25.3

Test Vehicle: 2005 Toyota Scion TC 3-Door Hatchback  
 Test Program: 2005 NHTSA 35mph NCAP

Test Date: 9/30/04  
 NHTSA No.: M55110

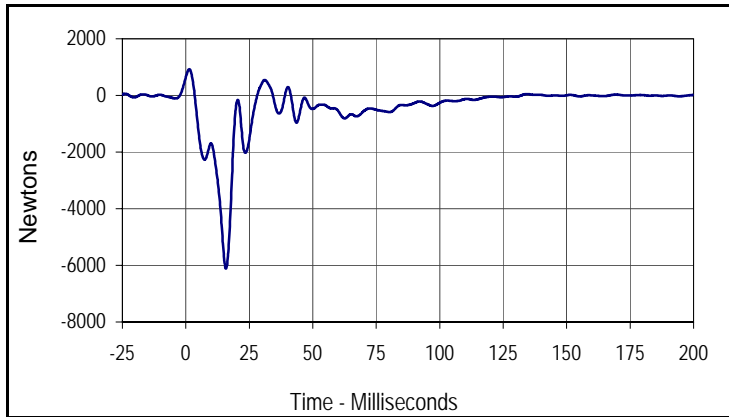

Curve Description			
Barrier Force A3			
CURNO	Type	SAE Class	Units
100	FIL	60	Newtons
Max	Time	Min	Time
927.0	1.4	-6117.4	15.8

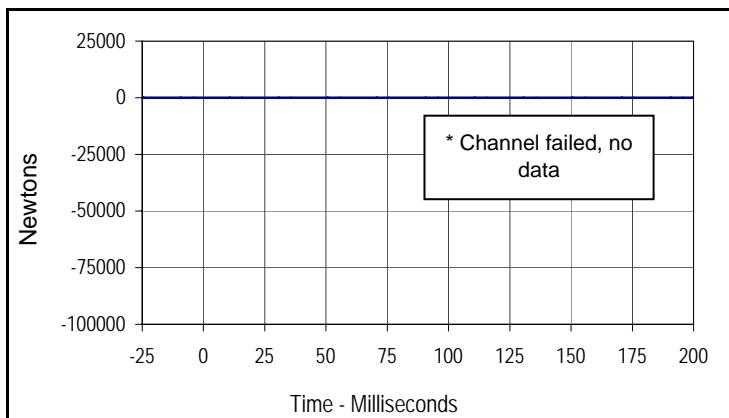

Curve Description			
Barrier Force B3			
CURNO	Type	SAE Class	Units
109	FIL	60	Newtons
Max	Time	Min	Time
0.0	0.0	0.0	0.0

\* Channel failed, no data

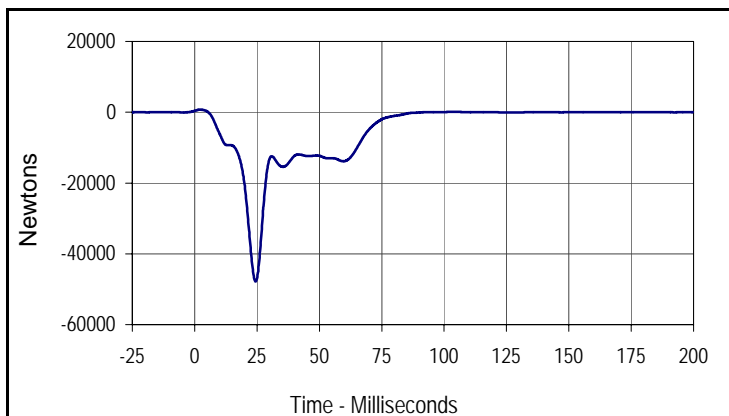

Curve Description			
Barrier Force C3			
CURNO	Type	SAE Class	Units
118	FIL	60	Newtons
Max	Time	Min	Time
722.9	2.3	-47825.4	24.4

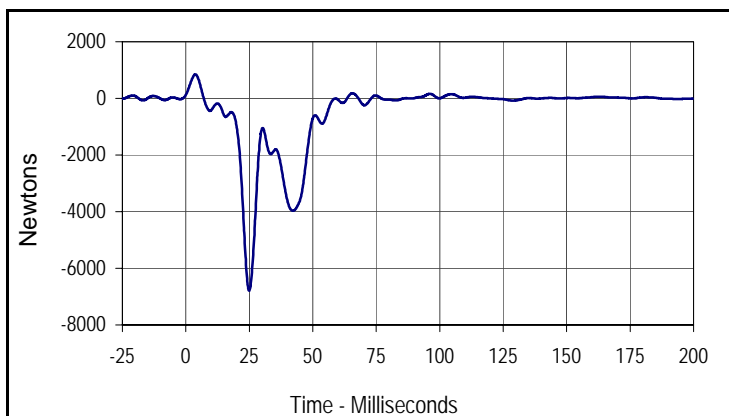

Curve Description			
Barrier Force D3			
CURNO	Type	SAE Class	Units
127	FIL	60	Newtons
Max	Time	Min	Time
846.6	3.7	-6787.6	24.9

Test Vehicle: 2005 Toyota Scion TC 3-Door Hatchback  
 Test Program: 2005 NHTSA 35mph NCAP

Test Date: 9/30/04  
 NHTSA No.: M55110

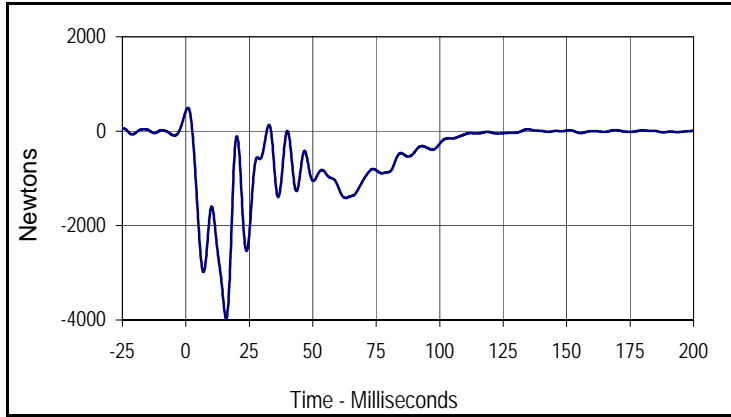

Curve Description			
Barrier Force A4			
CURNO	Type	SAE Class	Units
101	FIL	60	Newtons
Max	Time	Min	Time
497.0	0.8	-3967.5	15.9

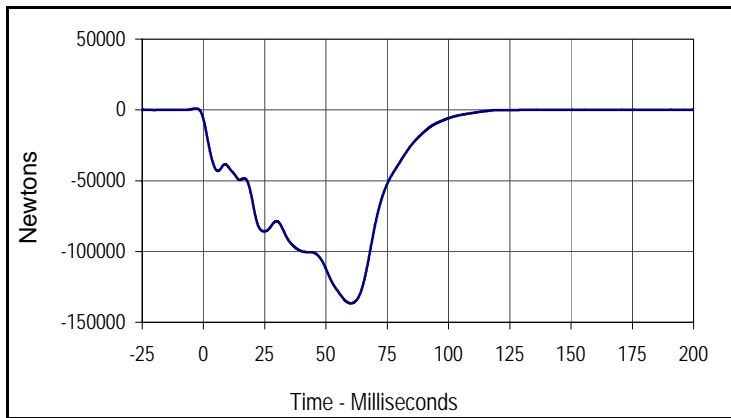

Curve Description			
Barrier Force B4			
CURNO	Type	SAE Class	Units
110	FIL	60	Newtons
Max	Time	Min	Time
76.2	135.5	-136645.9	60.1

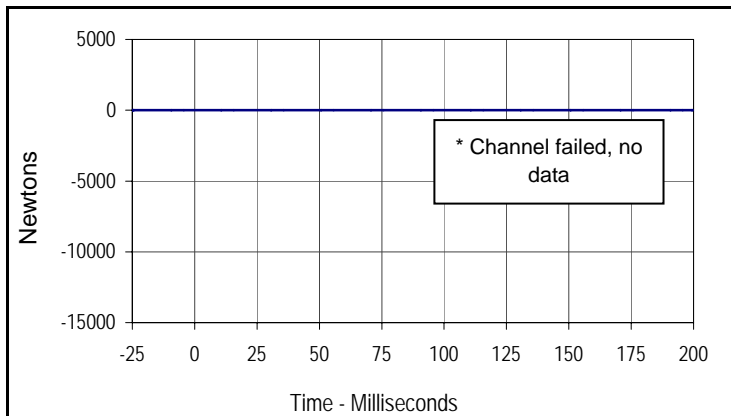

Curve Description			
Barrier Force C4			
CURNO	Type	SAE Class	Units
119	FIL	60	Newtons
Max	Time	Min	Time
0.0	0.0	0.0	0.0

\* Channel failed, no data

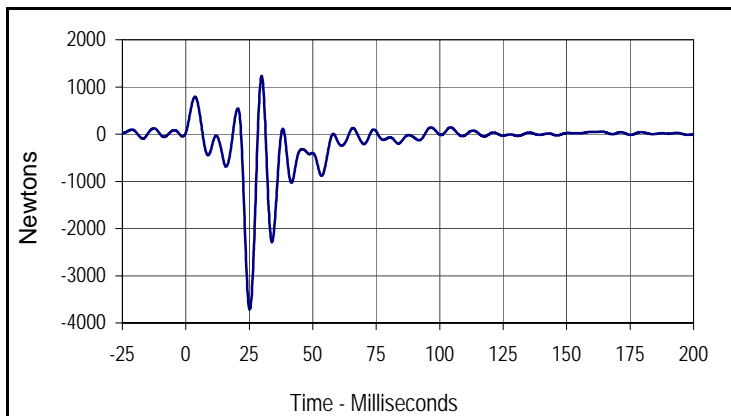

Curve Description			
Barrier Force D4			
CURNO	Type	SAE Class	Units
128	FIL	60	Newtons
Max	Time	Min	Time
1231.1	29.8	-3714.4	25.2

Test Vehicle: 2005 Toyota Scion TC 3-Door Hatchback  
 Test Program: 2005 NHTSA 35mph NCAP

Test Date: 9/30/04  
 NHTSA No.: M55110

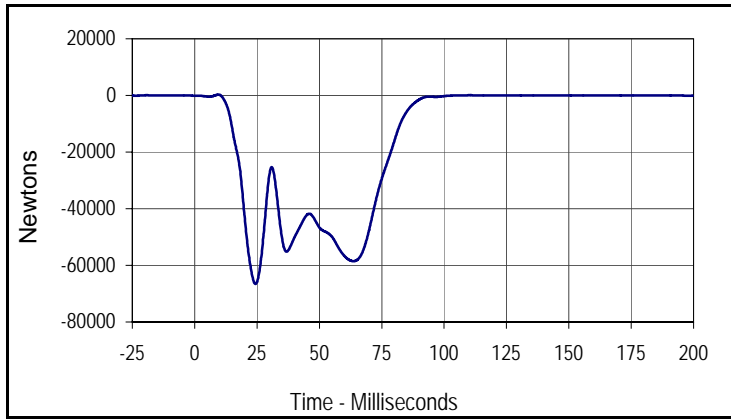

Curve Description			
Barrier Force A5			
CURNO	Type	SAE Class	Units
102	FIL	60	Newtons
Max	Time	Min	Time
286.6	9.4	-66578.2	24.4

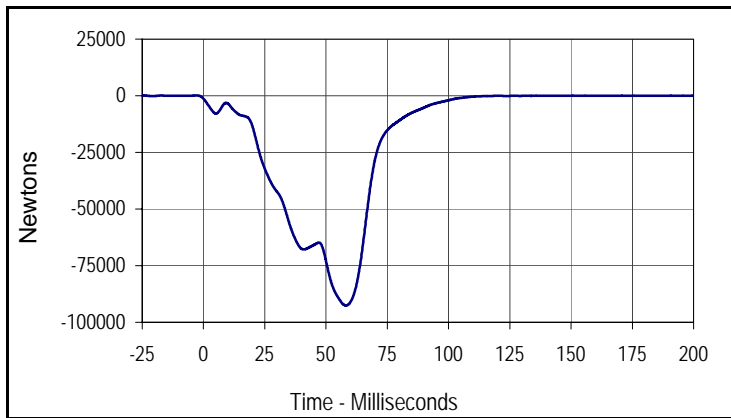

Curve Description			
Barrier Force B5			
CURNO	Type	SAE Class	Units
111	FIL	60	Newtons
Max	Time	Min	Time
61.4	160.1	-92591.3	58.1

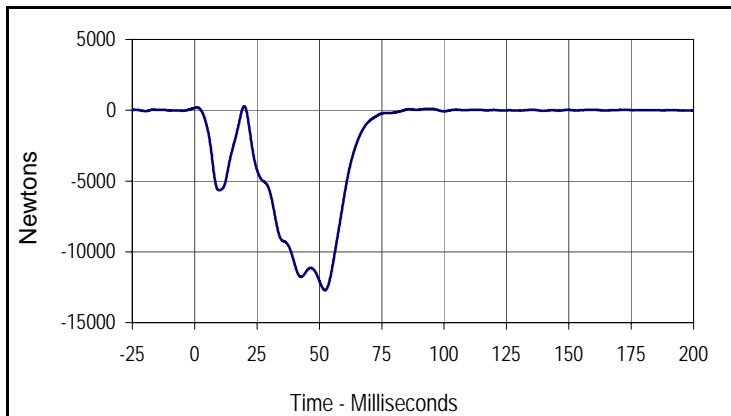

Curve Description			
Barrier Force C5			
CURNO	Type	SAE Class	Units
120	FIL	60	Newtons
Max	Time	Min	Time
287.7	19.9	-12714.4	52.2

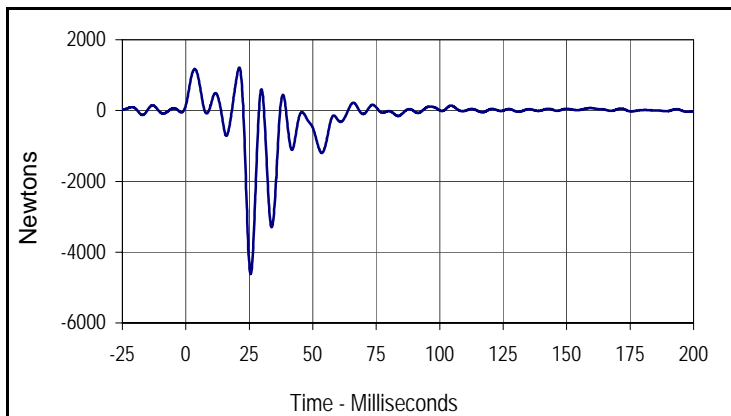

Curve Description			
Barrier Force D5			
CURNO	Type	SAE Class	Units
129	FIL	60	Newtons
Max	Time	Min	Time
1212.2	21.1	-4612.9	25.6

Test Vehicle: 2005 Toyota Scion TC 3-Door Hatchback  
 Test Program: 2005 NHTSA 35mph NCAP

Test Date: 9/30/04  
 NHTSA No.: M55110

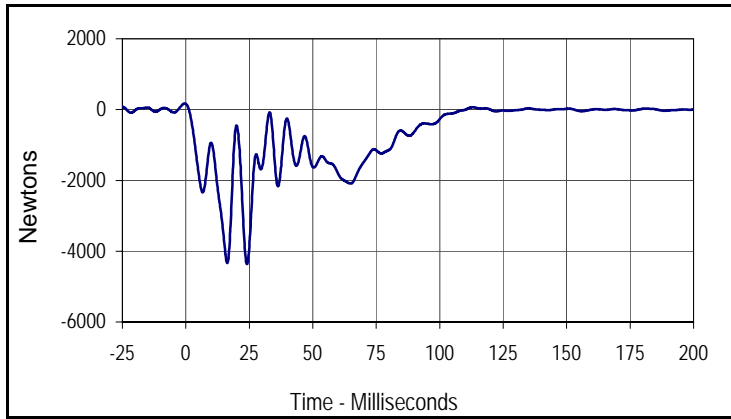

Curve Description			
Barrier Force A6			
CURNO	Type	SAE Class	Units
103	FIL	60	Newtons
Max	Time	Min	Time
159.9	0.0	-4368.1	24.1

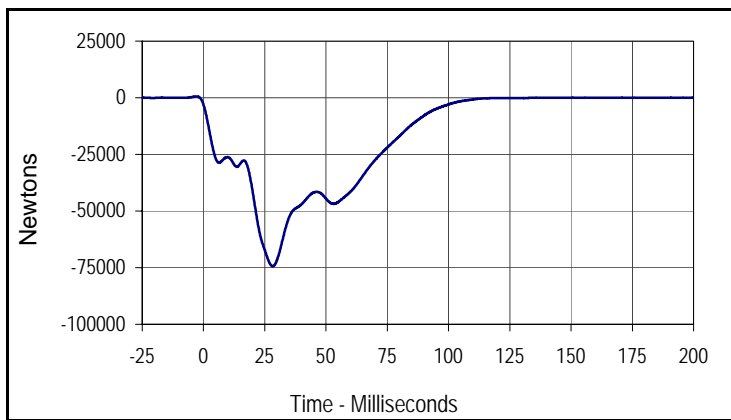

Curve Description			
Barrier Force B6			
CURNO	Type	SAE Class	Units
112	FIL	60	Newtons
Max	Time	Min	Time
26.3	169.0	-74375.5	28.2

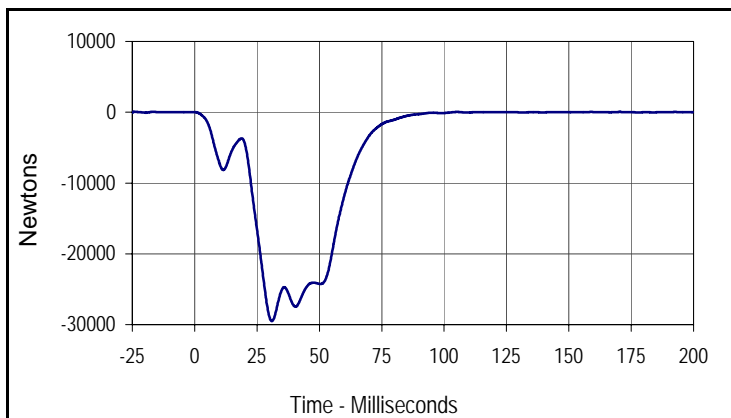

Curve Description			
Barrier Force C6			
CURNO	Type	SAE Class	Units
121	FIL	60	Newtons
Max	Time	Min	Time
38.0	105.2	-29498.6	30.9

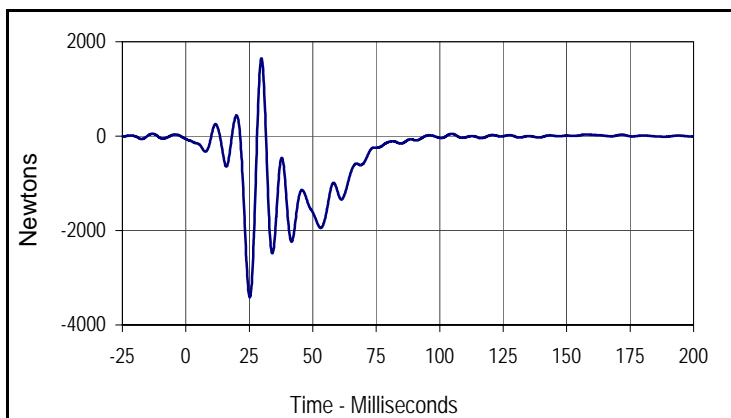

Curve Description			
Barrier Force D6			
CURNO	Type	SAE Class	Units
130	FIL	60	Newtons
Max	Time	Min	Time
1650.6	29.8	-3414.0	25.2

Test Vehicle: 2005 Toyota Scion TC 3-Door Hatchback  
 Test Program: 2005 NHTSA 35mph NCAP

Test Date: 9/30/04  
 NHTSA No.: M55110

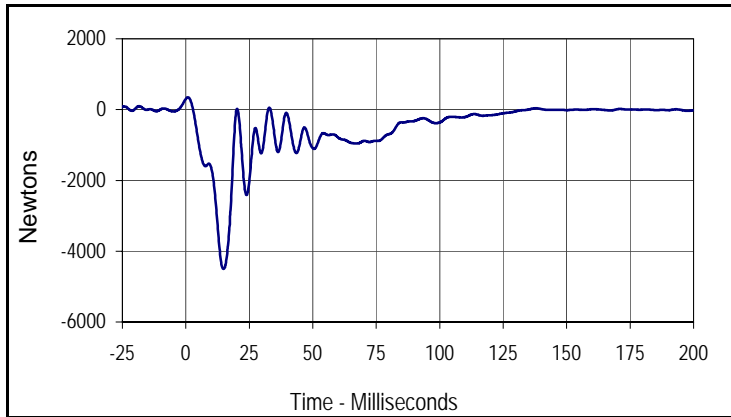

Curve Description			
Barrier Force A7			
CURNO	Type	SAE Class	Units
104	FIL	60	Newtons
Max	Time	Min	Time
346.9	0.8	-4503.0	14.8

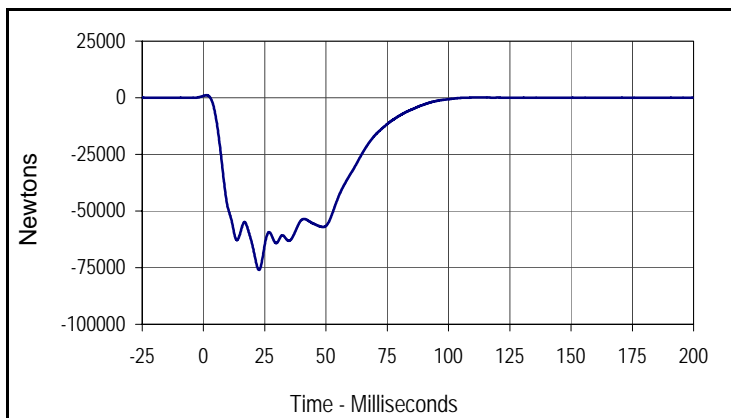

Curve Description			
Barrier Force B7			
CURNO	Type	SAE Class	Units
113	FIL	60	Newtons
Max	Time	Min	Time
1096.1	1.2	-75973.5	22.7

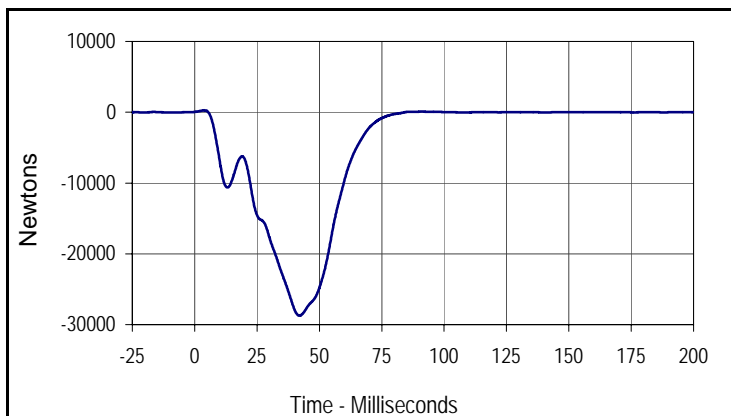

Curve Description			
Barrier Force C7			
CURNO	Type	SAE Class	Units
122	FIL	60	Newtons
Max	Time	Min	Time
262.4	3.9	-28738.1	42.0

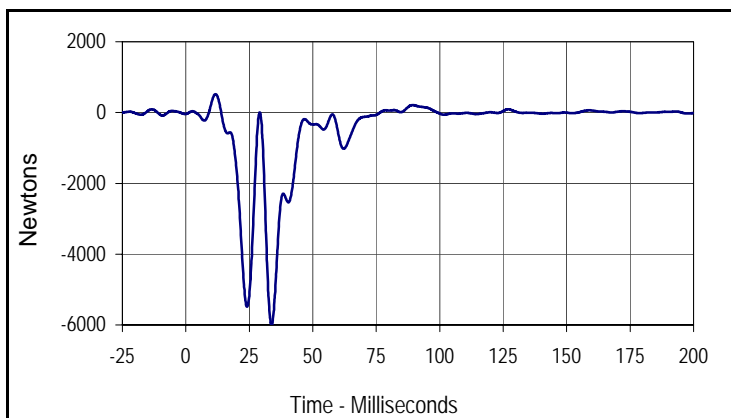

Curve Description			
Barrier Force D7			
CURNO	Type	SAE Class	Units
131	FIL	60	Newtons
Max	Time	Min	Time
519.2	11.6	-5991.2	33.7

Test Vehicle: 2005 Toyota Scion TC 3-Door Hatchback  
 Test Program: 2005 NHTSA 35mph NCAP

Test Date: 9/30/04  
 NHTSA No.: M55110

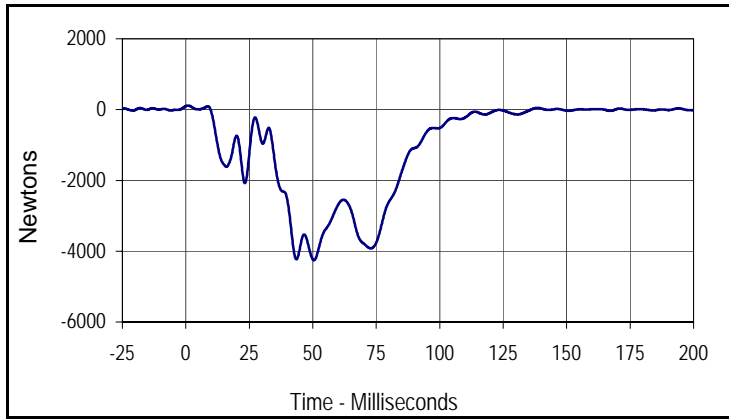

Curve Description			
Barrier Force A8			
CURNO	Type	SAE Class	Units
105	FIL	60	Newtons
Max	Time	Min	Time
111.6	0.7	-4254.8	50.4

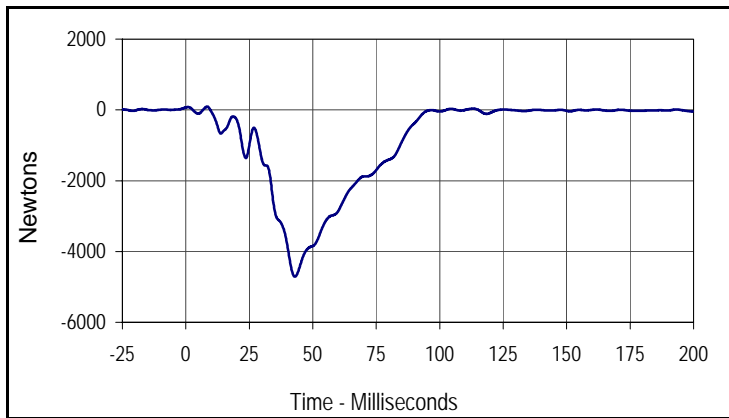

Curve Description			
Barrier Force B8			
CURNO	Type	SAE Class	Units
114	FIL	60	Newtons
Max	Time	Min	Time
91.6	8.4	-4711.1	42.9

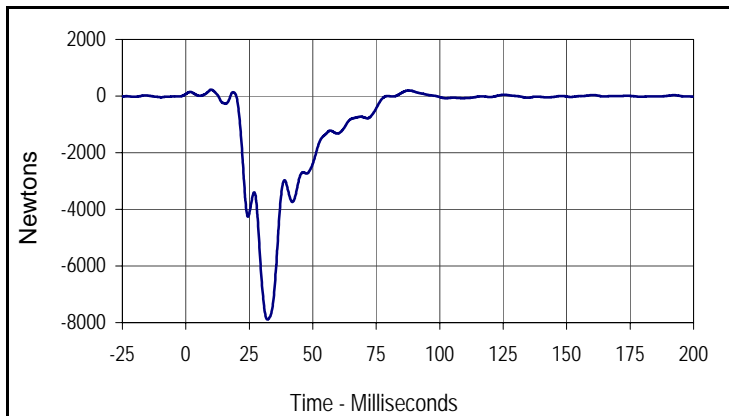

Curve Description			
Barrier Force C8			
CURNO	Type	SAE Class	Units
123	FIL	60	Newtons
Max	Time	Min	Time
227.9	10.0	-7889.2	32.1

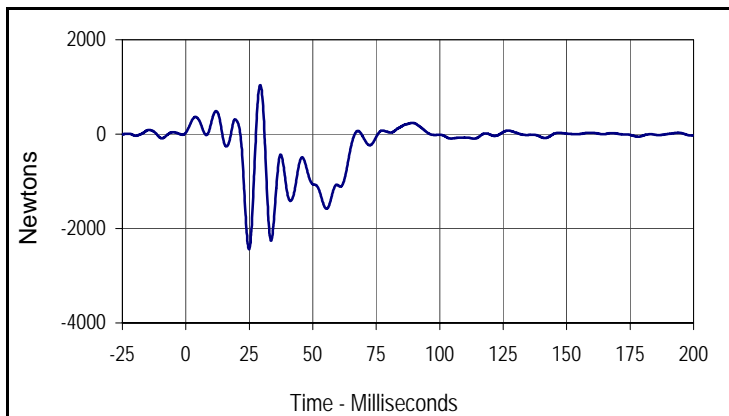

Curve Description			
Barrier Force D8			
CURNO	Type	SAE Class	Units
132	FIL	60	Newtons
Max	Time	Min	Time
1037.8	29.3	-2437.8	24.9

Test Vehicle: 2005 Toyota Scion TC 3-Door Hatchback  
 Test Program: 2005 NHTSA 35mph NCAP

Test Date: 9/30/04  
 NHTSA No.: M55110

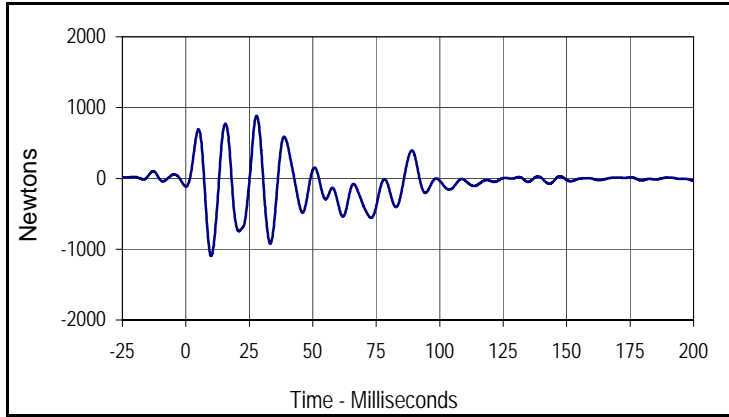

Curve Description			
Barrier Force A9			
CURNO	Type	SAE Class	Units
106	FIL	60	Newtons
Max	Time	Min	Time
883.2	27.8	-1098.3	10.0

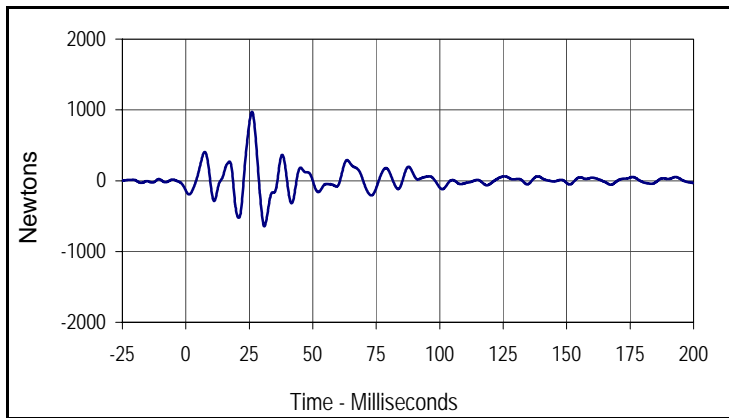

Curve Description			
Barrier Force B9			
CURNO	Type	SAE Class	Units
115	FIL	60	Newtons
Max	Time	Min	Time
973.2	26.1	-645.8	30.9

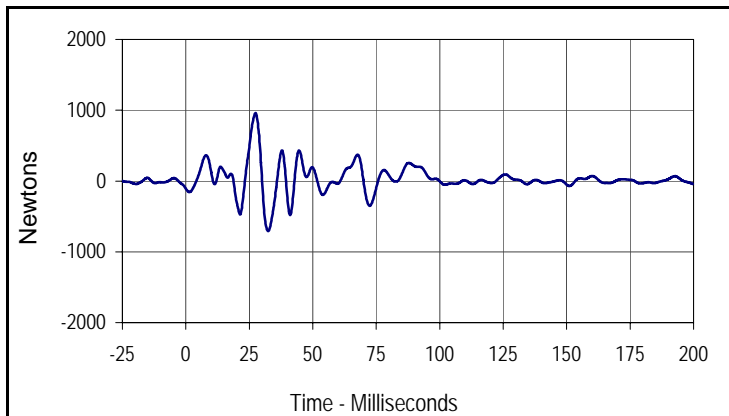

Curve Description			
Barrier Force C9			
CURNO	Type	SAE Class	Units
124	FIL	60	Newtons
Max	Time	Min	Time
959.7	27.4	-706.5	32.4

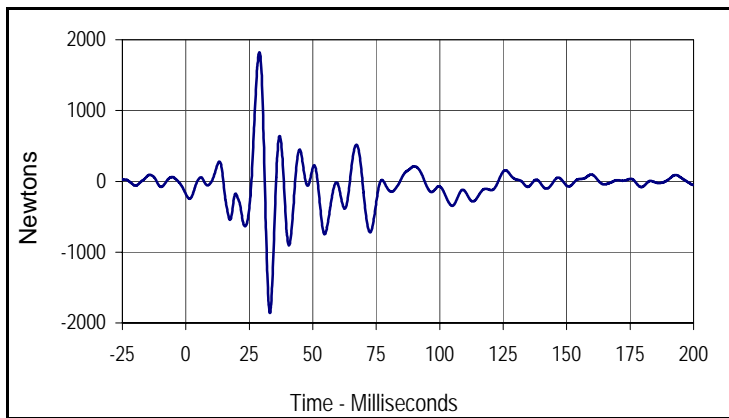

Curve Description			
Barrier Force D9			
CURNO	Type	SAE Class	Units
133	FIL	60	Newtons
Max	Time	Min	Time
1824.7	29.0	-1861.7	33.1

Test Vehicle: 2005 Toyota Scion TC 3-Door Hatchback  
 Test Program: 2005 NHTSA 35mph NCAP

Test Date: 9/30/04  
 NHTSA No.: M55110

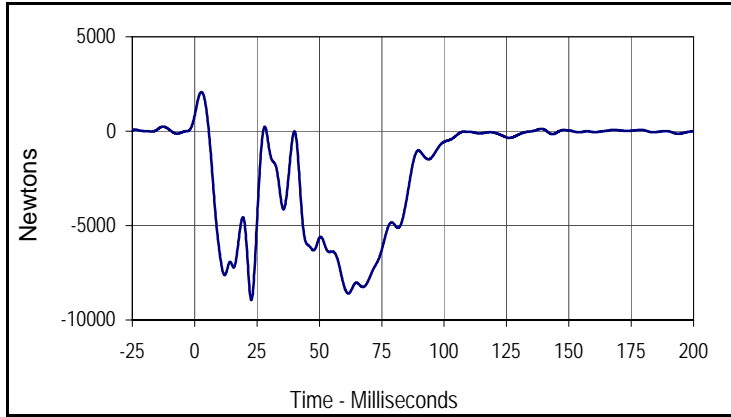

Curve Description			
Barrier Force Sum Group 1			
CURNO	Type	SAE Class	Units
001	SUM	60	Newtons
Max	Time	Min	Time
2076.2	2.7	-8942.8	22.7

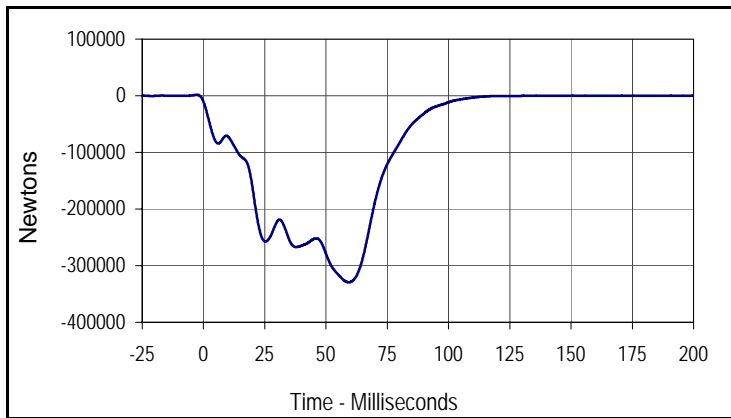

Curve Description			
Barrier Force Sum Group 2			
CURNO	Type	SAE Class	Units
002	SUM	60	Newtons
Max	Time	Min	Time
132.6	136.5	-329269.5	59.3

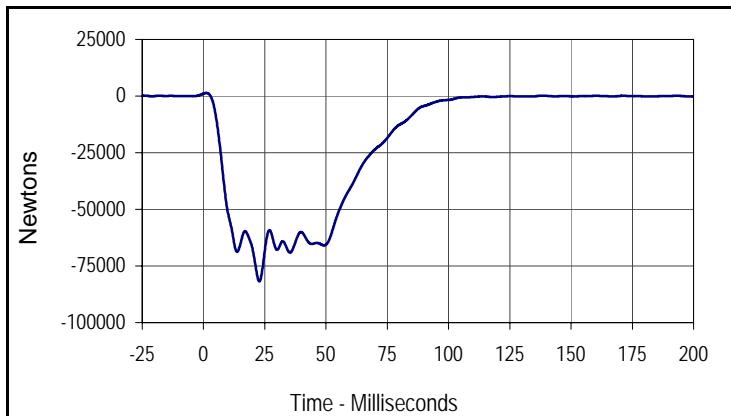

Curve Description			
Barrier Force Sum Group 3			
CURNO	Type	SAE Class	Units
003	SUM	60	Newtons
Max	Time	Min	Time
1370.7	1.2	-81761.3	22.8

Test Vehicle: 2005 Toyota Scion TC 3-Door Hatchback  
 Test Program: 2005 NHTSA 35mph NCAP

Test Date: 9/30/04  
 NHTSA No.: M55110

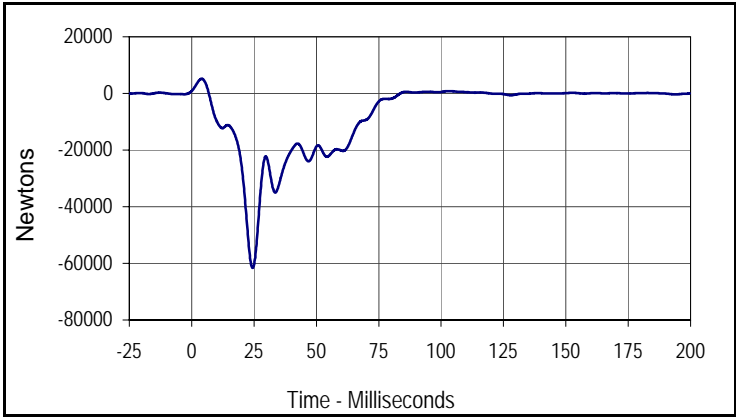

Curve Description			
Barrier Force Sum Group 4			
CURNO	Type	SAE Class	Units
004	SUM	60	Newtons
Max	Time	Min	Time
5166.7	4.0	-61633.1	24.4

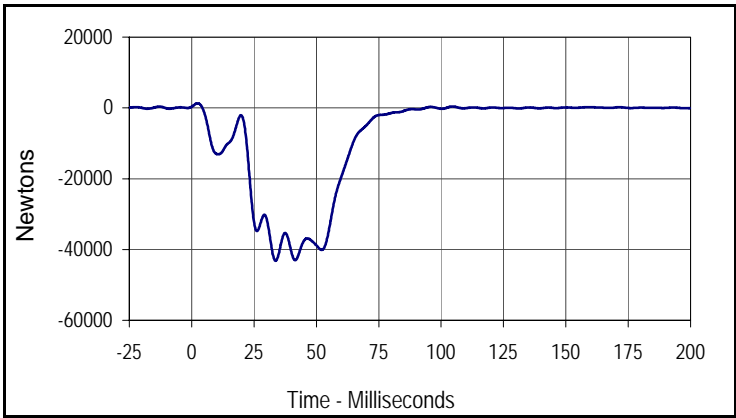

Curve Description			
Barrier Force Sum Group 5			
CURNO	Type	SAE Class	Units
005	SUM	60	Newtons
Max	Time	Min	Time
1297.0	2.4	-43174.5	33.6

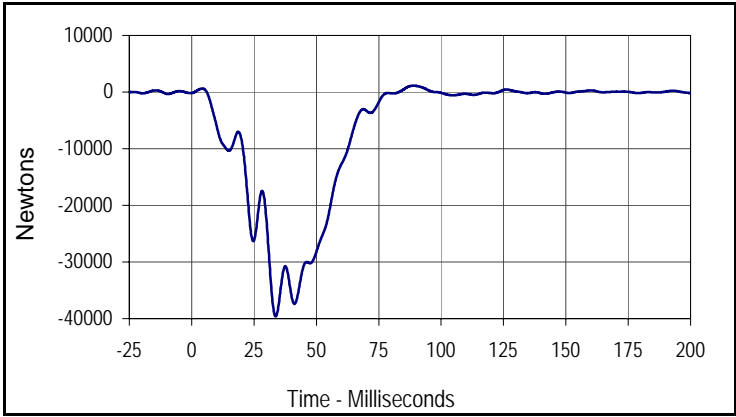

Curve Description			
Barrier Force Sum Group 6			
CURNO	Type	SAE Class	Units
006	SUM	60	Newtons
Max	Time	Min	Time
1132.1	89.0	-39618.1	33.7

Test Vehicle: 2005 Toyota Scion TC 3-Door Hatchback  
 Test Program: 2005 NHTSA 35mph NCAP

Test Date: 9/30/04  
 NHTSA No.: M55110

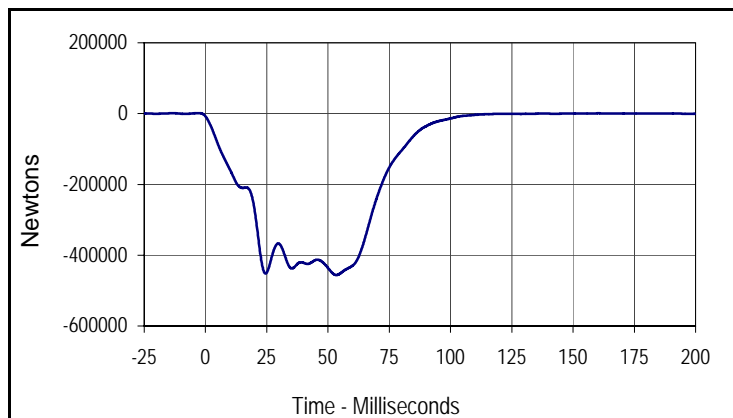

Curve Description			
Barrier Force Total Sum			
CURNO	Type	SAE Class	Units
007	SUM	60	Newtons
Max	Time	Min	Time
700.9	160.3	-456184.7	53.4

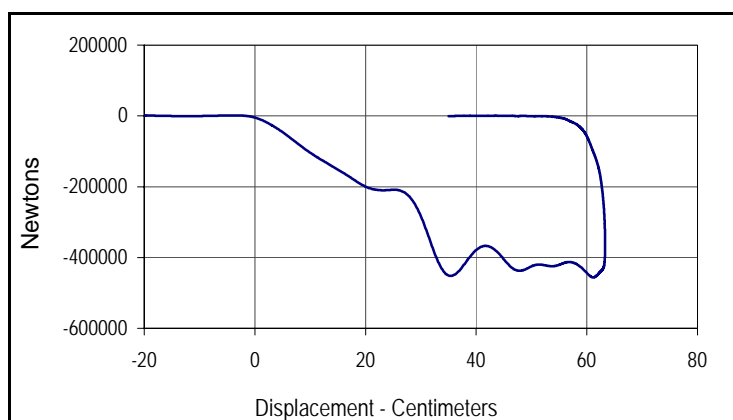

Curve Description			
Barrier Force Total Sum vs. Displ.			
CURNO	Type	SAE Class	Units
001	XVY	60	Newtons
Max	CM	Min	CM
700.9	43.6	-456184.7	61.1

## BARRIER LOAD CELL SUMMARY DATA

Test Vehicle: 2005 Toyota Scion TC 3-Door Hatchback

NHTSA No.: M55110

Test Program: 2005 NHTSA 35mph NCAP

Test Date: 9/30/04

Location	Units	Max	Time	Min	Time
Barrier Force A1	Newtons	1479.3	15.9	-1822.6	10.0
Barrier Force A2	Newtons	292.0	2.1	-3142.3	68.4
Barrier Force A3	Newtons	927.0	1.4	-6117.4	15.8
Barrier Force A4	Newtons	497.0	0.8	-3967.5	15.9
Barrier Force A5	Newtons	286.6	9.4	-66578.2	24.4
Barrier Force A6	Newtons	159.9	0.0	-4368.1	24.1
Barrier Force A7	Newtons	346.9	0.8	-4503.0	14.8
Barrier Force A8	Newtons	111.6	0.7	-4254.8	50.4
Barrier Force A9	Newtons	883.2	27.8	-1098.3	10.0
Barrier Force B1	Newtons	910.4	16.0	-1270.1	47.3
Barrier Force B2	Newtons	439.2	2.5	-3263.0	60.6
Barrier Force B3	Newtons	0.0	0.0	0.0	0.0
Barrier Force B4	Newtons	76.2	135.5	-136645.9	60.1
Barrier Force B5	Newtons	61.4	160.1	-92591.3	58.1
Barrier Force B6	Newtons	26.3	169.0	-74375.5	28.2
Barrier Force B7	Newtons	1096.1	1.2	-75973.5	22.7
Barrier Force B8	Newtons	91.6	8.4	-4711.1	42.9
Barrier Force B9	Newtons	973.2	26.1	-645.8	30.9
Barrier Force C1	Newtons	649.0	25.6	-1283.3	47.6
Barrier Force C2	Newtons	596.7	3.1	-14477.7	33.3
Barrier Force C3	Newtons	722.9	2.3	-47825.4	24.4
Barrier Force C4	Newtons	0.0	0.0	0.0	0.0
Barrier Force C5	Newtons	287.7	19.9	-12714.4	52.2
Barrier Force C6	Newtons	38.0	105.2	-29498.6	30.9
Barrier Force C7	Newtons	262.4	3.9	-28738.1	42.0
Barrier Force C8	Newtons	227.9	10.0	-7889.2	32.1
Barrier Force C9	Newtons	959.7	27.4	-706.5	32.4
Barrier Force D1	Newtons	1717.5	4.7	-1351.3	10.2
Barrier Force D2	Newtons	1005.4	4.3	-4788.6	25.3
Barrier Force D3	Newtons	846.6	3.7	-6787.6	24.9
Barrier Force D4	Newtons	1231.1	29.8	-3714.4	25.2
Barrier Force D5	Newtons	1212.2	21.1	-4612.9	25.6
Barrier Force D6	Newtons	1650.6	29.8	-3414.0	25.2
Barrier Force D7	Newtons	519.2	11.6	-5991.2	33.7
Barrier Force D8	Newtons	1037.8	29.3	-2437.8	24.9
Barrier Force D9	Newtons	1824.7	29.0	-1861.7	33.1
Barrier Force Sum Group 1	Newtons	2076.2	2.7	-8942.8	22.7
Barrier Force Sum Group 2	Newtons	132.6	136.5	-329269.5	59.3
Barrier Force Sum Group 3	Newtons	1370.7	1.2	-81761.3	22.8
Barrier Force Sum Group 4	Newtons	5166.7	4.0	-61633.1	24.4
Barrier Force Sum Group 5	Newtons	1297.0	2.4	-43174.5	33.6
Barrier Force Sum Group 6	Newtons	1132.1	89.0	-39618.1	33.7
Barrier Force Total Sum	Newtons	700.9	160.3	-456184.7	53.4

1.) Channels failed, no data

**APPENDIX D**

**INSTRUMENTATION DATA CHANNEL ASSIGNMENTS**

**2005 NHTSA 35mph NCAP  
Instrumentation Data Channel Assignments  
Driver A.T.D. Serial Number 34  
9/30/04  
2005 Toyota Scion TC 3-Door Hatchback**

CH.	LOCATION	AXIS	IDENT. NO.	DESCRIPTION	MFR	MODEL	UNITS
1	HEAD, PRIMARY	X	KEAC039	Accel., 1/2 bridge	Endevco	7264-2000	G
2	HEAD, PRIMARY	Y	KEAC038	Accel., 1/2 bridge	Endevco	7264-2000	G
3	HEAD, PRIMARY	Z	KEAC027	Accel., 1/2 bridge	Endevco	7264-2000	G
4	HEAD, REDUNDANT	X	KEAC031	Accel., 1/2 bridge	Endevco	7264-2000	G
5	HEAD, REDUNDANT	Y	KEAC032	Accel., 1/2 bridge	Endevco	7264-2000	G
6	HEAD, REDUNDANT	Z	KEAC026	Accel., 1/2 bridge	Endevco	7264-2000	G
7	NECK FORCE	X	GPUN02FX	Load cell, six axis neck	R. A. Denton	1716A	N
8	NECK FORCE	Y	GPUN02FY	Load cell, six axis neck	R. A. Denton	1716A	N
9	NECK FORCE	Z	GPUN02FZ	Load cell, six axis neck	R. A. Denton	1716A	N
10	NECK MOMENT	X	GPUN02MX	Load cell, six axis neck	R. A. Denton	1716A	Nm
11	NECK MOMENT	Y	GPUN02MY	Load cell, six axis neck	R. A. Denton	1716A	Nm
12	NECK MOMENT	Z	GPUN02MZ	Load cell, six axis neck	R. A. Denton	1716A	Nm
13	CHEST, PRIMARY	X	GPAC031	Accel., 1/2 bridge	Endevco	7264-2000	G
14	CHEST, PRIMARY	Y	GPAC024	Accel., 1/2 bridge	Endevco	7264-2000	G
15	CHEST, PRIMARY	Z	GPAC029	Accel., 1/2 bridge	Endevco	7264-2000	G
16	CHEST, REDUNDANT	X	KEAC023	Accel., 1/2 bridge	Endevco	7264-200	G
17	CHEST, REDUNDANT	Y	KEAC022	Accel., 1/2 bridge	Endevco	7264-200	G
18	CHEST, REDUNDANT	Z	KEAC024	Accel., 1/2 bridge	Endevco	7264-200	G
19	CHEST DISPLACEMENT	X	GPCP001	Rotary Pot Chest	Servo	14CBI	MM
20	PELVIS, PRIMARY	X	KEAC019	Accel., 1/2 bridge	Endevco	7264-200	G
21	PELVIS, PRIMARY	Y	KEAC020	Accel., 1/2 bridge	Endevco	7264-200	G
22	PELVIS, PRIMARY	Z	KEAC021	Accel., 1/2 bridge	Endevco	7264-200	G
23	LEFT FEMUR FORCE	Z	KEFF001	Load cell, Femur	R.A. Denton	2121	N
24	RIGHT FEMUR FORCE	Z	KEFF002	Load cell, Femur	R.A. Denton	2121	N

**2005 NHTSA 35mph NCAP  
Instrumentation Data Channel Assignments  
Driver A.T.D. Serial Number 34  
9/30/04  
2005 Toyota Scion TC 3-Door Hatchback**

CH.	LOCATION	AXIS	IDENT. NO.	DESCRIPTION	MFR	MODEL	UNITS
25	UP. TIBIA LEFT MOM.	X	GPUT09MX	2 ch., Upper tibia gage	R. A. Denton	1583	Nm
26	UP. TIBIA LEFT MOM.	Y	GPUT09MY	2 ch., Upper tibia gage	R. A. Denton	1583	Nm
27	UP. TIBIA RIGHT MOM.	X	GPUT09MX	2 ch., Upper tibia gage	R. A. Denton	1583	Nm
28	UP. TIBIA RIGHT MOM.	Y	GPUT09MY	2 ch., Upper tibia gage	R. A. Denton	1583	Nm
29	LWR. TIBIA LEFT MOM.	X	GPLT09MX	3 ch., lower tibia gage	R. A. Denton	3093	Nm
30	LWR. TIBIA LEFT MOM.	Y	GPLT09MY	3 ch., lower tibia gage	R. A. Denton	3093	Nm
31	LWR. TIBIA LEFT FORCE	Z	GPLT09FZ	3 ch., lower tibia gage	R. A. Denton	3093	N
32	LWR. TIBIA RIGHT MOM.	X	GPLT09MX	3 ch., lower tibia gage	R. A. Denton	3093	Nm
33	LWR. TIBIA RIGHT MOM.	Y	GPLT09MY	3 ch., lower tibia gage	R. A. Denton	3093	Nm
34	LWR. TIBIA RIGHT FORCE	Z	GPLT09FZ	3 ch., lower tibia gage	R. A. Denton	3093	N
35	FOOT LEFT, AFT	X	KEIC003X	Accel., Foot Triax	I.C. Sensor	3031-500	G
36	FOOT LEFT, AFT	Z	KEIC003Y	Accel., Foot Triax	I.C. Sensor	3031-500	G
37	FOOT LEFT, FORE	Z	KEIC003Z	Accel., Foot Triax	I.C. Sensor	3031-500	G
38	FOOT RIGHT, AFT	X	KEIC004X	Accel., Foot Triax	I.C. Sensor	3031-500	G
39	FOOT RIGHT, AFT	Z	KEIC004Y	Accel., Foot Triax	I.C. Sensor	3031-500	G
40	FOOT RIGHT, FORE	Z	KEIC004Z	Accel., Foot Triax	I.C. Sensor	3031-500	G
41	LAP BELT FORCE	X	BL134	Load cell, Seat belt	FGP	FN4060	N
42	SHOULDER BELT FORCE	X	BL135	Load cell, Seat belt	FGP	FN4060	N
43	SHOULDER BELT SPOOL	X	KEPP001	Pullout pot	Celesco	PTX101-0030	MM
44	SHOULDER BELT ELONG.	X	KEEP001	Linear pot., belt stretch	E.T.I.	LCP8-10 10K	MM/CM

**2005 NHTSA 35mph NCAP  
Instrumentation Data Channel Assignments  
Passenger A.T.D. Serial Number 35  
9/30/04  
2005 Toyota Scion TC 3-Door Hatchback**

CH.	LOCATION	AXIS	IDENT. NO.	DESCRIPTION	MFR	MODEL	UNITS
45	HEAD, PRIMARY	X	GPAC027	Accel., 1/2 bridge	Endevco	7264-2000	G
46	HEAD, PRIMARY	Y	GPAC002	Accel., 1/2 bridge	Endevco	7264-2000	G
47	HEAD, PRIMARY	Z	GPAC003	Accel., 1/2 bridge	Endevco	7264-2000	G
48	HEAD, REDUNDANT	X	GPAC032	Accel., 1/2 bridge	Endevco	7264-2000	G
49	HEAD, REDUNDANT	Y	GPAC021	Accel., 1/2 bridge	Endevco	7264-2000	G
50	HEAD, REDUNDANT	Z	GPAC026	Accel., 1/2 bridge	Endevco	7264-2000	G
51	NECK FORCE	X	GPUN01FX	Load cell, six axis neck	R. A. Denton	1716A	N
52	NECK FORCE	Y	GPUN01FY	Load cell, six axis neck	R. A. Denton	1716A	N
53	NECK FORCE	Z	GPUN01FZ	Load cell, six axis neck	R. A. Denton	1716A	N
54	NECK MOMENT	X	GPUN01MX	Load cell, six axis neck	R. A. Denton	1716A	Nm
55	NECK MOMENT	Y	GPUN01MY	Load cell, six axis neck	R. A. Denton	1716A	Nm
56	NECK MOMENT	Z	GPUN01MZ	Load cell, six axis neck	R. A. Denton	1716A	Nm
57	CHEST, PRIMARY	X	GPAC005	Accel., 1/2 bridge	Endevco	7264-2000	G
58	CHEST, PRIMARY	Y	GPAC011	Accel., 1/2 bridge	Endevco	7264-2000	G
59	CHEST, PRIMARY	Z	GPAC010	Accel., 1/2 bridge	Endevco	7264-2000	G
60	CHEST, REDUNDANT	X	GPAC034	Accel., 1/2 bridge	Endevco	7264-2000	G
61	CHEST, REDUNDANT	Y	GPAC023	Accel., 1/2 bridge	Endevco	7264-2000	G
62	CHEST, REDUNDANT	Z	GPAC020	Accel., 1/2 bridge	Endevco	7264-2000	G
63	CHEST DISPLACEMENT	X	GPCP002	Rotary Pot Chest	Servo	14CBI	MM
64	PELVIS, PRIMARY	X	GPAC025	Accel., 1/2 bridge	Endevco	7264-2000	G
65	PELVIS, PRIMARY	Y	GPAC022	Accel., 1/2 bridge	Endevco	7264-2000	G
66	PELVIS, PRIMARY	Z	GPAC019	Accel., 1/2 bridge	Endevco	7264-2000	G
67	LEFT FEMUR FORCE	Z	KEFF003	Load cell, Femur	R.A. Denton	2121	N
68	RIGHT FEMUR FORCE	Z	KEFF004	Load cell, Femur	R.A. Denton	2121	N

**2005 NHTSA 35mph NCAP  
Instrumentation Data Channel Assignments  
Passenger A.T.D. Serial Number 35  
9/30/04  
2005 Toyota Scion TC 3-Door Hatchback**

CH.	LOCATION	AXIS	IDENT. NO.	DESCRIPTION	MFR	MODEL	UNITS
69	UP. TIBIA LEFT MOM.	X	GPUT09MX	2 ch., Upper tibia gage	R. A. Denton	1583	Nm
70	UP. TIBIA LEFT MOM.	Y	GPUT09MY	2 ch., Upper tibia gage	R. A. Denton	1583	Nm
71	UP. TIBIA RIGHT MOM.	X	GPUT09MX	2 ch., Upper tibia gage	R. A. Denton	1583	Nm
72	UP. TIBIA RIGHT MOM.	Y	GPUT09MY	2 ch., Upper tibia gage	R. A. Denton	1583	Nm
73	LWR. TIBIA LEFT MOM.	X	GPLT09MX	3 ch., lower tibia gage	R. A. Denton	3093	Nm
74	LWR. TIBIA LEFT MOM.	Y	GPLT09MY	3 ch., lower tibia gage	R. A. Denton	3093	Nm
75	LWR. TIBIA LEFT FORCE	Z	GPLT09FZ	3 ch., lower tibia gage	R. A. Denton	3093	N
76	LWR. TIBIA RIGHT MOM.	X	GPLT09MX	3 ch., lower tibia gage	R. A. Denton	3093	Nm
77	LWR. TIBIA RIGHT MOM.	Y	GPLT09MY	3 ch., lower tibia gage	R. A. Denton	3093	Nm
78	LWR. TIBIA RIGHT FORCE	Z	GPLT09FZ	3 ch., lower tibia gage	R. A. Denton	3093	N
79	FOOT LEFT, AFT	X	KEIC002X	Accel., Foot Triax	I.C. Sensor	3031-500	G
80	FOOT LEFT, AFT	Z	KEIC002Y	Accel., Foot Triax	I.C. Sensor	3031-500	G
81	FOOT LEFT, FORE	Z	KEIC002Z	Accel., Foot Triax	I.C. Sensor	3031-500	G
82	FOOT RIGHT, AFT	X	KEIC001X	Accel., Foot Triax	I.C. Sensor	3031-500	G
83	FOOT RIGHT, AFT	Z	KEIC001Y	Accel., Foot Triax	I.C. Sensor	3031-500	G
84	FOOT RIGHT, FORE	Z	KEIC001Z	Accel., Foot Triax	I.C. Sensor	3031-500	G
85	LAP BELT FORCE	X	BL168	Load cell, Seat belt	First Tech	IF-964	N
86	SHOULDER BELT FORCE	X	BL169	Load cell, Seat belt	First Tech	IF-964	N
87	SHOULDER BELT SPOOL	X	KEPP001	Pullout pot	Celesco	PTX101-0030	MM
88	SHOULDER BELT ELONG.	X	KEEP001	Linear pot., belt stretch	E.T.I.	LCP8-10 10K	MM/CM

**2005 NHTSA 35mph NCAP  
Instrumentation Data Channel Assignments  
Vehicle Accelerometers  
9/30/04  
2005 Toyota Scion TC 3-Door Hatchback**

CH.	LOCATION	AXIS	IDENT. NO.	DESCRIPTION	MFR	MODEL	UNITS
89	LEFT REAR	X	KEVA002	Accel., Pre-Amp	I.C.S/Karco	3031-500	G
90	RIGHT REAR	X	KEVA006	Accel., Vehicle block	I.C. Sensor	3031-200	G
91	ENGINE TOP	X	KEVA009	Accel., Vehicle block	I.C. Sensor	3031-500	G
92	ENGINE BOTTOM	X	KEVA007	Accel., Vehicle block	I.C. Sensor	3031-500	G
93	LEFT BRAKE CALIPER	X	KEVA008	Accel., Vehicle block	I.C. Sensor	3031-500	G
94	RIGHT BRAKE CALIPER	X	KEVA012	Accel., Vehicle block	I.C. Sensor	3031-500	G
95	INSTRUMENT PANEL	X	KEVA011	Accel., Vehicle block	I.C. Sensor	3031-200	G
96	LEFT REAR	Z	KEVA001	Accel., Vehicle block	I.C. Sensor	3031-500	G
97	RIGHT REAR	Z	KEVA010	Accel., Vehicle block	I.C. Sensor	3031-200	G

**2005 NHTSA 35mph NCAP  
Instrumentation Data Channel Assignments  
Rigid Load Cell Barrier  
9/30/04  
2005 Toyota Scion TC 3-Door Hatchback**

CH.	LOCATION	AXIS	IDENT. NO.	DESCRIPTION	MFR	MODEL	UNITS
98	BARRIER FORCE A1	X	BARRIER	Load Cell, LCB	Interface	1220-FS	N
99	BARRIER FORCE A2	X	BARRIER	Load Cell, LCB	Interface	1220-FS	N
100	BARRIER FORCE A3	X	BARRIER	Load Cell, LCB	Interface	1220-FS	N
101	BARRIER FORCE A4	X	BARRIER	Load Cell, LCB	Interface	1220-FS	N
102	BARRIER FORCE A5	X	BARRIER	Load Cell, LCB	Interface	1220-FS	N
103	BARRIER FORCE A6	X	BARRIER	Load Cell, LCB	Interface	1220-FS	N
104	BARRIER FORCE A7	X	BARRIER	Load Cell, LCB	Interface	1220-FS	N
105	BARRIER FORCE A8	X	BARRIER	Load Cell, LCB	Interface	1220-FS	N
106	BARRIER FORCE A9	X	BARRIER	Load Cell, LCB	Interface	1220-FS	N
107	BARRIER FORCE B1	X	BARRIER	Load Cell, LCB	Interface	1220-FS	N
108	BARRIER FORCE B2	X	BARRIER	Load Cell, LCB	Interface	1220-FS	N
109	BARRIER FORCE B3	X	BARRIER	Load Cell, LCB	Interface	1220-FS	N
110	BARRIER FORCE B4	X	BARRIER	Load Cell, LCB	Interface	1220-FS	N
111	BARRIER FORCE B5	X	BARRIER	Load Cell, LCB	Interface	1220-FS	N
112	BARRIER FORCE B6	X	BARRIER	Load Cell, LCB	Interface	1220-FS	N
113	BARRIER FORCE B7	X	BARRIER	Load Cell, LCB	Interface	1220-FS	N
114	BARRIER FORCE B8	X	BARRIER	Load Cell, LCB	Interface	1220-FS	N
115	BARRIER FORCE B9	X	BARRIER	Load Cell, LCB	Interface	1220-FS	N

**2005 NHTSA 35mph NCAP  
Instrumentation Data Channel Assignments  
Rigid Load Cell Barrier  
9/30/04  
2005 Toyota Scion TC 3-Door Hatchback**

CH.	LOCATION	AXIS	IDENT. NO.	DESCRIPTION	MFR	MODEL	UNITS
116	BARRIER FORCE C1	X	BARRIER	Load Cell, LCB	Interface	1220-FS	N
117	BARRIER FORCE C2	X	BARRIER	Load Cell, LCB	Interface	1220-FS	N
118	BARRIER FORCE C3	X	BARRIER	Load Cell, LCB	Interface	1220-FS	N
119	BARRIER FORCE C4	X	BARRIER	Load Cell, LCB	Interface	1220-FS	N
120	BARRIER FORCE C5	X	BARRIER	Load Cell, LCB	Interface	1220-FS	N
121	BARRIER FORCE C6	X	BARRIER	Load Cell, LCB	Interface	1220-FS	N
122	BARRIER FORCE C7	X	BARRIER	Load Cell, LCB	Interface	1220-FS	N
123	BARRIER FORCE C8	X	BARRIER	Load Cell, LCB	Interface	1220-FS	N
124	BARRIER FORCE C9	X	BARRIER	Load Cell, LCB	Interface	1220-FS	N
125	BARRIER FORCE D1	X	BARRIER	Load Cell, LCB	Interface	1220-FS	N
126	BARRIER FORCE D2	X	BARRIER	Load Cell, LCB	Interface	1220-FS	N
127	BARRIER FORCE D3	X	BARRIER	Load Cell, LCB	Interface	1220-FS	N
128	BARRIER FORCE D4	X	BARRIER	Load Cell, LCB	Interface	1220-FS	N
129	BARRIER FORCE D5	X	BARRIER	Load Cell, LCB	Interface	1220-FS	N
130	BARRIER FORCE D6	X	BARRIER	Load Cell, LCB	Interface	1220-FS	N
131	BARRIER FORCE D7	X	BARRIER	Load Cell, LCB	Interface	1220-FS	N
132	BARRIER FORCE D8	X	BARRIER	Load Cell, LCB	Interface	1220-FS	N
133	BARRIER FORCE D9	X	BARRIER	Load Cell, LCB	Interface	1220-FS	N

**2005 NHTSA 35mph NCAP  
Instrumentation Data Channel Assignments  
Nine Accelerometer Array Head  
9/30/04  
2005 Toyota Scion TC 3-Door Hatchback**

CH.	LOCATION	AXIS	IDENT. NO.	DESCRIPTION	MFR	MODEL	UNITS
160	DRIVER X-ARM	Y	GPAC016	Accel., 1/2 bridge	Endevco	7264-2000	G
161	DRIVER X-ARM	Z	GPAC015	Accel., 1/2 bridge	Endevco	7264-2000	G
162	DRIVER Y-ARM	X	GPAC004	Accel., 1/2 bridge	Endevco	7264-2000	G
163	DRIVER Y-ARM	Z	GPAC018	Accel., 1/2 bridge	Endevco	7264-2000	G
164	DRIVER Z-ARM	X	GPAC006	Accel., 1/2 bridge	Endevco	7264-2000	G
165	DRIVER Z-ARM	Y	GPAC007	Accel., 1/2 bridge	Endevco	7264-2000	G
166	PASS. X-ARM	Y	GPAC012	Accel., 1/2 bridge	Endevco	7264-2000	G
167	PASS. X-ARM	Z	GPAC001	Accel., 1/2 bridge	Endevco	7264-2000	G
168	PASS. Y-ARM	X	GPAC036	Accel., 1/2 bridge	Endevco	7264-2000	G
169	PASS. Y-ARM	Z	GPAC014	Accel., 1/2 bridge	Endevco	7264-2000	G
170	PASS. Z-ARM	X	GPAC030	Accel., 1/2 bridge	Endevco	7264-2000	G
171	PASS. Z-ARM	Y	GPAC037	Accel., 1/2 bridge	Endevco	7264-2000	G

**APPENDIX E**  
**DUMMY CALIBRATION DATA**

Test Program: Hybrid III 50th Percentile Male Knee Impact Test

Test Date: 8/24/04

ATD Serial No.: 034

Test I.D.: LK08A , RK08A



**Left Knee**

Tested Parameter	Units	Specification	Result	Pass/Fail
Laboratory Temperature	°C	18.9 to 25.6	21.1	Pass
Laboratory Relative Humidity	%	10 to 70	30	Pass
Pendulum Velocity at T=0	m/sec	2.07 to 2.13	2.12	Pass
Peak Probe Force	Newtons	4715 to 5782	5707	Pass
Overall Test Results				Pass

**Right Knee**

Pendulum Velocity at T=0	m/sec	2.07 to 2.13	2.10	Pass
Peak Probe Force	Newtons	4715 to 5782	5736	Pass
Overall Test Results				Pass



Curve Description			
Left Knee Probe Force			
CURNO	Type	SAE Class	Units
001	FIL	600	Newtons
Max	Time	Min	Time
5706.8	2.4	-24.4	9.9

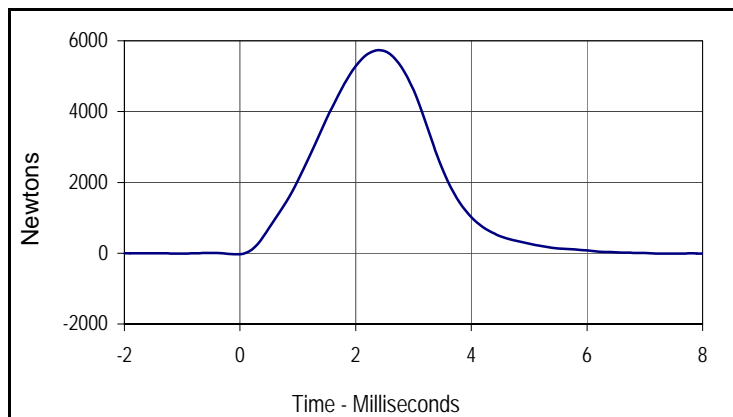

Curve Description			
Right Knee Probe Force			
CURNO	Type	SAE Class	Units
002	FIL	600	Newtons
Max	Time	Min	Time
5735.9	2.4	-29.0	-0.1

Test Program: Hybrid III 50th Percentile Male Head Drop Test

Test Date: 8/24/04

ATD Serial No.: 034

Test I.D.: HD08A



Tested Parameter	Units	Specification	Result	Pass/Fail
Laboratory Temperature	°C	18.9 to 25.6	21.1	Pass
Laboratory Relative Humidity	%	10 to 70	30	Pass
Peak Resultant Acceleration	G's	225.0 to 275.0	244.6	Pass
Peak Lateral Acceleration	G's	≤15.0	2.4	Pass
Is Acceleration Unimodal?	Yes/No	Yes	Yes	Pass
Overall Test Results			Pass	

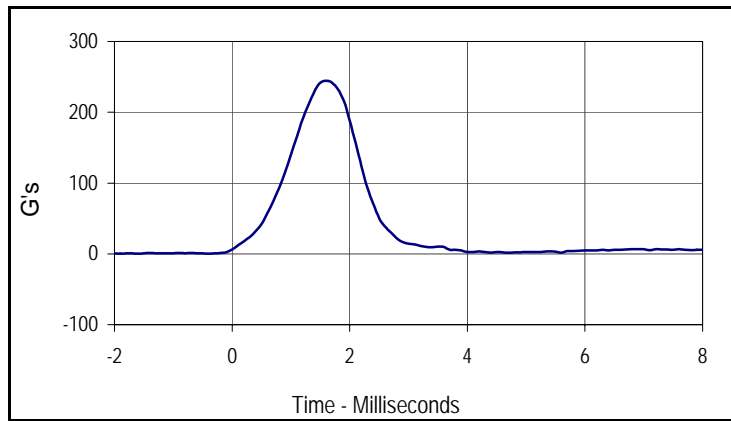

Curve Description			
Head Resultant			
CURNO	Type	SAE Class	Units
001	RES	1000	G's
Max	Time	Min	Time
244.6	1.6	0.4	-1.6

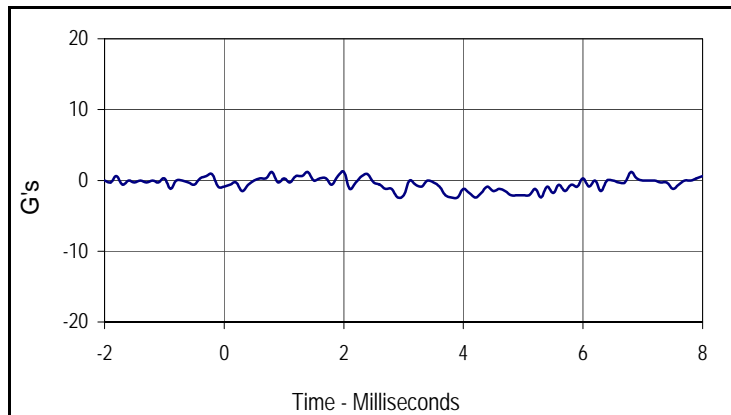

Curve Description			
Head Y			
CURNO	Type	SAE Class	Units
002	FIL	1000	G's
Max	Time	Min	Time
1.2	0.8	-2.4	2.9

Test Program: Hybrid III 50th Percentile Male Thorax Impact Test

Test Date: 8/25/04

ATD Serial No.: 034

Test I.D.: CH08A



Tested Parameter	Units	Specification	Result	Pass/Fail
Laboratory Temperature	°C	20.6 to 22.2	21.1	Pass
Laboratory Relative Humidity	%	10 to 70	30	Pass
Probe Velocity	m/s	6.58 to 6.82	6.74	Pass
Peak Probe Force	Newtons	5159 to 5893	5486	Pass
Peak Sternum Displacement	CM	6.35 to 7.26	6.85	Pass
Internal Hysteresis	%	69 to 85	69.8	Pass
Overall Test Results				Pass

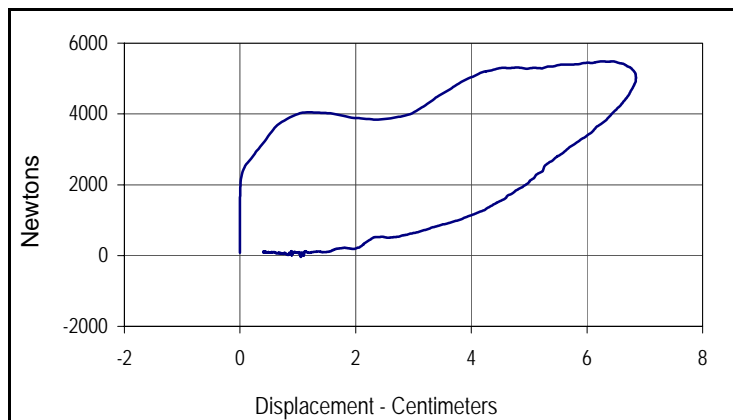

Curve Description			
Probe Force vs. Chest Displacement			
CURNO	Type	SAE Class	Hysteresis
001	FIL	600	69.8
Peak Probe Force		Peak Chest Displ.	
5486		6.85	



Tested Parameter	Units	Specification	Result	Pass/Fail	
Laboratory Temperature	°C	20.6 to 22.2	21.1	Pass	
Laboratory Relative Humidity	%	10 to 70	30	Pass	
Pendulum Velocity	m/s	6.89 to 7.13	7.11	Pass	
Pendulum Deceleration	10 Msec.	G's	22.5 to 27.5	23.4	Pass
	20 Msec.	G's	17.6 to 22.6	18.5	Pass
	30 Msec.	G's	12.5 to 18.5	17.2	Pass
Peak Pendulum Decel. after 30 Msec.	G's	≤ 29.0	18.7	Pass	
Deceleration Decay, Time to Cross 5 G's	Msec.	34.0 to 42.0	41.6	Pass	
Maximum "D" Plane Rotation	Max	Degrees	64.0 to 78.0	67.3	Pass
	Time	Msec.	57.0 to 64.0	59.7	Pass
"D" Plane Rotation Decay, Time To Zero Crossing	Msec.	113.0 to 128.0	121.3	Pass	
Moment About Occ. Condyle	Max	Nm	84.1 to 108.5	94.3	Pass
	Time	Msec.	47.0 to 58.0	56.8	Pass
Positive Moment Decay, Time To Zero Crossing	Msec.	97.0 to 107.0	105.2	Pass	
<b>Overall Test Results</b>				<b>Pass</b>	

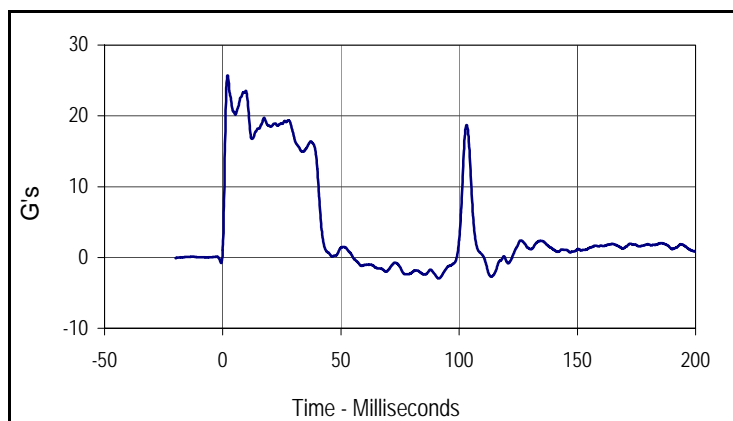

Curve Description			
Pendulum Deceleration			
CURNO	Type	SAE Class	Units
001	FIL	180	G's
Max	Time	Min	Time
25.7	2.0	-3.0	91.4

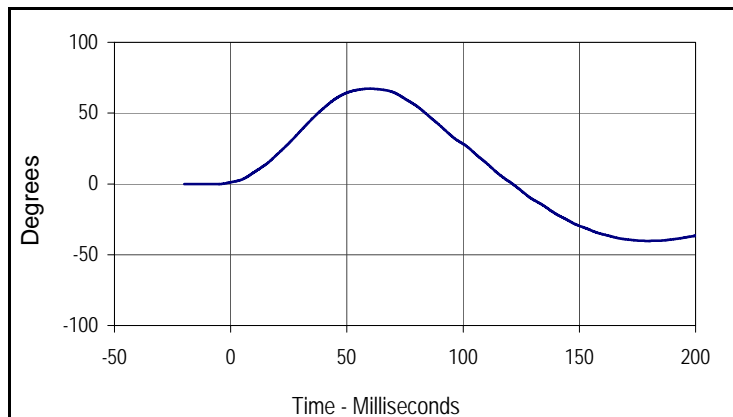

Curve Description			
"D" Plane Rotation			
CURNO	Type	SAE Class	Units
003	FIL	60	Degrees
Max	Time	Min	Time
67.3	59.7	-40.2	179.2

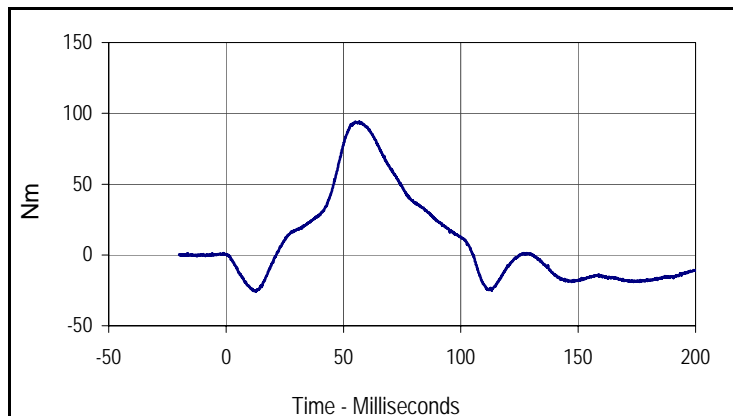

Curve Description			
Moment About Occipital Condyle			
CURNO	Type	SAE Class	Units
004	FIL	60	Nm
Max	Time	Min	Time
94.3	56.8	-25.7	12.6

Test Program: Hybrid III 50th Percentile Male Neck Extension Test

Test Date: 8/25/04

ATD Serial No.: 034

Test I.D.: NE08A



Tested Parameter	Units	Specification	Result	Pass/Fail	
Laboratory Temperature	°C	20.6 to 22.2	21.1	Pass	
Laboratory Relative Humidity	%	10 to 70	30	Pass	
Pendulum Velocity	m/s	5.94 to 6.19	6.03	Pass	
Pendulum Deceleration	10 Msec.	G's	17.2 to 21.2	17.4	Pass
	20 Msec.	G's	14.0 to 19.0	17.4	Pass
	30 Msec.	G's	11.0 to 16.0	14.1	Pass
Peak Pendulum Decel. after 30 Msec.	G's	≤ 22.0	14.1	Pass	
Deceleration Decay, Time to Cross 5 G's	Msec.	38.0 to 46.0	41.8	Pass	
Maximum "D" Plane Rotation	Max	Degrees	81.0 to 106.0	96.3	Pass
	Time	Msec.	72.0 to 82.0	74.8	Pass
"D" Plane Rotation Decay, Time To Zero Crossing	Msec.	147.0 to 174.0	152.3	Pass	
Moment About Occ. Condyle	Max	Nm	-52.9 to- 79.9	-78.8	Pass
	Time	Msec.	65.0 to 79.0	68.1	Pass
Positive Moment Decay, Time To Zero Crossing	Msec.	120.0 to 148.0	140.3	Pass	
<b>Overall Test Results</b>				<b>Pass</b>	

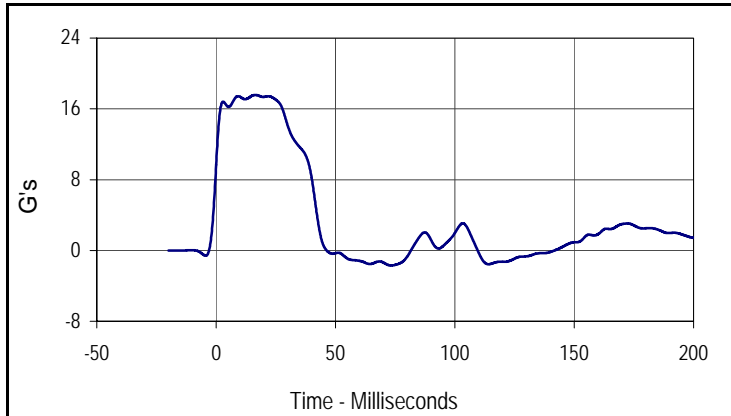

Curve Description			
Pendulum Deceleration			
CURNO	Type	SAE Class	Units
001	FIL	60	G's
Max	Time	Min	Time
17.6	16.5	-1.7	73.3

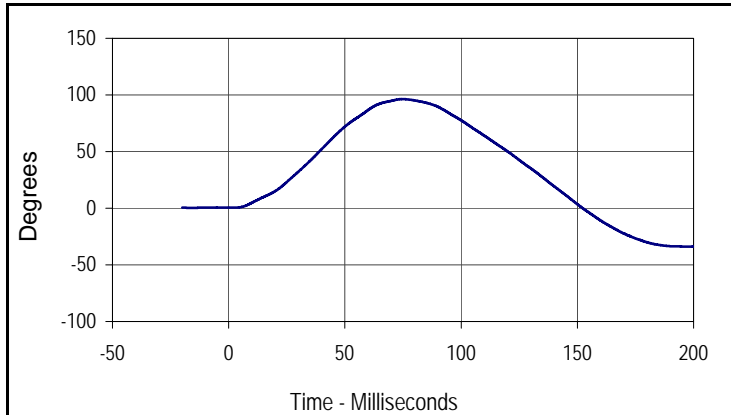

Curve Description			
"D" Plane Rotation			
CURNO	Type	SAE Class	Units
003	FIL	60	Degrees
Max	Time	Min	Time
96.3	74.8	-33.9	198.5

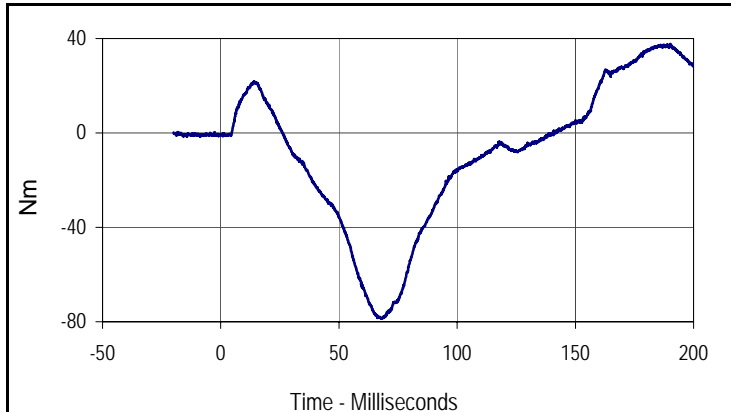

Curve Description			
Moment About Occipital Condyle			
CURNO	Type	SAE Class	Units
004	FIL	600	Nm
Max	Time	Min	Time
37.7	190.1	-78.8	68.1

Test Program: Hybrid III 50th Percentile Male External Measurements Test Date: 8/25/04  
 ATD Serial No.: 034 Test I.D.: N/A



Tested Parameter	Units	Specification	Result	Pass/Fail
Laboratory Temperature	°C	20.6 to 22.2	21.1	Pass
Laboratory Relative Humidity	%	10 to 70	30	Pass
A - Total sitting height	mm	879 to 889	886	Pass
B - Shoulder pivot height	mm	505 to 521	520	Pass
C - "H" point height	mm	84 to 89	87	Pass
D - "H" point from seat back	mm	135 to 140	136	Pass
E - Shoulder pivot from back	mm	84 to 94	89	Pass
F - Thigh clearance	mm	140 to 155	145	Pass
G - Elbow back to wrist pivot	mm	290 to 305	301	Pass
H - Skull cap to back line	mm	41 to 46	44	Pass
I - Shoulder to elbow length	mm	330 to 345	339	Pass
J - Elbow rest height	mm	190 to 211	198	Pass
K - Buttock to knee length	mm	579 to 604	600	Pass
L - Popliteal length	mm	429 to 455	451	Pass
M - Knee pivot height	mm	485 to 500	490	Pass
N - Buttock popliteal length	mm	452 to 477	459	Pass
O - Chest depth	mm	213 to 229	225	Pass
P - Foot length	mm	251 to 267	265	Pass
V - Shoulder breadth	mm	422 to 437	425	Pass
W - Foot breadth	mm	91 to 107	100	Pass
Y - Chest circumference	mm	970 to 1001	990	Pass
Z - Waist circumference	mm	836 to 866	860	Pass
AA - Location for chest circumference	mm	429 to 434	430	Pass
BB - Location for waist circumference	mm	226 to 231	230	Pass
Overall Test Results				Pass

Test Program: Hybrid III 50th Percentile Male Knee Impact Test

Test Date: 8/24/04

ATD Serial No.: 035

Test I.D.: LK08B , RK08B



**Left Knee**

Tested Parameter	Units	Specification	Result	Pass/Fail
Laboratory Temperature	°C	18.9 to 25.6	21.1	Pass
Laboratory Relative Humidity	%	10 to 70	30	Pass
Pendulum Velocity at T=0	m/sec	2.07 to 2.13	2.08	Pass
Peak Probe Force	Newtons	4715 to 5782	5383	Pass
Overall Test Results				Pass

**Right Knee**

Pendulum Velocity at T=0	m/sec	2.07 to 2.13	2.13	Pass
Peak Probe Force	Newtons	4715 to 5782	5260	Pass
Overall Test Results				Pass

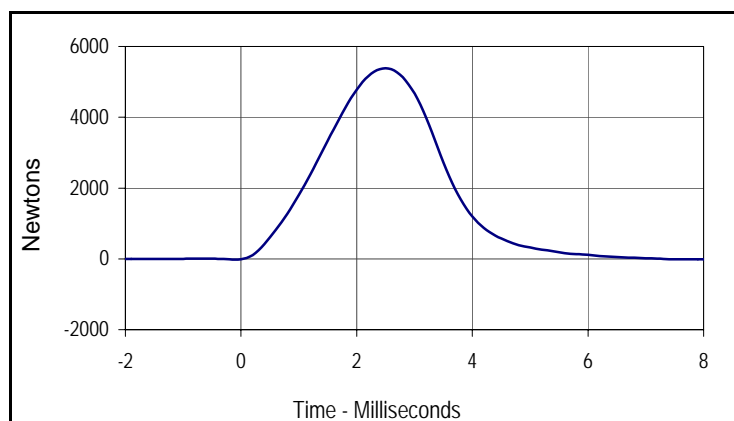

Curve Description			
Left Knee Probe Force			
CURNO	Type	SAE Class	Units
001	FIL	600	Newtons
Max	Time	Min	Time
5383.4	2.5	-21.8	9.9

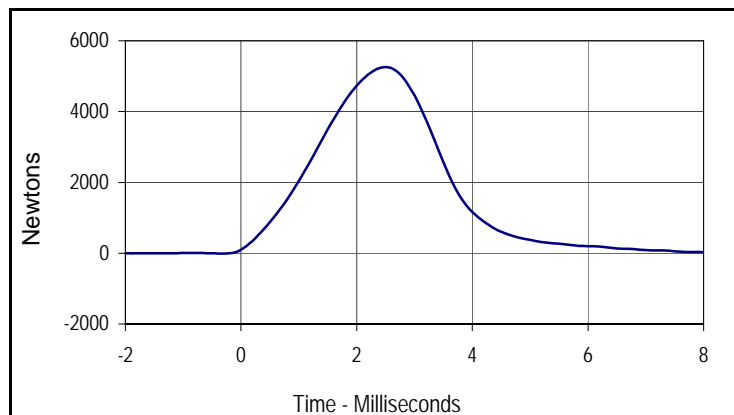

Curve Description			
Right Knee Probe Force			
CURNO	Type	SAE Class	Units
002	FIL	600	Newtons
Max	Time	Min	Time
5260.1	2.5	-24.1	9.2

Test Program: Hybrid III 50th Percentile Male Head Drop Test

Test Date: 8/24/04

ATD Serial No.: 035

Test I.D.: HD08B



Tested Parameter	Units	Specification	Result	Pass/Fail
Laboratory Temperature	°C	18.9 to 25.6	21.1	Pass
Laboratory Relative Humidity	%	10 to 70	30	Pass
Peak Resultant Acceleration	G's	225.0 to 275.0	242.1	Pass
Peak Lateral Acceleration	G's	≤15.0	2.4	Pass
Is Acceleration Unimodal?	Yes/No	Yes	Yes	Pass
Overall Test Results				Pass

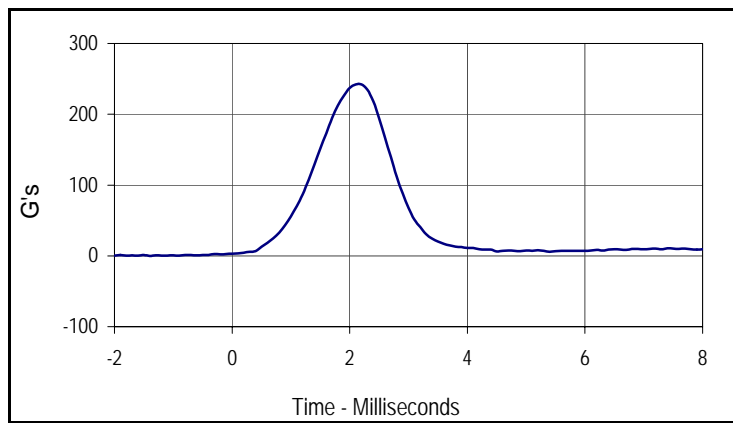

Curve Description			
Head Resultant			
CURNO	Type	SAE Class	Units
001	RES	1000	G's
Max	Time	Min	Time
242.1	2.2	0.0	-1.4

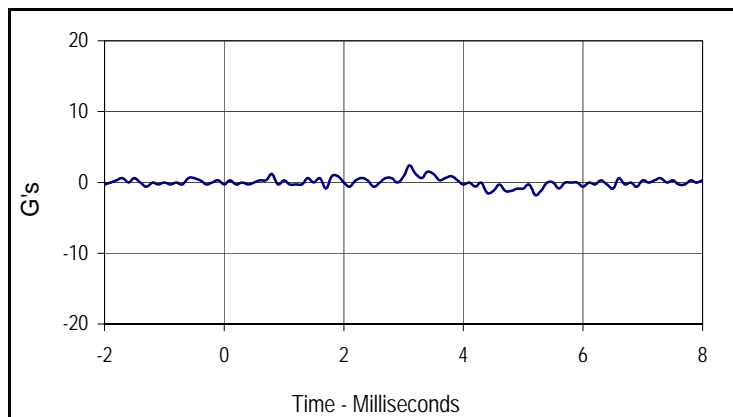

Curve Description			
Head Y			
CURNO	Type	SAE Class	Units
002	FIL	1000	G's
Max	Time	Min	Time
2.4	3.1	-1.8	5.2

Test Program: Hybrid III 50th Percentile Male Thorax Impact Test

Test Date: 8/25/04

ATD Serial No.: 035

Test I.D.: CH08B



Tested Parameter	Units	Specification	Result	Pass/Fail
Laboratory Temperature	°C	20.6 to 22.2	21.1	Pass
Laboratory Relative Humidity	%	10 to 70	30	Pass
Probe Velocity	m/s	6.58 to 6.82	6.64	Pass
Peak Probe Force	Newtons	5159 to 5893	5773	Pass
Peak Sternum Displacement	CM	6.35 to 7.26	6.59	Pass
Internal Hysteresis	%	69 to 85	75.1	Pass
Overall Test Results				Pass

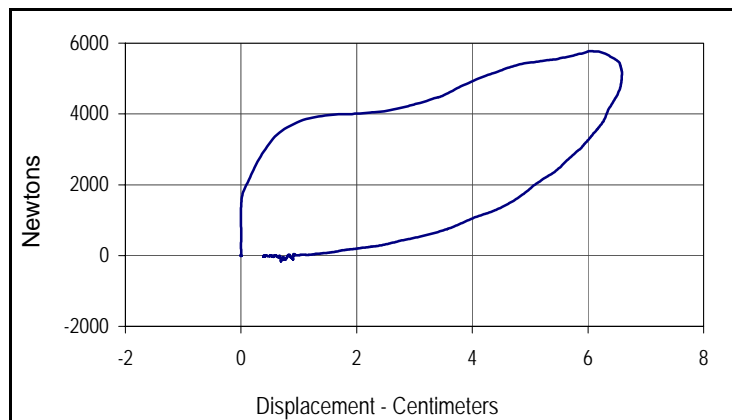

Curve Description			
Probe Force vs. Chest Displacement			
CURNO	Type	SAE Class	Hysteresis
001	FIL	600	75.1
Peak Probe Force		Peak Chest Displ.	
5773		6.59	

Test Program: Hybrid III 50th Percentile Male Neck Flexion Test

Test Date: 8/24/04

ATD Serial No.: 035

Test I.D.: NF08A



Tested Parameter	Units	Specification	Result	Pass/Fail	
Laboratory Temperature	°C	20.6 to 22.2	21.1	Pass	
Laboratory Relative Humidity	%	10 to 70	30	Pass	
Pendulum Velocity	m/s	6.89 to 7.13	7.11	Pass	
Pendulum Deceleration	10 Msec.	G's	22.5 to 27.5	23.0	Pass
	20 Msec.	G's	17.6 to 22.6	21.7	Pass
	30 Msec.	G's	12.5 to 18.5	17.3	Pass
Peak Pendulum Decel. after 30 Msec.	G's	≤ 29.0	19.8	Pass	
Deceleration Decay, Time to Cross 5 G's	Msec.	34.0 to 42.0	35.7	Pass	
Maximum "D" Plane Rotation	Max	Degrees	64.0 to 78.0	70.3	Pass
	Time	Msec.	57.0 to 64.0	60.3	Pass
"D" Plane Rotation Decay, Time To Zero Crossing	Msec.	113.0 to 128.0	122	Pass	
Moment About Occ. Condyle	Max	Nm	84.1 to 108.5	88.6	Pass
	Time	Msec.	47.0 to 58.0	47.7	Pass
Positive Moment Decay, Time To Zero Crossing	Msec.	97.0 to 107.0	99.9	Pass	
<b>Overall Test Results</b>				<b>Pass</b>	

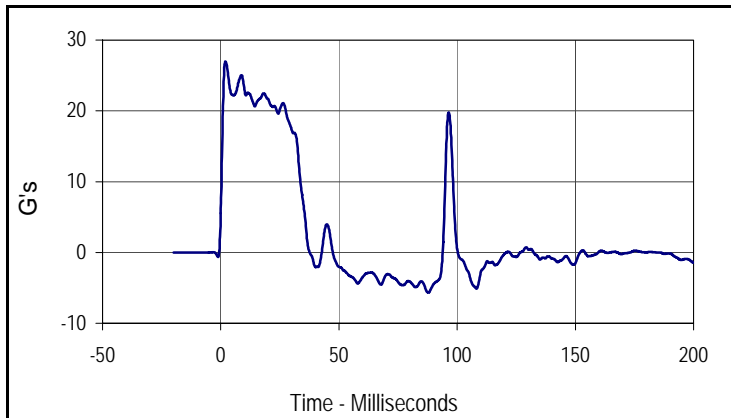

Curve Description			
Pendulum Deceleration			
CURNO	Type	SAE Class	Units
001	FIL	180	G's
Max	Time	Min	Time
27.0	2.0	-5.7	87.8

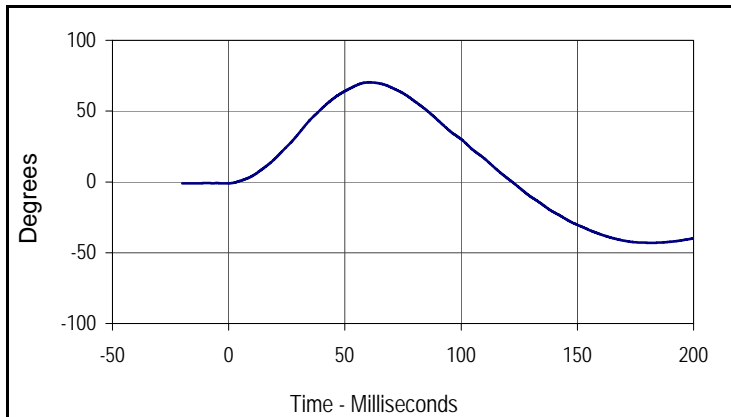

Curve Description			
"D" Plane Rotation			
CURNO	Type	SAE Class	Units
003	FIL	60	Degrees
Max	Time	Min	Time
70.3	60.3	-43.0	181.7

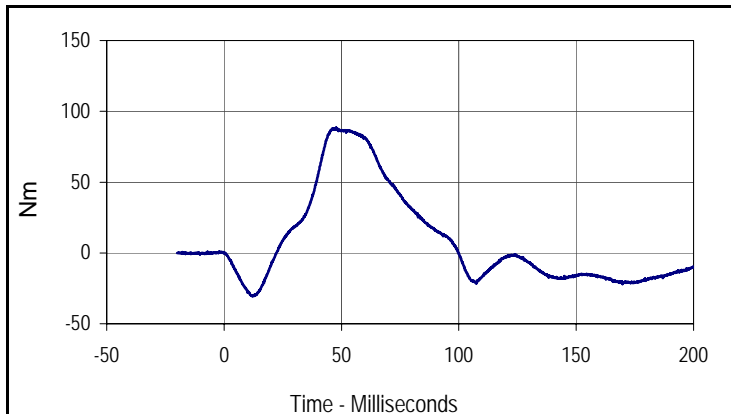

Curve Description			
Moment About Occipital Condyle			
CURNO	Type	SAE Class	Units
004	FIL	60	Nm
Max	Time	Min	Time
88.6	47.7	-30.5	12.1



Tested Parameter	Units	Specification	Result	Pass/Fail	
Laboratory Temperature	°C	20.6 to 22.2	21.1	Pass	
Laboratory Relative Humidity	%	10 to 70	30	Pass	
Pendulum Velocity	m/s	5.94 to 6.19	6.11	Pass	
Pendulum Deceleration	10 Msec.	G's	17.2 to 21.2	17.8	Pass
	20 Msec.	G's	14.0 to 19.0	17.5	Pass
	30 Msec.	G's	11.0 to 16.0	15.7	Pass
Peak Pendulum Decel. after 30 Msec.	G's	≤ 22.0	15.7	Pass	
Deceleration Decay, Time to Cross 5 G's	Msec.	38.0 to 46.0	45.6	Pass	
Maximum "D" Plane Rotation	Max	Degrees	81.0 to 106.0	92.7	Pass
	Time	Msec.	72.0 to 82.0	72.7	Pass
"D" Plane Rotation Decay, Time To Zero Crossing	Msec.	147.0 to 174.0	151.8	Pass	
Moment About Occ. Condyle	Max	Nm	-52.9 to- 79.9	-79.4	Pass
	Time	Msec.	65.0 to 79.0	69.6	Pass
Positive Moment Decay, Time To Zero Crossing	Msec.	120.0 to 148.0	136.2	Pass	
<b>Overall Test Results</b>				<b>Pass</b>	

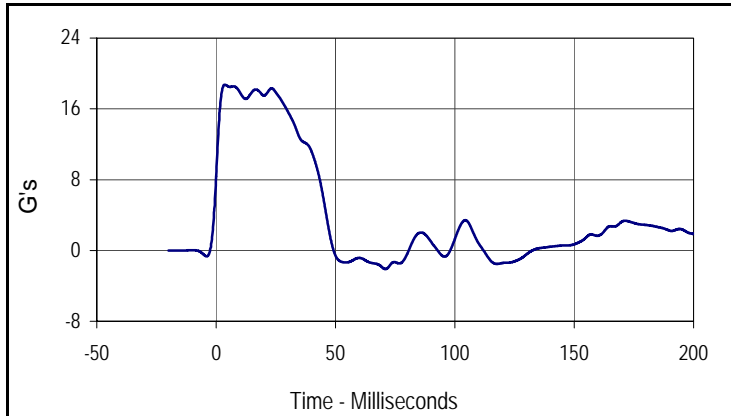

Curve Description			
Pendulum Deceleration			
CURNO	Type	SAE Class	Units
001	FIL	60	G's
Max	Time	Min	Time
18.7	3.6	-2.1	70.9

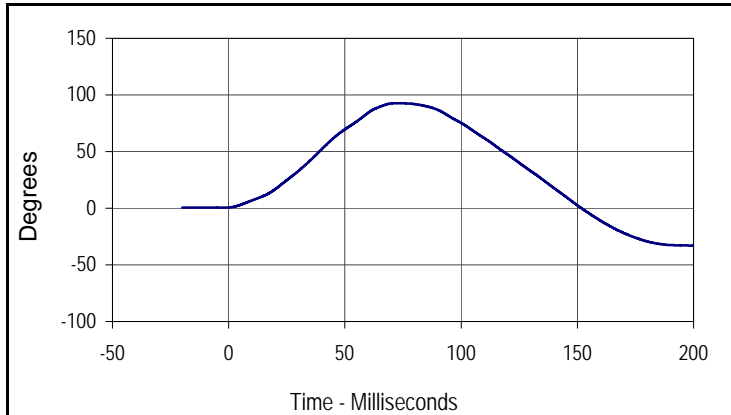

Curve Description			
"D" Plane Rotation			
CURNO	Type	SAE Class	Units
003	FIL	60	Degrees
Max	Time	Min	Time
92.7	72.7	-33.0	199.8

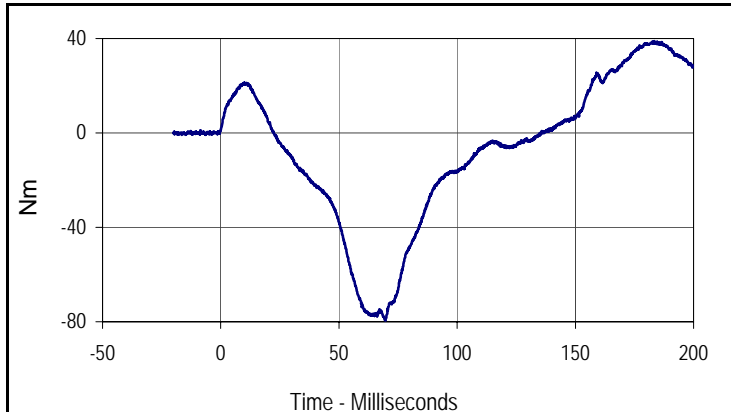

Curve Description			
Moment About Occipital Condyle			
CURNO	Type	SAE Class	Units
004	FIL	600	Nm
Max	Time	Min	Time
38.9	183.4	-79.4	69.6

Test Program: Hybrid III 50th Percentile Male External Measurements Test Date: 8/25/04  
 ATD Serial No.: 035 Test I.D.: N/A



Tested Parameter	Units	Specification	Result	Pass/Fail
Laboratory Temperature	°C	20.6 to 22.2	21.1	Pass
Laboratory Relative Humidity	%	10 to 70	30	Pass
A - Total sitting height	mm	879 to 889	885	Pass
B - Shoulder pivot height	mm	505 to 521	515	Pass
C - "H" point height	mm	84 to 89	86	Pass
D - "H" point from seat back	mm	135 to 140	138	Pass
E - Shoulder pivot from back	mm	84 to 94	90	Pass
F - Thigh clearance	mm	140 to 155	150	Pass
G - Elbow back to wrist pivot	mm	290 to 305	295	Pass
H - Skull cap to back line	mm	41 to 46	44	Pass
I - Shoulder to elbow length	mm	330 to 345	341	Pass
J - Elbow rest height	mm	190 to 211	210	Pass
K - Buttock to knee length	mm	579 to 604	585	Pass
L - Popliteal length	mm	429 to 455	445	Pass
M - Knee pivot height	mm	485 to 500	495	Pass
N - Buttock popliteal length	mm	452 to 477	470	Pass
O - Chest depth	mm	213 to 229	225	Pass
P - Foot length	mm	251 to 267	255	Pass
V - Shoulder breadth	mm	422 to 437	430	Pass
W - Foot breadth	mm	91 to 107	105	Pass
Y - Chest circumference	mm	970 to 1001	1000	Pass
Z - Waist circumference	mm	836 to 866	865	Pass
AA - Location for chest circumference	mm	429 to 434	430	Pass
BB - Location for waist circumference	mm	226 to 231	228	Pass
Overall Test Results				Pass

**APPENDIX F**  
**CHILD RESTRAIN SYSTEMS**

**REPORT NUMBER TR-P25001-03-NC**

**NEW CAR ASSESSMENT PROGRAM  
FRONTAL BARRIER IMPACT TEST**

**TOYOTA MOTOR CORPORATION  
2005 TOYOTA SCION TC 3-DOOR HATCHBACK**

**NHTSA NUMBER: M55110**

**PREPARED BY:  
KARCO ENGINEERING, LLC  
9270 HOLLY ROAD  
ADELANTO, CALIFORNIA 92301**



**SEPTEMBER 30, 2004**

**FINAL REPORT**

**PREPARED FOR:  
U.S. DEPARTMENT OF TRANSPORTATION  
NATIONAL HIGHWAY TRAFFIC SAFETY ADMINISTRATION  
RULEMAKING  
OFFICE OF CRASHWORTHINESS STANDARDS  
MAIL CODE: NVS-111  
400 SEVENTH STREET, SW, ROOM 5311  
WASHINGTON, D.C. 20590**

This final test report was prepared for the U.S. Department of Transportation, National Highway Traffic Safety Administration, in response to Contract Number DTNH22-01-D-02005.

This publication is distributed by the U.S. Department of Transportation, National Highway Traffic Safety Administration, in the interest of information exchange. The opinions, findings and conclusions expressed in this publication are those of the author(s) and not necessarily those of the Department of Transportation or the National Highway Traffic Safety Administration. The United States Government assumes no liability for its contents or use thereof. If trade or manufacturers' names or products are mentioned, it is only because they are considered essential to the object of the publication and should not be construed as an endorsement. The United States Government does not endorse products or manufacturers.

Prepared by: \_\_\_\_\_  
Mr. Yednesh Parnaik, Project Engineer  
KARCO Engineering, LLC

Date: October 13, 2004

Reviewed by: \_\_\_\_\_  
Mr. Michael L. Dunlap, Quality Assurance Manager  
KARCO Engineering, LLC

Date: October 13, 2004

Approved by: \_\_\_\_\_  
Mr. Frank D. Richardson, Program Manager  
KARCO Engineering, LLC

Date: October 13, 2004

FINAL REPORT ACCEPTED BY:

\_\_\_\_\_  
Manager, New Car Assessment Program

\_\_\_\_\_  
Date of Acceptance

\_\_\_\_\_  
COTR, NCAP Frontal Impact Program

\_\_\_\_\_  
Date of Acceptance

### Technical Report Documentation Page

<b>1. Report No.</b> TR-P25001-03-NC	<b>2. Government Accession No.</b>	<b>3. Recipients Catalog No.</b>		
<b>4. Title and Subtitle</b> Final Report of a Graco Hi-Back Turbo Booster CRS NHTSA NO. M55110	<b>5. Report Date</b> September 30, 2004		<b>6. Performing Organization Code</b> KAR	
	<b>8. Performing Organization Report No.</b> TR-P25001-03-NC			
<b>7. Authors</b> Mr. Yednesh Parnaik, Project Engineer, Karco Mr. Frank Richardson, Program Manager, Karco	<b>10. Work Unit No.</b>			
<b>9. Performing Organization Name and Address</b> Karco Engineering, LLC 9270 Holly Rd. Adelanto, CA, 92301	<b>11. Contract or Grant No.</b> DTNH22-01-D-02005			
	<b>13. Type of Report and Period Covered</b> Final Test Report Option Year 3			
<b>12. Sponsoring Agency Name and Address</b> U. S. Department of Transportation National Highway Traffic Safety Administration Rulemaking Office of Crashworthiness Standards Mail Code NPS-111 400 Seventh Street, SW, Room 5311 Washington, D.C 20590	<b>14. Sponsoring Agency Code</b> DOT/NHTSA/NRM/OCS			
	<b>15. Supplementary Notes</b>			
<b>16. Abstract</b>  A frontal barrier impact test was conducted on the subject Graco Hi-Back Turbo Booster CRS in conjunction with frontal NCAP testing on a 2005 Toyota Scion TC 3-Door Hatchback and in accordance with the specifications of the Office of Crashworthiness Standards Test Procedure for the determination of CRS crashworthiness. This test was conducted at Karco Engineering, LLC on September 30, 2004				
<b>Measurement Description</b>	<b>Units</b>	<b>Limits</b>	<b>Left Rear</b>	<b>Right Rear</b>
Head Injury Criteria (HIC) 36	N/A	1000		1873.0
Head Injury Criteria (HIC) 15	N/A	700		1393.1
3 msec. Chest Clip	G's	60		80.7
Peak Chest Displacement	mm	40		-47.0
<b>17. Key Words</b> 56.3 km/h NCAP Frontal Barrier Impact Test New Car Assessment Program (NCAP) Final Report of a Graco Hi-Back Turbo Booster NHTSA NO. M55110			<b>18. Distribution of Statement</b> Copies of this report available from: NHTSA Technical Reference Division National Highway Traffic Safety Admin. 400 Seventh St., SW, Room 5108 Washington, D.C. 20590	
<b>19. Security Classification (this report)</b> Unclassified	<b>20. Security Classification (this page)</b> Unclassified		<b>21. No. of Pages</b> 44	<b>22. Price</b>

Form DOT F1700.7 (8-72)

TR-P25001-03-NC

## TABLE OF CONTENTS

<u>Section</u>	<u>Description</u>	<u>Page</u>
F-1	Purpose and Summary of Test M55110	F1-1 to F1-9
F-2	Photographs	F2-1 to F2-19
F-3	Child Dummy Response and CRS Data Traces	F3-1 to F3-9
F-4	Child Dummy Instrumentation Information	F4-1 to F4-1
F-5	Child Dummy Calibration Information	F5-1 to F5-13

<u>Data Sheet</u>	<u>Description</u>	<u>Page</u>
1	Crash Test Summary	F1-2
2	CRS Parameter Data	F1-3
3	Child Dummy Positioning in Vehicle	F1-4
4	6 Year Old Hybrid III ATD Injury Criteria and Sensor Data	F1-6
5	CRS Performance Data	F1-8
6	CRS Camera Data	F1-9

## SECTION F-1

### PURPOSE AND SUMMARY OF TEST M55110

The purpose of this test is to obtain CRS performance data during an NCAP (35mph) frontal impact test.

The 35 mph (56.3 km/h) NCAP frontal impact test was conducted in accordance with the Office of Crashworthiness Standards (OCS) NCAP Laboratory Test Procedure.

### SUMMARY

One Part 572I, 6-year old child Hybrid III dummy was instrumented with head, chest, and pelvic triaxial accelerometers, a chest displacement potentiometer and six-axis upper neck load cells. In addition a triaxial accelerometer was installed on the CRS and a seatbelt load cell was placed on lap and shoulder belts to measure dummy torso and pelvic section loading. Also, shoulder belt spool-off and belt elongation was measured for the six year old dummy.

The right rear (Position 3) child dummy (Serial No. 027) was calibrated prior to this test. Child dummy certification information is found in Section F-5.

### CHILD DUMMY VALUES

Location	HIC 36 Values	HIC 15 Values	3 Msec. Chest Clip (g)	Peak Chest Disp. (mm)
Right Rear Child	1873.0	1393.1	80.7	-47.0
Left Rear Child				

**DATA SHEET NO.1 CRASH TEST SUMMARY**

Test Vehicle: 2005 Toyota Scion TC 3-Door Hatchback

NHTSA No.: M55110

Test Program 2005 NHTSA 35mph NCAP

Test Date: 9/30/04

**CHILD RESTRAINT SYSTEM INFORMATION**

Description	Position #3 CRS	Position #4 CRS
Manufacturer	Graco	
Model Name	Turbo Booster	
Serial No.	JJ 0519040969533	
Type	Hi-Back Booster	
Forward/Rearward	Forward	

**VISIBLE DUMMY CONTACT POINTS**

Description	Position #3 CRS	Position #4 CRS
Head Contact	Right Rear Panel	
Chest Contact	None	
Abdomen Contact	None	
Left Knee Contact	None	
Right Knee Contact	None	
Left Toe Contact	Front Seatback	
Right Toe Contact	Front Seatback	

**POST TEST DOOR OPENINGS**

Description	Position #3 CRS	Position #4 CRS
Left Side Doors	Remained closed/latched, opened w/o tools	
Right Side Doors	Remained closed/latched, opened w/o tools	
Hatch/Other Door	None	

**POST TEST SEAT DATA**

Location	Seat Movement (mm)	Seat Back Failure
Left Front	None	None
Right Front	None	None
Left Rear		
Right Rear	None	None

**CAMERA COVERAGE**

High Speed	2
Real Time	0
Total	2

**DATA CHANNELS**

Child Sensors	26
---------------	----

**DATA SHEET NO.2 CRS PARAMETER DATA**

Test Vehicle: 2005 Toyota Scion TC 3-Door Hatchback

NHTSA No.: M55110

Test Program 2005 NHTSA 35mph NCAP

Test Date: 9/30/04

**RETAINING CLIP INFORMATION**

Description	Position #3 CRS	Position #4 CRS
Ret. Clip Movement	N/A	

**CHILD HARNESS STRETCH**

Description	Position #3 CRS	Position #4 CRS
Harness Stretch	N/A	

**TEST VEHICLE WEIGHTS**

	Units	As Delivered Weights (UVW)			As Tested Weights (ATW)		
		Front Axle	Rear Axle	Total	Front Axle	Rear Axle	Total
Left	kg	402	261		433	327	
Right	kg	393	261		430	325	
Ratio	%	60.3	39.6		56.9	43.1	
Totals	kg	795	522	1317	863	652	1515

**TARGET TEST WEIGHT CALCULATION**

Measured Parameter	Units	Value
Total Delivered Weight (UVW)	kg	1317
Weight of 2 P572 ATD's	kg	152
Rated Cargo/Luggage Wt. (RCLW)	kg	52
Calculated Vehicle Target Wt. (TVTW)	kg	1521

### DATA SHEET NO.3 CHILD DUMMY POSITIONING IN VEHICLE

Test Vehicle: 2005 Toyota Scion TC 3-Door Hatchback

NHTSA No.: M55110

Test Program 2005 NHTSA 35mph NCAP

Test Date: 9/30/04

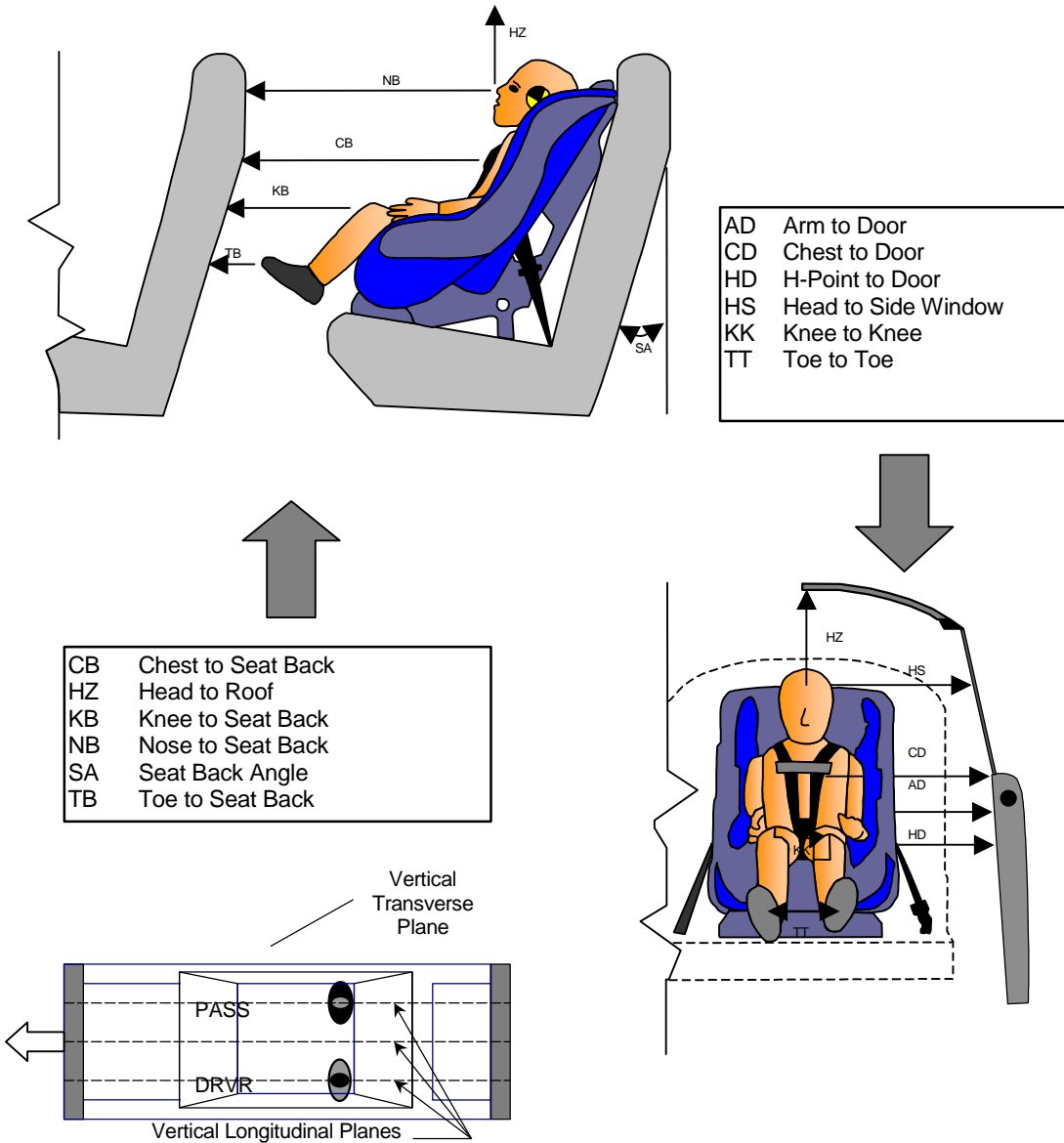

### DUMMY MEASUREMENTS FOR REAR SEAT OCCUPANTS

**DATA SHEET NO.3 CHILD DUMMY POSITIONING IN VEHICLE...(CONTINUED)**

Test Vehicle: 2005 Toyota Scion TC 3-Door Hatchback

NHTSA No.: M55110

Test Program 2005 NHTSA 35mph NCAP

Test Date: 9/30/04

**CHILD DUMMY POSITION MEASUREMENTS**

Code	Measurement	Units	P3 CRS Serial No. 027		
			Pre-Test	Post-Test	Diff.
SA	Seat Back Angle	deg.	65.1	66.0	0.9
HZ	Head to Roof (Z)	mm	240	275	35
CD	Chest to Dash	mm	315	350	35
KK	Knee to Knee (Y)	mm	150	135	-15
HS	Head to Side Window	mm	395	330	-65
HD	H-Point to Door (Y)	mm	180	300	120
AD	Arm to Door	mm	210	35	-175
NB	Nose to Seat Back	mm	530	465	-65
CB	Chest to Seat Back	mm	540	525	-15
FF	Foot to Foot	mm	170	155	-15
KB-Left	Knee to Seat Back	mm	370	395	25
KB-Right	Knee to Seat Back	mm	360	400	40
TB-Left	Toe to Seat Back	mm	160	125	-35
TB-Right	Toe to Seat Back	mm	130	190	60

**DATA SHEET NO. 4 - 3 YEAR OLD HYBRID III ATD INJURY CRITERIA AND SENSOR DATA**

Test Vehicle: 2005 Toyota Scion TC 3-Door Hatchback

NHTSA No.: M55110

Test Program: 2005 NHTSA 35mph NCAP

Test Date: 9/30/04

**HEAD PEAK ACCELERATIONS**

Location	Axis	Units	Right Rear (6 Yr.)			
			Max	Time	Min	Time
Head CG	X	G's	12.8	182.4	-84.7	106.6
Head CG	Y	G's	30.1	106.4	-12.0	169.7
Head CG	Z	G's	104.0	76.0	-2.7	36.6
Head CG Resultant	N/A	G's	128.5	106.5		

**HEAD INJURY CRITERIA (HIC)**

Location	Right Rear (6 Yr.)			
	HIC	T <sup>1</sup>	T <sup>2</sup>	Avg G
Head CG Primary (HIC36)	1873.0	61.5	92.0	82.2
Head CG Primary (HIC15)	1393.1	69.1	84.1	97.0

**CHEST PEAK ACCELERATIONS**

Location	Axis	Units	Right Rear (6 Yr.)			
			Max	Time	Min	Time
Chest CG	X	G's	4.2	182.5	-80.9	62.8
Chest CG	Y	G's	14.2	57.5	-10.5	75.5
Chest CG	Z	G's	11.5	86.0	-10.5	59.0
Chest CG Resultant	N/A	G's	82.0	63.9		

**CHEST CLIP (3MSEC)**

Location	Right Rear (6 Yr.)		
	CLIP	T <sup>1</sup>	T <sup>2</sup>
Chest CG Primary	80.7	62.0	65.0

**CHEST PEAK DISPLACEMENTS**

Location	Axis	Units	Right Rear (6 Yr.)			
			Max	Time	Min	Time
Chest	X	MM	0.0	0.9	-47.0	76.0

**PELVIC PEAK ACCELERATIONS**

Location	Axis	Units	Right Rear (6 Yr.)			
			Max	Time	Min	Time
Pelvis	X	G's	21.8	108.7	-82.4	60.2
Pelvis	Y	G's	13.6	55.2	-21.6	106.9
Pelvis	Z	G's	7.6	107.6	-35.8	65.3
Pelvis Resultant	N/A	G's	88.9	60.2		

**DATA SHEET NO. 4...(CONTINUED)**

Test Vehicle: 2005 Toyota Scion TC 3-Door Hatchback

NHTSA No.: M55110

Test Program: 2005 NHTSA 35mph NCAP

Test Date: 9/30/04

**UPPER NECK PEAK FORCES AND MOMENTS**

Location	Axis	Units	Right Rear (6 Yr.)			
			Max	Time	Min	Time
Neck Force	X	Newtons	113.8	56.8	-1058.4	66.5
Neck Force	Y	Newtons	266.6	96.4	-151.5	117.2
Neck Force	Z	Newtons	3363.1	76.3	-176.7	107.0
Neck Force Resultant	N/A	Newtons	3482.4	76.3		
Neck Moment	X	Nm	27.4	79.1	-14.6	133.2
Neck Moment	Y	Nm	24.7	110.3	-59.8	66.8
Neck Moment	Z	Nm	9.2	76.0	-5.9	95.3
Neck Moment Resultant	N/A	Nm	60.1	66.8		

**CHILD SEAT BELT SENSOR PEAK VALUES**

Location	Axis	Units	Right Rear (6 Yr.)			
			Max	Time	Min	Time
Lap Belt Force	N/A	Newtons	4763.2	62.9	-22.2	136.2
Shoulder Belt Force	N/A	Newtons	6248.5	67.8	-207.5	75.8
Shoulder Belt Pullout	N/A	MM	154.1	85.8	-0.4	11.0
Shoulder Belt Elongation	N/A	MM/CM	0.0	59.9	0.0	67.5

1.) Channel failed at 71.7 msec.

2.) Channel failed at 63.3 msec.

**CHILD SEAT ACCELEROMETER PEAK VALUES**

Location	Axis	Units	Right Rear (6 Yr.)			
			Max	Time	Min	Time
Child Seat	X	G's	19.9	115.4	-80.6	44.9
Child Seat	Y	G's	32.5	52.4	-31.7	118.1
Child Seat	Z	G's	11.9	69.6	-9.2	118.3
Child Seat Resultant	N/A	G's	81.0	44.9		
Child Seat Seatback	X	G's	0.0	0.0	0.0	0.0
Child Seat Seatback	Y	G's	0.0	0.0	0.0	0.0
Child Seat Seatback	Z	G's	0.0	0.0	0.0	0.0
Child Seat Seatback Res.	N/A	G's	0.0	0.0		

1.) Not installed

**DATA SHEET NO.5 CRS PERFORMANCE DATA**

Test Vehicle: 2005 Toyota Scion TC 3-Door Hatchback

NHTSA No.: M55110

Test Program 2005 NHTSA 35mph NCAP

Test Date: 9/30/04

**CRS PERFORMANCE DATA**

Location	P3 CRS	
	Damage	Post-Test
Upper Tether Strap	No	None
Upper Tether Buckle	No	None
Upper Tether Hook	No	None
Veh. Upper Tether Anchor	No	None
Lower Anchor Strap	No	None
Lower Anchor Buckle	No	None
Lower Anchor Hooks	No	None
Veh. Lower CRS Anchors	No	None
5 Point Harness Connections	No	None
Cracks on CRS	No	None
Fabric Tears on CRS	No	None
Vehicle Seat Structure	No	None
Vehicle Seat Fabric Tears	No	None

### DATA SHEET NO.6 CRS CAMERA DATA

Test Vehicle: 2005 Toyota Scion TC 3-Door Hatchback

NHTSA No.: M55110

Test Program 2005 NHTSA 35mph NCAP

Test Date: 9/30/04

#### CAMERA LOCATIONS

No.	Camera View	Location(mm)			Angle (Deg.)	Film Plane to Head	Lens (mm)	Speed (fps)
		X	Y	Z				
1	Right Rear Dummy Onboard	-2888	-663	-1900	-25	3173	4	1000
2	Left Rear Dummy Onboard	-2888	-669	-1070	-25	2395	4	1000

X = Barrier Face Y = Monorail Centerline Z = Ground DNR = Did Not Run NTM = No Time Marks

**SECTION F-2**  
**PHOTOGRAPHS**

### LIST OF PHOTOGRAPHS CRS #3

Figure		Page
1	Close-up, Position 3 CRS Label	F-1
2	Pre-Test Frontal View of Position 3 CRS	F-2
3	Post-Test Frontal View of Position 3 CRS	F-3
4	Pre-Test Rear View of Position 3 CRS	F-4
5	Post-Test Rear View of Position 3 CRS	F-5
6	Pre-Test Left Side View of Position 3 CRS	F-6
7	Post-Test Left Side View of Position 3 CRS	F-7
8	Pre-Test Right Side View of Position 3 CRS	F-8
9	Post-Test Right Side View of Position 3 CRS	F-9
10	Pre-Test Position 3 Front View (Head Position)	F-10
11	Post-Test Position 3 Front View (Head Position)	F-11
12	Pre-Test Position 3 Front View (Seatbelt Position)	F-12
13	Post-Test Position 3 Front View (Seatbelt Position)	F-13
14	Pre-Test Position 3 Left Side View	F-14
15	Post-Test Position 3 Left Side View	F-15
16	Pre-Test Position 3 Right Side View Through Window	F-16
17	Post-Test Position 3 Right Side View Through Window	F-17
18	Post-Test Position 3 Dummy Legs Contact Points	F-18
19	Post-Test Position 3 Dummy Head Contact with Right Rear Panel	F-19

... asiento a Graco Children's Products Inc., 150  
Exton, PA 19341 EE.UU. o llame al 1-800-345-4109.  
Para información sobre retiradas, llame a la línea de informa-  
seguridad automotriz del gobierno de EE.UU. al 1-800-424-9393  
(202-366-0123 en el Distrito de Columbia).

MODEL 8498ASH      NAME: TurboBooster  
SERIAL JJ 0519040969533  
Manufactured in 051904  
GRACO CHILDREN'S PRODUCTS, INC.  
EXTON, PA 19341 1-888-224-6549  
Made in China

LAPZ0004B

F2-1

TR-P24001-03-NC

Figure F2-1: Close-up, Position 3 CRS Label



Figure F2-2: Pre-Test Frontal View of Position 3 CRS



Figure F2-3: Post-Test Frontal View of Position 3 CRS



Figure F2-4: Pre-Test Rear View of Position 3 CRS

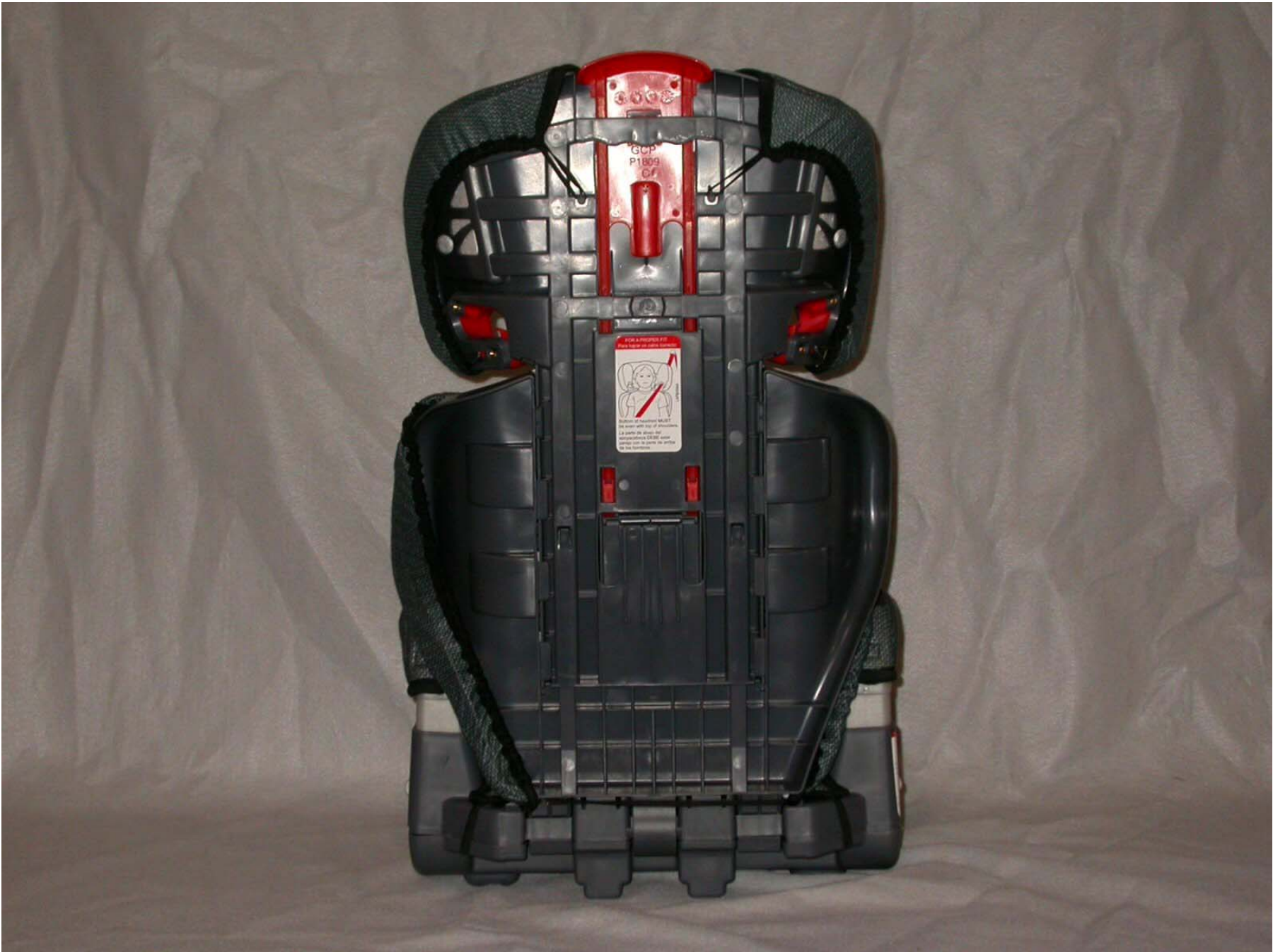

Figure F2-5: Post-Test Rear View of Position 3 CRS



Figure F2-6: Pre-Test Left Side View of Position 3 CRS



Figure F2-7: Post-Test Left Side View of Position 3 CRS



Figure F2-8: Pre-Test Right Side View of Position 3 CRS



Figure F2-9: Post-Test Right Side View of Position 3 CRS



Figure F2-10: Pre-Test Position 3 Front View (Head Position)

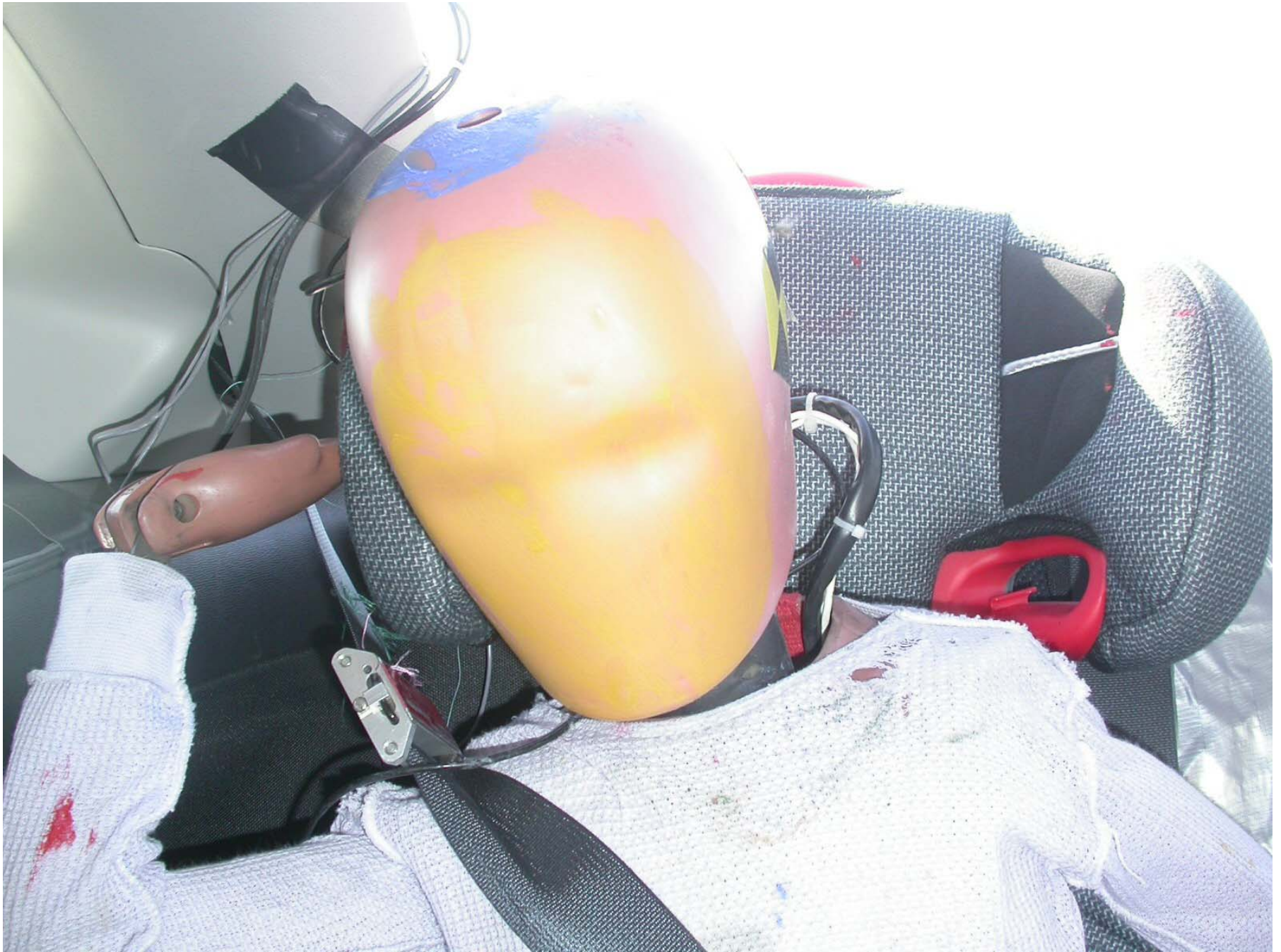

Figure F2-11: Post-Test Position 3 Front View (Head Position)



Figure F2-12: Pre-Test Position 3 Front View (Seatbelt Position)



Figure F2-13: Post-Test Position 3 Front View (Seatbelt Position)



Figure F2-14: Pre-Test Position 3 Left Side View



Figure F2-15: Post-Test Position 3 Left Side View



Figure F2-16: Pre-Test Position 3 Right Side View Through Window



Figure F2-16: Pre-Test Position 3 Right Side View Through Window



Figure F2-18: Post-Test Position 3 Dummy Legs Contact Points



Figure F2-19: Post-Test Position 3 Dummy Head Contact with Right Rear Panel

**SECTION F-3**

**CHILD DUMMY RESPONSE AND CRS DATA TRACES**

## LIST OF DATA PLOTS #4

<u>Data Plot</u>		<u>Page</u>
F3-1	Right Rear (6 Yr.) Head X	F3-1
	Right Rear (6 Yr.) Head Y	F3-1
	Right Rear (6 Yr.) Head Z	F3-1
	Right Rear (6 Yr.) Head Resultant	F3-1
F3-2	Right Rear (6 Yr.) Upper Neck Force X	F3-2
	Right Rear (6 Yr.) Upper Neck Force Y	F3-2
	Right Rear (6 Yr.) Upper Neck Force Z	F3-2
	Right Rear (6 Yr.) Upper Neck Force Resultant	F3-2
F3-3	Right Rear (6 Yr.) Upper Neck Moment X	F3-3
	Right Rear (6 Yr.) Upper Neck Moment Y	F3-3
	Right Rear (6 Yr.) Upper Neck Moment Z	F3-3
	Right Rear (6 Yr.) Upper Neck Moment Resultant	F3-3
F3-4	Right Rear (6 Yr.) Chest X	F3-4
	Right Rear (6 Yr.) Chest Y	F3-4
	Right Rear (6 Yr.) Chest Z	F3-4
	Right Rear (6 Yr.) Chest Resultant	F3-4
F3-5	Right Rear (6 Yr.) Chest Displacement	F3-5
F3-6	Right Rear (6 Yr.) Pelvis X	F3-6
	Right Rear (6 Yr.) Pelvis Y	F3-6
	Right Rear (6 Yr.) Pelvis Z	F3-6
	Right Rear (6 Yr.) Pelvis Resultant	F3-6
F3-7	Right Rear (6 Yr.) Lap Belt Force	F3-7
	Right Rear (6 Yr.) Shoulder Belt Force	F3-7
	Right Rear (6 Yr.) Shoulder Belt Pullout	F3-7
	Right Rear (6 Yr.) Shoulder Belt Elongation	F3-7
F3-8	Right Rear (6 Yr.) Car Seat X	F3-8
	Right Rear (6 Yr.) Car Seat Y	F3-8
	Right Rear (6 Yr.) Car Seat Z	F3-8
	Right Rear (6 Yr.) Car Seat Resultant	F3-8
F3-9	Right Rear (6 Yr.) Car Seatback X	F3-9
	Right Rear (6 Yr.) Car Seatback Y	F3-9
	Right Rear (6 Yr.) Car Seatback Z	F3-9
	Right Rear (6 Yr.) Car Seatback Resultant	F3-9

Test Vehicle: 2005 Toyota Scion TC 3-Door Hatchback  
 Test Program: 2005 NHTSA 35mph NCAP

Test Date: 9/30/04  
 NHTSA No.: M55110

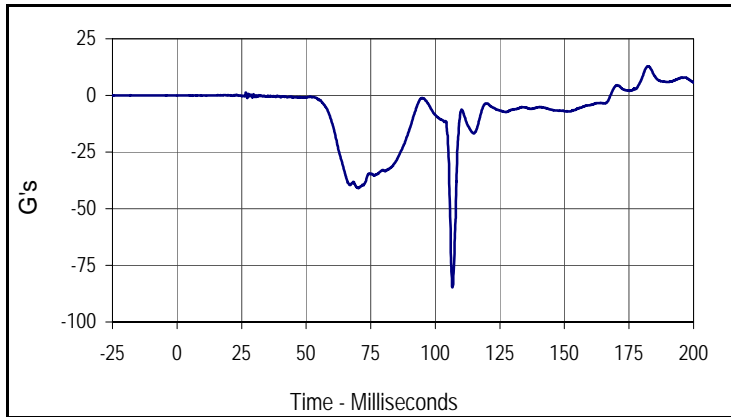

Curve Description			
Right Rear (6 Yr.) Head X			
CURNO	Type	SAE Class	Units
134	FIL	1000	G's
Max	Time	Min	Time
12.8	182.4	-84.7	106.6

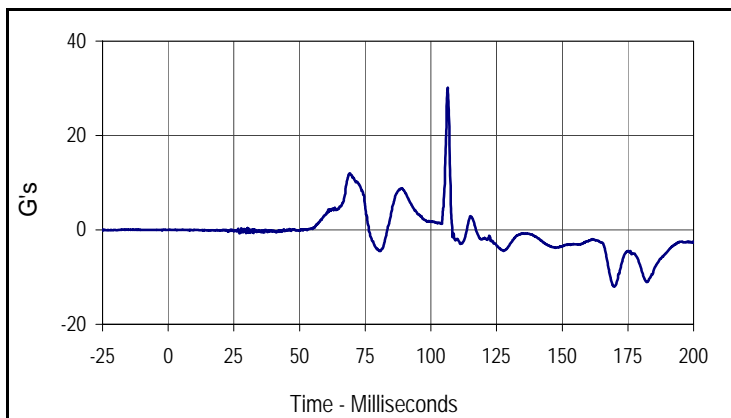

Curve Description			
Right Rear (6 Yr.) Head Y			
CURNO	Type	SAE Class	Units
135	FIL	1000	G's
Max	Time	Min	Time
30.1	106.4	-12.0	169.7

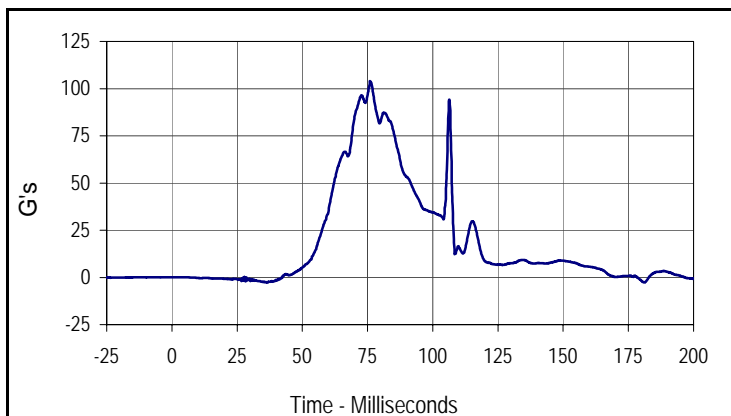

Curve Description			
Right Rear (6 Yr.) Head Z			
CURNO	Type	SAE Class	Units
136	FIL	1000	G's
Max	Time	Min	Time
104.0	76.0	-2.7	36.6

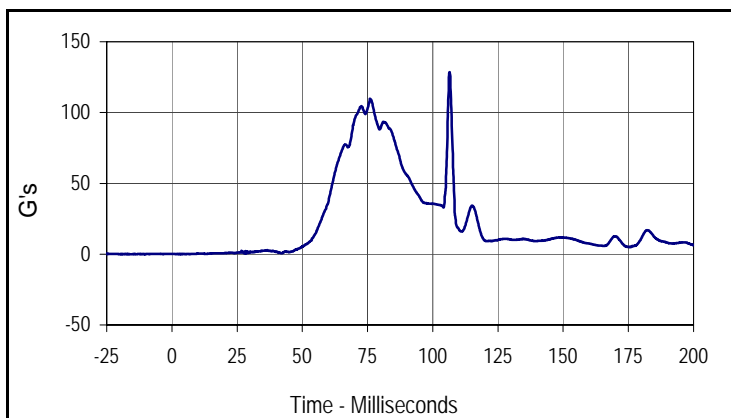

Curve Description			
Right Rear (6 Yr.) Head Resultant			
CURNO	Type	SAE Class	Units
134	RES	1000	G's
Max	Time	Min	Time
128.5	106.5	0.0	6.8

Test Vehicle: 2005 Toyota Scion TC 3-Door Hatchback  
 Test Program: 2005 NHTSA 35mph NCAP

Test Date: 9/30/04  
 NHTSA No.: M55110



Curve Description			
Right Rear (6 Yr.) Upper Neck Force X			
CURNO	Type	SAE Class	Units
137	FIL	1000	Newtons
Max	Time	Min	Time
113.8	56.8	-1058.4	66.5

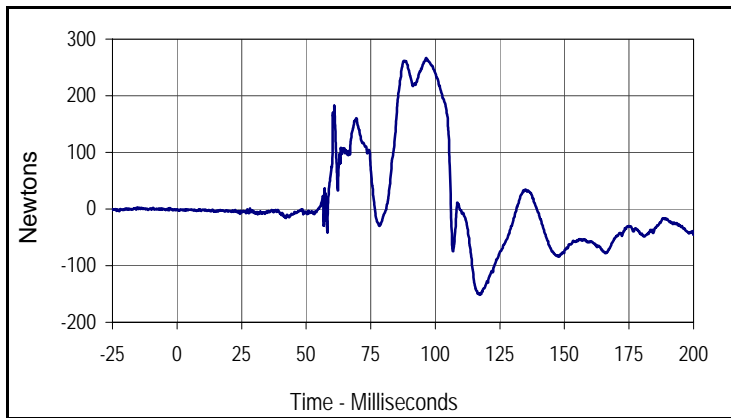

Curve Description			
Right Rear (6 Yr.) Upper Neck Force Y			
CURNO	Type	SAE Class	Units
138	FIL	1000	Newtons
Max	Time	Min	Time
266.6	96.4	-151.5	117.2

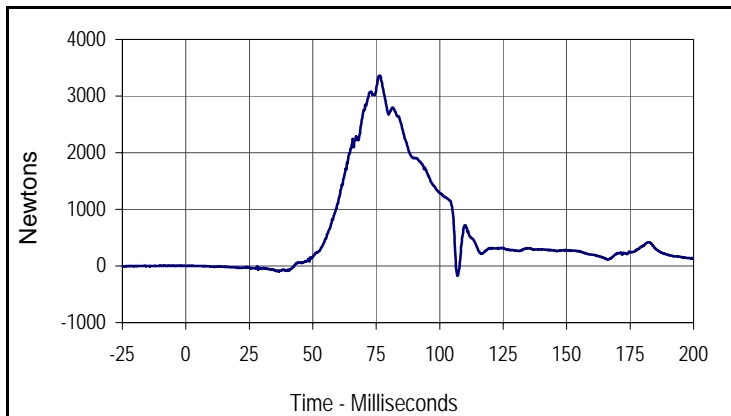

Curve Description			
Right Rear (6 Yr.) Upper Neck Force Z			
CURNO	Type	SAE Class	Units
139	FIL	1000	Newtons
Max	Time	Min	Time
3363.1	76.3	-176.7	107.0

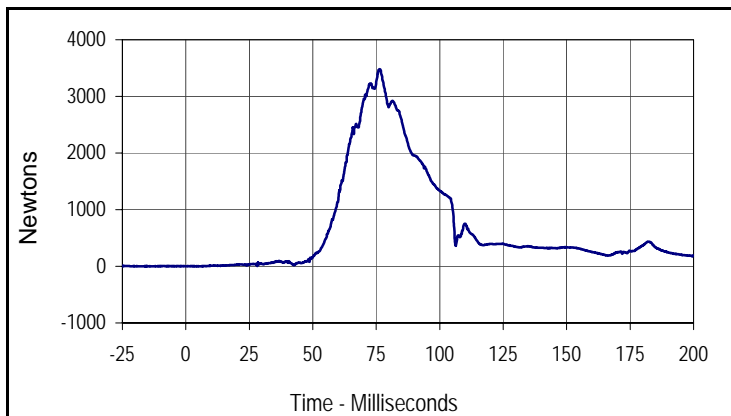

Curve Description			
Right Rear (6 Yr.) Upper Neck Force Res.			
CURNO	Type	SAE Class	Units
137	RES	1000	Newtons
Max	Time	Min	Time
3482.4	76.3	0.8	1.3

Test Vehicle: 2005 Toyota Scion TC 3-Door Hatchback  
 Test Program: 2005 NHTSA 35mph NCAP

Test Date: 9/30/04  
 NHTSA No.: M55110

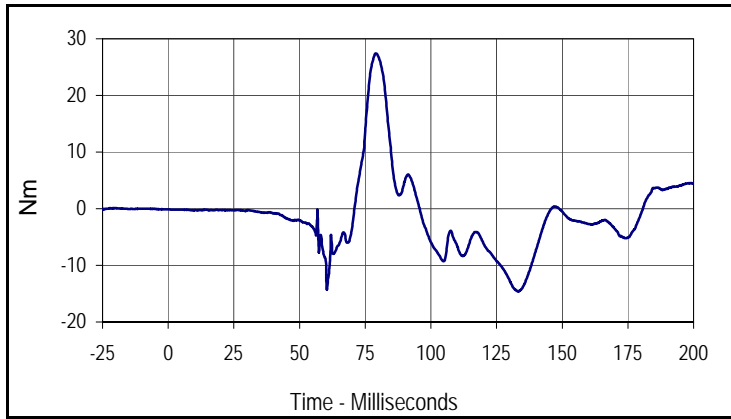

Curve Description			
Right Rear (6 Yr.) Upper Neck Moment X			
CURNO	Type	SAE Class	Units
140	FIL	600	Nm
Max	Time	Min	Time
27.4	79.1	-14.6	133.2

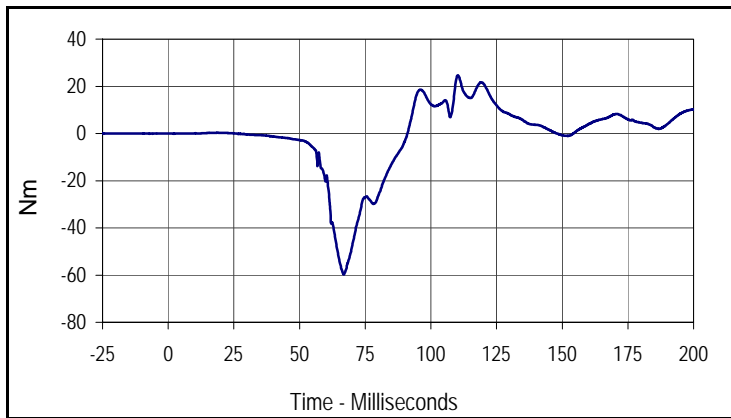

Curve Description			
Right Rear (6 Yr.) Upper Neck Moment Y			
CURNO	Type	SAE Class	Units
141	FIL	600	Nm
Max	Time	Min	Time
24.7	110.3	-59.8	66.8

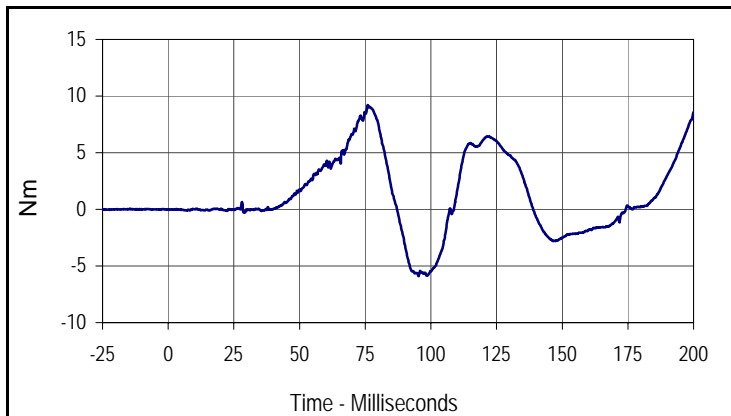

Curve Description			
Right Rear (6 Yr.) Upper Neck Moment Z			
CURNO	Type	SAE Class	Units
142	FIL	600	Nm
Max	Time	Min	Time
9.2	76.0	-5.9	95.3

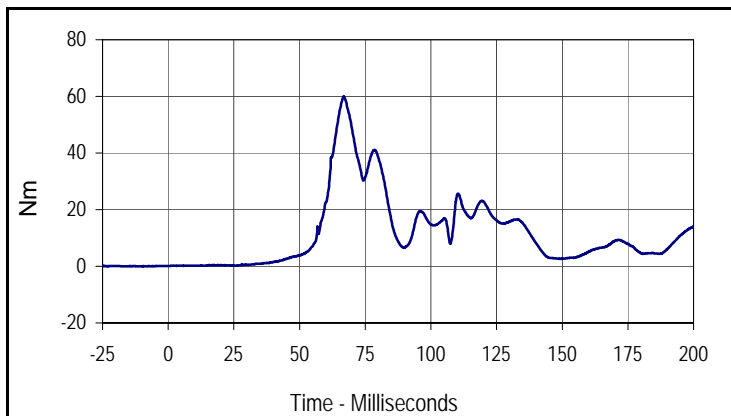

Curve Description			
Right Rear (6 Yr.) Upper Neck Moment Res.			
CURNO	Type	SAE Class	Units
140	RES	600	Nm
Max	Time	Min	Time
60.1	66.8	0.1	0.4

Test Vehicle: 2005 Toyota Scion TC 3-Door Hatchback  
 Test Program: 2005 NHTSA 35mph NCAP

Test Date: 9/30/04  
 NHTSA No.: M55110

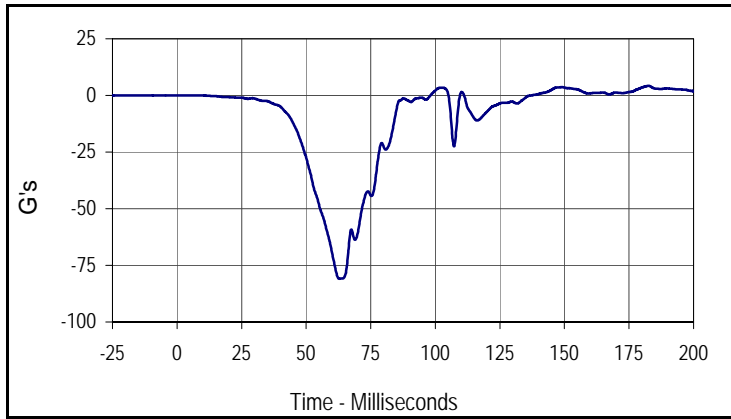

Curve Description			
Right Rear (6 Yr.) Chest X			
CURNO	Type	SAE Class	Units
143	FIL	180	G's
Max	Time	Min	Time
4.2	182.5	-80.9	62.8

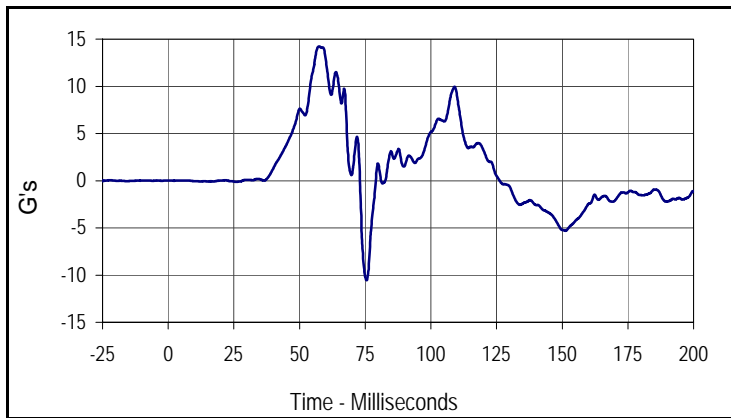

Curve Description			
Right Rear (6 Yr.) Chest Y			
CURNO	Type	SAE Class	Units
144	FIL	180	G's
Max	Time	Min	Time
14.2	57.5	-10.5	75.5

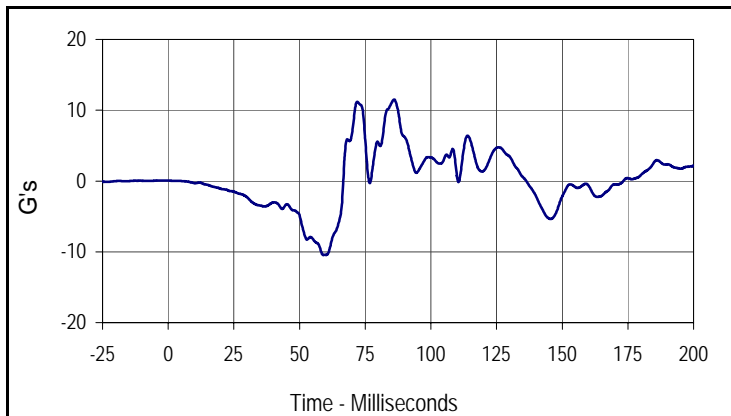

Curve Description			
Right Rear (6 Yr.) Chest Z			
CURNO	Type	SAE Class	Units
145	FIL	180	G's
Max	Time	Min	Time
11.5	86.0	-10.5	59.0

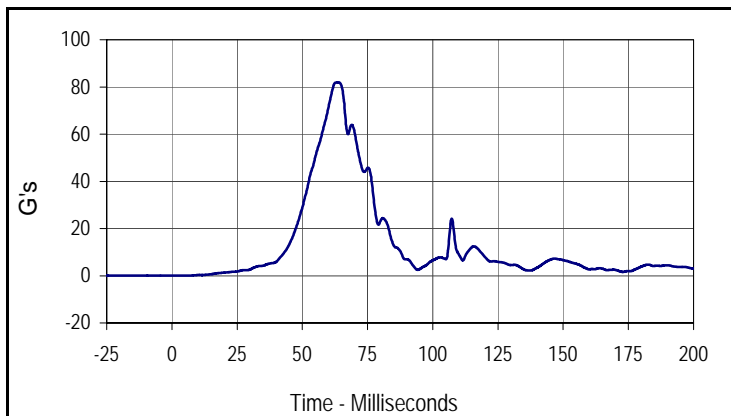

Curve Description			
Right Rear (6 Yr.) Chest Resultant Primary			
CURNO	Type	SAE Class	Units
143	RES	180	G's
Max	Time	Min	Time
82.0	63.9	0.0	4.7

Test Vehicle: 2005 Toyota Scion TC 3-Door Hatchback  
 Test Program: 2005 NHTSA 35mph NCAP

Test Date: 9/30/04  
 NHTSA No.: M55110

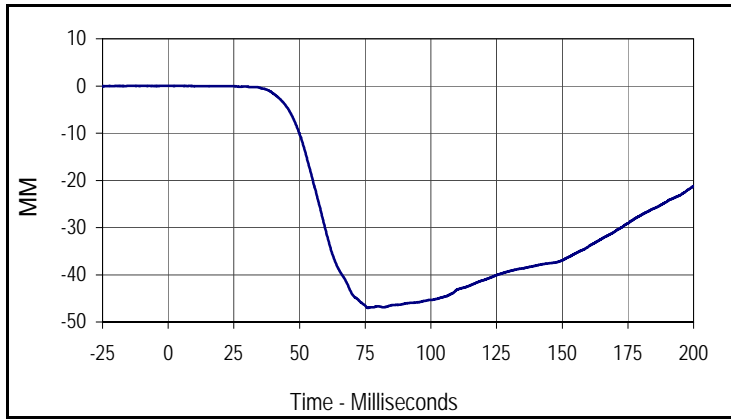

Curve Description			
Right Rear (6 Yr.) Chest Deflection			
CURNO	Type	SAE Class	Units
146	FIL	600	MM
Max	Time	Min	Time
0.0	0.9	-47.0	76.0

Test Vehicle: 2005 Toyota Scion TC 3-Door Hatchback  
 Test Program: 2005 NHTSA 35mph NCAP

Test Date: 9/30/04  
 NHTSA No.: M55110

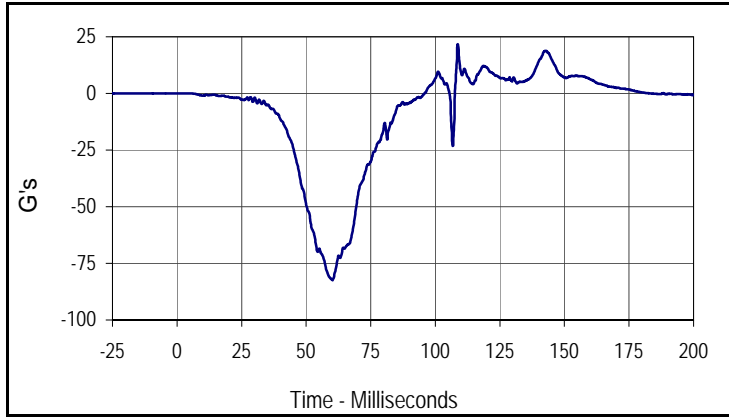

Curve Description			
Right Rear (6 Yr.) Pelvis X			
CURNO	Type	SAE Class	Units
147	FIL	1000	G's
Max	Time	Min	Time
21.8	108.7	-82.4	60.2

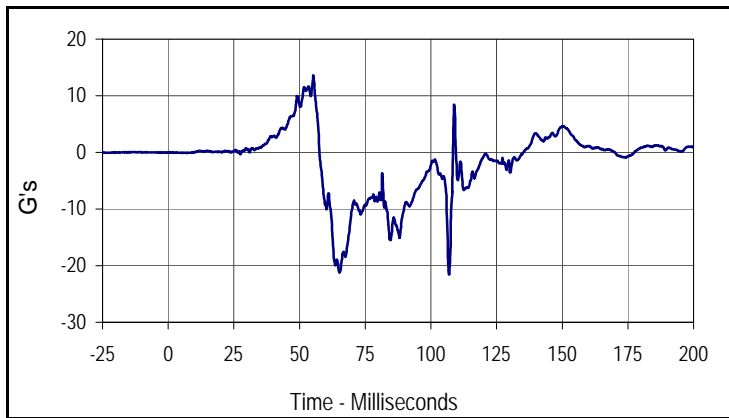

Curve Description			
Right Rear (6 Yr.) Pelvis Y			
CURNO	Type	SAE Class	Units
148	FIL	1000	G's
Max	Time	Min	Time
13.6	55.2	-21.6	106.9

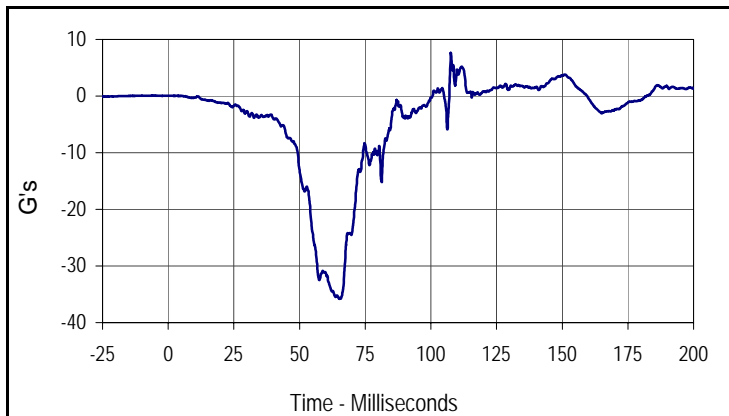

Curve Description			
Right Rear (6 Yr.) Pelvis Z			
CURNO	Type	SAE Class	Units
149	FIL	1000	G's
Max	Time	Min	Time
7.6	107.6	-35.8	65.3

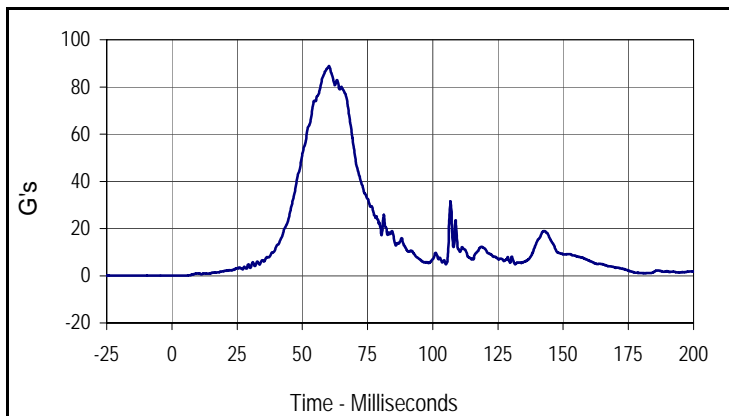

Curve Description			
Right Rear (6 Yr.) Pelvis Resultant			
CURNO	Type	SAE Class	Units
147	RES	1000	G's
Max	Time	Min	Time
88.9	60.2	0.0	1.3

Test Vehicle: 2005 Toyota Scion TC 3-Door Hatchback  
 Test Program: 2005 NHTSA 35mph NCAP

Test Date: 9/30/04  
 NHTSA No.: M55110

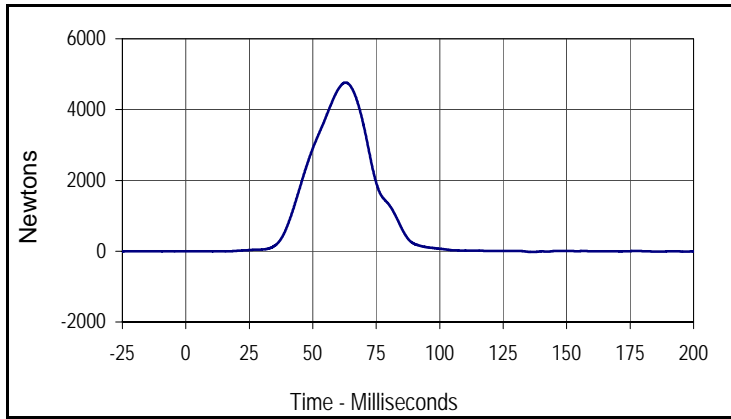

Curve Description			
Right Rear (6 Yr.) Lap Belt Force			
CURNO	Type	SAE Class	Units
150	FIL	60	Newtons
Max	Time	Min	Time
4763.2	62.9	-22.2	136.2

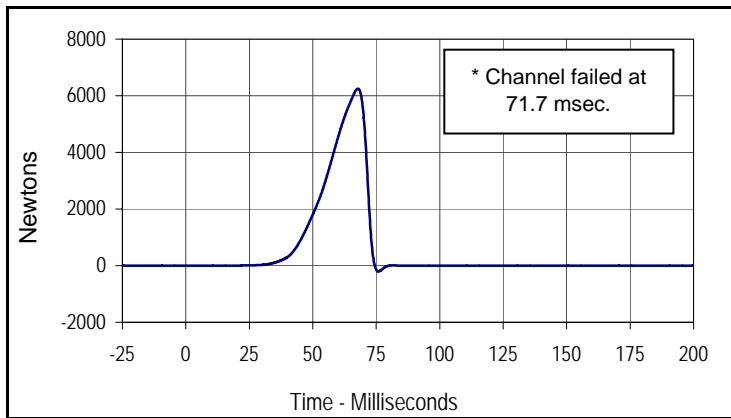

Curve Description			
Right Rear (6 Yr.) Shoulder Belt Force			
CURNO	Type	SAE Class	Units
151	FIL	60	Newtons
Max	Time	Min	Time
6248.5	67.8	-207.5	75.8

\* Channel failed at 71.7 msec.

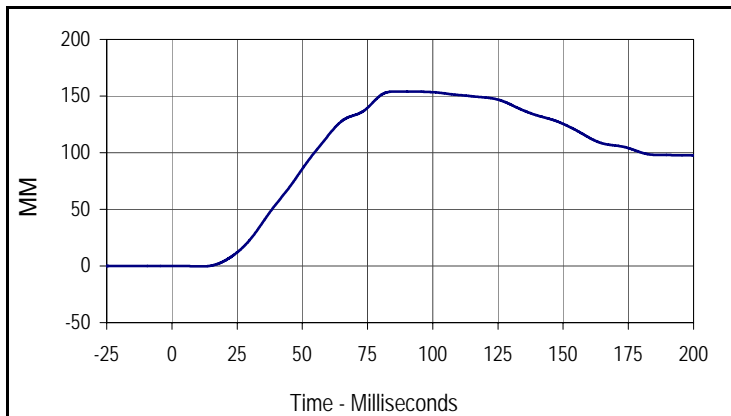

Curve Description			
Right Rear (6 Yr.) Shoulder Belt Pullout			
CURNO	Type	SAE Class	Units
152	FIL	60	MM
Max	Time	Min	Time
154.1	85.8	-0.4	11.0

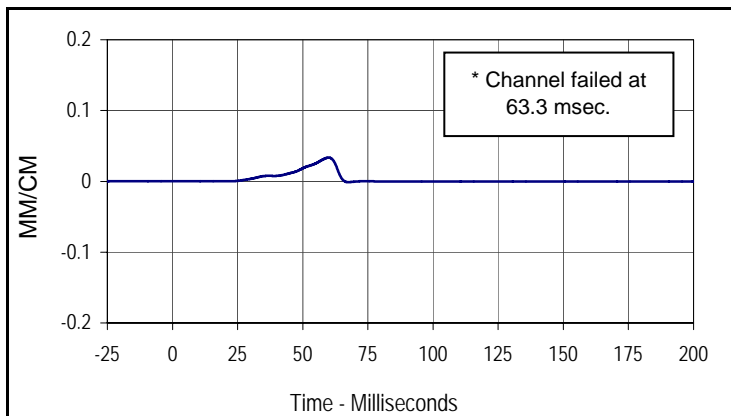

Curve Description			
Right Rear (6 Yr.) Shoulder Belt Elongation			
CURNO	Type	SAE Class	Units
153	FIL	60	MM/CM
Max	Time	Min	Time
0.03	59.9	0.00	67.5

\* Channel failed at 63.3 msec.

Test Vehicle: 2005 Toyota Scion TC 3-Door Hatchback  
 Test Program: 2005 NHTSA 35mph NCAP

Test Date: 9/30/04  
 NHTSA No.: M55110

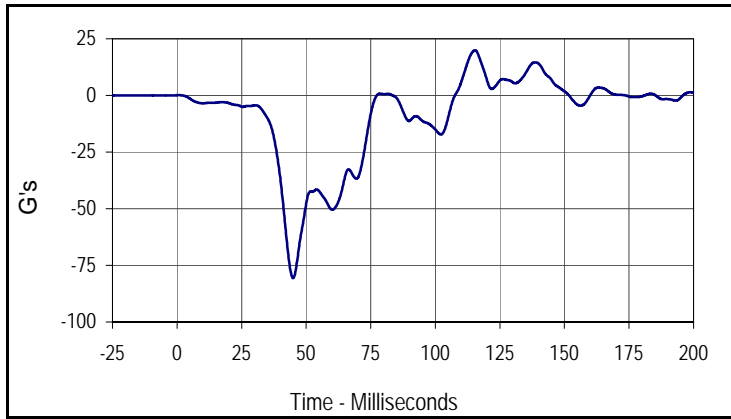

Curve Description			
Right Rear (6 Yr.) Car Seat X			
CURNO	Type	SAE Class	Units
154	FIL	60	G's
Max	Time	Min	Time
19.9	115.4	-80.6	44.9

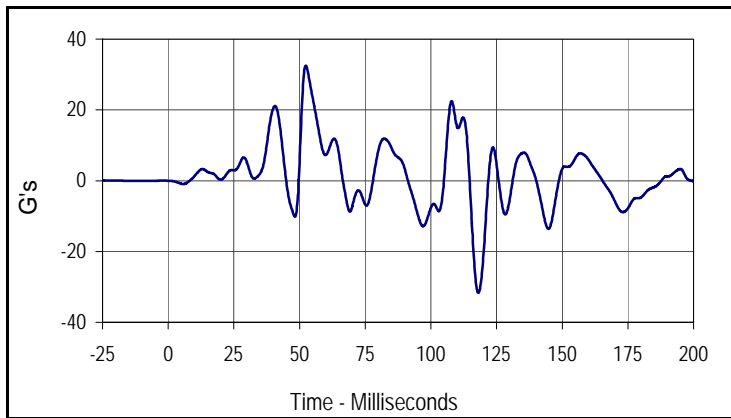

Curve Description			
Right Rear (6 Yr.) Car Seat Y			
CURNO	Type	SAE Class	Units
155	FIL	60	G's
Max	Time	Min	Time
32.5	52.4	-31.7	118.1

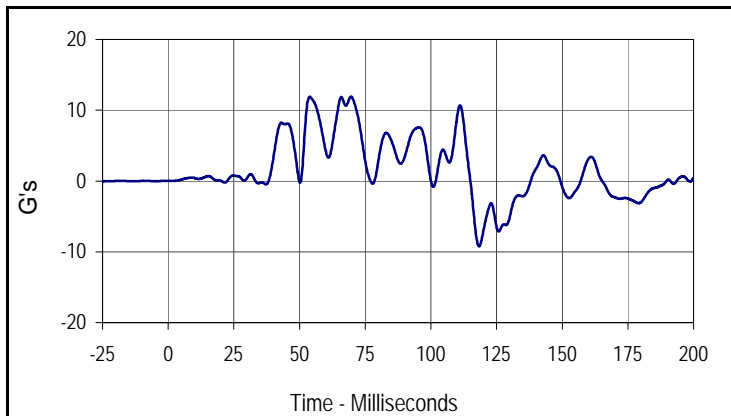

Curve Description			
Right Rear (6 Yr.) Car Seat Z			
CURNO	Type	SAE Class	Units
156	FIL	60	G's
Max	Time	Min	Time
11.9	69.6	-9.2	118.3

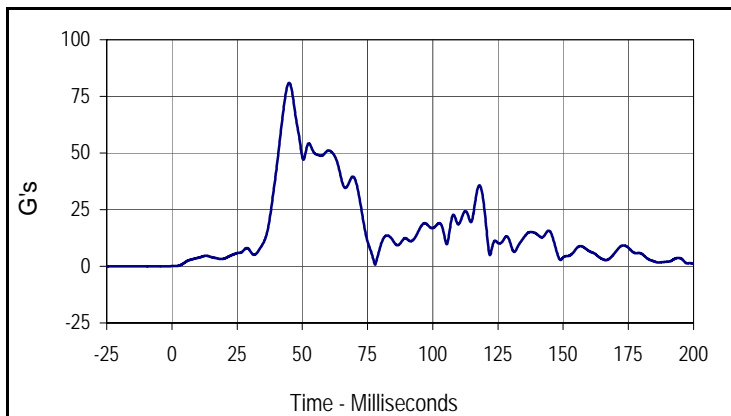

Curve Description			
Right Rear (6 Yr.) Car Seat Resultant			
CURNO	Type	SAE Class	Units
154	RES	60	G's
Max	Time	Min	Time
81.0	44.9	0.1	0.0

Test Vehicle: 2005 Toyota Scion TC 3-Door Hatchback  
 Test Program: 2005 NHTSA 35mph NCAP

Test Date: 9/30/04  
 NHTSA No.: M55110

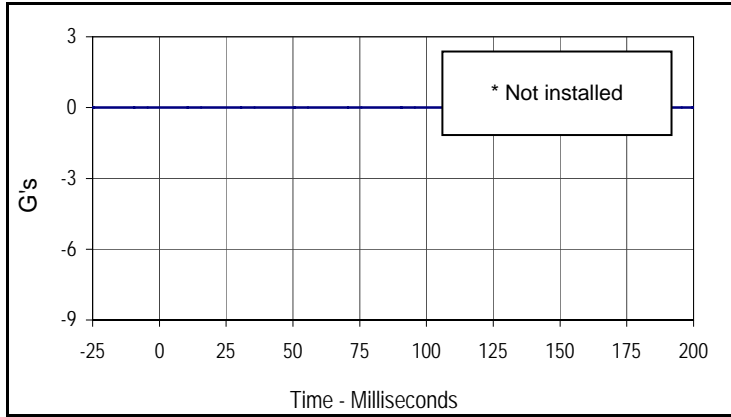

Curve Description			
Right Rear (6 Yr.) Car Seat Seatback X			
CURNO	Type	SAE Class	Units
157	FIL	60	G's
Max	Time	Min	Time
0.0	0.0	0.0	0.0

\* Not installed

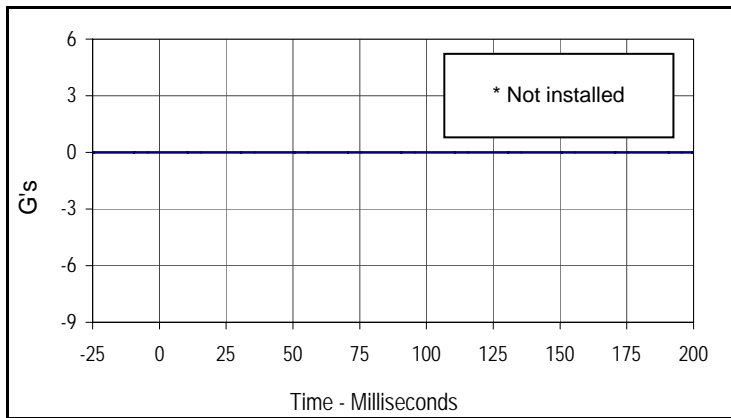

Curve Description			
Right Rear (6 Yr.) Car Seat Seatback Y			
CURNO	Type	SAE Class	Units
158	FIL	60	G's
Max	Time	Min	Time
0.0	0.0	0.0	0.0

\* Not installed

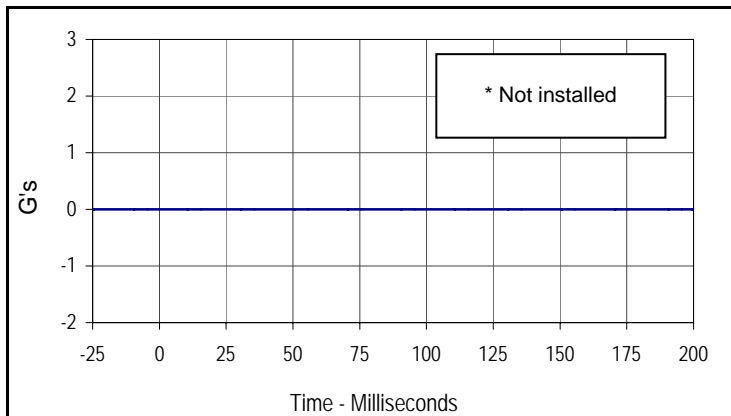

Curve Description			
Right Rear (6 Yr.) Car Seat Seatback Z			
CURNO	Type	SAE Class	Units
159	FIL	60	G's
Max	Time	Min	Time
0.0	0.0	0.0	0.0

\* Not installed

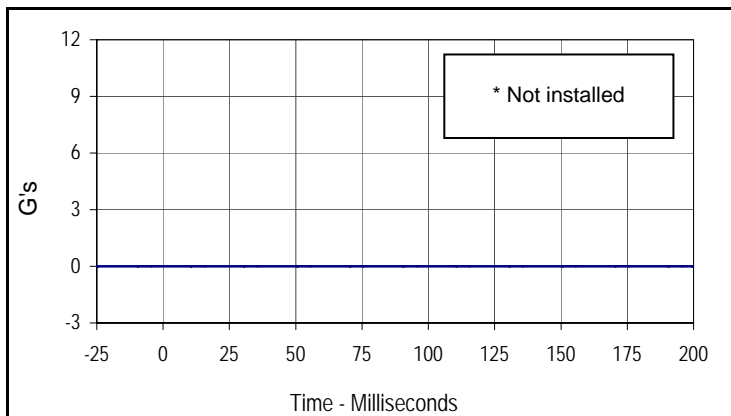

Curve Description			
Right Rear (6 Yr.) Car Seat Seatback Resultant			
CURNO	Type	SAE Class	Units
157	RES	60	G's
Max	Time	Min	Time
0.0	0.0	0.0	0.0

\* Not installed

**SECTION F-4**

**CHILD DUMMY INSTRUMENTATION INFORMATION**

**2005 NHTSA 35mph NCAP  
Instrumentation Data Channel Assignments  
Right Rear Child A.T.D. Serial Number 027 (6 Yr.)  
9/30/04  
2005 Toyota Scion TC 3-Door Hatchback**

CH.	LOCATION	AXIS	IDENT. NO.	DESCRIPTION	MFR	MODEL	UNITS
134	HEAD CG	X	GPAC047	Accel.,1/2 bridge	Endevco	7264-2000	G
135	HEAD CG	Y	GPAC048	Accel.,1/2 bridge	Endevco	7264-2000	G
136	HEAD CG	Z	GPAC049	Accel.,1/2 bridge	Endevco	7264-2000	G
137	UPPER NECK FORCE	X	139UNFX	Load cell, six axis neck	R. A. Denton	IF-234	N
138	UPPER NECK FORCE	Y	139UNFY	Load cell, six axis neck	R. A. Denton	IF-234	N
139	UPPER NECK FORCE	Z	139UNFZ	Load cell, six axis neck	R. A. Denton	IF-234	N
140	UPPER NECK MOMENT	X	139UNMX	Load cell, six axis neck	R. A. Denton	IF-234	Nm
141	UPPER NECK MOMENT	Y	139UNMY	Load cell, six axis neck	R. A. Denton	IF-234	Nm
142	UPPER NECK MOMENT	Z	139UNMZ	Load cell, six axis neck	R. A. Denton	IF-234	Nm
143	CHEST CG	X	2116-A01	Accel., Full Bridge	Entran	2000JF	G
144	CHEST CG	Y	2116-A06	Accel., Full Bridge	Entran	2000JF	G
145	CHEST CG	Z	2116-A07	Accel., Full Bridge	Entran	2000JF	G
146	CHEST DISPLACEMENT	X	139CP	Rotary Pot Chest	Servo	14CBI	MM
147	PELVIS	X	2116-N07	Accel., Full Bridge	Entran	2000JF	G
148	PELVIS	Y	2116-A03	Accel., Full Bridge	Entran	2000JF	G
149	PELVIS	Z	2116-A17	Accel., Full Bridge	Entran	2000JF	G
150	LAP BELT FORCE	X	BL168	Load cell, Seat belt	First Tech	IF-964	N
151	SHOULDER BELT FORCE	X	BL169	Load cell, Seat belt	First Tech	IF-964	N
152	SHOULDER BELT SPOOL	X	KEPP001	Pullout pot	Celesco	PTX101-0030	MM
153	SHOULDER BELT ELONG.	X	KEEP001	Linear pot., belt stretch	E.T.I.	LCP8-10 10K	MM/CM
154	CAR SEAT	X	KETX4A	Accel.,1/2 bridge	Endevco	7264-200	G
155	CAR SEAT	Y	KETX4B	Accel.,1/2 bridge	Endevco	7264-200	G
156	CAR SEAT	Z	KETX4C	Accel.,1/2 bridge	Endevco	7264-200	G
157	CAR SEAT SEATBACK	X	KETX4A	Accel.,1/2 bridge	Endevco	7264-200	G
158	CAR SEAT SEATBACK	Y	KETX4B	Accel.,1/2 bridge	Endevco	7264-200	G
159	CAR SEAT SEATBACK	Z	KETX4C	Accel.,1/2 bridge	Endevco	7264-200	G

E4-1

TR-P25001-03-NC

**SECTION F-5**

**CHILD DUMMY CALIBRATION INFORMATION**

Test Program: Hybrid III 6 Yr Head Drop Test  
 ATD Serial No.: 027

Test Date: 9/15/04  
 Test I.D.: HD11A



Tested Parameter	Units	Specification	Result	Pass/Fail
Laboratory Temperature	°C	18.9 to 25.6	21.1	Pass
Laboratory Relative Humidity	%	10 to 70	30	Pass
Peak Resultant Acceleration	G's	245.0 to 300.0	270.7	Pass
Peak Lateral Acceleration	G's	≤15.0	5.8	Pass
Is Acceleration Unimodal?	Yes/No	Yes	Yes	Pass
Overall Test Results			Pass	Pass

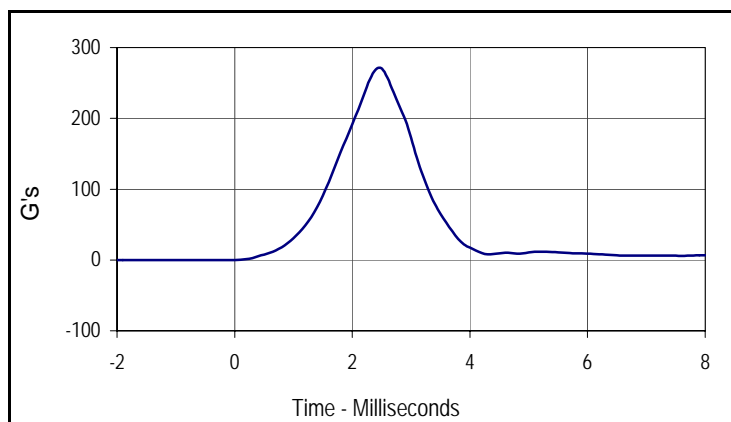

Curve Description			
Head Resultant			
CURNO	Type	SAE Class	Units
001	RES	1000	G's
Max	Time	Min	Time
270.7	2.5	0.0	-1.2

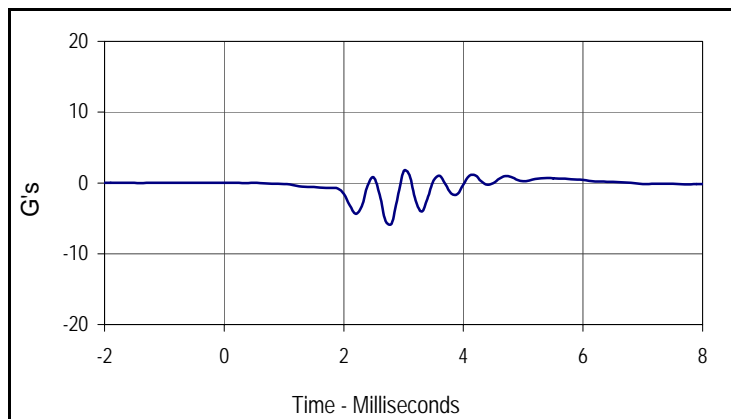

Curve Description			
Head Y			
CURNO	Type	SAE Class	Units
002	FIL	1000	G's
Max	Time	Min	Time
1.7	3.0	-5.8	2.8

Test Program: Hybrid III 6 Yr Thorax Impact  
 ATD Serial No.: 027

Test Date: 9/15/04  
 Test I.D.: CI11A



Tested Parameter	Units	Specification	Result	Pass/Fail
Laboratory Temperature	°C	20.6 to 22.2	21.1	Pass
Laboratory Relative Humidity	%	10 to 70	30	Pass
Probe Velocity	m/s	6.59 to 6.83	6.64	Pass
Peak Chest Compression	MM	38 to 46	39.7	Pass
Peak Force Between 38 and 46 MM	Newtons	1150 to 1380	1232.0	Pass
Peak Force Between 12.5 and 38 MM	Newtons	≤1500	1182.7	Pass
Internal Hysteresis	%	65 to 85	78.8	Pass
Overall Test Results			Pass	Pass

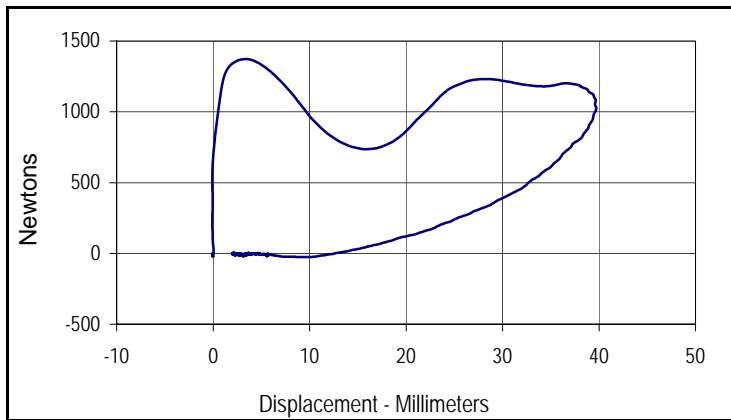

Curve Description			
Probe Force vs. Chest Displacement			
CURNO	Type	SAE Class	Hysteresis
003	FIL	180/600	78.8
Peak Probe Force		Peak Chest Displ.	
1371.6		39.7	

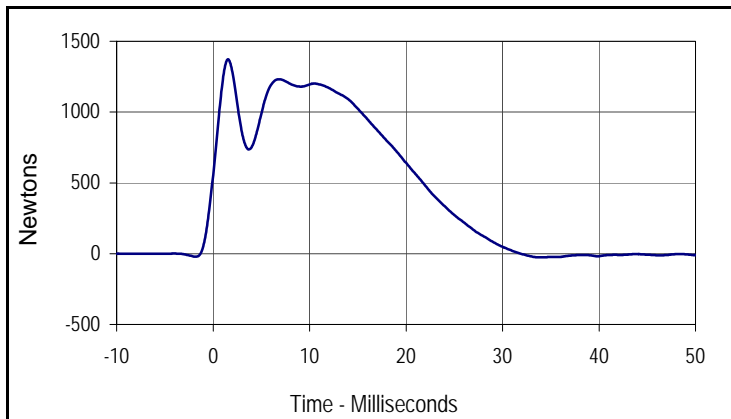

Curve Description			
Probe Force			
CURNO	Type	SAE Class	Units
002	FIL	180	Newtons
Max	Time	Min	Time
1371.6	1.5	-26.4	33.8

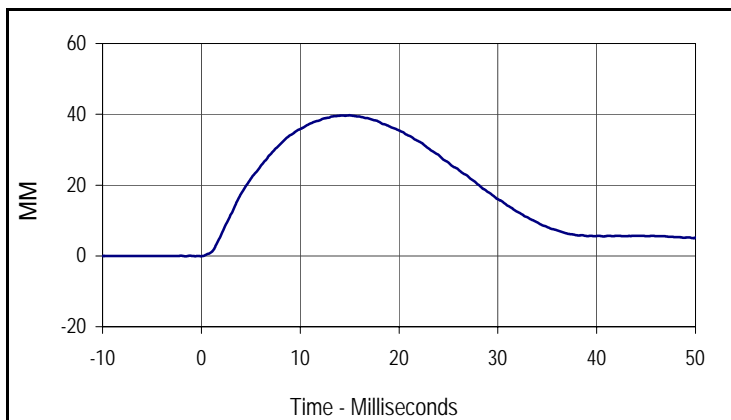

Curve Description			
Chest Compression			
CURNO	Type	SAE Class	Units
001	FIL	600	MM
Max	Time	Min	Time
39.7	15.0	-0.1	0.0

Test Program: Hybrid III 6 Yr Neck Flexion Test  
 ATD Serial No.: 027

Test Date: 9/16/04  
 Test I.D.: NF11A



Tested Parameter	Units	Specification	Result	Pass/Fail	
Laboratory Temperature	°C	20.6 to 22.2	21.1	Pass	
Laboratory Relative Humidity	%	10 to 70	30	Pass	
Pendulum Velocity	m/s	4.83 to 5.07	4.85	Pass	
Pendulum Deceleration	10 Msec.	m/s	1.2 to 1.6	1.6	Pass
	20 Msec.	m/s	2.4 to 3.4	3.3	Pass
	30 Msec.	m/s	3.8 to 5.0	3.8	Pass
"D" Plane Rotation	Max	Degrees	74.0 to 92.0	82.1	Pass
Peak Moment in Rotation	Max	Nm	27.0 to 33.0	29.0	Pass
Positive Moment Decay, Time To 5 Nm	Msec.		103.0 to 123.0	104.3	Pass
Overall Test Results				Pass	

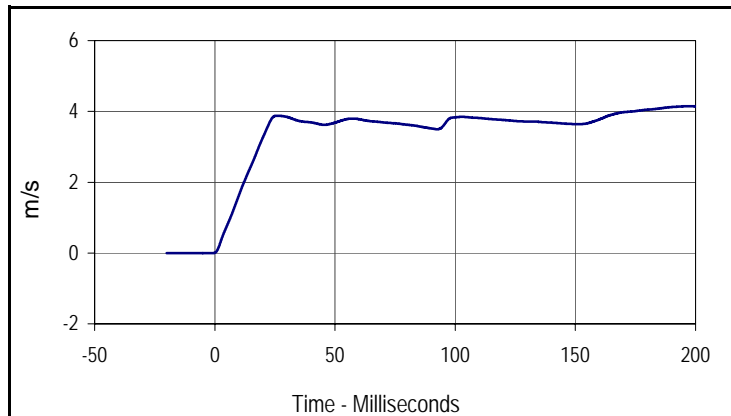

Curve Description			
Pendulum Velocity			
CURNO	Type	SAE Class	Units
001	FIL	180	m/s
Max	Time	Min	Time
4.3	220.0	0.0	-0.7

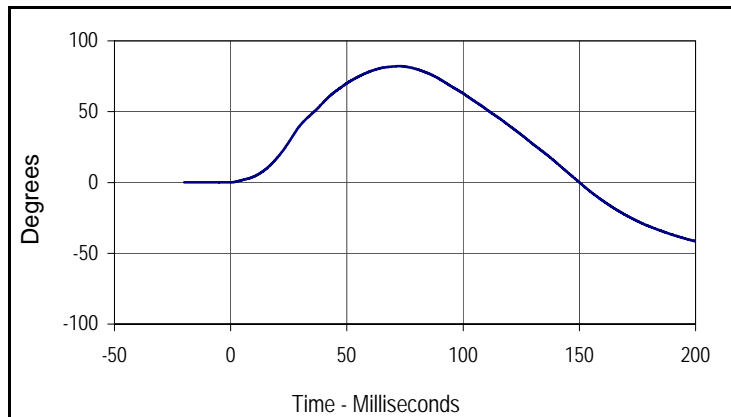

Curve Description			
"D" Plane Rotation			
CURNO	Type	SAE Class	Units
003	FIL	60	Degrees
Max	Time	Min	Time
82.1	72.5	-45.0	219.9

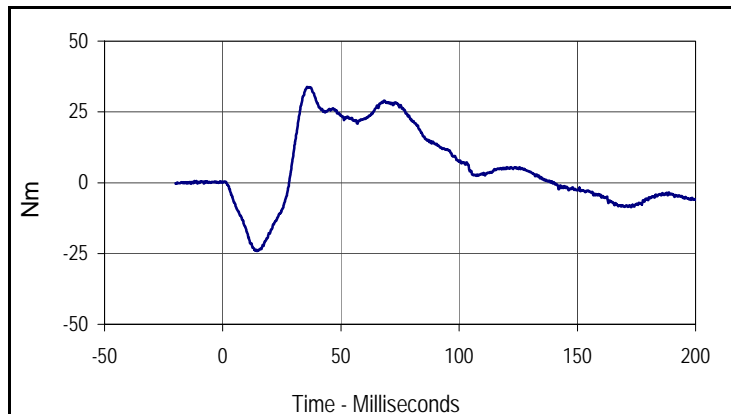

Curve Description			
Neck Moment Y			
CURNO	Type	SAE Class	Units
002	FIL	600	Nm
Max	Time	Min	Time
33.8	35.7	-24.1	14.4

Test Program: Hybrid III 6 Yr Neck Extension Test  
 ATD Serial No.: 027

Test Date: 9/16/04  
 Test I.D.: NE11A



Tested Parameter	Units	Specification	Result	Pass/Fail	
Laboratory Temperature	°C	20.6 to 22.2	21.1	Pass	
Laboratory Relative Humidity	%	10 to 70	30	Pass	
Pendulum Velocity	m/s	4.18 to 4.42	4.42	Pass	
Pendulum Deceleration	10 Msec.	m/s	1.0 to 1.4	1.3	Pass
	20 Msec.	m/s	2.2 to 3.0	2.7	Pass
	30 Msec.	m/s	3.2 to 4.2	3.7	Pass
"D" Plane Rotation	Max	Degrees	85.0 to 103.0	95.5	Pass
Peak Moment in Rotation	Max	Nm	-24.0 to -19.0	-21.2	Pass
Positive Moment Decay, Time To 5 Nm	Msec.		123.0 to 147.0	128.0	Pass
Overall Test Results				Pass	

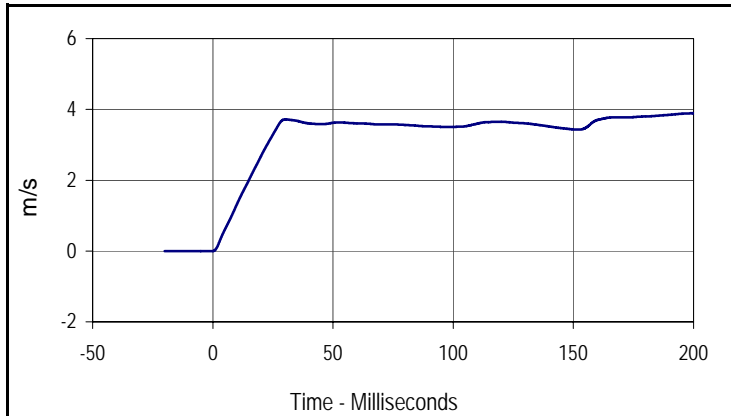

Curve Description			
Pendulum Velocity			
CURNO	Type	SAE Class	Units
001	FIL	180	m/s
Max	Time	Min	Time
4.0	220.0	0.0	-0.3

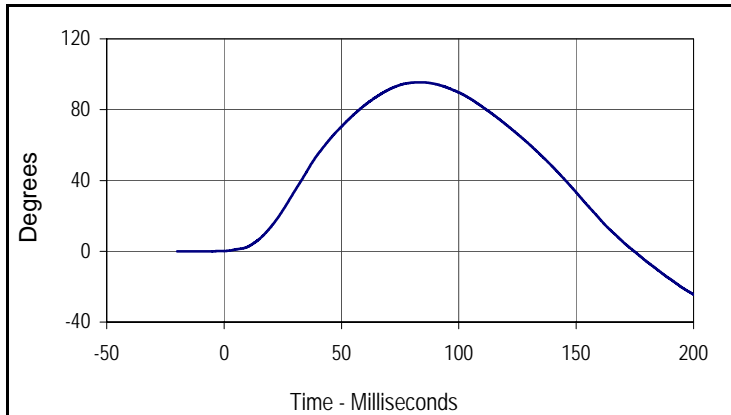

Curve Description			
"D" Plane Rotation			
CURNO	Type	SAE Class	Units
003	FIL	60	Degrees
Max	Time	Min	Time
95.5	83.6	-36.1	220.0

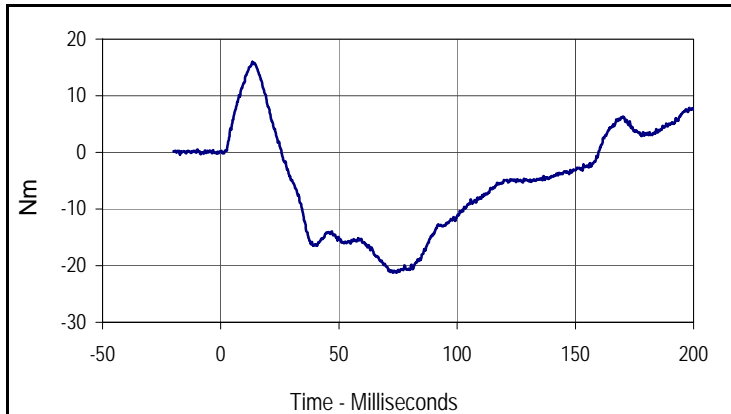

Curve Description			
Neck Moment Y			
CURNO	Type	SAE Class	Units
002	FIL	600	Nm
Max	Time	Min	Time
16.0	13.4	-21.2	72.8

Test Program: Hybrid III 6 Yr Torso Flexion Test  
ATD Serial No.: 027

Test Date: 9/20/04  
Test I.D.: TF11A



Tested Parameter	Units	Specification	Result	Pass/Fail
Laboratory Temperature	°C	18.9 to 25.6	21.1	Pass
Laboratory Relative Humidity	%	10 to 70	30	Pass
Initial reference plane angle	Degrees	≤22.0	3.5	Pass
Peak Force at 45 +/-0.5 degrees	Newtons	147.0 to 200.0	187.0	Pass
Torso rotation rate	deg/sec	0.5 to 1.5	0.8	Pass
Final reference plane angle	Degrees	+/-8	3.6	Pass
Overall Test Results				Pass

Test Program: Hybrid III 6 Yr Knee Impact Test  
 ATD Serial No.: 027

Test Date: 9/19/04  
 Test I.D.: LK11A , RK11A



**Left Knee**

Tested Parameter	Units	Specification	Result	Pass/Fail
Laboratory Temperature	°C	18.9 to 25.6	21.1	Pass
Laboratory Relative Humidity	%	10 to 70	30	Pass
Pendulum Velocity at T=0	m/sec	2.07 to 2.13	2.13	Pass
Peak Probe Force	Newtons	2000 to 3000	2221	Pass
Overall Test Results				Pass

**Right Knee**

Pendulum Velocity at T=0	m/sec	2.07 to 2.13	2.09	Pass
Peak Probe Force	Newtons	2000 to 3000	2716	Pass
Overall Test Results				Pass

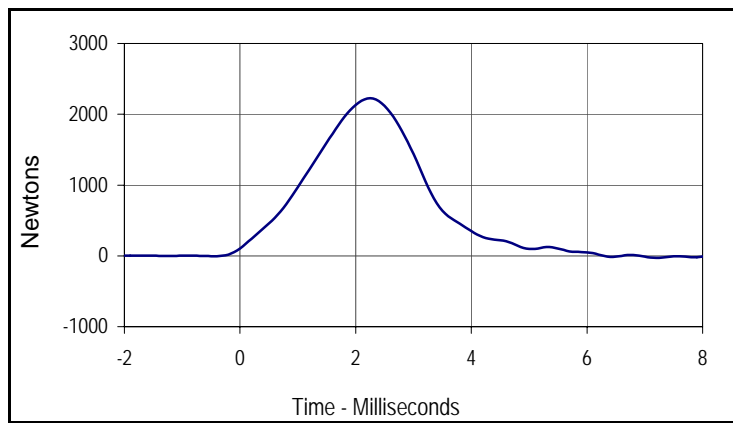

Curve Description			
Probe Force			
CURNO	Type	SAE Class	Units
001	FIL	600	Newtons
Max	Time	Min	Time
2221.0	2.2	-41.0	9.4

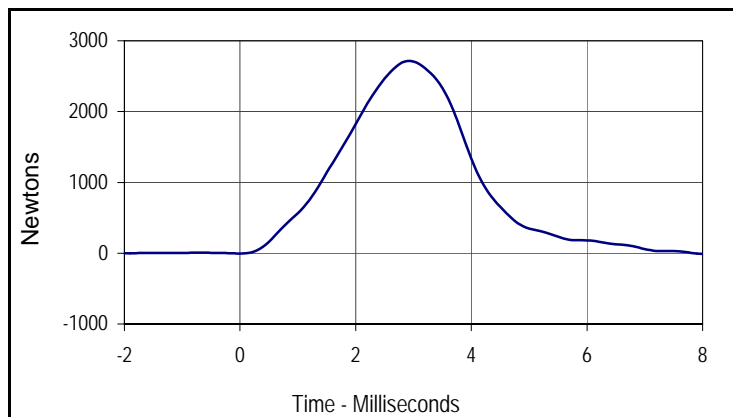

Curve Description			
Probe Force			
CURNO	Type	SAE Class	Units
002	FIL	600	Newtons
Max	Time	Min	Time
2715.7	2.9	-39.0	9.5

Test Program: Hybrid III 6 Yr External Measurements

Test Date: 9/21/04

ATD Serial No.: 027

Test I.D.: N/A



Tested Parameter	Units	Specification	Result	Pass/Fail
Laboratory Temperature	°C	20.6 to 22.2	21.1	Pass
Laboratory Relative Humidity	%	10 to 70	30	Pass
A - Total sitting height	mm	622 to 648	630	Pass
B - Shoulder pivot height	mm	348 to 363	348	Pass
C - "H" point height	mm	64 to 74	73	Pass
D - "H" point from backline	mm	89 to 99	99	Pass
E - Shoulder pivot from back	mm	53 to 64	54	Pass
F - Thigh clearance	mm	89 to 104	100	Pass
G - Elbow back to wrist pivot	mm	183 to 198	190	Pass
H - Skull cap to back line	mm	18 to 23	20	Pass
I - Shoulder to elbow length	mm	216 to 231	230	Pass
J - Elbow rest height	mm	157 to 178	160	Pass
K - Buttock to knee length	mm	371 to 391	390	Pass
L - Popliteal length	mm	269 to 290	275	Pass
M - Knee pivot height	mm	307 to 323	310	Pass
N - Buttock popliteal length	mm	320 to 340	325	Pass
O - Chest depth without jacket	mm	130 to 145	140	Pass
P - Foot length	mm	170 to 185	180	Pass
R - Buttock to knee pivot length	mm	343 to 363	350	Pass
S - Head Breadth	mm	137 to 147	145	Pass
T - Head Depth	mm	168 to 178	175	Pass
U - Hip breadth	mm	208 to 224	210	Pass
V - Shoulder breadth	mm	259 to 274	260	Pass
W - Foot breadth	mm	62 to 78	75	Pass
X - Head circumference	mm	511 to 531	530	Pass
Y - Chest circumference with jacket	mm	597 to 622	621	Pass
Z - Waist circumference	mm	559 to 584	565	Pass
AA - Location for chest circumference	mm	325 to 335	330	Pass
BB - Location for waist circumference	mm	154 to 164	160	Pass
Overall Test Results				Pass

**APPENDIX G**

**NINE ACCELEROMETER ARRAY HEAD DATA**

Test Vehicle: 2005 Toyota Scion TC 3-Door Hatchback  
 Test Program: 2005 NHTSA 35mph NCAP

Test Date: 9/30/04  
 NHTSA No.: M55110

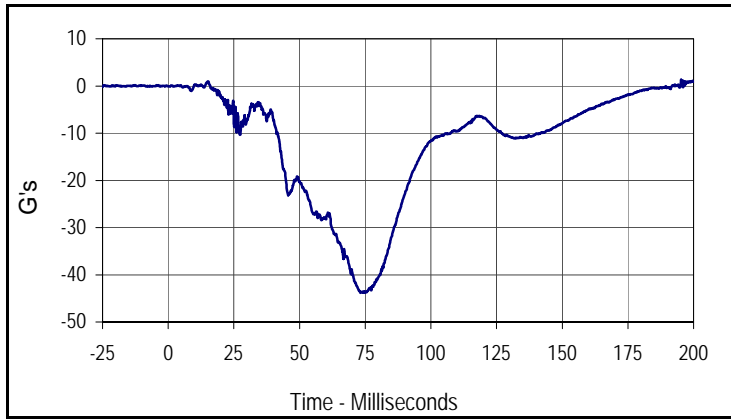

Curve Description			
Driver Head Primary X			
CURNO	Type	SAE Class	Units
001	FIL	1000	G's
Max	Time	Min	Time
1.3	195.3	-43.8	73.2

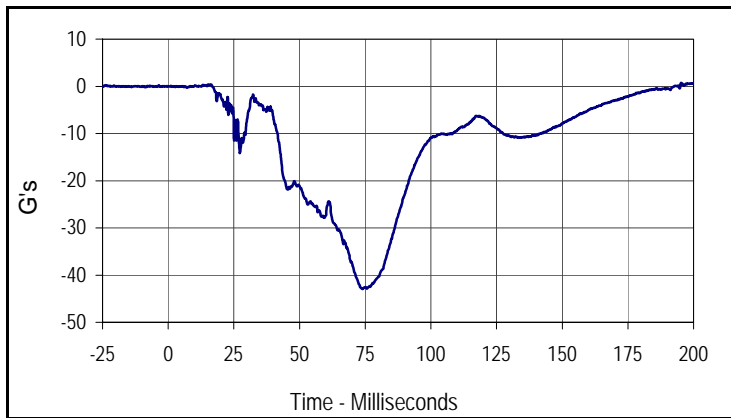

Curve Description			
Driver NAAH Yarm-X			
CURNO	Type	SAE Class	Units
162	FIL	1000	G's
Max	Time	Min	Time
0.7	195.2	-43.0	73.9

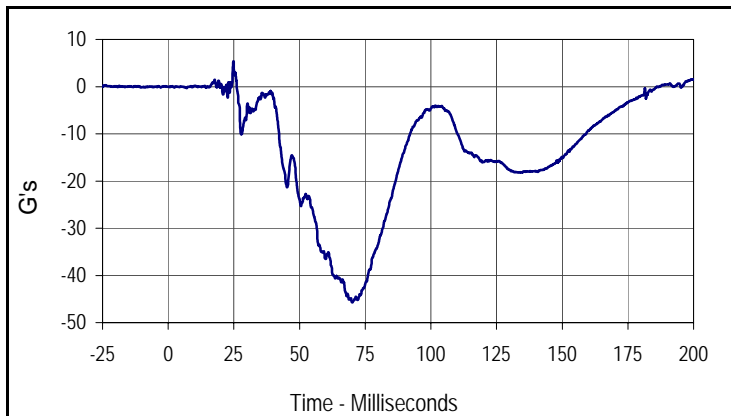

Curve Description			
Driver NAAH Zarm-X			
CURNO	Type	SAE Class	Units
164	FIL	1000	G's
Max	Time	Min	Time
5.4	24.8	-45.7	70.1

Test Vehicle: 2005 Toyota Scion TC 3-Door Hatchback  
 Test Program: 2005 NHTSA 35mph NCAP

Test Date: 9/30/04  
 NHTSA No.: M55110

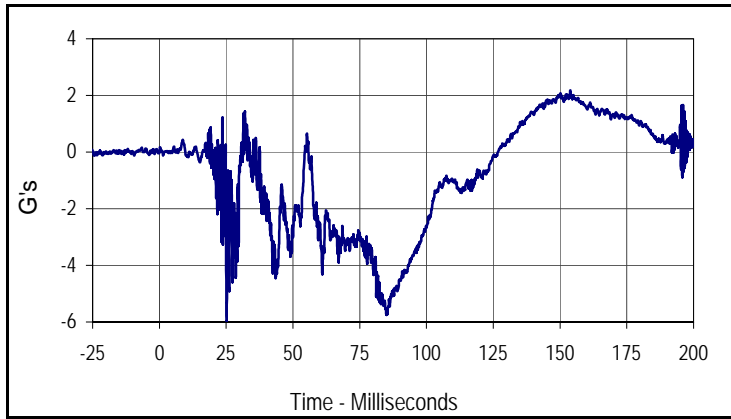

Curve Description			
Driver Head Primary Y			
CURNO	Type	SAE Class	Units
002	FIL	1000	G's
Max	Time	Min	Time
2.2	153.9	-6.0	25.2

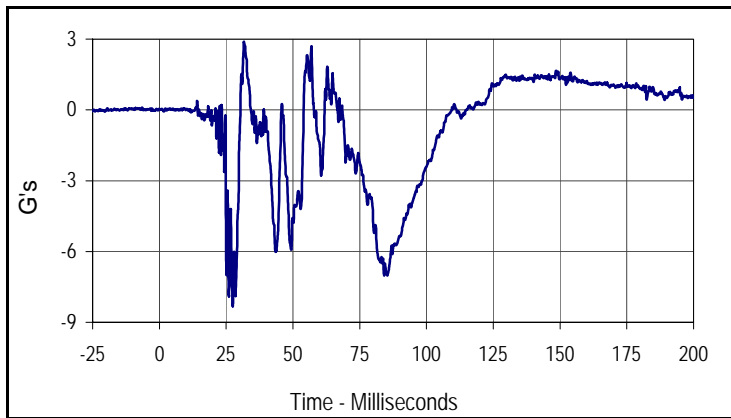

Curve Description			
Driver NAAH Xarm-Y			
CURNO	Type	SAE Class	Units
160	FIL	1000	G's
Max	Time	Min	Time
2.9	31.7	-8.3	27.5

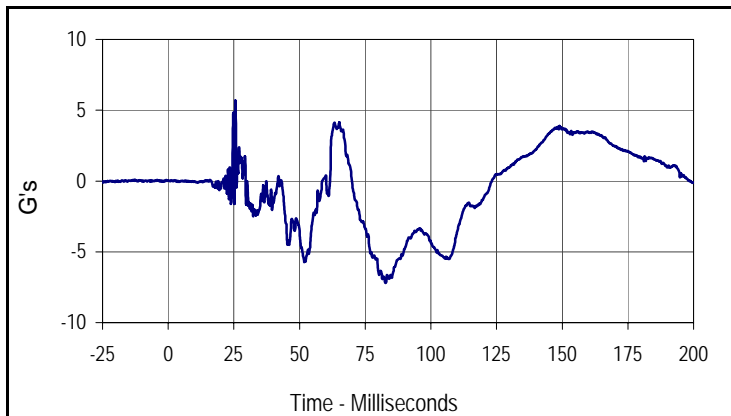

Curve Description			
Driver NAAH Zarm-Y			
CURNO	Type	SAE Class	Units
165	FIL	1000	G's
Max	Time	Min	Time
5.7	25.6	-7.2	82.7

Test Vehicle: 2005 Toyota Scion TC 3-Door Hatchback  
 Test Program: 2005 NHTSA 35mph NCAP

Test Date: 9/30/04  
 NHTSA No.: M55110

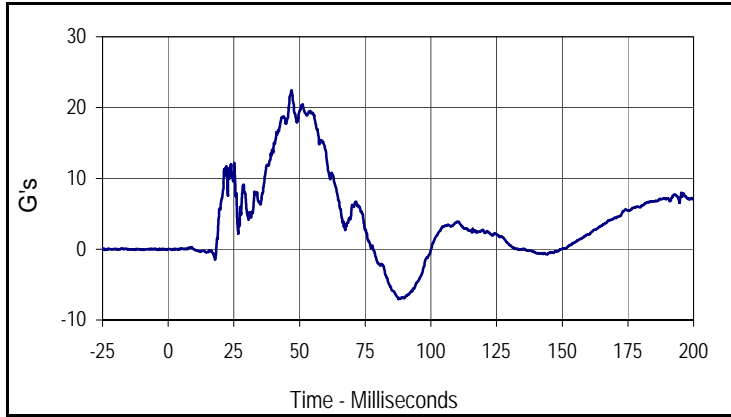

Curve Description			
Driver Head Primary Z			
CURNO	Type	SAE Class	Units
003	FIL	1000	G's
Max	Time	Min	Time
22.4	47.0	-7.0	87.7

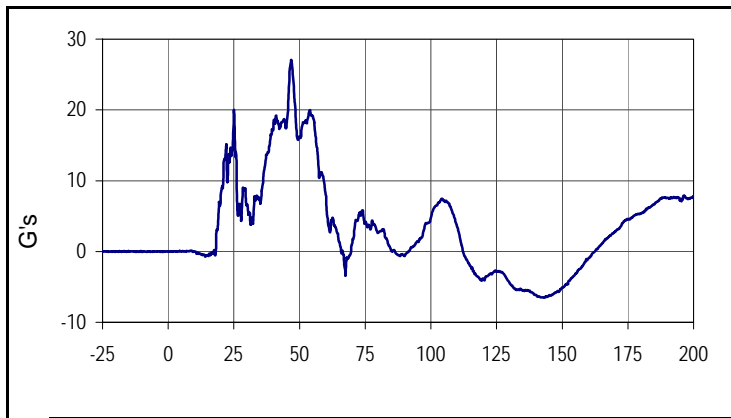

Curve Description			
Driver NAAH Xarm-Z			
CURNO	Type	SAE Class	Units
161	FIL	1000	G's
Max	Time	Min	Time
27.1	46.9	-6.5	143.1

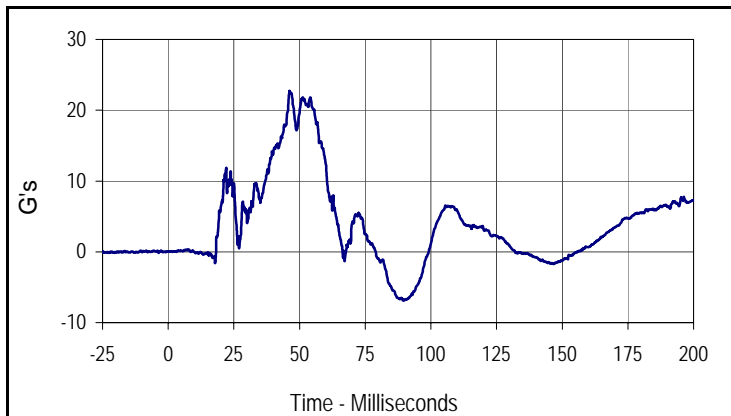

Curve Description			
Driver NAAH Yarm-Z			
CURNO	Type	SAE Class	Units
163	FIL	1000	G's
Max	Time	Min	Time
22.7	46.2	-6.9	89.4

Test Vehicle: 2005 Toyota Scion TC 3-Door Hatchback  
 Test Program: 2005 NHTSA 35mph NCAP

Test Date: 9/30/04  
 NHTSA No.: M55110

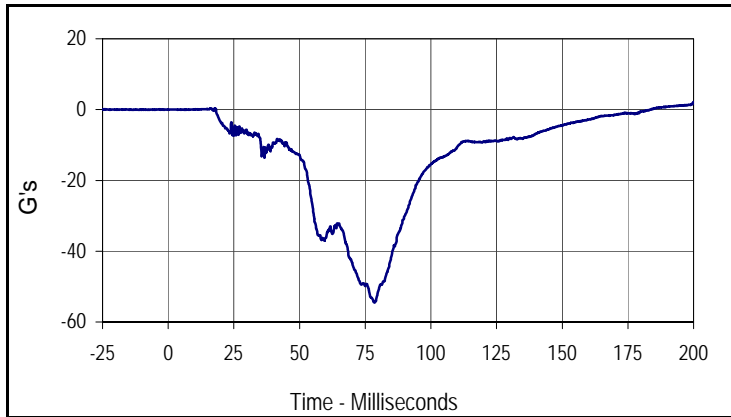

Curve Description			
Passenger Head Primary X			
CURNO	Type	SAE Class	Units
045	FIL	1000	G's
Max	Time	Min	Time
2.2	200.0	-54.5	78.6

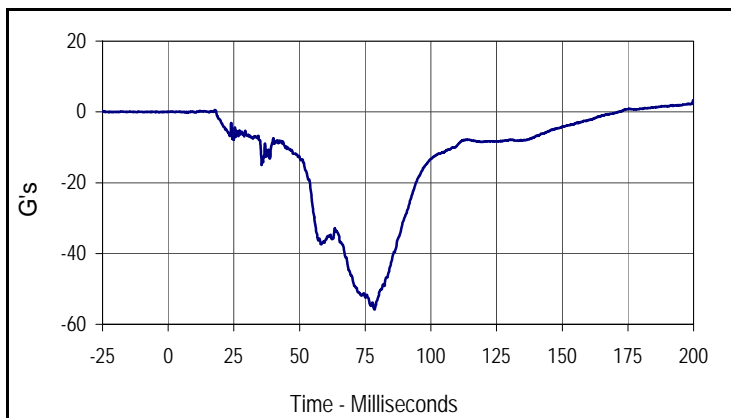

Curve Description			
Passenger NAAH Yarm-X			
CURNO	Type	SAE Class	Units
168	FIL	1000	G's
Max	Time	Min	Time
3.4	200.0	-55.9	78.6

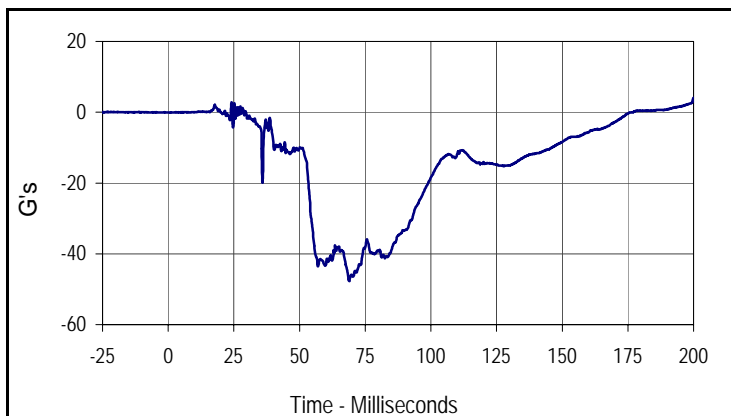

Curve Description			
Passenger NAAH Zarm-X			
CURNO	Type	SAE Class	Units
170	FIL	1000	G's
Max	Time	Min	Time
4.1	200.0	-47.7	68.9

Test Vehicle: 2005 Toyota Scion TC 3-Door Hatchback  
 Test Program: 2005 NHTSA 35mph NCAP

Test Date: 9/30/04  
 NHTSA No.: M55110

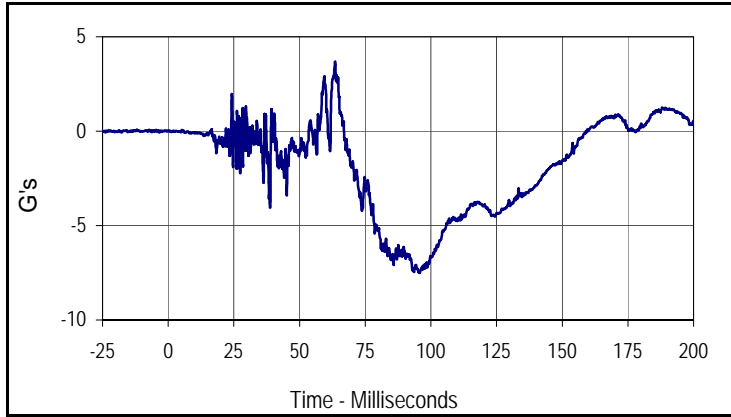

Curve Description			
Passenger Head Primary Y			
CURNO	Type	SAE Class	Units
046	FIL	1000	G's
Max	Time	Min	Time
3.7	63.6	-7.5	95.7

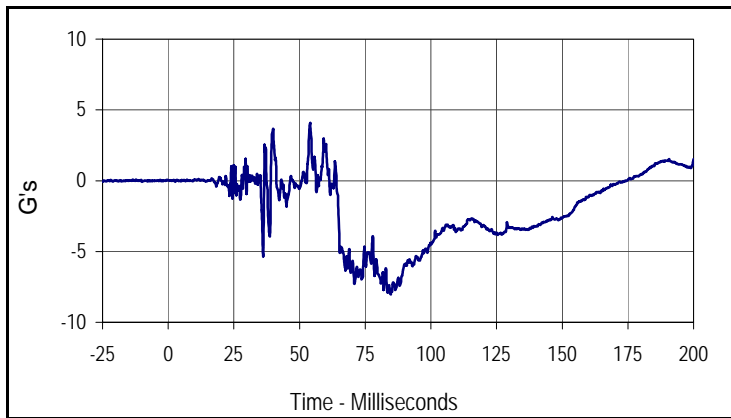

Curve Description			
Passenger NAAH Xarm-Y			
CURNO	Type	SAE Class	Units
166	FIL	1000	G's
Max	Time	Min	Time
4.1	54.0	-8.0	84.7

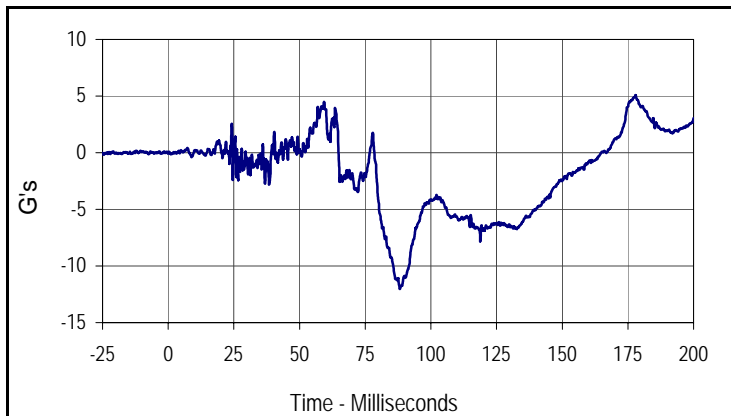

Curve Description			
Passenger NAAH Zarm-Y			
CURNO	Type	SAE Class	Units
171	FIL	1000	G's
Max	Time	Min	Time
5.1	177.9	-12.0	88.2

Test Vehicle: 2005 Toyota Scion TC 3-Door Hatchback  
 Test Program: 2005 NHTSA 35mph NCAP

Test Date: 9/30/04  
 NHTSA No.: M55110

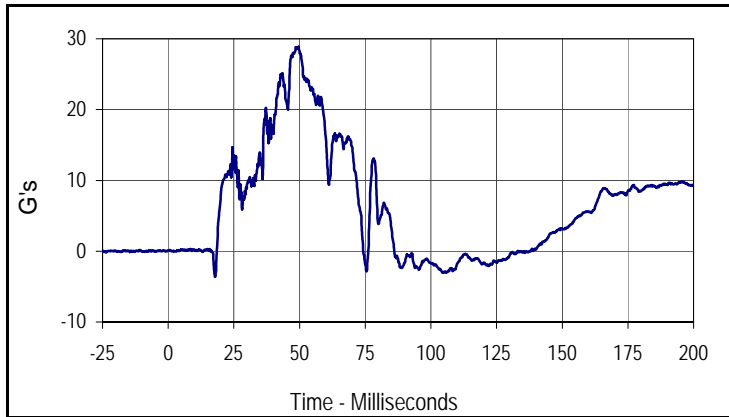

Curve Description			
Passenger Head Primary Z			
CURNO	Type	SAE Class	Units
047	FIL	1000	G's
Max	Time	Min	Time
28.8	49.5	-3.6	17.9

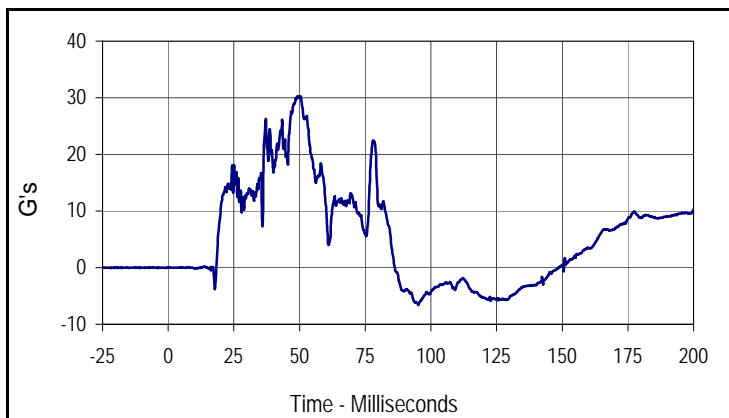

Curve Description			
Passenger NAAH Xarm-Z			
CURNO	Type	SAE Class	Units
167	FIL	1000	G's
Max	Time	Min	Time
30.3	50.3	-6.6	95.2

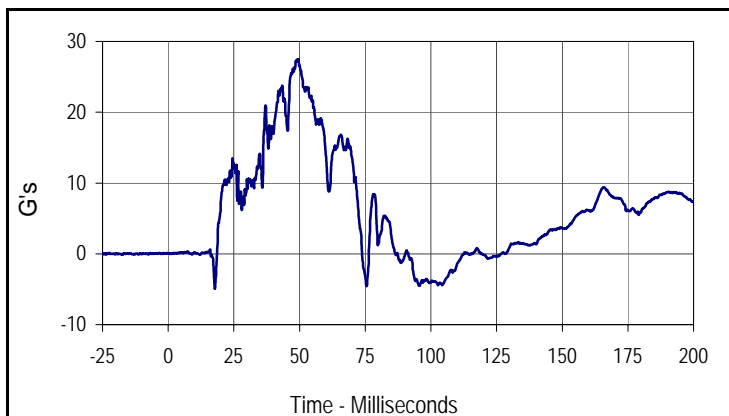

Curve Description			
Passenger NAAH Yarm-Z			
CURNO	Type	SAE Class	Units
169	FIL	1000	G's
Max	Time	Min	Time
27.5	49.6	-4.9	17.8