

REPORT NUMBER TR-P24104-10-NC

**2003 JEEP LIBERTY 4-DOOR MPV
FRONTAL VEHICLE CRASH TESTS
IN SUPPORT OF FMVSS 208 UPGRADE**

**KARCO ENGINEERING, LLC
9270 HOLLY ROAD
ADELANTO, CALIFORNIA 92301**



AUGUST 12, 2004

FINAL REPORT

PREPARED FOR:

**U.S. DEPARTMENT OF TRANSPORTATION
VOLPE NATIONAL TRANSPORTATION SYSTEMS CENTER
OFFICE OF SAFETY AND SECURITY
55 BROADWAY
CAMBRIDGE, MA 02142**

IN COOPERATION WITH:

**NATIONAL HIGHWAY TRAFFIC SAFETY ADMINISTRATION
OFFICE OF APPLIED VEHICLE SAFETY RESEARCH
400 SEVENTH STREET, SW
WASHINGTON, D.C. 20590**

This final test report was prepared for the U.S. Department of Transportation, Volpe National Transportation Systems Center, Office of Safety and Security in cooperation with the National Highway Traffic Safety Administration, in response to Contract Number DTRS57-04-D-30000.

This document is disseminated under the sponsorship of the Department of Transportation in the interest of information exchange. The United States Government assumes no liability for the contents or use thereof. If trade or manufacturers' names or products are mentioned, it is only because they are considered essential to the object of the publication and should not be construed as an endorsement. The United States Government does not endorse products or manufacturers.

Prepared by: _____
Mr. Matthew A. Ivory, Project Engineer
KARCO Engineering, LLC

Date: August 26, 2004

Reviewed by: _____
Mr. Michael L. Dunlap, Quality Assurance Manager
KARCO Engineering, LLC

Date: August 26, 2004

Approved by: _____
Mr. Frank D. Richardson, Program Manager
KARCO Engineering, LLC

Date: August 26, 2004

FINAL REPORT ACCEPTED BY:

COTR, DOT/RSPA/Volpe Center

Date of Acceptance

Technical Report Documentation Page

1. <i>Report No.</i> TR-P24104-10-NC	2. <i>Government Accession No.</i>	3. <i>Recipient's Catalog No.</i>					
4. <i>Title and Subtitle</i> Test Report of Vehicle Crash Test in Support of FMVSS 208 Upgrade 2004 Jeep Liberty 4-Door MPV NHTSA No. R40402			5. <i>Report Date</i> AUGUST 26, 2004				
			6. <i>Performing Organization Code</i> KAR				
7. <i>Author(s)</i> Mr. Matthew A. Ivory, Project Engineer, KARCO Mr. Biren J. Patel, Project Engineer, KARCO			8. <i>Performing Organization Report No.</i> TR-P24104-10-NC				
9. <i>Performing Organization Name and Address</i> KARCO Engineering, LLC 9270 Holly Road Adelanto, California 92301			10. <i>Work unit No.</i>				
			11. <i>Contract or Grant No.</i> DTRS57-04-D-30000				
12. <i>Sponsoring Agency Name and Address</i> U.S. Department of Transportation Volpe National Transportation Systems Center Office of Safety and Security 55 Broadway Cambridge, MA 02142			13. <i>Type of report and Period Covered</i> 05/20/2004 to 10/19/2004				
			14. <i>Sponsoring Agency Code</i> DOT/RSPA/Volpe Center				
15. <i>Supplementary Notes</i>							
16. <i>Abstract</i> A 35 mph (56.3 km/h) frontal barrier impact test was conducted on a 2004 Jeep Liberty 4-Door MPV at Karco Engineering, LLC on 08/12/04. This test was conducted to obtain data indicant of FMVSS 208, 212, 219 (partial), 301, and footwell intrusion performance. The impact velocity was 56.32 km/h. The ambient temperature at the barrier face at the time of impact was 41.1 degrees Celsius. The vehicle's maximum post-test static crush was 436 mm to the right of the vehicle centerline. The test vehicle was equipped with 3-point continuous loop belt systems and second-generation supplemental airbags in both front outboard seating positions. The rear center seat also was equipped with a 3-point belt continuous loop belt system. With respect to FMVSS 208 "Occupant Crash Protection", the occupant injury criteria summary is as follows:							
Measurement Description		Units	Threshold	Front ATDs		Rear ATDs	
				Driver (H3 95%)	Passenger (H3 95%)	Center	
Head Injury Criteria (HIC 36)		N/A	1000	725.7	832.3	1955.1	
Max. Chest Accel. (3 msec Clip)		G's	60	46.0	42.8	45.4	
Left Femur Force		Newtons	95% 12700 50% 10008	-4631.8	-6888.3	-805.2	
Right femur Force		Newtons	95%12700 50%10008	-3658.5	-5558.3	-1073.7	
17. <i>Key Words</i> 56.3 km/h FMVSS 208 Frontal Barrier Impact Test Research & Development 2004 Jeep Liberty 4-Door MPV NHTSA No. R40402				18. <i>Distribution Statement</i> Document is available to the U.S. public through the National Technical Information Service. Springfield, VA 22161			
19. <i>Security Classification (of this report)</i> UNCLASSIFIED		20. <i>Security Classification (of this page)</i> UNCLASSIFIED		21. <i>No. of Pages</i> 281		22. <i>Price</i>	

TABLE OF CONTENTS

Section	Description	Page
1	Purpose and Summary of Test R40402	1
2	Occupant and Vehicle Information/Data Sheets	3

Data Sheet	Description	Page
1	Crash Test Summary	4
2	General Test and Vehicle Data	6
3	Post Test Impact Data	9
4	Test Vehicle Information	10
5	Dummy Positioning in Vehicle	13
6	Seatbelt Assessment Test Data	16
7	Vehicle Accelerometer and Squib Sensor Location and Data Summary	18
8	Vehicle Accelerometer and Post Test Locations	19
9	Hybrid III ATD Injury Criteria and Sensor Data	20
10	Summary of FMVSS 212 Data	29
11	Windshield Zone Intrusion FMVSS 219 Data (Partial)	30
12	FMVSS 301 Fuel System Integrity Post Impact Data	31
13	FMVSS 301 Static Rollover Data	32
14	Vehicle Measurements	34
15	Camera Locations	42
16	Photographic Reference Target Locations	43
17	Test Vehicle Frontal Profile Data	44
18	Post Test Airbag Data	47
19	Fixed Barrier Load Cell Locations	48
20	Dummy/Vehicle Temperature Stabilization	49

Appendix	Description	Appendix
A	Photographs	A
B	Dummy and Vehicle Response Data Traces	B
C	Load Cell Barrier Data Traces	C
D	Instrumentation and Data Channel Assignments	D
E	Dummy Calibration Data Traces and Tables	E

SECTION 1
PURPOSE AND SUMMARY OF TEST R40402

1.1 PURPOSE

This 35 mph (56.3 km/h) frontal barrier impact test was conducted as a research study for frontal vehicle crash tests in support of the FMVSS 208 upgrade test program. It was sponsored by the Volpe National Transportation Systems Center (Volpe) in cooperation with the National Highway Traffic Safety Administration (NHTSA) under Contract DTRS57-04-D-30000. The purpose of this test program is to obtain vehicle crashworthiness and occupant restraint system performance data to evaluate and compare occupant responses with standard 50th percentile male dummies (unbelted tested at 30 mph) and the larger 95th percentile male dummies (belted tested at 35 mph) in the front outboard seating positions.

This 35 mph (56.3 km/h) frontal barrier impact test was conducted in accordance with The Laboratory Test Procedures for the Office of Vehicle Safety Compliance FMVSS 208 "Occupant Crash Protection" (TP208-10) and Office of Crashworthiness Standards New Car Assessment Program (NCAP) Frontal Impact testing.

1.2 SUMMARY

A load cell barrier consisting of 36 load cells was impacted by a 2004 Jeep Liberty 4-Door MPV at a velocity of 56.32 km/h (35.00 mph). The test was performed at KARCO Engineering, LLC on August 12, 2004.

Two Part 572M 95th percentile male anthropomorphic test devices (ATDs or dummies) were placed in the driver and right-front passenger seating positions. A Part 572E 50th percentile male ATD was placed in the passenger center-rear seat.

The ATDs were fully instrumented with head (primary and redundant), chest (primary and redundant) accelerometers, chest displacement potentiometers, six-axis upper neck transducers, right and left femur load cells, right and left knee sliders, and lower leg instrumentation. Load cells were placed on the ATDs lap and shoulder belts to measure dummy torso and pelvic section loading. The Driver (H3 95% in position 1) ATD (Serial No. 159), right-front Passenger (H3 95% in position 2) ATD (Serial No. 058), and center-rear passenger (H3 50% in position 6) ATD (Serial No. 001) were calibrated prior to this test.

One hundred twenty-seven (127) channels of data were recorded using an on-board data acquisition system. Three real-time and eighteen (18) high-speed cameras were used to document the frontal barrier impact event. Camera locations and other pertinent camera information can be found in this report.

Appendix A contains Pre- and Post-Test Photographs; Appendix B contains the vehicle and dummy response data traces; Appendix C contains the Load Cell Barrier information; Appendix D contains the Instrumentation Data Channel Assignments; and Appendix E contains the Dummy Calibration data.

There was 100 percent windshield retention and no intrusion into the protected zone of the windshield during the impact event. There was no Stoddard solvent leakage after the event or during any phase of the static rollover.

The maximum static crush of the vehicle was 436 mm. All four doors remained closed during impact and opened without the aid of tools. All doors were operable after the impact.

The Driver's (H3 95%) visible contact points were as follows: On impact the head contacted the airbag, the chest contacted the airbag, both knees contacted the knee bolster and steering column, both tibias contacted the knee bolster.

The right-front Passenger's (H3 95%) visible contact points were as follows: The head contacted the airbag, the chest contacted the airbag, both knees contacted the glove box and both tibias contacted the glove box.

The center-rear passenger's (H3 50%) visible contact points were as follows: The head and chest had no contact, the left knee and tibia contacted the left-front seatback. The right knee and tibia contacted the right-front seatback. During the event, the dummy's head contacted the right knee.

Occupant injury data is contained in table below.

OCCUPANT DATA SUMMARY

ATD Position	HIC	Chest Clip (g)	Chest Disp. (mm)	Left Femur (N)	Right Femur (N)	Belt Spool (mm)
Driver (H3 95%)	725.7	-46.0	-29.3	-4631.8	-3658.5	310.2
Passenger (H3 95%)	832.3	-42.8	-27.0	-6888.3	-5558.3	335.9
Left Rear Passenger						
Center Rear Passenger	1955.1	-45.4	-35.0	-805.2	-5558.3	363.3
Right Rear Passenger						

SECTION 2
OCCUPANT AND VEHICLE INFORMATION/DATA SHEETS

Test Vehicle: 2004 Jeep Liberty 4-Door MPV
Test Program: FMVSS 208 Upgrade

NHTSA No.: R40402
Test Date: 08/12/04

CONVERSION FACTORS USED IN THIS REPORT*

Quantity	Typical Application	Std Units	Metric Unit	Multiply By
Mass	Vehicle Weight	lb	kg	0.4536
Linear Velocity	Impact Velocity	mile/h	km/h	1.609
Length or Distance	Measurements	in	mm	25.4
Volume	Fuel Systems	gal	liter	3.785
Volume	Small Fluids	oz	mL	29.573
Pressure	Tire Pressures	lbf/in ²	kPa	7.0
Volume	Liquid	gal	liter	3.785
Temperature	General Use	°F	°C	=(tf -32)/1.8
Force	Dynamic Forces	lbf	N	4.448
Moment	Torque	lbf-ft	Nm	1.355

* Based on the Recommended Practice in SAE J916, May 85

**DATA SHEET NO. 1
CRASH TEST SUMMARY**

Test Vehicle: 2004 Jeep Liberty 4-Door MPV
 Test Program: FMVSS 208 Upgrade

NHTSA No.: R40402
 Test Date: 08/12/04

PRIMARY IMPACT DATA

Measured Parameter	Units	Value
Velocity at Impact	km/h	56.32
Test Weight	kg	2059
Impact Angle	degrees	0
Average Rebound	mm	770
Maximum Static Crush	mm	436

DOOR OPENING AND SEAT TRACK INFORMATION

Description	Driver (H3 95%) Side	Passenger (H3 95%) Side
Front Door opening	Remained closed, opened w/o tools	Remained closed, opened w/o tools
Rear Door Opening	Remained closed, opened w/o tools	Remained closed, opened w/o tools
Front Seat Track Shift (mm)	0	0
Front Seat Back Failure	No	No
Rear Seat Track Shift (mm)	0	0
Rear Seat Back Failure	No	No

HYBRID III DUMMY CONTACT INFORMATION

Description	Driver (H3 95%)	Passenger (H3 95%)	Center Rear (H3 50%)	Other
Dummy Type	95% Male	95% Male	50% Male	N/A
Serial No	159	058	001	N/A
Head	AIRBAG	AIRBAG	N/C	N/A
Chest	AIRBAG	AIRBAG	N/C	N/A
Left Knee	BOLSTER	GLOVE BOX	FRONT SEATBACK	N/A
Right Knee	BOLSTER	GLOVE BOX	FRONT SEATBACK, HEAD	N/A
Left Tibia	BOLSTER	GLOVE BOX	FRONT SEATBACK	N/A
Right Tibia	BOLSTER	GLOVE BOX	FRONT SEATBACK	N/A

DATA SHEET NO. 1...(CONTINUED)
CRASH TEST SUMMARY

FILM & VIDEO COVERAGE

Real-Time Video	3
High-Speed 16mm Movie	14
High-Speed Video	4
Total	21

DATA CHANNELS

Driver (H3 95%) ATD Sensors	35
Right Front Passenger (H3 95%) ATD Sensors	35
Left Rear Passenger ATD Sensors	
Center Passenger (50%) ATD Sensors	29
Right Rear Passenger ATD Sensors	
Belt Assessment Sensors	9
Airbag Timing Sensors	6
Vehicle Structure Accelerometers	13
Rigid Barrier Load Cells	36
Total	163

DATA SHEET NO. 2
GENERAL TEST AND VEHICLE DATA

Test Vehicle: 2004 Jeep Liberty 4-Door MPV
Test Program: FMVSS 208 Upgrade

NHTSA No.: R40402
Test Date: 08/12/04

TEST VEHICLE INFORMATION AND OPTIONS

NHTSA No.	R40402	Anti-Lock Brakes	Yes
Make	Jeep	All Wheel Drive	No
Model	Liberty	Power Steering	Yes
Body Style	4-Door MPV	Driver Front Airbag	Yes
VIN No.	1J4GK48K14W225983	Driver Side Airbag	No
Color	Red	Driver Head Airbag	No
Delivery Date	05/26/04	Driver Curtain Airbag	No
Odometer	16	Passenger Airbag	Yes
Dealer	Victorville-Chrysler-Jeep	Passenger Side Airbag	No
Transmission	4-Speed Automatic	Passenger Head Airbag	No
Final Drive	Rear	Passenger Curtain Airbag	No
Type/No. of Cylinders	V6	Pre-Tensioners	Yes
Engine Displacement (L)	3.7	Load Limiters	Yes
Engine Placement	Longitudinal	Bucket Seats	Yes
Roof Rack	Yes	Air Conditioner	Yes
Sunroof/T-Top	No	AM/FM Cassette	Yes
Tinted Glass	Yes	Tilt Steering	Yes
Traction Control	No	Automatic Door Locks	Yes
Power Brakes	Yes	Power Windows	Yes
Front Disc	Yes	Power Seats	Yes
Rear Disc	Yes	Other	N/A
Does Owners Manual provide instructions to turn off automatic door locks?			N/A

DATA FROM CERTIFICATION LABEL

Manufactured By	Jeep Motor Manufacturing	GVWR (kg)	2427
		GAWR Front (kg)	1247
Date of Manufacture	02/04	GAWR Rear (kg)	1429

VEHICLE SEATING AND CAPACITY WEIGHT INFORMATION

Measured Parameter	Front	Rear	Third	Total
Type of Seats	Bucket	Bench	None	
Number of Occupants	2	3	N/A	5
Capacity Weight (VCW) (kg)				522
Cargo Weight (RCLW) (kg)				136

**DATA SHEET NO. 2...(CONTINUED)
GENERAL TEST AND VEHICLE DATA**

Collect year, make, model, VIN, items circled in red, and tire manufacturer and tire name.

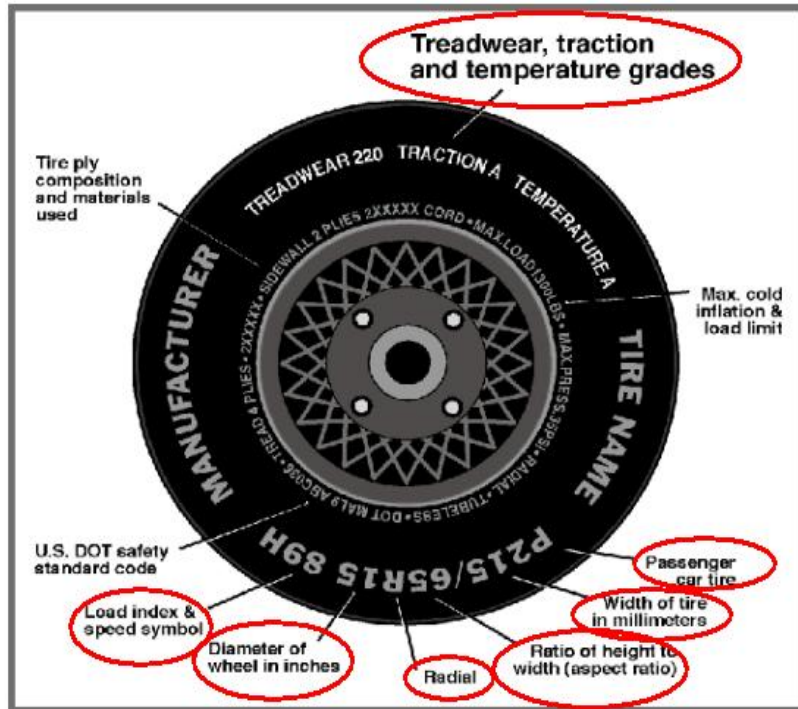

TIRE INFORMATION

Measured Parameter	Front	Rear
Max. Tire Pressure (kpa)	303	303
Cold Pressure (kpa)	230	230
Recommended Tire Size	P215/75R 16	P215/75R 16
Tire Size on Vehicle	P215/75R 16	P215/75R 16
Tire Manufacturer	Goodyear	Goodyear
Tread wear	340	340
Traction	A	A
Temperature Grades	B	B
Tire Plies Sidewall	2 Polyester	2 Polyester
Tire Plies Body	2 Polyester	2 Polyester
Load Index/Speed Symbol	1015	1015
Tire Material	Polyester & Steel	Polyester & Steel
DOT Safety Code Right	M6Y4-EYER-0204	M6Y4-EYER-0204
DOT Safety Code Left	M6Y4-EYER-0204	M6Y4-EYER-0204

DATA SHEET NO. 2...(CONTINUED)
GENERAL TEST AND VEHICLE DATA

TEST VEHICLE WEIGHTS

	Units	As Delivered Weights (UVW)			As Tested Weights (ATW)		
		Front Axle	Rear Axle	Total	Front Axle	Rear Axle	Total
Left	kg	453	416		507	544	
Right	kg	445	397		490	518	
Ratio	%	52%	39%		48%	52%	
Totals	kg	898	813	1711	997	1062	2059

TARGET TEST WEIGHT CALCULATION

Measured Parameter	Units	Value
Total Delivered Weight (UVW)	kg	1711
Weight of 2 P572 M ATD's	kg	152
Rated Cargo/Luggage Wt. (RCLW)	kg	136
Calculated Vehicle Target Wt. (TVTW)	kg	1999

TEST VEHICLE ATTITUDE AND CG

	Units	LF	RF	LR	RR	CG (aft of front axle)
As Delivered	mm	811	815	834	836	1034
As Tested	mm	788	800	790	800	1367

Vehicle Wheel Base (mm) 2650

Weight of Ballast Secured in cargo area (kg) N/A

Vehicle Components Removed Rear Windows, Trunk Lid, Rear Bumper,
Tail lights, Spare Tire and Tools.

* Ballast weight does not include cameras, instrumentation and brake abort system.

FUEL SYSTEM DATA

Fuel System Capacity From Owners Manual (L) 73.80

Usable Capacity Furnished by COTR (L) 67.9 to 69.4

Actual Test Volume with entire fuel System Filled (L) 68.60

Test Fluid Type: Stoddard Solvent

Kinematic Viscosity: as per ASTM Standard D484-71 Purple

Is Vehicle Fuel Pump Electric or Mechanical? Electric

If electric, does pump operate with ignition switch "On" & engine "OFF" Yes

Fuel System Particulars: Key operated with automatic shut-off when key is in 'OFF' position.

**DATA SHEET NO. 3
POST TEST IMPACT DATA**

Test Vehicle: 2004 Jeep Liberty 4-Door MPV
 Test Program: FMVSS 208 Upgrade

NHTSA No.: R40402
 Test Date: 08/12/04

SPEED TRAP DATA

Measured Parameter	Units	Requirement	Value
Trap No.1 Velocity (Primary)	km/h	55.51 to 57.12	56.32
Trap No. 1 Entry Distance	mm	<1524	1524
Trap No.1 Exit Distance	mm	<1524	305
Trap No.2 Velocity (Redun.)	km/h	55.51 to 57.12	56.15
Trap No.2 Entry Distance	mm	<1524	1524
Trap No.2 Exit Distance	mm	<1524	305

VEHICLE STATIC CRUSH

Measured Parameter	Units	Pre-Test	Post-Test	Difference
Left Side	mm	4036	3815	-221
Center	mm	4215	3840	-375
Right Side	mm	4035	3820	-215

VEHICLE REBOUND FROM BARRIER

Measured Parameter	Units	Value
Left Side	mm	800
Center	mm	770
Right Side	mm	740
Average	mm	770

**DATA SHEET NO. 4
TEST VEHICLE INFORMATION**

Test Vehicle: 2004 Jeep Liberty 4-Door MPV
 Test Program: FMVSS 208 Upgrade

NHTSA No.: R40402
 Test Date: 08/12/04

NOMINAL DESIGN RIDING POSITION

The driver and passenger seat backs are positioned to the manufacturers designated angle. The procedure is as follows: A special application tool with pointed probes is inserted through the fabric to make contact with the rigid portion of the lower seat frame assembly, approximately 13 inches above the pivot point of the seat back. An inclinometer is placed against the flat surface of the tool and the seat back angle is measured directly from the dial face.

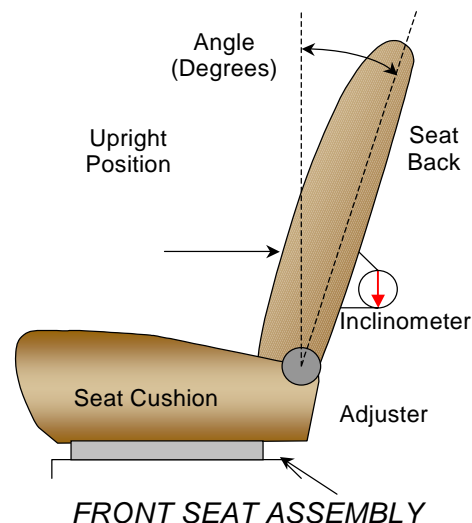

SEAT BACK ANGLES

	Deg.
Front Driver Side	23.5
Front Passenger Side	23.5
Rear Driver Side	N/A
Rear Passenger Side	24.0
Rear Center Passenger	N/A

SEAT FORE/AFT POSITIONS

The first or forward most position is counted as number one (1). The fore/aft position is set aft of the middle position for both the driver and passenger.

SEAT FORE/AFT POSITIONING

	Total Fore/Aft Travel	Placed in Position #
Front Driver Side	18	Full Rearward
Front Passenger Side	18	Full Rearward
Rear Driver Side	N/A	N/A
Rear Passenger Side	N/A	N/A
Rear Center Passenger	1	1

DATA SHEET NO. 4...(CONTINUED)
TEST VEHICLE INFORMATION

SEAT BELT UPPER ANCHORAGE

Position number one (1) is the uppermost position.

SEAT BELT UPPER ANCHORAGE

	Total # of Positions	Placed in Position #
Front Driver Side	4	1
Front Pass. Side	4	1
Rear Driver Side	N/A	N/A
Rear Pass. Side	N/A	N/A
Rear Center Pass.	1	1

STEERING COLUMN ADJUSTMENT

Steering wheel and column adjustments are made so that the steering wheel hub is at the geometric center of the locus it describes when moved through its full range of motion. An aluminum plate is placed across the rim of the steering wheel, an inclinometer is placed on the plate and the angle is measured.

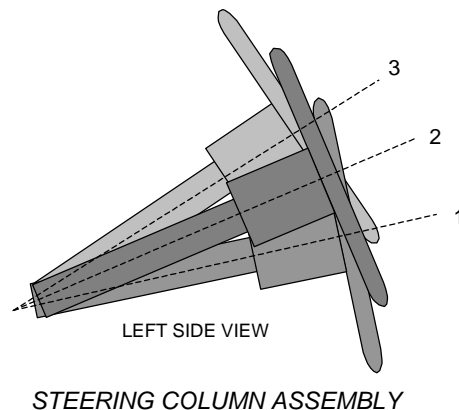

STEERING COLUMN POSITIONS

	Degrees
Lowermost position No. 1	22.0
Geometric center position No. 2	25.0
Uppermost position No. 3	28.0

Steering column placed in uppermost position.

DATA SHEET NO. 4...(CONTINUED)
TEST VEHICLE INFORMATION

FUEL TANK CAPACITY

	Liters
Usable Capacity of "Standard Tank"	73.8
Usable Capacity of "Optional" Tank	N/A
Usable Capacity used for FMVSS 301	67.9 to 69.4
Actual Amount of Solvent used	68.60

The test vehicle is equipped with an electric fuel pump. The fuel pump operates for approximately two seconds after the ignition is placed in the "ON" position, after which the fuel pump automatically shuts off. The fuel filler door is located on the left rear fender. The standard fuel tank occupies the area under the left rear seat forward of the rear axle.

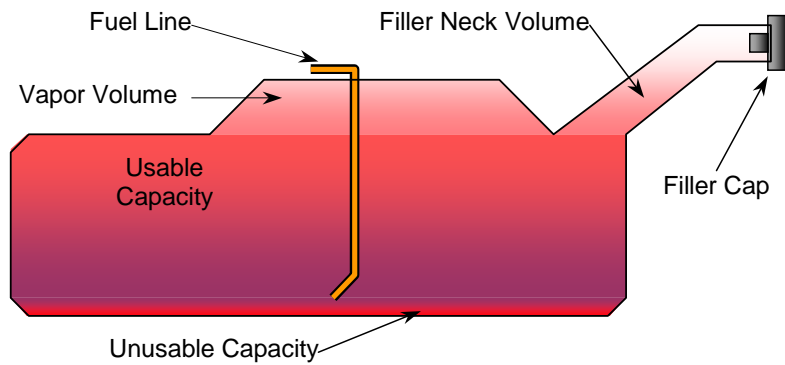

VEHICLE FUEL TANK ASSEMBLY

**DATA SHEET NO. 5
DUMMY POSITIONING IN VEHICLE**

Test Vehicle: 2004 Jeep Liberty 4-Door MPV
 Test Program: FMVSS 208 Upgrade

NHTSA No.: R40402
 Test Date: 08/12/04

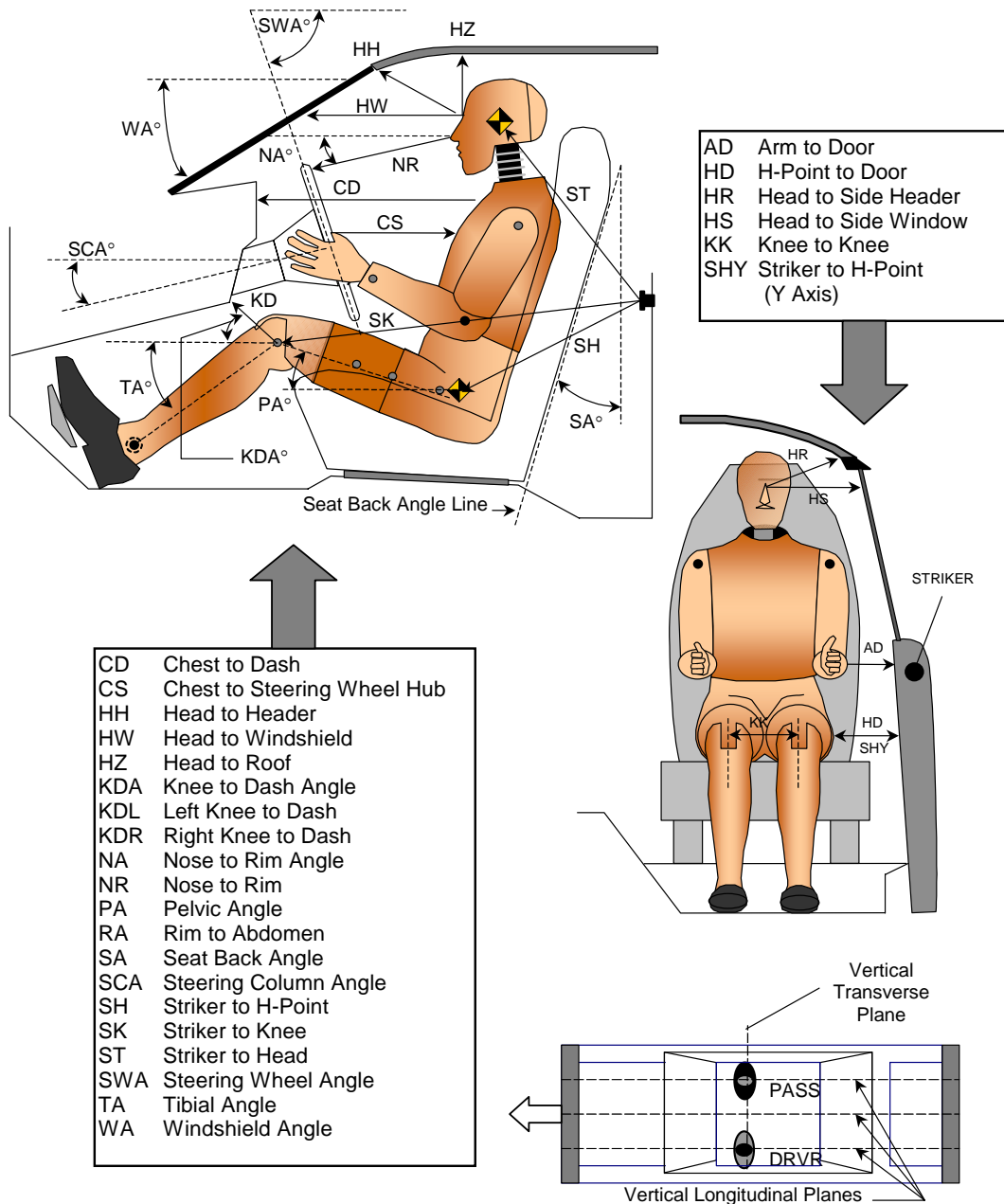

DUMMY MEASUREMENTS FOR FRONT SEAT OCCUPANTS

DATA SHEET NO. 5...(CONTINUED)
DUMMY POSITIONING IN VEHICLE

TEST DUMMY POSITION MEASUREMENTS - FRONT SEAT DUMMIES

Code	Measurement Description	Driver (H3 95%)		Passenger (H3 95%)	
		Length (mm)	Angle (deg)	Length (mm)	Angle (deg)
WA	Windshield Angle		59.0		
SWA	Steering Wheel Angle		62.7		
SCA	Steering Column Angle		28.6		
SA	Seat Back Angle		23.5		23.5
HZ	Head to Roof (Z)	235	90.0	230	90.0
HH	Head to Header	515		500	
HW	Head to Windshield	655		640	
HR	Head to Side Header (Y)	264		205	
NR	Nose to Rim	540	12.3		
CD	Chest to Dash	610		690	
CS	Chest to Steering Hub	360			
RA	Rim to Abdomen	240			
KDL	Left Knee to Dash	150	11.4	200	
KDR	Right Knee to Dash	170		195	11.7
PA	Pelvic Angle		22.7		24.5
TA	Tibia Angle		49.2		54.8
KK	Knee to Knee (Y)	290		288	
SK	Striker to Outboard Knee	578	4.8	555	7.2
ST	Striker to Head	623	88.1	635	88.4
SH	Striker to H-Point	160	22.6	150	19.0
SHY	Striker to H-Point (Y)	165		175	
HS	Head to Side Window	350		310	
HD	H-Point to Door (Y)	158		165	
AD	Arm to Door (Y)	60		10	

DATA SHEET NO. 5...(CONTINUED)
DUMMY POSITIONING IN VEHICLE

TEST DUMMY POSITION MEASUREMENTS - REAR SEAT DUMMIES

Code	Measurement Description	Center Seat (H3 50%)		Passenger	
		Length (mm)	Angle (deg)	Length (mm)	Angle (deg)
NR	Nose to Seat Back	455	23.0		
CD	Chest to Seat Back	385			
KDL	Left Knee to Seat Back	60			
KDR	Right Knee to Seat Back	45			
PA	Pelvic Angle		24.4		
TA	Tibia Angle		88.7		
KK	Knee to Knee (Y)	290			
SK	Striker to Outboard Knee	685	16.8		
HRW	Head to Rear Window	815			
SH	Striker to Head	450	82.5		
SHY	Striker to H-Point (Y)	320	51.2		

DATA SHEET NO. 6
SEATBELT ASSESSMENT TEST DATA

Test Vehicle: 2004 Jeep Liberty 4-Door MPV
Test Program: FMVSS 208 Upgrade

NHTSA No.: R40402
Test Date: 08/12/04

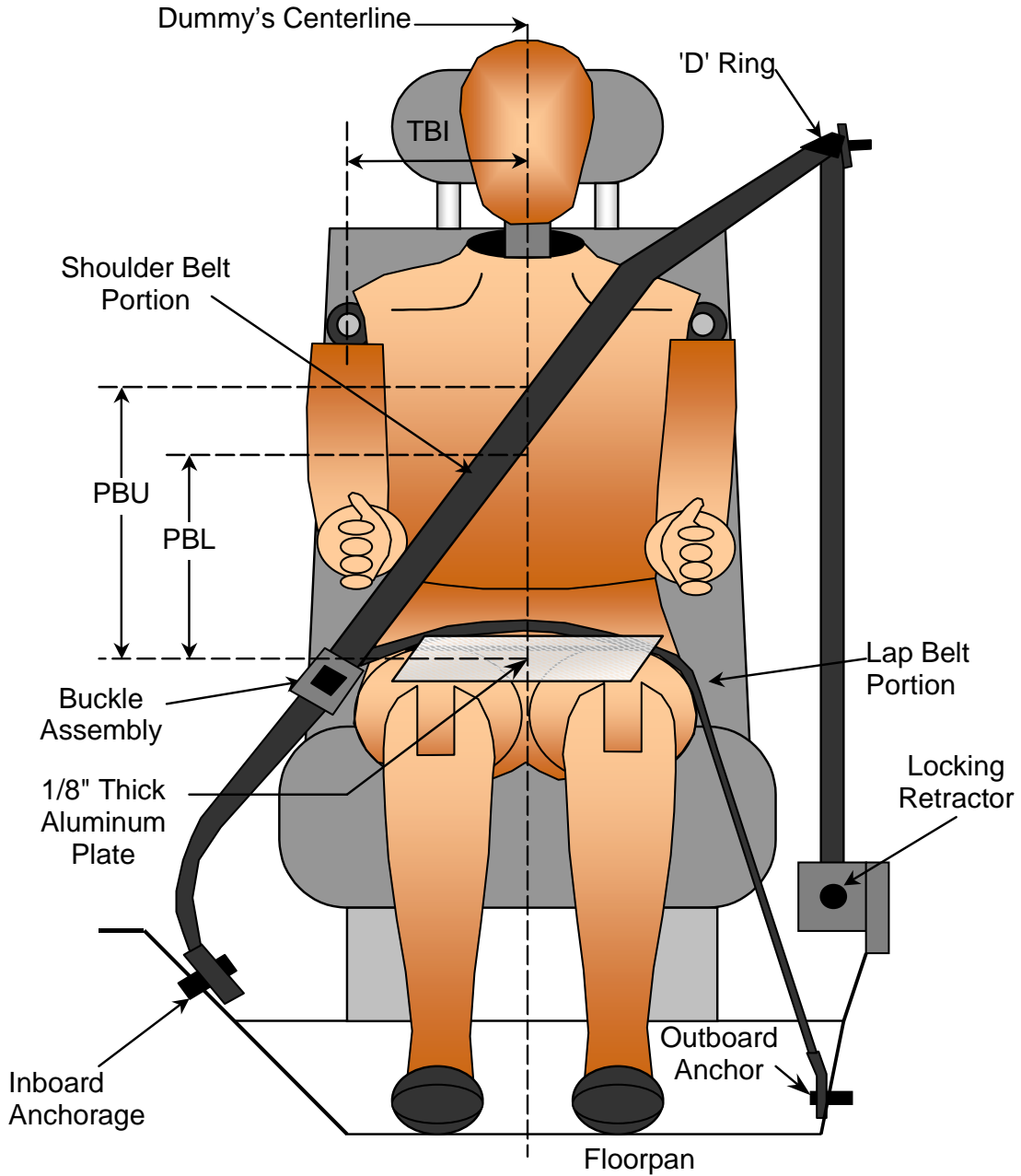

DATA SHEET NO. 6...(CONTINUED)
SEATBELT ASSESSMENT TEST DATA

SEAT BELT POSITIONING MEASUREMENTS; FRONT DUMMIES

Measurement Description	Units	Driver (H3 95%)	Passenger (H3 95%)
TBI -Dummy C/L to Lap/Shoulder Belt Intersect	mm	260	235
PBU - Top Surface of reference to belt upper edge	mm	365	335
PBL - Top Surface of reference to belt lower edge	mm	300	270
Lap Belt Tension	Newtons	10	10
Shoulder Belt Tension	N/A	Retractor	Retractor
Retractor Reel to "D" ring	mm	756	756
Shoulder Belt length as measured on ATD	mm	820	810
Lap Belt length as measured on ATD	mm	790	760
Remainder of belt on reel	mm	700	745
Total belt length for continuous webbing systems	mm	3066	3071

SHOULDER BELT SPOOL-OFF; FRONT DUMMIES

Measurement Description	Units	Driver (H3 95%)	Passenger (H3 95%)
As determined mechanically	mm	245.0	220.0
As determined electronically	mm	310.2	335.9

SEAT BELT POSITIONING MEASUREMENTS; REAR DUMMIES

Measurement Description	Units	Center (H3 50%)	
TBI -Dummy C/L to Lap/Shoulder Belt Intersect	mm	180	
PBU - Top Surface of reference to belt upper edge	mm	260	
PBL - Top Surface of reference to belt lower edge	mm	190	
Lap Belt Tension	Newtons	10	
Shoulder Belt Tension	N/A	Retractor	
Retractor Reel to "D" ring	mm	N/A	
Shoulder Belt length as measured on ATD	mm	1010	
Lap Belt length as measured on ATD	mm	760	
Remainder of belt on reel	mm	605	
Total belt length for continuous webbing systems	mm	2375	

SHOULDER BELT SPOOL-OFF; REAR DUMMIES

Measurement Description	Units	Center	
As determined mechanically	mm	70.0	
As determined electronically	mm	363.3	

DATA SHEET NO. 7
VEHICLE ACCELEROMETER LOCATION AND DATA SUMMARY

Test Vehicle: 2004 Jeep Liberty 4-Door MPV

NHTSA No.: R40402

Test Program: FMVSS 208 Upgrade

Test Date: 08/12/04

INSERT PAGES 18 THRU 25 FROM E.T SHOP DATA

INSERT PAGES 18 THRU 25 FROM E.T SHOP DATA

INSERT PAGES 18 THRU 25 FROM E.T SHOP DATA

INSERT PAGES 18 THRU 25 FROM E.T SHOP DATA

INSERT PAGES 18 THRU 25 FROM E.T SHOP DATA

INSERT PAGES 18 THRU 25 FROM E.T SHOP DATA

INSERT PAGES 18 THRU 25 FROM E.T SHOP DATA

INSERT PAGES 18 THRU 25 FROM E.T SHOP DATA

DATA SHEET NO. 9...(CONTINUED)
DUMMY INJURY CRITERIA DATA

Test Vehicle: 2004 Jeep Liberty 4-Door MPV

NHTSA No.: R40402

Test Program: FMVSS 208 Upgrade

Test Date: 08/12/04

DATA SHEET NO. 9...(CONTINUED)
DUMMY INJURY CRITERIA DATA

Test Vehicle: 2004 Jeep Liberty 4-Door MPV

NHTSA No.: R40402

Test Program: FMVSS 208 Upgrade

Test Date: 08/12/04

DATA SHEET NO. 9...(CONTINUED)
DUMMY INJURY CRITERIA DATA

Test Vehicle: 2004 Jeep Liberty 4-Door MPV

NHTSA No.: R40402

Test Program: FMVSS 208 Upgrade

Test Date: 08/12/04

DATA SHEET NO. 10
SUMMARY OF FMVSS 212 DATA

Test Vehicle: 2004 Jeep Liberty 4-Door MPV
 Test Program: FMVSS 208 Upgrade

NHTSA No.: R40402
 Test Date: 08/12/04

Windshield Mounting Details: Windshield glass is secured to the vehicle frame with a rubber type adhesive and plastic molding covers.

The standard requires that the posttest retention measurement be a minimum of 75 percent of the pretest total periphery measurement for vehicles not equipped with occupant passive restraints and 50 percent for each side of the windshield for vehicles that are equipped with occupant passive restraints.

Temperature of windshield molding during test: 41.1 °C

WINDSHIELD PERIPHERY MEASUREMENTS

Measurement	Pre-Test(mm)	Post-Test(mm)	% of Retention
Left Side	608	608	100%
Right Side	608	608	100%
Total	1216	1216	100%

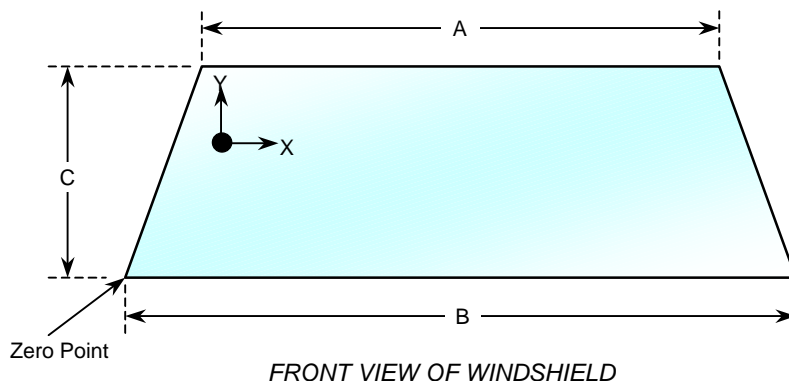

WINDSHIELD DIMENSIONS

Item	Units	Segment Length	Molding Width
A	mm	1200	8
B	mm	1500	8
C-Left	mm	810	21
C-Right	mm	810	21

DATA SHEET NO. 11
WINDSHIELD ZONE INTRUSION FMVSS 219 DATA (PARTIAL)

Test Vehicle: 2004 Jeep Liberty 4-Door MPV
 Test Program: FMVSS 208 Upgrade

NHTSA No.: R40402
 Test Date: 08/12/04

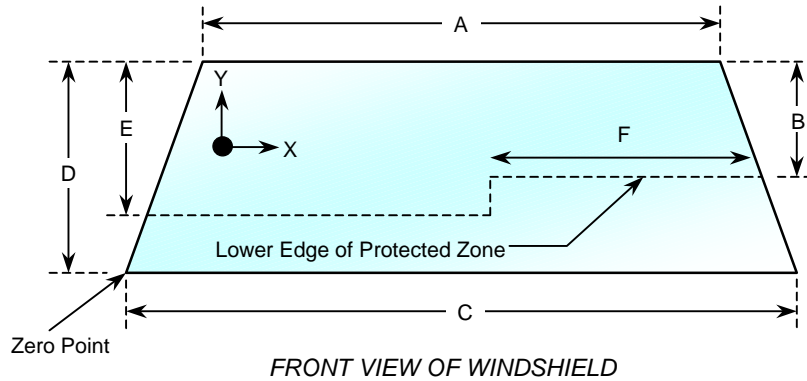

**WINDSHIELD AND
 PROTECTED ZONE**

Item	Units	Value
A	mm	1200
B	mm	430
C	mm	1500
D	mm	608
E	mm	435
F	mm	505

AREA OF PROTECTED ZONE FAILURES

A. Provide coordinates of the area that the protected zone was penetrated more than 0.25 in. by a vehicle component other than one that is normally in contact with the windshield.

X	Y
N/A	N/A
N/A	N/A
N/A	N/A
N/A	N/A

B. Provide coordinates of the area beneath the protected zone that the inner surface of the windshield was penetrated by a vehicle component.

X	Y
N/A	N/A
N/A	N/A
N/A	N/A
N/A	N/A

DATA SHEET NO. 12
FMVSS 301 FUEL SYSTEM INTEGRITY POST IMPACT DATA

Test Vehicle: 2004 Jeep Liberty 4-Door MPV

NHTSA No.: R40402

Test Program: FMVSS 208 Upgrade

Test Date: 08/12/04

Test Time: 12:51 PM

Temperature: 41.1 Deg. C.

STODDARD SOLVENT SPILLAGE MEASUREMENTS

A. From impact until vehicle motion ceases: 0.0 oz.
(Maximum Allowable = 1 ounce)

B. For the 5-minute period after motion ceases: 0.0 oz.
(Maximum Allowable = 5 ounces)

C. For the following 25 minutes: 0.0 oz.
(Maximum Allowable = 1 oz./minute)

D. Spillage Location Details: No leakage occurred

DATA SHEET NO. 13
FMVSS 301 STATIC ROLLOVER DATA

Test Vehicle: 2004 Jeep Liberty 4-Door MPV

NHTSA No.: R40402

Test Program: FMVSS 208 UPGRADE

Test Date: 08/12/04

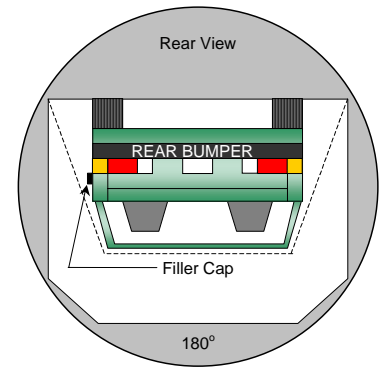
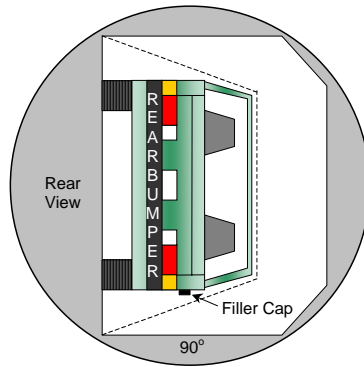
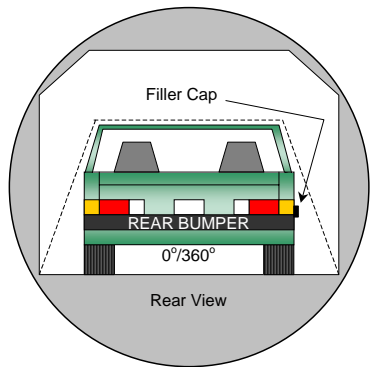

0° to 90°

90° to 180°

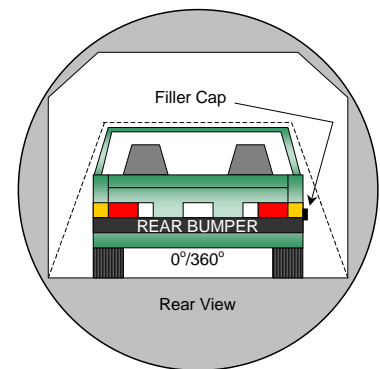
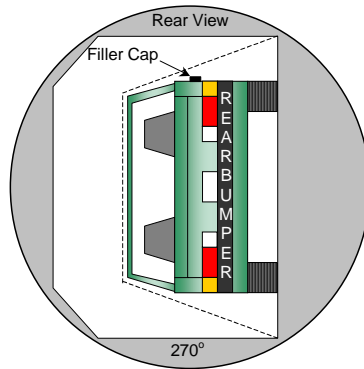
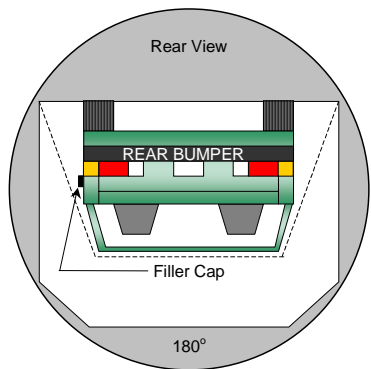

180° to 270°

270° to 360°

1. The specified fixture rollover rate for each 90° of rotation is 60 to 120 seconds.
2. The position hold time at each position is 300 seconds (minimum).
3. No solvent leakage occurred during rollover.

DATA SHEET NO. 13...(CONTINUED)
FMVSS 301 STATIC ROLLOVER DATA

SOLVENT COLLECTION TIME TABLE IN SECONDS

Test Phase	Rotation Time	Hold Time	Total Time
0° to 90°	81	300	381
90° to 180°	81	300	381
180° to 270°	81	300	381
270° to 360°	65	300	365

FMVSS 301 SPILLAGE TABLE REQUIREMENT (oz.)

First 5 Minutes	5.0
Sixth Minute	1.0
Seventh Minute	1.0
Eighth Minute	1.0

ACTUAL TEST VEHICLE SOLVENT SPILLAGE TABLE (oz.)

Test Phase	First 5 Minutes	Sixth Minute	Seventh Minute	Eighth Minute
0° to 90°	0	0	0	0
90° to 180°	0	0	0	0
180° to 270°	0	0	0	0
270° to 360°	0	0	0	0

SOLVENT SPILLAGE LOCATION TABLE

Test Phase	Spillage Location
0° to 90°	None
90° to 180°	None
180° to 270°	None
270° to 360°	None

DATA SHEET NO. 14
VEHICLE MEASUREMENTS

Test Vehicle: 2004 Jeep Liberty 4-Door MPV
 Test Program: FMVSS 208 Upgrade

NHTSA No.: R40402
 Test Date: 08/12/04

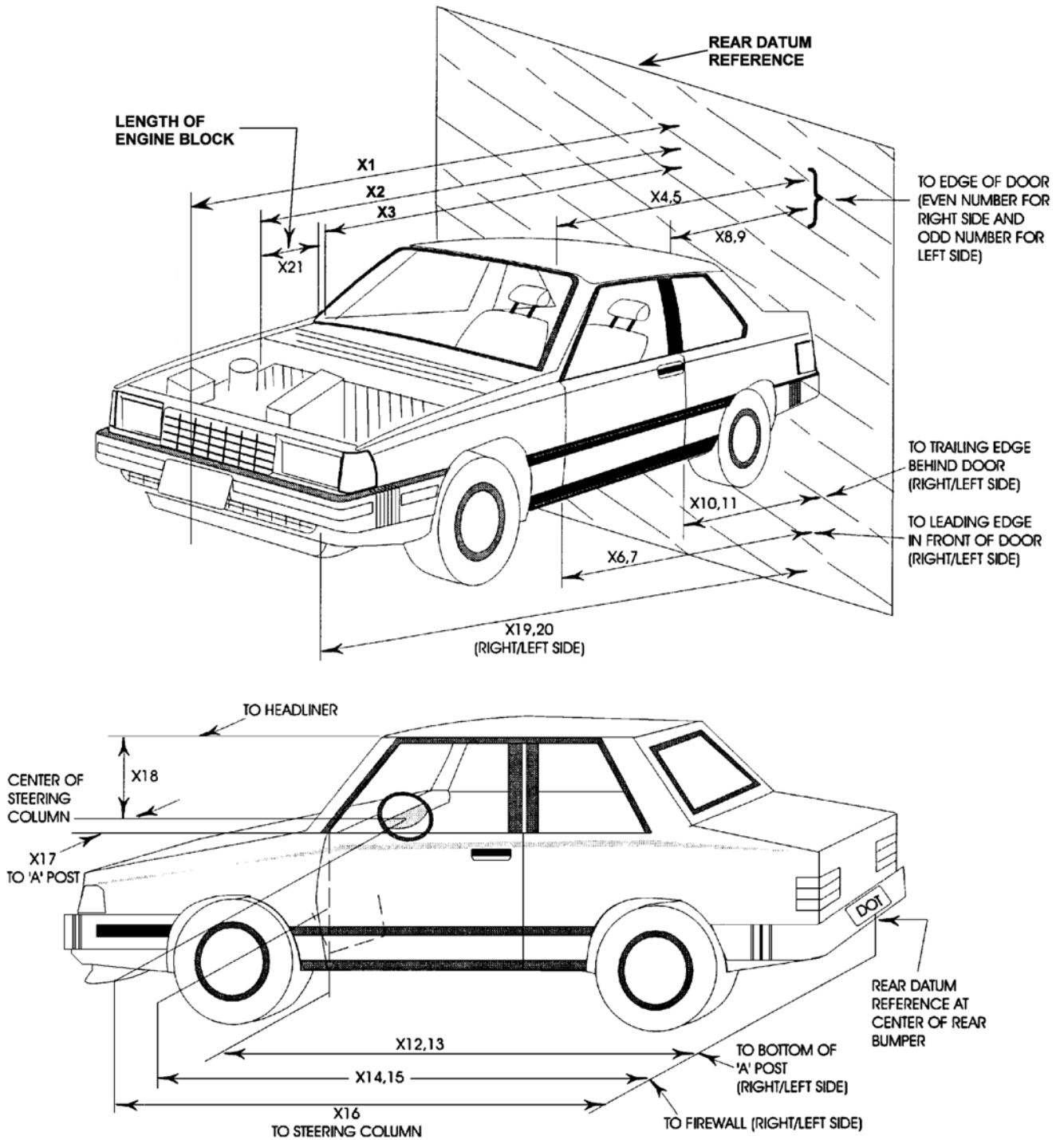

DATA SHEET NO. 14...(CONTINUED)
VEHICLE MEASUREMENTS

VEHICLE MEASUREMENT TABLE

No.	Measurement Description	Units	Pre-Test	Post-Test	Diff.
1	Total length of vehicle at centerline	mm	4215	3840	-375
2	RSOV to front of engine	mm	3635	3420	-215
3	RSOV to firewall centerline	mm	3145	3090	-55
4	RSOV to leading edge of right door	mm	2872	2865	-7
5	RSOV to leading edge of left door	mm	2873	2870	-3
6	RSOV to lower leading edge of right door	mm	2850	2830	-20
7	RSOV to lower leading edge of left door	mm	2854	2830	-24
8	RSOV to upper trailing edge of right door	mm	1835	1825	-10
9	RSOV to upper trailing edge of left door	mm	1834	1830	-4
10	RSOV to lower trailing edge of right door	mm	1850	1826	-24
11	RSOV to lower trailing edge of left door	mm	1850	1825	-25
12	RSOV to bottom of right 'A' pillar	mm	2824	2801	-23
13	RSOV to bottom of left 'A' pillar	mm	2824	2801	-23
14	RSOV to firewall on right side	mm	3185	3140	-45
15	RSOV to firewall on left side	mm	3195	3160	-35
16	RSOV to steering column hub	mm	2395	2410	15
17	Center of steering column to left 'A' pillar	mm	335	354	19
18	Center of steering column to headlining	mm	495	540	45
19	RSOV to right side of front bumper	mm	4035	3820	-215
20	RSOV to left side of front bumper	mm	4036	3815	-221
21	Length of engine block	mm	575	575	0
RD	RSOV to right side of dash panel	mm	2639	2636	-3
CD	RSOV to center of dash panel	mm	2565	2542	-23
LD	RSOV to left side of dash panel	mm	2641	2646	5

All measurements in millimeters

DATA SHEET NO. 14...(CONTINUED)
VEHICLE STRUCTURAL MEASUREMENTS

VEHICLE STRUCTURAL MEASUREMENT TABLE

No.	Measurement Description	Units	Pre-Test	Post-Test	Diff.
1	Total length	mm	4215	3840	-375
2	Total width	mm	1800	1800	0
3	Bumper top height	mm	710	765	55
4	Bumper bottom height	mm	352	400	48
5	Longitudinal member top height	mm	481	597	116
6	Longitudinal member bottom height	mm	419	446	27
7	Distance between longitudinal members	mm	853	735	-118
8	Longitudinal member width	mm	67	67	0
9	Engine top height	mm	1044	925	-119
10	Engine bottom height	mm	253	246	-7
11	Engine and gear box width	mm	650	650	0
12	Front bumper to engine distance	mm	570	480	-90
13	Front shock absorber fixing width	mm	735	790	55
14	Bonnet leading edge height	mm	921	1020	99
15	Front shock absorber fixing width	mm	893	810	-83
16	Front bumper to front axle distance	mm	723	415	-308
17	Front axle to 'A' pillar distance	mm	590	570	-20
18	'A' pillar to 'B' pillar distance	mm	1034	1035	1
19	'B' pillar to rear axle distance	mm	1001	985	-16
20	'B' pillar to 'C' pillar distance	mm	875	890	15
21	Roof sill bottom height	mm	1585	1550	-35
22	Roof sill top height	mm	1700	1705	5
23	Floor sill bottom height	mm	370	325	-45
24	Floor sill top height	mm	514	430	-84

All measurements in millimeters

DATA SHEET NO. 14...(CONTINUED)
VEHICLE STRUCTURAL MEASUREMENTS

DOOR OPENING WIDTH TABLE

Item	Description	Units	Pre-Test	Post-Test	Diff.
A	Left Side Upper	mm	943	931	-12
B	Left Side Lower	mm	896	896	0
D	Right Side Upper	mm	926	936	10
E	Right Side Lower	mm	896	896	0

WHEELBASE MEASUREMENT TABLE

Item	Description	Units	Pre-Test	Post-Test	Diff.
C	Left Side Wheel Base	mm	2650	2590	-60
F	Right Side Wheel Base	mm	2650	2610	-40

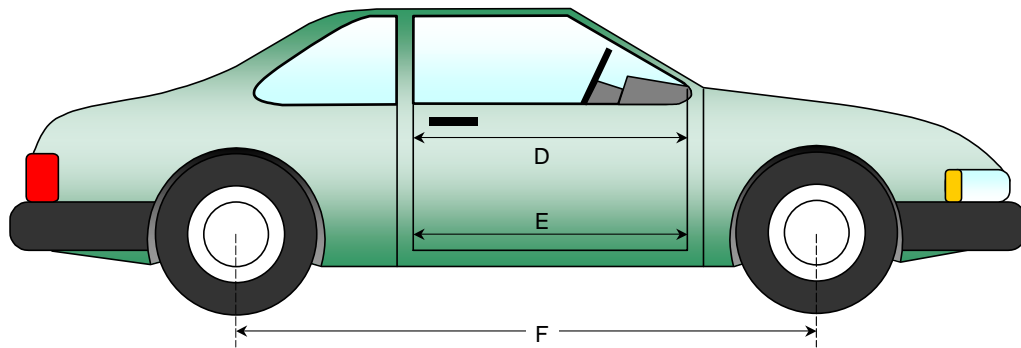
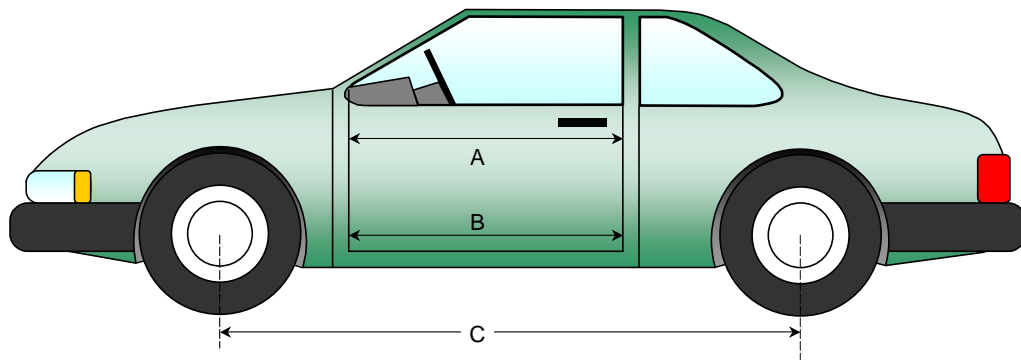

DATA SHEET NO. 14...(CONTINUED)
VEHICLE STRUCTURAL MEASUREMENTS

DRIVER COMPARTMENT INTRUSION TABLE

Item	Description	Units	Pre-Test	Post-Test	Diff.
AB	Door Opening (Inside window jam)	mm	943	931	-12
CX	Left Knee Bolster to X	mm	305	310	5
DX	Right Knee Bolster to X	mm	280	270	-10
EX	Brake Pedal to X	mm	516	568	52
FX	Foot Rest to X	mm	634	601	-33
GX	Center of Steering Wheel Hub to X	mm	75	45	-30

X = Left Front Seat Outboard Anchor Bolt Head

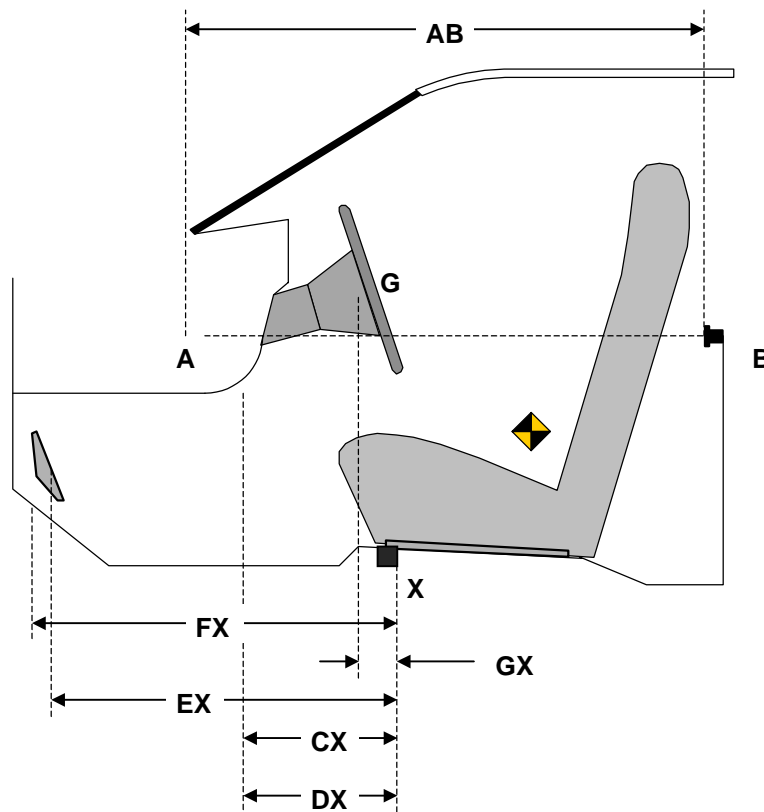

DATA SHEET NO. 14...(CONTINUED)
VEHICLE STRUCTURAL MEASUREMENTS

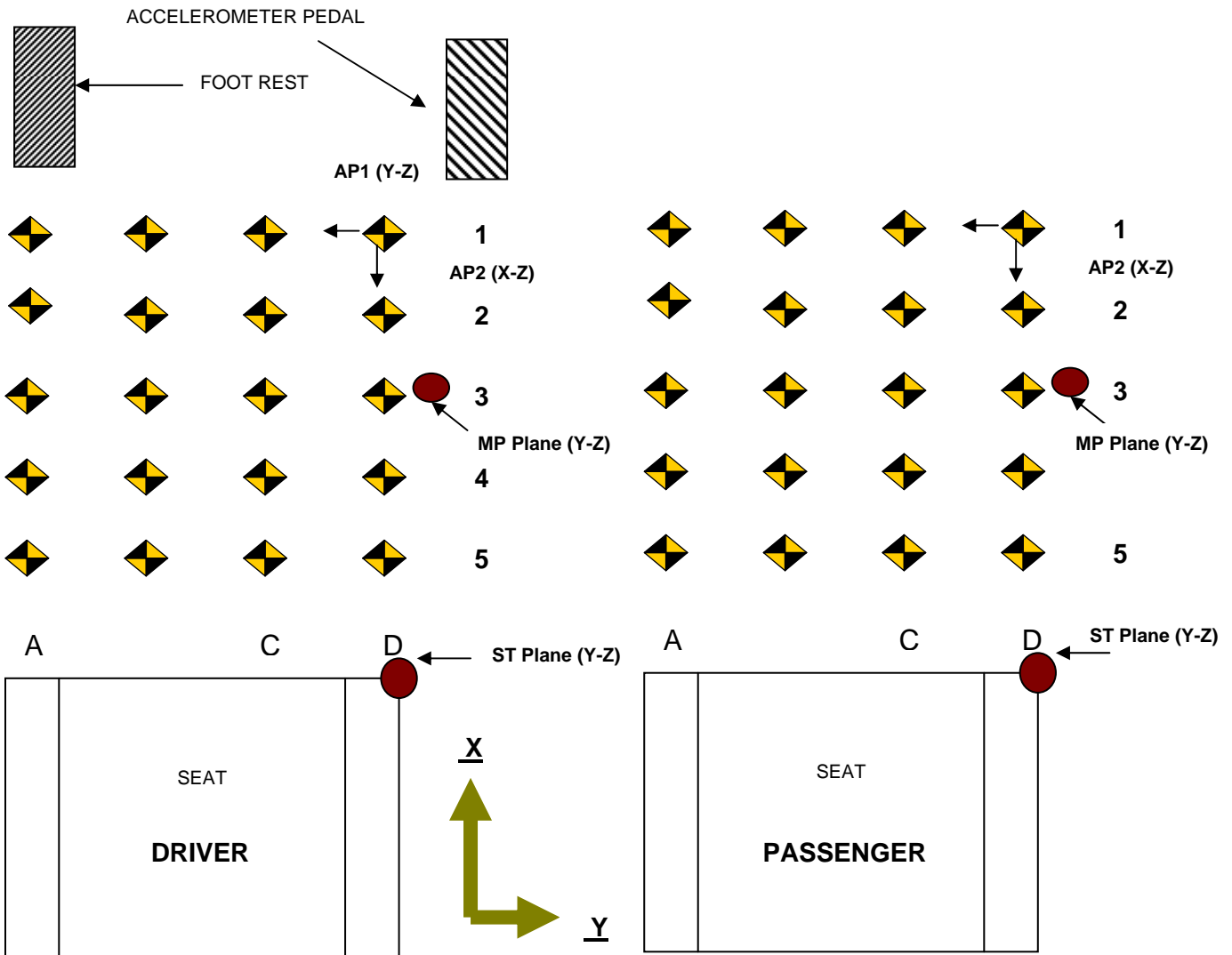

AP1: Y-Z Plane passing through D1

AP2: X-Z Plane passing through D1

AP3: X-Y plane passing through D1

MP: Y-Z plane, halfway between the ST plane and AP1 plane

CF Plane: X-Z plane passes through center of footrest.

BP Plane: X-Z plane passes through center of brake pedal

TP Plane: Y-Z plane, intersection of BP Plane and the intersection of the toe pan and floorboard

Column A: intersection of vehicle and CF plane

Column D: Intersection of vehicle and AP2 plane

Row 1: intersection of the vehicle and the AP3 Plane

Row 3: intersection of the vehicle and TP plane

Row 5: intersection of the vehicle and MP plane

Row 2: evenly spaced between row 1 and 3

Row 4: evenly spaced between row 3 and 5

DATA SHEET NO. 14...(CONTINUED)
VEHICLE STRUCTURAL MEASUREMENTS

All measurements in mm

DRIVER FLOOR PAN X-AXIS

	Pre-Test				Post-Test				Difference			
	A	B	C	D	A	B	C	D	A	B	C	D
1	-724	-778	-777	-738	683	705	685	641	1407	1483	1462	1379
2	-654	-687	-691	-682	642	630	626	608	1296	1317	1317	1290
3	-571	-580	-580	-577	556	551	545	535	1127	1131	1125	1112
4	-481	-483	-491	-484	422	416	412	404	903.2	899	902.6	888.2
5	-396	-397	-401	-405	289	284	276	274	685.3	680.8	676.7	678.9

DRIVER FLOOR PAN Y-AXIS

	Pre-Test				Post-Test				Difference			
	A	B	C	D	A	B	C	D	A	B	C	D
1	9.7	-93.6	-200	-296	20	147	280	418	10.3	240.6	480.4	714.4
2	17.6	-92	-202	-287	11	144	274	420	-6.6	236	475.6	706.8
3	21.8	-83.3	-187	-278	12	143	278	419	-9.8	226.3	465.4	696.6
4	19.6	-77.8	-182	-272	6	140	277	415	-13.6	217.8	459.4	687
5	22.7	-71.7	-175	-264	5	136	276	408	-17.7	207.7	450.9	671.6

DRIVER FLOOR PAN Z-AXIS

	Pre-Test				Post-Test				Difference			
	A	B	C	D	A	B	C	D	A	B	C	D
1	49.4	88.1	87.9	62	-35	4	-5	-51	-84.4	-84.1	-92.9	-113
2	114.1	165.4	152.6	161.4	62	61	47	15	-52.1	-104	-106	-146
3	190.6	220.2	212.1	222.1	96	98	95	91	-94.6	-122	-117	-131
4	223.4	230.2	224.8	228	86	86	86	93	-137	-144	-139	-135
5	222.2	227.9	223.7	224	85	87	87	95	-137	-141	-137	-129

DATA SHEET NO. 14...(CONTINUED)
VEHICLE STRUCTURAL MEASUREMENTS

All measurements in mm

PASSENGER FLOOR PAN X-AXIS

	Pre-Test				Post-Test				Difference			
	A	B	C	D	A	B	C	D	A	B	C	D
1	-649	-671	-686	-696	572	593	619	651	1221	1264	1305	1347
2	-542	-561	-569	-578	513	558	567	573	1055	1119	1136	1151
3	-436	-450	-459	-468	445	484	489	493	880.5	934.4	948.2	961.3
4	-343	-353	-361	-367	337	358	371	381	679.5	710.9	732.1	747.9
5	-266	-272	-276	-284	218	237	238	242	484.1	508.5	514.4	526.1

PASSENGER FLOOR PAN Y-AXIS

	Pre-Test				Post-Test				Difference			
	A	B	C	D	A	B	C	D	A	B	C	D
1	346.6	200.4	115.7	-13.5	-359	-229	-103	41	-706	-429	-219	54.5
2	336.9	192.9	96.0	-22.1	-349	-231	-100	42	-686	-424	-196	64.1
3	326.2	175.3	73.1	-26.6	-352	-231	-94	43	-678	-406	-167	69.6
4	316.2	164.4	61.4	-34.4	-357	-227	-88	45	-673	-391	-149	79.4
5	305.4	153.0	55.3	-39.6	-358	-219	-78	48	-663	-372	-133	87.6

PASSENGER FLOOR PAN Z-AXIS

	Pre-Test				Post-Test				Difference			
	A	B	C	D	A	B	C	D	A	B	C	D
1	135.1	160.5	161.9	160.2	-64	-18	-13	-13	-199	-179	-175	-173
2	192.6	214.4	225.4	221.9	-50	63	69	69	-243	-151	-156	-153
3	217.3	222.2	221.8	225.2	-27	96	94	94	-244	-126	-128	-131
4	210.4	220.8	223.3	223.1	26	94	95	95	-184	-127	-128	-128
5	185.7	220.8	222.0	222.0	51	90	89	89	-135	-131	-133	-133

**DATA SHEET NO. 15
CAMERA LOCATIONS**

Test Vehicle: 2004 Jeep Liberty 4-Door MPV
 Test Program: FMVSS 208 Upgrade

NHTSA No.: R40402
 Test Date: 08/12/04

VEHICLE CAMERA MEASUREMENT TABLE

No.	Camera		Location (mm)			Angle (deg.)	Film Plane to Head	Lens (mm)	Speed (fps)
	View	Type	X	Y	Z				
1	Real-time (Panning)	Video	-12192	-6096	-1651	-10	N/A	Zoom	30
1B	Real Time (Still)	Video	-1219	-8585	-1372	0	8188	Zoom	30
1C	Real Time (Still)	Video	-1067	7976	-991	0	7620	Zoom	30
2	Overall Left Side	16mm	-2489	8280	-1143	-4	7834	13	1030
2B	Overall Left Side	Video	-1883	-7671	-1143	-2	7228	10	1000
3	Left Side View	Video	-1677	-7773	-1270	-4	7338	50	1000
3B	Left Side View	16mm	-2134	-8230	-1449	-4	7773	35	1000
3C	Left Side View	16mm	-1880	-8230	-1449	-2	7780		890
4	Driver & Interior	16mm	-5257	-10897	-4648	-13	11329	75	1005
4B	Driver & Interior	Video	-5360	-10846	-4648	-13	11310	Zoom	1000
5	Steering Column (Bottom)	16mm	-2134	-8230	-2997	-16	7921	19	990
6	Steering Column (Top)	16mm	-2134	-8230	-3404	-20	8009	19	1010
7	Left Rear Dummy On-Board	Video	-2819	-635	-1626	-5	668	4.2	DNR
8	Overall Right Side	16mm	-2083	8230	-1270	-6	7776	13	1005
9	Right Side View	Video	-1880	8230	-1575	-4	7780	50	DNR
9B	Right Side View	16mm	-2083	8230	-1575	-4	7774	35	1020
10	Right Passenger View	16mm	-1677	10871	-1219	4	10430	80	980
11	Passenger & Interior View	16mm	-6781	9144	-2997	-9	9933	50	895
11B	Passenger & Interior View	Video	-6477	9068	-2946	-9	9722	Zoom	1000
12	Right Rear Dummy On-Board	Video	-2819	-635	-1626	-5	668	5.7	DNR
13	Passenger Front View	16mm	610	432	-2667	-40	N/A	13	730
14	Driver Front View	16mm	610	-432	-2667	-40	N/A	13	1030
15	Windshield View	16mm	-610	0	-5944	-90	N/A	13	NTM
16	Pit View of Engine	16mm	-914	0	1499	90	N/A	9	1010
17	Pit View of Fuel Tank	16mm	-2438	0	-1499	90	N/A	6	DNR

DATA SHEET NO. 16
PHOTOGRAPHIC REFERENCE TARGET LOCATIONS

Test Vehicle: 2004 Jeep Liberty 4-Door MPV
 Test Program: FMVSS 208 Upgrade

NHTSA No.: R40402
 Test Date: 08/12/04

All Dimensions in (mm)	
Item	Value
A	395
B	1800
C	2042
D	605
E	1565
F	150
G	1613
H	920
I	1240
J	817
K	817
L	1341
M	920
N	1341
O	817
P	817
Q	1240

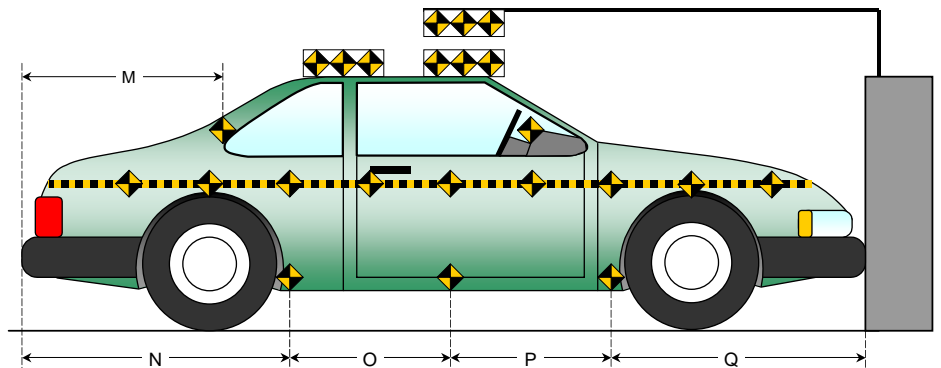
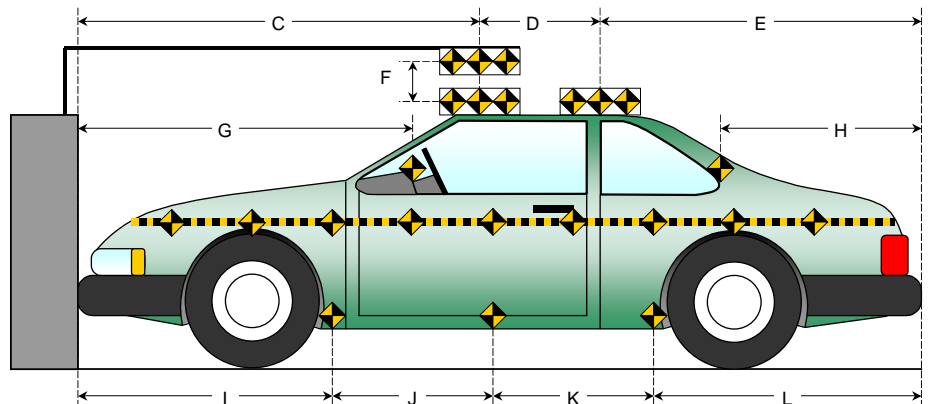
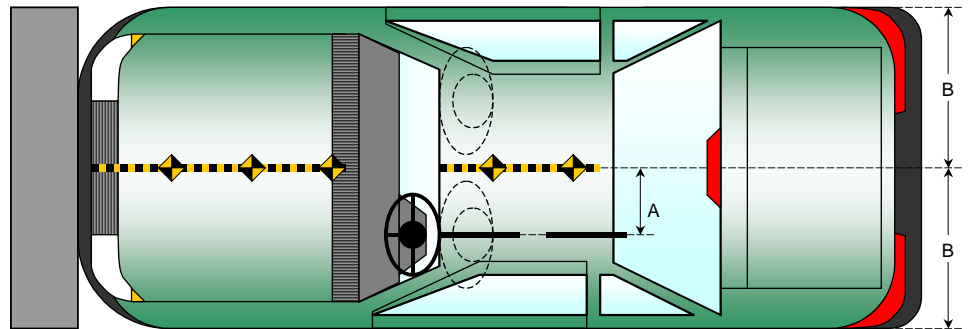

DATA SHEET NO. 17
TEST VEHICLE FRONTAL PROFILE DATA

Test Vehicle: 2004 Jeep Liberty 4-Door MPV
 Test Program: FMVSS 208 Upgrade

NHTSA No.: R40402
 Test Date: 08/12/04

Pre-Test Measurements in mm.							
		Vehicle Left			Vehicle Right		
		C1	C2	C3	C4	C5	C6
Leading edge of Hood	X	-293	-283	-284	-289	-306	-335
	Y	-421	-253	-83	91	264	433
	Z	-919	-926	-933	-930	-928	-928
Grille	X	-244	-236	-232	-250	-264	-280
	Y	-374	-269	-155	179	288	394
	Z	-762	-764	-762	-780	-785	-776
Top of Bumper	X	-213	-103	-108	-120	-141	-285
	Y	-699	-399	-112	152	433	730
	Z	-565	-596	-563	-566	-602	-583
Bottom of Bumper	X	-241	-200	-212	-220	-234	-309
	Y	-662	-391	-119	174	419	716
	Z	-379	-384	-365	-374	-396	-415

Test Vehicle Pre-Crash Frontal Profile (Jeep Liberty)

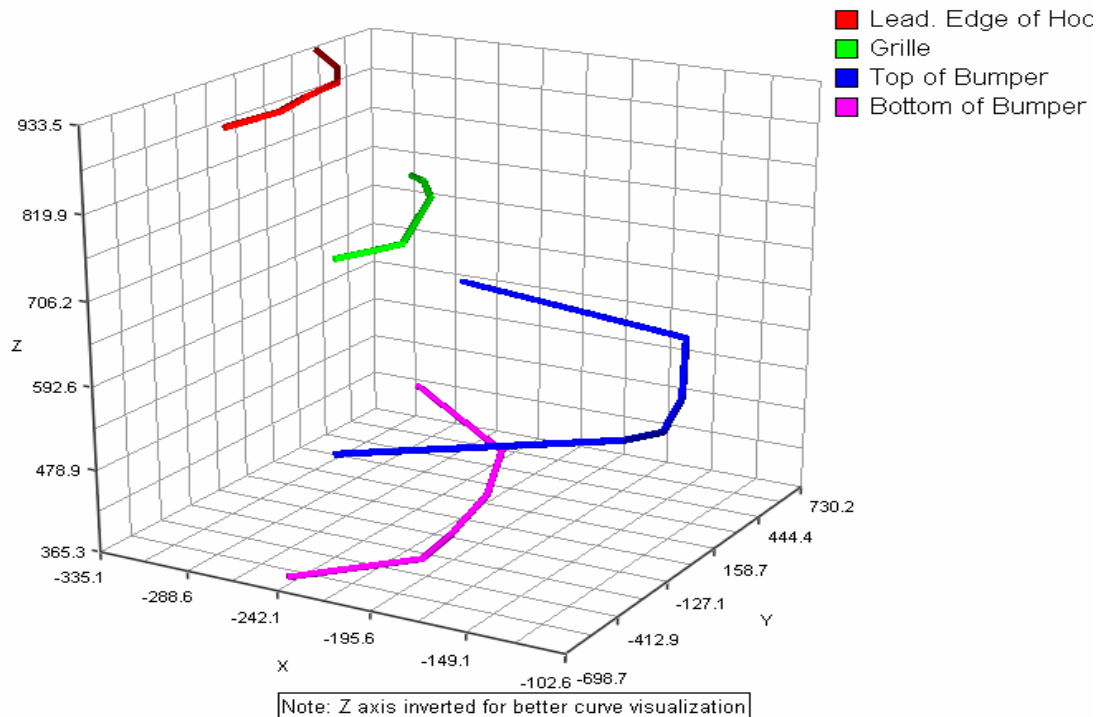

DATA SHEET NO. 17...(CONTINUED)
TEST VEHICLE FRONTAL PROFILE DATA

Test Vehicle: 2004 Jeep Liberty 4-Door MPV
 Test Program: FMVSS 208 Upgrade

NHTSA No.: R40402
 Test Date: 08/12/04

Post Test Measurements in mm.							
		Vehicle Left			Vehicle Right		
		C1	C2	C3	C4	C5	C6
Leading edge of Hood	X	-517	-504	-532	-567	-600	-639
	Y	-301	-132	33	200	368	532
	Z	-967	-965	-972	-985	-996	-1016
Grille	X	-521	-528	-538	-582	-604	-634
	Y	-453	-343	-232	98	206	316
	Z	-876	-865	-860	-835	-830	-832
Top of Bumper	X	-488	-498	-516	-538	-577	-596
	Y	-693	-406	-130	144	421	669
	Z	-642	-668	-667	-666	-662	-658
Bottom of Bumper	X	-472	-555	-539	-570	-651	-574
	Y	-672	-408	-137	144	414	666
	Z	-460	-444	-437	-439	-443	-469

Test Vehicle Post Crash Frontal Profile (Jeep Liberty)

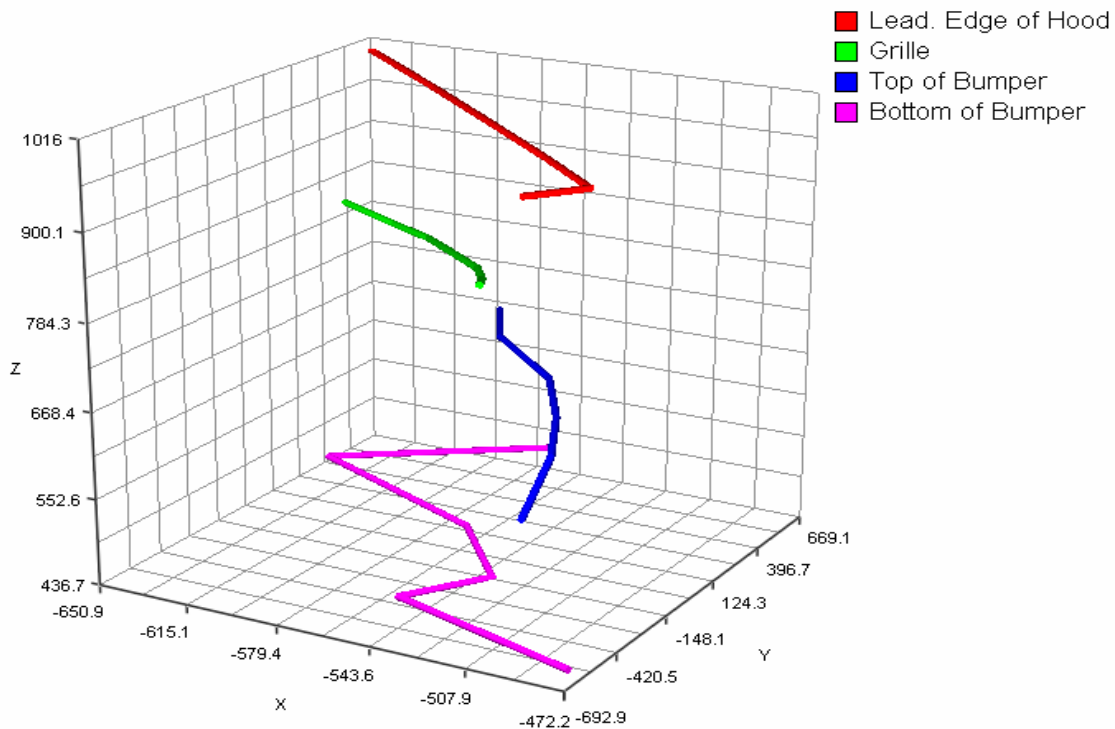

DATA SHEET NO. 17...(CONTINUED)
TEST VEHICLE FRONTAL PROFILE DATA

Test Vehicle: 2004 Jeep Liberty 4-Door MPV

NHTSA No.: R40402

Test Program: FMVSS 208 Upgrade

Test Date: 08/12/04

Change (Post - Pre) Test Measurements in mm.							
		Vehicle Left			Vehicle Right		
		C1	C2	C3	C4	C5	C6
Leading edge of Hood							
	X	-224	-221	-249	-278	-294	-304
	Y	120	120	116	109	104	100
	Z	-49	-39	-38	-55	-68	-88
Grille							
	X	-277	-292	-306	-332	-341	-353
	Y	-79	-74	-77	-81	-82	-78
	Z	-114	-102	-98	-55	-44	-56
Top of Bumper							
	X	-275	-395	-408	-418	-437	-311
	Y	6	-7	-18	-7	-11	-61
	Z	-77	-72	-104	-100	-60	-74
Bottom of Bumper							
	X	-231	-356	-327	-351	-417	-265
	Y	-10	-17	-19	-30	-5	-50
	Z	-82	-60	-71	-65	-47	-54

**DATA SHEET NO. 18
POST-TEST AIRBAG DATA**

Test Vehicle: 2004 Jeep Liberty 4-Door MPV
 Test Program: FMVSS 208 Upgrade

NHTSA No.: R40402
 Test Date: 08/12/04

POST-TEST AIRBAG DATA

	DRIVER	PASSENGER
No. of vent holes	2	2
Size of vent holes (mm ²)	491	1963
Total vent area (mm ²)	982	3927

Deflated airbag length and width dimensions or, if round, diameter (mm)		
Length	580	530
Width	630	430
Depth/Diameter	320	460

Tethering information		
Is the airbag tethered?	YES	NO
Record length of tether (mm)	270	N/A

Airbag manufacturing information		
Manufacturer	AIRBAG LABEL WAS MELTED AFTER IMPACT. COULD NOT OBTAIN INFORMATION	AIRBAG LABEL WAS MELTED AFTER IMPACT. COULD NOT OBTAIN INFORMATION
Part No.	GA 120-05520 05523180349	GO 2605000D TJYR1U02AHJ
Gas Generator	AIRBAG LABEL WAS MELTED AFTER IMPACT. COULD NOT OBTAIN INFORMATION	AIRBAG LABEL WAS MELTED AFTER IMPACT. COULD NOT OBTAIN INFORMATION

The following sketch shows the airbag with location of the vent holes (v1 and v2), along with the tethers attachment points (T1 and T2). The tethers are sewed to the both bag and the steering wheel end.

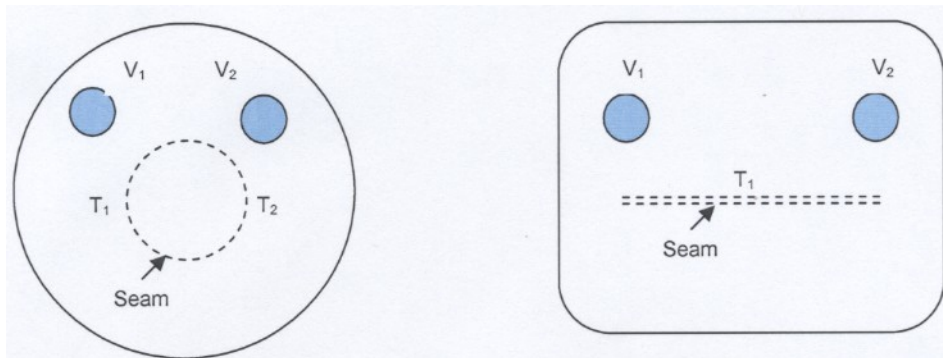

DATA SHEET NO. 19
FIXED BARRIER LOAD CELL LOCATIONS

Test Vehicle: 2004 Jeep Liberty 4-Door MPV
 Test Program: FMVSS 208 Upgrade

NHTSA No.: R40402
 Test Date: 08/12/04

36 Load Cell Rigid Barrier (NHTSA Standard)
Load Cell Locations on Fixed Barrier

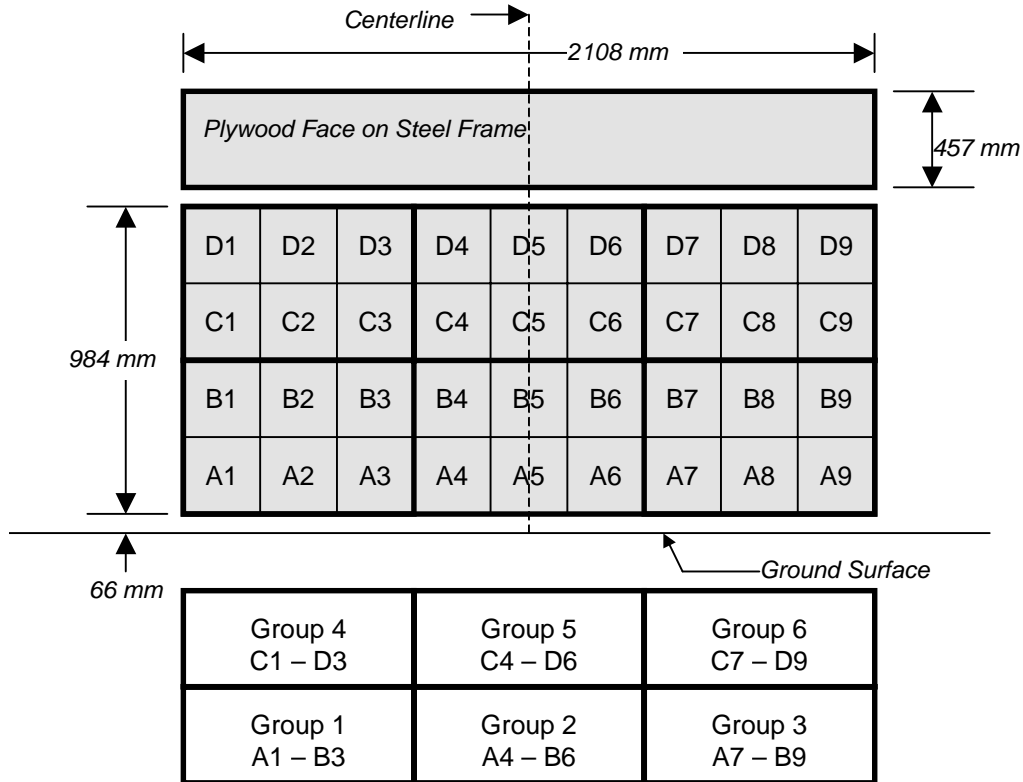

6 Groups of 6 Load Cells Each

The Data is presented in Appendix C with the following requirements:

- 1.) Data from 36 individual load cells
- 2.) Sum data from 6 groupings shown above (6 cells/group)
- 3.) Total or sum of all 36 individual load cells
- 4.) Sum of all 36 individual load cells vs. vehicle dynamic crush

DATA SHEET NO. 20
DUMMY/VEHICLE TEMPERATURE STABILIZATION

Test Vehicle: 2004 Jeep Liberty 4-Door MPV
 Test Program: FMVSS 208 Upgrade

NHTSA No.: R40402
 Test Date: 08/12/04

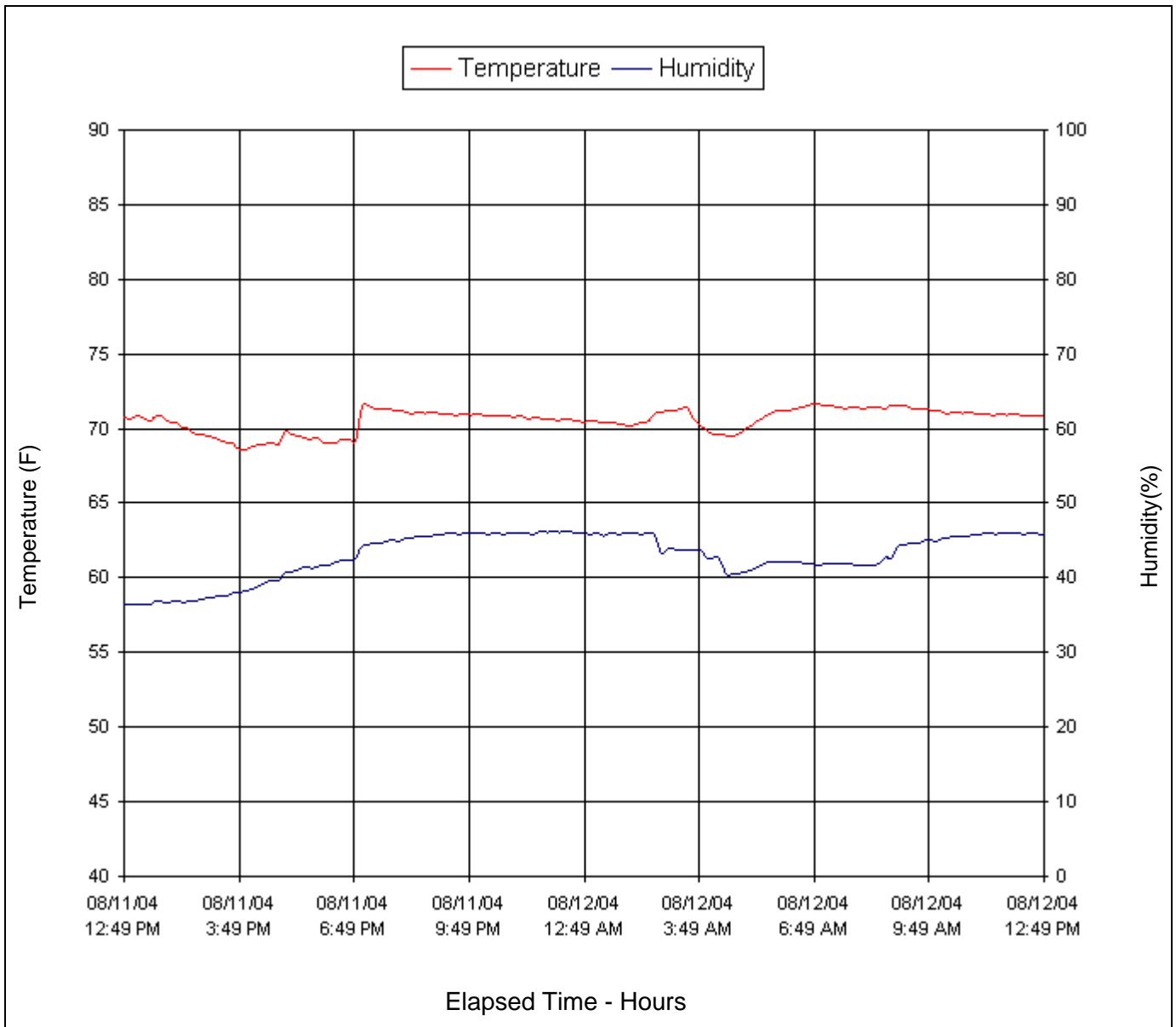

APPENDIX A
PHOTOGRAPHS

LIST OF PHOTOGRAPHS

Figure		Page
A-1	Load Cell Location	A-1
A-2	Vehicle Certification Label	A-2
A-3	Vehicle Tire Label	A-3
A-4	Right Front $\frac{3}{4}$ View, As Received	A-4
A-5	Left Rear $\frac{3}{4}$ View, As Received	A-5
A-6	Pre-Test Front View	A-6
A-7	Post-Test Front View (Vehicle Moved)	A-7
A-8	Pre-Test Left Side View	A-8
A-9	Post-Test Left Side View	A-9
A-10	Pre-Test Right Side View	A-10
A-11	Post-Test Right Side View	A-11
A-12	Pre-Test Right Front $\frac{3}{4}$ View	A-12
A-13	Post-Test Right Front $\frac{3}{4}$ View	A-13
A-14	Pre-Test Left Rear $\frac{3}{4}$ View	A-14
A-15	Post-Test Left Rear $\frac{3}{4}$ View	A-15
A-16	Post-Test Left Rear $\frac{3}{4}$ View of Doors After Impact	A-16
A-17	Post-Test Driver Side A-Pillar	A-17
A-18	Post-Test Driver Side B-Pillar	A-18
A-19	Post-Test Driver Side C-Pillar	A-19
A-20	Post-Test Driver Side D Pillar	A-20
A-21	Post-test Driver Side Rear Door Sill	A-21
A-22	Post-Test Driver Side Rear Door Sill	A-22
A-23	Post-Test Right Rear $\frac{3}{4}$ View of Doors After Impact	A-23
A-24	Post-Test Passenger Side A Pillar	A-24
A-25	Post-Test Passenger Side B-Pillar	A-25
A-26	Post-Test Passenger Side C-Pillar	A-26
A-27	Post-Test Passenger Side D Pillar	A-27
A-28	Post-Test Passenger Side Front Door Sill	A-28
A-29	Post-Test Passenger Side Rear Door Sill	A-29
A-30	Pre-Test Windshield View	A-30
A-31	Post-Test Windshield View	A-31
A-32	Pre-Test Engine Compartment	A-32
A-33	Post-Test Engine Compartment (Vehicle Moved)	A-33
A-34	Pre-Test Fuel Cap	A-34

LIST OF PHOTOGRAPHS...(Continued)

Figure		Page
A-35	Post-Test Fuel Cap	A-35
A-36	Pre-Test Front Underbody View (Front of Test Vehicle is to the Left)	A-36
A-37	Post-Test Front Underbody View (Front of Test Vehicle is to the Left)	A-37
A-38	Pre-Test Mid Underbody View (Front of Test Vehicle is to the Left)	A-38
A-39	Post-Test Mid Underbody View (Front of Test Vehicle is to the Left)	A-39
A-40	Pre-Test Rear Underbody View (Front of Test Vehicle is to the Left)	A-40
A-41	Post-Test Rear Underbody View (Front of Test Vehicle is to the Left)	A-41
A-42	Post-Test Left Front Wheel Well Close-up with Tire and Wheel Removed	A-42
A-43	Post-Test Left Front Wheel Well with Tire and Wheel Removed	A-43
A-44	Post-Test Left Front Wheel Close-Up with Tire and Wheel Removed	A-44
A-45	Post-Test Front Wheel Well Underside View (Front of Vehicle is to the Left)	A-45
A-46	Post-Test Left Front Bumper to Rail Attachment (Front of Vehicle is to the Left)	A-46
A-47	Post-Test Left Front Sub Frame Mount Damage (Front of Vehicle is to the Left)	A-47
A-48	Post-Test Right Front Wheel Well (Front of Test Vehicle is to the Right)	A-48
A-49	Post-Test Right Front Wheel Well with Tire and Wheel Removed	A-49
A-50	Post-Test Right Front Wheel Well with Tire and Wheel Removed Close-Up (Front of test Vehicle is to the Right)	A-50
A-51	Post-Test Right Front Wheel Well Underside View (Front of Test Vehicle is to the Left)	A-51
A-52	Right Front Bumper to Rail Attachment (Front of Test Vehicle is to the Left)	A-52
A-53	Post-Test Right Sub Frame Mount Damage (Front of Test Vehicle is to the Left)	A-53
A-54	Pre-Test Driver Dummy Front View (Head Position)	A-54
A-55	Post-Test Driver Dummy Front View (Head Position)	A-55
A-56	Pre-Test Driver Dummy Front Through Window	A-56
A-57	Post-Test Driver Dummy Front Through Window	A-57
A-58	Pre-Test Driver Dummy Door Open	A-58
A-59	Post-Test Driver Dummy Door Open	A-59
A-60	Pre-Test Driver Dummy Abdomen	A-60
A-61	Post-Test Driver Dummy Abdomen	A-61
A-62	Pre-Test Driver Dummy Feet	A-62
A-63	Post-Test Driver Dummy Feet	A-63
A-64	Pre-Test Driver Side Knee Bolster	A-64
A-65	Post-Test Driver Side knee Bolster	A-65
A-66	Pre-Test Driver Side Floor Pan	A-66

LIST OF PHOTOGRAPHS...(Continued)

Figure		Page
A-67	Post-Test Driver Seat Side Floor Pan	A-67
A-68	Pre-Test Driver Seat Track	A-68
A-69	Post-Test Driver Seat Track	A-69
A-70	Post-Test Driver Dummy Head	A-70
A-71	Post-Test Driver Dummy Contact to Air Bag	A-71
A-72	Post-Test Passenger Dummy Contact with Seat Head Rest	A-72
A-73	Post-Test Driver Dummy Contact with Door Panel	A-73
A-74	Pre-Test Passenger Dummy Front View (Head Position)	A-74
A-75	Post-Test Passenger Dummy Front View (Head Position)	A-75
A-76	Pre-Test Passenger Dummy Front Through Window	A-76
A-77	Post-Test Passenger Dummy Front Through Window	A-77
A-78	Pre-Test Passenger Dummy Door Open	A-78
A-79	Post-Test Passenger Dummy Door Open	A-79
A-80	Pre-Test Passenger Dummy Feet	A-80
A-81	Post-Test Passenger Dummy Feet	A-81
A-82	Pre-Test Passenger Side Knee Bolster	A-82
A-83	Post-Test Passenger Side Knee Bolster	A-83
A-84	Pre-Test Passenger Side Floor Pan	A-84
A-85	Post-Test Passenger Side Floor Pan	A-85
A-86	Pre-Test Passenger Seat Track	A-86
A-87	Post-Test Passenger Seat Track	A-87
A-88	Post-Test Passenger Dummy Head	A-88
A-89	Post-Test Passenger Dummy Contact to Air Bag	A-89
A-90	Post-Test Passenger Dummy Contact with Seat Back	A-90
A-91	Pre-Test Center Rear Dummy (Front View)	A-91
A-92	Post-Test Center Rear Dummy (Front View)	A-92
A-93	Pre-Test Center Rear Dummy Door Open (Left side View)	A-93
A-94	Post-Test Center Rear Dummy Door Open (Left Side View)	A-94
A-95	Pre-Test Center Rear Dummy Left Leg	A-95
A-96	Post-Test Center Rear Dummy Left Leg	A-96
A-97	Pre-Test Center Rear Dummy Door Open (Right Side View)	A-97
A-98	Post-Test Center Rear Dummy Door Open (Right Side View)	A-98
A-99	Pre-Test Center Rear Dummy Right Leg	A-99
A-100	Post-Test Center Rear Dummy Right Leg	A-100

LIST OF PHOTOGRAPHS...(Continued)

Figure		Page
A-101	Post-Test Center Rear Dummy Knees (Overhead View)	A-101
A-102	Post-Test Center Rear Dummy Knees (Overhead View)	A-102
A-103	Post-Test Center Rear Dummy Head to Knee Contact	A-103
A-104	Post-Test Center Rear Dummy Contact Points	A-104
A-105	Vehicle on Rollover Device (0°)	A-105
A-106	Vehicle on Rollover Device (90°)	A-106
A-107	Vehicle on Rollover Device (90°)	A-107
A-108	Vehicle on Rollover Device (270°)	A-108
A-109	Vehicle During Impact	A-109
A-110	Driver's Airbag Label	A-110
A-111	Driver's Airbag Label	A-111
A-112	Passenger's Airbag Label	A-112
A-113	Passenger'	A-113
A-114	Window Sticker	A-114

APPENDIX B

DATA PLOTS

LIST OF DATA PLOTS

Data Plot	Page	
B-1	Driver (H3 95%) Head Primary X	B-1
	Driver (H3 95%) Head Primary Y	B-1
	Driver (H3 95%) Head Primary Z	B-1
	Driver (H3 95%) Head Resultant Primary	B-1
B-2	Driver (H3 95%) Head Primary X Velocity	B-2
	Driver (H3 95%) Head Primary X Displacement	B-2
B-3	Driver (H3 95%) Head Redundant X	B-3
	Driver (H3 95%) Head Redundant Y	B-3
	Driver (H3 95%) Head Redundant Z	B-3
	Driver (H3 95%) Head Resultant Redundant	B-3
B-4	Driver (H3 95%) Head Redundant X Velocity	B-4
	Driver (H3 95%) Head Redundant X Displacement	B-4
B-5	Driver (H3 95%) Upper Neck Force X	B-5
	Driver (H3 95%) Upper Neck Force Y	B-5
	Driver (H3 95%) Upper Neck Force Z	B-5
	Driver (H3 95%) Upper Neck Force Resultant	B-5
B-6	Driver (H3 95%) Upper Neck Moment X	B-6
	Driver (H3 95%) Upper Neck Moment Y	B-6
	Driver (H3 95%) Upper Neck Moment Z	B-6
	Driver (H3 95%) Upper Neck Moment Resultant	B-6
B-7	Driver (H3 95%) Chest Primary X	B-7
	Driver (H3 95%) Chest Primary Y	B-7
	Driver (H3 95%) Chest Primary Z	B-7
	Driver (H3 95%) Chest Resultant Primary	B-7
B-8	Driver (H3 95%) Chest Primary X Velocity	B-8
	Driver (H3 95%) Chest Primary X Displacement	B-8
B-9	Driver (H3 95%) Chest Redundant X	B-9
	Driver (H3 95%) Chest Redundant Y	B-9
	Driver (H3 95%) Chest Redundant Z	B-9
	Driver (H3 95%) Chest Resultant Redundant	B-9
B-10	Driver (H3 95%) Chest Redundant X Velocity	B-10
	Driver (H3 95%) Chest Redundant X Displacement	B-10
B-11	Driver (H3 95%) Chest Displacement	B-11

LIST OF DATA PLOTS...(Continued)

Data Plot	Page	
B-12	Driver (H3 95%) Left Femur Force	B-12
	Driver (H3 95%) Right Femur Force	B-12
	Driver (H3 95%) Left Knee Displacement	B-12
	Driver (H3 95%) Right Knee Displacement	B-12
B-13	Driver (H3 95%) Left Upper Tibia Moment X	B-13
	Driver (H3 95%) Left Upper Tibia Moment Y	B-13
B-14	Driver (H3 95%) Left Lower Tibia Force X	B-14
	Driver (H3 95%) Left Lower Tibia Force Z	B-14
	Driver (H3 95%) Left Lower Tibia Moment X	B-14
	Driver (H3 95%) Left Lower Tibia Moment Y	B-14
B-15	Driver (H3 95%) Right Upper Tibia Moment X	B-15
	Driver (H3 95%) Right Upper Tibia Moment Y	B-15
B-16	Driver (H3 95%) Right Lower Tibia Force X	B-16
	Driver (H3 95%) Right Lower Tibia Force Z	B-16
	Driver (H3 95%) Right Lower Tibia Moment X	B-16
	Driver (H3 95%) Right Lower Tibia Moment Y	B-16
B-17	Driver (H3 95%) Lap Belt Force	B-17
	Driver (H3 95%) Shoulder Belt Force	B-17
	Driver (H3 95%) Shoulder Belt Pullout	B-17
B-18	Passenger (H3 95%) Head Primary X	B-18
	Passenger (H3 95%) Head Primary Y	B-18
	Passenger (H3 95%) Head Primary Z	B-18
	Passenger (H3 95%) Head Resultant Primary	B-18
B-19	Passenger (H3 95%) Head Primary X Velocity	B-19
	Passenger (H3 95%) Head Primary X Displacement	B-19
B-20	Passenger (H3 95%) Head Redundant X	B-20
	Passenger (H3 95%) Head Redundant Y	B-20
	Passenger (H3 95%) Head Redundant Z	B-20
	Passenger (H3 95%) Head Resultant Redundant	B-20
B-21	Passenger (H3 95%) Head Redundant X Velocity	B-21
	Passenger (H3 95%) Head Redundant X Displacement	B-21

LIST OF DATA PLOTS...(Continued)

Data Plot	Page	
B-22	Passenger (H3 95%) Upper Neck Force X	B-22
	Passenger (H3 95%) Upper Neck Force Y	B-22
	Passenger (H3 95%) Upper Neck Force Z	B-22
	Passenger (H3 95%) Upper Neck Force Resultant	B-22
B-23	Passenger (H3 95%) Upper Neck Moment X	B-23
	Passenger (H3 95%) Upper Neck Moment Y	B-23
	Passenger (H3 95%) Upper Neck Moment Z	B-23
	Passenger (H3 95%) Upper Neck Moment Resultant	B-23
B-24	Passenger (H3 95%) Chest Primary X	B-24
	Passenger (H3 95%) Chest Primary Y	B-24
	Passenger (H3 95%) Chest Primary Z	B-24
	Passenger (H3 95%) Chest Resultant Primary	B-24
B-25	Passenger (H3 95%) Chest Primary X Velocity	B-25
	Passenger (H3 95%) Chest Primary X Displacement	B-25
B-26	Passenger (H3 95%) Chest Redundant X	B-26
	Passenger (H3 95%) Chest Redundant Y	B-26
	Passenger (H3 95%) Chest Redundant Z	B-26
	Passenger (H3 95%) Chest Resultant Redundant	B-26
B-27	Passenger (H3 95%) Chest Redundant X Velocity	B-27
	Passenger (H3 95%) Chest Redundant X Displacement	B-27
B-28	Passenger (H3 95%) Chest Displacement	B-28
B-29	Passenger (H3 95%) Left Femur Force	B-29
	Passenger (H3 95%) Right Femur Force	B-29
	Passenger (H3 95%) Left Knee Displacement	B-29
	Passenger (H3 95%) Right Knee Displacement	B-29
B-30	Passenger (H3 95%) Left Upper Tibia Moment X	B-30
	Passenger (H3 95%) Left Upper Tibia Moment Y	B-30
B-31	Passenger (H3 95%) Left Lower Tibia Force X	B-31
	Passenger (H3 95%) Left Lower Tibia Force Z	B-31
	Passenger (H3 95%) Left Lower Tibia Moment X	B-31
	Passenger (H3 95%) Left Lower Tibia Moment Y	B-31
B-32	Passenger (H3 95%) Right Upper Tibia Moment X	B-32
	Passenger (H3 95%) Right Upper Tibia Moment Y	B-32

LIST OF DATA PLOTS...(Continued)

Data Plot	Page	
B-33	Passenger (H3 95%) Right Lower Tibia Force X	B-33
	Passenger (H3 95%) Right Lower Tibia Force Z	B-33
	Passenger (H3 95%) Right Lower Tibia Moment X	B-33
	Passenger (H3 95%) Right Lower Tibia Moment Y	B-33
B-34	Passenger (H3 95%) Lap Belt Force	B-34
	Passenger (H3 95%) Shoulder Belt Force	B-34
	Passenger (H3 95%) Shoulder Belt Pullout	B-34
B-35	Center Rear Passenger (H3 50%) Primary X	B-35
	Center Rear Passenger (H3 50%) Head Primary Y	B-35
	Center Rear Passenger (H3 50%) Head Primary Z	B-35
	Center Rear Passenger (H3 50%) Head Resultant Primary	B-35
B-36	Center Rear Passenger (H3 50%) Head Primary X Velocity	B-36
	Center Rear Passenger (H3 50%) Head Primary X Displacement	B-36
B-37	Center Rear Passenger (H3 50%) NAAH CG X	B-37
	Center Rear Passenger (H3 50%) NAAH CG Y	B-37
	Center Rear Passenger (H3 50%) NAAH CG Z	B-37
	Center Rear Passenger (H3 50%) NAAH CG Resultant	B-37
B-38	Center Rear Passenger (H3 50%) NAAH CG X Velocity	B-38
	Center Rear Passenger (H3 50%) NAAH CG X Displacement	B-38
B-39	Center Rear Passenger (H3 50%) NAHA Xarm-X	B-39
	Center Rear Passenger (H3 50%) NAHA Xarm-Z	B-39
	Center Rear Passenger (H3 50%) NAHA Yarm-X	B-39
B-40	Center Rear Passenger (H3 50%) NAHA Yarm-Z	B-40
	Center Rear Passenger (H3 50%) NAHA Zarm-X	B-40
	Center Rear Passenger (H3 50%) NAHA Zarm-Y	B-40
B-41	Center Rear Passenger (H3 50%) Upper Neck Force X	B-41
	Center Rear Passenger (H3 50%) Upper Neck Force Y	B-41
	Center Rear Passenger (H3 50%) Upper Neck Force Z	B-41
	Center Rear Passenger (H3 50%) Upper Neck Force Resultant	B-41
B-42	Center Rear Passenger (H3 50%) Upper Neck Moment X	B-42
	Center Rear Passenger (H3 50%) Upper Neck Moment Y	B-42
	Center Rear Passenger (H3 50%) Upper Neck Moment Z	B-42
	Center Rear Passenger (H3 50%) Upper Neck Moment Resultant	B-42

LIST OF DATA PLOTS...(Continued)

Data Plot	Page	
B-43	Center Rear Passenger (H3 50%) Chest Primary X	B-43
	Center Rear Passenger (H3 50%) Chest Primary Y	B-43
	Center Rear Passenger (H3 50%) Chest Primary Z	B-43
	Center Rear Passenger (H3 50%) Chest Resultant Primary	B-43
B-44	Center Rear Passenger (H3 50%) Chest Primary X Velocity	B-44
	Center Rear Passenger (H3 50%) Chest Primary X Displacement	B-44
B-45	Center Rear Passenger (H3 50%) Chest Redundant X	B-45
	Center Rear Passenger (H3 50%) Chest Redundant Y	B-45
	Center Rear Passenger (H3 50%) Chest Redundant Z	B-45
	Center Rear Passenger (H3 50%) Chest Resultant Redundant	B-45
B-46	Center Rear Passenger (H3 50%) Chest Redundant X Velocity	B-46
	Center Rear Passenger (H3 50%) Chest Redundant X Displacement	B-46
B-47	Center Rear Passenger (H3 50%) Chest Displacement	B-47
B-48	Center Rear Passenger (H3 50%) Left Femur Force	B-48
	Center Rear Passenger (H3 50%) Right Femur Force	B-48
	Center Rear Passenger (H3 50%) Left Knee Displacement	B-48
	Center Rear Passenger (H3 50%) Right Knee Displacement	B-48
B-49	Center Rear Passenger Lap Belt Force	B-49
	Center Rear Passenger Belt Force	B-49
	Center Rear Passenger Belt Pullout	B-49
B-50	Vehicle Left Rear X	B-50
	Vehicle Left Rear X Velocity	B-50
	Vehicle Left Rear X Displacement	B-50
B-51	Vehicle Right Rear X	B-51
	Vehicle Right Rear X Velocity	B-51
	Vehicle Right Rear X Displacement	B-51
B-52	Vehicle Left Brake Caliper	B-52
	Vehicle Left Brake Caliper Velocity	B-52
	Vehicle Left Brake Caliper Displacement	B-52
B-53	Vehicle Right Brake Caliper	B-53
	Vehicle Right Brake Caliper Velocity	B-53
	Vehicle Right Brake Caliper Displacement	B-53

LIST OF DATA PLOTS...(Continued)

Data Plot	Page	
B-54	Vehicle Instrument Panel	B-54
	Vehicle Instrument Panel Velocity	B-54
	Vehicle Instrument Panel Displacement	B-54
B-55	Vehicle Engine Top	B-55
	Vehicle Engine Top Velocity	B-55
	Vehicle Engine Top Displacement	B-55
B-56	Vehicle Engine Bottom	B-56
	Vehicle Engine Bottom Velocity	B-56
	Vehicle Engine Bottom Displacement	B-56
B-57	Vehicle Toe Pan Accelerator X	B-57
	Vehicle Toe Pan Accelerator X Velocity	B-57
	Vehicle Toe Pan Accelerator X Displacement	B-57
B-58	Vehicle Toe Pan Accelerator Z	B-58
	Vehicle Toe Pan Accelerator Z Velocity	B-58
	Vehicle Toe Pan Accelerator Z Displacement	B-58
B-59	Vehicle Toe Pan Foot Rest X	B-59
	Vehicle Toe Pan Foot Rest X Velocity	B-59
	Vehicle Toe Pan Foot Rest X Displacement	B-59
B-60	Vehicle Toe Pan Foot Rest Z	B-60
	Vehicle Toe Pan Foot Rest Z Velocity	B-60
	Vehicle Toe Pan Foot Rest Z Displacement	B-60
B-61	Vehicle Rear Deck Z	B-61
	Vehicle Rear Deck Z Velocity	B-61
	Vehicle Rear Deck Z Displacement	B-61
B-62	Vehicle Rear Center Compartment X	B-62
	Vehicle Rear Center Compartment X Velocity	B-62
	Vehicle Rear Center Compartment X Displacement	B-62
B-63	Driver Airbag Squib Stage 1	B-63
	Driver Airbag Squib Stage 2	B-63
	Driver Pre-Tensioner Squib	B-63
B-64	Passenger Airbag Squib Stage 1	B-64
	Passenger Airbag Squib Stage 2	B-64
	Passenger Pre-Tensioner Squib	B-64

APPENDIX C

LOAD CELL BARRIER DATA PLOTS

APPENDIX D

INSTRUMENTATION DATA CHANNEL ASSIGNMENTS

APPENDIX E
DUMMY CALIBRATION DATA