

REPORT NUMBER: 301-CAL-04-01

**SAFETY COMPLIANCE TESTING FOR FMVSS 301  
FUEL SYSTEM INTEGRITY**

GENERAL MOTORS OF CANADA LTD.  
2004 PONTIAC GRAND PRIX  
FOUR-DOOR SEDAN

NHTSA NUMBER: C40101

GDAIS TEST NUMBER: 8655-F301-18

June 14, 2004

GENERAL DYNAMICS  
ADVANCED INFORMATION ENGINEERING SERVICES  
P.O. BOX 400  
BUFFALO, NEW YORK 14225



FINAL REPORT

PREPARED FOR:

U. S. Department of Transportation  
National Highway Traffic Safety Administration  
Enforcement  
Office of Vehicle Safety Compliance  
400 Seventh Street, S. W.  
Room No. 6115 (NVS-220)  
Washington, DC 20590

This publication is distributed by the U.S. Department of Transportation, National Highway Traffic Safety Administration, in the interest of information exchange. The opinions, findings and conclusions expressed in this publication are those of the author(s) and not necessarily those of the Department of Transportation or the National Highway Traffic Safety Administration. The United States Government assumes no liability for its contents or use thereof. If trade or manufacturers' names or products are mentioned, it is only because they are considered essential to the object of the publication and should not be construed as an endorsement. The United States Government does not endorse products or manufacturers.

Prepared By: \_\_\_\_\_  
Patrick G. MacDiarmid, Jr., Project Engineer

Approved By: \_\_\_\_\_  
David J. Travale, Program Manager  
Transportation Sciences Center

Approval Date: \_\_\_\_\_

FINAL REPORT ACCEPTANCE BY OVSC:

Accepted By: \_\_\_\_\_

Acceptance Date: \_\_\_\_\_

**TECHNICAL REPORT STANDARD TITLE PAGE**

1. Report No. 301-CAL-04-01	2. Government Accession No.	3. Recipient's Catalog No.	
4. Title and Subtitle Final Report of FMVSS 301 Compliance Testing of a 2004 Pontiac Grand Prix Four-Door Sedan NHTSA No. C40101		5. Report Date June 14, 2004	
		6. Performing Organization Code CAL	
7. Author(s) Patrick G. MacDiarmid, Jr., Project Engineer David J. Travale, Program Manager		8. Performing Organization Report No. 8655-F301-18	
9. Performing Organization Name and Address Advance Information Engineering Services 4455 Genesee Street Buffalo, New York 14225		10. Work Unit No.	
		11. Contract or Grant No. DTNH22-01-C-01025	
12. Sponsoring Agency Name and Address U.S. Department of Transportation National Highway Traffic Safety Administration Office of Vehicle Safety Compliance (NVS-220) 400 Seventh St , S.W., Rm. 6111, Washington, D.C. 20590		13. Type of Report and Period Covered Final Test Report	
		14. Sponsoring Agency Code NVS-220	
15. Supplementary Notes			
16. Abstract  Compliance tests were conducted on the subject 2004 Pontiac Grand Prix Four-Door Sedan in accordance with the specifications of the Office of Vehicle Safety Compliance Test Procedure No. TP-301-03 for the determination of FMVSS 301 compliance. For the purpose of acquiring information for applied research, two instrumented Anthropomorphic Test Devices (ATDs) were placed in the front occupant seating positions and various instrumentation was added to the test vehicle. Test failures identified were as follows:  The test vehicle appeared to comply with all requirements of FMVSS 301 "Fuel System Integrity."			
17. Key Words Compliance Testing Safety Engineering FMVSS 301		18. Distribution Statement <u>Copies of this report are available from</u> NHTSA Technical Reference Division Room 5108 (NPO-230), 400 Seventh , S.W., Washington, D.C. 20590 Telephone No. (202) 366-4946	
19. Security Classif. (of this report) UNCLASSIFIED	20. Security Classif. (of this page) UNCLASSIFIED	21. No. of Pages 40	22. Price

## TABLE OF CONTENTS

<u>Section</u>		<u>Page No.</u>
1	PURPOSE OF COMPLIANCE TEST	1-1
2	COMPLIANCE TEST RESULTS SUMMARY	2-1
3	COMPLIANCE TEST DATA	3-1
	Data Sheet 1 – Test Vehicle Specifications	3-2
	Data Sheet 2 – Pre-Test Data	3-3
	Data Sheet 3 – Moving Barrier Data	3-5
	Data Sheet 4 – Post Test Data	3-6
	Data Sheet 5 – Static Rollover Test Data	3-8
	Data Sheet 6 – High Speed Camera Locations	3-9
APPENDIX A	PHOTOGRAPHS	A-1

## SECTION 1

### PURPOSE OF COMPLIANCE TEST

This 30 mph rear moving barrier impact test is part of the Federal Motor Vehicle Safety Standard (FMVSS) 301 Compliance Test Program conducted for the National Highway Traffic Safety Administration (NHTSA) by Advanced Information Engineering Services under Contract No. DTNH22-01-C-01025. The purpose of this test was to determine if the subject vehicle, a 2004 Pontiac Grand Prix Four-Door Sedan, meets the performance requirements of FMVSS No. 301, "Fuel System Integrity." This compliance test was conducted using the requirements found in the OVSC Laboratory Test Procedure No. TP-301-03, dated February 28, 2003.

## SECTION 2

### COMPLIANCE TEST RESULTS SUMMARY

A 1795.0 kg 2004 Pontiac Grand Prix Four-Door Sedan was impacted from the rear by a 1797 kg moving barrier at a velocity of 46.51 kph (28.9 mph). The test was performed by Advanced Information Engineering Services on June 14, 2004.

The test vehicle was equipped with a 62.7 liter fuel tank which was filled to 94 percent capacity with stoddard fluid prior to impact. Additional ballast (12 kg) was secured in the vehicle cargo area. For the purpose of acquiring information for applied research, one instrumented Part 572 E 50th percentile male Anthropomorphic Test Device (ATD) and one instrumented Part 572 E 50th percentile male ATD were placed in the Left Front and Right Rear occupant seating positions and various instruments were added to the test vehicle. Research data is presented in a separate report.

The crash event was recorded by eleven high-speed cameras and one real-time camera. Camera locations and other pertinent camera information are found on pages 3-9 and 3-10 of this report. Pre- and post-test photographs of the vehicle can be found in Appendix A.

There was no fuel system fluid spillage following the impact or during any portion of the static rollover test. The average vehicle longitudinal crush was 271 millimeters. The vehicle appeared to comply with all the requirements of FMVSS No. 301 "Fuel System Integrity."

SECTION 3  
COMPLIANCE TEST DATA

DATA SHEET 1

TEST VEHICLE SPECIFICATIONS

TEST VEHICLE INFORMATION:

Year/Make/Model/Body Style: 2004 Pontiac Grand Prix Four-Door Sedan

NHTSA No.: C40101 ; Color: White

Engine Data: 6 Cylinders; - CID; 3.8 Liters; - cc

Placement: - Longitudinal or In-Line; X Transverse or Lateral

Transmission Data: 4 Speeds; - Manual; X Automatic; X Overdrive

Final Drive: - Rear Wheel Drive; X Front Wheel Drive; - Four Wheel Drive

Major Options: X A/C; X Power Steering; X Power Brakes

X Power Windows; X Power Door Locks; X Tilt Wheel

Date Received: 10/23/2004 ; Odometer Reading 60 km

Selling Dealer: #1 Cochran of Monroeville

& Address: 4200 William Penn Highway Monroeville, PA 15146

DATA FROM VEHICLE'S CERTIFICATION LABEL:

Vehicle Manufactured by: General Motors of Canada Ltd.

Date of Manufacture: 08/03

VIN: 2G2WS542X41171754

GVWR: 2014 kg; GAWR-FRONT: 1103 kg; GAWR-REAR: 911 kg

DATA FROM VEHICLE'S TIRE LABEL:

Location of Placard on Vehicle: Trunk Lid

Recommended Tire Size: P225/60R16

\* Recommended Cold Tire Pressure: FRONT: 210 kPa; REAR: 210 kPa

DATA FROM TIRE SIDEWALL:

Size of Tires on Test Vehicle: P225/60R16 97S Manufacturer: Goodyear

Tire Pressure with Maximum Capacity Vehicle Load: FRONT: 300 kPa; REAR: 300 kPa

Type of Spare Tire: Temporary

VEHICLE CAPACITY DATA:

Type of Front Seats: - Bench; X Bucket; - Split Bench

Number of Occupants: 2 Front; 3 Rear; 5 Total

Vehicle Capacity Weight (VCW) = 416 kg

No. of Occupants x 68.04 kg = 340.2 kg

Rated Cargo/Luggage Weight (RCLW) = 75.8 kg

\*Tire pressure used for test

DATA SHEET 2

PRE-TEST DATA

WEIGHT OF TEST VEHICLE AS RECEIVED FROM DEALER (with maximum fluids)= UDW:

Right Front	=	<u>498.5</u>	kg	Right Rear	=	<u>299.0</u>	kg
Left Front	=	<u>496.0</u>	kg.	Left Rear	=	<u>284.5</u>	kg
TOTAL FRONT	=	<u>994.5</u>	kg	TOTAL REAR	=	<u>583.5</u>	kg
TOTAL DELIVERED WEIGHT	=	<u>1578.0</u>	kg				
% of Total Front of Vehicle Weight	=	<u>63.0%</u>		of Total Rear Weight	=	<u>37.0%</u>	

CALCULATION OF VEHICLE'S TARGET TEST WEIGHT:

Total Delivered Weight	=	<u>1578.0</u>	kg
Rated Cargo/Luggage Weight (RCLW)	=	<u>75.8</u>	kg
Weight of 2 p.572 Dummies, 74.4 kg	=	<u>148.8</u>	kg
TARGET TEST WEIGHT	=	<u>1802.6</u>	kg

WEIGHT OF TEST VEHICLE WITH TWO DUMMIES AND 68.2 KG OF CARGO WEIGHT:

Right Front	=	<u>547.0</u>	kg	Right Rear	=	<u>341.0</u>	kg
Left Front	=	<u>562.0</u>	kg	Left Rear	=	<u>345.0</u>	kg
TOTAL FRONT	=	<u>1109.0</u>	kg	TOTAL REAR	=	<u>686.0</u>	kg
TOTAL TEST WEIGHT	=	<u>1795.0</u>	kg				
% of Total Front of Vehicle Weight	=	<u>61.8%</u>		of Total Rear Weight	=	<u>38.2%</u>	

\* Weight of Ballast Secured in Vehicle Cargo Area = 12.0 kg

Type of Ballast: Lead Shot

Method of Securing Ballast: Secured to Floor

Vehicle Components Removed for Weight Reduction: Right Front Passenger Seat

VEHICLE ATTITUDE (all dimension in millimeters):

AS DELIVERED:	RF	<u>733</u>	LF	<u>736</u>	RR	<u>750</u>	LR	<u>751</u>
AS TESTED:	RF	<u>718</u>	LF	<u>712</u>	RR	<u>730</u>	LR	<u>725</u>
Vehicle's Wheel Base:		<u>2814</u>	mm					
Location of Vehicle's C.G.:		<u>1075</u>	millimeters rearward of front wheel center.					

FUEL SYSTEM DATA:

Fuel System Capacity From Owner's Manual	=	<u>64.4</u>	liters
Usable Capacity Figure Furnished by COTR	=	<u>62.7</u>	liters
Test Volume Range (91 to 94% of Usable Capacity)	=	<u>57.06</u>	to <u>58.94</u> liters
ACTUAL TEST VOLUME=		<u>58.9</u>	liters (with entire fuel system filled)

\* Ballast weight includes the RCLW, the weight of drained vehicle fluids and the weight of any removed vehicle components less the weight of onboard instrumentation, cameras, and hardware.

DATA SHEET 2 (continued)

PRE-TEST DATA

FUEL SYSTEM DATA (continued):

Test Fluid Type: Stoddard Solution

Test Fluid Specific Gravity: 0.764

Test Fluid Kinematic Viscosity: 0.96 centistokes

Test Fluid Color: Orange ("red" is preferred)

Type of Vehicle Fuel Pump: Electric

Electric Fuel Pump Operation with Ignition Switch ON and Engine OFF -

Fuel pump operated.

Details of Fuel System: The fuel tank is centered ahead of the rear axle; The fuel lines run along the inner rail of the left frame stiffener; The fuel filler neck is located on the left side of the vehicle behind the rear axle.

Comments: The rear windshield glass shattered during the impact.

DATA SHEET 3

MOVING BARRIER DATA

WEIGHT OF MOVING BARRIER:

Right Front	=	<u>504.9</u>	kg	Right Rear	=	<u>393.7</u>	kg.
Left Front	=	<u>499.9</u>	kg	Left Rear	=	<u>398.3</u>	kg
TOTAL FRONT	=	<u>1004.8</u>	kg	TOTAL REAR	=	<u>792.0</u>	kg
TOTAL BARRIER WEIGHT	=	<u>1796.8</u>	kg				

MOVING BARRIER DIMENSIONS:

Barrier Face Height: 1524 mm  
Barrier Face Width: 1981 mm  
Barrier Face Ground Clearance: 127 mm  
Tread Width: 1511 mm  
Wheel Base: 3048 mm  
Location of C.G.: X: 1344 mm rearward of front wheel center.  
Y: 0 mm from longitudinal-vertical plane of symmetry.  
Z: 414 mm above ground.

MOVING BARRIER TIRES:

Manufacturer: Dunlop  
Model: AT Radial Rover  
Size: P205/75R15  
Recommended Max Pressure: 240 kPa:

MOVING BARRIER ABORT SYSTEM:

Type: Trailing cable

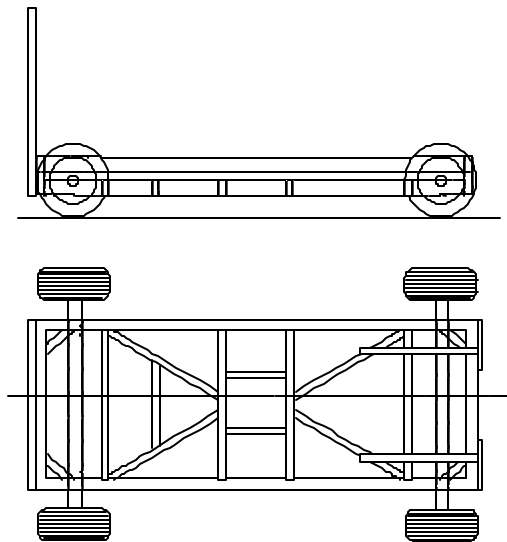

DATA SHEET 4

POST TEST DATA

TYPE OF TEST:

Type of Test: Rear Barrier Impact Angle: 0°  
Test Date: June 14, 2004 Time: 13:46 Temperature: 21 °C  
Vehicle NHTSA No.: C40101 VIN: 2G2WS542X41171754  
Required Impact Velocity Range: 46.51 to 48.12 kph

BARRIER IMPACT VELOCITY: (Speed traps within 5 feet of impact plane.)

Trap No. 1 = 46.51 kph; Trap No. 2 = 46.51 kph  
Average Impact Speed = 46.51 kph

VEHICLE STATIC CRUSH:

Vehicle Length:

Pre-Test Left = 4890 ; C/L = 5045 Right = 4890  
Post-Test Left = 4620 ; C/L = 4762 Right = 4630  
Crush Left = 270 ; C/L = 283 Right = 260  
AVERAGE = 271 millimeters

DATA SHEET 4 (continued)

POST TEST DATA

TEST VEHICLE NHTSA NO.: C40101 TEST DATE: June 14, 2004

Vehicle Mfgr./Make/Model: 2004 Pontiac Grand Prix Four-Door Sedan

Test vehicle fuel tank filled to 91% to 94% of manufacturer's "usable" capacity and with electric fuel pump operating (if it will operate without engine operation). Part 572 test dummies located at each front designated seating position.

\*\*\*\*\*

TEST VEHICLE IMPACT TYPE:

- Frontal (42.28 kph target velocity)
- Oblique (42.28 kph target velocity) with      -     ° barrier face first contacting      -      (driver/passenger) side
- X - Rear Moving Barrier (42.28 kph target velocity)
- Lateral Moving Barrier (32.19 kph target velocity)

FUEL SPILLAGE MEASUREMENT:

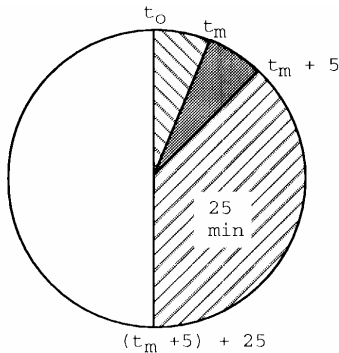

1. From impact until vehicle motion ceases
2. For five minute period after vehicle motion ceases
3. For next 25 minutes

ACTUAL	MAX ALLOWED
0	28 g
0	28 g.
0	28 g/min.

SOLVENT SPILLAGE DETAILS:

None

DATA SHEET 5

STATIC ROLLOVER TEST DATA

Table 7 FMVSS NO. 301 - STATIC ROLLOVER DATA SHEET

Vehicle: 2004 Pontiac Grand Prix Four-Door Sedan

NHTSA No.: C40101

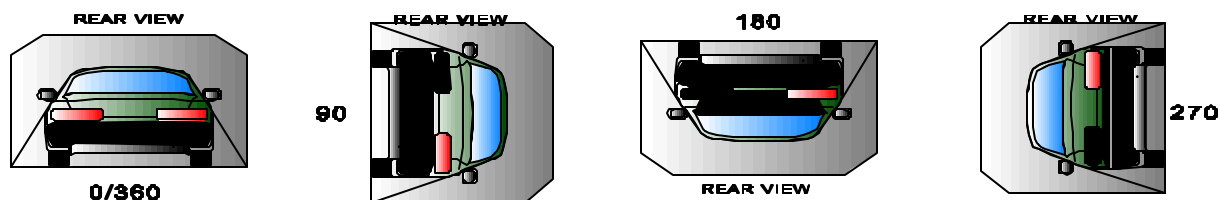

I. DETERMINATION OF SOLVENT COLLECTION TIME PERIOD:

Rollover Stage	Rotation Time (spec. 1 -3 min)				FMVSS 301 Hold Time		Total Time				Next Whole Minute Interval	
	1	minutes	12	seconds	5	minutes	5	minutes	0	seconds	6	minutes
0° - 90°	1	minutes	12	seconds	5	minutes	5	minutes	0	seconds	6	minutes
90° - 180°	1	minutes	03	seconds	5	minutes	5	minutes	0	seconds	6	minutes
180°-270°	1	minutes	01	seconds	5	minutes	5	minutes	0	seconds	6	minutes
270°-360°	1	minutes	09	seconds	5	minutes	5	minutes	0	seconds	6	minutes

II. FMVSS 301 REQUIREMENTS: (Maximum allowable solvent spillage):

First 5 minutes from onset of rotation	6th min.	7th min.	8th min. (if required)
142 g	28 g	28 g	28 g

III. ACTUAL TEST VEHICLE SOLVENT SPILLAGE:

Rollover Stage	First 5 minutes from onset of rotation (g)	6th min. (g)	7th min. (g)	8th min. (if required) (g)
0° - 90°	0	0	0	N/A
90° - 180°	0	0	0	N/A
180°-270°	0	0	0	N/A
270°-360°	0	0	0	N/A

Note: Record spillage for whole minute intervals only as determined above.

IV. SOLVENT SPILLAGE LOCATION(S):

Rollover Stage	Spillage Location
0° - 90°	None
90° - 180°	None
180°-270°	None
270°-360°	None

DATA SHEET 6

HIGH SPEED CAMERA LOCATIONS

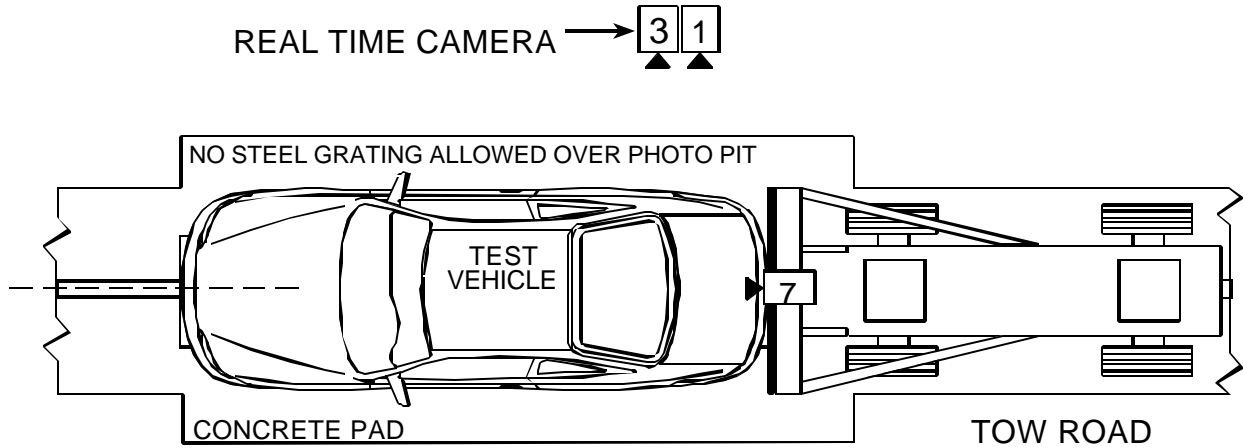

[2]

TOP VIEW

This caption indicates the top view of the test vehicle and tow road setup, with a box containing the number 2 and a downward-pointing arrow.

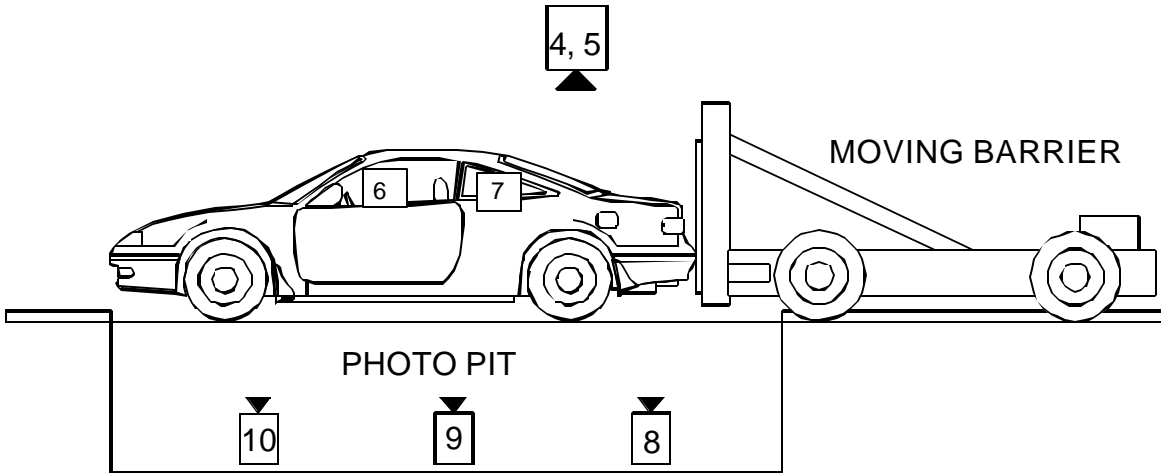

LEFT SIDE VIEW

This caption indicates the left side view of the test vehicle and tow road setup.

DATA SHEET 6 (continued)

HIGH SPEED CAMERA LOCATIONS

NHTSA No. : C40101

Vehicle : 2004 Pontiac Grand Prix Four-Door Sedan

CAMERA NO.	VIEW	CAMERA POSITIONS (mm)*			ANGLE** (degrees)	LENS (mm)	SPEED (fps)
		X	Y	Z			
1	Real-Time Camera	-	-	-	-	-	24
2	Left Side View	17221	2134	1100	0	13	1000
3	Right Side View	17348	2438	1096	0	35	1005
4	Overhead Overall View	-508	0	9804	-90	13	1000
5	Overhead Close View	-508	0	9804	-105	13	1000
6†	Onboard Driver View	905	2485	1010	-9	8	1005
7†	Onboard Passenger View	918	1818	1110	-11	8	1000
8	Vehicle Rear Underbody View	0	1307	-1956	90	13	1030
9	Vehicle Mid-Section Underbody View	0	2411	-1956	90	13	1005
10	Vehicle Front Underbody View	0	3066	-1956	90	13	1000

- \* X = film plant to monorail centerline (+ to left of rail)
- Y = film plane to impact location (+ ahead of impact location)
- Z = film plane to ground (+ above ground)
- \*\* = referenced to horizontal plane

† Research cameras – X distance is measured to the reference target plane.

Appendix A  
PHOTOGRAPHS

LIST OF PHOTOGRAPHS

<u>Figure</u>	<u>Photograph Title</u>	<u>Page</u>
A-1	PRE-TEST FRONT VIEW	A-3
A-2	POST-TEST FRONT VIEW	A-4
A-3	PRE-TEST LEFT SIDE VIEW	A-5
A-4	POST-TEST LEFT SIDE VIEW	A-6
A-5	PRE-TEST RIGHT SIDE VIEW	A-7
A-6	POST-TEST RIGHT SIDE VIEW	A-8
A-7	PRE-TEST REAR VIEW	A-9
A-8	POST-TEST REAR VIEW	A-10
A-9	PRE-TEST LEFT FRONT THREE-QUARTER VIEW	A-11
A-10	POST-TEST LEFT FRONT THREE-QUARTER VIEW	A-12
A-11	PRE-TEST RIGHT REAR THREE-QUARTER VIEW	A-13
A-12	POST-TEST RIGHT REAR THREE-QUARTER VIEW	A-14
A-13	PRE-TEST FRONT UNDERBODY VIEW	A-15
A-14	POST-TEST FRONT UNDERBODY VIEW	A-16
A-15	PRE-TEST REAR UNDERBODY VIEW	A-17
A-16	POST-TEST REAR UNDERBODY VIEW	A-18
A-17	CERTIFICATION PLACARD	A-19
A-18	TIRE PLACARD	A-20
A-19	ROLLOVER 90▼	A-21
A-20	ROLLOVER 180▼	A-22
A-21	ROLLOVER 270▼	A-23
A-22	ROLLOVER 360▼	A-24



Figure A-1 PRE-TEST FRONT VIEW



Figure A-2 POST-TEST FRONT VIEW



Figure A-3 PRE-TEST LEFT SIDE VIEW



Figure A-4 POST-TEST LEFT SIDE VIEW



Figure A-5 PRE-TEST RIGHT SIDE VIEW



Figure A-6 POST-TEST RIGHT SIDE VIEW



Figure A-7 PRE-TEST REAR VIEW



Figure A-8 POST-TEST REAR VIEW



Figure A-9 PRE-TEST LEFT FRONT THREE-QUARTER VIEW



Figure A-10 POST-TEST LEFT FRONT THREE-QUARTER VIEW



Figure A-11 PRE-TEST RIGHT REAR THREE-QUARTER VIEW



Figure A-12 POST-TEST RIGHT REAR THREE-QUARTER VIEW



A-15

8655-F301-18

Figure A-13 PRE-TEST FRONT UNDERBODY VIEW



A-16

8655-F301-18

Figure A-14 POST-TEST FRONT UNDERBODY VIEW



A-17

8655-F301-18

Figure A-15 PRE-TEST REAR UNDERBODY VIEW



A-18

8655-F301-18

Figure A-16 POST-TEST REAR UNDERBODY VIEW



MFD BY GENERAL MOTORS OF CANADA LTD.

DATE	GVWR	GAWR FRT	GAWR RR
08/03	2014 KG	1103 KG	911 KG
	4440 LB	2432 LB	2008 LB

THIS VEHICLE CONFORMS TO ALL APPLICABLE U.S. FEDERAL MOTOR VEHICLE SAFETY, BUMPER, AND THEFT PREVENTION STANDARDS IN EFFECT ON THE DATE OF MANUFACTURE SHOWN ABOVE.

2G2WS542X41171754 TYPE: PASS CAR

Figure A-17 CERTIFICATION PLACARD



TIRE - LOADING INFORMATION

OCCUPANTS				VEHICLE CAP. WT.	
FRT.	CTR.	RR.	TOTAL	KG	LBS
2	0	3	5	416	917

MAX. LOADING @ GVWR SAME AS VEHICLE CAPACITY WEIGHT.

**2G2WS542X41171754**

MODEL: WP69 WAJ

	TIRE SIZE	SPEED RTG	COLD TIRE PRESSURE
FRT	P225/60R16	S	210KPA(30PSI)
RR	P225/60R16	S	210KPA(30PSI)
SPA	T125/70D16	M	420KPA(60PSI)

IF TIRES ARE HOT, ADD 28KPA(4PSI).

SEE OWNER'S MANUAL  FOR MORE INFORMATION.

**SERVICE PARTS IDENTIFICATION**

**2G2WS542X41171754**

AG1	AL9	AP9	AR9	AY1	A85	B34
DH6	DK6	DL5	FE2	FE9	F83	IPB
M15	NP5	NT7	NV7	NW7	OST	QDI
UK3	UW6	UIQ	U77	VH9	VM3	VY7
1SZ	15P	40U	52B	52I	6JT	7JT
BC/CC	U 8554					5

Figure A-18 TIRE PLACARD



Figure A-19 ROLLOVER 90°



Figure A-20 ROLLOVER 180°



Figure A-21 ROLLOVER 270°



Figure A-22 ROLLOVER 360°