

REPORT NUMBER: 208-MGA-2004-001

**VEHICLE SAFETY COMPLIANCE TESTING
FOR
FMVSS 208, OCCUPANT CRASH PROTECTION
FMVSS 212, WINDSHIELD MOUNTING
FMVSS 219, WINDSHIELD INTRUSION (PARTIAL)
FMVSS 301, FUEL SYSTEM INTEGRITY**

**Daimler Chrysler Corp.
2004 Jeep Liberty MPV
NHTSA No.: C40300**

**PREPARED BY:
MGA RESEARCH CORPORATION
5000 WARREN ROAD
BURLINGTON, WI 53105**



Test Dates: January 12 – February 27, 2004

Final Report Date: June 10, 2004

FINAL REPORT

**PREPARED FOR:
U.S. DEPARTMENT OF TRANSPORTATION
NATIONAL HIGHWAY TRAFFIC SAFETY ADMINISTRATION
OFFICE OF ENFORCEMENT
OFFICE OF VEHICLE SAFETY COMPLIANCE
MAIL CODE: NVS-220
400 SEVENTH STREET, SW, ROOM 6115
WASHINGTON, D.C. 20590**

This final test report was prepared for the U.S. Department of Transportation, National Highway Traffic Safety Administration, in response to Contract Number DTNH22-03-D-11002.

This publication is distributed by the U.S. Department of Transportation, National Highway Traffic Safety Administration, in the interest of information exchange. The opinions, findings and conclusions expressed in this publication are those of the author(s) and not necessarily those of the Department of Transportation or the National Highway Traffic Safety Administration. The United States Government assumes no liability for its contents or use thereof. If trade or manufacturers' names or products are mentioned it is only because they are considered essential to the object of the publication and should not be construed as an endorsement. The United States Government does not endorse products or manufacturers.

Prepared Jeff Lewandowski Date: June 10, 2004
Jeff Lewandowski, Project Engineer

Reviewed by: David Winkelbauer Date: June 10, 2004
David Winkelbauer, Facility Director

FINAL REPORT ACCEPTED BY OVSC:

Accepted By: _____

Acceptance Date: _____

Technical Report Documentation Page

1. Report No. 208-MGA-2004-001		2. Government Accession No.		3. Recipient's Catalog No.	
4. Title and Subtitle Final Report of FMVSS 208 Compliance Testing of a 2004 Jeep Liberty NHTSA No.: C40300				5. Report Date June 10, 2004	
				6. Performing Organization Code MGA	
7. Author(s) Jeff Lewandowski, Project Engineer				8. Performing Organization Report No. 208-MGA-2004-001	
9. Performing Organization Name and Address MGA Research Corporation 5000 Warren Road Burlington, WI 53105				10. Work Unit No.	
				11. Contract or Grant No. DTNH22-03-D-11002	
12. Sponsoring Agency Name and Address U.S. Department of Transportation National Highway Traffic Safety Administration Office of Enforcement Office of Vehicle Safety Compliance 400 Seventh St., S.W., Room 6115 Washington, D.C. 20590				13. Type of Report and Period Covered 1/12/04 to 6/10/04	
				14. Sponsoring Agency Code NVS-220	
15. Supplementary Notes					
16. Abstract Compliance tests were conducted on the subject 2004 Jeep Liberty in accordance with the specifications of the Office of Vehicle Safety Compliance Test Procedure No. TP208-12 for the determination of FMVSS 208 compliance. Test failures identified were as follows: TEST FAILURES: S.4.5.1 Air Bag Labels					
17. Key Words Frontal Impact 40 kmph Vehicle Safety Compliance Testing FMVSS 208, "Occupant Crash Protection" FMVSS 212, "Windshield Mounting" FMVSS 219, (partial), "Windshield Zone Intrusion" FMVSS 301, "Fuel System Integrity"				18. Distribution Statement Copies of this report are available from the following: NHTSA Technical Information Services (TIS), Mail Code: NPO-230 400 Seventh Street, S.W., Room 5108 Washington, D.C. 20590 Tel. No.: (202) 366-4946	
19. Security Classif. (of this report) Unclassified		20. Security Classif. (of this page) Unclassified		21. No. of Pages 375	22. Price

Form DOT F1700.7 (8-72)

TABLE OF CONTENTS

<u>Section</u>		<u>Page No</u>
1	Purpose of Compliance Test	1
2	Tests Performed	2
3	Injury Result Summary	4
4	Discussion of Test (if applicable)	6
5	Test Data Sheets	7
 <u>Data Sheet</u>		
1	COTR Vehicle Work Order	8
2	Report of Vehicle Condition	12
3	Certification Label and Tire Placard Information	14
4	Rear Outboard Seating Position Seat Belts	15
5	Air Bag Labels	16
6	Readiness Indicator	29
7	Passenger Air Bag Manual Cut-Off Device	30
8	Lap Belt Lockability	34
9	Seat Belt Warning System	42
10	Belt Contact Force	44
11	Latch Plate Access	54
12	Seat Belt Retraction	62
13	Seat Belt Guides and Hardware	70
14	Marking of Reference Points for Various Test Positions & Points	74
15	Summary of Suppression Test Using 12-Month CRABI Dummy	80
16	Summary of Suppression Test Using Newborn Infant Dummy	87
17	Summary of Suppression Test Using 3-YO Dummy and Booster Seats	88
18	Summary of Suppression Test Using 3-YO Dummy and Fwd Facing Restraints	90
19	Summary of Suppression Test Using an Unbelted 3-YO Dummy	93
20	Summary of Suppression Test Using 6-YO Dummy and Booster Seats	94
21	Summary of Suppression Test Using an Unbelted 6-YO Dummy	97
27	Summary of Low Risk Deployment Using an Unbelted 5 th % Dummy Position 1	98
28	Summary of Low Risk Deployment Using an Unbelted 5 th % Dummy Position 2	99
30	Vehicle Weight, Fuel Tank, and Attitude Data	100

<u>Data Sheet</u>		<u>Page No</u>
31	Vehicle Accelerometer Locations and Measurements	104
32	Photographic Targets	107
33	Camera Locations	113
34	Dummy Positioning	115
35	Dummy Measurements	132
36	Crash Test	136
38	Accident Investigation Measurements	138
39	Windshield Mounting (FMVSS 212)	140
40	Windshield Zone Intrusion (FMVSS 219)	142
41	Fuel System Integrity (FMVSS 301)	144

Appendix

A	Crash Test Data	A-1
B	Low Risk Test Data	B-1
C	Crash Test Photographs	C-1
D	Low Risk Photographs	D-1
E	Suppression Photographs	E-1
F	Instrumentation Calibration	F-1
G	Notice of Test Failure (If Applicable)	G-1

SECTION 1
PURPOSE OF COMPLIANCE TEST

This Federal Motor Vehicle Safety Standard (FMVSS) 208 compliance test is part of a program conducted for the National Highway Traffic Safety Administration (NHTSA) by MGA Research Corporation (MGA) under Contract No. DTNH22-03-D-11002. The purpose of this test was to determine whether the subject vehicle, a 2004 Jeep Liberty, NHTSA No. C40300, meets certain performance requirements of FMVSS 208, "Occupant Crash Protection"; FMVSS 212, "Windshield Mounting"; FMVSS 219, "Windshield Zone Intrusion"; and FMVSS 301, "Fuel System Integrity". The compliance test was conducted in accordance with OVSC Laboratory Test Procedure No. TP208-12 dated January 14, 2003.

SECTION 2 TESTS PERFORMED

Test Vehicle: 2004 Jeep Liberty
 Test Program: FMVSS 208 Compliance

NHTSA No.: C40300
 Test Dates: 1/12-2/27/04

The following checked items indicate the tests that were performed:

- | | | |
|-------------------------------------|-----|---------------------------------------------------------------------------------------------------------------|
| <input checked="" type="checkbox"/> | 1. | Rear outboard seating position seat belts (S4.1.1.2(b) & (S4.2.4)) |
| <input checked="" type="checkbox"/> | 2. | Air bag labels (S4.5.1) |
| <input checked="" type="checkbox"/> | 3. | Readiness indicator (S4.5.2) |
| <input checked="" type="checkbox"/> | 4. | Passenger air bag manual cut-off device (S4.5.4) |
| <input checked="" type="checkbox"/> | 5. | Lap belt lockability (S7.1.1.5) |
| <input checked="" type="checkbox"/> | 6. | Seat belt warning system (S7.3) |
| <input checked="" type="checkbox"/> | 7. | Seat belt contact force (S7.4.4) |
| <input checked="" type="checkbox"/> | 8. | Seat belt latch plate access (S7.4.4) |
| <input checked="" type="checkbox"/> | 9. | Seat belt retraction (S7.4.5) |
| <input checked="" type="checkbox"/> | 10. | Seat belt guides and hardware (S7.4.6) |
| <input checked="" type="checkbox"/> | 11. | Suppression tests with 12-month-old CRABI dummy (Part 572, Subpart N) |
| <input checked="" type="checkbox"/> | 12. | Suppression tests with newborn infant (Part 572, Subpart K) |
| <input checked="" type="checkbox"/> | 13. | Suppression tests with 3-year-old dummy (Part 572, Subpart P) |
| <input checked="" type="checkbox"/> | 14. | Suppression tests with 6-year-old dummy (Part 572, Subpart O) |
| <input checked="" type="checkbox"/> | 15. | Test of reactivation of the passenger air bag system with an unbelted 5 th percentile female dummy |
| <input type="checkbox"/> | 16. | Low risk deployment test with 12-month-old dummy (Part 572, Subpart N) |
| <input type="checkbox"/> | 17. | Low risk deployment test with 3-year-old dummy (Part 572, Subpart P) |
| <input type="checkbox"/> | 18. | Low risk deployment test with 6-year-old dummy (Part 572, Subpart R) |
| <input checked="" type="checkbox"/> | 19. | Low risk deployment test with 5 th female dummy (Part 572, Subpart O) |
| <input checked="" type="checkbox"/> | 20. | Impact Tests |
| <input type="checkbox"/> | | Frontal Oblique |
| <input type="checkbox"/> | | Belted 50 th male dummy driver and passenger (0 to 48 kmph) (S5.1.1(a)) |
| <input type="checkbox"/> | | Unbelted 50 th male dummy driver and passenger (0 to 48 kmph) (S5.1.2(a)(1)) |
| <input type="checkbox"/> | | Unbelted 50 th male dummy driver and passenger (32 to 40 kmph) (S5.1.2(a) (1) or S5.1.2(b)) |
| <input checked="" type="checkbox"/> | | Frontal 0° |
| <input type="checkbox"/> | | Belted 50 th male dummy driver (0 to 48 kmph) (S5.1.1.(b)(1) or S5.1.1(a)) |
| <input type="checkbox"/> | | Belted 50 th male dummy passenger (0 to 48 kmph) (S5.1.1.(b)(1) or S5.1.1(a)) |
| <input type="checkbox"/> | | Belted 5 th female dummy driver (0 to 48 kmph) (S16.1(a)) |
| <input type="checkbox"/> | | Belted 5 th female dummy passenger (0 to 48 kmph) (S16.1(a)) |
| <input type="checkbox"/> | | Belted 50 th male dummy driver and passenger (0 to 56 kmph) (S5.1.1.(b)(2)) |
| <input type="checkbox"/> | | Unbelted 50 th male dummy driver and passenger (0 to 48 kmph) (S5.1.2(a) (1)) |
| <input type="checkbox"/> | | Unbelted 50 th male dummy driver (32 to 40 kmph) (S5.1.2.(a)(2) or S5.1.2(b)) |
| <input type="checkbox"/> | | Unbelted 50 th male dummy passenger (32 to 40 kmph) (S5.1.2.(a)(2) or S5.1.2(b)) |

- | | |
|-------------------------------------|---------------------------------------------------------------------------------------------|
| <input checked="" type="checkbox"/> | Unbelted 5 th female dummy driver (32 to 40 kmph) (S16.1(b)) |
| <input checked="" type="checkbox"/> | Unbelted 5 th female dummy passenger (32 to 40 kmph) (S16.1(b)) |
| <input type="checkbox"/> | 40% Offset 0° Belted 5 th male dummy driver and passenger (0 to 40 kmph) (S18.1) |
| <input type="checkbox"/> | 21. Sled Test: unbelted 50 th male dummy driver and passenger (S13) |
| <input type="checkbox"/> | 22. FMVSS 204 Indicant Test |
| <input checked="" type="checkbox"/> | 23. FMVSS 212 Test |
| <input checked="" type="checkbox"/> | 24. FMVSS 219 Indicant Test |
| <input checked="" type="checkbox"/> | 25. FMVSS 301 Frontal Test |

For the crash tests, the vehicle was instrumented with 8 accelerometers. The accelerometer data from the vehicle and dummies were sampled at 10,000 samples per second and processed as specified in SAE J211/1 MAR95 and FMVSS 208, S4.13.

The dynamic tests were recorded using high speed film and high speed digital video.

The vehicle appears to meet the performance requirements to which it was tested.

SECTION 3

INJURY RESULT SUMMARY FOR FMVSS 208 TESTS

Test Vehicle: 2004 Jeep Liberty
 Test Program: FMVSS 208 Compliance

NHTSA No.: C40300
 Test Dates: 1/16&1/30/04

5th Percentile Female Low Risk Deployments

5th Percentile Female SN 494 Position 1 (Chin On Module) 1-16-04

Injury Criteria	Max. Allowable Injury Assessment Values	Measured Value
HIC15	700	28
Peak Nij (Nte)	1.0	0.3
Time (ms)	NA	118.7
Peak Nij (Ntf)	1.0	0.4
Time (ms)	NA	28.1
Peak Nij (Nce)	1.0	0.5
Time (ms)	NA	169
Peak Nij (Ncf)	1.0	0.0
Time (ms)	NA	0.9
Neck Tension	2070 N	806
Neck Compression	2520 N	-437
Chest g	60 g	17
Chest Displacement	52 mm	-9
Left Femur	6805 N	-24
Right Femur	6805 N	-37

Second stage fire time of 45 ms; Injuries calculated on 0 ms to 170 ms

5th Percentile Female SN 515 Position 2 (Chin On Rim) 1-30-04

Injury Criteria	Max. Allowable Injury Assessment Values	Measured Value
HIC15	700	15
Peak Nij (Nte)	1.0	0.6
Time (ms)	NA	17.5
Peak Nij (Ntf)	1.0	0.2
Time (ms)	NA	29.1
Peak Nij (Nce)	1.0	0.1
Time (ms)	NA	163.2
Peak Nij (Ncf)	1.0	0.2
Time (ms)	NA	53.7
Neck Tension	2070 N	1085
Neck Compression	2520 N	-135
Chest g	60 g	13
Chest Displacement	52 mm	-23
Left Femur	6805 N	-42
Right Femur	6805 N	-148

Second stage fire time of 45 ms; Injuries calculated on 0 ms to 170 ms

SECTION 3...(continued)

INJURY RESULT SUMMARY FOR FMVSS 208 TESTS

Test Vehicle: 2004 Jeep Liberty NHTSA No.: C40300
 Test Program: FMVSS 208 Compliance Test Date: 2/27/04

40 kmph Frontal Crash

Impact Angle: Zero degrees

Belted Dummies: Yes (Rear Passenger) No (Driver and Front Passenger)
 Speed Range: 0 to 40 kmph 32 to 40 kmph
 0 to 48 kmph 0 to 56 kmph

Test Speed: 39.8 kmph Test Weight: 1954.6 kg

Driver Dummy: 5th female 50th male
 Passenger Dummy: 5th female 50th male
 Center Rear Passenger Dummy: 5th female 50th male

**5th Percentile Female Frontal Crash Test
 Vehicles certified to S16.1(a), S16.1(b), or S18.1**

Injury Criteria	Max. Allowable Injury Assessment Values	Driver	Passenger
HIC15	700	87	222
N _{te}	1.0	0.4	0.3
N _{tf}	1.0	0.3	0.5
N _{ce}	1.0	0.1	0.1
N _{cf}	1.0	0.2	0.3
Neck Tension	2620 N	1401	710
Neck Compression	2520 N	-126	-607
Chest g	60 g	40	45
Chest Displacement	52 mm	-20	-4
Left Femur	6805 N	-3087	-4620
Right Femur	6805 N	-3852	-4835

50th Percentile Male Center Rear Passenger Frontal Crash Test

Injury Criteria	Max. Allowable Injury Assessment Values	Center Rear Passenger
HIC15	700	280
N _{te}	1.0	0.4
N _{tf}	1.0	0.6
N _{ce}	1.0	0.0
N _{cf}	1.0	0.0
Neck Tension	4170 N	2220
Neck Compression	4000 N	-31
Chest g	60 g	35
Chest Displacement	63 mm	-32
Left Femur	10,000 N	-1474
Right Femur	10,000 N	-1864

SECTION 4
DISCUSSION OF TESTS

Test Vehicle: 2004 Jeep Liberty
Test Program: FMVSS 208 Compliance

NHTSA No.: C40300
Test Date: 1/12-2/27/04

The vehicle did not meet the performance requirements of S.4.5.1 Air Bag Labels.

The air bag system operation and maintenance information was contained in an addendum inserted in the owner's manual.

A blanket and visor were not used in the suppression testing because they did not affect the weight sensing system used on the vehicle.

The Cosco Dream Ride Car Bed was tested for suppression in the Middle Seat Slide position. Its orientation was lateral with the Newborn dummy's head placed to the left hand side of the vehicle. The CRS would not fit in the Forward Seat Slide position due to interference with the transmission shifter. The CRS would not fit in the Rearward Seat Slide position due to interference with the center console.

Empty seat detection during Suppression testing was performed with the DRB III diagnostic tool.

MGA dummy (SN494) was used for 5th percentile Position 1 Low Risk Deployment due to dummy availability.

A 50th percentile dummy (S/N 401) was positioned as a Center Rear Passenger during the 25 mph frontal crash test.

There were no other unexpected events or items to discuss.

SECTION 5
TEST DATA SHEETS

Test Vehicle: 2004 Jeep Liberty
Test Program: FMVSS 208 Compliance

NHTSA No.: C40300
Test Dates: 1/12-2/27/04

DATA SHEET 1

COTR VEHICLE WORK ORDER

Test Vehicle: 2004 Jeep Liberty
 Test Program: FMVSS 208 Compliance

NHTSA No.: C40300
 Test Dates: 1/12-2/27/04

COTR Signature: Charles R. Case

Test to be performed for this vehicle are checked below:

- | | | |
|---|-----|-----------------------------------------------------------------------------------------------------------------------|
| X | 1. | Rear Outboard Seating Position Seat Belts (S4.1.2(b)) & (S4.2.4) |
| X | 2. | Air Bag Labels (S4.5.1) |
| X | 3. | Readiness Indicator (S4.5.2) |
| X | 4. | Passenger Air Bag Manual Cut-off Device (S4.5.4) |
| X | 5. | Lap Belt Lockability (S7.1.1.5) |
| X | 6. | Seat Belt Warning System (S7.3) |
| X | 7. | Seat Belt Contact Force (S7.4.4) |
| X | 8. | Seat Belt Latch Plate Access (S7.4.4) |
| X | 9. | Seat Belt Retraction (S7.4.5) |
| X | 10. | Seat Belt Guides and Hardware (S7.4.6) |
| X | 11. | Suppression tests with 12-month-old CRABI dummy (Part 572, Subpart N) using the following indicated child restraints. |

Section B

X	Britax Handle with Care 191	X	Full Rearward	X	Mid Position	X	Full Forward
	Century Assura 4553		Full Rearward		Mid Position		Full Forward
	Century Avanta SE 41530		Full Rearward		Mid Position		Full Forward
	Century Smart Fit 4543		Full Rearward		Mid Position		Full Forward
	Cosco Arriva 02727		Full Rearward		Mid Position		Full Forward
	Cosco Opus 35 02603		Full Rearward		Mid Position		Full Forward
	Evenflo Discovery Adjust Right 212		Full Rearward		Mid Position		Full Forward
X	Evenflo First Choice 204	X	Full Rearward	X	Mid Position	X	Full Forward
	Evenflo On My Way Position Right V 282		Full Rearward		Mid Position		Full Forward
X	Graco Infant 8457	X	Full Rearward	X	Mid Position	X	Full Forward

Section C

X	Britax Roundabout 161	X	Full Rearward	X	Mid Position	X	Full Forward
X	Century Encore 4612	X	Full Rearward	X	Mid Position	X	Full Forward
	Century STE 1000 4416		Full Rearward		Mid Position		Full Forward
	Cosco Olympian 02803		Full Rearward		Mid Position		Full Forward
	Cosco Touriva 02519		Full Rearward		Mid Position		Full Forward
	Evenflo Horizon V 425		Full Rearward		Mid Position		Full Forward
X	Evenflo Medallion 254	X	Full Rearward	X	Mid Position	X	Full Forward

- | | | |
|---|-----|-------------------------------------------------------------------------------------------------------------|
| X | 12. | Suppression tests with newborn infant (Part 572, Subpart K) using the following indicated child restraints. |
|---|-----|-------------------------------------------------------------------------------------------------------------|

Section A

X	Cosco Dream Ride 02-719		Full Rearward		Mid Position		Full Forward
---	-------------------------	--	---------------	--	--------------	--	--------------

- | | | |
|---|-----|---------------------------------------------------------------------------------------------------------------------------------------------------|
| X | 13. | Suppression tests with 3-year-old dummy (Part 572, Subpart P) using the following indicated child restraints where a child restraint is required. |
|---|-----|---------------------------------------------------------------------------------------------------------------------------------------------------|

Section C

X	Britax Roundabout 161	X	Full Rearward	X	Mid Position	X	Full Forward
X	Century Encore 4612	X	Full Rearward	X	Mid Position	X	Full Forward
	Century STE 1000 4416		Full Rearward		Mid Position		Full Forward
	Cosco Olympian 02803		Full Rearward		Mid Position		Full Forward
	Cosco Touriva 02519		Full Rearward		Mid Position		Full Forward
	Evenflo Horizon V 425		Full Rearward		Mid Position		Full Forward
X	Evenflo Medallion 254	X	Full Rearward	X	Mid Position	X	Full Forward

Section D

	Britax Roadster 9004		Full Rearward		Mid Position		Full Forward
X	Century Next Step 4920	X	Full Rearward	X	Mid Position	X	Full Forward
X	Cosco High Back Booster 02-442	X	Full Rearward	X	Mid Position	X	Full Forward
	Evenflo Right Fit 245		Full Rearward		Mid Position		Full Forward

14. Suppression tests with representative 3-year-old child using the following indicated child restraints where a child restraint is required. (Appendix H, Data Sheet 16H and 17H)

Section C

	Britax Roundabout 161		Full Rearward		Mid Position		Full Forward
	Century Encore 4612		Full Rearward		Mid Position		Full Forward
	Century STE 1000 4416		Full Rearward		Mid Position		Full Forward
	Cosco Olympian 02803		Full Rearward		Mid Position		Full Forward
	Cosco Touriva 02519		Full Rearward		Mid Position		Full Forward
	Evenflo Horizon V 425		Full Rearward		Mid Position		Full Forward
	Evenflo Medallion 254		Full Rearward		Mid Position		Full Forward

Section D

	Britax Roadster 9004		Full Rearward		Mid Position		Full Forward
	Century Next Step 4920		Full Rearward		Mid Position		Full Forward
	Cosco High Back Booster 02-442		Full Rearward		Mid Position		Full Forward
	Evenflo Right Fit 245		Full Rearward		Mid Position		Full Forward

X 15. Suppression tests with 3-year-old dummy (Part 572, Subpart P) in the following Forward, Middle, and Rearward seat track positions

- X Sitting on seat with back against seat back (S22.2.2.1)
- X Sitting on seat with back against reclined seat back (S22.2.2.2)
- X Sitting on seat with back not against seat back (S22.2.2.3)
- X Sitting on seat edge, spine vertical, hands by the child's side (S22.2.2.4)
- X Standing on seat, facing forward (S22.2.2.5)
- X Kneeling on seat facing forward (S22.2.2.6)
- X Kneeling on seat facing rearward (S22.2.2.7)
- Lying on seat (S22.2.2.8)

16. Suppression tests with representative 3-year-old child in the following positions

- Sitting on seat with back against seat back (S22.2.2.1)
- Sitting on seat with back against reclined seat back (S22.2.2.2)
- Sitting on seat with back not against seat back (S22.2.2.3)
- Sitting on seat edge, spine vertical, hands by the child's side (S22.2.2.4)
- Standing on seat, facing forward (S22.2.2.5)
- Kneeling on seat facing forward (S22.2.2.6)
- Kneeling on seat facing rearward (S22.2.2.7)
- Lying on seat (S22.2.2.8)

X 17. Suppression tests with 6-year-old dummy (Part 572, Subpart N) using the following indicated child restraints where a child restraint is required.

Section D

	Britax Roadster 9004		Full Rearward		Mid Position		Full Forward
X	Century Next Step 4920	X	Full Rearward	X	Mid Position	X	Full Forward
X	Cosco High Back Booster 02-442	X	Full Rearward	X	Mid Position	X	Full Forward
X	Evenflo Right Fit 245	X	Full Rearward	X	Mid Position	X	Full Forward

18. Suppression tests with representative 6-year-old child using the following indicated child restraints where a child restraint is required.

Section D

	Britax Roadster 9004		Full Rearward		Mid Position		Full Forward
	Century Next Step 4920		Full Rearward		Mid Position		Full Forward
	Cosco High Back Booster 02-442		Full Rearward		Mid Position		Full Forward
	Evenflo Right Fit 245		Full Rearward		Mid Position		Full Forward

X 19. Suppression tests with 6-year-old dummy (Part 572, Subpart N) in the following Forward, Middle, and Rearward seat track positions

X	Sitting on seat with back against seat back (S22.2.2.1)
X	Sitting on seat with back against reclined seat back (S22.2.2.2)
X	Sitting on seat edge, spine vertical, hands by the child's side (S22.2.2.4)
X	Sitting back in the seat and leaning on the right front passenger door (S24.2.3)

20. Suppression tests with representative 6-year-old child in the following positions

	Sitting on seat with back against seat back (S22.2.2.1)
	Sitting on seat with back against reclined seat back (S22.2.2.2)
	Sitting on seat edge, spine vertical, hands by the child's side (S22.2.2.4)
	Sitting back in the seat and leaning on the right front passenger door (S24.2.3)

X 21. Test of Reactivation of the Passenger Air Bag System with an Unbelted 5th percentile female dummy (S20.3, 22.3, S24.3). Perform this test after the following suppression tests: After each restraint.

22. Test of Reactivation of the passenger air bag system with a representative 5th percentile female (S20.3, 22.3, S24.3). Perform this test after the following suppression tests:

23. Low risk deployment test with 12-month-old dummy (Part 572, Subpart R) using the following indicated child restraints.

Section B

	Britax Handle with Care 191		Full Rearward		Mid Position		Full Forward
	Century Assura 4553		Full Rearward		Mid Position		Full Forward
	Century Avanta SE 41530		Full Rearward		Mid Position		Full Forward
	Century Smart Fit 4543		Full Rearward		Mid Position		Full Forward
	Cosco Arriva 02727		Full Rearward		Mid Position		Full Forward
	Cosco Opus 35 02603		Full Rearward		Mid Position		Full Forward
	Evenflo Discovery Adjust Right 212		Full Rearward		Mid Position		Full Forward
	Evenflo First Choice 204		Full Rearward		Mid Position		Full Forward
	Evenflo On My Way Position Right V 282		Full Rearward		Mid Position		Full Forward
	Graco Infant 8457		Full Rearward		Mid Position		Full Forward

Section C

	Britax Roundabout 161		Full Rearward		Mid Position		Full Forward
	Century Encore 4612		Full Rearward		Mid Position		Full Forward
	Century STE 1000 4416		Full Rearward		Mid Position		Full Forward
	Cosco Olympian 02803		Full Rearward		Mid Position		Full Forward
	Cosco Touriva 02519		Full Rearward		Mid Position		Full Forward
	Evenflo Horizon V 425		Full Rearward		Mid Position		Full Forward

Evenflo Medallion 254

Full Rearward

Mid Position

Full Forward

24. Low risk deployment test with 3-year-old dummy (Part 572, Subpart P) in the following positions

Position 1

Position 2

25. Low risk deployment test with 6-year-old dummy (Part 572, Subpart N) in the following positions

Position 1

Position 2

26. Low risk deployment test with 5th percentile female dummy (Part 572, Subpart O) in the following positions

Position 1

Position 2

27. Impact Tests

Frontal Oblique – Test Speed:

Belted 50th male dummy driver and passenger (0 to 48 kmph) (S5.1.1(a))

Unbelted 50th male dummy driver and passenger (0 to 48 kmph) (S5.1.2(a)(1))

Unbelted 50th male dummy driver and passenger (32 to 40 kmph) (S5.1.2(a) (1) or S5.1.2(b))

Frontal 0° - Test Speed: 39.8 kmph

Belted 50th male dummy driver (0 to 48 kmph) (S5.1.1.(b)(1) or S5.1.1(a))

Belted 50th male dummy passenger (0 to 48 kmph) (S5.1.1.(b)(1) or S5.1.1(a))

Belted 5th female dummy driver (0 to 48 kmph) (S16.1(a))

Belted 5th female dummy passenger (0 to 48 kmph) (S16.1(a))

Belted 50th male dummy driver and passenger (0 to 56 kmph) (S5.1.1.(b)(2))

Unbelted 50th male dummy driver and passenger (0 to 48 kmph) (S5.1.2(a) (1))

Unbelted 50th male dummy driver (32 to 40 kmph) (S5.1.2.(a)(2) or S5.1.2(b))

Unbelted 50th male dummy passenger (32 to 40 kmph) (S5.1.2.(a)(2) or S5.1.2(b))

Unbelted 5th female dummy driver (32 to 40 kmph) (S16.1(b))

Unbelted 5th female dummy passenger (32 to 40 kmph) (S16.1(b))

40% Offset 0° Belted 5th male dummy driver and passenger (0 to 40 kmph) (S18.1) – Test Speed:

28. Sled Test: Unbelted 50th male dummy driver and passenger (S13)

29. FMVSS 204 Indicant Test

30. FMVSS 212 Indicant Test

31. FMVSS 219 Indicant Test

32. FMVSS 301 Indicant Frontal Test

REPORT OF VEHICLE CONDITION AT THE COMPLETION OF TESTING

LIST OF FMVSS TESTS PERFORMED BY THIS LAB: FMVSS 208, 212, 219, 301

VEHICLE: 2004 JEEP LIBERTY MPV NHTSA NO. C40300

REMARKS:

Equipment that is no longer on the test vehicle as noted on previous page:
RH rear window glass / motor, RH rear tail light, hub covers, and headrests.

Explanation for equipment removal:
Components removed for instrumentation installation and to meet target weight.

Test Vehicle Condition:
Normal frontal impact damage

RECORDED BY: Jeff Lewandowski DATE: 3/12/2004
APPROVED BY: David Winkelbauer DATE: 3/12/2004

#####

RELEASE OF TEST VEHICLE

The vehicle described above is released from MGA to be delivered to:

Date: Time: Odometer:
Lab Rep's Signature:
Title:
Carrier/Customer Rep:
Date:

DATA SHEET 3

CERTIFICATION LABEL AND TIRE PLACARD INFORMATION

Test Vehicle: 2004 Jeep Liberty
 Test Program: FMVSS 208 Compliance
 Test Technician: Clark Subrt

NHTSA No.: C40300
 Test Date: 2/27/04

Certification Label	
Manufacturer:	Daimler Chrysler Corp.
Date of Manufacture:	10/03
VIN:	1J4GK48KX4W162401
Vehicle Certified As (Pass. Car/MPV/Truck/Bus):	MPV
Front Axle GVWR:	2427 kg (5350 lbs)
Rear Axle GVWR:	1248 kg (2750 lbs)
Total GVWR:	1429 kg (3150 lbs)

Tire Placard	
Not applicable, vehicle is not a passenger car and does not have a tire placard.	YES (MPV)
This is not a passenger car, but all or part of this information is still contained on a vehicle label and is reported here.	YES (MPV)
Vehicle Capacity Weight:	522 kg (1150 lbs)
Designated Seating Capacity Front:	2
Designated Seating Capacity Rear:	3
Total Designated Seating Capacity:	5
Recommended Cold Tire Inflation Pressure Front:	227 kpa (33 psi)
Recommended Cold Tire Inflation Pressure Rear:	227 kpa (33 psi)
Recommended Tire Size:	P215/75R16

Signature: 

Date: 2/23/04

DATA SHEET 4

REAR OUTBOARD SEATING POSITION SEAT BELTS

Test Vehicle: 2004 Jeep Liberty
Test Program: FMVSS 208 Compliance
Test Technician: Wayne Dahlke

NHTSA No.: C40300
Test Date: 1/15/04

	Yes	No
Do all rear outboard seating positions have Type 2 seat belts?	X	

If NO, describe the seat belt installed, the seat location, and any other information about the seat that would explain why a Type 2 seat belt was not installed.

REMARKS: NONE

Signature: Wayne Dahlke

Date: 1/15/04

DATA SHEET 5
AIR BAG LABELS (S4.5.1)

Test Vehicle: 2004 Jeep Liberty
 Test Program: FMVSS 208 Compliance
 Test Technician: Wayne Dahlke

NHTSA No.: C40300
 Test Date: 1/15/04

1. Air bag maintenance label and owner's manual instructions: (S4.5.1(a))
- 1.1 Does the manufacturer recommend periodic maintenance or replacement of the air bag?
- Yes, go to 1.2
 No – go to 2
- 1.2 Does the vehicle have a label specifying air bag maintenance or replacement?
- Yes – Pass
 No – Fail
- 1.3 Does the label contain one of the following?
- Yes – Pass
 No – Fail
- Check applicable schedule:
 ___ Schedule on label specifies month and year (Record date _____)
 ___ Schedule on label specified vehicle mileage (Record mileage _____)
 ___ Schedule on label specifies interval measured from date on certification label
 (Record interval _____)
- 1.4 Is the label permanently affixed within the passenger compartment such that it cannot be removed without destroying or defacing the label or the sunvisor?
- Yes – Pass
 No – Fail
- 1.5 Is the label lettered in English?
- Yes – Pass
 No – Fail
- 1.6 Is the label in block capitals and numerals?
- Yes – Pass
 No – Fail
- 1.7 Are the letters and numerals at least 3/32 inches high?
- Yes – Pass
 No – Fail
- 1.8 Does the owner's manual set forth the recommended schedule for maintenance or replacement?
2. Does the owner's manual: (S4.5.1(f))
- 2.1 Include a description of the vehicle's air bag system in an easily understandable format?
- Yes – Pass
 No – Fail
- 2.2 Include a statement that the vehicle is equipped with an air bag and a lap/shoulder belt at the front outboard seating position?
- Yes – Pass

- No – Fail
- 2.3 Include a statement that the air bag is a supplement restraint at the front outboard seating position?
- Yes – Pass
 No – Fail
- 2.4 Emphasize that all occupants, including the driver, should always wear their seat belts whether or not an air bag is also provided at their seating positions to minimize the risk of severe injury or death in the event of a crash?
- Yes – Pass
 No – Fail
- 2.5 Provide any necessary precautions regarding the proper positioning of occupants, including children, at seating positions equipped with air bags to ensure maximum safety protection for those occupants?
- Yes – Pass
 No – Fail
- 2.6 Explain that no objects should be placed over or near the air bag on the steering wheel or on the instrument panel, because any such objects could cause harm if the vehicle is in a crash severe enough to cause the air bag to inflate?
- Yes – Pass
 No – Fail
- 2.7 Is the vehicle certified to meet the requirements of S14.5, S15, S17, S19, S21, S23, and S25? (Obtain answer from COTR) (S4.5.1(f)(2))
- Yes – (Go to 2.7.1)
 No – (Go to 3.)
- 2.7.1 Explain the proper functioning of the advanced air bag system? (S4.5.1(f)(2))
- Yes – Pass
 No – Fail
- 2.7.2 Provide a summary of the actions that may affect the proper functioning of the system? (S4.5.1(f)(2))
- Yes – Pass
 No – Fail
- 2.7.3 Present and explain the main components of the advanced passenger air bag system? (S4.5.1(f)(2)(i))
- Yes – Pass
 No – Fail
- 2.7.4 Explain how the components function together as part of the advanced passenger air bag system? (S4.5.1(f)(2)(ii))
- Yes – Pass
 No – Fail
- 2.7.5 Contain the basic requirements for proper operation, including an explanation of the actions that may affect the proper functioning of the system? (S4.5.1(f)(2)(iii))
- Yes – Pass
 No – Fail
- 2.7.6 Is the vehicle certified to the requirements of S19.2, S21.2, or 23.2 (automatic suppression)?
- Yes, continue with 2.7.6
 No, go to 2.7.7

- 2.7.6.1 Contain a complete description of the passenger air bag suppression system installed in the vehicle, including a discussion of any suppression zone? (S4.5.1(f)(2)(iv))
- Yes – Pass
 No – Fail
- 2.7.6.2 Discuss the telltale light, specifying its location in the vehicle and explaining when the light is illuminated?
- Yes – Pass
 No – Fail
- 2.7.7 Explain the interaction of the advanced passenger air bag system with other vehicle components, such as seat belts, seats or other components? (S4.5.1(f)(2)(v))
- Yes – Pass
 No – Fail
- 2.7.8 Summarize the expected outcomes when child restraint systems, children and small teenagers or adults are both properly and improperly positioned in the passenger seat, including cautionary advice against improper placement of child restraint systems? (S4.5.1(f)(2)(vi))
- Yes – Pass
 No – Fail
- 2.7.9 Provide information on how to contact the vehicle manufacturer concerning modifications for persons with disabilities that may affect the advanced air bag system? (S4.5.1(f)(2)(vii))
- Yes – Pass
 No – Fail
3. Sun Visor Air Bag Warning Label (S4.5.1(b)) Check only one of the following:
- The vehicle is not certified to meet the requirements of S19, S21, and S23 (Obtain answer from COTR) (S4.5.1(b)(1)) Go to 3.1 and skip 3.2 and 3.3
- The vehicle is certified to meet the requirements of S19, S21, and S23 before 9/1/03. (Obtain answer from COTR) (S4.5.1(b)(2)) Go to 3.2 and skip 3.1 and 3.3
- The vehicle is certified to meet the requirements of S19, S21, and S23 on 9/1/03 or later. (Obtain answer from COTR) (S4.5.1(b)(3)) Go to 3.3 and skip 3.1 and 3.2
- 3.1 Vehicles not certified to meet the requirements of S19, S21, and S23.
- 3.1.1 Is the label permanently affixed (including permanent marking on the visor material or molding into the visor material) to either side of the sun visor at each front outboard seating position such that it cannot be removed without destroying or defacing it? (S4.5.1(b)(1))
- Driver Side, Yes – Pass
 Driver Side, No – Fail
 Passenger Side, Yes – Pass
 Passenger Side, No – Fail



3.1.2

Does the label conform in content to the label shown in either Figure 6A or 6B (Figure 6b is for vehicles with passenger air bag on-off switches), as appropriate, at each front outboard seating position? (S4.5.1(b)(1)) (Vehicles without back seats may omit the statement: "The back seat is the safest place for children." (S4.5.1(b)(1)(iv))



Figure 6a. Sun Visor Label Visible When Visor is in Down Position.



Figure 6b. Sun Visor Label Visible When Visor is in Down Position.

- Driver Side, Yes – Pass
- Driver Side, No – Fail
- Passenger Side, Yes – Pass
- Passenger Side, No – Fail



3.1.3

Is the label heading area yellow with the word "WARNING" and the alert symbol in black? (S4.5.1(b)(1)(i))

- Driver Side, Yes – Pass
- Driver Side, No – Fail
- Passenger Side, Yes – Pass
- Passenger Side, No – Fail



3.14

Is the message area white with black text? (S4.5.1(b)(1)(ii))

- Driver Side, Yes – Pass
- Driver Side, No – Fail
- Passenger Side, Yes – Pass
- Passenger Side, No – Fail



3.15 Is the message area at least 30 cm²? (S4.5.1(b)(1)(ii))
 Driver Side: Length _____, Width _____
 Passenger Side: Length _____, Width _____
 Actual message area _____ cm²



Driver Side, Yes – Pass



Driver Side, No – Fail



Passenger Side, Yes – Pass



Passenger Side, No – Fail



3.16 Is the pictogram black with a red circle and slash on a white background?
 (S4.5.1(b)(2)(iii))



Driver Side, Yes – Pass



Driver Side, No – Fail



Passenger Side, Yes – Pass



Passenger Side, No – Fail



3.17 Is the pictogram at least 30 mm in diameter? (S4.5.1(b)(2)(iii))
 Actual diameter _____ mm



Driver Side, Yes – Pass



Driver Side, No – Fail



Passenger Side, Yes – Pass



Passenger Side, No – Fail



3.2 Vehicles certified to meet the requirements of S19, S21, and S23 before 9/1/03.



3.2.1 Is the label permanently affixed (including permanent marking on the visor material or molding into the visor material) to either side of the sun visor at each front outboard seating position such that it cannot be removed without destroying or defacing the label or the sun visor? (S4.5.1(b)(2))



Driver Side, Yes – Pass



Driver Side, No – Fail



Passenger Side, Yes – Pass



Passenger Side, No – Fail



3.2.2

Does the label conform in content to the label shown in either Figure 8 or 11 at each front outboard seating position? (S4.5.1(b)(2)) (Vehicles without back seats may omit the statement: "The back seat is the safest place for children." (S4.5.1(b)(2)(iv)) Vehicles without back seats or the back seat is too small to accommodate a rear-facing child restraint may omit the statement "Never put a rear-facing child seat in the front."(S4.5.1(b)(2)(v))



Figure 8. Sun Visor Label Visible when Visor is in Down Position.



Figure 11. Sun Visor Label Visible when Visor is in Down Position.



- Driver Side, Yes – Pass
- Driver Side, No – Fail
- Passenger Side, Yes – Pass
- Passenger Side, No – Fail



3.2.3

Is the label heading area yellow with the word "WARNING" and the alert symbol in black? (S4.5.1(b)(2)(i))



- Driver Side, Yes – Pass
- Driver Side, No – Fail
- Passenger Side, Yes – Pass
- Passenger Side, No – Fail



3.2.4

Is the message area white with black text? (S4.5.1(b)(2)(ii))



- Driver Side, Yes – Pass
- Driver Side, No – Fail
- Passenger Side, Yes – Pass
- Passenger Side, No – Fail

- 3.2.5 Is the message area at least 30 cm²? (S4.5.1(b)(2)(ii))
 Driver Side: Length _____, Width _____
 Passenger Side: Length _____, Width _____
 Actual message area _____ cm²
- Driver Side, Yes – Pass
 Driver Side, No – Fail
 Passenger Side, Yes – Pass
 Passenger Side, No – Fail
- 3.2.6 Is the pictogram black on a white background? (S4.5.1(b)(2)(iii))
- Driver Side, Yes – Pass
 Driver Side, No – Fail
 Passenger Side, Yes – Pass
 Passenger Side, No – Fail
- 3.2.7 Is the pictogram at least 30 mm (1.2 inches) in length? (S4.5.1(b)(2)(iii))
 Driver Side: Length _____
 Passenger Side: Length _____
- Driver Side, Yes – Pass
 Driver Side, No – Fail
 Passenger Side, Yes – Pass
 Passenger Side, No – Fail
- 3.3 Vehicles certified to meet the requirements of S19, S21, and S23 on 9/1/03 and later. (S4.5.1(b)(3))
- 3.3.1 Is the label permanently affixed (including permanent marking on the visor material or molding into the visor material) to either side of the sun visor at each front outboard seating position such that it cannot be removed without destroying or defacing the label or the sun visor? (S4.5.1(b)(3))
- Driver Side, Yes – Pass
 Driver Side, No – Fail
 Passenger Side, Yes – Pass
 Passenger Side, No – Fail
- 3.3.2 Does the label conform in content to the label shown in either Figure 11 at each front outboard seating position? (S4.5.1(b)(2)) (Vehicles without back seats may omit the statement: "The back seat is the safest place for children." (S4.5.1(b)(3)(iv)) Vehicles without back seats or the back seat is too small to accommodate a rear-facing child restraint may omit the statement "Never put a rear-facing child seat in the front." (S4.5.1(b)(3)(v))

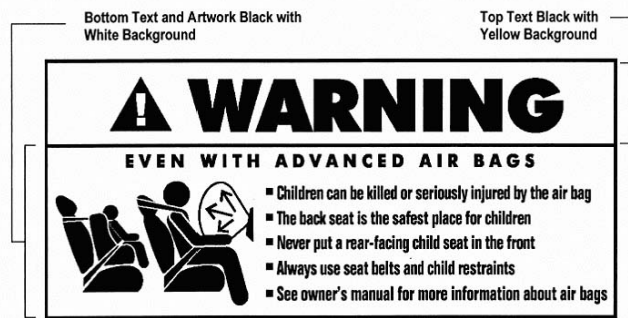

Figure 11. Sun Visor Label Visible when Visor is in Down Position.

- | | | |
|-------------------------------------|-------------------------------------|-----------------------------------------------------------------------------------------------------------|
| | <input checked="" type="checkbox"/> | Driver Side, Yes – Pass |
| | <input type="checkbox"/> | Driver Side, No – Fail |
| | <input checked="" type="checkbox"/> | Passenger Side, Yes – Pass |
| | <input type="checkbox"/> | Passenger Side, No – Fail |
| <input checked="" type="checkbox"/> | 3.3.3 | Is the label heading area yellow with the word “WARNING” and the alert symbol in black? (S4.5.1(b)(3)(i)) |
| | <input checked="" type="checkbox"/> | Driver Side, Yes – Pass |
| | <input type="checkbox"/> | Driver Side, No – Fail |
| | <input checked="" type="checkbox"/> | Passenger Side, Yes – Pass |
| | <input type="checkbox"/> | Passenger Side, No – Fail |
| <input checked="" type="checkbox"/> | 3.3.4 | Is the message area white with black text? (S4.5.1(b)(3)(ii)) |
| | <input checked="" type="checkbox"/> | Driver Side, Yes – Pass |
| | <input type="checkbox"/> | Driver Side, No – Fail |
| | <input checked="" type="checkbox"/> | Passenger Side, Yes – Pass |
| | <input type="checkbox"/> | Passenger Side, No – Fail |
| <input checked="" type="checkbox"/> | 3.3.5 | Is the message area at least 30 cm ² ? (S4.5.1(b)(3)(ii)) |
| | | Driver Side: Length <u>8.7 cm</u> , Width <u>4.8 cm</u> |
| | | Passenger Side: Length <u>8.7 cm</u> , Width <u>4.8 cm</u> |
| | | Driver Actual message area <u>41.76 cm²</u> |
| | | Passenger Actual message area <u>41.76 cm²</u> |
| | <input checked="" type="checkbox"/> | Driver Side, Yes – Pass |
| | <input type="checkbox"/> | Driver Side, No – Fail |
| | <input checked="" type="checkbox"/> | Passenger Side, Yes – Pass |
| | <input type="checkbox"/> | Passenger Side, No – Fail |
| <input checked="" type="checkbox"/> | 3.3.6 | Is the pictogram black on a white background? (S4.5.1(b)(3)(iii)) |
| | <input checked="" type="checkbox"/> | Driver Side, Yes – Pass |
| | <input type="checkbox"/> | Driver Side, No – Fail |
| | <input checked="" type="checkbox"/> | Passenger Side, Yes – Pass |
| | <input type="checkbox"/> | Passenger Side, No – Fail |
| <input type="checkbox"/> | 3.3.7 | Is the pictogram at least 30 mm (1.2 inches) in length? (S4.5.1(b)(3)(iii)) |
| | | Driver Side: Length <u>45 mm</u> |
| | | Passenger Side: Length <u>45 mm</u> |
| | <input checked="" type="checkbox"/> | Driver Side, Yes – Pass |

- Driver Side, No – Fail
 Passenger Side, Yes – Pass
 Passenger Side, No – Fail
- 3.4 Is the same side of the sun visor that contains the air bag warning label free of other information with the exception of the air bag maintenance label and/or the rollover-warning label? (S4.5.1(b)(5)(i))
- Driver Side, Yes – Pass
 Driver Side, No – Fail
 Passenger Side, Yes – Pass
 Passenger Side, No – Fail
- 3.5 Is the sun visor free of other information about air bags or the need to wear seat belts with the exception of the air bag alert label and/or the rollover-warning label? (S4.5.1(b)(5)(ii))
- Driver Side, Yes – Pass
 Driver Side, No – Fail
 Passenger Side, Yes – Pass
 Passenger Side, No – Fail
- 3.6 Does the driver side visor contain a rollover-warning label on the same side of the visor as the air bag warning label?
 Yes, go to 3.6.1
 No, go to 4 (skipping 3.6.1 through 3.6.3)
- 3.6.1 Are both the rollover-warning label and the air bag warning label surrounded by a continuous solid-lined border?
 Yes, go to 3.6.2 and skip 3.6.3
 No, go to 3.6.3 and skip 3.6.2
- 3.6.2 Is the shortest distance from the border of the rollover label to the border of the air bag warning label at least 1 cm? (575.105 (d)(1)(iv)(B))
_____ actual distance
- 3.6.3 Is the shortest distance from any of the lettering or graphics on the rollover-warning label to any of the lettering or graphics of the air bag warning label at least 3 cm? (575.105 (d)(1)(iv)(A))
17mm (1.7cm) actual distance
 Yes-Pass **No-FAIL**
4. Air Bag Alert Label (S4.5.1(c) (A “Rollover Warning Label” or “Rollover Alert Label” may be on the same side of the driver’s sun visor as the “Air Bag Alert Label.” 575.105(d))
- 4.1 Is the sun visor warning label visible when the sun visor is in the stowed position?
 If yes for driver and passenger, go to 5.
 Driver Side, Yes – Pass
 Driver Side, No – Fail

- Passenger Side, Yes – Pass
 - Passenger Side, No – Fail
- 4.2 Is the air bag alert label permanently affixed (including permanent marking on the visor material or molding into the visor material) to the sun visor at each front outboard seating position such that it cannot be removed without destroying or defacing the label or the sun visor? (S4.5.1(c))

- Driver Side, Yes – Pass
 - Driver Side, No – Fail
 - Passenger Side, Yes – Pass
 - Passenger Side, No – Fail
- 4.3 Is the air bag alert label visible when the visor is in the stowed position? (S4.5.1(c))

- Driver Side, Yes – Pass
- Driver Side, No – Fail
- Passenger Side, Yes – Pass
- Passenger Side, No – Fail

- 4.4 Does the label conform in content to the label shown in Figure 6C? (S4.5.1(c))

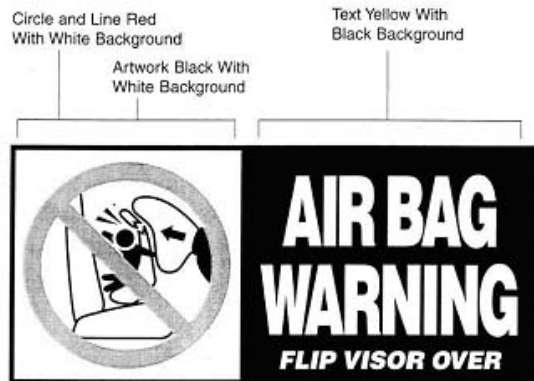

Figure 6c. Sun Visor Label Visible When Visor is in Up Position.

- Driver Side, Yes – Pass
 - Driver Side, No – Fail
 - Passenger Side, Yes – Pass
 - Passenger Side, No – Fail
- 4.5 Is the message area black with yellow text? (S4.5.1(c)(1))
- Driver Side, Yes – Pass
 - Driver Side, No – Fail
 - Passenger Side, Yes – Pass
 - Passenger Side, No – Fail

- 4.6 Is the message area at least 20 cm²? (S4.5.1(c)(1))
 Driver Side: Length_____, Width_____
 Passenger Side: Length_____, Width_____
 Actual message area _____ cm²
- Driver Side, Yes – Pass
 Driver Side, No – Fail
 Passenger Side, Yes – Pass
 Passenger Side, No – Fail
- 4.7 Is the pictogram black with a red circle and slash on a white background? (S4.5.1(c)(2))
- Driver Side, Yes – Pass
 Driver Side, No – Fail
 Passenger Side, Yes – Pass
 Passenger Side, No – Fail
- 4.8 Is the pictogram at least 20 mm in diameter? (S4.5.1(c)(2))
 Driver Side Diameter_____mm
 Passenger Side Diameter_____mm
- Driver Side, Yes – Pass
 Driver Side, No – Fail
 Passenger Side, Yes – Pass
 Passenger Side, No – Fail
5. Label on the Dashboard
- 5.1 Is the vehicle certified to meet the requirements of S19, S21, and S23? (Obtain answer from COTR) (S4.5.1(3)(2))
- Yes, go to 5.1.1 and **skip 5.2**
 No, go to 5.2, skipping 5.1.1 through 5.1.6
- 5.1.1 Does the vehicle have a label on the dash or steering wheel hub? (S4.5.1(e)(2))
- Yes – Pass
 No – Fail
- 5.1.2 Is the label clearly visible from all front seating positions? (S4.5.1(e)(2))
- Yes – Pass
 No - Fail
- 5.1.3 Does the label conform in content to the label shown in Figure 9? (S4.5.1(e)(2))
 Vehicles without back seats may omit the statement: “The back seat is the safest place for children.” (S4.5.1(e)(2)(iii))
- Yes – Pass
 No - Fail



Figure 9. Removable Label on Dash.

5.1.4 Is the heading area yellow with black text? (S4.5.1(e)(2)(i))

Yes – Pass

No - Fail

5.1.5 Is the message white with black text? (S4.5.1(e)(2)(ii))

Yes – Pass

No - Fail

5.1.6 Is the message area at least 30 cm²? (S4.5.1(e)(2)(ii))

Length 8.7 cm , Width 3.5 cm

Actual message area 30.45 cm²

Yes – Pass

No - Fail

5.2 Does the vehicle have a label on the dash or steering wheel hub? (S4.5.1(e)(1))

Yes – Pass

No - Fail

5.2.1 Is the label clearly visible from all front seating positions? (S4.5.1(e)(1))

Yes – Pass

No - Fail

5.2.2 Does the label conform in content to the label shown in Figure 7? (S4.5.1(e)(1)(iii))

Vehicles without back seats may omit the statement: "The back seat is the safest place for children." (S4.5.1(e)(2)(iii))

Yes – Pass

No - Fail

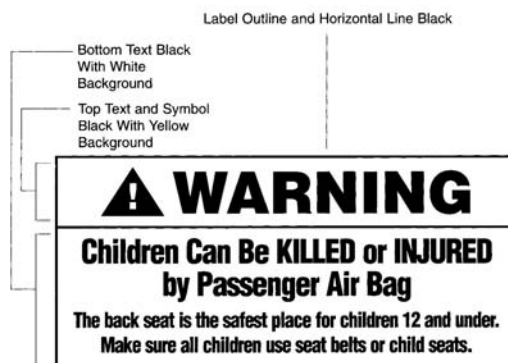

Figure 7. Removable Label on Dash.

- 5.2.3 Is the heading area yellow with the word "WARNING" and the alert symbol in black? (S4.5.1(e)(1)(i))
- Yes – Pass
 No - Fail
- 5.2.4 Is the message white with black text? (S4.5.1(e)(1)(ii))
- Yes – Pass
 No - Fail
- 5.2.5 Is the message area at least 30 cm²? (S4.5.1(e)(1)(ii))
Length _____, Width _____
Actual message area _____ cm²
- Yes – Pass
 No - Fail

I certify that I have read and performed each instruction.

Signature:

Wayne Gahlh

Date:

1/15/04

DATA SHEET 6

FMVSS 208 READINESS INDICATOR (S4.5.2)

Test Vehicle: 2004 Jeep Liberty
Test Program: FMVSS 208 Compliance
Test Technician: Wayne Dahlke

NHTSA No.: C40300
Test Date: 1/15/04

An occupant restraint system that deploys in the event of a crash shall have a monitoring system with a readiness indicator. A totally mechanical system is exempt from this requirement. (11/8/94 legal interpretation to Lawrence F. Hennegerger on behalf of Breed)

- 1. Is the system totally mechanical? If Yes, this data sheet is complete.
 Yes
 No
- 2. Describe the location of the readiness indicator: Left side of instrument cluster
- 3. Is the readiness indicator clearly visible to the driver?
 Yes – Pass
 No - Fail
- 4. Is a list of the elements in the occupant restraint system, being monitored by the readiness indicator, provided on a label or in the owner’s manual?
 Yes – Pass
 No - Fail
- 5. Does the vehicle have an on-off switch for the passenger air bag?
 If Yes, go to 6
 If No, this form is complete.
- 6. Is the air bag readiness indicator off when the passenger air bag switch is in the off position?
 Yes – Pass
 No - Fail

REMARKS:

I certify that I have read and performed each instruction.

Signature: Wayne Dahlke

Date: 1/15/04

DATA SHEET 7

PASSENGER AIR BAG MANUAL CUT-OFF DEVICE (S4.5.4)

Test Vehicle: 2004 Jeep Liberty
Test Program: FMVSS 208 Compliance
Test Technician: Wayne Dahlke

NHTSA No.: C40300
Test Date: 1/15/04

1. Is the vehicle equipped with an on-off switch that deactivates the air bag installed at the right front outboard seating position?
 Yes, go to 2
 No, this sheet is complete
2. Does the vehicle have any forward-facing rear designated seating positions? (S4.5.4(a))
 Yes, go to 3
 No, go to 4
3. Verification of the lack of room for a child restraint in the rear seat behind the driver's seat. (S4.5.4(b))
- 3.1 Position the seat's adjustable lumbar supports to that the lumbar support is in its lowest, retracted or deflated adjustment position (S8.1.3)
 N/A, no lumbar adjustment
- 3.2 Position any adjustable parts of the seat that provide additional support so that they are in the lowest or most open adjustment position. (S16.2.10.02)
 N/A, no additional support adjustment
- 3.3 If the seat cushion adjusts fore and aft, independent of the seat back, set this adjustment to the full rearward position. (S16.2.10.3.1)
 N/A, no independent fore-aft seat cushion adjustment
- 3.4 If the seat cushion height adjusts independent of the seat back, set this adjustment to the full down position (S16.2.10.3.1)
 N/A, no independent seat cushion height adjustment
- 3.5 Put the seat in its full rearward position. (S16.2.10.3.1)
 N/A, the seat does not have a fore-aft adjustment
- 3.6 If the seat height is adjustable, put it in the full down position. (S16.2.10.3.1)
 N/A, no seat height adjustment
- 3.7 Draw a horizontal reference line on the side of the seat cushion.
- 3.8 Using only the controls that change the seat in the fore-aft direction, mark the fore-aft seat positions. Mark the side of the seat and a reference position directly below on a part of the vehicle that does not adjust. For manual seats, move the seat forward one detent at a time and mark each detent as was done for the full rearward position. For power seats, mark only the full rearward, middle, and full forward positions. Label three of the positions with the following: F for full forward, M for mid-position (if there is no mid position, label the closest adjustment position to the rear of the mid-point), and R for full rearward.
 N/A – the seat does not have a fore-aft adjustment.
- 3.9 Using only the controls that change the seat in the fore-aft direction, place the seat in the full rearward position and then place the seat in the middle fore-aft position. (S8.1.2)
 N/A – the seat does not have fore-aft adjustment.

- Mid position
If there is no mid position, put the seat in the closest adjustment position to the rear of the midpoint. Describe the location of the seat:
- 3.10 If seat adjustments, other than fore-aft, are present and the horizontal reference line is no longer horizontal, use those adjustments to maintain the reference line as closely as possible to the horizontal.
- N/A – No adjustments
Angle of reference line as tested:
- 3.11 The seat back angle, if adjustable, is set at the manufacturer's nominal design riding position for a 50th percentile adult male in the manner specified by the manufacturer. (S4.5.4.1 (b) and S8.1.3)
- N/A – No seat back angle adjustment
Manufacturers design seat back angle:
Tested seat back angle:
- 3.12 Is the driver seat a bucket seat?
- Yes, go to 3.12.1 and skip 3.12.2
 No, go to 3.12.2 and skip 3.12.1
- 3.12.1 Bucket Seats:
- 3.12.1.1 Locate and mark a vertical Plane B through the longitudinal centerline of the seat driver's seat cushion. (S22.2.1.3) The longitudinal centerline of a bucket seat cushion is determined at the widest part of the seat cushion. Measure perpendicular to the longitudinal centerline of the vehicle.
- Record the width of the seat:
Record the distance from the edge of the seat to Plane B:
- 3.12.1.2 Locate the longitudinal horizontal line in plane B that is tangent to the highest point of the rear seat cushion behind the driver's seat. Measure along this line from the front of the seat back of the rear seat to the rear of the seat back of the driver's seat.
- Distance (mm):
 Less than 720 mm – Pass
 More then 720 mm – Fail
Go to 4
- 3.12.2 Bench seats (including split bench seats):
- 3.12.2.1 Locate and mark a vertical Plane B through the center of the steering wheel parallel to the vehicle longitudinal centerline.
- 3.12.2.2 Locate the longitudinal horizontal line in plane B that is tangent to the highest point of the rear seat cushion. Measure along this line from the front of the seat back of the rear seat to the rear of the seat back of the front seat.
- Distance (mm):
 Less than 720 mm – Pass
 More then 720 mm – Fail
Go to 4
4. Does the device turn the air bag on and off using the vehicle's ignition key? (S4.5.4.2)
 Yes – Pass

- No – Fail
5. Is the on-off device separate from the ignition switch? (S4.5.4.2)
- Yes – Pass
- No – Fail
6. Is there a telltale light that comes on when the passenger air bag is turned off? (S4.5.4.2)
- Yes – Pass
- No – Fail
7. Telltale light (S4.5.4.3)
- 7.1 Is the light yellow? S4.5.4.3(a)
- Yes – Pass
- No – Fail
- 7.2 Are the words “PASSENGER AIR BAG OFF” (S4.5.4.3(b))
- 7.2.1 on the telltale?
- Yes – Pass, go to 7.3
- No – go to 7.2.2
- 7.2.2 within 25 mm of the telltale?
- Measurement from the edge of the telltale light (mm):
- Yes – Pass
- No – Fail
- 7.3 Does the telltale remain illuminated while the air bag is turned off? (S4.5.4.3c) (Leave the air bag off for 5 minutes.)
- Yes – Pass
- No – Fail
- 7.4 Is the telltale illuminated while the air bag is turned on? (S4.5.4.3(d))
- Yes – Fail
- No – Pass
- 7.5 Is the telltale combined with the air bag readiness indicator? (S4.5.4.3(e))
- Yes – Fail
- No – Pass
8. Owner’s Manual
- 8.1 Does the owner’s manual contain complete instructions on the operation of the on-off switch? (S4.5.4.4(a))
- Yes – Pass
- No – Fail
- 8.2 Does the owner’s manual contain a statement that the on-off switch should only be used when a member of one of the following risk groups is occupying the right front passenger seating position? (S4.5.4.4(b))
- Infants: there is no back seat
the rear seat is too small to accommodate a child restraint
there is a medical condition that must be monitored constantly
- Children aged 1 to 12: there is no back seat
space is not always available in the rear seat
there is a medical condition that must be monitored constantly
- Medical condition: medical risk causes special risk for passenger
greater risk for harm than with the air bag on

<input type="checkbox"/>		<input type="checkbox"/> Yes – Pass
		<input type="checkbox"/> No – Fail
<input type="checkbox"/>	8.3	Does the owner's manual contain a warning about the safety consequences of using the on-off switch at other times?
		<input type="checkbox"/> Yes – Pass
		<input type="checkbox"/> No – Fail

REMARKS:

I certify that I have read and performed each instruction.

Signature: Wayne Jahlh

Date: 1/15/04

DATA SHEET 8

LAP BELT LOCKABILITY

Passenger cars, trucks, buses, and multipurpose passenger
Vehicles with a GVWR of 10,000 pounds or less. (S7.1.1.5)

Test Vehicle: 2004 Jeep Liberty
Test Program: FMVSS 208 Compliance
Test Technician: Wayne Dahlke

NHTSA No.: C40300
Test Date: 1/15/04

Complete one of these forms for **each** designated seating position that can be adjusted to forward-facing or that is a forward-facing seat, other than the driver's seat (S7.1.1.5(a), **and** that has seat belt retractors that are not solely automatic locking retractors. (S7.1.1.5(c))

DESIGNATED SEATING POSITION: **Front Passenger**

- | | |
|-------------------------------------|--------------------------------------------------------------------------------------------------------------------------------------------------------------------------------------------------------------------------------------------------------------------------------------------------------------|
| <input type="checkbox"/> | N/A – no retractor is at this position |
| <input type="checkbox"/> | N/A – the retractor is an automatic locking retractor ONLY |
| <input checked="" type="checkbox"/> | 1. Record test fore-aft seat position: Full Aft (S7.1.1.5(c)(1)) (Any position is acceptable) |
| <input checked="" type="checkbox"/> | 2. Does the lap belt portion of the seat belt in the forward-facing seat or seat that can be adjusted to forward-facing consist of a locking device that does NOT have to be attached by the vehicle user to the seat belt webbing, retractor, or any other part of the vehicle. (S7.1.1.5 (a)) |
| <input checked="" type="checkbox"/> | Yes – Pass |
| <input type="checkbox"/> | No – Fail |
| <input checked="" type="checkbox"/> | 3. Does the lap belt portion of the seat belt in the forward-facing seat or seat that can be adjusted to forward-facing consist of a locking device that does NOT require inverting, twisting or deforming of the belt webbing. (S7.1.1.5 (a)) |
| <input checked="" type="checkbox"/> | Yes – Pass |
| <input type="checkbox"/> | No – Fail |
| <input checked="" type="checkbox"/> | 4. Buckle the seat belt. (S7.1.1.5(c)(1)) |
| <input checked="" type="checkbox"/> | 5. Locate a reference point A on the seat belt buckle. (S7.1.1.5(c)(2)) |
| <input checked="" type="checkbox"/> | 6. Locate a reference point B on the attachment hardware or retractor assembly at the other end of the lap belt or lap belt portion of the seat belt assembly. (S7.1.1.5(c)(2)) |
| <input checked="" type="checkbox"/> | 7. Does the vehicle user need to take some action to activate the locking feature on the lap belt portion of the seat belt in any forward-facing seat or seat that can be adjusted to forward-facing? |
| <input checked="" type="checkbox"/> | Yes, go to 7.1 |
| <input type="checkbox"/> | No, go to 8 |
| <input checked="" type="checkbox"/> | 7.1 Does the vehicle owner's manual include a description in words and/or diagrams describing how to activate the locking feature so that the seat belt assembly can tightly secure a child restraint system and how to deactivate the locking feature to remove the child restraint system. (S7.1.1.5(b)) |
| <input checked="" type="checkbox"/> | Yes – Pass |
| <input type="checkbox"/> | No – Fail |
| <input checked="" type="checkbox"/> | 8. Adjust the lap belt or lap belt portion of the seat belt assembly according to any procedures recommended in the vehicle owner's manual to activate any locking feature so that the webbing between points A and B is at the maximum length allowed by the belt system. (S7.1.1.5(c)(2) & S7.1.1.5(c)(1)) |

9. Measure and record the distance between points A and B along the longitudinal centerline of the webbing for the lap belt or lap belt portion of the seat belt assembly. (S7.1.1.5(c)(2))
- Measured distance between A and B (inches): 65 1/4
10. Readjust the belt system so that the webbing between points A and B is at any length that is 5 inches or more shorter than the maximum length of the webbing. (S7.1.1.5(c)(3))
11. To the lap belt or lap belt portion of the seat belt assembly, apply a preload of 10 pounds using the webbing tension pull device in Figure 5. Apply the load in a vertical plane parallel to the longitudinal axis of the vehicle and passing through the seating reference point of the designated seating position. Apply the preload in a horizontal direction toward the front of the vehicle with a force application angle of not less than 5 degrees nor more than 15 degrees above the horizontal. (S7.1.1.5(c)(4))
- Measured force application angle (Spec. 5-15 degrees): 14.5
12. Measure the length between points A and B along the longitudinal centerline of the webbing while the preload is being applied. (S7.1.1.5(c)(4))
- Measured distance between A and B (inches): 45 1/4
13. Increase the load to 50 pounds at a rate of no more than 50 pounds per second. Attain the load in not more than 5 seconds. (If webbing sensitive emergency locking retractors are installed as part of the lap belt or lap belt portion of the seat belt assembly, apply the load at a rate less than the threshold value for lock-up specified by the manufacturer.) Maintain the load for at least 5 seconds. Measure and record the distance between points A and B along the longitudinal centerline of the webbing. (S7.1.1.5(c)(5))
- Record onset rate (lb/sec) (spec. 10 to 50 lb/sec) (S7.1.1.5(c)(5)): 10
- Measured distance between A and B (inches) (S7.1.1.5(c)(6)): 45 1/2
14. Subtract the measurement in 12 from the measurement in 13. Is the difference 2 inches or less? (S7.1.1.5(c)(7))
- $13 - 12 = 1/4$
- Yes – Pass
- No – Fail
15. Subtract the measurement in 9 from the measurement in 13. Is the difference 3 inches or more? (S7.1.1.5(c)(8))
- $9 - 13 = 19 3/4$
- Yes – Pass
- No – Fail

REMARKS:

I certify that I have read and performed each instruction.

Signature: Wayne Gahl

Date: 1/15/04

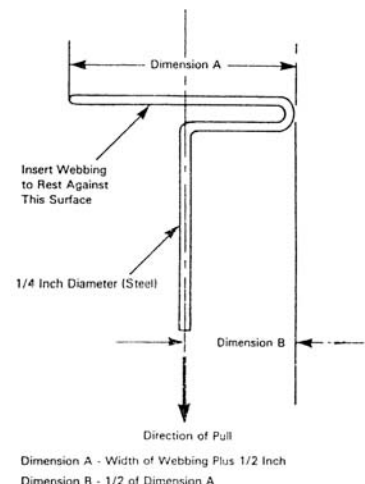

Figure 5. - Webbing Tension Pull Device

DATA SHEET 8

LAP BELT LOCKABILITY

Passenger cars, trucks, buses, and multipurpose passenger Vehicles with a GVWR of 10,000 pounds or less. (S7.1.1.5)

Test Vehicle: 2004 Jeep Liberty
Test Program: FMVSS 208 Compliance
Test Technician: Wayne Dahlke

NHTSA No.: C40300
Test Date: 1/15/04

Complete one of these forms for **each** designated seating position that can be adjusted to forward-facing or that is a forward-facing seat, other than the driver's seat (S7.1.1.5(a), **and** that has seat belt retractors that are not solely automatic locking retractors. (S7.1.1.5(c))

DESIGNATED SEATING POSITION: **Left Rear Passenger**

- | | |
|-------------------------------------|--------------------------------------------------------------------------------------------------------------------------------------------------------------------------------------------------------------------------------------------------------------------------------------------------------------|
| <input type="checkbox"/> | N/A – no retractor is at this position |
| <input type="checkbox"/> | N/A – the retractor is an automatic locking retractor ONLY |
| <input checked="" type="checkbox"/> | 1. Record test fore-aft seat position: Not Adjustable (S7.1.1.5(c)(1)) (Any position is acceptable) |
| <input checked="" type="checkbox"/> | 2. Does the lap belt portion of the seat belt in the forward-facing seat or seat that can be adjusted to forward-facing consist of a locking device that does NOT have to be attached by the vehicle user to the seat belt webbing, retractor, or any other part of the vehicle. (S7.1.1.5 (a)) |
| <input checked="" type="checkbox"/> | Yes – Pass |
| <input type="checkbox"/> | No – Fail |
| <input checked="" type="checkbox"/> | 3. Does the lap belt portion of the seat belt in the forward-facing seat or seat that can be adjusted to forward-facing consist of a locking device that does NOT require inverting, twisting or deforming of the belt webbing. (S7.1.1.5 (a)) |
| <input checked="" type="checkbox"/> | Yes – Pass |
| <input type="checkbox"/> | No – Fail |
| <input checked="" type="checkbox"/> | 4. Buckle the seat belt. (S7.1.1.5(c)(1)) |
| <input checked="" type="checkbox"/> | 5. Locate a reference point A on the seat belt buckle. (S7.1.1.5(c)(2)) |
| <input checked="" type="checkbox"/> | 6. Locate a reference point B on the attachment hardware or retractor assembly at the other end of the lap belt or lap belt portion of the seat belt assembly. (S7.1.1.5(c)(2)) |
| <input checked="" type="checkbox"/> | 7. Does the vehicle user need to take some action to activate the locking feature on the lap belt portion of the seat belt in any forward-facing seat or seat that can be adjusted to forward-facing? |
| <input checked="" type="checkbox"/> | Yes, go to 7.1 |
| <input type="checkbox"/> | No, go to 8 |
| <input checked="" type="checkbox"/> | 7.1 Does the vehicle owner's manual include a description in words and/or diagrams describing how to activate the locking feature so that the seat belt assembly can tightly secure a child restraint system and how to deactivate the locking feature to remove the child restraint system. (S7.1.1.5(b)) |
| <input checked="" type="checkbox"/> | Yes – Pass |
| <input type="checkbox"/> | No – Fail |
| <input checked="" type="checkbox"/> | 8. Adjust the lap belt or lap belt portion of the seat belt assembly according to any procedures recommended in the vehicle owner's manual to activate any locking feature so that the webbing between points A and B is at the maximum length allowed by the belt system. (S7.1.1.5(c)(2) & S7.1.1.5(c)(1)) |

9. Measure and record the distance between points A and B along the longitudinal centerline of the webbing for the lap belt or lap belt portion of the seat belt assembly. (S7.1.1.5(c)(2))
- Measured distance between A and B (inches): 65 3/4
10. Readjust the belt system so that the webbing between points A and B is at any length that is 5 inches or more shorter than the maximum length of the webbing. (S7.1.1.5(c)(3))
11. To the lap belt or lap belt portion of the seat belt assembly, apply a preload of 10 pounds using the webbing tension pull device in Figure 5. Apply the load in a vertical plane parallel to the longitudinal axis of the vehicle and passing through the seating reference point of the designated seating position. Apply the preload in a horizontal direction toward the front of the vehicle with a force application angle of not less than 5 degrees nor more than 15 degrees above the horizontal. (S7.1.1.5(c)(4))
- Measured force application angle (Spec. 5-15 degrees): 15
12. Measure the length between points A and B along the longitudinal centerline of the webbing while the preload is being applied. (S7.1.1.5(c)(4))
- Measured distance between A and B (inches): 31 7/8
13. Increase the load to 50 pounds at a rate of no more than 50 pounds per second. Attain the load in not more than 5 seconds. (If webbing sensitive emergency locking retractors are installed as part of the lap belt or lap belt portion of the seat belt assembly, apply the load at a rate less than the threshold value for lock-up specified by the manufacturer.) Maintain the load for at least 5 seconds. Measure and record the distance between points A and B along the longitudinal centerline of the webbing. (S7.1.1.5(c)(5))
- Record onset rate (lb/sec) (spec. 10 to 50 lb/sec) (S7.1.1.5(c)(5)): 10
- Measured distance between A and B (inches) (S7.1.1.5(c)(6)): 32 3/8
14. Subtract the measurement in 12 from the measurement in 13. Is the difference 2 inches or less? (S7.1.1.5(c)(7))
- 13 - 12 = 1/2
- Yes – Pass
- No – Fail
15. Subtract the measurement in 9 from the measurement in 13. Is the difference 3 inches or more? (S7.1.1.5(c)(8))
- 9 - 13 = 33 3/8
- Yes – Pass
- No – Fail

REMARKS:

I certify that I have read and performed each instruction.

Signature: Wayne Gahl

Date: 1/15/04

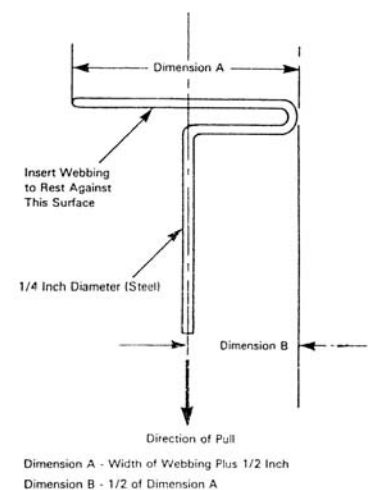

Figure 5. - Webbing Tension Pull Device

DATA SHEET 8

LAP BELT LOCKABILITY

**Passenger cars, trucks, buses, and multipurpose passenger
Vehicles with a GVWR of 10,000 pounds or less. (S7.1.1.5)**

Test Vehicle: 2004 Jeep Liberty
Test Program: FMVSS 208 Compliance
Test Technician: Wayne Dahlke

NHTSA No.: C40300
Test Date: 1/15/04

Complete one of these forms for **each** designated seating position that can be adjusted to forward-facing or that is a forward-facing seat, other than the driver's seat (S7.1.1.5(a), **and** that has seat belt retractors that are not solely automatic locking retractors. (S7.1.1.5(c))

DESIGNATED SEATING POSITION: **Center Rear Passenger**

- | | |
|-------------------------------------|--------------------------------------------------------------------------------------------------------------------------------------------------------------------------------------------------------------------------------------------------------------------------------------------------------------|
| <input type="checkbox"/> | N/A – no retractor is at this position |
| <input type="checkbox"/> | N/A – the retractor is an automatic locking retractor ONLY |
| <input checked="" type="checkbox"/> | 1. Record test fore-aft seat position: Not Adjustable (S7.1.1.5(c)(1)) (Any position is acceptable) |
| <input checked="" type="checkbox"/> | 2. Does the lap belt portion of the seat belt in the forward-facing seat or seat that can be adjusted to forward-facing consist of a locking device that does NOT have to be attached by the vehicle user to the seat belt webbing, retractor, or any other part of the vehicle. (S7.1.1.5 (a)) |
| <input checked="" type="checkbox"/> | Yes – Pass |
| <input type="checkbox"/> | No – Fail |
| <input checked="" type="checkbox"/> | 3. Does the lap belt portion of the seat belt in the forward-facing seat or seat that can be adjusted to forward-facing consist of a locking device that does NOT require inverting, twisting or deforming of the belt webbing. (S7.1.1.5 (a)) |
| <input checked="" type="checkbox"/> | Yes – Pass |
| <input type="checkbox"/> | No – Fail |
| <input checked="" type="checkbox"/> | 4. Buckle the seat belt. (S7.1.1.5(c)(1)) |
| <input checked="" type="checkbox"/> | 5. Locate a reference point A on the seat belt buckle. (S7.1.1.5(c)(2)) |
| <input checked="" type="checkbox"/> | 6. Locate a reference point B on the attachment hardware or retractor assembly at the other end of the lap belt or lap belt portion of the seat belt assembly. (S7.1.1.5(c)(2)) |
| <input checked="" type="checkbox"/> | 7. Does the vehicle user need to take some action to activate the locking feature on the lap belt portion of the seat belt in any forward-facing seat or seat that can be adjusted to forward-facing? |
| <input checked="" type="checkbox"/> | Yes, go to 7.1 |
| <input type="checkbox"/> | No, go to 8 |
| <input checked="" type="checkbox"/> | 7.1 Does the vehicle owner's manual include a description in words and/or diagrams describing how to activate the locking feature so that the seat belt assembly can tightly secure a child restraint system and how to deactivate the locking feature to remove the child restraint system. (S7.1.1.5(b)) |
| <input checked="" type="checkbox"/> | Yes – Pass |
| <input type="checkbox"/> | No – Fail |
| <input checked="" type="checkbox"/> | 8. Adjust the lap belt or lap belt portion of the seat belt assembly according to any procedures recommended in the vehicle owner's manual to activate any locking feature so that the webbing between points A and B is at the maximum length allowed by the belt system. (S7.1.1.5(c)(2) & S7.1.1.5(c)(1)) |

9. Measure and record the distance between points A and B along the longitudinal centerline of the webbing for the lap belt or lap belt portion of the seat belt assembly. (S7.1.1.5(c)(2))
- Measured distance between A and B (inches): 66
10. Readjust the belt system so that the webbing between points A and B is at any length that is 5 inches or more shorter than the maximum length of the webbing. (S7.1.1.5(c)(3))
11. To the lap belt or lap belt portion of the seat belt assembly, apply a preload of 10 pounds using the webbing tension pull device in Figure 5. Apply the load in a vertical plane parallel to the longitudinal axis of the vehicle and passing through the seating reference point of the designated seating position. Apply the preload in a horizontal direction toward the front of the vehicle with a force application angle of not less than 5 degrees nor more than 15 degrees above the horizontal. (S7.1.1.5(c)(4))
- Measured force application angle (Spec. 5-15 degrees): 15
12. Measure the length between points A and B along the longitudinal centerline of the webbing while the preload is being applied. (S7.1.1.5(c)(4))
- Measured distance between A and B (inches): 30 3/4
13. Increase the load to 50 pounds at a rate of no more than 50 pounds per second. Attain the load in not more than 5 seconds. (If webbing sensitive emergency locking retractors are installed as part of the lap belt or lap belt portion of the seat belt assembly, apply the load at a rate less than the threshold value for lock-up specified by the manufacturer.) Maintain the load for at least 5 seconds. Measure and record the distance between points A and B along the longitudinal centerline of the webbing. (S7.1.1.5(c)(5))
- Record onset rate (lb/sec) (spec. 10 to 50 lb/sec) (S7.1.1.5(c)(5)): 10
- Measured distance between A and B (inches) (S7.1.1.5(c)(6)): 31
14. Subtract the measurement in 12 from the measurement in 13. Is the difference 2 inches or less? (S7.1.1.5(c)(7))
- $13 - 12 = 1/4$
- Yes – Pass
- No – Fail
15. Subtract the measurement in 9 from the measurement in 13. Is the difference 3 inches or more? (S7.1.1.5(c)(8))
- $9 - 13 = 35$
- Yes – Pass
- No – Fail

REMARKS:

I certify that I have read and performed each instruction.

Signature: Wayne Gahl

Date: 1/15/04

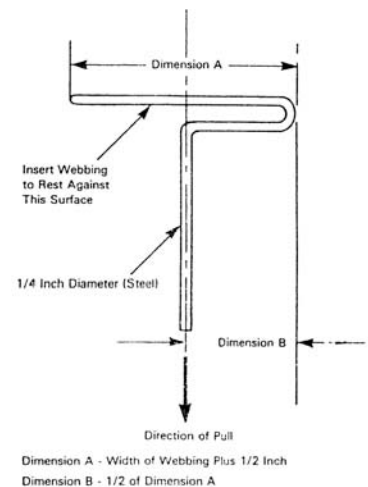

Figure 5. - Webbing Tension Pull Device

DATA SHEET 8

LAP BELT LOCKABILITY

**Passenger cars, trucks, buses, and multipurpose passenger
Vehicles with a GVWR of 10,000 pounds or less. (S7.1.1.5)**

Test Vehicle: 2004 Jeep Liberty
Test Program: FMVSS 208 Compliance
Test Technician: Wayne Dahlke

NHTSA No.: C40300
Test Date: 1/15/04

Complete one of these forms for **each** designated seating position that can be adjusted to forward-facing or that is a forward-facing seat, other than the driver's seat (S7.1.1.5(a), **and** that has seat belt retractors that are not solely automatic locking retractors. (S7.1.1.5(c))

DESIGNATED SEATING POSITION: **Right Rear Passenger**

- | | |
|-------------------------------------|--------------------------------------------------------------------------------------------------------------------------------------------------------------------------------------------------------------------------------------------------------------------------------------------------------------|
| <input type="checkbox"/> | N/A – no retractor is at this position |
| <input type="checkbox"/> | N/A – the retractor is an automatic locking retractor ONLY |
| <input checked="" type="checkbox"/> | 1. Record test fore-aft seat position: Not Adjustable (S7.1.1.5(c)(1)) (Any position is acceptable) |
| <input checked="" type="checkbox"/> | 2. Does the lap belt portion of the seat belt in the forward-facing seat or seat that can be adjusted to forward-facing consist of a locking device that does NOT have to be attached by the vehicle user to the seat belt webbing, retractor, or any other part of the vehicle. (S7.1.1.5 (a)) |
| <input checked="" type="checkbox"/> | Yes – Pass |
| <input type="checkbox"/> | No – Fail |
| <input checked="" type="checkbox"/> | 3. Does the lap belt portion of the seat belt in the forward-facing seat or seat that can be adjusted to forward-facing consist of a locking device that does NOT require inverting, twisting or deforming of the belt webbing. (S7.1.1.5 (a)) |
| <input checked="" type="checkbox"/> | Yes – Pass |
| <input type="checkbox"/> | No – Fail |
| <input checked="" type="checkbox"/> | 4. Buckle the seat belt. (S7.1.1.5(c)(1)) |
| <input checked="" type="checkbox"/> | 5. Locate a reference point A on the seat belt buckle. (S7.1.1.5(c)(2)) |
| <input checked="" type="checkbox"/> | 6. Locate a reference point B on the attachment hardware or retractor assembly at the other end of the lap belt or lap belt portion of the seat belt assembly. (S7.1.1.5(c)(2)) |
| <input checked="" type="checkbox"/> | 7. Does the vehicle user need to take some action to activate the locking feature on the lap belt portion of the seat belt in any forward-facing seat or seat that can be adjusted to forward-facing? |
| <input checked="" type="checkbox"/> | Yes, go to 7.1 |
| <input type="checkbox"/> | No, go to 8 |
| <input checked="" type="checkbox"/> | 7.1 Does the vehicle owner's manual include a description in words and/or diagrams describing how to activate the locking feature so that the seat belt assembly can tightly secure a child restraint system and how to deactivate the locking feature to remove the child restraint system. (S7.1.1.5(b)) |
| <input checked="" type="checkbox"/> | Yes – Pass |
| <input type="checkbox"/> | No – Fail |
| <input checked="" type="checkbox"/> | 8. Adjust the lap belt or lap belt portion of the seat belt assembly according to any procedures recommended in the vehicle owner's manual to activate any locking feature so that the webbing between points A and B is at the maximum length allowed by the belt system. (S7.1.1.5(c)(2) & S7.1.1.5(c)(1)) |

9. Measure and record the distance between points A and B along the longitudinal centerline of the webbing for the lap belt or lap belt portion of the seat belt assembly. (S7.1.1.5(c)(2))
- Measured distance between A and B (inches): 66
10. Readjust the belt system so that the webbing between points A and B is at any length that is 5 inches or more shorter than the maximum length of the webbing. (S7.1.1.5(c)(3))
11. To the lap belt or lap belt portion of the seat belt assembly, apply a preload of 10 pounds using the webbing tension pull device in Figure 5. Apply the load in a vertical plane parallel to the longitudinal axis of the vehicle and passing through the seating reference point of the designated seating position. Apply the preload in a horizontal direction toward the front of the vehicle with a force application angle of not less than 5 degrees nor more than 15 degrees above the horizontal. (S7.1.1.5(c)(4))
- Measured force application angle (Spec. 5-15 degrees): 15
12. Measure the length between points A and B along the longitudinal centerline of the webbing while the preload is being applied. (S7.1.1.5(c)(4))
- Measured distance between A and B (inches): 32 3/4
13. Increase the load to 50 pounds at a rate of no more than 50 pounds per second. Attain the load in not more than 5 seconds. (If webbing sensitive emergency locking retractors are installed as part of the lap belt or lap belt portion of the seat belt assembly, apply the load at a rate less than the threshold value for lock-up specified by the manufacturer.) Maintain the load for at least 5 seconds. Measure and record the distance between points A and B along the longitudinal centerline of the webbing. (S7.1.1.5(c)(5))
- Record onset rate (lb/sec) (spec. 10 to 50 lb/sec) (S7.1.1.5(c)(5)): 10
- Measured distance between A and B (inches) (S7.1.1.5(c)(6)): 33 3/8
14. Subtract the measurement in 12 from the measurement in 13. Is the difference 2 inches or less? (S7.1.1.5(c)(7))
- $13 - 12 = 5/8$
- Yes – Pass
- No – Fail
15. Subtract the measurement in 9 from the measurement in 13. Is the difference 3 inches or more? (S7.1.1.5(c)(8))
- $9 - 13 = 32 5/8$
- Yes – Pass
- No – Fail

REMARKS:

I certify that I have read and performed each instruction.

Signature: Wayne Gahl

Date: 1/15/04

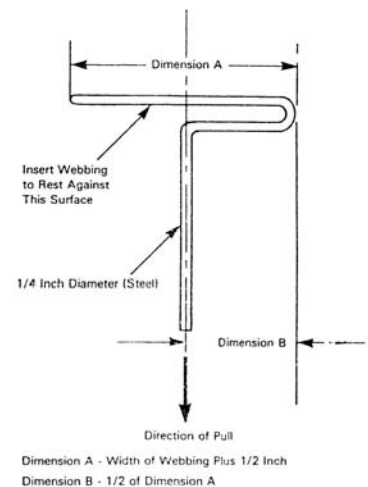

Figure 5. - Webbing Tension Pull Device

DATA SHEET 9

FMVSS 208 SEAT BELT WARNING SYSTEM CHECK (S7.3)

Test Vehicle: 2004 Jeep Liberty
 Test Program: FMVSS 208 Compliance
 Test Technician: Wayne Dahlke

NHTSA No.: C40300
 Test Date: 1/15/04

- 1. The occupant is in the driver's seat.
- 2. The seat belt is in the stowed position.
- 3. The key is in the "on" or "start" position.
- 4. The time duration of the audible signal beginning with key "on" or "start" is
Seconds: 6.0
- 5. The occupant is in the driver's seat.
- 6. The seat belt is in the stowed position.
- 7. The key is in the "on" or "start" position.
- 8. The time duration of the warning light beginning with key "on" or "start" is
Seconds: Stays On
- 9. The occupant is in the driver's seat.
- 10. The seat belt is in the latched position and with at least 4 inches of belt webbing extended.
- 11. The key is in the "on" or "start" position.
- 12. The time duration of the audible signal beginning with key "on" or "start" is
Seconds: 0.0
- 13. The occupant is in the driver's seat.
- 14. The seat belt is in the latched position and with at least 4 inches of belt webbing extended.
- 15. The key is in the "on" or "start" position.
- 16. The time duration of the warning light beginning with key "on" or "start" is
Seconds: 7.0
- 17. Complete the following table with the data from 4, 8, 12, and 16 to determine which option is used.

		Warning light	Warning light specification	Audible signal	Audible signal specification*
S7.3 (a)(1)	Belt latched & key on or start	Item 16: 7.0		Item 12: 0.0	0 seconds**
	Belt stowed & key on or start	Item 8: Stays On	60 seconds minimum	Item 4: 6.0	4 to 8 seconds
S7.3 (a)(2)	Belt latched & key on or start	Item 16: 7.0	4 to 8 seconds	Item 12: 0.0	0 seconds**
	Belt stowed & key on or start	Item 8: Stays On	4 to 8 seconds	Item 4: 6.0	4 to 8 seconds

* 49 USCS @ 30124 does NOT allow an audible signal to operate for more than 8 seconds.

** 0 seconds means the light or audible signal are NOT permitted to operate under these conditions.
 See 7/12/00 interpretation to Patrick Raheer of Hogan and Hartson

18. The seat belt warning system meets the requirements of (manufacturers may comply with either section)
- S7.3 (a)(1)
 - S7.3 (a)(2)
 - FAIL – does not meet the requirements of either option
19. Note wording of visual warning: (S7.3(a)(1) and S7.3(a)(2))
- Fasten seat belts
 - Fasten belts
 - Symbol 101
 - FAIL – does not used any of the above working or symbol

I certify that I have read and performed each instruction.

Signature: Wayne Gahl

Date: 1/15/04

DATA SHEET 10
BELT CONTACT FORCE (S7.4.3)

Test Vehicle: 2004 Jeep Liberty
 Test Program: FMVSS 208 Compliance
 Test Technician: Wayne Dahlke

NHTSA No.: C40300
 Test Date: 1/15/04

Test all Type 2 seat belts other than those in walk-in van-type vehicles and those at front outboard designated seating positions in passenger cars. Complete a form for each applicable seat belt.

DESIGNATED SEATING POSITION:	Left Front Driver
------------------------------	-------------------

- | | | |
|----------|----|------------------------------------------------------------------------|
| X | 1. | Does the vehicle incorporate a webbing tension-relieving device? |
| | | <input type="checkbox"/> Yes, this form is complete |
| | | <input checked="" type="checkbox"/> No, continue with this check sheet |
- | | | |
|----------|----|-------------------------------------------------------------------------------------------------------------------------------------------------|
| X | 2. | Position the seat's adjustable lumbar supports so that the lumbar support is in its lowest, retracted or deflated adjustment position. (S8.1.3) |
| | | <input checked="" type="checkbox"/> N/A, no lumbar adjustment |
- | | | |
|----------|----|---------------------------------------------------------------------------------------------------------------------------------------------------------|
| X | 3. | Position any adjustable parts of the seat that provide additional support so that they are in the lowest or most open adjustment position. (S16.2.10.2) |
| | | <input checked="" type="checkbox"/> N/A, no additional support adjustment |
- | | | |
|----------|----|---------------------------------------------------------------------------------------------------------------------------------------------------------|
| X | 4. | Position any adjustable parts of the seat that provide additional support so that they are in the lowest or most open adjustment position. (S16.2.10.2) |
| | | <input checked="" type="checkbox"/> N/A, no independent fore-aft seat cushion adjustment |
- | | | |
|----------|----|-------------------------------------------------------------------------------------------------------------------------------------------|
| X | 5. | If the seat cushion adjusts fore and aft, independent of the seat back, set this adjustment to the full rearward position. (S16.2.10.3.1) |
| | | <input checked="" type="checkbox"/> N/A, no independent seat cushion height adjustment |
- | | | |
|----------|----|----------------------------------------------------------------------------|
| X | 6. | Put the seat in its full rearward position. (S16.2.10.3.1) |
| | | <input type="checkbox"/> N/A, the seat does not have a fore-aft adjustment |
- | | | |
|----------|----|--------------------------------------------------------------------------------------------------------------------------------|
| X | 7. | If the seat cushion height adjusts independent of the seat back, set this adjustment to the full down position. (S16.2.10.3.1) |
| | | <input checked="" type="checkbox"/> N/A, no seat height adjustment |
- | | | |
|----------|----|-------------------------------------------------------------------|
| X | 8. | Draw a horizontal reference line on the side of the seat cushion. |
|----------|----|-------------------------------------------------------------------|
- | | | |
|----------|----|----------------------------------------------------------------------------------------------------------------------------------------------------------------------------------------------------------------------------------------------------------------------------------------------------------------------------------------------------------------------------------------------------------------------------------------------------------------------------------------------------------------------------------------------------------------------------------------------------------------------------------------------------------------|
| X | 9. | Using only the controls that change the seat in the fore-aft direction, mark the fore-aft seat positions. Mark the side of the seat and a reference position directly below on a part of the vehicle that does not adjust. For manual seats, move the seat forward one detent at a time and mark each detent as was done for the full rearward position. For power seats, mark only the full rearward, middle, and full forward positions. Label three of the positions with the following: F for full forward, M for mid-position (if there is no mid position, label the closest adjustment position to the rear of the mid-point), and R for full rearward. |
| | | <input type="checkbox"/> N/A, the seat does not have a fore-aft adjustment |
- | | | |
|----------|-----|------------------------------------------------------------------------------------------------------------------------------------------------------------------------------------------------------|
| X | 10. | Using only the controls that change the seat in the fore-aft direction, place the seat in the full rearward position and then place the seat in the middle fore-aft position for this test. (S8.1.2) |
|----------|-----|------------------------------------------------------------------------------------------------------------------------------------------------------------------------------------------------------|

- Mid position
If there is no mid position, put the seat in the closest adjustment position to the rear of the midpoint. Describe the location of the seat:
11. If seat adjustments other than fore-aft are present and the horizontal reference line is no longer horizontal, use those adjustments to maintain the reference line as closely as possible to the horizontal. (S16.2.10.3.2.1)
- N/A, no adjustments
Reference line angle as tested: Zero
12. The seat back angle, if adjustable, is set at the manufacturer's nominal design riding position for a 50th percentile adult male in the manner specified by the manufacturer. (S4.5.4.1 (b) and S8.1.3)
- N/A, no seat back angle adjustment
Manufacturer's design seat back angle: 23.5
13. Tested seat back angle: 23.5
13. Position the test dummies according to dummy position placement instructions in Appendix F.
14. Fasten the seat belt latch.
15. Pull either 12 inches of belt webbing or the maximum available amount of belt webbing, whichever is less, from the retractor and then release it, allowing the belt webbing to return to the dummy's chest.
16. Locate the point where the centerline of the upper torso belt webbing crosses the midsagittal line on the dummy's chest. At that point pull the belt webbing out 3 inches from the dummy's chest and release until it is within one inch from the dummy's chest. (S10.8) Using a force measuring gage with a full scale range of no more than 1.5 pounds, measure the contact force perpendicular to the dummy's chest exerted by the belt webbing.
- Contact Force (lb): 0.6
- 0.0 to 0.7 pounds – Pass
 Greater than 0.7 pounds - Fail

REMARKS:

I certify that I have read and performed each instruction.

Signature: Wayne Jahl

Date: 1/15/04

DATA SHEET 10
BELT CONTACT FORCE (S7.4.3)

Test Vehicle: 2004 Jeep Liberty
 Test Program: FMVSS 208 Compliance
 Test Technician: Wayne Dahlke

NHTSA No.: C40300
 Test Date: 1/15/04

Test all Type 2 seat belts other than those in walk-in van-type vehicles and those at front outboard designated seating positions in passenger cars. Complete a form for each applicable seat belt.

DESIGNATED SEATING POSITION:	Right Front Passenger
------------------------------	-----------------------

- | | | |
|----------|----|------------------------------------------------------------------------|
| X | 1. | Does the vehicle incorporate a webbing tension-relieving device? |
| | | <input type="checkbox"/> Yes, this form is complete |
| | | <input checked="" type="checkbox"/> No, continue with this check sheet |
- | | | |
|----------|----|-------------------------------------------------------------------------------------------------------------------------------------------------|
| X | 2. | Position the seat's adjustable lumbar supports so that the lumbar support is in its lowest, retracted or deflated adjustment position. (S8.1.3) |
| | | <input checked="" type="checkbox"/> N/A, no lumbar adjustment |
- | | | |
|----------|----|---------------------------------------------------------------------------------------------------------------------------------------------------------|
| X | 3. | Position any adjustable parts of the seat that provide additional support so that they are in the lowest or most open adjustment position. (S16.2.10.2) |
| | | <input checked="" type="checkbox"/> N/A, no additional support adjustment |
- | | | |
|----------|----|---------------------------------------------------------------------------------------------------------------------------------------------------------|
| X | 4. | Position any adjustable parts of the seat that provide additional support so that they are in the lowest or most open adjustment position. (S16.2.10.2) |
| | | <input checked="" type="checkbox"/> N/A, no independent fore-aft seat cushion adjustment |
- | | | |
|----------|----|-------------------------------------------------------------------------------------------------------------------------------------------|
| X | 5. | If the seat cushion adjusts fore and aft, independent of the seat back, set this adjustment to the full rearward position. (S16.2.10.3.1) |
| | | <input checked="" type="checkbox"/> N/A, no independent seat cushion height adjustment |
- | | | |
|----------|----|----------------------------------------------------------------------------|
| X | 6. | Put the seat in its full rearward position. (S16.2.10.3.1) |
| | | <input type="checkbox"/> N/A, the seat does not have a fore-aft adjustment |
- | | | |
|----------|----|--------------------------------------------------------------------------------------------------------------------------------|
| X | 7. | If the seat cushion height adjusts independent of the seat back, set this adjustment to the full down position. (S16.2.10.3.1) |
| | | <input checked="" type="checkbox"/> N/A, no seat height adjustment |
- | | | |
|----------|----|-------------------------------------------------------------------|
| X | 8. | Draw a horizontal reference line on the side of the seat cushion. |
|----------|----|-------------------------------------------------------------------|
- | | | |
|----------|----|----------------------------------------------------------------------------------------------------------------------------------------------------------------------------------------------------------------------------------------------------------------------------------------------------------------------------------------------------------------------------------------------------------------------------------------------------------------------------------------------------------------------------------------------------------------------------------------------------------------------------------------------------------------|
| X | 9. | Using only the controls that change the seat in the fore-aft direction, mark the fore-aft seat positions. Mark the side of the seat and a reference position directly below on a part of the vehicle that does not adjust. For manual seats, move the seat forward one detent at a time and mark each detent as was done for the full rearward position. For power seats, mark only the full rearward, middle, and full forward positions. Label three of the positions with the following: F for full forward, M for mid-position (if there is no mid position, label the closest adjustment position to the rear of the mid-point), and R for full rearward. |
| | | <input type="checkbox"/> N/A, the seat does not have a fore-aft adjustment |
- | | | |
|----------|-----|------------------------------------------------------------------------------------------------------------------------------------------------------------------------------------------------------|
| X | 10. | Using only the controls that change the seat in the fore-aft direction, place the seat in the full rearward position and then place the seat in the middle fore-aft position for this test. (S8.1.2) |
|----------|-----|------------------------------------------------------------------------------------------------------------------------------------------------------------------------------------------------------|

- Mid position
If there is no mid position, put the seat in the closest adjustment position to the rear of the midpoint. Describe the location of the seat:
11. If seat adjustments other than fore-aft are present and the horizontal reference line is no longer horizontal, use those adjustments to maintain the reference line as closely as possible to the horizontal. (S16.2.10.3.2.1)
- N/A, no adjustments
Reference line angle as tested: Zero
12. The seat back angle, if adjustable, is set at the manufacturer's nominal design riding position for a 50th percentile adult male in the manner specified by the manufacturer. (S4.5.4.1 (b) and S8.1.3)
- N/A, no seat back angle adjustment
Manufacturer's design seat back angle: 23.5
13. Tested seat back angle: 23.5
13. Position the test dummies according to dummy position placement instructions in Appendix F.
14. Fasten the seat belt latch.
15. Pull either 12 inches of belt webbing or the maximum available amount of belt webbing, whichever is less, from the retractor and then release it, allowing the belt webbing to return to the dummy's chest.
16. Locate the point where the centerline of the upper torso belt webbing crosses the midsagittal line on the dummy's chest. At that point pull the belt webbing out 3 inches from the dummy's chest and release until it is within one inch from the dummy's chest. (S10.8) Using a force measuring gage with a full scale range of no more than 1.5 pounds, measure the contact force perpendicular to the dummy's chest exerted by the belt webbing.
- Contact Force (lb): 0.6
- 0.0 to 0.7 pounds – Pass
 Greater than 0.7 pounds - Fail

REMARKS:

I certify that I have read and performed each instruction.

Signature: Wayne Jahl

Date: 1/15/04

DATA SHEET 10
BELT CONTACT FORCE (S7.4.3)

Test Vehicle: 2004 Jeep Liberty
 Test Program: FMVSS 208 Compliance
 Test Technician: Wayne Dahlke

NHTSA No.: C40300
 Test Date: 1/15/04

Test all Type 2 seat belts other than those in walk-in van-type vehicles and those at front outboard designated seating positions in passenger cars. Complete a form for each applicable seat belt.

DESIGNATED SEATING POSITION:	Left Rear Passenger
------------------------------	---------------------

- | | | |
|----------|-----|----------------------------------------------------------------------------------------------------------------------------------------------------------------------------------------------------------------------------------------------------------------------------------------------------------------------------------------------------------------------------------------------------------------------------------------------------------------------------------------------------------------------------------------------------------------------------------------------------------------------------------------------------------------|
| X | 1. | Does the vehicle incorporate a webbing tension-relieving device? |
| | | <input type="checkbox"/> Yes, this form is complete |
| | | <input checked="" type="checkbox"/> No, continue with this check sheet |
| X | 2. | Position the seat's adjustable lumbar supports so that the lumbar support is in its lowest, retracted or deflated adjustment position. (S8.1.3) |
| | | <input checked="" type="checkbox"/> N/A, no lumbar adjustment |
| X | 3. | Position any adjustable parts of the seat that provide additional support so that they are in the lowest or most open adjustment position. (S16.2.10.2) |
| | | <input checked="" type="checkbox"/> N/A, no additional support adjustment |
| X | 4. | Position any adjustable parts of the seat that provide additional support so that they are in the lowest or most open adjustment position. (S16.2.10.2) |
| | | <input checked="" type="checkbox"/> N/A, no independent fore-aft seat cushion adjustment |
| X | 5. | If the seat cushion adjusts fore and aft, independent of the seat back, set this adjustment to the full rearward position. (S16.2.10.3.1) |
| | | <input checked="" type="checkbox"/> N/A, no independent seat cushion height adjustment |
| X | 6. | Put the seat in its full rearward position. (S16.2.10.3.1) |
| | | <input checked="" type="checkbox"/> N/A, the seat does not have a fore-aft adjustment |
| X | 7. | If the seat cushion height adjusts independent of the seat back, set this adjustment to the full down position. (S16.2.10.3.1) |
| | | <input checked="" type="checkbox"/> N/A, no seat height adjustment |
| X | 8. | Draw a horizontal reference line on the side of the seat cushion. |
| X | 9. | Using only the controls that change the seat in the fore-aft direction, mark the fore-aft seat positions. Mark the side of the seat and a reference position directly below on a part of the vehicle that does not adjust. For manual seats, move the seat forward one detent at a time and mark each detent as was done for the full rearward position. For power seats, mark only the full rearward, middle, and full forward positions. Label three of the positions with the following: F for full forward, M for mid-position (if there is no mid position, label the closest adjustment position to the rear of the mid-point), and R for full rearward. |
| | | <input checked="" type="checkbox"/> N/A, the seat does not have a fore-aft adjustment |
| X | 10. | Using only the controls that change the seat in the fore-aft direction, place the seat in the full rearward position and then place the seat in the middle fore-aft position for this test. (S8.1.2) |

- Mid position
If there is no mid position, put the seat in the closest adjustment position to the rear of the midpoint. Describe the location of the seat: Not adjustable
11. If seat adjustments other than fore-aft are present and the horizontal reference line is no longer horizontal, use those adjustments to maintain the reference line as closely as possible to the horizontal. (S16.2.10.3.2.1)
- N/A, no adjustments
Reference line angle as tested: N/A
12. The seat back angle, if adjustable, is set at the manufacturer's nominal design riding position for a 50th percentile adult male in the manner specified by the manufacturer. (S4.5.4.1 (b) and S8.1.3)
- N/A, no seat back angle adjustment
Manufacturer's design seat back angle:
Tested seat back angle:
13. Position the test dummies according to dummy position placement instructions in Appendix F.
14. Fasten the seat belt latch.
15. Pull either 12 inches of belt webbing or the maximum available amount of belt webbing, whichever is less, from the retractor and then release it, allowing the belt webbing to return to the dummy's chest.
16. Locate the point where the centerline of the upper torso belt webbing crosses the midsagittal line on the dummy's chest. At that point pull the belt webbing out 3 inches from the dummy's chest and release until it is within one inch from the dummy's chest. (S10.8) Using a force measuring gage with a full scale range of no more than 1.5 pounds, measure the contact force perpendicular to the dummy's chest exerted by the belt webbing.
Contact Force (lb): 0.6
- 0.0 to 0.7 pounds – Pass
 Greater than 0.7 pounds - Fail

REMARKS:

I certify that I have read and performed each instruction.

Signature: Wayne Jahlh

Date: 1/15/04

DATA SHEET 10
BELT CONTACT FORCE (S7.4.3)

Test Vehicle: 2004 Jeep Liberty
 Test Program: FMVSS 208 Compliance
 Test Technician: Wayne Dahlke

NHTSA No.: C40300
 Test Date: 1/15/04

Test all Type 2 seat belts other than those in walk-in van-type vehicles and those at front outboard designated seating positions in passenger cars. Complete a form for each applicable seat belt.

DESIGNATED SEATING POSITION:	Center Rear Passenger
------------------------------	-----------------------

- | | | |
|----------|----|------------------------------------------------------------------|
| X | 1. | Does the vehicle incorporate a webbing tension-relieving device? |
| | | <input type="checkbox"/> Yes, this form is complete |
| | | X No, continue with this check sheet |
- | | | |
|----------|----|-------------------------------------------------------------------------------------------------------------------------------------------------|
| X | 2. | Position the seat's adjustable lumbar supports so that the lumbar support is in its lowest, retracted or deflated adjustment position. (S8.1.3) |
| | | X N/A, no lumbar adjustment |
- | | | |
|----------|----|---------------------------------------------------------------------------------------------------------------------------------------------------------|
| X | 3. | Position any adjustable parts of the seat that provide additional support so that they are in the lowest or most open adjustment position. (S16.2.10.2) |
| | | X N/A, no additional support adjustment |
- | | | |
|----------|----|---------------------------------------------------------------------------------------------------------------------------------------------------------|
| X | 4. | Position any adjustable parts of the seat that provide additional support so that they are in the lowest or most open adjustment position. (S16.2.10.2) |
| | | X N/A, no independent fore-aft seat cushion adjustment |
- | | | |
|----------|----|-------------------------------------------------------------------------------------------------------------------------------------------|
| X | 5. | If the seat cushion adjusts fore and aft, independent of the seat back, set this adjustment to the full rearward position. (S16.2.10.3.1) |
| | | X N/A, no independent seat cushion height adjustment |
- | | | |
|----------|----|------------------------------------------------------------|
| X | 6. | Put the seat in its full rearward position. (S16.2.10.3.1) |
| | | X N/A, the seat does not have a fore-aft adjustment |
- | | | |
|----------|----|--------------------------------------------------------------------------------------------------------------------------------|
| X | 7. | If the seat cushion height adjusts independent of the seat back, set this adjustment to the full down position. (S16.2.10.3.1) |
| | | X N/A, no seat height adjustment |
- | | | |
|----------|----|-------------------------------------------------------------------|
| X | 8. | Draw a horizontal reference line on the side of the seat cushion. |
|----------|----|-------------------------------------------------------------------|
- | | | |
|----------|----|----------------------------------------------------------------------------------------------------------------------------------------------------------------------------------------------------------------------------------------------------------------------------------------------------------------------------------------------------------------------------------------------------------------------------------------------------------------------------------------------------------------------------------------------------------------------------------------------------------------------------------------------------------------|
| X | 9. | Using only the controls that change the seat in the fore-aft direction, mark the fore-aft seat positions. Mark the side of the seat and a reference position directly below on a part of the vehicle that does not adjust. For manual seats, move the seat forward one detent at a time and mark each detent as was done for the full rearward position. For power seats, mark only the full rearward, middle, and full forward positions. Label three of the positions with the following: F for full forward, M for mid-position (if there is no mid position, label the closest adjustment position to the rear of the mid-point), and R for full rearward. |
| | | <input type="checkbox"/> N/A, the seat does not have a fore-aft adjustment |
- | | | |
|----------|-----|------------------------------------------------------------------------------------------------------------------------------------------------------------------------------------------------------|
| X | 10. | Using only the controls that change the seat in the fore-aft direction, place the seat in the full rearward position and then place the seat in the middle fore-aft position for this test. (S8.1.2) |
|----------|-----|------------------------------------------------------------------------------------------------------------------------------------------------------------------------------------------------------|

- Mid position
If there is no mid position, put the seat in the closest adjustment position to the rear of the midpoint. Describe the location of the seat: Not adjustable
11. If seat adjustments other than fore-aft are present and the horizontal reference line is no longer horizontal, use those adjustments to maintain the reference line as closely as possible to the horizontal. (S16.2.10.3.2.1)
- N/A, no adjustments
Reference line angle as tested: N/A
12. The seat back angle, if adjustable, is set at the manufacturer's nominal design riding position for a 50th percentile adult male in the manner specified by the manufacturer. (S4.5.4.1 (b) and S8.1.3)
- N/A, no seat back angle adjustment
Manufacturer's design seat back angle:
Tested seat back angle:
13. Position the test dummies according to dummy position placement instructions in Appendix F.
14. Fasten the seat belt latch.
15. Pull either 12 inches of belt webbing or the maximum available amount of belt webbing, whichever is less, from the retractor and then release it, allowing the belt webbing to return to the dummy's chest.
16. Locate the point where the centerline of the upper torso belt webbing crosses the midsagittal line on the dummy's chest. At that point pull the belt webbing out 3 inches from the dummy's chest and release until it is within one inch from the dummy's chest. (S10.8) Using a force measuring gage with a full scale range of no more than 1.5 pounds, measure the contact force perpendicular to the dummy's chest exerted by the belt webbing.
Contact Force (lb): 0.5
- 0.0 to 0.7 pounds – Pass
 Greater than 0.7 pounds - Fail

REMARKS:

I certify that I have read and performed each instruction.

Signature: Wayne Jahl

Date: 1/15/04

DATA SHEET 10
BELT CONTACT FORCE (S7.4.3)

Test Vehicle: 2004 Jeep Liberty
 Test Program: FMVSS 208 Compliance
 Test Technician: Wayne Dahlke

NHTSA No.: C40300
 Test Date: 1/15/04

Test all Type 2 seat belts other than those in walk-in van-type vehicles and those at front outboard designated seating positions in passenger cars. Complete a form for each applicable seat belt.

DESIGNATED SEATING POSITION:	Right Rear Passenger
------------------------------	----------------------

- | | | |
|----------|-----|----------------------------------------------------------------------------------------------------------------------------------------------------------------------------------------------------------------------------------------------------------------------------------------------------------------------------------------------------------------------------------------------------------------------------------------------------------------------------------------------------------------------------------------------------------------------------------------------------------------------------------------------------------------|
| X | 1. | Does the vehicle incorporate a webbing tension-relieving device? |
| | | <input type="checkbox"/> Yes, this form is complete |
| | | <input checked="" type="checkbox"/> No, continue with this check sheet |
| X | 2. | Position the seat's adjustable lumbar supports so that the lumbar support is in its lowest, retracted or deflated adjustment position. (S8.1.3) |
| | | <input checked="" type="checkbox"/> N/A, no lumbar adjustment |
| X | 3. | Position any adjustable parts of the seat that provide additional support so that they are in the lowest or most open adjustment position. (S16.2.10.2) |
| | | <input checked="" type="checkbox"/> N/A, no additional support adjustment |
| X | 4. | Position any adjustable parts of the seat that provide additional support so that they are in the lowest or most open adjustment position. (S16.2.10.2) |
| | | <input checked="" type="checkbox"/> N/A, no independent fore-aft seat cushion adjustment |
| X | 5. | If the seat cushion adjusts fore and aft, independent of the seat back, set this adjustment to the full rearward position. (S16.2.10.3.1) |
| | | <input checked="" type="checkbox"/> N/A, no independent seat cushion height adjustment |
| X | 6. | Put the seat in its full rearward position. (S16.2.10.3.1) |
| | | <input checked="" type="checkbox"/> N/A, the seat does not have a fore-aft adjustment |
| X | 7. | If the seat cushion height adjusts independent of the seat back, set this adjustment to the full down position. (S16.2.10.3.1) |
| | | <input checked="" type="checkbox"/> N/A, no seat height adjustment |
| X | 8. | Draw a horizontal reference line on the side of the seat cushion. |
| X | 9. | Using only the controls that change the seat in the fore-aft direction, mark the fore-aft seat positions. Mark the side of the seat and a reference position directly below on a part of the vehicle that does not adjust. For manual seats, move the seat forward one detent at a time and mark each detent as was done for the full rearward position. For power seats, mark only the full rearward, middle, and full forward positions. Label three of the positions with the following: F for full forward, M for mid-position (if there is no mid position, label the closest adjustment position to the rear of the mid-point), and R for full rearward. |
| | | <input type="checkbox"/> N/A, the seat does not have a fore-aft adjustment |
| X | 10. | Using only the controls that change the seat in the fore-aft direction, place the seat in the full rearward position and then place the seat in the middle fore-aft position for this test. (S8.1.2) |

- Mid position
If there is no mid position, put the seat in the closest adjustment position to the rear of the midpoint. Describe the location of the seat: Not adjustable
11. If seat adjustments other than fore-aft are present and the horizontal reference line is no longer horizontal, use those adjustments to maintain the reference line as closely as possible to the horizontal. (S16.2.10.3.2.1)
- N/A, no adjustments
Reference line angle as tested: N/A
12. The seat back angle, if adjustable, is set at the manufacturer's nominal design riding position for a 50th percentile adult male in the manner specified by the manufacturer. (S4.5.4.1 (b) and S8.1.3)
- N/A, no seat back angle adjustment
Manufacturer's design seat back angle:
Tested seat back angle:
13. Position the test dummies according to dummy position placement instructions in Appendix F.
14. Fasten the seat belt latch.
15. Pull either 12 inches of belt webbing or the maximum available amount of belt webbing, whichever is less, from the retractor and then release it, allowing the belt webbing to return to the dummy's chest.
16. Locate the point where the centerline of the upper torso belt webbing crosses the midsagittal line on the dummy's chest. At that point pull the belt webbing out 3 inches from the dummy's chest and release until it is within one inch from the dummy's chest. (S10.8) Using a force measuring gage with a full scale range of no more than 1.5 pounds, measure the contact force perpendicular to the dummy's chest exerted by the belt webbing.
Contact Force (lb): 0.6
- 0.0 to 0.7 pounds – Pass
 Greater than 0.7 pounds - Fail

REMARKS:

I certify that I have read and performed each instruction.

Signature: Wayne Jahl

Date: 1/15/04

DATA SHEET 11
LATCH PLATE ACCESS (S7.4.4)

Test Vehicle: 2004 Jeep Liberty
 Test Program: FMVSS 208 Compliance
 Test Technician: Wayne Dahlke

NHTSA No.: C40300
 Test Date: 1/15/04

Test all front outboard seat belts other than those in walk-in van-type vehicles and those at front outboard designated seating positions in passenger cars. Complete a form for each applicable seat belt.

DESIGNATED SEATING POSITION:	Left Front Driver
------------------------------	-------------------

- | | | |
|-------------------------------------|----|------------------------------------------------------------------------------------------------------------------------------------------------|
| <input checked="" type="checkbox"/> | 1. | Position the seat's adjustable lumbar supports so that the lumbar support is in its lowest, retracted or deflated adjustment position. (8.1.3) |
| | | <input checked="" type="checkbox"/> N/A, no lumbar adjustment |
- | | | |
|-------------------------------------|----|---------------------------------------------------------------------------------------------------------------------------------------------------------|
| <input checked="" type="checkbox"/> | 2. | Position any adjustable parts of the seat that provide additional support so that they are in the lowest or most open adjustment position. (S16.2.10.2) |
| | | <input checked="" type="checkbox"/> N/A, no additional support adjustment |
- | | | |
|-------------------------------------|----|-------------------------------------------------------------------------------------------------------------------------------------------|
| <input checked="" type="checkbox"/> | 3. | If the seat cushion adjusts fore and aft, independent of the seat back, set this adjustment to the full rearward position. (S16.2.10.3.1) |
| | | <input checked="" type="checkbox"/> N/A, no independent fore-aft seat cushion adjustment |
- | | | |
|-------------------------------------|----|--------------------------------------------------------------------------------------------------------------------------------|
| <input checked="" type="checkbox"/> | 4. | If the seat cushion height adjusts independent of the seat back, set this adjustment to the full down position. (S16.2.10.3.1) |
| | | <input checked="" type="checkbox"/> N/A, no independent seat cushion height adjustment |
- | | | |
|-------------------------------------|----|----------------------------------------------------------------------------|
| <input checked="" type="checkbox"/> | 5. | Put the seat in its full rearward position. (S16.2.10.3.1) |
| | | <input type="checkbox"/> N/A, the seat does not have a fore-aft adjustment |
- | | | |
|-------------------------------------|----|------------------------------------------------------------------------------------|
| <input checked="" type="checkbox"/> | 6. | If the seat height is adjustable, put it in the full down position. (S16.2.10.3.1) |
| | | <input checked="" type="checkbox"/> N/A, no seat height adjustment |
- | | | |
|-------------------------------------|----|------------------------------------------------------------------|
| <input checked="" type="checkbox"/> | 7. | Draw a horizontal reference line on the side of the seat cushion |
|-------------------------------------|----|------------------------------------------------------------------|
- | | | |
|-------------------------------------|----|----------------------------------------------------------------------------------------------------------------------------------------------------------------------------------------------------------------------------------------------------------------------------------------------------------------------------------------------------------------------------------------------------------------------------------------------------------------------------------------------------------------------------------------------------------------------------------------------------------------------------------------------------------------|
| <input checked="" type="checkbox"/> | 8. | Using only the controls that change the seat in the fore-aft direction, mark the fore-aft seat positions. Mark the side of the seat and a reference position directly below on a part of the vehicle that does not adjust. For manual seats, move the seat forward one detent at a time and mark each detent as was done for the full rearward position. For power seats, mark only the full rearward, middle, and full forward positions. Label three of the positions with the following: F for full forward, M for mid-position (if there is no mid position, label the closest adjustment position to the rear of the mid-point), and R for full rearward. |
| | | <input type="checkbox"/> N/A, the seat does not have a fore-aft adjustment. |
- | | | |
|-------------------------------------|----|-----------------------------------------------------------------------------------------------------------------------------------------------------------------------------------------------------------|
| <input checked="" type="checkbox"/> | 9. | Using only the controls that change the seat in the fore-aft direction, place the seat in the full rearward position and then place the seat in the forward most fore-aft position for this test. (S10.7) |
|-------------------------------------|----|-----------------------------------------------------------------------------------------------------------------------------------------------------------------------------------------------------------|
- | | | |
|-------------------------------------|-----|-----------------------------------------------------------------------------------------------------------------------------------------------------------------------------------------------------------------|
| <input checked="" type="checkbox"/> | 10. | If seat adjustments, other than fore-aft, are present and the horizontal reference line is no longer horizontal, use those adjustments to maintain the reference line as closely as possible to the horizontal. |
| | | <input type="checkbox"/> N/A, no adjustments |

- Reference line angle as tested: Zero
11. The seat back angle, if adjustable, is set at the manufacturer's nominal design riding position for a 50th percentile adult male in the manner specified by the manufacturer. (S4.5.4.1 (b) and S8.1.3)
- N/A, no seat back angle adjustment
- Manufacturer's design seat back angle: 23.5
- Tested seat back angle: 23.5
12. Position the test dummy using the procedures in Appendix A. (Some modifications to the positioning procedure may need to be made because the seat is in its forward most position. Note on the Appendix A positioning check sheet any deviations necessary to position the Part 572, Subpart E dummy.) Include the positioning check sheet with this form.
13. Position the adjustable seat belt anchorage in the manufacturer's nominal design position for a 50th percentile adult male occupant.
14. Attach the inboard reach string to the base of the head following the instructions on Figure 3.
15. Attach the outboard reach string to the torso sheath following the instructions on Figure 3.
16. Place the latch plate in the stowed position.
17. Extend inboard reach string in front of the dummy and then backward and outboard to the latch plate to generate an arc of the reach envelope of the test dummy's arms. Is the latch plate within the reach envelope?
- Yes – Pass
- No
18. Extend outboard reach string in front of the dummy and then backward and outboard to the latch plate to generate an arc of the reach envelope of the test dummy's arms. Is the latch plate within the reach envelope?
- Yes – Pass
- No
19. Is the latch plate within the inboard (item 17) or outboard (item 18) reach envelope?
- Yes – Pass
- No – Fail
20. Using the clearance test block, specified in Figure 4, is there sufficient clearance between the vehicle seat and the side of vehicle interior to allow the test block to move unhindered to the latch plate or buckle?
- Yes – Pass
- No – Fail

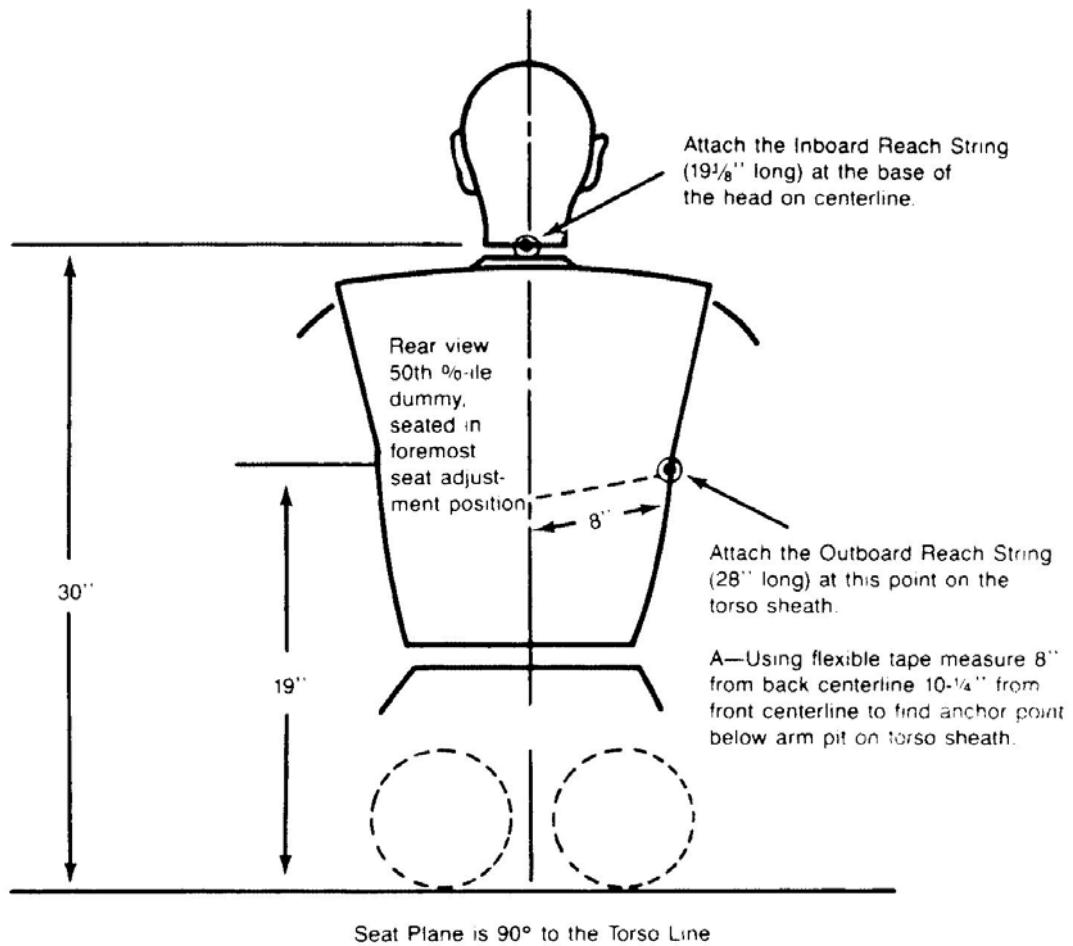

Figure 3. Location of Anchoring Points for Latchplate Reach Limiting Chains or Strings to Test for Latchplate Accessibility Using Subpart E Test Device

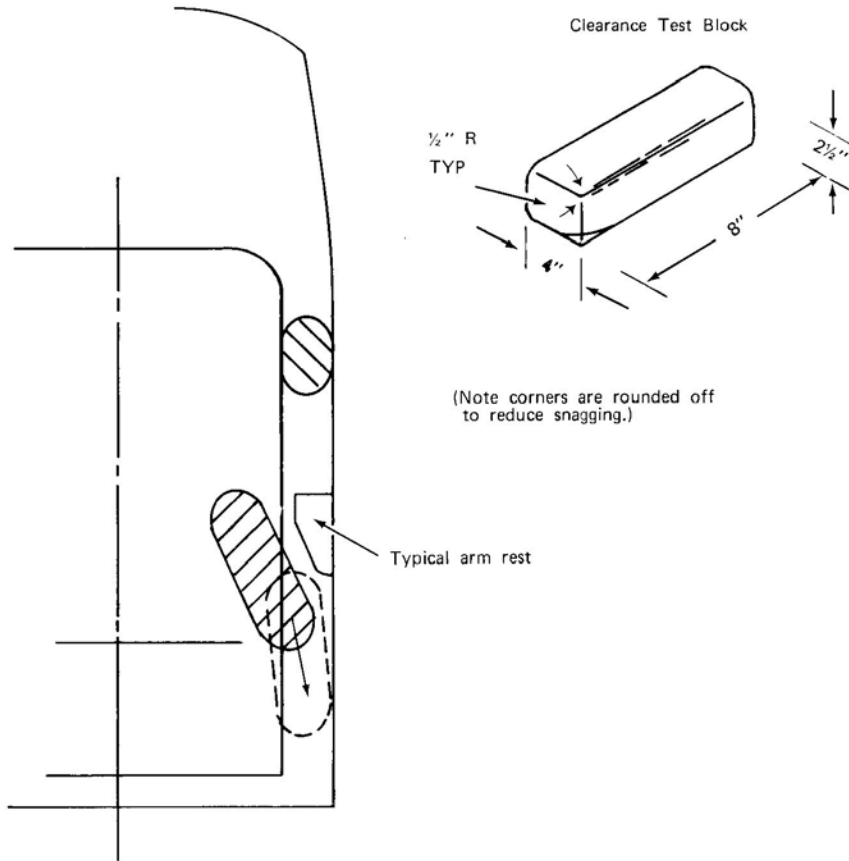

Figure 4—USE OF CLEARANCE TEST BLOCK TO DETERMINE HAND/ARM ACCESS

REMARKS:

I certify that I have read and performed each instruction.

Signature: Wayne Gahl

Date: 1/15/04

DATA SHEET 11

LATCH PLATE ACCESS (S7.4.4)

Test Vehicle: 2004 Jeep Liberty
Test Program: FMVSS 208 Compliance
Test Technician: Wayne Dahlke

NHTSA No.: C40300
Test Date: 1/15/04

Test all front outboard seat belts other than those in walk-in van-type vehicles and those at front outboard designated seating positions in passenger cars. Complete a form for each applicable seat belt.

DESIGNATED SEATING POSITION: **Right Front Passenger**

1. Position the seat's adjustable lumbar supports so that the lumbar support is in its lowest, retracted or deflated adjustment position. (8.1.3)
 N/A, no lumbar adjustment
2. Position any adjustable parts of the seat that provide additional support so that they are in the lowest or most open adjustment position. (S16.2.10.2)
 N/A, no additional support adjustment
3. If the seat cushion adjusts fore and aft, independent of the seat back, set this adjustment to the full rearward position. (S16.2.10.3.1)
 N/A, no independent fore-aft seat cushion adjustment
4. If the seat cushion height adjusts independent of the seat back, set this adjustment to the full down position. (S16.2.10.3.1)
 N/A, no independent seat cushion height adjustment
5. Put the seat in its full rearward position. (S16.2.10.3.1)
 N/A, the seat does not have a fore-aft adjustment
6. If the seat height is adjustable, put it in the full down position. (S16.2.10.3.1)
 N/A, no seat height adjustment
7. Draw a horizontal reference line on the side of the seat cushion
8. Using only the controls that change the seat in the fore-aft direction, mark the fore-aft seat positions. Mark the side of the seat and a reference position directly below on a part of the vehicle that does not adjust. For manual seats, move the seat forward one detent at a time and mark each detent as was done for the full rearward position. For power seats, mark only the full rearward, middle, and full forward positions. Label three of the positions with the following: F for full forward, M for mid-position (if there is no mid position, label the closest adjustment position to the rear of the mid-point), and R for full rearward.
 N/A, the seat does not have a fore-aft adjustment.
9. Using only the controls that change the seat in the fore-aft direction, place the seat in the full rearward position and then place the seat in the forward most fore-aft position for this test. (S10.7)
10. If seat adjustments, other than fore-aft, are present and the horizontal reference line is no longer horizontal, use those adjustments to maintain the reference line as closely as possible to the horizontal.
 N/A, no adjustments

- Reference line angle as tested: Zero
11. The seat back angle, if adjustable, is set at the manufacturer's nominal design riding position for a 50th percentile adult male in the manner specified by the manufacturer. (S4.5.4.1 (b) and S8.1.3)
- N/A, no seat back angle adjustment
- Manufacturer's design seat back angle: 23.5
- Tested seat back angle: 23.5
12. Position the test dummy using the procedures in Appendix A. (Some modifications to the positioning procedure may need to be made because the seat is in its forward most position. Note on the Appendix A positioning check sheet any deviations necessary to position the Part 572, Subpart E dummy.) Include the positioning check sheet with this form.
13. Position the adjustable seat belt anchorage in the manufacturer's nominal design position for a 50th percentile adult male occupant.
14. Attach the inboard reach string to the base of the head following the instructions on Figure 3.
15. Attach the outboard reach string to the torso sheath following the instructions on Figure 3.
16. Place the latch plate in the stowed position.
17. Extend inboard reach string in front of the dummy and then backward and outboard to the latch plate to generate an arc of the reach envelope of the test dummy's arms. Is the latch plate within the reach envelope?
- Yes – Pass
- No
18. Extend outboard reach string in front of the dummy and then backward and outboard to the latch plate to generate an arc of the reach envelope of the test dummy's arms. Is the latch plate within the reach envelope?
- Yes – Pass
- No
19. Is the latch plate within the inboard (item 17) or outboard (item 18) reach envelope?
- Yes – Pass
- No – Fail
20. Using the clearance test block, specified in Figure 4, is there sufficient clearance between the vehicle seat and the side of vehicle interior to allow the test block to move unhindered to the latch plate or buckle?
- Yes – Pass
- No – Fail

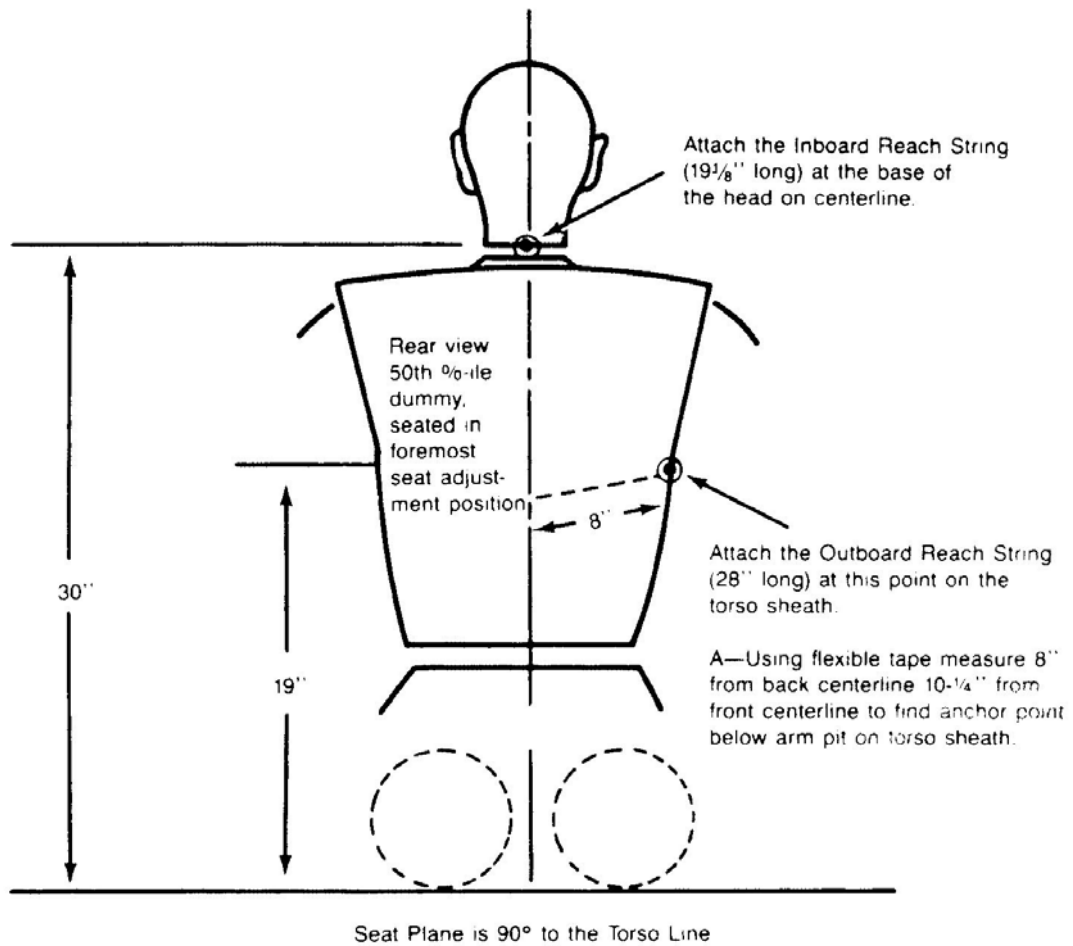

Figure 3. Location of Anchoring Points for Latchplate Reach Limiting Chains or Strings to Test for Latchplate Accessibility Using Subpart E Test Device

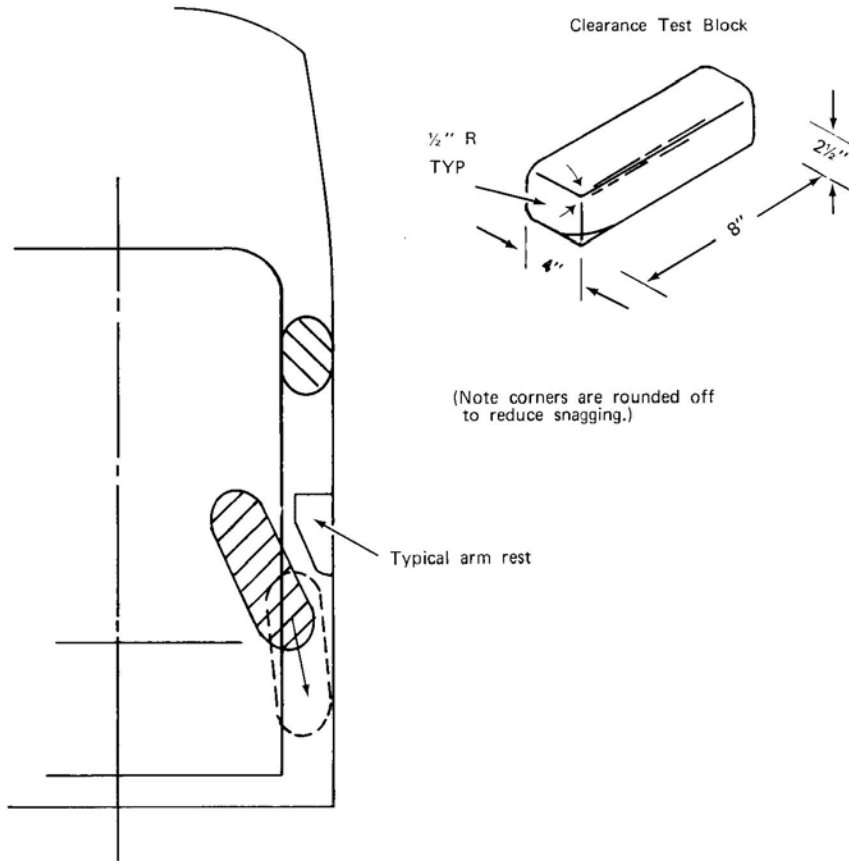

Figure 4—USE OF CLEARANCE TEST BLOCK TO DETERMINE HAND/ARM ACCESS

REMARKS:

I certify that I have read and performed each instruction.

Signature: Wayne Gahl

Date: 1/15/04

DATA SHEET 12

SEAT BELT RETRACTION (S7.4.5)

Test Vehicle: 2004 Jeep Liberty
 Test Program: FMVSS 208 Compliance
 Test Technician: Wayne Dahlke

NHTSA No.: C40300
 Test Date: 1/15/04

Test all front outboard seat belts other than those in walk-in van-type vehicles and those at front outboard designated seating positions in passenger cars. Complete a form for each applicable seat belt.

DESIGNATED SEATING POSITION:	Left Front Driver
GVWR:	2427 kg

1. Is the vehicle a passenger car or walk-in van-type vehicle?
 - Yes, this form is complete
 - No
2. Position the seat's adjustable lumbar supports so that the lumbar support is in its lowest, retracted or deflated adjustment position. (S8.1.3)
 - N/A, no lumbar adjustment
3. Position any adjustable parts of the seat that provide additional support so that they are in the lowest or most open adjustment position. (S16.2.10.2)
 - N/A, no additional support adjustment
4. If the seat cushion adjusts fore and aft, independent of the seat back, set this adjustment to the full rearward position. (S16.2.10.3.1)
 - N/A, no independent fore-aft seat cushion adjustment
5. If the seat cushion height adjusts independent of the seat back, set this adjustment to the full down position. (S16.2.10.3.1)
 - N/A, no independent seat cushion height adjustment
6. Put the seat in its full rearward position.
 - N/A, the seat does not have a fore-aft adjustment
7. If the seat height is adjustable, put it in the full down position. (S8.1.2)
 - N/A, no seat adjustment
8. Draw a horizontal line on the side of the seat cushion.
9. Using only the controls that change the seat in the fore-aft direction, mark the fore-aft seat positions. Mark the side of the seat and a reference position directly below on a part of the vehicle that does not adjust. For manual seats, move the seat forward one detent at a time and mark each detent as was done for the full rearward position. For power seats, mark only the full rearward, middle, and full forward positions. Label three of the positions with the following: F for full forward, M for mid-position (if there is no mid position, label the closest adjustment position to the rear of the mid-point), and R for full rearward.
 - N/A, the seat does not have a fore-aft adjustment.
10. Using only the controls that change the seat in the fore-aft direction, place the seat in the middle fore-aft position. (S8.1.2)
 - N/A, there is no mid position, put the seat in the closest adjustment position to the rear of the midpoint. Describe the location of the seat:

11. If seat adjustments, other than fore-aft, are present and the reference line is no longer horizontal, use those adjustments to maintain the reference line as closely as possible to the horizontal. (S16.2.10.3.2)
- N/A – no seat adjustment
- Reference angle as tested: Zero
12. The seat back angle, if adjustable, is set at the manufacturer’s nominal design riding position for a 50th percentile adult male in the manner specified by the manufacturer. (S8.1.3)
- N/A – no seat back angle adjustment
- Manufacturer’s design seat back angle: 23.5
- Tested seat back angle: 23.5
13. If adjustable, set the head restraint at the full up and full forward position. (S8.1.3) Any adjustment of the head restraint shall be used to position it full forward. For example, if it rotates, rotate it such that the head restraint extends as far forward as possible.
- N/A – no head restraint adjustment
14. Place any adjustable seat belt anchorages at the vehicle manufacturer’s nominal design position for a 50th percentile adult male occupant (S8.1.3)
- N/A – no adjustable upper seat belt anchorage
- Manufacturer’s specified anchorage position: 2nd Down
- Tested anchorage position: 2nd Down
15. Is the driver seat a bucket seat?
- Yes, go to 15.1 and skip 15.2.
- No, go to 15.2 and skip 15.1
- 15.1 Bucket seats - Locate and mark a vertical Plane B through the longitudinal centerline of the seat. The longitudinal centerline of a bucket seat cushion is determined at the widest part of the seat cushion. Measure perpendicular to the longitudinal centerline of the vehicle.
- Record the width of the seat: 520 mm
- Record the distance from the edge of the seat to Plane B. 260 mm
- 15.2 Bench seats (including split bench seats):
- Driver seat: Locate and mark a vertical Plane B through the center of the steering wheel parallel to the vehicle longitudinal centerline.
- Passenger seat: Locate and mark a vertical longitudinal Plane B on the seat that is the same distance from the longitudinal centerline of the vehicle as the center of the steering wheel.
- Distance from the vehicle centerline to the center of the steering wheel:
- Distance from the vehicle centerline to Plane B:
16. Stow outboard armrests that are capable of being stowed. (S7.4.5)
17. Remove the arms of a Subpart E dummy and place it in the seat such that the midsagittal plane is coincident with Plane B and the upper torso rests against the seat back. (S10.4.1.1 & S10.4.1.2)
18. Rest the thighs on the seat cushion

19. Position the H-point of the dummy within 0.5 inch of the vertical dimension and 0.5 inch of the horizontal dimension of a point 0.25 inch below the H-point determined by using the equipment and procedures specified in SAE J826 (APR 1980). (S10.4.2.1) Then measure the pelvic angle with respect to the horizontal using the pelvic angle gage. Adjust the dummy position until these three measurements are within the specifications. (S10.4.2.1 and S10.4.2.2)
- Horizontal inches from the point 0.25 below the determined H-point (0.5 inch max.) (S10.4.2.1)
 - Vertical inches from the point 0.25 below the determined H-point (0.5 inch max.) (S10.4.2.1)
 - Pelvic angle (20° to 25°)
 - Vertical inches from the point 0.25 below the determined H-point (0.5 inch max.) (S10.4.2.1)
 - Pelvic angle (20° to 25°) (S10.4.2.2)
20. Set the distance between the outboard knee clevis flange surfaces at 10.6 inches.
Measured distance (10.6 inches) (S10.5): 10.6
21. To the extent practicable keep the thighs and the legs in a vertical plane (S10.5) and rest the thighs on the seat cushion while resting the feet on the floorpan or toe board.
22. Fasten the seat belt around the dummy.
23. Remove all slack from the lap belt portion. (S10.9)
24. Pull the upper torso webbing out of the retractor and allow it to retract; repeat this four times. (S10.9)
25. Apply a 2 to 4 pound tension load to the lap belt. (S10.9)
Pound load applied: 3
26. Is the belt system equipped with a tension relieving device?
- __ Yes, continue
 - __ No, go to 27
- 26.1 Introduce the maximum amount of slack into the upper torso bet that is recommended by the vehicle manufacturer in the vehicle owner's manual. (S10.9). Go to 25.
27. Check the statement that applies to this test vehicle:
- 27.1 Check the statement that applies to this test vehicle:
The torso and lap belt webbing of the seat belt system automatically retracts to a stowed position when the adjacent vehicle door is in an open position and the seat belt latch plate is released.
- Pass
- 27.2 The torso and lap belt webbing of the seat belt system automatically retracts when the seat belt latch plate is released.
- Pass
- 27.3
- Neither A or B apply
 - Fail
28. With the webbing and hardware in the stowed position are the webbing and hardware prevented from being pinched when the door is closed?
- Yes – Pass
 - No – Fail

29. If this test vehicle has an open body (without doors) and has a belt system with a tension-relieving device, does the belt system fully retract when the tension-relieving device is deactivated?

- N/A
- Yes – Pass
- No – Fail

REMARKS:

I certify that I have read and performed each instruction.

Signature: Wayne Gahl

Date: 1/15/04

DATA SHEET 12
SEAT BELT RETRACTION (S7.4.5)

Test Vehicle: 2004 Jeep Liberty
 Test Program: FMVSS 208 Compliance
 Test Technician: Wayne Dahlke

NHTSA No.: C40300
 Test Date: 1/15/04

Test all front outboard seat belts other than those in walk-in van-type vehicles and those at front outboard designated seating positions in passenger cars. Complete a form for each applicable seat belt.

DESIGNATED SEATING POSITION:	Right Front Passenger
GVWR:	2427 kg

1. Is the vehicle a passenger car or walk-in van-type vehicle?
 Yes, this form is complete
 No
2. Position the seat's adjustable lumbar supports so that the lumbar support is in its lowest, retracted or deflated adjustment position. (S8.1.3)
 N/A, no lumbar adjustment
3. Position any adjustable parts of the seat that provide additional support so that they are in the lowest or most open adjustment position. (S16.2.10.2)
 N/A, no additional support adjustment
4. If the seat cushion adjusts fore and aft, independent of the seat back, set this adjustment to the full rearward position. (S16.2.10.3.1)
 N/A, no independent fore-aft seat cushion adjustment
5. If the seat cushion height adjusts independent of the seat back, set this adjustment to the full down position. (S16.2.10.3.1)
 N/A, no independent seat cushion height adjustment
6. Put the seat in its full rearward position.
 N/A, the seat does not have a fore-aft adjustment
7. If the seat height is adjustable, put it in the full down position. (S8.1.2)
 N/A, no seat adjustment
8. Draw a horizontal line on the side of the seat cushion.
9. Using only the controls that change the seat in the fore-aft direction, mark the fore-aft seat positions. Mark the side of the seat and a reference position directly below on a part of the vehicle that does not adjust. For manual seats, move the seat forward one detent at a time and mark each detent as was done for the full rearward position. For power seats, mark only the full rearward, middle, and full forward positions. Label three of the positions with the following: F for full forward, M for mid-position (if there is no mid position, label the closest adjustment position to the rear of the mid-point), and R for full rearward.
 N/A, the seat does not have a fore-aft adjustment.
10. Using only the controls that change the seat in the fore-aft direction, place the seat in the middle fore-aft position. (S8.1.2)
 N/A
 If there is no mid position, put the seat in the closest adjustment position to the rear of the midpoint. Describe the location of the seat:

11. If seat adjustments, other than fore-aft, are present and the reference line is no longer horizontal, use those adjustments to maintain the reference line as closely as possible to the horizontal. (S16.2.10.3.2)
- N/A – no seat adjustment
- Reference angle as tested: Zero
12. The seat back angle, if adjustable, is set at the manufacturer’s nominal design riding position for a 50th percentile adult male in the manner specified by the manufacturer. (S8.1.3)
- N/A – no seat back angle adjustment
- Manufacturer’s design seat back angle: 23.5
- Tested seat back angle: 23.5
13. If adjustable, set the head restraint at the full up and full forward position. (S8.1.3) Any adjustment of the head restraint shall be used to position it full forward. For example, if it rotates, rotate it such that the head restraint extends as far forward as possible.
- N/A – no head restraint adjustment
14. Place any adjustable seat belt anchorages at the vehicle manufacturer’s nominal design position for a 50th percentile adult male occupant (S8.1.3)
- N/A – no adjustable upper seat belt anchorage
- Manufacturer’s specified anchorage position: 2nd Down
- Tested anchorage position: 2nd Down
15. Is the driver seat a bucket seat?
- Yes, go to 15.1 and skip 15.2.
- No, go to 15.2 and skip 15.1
- 15.1 Bucket seats - Locate and mark a vertical Plane B through the longitudinal centerline of the seat. The longitudinal centerline of a bucket seat cushion is determined at the widest part of the seat cushion. Measure perpendicular to the longitudinal centerline of the vehicle.
- Record the width of the seat: 520 mm
- Record the distance from the edge of the seat to Plane B. 260 mm
- 15.2 Bench seats (including split bench seats):
- Driver seat: Locate and mark a vertical Plane B through the center of the steering wheel parallel to the vehicle longitudinal centerline.
- Passenger seat: Locate and mark a vertical longitudinal Plane B on the seat that is the same distance from the longitudinal centerline of the vehicle as the center of the steering wheel.
- Distance from the vehicle centerline to the center of the steering wheel:
- Distance from the vehicle centerline to Plane B:
16. Stow outboard armrests that are capable of being stowed. (S7.4.5)
17. Remove the arms of a Subpart E dummy and place it in the seat such that the midsagittal plane is coincident with Plane B and the upper torso rests against the seat back. (S10.4.1.1 & S10.4.1.2)
18. Rest the thighs on the seat cushion

19. Position the H-point of the dummy within 0.5 inch of the vertical dimension and 0.5 inch of the horizontal dimension of a point 0.25 inch below the H-point determined by using the equipment and procedures specified in SAE J826 (APR 1980). (S10.4.2.1) Then measure the pelvic angle with respect to the horizontal using the pelvic angle gage. Adjust the dummy position until these three measurements are within the specifications. (S10.4.2.1 and S10.4.2.2)
- Horizontal inches from the point 0.25 below the determined H-point (0.5 inch max.) (S10.4.2.1)
 - Vertical inches from the point 0.25 below the determined H-point (0.5 inch max.) (S10.4.2.1)
 - Pelvic angle (20° to 25°)
 - Vertical inches from the point 0.25 below the determined H-point (0.5 inch max.) (S10.4.2.1)
 - Pelvic angle (20° to 25°) (S10.4.2.2)
20. Set the distance between the outboard knee clevis flange surfaces at 10.6 inches.
Measured distance (10.6 inches) (S10.5): 10.6
21. To the extent practicable keep the thighs and the legs in a vertical plane (S10.5) and rest the thighs on the seat cushion while resting the feet on the floorpan or toe board.
22. Fasten the seat belt around the dummy.
23. Remove all slack from the lap belt portion. (S10.9)
24. Pull the upper torso webbing out of the retractor and allow it to retract; repeat this four times. (S10.9)
25. Apply a 2 to 4 pound tension load to the lap belt. (S10.9)
Pound load applied: 3
26. Is the belt system equipped with a tension relieving device?
- __ Yes, continue
 - __ No, go to 27
- 26.1 Introduce the maximum amount of slack into the upper torso bet that is recommended by the vehicle manufacturer in the vehicle owner's manual. (S10.9). Go to 25.
27. Check the statement that applies to this test vehicle:
- 27.1 Check the statement that applies to this test vehicle:
The torso and lap belt webbing of the seat belt system automatically retracts to a stowed position when the adjacent vehicle door is in an open position and the seat belt latch plate is released.
- Pass
- 27.2 The torso and lap belt webbing of the seat belt system automatically retracts when the seat belt latch plate is released.
- Pass
- 27.3
- Neither A or B apply
 - Fail
28. With the webbing and hardware in the stowed position are the webbing and hardware prevented from being pinched when the door is closed?
- Yes – Pass
 - No – Fail

29. If this test vehicle has an open body (without doors) and has a belt system with a tension-relieving device, does the belt system fully retract when the tension-relieving device is deactivated?

- N/A
- Yes – Pass
- No – Fail

REMARKS:

I certify that I have read and performed each instruction.

Signature: Wayne Gahl

Date: 1/15/04

DATA SHEET 13

SEAT BELT GUIDES AND HARDWARE (S7.4.6)

Test Vehicle: 2004 Jeep Liberty
Test Program: FMVSS 208 Compliance
Test Technician: Wayne Dahlke

NHTSA No.: C40300
Test Date: 1/15/04

Test seat belts except those in walk-in van-type vehicles and those at front outboard designated seating positions in passenger cars. Complete a form for each applicable seat belt.

DESIGNATED SEATING POSITION:	Left Front Driver
------------------------------	-------------------

1. Is the seat cushion movable so that the seat back serves a function other than seating? (S7.4.6.1 (b))
 Yes, this form is complete
 No, go to 2
2. Is the seat removable? (S7.4.6.1(b))
 Yes, this form is complete
 No, go to 3
3. Is the seat movable so that the space formerly occupied by the seat can be used for a secondary function? (S7.4.6.1(b))
 Yes, this form is complete
 No, go to 4
4. Is the webbing designed to pass through the seat cushion or between the seat cushion and seat back? (S7.4.6.1(a))
 Yes, go to 5
 No, this form is complete
5. Does one of the following three parts, the seat belt latch plate, the buckle, or the seat belt webbing, stay on top of or above the seat cushion under normal conditions (i.e., conditions other than when belt hardware is intentionally pushed behind the seat by a vehicle occupant)? (S7.4.6.1(a))
 Yes – Pass
 No – Fail
Identify the part(s) on top or above the seat.
 Seat belt latch plate
 Buckle
 Seat belt webbing
6. Are the remaining two seat belt parts accessible under normal conditions?
 Yes – Pass
 No – Fail
7. The buckle and latch plate do not pass through the guides or conduits provided and fall behind the seat when the belt is completely retracted or, if the belt is nonretractable, the belt is unlatched. (S7.4.6.2)

- Yes – Pass
- No – Fail

8. The buckle and latch plate do not pass through the guides or conduits provided and fall behind the seat when the seat is moved to any position to which it is designed to be adjusted. (S7.4.6.2)

- Yes – Pass
- No – Fail

9. The buckle and latch plate do not pass through the guides or conduits provided and fall behind the seat back, if foldable, is folded forward as far as possible and then moved backward into position. (S7.4.6.2)

- Yes – Pass
- No – Fail

10. Is the inboard receptacle end of the seat belt assembly, installed in the front outboard designated seating position, accessible with the center armrest in any position to which it can be adjusted (without moving the armrest)? (S7.4.6.2)

- Yes – Pass
- No – Fail
- N/A – Rear seat

REMARKS:

I certify that I have read and performed each instruction.

Signature: Wayne Gahl

Date: 1/15/04

DATA SHEET 13

SEAT BELT GUIDES AND HARDWARE (S7.4.6)

Test Vehicle: 2004 Jeep Liberty
Test Program: FMVSS 208 Compliance
Test Technician: Wayne Dahlke

NHTSA No.: C40300
Test Date: 1/15/04

Test seat belts except those in walk-in van-type vehicles and those at front outboard designated seating positions in passenger cars. Complete a form for each applicable seat belt.

DESIGNATED SEATING POSITION: **Right Front Passenger**

1. Is the seat cushion movable so that the seat back serves a function other than seating? (S7.4.6.1 (b))
 Yes, this form is complete
 No, go to 2
2. Is the seat removable? (S7.4.6.1(b))
 Yes, this form is complete
 No, go to 3
3. Is the seat movable so that the space formerly occupied by the seat can be used for a secondary function? (S7.4.6.1(b))
 Yes, this form is complete
 No, go to 4
4. Is the webbing designed to pass through the seat cushion or between the seat cushion and seat back? (S7.4.6.1(a))
 Yes, go to 5
 No, this form is complete
5. Does one of the following three parts, the seat belt latch plate, the buckle, or the seat belt webbing, stay on top of or above the seat cushion under normal conditions (i.e., conditions other than when belt hardware is intentionally pushed behind the seat by a vehicle occupant)? (S7.4.6.1(a))
 Yes – Pass
 No – Fail
Identify the part(s) on top or above the seat.
 Seat belt latch plate
 Buckle
 Seat belt webbing
6. Are the remaining two seat belt parts accessible under normal conditions?
 Yes – Pass
 No – Fail
7. The buckle and latch plate do not pass through the guides or conduits provided and fall behind the seat when the belt is completely retracted or, if the belt is nonretractable, the belt is unlatched. (S7.4.6.2)
 Yes – Pass
 No – Fail

8. The buckle and latch plate do not pass through the guides or conduits provided and fall behind the seat when the seat is moved to any position to which it is designed to be adjusted. (S7.4.6.2)
- Yes – Pass
 No – Fail
9. The buckle and latch plate do not pass through the guides or conduits provided and fall behind the seat back, if foldable, is folded forward as far as possible and then moved backward into position. (S7.4.6.2)
- Yes – Pass
 No – Fail
10. Is the inboard receptacle end of the seat belt assembly, installed in the front outboard designated seating position, accessible with the center armrest in any position to which it can be adjusted (without moving the armrest)? (S7.4.6.2)
- Yes – Pass
 No – Fail
 N/A – Rear seat

REMARKS:

I certify that I have read and performed each instruction.

Signature: Wayne Gahl

Date: 1/15/04

DATA SHEET 14

MARKING OF REFERENCE POINTS FOR VARIOUS TEST POSITIONS AND POINTS

Test Vehicle: 2004 Jeep Liberty
Test Program: FMVSS 208 Compliance
Test Technician: Eric Peschman

NHTSA No.: C40300
Test Date: 2/27/04

1. Driver Designated Seating Position:

- 1.1 Position the seat's adjustable lumbar supports so that the lumbar supports are in the lowest, retracted or deflated adjustment positions. (S16.2.10.1)
- N/A – No lumbar adjustment
- 1.2 Position any adjustable parts of the seat that provide additional support so that they are in the lowest or most open adjustment position (S16.2.10.2)
- N/A – No additional support adjustment
- 1.3 Mark a point (seat cushion reference point) on the side of the seat cushion that is between 150 mm and 250 mm from the front edge of the seat cushion.
- 1.4 Draw a line (seat cushion reference line) through the seat cushion reference point.
- 1.5 Using only the controls that primarily move the seat in the fore-aft direction, move the seat cushion reference point to the rearmost position.
- 1.6 If the seat cushion adjusts fore-aft, independent of the seat back, use only the controls that primarily move the seat cushion in the fore-aft direction to move the seat cushion reference point to the rearmost position (S16.2.10.3)
- N/A – No independent fore-aft seat cushion adjustment
- 1.7 Using any part of any control, other than the parts just used for fore-aft positioning, determine the range of angles of the seat cushion reference line and set the seat cushion reference line at the mid-angle.
- Maximum Angle: Zero Degrees
- Minimum Angle: Zero Degrees
- Mid-angle: Zero Degrees
- 1.8 If the seat and/or seat cushion height is adjustable, use any part of any control other than those which primarily move the seat or seat cushion fore-aft, to put the seat cushion reference point in its lowest position with the seat cushion reference line angle at the mid-angle found in 1.7.
- N/A – No seat height adjustment
- 1.9 Using only the controls that primarily move the seat in the fore-aft direction, verify the seat is in the rearmost position.
- 1.10 Using only the controls that primarily move the seat in the fore-aft direction, mark for future reference the fore-aft seat positions. Mark each position so that there is a visual indication when the seat is at a particular position. For manual seats, move the seat forward one detent at a time and mark each detent. For power seats, mark only the rearmost, middle, and foremost positions. Label three of the positions with the following: F for foremost, M for mid-position (if there is no mid-position, label the closest adjustment position to the rear of the mid-point), and R for rearmost.
- 1.11 Use only the controls that primarily move the seat in the fore-aft direction to place the seat in the rearmost position.

- 1.12 Using any controls, other than the controls that primarily move the seat and/or seat cushion in the fore-aft direction, find and visually mark for future reference the maximum, minimum, and middle height of the seat cushion reference point with the seat cushion reference line at the mid-angle determined in 1.7.
- 1.13 Using only the controls that primarily move the seat and/or seat cushion in the fore-aft direction, place the seat in the mid-fore-aft position.
- 1.14 Using any controls, other than the controls that primarily move the seat in the fore-aft direction, find and visually mark for future reference the maximum, minimum, and middle height of the seat cushion reference point with the seat cushion reference line at the mid-angle determined in 1.7.
- 1.15 Using only the controls that change the seat in the fore-aft direction, place the seat in the foremost position.
- 1.16 Using any controls, other than the controls that primarily move the seat in the fore-aft direction, find and visually mark for future reference the maximum, minimum, and middle height of the seat cushion reference point with the seat cushion reference line at the mid-angle determined in 1.7.
- 1.17 Visually mark for future reference the seat back angle, if adjustable, at the manufacturer's nominal design riding position for a 50th percentile adult male in the manner specified by the manufacturer.
- N/A – No seat back angle adjustment
 Manufacturer's design seat back angle: 23.5
- 1.18 Is the seat a bucket seat?
- Yes, go to 1.18.1 and skip 1.18.2
- No, go to 1.18.2 and skip 1.18.1
- 1.18.1 Bucket seats:
- Locate and mark for future reference the longitudinal centerline of the seat cushion. The longitudinal centerline of a bucket seat cushion is determined at the widest part of the seat cushion. Measure perpendicular to the longitudinal centerline of the vehicle. (S16.3.1.10)
- Record the width of the seat cushion: 520 mm
- One half the width of the seat cushion is: 260 mm
- Record the distance from the edge of the seat cushion to the seat mark: 260 mm
- 1.18.2 Bench seats:
- Locate and mark for future reference the longitudinal line on the seat cushion that marks the longitudinal vertical plane through the centerline of the steering wheel.
2. Passenger Designated Seating Position
- 2.1 Is the seat adjustable independent of the driver seating position?
- Yes, go to 2.2
- No, go to 2.18
- 2.2 Position the seat's adjustable lumbar supports so that the lumbar supports are in the lowest, retracted or deflated adjustment positions (S16.2.10.1, S20.1.9.1, S22.1.7.1)
- N/A – No lumbar adjustment
- 2.3 Position any adjustable parts of the seat that provide additional support so that they are in the lowest or most open adjustment position. (S16.2.10.2, S20.1.9.2, S22.1.7.2)
- N/A – No additional support adjustment
- 2.4 Mark a point (seat cushion reference point) on the side of the seat cushion that is between 150 mm and 250 mm from the front edge of the seat cushion.

- 2.5 Draw a line (seat cushion reference line) through the seat cushion reference point.
- 2.6 Using only the controls that primarily move the seat in the fore-aft direction, move the seat cushion reference point to the rearmost position.
- 2.7 If the seat cushion adjusts fore-aft, independent of the seat back, use only the controls that primarily move the seat cushion in the fore-aft direction to move the seat cushion reference point to the rearmost position (S16.2.10.3, S20.1.9.3, S22.1.7.3)
- N/A – No independent fore-aft seat cushion adjustment.
- 2.8 Using any part of the control, other than the parts just used for fore-aft positioning, determine the range of angles of the seat cushion reference line and set the seat cushion reference line at the mid-angle.
 - Maximum Angle: Zero Degrees
 - Minimum Angle: Zero Degrees
 - Mid-angle: Zero Degrees
- 2.9 If the seat and/or seat cushion height is adjustable, use any part of any control other than those which primarily move the seat or seat cushion fore-aft, to put the seat cushion reference point in its lowest position with the seat cushion reference line angle at the mid-range angle.
 - N/A – No seat height adjustment
- 2.10 Using only the controls that primarily move the seat and/or seat cushion in the fore-aft direction, verify the seat is in the rearmost position.
- 2.11 Using only the controls that primarily move the seat in the fore-aft direction, mark for future reference the fore-aft seat positions. Mark each position so that there is a visual indication when the seat is at a particular position. For manual seats, move the seat forward one detent at a time and mark each detent. For power seats, mark only the rearmost, middle, and foremost positions. Label three of the positions with the following: F for foremost, M for mid-position (if there is no mid-position, label the closest adjustment position to the rear of the mid-point), and R for rearmost.
- 2.12 Using only the controls that primarily move the seat in the fore-aft direction, place the seat in the rearmost position.
- 2.13 Using any controls, other than the controls that primarily move the seat in the fore-aft direction, find and visually mark for future reference the maximum, minimum, and middle height of the seat cushion reference point with the seat cushion reference line at the mid-angle determined in 2.8.
- N/A – No seat height adjustment Go to 2.18
- 2.14 Using only the controls that primarily move the seat in the fore-aft direction, place the seat in the mid-fore-aft position.
- 2.15 Using any controls, other than the controls that primarily move the seat in the fore-aft direction, find and visually mark for future reference the maximum, minimum, and middle height of the seat cushion reference point with the seat cushion reference line at the mid-angle determined in 2.8.
- 2.16 Using only the controls that change the seat in the fore-aft direction, place the seat in the foremost position.
- 2.17 Using any controls, other than the controls that primarily move the seat in the fore-aft direction, find and visually mark for future reference the maximum, minimum, and middle height of the seat cushion reference point with the seat cushion reference line at the mid-angle determined in 2.8.

- 2.18 Visually mark for future reference the seat back angle, if adjustable, at the manufacturer's nominal design riding position for a 50th percentile adult male in the manner specified by the manufacturer.
- N/A – No seat back angle adjustment
- N/A – The seat back angle adjustment is controlled by the setting of the driver seat back angle.
- Manufacturer's design seat back angle: 23.5
- Actual seat back angle: 23.5
- 2.19 Is the seat a bucket seat?
- Yes, go to 2.19.1 and skip 2.19.2
- No, go to 2.19.2 and skip 2.19.1
- 2.19.1 Bucket seats:
- Locate and mark for future reference the longitudinal centerline of the seat cushion. (S20.2.1.3, S22.2.1.3) The longitudinal centerline of a bucket seat cushion is determined at the widest part of the seat cushion. Measure perpendicular to the longitudinal centerline of the vehicle. (S20.1.10)
- Record the width of the seat cushion: 520 mm
- One half the width of the seat cushion is: 260 mm
- Record the distance from the edge of the seat cushion to the longitudinal centerline of the seat cushion. (The vertical plane through this longitudinal centerline is Plane B for suppression.) 260 mm
- 2.19.2 Bench seats:
- Locate and mark for future reference the longitudinal centerline of the passenger seat cushion. The longitudinal centerline is the same distance from the longitudinal centerline of the vehicle as the center of the steering wheel. (S20.2.1.3, S22.2.1.3)
- Record the distance from the longitudinal centerline of the vehicle to the center of the steering wheel:
- Record the distance from the longitudinal centerline of the vehicle to the longitudinal centerline of the seat cushion. (The vertical plane through this longitudinal centerline is Plane B for suppression.)
3. Head Restraints
- N/A, vehicle contains automatic head restraints
- N/A, there is no head restraint adjustment
- 3.1 Left outboard
- 3.1.1 Adjust the head restraint to its lowest position. (S16.3.4.2)
- 3.1.2 Any adjustment of the head restraint shall be used to position it full forward. For example, if it rotates, rotate it such that the head restraint extends as far forward as possible. **Mark** the foremost position.
- 3.1.3 Measure the vertical distance from the top most point of the head restraint to the bottom most point. Locate and **mark** a horizontal plane through the midpoint of this distance.
- Vertical height of head restraint (mm):
- Mid-point height (mm):
- 3.2 Right outboard
- 3.2.1 Adjust the head restraint to its lowest position. (S16.3.4.2)
- 3.2.2 Any adjustment of the head restraint shall be used to position it full forward. For example, if it rotates, rotate it such that the head restraint extends as far forward as possible. **Mark** the foremost position.

3.2.3 Measure the vertical distance from the top most point of the head restraint to the bottom most point. Locate and **mark** a horizontal plane through the midpoint of this distance.

Vertical height of head restraint (mm): 190 mm

Mid-point height (mm): 95 mm

4. Steering Wheel

4.1 Is the steering wheel adjustable up and down and/or in and out?

Yes, go to 4.2

No, this form is complete

4.2 Find and **mark** for future reference each up and down position. Label three of the positions with the following: H for highest, M for mid-position (if there is no mid-position, label the next lowest adjustment position), and L for lowest.

N/A, steering wheel is not adjustable up and down

4.3 Find and **mark** for future references each in and out position. Label three of the positions with the following: F for foremost, M for mid-position (if there is no mid-position, label the next rearmost adjustment position), and R for rearmost.

N/A, steering wheel is not adjustable in and out

5. Driver Low Risk Deployment

N/A, no low risk deployment tests scheduled

5.1 Position the steering wheel so the front wheels are in the straight-ahead position. (S26.2.1)

5.2 Position any adjustable parts of the steering controls to the mid-position as determined in item 3 above. If a mid-position adjustment is not achievable, position the controls to the next lowest detent position. (S26.2.1)

5.3 Locate the vertical plane parallel to the vehicle longitudinal centerline through the geometric center of the opening through which the driver air bag deploys into the occupant compartment. This is referred to as "Plane E". (Check determination method below.) (S26.2.6)

Plane E determined using manufacturer's information supplied by the COTR. (Found in Appendix D on page D-26) OR

Plane E determined by test lab personnel and approved by the COTR. (Include supporting documentation in the test report.)

	Ey (mm)
"Plane E" Measurement::	
Measured:	
Specified:	
Verify Measured Equals Specified +/- 6mm:	

5.4 Locate the horizontal plane through the highest point of the air bag module cover. This is referred to as "Plane F." (Check determination method below.) (S26.2.6)

Plane F determined using manufacturer's information supplied by the COTR. (Found in Appendix D on page D-26) OR

Plane F determined by test lab personnel and approved by the COTR. (Include supporting documentation in the test report.)

	Fz (mm)
"Plane F" Measurement::	
Measured:	

Specified:	
Verify Measured Equals Specified +/- 6mm:	

X

6. Passenger Low Risk Deployment – Planes C and D

X

N/A, no low risk deployment tests scheduled

6.1 Locate the horizontal plane through the geometric center of the opening through which the right front air bag deploys into the occupant compartment. This is referred to as "Plane C." (Check location method below.) (S22.4.1.3)

Plane C located using manufacturer's information supplied by the COTR. (Include manufacturer's information in the test report.) OR

Plane C located by test lab personnel and approved by the COTR. (Include supporting documentation in the test report.)

	Cz (mm)
"Plane C" Measurement::	
Measured:	
Specified:	
Verify Measured Equals Specified +/- 6mm:	

6.2 Locate the vertical plane parallel to the vehicle longitudinal centerline through the geometric center of the opening through which the right front air bag deploys into the occupant compartment. This is referred to as "Plane D." (Check determination method below.) (S22.4.1.2)

Plane D determined using manufacturer's information supplied by the COTR. (Include manufacturer's information in the test report.) OR

Plane D determined by test lab personnel and approved by the COTR. (Include supporting documentation in the test report.)

	Dy (mm)
"Plane D" Measurement:	
Measured:	
Specified:	
Verify Measured Equals Specified +/- 6mm:	

6.3 **Mark** the intersection of Planes C and D on the instrument panel.

X

7. 5th Female Dummy

Mark a point on the chin of the dummy 40 mm below the center of the mouth. (Chin Point) (S26.2.6)

8. 6-Year-Old Dummy

Locate and **mark** a point on the front of the dummy's chest jacket on the midsagittal plane which is 139 mm (5.5 in) ± 3 mm (± 0.1 in) along the surface of the skin down from the top of the skin at the neck line. Designate this point as "Point 1." (S24.4.1.1)

"Point 1" measurement (mm):

9. 3-Year-Old Dummy

Locate and **mark** a point on the front of the dummy's chest jacket on the midsagittal plane which is 114 mm (4.5 in) ± 3 mm (± 0.1 in) along the surface of the skin down from the top of the skin at the neck line. Designate this point as "Point 1." (S22.4.1.1)

"Point 1" measurement (mm +/- 3 mm):

REMARKS:

I certify that I have read and performed each instruction.

Signature:

Evo Lead

Date: 2/27/04

DATA SHEET 15 SUMMARY

Suppression Test Using 12-month-old CRABI Dummy (Part 572, Subpart R)
Section B Rear Facing CRS

NHTSA No.:	C40300	TEST DATE:	1-14-04
LABORATORY:	MGA	TECHNICIANS:	JL/TB
DUMMY TYPE:	12 Month Old	DUMMY SERIAL NO.:	082

CHILD RESTRAINT NAME:	Britax
CHILD RESTRAINT MODEL:	Handle With Care 191
DATE OF MANUFACTURE:	5-26-2000

Base: On Off N/A-Restraint does not have a removable base

Manufacturer's design seat back angle: 23.5°
 Tested seat back angle: 23.5°
 Manufacturer's specified anchorage position: 2nd Down
 Tested anchorage position: 2nd Down

A blanket and visor were not used in the suppression testing because they did not affect the weight sensing system used on the vehicle.

Test Summary

Seat Belt	Seat Slide	Cinch Load (N)	Handle Down	Handle Up
Belted Rear Facing	Forward 3	130	N/A	Suppressed *
	Middle	130	N/A	Suppressed
	Rearward	133	Suppressed	N/A
Unbelted Rear Facing	Forward 3	N/A	N/A	Suppressed *
	Middle	N/A	N/A	Suppressed
	Rearward	N/A	Suppressed	N/A
Unbelted Forward Facing	Forward 3	N/A	Suppressed *	N/A
	Middle	N/A	Suppressed	N/A
	Rearward	N/A	Suppressed	N/A

Successful Unbelted 5th percentile Female Dummy Reactivation was performed with the seat in the Rearward position. (SN513)

* The CRS would not fit in this Seat Slide position; but is at the detent indicated in the Seat Slide field (1 = Full Forward; 19 = Full Rearward; 19 detents total Seat Slide travel)

DATA SHEET 15 SUMMARY

Suppression Test Using 12-month-old CRABI Dummy (Part 572, Subpart R)
Section B Rear Facing CRS

NHTSA No.:	C40300	TEST DATE:	1-14-04
LABORATORY:	MGA	TECHNICIANS:	JL/TB
DUMMY TYPE:	12 Month Old	DUMMY SERIAL NO.:	082

CHILD RESTRAINT NAME:	Evenflo
CHILD RESTRAINT MODEL:	First Choice 204
DATE OF MANUFACTURE:	6-20-2000

Base: On Off N/A-Restraint does not have a removable base

Manufacturer's design seat back angle: 23.5°
 Tested seat back angle: 23.5°
 Manufacturer's specified anchorage position: 2nd Down
 Tested anchorage position: 2nd Down

A blanket and visor were not used in the suppression testing because they did not affect the weight sensing system used on the vehicle.

Test Summary

Seat Belt	Seat Slide	Cinch Load (N)	Handle Down	Handle Up
Belted Rear Facing	Forward 4	130	Suppressed *	N/A
	Middle	133	Suppressed	N/A
	Rearward	127	Suppressed	N/A
Unbelted Rear Facing	Forward 4	N/A	Suppressed *	N/A
	Middle	N/A	Suppressed	N/A
	Rearward	N/A	Suppressed	N/A
Unbelted Forward Facing	Forward 2	N/A	Suppressed *	N/A
	Middle	N/A	Suppressed	N/A
	Rearward	N/A	Suppressed	N/A

Successful Unbelted 5th percentile Female Dummy Reactivation was performed with the seat in the Forward position. (SN513)

* The CRS would not fit in this Seat Slide position; but is at the detent indicated in the Seat Slide field (1 = Full Forward; 19 = Full Rearward; 19 detents total Seat Slide travel)

DATA SHEET 15 SUMMARY

Suppression Test Using 12-month-old CRABI Dummy (Part 572, Subpart R)
Section B Rear Facing CRS

NHTSA No.:	C40300	TEST DATE:	1-14-04
LABORATORY:	MGA	TECHNICIANS:	JL/TB
DUMMY TYPE:	12 Month Old	DUMMY SERIAL NO.:	082

CHILD RESTRAINT NAME:	Graco
CHILD RESTRAINT MODEL:	Infant 8457
DATE OF MANUFACTURE:	8-31-2000

Base: On Off N/A-Restraint does not have a removable base

Manufacturer's design seat back angle: 23.5°
 Tested seat back angle: 23.5°
 Manufacturer's specified anchorage position: 2nd Down
 Tested anchorage position: 2nd Down

A blanket and visor were not used in the suppression testing because they did not affect the weight sensing system used on the vehicle.

Test Summary

Seat Belt	Seat Slide	Cinch Load (N)	Handle Down	Handle Up
Belted Rear Facing	Forward 5	128	N/A	Suppressed *
	Middle	132	N/A	Suppressed
	Rearward	133	Suppressed	N/A
Unbelted Rear Facing	Forward 6	N/A	N/A	Suppressed *
	Middle	N/A	N/A	Suppressed
	Rearward	N/A	Suppressed	N/A
Unbelted Forward Facing	Forward 5	N/A	N/A	Suppressed *
	Middle	N/A	N/A	Suppressed
	Rearward	N/A	Suppressed	N/A

* The CRS would not fit in this Seat Slide position; but is at the detent indicated in the Seat Slide field (1 = Full Forward; 19 = Full Rearward; 19 detents total Seat Slide travel)

DATA SHEET 15 SUMMARY

Suppression Test Using 12-month-old CRABI Dummy (Part 572, Subpart R)
Section B Rear Facing CRS

NHTSA No.:	C40300	TEST DATE:	1-14-04
LABORATORY:	MGA	TECHNICIANS:	JL/TB
DUMMY TYPE:	12 Month Old	DUMMY SERIAL NO.:	082

CHILD RESTRAINT NAME:	Graco
CHILD RESTRAINT MODEL:	Infant 8457
DATE OF MANUFACTURE:	8-31-2000

Base: On Off N/A-Restraint does not have a removable base

Manufacturer's design seat back angle: 23.5°
 Tested seat back angle: 23.5°
 Manufacturer's specified anchorage position: 2nd Down
 Tested anchorage position: 2nd Down

A blanket and visor were not used in the suppression testing because they did not affect the weight sensing system used on the vehicle.

Test Summary

Seat Belt	Seat Slide	Cinch Load (N)	Handle Down	Handle Up
Belted Rear Facing	Forward 4	129	N/A	Suppressed *
	Middle	131	Suppressed	N/A
	Rearward	129	Suppressed	N/A
Unbelted Rear Facing	Forward 4	N/A	N/A	Suppressed *
	Middle	N/A	N/A	Suppressed
	Rearward	N/A	Suppressed	Suppressed
Unbelted Forward Facing	Forward 3	N/A	N/A	Suppressed *
	Middle	N/A	N/A	Suppressed
	Rearward	N/A	N/A	Suppressed

Successful Unbelted 5th percentile Female Dummy Reactivation was performed with the seat in the Rearward position. (SN513)

* The CRS would not fit in this Seat Slide position; but is at the detent indicated in the Seat Slide field (1 = Full Forward; 19 = Full Rearward; 19 detents total Seat Slide travel)

DATA SHEET 15 SUMMARY

Suppression Test Using 12-month-old CRABI Dummy (Part 572, Subpart R)
Section C Forward Facing Convertible CRS

NHTSA No.:	C40300	TEST DATE:	1-14-04
LABORATORY:	MGA	TECHNICIANS:	JL/TB
DUMMY TYPE:	12 Month Old	DUMMY SERIAL NO.:	082

CHILD RESTRAINT NAME:	Britax
CHILD RESTRAINT MODEL:	Roundabout 161
DATE OF MANUFACTURE:	7-21-2000

Base: On Off N/A-Restraint does not have a removable base

Manufacturer's design seat back angle: 23.5°
 Tested seat back angle: 23.5°
 Manufacturer's specified anchorage position: 2nd Down
 Tested anchorage position: 2nd Down

A blanket was not used in the suppression testing because it did not affect the weight sensing system used on the vehicle.

Test Summary

Seat Belt	Seat Slide	Cinch Load (N)	No Blanket
Belted Forward Facing	Forward	133	Suppressed
	Middle	133	Suppressed
	Rearward	132	Suppressed
Unbelted Forward Facing	Forward	N/A	Suppressed
	Middle	N/A	Suppressed
	Rearward	N/A	Suppressed
Belted Rear Facing	Forward	133	Suppressed
	Middle	127	Suppressed
	Rearward	130	Suppressed
Unbelted Rear Facing	Forward	N/A	Suppressed
	Middle	N/A	Suppressed
	Rearward	N/A	Suppressed

Unbelted 5th percentile Female Dummy Reactivation was not performed.

DATA SHEET 15 SUMMARY

Suppression Test Using 12-month-old CRABI Dummy (Part 572, Subpart R)
Section C Forward Facing Convertible CRS

NHTSA No.:	C40300	TEST DATE:	1-14-04
LABORATORY:	MGA	TECHNICIANS:	JL/TB
DUMMY TYPE:	12 Month Old	DUMMY SERIAL NO.:	082

CHILD RESTRAINT NAME:	Century
CHILD RESTRAINT MODEL:	Encore 4612
DATE OF MANUFACTURE:	8-16-2000

Base: On Off N/A-Restraint does not have a removable base

Manufacturer's design seat back angle: 23.5°
 Tested seat back angle: 23.5°
 Manufacturer's specified anchorage position: 2nd Down
 Tested anchorage position: 2nd Down

A blanket was not used in the suppression testing because it did not affect the weight sensing system used on the vehicle.

Test Summary

Seat Belt	Seat Slide	Cinch Load (N)	No Blanket
Belted Forward Facing	Forward	130	Suppressed
	Middle	133	Suppressed
	Rearward	131	Suppressed
Unbelted Forward Facing	Forward	N/A	Suppressed
	Middle	N/A	Suppressed
	Rearward	N/A	Suppressed
Belted Rear Facing	Forward	127	Suppressed
	Middle	130	Suppressed
	Rearward	133	Suppressed
Unbelted Rear Facing	Forward	N/A	Suppressed
	Middle	N/A	Suppressed
	Rearward	N/A	Suppressed

Successful Unbelted 5th percentile Female Dummy Reactivation was performed with the seat in the Middle position. (SN513)

DATA SHEET 15 SUMMARY

Suppression Test Using 12-month-old CRABI Dummy (Part 572, Subpart R)
Section C Forward Facing Convertible CRS

NHTSA No.:	C40300	TEST DATE:	1-14-04
LABORATORY:	MGA	TECHNICIANS:	JL/TB
DUMMY TYPE:	12 Month Old	DUMMY SERIAL NO.:	082

CHILD RESTRAINT NAME:	Evenflo
CHILD RESTRAINT MODEL:	Medallion 254
DATE OF MANUFACTURE:	6-1-2000

Base: On Off N/A-Restraint does not have a removable base

Manufacturer's design seat back angle: 23.5°
 Tested seat back angle: 23.5°
 Manufacturer's specified anchorage position: 2nd Down
 Tested anchorage position: 2nd Down

A blanket was not used in the suppression testing because it did not affect the weight sensing system used on the vehicle.

Test Summary

Seat Belt	Seat Slide	Cinch Load (N)	No Blanket
Belted Forward Facing	Forward	130	Suppressed
	Middle	127	Suppressed
	Rearward	127	Suppressed
Unbelted Forward Facing	Forward	N/A	Suppressed
	Middle	N/A	Suppressed
	Rearward	N/A	Suppressed
Belted Rear Facing	Forward	127	Suppressed
	Middle	132	Suppressed
	Rearward	133	Suppressed
Unbelted Rear Facing	Forward	N/A	Suppressed
	Middle	N/A	Suppressed
	Rearward	N/A	Suppressed

Successful Unbelted 5th percentile Female Dummy Reactivation was performed with the seat in the Forward position. (SN513)

DATA SHEET 16 SUMMARY

Suppression Test Using Newborn Infant Dummy (Part 572, Subpart K) Section A Car Bed

NHTSA No.:	C40300	TEST DATE:	1-14-04
LABORATORY:	MGA	TECHNICIANS:	JL/TB
DUMMY TYPE:	Newborn Infant	DUMMY SERIAL NO.:	003

CAR BED NAME:	Cosco
CAR BED MODEL:	Dream Ride 02-719
DATE OF MANUFACTURE:	6-16-2000

Base: On Off N/A-Constraint does not have a removable base
 (A car bed with a removable base shall be treated as two separate models, i.e. this form and test procedure will be completed with the base on and then repeated on a new form with the base off.

Manufacturer's design seat back angle: 23.5°
 Tested seat back angle: 23.5°
 Manufacturer's specified anchorage position: 2nd Down
 Tested anchorage position: 2nd Down

A blanket and visor were not used in the suppression testing because they did not affect the weight sensing system used on the vehicle.

Test Summary

Seat Belt	Seat Slide	Handle Down	Handle Up
Belted	Forward	N/A	N/A
	Middle	Suppressed	N/A
	Rearward	N/A	N/A

Unbelted 5th percentile Female Dummy Reactivation was not performed.

The CRS would not fit in the Forward Seat Slide position due to interference with the transmission shifter.

The CRS would not fit in the Rearward Seat Slide position due to interference with the center console.

DATA SHEET 17 SUMMARY

Suppression Test Using 3 Year Old Dummy And Booster Seats (Part 572, Subpart P)
Section D Forward Facing Belt Positioning Booster

NHTSA No.:	C40300	TEST DATE:	1-13-04
LABORATORY:	MGA	TECHNICIANS:	JL/TB
DUMMY TYPE:	3 Year Old	DUMMY SERIAL NO.:	031

BOOSTER SEAT NAME:	Century
BOOSTER SEAT MODEL:	Next Step 4920
DATE OF MANUFACTURE:	8-16-2000

Manufacturer's design seat back angle: 23.5°
 Tested seat back angle: 23.5°
 Manufacturer's specified anchorage position: 2nd Down
 Tested anchorage position: 2nd Down

Test Summary

Seat Belt	Seat Slide	Cinch Load (N)	No Blanket
Belted Forward Facing Without Harness	Forward 7	14	Suppressed *
	Middle	10	Suppressed
	Rearward	17	Suppressed
Belted Forward Facing Cinched With Harness	Forward	133	Not Performed
	Middle	129	Not Performed
	Rearward	127	Not Performed

Successful Unbelted 5th percentile Female Dummy Reactivation was performed with the seat in the Forward position. (SN513)

* The CRS would not fit in this Seat Slide position; but is at the detent indicated in the Seat Slide field (1 = Full Forward; 19 = Full Rearward; 19 detents total Seat Slide travel)

DATA SHEET 17 SUMMARY

Suppression Test Using 3 Year Old Dummy And Booster Seats (Part 572, Subpart P)
Section D Forward Facing Toddler Belt Positioning Booster Seat

NHTSA No.:	C40300	TEST DATE:	1-13-04
LABORATORY:	MGA	TECHNICIANS:	JL/TB
DUMMY TYPE:	3 Year Old	DUMMY SERIAL NO.:	031

BOOSTER SEAT NAME:	Cosco
BOOSTER SEAT MODEL:	High Back Booster 02-442
DATE OF MANUFACTURE:	4-28-2000

Manufacturer's design seat back angle: 23.5°
 Tested seat back angle: 23.5°
 Manufacturer's specified anchorage position: 2nd Down
 Tested anchorage position: 2nd Down

Test Summary

Seat Belt	Seat Slide	Cinch Load (N)	No Blanket
Belted Forward Facing Without Harness	Forward	12	Would Not Fit
	Middle	13	Suppressed
	Rearward	13	Suppressed
Belted Forward Facing Cinched With Harness	Forward	133	Would Not Fit
	Middle	129	Suppressed
	Rearward	128	Suppressed

Successful Unbelted 5th percentile Female Dummy Reactivation was performed with the seat in the Rearward position. (SN513)

DATA SHEET 18 SUMMARY

Suppression Test Using 3 Year Old Dummy And Convertible Restraints (Part 572, Subpart P)
Section C Forward Facing Convertible CRS

NHTSA No.:	C40300	TEST DATE:	1-14-04
LABORATORY:	MGA	TECHNICIANS:	JL/TB
DUMMY TYPE:	3 Year Old	DUMMY SERIAL NO.:	031

CHILD RESTRAINT NAME:	Britax
CHILD RESTRAINT MODEL:	Roundabout 161
DATE OF MANUFACTURE:	7-21-2000

Manufacturer's design seat back angle: 23.5°
 Tested seat back angle: 23.5°
 Manufacturer's specified anchorage position: 2nd Down
 Tested anchorage position: 2nd Down

Test Summary

Seat Belt	Seat Slide	Cinch Load (N)	Result
Belted	Forward	133	Suppressed
	Middle	130	Suppressed
	Rearward	134	Suppressed

Successful Unbelted 5th percentile Female Dummy Reactivation was performed with the seat in the Rearward position. (SN513)

DATA SHEET 18 SUMMARY

Suppression Test Using 3 Year Old Dummy And Convertible Restraints (Part 572, Subpart P)
Section C Forward Facing Convertible CRS

NHTSA No.:	C40300	TEST DATE:	1-14-04
LABORATORY:	MGA	TECHNICIANS:	JL/TB
DUMMY TYPE:	3 Year Old	DUMMY SERIAL NO.:	031

CHILD RESTRAINT NAME:	Century
CHILD RESTRAINT MODEL:	Encore 4612
DATE OF MANUFACTURE:	8-16-2000

Manufacturer's design seat back angle: 23.5°
 Tested seat back angle: 23.5°
 Manufacturer's specified anchorage position: 2nd Down
 Tested anchorage position: 2nd Down

Test Summary

Seat Belt	Seat Slide	Cinch Load (N)	Result
Belted	Forward	130	Suppressed
	Middle	129	Suppressed
	Rearward	133	Suppressed

Unbelted 5th percentile Female Dummy Reactivation was not performed.

DATA SHEET 18 SUMMARY

Suppression Test Using 3 Year Old Dummy And Convertible Restraints (Part 572, Subpart P)
Section C Forward Facing Convertible CRS

NHTSA No.:	C40300	TEST DATE:	1-14-04
LABORATORY:	MGA	TECHNICIANS:	JL/TB
DUMMY TYPE:	3 Year Old	DUMMY SERIAL NO.:	031

CHILD RESTRAINT NAME:	Evenflo
CHILD RESTRAINT MODEL:	Medallion 254
DATE OF MANUFACTURE:	6-1-2000

Manufacturer's design seat back angle: 23.5°
 Tested seat back angle: 23.5°
 Manufacturer's specified anchorage position: 2nd Down
 Tested anchorage position: 2nd Down

Test Summary

Seat Belt	Seat Slide	Cinch Load (N)	Result
Belted	Forward	129	Suppressed
	Middle	130	Suppressed
	Rearward	130	Suppressed

Unbelted 5th percentile Female Dummy Reactivation was not performed.

DATA SHEET 19 SUMMARY

Suppression Test Using An Unbelted 3 Year Old Dummy (Part 572, Subpart P)
No CRS

NHTSA No.:	C40300	TEST DATE:	1-13-04
LABORATORY:	MGA	TECHNICIANS:	JL/TB
DUMMY TYPE:	3 Year Old	DUMMY SERIAL NO.:	031

Test Summary

Position	Seat Slide	Seat Back Angle	Result
Position 1 Sitting on seat with back against seat back	Forward	23.5	Suppressed
	Middle	23.5	Suppressed
	Rearward	23.5	Suppressed
Position 2 Sitting on seat with back against reclined seat back	Forward	48.2	Suppressed
	Middle	48.2	Suppressed
	Rearward	48.2	Suppressed
Position 3 Sitting on seat with back not against seat back	Forward	23.5	Would Not Fit
	Middle	23.5	Suppressed
	Rearward	23.5	Suppressed
Position 4 Sitting on seat edge, spine vertical, hands at dummy's sides	Forward	23.5	Suppressed
	Middle	23.5	Suppressed
	Rearward	23.5	Suppressed
Position 5 Standing on seat, facing forward	Forward	23.5	Suppressed
	Middle	23.5	Suppressed
	Rearward	23.5	Suppressed
Position 6 Kneeling on seat, facing forward	Forward	23.5	Suppressed
	Middle	23.5	Suppressed
	Rearward	23.5	Suppressed
Position 7 Kneeling on seat, facing rearward	Forward	23.5	Suppressed
	Middle	23.5	Suppressed
	Rearward	23.5	Suppressed
Position 8 Lying on seat. (Three designated seating positions only)	Forward	23.5	N/A
	Middle	23.5	N/A
	Rearward	23.5	N/A

Successful Unbelted 5th percentile Female Dummy Reactivation was performed with the seat in the Forward position. (SN513)

DATA SHEET 20 SUMMARY

Suppression Test Using 6 Year Old Dummy And Booster Seats (Part 572, Subpart N)
Section D Forward Facing Toddler Belt Positioning Booster Seat

NHTSA No.:	C40300	TEST DATE:	1-12-04
LABORATORY:	MGA	TECHNICIANS:	JL/TB
DUMMY TYPE:	6 Year Old	DUMMY SERIAL NO.:	152

BOOSTER SEAT NAME:	Century
BOOSTER SEAT MODEL:	Next Step 4920
DATE OF MANUFACTURE:	8-16-2000

Manufacturer's design seat back angle: 23.5°
 Tested seat back angle: 23.5°
 Manufacturer's specified anchorage position: 2nd Down
 Tested anchorage position: 2nd Down

Test Summary

Seat Belt	Seat Slide	Cinch Load (N)	Result
Belted	Forward 3	9	Suppressed *
	Middle	11	Suppressed
	Rearward	16	Suppressed
Unbelted	Forward 3	N/A	Suppressed *
	Middle	N/A	Suppressed
	Rearward	N/A	Suppressed

Successful Unbelted 5th percentile Female Dummy Reactivation was performed with the seat in the Rearward position. (SN513)

* The CRS would not fit in this Seat Slide position; but is at the detent indicated in the Seat Slide field (1 = Full Forward; 19 = Full Rearward; 19 detents total Seat Slide travel)

DATA SHEET 20 SUMMARY

Suppression Test Using 6 Year Old Dummy And Booster Seats (Part 572, Subpart N)
Section D Forward Facing Toddler Belt Positioning Booster Seat

NHTSA No.:	C40300	TEST DATE:	1-12-04
LABORATORY:	MGA	TECHNICIANS:	JL/TB
DUMMY TYPE:	6 Year Old	DUMMY SERIAL NO.:	152

BOOSTER SEAT NAME:	Cosco
BOOSTER SEAT MODEL:	High Back Booster 02-442
DATE OF MANUFACTURE:	4-28-2000

Manufacturer's design seat back angle: 23.5°
Tested seat back angle: 23.5°
Manufacturer's specified anchorage position: 2nd Down
Tested anchorage position: 2nd Down

Test Summary

Seat Belt	Seat Slide	Cinch Load (N)	Result
Belted	Forward	16	Suppressed
	Middle	13	Suppressed
	Rearward	17	Suppressed

Successful Unbelted 5th percentile Female Dummy Reactivation was performed with the seat in the Forward position. (SN513)

DATA SHEET 20 SUMMARY

Suppression Test Using 6 Year Old Dummy And Booster Seats (Part 572, Subpart N)
Section D Forward Facing Toddler Belt Positioning Booster Seat

NHTSA No.:	C40300	TEST DATE:	1-12-04
LABORATORY:	MGA	TECHNICIANS:	JL/TB
DUMMY TYPE:	6 Year Old	DUMMY SERIAL NO.:	152

BOOSTER SEAT NAME:	Evenflo
BOOSTER SEAT MODEL:	Right Fit 245
DATE OF MANUFACTURE:	6-26-2000

Manufacturer's design seat back angle: 23.5°
 Tested seat back angle: 23.5°
 Manufacturer's specified anchorage position: 2nd Down
 Tested anchorage position: 2nd Down

Test Summary

Seat Belt	Seat Slide	Cinch Load (N)	Result
Belted	Forward	10	Suppressed
	Middle	12	Suppressed
	Rearward	16	Suppressed

Successful Unbelted 5th percentile Female Dummy Reactivation was performed with the seat in the Middle position. (SN513)

DATA SHEET 21 SUMMARY

Suppression Test Using An Unbelted 6 Year Old Dummy (Part 572, Subpart N)
No CRS

NHTSA No.:	C40300	TEST DATE:	1-13-04
LABORATORY:	MGA	TECHNICIANS:	JL/TB
DUMMY TYPE:	6 Year Old	DUMMY SERIAL NO.:	152

Test Summary

Position	Seat Slide	Seat Back Angle	Result
Position 1 Sitting on seat with back against seat back	Forward 6	23.5	Suppressed *
	Middle	23.5	Suppressed
	Rearward	23.5	Suppressed
Position 2 Sitting on seat with back against reclined seat back	Forward 6	48.2	Suppressed *
	Middle	48.2	Suppressed
	Rearward	48.2	Suppressed
Position 3 Sitting on seat edge, spine vertical, hands at dummy's sides	Forward 6	23.5	Suppressed *
	Middle	23.5	Suppressed
	Rearward	23.5	Suppressed
Position 4 Sitting on seat with back against seat back then leaning on the door	Forward 6	23.5	Suppressed *
	Middle	23.5	Suppressed
	Rearward	23.5	Suppressed

Successful Unbelted 5th percentile Female Dummy Reactivation was performed with the seat in the Rearward position. (SN513)

* The Dummy would not fit in this Seat Slide position; but is at the detent indicated in the Seat Slide field (1 = Full Forward; 19 = Full Rearward; 19 detents total Seat Slide travel)

DATA SHEET 27 SUMMARY

Low Risk Deployment Tests Using an Unbelted 5th Percentile Female
 Dummy (Part 572, Subpart O) (S26)
 Position 1 - Chin On Module (S26.2)

NHTSA No.:	C40300	TEST DATE:	1-16-04
LABORATORY:	MGA	TECHNICIANS:	WD/DW/BR
DUMMY TYPE:	5 th Percentile Female	DUMMY SERIAL NO.:	494

Manufacturer's design seat back angle: 23.5°
 Tested seat back angle: 23.5°
 Tested seat position: Full Aft

 Tested steering wheel angle: 24.3°
 Thorax cavity angle: 29.4°
 Chin Point height: 15 mm Above Module

Air Bag Deployment Timing

Stage No.	Firing time (ms)	Recorded firing time (ms)
1	0.0	0.0
2	45.0	45.2

5th Percentile Female SN 494 Position 1 (Chin On Module)

Injury Criteria	Max. Allowable Injury Assessment Values	Measured Value
HIC15	700	28
Peak Nij (Nte)	1.0	0.3
Time (ms)	NA	118.7
Peak Nij (Ntf)	1.0	0.4
Time (ms)	NA	28.1
Peak Nij (Nce)	1.0	0.5
Time (ms)	NA	169
Peak Nij (Ncf)	1.0	0.0
Time (ms)	NA	0.9
Neck Tension	2070 N	806
Neck Compression	2520 N	-437
Chest g	60 g	17
Chest Displacement	52 mm	-9
Left Femur	6805 N	-24
Right Femur	6805 N	-37

Calculated on data recorded for 125 ms after the initiation of the final stage of air bag deployment designed to deploy in any full frontal rigid barrier crash up to 26 km/h. (S4.11(d))
 Second stage fire time of 45 ms; Injuries calculated on 0 ms to 170 ms

DATA SHEET 28 SUMMARY

Low Risk Deployment Tests Using an Unbelted 5th Percentile Female
 Dummy (Part 572, Subpart O) (S26)
 Position 2 - Chin On Rim (S26.3)

NHTSA No.:	C40300	TEST DATE:	1-30-04
LABORATORY:	MGA	TECHNICIANS:	WD/DW/BR
DUMMY TYPE:	5 th Percentile Female	DUMMY SERIAL NO.:	515

Manufacturer's design seat back angle: 23.5°
 Tested seat back angle: 23.5°
 Tested seat position: Full Aft

Tested steering wheel angle: 24.4°
 Thorax cavity angle: 30.7°
 Chin Point height: 4 mm Below Rim

Air Bag Deployment Timing

Stage No.	Firing time (ms)	Recorded firing time (ms)
1	0.0	0.0
2	45.0	45.3

5th Percentile Female SN 515 Position 2 (Chin On Rim) 1-30-04

Injury Criteria	Max. Allowable Injury Assessment Values	Measured Value
HIC15	700	15
Peak Nij (Nte)	1.0	0.6
Time (ms)	NA	17.5
Peak Nij (Ntf)	1.0	0.2
Time (ms)	NA	29.1
Peak Nij (Nce)	1.0	0.1
Time (ms)	NA	163.2
Peak Nij (Ncf)	1.0	0.2
Time (ms)	NA	53.7
Neck Tension	2070 N	1085
Neck Compression	2520 N	-135
Chest g	60 g	13
Chest Displacement	52 mm	-23
Left Femur	6805 N	-42
Right Femur	6805 N	-148

Calculated on data recorded for 125 ms after the initiation of the final stage of air bag deployment
 designed to deploy in any full frontal rigid barrier crash up to 26 km/h. (S4.11(d))
 Second stage fire time of 45 ms; Injuries calculated on 0 ms to 170 ms

DATA SHEET 30
VEHICLE WEIGHT, FUEL TANK, AND ATTITUDE DATA

Test Vehicle: 2004 Jeep Liberty
 Test Program: FMVSS 208 Compliance
 Test Technician: Wayne Dahlke

NHTSA No.: C40300
 Test Date: 2/27/04

IMPACT ANGLE:	Zero Degrees		
BELTED DUMMIES (YES/NO):	No – Front Occupants		Yes – Center Rear Passenger
TEST SPEED:	<input checked="" type="checkbox"/> 32 to 40 kmph	<input type="checkbox"/> 0 to 48 kmph	<input type="checkbox"/> 0 to 56 kmph
DRIVER DUMMY:	<input checked="" type="checkbox"/> 5 TH female		<input type="checkbox"/> 50 th Male
PASSENGER DUMMY:	<input checked="" type="checkbox"/> 5 TH female	<input checked="" type="checkbox"/> 50 th Male Ctr Rear	

- 1. Fill the transmission with transmission fluid to the satisfactory range.
- 2. Drain fuel from vehicle
- 3. Run the engine until fuel remaining in the fuel delivery system is used and the engine stops.
- 4. Record the useable fuel tank capacity supplied by the COTR
Useable Fuel Tank Capacity supplied by COTR: 50 liters (19.5 gallons)
- 5. Record the fuel tank capacity supplied in the owner’s manual.
Useable Fuel Tank Capacity in owner’s manual: 50 liters (19.5 gallons)
- 6. Using purple dyed Stoddard solvent having the physical and chemical properties of Type 1 solvent or cleaning fluid, Table 1, ASTM Standard D484-71, “Standard Specifications for Hydrocarbon Dry-cleaning Solvents,” or gasoline, fill the fuel tank.
Amount Added: 50 liters (19.5 gallons)
- 7. Fill the coolant system to capacity.
- 8. Fill the engine with motor oil to the Max. mark on the dip stick.
- 9. Fill the brake reservoir with brake fluid to its normal level.
- 10. Fill the windshield washer reservoir to capacity.
- 11. Inflate the tires to the tire pressure on the tire placard. If no tire placard is available, inflate the tires to the recommended pressure in the owner’s manual.

Tire placard pressure:	RF:	33 psi	LF:	33 psi	RR:	33 psi	LR:	33 psi
Owner’s manual pressure:	RF:	33 psi	LF:	33 psi	RR:	33 psi	LR:	33 psi
Actual inflated pressure:	RF:	33 psi	LF:	33 psi	RR:	33 psi	LR:	33 psi

- 12. Record the vehicle weight at each wheel to determine the unloaded vehicle weight (UVW), i.e. "as delivered" weight).

Right Front (kg):	446.8	Right Rear (kg):	410.1
Left Front (kg):	452.2	Left Rear (kg):	416.4
Total Front (kg):	899.0	Total Rear (kg):	826.5
% Total Weight:	52.1	% Total Weight:	47.8
UVW = TOTAL FRONT PLUS TOTAL REAR (KG):		1725.5	

- 13. UVW Test Vehicle Attitude: (All dimensions in millimeters)
- 13.1 Mark a point on the vehicle above the center of each wheel.
- 13.2 Place the vehicle on a level surface.

- 13.3 Measure perpendicular to the level surface to the 4 points marked on the body and record the measurements

RF:	812	LF:	808	RR:	822	LR:	820
-----	-----	-----	-----	-----	-----	-----	-----

14. Calculate the Rated Cargo and Luggage Weight (RCLW).
- 14.1 Does the vehicle have the vehicle capacity weight (VCW) on the certification label or tire placard?
- Yes, go to 14.3 Information on sticker in glovebox
- No, go to 14.2
- 14.2 VCW = Gross Vehicle Weight – UVW

$$VCW = \underline{\hspace{2cm}} - \underline{\hspace{2cm}} = \underline{\hspace{2cm}}$$

- 14.3 VCW = 521.6 kg (1150 lbs)
- 14.4 Does the certification or tire placard contain the Designated Seating Capacity (DSC)?

- Yes, go to 14.6
- No, go to 14.5 and skip 14.6

- 14.5 DSC = Total number of seat belt assemblies = _____

- 14.6 DSC = 5

- 14.7 RCLW = VCW – (68 kg x DSC) = 521.6 kg - (68 kg x 5) = 181.6 kg

- 14.8 Is the vehicle certified as a truck, MPV or bus (see the certification label on the door jamb)?

- Yes, if the calculated RCLW is greater than 136 kg, use 136 kg as the RCLW. (S8.1.1)
- No, use the RCLW calculated in 14.7

15. Fully Loaded Weight (100% fuel fill)

- 15.1 Place the appropriate test dummy in both front outboard seating positions.

Driver: 5th female 50th male

Passenger: 5th female 50th male

- 15.2 Load the vehicle with the RCLW from 14.7 or 14.8 whichever is applicable.

- 15.3 Place the RCLW in the cargo area. Center the load over the longitudinal centerline of the vehicle. (S8.1.1 (d))

- 15.4 Record the vehicle weight at each wheel to determine the Fully Loaded Weight.

Right Front (kg):	463.6	Right Rear (kg):	514.8
Left Front (kg):	465.4	Left Rear (kg):	518.5
Total Front (kg):	929.0	Total Rear (kg):	1033.3
% Total Weight:	47.3	% Total Weight:	52.7
% GVW	51.4	% GVW	58.9
Fully Loaded Weight = Total Front Plus Total Rear (kg):		1962.3	

16. Fully Loaded Test Vehicle Attitude: (All dimensions in millimeters)

- 16.1 Place the vehicle on a level surface.

- 16.2 Measure perpendicular to the level surface to the 4 points marked on the body (see 13.1 above) and record the measurements

RF:	807	LF:	804	RR:	790	LR:	788
-----	-----	-----	-----	-----	-----	-----	-----

- 17. Drain the fuel system
- 18. Using purple dyed Stoddard solvent having the physical and chemical properties of Type 1 solvent or cleaning fluid, Table 1, ASTM Standard D484-71, "Standard Specifications for Hydrocarbon Dry-cleaning Solvents," fill the fuel tank to 92 - 94 percent of useable capacity.

Fuel tank capacity x .94 = 73.8 liters (19.5 gallons) x .94 = 69.4 liters (18.33 gallons)
 Amount added 69.4 liters (18.33 gallons) 94%

- 19. Crank the engine to fill the fuel delivery system with Stoddard solvent
- 20. Calculate the test weight range.
- 20.1 Calculated Weight = UVW (see 12 above) + RCLW (see 14 above) + 2x(dummy weight)

$$1959.5 \text{ kg} = 1725.5 \text{ kg} + 136.0 \text{ kg} + 98.0 \text{ kg}$$

- 20.2 Test Weight Range = Calculated Weight (- 4.5 kg, - 9 kg.)
 Max. Test Weight = Calculated Test Weight - 4.5 kg = 1955.0 kg
 Min. Test Weight = Calculated Test Weight - 9 kg = 1950.5 kg

- 21. Remove the RCLW from the cargo area.
- 22. Drain transmission fluid, engine coolant, motor oil, and windshield washer fluid from the test vehicle so that Stoddard solvent leakage from the fuel system will be evident.

- 23. Vehicle Components Removed For Weight Reduction:
Cargo interior, RH rear tail light, hub covers, right rear window glass, and right rear window motor.

- 24. Secure the equipment and ballast in the load carrying area and distribute it, as nearly as possible, to obtain the proportion of axle weight indicated by the gross axle weight ratings and center it over the longitudinal centerline of the vehicle.

- 25. If necessary, add ballast to achieve the actual test weight.

N/A

Weight of Ballast:

- 26. Ballast, including test equipment, must be contained so that it will not shift during the impact event or interfere with data collection or interfere with high-speed film recordings or affect the structural integrity of the vehicle or do anything else to affect test results. Care must be taken to assure that any attachment hardware added to the vehicle is not in the vicinity of the fuel tank or lines.

- 27. Record the vehicle weight at each wheel to determine the actual test weight.

Right Front (kg):	469.9	Right Rear (kg):	484.0
Left Front (kg):	494.0	Left Rear (kg):	506.7
Total Front (kg):	963.9	Total Rear (kg):	990.7
% Total Weight:	49.3	% Total Weight:	50.7
% GVW	51.4	% GVW	58.9
(% GVW = Axle GVW divided by Vehicle GVW)			
TOTAL FRONT PLUS TOTAL REAR (kg):			1954.6

28. Is the test weight between the Max. Weight and the Min. Weight (See 20.2)?
- Yes
- No, explain why not.
29. Test Weight Vehicle Attitude: (all dimensions in millimeters)
- 29.1 Place the vehicle on a level surface
- 29.2 Measure perpendicular to the level surface to the 4 points marked on the body (see 13 above) and record the measurements

RF:	803	LF:	798	RR:	800	LR:	793
-----	-----	-----	-----	-----	-----	-----	-----

30. Summary of test attitude
- 30.1 AS DELIVERED:

RF:	812	LF:	808	RR:	822	LR:	820
-----	-----	-----	-----	-----	-----	-----	-----

AS TESTED:

RF:	803	LF:	798	RR:	800	LR:	793
-----	-----	-----	-----	-----	-----	-----	-----

FULLY LOADED:

RF:	807	LF:	804	RR:	790	LR:	788
-----	-----	-----	-----	-----	-----	-----	-----

- 30.2 Is the "as tested" test attitude equal to or between the "fully loaded" and "as delivered" attitude?
- Yes
- No, explain why not. Mass distribution altered by 50th% Center Rear Passenger

REMARKS:

I certify that I have read and performed each instruction.

Signature: Clark Sulet

Date: 2/23/04

DATA SHEET 31

VEHICLE ACCELEROMETER LOCATION AND MEASUREMENT

Test Vehicle: 2004 Jeep Liberty
 Test Program: FMVSS 208 Compliance
 Test Technician: Clark Subrt

NHTSA No.: C40300
 Test Date: 2/27/04

IMPACT ANGLE:	Zero Degrees		
BELTED DUMMIES (YES/NO):	No – Front Occupants		Yes – Center Rear Passenger
TEST SPEED:	X 32 to 40 kmph	0 to 48 kmph	0 to 56 kmph
DRIVER DUMMY:	X 5 TH female		50 th Male
PASSENGER DUMMY:	X 5 TH female	X 50 th Male Ctr Rear	

- 1. Find the location where the vertical plane parallel to the longitudinal centerline of the vehicle and through the center of the left front outboard seating position intersects the left rear seat cross member. Install an accelerometer at this intersection on the rear seat cross member to record x-direction accelerations. Record the location on the following chart.
- 2. Find the location where the vertical plane parallel to the longitudinal centerline of the vehicle and through the center of the right front outboard seating position intersects the right rear seat cross member. Install an accelerometer at this intersection on the rear seat cross member to record x-direction accelerations. Record the location on the following chart.
- 3. Find the location where a vertical plane through the longitudinal centerline of the vehicle and a vertical transverse plane through the center of the two wheels on opposite sides of the engine intersect at the top of the engine. Install an accelerometer at this intersection to record x-direction accelerations. Record the location on the following chart.
- 4. Find the location where a vertical plane through the longitudinal centerline of the vehicle and a vertical transverse plane through the center of the two wheels on opposite sides of the engine intersect the bottom of the engine. Install an accelerometer at this intersection to record x-direction accelerations. Record the location on the following chart.
- 5. Install an accelerometer on the right front brake caliper to record x-direction accelerations. Record the location on the following chart.
- 6. Find the location where a vertical plane through the longitudinal centerline of the vehicle intersects the top of the instrument panel. Install an accelerometer at this intersection to record x-direction accelerations. Record the location on the following chart.
- 7. Install an accelerometer on the left front brake caliper to record x-direction accelerations. Record the location on the following chart.
- 8. Find the location where a vertical plane through the longitudinal centerline of the vehicle intersects the floor of the trunk. Install an accelerometer on the trunk floor at this intersection to record z-direction accelerations. Record the location on the following chart.

REMARKS:

I certify that I have read and performed each instruction.

Signature: *Clark Subrt*

Date: 2/24/04

VEHICLE ACCELEROMETER LOCATION AND DATA SUMMARY

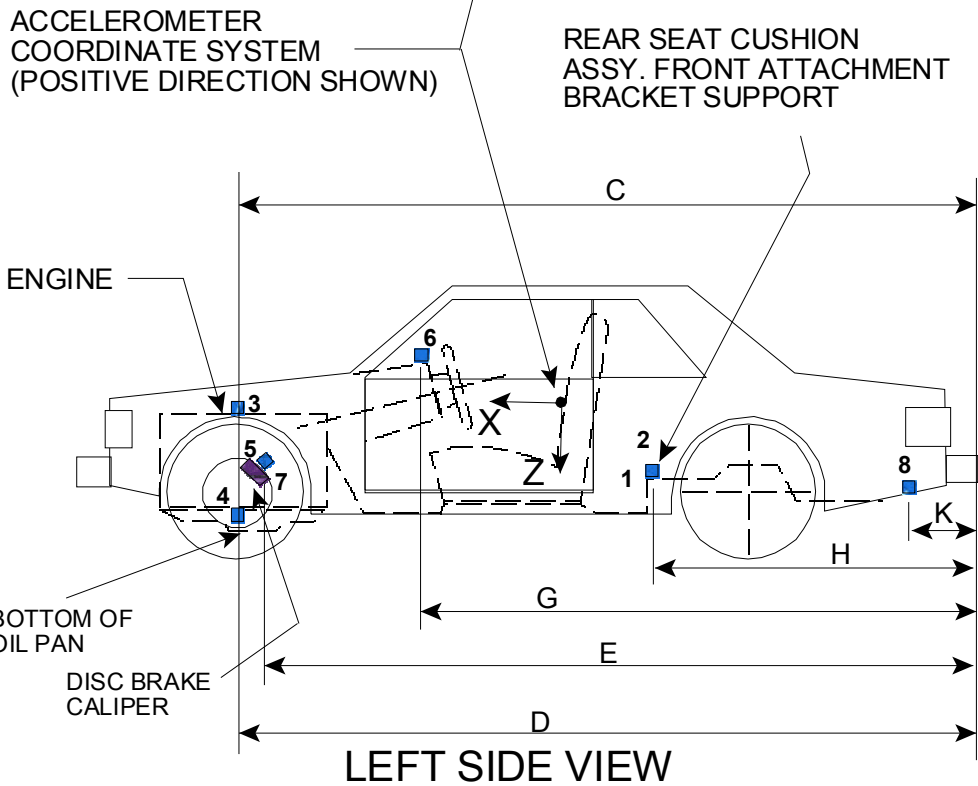
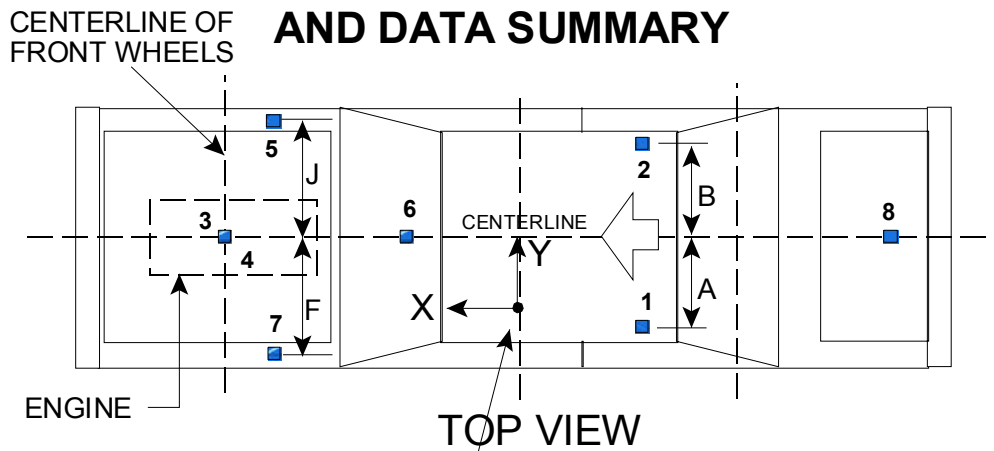

Dimensions Corresponding To The Letters "A" Through "K" (Excluding "I") Are
Recorded In The Table On The Following Page.
Accelerometers Corresponding To The Numbers 1 Through 8 Are Specified On The
Preceding Page.

DATA SHEET 31
VEHICLE ACCELEROMETER LOCATION AND MEASUREMENTS

<u>DIMENSION</u>	<u>LENGTH (mm)</u>			
PRETEST VALUES				
<u>A</u> (LH Rear Seat Xmbr)	435			
<u>B</u> (RH Rear Seat Xmbr)	431			
<u>C</u> (Engine Top)	3410			
<u>D</u> (Engine Bottom)	3475			
<u>E</u> (Caliper)	Right Side	3405	Left Side	3405
<u>F</u> (Left Caliper)	650			
<u>G</u> (IP)	2773			
<u>H</u> (Seat)	1535			
<u>J</u> (Right Caliper)	650			
<u>K</u> (Trunk)	920			
POST TEST VALUES				
<u>A</u> (LH Rear Seat Xmbr)	435			
<u>B</u> (RH Rear Seat Xmbr)	431			
<u>C</u> (Engine Top)	3426			
<u>D</u> (Engine Bottom)	3482			
<u>E</u> (Caliper)	Right Side	3407	Left Side	3408
<u>F</u> (Left Caliper)	650			
<u>G</u> (IP)	2774			
<u>H</u> (Seat)	1535			
<u>J</u> (Right Caliper)	650			
<u>K</u> (Trunk)	920			

DATA SHEET 32
PHOTOGRAPHIC TARGETS



Test Vehicle: 2004 Jeep Liberty
 Test Program: FMVSS 208 Compliance
 Test Technician: Clark Subrt

NHTSA No.: C40300
 Test Date: 2/27/04

IMPACT ANGLE:	Zero Degrees		
BELTED DUMMIES (YES/NO):	No – Front Occupants Yes – Center Rear Passenger		
TEST SPEED:	<u>X</u> 32 to 40 kmph	<u> </u> 0 to 48 kmph	<u> </u> 0 to 56 kmph
DRIVER DUMMY:	<u>X</u> 5 TH female		<u> </u> 50 th Male
PASSENGER DUMMY:	<u>X</u> 5 TH female	<u>X</u> 50 th Male Ctr Rear	

- 1. FMVSS 208 vehicle targeting requirements (See Figures 28A and 28B)
- 1.1 Targets A1 and A2 are on flat rectangular panels.
- 1.2 Three circular targets at least 90 mm in diameter and with black and yellow quadrants are mounted at the front on the outboard sides of A1 and A2. The center of each circular target is 100 mm from the one next to it.
- Distance between targets (mm): 100 mm
- 1.3 Three circular targets at least 90 mm in diameter and with black and yellow quadrants are mounted at the back on the outboard sides of on A1 and A2. The center of each circular target is 100 mm from the one next to it.
- Distance between targets (mm): 100 mm
- 1.4 The distance between the first circular target at the front of A1 and A2 and the last circular target at the back of A1 and A2 is at least 915 mm.
- Distance between the first and last circular targets (mm): 915 mm
- 1.5 Firmly fix target A1 on the vehicle roof in the vertical longitudinal plane that is coincident with the midsagittal plane of the driver dummy.
- 1.6 Firmly fix target A2 on the vehicle roof in the vertical longitudinal plane that is coincident with the midsagittal plane of the passenger dummy.
- 1.7 Two circular targets (C1 and C2) at least 90 mm in diameter and with black and yellow quadrants are mounted on the outside of the driver door. The centers of each circular target are at least 610 mm apart.
- Distance between targets (mm): 610 mm
- 1.8 Two circular targets (C1 and C2) at least 90 mm in diameter and with black and yellow quadrants are mounted on the outside of the passenger door. The centers of each circular target are at least 610 mm apart.
- Distance between targets (mm): 610 mm
- 1.9 Place tape with squares having alternating colors on the top portion of the steering wheel.
- 1.10 Chalk the bottom portion of the steering wheel
- 1.11 Is this an offset test?
 - Yes, continue with this section
 - No, go to 2.
- 1.12 Measure the width of the vehicle.
- Vehicle width (mm):

- 1.13 Find the centerline of the vehicle. ($\frac{1}{2}$ of the vehicle width)
- 1.14 Find the line parallel to the centerline of the vehicle and 0.1 x vehicle width from the centerline of the vehicle.
- 1.15 Apply 25 mm wide tape with alternating black and yellow squares parallel to and on each side of the line found in 1.14. The edge of each tape shall be 50 mm from the line found in 1.14. The tape shall extend from the bottom of the bumper to the front edge of the windshield. (Figure 28D)
2. Barrier Targeting
- 2.1 Fix two stationary targets D1 and D2 to the barrier as shown in the Figure 28A. One target is in the vertical longitudinal plane that is coincident with the midsagittal plane of the driver dummy. The other is in the vertical longitudinal plane that is coincident with the midsagittal plane of the passenger dummy
- 2.2 Targets D1 and D2 are on a rectangular panel.
- 2.3 Three circular targets at least 90 mm in diameter and with black and yellow quadrants are mounted on the sides of the rectangular panel away from the longitudinal centerline of the vehicle. The center of each circular target is 100 mm from the one next to it.
- Distance between circular targets on D1 (mm): 100mm
- Distance between circular targets on D2 (mm): 100mm
3. FMVSS 208 Dummy Targeting Requirements
- 3.1 Place a circular target with black and yellow quadrants on both sides of the driver dummy head as close as possible to the center of gravity of the head in the x and z direction (relative to the measuring directions of the accelerometers).
- 3.2 Place a circular target with black and yellow quadrants on both sides of the passenger dummy head as close as possible to the center of gravity of the head in the x and z direction (relative to the measuring directions of the accelerometers).
- 3.3 Place a circular target with black and yellow quadrants on the outboard shoulder of the driver dummy. Place the target as high up on the arm as possible at the intersection of the arm and shoulder. The sleeve of the shirt on the dummy may be cut to make the target visible, but do not remove any material.
- 3.4 Place a circular target with black and yellow quadrants on the outboard shoulder of the passenger dummy. Place the target as high up on the arm as possible at the intersection of the arm and shoulder. The sleeve of the shirt on the dummy may be cut to make the target visible, but do not remove any material.
4. FMVSS 204 Targeting Requirements
- 4.1 Is an FMVSS 204 indicant test ordered on the "COTR Vehicle Work Order?"
- Yes, continue with this form.
- No, this form is complete. (Removed at manufacturer's request with COTR approval)
- 4.2 Resection panel (Figure 28C)
- 4.2.1 The panel deviates no more than 6 mm from perfect flatness when suspended vertically
- 4.2.2 The 8 targets on the panel are circular targets at least 90 mm in diameter and with black and yellow quadrants.
- 4.2.3 The center of each of the 4 outer targets are placed within 1 mm of the corners of a square measuring 914 mm on each side.
- 4.2.4 Locate another square with 228 mm sides and with the center of this square coincident with the center of the 914 mm square.
- 4.2.5 The center of the 4 inner targets are placed at the midpoints of each of the 228 mm sides.

-  4.3 Place a circular target at least 90 mm in diameter and with black and yellow quadrants on a material (cardboard, metal, etc.) that can be taped to the top of the steering column.
-  4.4 Tape the target from 4.3 to the top of the steering column in a manner that does not interfere with the movement of the steering column in a crash

REMARKS: Center Rear Passenger Dummy Target Information:

Horizontal distance from camera to dummy reference targets: 759 mm
Horizontal distance from camera to vehicle reference targets: 1197 mm
Distance between 1" reference targets: 75 mm
Reference targets were placed on inch tape for continuous reference.

I certify that I have read and performed each instruction.

Signature: 

Date: 2/27/04

REFERENCE PHOTO TARGETS

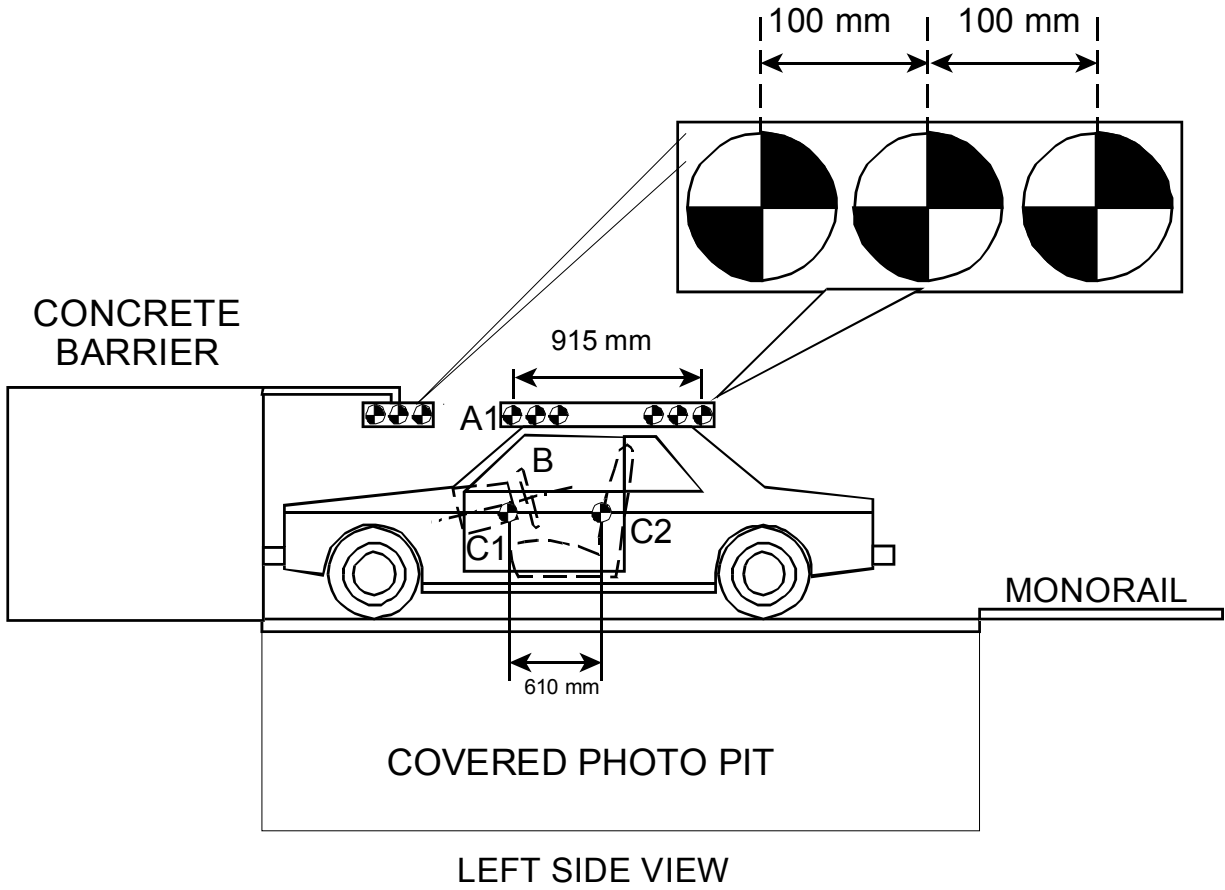

RESECTION PANEL TARGETING ALIGNMENT

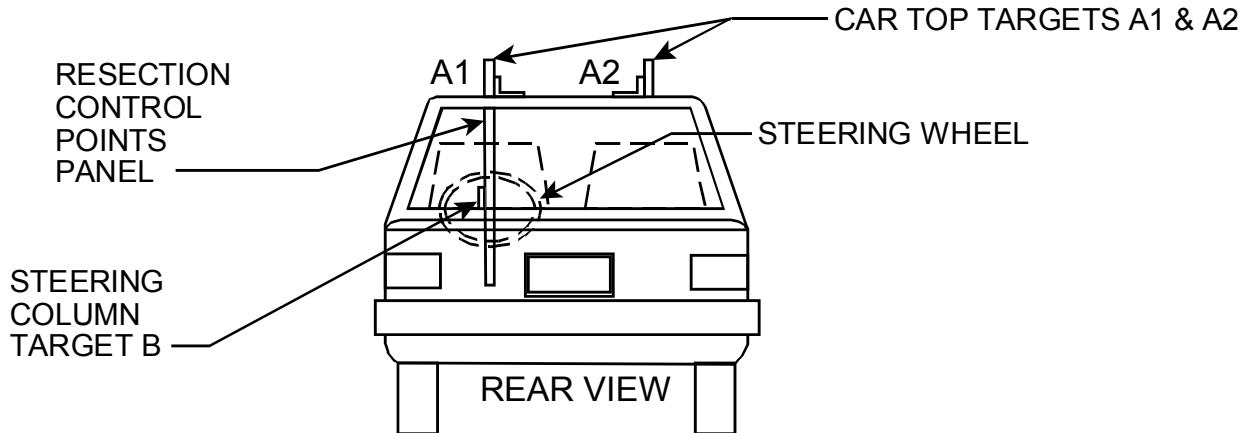

TEST RUN STEERING COLUMN CAMERA VIEW OF TYPICAL TIME ZERO VEHICLE POSITION

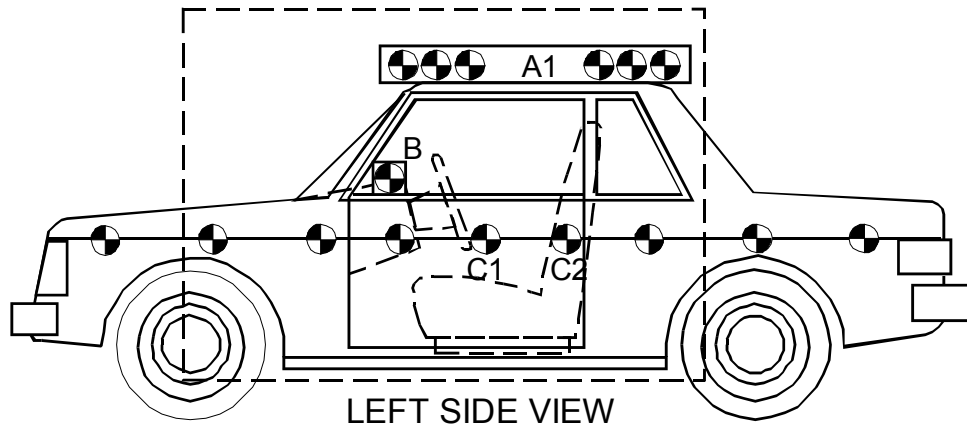

PRE-RUN STEERING COLUMN HIGH SPEED CAMERA VIEW

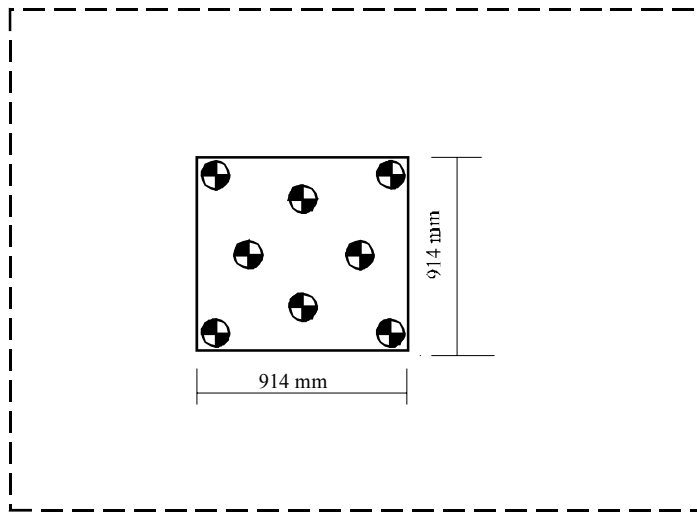

LEFT SIDE VIEW

DATA SHEET 33
CAMERA LOCATIONS

Test Vehicle: 2004 Jeep Liberty
Test Program: FMVSS 208 Compliance

NHTSA No.: C40300
Test Date: 2/27/04
Time: 1:33 pm

CAMERA NO.	VIEW	CAMERA POSITIONS (mm) *			LENS (mm)	SPEED (fps)
		X	Y	Z		
1	Real Time Left Side View				13	24
2	Left Side View (Barrier face to front seat backs)	1000	-8000	1590	25	1031
3	Left Side View (Driver)	1550	-8500	1550	25	1036
4	Left Side View (B-post aimed toward center of steering wheel)	4510	-5000	2010	50	1258
5	Left Side View (Steering Column)	2000	-8000	1560	25	1036
6	Left Side View (Steering Column)	2000	-8000	1030	25	1047
7	Right Side View (Overall)	1926	6422	1505	13	1031
8	Right Side View (Passenger)	1329	10066	1420	75	1183
9	Right Side View (Angle)	5016	5608	2147	50	**
10	Right Side View (Front door)	1012	7620	1465	25	840
11	Front View Windshield	390	0	2920	13	1036
12	Front View Driver	130	-500	2260	13	1036
13	Front View Passenger	130	470	2260	13	1042
14	Overhead Barrier Impact View	2880	0	5000	8	1053
15	Pit Camera Engine View	1280	0	-3170	13	1031
16	Pit Camera Fuel Tank View	3530	0	-3230	13	1026
17	Onboard Rear Passenger View				8	1053

*COORDINATES:

- +X – forward of impact plane
- +Y – right of monorail centerline
- +Z – above ground level

** No usable film

CAMERA POSITIONS FOR FMVSS 208

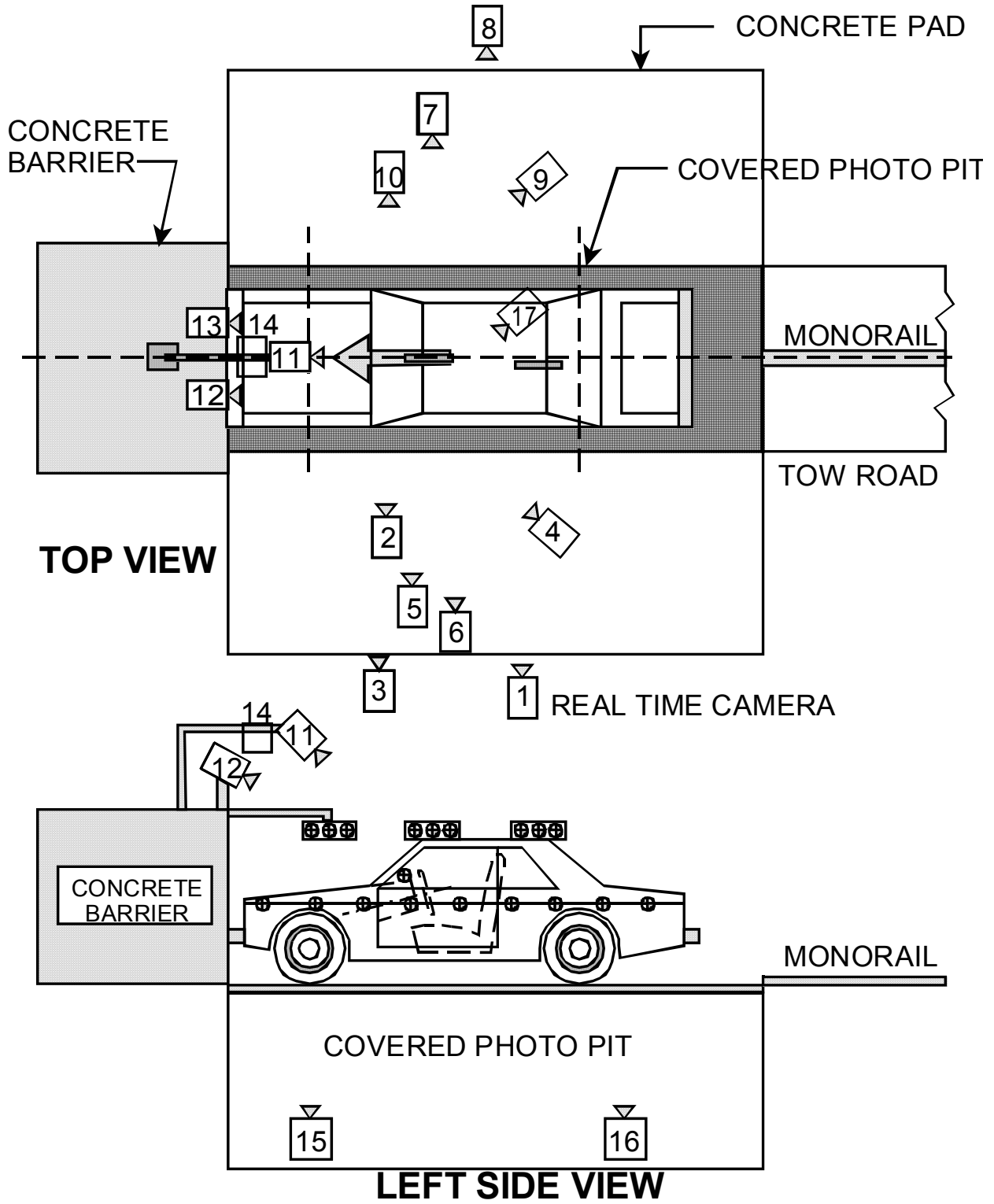

DATA SHEET 34

APPENDIX G DUMMY POSITIONING PROCEDURES FOR 5th% DRIVER TEST DUMMY CONFORMING TO SUBPART O OF PART 572

Test Vehicle: 2004 Jeep Liberty
 Test Program: FMVSS 208 Compliance
 Test Technician: Eric Peschman

NHTSA No.: C40300
 Test Date: 2/27/04

IMPACT ANGLE:	Zero Degrees		
BELTED DUMMIES (YES/NO):	No – Front Occupants	Yes – Center Rear	Passenger
TEST SPEED:	<input checked="" type="checkbox"/> 32 to 40 kmph	<input type="checkbox"/> 0 to 48 kmph	<input type="checkbox"/> 0 to 56 kmph
DRIVER DUMMY:	<input checked="" type="checkbox"/> 5 TH female		<input type="checkbox"/> 50 th Male
PASSENGER DUMMY:	<input checked="" type="checkbox"/> 5 TH female	<input checked="" type="checkbox"/> 50 th Male Ctr Rear	

- X 1. Position the seat's adjustable lumbar supports so that the lumbar supports are in the lowest, retracted or deflated adjustment position. (S16.2.10.1)
 N/A – No lumbar adjustment
- X 2. Position any adjustable parts of the seat that provide additional support so that they are in the lowest or most open adjustment position. (S16.2.10.2)
 N/A – No additional support adjustment
- X 3. If the seat cushion adjusts fore and aft, independent of the seat back, set this adjustment to the full rearward position. (S16.2.10.3.1)
 N/A – No independent fore-aft seat cushion adjustment
- X 4. Use the seat markings determined during the completion of Data Sheet 14 to set the rearmost fore-aft position, mid-height position and the seat cushion mid-angle. (S16.3.2.1.1)
- X 5. If the vehicle has an adjustable accelerator pedal, place it in the full forward position. (S16.3.2.2.1)
 N/A accelerator pedal not adjustable
- X 6. Set the steering wheel hub at the geometric center of the full range of driving positions including any telescoping positions as determined in data sheet 14. (S16.2.9)
- X 7. Fully recline the seat back. (S16.3.2.1.2)
 N/A seat back not adjustable.
- X 8. Place the dummy in the seat with the legs at an angle of 120 degrees to the thighs. The calves should not be touching the seat cushion. (S16.3.2.1.2)
- X 9. Position the dummy in the seat such that the midsagittal plane is coincident with the longitudinal seat cushion markings as determined in item 1.18 of Data Sheet 14 (S16.3.2.1.3 and S16.3.2.1.4)
- X 10. Hold down the dummy's thighs and push rearward on the upper torso to maximize the pelvic angle. (S16.3.2.1.5)
- X 11. Set the angle between the legs and the thighs to 120 degrees. (S16.3.2.1.6)

12. Set the transverse distance between the centers of the front of the knees at 160 to 170 mm. (6.3 to 6.7 inches) Center the knee separation with respect to the longitudinal seat cushion marking as determined in item 1.18 of Data Sheet 14. (S16.3.2.1.6)
Record Knee Separation 170 mm
13. Push rearward on the dummy's knees until the pelvis contacts the seat back, or the backs of the calves contact the seat cushion, whichever occurs first. (S16.3.2.1.6)
 Pelvis contacted seat back.
 Calves contacted seat cushion.
14. Gently rock the upper torso ± 5 degrees (approximately 51 mm (2 inches)) side to side three time. (S16.3.2.1.7)
15. If needed, extend the legs until the feet do not contact the floor pan. The thighs should be resting on the seat cushion. (S16.3.2.1.8)
16. Position the right foot until the foot is in line with a longitudinal vertical plane passing through the center of the accelerator pedal. Maintain the leg and thigh in a vertical plane. (S16.3.2.1.8)
17. Rotate the left leg and thigh laterally to equalize the distance between each knee and the longitudinal seat cushion marking as determined in item 1.18 of Data Sheet 14. (S16.3.2.1.8)
18. Attempt to return the seat to the foremost fore-aft position, mid-height, and seat cushion mid-angle. The foot may contact and depress the accelerator and/or change the angle of the foot with respect to the leg. (S16.3.2.1.8)
 Foremost position achieved. Proceed to step 23.
 Foremost not achieved because of foot interference. Proceed to step 20.
 Foremost not achieved because of steering wheel contact.
19. If the dummy's legs contact the steering wheel, move the steering wheel up the minimum amount required to avoid contact. If the steering wheel is not adjustable separate the knees the minimum required to avoid contact. (S16.3.2.1.8)
 N/A- there was no leg contact
 Steering wheel repositioned
 Knees separated
20. If the left foot interferes with the clutch or brake pedals, rotate the left foot about the leg to provide clearance. If this is not sufficient, rotate the thigh outboard at the hip the minimum amount required for clearance. (S16.3.2.1.8)
 N/A, No foot interference with pedals.
 Foot adjusted to provide clearance.
 Foot and Thigh adjusted to provide clearance.

21. Continue to move the seat. Use seat controls to line up the seat markings determined during the completion of Data Sheet 14 to set the foremost fore-aft position, mid-height position and the seat cushion mid-angle. If the dummy contacts the interior move the seat rearward until a maximum clearance of 5 mm (0.2 inches) is achieved or the seat is in the closest detent position that does not cause dummy contact. (S16.3.2.1.8)

 Foremost, mid-height position and the seat cushion mid-angle reached

 Dummy contact. Clearance set at maximum of 5mm

Measured Clearance _____

 Dummy Contact. Seat set at nearest detent position.

Seat position detent positions rearward of foremost
(Foremost is position zero)

 22. If the steering wheel was repositioned in step 19, return the steering wheel to the original position. If the steering wheel contacts the dummy before reaching the original position, position the wheel until a maximum clearance of 5mm (.2 inches) is achieved, or the steering wheel is in the closest detent position that does not cause dummy contact. (S16.3.2.1.8)

 N/A Steering wheel was not repositioned.

 Original position achieved.

 Dummy contact. Clearance set at maximum of 5mm

Measured Clearance _____

 Dummy Contact. Steering wheel set at nearest detent position.

Steering wheel position detent positions upward of original position.
(Original position is position zero)

X23. If the seat back is adjustable, rotate the seat back forward while holding the thighs in place. Continue rotating the seat back forward until the transverse instrument platform of the dummy head is level ± 0.5 degrees. If the head cannot be leveled using the seat back adjustment, or the seat back is not adjustable, use the lower neck bracket adjustment to level the head. If a level position cannot be achieved, minimize the angle. (S16.3.2.1.9)

X Head Level Achieved. (Check all that apply)

X Head leveled using the adjustable seat back

 Head leveled using the neck bracket.

Head Angle 0.3 degrees

 Head Level NOT Achieved. (Check all that apply)

 Head adjusted using the adjustable seat back

 Head adjusted using the neck bracket.

Head Angle _____ degrees

X24. Verify the pelvis is not interfering with the seat bight. (S16.3.2.1.9)

X No interference

 Pelvis moved forward the minimum amount so that it is not caught in the seat bight.

25. Verify the dummy abdomen is properly installed. (S16.3.2.1.9)
 Abdomen still seated properly into dummy
 Abdomen was adjusted because it was not seated properly into dummy

26. Head Angle
 N/A, neither the pelvis nor the abdomen were adjusted.

26.1 Head still level (Go to 27)

26.2 Head level adjusted

Head Level Achieved. (Check all that apply)
 Head leveled using the adjustable seat back
 Head leveled using the neck bracket.
Head Angle _____ degrees

Head Level NOT Achieved. (Check all that apply)
 Head level adjusted using the adjustable seat back
 Head level adjusted using the neck bracket.
Head Angle _____ degrees

27. If the dummy torso contacts the steering wheel while performing step 23, reposition the steering wheel in the following order to eliminate contact.
 N/A, No dummy torso contact with the steering wheel.

27.1 Adjust telescoping mechanism.
 N/A No telescoping adjustment.
 Adjustment performed (fill in appropriate change)
Steering wheel moved _____ detent positions in the forward direction.
Steering wheel moved _____ mm in the forward direction.

27.2 Adjust tilt mechanism.
 N/A No tilt adjustment.
 No adjustment performed.
 Adjustment performed.
Steering wheel moved _____ detent positions Upward/Downward.
(circle one)
Steering wheel moved _____ degrees Upward/Downward

27.3 Adjust Seat in the aft direction.
 No Adjustment performed.
 Seat moved aft _____ mm from original position.
 Seat moved aft _____ detent positions from the original position.

28. Measure and set the pelvic angle using the pelvic angle gage TE-2504. The pelvic angle should be 20.0 degrees \pm 2.5 degrees. If the pelvic angle cannot be set to the specified range because the head will not be level, adjust the pelvis as closely as possible to the angle range, but keep the head level.
 Pelvic angle set to 20.0 degrees \pm 2.5 degrees.
 Pelvic angle of 20.0 degrees not achieved, the angular difference was minimized.
 Record the pelvic angle. 22.8 degrees

- X 29. Check the dummy for contact with the interior after completing adjustments.
X No contact.
 ___ Dummy in contact with interior.
 ___ Seat moved aft ___ mm from the previous position.
 ___ Seat moved aft ___ detent positions from the previous position.
- X 30. Check the dummy to see if additional interior clearance is obtained, allowing the seat to be moved forward.
X N/A, Seat already at foremost position.
 ___ Clearance unchanged. No adjustments required.
 ___ Additional clearance available
 ___ Seat moved Forward ___ mm from the previous position.
 ___ Seat moved Forward ___ detent positions from the previous position.
- X 31. Driver's foot positioning, right foot. Place the foot perpendicular to the leg and determine if the heel contacts the floor pan at any leg position. If the heel contacts the floor pan proceed to step 32 otherwise, proceed to step 33.
- X 32. Perform the following steps until either all steps are completed, or the foot contacts the accelerator pedal. Step 32.6 shall be completed in all cases.
- X 32.1 With the rear of the heel contacting the floor pan, move the foot forward until pedal contact occurs or the foot is at the full forward position.
- X 32.2 If the vehicle has an adjustable accelerator pedal, move the pedals rearward until pedal contact occurs or the pedals reach the full rearward position. Not Applicable
- X 32.3 Extend the leg, allowing the heel to lose contact with the floor until the foot contacts the pedal. Do not raise the toe of the foot higher than the top of the accelerator pedal. If the foot does not contact the pedal, proceed to the next step. If pedal contact does occur, place a tapered foam block as shown in Figure G1 under the heel with the shallow part of the taper facing forward.
- X 32.4 Angle the foot to achieve contact between the foot and the pedal. If the foot does not contact the pedal, return the foot to the perpendicular orientation. If pedal contact does occur, place a tapered foam block as shown in Figure G1 under the heel with the shallow part of the taper facing forward.
- X 32.5 Align the centerline of the foot with the vertical-longitudinal plane passing through the center of the accelerator pedal. Place a tapered foam block as shown in Figure G1 under the heel with the shallow part of the taper facing forward.
- X 32.6 Record foot position
X Pedal Contact achieved. Contact occurred at step 32.1 .
 X Heel contacts floor pan
 ___ Heel set _____ mm from floor pan.
 ___ Pedal Contact not achieved. Heel set _____ mm from the floor pan.

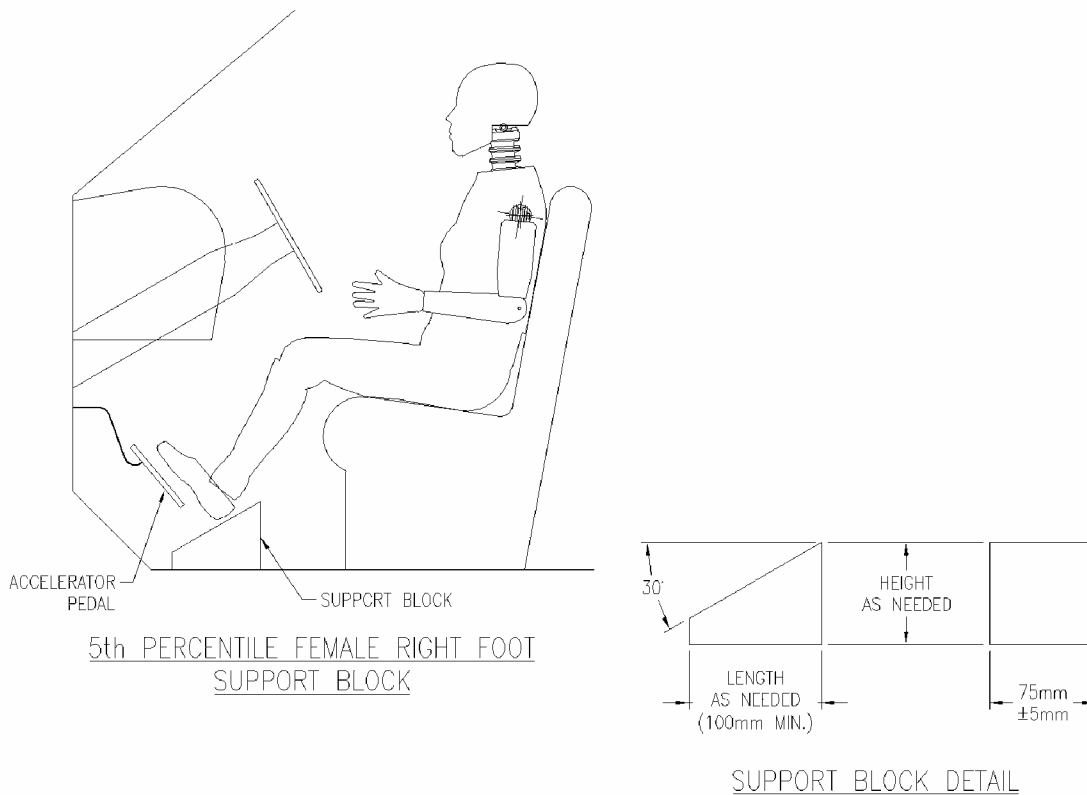

FIGURE G1

- __33. Perform the following steps until either all steps are completed, or the foot contacts the accelerator pedal. Step 33.5 shall be completed in all cases.
- __33.1 Extend the leg until the foot contacts the pedal. Do not raise the toe of the foot higher than the top of the accelerator pedal. If the foot does not contact the pedal, proceed to the next step. If pedal contact does occur, place a tapered foam block as shown in Figure G1 under the heel with the shallow part of the taper facing forward.
- __33.2 If the vehicle has an adjustable accelerator pedal, move the pedals rearward until pedal contact occurs or the pedals reach the full rearward position. If pedal contact does occur, place a tapered foam block as shown in Figure G1 under the heel with the shallow part of the taper facing forward.
- __33.3 Angle the foot to achieve contact between the foot and the pedal. If the foot does not contact the pedal, return the foot to the perpendicular orientation. If pedal contact does occur, place a tapered foam block as shown in Figure G1 under the heel with the shallow part of the taper facing forward.
- __33.4 Align the centerline of the foot in the same horizontal plane as the centerline of the accelerator pedal. Place a tapered foam block as shown in Figure G1 under the heel with the shallow part of the taper facing forward.

X 33.5 Record foot position

X Pedal Contact achieved. Contact occurred at step 32.1.

 Heel set _____ mm from floor pan.

 Pedal Contact not achieved. Heel set _____ mm from the floor pan.

X 34. Driver's foot positioning, left foot.

X 34.1 Place the foot perpendicular to the leg and determine if the heel contacts the floor pan at any leg position. If the heel contacts the floor pan proceed to step 34.2, otherwise position the leg as perpendicular to the thigh as possible with the foot parallel to the floor pan.

 34.2 Place the foot on the toe board with the heel resting on the floor pan as close to the intersection of the floor pan and the toe board as possible. Adjust the angle of the foot if necessary to contact the toe board. If the foot will not contact the toe board, set the foot perpendicular to the leg, and set the heel on the floor pan as far forward as possible. Do not place the foot on the wheel well projection or footrest. If the pedals interfere with the placement of the foot, reposition the foot by rotating the foot about the leg, or rotate the leg outboard about the hip if necessary.

 Foot rotated about the leg

 Foot rotated about the leg, and the leg rotated about the hip.

 No pedal interference

 34.3 Record foot position.

 Heel does not contact floor pan.

 Foot placed on toe board.

 Foot placed on floor pan.

X 35. Driver arm/hand positioning.

X 35.1 Place the dummy's upper arms adjacent to the torso with the arm centerlines as close to a vertical longitudinal plane as possible. (S16.3.2.3.1)

X 35.2 Place the palms of the dummy in contact with the outer part of the steering wheel rim at its horizontal centerline with the thumbs over the steering wheel rim. (S16.3.2.3.2)

 35.3 If it is not possible to position the thumbs inside the steering wheel rim at its horizontal centerline, then position them above and as close to the horizontal centerline of the steering wheel rim as possible. (S16.3.2.3.3)

X 35.4 Lightly tape the hands to the steering wheel rim so that if the hand of the test dummy is pushed upward by a force of not less than 9 N (2 lb) and not more than 22 N (5 lb), the tape releases the hand from the steering wheel rim. S16.3.2.3.4

X 36. Adjustable head restraints

X N/A, there is no head restraint adjustment

 36.1 If the head restraint has an automatic adjustment, leave it where the system positions the restraint after the dummy is placed in the seat. (S16.3.4.1) Go to 37.

36.2 Adjust each head restraint vertically so that the horizontal plane determined in item 3 of Data Sheet 14 is aligned with the center of gravity (CG) of the dummy head. (S16.3.4.3)

36.3 If the above position is not attainable, move the vertical center of the head restraint to the closest detent below the center of the head CG. (S16.3.4.3)

N/A midpoint position attained in previous step

Headrest set at nearest detent below the head CG

36.4 If the head restraint has a fore and aft adjustment, place the restraint in the foremost position or until contact with the head is made, whichever occurs first. (S16.3.4.4)

37. Driver and passenger manual belt adjustment (for tests conducted with a belted dummy). (S16.3.5) **Unbelted Test**

37.1 If an adjustable seat belt D-ring anchorage exists, place it in the manufacturer's design position for a 5th percentile adult female.

This information will be supplied by the COTR.

Manufacturer's specified position _____

Actual Position _____

37.2 Place the Type 2 manual belt around the test dummy and fasten the latch. (S16.3.5.2)

37.3 Ensure that the dummy's head remains as level as possible. (S16.3.5.3)

37.4 Remove all slack from the lap belt. Pull the upper torso webbing out of the retractor and allow it to retract; repeat this operation four times. Apply a 9 N (2 lbf) to 18 N (4 lbf) tension load to the lap belt. If the belt system is equipped with a tension-relieving device, introduce the maximum amount of slack into the upper torso belt that is recommended by the manufacturer. If the belt system is not equipped with a tension-relieving device, allow the excess webbing in the shoulder belt to be retracted by the retractive force of the retractor. (S16.3.5.4)

REMARKS:

I certify that I have read and performed each instruction.

Signature: 

Date: 2/27/04

APPENDIX G
DUMMY POSITIONING PROCEDURES
FOR 5th% PASSENGER TEST DUMMY CONFORMING TO SUBPART O OF PART 572

IMPACT ANGLE:	Zero Degrees		
BELTED DUMMIES (YES/NO):	No – Front Occupants	Yes – Center Rear Passenger	
TEST SPEED:	<input checked="" type="checkbox"/> 32 to 40 kmph	<input type="checkbox"/> 0 to 48 kmph	<input type="checkbox"/> 0 to 56 kmph
DRIVER DUMMY:	<input checked="" type="checkbox"/> 5 TH female		<input type="checkbox"/> 50 th Male
PASSENGER DUMMY:	<input checked="" type="checkbox"/> 5 TH female	<input checked="" type="checkbox"/> 50 th Male Ctr Rear	

(Check this item ONLY if it applies to this vehicle.)

The passenger seat adjustments are controlled by the adjustments made to the driver's seat. Therefore, positioning of the passenger dummy is made simultaneously with the driver dummy. Adjustments made to the seat to position the driver will over ride any adjustments that would normally be made to position the passenger. (S16.2.10.3)

- 1. Position the seat's adjustable lumbar supports so that the lumbar supports are in the lowest, retracted or deflated adjustment position. (S16.2.10.1)
 N/A – No lumbar adjustment
- 2. Position any adjustable parts of the seat that provide additional support so that they are in the lowest or most open adjustment position. (S16.2.10.2)
 N/A – No additional support adjustment
- 3. If the seat cushion adjusts fore and aft, independent of the seat back, set this adjustment to the full rearward position. (S16.2.10.3.1)
 N/A – No independent fore-aft seat cushion adjustment
- 4. Use the seat markings determined during the completion of Data Sheet 14 to set the rearmost fore-aft position, mid-height position and the seat cushion mid-angle. (S16.3.3.1.1)
- 5. Fully recline the seat back. (S16.3.3.1.2)
 N/A seat back not adjustable.
- 6. Place the dummy in the seat with the legs at an angle of 120 degrees to the thighs. The calves should not be touching the seat cushion. (S16.3.3.1.2)
- 7. Position the dummy in the seat such that the midsagittal plane is coincident with the longitudinal seat cushion marking that was determined in item 2.19 of Data Sheet 14 (S16.3.3.1.3 and S16.3.3.1.4)
- 8. Hold down the dummy's thighs and push rearward on the upper torso to maximize the pelvic angle. (S16.3.3.1.5)
- 9. Set the angle between the legs and the thighs to 120 degrees. (S16.3.3.1.6)

- X 10. Set the transverse distance between the centers of the front of the knees at 160 to 170 mm. (6.3 to 6.7 inches) Center the knee separation with respect to the longitudinal seat cushion marking that was determined in item 2.19 of Data Sheet 14. (S16.3.3.1.6)
Record Knee Separation 165 mm
- X 11. Push rearward on the dummy's knees until the pelvis contacts the seat back, or the backs of the calves contact the seat cushion, whichever occurs first. (S16.3.3.1.6)
 ___ Pelvis contacted seat back.
X Calves contacted seat cushion.
- X 12. Gently rock the upper torso ± 5 degrees (approximately 51 mm (2 inches)) side-to-side three times. (S16.3.3.1.7)
- X 13. If needed, extend the legs until the feet do not contact the floor pan. The thighs should be resting on the seat cushion. (S16.3.3.1.8)
- X 14. Use seat controls to line up the seat markings determined during the completion of Data Sheet 14 to set the foremost fore-aft position, mid-height position and the seat cushion mid-angle. If the dummy contacts the interior move the seat rearward until a maximum clearance of 5 mm (0.2 inches) is achieved or the seat is in the closest detent position that does not cause dummy contact. (S16.3.3.1.8)
X Foremost, mid-height position and the seat cushion mid-angle reached
 ___ Dummy contact. Clearance set at maximum of 5mm
 Measured Clearance _____
 ___ Dummy Contact. Seat set at nearest detent position.
 Seat position ___ detent positions rearward of foremost
 (Foremost is position zero)
- X 15. If the seat back is adjustable, rotate the seat back forward while holding the thighs in place. Continue rotating the seat back forward until the transverse instrument platform of the dummy head is level ± 0.5 degrees. If head cannot be leveled using the seat back adjustment, or the seat back is not adjustable, use the lower neck bracket adjustment to level the head. If a level position cannot be achieved, adjust the head as closely as possible to the ± 0.5 degree range. (S16.3.3.1.9 and S16.3.3.1.10)
 (Check All That Apply)
 ___ Seat back not adjustable
 ___ Seat back not independent of driver side seat back
X Head Level Achieved. (Check all that apply)
X Head leveled using the adjustable seat back
 ___ Head leveled using the neck bracket.
 Head Angle 0.3 degrees
 ___ Head Level NOT Achieved. (Check all that apply)
 ___ Head adjusted using the adjustable seat back
 ___ Head adjusted using the neck bracket.
 Head Angle _____ degrees

16. Verify the pelvis is not interfering with the seat bight. (S16.3.3.1.9)
 No interference
 Pelvis moved forward the minimum amount so that it is not caught in the seat bight.

17. Verify the dummy abdomen is properly installed. (S16.3.3.1.9)
 Abdomen still seated properly into dummy
 Abdomen was adjusted because it was not seated properly into dummy

18. Head Angle
 N/A, neither the pelvis nor the abdomen were adjusted.

18.1 Head still level (Go to 19)

18.2 Head level adjusted

Head Level Achieved. (Check all that apply)
 Head leveled using the adjustable seat back
 Head leveled using the neck bracket.
Head Angle _____ degrees

Head Level NOT Achieved. (Check all that apply)
 Head adjusted using the adjustable seat back
 Head adjusted using the neck bracket.
Head Angle _____ degrees

19. Measure and set the pelvic angle using the pelvic angle gage TE-2504. The pelvic angle should be 20.0 degrees \pm 2.5 degrees. If the pelvic angle cannot be set to the specified range because the head will not be level, adjust the pelvis as closely as possible to the angle range, but keep the head level.
 Pelvic angle set to 20.0 degrees \pm 2.5 degrees.
 Pelvic angle of 20.0 degrees not achieved, the angular difference was minimized.
 Record the pelvic angle. 23.8 degrees

20. Check the dummy for contact with the interior after completing adjustments.
 No contact.
 Dummy in contact with interior.
 Seat moved aft _____ mm from the previous position.
 Seat moved aft _____ detent positions from the previous position.

21. Verify the transverse instrument platform of the dummy head is level \pm 0.5 degrees. Use the lower neck bracket adjustment to level the head. If a level position cannot be achieved, minimize the angle. (S16.3.3.1.9, S16.3.3.1.10, and S16.3.3.1.11)
 Head Level Achieved
Head Angle 0.2 degrees
 Head Level NOT Achieved.
Head Angle _____ degrees

22. Check the dummy to see if additional interior clearance is obtained, allowing the seat to be moved forward. (S16.3.3.1.12)

N/A Bench Seat

N/A Seat already at full forward position.

Clearance unchanged. No adjustments required.

Additional clearance available

Seat moved Forward ___ mm from the previous position.

Seat moved Forward ___ detent positions from the previous position.

Seat moved Forward, Full Forward position reached.

23. Passenger foot positioning. (Indicate final position achieved) (S16.3.3.2)

23.1 Place feet flat on the toe board; OR

23.2 If the feet cannot be placed flat on the toe board, set the feet perpendicular to the lower leg, and rest the heel as far forward on the floor pan as possible; OR

23.3 If the heels do not touch the floor pan, set the legs to vertical and set the feet parallel to the floor pan.

24. Passenger arm/hand positioning. (S16.3.3.3)

24.1 Place the dummy's upper arms adjacent to the torso with the arm centerlines as close to a vertical longitudinal plane as possible. (S16.3.2.3.1)

24.2 Place the palms of the dummy in contact with the outer part of the thighs (S16.3.3.3.2)

24.3 Place the little fingers in contact with the seat cushion. (S16.3.3.3.3)

25. Adjustable head restraints

N/A, there is no head restraint adjustment

25.1 If the head restraint has an automatic adjustment, leave it where the system positions the restraint after the dummy is placed in the seat. (S16.3.4.1) Go to 26.

25.2 Adjust each head restraint vertically so that the horizontal plane determined in item 3 of Data Sheet 14 is aligned with the center of gravity (CG) of the dummy head. (S16.3.4.3)

25.3 If the above position is not attainable, move the vertical center of the head restraint to the closest detent below the center of the head CG. (S16.3.4.3)

N/A midpoint position attained in previous step

Headrest set at nearest detent below the head CG

25.4 If the head restraint has a fore and aft adjustment, place the restraint in the foremost position or until contact with the head is made, whichever occurs first. (S16.3.4.4)

26. Manual belt adjustment (for tests conducted with a belted dummy) S16.3.5

N/A, **Unbelted test**

__26.1 If an adjustable seat belt D-ring anchorage exists, place it in the manufacturer's design position for a 5th percentile adult female.

This information will be supplied by the COTR.

Manufacturer's specified position _____

Actual Position _____

__26.2 Place the Type 2 manual belt around the test dummy and fasten the latch. (S16.3.5.2)

__26.3 Ensure that the dummy's head remains as level as possible. (S16.3.5.3)

__26.4 Remove all slack from the lap belt. Pull the upper torso webbing out of the retractor and allow it to retract; repeat this operation four times. Apply a 9 N (2 lbf) to 18 N (4 lbf) tension load to the lap belt. If the belt system is equipped with a tension-relieving device, introduce the maximum amount of slack into the upper torso belt that is recommended by the manufacturer. If the belt system is not equipped with a tension-relieving device, allow the excess webbing in the shoulder belt to be retracted by the retractive force of the retractor. (S16.3.5.4)

REMARKS:

I certify that I have read and performed each instruction.

Signature: Wayne Jahlh

Date: 2/27/04

**DUMMY POSITIONING PROCEDURES
FOR REAR PASSENGER TEST DUMMY CONFORMING TO SUBPART E OF PART 572**

IMPACT ANGLE:	Zero Degrees		
BELTED DUMMIES (YES/NO):	No – Front Occupants		Yes – Center Rear Passenger
TEST SPEED:	<input checked="" type="checkbox"/> 32 to 40 kmph	<input type="checkbox"/> 0 to 48 kmph	<input type="checkbox"/> 0 to 56 kmph
DRIVER DUMMY:	<input checked="" type="checkbox"/> 5 TH female		<input type="checkbox"/> 50 th Male
PASSENGER DUMMY:	<input checked="" type="checkbox"/> 5 TH female		<input checked="" type="checkbox"/> 50 th Male Ctr Rear

1. If the seat is a bench seat for which there are no independent adjustments that can be made, Go to step 7.
2. Position the seat's adjustable lumbar supports so that the lumbar support is in its lowest, retracted or deflated adjustment position. (S8.1.3)
 N/A – No lumbar adjustment
3. Position any adjustable parts of the seat that provide additional support so that they are in the lowest or most open adjustment position. (S20.1.8.2)
 N/A – No additional support adjustment
4. If the seat cushion adjusts fore and aft, independent of the seat back, set this adjustment to the full rearward position. (S20.1.9.3)
 N/A – No independent fore-aft seat cushion adjustment
5. If the seat and/or seat cushion height is adjustable, put the seat in the full down height position. (S8.1.2)
 N/A – No seat height adjustment
6. Using only the controls that move the seat in the fore-aft direction, place the seat in the rearmost position. (S8.1.2)
7. The seat back angle, if adjustable, is set at the manufacturer's nominal design riding position for a 50th percentile adult male in the manner specified by the manufacturer. (S4.5.4.1 (b) and S8.1.3)
 N/A – No seat back angle adjustment
Manufacturer's design seat back angle _____
Tested seat back angle _____
8. If adjustable, set the head restraint at the full up and full forward position. Any adjustment of the head restraint shall be used to position it full forward. For example, if it rotates, rotate it such that the head restraint extends as far forward as possible. (S8.1.3)
 N/A – No head restraint adjustment
9. Place any adjustable seat belt anchorages at the vehicle manufacturer's nominal design position for a 50th percentile adult male occupant (S8.1.3)
 N/A – No adjustable upper seat belt anchorage
Manufacturer's specified anchorage position. _____
Tested anchorage position _____

10. Place the dummy in the seat such that the midsagittal plane is vertical and coincides with the vertical longitudinal plane that passes through the SgRP and is parallel to the longitudinal centerline of the vehicle and the upper torso rests against the seat back.
11. Rest the thighs on the seat cushion. (S10.5)
12. Position the H-point of the dummy within 0.5 inch of the vertical dimension and 0.5 inch of the horizontal dimension of a point 0.25 inch below the H-point determined by using the equipment and procedures specified in SAE J826 (APR 1980). (S10.4.2.1) Then measure the pelvic angle with respect to the horizontal using the pelvic angle gage. Adjust the dummy position until these three measurements are within the specifications. (S10.4.2.1 and S10.4.2.2)
39 horizontal inches from the point 0.25 below the determined H-point (0.5 inch max.) (S10.4.2.1)
43 vertical inches from the point 0.25 below the determined H-point (0.5 inch max.) (S10.4.2.1)
22.2° pelvic angle (20° to 25°)
13. Is the head level within $\pm 0.5^\circ$? (S10.1)
 Yes, go to 14
 No, go to 13.1
- 13.1 Adjust the position of the H-point. (S10.1 and S10.4.2.1)
- 13.2 Is the head level within $\pm 0.5^\circ$? (S10.1)
 Yes, record the following, then go to 13. No, go to 12.3
 horizontal inches from the point 0.25 below the determined H-point (0.5 inch max.) (S10.4.2.1)
 vertical inches from the point 0.25 below the determined H-point (0.5 inch max.) (S10.4.2.1)
 pelvic angle (20° to 25°) (S10.4.2.2)
- 13.3 Adjust the pelvic angle. (S10.1)
- 13.4 Is the head level within $\pm 0.5^\circ$? (S10.1)
 Yes, record the following, then go to 13. No, go to 12.5
 horizontal inches from the point 0.25 below the determined H-point (0.5 inch max.) (S10.4.2.1)
 vertical inches from the point 0.25 below the determined H-point (0.5 inch max.) (S10.4.2.1)
 pelvic angle (20° to 25°) (S10.4.2.2)
- 13.5 Adjust the neck bracket of the dummy the minimum amount necessary from the non-adjusted "0" setting until the head is level within $\pm 0.5^\circ$. (S10.1)
Record the following, then go to 13
 horizontal inches from the point 0.25 below the determined H-point (0.5 inch max.) (S10.4.2.1)
 vertical inches from the point 0.25 below the determined H-point (0.5 inch max.) (S10.4.2.1)
 pelvic angle (20° to 25°) (S10.4.2.2)

14. Set the distance between the outboard knee clevis flange surfaces at 10.6 inches.
10.6" measured distance (10.6 inches) (S10.5)
15. Check only one of the following that applies:
 Outboard seating position
Keeping the right thigh and leg in a vertical plane and the left thigh and leg in a vertical plane, place the feet flat on the floorpan and beneath the front seat as far as possible without front seat interference. If necessary, the distance between the knees can be changed in order to place the feet beneath the seat. Record new distance between the outboard knee clevis flange surfaces if knees have been repositioned. _____ measured distance (inches)
- Center seating position**
Keeping the left thigh and leg in a vertical plane, place the left foot flat on the floorpan on the left side of the transmission tunnel (if present). Keeping the right thigh and leg in a vertical plane, place the right foot flat on the floorpan on the right side of the transmission tunnel. If necessary, the distance between the knees can be changed in order to place the feet flat on the floor. If possible, the knees should remain as close to the distance as measured in #13 above. Record new distance between the outboard knee clevis flange surfaces if knees have been repositioned. _____ measured distance (inches)
16. Place the left upper arm in contact with the seat back and side of the torso. (S10.2.2)
17. Is the passenger seat belt used for this test?
 Yes, continue
 No, go to 18
- 17.1 Fasten the seat belt around the dummy.
- 17.2 Remove all slack from the lap belt portion. (S10.9)
- 17.3 Pull the upper torso webbing out of the retractor and allow it to retract; repeat this four times. (S10.9)
- 17.4 Apply a 2 to 4 pound tension load to the lap belt. (S10.9)
3 pound load applied
- 17.5 Is the belt system equipped with a tension relieving device?
 Yes, continue
 No, go to 18
- 17.6 Introduce the maximum amount of slack into the upper torso bet that is recommended by the vehicle manufacturer in the vehicle owner's manual. (S10.9). Go to 17.
18. Place the right upper arm in contact with the seat back and side of the torso. (S10.2.2)
19. Place the left hand palm in contact with the outside of the left thigh and the little finger in contact with the seat cushion. (S10.3.2)
20. Place the right hand palm in contact with the outside of the right thigh and the little finger in contact with the seat cushion. (S10.3.2)

I certify that I have read and performed each instruction.

Signature: 

Date: 2/27/04

DATA SHEET 35

DUMMY MEASUREMENTS

Test Vehicle: 2004 Jeep Liberty
 Test Program: FMVSS 208 Compliance
 Test Technician: Eric Peschman

NHTSA No.: C40300
 Test Date: 2/27/04

DUMMY MEASUREMENTS FOR FRONT SEAT OCCUPANTS

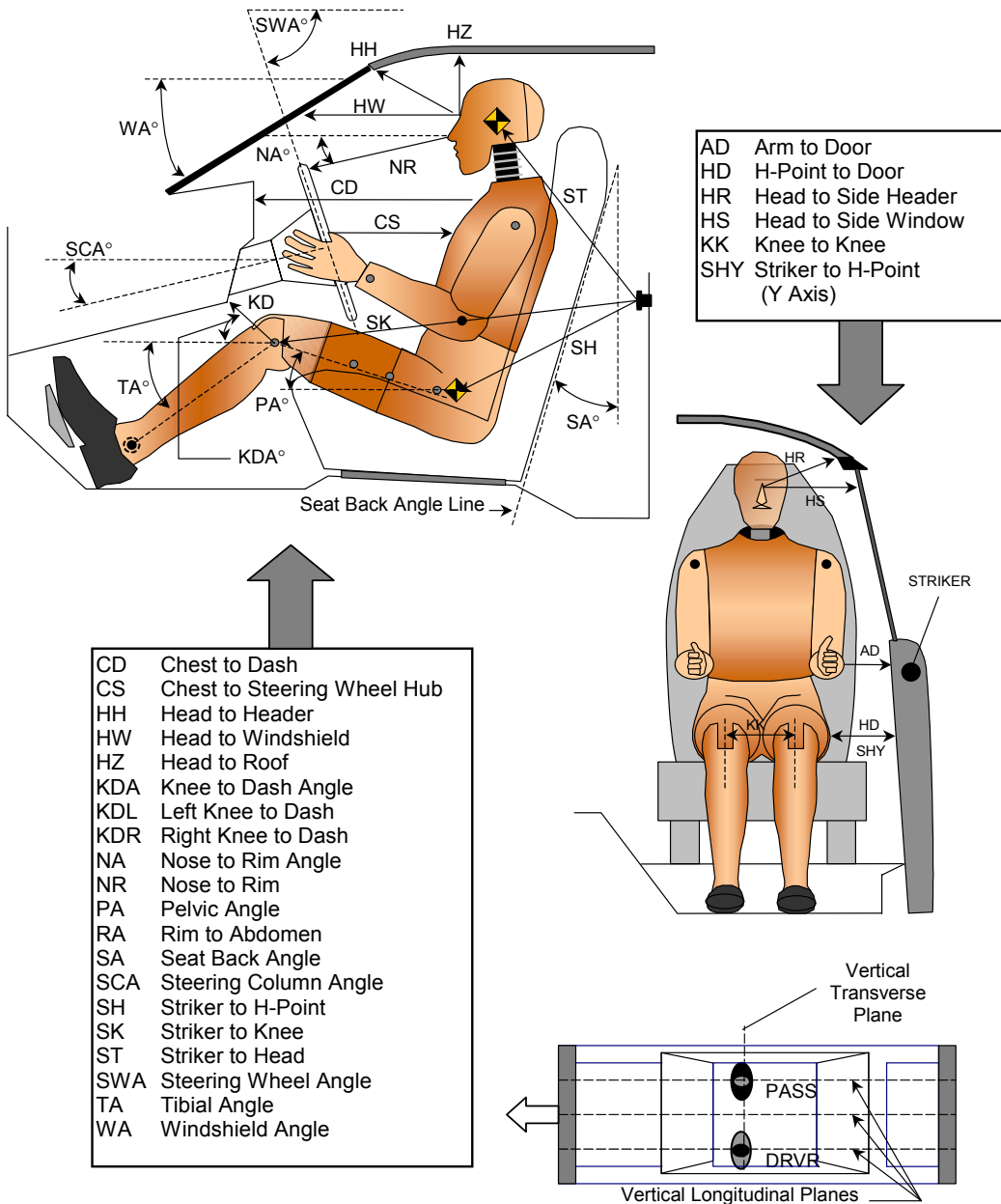

DATA SHEET 35
DUMMY MEASUREMENTS

Test Vehicle: 2004 Jeep Liberty
 Test Program: FMVSS 208 Compliance
 Test Technician: Eric Peschman

NHTSA No.: C40300
 Test Date: 2/27/04

TEST DUMMY POSITION MEASUREMENTS

Code	Measurement Description	Driver SN 506		Passenger SN 517	
		Length (mm)	Angle (°)	Length (mm)	Angle (°)
WA	Windshield Angle		42.6		
SWA	Steering Wheel Angle		66.9		
SCA	Steering Column Angle		23.2		
SA	Seat Back Angle		21.5		19.7
HZ	Head to Roof (Z)	247		219	
HH	Head to Header	346		331	
HW	Head to Windshield	523		490	
HR	Head to Side Header (Y)	254		219	
NR	Nose to Rim	281	8.1		
CD	Chest to Dash	432		461	
CS	Chest to Steering Hub	224			
RA	Rim to Abdomen	90			
KDL	Left Knee to Dash	89	10.8	78	
KDR	Right Knee to Dash	88		74	18.5
PA	Pelvic Angle		22.8		23.8
TA	Tibia Angle		63.0		65.6
KK	Knee to Knee (Y)	235		208	
SK	Striker to Knee	643	87.7	648	88.3
ST	Striker to Head	564	22.2	592	18.8
SH	Striker to H-Point	318	83.2	318	87.7
SHY	Striker to H-Point (Y)	253		253	
HS	Head to Side Window	336		309	
HD	H-Point to Door (Y)	228		172	
AD	Arm to Door (Y)	162		144	
AA	Ankle to Ankle	209		150	

DATA SHEET 35 SUPPLIMENTAL
CENTER REAR PASSENGER DUMMY MEASUREMENTS

Test Vehicle: 2004 Jeep Liberty
 Test Program: FMVSS 208 Compliance
 Test Technician: Eric Peschman

NHTSA No.: C40300
 Test Date: 2/27/04

TEST DUMMY POSITION MEASUREMENTS (S/N 401)

Measurement Description	Units	Measurement
Head to string plane	mm	548
Chest to string plane	mm	519
Right Knee to string plane	mm	144
Left Knee to string plane	mm	123
Rear Console to string plane	mm	-23
Knee to Knee	mm	362
Right Tibia Angle	degrees	74.0
Left Tibia Angle	degrees	76.9

Dummy measurements were taken to a plane defined by a string placed between the Front Seat upper seat belt anchorage points.

SEAT BELT POSITIONING DATA

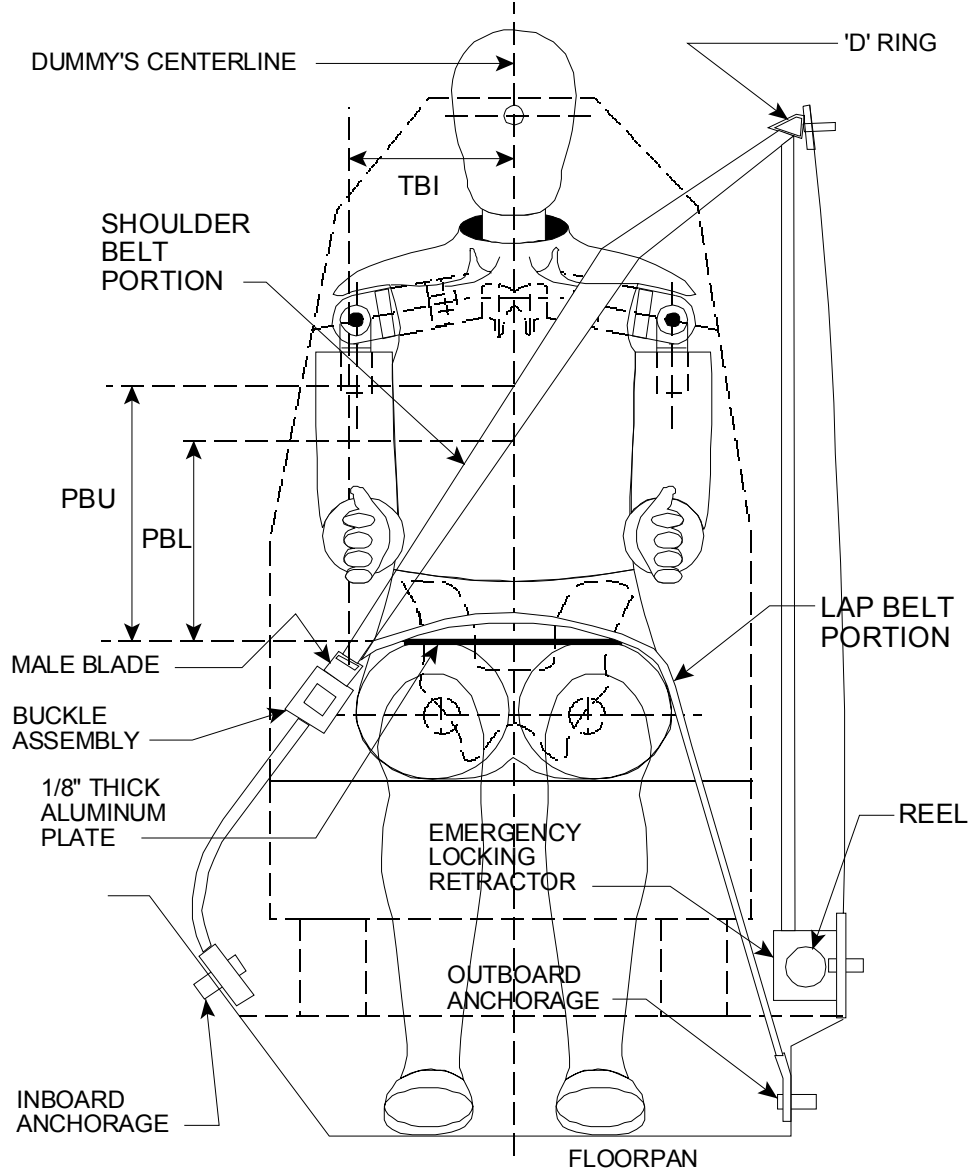

FRONT VIEW OF DUMMY

SEAT BELT POSITIONING MEASUREMENTS

Measurement Description	Units	Driver	Passenger	Rear Passenger
PBU - Top surface of reference to belt upper edge	mm	N/A	N/A	336
PBL - To surface of reference to belt lower edge	mm	N/A	N/A	239

DATA SHEET 36

CRASH TEST

Test Vehicle: 2004 Jeep Liberty
 Test Program: FMVSS 208 Compliance
 Test Technician: Eric Peschman

NHTSA No.: C40300
 Test Date: 2/27/04

IMPACT ANGLE:	Zero Degrees		
BELTED DUMMIES (YES/NO):	No – Front Occupants Yes – Center Rear Passenger		
TEST SPEED:	<u>X</u> 32 to 40 kmph	<u> </u> 0 to 48 kmph	<u> </u> 0 to 56 kmph
DRIVER DUMMY:	<u>X</u> 5 TH female	<u> </u> 50 th Male	
PASSENGER DUMMY:	<u>X</u> 5 TH female	<u>X</u> 50 th Male Ctr Rear	

- 1. Vehicle underbody painted
- 2. The speed measuring devices are in place and functioning.
- 3. The speed measuring devices are 1.0 m from the barrier (spec. 1.5m) and 30 cm from the barrier (spec. is 30 cm)
- 4. Convertible top is in the closed position.
- N/A, not a convertible
- 5. Instrumentation and wires are placed so the motion of the dummies during impact is not affected.
- 6. Tires inflated to pressure on tire placard or if it does not have a tire placard because it is not a passenger car, then inflated to the tire pressure specified in the owner information.

231 kpa front left tire 231 kpa specified on tire placard or in owner information
231 kpa front right tire 231 kpa specified on tire placard or in owner information
231 kpa rear left tire 231 kpa specified on tire placard or in owner information
231 kpa rear right tire 231 kpa specified on tire placard or in owner information

- 7. Time zero markers and switches in place.
- 8. Pre test zero and shunt calibration adjustments performed and recorded
- 9. Dummy temperature meets requirements of section 12.2 of the test procedure.
- 10. Vehicle hood closed and latched
- 11. Transmission placed in neutral
- 12. Parking brake off
- 13. Ignition in the ON position
- 14. Doors closed and latched but not locked
- 15. Posttest zero and shunt calibration checks performed and recorded
- 16. Actual test speed 39.8 kmph
- 17. Vehicle rebound from the barrier 136 cm
- 18. Describe whether the doors open after the test and what method is used to open the doors.
 - Left Front Door: Door remained closed and latched; Door opened without tools
 - Right Front Door: Door remained closed and latched; Door opened without tools
 - Left Rear Door: Door remained closed and latched; Door opened without tools

Right Rear Door: Door remained closed and latched; Door opened without tools

19. Describe the contact points of the dummy with the interior of the vehicle.

Driver Dummy: Head to Air Bag and Headrest; Chest and Abdomen to Air Bag;
Knees to Knee Bolster

Passenger Dummy: Head to Air Bag and Headrest; Chest and Abdomen to Air Bag;
Knees to Glove Box

REMARKS:

I certify that I have read and performed each instruction.

Signature: 

Date: 2/27/04

DATA SHEET NO. 38

ACCIDENT INVESTIGATION DIVISION DATA

Test Vehicle: 2004 Jeep Liberty
 Test Program: FMVSS 208 Compliance
 Test Technician: Eric Peschman

NHTSA No.: C40300
 Test Date: 2/27/04

IMPACT ANGLE:	Zero Degrees		
BELTED DUMMIES (YES/NO):	No – Front Occupants Yes – Center Rear Passenger		
TEST SPEED:	<input checked="" type="checkbox"/> 32 to 40 kmph	<input type="checkbox"/> 0 to 48 kmph	<input type="checkbox"/> 0 to 56 kmph
DRIVER DUMMY:	<input checked="" type="checkbox"/> 5 TH female	<input type="checkbox"/> 50 th Male	
PASSENGER DUMMY:	<input checked="" type="checkbox"/> 5 TH female	<input checked="" type="checkbox"/> 50 th Male Ctr Rear	

Vehicle Year/Make/Model/Body Style:	2004 JEEP LIBERTY MPV
VIN:	1J4GK48KX4W162401
Wheelbase:	2659 mm
Build Date:	10/03
Vehicle Size Category:	3
Test Weight:	1954.6 kg
Front Overhang:	726 mm
Overall Width:	1758 mm
Overall Length Center:	4437 mm

Accelerometer Data	
Location:	As per measurements on Data Sheet 31
Linearity:	>99.9%

Integration Algorithm:	Trapezoidal
Vehicle Impact Speed:	39.8 kmph
Time of Separation:	108.8 ms
Velocity Change:	43.5 kmph

CRUSH PROFILE

Collision Deformation Classification: 12FDEW6
Midpoint of Damage: Vehicle Longitudinal Centerline
Damage Region Length (mm): 1367
Impact Mode: Frontal Barrier

No.	Measurement Description	Units	Pre-Test	Post-Test	Difference
C1	Crush zone 1 at left side	mm	4104	3985	119
C2	Crush zone 2 at left side	mm	4210	4043	167
C3	Crush zone 3 at left side	mm	4209	4030	179
C4	Crush zone 4 at right side	mm	4210	4038	172
C5	Crush zone 5 at right side	mm	4212	4039	173
C6	Crush zone 6 at right side	mm	4206	3967	239

REMARKS:

I certify that I have read and performed each instruction.

Signature: Clark Subit

Date: 2/27/04

DATA SHEET 39

WINDSHIELD MOUNTING (FMVSS 212)

Test Vehicle: 2004 Jeep Liberty
 Test Program: FMVSS 208 Compliance
 Test Technician: Clark Subrt

NHTSA No.: C40300
 Test Date: 2/27/04

IMPACT ANGLE:	Zero Degrees		
BELTED DUMMIES (YES/NO):	No – Front Occupants Yes – Center Rear Passenger		
TEST SPEED:	<input checked="" type="checkbox"/> 32 to 40 kmph	<input type="checkbox"/> 0 to 48 kmph	<input type="checkbox"/> 0 to 56 kmph
DRIVER DUMMY:	<input checked="" type="checkbox"/> 5 TH female		<input type="checkbox"/> 50 th Male
PASSENGER DUMMY:	<input checked="" type="checkbox"/> 5 TH female	<input checked="" type="checkbox"/> 50 th Male Ctr Rear	

1. Pre-Crash
- 1.1 Describe from visual inspection how the windshield is mounted and describe any trim material.
- Retained with glue
Rubber and plastic trim
- 1.2 Mark the longitudinal centerline of the windshield
- 1.3 Measure pre-crash A, B, and C for the left side and record in the chart below.
- 1.4 Measure pre-crash C, D, and E for the right side and record in the chart below.
- 1.5 Measure from the edge of the retainer or molding to the edge of the windshield.
- Dimension G (mm): 10
2. Post Crash
- 2.1 Can a single thickness of copier type paper (as small a piece as necessary) slide between the windshield and the vehicle body?
- No – Pass. Skip to the table of measurements, complete it by repeating the pre-crash measurements in the post crash column, and calculate the retention percentage, which will be 100%.
- Yes, go to 2.2
- 2.2 Visibly mark the beginning and end of the portions of the periphery where the paper slides between the windshield and the vehicle body.
- 2.3 Measure and record post-crash A, B, C, D, E, and F such that the measurements do not include any of the parts of the windshield where the paper slides between the windshield and the vehicle body.
- 2.4 Calculate and record the percent retention for the right and left side of the windshield.
- 2.5 Is total right side percent retention less than 75%?
- Yes, Fail
- No, Pass
6. Is total left side percent retention less than 75%?
- Yes, Fail
- No, Pass

WINDSHIELD RETENTION MEASUREMENTS

	Dimension	Pre-Crash (mm)	Post-Crash (mm)	Percent Retention (Post-Test ÷ Pre-Crash)
Left Side	A	600	600	100%
	B	605	605	100%
	C	749	749	100%
	Total	1954	1954	100%
Right Side	D	600	600	100%
	E	607	607	100%
	F	749	749	100%
	Total	1956	1956	100%

Indicate area of mounting failure. NONE

FRONT VIEW OF WINDSHIELD

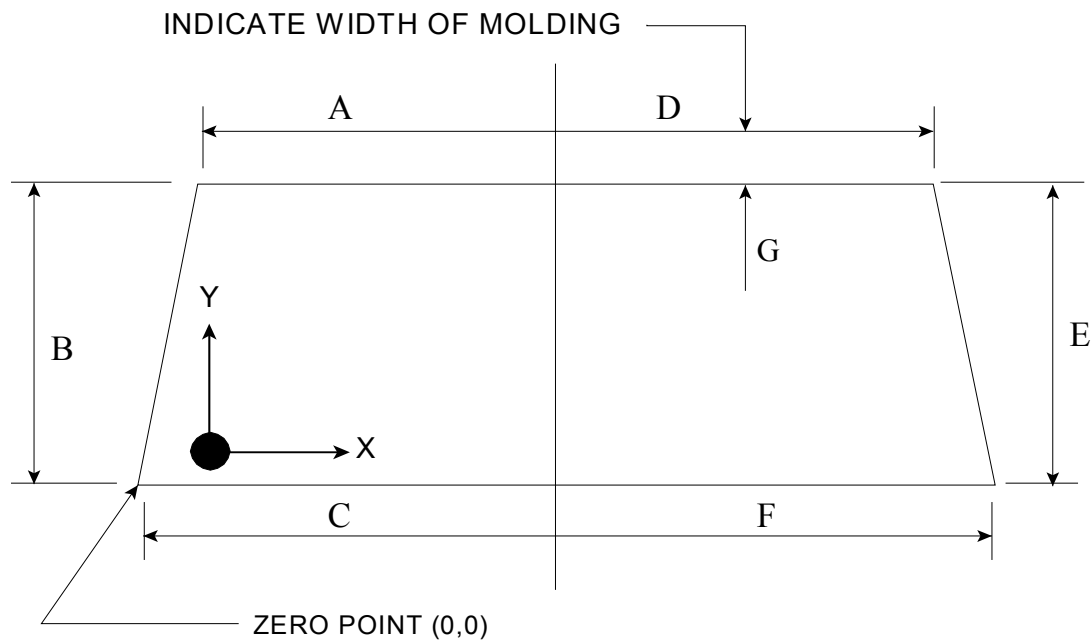

REMARKS:

I certify that I have read and performed each instruction.

Signature: Clark Sulet

Date: 2/24/04

DATA SHEET 40
WINDSHIELD ZONE INTRUSION (FMVSS 219)

Test Vehicle: 2004 Jeep Liberty
 Test Program: FMVSS 208 Compliance
 Test Technician: Clark Subrt

NHTSA No.: C40300
 Test Date: 2/27/04

IMPACT ANGLE:	Zero Degrees		
BELTED DUMMIES (YES/NO):	No – Front Occupants Yes – Center Rear Passenger		
TEST SPEED:	<input checked="" type="checkbox"/> 32 to 40 kmph	<input type="checkbox"/> 0 to 48 kmph	<input type="checkbox"/> 0 to 56 kmph
DRIVER DUMMY:	<input checked="" type="checkbox"/> 5 TH female		<input type="checkbox"/> 50 th Male
PASSENGER DUMMY:	<input checked="" type="checkbox"/> 5 TH female	<input checked="" type="checkbox"/> 50 th Male Ctr Rear	

- 1. Place a 165 mm diameter rigid sphere, with a mass of 6.8 kg on the instrument panel so that it is simultaneously touching the instrument panel and the windshield. (571.219 S6.1(a))
- 2. Roll the sphere from one side of the windshield to the other while marking on the windshield where the sphere contacts the windshield. (571.219 S6.1(b))
- 3. From the outermost contactable points on the windshield draw a horizontal line to the edges of the windshield. (571.219 S6.1(b))
- 4. Draw a line on the inner surface of the windshield that is 13 mm below the line determined in items 2 and 3
- 5. After the crash test, record any points where a part of the exterior of the vehicle has marked, penetrated, or broken the windshield.

Provide all dimensions necessary to reproduce the protected area.

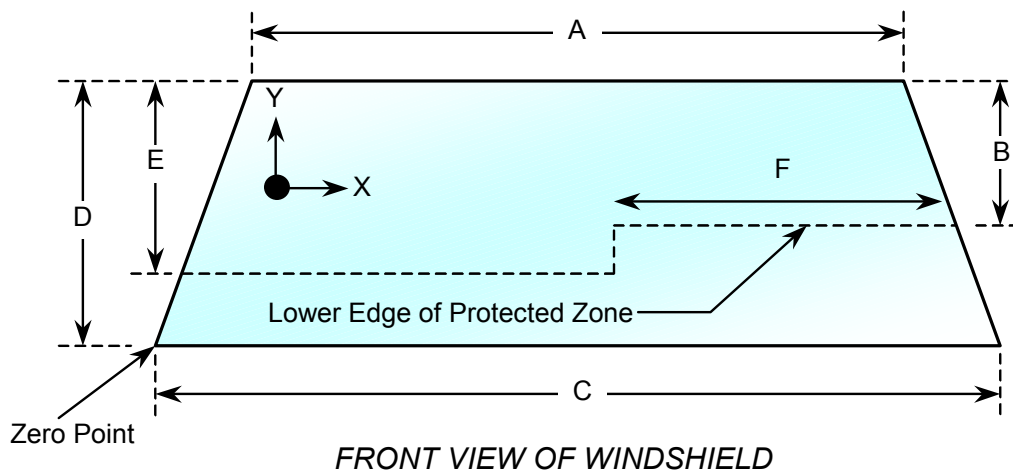

WINDSHIELD DIMENSIONS

Item	Units	Value
A	mm	1200
B	mm	364
C	mm	1498
D	mm	605
E	mm	445
F	mm	485

AREA OF PROTECTED ZONE FAILURES:

- B. Provide coordinates of the area that the protected zone was penetrated more than 0.25 inches by a vehicle component other than one which is normally in contact with the windshield.

X	Y
NONE	

- C. Provide coordinates of the area beneath the protected zone template that the inner surface of the windshield was penetrated by a vehicle component.

X	Y
NONE	

REMARKS:

I certify that I have read and performed each instruction.

Signature: Clark Subit

Date: 2/27/04

DATA SHEET 41

FUEL SYSTEM INTEGRITY (FMVSS 301)

Test Vehicle: 2004 Jeep Liberty
Test Program: FMVSS 208 Compliance
Test Technician: Eric Peschman

NHTSA No.: C40300
Test Date: 2/27/04

TYPE OF IMPACT:	25 mph Unbelted Flat Frontal
-----------------	------------------------------

Stoddard Solvent Spillage Measurements

- A. From impact until vehicle motion ceases: 0.0 grams
(Maximum Allowable = 28 grams)
- B. For the 5 minute period after motion ceases: 0.0 grams
(Maximum Allowable = 142 grams)
- C. For the following 25 minutes: 0.0 grams
(Maximum Allowable = 28 grams/minute)
- D. Spillage: NONE

REMARKS: NO SPILLAGE

DATA SHEET NO. 41
FMVSS 301 STATIC ROLLOVER DATA

Test Vehicle: 2004 Jeep Liberty
 Test Program: FMVSS 208 Compliance

NHTSA No.: C40300
 Test Date: 2/27/04

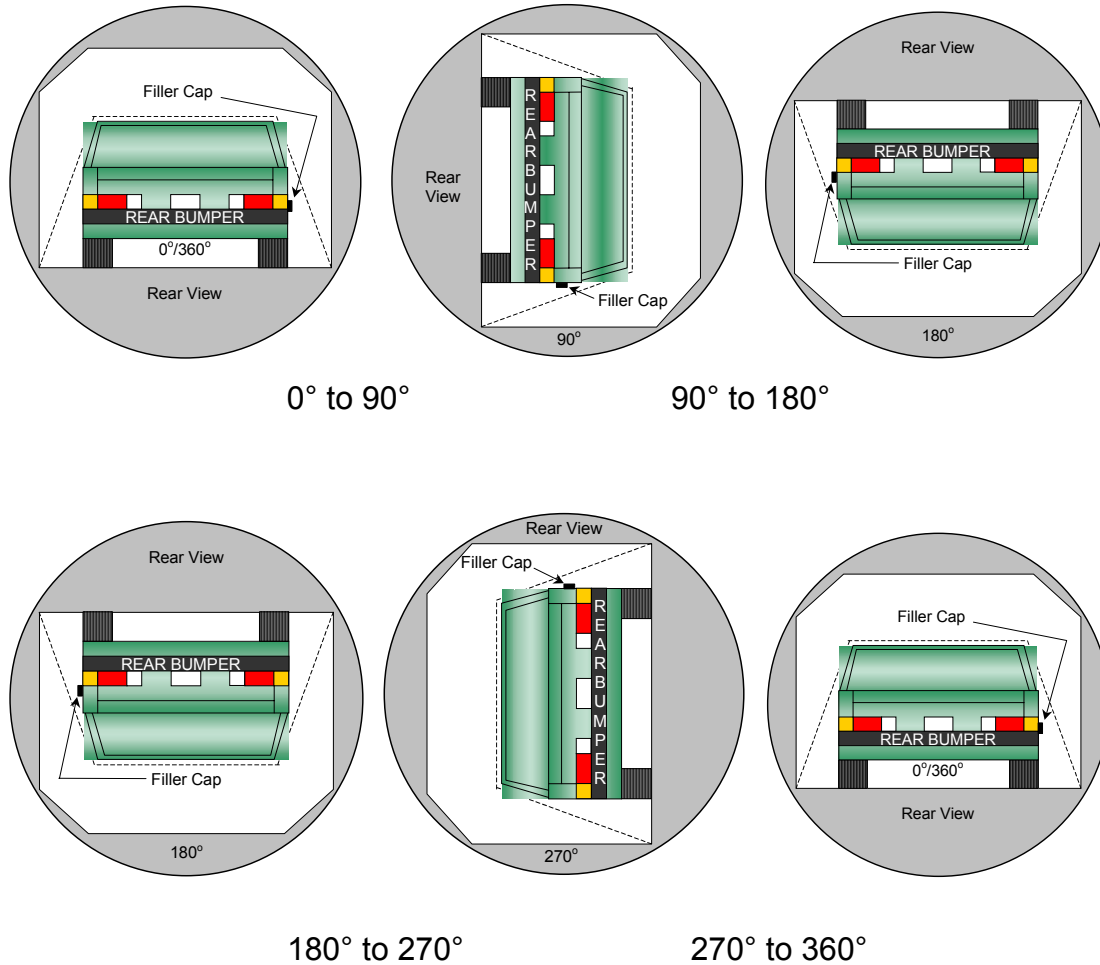

1. The specified fixture rollover rate for each 90° of rotation is 60 to 180 seconds.
2. The position hold time at each position is 300 seconds (minimum).
3. Details of Stoddard Solvent spillage locations: None

Test Phase	Rotation Time (sec.)	Hold Time (sec.)	Spillage (grams)
0° to 90°	160	300	0.0
90° to 180°	150	300	0.0
180° to 270°	145	300	0.0
270° to 360°	167	300	0.0

APPENDIX A
CRASH TEST DATA

TABLE OF DATA PLOTS

		<u>Page No.</u>
Figure No. 1.	Driver Head X Acceleration vs. Time	A-1
Figure No. 2.	Driver Head Y Acceleration vs. Time	A-1
Figure No. 3.	Driver Head Z Acceleration vs. Time	A-1
Figure No. 4.	Driver Head Resultant Acceleration vs. Time	A-1
Figure No. 5.	Driver Head X Velocity vs. Time	A-2
Figure No. 6.	Driver Head Y Velocity vs. Time	A-2
Figure No. 7.	Driver Head Z Velocity vs. Time	A-2
Figure No. 8.	Driver Neck Force X vs. Time	A-3
Figure No. 9.	Driver Neck Force Y vs. Time	A-3
Figure No. 10.	Driver Neck Force Z vs. Time	A-3
Figure No. 11.	Driver Neck Force Resultant vs. Time	A-3
Figure No. 12.	Driver Neck Moment X vs. Time	A-4
Figure No. 13.	Driver Neck Moment Y vs. Time	A-4
Figure No. 14.	Driver Neck Moment Z vs. Time	A-4
Figure No. 15.	Driver Neck Moment Resultant vs. Time	A-4
Figure No. 16.	Driver Chest X Acceleration vs. Time	A-5
Figure No. 17.	Driver Chest Y Acceleration vs. Time	A-5
Figure No. 18.	Driver Chest Z Acceleration vs. Time	A-5
Figure No. 19.	Driver Chest Resultant Acceleration vs. Time	A-5
Figure No. 20.	Driver Chest X Velocity vs. Time	A-6
Figure No. 21.	Driver Chest Y Velocity vs. Time	A-6
Figure No. 22.	Driver Chest Z Velocity vs. Time	A-6
Figure No. 23.	Driver Chest Displacement vs. Time	A-6
Figure No. 24.	Driver Left Femur Force vs. Time	A-7
Figure No. 25.	Driver Right Femur Force vs. Time	A-7
Figure No. 26.	Passenger Head X Acceleration vs. Time	A-8
Figure No. 27.	Passenger Head Y Acceleration vs. Time	A-8
Figure No. 28.	Passenger Head Z Acceleration vs. Time	A-8
Figure No. 29.	Passenger Head Resultant Acceleration vs. Time	A-8

		<u>Page No.</u>
Figure No. 30.	Passenger Head X Velocity vs. Time	A-9
Figure No. 31.	Passenger Head Y Velocity vs. Time	A-9
Figure No. 32.	Passenger Head Z Velocity vs. Time	A-9
Figure No. 33.	Passenger Neck Force X vs. Time	A-10
Figure No. 34.	Passenger Neck Force Y vs. Time	A-10
Figure No. 35.	Passenger Neck Force Z vs. Time	A-10
Figure No. 36.	Passenger Neck Force Resultant vs. Time	A-10
Figure No. 37.	Passenger Neck Moment X vs. Time	A-11
Figure No. 38.	Passenger Neck Moment Y vs. Time	A-11
Figure No. 39.	Passenger Neck Moment Z vs. Time	A-11
Figure No. 40.	Passenger Neck Moment Resultant vs. Time	A-11
Figure No. 41.	Passenger Chest X Acceleration vs. Time	A-12
Figure No. 42.	Passenger Chest Y Acceleration vs. Time	A-12
Figure No. 43.	Passenger Chest Z Acceleration vs. Time	A-12
Figure No. 44.	Passenger Chest Resultant Acceleration vs. Time	A-12
Figure No. 45.	Passenger Chest X Velocity vs. Time	A-13
Figure No. 46.	Passenger Chest Y Velocity vs. Time	A-13
Figure No. 47.	Passenger Chest Z Velocity vs. Time	A-13
Figure No. 48.	Passenger Chest Displacement vs. Time	A-13
Figure No. 49.	Passenger Left Femur Force vs. Time	A-14
Figure No. 50.	Passenger Right Femur Force vs. Time	A-14
Figure No. 51.	CRP Head X Acceleration vs. Time	A-15
Figure No. 52.	CRP Head Y Acceleration vs. Time	A-15
Figure No. 53.	CRP Head Z Acceleration vs. Time	A-15
Figure No. 54.	CRP Head Resultant Acceleration vs. Time	A-15
Figure No. 55.	CRP Head X Velocity vs. Time	A-16
Figure No. 56.	CRP Head Y Velocity vs. Time	A-16
Figure No. 57.	CRP Head Z Velocity vs. Time	A-16
Figure No. 58.	CRP Neck Force X vs. Time	A-17
Figure No. 59.	CRP Neck Force Y vs. Time	A-17

		<u>Page No.</u>
Figure No. 60.	CRP Neck Force Z vs. Time	A-17
Figure No. 61.	CRP Neck Force Resultant vs. Time	A-17
Figure No. 62.	CRP Neck Moment X vs. Time	A-18
Figure No. 63.	CRP Neck Moment Y vs. Time	A-18
Figure No. 64.	CRP Neck Moment Z vs. Time	A-18
Figure No. 65.	CRP Neck Moment Resultant vs. Time	A-18
Figure No. 66.	CRP Chest X Acceleration vs. Time	A-19
Figure No. 67.	CRP Chest Y Acceleration vs. Time	A-19
Figure No. 68.	CRP Chest Z Acceleration vs. Time	A-19
Figure No. 69.	CRP Chest Resultant Acceleration vs. Time	A-19
Figure No. 70.	CRP Chest X Velocity vs. Time	A-20
Figure No. 71.	CRP Chest Y Velocity vs. Time	A-20
Figure No. 72.	CRP Chest Z Velocity vs. Time	A-20
Figure No. 73.	CRP Chest Displacement vs. Time	A-20
Figure No. 74.	CRP Right Femur Force vs. Time	A-21
Figure No. 75.	CRP Left Femur Force vs. Time	A-21
Figure No. 76.	CRP Shoulder Belt Force vs. Time	A-22
Figure No. 77.	CRP Lap Belt Force vs. Time	A-22
Figure No. 78.	CRP Belt SP Displacement vs. Time	A-22
Figure No. 79.	CRP Roof to Belt SP Displacement vs. Time	A-22
Figure No. 80.	Left Rear Seat Crossmember X Acceleration vs. Time	A-23
Figure No. 81.	Left Rear Seat Crossmember X Velocity vs. Time	A-23
Figure No. 82.	Right Rear Seat Crossmember X Acceleration vs. Time	A-23
Figure No. 83.	Right Rear Seat Crossmember X Velocity vs. Time	A-23
Figure No. 84.	Top of Engine X Acceleration vs. Time	A-24
Figure No. 85.	Top of Engine X Velocity vs. Time	A-24
Figure No. 86.	Bottom of Engine X Acceleration vs. Time	A-24
Figure No. 87.	Bottom of Engine X Velocity vs. Time	A-24
Figure No. 88.	Left Brake Caliper X Acceleration vs. Time	A-25
Figure No. 89.	Left Brake Caliper X Velocity vs. Time	A-25

		<u>Page No.</u>
Figure No. 90.	Right Brake Caliper X Acceleration vs. Time	A-25
Figure No. 91.	Right Brake Caliper X Velocity vs. Time	A-25
Figure No. 92.	Instrument Panel X Acceleration vs. Time	A-26
Figure No. 93.	Instrument Panel X Velocity vs. Time	A-26
Figure No. 94.	Trunk Z Acceleration vs. Time	A-26
Figure No. 95.	Trunk Z Velocity vs. Time	A-26
Figure No. 96.	Barrier Force – Upper Left vs. Time	A-27
Figure No. 97.	Barrier Force – Upper Center vs. Time	A-27
Figure No. 98.	Barrier Force – Upper Right vs. Time	A-27
Figure No. 99.	Barrier Force – Lower Left vs. Time	A-28
Figure No. 100.	Barrier Force – Lower Center vs. Time	A-28
Figure No. 101.	Barrier Force – Lower Right vs. Time	A-28
Figure No. 102.	Barrier Force – Sum Left vs. Time	A-29
Figure No. 103.	Barrier Force – Sum Center vs. Time	A-29
Figure No. 104.	Barrier Force – Sum Right vs. Time	A-29
Figure No. 105.	Barrier Force – Sum All vs. Time	A-29
Figure No. 106.	Barrier Force – Sum All vs. Average Seat X-member Displacement	A-30



25 MPH FRONTAL UNBELTED
2004 JEEP LIBERTY (C40300)

Test Date: 2/27/2004
Speed: 24.7 mph (39.8 km/h)

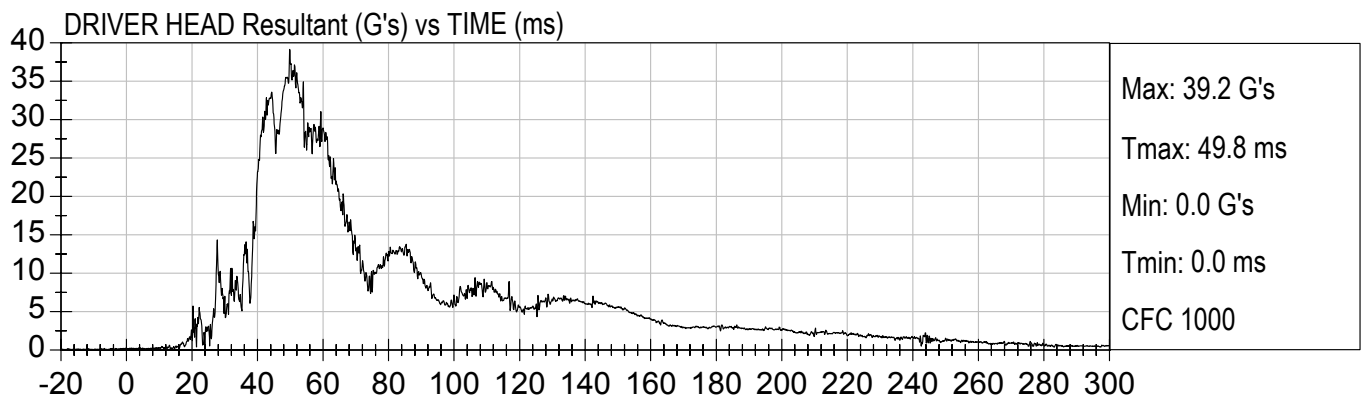
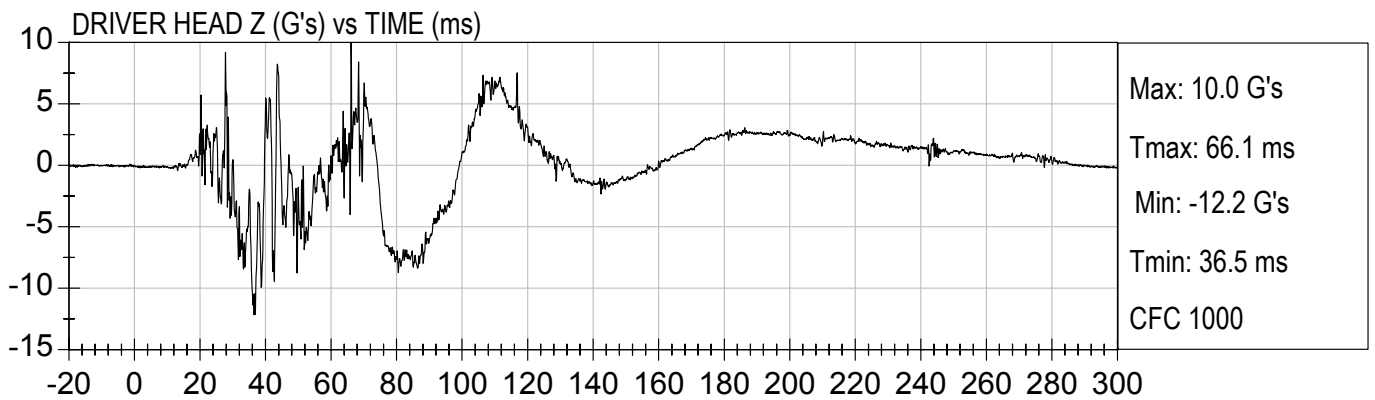
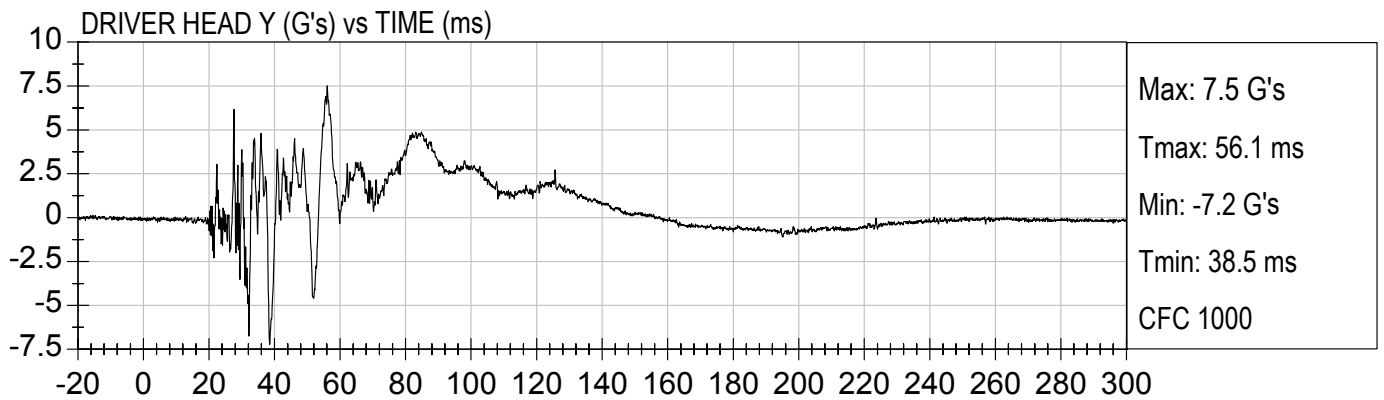
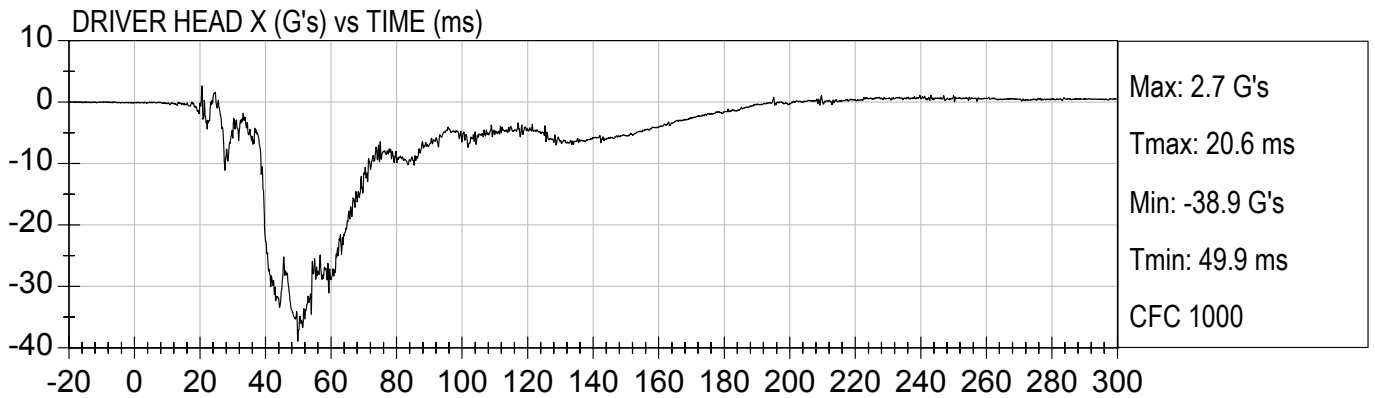

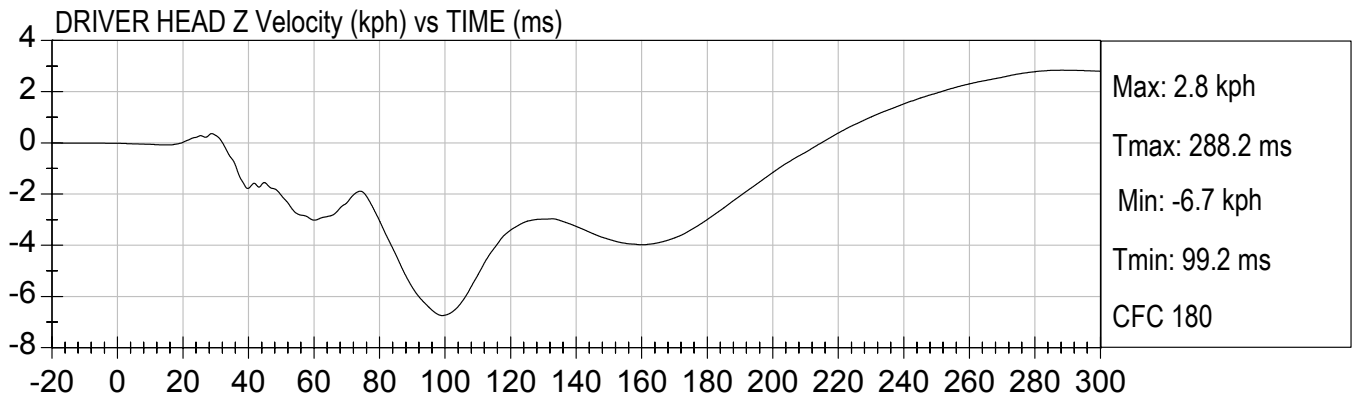
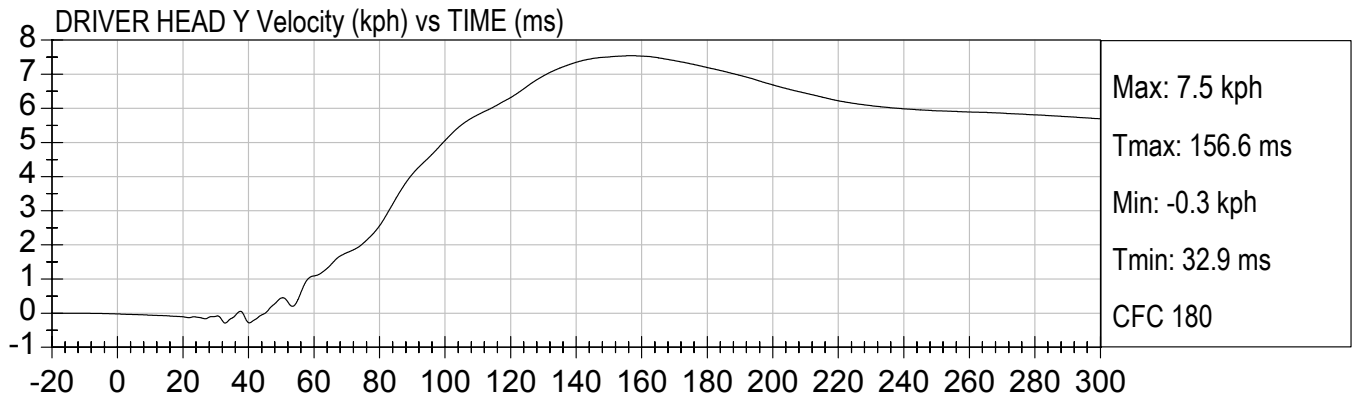
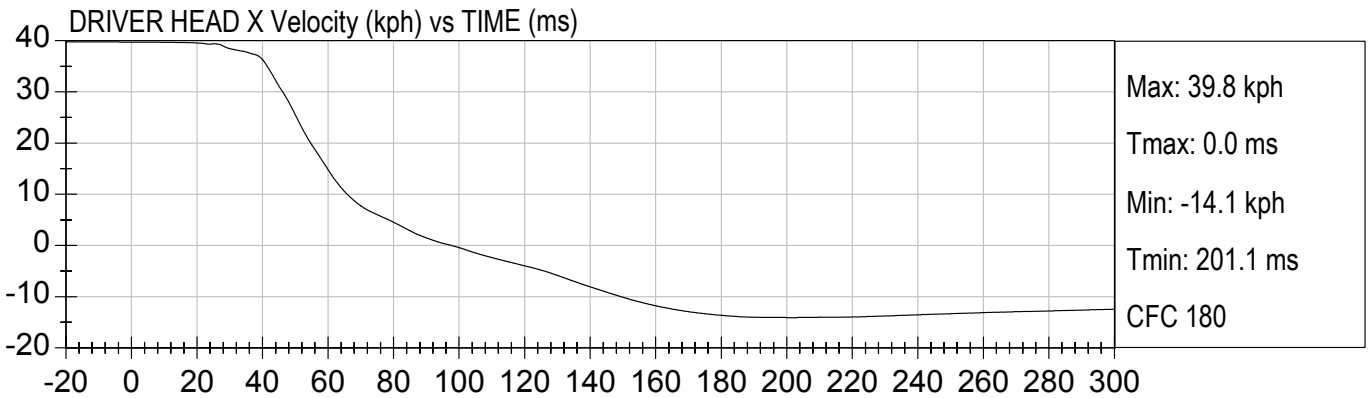



DRIVER NECK FX (N) vs TIME (ms)

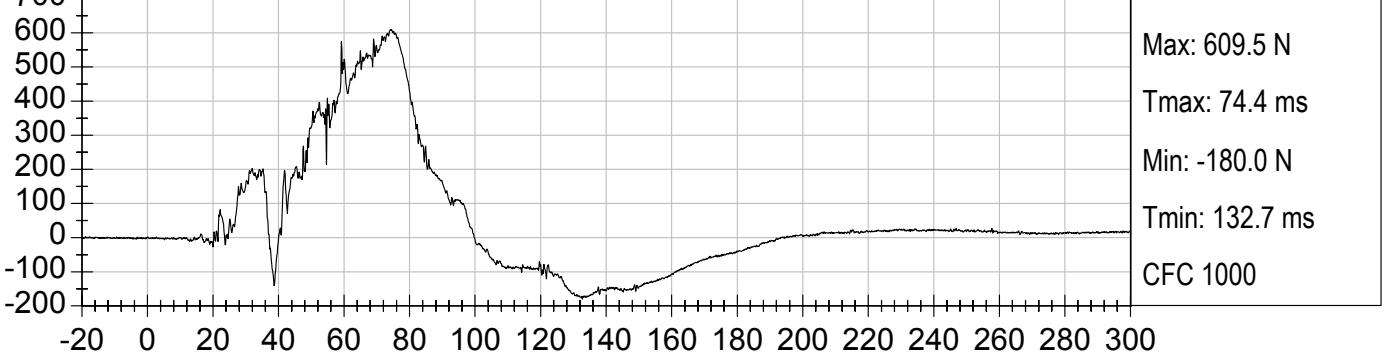

DRIVER NECK FY (N) vs TIME (ms)



DRIVER NECK FZ (N) vs TIME (ms)



DRIVER NECK FResultant (N) vs TIME (ms)

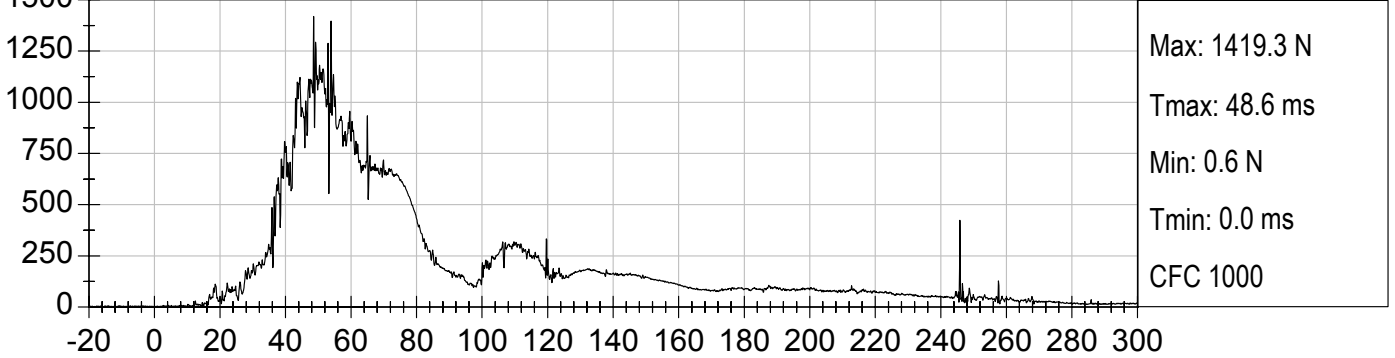



DRIVER NECK MX (Nm) vs TIME (ms)

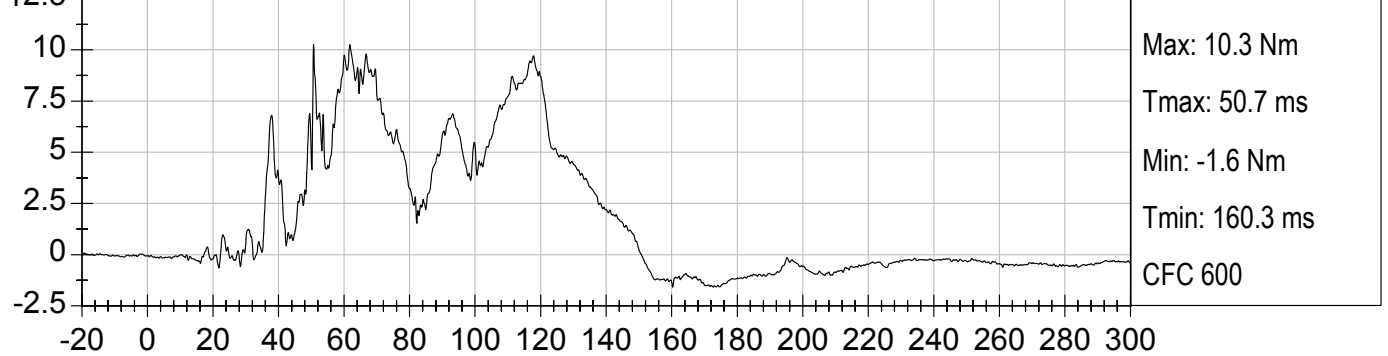

DRIVER NECK MY (Nm) vs TIME (ms)

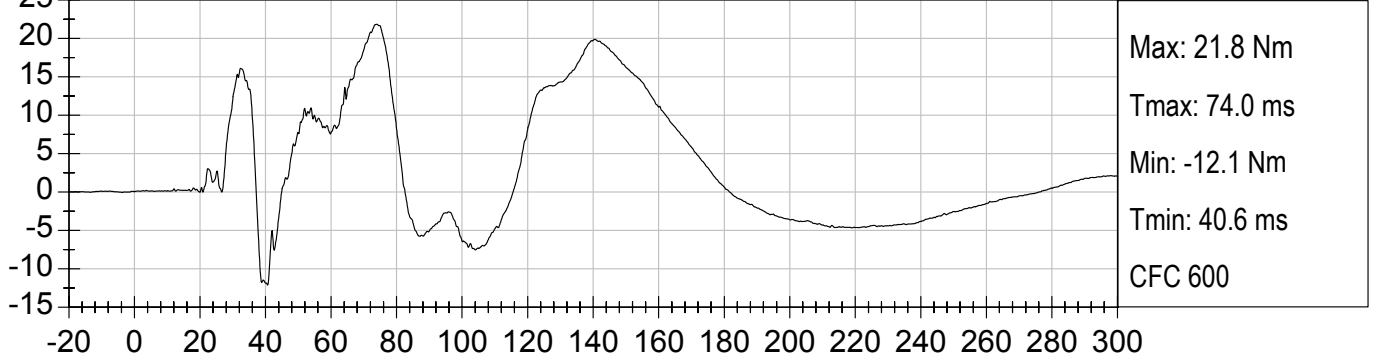

DRIVER NECK MZ (Nm) vs TIME (ms)

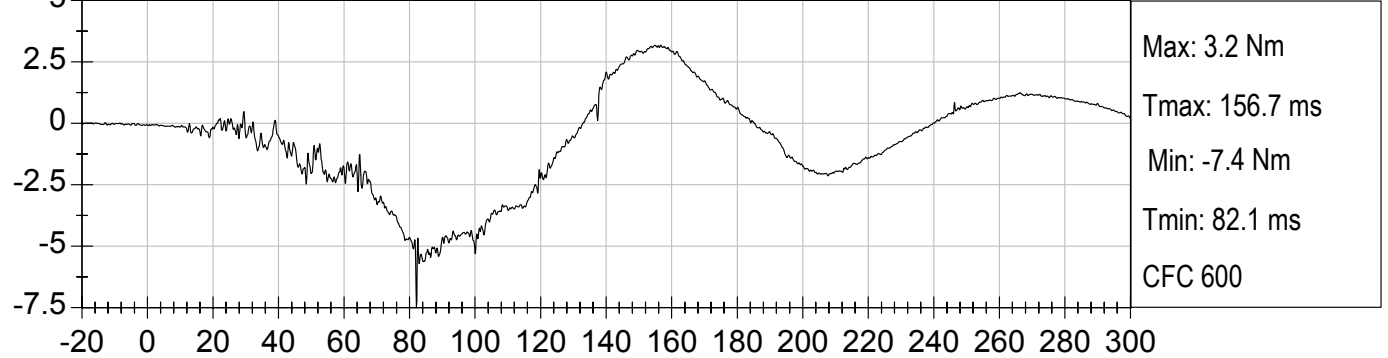

DRIVER NECK MResultant (Nm) vs TIME (ms)

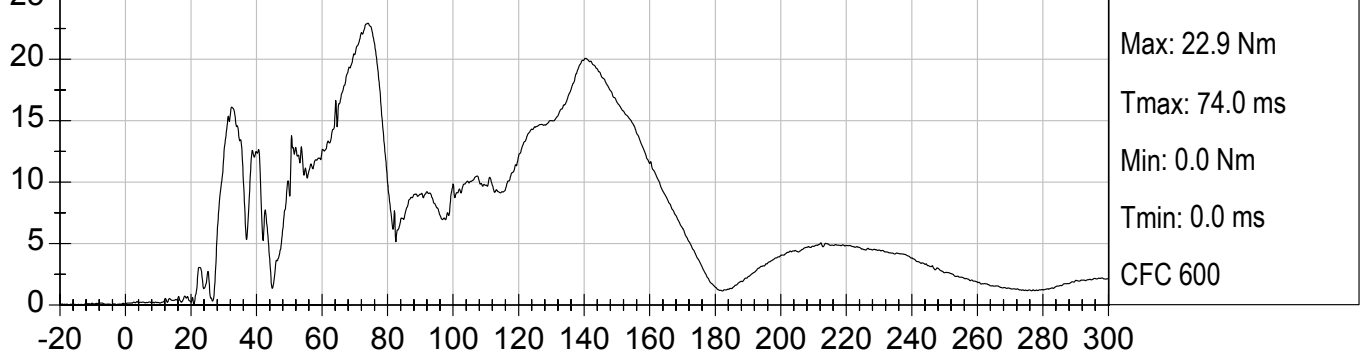

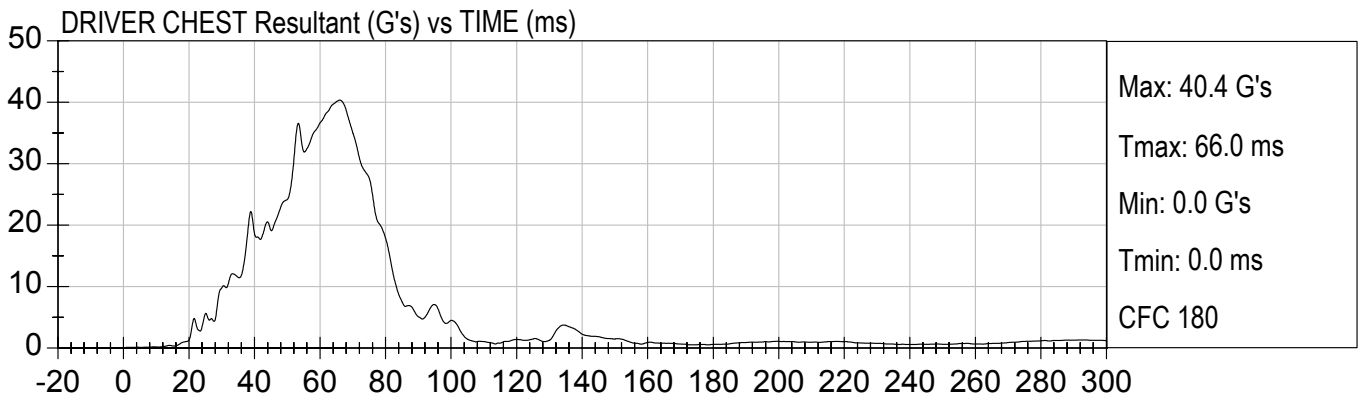
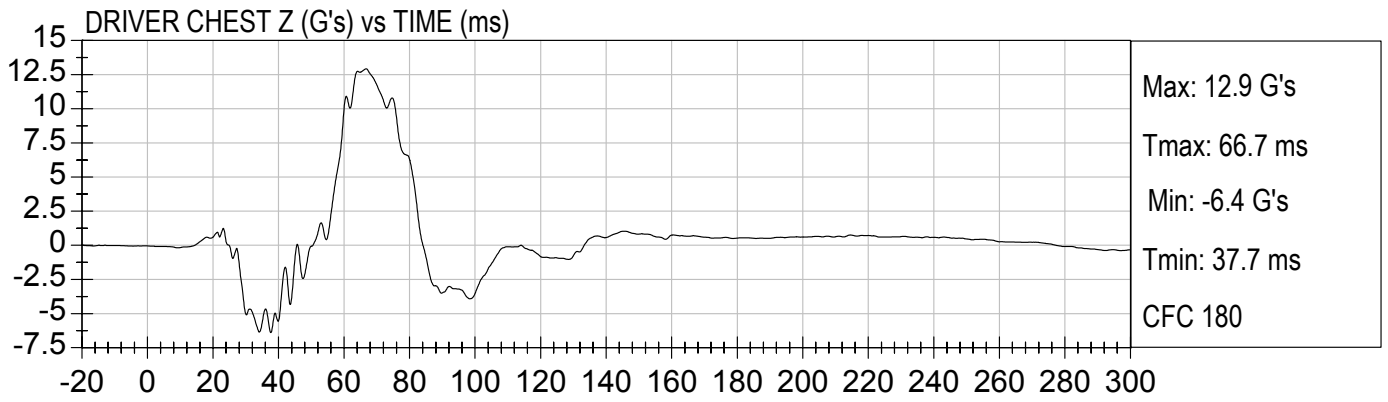
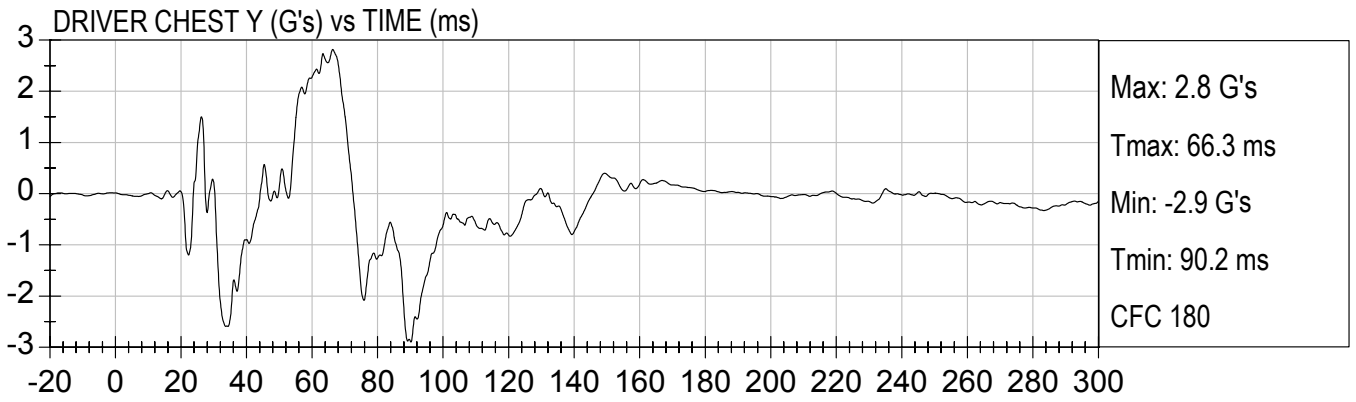
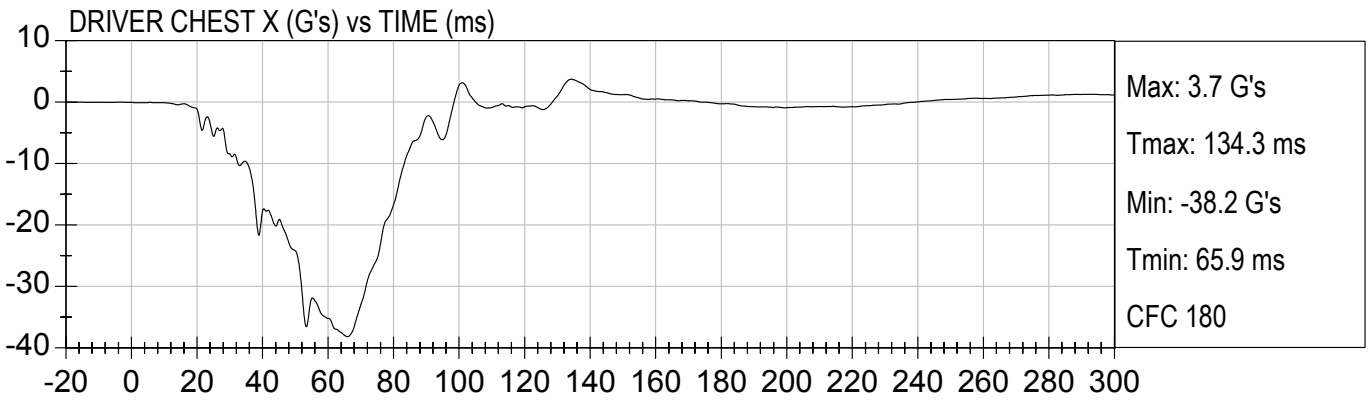

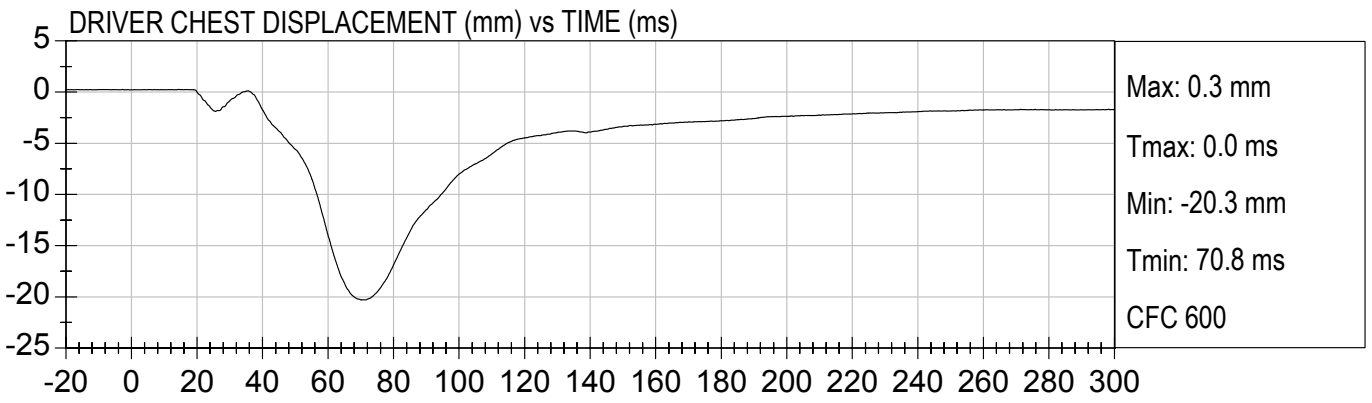
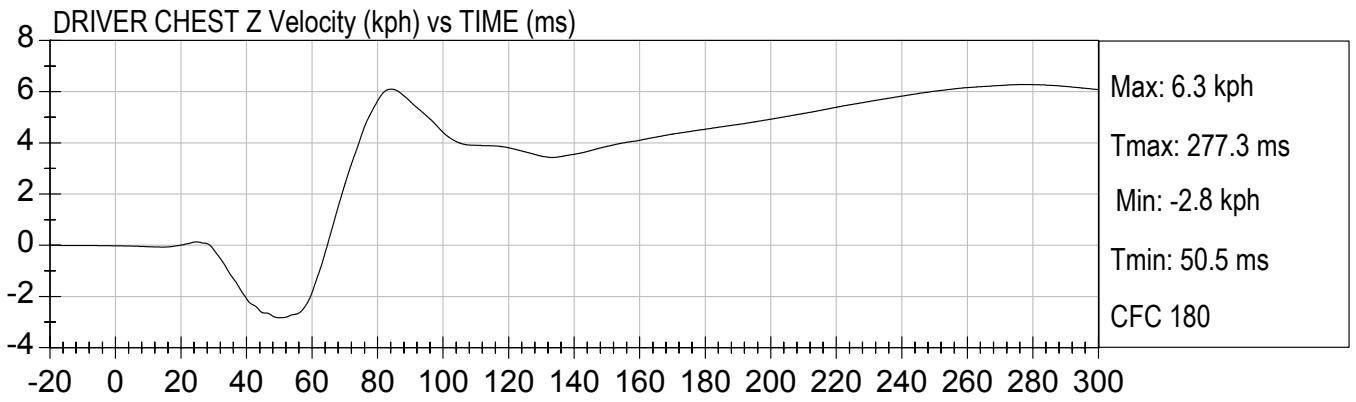
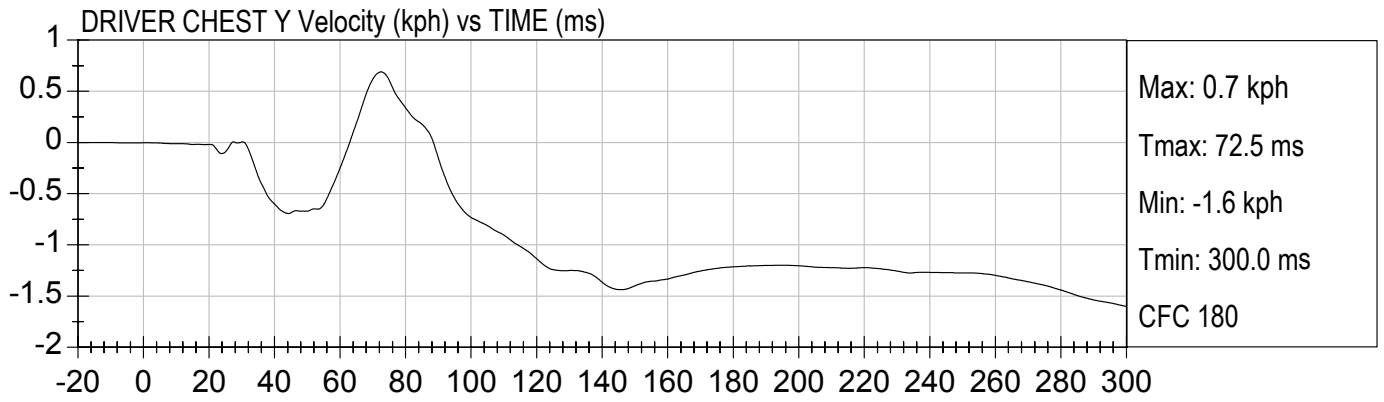
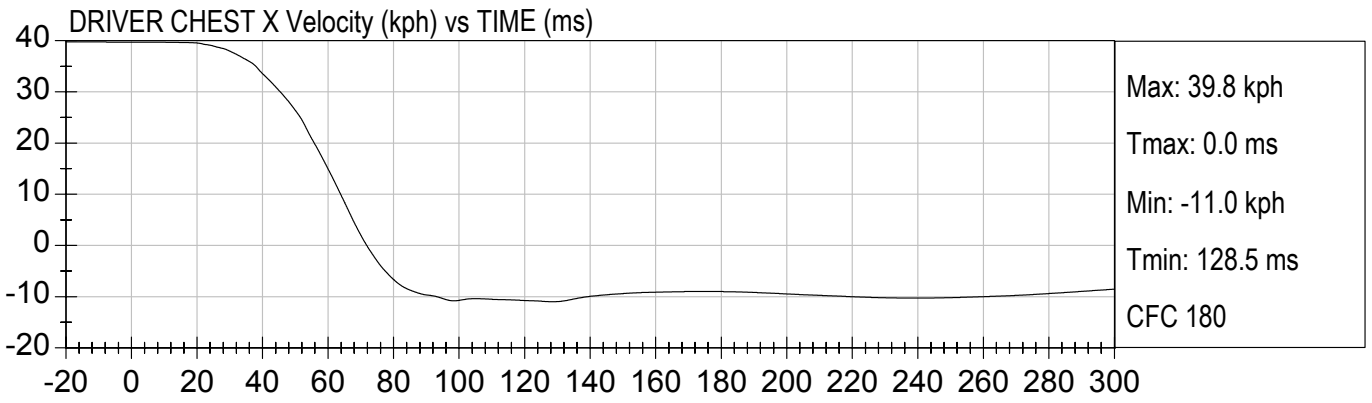



25 MPH FRONTAL UNBELTED
2004 JEEP LIBERTY (C40300)

Test Date: 2/27/2004
Speed: 24.7 mph (39.8 km/h)

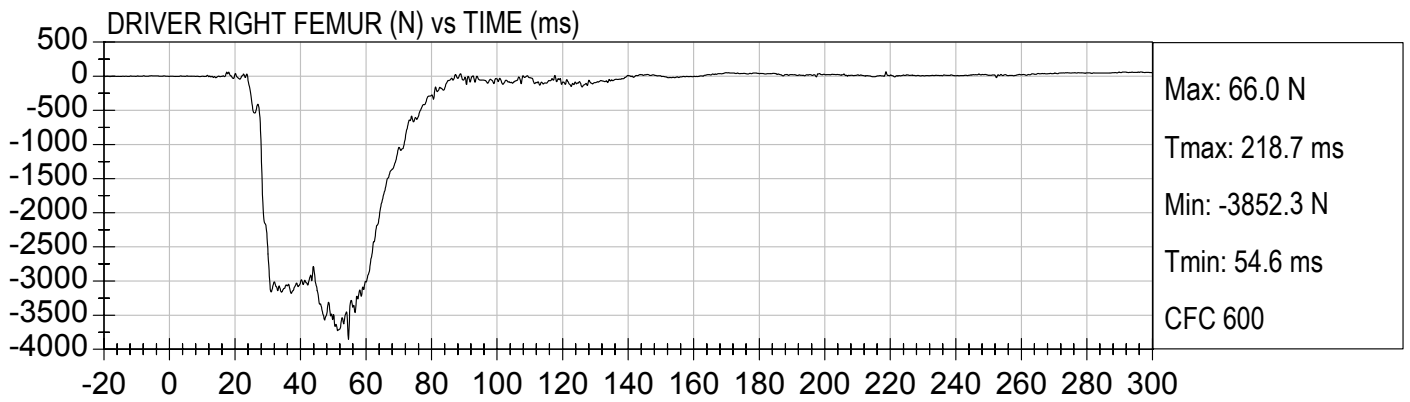
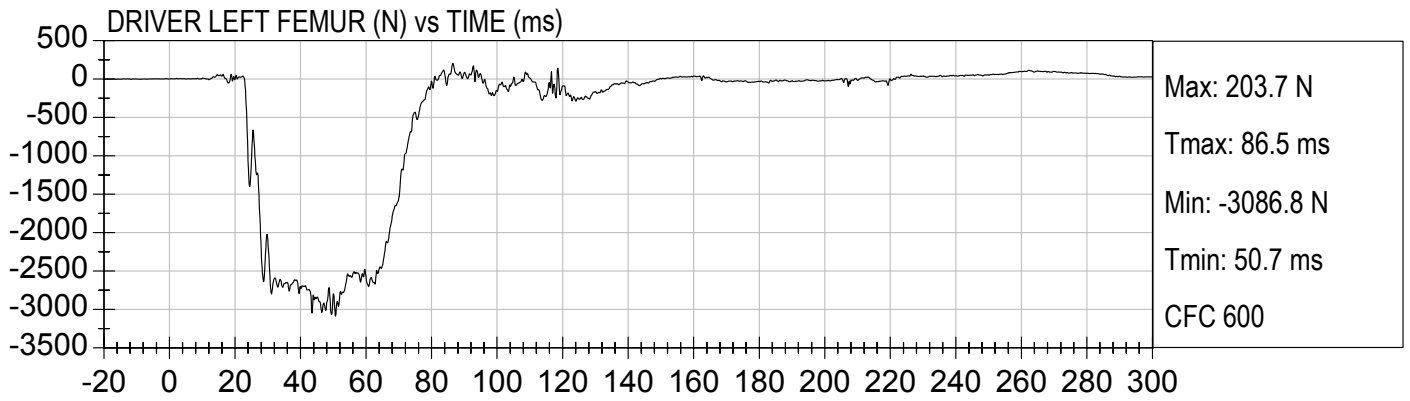

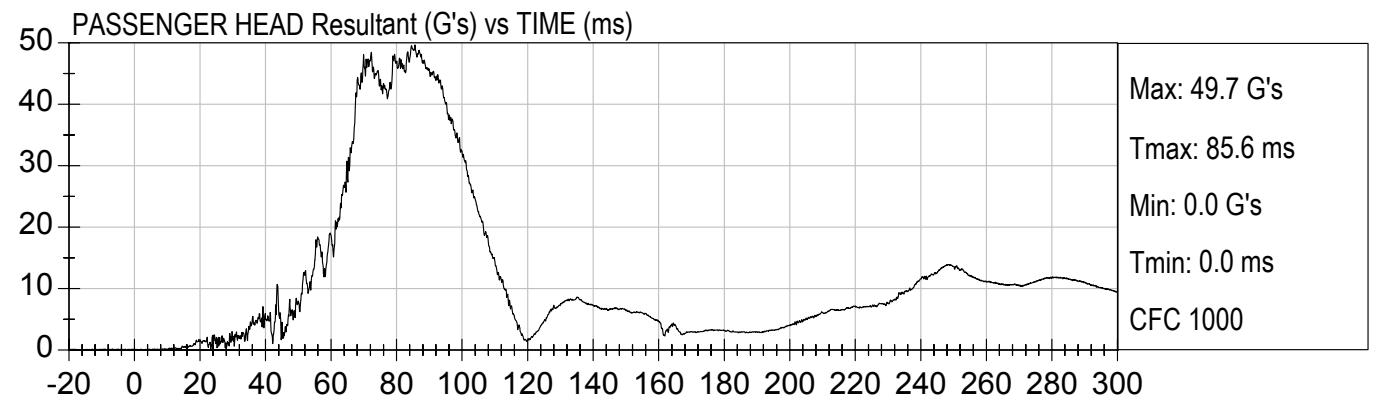
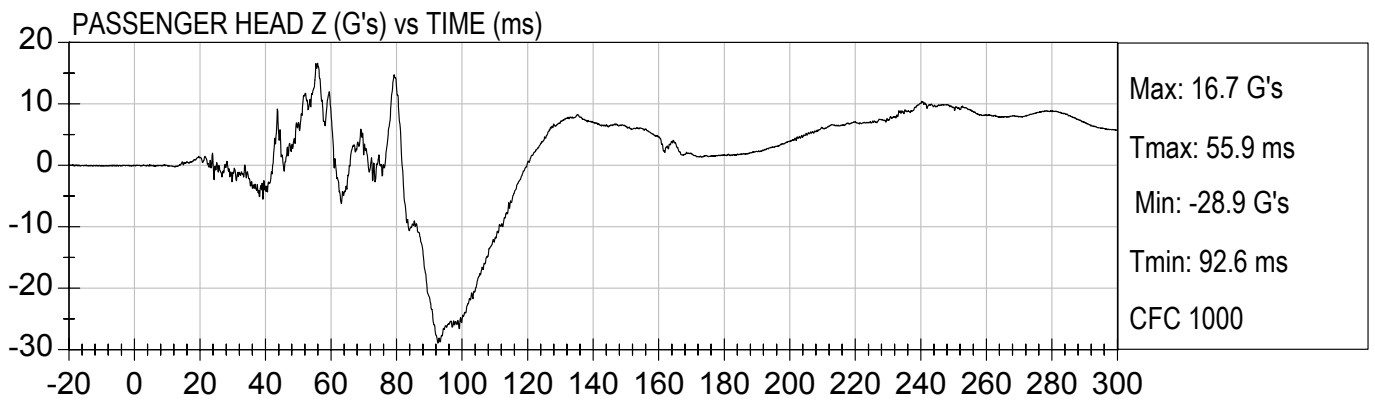
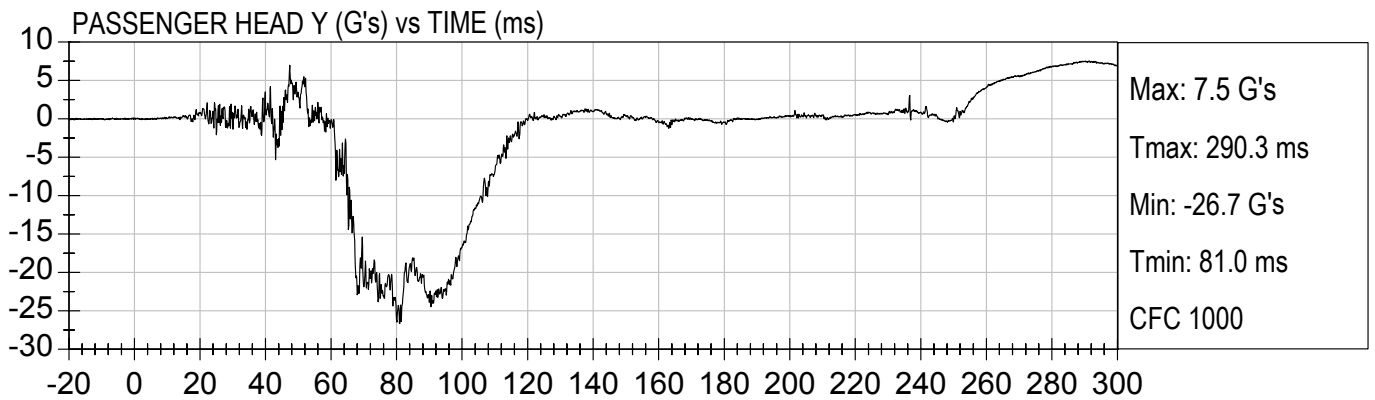
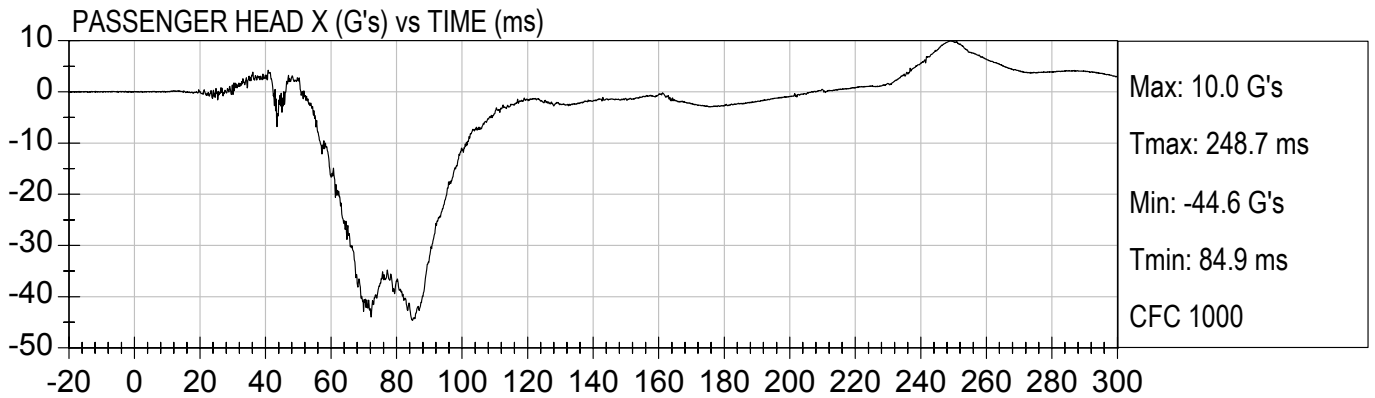

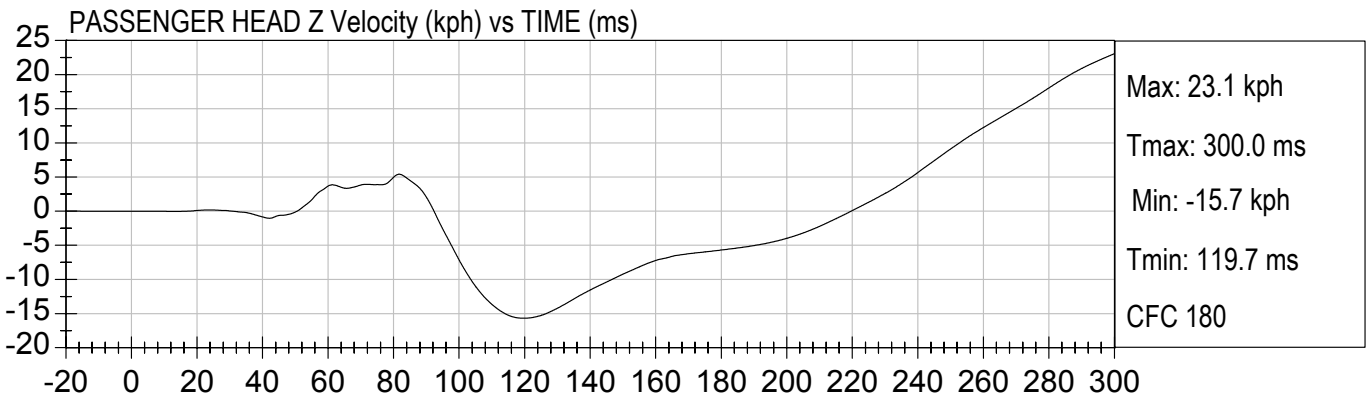
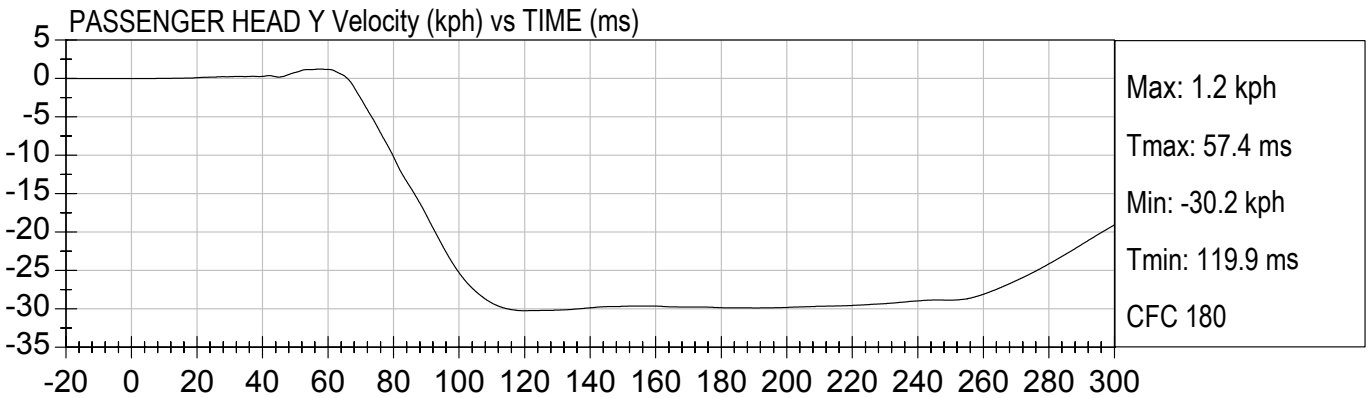
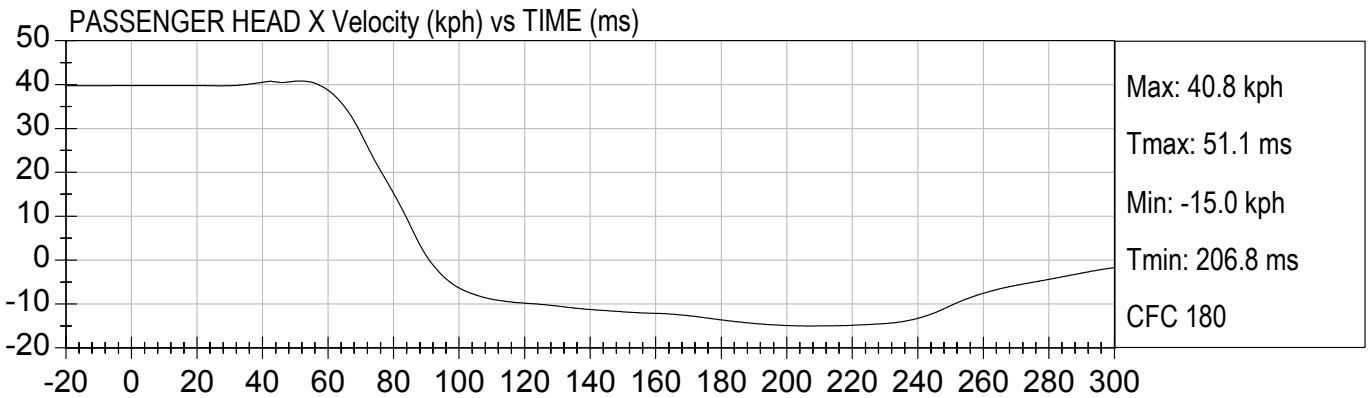



25 MPH FRONTAL UNBELTED
2004 JEEP LIBERTY (C40300)

Test Date: 2/27/2004
Speed: 24.7 mph (39.8 km/h)

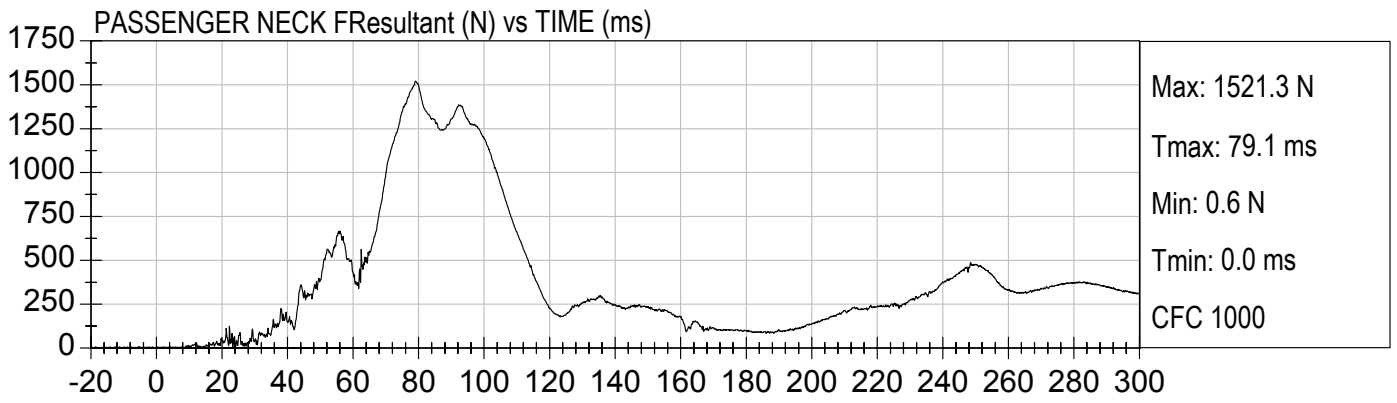
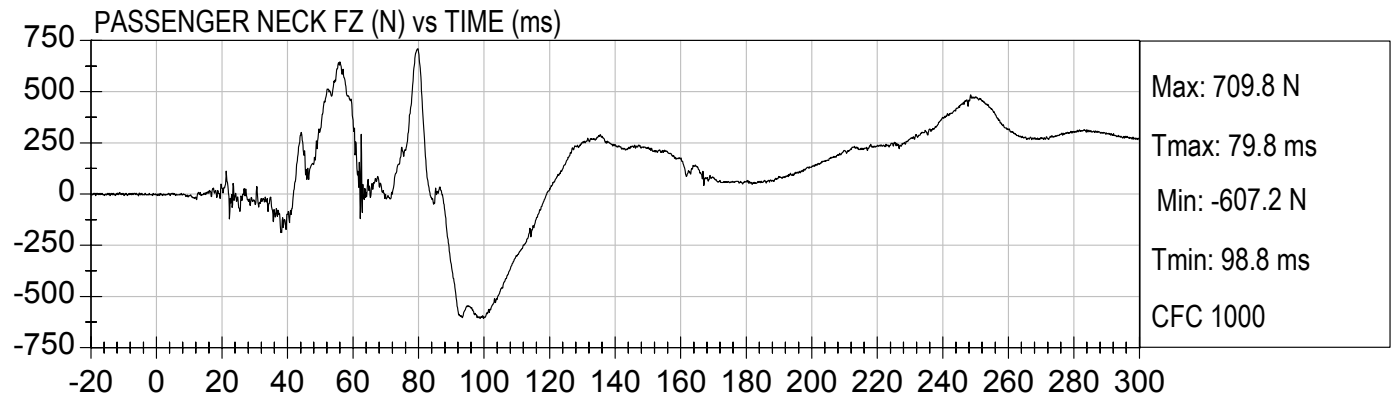
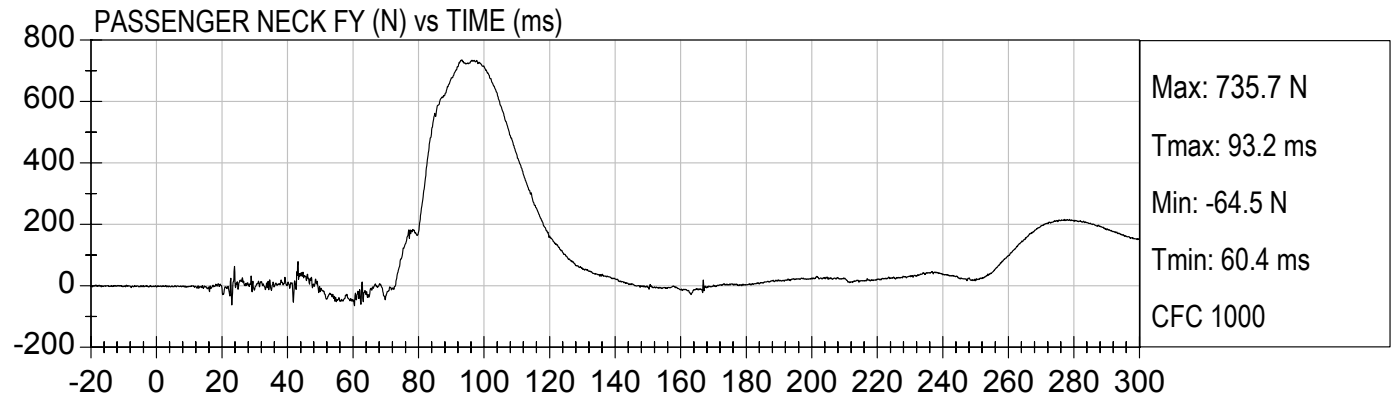
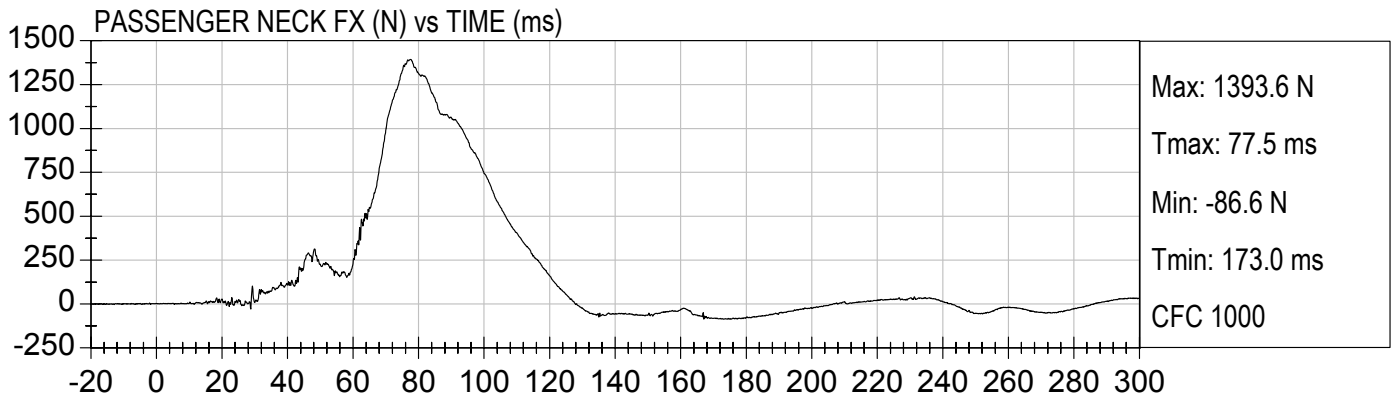

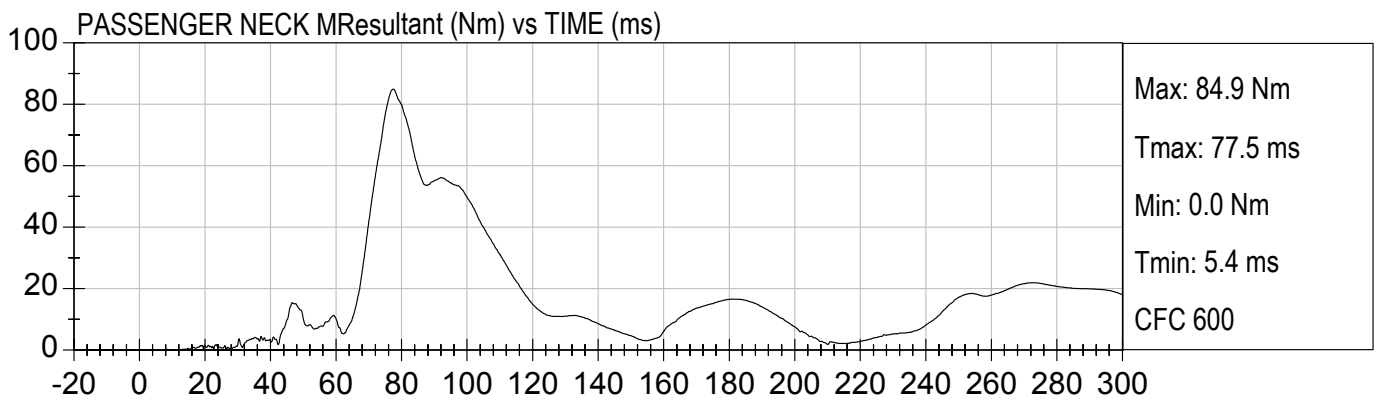
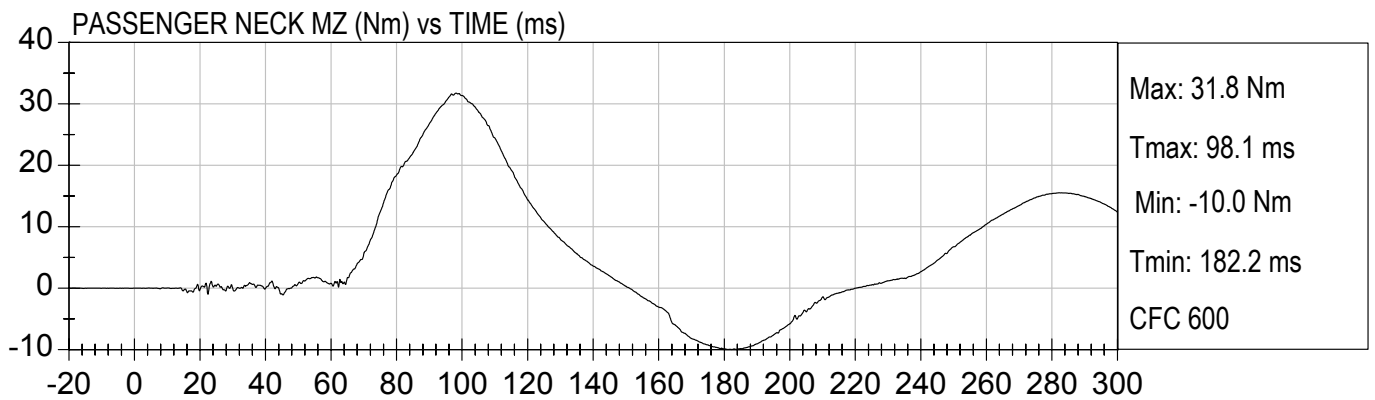
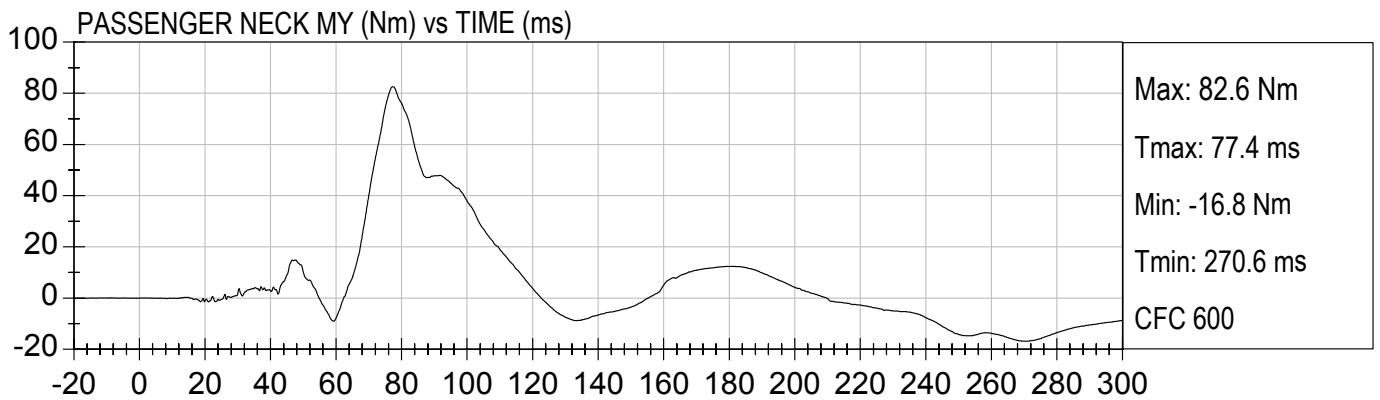
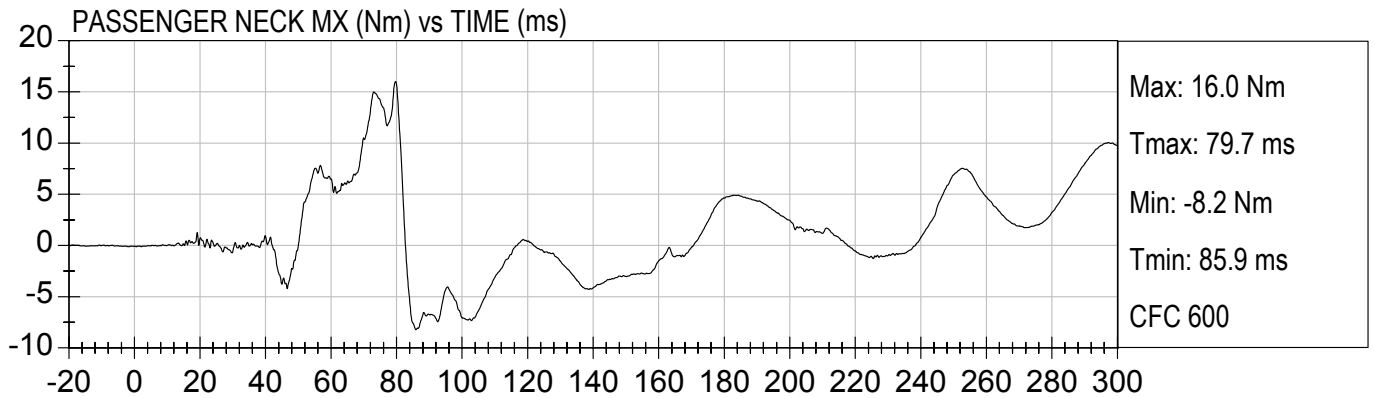



25 MPH FRONTAL UNBELTED
2004 JEEP LIBERTY (C40300)

Test Date: 2/27/2004
Speed: 24.7 mph (39.8 km/h)

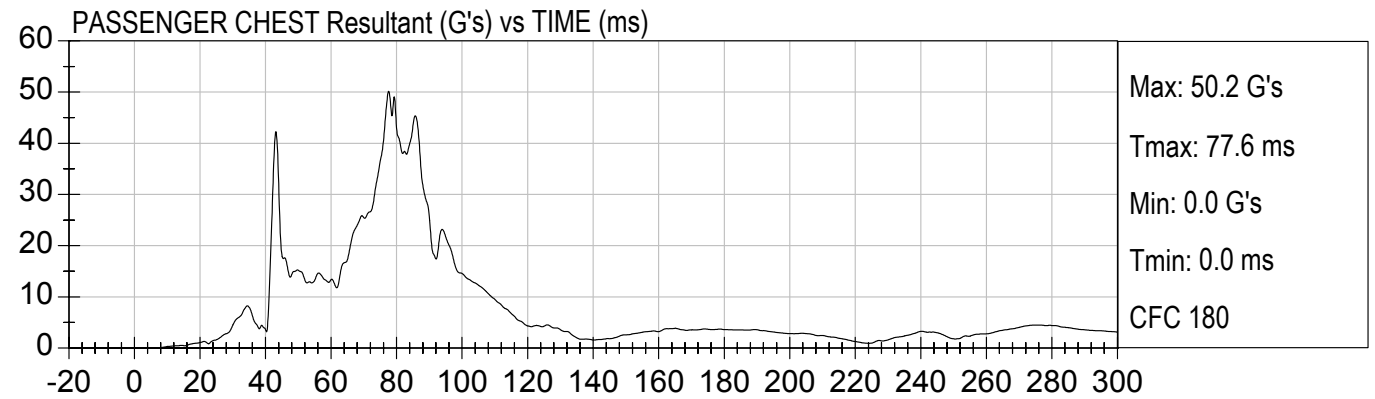
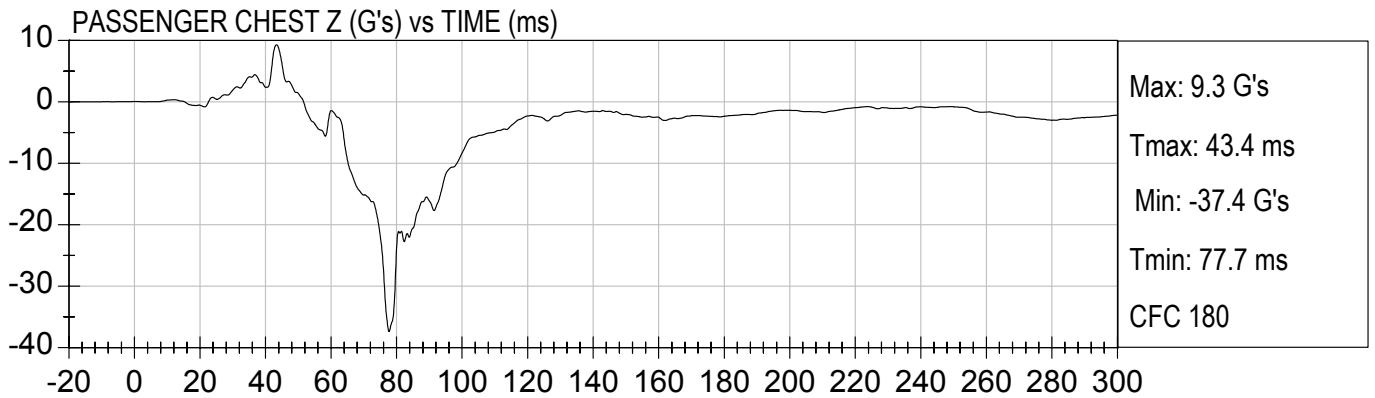
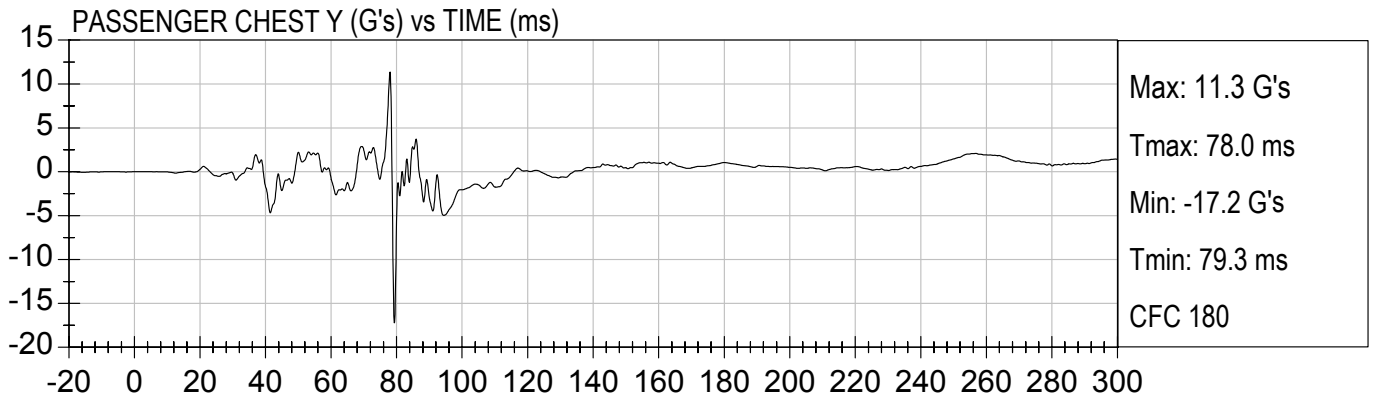
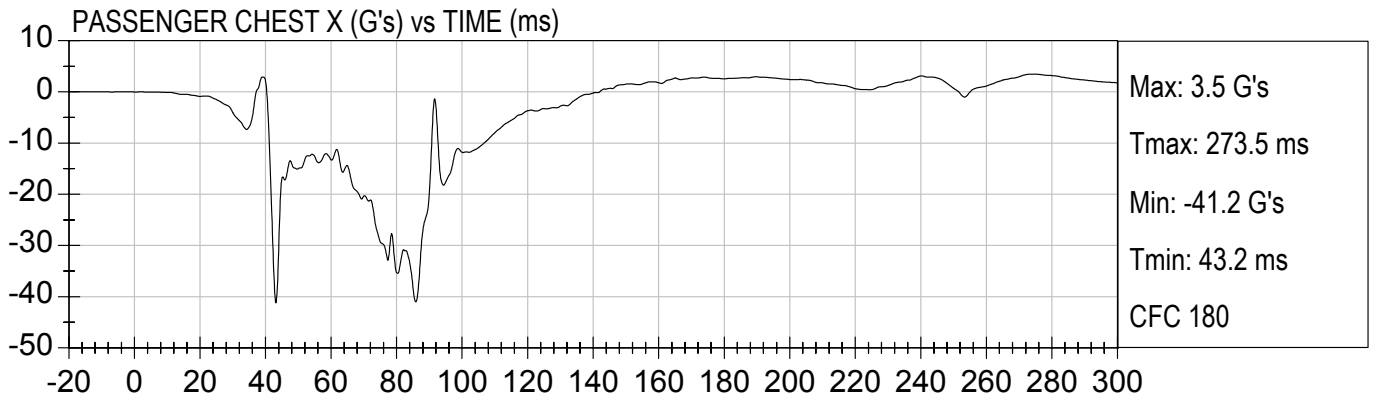

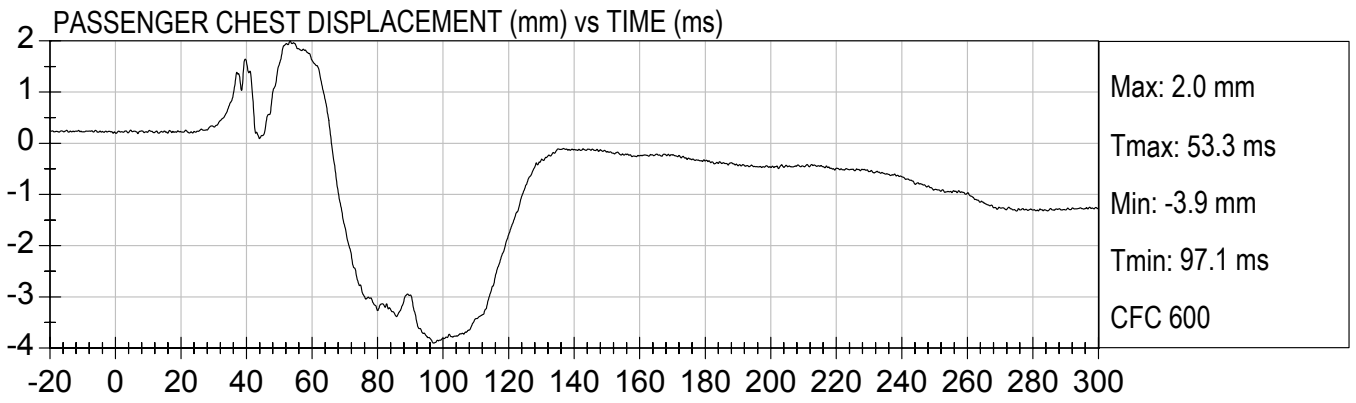
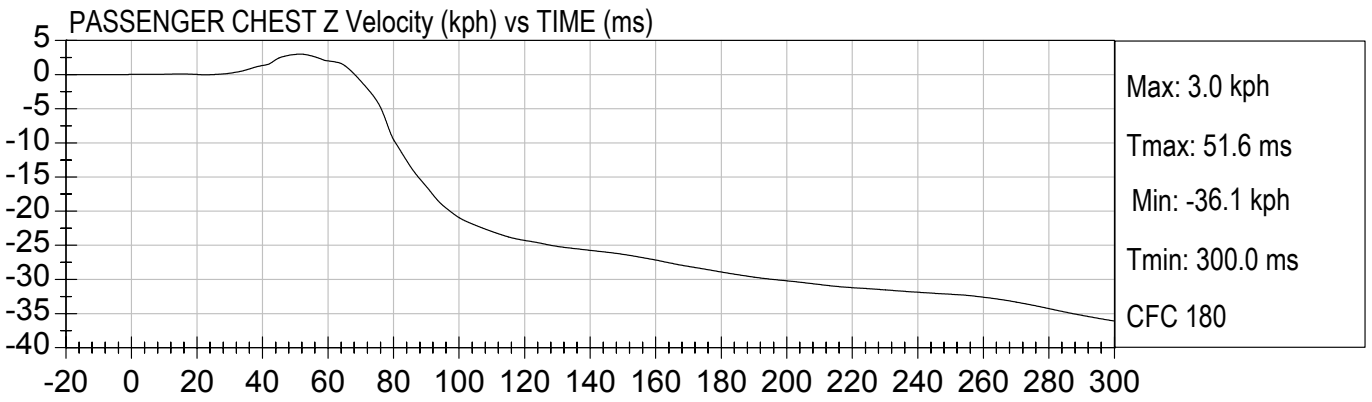
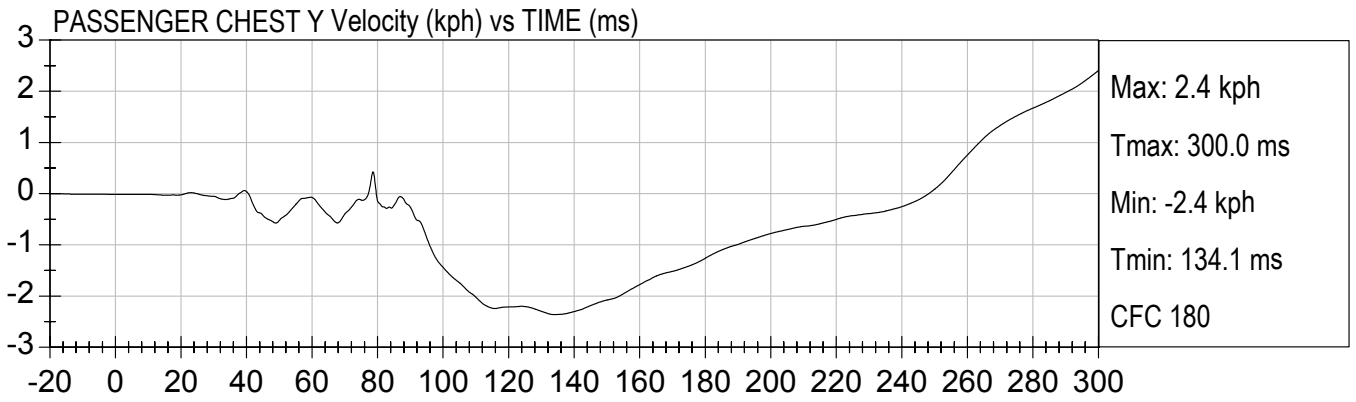
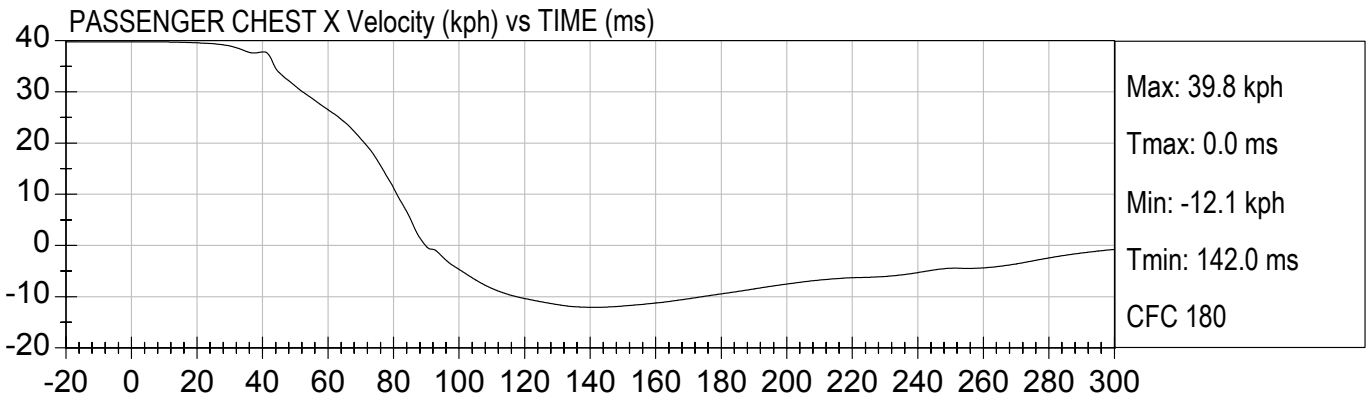



25 MPH FRONTAL UNBELTED
2004 JEEP LIBERTY (C40300)

Test Date: 2/27/2004
Speed: 24.7 mph (39.8 km/h)

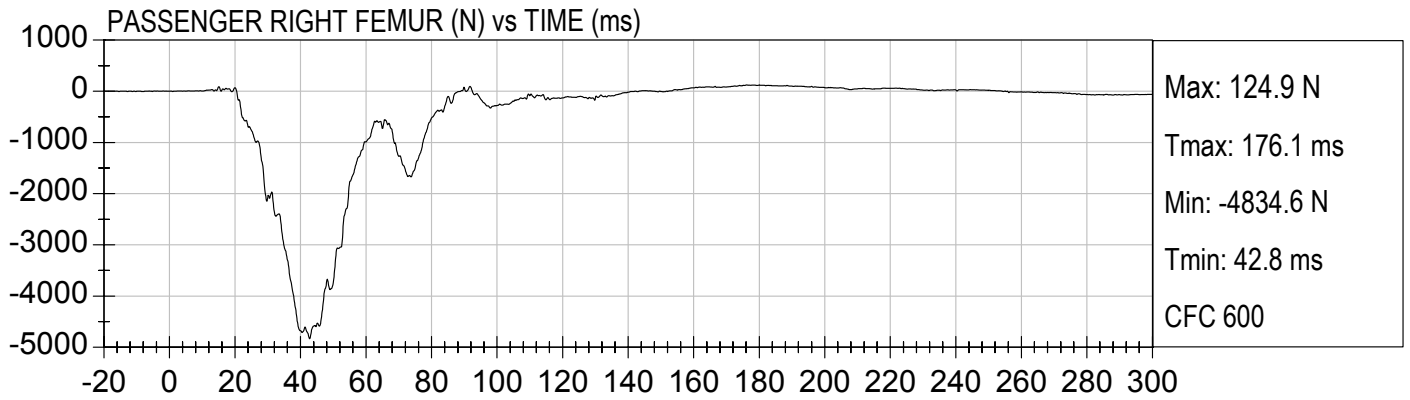
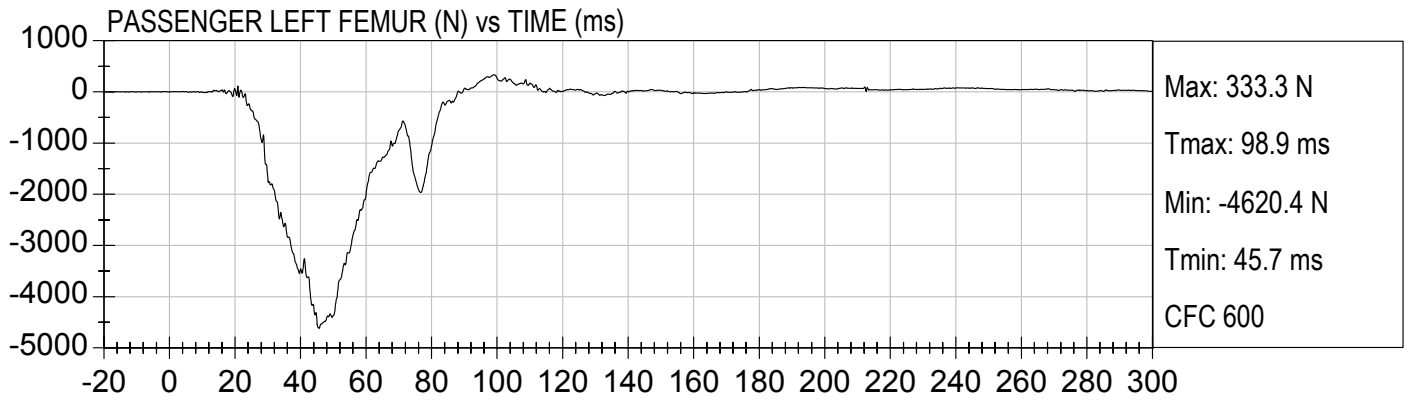



25 MPH FRONTAL UNBELTED
2004 JEEP LIBERTY (C40300)

Test Date: 2/27/2004
Speed: 24.7 mph (39.8 km/h)

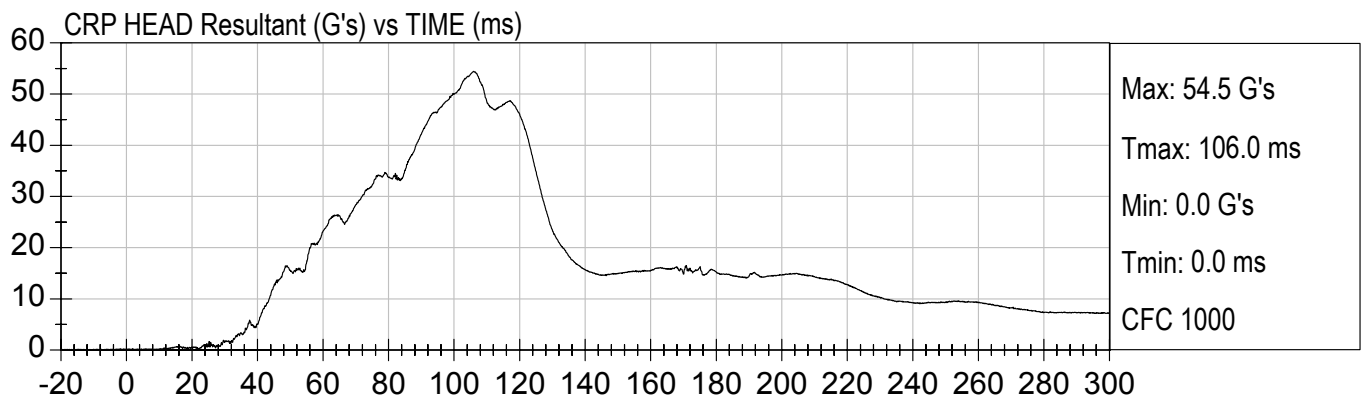
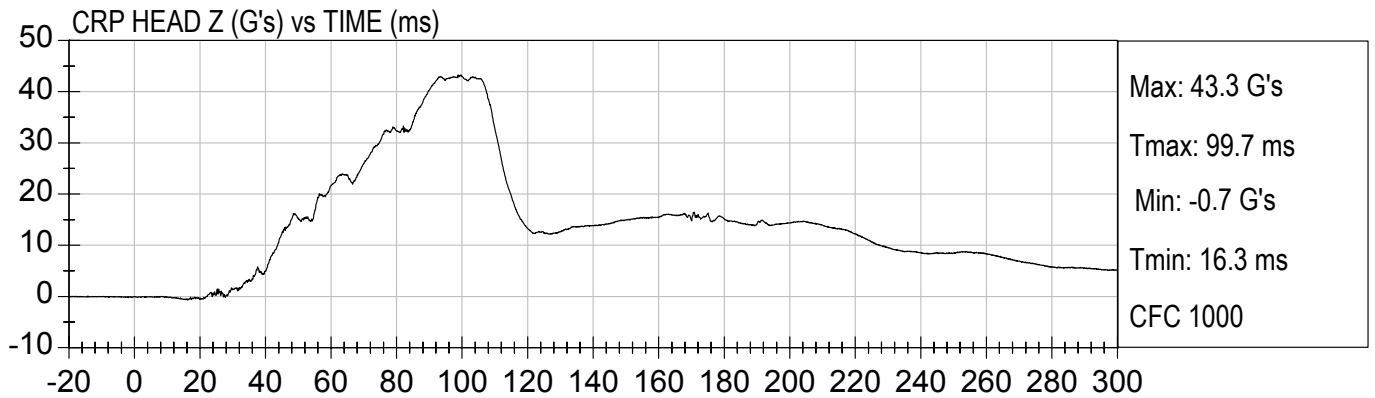
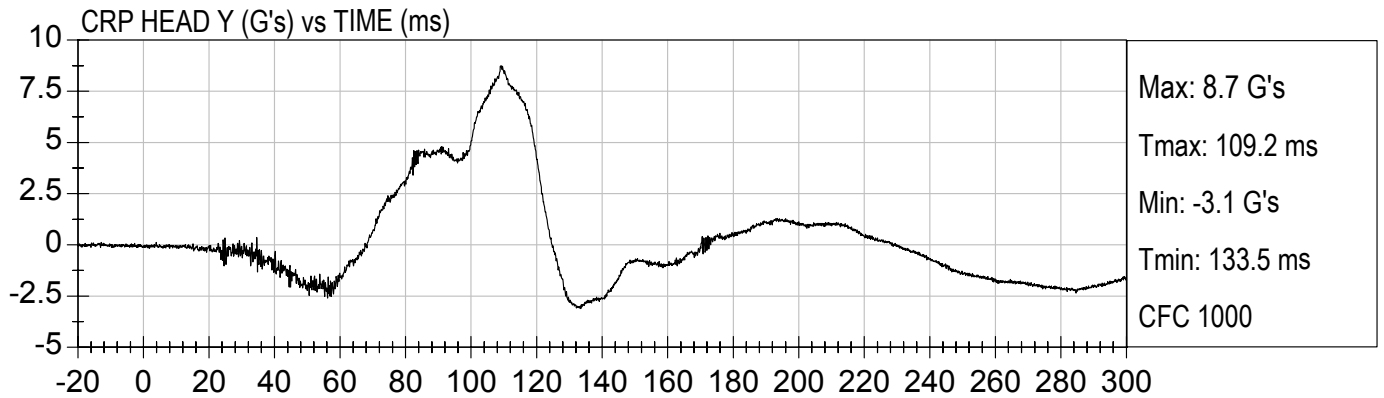
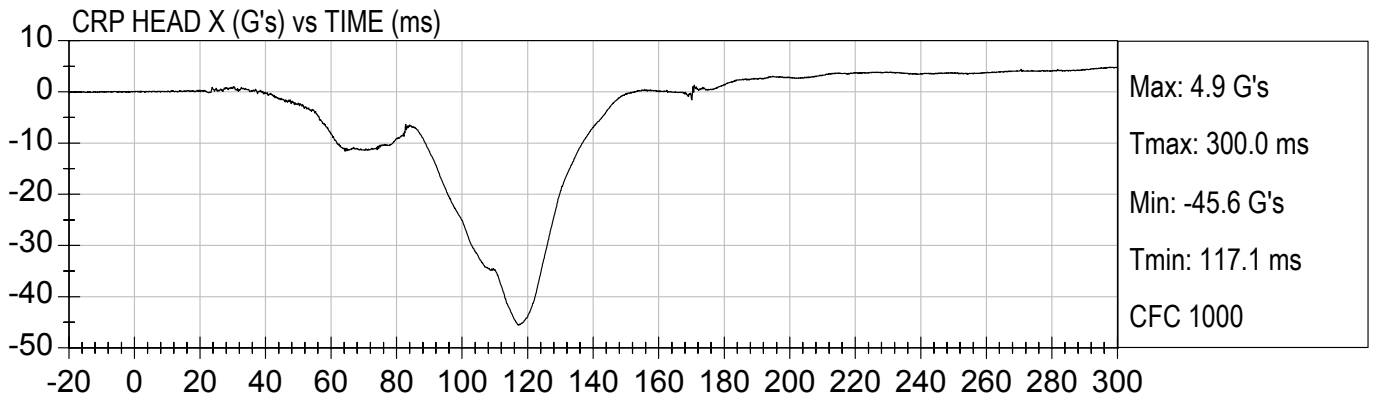

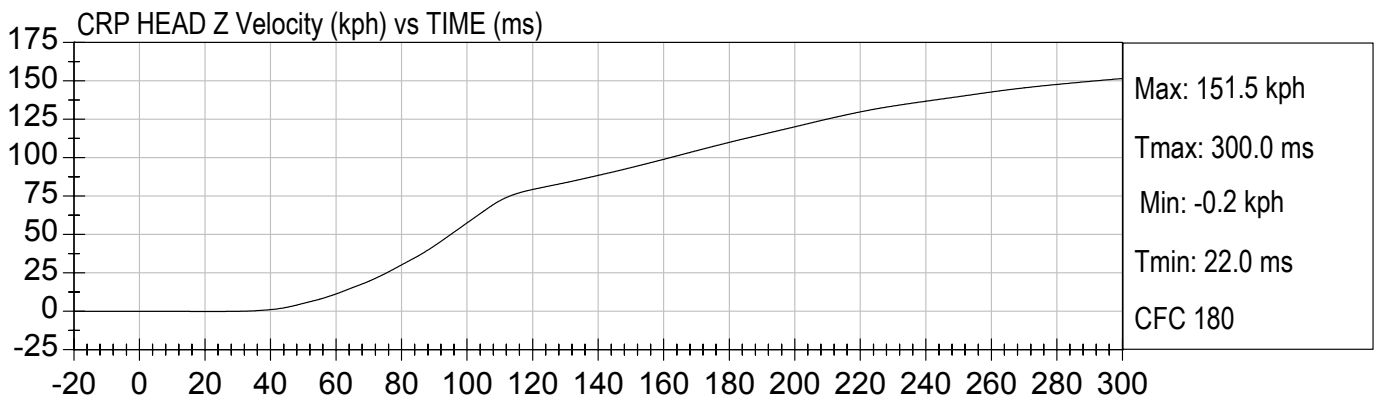
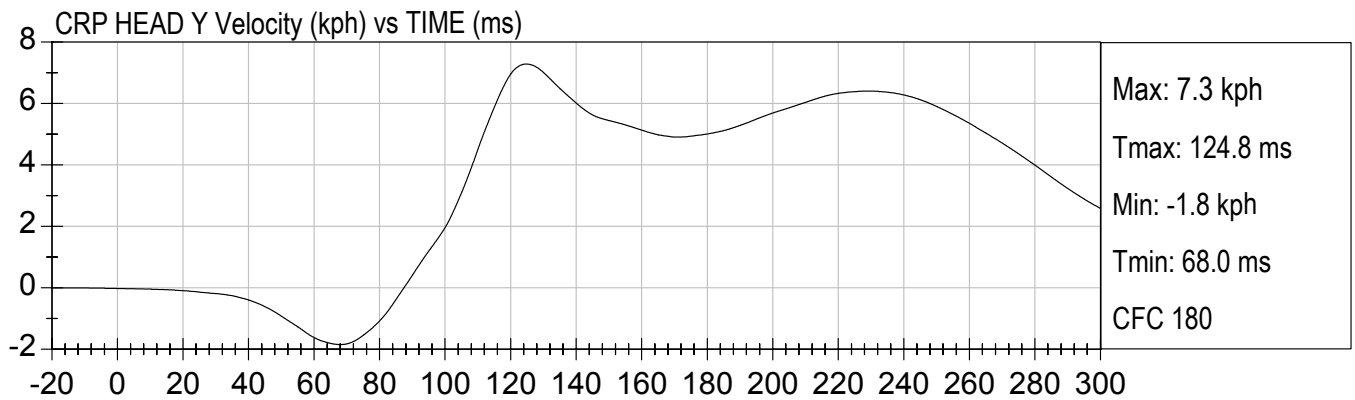
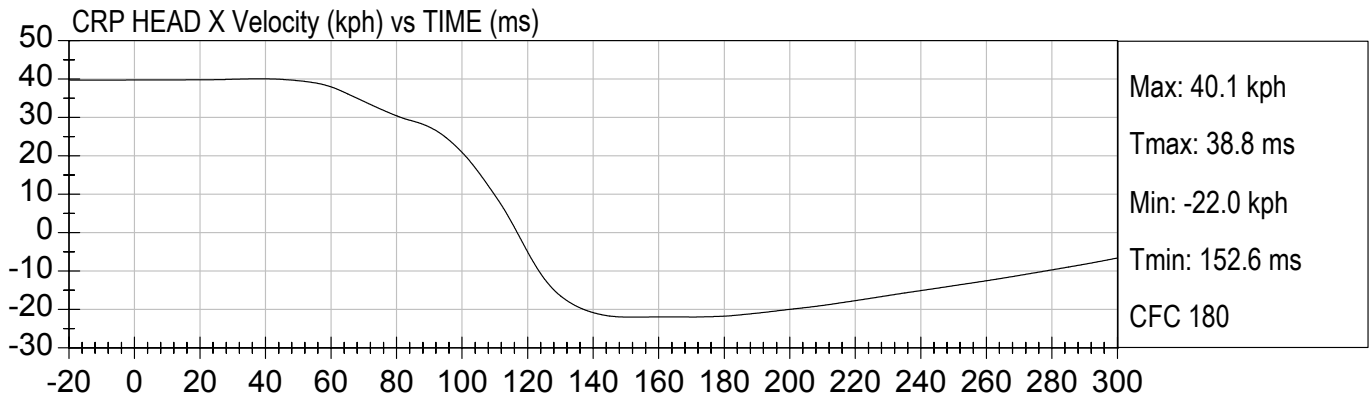

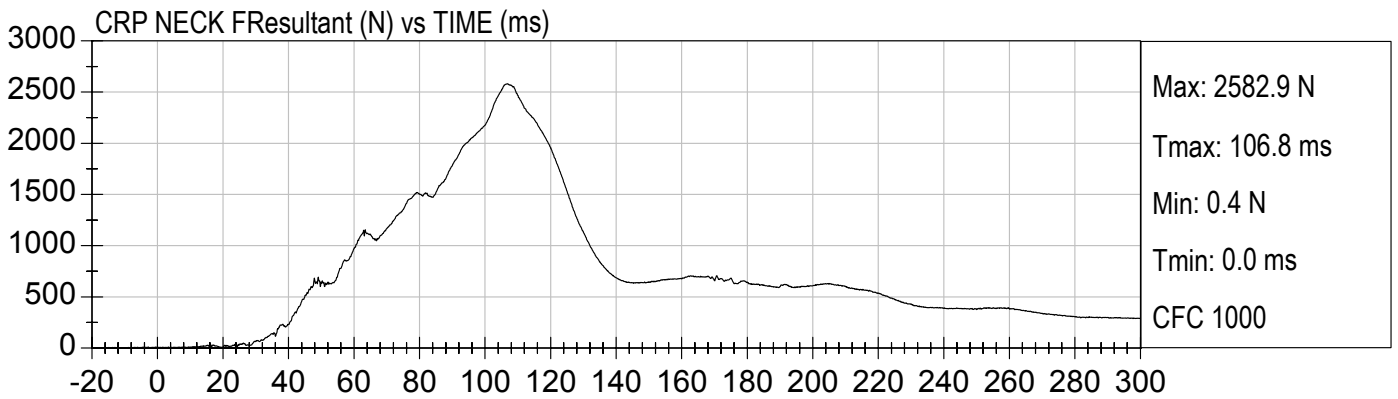
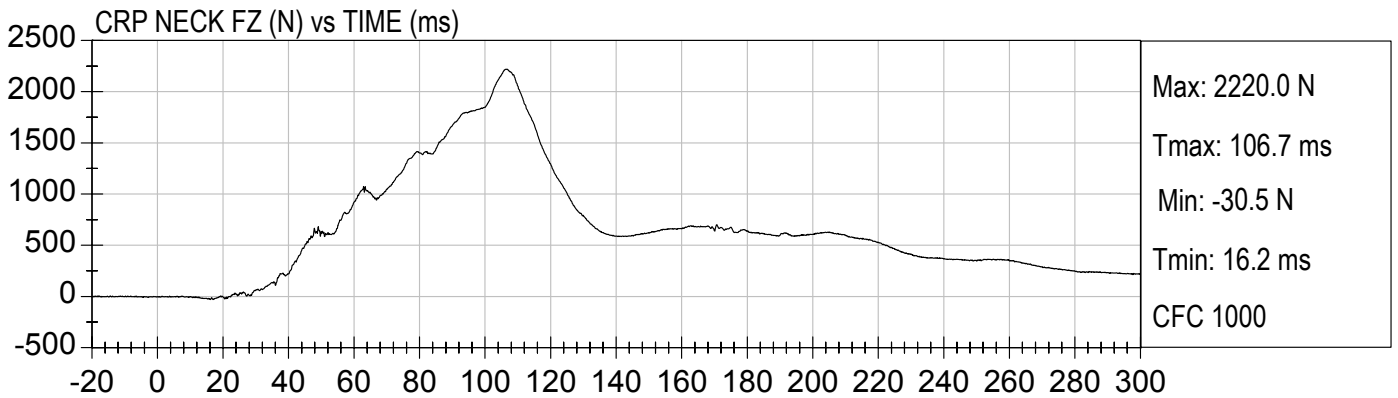
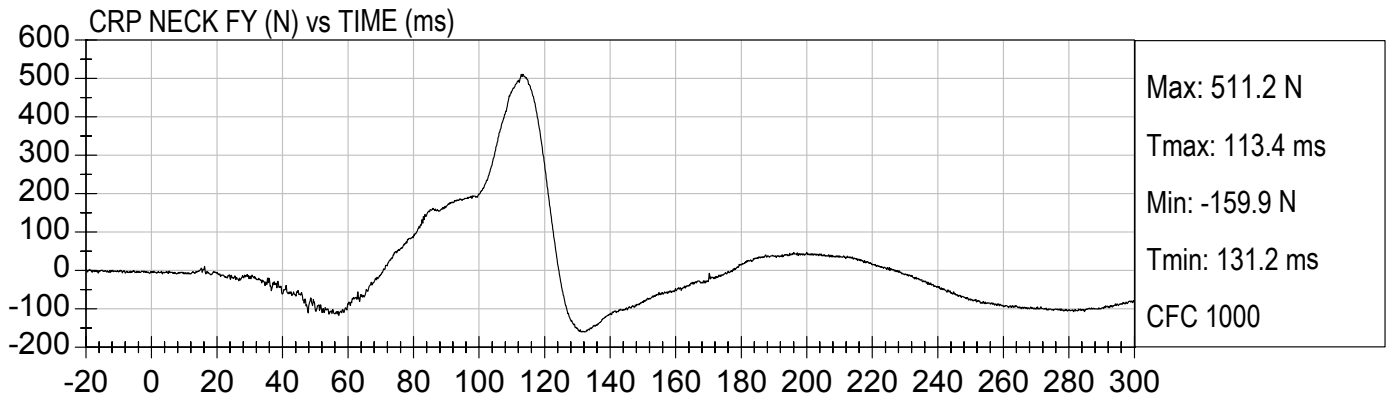
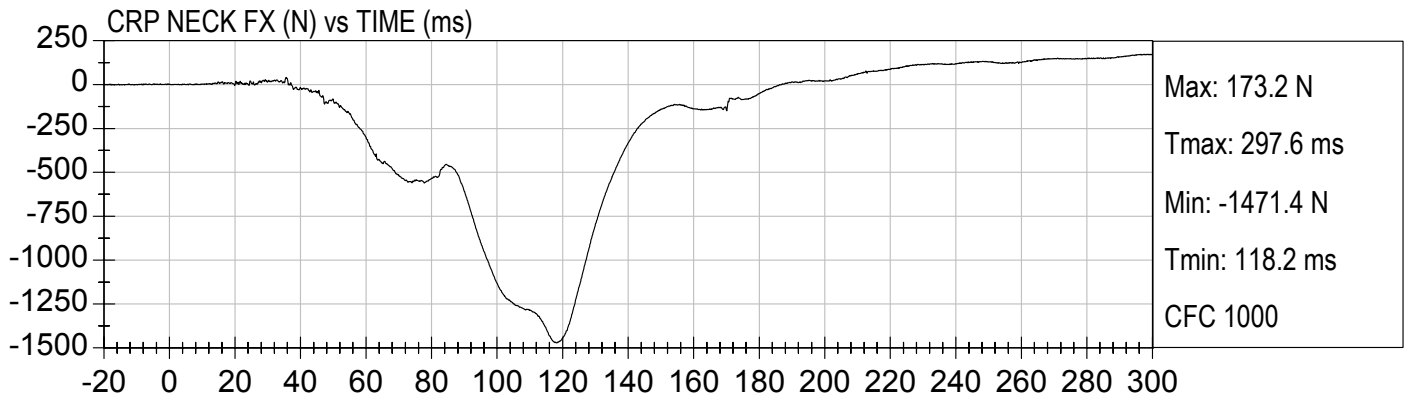

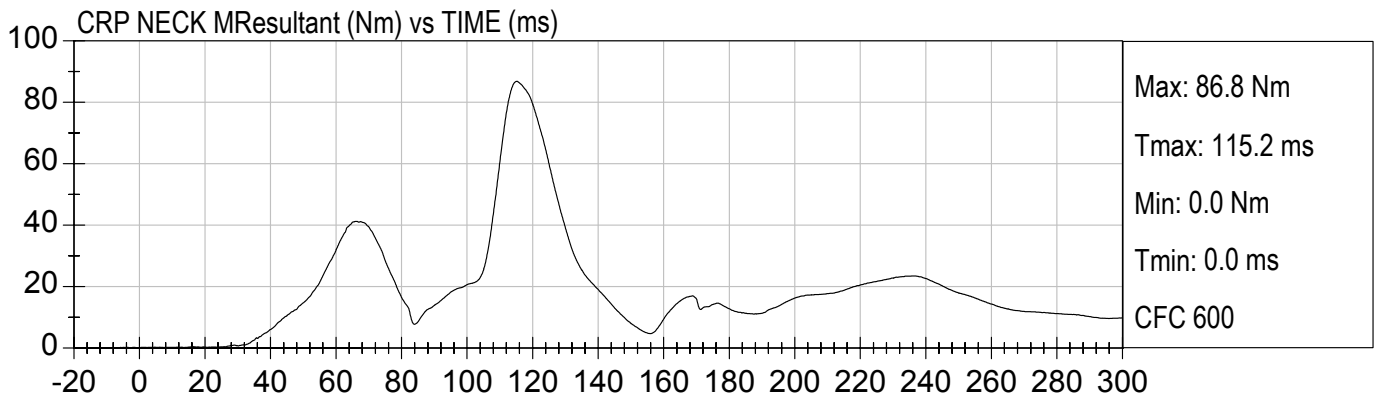
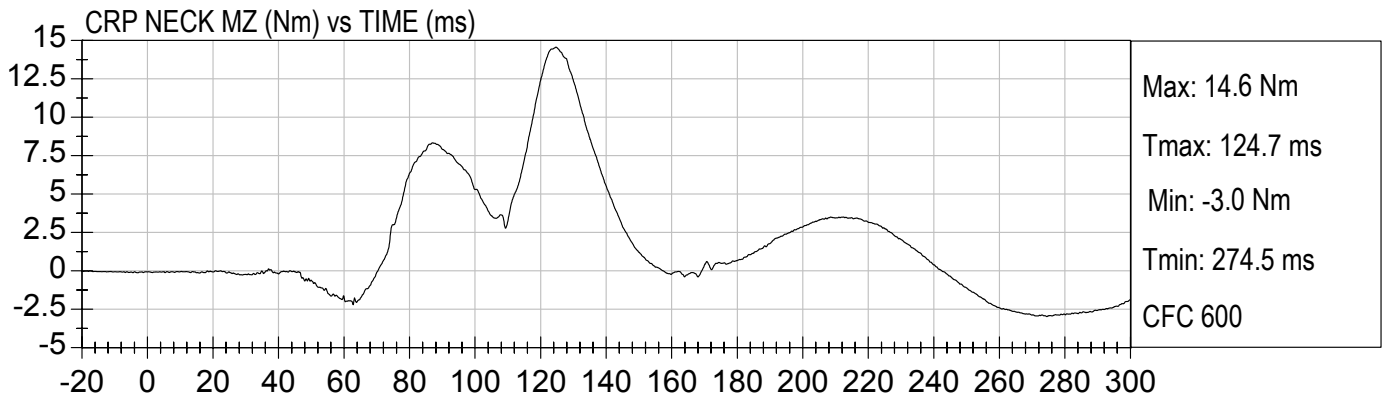
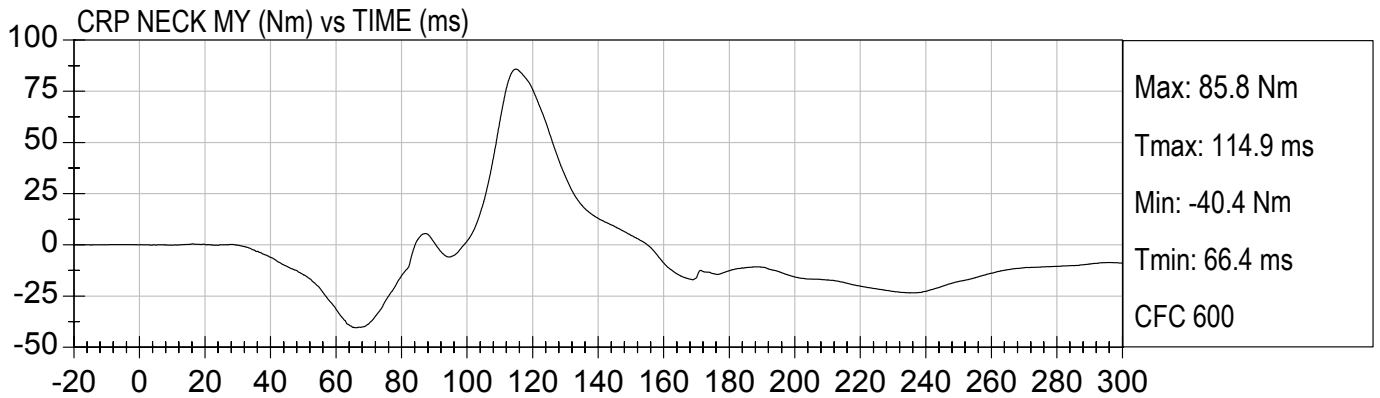
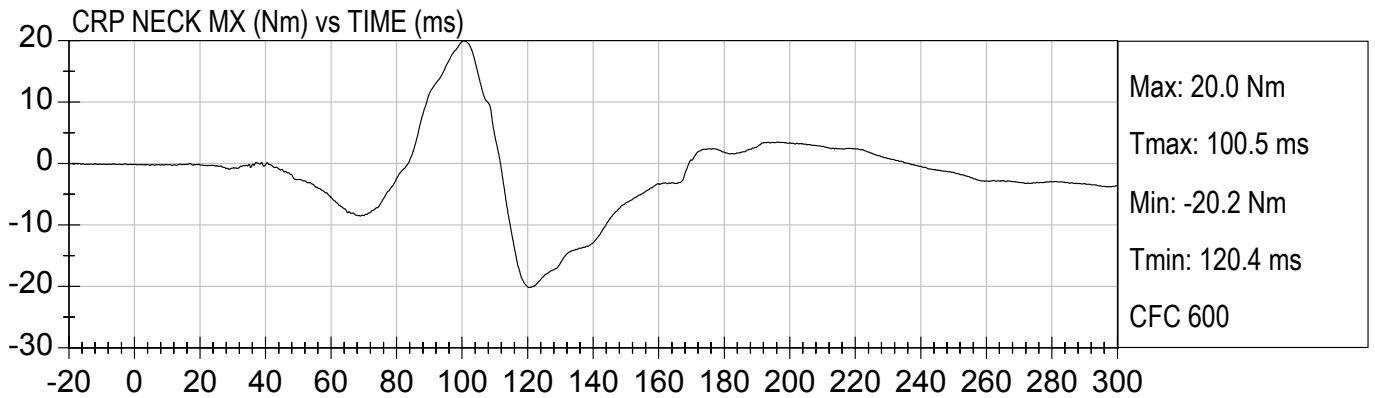



25 MPH FRONTAL UNBELTED
2004 JEEP LIBERTY (C40300)

Test Date: 2/27/2004
Speed: 24.7 mph (39.8 km/h)

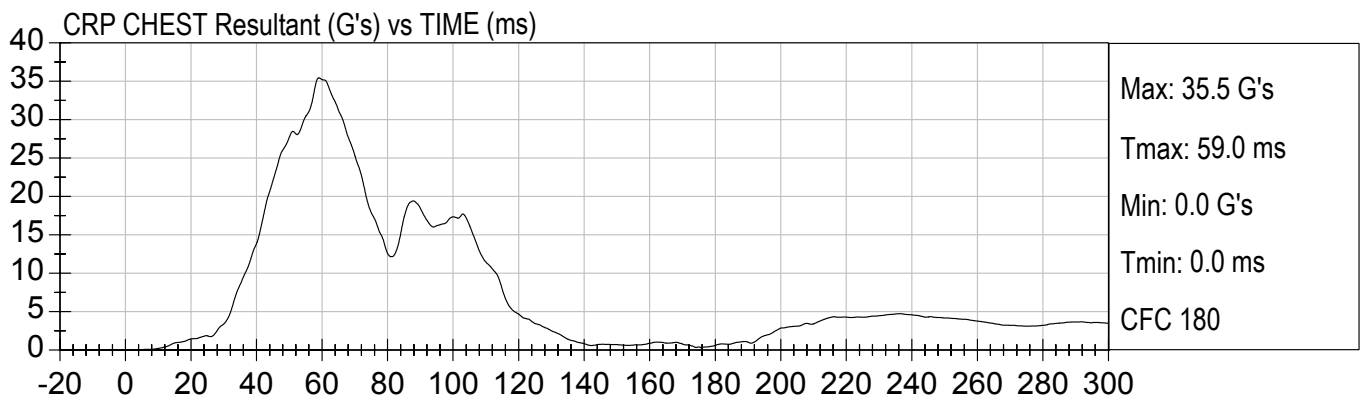
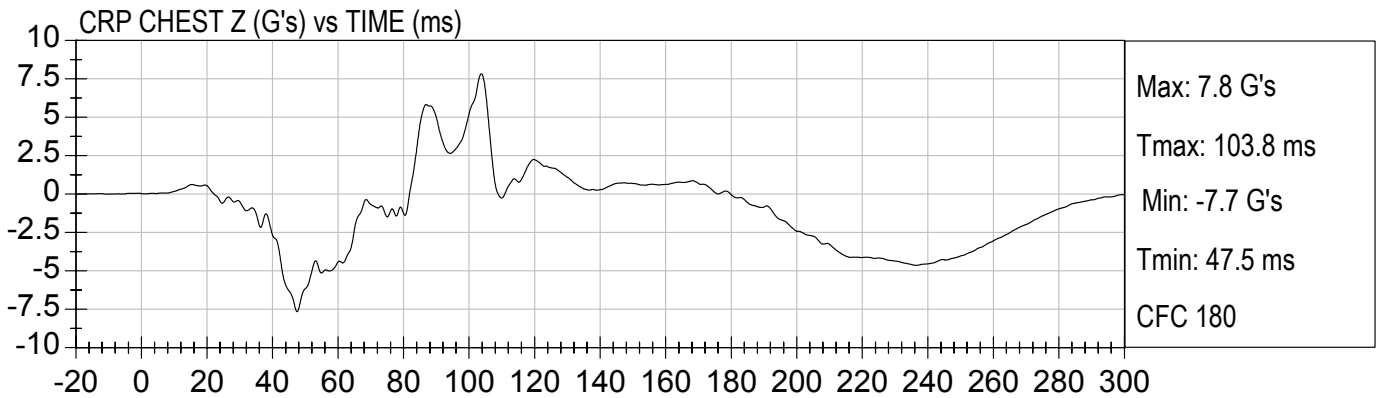
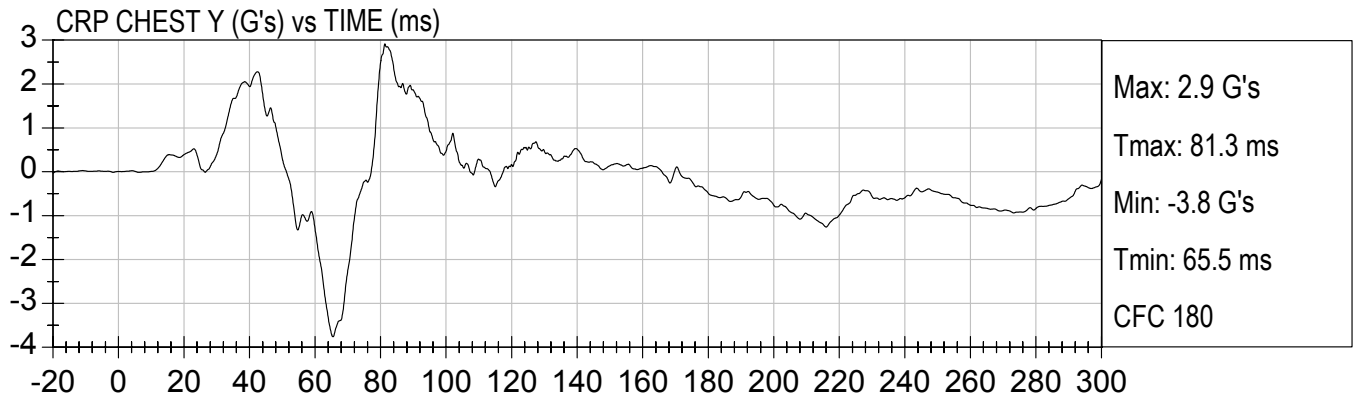
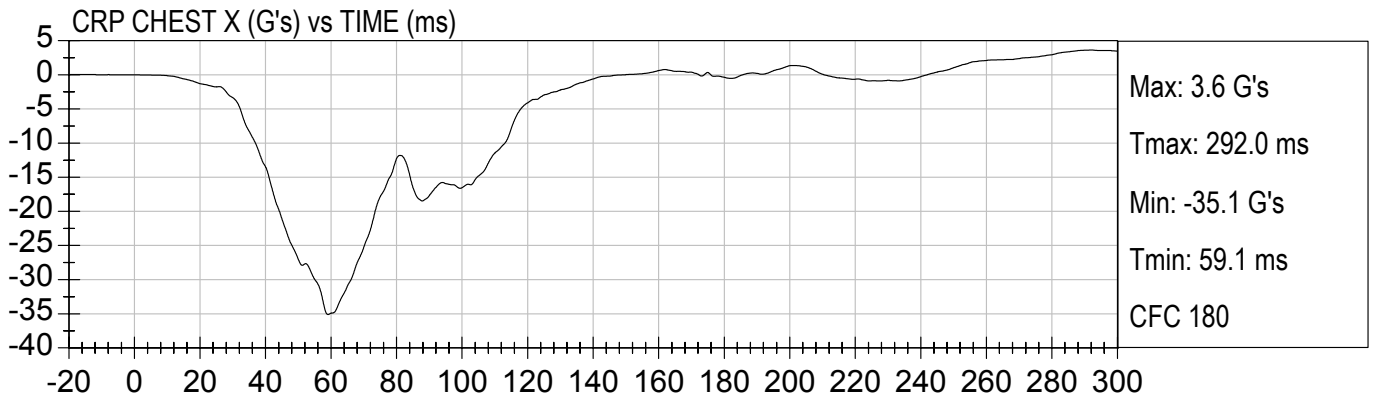



CRP CHEST X Velocity (kph) vs TIME (ms)

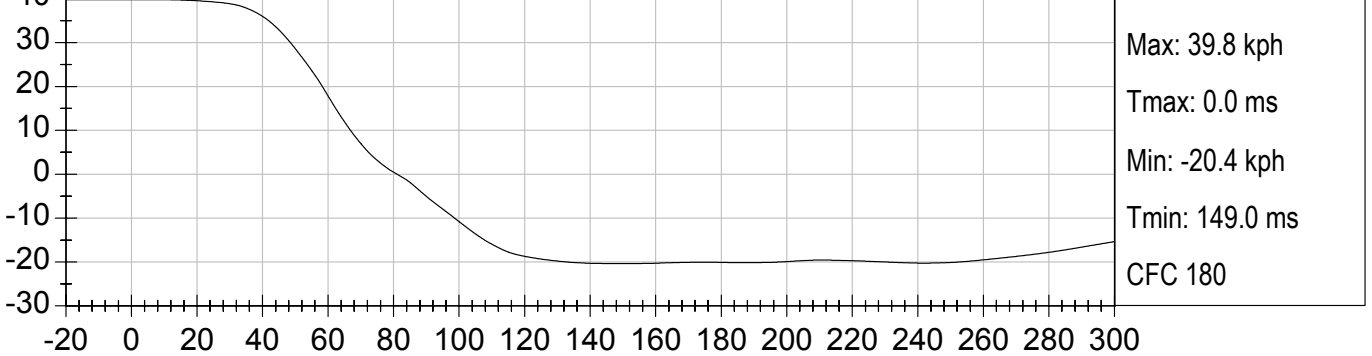

CRP CHEST Y Velocity (kph) vs TIME (ms)

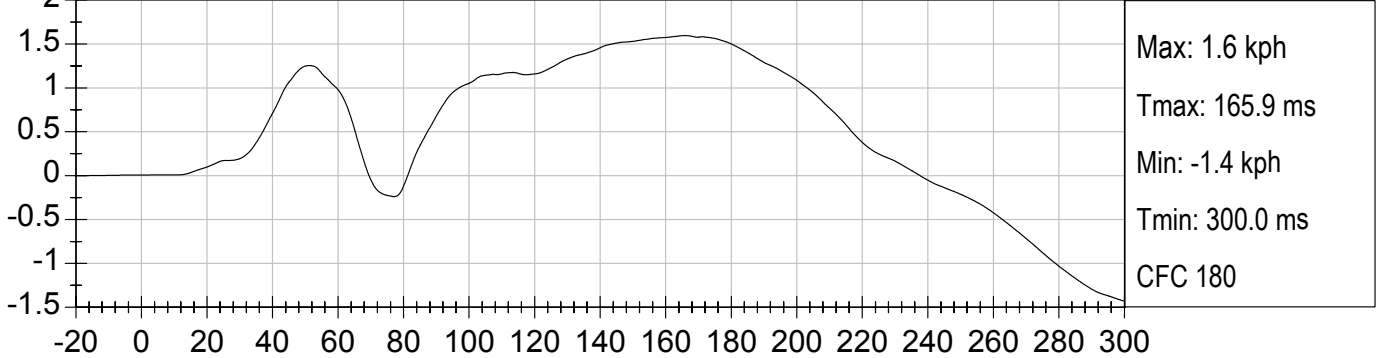

CRP CHEST Z Velocity (kph) vs TIME (ms)

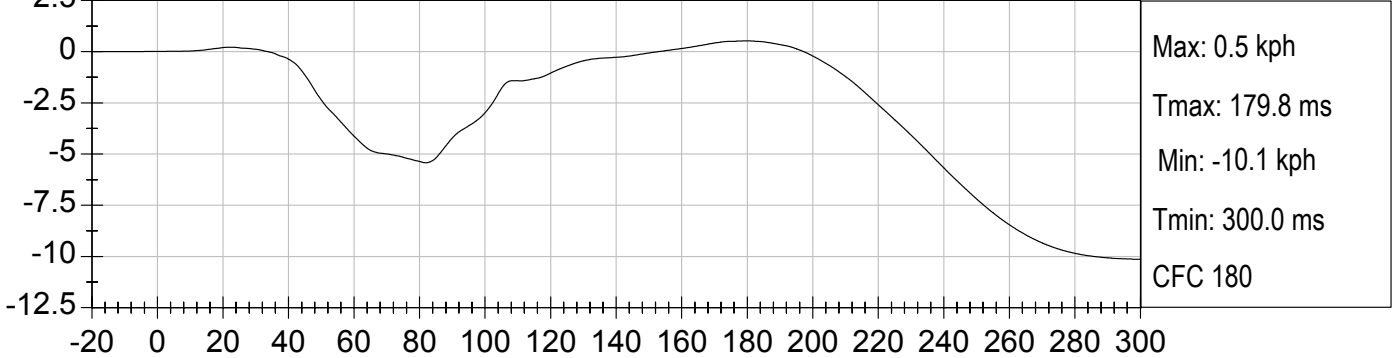

CRP CHEST DISPLACEMENT (mm) vs TIME (ms)

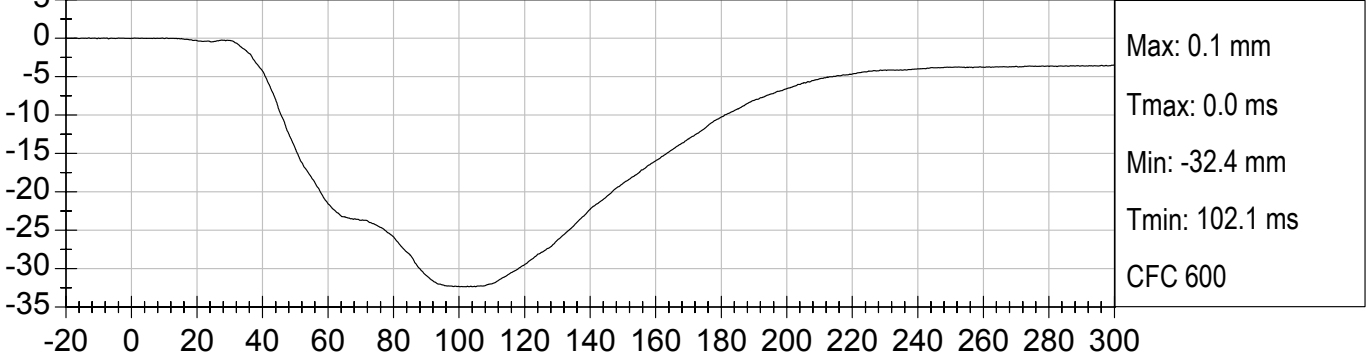



25 MPH FRONTAL UNBELTED
2004 JEEP LIBERTY (C40300)

Test Date: 2/27/2004
Speed: 24.7 mph (39.8 km/h)

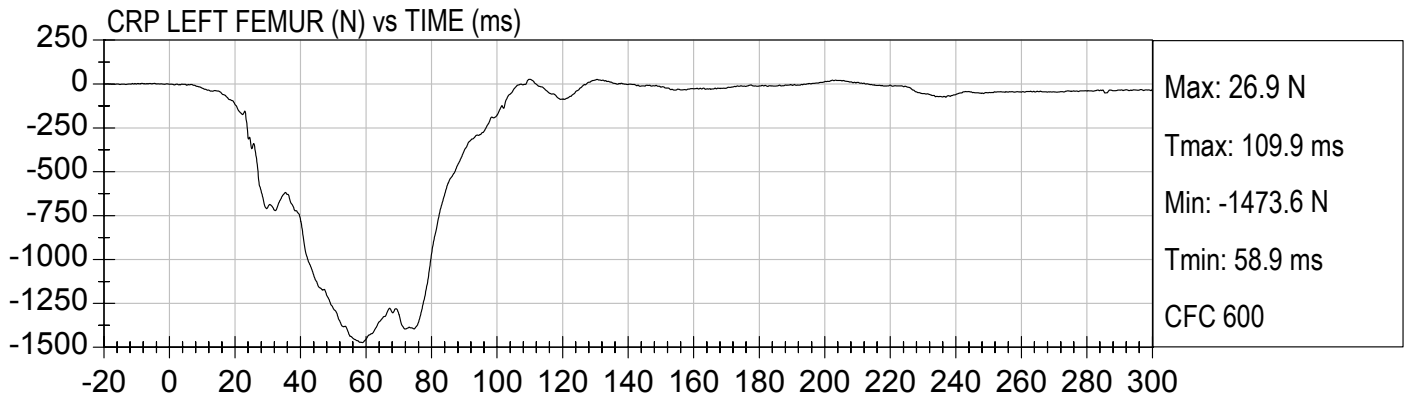
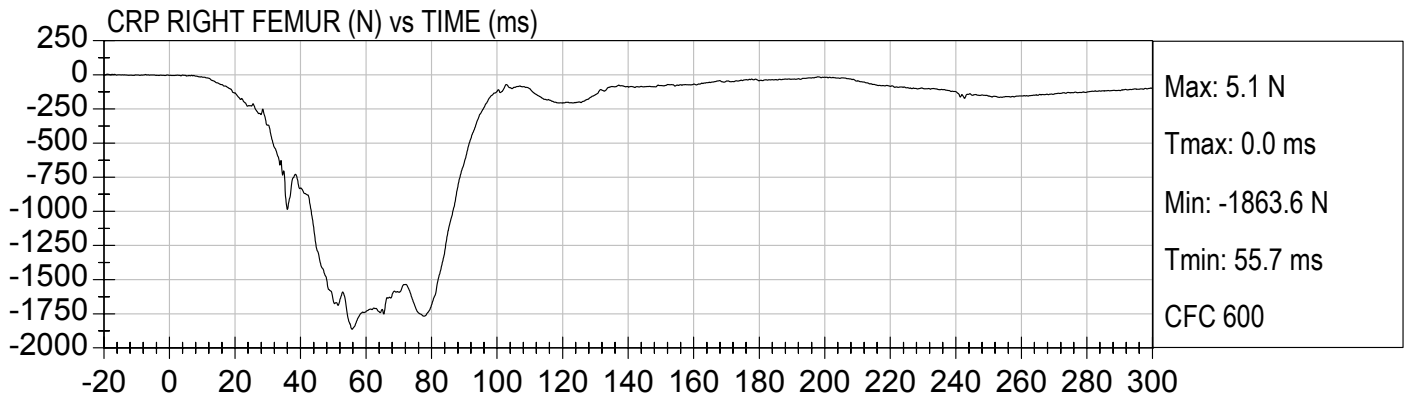



25 MPH FRONTAL UNBELTED
2004 JEEP LIBERTY (C40300)

Test Date: 2/27/2004
Speed: 24.7 mph (39.8 km/h)

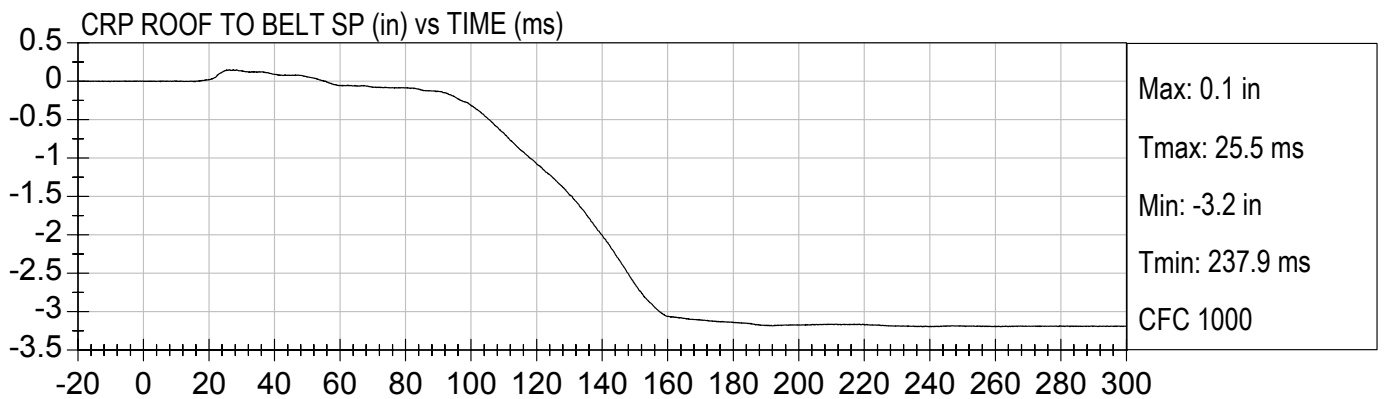
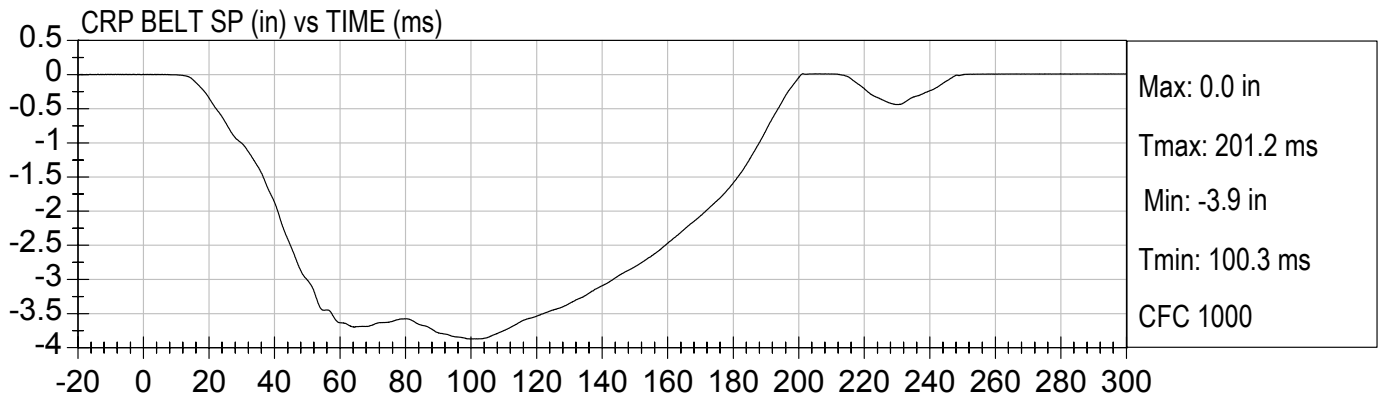
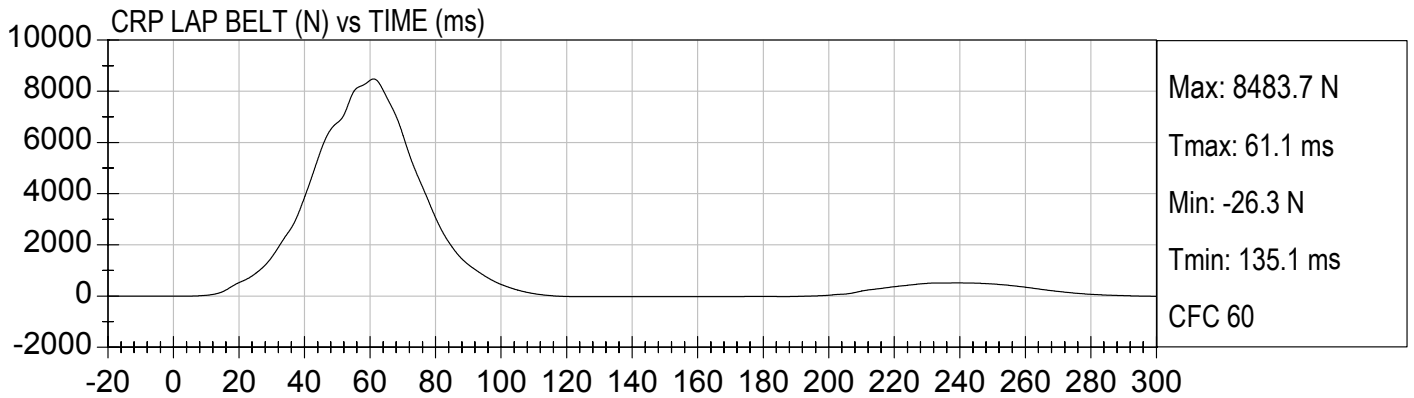
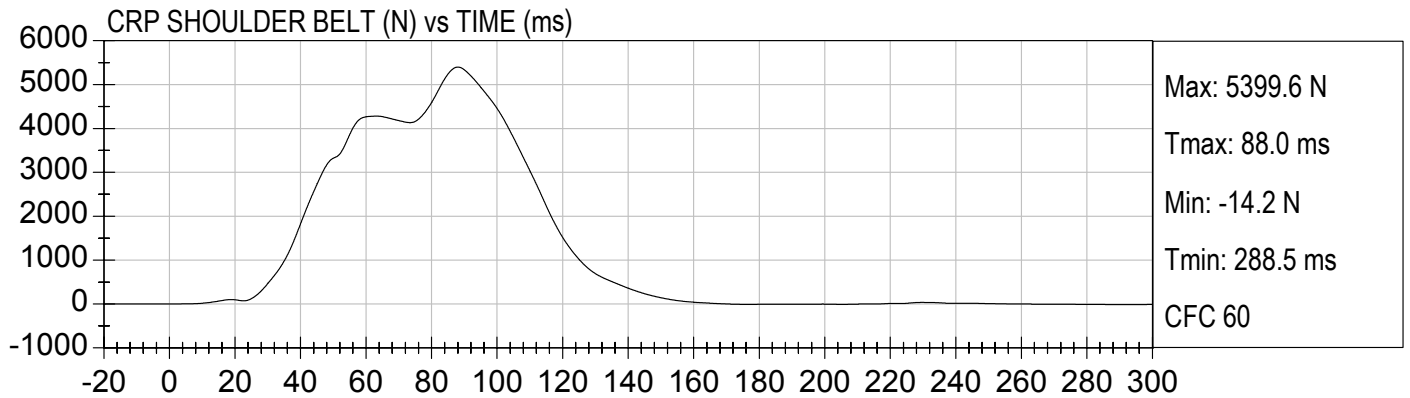

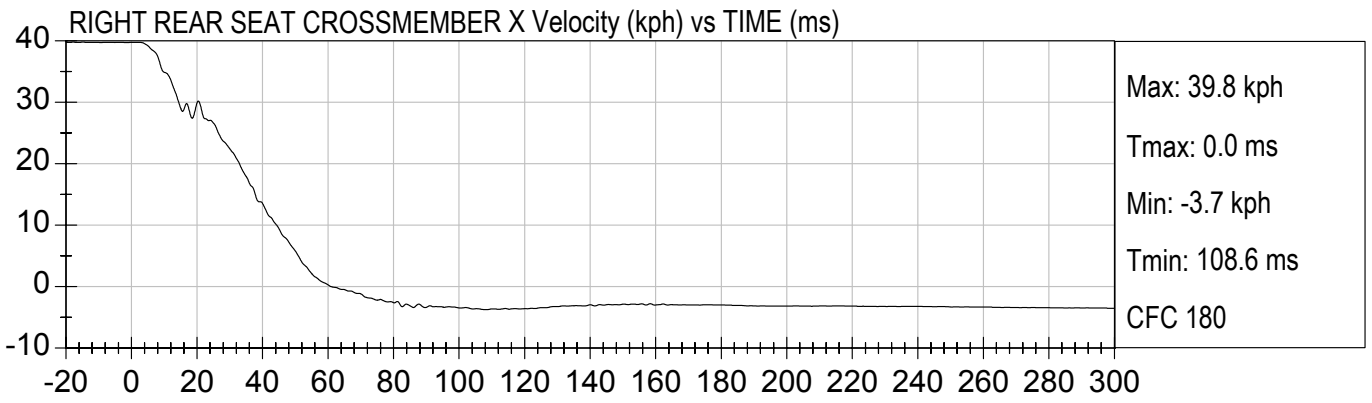
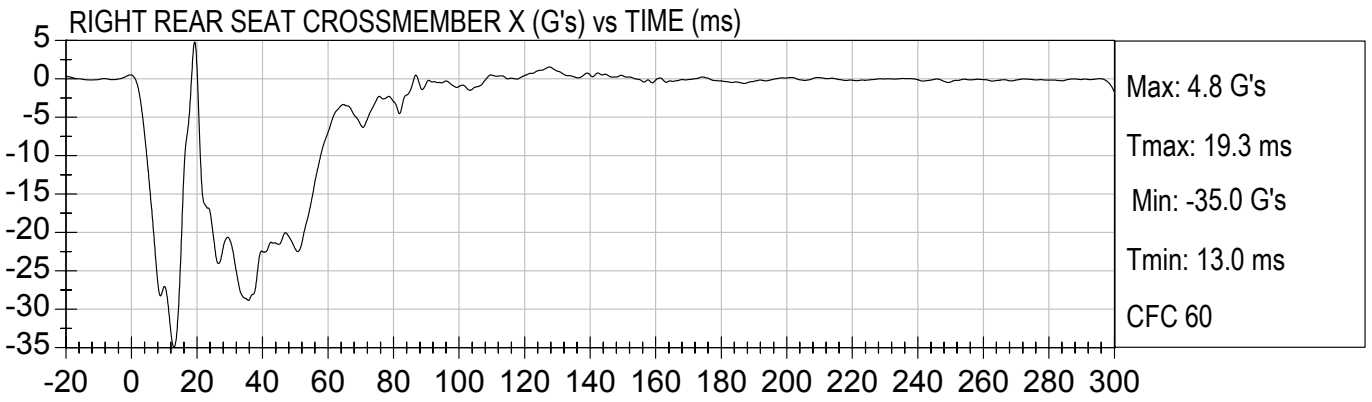
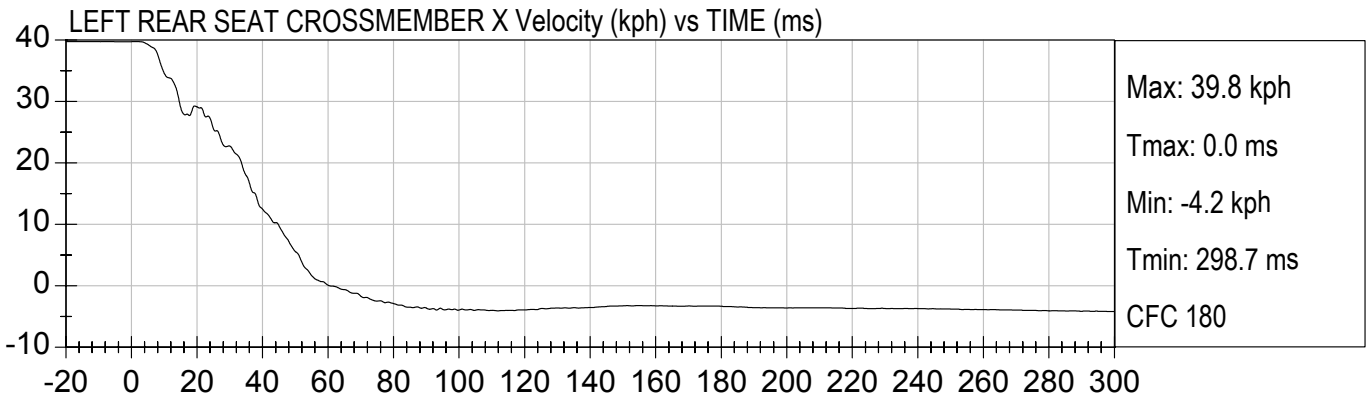
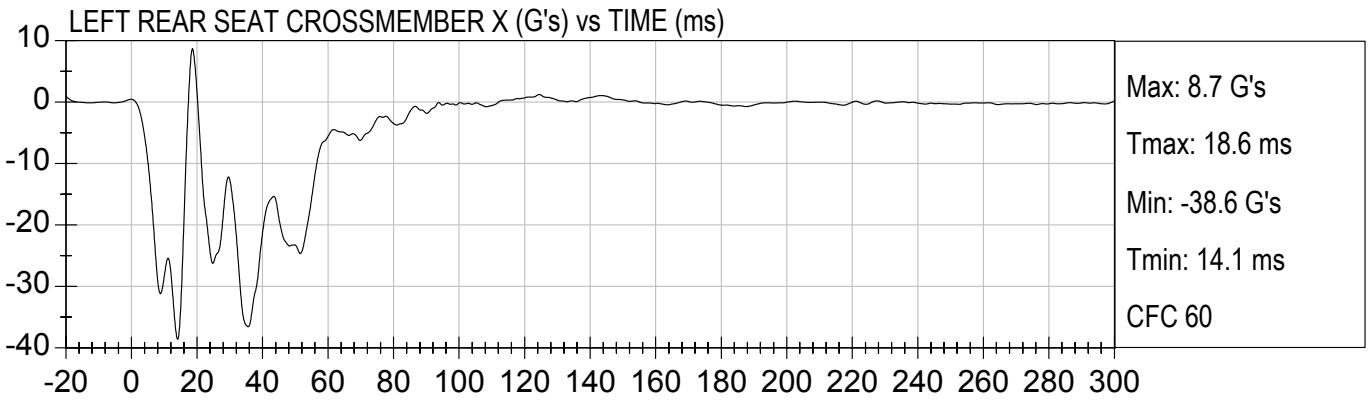

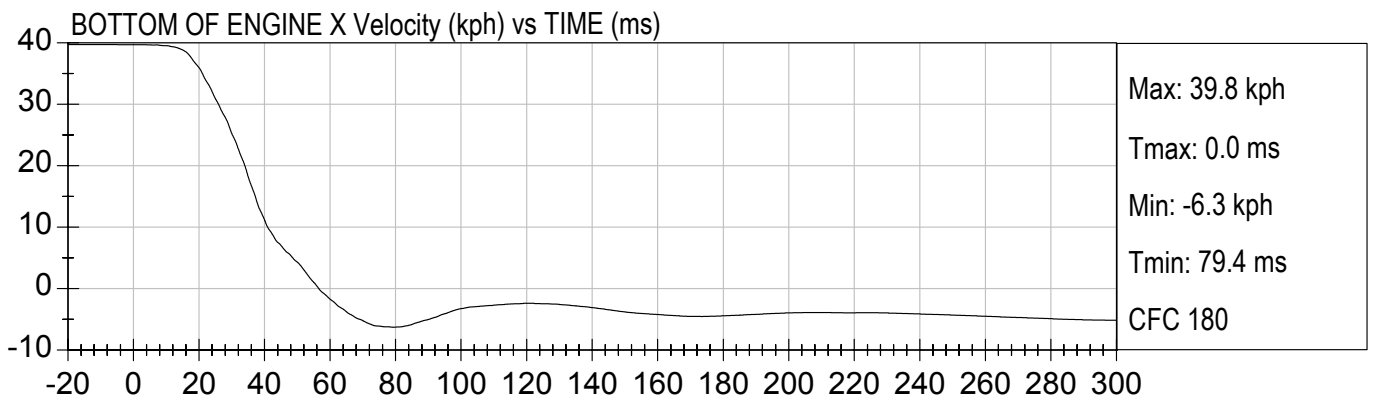
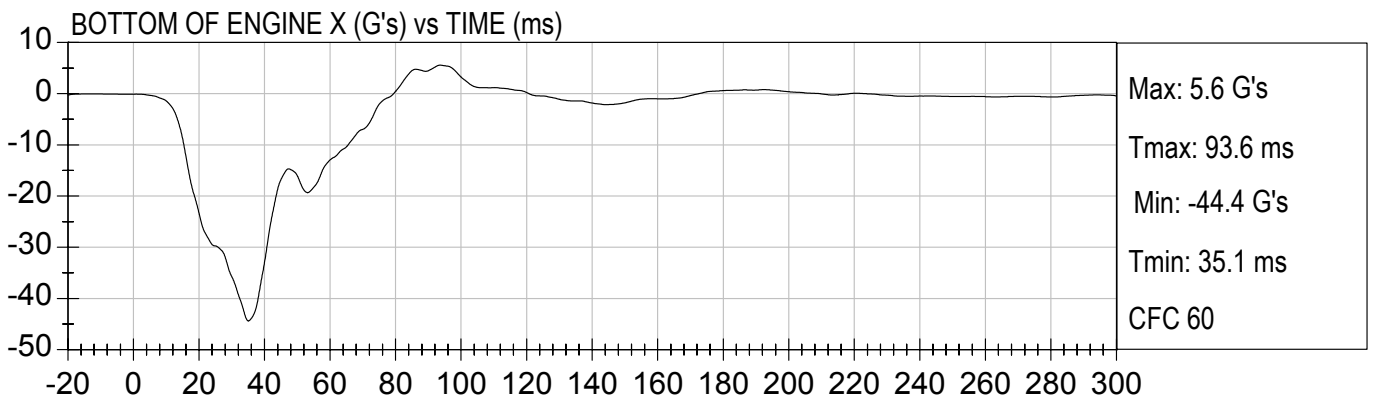
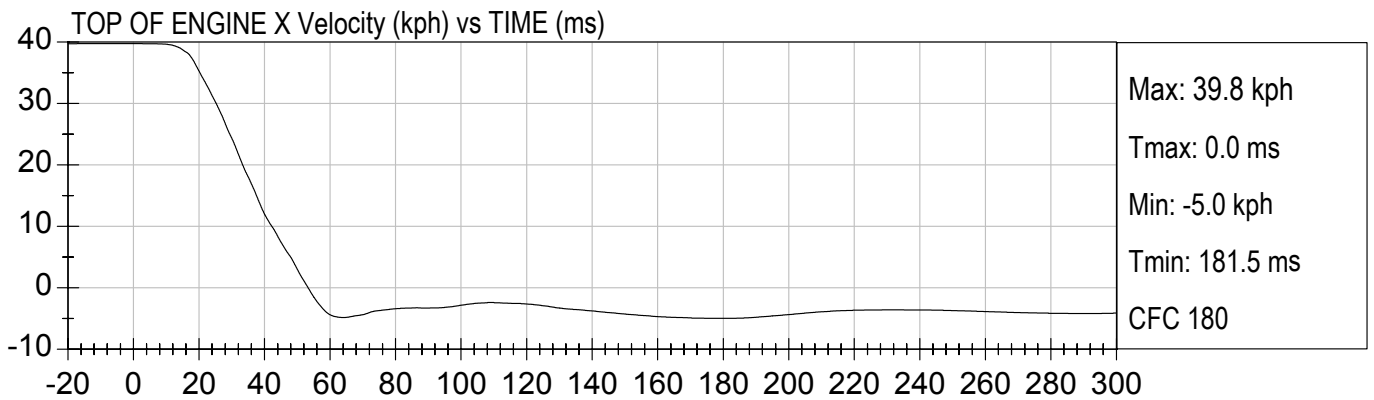
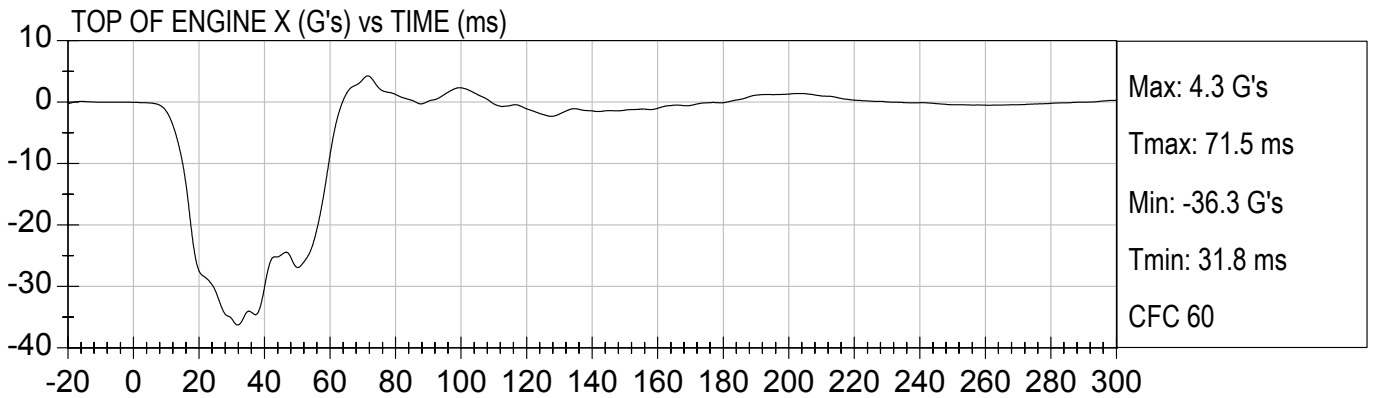

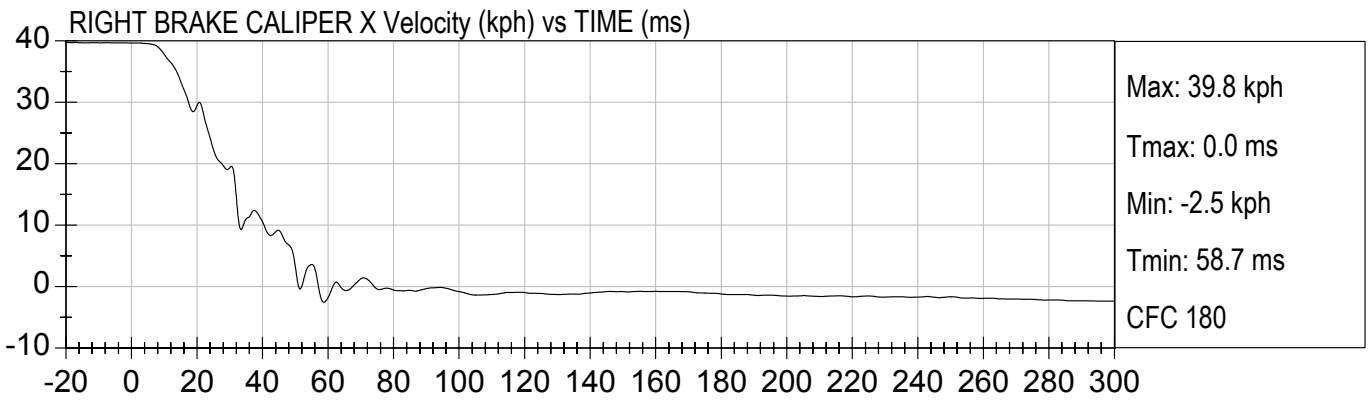
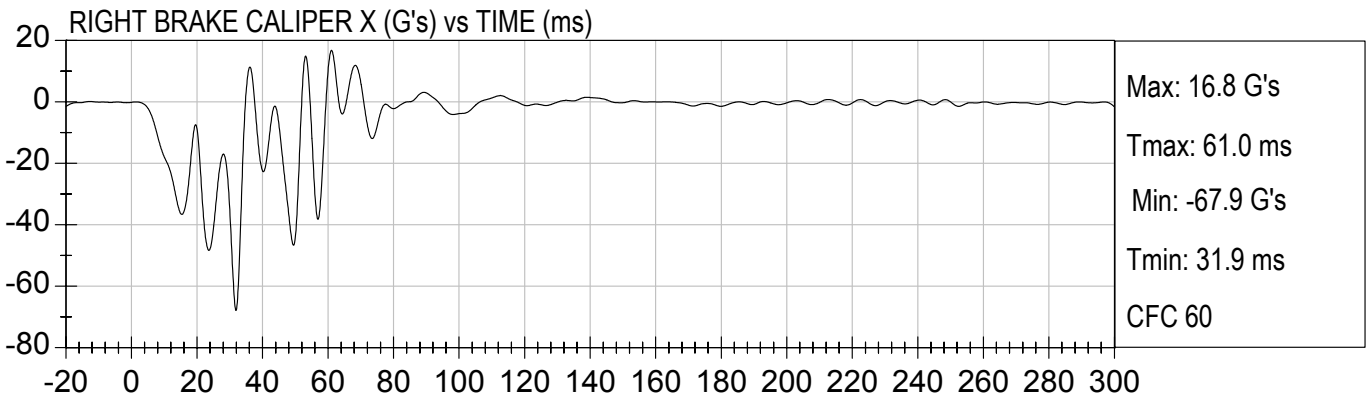
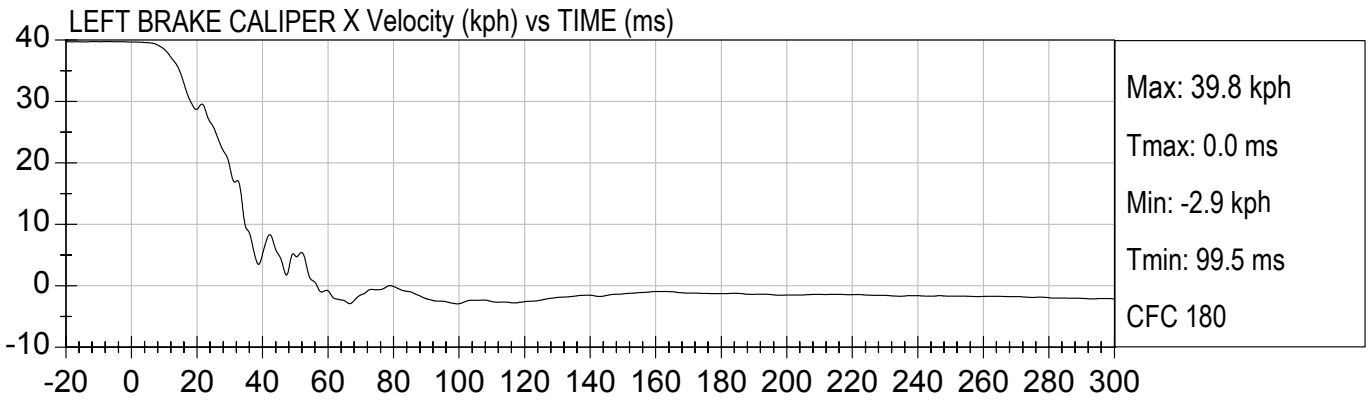
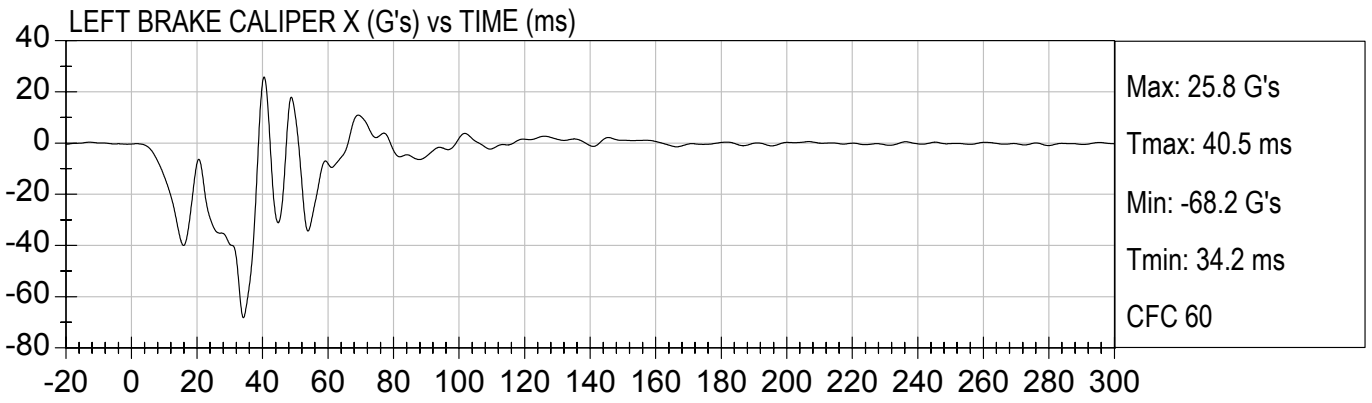

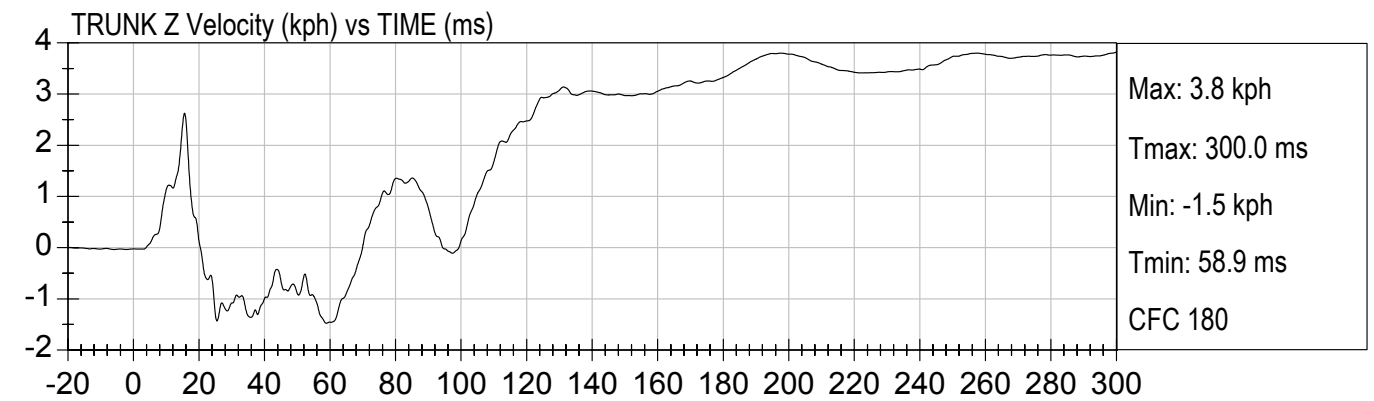
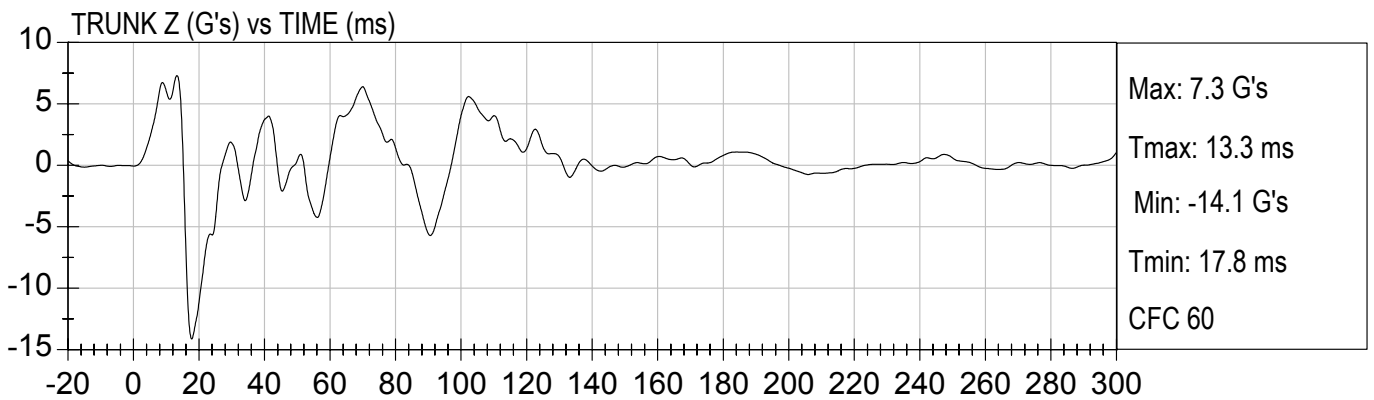
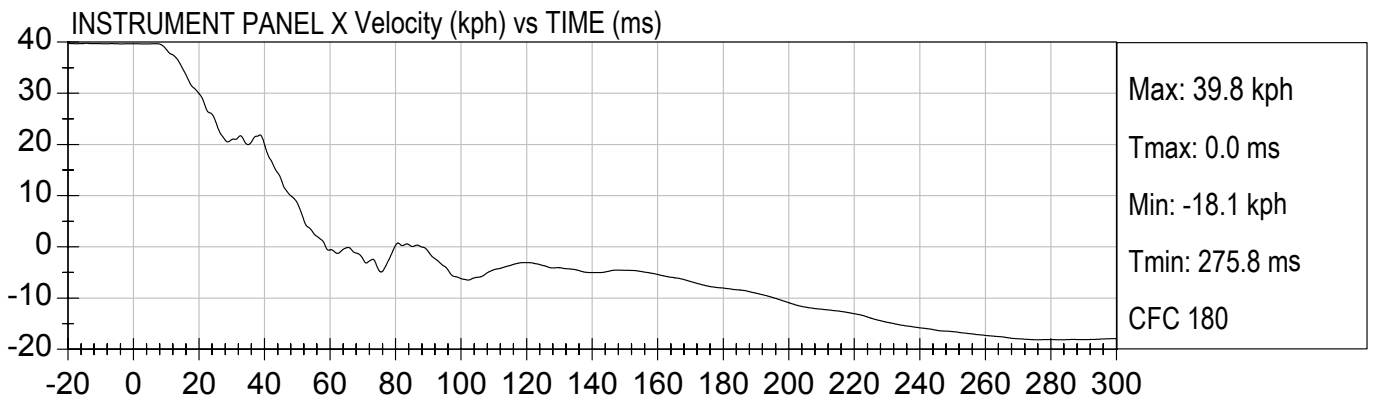
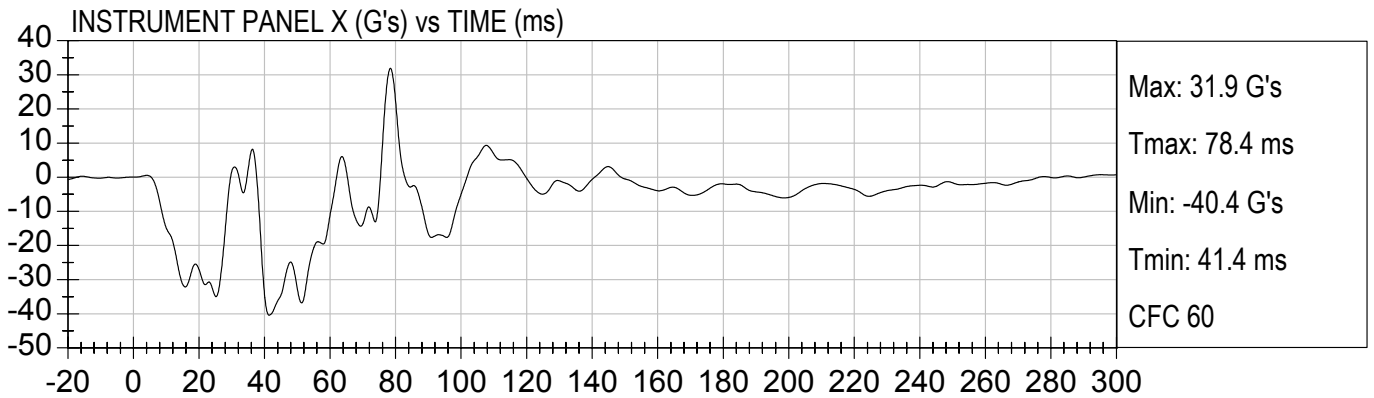

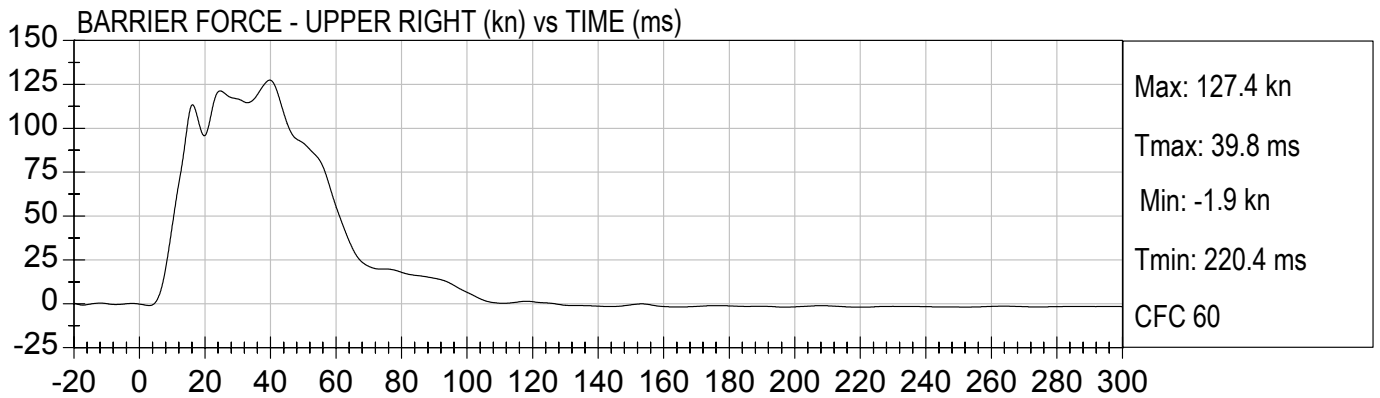
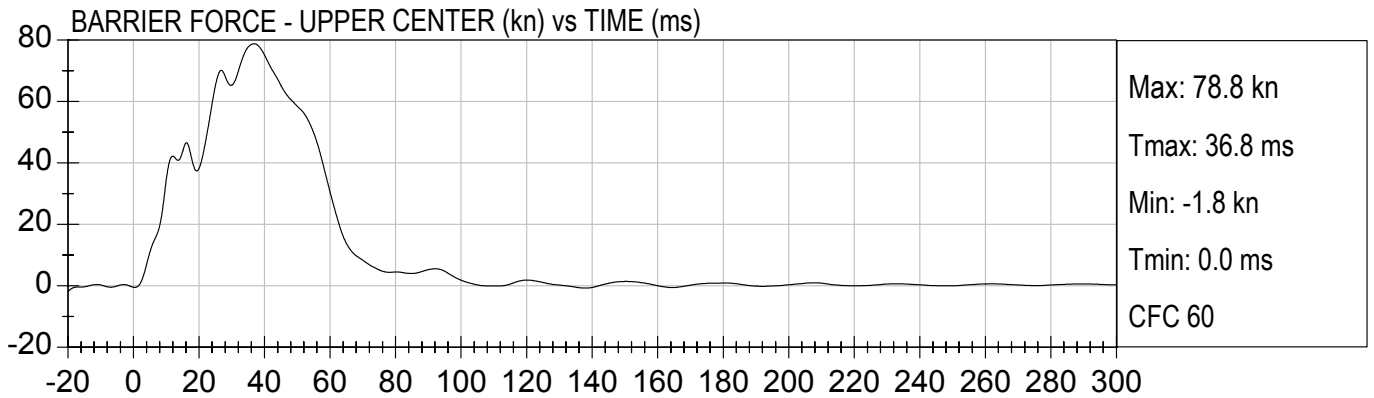
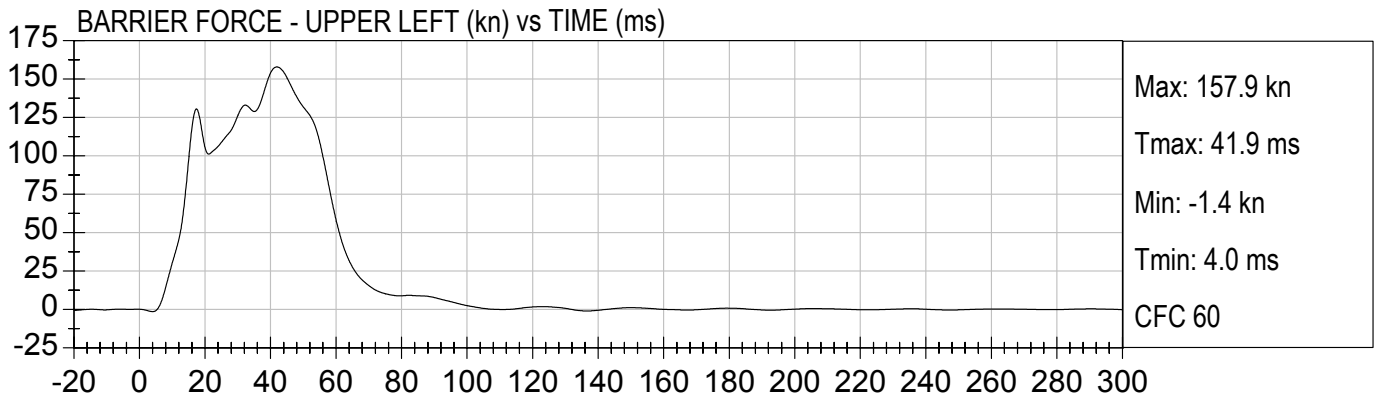



BARRIER FORCE - LOWER LEFT (kn) vs TIME (ms)

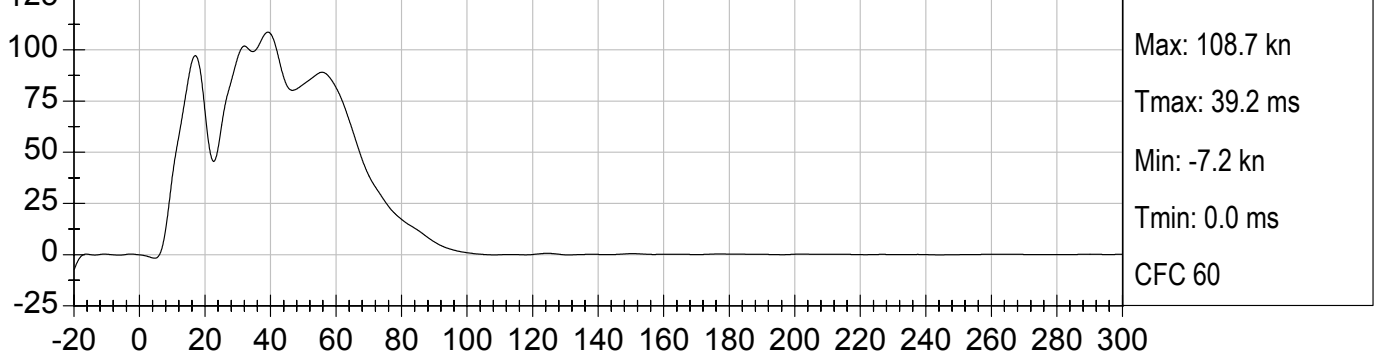

BARRIER FORCE - LOWER CENTER (kn) vs TIME (ms)

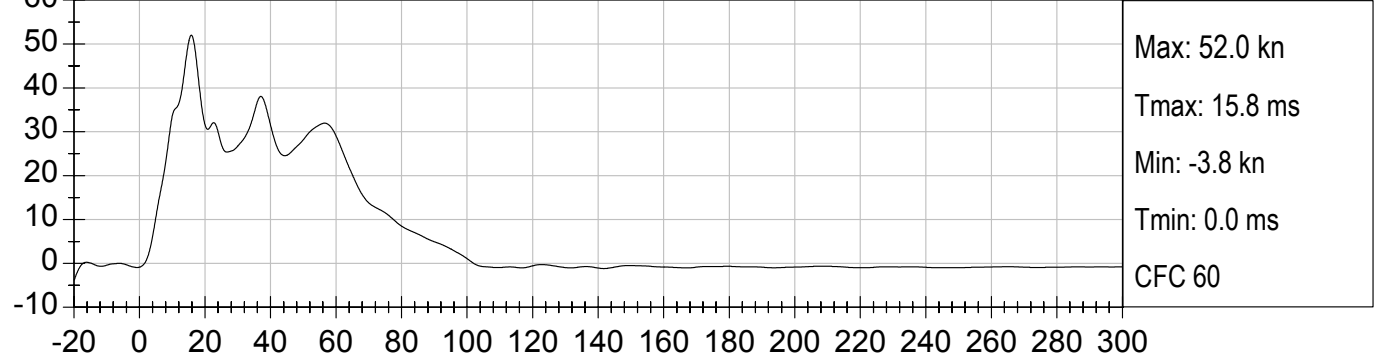

BARRIER FORCE - LOWER RIGHT (kn) vs TIME (ms)

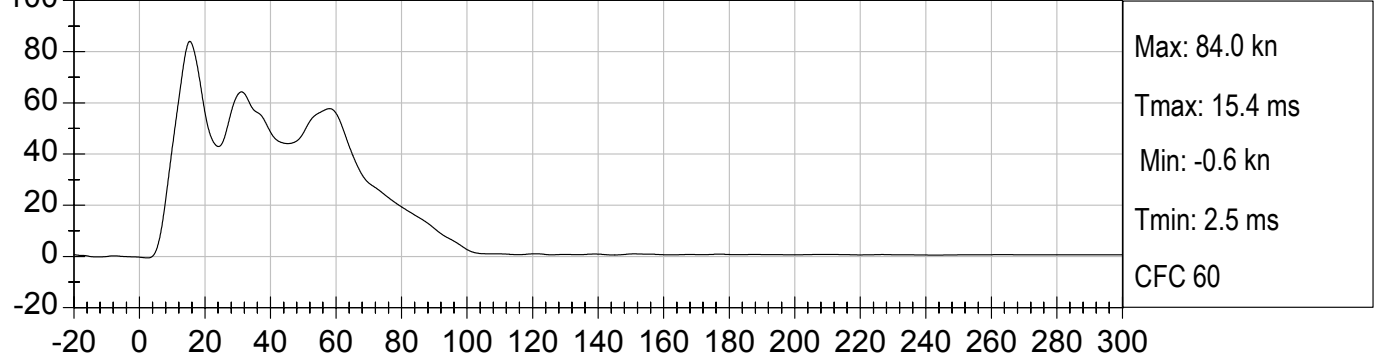

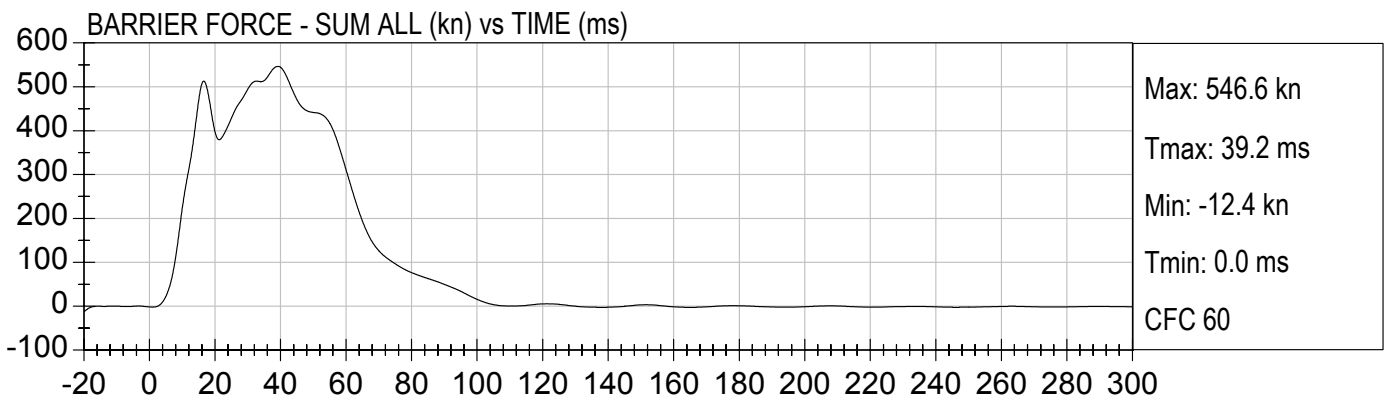
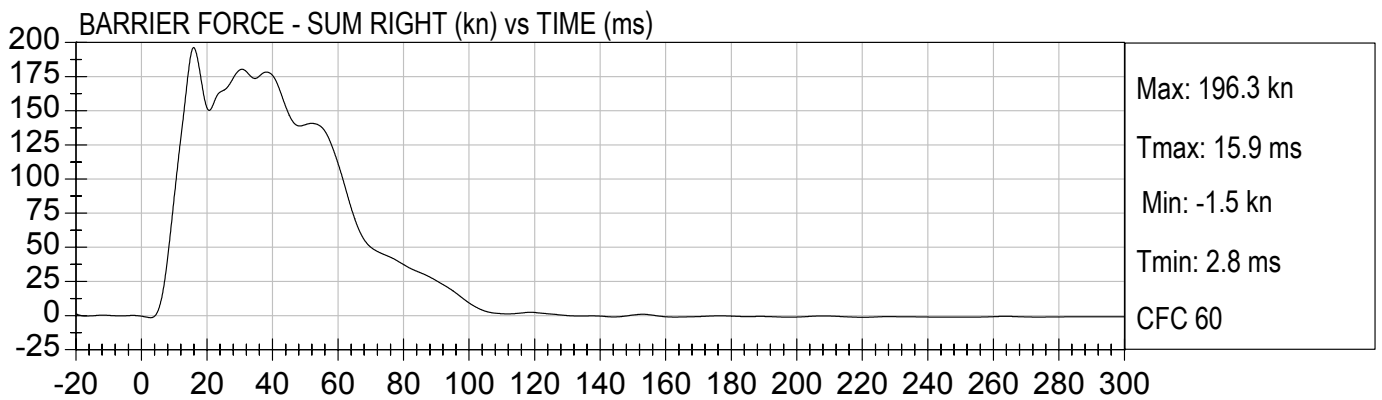
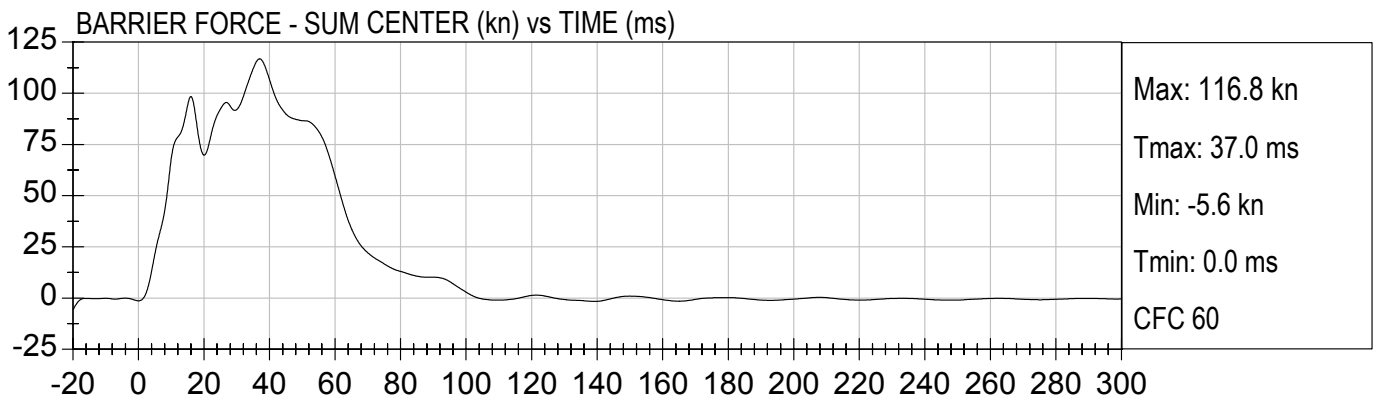
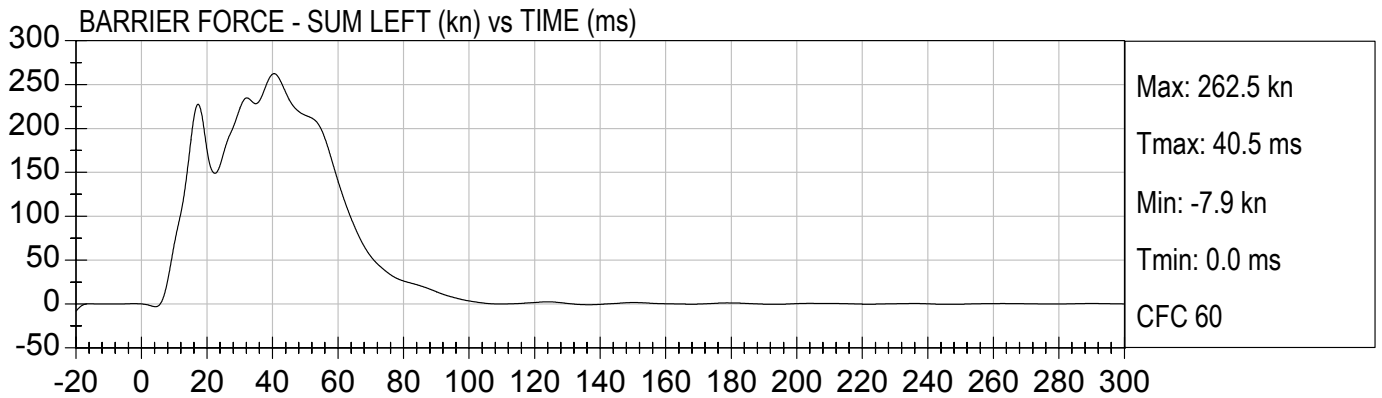



25 MPH FRONTAL UNBELTED
2004 JEEP LIBERTY (C40300)

Test Date: 2/27/2004
Speed: 24.7 mph (39.8 km/h)

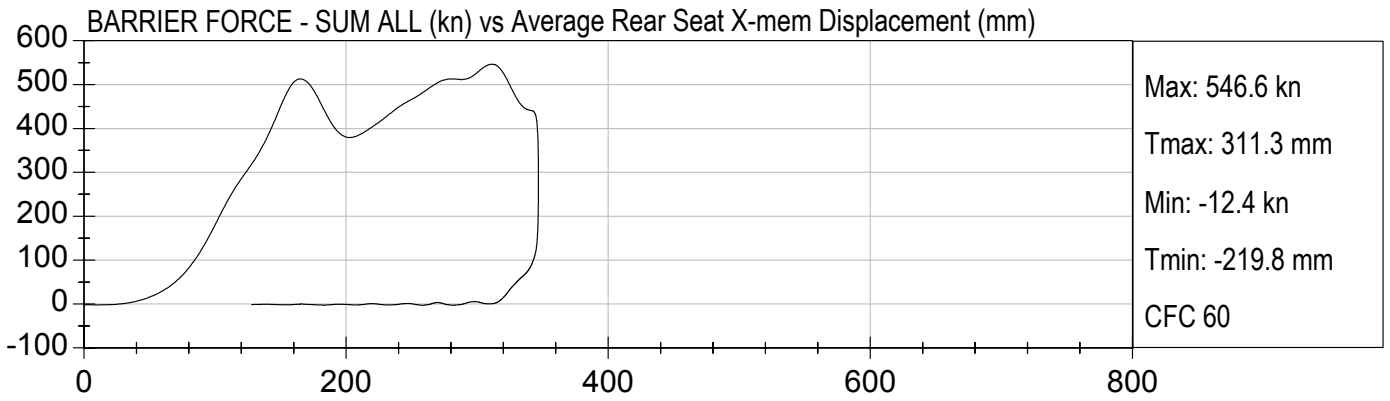

APPENDIX B
LOW RISK TEST DATA

TABLE OF DATA PLOTS

		<u>Page No.</u>
Figure No. 1.	5 th Fem. P1 Driver Head X Acceleration vs. Time	B-1
Figure No. 2.	5 th Fem. P1 Driver Head Y Acceleration vs. Time	B-1
Figure No. 3.	5 th Fem. P1 Driver Head Z Acceleration vs. Time	B-1
Figure No. 4.	5 th Fem. P1 Driver Head Resultant Acceleration vs. Time	B-1
Figure No. 5.	5 th Fem. P1 Driver Head X Velocity vs. Time	B-2
Figure No. 6.	5 th Fem. P1 Driver Head Y Velocity vs. Time	B-2
Figure No. 7.	5 th Fem. P1 Driver Head Z Velocity vs. Time	B-2
Figure No. 8.	5 th Fem. P1 Driver Neck Force X vs. Time	B-3
Figure No. 9.	5 th Fem. P1 Driver Neck Force Y vs. Time	B-3
Figure No. 10.	5 th Fem. P1 Driver Neck Force Z vs. Time	B-3
Figure No. 11.	5 th Fem. P1 Driver Neck Force Resultant vs. Time	B-3
Figure No. 12.	5 th Fem. P1 Driver Neck Moment X vs. Time	B-4
Figure No. 13.	5 th Fem. P1 Driver Neck Moment Y vs. Time	B-4
Figure No. 14.	5 th Fem. P1 Driver Neck Moment Z vs. Time	B-4
Figure No. 15.	5 th Fem. P1 Driver Neck Moment Resultant vs. Time	B-4
Figure No. 16.	5 th Fem. P1 Driver Chest X Acceleration vs. Time	B-5
Figure No. 17.	5 th Fem. P1 Driver Chest Y Acceleration vs. Time	B-5
Figure No. 18.	5 th Fem. P1 Driver Chest Z Acceleration vs. Time	B-5
Figure No. 19.	5 th Fem. P1 Driver Chest Resultant Acceleration vs. Time	B-5
Figure No. 20.	5 th Fem. P1 Driver Chest X Velocity vs. Time	B-6
Figure No. 21.	5 th Fem. P1 Driver Chest Y Velocity vs. Time	B-6
Figure No. 22.	5 th Fem. P1 Driver Chest Z Velocity vs. Time	B-6
Figure No. 23.	5 th Fem. P1 Driver Chest Displacement vs. Time	B-6
Figure No. 24.	5 th Fem. P1 Driver Left Femur Force vs. Time	B-7
Figure No. 25.	5 th Fem. P1 Driver Right Femur Force vs. Time	B-7
Figure No. 26.	Fire Voltage #1 Voltage vs. Time	B-8
Figure No. 27.	Fire Current #1 Voltage vs. Time	B-8
Figure No. 28.	Fire Voltage #2 Voltage vs. Time	B-8
Figure No. 29.	Fire Current #2 Voltage vs. Time	B-8

	<u>Page No.</u>	
Figure No. 30.	5 th Fem. P2 Driver Head X Acceleration vs. Time	B-9
Figure No. 31.	5 th Fem. P2 Driver Head Y Acceleration vs. Time	B-9
Figure No. 32.	5 th Fem. P2 Driver Head Z Acceleration vs. Time	B-9
Figure No. 33.	5 th Fem. P2 Driver Head Resultant Acceleration vs. Time	B-9
Figure No. 34.	5 th Fem. P2 Driver Head X Velocity vs. Time	B-10
Figure No. 35.	5 th Fem. P2 Driver Head Y Velocity vs. Time	B-10
Figure No. 36.	5 th Fem. P2 Driver Head Z Velocity vs. Time	B-10
Figure No. 37.	5 th Fem. P2 Driver Neck Force X vs. Time	B-11
Figure No. 38.	5 th Fem. P2 Driver Neck Force Y vs. Time	B-11
Figure No. 39.	5 th Fem. P2 Driver Neck Force Z vs. Time	B-11
Figure No. 40.	5 th Fem. P2 Driver Neck Force Resultant vs. Time	B-11
Figure No. 41.	5 th Fem. P2 Driver Neck Moment X vs. Time	B-12
Figure No. 42.	5 th Fem. P2 Driver Neck Moment Y vs. Time	B-12
Figure No. 43.	5 th Fem. P2 Driver Neck Moment Z vs. Time	B-12
Figure No. 44.	5 th Fem. P2 Driver Neck Moment Resultant vs. Time	B-12
Figure No. 45.	5 th Fem. P2 Driver Chest X Acceleration vs. Time	B-13
Figure No. 46.	5 th Fem. P2 Driver Chest Y Acceleration vs. Time	B-13
Figure No. 47.	5 th Fem. P2 Driver Chest Z Acceleration vs. Time	B-13
Figure No. 48.	5 th Fem. P2 Driver Chest Resultant Acceleration vs. Time	B-13
Figure No. 49.	5 th Fem. P2 Driver Chest X Velocity vs. Time	B-14
Figure No. 50.	5 th Fem. P2 Driver Chest Y Velocity vs. Time	B-14
Figure No. 51.	5 th Fem. P2 Driver Chest Z Velocity vs. Time	B-14
Figure No. 52.	5 th Fem. P2 Driver Chest Displacement vs. Time	B-14
Figure No. 53.	5 th Fem. P2 Driver Left Femur Force vs. Time	B-15
Figure No. 54.	5 th Fem. P2 Driver Right Femur Force vs. Time	B-15
Figure No. 55.	Fire Voltage #1 Voltage vs. Time	B-16
Figure No. 56.	Fire Current #1 Voltage vs. Time	B-16
Figure No. 57.	Fire Voltage #2 Voltage vs. Time	B-16
Figure No. 58.	Fire Current #2 Voltage vs. Time	B-16

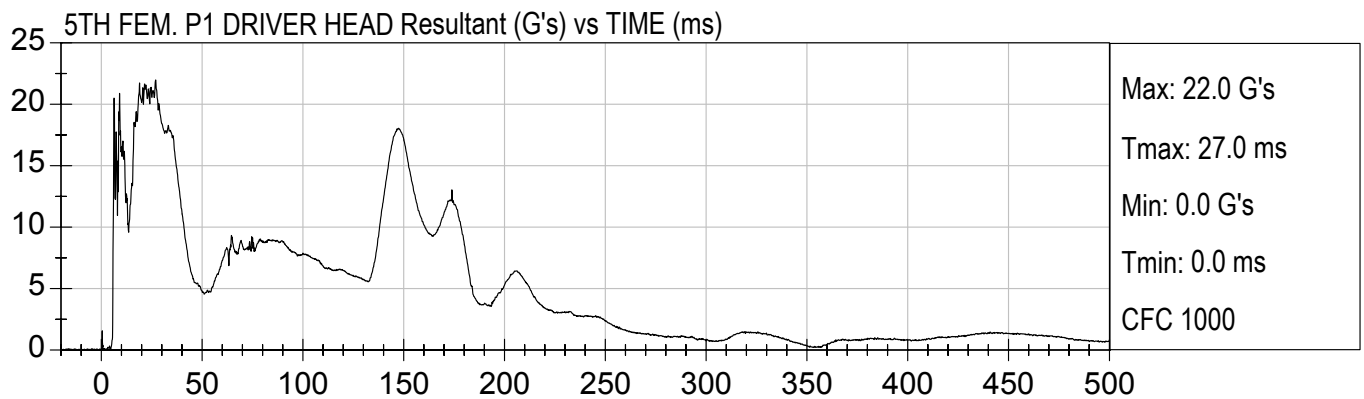
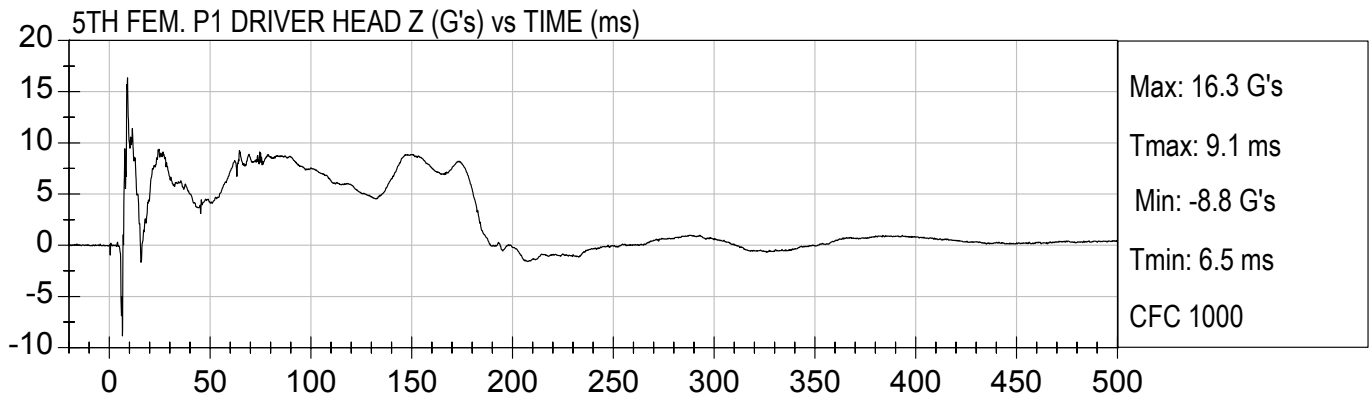
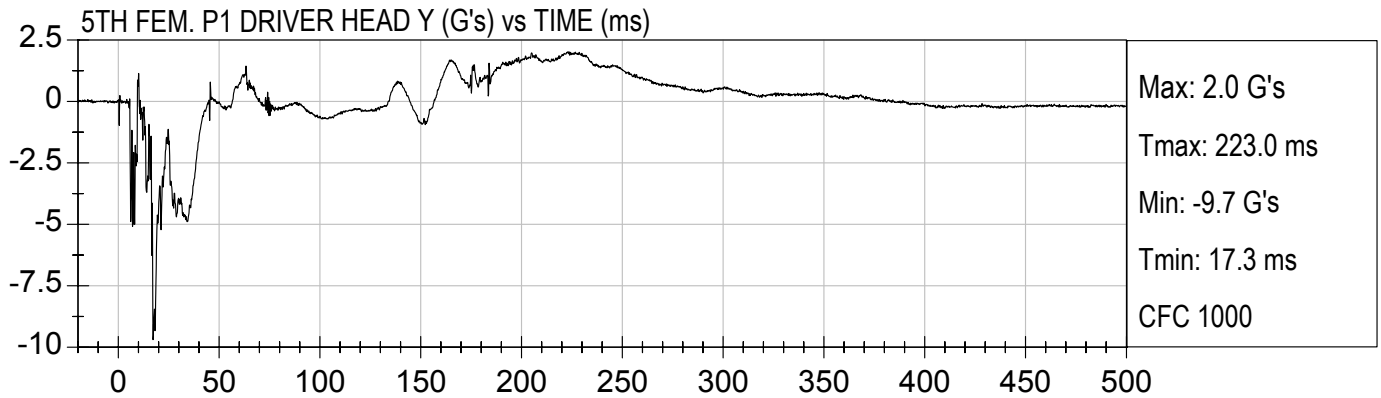
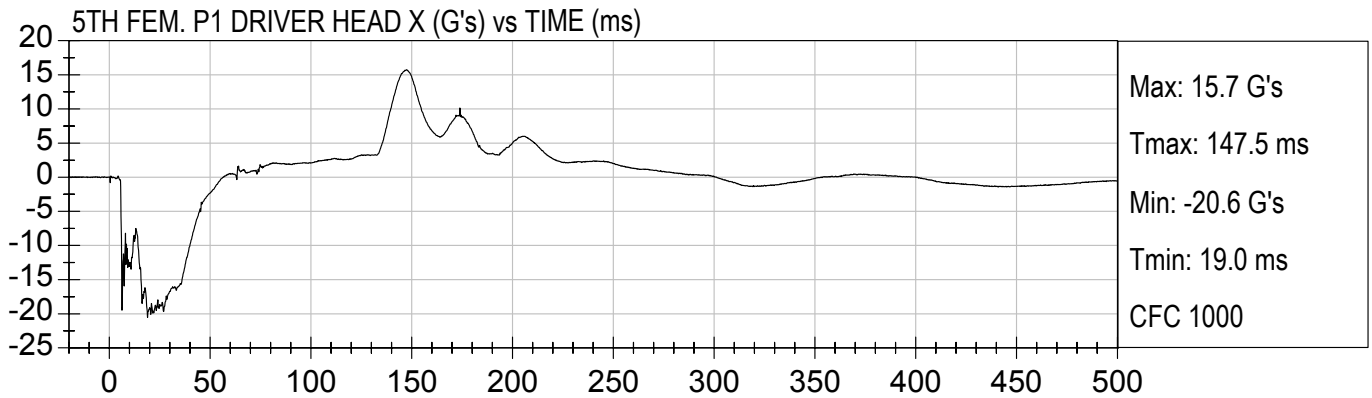

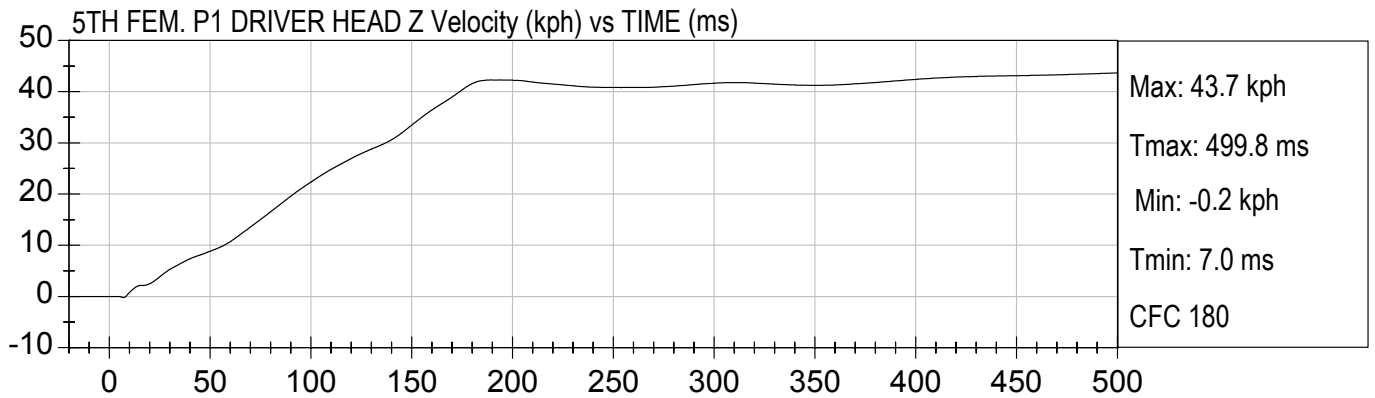
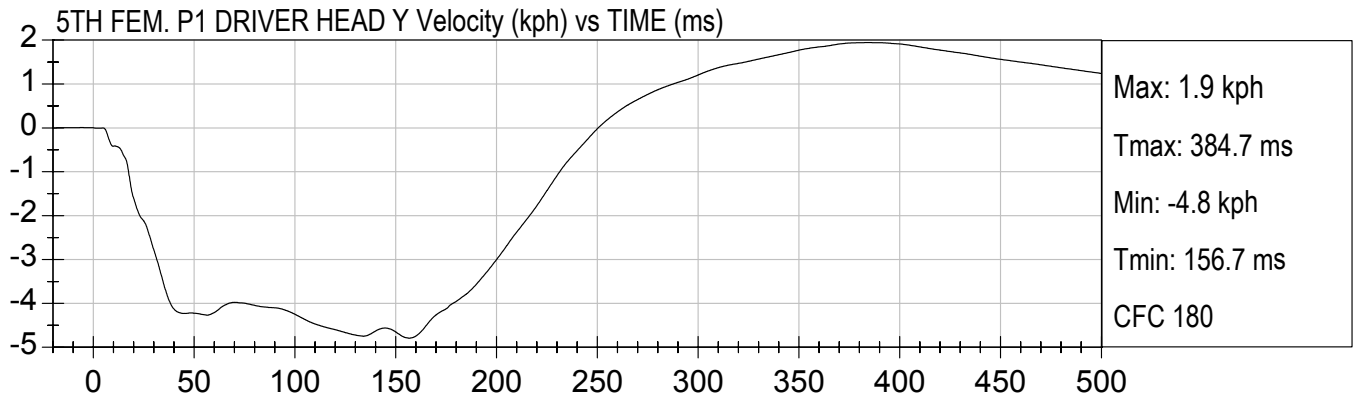
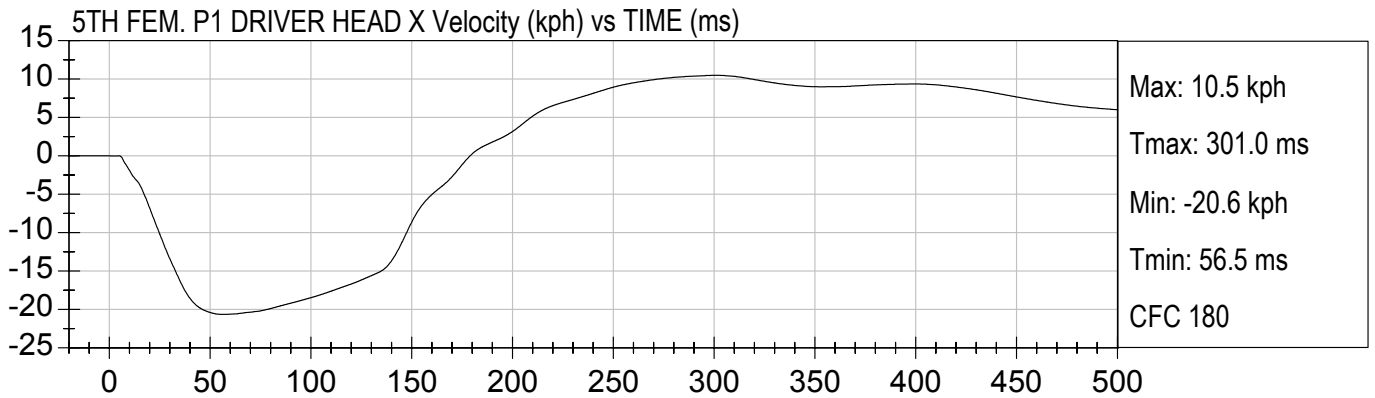

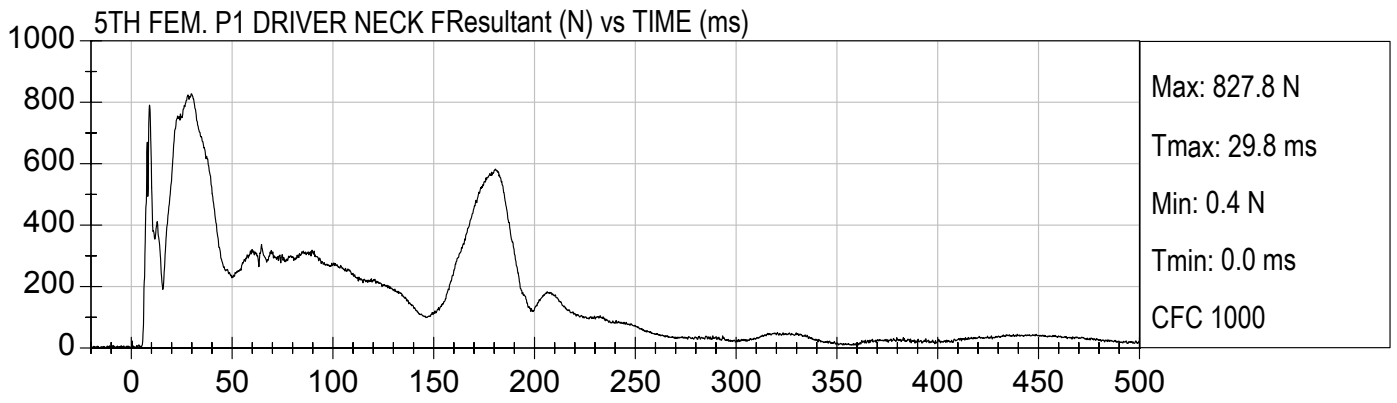
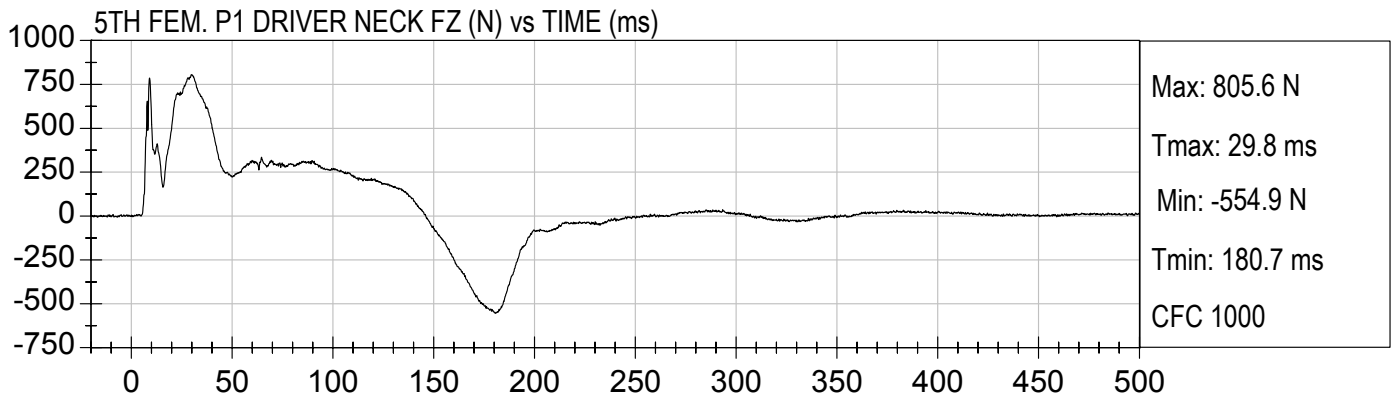
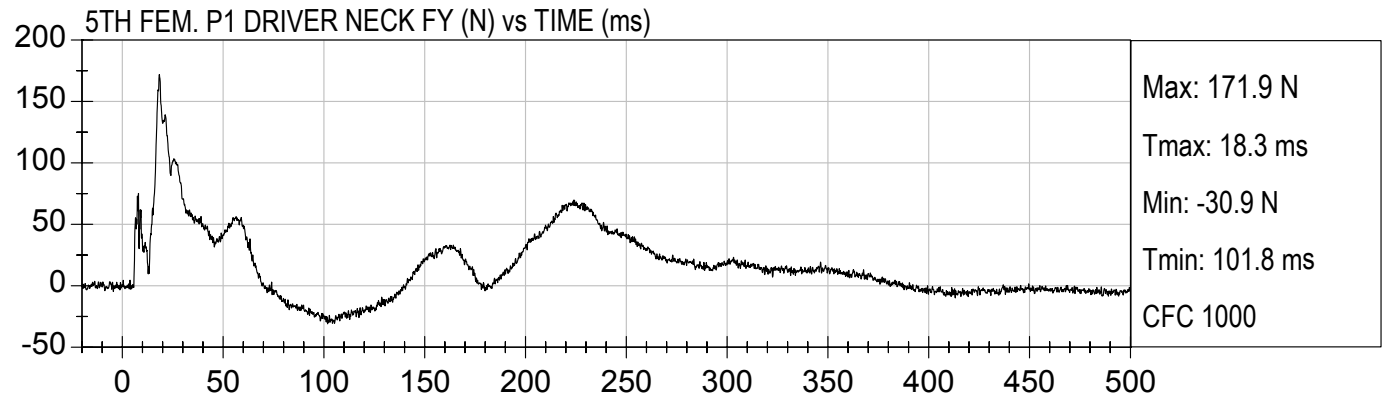
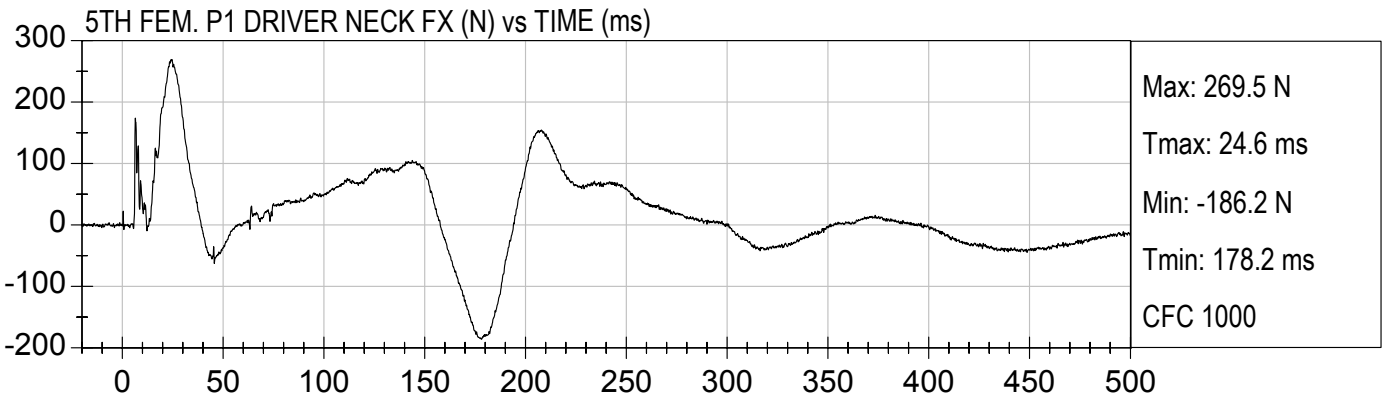

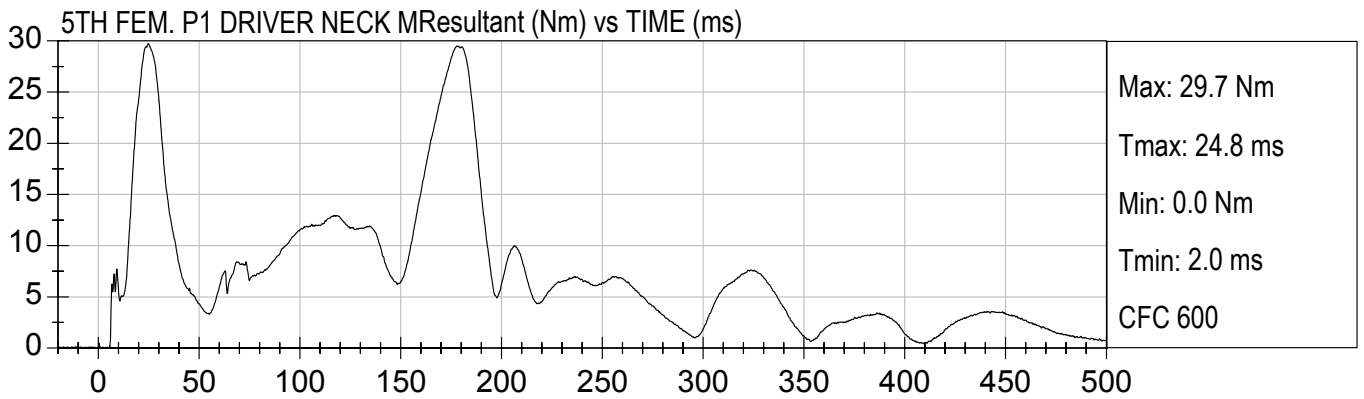
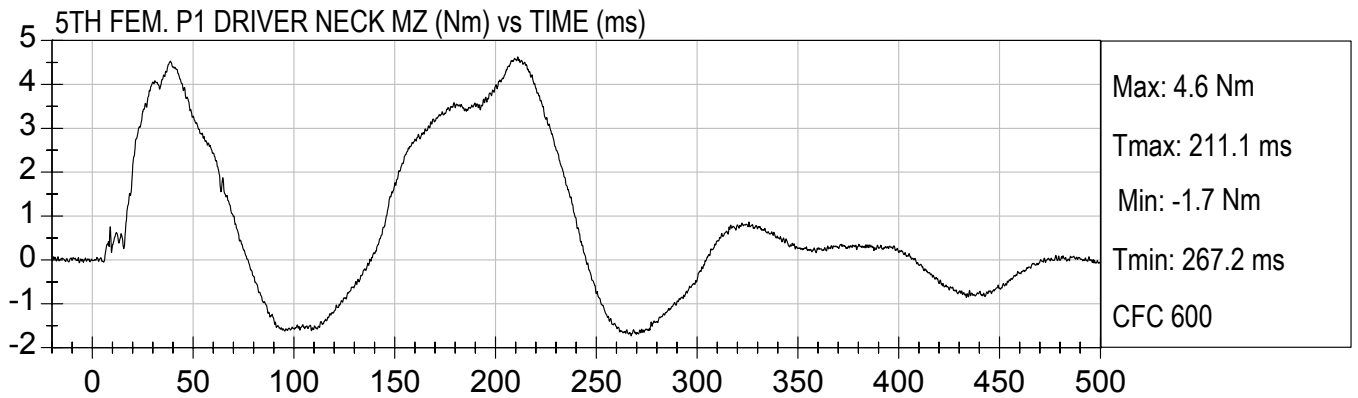
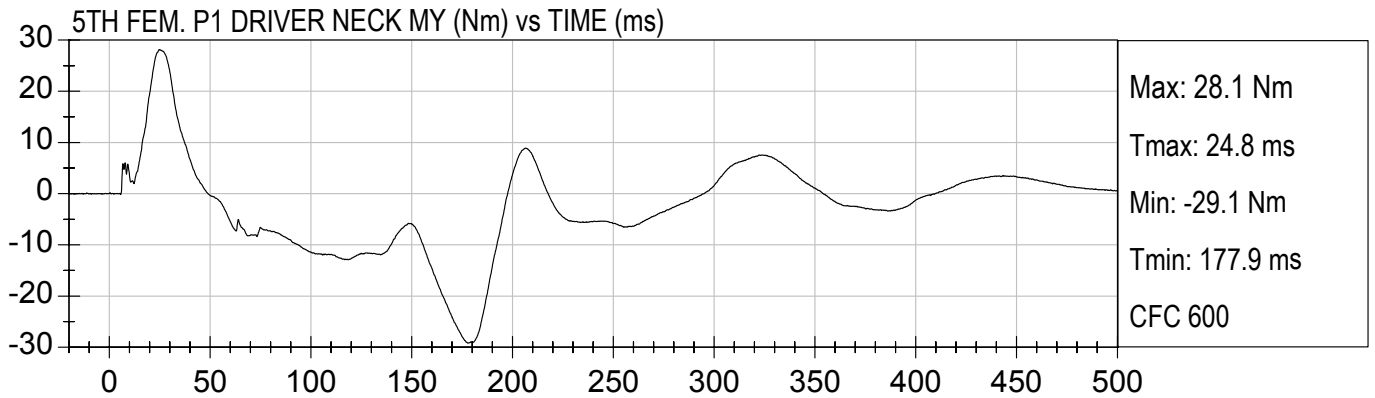
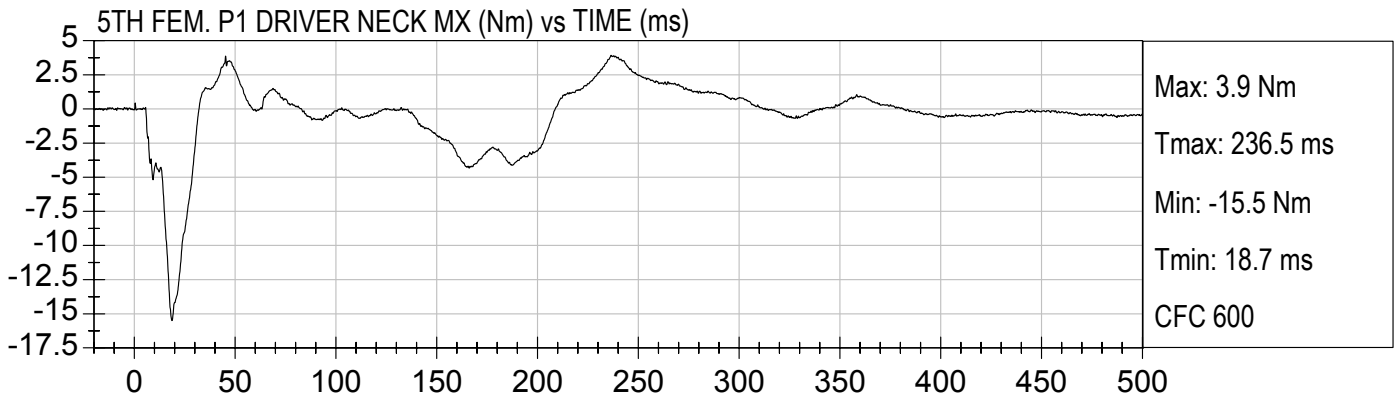

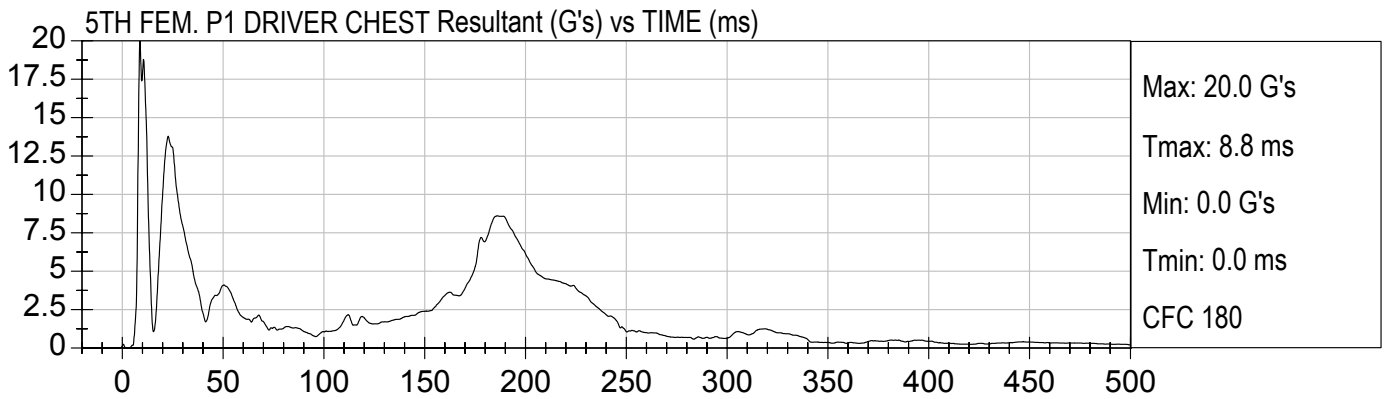
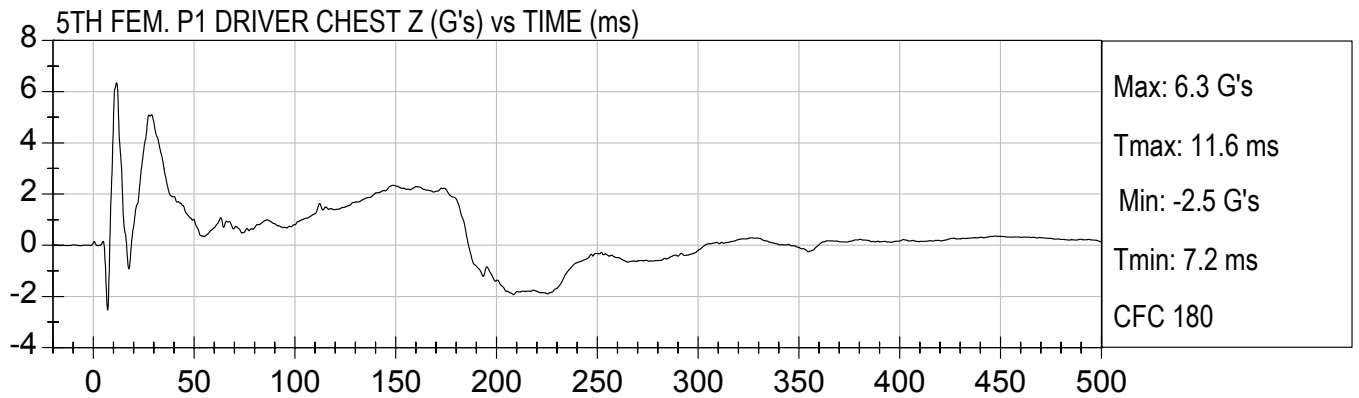
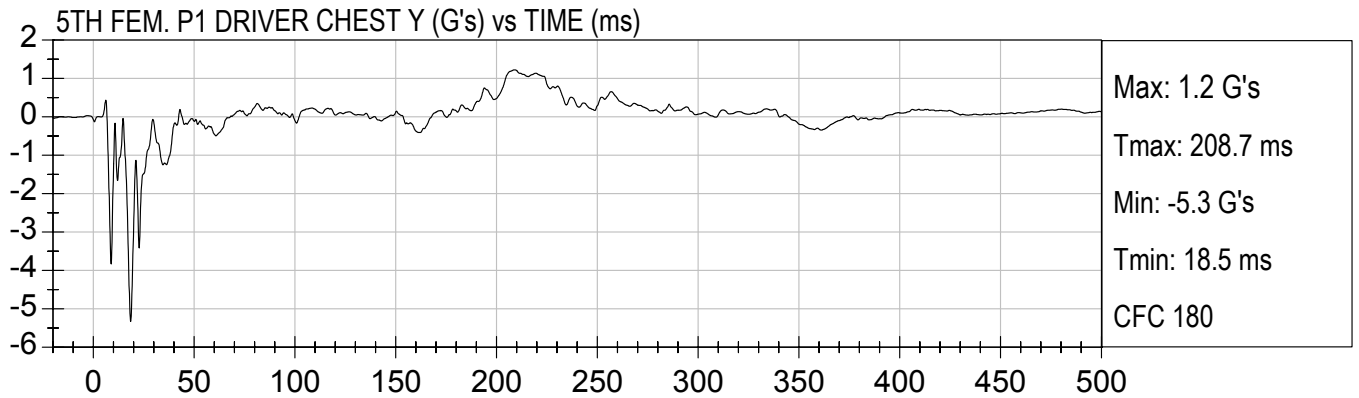
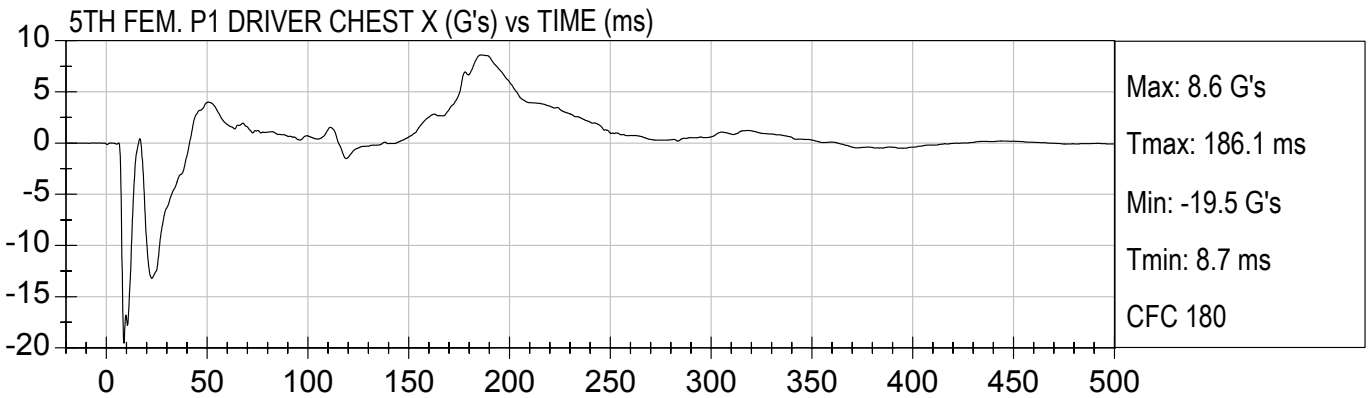

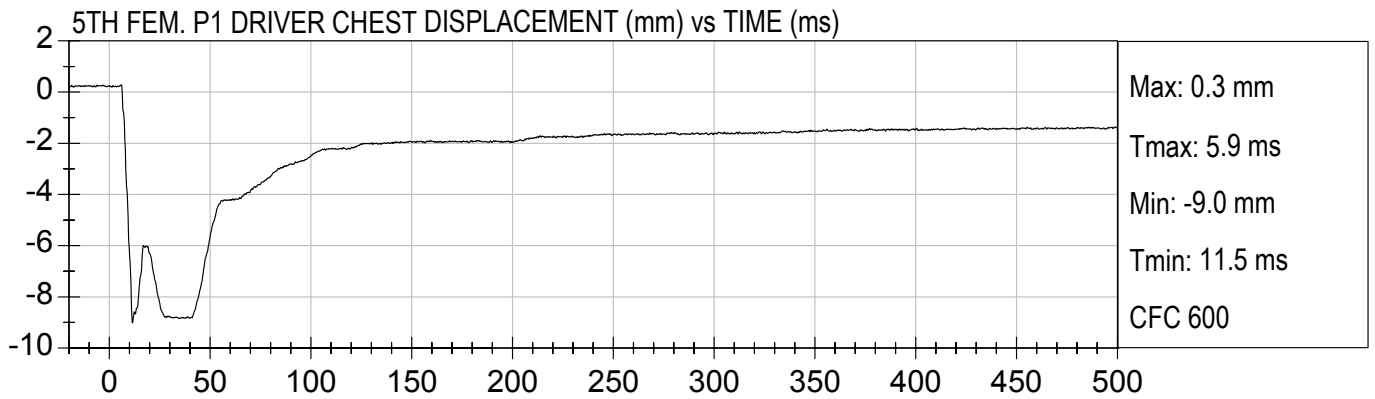
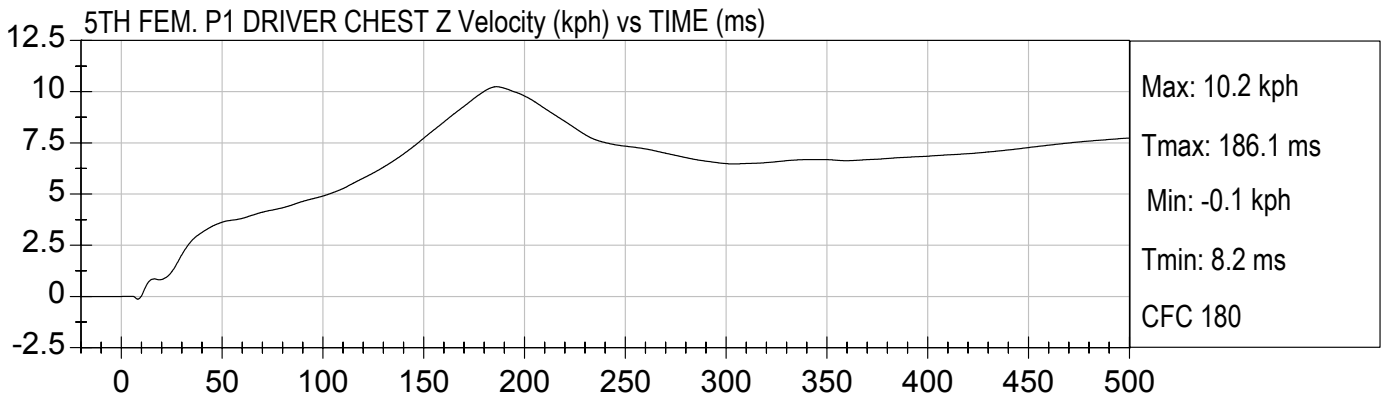
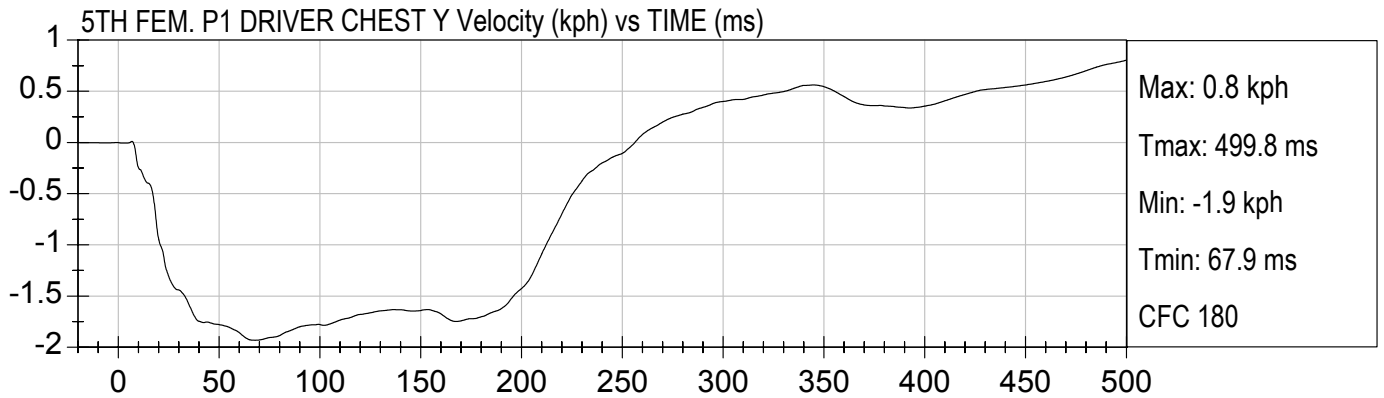
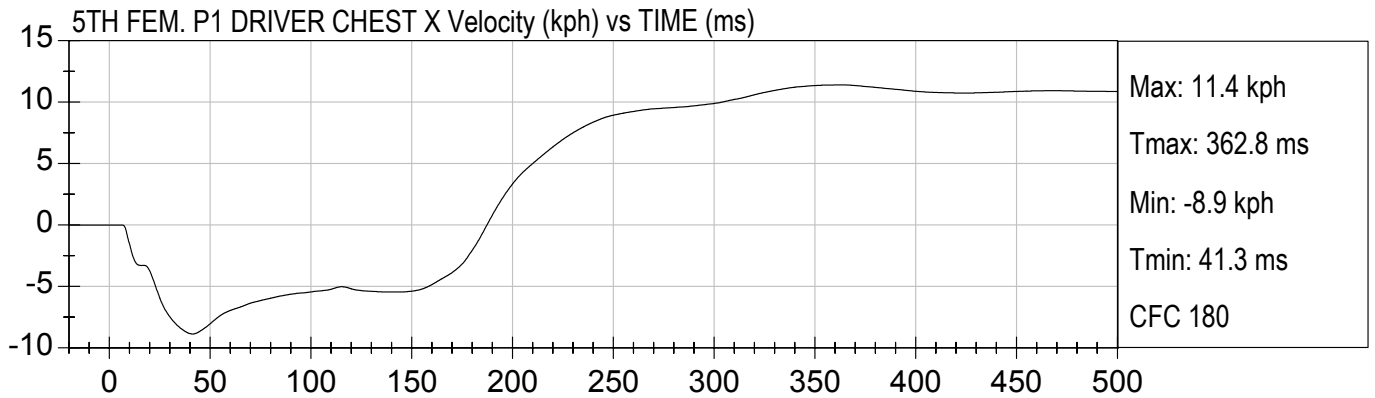



5TH FEM. P1 DRIVER LEFT FEMUR (N) vs TIME (ms)

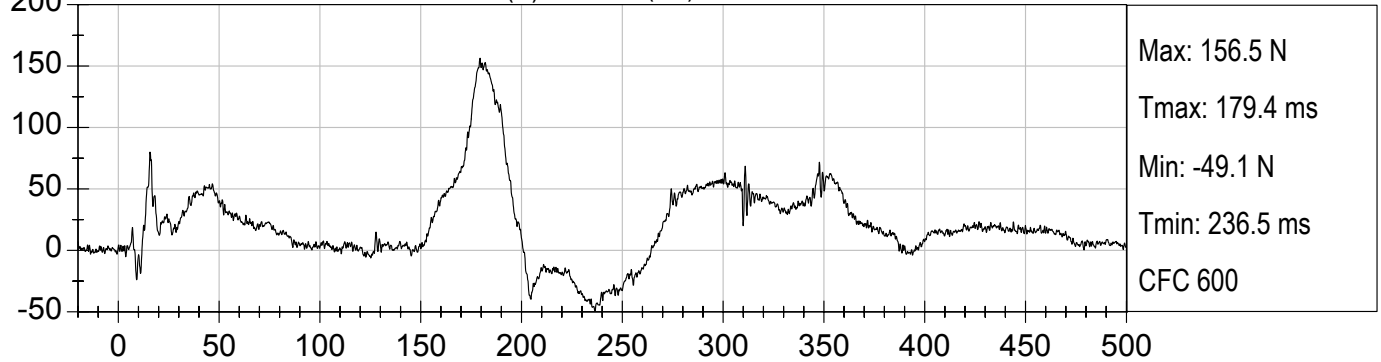

5TH FEM. P1 DRIVER RIGHT FEMUR (N) vs TIME (ms)

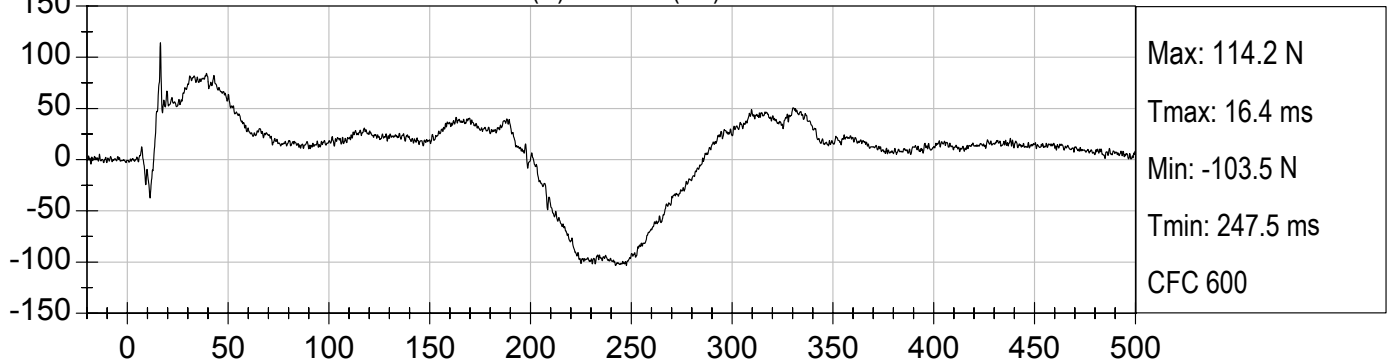



FIRE VOLTAGE #1 (Volts) vs TIME (ms)

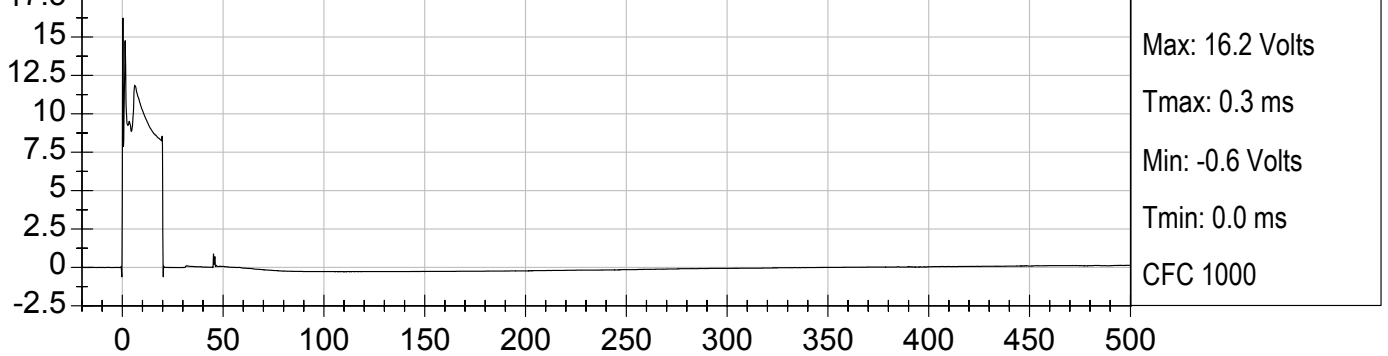

FIRE CURRENT #1 (Amps) vs TIME (ms)

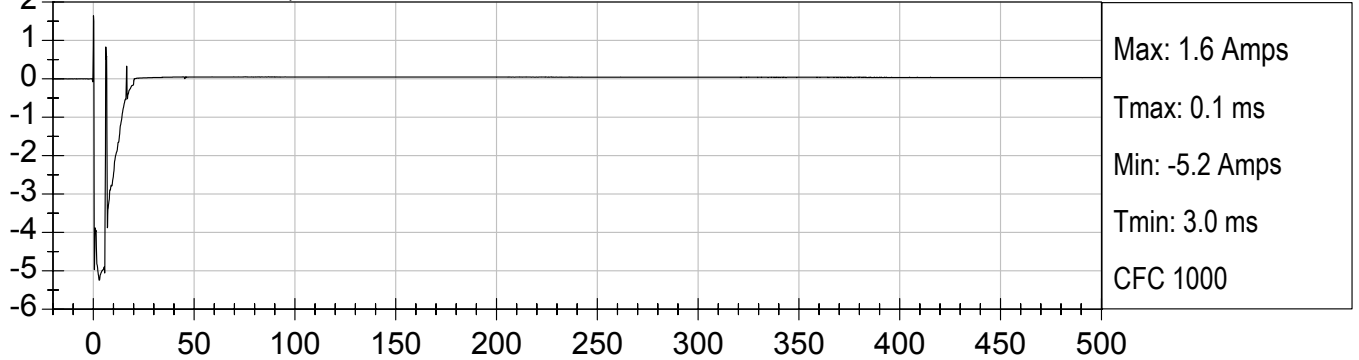

FIRE VOLTAGE #2 (Volts) vs TIME (ms)

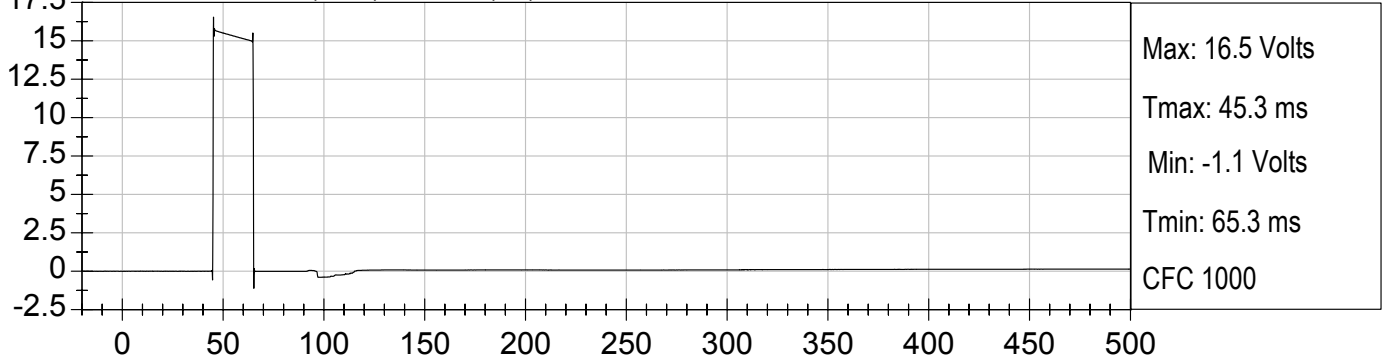

FIRE CURRENT #2 (Amps) vs TIME (ms)

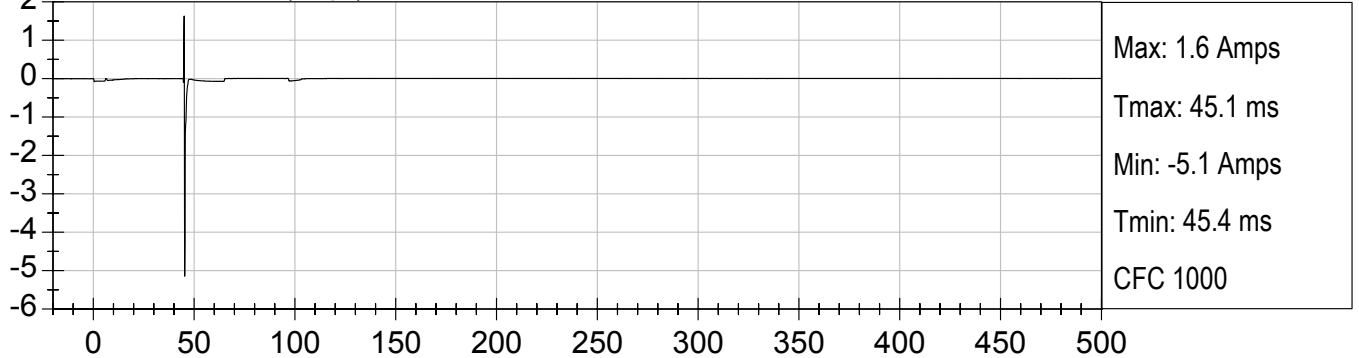

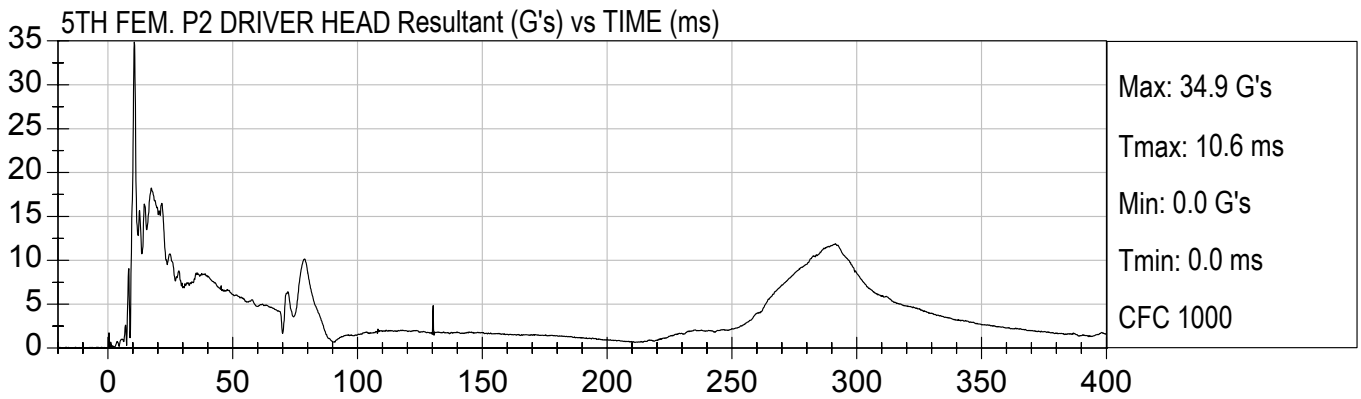
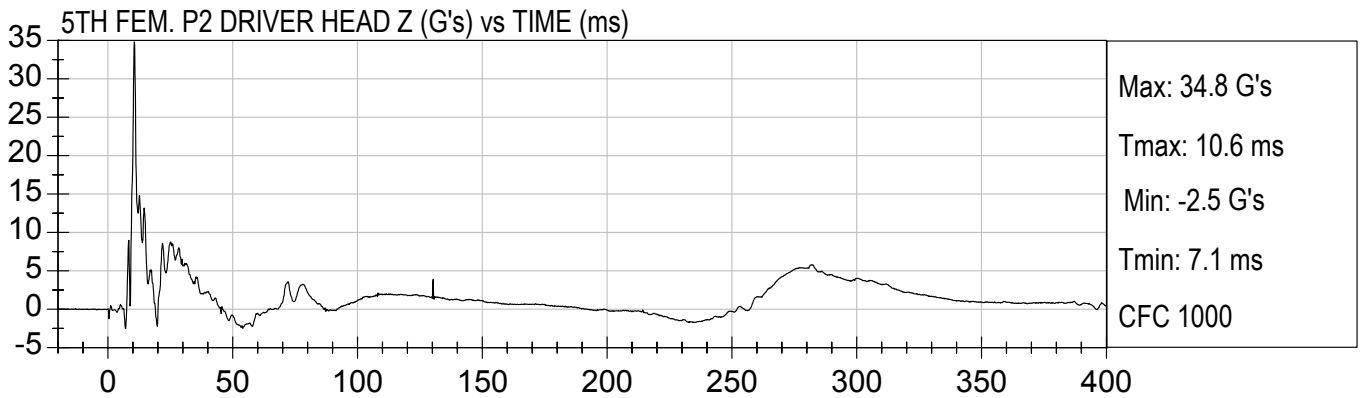
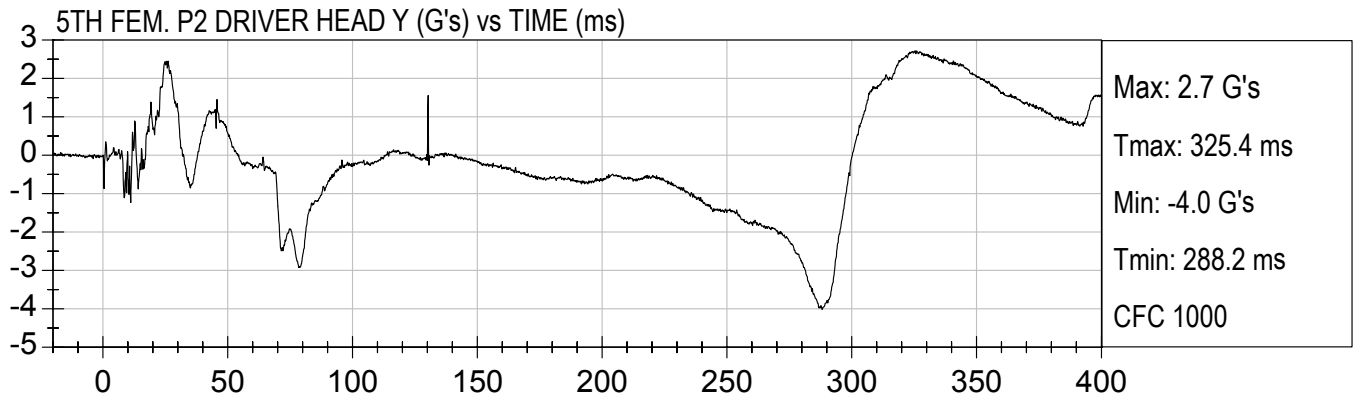
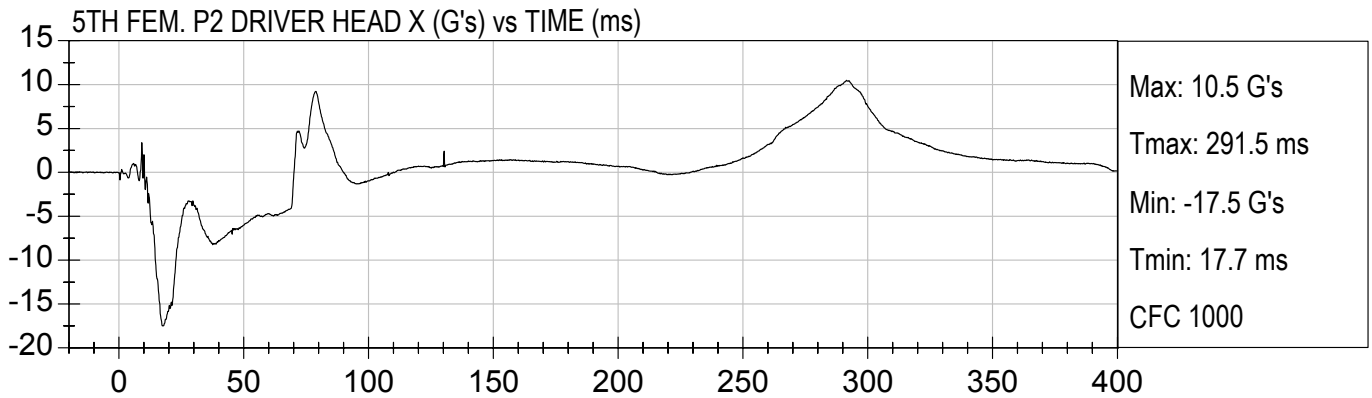

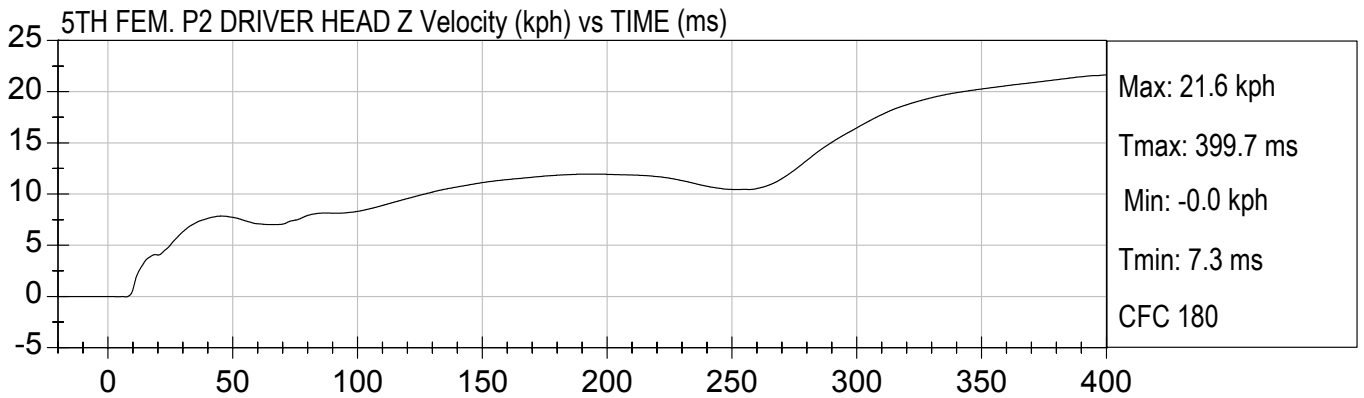
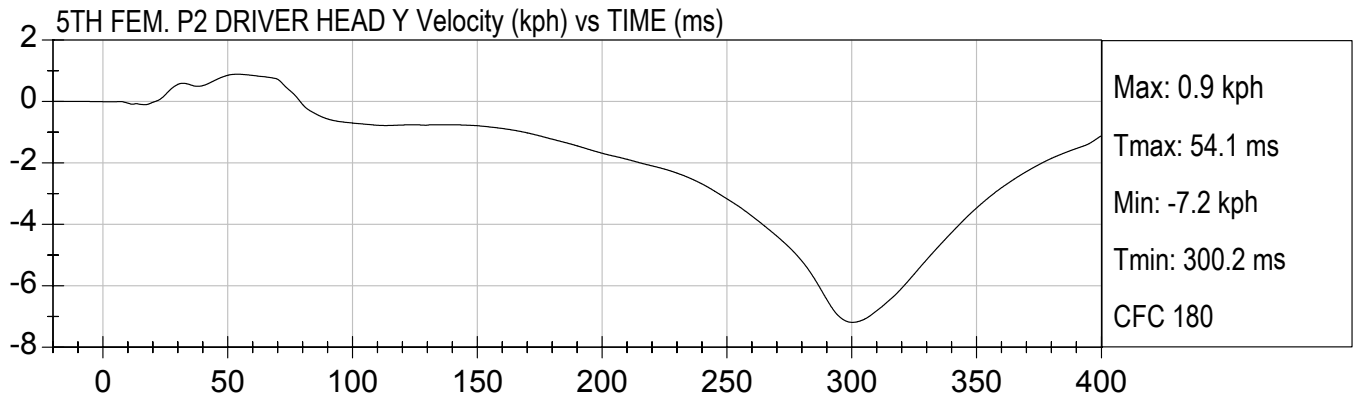
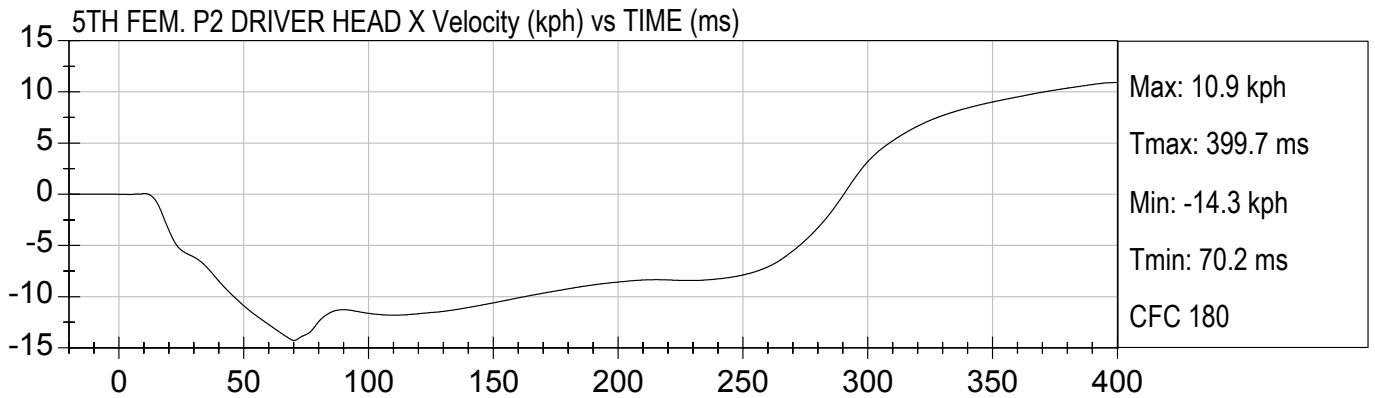

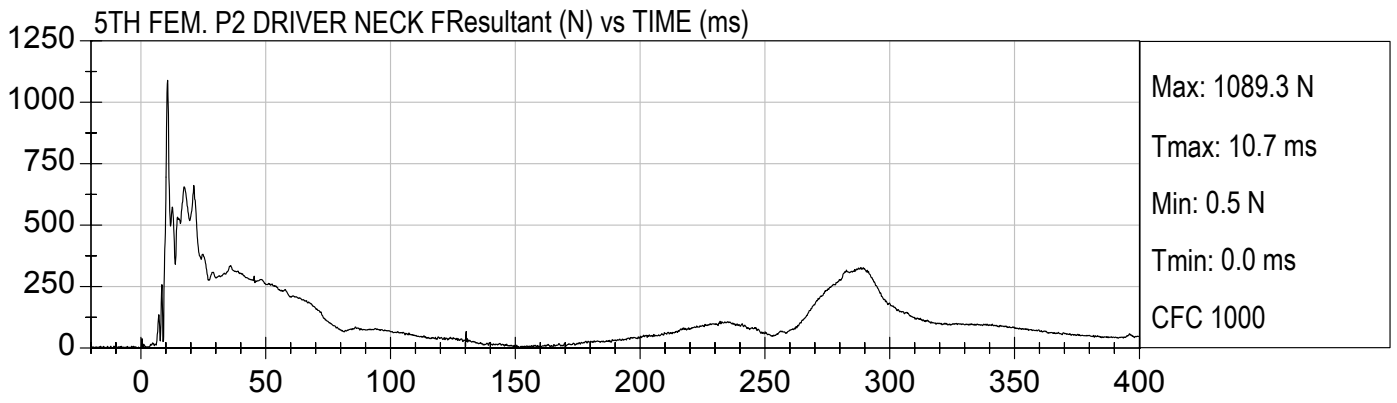
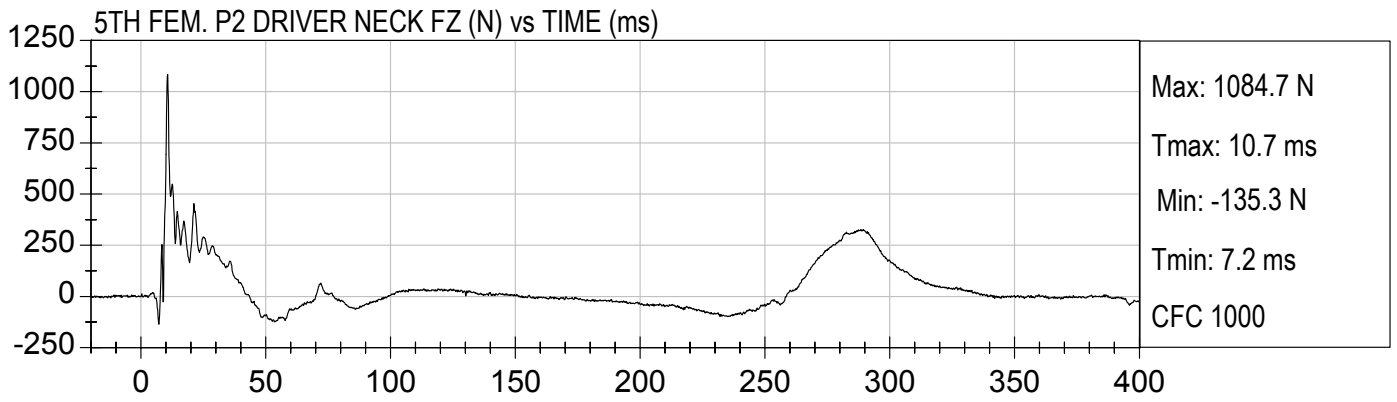
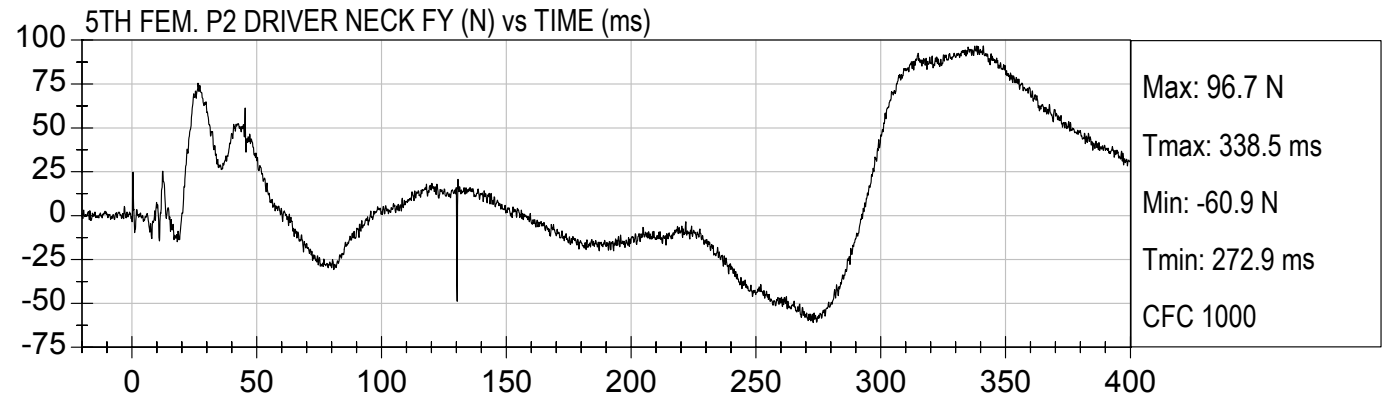
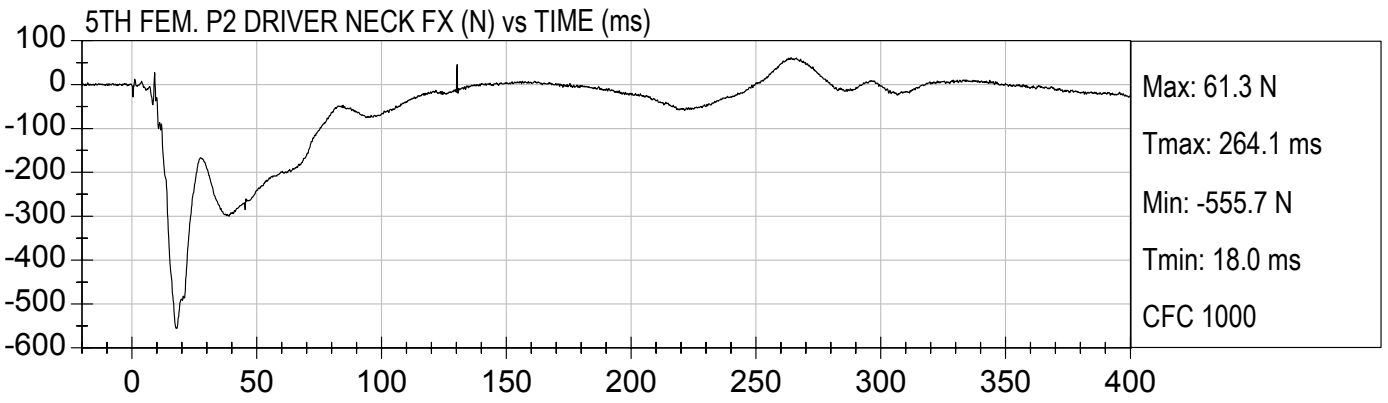

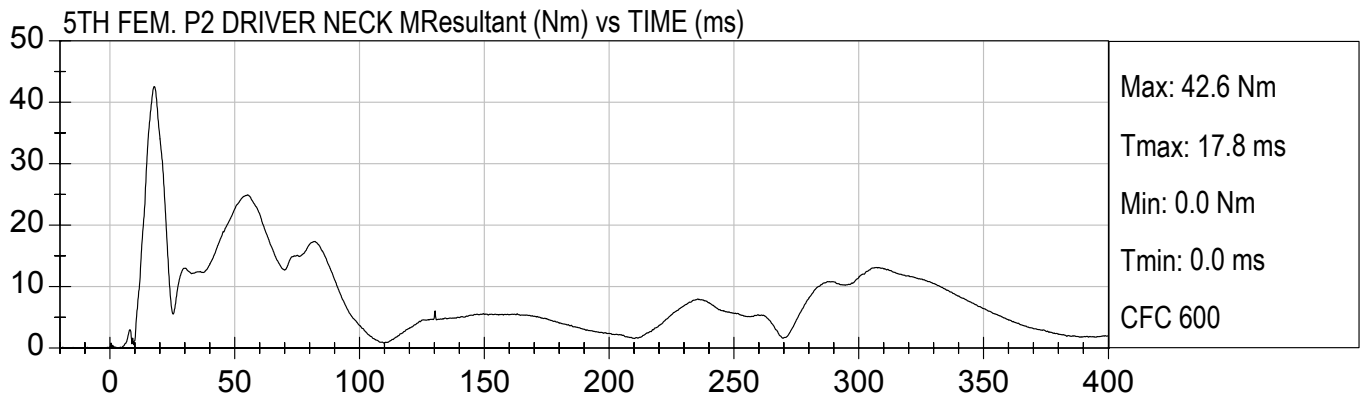
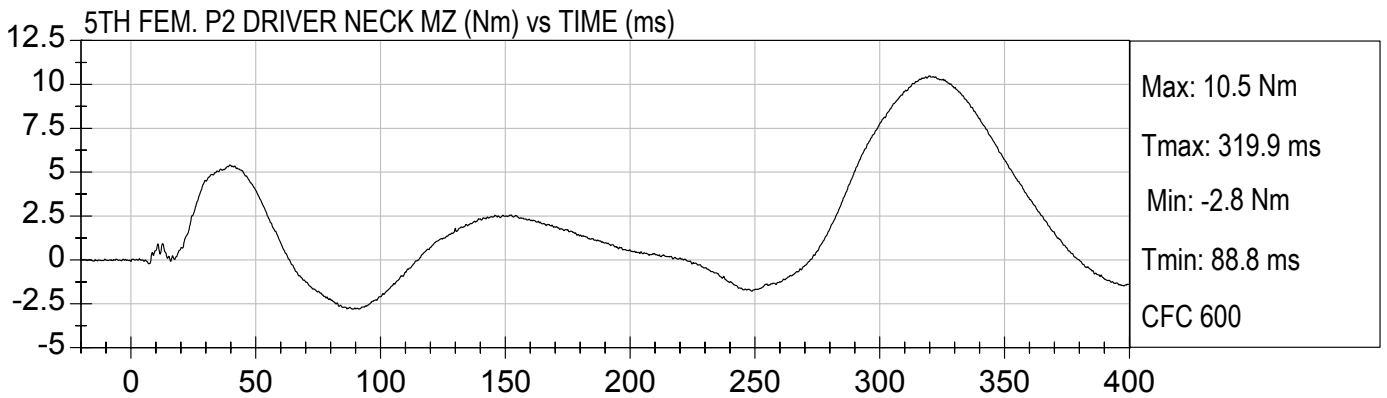
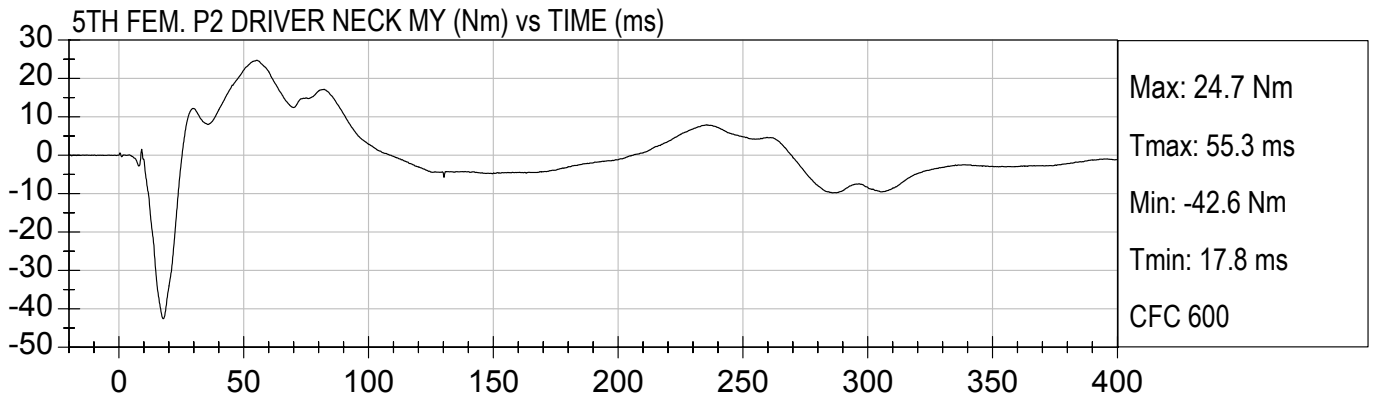
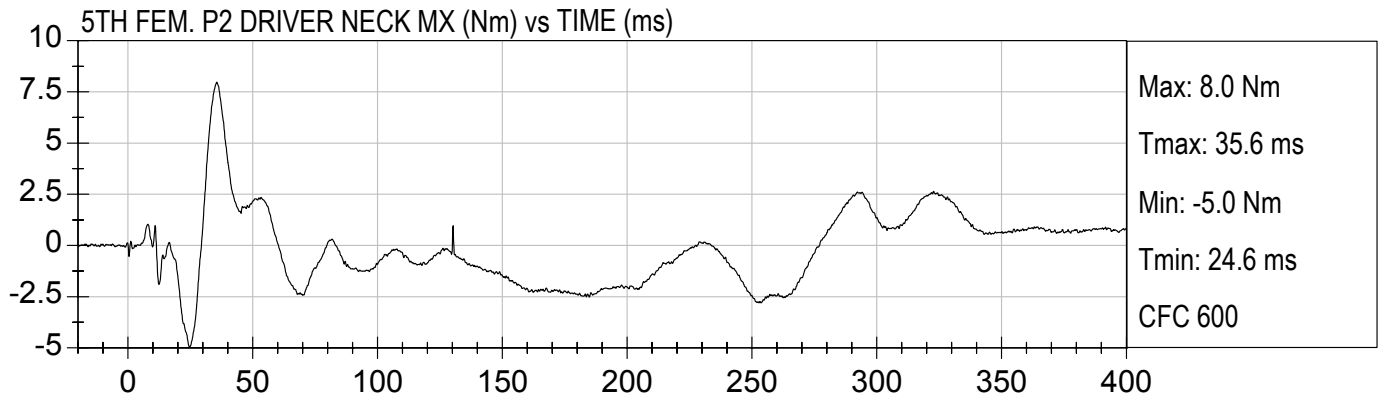

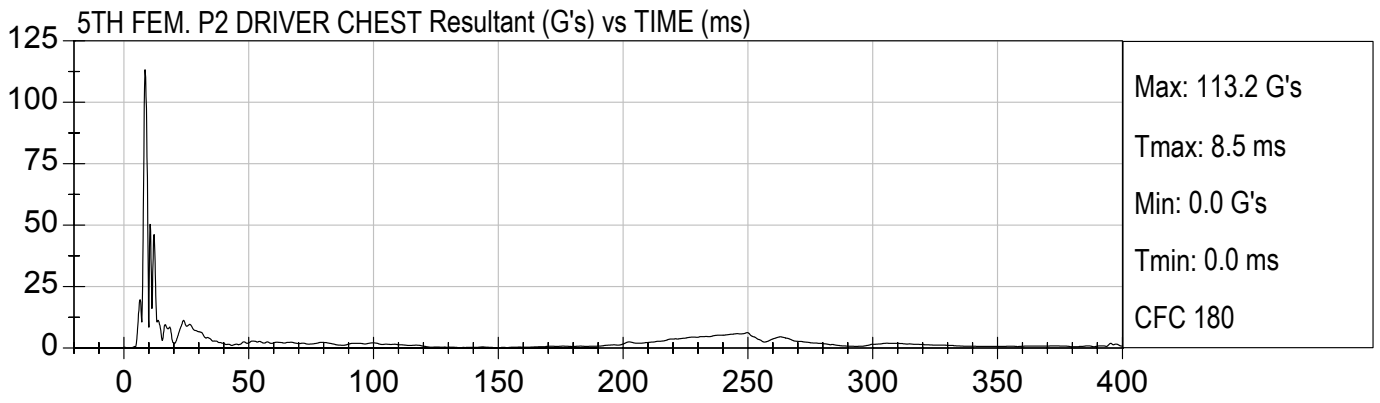
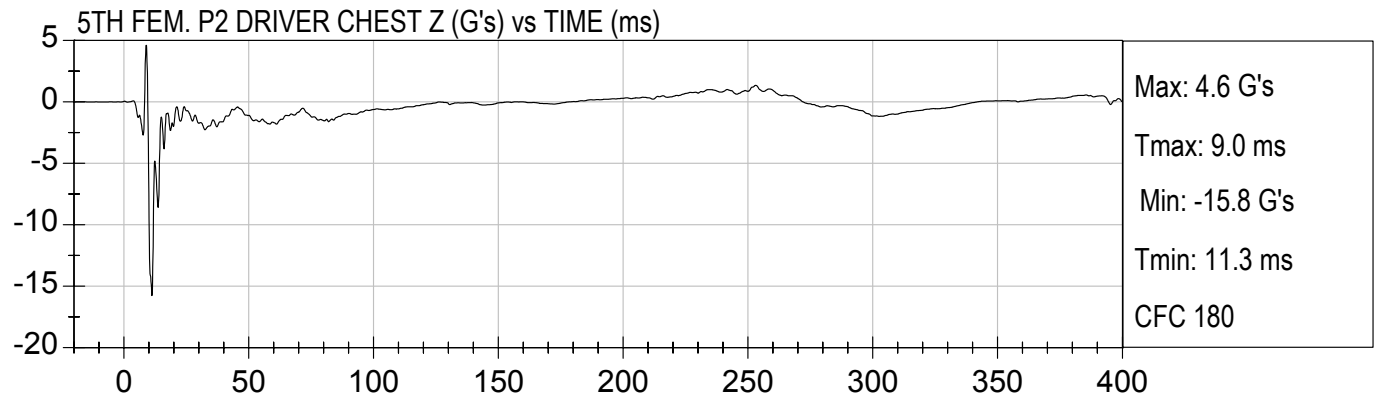
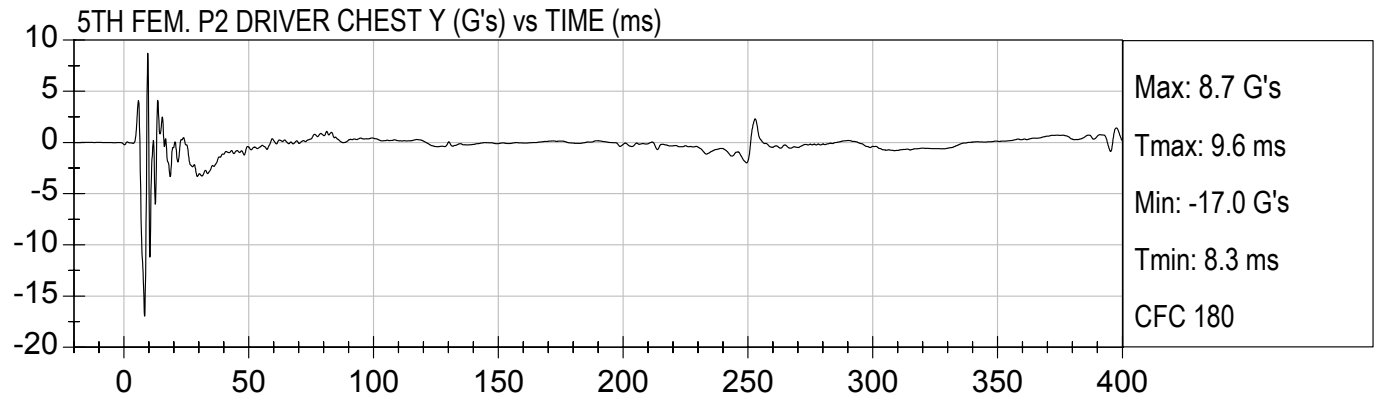
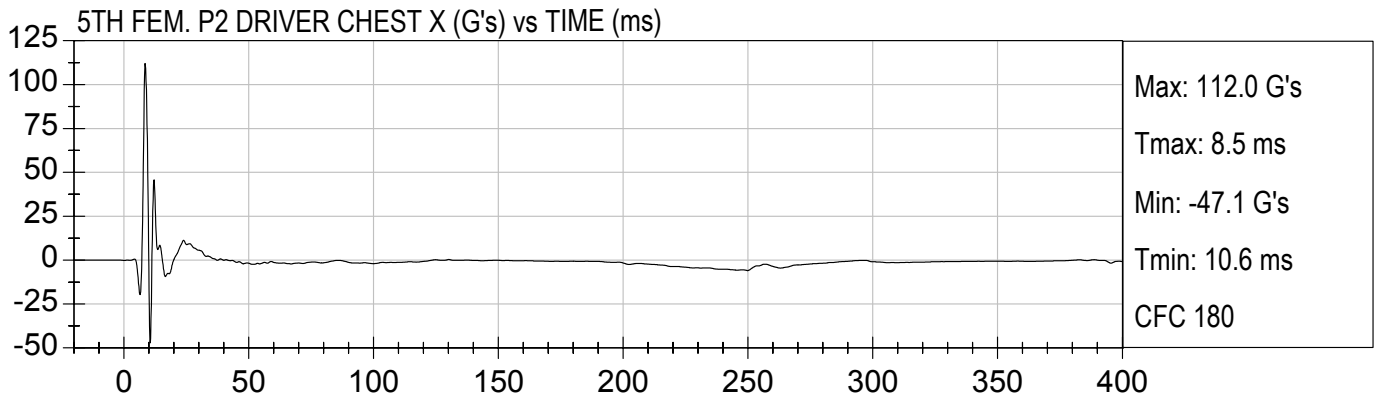

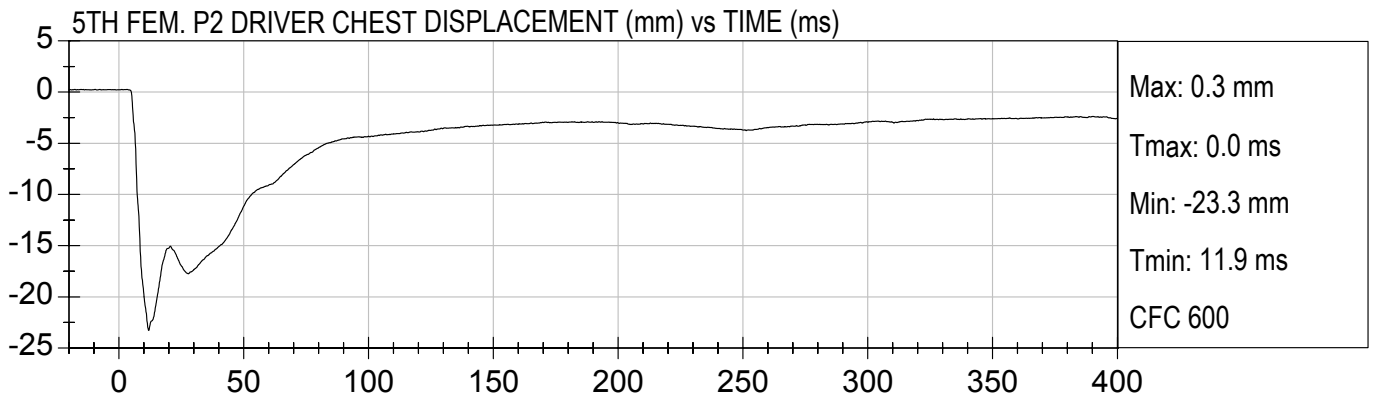
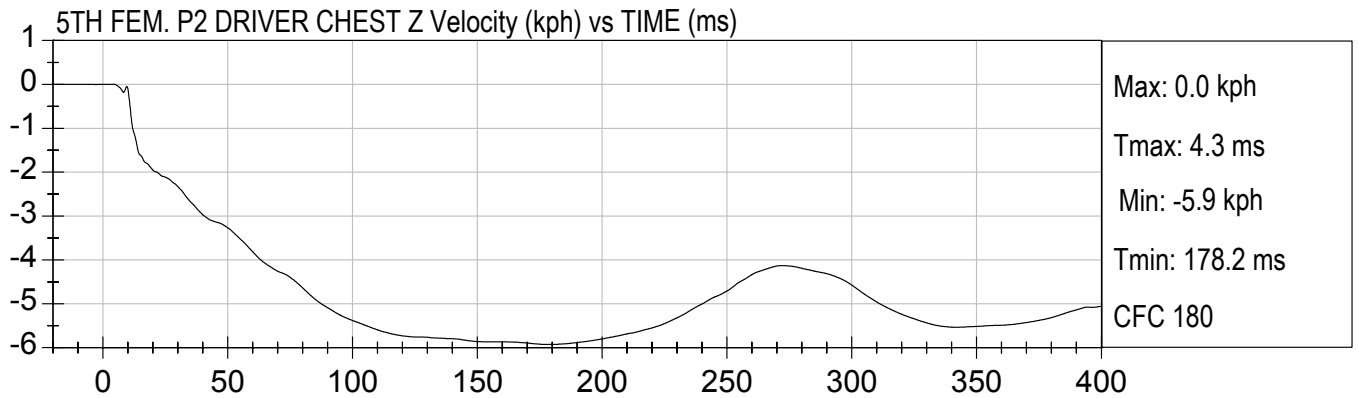
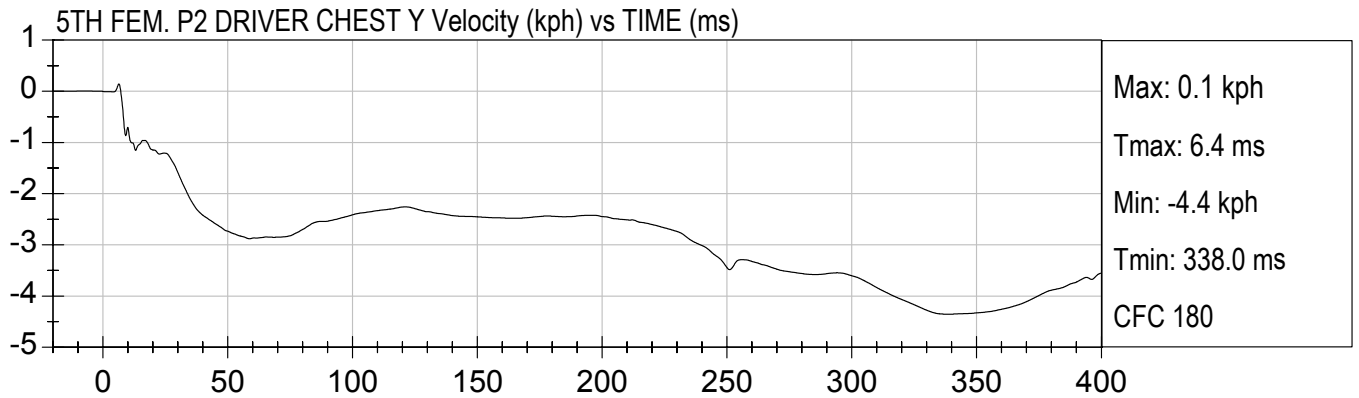
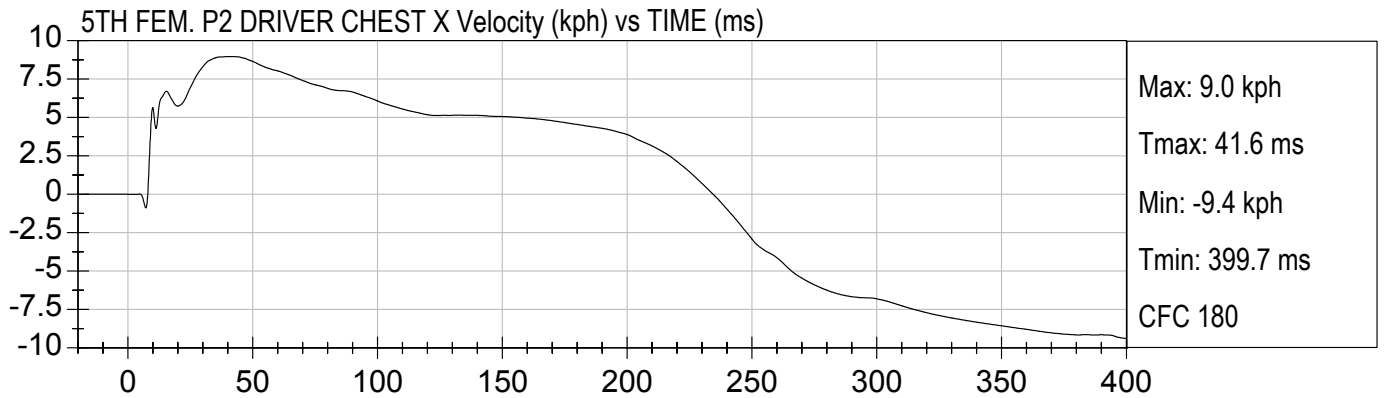

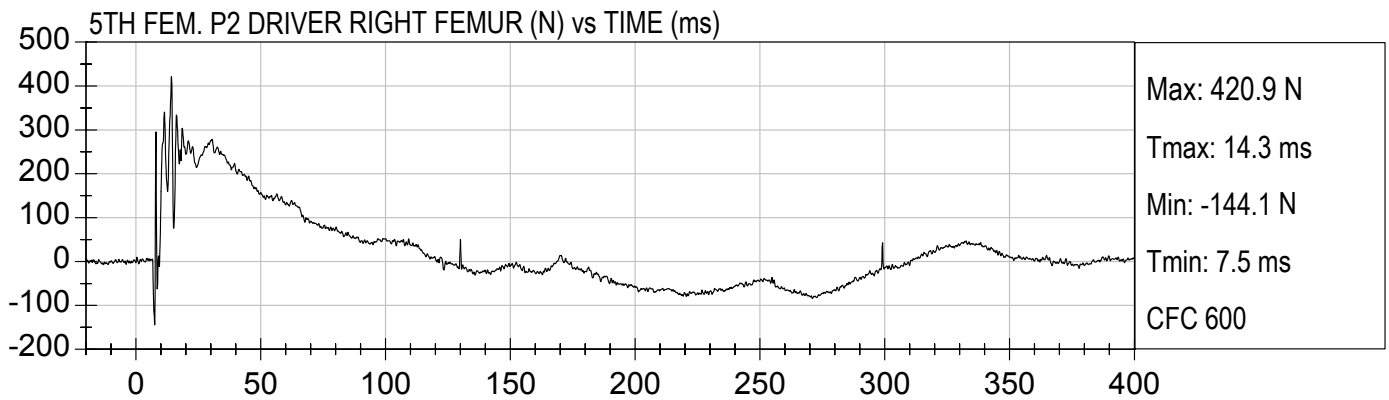
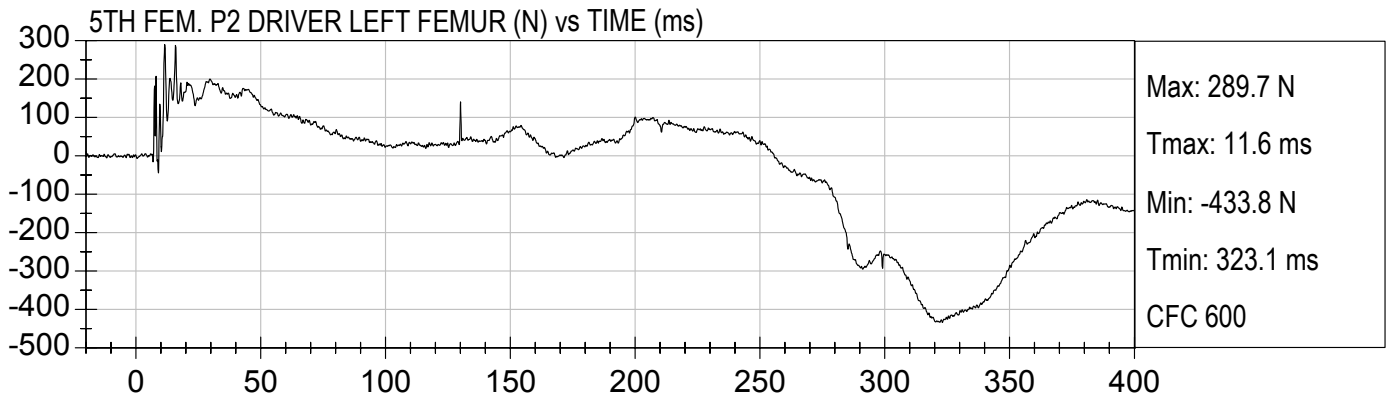

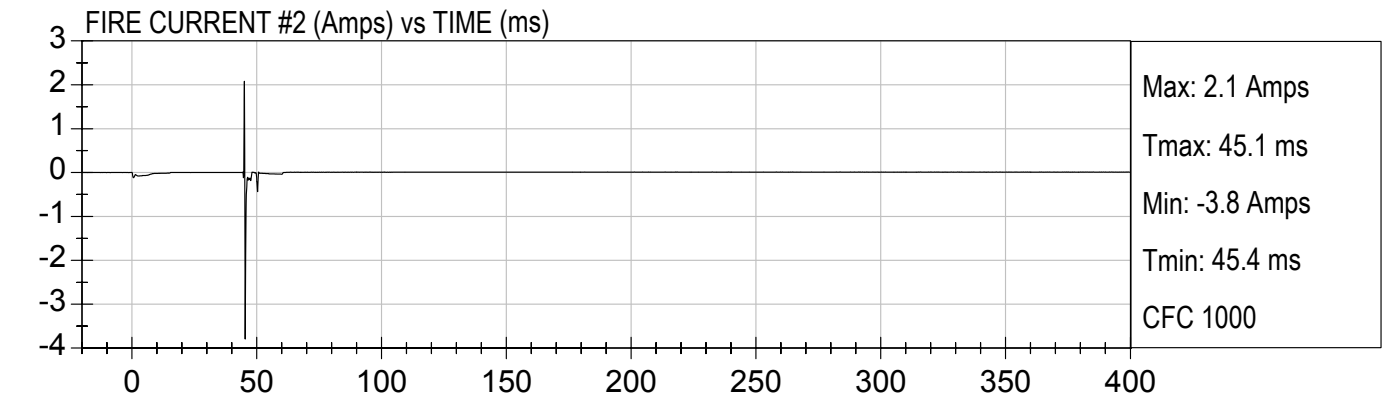
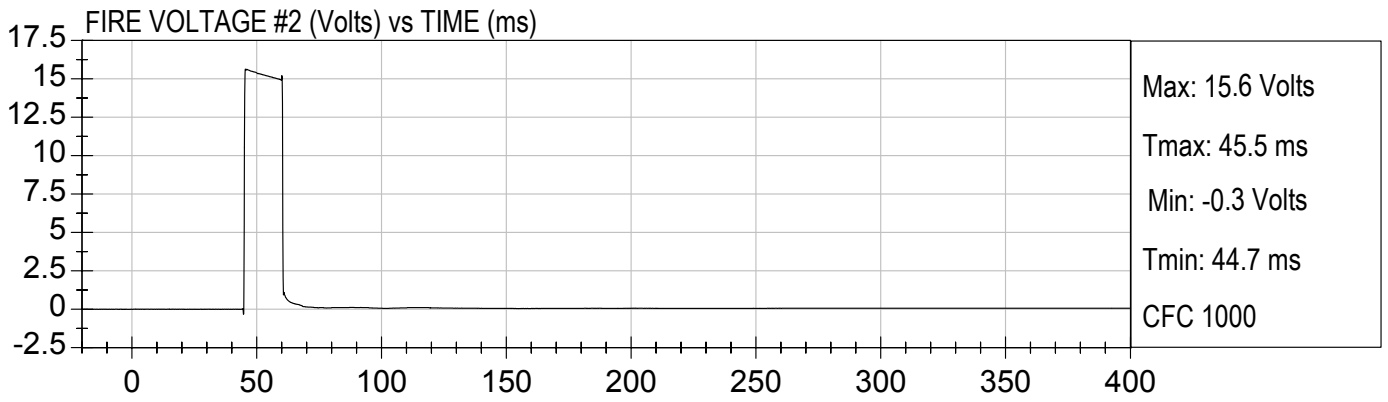
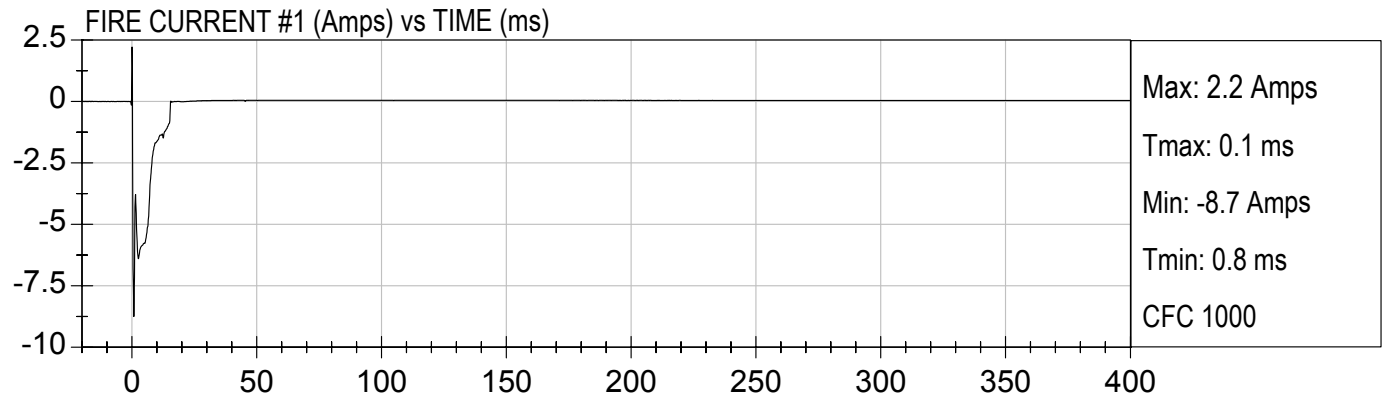
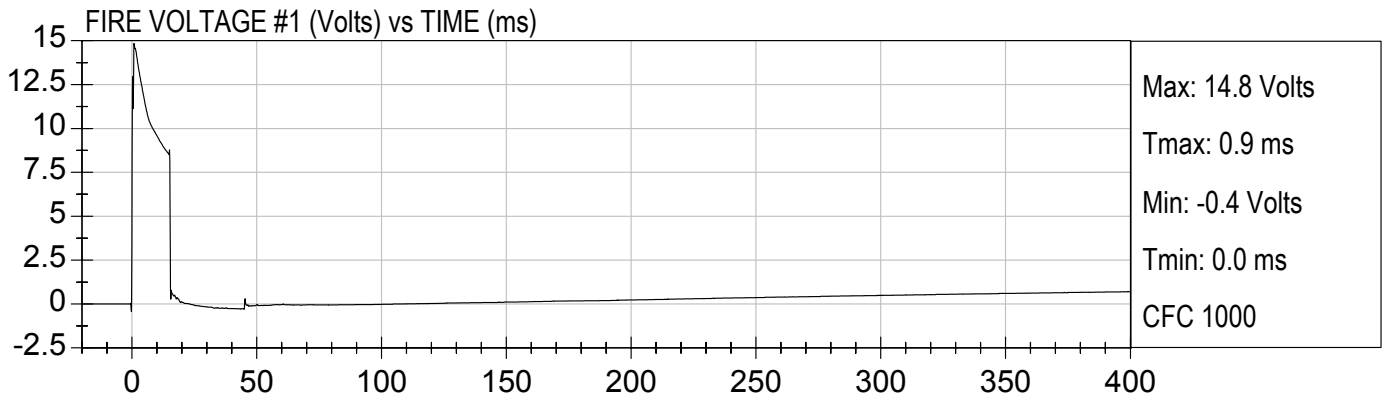

APPENDIX C
CRASH TEST PHOTOGRAPHS

TABLE OF PHOTOGRAPHS

		<u>Page No.</u>
Photo No. 1.	Vehicle Certification Label/Tire Placard	C-1
Photo No. 2.	Tire Placard	C-2
Photo No. 3.	Pre-Test Front View of Test Vehicle	C-3
Photo No. 4.	Post-Test Front View of Test Vehicle	C-4
Photo No. 5.	Pre-Test Left Side View of Test Vehicle	C-5
Photo No. 6.	Post-Test Left Side View of Test Vehicle	C-6
Photo No. 7.	Pre-Test Right Side View of Test Vehicle	C-7
Photo No. 8.	Post-Test Right Side View of Test Vehicle	C-8
Photo No. 9.	Pre-Test Right Front Three-Quarter View of Test Vehicle	C-9
Photo No. 10.	Post-Test Right Front Three-Quarter View of Test Vehicle	C-10
Photo No. 11.	Pre-Test Left Front Three-Quarter View of Test Vehicle	C-11
Photo No. 12.	Post-Test Left Front Three-Quarter View of Test Vehicle	C-12
Photo No. 13.	Pre-Test Left Rear Three-Quarter View of Test Vehicle	C-13
Photo No. 14.	Post-Test Left Rear Three-Quarter View of Test Vehicle	C-14
Photo No. 15.	Pre-Test Right Rear Three-Quarter View of Test Vehicle	C-15
Photo No. 16.	Post-Test Right Rear Three-Quarter View of Door After Impact	C-16
Photo No. 17.	Pre-Test Rear View of Test Vehicle	C-17
Photo No. 18.	Post-Test Rear View of Test Vehicle	C-18
Photo No. 19.	Pre-Test Windshield View	C-19
Photo No. 20.	Post-Test Windshield View	C-20
Photo No. 21.	Pre-Test Engine Compartment View	C-21
Photo No. 22.	Post-Test Engine Compartment View	C-22
Photo No. 23.	Pre-Test Fuel Filler Cap View	C-23
Photo No. 24.	Post-Test Fuel Filler Cap View	C-24
Photo No. 25.	Pre-Test Front Underbody View	C-25
Photo No. 26.	Post-Test Front Underbody View	C-26
Photo No. 27.	Pre-Test Mid Underbody	C-27
Photo No. 28.	Post-Test Mid Underbody	C-28

Page No.

Photo No. 29.	Pre-Test Rear Underbody View	C-29
Photo No. 30.	Post-Test Rear Underbody View	C-30
Photo No. 31.	Pre-Test Fuel Tank View	C-31
Photo No. 32.	Post-Test Fuel Tank View	C-32
Photo No. 33.	Pre-Test Driver Dummy Front View (head position)	C-33
Photo No. 34.	Post-Test Driver Dummy Front View (head position)	C-34
Photo No. 35.	Pre-Test Driver Dummy Position Left Side View	C-35
Photo No. 36.	Post-Test Driver Dummy Position Left Side View	C-36
Photo No. 37.	Pre-Test Driver Dummy Position Left Side View (Door Open)	C-37
Photo No. 38.	Post-Test Driver Dummy Position Left Side View (Door Open)	C-38
Photo No. 39.	Pre-Test Driver Dummy Seat Position	C-39
Photo No. 40.	Post-Test Driver Dummy Seat Position	C-40
Photo No. 41.	Pre-Test Driver Dummy Feet Position	C-41
Photo No. 42.	Post-Test Driver Dummy Feet Position	C-42
Photo No. 43.	Pre-Test Driver Side Knee Bolster View	C-43
Photo No. 44.	Post-Test Driver Side Knee Bolster View	C-44
Photo No. 45.	Post-Test Driver Dummy Head Contact	C-45
Photo No. 46.	Post-Test Driver Dummy Head Contact	C-46
Photo No. 47.	Post-Test Driver Dummy Knee Contact	C-47
Photo No. 48.	Post-Test Driver Dummy Airbag Contact	C-48
Photo No. 49.	Pre-Test Passenger Dummy Front View (head position)	C-49
Photo No. 50.	Post-Test Passenger Dummy Front View (head position)	C-50
Photo No. 51.	Pre-Test Passenger Dummy Position Right Side View	C-51
Photo No. 52.	Post-Test Passenger Dummy Position Right Side View	C-52
Photo No. 53.	Pre-Test Passenger Dummy Position Right Side View (Door Open)	C-53
Photo No. 54.	Post-Test Passenger Dummy Position Right Side View (Door Open)	C-54
Photo No. 55.	Pre-Test Passenger Dummy Seat Position	C-55
Photo No. 56.	Post-Test Passenger Dummy Seat Position	C-56
Photo No. 57.	Pre-Test Passenger Dummy Feet Position	C-57
Photo No. 58.	Post-Test Passenger Dummy Feet Position	C-58

Page No.

Photo No. 59.	Pre-Test Passenger Side Knee Bolster View	C-59
Photo No. 60.	Post-Test Passenger Side Knee Bolster View	C-60
Photo No. 61.	Post-Test Passenger Dummy Head Contact	C-61
Photo No. 62.	Post-Test Passenger Dummy Knee Contact	C-62
Photo No. 63.	Post-Test Passenger Dummy Airbag Contact	C-63
Photo No. 64.	Pre-Test Rear Passenger Dummy Front View (head position)	C-64
Photo No. 65.	Post-Test Rear Passenger Dummy Front View (head position)	C-65
Photo No. 66.	Pre-Test Rear Passenger Dummy Position Left Side View	C-66
Photo No. 67.	Post-Test Rear Passenger Dummy Position Left Side View	C-67
Photo No. 68.	Pre-Test Rear Pass. Dummy Position Left Side View (Door Open)	C-68
Photo No. 69.	Post-Test Rear Pass. Dummy Position Left Side View (Door Open)	C-69
Photo No. 70.	Pre-Test Rear Passenger Dummy Position Right Side View	C-70
Photo No. 71.	Post-Test Rear Passenger Dummy Position Right Side View	C-71
Photo No. 72.	Pre-Test Rear Passenger Dummy Feet Position	C-72
Photo No. 73.	Post-Test Rear Passenger Dummy Feet Position	C-73
Photo No. 74.	Pre-Test Rear Passenger Left Side Knee Bolster View	C-74
Photo No. 75.	Post-Test Rear Passenger Left Side Knee Bolster View	C-75
Photo No. 76.	Pre-Test Rear Passenger Right Side Knee Bolster View	C-76
Photo No. 77.	Post-Test Rear Passenger Right Side Knee Bolster View	C-77
Photo No. 78.	Post-Test Rear Passenger Dummy Knee Contact	C-78
Photo No. 79.	Rollover 90 Degrees	C-79
Photo No. 80.	Rollover 180 Degrees	C-80
Photo No. 81.	Rollover 270 Degrees	C-81
Photo No. 82.	Rollover 360 Degrees	C-82
Photo No. 83.	Vehicle Impact	C-83
Photo No. 84.	Temperature Plot	C-84

C-1.

MFD BY	DAIMLERCHRYSLER CORPORATION	DATE OF MFR	10-03	GWR	2427 KG(05350 LB)
GAWR FRONT	WITH TIRES	RIMS AT	COLD		
1248 KG(2750 LB)	P215/75R16	16X7	227 KPA(33 PSI)		
GAWR REAR	WITH TIRES	RIMS AT	COLD		
1429 KG(3150 LB)	P215/75R16	16X7	227 KPA(33 PSI)		

THIS VEHICLE CONFORMS TO ALL APPLICABLE FEDERAL MOTOR VEHICLE SAFETY AND THEFT PREVENTION STANDARDS IN EFFECT ON THE DATE OF MANUFACTURE SHOWN ABOVE.

VIN: 1J4GK48KX4W162401 TYPE: MPV SINGLE X DUAL



MDH: 100300 080AA PNT:PW1 VEHICLE MADE IN U.S.A. TRM:M5L5 4648503

Vehicle Certification Label/Tire Placard

<p><u>TIRE INFLATION PRESSURE</u> INFLATE TIRES COLD BEFORE RUNNING. DO NOT REDUCE PRESSURE IF TIRES ARE WARM.</p>	<p> SEE OWNERS MANUAL FOR HIGH SPEED OPERATION AND ADDITIONAL DATA.</p>
<p>RECOMMENDED INFLATION PRESSURE AND TIRE SIZES.</p> <p>P215/75R16 33 psi/227 kPa P235/70R16 33 psi/227 kPa P235/65R17 33 psi/227 kPa (AT FULL LOAD)</p>	<p>MINIMUM TIRE SIZE</p> <p>P215/75R16 (W/3.7L OR 2.4L)</p>
<p>VEHICLE CAPACITY 1150 lb/522 kg</p>	<p>SEATING CAPACITY FRONT 2 REAR 3</p>

52088962AB

Tire Placard



Pre-Test Front View of Test Vehicle

C-4.



Post-Test Front View of Test Vehicle



Pre-Test Left Side View of Test Vehicle



Post-Test Left Side View of Test Vehicle

C-7.



Pre-Test Right Side View of Test Vehicle



Post-Test Right Side View of Test Vehicle



C-9.

Pre-Test Right Front Three-Quarter View of Test Vehicle



Post-Test Right Front Three-Quarter View of Test Vehicle



Pre-Test Left Front Three-Quarter View of Test Vehicle



Post-Test Left Front Three-Quarter View of Test Vehicle



Pre-Test Left Rear Three-Quarter View of Test Vehicle



Post-Test Left Rear Three-Quarter View of Test Vehicle



Post-Test Right Rear Three-Quarter View of Door After Impact

C-17.



Pre-Test Rear View of Test Vehicle



Post-Test Rear View of Test Vehicle

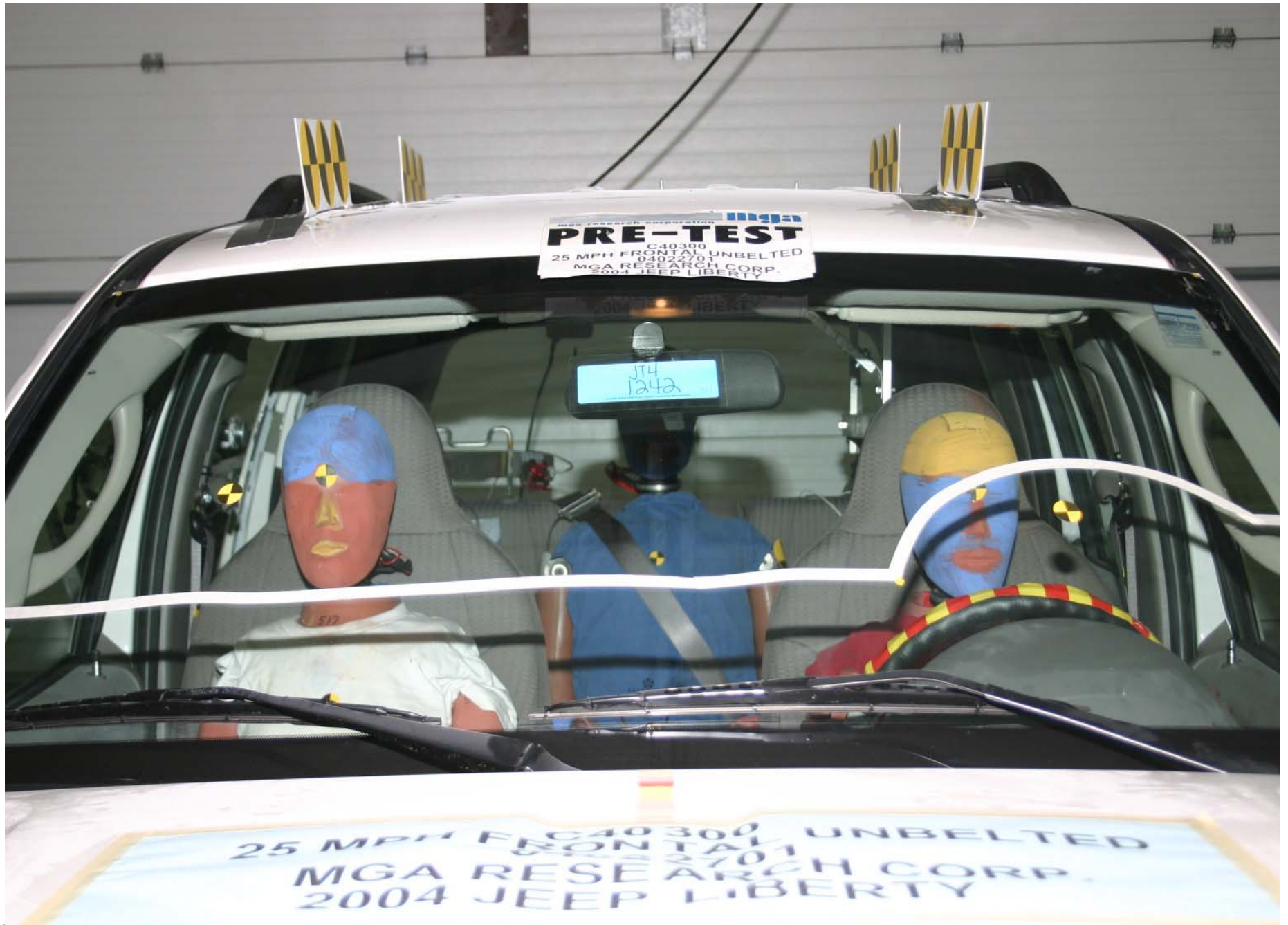

Pre-Test Windshield View



Post-Test Windshield View



Pre-Test Engine Compartment View



Post-Test Engine Compartment View



Pre-Test Fuel Filler Cap View



Post-Test Fuel Filler Cap View

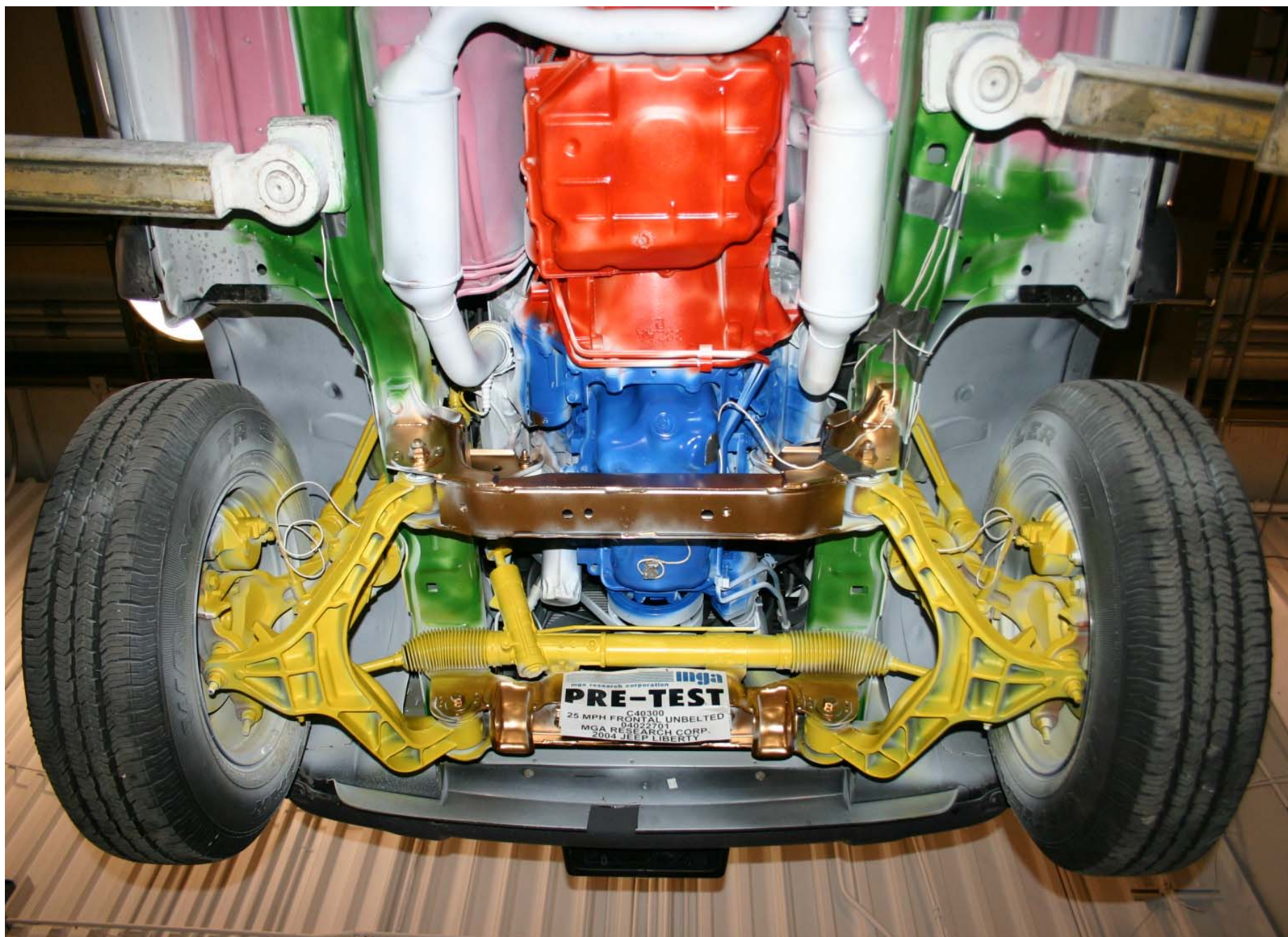

Pre-Test Front Underbody View

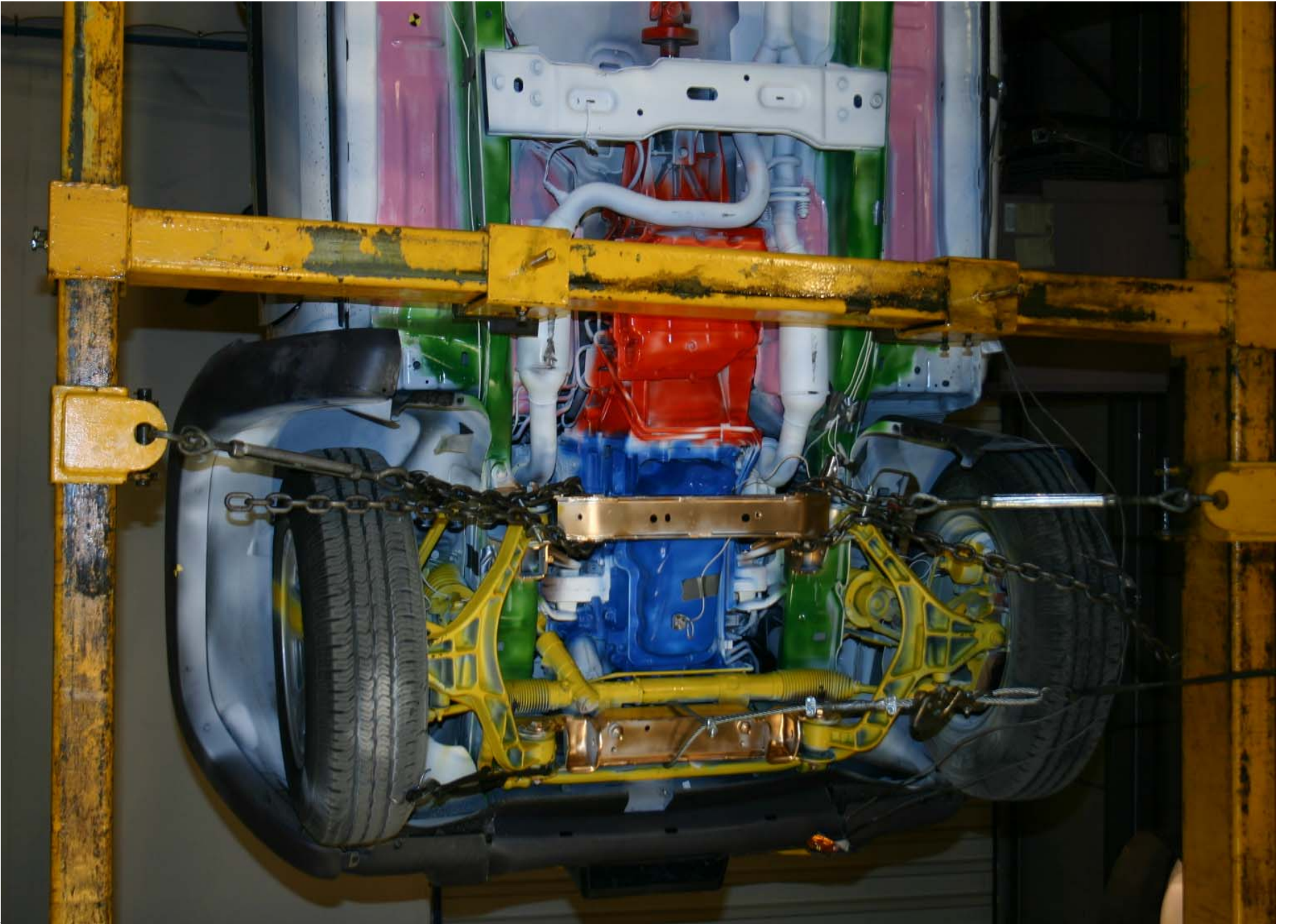

Post-Test Front Underbody View



Pre-Test Mid Underbody

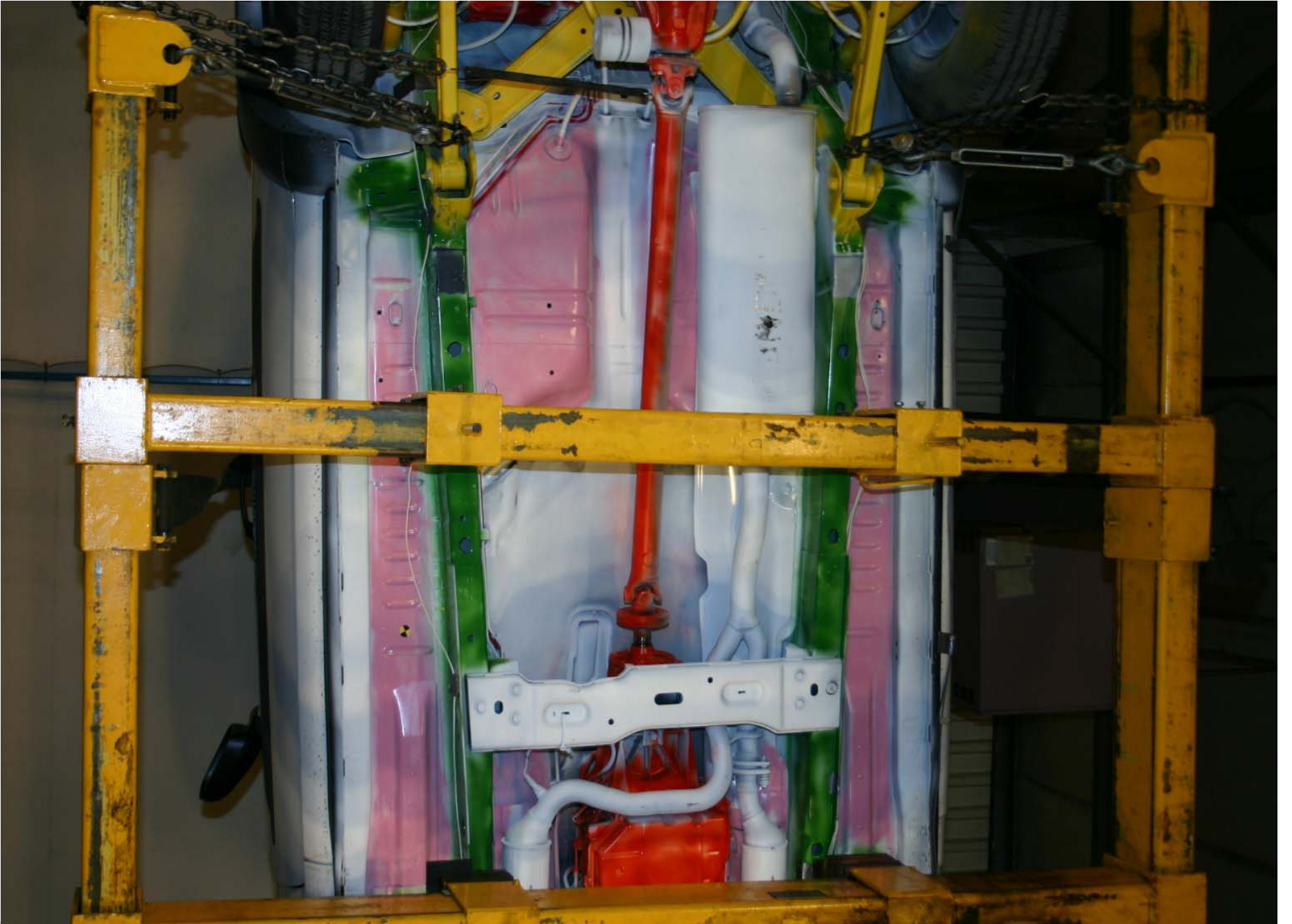

C-28.

Post-Test Mid Underbody

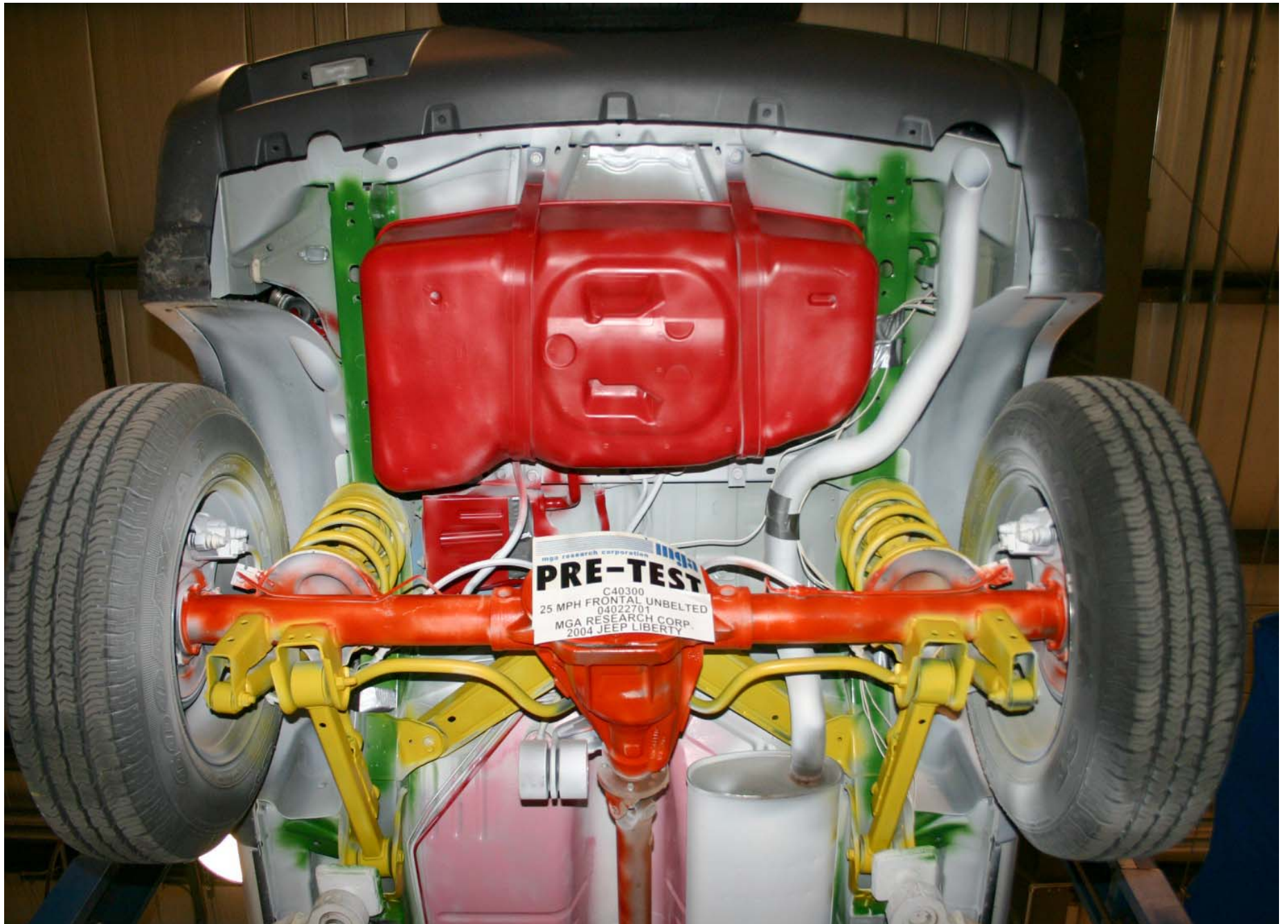

Pre-Test Rear Underbody View

C-30.



Post-Test Rear Underbody View



Pre-Test Fuel Tank View

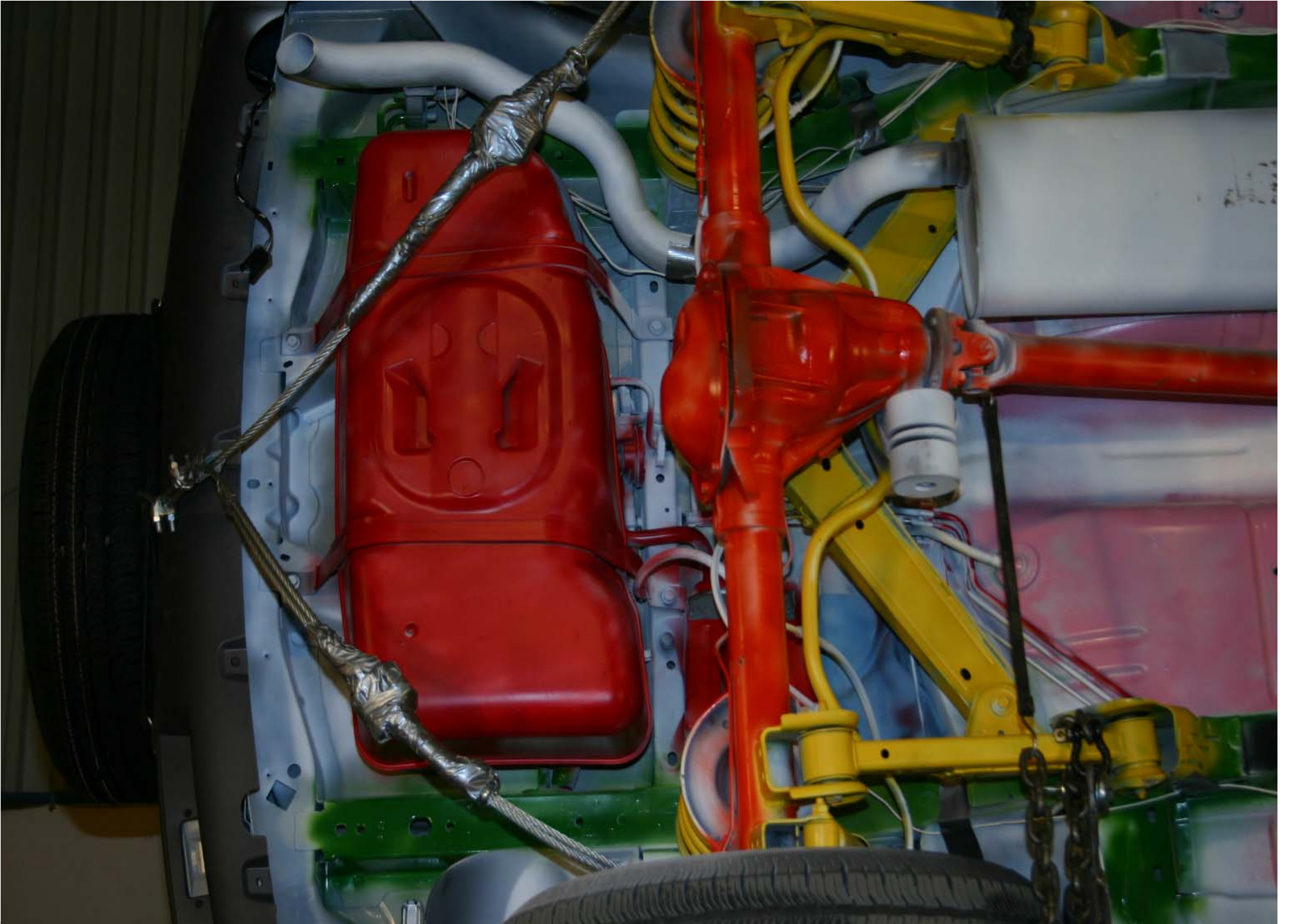

C-32.

Post-Test Fuel Tank View

MGA RESEARCH CORPORATION
PRE-TEST
C40300
25 MPH FRONTAL UNBELTED
04022701
MGA RESEARCH CORP.
2004 JEEP LIBERTY



Pre-Test Driver Dummy Front View (head position)

C-33.

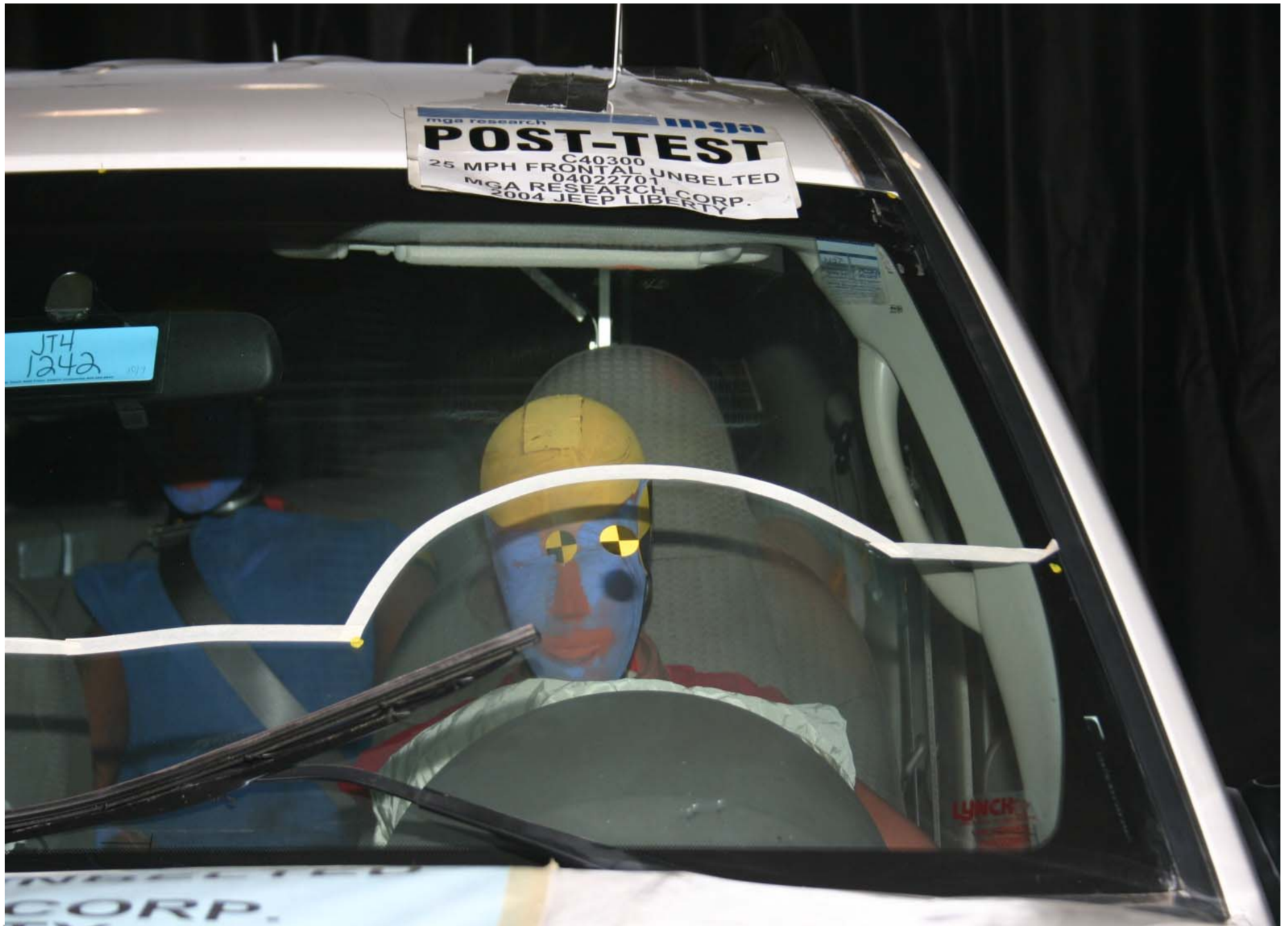

C-34.

Post-Test Driver Dummy Front View (head position)

C-35.



Pre-Test Driver Dummy Position Left Side View



Post-Test Driver Dummy Position Left Side View



Pre-Test Driver Dummy Position Left Side View (Door Open)

C-38.



Post-Test Driver Dummy Position Left Side View (Door Open)



Pre-Test Driver Dummy Seat Position

C-40.



Post-Test Driver Dummy Seat Position

C-41.



Pre-Test Driver Dummy Feet Position

C-42.



Post-Test Driver Dummy Feet Position

C-43.



Pre-Test Driver Side Knee Bolster View

C-44.



Post-Test Driver Side Knee Bolster View



Post-Test Driver Dummy Head Contact



Post-Test Driver Dummy Head Contact

C-47.



Post-Test Driver Dummy Knee Contact

C-48.



Post-Test Driver Dummy Airbag Contact

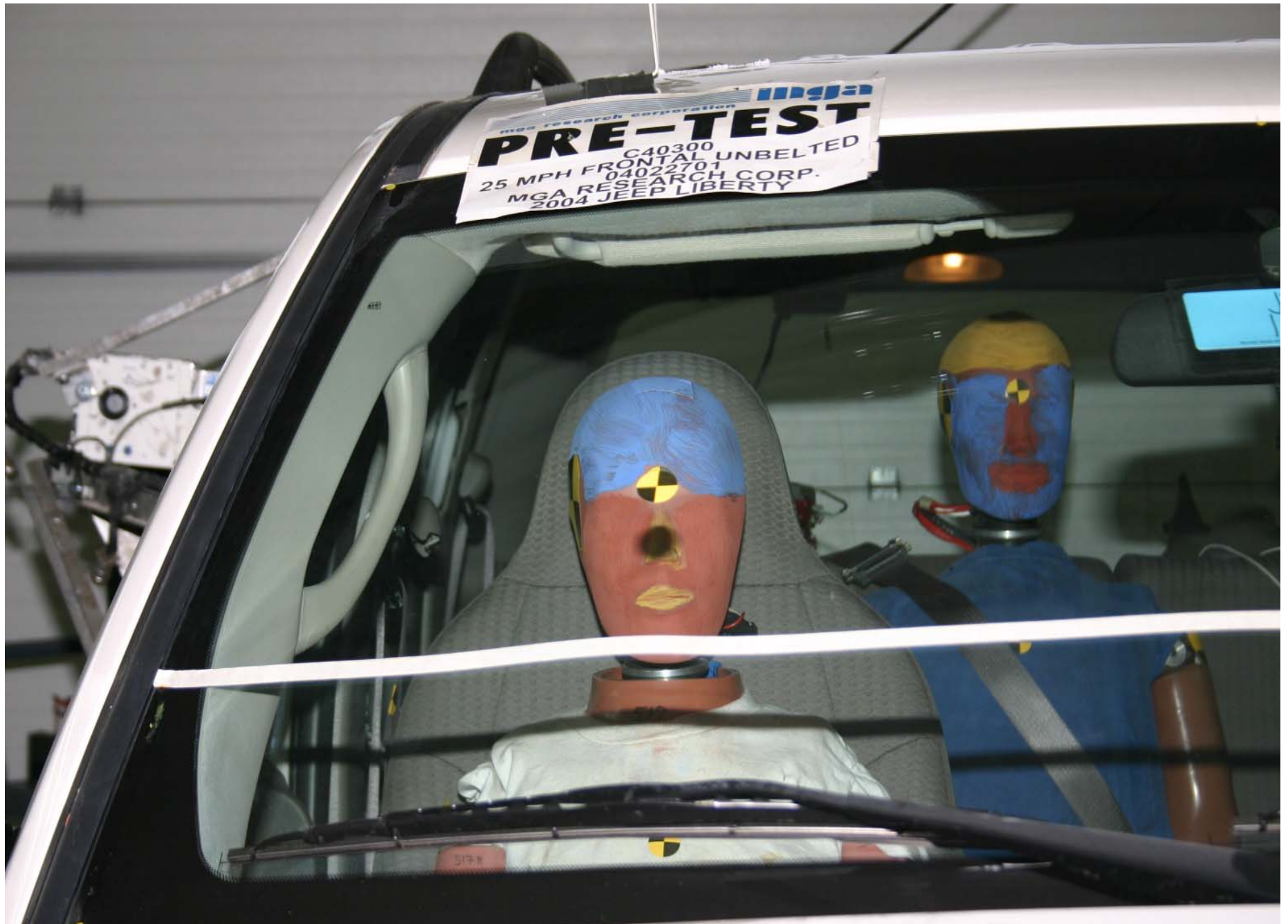

Pre-Test Passenger Dummy Front View (head position)



Post-Test Passenger Dummy Front View (head position)

C-51.

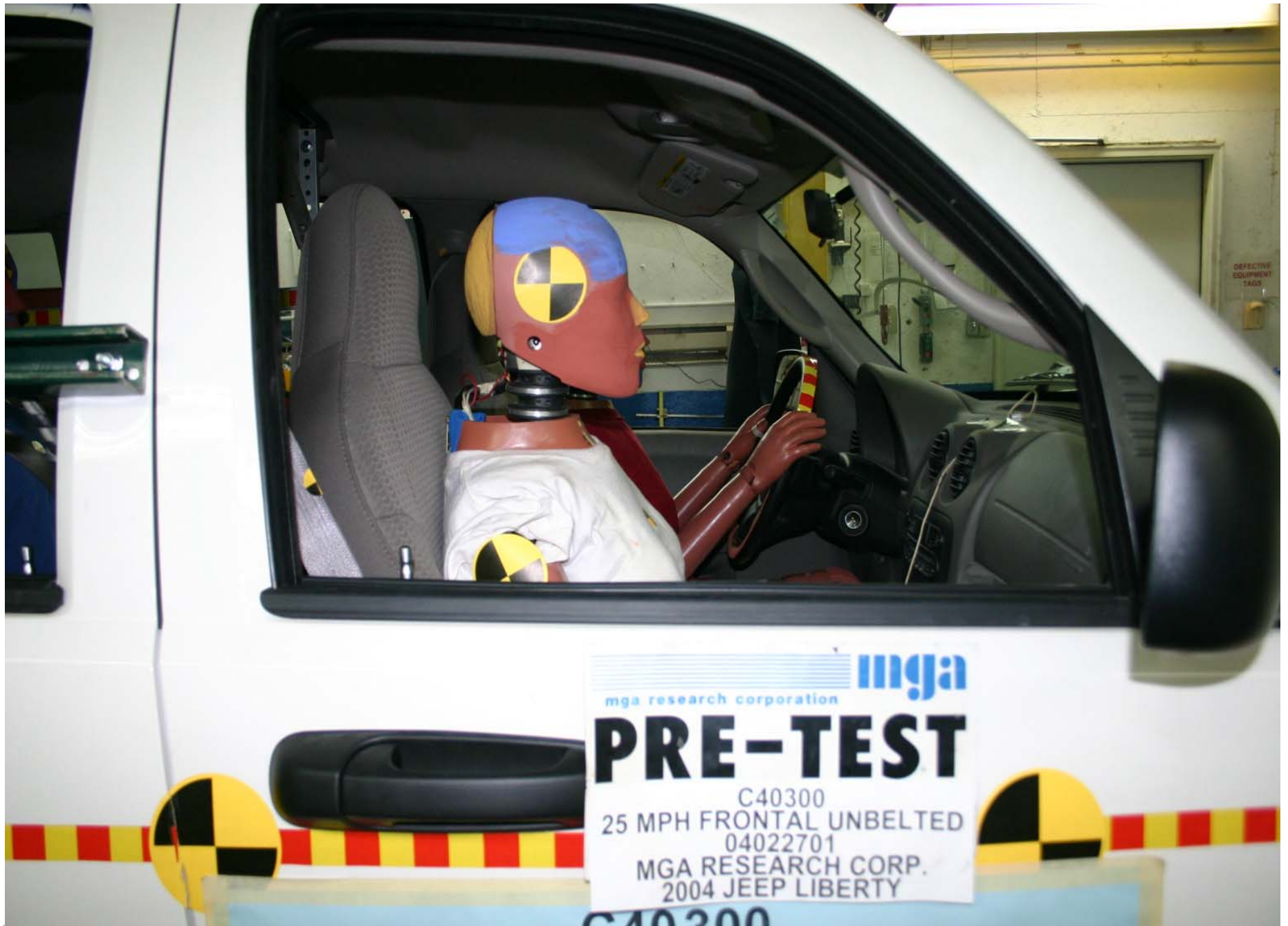

Pre-Test Passenger Dummy Position Right Side View

C-52.



Post-Test Passenger Dummy Position Right Side View

C-53.



Pre-Test Passenger Dummy Position Right Side View (Door Open)

C-54.



Post-Test Passenger Dummy Position Right Side View (Door Open)



Pre-Test Passenger Dummy Seat Position

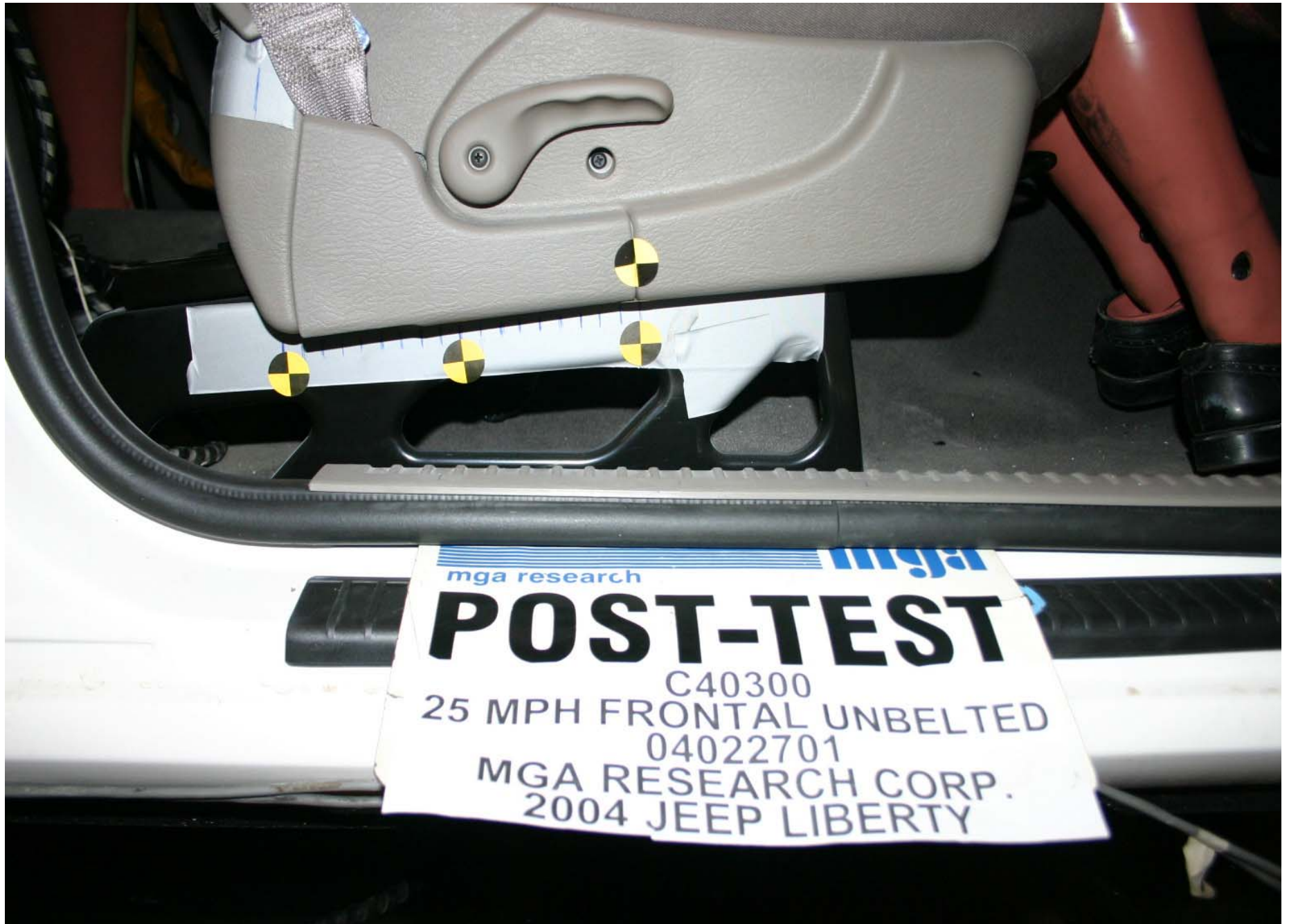

Post-Test Passenger Dummy Seat Position



Pre-Test Passenger Dummy Feet Position



Post-Test Passenger Dummy Feet Position



Pre-Test Passenger Side Knee Bolster View

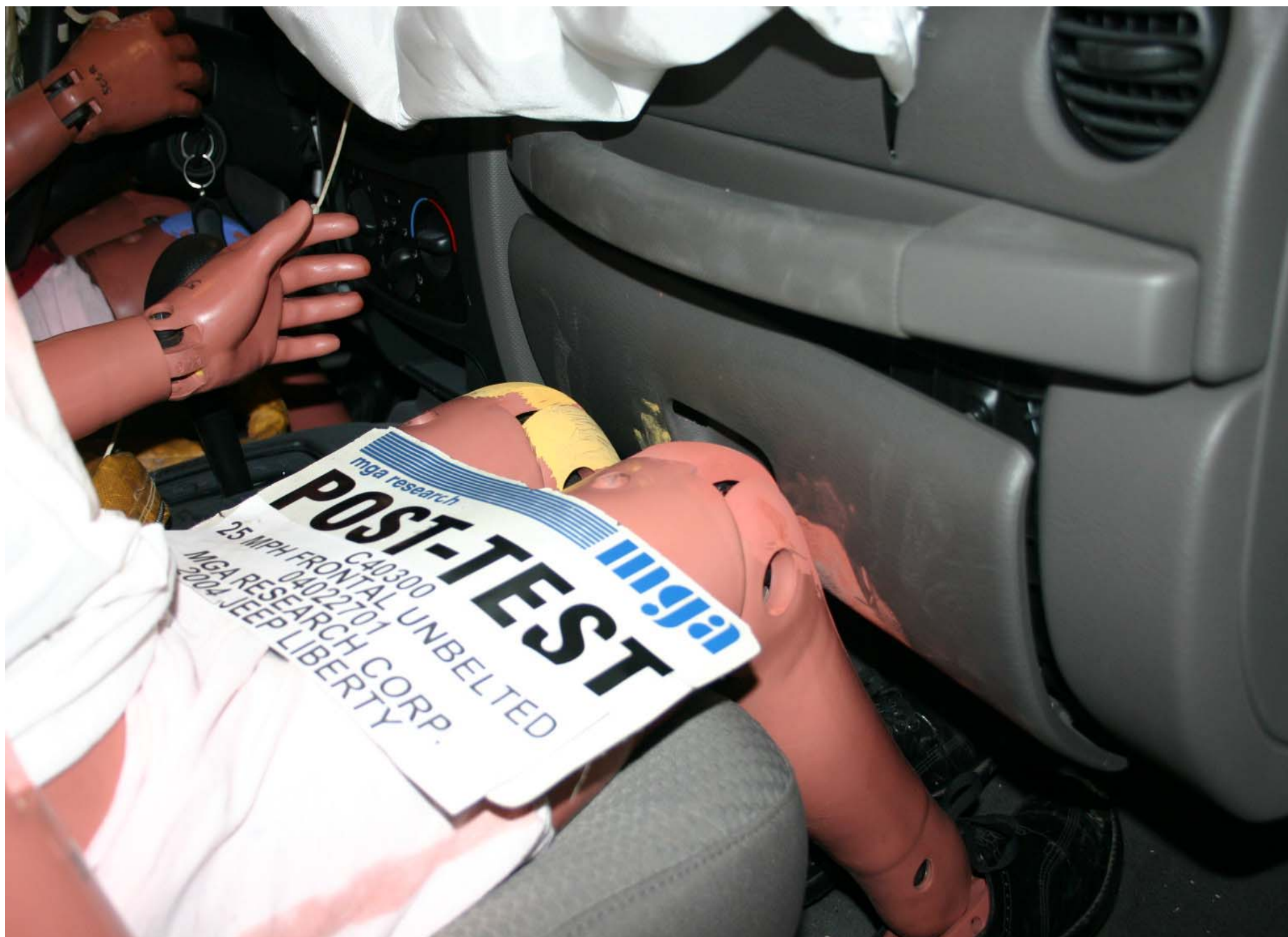

Post-Test Passenger Side Knee Bolster View

C-61.

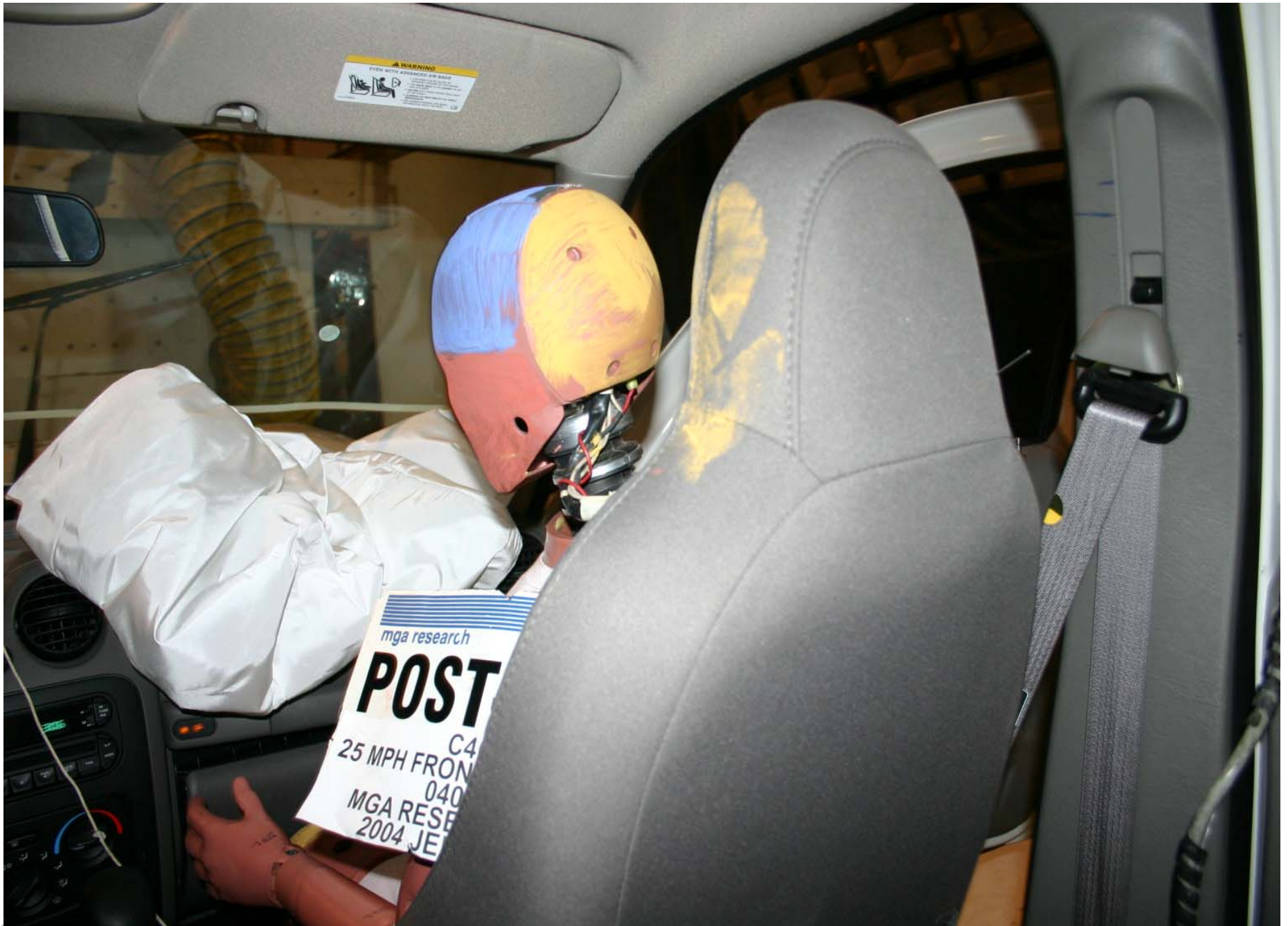

Post-Test Passenger Dummy Head Contact



Post-Test Passenger Dummy Knee Contact



Post-Test Passenger Dummy Airbag Contact



Pre-Test Rear Passenger Dummy Front View (head position)

mga research
POST-TEST
C40300
25 MPH FRONTAL UNBELTED
04022701
MGA RESEARCH CORP.
2004 JEEP LIBERTY

4
1242

C-65.



Post-Test Rear Passenger Dummy Front View (head position)

C-66.



Pre-Test Rear Passenger Dummy Position Left Side View

C-67.



Post-Test Rear Passenger Dummy Position Left Side View

C-68.



Pre-Test Rear Pass. Dummy Position Left Side View (Door Open)



Post-Test Rear Pass. Dummy Position Left Side View (Door Open)

C-70.



Pre-Test Rear Passenger Dummy Position Right Side View

C-71.



Post-Test Rear Passenger Dummy Position Right Side View



Pre-Test Rear Passenger Dummy Feet Position



Post-Test Rear Passenger Dummy Feet Position

C-74.



Pre-Test Rear Passenger Left Side Knee Bolster View



Post-Test Rear Passenger Left Side Knee Bolster View



Pre-Test Rear Passenger Right Side Knee Bolster View

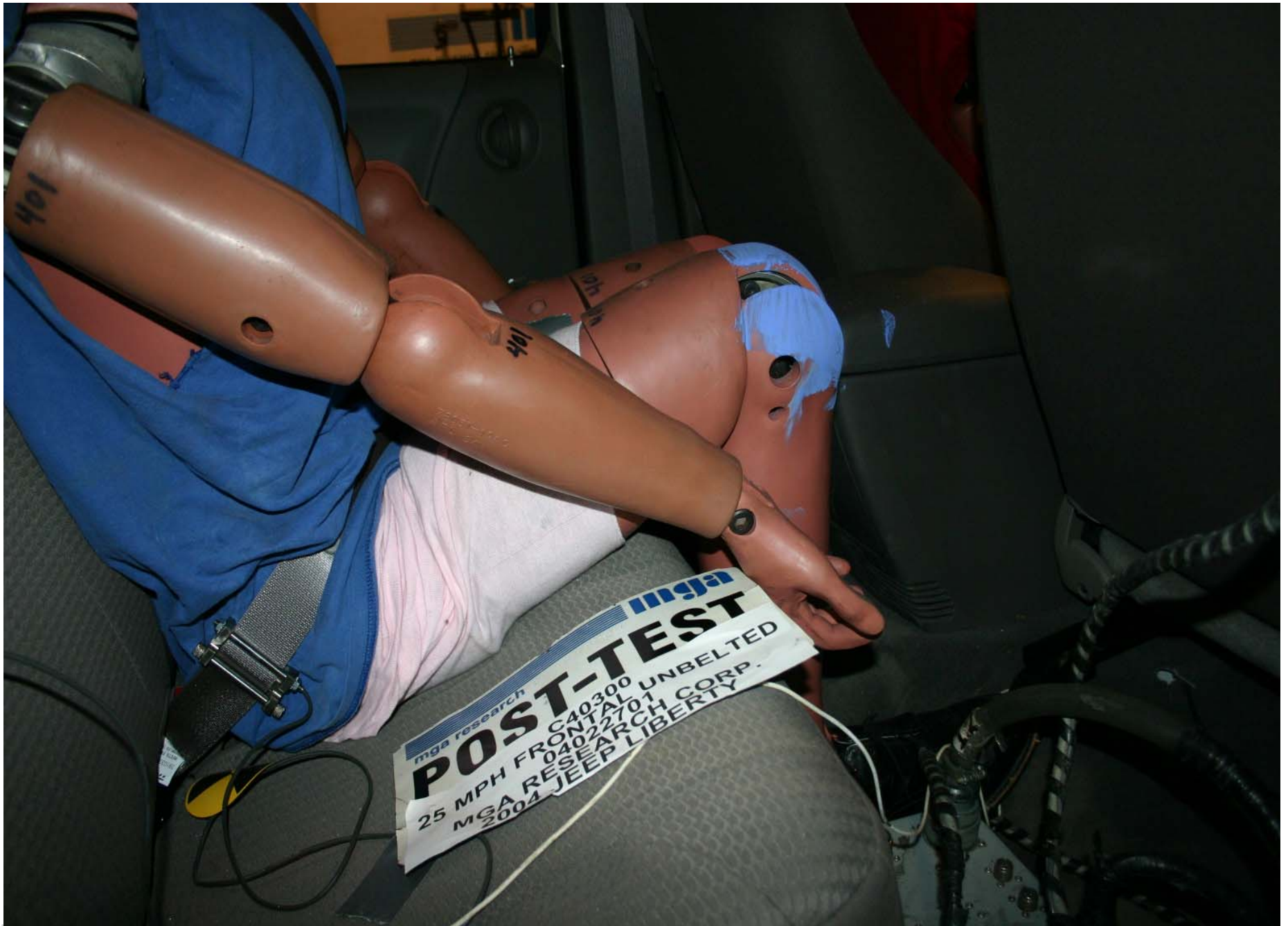

Post-Test Rear Passenger Right Side Knee Bolster View



Post-Test Rear Passenger Dummy Knee Contact

C-79.



Rollover 90 Degrees



Rollover 180 Degrees

C-81.



Rollover 270 Degrees



Rollover 360 Degrees



Vehicle Impact

C-84.

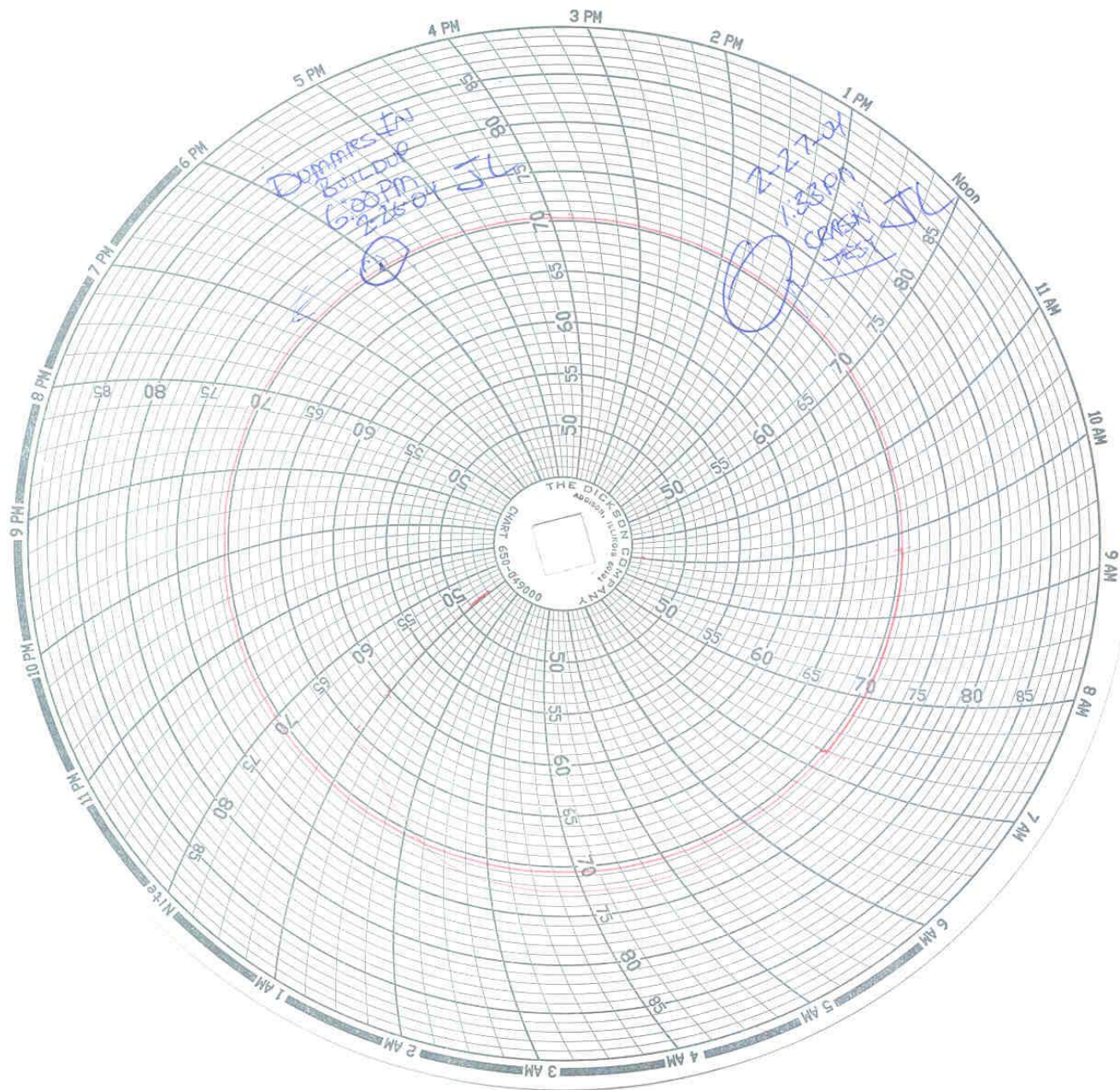

Temperature Plot

APPENDIX D
LOW RISK PHOTOGRAPHS

TABLE OF PHOTOGRAPHS

	<u>Page No.</u>	
Photo No. 1.	Pre-Test 5 th Fem. P1 Driver Dummy Left Side View	D-1
Photo No. 2.	Post-Test 5 th Fem. P1 Driver Dummy Left Side View	D-2
Photo No. 3.	Pre-Test 5 th Fem. P1 Driver Dummy Left Side View (Door Open)	D-3
Photo No. 4.	Pre-Test 5 th Fem. P1 Driver Dummy Left Side View (Door Open, Closeup)	D-4
Photo No. 5.	Post-Test 5 th Fem. P1 Driver Dummy Left Side View (Door Open)	D-5
Photo No. 6.	Pre-Test 5 th Fem. P1 Driver Dummy Right Side View (Door Open)	D-6
Photo No. 7.	Pre-Test 5 th Fem. P1 Driver Dummy Right Side View (Door Open, Closeup)	D-7
Photo No. 8.	Post-Test 5 th Fem. P1 Driver Dummy Right Side View (Door Open)	D-8
Photo No. 9.	Pre-Test 5 th Fem. P1 Driver Dummy Front Head Position View	D-9
Photo No. 10.	Post-Test 5 th Fem. P1 Driver Dummy Front Head Position View	D-10
Photo No. 11.	Pre-Test 5 th Fem. P1 Driver Dummy Head and Airbag Position View	D-11
Photo No. 12.	Post-Test 5 th Fem. P1 Driver Dummy and Airbag View	D-12
Photo No. 13.	Post-Test 5 th Fem. P1 Driver Dummy Head Contact View (Headrest)	D-13
Photo No. 14.	Pre-Test 5 th Fem. P2 Driver Dummy Left Side View	D-14
Photo No. 15.	Post-Test 5 th Fem. P2 Driver Dummy Left Side View	D-15
Photo No. 16.	Pre-Test 5 th Fem. P2 Driver Dummy Left Side View (Door Open)	D-16
Photo No. 17.	Post-Test 5 th Fem. P2 Driver Dummy Left Side View (Door Open)	D-17
Photo No. 18.	Pre-Test 5 th Fem. P2 Driver Dummy Right Side View	D-18
Photo No. 19.	Post-Test 5 th Fem. P2 Driver Dummy Right Side View	D-19
Photo No. 20.	Pre-Test 5 th Fem. P2 Driver Dummy Right Side View (Door Open)	D-20
Photo No. 21.	Post-Test 5 th Fem. P2 Driver Dummy Right Side View (Door Open)	D-21
Photo No. 22.	Pre-Test 5 th Fem. P2 Driver Dummy Left Side Head Position View	D-22
Photo No. 23.	Pre-Test 5 th Fem. P2 Driver Dummy Right Side Head Position View	D-23
Photo No. 24.	Post-Test 5 th Fem. P2 Driver Dummy and Airbag View	D-24
Photo No. 25.	Post-Test 5 th Fem. P2 Driver Dummy and Airbag View	D-25
Photo No. 26.	Geometric Center (2004 Jeep Liberty)	D-26



Pre-Test 5th Fem. P1 Driver Dummy Left Side View



Post-Test 5th Fem. P1 Driver Dummy Left Side View



Pre-Test 5th Fem. P1 Driver Dummy Left Side View (Door Open)



Pre-Test 5th Fem. P1 Driver Dummy Left Side View (Door Open, Closeup)

D-5



Post-Test 5th Fem. P1 Driver Dummy Left Side View (Door Open)



Pre-Test 5th Fem. P1 Driver Dummy Right Side View (Door Open)

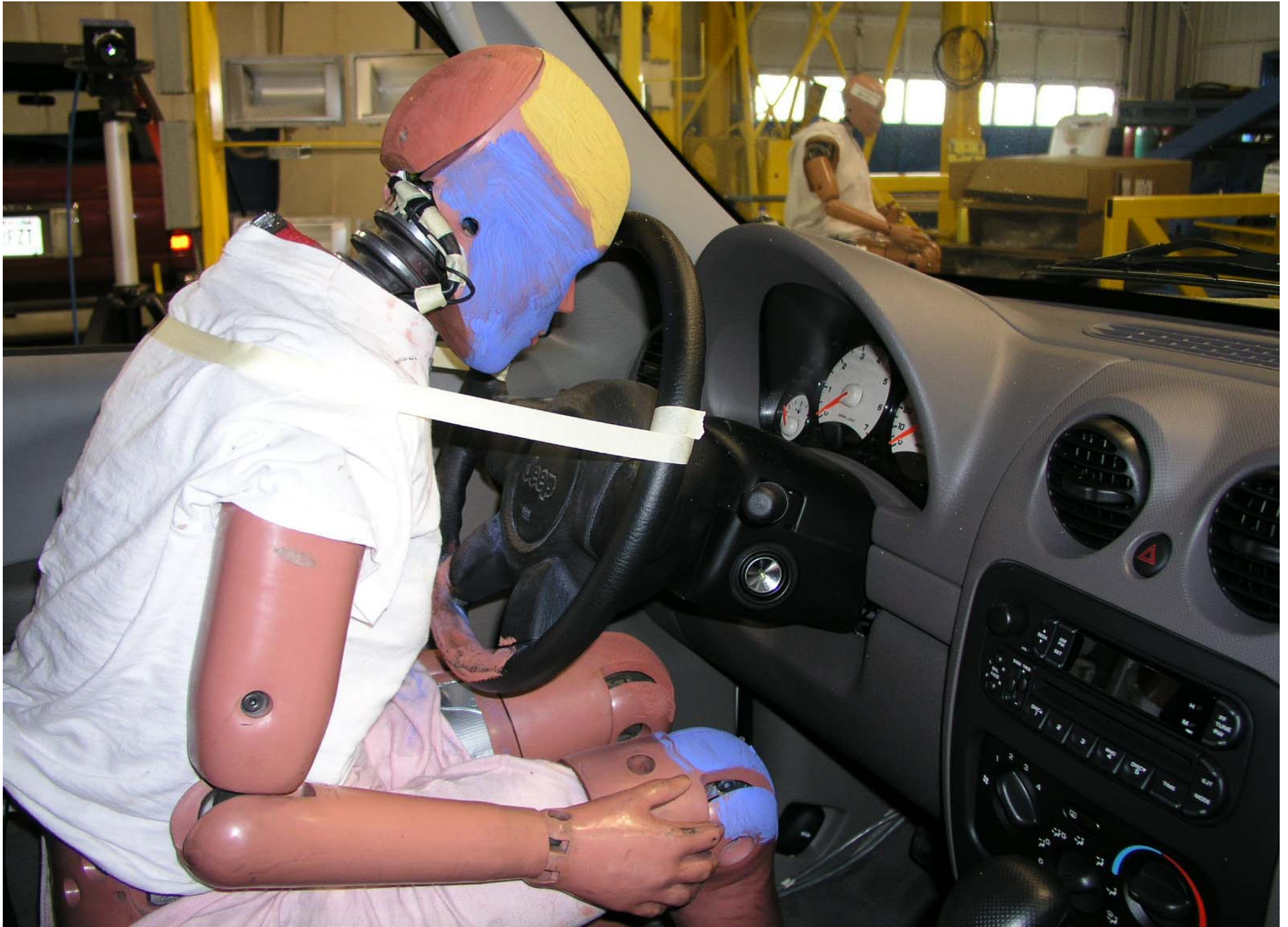

Pre-Test 5th Fem. P1 Driver Dummy Right Side View (Door Open, Closeup)



Post-Test 5th Fem. P1 Driver Dummy Right Side View (Door Open)

D-9



Pre-Test 5th Fem. P1 Driver Dummy Front Head Position View

D-10



Post-Test 5th Fem. P1 Driver Dummy Front Head Position View



Pre-Test 5th Fem. P1 Driver Dummy Head and Airbag Position View



Post-Test 5th Fem. P1 Driver Dummy and Airbag View



Post-Test 5th Fem. P1 Driver Dummy Head Contact View (Headrest)



Pre-Test 5th Fem. P2 Driver Dummy Left Side View



2004 Jee p Liberty
5th % Low Risk Dep loyment Position 2
C40300 1-30-04
MGA Rese arch Corp.

mga
mga research corp. ation
POST-TEST
5th % Low Risk Deployment Position 2
C40300 1-30-04
2004 Jeep Liberty
MGA Research Corp.

Post-Test 5th Fem. P2 Driver Dummy Left Side View



Pre-Test 5th Fem. P2 Driver Dummy Left Side View (Door Open)



Post-Test 5th Fem. P2 Driver Dummy Left Side View (Door Open)



Pre-Test 5th Fem. P2 Driver Dummy Right Side View



mga
mga research corporation
POST-TEST
5th % Low Risk Deployment Position 2
C40300 1-30-04
2004 Jeep Liberty
MGA Research Corp.

2004 Jee p Liberty
5th % Low Risk Dep loyment Position 2
C40300 1-30-04

Post-Test 5th Fem. P2 Driver Dummy Right Side View



Pre-Test 5th Fem. P2 Driver Dummy Right Side View (Door Open)



Post-Test 5th Fem. P2 Driver Dummy Right Side View (Door Open)



Pre-Test 5th Fem. P2 Driver Dummy Left Side Head Position View



Pre-Test 5th Fem. P2 Driver Dummy Right Side Head Position View



Post-Test 5th Fem. P2 Driver Dummy and Airbag View



Post-Test 5th Fem. P2 Driver Dummy and Airbag View

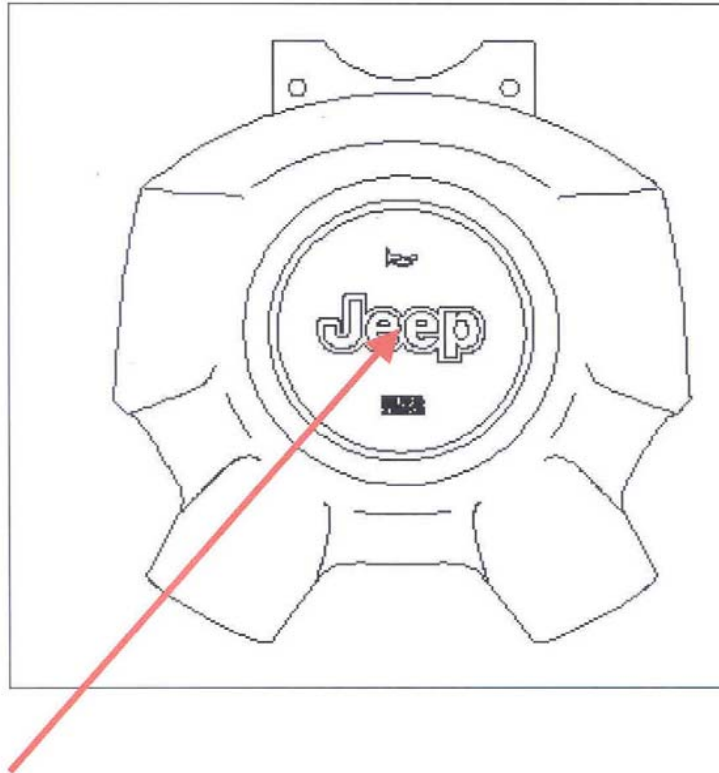

The “geometric center of the opening through which the air bag deploys into the occupant compartment” is the center of the Jeep emblem.

Jeep Liberty (KJ)

APPENDIX E
SUPPRESSION PHOTOGRAPHS

TABLE OF PHOTOGRAPHS

		<u>Page #</u>
Photo No. 1.	Cosco Dream Ride Car Bed With Belt, Middle Seat Track	E-1
Photo No. 2.	Cosco Dream Ride Car Bed With Belt, Middle Seat Track, 2 nd View	E-1
Photo No. 3.	Britax Handle With Care With Belt, Forward Seat Track, Handle Down	E-2
Photo No. 4.	Britax Handle With Care With Belt, Middle Seat Track, Handle Down	E-2
Photo No. 5.	Britax Handle With Care With Belt, Rearward Seat Track, Handle Down	E-2
Photo No. 6.	Britax Handle With Care Unbelted, Forward Seat Track, Handle Down	E-2
Photo No. 7.	Britax Handle With Care Unbelted, Middle Seat Track, Handle Down	E-3
Photo No. 8.	Britax Handle With Care Unbelted, Rearward Seat Track, Handle Down	E-3
Photo No. 9.	Britax Handle With Care Fwd Facing Unbelted, Forward Seat Track, Handle Down	E-3
Photo No. 10.	Britax Handle With Care Fwd Facing Unbelted, Middle Seat Track, Handle Down	E-3
Photo No. 11.	Britax Handle With Care Fwd Facing Unbelted, Rearward Seat Track, Handle Down	E-4
Photo No. 12.	Unbelted 5 th Percentile Female Reactivation Seat, Rearward Seat Track	E-4
Photo No. 13.	Evenflo First Choice With Belt, Forward Seat Track, Handle Up	E-5
Photo No. 14.	Evenflo First Choice With Belt, Middle Seat Track, Handle Up	E-5
Photo No. 15.	Evenflo First Choice With Belt, Rearward Seat Track, Handle Down	E-5
Photo No. 16.	Evenflo First Choice Unbelted, Forward Seat Track, Handle Up	E-5
Photo No. 17.	Evenflo First Choice Unbelted, Middle Seat Track, Handle Up	E-6
Photo No. 18.	Evenflo First Choice Unbelted, Rearward Handle Down	E-6
Photo No. 19.	Evenflo First Choice Fwd Facing Unbelted, Forward Seat Track, Handle Down	E-6
Photo No. 20.	Evenflo First Choice Fwd Facing Unbelted, Middle Seat Track, Handle Down	E-6
Photo No. 21.	Evenflo First Choice Fwd Facing Unbelted, Rearward Seat Track, Handle Down	E-7
Photo No. 22.	Unbelted 5 th Percentile Female Reactivation Seat, Forward Seat Track	E-7
Photo No. 23.	Graco Infant W/ Base With Belt, Forward Seat Track, Handle Up	E-8
Photo No. 24.	Graco Infant W/ Base With Belt, Middle Seat Track, Handle Up	E-8
Photo No. 25.	Graco Infant W/ Base With Belt, Rearward Seat Track, Handle Down	E-8
Photo No. 26.	Graco Infant W/ Base Unbelted, Forward Seat Track, Handle Up	E-8
Photo No. 27.	Graco Infant W/ Base Unbelted, Middle Seat Track, Handle Up	E-9
Photo No. 28.	Graco Infant W/ Base Unbelted, Rearward Seat Track, Handle Down	E-9
Photo No. 29.	Graco Infant W/ Base Fwd Facing Unbelted, Forward Seat Track, Handle Up	E-9
Photo No. 30.	Graco Infant W/ Base Fwd Facing Unbelted, Middle Seat Track, Handle Up	E-9
Photo No. 31.	Graco Infant W/ Base Fwd Facing Unbelted, Rearward Seat Track, Handle Up	E-10
Photo No. 32.	Graco Infant W/O Base With Belt, Forward Seat Track, Handle Up	E-10
Photo No. 33.	Graco Infant W/O Base With Belt, Middle Seat Track, Handle Down	E-10
Photo No. 34.	Graco Infant W/O Base With Belt, Rearward Seat Track, Handle Down	E-10

Photo No. 35.	Graco infant W/O Base Unbelted, Forward Seat Track, Handle Up	E-11
Photo No. 36.	Graco Infant W/O Base Unbelted, Middle Seat Track, Handle Up	E-11
Photo No. 37.	Graco Infant W/O Base Unbelted, Rearward Seat Track, Handle Down	E-11
Photo No. 38.	Graco Infant W/O Base Fwd Facing Unbelted, Forward Seat Track, Handle Down	E-11
Photo No. 39.	Graco Infant W/O Base Fwd Facing Unbelted, Middle Seat Track, Handle Down	E-12
Photo No. 40.	Graco Infant W/O Base Fwd Facing Unbelted, Rearward Seat Track, Handle Down	E-12
Photo No. 41.	Unbelted 5 th Percentile Female Reactivation Seat, Rearward Seat Track	E-12
Photo No. 42.	Britax Roundabout Fwd Facing With Belt, Forward Seat Track, No Blanket	E-13
Photo No. 43.	Britax Roundabout Fwd Facing With Belt, Middle Seat Track, No Blanket	E-13
Photo No. 44.	Britax Roundabout Fwd Facing With Belt, Rearward Seat Track, No Blanket	E-13
Photo No. 45.	Britax Roundabout Fwd Facing Unbelted, Forward Seat Track, No Blanket	E-13
Photo No. 46.	Britax Roundabout Fwd Facing Unbelted, Middle Seat Track, No Blanket	E-14
Photo No. 47.	Britax Roundabout Fwd Facing Unbelted, Rearward Seat Track, No Blanket	E-14
Photo No. 48.	Britax Roundabout Rear Facing With Belt, Forward Seat Track, No Blanket	E-14
Photo No. 49.	Britax Roundabout Rear Facing With Belt, Middle Seat Track, No Blanket	E-14
Photo No. 50.	Britax Roundabout Rear Facing With Belt, Rearward Seat Track, No Blanket	E-15
Photo No. 51.	Britax Roundabout Rear Facing Unbelted, Forward Seat Track, No Blanket	E-15
Photo No. 52.	Britax Roundabout Rear Facing Unbelted, Middle Seat Track, No Blanket	E-15
Photo No. 53.	Britax Roundabout Rear Facing Unbelted, Rearward Seat Track, No Blanket	E-15
Photo No. 54.	Century Encore Fwd Facing With Belt, Forward Seat Track, No Blanket	E-16
Photo No. 55.	Century Encore Fwd Facing With Belt, Middle Seat Track, No Blanket	E-16
Photo No. 56.	Century Encore Fwd Facing With Belt, Rearward Seat Track, No Blanket	E-16
Photo No. 57.	Century Encore Fwd Facing Unbelted, Forward Seat Track, No Blanket	E-16
Photo No. 58.	Century Encore Fwd Facing Unbelted, Middle Seat Track, No Blanket	E-17
Photo No. 59.	Century Encore Fwd Facing Unbelted, Rearward Seat Track, No Blanket	E-17
Photo No. 60.	Century Encore Rear Facing With Belt, Forward Seat Track, No Blanket	E-17
Photo No. 61.	Century Encore Rear Facing With Belt, Middle Seat Track, No Blanket	E-17
Photo No. 62.	Century Encore Rear Facing With Belt, Rearward Seat Track, No Blanket	E-18
Photo No. 63.	Century Encore Rear Facing Unbelted, Forward Seat Track, No Blanket	E-18
Photo No. 64.	Century Encore Rear Facing Unbelted, Middle Seat Track, No Blanket	E-18
Photo No. 65.	Century Encore Rear Facing Unbelted, Rearward Seat Track, No Blanket	E-18
Photo No. 66.	Unbelted 5 th Percentile Female Reactivation Seat, Middle Seat Track	E-19
Photo No. 67.	Evenflo Medallion Fwd Facing With Belt, Forward Seat Track, No Blanket	E-20
Photo No. 68.	Evenflo Medallion Fwd Facing With Belt, Middle Seat Track, No Blanket	E-20
Photo No. 69.	Evenflo Medallion Fwd Facing With Belt, Rearward Seat Track, No Blanket	E-20
Photo No. 70.	Evenflo Medallion Fwd Facing Unbelted, Forward Seat Track, No Blanket	E-20

Photo No. 71.	Evenflo Medallion Fwd Facing Unbelted, Middle Seat Track, No Blanket	E-21
Photo No. 72.	Evenflo Medallion Fwd Facing Unbelted, Rearward Seat Track, No Blanket	E-21
Photo No. 73.	Evenflo Medallion Rear Facing With Belt, Forward Seat Track, No Blanket	E-21
Photo No. 74.	Evenflo Medallion Rear Facing With Belt, Middle Seat Track, No Blanket	E-21
Photo No. 75.	Evenflo Medallion Rear Facing With Belt, Rearward Seat Track, No Blanket	E-22
Photo No. 76.	Evenflo Medallion Rear Facing Unbelted, Forward Seat Track, No Blanket	E-22
Photo No. 77.	Evenflo Medallion Rear Facing Unbelted, Middle Seat Track, No Blanket	E-22
Photo No. 78.	Evenflo Medallion Rear Facing Unbelted, Rearward Seat Track, No Blanket	E-22
Photo No. 79.	Unbelted 5 th Percentile Female Reactivation Seat, Forward Seat Track	E-23
Photo No. 80.	3-Year-Old Fwd Facing Britax Roundabout Belted, Forward Seat Track	E-24
Photo No. 81.	3-Year-Old Fwd Facing Britax Roundabout Belted, Middle Seat Track	E-24
Photo No. 82.	3-Year-Old Fwd Facing Britax Roundabout Belted, Rearward Seat Track	E-24
Photo No. 83.	Unbelted 5 th Percentile Female Reactivation Seat, Rearward Seat Track	E-24
Photo No. 84.	3-Year-Old Fwd Facing Century Encore Belted, Forward Seat Track	E-25
Photo No. 85.	3-Year-Old Fwd Facing Century Encore Belted, Middle Seat Track	E-25
Photo No. 86.	3-Year-Old Fwd Facing Century Encore Belted, Rearward Seat Track	E-25
Photo No. 87.	3-Year-Old Fwd Facing Evenflo Medallion Belted, Forward Seat Track	E-26
Photo No. 88.	3-Year-Old Fwd Facing Evenflo Medallion Belted, Middle Seat Track	E-26
Photo No. 89.	3-Year-Old Fwd Facing Evenflo Medallion Belted, Rearward Seat Track	E-26
Photo No. 90.	3-Year-Old Century Next Step Belted, Forward Seat Track	E-27
Photo No. 91.	3-Year-Old Century Next Step Belted, Middle Seat Track	E-27
Photo No. 92.	3-Year-Old Century Next Step Belted, Rearward Seat Track	E-27
Photo No. 93.	Unbelted 5 th Percentile Female Reactivation Seat, Forward Seat Track	E-27
Photo No. 94.	3-Year-Old Cosco High Back Belted, Middle Seat Track	E-28
Photo No. 95.	3-Year-Old Cosco High Back Belted, Rearward Seat Track	E-28
Photo No. 96.	3-Year-Old Cosco High Back Cinched With Harness, Middle Seat Track	E-28
Photo No. 97.	3-Year-Old Cosco High Back Cinched With Harness, Rearward Seat Track	E-28
Photo No. 98.	Unbelted 5 th Percentile Female Reactivation Seat, Rearward Seat Track	E-29
Photo No. 99.	6-Year-Old Century Next Step Belted, Forward Seat Track	E-30
Photo No. 100.	6-Year-Old Century Next Step Belted, Middle Seat Track	E-30
Photo No. 101.	6-Year-Old Century Next Step Belted, Rearward Seat Track	E-30
Photo No. 102.	6-Year-Old Century Next Step Unbelted, Forward Seat Track	E-30
Photo No. 103.	6-Year-Old Century Next Step Unbelted, Middle Seat Track	E-31
Photo No. 104.	6-Year-Old Century Next Step Unbelted, Rearward Seat Track	E-31
Photo No. 105.	Unbelted 5 th Percentile Female Reactivation Seat, Rearward Seat Track	E-31
Photo No. 106.	6-Year-Old Cosco High Back Belted, Forward Seat Track	E-32

Photo No. 107.	6-Year-Old Cosco High Back Belted, Middle Seat Track	E-32
Photo No. 108.	6-Year-Old Cosco High Back Belted, Rearward Seat Track	E-32
Photo No. 109.	Unbelted 5 th Percentile Female Reactivation Seat, Forward Seat Track	E-32
Photo No. 110.	6-Year-Old Evenflo Right Fit Belted, Forward Seat Track	E-33
Photo No. 111.	6-Year-Old Evenflo Right Fit Belted, Middle Seat Track	E-33
Photo No. 112.	6-Year-Old Evenflo Right Fit Belted, Rearward Seat Track	E-33
Photo No. 113.	Unbelted 5 th Percentile Female Reactivation Seat, Middle Seat Track	E-33
Photo No. 114.	3-Year-Old Unbelted, Forward Seat Track, Position 1	E-34
Photo No. 115.	3-Year-Old Unbelted, Forward Seat Track, Position 2	E-34
Photo No. 116.	3-Year-Old Unbelted, Forward Seat Track, Position 4	E-34
Photo No. 117.	3-Year-Old Unbelted, Forward Seat Track, Position 5	E-34
Photo No. 118.	3-Year-Old Unbelted, Forward Seat Track, Position 5, Forward View	E-35
Photo No. 119.	3-Year-Old Unbelted, Forward Seat Track, Position 6	E-35
Photo No. 120.	3-Year-Old Unbelted, Forward Seat Track, Position 7	E-35
Photo No. 121.	3-Year-Old Unbelted, Middle Seat Track, Position 1	E-35
Photo No. 122.	3-Year-Old Unbelted, Middle Seat Track, Position 2	E-36
Photo No. 123.	3-Year-Old Unbelted, Middle Seat Track, Position 3	E-36
Photo No. 124.	3-Year-Old Unbelted, Middle Seat Track, Position 4	E-36
Photo No. 125.	3-Year-Old Unbelted, Middle Seat Track, Position 5	E-36
Photo No. 126.	3-Year-Old Unbelted, Middle Seat Track, Position 5, Forward View	E-37
Photo No. 127.	3-Year-Old Unbelted, Middle Seat Track, Position 6	E-37
Photo No. 128.	3-Year-Old Unbelted, Middle Seat Track, Position 7	E-37
Photo No. 129.	3-Year-Old Unbelted, Rearward Seat Track, Position 1	E-37
Photo No. 130.	3-Year-Old Unbelted, Rearward Seat Track, Position 2	E-38
Photo No. 131.	3-Year-Old Unbelted, Rearward Seat Track, Position 3	E-38
Photo No. 132.	3-Year-Old Unbelted, Rearward Seat Track, Position 4	E-38
Photo No. 133.	3-Year-Old Unbelted, Rearward Seat Track, Position 5	E-38
Photo No. 134.	3-Year-Old Unbelted, Rearward Seat Track, Position 5, Forward View	E-39
Photo No. 135.	3-Year-Old Unbelted, Rearward Seat Track, Position 6	E-39
Photo No. 136.	3-Year-Old Unbelted, Rearward Seat Track, Position 7	E-39
Photo No. 137.	Unbelted 5 th Percentile Female Reactivation Seat, Forward Seat Track	E-39
Photo No. 138.	6-Year-Old Unbelted, Forward Seat Track, Position 1	E-40
Photo No. 139.	6-Year-Old Unbelted, Forward Seat Track, Position 2	E-40
Photo No. 140.	6-Year-Old Unbelted, Forward Seat Track, Position 3	E-40
Photo No. 141.	6-Year-Old Unbelted, Forward Seat Track, Position 4, Side View	E-40
Photo No. 142.	6-Year-Old Unbelted, Middle Seat Track, Position 1	E-41

	<u>Page #</u>
Photo No. 143. 6-Year-Old Unbelted, Middle Seat Track, Position 2	E-41
Photo No. 144. 6-Year-Old Unbelted, Middle Seat Track, Position 3	E-41
Photo No. 145. 6-Year-Old Unbelted, Middle Seat Track, Position 4, Forward View	E-41
Photo No. 146. 6-Year-Old Unbelted, Forward Seat Track, Position 4, Side View	E-42
Photo No. 147. 6-Year-Old Unbelted, Rearward Seat Track, Position 1	E-42
Photo No. 148. 6-Year-Old Unbelted, Rearward Seat Track, Position 2	E-42
Photo No. 149. 6-Year-Old Unbelted, Rearward Seat Track, Position 3	E-42
Photo No. 150. 6-Year-Old Unbelted, Rearward Seat Track, Position 4, Forward View	E-43
Photo No. 151. 6-Year-Old Unbelted, Forward Seat Track, Position 4, Side View	E-43
Photo No. 152. Unbelted 5 th Percentile Female Reactivation Seat, Rearward Seat Track	E-43

DOT/NHTSA 208 Suppression Test - 2004 Jeep Liberty (C40300)

Newborn

Section A

Car Bed



Cosco Dream Ride Car Bed With Belt, Middle Seat Track



Cosco Dream Ride Car Bed With Belt, Middle Seat Track,
2nd View

DOT/NHTSA 208 Suppression Test - 2004 Jeep Liberty (C40300)

12 Month

Section B

Rear Facing CRS

E-2



Britax Handle With Care With Belt, Forward Seat Tack, Handle Down



Britax Handle With Care With Belt, Middle Seat Track, Handle Down



Britax Handle With Care With Belt, Rearward Seat Track, Handle Down



Britax Handle With Care Unbelted, Forward Seat Track, Handle Down

DOT/NHTSA 208 Suppression Test - 2004 Jeep Liberty (C40300)

12 Month

Section B

Rear Facing CRS

E-3



Britax Handle With Care Unbelted, Middle Seat Track, Handle Down



Britax Handle With Care Unbelted, Rearward Seat Track, Handle Down



Britax Handle With Care Fwd Facing Unbelted, Forward Seat Track, Handle Down



Britax Handle With Care Fwd Facing Unbelted, Middle Seat Track, Handle Down

DOT/NHTSA 208 Suppression Test - 2004 Jeep Liberty (C40300)

12 Month

Section B

Rear Facing CRS



Britax Handle With Care Forward Facing Unbelted,
Rearward Seat Track, Handle Dwn



Unbelted 5th Percentile Female Reactivation Seat,
Rearward Seat Track

DOT/NHTSA 208 Suppression Test - 2004 Jeep Liberty (C40300)

12 Month

Section B

Rear Facing CRS

E-5



Evenflo First Choice With Belt, Forward Seat Track, Handle Up



Evenflo First Choice With Belt, Middle Seat Track, Handle Up



Evenflo First Choice With Belt, Rearward Seat Track, Handle Down



Evenflo First Choice Unbelted, Forward Seat Track, Handle Up

DOT/NHTSA 208 Suppression Test - 2004 Jeep Liberty (C40300)

12 Month

Section B

Rear Facing CRS

E-6



Evenflo First Choice Unbelted, Middle Seat Track, Handle Up



Evenflo First Choice Unbelted, Rearward Seat Track, Handle Down



Evenflo First Choice Fwd Facing Unbelted, Forward Seat Track, Handle Down



Evenflo First Choice Fwd Facing Unbelted, Middle Seat Track, Handle Down

DOT/NHTSA 208 Suppression Test - 2004 Jeep Liberty (C40300)

12 Month

Section B

Rear Facing CRS



Evenflo First Choice Forward Facing Unbelted,
Rearward Seat Track, Handle Down



Unbelted 5th Percentile Female Reactivation Seat,
Forward Seat Track

DOT/NHTSA 208 Suppression Test - 2004 Jeep Liberty (C40300)

12 Month

Section B

Rear Facing CRS

E-8



Graco Infant W/ Base With Belt, Forward Seat Track, Handle Up



Graco Infant W/ Base With Belt, Middle Seat Track, Handle Up



Graco Infant W/ Base With Belt, Rearward Seat Track, Handle Down



Graco Infant W/ Base Unbelted, Forward Seat Track, Handle Up

DOT/NHTSA 208 Suppression Test - 2004 Jeep Liberty (C40300)

12 Month

Section B

Rear Facing CRS

E-9



Graco Infant W/ Base Unbelted, Middle Seat Track, Handle Up



Graco Infant W/ Base Unbelted, Rearward Seat Track, Handle Down



Graco Infant W/ Base Fwd Facing Unbelted, Forward Seat Track, Handle Up



Graco Infant W/ Base Fwd Facing Unbelted, Middle Seat Track, Handle Up

DOT/NHTSA 208 Suppression Test - 2004 Jeep Liberty (C40300)

12 Month

Section B

Rear Facing CRS

E-10



Graco Infant W/ Base Fwd Facing Unbelted,
Rearward Seat Track, Handle Up



Graco Infant W/O Base With Belt, Forward Seat Track,
Handle Up



Graco Infant W/O Base With Belt, Middle Seat Track,
Handle Down



Graco Infant W/O Base With Belt, Rearward Seat Track,
Handle Down

DOT/NHTSA 208 Suppression Test - 2004 Jeep Liberty (C40300)

12 Month

Section B

Rear Facing CRS

E-11



Graco infant W/O Base Unbelted, Forward Seat Track Handle Up



Graco Infant W/O Base Unbelted, Middle Seat Track, Handle Up



Graco Infant W/O Base Unbelted, Rearward Seat Track, Handle Down



Graco Infant W/O Base Fwd Facing Unbelted, Forward Seat Track, Handle Down

DOT/NHTSA 208 Suppression Test - 2004 Jeep Liberty (C40300)

12 Month

Section B

Rear Facing CRS

E-12



Graco Infant W/O Base Fwd Facing Unbelted,
Middle Seat Track, Handle Down



Graco Infant W/O Base Fwd Facing Unbelted,
Rearward Seat Track, Handle Down



Unbelted 5th Percentile Female Reactivation Seat,
Rearward Seat Track

DOT/NHTSA 208 Suppression Test - 2004 Jeep Liberty (C40300)

12 Month

Section C

Forward Facing Convertible CRS

E-13



Britax Roundabout Fwd Facing With Belt, Forward Seat Track, No Blanket



Britax Roundabout Fwd Facing With Belt, Middle Seat Track, No Blanket



Britax Roundabout Fwd Facing With Belt, Rearward Seat Track, No Blanket



Britax Roundabout Fwd Facing Unbelted, Forward Seat Track, No Blanket

DOT/NHTSA 208 Suppression Test - 2004 Jeep Liberty (C40300)

12 Month

Section C

Forward Facing Convertible CRS

E-14



Britax Roundabout Fwd Facing Unbelted, Middle Seat Track, No Blanket



Britax Roundabout Fwd Facing Unbelted, Rearward Seat Track, No Blanket



Britax Roundabout Rear Facing With Belt, Forward Seat Track, No Blanket



Britax Roundabout Rear Facing With Belt, Middle Seat Track, No Blanket

DOT/NHTSA 208 Suppression Test - 2004 Jeep Liberty (C40300)

12 Month

Section C

Forward Facing Convertible CRS

E-15



Britax Roundabout Rear Facing With Belt, Rearward Seat Track, No Blanket



Britax Roundabout Rear Facing Unbelted, Forward Seat Track, No Blanket



Britax Roundabout Rear Facing Unbelted, Middle Seat Track, No Blanket



Britax Roundabout Rear Facing Unbelted, Rearward Seat Track, No Blanket

DOT/NHTSA 208 Suppression Test - 2004 Jeep Liberty (C40300)

12 Month

Section C

Forward Facing Convertible CRS

E-16



Century Encore Fwd Facing With Belt, Forward Seat Track, No Blanket



Century Encore Fwd Facing With Belt, Middle Seat Track, No Blanket



Century Encore Fwd Facing With Belt, Rearward Seat Track, No Blanket



Century Encore Fwd Facing Unbelted, Forward Seat Track, No Blanket

DOT/NHTSA 208 Suppression Test - 2004 Jeep Liberty (C40300)

12 Month

Section C

Forward Facing Convertible CRS

E-17



Century Encore Fwd Facing Unbelted, Middle Seat Track, No Blanket



Century Encore Fwd Facing Unbelted, Rearward Seat Track, No Blanket



Century Encore Rear Facing With Belt, Forward Seat Track, No Blanket



Century Encore Rear Facing With Belt, Middle Seat Track, No Blanket

DOT/NHTSA 208 Suppression Test - 2004 Jeep Liberty (C40300)

12 Month

Section C

Forward Facing Convertible CRS

E-18



Century Encore Rear Facing With Belt, Rearward Seat Track, No Blanket



Century Encore Rear Facing Unbelted, Forward Seat Track, No Blanket



Century Encore Rear Facing Unbelted, Middle Seat Track, No Blanket



Century Encore Rear Facing Unbelted, Rearward Seat Track, No Blanket

DOT/NHTSA 208 Suppression Test - 2004 Jeep Liberty (C40300)

12 Month

Section C

Forward Facing Convertible CRS



Unbelted 5th Percentile Female Reactivation Seat,
Middle Seat Track

DOT/NHTSA 208 Suppression Test - 2004 Jeep Liberty (C40300)

12 Month

Section C

Forward Facing Convertible CRS

E-20



Evenflo Medallion Fwd Facing With Belt, Forward Seat Track, No Blanket



Evenflo Medallion Fwd Facing With Belt, Middle Seat Track, No Blanket



Evenflo Medallion Fwd Facing With Belt, Rearward Seat Track, No Blanket



Evenflo Medallion Fwd Facing Unbelted, Forward Seat Track, No Blanket

DOT/NHTSA 208 Suppression Test - 2004 Jeep Liberty (C40300)

12 Month

Section C

Forward Facing Convertible CRS

E-21



Evenflo Medallion Fwd Facing Unbelted, Middle Seat Track, No Blanket



Evenflo Medallion Fwd Facing Unbelted, Rearward Seat Track, No Blanket



Evenflo Medallion Rear Facing With Belt, Forward Seat Track, No Blanket



Evenflo Medallion Rear Facing With Belt, Middle Seat Track, No Blanket

DOT/NHTSA 208 Suppression Test - 2004 Jeep Liberty (C40300)

12 Month

Section C

Forward Facing Convertible CRS

E-22



Evenflo Medallion Rear Facing With Belt, Rearward Seat Track, No Blanket



Evenflo Medallion Rear Facing Unbelted, Forward Seat Track, No Blanket



Evenflo Medallion Rear Facing Unbelted, Middle Seat Track, No Blanket



Evenflo Medallion Rear Facing Unbelted, Rearward Seat Track, No Blanket

DOT/NHTSA 208 Suppression Test - 2004 Jeep Liberty (C40300)

12 Month

Section C

Forward Facing Convertible CRS



Unbelted 5th Percentile Female Reactivation Seat,
Forward Seat Track

DOT/NHTSA 208 Suppression Test - 2004 Jeep Liberty (C40300)

3 Year Old

Section C

Forward Facing Convertible CRS

E-24



3-Year-Old Fwd Facing Britax Roundabout Belted, Forward Seat Track



3-Year-Old Fwd Facing Britax Roundabout Belted, Middle Seat Track



3-Year-Old Fwd Facing Britax Roundabout Belted, Rearward Seat Track



Unbelted 5th Percentile Female Reactivation Seat, Rearward Seat Track

DOT/NHTSA 208 Suppression Test - 2004 Jeep Liberty (C40300)

3 Year Old

Section C

Forward Facing Convertible CRS

E-25



3-Year-Old Fwd Facing Century Encore Belted,
Forward Seat Track



3-Year-Old Fwd Facing Century Encore Belted,
Middle Seat Track



3-Year-Old Fwd Facing Century Encore Belted,
Rearward Seat Track

DOT/NHTSA 208 Suppression Test - 2004 Jeep Liberty (C40300)

3 Year Old

Section C

Forward Facing Convertible CRS

E-26



3-Year-Old Fwd Facing Evenflo Medallion Belted,
Forward Seat Track



3-Year-Old Fwd Facing Evenflo Medallion Belted,
Middle Seat Track



3-Year-Old Fwd Facing Evenflo Medallion Belted,
Rearward Seat Track

DOT/NHTSA 208 Suppression Test - 2004 Jeep Liberty (C40300)

3 Year Old

Section D

Forward Facing Toddler

Belt Positioning Booster Seat

E-27



3-Year-Old Century Next Step Belted, Forward Seat Track



3-Year-Old Century Next Step Belted, Middle Seat Track



3-Year-Old Century Next Step Belted, Rearward Seat Track

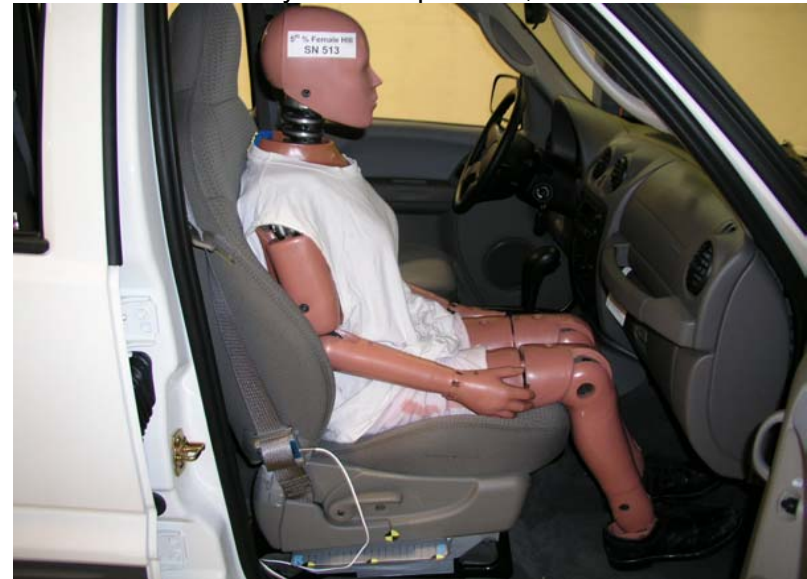

Unbelted 5th Percentile Female Reactivation Seat, Forward Seat Track

DOT/NHTSA 208 Suppression Test - 2004 Jeep Liberty (C40300)

3 Year Old

Section D

Forward Facing Toddler

Belt Positioning Booster Seat

E-28



3-Year-Old Cosco High Back Belted, Middle Seat Track



3-Year-Old Cosco High Back Belted, Rearward Seat Track



3-Year-Old Cosco High Back Cinched With Harness,
Middle Seat Track



3-Year-Old Cosco High Back Cinched With Harness,
Rearward Seat Track

DOT/NHTSA 208 Suppression Test - 2004 Jeep Liberty (C40300)

3 Year Old

Section D

Forward Facing Toddler

Belt Positioning Booster Seat



Unbelted 5th Percentile Female Reactivation Seat,
Rearward Seat Track

DOT/NHTSA 208 Suppression Test - 2004 Jeep Liberty (C40300)

6Year Old

Section D

Forward Facing Toddler

Belt Positioning Booster Seat

E-30



6-Year-Old Century Next Step Belted, Forward Seat Track



6-Year-Old Century Next Step Belted, Middle Seat Track



6-Year-Old Century Next Step Belted, Rearward Seat Track



6-Year-Old Century Next Step Unbelted, Forward Seat Track

DOT/NHTSA 208 Suppression Test - 2004 Jeep Liberty (C40300)

6Year Old

Section D

Forward Facing Toddler

Belt Positioning Booster Seat

E-31



6-Year-Old Century Next Step Unbelted, Middle Seat Track



6-Year-Old Century Next Step Unbelted, Rearward Seat Track



Unbelted 5th Percentile Female Reactivation Seat,
Rearward Seat Track

DOT/NHTSA 208 Suppression Test - 2004 Jeep Liberty (C40300)

6Year Old

Section D

Forward Facing Toddler

Belt Positioning Booster Seat

E-32



6-Year-Old Cosco High Back Belted, Forward Seat Track



6-Year-Old Cosco High Back Belted, Middle Seat Track



6-Year-Old Cosco High Back Belted, Rearward Seat Track



Unbelted 5th Percentile Female Reactivation Seat, Forward Seat Track

DOT/NHTSA 208 Suppression Test - 2004 Jeep Liberty (C40300)

6Year Old

Section D

Forward Facing Toddler

Belt Positioning Booster Seat

E-33



6-Year-Old Evenflo Right Fit Belted, Forward Seat Track



6-Year-Old Evenflo Right Fit Belted, Middle Seat Track



6-Year-Old Evenflo Right Fit Belted, Rearward Seat Track



Unbelted 5th Percentile Female Reactivation Seat, Middle Seat Track

DOT/NHTSA 208 Suppression Test - 2004 Jeep Liberty (C40300)

3 Year Old

No CRS

E-34



3-Year-Old Unbelted, Forward Seat Track, Position 1



3-Year-Old Unbelted, Forward Seat Track, Position 2



3-Year-Old Unbelted, Forward Seat Track, Position 4



3-Year-Old Unbelted, Forward Seat Track, Position 5

DOT/NHTSA 208 Suppression Test - 2004 Jeep Liberty (C40300)
3 Year Old No CRS

E-35



3-Year-Old Unbelted, Forward Seat Track, Position 5,
Forward View



3-Year-Old Unbelted, Forward Seat Track, Position 6



3-Year-Old Unbelted, Forward Seat Track, Position 7



3-Year-Old Unbelted, Middle Seat Track, Position 1

DOT/NHTSA 208 Suppression Test - 2004 Jeep Liberty (C40300)
3 Year Old No CRS

E-36



3-Year-Old Unbelted, Middle Seat Track, Position 2



3-Year-Old Unbelted, Middle Seat Track, Position 3



3-Year-Old Unbelted, Middle Seat Track, Position 4



3-Year-Old Unbelted, Middle Seat Track, Position 5

DOT/NHTSA 208 Suppression Test - 2004 Jeep Liberty (C40300)
3 Year Old No CRS

E-37



3-Year-Old Unbelted, Middle Seat Track, Position 5,
Forward View



3-Year-Old Unbelted, Middle Seat Track, Position 6



3-Year-Old Unbelted, Middle Seat Track, Position 7



3-Year-Old Unbelted, Rearward Seat Track, Position 1

DOT/NHTSA 208 Suppression Test - 2004 Jeep Liberty (C40300)

3 Year Old

No CRS

E-38



3-Year-Old Unbelted, Rearward Seat Track, Position 2



3-Year-Old Unbelted, Rearward Seat Track, Position 3



3-Year-Old Unbelted, Rearward Seat Track, Position 4



3-Year-Old Unbelted, Rearward Seat Track, Position 5

DOT/NHTSA 208 Suppression Test - 2004 Jeep Liberty (C40300)
3 Year Old No CRS

E-39



3-Year-Old Unbelted, Rearward Seat Track, Position 5,
Forward View



3-Year-Old Unbelted, Rearward Seat Track, Position 6



3-Year-Old Unbelted, Rearward Seat Track, Position 7



Unbelted 5th Percentile Female Reactivation Seat,
Forward Seat Track

DOT/NHTSA 208 Suppression Test - 2004 Jeep Liberty (C40300)

6 Year Old

No CRS

E-40



6-Year-Old Unbelted, Forward Seat Track, Position 1



6-Year-Old Unbelted, Forward Seat Track, Position 2



6-Year-Old Unbelted, Forward Seat Track, Position 3



6-Year-Old Unbelted, Forward Seat Track, Position 4, Side View

DOT/NHTSA 208 Suppression Test - 2004 Jeep Liberty (C40300)

6 Year Old

No CRS

E-41



6-Year-Old Unbelted, Middle Seat Track, Position 1



6-Year-Old Unbelted, Middle Seat Track, Position 2



6-Year-Old Unbelted, Middle Seat Track, Position 3



6-Year-Old Unbelted, Middle Seat Track, Position 4,
Forward View

DOT/NHTSA 208 Suppression Test - 2004 Jeep Liberty (C40300)

6 Year Old

No CRS

E-42



6-Year-Old Unbelted, Forward Seat Track, Position 4, Side View



6-Year-Old Unbelted, Rearward Seat Track, Position 1



6-Year-Old Unbelted, Rearward Seat Track, Position 2



6-Year-Old Unbelted, Rearward Seat Track, Position 3

DOT/NHTSA 208 Suppression Test - 2004 Jeep Liberty (C40300)
6 Year Old No CRS



6-Year-Old Unbelted, Rearward Seat Track, Position 4, Forward View



6-Year-Old Unbelted, Forward Seat Track, Position 4, Side View

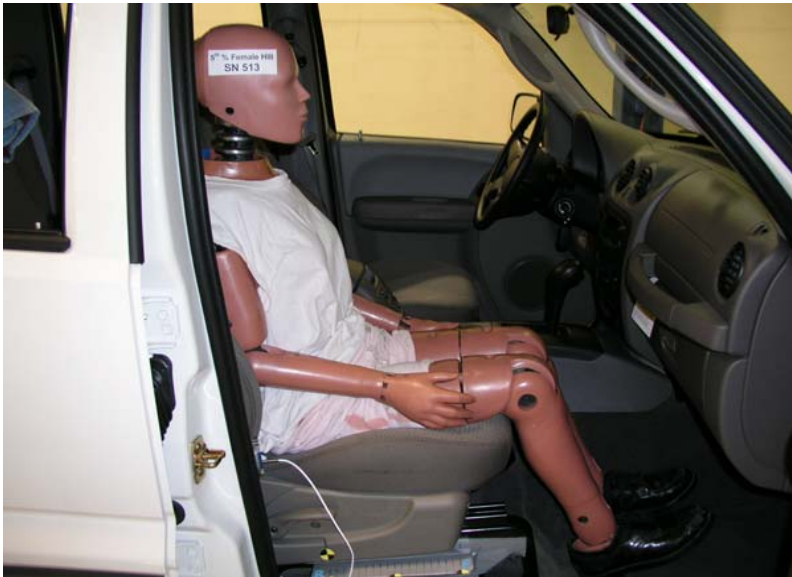

Unbelted 5th Percentile Female Reactivation Seat, Rearward Seat Track

APPENDIX F
INSTRUMENTATION CALIBRATION

INSTRUMENTS FOR DRIVER DUMMY NO. 506

	SERIAL NO.	MANUFACTURER	CALIBRATION DATE
Head X	J10866	Endevco	2/23/04
Head Y	J11548	Endevco	2/23/04
Head Z	AK972	Endevco	2/23/04
Neck Load Cell	1561	Denton	1/13/04
Chest X	A12-A14	Endevco	2/04/04
Chest Y	L17-Z13	Endevco	2/04/04
Chest Z	L18-N01	Endevco	2/04/04
Chest Displacement	506	Servo	2/24/04
Left Femur Load Cell	9426	Denton	1/23/04
Right Femur Load Cell	9425	Denton	1/23/04

INSTRUMENTS FOR PASSENGER DUMMY NO. 517

	SERIAL NO.	MANUFACTURER	CALIBRATION DATE
Head X	APYN0	Endevco	2/20/04
Head Y	ALFJ7	Endevco	2/20/04
Head Z	APYN3	Endevco	2/20/04
Neck Load Cell	1562	Denton	2/07/04
Chest X	J12471	Endevco	1/14/04
Chest Y	AP179	Endevco	1/13/04
Chest Z	J12423	Endevco	1/14/04
Chest Displacement	517	Servo	1/26/04
Left Femur Load Cell	946	Denton	1/17/04
Right Femur Load Cell	945	Denton	1/17/04

INSTRUMENTS FOR REAR CENTER PASSENGER DUMMY NO. 401

	SERIAL NO.	MANUFACTURER	CALIBRATION DATE
Head X	AGH79	Endevco	2/25/04
Head Y	AGH89	Endevco	2/25/04
Head Z	AGH55	Endevco	2/25/04
Neck Load Cell	253	Denton	10/17/03
Chest X	C12883	Endevco	2/25/04
Chest Y	C13081	Endevco	2/25/04
Chest Z	C12881	Endevco	2/25/04
Chest Displacement	401	Servo	2/25/04
Left Femur Load Cell	86	Denton	12/05/03
Right Femur Load Cell	85	Denton	12/05/03
Shoulder Belt Load Cell	172	Denton	10/11/03
Lap Belt Load Cell	198	Denton	12/09/03
Belt SP	607	Denton	2/04/03

INSTRUMENTS FOR LOW RISK 5TH FEMALE DUMMY NO. 494 (P1)

	SERIAL NO.	MANUFACTURER	CALIBRATION DATE
Head X	AKAD6	Endevco	11/13/03
Head Y	AM748	Endevco	11/13/03
Head Z	AHTF1	Endevco	11/13/03
Neck Load Cell	376	Denton	8/14/03
Chest X	J14006	Endevco	11/13/03
Chest Y	J13652	Endevco	11/13/03
Chest Z	J13628	Endevco	11/13/03
Chest Displacement	494	Servo	1/14/04
Left Femur Load Cell	83	Denton	11/13/03
Right Femur Load Cell	84	Denton	11/13/03

INSTRUMENTS FOR LOW RISK 5TH FEMALE DUMMY NO. 515 (P2)

	SERIAL NO.	MANUFACTURER	CALIBRATION DATE
Head X	AGRW3	Endevco	1/13/04
Head Y	J14896	Endevco	1/13/04
Head Z	AMPY0	Endevco	1/13/04
Neck Load Cell	253	Denton	10/17/03
Chest X	AJ819	Endevco	1/13/04
Chest Y	AJ9J7	Endevco	1/13/04
Chest Z	AJ7A2	Endevco	1/13/04
Chest Displacement	515	Servo	1/26/04
Left Femur Load Cell	956	Denton	9/30/03
Right Femur Load Cell	957	Denton	9/30/03

VEHICLE INSTRUMENTS

	SERIAL NO.	MANUFACTURER	CALIBRATION DATE
Left Rear Seat Crossmember X	K18-D16	Entran	12/15/03
Right Rear Seat Crossmember X	K07-R26	Entran	1/21/04
Top of Engine X	I16-B03	Entran	11/11/03
Bottom of Engine X	H20-R07	Entran	10/09/03
Left Brake Caliper X	L19-K05	Entran	1/23/04
Right Brake Caliper X	L17-D10	Entran	1/23/04
Instrument Panel X	F20-G10	Entran	10/08/03
Trunk Z	A27-R14	Entran	10/09/03

APPENDIX G

NOTICE OF TEST FAILURE

LABORATORY NOTICE OF APPARENT TEST FAILURE TO OVSC

FMVSS NO. 208 TEST DATE: January 28, 2004

LABORATORY: MGA Research Corporation

CONTRACT NO.: DTNH22-03-D-11002 DELV. ORDER NO.: Contract

LABORATORY PROJECT ENGINEER'S NAME: Jeff Lewandowski

TEST SPECIMEN DESCRIPTION: 2004 Jeep Liberty MPV

VEHICLE NHTSA NO.: C40300 VIN: 1J4GK48KX4W162401

MFR: Daimler Chrysler Corp.

APPARENT TEST FAILURE DESCRIPTION: Air bag labeling on Data Sheet 5

3.6.3 Is the shortest distance from any of the lettering or graphics on the rollover-warning label to any of the lettering or graphics of the air bag warning label at least 3 cm? (575.105(d)(1)(iv)(A))
17mm (1.7cm) actual distance
 Yes-Pass **No-FAIL**

FMVSS REQUIREMENT, PARAGRAPH S___ :
S.4.5.1 Air Bag Labels

NOTIFICATION TO NHTSA (COTR): Charles Case

DATE: 1-28-2004 BY: Jeff Lewandowski

REMARKS: See Included Photo



2004 Jeep Liberty MPV S.4.5.1 Air Bag Labeling Failure (Data Sheet 5 – 3.6.3)

LABORATORY NOTICE OF APPARENT TEST FAILURE TO OVSC

FMVSS NO. 208 TEST DATE: January 28, 2004

LABORATORY: MGA Research Corporation

CONTRACT NO.: DTNH22-03-D-11002 DELV. ORDER NO.: Contract

LABORATORY PROJECT ENGINEER'S NAME: Jeff Lewandowski

TEST SPECIMEN DESCRIPTION: 2004 Jeep Liberty MPV

VEHICLE NHTSA NO.: C40300 VIN: 1J4GK48KX4W162401

MFR: Daimler Chrysler Corp.

APPARENT TEST FAILURE DESCRIPTION:
Seat Belt Warning System Check on Data Sheet 9

18. The seat belt warning system meets the requirements of (manufacturers may comply with either section)
 S7.3 (a)(1)
 S7.3 (a)(2)
 FAIL - Does NOT meet the requirements of either option

FMVSS REQUIREMENT, PARAGRAPH S___ :
The vehicle did not meet the performance requirements of S.7.3 FMVSS 208 Seat Belt Warning System Check. The system met requirements partly in S7.3 (a)(1) and partly in S7.3 (a)(2).

NOTIFICATION TO NHTSA (COTR): Charles Case

DATE: 1-28-2004 BY: Jeff Lewandowski

REMARKS: