

REPORT NUMBER: NCAPCHILD-MGA-2004-007

**NEW CAR ASSESSMENT PROGRAM
FRONTAL BARRIER IMPACT TEST**

**Evenflo Vanguard 5
Cosco Touriva**

NHTSA NUMBER: M40203

**PREPARED BY:
MGA RESEARCH CORPORATION
5000 WARREN ROAD
BURLINGTON, WI 53105**



Test Date: January 20, 2004

Report Date: February 20, 2004

FINAL REPORT

**PREPARED FOR:
U.S. DEPARTMENT OF TRANSPORTATION
NATIONAL HIGHWAY TRAFFIC SAFETY ADMINISTRATION
RULEMAKING
OFFICE OF CRASHWORTHINESS STANDARDS
400 SEVENTH STREET, SW, ROOM 5311
WASHINGTON, D.C. 20590**

This final test report was prepared for the U.S. Department of Transportation, National Highway Traffic Safety Administration, in response to Contract Number DTNH22-01-D-12005.

This publication is distributed by the U.S. Department of Transportation, National Highway Traffic Safety Administration, in the interest of information exchange. The opinions, findings and conclusions expressed in this publication are those of the author(s) and not necessarily those of the Department of Transportation or the National Highway Traffic Safety Administration. The United States Government assumes no liability for its contents or use thereof. If trade or manufacturers' names or products are mentioned it is only because they are considered essential to the object of the publication and should not be construed as an endorsement. The United States Government does not endorse products or manufacturers.

Prepared by: Shefalika Agarwal Date: 2/20/04
Shefalika Agarwal, Project Engineer

Reviewed by: David Winkelbauer Date: 2/20/04
David Winkelbauer, Facility Director

FINAL REPORT ACCEPTED BY:

Manager, New Car Assessment Program

Date of Acceptance

COTR, NCAP Frontal Impact Program

Date of Acceptance

Technical Report Documentation Page

1. Report No. NCAPCHILD-MGA-2004-007		2. Government Accession No.		3. Recipient's Catalog No.																	
4. Title and Subtitle Final Report of New Car Assessment Program Testing of Evenflo Vanguard 5 and Cosco Touriva Child Restraint Systems NHTSA No.: M40203				5. Report Date February 20, 2004																	
				6. Performing Organization Code MGA																	
7. Author(s) Shefalika Agarwal, Project Engineer				8. Performing Organization Report No. NCAPCHILD-MGA-2004-007																	
9. Performing Organization Name and Address MGA Research Corporation 5000 Warren Road Burlington, WI 53105				10. Work Unit No.																	
				11. Contract or Grant No. DTNH22-01-D-12005																	
12. Sponsoring Agency Name and Address U.S. Department of Transportation National Highway Traffic Safety Administration Rulemaking, Office of Crashworthiness Standards 400 Seventh Street, SW, Room 5311 Washington, D.C. 20590				13. Type of Report and Period Covered Final Report 1/20/04 to 2/20/04																	
				14. Sponsoring Agency Code NVS-111																	
15. Supplementary Notes																					
16. Abstract The subjects CRS Evenflo Vanguard 5 and Cosco Touriva were tested in conjunction with a Frontal NCAP test in support of research in accordance with the specifications of the Office of Crashworthiness Standards Test Procedure for the determination of CRS crashworthiness. This test was conducted at MGA Research Corporation in Burlington, Wisconsin on January 20, 2004, in conjunction with frontal NCAP.																					
<table border="1"> <thead> <tr> <th>Measurement Description</th> <th>Units</th> <th>Pos. 3 ATD</th> <th>Pos. 4 ATD</th> </tr> </thead> <tbody> <tr> <td>Head Injury Criteria (HIC36)</td> <td>N/A</td> <td>605</td> <td>482</td> </tr> <tr> <td>Head Injury Criteria (HIC15)</td> <td>N/A</td> <td>388</td> <td>254</td> </tr> <tr> <td>Max. Thorax Accel. (3msec Clip)</td> <td>G's</td> <td>43</td> <td>40</td> </tr> </tbody> </table>						Measurement Description	Units	Pos. 3 ATD	Pos. 4 ATD	Head Injury Criteria (HIC36)	N/A	605	482	Head Injury Criteria (HIC15)	N/A	388	254	Max. Thorax Accel. (3msec Clip)	G's	43	40
Measurement Description	Units	Pos. 3 ATD	Pos. 4 ATD																		
Head Injury Criteria (HIC36)	N/A	605	482																		
Head Injury Criteria (HIC15)	N/A	388	254																		
Max. Thorax Accel. (3msec Clip)	G's	43	40																		
17. Key Words 56.3 km/h NCAP Frontal Barrier Impact Test New Car Assessment Program (NCAP) Evenflo Vanguard 5 Cosco Touriva NHTSA No: M40203				18. Distribution Statement Copies of this report are available from: National Highway Traffic Safety Admin., Technical Ref. Division, Room 5108 (NPO-230) 400 Seventh Street, S.W. Washington, D.C. 20590																	
19. Security Classif. (of this report) Unclassified		20. Security Classif. (of this page) Unclassified		21. No. of Pages 109	22. Price																

TABLE OF CONTENTS

<u>Section</u>		<u>Page No</u>
1	Purpose and Summary of Test	1
2	Data Sheets	2
<u>Data Sheet No.</u>		
1	Crash Test Summary	2
2	CRS Parameter Data	3
3	Child Dummy Positioning in Vehicle	4
4	Child Dummy Injury Criteria Values	6
5	CRS Performance Data	9
6	CRS Camera Data	10
<u>Appendix</u>		
A	Photographs	A
B	Child Dummy Response Data Traces	B
C	Child Dummy Calibration Information	C
D	Test Equipment List and Calibration Information	D

SECTION 1

PURPOSE AND SUMMARY OF TEST

PURPOSE

The purpose of this test was to obtain CRS performance data in a frontal impact NCAP condition.

This 56.5 km/h frontal barrier impact test is part of the Vehicle Barrier Impact Testing Program sponsored by the National Highway Traffic Safety Administration (NHTSA) under contract number DTNH22-01-D-12005.

SUMMARY

Both child dummies were instrumented with head, chest, and pelvic triaxial accelerometers. In addition, both dummies had six upper axial neck force and moment sensors.

The right rear (Position 3) child dummy (S/N 40) and left rear (Position 4) child dummy (S/N 42) were calibrated previous to this test. Child dummy certification information is found in Appendix C.

The right rear child dummy's HIC36 was 604.9; maximum chest deceleration over 3 msec was 42.8 g's. The left rear child dummy's HIC36 was 482.3. The maximum chest deceleration over 3 msec was 39.6 g's. Position 3 and Position 4 were forward facing and used the vehicle LATCH and top tether for attachments.

TEST NOTES

There was no valid data collected for the following channels:

LRP Head Xr

RRP Pelvis Y after 35 msec.

SECTION 2

DATA SHEET NO. 1 CRASH TEST SUMMARY

TEST DUMMY INFORMATION

Description	Position 3 CRS	Position 4 CRS
Dummy Type / Serial No.	HIII 3 Year Old / 40	HIII 3 Year Old / 42
Number of Data Channels	22	22
Restraint System	Evenflo Vanguard 5 (Forward Facing)	Cosco Touriva (Forward Facing)

CAMERA COVERAGE

High Speed	16
Real Time	1
Total	17

POST TEST DOOR OPENING

Description	Front	Rear
Locked/Unlocked Doors	Doors were unlocked	Doors were unlocked
Left Side Doors	Door remained closed and latched; Door opened without tools	Door remained closed and latched; Door opened without tools
Right Side Doors	Door remained closed and latched; Door opened without tools	Door remained closed and latched; Door opened without tools
Hatch/Other Door	None	None

POST TEST SEAT DATA

Location	Seat Movement (mm)	Seat Back Failure
P1 (Left Front)	0	None
P2 (Right Front)	0	None
P3 (Right Rear)	0	None
P4 (Left Rear)	0	None

VISIBLE DUMMY CONTACT POINTS

Description	Position 3 CRS (S/N 40)	Position 4 CRS (S/N 42)
Head Contact	Back of head to CRS, Chin to Chest Clip	Back of head to CRS
Upper Torso Contact	None	None
Lower Torso Contact	None	Shield
Left Foot Contact	Passenger seat back	Driver seat back
Right Foot Contact	Passenger seat back	Driver seat back

SECTION 2... (continued)

**DATA SHEET NO. 2
CRS PARAMETER DATA**

Child Restraint System (Position 3)	Evenflo Vanguard 5 (Forward Facing)
Child Restraint System (Position 4)	Cosco Touriva (Forward Facing)
NHTSA No.	M40203

TARGET TEST WEIGHT CALCULATION

Measured Parameter	Units	Value
Total Delivered Weight (UVW)	kg	2342.4
Weight of 2 P572E ATDs	kg	156.0
Rated Cargo/Luggage Weight (RCLW)	kg	136.1
Calculated Vehicle Target Weight (TVTW)	kg	2634.5

TEST VEHICLE WEIGHTS

	Units	As Tested (ATW) (Axle)		
		Front	Rear	Total
Left	kg	709.9	616.4	
Right	kg	721.2	578.8	
Ratio	%	54.5	45.5	
Totals	kg	1431.1	1195.2	2626.3

As tested weight of vehicle includes two 50th percentile ATDs, two 3 year old with CRS, cargo, equipment and instrumentation.

CHEST CLIP DISPLACEMENT

	Units	Left	Right
Right Child Dummy	mm	52	60
Left Child Dummy	mm	54	51

SECTION 2... (continued)
DATA SHEET NO. 3
CHILD DUMMY POSITIONING IN VEHICLE

Child Restraint System (Position 3)	Evenflo Vanguard 5 (Forward Facing)
NHTSA No.	M40203

Dummy Measurements for CRS Passengers

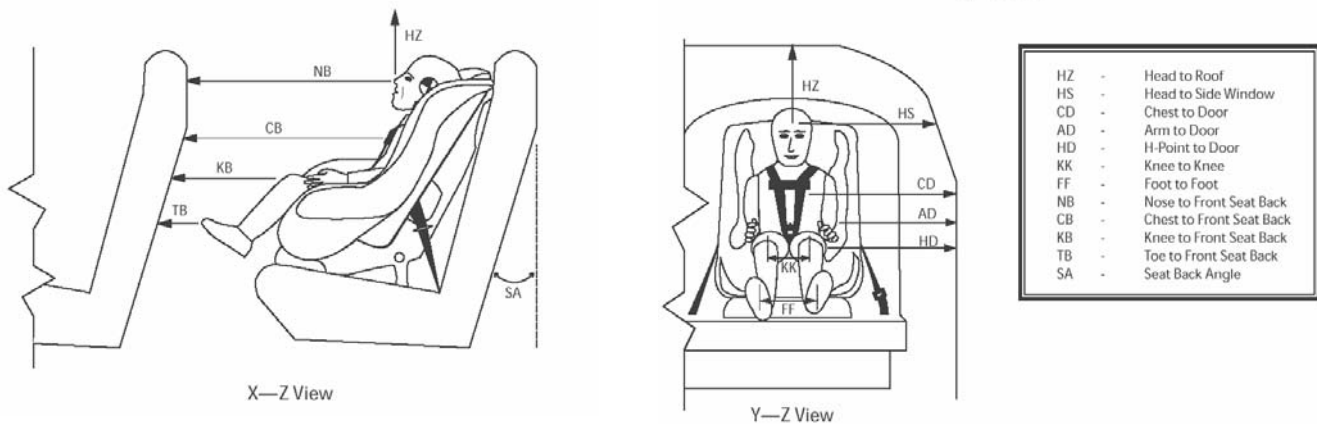

Measurement	Pre-Test (mm)	Post-Test (mm)
	P3 CRS (40)	P3 CRS (40)
SA (deg)	4.7	4.7
HS	411	424
CD	399	392
AD	236	249
HD	293	272
HZ	381	405
NB	387	425
CB	370	436
KK	159	147
FF	158	150
KB - LEFT	232	284
KB - RIGHT	227	274
TB - LEFT	0	0
TB - RIGHT	0	0

All dimensions in mm (unless noted)
P3 – Right Rear Passenger (Forward Facing)

SECTION 2... (continued)
DATA SHEET NO. 3
CHILD DUMMY POSITIONING IN VEHICLE

Child Restraint System (Position 4)	Cosco Touriva (Forward Facing)
NHTSA No.	M40203

Dummy Measurements for CRS Passengers

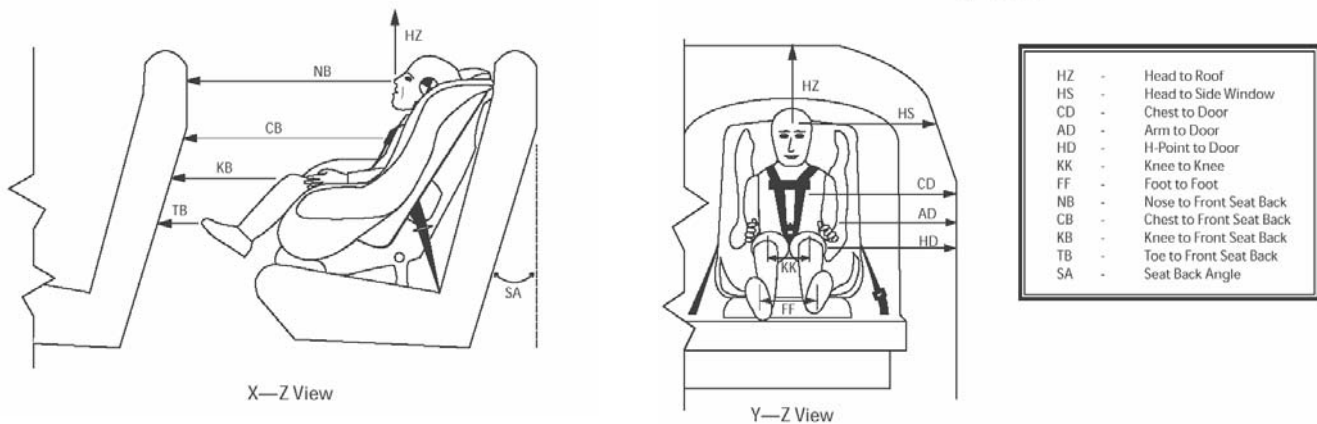

Measurement	Pre-Test (mm)	Post-Test (mm)
	P4 CRS (42)	P4 CRS (42)
SA (deg)	4.7	4.7
HS	416	454
CD	404	411
AD	264	274
HD	312	311
HZ	391	408
NB	360	404
CB	356	413
KK	137	132
FF	135	122
KB - LEFT	227	262
KB - RIGHT	231	254
TB - LEFT	0	0
TB - RIGHT	0	21

All dimensions in mm (unless noted)
P4 – Left Rear Passenger (Forward facing)

**DATA SHEET NO. 4
CHILD DUMMY INJURY CRITERIA VALUES**

Child Restraint System (Position 3)	Evenflo Vanguard 5
Child Restraint System (Position 4)	Cosco Touriva Overhead Shield
NHTSA No.	M40203

HEAD PEAK ACCELERATIONS

Location	Axis	Units	Position 3				Position 4			
			Max	Time	Min	Time	Max	Time	Min	Time
Head CG	X	G's	5.4	26	-30.7	99	3.9	10	-29.2	78
Head CG	Y	G's	3.6	184	-13.3	99	3.4	20	-3.8	70
Head CG	Z	G's	61.3	73	-9.4	37	51.8	71	-13.5	36
Resultant	N/A	G's	65.2	73			55.5	69		

UPPER NECK PEAK FORCES AND MOMENTS

Location	Axis	Units	Position 3				Position 4			
			Max	Time	Min	Time	Max	Time	Min	Time
Neck Force	X	N	12	179	-678	88	3	178	-220	78
Neck Force	Y	N	73	100	-70	77	2	35	-33	70
Neck Force	Z	N	1723	87	-241	38	2358	78	-408	37
Resultant	N/A	N	1848	87			2368	78		
Neck Moment	X	N•m	4.7	122	-6.6	97	1.1	124	-1.4	184
Neck Moment	Y	N•m	5.4	79	-12.8	60	3.9	71	-4.8	56
Neck Moment	Z	N•m	3.0	81	-1.9	107	2.0	73	-1.9	200
Resultant	N/A	N•m	12.9	60			4.9	56		

CHEST PRIMARY PEAK ACCELERATIONS

Location	Axis	Units	Position 3				Position 4			
			Max	Time	Min	Time	Max	Time	Min	Time
Chest CG	X	G's	1.8	183	-39.8	58	3.0	140	-38.7	62
Chest CG	Y	G's	2.9	166	-4.4	65	1.9	168	-5.6	77
Chest CG	Z	G's	18.5	86	-22.7	57	10.6	190	-18.6	43
Resultant	N/A	G's	45.4	58			40.7	62		

SECTION 2... (continued)
DATA SHEET NO. 4... (continued)
CHILD DUMMY INJURY CRITERIA VALUES

Child Restraint System (Position 3)	Evenflo Vanguard 5
Child Restraint System (Position 4)	Cosco Touriva Overhead Shield
NHTSA No.	M40203

TETHER FORCE

Location	Axis	Units	Position 3				Position 4			
			Max	Time	Min	Time	Max	Time	Min	Time
Tether Force	N/A	N	993	62	-21	176	2189	93	-15	187

PELVIC PEAK ACCELERATIONS

Location	Axis	Units	Position 3				Position 4			
			Max	Time	Min	Time	Max	Time	Min	Time
Pelvis	X	G's	8.1	102	-46.2	56	13.5	115	-58.9	60
Pelvis	Y	G's	*	*	*	*	4.6	106	-9.3	64
Pelvis	Z	G's	15.0	85	-28.9	49	10.7	191	-25.5	58
Resultant	N/A	G's					63.4	59		

* No valid data collected after 35 msec.

HEAD PEAK REDUNDANT ACCELERATIONS

Location	Axis	Units	Position 3				Position 4			
			Max	Time	Min	Time	Max	Time	Min	Time
Head CG	X	G's	0.9	31	-31.5	99	**	**	**	**
Head CG	Y	G's	2.6	118	-13.3	99	1.9	36	-2.8	40
Head CG	Z	G's	60.7	74	-9.8	39	51.0	70	-9.8	39
Resultant	N/A	G's	64.5	72.4						

** No valid data collected

CHEST PEAK REDUNDANT ACCELERATIONS

Location	Axis	Units	Position 3				Position 4			
			Max	Time	Min	Time	Max	Time	Min	Time
Chest CG	X	G's	1.9	181	-40.7	58	3.0	142	-38.7	62
Chest CG	Y	G's	3.0	165	-4.3	62	2.1	97	-5.3	75
Chest CG	Z	G's	18.1	86	-23.7	57	10.6	190	-18.8	43
Resultant	N/A	G's	46.5	58			40.7	62		

SECTION 2... (continued)
DATA SHEET NO. 4... (continued)
CHILD DUMMY INJURY CRITERIA VALUES

Child Restraint System (Position 3)	Evenflo Vanguard 5
Child Restraint System (Position 4)	Cosco Touriva Overhead Shield
NHTSA No.	M40203

HEAD INJURY CRITERIA (HIC36)

Location	HIC	T ¹ (msec)	T ² (msec)	Average Acceleration (G's)
Position 3 - Right	604.9	59.8	95.8	48.99
Position 4 - Left	482.3	56.5	92.5	44.8

HIC is as defined in FMVSS 208. The maximum time interval from t1 to t2 is 36 milliseconds.

HEAD INJURY CRITERIA (HIC15)

Location	HIC	T ¹ (msec)	T ² (msec)	Average Acceleration (G's)
Position 3 - Right	388.3	65.3	80.3	58.2
Position 4 - Left	253.5	65.6	80.6	49.1

HIC is as defined in FMVSS 208. The maximum time interval from t1 to t2 is 15 milliseconds.

CLIP SUMMARY

Location	CLIP	T ¹ (msec)	T ² (msec)
Position 3 - Right	42.8	56.3	59.3
Position 4 - Left	39.6	60.0	63.0

The maximum chest resultant acceleration is defined as the maximum acceleration, which exceeds 0.003 seconds in duration.

SECTION 2... (continued)

**DATA SHEET NO. 5
CRS PERFORMANCE DATA**

Child Restraint System (Position 3)	Evenflo Vanguard 5 (Forward Facing)
Child Restraint System (Position 4)	Cosco Touriva (Forward Facing)
NHTSA No.	M40203

POSITION 3 CRS POST-TEST INSPECTION

Location	Damage	Remarks
Upper Tether Strap	None	
Upper Tether Buckle	None	
Upper Tether Hook	None	
Vehicle Upper Tether Anchor	None	
Lower Anchor Strap	None	
Lower Anchor Buckle	None	
Lower Anchor Hooks	None	
Vehicle Lower CRS Anchors	None	
Five Point Harness Connections	None	
CRS Shell	Yes	Dent seen on child seat
Fabric Tears on CRS	None	
Vehicle Seat Structure	None	
Vehicle Seat Fabric Tears	None	
Child Dummy	None	

POSITION 4 CRS POST-TEST INSPECTION

Location	Damage	Remarks
Upper Tether Strap	None	
Upper Tether Buckle	None	
Upper Tether Hook	None	
Vehicle Upper Tether Anchor	None	
Lower Anchor Strap	None	
Lower Anchor Buckle	None	
Lower Anchor Hooks	None	
Vehicle Lower CRS Anchors	None	
Five Point Harness Connections	None	
CRS Shell	Yes	Dent/stress mark seen on child seat
Fabric Tears on CRS	None	
Vehicle Seat Structure	None	
Vehicle Seat Fabric Tears	None	
Child Dummy	None	

SECTION 2... (continued)

DATA SHEET NO. 6
CRS CAMERA DATA

Child Restraint System (Position 3)	Evenflo Vanguard 5 (Forward Facing)
Child Restraint System (Position 4)	Cosco Touriva (Forward Facing)
NHTSA No.	M40203

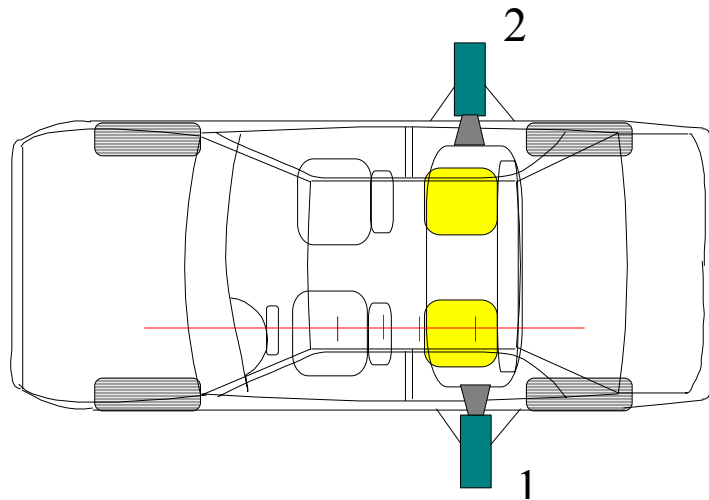

No.	Camera View	Location (mm) *			Angle (deg)	Lens (mm)	Speed (fps)
		X	Y	Z			
1	Left Side CRS Lateral View					13	526
2	Right Side CRS Lateral View					13	513

*COORDINATES:

- +X = film plane rearward of barrier
- +Y = film plane to right of monorail centerline
- +Z = film plane above ground level

APPENDIX A
PHOTOGRAPHS

TABLE OF PHOTOGRAPHS

		<u>Page No.</u>
Photo No. 1.	Close-up View of Position 3 CRS Label	A-1
Photo No. 2.	Pre-Test Front View of Position 3 CRS	A-2
Photo No. 3.	Post-Test Front View of Position 3 CRS	A-3
Photo No. 4.	Pre-Test Rear View of Position 3 CRS	A-4
Photo No. 5.	Post-Test Rear View of Position 3 CRS	A-5
Photo No. 6.	Pre-Test Left Side View of Position 3 CRS	A-6
Photo No. 7.	Post-Test Left Side View of Position 3 CRS	A-7
Photo No. 8.	Pre-Test Right Side View of Position 3 CRS	A-8
Photo No. 9.	Post-Test Right Side View of Position 3 CRS	A-9
Photo No. 10.	Close-up View of Position 4 CRS Label	A-10
Photo No. 11.	Pre-Test Front View of Position 4 CRS	A-11
Photo No. 12.	Post-Test Front View of Position 4 CRS	A-12
Photo No. 13.	Pre-Test Rear View of Position 4 CRS	A-13
Photo No. 14.	Post-Test Rear View of Position 4 CRS	A-14
Photo No. 15.	Pre-Test Left Side View of Position 4 CRS	A-15
Photo No. 16.	Post-Test Left Side View of Position 4 CRS	A-16
Photo No. 17.	Pre-Test Right Side View of Position 4 CRS	A-17
Photo No. 18.	Post-Test Right Side View of Position 4 CRS	A-18
Photo No. 19.	Pre-Test Position 3 Left Side View	A-19
Photo No. 20.	Post-Test Position 3 Left Side View	A-20
Photo No. 21.	Pre-Test Position 4 Left Side View	A-21
Photo No. 22.	Post-Test Position 4 Left Side View	A-22
Photo No. 23.	Pre-Test Position 3 Right Side View	A-23
Photo No. 24.	Post-Test Position 3 Right Side View	A-24
Photo No. 25.	Pre-Test Position 4 Right Side View	A-25
Photo No. 26.	Post-Test Position 4 Right Side View	A-26
Photo No. 27.	Post-Test Position 3 Foot Contact View	A-27
Photo No. 28.	Post-Test Position 4 Foot Contact View	A-28

		<u>Page No.</u>
Photo No. 29.	Pre-Test Position 3 Rear View	A-29
Photo No. 30.	Post-Test Position 3 Rear View	A-30
Photo No. 31.	Pre-Test Position 4 Rear View	A-31
Photo No. 32.	Post-Test Position 4 Rear View	A-32
Photo No. 33.	Post-Test Dent in Position 3 CRS	A-33
Photo No. 34.	Post-Test Stress Mark/Dent in Position 4 CRS	A-34

A-1.



Close-up View of Position 3 CRS Label

A-2.



Pre-Test Front View of Position 3 CRS

A-3.



Post-Test Front View of Position 3 CRS

A-4.



Pre-Test Rear View of Position 3 CRS

A-5.



Post-Test Rear View of Position 3 CRS

A-6.



Pre-Test Left Side View of Position 3 CRS

A-7.



Post-Test Left Side View of Position 3 CRS

A-8.



Pre-Test Right Side View of Position 3 CRS

A-9.



Post-Test Right Side View of Position 3 CRS

... (70-91 cm) and who are under 1 year of age.
... (2.3-16 kg).
Use this child restraint with this child restraint around your child.
Use this child restraint with the vehicle's child restraint anchorage system
available or with a vehicle belt.
Follow all instructions on this child restraint and in the written instructions
located in the recline stand.
Register your child restraint with the manufacturer.

Delaware Juvenile Group, Inc.
25 State Street
Columbus, IN 47201
www.djgusa.com - 1-800-544-1108
60-5357

Manufactured in
22-130-WAL
12/17/2003 TO2B

A-10.

Close-up View of Position 4 CRS Label

A-11.



Pre-Test Front View of Position 4 CRS

A-12.



Post-Test Front View of Position 4 CRS

A-13.



Pre-Test Rear View of Position 4 CRS



Post-Test Rear View of Position 4 CRS

A-15.



Pre-Test Left Side View of Position 4 CRS



Post-Test Left Side View of Position 4 CRS

A-17.



Pre-Test Right Side View of Position 4 CRS

A-18.



Post-Test Right Side View of Position 4 CRS

A-19.



Pre-Test Position 3 Left Side View



Post-Test Position 3 Left Side View

A-21.



Pre-Test Position 4 Left Side View

A-22.



Post-Test Position 4 Left Side View



Pre-Test Position 3 Right Side View

A-24.



Post-Test Position 3 Right Side View

A-25.



Pre-Test Position 4 Right Side View



Post-Test Position 4 Right Side View

A-27.



Post-Test Position 3 Foot Contact View



Post-Test Position 4 Foot Contact View



A-29.

Pre-Test Position 3 Rear View



A-30.

Post-Test Position 3 Rear View



A-31.

Pre-Test Position 4 Rear View



A-32.

Post-Test Position 4 Rear View

A-33.



Post-Test Dent in Position 3 CRS

A-34.



Post-Test Stress Mark/Dent in Position 4 CRS

APPENDIX B
CHILD DUMMY RESPONSE DATA TRACES

TABLE OF DATA PLOTS

		<u>Page No.</u>
Figure No. 1.	LRP Child Head X Acceleration vs. Time	B-1
Figure No. 2.	LRP Child Head Y Acceleration vs. Time	B-1
Figure No. 3.	LRP Child Head Z Acceleration vs. Time	B-1
Figure No. 4.	LRP Child Head Resultant Acceleration vs. Time	B-1
Figure No. 5.	LRP Child Head X Velocity vs. Time	B-2
Figure No. 6.	LRP Child Head Y Velocity vs. Time	B-2
Figure No. 7.	LRP Child Head Z Velocity vs. Time	B-2
Figure No. 8.	LRP Child Head Y Redundant Acceleration vs. Time	B-3
Figure No. 9.	LRP Child Head Z Redundant Acceleration vs. Time	B-3
Figure No. 10.	LRP Child Head Y Redundant Velocity vs. Time	B-3
Figure No. 11.	LRP Child Head Z Redundant Velocity vs. Time	B-3
Figure No. 12.	LRP Child Upper Neck Force X vs. Time	B-4
Figure No. 13.	LRP Child Upper Neck Force Y vs. Time	B-4
Figure No. 14.	LRP Child Upper Neck Force Z vs. Time	B-4
Figure No. 15.	LRP Child Upper Neck Force Resultant vs. Time	B-4
Figure No. 16.	LRP Child Upper Neck Moment X vs. Time	B-5
Figure No. 17.	LRP Child Upper Neck Moment Y vs. Time	B-5
Figure No. 18.	LRP Child Upper Neck Moment Z vs. Time	B-5
Figure No. 19.	LRP Child Upper Neck Moment Resultant vs. Time	B-5
Figure No. 20.	LRP Child Chest X Acceleration vs. Time	B-6
Figure No. 21.	LRP Child Chest Y Acceleration vs. Time	B-6
Figure No. 22.	LRP Child Chest Z Acceleration vs. Time	B-6
Figure No. 23.	LRP Child Chest Resultant Acceleration vs. Time	B-6
Figure No. 24.	LRP Child Chest X Velocity vs. Time	B-7
Figure No. 25.	LRP Child Chest Y Velocity vs. Time	B-7
Figure No. 26.	LRP Child Chest Z Velocity vs. Time	B-7
Figure No. 27.	LRP Child Chest Displacement vs. Time	B-7
Figure No. 28.	LRP Child Chest X Redundant Acceleration vs. Time	B-8
Figure No. 29.	LRP Child Chest Y Redundant Acceleration vs. Time	B-8

		<u>Page No.</u>
Figure No. 30.	LRP Child Chest Z Redundant Acceleration vs. Time	B-8
Figure No. 31.	LRP Child Chest Resultant Redundant Acceleration vs. Time	B-8
Figure No. 32.	LRP Child Chest X Redundant Velocity vs. Time	B-9
Figure No. 33.	LRP Child Chest Y Redundant Velocity vs. Time	B-9
Figure No. 34.	LRP Child Chest Z Redundant Velocity vs. Time	B-9
Figure No. 35.	LRP Child Pelvis X Acceleration vs. Time	B-10
Figure No. 36.	LRP Child Pelvis Y Acceleration vs. Time	B-10
Figure No. 37.	LRP Child Pelvis Z Acceleration vs. Time	B-10
Figure No. 38.	LRP Child Pelvis Resultant Acceleration vs. Time	B-10
Figure No. 39.	LRP Child Pelvis X Velocity vs. Time	B-11
Figure No. 40.	LRP Child Pelvis Y Velocity vs. Time	B-11
Figure No. 41.	LRP Child Pelvis Z Velocity vs. Time	B-11
Figure No. 42.	RRP Child Head X Acceleration vs. Time	B-12
Figure No. 43.	RRP Child Head Y Acceleration vs. Time	B-12
Figure No. 44.	RRP Child Head Z Acceleration vs. Time	B-12
Figure No. 45.	RRP Child Head Resultant Acceleration vs. Time	B-12
Figure No. 46.	RRP Child Head X Velocity vs. Time	B-13
Figure No. 47.	RRP Child Head Y Velocity vs. Time	B-13
Figure No. 48.	RRP Child Head Z Velocity vs. Time	B-13
Figure No. 49.	RRP Child Head X Redundant Acceleration vs. Time	B-14
Figure No. 50.	RRP Child Head Y Redundant Acceleration vs. Time	B-14
Figure No. 51.	RRP Child Head Z Redundant Acceleration vs. Time	B-14
Figure No. 52.	RRP Child Head Resultant Redundant Acceleration vs. Time	B-14
Figure No. 53.	RRP Child Head X Redundant Velocity vs. Time	B-15
Figure No. 54.	RRP Child Head Y Redundant Velocity vs. Time	B-15
Figure No. 55.	RRP Child Head Z Redundant Velocity vs. Time	B-15
Figure No. 56.	RRP Child Upper Neck Force X vs. Time	B-16
Figure No. 57.	RRP Child Upper Neck Force Y vs. Time	B-16
Figure No. 58.	RRP Child Upper Neck Force Z vs. Time	B-16
Figure No. 59.	RRP Child Upper Neck Force Resultant vs. Time	B-16

		<u>Page No.</u>
Figure No. 60.	RRP Child Upper Neck Moment X vs. Time	B-17
Figure No. 61.	RRP Child Upper Neck Moment Y vs. Time	B-17
Figure No. 62.	RRP Child Upper Neck Moment Z vs. Time	B-17
Figure No. 63.	RRP Child Upper Neck Moment Resultant vs. Time	B-17
Figure No. 64.	RRP Child Chest X Acceleration vs. Time	B-18
Figure No. 65.	RRP Child Chest Y Acceleration vs. Time	B-18
Figure No. 66.	RRP Child Chest Z Acceleration vs. Time	B-18
Figure No. 67.	RRP Child Chest Resultant Acceleration vs. Time	B-18
Figure No. 68.	RRP Child Chest X Velocity vs. Time	B-19
Figure No. 69.	RRP Child Chest Y Velocity vs. Time	B-19
Figure No. 70.	RRP Child Chest Z Velocity vs. Time	B-19
Figure No. 71.	RRP Child Chest Displacement vs. Time	B-19
Figure No. 72.	RRP Child Chest X Redundant Acceleration vs. Time	B-20
Figure No. 73.	RRP Child Chest Y Redundant Acceleration vs. Time	B-20
Figure No. 74.	RRP Child Chest Z Redundant Acceleration vs. Time	B-20
Figure No. 75.	RRP Child Chest Resultant Redundant Acceleration vs. Time	B-20
Figure No. 76.	RRP Child Chest X Redundant Velocity vs. Time	B-21
Figure No. 77.	RRP Child Chest Y Redundant Velocity vs. Time	B-21
Figure No. 78.	RRP Child Chest Z Redundant Velocity vs. Time	B-21
Figure No. 79.	RRP Child Pelvis X Acceleration vs. Time	B-22
Figure No. 80.	RRP Child Pelvis Y Acceleration vs. Time	B-22
Figure No. 81.	RRP Child Pelvis Z Acceleration vs. Time	B-22
Figure No. 82.	RRP Child Pelvis Resultant Acceleration vs. Time	B-22
Figure No. 83.	RRP Child Pelvis X Velocity vs. Time	B-23
Figure No. 84.	RRP Child Pelvis Y Velocity vs. Time	B-23
Figure No. 85.	RRP Child Pelvis Z Velocity vs. Time	B-23
Figure No. 86.	LRP Tether Force vs. Time	B-24
Figure No. 87.	RRP Tether Force vs. Time	B-24

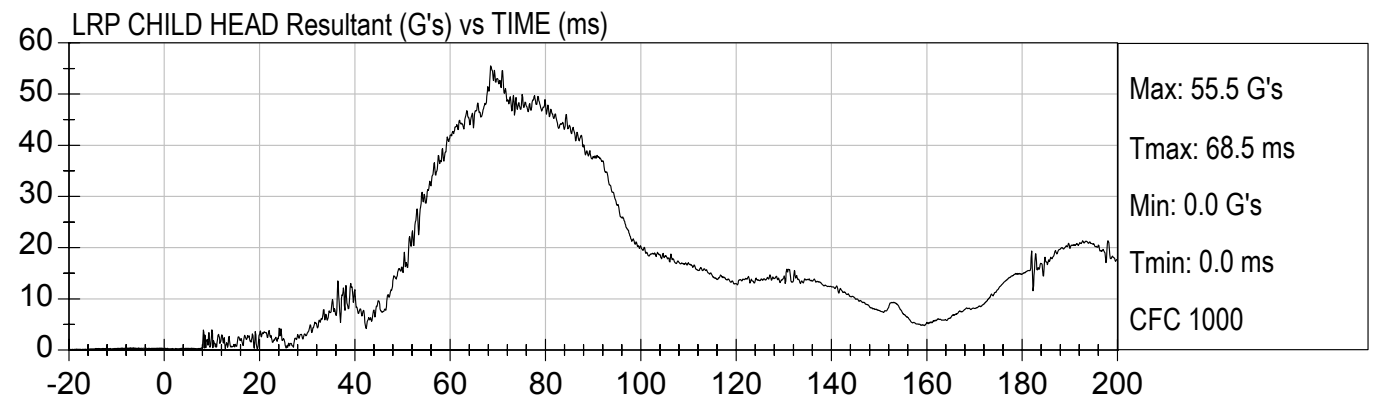
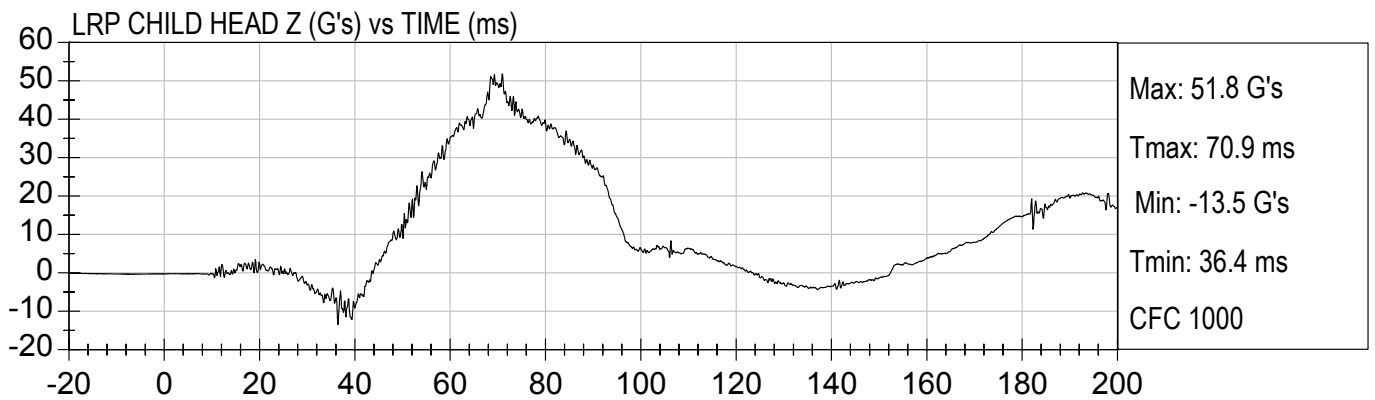
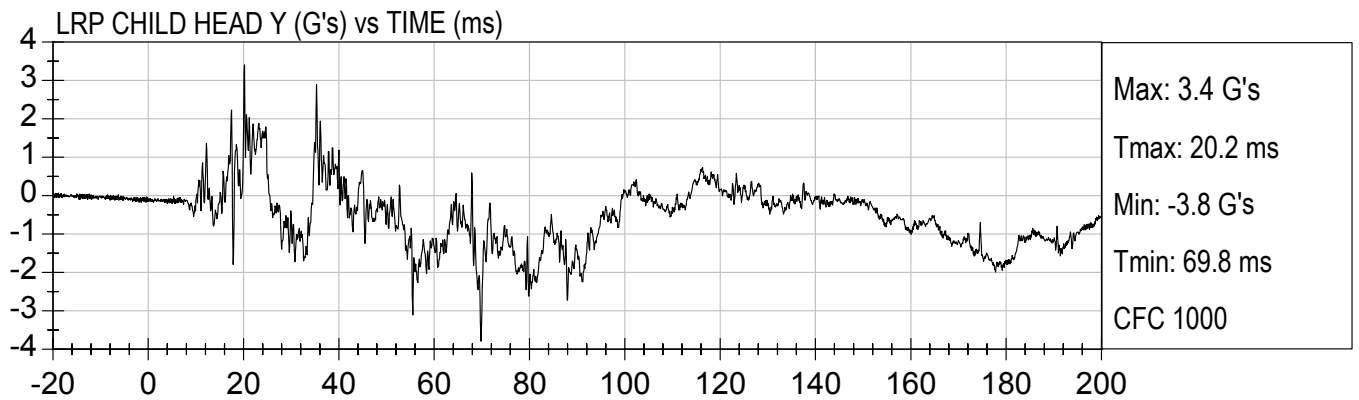
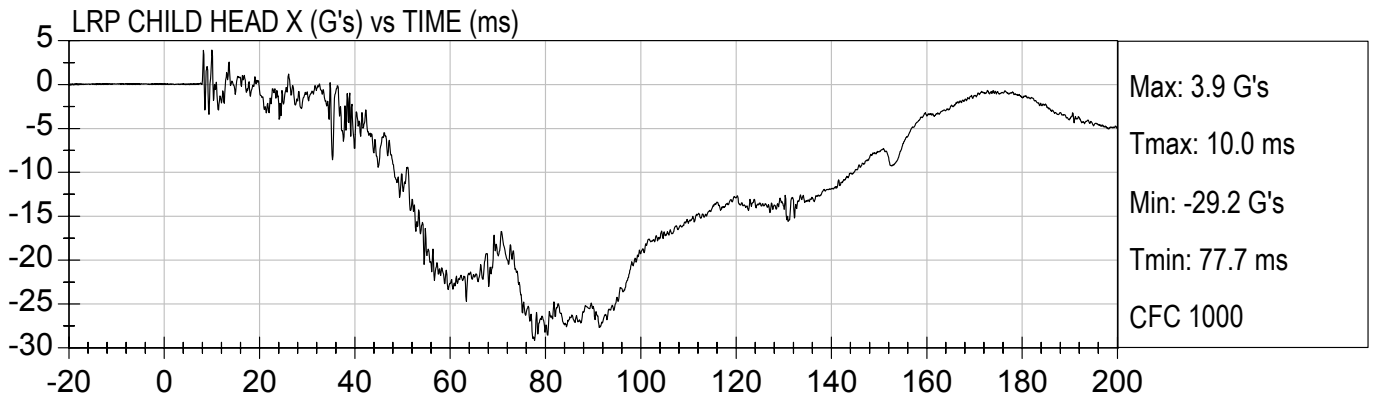

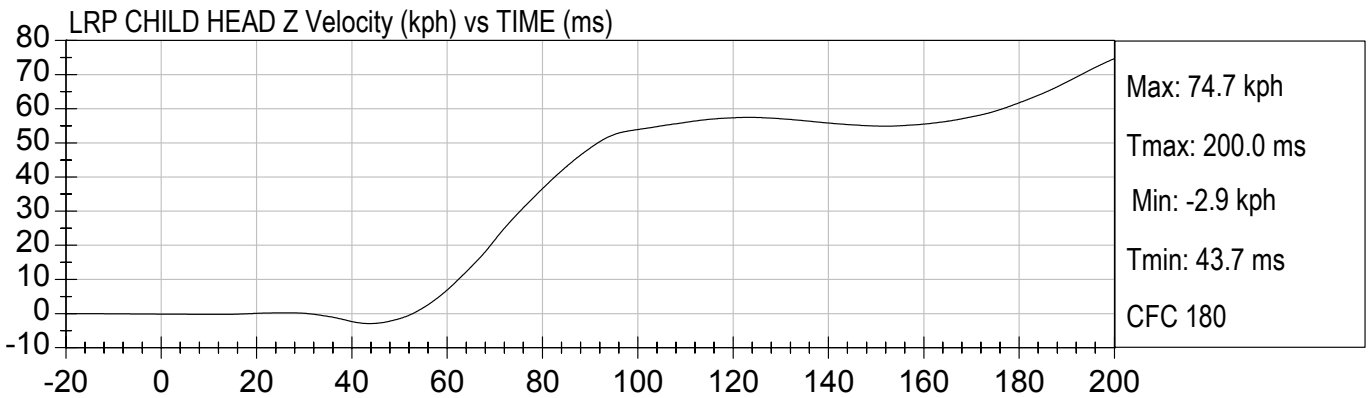
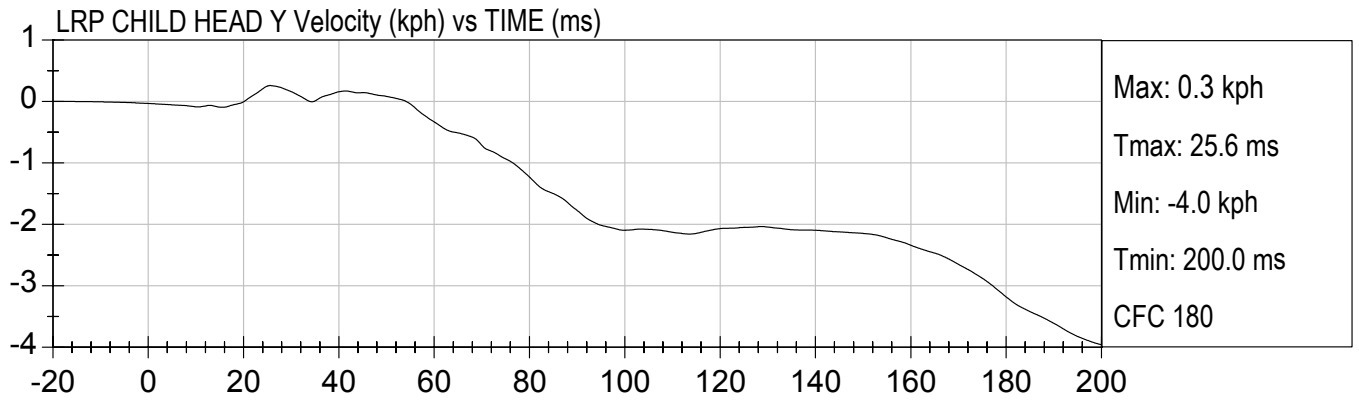
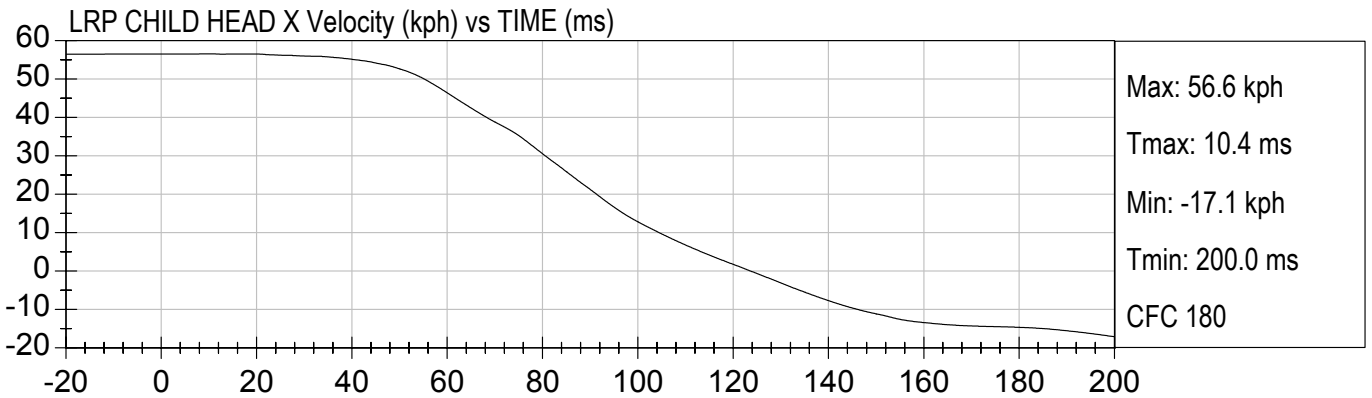



LRP CHILD HEAD Yr (G's) vs TIME (ms)

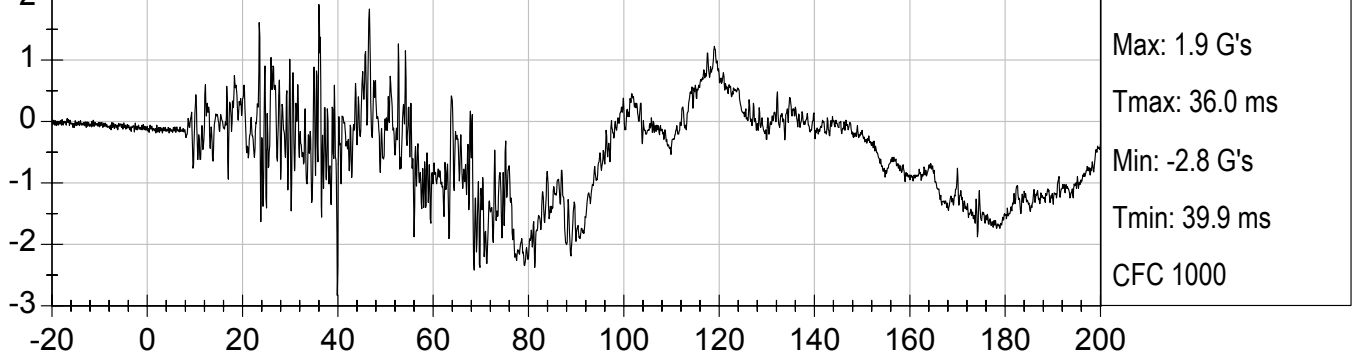

LRP CHILD HEAD Zr (G's) vs TIME (ms)

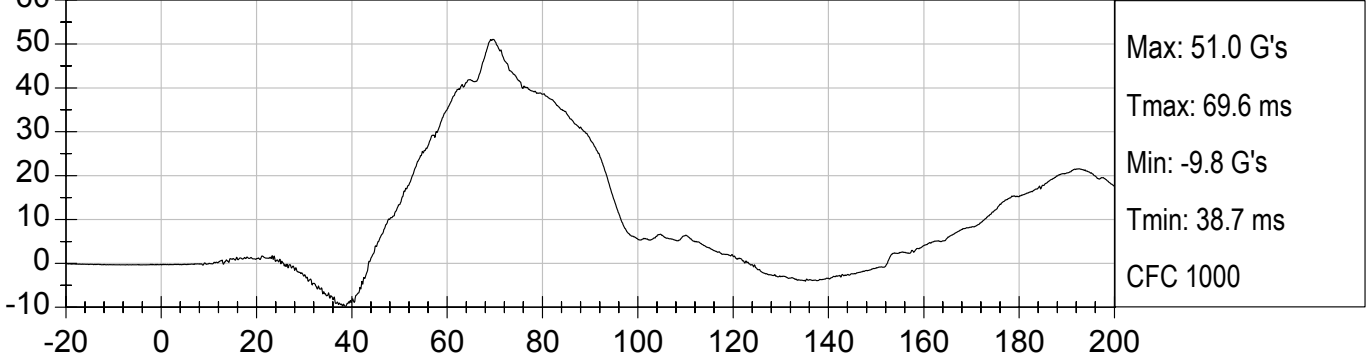

LRP CHILD HEAD Yr Velocity (kph) vs TIME (ms)

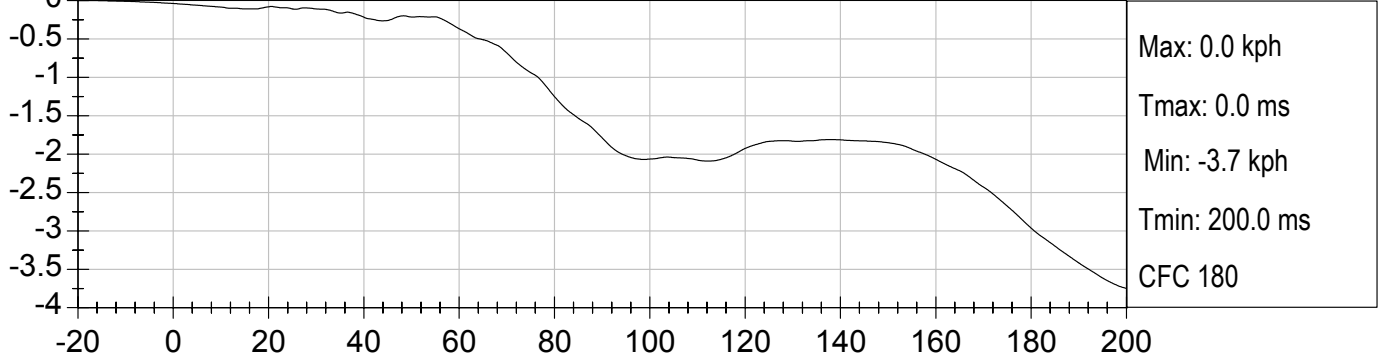

LRP CHILD HEAD Zr Velocity (kph) vs TIME (ms)

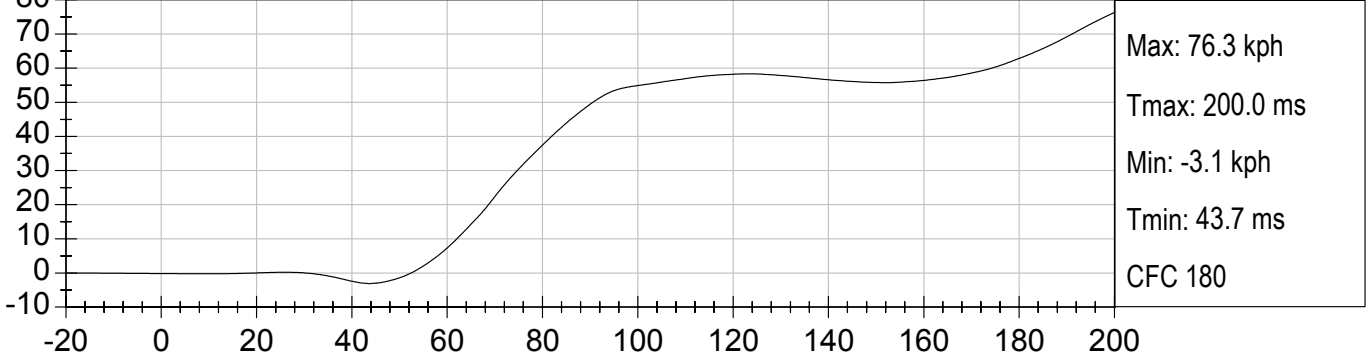

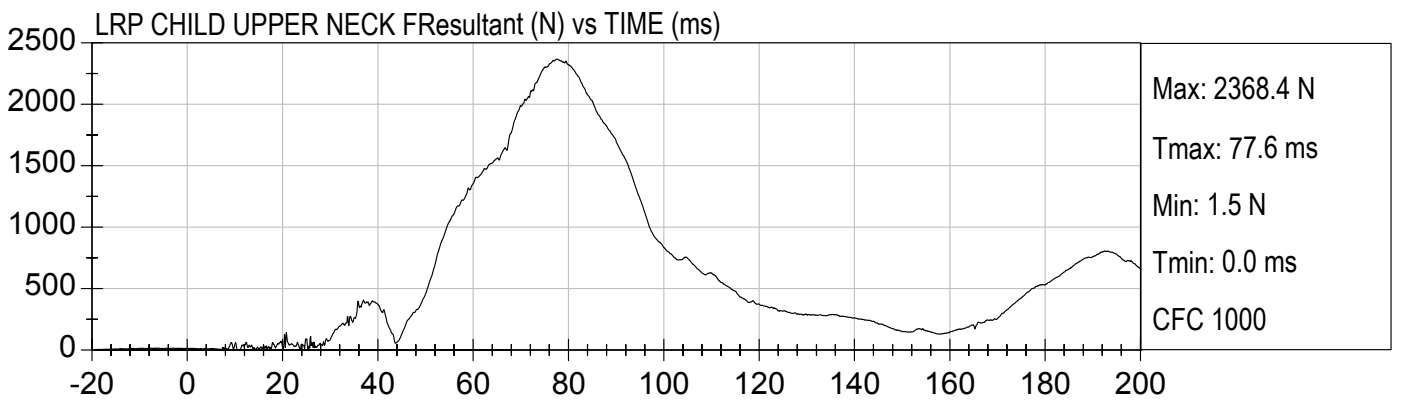
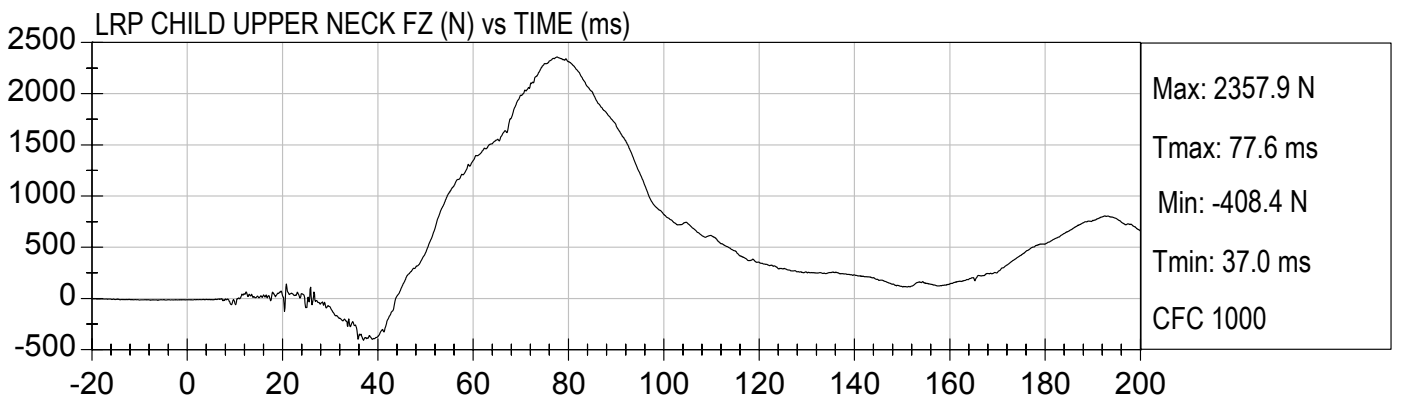
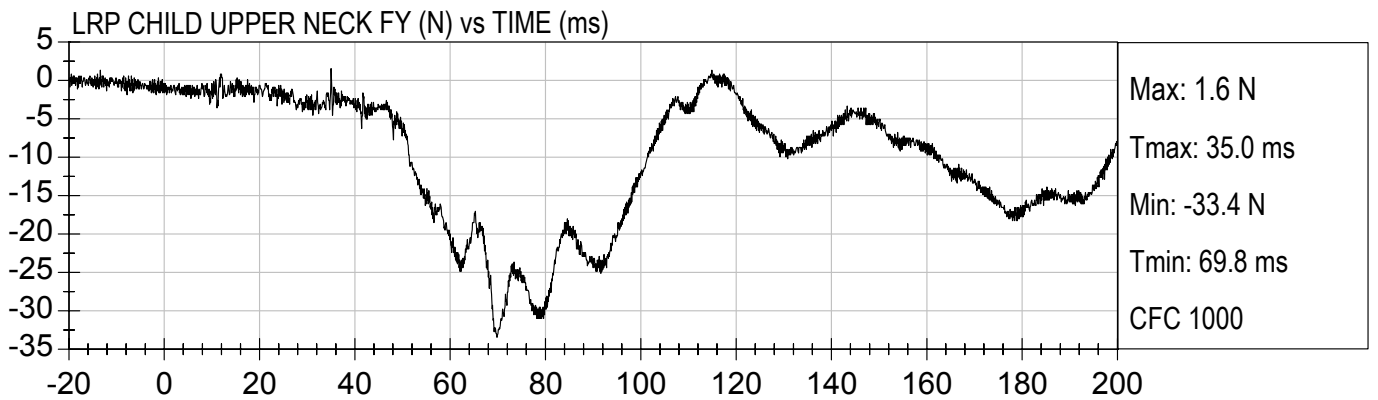
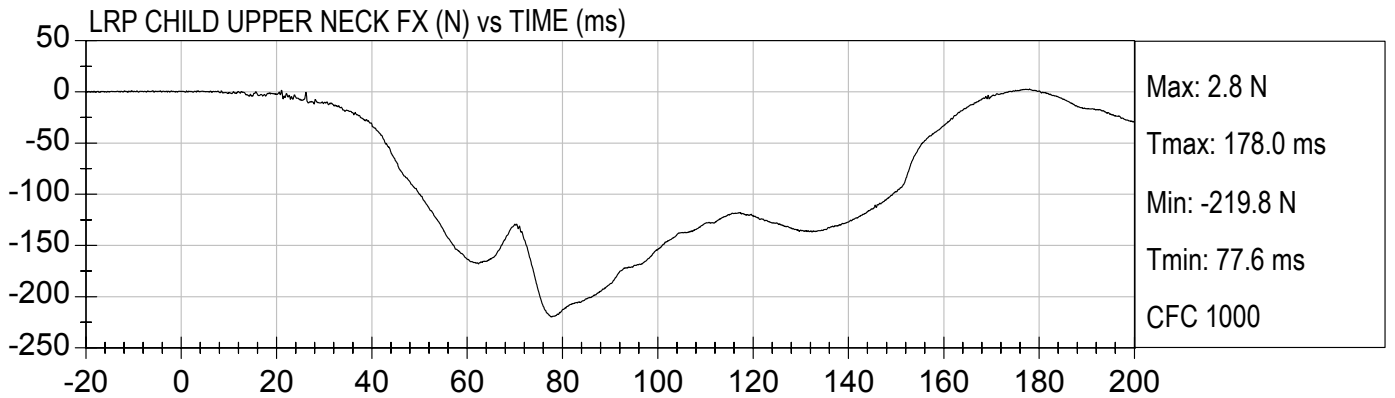

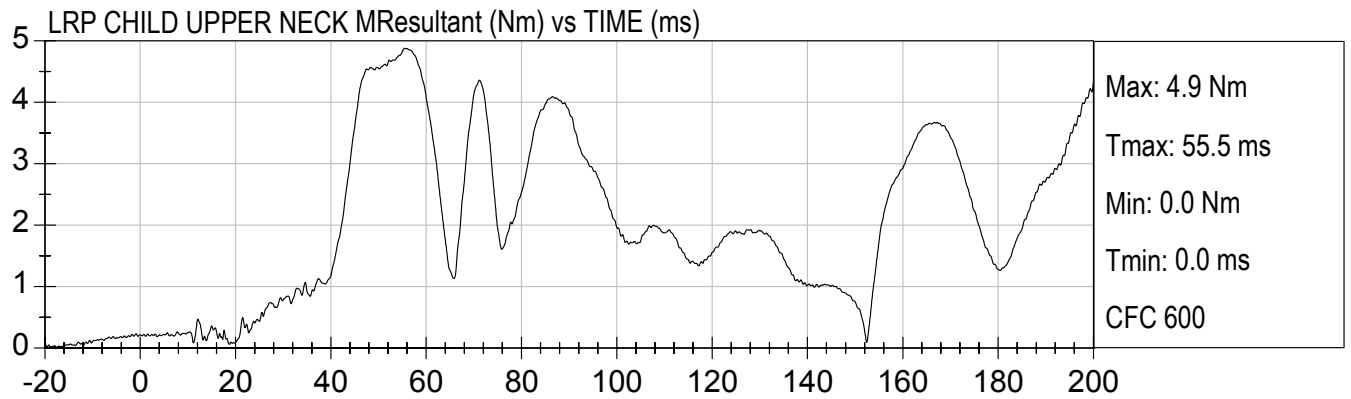
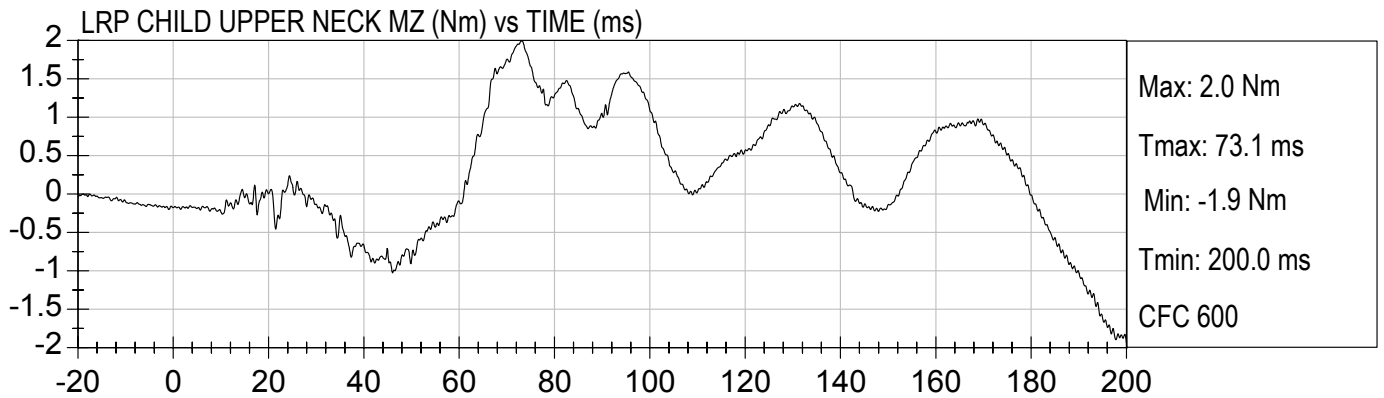
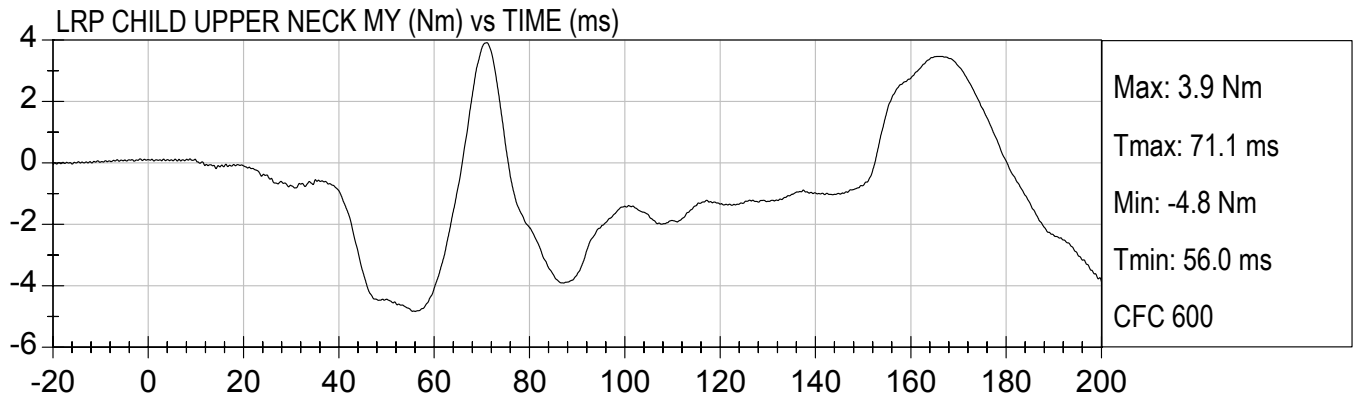
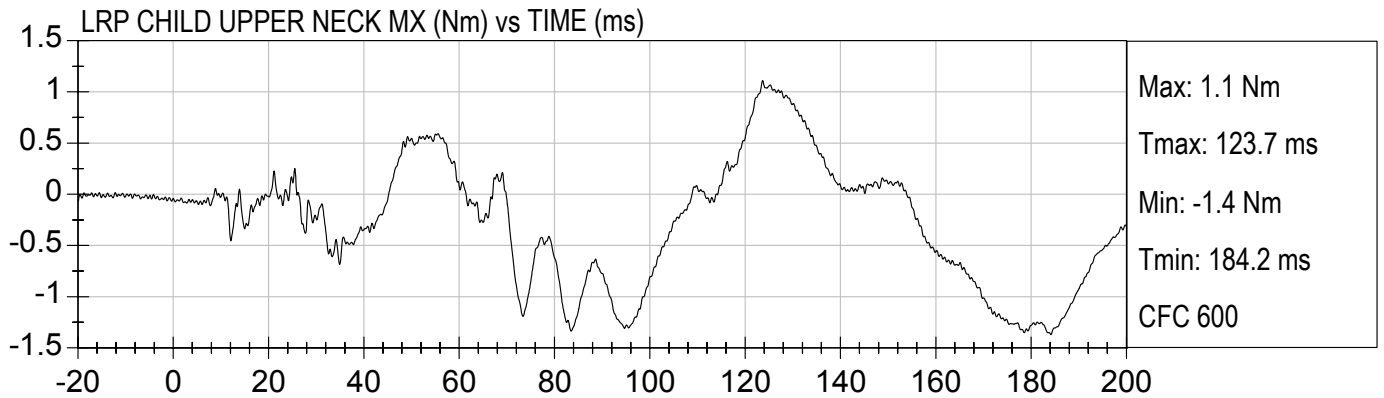

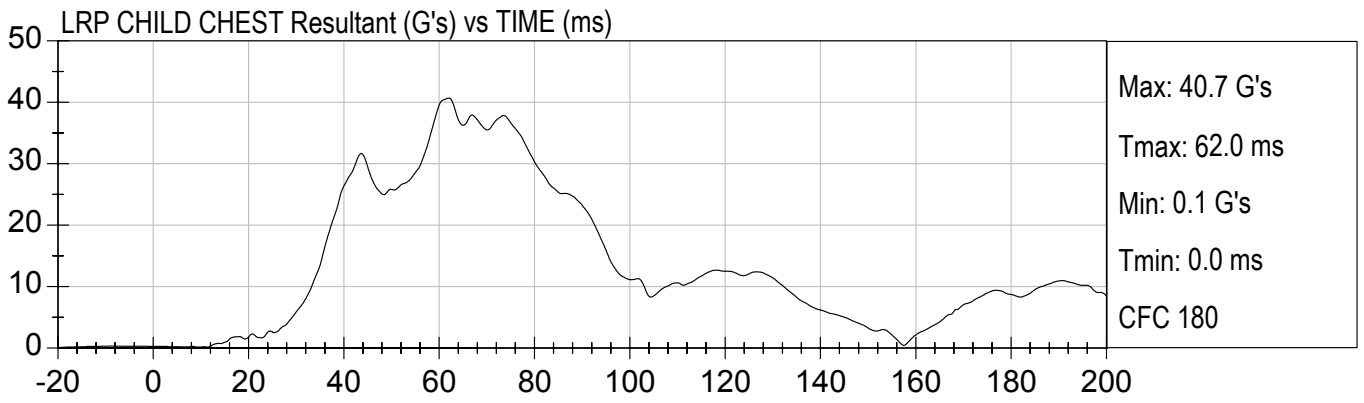
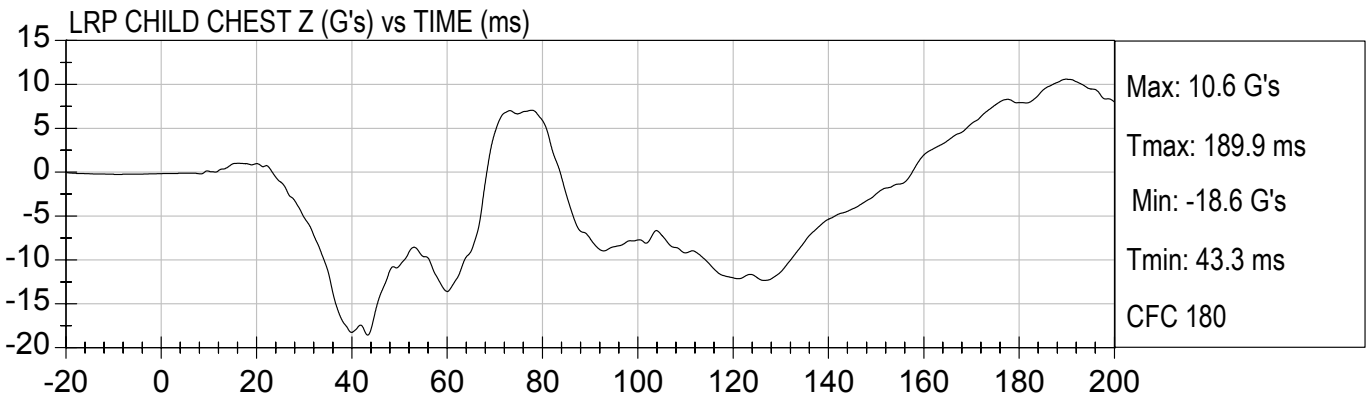
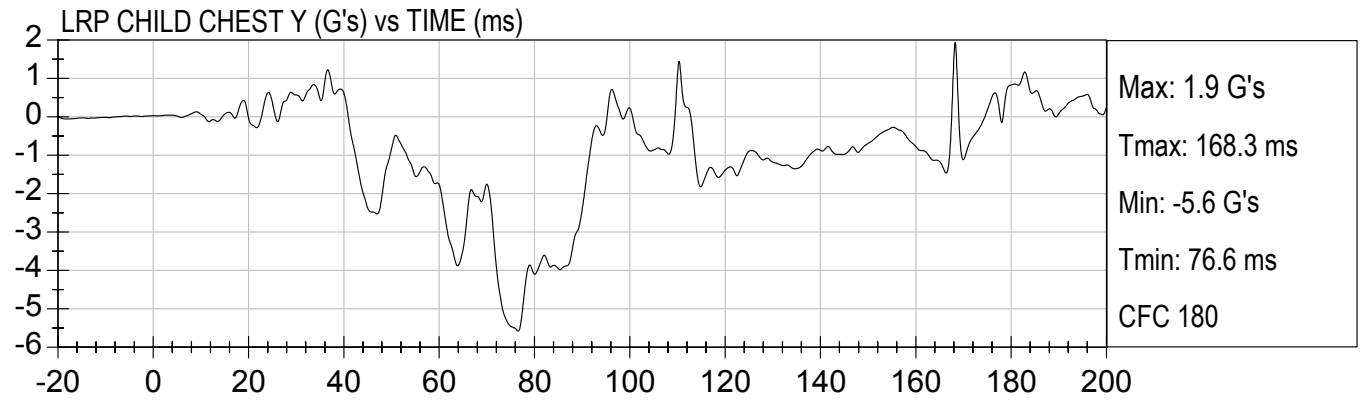
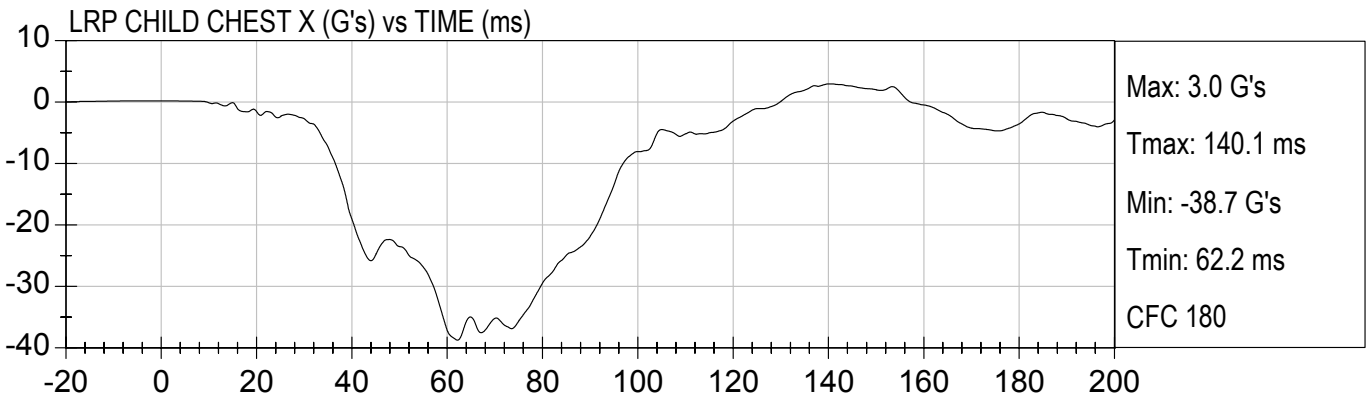

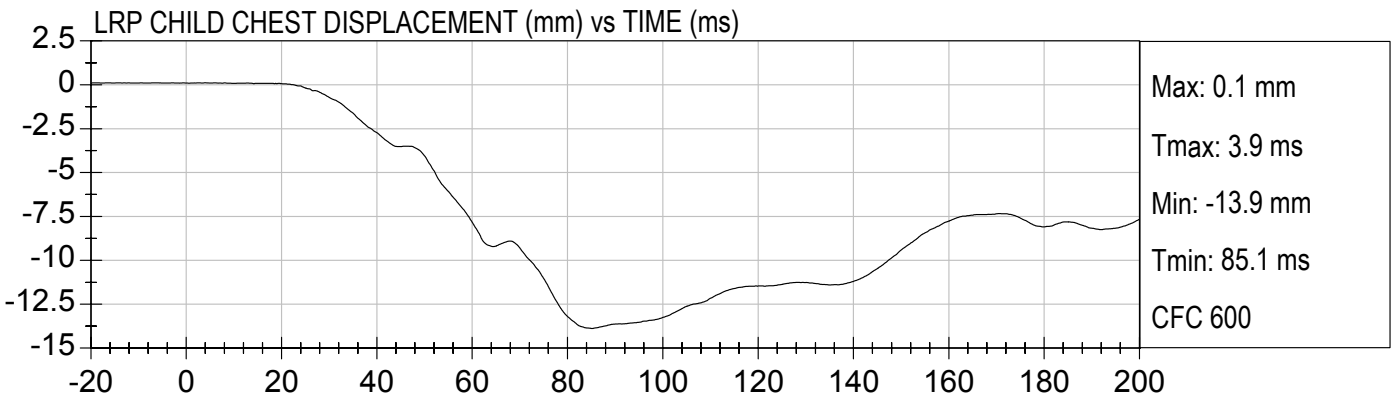
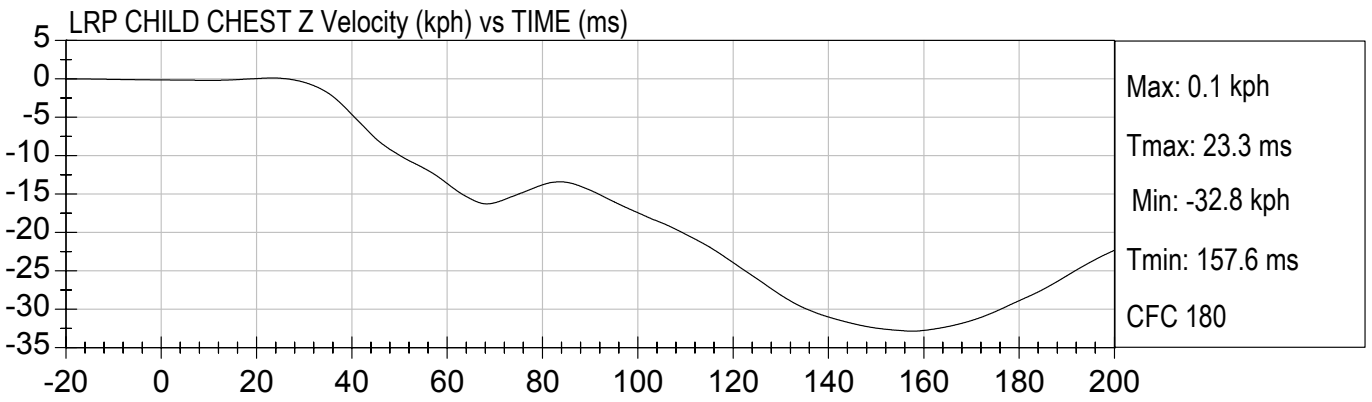
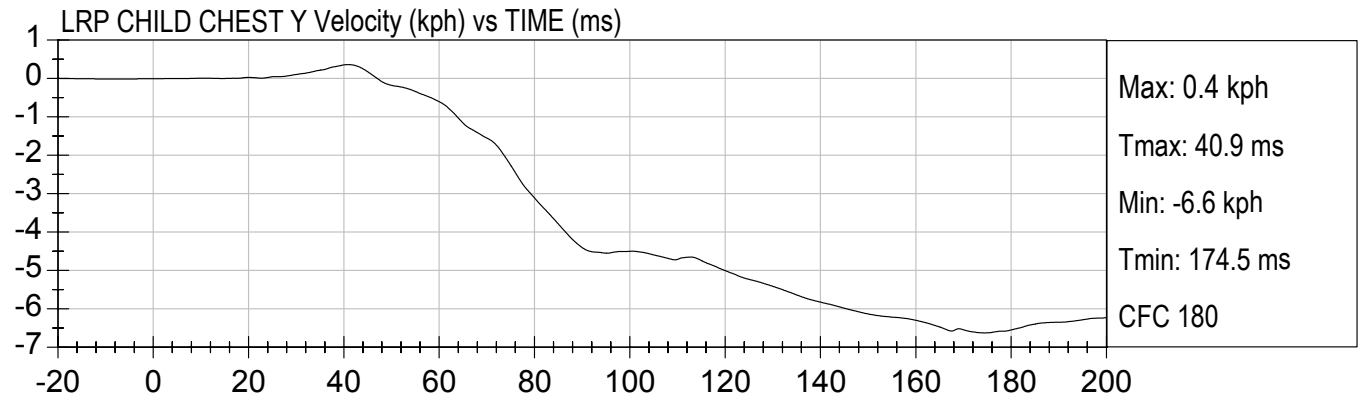
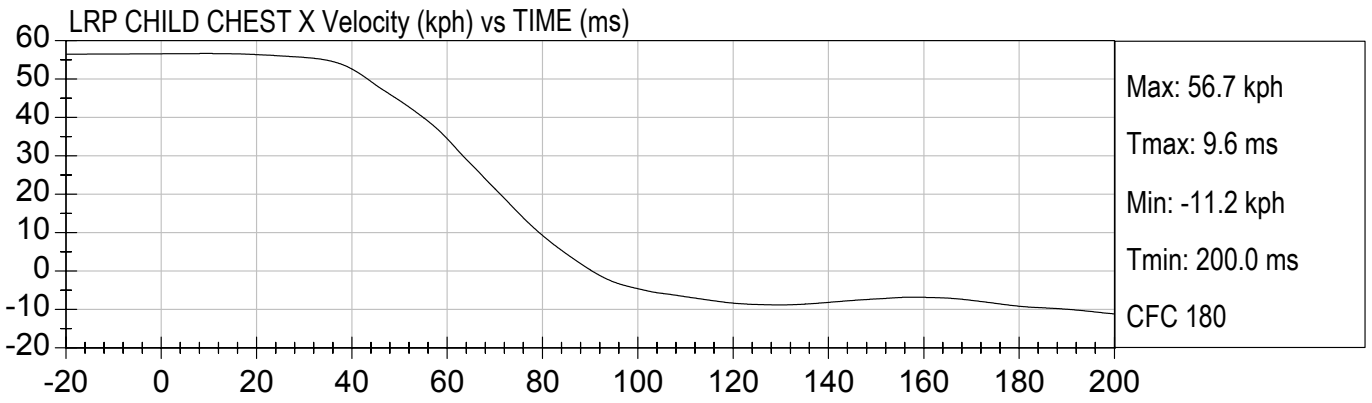

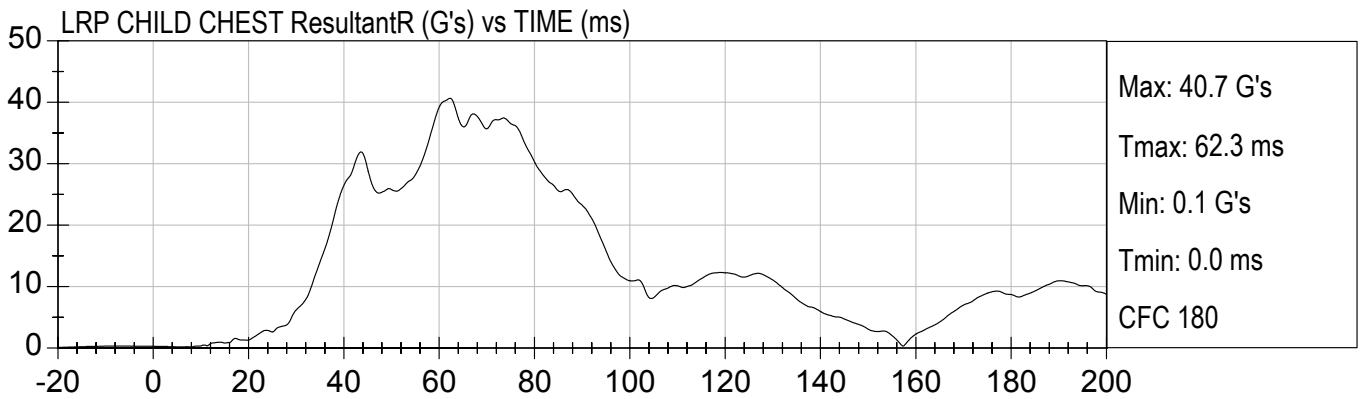
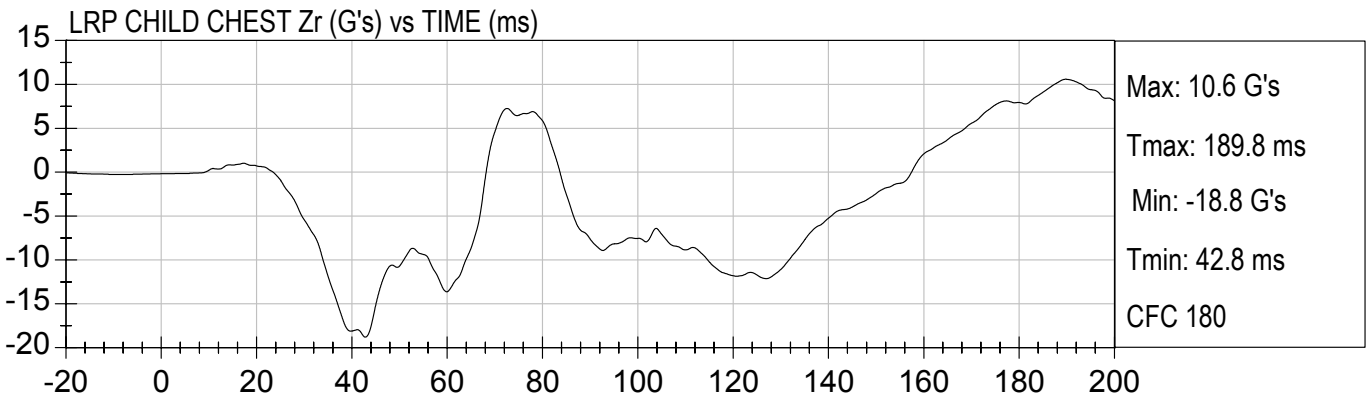
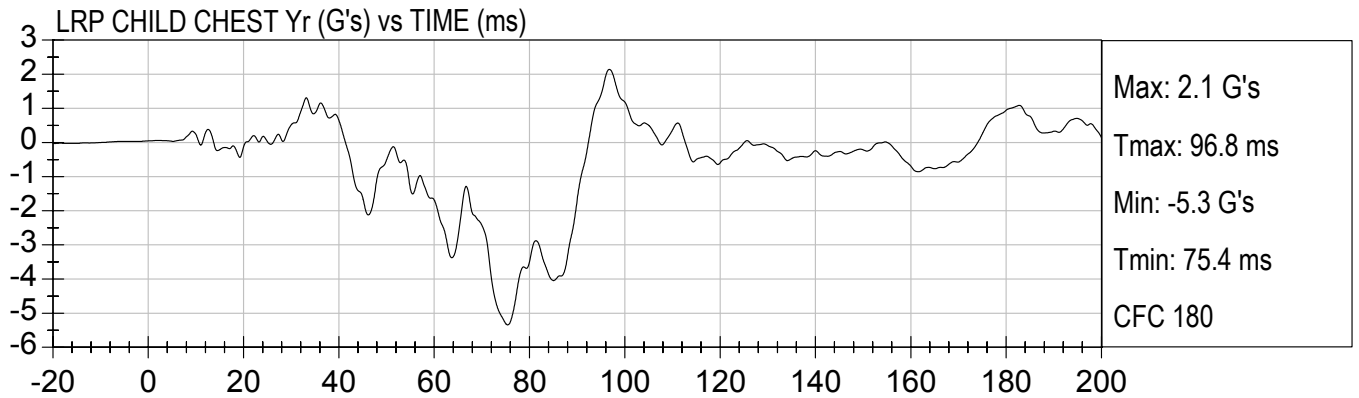
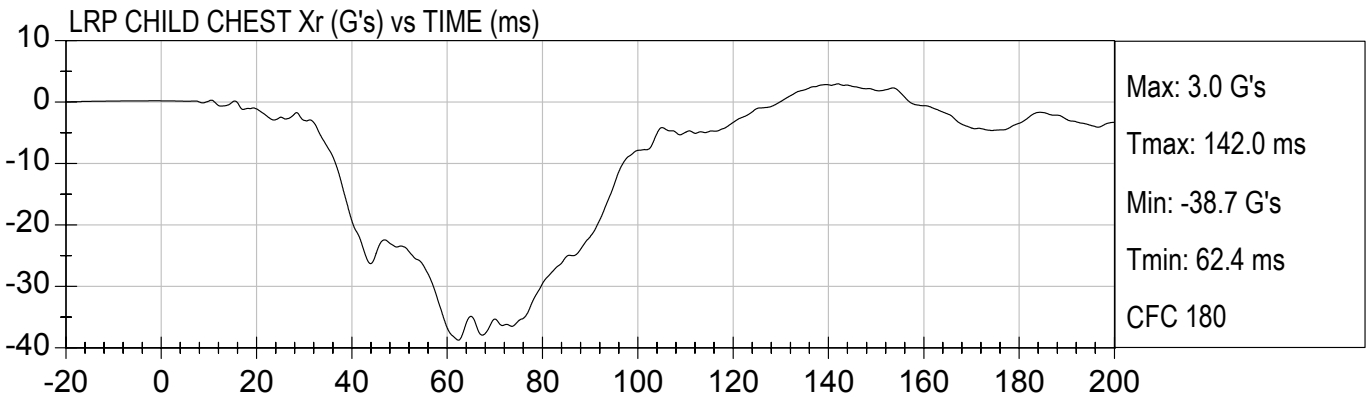

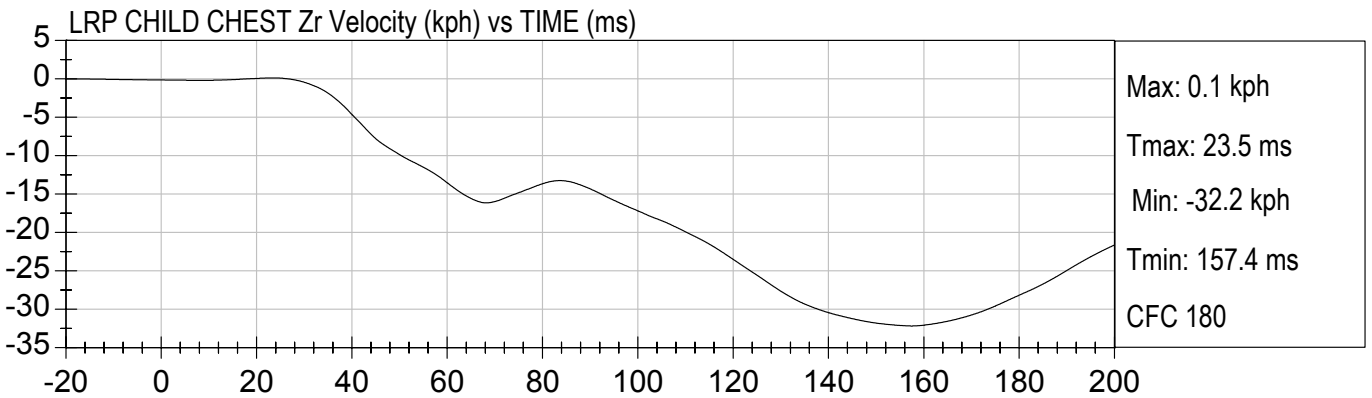
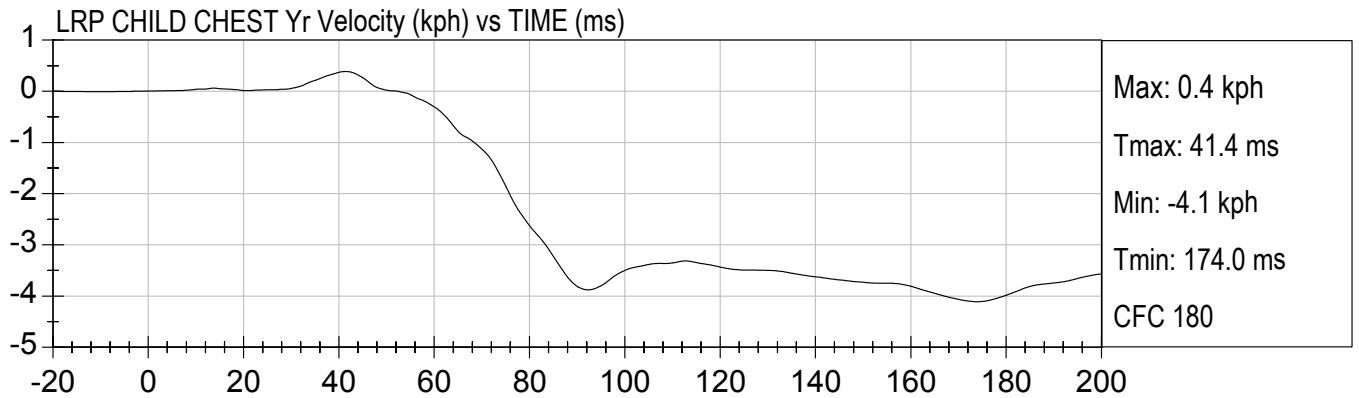
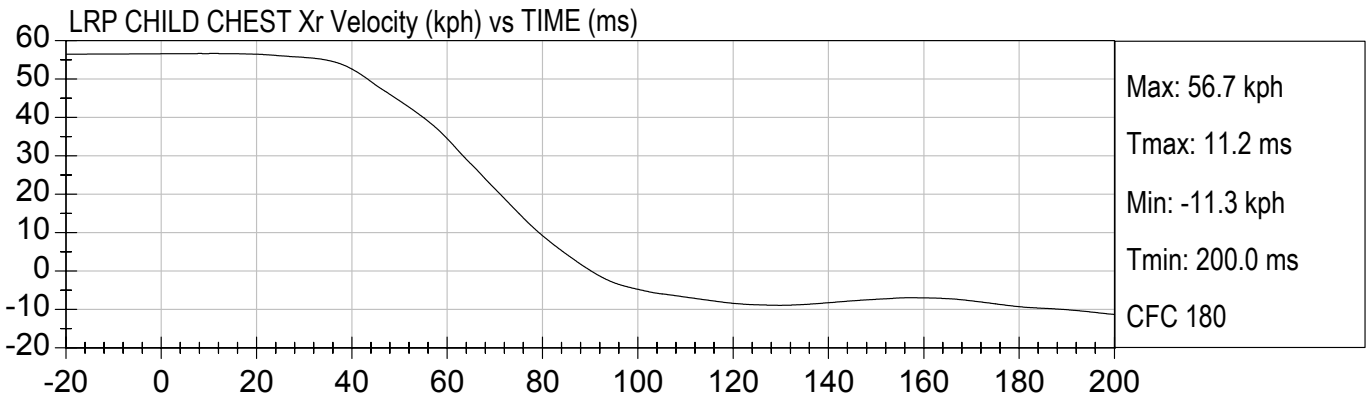

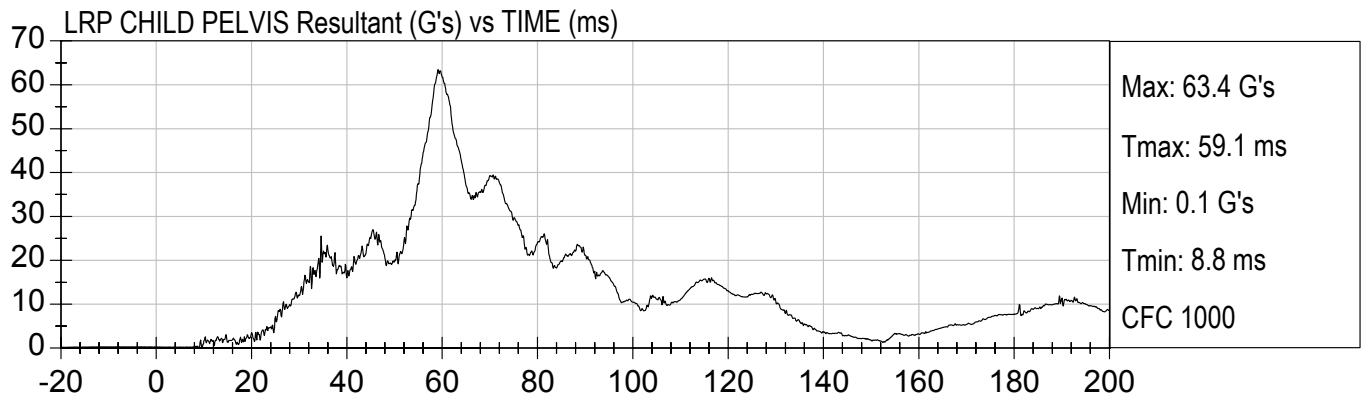
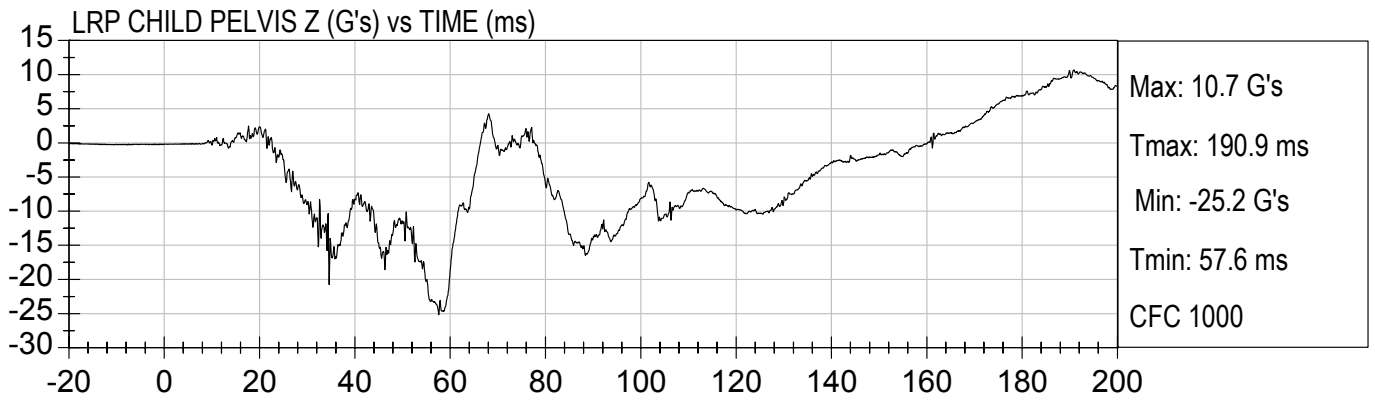
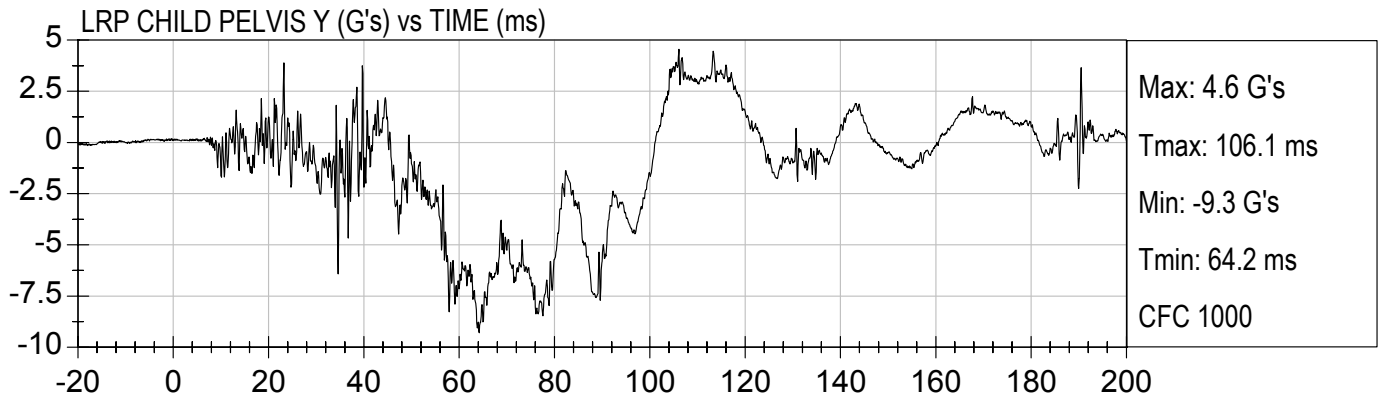
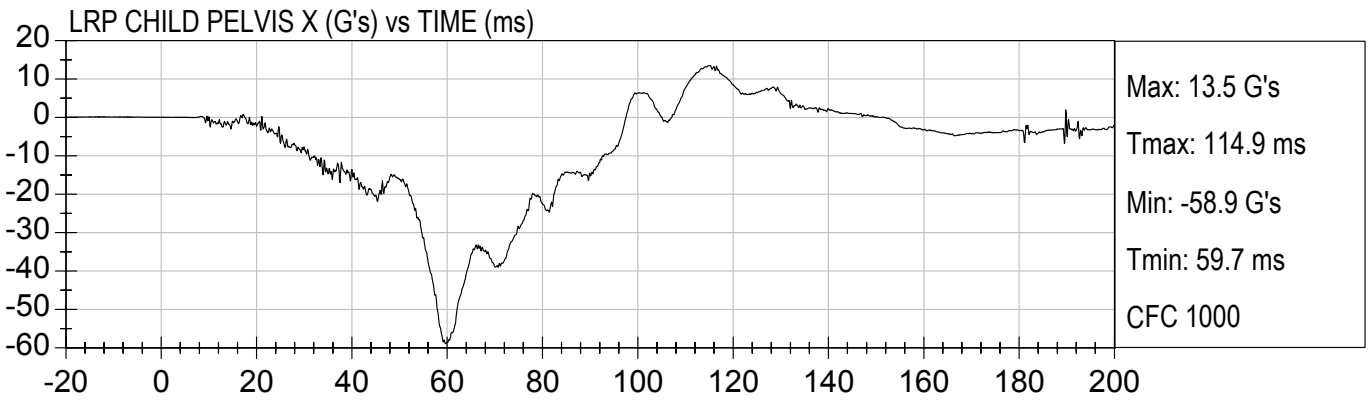

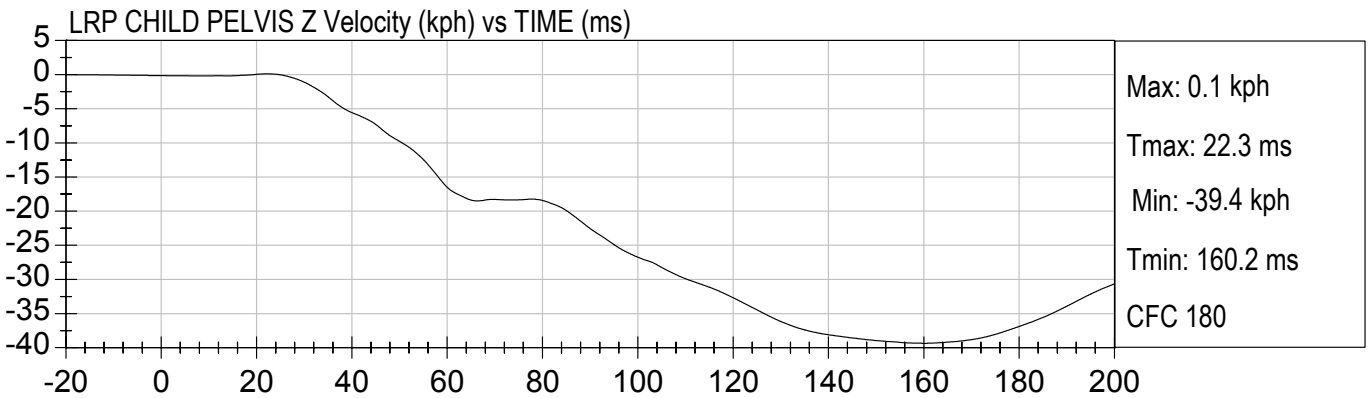
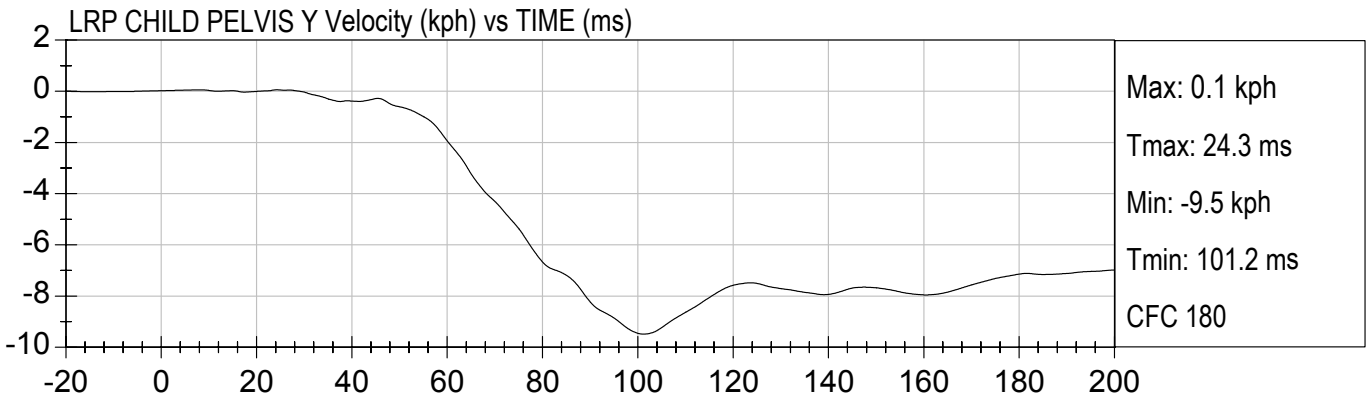
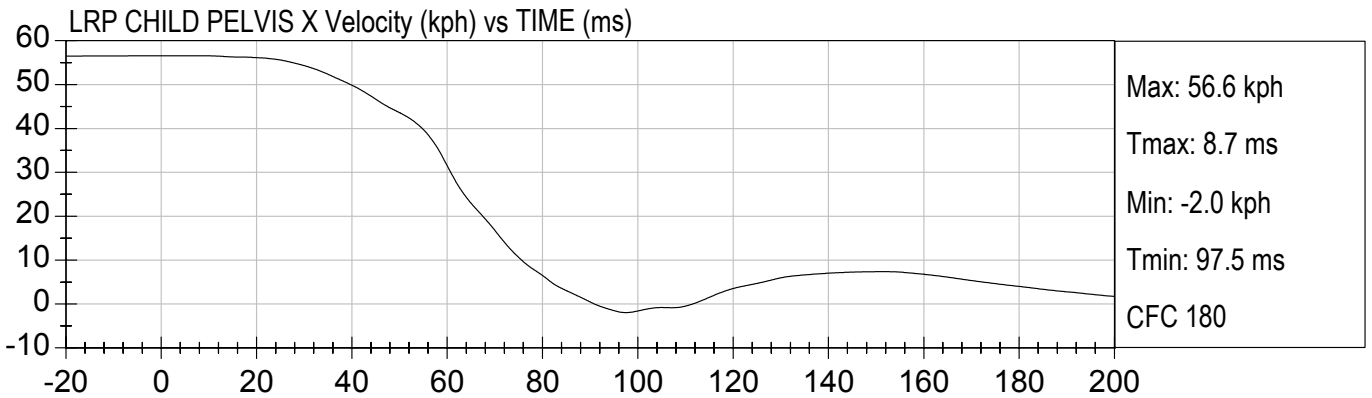



RRP CHILD HEAD X (G's) vs TIME (ms)

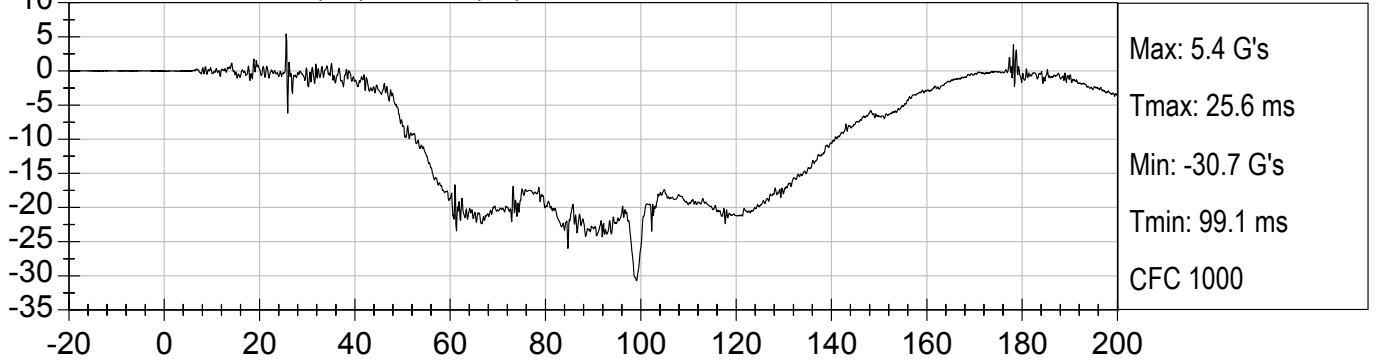

RRP CHILD HEAD Y (G's) vs TIME (ms)

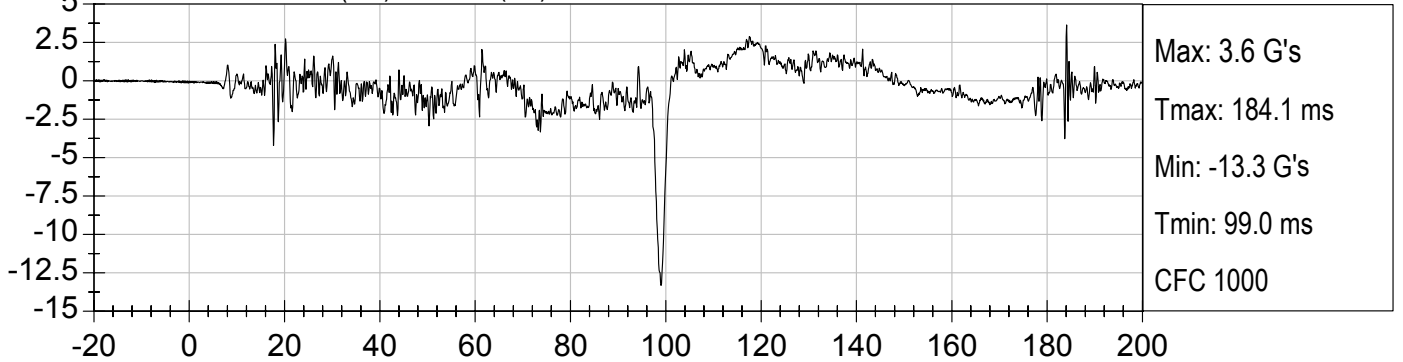

RRP CHILD HEAD Z (G's) vs TIME (ms)

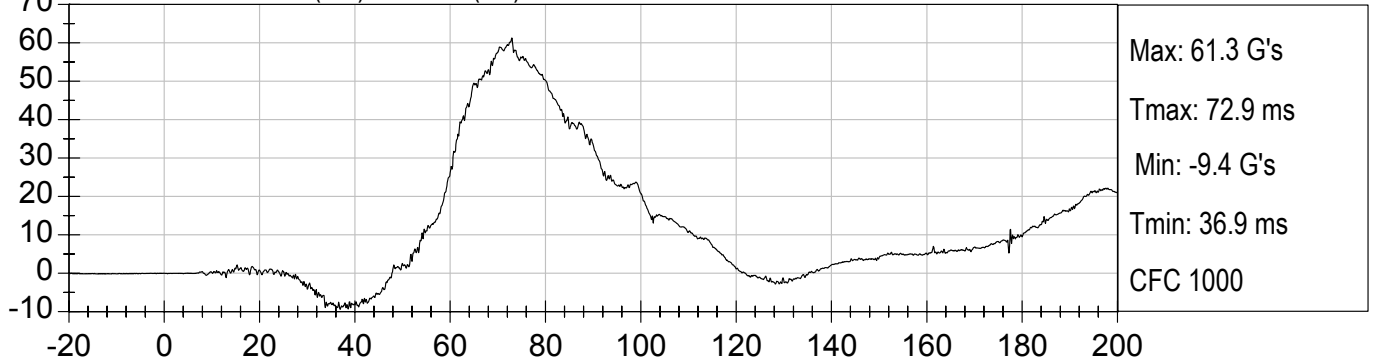

RRP CHILD HEAD Resultant (G's) vs TIME (ms)

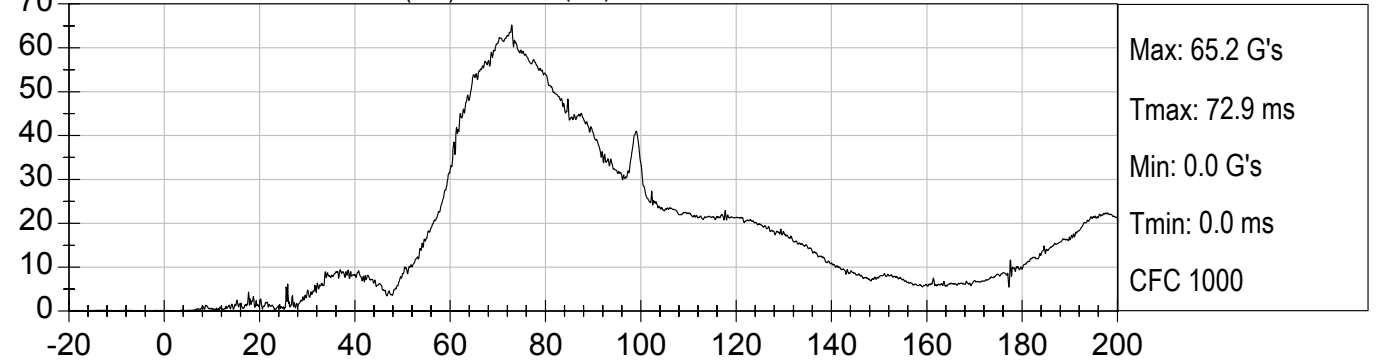

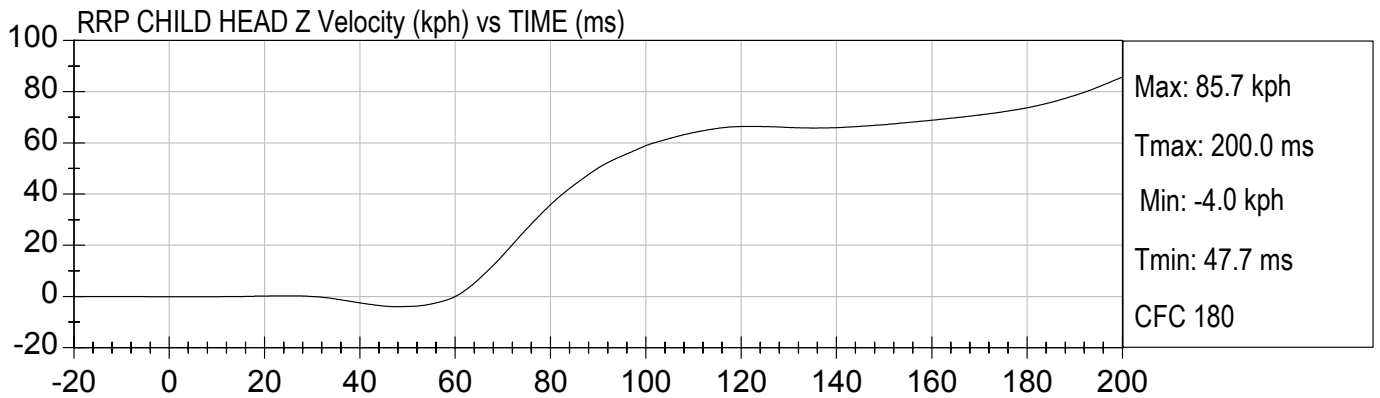
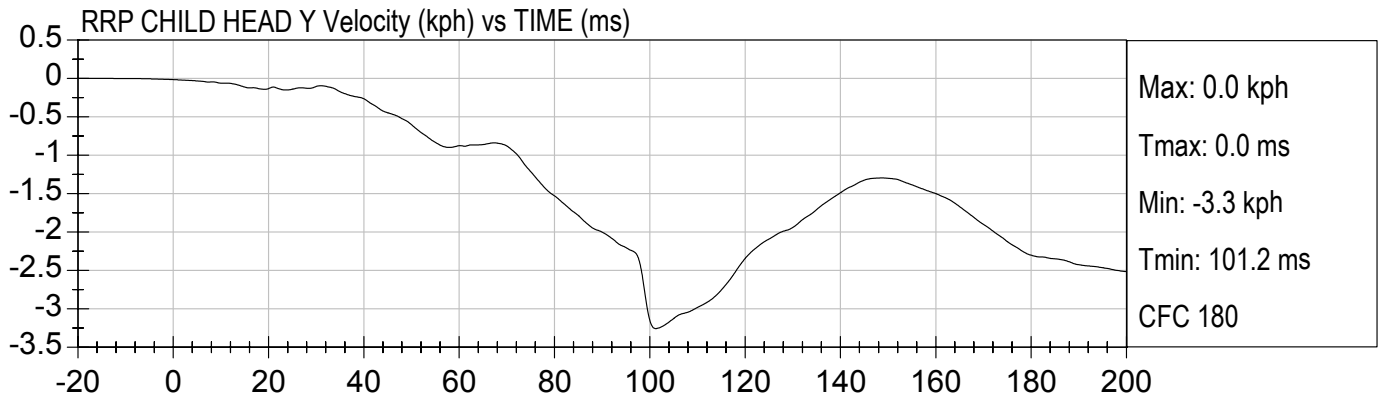
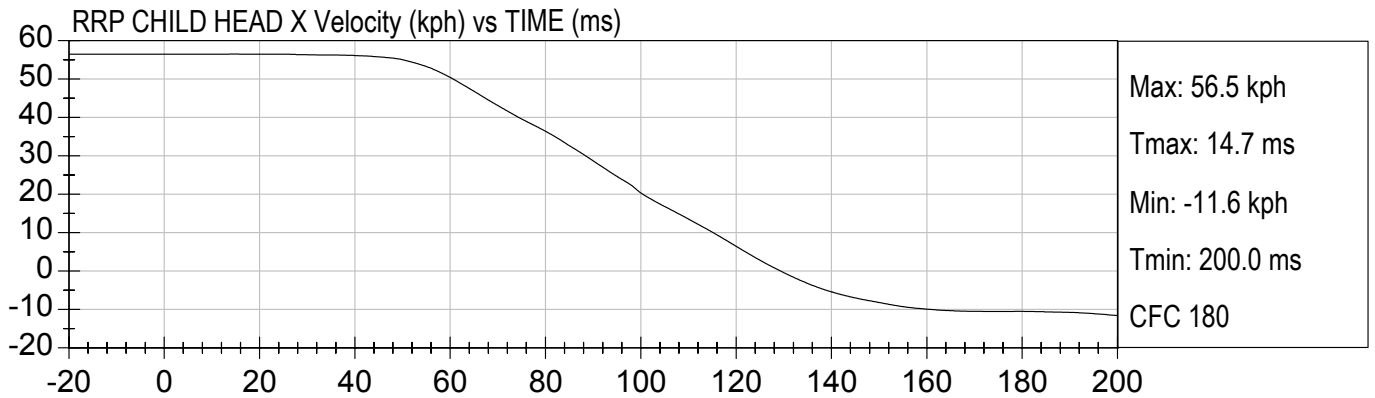

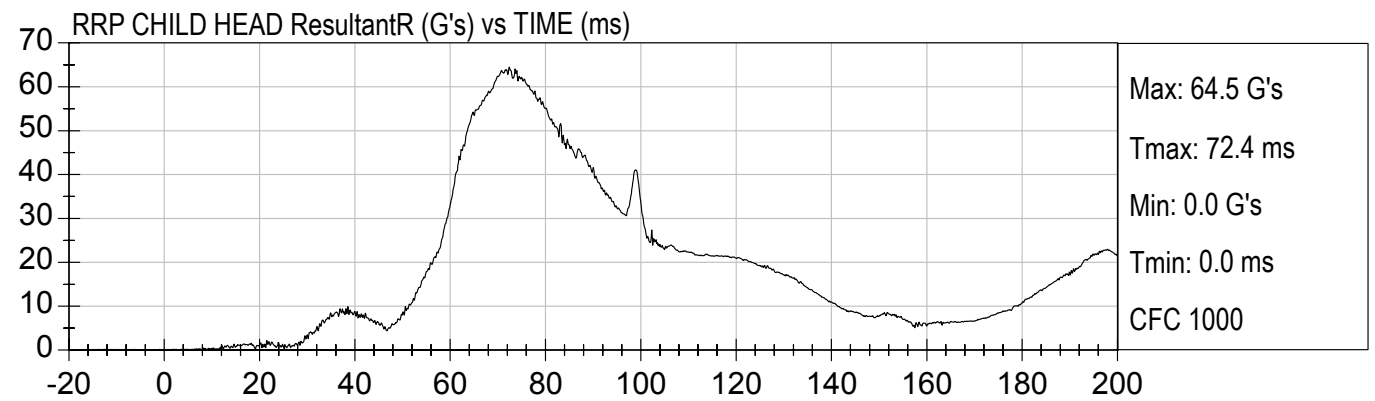
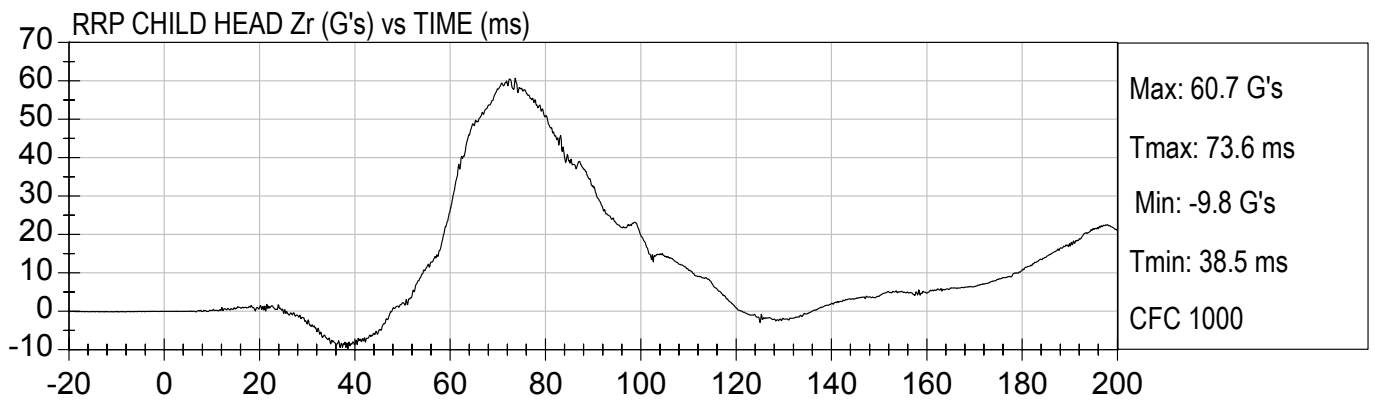
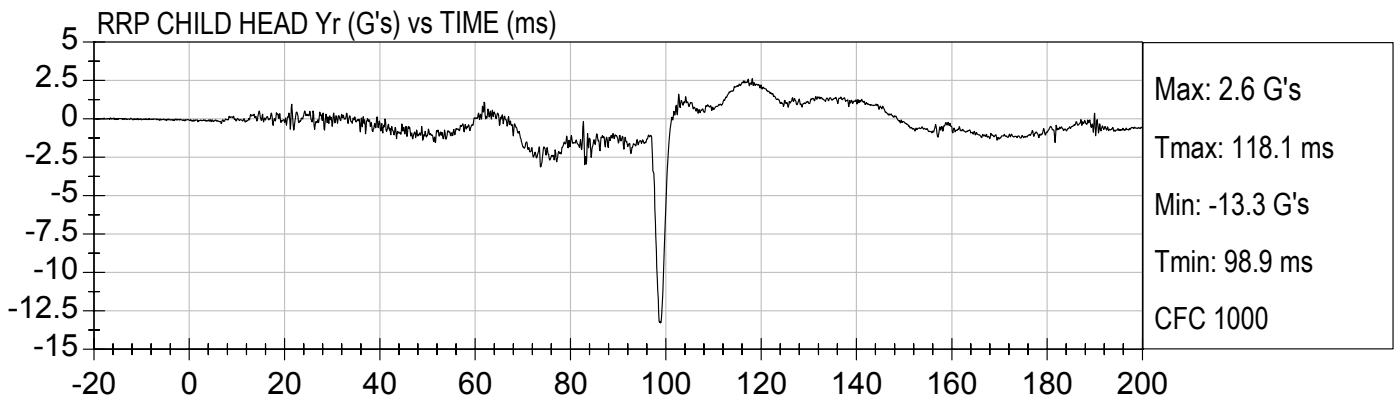
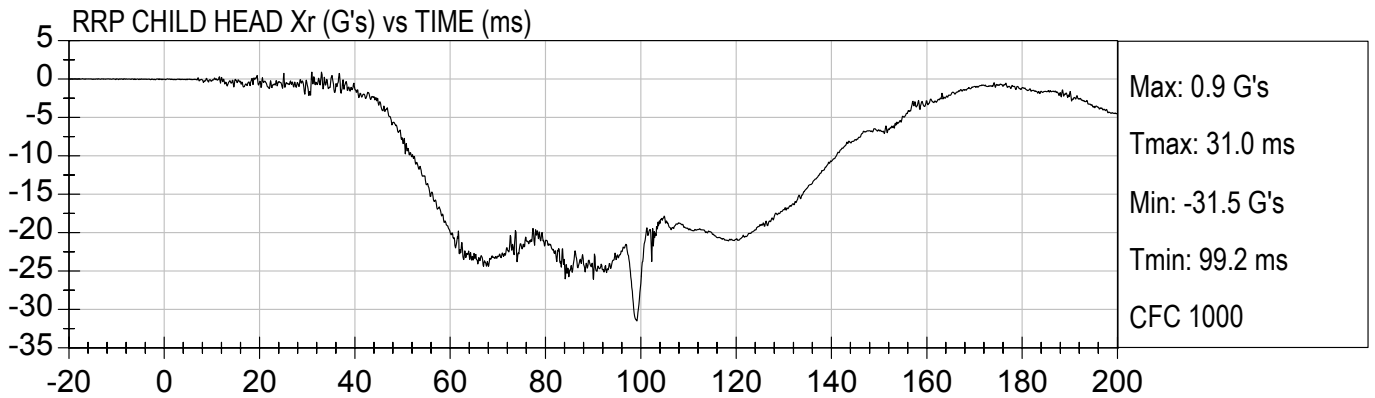

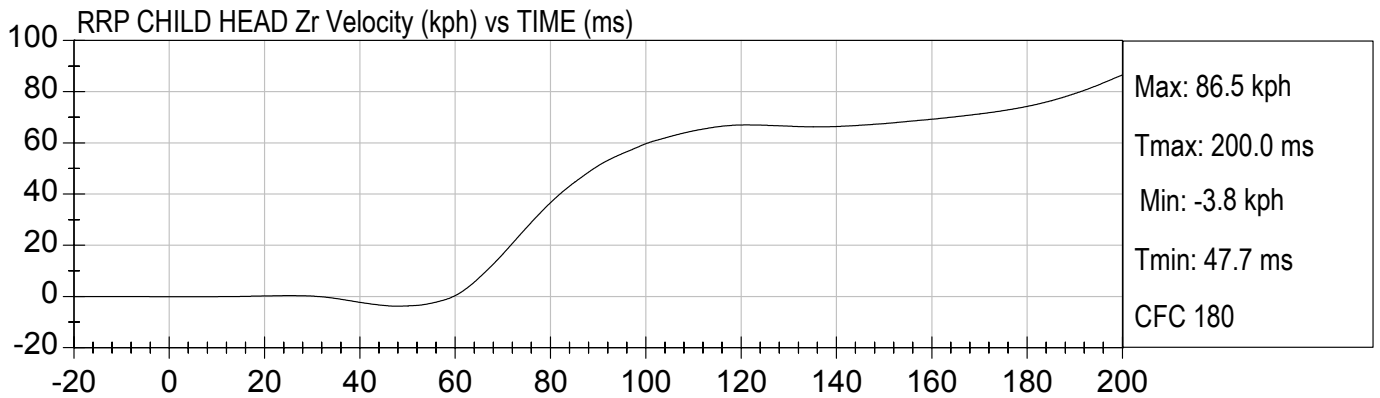
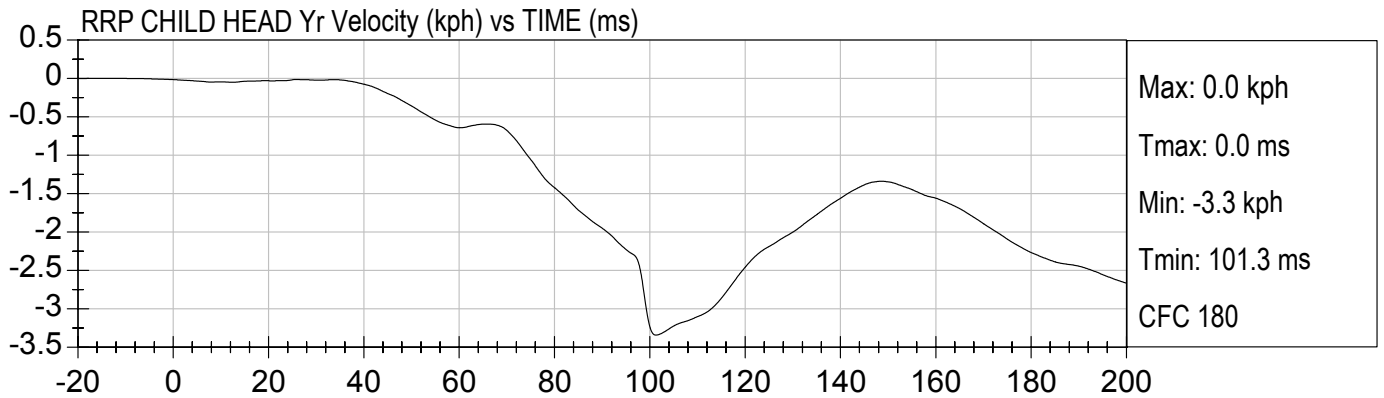
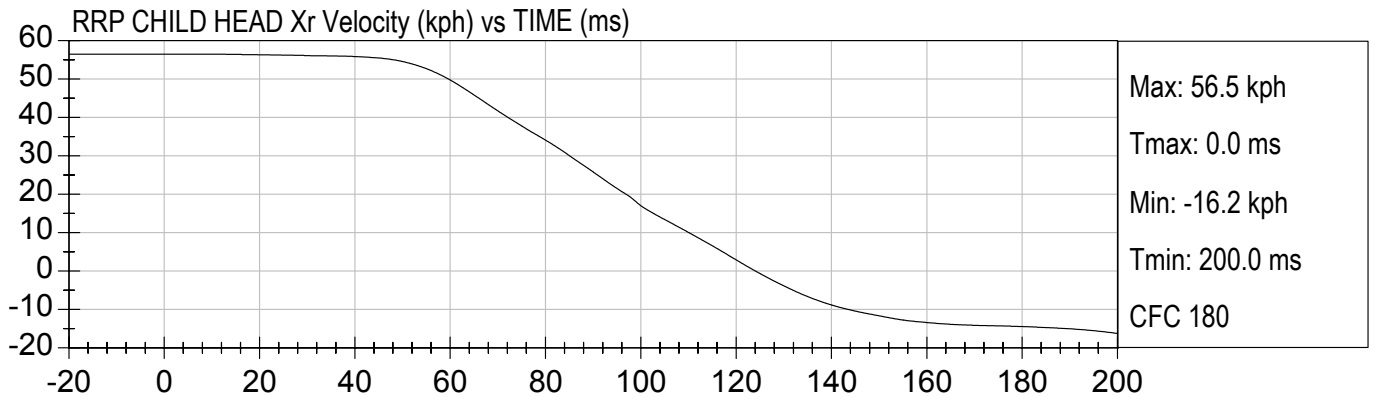

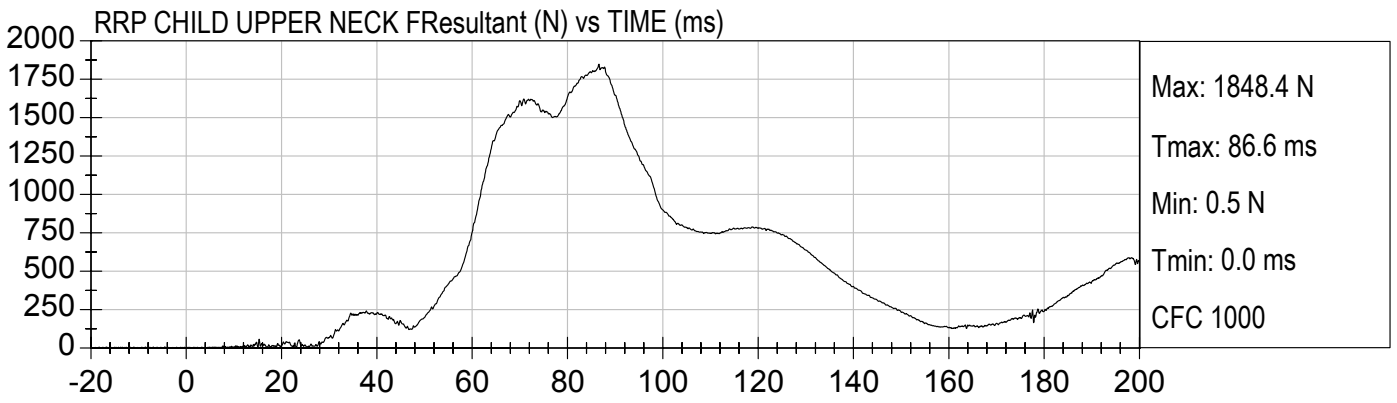
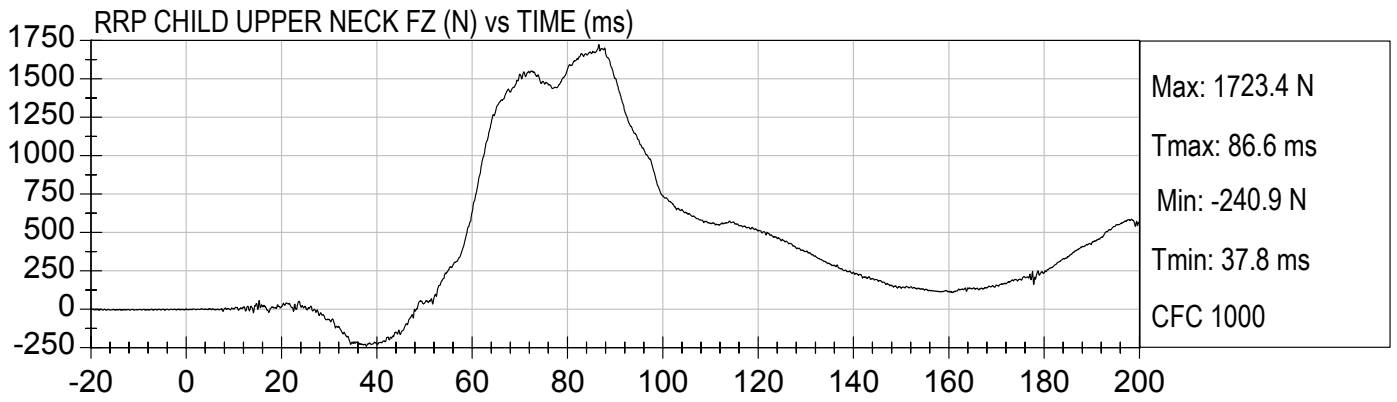
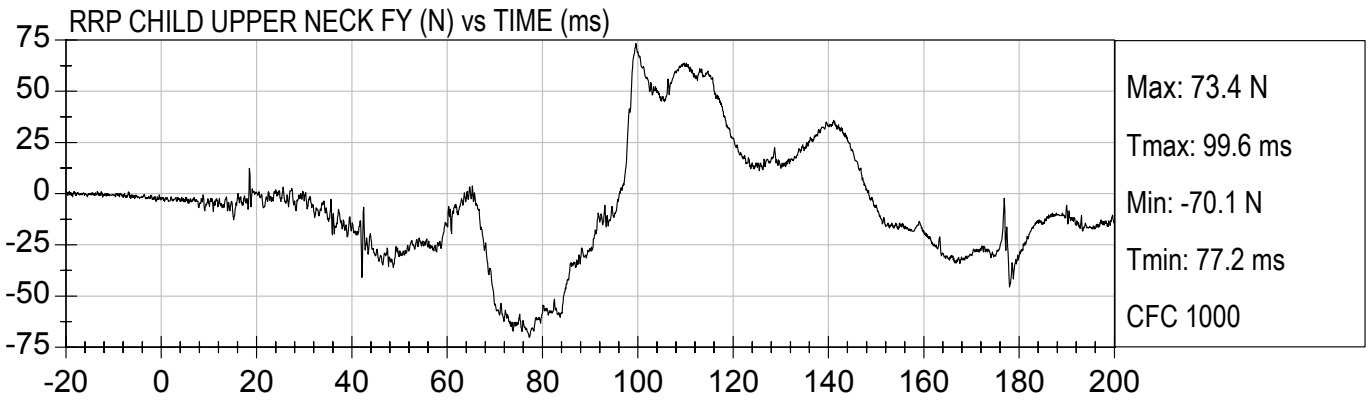
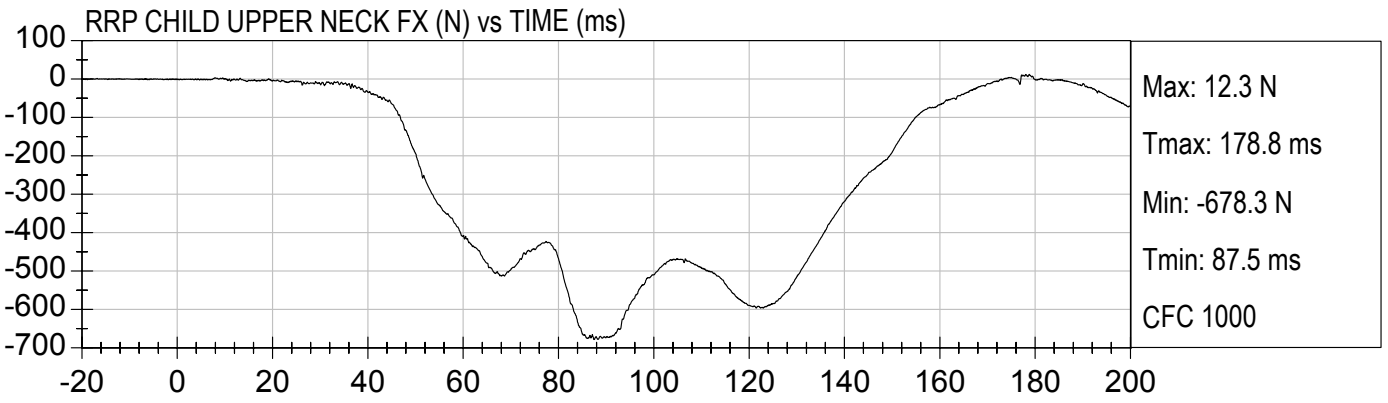

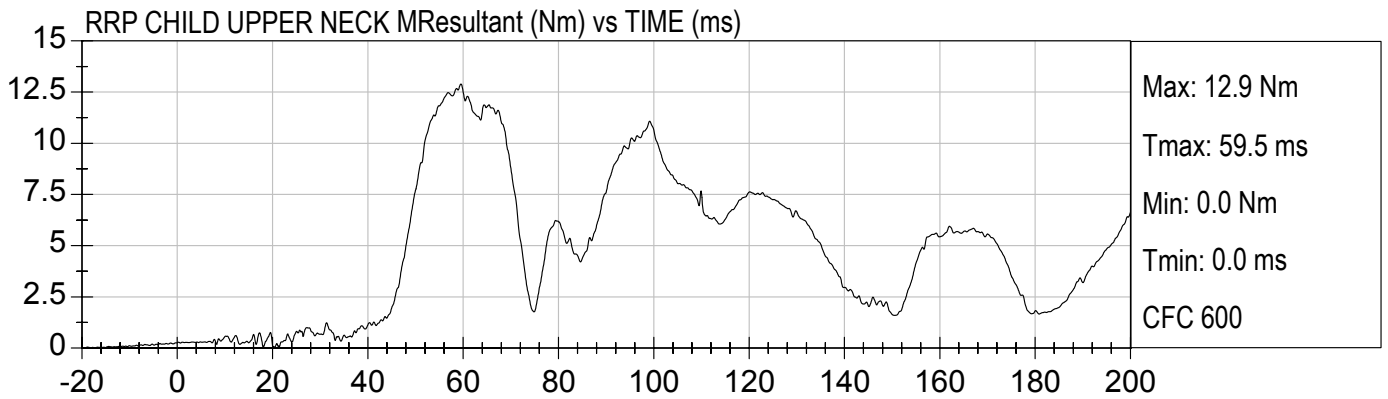
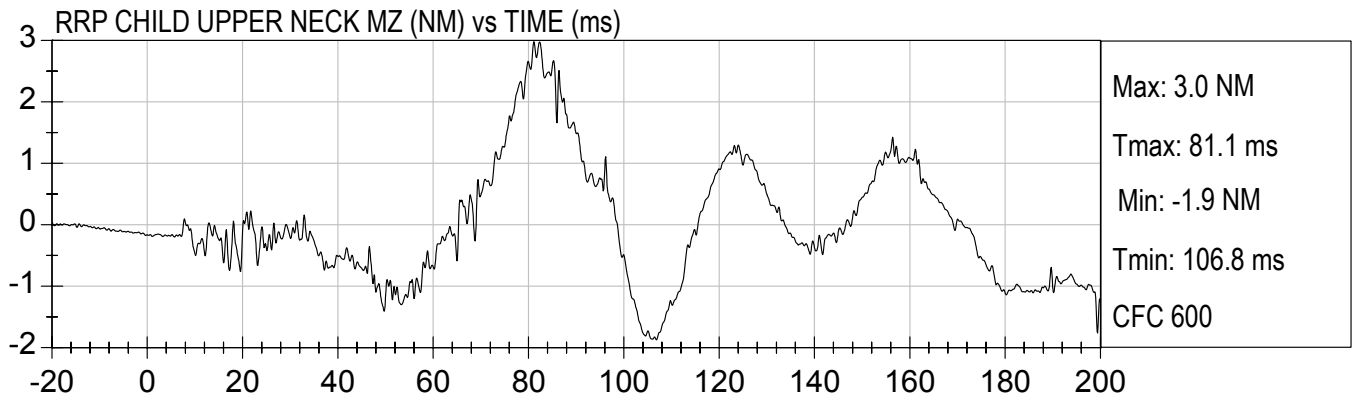
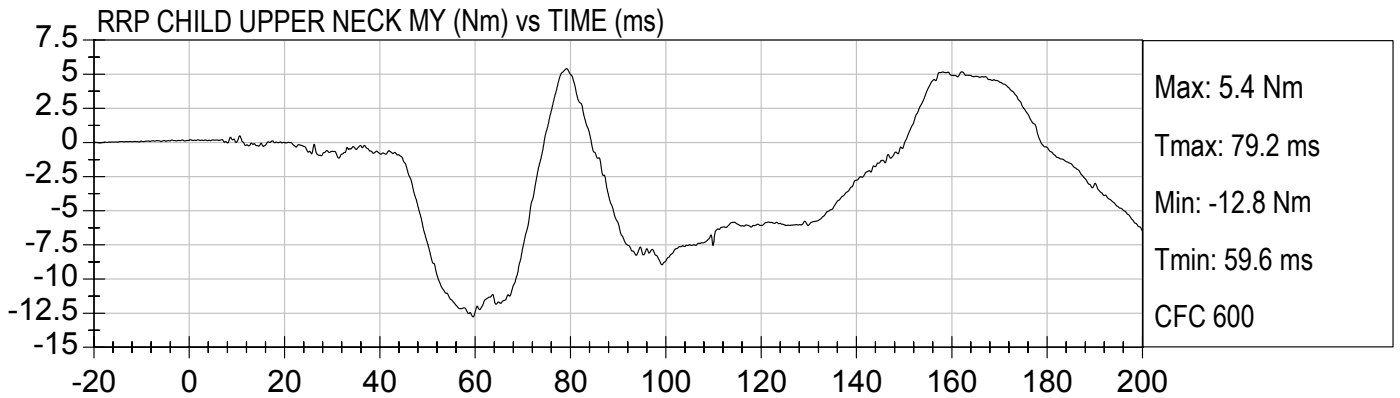
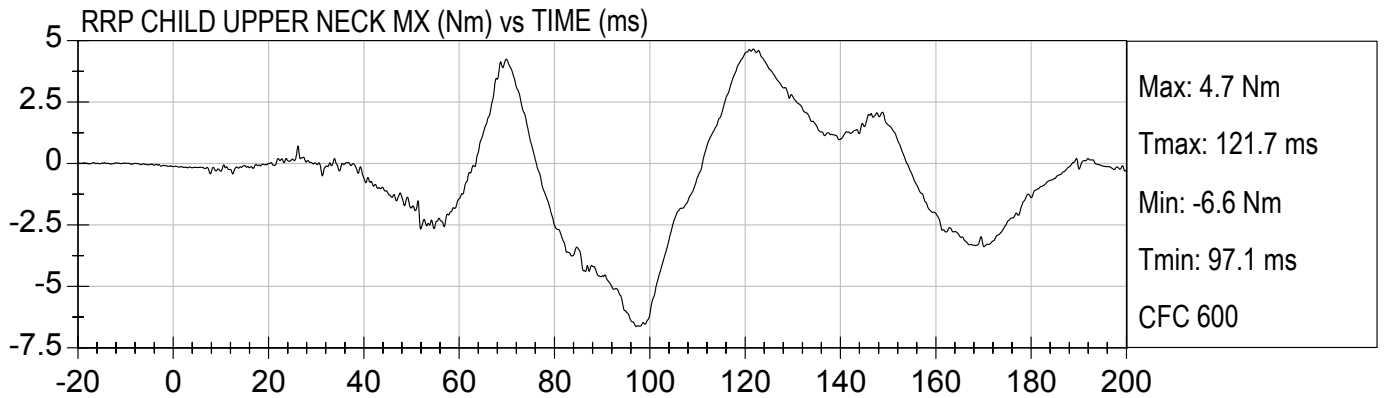

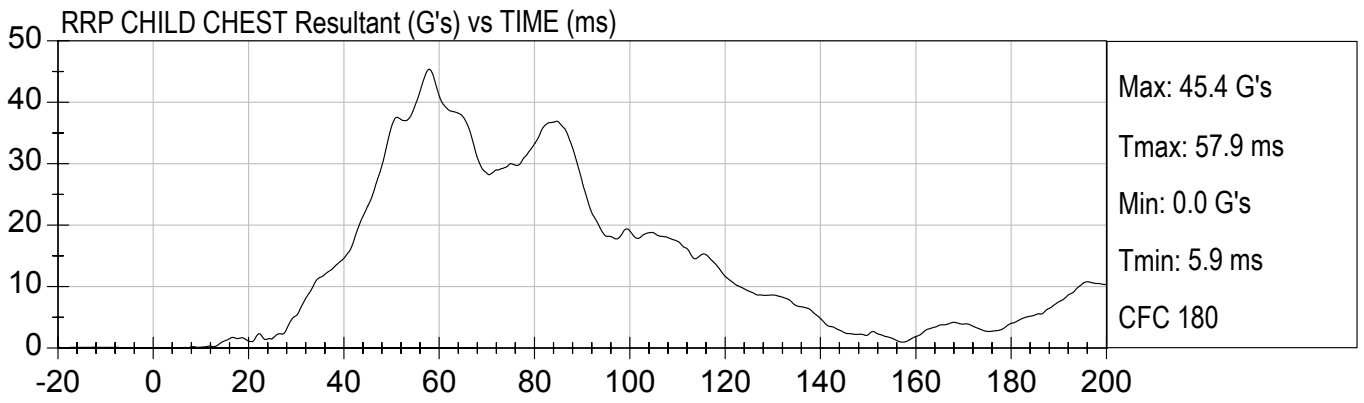
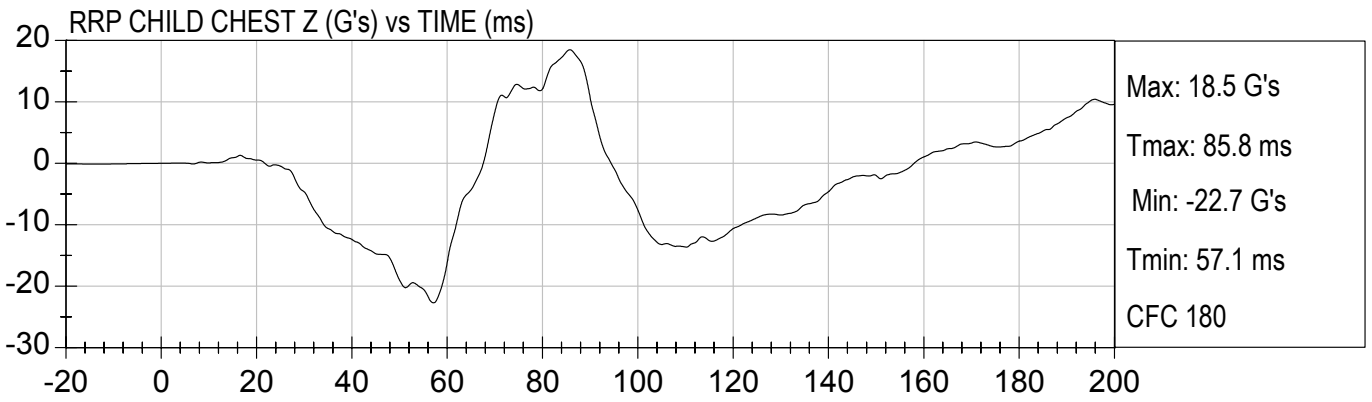
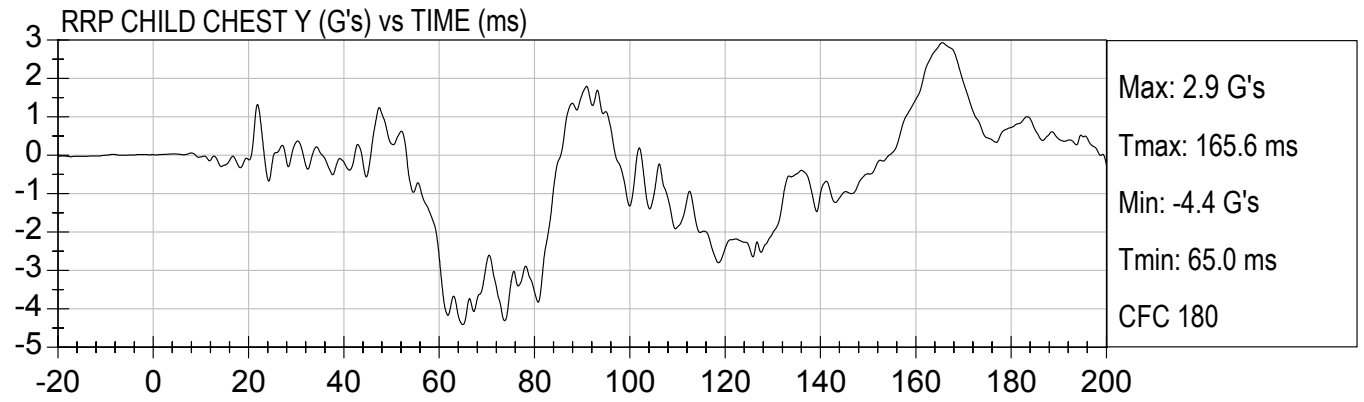
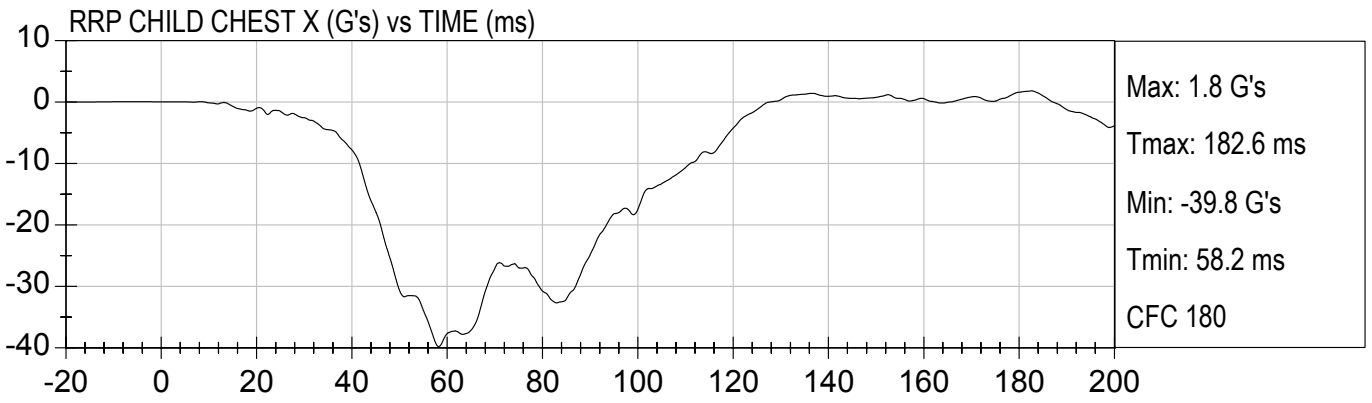

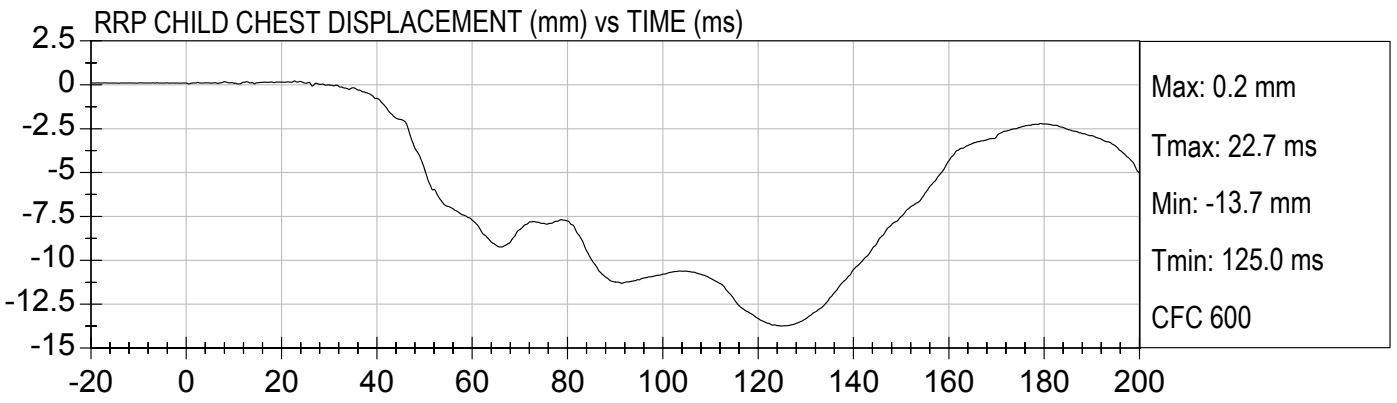
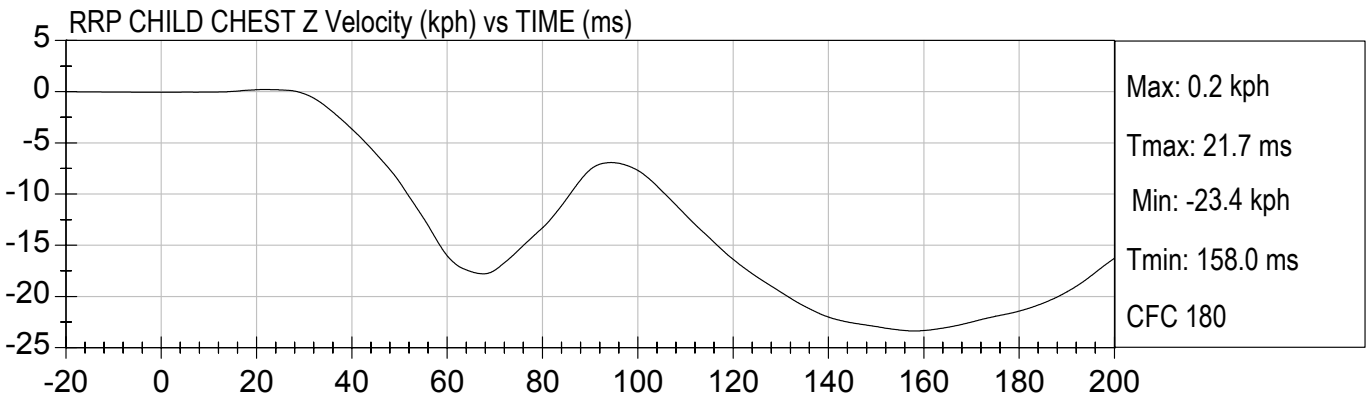
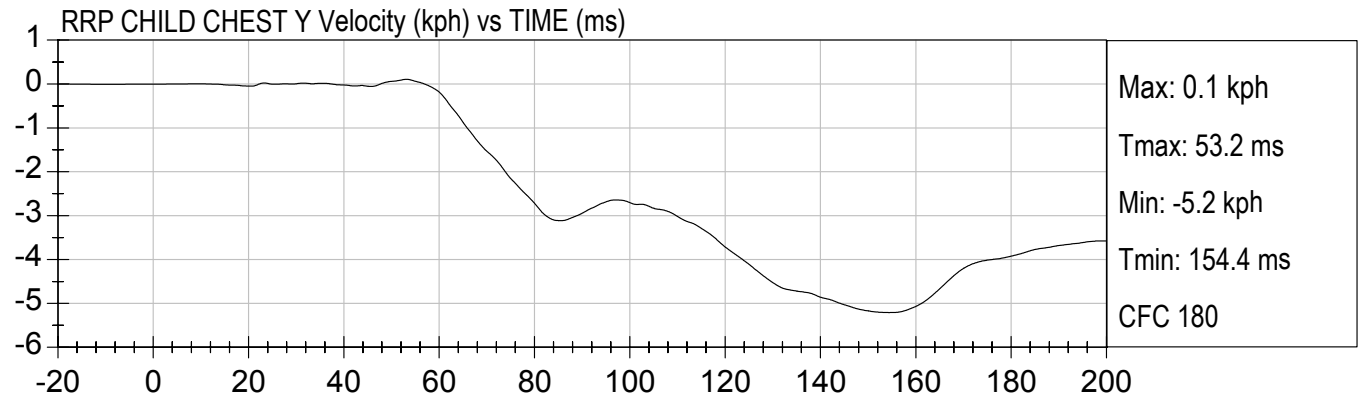
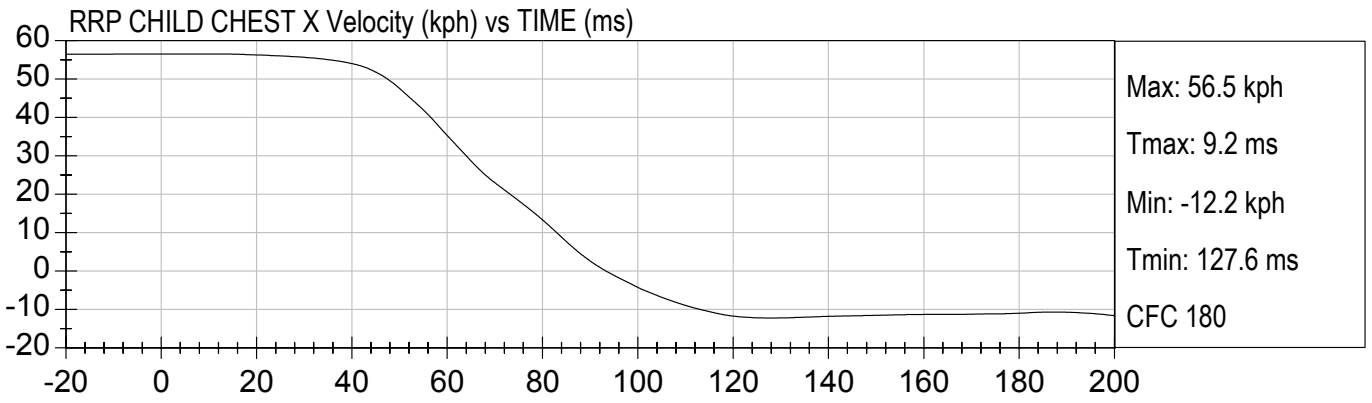

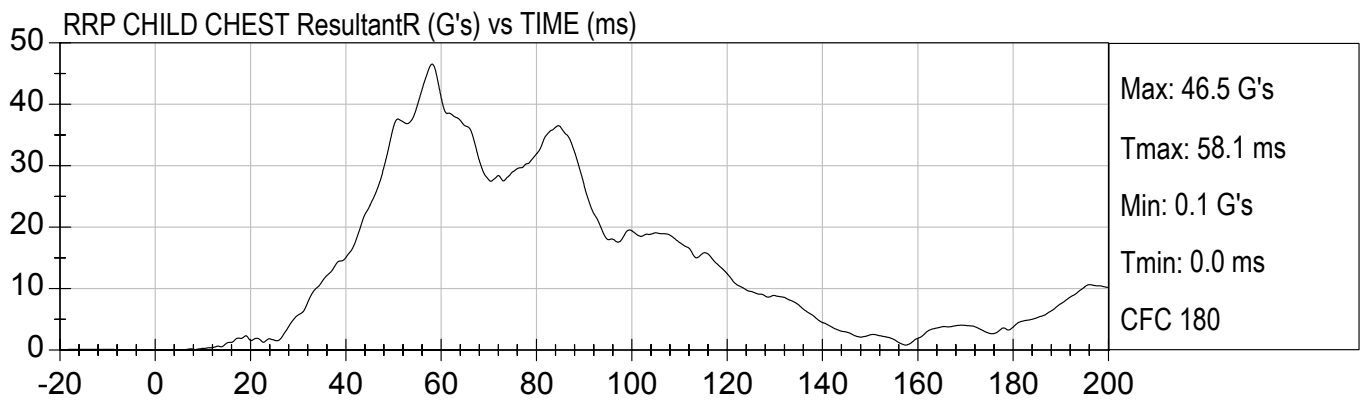
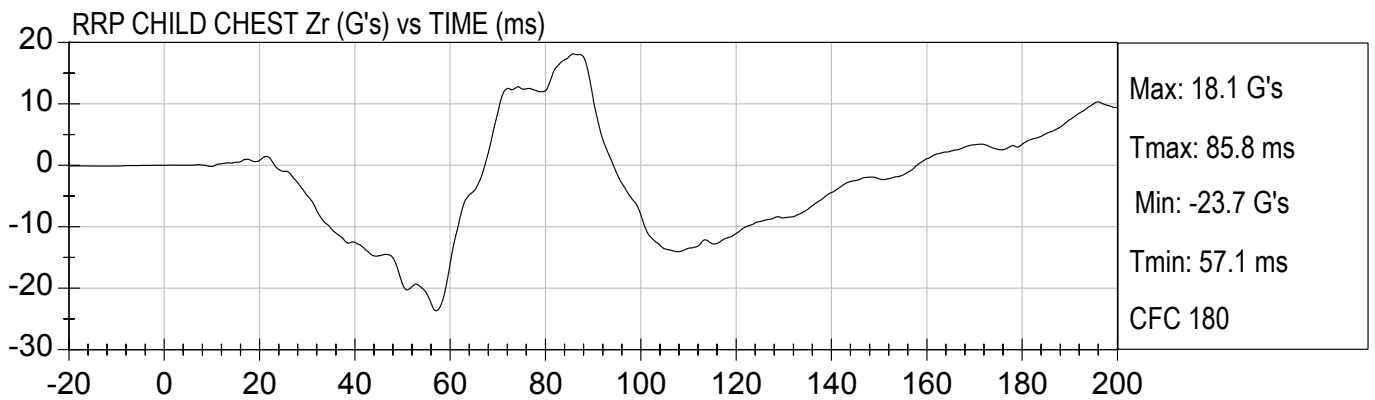
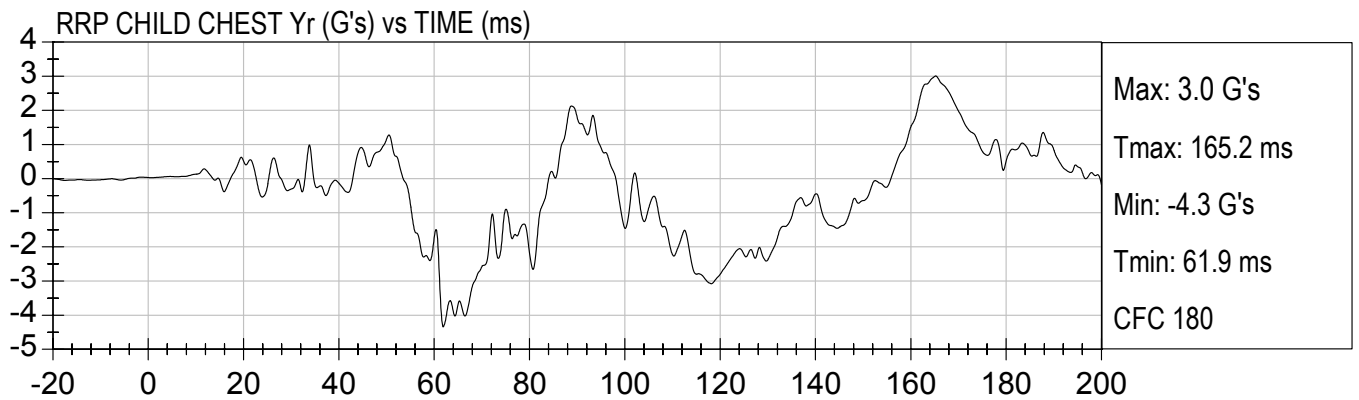
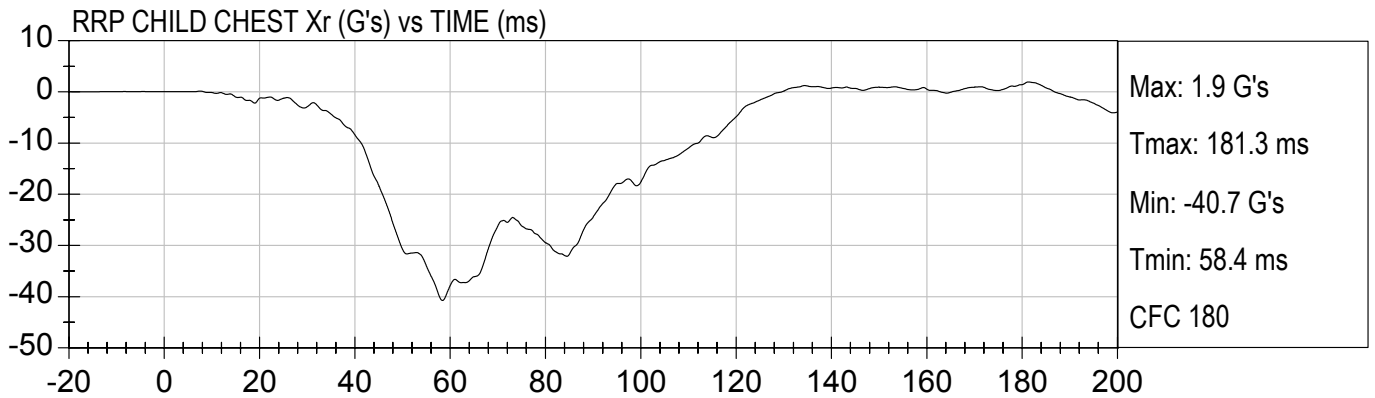

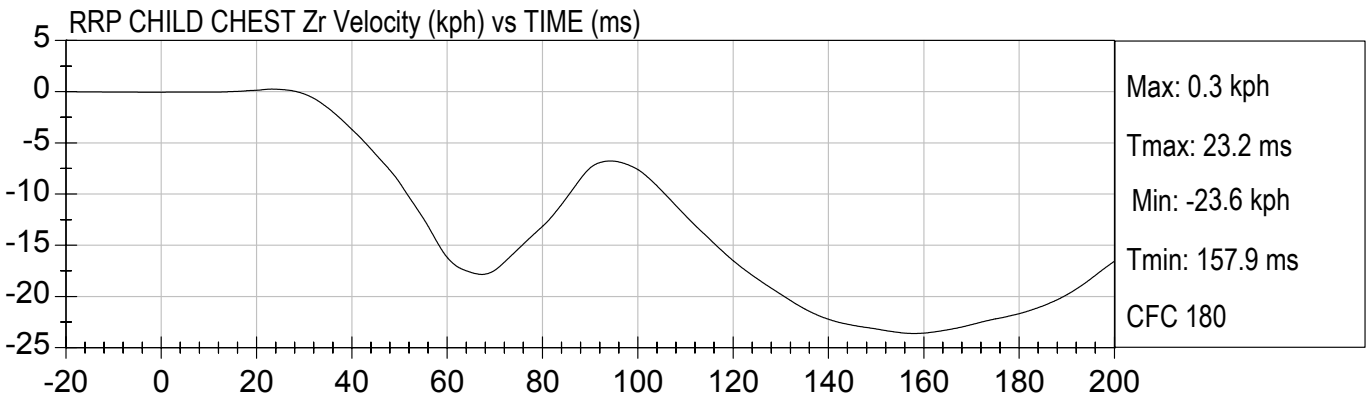
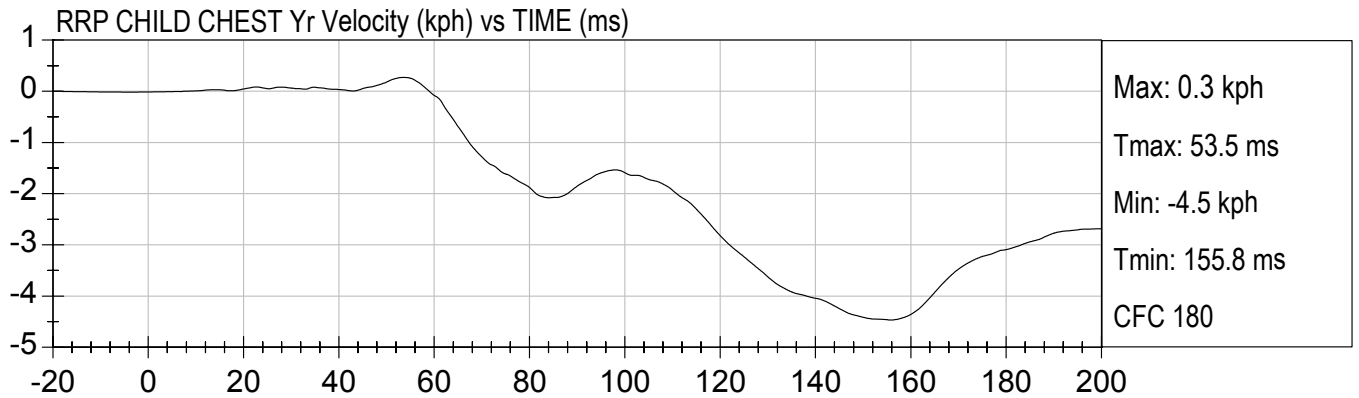
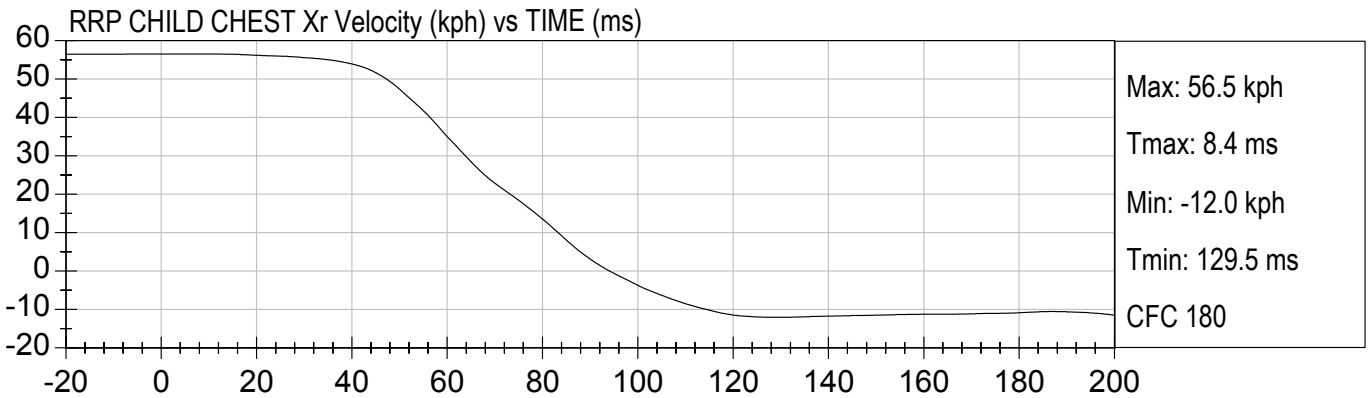

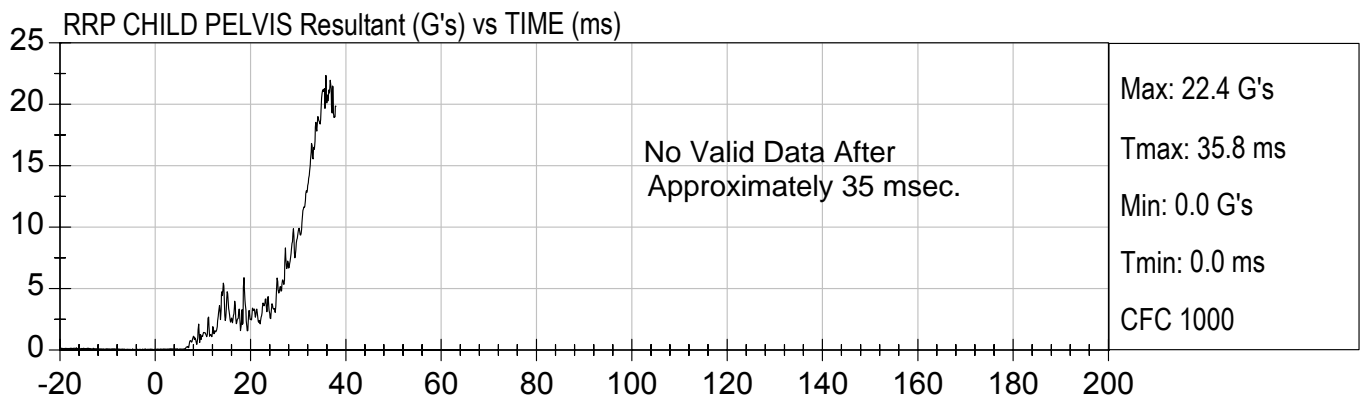
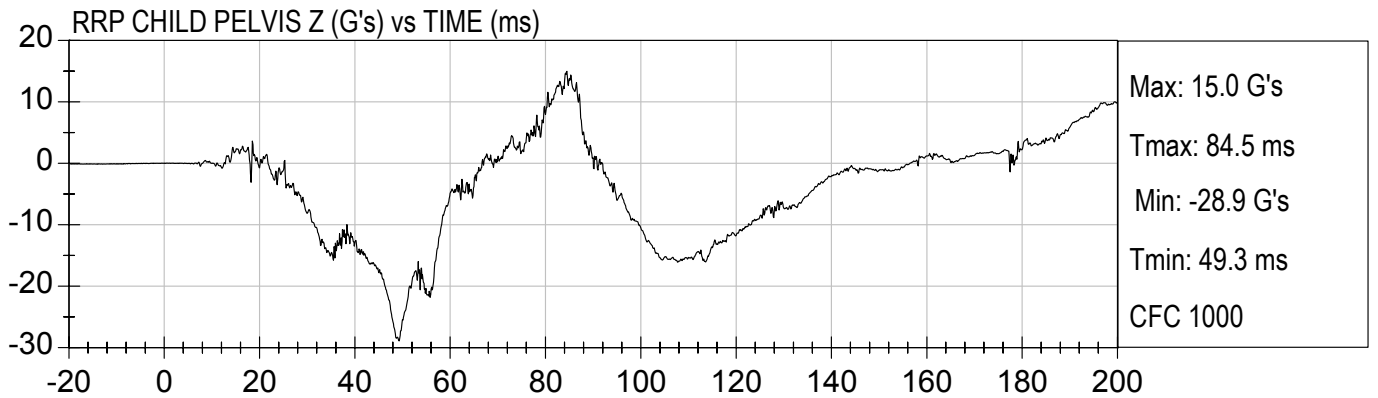
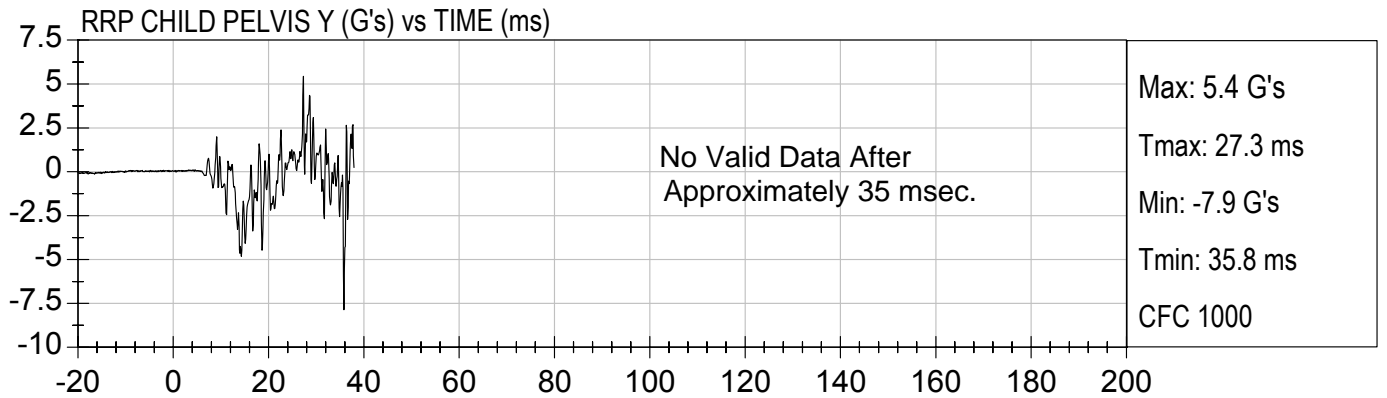
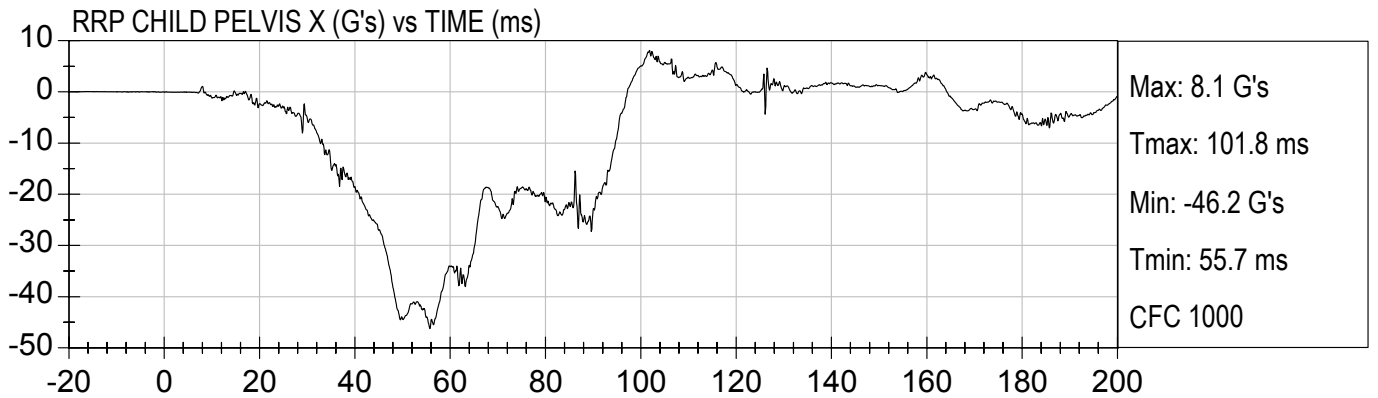

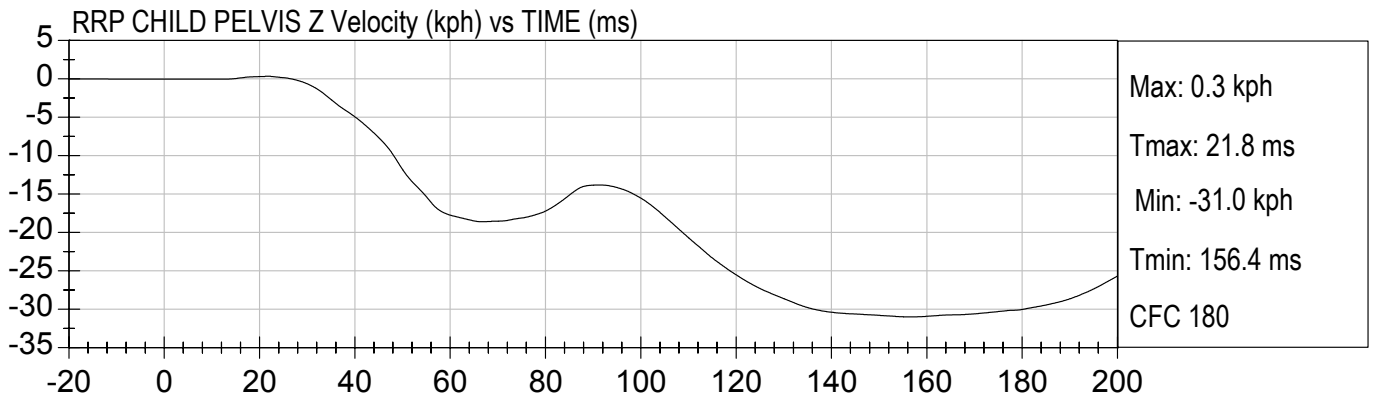
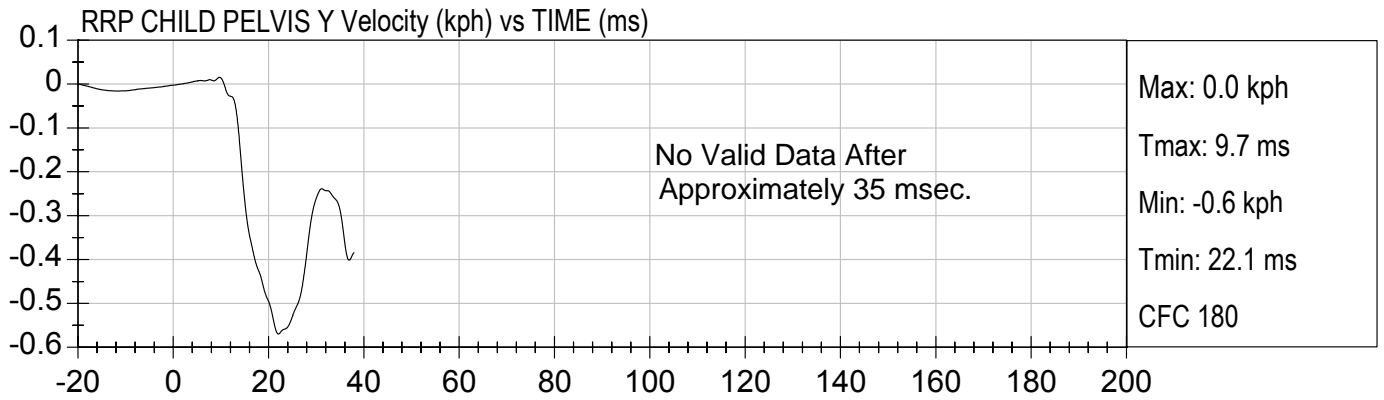
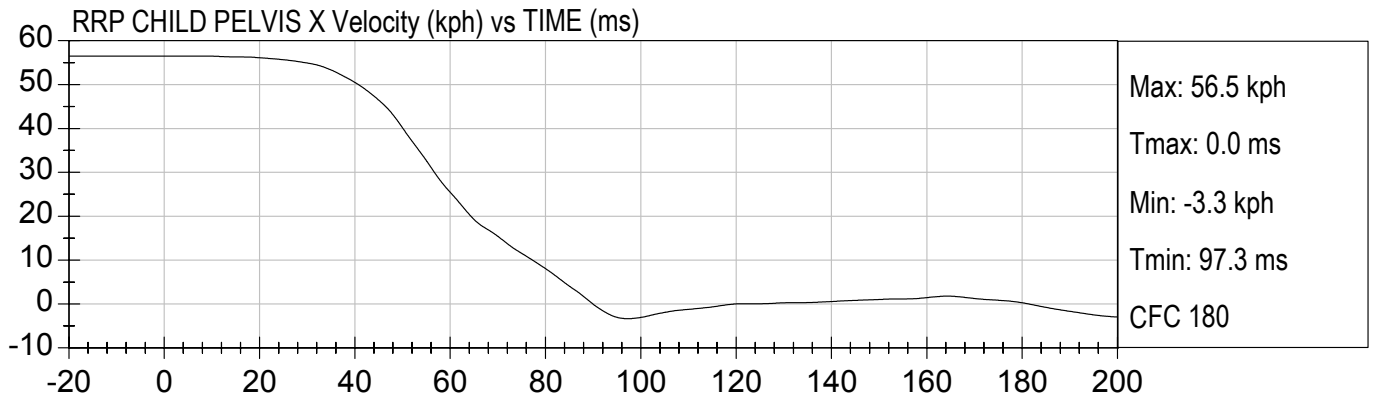



LRP TETHER FORCE (N) vs TIME (ms)

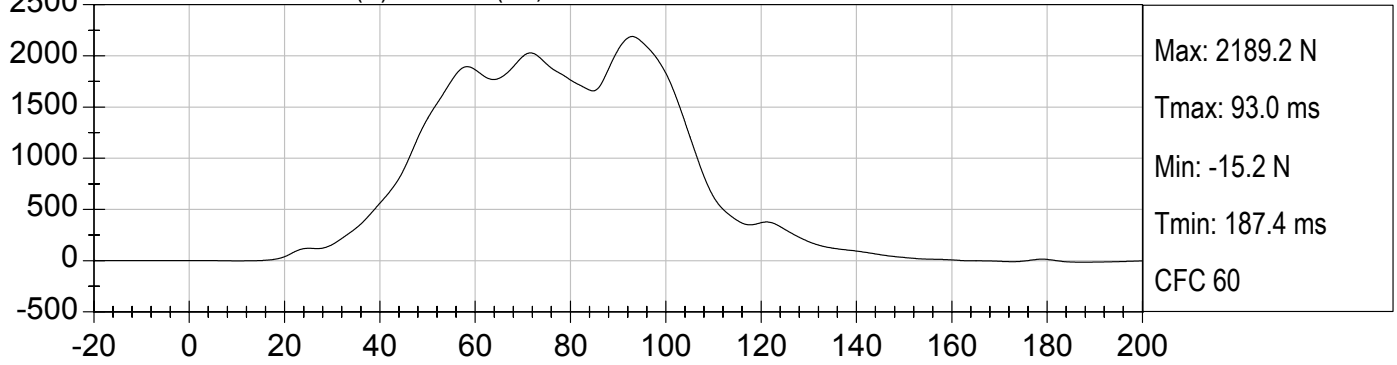

RRP TETHER FORCE (N) vs TIME (ms)

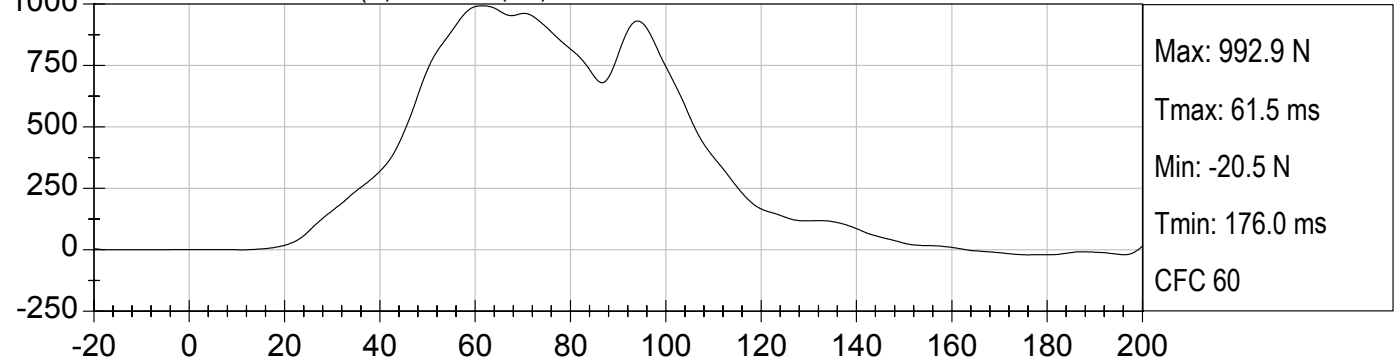

APPENDIX C
CHILD DUMMY CALIBRATION INFORMATION

**Transportation Research Center
Inc.**

ATD Calibration Report

for

VRTC

**HIII 3 Year Old Serial No. 040
Calibration No. 02**



Transportation Research Center Inc.
P.O. Box B-67
10820 St. Rt. 347
East Liberty, OH 43319-0367

Transportation Research Center Inc.
572P HIII 3 Year Old Dummy
External Dimensions
Serial No. 040 Calibration No. 02

Test Parameter	Dimension	Specification	Results	Pass
Total Sitting Height	A	538.5 - 553.7 mm	550 mm	Yes
Shoulder Pivot Height	B	307.3 - 322.6 mm	315 mm	Yes
Hip Pivot Height	C	33.0 - 43.2 mm	40 mm	Yes
Hip Pivot from Backline	D	56.9 - 67.1 mm	60 mm	Yes
Shoulder Pivot from Backline	E	58.4 - 68.6 mm	64 mm	Yes
Thigh Clearance	F	81.0 - 91.2 mm	86 mm	Yes
Back of Elbow to Wrist Pivot	G	247.4 - 262.6 mm	251 mm	Yes
Head Back to Backline	H	48.3 - 58.4 mm	55 mm	Yes
Shoulder to Elbow Length	I	185.0 - 200.7 mm	196 mm	Yes
Elbow Rest Height	J	133.6 - 148.8 mm	139 mm	Yes
Buttock to Knee Length	K	287.3 - 302.5 mm	297 mm	Yes
Popliteal Height	L	221.0 - 236.2 mm	229 mm	Yes
Knee to Floor Height	M	241.6 - 256.8 mm	254 mm	Yes
Buttock Popliteal Height	N	217.9 - 233.2 mm	225 mm	Yes
Chest Depth without Jacket	O	134.6 - 149.9 mm	145 mm	Yes
Foot Length	P	137.7 - 147.8 mm	140 mm	Yes
Stature	Q	932.2 - 957.6 mm	950 mm	Yes
Buttock to Knee Pivot Length	R	251.5 - 261.6 mm	254 mm	Yes
Head Breadth	S	128.3 - 143.5 mm	138 mm	Yes
Head Depth	T	167.4 - 182.6 mm	178 mm	Yes
Hip Breadth	U	200.7 - 215.9 mm	204 mm	Yes
Shoulder Breadth	V	236.5 - 251.7 mm	239 mm	Yes
Foot Breadth	W	53.6 - 63.8 mm	57 mm	Yes
Head Circumference	X	500.4 - 515.6 mm	503 mm	Yes
Chest Circumference with Jacket	Y	527.1 - 552.5 mm	531 mm	Yes
Waist Circumference	Z	527.1 - 552.5 mm	540 mm	Yes
Reference Location for Chest Circumference	AA	248.9 - 259.1 mm	254 mm	Yes
Reference Location for Waist Circumference	BB	160.0 - 170.2 mm	165 mm	Yes

Technician



Approved



Transportation Research Center Inc.

572P Head Drop Test

HIII 3 Year Old Serial No. 040 Calibration No. 02 - 1

Test Date 10/09/2003

Test Parameter	Specification	Test Results	Pass
Temperature	18.9 - 25.6 °C	21.1 °C	Yes
Relative Humidity	10 - 70 %	47 %	Yes
Peak Resultant Acceleration	250 - 280 g	262.1 g	Yes
Peak Lateral Acceleration	15 g Max	-4.5 g	Yes
Is Acceleration Curve Unimodal?	Yes	Yes	Yes

Comments:

Technician



Approved



10.09.2003 09:57:28 607



Transportation Research Center Inc.

572P Head Drop Test

HIII 3 Year Old Serial No. 040 Calibration No. 02 - 1

Test Date 10/09/2003

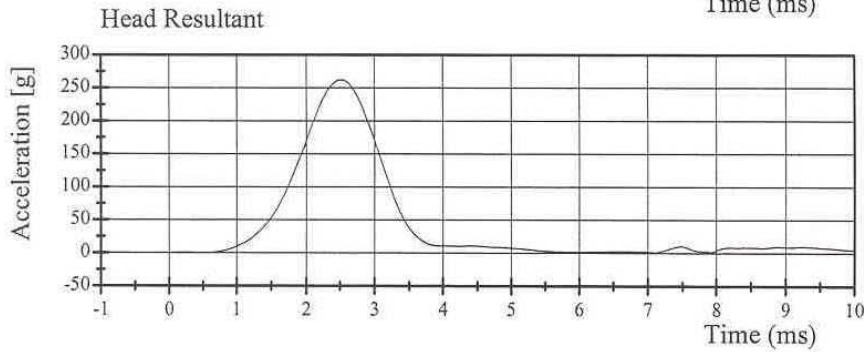
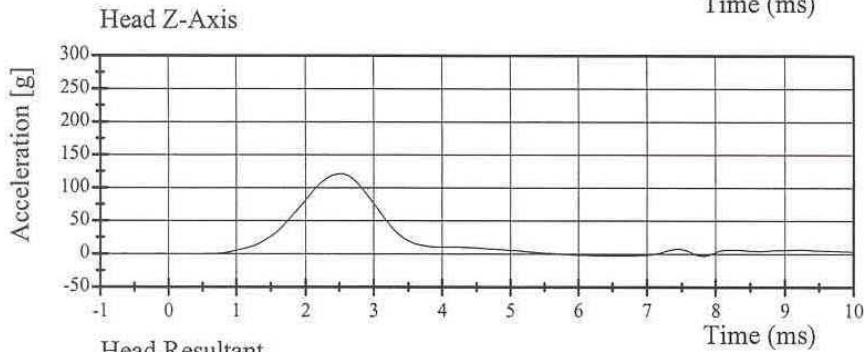
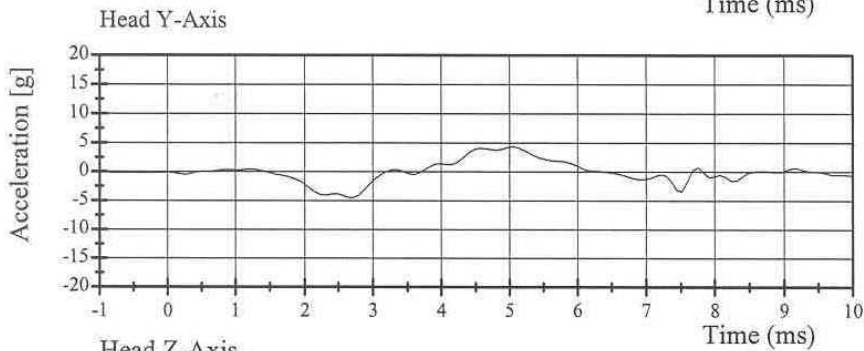
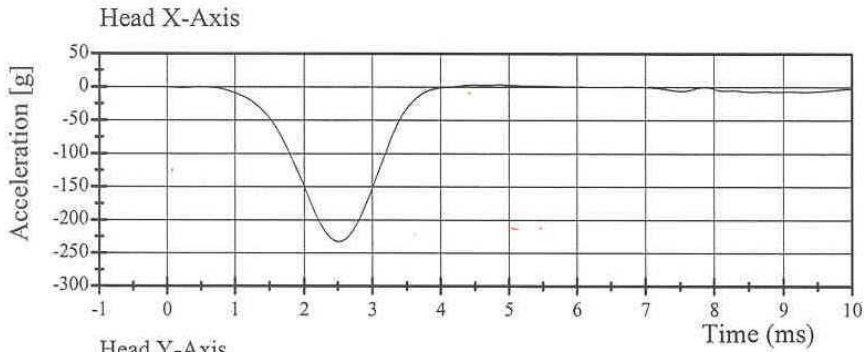

10.09.2003 09:57:30 607



Transportation Research Center Inc.

572P Neck Flexion Test - 6 Channel Transducer

HIII 3 Year Old Serial No. 040 Calibration No. 02 - 3

Test Date 10/09/2003

Test Parameter	Specification	Test Results	Pass
Temperature	20.6 - 22.2 °C	21.1 °C	Yes
Relative Humidity	10 - 70 %	44 %	Yes
Impact Velocity	5.40 - 5.60 m/s	5.58 m/s	Yes
Integrated Pendulum Velocity			
10 ms	2.00 - 2.70 m/s	2.60 m/s	Yes
15 ms	3.00 - 4.00 m/s	3.71 m/s	Yes
20 ms	4.00 - 5.10 m/s	5.03 m/s	Yes
Peak D Plane Rotation	70 - 82 °	71.8 °	Yes
Peak Moment About Occipital Condyles (During time interval rotation is within specified corridors)	42.0 - 53.0 N·m	46.29 N·m	Yes
Positive Moment Decay Time To 10 N·m	60 - 80 ms	69.12 ms	Yes

Comments:

Technician



Approved



10.09.2003 08:57:58 637



Transportation Research Center Inc.

572P Neck Flexion Test

HIII 3 Year Old Serial No. 040 Calibration No. 02 - 3

Test Date 10/09/2003

Pendulum Deceleration

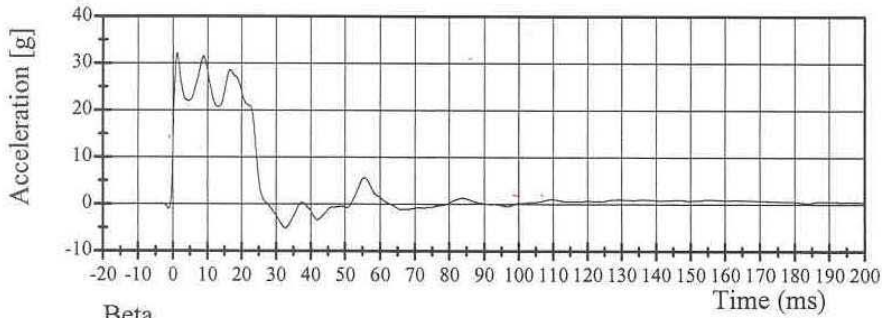

Filter Class: 180

Max: 32.1 g at 1.3 ms

Min: -5.1 g at 32.7 ms

Beta

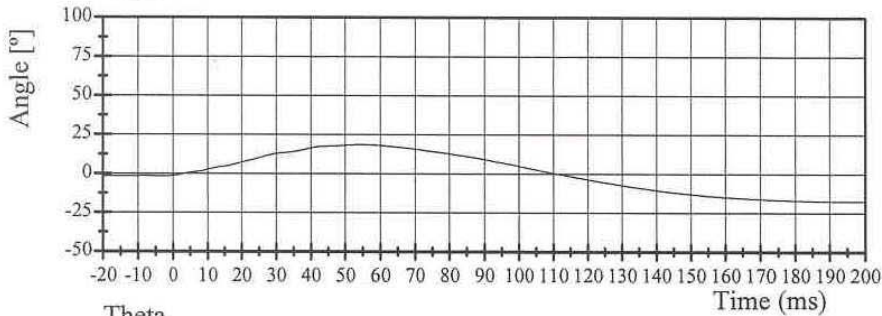

Filter Class: 60

Max: 18.5 ° at 55.1 ms

Min: -17.6 ° at 201.9 ms

Theta

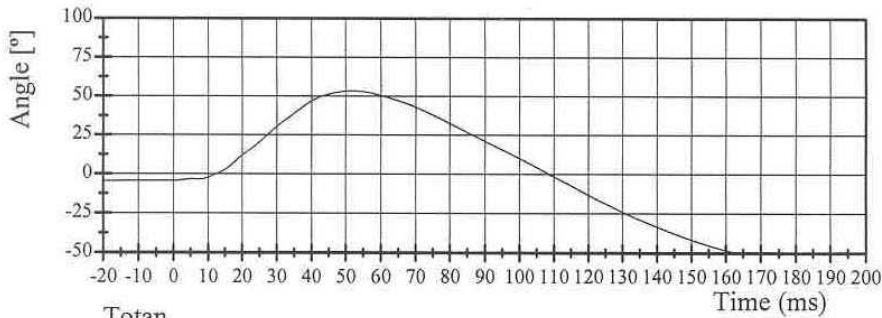

Filter Class: 60

Max: 53.4 ° at 51.7 ms

Min: -57.3 ° at 192.6 ms

Totan

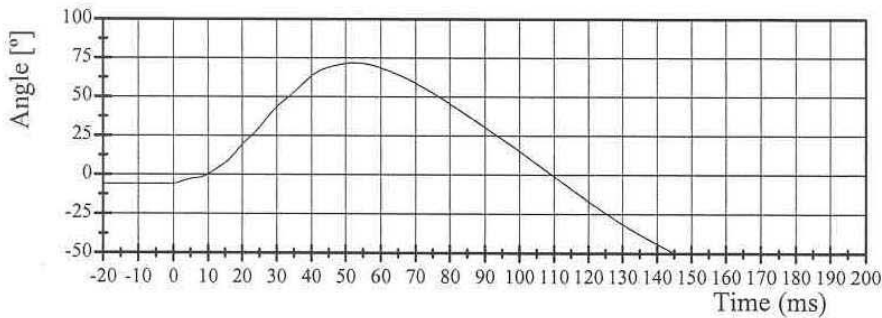

Filter Class: 60

Max: 71.8 ° at 52.6 ms

Min: -74.9 ° at 192.9 ms

10.09.2003 08:57:59 637



Transportation Research Center Inc.

572P Neck Flexion Test

HIII 3 Year Old Serial No. 040 Calibration No. 02 - 3

Test Date 10/09/2003

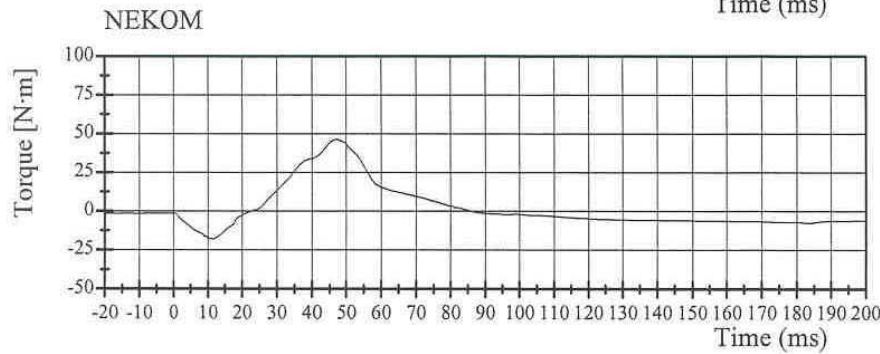
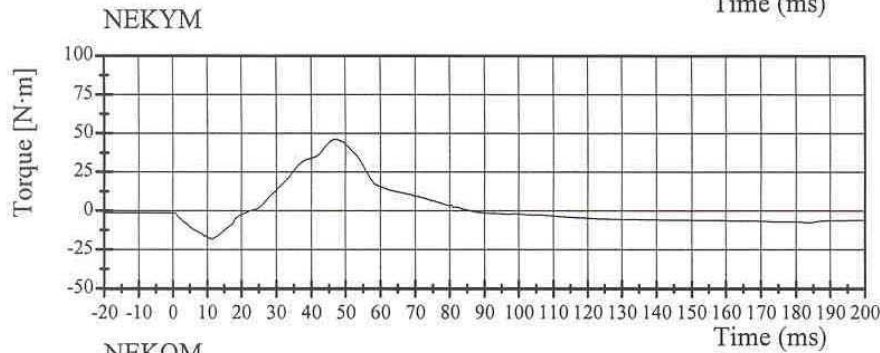
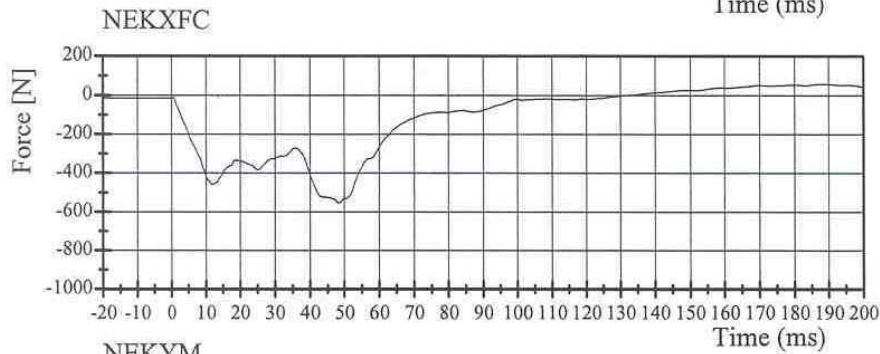
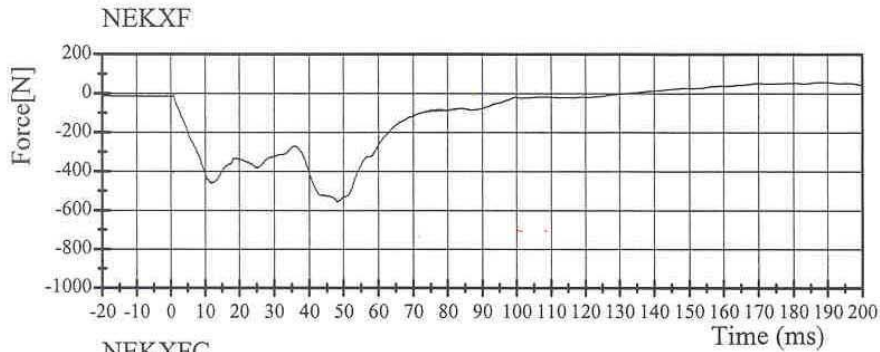

10.09.2003 08:58:00 637



Transportation Research Center Inc.

572P Neck Extension Test - 6 Channel Transducer

HIII 3 Year Old Serial No. 040 Calibration No. 02 - 2

Test Date 10/09/2003

Test Parameter	Specification	Test Results	Pass
Temperature	20.6 - 22.2 °C	21.1 °C	Yes
Relative Humidity	10 - 70 %	47 %	Yes
Impact Velocity	3.55 - 3.75 m/s	3.71 m/s	Yes
Integrated Pendulum Velocity			
10 ms	1.00 - 1.40 m/s	1.38 m/s	Yes
15 ms	1.90 - 2.50 m/s	2.44 m/s	Yes
20 ms	2.80 - 3.50 m/s	3.32 m/s	Yes
Peak D Plane Rotation	83 - 93 °	86.8 °	Yes
Peak Moment About Occipital Condyles (During time interval rotation is within specified corridors)	-53.3 - (-43.7) N·m	-46.33 N·m	Yes
Positive Moment Decay Time To -10 N·m	60 - 80 ms	66.16 ms	Yes

Comments:

Technician



Approved



10.09.2003 09:53:50 953



Transportation Research Center Inc.

572P Neck Extension Test

HIII 3 Year Old Serial No. 040 Calibration No. 02 - 2

Test Date 10/09/2003

Pendulum Deceleration

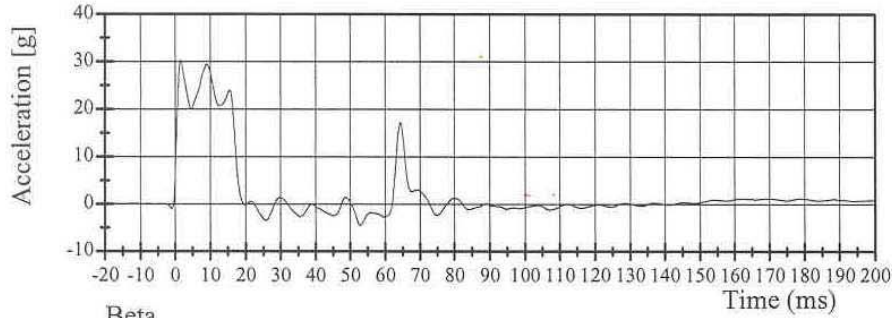

Filter Class: 180

Max: 30.2 g at 1.7 ms

Min: -4.5 g at 52.8 ms

Beta

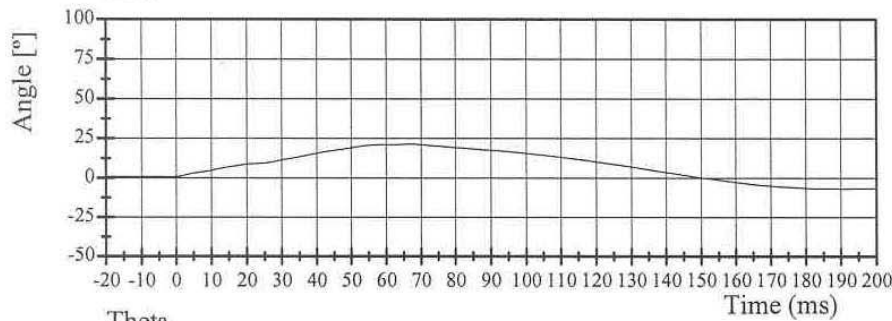

Filter Class: 60

Max: 21.4° at 67.0 ms

Min: -6.8° at 190.8 ms

Theta

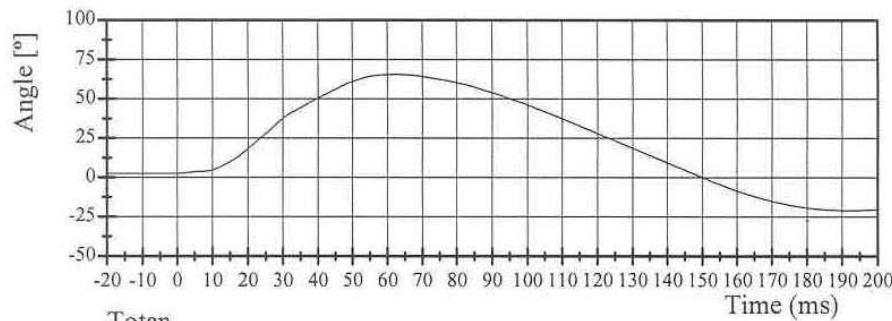

Filter Class: 60

Max: 65.5° at 62.4 ms

Min: -20.9° at 191.8 ms

Totan

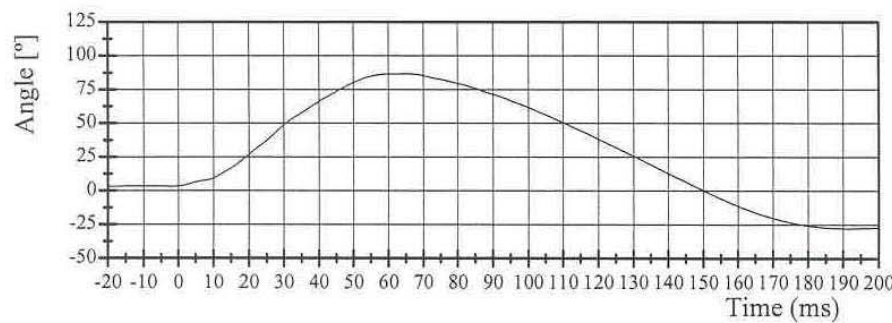

Filter Class: 60

Max: 86.8° at 65.4 ms

Min: -27.8° at 191.6 ms

10.09.2003 09:53:51 953



Transportation Research Center Inc.

572P Neck Extension Test

HIII 3 Year Old Serial No. 040 Calibration No. 02 - 2

Test Date 10/09/2003

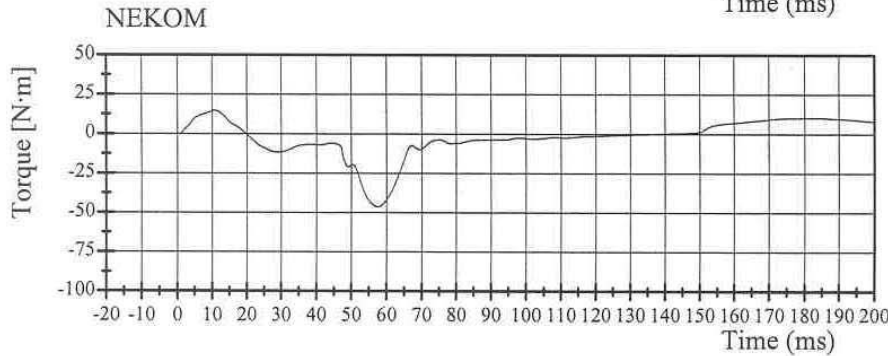
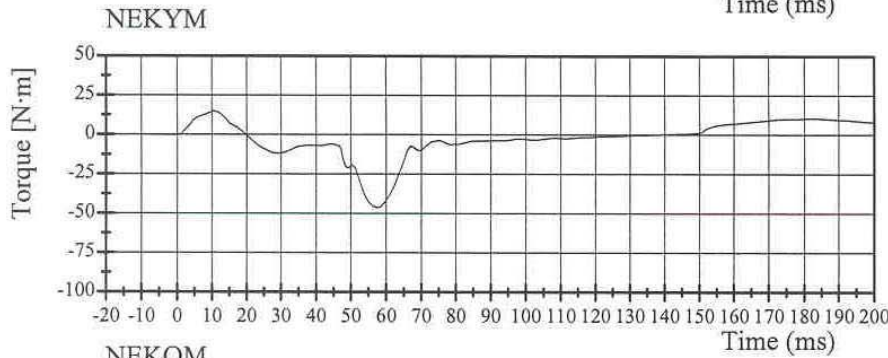
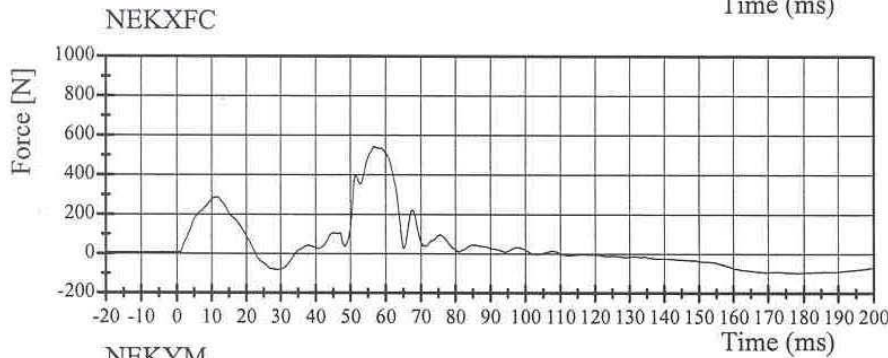
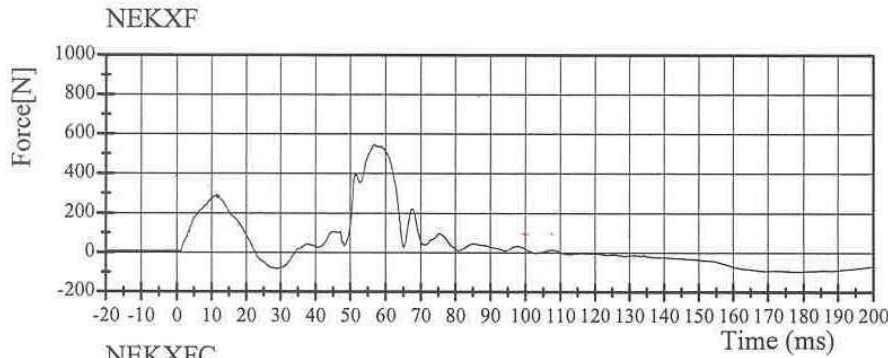

10.09.2003 09:53:52 953



Transportation Research Center Inc.

572P Thorax Test

HIII 3 Year Old Serial No. 040 Calibration No. 02 - 3

Test Date 10/10/2003

Test Parameter	Specification	Test Results	Pass
Temperature	20.6 - 22.2 °C	21.1 °C	Yes
Relative Humidity	10 - 70 %	62 %	Yes
Pendulum Velocity	5.90 - 6.10 m/s	6.05 m/s	Yes
Maximum Chest Deflection	-38.0 - (-32.0) mm	-32.5 mm	Yes
Peak Impact Probe Force Within Compression Corridor	680 - 810 N	715 N	Yes
Internal Hysteresis	65 - 85 %	71 %	Yes
Maximum Force Between 12.5 mm & 32 mm Of Deflection	<= 910	778	Yes

Comments:

Technician



Approved



10.10.2003 09:47:24 998



Transportation Research Center Inc.

572P Thorax Test

HIII 3 Year Old Serial No. 040 Calibration No. 02 - 3

Test Date 10/10/2003

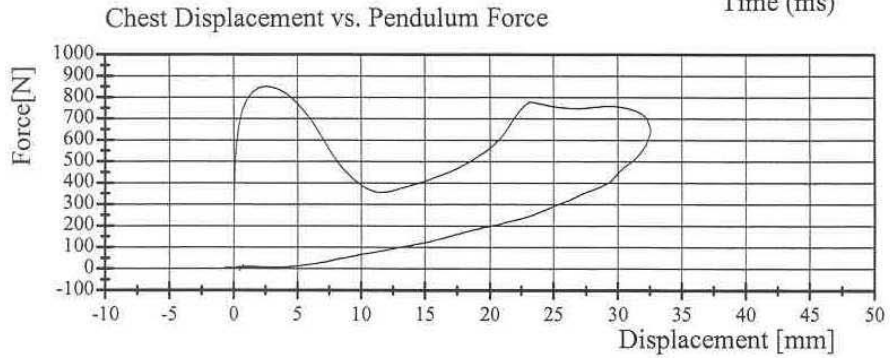
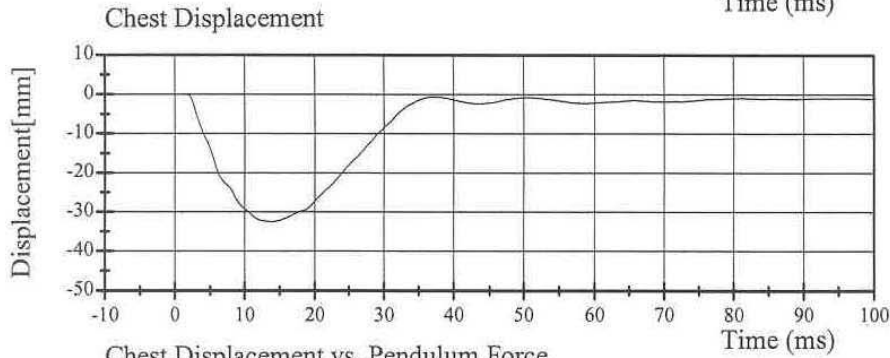
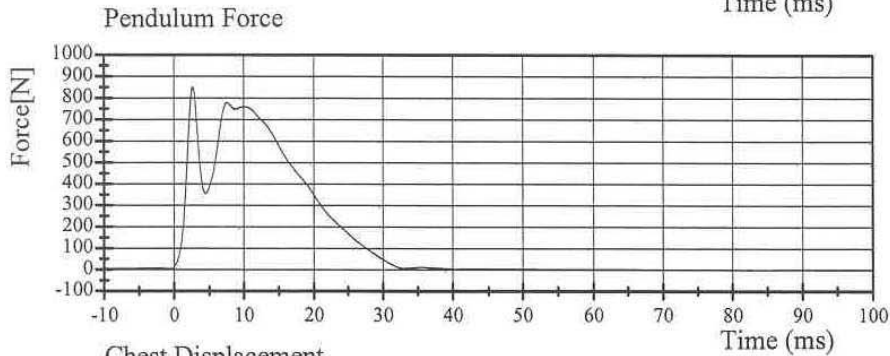
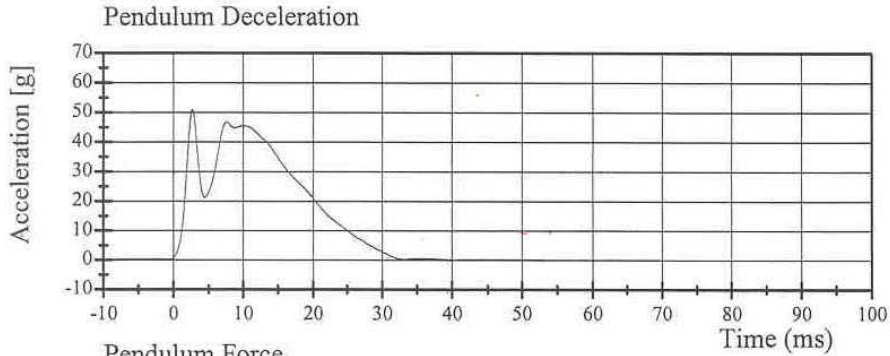

10.10.2003 09:47:25 998



TRANSPORTATION RESEARCH CENTER INC.

TORSO FLEXION TEST

HYBRID III THREE-YEAR-OLD

CAL DATE: 09-Oct-03

TRC, INC. TEST NO: 040C02TF1 572 P SN 040 TORSO FLEX CAL 02

TEST PARAMETER	SPECIFICATION	TEST RESULTS
TEMPERATURE	18.9 – 25.6 DEG. C	21.7 DEG. C
RELATIVE HUMIDITY	10 – 70 %	44 %
INITIAL ANGLE OF UNSUPPORTRED DUMMY	<= 15 DEG. REFERENCED TO VERTICAL	9.2 DEG.
MAXIMUM FORCE AT 45 DEG. DURING 10 SECOND PERIOD	130 – 180 N	152.6 N
RETURN ANGLE		14.8 °
DIFFERENCE BETWEEN RETURN ANGLE & INTIAL ANGLE	+/- 8 ° OF INTIAL ANGLE	5.6 °
RATE	0.5° - 1.5°/sec	1.0 °/sec

TEST MEETS SPECIFICATIONS

TECHNICIAN 

**Transportation Research Center
Inc.**

ATD Calibration Report

for

VRTC

**HIII 3 Year Old Serial No. 042
Calibration No. 02**



Transportation Research Center Inc.
P.O. Box B-67
10820 St. Rt. 347
East Liberty, OH 43319-0367

Transportation Research Center Inc.
572P HIII 3 Year Old Dummy
External Dimensions
Serial No. 042 Calibration No. 02

Test Parameter	Dimension	Specification	Results	Pass
Total Sitting Height	A	538.5 - 553.7 mm	546 mm	Yes
Shoulder Pivot Height	B	307.3 - 322.6 mm	313 mm	Yes
Hip Pivot Height	C	33.0 - 43.2 mm	37 mm	Yes
Hip Pivot from Backline	D	56.9 - 67.1 mm	59 mm	Yes
Shoulder Pivot from Backline	E	58.4 - 68.6 mm	63 mm	Yes
Thigh Clearance	F	81.0 - 91.2 mm	87 mm	Yes
Back of Elbow to Wrist Pivot	G	247.4 - 262.6 mm	253 mm	Yes
Head Back to Backline	H	48.3 - 58.4 mm	49 mm	Yes
Shoulder to Elbow Length	I	185.0 - 200.7 mm	193 mm	Yes
Elbow Rest Height	J	133.6 - 148.8 mm	136 mm	Yes
Buttock to Knee Length	K	287.3 - 302.5 mm	293 mm	Yes
Popliteal Height	L	221.0 - 236.2 mm	228 mm	Yes
Knee to Floor Height	M	241.6 - 256.8 mm	249 mm	Yes
Buttock Popliteal Height	N	217.9 - 233.2 mm	229 mm	Yes
Chest Depth without Jacket	O	134.6 - 149.9 mm	137 mm	Yes
Foot Length	P	137.7 - 147.8 mm	141 mm	Yes
Stature	Q	932.2 - 957.6 mm	936 mm	Yes
Buttock to Knee Pivot Length	R	251.5 - 261.6 mm	258 mm	Yes
Head Breadth	S	128.3 - 143.5 mm	136 mm	Yes
Head Depth	T	167.4 - 182.6 mm	176 mm	Yes
Hip Breadth	U	200.7 - 215.9 mm	209 mm	Yes
Shoulder Breadth	V	236.5 - 251.7 mm	243 mm	Yes
Foot Breadth	W	53.6 - 63.8 mm	57 mm	Yes
Head Circumference	X	500.4 - 515.6 mm	510 mm	Yes
Chest Circumference with Jacket	Y	527.1 - 552.5 mm	536 mm	Yes
Waist Circumference	Z	527.1 - 552.5 mm	543 mm	Yes
Reference Location for Chest Circumference	AA	248.9 - 259.1 mm	254 mm	Yes
Reference Location for Waist Circumference	BB	160.0 - 170.2 mm	165 mm	Yes

Technician



Approved



Transportation Research Center Inc.

572P Head Drop Test

HIII 3 Year Old Serial No. 042 Calibration No. 02 - 1

Test Date 10/15/2003

Test Parameter	Specification	Test Results	Pass
Temperature	18.9 - 25.6 °C	21.1 °C	Yes
Relative Humidity	10 - 70 %	32 %	Yes
Peak Resultant Acceleration	250 - 280 g	259.5 g	Yes
Peak Lateral Acceleration	15 g Max	-8.0 g	Yes
Is Acceleration Curve Unimodal?	Yes	Yes	Yes

Comments:

Technician



Approved



10.15.2003 14:25:05 611



Transportation Research Center Inc.

572P Head Drop Test

HIII 3 Year Old Serial No. 042 Calibration No. 02 - 1

Test Date 10/15/2003

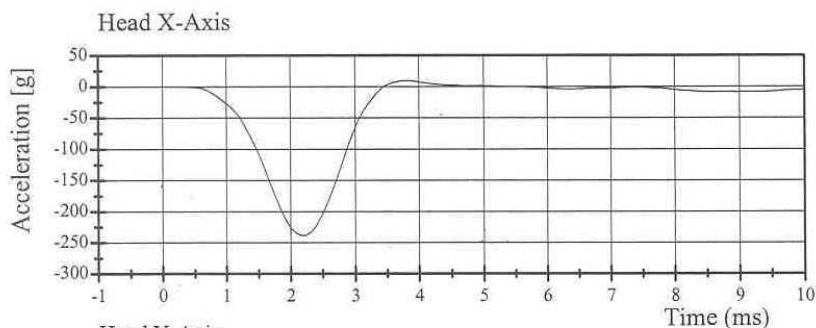

Filter Class: 1000

Max: 9.9 g at 3.8 ms

Min: -238.1 g at 2.2 ms

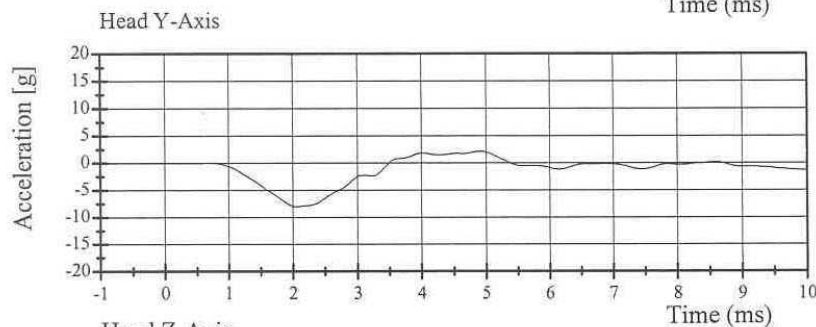

Filter Class: 1000

Max: 2.2 g at 4.9 ms

Min: -8.0 g at 2.1 ms

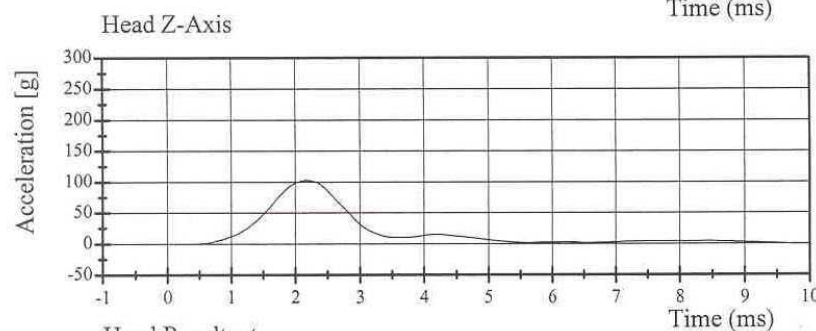

Filter Class: 1000

Max: 103.0 g at 2.2 ms

Min: -0.8 g at 10.0 ms

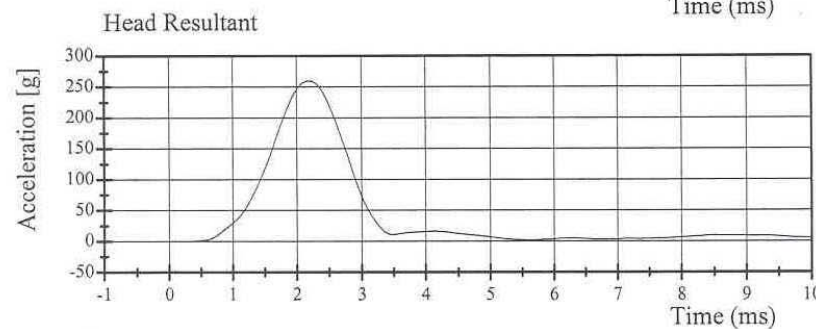

Filter Class: 1000

Max: 259.5 g at 2.2 ms

Min: 0.0 g at 4.9 ms

10.15.2003 14:25:05 611



Transportation Research Center Inc.

572P Neck Flexion Test - 6 Channel Transducer

HIII 3 Year Old Serial No. 042 Calibration No. 02 - 2

Test Date 10/15/2003

Test Parameter	Specification	Test Results	Pass
Temperature	20.6 - 22.2 °C	21.1 °C	Yes
Relative Humidity	10 - 70 %	31 %	Yes
Impact Velocity	5.40 - 5.60 m/s	5.47 m/s	Yes
Integrated Pendulum Velocity			
10 ms	2.00 - 2.70 m/s	2.36 m/s	Yes
15 ms	3.00 - 4.00 m/s	3.41 m/s	Yes
20 ms	4.00 - 5.10 m/s	4.62 m/s	Yes
Peak D Plane Rotation	70 - 82 °	73.7 °	Yes
Peak Moment About Occipital Condyles (During time interval rotation is within specified corridors)	42.0 - 53.0 N·m	42.46 N·m	Yes
Positive Moment Decay Time To 10 N·m	60 - 80 ms	71.36 ms	Yes

Comments:

Technician



Approved



10.15.2003 15:21:00 640



Transportation Research Center Inc.

572P Neck Flexion Test

HIII 3 Year Old Serial No. 042 Calibration No. 02 - 2

Test Date 10/15/2003

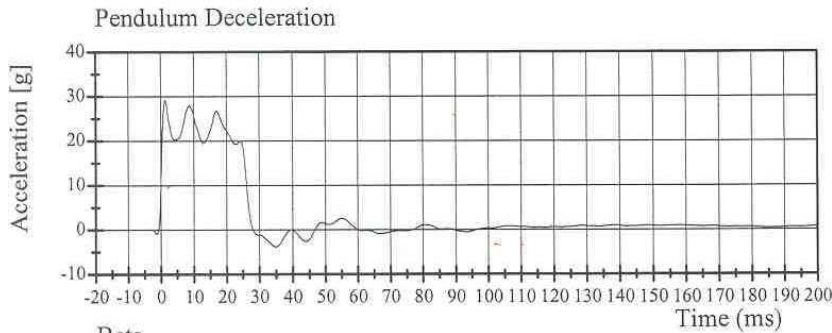

Filter Class: 180

Max: 29.2 g at 1.4 ms

Min: -3.8 g at 35.0 ms

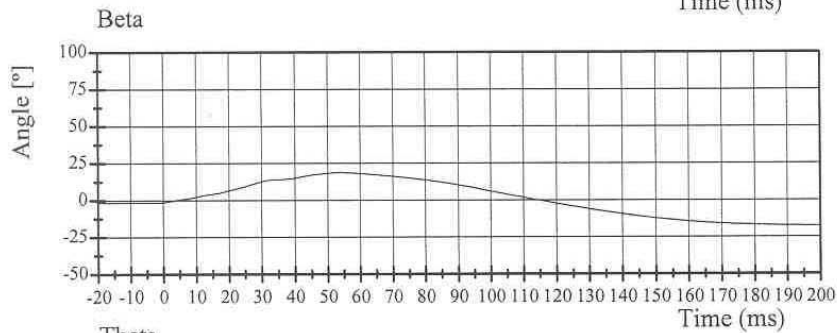

Filter Class: 60

Max: 18.7 ° at 53.9 ms

Min: -17.6 ° at 214.3 ms

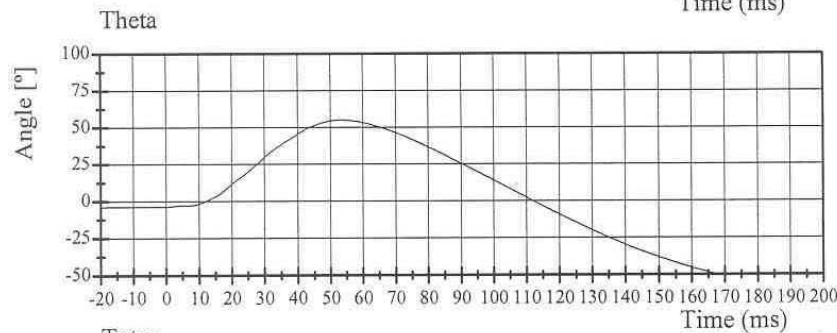

Filter Class: 60

Max: 55.0 ° at 53.4 ms

Min: -56.8 ° at 200.0 ms

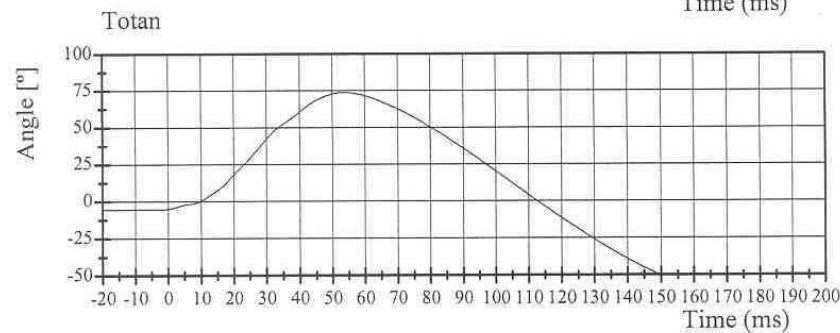

Filter Class: 60

Max: 73.7 ° at 53.6 ms

Min: -74.4 ° at 201.8 ms

10.15.2003 15:21:01 640



Transportation Research Center Inc.

572P Neck Flexion Test

HIII 3 Year Old Serial No. 042 Calibration No. 02 - 2

Test Date 10/15/2003

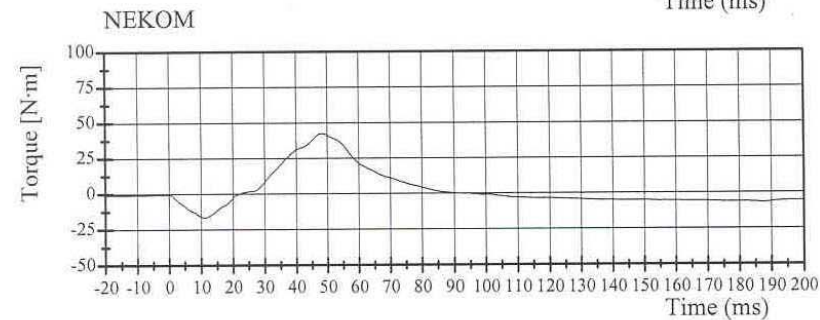
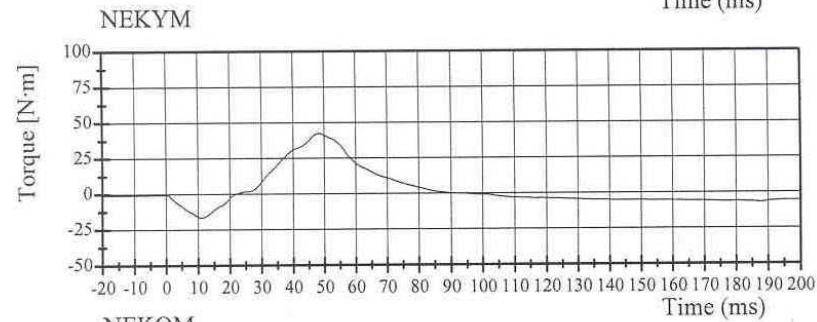
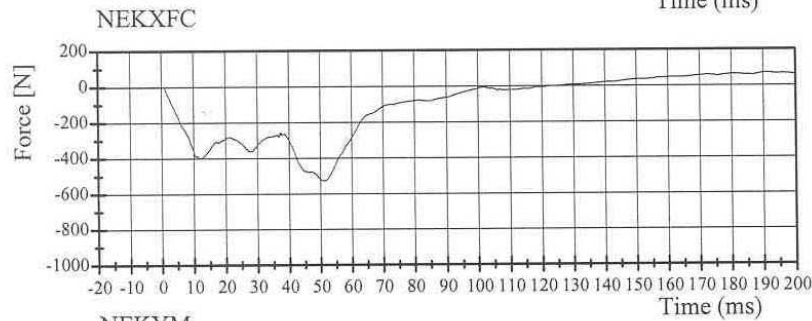
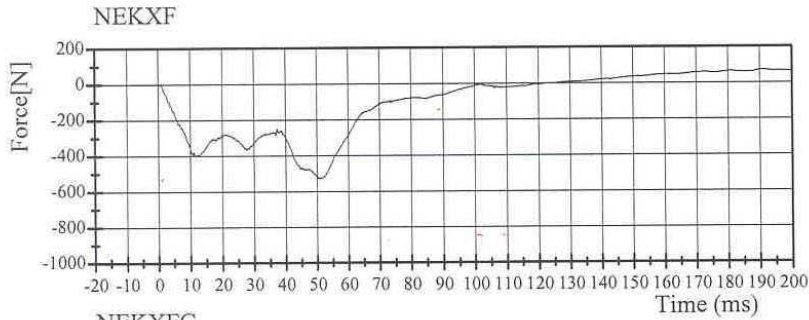

10.15.2003 15:21:02 640



Transportation Research Center Inc.

572P Neck Extension Test - 6 Channel Transducer

HIII 3 Year Old Serial No. 042 Calibration No. 02 - 3

Test Date 10/16/2003

Test Parameter	Specification	Test Results	Pass
Temperature	20.6 - 22.2 °C	21.1 °C	Yes
Relative Humidity	10 - 70 %	32 %	Yes
Impact Velocity	3.55 - 3.75 m/s	3.72 m/s	Yes
Integrated Pendulum Velocity			
10 ms	1.00 - 1.40 m/s	1.37 m/s	Yes
15 ms	1.90 - 2.50 m/s	2.44 m/s	Yes
20 ms	2.80 - 3.50 m/s	3.29 m/s	Yes
Peak D Plane Rotation	83 - 93 °	87.0 °	Yes
Peak Moment About Occipital Condyles (During time interval rotation is within specified corridors)	-53.3 - (-43.7) N·m	-47.07 N·m	Yes
Positive Moment Decay Time To -10 N·m	60 - 80 ms	72.08 ms	Yes

Comments:

Technician



Approved

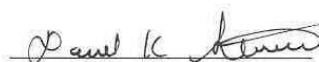

10.16.2003 08:30:06 942



Transportation Research Center Inc.

572P Neck Extension Test

HIII 3 Year Old Serial No. 042 Calibration No. 02 - 3

Test Date 10/16/2003

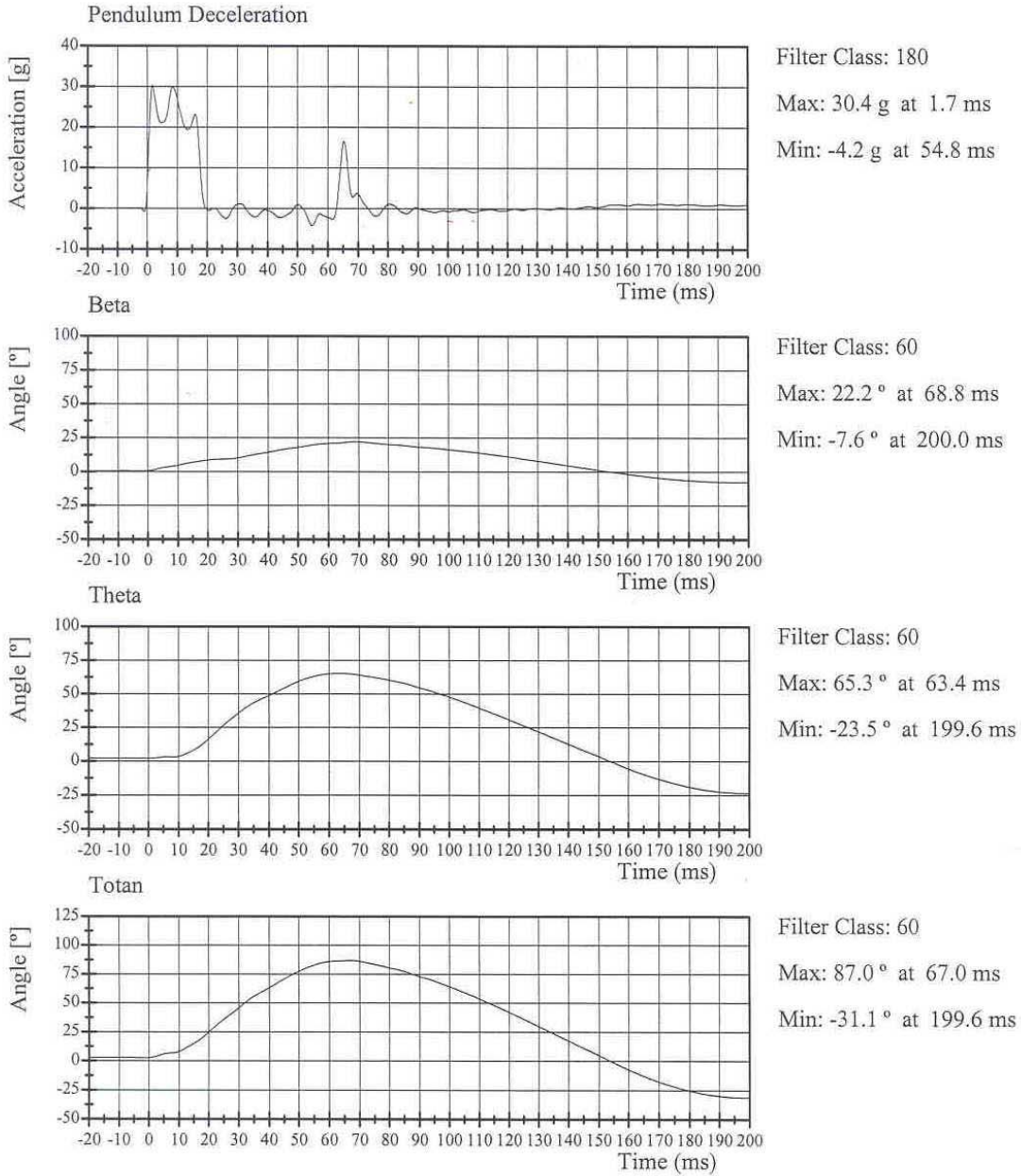

10.16.2003 08:30:07 942



Transportation Research Center Inc.

572P Neck Extension Test

HIII 3 Year Old Serial No. 042 Calibration No. 02 - 3

Test Date 10/16/2003

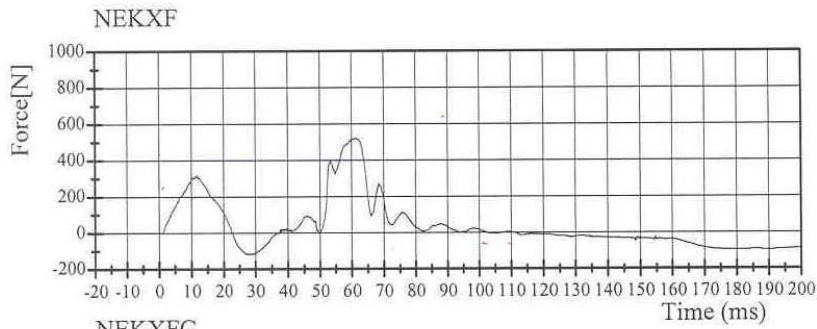

Filter Class: 1000

Max: 521.6 N at 61.4 ms

Min: -119.7 N at 28.4 ms

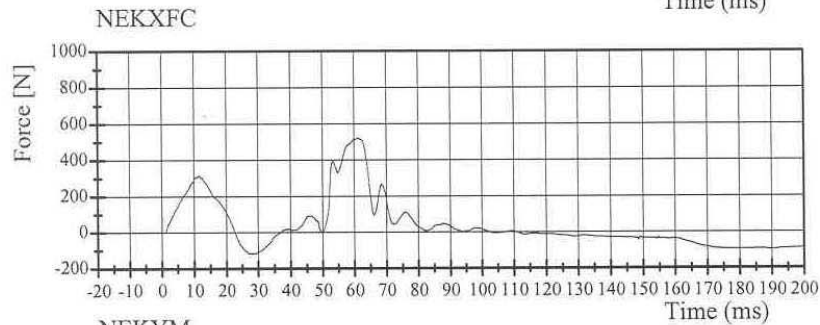

Filter Class: 600

Max: 520.8 N at 61.3 ms

Min: -119.0 N at 28.3 ms

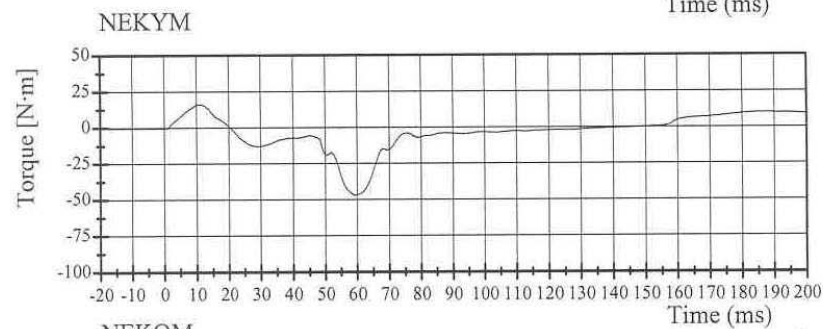

Filter Class: 600

Max: 16.2 N·m at 11.3 ms

Min: -47.1 N·m at 59.7 ms

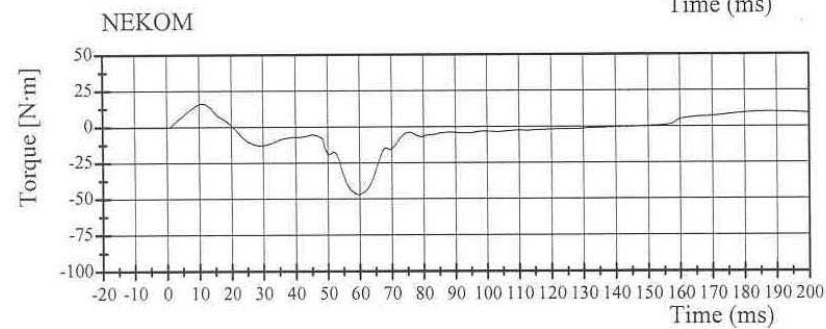

Filter Class: 600

Max: 16.2 N·m at 11.3 ms

Min: -47.1 N·m at 59.7 ms

10.16.2003 08:30:08 942



Transportation Research Center Inc.

572P Thorax Test

HIII 3 Year Old Serial No. 042 Calibration No. 02 - 1

Test Date 10/17/2003

Test Parameter	Specification	Test Results	Pass
Temperature	20.6 - 22.2 °C	21.7 °C	Yes
Relative Humidity	10 - 70 %	30 %	Yes
Pendulum Velocity	5.90 - 6.10 m/s	6.05 m/s	Yes
Maximum Chest Deflection	-38.0 - (-32.0) mm	-35.0 mm	Yes
Peak Impact Probe Force Within Compression Corridor	680 - 810 N	746 N	Yes
Internal Hysteresis	65 - 85 %	71 %	Yes
Maximum Force Between 12.5 mm & 32 mm Of Deflection	<= 910	795	Yes

Comments:

Technician



Approved

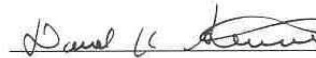

10.17.2003 13:12:32 991



Transportation Research Center Inc.

572P Thorax Test

HIII 3 Year Old Serial No. 042 Calibration No. 02 - 1

Test Date 10/17/2003

Pendulum Deceleration

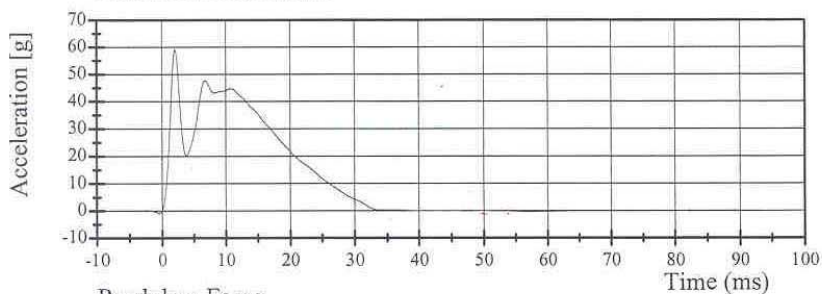

Filter Class: 180

Max: 59.1 g at 2.1 ms

Min: -0.9 g at -0.4 ms

Pendulum Force

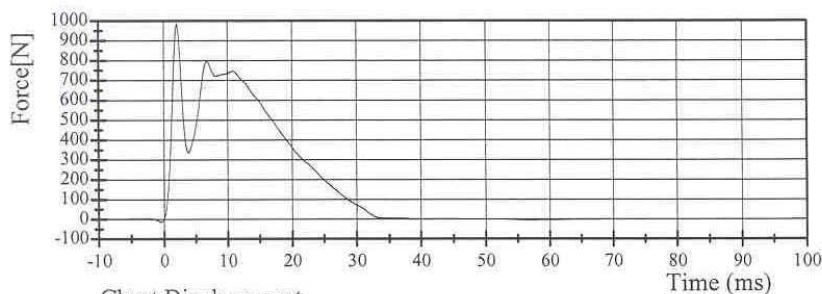

Filter Class: 180

Max: 984.8 N at 2.1 ms

Min: -15.2 N at -0.4 ms

Chest Displacement

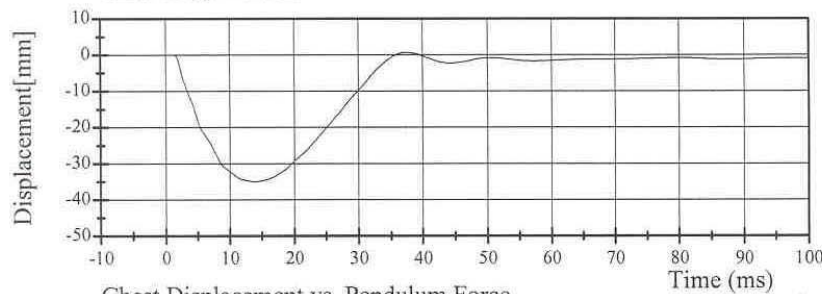

Filter Class: 600

Max: 0.7 mm at 37.3 ms

Min: -35.0 mm at 14.0 ms

Chest Displacement vs. Pendulum Force

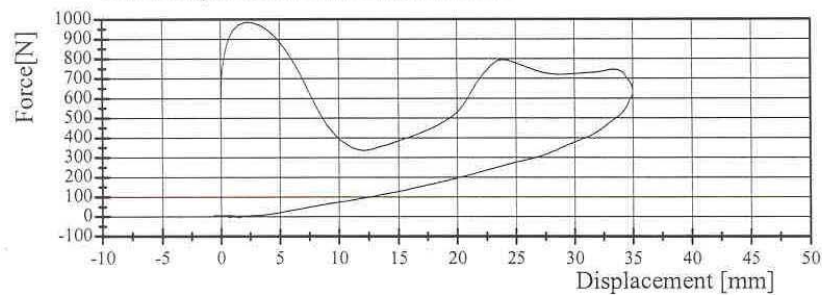

10.17.2003 13:12:33 991



TRANSPORTATION RESEARCH CENTER INC.

TORSO FLEXION TEST

HYBRID III THREE-YEAR-OLD

CAL DATE: 16-Oct-03

TRC, INC. TEST NO: 042C02TF1 572 P SN 042 TORSO FLEX CAL 02

TEST PARAMETER	SPECIFICATION	TEST RESULTS
TEMPERATURE	18.9 – 25.6 DEG. C	21.7 DEG. C
RELATIVE HUMIDITY	10 – 70 %	36 %
INITIAL ANGLE OF UNSUPPORTED DUMMY	≤ 15 DEG. REFERENCED TO VERTICAL	4.9 DEG.
MAXIMUM FORCE AT 45 DEG. DURING 10 SECOND PERIOD	130 – 180 N	179.8 N
RETURN ANGLE		2.5 DEG.
DIFFERENCE BETWEEN RETURN ANGLE & INTIAL ANGLE	$\pm 10^\circ$ OF INTIAL ANGLE	7.4 °
RATE	0.5° - 1.5°/sec	1.0 °/sec

TEST MEETS SPECIFICATIONS

TECHNICIAN 

APPENDIX D

TEST EQUIPMENT LIST AND CALIBRATION INFORMATION

INSTRUMENTS FOR RRP CHILD DUMMY S/N: 040

	SERIAL NO.	MANUFACTURER	CALIBRATION DATE
Head X	AP1Y1	Endevco	8/07/03
Head Y	ACC81	Endevco	8/07/03
Head Z	AHY71	Endevco	8/07/03
Head X Redundant	P22190	Endevco	9/04/03
Head Y Redundant	P22180	Endevco	9/04/03
Head Z Redundant	P22805	Endevco	9/04/03
Upper Neck Load Cell	210	Denton	8/25/03
Chest X	J13649	Endevco	10/06/03
Chest Y	ANBP7	Endevco	9/04/03
Chest Z	J13422	Entran	10/06/03
Chest X Redundant	040	Endevco	10/14/03
Chest Y Redundant	J13653	Endevco	10/06/03
Chest Z Redundant	AP1C6	Endevco	9/04/03
Chest Displacement	J13713	Servo	10/06/03
Pelvis X	AMTG3	Endevco	8/06/03
Pelvis Y	AMTL6	Endevco	8/06/03
Pelvis Z	ALC37	Endevco	8/06/03
Tether Force	104	FTSS	11/04/03

INSTRUMENTS FOR LRP CHILD DUMMY S/N: 042

	SERIAL NO.	MANUFACTURER	CALIBRATION DATE
Head X	AKAH1	Entran	8/06/03
Head Y	J17709	Entran	8/06/03
Head Z	AJ4J0	Endevco	11/10/03
Head X Redundant	J18260	Endevco	8/06/03
Head Y Redundant	J20298	Endevco	8/06/03
Head Z Redundant	AJ9C2	Endevco	11/10/03
Upper Neck Load Cell	94	FTSS	9/02/03
Chest X	J12449	Endevco	8/07/03
Chest Y	J12425	Endevco	8/07/03
Chest Z	J12462	Endevco	8/07/03
Chest X Redundant	P24154	Endevco	12/05/03
Chest Y Redundant	P23012	Endevco	9/04/03
Chest Z Redundant	P23059	Endevco	12/05/03
Chest Displacement	042	Servo	10/23/03
Pelvis X	AGTT3	Endevco	8/07/03
Pelvis Y	AHTT2	Endevco	11/10/03
Pelvis Z	AJ9D2	Entran	1/14/04
Tether Force	157	Denton	8/21/03