

REPORT NUMBER: TO11-MGA-2003-004

FULL SCALE SIDE IMPACT POLE TESTS OF BASELINE VEHICLES

**SID IIs with Floating Rib Guides
Task Order T0007 / RFP 0011**

**FORD MOTOR COMPANY
2002 FORD EXPLORER
NHTSA NUMBER: R20235**

**PREPARED BY:
MGA RESEARCH CORPORATION
5000 WARREN ROAD
BURLINGTON, WI 53105**



TEST DATE: February 19, 2003

FINAL REPORT SUBMITTED: September 2, 2003

**PREPARED FOR:
U.S. DEPARTMENT OF TRANSPORTATION
VOLPE NATIONAL TRANSPORTATION SYSTEM CENTER
55 BROADWAY, KENDALL SQUARE
CAMBRIDGE, MA 02142**

This final test report was prepared for the U.S. Department of Transportation, Volpe National Transportation System Center, in response to Contract Number DTRS57-98-D-00041.

This document is disseminated under the sponsorship of the U.S. Department of Transportation in the interest of information exchange. The United States Government assumes no liability for its content or use thereof.

Prepared by: David Winkelbauer
David Winkelbauer, Project Engineer

Reviewed by: Gary Strassburg
Gary Strassburg, Project Engineer

Approval Date: 3/19/2003

Technicians: Wayne Dahlke
Jordan Haynes
Erik Nelson
Chris Nowak
Eric Peschman

Photographic: Tammy Brausch
Chris Kulis

Instrumentation/
Calibration: Jamie Aide
Tim Michnay

Secretary: Susan Kozlowski

FINAL REPORT ACCEPTED BY:

Accepted By: _____
Contract Technical Manager

Acceptance Date: _____

TABLE OF CONTENTS

<u>Section</u>		<u>Page No.</u>
1	Purpose and Test Procedure	1
2	Summary of Side Impact Test	2
3	Side Impact Dummy (SID IIs) and Vehicle Test Data	5
4	Occupant and Vehicle Information	11

<u>Data Sheet No.</u>		<u>Page No.</u>
1	General Test and Vehicle Parameter Data	6
2	Test Vehicle Tire Information	9
3	Post Test Observations	10
4	Vehicle Pre-Test and Post-Test Measurements	12
5	SID IIs Clearance Dimensions	13
6	Vehicle Side Measurements	14
7	Vehicle Exterior Crush Profiles	15
8	Vehicle Damage Profile Distances	17
9	Vehicle Accelerometer Locations and Data Summary	18
10	High Speed Camera Locations and Data	21

<u>Appendix</u>		
A	Photographs	A
B	Vehicle and Dummy Response Data Traces	B
C	SID IIs Configuration and Performance Verification Data	C
D	Test Equipment List and Calibration Information	D
E	Dummy Peak Responses	E

SECTION 1
PURPOSE AND TEST PROCEDURE

This Side Impact test is conducted as part of Contract No. DTRS57-98-D-00041, task order 11, sponsored by the U.S. Department of Transportation, Volpe National Transportation System Center. The purpose of this test is to evaluate the responses of the SID IIs with floating rib guides in a 2002 Ford Explorer, when subjected to a rigid pole side impact at 285 degrees.

MGA does not endorse or certify products. The manufacturer's name appears solely for identification purposes.

SECTION 2 SUMMARY OF SIDE IMPACT TEST

A rigid pole side impact test at 285 degrees was performed on a 2002 Ford Explorer. The subject vehicle was towed into a rigid pole at a velocity of 31.7 km/h. The weight of the vehicle as tested was 2218.6 kg. The test was conducted at MGA Research Corporation in Burlington, Wisconsin, on February 19, 2003. Pre- and post-test photographs of the test vehicle and the dummies are included in Appendix A.

One SID IIS side impact dummy with floating rib guides was placed in the left front designated seating position according to instructions specified in the FMVSS 208 Laboratory Test Procedure (TP208-12), appendix G which is dated January 14, 2003. The side impact event was documented by ten high speed cameras. Camera locations and other pertinent camera information can be found in this report.

Appendix B contains the vehicle and dummy response data traces. A summary of the dummy configuration and performance verification test data is shown in Appendix C. Dummy and vehicle calibration data can be found in Appendix D of this report. Appendix E contains the dummy peak responses.

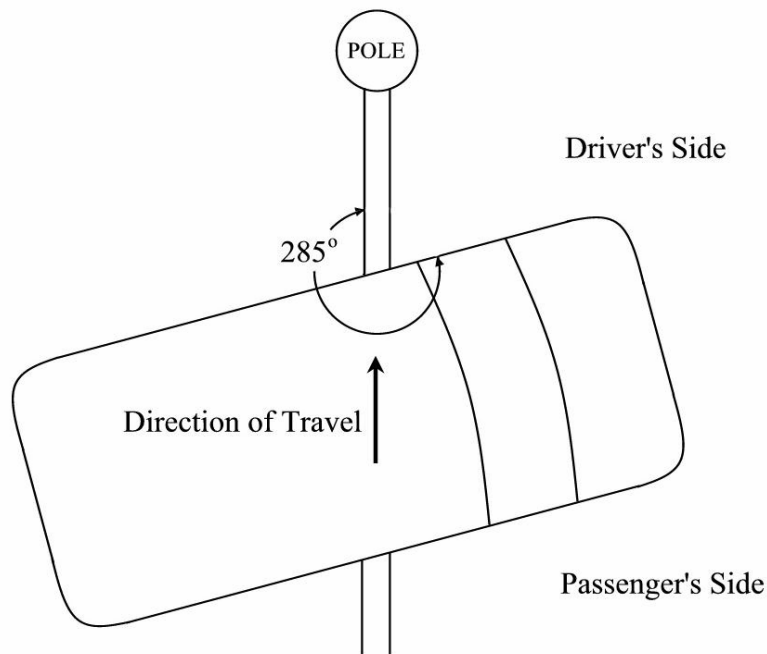

SECTION 2... (continued)
SUMMARY OF SIDE IMPACT TEST

The following table summarizes the results of the Left Side Impact Test:

Rib Deflection (mm) CFC 180	
Upper Thorax Rib	**
Mid Thorax Rib	**
Lower Thorax Rib	**
Upper Abdominal Rib	**
Lower Abdominal Rib	**
Rib Deflection Rate (m/sec) CFC 180	
Upper Thorax Rib	**
Mid Thorax Rib	**
Lower Thorax Rib	**
Upper Abdominal Rib	**
Lower Abdominal Rib	**
Viscous Criteria CFC 180	
Upper Thorax Rib	**
Mid Thorax Rib	**
Lower Thorax Rib	**
Upper Abdominal Rib	**
Lower Abdominal Rib	**

** There was no valid data collected for the rib deflection channels.

Abdominal Forces (N) CFC 600	
Left Acetabulum Force	1950
Left Ilium Crest Force	5263
Right Ilium Crest Force	-467
Pubic Symphysis Force	-680
Sum of Left Acetabulum and Left Ilium	7164

		Left Front
HIC 15	T1 (msec)	53.6
	T2 (msec)	54.5
	T2 – T1 (msec)	0.9
	HIC	14,361

Fir Filtered	Left Front
Upper Thorax Rib Y (g's)	111.7
Mid Thorax Rib Y (g's)	107.9
Lower Thorax Rib Y (g's)	115.1
Upper Abdominal Rib Y (g's)	112.9
Lower Abdominal Rib Y (g's)	165.6
Lower Spine Y (g's)	96.6
Pelvis Y (g's)	80.4

TEST NOTES

The dummy and vehicle X and y velocities presented in this report do not contain the correct initial velocity. The correct initial velocities should be:

X – Test Speed * Sine 15 Degrees

Y – Test Speed * Cosine 15 Degrees

The following data channels were not collected due to a wiring problem:

- Upper Thorax Rib
- Mid Thorax Rib
- Lower Thorax Rib
- Upper Abdominal Rib
- Lower Abdominal Rib

The SID IIs was fitted with floating rib guides.

The curtain airbag did not deploy.

SECTION 3
SIDE IMPACT DUMMY (SID IIS) AND VEHICLE TEST DATA

**DATA SHEET NO. 1
GENERAL TEST AND VEHICLE PARAMETER DATA**

Test Vehicle: 2002 Ford Explorer SUV

Test Date: February 19, 2003

TEST VEHICLE INFORMATION

Make	Ford
Model	Explorer
Body Style	SUV
VIN	1FMDU75W52ZA94852
Color	Painted Orange
Odometer Reading (mile)	24,715
Transmission	4 Sp Automatic
Final Drive	4 WD
Number of Cylinders	8
Engine Displacement (L)	4.6
Engine Placement	Longitudinal

TEST VEHICLE OPTIONS

Front Airbag	Yes
Side Airbags	Curtain
Power Windows	Yes
Power Steering	Yes
Power Door Locks	Yes
Tilt Wheel	Yes
Air Conditioning	Yes
Power Brakes	Yes
Anti-lock Brakes	No
AM/FM/CD	Yes
Cruise Control	Yes

DATA FROM CERTIFICATION LABEL

Manufactured By	Ford Motor Co.	GVWR (kg)	2648
Date of Manufacture	7/01	GAWR Front (kg)	1240
		GAWR Rear (kg)	1508

DATA FROM TIRE PLACARD

Measured Parameter	Front	Rear
Maximum Tire Pressure (kPa)	300	300
Cold Pressure (kPa)	207	241
Recommended Tire Size	P245/70R16	P245/70R16
Tire Size on Vehicle	P245/70R16	P245/70R16
Tire Manufacturer	Goodyear	Goodyear

Measured Parameter	Front	Rear	Third	Total
Type of Seats	Bucket	Bucket	Bench	
Number Of Occupants x 68.04 kg.	136.1	204.1	136.1	476.3

DATA SHEET NO. 1... (continued)
GENERAL TEST AND VEHICLE PARAMETER DATA

Test Vehicle: 2002 Ford Explorer SUV

Test Date: February 19, 2003

TEST VEHICLE WEIGHTS

	Units	As Delivered (UVW) (Axle)			As Tested (ATW) (Axle)		
		Front	Rear	Total	Front	Rear	Total
Left	kg	503.5	539.8		581.1	532.1	
Right	kg	597.8	452.2		592.4	513.0	
Ratio	%	52.6	47.4		52.9	47.1	
Totals	kg	1101.3	992.0	2093.3	1173.5	1045.1	2218.6

TARGET TEST WEIGHT CALCULATION

Measured Parameter	Units	Value
Vehicle Target Weight	kg	2219*

* Set To Match Previous Tests

TEST VEHICLE ATTITUDES

	Unit	As Delivered	Fully Loaded	Ready for Test
Right Door Sill Angle	Deg	0.9 ND	0.6 ND	0.9 ND
Left Door Sill Angle	Deg	0.9 ND	0.6 ND	0.9 ND
Front Bumper Angle	Deg	0.0	0.1 LD	0.0
Rear Bumper Angle	Deg	0.0	0.1 LD	0.0

ND=Nose down, BD = Back Down, LD = Left Down, RD = Right Down

GENERAL TEST VEHICLE DATA

Measurement Description	Units	Value
Test Vehicle Wheel Base	mm	2885
Total Vehicle Length at Left Side	mm	4040
Total Vehicle Length at Centerline	mm	4834
Total Vehicle Length at Right Side	mm	4040
Total Vehicle Width	mm	1804
Weight of Ballast in Cargo Area	kg	0
Amount of water in Fuel Tank	liters	30.3

TEST VEHICLE VERTICAL IMPACT LINE DATA

Measurement Description	Units	Value
Actual Impact Point	mm	8 Rear

DATA SHEET NO. 1... (continued)
GENERAL TEST AND VEHICLE PARAMETER DATA

Test Vehicle: 2002 Ford Explorer SUV

Test Date: February 19, 2003

NORMAL DESIGN RIDING POSITION

Driver seat back angle: 6.7 degrees on seat frame

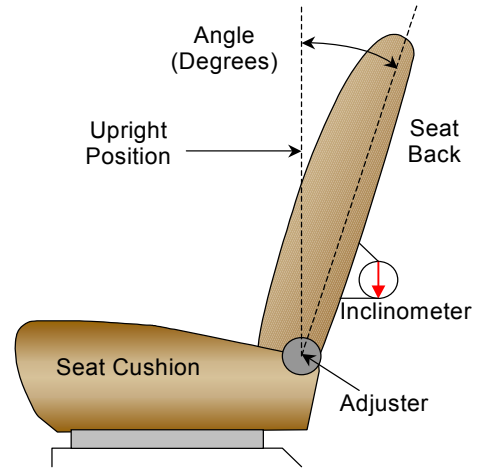

FRONT SEAT ASSEMBLY

SEAT FORE/AFT POSITIONS

The driver's seat is electronically operated.

Driver seat fore/aft total travel: 250 mm

Driver seat fore/aft position: 5 mm back from full forward

SEAT BELT UPPER ANCHORAGE

The test vehicle "D" ring anchorage for the driver's seat position was placed in the lowest position.

STEERING COLUMN ADJUSTMENT

The steering column was placed in the mid position of travel.

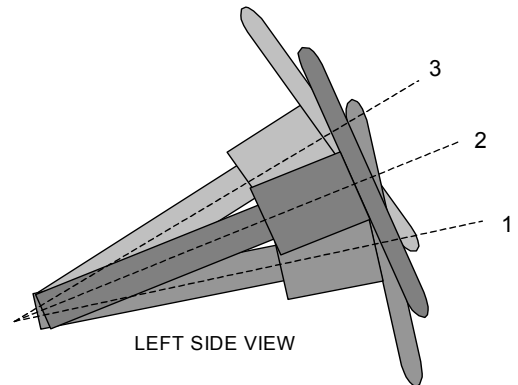

STEERING COLUMN ASSEMBLY

DATA SHEET NO. 2 TEST VEHICLE TIRE INFORMATION

Test Vehicle: 2002 Ford Explorer SUV

Test Date: February 19, 2003

Vehicle Year	2002	Vehicle Make	Ford
Vin	1FMDU75W52ZA94852	Vehicle Model	Explorer

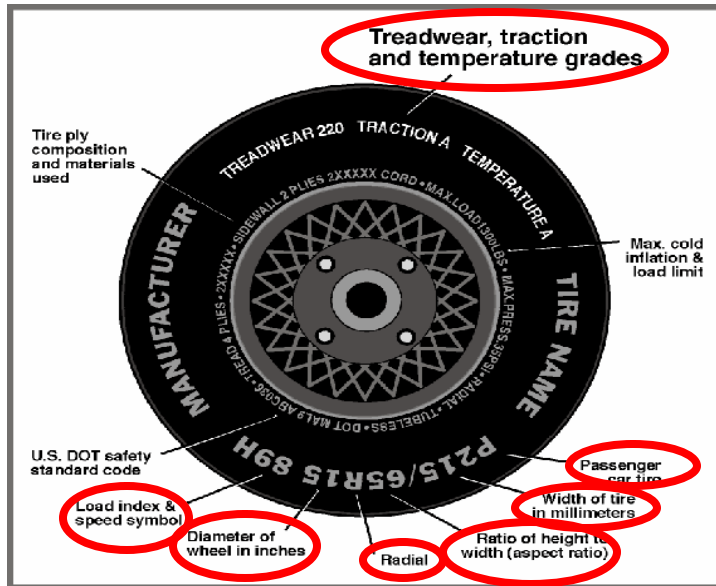

	Front	Rear
Tire Manufacturer	Goodyear	Goodyear
Tire Name	Wrangler AP	Wrangler AP
Tire Type	Passenger	Passenger
Tire Width (mm)	245	245
Ratio of Height to Width (aspect ratio)	70	70
Radial	Radial	Radial
Wheel Diameter	16	16
Load Index & Speed Symbol	106S	106S
Treadwear	340	340
Traction Grade	A	A
Temperature Grade	B	B

**DATA SHEET NO. 3
POST TEST OBSERVATIONS**

Test Vehicle: 2002 Ford Explorer SUV

Test Date: February 19, 2003

TEST DUMMY INFORMATION AND CONTACT POINTS

Description	Left Front
Dummy Type	SID IIs
Head Contact	Side headliner, pole
Upper Torso Contact	Door trim panel
Lower Torso Contact	Mid door trim panel
Left Knee Contact	Lower door trim panel
Right Knee Contact	Left knee

POST TEST DOOR OPENING

Description	Left Front	Left Rear
Left Side Door Opening	Remained latched and closed	Remained latched and closed
Right Side Door Opening	Remained latched and closed	Remained latched and closed

POST TEST STRUCTURAL OBSERVATIONS

Critical Areas of Performance	Observations and Conclusions
Pillar Performance	No failures
Sill Separation	None
Windshield Damage	Left side shattered
Window Damage	Left side windows down for test
Other Notable Effects	None

AIRBAG DEPLOYMENT

	Driver
Front	No
Side	None
Curtain	No

**SECTION 4
OCCUPANT AND VEHICLE INFORMATION**

DATA SHEET NO. 4
VEHICLE PRE-TEST AND POST-TEST MEASUREMENTS

Test Vehicle: 2002 Ford Explorer SUV

Test Date: February 19, 2003

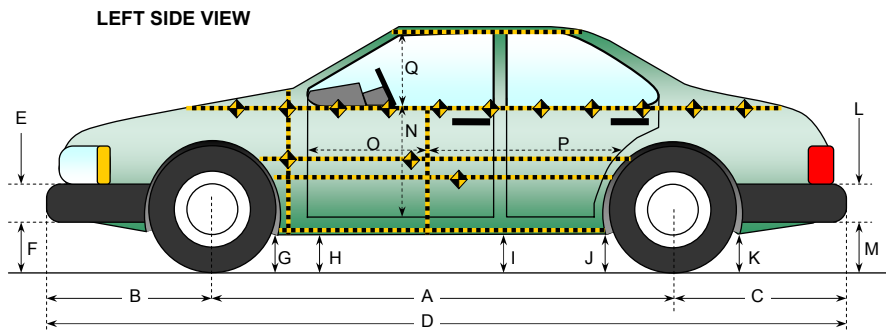

All Measurements in mm

Code	Measurement Description	Pre-Test	Post-Test	Difference
A	Wheelbase	2885	2809	76
B	Front Axle to FSOV	832	830	2
C	Rear Axle to RSOV	1117	1172	-55
D	Total Length at Centerline	4834	4811	23
E	Front Bumper Thickness	80	80	0
F	Front Bumper Bottom to Ground	749	768	-19
G	Sill Height at Front Wheel Well	428	426	2
H	Sill Height at Front Door Leading Edge	330	307	23
I	Sill Height at "B" Pillar	343	325	18
J1	Sill Height at Rear Wheel Well	468	440	28
J2	Pinch Weld Height at Rear Wheel Well	352	338	14
K	Sill Height Aft of Rear Wheel Well	514	500	14
L	Rear Bumper Thickness	180	180	0
M	Rear Bumper Bottom to Ground	557	566	-9
N	Sill Height to Window Bottom Sill	770	799	-29
O	Front Door Leading Edge to Impact CL	776	640	136
P	Rear Door Trailing Edge to Impact CL	1374	1233	141
Q	Front Window Opening	494	456	38
R	Right Side Length	4040	4047	-7
S	Left Side Length	4040	3890	150
T	Vehicle Width at "B" Post	1804	1703	101

DATA SHEET NO. 5
SID IIS CLEARANCE DIMENSIONS

Test Vehicle: 2002 Ford Explorer SUV

Test Date: February 19, 2003

AA	Ankle to Ankle	Taken between the center points of both ankles, after the feet are placed.	238
AD	Arm to Door	Horizontal measurement taken from the center point of the elbow to the first contact point of the door panel.	152
HA	Head to A pillar	Horizontal measurement taken from the center of the head's outboard CG target to the A pillar.	312
HCM	Hub to Chest	Minimum horizontal distance measured from the hub to the dummy's chest.	118
HD	H point to Door	Horizontal measurement taken from the H point hole to the first contact point of the door panel.	166
HH	Head to Header	Taken from center point between eyes to header directly in front of dummy.	233
HR	Head to Roof	Taken from the center of the outboard target to the roof edge (not the upper edge of the car door), perpendicular to the long axis of the car. If a tape measure is held from the target and extends below the roof, the point to measure is at the low edge of the roof line, which will make contact with the tape measure.	219
HS	Head to Side Window	Taken from the center of the outboard target to the side window, measured horizontally and perpendicular to the long axis of the car. In cases where the window is not fully up, a flat bar should be placed across the window opening to simulate the position of the window.	284
HW	Head to Windshield	Taken from the center point between the dummy's eyes to the point on the windshield directly level with the dummy's forehead.	418
KDL	Knee to Dash Left	Taken from the knee pivot point to the point on the dash that is directly level with the center of the knee.	101
KK	Knee to Knee	With the legs in a vertical plane after the feet are placed, the measurement is taken from outside flange to outside flange.	211
NAS	Neck Angle Seated	Taken from the neck when the dummy is seated across two of the "vertebral discs" of the neck.	6.7
NR	Nose to Rim	Taken from the tip of the nose to the steering wheel rim at the 12 o'clock position.	171
PA	Pelvic Angle	Taken by placing an inclinometer on the H point bar.	19.8
RA	Rim to Abdomen	Taken from the point where the bottom of the chest jacket and the pelvic structure meet to the steering wheel rim at the 6 o'clock position.	41
SA	Seat Back Angle	Taken from the lower left corner of the driver seat frame, above the pivot, below the joint.	6.7
SCH	Steering Wheel to Chest	Horizontal measurement taken from the center of the steering wheel to the dummy's chest.	118
SCR	Steering Wheel to Chest	Taken from the center of the steering wheel to the top of the rib guide.	120
SHH	Striker to H point Horizontal	Taken from the H point to the driver door striker.	339
SHV	Striker to H point Vertical	Taken from the H point to the driver door striker. Value is negative if the striker is above the H point and positive if the striker is below the H point.	-7
SK	Striker to Knee	Taken from the center point of the knee to the striker.	750
SKA	Striker to Knee Angle	Taken on top of the tape measure while it is extended from the center point of the knee to the striker.	3.1

DATA SHEET NO. 6 VEHICLE SIDE MEASUREMENTS

Test Vehicle: 2002 Ford Explorer SUV

Test Date: February 19, 2003

PRETEST AND POST TEST EXTERIOR PROFILE MEASUREMENTS

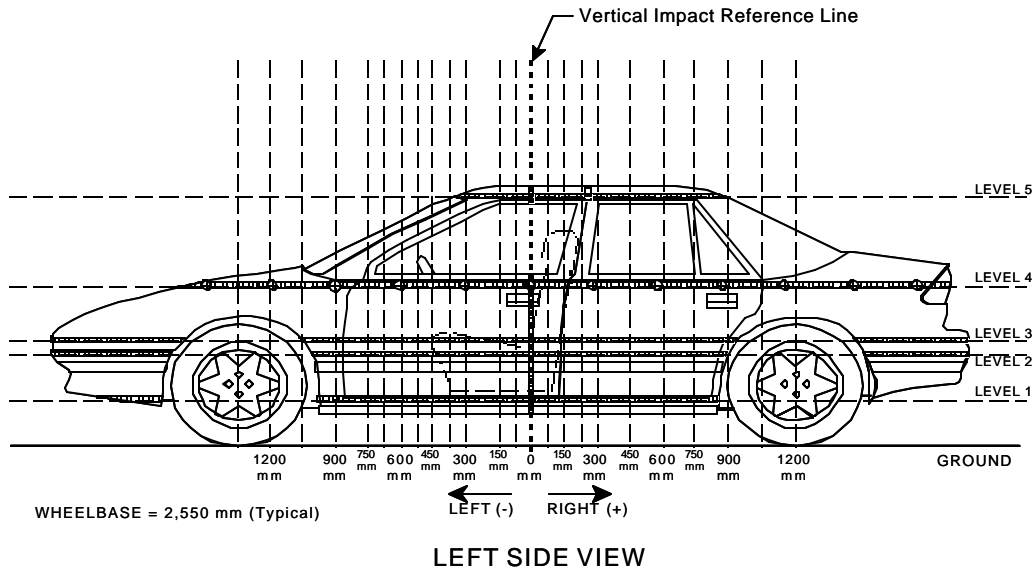

Measurements are taken with vehicle in the as tested condition.
Measurements along the vertical 0 mm.
All measurements below in mm.

Level	Measurement Description	Height Above Ground
5	Window	1715
4	Window Sill	1200
3	Mid Door	924
2	Occupant H-Point	840
1	Sill Top	515

DATA SHEET NO. 7
VEHICLE EXTERIOR CRUSH PROFILES

Test Vehicle: 2002 Ford Explorer SUV

Test Date: February 19, 2003

	Pre-Test					Post-Test					Difference				
	1	2	3	4	5	1	2	3	4	5	1	2	3	4	5
-1650															
-1500				298					292					-6	
-1350				278					281					3	
-1200				264					265					1	
-1050				253					261					8	
-900				245					259					14	
-825				239					253					14	
-750		200	200	235			228	227	254			28	27	19	
-675	228	204	199	233		253	235	229	255		25	31	30	22	
-600	225	208	202	233		253	243	237	240		28	35	35	7	
-525	234	206	201	233		306	288	280	271		72	82	79	38	
-450	227	205	200	232		337	329	323	309		110	124	123	77	
-375	229	204	199	232		367	371	365	352		138	167	166	120	
-300	228	204	199	231		402	414	407	396		174	210	208	165	
-225	224	203	198	231		439	455	449	440		215	252	251	209	
-150	224	202	197	230		478	498	494	490		254	296	297	260	
-75	224	202	197	229	443	524	545	542	540	575	300	343	345	311	132
0	224	202	197	229	440	577	589	591	591	611	353	387	394	362	171
75	224	202	197	229	438	593	600	606	604	626	369	398	409	375	188
150	225	201	197	228	437	572	588	597	588	609	347	387	400	360	172
225	225	201	197	228	439	513	547	543	549	572	288	346	346	321	133
300	226	201	197	228	440	440	470	473	479	529	214	269	276	251	89
375	226	201	197	228	440	380	402	403	414	488	154	201	206	186	48
450	225	202	197	228	441	321	340	335	349	452	96	138	138	121	11
600	233	200	196	229	441	322	295	288	326	410	89	95	92	97	-31
750	225	201	196	229	441	304	283	277	313	467	79	82	81	84	26
900	228	202	197	230	442	291	268	262	298	461	63	66	65	68	19
1050	229	204	199	232	444	283	259	253	289	464	54	55	54	57	20
1200	232	206	201	234	445	261	238	233	268	455	29	32	32	34	10
1350	233	201	204	236	447	246	218	217	254	452	13	17	13	18	5
1500			190	239	450			194	238	445			4	-1	-5
1650				244	453				262	467				18	14
1800				248	457				267	470				19	13
1950				252	463				267	471				15	8
2100				256	467				268	475				12	8
2250				261	477				271	479				10	2
2400				267					278					11	

Reference plane is parallel to test vehicle longitudinal centerline.

Given dimensions = Reference plane to car body.

Measurements in mm.

DATA SHEET NO. 7... (continued)
VEHICLE EXTERIOR CRUSH PROFILES

Test Vehicle: 2002 Ford Explorer SUV

Test Date: February 19, 2003

16

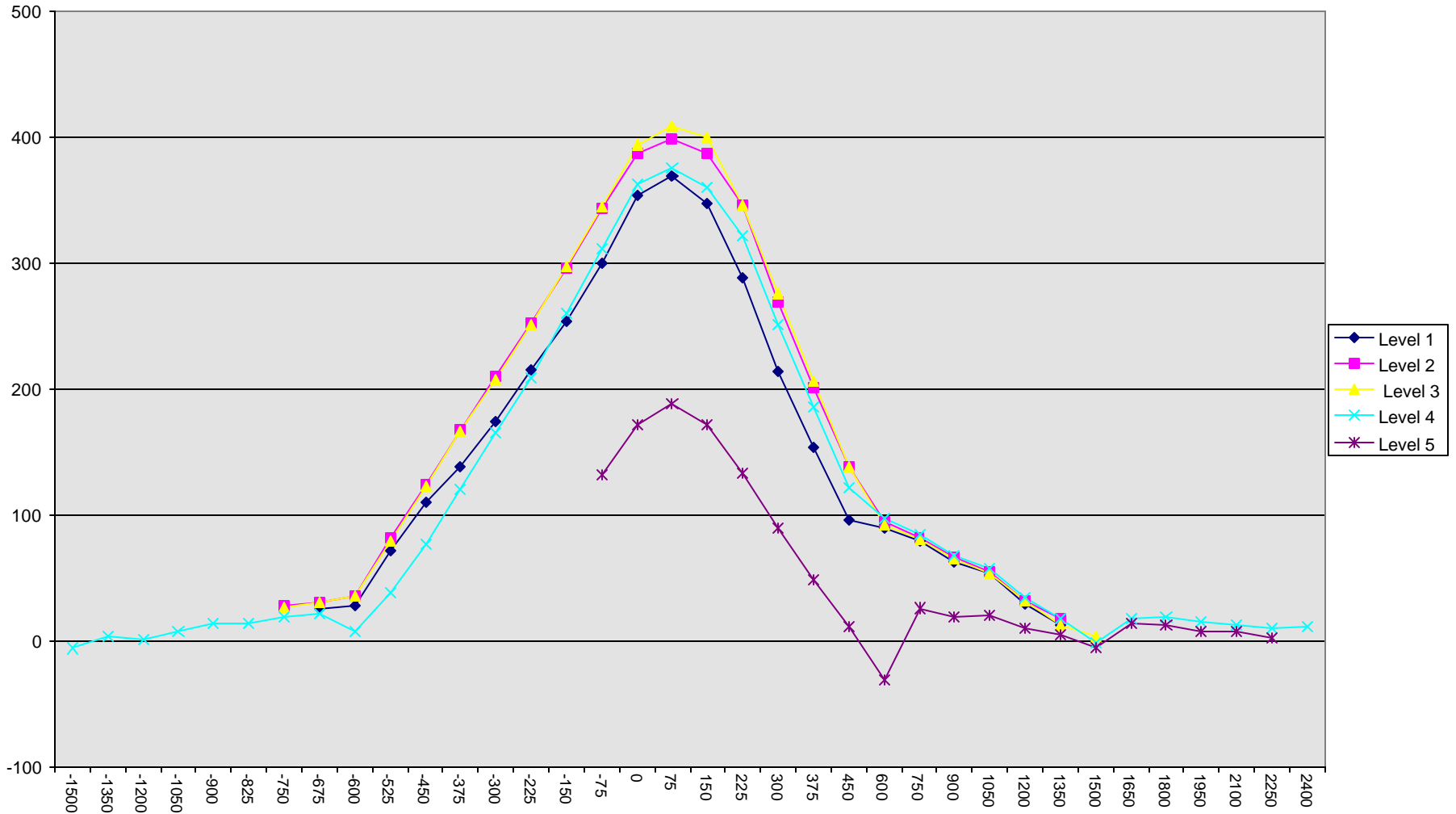

Measurement in mm.

**DATA SHEET NO. 8
VEHICLE DAMAGE PROFILE DISTANCES**

Test Vehicle: 2002 Ford Explorer SUV

Test Date: February 19, 2003

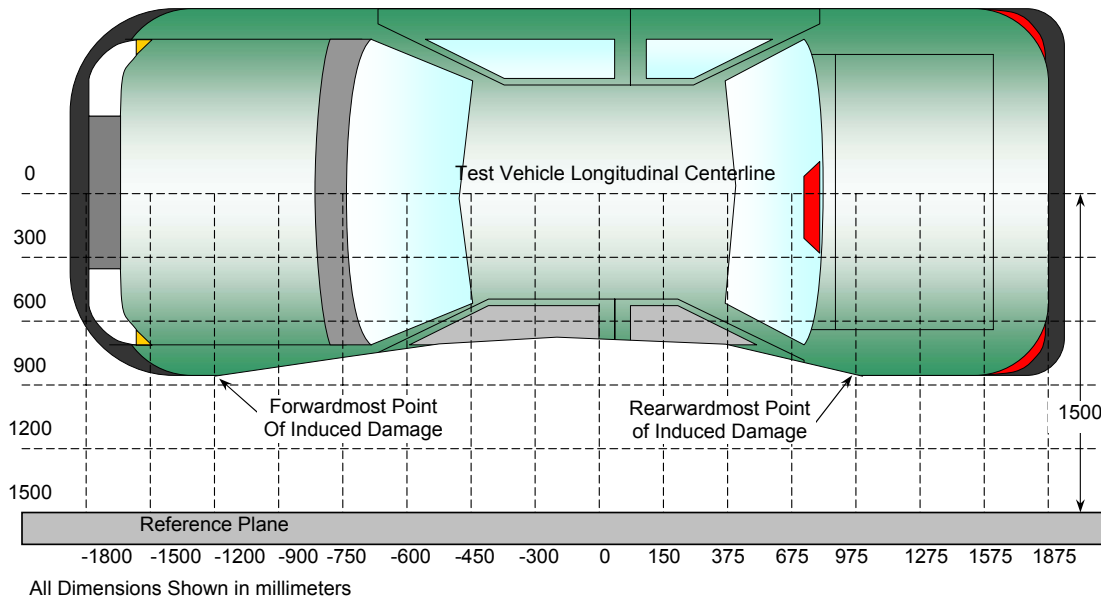

TOP VIEW

Damage Profile Distances

DPD	Distance from Impact Point in mm	Level	Pre-Test (mm)	Post-Test (mm)	Max Static Crush (mm)
1	2400 mm	4	321	321	0
2	1585 mm	4	250	265	15
3	792 mm	2	205	251	46
4	-122 mm	3	197	603	406
5	-990 mm	4	237	254	17
6	-1800 mm	4	298	292	-6

Reference plane is parallel to test vehicle longitudinal centerline.

Given dimensions = Reference plane to car body.

DATA SHEET NO. 9
VEHICLE ACCELEROMETER LOCATIONS AND DATA SUMMARY

Test Vehicle: 2002 Ford Explorer SUV

Test Date: February 19, 2003

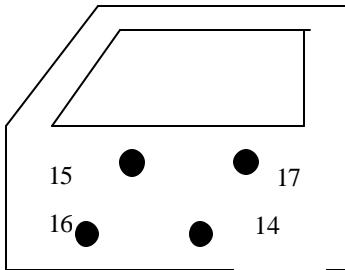
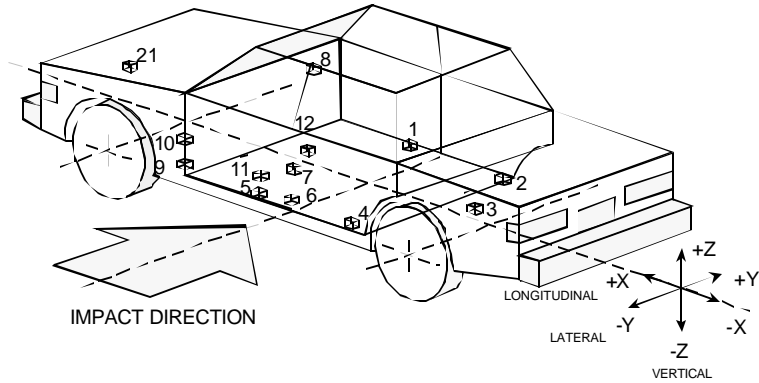

No.	Location
1	Right Side Sill at Front Seat
2	Right Side Sill at Rear Seat
3	Rear Floorpan Above Axle
4	Left Side Sill at Rear Door
5	Left Side Sill at Front Door
6	Left Lower B-Post
7	Left Mid B-Post
8	Left Upper B-Post
9	Left Lower A-Post
10	Left Mid A-Post
11	Driver Seat Track

No.	Location
12	Vehicle CG
13	Left A-Pillar @ Roof
14	Left Front Door @ Pelvis
15	Left Front Door @ Arm
16	Left Front Door @ Knee
17	Left Front Door @ Rib
19	Left Driver Seat Frame
20	Right Driver Seat Frame
21	Lower Center Radiator Support

DATA SHEET NO. 9... (continued)
VEHICLE ACCELEROMETER LOCATIONS AND DATA SUMMARY

Test Vehicle: 2002 Ford Explorer SUV

Test Date: February 19, 2003

VEHICLE ACCELEROMETER PEAK DATA AND PRE-TEST LOCATIONS

Loc. No.	Accelerometer Location	Long (X) Maximums (g's) (CFC 60)		Lat. (Y) Maximums (g's) (CFC 60)		Vert. (Z) Maximums (g's) (CFC 60)		Resultant (g's) (CFC 60)
		Pos.	Neg.	Pos.	Neg.	Pos.	Neg.	Max.
1	Right Side Sill at Front Seat	1.7	8.2	21.4	0.8	6.7	6.0	22.3
2	Right Side Sill at Rear Seat	3.0	6.2	20.1	1.5	4.2	7.8	20.3
3	Rear Floorpan Above Axle	0.8	5.9	18.3	2.0	2.4	8.1	19.1
4	Left Side Sill at Rear Door			20.4	6.2			
5	Left Side Sill at Front Door			43.6	13.2			
6	Left Lower B-Post			28.8	7.1			
7	Left Mid B-Post			33.0	13.8			
8	Left Upper B-Post*							
9	Left Lower A-Post			24.8	19.8			
10	Left Mid A-Post			20.4	0.5			
11	Driver Left Seat Track			62.3	1.2			
12	Vehicle CG	2.5	10.5	24.5	1.9	22.1	32.1	41.1
13	Left A-Post at Roof*							
14	Left Front Door at Pelvis **			128.8	28.4			
15	Left Front Door at Arm			110.1	79.2			
16	Left Front Door at Knee			88.3	49.9			
17	Left Front Door at Rib			117.9	42.3			
19	Left Driver Seat Frame			67.2	16.1			
20	Right Driver Seat Frame			70.1	26.7			
21	Lower Center Radiator Support	10.5	8.6	14.7	4.1	7.4	9.0	16.4

Sign Convention X - + forward
 Y - + to right
 Z - + down

*= Not used to avoid interference with restraint system.

**=No valid data collected after 20 msec.

DATA SHEET NO. 9... (continued)
VEHICLE ACCELEROMETER LOCATIONS AND DATA SUMMARY

Test Vehicle: 2002 Ford Explorer SUV

Test Date: February 19, 2003

VEHICLE ACCELEROMETER COORDINATES

Loc. No.	Description	Coordinates (mm)		
		X	Y	Z
1	Right Side Sill at Front Seat	2568	616	420
2	Right Side Sill at Rear Seat	1594	616	473
3	Rear Floorpan Above Axle	1134	0	734
4	Left Side Sill at Rear Door	1612	-652	383
5	Left Side Sill at Front Door	2538	-652	365
6	Left Lower B-Post	2240	-720	608
7	Left Mid B-Post	2262	-738	1158
8	Left Upper B-Post	*	*	*
9	Left Lower A-Post	3208	-732	574
10	Left Mid A-Post	3324	-828	1213
11	Driver Left Seat Track	2495	-559	603
12	Vehicle CG	2512	0	833
13	Left A-Pillar @ Roof	*	*	*
14	Left Door @ Pelvis	2455	-779	854
15	Left Door @ Arm	2792	-769	1094
16	Left Door @ Knee	2222	-574	1104
17	Left Door @ Rib	2222	-193	1109
19	Left Driver Seat Frame	4268	0	246
20	Right Driver Seat Frame	2568	616	420
21	Lower Center Radiator Support	1594	616	473

Sign Convention

X – Rear Bumper (+ forward)

Y – Vehicle Centerline (+ to right)

Z – Ground Plane (+ up)

* = Not used to avoid interference with restraint system.

**DATA SHEET NO. 10
HIGH SPEED CAMERA LOCATIONS AND DATA**

Test Vehicle: 2002 Ford Explorer SUV

Test Date: February 19, 2003

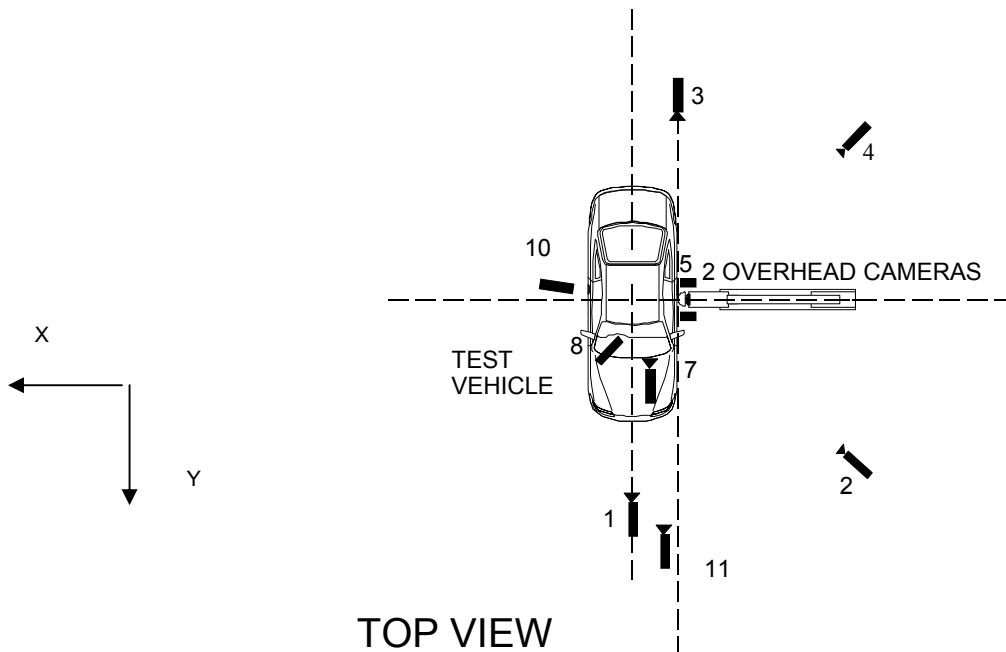

No.	Camera View	Location (mm)			Lens (mm)	Film Speed (fps)
		X	Y	Z		
1	Front Ground Level	400	9170	1530	25	769
2	Front Angle	-3000	4000	1210	50	1031
3	Rear Ground Level	830	-9680	1450	25	1053
4	Rear Angle	-2070	-3310	1460	50	1042
5	Overhead View	860	0	5000	8	1036
6	Overhead View, Close-up	0	0	5000	13	1026
7	Onboard Hood				13	556
8	Onboard Hip				13	518
9	Onboard Perp.				13	524
10	Onboard B-Post				13	521
11	Real Time				13	24

Reference Points X - + Forward of Impact
 Y - + Right of Impact
 Z - + Up from Ground

APPENDIX A
PHOTOGRAPHS

TABLE OF PHOTOGRAPHS

		<u>Page No.</u>
Photo No. A-1	Pre-Test Front View of Test Vehicle	A-1
Photo No. A-2	Post-Test Front View of Test Vehicle	A-2
Photo No. A-3	Pre-Test Rear View of Test Vehicle	A-3
Photo No. A-4	Post-Test Rear View of Test Vehicle	A-4
Photo No. A-5	Pre-Test Left Side View of Test Vehicle	A-5
Photo No. A-6	Post-Test Left Side View of Test Vehicle	A-6
Photo No. A-7	Pre-Test Left Front $\frac{3}{4}$ Side View of Test Vehicle	A-7
Photo No. A-8	Post-Test Left Front $\frac{3}{4}$ Side View of Test Vehicle	A-8
Photo No. A-9	Pre-Test Left Rear $\frac{3}{4}$ Side View of Test Vehicle	A-9
Photo No. A-10	Post-Test Left Rear $\frac{3}{4}$ Side View of Test Vehicle	A-10
Photo No. A-11	Pre-Test Vehicle Positioned Against Pole (left side)	A-11
Photo No. A-12	Pre-Test Vehicle Positioned Against Pole (right side)	A-12
Photo No. A-13	Pre-Test Vehicle Positioned Against Pole Overhead View	A-13
Photo No. A-14	Post-Test Pole and Vehicle Overhead View	A-14
Photo No. A-15	Pre-Test Driver Seat Position	A-15
Photo No. A-16	Pre-Test Driver Dummy Left Side View	A-16
Photo No. A-17	Post-Test Driver Dummy Left Side View	A-17
Photo No. A-18	Pre-Test Driver Dummy Right Side View	A-18
Photo No. A-19	Post-Test Driver Dummy Right Side View	A-19
Photo No. A-20	Pre-Test Driver Dummy Left Side View (Door Open)	A-20
Photo No. A-21	Pre-Test Driver Dummy Shoulder and Door Top View	A-21
Photo No. A-22	Post-Test Driver Dummy Shoulder and Door Top View	A-22
Photo No. A-23	Post-Test Driver Dummy Contact	A-23
Photo No. A-24	Post-Test Driver Dummy Head Contact	A-24
Photo No. A-25	Post-Test Driver Dummy Back of Head Contact	A-25
Photo No. A-26	Post-Test Driver Dummy Contact with Pole	A-26
Photo No. A-27	Pre-Test Impact Point on Vehicle	A-27
Photo No. A-28	Post-Test Impact Point on Vehicle	A-28
Photo No. A-29	Impact	A-29

A-1.



Pre-Test Front View of Test Vehicle



Post-Test Front View of Test Vehicle



Pre-Test Rear View of Test Vehicle



Post-Test Rear View of Test Vehicle

A-5.



Pre-Test Left Side View of Test Vehicle

A-6.



Post-Test Left Side View of Test Vehicle



Pre-Test Left Front ¼ Side View of Test Vehicle



Post-Test Left Front $\frac{3}{4}$ Side View of Test Vehicle



Pre-Test Left Rear ¾ Side View of Test Vehicle

A-10.



Post-Test Left Rear $\frac{3}{4}$ Side View of Test Vehicle

A-11.

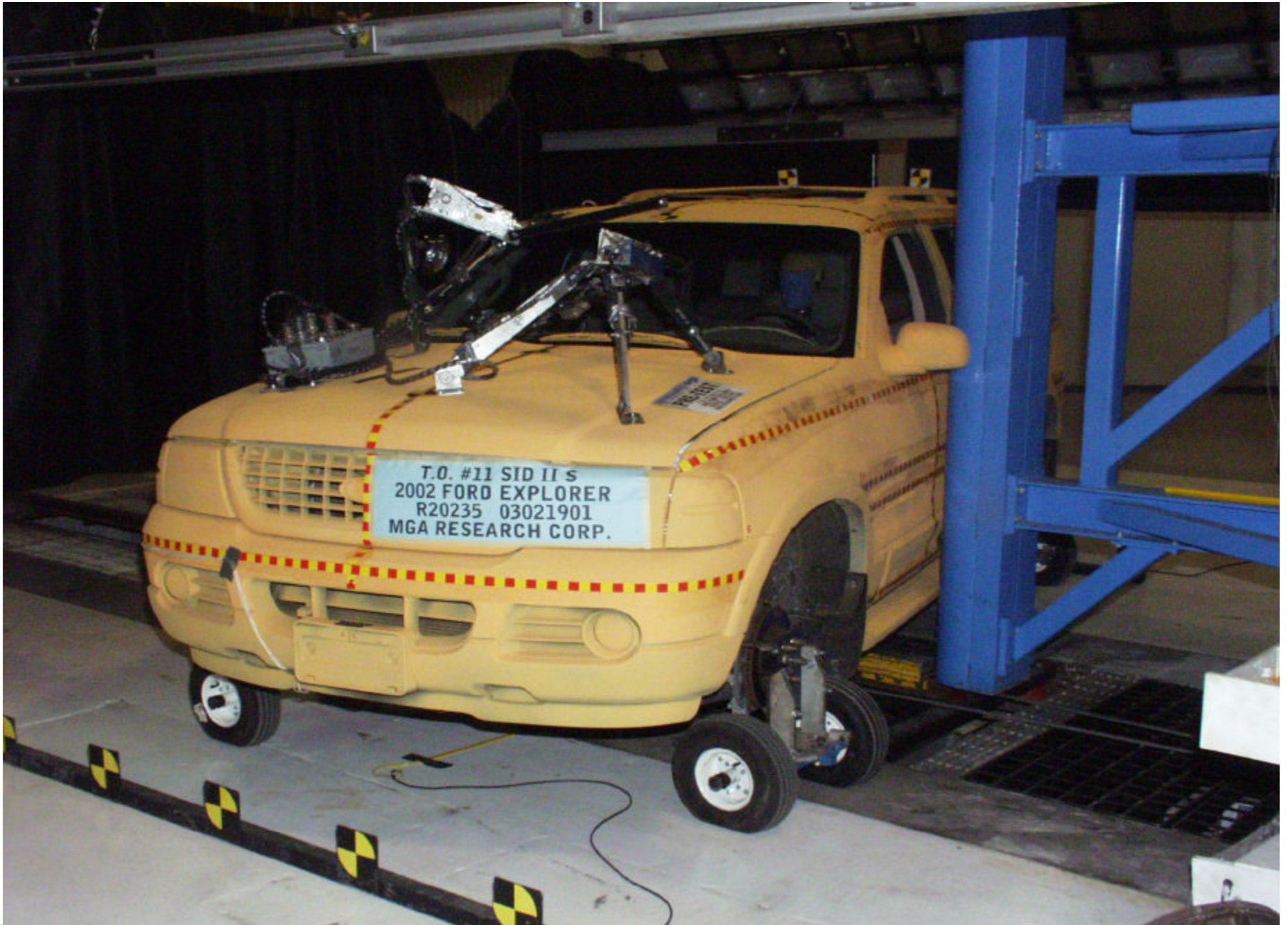

Pre-Test Vehicle Positioned Against Pole (left side)

A-12.



Pre-Test Vehicle Positioned Against Pole (right side)

A-13.

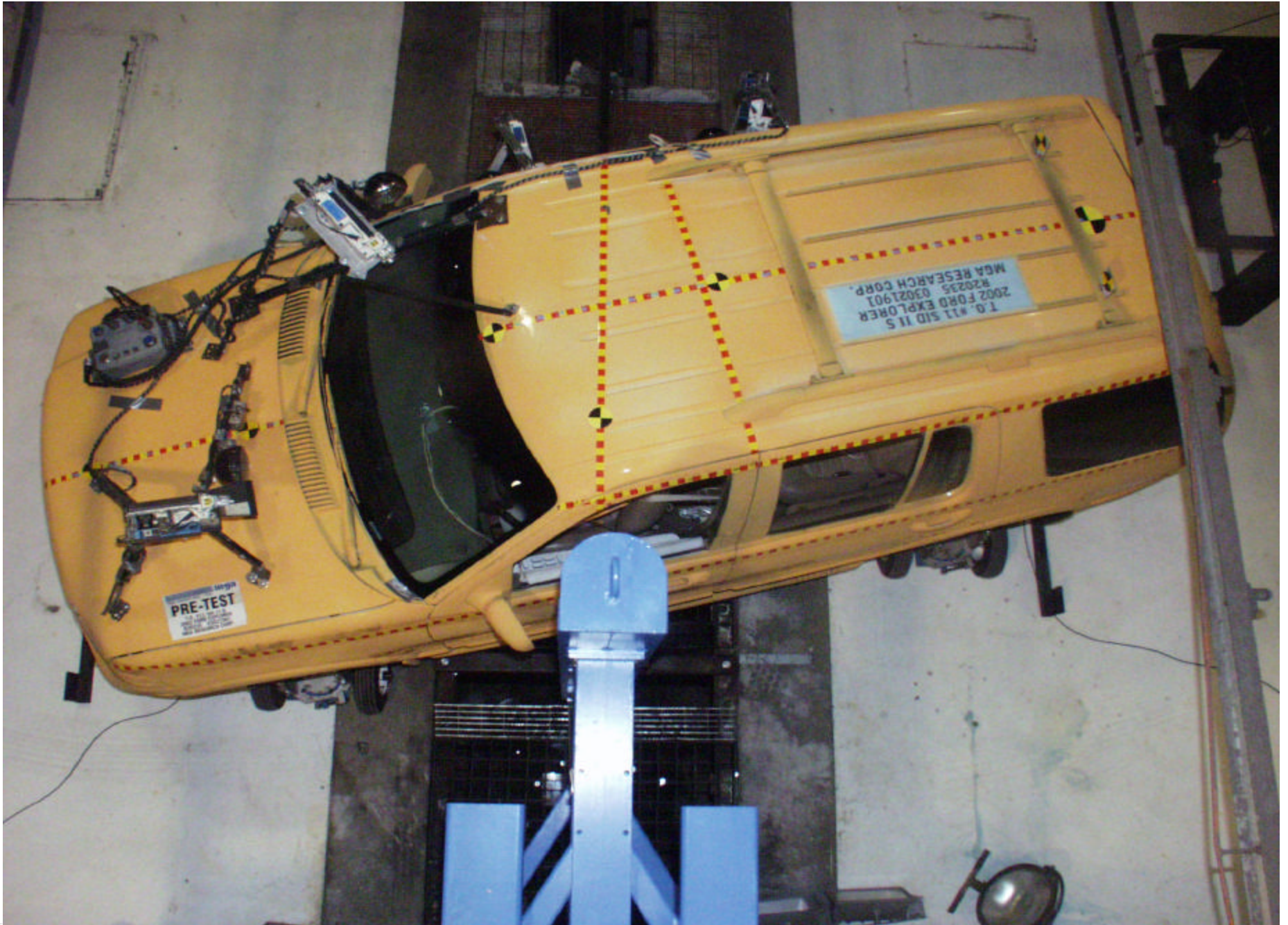

Pre-Test Vehicle Positioned Against Pole Overhead View



Post-Test Pole and Vehicle Overhead View

A-15.



Pre-Test Driver Seat Position

A-16.



Pre-Test Driver Dummy Left Side View

A-17.



Post-Test Driver Dummy Left Side View

A-18.



Pre-Test Driver Dummy Right Side View

A-19.



Post-Test Driver Dummy Right Side View



Pre-Test Driver Dummy Left Side View (Door Open)



Pre-Test Driver Dummy Shoulder and Door Top View



Post-Test Driver Dummy Shoulder and Door Top View

A-23.



Post-Test Driver Dummy Contact

A-24.



Post-Test Driver Dummy Head Contact



Post-Test Driver Dummy Back of Head Contact



Post-Test Driver Dummy Contact with Pole



Pre-Test Impact Point on Vehicle

A-28.



Post-Test Impact Point on Vehicle

A-29.



Impact

APPENDIX B

VEHICLE AND DUMMY RESPONSE DATA TRACES

TABLE OF DATA PLOTS

The dummy and vehicle X and Y Velocities presented in this report do not contain the correct initial velocity. The correct initial velocities should be:

X – Test Speed * Sine 15 Degrees

Y – Test Speed * Cosine 15 Degrees

Figure No. 1	Driver Head X Acceleration vs. Time	B-1
Figure No. 2	Driver Head Y Acceleration vs. Time	B-1
Figure No. 3	Driver Head Z Acceleration vs. Time	B-1
Figure No. 4	Driver Head Resultant Acceleration vs. Time	B-1
Figure No. 5	Driver Head X Velocity vs. Time	B-2
Figure No. 6	Driver Head Y Velocity vs. Time	B-2
Figure No. 7	Driver Head Z Velocity vs. Time	B-2
Figure No. 8	Driver Upper Neck Force X vs. Time	B-3
Figure No. 9	Driver Upper Neck Force Y vs. Time	B-3
Figure No. 10	Driver Upper Neck Force Z vs. Time	B-3
Figure No. 11	Driver Upper Neck Force Resultant vs. Time	B-3
Figure No. 12	Driver Upper Neck Moment X vs. Time	B-4
Figure No. 13	Driver Upper Neck Moment Y vs. Time	B-4
Figure No. 14	Driver Upper Neck Moment Z vs. Time	B-4
Figure No. 15	Driver Upper Neck Moment Resultant vs. Time	B-4
Figure No. 16	Driver Shoulder X Acceleration vs. Time (CFC 1000)	B-5
Figure No. 17	Driver Shoulder Y Acceleration vs. Time (CFC 1000)	B-5
Figure No. 18	Driver Shoulder Z Acceleration vs. Time (CFC 1000)	B-5
Figure No. 19	Driver Shoulder Resultant Acceleration vs. Time (CFC 1000)	B-5
Figure No. 20	Driver Shoulder X Acceleration vs. Time (CFC 180)	B-6
Figure No. 21	Driver Shoulder Y Acceleration vs. Time (CFC 180)	B-6
Figure No. 22	Driver Shoulder Z Acceleration vs. Time (CFC 180)	B-6
Figure No. 23	Driver Shoulder Resultant Acceleration vs. Time (CFC 180)	B-6
Figure No. 24	Driver Shoulder X Velocity vs. Time	B-7
Figure No. 25	Driver Shoulder Y Velocity vs. Time	B-7
Figure No. 26	Driver Shoulder Z Velocity vs. Time	B-7
Figure No. 27	Driver Shoulder Force X vs. Time (CFC 1000)	B-8

Figure No. 28	Driver Shoulder Force Y vs. Time (CFC 1000)	B-8
Figure No. 29	Driver Shoulder Force Z vs. Time (CFC 1000)	B-8
Figure No. 30	Driver Shoulder Force X vs. Time (CFC 600)	B-9
Figure No. 31	Driver Shoulder Force Y vs. Time (CFC 600)	B-9
Figure No. 32	Driver Shoulder Force Z vs. Time (CFC 600)	B-9
Figure No. 33	Driver Upper Arm X Acceleration vs. Time (CFC 1000)	B-10
Figure No. 34	Driver Upper Arm Y Acceleration vs. Time (CFC 1000)	B-10
Figure No. 35	Driver Upper Arm Z Acceleration vs. Time (CFC 1000)	B-10
Figure No. 36	Driver Upper Arm Resultant Acceleration vs. Time (CFC 1000)	B-10
Figure No. 37	Driver Upper Arm X Acceleration vs. Time (CFC 180)	B-11
Figure No. 38	Driver Upper Arm Y Acceleration vs. Time (CFC 180)	B-11
Figure No. 39	Driver Upper Arm Z Acceleration vs. Time (CFC 180)	B-11
Figure No. 40	Driver Upper Arm Resultant Acceleration vs. Time (CFC 180)	B-11
Figure No. 41	Driver Upper Arm X Velocity vs. Time (CFC 180)	B-12
Figure No. 42	Driver Upper Arm Y Velocity vs. Time (CFC 180)	B-12
Figure No. 43	Driver Upper Arm Z Velocity vs. Time (CFC 180)	B-12
Figure No. 44	Driver Upper Spine X Acceleration vs. Time	B-13
Figure No. 45	Driver Upper Spine Y Acceleration vs. Time	B-13
Figure No. 46	Driver Upper Spine Z Acceleration vs. Time	B-13
Figure No. 47	Driver Upper Spine Resultant Acceleration vs. Time	B-13
Figure No. 48	Driver Upper Spine X Velocity vs. Time	B-14
Figure No. 49	Driver Upper Spine Y Velocity vs. Time	B-14
Figure No. 50	Driver Upper Spine Z Velocity vs. Time	B-14
Figure No. 51	Driver Lower Spine X Acceleration vs. Time	B-15
Figure No. 52	Driver Lower Spine Y Acceleration vs. Time	B-15
Figure No. 53	Driver Lower Spine Z Acceleration vs. Time	B-15
Figure No. 54	Driver Lower Spine Resultant Acceleration vs. Time	B-15
Figure No. 55	Driver Lower Spine X Velocity vs. Time	B-16
Figure No. 56	Driver Lower Spine Y Velocity vs. Time	B-16
Figure No. 57	Driver Lower Spine Z Velocity vs. Time	B-16
Figure No. 58	Driver Upper Thorax Rib Y Acceleration vs. Time (CFC 1000)	B-17

Figure No. 59	Driver Mid Thorax Rib Y Acceleration vs. Time (CFC 1000)	B-17
Figure No. 60	Driver Lower Thorax Rib Y Acceleration vs. Time (CFC 1000)	B-17
Figure No. 61	Driver Upper Thorax Rib Y Acceleration vs. Time (CFC 180)	B-18
Figure No. 62	Driver Mid Thorax Rib Y Acceleration vs. Time (CFC 180)	B-18
Figure No. 63	Driver Lower Thorax Rib Y Acceleration vs. Time (CFC 180)	B-18
Figure No. 64	Driver Upper Thorax Rib Y Velocity vs. Time (CFC 180)	B-19
Figure No. 65	Driver Mid Thorax Rib Y Velocity vs. Time (CFC 180)	B-19
Figure No. 66	Driver Lower Thorax Rib Y Velocity vs. Time (CFC 180)	B-19
Figure No. 67	Driver Upper Abdominal Rib Y Acceleration vs. Time (CFC 1000)	B-20
Figure No. 68	Driver Lower Abdominal Rib Y Acceleration vs. Time (CFC 1000)	B-20
Figure No. 69	Driver Upper Abdominal Rib Y Acceleration vs. Time (CFC 180)	B-20
Figure No. 70	Driver Lower Abdominal Rib Y Acceleration vs. Time (CFC 180)	B-20
Figure No. 71	Driver Upper Abdominal Rib Y Velocity vs. Time	B-21
Figure No. 72	Driver Lower Abdominal Rib Y Velocity vs. Time	B-21
Figure No. 73	Driver Lumbar Force X vs. Time	B-22
Figure No. 74	Driver Lumbar Force Y vs. Time	B-22
Figure No. 75	Driver Lumbar Force Z vs. Time	B-22
Figure No. 76	Driver Lumbar Force Resultant vs. Time	B-22
Figure No. 77	Driver Lumbar Moment X vs. Time	B-23
Figure No. 78	Driver Lumbar Moment Y vs. Time	B-23
Figure No. 79	Driver Lumbar Moment Z vs. Time	B-23
Figure No. 80	Driver Lumbar Moment Resultant vs. Time	B-23
Figure No. 81	Driver Pelvis X Acceleration vs. Time	B-24
Figure No. 82	Driver Pelvis Y Acceleration vs. Time	B-24
Figure No. 83	Driver Pelvis Z Acceleration vs. Time	B-24
Figure No. 84	Driver Pelvis Resultant Acceleration vs. Time	B-24
Figure No. 85	Driver Pelvis X Velocity vs. Time	B-25
Figure No. 86	Driver Pelvis Y Velocity vs. Time	B-25
Figure No. 87	Driver Pelvis Z Velocity vs. Time	B-25
Figure No. 88	Driver Left Femur Force X vs. Time	B-26
Figure No. 89	Driver Left Femur Force Y vs. Time	B-26

Figure No. 90	Driver Left Femur Force Z vs. Time	B-26
Figure No. 91	Driver Left Femur Force Resultant vs. Time	B-26
Figure No. 92	Driver Left Femur Moment X vs. Time	B-27
Figure No. 93	Driver Left Femur Moment Y vs. Time	B-27
Figure No. 94	Driver Left Femur Moment Z vs. Time	B-27
Figure No. 95	Driver Left Femur Moment Resultant vs. Time	B-27
Figure No. 96	Driver Right Femur Force X vs. Time	B-28
Figure No. 97	Driver Right Femur Force Y vs. Time	B-28
Figure No. 98	Driver Right Femur Force Z vs. Time	B-28
Figure No. 99	Driver Right Femur Force Resultant vs. Time	B-28
Figure No. 100	Driver Right Femur Moment X vs. Time	B-29
Figure No. 101	Driver Right Femur Moment Y vs. Time	B-29
Figure No. 102	Driver Right Femur Moment Z vs. Time	B-29
Figure No. 103	Driver Right Femur Moment Resultant vs. Time	B-29
Figure No. 104	Driver Left Acetabulum Force Y vs. Time (CFC 1000)	B-30
Figure No. 105	Driver Left Ilium Crest Force Y vs. Time (CFC 1000)	B-30
Figure No. 106	Driver Right Ilium Crest Force Y vs. Time (CFC 1000)	B-30
Figure No. 107	Driver Pubic Symphysis Force Y vs. Time (CFC 1000)	B-30
Figure No. 108	Driver Left Acetabulum Force Y vs. Time (CFC 600)	B-31
Figure No. 109	Driver Left Ilium Crest Force Y vs. Time (CFC 600)	B-31
Figure No. 110	Driver Right Ilium Crest Force Y vs. Time (CFC 600)	B-31
Figure No. 111	Driver Pubic Symphysis Force Y vs. Time (CFC 600)	B-31
Figure No. 112	Driver Rib Contact	B-32
Figure No. 113	Driver Pelvis Contact	B-32
Figure No. 114	Driver Arm Contact	B-32
Figure No. 115	Driver Shoulder DY vs. Time (CFC 180)	B-33
Figure No. 116	Shoulder – Deflection Rate vs. Time (CFC 180)	B-33
Figure No. 117	Shoulder – VC vs. Time (CFC 180)	B-33
Figure No. 118	Driver Shoulder DY vs. Time (CFC 600)	B-34
Figure No. 119	Shoulder – Deflection Rate vs. Time (CFC 600)	B-34
Figure No. 120	Shoulder – VC vs. Time (CFC 600)	B-34

Figure No. 121	Lateral Pelvic Force vs. Time (CFC 1000)	B-35
Figure No. 122	Driver Left Acetabulum Force Y vs. Time (CFC 1000)	B-35
Figure No. 123	Driver Left Ilium Crest Force Y vs. Time (CFC 1000)	B-35
Figure No. 124	Lateral Pelvic Force vs. Time (CFC 600)	B-36
Figure No. 125	Driver Left Acetabulum Force Y vs. Time (CFC 600)	B-36
Figure No. 126	Driver Left Ilium Crest Force Y vs. Time (CFC 600)	B-36
Figure No. 127	Right Front Sill X Acceleration vs. Time	B-37
Figure No. 128	Right Front Sill Y Acceleration vs. Time	B-37
Figure No. 129	Right Front Sill Z Acceleration vs. Time	B-37
Figure No. 130	Right Front Sill Resultant Acceleration vs. Time	B-37
Figure No. 131	Right Front Sill X Velocity vs. Time	B-38
Figure No. 132	Right Front Sill Y Velocity vs. Time	B-38
Figure No. 133	Right Front Sill Z Velocity vs. Time	B-38
Figure No. 134	Right Rear Sill X Acceleration vs. Time	B-39
Figure No. 135	Right Rear Sill Y Acceleration vs. Time	B-39
Figure No. 136	Right Rear Sill Z Acceleration vs. Time	B-39
Figure No. 137	Right Rear Sill Resultant Acceleration vs. Time	B-39
Figure No. 138	Right Rear Sill X Velocity vs. Time	B-40
Figure No. 139	Right Rear Sill Y Velocity vs. Time	B-40
Figure No. 140	Right Rear Sill Z Velocity vs. Time	B-40
Figure No. 141	Left Front Sill Y Acceleration vs. Time	B-41
Figure No. 142	Left Front Sill Y Velocity vs. Time	B-41
Figure No. 143	Left Rear Sill Y Acceleration vs. Time	B-41
Figure No. 144	Left Rear Sill Y Velocity vs. Time	B-41
Figure No. 145	Left Lower A-Post Y Acceleration vs. Time	B-42
Figure No. 146	Left Lower A-Post Y Velocity vs. Time	B-42
Figure No. 147	Left Mid A-Post Y Acceleration vs. Time	B-42
Figure No. 148	Left Mid A-Post Y Velocity vs. Time	B-42
Figure No. 149	Left Lower B-Post Y Acceleration vs. Time	B-43
Figure No. 150	Left Lower B-Post Y Velocity vs. Time	B-43
Figure No. 151	Left Mid B-Post Y Acceleration vs. Time	B-43

Figure No. 152	Left Mid B-Post Y Velocity vs. Time	B-43
Figure No. 153	Driver Seat Track Y Acceleration vs. Time	B-44
Figure No. 154	Driver Seat Track Y Velocity vs. Time	B-44
Figure No. 155	Driver Left Seat Frame Y Acceleration vs. Time	B-45
Figure No. 156	Driver Left Seat Frame Y Velocity vs. Time	B-45
Figure No. 157	Driver Right Seat Frame Y Acceleration vs. Time	B-45
Figure No. 158	Driver Right Seat Frame Y Velocity vs. Time	B-45
Figure No. 159	Vehicle CG X Acceleration vs. Time	B-46
Figure No. 160	Vehicle CG Y Acceleration vs. Time	B-46
Figure No. 161	Vehicle CG Z Acceleration vs. Time	B-46
Figure No. 162	Vehicle CG Resultant Acceleration vs. Time	B-46
Figure No. 163	Vehicle CG X Velocity vs. Time	B-47
Figure No. 164	Vehicle CG Y Velocity vs. Time	B-47
Figure No. 165	Vehicle CG Z Velocity vs. Time	B-47
Figure No. 166	LF Door @ Arm Y Acceleration vs. Time	B-48
Figure No. 167	LF Door @ Rib Y Acceleration vs. Time	B-48
Figure No. 168	LF Door @ Pelvis Y Acceleration vs. Time	B-48
Figure No. 169	LF Door @ Knee Y Acceleration vs. Time	B-48
Figure No. 170	LF Door @ Arm Y Velocity vs. Time	B-49
Figure No. 171	LF Door @ Rib Y Velocity vs. Time	B-49
Figure No. 172	LF Door @ Pelvis Y Velocity vs. Time	B-49
Figure No. 173	LF Door @ Knee Y Velocity vs. Time	B-49
Figure No. 174	LC Radiator Support X Acceleration vs. Time	B-50
Figure No. 175	LC Radiator Support Y Acceleration vs. Time	B-50
Figure No. 176	LC Radiator Support Z Acceleration vs. Time	B-50
Figure No. 177	LC Radiator Support Resultant Acceleration vs. Time	B-50
Figure No. 178	LC Radiator Support X Velocity vs. Time	B-51
Figure No. 179	LC Radiator Support Y Velocity vs. Time	B-51
Figure No. 180	LC Radiator Support Z Velocity vs. Time	B-51
Figure No. 181	Floorpan @ Rear Axle X Acceleration vs. Time	B-52
Figure No. 182	Floorpan @ Rear Axle Y Acceleration vs. Time	B-52

Figure No. 183	Floorpan @ Rear Axle Z Acceleration vs. Time	B-52
Figure No. 184	Floorpan @ Rear Axle Resultant Acceleration vs. Time	B-52
Figure No. 185	Floorpan @ Rear Axle X Velocity vs. Time	B-53
Figure No. 186	Floorpan @ Rear Axle Y Velocity vs. Time	B-53
Figure No. 187	Floorpan @ Rear Axle Z Velocity vs. Time	B-53
Figure No. 188	Driver Upper Spine X Acceleration vs. Time (FIR Filtered)	B-54
Figure No. 189	Driver Upper Spine Y Acceleration vs. Time (FIR Filtered)	B-54
Figure No. 190	Driver Upper Spine Z Acceleration vs. Time (FIR Filtered)	B-54
Figure No. 191	Driver Lower Spine X Acceleration vs. Time (FIR Filtered)	B-55
Figure No. 192	Driver Lower Spine Y Acceleration vs. Time (FIR Filtered)	B-55
Figure No. 193	Driver Lower Spine Z Acceleration vs. Time (FIR Filtered)	B-55
Figure No. 194	Driver Pelvis X Acceleration vs. Time (FIR Filtered)	B-56
Figure No. 195	Driver Pelvis Y Acceleration vs. Time (FIR Filtered)	B-56
Figure No. 196	Driver Pelvis Z Acceleration vs. Time (FIR Filtered)	B-56
Figure No. 197	Driver Upper Thorax Rib Y Acceleration vs. Time (FIR Filtered)	B-57
Figure No. 198	Driver Mid Thorax Rib Y Acceleration vs. Time (FIR Filtered)	B-57
Figure No. 199	Driver Lower Thorax Rib Y Acceleration vs. Time (FIR Filtered)	B-57
Figure No. 200	Driver Upper Abdominal Rib Y Acceleration vs. Time (FIR Filtered)	B-58
Figure No. 201	Driver Lower Abdominal Rib Y Acceleration vs. Time (FIR Filtered)	B-58
Figure No. 202	Front Rib to Rib Guide 1 vs. Time	B-59
Figure No. 203	Front Rib to Rib Guide 2 vs. Time	B-59
Figure No. 204	Front Rib to Rib Guide 3 vs. Time	B-59
Figure No. 205	Front Rib to Rib Guide 4 vs. Time	B-59
Figure No. 206	Rear Rib to Rib Guide 1 vs. Time	B-60
Figure No. 207	Rear Rib to Rib Guide 2 vs. Time	B-60
Figure No. 208	Rear Rib to Rib Guide 3 vs. Time	B-60
Figure No. 209	Rear Rib to Rib Guide 4 vs. Time	B-60
Figure No. 210	Front Rib to Rib Guide 5 vs. Time	B-61
Figure No. 211	Rear Rib to Rib Guide 5 vs. Time	B-61
Figure No. 212	Front Rib to Stop 1 vs. Time	B-62
Figure No. 213	Front Rib to Stop 2 vs. Time	B-62

Figure No. 214	Front Rib to Stop 3 vs. Time	B-62
Figure No. 215	Front Rib to Stop 4 vs. Time	B-62
Figure No. 216	Front Rib to Stop 5 vs. Time	B-63
Figure No. 217	Rear Rib to Stop 1 vs. Time	B-64
Figure No. 218	Rear Rib to Stop 2 vs. Time	B-64
Figure No. 219	Rear Rib to Stop 3 vs. Time	B-64
Figure No. 220	Rear Rib to Stop 4 vs. Time	B-64
Figure No. 221	Rear Rib to Stop 5 vs. Time	B-65

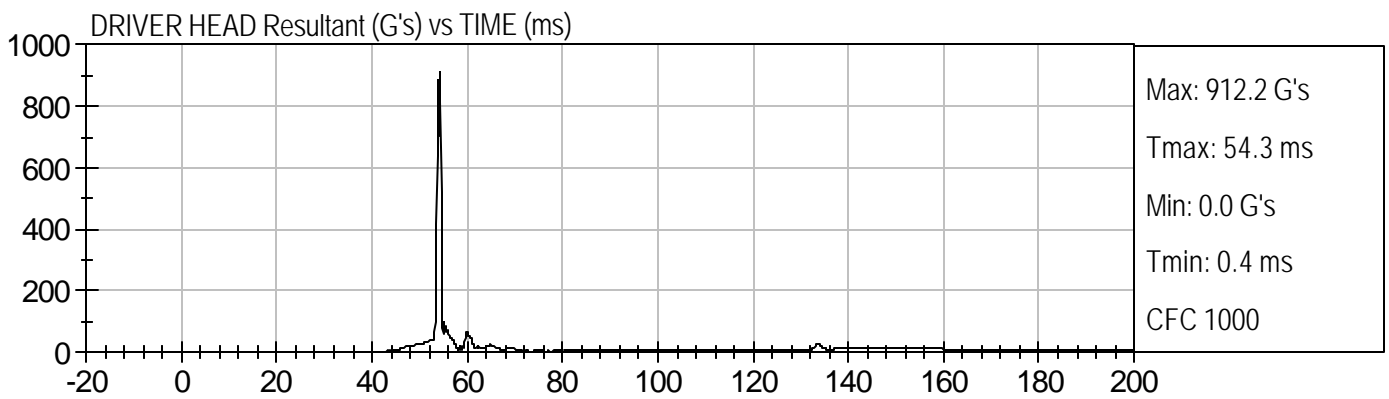
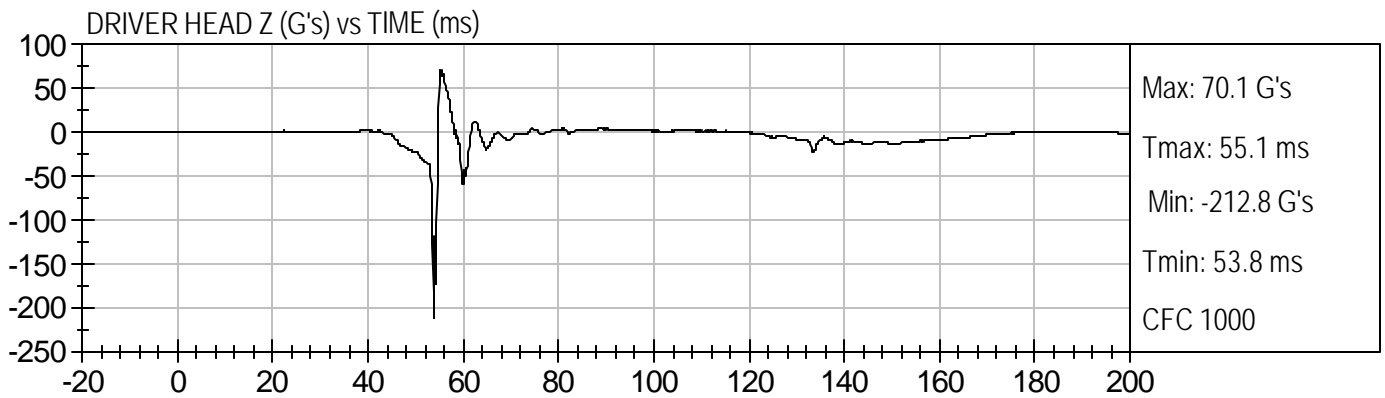
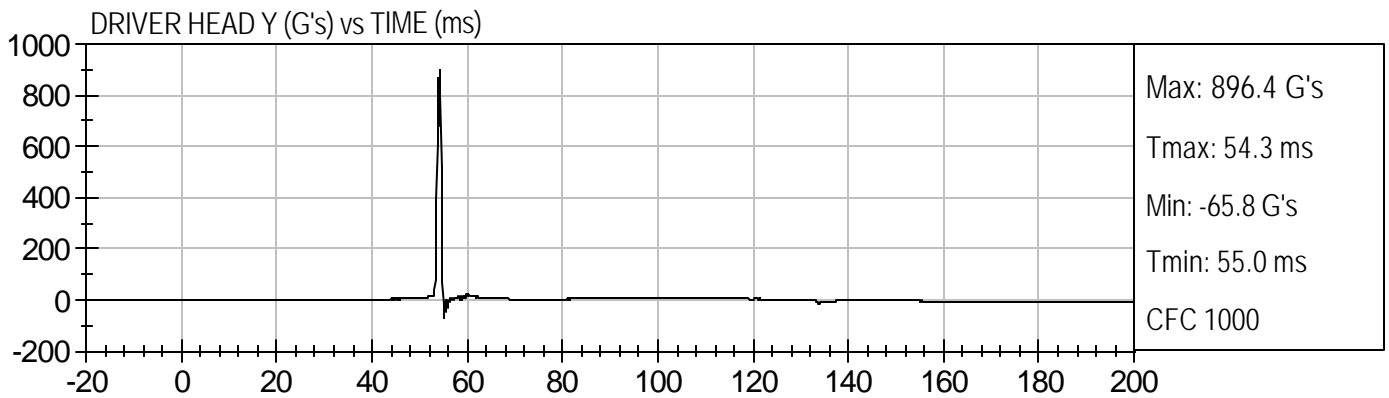
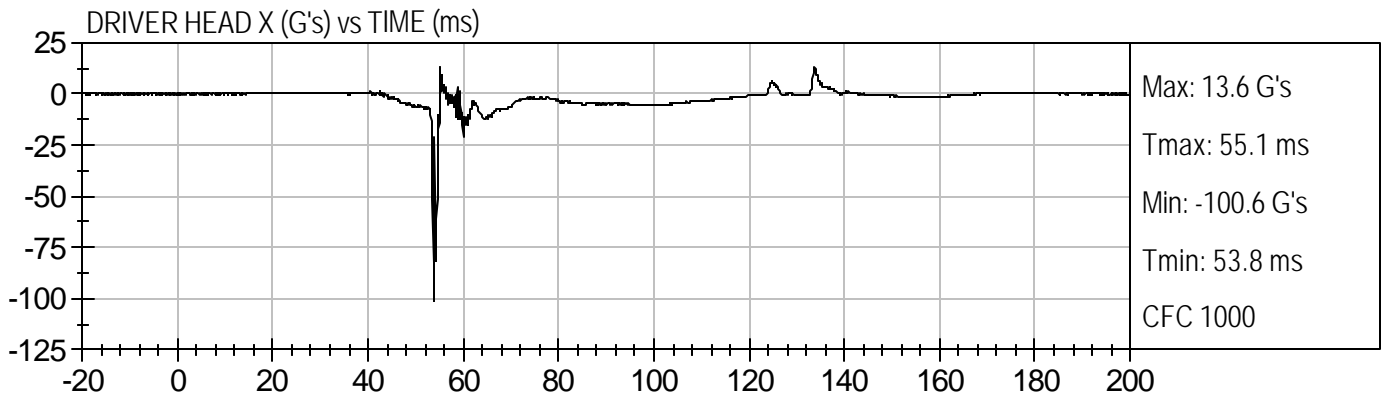

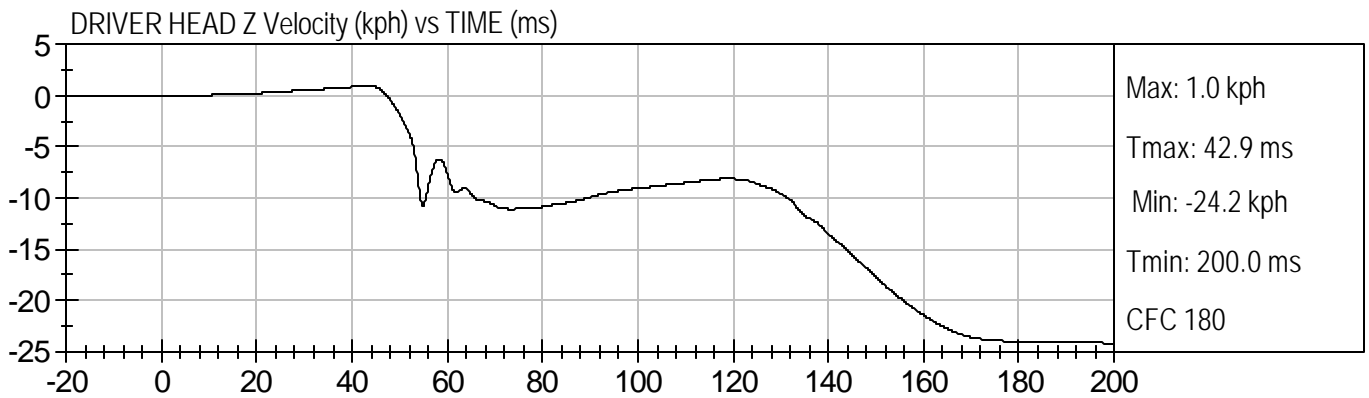
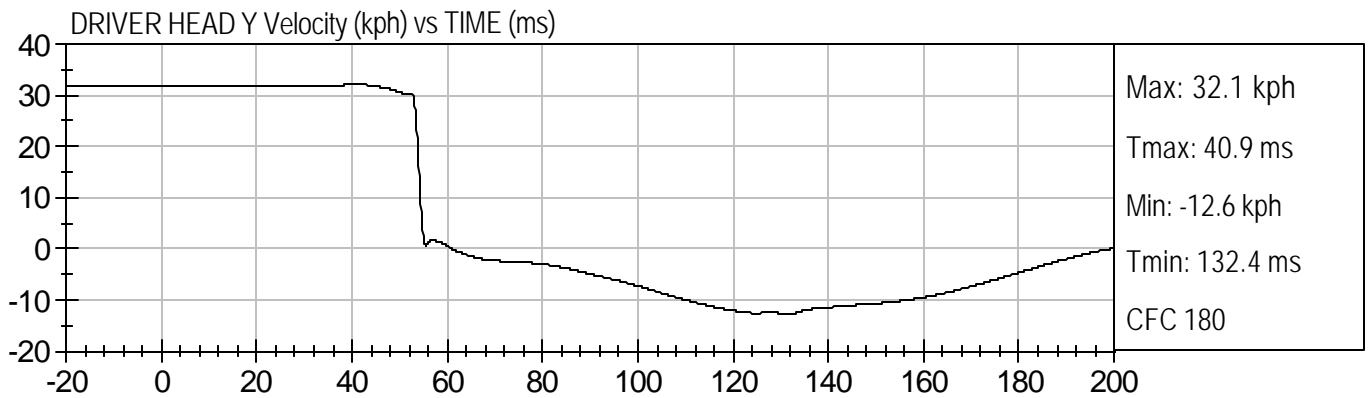
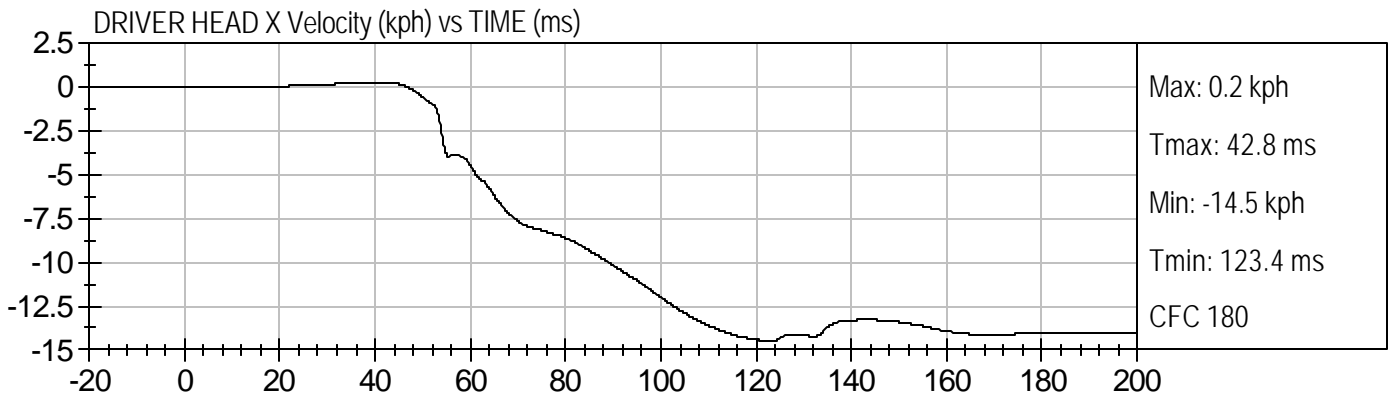

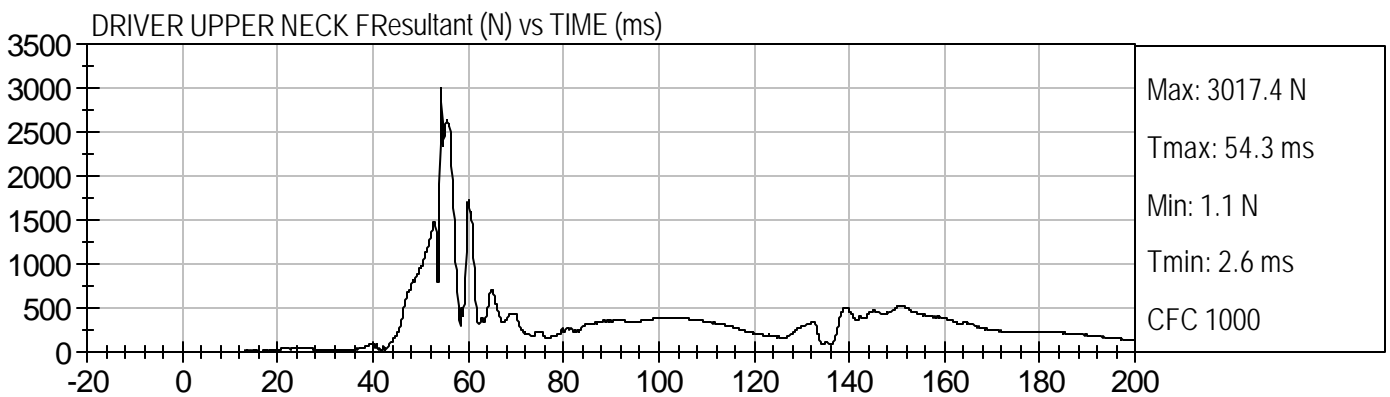
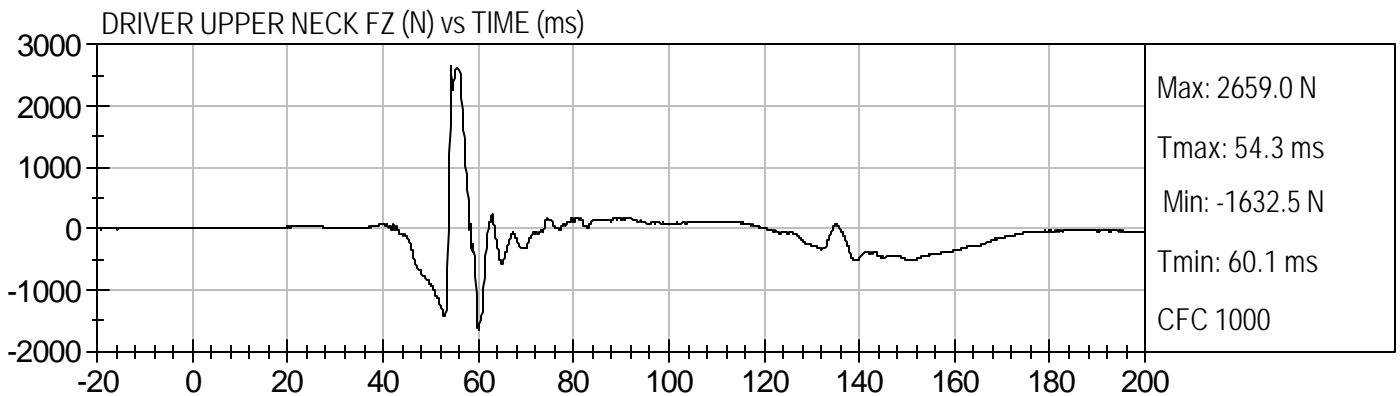
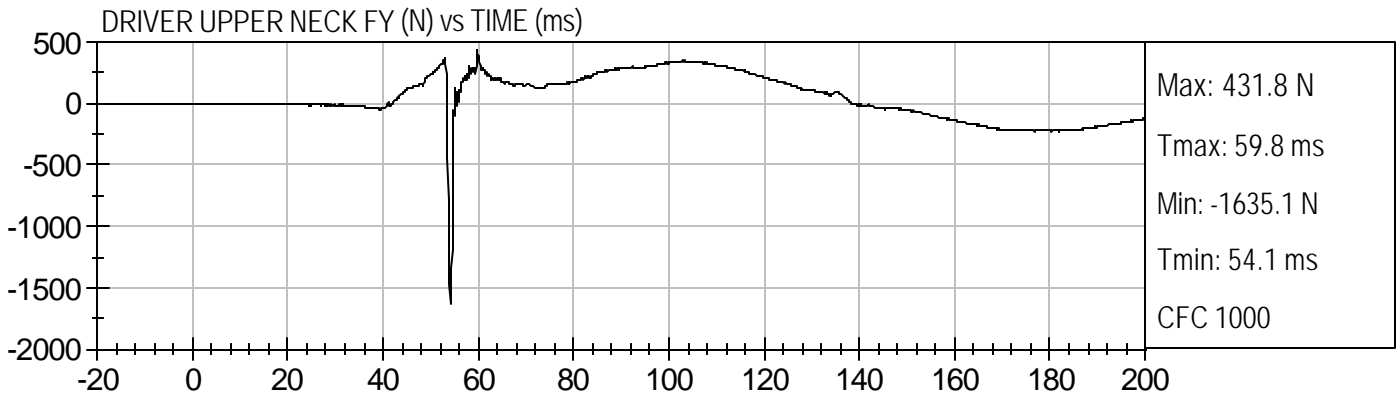
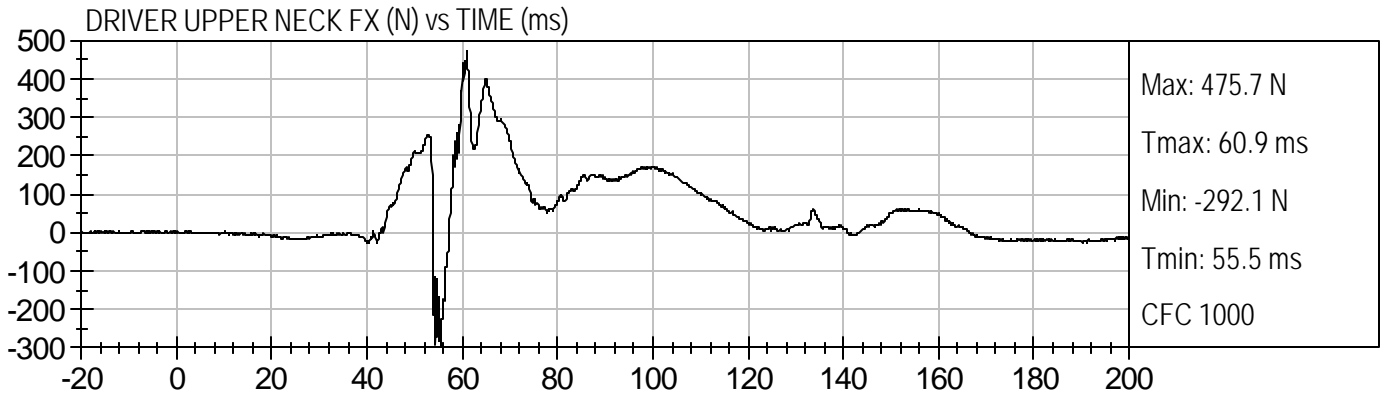

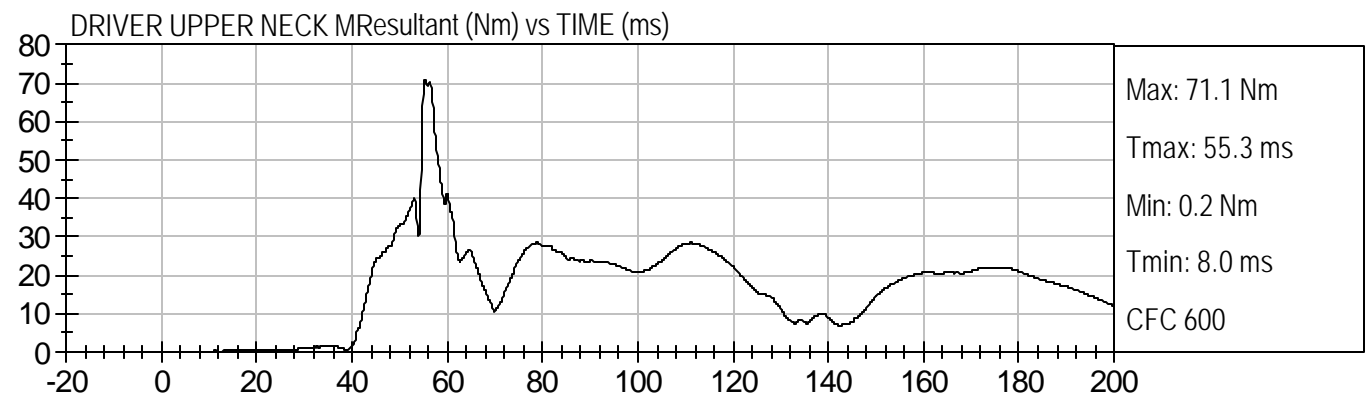
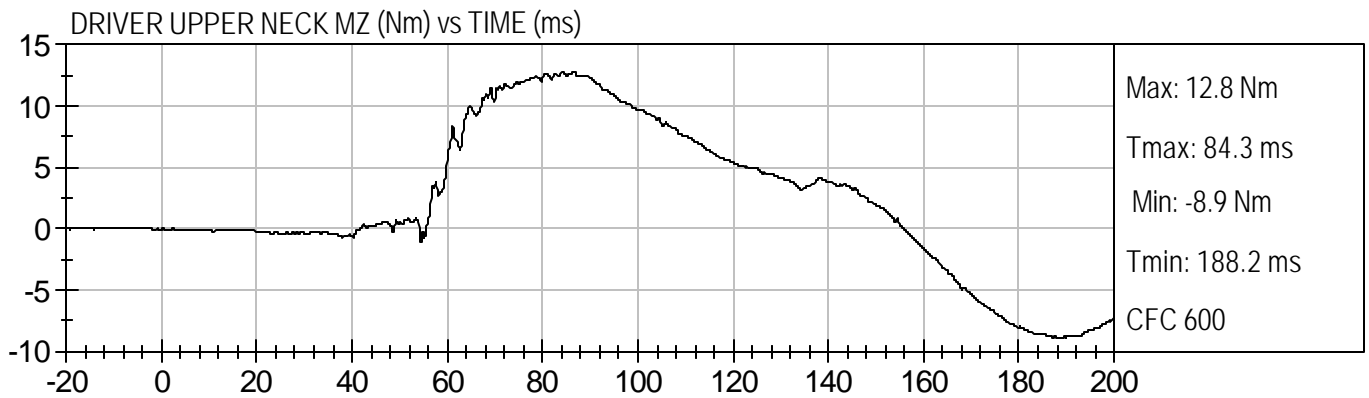
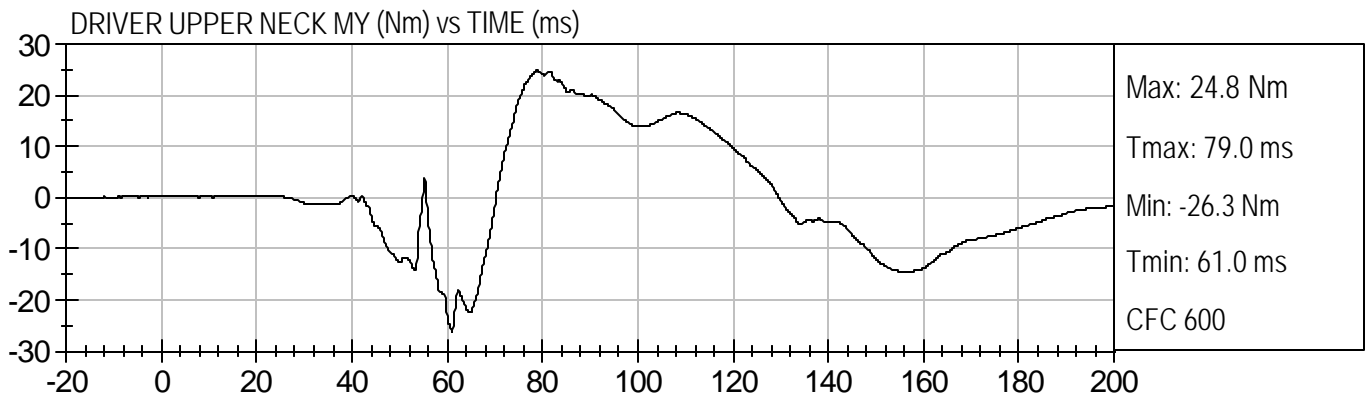
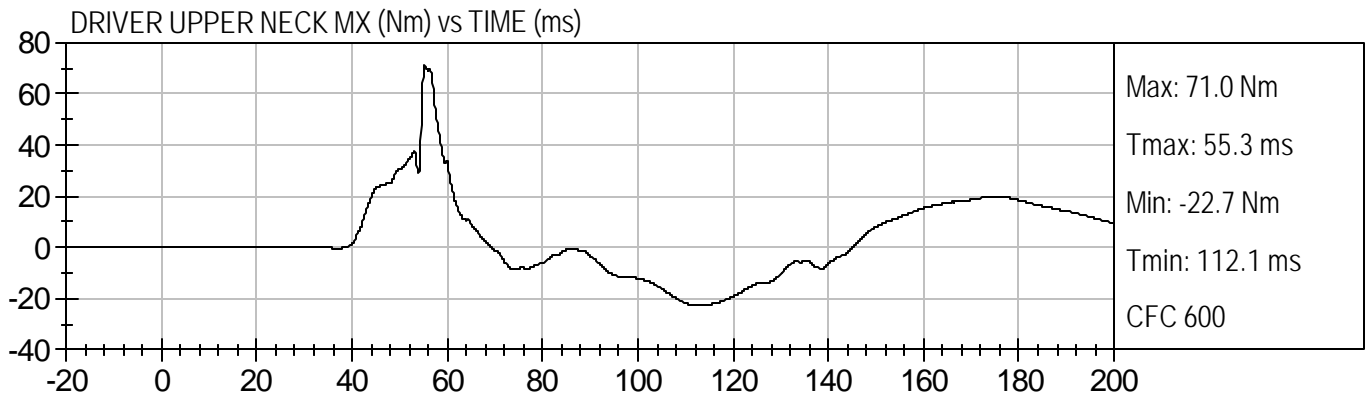

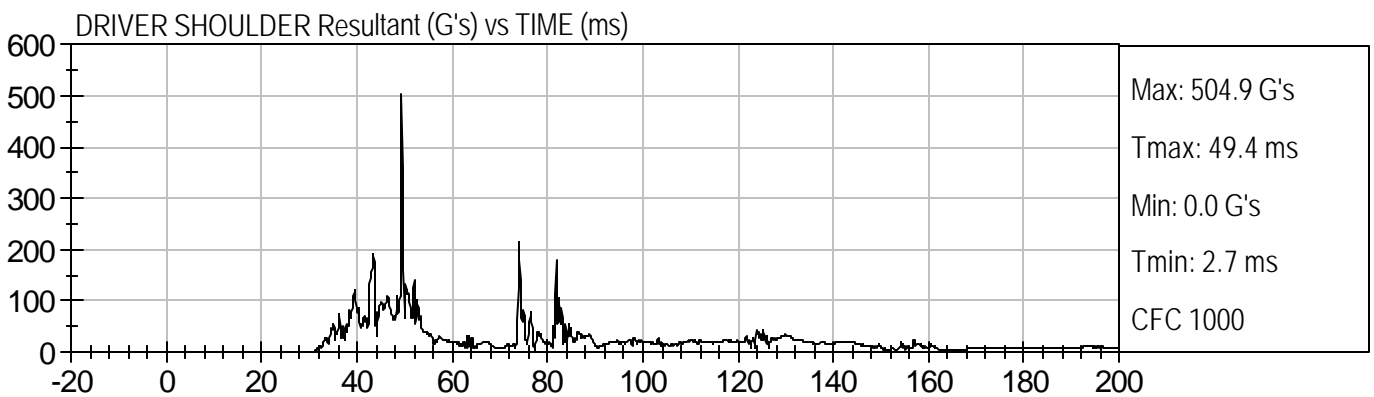
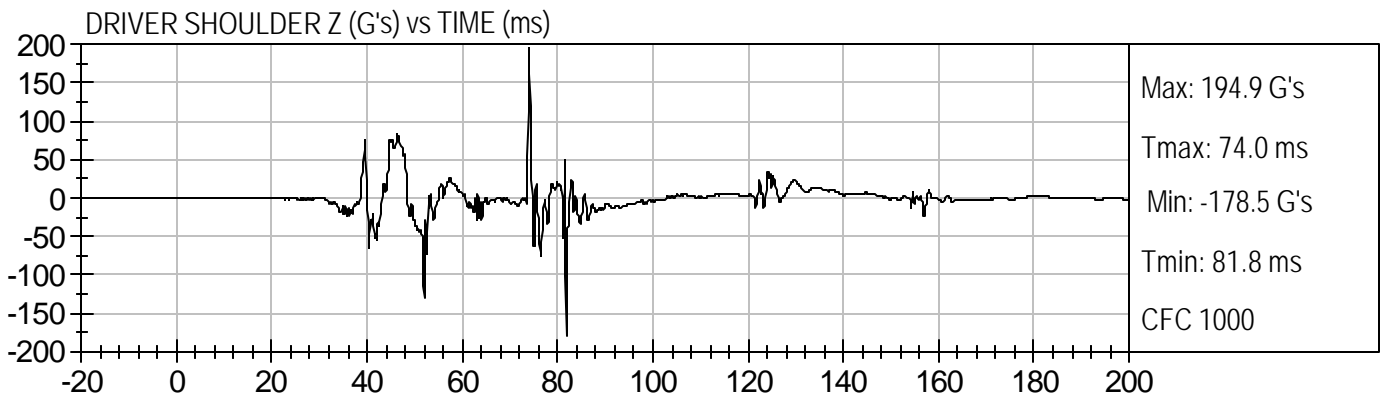
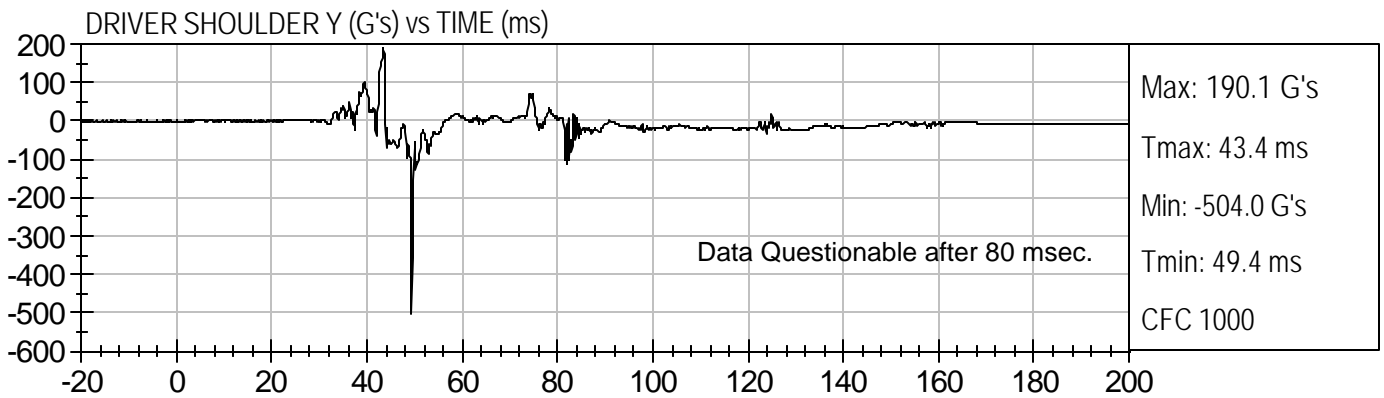
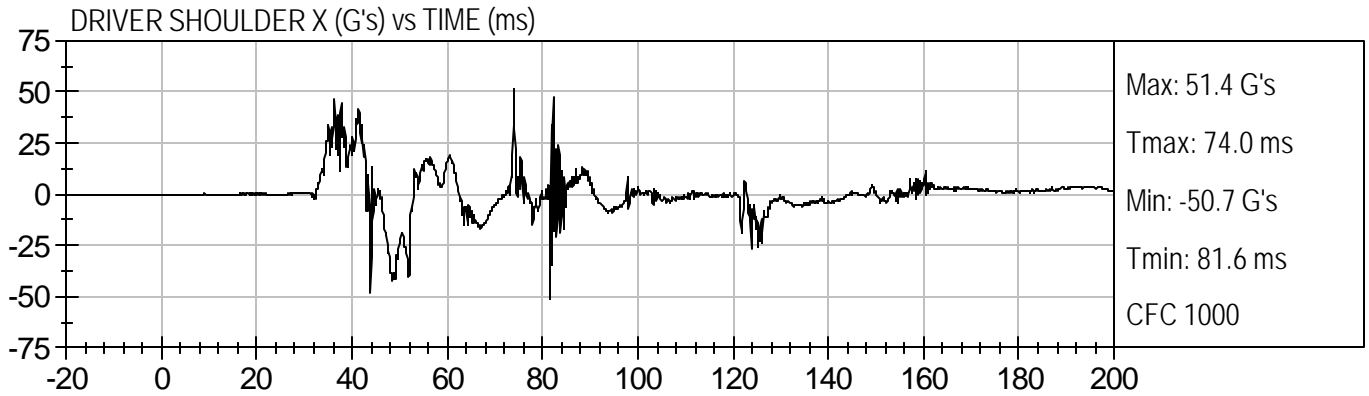

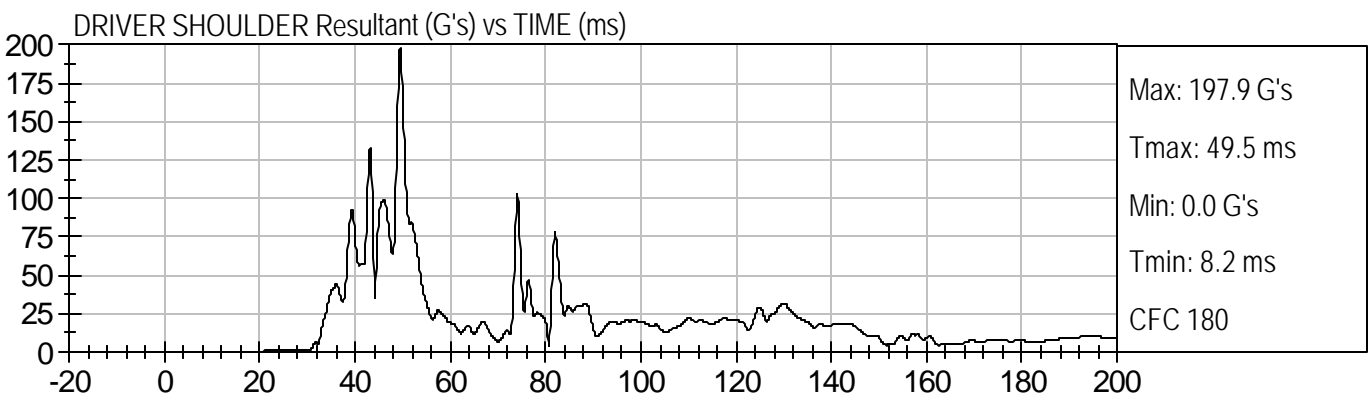
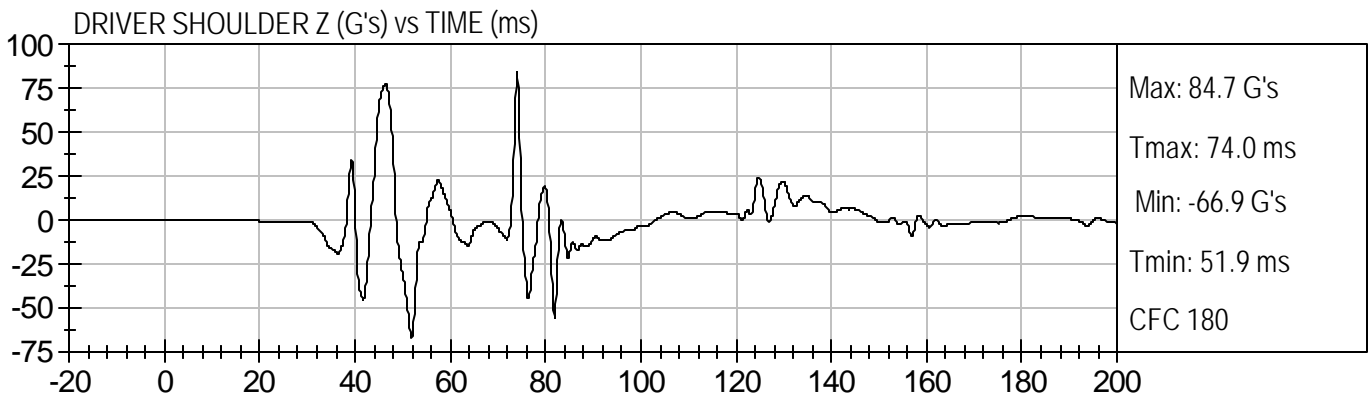
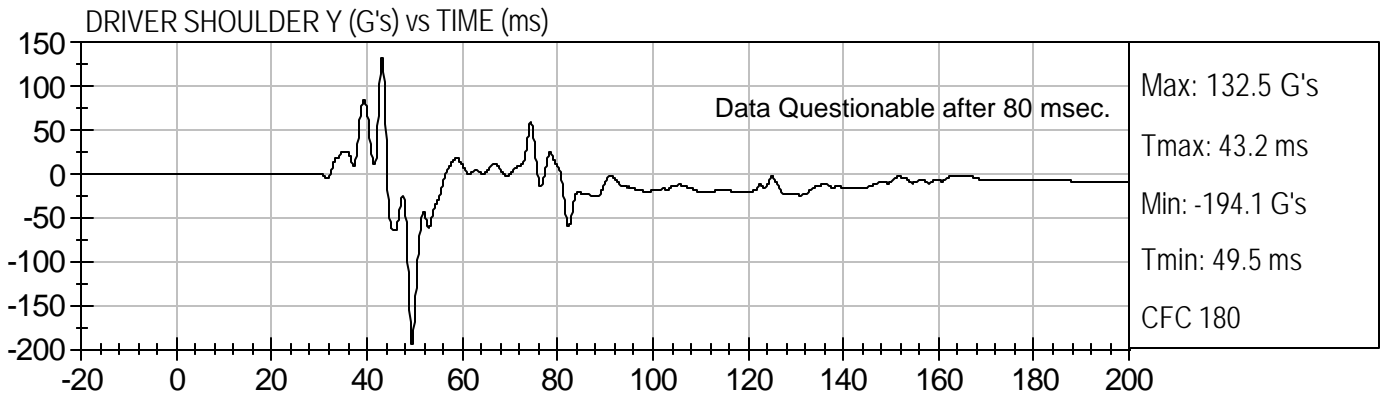
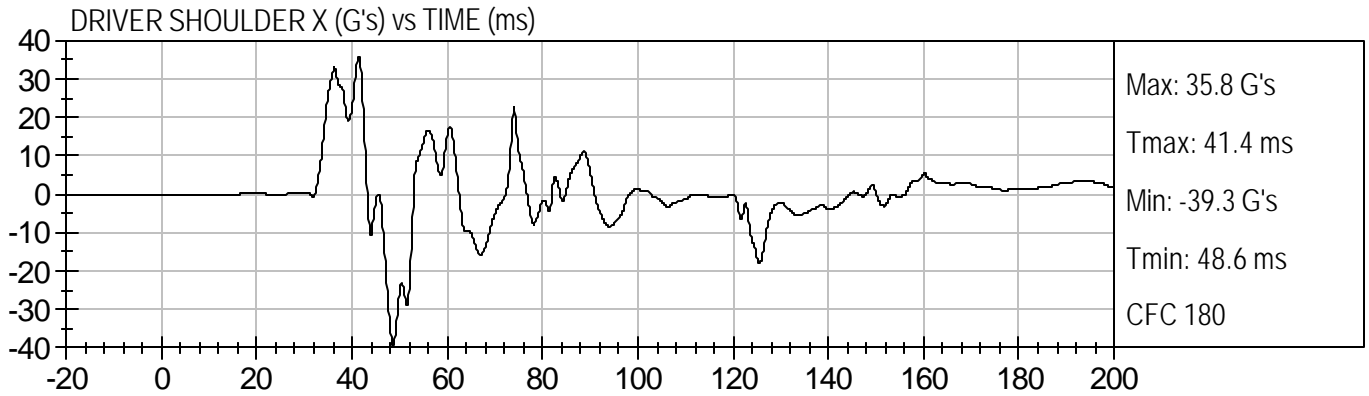



DRIVER SHOULDER X Velocity (kph) vs TIME (ms)

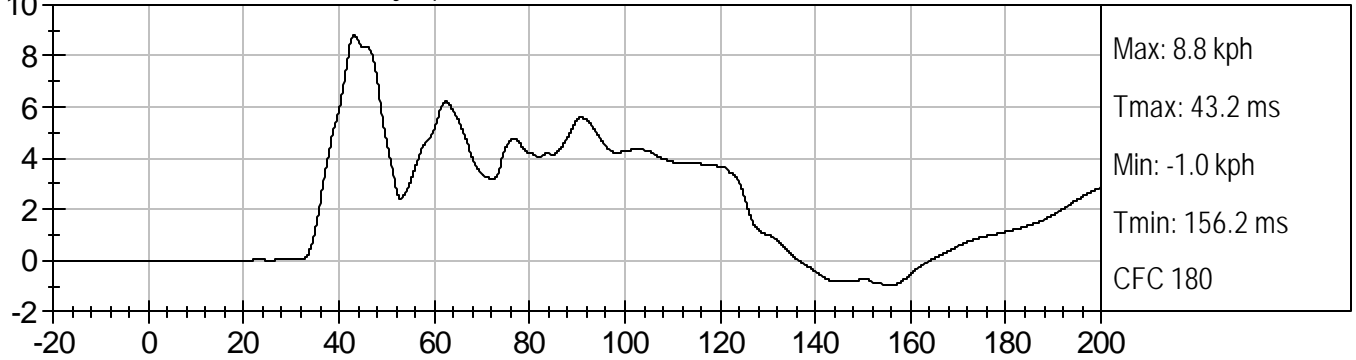

DRIVER SHOULDER Y Velocity (kph) vs TIME (ms)

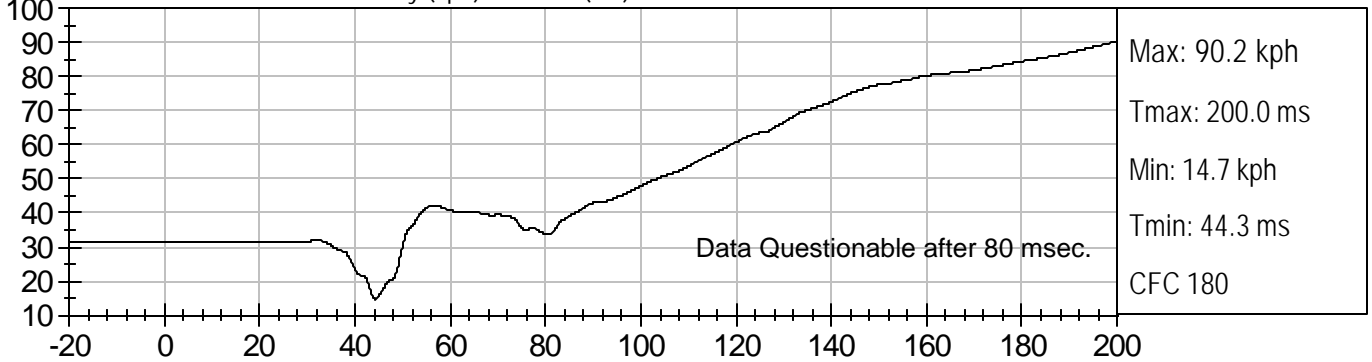

DRIVER SHOULDER Z Velocity (kph) vs TIME (ms)

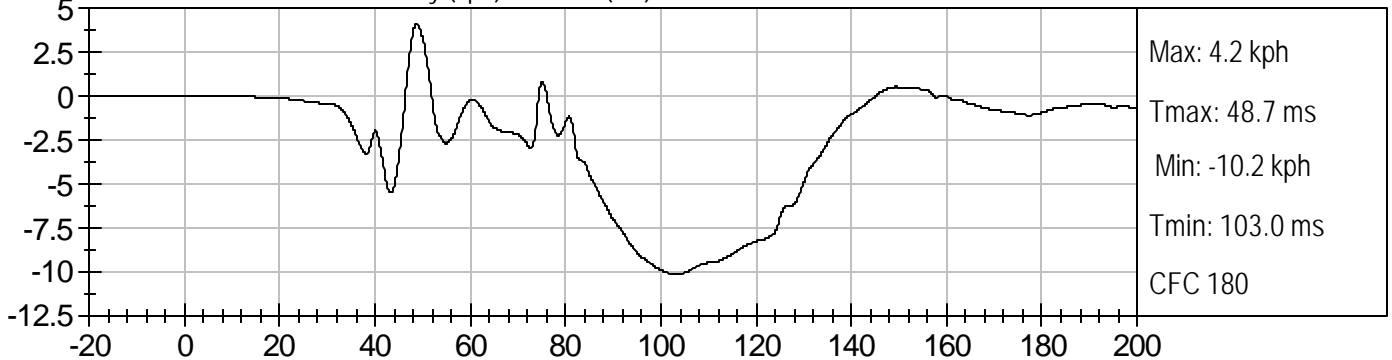

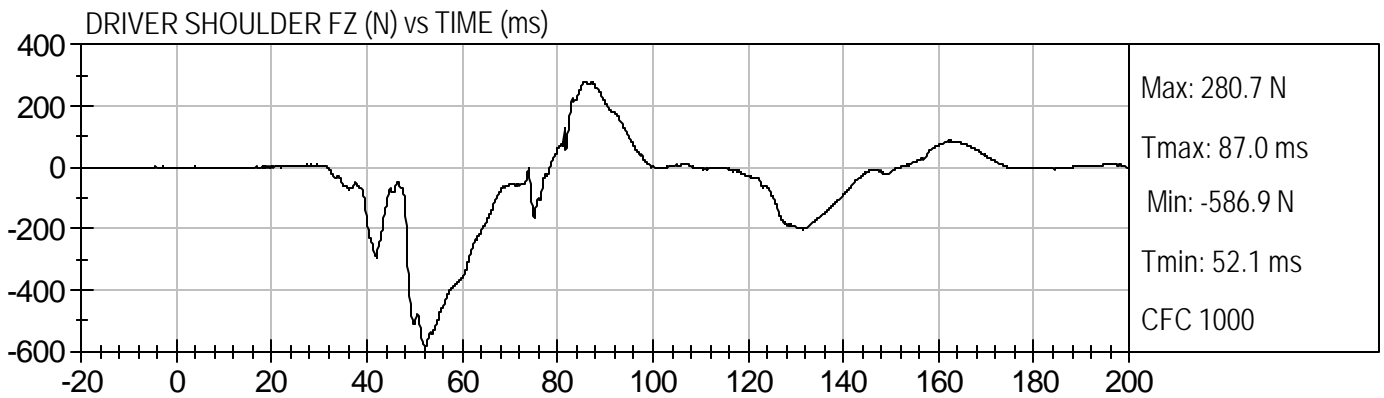
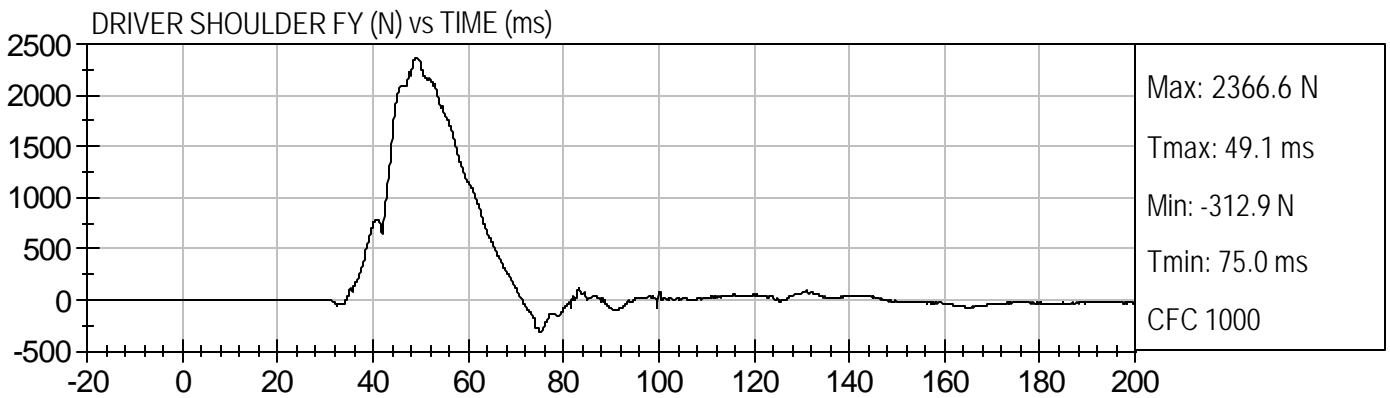
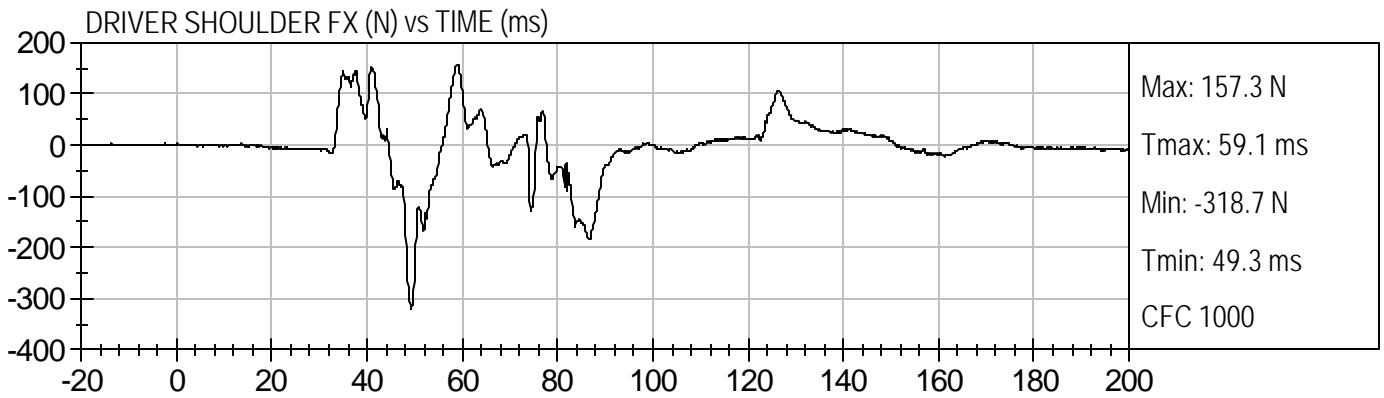

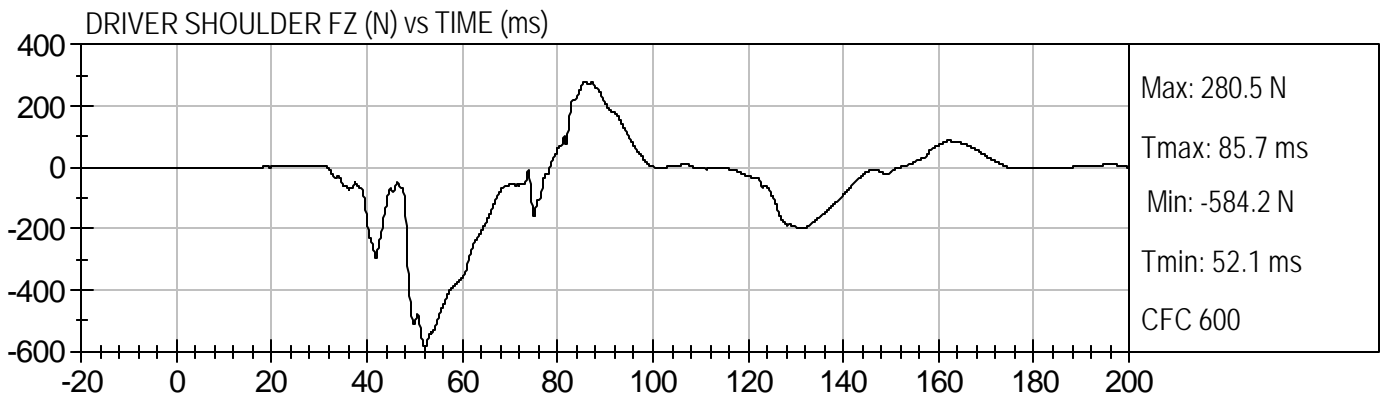
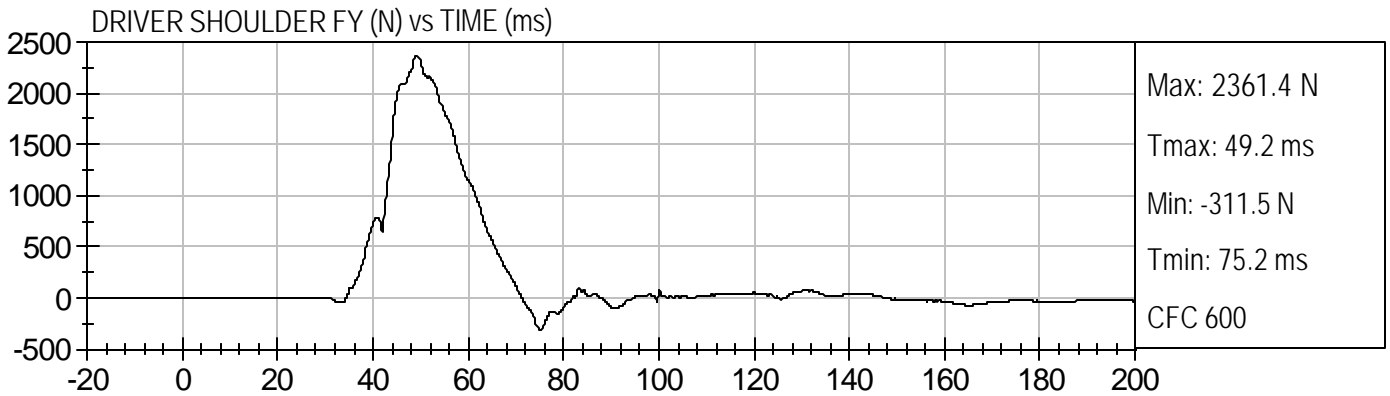
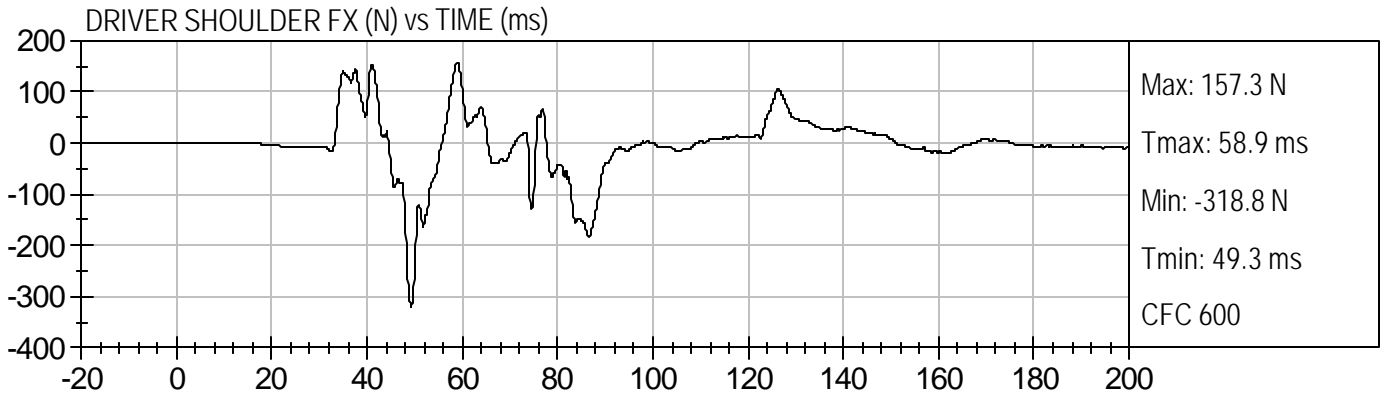

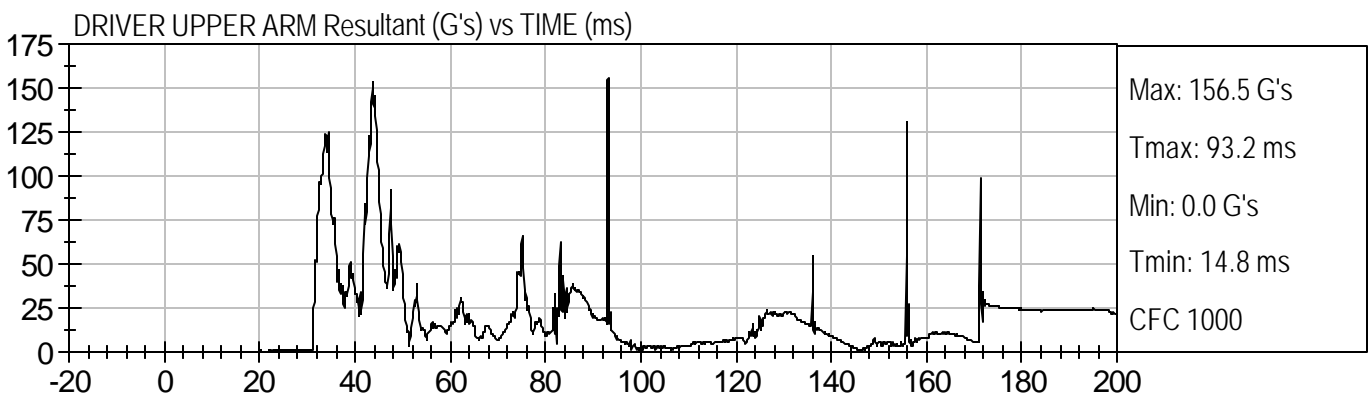
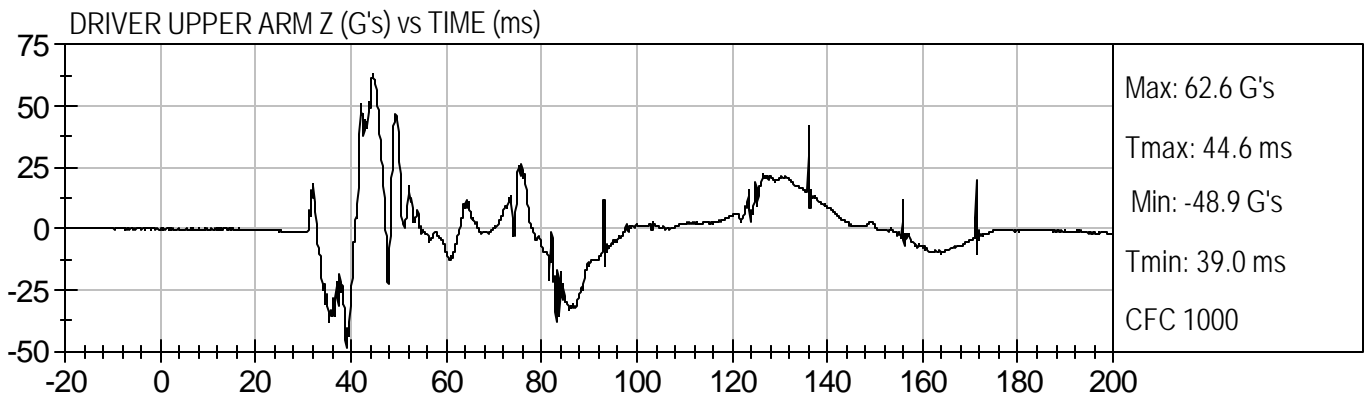
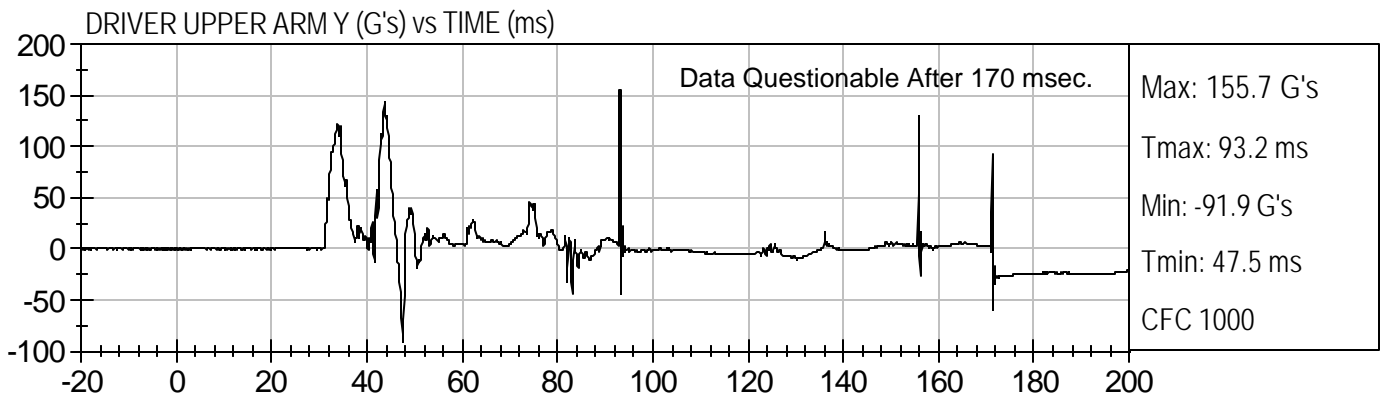
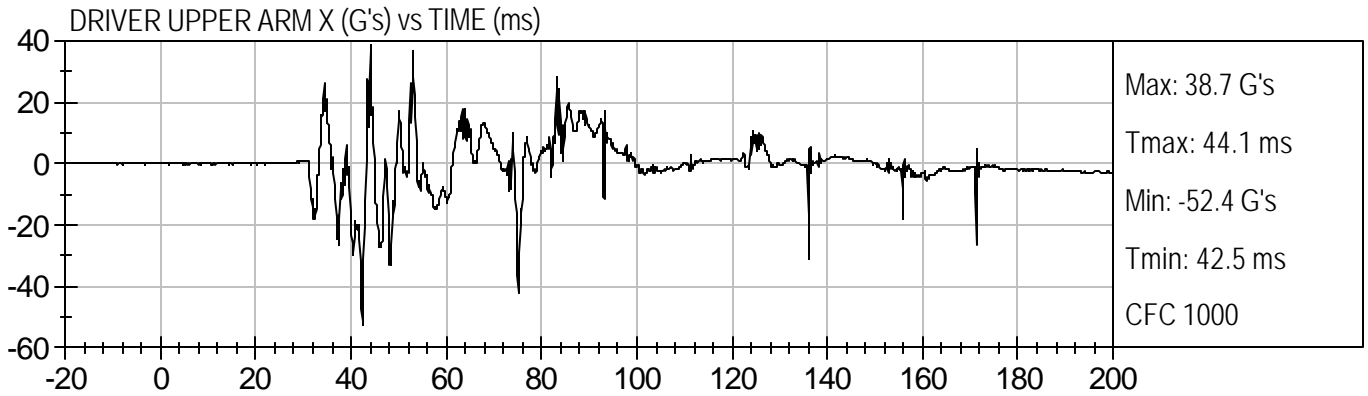

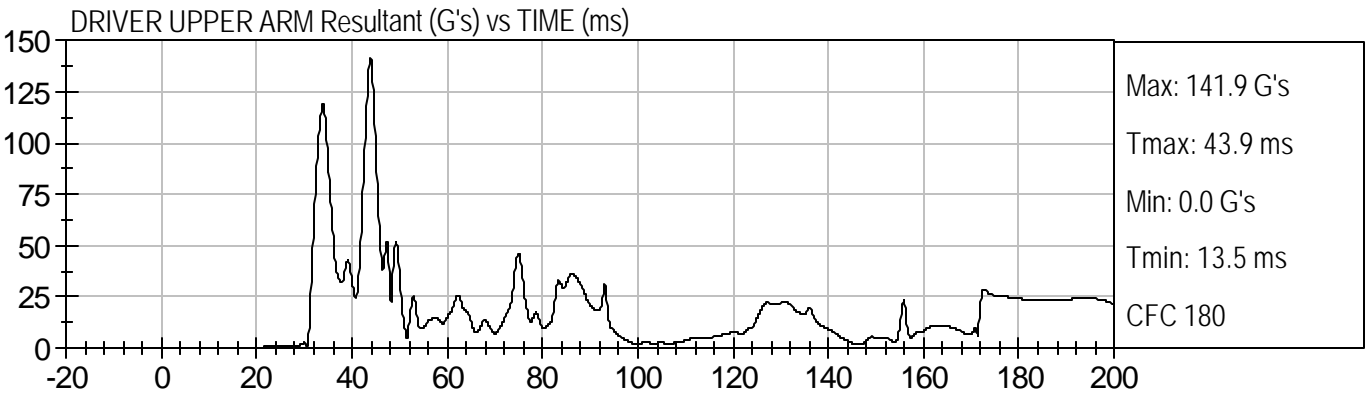
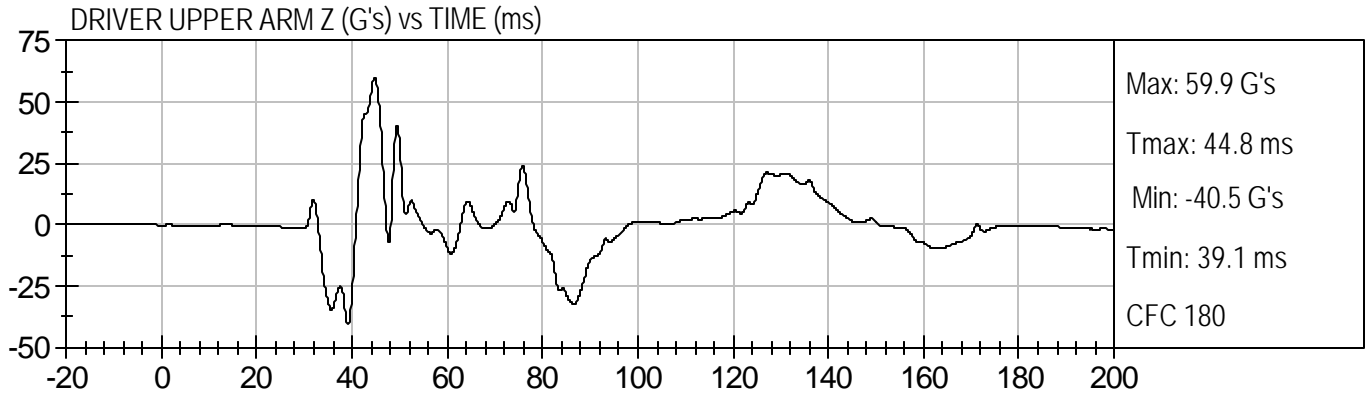
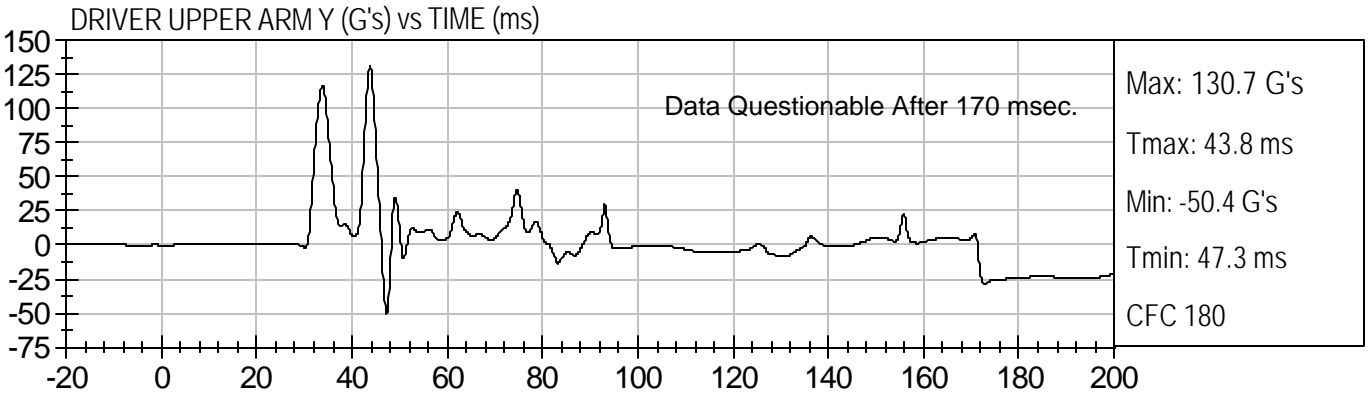
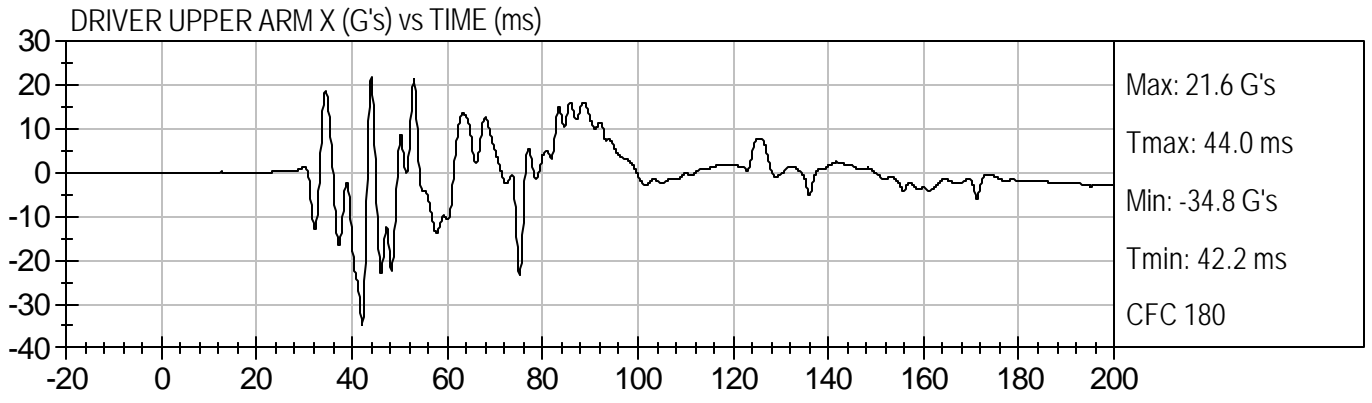



DRIVER UPPER ARM X Velocity (kph) vs TIME (ms)

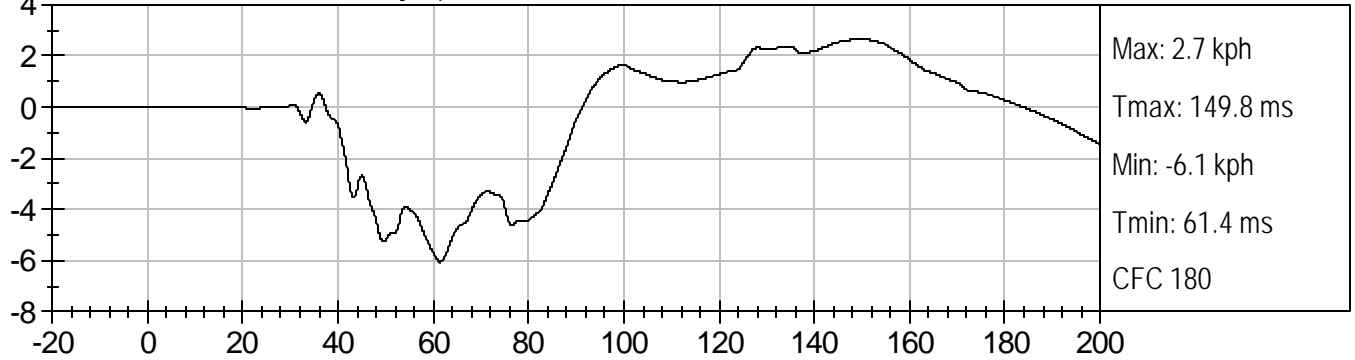

DRIVER UPPER ARM Y Velocity (kph) vs TIME (ms)

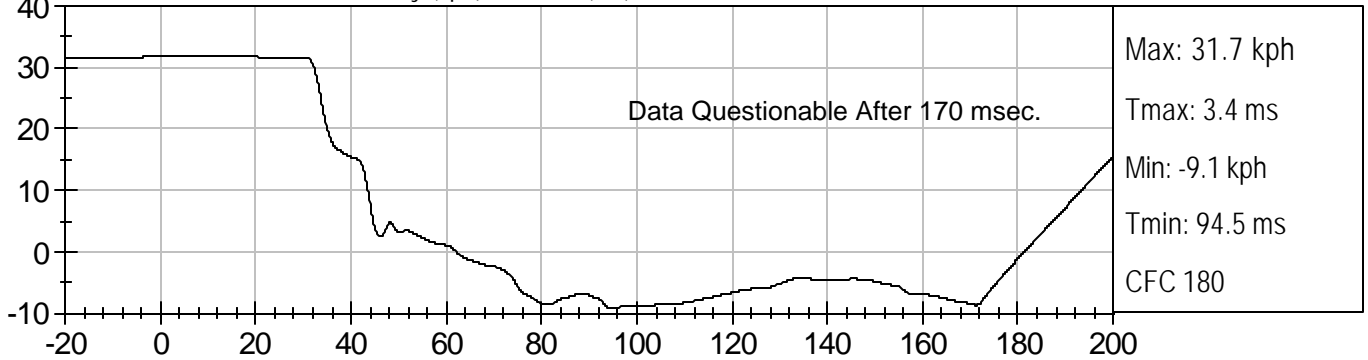

DRIVER UPPER ARM Z Velocity (kph) vs TIME (ms)

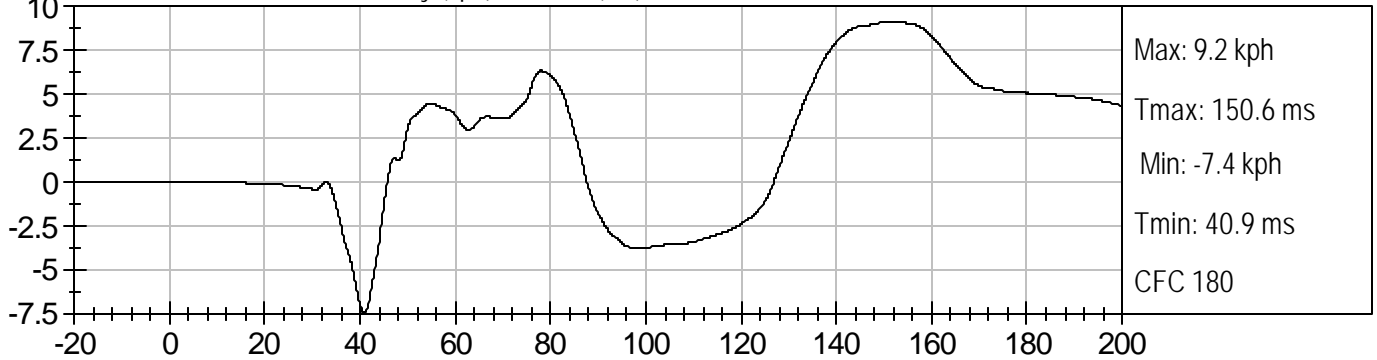

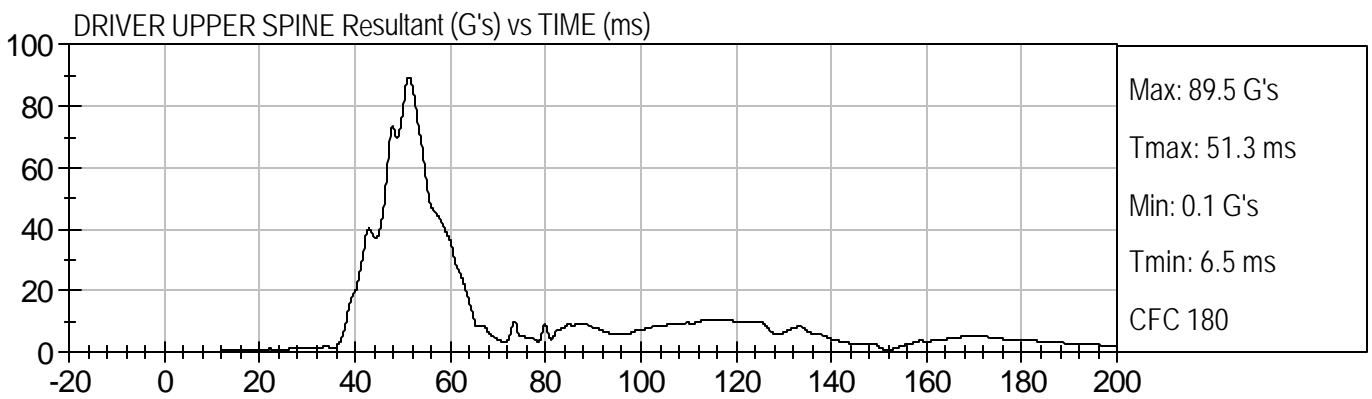
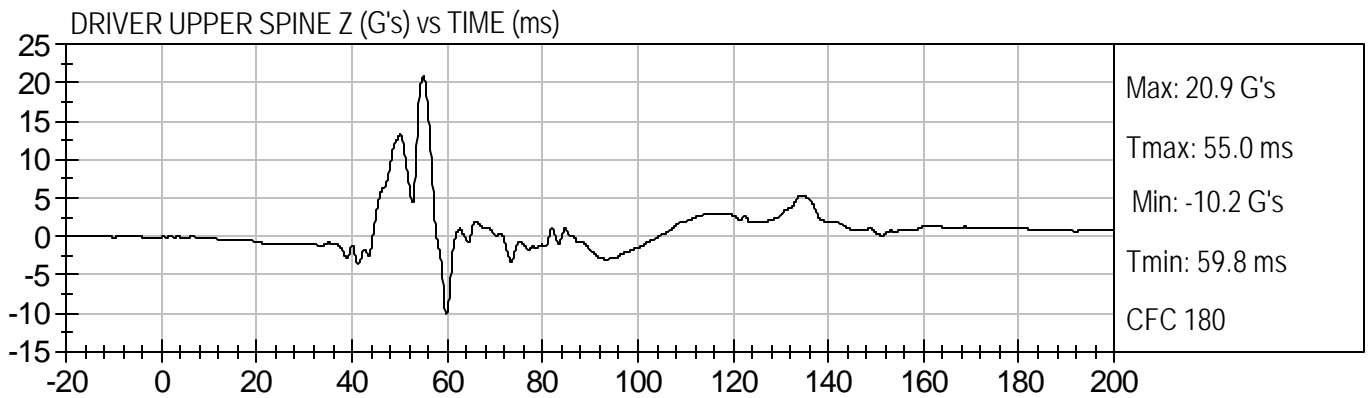
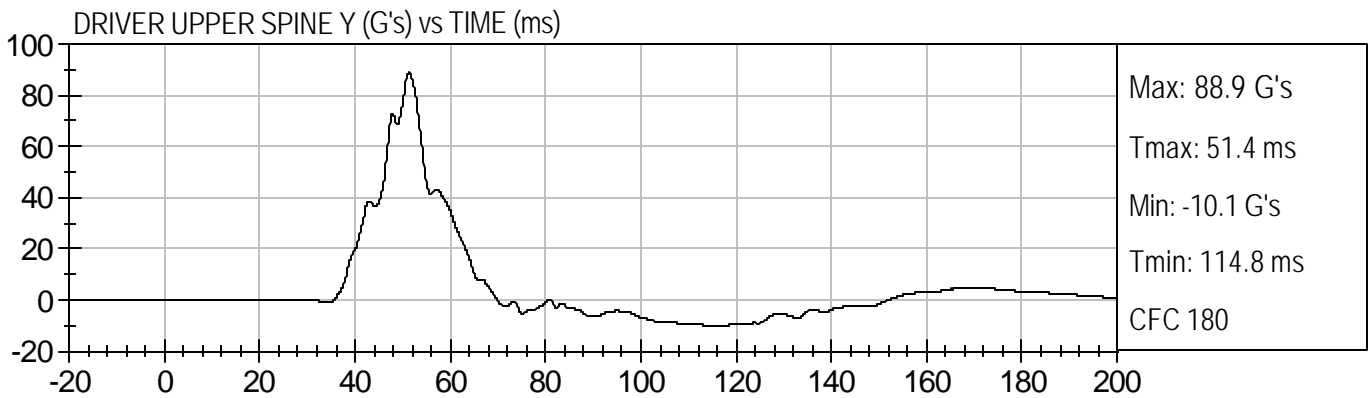
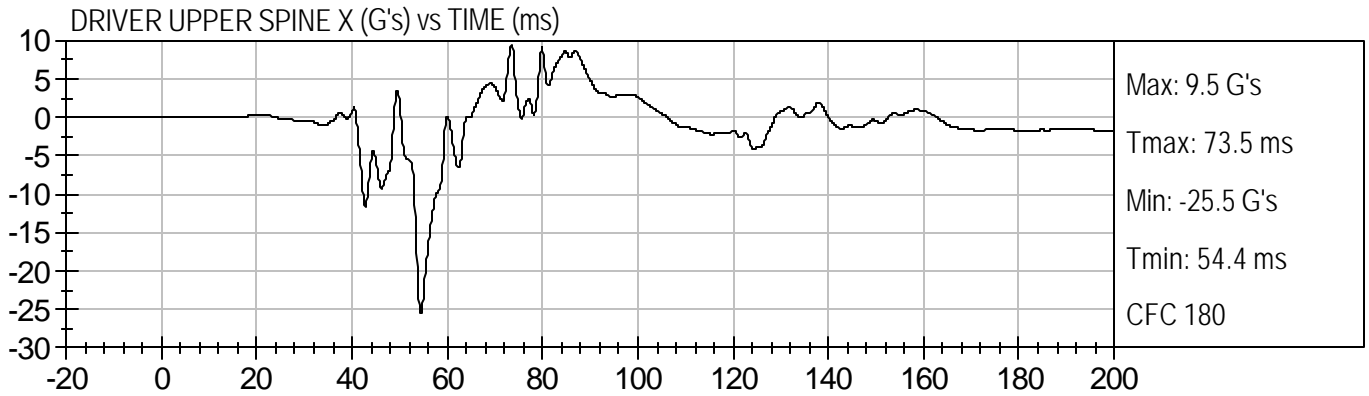

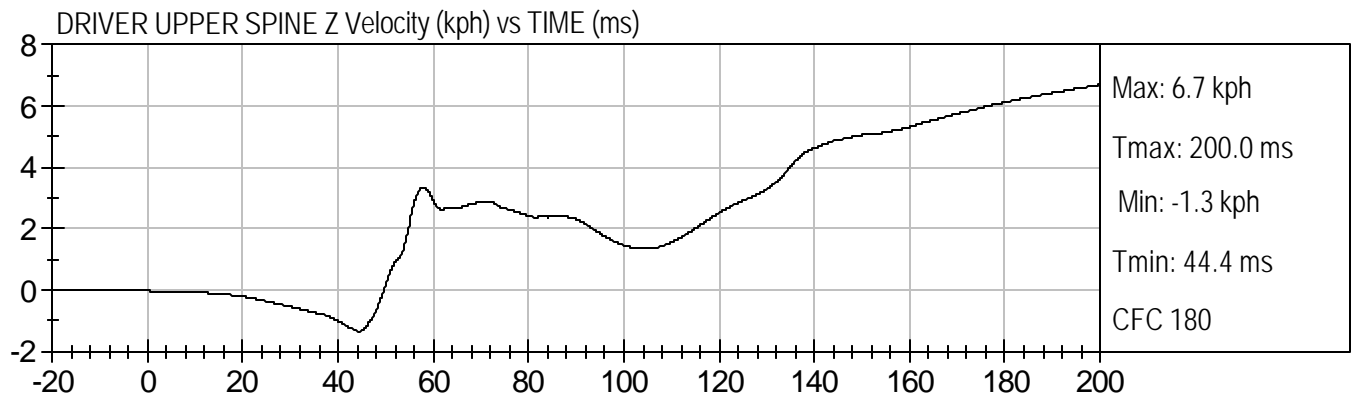
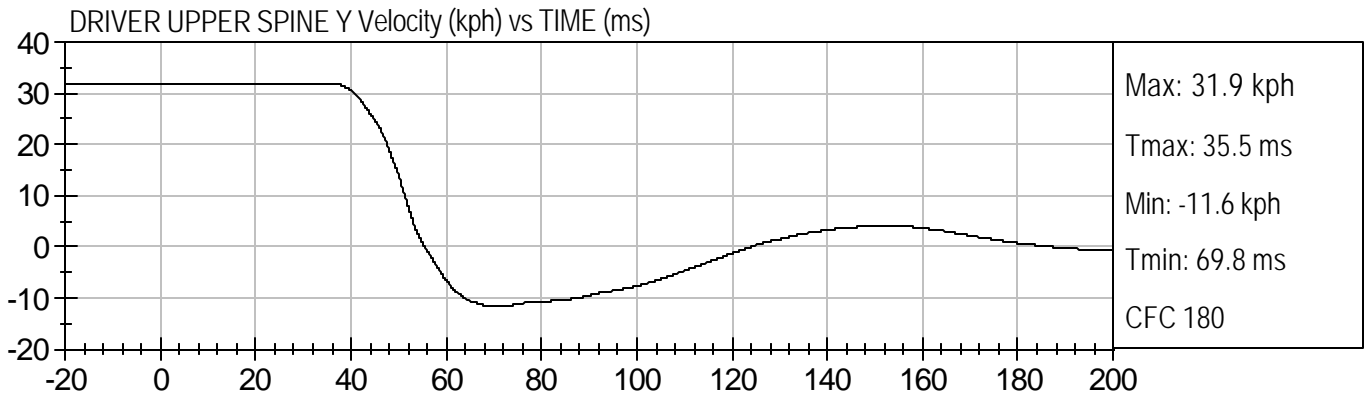
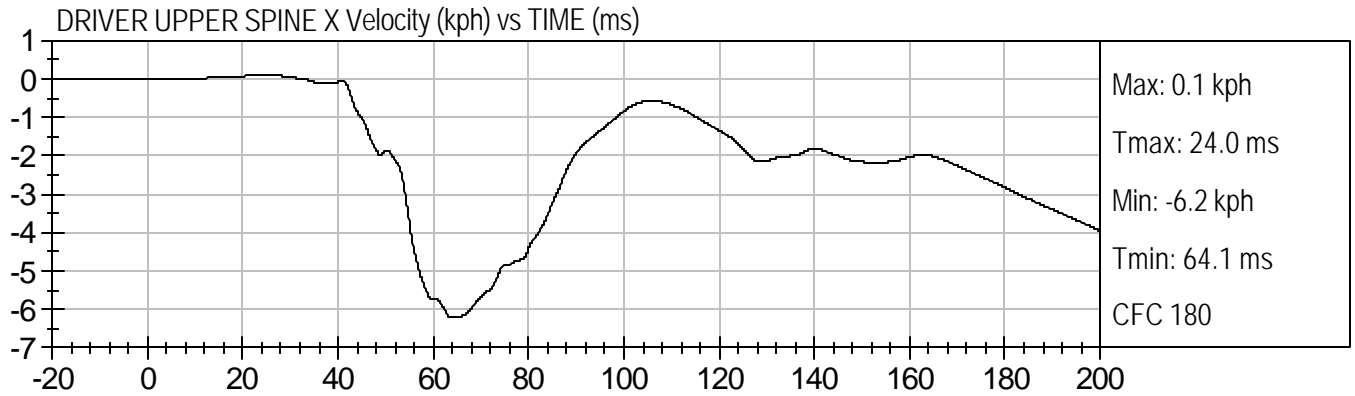

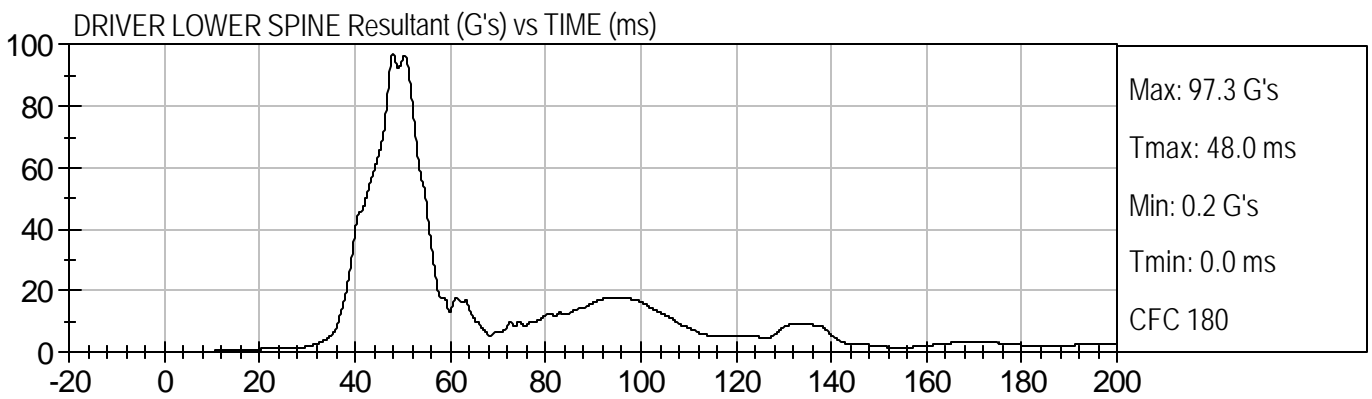
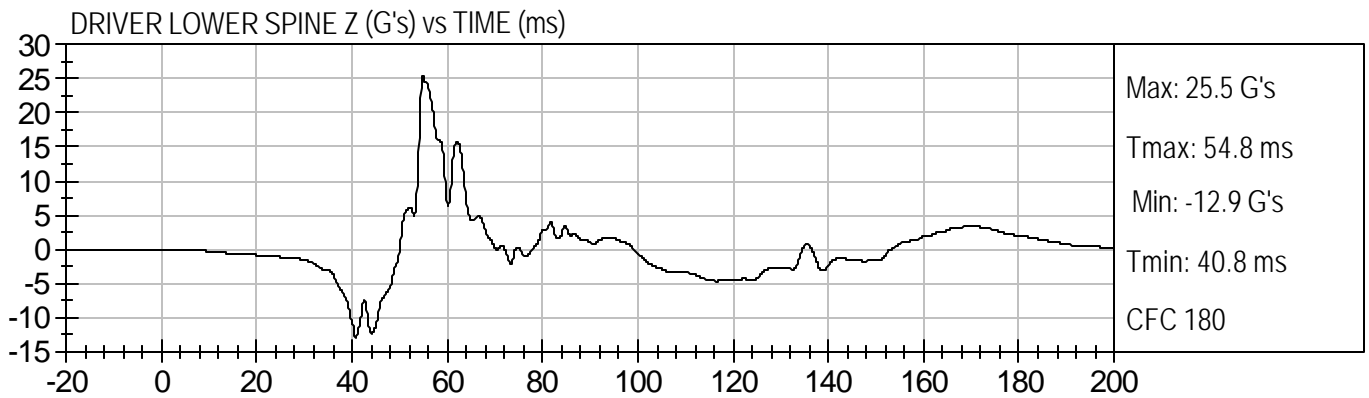
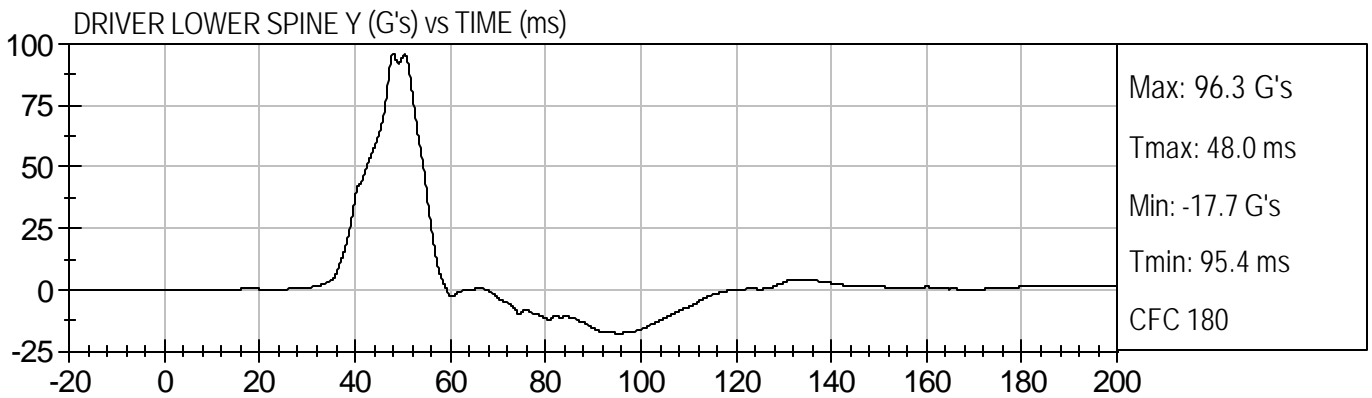
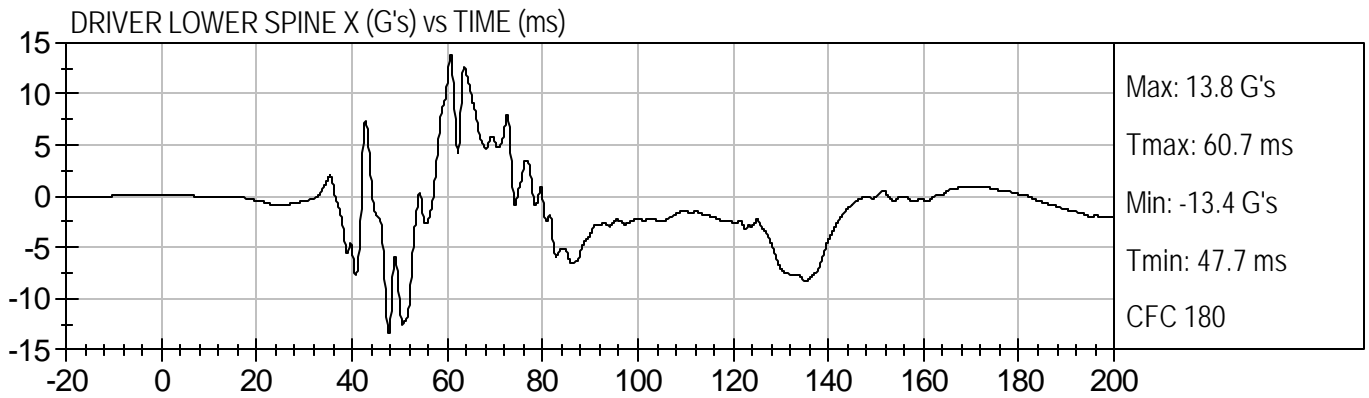

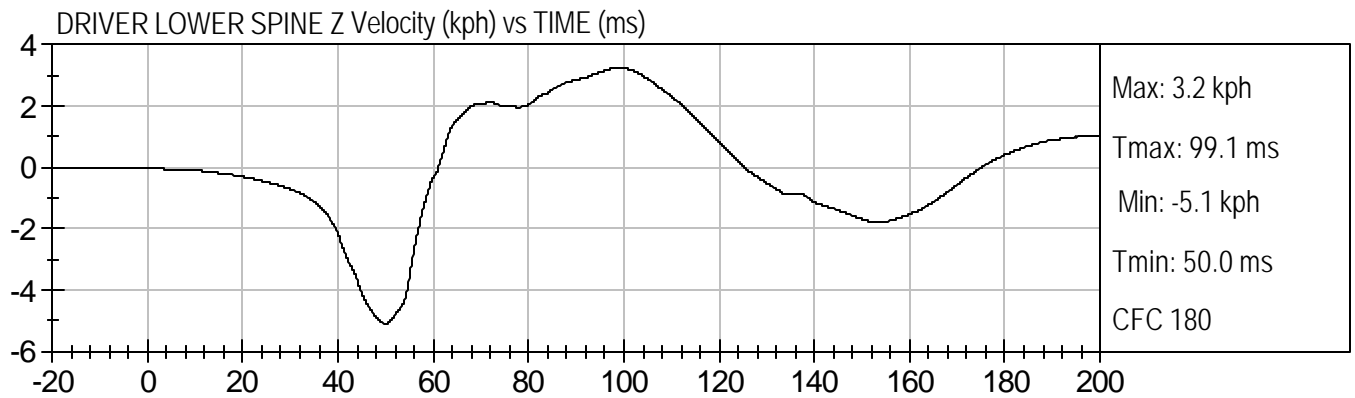
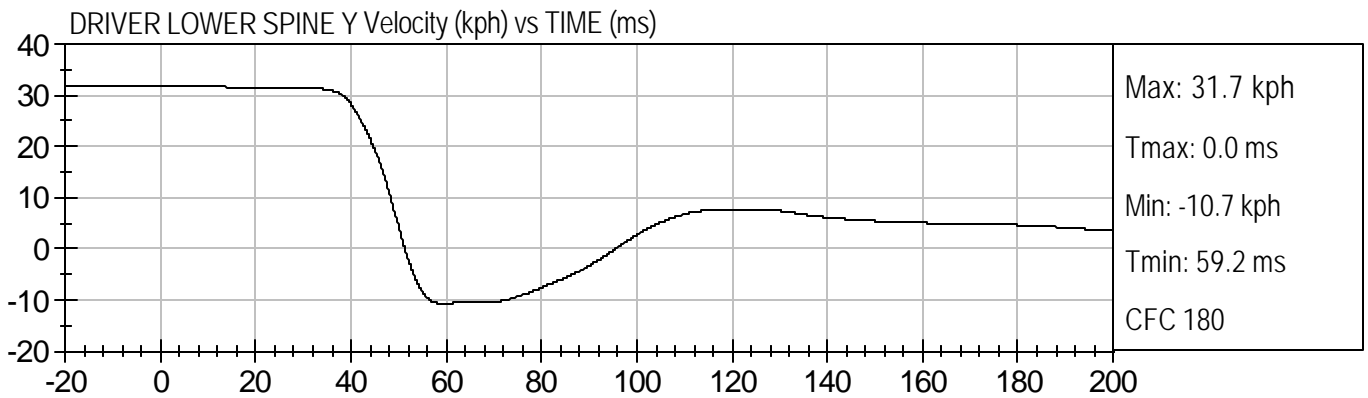
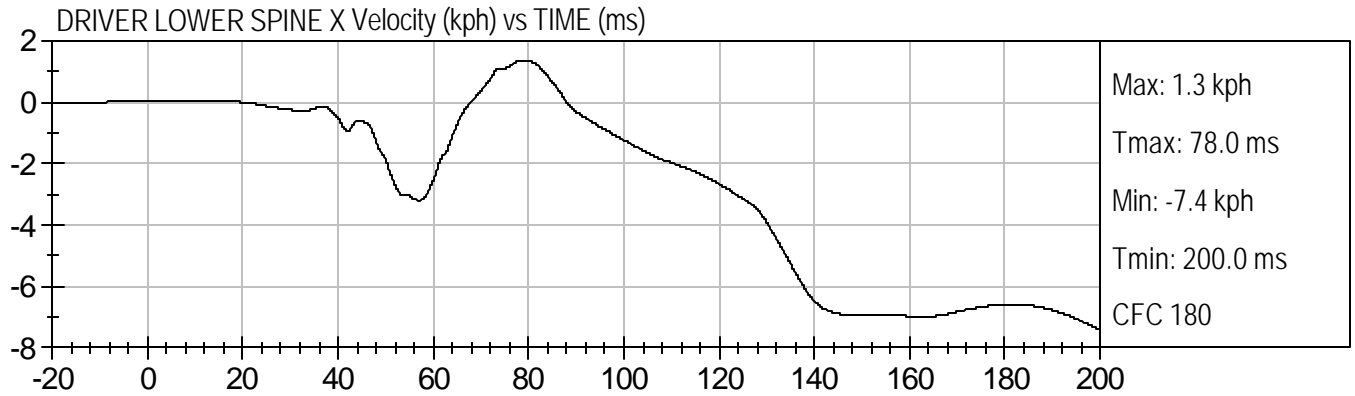

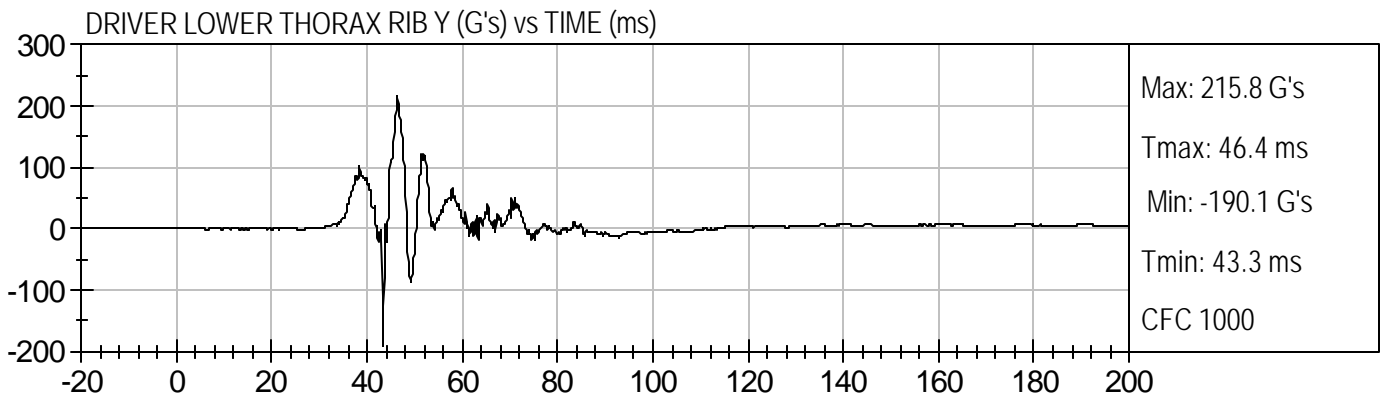
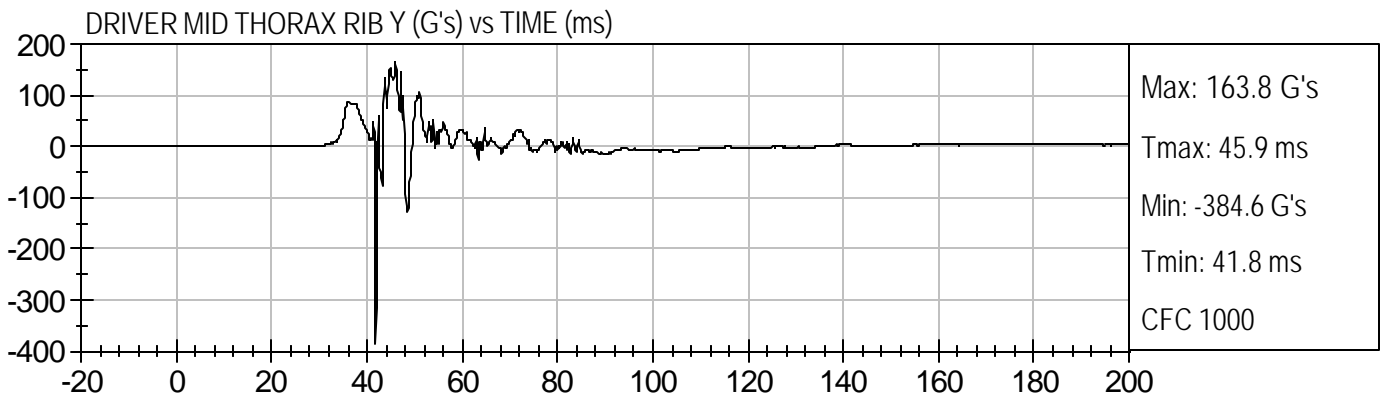
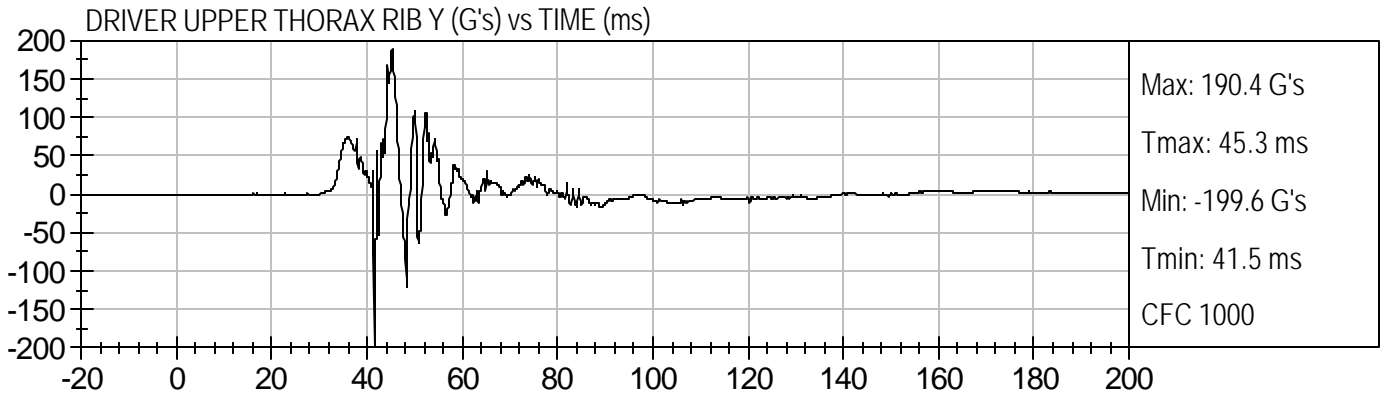

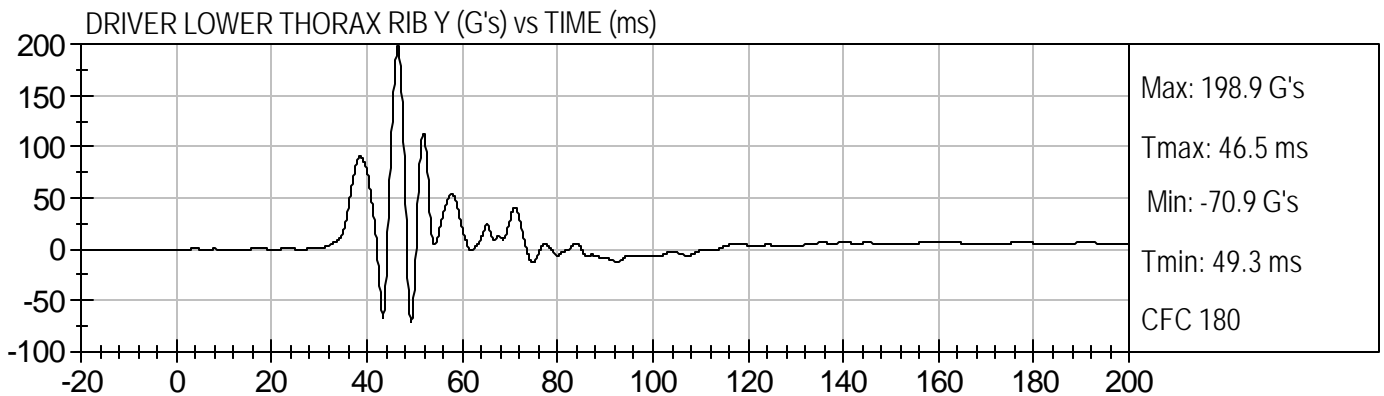
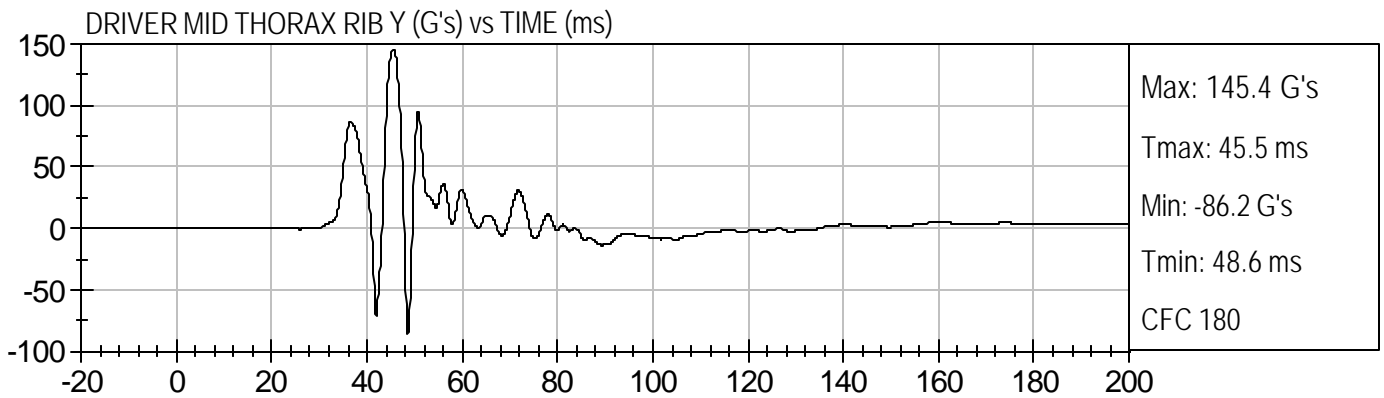
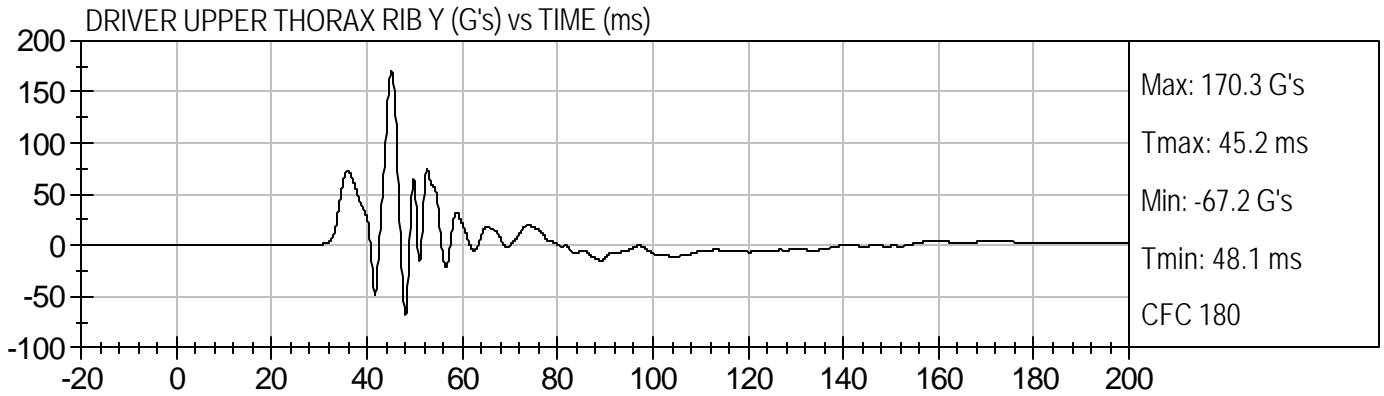

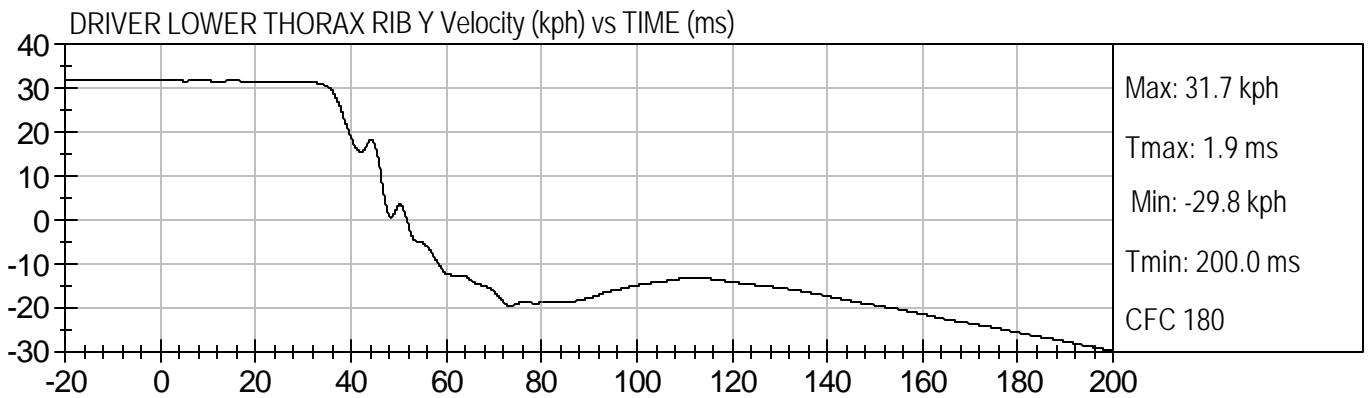
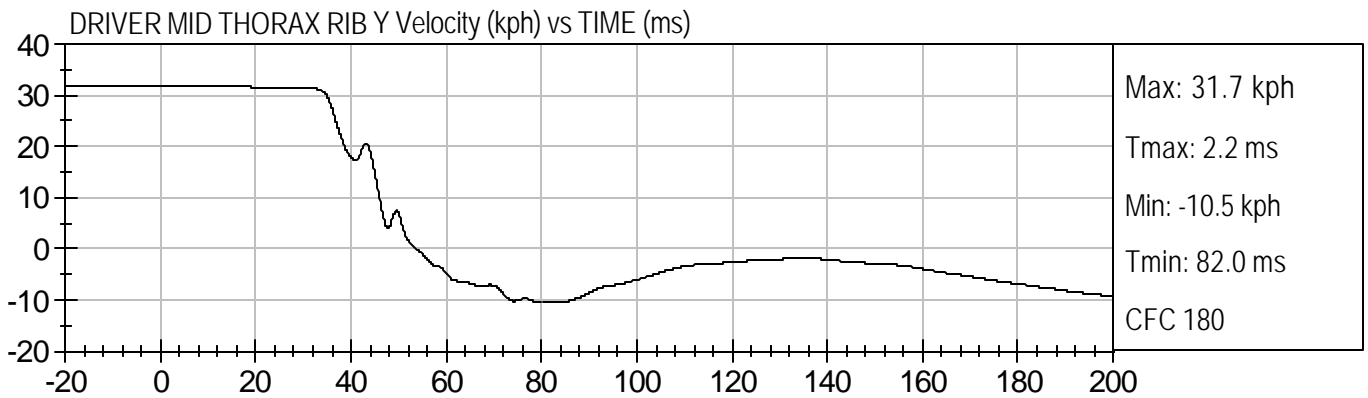
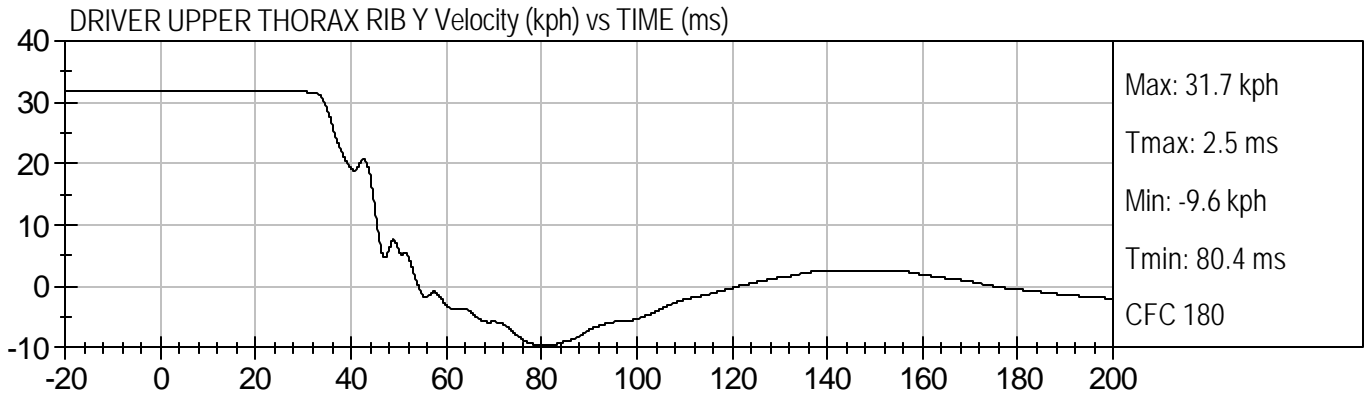

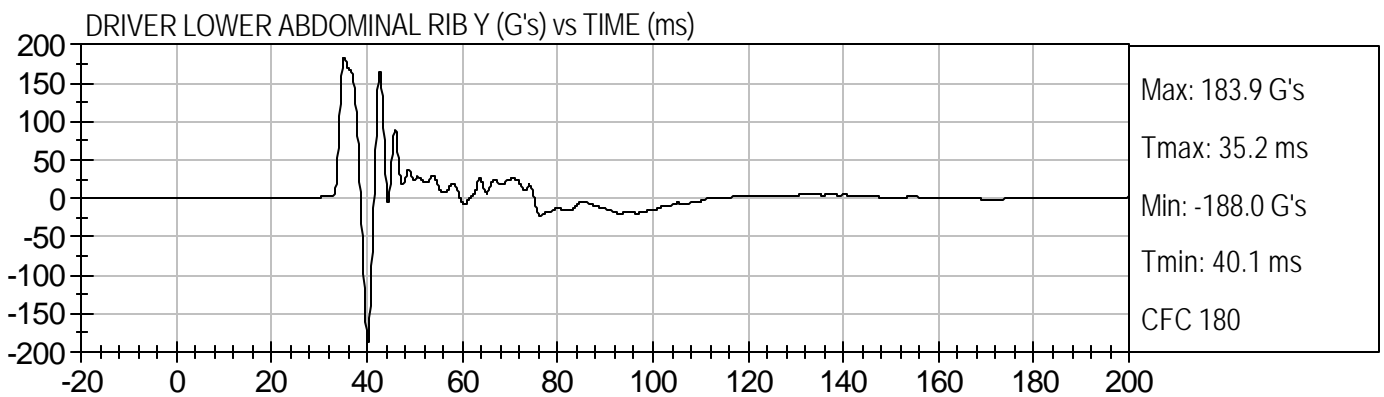
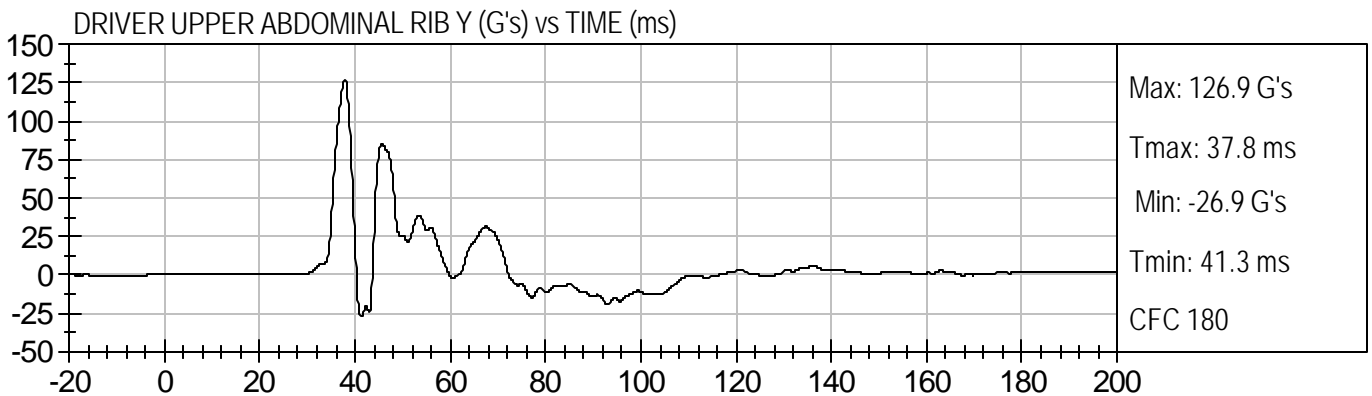
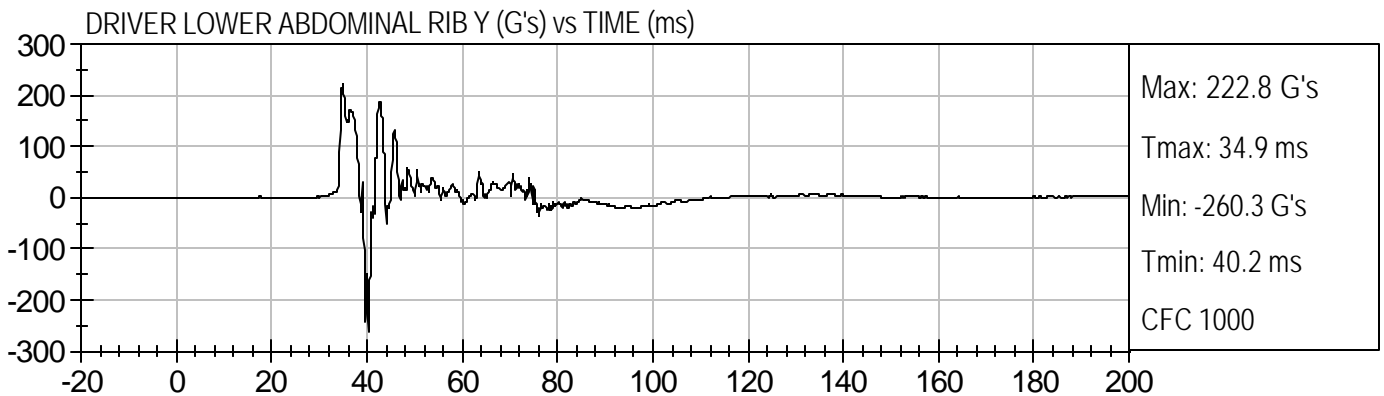
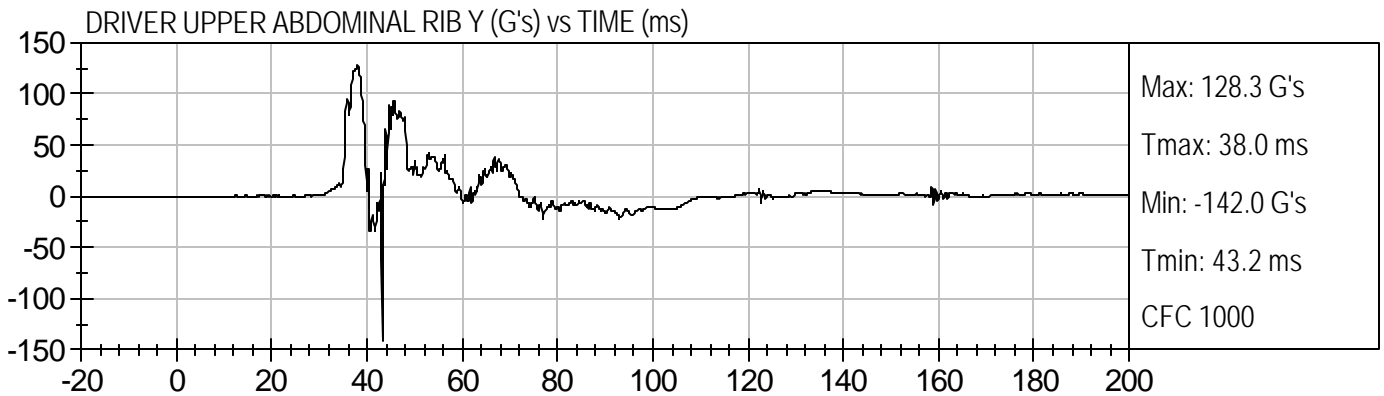

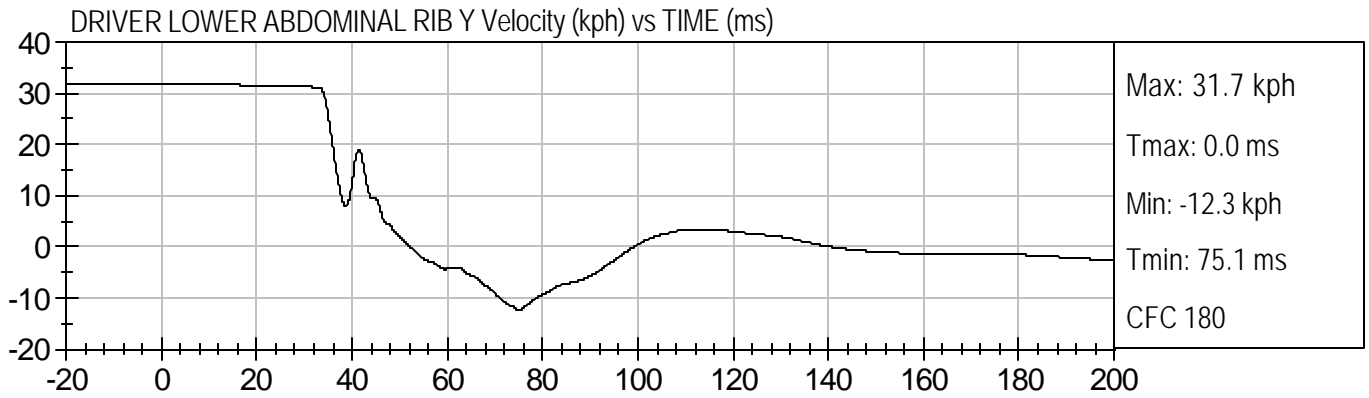
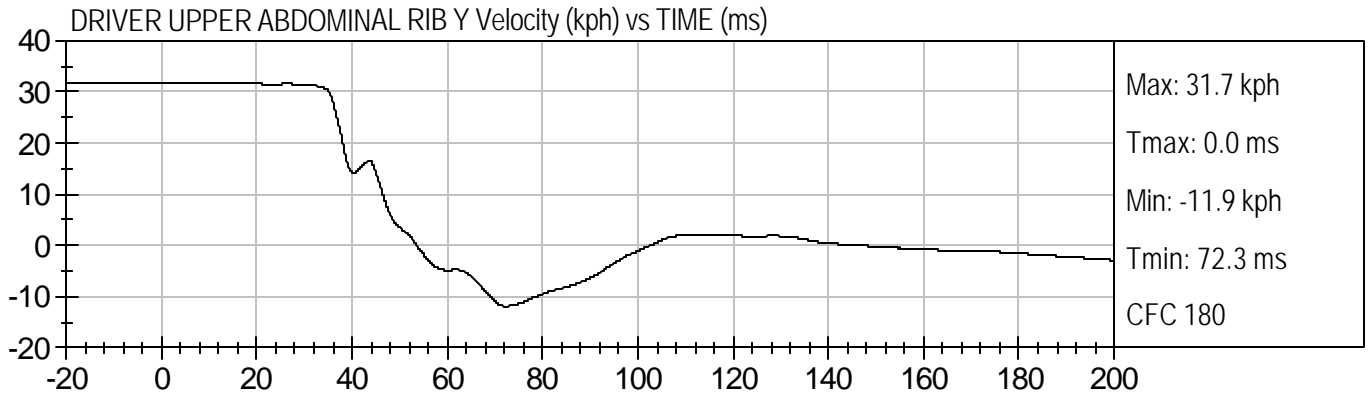

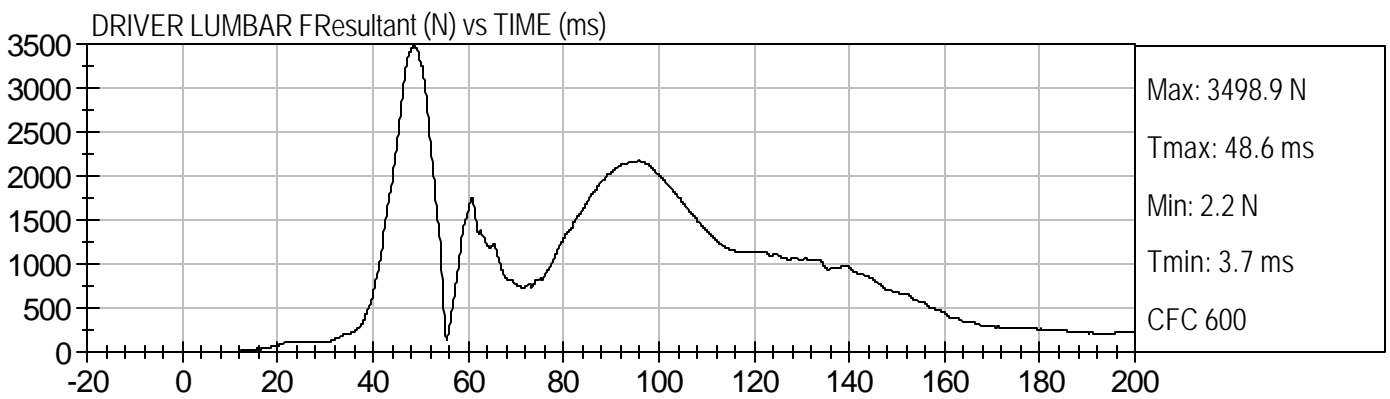
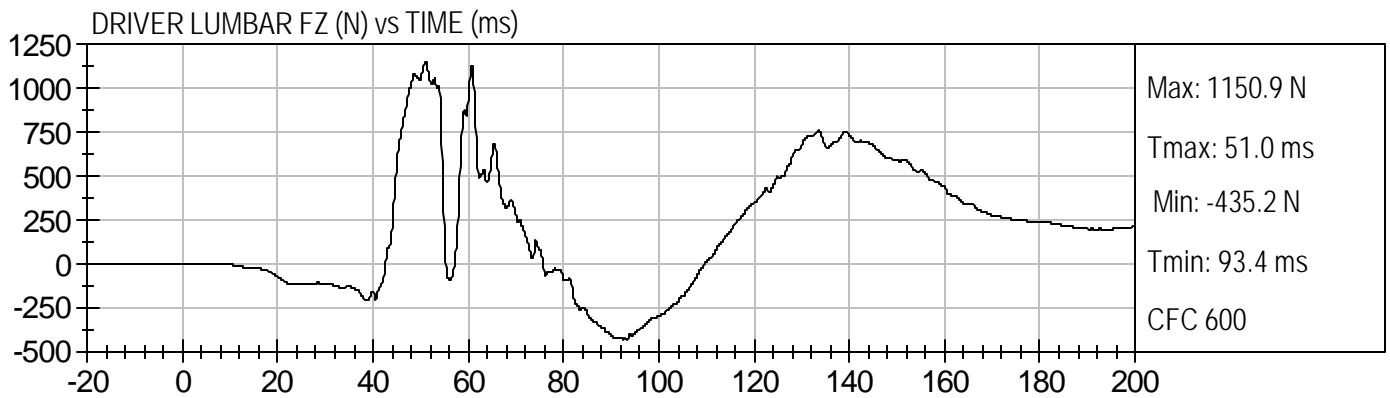
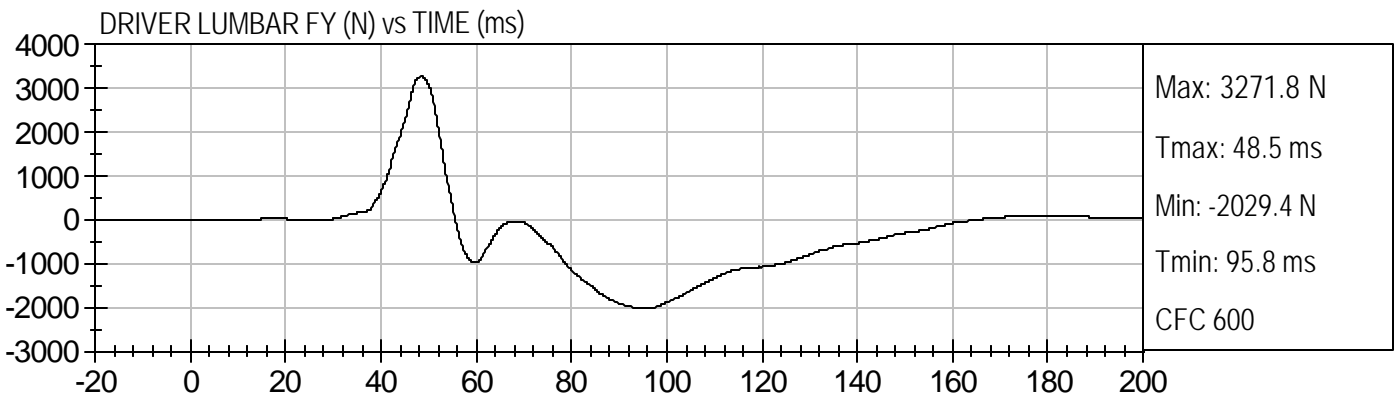
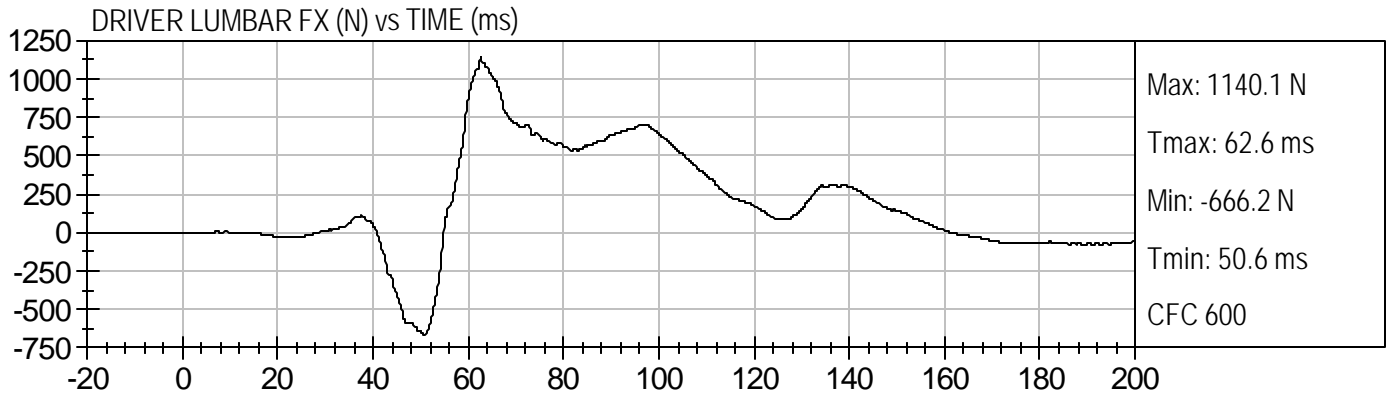

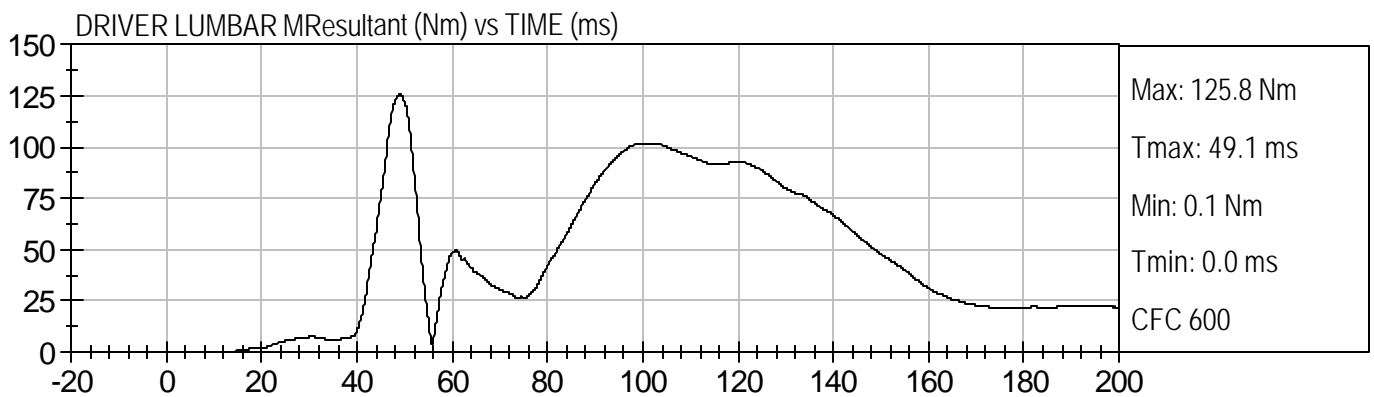
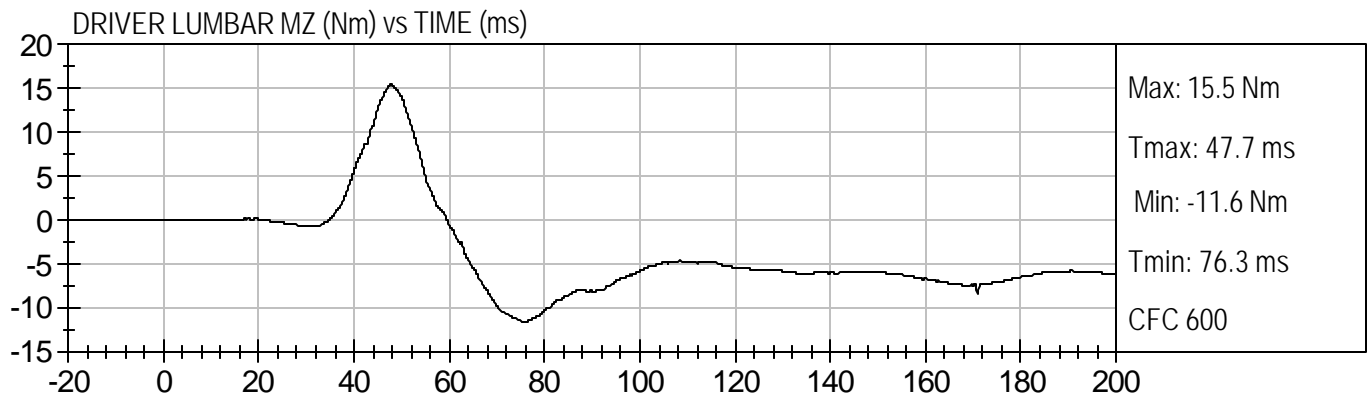
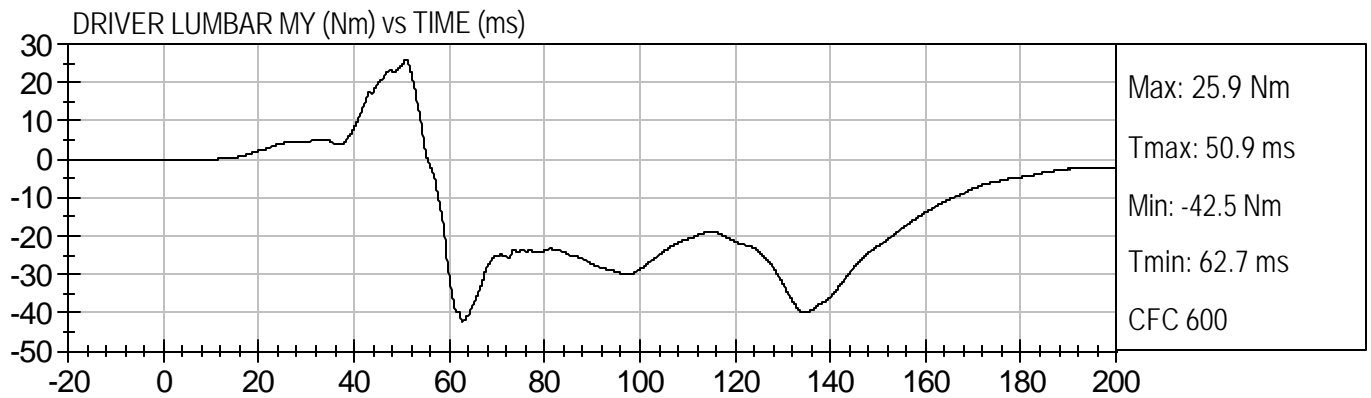
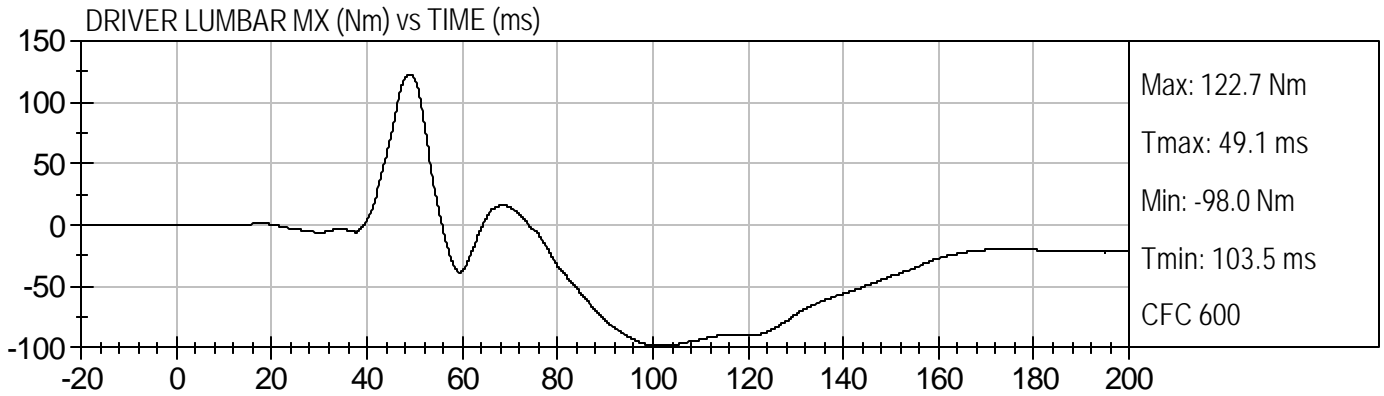

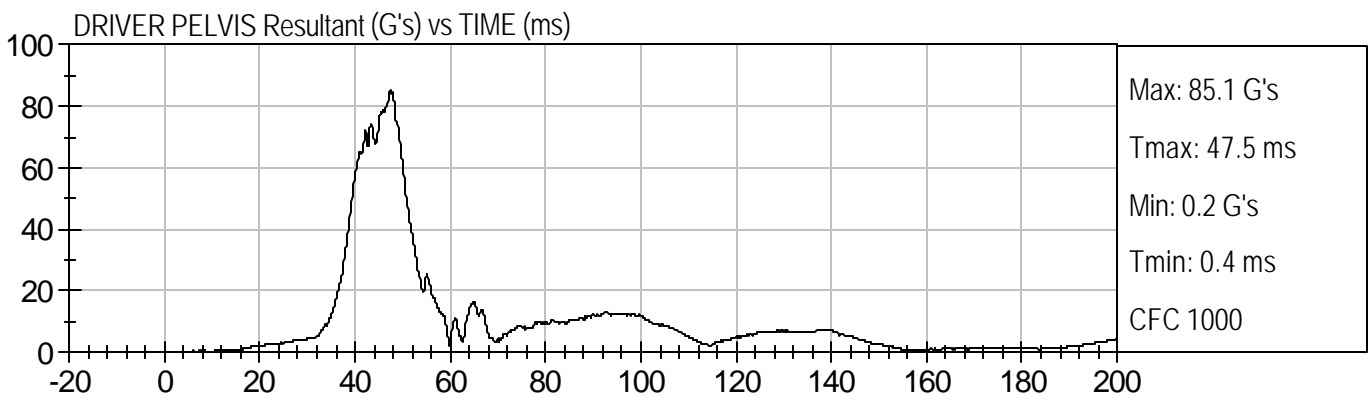
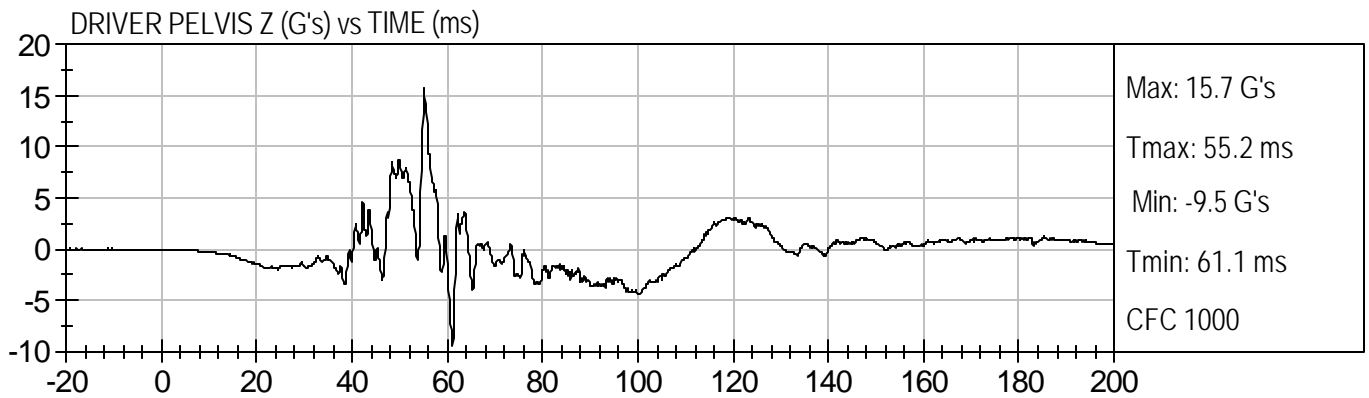
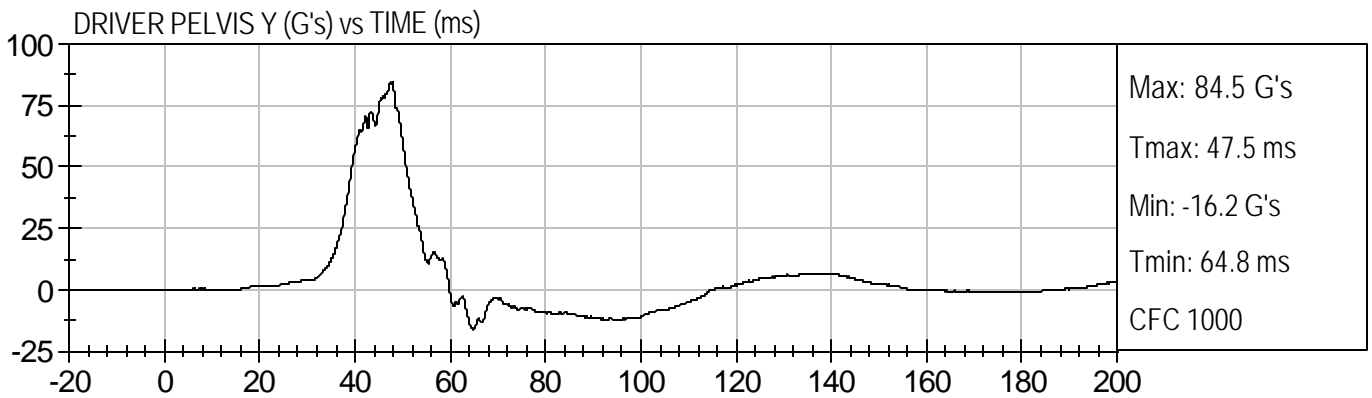
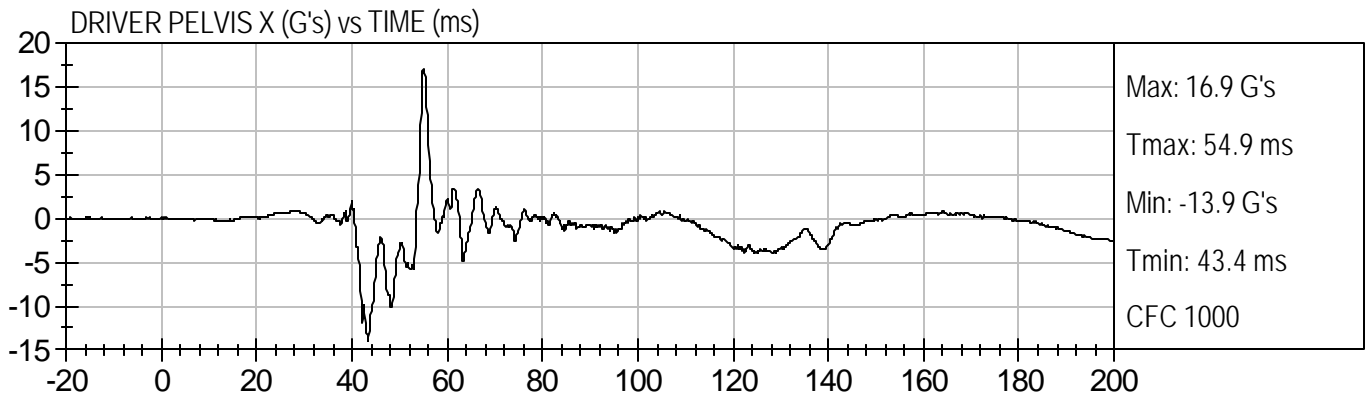



DRIVER PELVIS X Velocity (kph) vs TIME (ms)

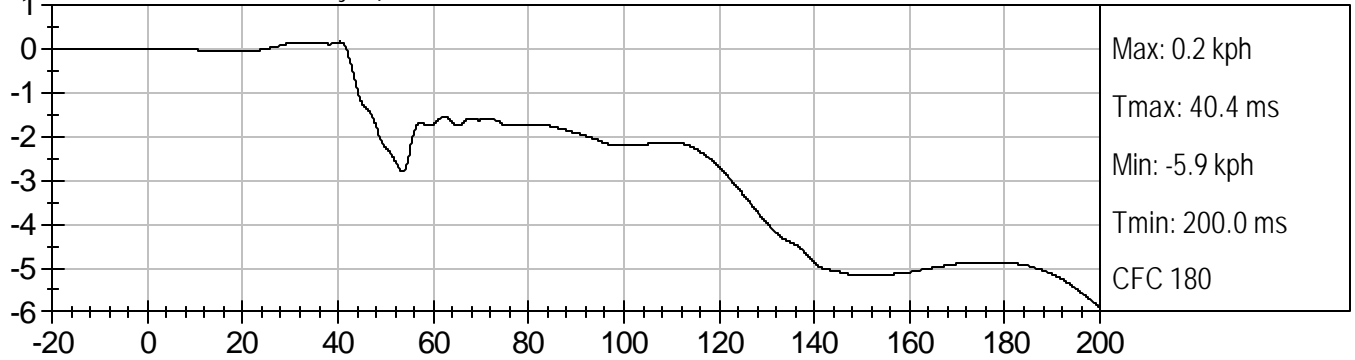

DRIVER PELVIS Y Velocity (kph) vs TIME (ms)

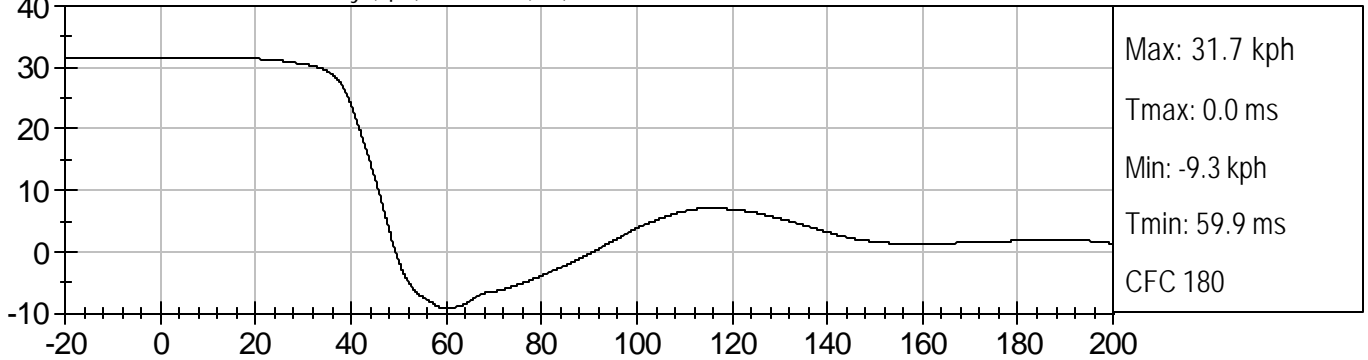

DRIVER PELVIS Z Velocity (kph) vs TIME (ms)

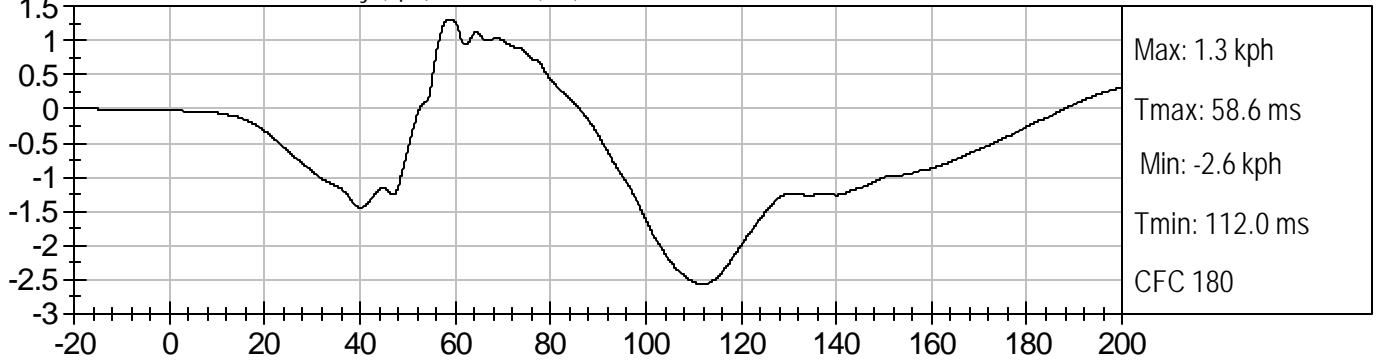

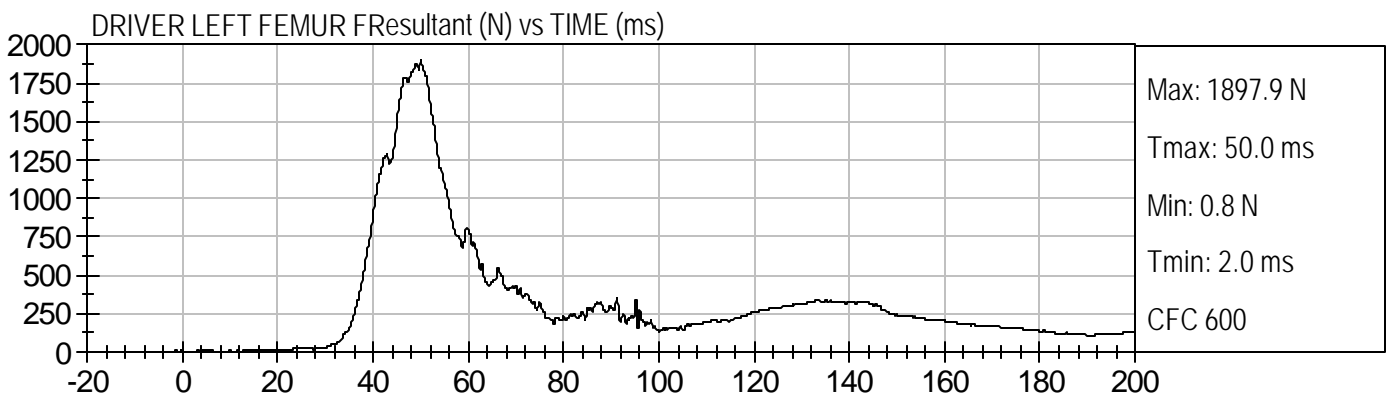
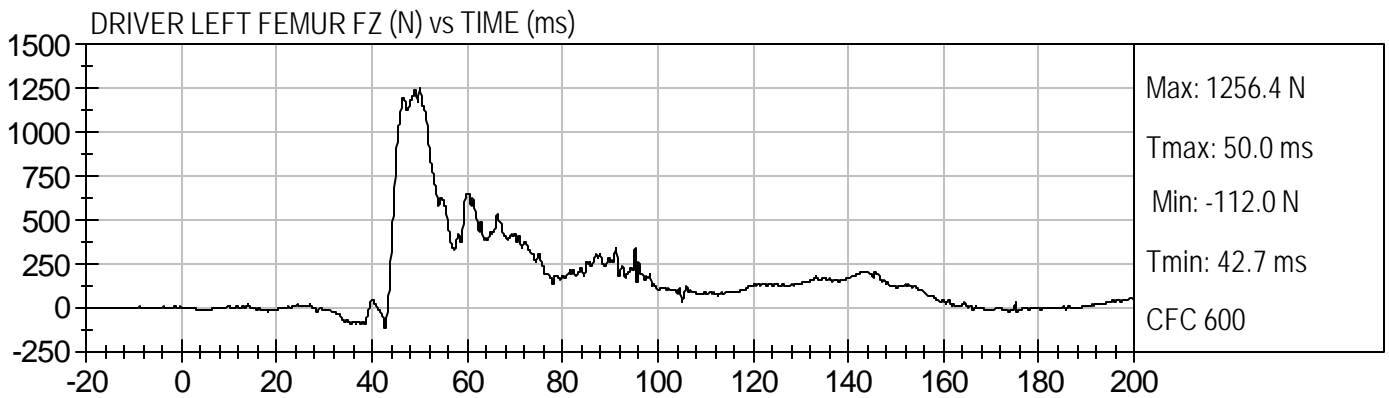
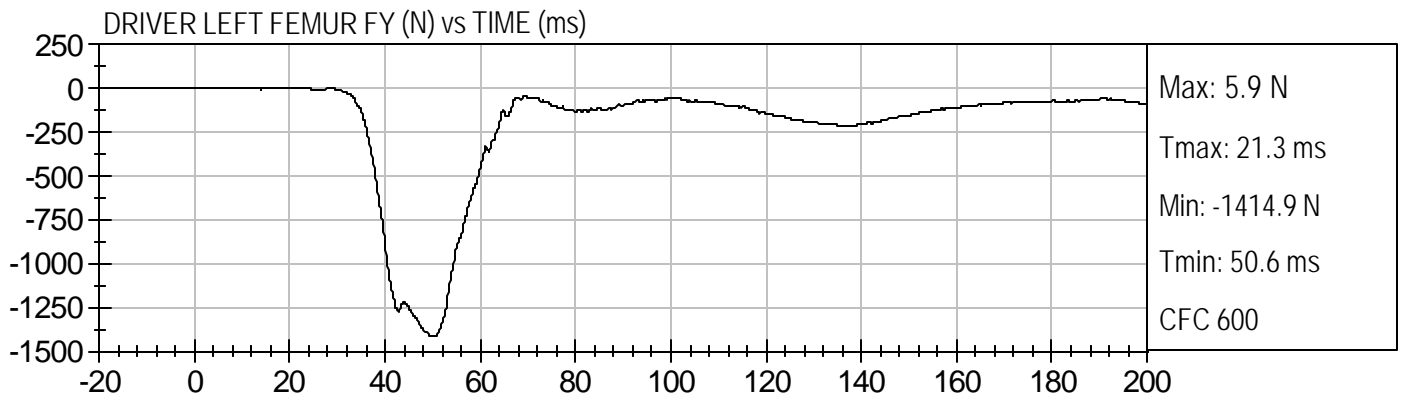
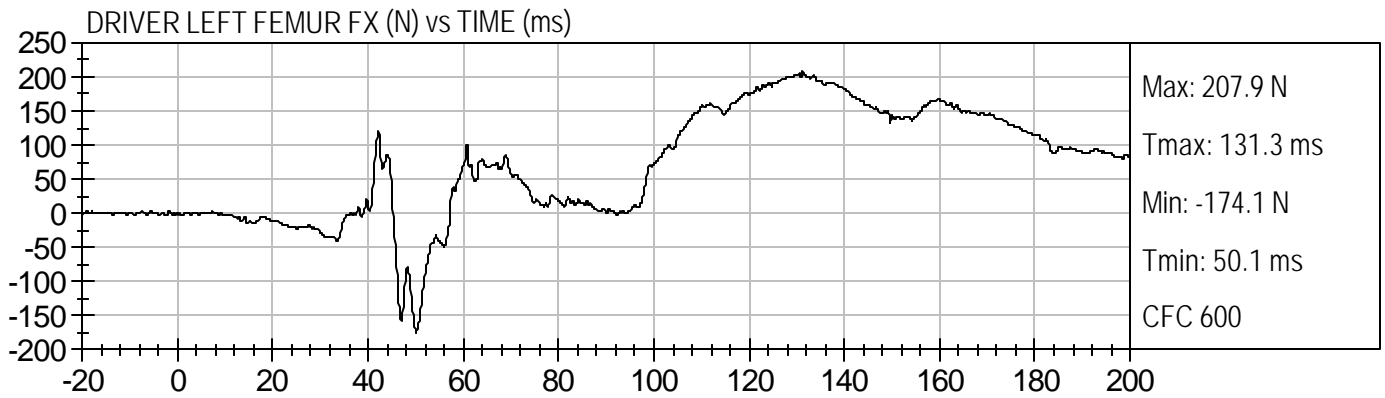

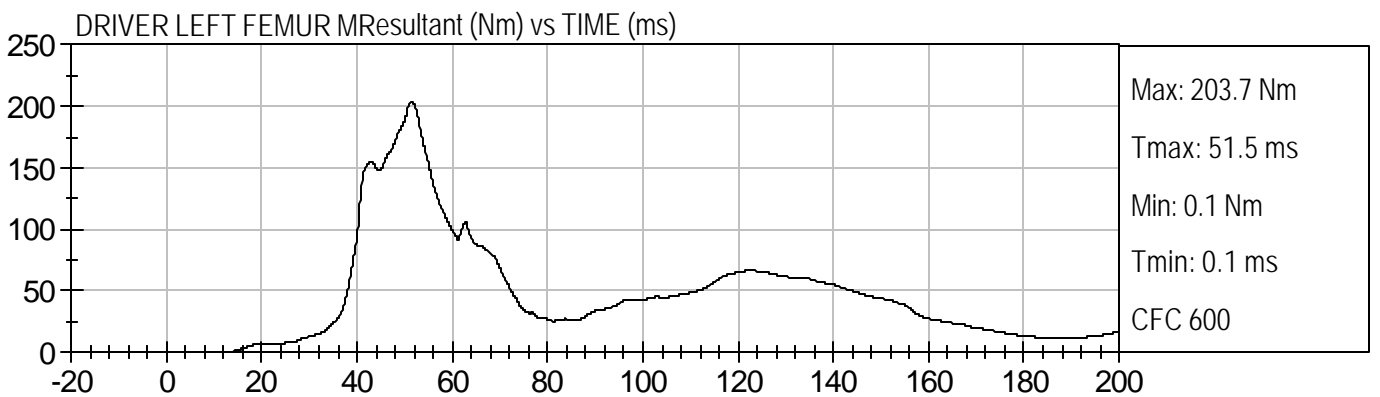
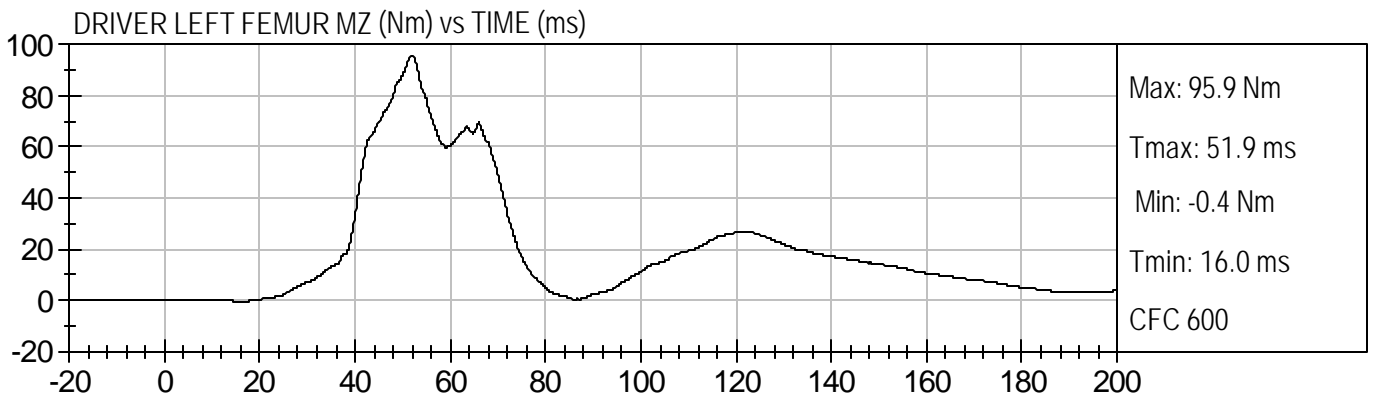
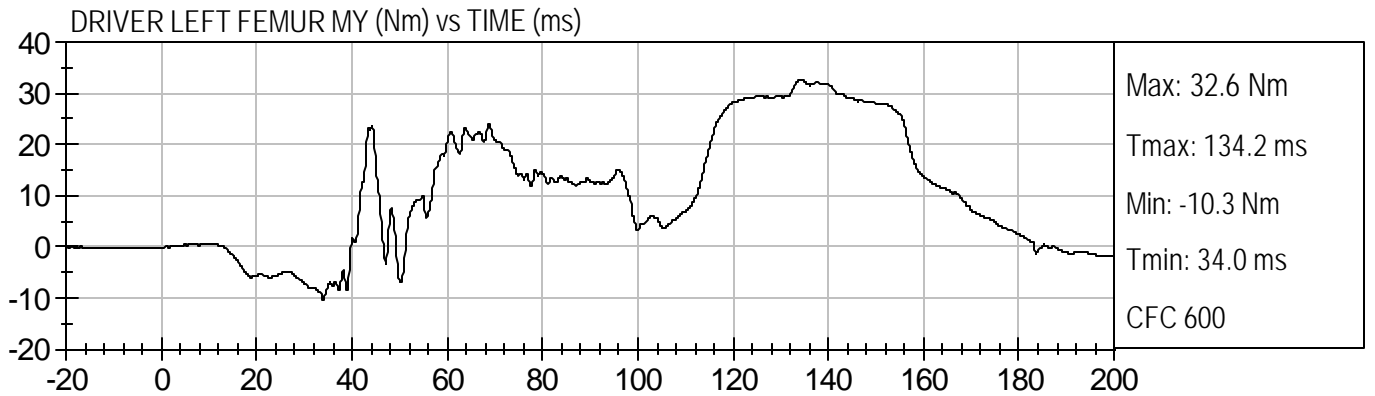
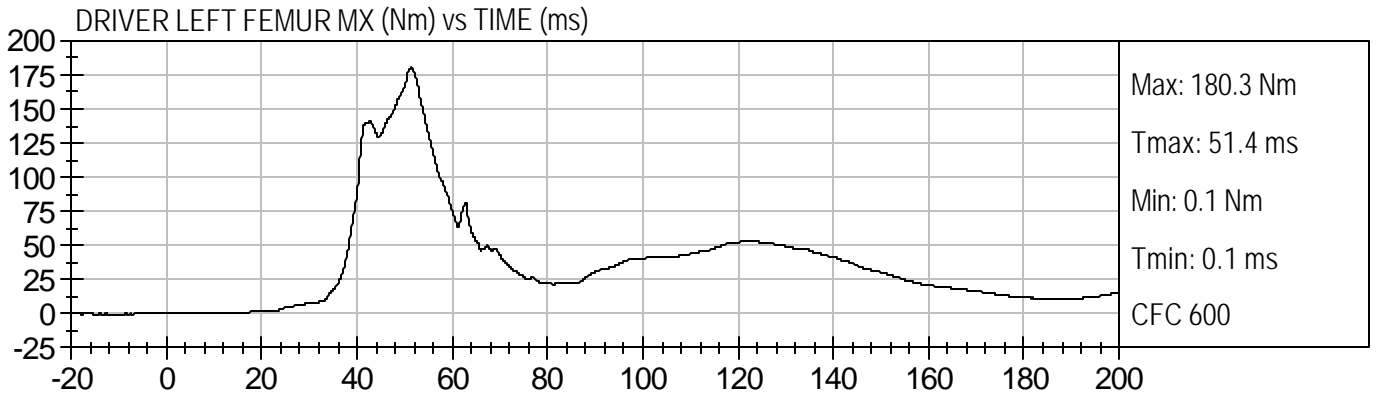

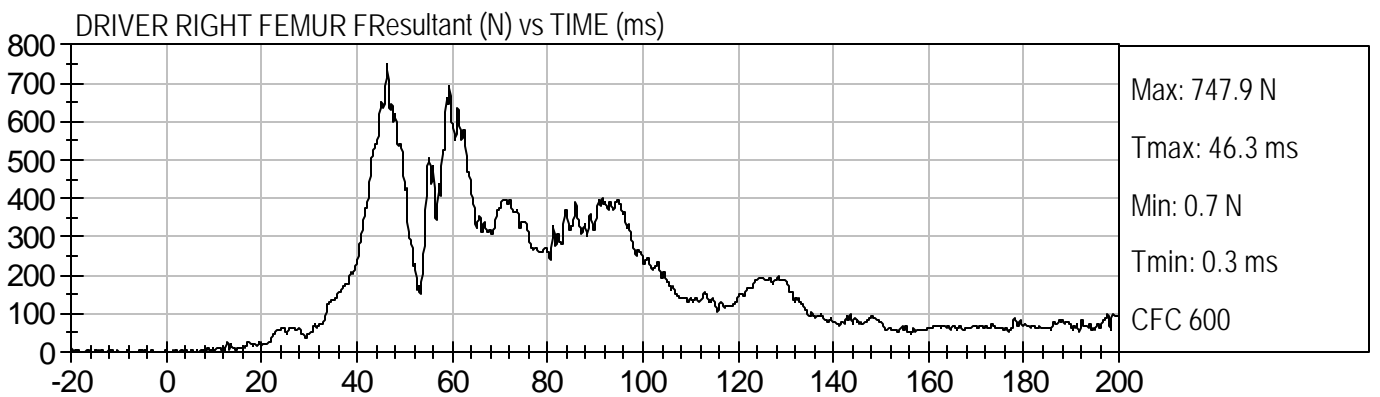
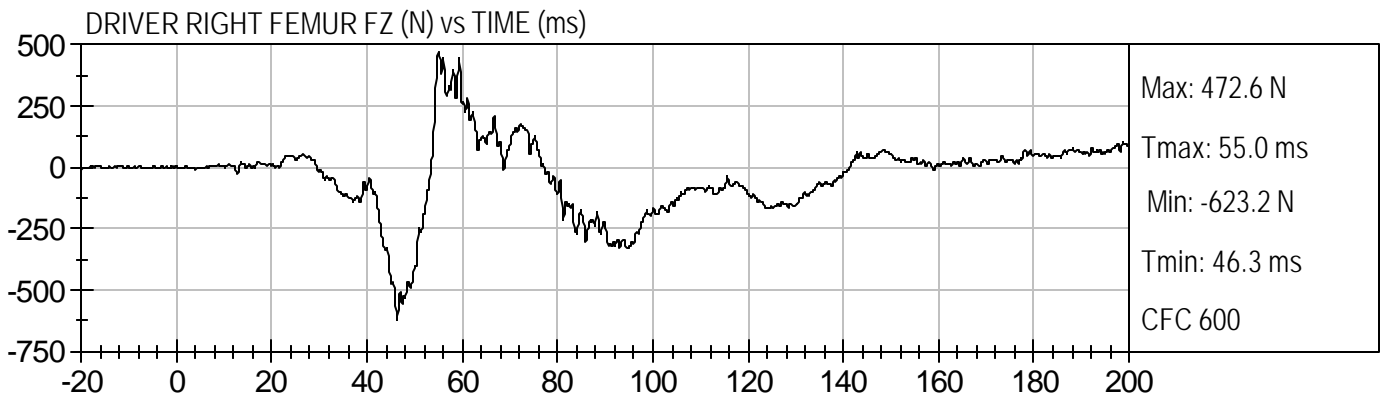
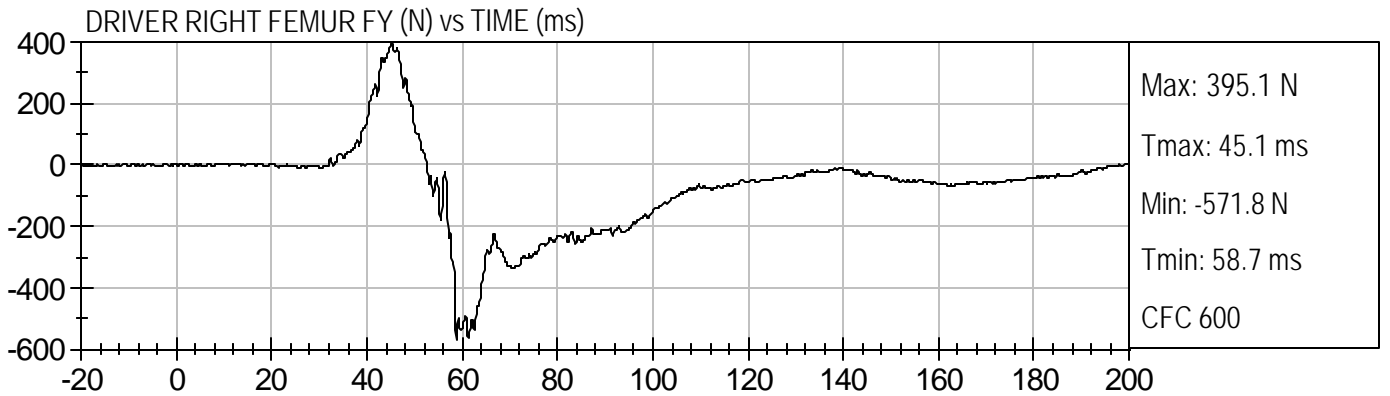
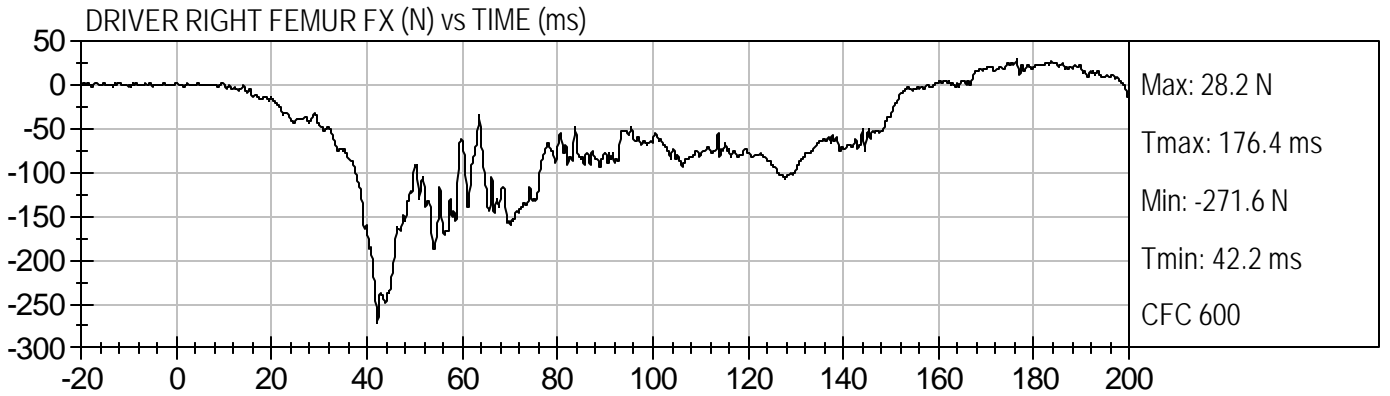

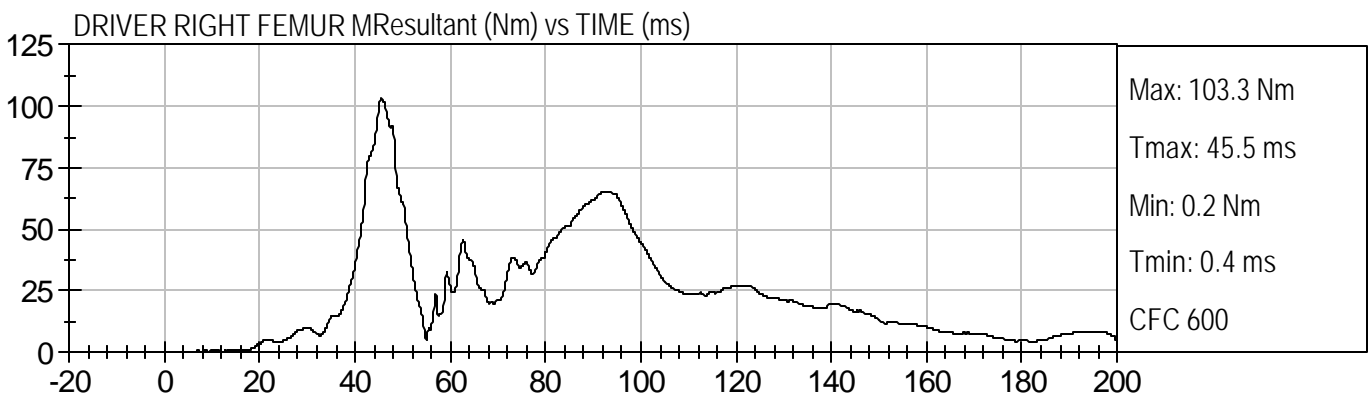
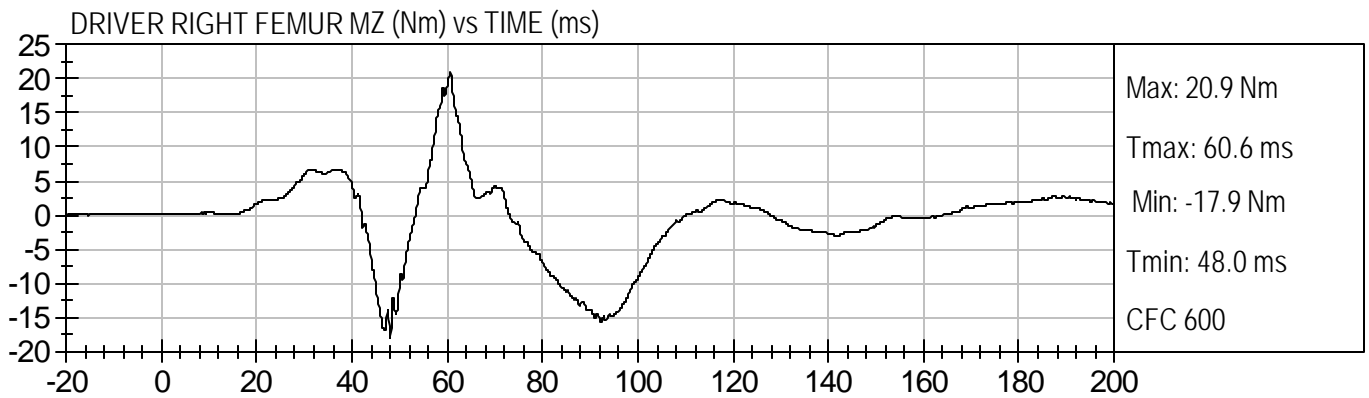
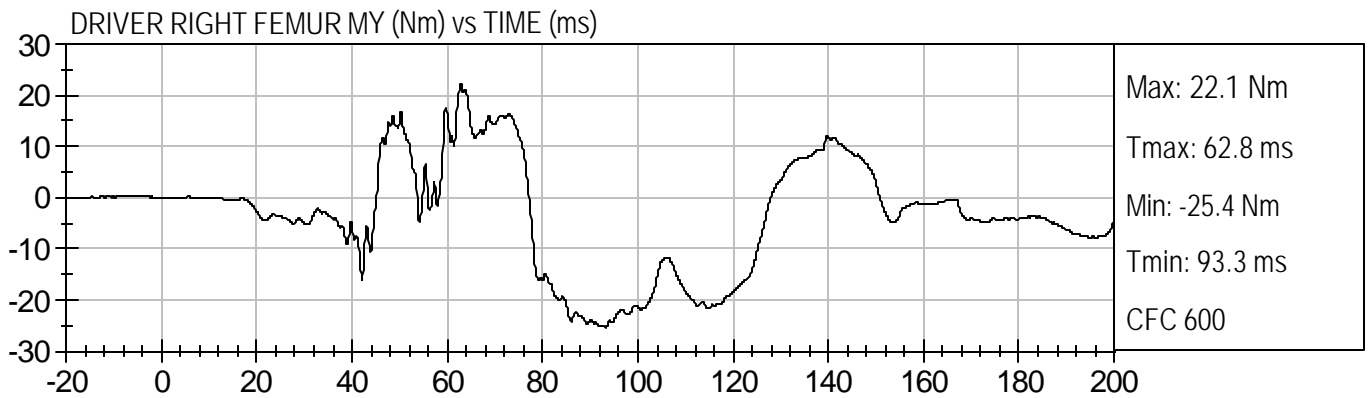
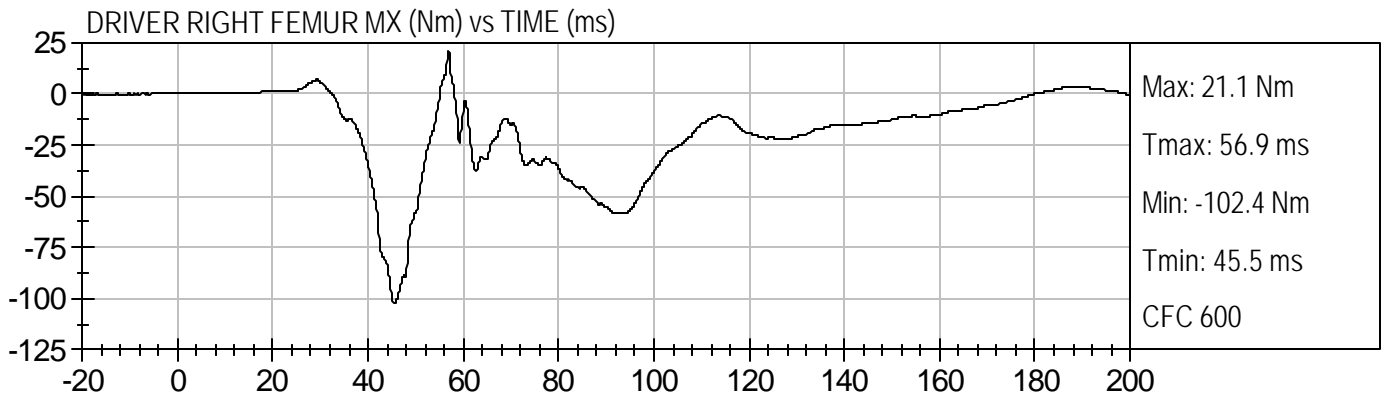

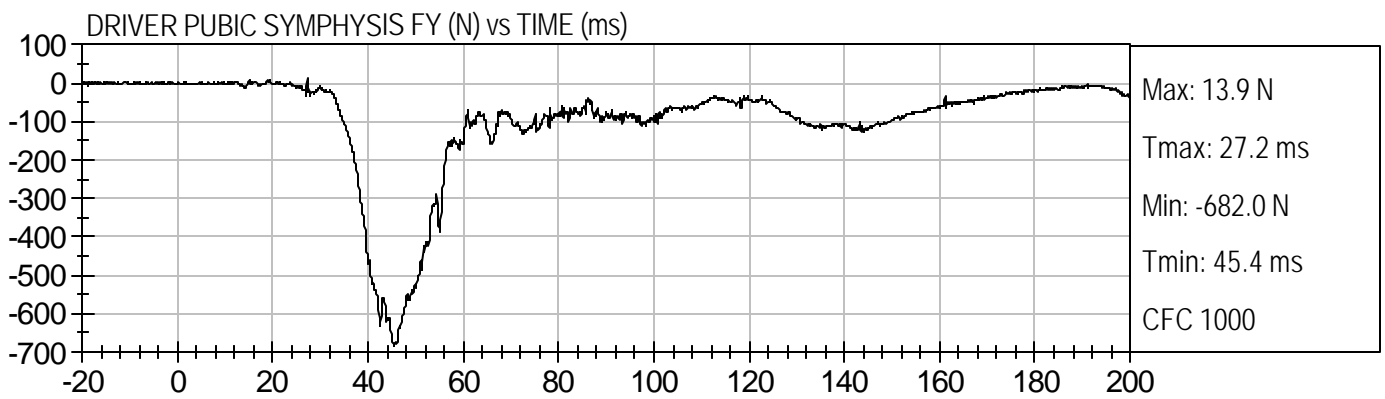
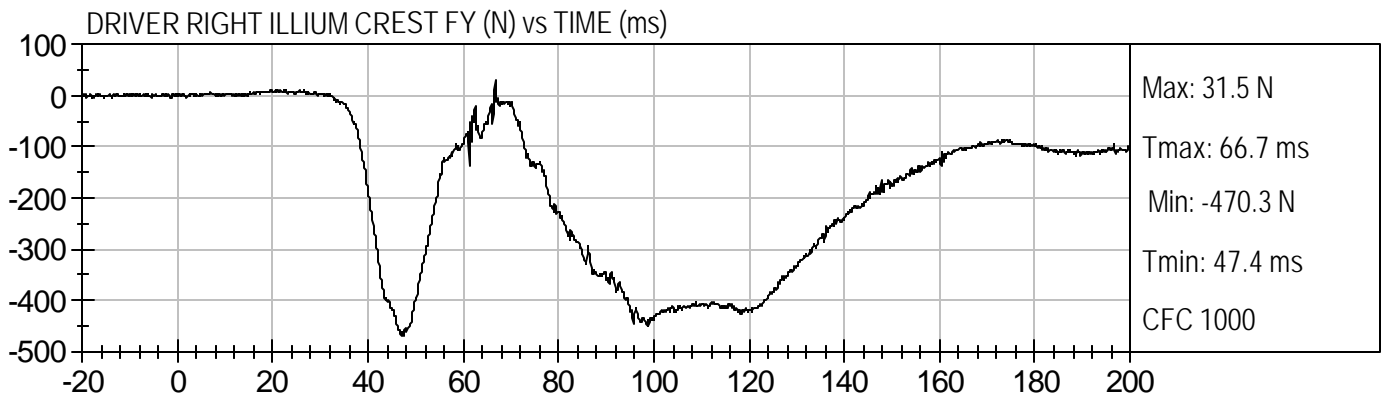
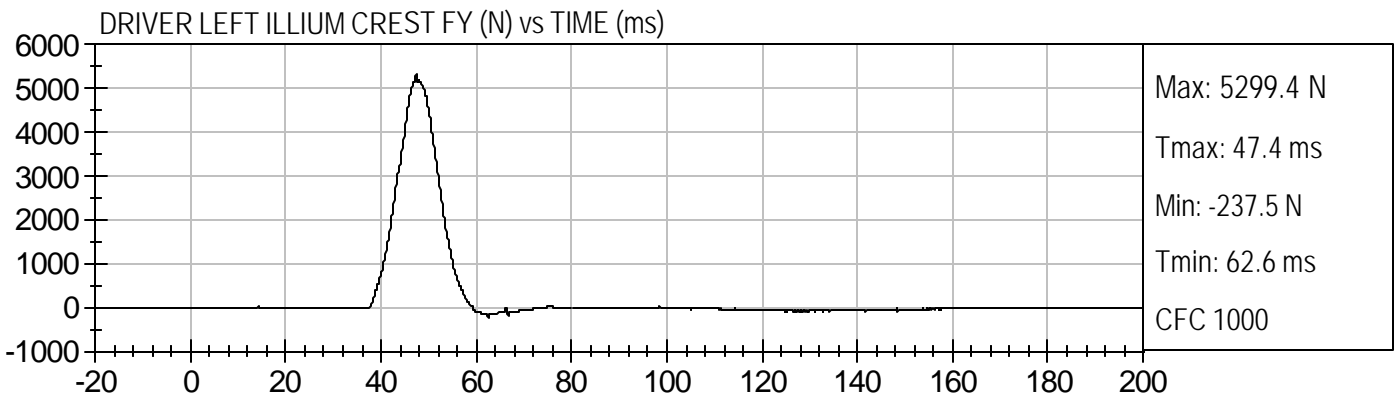
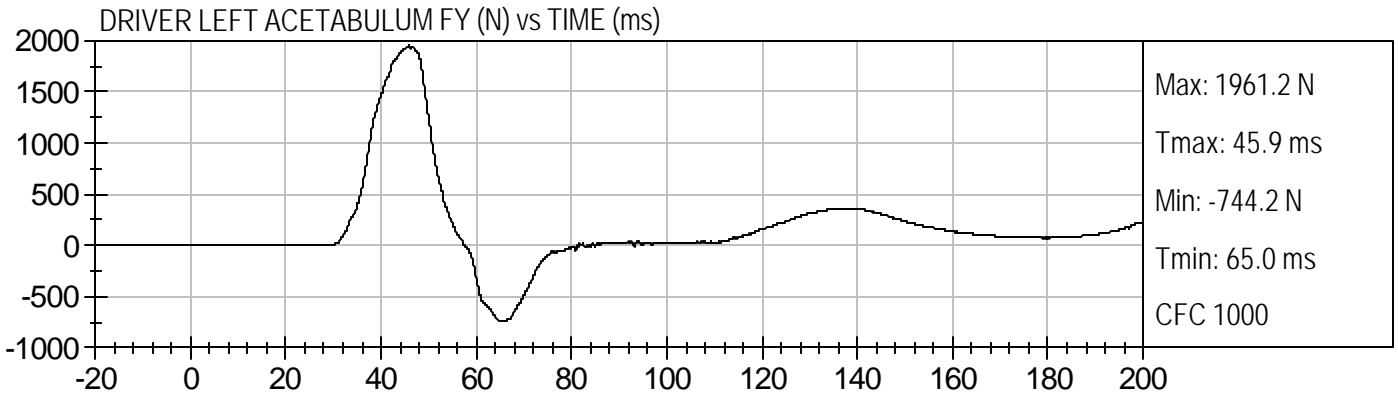

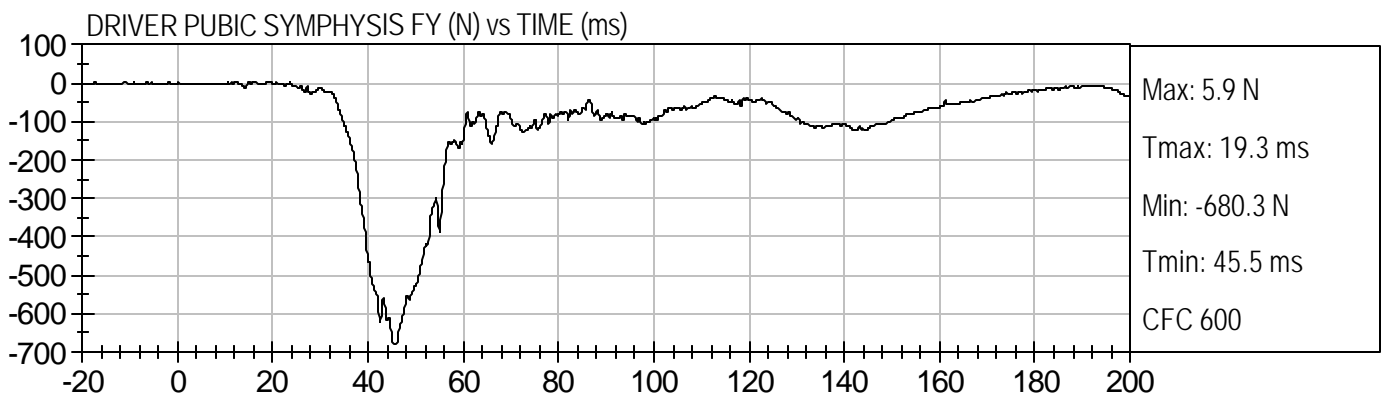
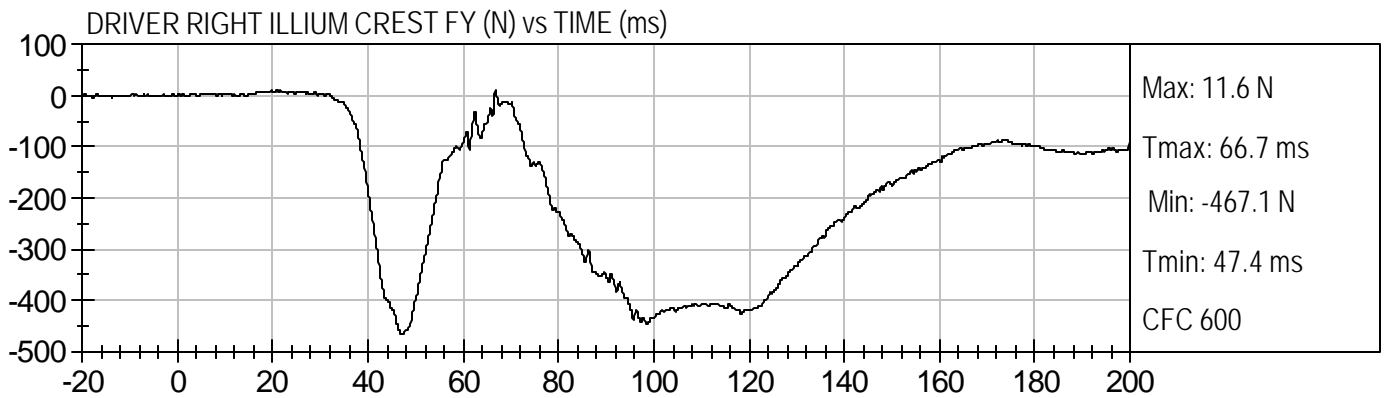
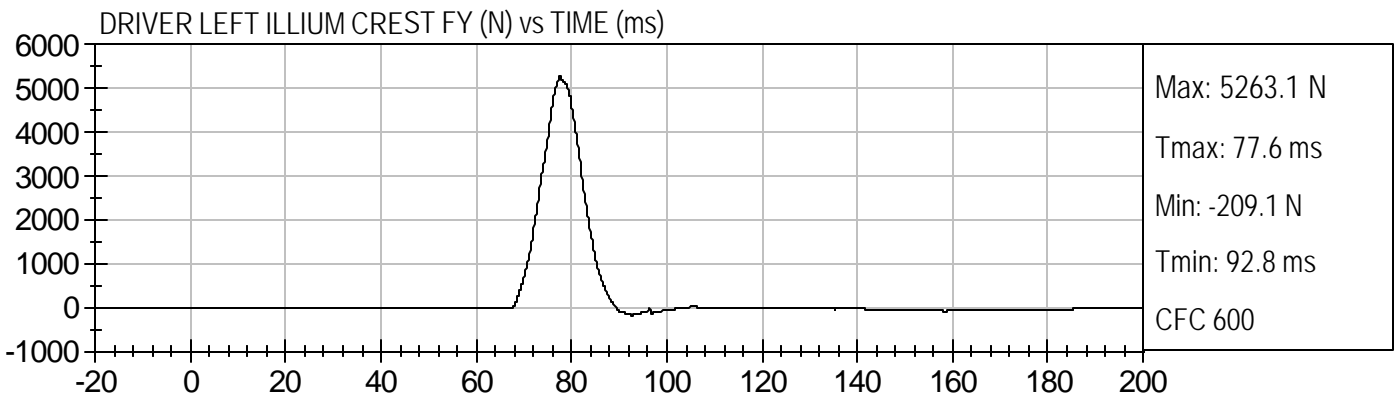
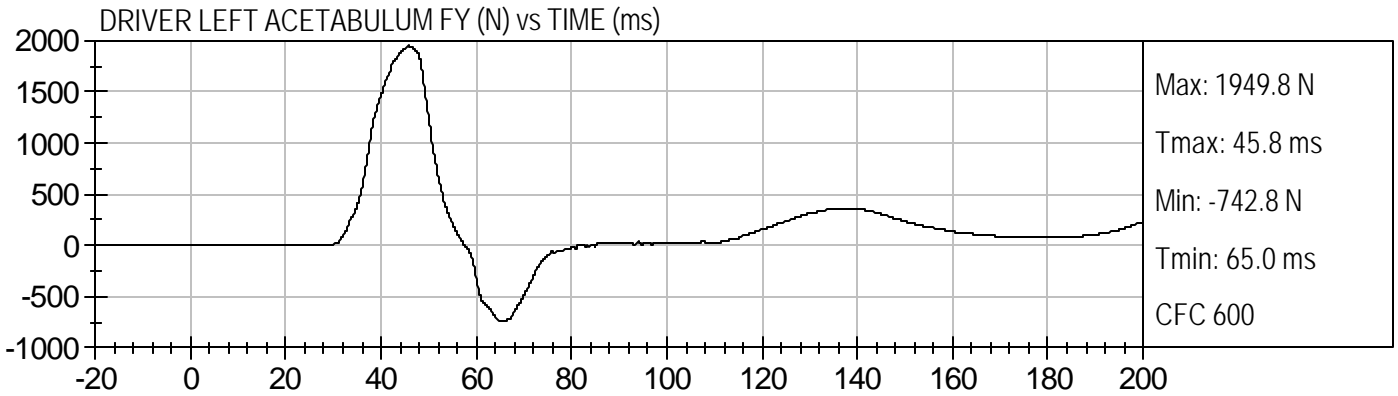



DRIVER RIB CONTACT (Volts) vs TIME (ms)

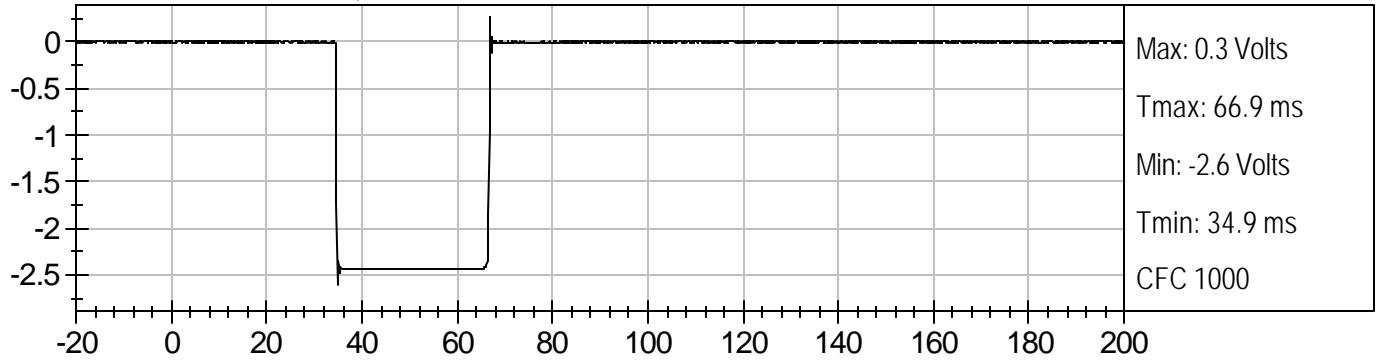

DRIVER PELVIS CONTACT (Volts) vs TIME (ms)

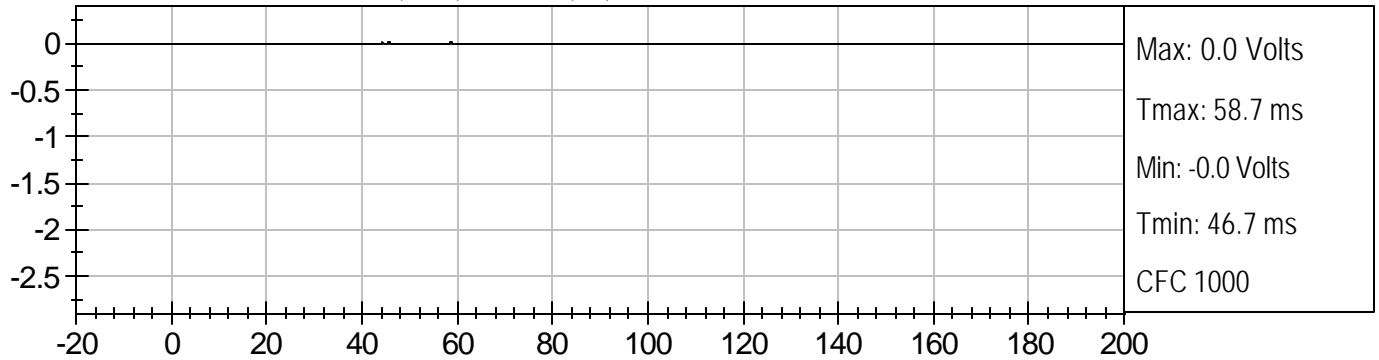

DRIVER ARM CONTACT (Volts) vs TIME (ms)

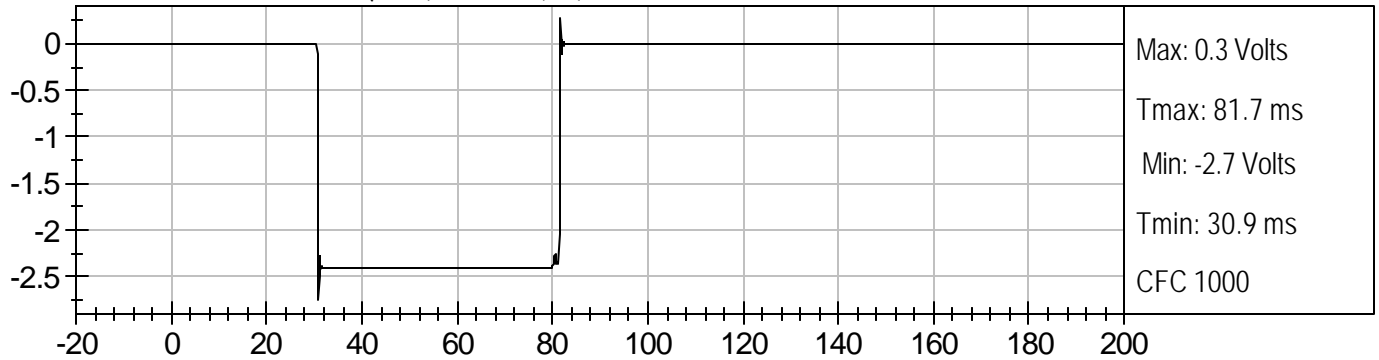

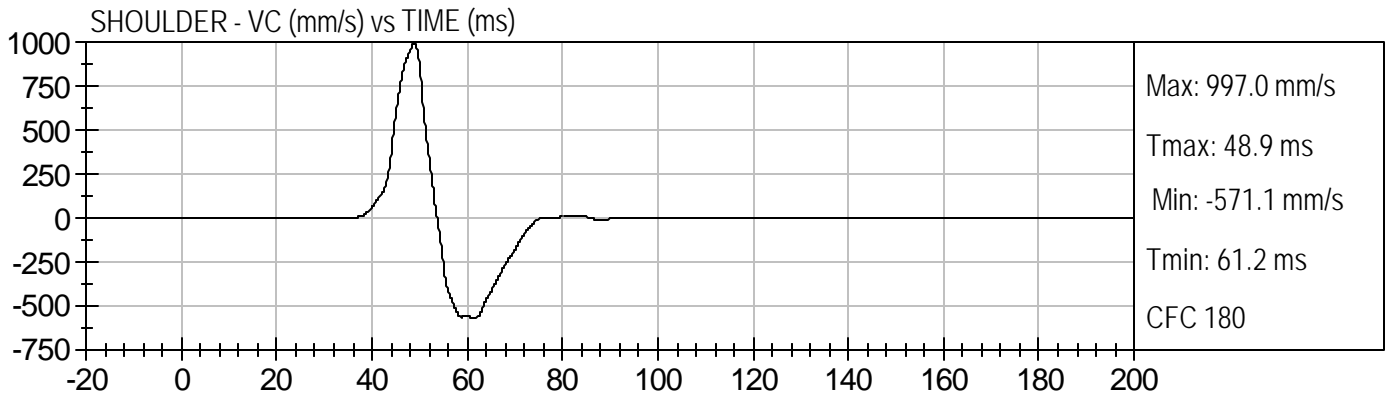
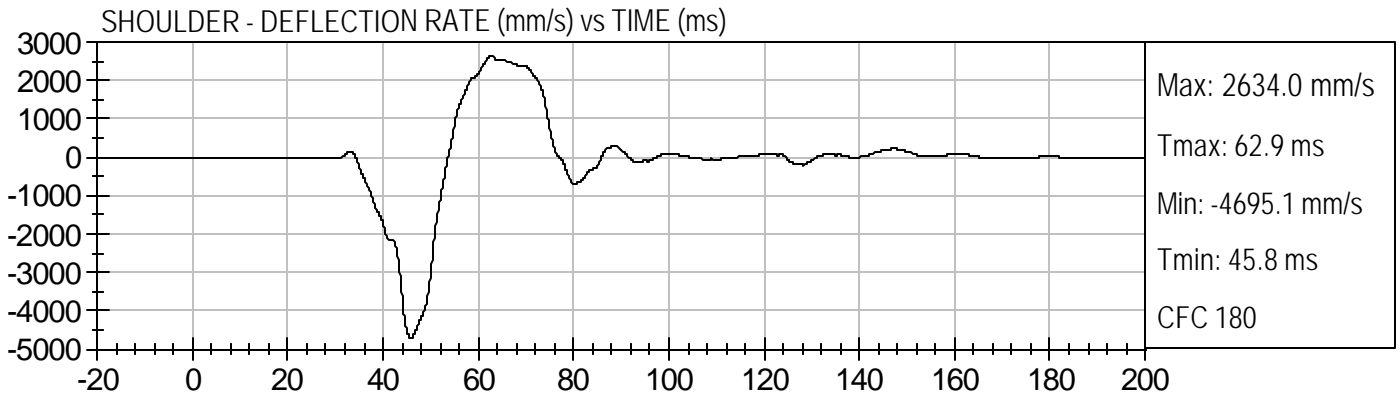
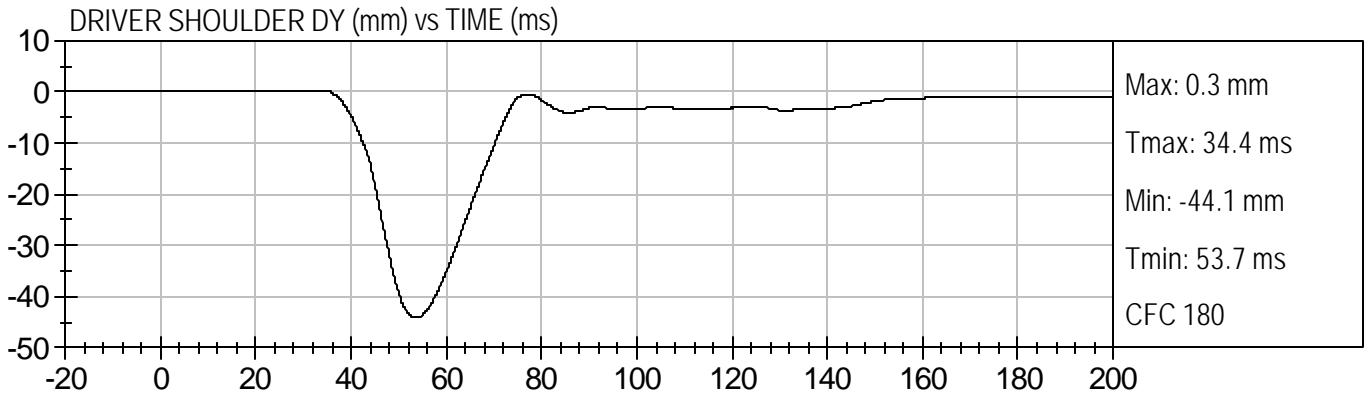

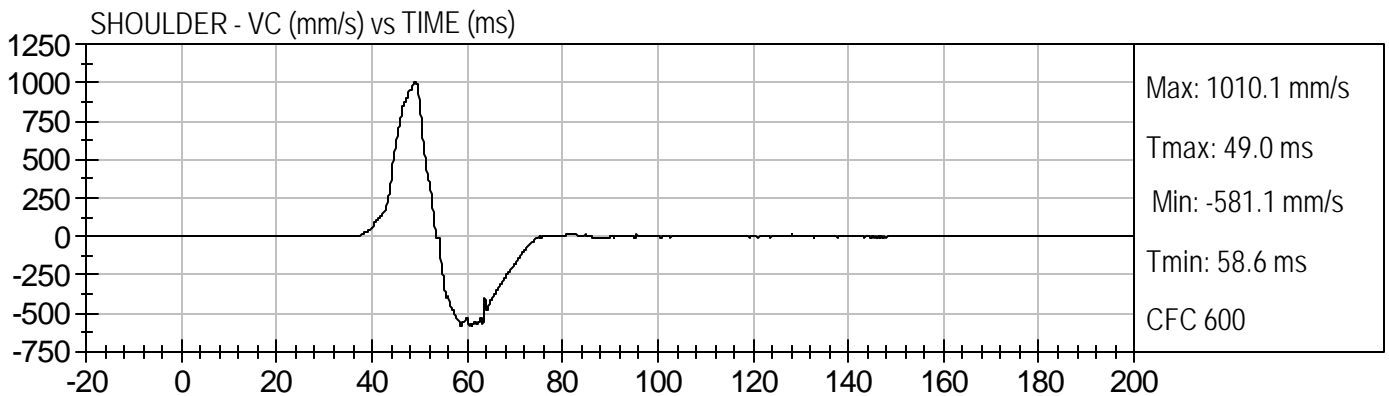
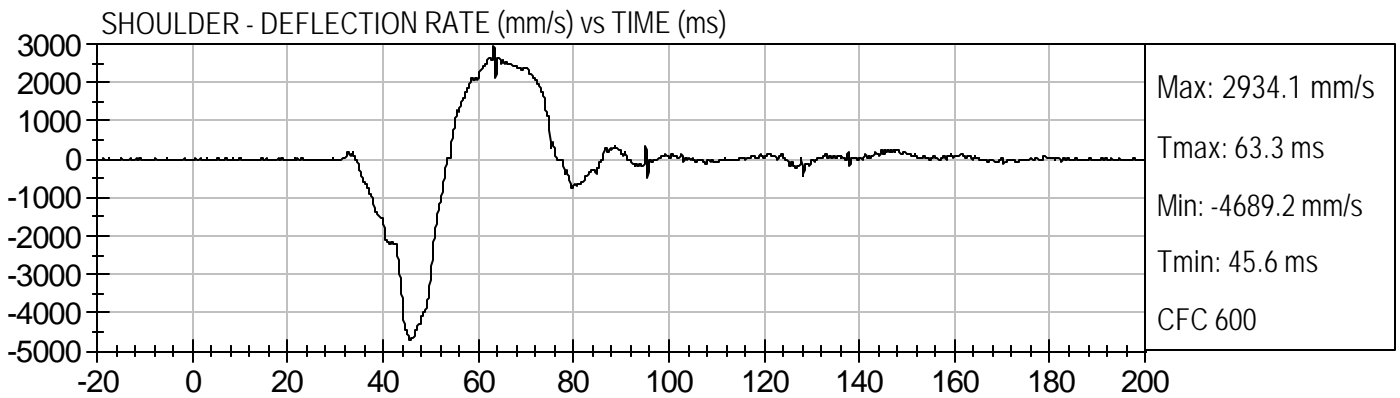
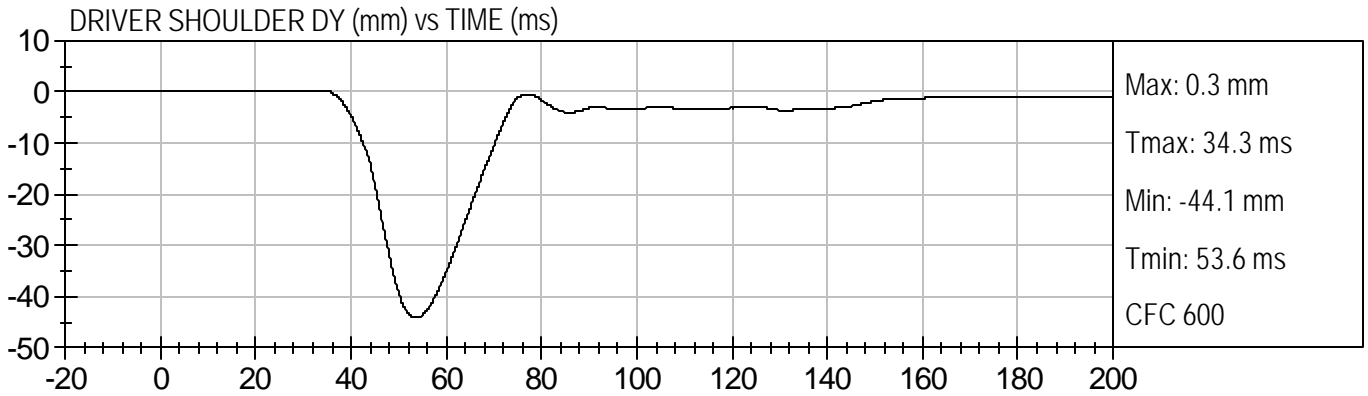

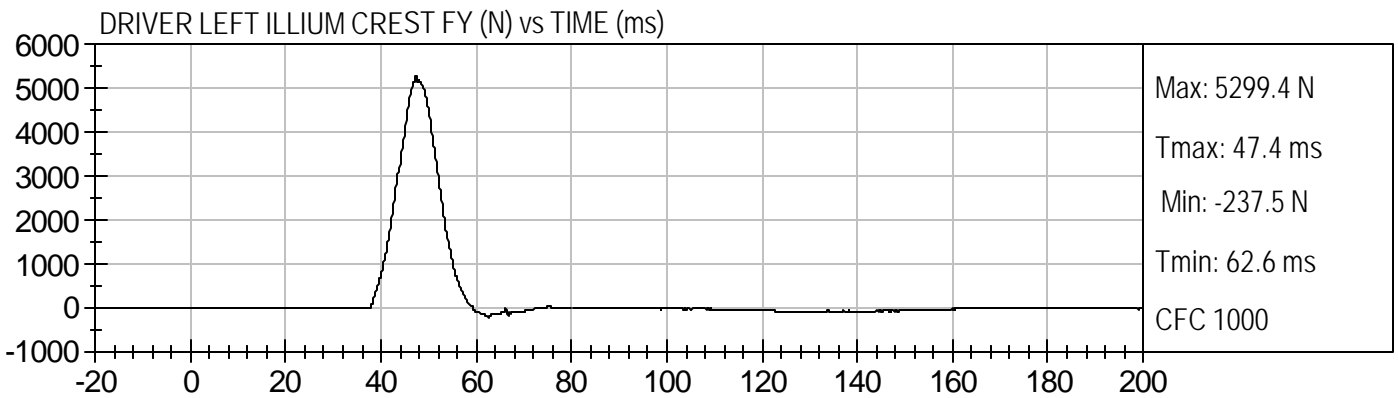
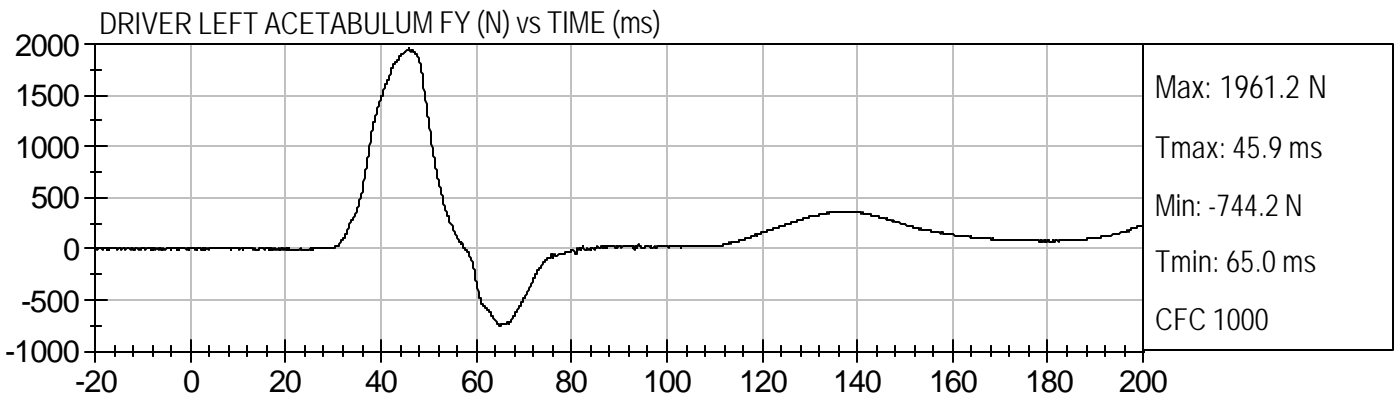
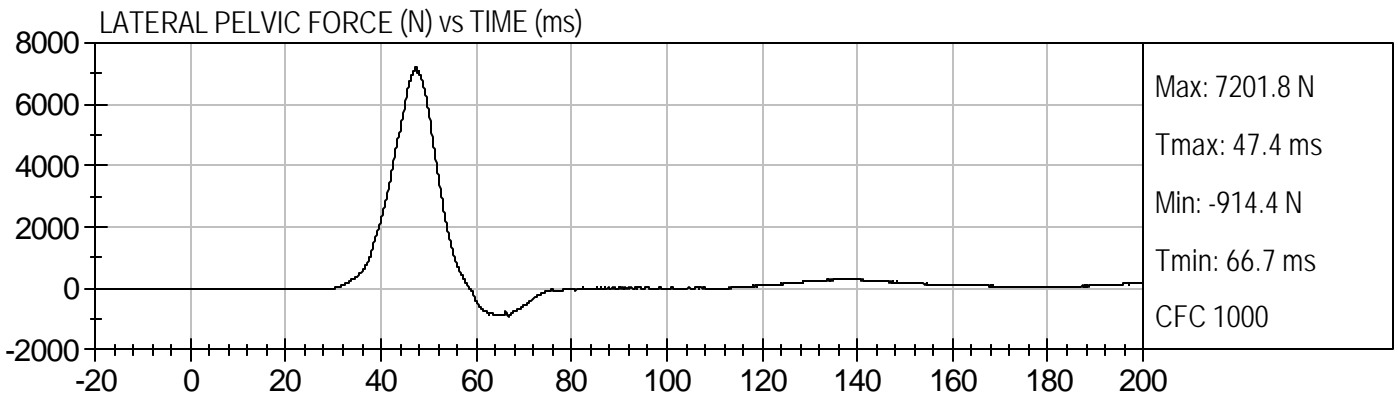

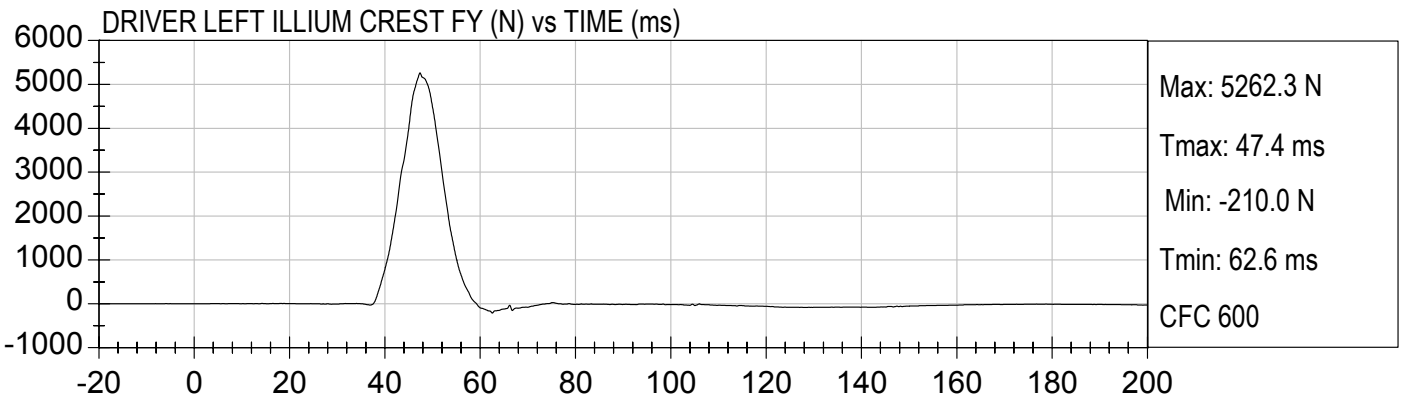
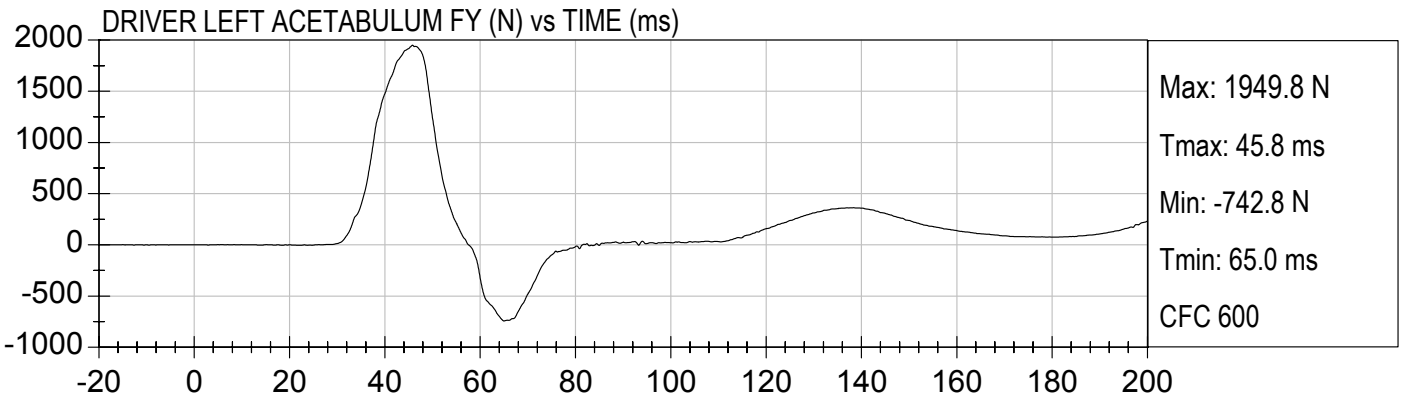
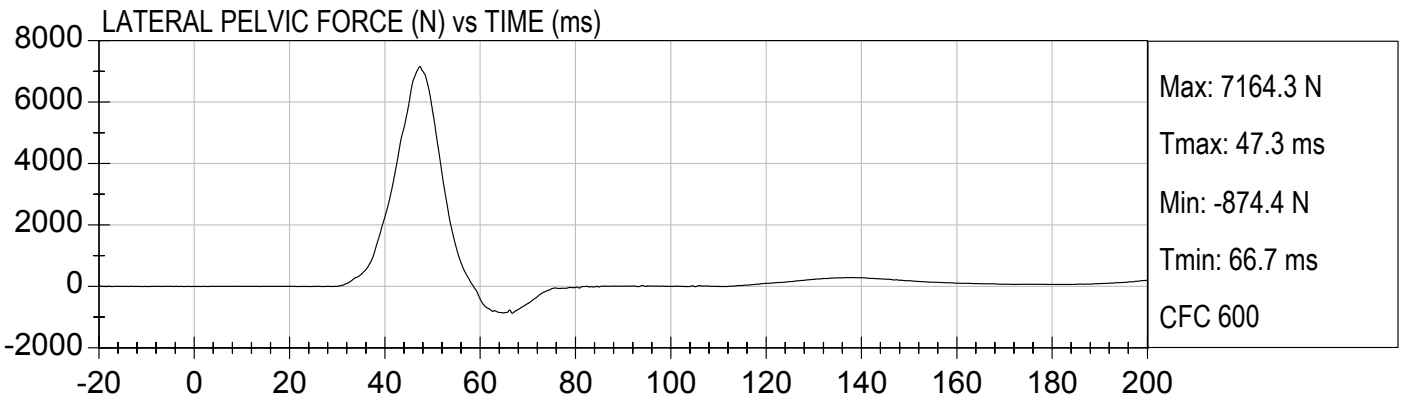

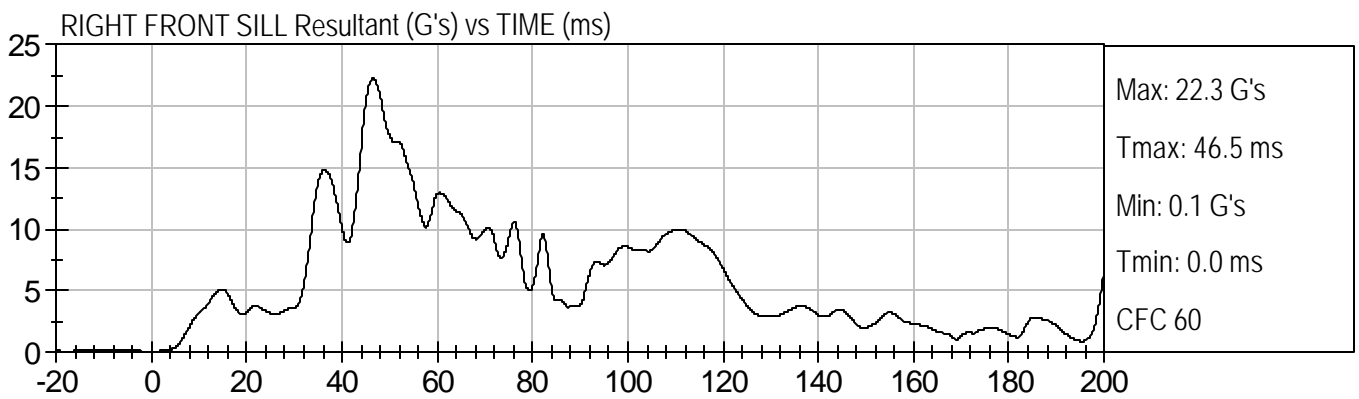
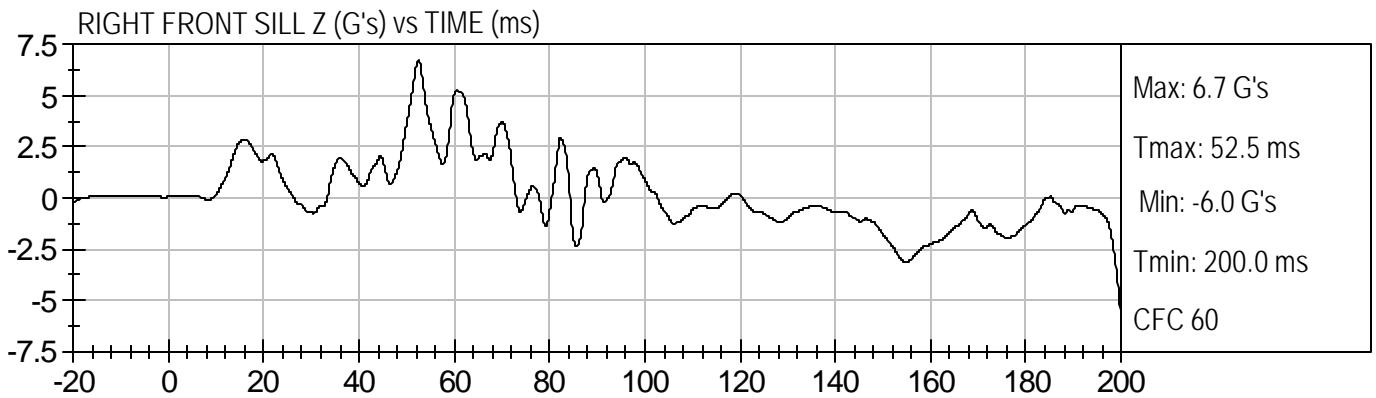
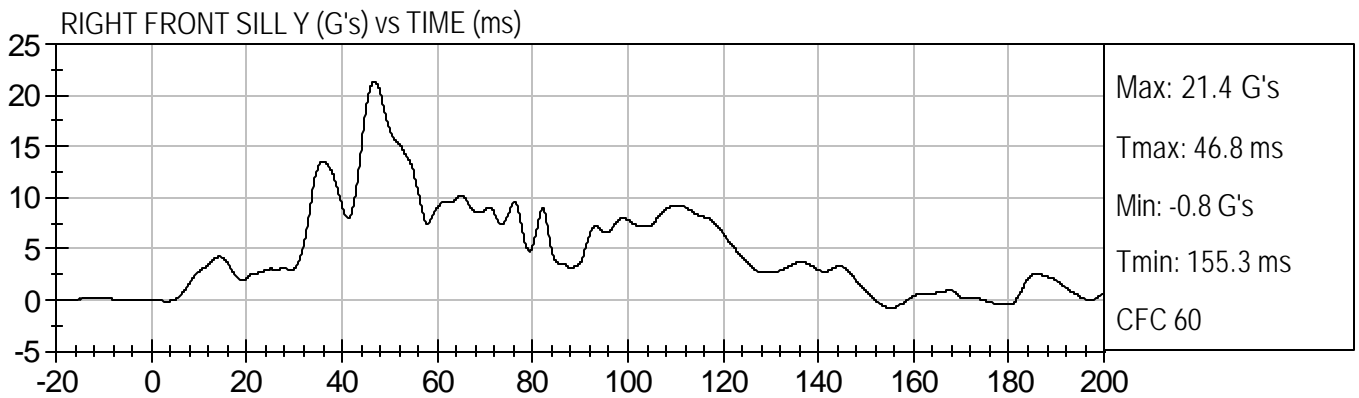
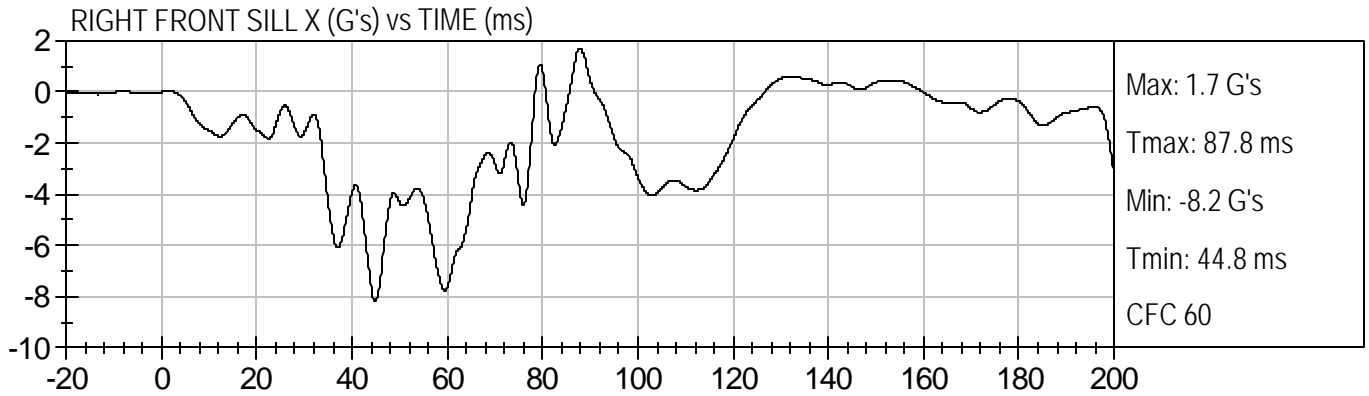

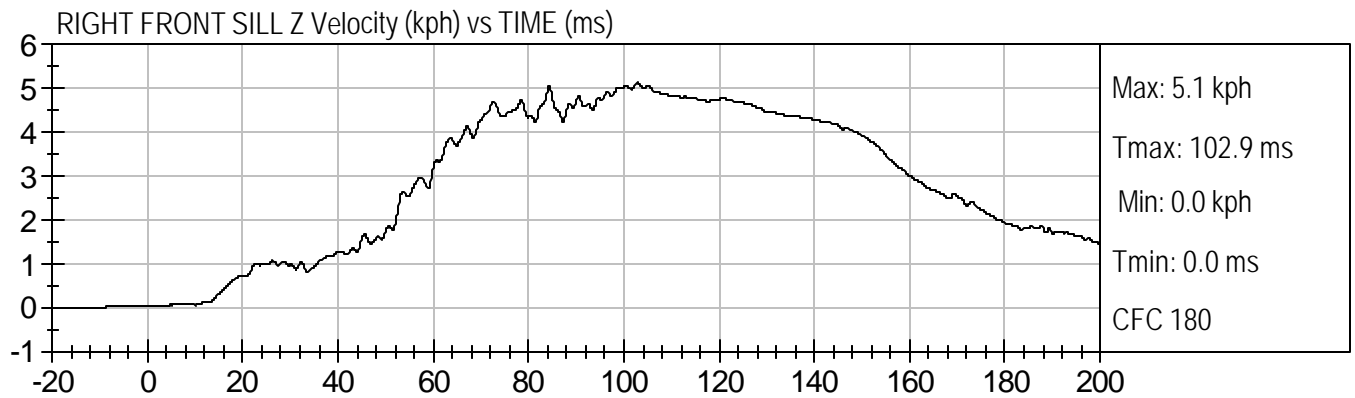
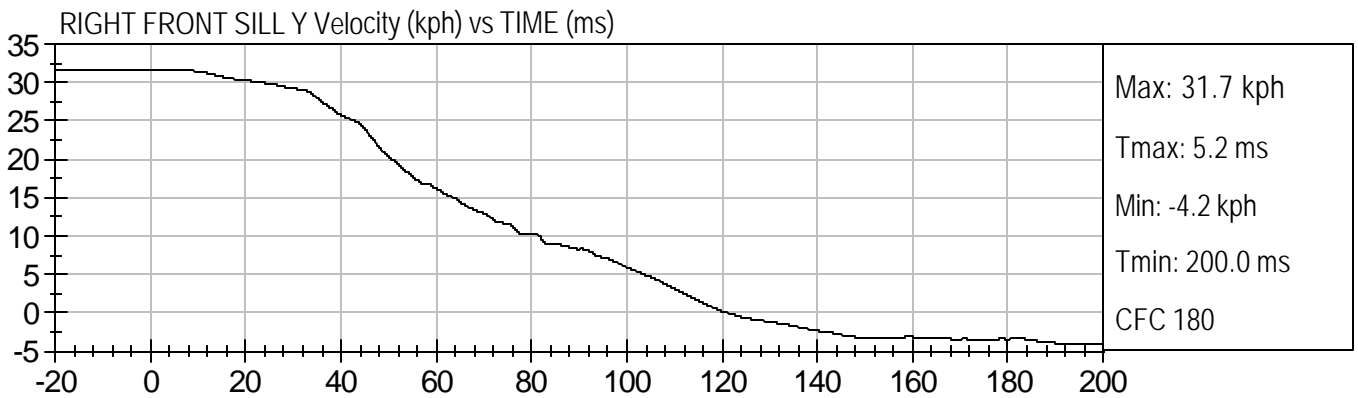
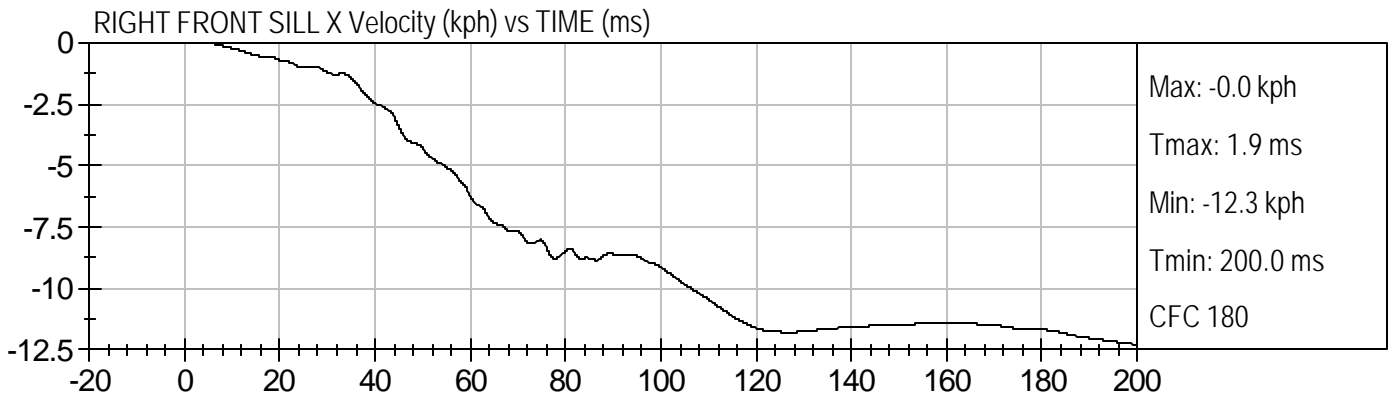



RIGHT REAR SILL X (G's) vs TIME (ms)

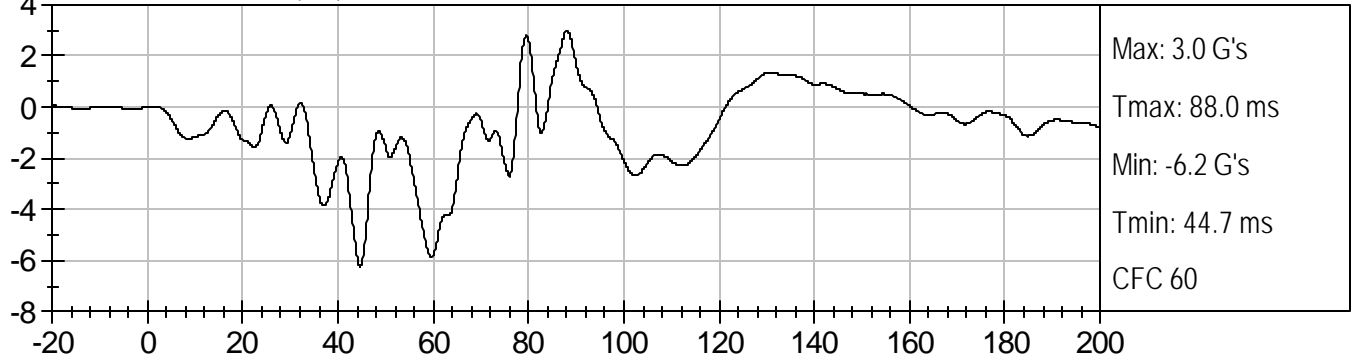

RIGHT REAR SILL Y (G's) vs TIME (ms)

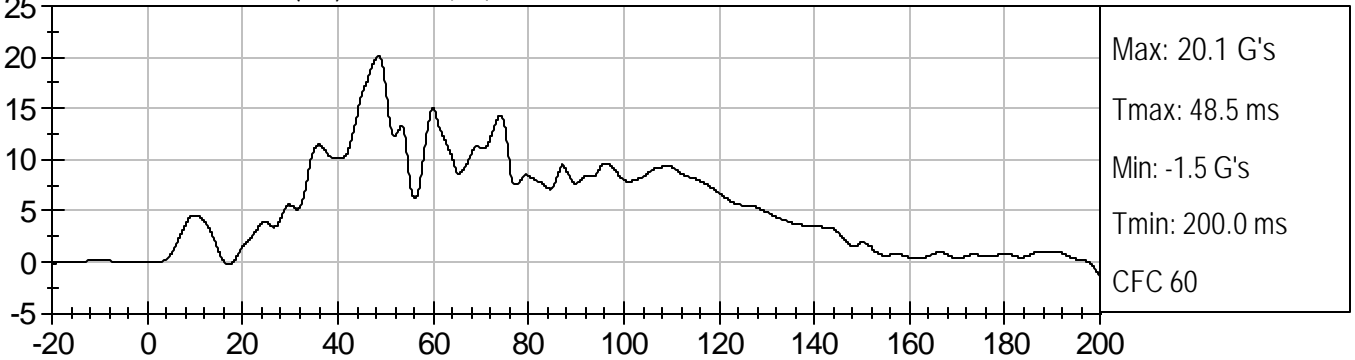

RIGHT REAR SILL Z (G's) vs TIME (ms)

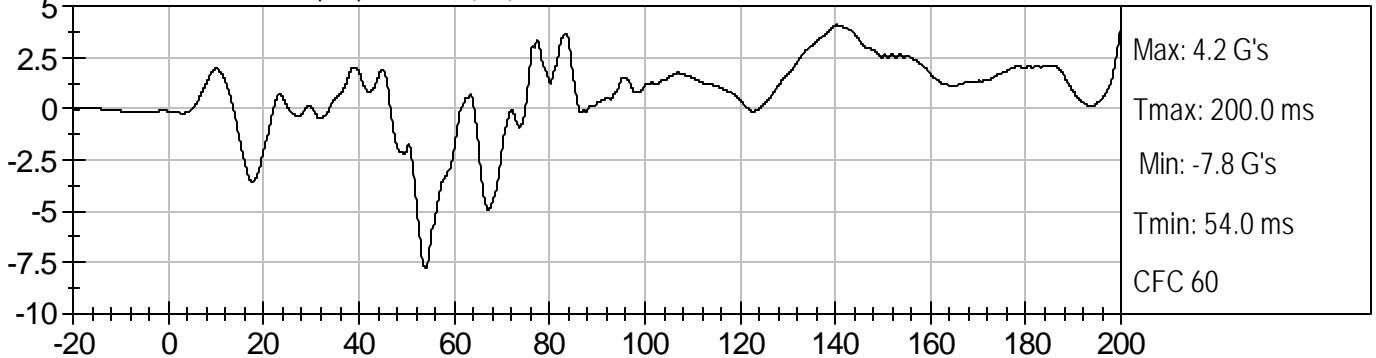

RIGHT REAR SILL Resultant (G's) vs TIME (ms)

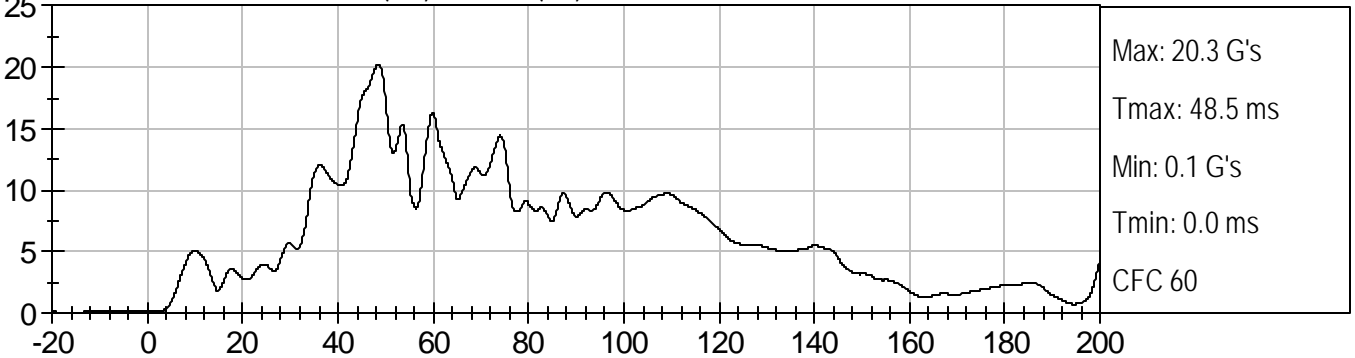



RIGHT REAR SILL X Velocity (kph) vs TIME (ms)

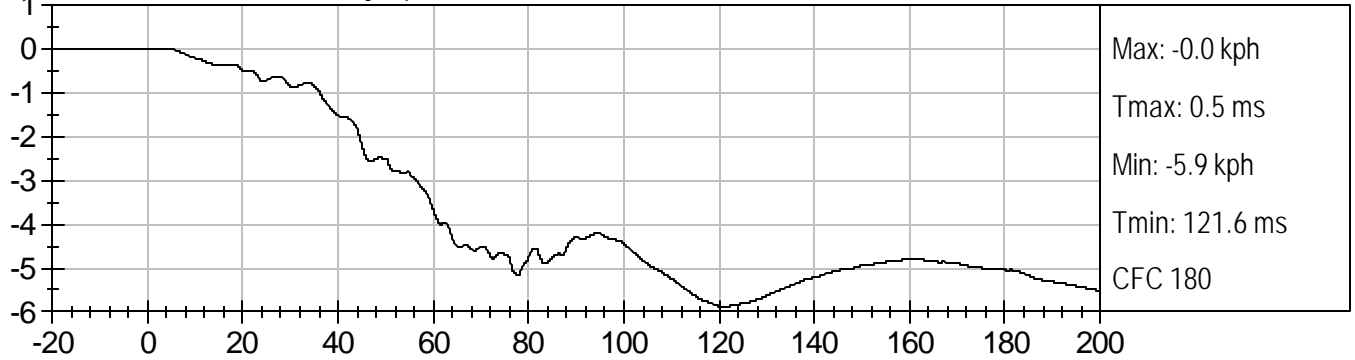

RIGHT REAR SILL Y Velocity (kph) vs TIME (ms)

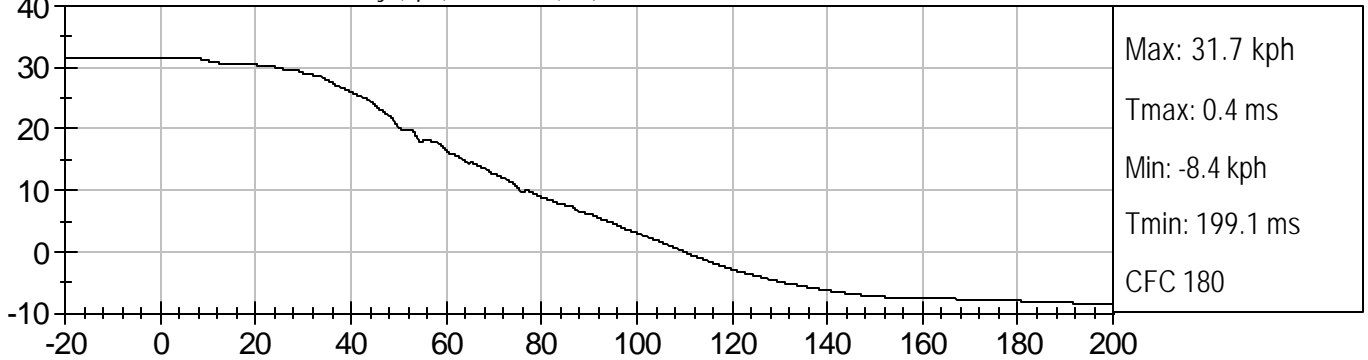

RIGHT REAR SILL Z Velocity (kph) vs TIME (ms)

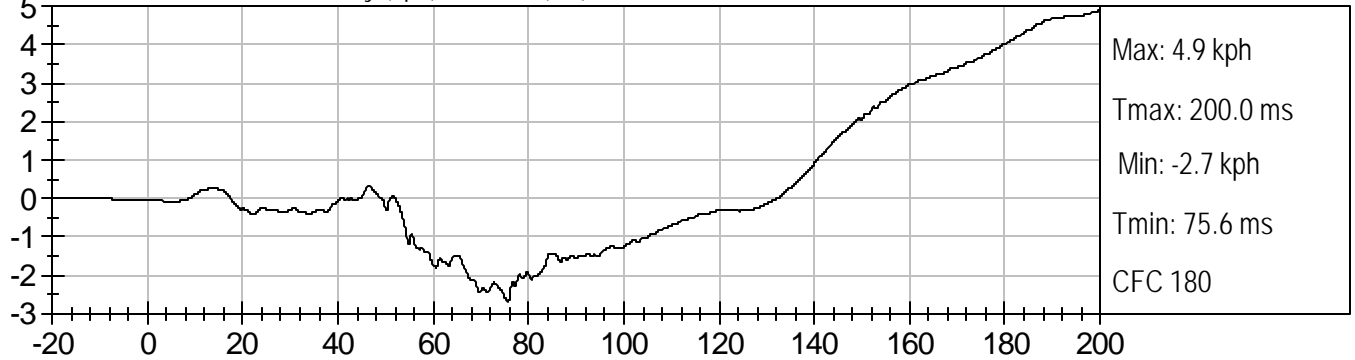

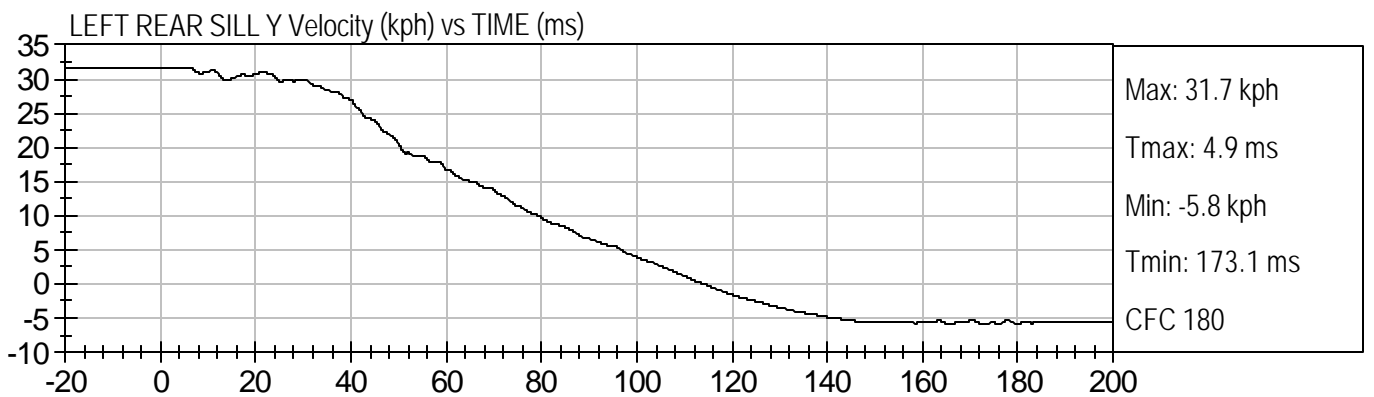
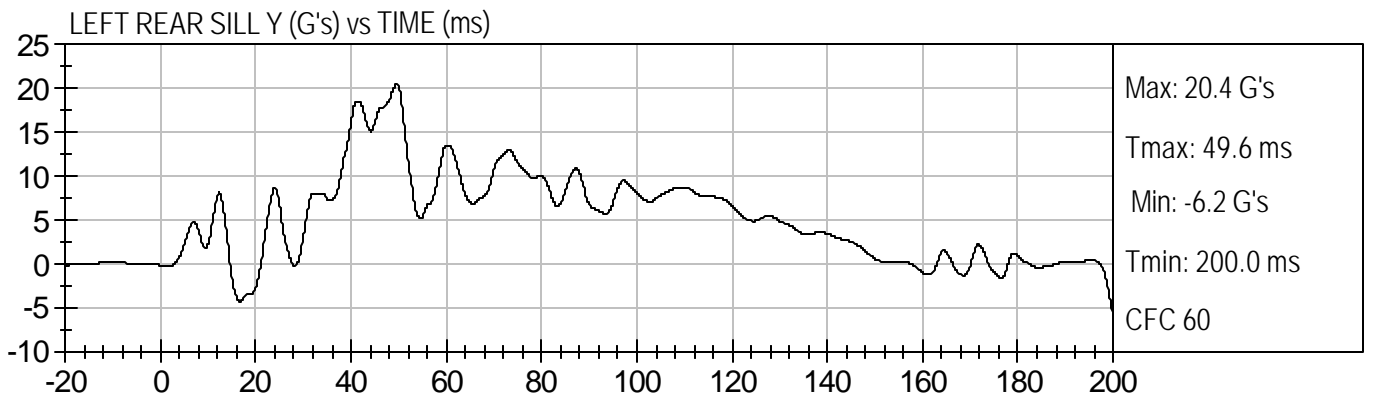
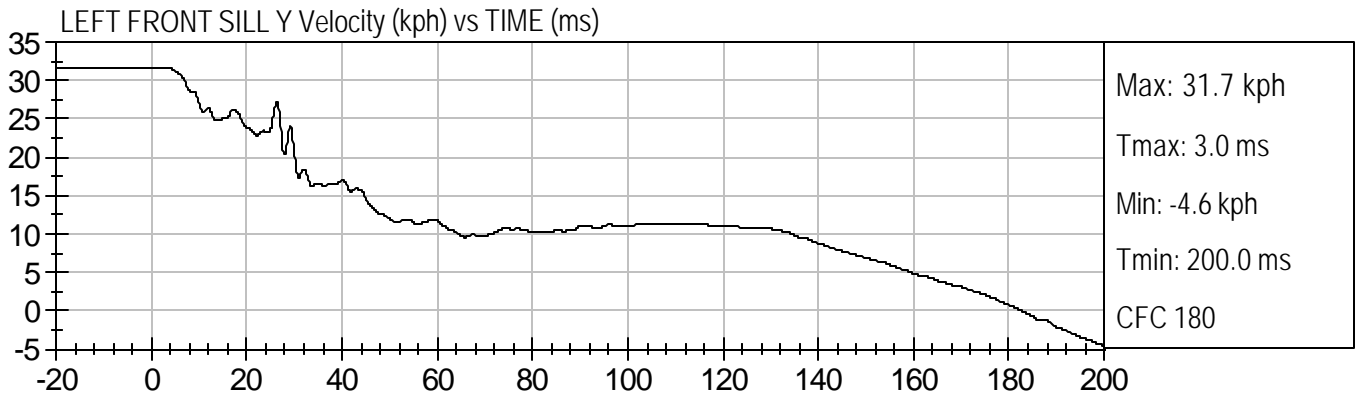
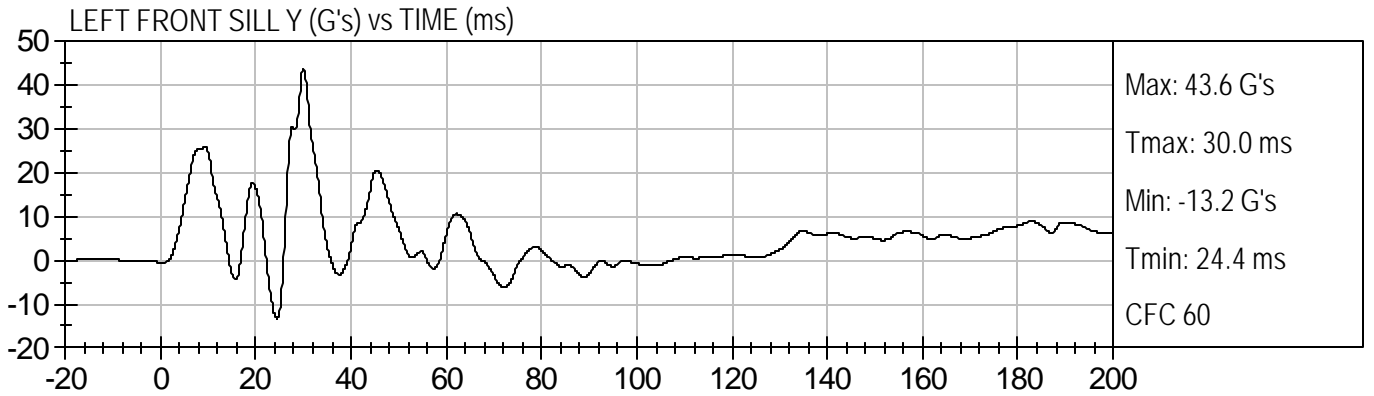

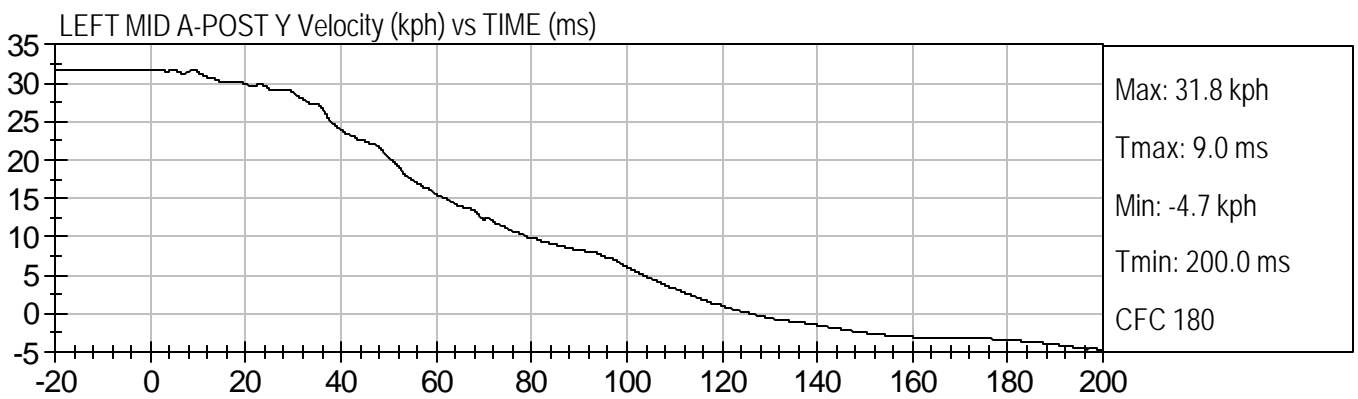
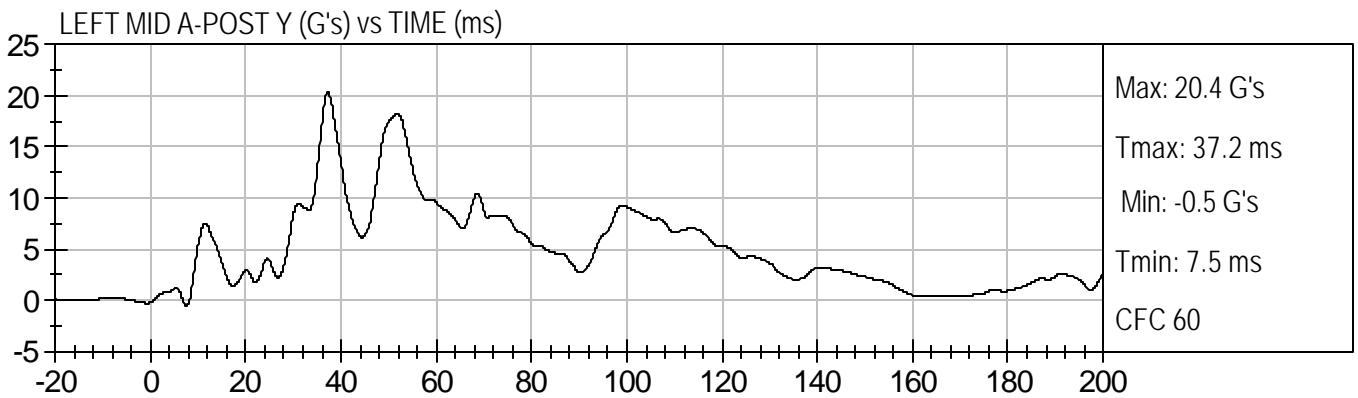
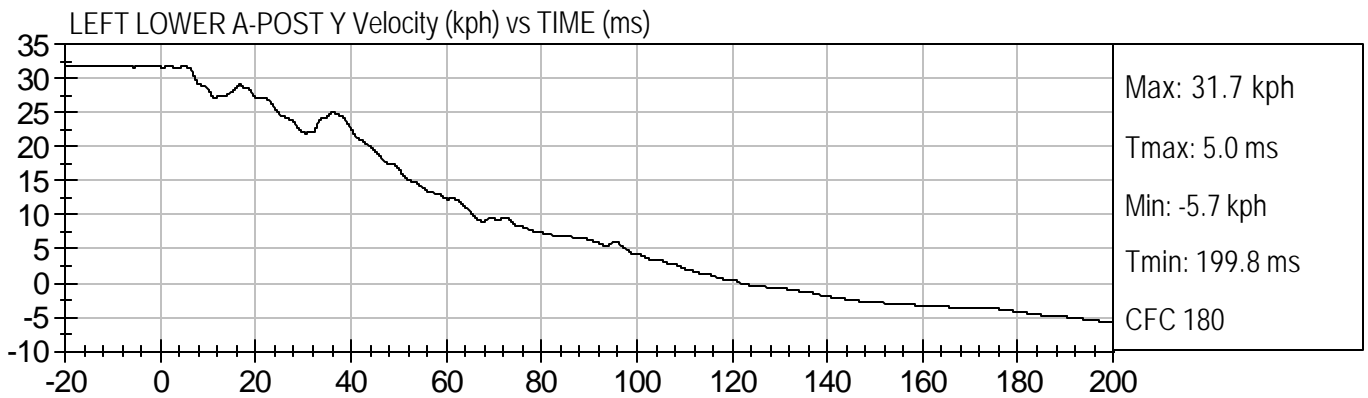
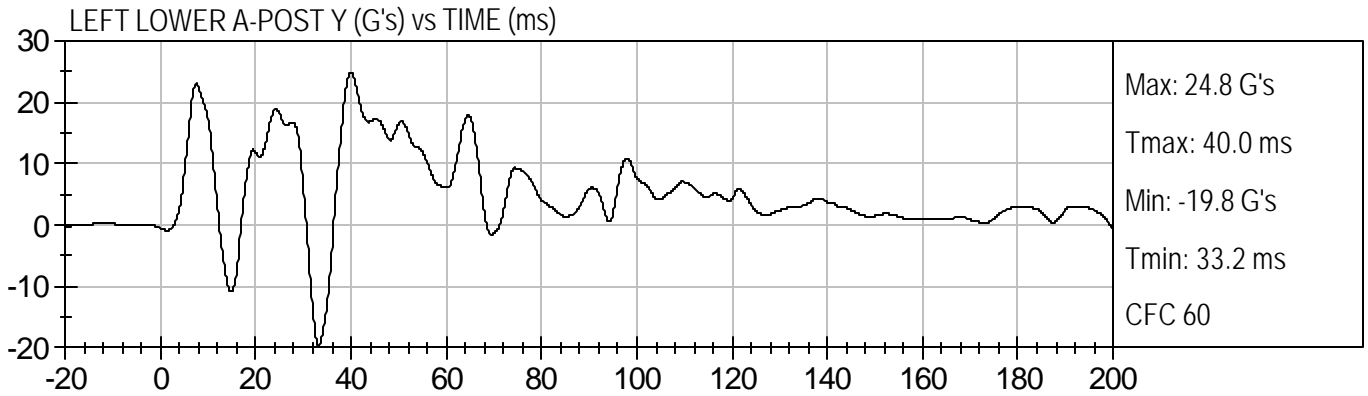

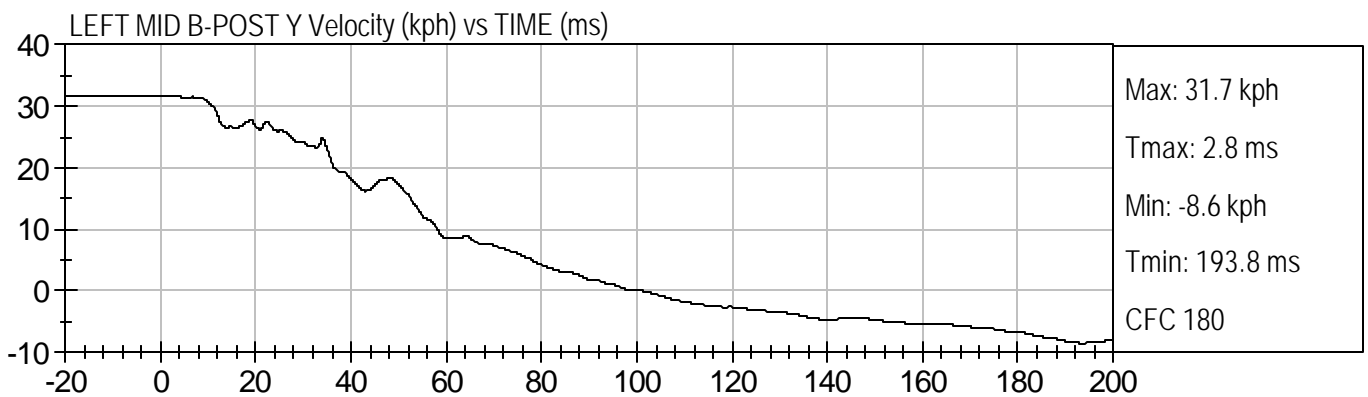
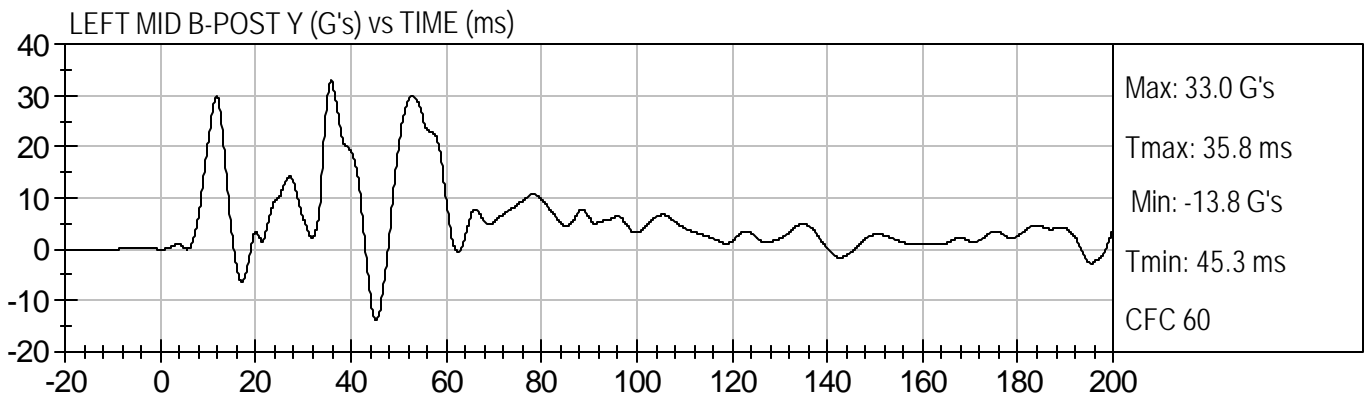
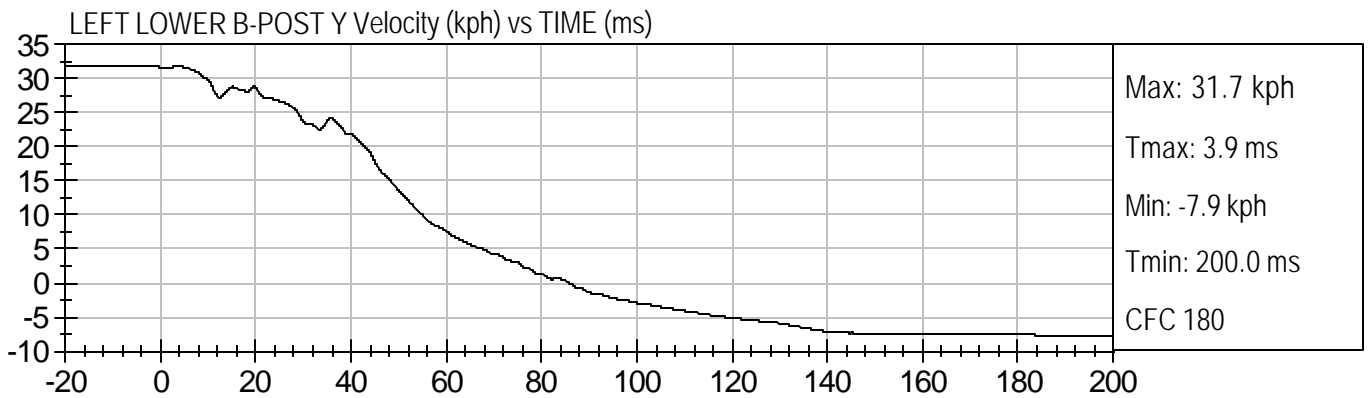
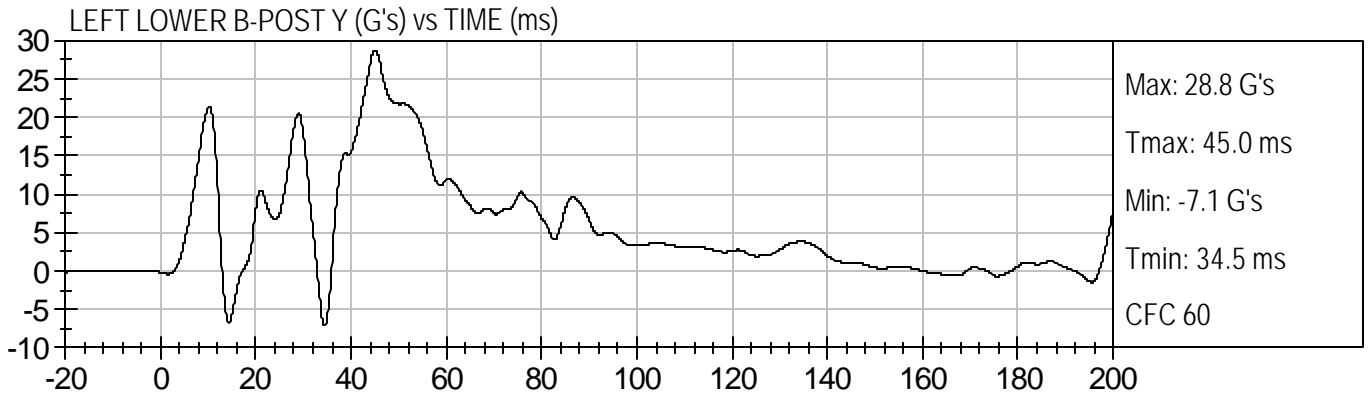

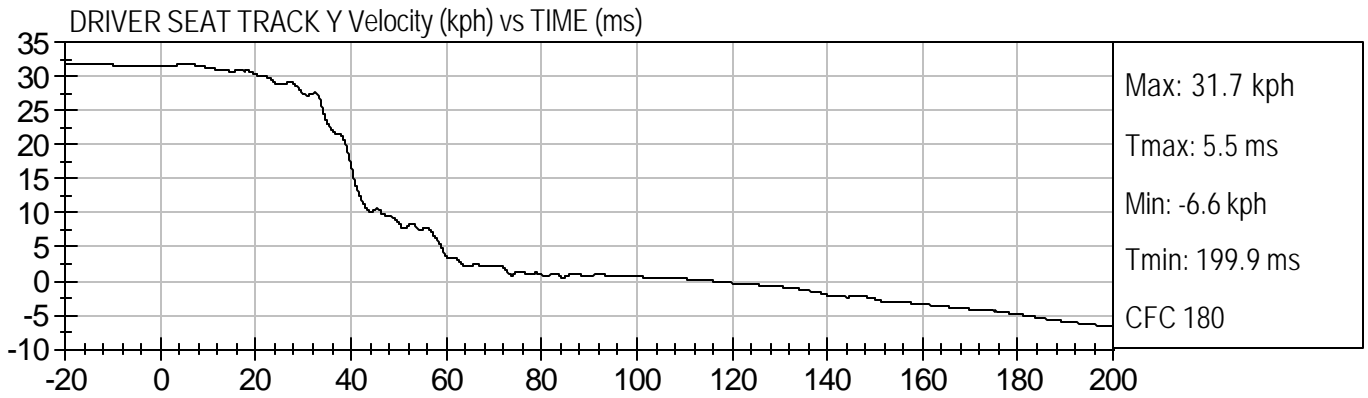
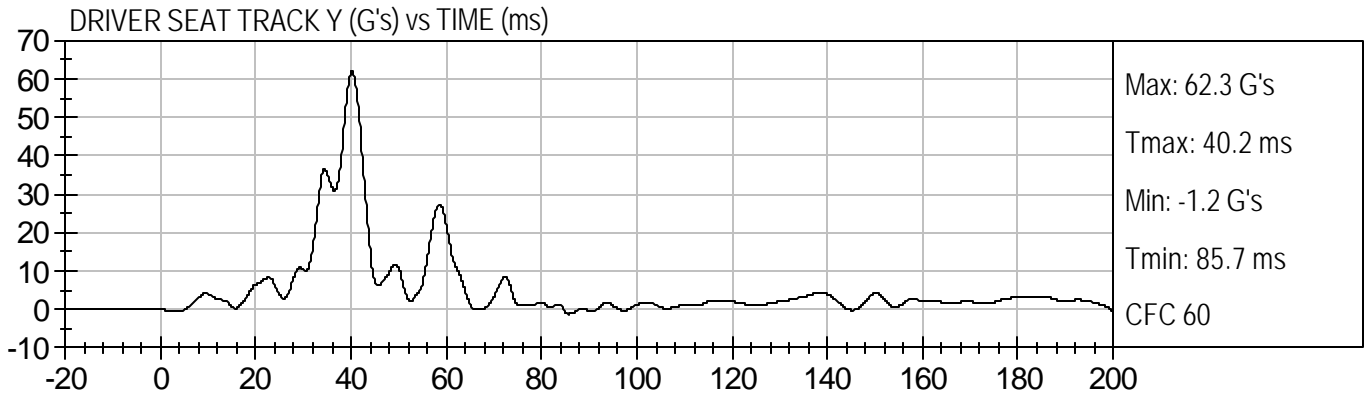

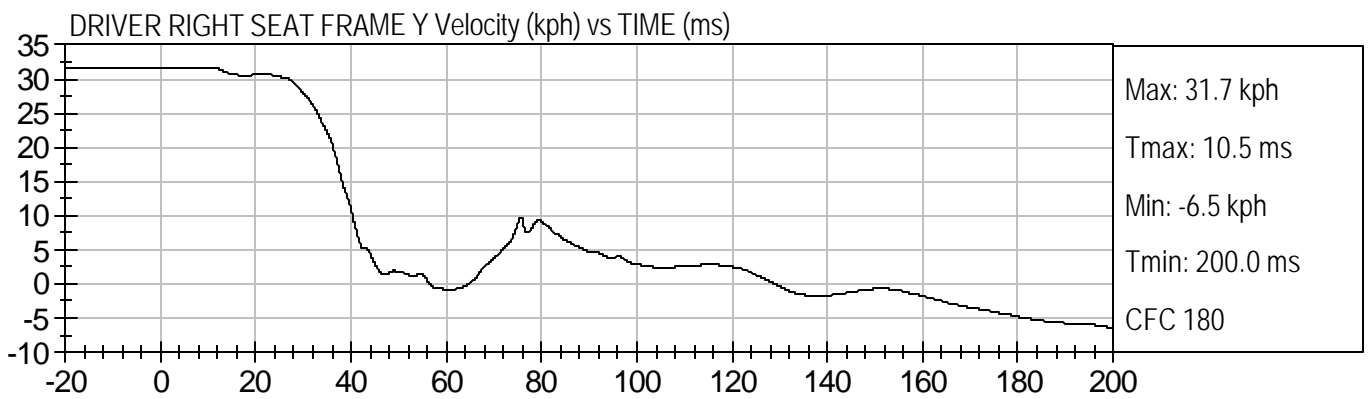
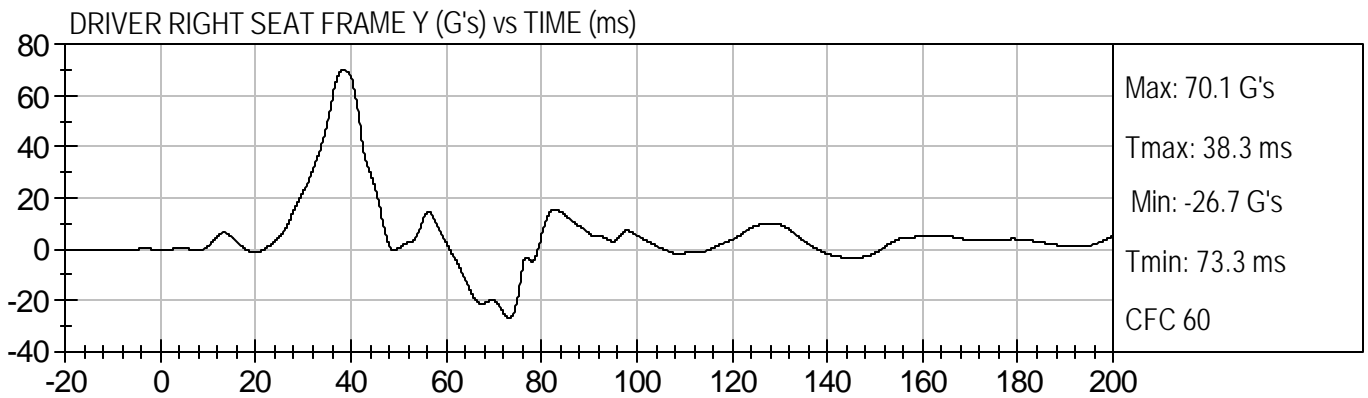
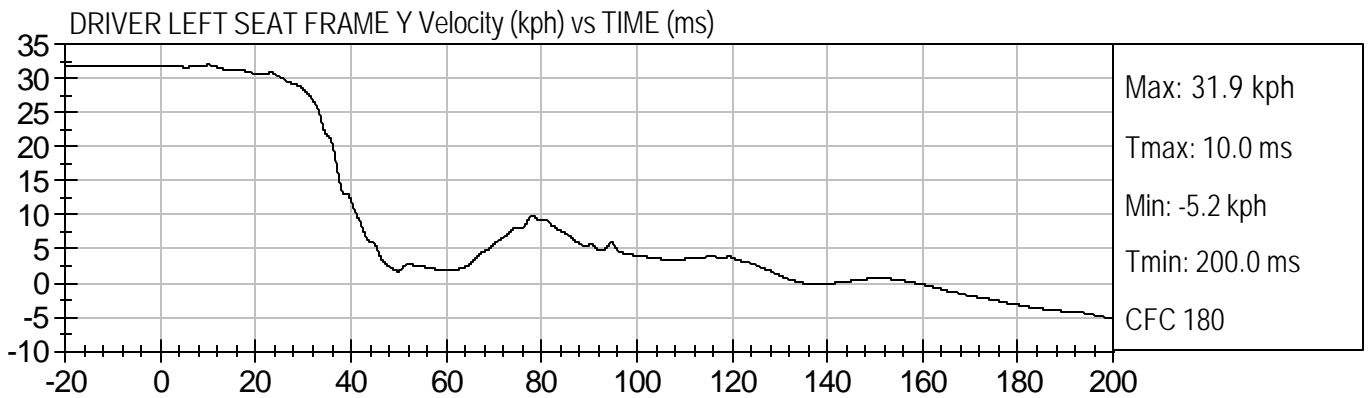
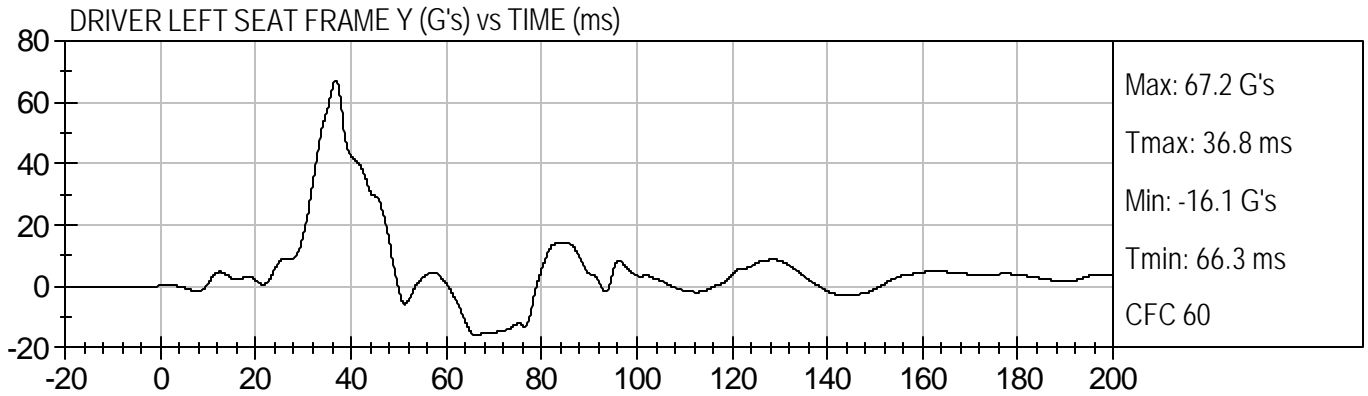

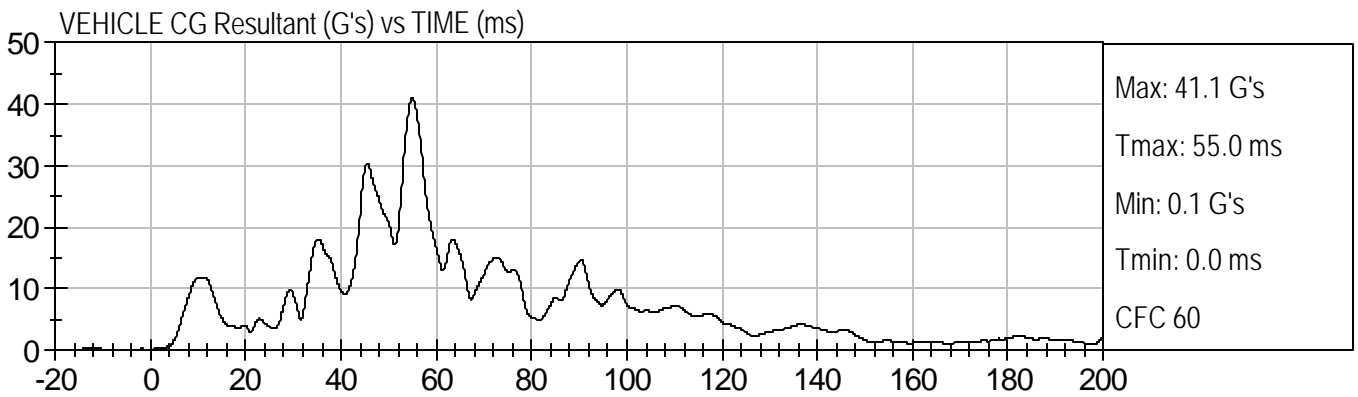
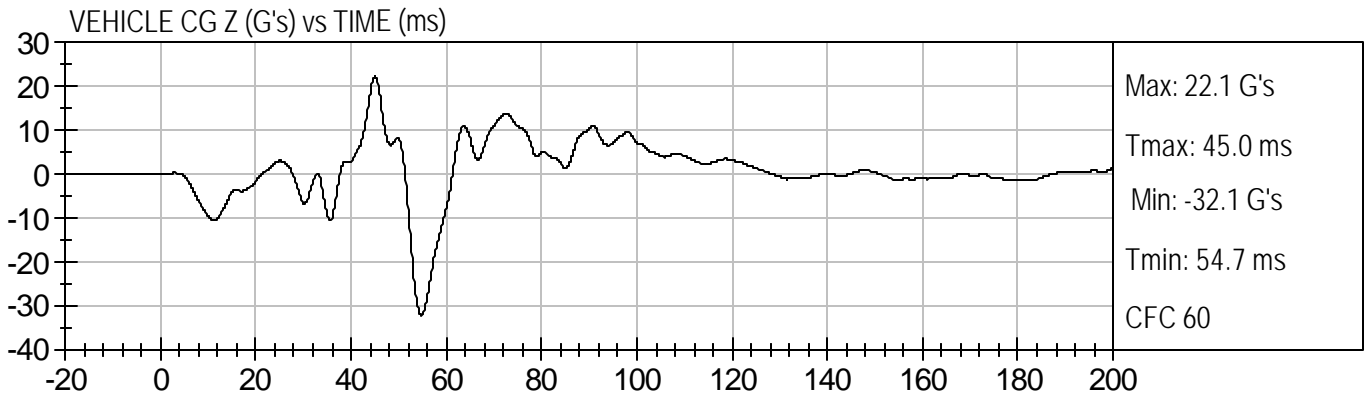
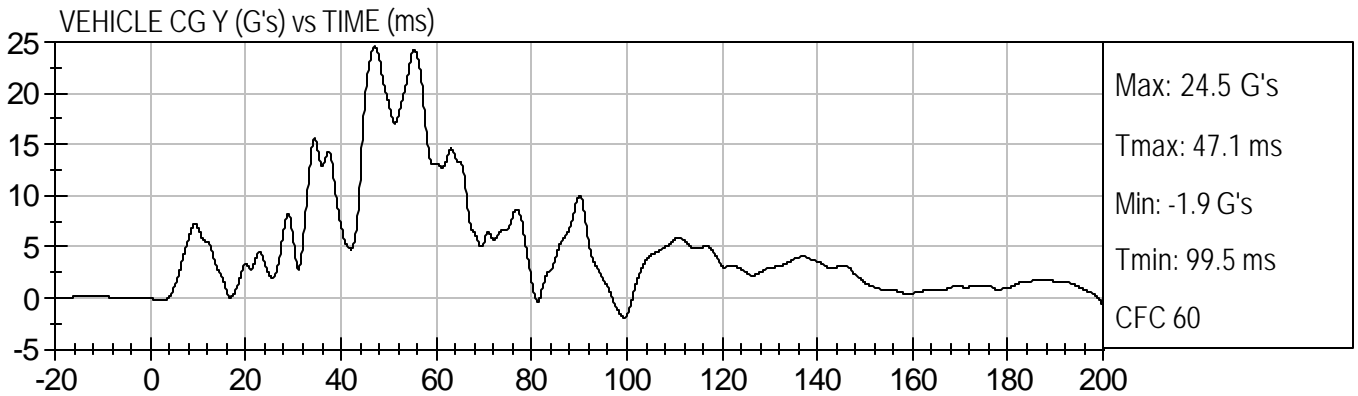
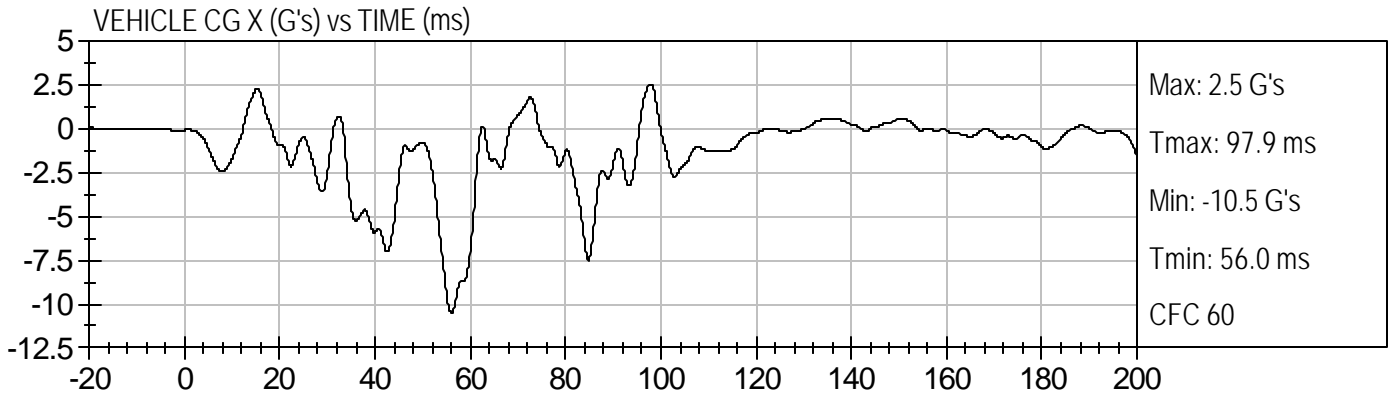

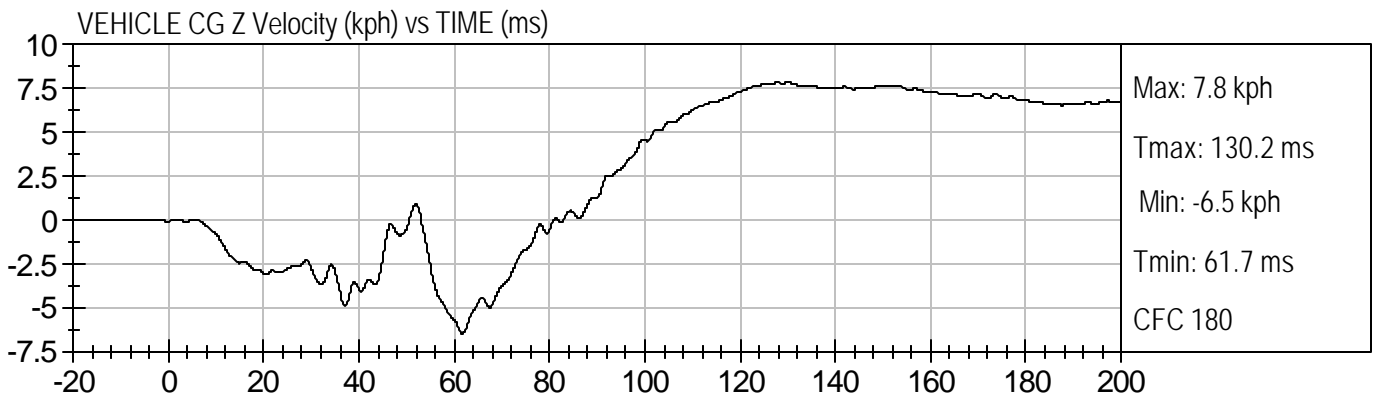
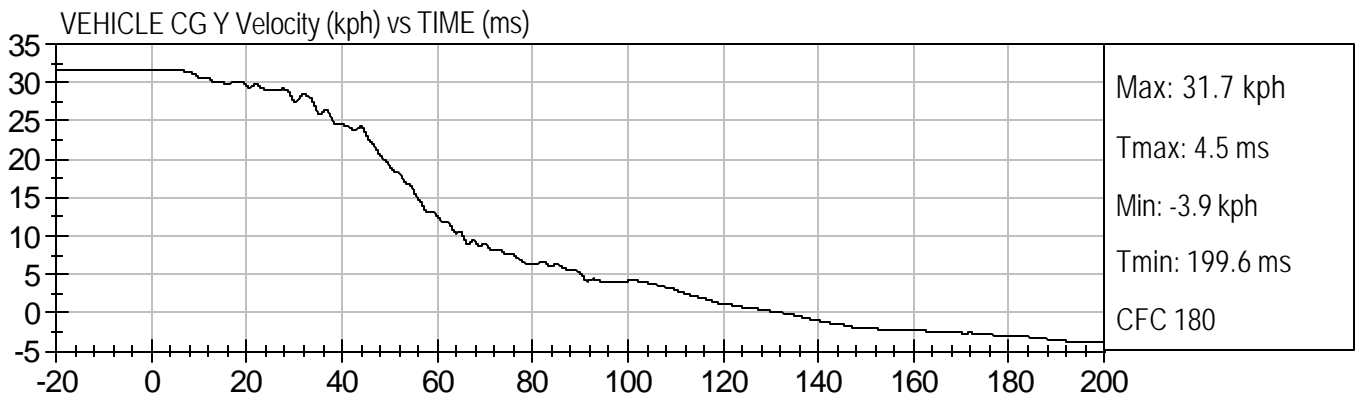
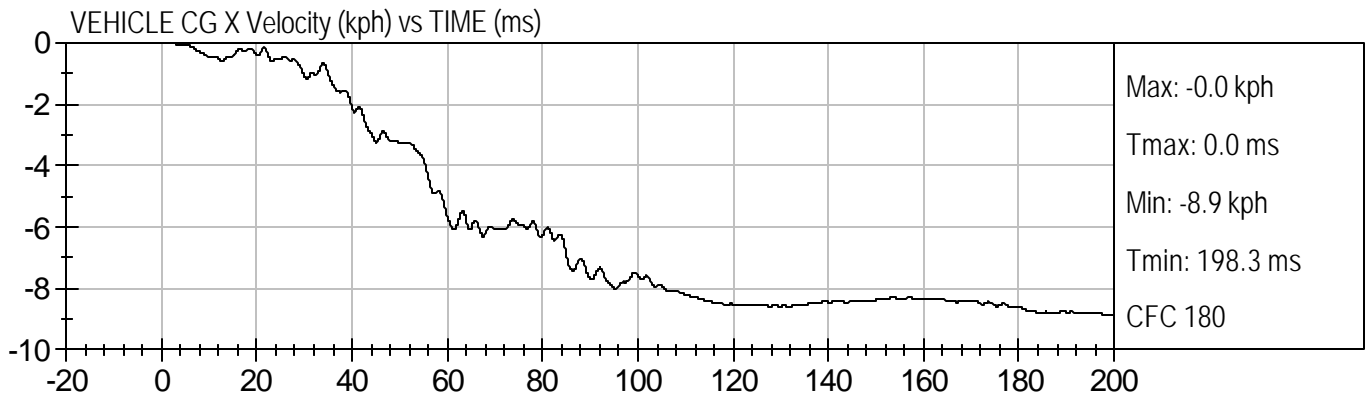

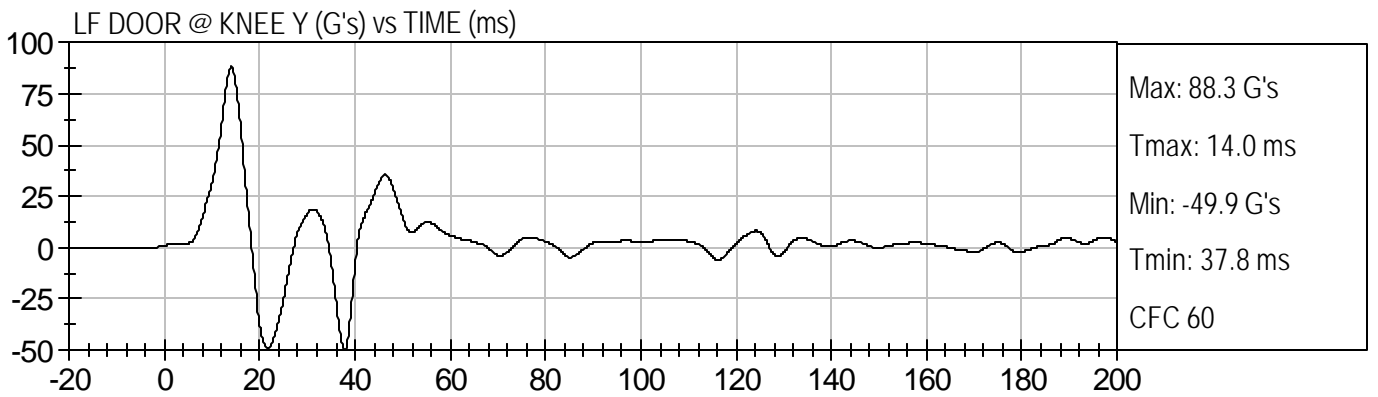
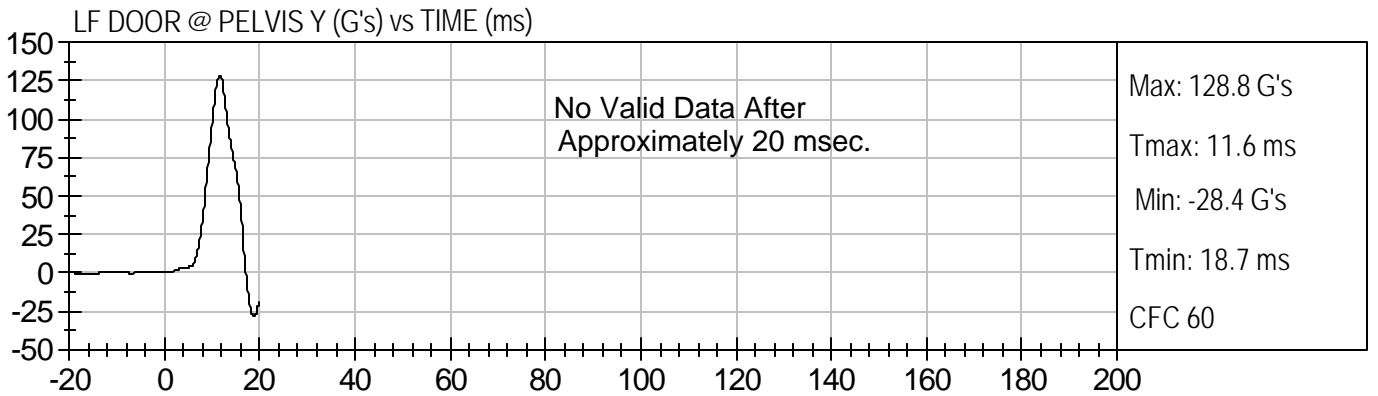
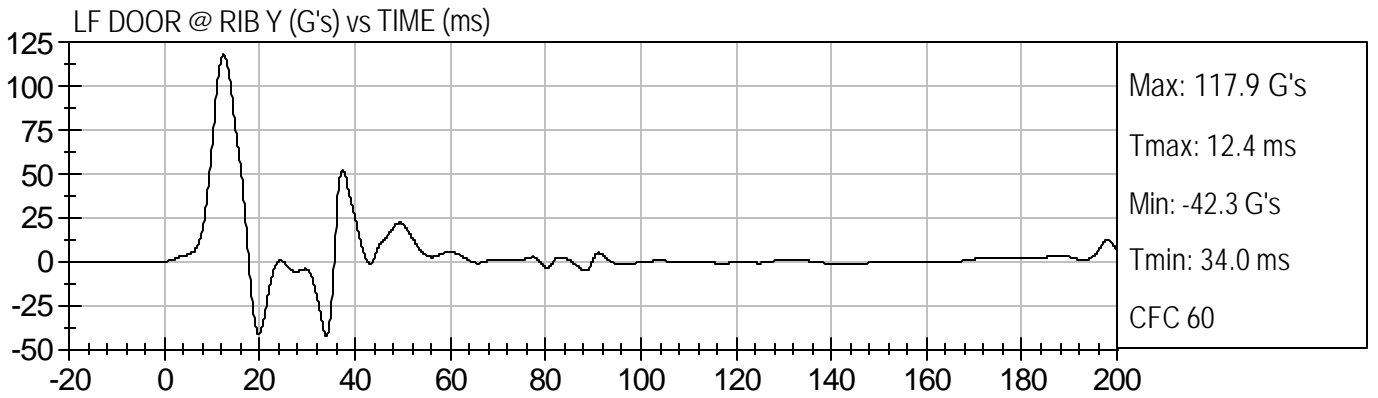
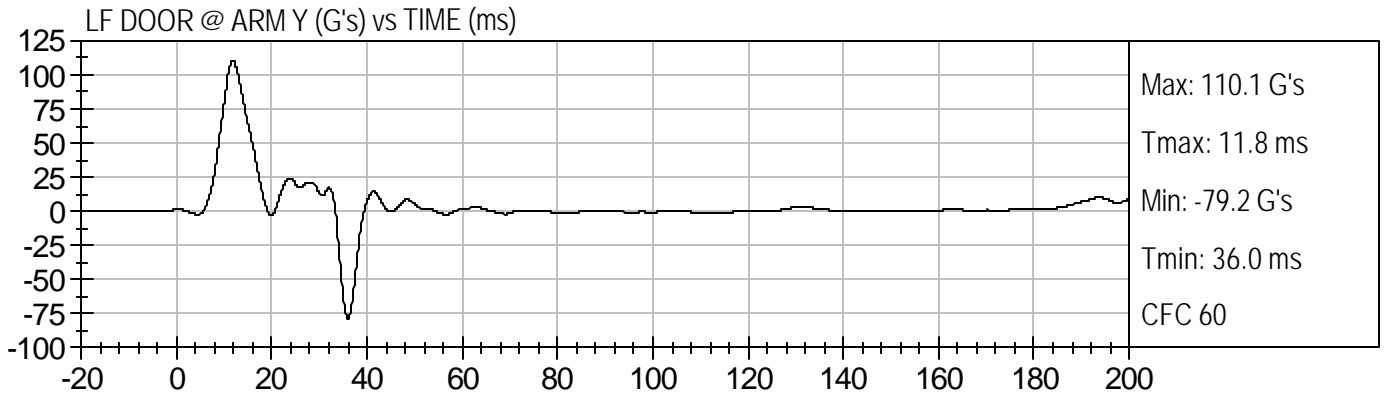



LF DOOR @ ARM Y Velocity (kph) vs TIME (ms)

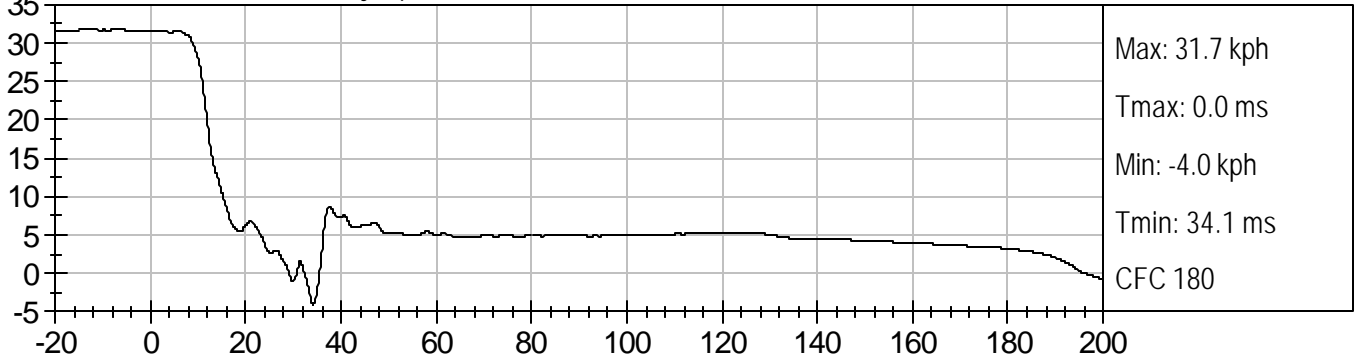

LF DOOR @ RIB Y Velocity (kph) vs TIME (ms)

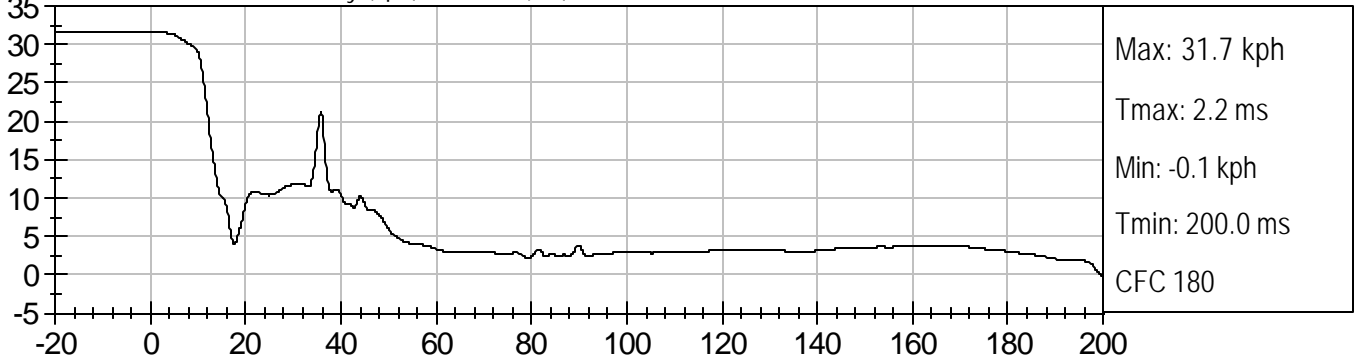

LF DOOR @ PELVIS Y Velocity (kph) vs TIME (ms)

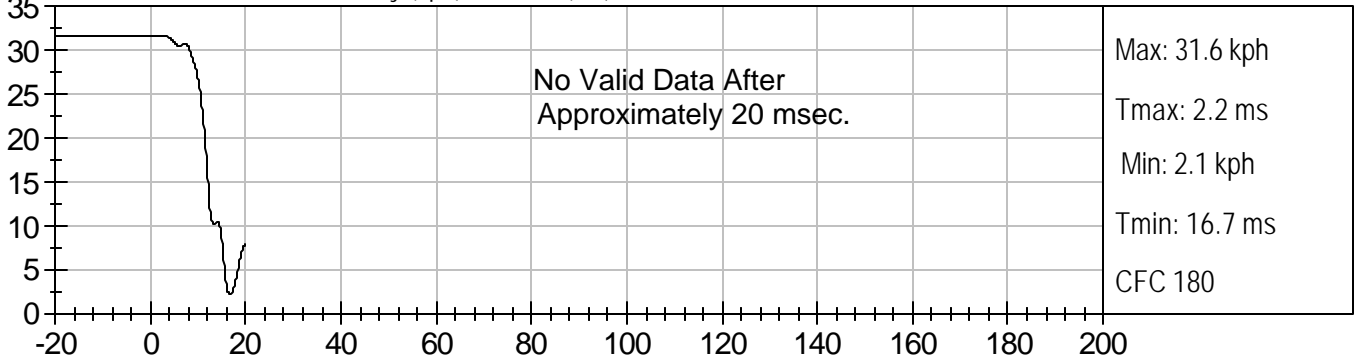

LF DOOR @ KNEE Y Velocity (kph) vs TIME (ms)

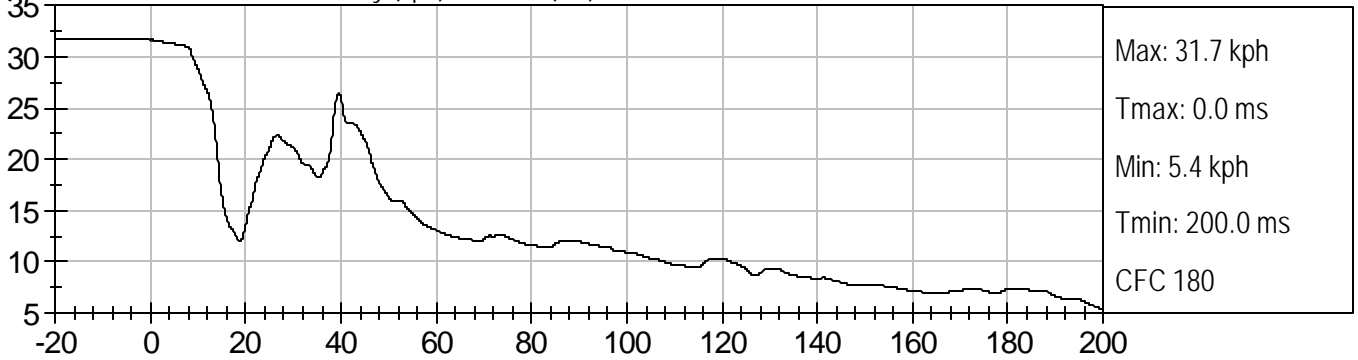

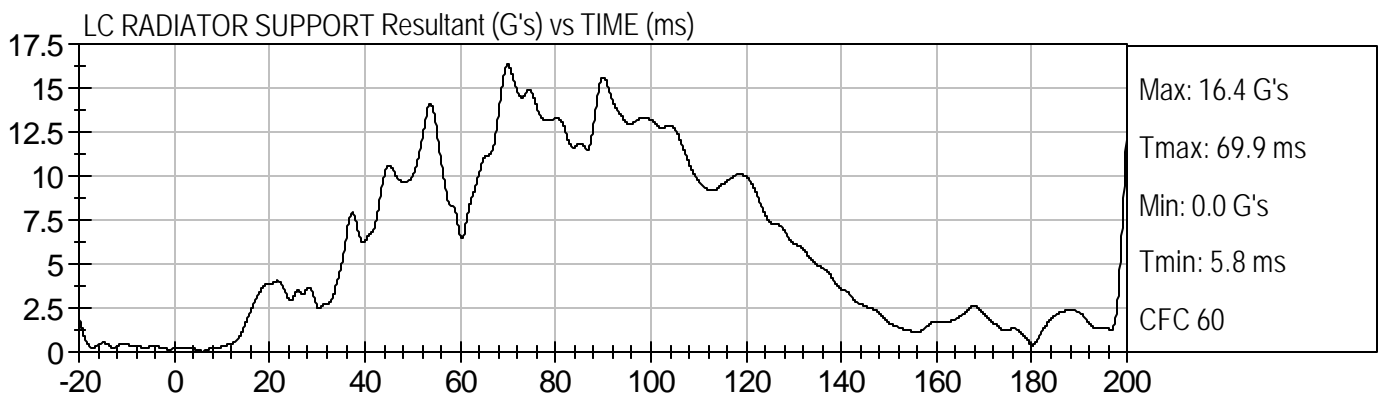
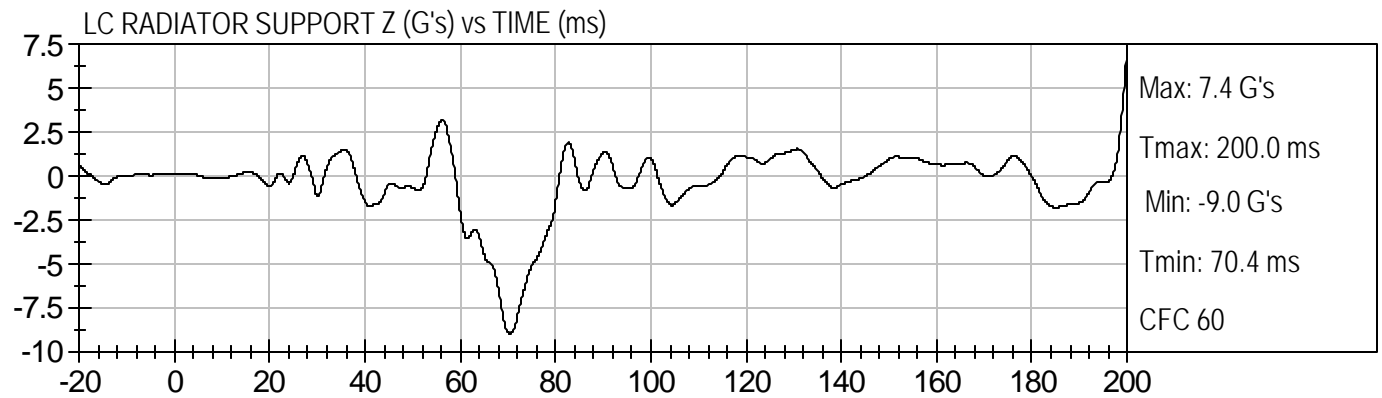
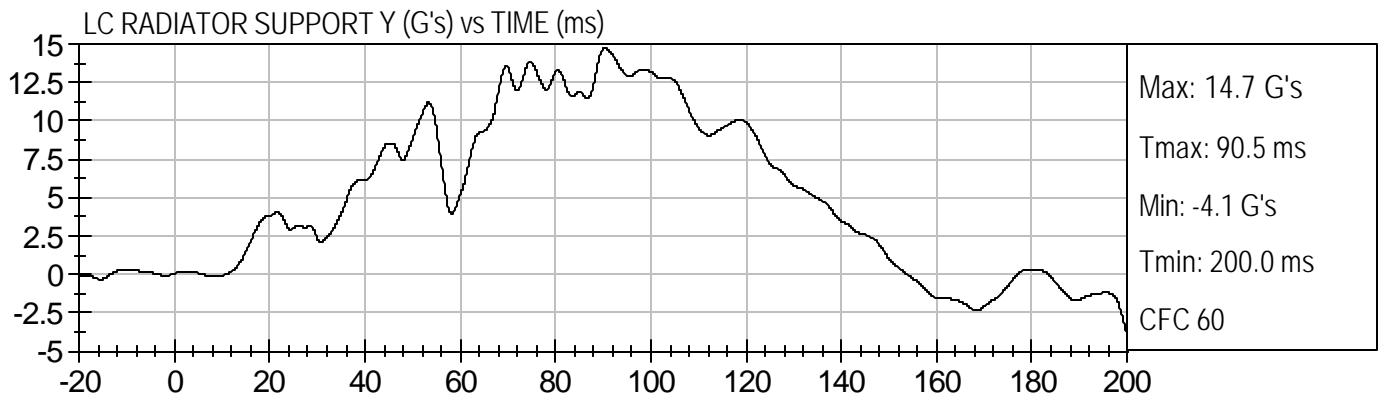
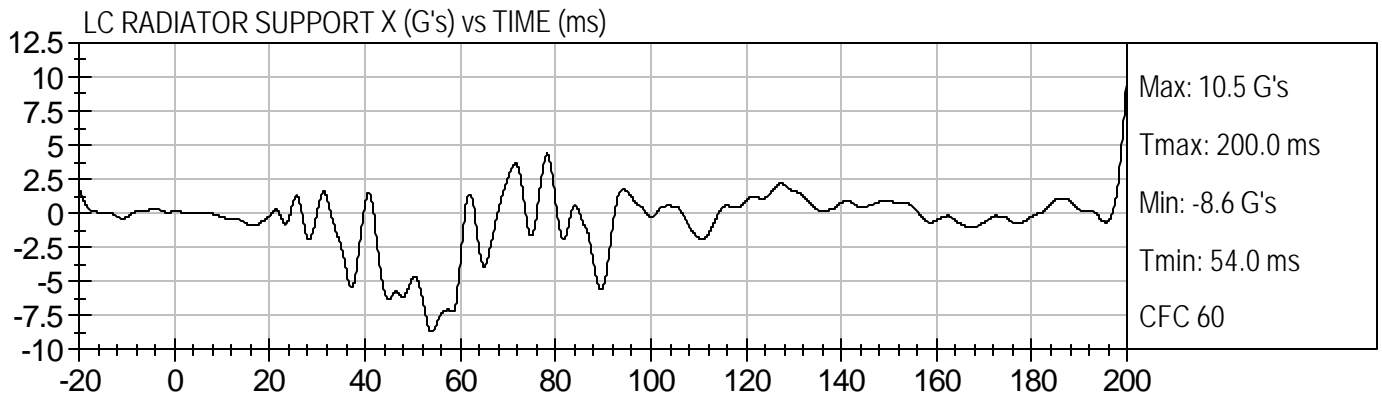



LC RADIATOR SUPPORT X Velocity (kph) vs TIME (ms)

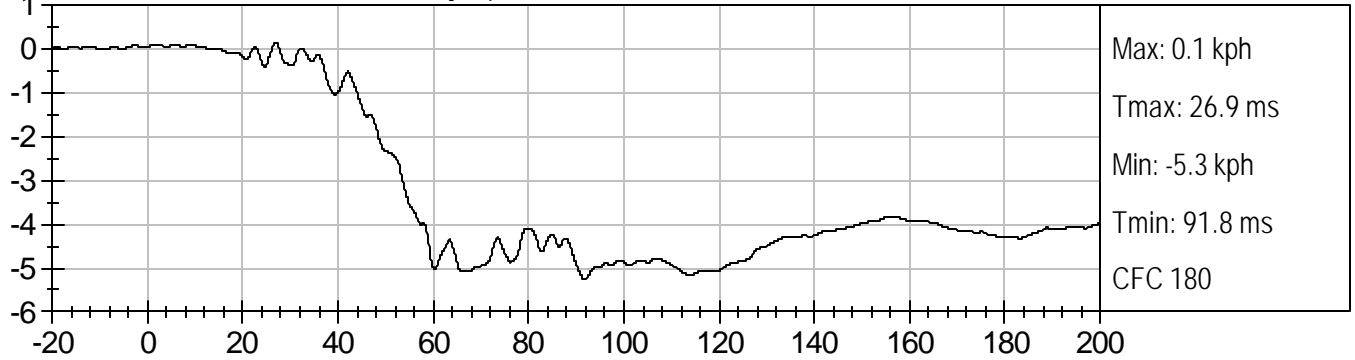

LC RADIATOR SUPPORT Y Velocity (kph) vs TIME (ms)

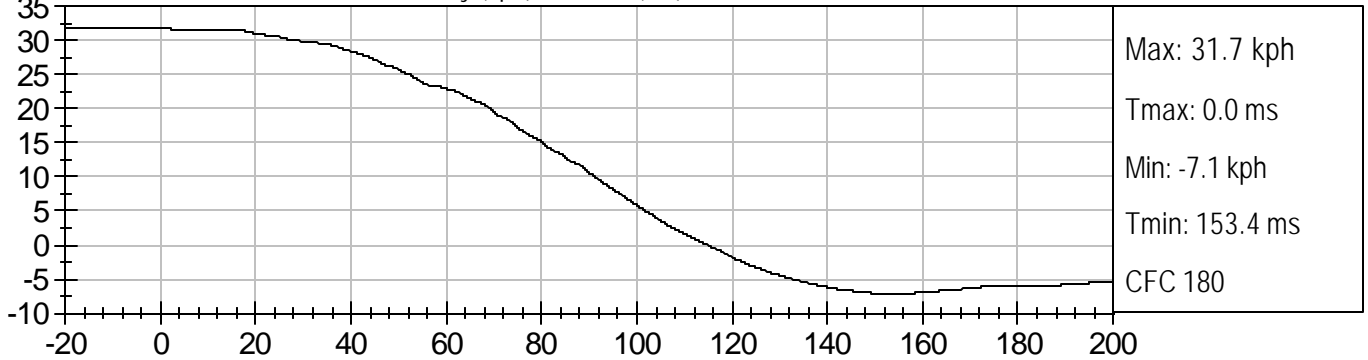

LC RADIATOR SUPPORT Z Velocity (kph) vs TIME (ms)

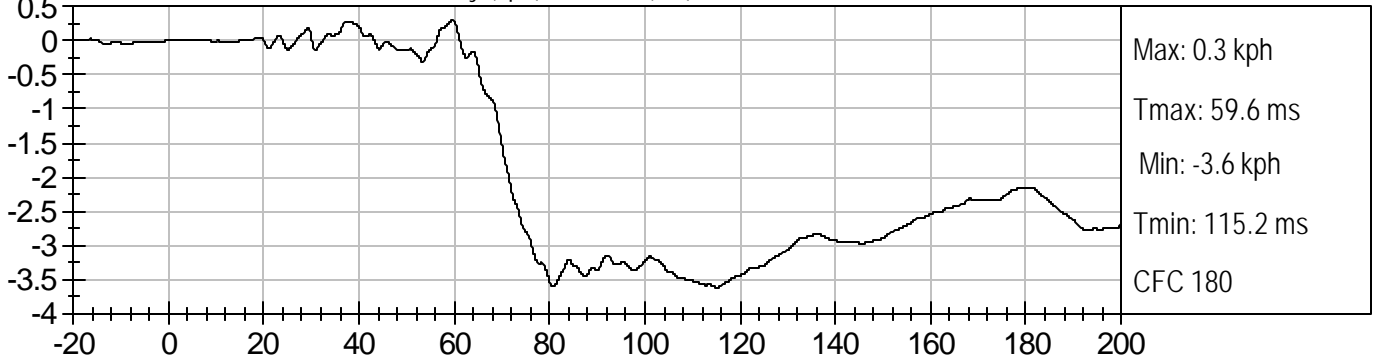



FLOORPAN @ REAR AXLE X (G's) vs TIME (ms)

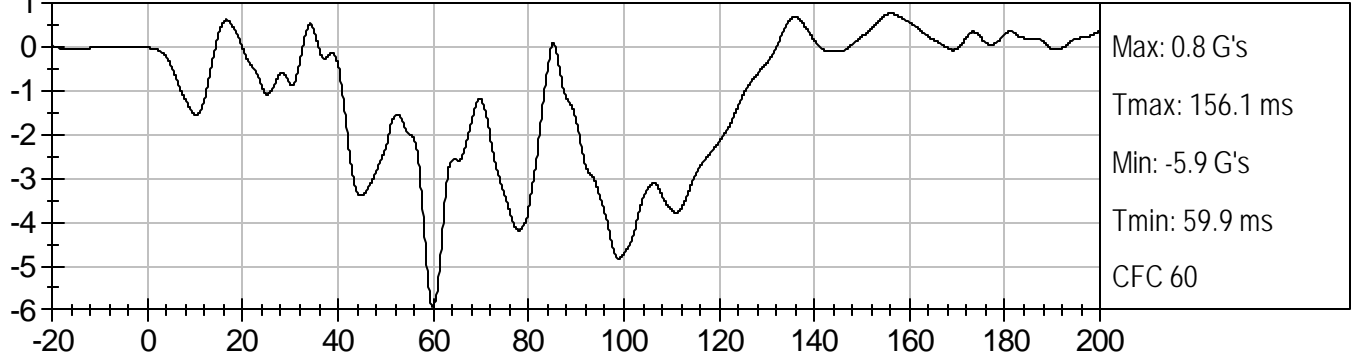

FLOORPAN @ REAR AXLE Y (G's) vs TIME (ms)

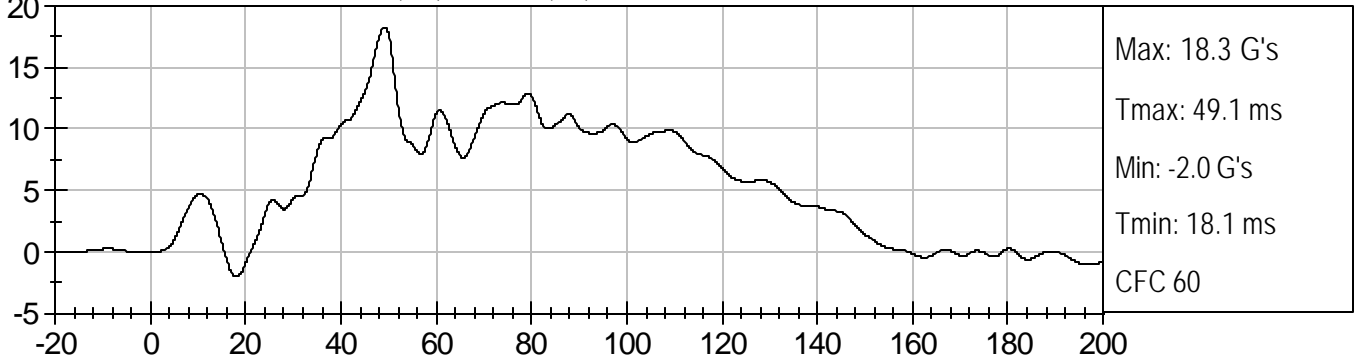

FLOORPAN @ REAR AXLE Z (G's) vs TIME (ms)

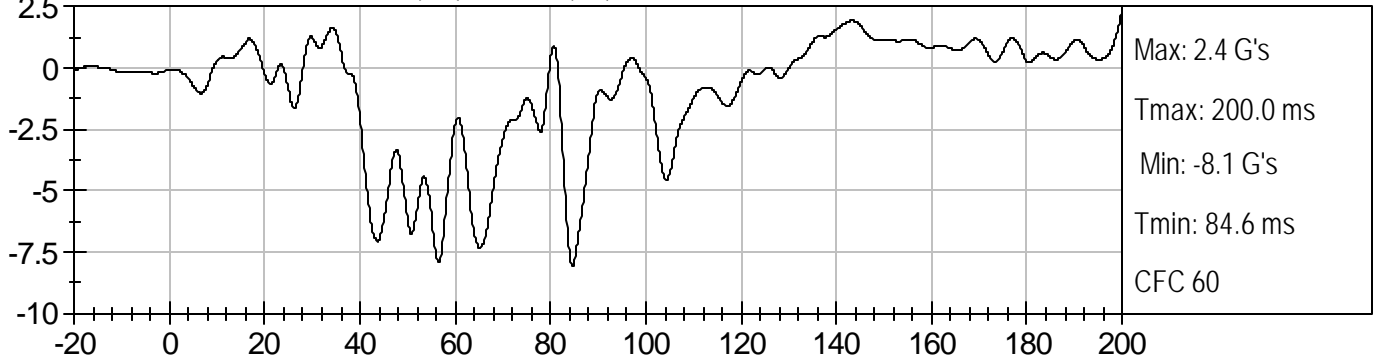

FLOORPAN @ REAR AXLE Resultant (G's) vs TIME (ms)



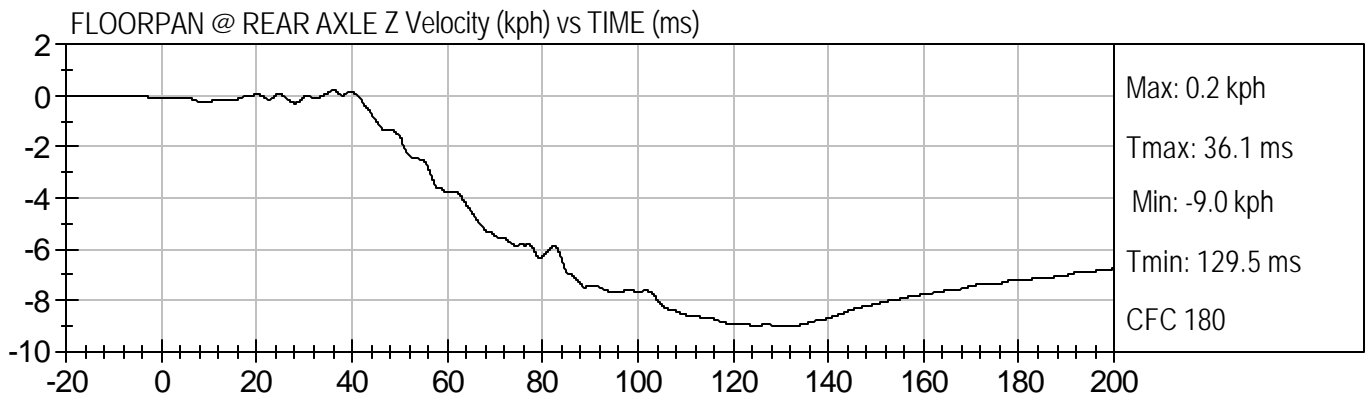
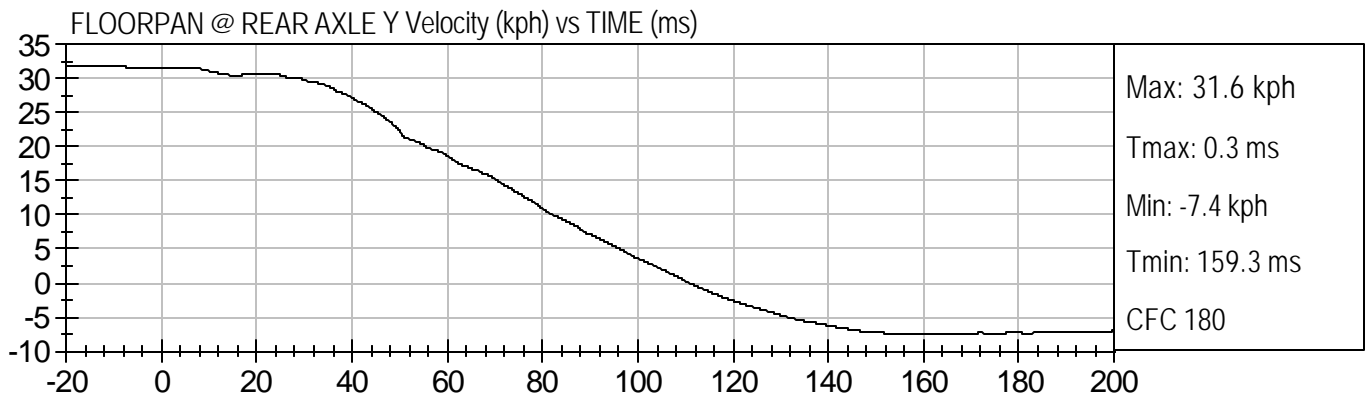
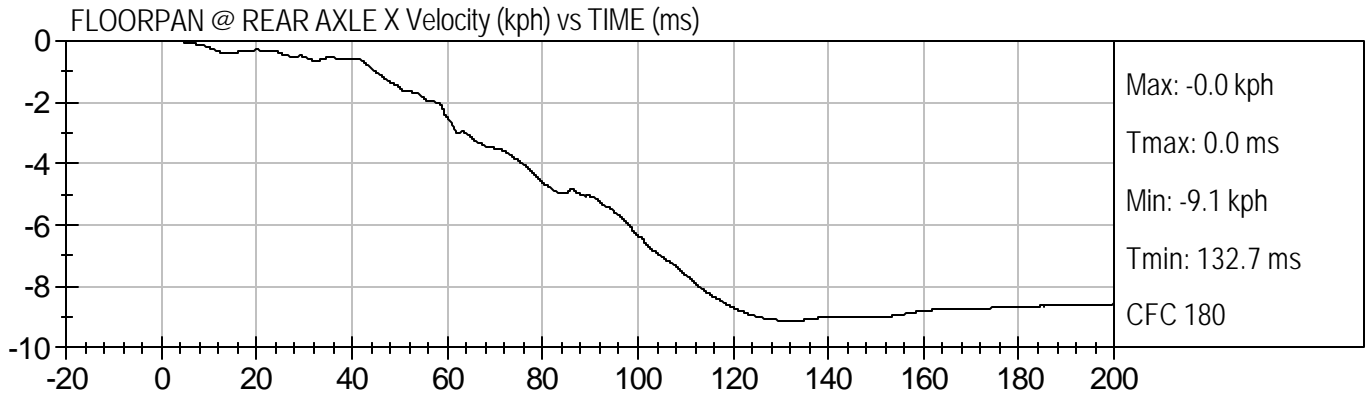

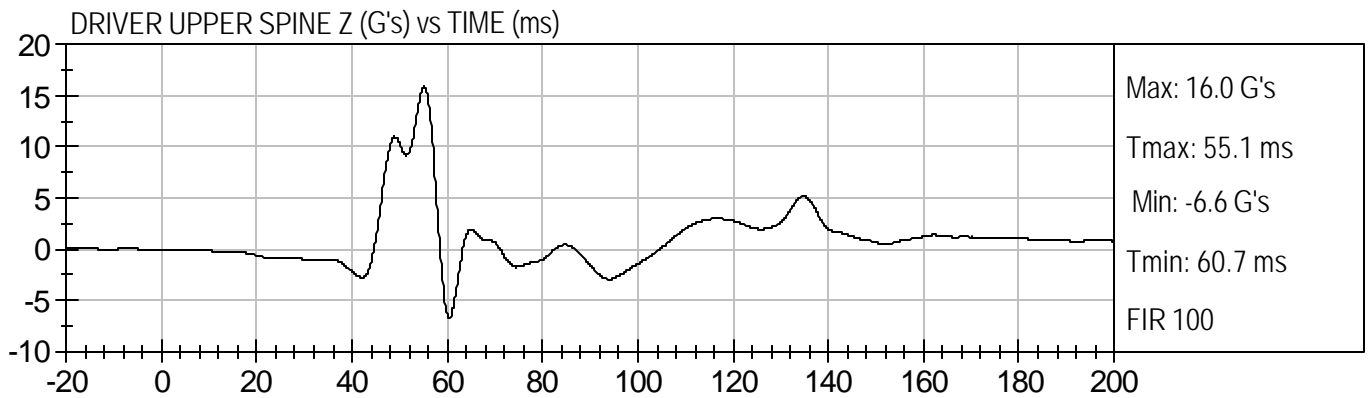
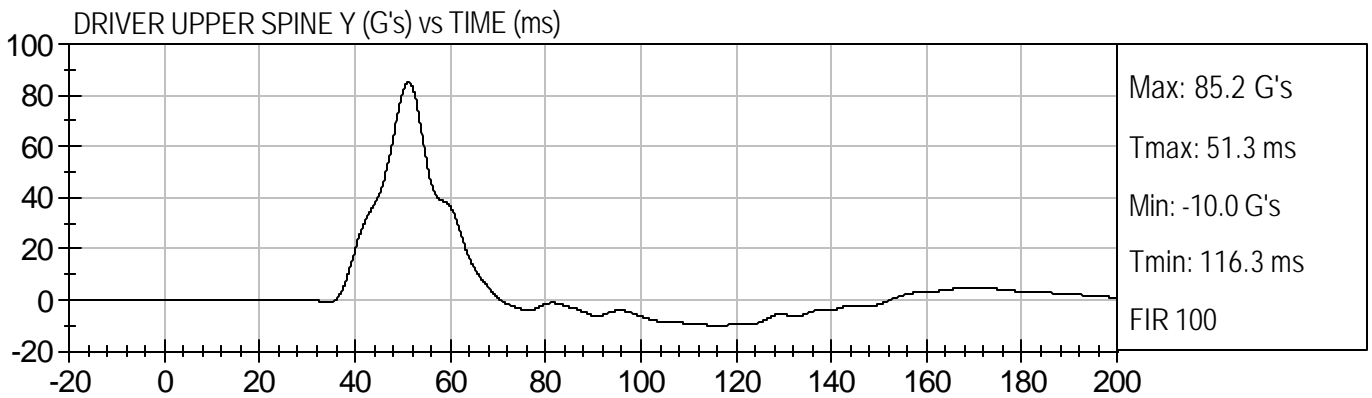
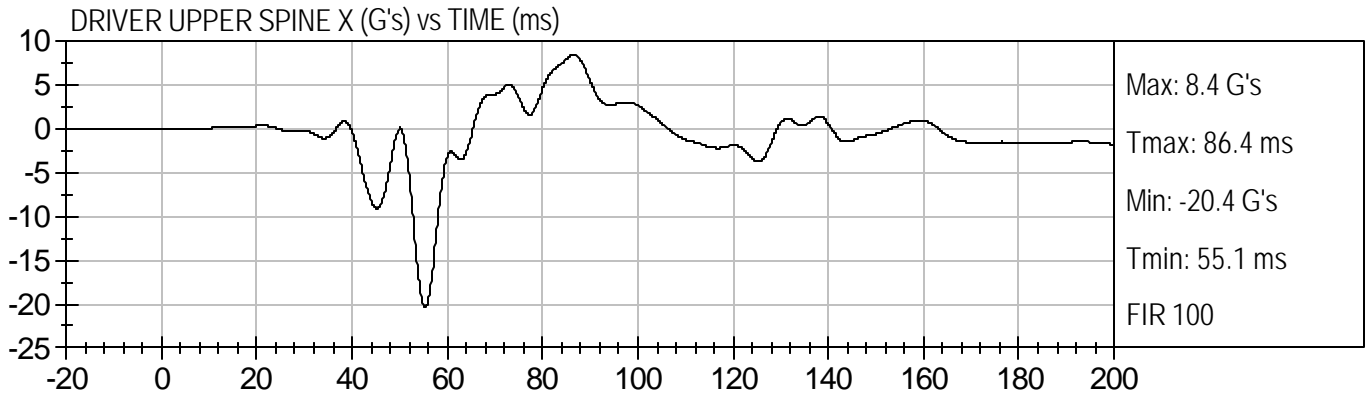

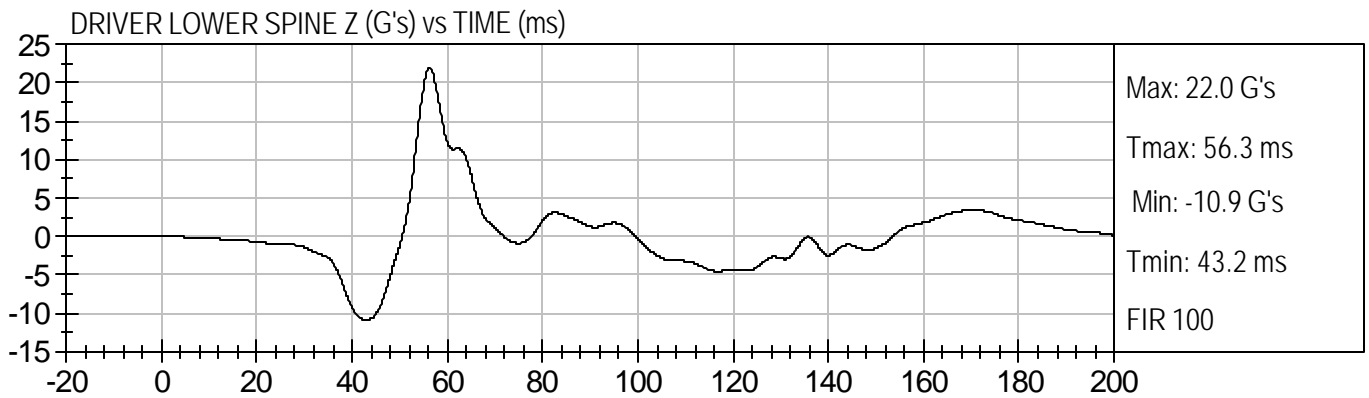
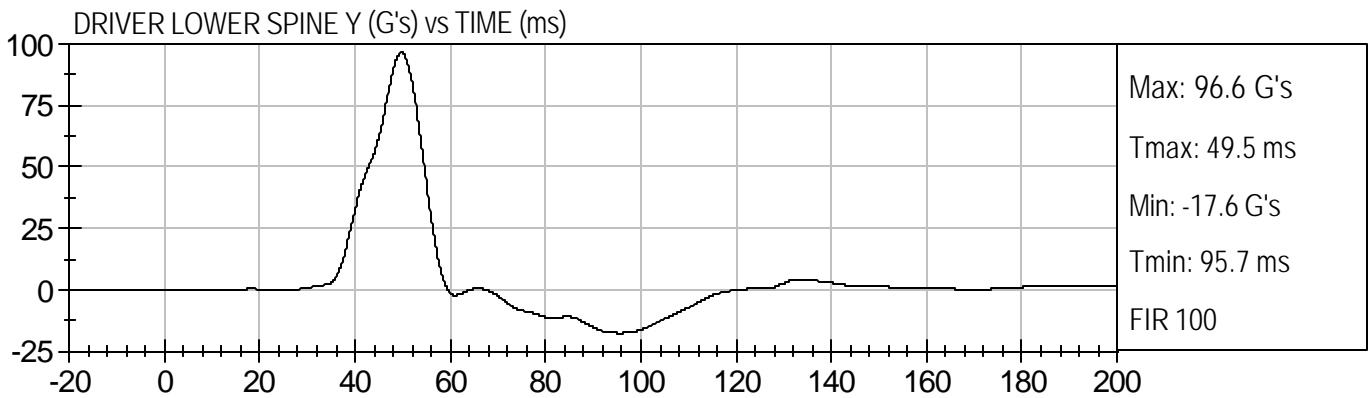
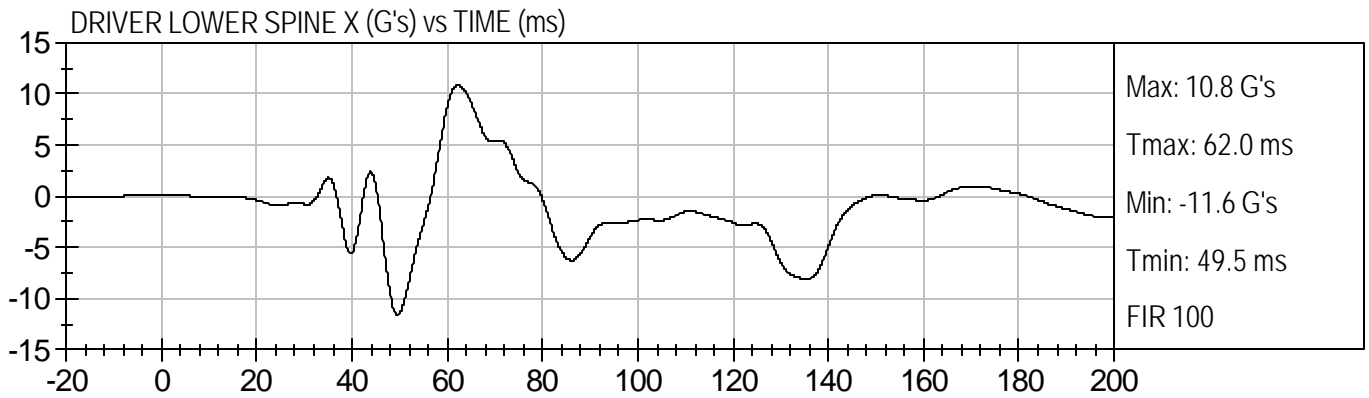

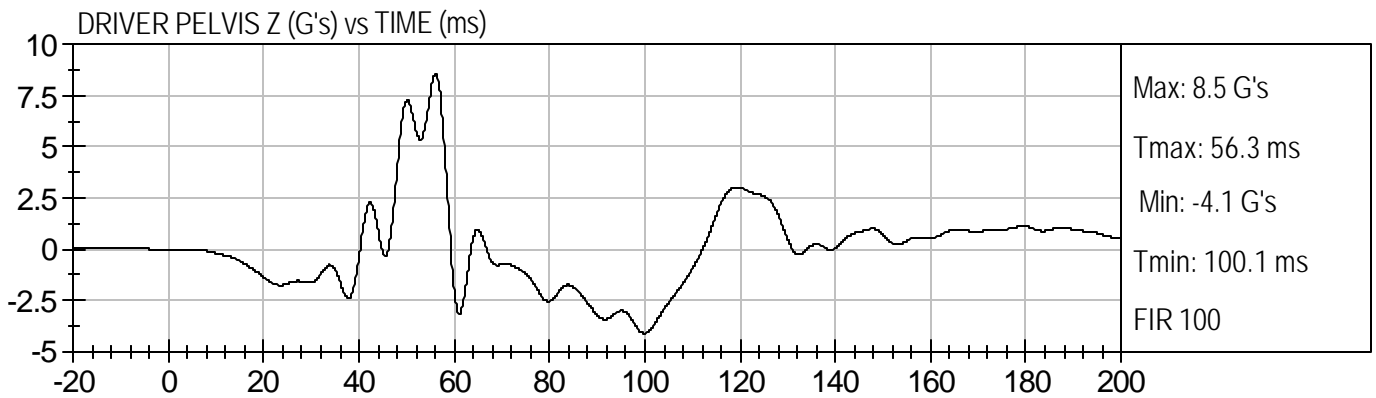
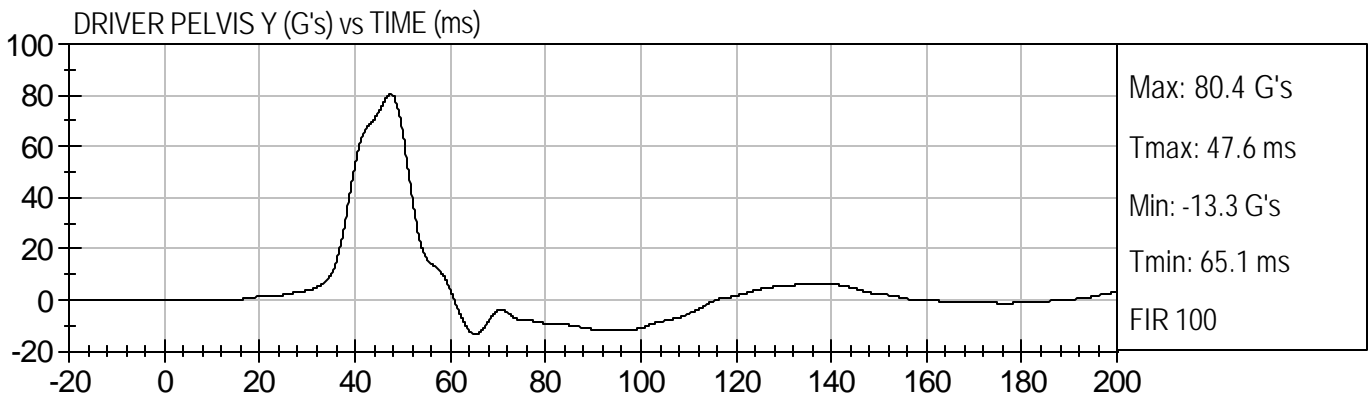
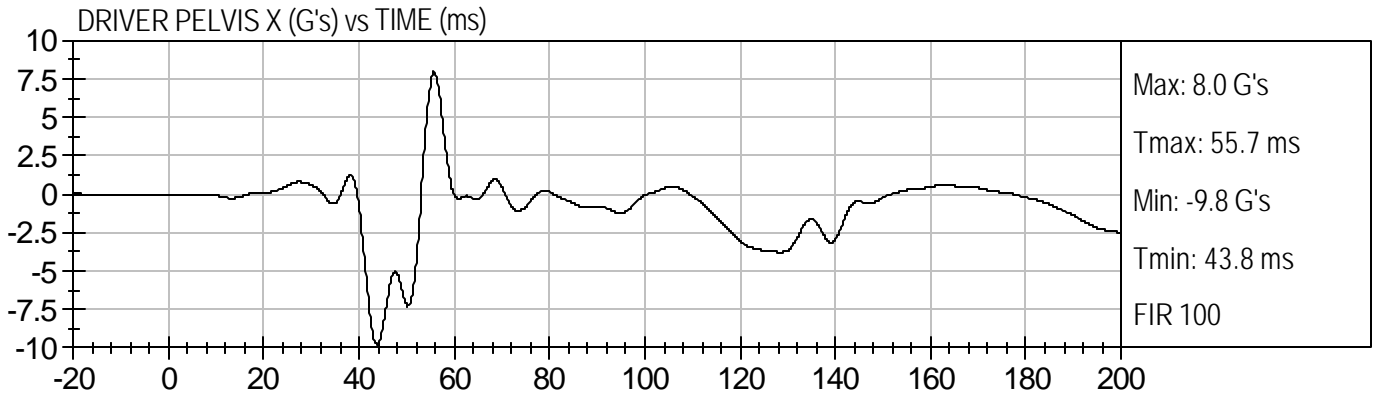

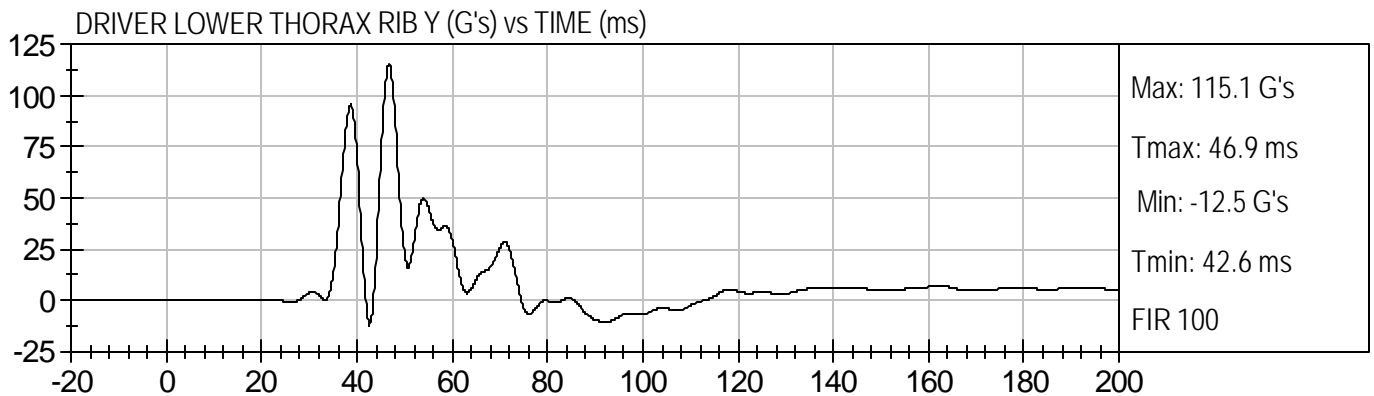
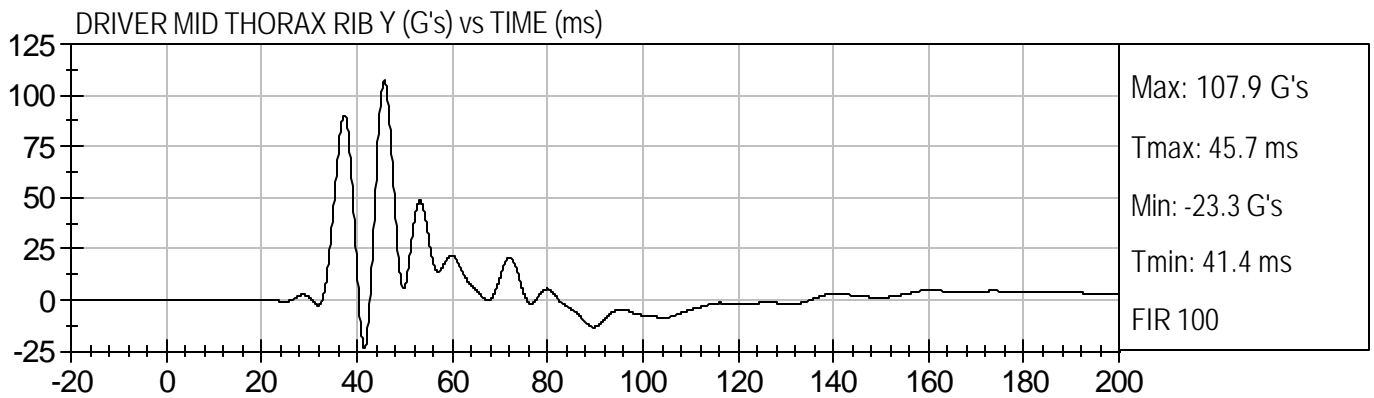
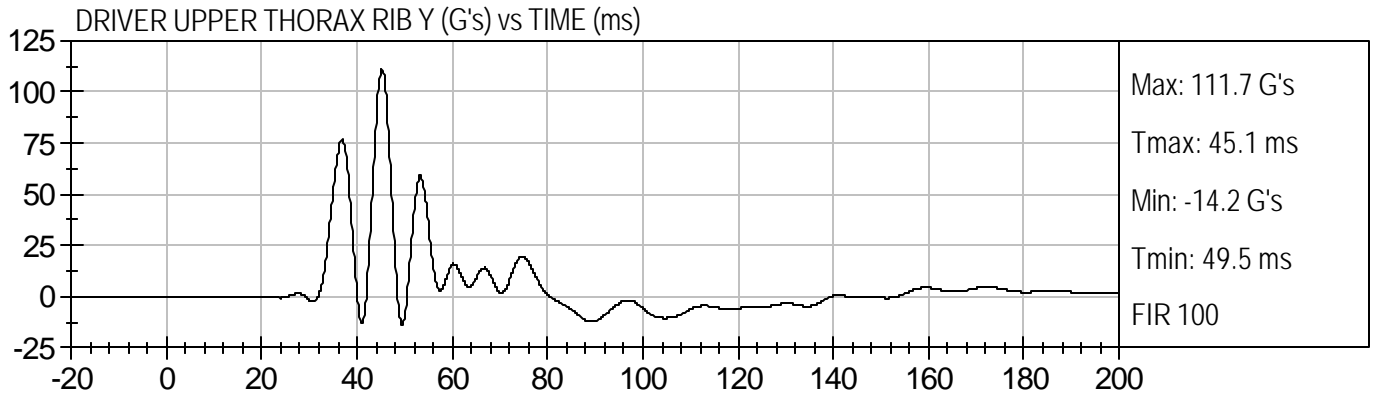



DRIVER UPPER ABDOMINAL RIB Y (G's) vs TIME (ms)

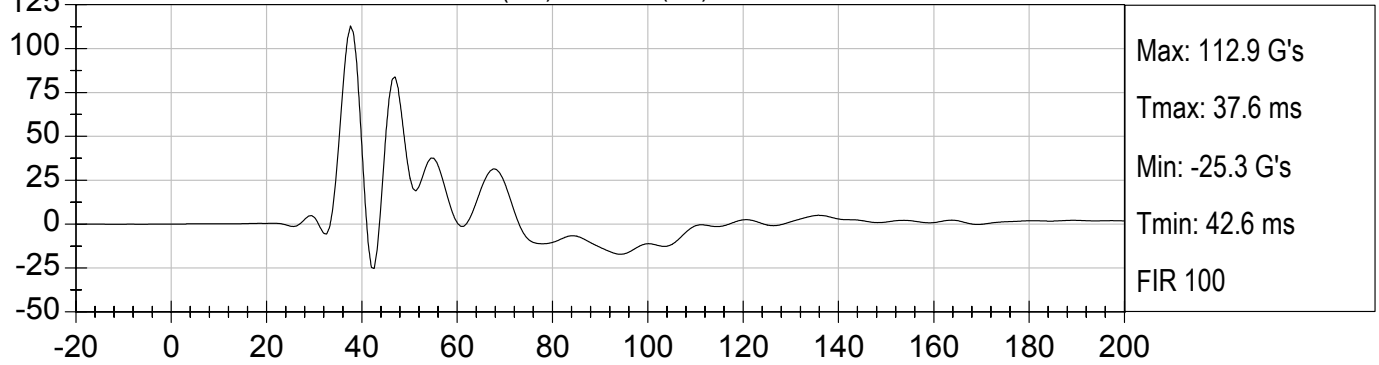

DRIVER LOWER ABDOMINAL RIB Y (G's) vs TIME (ms)

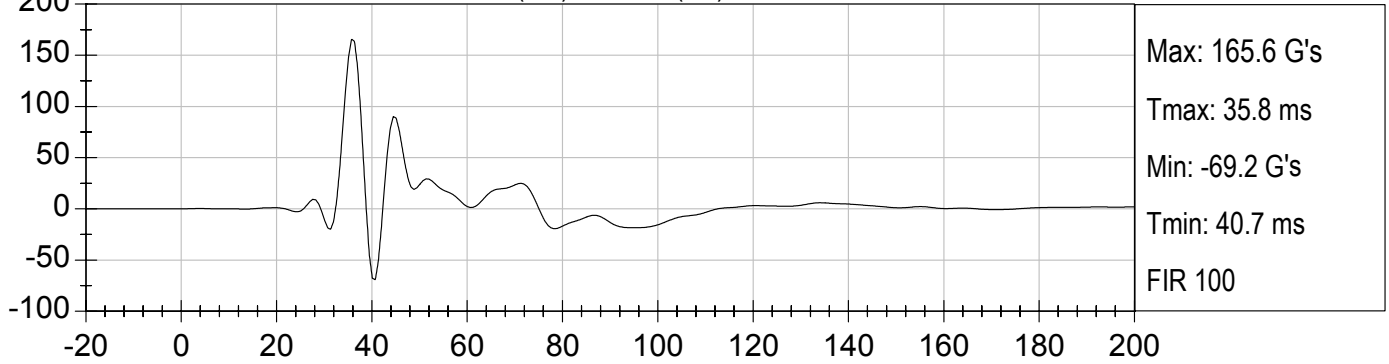

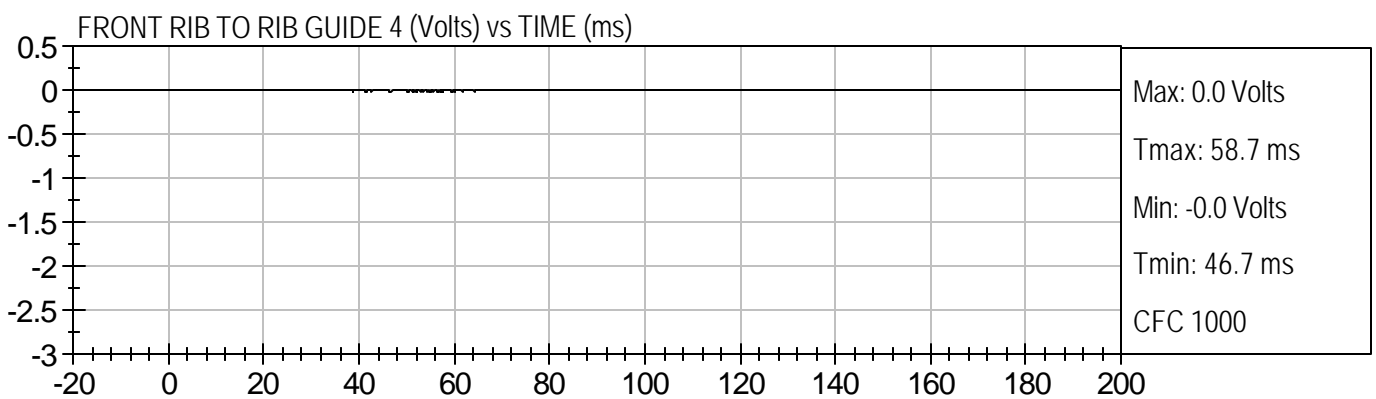
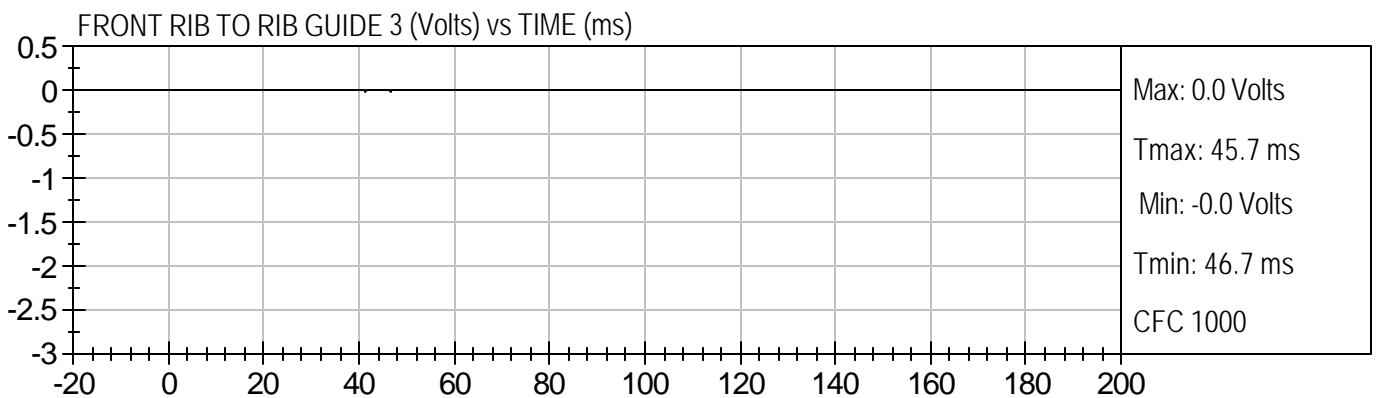
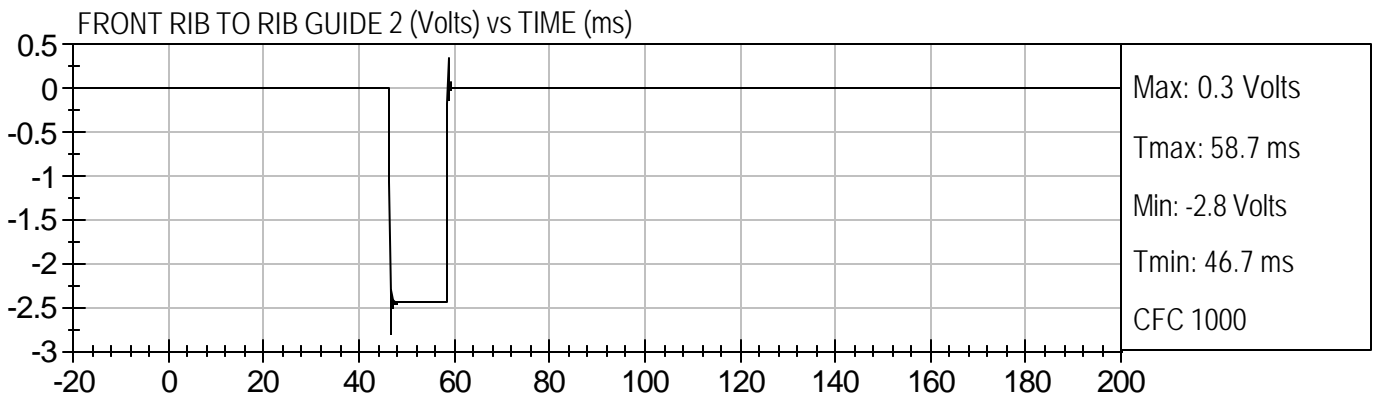
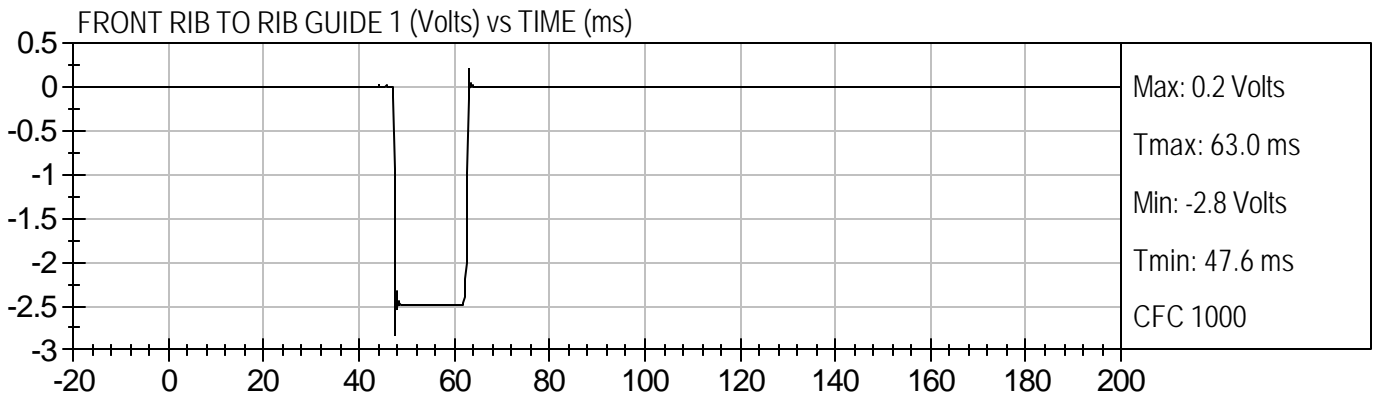

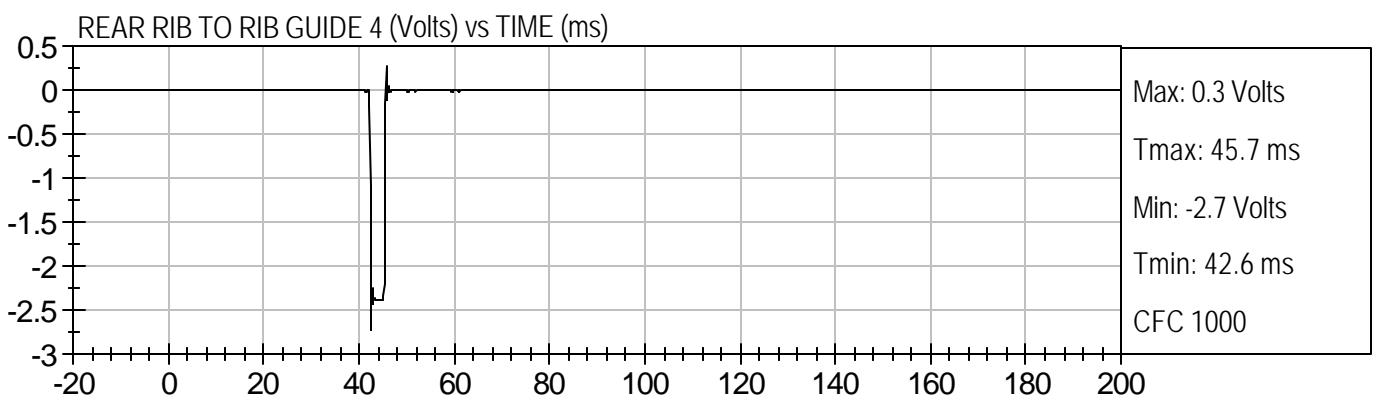
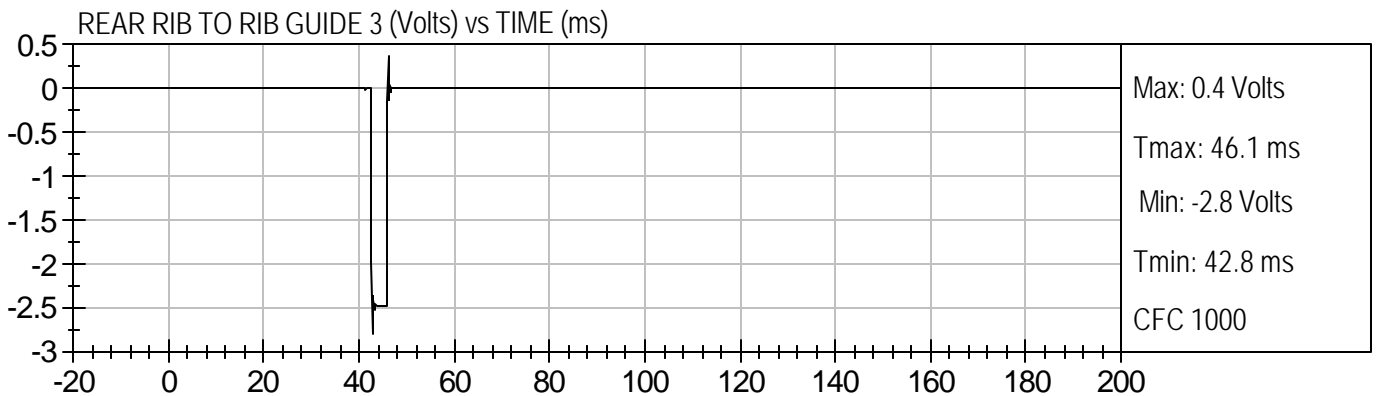
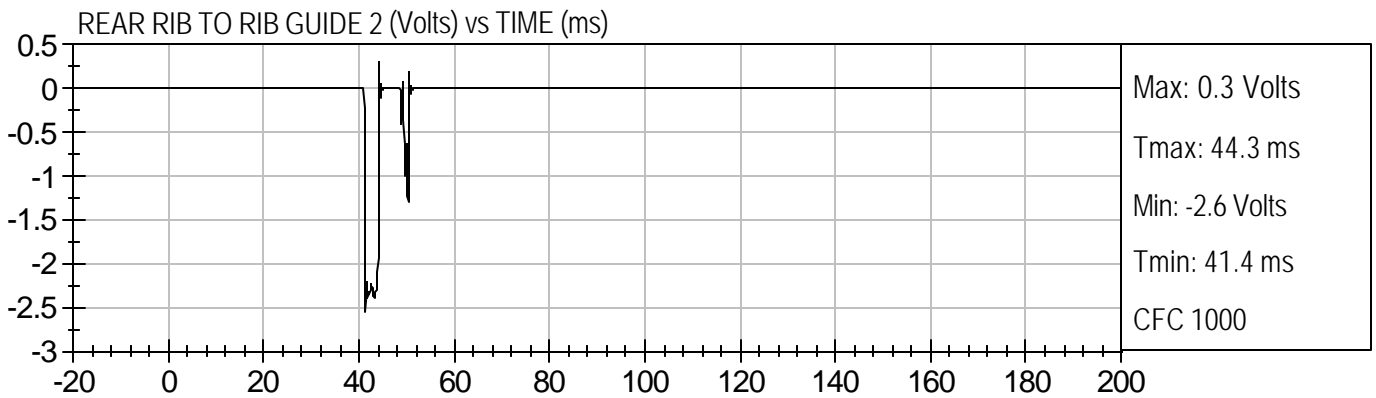
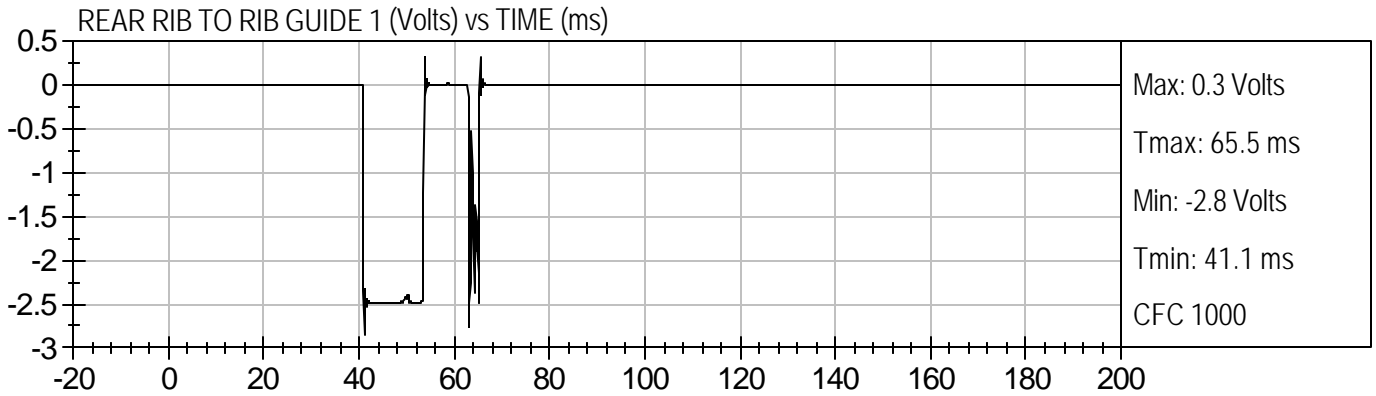

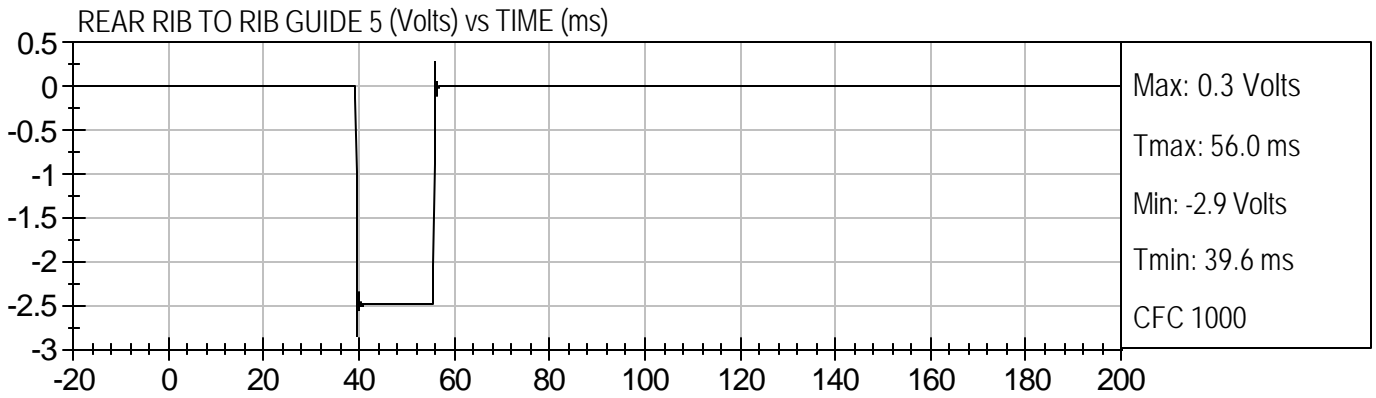
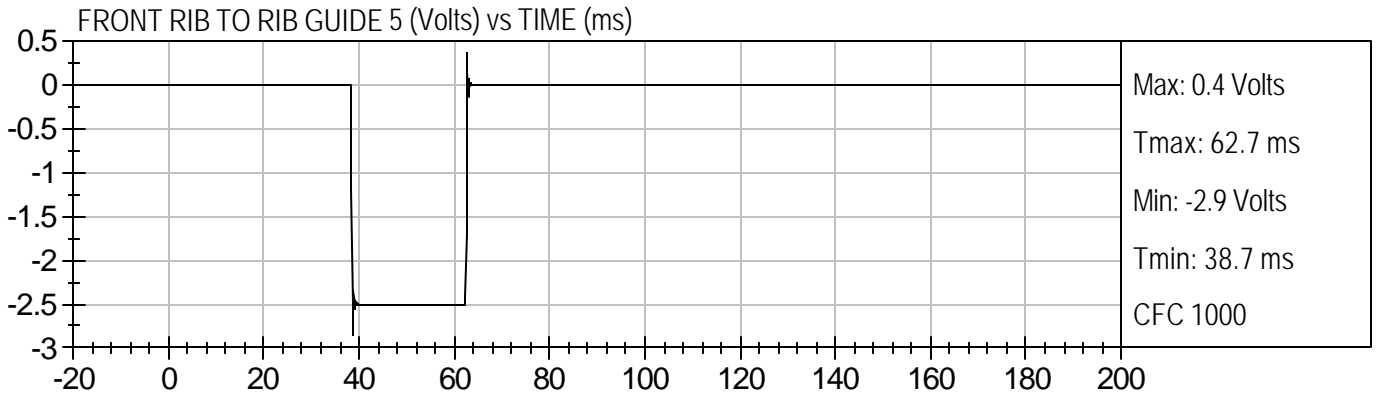

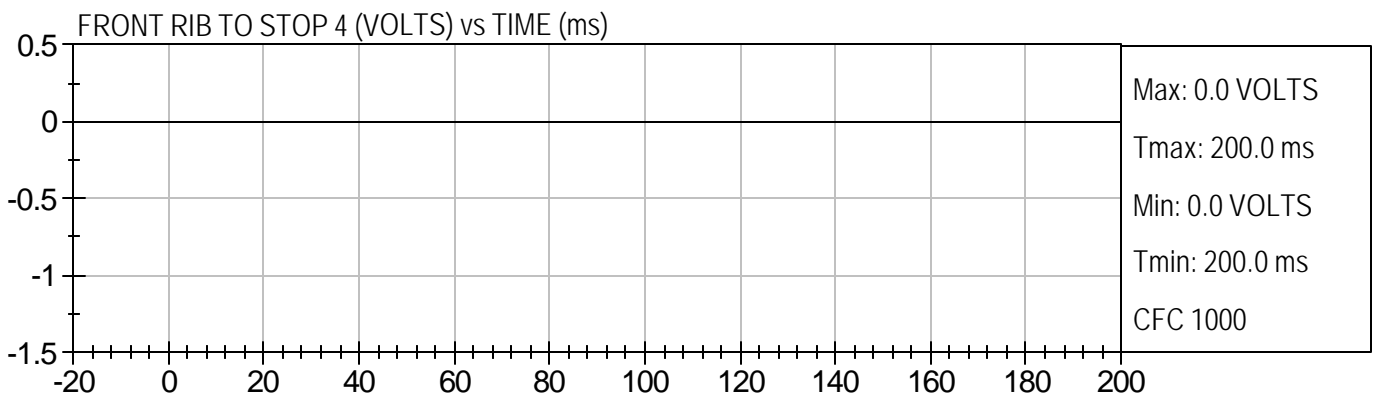
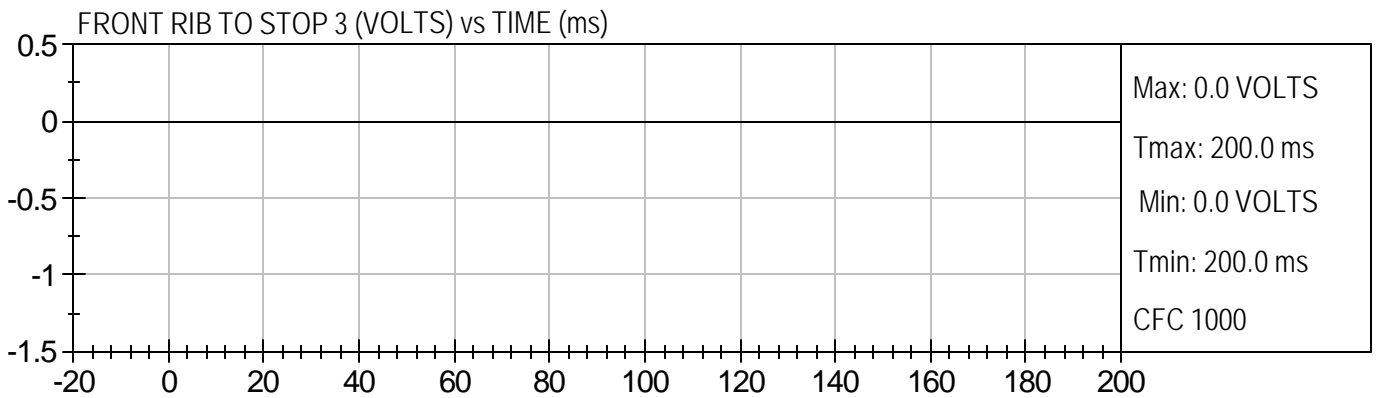
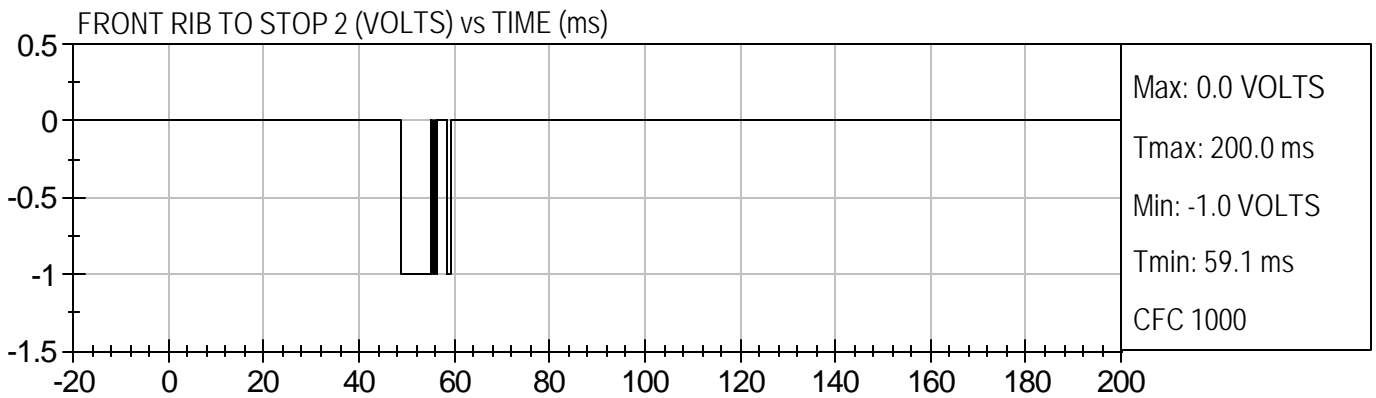
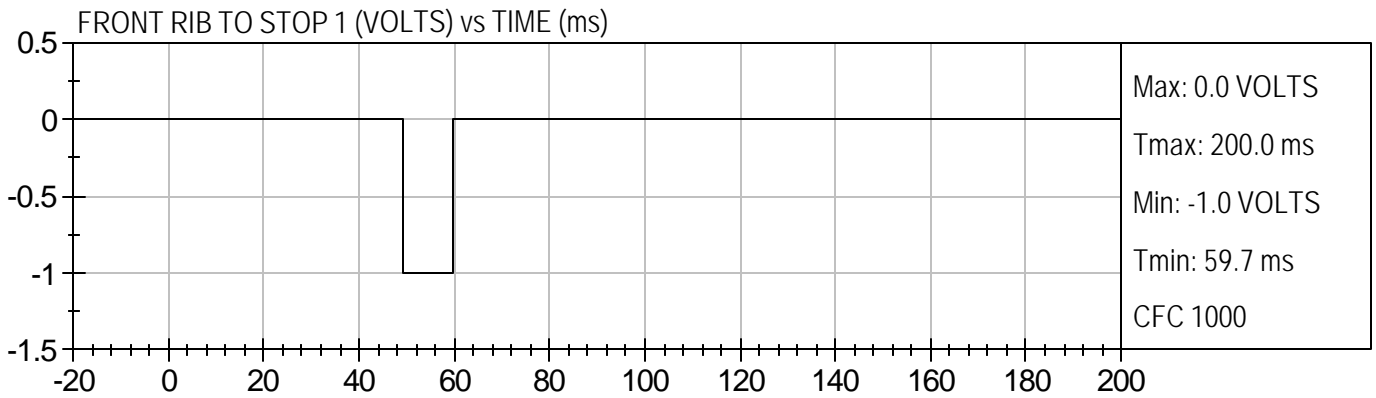



2002 FORD EXPLORER
TO #11 SID2S SIDE POLE

Test Date: 2/19/2003
Speed: 19.7 mph (31.7 km/h)

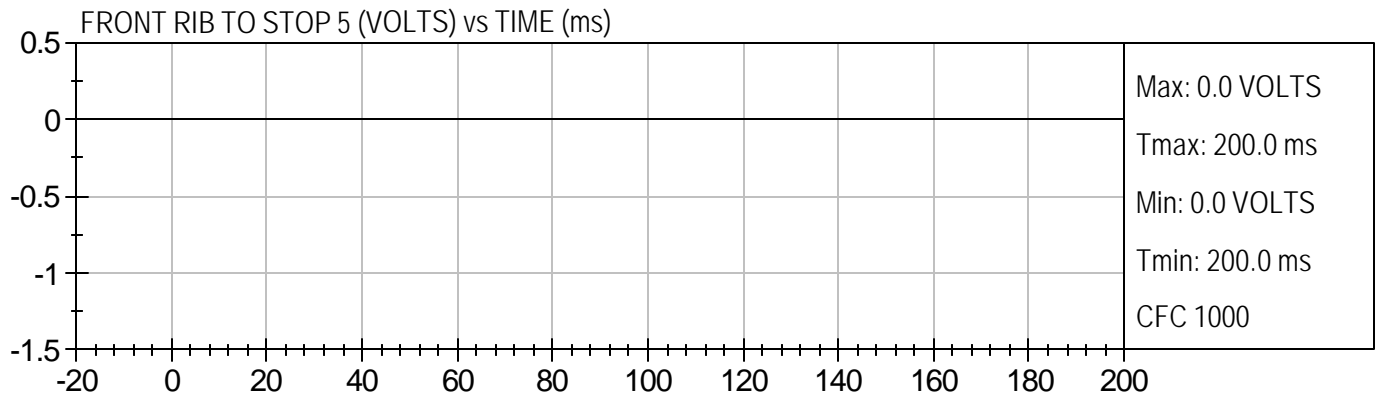

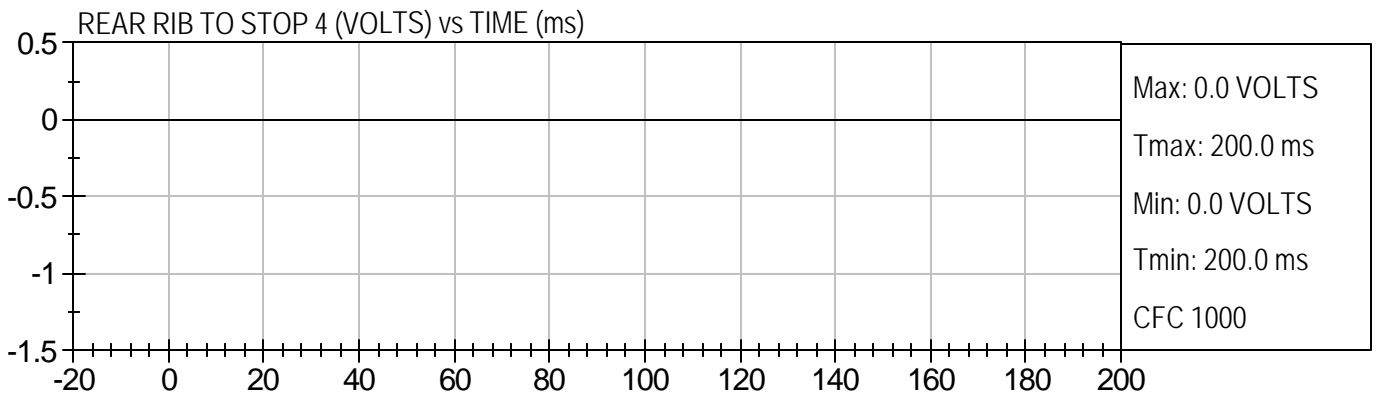
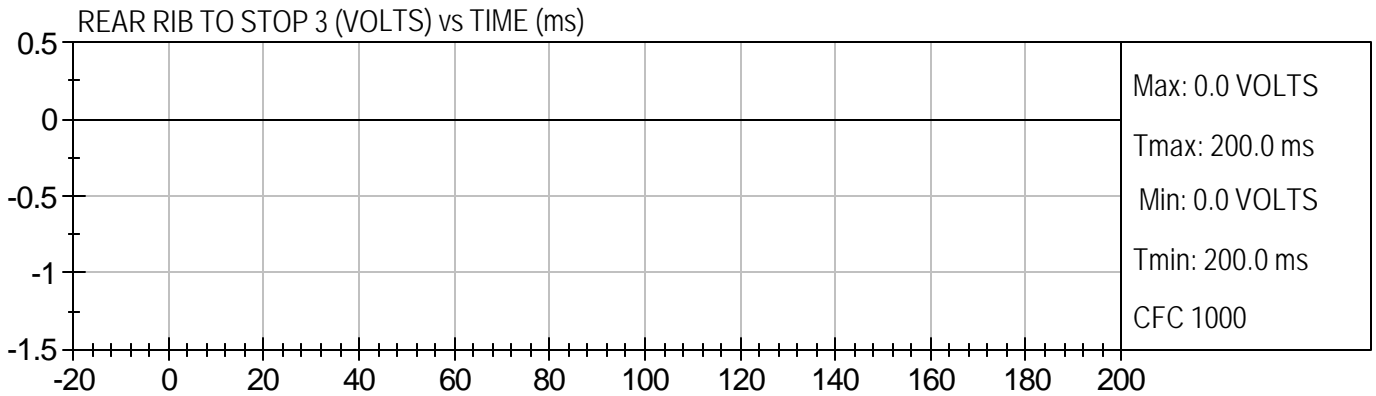
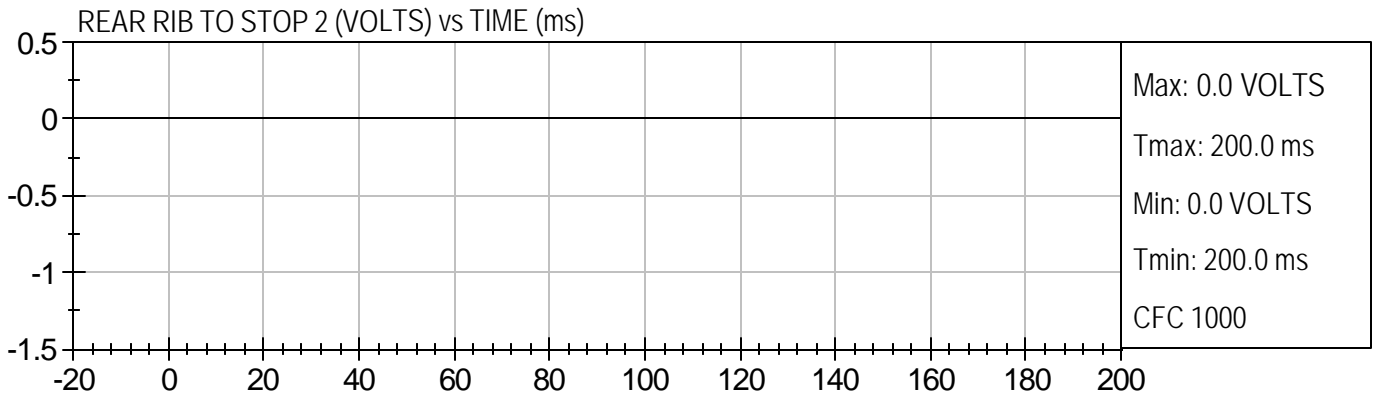
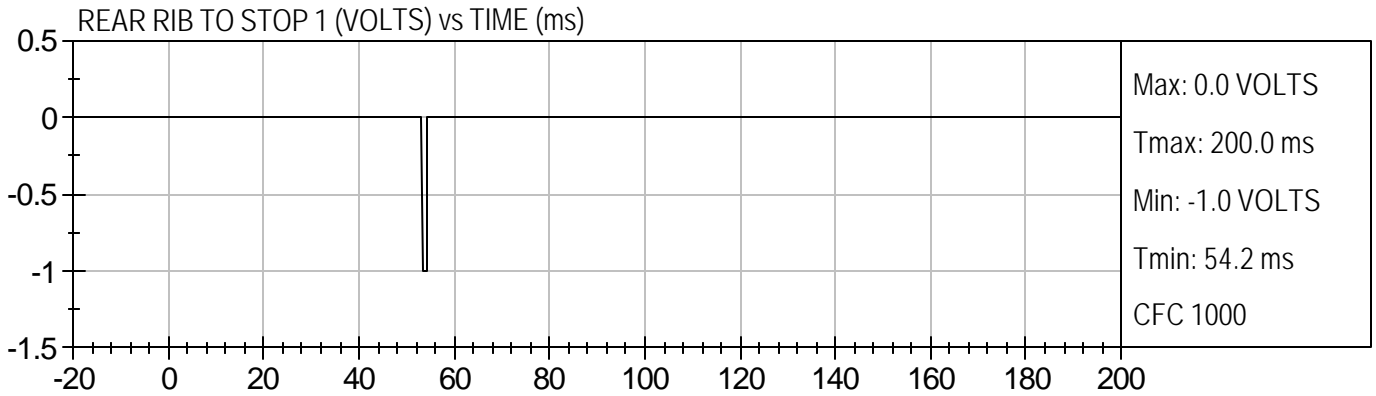



2002 FORD EXPLORER
TO #11 SID2S SIDE POLE

Test Date: 2/19/2003
Speed: 19.7 mph (31.7 km/h)

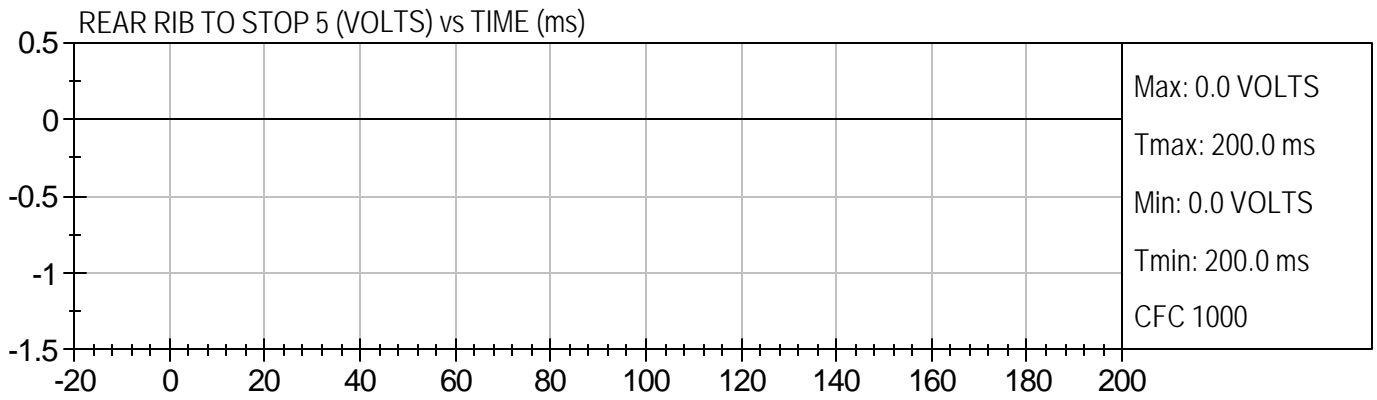

APPENDIX C

SID IIs CONFIGURATION AND PERFORMANCE VERIFICATION DATA

CERTIFICATION DATA

Dummy Serial Number: 033

Calibration Test Results Summary

Dummy Serial Number: 033

Pre-Test Calibration

Head Drop Test:	The head passed all drop test requirements.
Neck Pendulum Test:	The neck passed all impact test requirements.
Shoulder Impact Test:	The shoulder passed all impact test requirements.
Thorax (with arm) Test:	The thorax did not pass all impact test requirements.
Thorax (without arm) Test:	The thorax passed all impact test requirements.
Abdomen Impact Test:	The abdomen did not pass all impact test requirements.
Pelvis Test:	The pelvis passed all impact test requirements.

Note: Calibrations performed at VRTC.

Temperature and Humidity were not recorded.

MGA RESEARCH CORPORATION
 HEAD DROP TEST
 SID IIs DUMMY

Date: 1/13/03 – 1/14/03

Dummy Serial Number: 033

Test Number: Not Available

TEST PARAMETER	SPECIFICATION	TEST RESULTS	
		Hdl 01	Hdl 02
Temperature	18.9° – 25.6°		
Humidity	10% - 70%		
Resultant Accel	115 - 145 g's	119.81	121.369
Peak Longitude Accel	(-15) – (+ 15) g's	4.448	4.75

TEST MEETS SPECIFICATIONS

MGA RESEARCH CORPORATION
LATERAL NECK PENDULUM TEST
SID IIs DUMMY

Date: 1/13/03
 Dummy Serial Number: 033
 Test Number: Not Available

TEST PARAMETER		SPECIFICATION	TEST RESULTS	
			Neck 01	Neck 02
Temperature		18.9° – 25.6°		
Humidity		10% - 70%		
Impact Velocity (m/s)		5.51-5.63	5.594	5.572
Delta Velocity (m/s)	10 ms	2.10-2.70	2.142	2.231
	15 ms	3.00-3.80	3.183	3.29
	20 ms	4.20-5.20	4.319	4.433
	25-60 ms	5.00-6.40	5.935	5.945
Peak D-Plane Rotation (deg)		72-82	73.591	73.4
Decay Time of D-Plane Rotation Peak to Zero Degree (ms)		60-83	69.78	69.36
Peak Occipital Condyle Moment (Nm)		{-43} – (-36)	-40.185	-41.036
Time at 10 or -10 Nm after Peak Moment (ms)		90 - 98	93.7	92.68
Time of last Moment Peak to Max Rotation (ms)		<14	8.94	8.16
Front Pot Peak Rotation Deg)		59 - 72	62.326	62.53
Time of Front Pot Peak Rotation (ms)		61 - 73	65.48	64.84
Rear Pot Peak Rotation (deg)		47 - 56	49.701	49.932
Time of Rear Pot Peak Rotation (ms)		62 - 73	65.58	64.9

TEST MEETS SPECIFICATIONS

MGA RESEARCH CORPORATION
 SHOULDER IMPACT TEST
 SID IIs DUMMY

Date: 1/15/03
 Dummy Serial Number: 033
 Test Number: Not Available

TEST PARAMETER	SPECIFICATION	TEST RESULTS	
		Shl 01	Shl 02
Temperature	18.9° – 25.6°		
Humidity	10% - 70%		
Impact Velocity	4.41 - 4.59 m/s	4.536	4.52
SHLYD	27-39 mm	32.972	31.58
Resistive Force	1.6 - 2.4 kN	2.242	2.29

TEST MEETS SPECIFICATIONS

MGA RESEARCH CORPORATION
 THORAX (WITH ARM) IMPACT TESTS
 SID IIs DUMMY

Date: 1/15/03
 Dummy Serial Number: 033
 Test Number: Not Available

TEST PARAMETER	SPECIFICATION	TEST RESULTS	
		Thwa 01	Thwa 02
Temperature	18.9° – 25.6°		
Humidity	10% - 70%		
Impact Velocity	6.57 - 6.84 m/s	6.791	6.83
Probe Force	4.3 - 5.3 kN	4.748	4.771
SRB4YG (T12)	31 - 36 g's	37.67*	37.2*
RB1YD	23 - 35 mm	28.297	28.179
RB2YD	29 - 44 mm	31.522	32.395
RB3YD	33 - 40 mm	33.469	35.485
SHLYD	30 - 42 mm	34.018	33.753

* TEST DOES NOT MEET SPECIFICATIONS

MGA RESEARCH CORPORATION
 THORAX (WITHOUT ARM) IMPACT TESTS
 SID IIs DUMMY

Date: 1/15/03
 Dummy Serial Number: 033
 Test Number: Not Available

TEST PARAMETER	SPECIFICATION	TEST RESULTS	
		Thwoa 01	Thwoa -02
Temperature	18.9° – 25.6°		
Humidity	10% - 70%		
Impact Velocity	4.2 - 4.4m/s	4.305	4.305
Probe Force	1.6 - 2.4 kN	2.098	2.082
T01YG	13 - 18 g's	16.914	15.84
SRB4YG (T12)	8 - 13 g's	9.85	9.98
RB1YD	32 - 41 mm	36.221	35.85
RB2YD	40 - 51 mm	42.031	42.31
RB3YD	34 - 47 mm	41.724	42.108

TEST MEETS SPECIFICATIONS

MGA RESEARCH CORPORATION
 ABDOMINAL IMPACT TEST
 SID IIs DUMMY

Date: 1/15/03
 Dummy Serial Number: 033
 Test Number: Not Available

TEST PARAMETER	SPECIFICATION	TEST RESULTS	
		ABD 01	ABD 02
Temperature	18.9° – 25.6°		
Humidity	10% - 70%		
Impact Velocity	4.41 - 4.59 m/s	4.5366	4.552
Resistive Force	1.4 - 1.6 kN	1.842*	2.004*
T01YG	5 - 9 g's	7.52	7.546
SRB4YG (T12)	10 - 12 g's	15.609*	15.091*
RB4YD	44 - 55 mm	45.959	43.752*
RB5YD	44 - 56 mm	42.242*	43.695*

* TEST DOES NOT MEET SPECIFICATIONS

MGA RESEARCH CORPORATION
 PELVIS IMPACT TEST
 SID IIs DUMMY

Date: 1/15/03
 Dummy Serial Number: 033
 Test Number: Not Available

TEST PARAMETER	SPECIFICATION	TEST RESULTS	
		Pev 01	Pev 02
Temperature	18.9° – 25.6°		
Humidity	10% - 70%		
Impact Velocity	6.57 - 6.84 m/s	6.72	6.72
Resistive Force	5.0 - 7.2 kN	6.087	6.111
PEVYG	46 - 60 g's	48.393	51.1

TEST MEETS SPECIFICATIONS

CERTIFICATION DATA

Dummy Serial Number: 033

Calibration Test Results Summary

Dummy Serial Number: 033

Post-Test Calibration

Head Drop Test:	The head passed all drop test requirements.
Neck Pendulum Test:	The neck passed all impact test requirements.
Shoulder Impact Test:	The shoulder passed all impact test requirements.
Thorax (with arm) Tests:	The thorax did not pass all impact test requirements.
Thorax (without arm) Test:	The thorax passed all impact test requirements.
Abdomen Impact Test:	The abdomen did not pass all impact test requirements.
Pelvis Test:	The pelvis did not pass all impact test requirements.

Note: Calibrations performed at VRTC.

Temperature and Humidity were not recorded.

MGA RESEARCH CORPORATION
 HEAD DROP TEST
 SID IIs DUMMY

Date: 2/25/03
 Dummy Serial Number: 033
 Test Number: Not Available

TEST PARAMETER	SPECIFICATION	TEST RESULTS	
		Hdl 01	Hdl 02
Temperature	18.9° – 25.6°		
Humidity	10% - 70%		
Resultant Accel	115 - 145 g's	118.099	117.173
Peak Longitude Accel	{-15) – (+ 15) g's	-2.969	2.293

TEST MEETS SPECIFICATIONS

MGA RESEARCH CORPORATION
LATERAL NECK PENDULUM TEST
SID IIs DUMMY

Date: 2/25/03
 Dummy Serial Number: 033
 Test Number: Not Available

TEST PARAMETER		SPECIFICATION	TEST RESULTS	
			Neck 01	Neck 02
Temperature		18.9° – 25.6°		
Humidity		10% - 70%		
Impact Velocity (m/s)		5.51-5.63	5.594	5.594
Delta Velocity (m/s)	10 ms	2.10-2.70	2.252	2.166
	15 ms	3.00-3.80	3.334	3.197
	20 ms	4.20-5.20	4.46	4.363
	25-60 ms	5.00-6.40	5.98	5.963
Peak D-Plane Rotation (deg)		72-82	73.284	73.795
Decay Time of D-Plane Rotation Peak to Zero Degree (ms)		60-83	69.24	61.88
Peak Occipital Condyle Moment (Nm)		{-43} – (-36)	-42.138	-41.62
Time at 10 or -10 Nm after Peak Moment (ms)		90 - 98	92.64	93.04
Time of last Moment Peak to Max Rotation (ms)		<14	8.24	8.02
Front Pot Peak Rotation Deg)		59 - 72	61.139	61.688
Time of Front Pot Peak Rotation (ms)		61 - 73	64.24	64.46
Rear Pot Peak Rotation (deg)		47 - 56	48.697	48.996
Time of Rear Pot Peak Rotation (ms)		62 - 73	63	63.62

TEST MEETS SPECIFICATIONS

MGA RESEARCH CORPORATION
 SHOULDER IMPACT TEST
 SID IIs DUMMY

Date: 2/28/03
 Dummy Serial Number: 033
 Test Number: Not Available

TEST PARAMETER	SPECIFICATION	TEST RESULTS	
		Shl 01	Shl 02
Temperature	18.9° – 25.6°		
Humidity	10% - 70%		
Impact Velocity	4.41 - 4.59 m/s	4.456	4.456
SHLYD	27-39 mm	30.612	30.522
Resistive Force	1.6 - 2.4 kN	2.382	2.351

TEST MEETS SPECIFICATIONS

MGA RESEARCH CORPORATION
 THORAX (WITH ARM) IMPACT TESTS
 SID IIs DUMMY

Date: 2/28/03
 Dummy Serial Number: 033
 Test Number: Not Available

TEST PARAMETER	SPECIFICATION	TEST RESULTS	
		Thwa 01	Thwa 02
Temperature	18.9° – 25.6°		
Humidity	10% - 70%		
Impact Velocity	6.57 - 6.84 m/s	6.58	6.58
Probe Force	4.3 - 5.3 kN	4.86	4.81
T01YG	34 – 48 g's	44.7	43.5
SRB4YG (T12)	31 - 36 g's	38.4*	38.6*
RB1YD	23 - 35 mm	26.8	27.2
RB2YD	29 - 44 mm	30.8	30.6
RB3YD	33 - 40 mm	32.5*	31.6*
SHLYD	30 - 42 mm	34.2	35.2

* TEST DOES NOT MEET SPECIFICATIONS

MGA RESEARCH CORPORATION
 THORAX (WITHOUT ARM) IMPACT TESTS
 SID IIs DUMMY

Date: 2/27/03
 Dummy Serial Number: 033
 Test Number: Not Available

TEST PARAMETER	SPECIFICATION	TEST RESULTS	
		Thwoa 01	Thwoa -02
Temperature	18.9° – 25.6°		
Humidity	10% - 70%		
Impact Velocity	4.2 - 4.4m/s	4.364	4.364
Probe Force	1.6 - 2.4 kN	2.278	2.257
T01YG	13 - 18 g's	15.852	16.308
SRB4YG (T12)	8 - 13 g's	10.461	10.557
RB1YD	32 - 41 mm	37.166	37.702
RB2YD	40 - 51 mm	43.671	43.749
RB3YD	34 - 47 mm	40.825	40.713

TEST MEETS SPECIFICATIONS

MGA RESEARCH CORPORATION
 ABDOMINAL IMPACT TEST
 SID IIs DUMMY

Date: 2/27/03
 Dummy Serial Number: 033
 Test Number: Not Available

TEST PARAMETER	SPECIFICATION	TEST RESULTS	
		ABD 01	ABD 02
Temperature	18.9° – 25.6°		
Humidity	10% - 70%		
Impact Velocity	4.41 - 4.59 m/s	4.536	4.536
Resistive Force	1.4 - 1.6 kN	1.961*	1.937*
T01YG	5 - 9 g's	7.619	7.509
SRB4YG (T12)	10 - 12 g's	16.006*	16.266*
RB4YD	44 - 55 mm	45.309	46.89
RB5YD	44 - 56 mm	46.096	46.409

* TEST DOES NOT MEET SPECIFICATIONS

MGA RESEARCH CORPORATION
 PELVIS IMPACT TEST
 SID IIs DUMMY

Date: 2/27/03
 Dummy Serial Number: 033
 Test Number: Not Available

TEST PARAMETER	SPECIFICATION	TEST RESULTS	
		Pev 01	Pev 02
Temperature	18.9° – 25.6°		
Humidity	10% - 70%		
Impact Velocity	6.57 - 6.84 m/s	6.72	6.791
Resistive Force	5.0 - 7.2 kN	6.193	7.412*
PEVYG	46 - 60 g's	50.977	53.347

* TEST DOES NOT MEET SPECIFICATIONS

APPENDIX D
TEST EQUIPMENT LIST AND CALIBRATION INFORMATION

DUMMY AND VEHICLE CALIBRATION DATA

	INSTRUMENTS FOR LEFT FRONT DUMMY SID IIS		
	SERIAL NO.	MANUFACTURER	CALIBRATION DATE
Head X Accelerometer	P17858	Endevco	1/10/03
Head Y Accelerometer	P12566	Endevco	1/10/03
Head Z Accelerometer	P15638	Endevco	1/10/03
Driver Upper Thorax Rib Y	01J02-F07	Entran	1/8/03
Driver Mid Thorax Rib Y	B02A18-N03	Entran	1/8/03
Driver Lower Thorax Rib Y	P15951	Endevco	1/10/03
Driver Upper Abdominal Rib Y	99H30-Z07	Entran	1/9/03
Driver Lower Abdominal Rib Y	01J02-F12	Entran	1/9/03
Driver Upper Neck FX	N304FX	FTSS	6/14/02
Driver Upper Neck FY	N304FY	FTSS	6/14/02
Driver Upper Neck FZ	N304FZ	FTSS	6/14/02
Driver Upper Neck MX	N304MX	FTSS	6/14/02
Driver Upper Neck MY	N304MY	FTSS	6/14/02
Driver Upper Neck MZ	N304MZ	FTSS	6/14/02
Driver Upper Spine X	B02A09-F04	Entran	1/9/03
Driver Upper Spine Y	01G25-N18	Entran	1/9/03
Driver Upper Spine Z	02A16-A12	Entran	1/9/03
Driver Lower Spine X	02A16-A03	Entran	1/9/03
Driver Lower Spine Y	B02A18-N14	Entran	1/9/03
Driver Lower Spine Z	02A04-A24	Entran	1/9/03
Driver Shoulder X	P17848	Entran	1/10/03
Driver Shoulder Y	P16336	Entran	1/10/03
Driver Shoulder Z	P16225	Entran	1/10/03
Driver Upper Thorax Rib DY	020RB1	Honeywell	1/13/03
Driver Mid Thorax Rib DY	020RB2	Honeywell	1/13/03
Driver Lower Thorax Rib DY	020RB3	Honeywell	1/13/03
Driver Upper Abdominal Rib DY	020RB4	Honeywell	1/13/03
Driver Lower Abdominal Rib DY	020RB5	Honeywell	1/13/03
Driver Shoulder FX	S101FX	FTSS	6/25/02
Driver Shoulder FY	S101FY	FTSS	6/25/02
Driver Shoulder FZ	S101FZ	FTSS	6/25/02
Driver Lumbar FX	L104FX	FTSS	5/10/02
Driver Lumbar FY	L104FY	FTSS	5/10/02
Driver Lumbar FZ	L104FZ	FTSS	8/15/02
Driver Lumbar MX	L104MX	FTSS	8/15/02
Driver Lumbar MY	L104MY	FTSS	6/24/02
Driver Lumbar MZ	L104MZ	FTSS	6/24/02
Driver Upper Arm X	B02A25-N01	Entran	1/9/03
Driver Upper Arm Y	02A16-A13	Entran	1/9/03
Driver Upper Arm Z	B02A25-N04	Entran	1/9/03

DUMMY AND VEHICLE CALIBRATION DATA (Continued)

	INSTRUMENTS FOR LEFT FRONT DUMMY SID IIS		
	SERIAL NO.	MANUFACTURER	CALIBRATION DATE
Driver Left Acetabulum FY	AC111FY	FTSS	6/25/02
Driver Left Ilium Crest FY	IW113FY	FTSS	6/25/02
Driver Right Ilium Crest FY	IW115FY	FTSS	6/25/02
Pubic Symphysis FY	P106FY	FTSS	6/24/02
Driver Right Femur FX	F109FX	FTSS	1/20/03
Driver Right Femur FY	F109FY	FTSS	1/20/03
Driver Right Femur FZ	F109FZ	FTSS	1/20/03
Driver Right Femur MX	F109MX	FTSS	1/20/03
Driver Right Femur MY	F109MY	FTSS	1/20/03
Driver Right Femur MZ	F109MZ	FTSS	1/20/03
Driver Left Femur FX	F107FX	FTSS	1/20/03
Driver Left Femur FY	F107MY	FTSS	1/20/03
Driver Left Femur FZ	F107FZ	FTSS	1/20/03
Driver Left Femur MX	F107MX	FTSS	1/20/03
Driver Left Femur MY	F107MY	FTSS	1/20/03
Driver Left Femur MZ	F107FZ	FTSS	1/20/03
Pelvis X Accelerometer	B02A25-N05	Entran	1/9/03
Pelvis Y Accelerometer	B02A18-N13	Entran	1/9/03
Pelvis Z Accelerometer	02A18-N03	Entran	1/9/03

VEHICLE INSTRUMENT CALIBRATION

	VEHICLE ACCELEROMETERS		
	SERIAL NO.	MANUFACTURER	CALIBRATION DATE
Left Mid A-Post Y	I25-F05	ENTRAN	1/16/03
Left Lower A-Post Y	D11-F01	ENTRAN	11/19/02
Left Mid B-Post Y	G03-N04	ENTRAN	1/24/03
Left Lower B-Post Y	G03-N08	ENTRAN	9/6/02
Floorpan @ Rear Axle X	99F251	ENTRAN	1/15/03
Floorpan @ Rear Axle Y	D11-F14	ENTRAN	11/19/02
Floorpan @ Rear Axle Z	I25-J09	ENTRAN	10/7/02
Driver Seat Track Y	K21-N31	ENTRAN	10/9/02
Driver Left Seat Frame Y	K21-N04	ENTRAN	1/16/03
Driver Right Seat Frame Y	H07-F07	ENTRAN	1/16/03
Right Front Sill X	K21-N01	ENTRAN	1/24/03
Right Front Sill Y	H05-F07	ENTRAN	11/19/02
Right Front Sill Z	G13-F03	ENTRAN	1/24/03
Right Rear Sill X	K21-N12	ENTRAN	9/6/02
Right Rear Sill Y	H01-N27	ENTRAN	10/30/02
Right Rear Sill Z	K21-N20	ENTRAN	10/18/02
Left Rear Sill Y	99F18A	ENTRAN	11/4/02
Left Front Sill Y	99F254	ENTRAN	10/31/02
Vehicle CG X	H01-N26	ENTRAN	11/19/02
Vehicle CG Y	H01-N09	ENTRAN	11/19/02
Vehicle CG Z	99F216	ENTRAN	10/31/02
Left Front Door @ Pelvis Y	H01-N11	ENTRAN	10/31/02
Left Front Door @ Arm Y	K21-N05	ENTRAN	1/16/03
Left Front Door @ Knee Y	99F272	ENTRAN	1/16/03
Left Rear Door @ Rib Y	I12-F12	ENTRAN	1/16/03
Lower Center Radiator Support X	K21-N1	ENTRAN	1/16/03
Lower Center Radiator Support Y	G03-N06	ENTRAN	1/16/03
Lower Center Radiator Support Z	G01-N01	ENTRAN	1/16/03

Note: All Endevco accelerometers are Model No. 7264-2000
 All Entran accelerometers are Model No. EGE-72

APPENDIX E
DUMMY PEAK RESPONSE

DUMMY PEAK RESPONSE COMPARISON TABLE

Location	Peak Values				
				2002 Ford Explorer 2/19/03	
	Class	Axis	Units	Peak	Time
Head	1000	X	G	-100.6	53.8
	1000	Y	G	896.4	54.3
	1000	Z	G	-212.8	53.8
	1000	RES	G	912.2	54.3
Head Injury Criteria (HIC)				14362	
t1				53.6	
t2				54.5	
Upper Neck Force	1000	X	N	476	60.9
	1000	Y	N	-1635	54.1
	1000	Z	N	2659	54.3
	1000	RES	N	3017	54.3
Upper Neck Moment	600	X	Nm	71	55.3
	600	Y	Nm	-26.3	61.0
	600	Z	Nm	12.8	84.3
	600	RES	Nm	71.1	55.3
Shoulder G's	180	X	G	-39.3	48.6
	180	Y	G	-194.1	49.5
	180	Z	G	84.7	74.0
	180	RES	G	197.9	49.5
Shoulder Force	600	X	N	-319	49.3
	600	Y	N	2361	49.2
	600	Z	N	-584	52.1

DUMMY PEAK RESPONSE COMPARISON TABLE...(continued)

Location	Peak Values				
				2002 Ford Explorer 2/19/03	
	Class	Axis	Units	Peak	Time
Upper Arm	180	X	G	-34.6	42.2
	180	Y	G	130.7	43.8
	180	Z	G	59.9	44.8
	180	RES	G	141.9	43.9
Upper Spine	180	X	G	-25.5	54.4
	180	Y	G	88.9	51.4
	180	Z	G	20.9	55
	180	RES	G	89.5	51.3
Upper Thorax Rib	180	Y	G	170.3	45.2
Mid Thorax Rib	180	Y	G	145.4	45.5
Lower Thorax Rib	180	Y	G	198.9	46.5
Upper Abdominal Rib	180	Y	G	126.9	37.8
Lower Abdominal Rib	180	Y	G	183.9	35.2
Shoulder Deflection	180	Y	mm	-44.1	53.7
Upper Thorax Deflection	180	Y	mm		
Middle Thorax Deflection	180	Y	mm		
Lower Thorax Deflection	180	Y	mm		
Upper Abdominal Rib Deflection	180	Y	mm		
Lower Abdominal Rib Deflection	180	Y	mm		
Shoulder Deflection Rate	180		m/sec	-4.7	45.8
Upper Thorax Deflection Rate	180		m/sec		
Middle Thorax Deflection Rate	180		m/sec		
Lower Thorax Deflection Rate	180		m/sec		
Upper Abdominal Rib Deflection Rate	180		m/sec		

DUMMY PEAK RESPONSE COMPARISON TABLE...(continued)

Location	Peak Values				
				2002 Ford Explorer 2/19/03	
	Class	Axis	Units	Peak	Time
Lower Abdominal Rib Deflection	180		mm		
Shoulder VC	180	Y	m	1.0	48.9
Upper Thorax Rib VC	180	Z	m		
Mid Thorax Rib VC	180	RES	m		
Lower Thorax Rib VC	180	X	m		
Upper Abdominal Rib VC	180	Y	m		
Lower Abdominal Rib VC	180	Z	m		
Lower Spine	180	X	G	13.8	60.7
	180	Y	G	96.3	48.0
	180	Z	G	25.5	54.8
	180	Res	G	97.3	48.0
Lumbar Force	600	X	N	1140	62.6
	600	Y	N	3272	48.5
	600	Z	N	1151	51.0
Left Acetabulum Force	600	Y	N	1950	45.8
Left Ilium Crest Force	600	Y	N	5263	77.6
Sum of Left Acetabulum & Left Ilium Crest	600	Y	N	7164	47.3
Right Ilium Crest	600	Y	N	-467.1	47.4
Pubic Symphysis Force	600	Y	N	-680.3	45.5

DUMMY PEAK RESPONSE COMPARISON TABLE...(continued)

Location	Peak Values				
				2002 Ford Explorer 2/19/03	
	Class	Axis	Units	Peak	Time
Right Femur Force	600	X	N	-272	42.2
	600	Y	N	-572	58.7
	600	Z	N	-623	46.3
	600	Res	N	748	46.3
Right Femur Moment	600	X	Nm	-102.4	45.5
	600	Y	Nm	-25.4	93.3
	600	Z	Nm	20.9	60.6
	600	Res	Nm	103.3	45.5
Left Femur Force	600	X	N	208	131.3
	600	Y	N	-1415	50.6
	600	Z	N	1256	50.0
	600	Res	N	1898	50.0
Left Femur Moment	600	X	Nm	180.3	51.4
	600	Y	Nm	32.6	134.2
	600	Z	Nm	95.9	51.9
	600	Res	Nm	203.7	51.5
Pelvis	1000	X	G	16.9	54.9
	1000	Y	G	84.5	47.5
	1000	Z	G	15.7	55.2