

REPORT NUMBER TR-P23003-05-NC

**NEW CAR ASSESSMENT PROGRAM
SIDE IMPACT TEST**

**TOYOTA MOTOR CORPORATION
2003 TOYOTA 4 RUNNER SR5
4WD SUV**

NHTSA NUMBER: M35107

**Prepared By:
KARCO ENGINEERING, LLC
9270 HOLLY ROAD
ADELANTO, CALIFORNIA 92301**



FEBRUARY 27, 2003

FINAL REPORT

**PREPARED FOR:
U.S. DEPARTMENT OF TRANSPORTATION
NATIONAL HIGHWAY TRAFFIC SAFETY ADMINISTRATION
RULEMAKING
OFFICE OF CRASHWORTHINESS STANDARDS
MAIL CODE: NVS-111
400 SEVENTH STREET, SW, ROOM 5311
WASHINGTON, D.C. 20590**

TR-P23003-05-NC

This final test report was prepared for the U.S. Department of Transportation, National Highway Traffic Safety Administration, in response to Contract Number DTNH22-99-D-02041.

This publication is distributed by the U.S. Department of Transportation, National Highway Traffic Safety Administration, in the interest of information exchange. The opinions, findings and conclusions expressed in this publication are those of the author(s) and not necessarily those of the Department of Transportation or the National Highway Traffic Safety Administration. The United States Government assumes no liability for its contents or use thereof. If trade or manufacturers' names or products are mentioned it is only because they are considered essential to the object of the publication and should not be construed as an endorsement. The United States Government does not endorse products or manufacturers.

Prepared by: _____
Mr. James E. Gorth, Project Engineer
KARCO Engineering, LLC

Date: March 10, 2003

Reviewed by: _____
Mr. Jerry L. Kratzke, Director of Operations
KARCO Engineering, LLC

Date: March 10, 2003

Approved by: _____
Mr. Frank D. Richardson, Program Manager
KARCO Engineering, LLC

Date: March 10, 2003

FINAL REPORT ACCEPTED BY:

Manager, Side Impact NCAP

Date of Acceptance

Technical Report Documentation Page

1. Report No. TR-23003-05-NC	2. Government Accession No.	3. Recipients Catalog No.																			
4. Title and Subtitle Final Report of New Car Assessment Program Testing Side Impact Testing of a 2003 Toyota 4 Runner SR5 4WD SUV NHTSA NO. M35107		5. Report Date March 10, 2003																			
		6. Performing Organization Code KAR																			
7. Author(s) Mr. James E Gorth, Project Engineer, Karco Mr. Frank Richardson, Program Manager, Karco		8. Performing Organization Report No. TR-23003-05-NC																			
		10. Work Unit No.																			
9. Performing Organization Name and Address KARCO Engineering, LLC 9270 Holly Road Adelanto, CA 92301		11. Contract or Grant No. DTNH22-99-D-02041																			
		13. Type of Report and Period Covered Final Test Report Option Year 3																			
12. Sponsoring Agency Name and Address U.S. Department of Transportation National Highway Traffic Safety Administration Rulemaking Office of Crashworthiness Standards Mail Code: NVS-111 400 Seventh Street, SW, Room 5311 Washington, D.C. 20590		14. Sponsoring Agency Code DOT/NHTSA/NRM/OCS																			
		15. Supplementary Notes																			
16. Abstract A 55/28 km/h 90 deg. Moving Deformable Barrier Side Impact NCAP Test was conducted on the subject 2003 Toyota \$ Runner SR5 4Wd SUV in accordance with the specifications of the Office of Crash Worthiness Standards Test Procedure for the generation of consumer information on vehicle side crash protection. The test was conducted at KARCO Engineering laboratories in Adelanto, California, on February 27, 2003. The impact velocity of the Moving Deformable Barrier was 61.51 km/h, and the outside ambient temperature at the struck (driver's) side of the vehicle was 10.0 deg. C. The target vehicle's maximum post test static crush was 251 mm located at level 2 . The test vehicle's occupant performance is as follows:																					
<table border="1" style="width: 100%; border-collapse: collapse;"> <thead> <tr> <th style="width: 35%;">Measurement Description</th> <th style="width: 30%;">Driver SID/HIII</th> <th style="width: 30%;">Pass. SID/HIII</th> </tr> </thead> <tbody> <tr> <td>Left Upper Rib (LUR) G's</td> <td style="text-align: center;">28.3</td> <td style="text-align: center;">22.9</td> </tr> <tr> <td>Left Lower Rib (LLR) G's</td> <td style="text-align: center;">25.8</td> <td style="text-align: center;">29.5</td> </tr> <tr> <td>Lower Spine (T₁₂) G's</td> <td style="text-align: center;">37.6</td> <td style="text-align: center;">30.8</td> </tr> <tr> <td>Thoracic Trauma Index (TTI) G's</td> <td style="text-align: center;">33</td> <td style="text-align: center;">30</td> </tr> <tr> <td>Pelvis (PEV) G's</td> <td style="text-align: center;">42</td> <td style="text-align: center;">29</td> </tr> </tbody> </table>				Measurement Description	Driver SID/HIII	Pass. SID/HIII	Left Upper Rib (LUR) G's	28.3	22.9	Left Lower Rib (LLR) G's	25.8	29.5	Lower Spine (T ₁₂) G's	37.6	30.8	Thoracic Trauma Index (TTI) G's	33	30	Pelvis (PEV) G's	42	29
Measurement Description	Driver SID/HIII	Pass. SID/HIII																			
Left Upper Rib (LUR) G's	28.3	22.9																			
Left Lower Rib (LLR) G's	25.8	29.5																			
Lower Spine (T ₁₂) G's	37.6	30.8																			
Thoracic Trauma Index (TTI) G's	33	30																			
Pelvis (PEV) G's	42	29																			
17. Key Words New Car Assessment Program (NCAP) Side Impact Moving Deformable Barrier (MDB) Side Impact Dummy (SID/HIII)		18. Distribution Statement Copies of this report are available from: National Highway Traffic Safety Admin. NHTSA Technical Reference Division 400 Seventh St., SW, Room 5108 Washington, DC 20590																			
19. Security Classification(of this report) UNCLASSIFIED	20. Security Classification(of this page) UNCLASSIFIED	21. No. of Pages 312	22. Price																		

Form DOT F1700.7 (8-72)

TABLE OF CONTENTS

Section		Page
1	Purpose and Test Procedure	1
2	Summary of Side Impact Test	2
3	Side Impact Dummy (SIDHIII) and Vehicle Test Data	3
4	Occupant and Vehicle Information	11

Data Sheet No.		Page
1	General Test and Vehicle Parameter Data	4
2	Test Vehicle Summary of Results	8
3	Moving Deformable Barrier (MDB) Summary of Results	9
4	Post Test Observations	10
5	SID/HII Injury Criteria and Sensor Data	12
6	Vehicle Pre-Test and Post-Test Measurements	14
7	SID/HIII Longitudinal Clearance Dimensions	15
8	SID/HIII Lateral Clearance Dimensions	16
9	Vehicle Side Measurements	17
10	Vehicle Exterior Crush Profiles	18
11	Vehicle Damage Profile Distances	20
12	Deformable Barrier Honeycomb Face Static Crush	21
13	Vehicle Accelerometer Locations and Data Summary	22
14	MDB Accelerometer Location and Data Summary	24
15	High Speed Camera Locations and Data	25
16	FMVSS 301 Fuel System Integrity Post Impact Data	26
17	FMVSS 301 Static Rollover Data Sheet	27

Appendix		
A	Photographs	A
B	SID/HII Vehicle, and MDB Response Data	B
C	SID/HII Configuration and Performance Verification Data	C
D	Test Equipment List and Calibration Information	D

SECTION 1
PURPOSE and TEST PROCEDURE

1.1 PURPOSE

This Side Impact NCAP test is conducted as part of the FY' 2003 test program sponsored by the National Highway Traffic Safety Administration (NHTSA), under contract No. DTNH22-99-D-02041. The purpose of this test is to generate comparative side impact data on a 2003 Toyota 4 Runner SR5 4WD SUV manufactured by Toyota Motor Corporation.

1.2 TEST PROCEDURE

The side impact test was conducted in accordance with the current National Highway Traffic Safety Administration (NHTSA), Office of Crashworthiness Standards (OCS), laboratory test procedure NCAP Side Impact Testing, dated July 1997 and the corresponding KARCO Engineering Test Procedure KTP-214D, dated November 18, 1998. The procedures for receiving, inspection, testing, and reporting of test results are described in the test procedures and are not repeated in this report.

SECTION 2

SUMMARY OF SIDE IMPACT TEST

2.1 SUMMARY OF SIDE IMPACT NCAP TEST

A model year 2003 Toyota 4 Runner SR5 4WD SUV was impacted on the left (driver's) side by a Moving Deformable Barrier (MDB) which was moving forward in a 27° crabbed position to the tow road guidance system at a velocity of 61.51 km/h. The specified impact velocity range is from 61.1 to 62.7 km/h. The test (target) vehicle was stationary and positioned 63° to the line of forward motion. The weight of the vehicle as tested was 2179kg and the test weight of the MDB was 1361 kg. The test was conducted at KARCO Engineering, LLC in Adelanto, California, on February 27, 2003.

SUPPLEMENTAL RESTRAINT INFORMATION

Restraint Type	Left Front (Driver)		Left Rear (Passenger)	
	Installed	Operation	Installed	Operation
Front Airbag	Yes	Not Deployed	None	Not Applicable
Side Torso Airbag	None	Not Applicable	None	Not Applicable
Head Curtain Airbag	None	Not Applicable	None	Not Applicable

One (1) real-time motion picture camera and ten (10) high-speed motion picture cameras were used to document the impact event. The pre-test and post-test conditions were recorded by one (1) real-time motion picture camera. Camera locations and pertinent camera information is documented in the data sheets. Pre- and post-test photographs of the vehicle and SID's/HII's can be found in Appendix A. Two 50th percentile adult male Side Impact Dummy's (SID's/HII's) were placed in the driver's and left rear passenger designated seating positions according to the test procedure. Each SID/HII is instrumented with contact switches on the pelvis and thorax and six-axis neck load cells, and fourteen accelerometers in the following locations:

- Left Upper Rib (LUR) uni-axial accelerometer (Y-axis primary and redundant)
- Left Lower Rib (LLR) uni-axial accelerometer (Y-axis primary and redundant)
- Lower Thoracic Spine (T12) uni-axial accelerometer (Y-axis primary and redundant)
- Pelvic (PEV) section uni-axial accelerometer (Y-axis primary and redundant)
- Head Center of Gravity (CG) tri-axial accelerometers (X, Y, and Z axes primary and redundant)

The test vehicle was instrumented with twenty-five (25) structural accelerometers and the MDB was instrumented with five (5) accelerometers and a one (2) contact switch on the right bumper to compare left side to right side bumper impact timing. All data channels were recorded with a fully self contained on-board Test Data Acquisition System (TDAS). The data was digitally sampled at 10,000 samples per second and processed per Appendix V of the Test Procedure.

2.2 GENERAL COMMENTS

The test vehicle sustained a maximum static crush of 251 mm at level 2, 1350mm rearward of the left vertical impact point. The driver SID/HIII, Serial No. 274 and the passenger SID/HIII, Serial No. 275 were calibrated just prior to this test. The SID/HIII injury criteria is summarized as follows:

Measurement	Units	Driver	Passenger
Thoracic Trauma Index (TTI)	G's	33	30
Peak Pelvic G's (PEV)	G's	42	29

Tests summaries and post-test observations are presented in Section 3. The vehicle, camera, and occupant measurements are presented in Section 4. Appendix A contains the still photograph prints. Appendix B contains the driver and passenger SID's/HIII, vehicle, and MDB response data traces. Appendix C contains the SID's/HIII Configuration and performance verification data. Appendix D contains the test equipment information.

SECTION 3

SIDE IMPACT DUMMY (SID/HIII) AND VEHICLE TEST DATA

Test Vehicle: 2003 Toyota 4 Runner SR5 4WD SUV

NHTSA No. M35107

Test Program: 55/28 km/h 90° Side Impact NCAP

Test Date: 2/27/03

CONVERSION FACTORS USED IN THIS REPORT*

Quantity	Typical Application	Std Units	Metric Unit	Multiply By
Mass	Vehicle Weight	lb	kg	0.4536
Linear Velocity	Impact Velocity	mile/h	km/h	1.609
Length or Distance	Measurements	in	mm	25.4
Volume	Fuel Systems	gal	liter	3.785
Volume	Small Fluids	oz	mL	29.573
Pressure	Tire Pressures	lbf/in ²	kPa	7.0
Volume	Liquid	gal	liter	3.785
Temperature	General Use	°F	°C	$=(tf - 32)/1.8$
Force	Dynamic Forces	lbf	N	4.448
Moment	Torque	lbf/ft	Nm	1.355

* Based on the Recommended Practice in SAE J916, May 85

DATA SHEET NO. 1

GENERAL TEST AND VEHICLE PARAMETER DATA

Test Vehicle: 2003 Toyota 4 Runner SR5 4WD SUV

NHTSA No. M35107

Test Program: 55/28 km/h 90° Side Impact NCAP

Test Date: 2/27/03

TEST VEHICLE INFORMATION

Make	Toyota
Model	4 Runner
Body Style	4 Door MPV
NHTSA No.	M35107
VIN	JTEBU14R430007612
Color	Gold
Delivery Date	2/14/2003
Odometer Reading (mile)	66
Dealer	Crown Toyota
Transmission	4-Speed Automatic
Final Drive	Rear
Type/Number Cylinders	V-6
Engine Displacement (L)	4
Engine Placement	Longitudinal

TEST VEHICLE OPTIONS

Driver Front Airbag	Yes
Driver Side Torso Airbag	No
Driver Side Head Airbag	No
Rear Pass. Airbag	No
Rear Pass. Torso Airbag	No
Rear Pass. Head Airbag	No
Power Brakes	Yes
Power Steering	Yes
Disc Brakes, Front	Yes
Disc Brakes, Rear	Yes
Anti-lock Brakes	Yes
Tilt Steering Wheel	Yes
Power Windows	Yes
Power Seats	No

DATA FROM CERTIFICATION LABEL

Manufactured By	Toyota Motor Corporation	GVWR (kg)	2440
Date of Manufacture	January-03	GAWR Front (kg)	1185
		GAWR Rear (kg)	1330

DATA FROM TIRE PLACARD

Measured Parameter	Front	Rear
Maximum Tire Pressure (kPa)	220	220
Cold Pressure (kPa)	220	220
Recommend Tire Size	P265/70R16	P265/70R16
Tire Size on Vehicle	P265/70R16	P265/70R16
Tire Manufacturer	Dunlop	Dunlop

Measured Parameter	Front	Rear	Third	Total
Type of Seats	Split Bench	Bench	None	
Number of Occupants	2	3	0	5
Capacity Wt. (VCW) (kg)				508
Cargo Weight (RCLW) (kg)				91

DATA SHEET NO. 1...(CONTINUED)

GENERAL TEST AND VEHICLE PARAMETER DATA

Test Vehicle: 2003 Toyota 4 Runner SR5 4WD SUV

NHTSA No. M35107

Test Program: 55/28 km/h 90° Side Impact NCAP

Test Date: 2/27/03

TEST VEHICLE WEIGHTS

	Units	As Delivered (<i>UVW</i>)			As Tested (<i>ATW</i>)		
		Front Axle	Rear Axle	Total	Front Axle	Rear Axle	Total
Left	kg	557	447		601	555	
Right	kg	490	439		495	528	
Ratio	%	54.2	45.8		50.3	49.7	
Totals	kg	1047	886	1933	1096	1083	2179

TARGET TEST WEIGHT CALCULATION*

Measured Parameter	Units	Value
Total Delivered Weight (<i>UVW</i>)	kg	1933
Weight of 2 P572M Sid's/HIII Dummies	kg	161
Rated Cargo/Luggage Weight (<i>RCLW</i>)	kg	91
Calculated Vehicle Target Weight (<i>TVTW</i>)	kg	2185

*Actual As Tested Weight (*ATW*) will be *TVTW* -5/-10 kg

TEST VEHICLE ATTITUDES AND CG

	Units	LF	RF	LR	RR	CG (aft of front axle)
As Delivered	mm	852	858	906	921	1276
As Tested	mm	841	853	872	889	1384
Fully Loaded	mm	844	858	877	892	

GENERAL TEST VEHICLE DATA

Measurement Description	Units	Value
Test Vehicle Wheel base	mm	2785
Total Vehicle Length at Left Side	mm	3280
Total Vehicle Length at Centerline	mm	4780
Total Vehicle Length at Right Side	mm	3280
Weight of Ballast In Cargo Area	kg	0
Amount of Stoddard Solvent in Fuel Tank	Liters	67.0

TEST VEHICLE VERTICAL IMPACT LINE DATA

Measurement Description	Units	Value
Test Vehicle Wheel base	mm	2785
Target Impact Point Aft of Front Axle	mm	452
Actual Impact Point Aft of Front Axle	mm	459

DATA SHEET NO. 1...(continued)

GENERAL TEST AND VEHICLE PARAMETER DATA

Test Vehicle: 2003 Toyota 4 Runner SR5 4WD SUV

NHTSA No. M35107

Test Program: 55/28 km/h 90° Side Impact NCAP

Test Date: 2/27/03

NOMINAL DESIGN RIDING POSITION

The driver's seat back is positioned to the manufacturer's designated angle. The procedure for positioning the seat is as follows: A slit is cut into fabric of the seat at the outboard edge, approximately 10-13 inches above the pivot point to expose the frame of the seat. An inclinometer is firmly placed against the flat portion of the frame surface and the seat back is adjusted to the manufacturers designated angle.

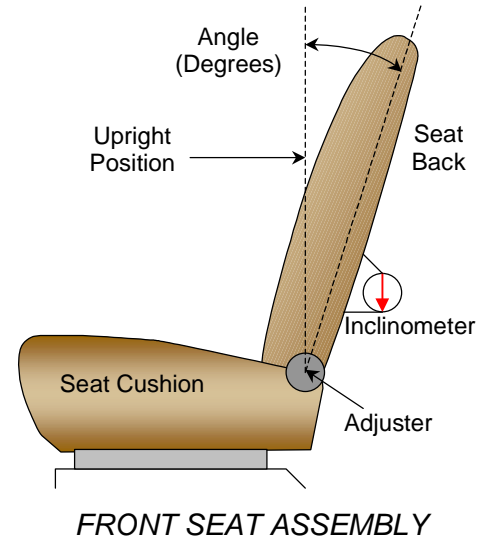

Driver seat back angle: 7.3° with a seated dummy

Rear seat back angle: 24° fixed

SEAT FORE/AFT POSITIONS

The driver's seat is adjustable. The fore/aft position is set to the middle.

Driver seat fore/aft total travel: 17 seat detents

Rear seat fore/aft total travel: Seat is fixed

Driver seat fore/aft position: Placed in the 9th detent

Rear seat fore/aft position: Seat is fixed

SEAT BELT UPPER ANCHORAGE

The driver's "D" ring anchorage has 5 positions and is placed in the 2nd position from the top, the rear passenger seat is non-adjustable.

DATA SHEET NO. 1...(continued)

GENERAL TEST AND VEHICLE PARAMETER DATA

Test Vehicle: 2003 Toyota 4 Runner SR5 4WD SUV

NHTSA No. M35107

Test Program: 55/28 km/h 90° Side Impact NCAP

Test Date: 2/27/03

FUEL TANK CAPACITY DATA

The "Usable Capacity" of the standard equipment fuel tank is: 72.3 liters

The "Usable Capacity" of any optional equipment fuel tank is: N/A liters

92-94% of "Usable Capacity" for certification to FMVSS 301 requirement: 66.5 to 67.9 liters

Actual amount of Stoddard solvent added to vehicle for certification test: 67.0 liters

The test vehicle is equipped with an electric fuel pump. The fuel pump will operate for approximately three (3) seconds with the ignition in the "ON" position, after which the fuel pump automatically shuts off. The fuel filler door is located on the left rear fender.

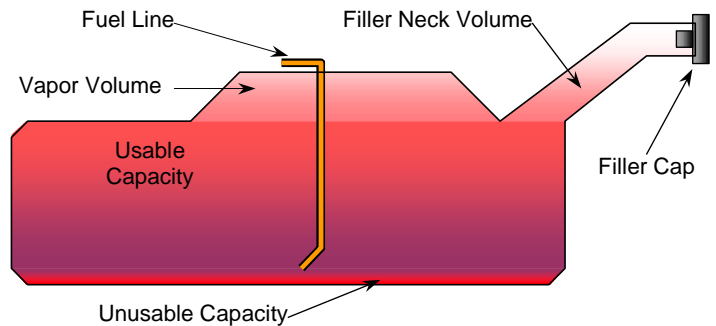

VEHICLE FUEL TANK ASSEMBLY

STEERING COLUMN ADJUSTMENT

Steering wheel and column adjustments are made so that the steering wheel hub is at the geometric center of the locus it describes, when it is moved through its full range of motion. An aluminum plate is placed across the rim of the steering wheel, an inclinometer is placed onto the plate and the angle is measured. The tested vehicle has its steering column set at position 2 as indicated in the drawing at right and the angle below.

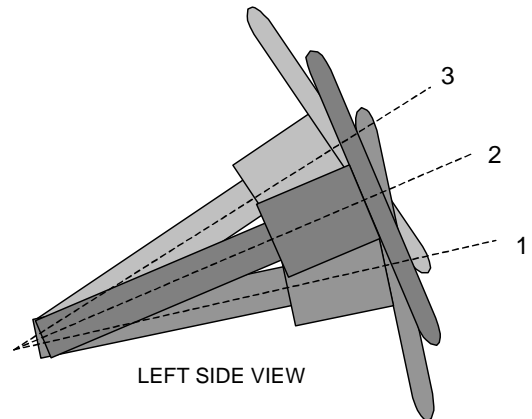

STEERING COLUMN ASSEMBLY

Lowermost, position 1: 22.5°

Geometric center, position 2: 30.0°

Uppermost, position 3: 37.5°

DATA SHEET NO. 2
TEST VEHICLE SUMMARY OF RESULTS

Test Vehicle: 2003 Toyota 4 Runner SR5 4WD SUV
Test Program: 55/28 km/h 90° Side Impact NCAP

NHTSA No. M35107
Test Date: 2/27/03

TEST VEHICLE WEIGHTS

	Units	As Delivered (UVM)			As Tested (ATW)		
		Front Axle	Rear Axle	Total	Front Axle	Rear Axle	Total
Left	kg	557	447		601	555	
Right	kg	490	439		495	528	
Weight Ratio	%	54.2	45.8		50.3	49.7	
Totals	kg	1047	886	1933	1096	1083	2179

MAXIMUM EXTERIOR STATIC CRUSH

Level	Measured Parameter	Units	Maximum Crush	Above Ground
Level 1	Sill Top Height	mm	184	404
Level 2	Occupant H-Point	mm	251	775
Level 3	Mid Door	mm	230	790
Level 4	Window Sill	mm	134	1120
Level 5	Window Top	mm	60	1555
N/A	Maximum Penetration	mm	251	

INSTRUMENTATION

Driver SID/HIII Accelerometers	20
Passenger SID/HIII Accelerometers	20
Vehicle Structure Accelerometers	25
MDB Accelerometers	5
Total	70

16mm MOVIE COVERAGE

High Speed, Vehicle On-Board	2
High Speed, Off-Board	6
High Speed, MDB On-Board	2
Real Time, Panning	1
Total	11

DATA SHEET NO. 3
MOVING DEFORMABLE BARRIER (MDB) SUMMARY OF RESULTS

Test Vehicle: 2003 Toyota 4 Runner SR5 4WD SUV
 Test Program: 55/28 km/h 90° Side Impact NCAP

NHTSA No. M35107
 Test Date: 2/27/03

MDB SPECIFICATIONS (mm)

Measurement Description	Length
Overall Width of Framework Carriage	1252
Overall Length Including Honeycomb Face	4115
Wheel base of Framework Carriage	2590
C.G. Location aft of Front Axle	1127

MDB WEIGHTS

	Units	Front Axle	Rear Axle	Total
Left	kg	384	308	
Right	kg	385	284	
Ratio	%	56.5	43.5	
Totals	kg	769	592	1361

SPEED AND IMPACT ANGLE DATA

Measured Parameter	Units	Requirement	Value
Trap No. 1 Velocity (Primary)	km/h	61.1 to 62.7	61.51
Trap No. 2 Velocity (Redn.)	km/h	61.1 to 62.7	61.53
MDB CL to Target Vehicle CL	degrees	88.5 to 91.5	89.5

MAXIMUM STATIC CRUSH OF HONEYCOMB FACE (mm)

Vertical Location			From Centerline		Max Crush
Row	Description	Height	Distance	Direction	
A	Center of Bumper	432	800	Left	248
B	Top of Bumper	533	800	Left	215
C	Mid Level	686	700	Left	202
D	Top of Stack	813	800	Left	186

MDB INSTRUMENTATION AND CAMERAS

Accelerometers	5
Contact Switches	2
High Speed Cameras	2

**DATA SHEET NO. 4
POST TEST OBSERVATIONS**

Test Vehicle: 2003 Toyota 4 Runner SR5 4WD SUV
 Test Program: 55/28 km/h 90° Side Impact NCAP

NHTSA No.: M35107
 Test Date: 2/27/03

TEST DUMMY INFORMATION AND CONTACT POINTS

Description	Front Seat SID/HIII	Rear Seat SID/HIII
Dummy Type / Serial No.	P572F, SID /HIII No. 274	P572F, SID /HIII No. 275
Head Contact	Window	C-Pillar/Roof Panel
Upper Torso Contact	Panel	Panel
Lower Torso Contact	Panel	Panel
Left Knee Contact	None	Panel
Right Knee Contact	None	Knee

POST TEST DOOR OPENING AND SEAT TRACK INFORMATION

Description	Front	Rear
Left Side Door Opening	Remained closed/latched inoperable	Remained closed/latched inoperable
Right Side Door Opening	Remained closed/latched operable	Remained closed/latched operable
Seat Movement	None	None
Seat Back Failure	None	None

POST TEST STRUCTURAL OBSERVATIONS

Critical Areas of Performance	Observations and Conclusions
Pillar Performance	Pillars pushed inward with no apparent failure
Sill Separation	No Apparent Visible Failure
Windshield Damage	Glazing Cracks on Struck Side Only
Window Damage	Drivers window intact, rear passenger window broke
Other Notable Effects	No significant items to note.

SUPPLEMENTAL RESTRAINT INFORMATION

Restraint Type	Left Front (Driver) Occupant Location 01		Left Rear (Passenger) Occupant Location 04	
	Installed	Operation	Installed	Operation
Front Airbag	Yes	Not Deployed	None	Not Applicable
Side Torso Airbag	None	Not Applicable	None	Not Applicable
Head Curtain Airbag	None	Not Applicable	None	Not Applicable
Seat Belt Pretensioner	None	N/A	None	N/A
Seat Belt Load Limiter	None	N/A	None	N/A

MDB LEFT EDGE IMPACT POINT DATA

Measured Parameter	Units	Requirement	Value
Horizontal Offset	mm	+/- 50	3(left)
Vertical Offset	mm	+/- 20	7(Below)

SECTION 4
OCCUPANT AND VEHICLE INFORMATION

DATA SHEET NO. 5
HIIL/SID INJURY CRITERIA AND SENSOR DATA

Test Vehicle: 2003 Toyota 4 Runner SR5 4WD SUV

NHTSA No.: M35107

Test Program: 55/28 km/h Side Impact NCAP

Test Date: 2/27/03

THORAX AND PELVIS PEAK ACCELERATIONS, PRIMARY (FIR 100 Filtered)

Location	Axis	Units	Driver				Passenger			
			Max	Time	Min	Time	Max	Time	Min	Time
Upper Rib (LUR)	Y	G's	28.3	35.6	-15.6	41.9	22.9	61.3	-1.7	113.8
Lower Rib (LLR)	Y	G's	25.8	35.6	-3.8	79.4	29.5	58.1	-0.5	113.1
Lower Spine (T ₁₂)	Y	G's	37.6	31.9	-18.0	66.9	30.8	60.6	-4.8	79.4
Pelvis (PEV)	Y	G's	42.2	31.9	-14.4	71.3	29.0	49.4	-5.0	83.1

THORACIC TRAUMA INDEX (TTI) AND PELVIC ACCELERATION, PRIMARY (FIR 100 Filtered)

Location	Driver				Passenger			
	LUR	T ₁₂	TTI(g)	PEV(g)	LLR	T ₁₂	TTI(g)	PEV(g)
Primary Rib, Spine, and Pelvis	28.325	37.623	33	42	29.487	30.758	30	29

THORAX AND PELVIS PEAK ACCELERATIONS, REDUNDANT (FIR 100 Filtered)

Location	Axis	Units	Driver				Passenger			
			Max	Time	Min	Time	Max	Time	Min	Time
Upper Rib (LUR)	Y	G's	28.3	35.6	-15.4	41.9	23.1	61.3	-0.9	113.8
Lower Rib (LLR)	Y	G's	25.8	35.6	-3.4	79.4	29.9	58.1	-.59	226.3
Lower Spine (T ₁₂)	Y	G's	37.9	31.9	-18.3	66.9	30.8	60.6	-4.8	79.4
Pelvis (PEV)	Y	G's	0.0	0.0	0.0	0.0	29.3	50.0	-4.4	83.8

1.) Driver channel failed, no data

THORACIC TRAUMA INDEX (TTI) AND PELVIC ACCELERATION, REDUNDANT (FIR 100 Filtered)

Location	Driver				Passenger			
	LUR	T ₁₂	TTI(g)	PEV(g)	LLR	T ₁₂	TTI(g)	PEV(g)
Redundant Rib, Spine, and Pelvis	28.320	37.940	33	0	29.949	30.812	30	29

Positive Acceleration Polarities:
 Longitudinal (X) = Forward
 Lateral (Y) = Right
 Vertical (Z) = Down

DATA SHEET NO. 5...(continued)
HIII/SID INJURY CRITERIA AND SENSOR DATA

Test Vehicle: 2003 Toyota 4 Runner SR5 4WD SUV

NHTSA No.: M35107

Test Program: 55/28 km/h Side Impact NCAP

Test Date: 2/27/03

HEAD PRIMARY PEAK ACCELERATIONS (SAE CLASS 1000 Filtered)

Location	Axis	Units	Driver				Passenger			
			Max	Time	Min	Time	Max	Time	Min	Time
Head CG	X	G's	3.5	33.5	-14.0	109.8	6.6	83.7	-32.6	68.4
Head CG	Y	G's	27.6	110.3	-4.1	52.6	72.3	72.1	-4.6	62.7
Head CG	Z	G's	30.3	66.9	-12.0	32.1	7.3	63.9	-20.7	76.9
Head CG Resultant	N/A	G's	32.0	66.9			78.4	72.1		

HEAD PRIMARY INJURY CRITERIA (SAE CLASS 1000 Filtered)

Location	Driver				Passenger			
	HIC	T ¹	T ²	Avg G	HIC	T ¹	T ²	Avg G
Head CG	64.9	62.2	98.1	20.1	284.1	65.3	76.9	56.8

HEAD REDUNDANT PEAK ACCELERATIONS (SAE CLASS 1000 Filtered)

Location	Axis	Units	Driver				Passenger			
			Max	Time	Min	Time	Max	Time	Min	Time
Head CG	X	G's	3.5	33.6	-14.3	109.8	5.6	83.3	-32.6	71.3
Head CG	Y	G's	26.9	110.5	-4.2	35.5	71.5	72.1	-5.3	90.7
Head CG	Z	G's	30.1	67.0	-12.6	32.4	6.3	19.6	-18.5	76.9
Head CG Resultant	N/A	G's	31.8	67.3			77.1	72.1		

HEAD REDUNDANT INJURY CRITERIA (SAE CLASS 1000 Filtered)

Location	Driver				Passenger			
	HIC	T ¹	T ²	Avg G	HIC	T ¹	T ²	Avg G
Head CG	65.5	62.2	98.1	20.1	280.8	65.3	76.8	56.7

UPPER NECK PEAK FORCES AND MOMENTS

Location	Axis	Units	Driver				Passenger			
			Max	Time	Min	Time	Max	Time	Min	Time
Neck Force	X	Newtons	150.8	26.4	-482.9	98.7	1006.1	75.5	-145.2	187.5
Neck Force	Y	Newtons	413.9	87.0	-244.1	35.5	174.3	149.1	-1407.6	75.6
Neck Force	Z	Newtons	1308.1	67.3	-753.8	111.2	482.0	62.8	-2882.7	75.4
Neck Force Resultant	N/A	Newtons	1365.5	67.3			3341.5	75.4		
Neck Moment	X	N•m	35.6	96.0	-24.0	44.5	11.9	159.5	-36.7	68.8
Neck Moment	Y	N•m	28.1	109.2	-30.2	71.8	32.8	77.0	-26.4	92.1
Neck Moment	Z	N•m	16.0	126.1	-6.2	37.4	8.9	47.1	-14.8	83.3
Neck Moment Resultant	N/A	N•m	41.9	99.5			38.2	91.5		

DATA SHEET NO. 6

VEHICLE PRE-TEST AND POST TEST MEASUREMENTS

Test Vehicle: 2003 Toyota 4 Runner SR5 4WD SUV

NHTSA No. M35107

Test Program: 55/28 km/h 90° Side Impact NCAP

Test Date: 2/27/03

LEFT SIDE VIEW

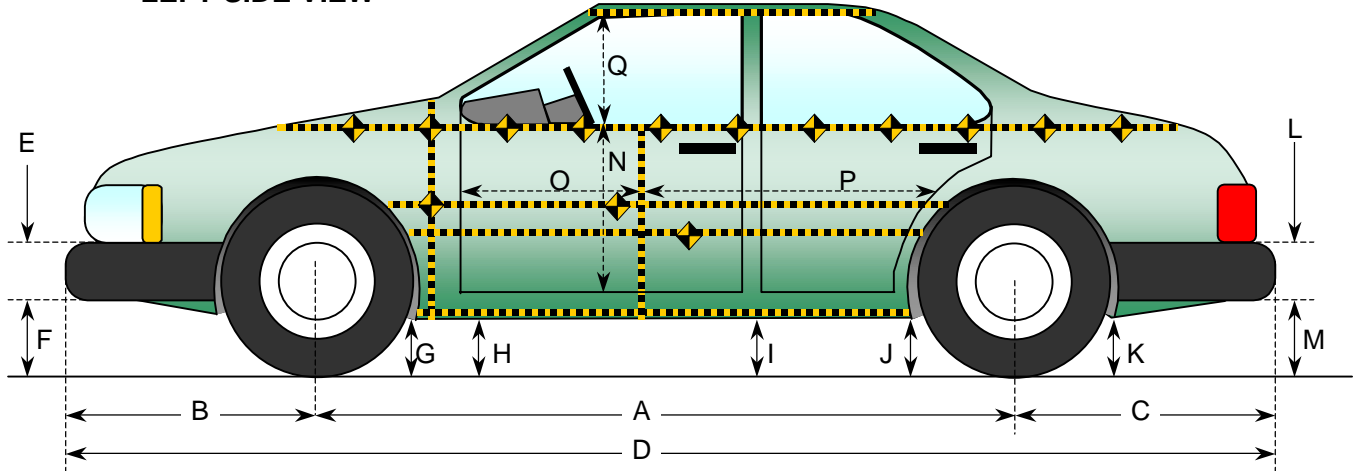

All Measurements in mm

Code	Measurement Description	Pre-Test	Post-Test	Difference
A	Wheelbase	2785	2800	15
B	Front Axle To FSOV	853	930	77
C	Rear Axle to RSOV	1093	1104	11
D	Total Length at Centerline	4780	4781	1
E	Front Bumper Thickness	376	376	0
F	Front Bumper Bottom to Ground	402	404	2
G	Sill Height at Front Wheel Well	312	321	9
H	Sill Height at Front Door Leading Edge	312	321	9
I	Sill Height at "B" Pillar	309	324	15
J1	Sill Height at Rear Wheel Well	302	315	13
J2	Pinch Weld Height at Rear Wheel Well	311	336	25
K	Sill Height aft of Rear Wheel Well	412	439	27
L	Rear Bumper Thickness	160	160	0
M	Rear Bumper Bottom to Ground	440	467	27
N	Sill Height to Window Bottom Sill	708	700	-8
O	Front Door Leading Edge to Impact CL	723	707	-16
P	Rear Door Trailing Edge to Impact CL	1325	1295	-30
Q	Front Window Opening	428	419	-9
R	Right Side Length	3280	3290	10
S	Left Side Length	3280	3225	-55
T	Vehicle Width at "B" Post	1839	1700	-139

DATA SHEET NO. 7

SID/HIII LONGITUDINAL CLEARANCE DIMENSIONS

Test Vehicle: 2003 Toyota 4 Runner SR5 4WD SUV

NHTSA No. M35107

Test Program: 55/28 km/h 90° Side Impact NCAP

Test Date: 2/27/03

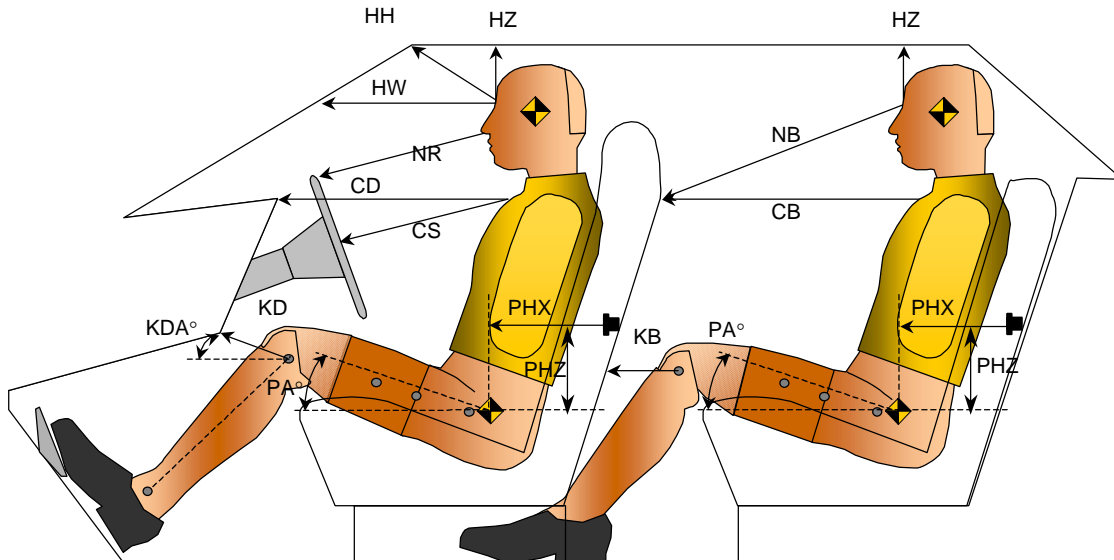

Driver Code	Pass. Code	Measurement Description	Driver		Passenger	
			Length(mm)	Angle(°)	Length(mm)	Angle(°)
HH		Head to Header	480	12		
HW		Head to Windshield	723			
HZ	HZ	Head to Roof	195	90	200	90
NR	NB	Nose to Rim/Nose to Seatback	487	17	687	22
CD	CB	Chest to Dash or Seatback	580	6	600	5
CS		Chest to Steering Wheel	305	0		
KDL	KBL	Left Knee to Dash or Seatback	195	3	238	0
KDR	KBR	Right Knee to Dash or Seatback	200		245	
PA	PA	Pelvic Angle		24		23
PHX	PHX	H-Point to Striker (X-Axis)	268		260	
PHZ	PHZ	H-Point to Striker (Z-Axis)	208		253	

DATA SHEET NO. 8

SIDHIII LATERAL CLEARANCE DIMENSIONS

Test Vehicle: 2003 Toyota 4 Runner SR5 4WD SUV

NHTSA No. M35107

Test Program: 55/28 km/h 90° Side Impact NCAP

Test Date: 2/27/03

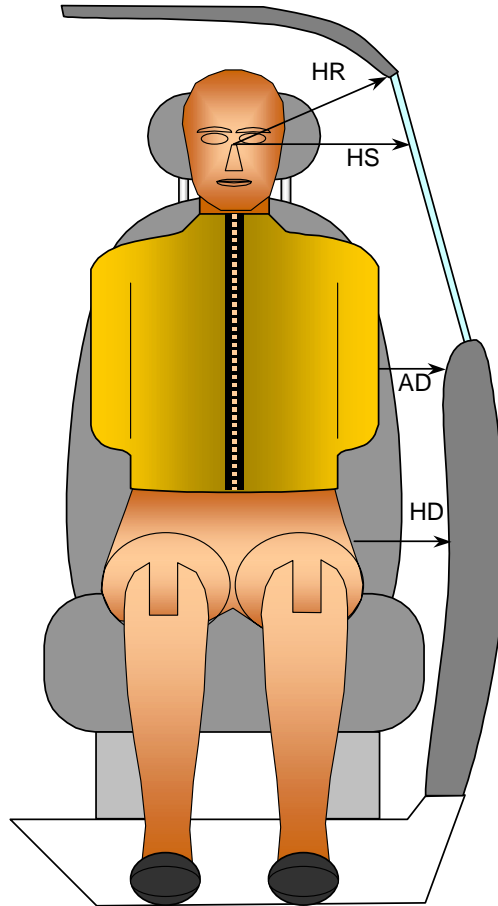

FRONT VIEW OF DUMMY

Code	Measurement Description	Units	Driver	Passenger
HR	Head to Side Header	mm	267	282
HS	Head to Side Window	mm	320	323
AD	Arm to Door	mm	109	84
HD	H-Point to Door	mm	210	157

DATA SHEET NO. 9

VEHICLE SIDE MEASUREMENTS

Test Vehicle: 2003 Toyota 4 Runner SR5 4WD SUV

NHTSA No.: M35107

Test Program: 55/28 km/h 90° Side Impact NCAP

Test Date: 2/27/03

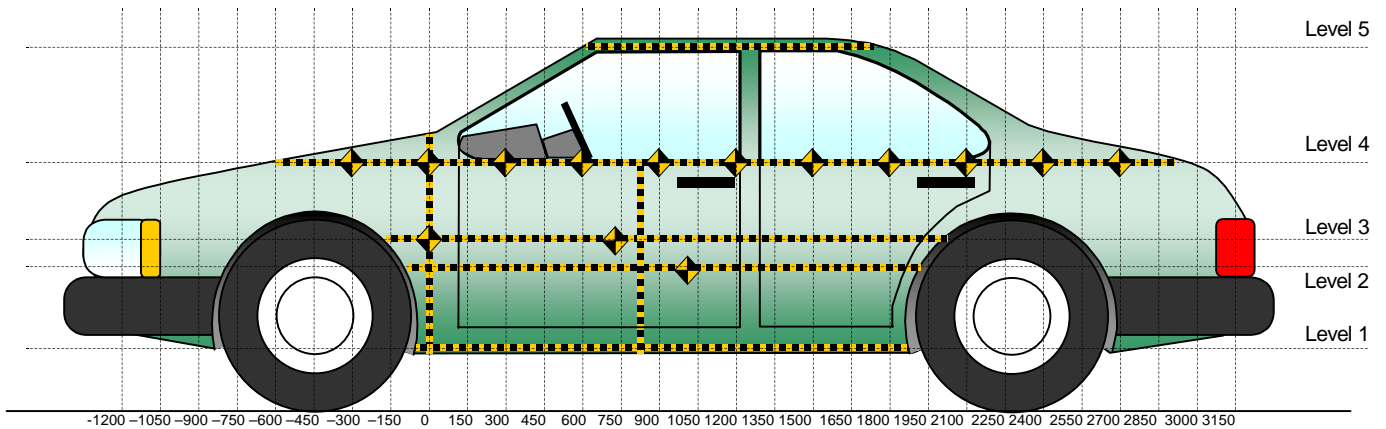

All Measurements Shown in mm

LEFT SIDE VIEW

Measurements are taken with vehicle in the as tested condition.

Measurements taken 900mm right of impact reference.

All measurements below in mm.

Level	Measurement Description	Height Above Ground
5	Window Top	1555
4	Window Sill	1120
3	Mid Door	790
2	Occupant H-Point	775
1	Sill Top	404

DATA SHEET NO. 10 – VEHICLE EXTERIOR CRUSH PROFILES

Test Vehicle: 2003 Toyota 4 Runner SR5 4WD SUV

NHTSA No.: M35107

Test Program: 55/28 km/h 90° Side Impact NCAP

Test Date: 2/27/03

	Pre-Test					Post-Test					Difference				
	1	2	3	4	5	1	2	3	4	5	1	2	3	4	5
-900															
-750															
-600															
-450															
-300															
-150		539	539	626			611	609	698			72	70	72	
0	624	549	549	626		676	616	615	696		52	67	66	70	
150	643	578	576	626		760	689	682	676		117	111	106	50	
300	641	584	586	626		784	753	748	677		143	169	162	51	
450	646	588	586	621		806	806	790	683		160	218	204	62	
600	650	586	586	616		826	810	786	689		176	224	200	73	
750	654	588	586	616	828	832	813	792	696	888	178	225	206	80	60
900	654	589	586	616	818	814	818	798	704	876	160	229	212	88	58
1050	657	590	591	616	818	822	810	790	711	866	165	220	199	95	48
1200	656	591	590	616	809	840	801	792	727	869	184	210	202	111	60
1350	656	594	593	616	814	836	845	822	750	869	180	251	229	134	55
1500	658	599	597	621	821	820	847	827	734	866	162	248	230	113	45
1650	636	596	597	621	818	820	822	812	722	866	184	226	215	101	48
1800	626	570	575	622	819	780	766	781	708	866	154	196	206	86	47
1950		550	551	628	820		676	686	696	862		126	135	68	42
2100				630	825				659	868				29	43
2250				631	807				680	862				49	55
2400				623	814				676	869				53	55
2550				627	814				669	872				42	58
2700				631	820				671	872				40	52
2850				632	822				671	862				39	40
3000				638					671					33	

Measurements are taken from fixed reference 1000mm from vehicle CL.

DATA SHEET NO. 10.....(CONTINUED)

Test Vehicle: 2003 Toyota 4 Runner SR5 4WD SUV

NHTSA No.: M35107

Test Program: 55/28 km/h 90° Side Impact NCAP

Test Date: 2/27/03

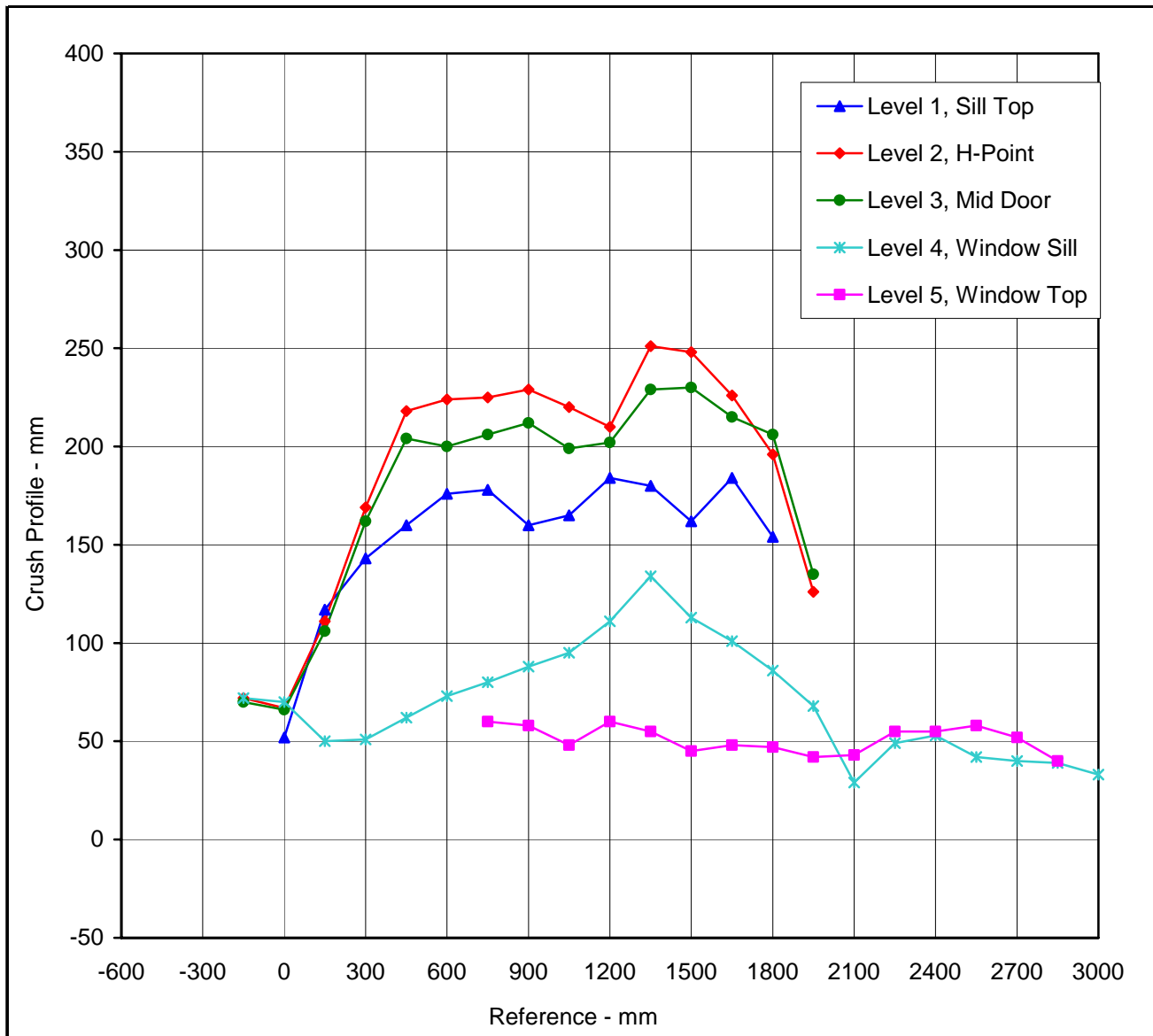

	Units	Level 1	Level 2	Level 3	Level 4	Level 5
Maximum Crush	mm	184	251	230	134	60
Distance from Impact	mm	1200	1350	1500	1350	750

DATA SHEET NO. 11

VEHICLE DAMAGE PROFILE DISTANCES

Test Vehicle: 2003 Toyota 4 Runner SR5 4WD SUV

NHTSA No.: M35107

Test Program: 55/28 km/h 90° Side Impact NCAP

Test Date: 2/27/03

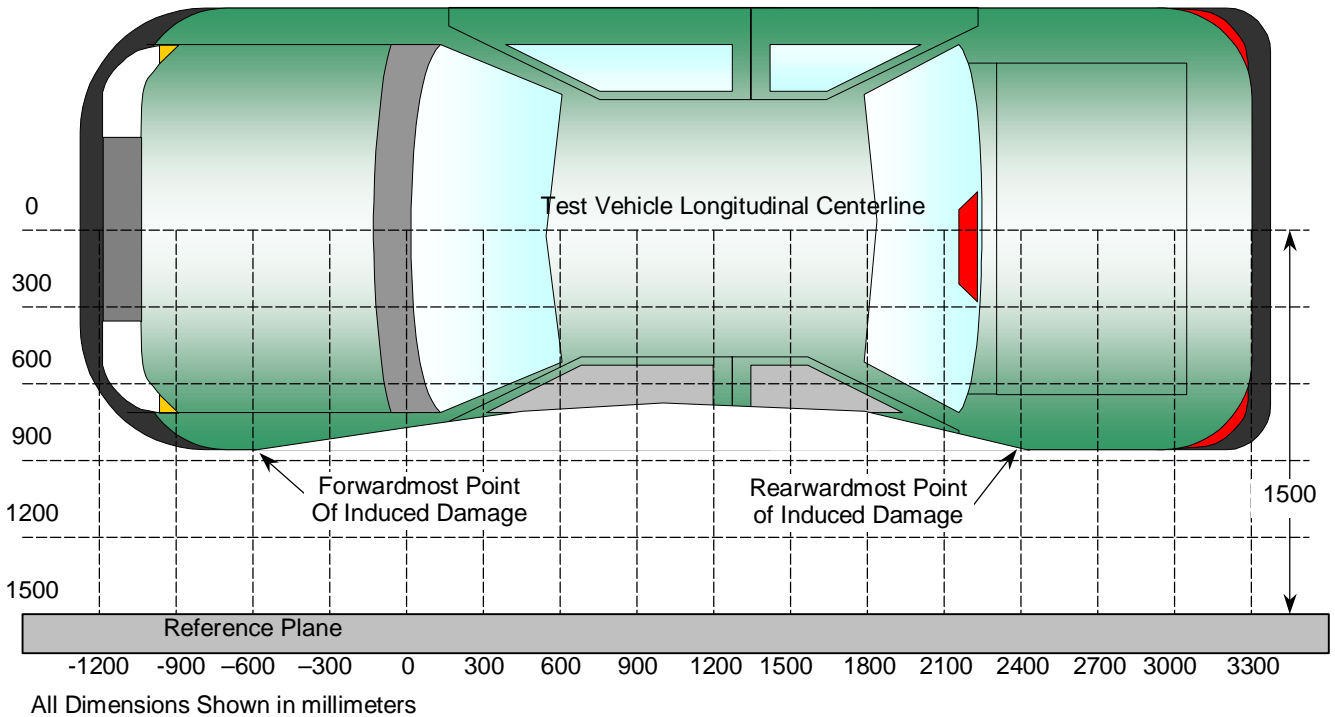

TOP VIEW

Damage Profile Distances

DPD	Distance From Impact Point in mm	Level	Pre-Test (mm)	Post-Test (mm)	Max Static Crush (mm)
1	-150	2	539	611	-72
2	300	2	584	753	-169
3	900	2	589	818	-229
4	1500	2	599	847	-248
5	2100	5	825	868	-43
6	3000	4	638	671	-33

Pre-Test and Post-Test measurements are distance from vehicle centerline.

DATA SHEET NO. 12

DEFORMABLE BARRIER HONEYCOMB FACE STATIC CRUSH

Test Vehicle: 2003 Toyota 4 Runner SR5 4WD SUV

NHTSA No.: M35107

Test Program: 55/28 km/h 90° Side Impact NCAP

Test Date: 2/27/03

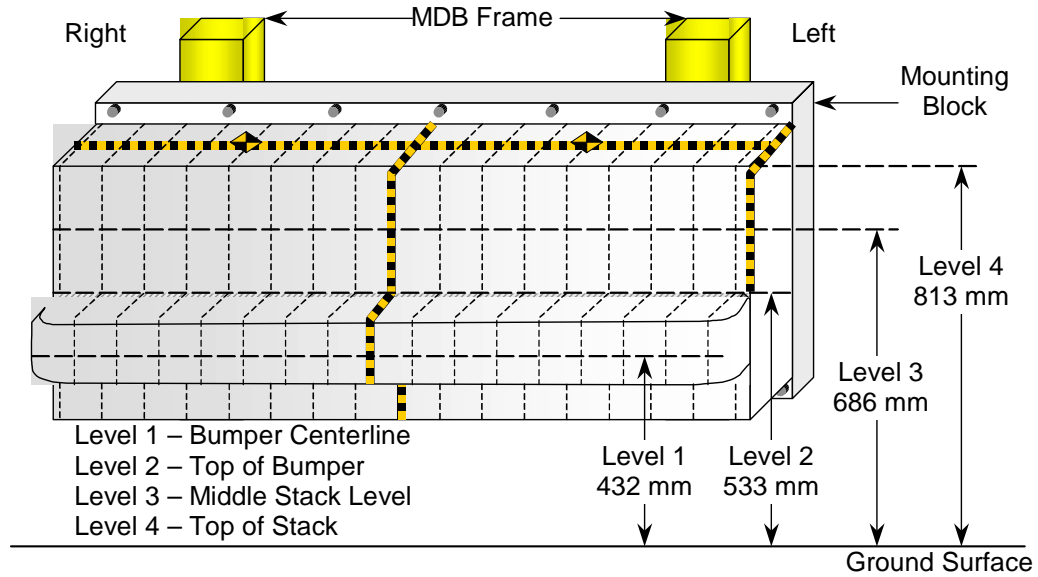

DEFORMABLE BARRIER STATIC CRUSH

Stack	Distance Right of Center								C _L	Distance Left of Center							
	800	700	600	500	400	300	200	100		0	100	200	300	400	500	600	700
1	192	178	164	153	149	148	147	146	148	148	148	149	158	174	197	222	248
2	170	172	156	154	152	148	151	149	151	151	151	151	142	131	132	166	215
3	176	106	99	90	90	86	81	82	89	96	111	101	86	102	129	164	202
4	171	119	91	76	61	58	52	48	50	73	76	73	73	81	103	132	186

All Dimensions in mm

DATA SHEET NO. 13

VEHICLE ACCELEROMETER LOCATION AND DATA SUMMARY

Test Vehicle: 2003 Toyota 4 Runner SR5 4WD SUV

NHTSA No.: M35107

Test Program: 55/28 km/h 90° Side Impact NCAP

Test Date: 2/27/03

LEFT SIDE VIEW

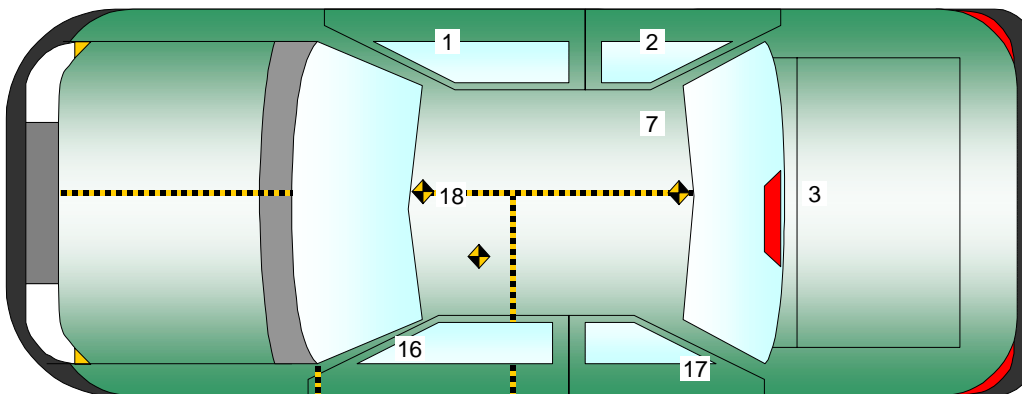
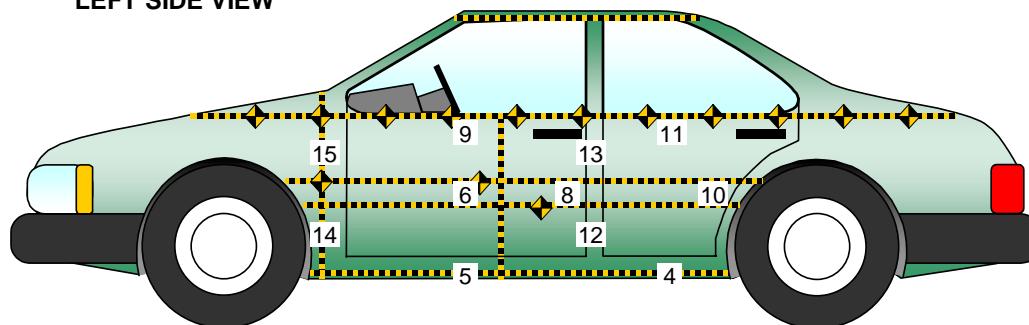

No.	Location
1	Right Sill at Front Seat
2	Right Sill at Rear Seat
3	Rear Floorpan Above Axle
4	Left Sill at Rear Door
5	Left Sill at Front Door
6	Left Front Door Centerline
7	Right Rear Occupant Compartment
8	Left Front Door Mid-Rear
9	Left Front Door Upper Centerline

No.	Location
10	Left Rear Door Mid-Rear
11	Left Rear Door Upper Centerline
12	Left Lower B-Post
13	Left Middle B-Post
14	Left Lower A-Post
15	Left Middle A-Post
16	Front Seat Track
17	Rear Seat Track or Structure
18	Vehicle CG

DATA SHEET NO. 13

VEHICLE ACCELEROMETER LOCATION AND DATA SUMMARY

Test Vehicle: 2003 Toyota 4 Runner SR5 4WD SUV

NHTSA No.: M35107

Test Program: 55/28 km/h Side Impact NCAP

Test Date: 2/27/03

VEHICLE ACCELEROMETER PEAK DATA AND PRE-TEST LOCATIONS

Loc. No.	Accelerometer Location	Measurements (mm)			Peak Values (G's)				
		X	Y	Z	Axis	Max	Time	Min	Time
1	Right Sill at Front Seat	2675	730	515	X	2.5	42.8	-6.2	11.9
					Y	34.8	9.1	-3.3	17.2
					Z	6.6	73.0	-10.6	15.1
					RES	34.9	9.1		
2	Right Sill at Rear Seat	2050	740	515	X	2.9	42.9	-5.4	11.3
					Y	42.2	8.6	-2.4	140.6
					Z	5.1	99.0	-7.7	22.7
					RES	42.2	8.6		
3	Rear Floorpan Above Axle	1170	200	720	X	12.9	14.3	-10.3	8.7
					Y	41.3	9.6	-6.8	14.8
					Z	21.6	26.6	-21.0	30.8
					RES	44.6	9.7		
4	Left Sill at Rear Door	2055	-600	300	Y	91.1	18.9	-9.0	29.2
5	Left Sill at Front Door	2840	-600	300	Y	0.0	0.0	0.0	0.0
6	Front Door Centerline	2300	-720	925	Y	156.6	14.5	-96.1	36.1
7	Rt. Rear Occ. Compartment	2300	365	520	Y	48.6	9.1	-5.2	17.1
8	Front Door Mid-Rear	2500	-725	880	Y	131.7	12.3	-63.9	18.5
9	Front Door Upper Centerline	2810	-735	1025	Y	112.3	17.4	-103.6	27.0
10	Rear Door Mid-Rear	1650	-815	895	Y	75.5	9.1	-55.8	22.3
11	Rear Door Upper Centerline	1840	-815	1080	Y	99.4	13.6	-146.3	31.1
12	B-Post Lower	2330	-740	800	Y	143.1	8.1	-82.7	24.5
13	B-Post Middle	2330	-740	1090	Y	85.8	11.3	-34.7	25.6
14	A-Post Lower	3325	-770	1065	Y	94.2	7.0	-51.6	24.8
15	A-Post Middle	3325	-770	730	Y	35.9	8.5	-12.2	26.4
16	Front Seat Track	2850	-620	570	Y	0.0	0.0	0.0	0.0
17	Rear Seat Structure				Y				
18	Vehicle CG	2170	35	610	X	0.0	0.0	0.0	0.0
					Y	0.0	0.0	0.0	0.0
					Z	0.0	0.0	0.0	0.0
					RES	0.0	0.0		

1.) Channel failed, no data

2.) Not installed

DATA SHEET NO. 14
MDB ACCELEROMETER LOCATION AND DATA SUMMARY

Test Vehicle: 2003 Toyota 4 Runner SR5 4WD SUV
 Test Program: 55/28 km/h Side Impact NCAP

NHTSA No.: M35107
 Test Date: 2/27/03

MDB ACCELEROMETER PEAK DATA AND LOCATIONS

Loc. No.	Accelerometer Location	Measurements (mm)			Peak Values (G's)				
		X	Y	Z	Axis	Max	Time	Min	Time
1	MDB CG	-1195	0	430	X	3.8	91.8	-25.5	34.7
					Y	1.7	87.2	-10.5	49.1
					Z	11.6	60.4	-13.3	35.9
					RES	28.9	35.2		
2	MDB Rear	-2642	-593	608	X	2.1	102.9	-25.4	34.3
					Y	1.9	63.1	-5.9	10.2

Reference Points X - MDB Front Axle Y - MDB Centerline Z - Ground Plane

MDB BUMPER CONTACT SWITCH DATA

Loc. No.	Contact Switch Location	Units	Peak and 50% Crossing Point			
			Max	Time	50%	Time
3	MDB Left Bumper (T=0)	% F.S	100.0	0.0	50.0	0.0
4	MDB Right Bumper	% F.S.	100.8	71.5	50.0	-0.8

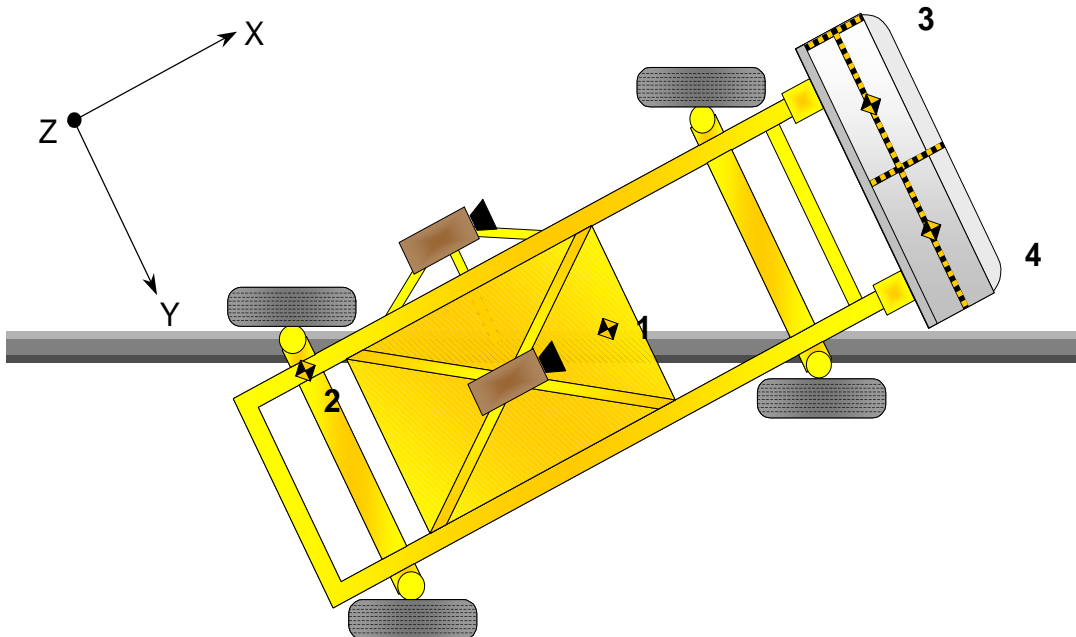

DATA SHEET NO. 15

HIGH SPEED CAMERA LOCATIONS AND DATA

Test Vehicle: 2003 Toyota 4 Runner SR5 4WD SUV

NHTSA No.: M35107

Test Program: 55/28 km/h 90° Side Impact NCAP

Test Date: 2/27/03

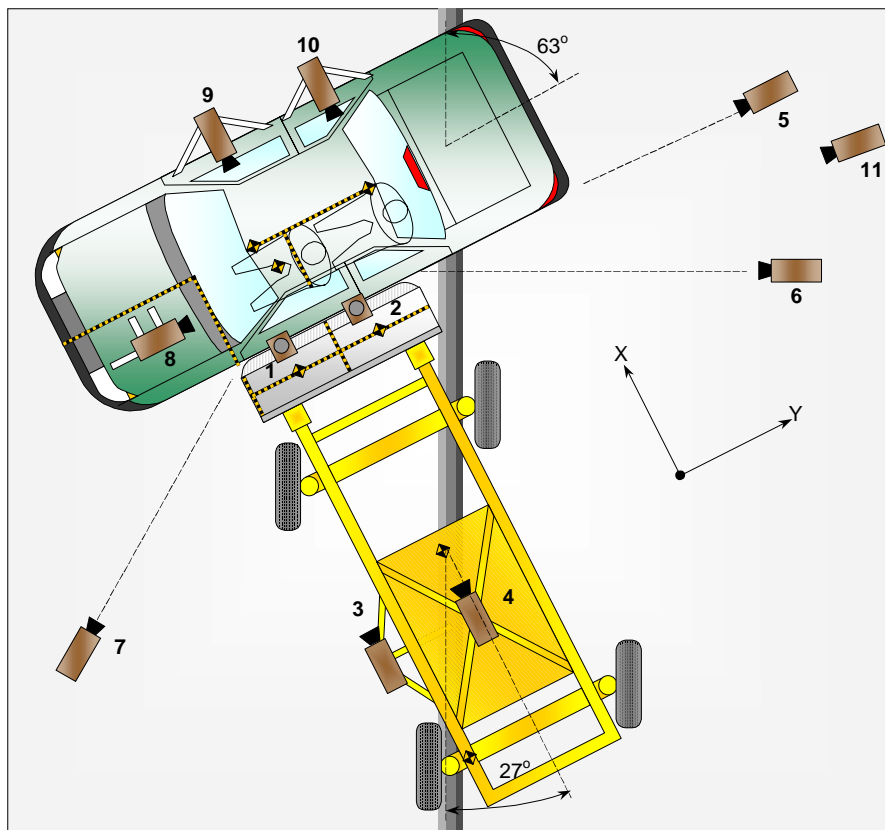

No.	Camera View	Location (mm)			Angle (deg.)	Lens (mm)	Film Speed (fr./sec.)
		X	Y	Z			
1	Overhead Overall	2438	609	5486	90	8	1020
2	Overhead Close-up	1676	-1067	5486	90	35	900
3	Impact Point	0	-2134	1143	7	13	No Time
4	Side Overall	838	-3912	1829	11	13	No Time
5	Rear	15545	228	1371	1	35-80	1000
6	Left Rear	16459	-7188	939	1	80	920
7	Left Front	-4775	-2666	1473	7	13	1030
7B	Left Front	-5080	-3531	1524	8	17	No Time
8	Driver Front	-508	508	1575	16	19	DNR
9	Driver Side	-144	1626	1321	7	6	1030
10	Rear Passenger	1676	1626	1321	7	6	1000
11	Overall	41148	64008	1575	1	100	DNR
12	Real Time	22860	3658	1727	5	17-20	24

DATA SHEET NO. 16

FMVSS 301 FUEL SYSTEM INTEGRITY POST IMPACT DATA

Test Vehicle: 2003 Toyota 4 Runner SR5 4WD SUV

NHTSA No.: M35107

Test Program: 55/28 km/h 90° Side Impact NCAP

Test Date: 2/27/03

Test Time: 3:04 PM

Temperature at Time of Impact: 10.0 °C

Stoddard Solvent Spillage Measurements

- A. From impact until vehicle motion ceases: 0.0 oz.
(Maximum Allowable = 1 ounce)
- B. For the 5 minute period after motion ceases: 0.0 oz.
(Maximum Allowable = 5 ounces)
- C. For the following 25 minutes: 0.0 oz.
(Maximum Allowable = 1 oz./minute)
- D. Spillage Details: No leakage occurred

DATA SHEET NO. 17

FMVSS 301 STATIC ROLLOVER DATA SHEET

Test Vehicle: 2003 Toyota 4 Runner SR5 4WD SUV

NHTSA No.: M35107

Test Program: 55/28 km/h 90° Side Impact NCAP

Test Date: 2/27/03

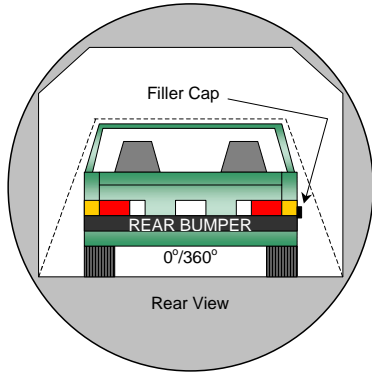

0° TO 90°

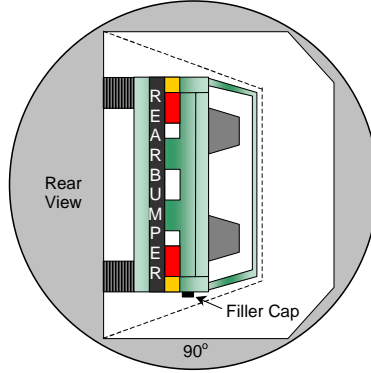

90° TO 180°

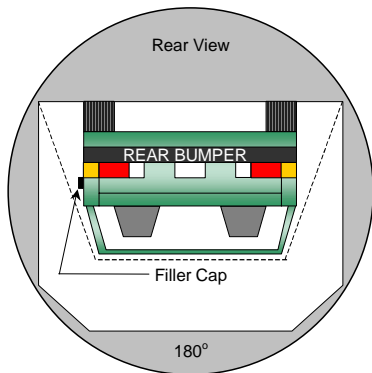
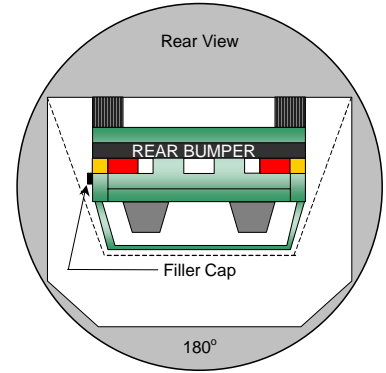

180° TO 270°

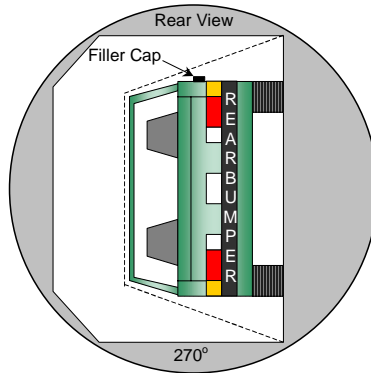

270° TO 360°

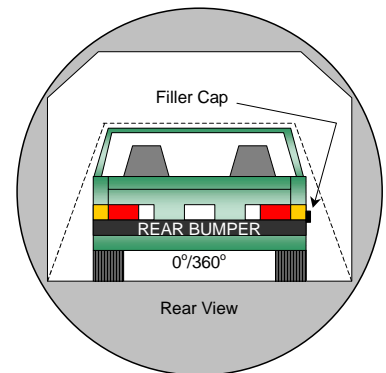

1. The specified fixture rollover rate for each 90° of rotation is 60 to 120 seconds.
2. The position hold time at each position is 300 seconds (minimum).
3. Details of Stoddard Solvent spillage locations.

No solvent leakage occurred during static rollover testing.

Rollover Test Phase	Rotation Time (sec.)	Hold Time (sec.)	Spillage (oz.)
0° TO 90°	81	300	0.0
90° TO 180°	80	300	0.0
180° TO 270°	78	300	0.0
270° TO 360°	79	300	0.0

APPENDIX A
PHOTOGRAPHS

LIST OF PHOTOGRAPHS

Figure		Page
A-1	Left Front as Received	A-1
A-2	Right Rear as Received	A-2
A-3	Vehicle Certification Label	A-3
A-4	Vehicle Tire Label	A-4
A-5	Front View, Pre-test	A-5
A-6	Front View, Post-Test	A-6
A-7	Left Front $\frac{3}{4}$ View, Pre-Test	A-7
A-8	Left Front $\frac{3}{4}$ View, Post -Test	A-8
A-9	Left (Impacted) Side View, Pre-Test	A-9
A-10	Left (Impacted) Side View, Post-Test	A-10
A-11	Left Rear $\frac{3}{4}$ View, Pre-Test	A-11
A-12	Left Rear $\frac{3}{4}$ View, Post Test	A-12
A-13	Rear View, Pre-Test	A-13
A-14	Rear View, Post-Test	A-14
A-15	Overhead Overall View, Pre-Test	A-15
A-16	Overhead Overall View, Post-Test	A-16
A-17	Overhead Close-up View, Pre-Test	A-17
A-18	Overhead Close-up View, Post-Test	A-18
A-19	Impact Point Target Set-up, Pre-Test	A-19
A-20	Impact Point Target Set-up, Post-Test	A-20
A-21	Front $\frac{3}{4}$ View of Left Side Doors, Pre-Test	A-21
A-22	Front $\frac{3}{4}$ View of Left Side Doors, Post-Test	A-22
A-23	Rear $\frac{3}{4}$ View of Left Side Doors, Pre-Test	A-23
A-24	Rear $\frac{3}{4}$ View of Left Side Doors, Post-Test	A-24
A-25	Driver Dummy Left Side with Door Open, Pre-Test	A-25
A-26	Driver Dummy Left Side, Pre-Test	A-26
A-27	Driver Dummy Left Side, Post-Test	A-27
A-28	Driver Dummy Clearance, Pre-Test	A-28
A-29	Driver Dummy Clearance, Post-Test	A-29
A-30	Driver Dummy Inside View, Pre-Test	A-30
A-31	Driver Dummy Inside View, Post-Test	A-31
A-32	Driver Door Inside View, Pre-Test	A-32
A-33	Driver Dummy Contact Points Inside View, Post-Test	A-33

LIST OF PHOTOGRAPHS, ...(Continued)

Figure		Page
A-34	Passenger Dummy Left Side with Door Open, Pre-Test	A-34
A-35	Passenger Dummy Left Side, Pre-Test	A-35
A-36	Passenger Dummy Left Side, Post-Test	A-36
A-37	Passenger Dummy Clearance, Pre-Test	A-37
A-38	Passenger Dummy Clearance, Post-Test	A-38
A-39	Passenger Dummy Inside View, Pre-Test	A-39
A-40	Passenger Dummy Inside View, Post-Test	A-40
A-41	Passenger Dummy Inside View, Pre-Test	A-41
A-42	Passenger Dummy Contact Points Inside View, Post-Test	A-42
A-43	Front View of Deformable Barrier, Pre-Test	A-43
A-44	Front View of Deformable Barrier, Post-Test	A-44
A-45	Top View of Deformable Barrier, Pre-Test	A-45
A-46	Top View of Deformable Barrier, Post-Test	A-46
A-47	Right Side View of Deformable Barrier, Pre-Test	A-47
A-48	Right Side View of Deformable Barrier, Post-Test	A-48
A-49	Left Side View of Deformable Barrier, Pre-Test	A-49
A-50	Left Side View of Deformable Barrier, Post-Test	A-50
A-51	Vehicle On Rollover Device, Top View	A-51
A-52	Vehicle During Impact	A-52



Figure A-1: Left Front, as Received



Figure A-2: Right Rear, as Received

*

MFD. BY: TOYOTA MOTOR CORPORATION

DATE 01/03

GVWR: 2440KG (5380LB)

GAWR: FRT. 1185KG (2610LB) WITH P265/70R16 TIRES.

16X7J. RIMS. AT 220KPA (32PSI) COLD.

RR. 1330KG (2935LB) WITH P265/70R16 TIRES.

16X7J RIMS. AT 220KPA (32PSI) COLD.

THIS VEHICLE CONFORMS TO ALL APPLICABLE FEDERAL MOTOR VEHICLE SAFETY AND THEFT PREVENTION STANDARDS IN EFFECT ON THE DATE OF MANUFACTURE SHOWN ABOVE.

JTEBU14R430007612 MPV

GRN215L-GKPGKA

C/TR 587/FA42

A/TM A02A/

A340F

MADE IN JAPAN

NO. 010



*

A-3

TR-P23003-05-NC

Figure A-3: Vehicle Certification Label

RECOMMENDED COLD TIRE
INFLATION PRESSURE (kPa)
PRESSION DE PNEUS (psi)

TIRE SIZE DIMENSIONS	FRONT AV	REAR AR
P265/65R17 110S	220 (32)	220 (32)
P265/70R16 111S	220 (32)	220 (32)

See Owner's Manual
for additional information.
Voir le Manuel du Propriétaire
pour de plus amples informations.

35600

PP

Figure A-4: Vehicle Tire Label



Figure A-5: Front View, Pre-Test



Figure A-6: Front View, Post-Test (Driver Door Unlatched Prior to Photo)



Figure A-7: Left Front $\frac{3}{4}$ View, Pre-Test



Figure A-8: Left Front ¾ View, Post-Test



Figure A-9: Left (Impacted) Side View, Pre-Test



Figure A-10: Left (Impacted) Side View, Post-Test (Driver Door Unlatched Prior to Photo)



Figure A-11: Left Rear 3/4 View, Pre-Test



Figure A-12: Left Rear ¾ View, Post-Test (Driver Door Unlatched Prior to Photo)



Figure A-13: Rear View, Pre-Test



Figure A-14: Rear View, Post-Test



Figure A-15: Overhead Overall View, Pre-Test



Figure A-16: Overhead Overall View, Post-Test (Driver Door Unlatched Prior to Photo)



Figure A-17: Overhead Close-up View, Pre-Test



Figure A-18: Overhead Close-up View, Post-Test (Driver Door Unlatched Prior to Photo)



Figure A-19: Impact Point Target Set-up, Pre-Test

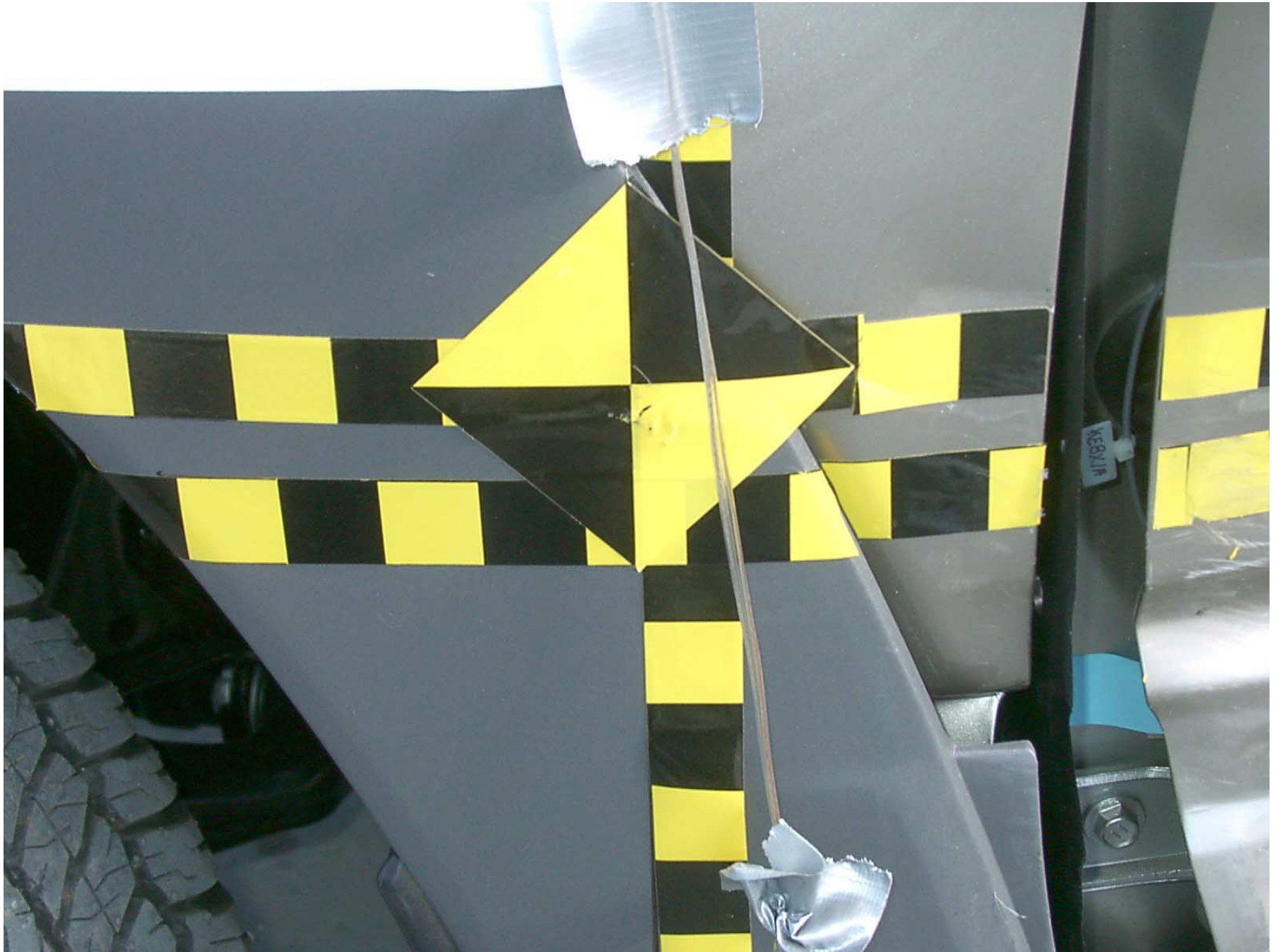

Figure A-20: Impact Point Target, Post-Test



Figure A-21: Front $\frac{3}{4}$ View of Left Side Doors, Pre-Test



Figure A-22: Front ¾ View of Left Side Doors, Post-Test



Figure A-23: Rear ¾ View of Left Side Doors, Pre-Test



Figure A-24: Rear ¾ View of Left Side Doors, Post-Test



Figure A-25: Driver Dummy Left Side with Door Open, Pre-Test



Figure A-26: Driver Dummy Left Side, Pre-test



Figure A-27: Driver Dummy Left Side, Post-Test (Driver Door Unlatched Prior to Photo)



Figure A-28: Driver Dummy Clearance, Pre-Test



Figure A-29: Driver Dummy Clearance, Post-Test (Driver Door Unlatched Prior to Photo)



Figure A-30: Driver Dummy Inside View, Pre-Test



Figure A-31: Driver Dummy Inside View, Post-Test



Figure A-32: Driver Door Inside View, Pre-Test



Figure A-33: Driver Dummy Contact Points Inside View, Post-Test



Figure A-34: Passenger Dummy Left Side with Door Open, Pre-Test



Figure A-35: Passenger Dummy Left Side, Pre-Test



Figure A-36: Passenger Dummy Left Side, Post-Test



Figure A-37: Passenger Dummy Clearance, Pre-Test



Figure A-38: Passenger Dummy Clearance, Post-Test



Figure A-39: Passenger Dummy Inside View, Pre-Test



Figure A-40: Passenger Dummy Inside View, Post-Test



Figure A-41: Passenger Door Inside View, Pre-Test



Figure A-42: Passenger Dummy Contact Points Inside View, Post-Test



Figure A-43: Front View of Deformable Barrier, Pre-Test



Figure A-44: Front View of Deformable Barrier, Post-Test

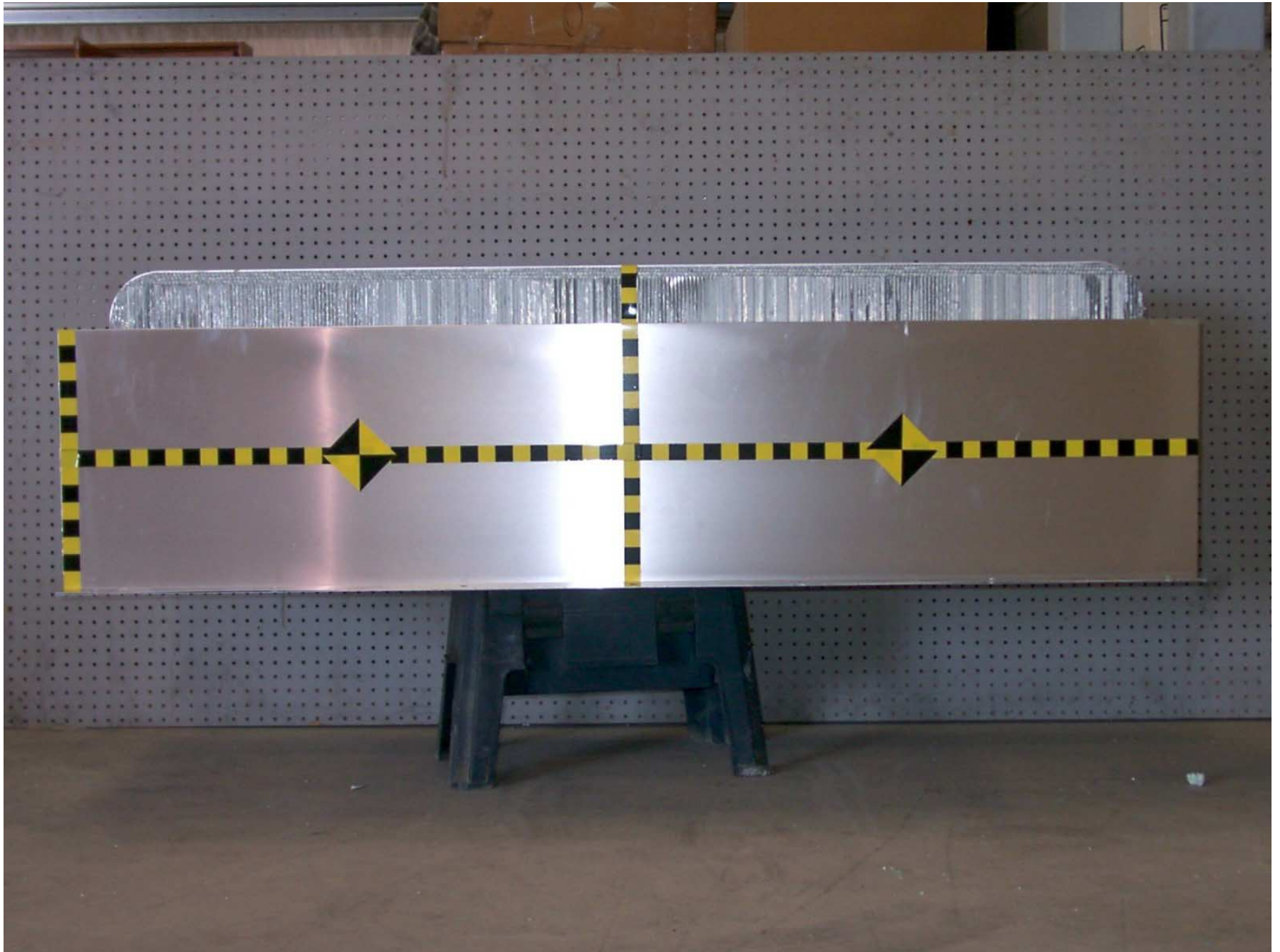

Figure A-45: Top View of Deformable Barrier, Pre-Test



Figure A-46: Top View of Deformable Barrier, Post-Test



Figure A-47: Right Side View of Deformable Barrier, Pre-Test



Figure A-48: Right Side View of Deformable Barrier, Post-Test



Figure A-49: Left Side View of Deformable Barrier, Pre-Test



Figure A-50: Left Side View of Deformable Barrier, Post-Test



A-51

TR-P23003-05-NC

Figure A-51: Vehicle on Rollover Device, Top View



Figure A-52: Vehicle During Impact

APPENDIX B
SID/HIII, VEHICLE, AND MDB RESPONSE DATA

LIST OF DATA PLOTS

Data Plot	Page	
B-1	Driver Head Primary X	B-1
B-2	Driver Head Primary X Velocity	B-2
B-3	Driver Head Primary Y	B-3
B-4	Driver Head Primary Y Velocity	B-4
B-5	Driver Head Primary Z	B-5
B-6	Driver Head Primary Z Velocity	B-6
B-7	Driver Head Resultant Primary	B-7
B-8	Driver Head Redundant X	B-8
B-9	Driver Head Redundant X Velocity	B-9
B-10	Driver Head Redundant Y	B-10
B-11	Driver Head Redundant Y Velocity	B-11
B-12	Driver Head Redundant Z	B-12
B-13	Driver Head Redundant Z Velocity	B-13
B-14	Driver Head Resultant Redundant	B-14
B-15	Driver Neck Force X	B-15
B-16	Driver Neck Force Y	B-16
B-17	Driver Neck Force Z	B-17
B-18	Driver Neck Force Resultant	B-18
B-19	Driver Neck Moment X	B-19
B-20	Driver Neck Moment Y	B-20
B-21	Driver Neck Moment Z	B-21
B-22	Driver Neck Moment Resultant	B-22
B-23	Driver Upper Rib Primary Y	B-23
B-24	Driver Upper Rib Primary Y Velocity	B-24
B-25	Driver Lower Rib Primary Y	B-25
B-26	Driver Lower Rib Primary Y Velocity	B-26
B-27	Driver Lower Spine primary Y	B-27
B-28	Driver Lower Spine Primary Y Velocity	B-28
B-29	Driver Pelvis Primary Y	B-29
B-30	Driver Pelvis Primary Y Velocity	B-30
B-31	Driver Upper Rib Redundant Y	B-31
B-32	Driver Upper Rib Redundant Y Velocity	B-32
B-33	Driver Lower Rib Redundant Y	B-33

LIST OF DATA PLOTS...(Continued)

Data Plot		Page
B-34	Driver Lower Rib Redundant Y Velocity	B-34
B-35	Driver Lower Spine Redundant Y	B-35
B-36	Driver Lower Spine Redundant Y Velocity	B-36
B-37	Driver Pelvis Redundant Y	B-37
B-38	Driver Pelvis Redundant Y Velocity	B-38
B-39	Driver Thorax Contact	B-39
B-40	Driver Pelvis Contact	B-40
B-41	Passenger Head Primary X	B-41
B-42	Passenger Head Primary X Velocity	B-42
B-43	Passenger Head Primary Y	B-43
B-44	Passenger Head Primary Y Velocity	B-44
B-45	Passenger Head Primary Z	B-45
B-46	Passenger Head Primary Z Velocity	B-46
B-47	Passenger Head Resultant Primary	B-47
B-48	Passenger Head Redundant X	B-48
B-49	Passenger Head Redundant X Velocity	B-49
B-50	Passenger Head Redundant Y	B-50
B-51	Passenger Head Redundant Y Velocity	B-51
B-52	Passenger Head Redundant Z	B-52
B-53	Passenger Head Redundant Z Velocity	B-53
B-54	Passenger Head Resultant Redundant	B-54
B-55	Passenger Neck Force X	B-55
B-56	Passenger Neck Force Resultant	B-56
B-57	Passenger Neck Force Z	B-57
B-58	Passenger Neck Force Resultant	B-58
B-59	Passenger Neck Moment X	B-59
B-60	Passenger Neck Moment Y	B-60
B-61	Passenger Neck Moment Z	B-61
B-62	Passenger Neck Moment Resultant	B-62
B-63	Passenger Upper Rib Primary Y	B-63
B-64	Passenger Upper Rib Primary Y Velocity	B-64
B-65	Passenger Lower Rib Primary Y	B-65
B-66	Passenger Lower Rib Primary Y Velocity	B-66
B-67	Passenger Lower Spine Primary Y	B-67
B-68	Passenger Lower Spine Primary Y Velocity	B-68
B-69	Passenger Pelvis Primary Y	B-69

LIST OF DATA PLOTS...(Continued)

Data Plot	Page	
B-70	Passenger Pelvis Primary Y Velocity	B-70
B-71	Passenger Upper Rib Redundant Y	B-71
B-72	Passenger Upper Rib Redundant Y Velocity	B-72
B-73	Passenger Lower Rib Redundant Y	B-73
B-74	Passenger Lower Rib Redundant Y Velocity	B-74
B-75	Passenger Lower Spine Redundant Y	B-75
B-76	Passenger Lower Spine Redundant Y Velocity	B-76
B-77	Passenger Pelvis Redundant Y	B-77
B-78	Passenger Pelvis Redundant Y Velocity	B-78
B-79	Passenger Thorax Contact	B-79
B-80	Passenger Pelvic Contact	B-80
B-81	Right Sill Front Seat X	B-81
B-82	Right Sill Front Seat X Velocity	B-82
B-83	Right Sill Front Seat Y	B-83
B-84	Right Sill Front Seat Y Velocity	B-84
B-85	Right Sill Front Seat Z	B-85
B-86	Right Sill Front Seat Z Velocity	B-86
B-87	Right Sill Front Seat Resultant	B-87
B-88	Right Sill Rear Seat X	B-88
B-89	Right Sill Rear Seat X Velocity	B-89
B-90	Right Sill Rear Seat Y	B-90
B-91	Right Sill Rear Seat Y Velocity	B-91
B-92	Right Sill Rear Seat Z	B-92
B-93	Right Sill Rear Seat Z Velocity	B-93
B-94	Right Sill Rear Seat Resultant	B-94
B-95	Rear Floor Above Axle X	B-95
B-96	Rear Floor Above Axle X Velocity	B-96
B-97	Rear Floor Above Axle Y	B-97
B-98	Rear Floor Above Axle Y Velocity	B-98
B-99	Rear Floor Above Axle Z	B-99
B-100	Rear Floor Above Axle Z Velocity	B-100
B-101	Rear Floor Above Axle Resultant	B-101
B-102	Left Sill Rear Seat Y	B-102
B-103	Left Sill Rear Door Y Velocity	B-103
B-104	Left Sill Front Seat Y	B-104
B-105	Left Sill Front Door Y Velocity	B-105

LIST OF DATA PLOTS...(Continued)

Data Plot		Page
B-106	Left Front Door C/L Y	B-106
B-107	Left Front Door C/L Y Velocity	B-107
B-108	Right Rear Occupant Compartment Y	B-108
B-109	Right Rear Occupant Compartment Y Velocity	B-109
B-110	Left Front Door Mid Rear Y	B-110
B-111	Left Front Door Mid Rear Y Velocity	B-111
B-112	Left Front Door upper C/L Y	B-112
B-113	Left Front Door Upper C/L Y Velocity	B-113
B-114	Left Rear Door Mid Rear Y	B-114
B-115	Left Rear Door Mid Rear Y Velocity	B-115
B-116	Left Rear Door Upper C/L Y	B-116
B-117	Left Rear Door Upper C/L Y Velocity	B-117
B-118	B-Post Lower Y	B-118
B-119	B-Post Lower Y Velocity	B-119
B-120	B-Post Middle Y	B-120
B-121	B-Post Middle Y Velocity	B-121
B-122	A-Post Lower Y	B-122
B-123	A-Post Lower Y Velocity	B-123
B-124	A-Post Middle Y	B-124
B-125	A-Post Middle Y Velocity	B-125
B-126	Left Front Seat Track Y	B-126
B-127	Left Front Seat Track Y Velocity	B-127
B-128	Rear Seat Structure Y	B-128
B-129	Rear Seat structure Y Velocity	B-129
B-130	Vehicle CG X	B-130
B-131	Vehicle CG X Velocity	B-131
B-132	Vehicle CG Y	B-132
B-133	Vehicle CG Y Velocity	B-133
B-134	Vehicle CG Z	B-134
B-135	Vehicle CG Z Velocity	B-135
B-136	Vehicle CG Resultant	B-136
B-137	MDB CG X	B-137
B-138	MDB CG X Velocity	B-138
B-139	MDB CG Y	B-139
B-140	MDB CG Y Velocity	B-140
B-141	MDB CG Z	B-141

LIST OF DATA PLOTS...(Continued)

<u>Data Plot</u>		<u>Page</u>
B-142	MDB CG Z Velocity	B-142
B-143	CG Resultant	B-143
B-144	MDB Rear X	B-144
B-145	MDB Rear X Velocity	B-145
B-146	MDB Rear Y	B-146
B-147	MDB Rear Y Velocity	B-147
B-148	MDB Right Bumper Contact	B-148
B-149	Driver Upper Rib Primary Y	B-149
B-150	Driver Lower Rib Primary Y	B-150
B-151	Driver Lower Spine Primary Y	B-151
B-152	Driver Pelvis Primary Y	B-152
B-153	Driver Upper Rib Redundant Y	B-153
B-154	Driver Lower Rib Redundant y	B-154
B-155	Driver Lower Spine Redundant Y	B-155
B-156	Driver Pelvis Redundant Y	B-156
B-157	Passenger Upper Rib Primary Y	B-157
B-158	Passenger Lower Rib Primary Y	B-158
B-159	Passenger Lower Spine Primary Y	B-159
B-160	Passenger Pelvis Primary Y	B-160
B-161	Passenger Upper Rib Redundant Y	B-161
B-162	Passenger Lower Rib Redundant Y	B-162
B-163	Passenger Lower Spine Redundant Y	B-163
B-164	Passenger Pelvis Redundant Y	B-164

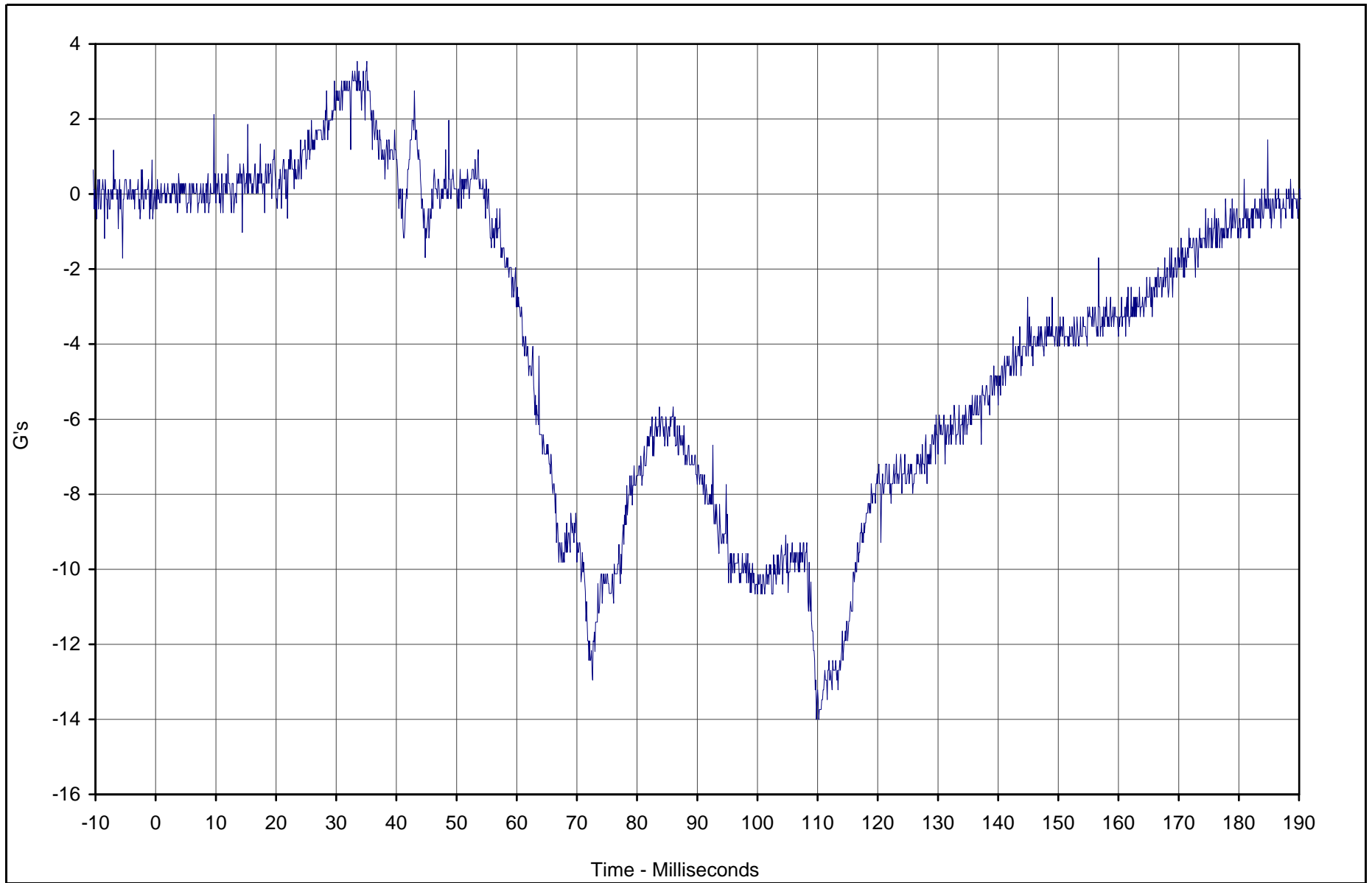

Curve Description	CURNO	Type	Units	Max	Time	Min	Time	SAE Class
Driver Head Primary X	001	FIL	G's	3.5	33.5	-14.0	109.8	1000



Test Vehicle: 2003 Toyota 4 Runner SR5 4WD SUV

Test Date: 2/27/03

Test Program: 55/28 km/h Side Impact NCAP

NHTSA No.: M35107

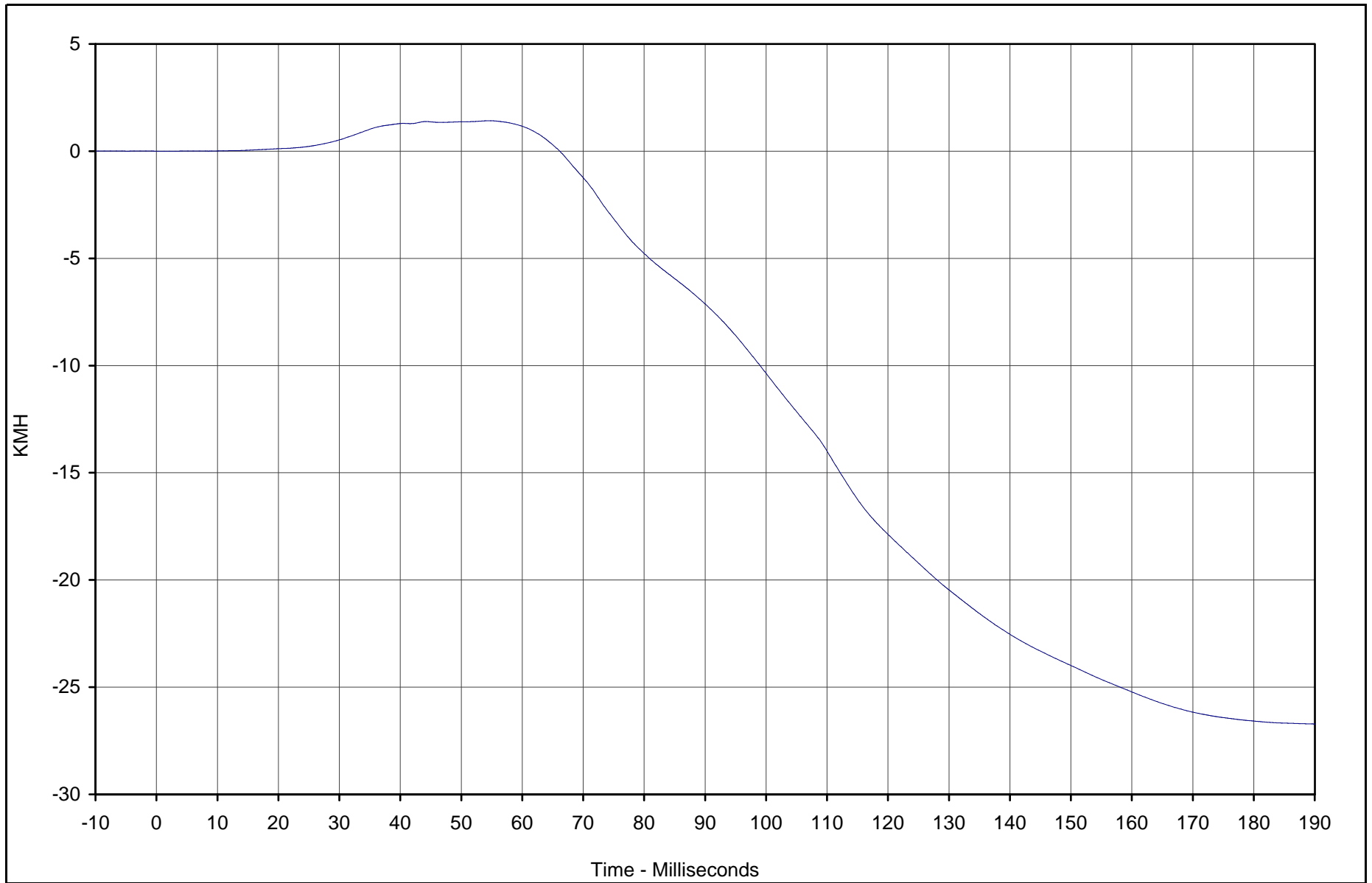

Curve Description	CURNO	Type	Units	Max	Time	Min	Time	SAE Class
Driver Head Primary X Velocity	001	IN1	KMH	1.4	54.6	-26.7	189.9	180



Test Vehicle: 2003 Toyota 4 Runner SR5 4WD SUV

Test Date: 2/27/03

Test Program: 55/28 km/h Side Impact NCAP

NHTSA No.: M35107

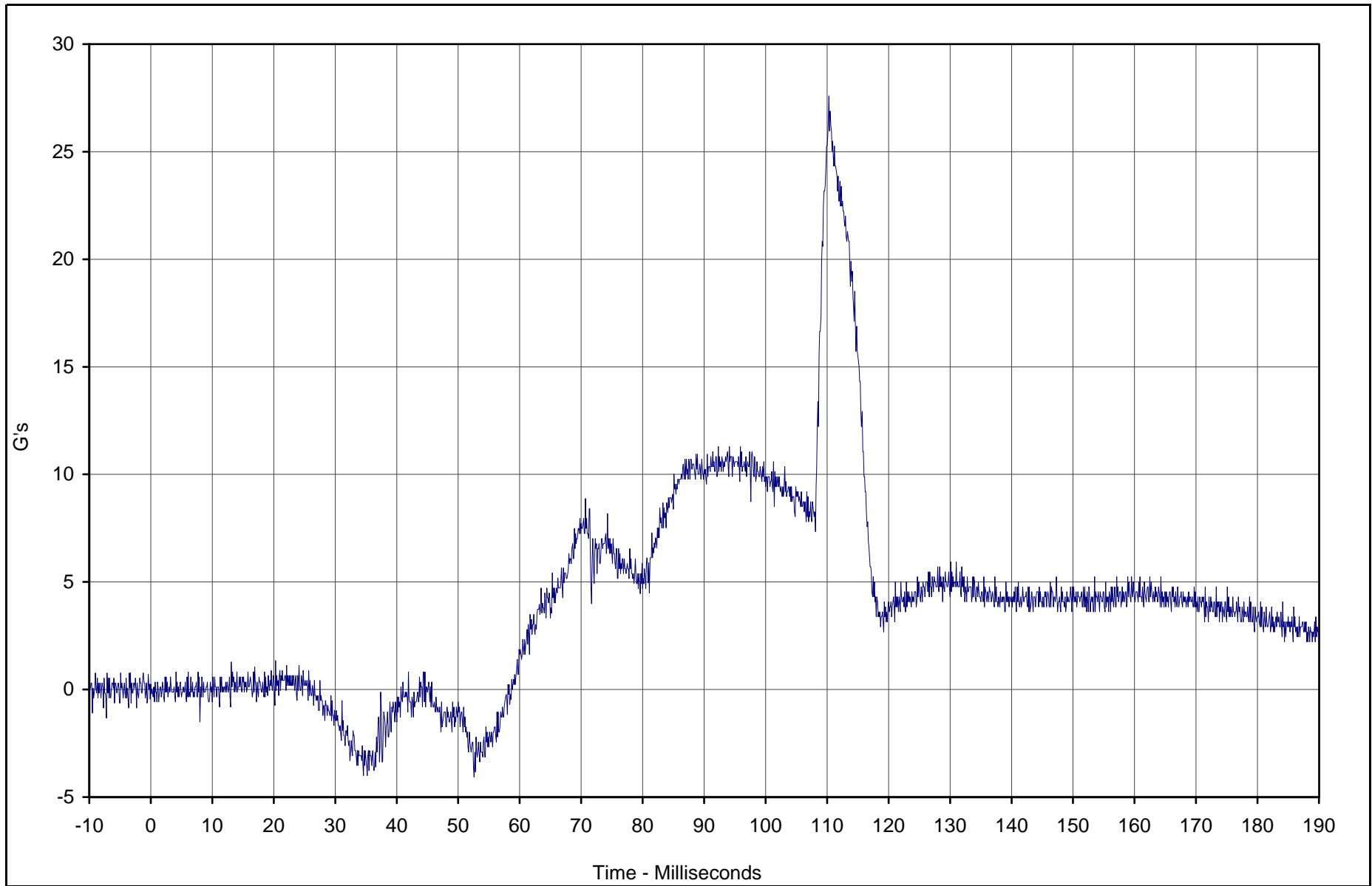

Curve Description	CURNO	Type	Units	Max	Time	Min	Time	SAE Class
Driver Head Primary Y	002	FIL	G's	27.6	110.3	-4.1	52.6	1000



Test Vehicle: 2003 Toyota 4 Runner SR5 4WD SUV

Test Date: 2/27/03

Test Program: 55/28 km/h Side Impact NCAP

NHTSA No.: M35107

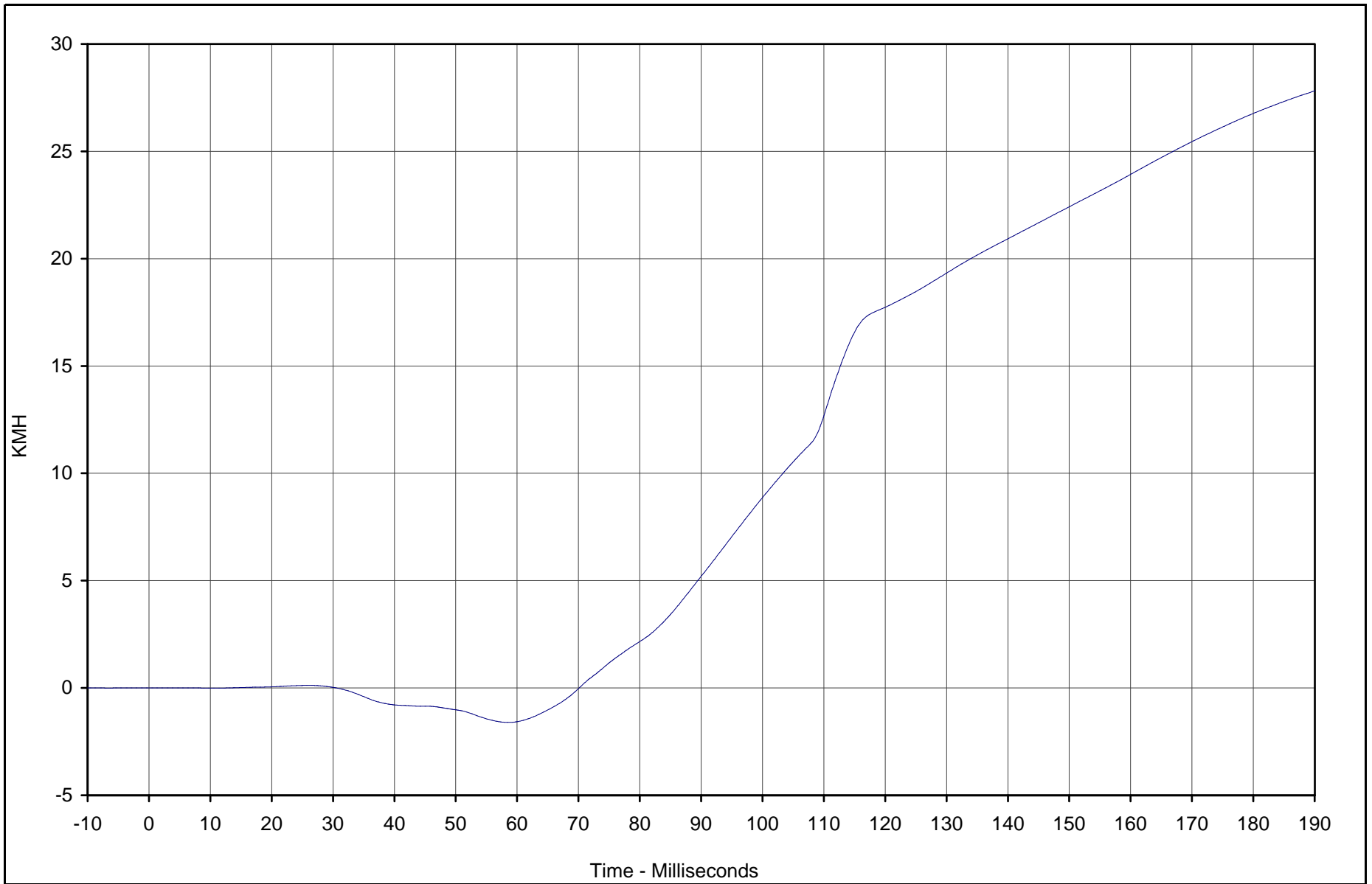

Curve Description	CURNO	Type	Units	Max	Time	Min	Time	SAE Class
Driver Head Primary Y Velocity	002	IN1	KMH	27.8	189.9	-1.6	58.6	180



Test Vehicle: 2003 Toyota 4 Runner SR5 4WD SUV

Test Date: 2/27/03

Test Program: 55/28 km/h Side Impact NCAP

NHTSA No.: M35107

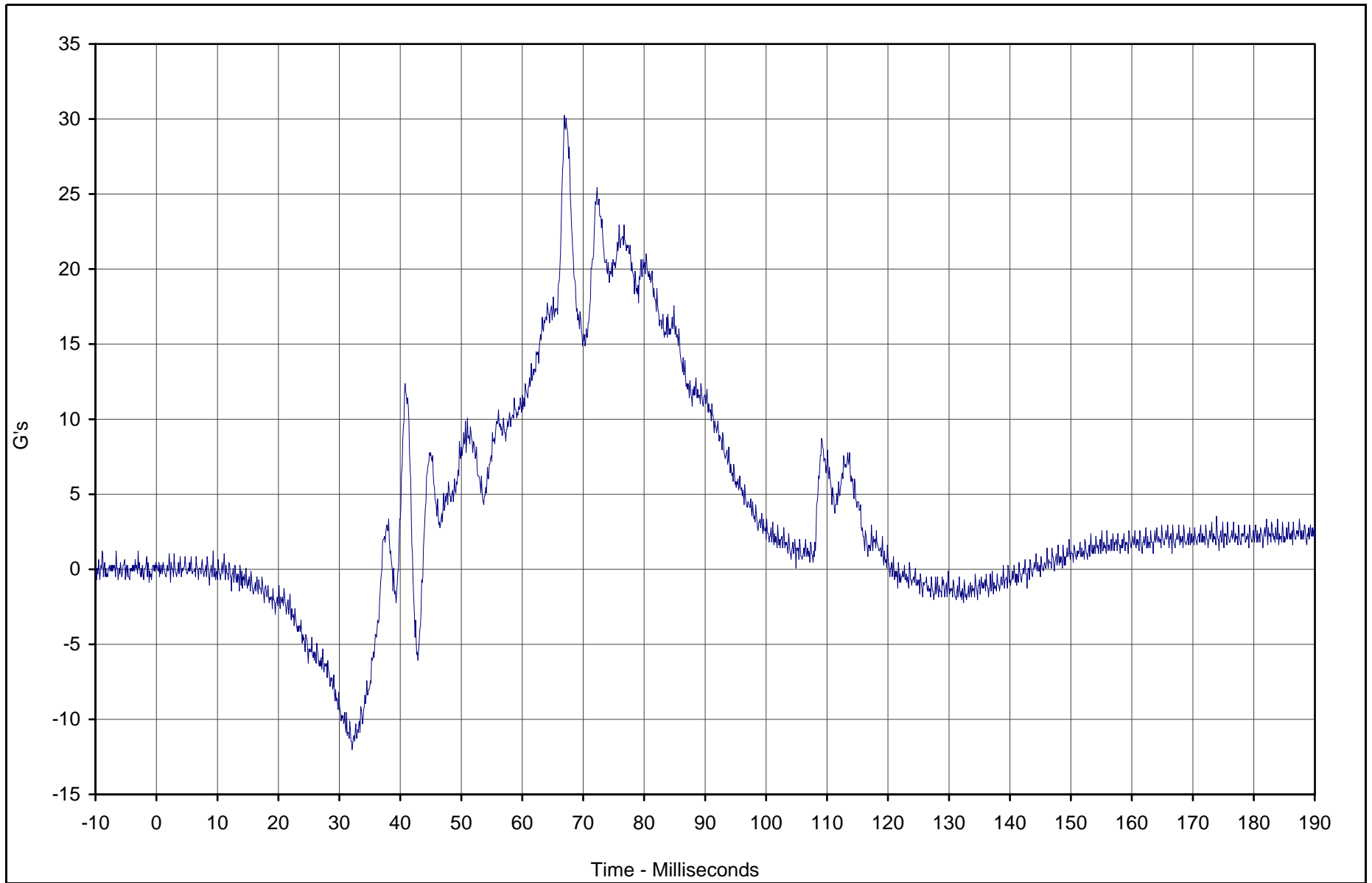

Curve Description	CURNO	Type	Units	Max	Time	Min	Time	SAE Class
Driver Head Primary Z	003	FIL	G's	30.3	66.9	-12.0	32.1	1000



Test Vehicle: 2003 Toyota 4 Runner SR5 4WD SUV

Test Date: 2/27/03

Test Program: 55/28 km/h Side Impact NCAP

NHTSA No.: M35107

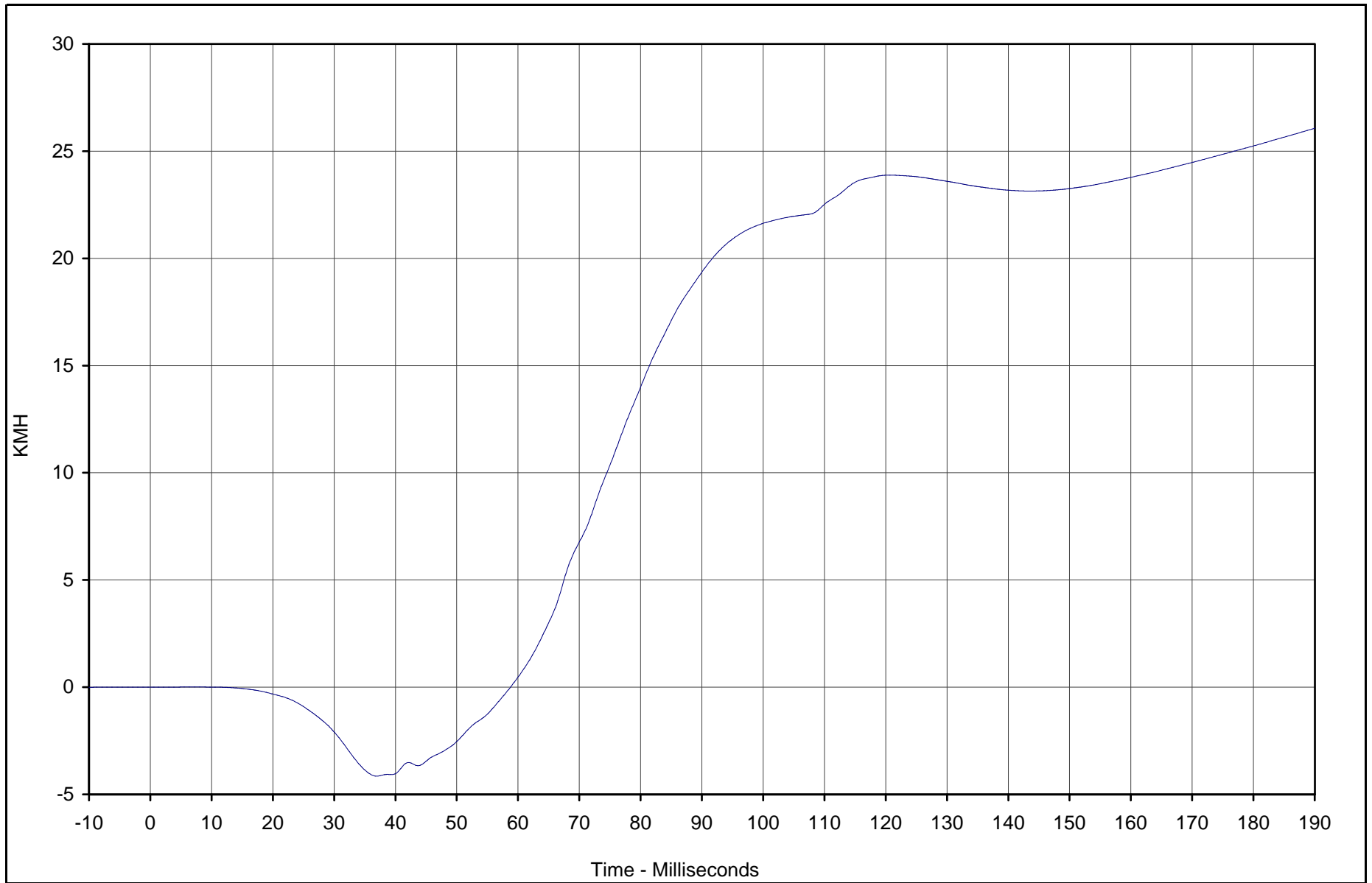

Curve Description	CURNO	Type	Units	Max	Time	Min	Time	SAE Class
Driver Head Primary Z Velocity	003	IN1	KMH	26.1	189.9	-4.1	36.9	180



Test Vehicle: 2003 Toyota 4 Runner SR5 4WD SUV
 Test Program: 55/28 km/h Side Impact NCAP

Test Date: 2/27/03
 NHTSA No.: M35107

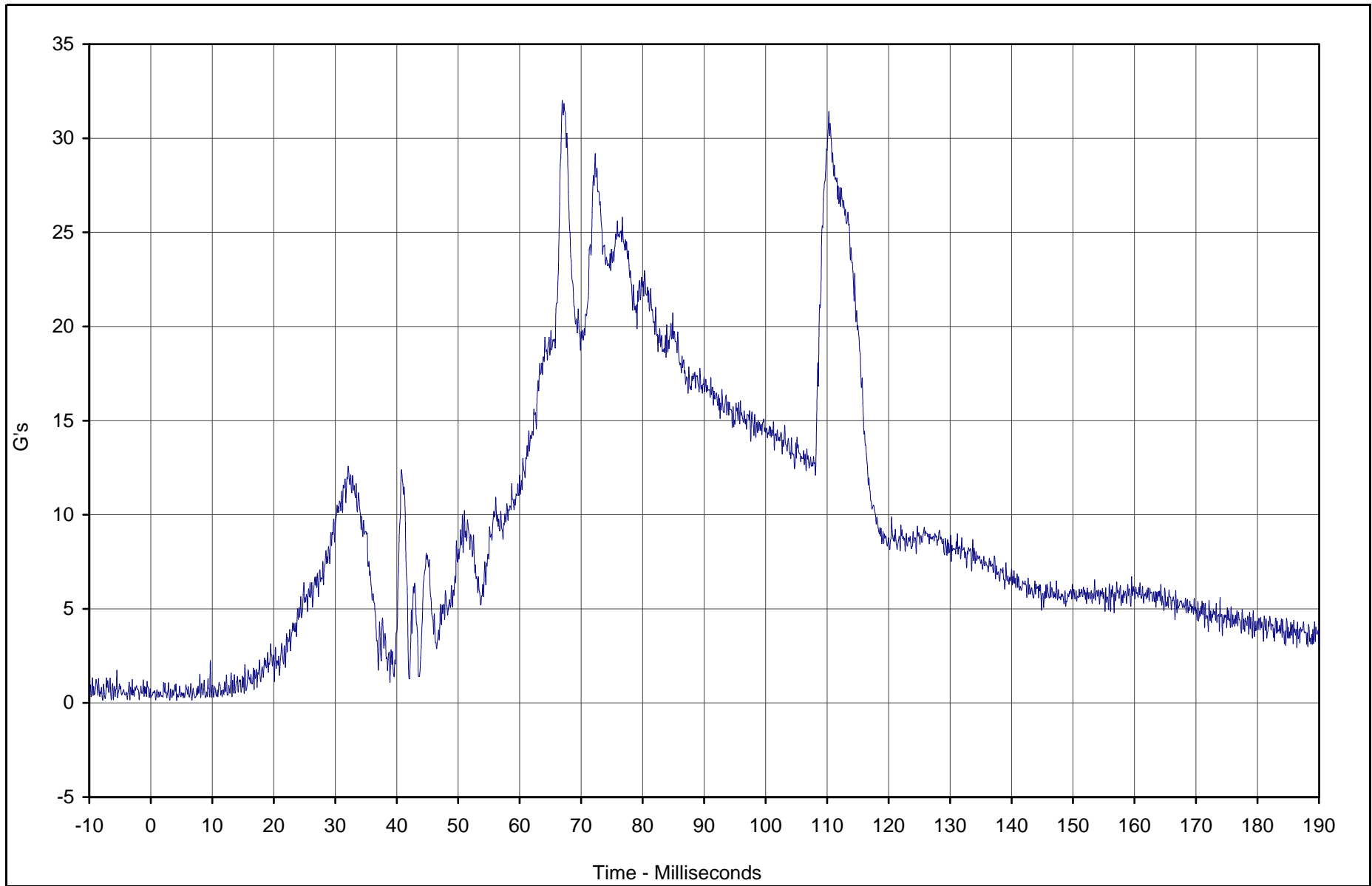

Curve Description	CURNO	Type	Units	Max	Time	Min	Time	SAE Class
Driver Head Resultant Primary	001	RES	G's	32.0	66.9	0.1	4.2	1000



Test Vehicle: 2003 Toyota 4 Runner SR5 4WD SUV

Test Date: 2/27/03

Test Program: 55/28 km/h Side Impact NCAP

NHTSA No.: M35107

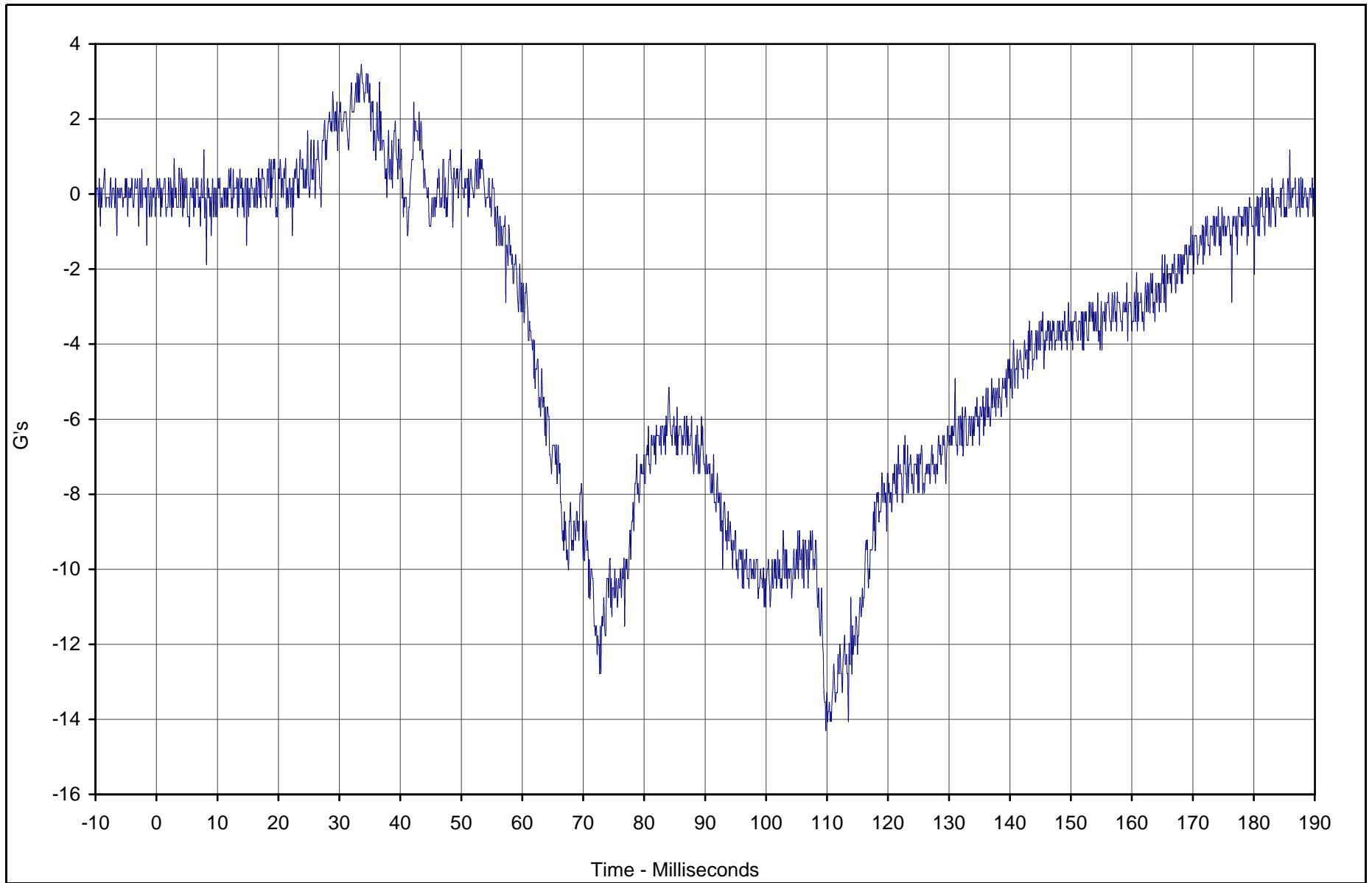

Curve Description	CURNO	Type	Units	Max	Time	Min	Time	SAE Class
Driver Head Redundant X	004	FIL	G's	3.5	33.6	-14.3	109.8	1000



Test Vehicle: 2003 Toyota 4 Runner SR5 4WD SUV

Test Date: 2/27/03

Test Program: 55/28 km/h Side Impact NCAP

NHTSA No.: M35107

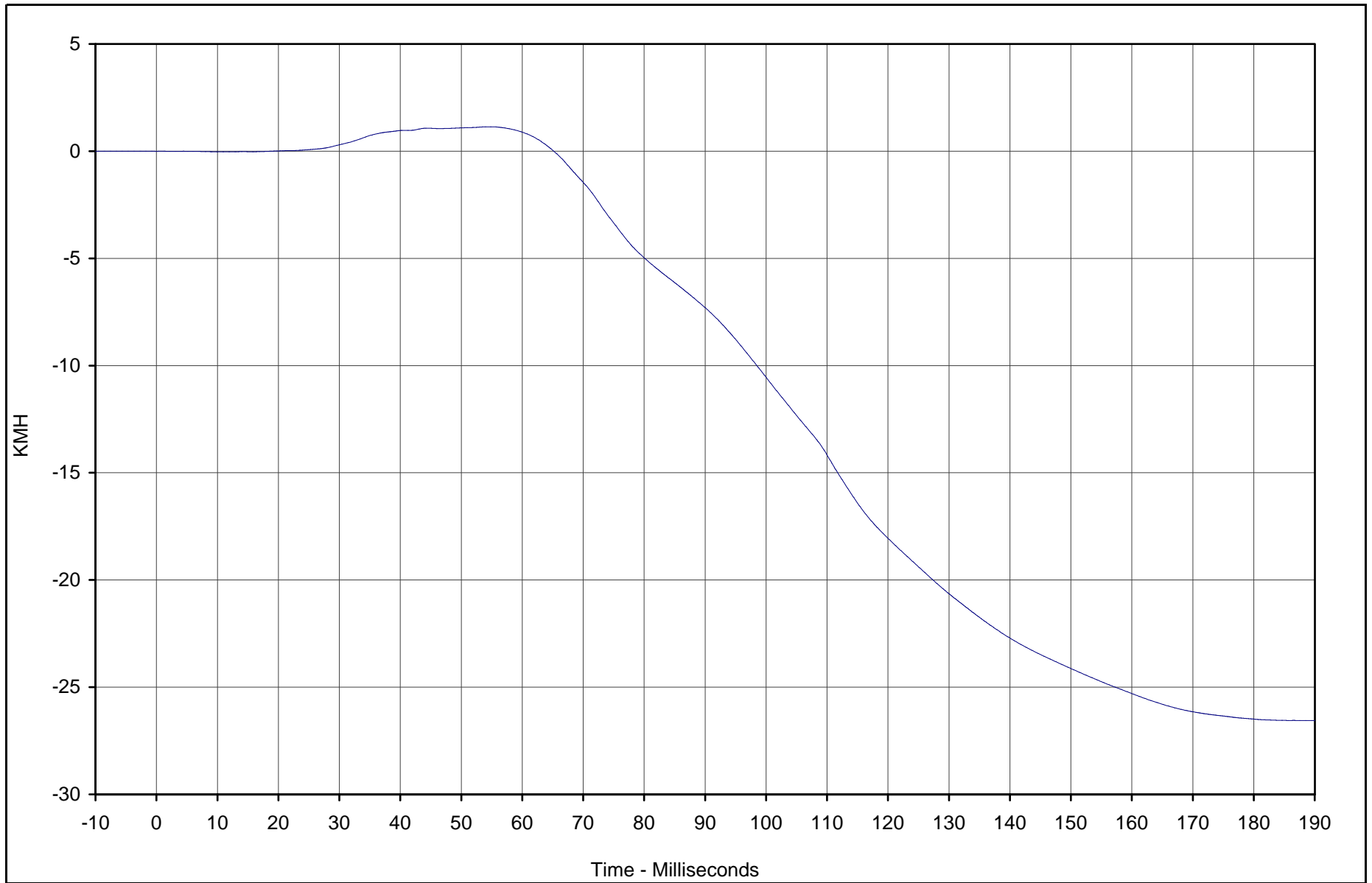

Curve Description	CURNO	Type	Units	Max	Time	Min	Time	SAE Class
Driver Head Redundant X Velocity	004	IN1	KMH	1.1	54.6	-26.6	189.9	180



Test Vehicle: 2003 Toyota 4 Runner SR5 4WD SUV

Test Date: 2/27/03

Test Program: 55/28 km/h Side Impact NCAP

NHTSA No.: M35107

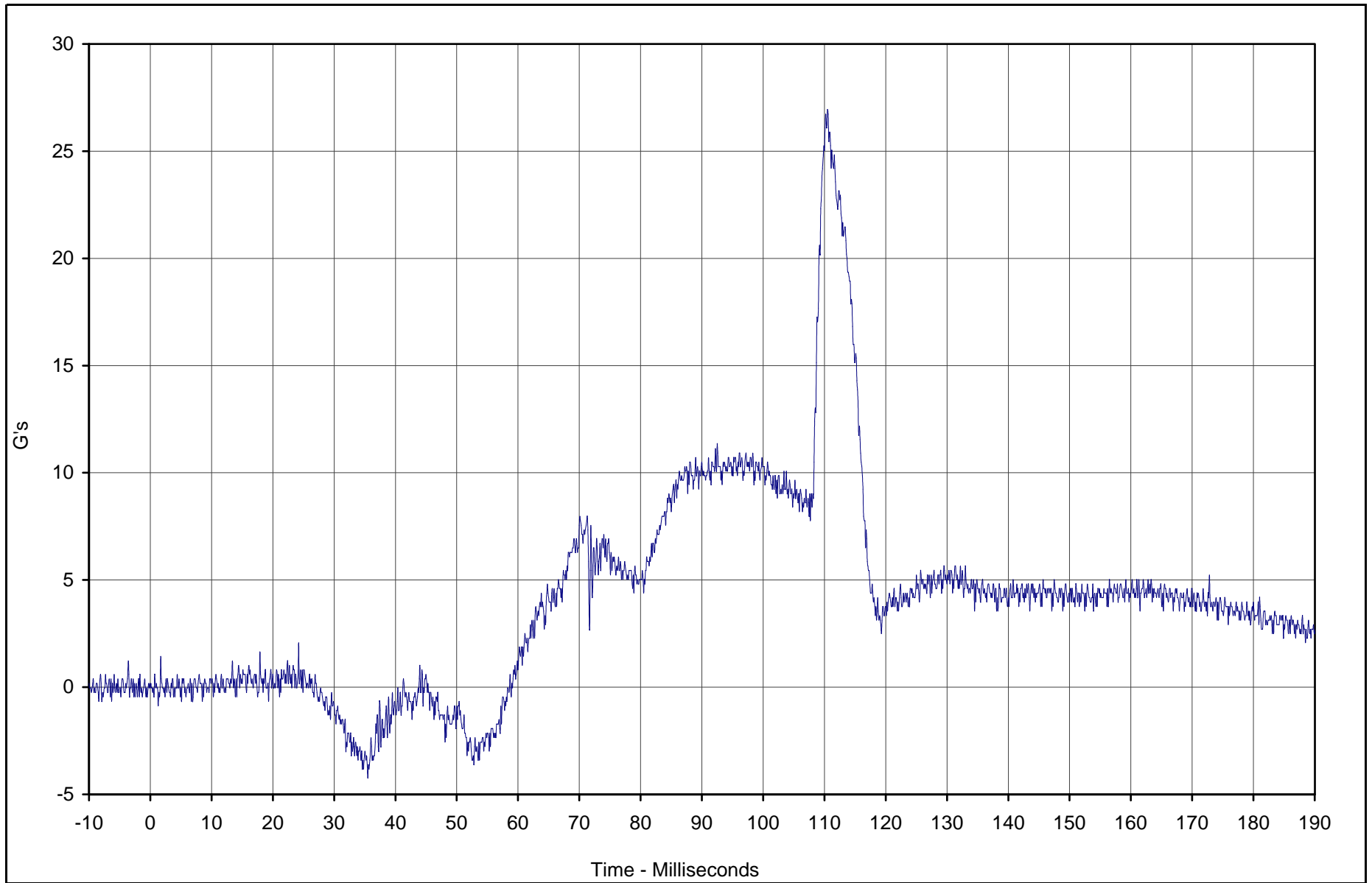

Curve Description	CURNO	Type	Units	Max	Time	Min	Time	SAE Class
Driver Head Redundant Y	005	FIL	G's	26.9	110.5	-4.2	35.5	1000



Test Vehicle: 2003 Toyota 4 Runner SR5 4WD SUV

Test Date: 2/27/03

Test Program: 55/28 km/h Side Impact NCAP

NHTSA No.: M35107

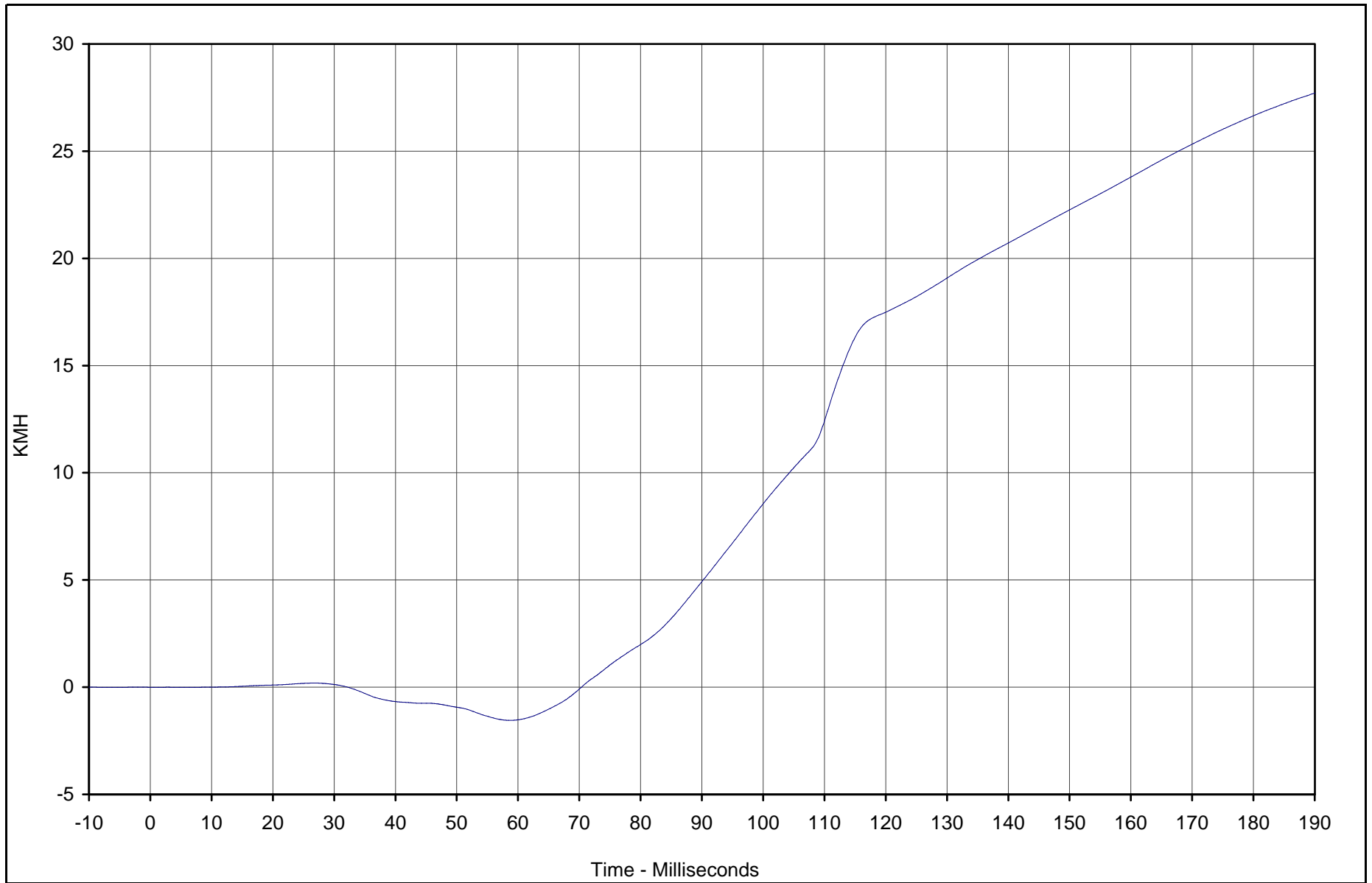

Curve Description	CURNO	Type	Units	Max	Time	Min	Time	SAE Class
Driver Head Redundant Y Velocity	005	IN1	KMH	27.7	189.9	-1.5	58.7	180



Test Vehicle: 2003 Toyota 4 Runner SR5 4WD SUV

Test Date: 2/27/03

Test Program: 55/28 km/h Side Impact NCAP

NHTSA No.: M35107

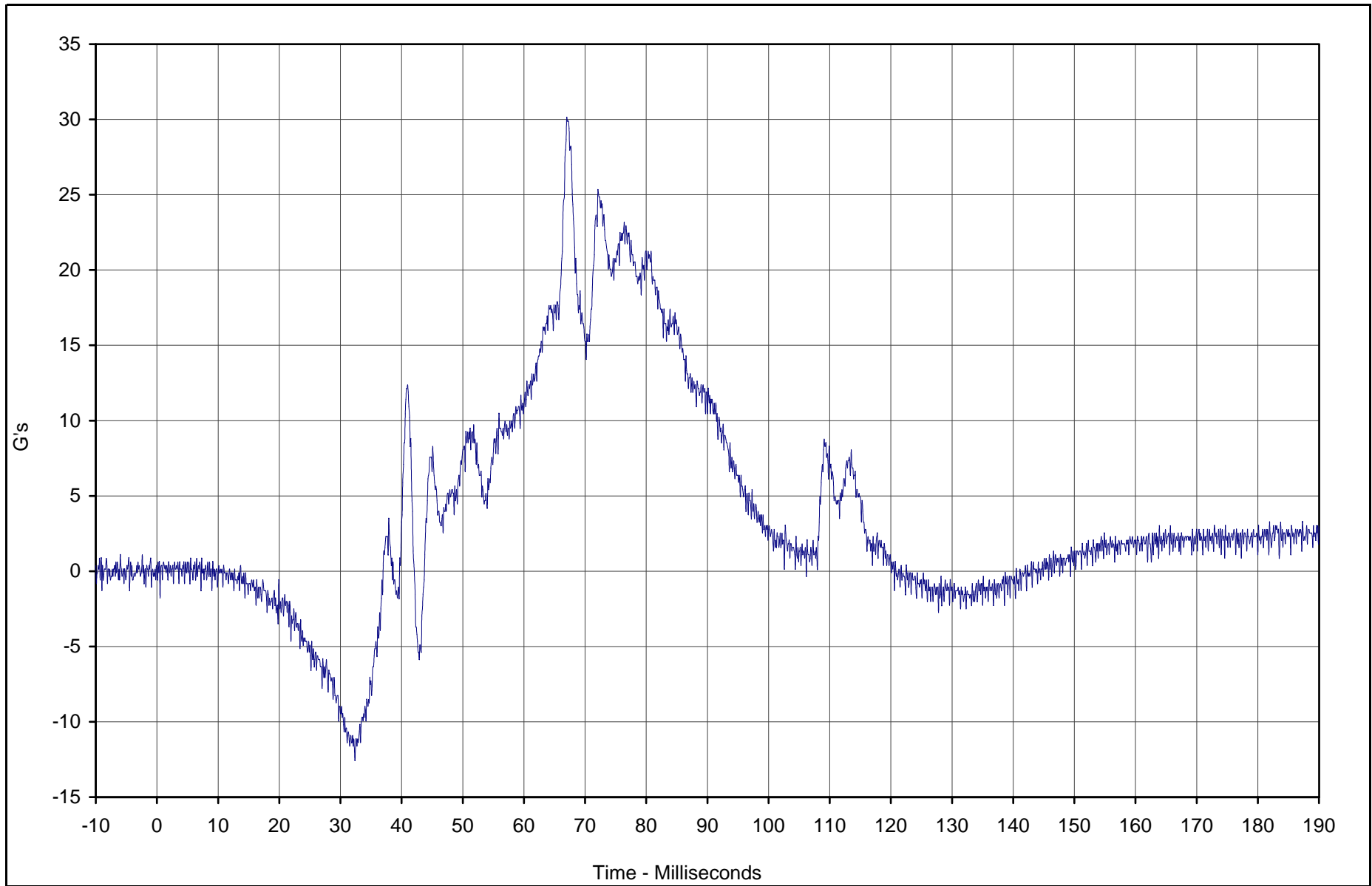

Curve Description	CURNO	Type	Units	Max	Time	Min	Time	SAE Class
Driver Head Redundant Z	006	FIL	G's	30.1	67.0	-12.6	32.4	1000



Test Vehicle: 2003 Toyota 4 Runner SR5 4WD SUV

Test Date: 2/27/03

Test Program: 55/28 km/h Side Impact NCAP

NHTSA No.: M35107

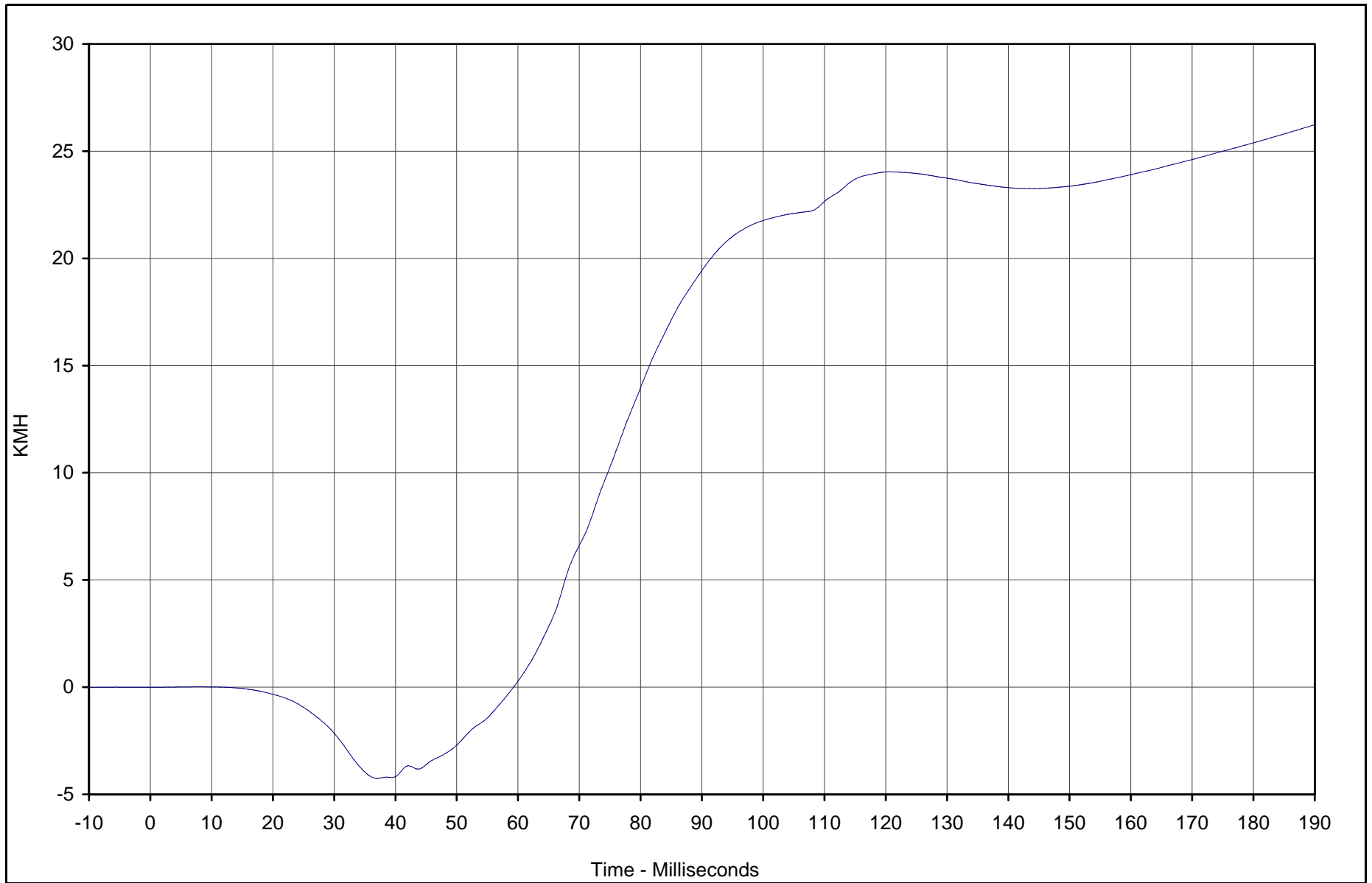

Curve Description	CURNO	Type	Units	Max	Time	Min	Time	SAE Class
Driver Head Redundant Z Velocity	006	IN1	KMH	26.2	189.9	-4.3	37.0	180



Test Vehicle: 2003 Toyota 4 Runner SR5 4WD SUV

Test Date: 2/27/03

Test Program: 55/28 km/h Side Impact NCAP

NHTSA No.: M35107

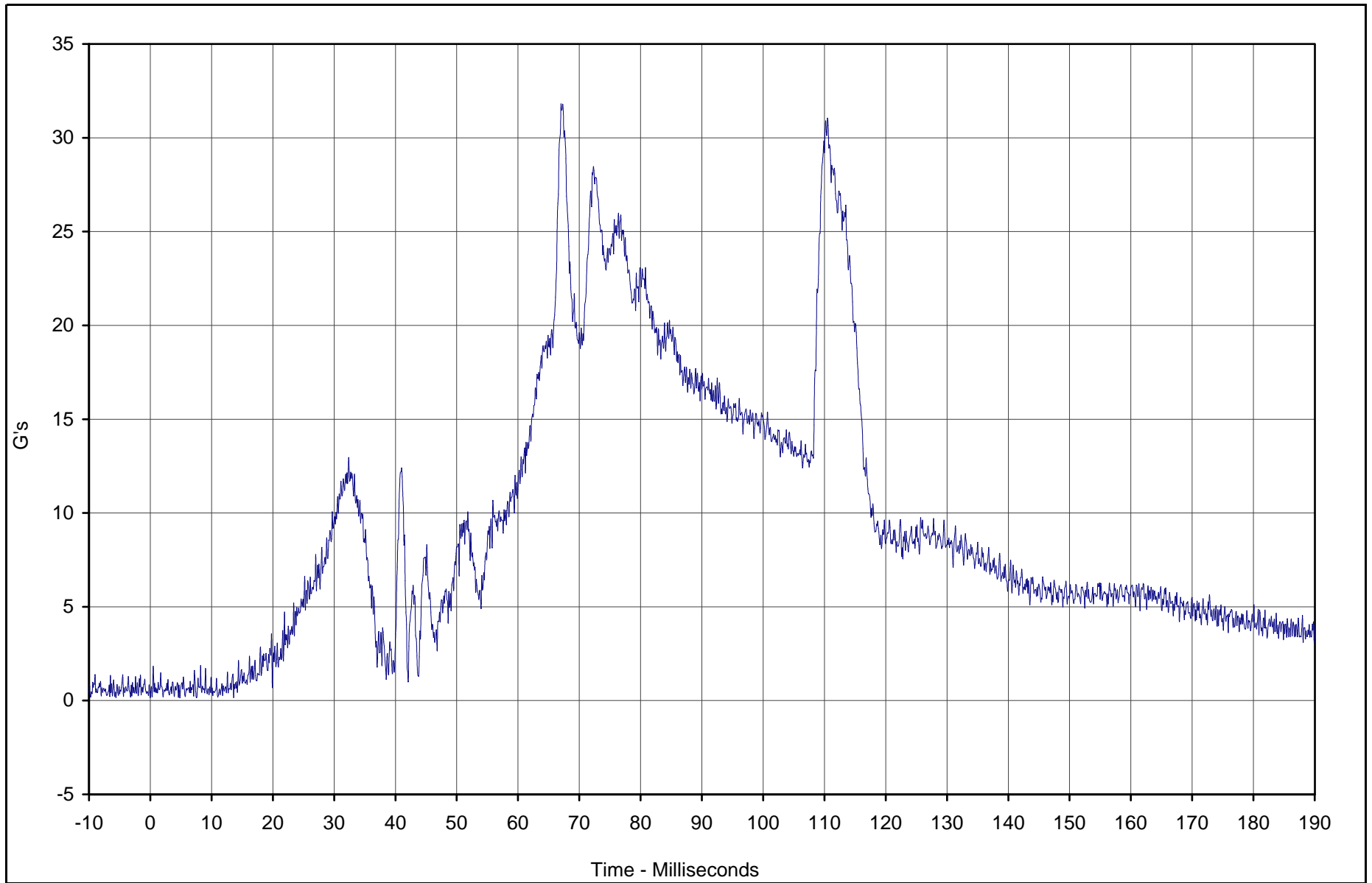

Curve Description	CURNO	Type	Units	Max	Time	Min	Time	SAE Class
Driver Head Resultant Redundant	004	RES	G's	31.8	67.3	0.1	0.0	1000



Test Vehicle: 2003 Toyota 4 Runner SR5 4WD SUV

Test Date: 2/27/03

Test Program: 55/28 km/h Side Impact NCAP

NHTSA No.: M35107

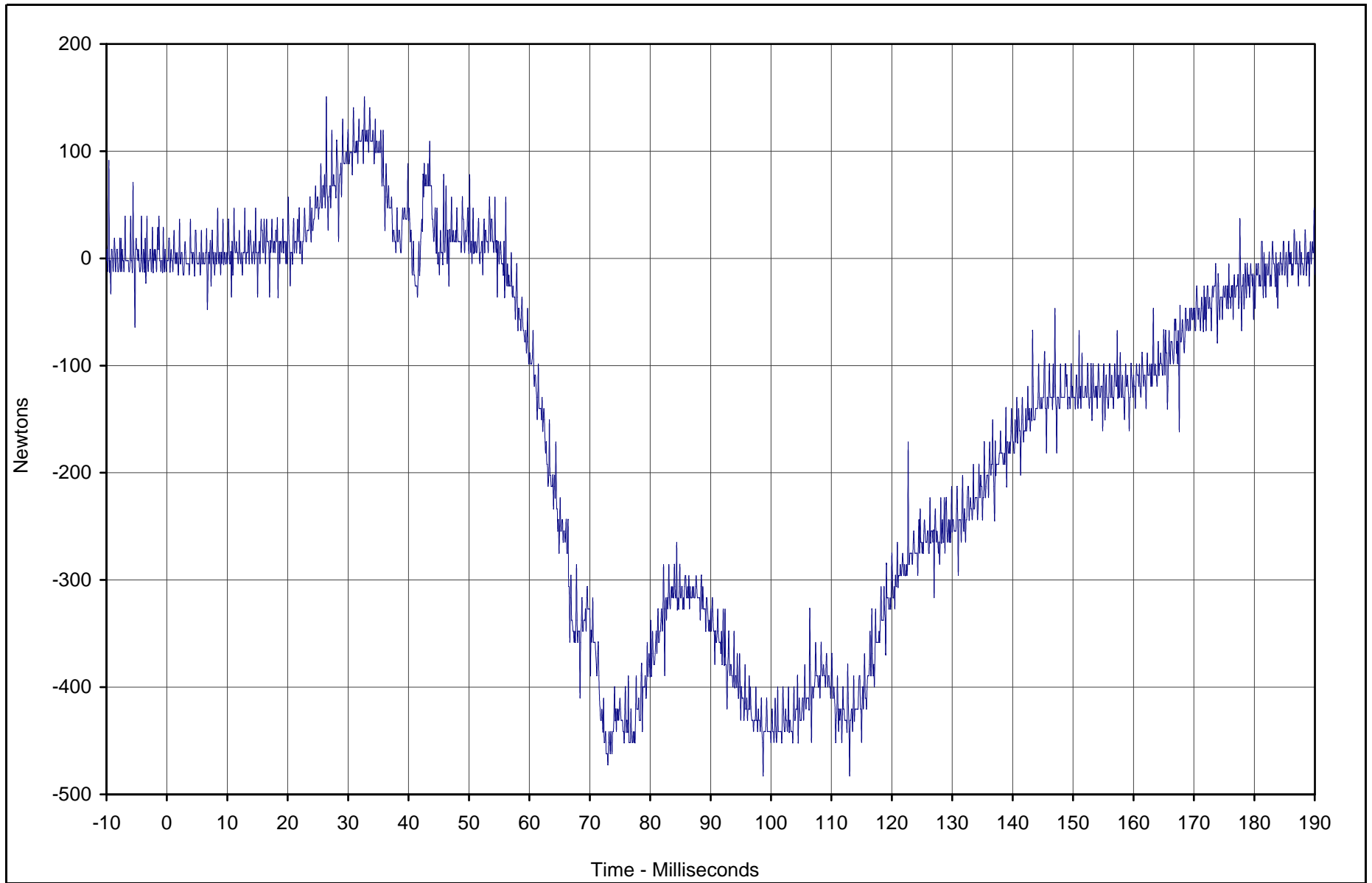

Curve Description	CURNO	Type	Units	Max	Time	Min	Time	SAE Class
Driver Neck Force X	007	FIL	Newtons	150.8	26.4	-482.9	98.7	1000



Test Vehicle: 2003 Toyota 4 Runner SR5 4WD SUV

Test Date: 2/27/03

Test Program: 55/28 km/h Side Impact NCAP

NHTSA No.: M35107

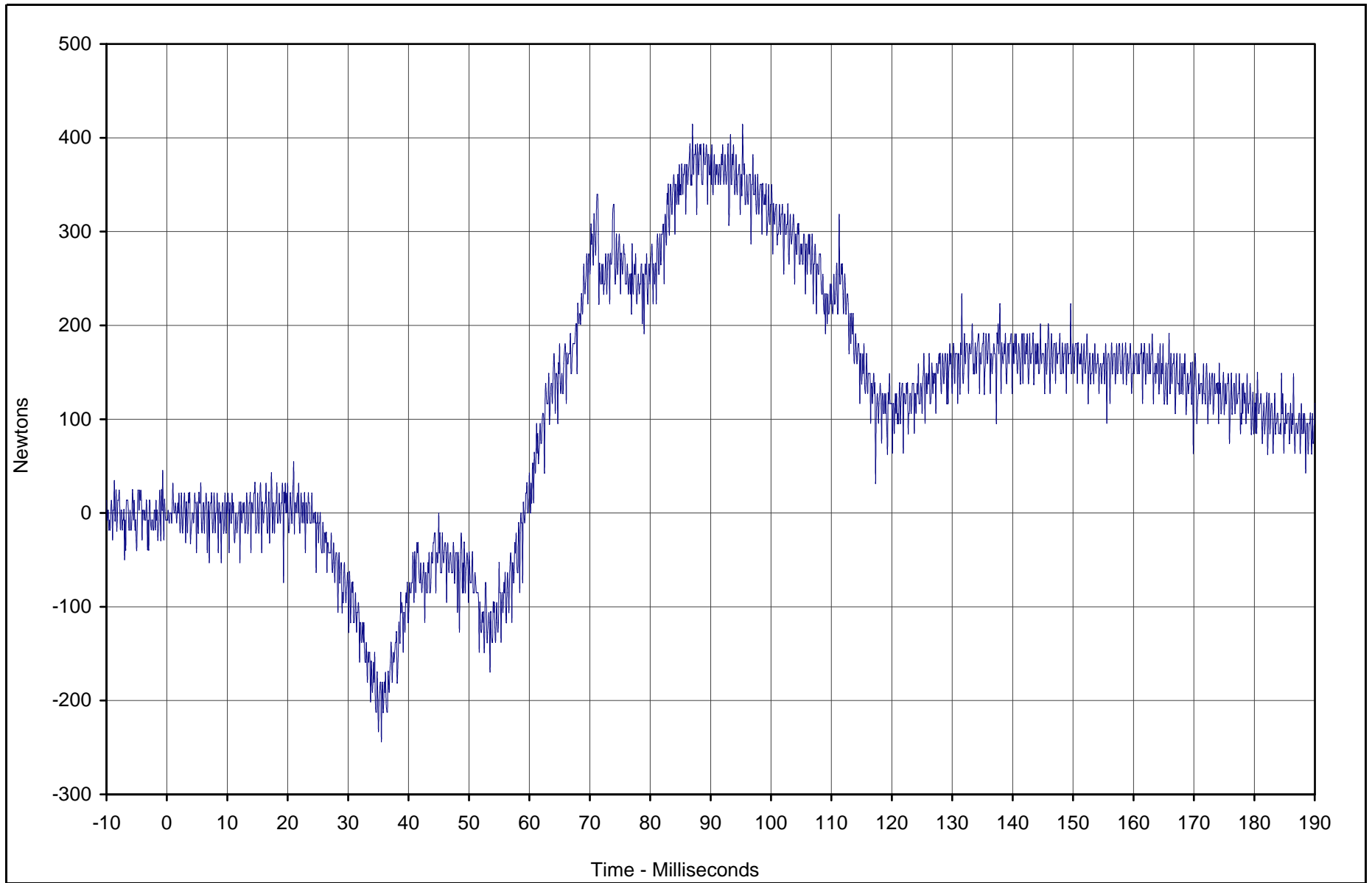

Curve Description	CURNO	Type	Units	Max	Time	Min	Time	SAE Class
Driver Neck Force Y	008	FIL	Newtons	413.9	87.0	-244.1	35.5	1000



Test Vehicle: 2003 Toyota 4 Runner SR5 4WD SUV

Test Date: 2/27/03

Test Program: 55/28 km/h Side Impact NCAP

NHTSA No.: M35107

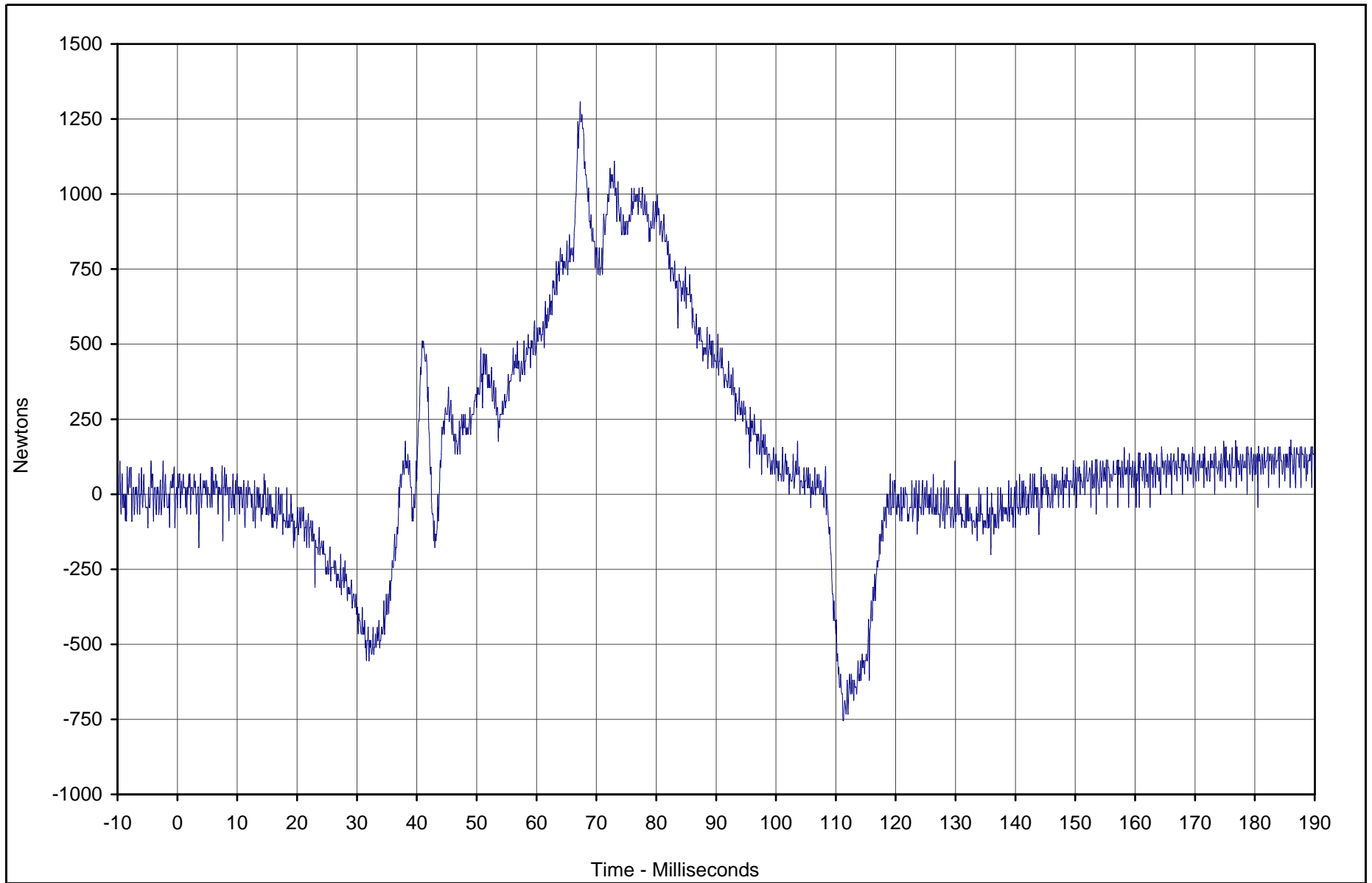

Curve Description	CURNO	Type	Units	Max	Time	Min	Time	SAE Class
Driver Neck Force Z	009	FIL	Newtons	1308.1	67.3	-753.8	111.2	1000



Test Vehicle: 2003 Toyota 4 Runner SR5 4WD SUV

Test Date: 2/27/03

Test Program: 55/28 km/h Side Impact NCAP

NHTSA No.: M35107

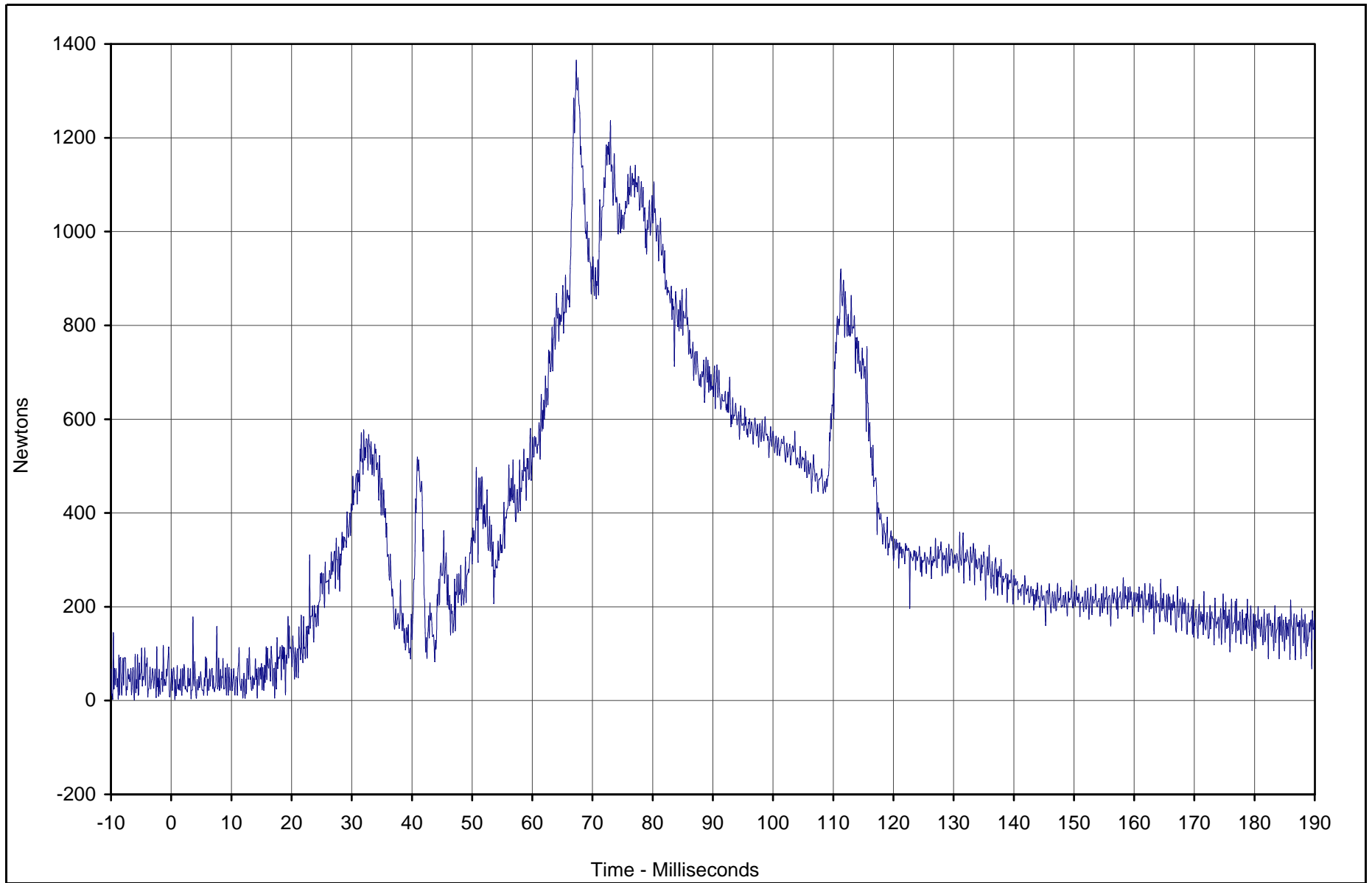

Curve Description	CURNO	Type	Units	Max	Time	Min	Time	SAE Class
Driver Neck Force Resultant	007	RES	Newtons	1365.5	67.3	2.0	0.6	1000



Test Vehicle: 2003 Toyota 4 Runner SR5 4WD SUV

Test Date: 2/27/03

Test Program: 55/28 km/h Side Impact NCAP

NHTSA No.: M35107

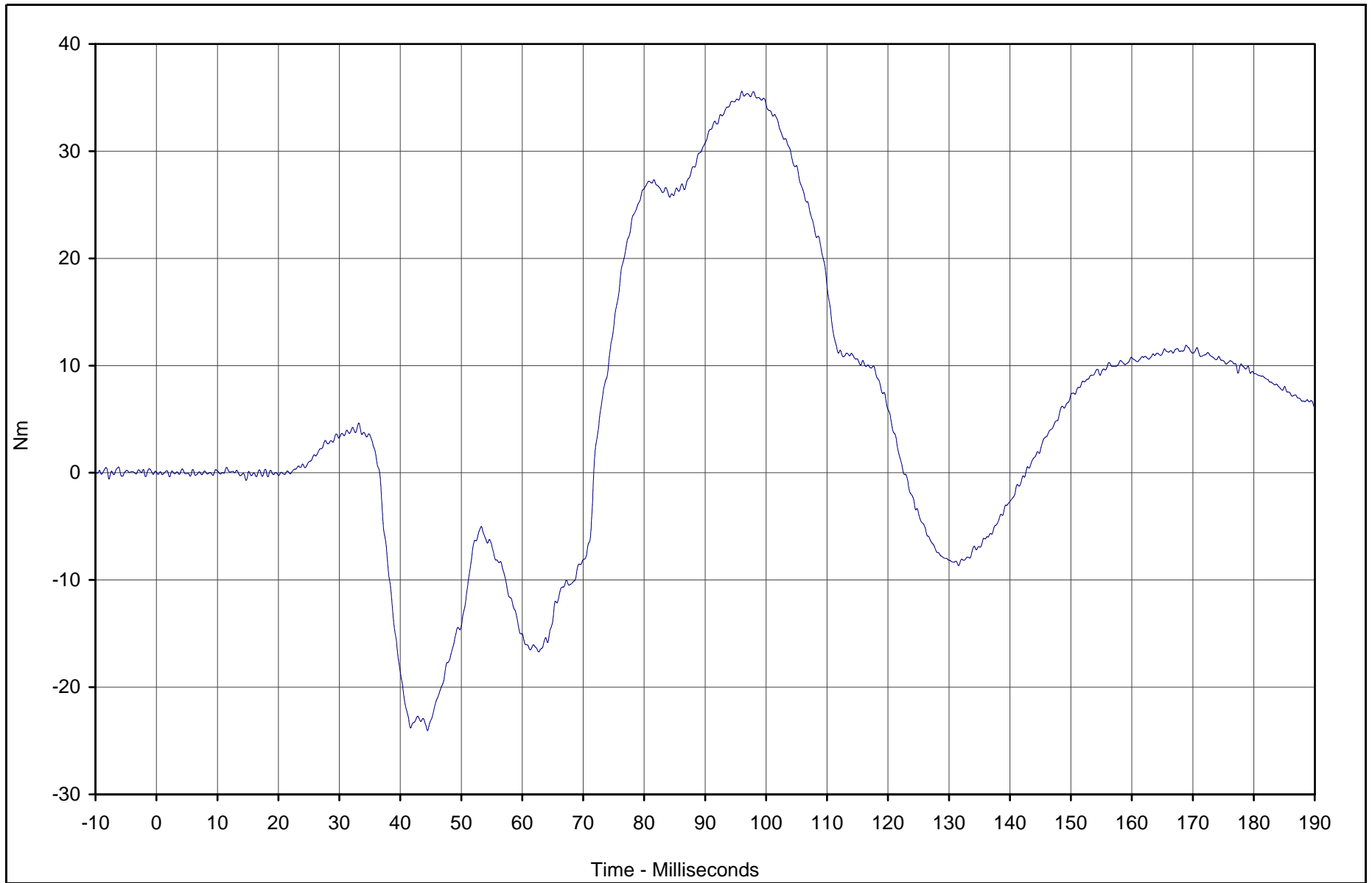

Curve Description	CURNO	Type	Units	Max	Time	Min	Time	SAE Class
Driver Neck Moment X	010	FIL	Nm	35.6	96.0	-24.0	44.5	600



Test Vehicle: 2003 Toyota 4 Runner SR5 4WD SUV

Test Date: 2/27/03

Test Program: 55/28 km/h Side Impact NCAP

NHTSA No.: M35107

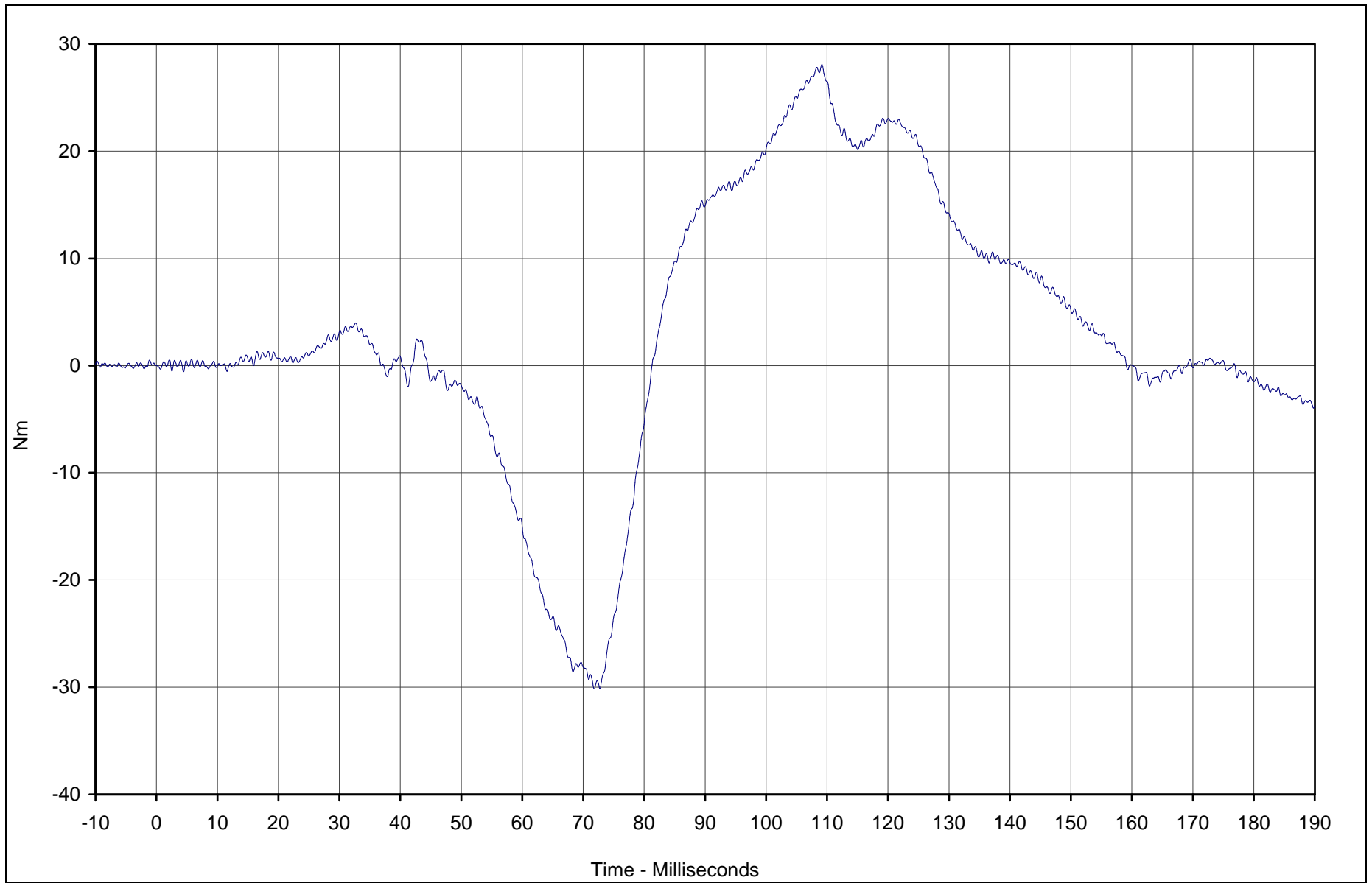

Curve Description	CURNO	Type	Units	Max	Time	Min	Time	SAE Class
Driver Neck Moment Y	011	FIL	Nm	28.1	109.2	-30.2	71.8	600



Test Vehicle: 2003 Toyota 4 Runner SR5 4WD SUV

Test Date: 2/27/03

Test Program: 55/28 km/h Side Impact NCAP

NHTSA No.: M35107

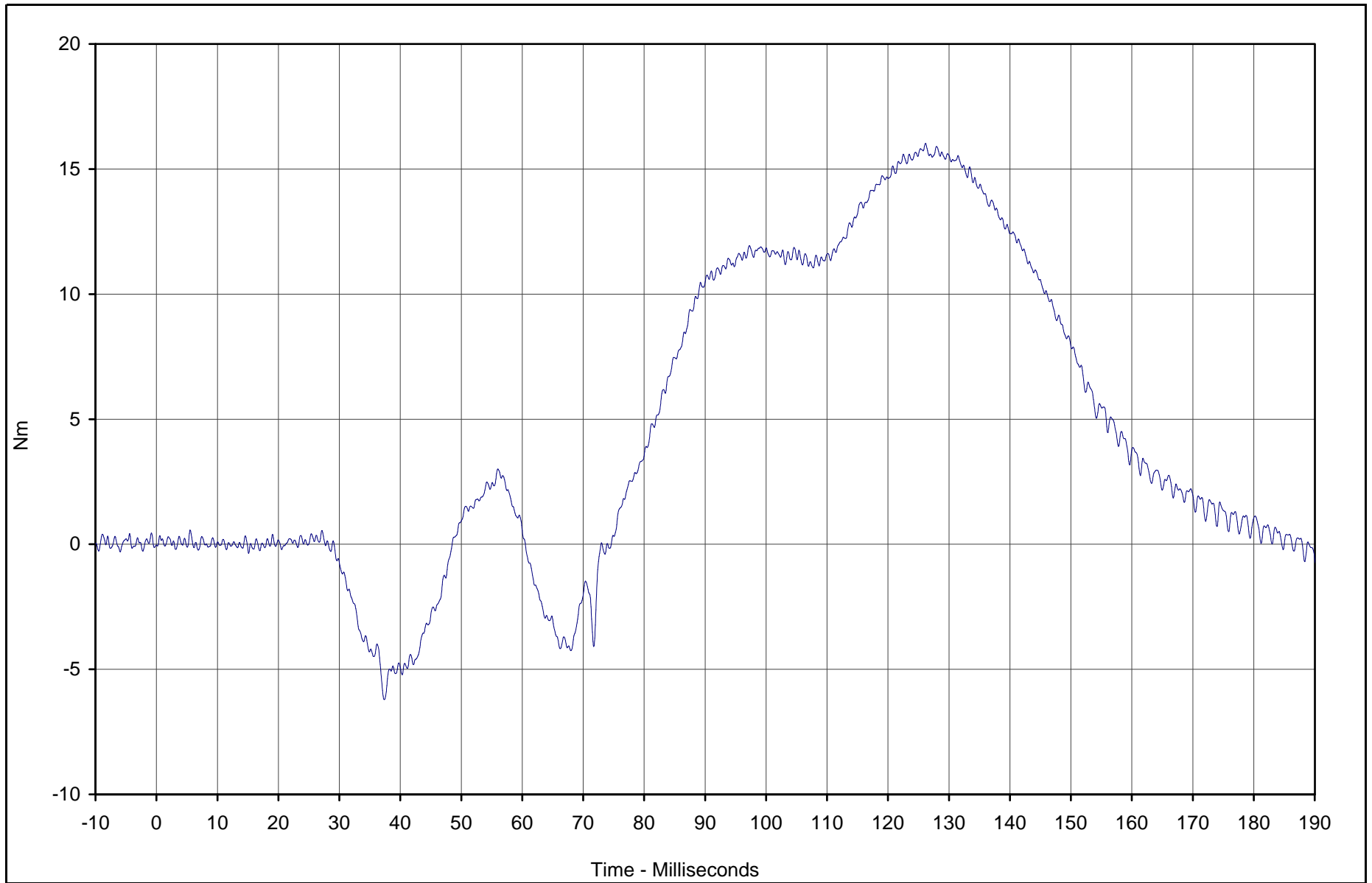

Curve Description	CURNO	Type	Units	Max	Time	Min	Time	SAE Class
Driver Neck Moment Z	012	FIL	Nm	16.0	126.1	-6.2	37.4	600



Test Vehicle: 2003 Toyota 4 Runner SR5 4WD SUV

Test Date: 2/27/03

Test Program: 55/28 km/h Side Impact NCAP

NHTSA No.: M35107

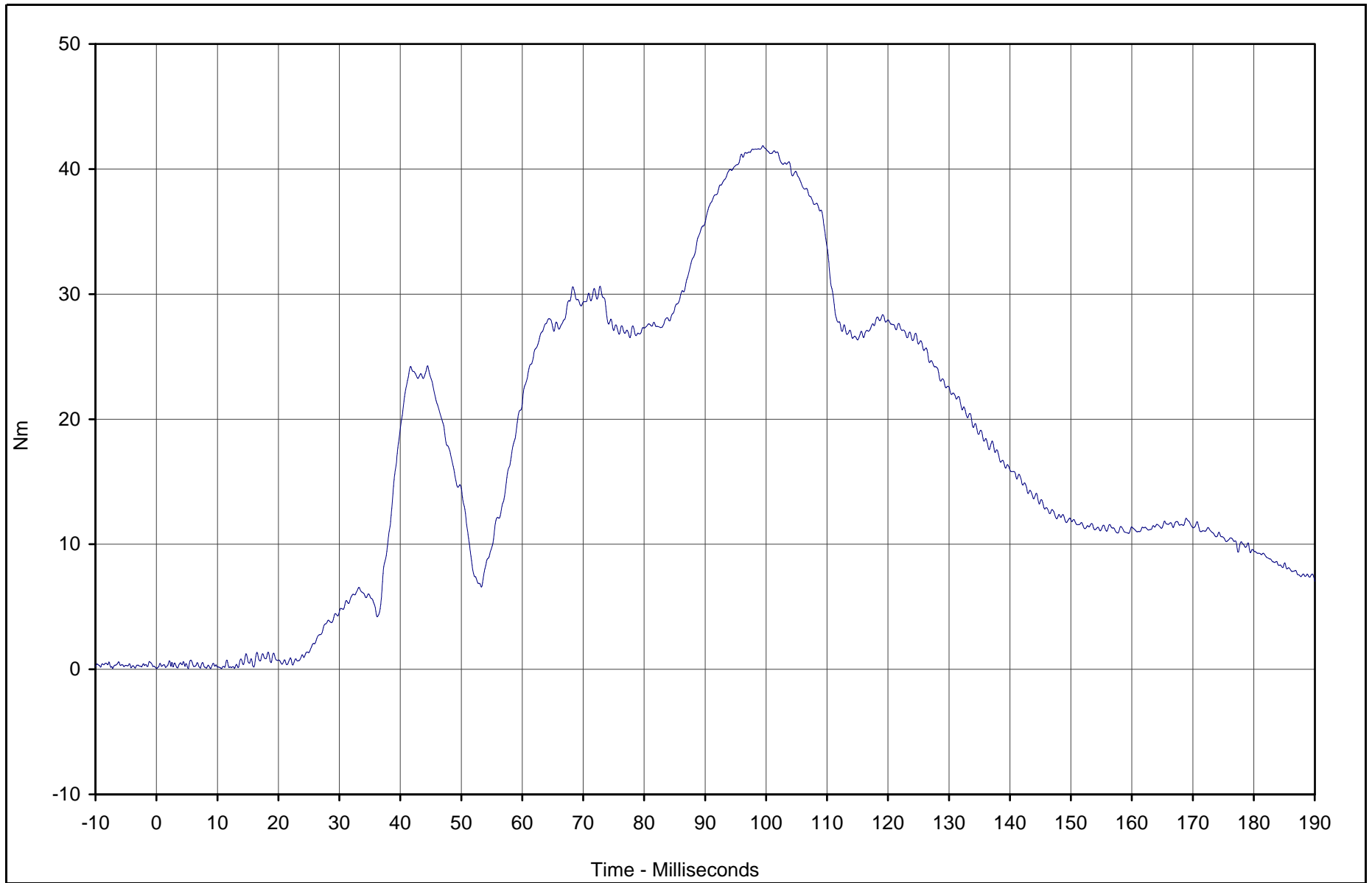

Curve Description	CURNO	Type	Units	Max	Time	Min	Time	SAE Class
Driver Neck Moment Resultant	010	RES	Nm	41.9	99.5	0.0	5.2	600



Test Vehicle: 2003 Toyota 4 Runner SR5 4WD SUV

Test Date: 2/27/03

Test Program: 55/28 km/h Side Impact NCAP

NHTSA No.: M35107

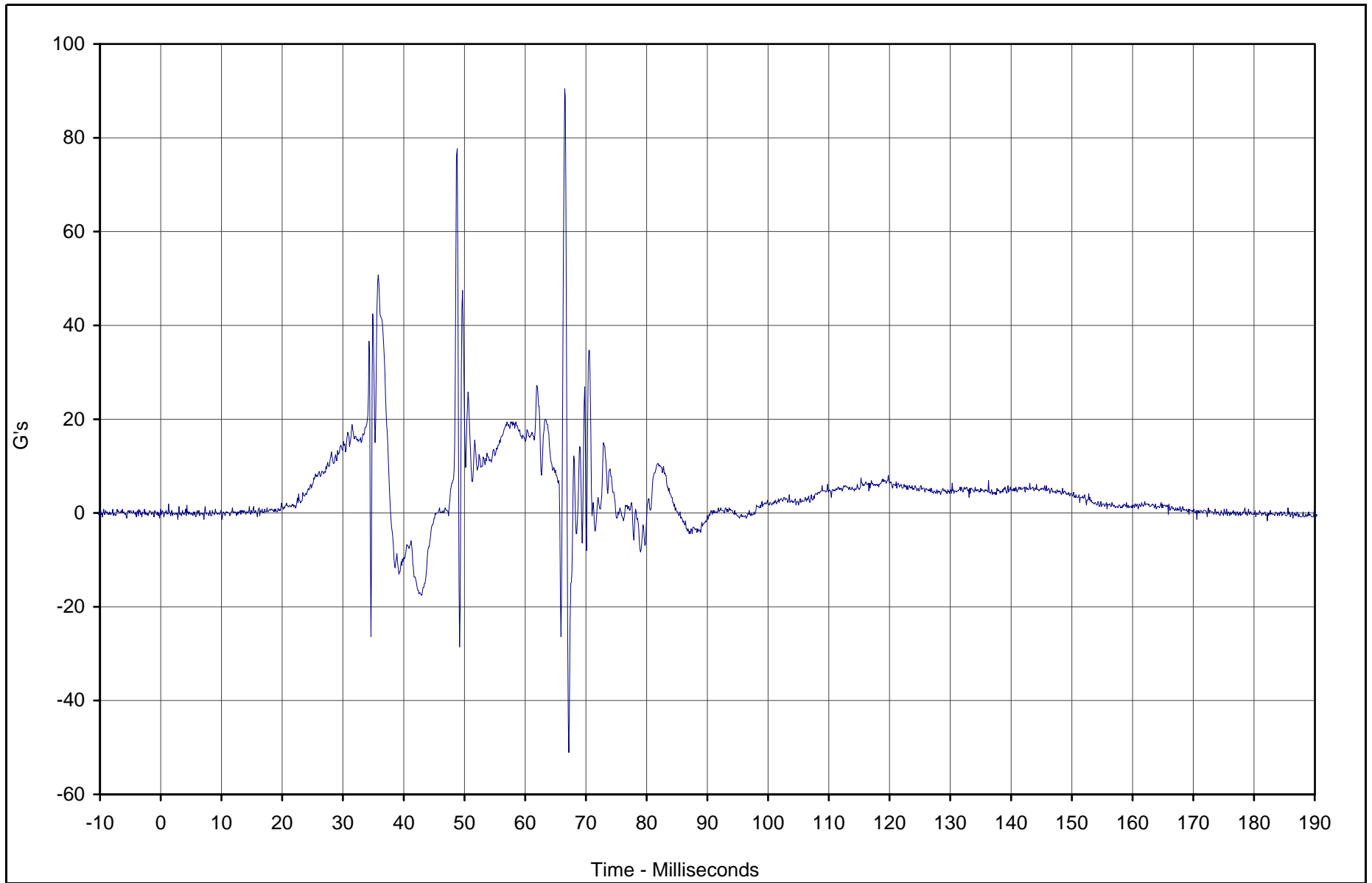

Curve Description	CURNO	Type	Units	Max	Time	Min	Time	SAE Class
Driver Upper Rib Primary Y	013	FIL	G's	90.5	66.5	-51.1	67.2	1000



Test Vehicle: 2003 Toyota 4 Runner SR5 4WD SUV

Test Date: 2/27/03

Test Program: 55/28 km/h Side Impact NCAP

NHTSA No.: M35107

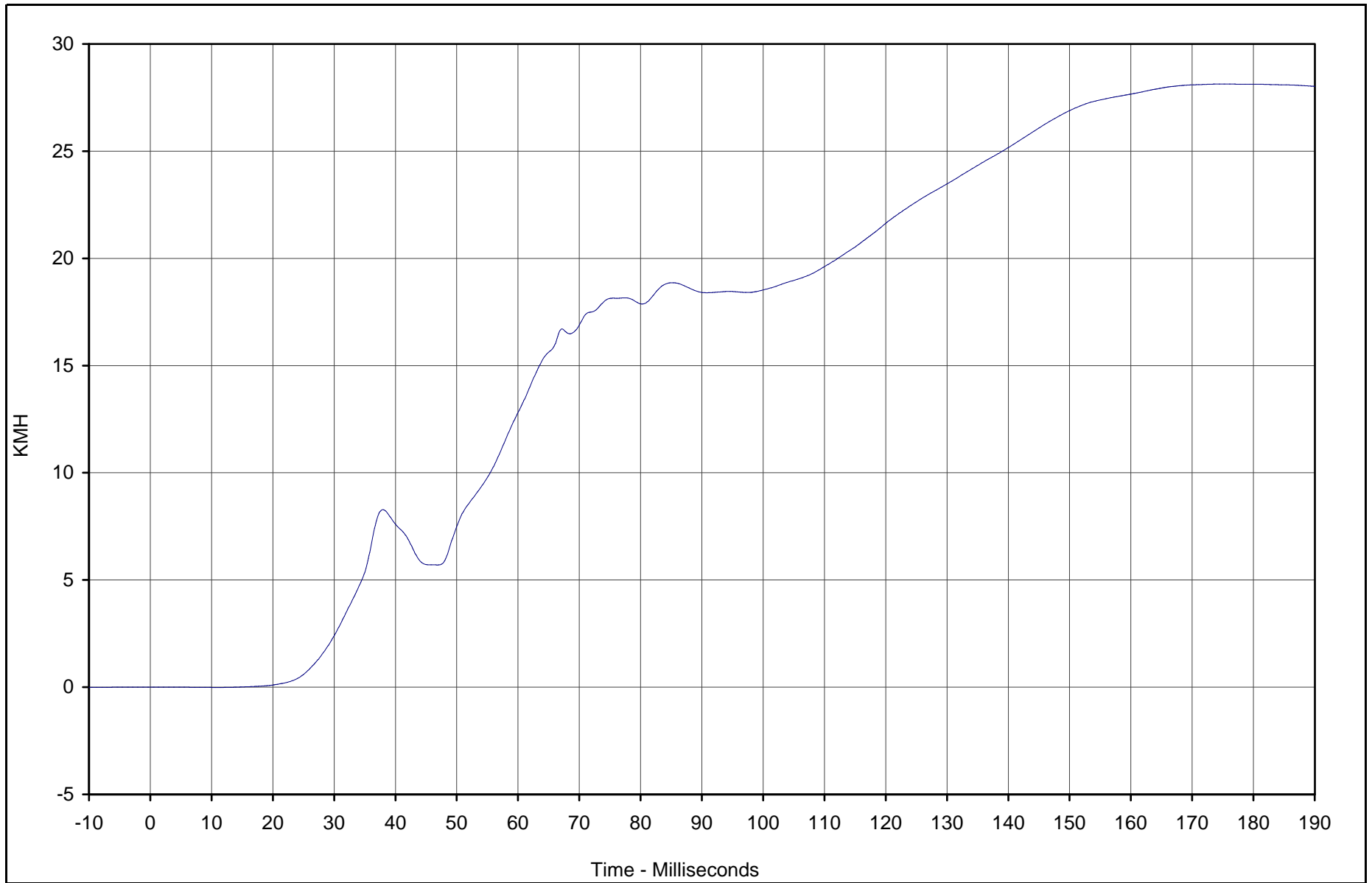

Curve Description	CURNO	Type	Units	Max	Time	Min	Time	SAE Class
Driver Upper Rib Primary Y Velocity	013	IN1	KMH	28.1	174.1	0.0	11.0	180



Test Vehicle: 2003 Toyota 4 Runner SR5 4WD SUV

Test Date: 2/27/03

Test Program: 55/28 km/h Side Impact NCAP

NHTSA No.: M35107

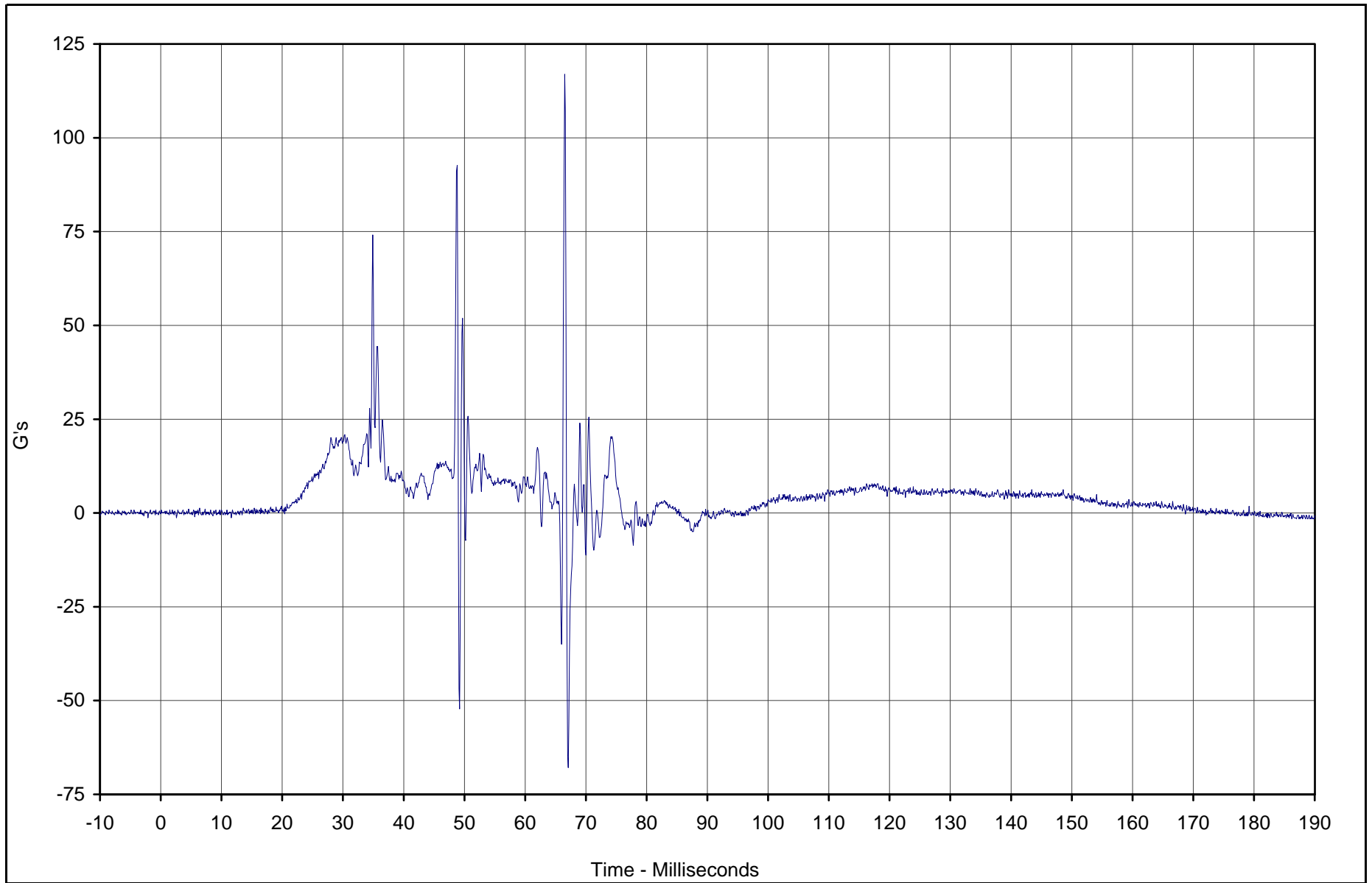

Curve Description	CURNO	Type	Units	Max	Time	Min	Time	SAE Class
Driver Lower Rib Primary Y	014	FIL	G's	117.0	66.5	-67.9	67.1	1000



Test Vehicle: 2003 Toyota 4 Runner SR5 4WD SUV

Test Date: 2/27/03

Test Program: 55/28 km/h Side Impact NCAP

NHTSA No.: M35107

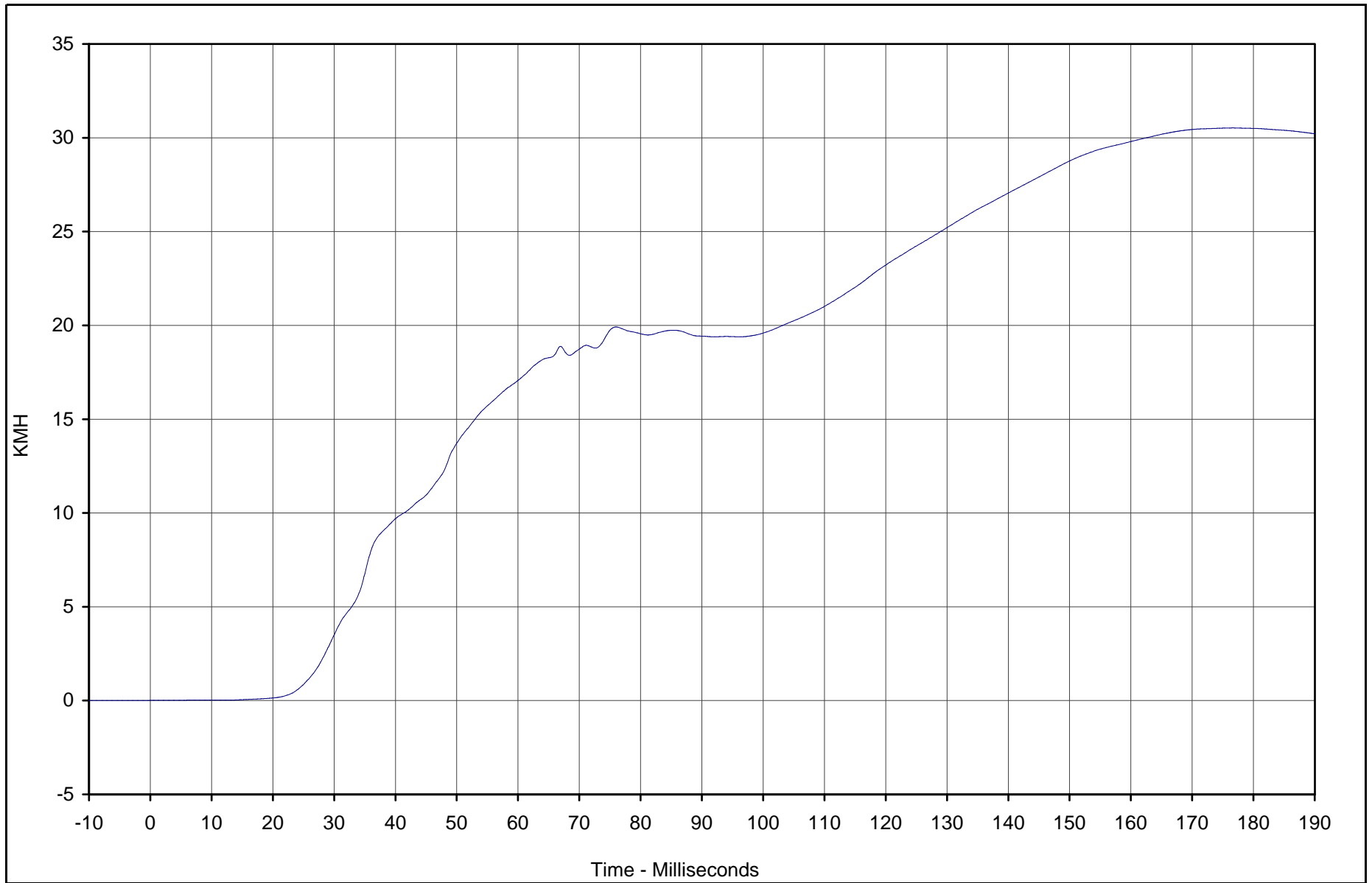

Curve Description	CURNO	Type	Units	Max	Time	Min	Time	SAE Class
Driver Lower Rib Primary Y Velocity	014	IN1	KMH	30.5	176.7	0.0	0.0	180



Test Vehicle: 2003 Toyota 4 Runner SR5 4WD SUV
 Test Program: 55/28 km/h Side Impact NCAP

Test Date: 2/27/03
 NHTSA No.: M35107

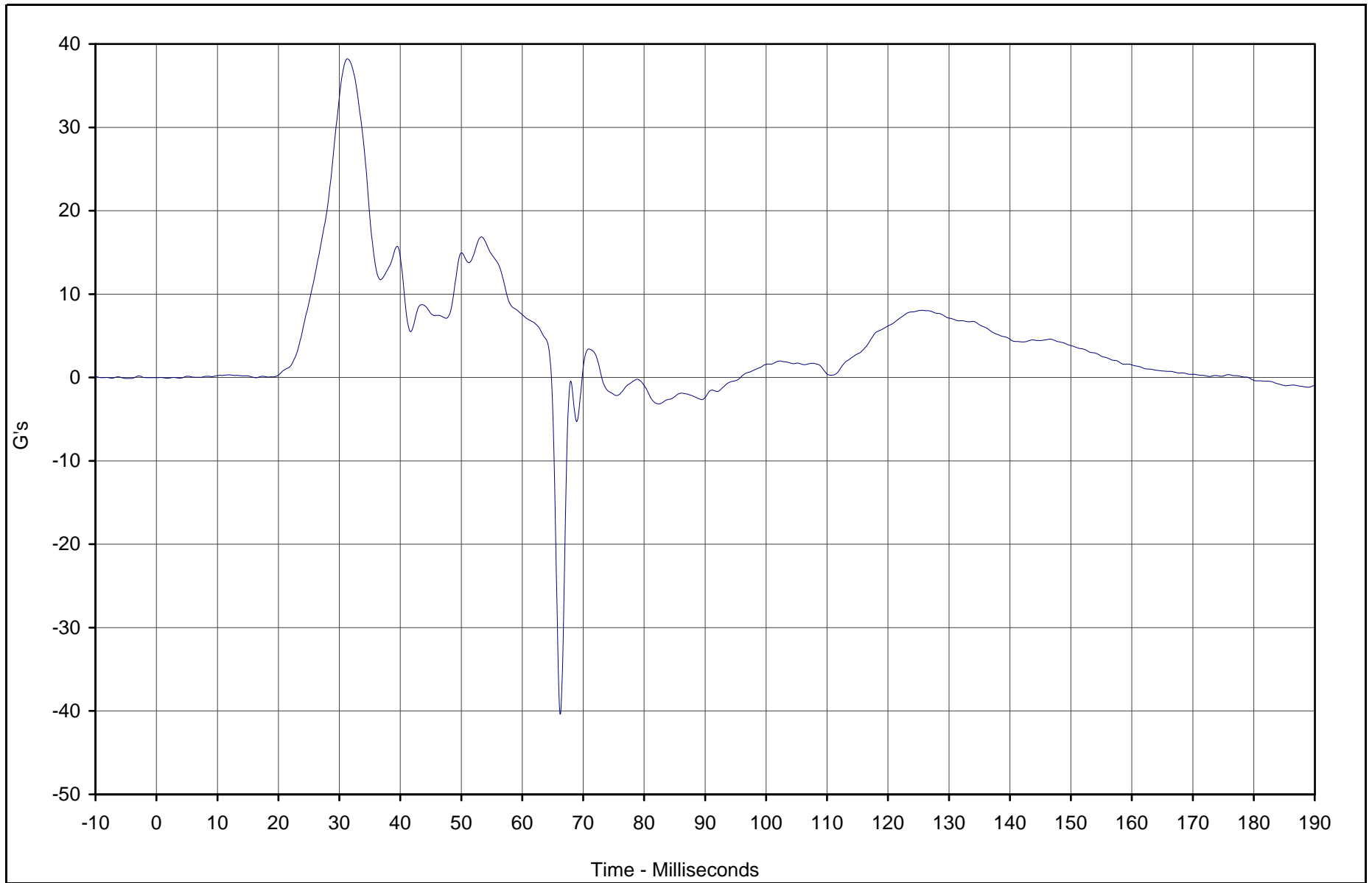

Curve Description	CURNO	Type	Units	Max	Time	Min	Time	SAE Class
Driver Lower Spine Primary Y	015	FIL	G's	38.2	31.3	-40.4	66.2	180



Test Vehicle: 2003 Toyota 4 Runner SR5 4WD SUV

Test Date: 2/27/03

Test Program: 55/28 km/h Side Impact NCAP

NHTSA No.: M35107

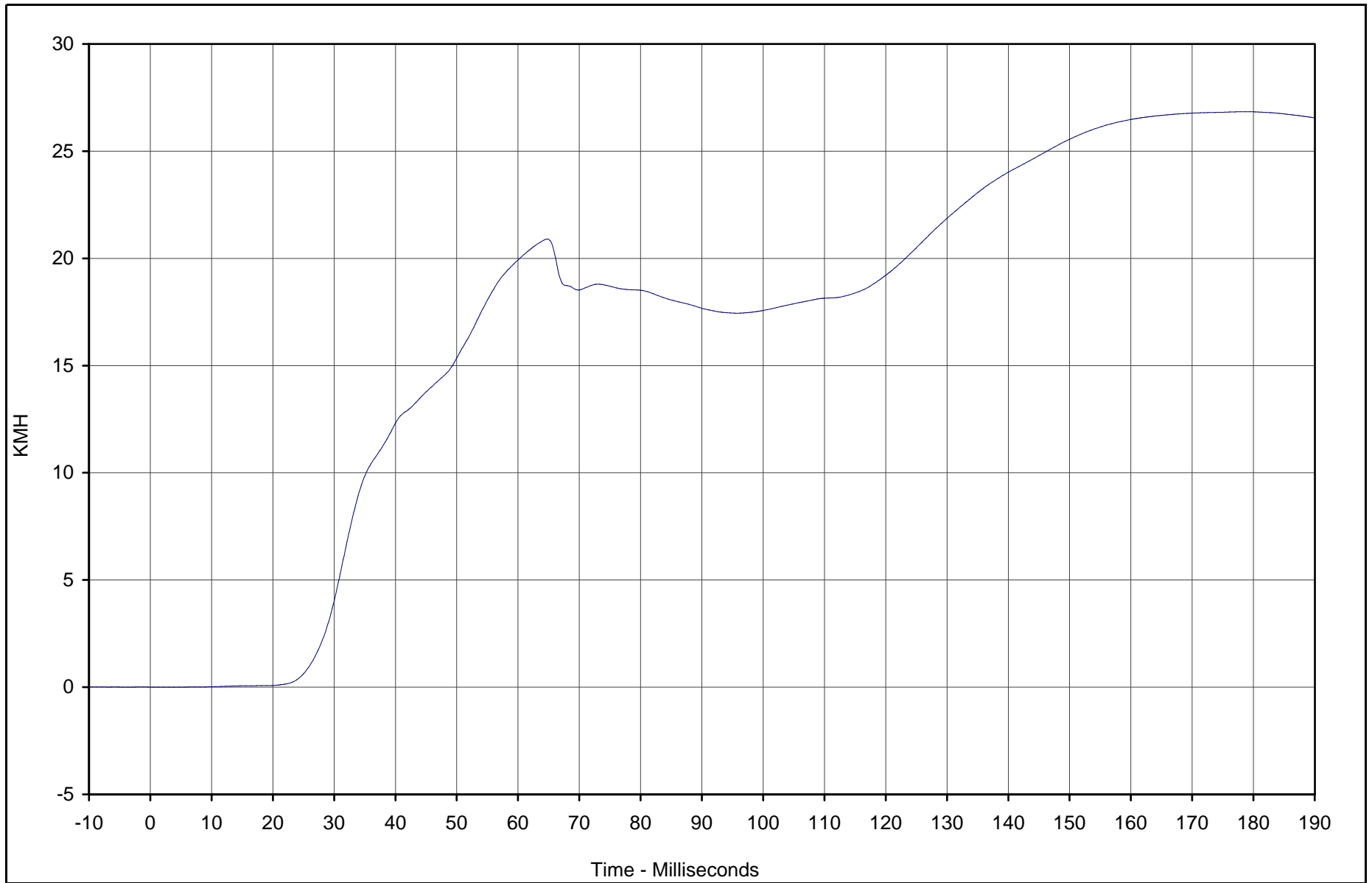

Curve Description	CURNO	Type	Units	Max	Time	Min	Time	SAE Class
Driver Lower Spine Primary Y Velocity	015	IN1	KMH	26.8	179.1	0.0	4.3	180



Test Vehicle: 2003 Toyota 4 Runner SR5 4WD SUV

Test Date: 2/27/03

Test Program: 55/28 km/h Side Impact NCAP

NHTSA No.: M35107

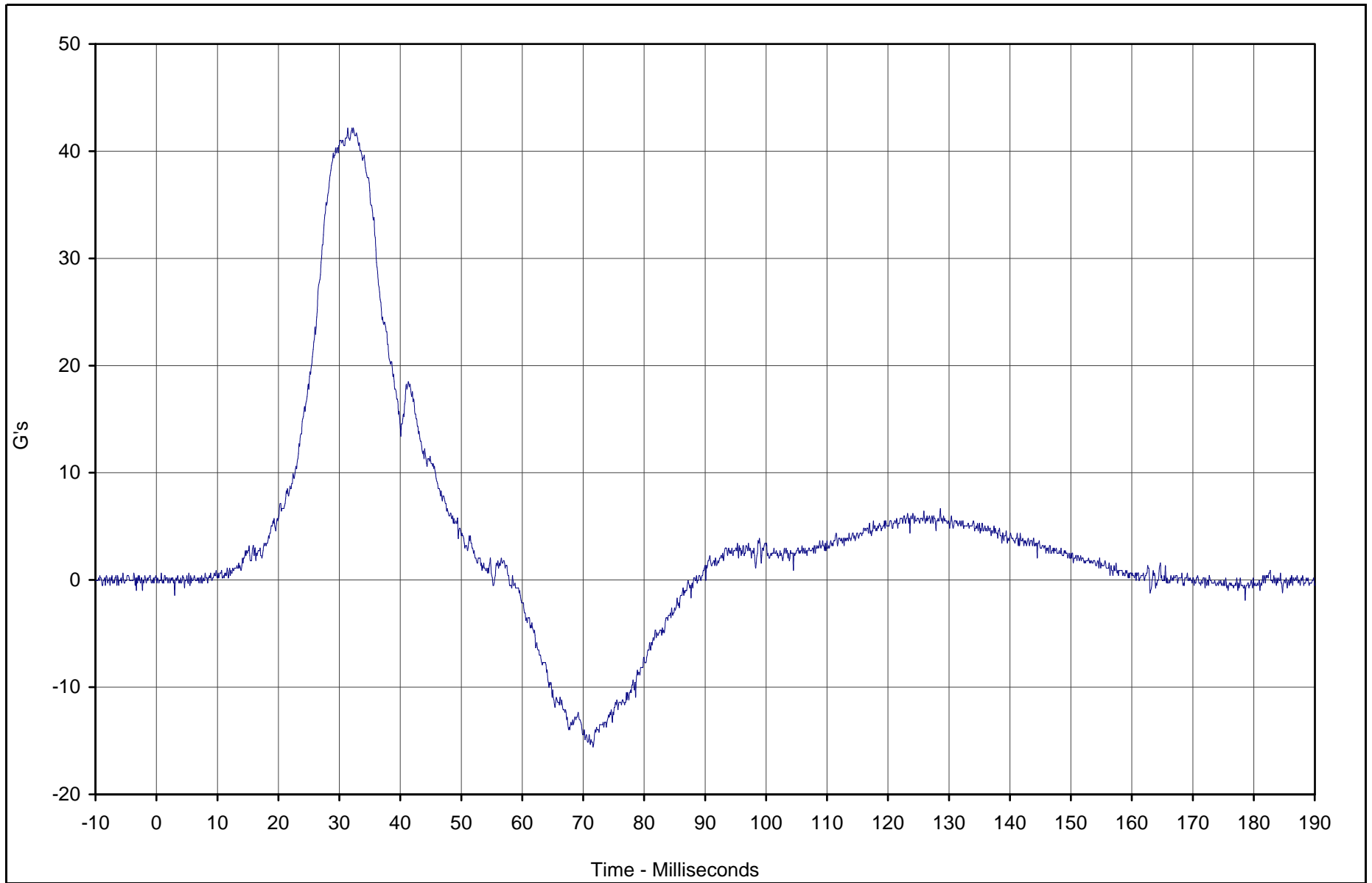

Curve Description	CURNO	Type	Units	Max	Time	Min	Time	SAE Class
Driver Pelvis Primary Y	016	FIL	G's	42.2	31.4	-15.6	71.6	1000



Test Vehicle: 2003 Toyota 4 Runner SR5 4WD SUV

Test Date: 2/27/03

Test Program: 55/28 km/h Side Impact NCAP

NHTSA No.: M35107

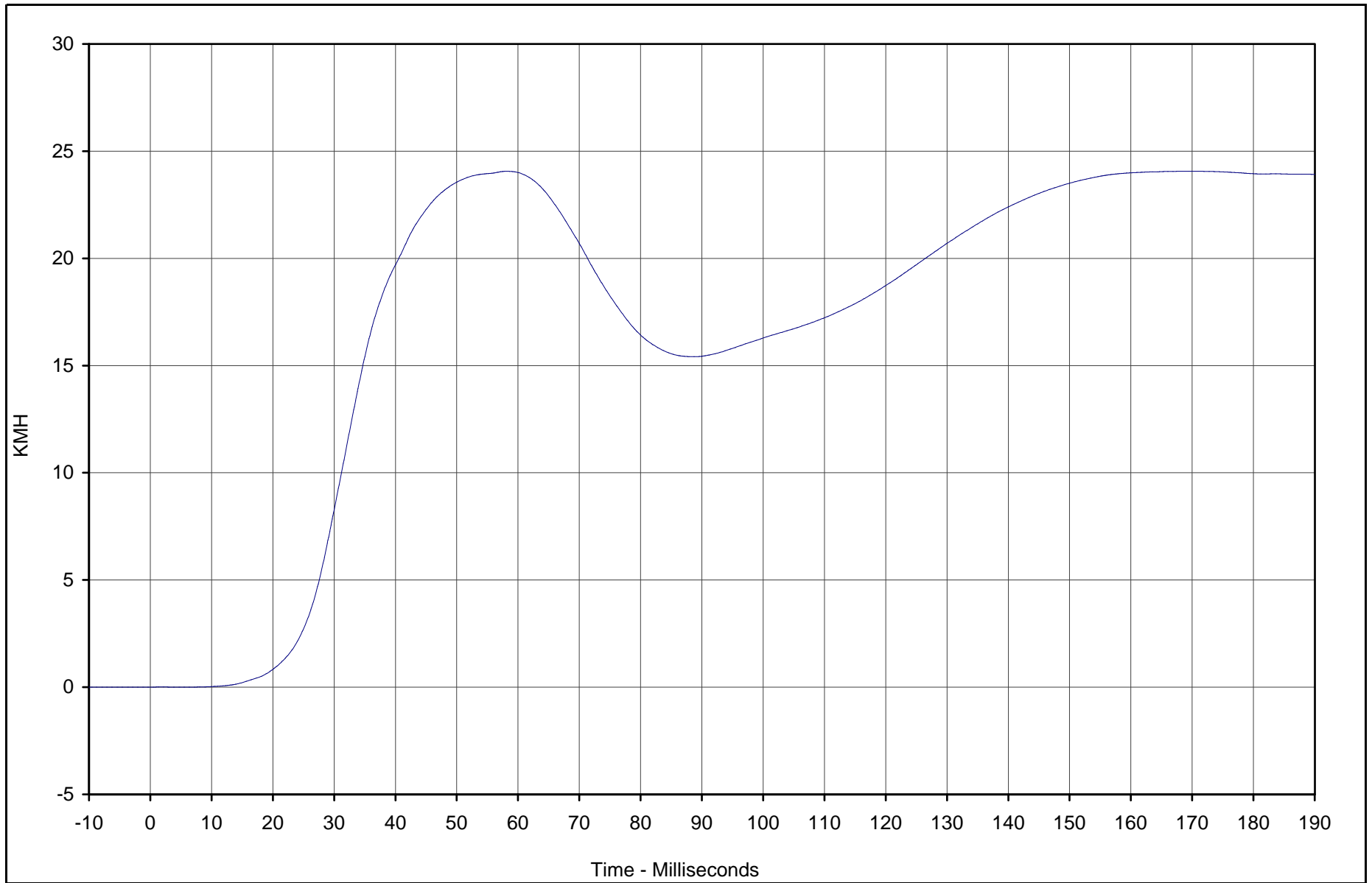

Curve Description	CURNO	Type	Units	Max	Time	Min	Time	SAE Class
Driver Pelvis Primary Y Velocity	016	IN1	KMH	24.1	169.8	0.0	4.8	180



Test Vehicle: 2003 Toyota 4 Runner SR5 4WD SUV

Test Date: 2/27/03

Test Program: 55/28 km/h Side Impact NCAP

NHTSA No.: M35107

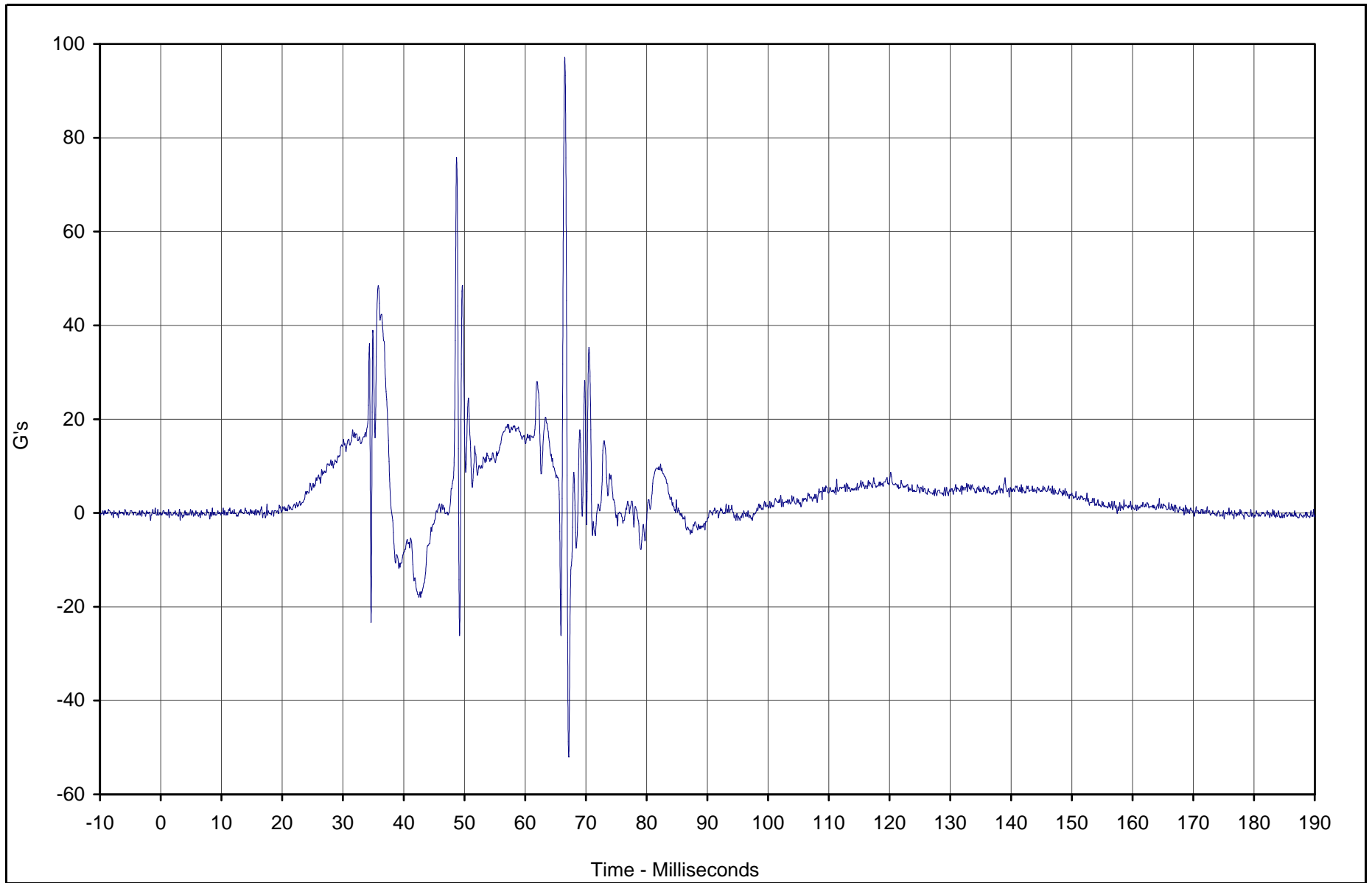

Curve Description	CURNO	Type	Units	Max	Time	Min	Time	SAE Class
Driver Upper Rib Redundant Y	017	FIL	G's	97.1	66.5	-51.9	67.2	1000



Test Vehicle: 2003 Toyota 4 Runner SR5 4WD SUV

Test Date: 2/27/03

Test Program: 55/28 km/h Side Impact NCAP

NHTSA No.: M35107

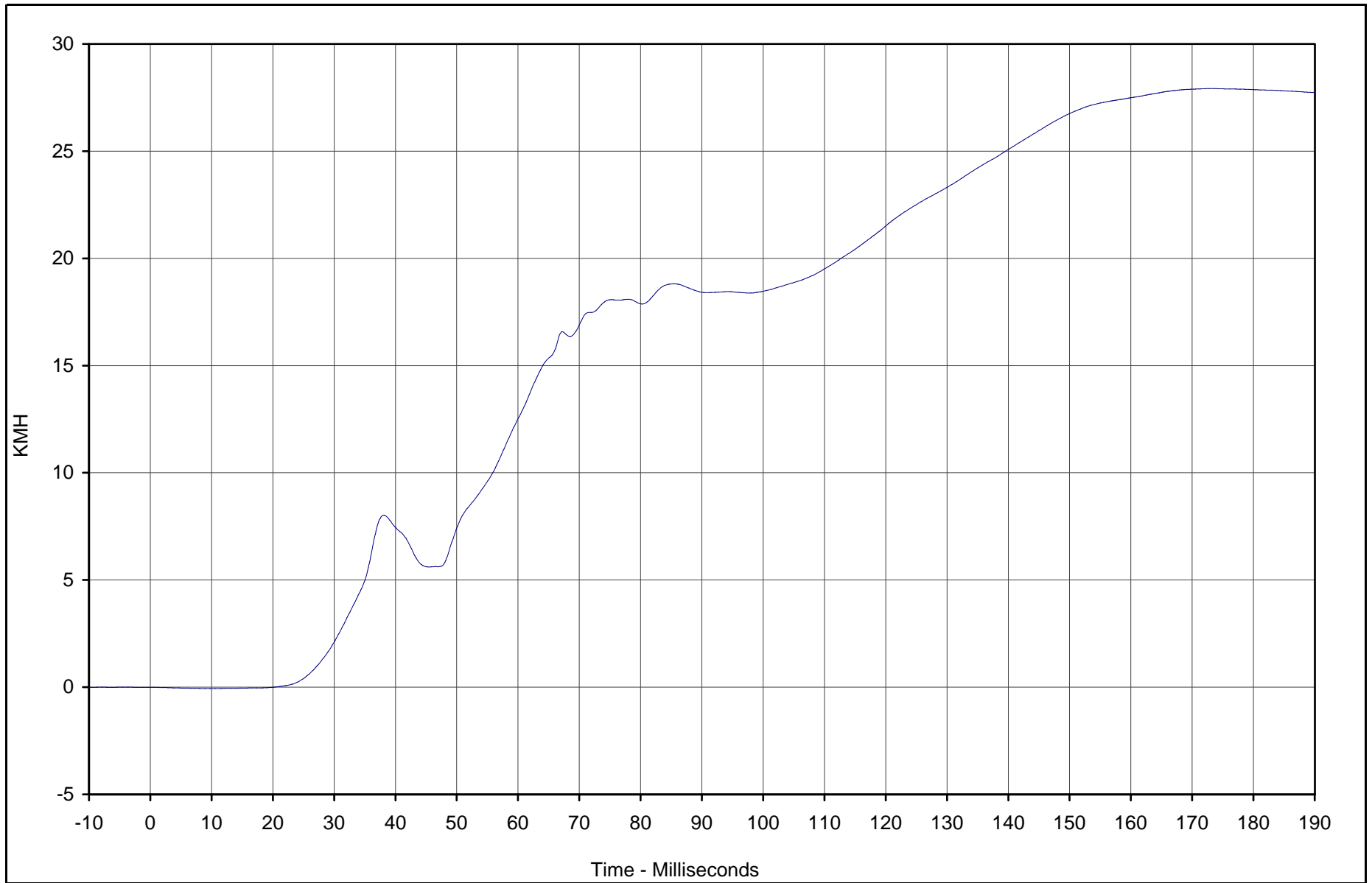

Curve Description	CURNO	Type	Units	Max	Time	Min	Time	SAE Class
Driver Upper Rib Redundant Y Velocity	017	IN1	KMH	27.9	173.1	-0.1	10.0	180



Test Vehicle: 2003 Toyota 4 Runner SR5 4WD SUV

Test Date: 2/27/03

Test Program: 55/28 km/h Side Impact NCAP

NHTSA No.: M35107

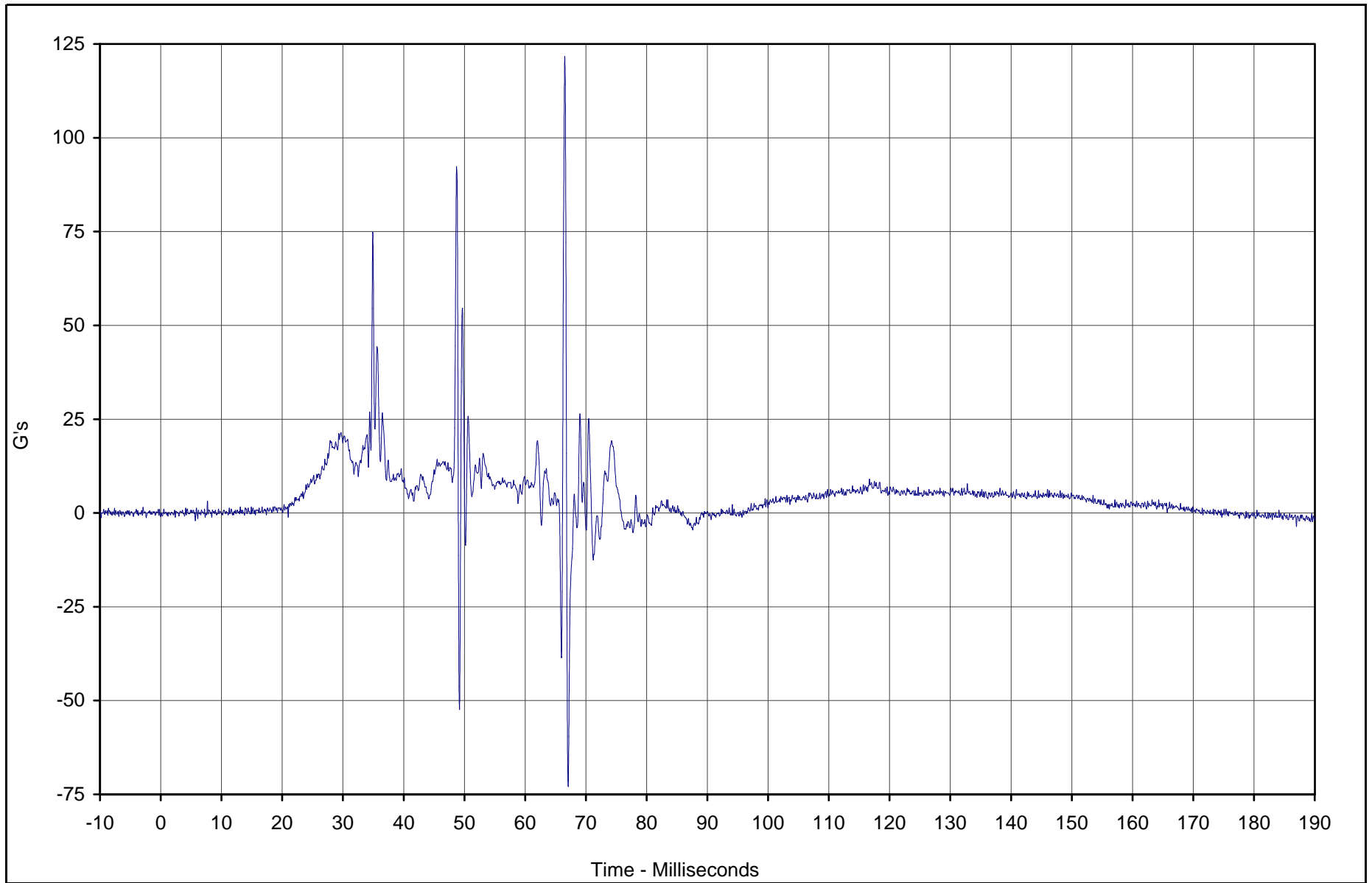

Curve Description	CURNO	Type	Units	Max	Time	Min	Time	SAE Class
Driver Lower Rib Redundant Y	018	FIL	G's	121.6	66.5	-72.9	67.1	1000



Test Vehicle: 2003 Toyota 4 Runner SR5 4WD SUV

Test Date: 2/27/03

Test Program: 55/28 km/h Side Impact NCAP

NHTSA No.: M35107

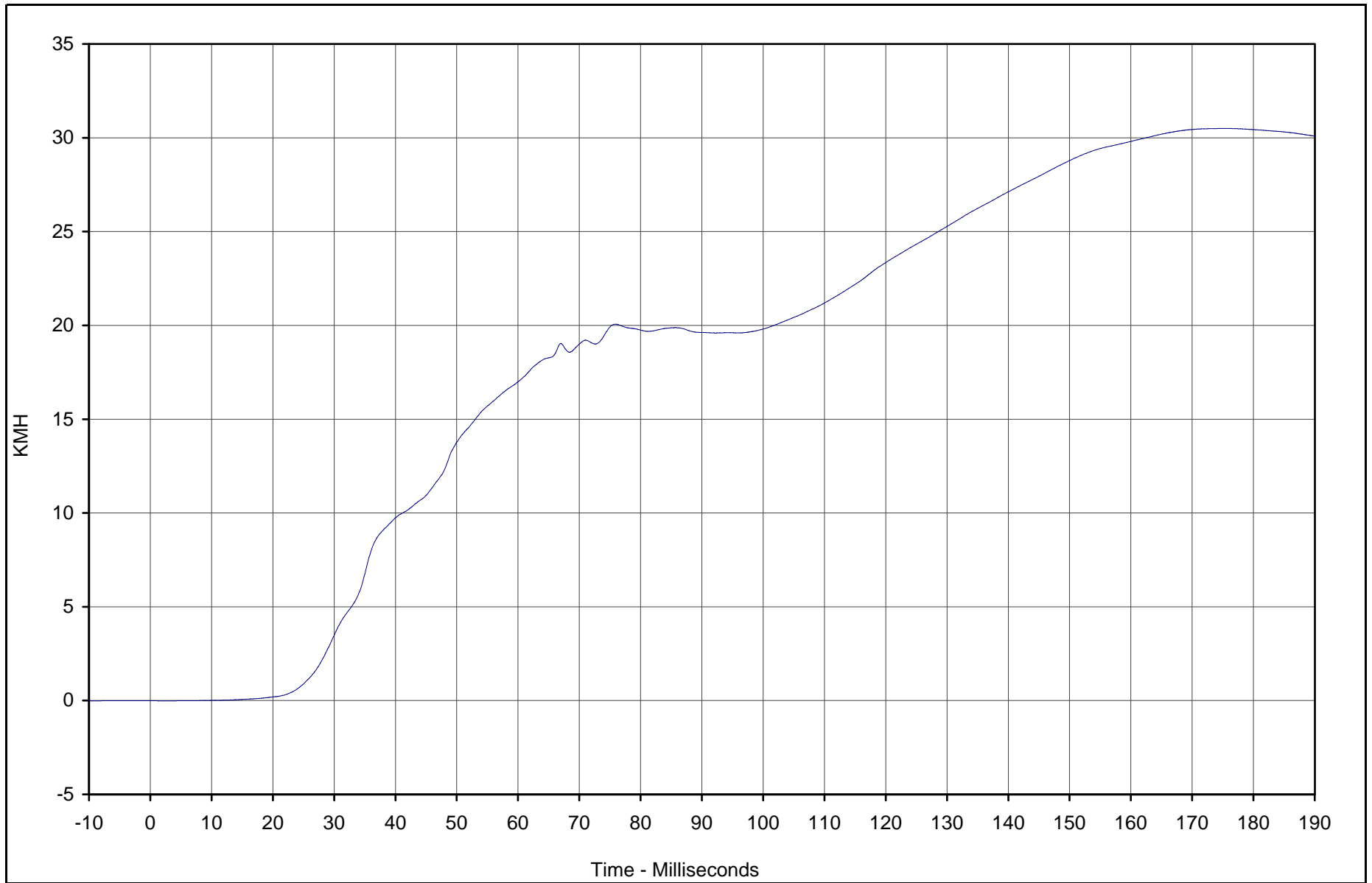

Curve Description	CURNO	Type	Units	Max	Time	Min	Time	SAE Class
Driver Lower Rib Redundant Y Velocity	018	IN1	KMH	30.5	175.8	0.0	2.8	180



Test Vehicle: 2003 Toyota 4 Runner SR5 4WD SUV

Test Date: 2/27/03

Test Program: 55/28 km/h Side Impact NCAP

NHTSA No.: M35107

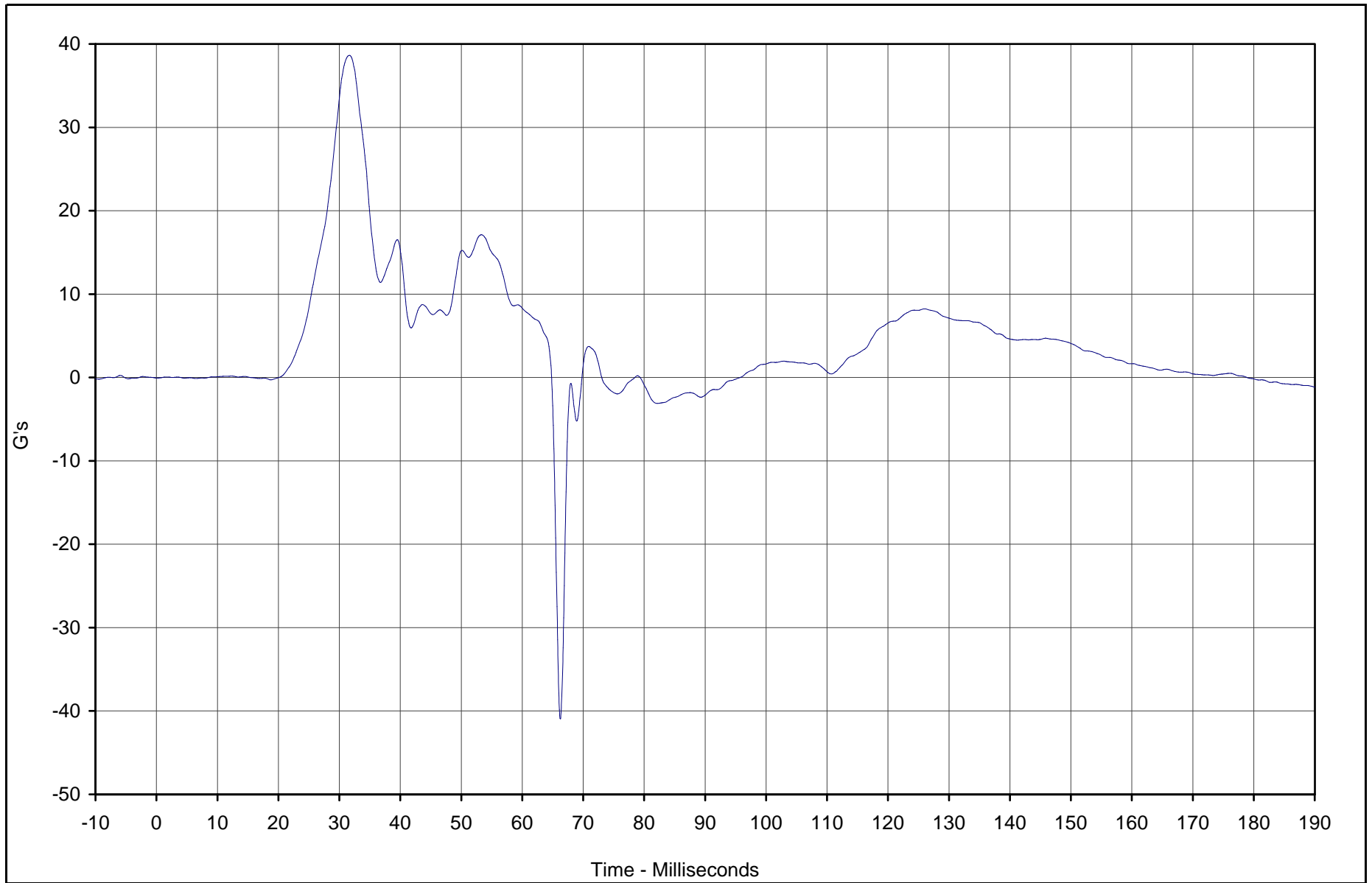

Curve Description	CURNO	Type	Units	Max	Time	Min	Time	SAE Class
Driver Lower Spine Redundant Y	019	FIL	G's	38.6	31.7	-40.9	66.3	180



Test Vehicle: 2003 Toyota 4 Runner SR5 4WD SUV

Test Date: 2/27/03

Test Program: 55/28 km/h Side Impact NCAP

NHTSA No.: M35107

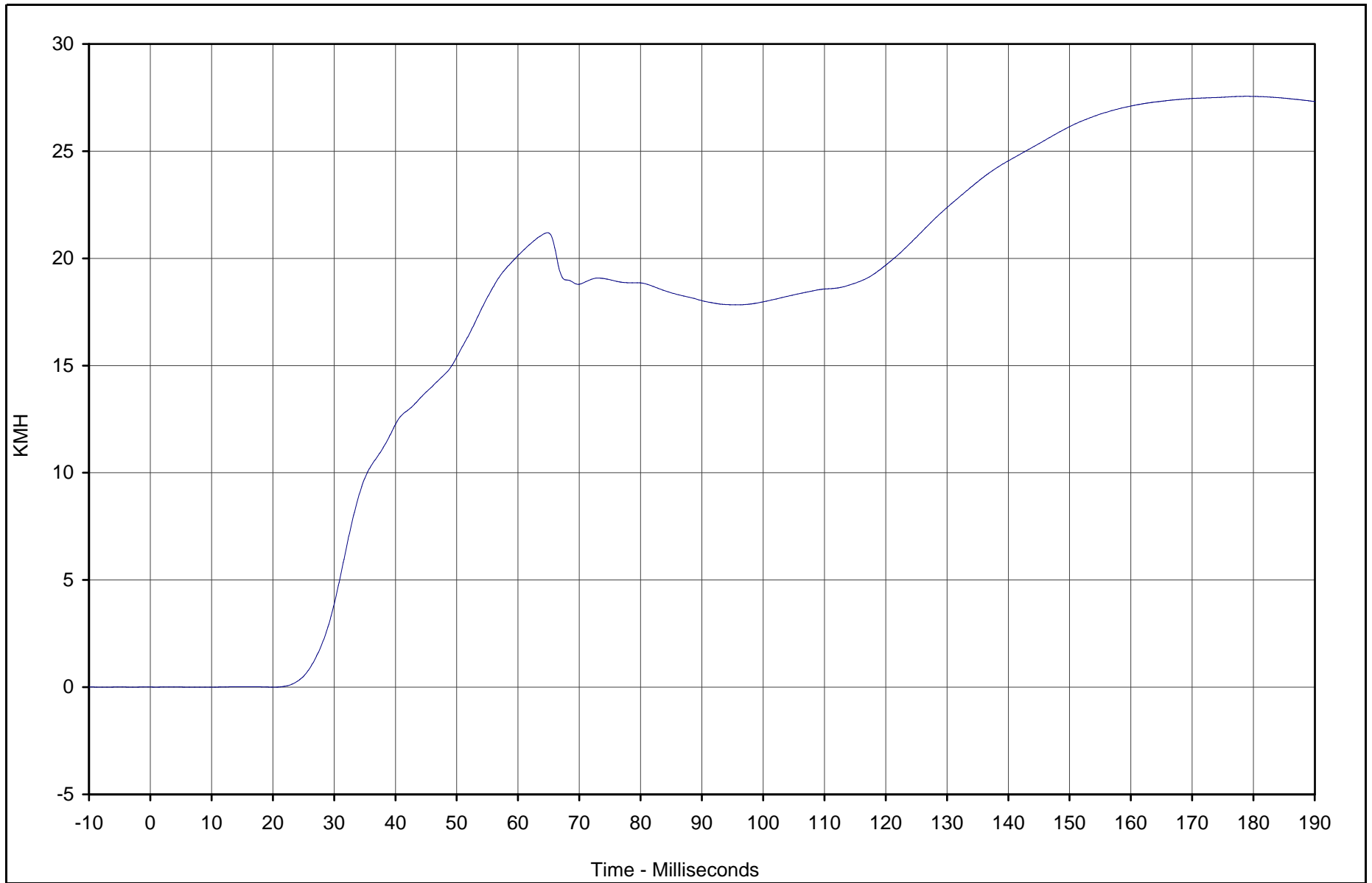

Curve Description	CURNO	Type	Units	Max	Time	Min	Time	SAE Class
Driver Lower Spine Redundant Y Velocity	019	IN1	KMH	27.6	178.9	0.0	8.5	180



Test Vehicle: 2003 Toyota 4 Runner SR5 4WD SUV

Test Date: 2/27/03

Test Program: 55/28 km/h Side Impact NCAP

NHTSA No.: M35107

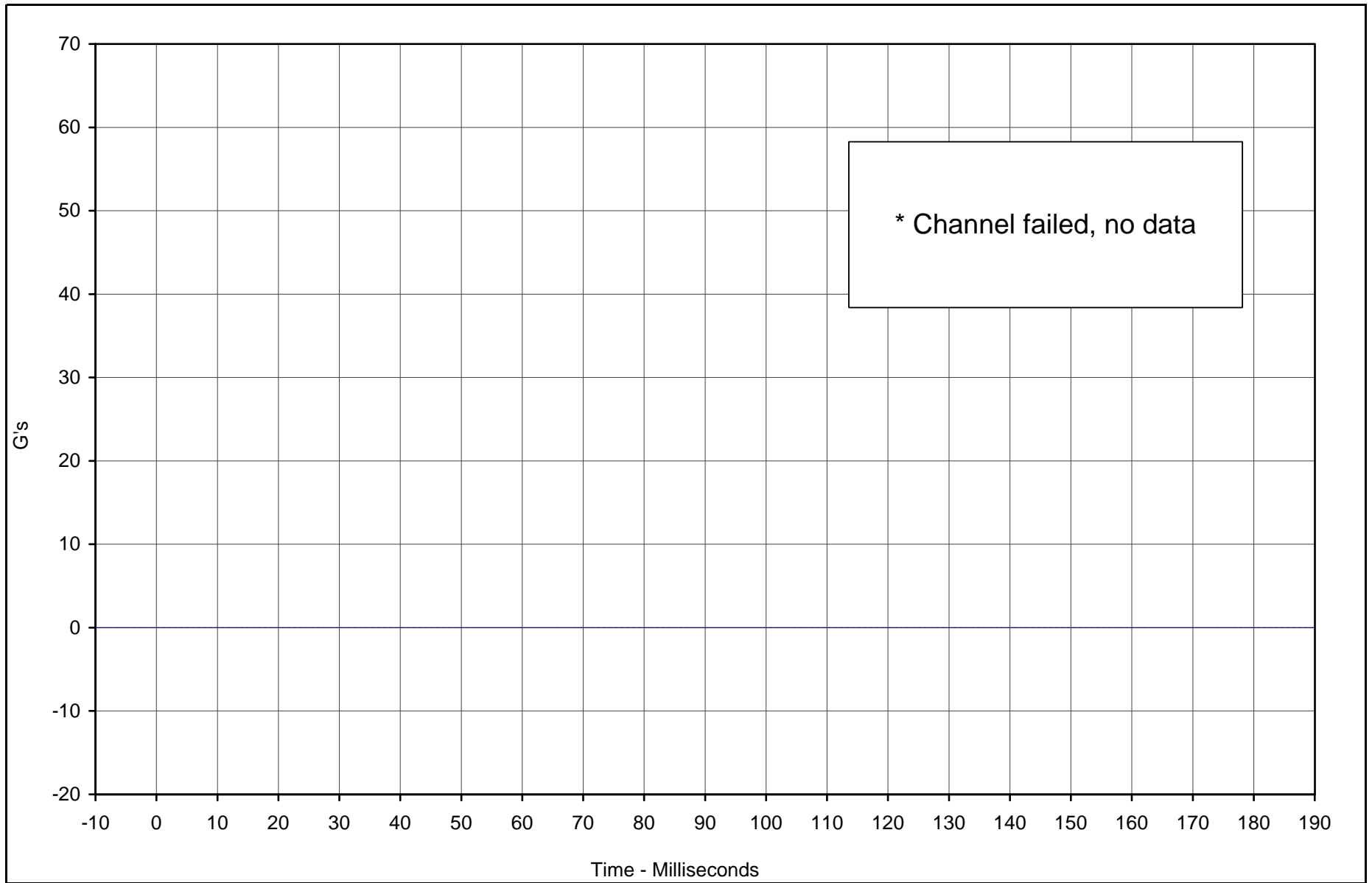

* Channel failed, no data

Curve Description	CURNO	Type	Units	Max	Time	Min	Time	SAE Class
Driver Pelvis Redundant Y	020	FIL	G's	0.0	0.0	0.0	0.0	1000



Test Vehicle: 2003 Toyota 4 Runner SR5 4WD SUV

Test Date: 2/27/03

Test Program: 55/28 km/h Side Impact NCAP

NHTSA No.: M35107

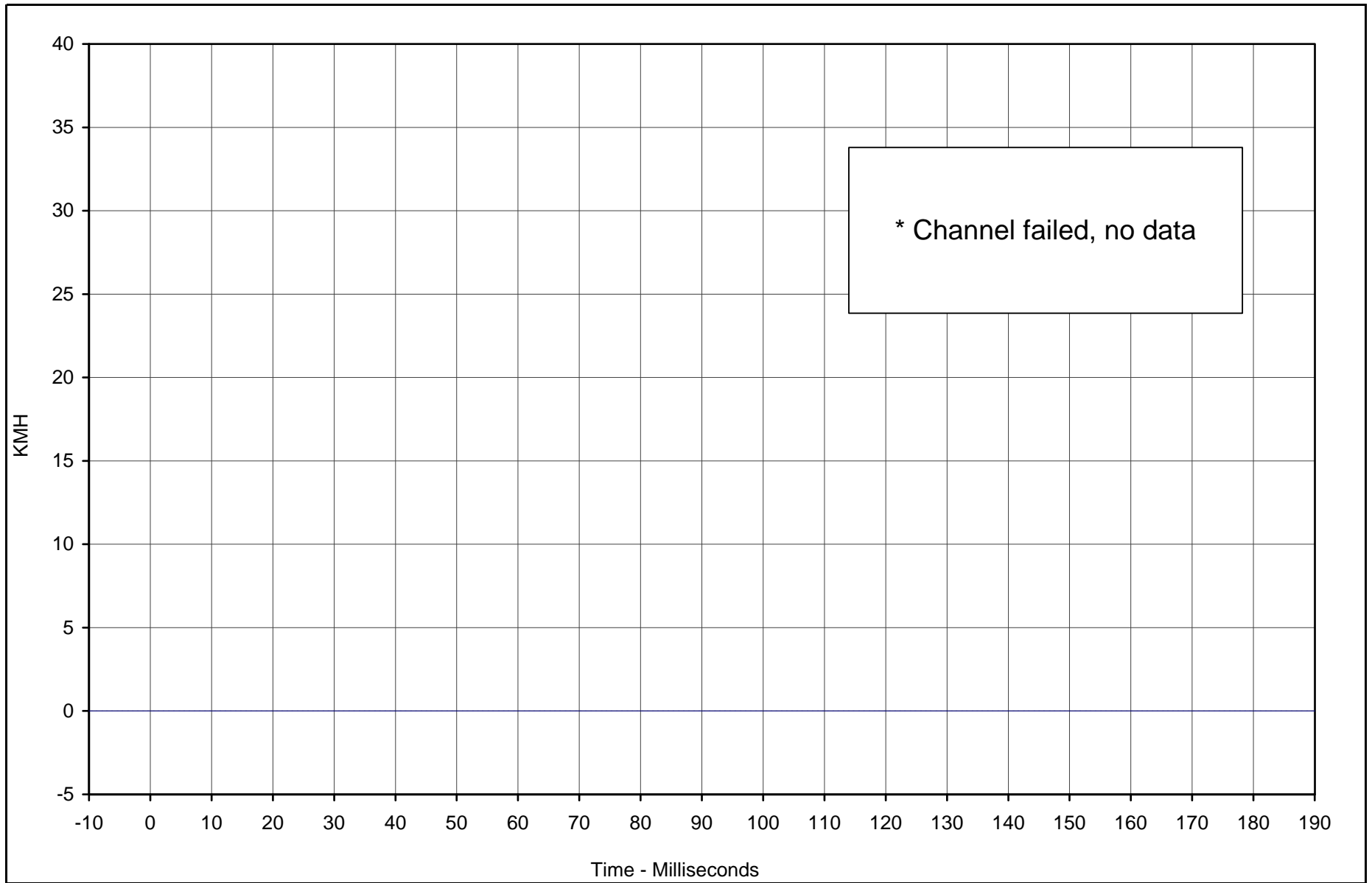

* Channel failed, no data

Curve Description	CURNO	Type	Units	Max	Time	Min	Time	SAE Class
Driver Pelvis Redundant Y Velocity	020	IN1	KMH	0.0	0.0	0.0	0.0	180



Test Vehicle: 2003 Toyota 4 Runner SR5 4WD SUV

Test Date: 2/27/03

Test Program: 55/28 km/h Side Impact NCAP

NHTSA No.: M35107

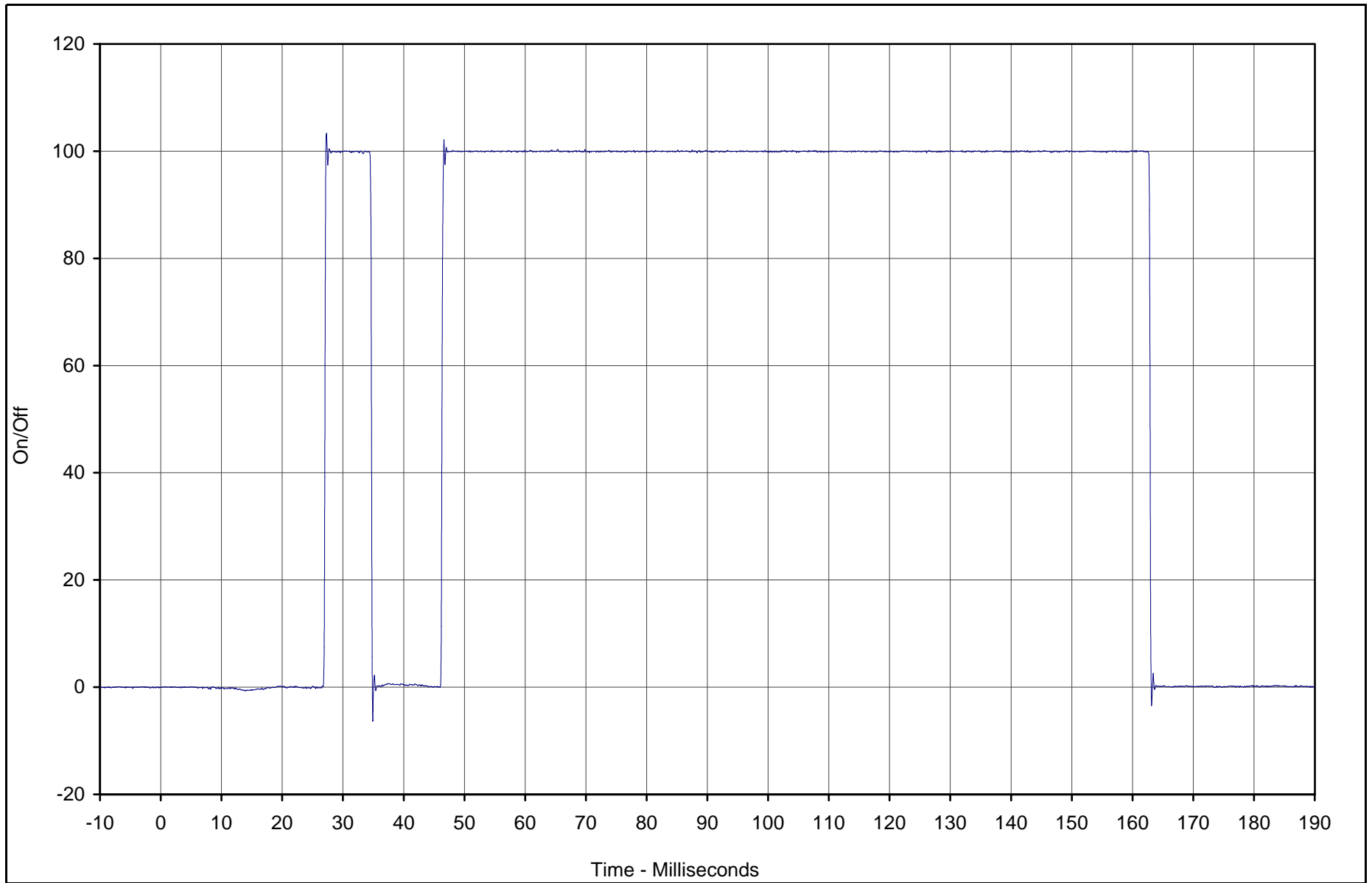

Curve Description	CURNO	Type	Units	Max	Time	Cross %	Time	SAE Class
Driver Thorax Contact	021	FIL	On/Off	103.3	27.3	50.0	45.6	1000



Test Vehicle: 2003 Toyota 4 Runner SR5 4WD SUV

Test Date: 2/27/03

Test Program: 55/28 km/h Side Impact NCAP

NHTSA No.: M35107

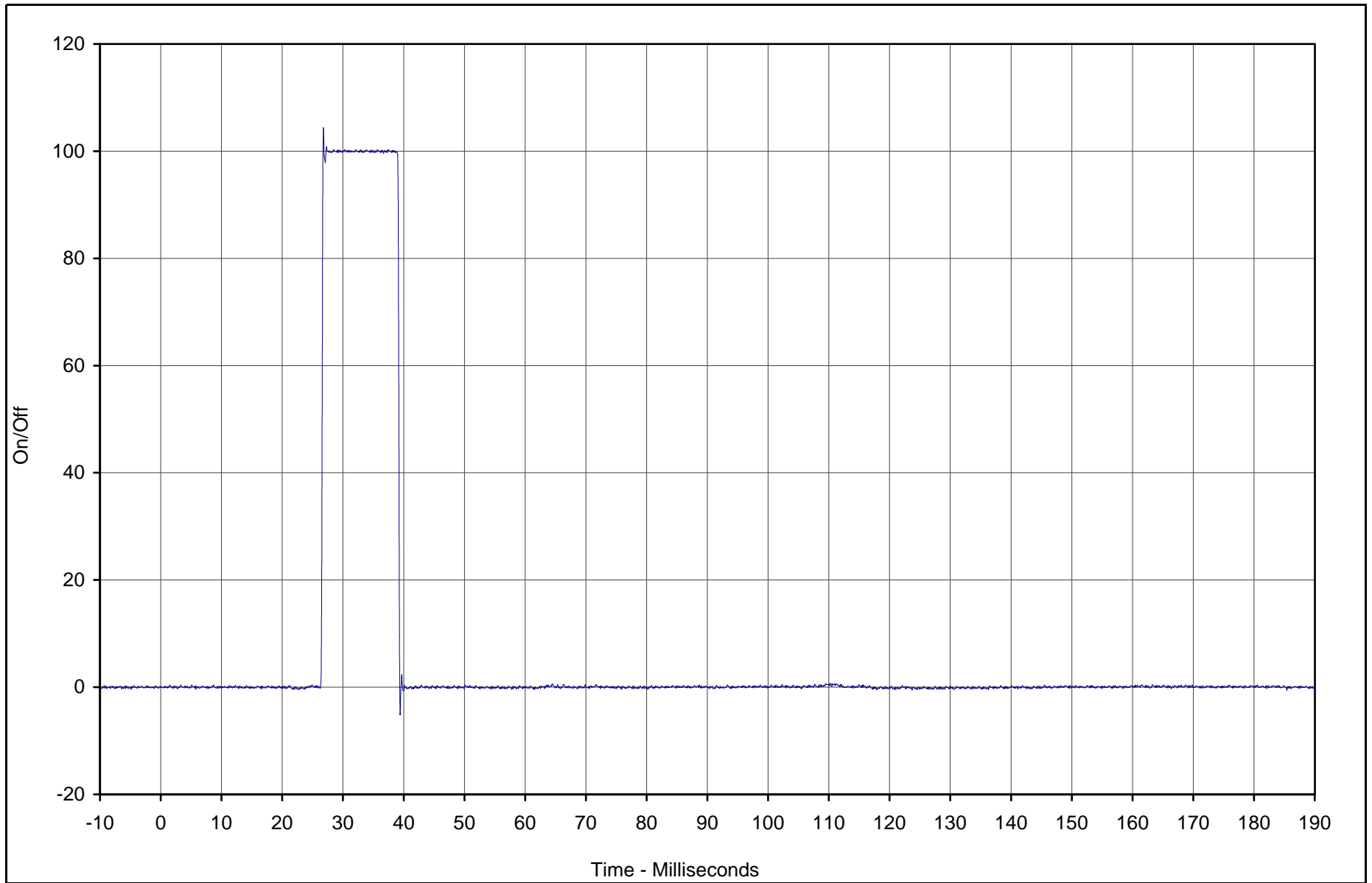

Curve Description	CURNO	Type	Units	Max	Time	Cross %	Time	SAE Class
Driver Pelvis Contact	022	FIL	On/Off	104.3	26.8	50.0	26.6	1000



Test Vehicle: 2003 Toyota 4 Runner SR5 4WD SUV

Test Date: 2/27/03

Test Program: 55/28 km/h Side Impact NCAP

NHTSA No.: M35107

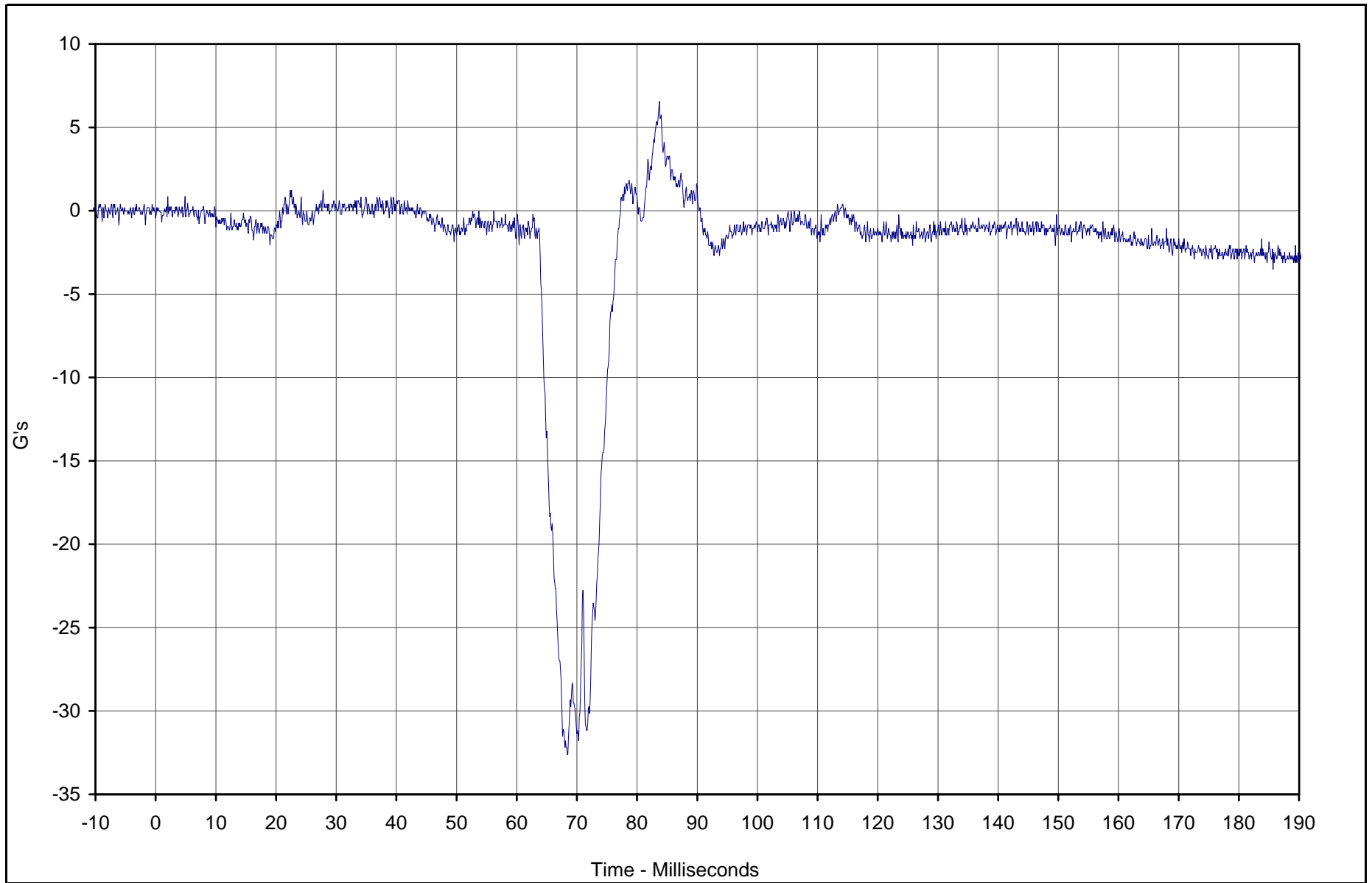

Curve Description	CURNO	Type	Units	Max	Time	Min	Time	SAE Class
Pass. Head Primary X	023	FIL	G's	6.6	83.7	-32.6	68.4	1000



Test Vehicle: 2003 Toyota 4 Runner SR5 4WD SUV

Test Date: 2/27/03

Test Program: 55/28 km/h Side Impact NCAP

NHTSA No.: M35107

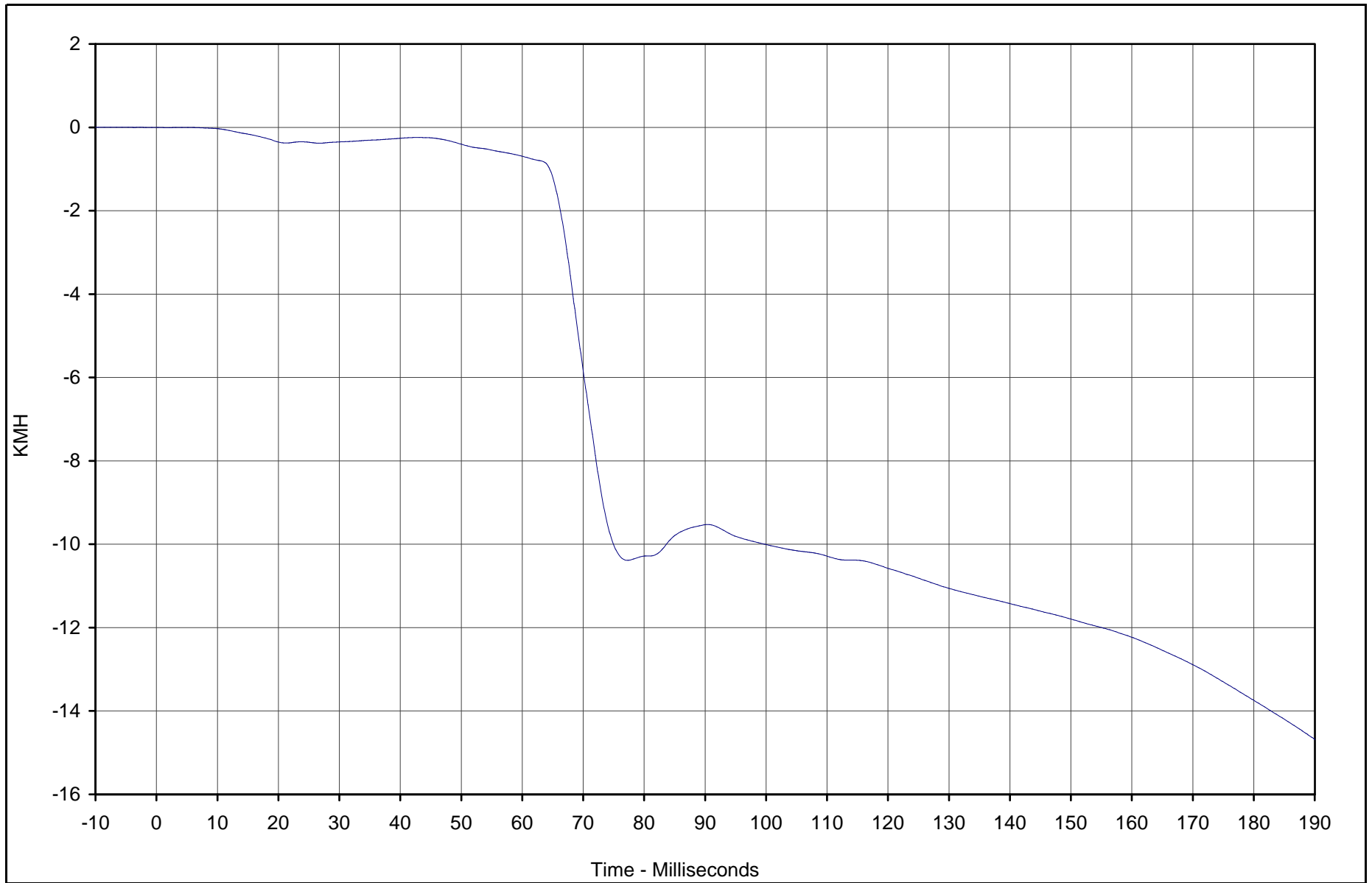

Curve Description	CURNO	Type	Units	Max	Time	Min	Time	SAE Class
Pass. Head Primary X Velocity	023	IN1	KMH	0.0	0.0	-14.7	189.9	180



Test Vehicle: 2003 Toyota 4 Runner SR5 4WD SUV

Test Date: 2/27/03

Test Program: 55/28 km/h Side Impact NCAP

NHTSA No.: M35107

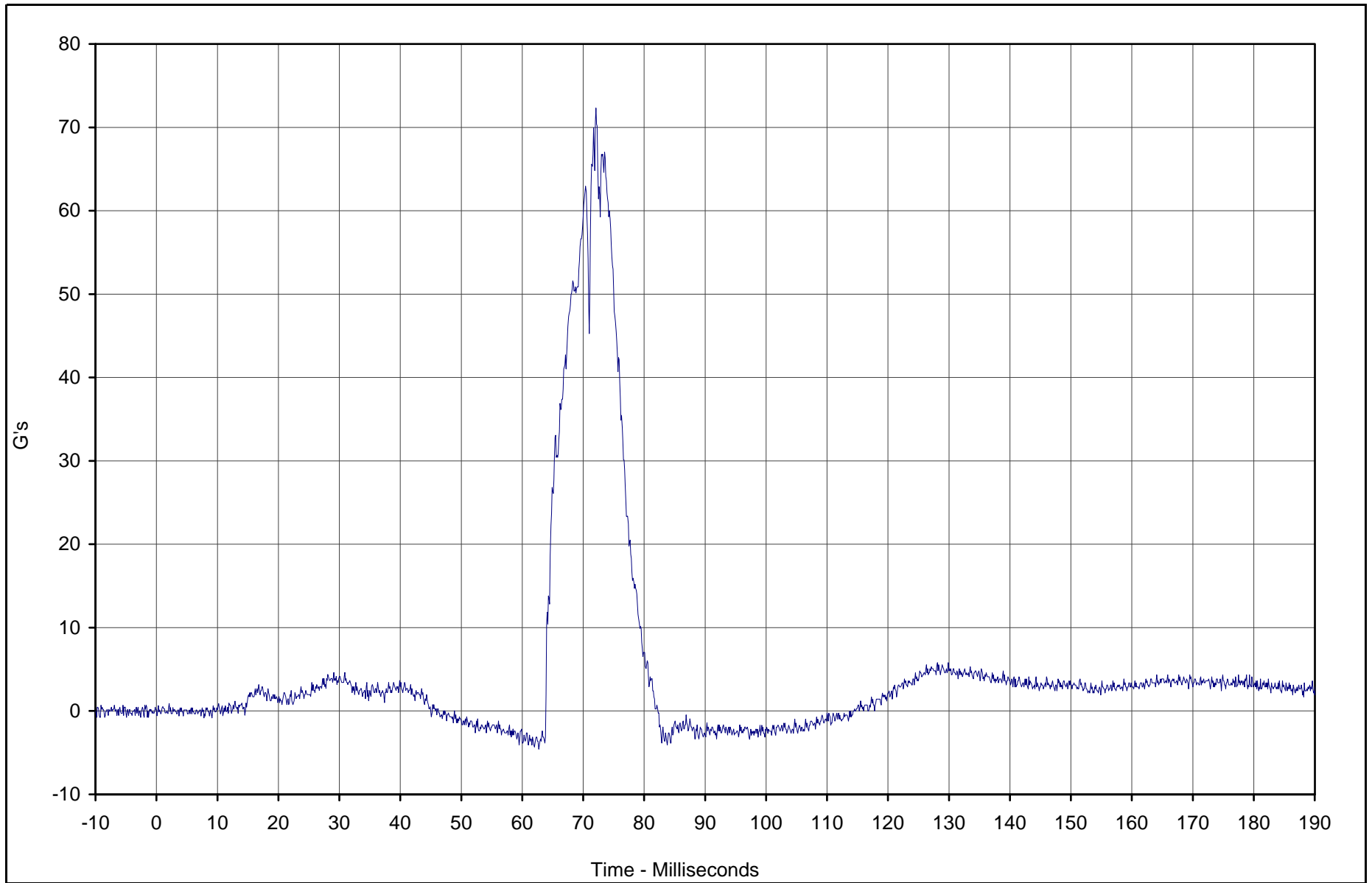

Curve Description	CURNO	Type	Units	Max	Time	Min	Time	SAE Class
Pass. Head Primary Y	024	FIL	G's	72.3	72.1	-4.6	62.7	1000



Test Vehicle: 2003 Toyota 4 Runner SR5 4WD SUV
 Test Program: 55/28 km/h Side Impact NCAP

Test Date: 2/27/03
 NHTSA No.: M35107

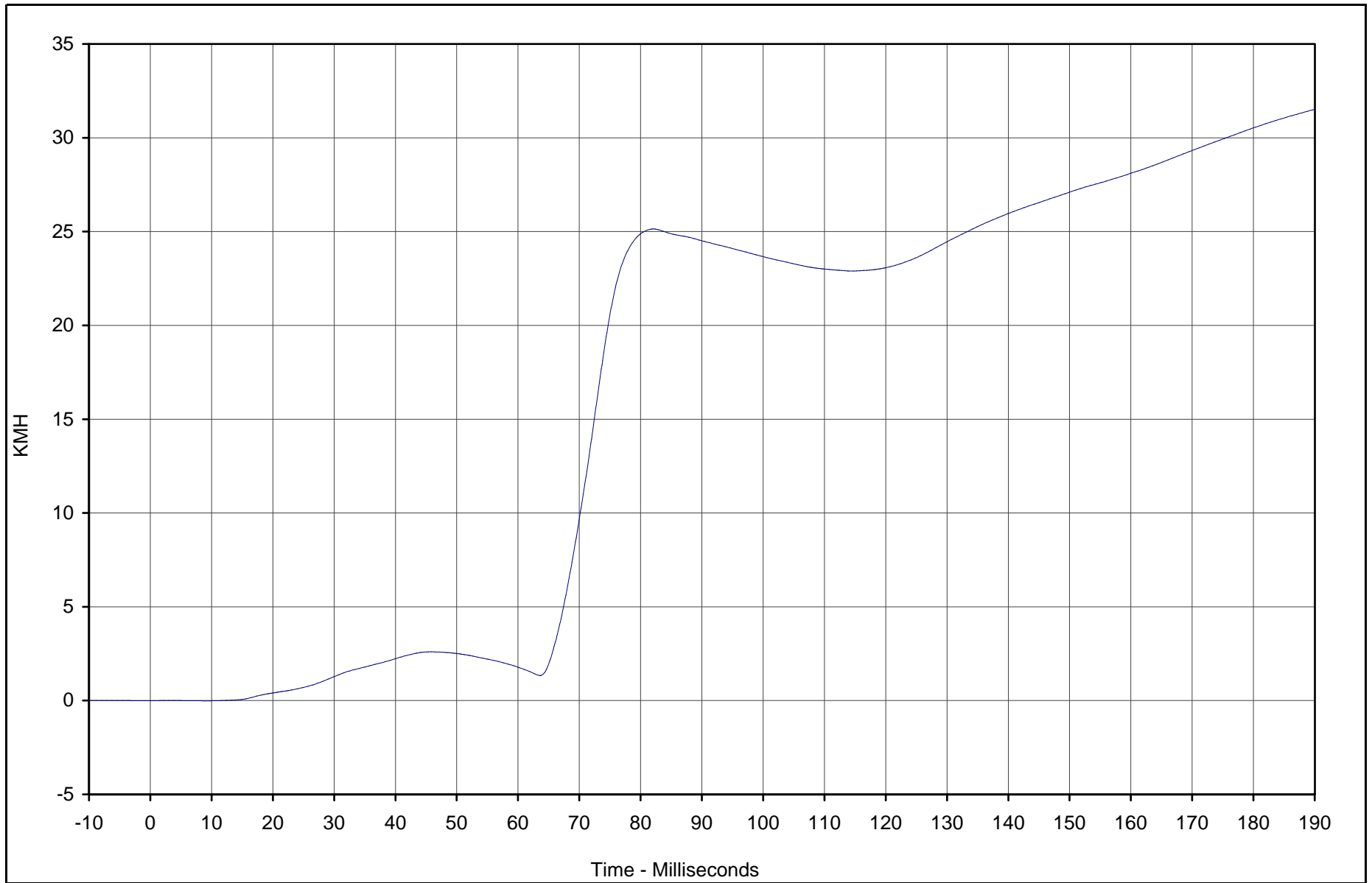

Curve Description	CURNO	Type	Units	Max	Time	Min	Time	SAE Class
Pass. Head Primary Y Velocity	024	IN1	KMH	31.5	189.9	0.0	9.2	180



Test Vehicle: 2003 Toyota 4 Runner SR5 4WD SUV

Test Date: 2/27/03

Test Program: 55/28 km/h Side Impact NCAP

NHTSA No.: M35107

B-45

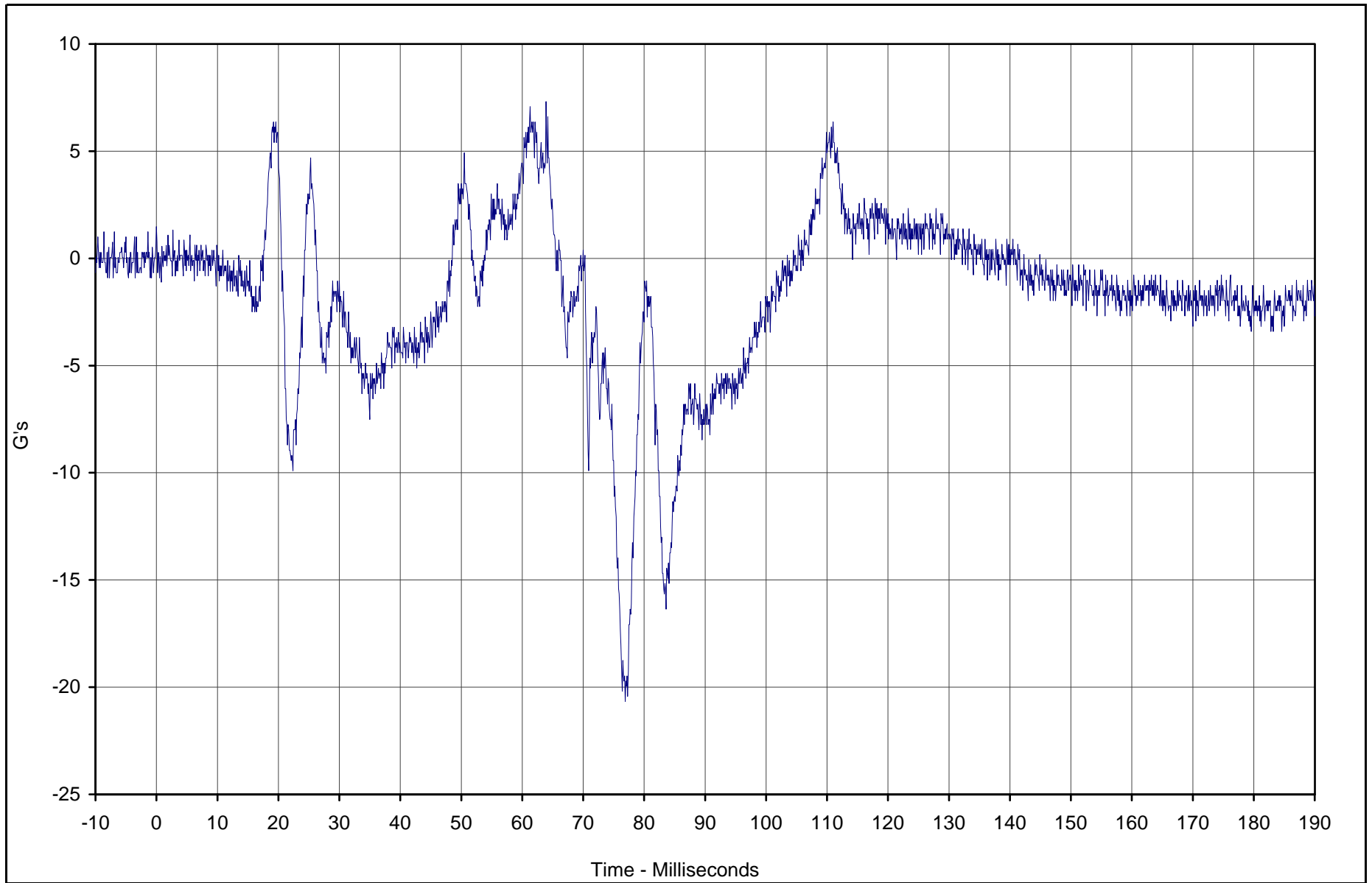

Curve Description	CURNO	Type	Units	Max	Time	Min	Time	SAE Class
Pass. Head Primary Z	025	FIL	G's	7.3	63.9	-20.7	76.9	1000



Test Vehicle: 2003 Toyota 4 Runner SR5 4WD SUV

Test Date: 2/27/03

Test Program: 55/28 km/h Side Impact NCAP

NHTSA No.: M35107

TR-P23003-05-NC

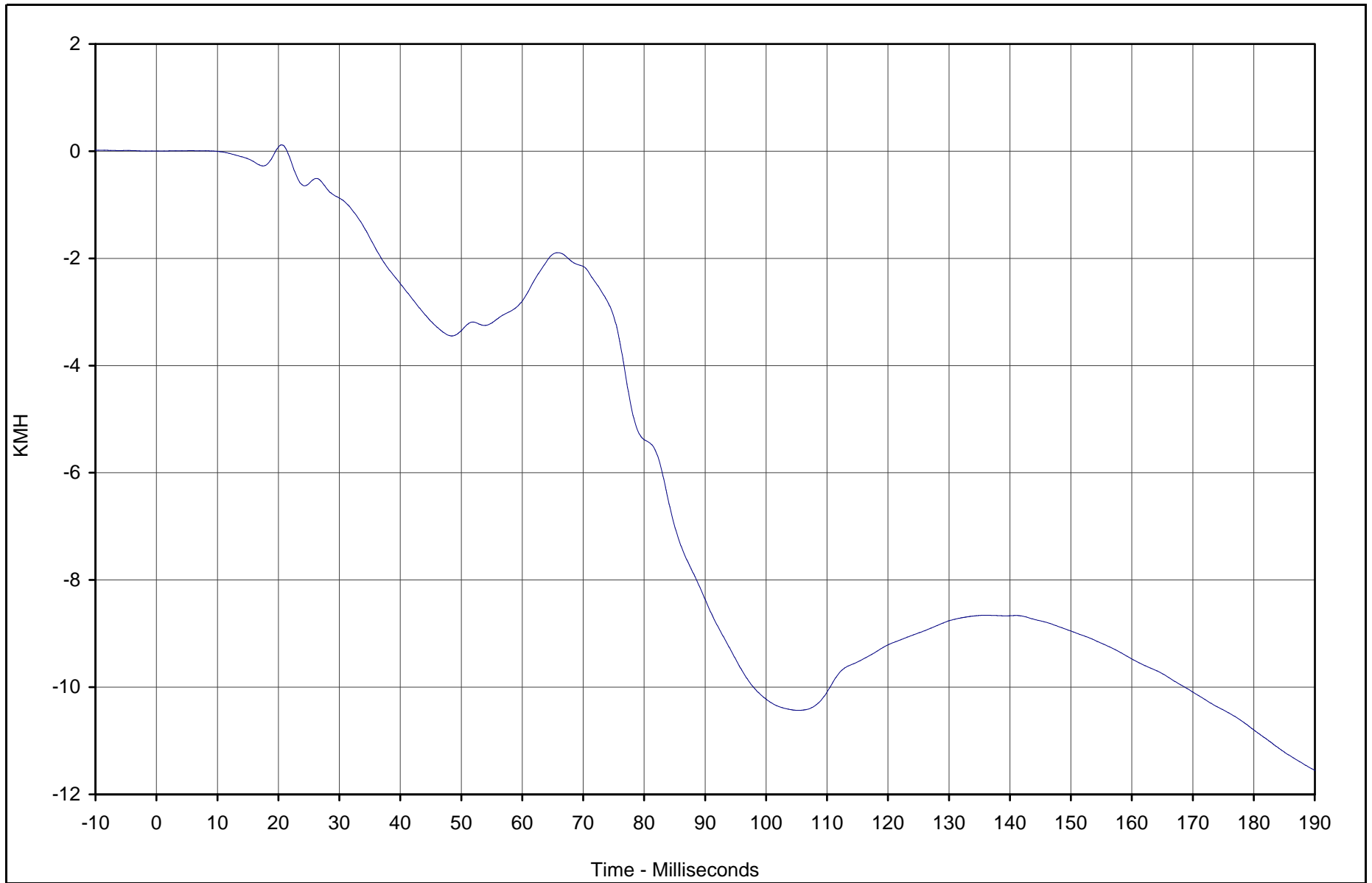

Curve Description	CURNO	Type	Units	Max	Time	Min	Time	SAE Class
Pass. Head Primary Z Velocity	025	IN1	KMH	0.1	20.5	-11.5	189.9	180



Test Vehicle: 2003 Toyota 4 Runner SR5 4WD SUV
 Test Program: 55/28 km/h Side Impact NCAP

Test Date: 2/27/03
 NHTSA No.: M35107

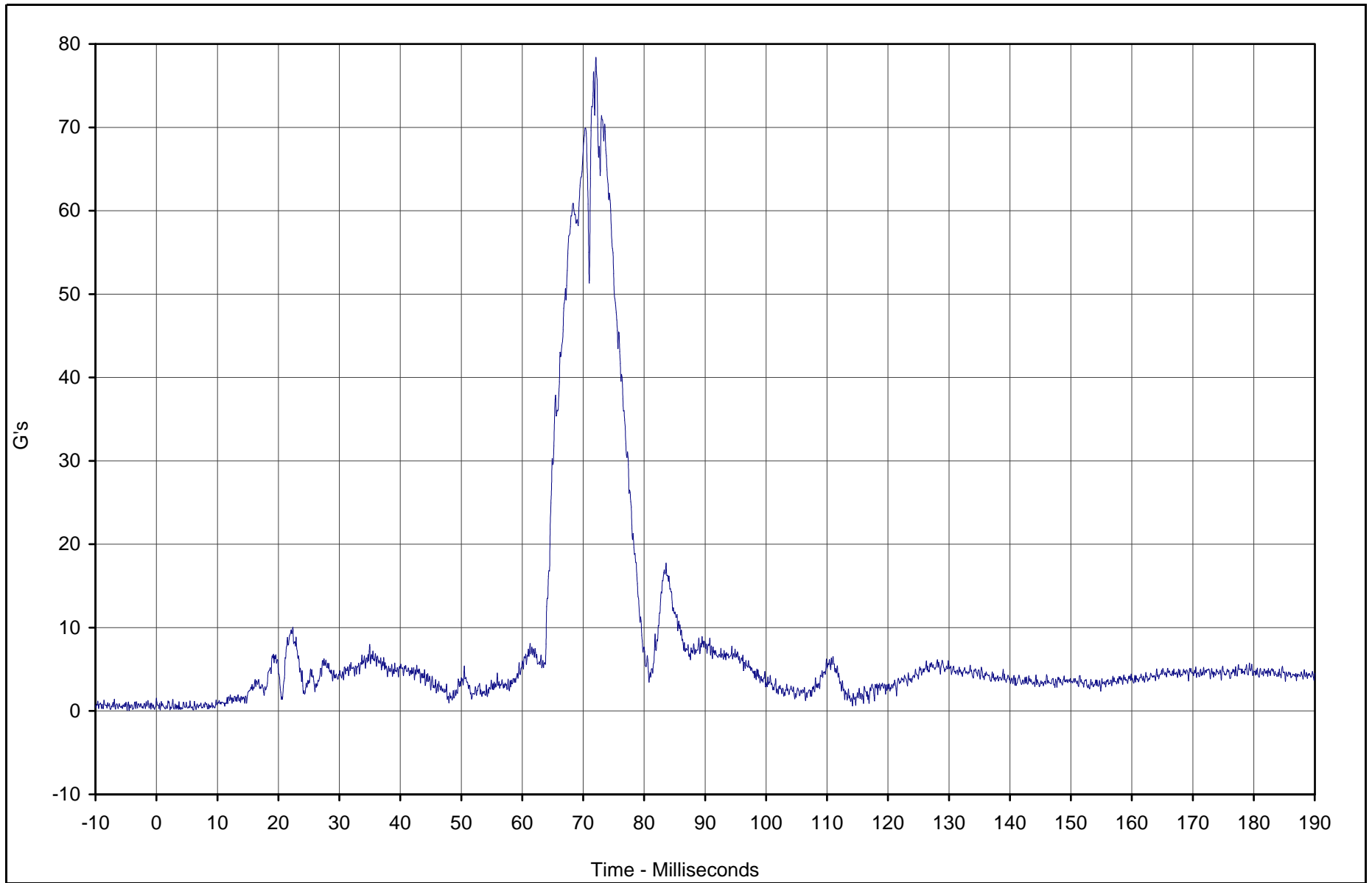

Curve Description	CURNO	Type	Units	Max	Time	Min	Time	SAE Class
Pass. Head Resultant Primary	023	RES	G's	78.4	72.1	0.1	0.6	1000



Test Vehicle: 2003 Toyota 4 Runner SR5 4WD SUV

Test Date: 2/27/03

Test Program: 55/28 km/h Side Impact NCAP

NHTSA No.: M35107

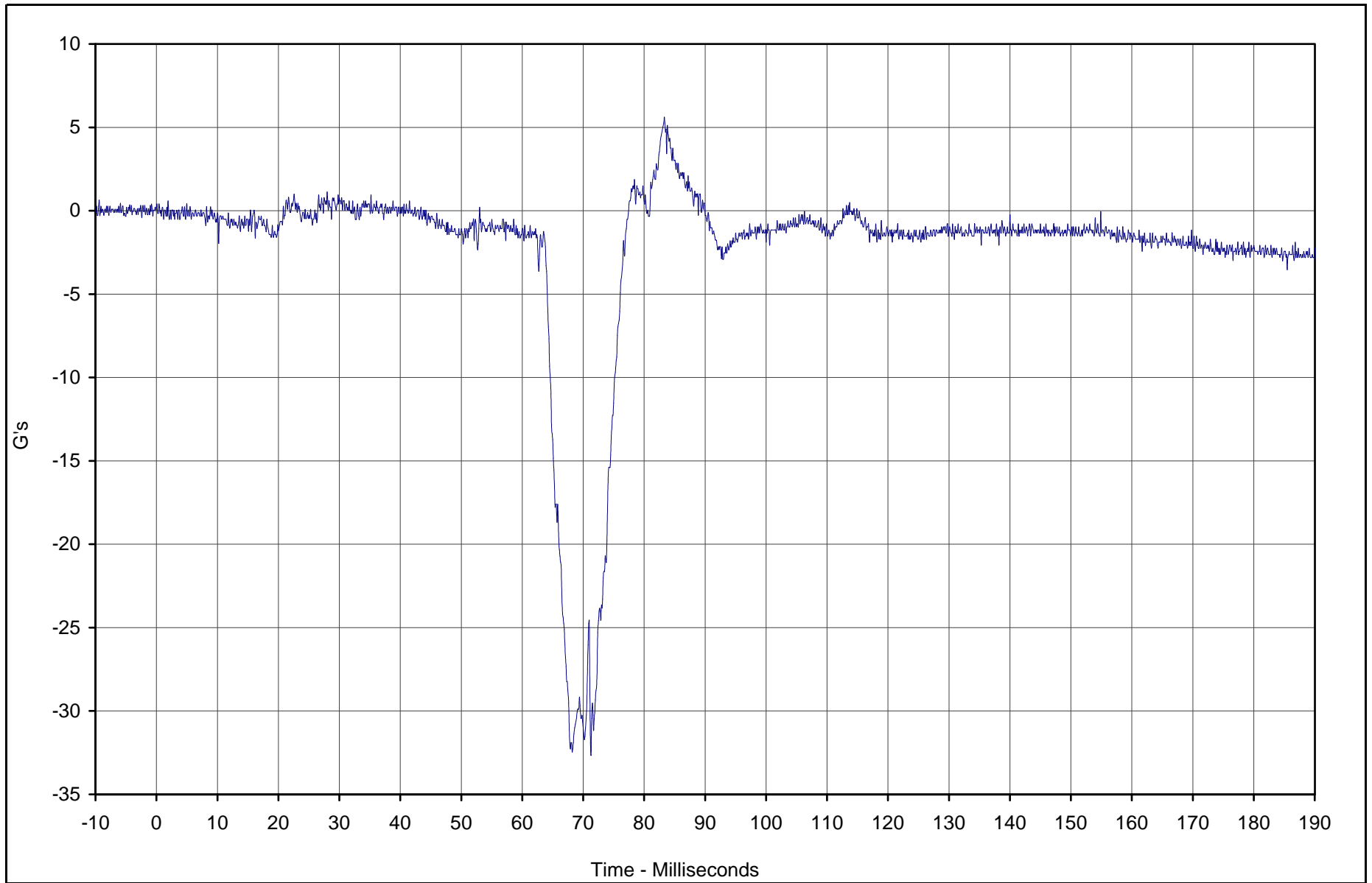

Curve Description	CURNO	Type	Units	Max	Time	Min	Time	SAE Class
Pass. Head Redundant X	026	FIL	G's	5.6	83.3	-32.6	71.3	1000



Test Vehicle: 2003 Toyota 4 Runner SR5 4WD SUV

Test Date: 2/27/03

Test Program: 55/28 km/h Side Impact NCAP

NHTSA No.: M35107

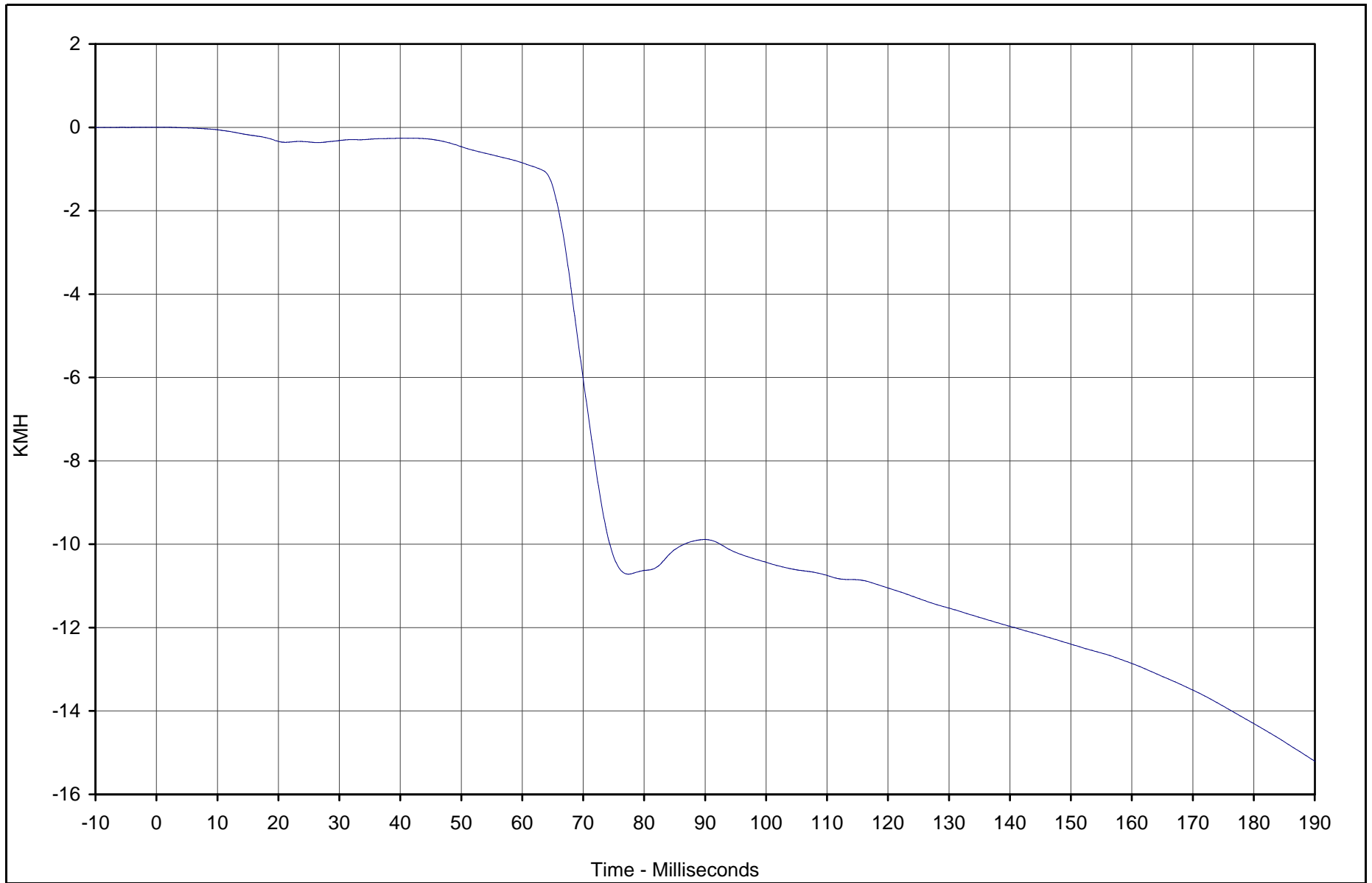

Curve Description	CURNO	Type	Units	Max	Time	Min	Time	SAE Class
Pass. Head Redundant X Velocity	026	IN1	KMH	0.0	0.8	-15.2	189.9	180



Test Vehicle: 2003 Toyota 4 Runner SR5 4WD SUV

Test Date: 2/27/03

Test Program: 55/28 km/h Side Impact NCAP

NHTSA No.: M35107

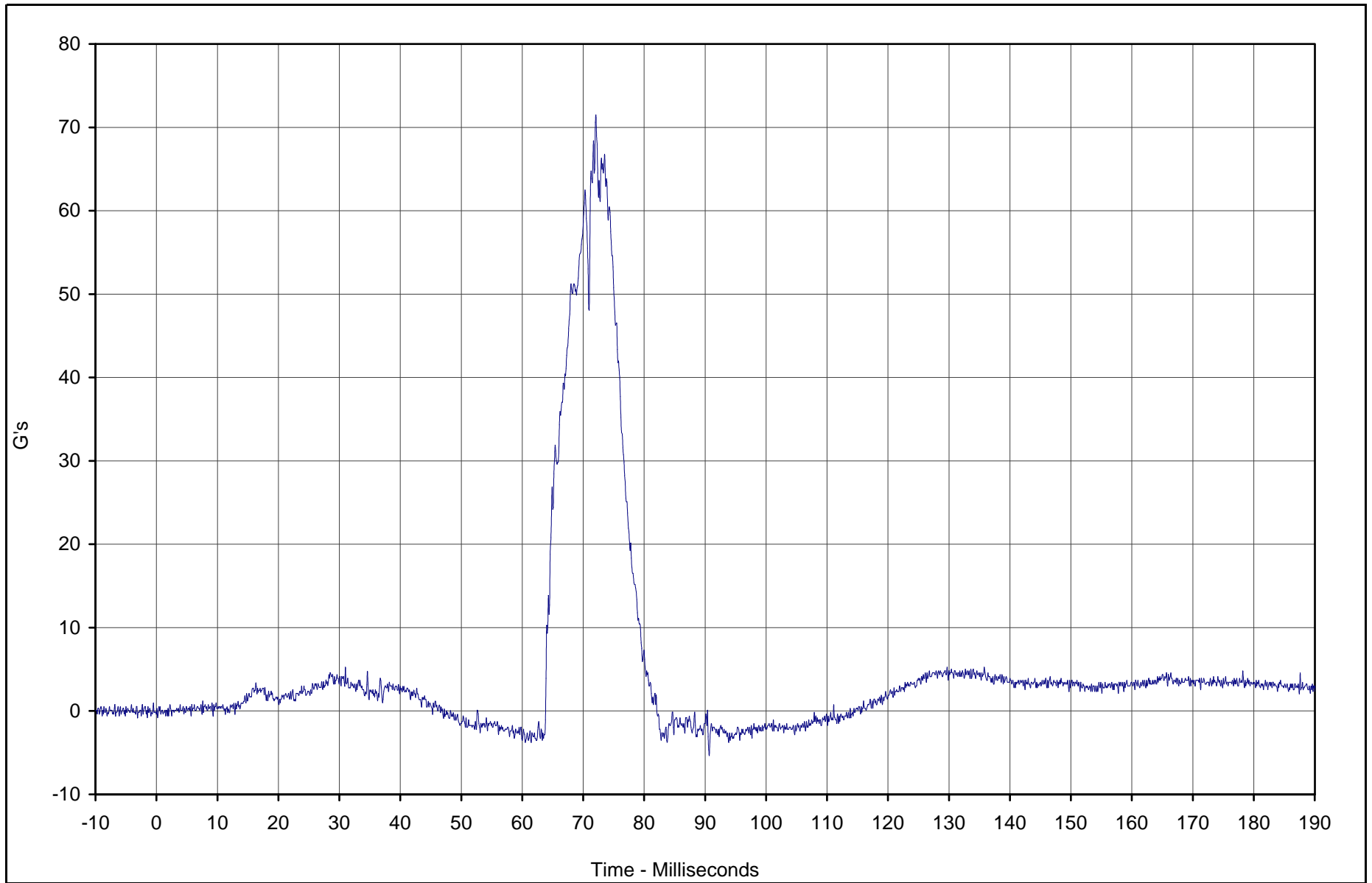

Curve Description	CURNO	Type	Units	Max	Time	Min	Time	SAE Class
Pass. Head Redundant Y	027	FIL	G's	71.5	72.1	-5.3	90.7	1000



Test Vehicle: 2003 Toyota 4 Runner SR5 4WD SUV

Test Date: 2/27/03

Test Program: 55/28 km/h Side Impact NCAP

NHTSA No.: M35107

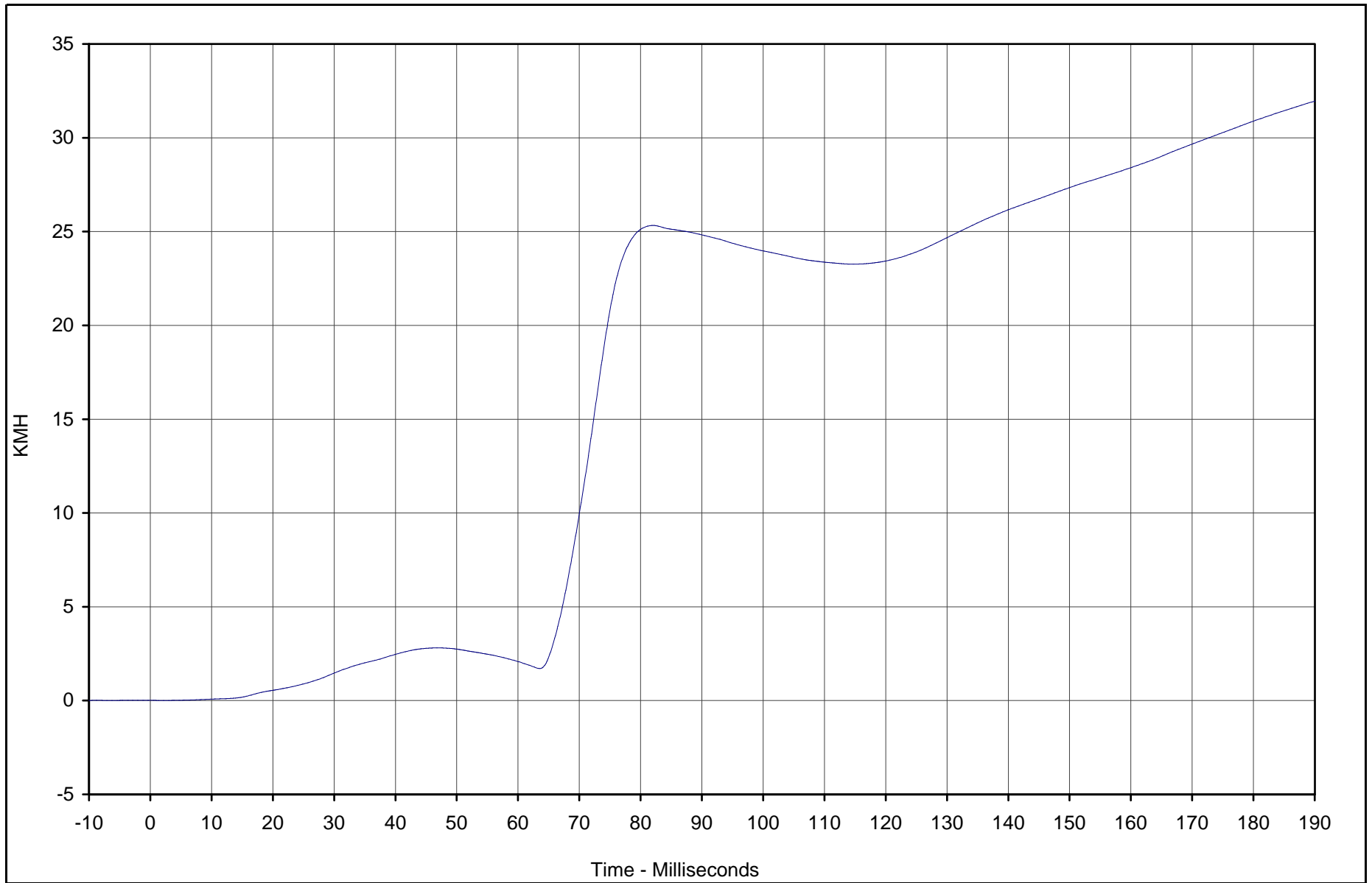

Curve Description	CURNO	Type	Units	Max	Time	Min	Time	SAE Class
Pass. Head Redundant Y Velocity	027	IN1	KMH	31.9	189.9	0.0	2.3	180



Test Vehicle: 2003 Toyota 4 Runner SR5 4WD SUV

Test Date: 2/27/03

Test Program: 55/28 km/h Side Impact NCAP

NHTSA No.: M35107

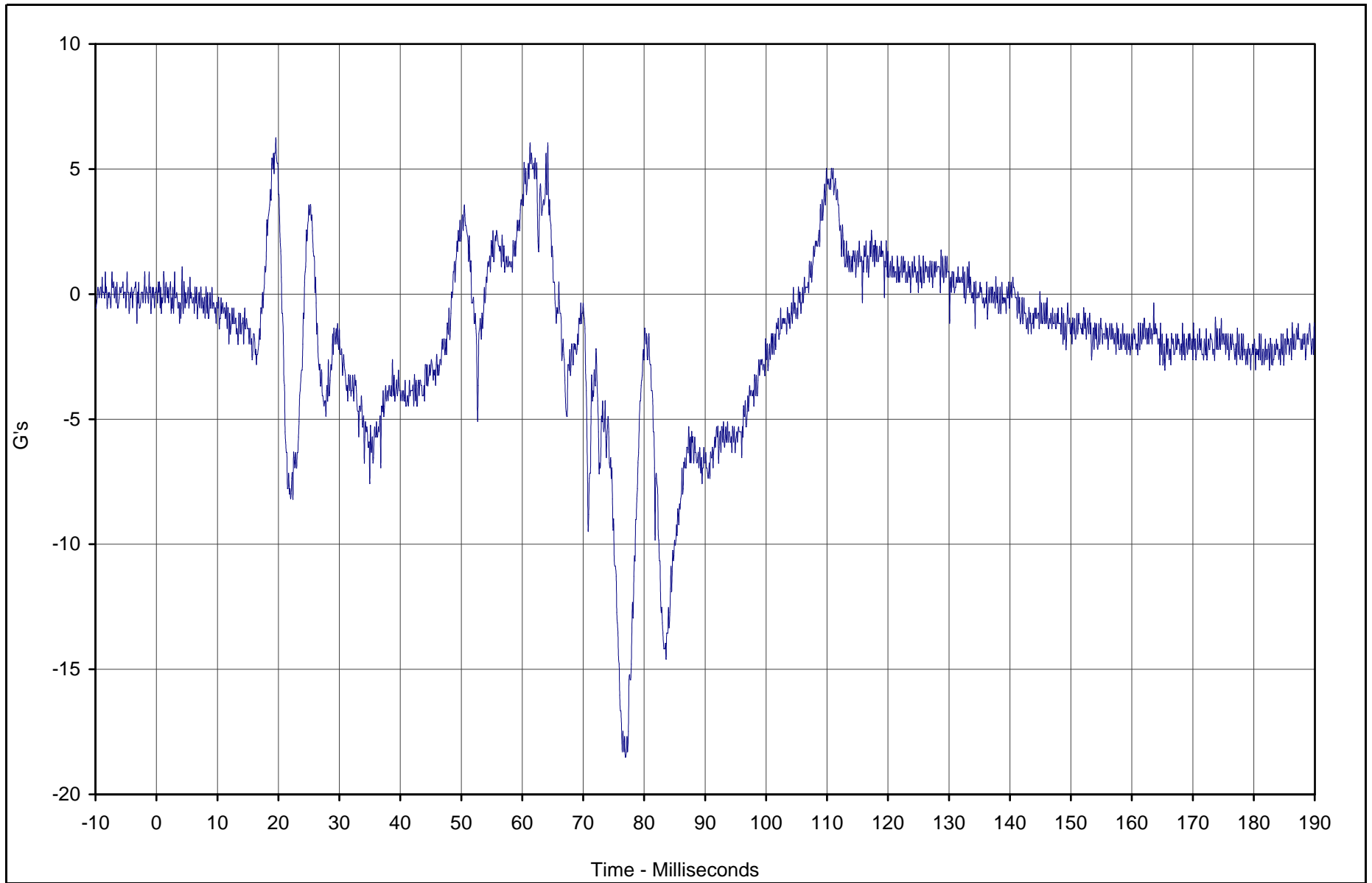

Curve Description	CURNO	Type	Units	Max	Time	Min	Time	SAE Class
Pass. Head Redundant Z	028	FIL	G's	6.3	19.6	-18.5	76.9	1000



Test Vehicle: 2003 Toyota 4 Runner SR5 4WD SUV

Test Date: 2/27/03

Test Program: 55/28 km/h Side Impact NCAP

NHTSA No.: M35107

B-53

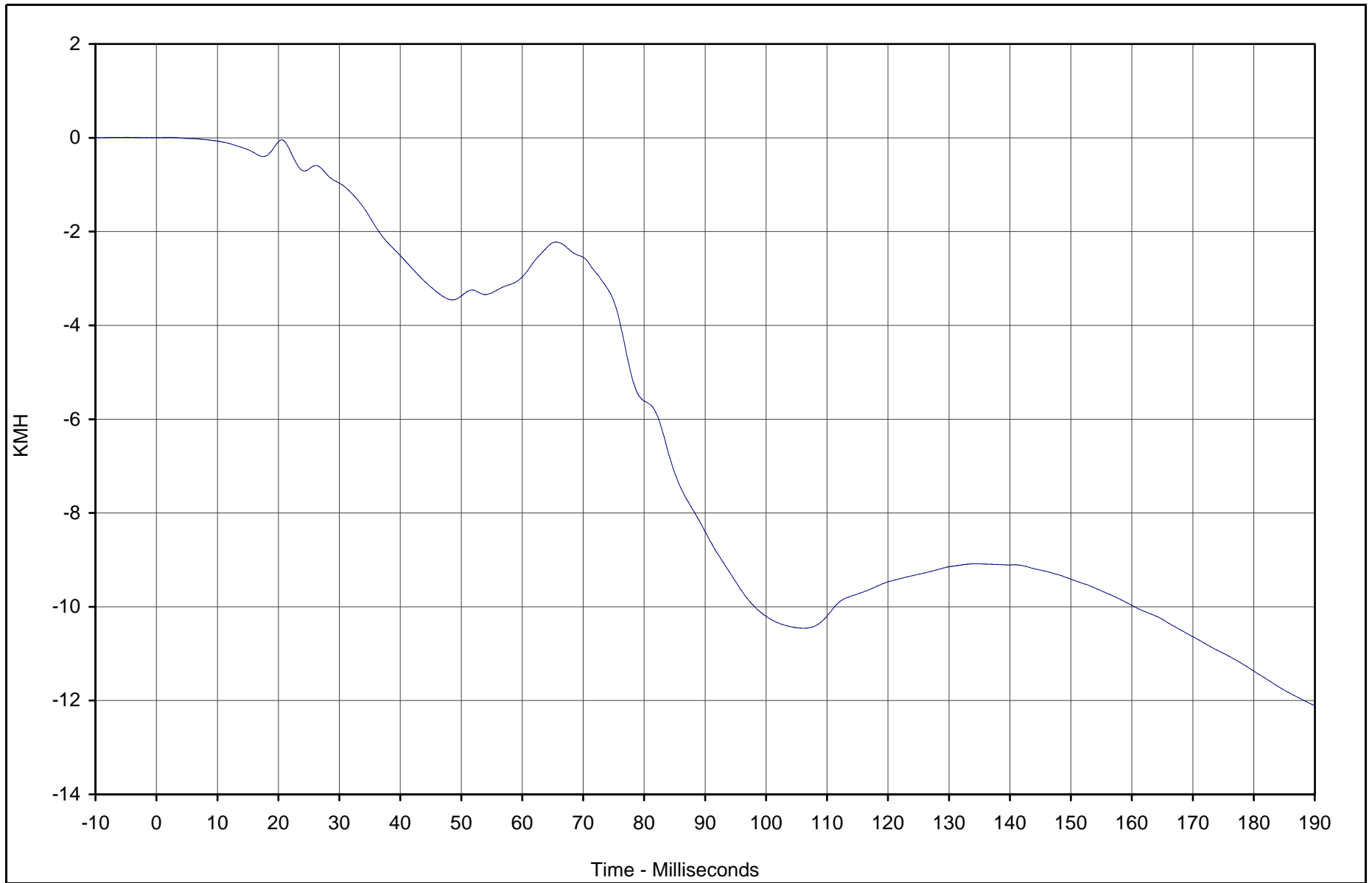

Curve Description	CURNO	Type	Units	Max	Time	Min	Time	SAE Class
Pass. Head Redundant Z Velocity	028	IN1	KMH	0.0	2.1	-12.1	189.9	180



Test Vehicle: 2003 Toyota 4 Runner SR5 4WD SUV

Test Date: 2/27/03

Test Program: 55/28 km/h Side Impact NCAP

NHTSA No.: M35107

TR-P23003-05-NC

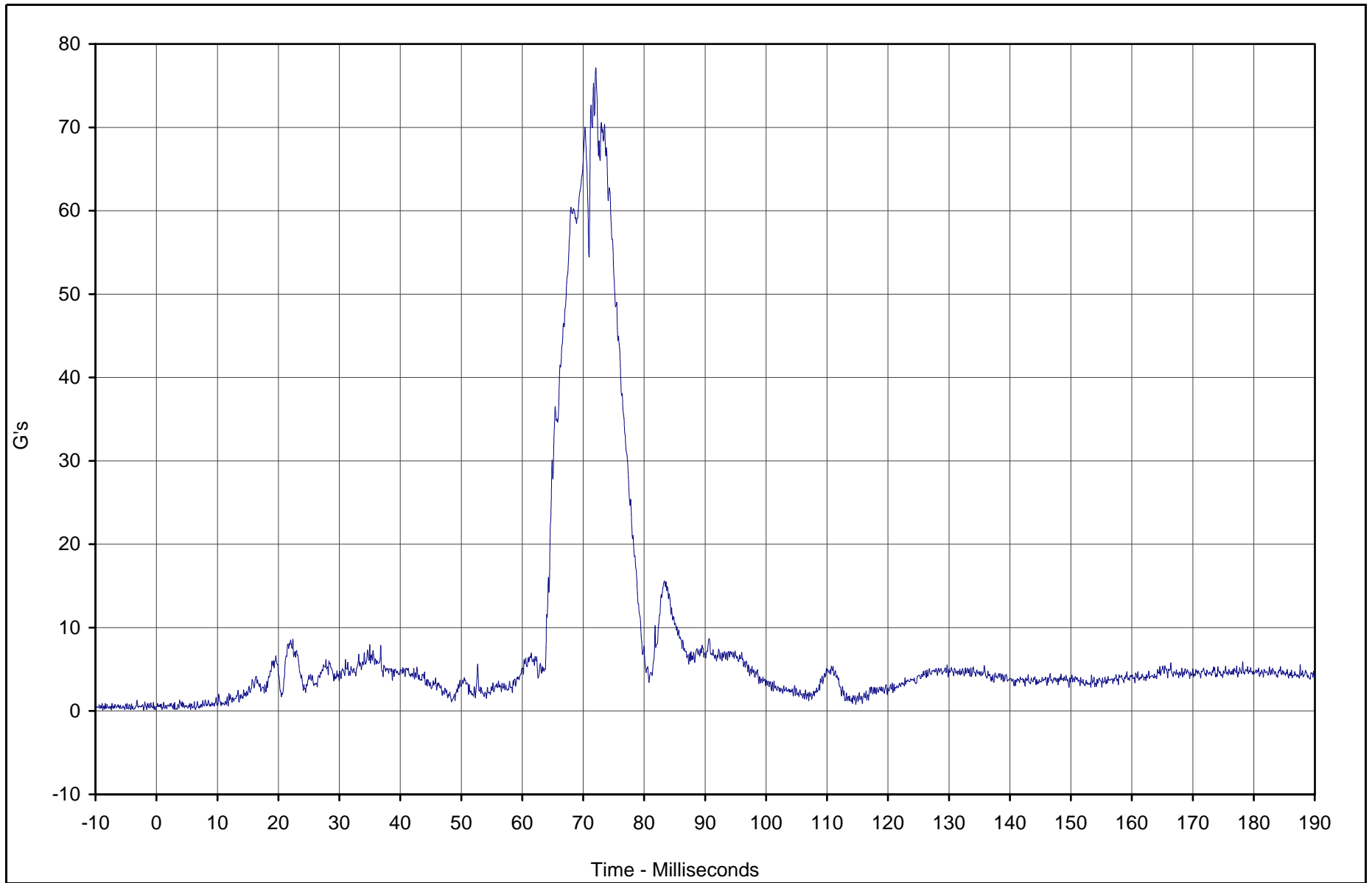

Curve Description	CURNO	Type	Units	Max	Time	Min	Time	SAE Class
Pass. Head Resultant Redundant	026	RES	G's	77.1	72.1	0.2	0.9	1000



Test Vehicle: 2003 Toyota 4 Runner SR5 4WD SUV

Test Date: 2/27/03

Test Program: 55/28 km/h Side Impact NCAP

NHTSA No.: M35107

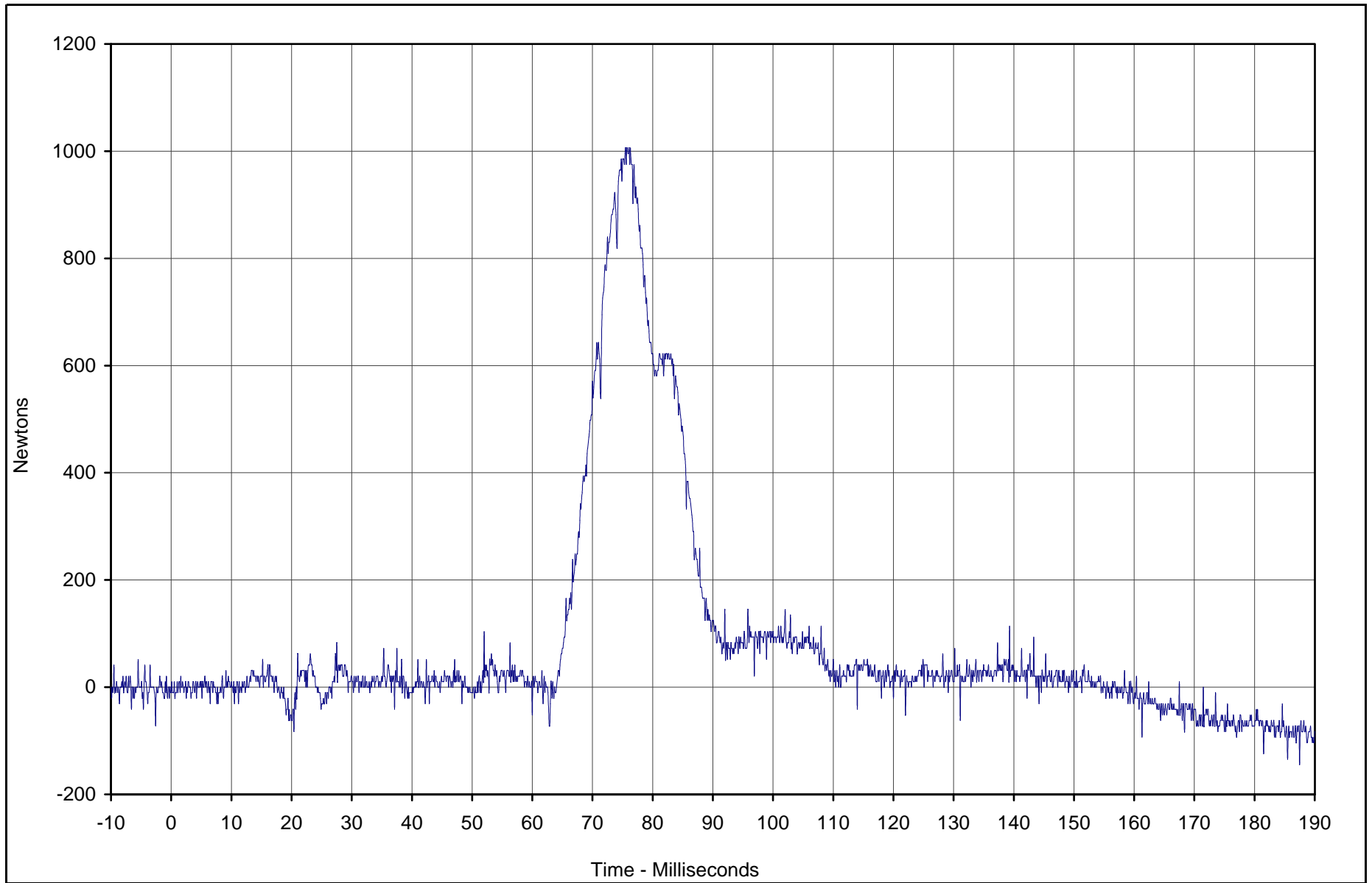

Curve Description	CURNO	Type	Units	Max	Time	Min	Time	SAE Class
Pass. Neck Force X	029	FIL	Newtons	1006.1	75.5	-145.2	187.5	1000



Test Vehicle: 2003 Toyota 4 Runner SR5 4WD SUV

Test Date: 2/27/03

Test Program: 55/28 km/h Side Impact NCAP

NHTSA No.: M35107

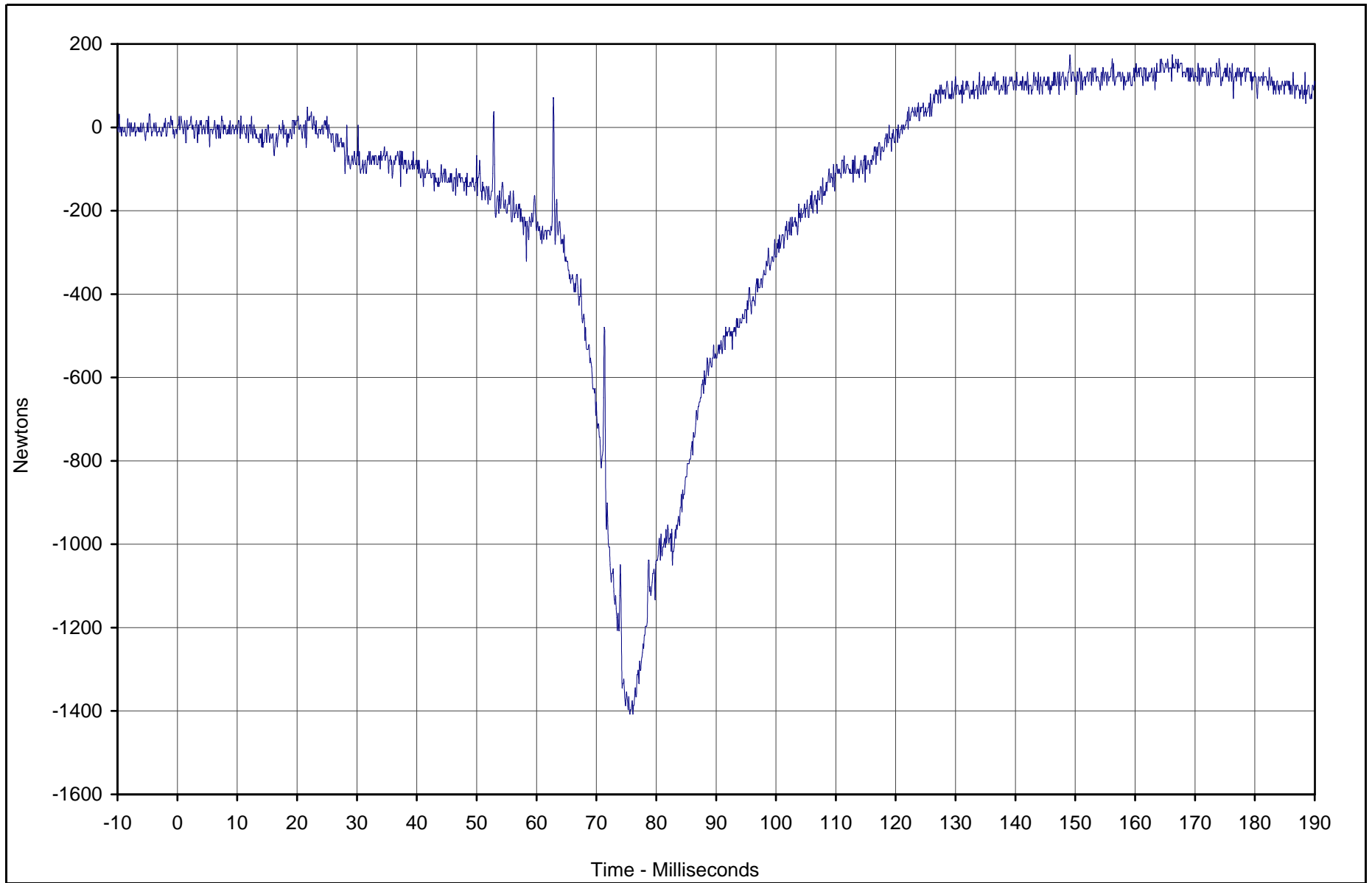

Curve Description	CURNO	Type	Units	Max	Time	Min	Time	SAE Class
Pass. Neck Force Y	030	FIL	Newtons	174.3	149.1	-1407.6	75.6	1000



Test Vehicle: 2003 Toyota 4 Runner SR5 4WD SUV

Test Date: 2/27/03

Test Program: 55/28 km/h Side Impact NCAP

NHTSA No.: M35107

B-57

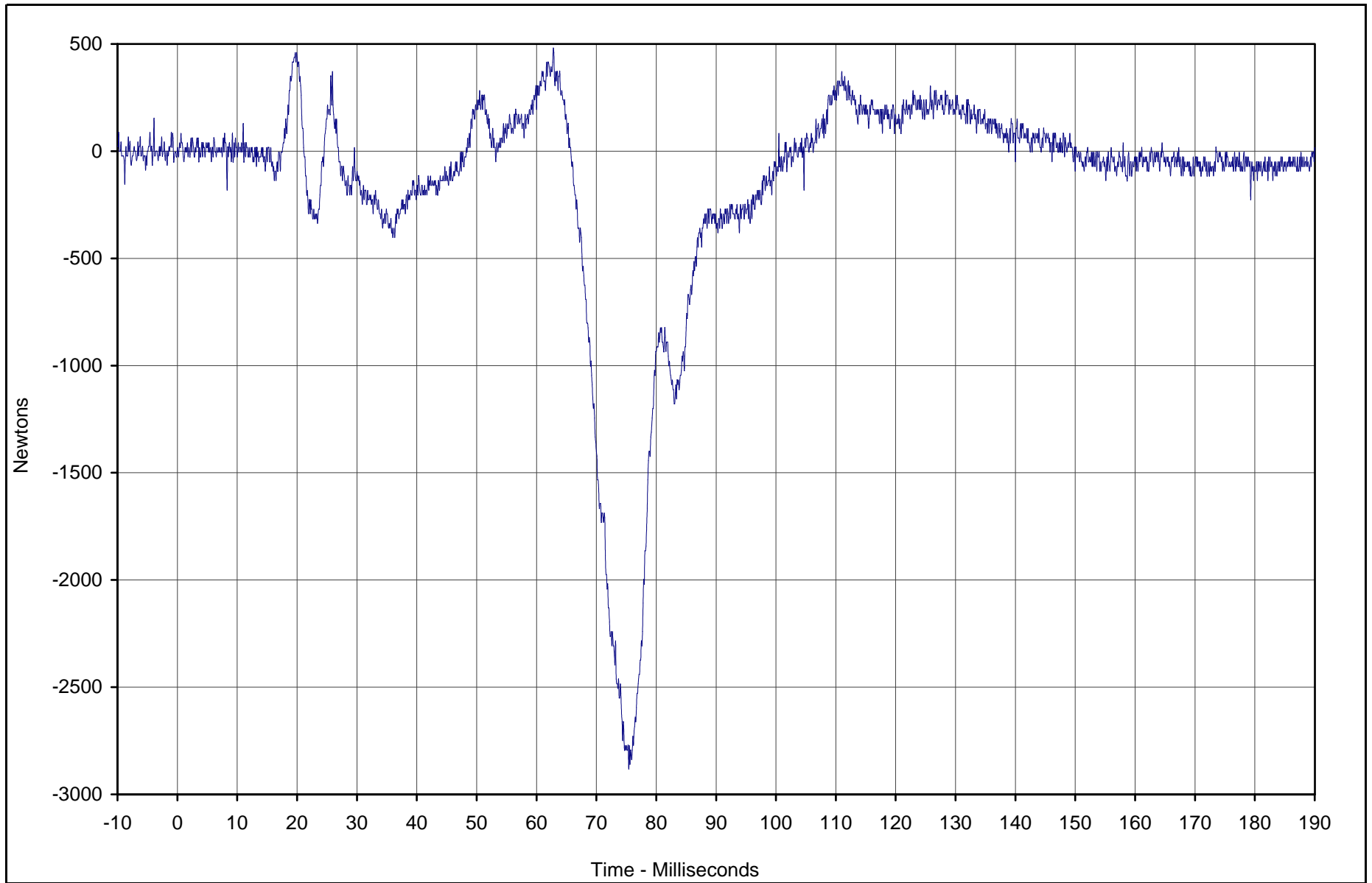

Curve Description	CURNO	Type	Units	Max	Time	Min	Time	SAE Class
Pass. Neck Force Z	031	FIL	Newtons	482.0	62.8	-2882.7	75.4	1000



Test Vehicle: 2003 Toyota 4 Runner SR5 4WD SUV

Test Date: 2/27/03

Test Program: 55/28 km/h Side Impact NCAP

NHTSA No.: M35107

TR-P23003-05-NC

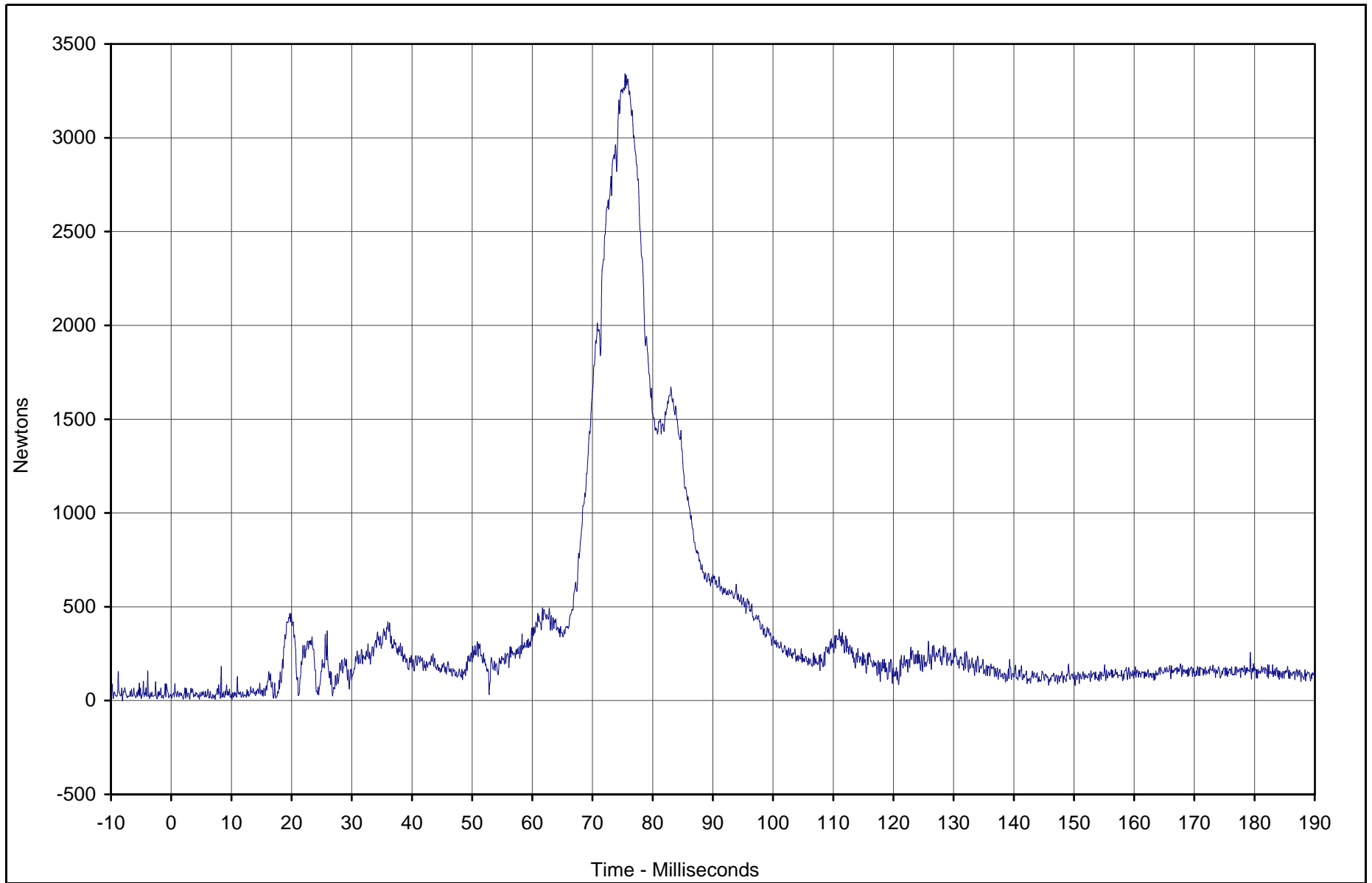

Curve Description	CURNO	Type	Units	Max	Time	Min	Time	SAE Class
Pass. Neck Force Resultant	029	RES	Newtons	3341.5	75.4	7.1	4.7	1000



Test Vehicle: 2003 Toyota 4 Runner SR5 4WD SUV

Test Date: 2/27/03

Test Program: 55/28 km/h Side Impact NCAP

NHTSA No.: M35107

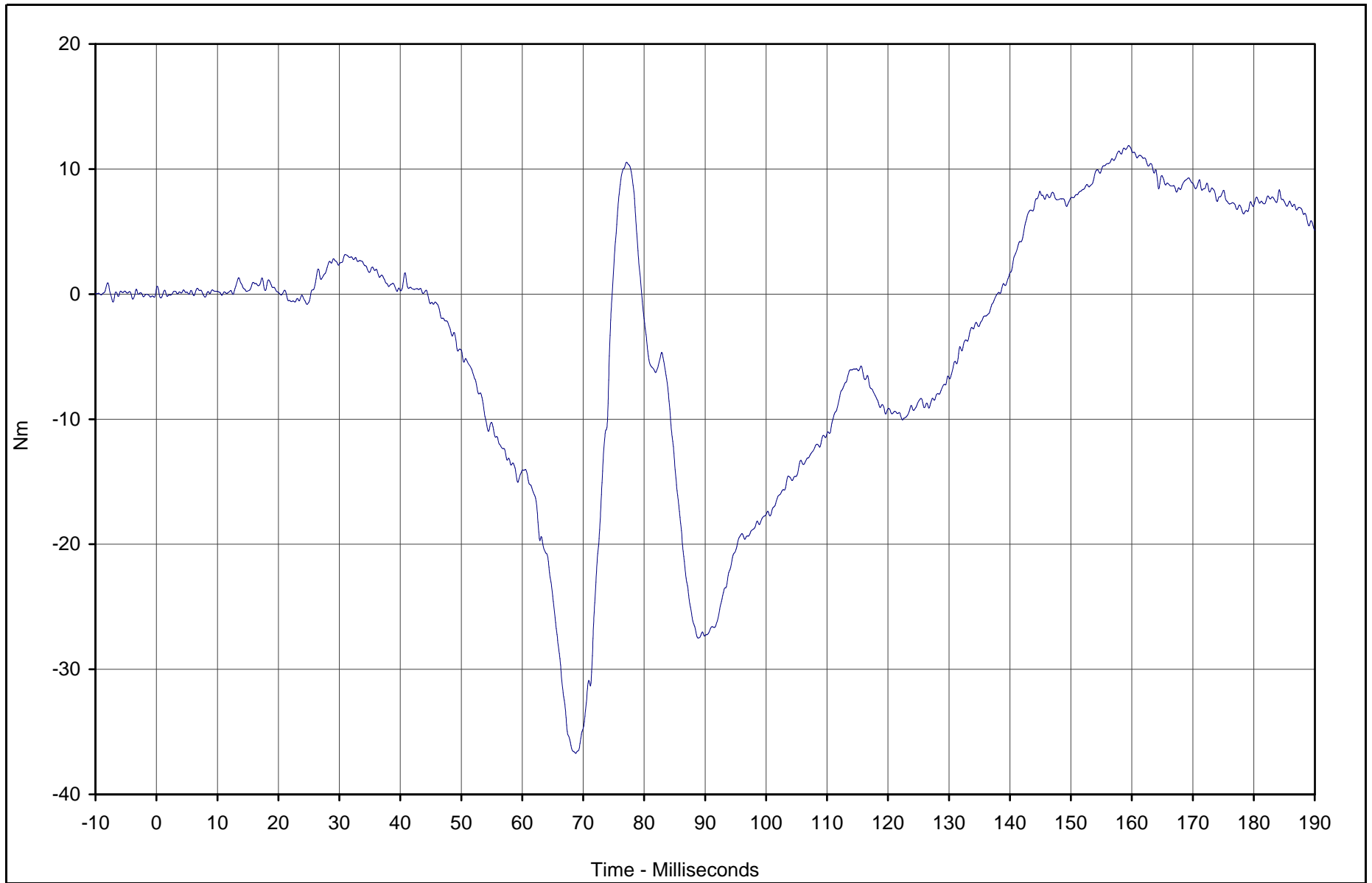

Curve Description	CURNO	Type	Units	Max	Time	Min	Time	SAE Class
Pass. Neck Moment X	032	FIL	Nm	11.9	159.5	-36.7	68.8	600



Test Vehicle: 2003 Toyota 4 Runner SR5 4WD SUV

Test Date: 2/27/03

Test Program: 55/28 km/h Side Impact NCAP

NHTSA No.: M35107

B-60

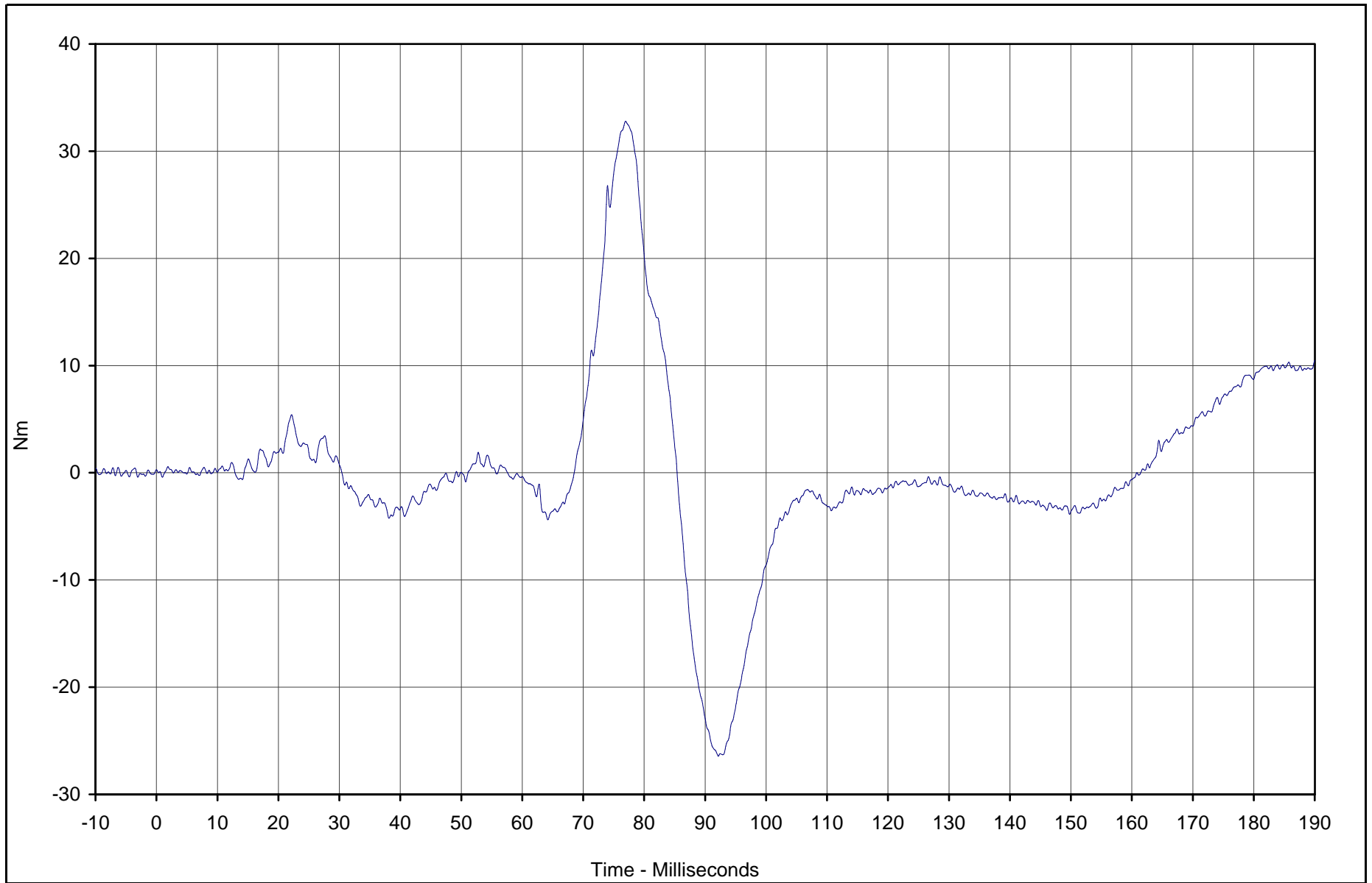

Curve Description	CURNO	Type	Units	Max	Time	Min	Time	SAE Class
Pass. Neck Moment Y	033	FIL	Nm	32.8	77.0	-26.4	92.1	600



Test Vehicle: 2003 Toyota 4 Runner SR5 4WD SUV

Test Date: 2/27/03

Test Program: 55/28 km/h Side Impact NCAP

NHTSA No.: M35107

TR-P23003-05-NC

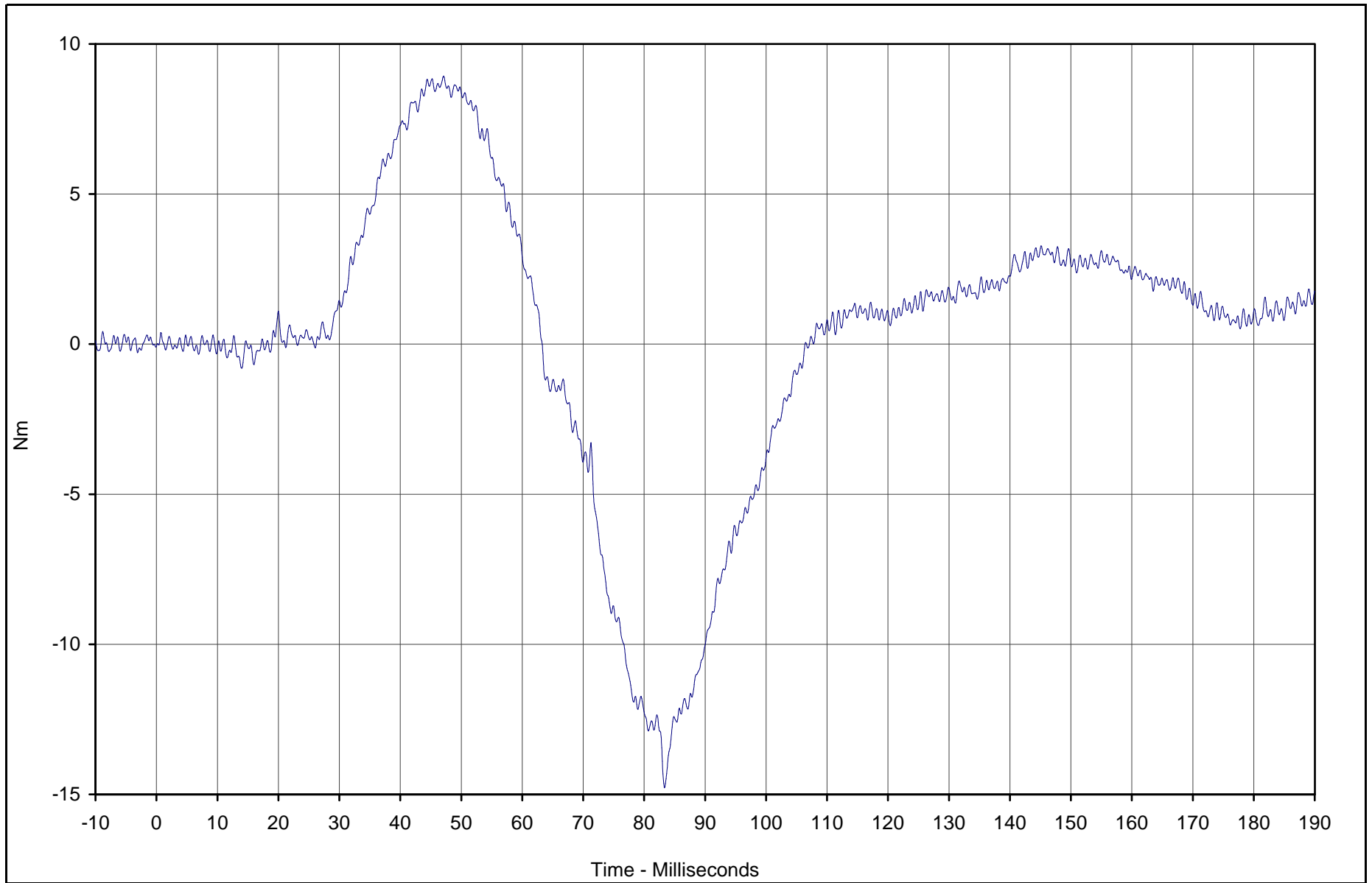

Curve Description	CURNO	Type	Units	Max	Time	Min	Time	SAE Class
Pass. Neck Moment Z	034	FIL	Nm	8.9	47.1	-14.8	83.3	600



Test Vehicle: 2003 Toyota 4 Runner SR5 4WD SUV

Test Date: 2/27/03

Test Program: 55/28 km/h Side Impact NCAP

NHTSA No.: M35107

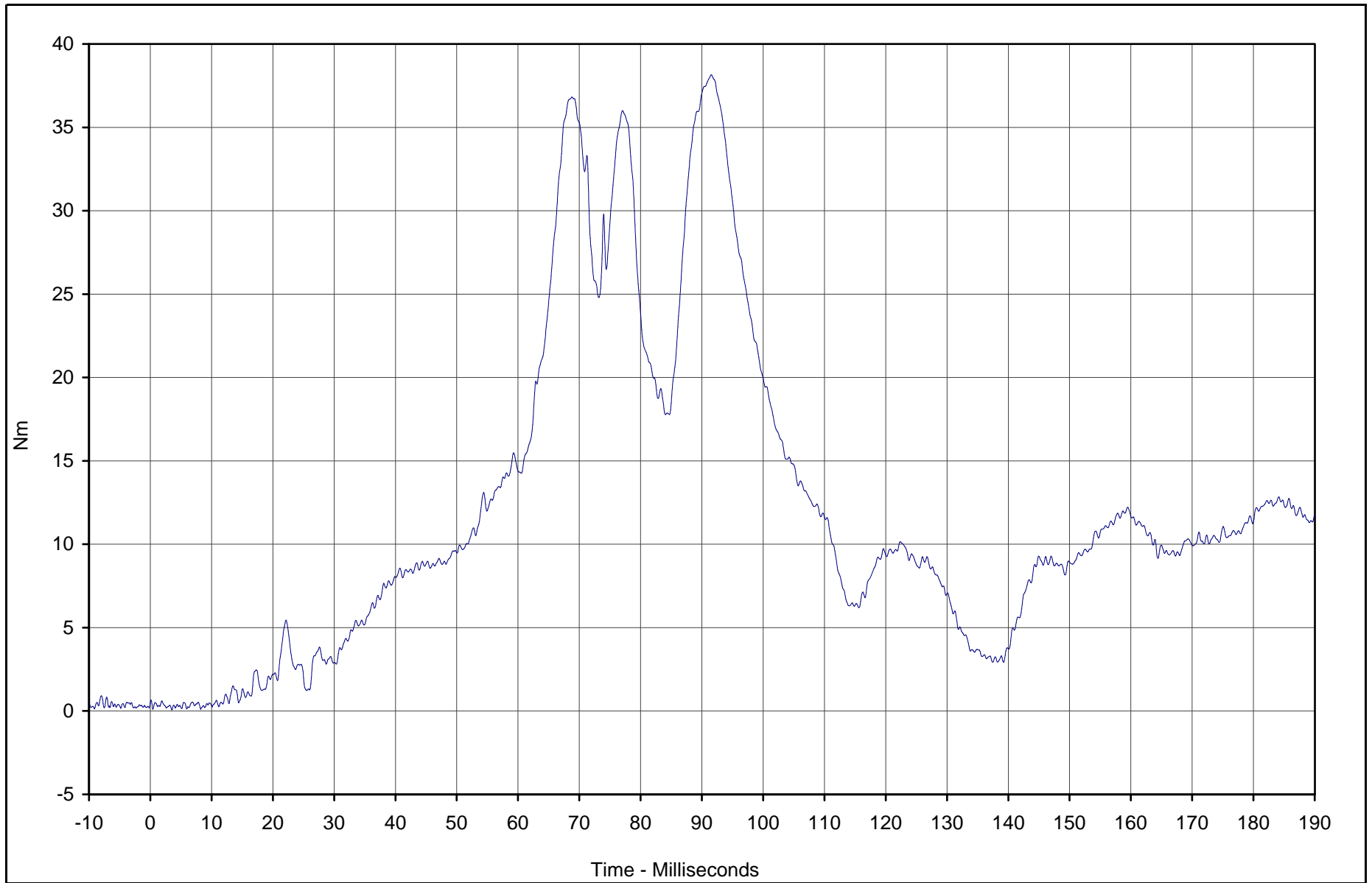

Curve Description	CURNO	Type	Units	Max	Time	Min	Time	SAE Class
Pass. Neck Moment Resultant	032	RES	Nm	38.2	91.5	0.1	3.5	600



Test Vehicle: 2003 Toyota 4 Runner SR5 4WD SUV

Test Date: 2/27/03

Test Program: 55/28 km/h Side Impact NCAP

NHTSA No.: M35107

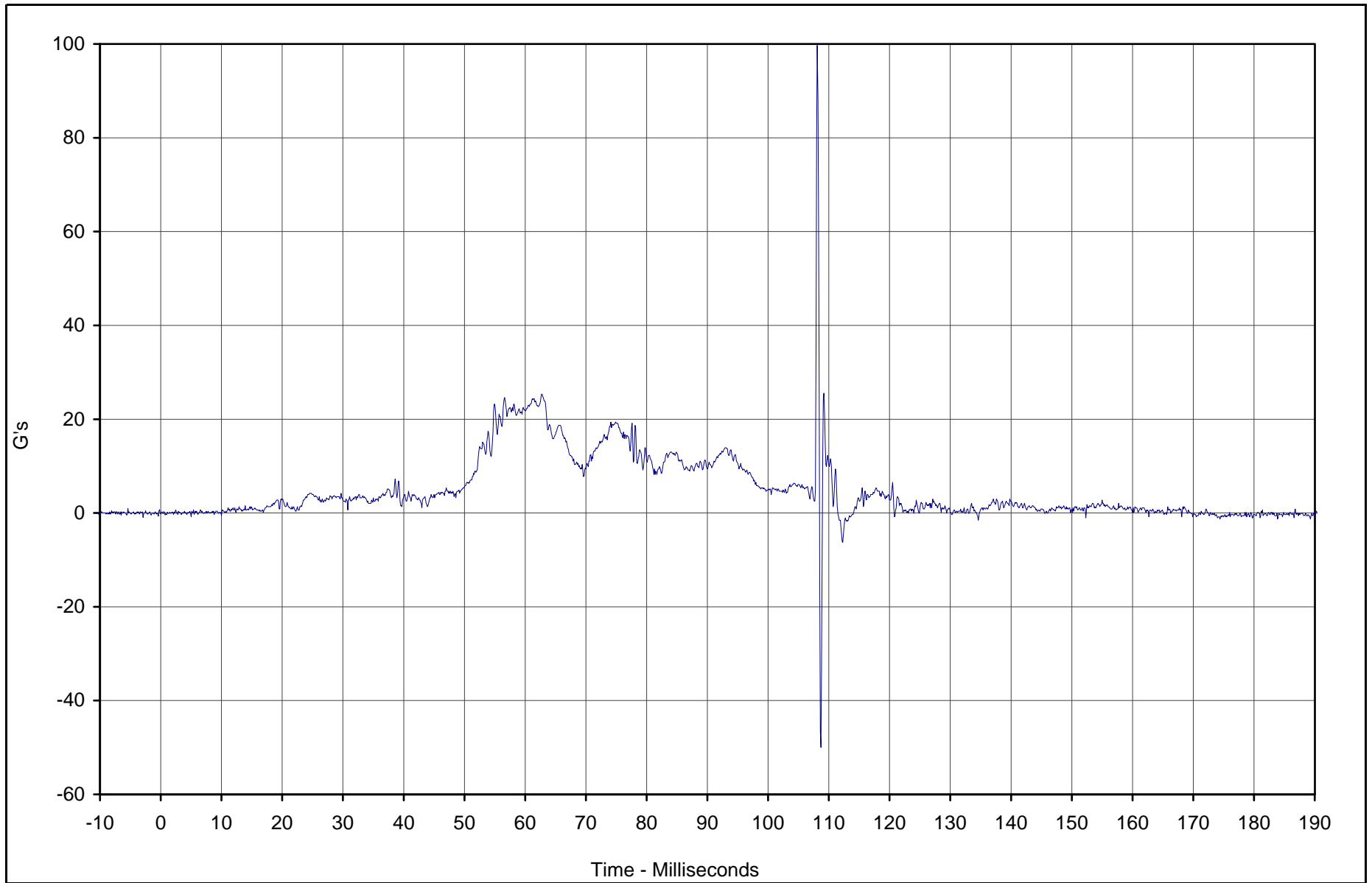

Curve Description	CURNO	Type	Units	Max	Time	Min	Time	SAE Class
Pass. Upper Rib Primary Y	035	FIL	G's	99.7	108.1	-50.0	108.7	1000



Test Vehicle: 2003 Toyota 4 Runner SR5 4WD SUV

Test Date: 2/27/03

Test Program: 55/28 km/h Side Impact NCAP

NHTSA No.: M35107

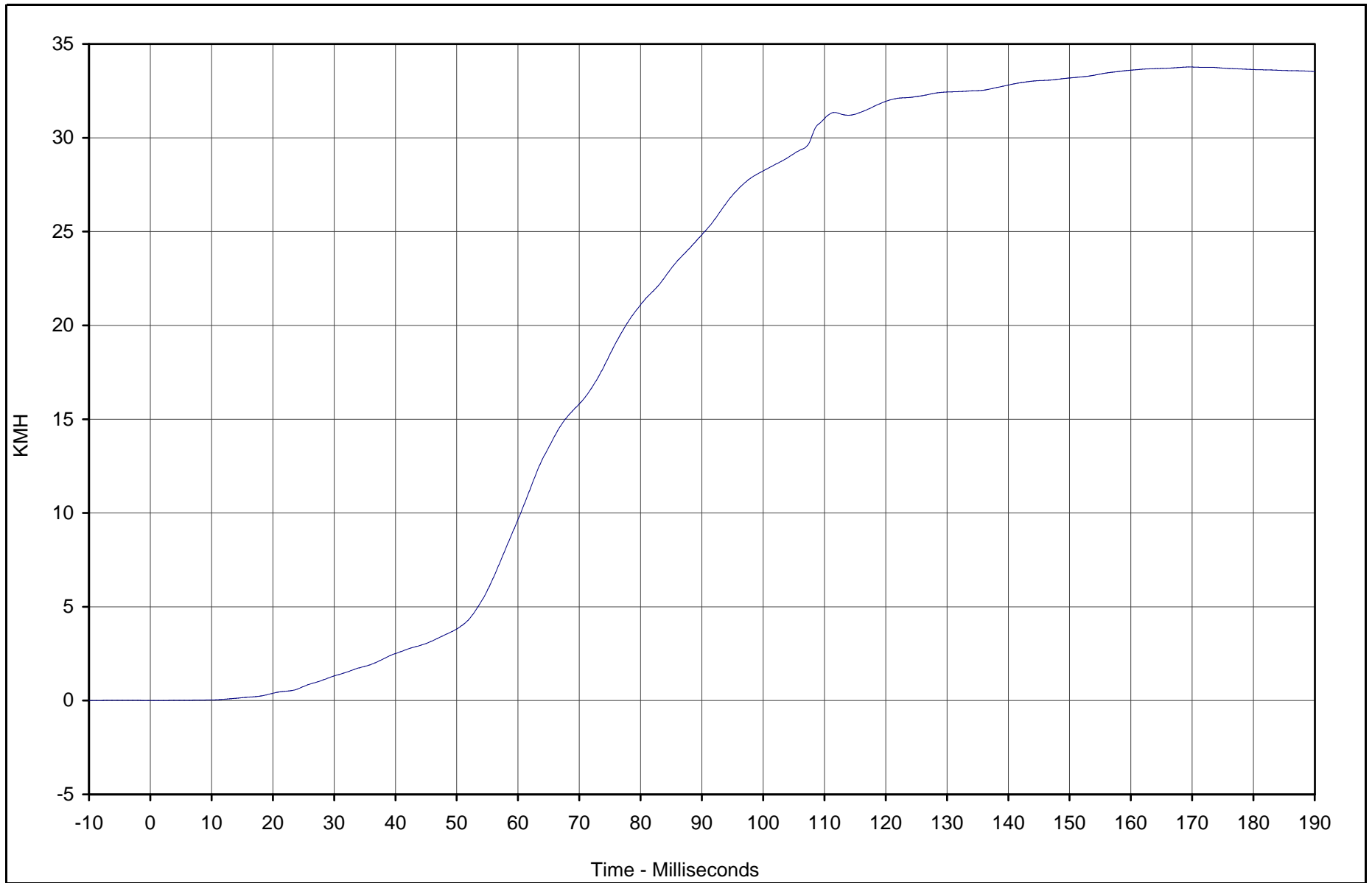

Curve Description	CURNO	Type	Units	Max	Time	Min	Time	SAE Class
Pass. Upper Rib Primary Y Velocity	035	IN1	KMH	33.8	169.5	0.0	1.6	180



Test Vehicle: 2003 Toyota 4 Runner SR5 4WD SUV

Test Date: 2/27/03

Test Program: 55/28 km/h Side Impact NCAP

NHTSA No.: M35107

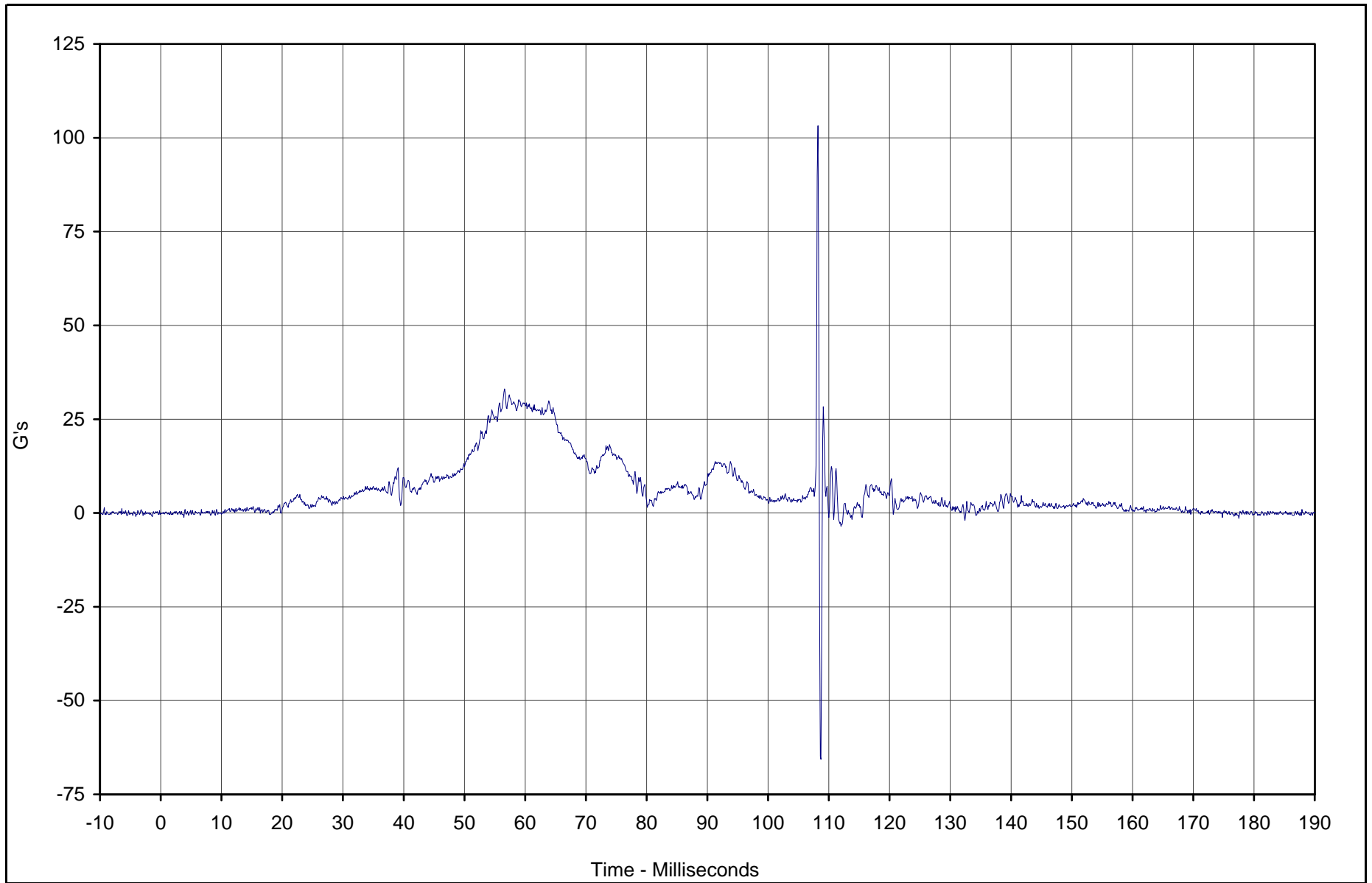

Curve Description	CURNO	Type	Units	Max	Time	Min	Time	SAE Class
Pass. Lower Rib Primary Y	036	FIL	G's	103.2	108.2	-65.7	108.7	1000



Test Vehicle: 2003 Toyota 4 Runner SR5 4WD SUV

Test Date: 2/27/03

Test Program: 55/28 km/h Side Impact NCAP

NHTSA No.: M35107

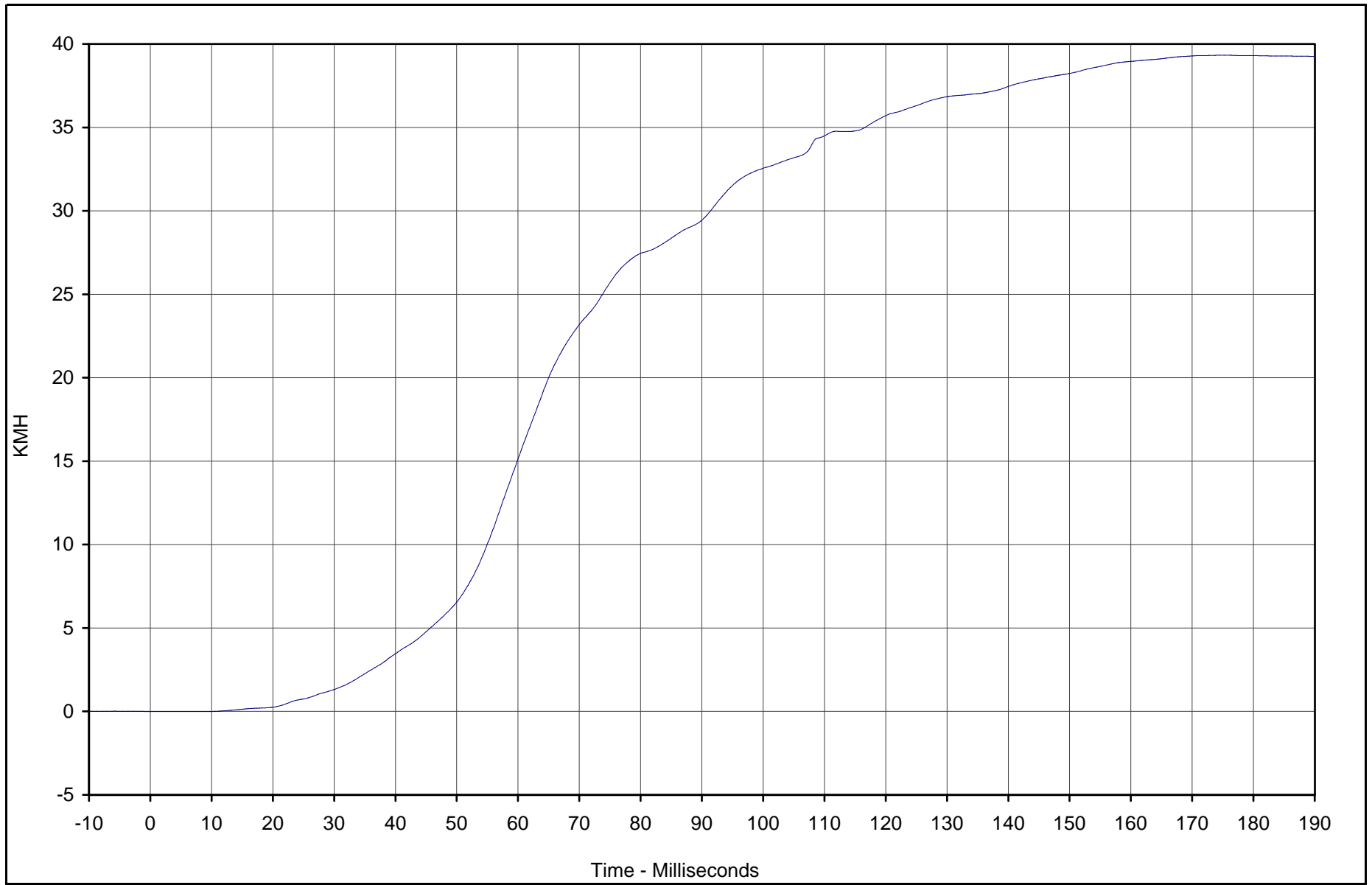

Curve Description	CURNO	Type	Units	Max	Time	Min	Time	SAE Class
Pass. Lower Rib Primary Y Velocity	036	IN1	KMH	39.3	175.5	0.0	6.2	180



Test Vehicle: 2003 Toyota 4 Runner SR5 4WD SUV

Test Date: 2/27/03

Test Program: 55/28 km/h Side Impact NCAP

NHTSA No.: M35107

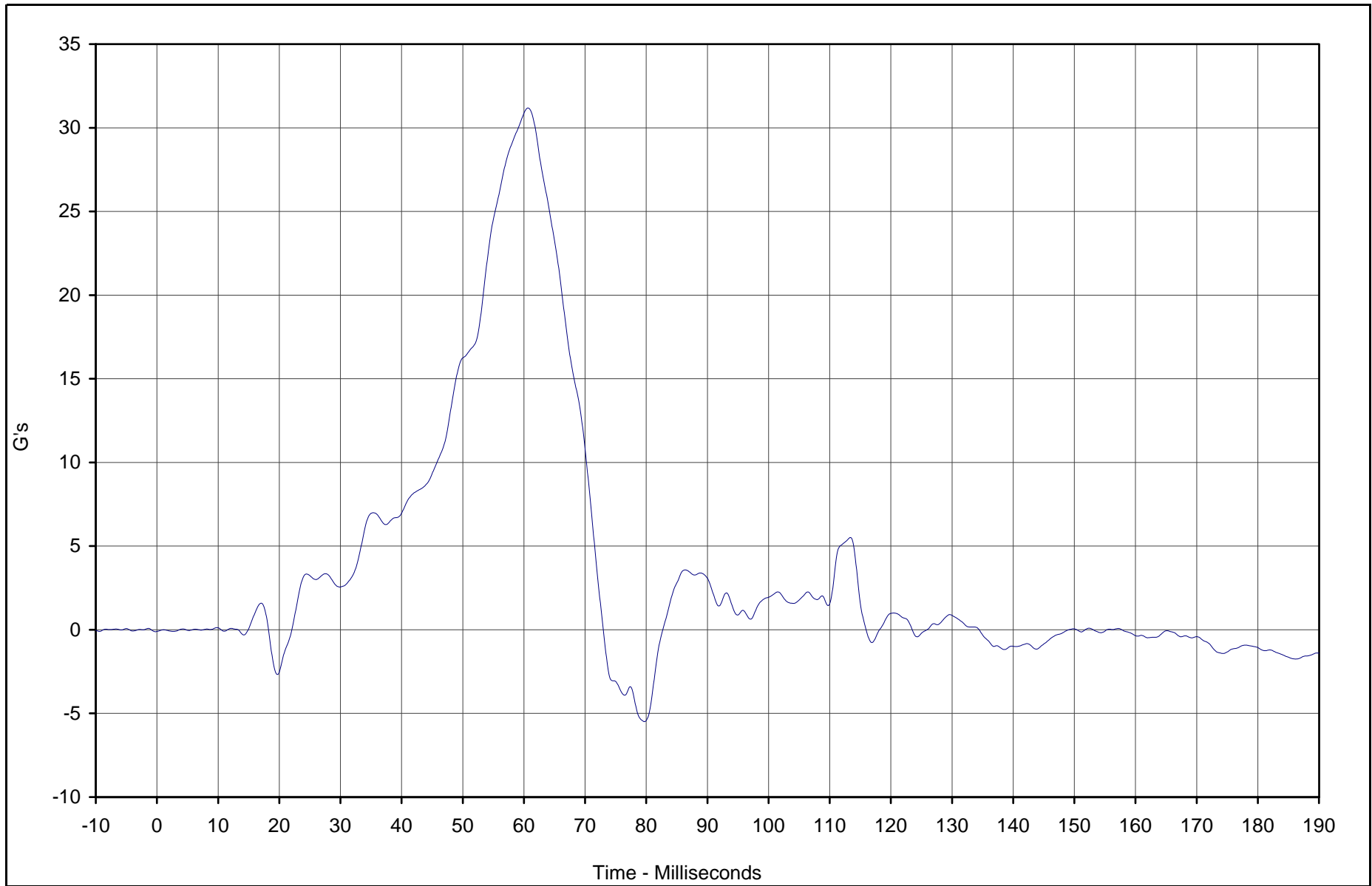

Curve Description	CURNO	Type	Units	Max	Time	Min	Time	SAE Class
Pass. Lower Spine Primary Y	037	FIL	G's	31.2	60.7	-5.5	79.7	180



Test Vehicle: 2003 Toyota 4 Runner SR5 4WD SUV

Test Date: 2/27/03

Test Program: 55/28 km/h Side Impact NCAP

NHTSA No.: M35107

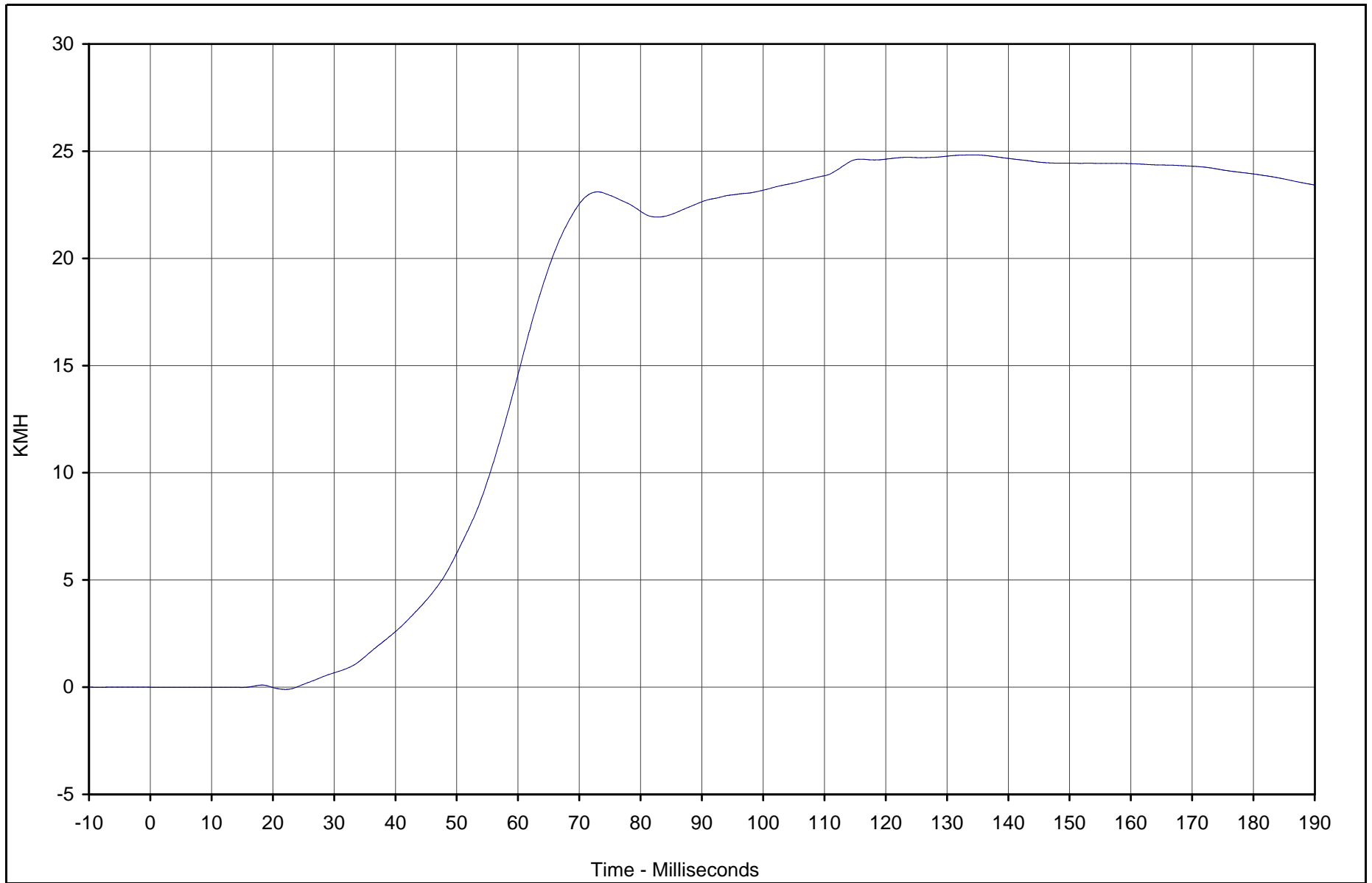

Curve Description	CURNO	Type	Units	Max	Time	Min	Time	SAE Class
Pass. Lower Spine Primary Y Velocity	037	IN1	KMH	24.8	134.4	-0.1	22.0	180



Test Vehicle: 2003 Toyota 4 Runner SR5 4WD SUV

Test Date: 2/27/03

Test Program: 55/28 km/h Side Impact NCAP

NHTSA No.: M35107

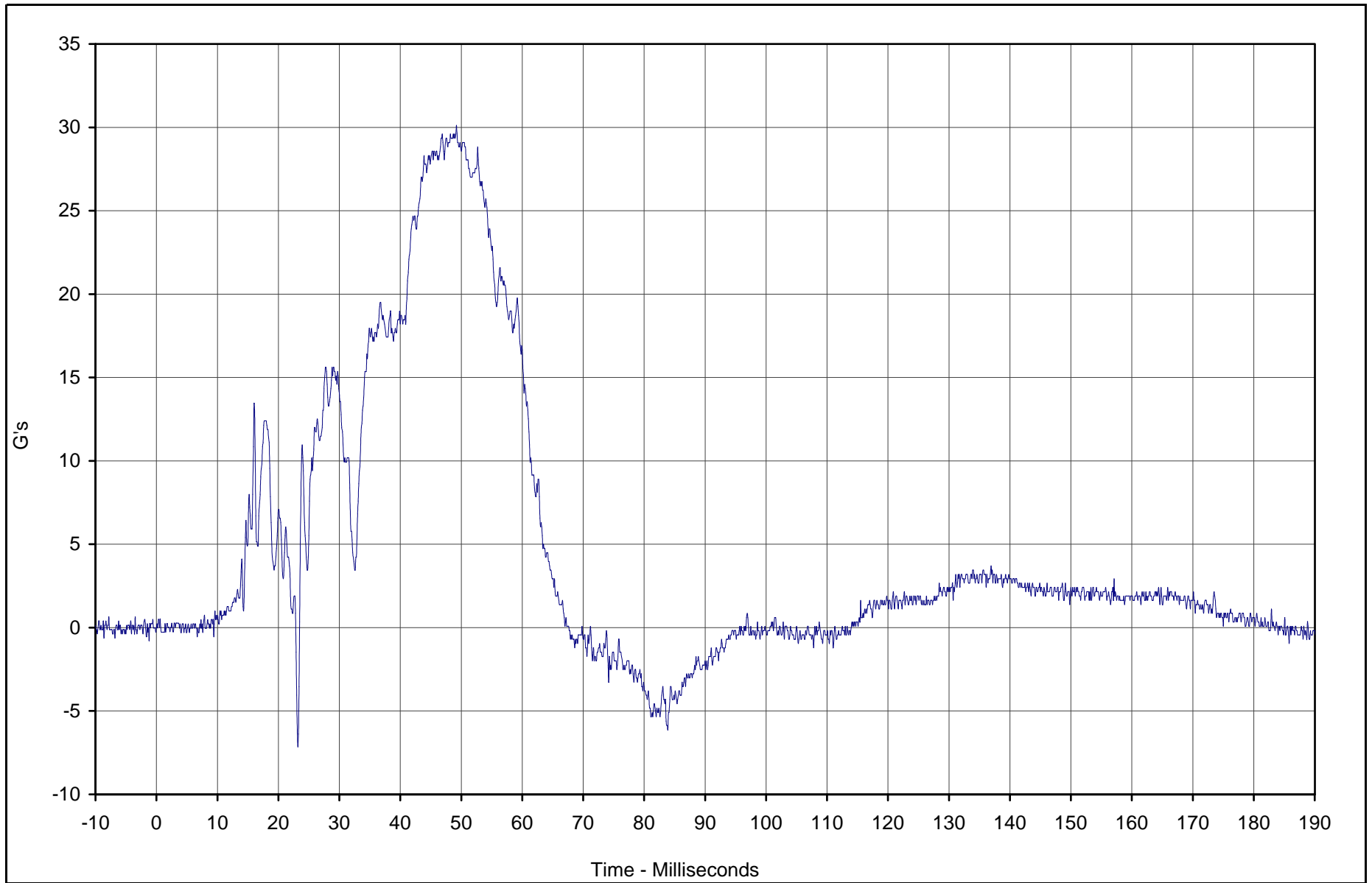

Curve Description	CURNO	Type	Units	Max	Time	Min	Time	SAE Class
Pass. Pelvis Primary Y	038	FIL	G's	30.1	49.2	-7.2	23.2	1000



Test Vehicle: 2003 Toyota 4 Runner SR5 4WD SUV

Test Date: 2/27/03

Test Program: 55/28 km/h Side Impact NCAP

NHTSA No.: M35107

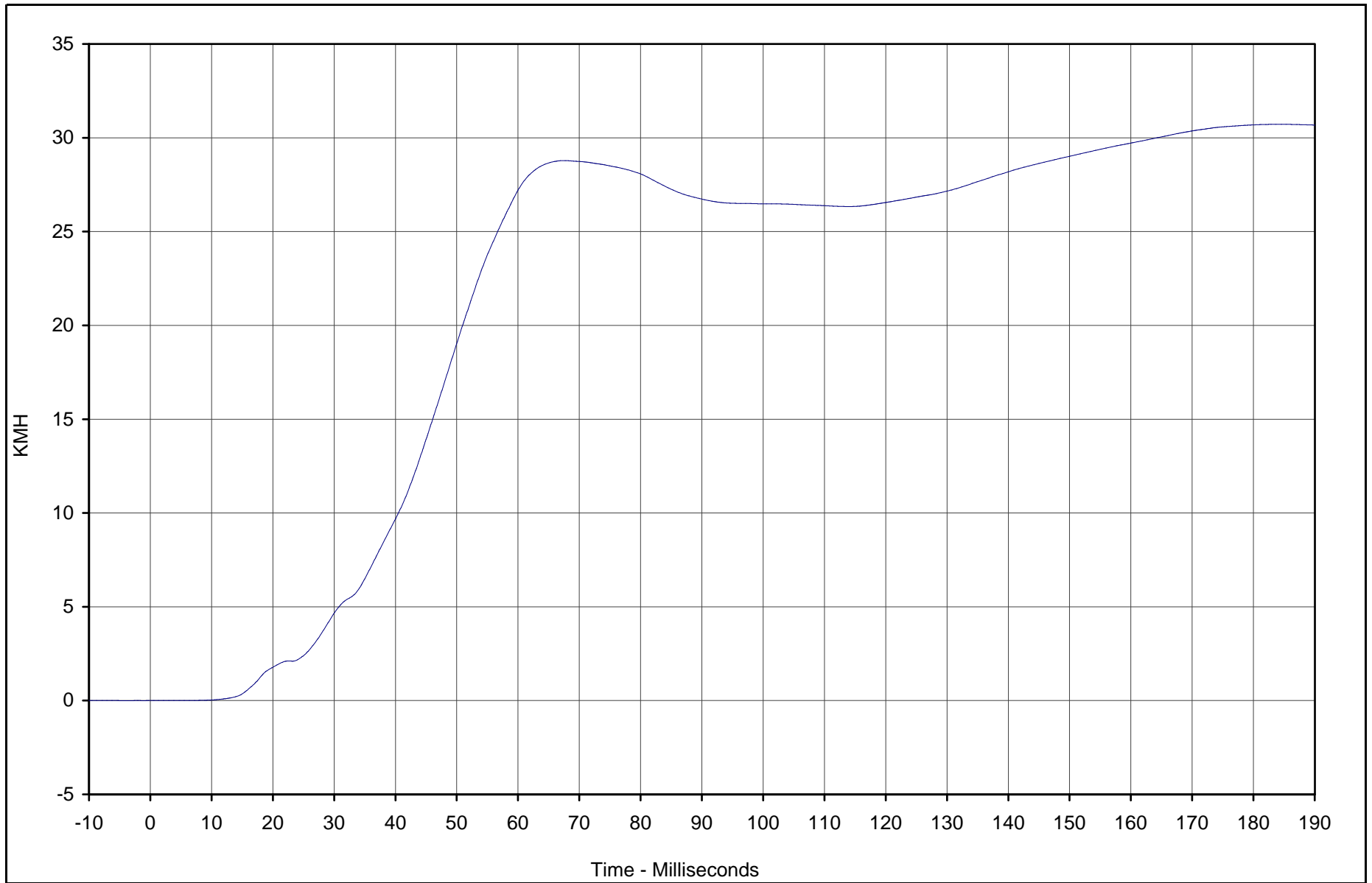

Curve Description	CURNO	Type	Units	Max	Time	Min	Time	SAE Class
Pass. Pelvis Primary Y Velocity	038	IN1	KMH	30.7	184.2	0.0	2.1	180



Test Vehicle: 2003 Toyota 4 Runner SR5 4WD SUV

Test Date: 2/27/03

Test Program: 55/28 km/h Side Impact NCAP

NHTSA No.: M35107

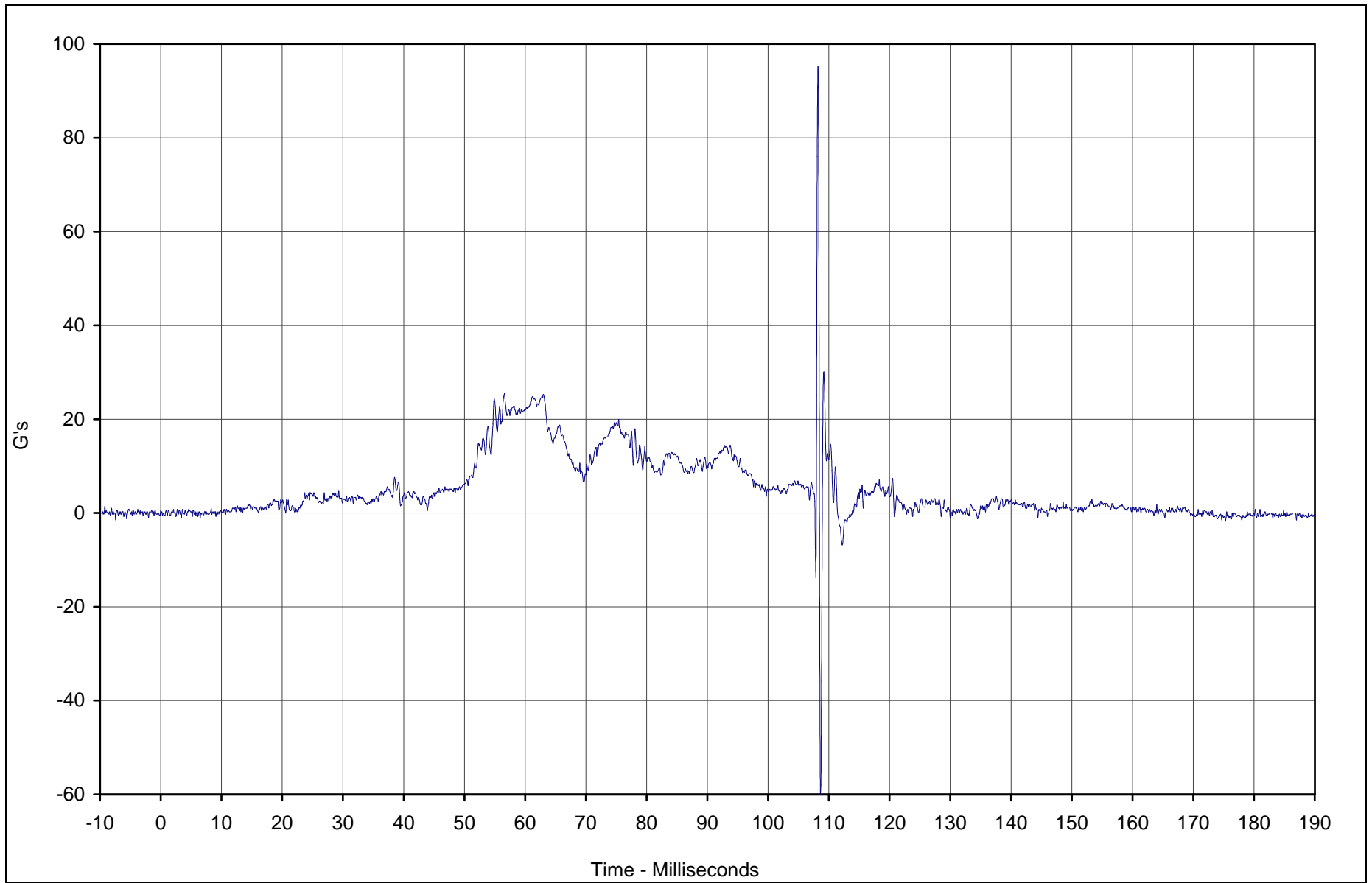

Curve Description	CURNO	Type	Units	Max	Time	Min	Time	SAE Class
Pass. Upper Rib Redundant Y	039	FIL	G's	95.3	108.2	-59.9	108.6	1000



Test Vehicle: 2003 Toyota 4 Runner SR5 4WD SUV

Test Date: 2/27/03

Test Program: 55/28 km/h Side Impact NCAP

NHTSA No.: M35107

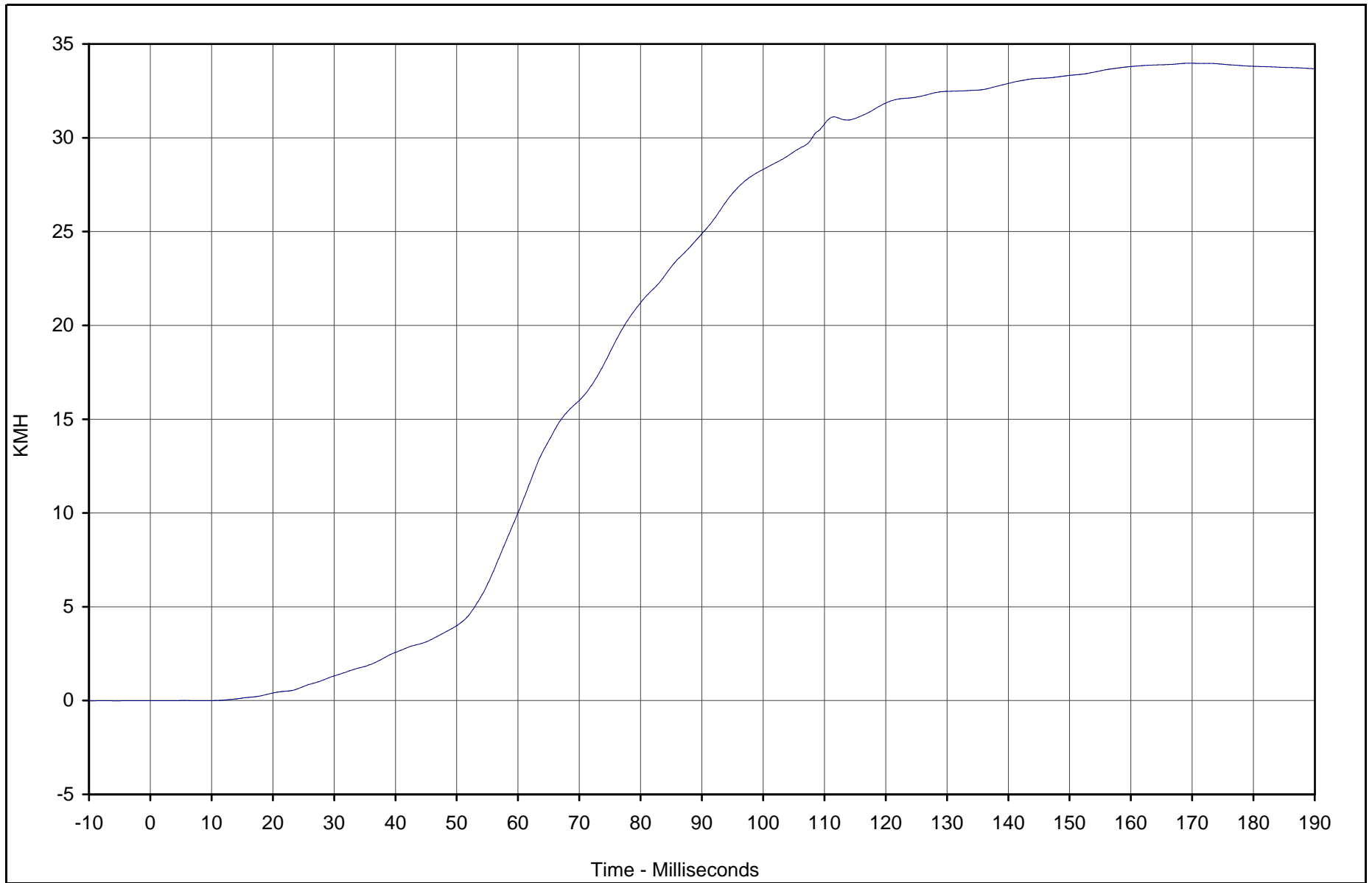

Curve Description	CURNO	Type	Units	Max	Time	Min	Time	SAE Class
Pass. Upper Rib Redundant Y Velocity	039	IN1	KMH	34.0	169.6	0.0	1.3	180



Test Vehicle: 2003 Toyota 4 Runner SR5 4WD SUV

Test Date: 2/27/03

Test Program: 55/28 km/h Side Impact NCAP

NHTSA No.: M35107

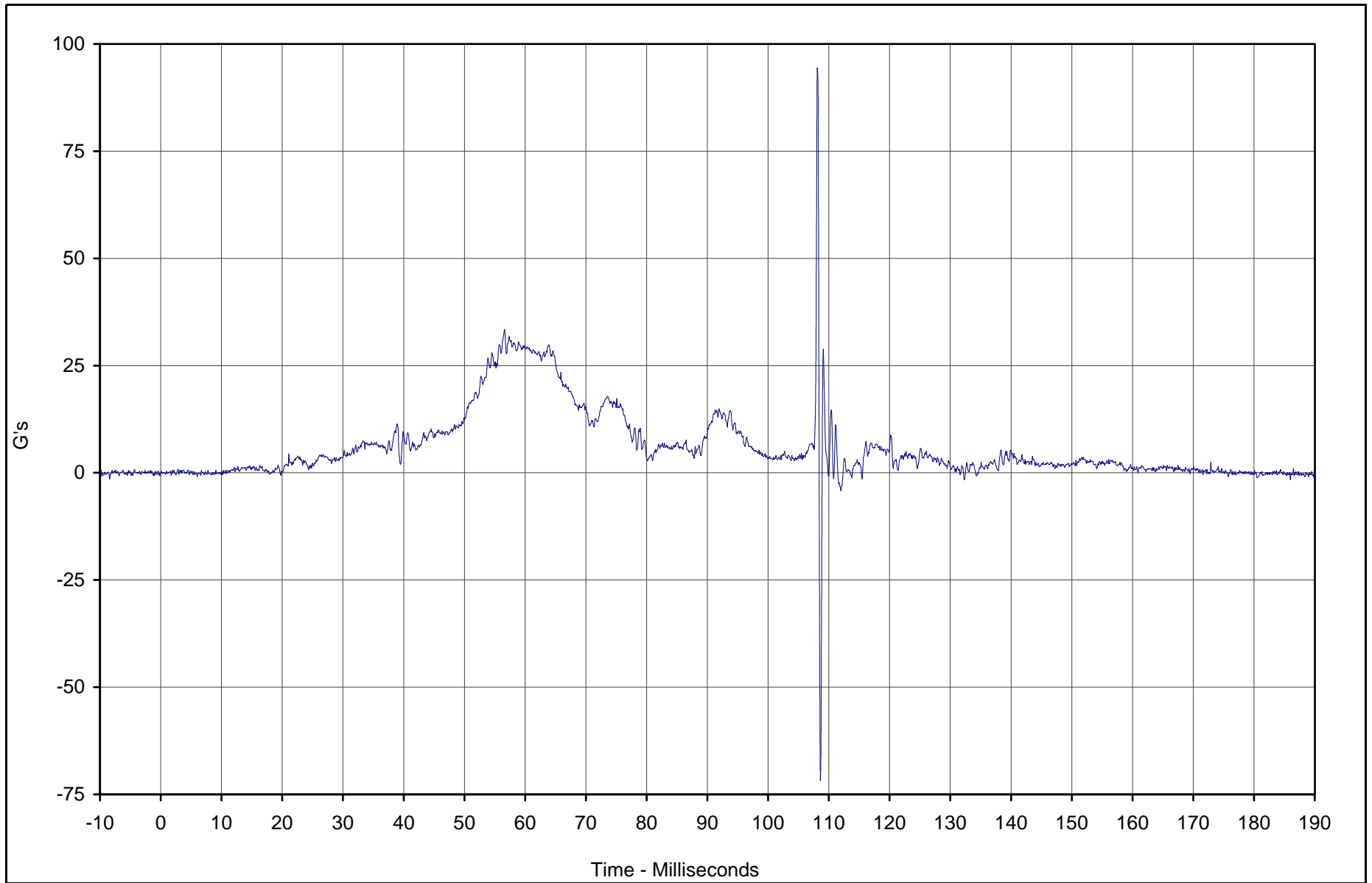

Curve Description	CURNO	Type	Units	Max	Time	Min	Time	SAE Class
Pass. Lower Rib Redundant Y	040	FIL	G's	94.2	108.1	-71.5	108.6	1000



Test Vehicle: 2003 Toyota 4 Runner SR5 4WD SUV

Test Date: 2/27/03

Test Program: 55/28 km/h Side Impact NCAP

NHTSA No.: M35107

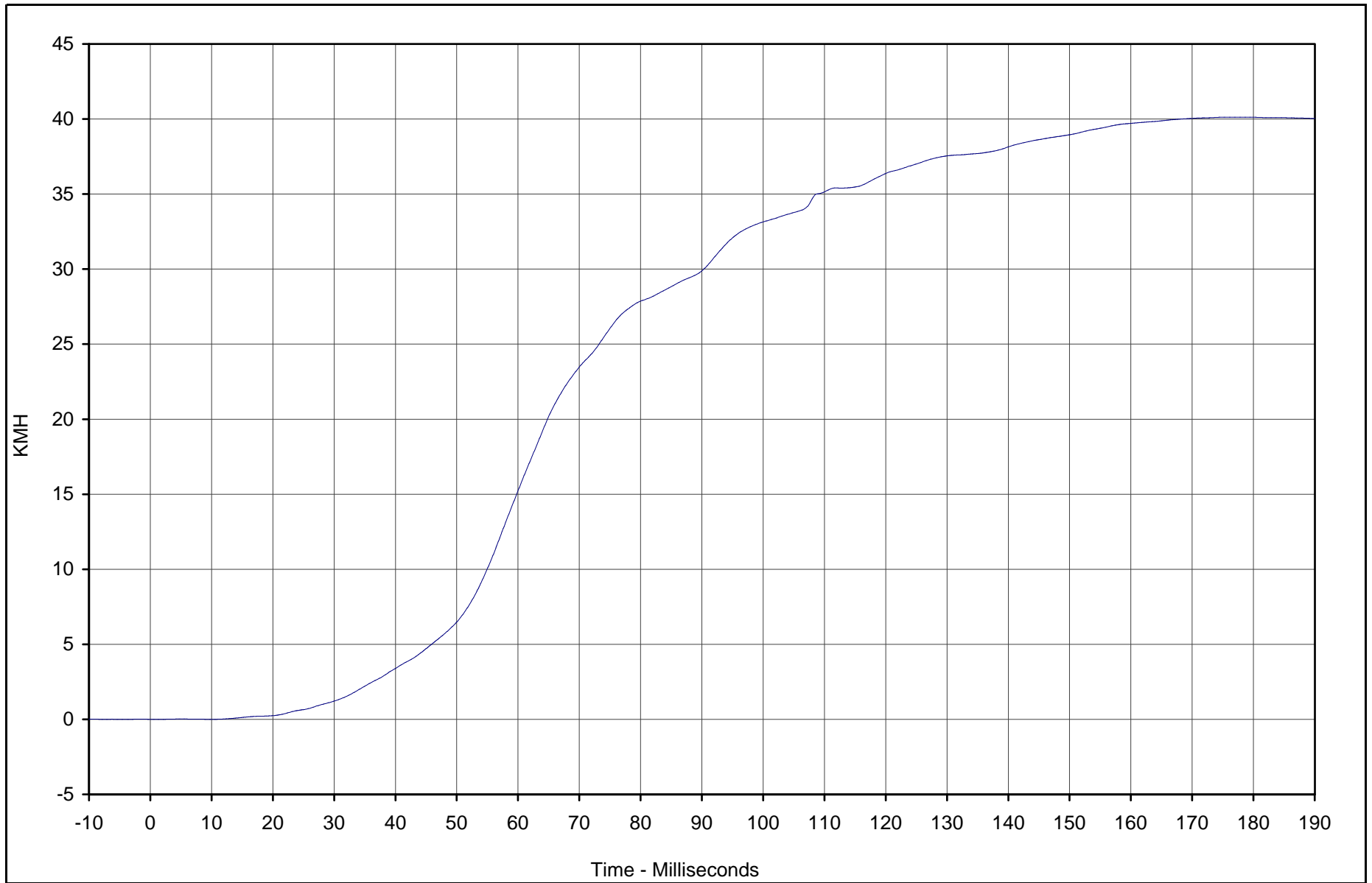

Curve Description	CURNO	Type	Units	Max	Time	Min	Time	SAE Class
Pass. Lower Rib Redundant Y Velocity	040	IN1	KMH	40.1	175.6	0.0	1.1	180



Test Vehicle: 2003 Toyota 4 Runner SR5 4WD SUV

Test Date: 2/27/03

Test Program: 55/28 km/h Side Impact NCAP

NHTSA No.: M35107

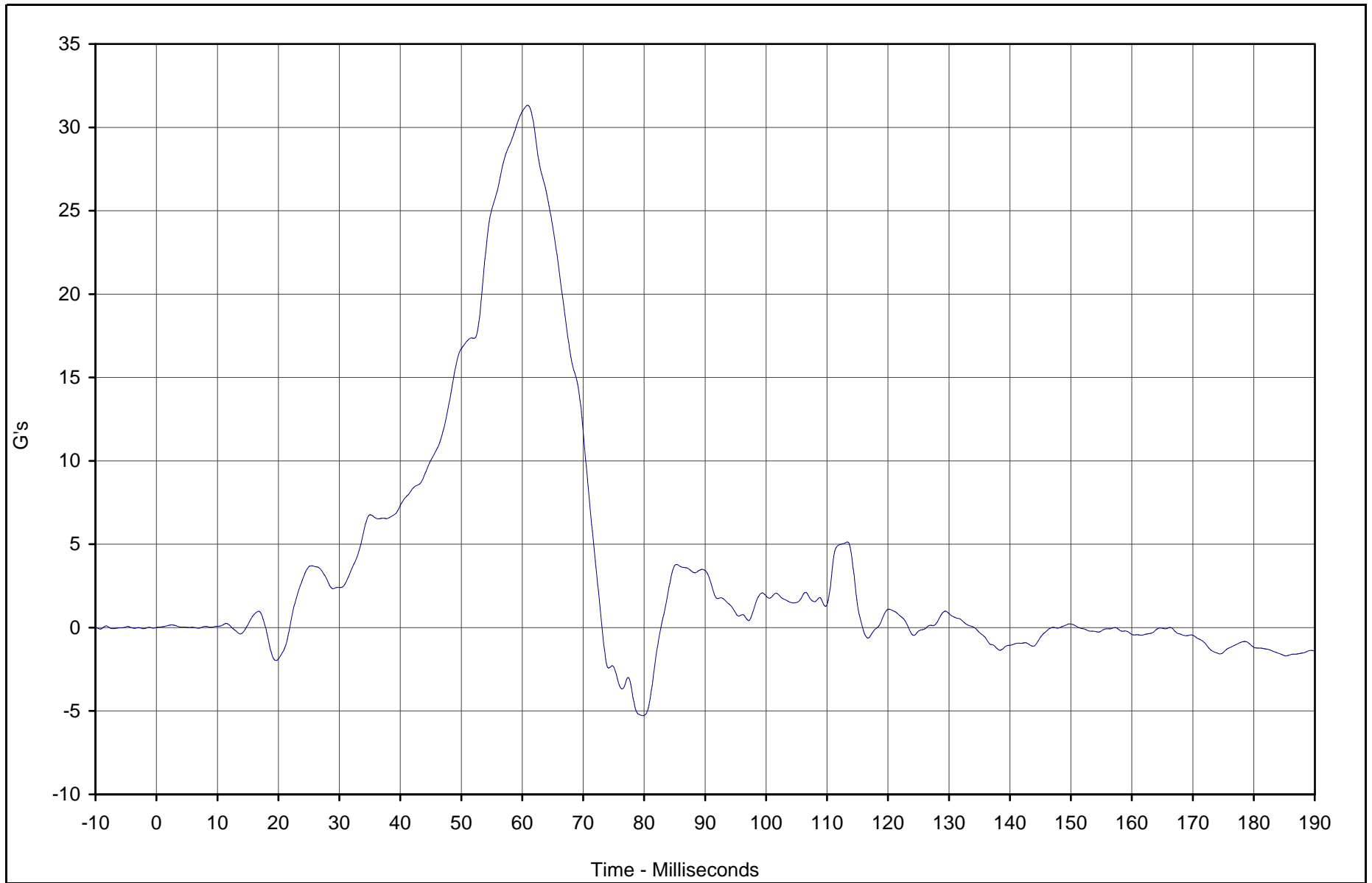

Curve Description	CURNO	Type	Units	Max	Time	Min	Time	SAE Class
Pass. Lower Spine Redundant Y	041	FIL	G's	31.3	60.9	-5.3	79.8	180



Test Vehicle: 2003 Toyota 4 Runner SR5 4WD SUV

Test Date: 2/27/03

Test Program: 55/28 km/h Side Impact NCAP

NHTSA No.: M35107

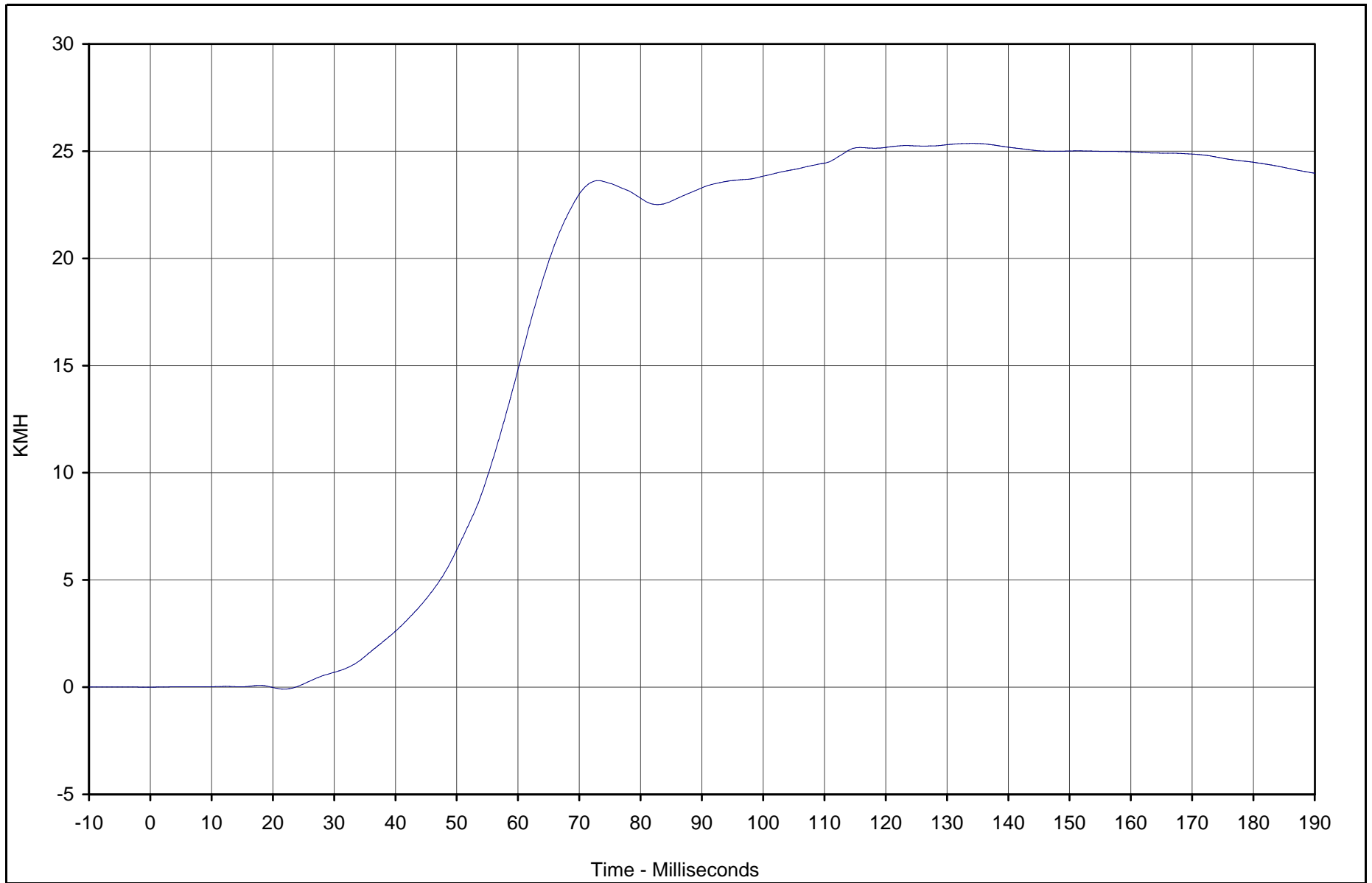

Curve Description	CURNO	Type	Units	Max	Time	Min	Time	SAE Class
Pass. Lower Spine Redundant Y Velocity	041	IN1	KMH	25.4	134.2	-0.1	21.9	180



Test Vehicle: 2003 Toyota 4 Runner SR5 4WD SUV

Test Date: 2/27/03

Test Program: 55/28 km/h Side Impact NCAP

NHTSA No.: M35107

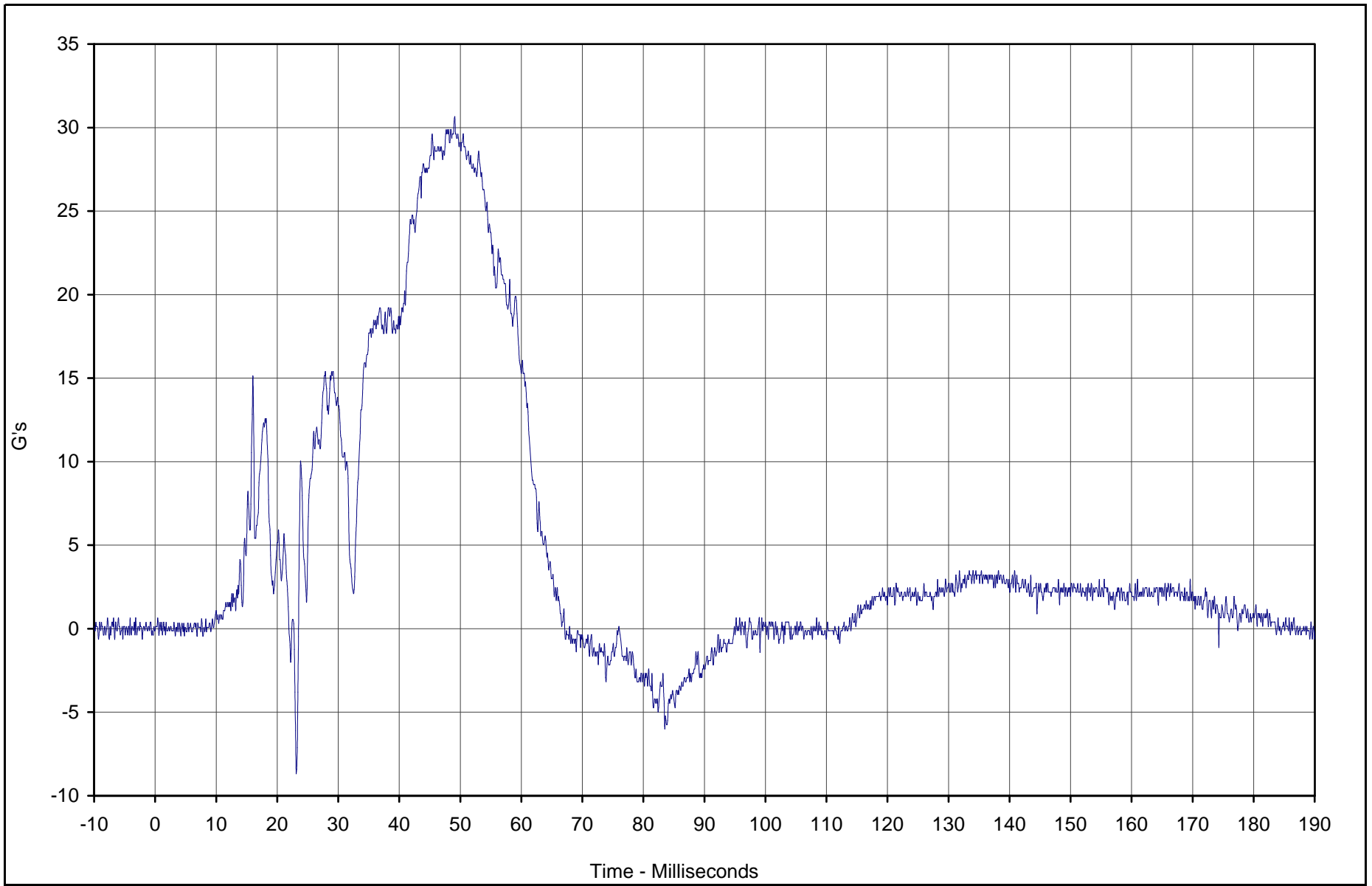

Curve Description	CURNO	Type	Units	Max	Time	Min	Time	SAE Class
Pass. Pelvis Redundant Y	042	FIL	G's	30.6	49.1	-8.7	23.1	1000



Test Vehicle: 2003 Toyota 4 Runner SR5 4WD SUV

Test Date: 2/27/03

Test Program: 55/28 km/h Side Impact NCAP

NHTSA No.: M35107

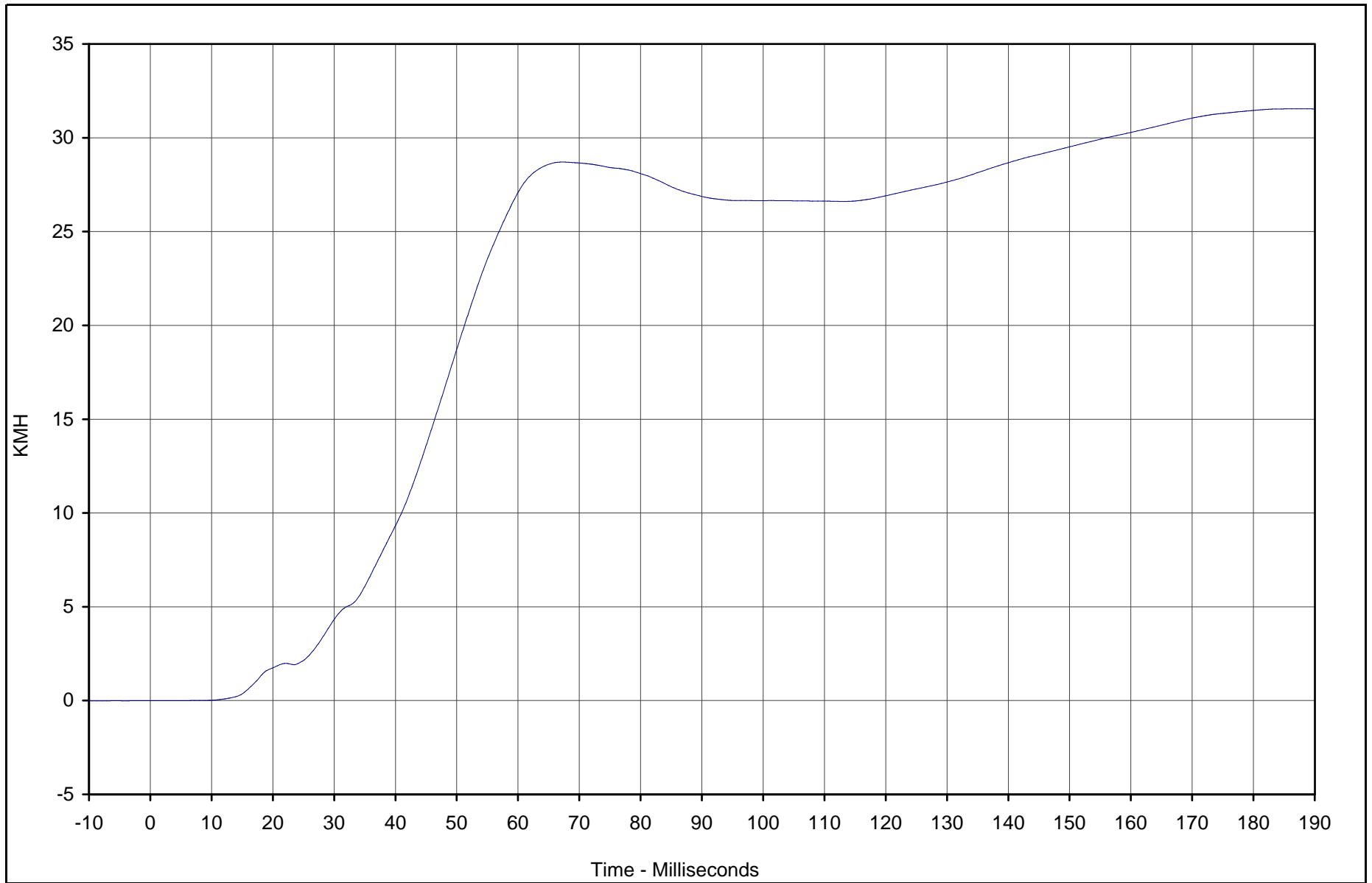

Curve Description	CURNO	Type	Units	Max	Time	Min	Time	SAE Class
Pass. Pelvis Redundant Y Velocity	042	IN1	KMH	31.5	187.0	0.0	0.0	180



Test Vehicle: 2003 Toyota 4 Runner SR5 4WD SUV

Test Date: 2/27/03

Test Program: 55/28 km/h Side Impact NCAP

NHTSA No.: M35107

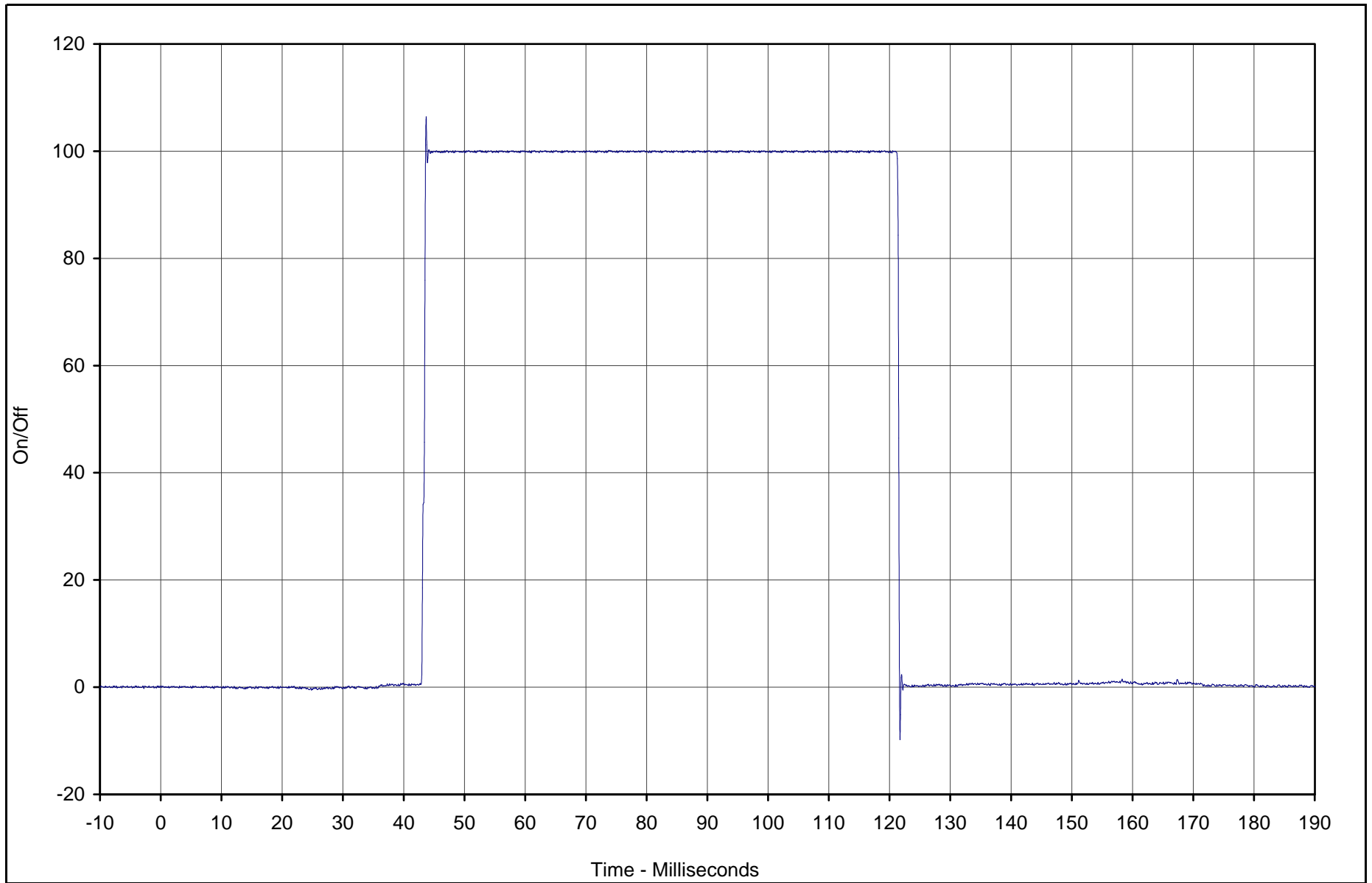

Curve Description	CURNO	Type	Units	Max	Time	Cross %	Time	SAE Class
Pass. Thorax Contact	043	FIL	On/Off	106.5	43.7	50.0	43.5	1000



Test Vehicle: 2003 Toyota 4 Runner SR5 4WD SUV

Test Date: 2/27/03

Test Program: 55/28 km/h Side Impact NCAP

NHTSA No.: M35107

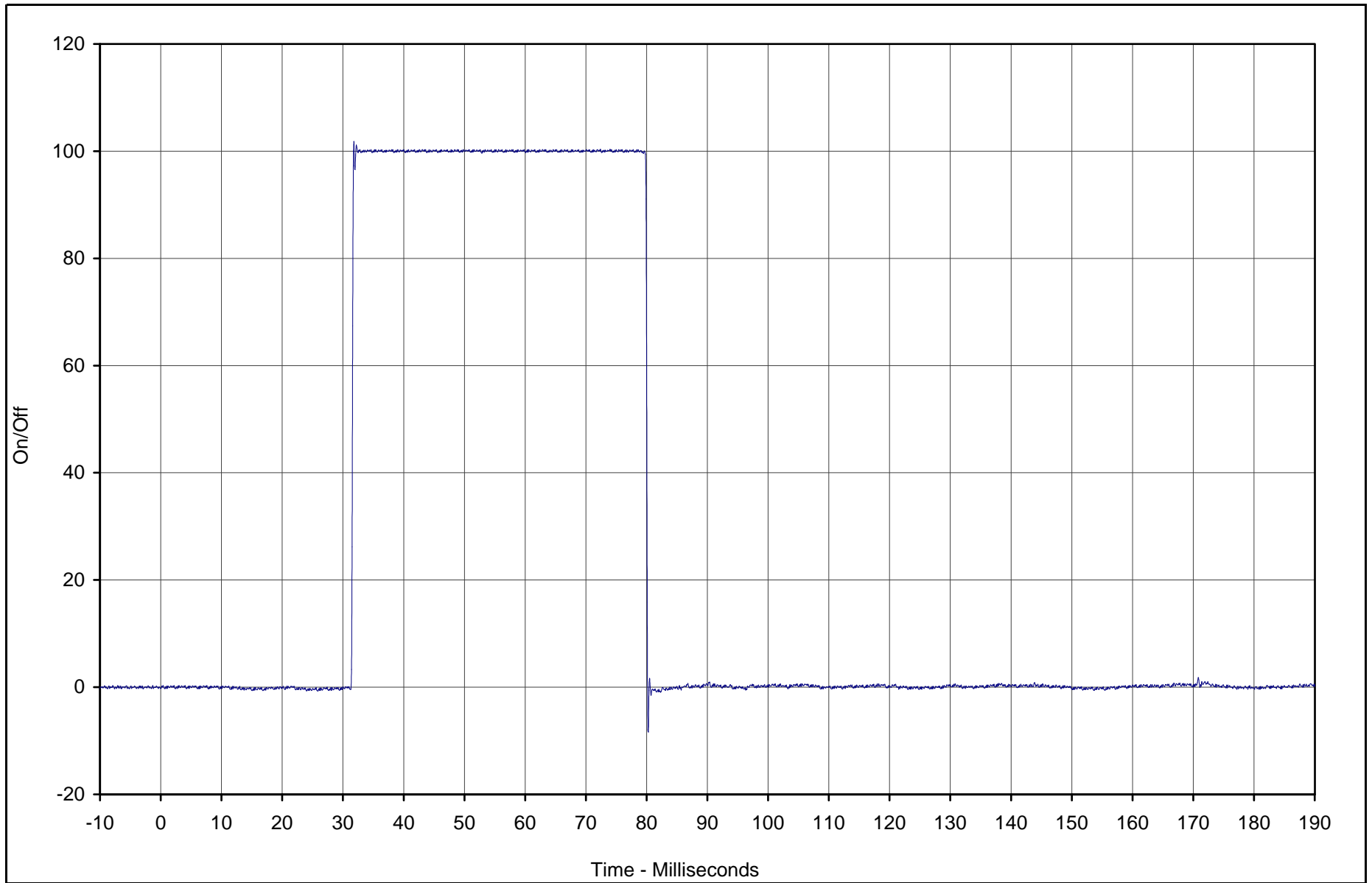

Curve Description	CURNO	Type	Units	Max	Time	Cross %	Time	SAE Class
Pass. Pelvis Contact	044	FIL	On/Off	101.8	31.8	50.0	31.6	1000



Test Vehicle: 2003 Toyota 4 Runner SR5 4WD SUV

Test Date: 2/27/03

Test Program: 55/28 km/h Side Impact NCAP

NHTSA No.: M35107

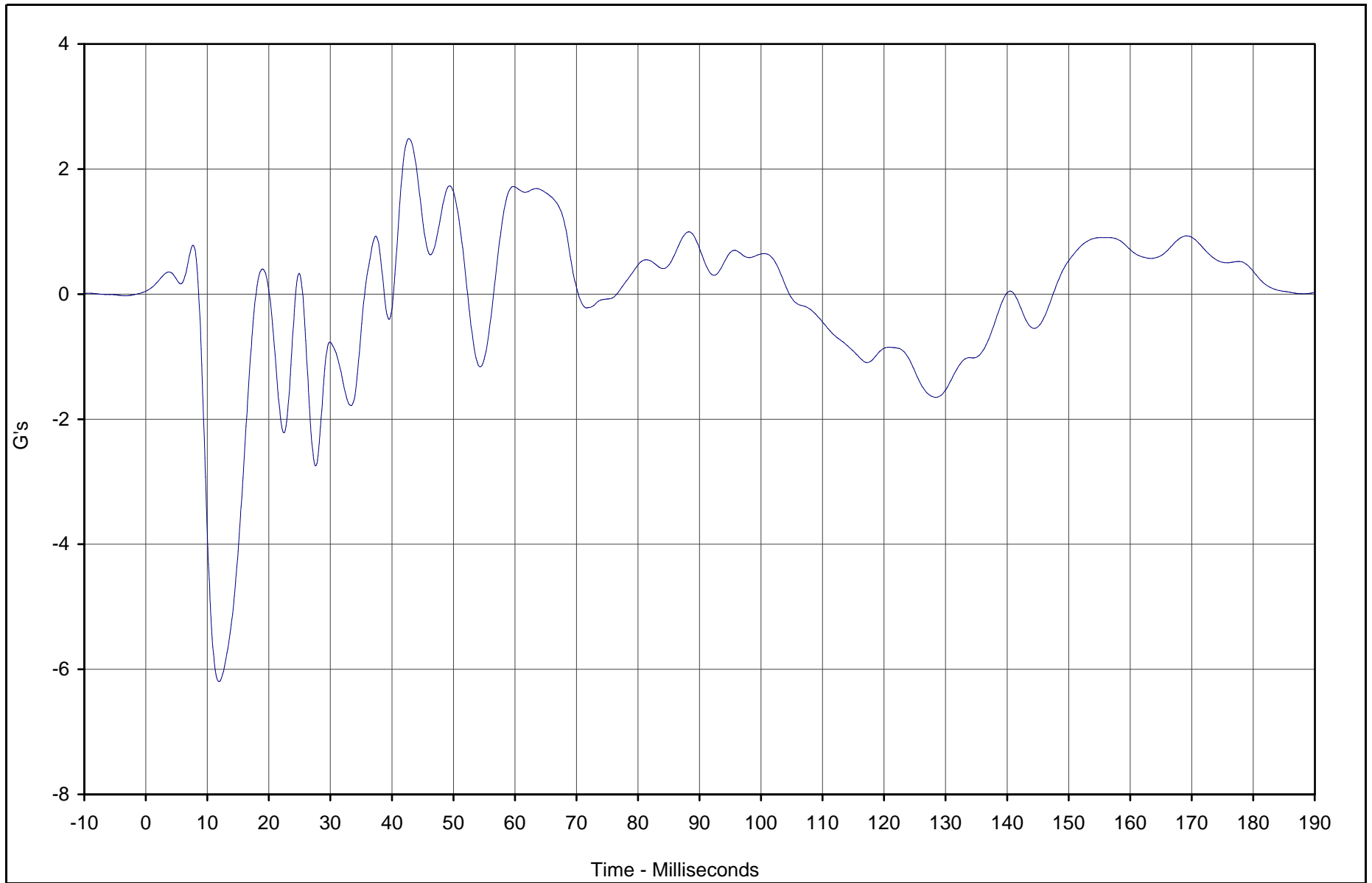

Curve Description	CURNO	Type	Units	Max	Time	Min	Time	SAE Class
Right Sill Front Seat X	045	FIL	G's	2.5	42.8	-6.2	11.9	60



Test Vehicle: 2003 Toyota 4 Runner SR5 4WD SUV

Test Date: 2/27/03

Test Program: 55/28 km/h Side Impact NCAP

NHTSA No.: M35107

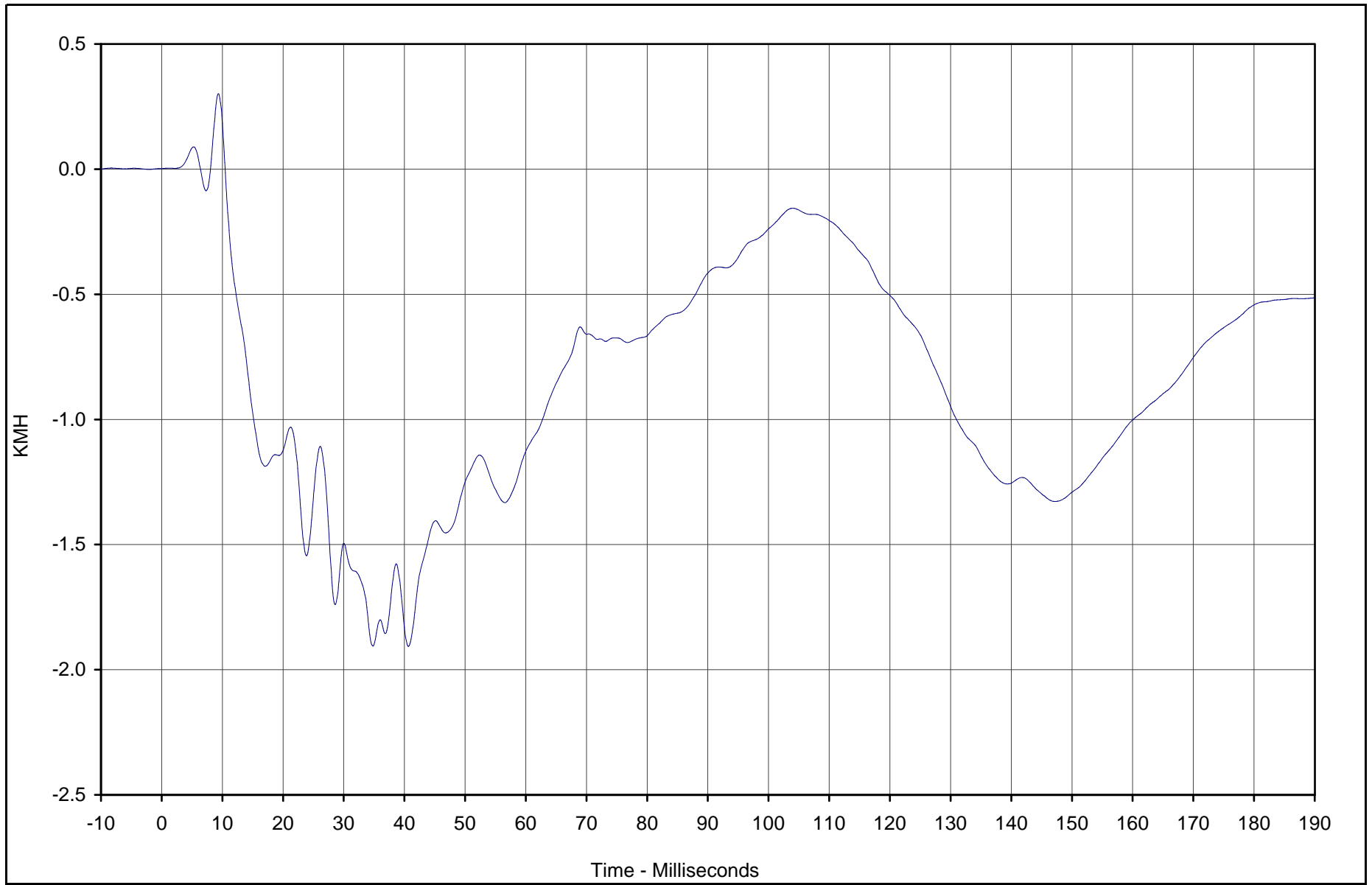

Curve Description	CURNO	Type	Units	Max	Time	Min	Time	SAE Class
Right Sill Front Seat X Velocity	045	IN1	KMH	0.3	9.4	-1.9	40.7	180



Test Vehicle: 2003 Toyota 4 Runner SR5 4WD SUV

Test Date: 2/27/03

Test Program: 55/28 km/h Side Impact NCAP

NHTSA No.: M35107

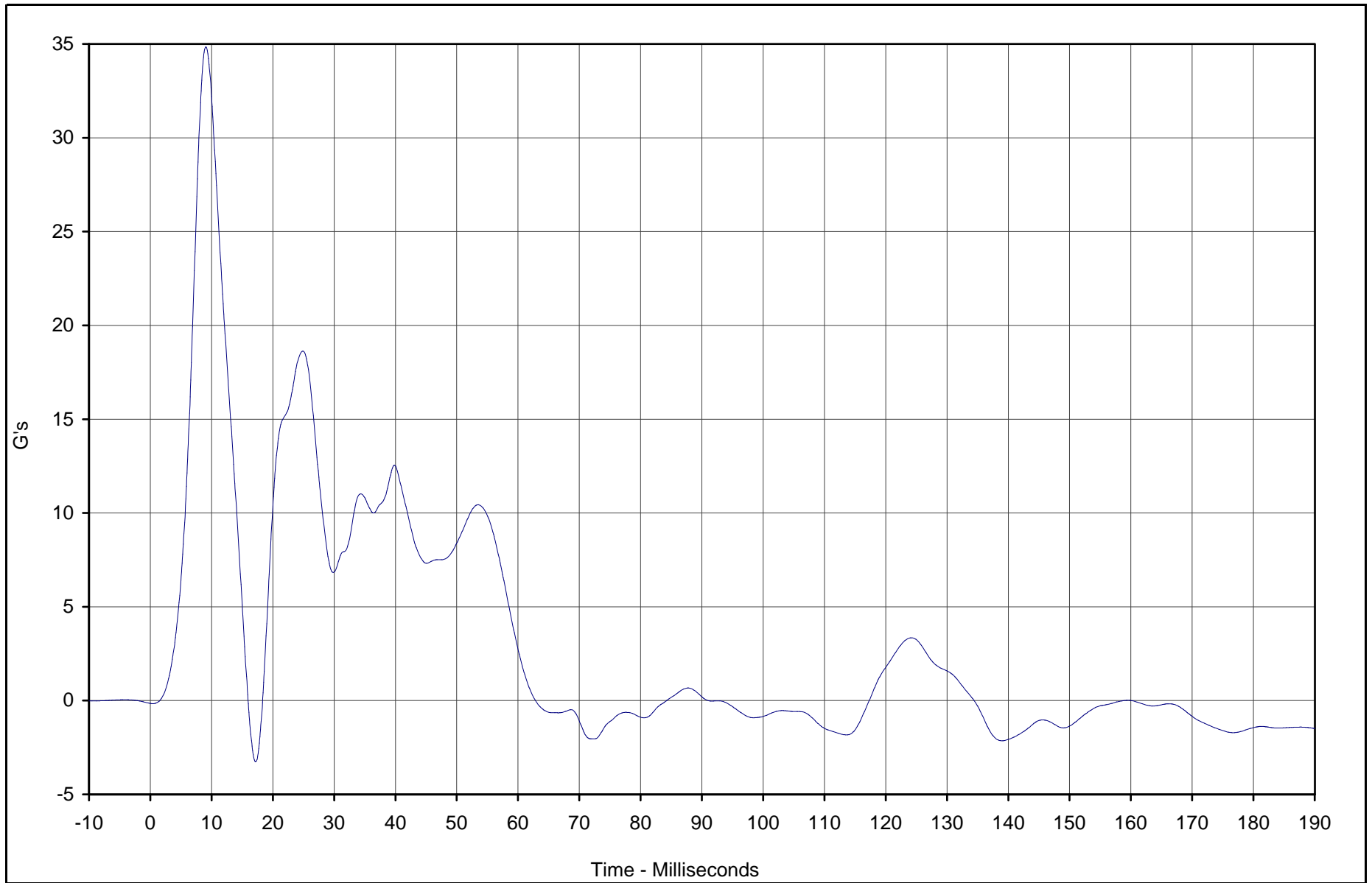

Curve Description	CURNO	Type	Units	Max	Time	Min	Time	SAE Class
Right Sill Front Seat Y	046	FIL	G's	34.8	9.1	-3.3	17.2	60



Test Vehicle: 2003 Toyota 4 Runner SR5 4WD SUV

Test Date: 2/27/03

Test Program: 55/28 km/h Side Impact NCAP

NHTSA No.: M35107

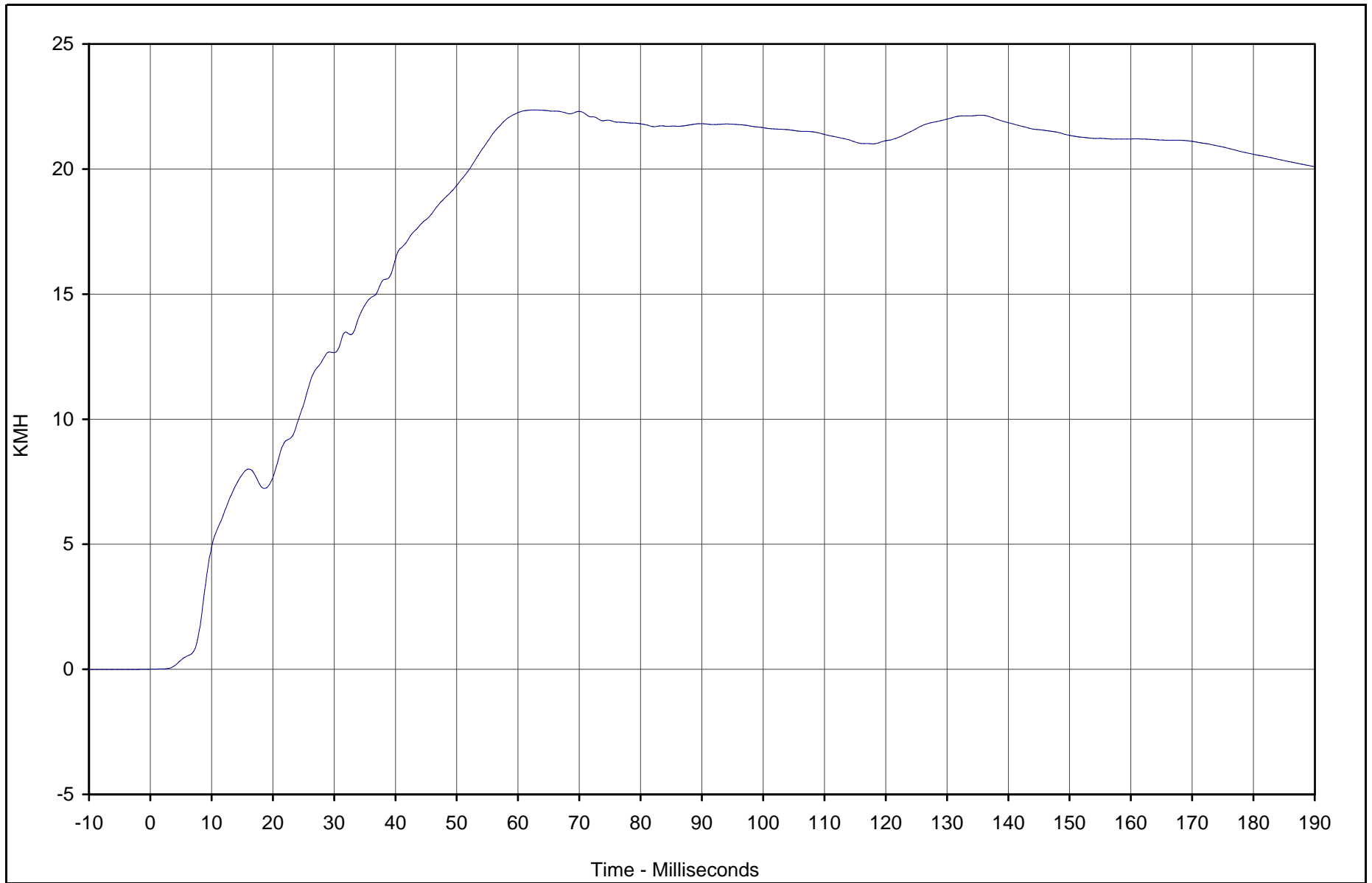

Curve Description	CURNO	Type	Units	Max	Time	Min	Time	SAE Class
Right Sill Front Seat Y Velocity	046	IN1	KMH	22.4	62.6	0.0	0.0	180



Test Vehicle: 2003 Toyota 4 Runner SR5 4WD SUV

Test Date: 2/27/03

Test Program: 55/28 km/h Side Impact NCAP

NHTSA No.: M35107

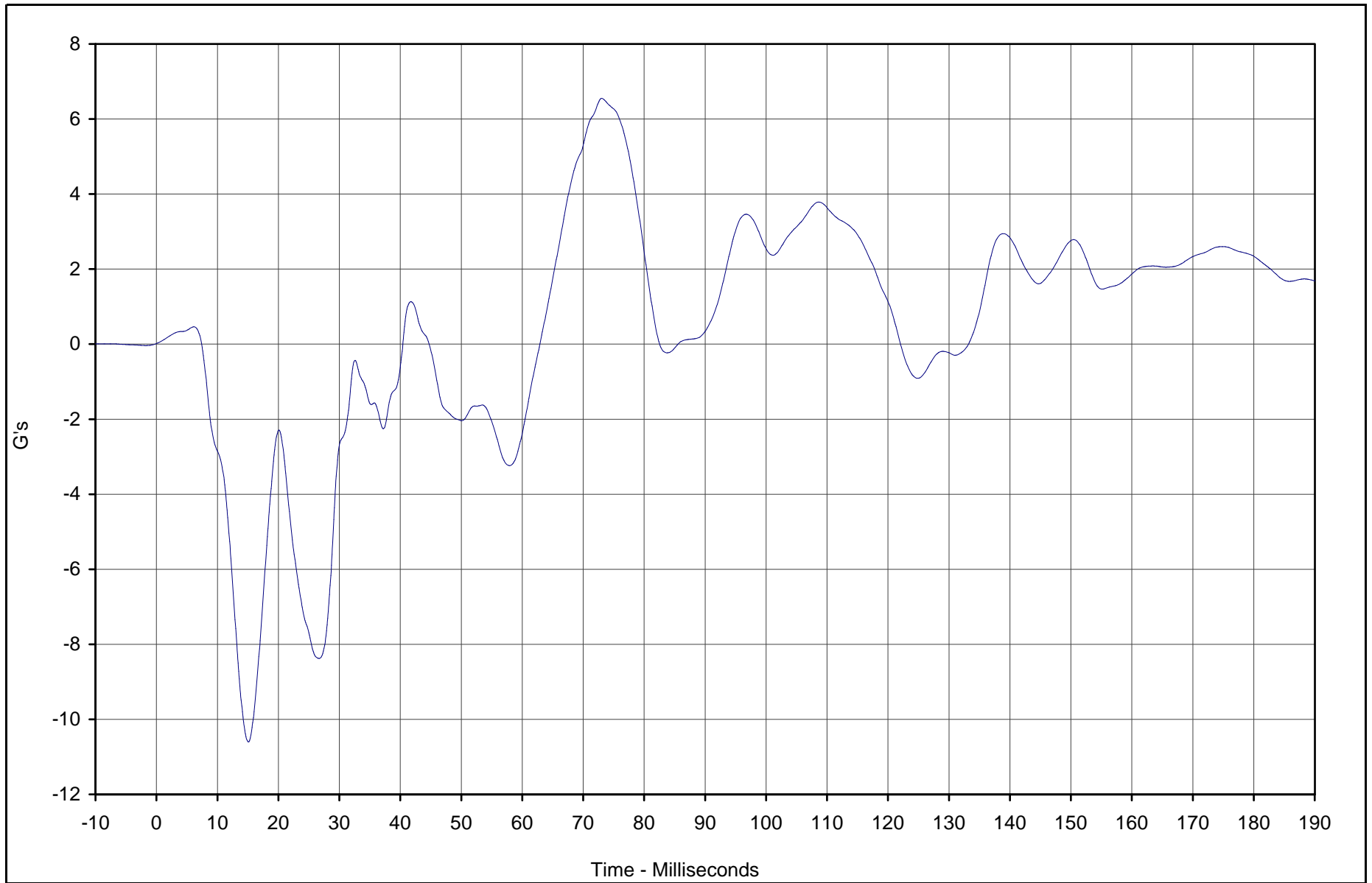

Curve Description	CURNO	Type	Units	Max	Time	Min	Time	SAE Class
Right Sill Front Seat Z	047	FIL	G's	6.6	73.0	-10.6	15.1	60



Test Vehicle: 2003 Toyota 4 Runner SR5 4WD SUV

Test Date: 2/27/03

Test Program: 55/28 km/h Side Impact NCAP

NHTSA No.: M35107

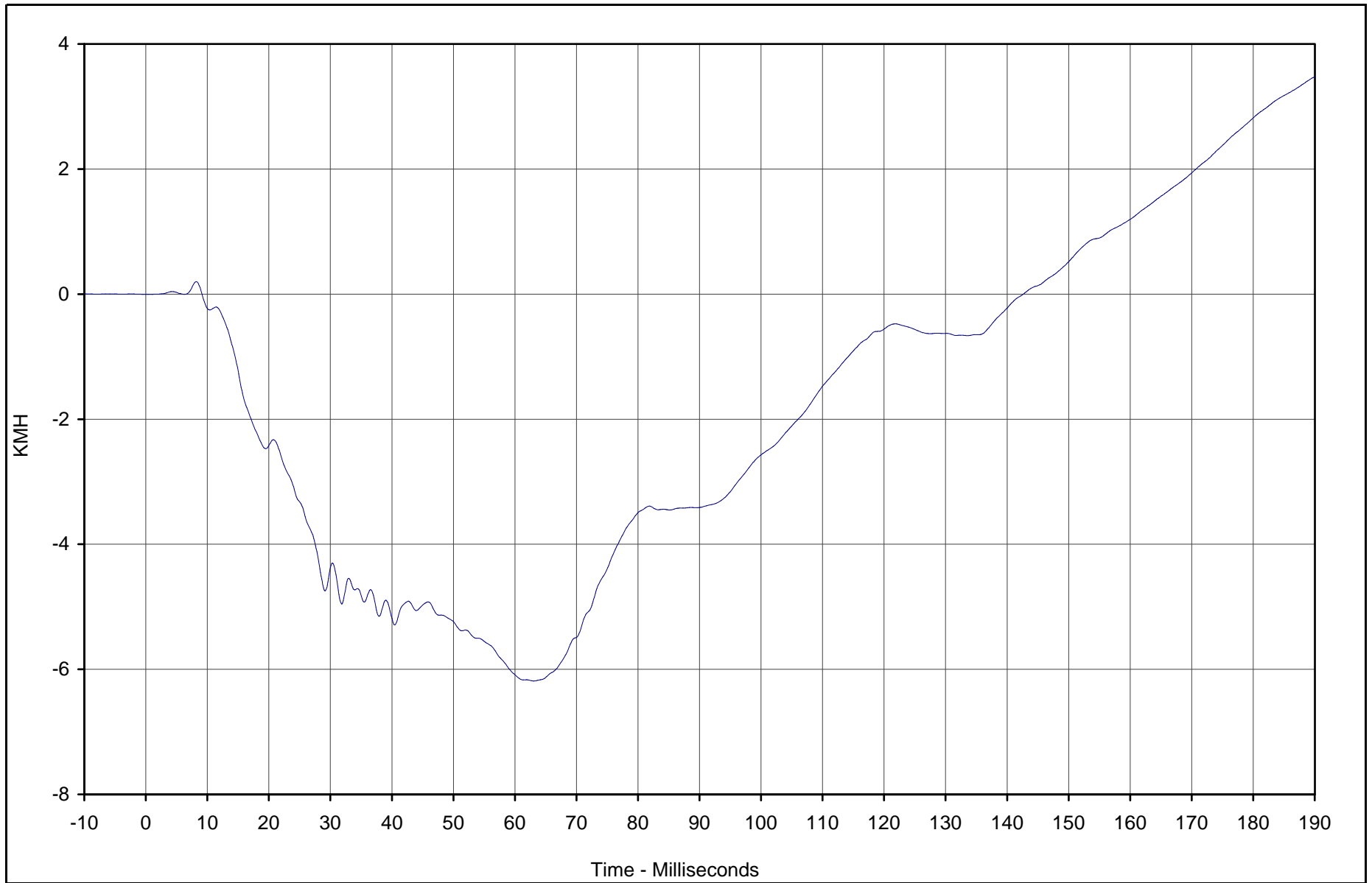

Curve Description	CURNO	Type	Units	Max	Time	Min	Time	SAE Class
Right Sill Front Seat Z Velocity	047	IN1	KMH	3.5	189.9	-6.2	63.1	180



Test Vehicle: 2003 Toyota 4 Runner SR5 4WD SUV

Test Date: 2/27/03

Test Program: 55/28 km/h Side Impact NCAP

NHTSA No.: M35107

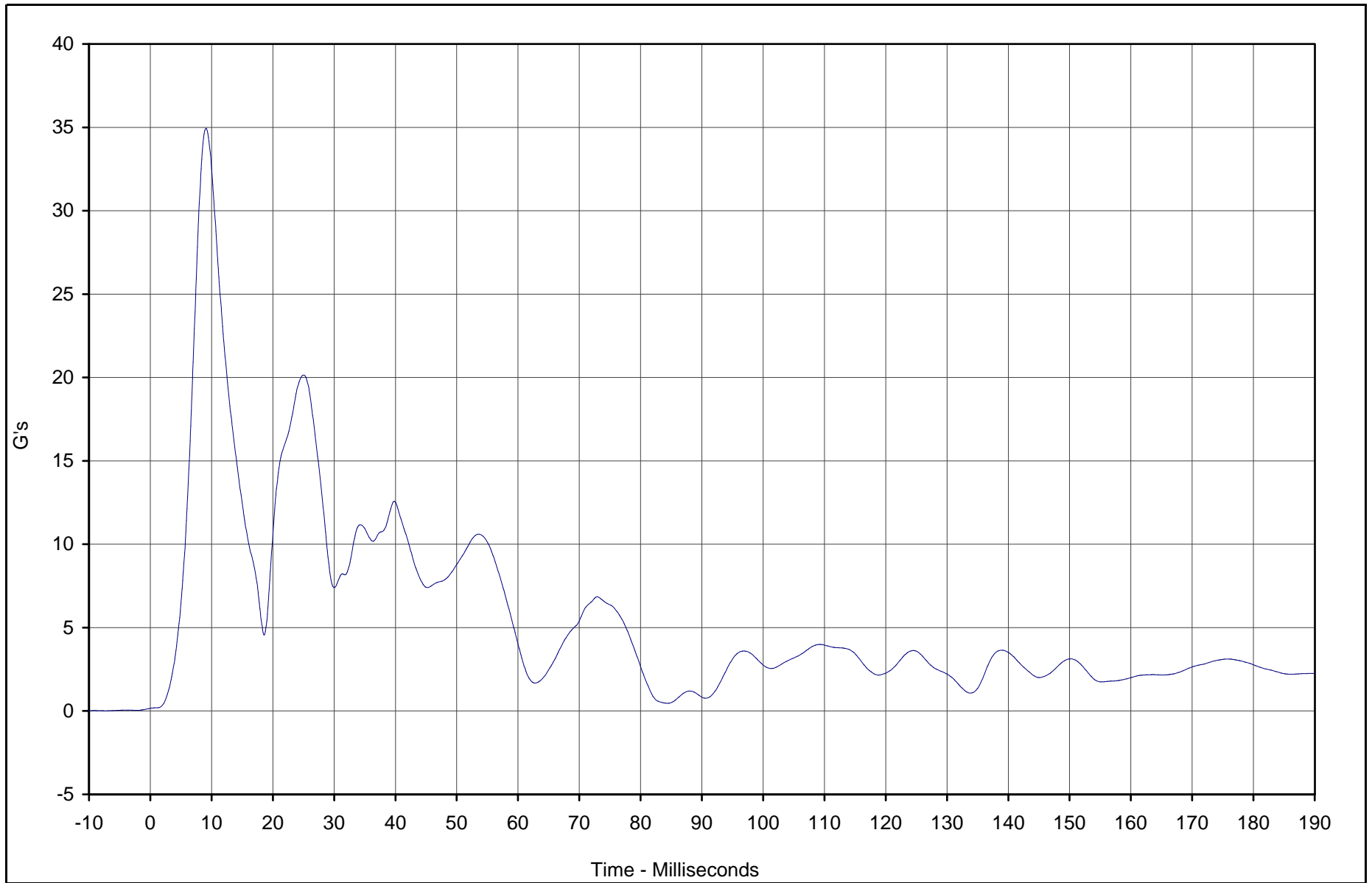

Curve Description	CURNO	Type	Units	Max	Time	Min	Time	SAE Class
Right Sill Front Seat Resultant	045	RES	G's	34.9	9.1	0.2	0.0	60



Test Vehicle: 2003 Toyota 4 Runner SR5 4WD SUV

Test Date: 2/27/03

Test Program: 55/28 km/h Side Impact NCAP

NHTSA No.: M35107

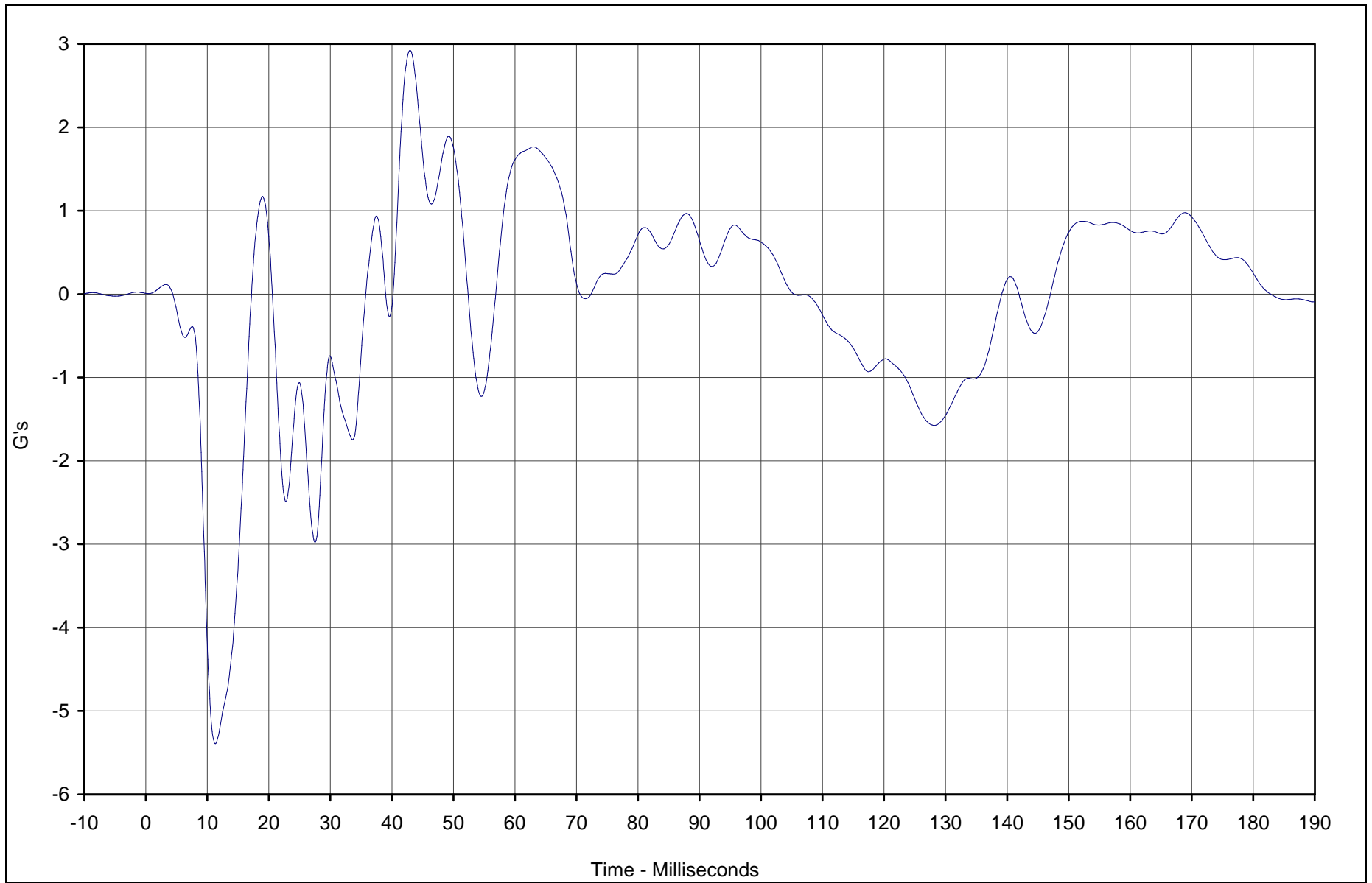

Curve Description	CURNO	Type	Units	Max	Time	Min	Time	SAE Class
Right Sill Rear Seat X	048	FIL	G's	2.9	42.9	-5.4	11.3	60



Test Vehicle: 2003 Toyota 4 Runner SR5 4WD SUV

Test Date: 2/27/03

Test Program: 55/28 km/h Side Impact NCAP

NHTSA No.: M35107

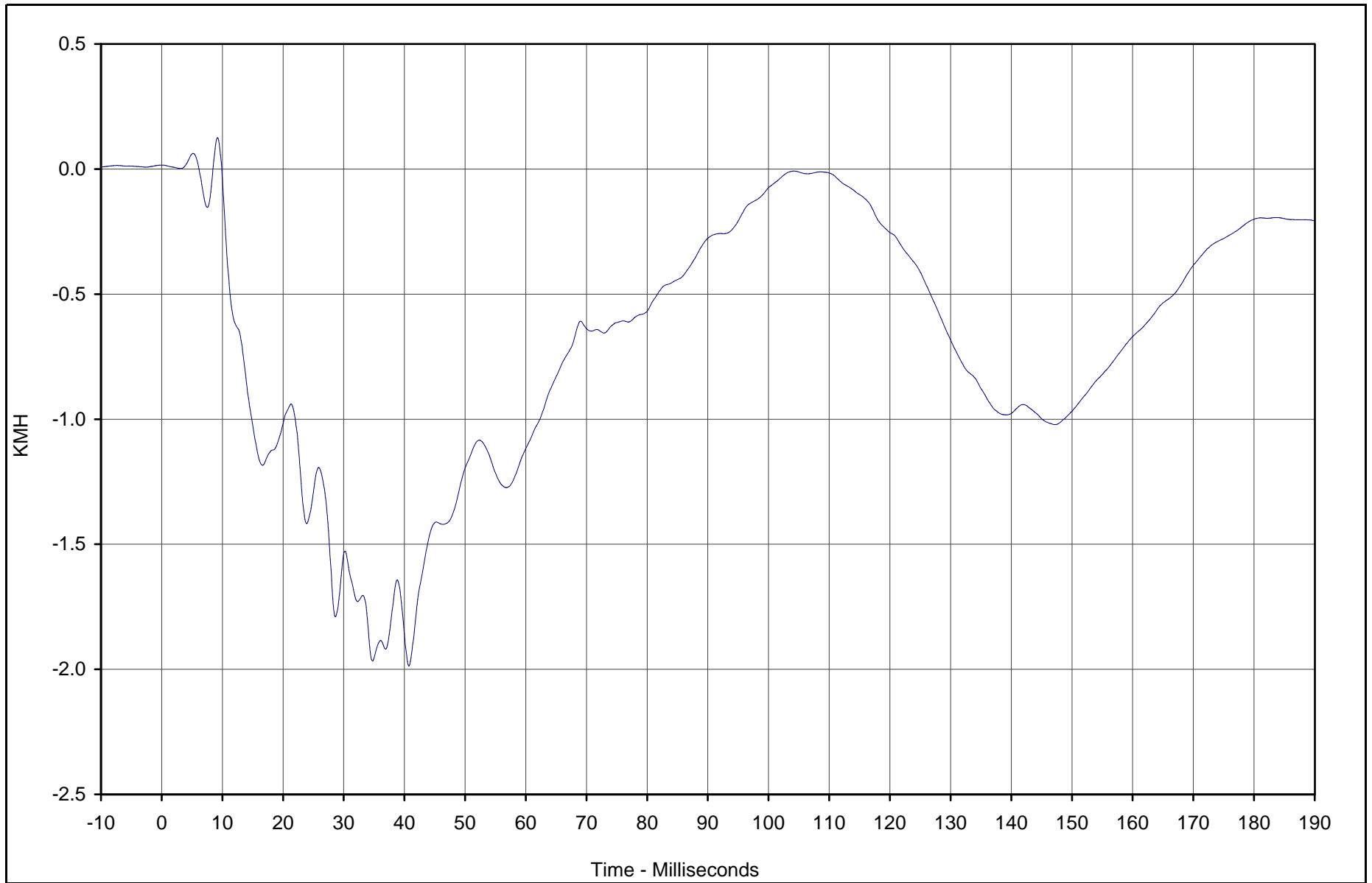

Curve Description	CURNO	Type	Units	Max	Time	Min	Time	SAE Class
Right Sill Rear Seat X Velocity	048	IN1	KMH	0.1	9.2	-2.0	40.7	180



Test Vehicle: 2003 Toyota 4 Runner SR5 4WD SUV
 Test Program: 55/28 km/h Side Impact NCAP

Test Date: 2/27/03
 NHTSA No.: M35107

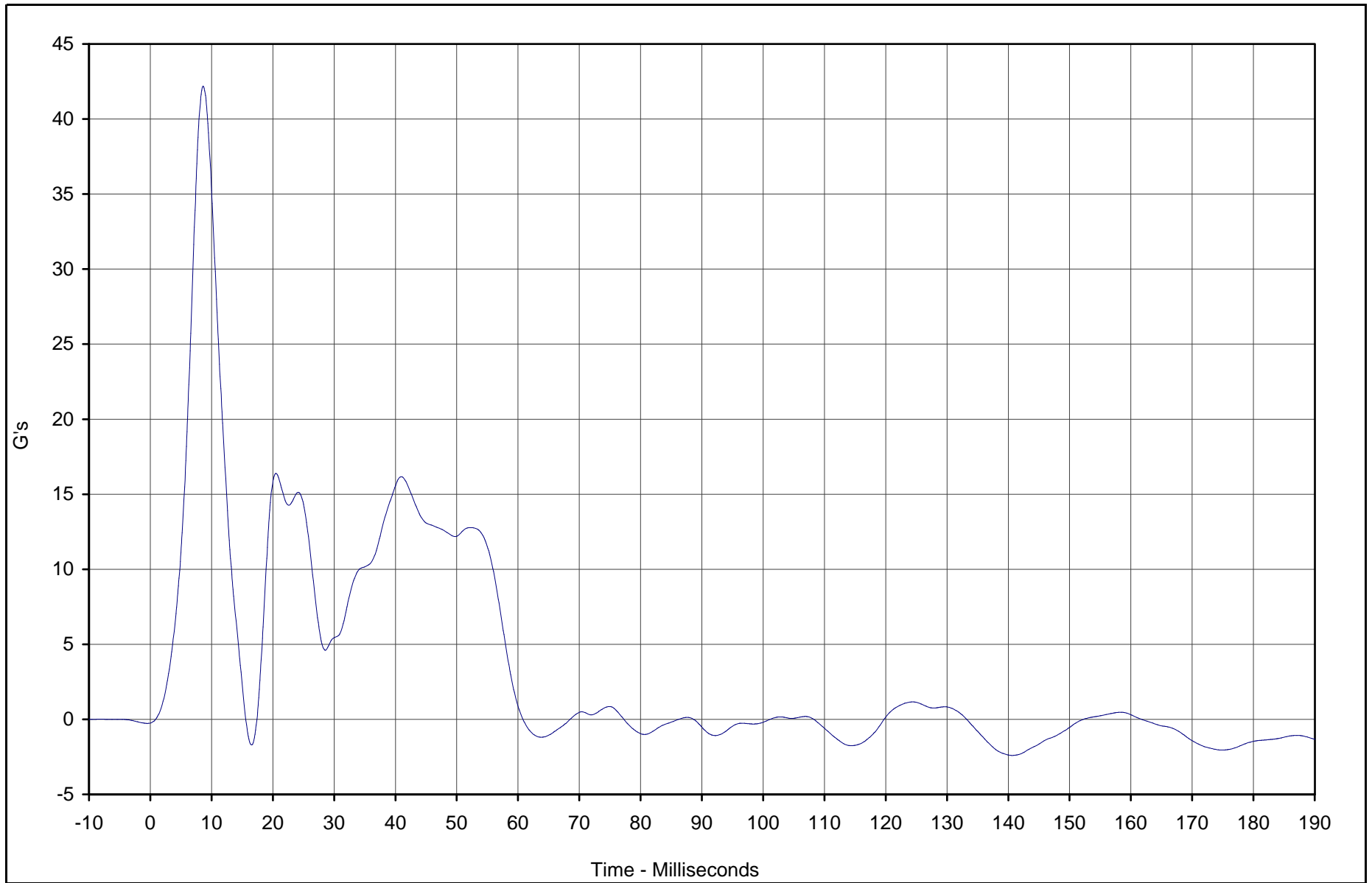

Curve Description	CURNO	Type	Units	Max	Time	Min	Time	SAE Class
Right Sill Rear Seat Y	049	FIL	G's	42.2	8.6	-2.4	140.6	60



Test Vehicle: 2003 Toyota 4 Runner SR5 4WD SUV

Test Date: 2/27/03

Test Program: 55/28 km/h Side Impact NCAP

NHTSA No.: M35107

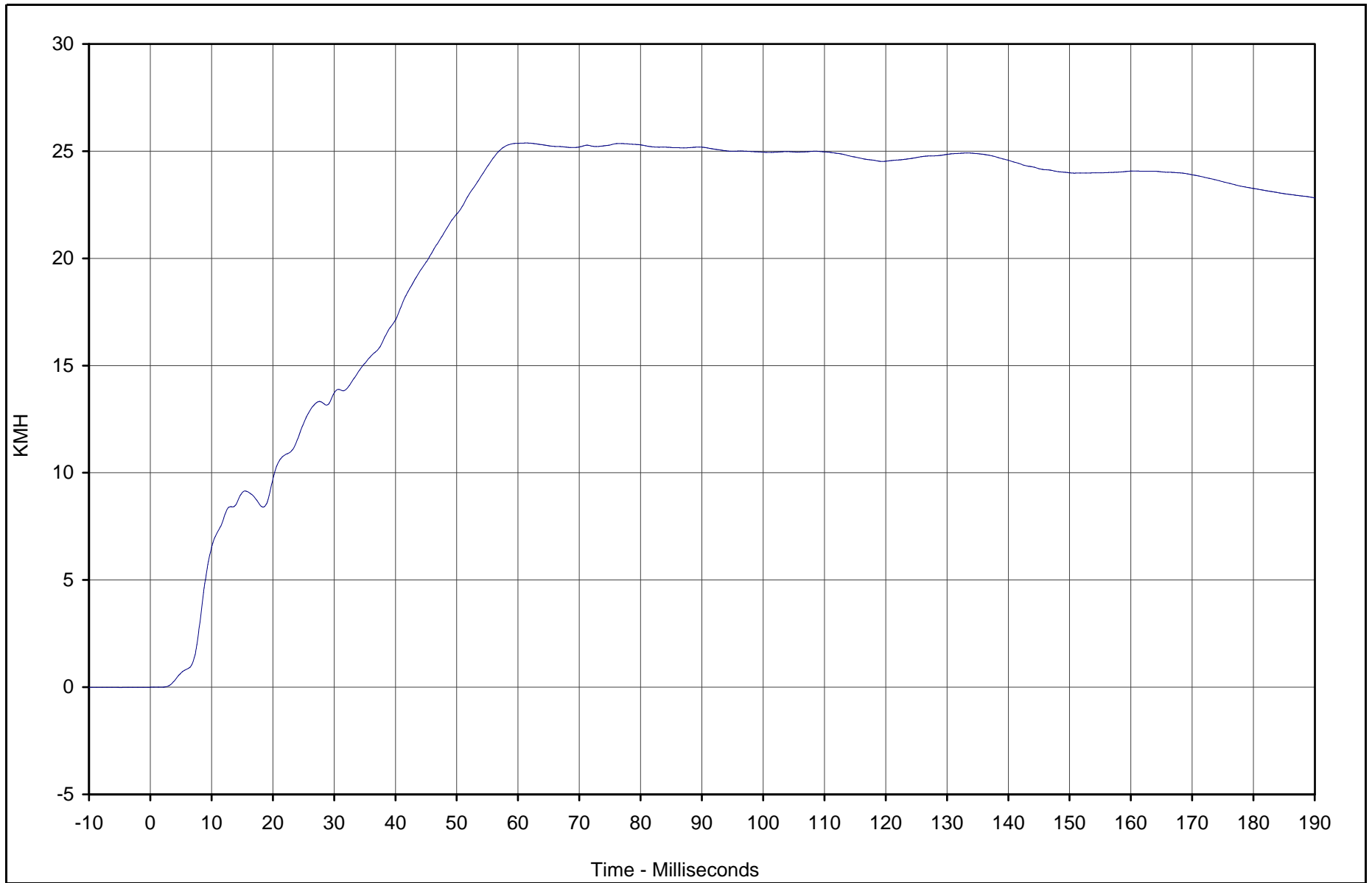

Curve Description	CURNO	Type	Units	Max	Time	Min	Time	SAE Class
Right Sill Rear Seat Y Velocity	049	IN1	KMH	25.4	61.3	0.0	0.0	180



Test Vehicle: 2003 Toyota 4 Runner SR5 4WD SUV

Test Date: 2/27/03

Test Program: 55/28 km/h Side Impact NCAP

NHTSA No.: M35107

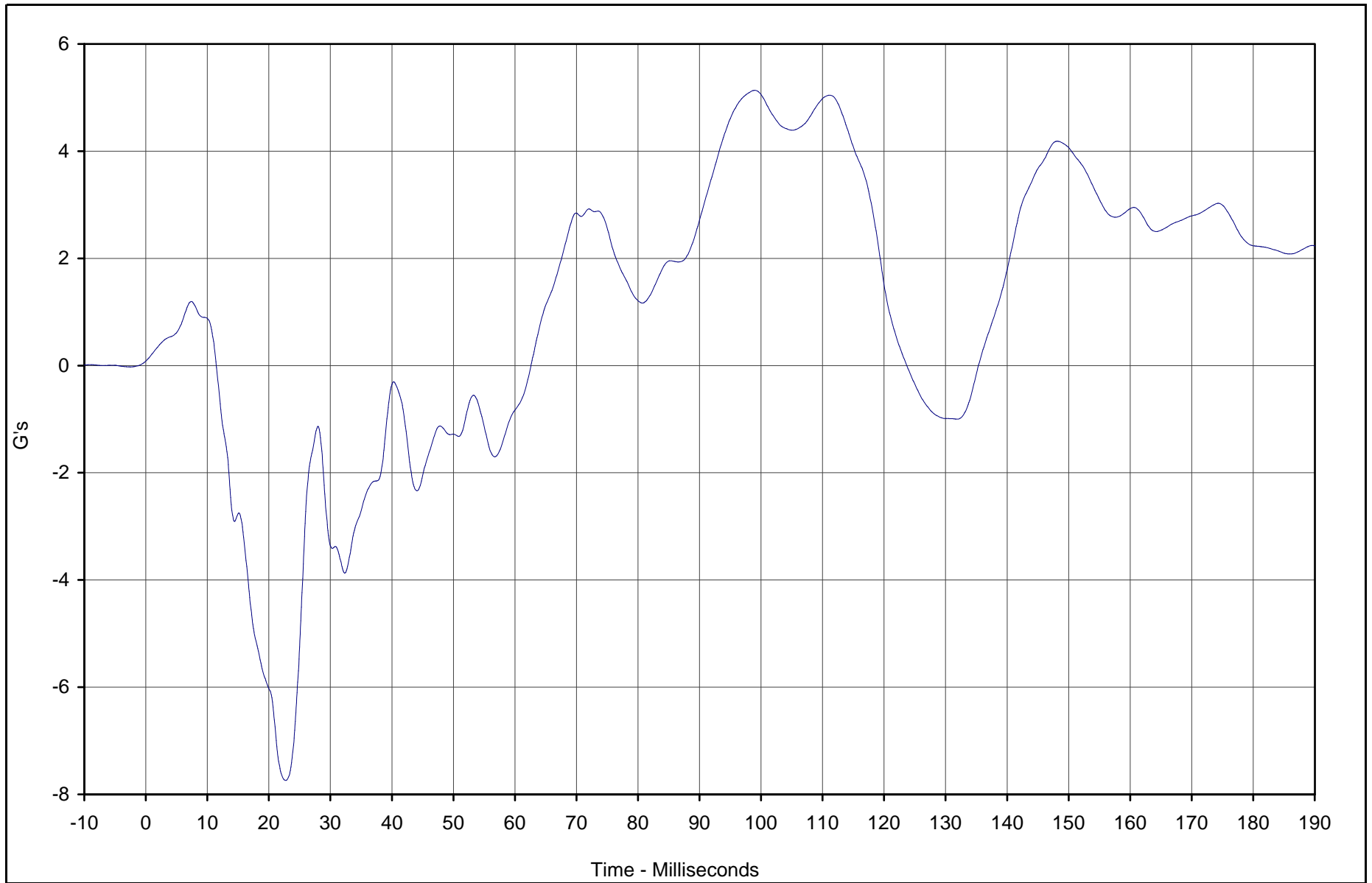

Curve Description	CURNO	Type	Units	Max	Time	Min	Time	SAE Class
Right Sill Rear Seat Z	050	FIL	G's	5.1	99.0	-7.7	22.7	60



Test Vehicle: 2003 Toyota 4 Runner SR5 4WD SUV

Test Date: 2/27/03

Test Program: 55/28 km/h Side Impact NCAP

NHTSA No.: M35107

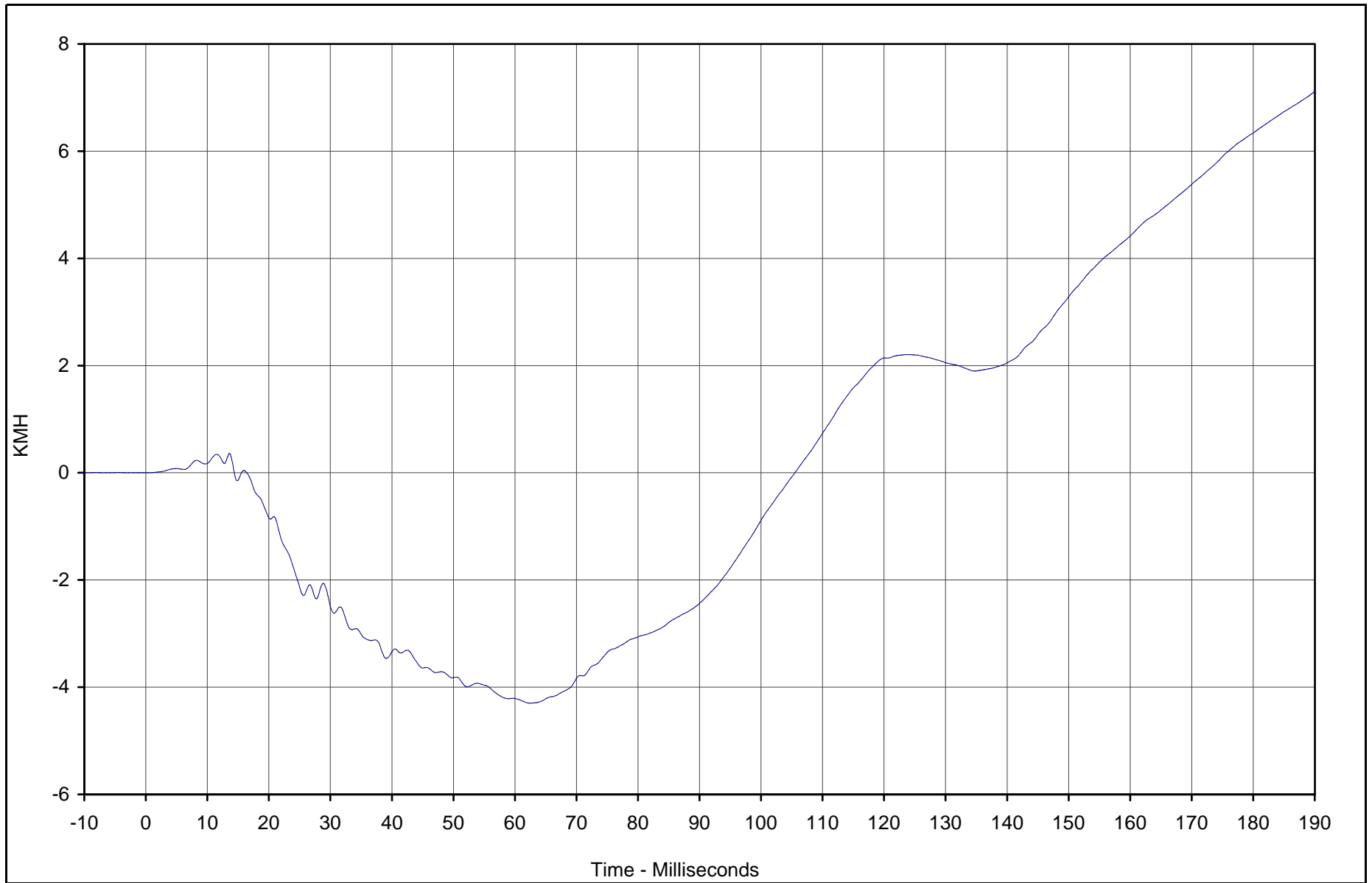

Curve Description	CURNO	Type	Units	Max	Time	Min	Time	SAE Class
Right Sill Rear Seat Z Velocity	050	IN1	KMH	7.1	189.9	-4.3	62.5	180



Test Vehicle: 2003 Toyota 4 Runner SR5 4WD SUV

Test Date: 2/27/03

Test Program: 55/28 km/h Side Impact NCAP

NHTSA No.: M35107

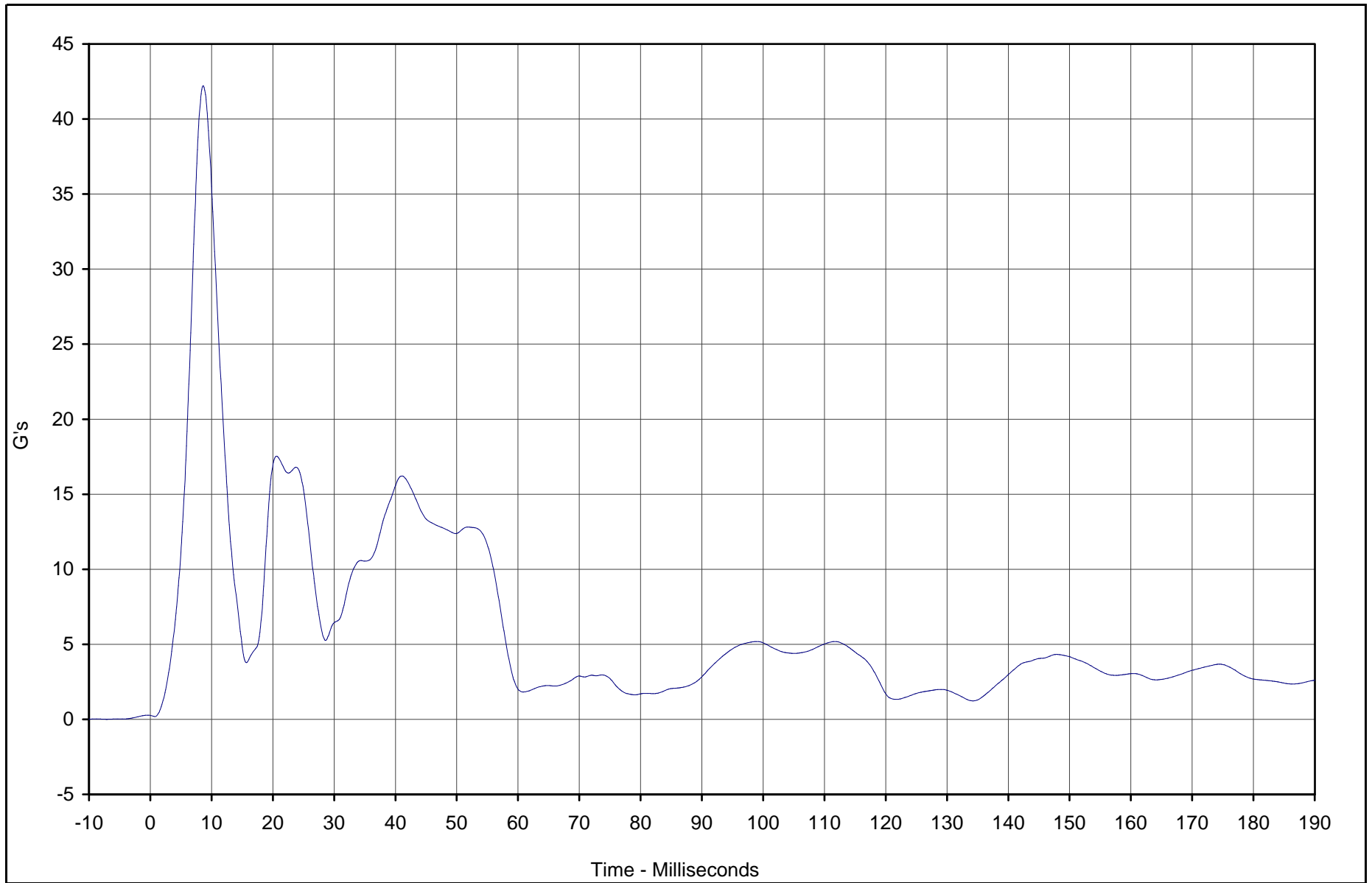

Curve Description	CURNO	Type	Units	Max	Time	Min	Time	SAE Class
Right Sill Rear Seat Resultant	048	RES	G's	42.2	8.6	0.2	0.7	60



Test Vehicle: 2003 Toyota 4 Runner SR5 4WD SUV

Test Date: 2/27/03

Test Program: 55/28 km/h Side Impact NCAP

NHTSA No.: M35107

B-95

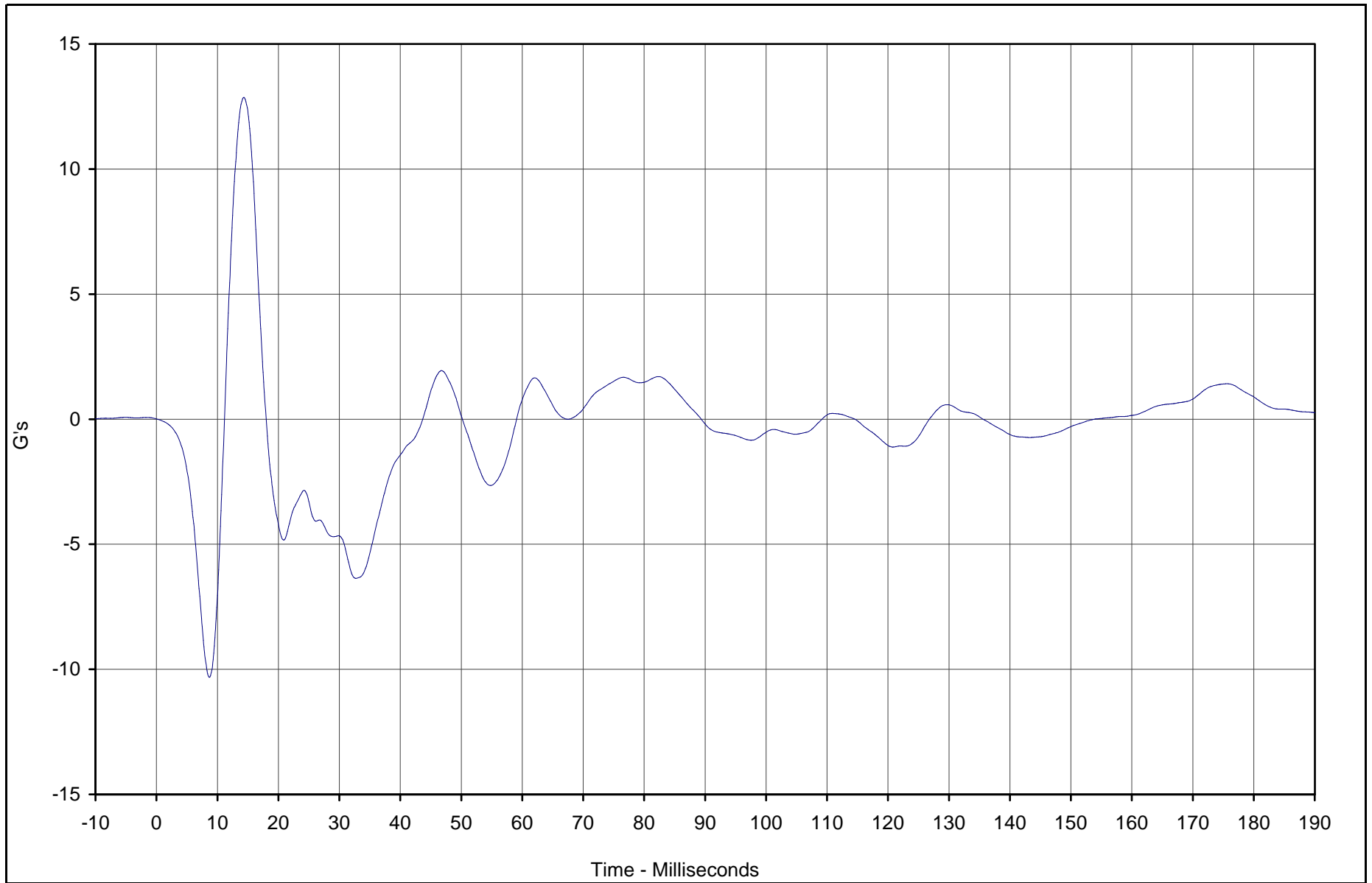

Curve Description	CURNO	Type	Units	Max	Time	Min	Time	SAE Class
Rear Floor Above Axle X	051	FIL	G's	12.9	14.3	-10.3	8.7	60



Test Vehicle: 2003 Toyota 4 Runner SR5 4WD SUV

Test Date: 2/27/03

Test Program: 55/28 km/h Side Impact NCAP

NHTSA No.: M35107

TR-P23003-05-NC

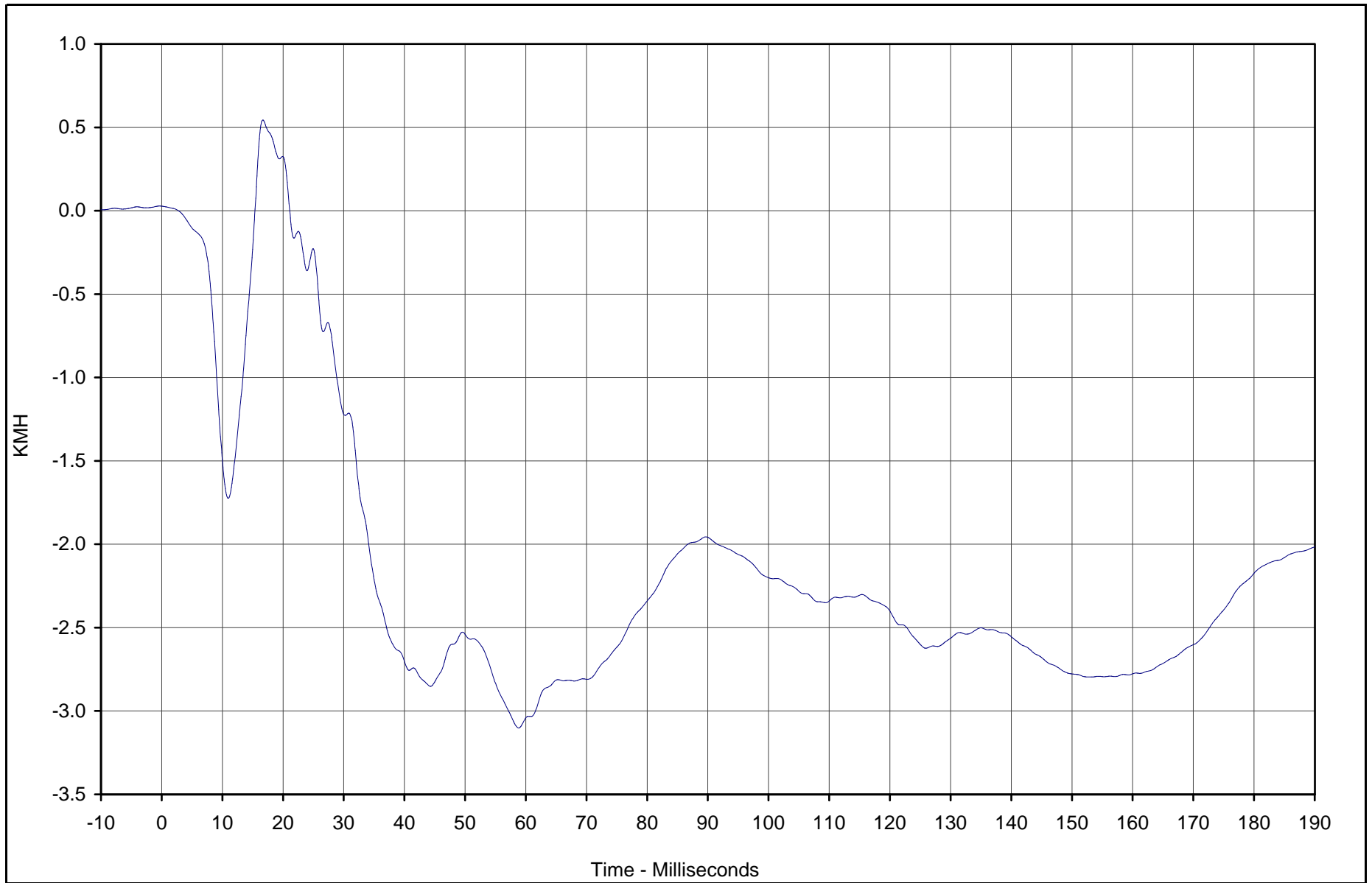

Curve Description	CURNO	Type	Units	Max	Time	Min	Time	SAE Class
Rear Floor Above Axle X Velocity	051	IN1	KMH	0.5	16.7	-3.1	58.8	180



Test Vehicle: 2003 Toyota 4 Runner SR5 4WD SUV
 Test Program: 55/28 km/h Side Impact NCAP

Test Date: 2/27/03
 NHTSA No.: M35107

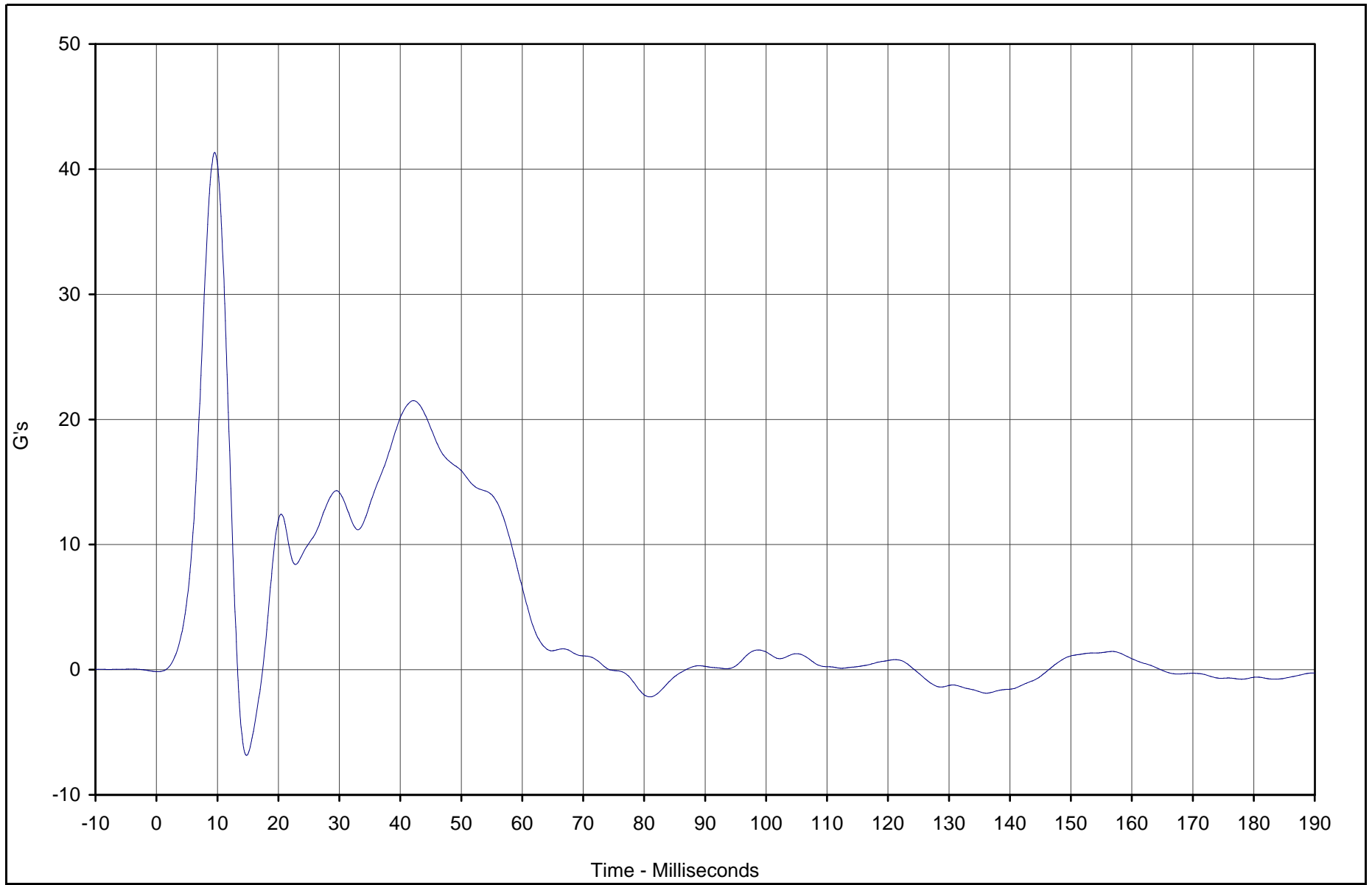

Curve Description	CURNO	Type	Units	Max	Time	Min	Time	SAE Class
Rear Floor Above Axle Y	052	FIL	G's	41.3	9.6	-6.8	14.8	60



Test Vehicle: 2003 Toyota 4 Runner SR5 4WD SUV

Test Date: 2/27/03

Test Program: 55/28 km/h Side Impact NCAP

NHTSA No.: M35107

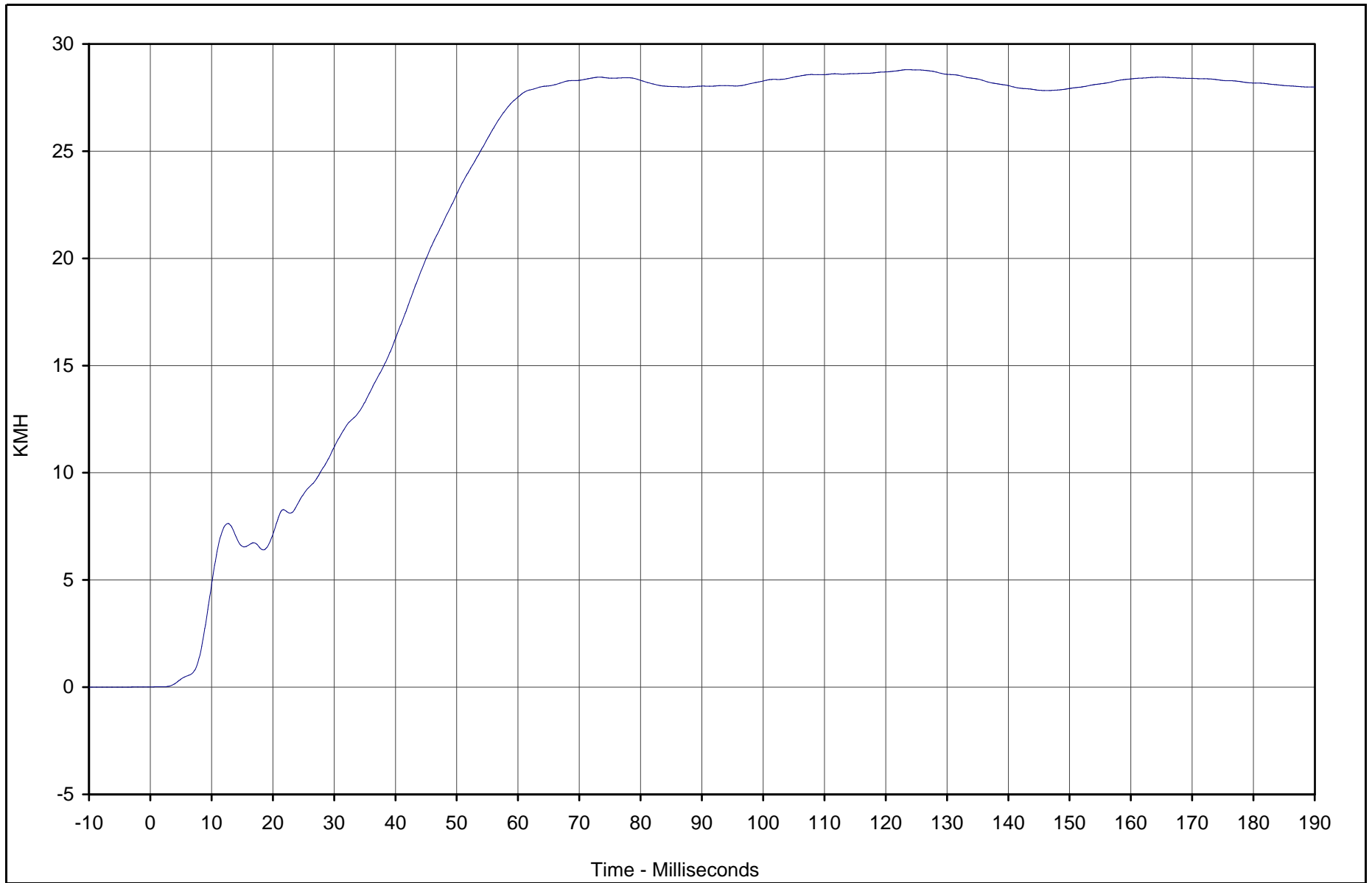

Curve Description	CURNO	Type	Units	Max	Time	Min	Time	SAE Class
Rear Floor Above Axle Y Velocity	052	IN1	KMH	28.8	123.6	0.0	0.0	180



Test Vehicle: 2003 Toyota 4 Runner SR5 4WD SUV

Test Date: 2/27/03

Test Program: 55/28 km/h Side Impact NCAP

NHTSA No.: M35107

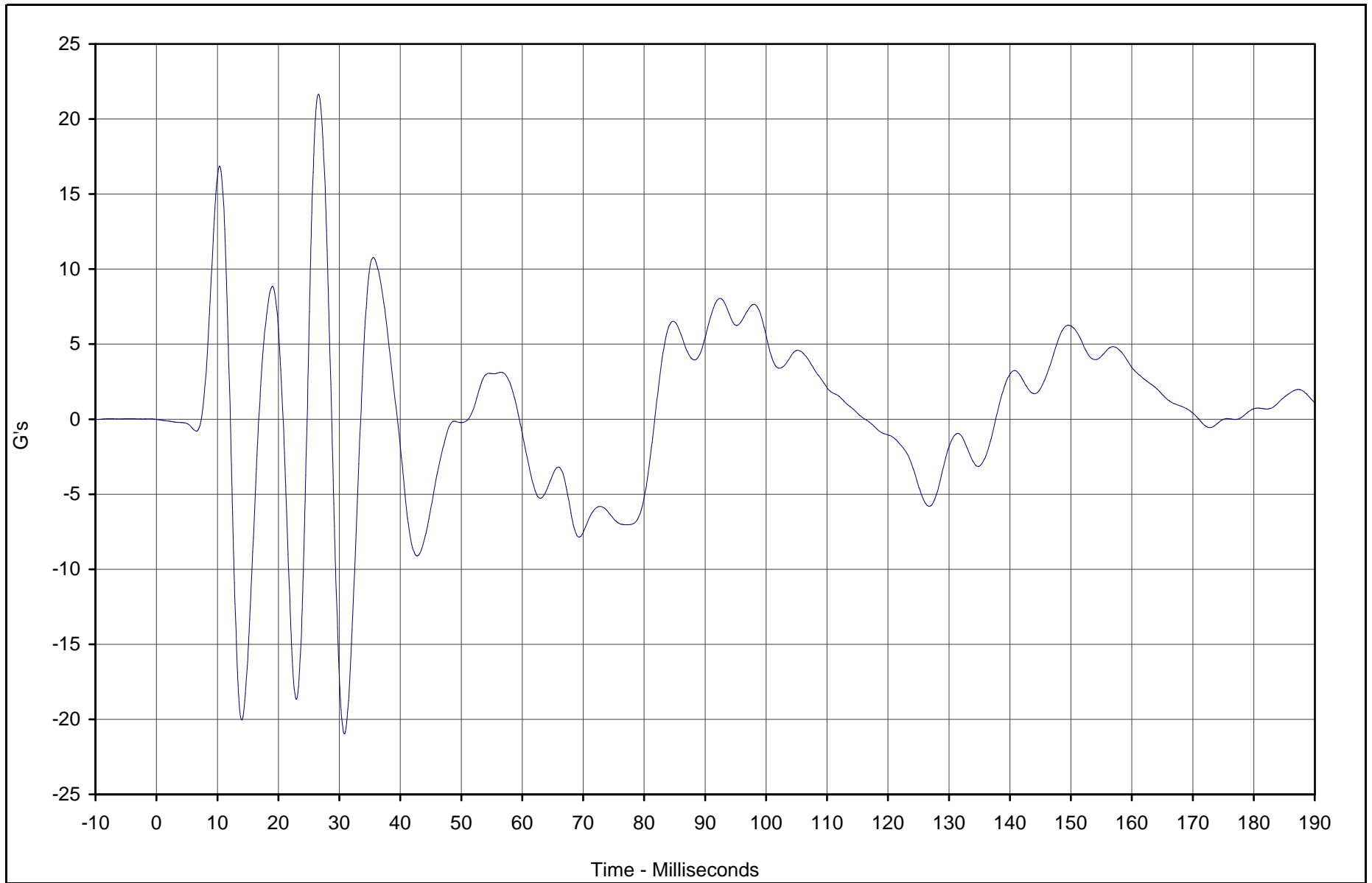

Curve Description	CURNO	Type	Units	Max	Time	Min	Time	SAE Class
Rear Floor Above Axle Z	053	FIL	G's	21.6	26.6	-21.0	30.8	60



Test Vehicle: 2003 Toyota 4 Runner SR5 4WD SUV

Test Date: 2/27/03

Test Program: 55/28 km/h Side Impact NCAP

NHTSA No.: M35107

B-100

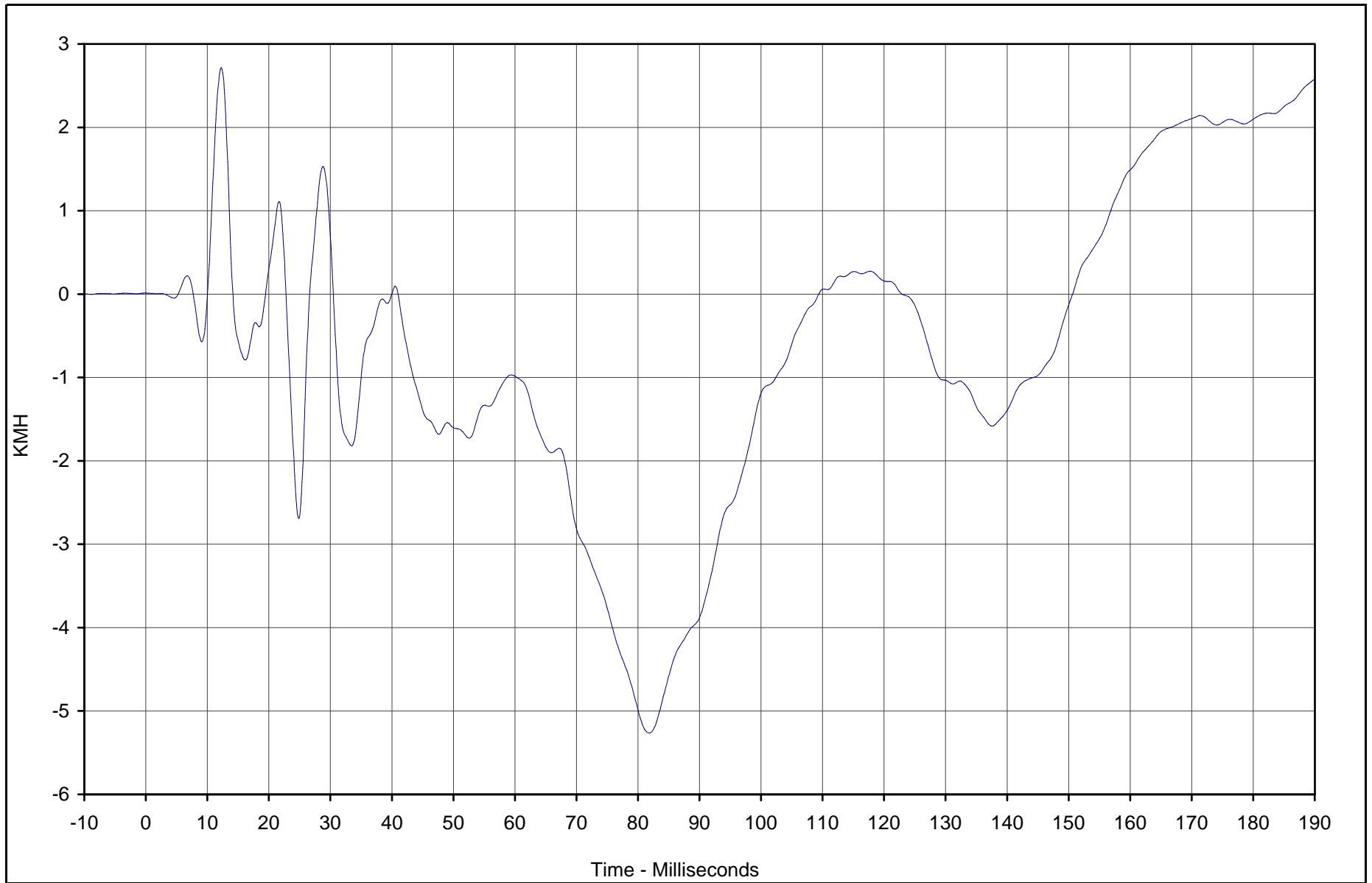

Curve Description	CURNO	Type	Units	Max	Time	Min	Time	SAE Class
Rear Floor Above Axle Z Velocity	053	IN1	KMH	2.7	12.3	-5.3	81.8	180



Test Vehicle: 2003 Toyota 4 Runner SR5 4WD SUV

Test Date: 2/27/03

Test Program: 55/28 km/h Side Impact NCAP

NHTSA No.: M35107

TR-P23003-05-NC

B-101

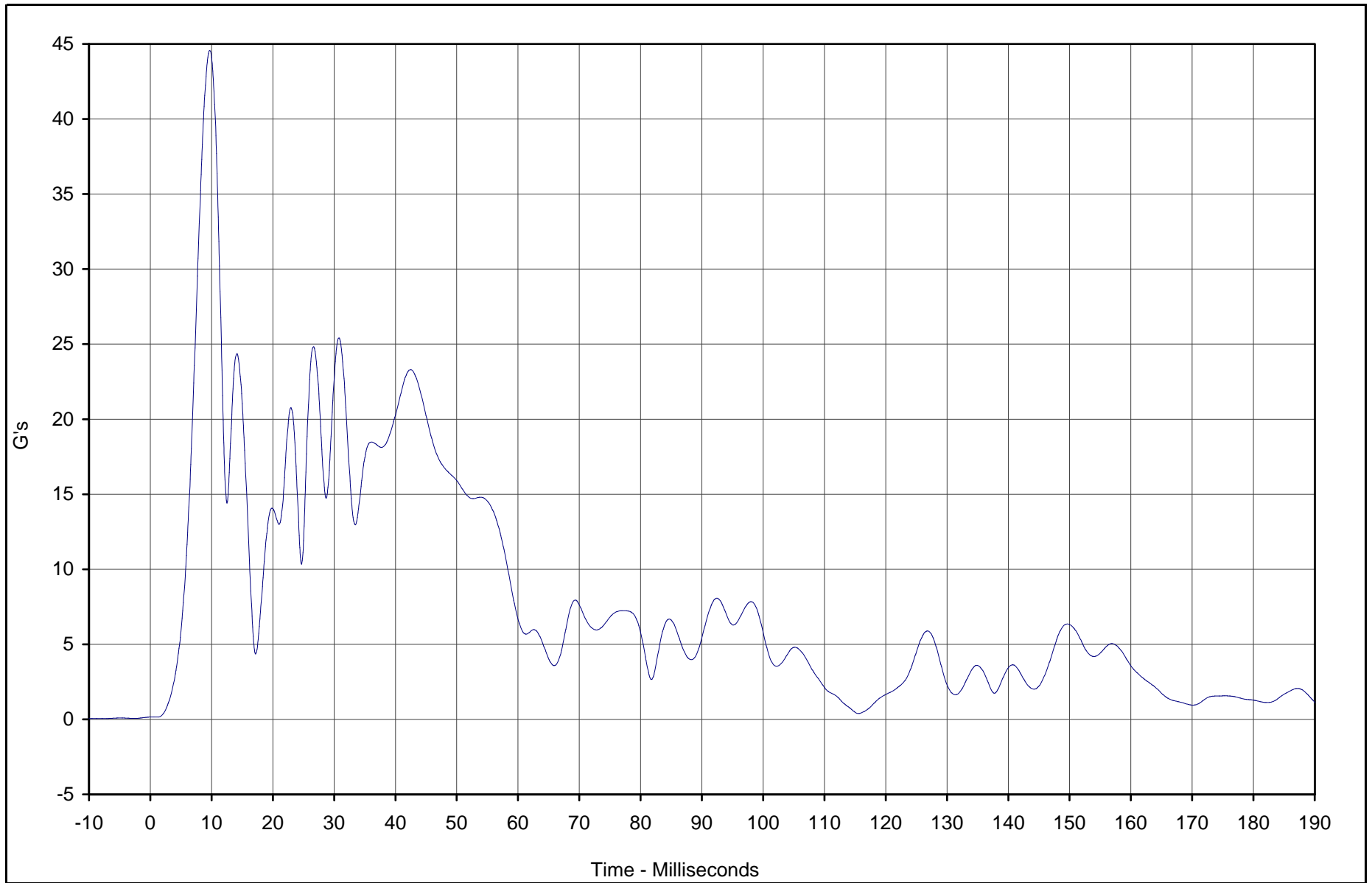

Curve Description	CURNO	Type	Units	Max	Time	Min	Time	SAE Class
Rear Floor Above Axle Resultant	051	RES	G's	44.6	9.7	0.2	1.2	60



Test Vehicle: 2003 Toyota 4 Runner SR5 4WD SUV

Test Date: 2/27/03

Test Program: 55/28 km/h Side Impact NCAP

NHTSA No.: M35107

TR-P23003-05-NC

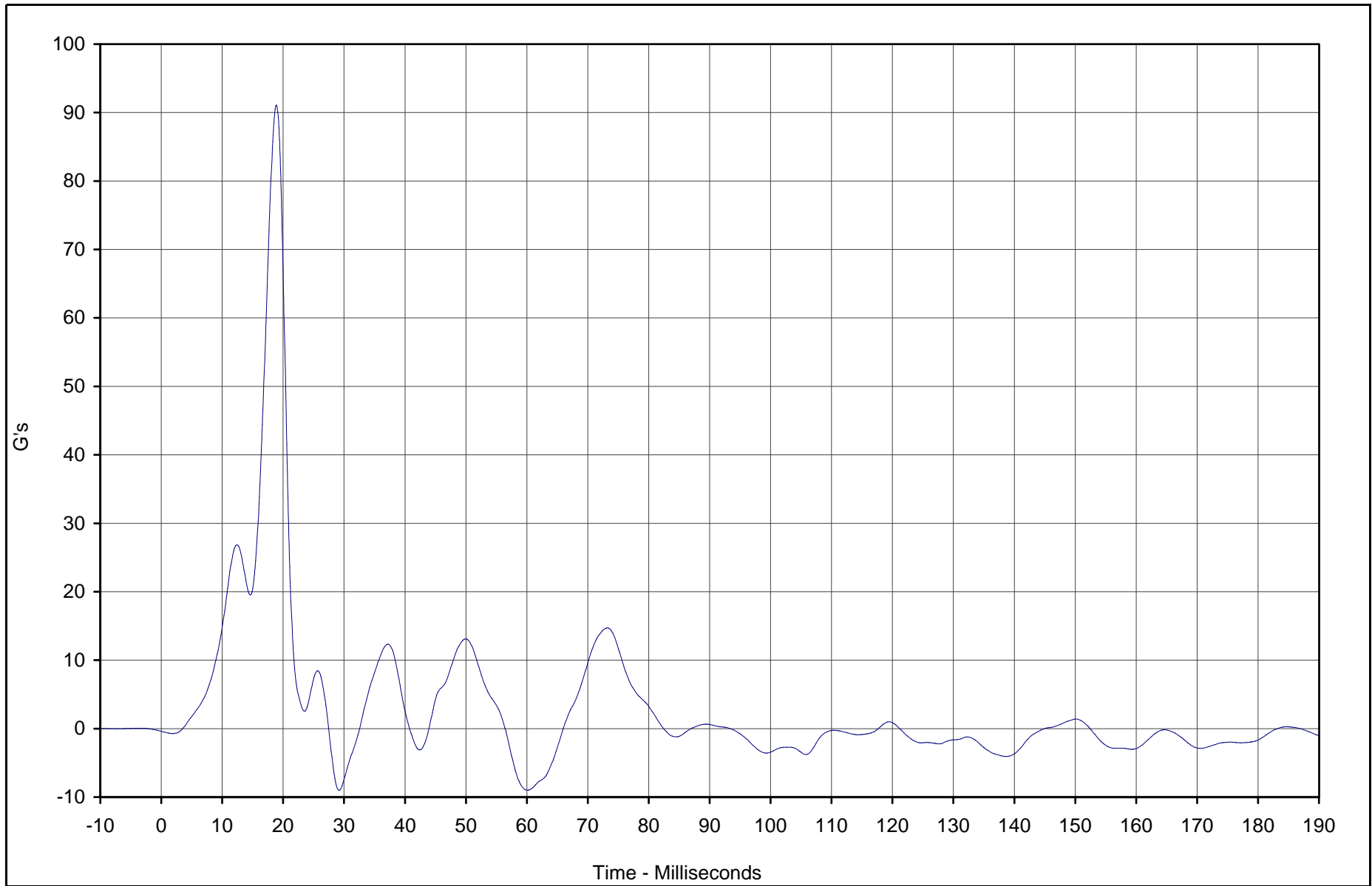

Curve Description	CURNO	Type	Units	Max	Time	Min	Time	SAE Class
Left Sill Rear Seat Y	054	FIL	G's	91.1	18.9	-9.0	29.2	60



Test Vehicle: 2003 Toyota 4 Runner SR5 4WD SUV

Test Date: 2/27/03

Test Program: 55/28 km/h Side Impact NCAP

NHTSA No.: M35107

B-103

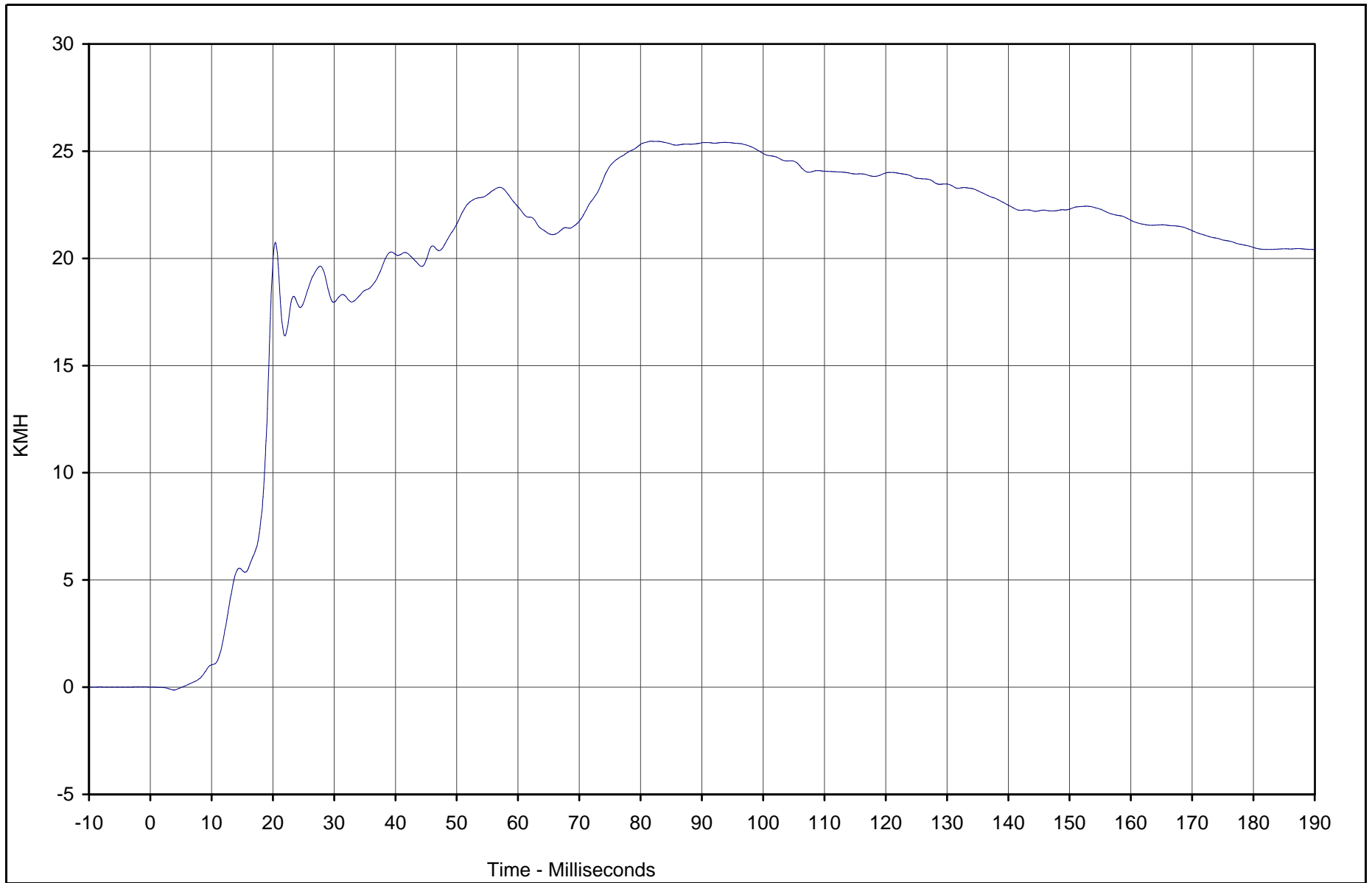

Curve Description	CURNO	Type	Units	Max	Time	Min	Time	SAE Class
Left Sill Rear Door Y Velocity	054	IN1	KMH	25.5	81.8	-0.1	3.8	180



Test Vehicle: 2003 Toyota 4 Runner SR5 4WD SUV

Test Date: 2/27/03

Test Program: 55/28 km/h Side Impact NCAP

NHTSA No.: M35107

TR-P23003-05-NC

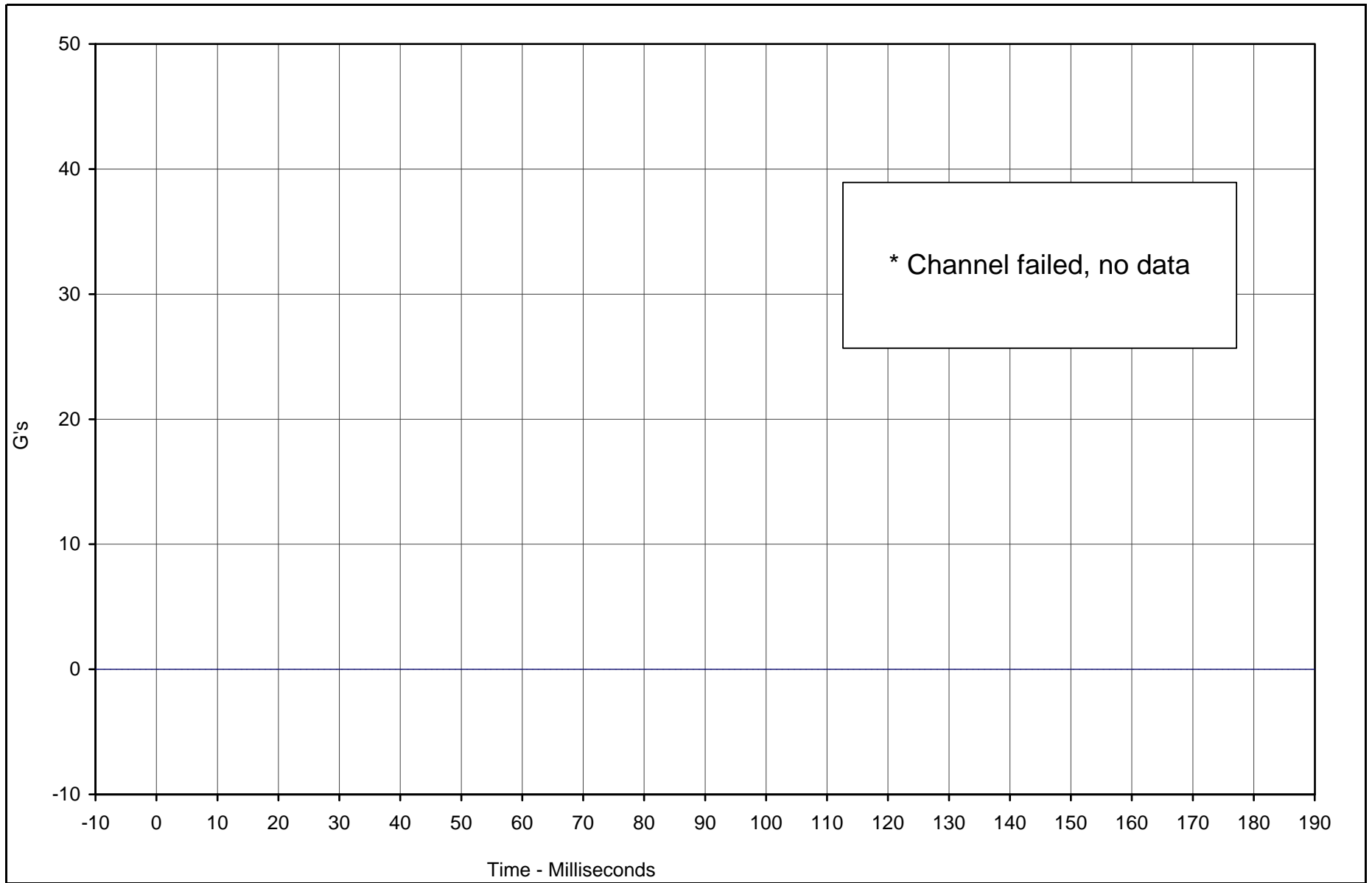

* Channel failed, no data

Curve Description	CURNO	Type	Units	Max	Time	Min	Time	SAE Class
Left Sill Front Seat Y	055	FIL	G's	0.0	0.0	0.0	0.0	60



Test Vehicle: 2003 Toyota 4 Runner SR5 4WD SUV

Test Date: 2/27/03

Test Program: 55/28 km/h Side Impact NCAP

NHTSA No.: M35107

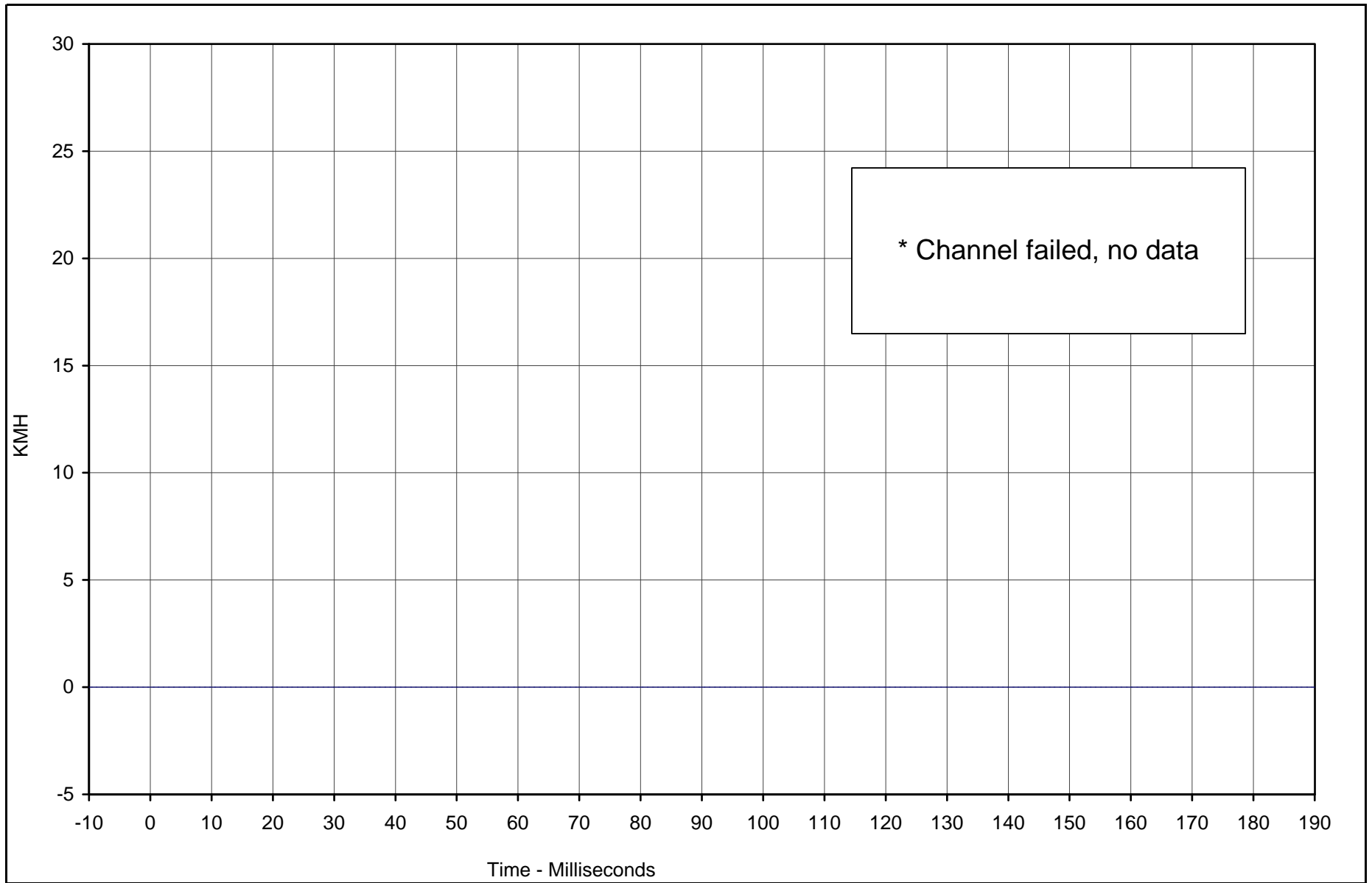

* Channel failed, no data

Curve Description	CURNO	Type	Units	Max	Time	Min	Time	SAE Class
Left Sill Front Door Y Velocity	055	IN1	KMH	0.0	0.0	0.0	0.0	180



Test Vehicle: 2003 Toyota 4 Runner SR5 4WD SUV

Test Date: 2/27/03

Test Program: 55/28 km/h Side Impact NCAP

NHTSA No.: M35107

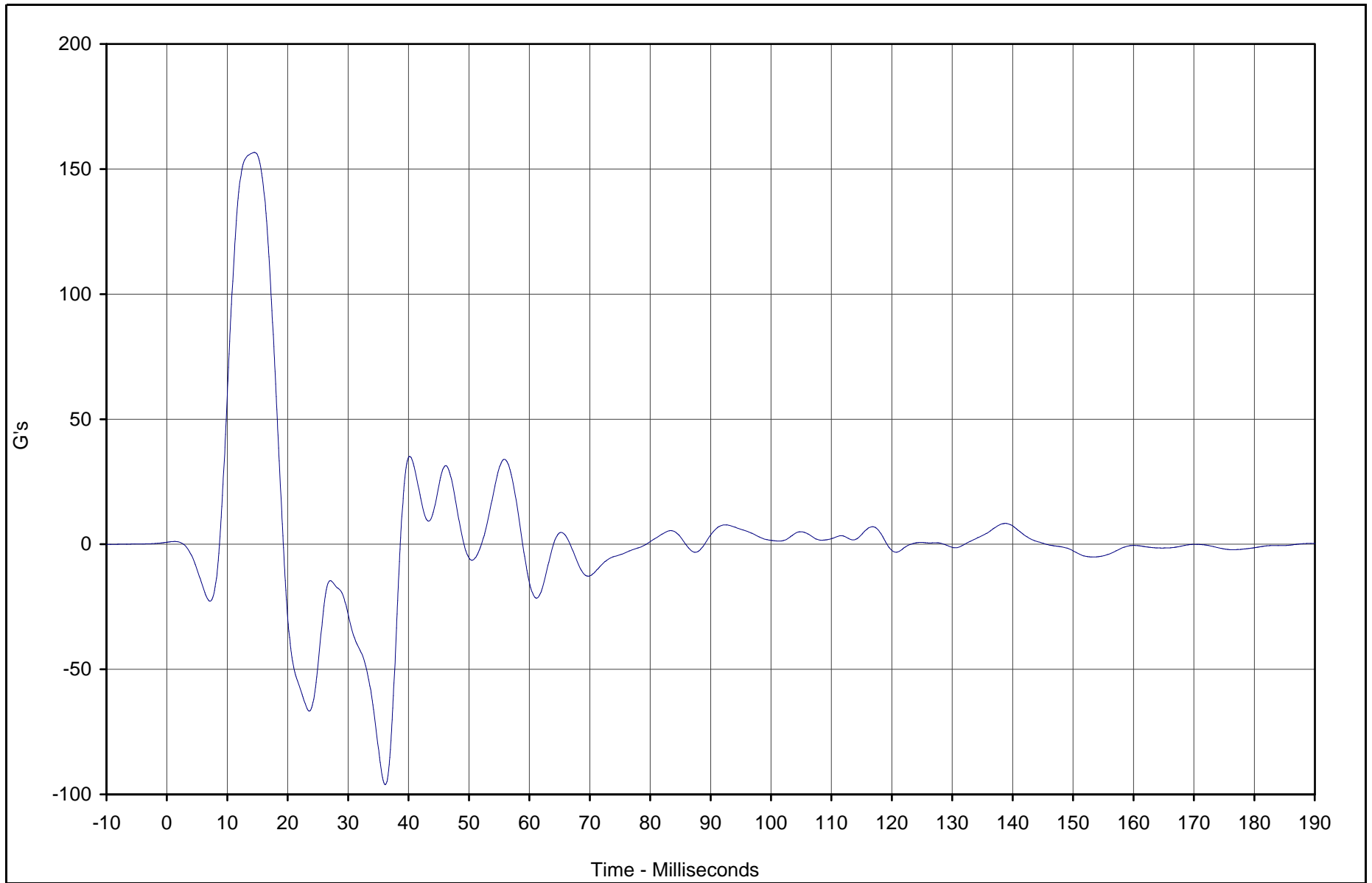

Curve Description	CURNO	Type	Units	Max	Time	Min	Time	SAE Class
Left Front Door CL Y	056	FIL	G's	156.6	14.5	-96.1	36.1	60



Test Vehicle: 2003 Toyota 4 Runner SR5 4WD SUV

Test Date: 2/27/03

Test Program: 55/28 km/h Side Impact NCAP

NHTSA No.: M35107

B-107

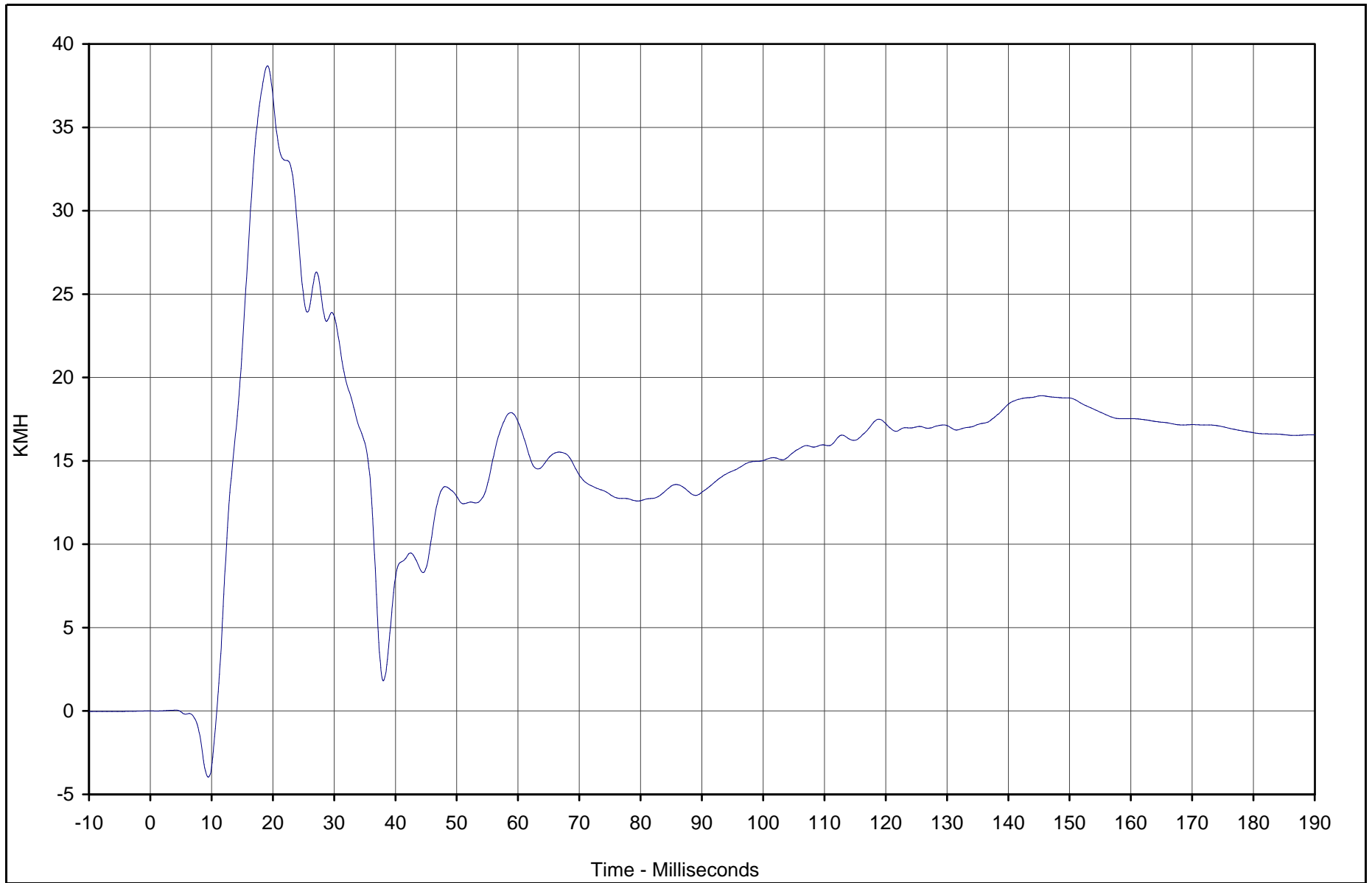

Curve Description	CURNO	Type	Units	Max	Time	Min	Time	SAE Class
Left Front Door CL Y Velocity	056	IN1	KMH	38.7	19.1	-4.0	9.5	180



Test Vehicle: 2003 Toyota 4 Runner SR5 4WD SUV

Test Date: 2/27/03

Test Program: 55/28 km/h Side Impact NCAP

NHTSA No.: M35107

TR-P23003-05-NC

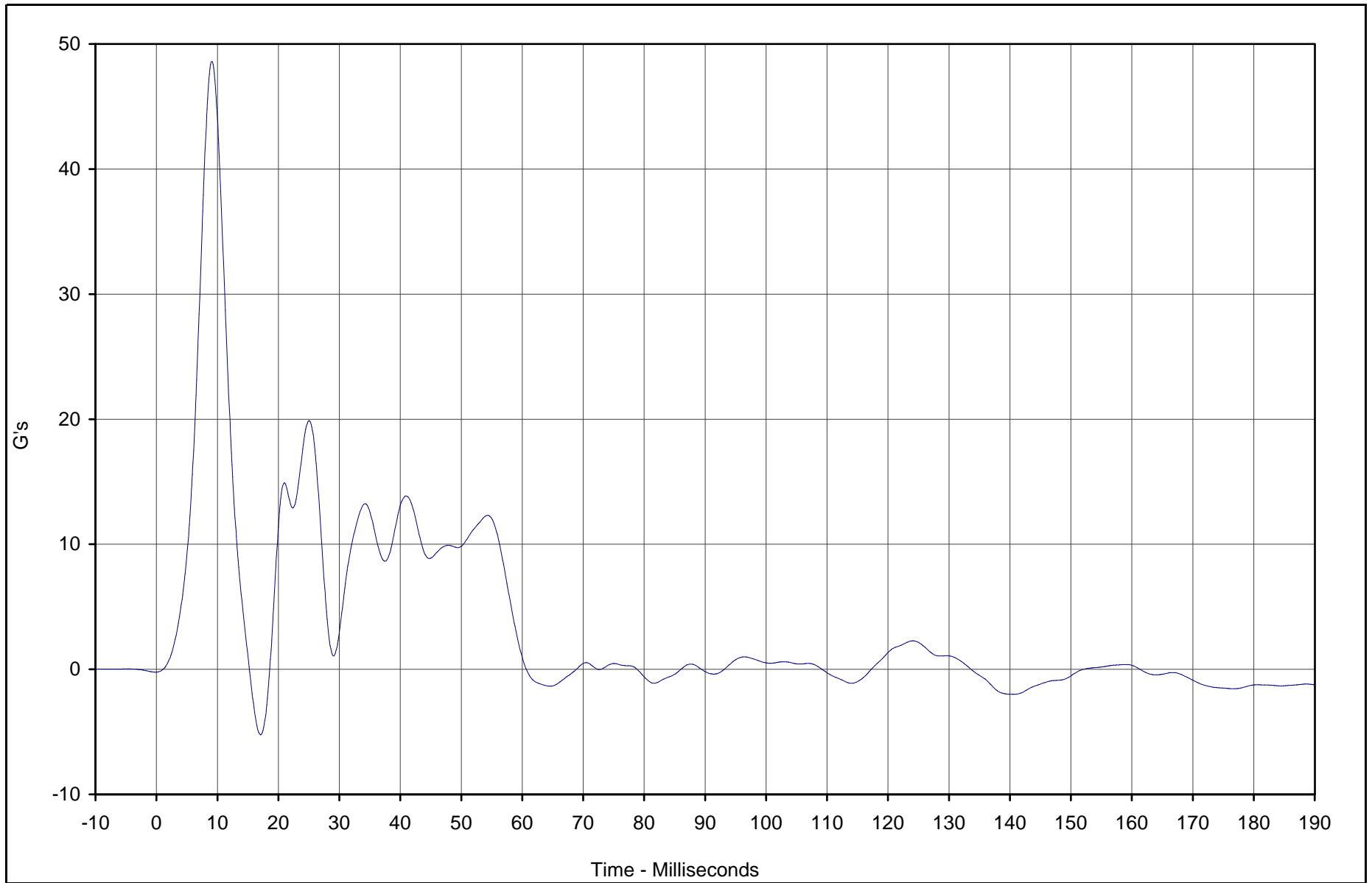

Curve Description	CURNO	Type	Units	Max	Time	Min	Time	SAE Class
Right Rear Occ. Comp. Y	057	FIL	G's	48.6	9.1	-5.2	17.1	60



Test Vehicle: 2003 Toyota 4 Runner SR5 4WD SUV

Test Date: 2/27/03

Test Program: 55/28 km/h Side Impact NCAP

NHTSA No.: M35107

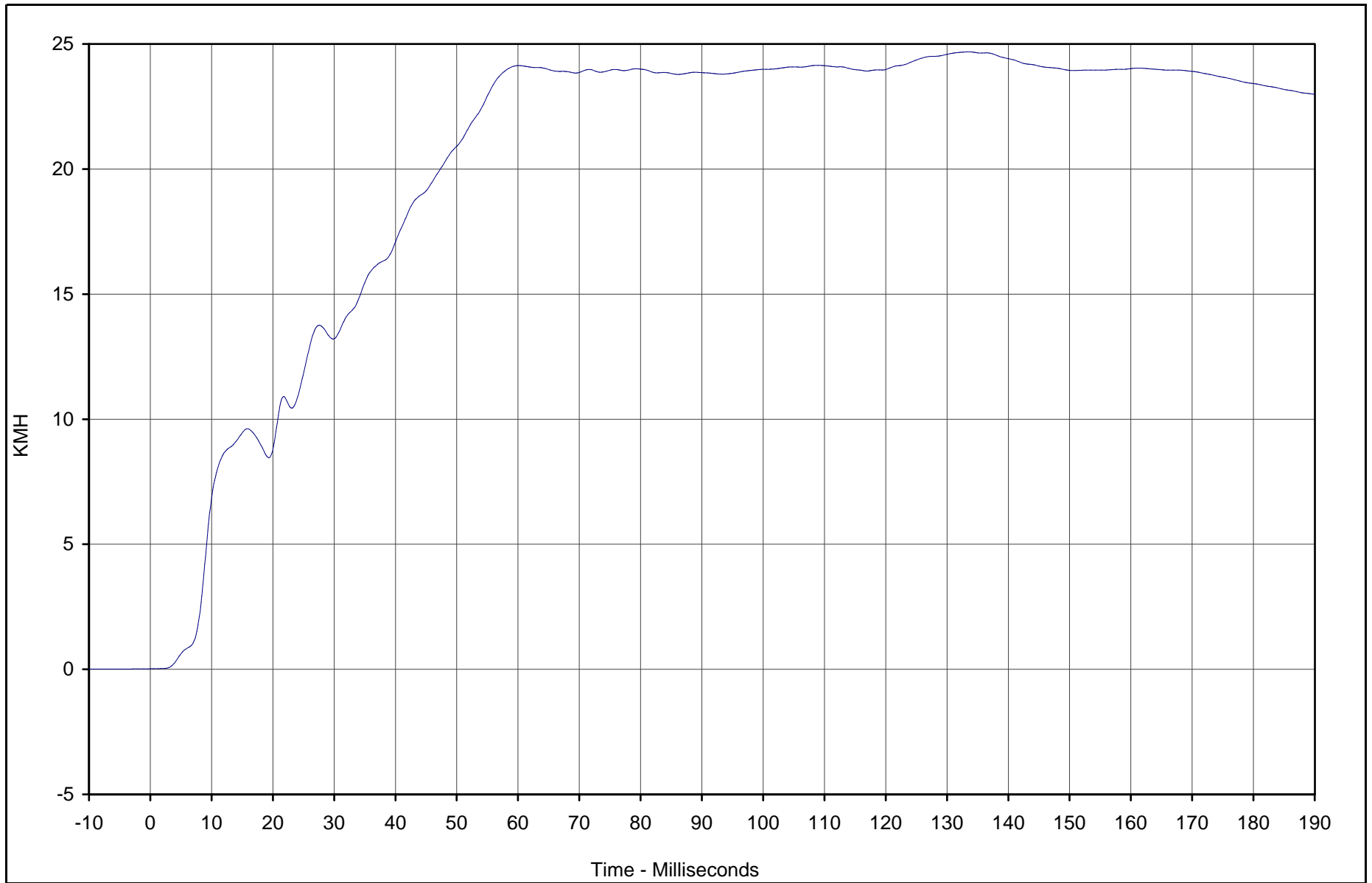

Curve Description	CURNO	Type	Units	Max	Time	Min	Time	SAE Class
Right Rear Occ. Comp. Y Velocity	057	IN1	KMH	24.7	133.6	0.0	0.0	180



Test Vehicle: 2003 Toyota 4 Runner SR5 4WD SUV

Test Date: 2/27/03

Test Program: 55/28 km/h Side Impact NCAP

NHTSA No.: M35107

B-110

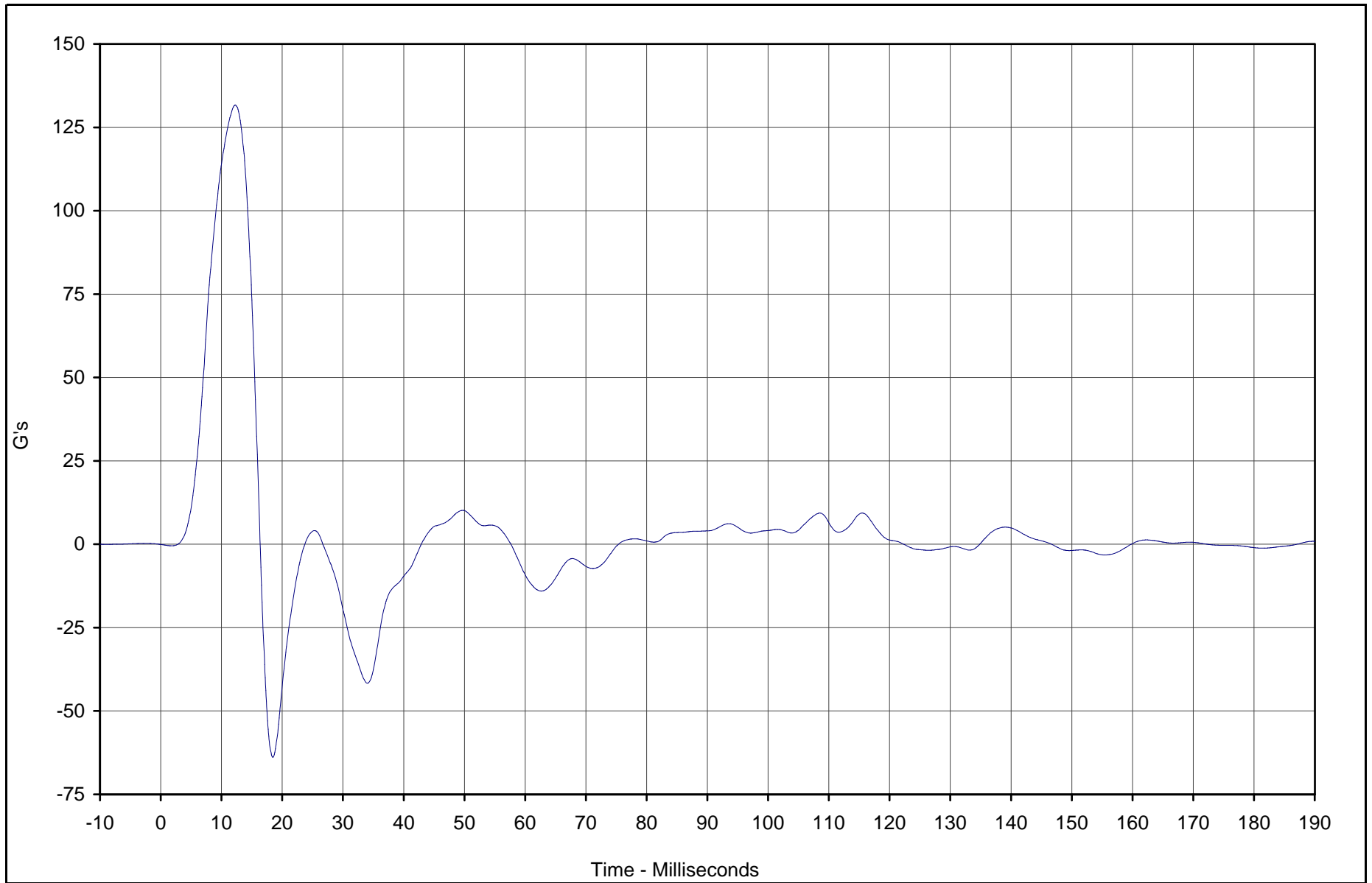

Curve Description	CURNO	Type	Units	Max	Time	Min	Time	SAE Class
Left Front Door Mid Rear Y	058	FIL	G's	131.7	12.3	-63.9	18.5	60



Test Vehicle: 2003 Toyota 4 Runner SR5 4WD SUV

Test Date: 2/27/03

Test Program: 55/28 km/h Side Impact NCAP

NHTSA No.: M35107

TR-P23003-05-NC

B-111

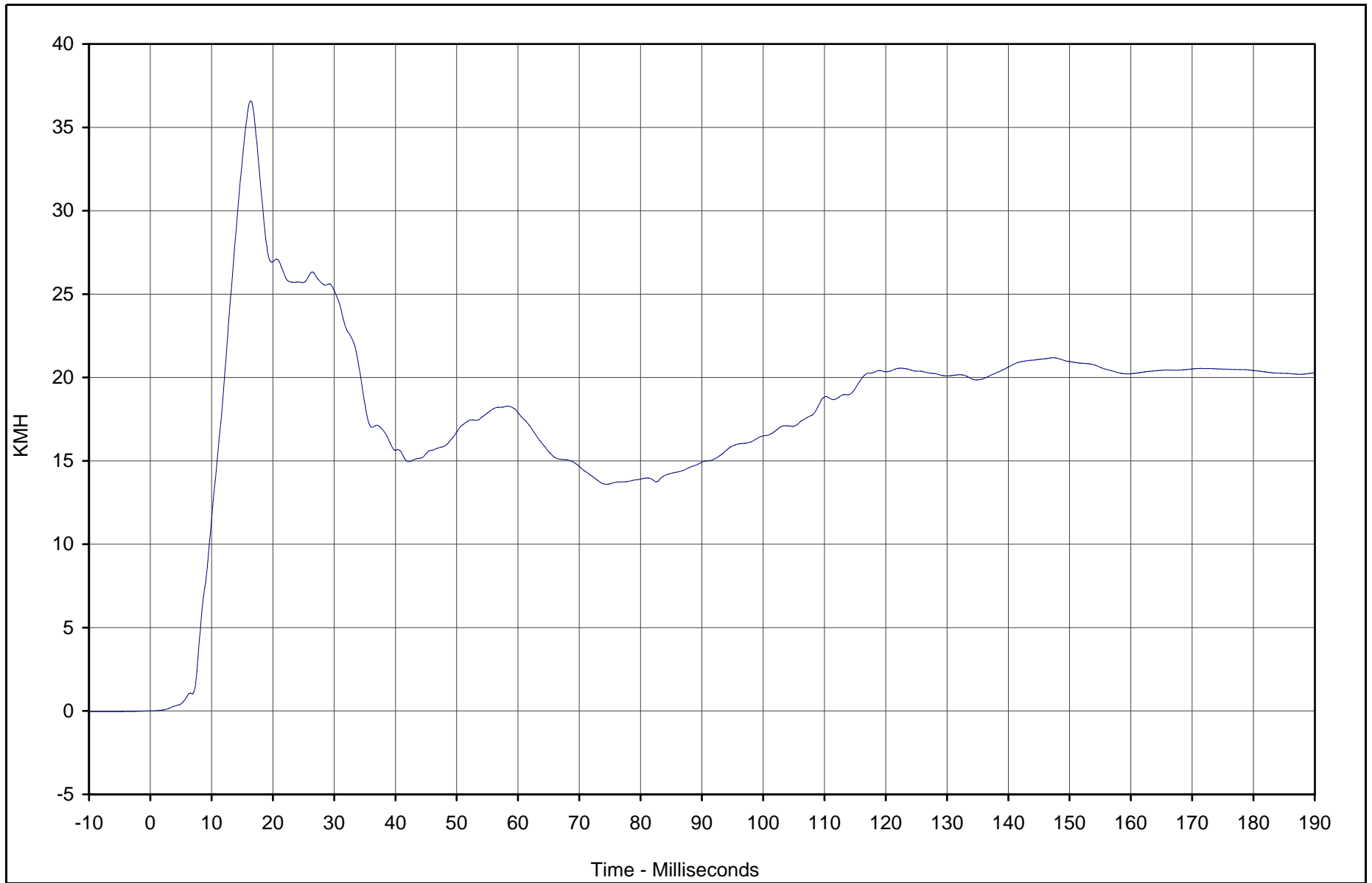

TR-P23003-05-NC

Curve Description	CURNO	Type	Units	Max	Time	Min	Time	SAE Class
Left Front Door Mid Rear Y Vel.	058	IN1	KMH	36.6	16.4	0.0	0.0	180



Test Vehicle: 2003 Toyota 4 Runner SR5 4WD SUV

Test Date: 2/27/03

Test Program: 55/28 km/h Side Impact NCAP

NHTSA No.: M35107

B-112

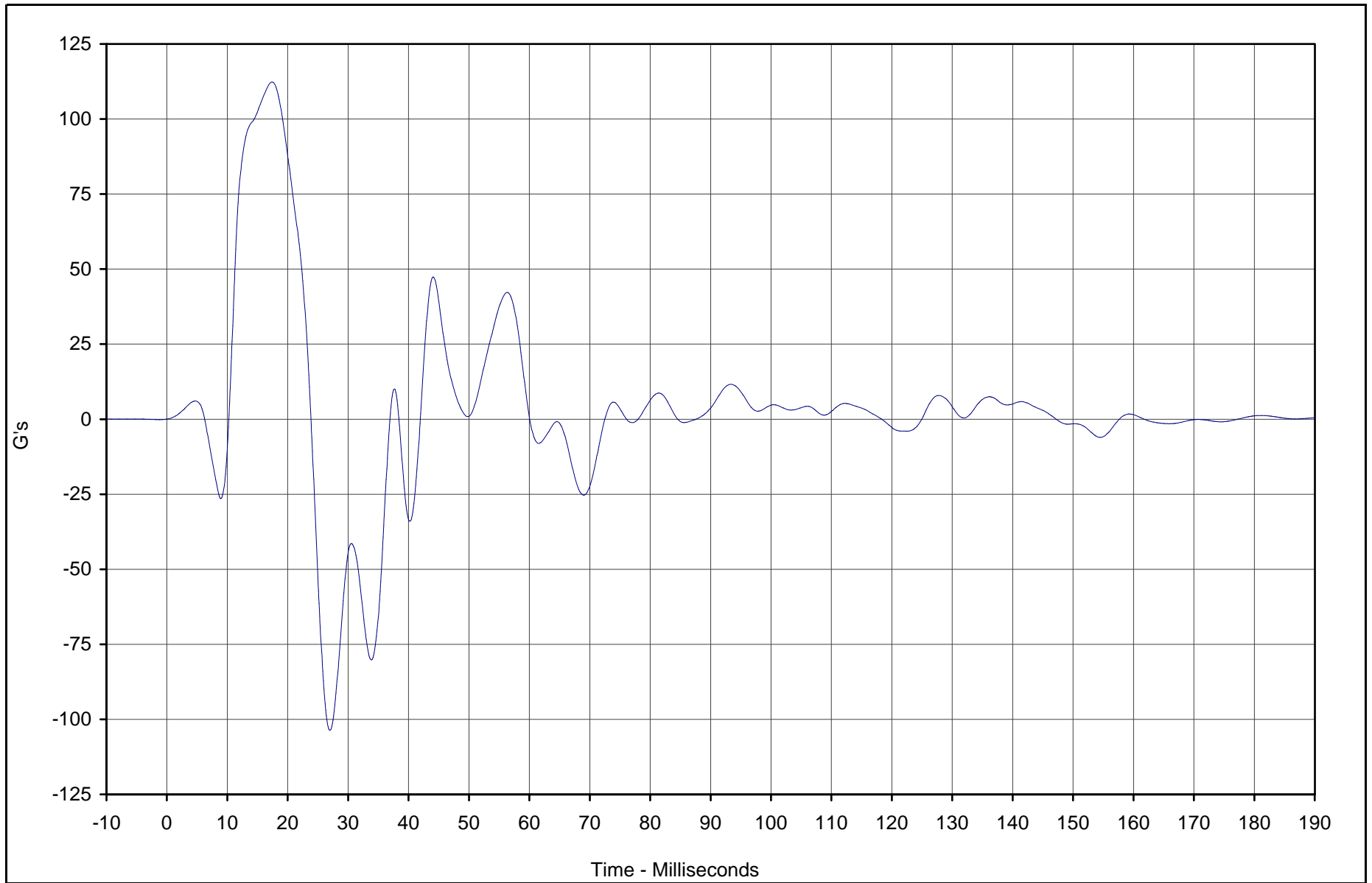

Curve Description	CURNO	Type	Units	Max	Time	Min	Time	SAE Class
Left Front Door Upper CL Y	059	FIL	G's	112.3	17.4	-103.6	27.0	60



Test Vehicle: 2003 Toyota 4 Runner SR5 4WD SUV

Test Date: 2/27/03

Test Program: 55/28 km/h Side Impact NCAP

NHTSA No.: M35107

TR-P23003-05-NC

B-113

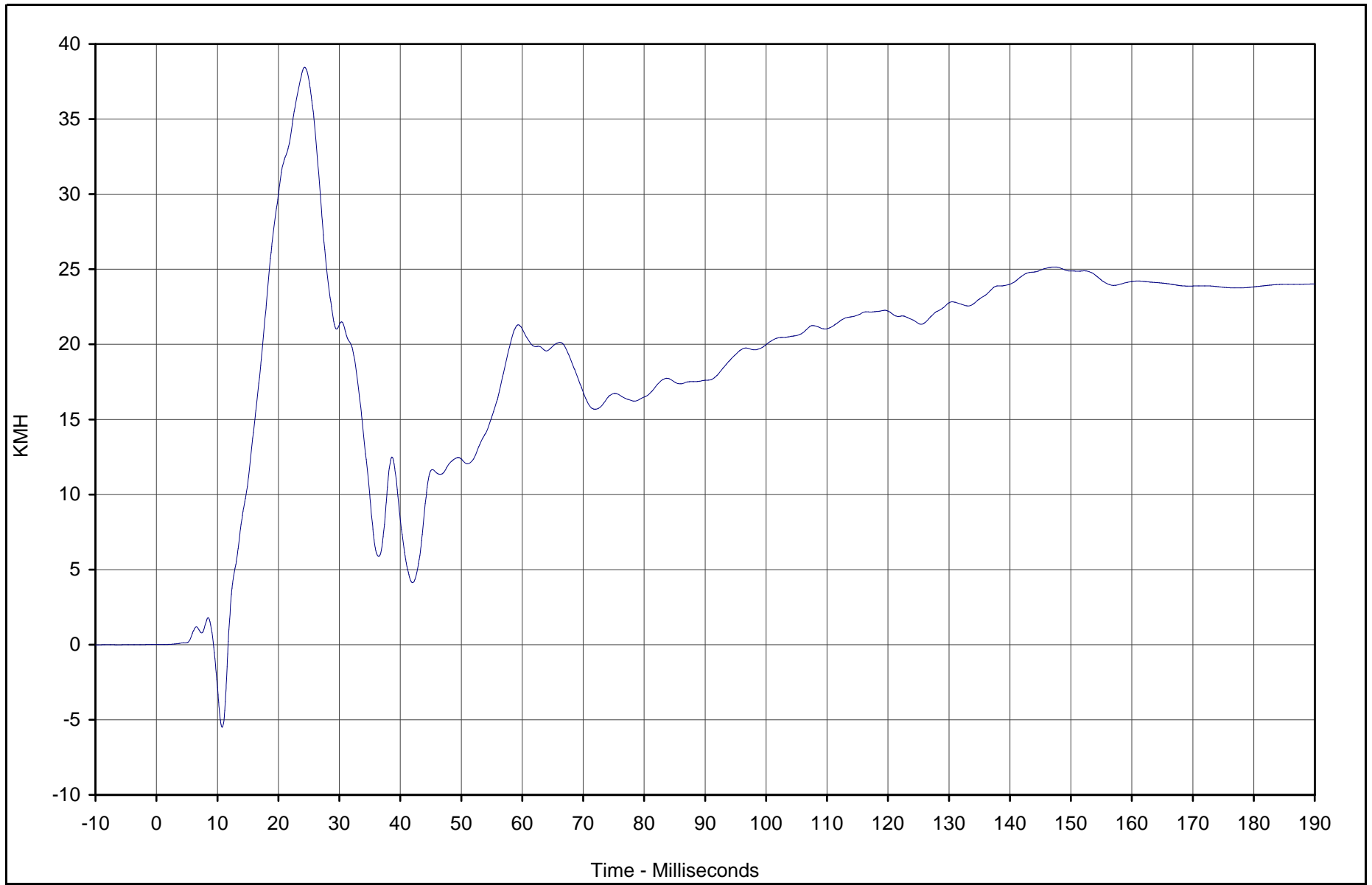

Curve Description	CURNO	Type	Units	Max	Time	Min	Time	SAE Class
Left Front Door Upper CL Y Vel.	059	IN1	KMH	38.5	24.3	-5.5	10.8	180



Test Vehicle: 2003 Toyota 4 Runner SR5 4WD SUV

Test Date: 2/27/03

Test Program: 55/28 km/h Side Impact NCAP

NHTSA No.: M35107

TR-P23003-05-NC

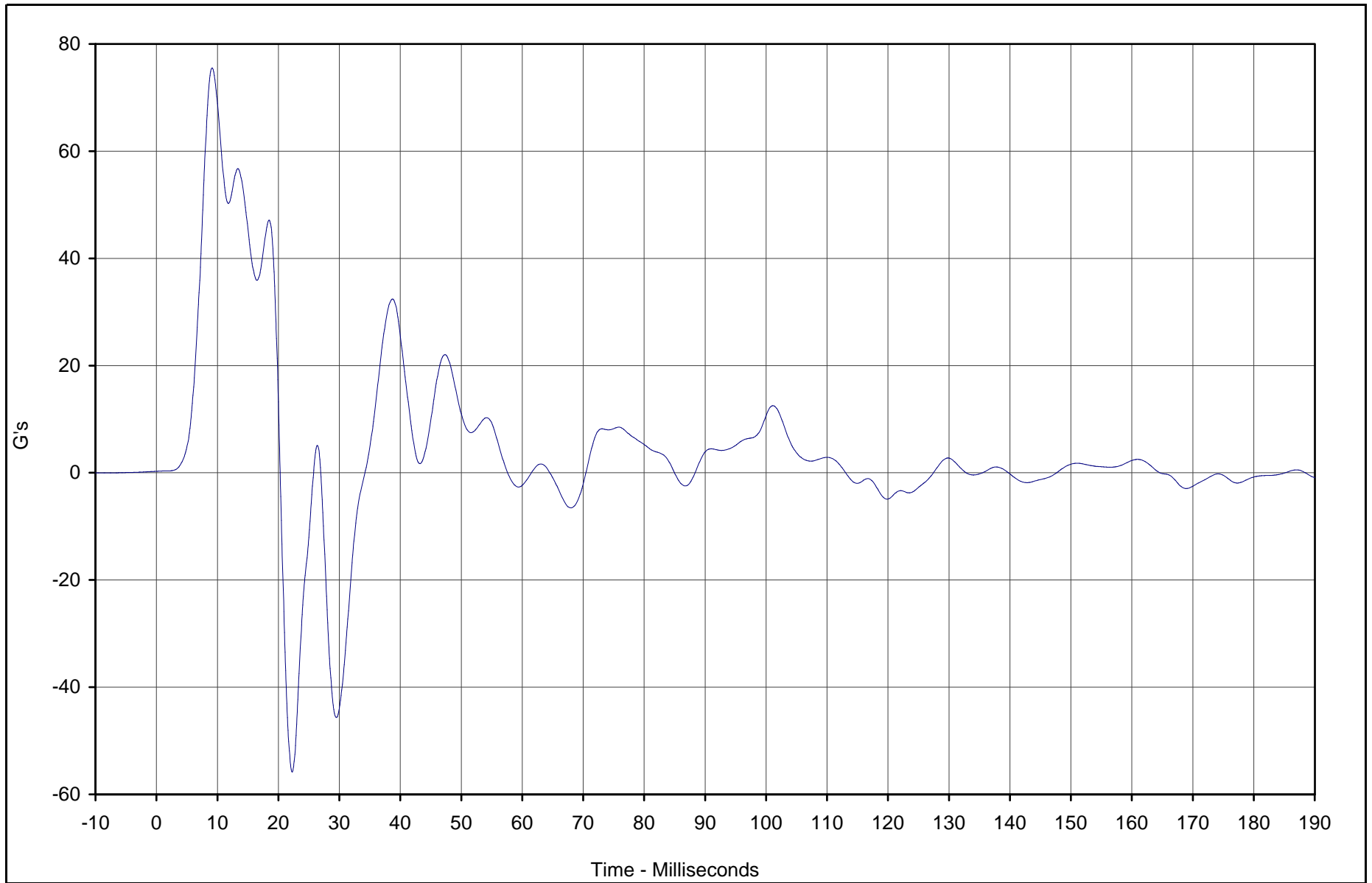

Curve Description	CURNO	Type	Units	Max	Time	Min	Time	SAE Class
Left Rear Door Mid Rear Y	060	FIL	G's	75.5	9.1	-55.8	22.3	60



Test Vehicle: 2003 Toyota 4 Runner SR5 4WD SUV

Test Date: 2/27/03

Test Program: 55/28 km/h Side Impact NCAP

NHTSA No.: M35107

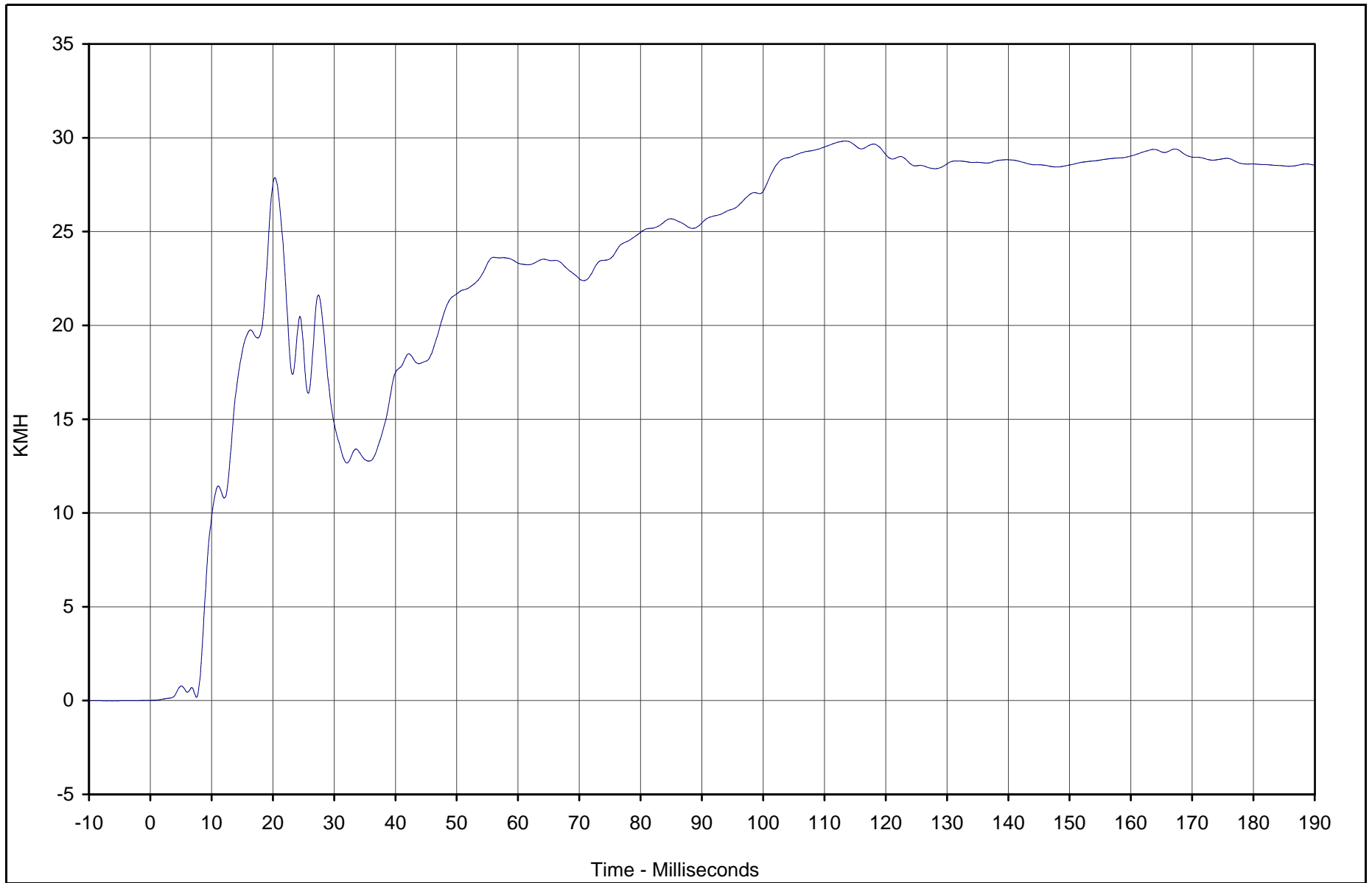

Curve Description	CURNO	Type	Units	Max	Time	Min	Time	SAE Class
Left Rear Door Mid Rear Y Vel.	060	IN1	KMH	29.8	113.4	0.0	0.0	180



Test Vehicle: 2003 Toyota 4 Runner SR5 4WD SUV

Test Date: 2/27/03

Test Program: 55/28 km/h Side Impact NCAP

NHTSA No.: M35107

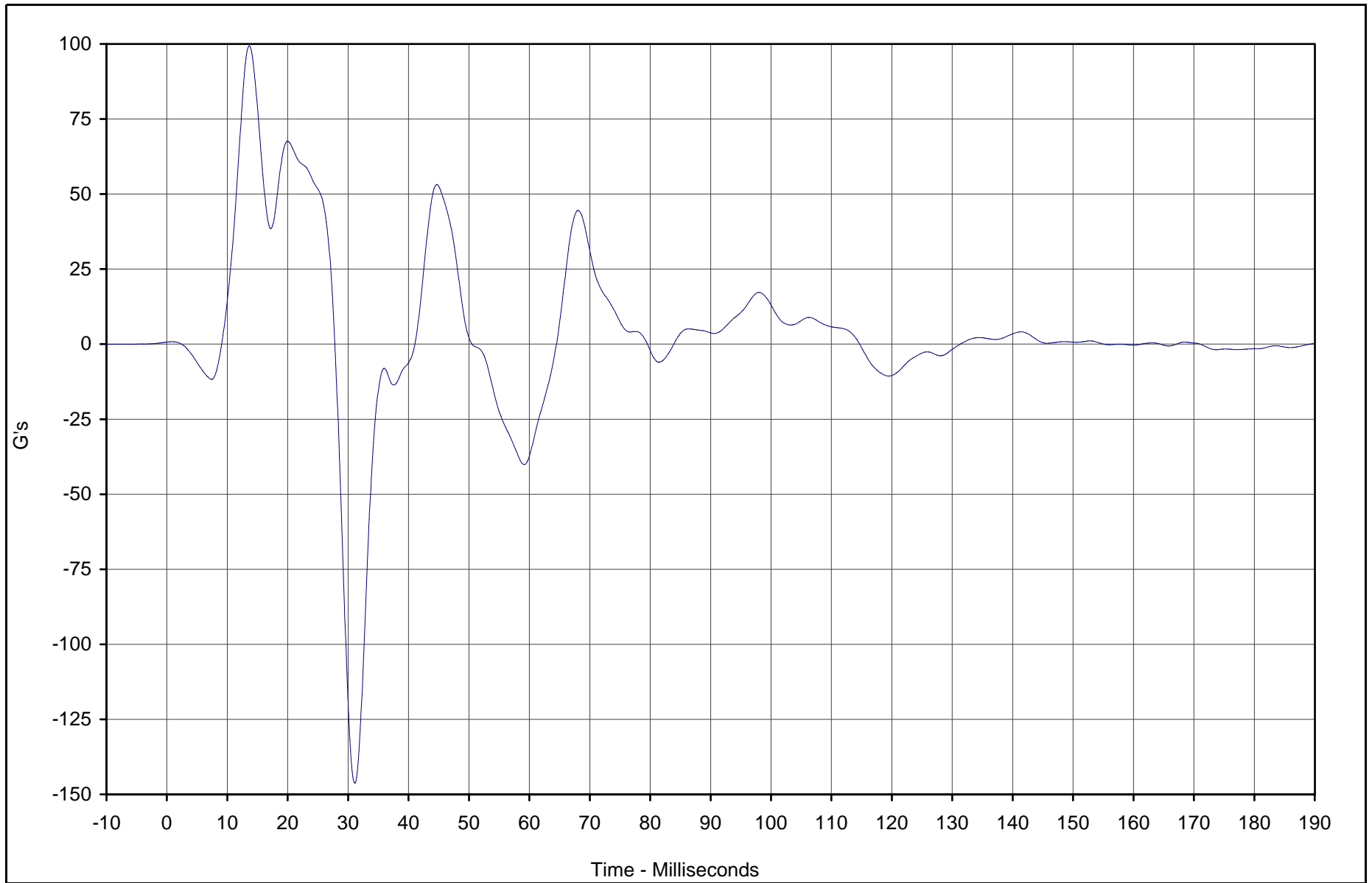

Curve Description	CURNO	Type	Units	Max	Time	Min	Time	SAE Class
Left Rear Door Upper CL Y	061	FIL	G's	99.4	13.6	-146.3	31.1	60



Test Vehicle: 2003 Toyota 4 Runner SR5 4WD SUV

Test Date: 2/27/03

Test Program: 55/28 km/h Side Impact NCAP

NHTSA No.: M35107

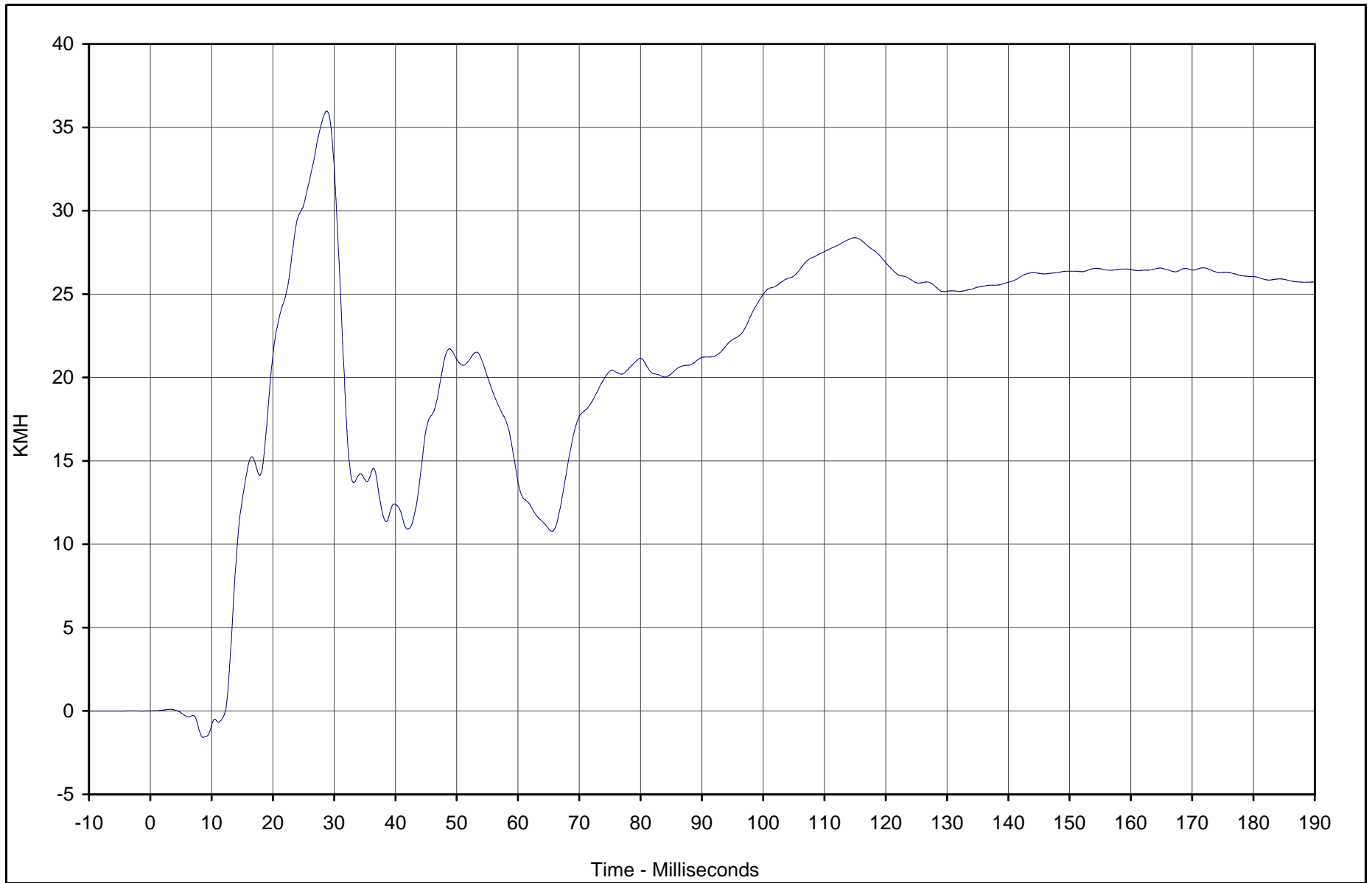

Curve Description	CURNO	Type	Units	Max	Time	Min	Time	SAE Class
Left Rear Door Upper CL Y Vel.	061	IN1	KMH	36.0	28.8	-1.6	8.6	180



Test Vehicle: 2003 Toyota 4 Runner SR5 4WD SUV

Test Date: 2/27/03

Test Program: 55/28 km/h Side Impact NCAP

NHTSA No.: M35107

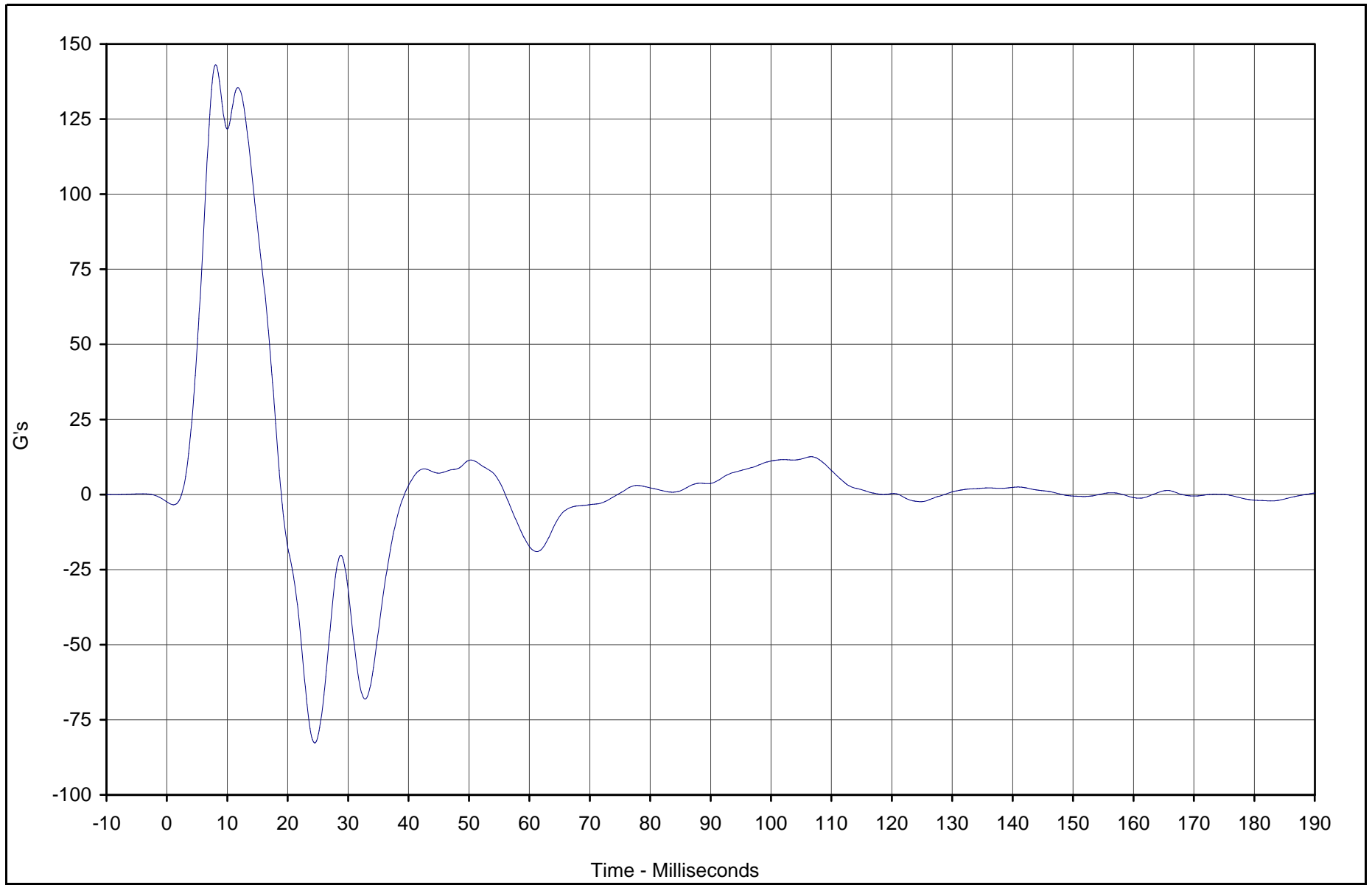

Curve Description	CURNO	Type	Units	Max	Time	Min	Time	SAE Class
B-Post Lower Y	062	FIL	G's	143.1	8.1	-82.7	24.5	60



Test Vehicle: 2003 Toyota 4 Runner SR5 4WD SUV

Test Date: 2/27/03

Test Program: 55/28 km/h Side Impact NCAP

NHTSA No.: M35107

B-119

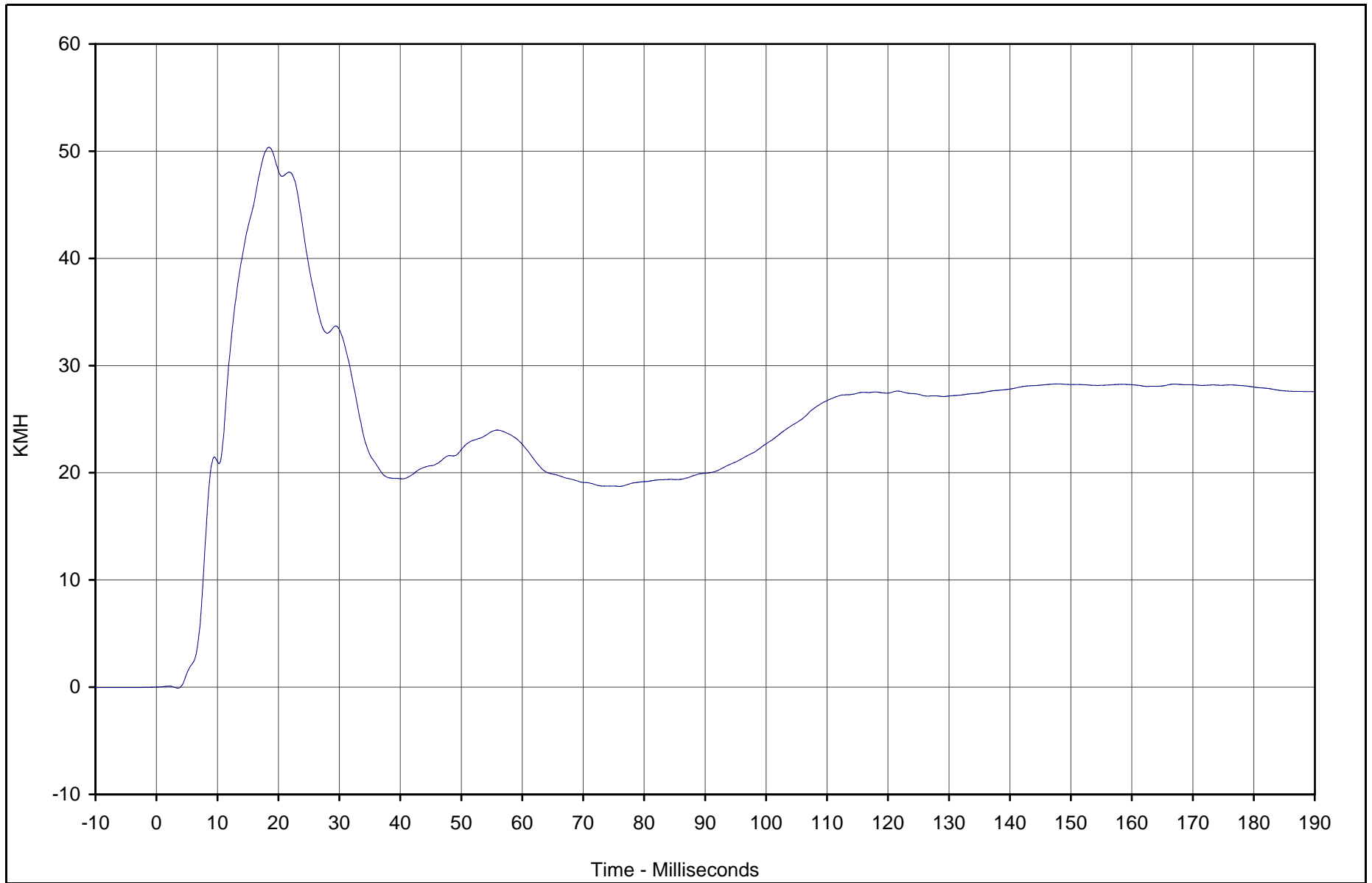

TR-P23003-05-NC

Curve Description	CURNO	Type	Units	Max	Time	Min	Time	SAE Class
B-Post Lower Y Velocity	062	IN1	KMH	50.4	18.5	-0.1	3.5	180



Test Vehicle: 2003 Toyota 4 Runner SR5 4WD SUV

Test Date: 2/27/03

Test Program: 55/28 km/h Side Impact NCAP

NHTSA No.: M35107

B-120

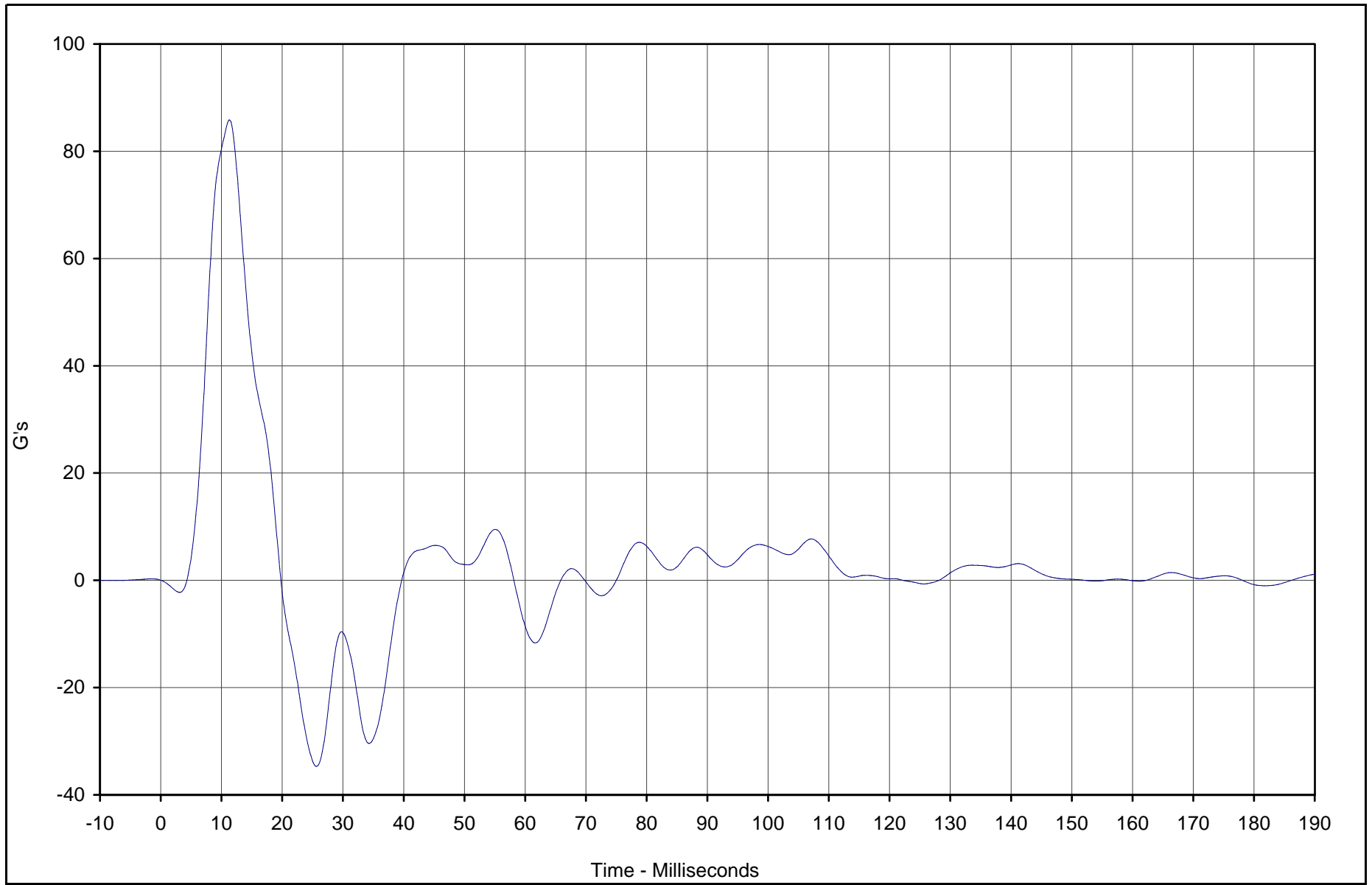

Curve Description	CURNO	Type	Units	Max	Time	Min	Time	SAE Class
B-Post Middle Y	063	FIL	G's	85.8	11.3	-34.7	25.6	60



Test Vehicle: 2003 Toyota 4 Runner SR5 4WD SUV

Test Date: 2/27/03

Test Program: 55/28 km/h Side Impact NCAP

NHTSA No.: M35107

TR-P23003-05-NC

B-121

TR-P23003-05-NC

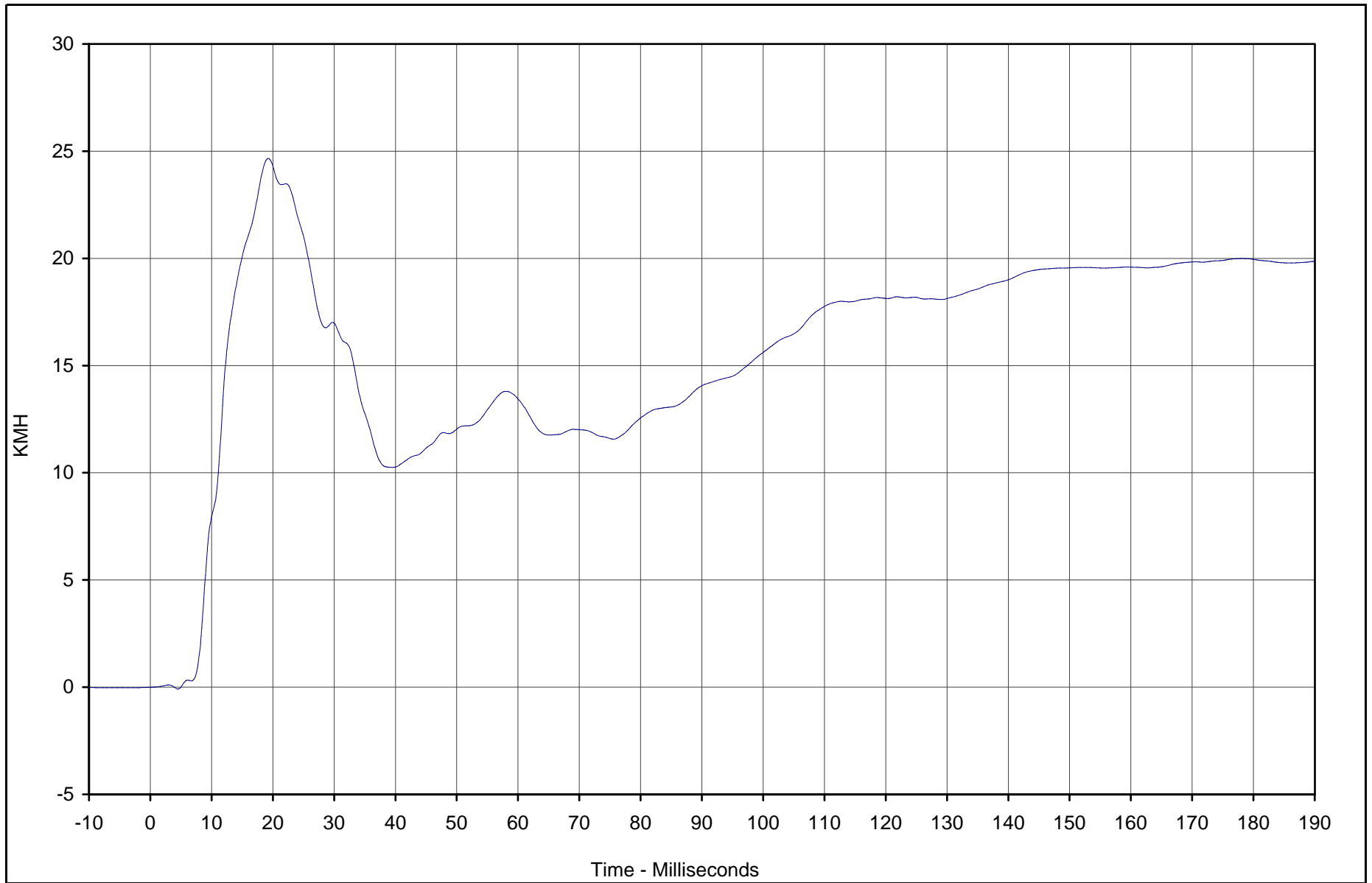

Curve Description	CURNO	Type	Units	Max	Time	Min	Time	SAE Class
B-Post Middle Y Velocity	063	IN1	KMH	24.7	19.3	-0.1	4.5	180



Test Vehicle: 2003 Toyota 4 Runner SR5 4WD SUV

Test Date: 2/27/03

Test Program: 55/28 km/h Side Impact NCAP

NHTSA No.: M35107

B-122

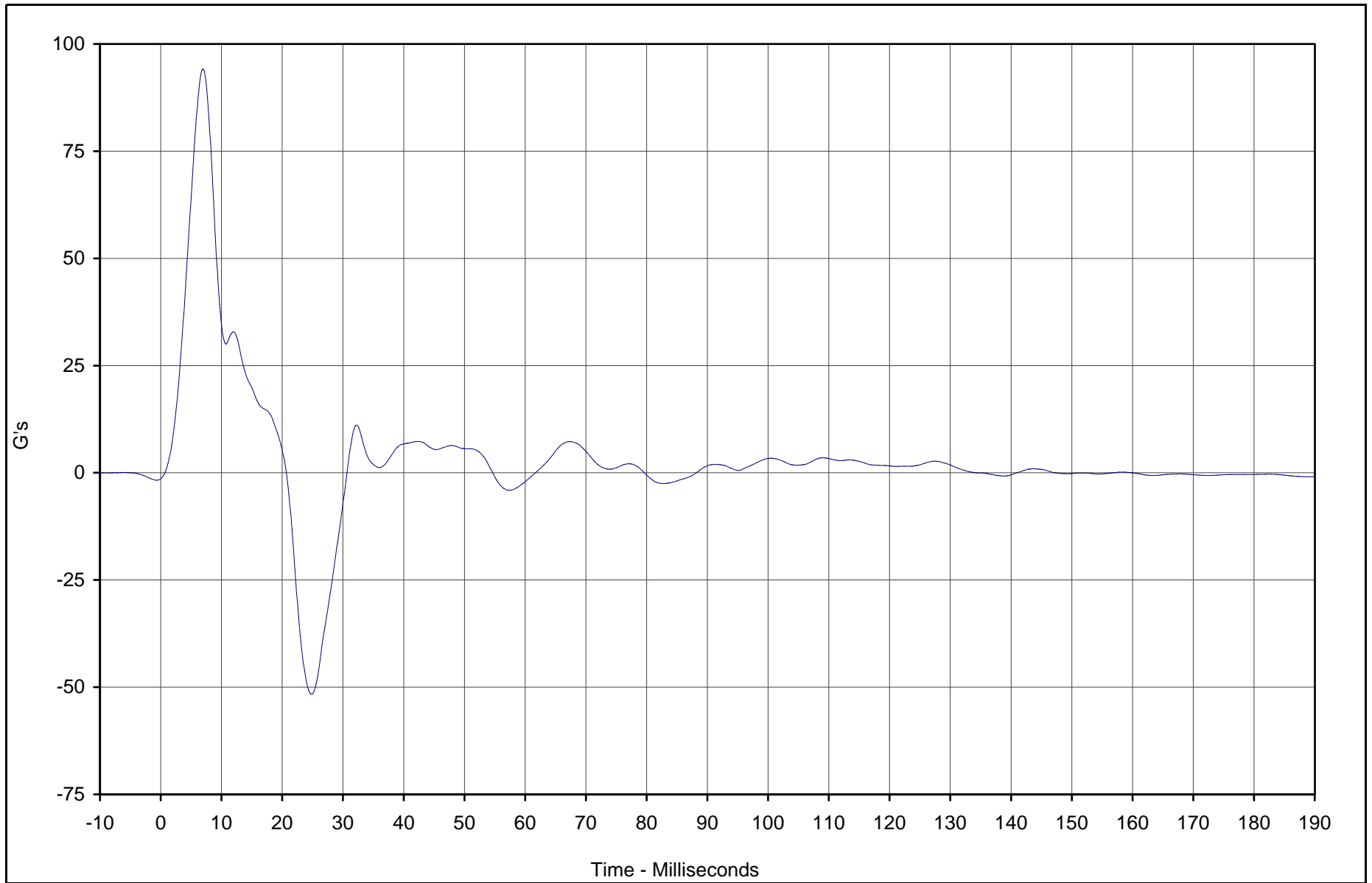

Curve Description	CURNO	Type	Units	Max	Time	Min	Time	SAE Class
A-Post Lower Y	064	FIL	G's	94.2	7.0	-51.6	24.8	60



Test Vehicle: 2003 Toyota 4 Runner SR5 4WD SUV

Test Date: 2/27/03

Test Program: 55/28 km/h Side Impact NCAP

NHTSA No.: M35107

TR-P23003-05-NC

B-123

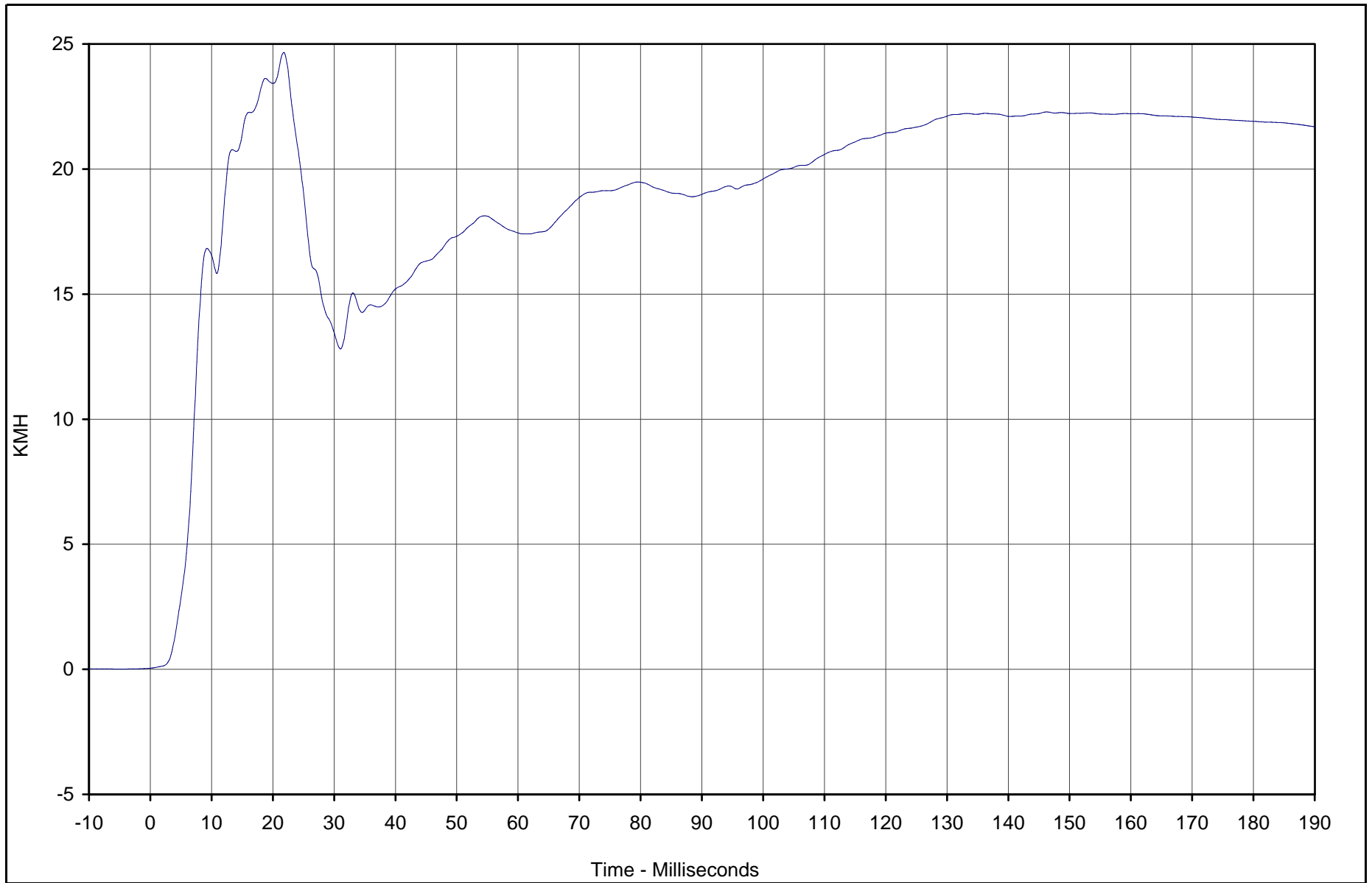

Curve Description	CURNO	Type	Units	Max	Time	Min	Time	SAE Class
A-Post Lower Y Velocity	064	IN1	KMH	24.7	21.8	0.0	0.0	180



Test Vehicle: 2003 Toyota 4 Runner SR5 4WD SUV

Test Date: 2/27/03

Test Program: 55/28 km/h Side Impact NCAP

NHTSA No.: M35107

TR-P23003-05-NC

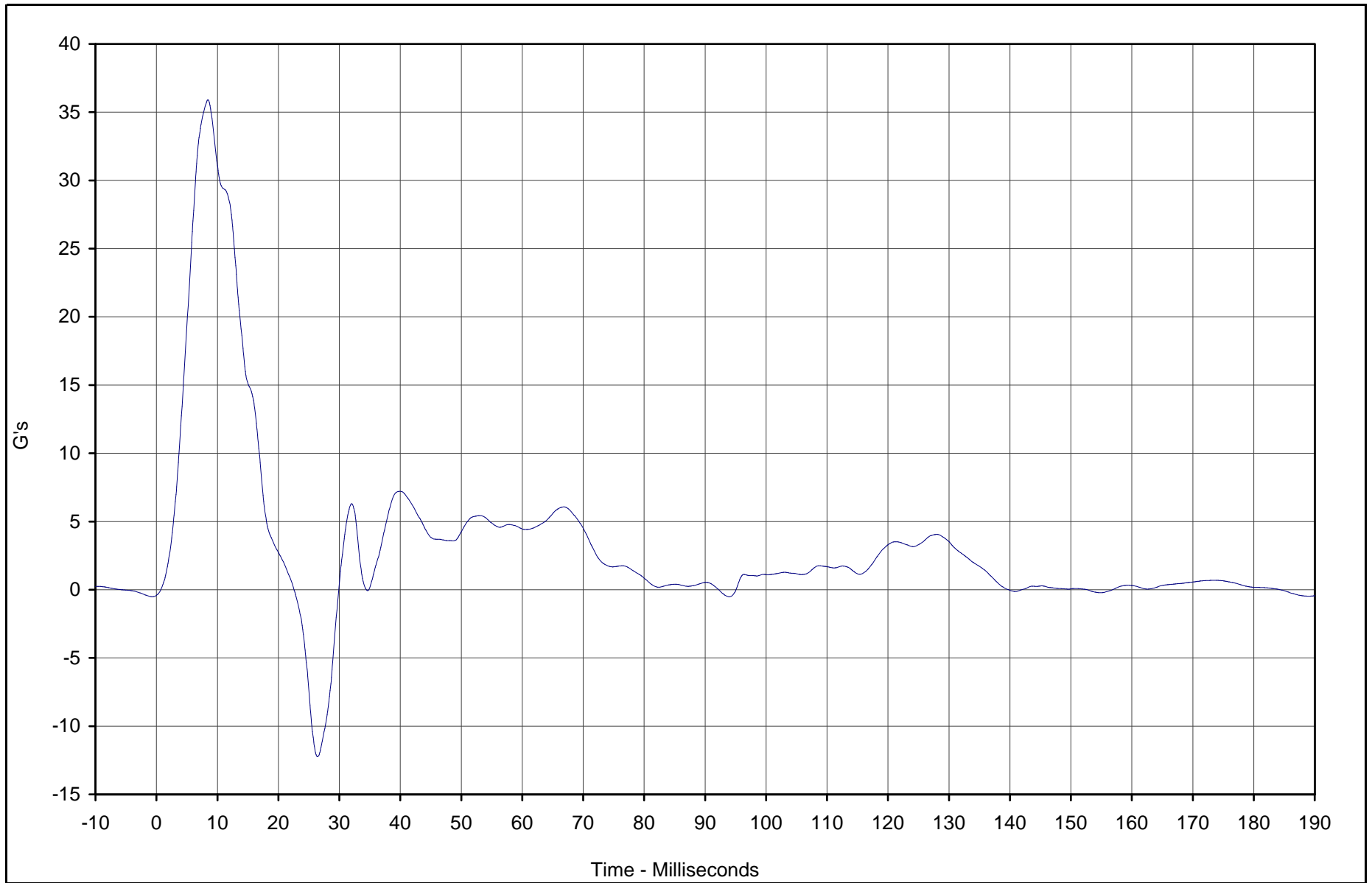

Curve Description	CURNO	Type	Units	Max	Time	Min	Time	SAE Class
A-Post Middle Y	065	FIL	G's	35.9	8.5	-12.2	26.4	60



Test Vehicle: 2003 Toyota 4 Runner SR5 4WD SUV

Test Date: 2/27/03

Test Program: 55/28 km/h Side Impact NCAP

NHTSA No.: M35107

B-125

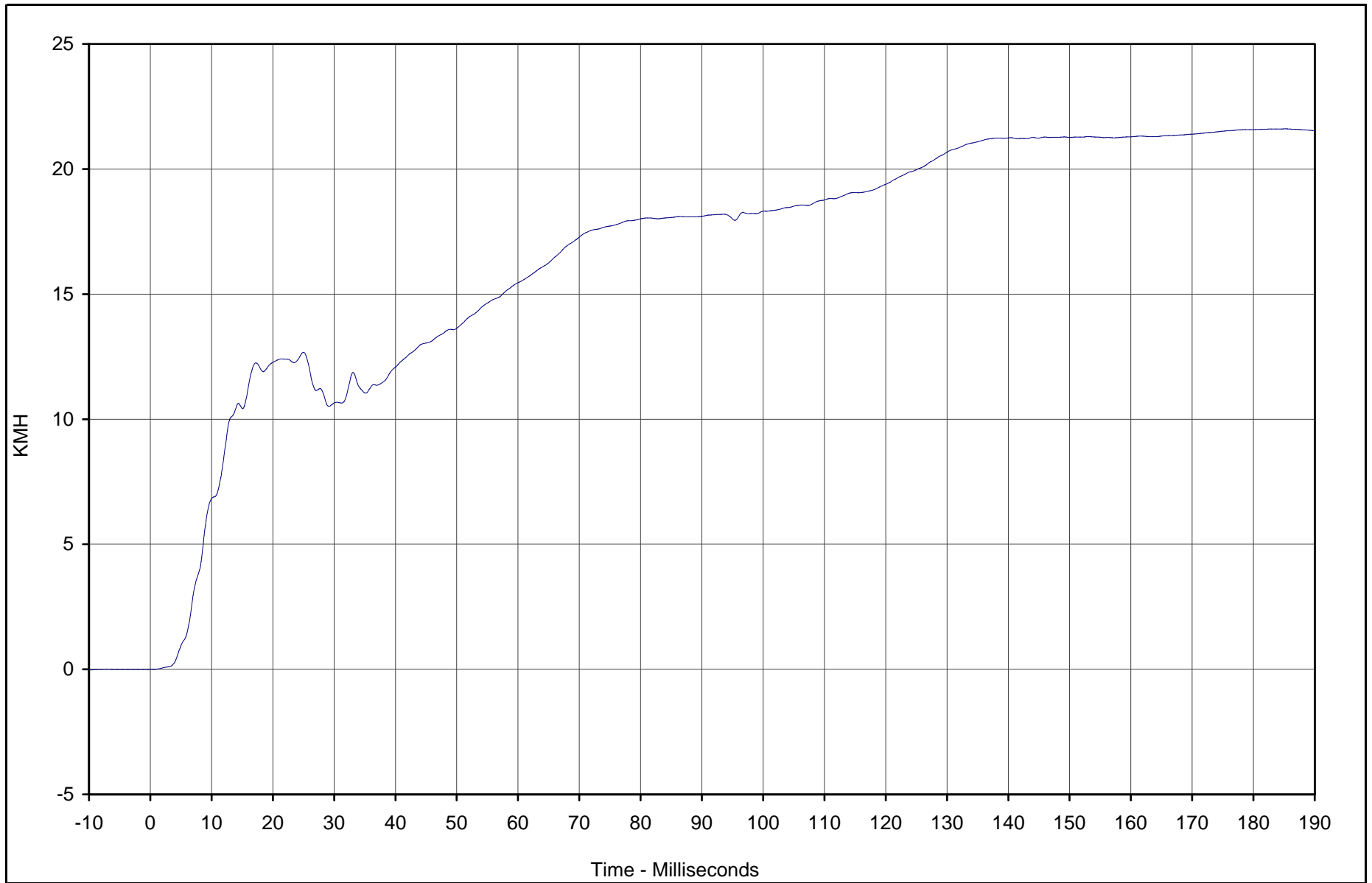

Curve Description	CURNO	Type	Units	Max	Time	Min	Time	SAE Class
A-Post Middle Y Velocity	065	IN1	KMH	21.6	185.2	0.0	0.0	180



Test Vehicle: 2003 Toyota 4 Runner SR5 4WD SUV

Test Date: 2/27/03

Test Program: 55/28 km/h Side Impact NCAP

NHTSA No.: M35107

TR-P23003-05-NC

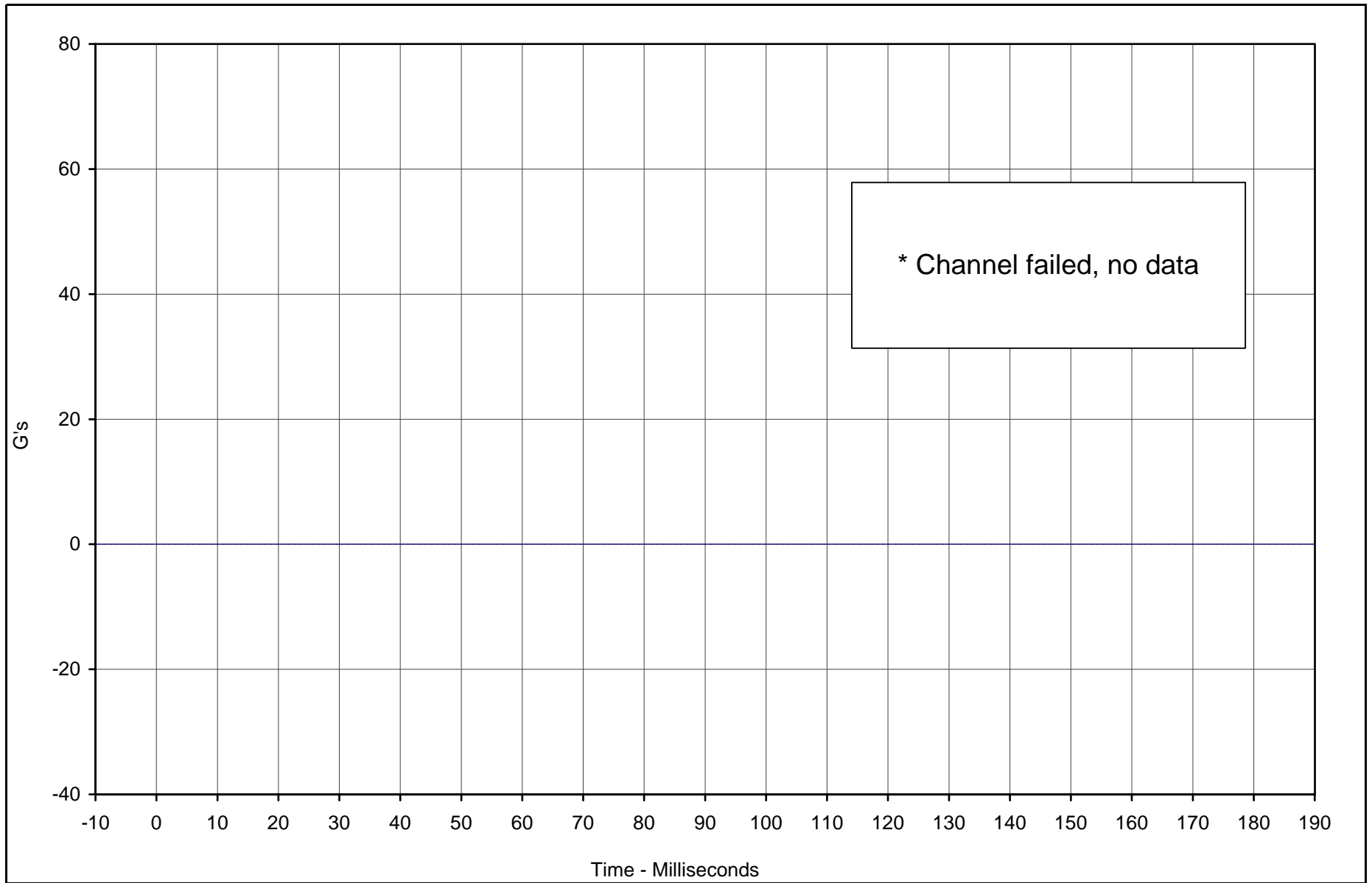

* Channel failed, no data

Curve Description	CURNO	Type	Units	Max	Time	Min	Time	SAE Class
Left Front Seat Track Y	066	FIL	G's	0.0	0.0	0.0	0.0	60



Test Vehicle: 2003 Toyota 4 Runner SR5 4WD SUV

Test Date: 2/27/03

Test Program: 55/28 km/h Side Impact NCAP

NHTSA No.: M35107

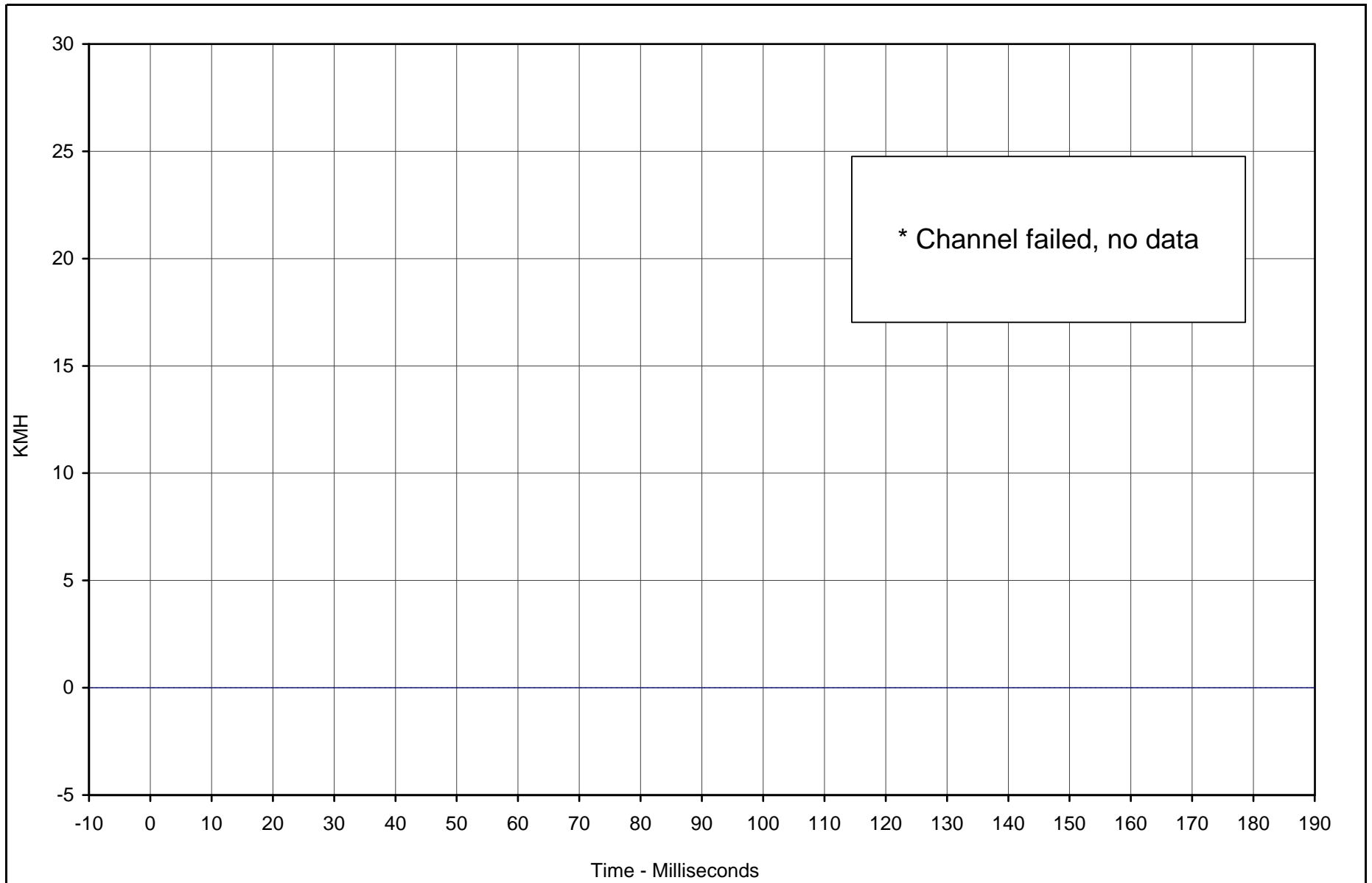

* Channel failed, no data

Curve Description	CURNO	Type	Units	Max	Time	Min	Time	SAE Class
Left Front Seat Track Y Velocity	066	IN1	KMH	0.0	0.0	0.0	0.0	180



Test Vehicle: 2003 Toyota 4 Runner SR5 4WD SUV

Test Date: 2/27/03

Test Program: 55/28 km/h Side Impact NCAP

NHTSA No.: M35107

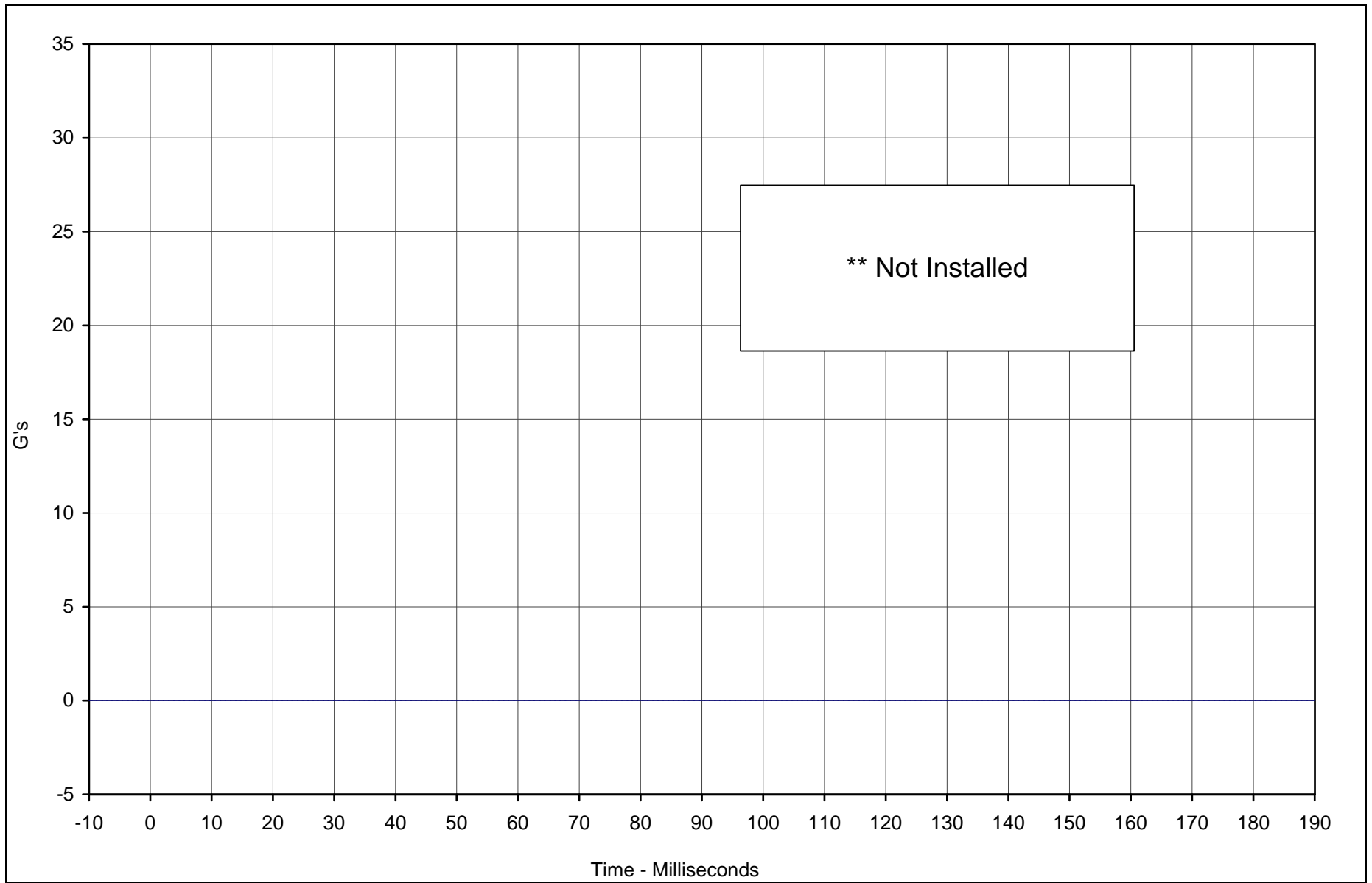

** Not installed

Curve Description	CURNO	Type	Units	Max	Time	Min	Time	SAE Class
Rear Seat Structure Y	067	FIL	G's	0.0	0.0	0.0	0.0	60



Test Vehicle: 2003 Toyota 4 Runner SR5 4WD SUV

Test Date: 2/27/03

Test Program: 55/28 km/h Side Impact NCAP

NHTSA No.: M35107

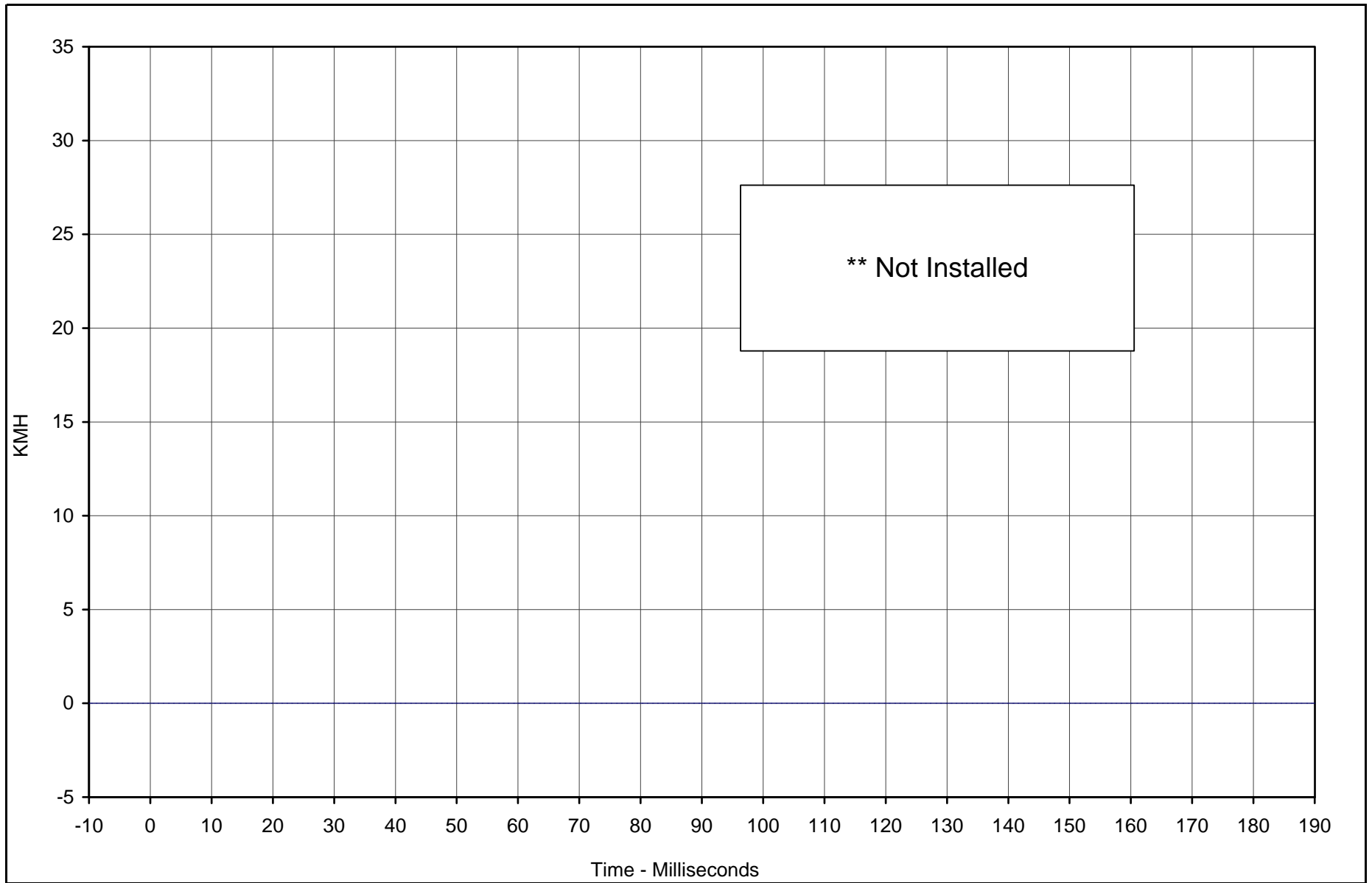

** Not installed

Curve Description	CURNO	Type	Units	Max	Time	Min	Time	SAE Class
Rear Seat Structure Y Velocity	067	IN1	KMH	0.0	0.0	0.0	0.0	180



Test Vehicle: 2003 Toyota 4 Runner SR5 4WD SUV

Test Date: 2/27/03

Test Program: 55/28 km/h Side Impact NCAP

NHTSA No.: M35107

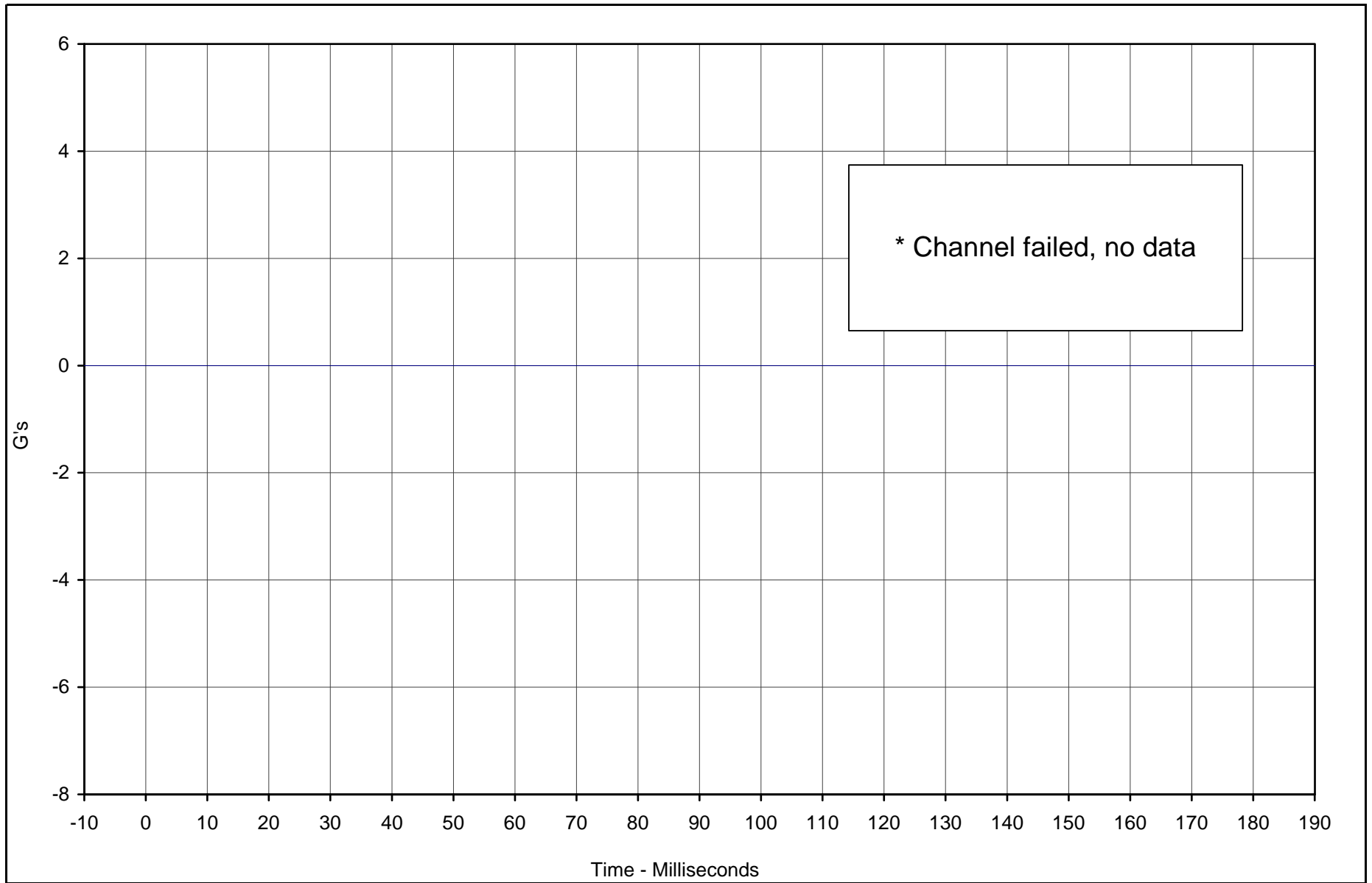

* Channel failed, no data

Curve Description	CURNO	Type	Units	Max	Time	Min	Time	SAE Class
Vehicle CG X	068	FIL	G's	0.0	0.0	0.0	0.0	60



Test Vehicle: 2003 Toyota 4 Runner SR5 4WD SUV

Test Date: 2/27/03

Test Program: 55/28 km/h Side Impact NCAP

NHTSA No.: M35107

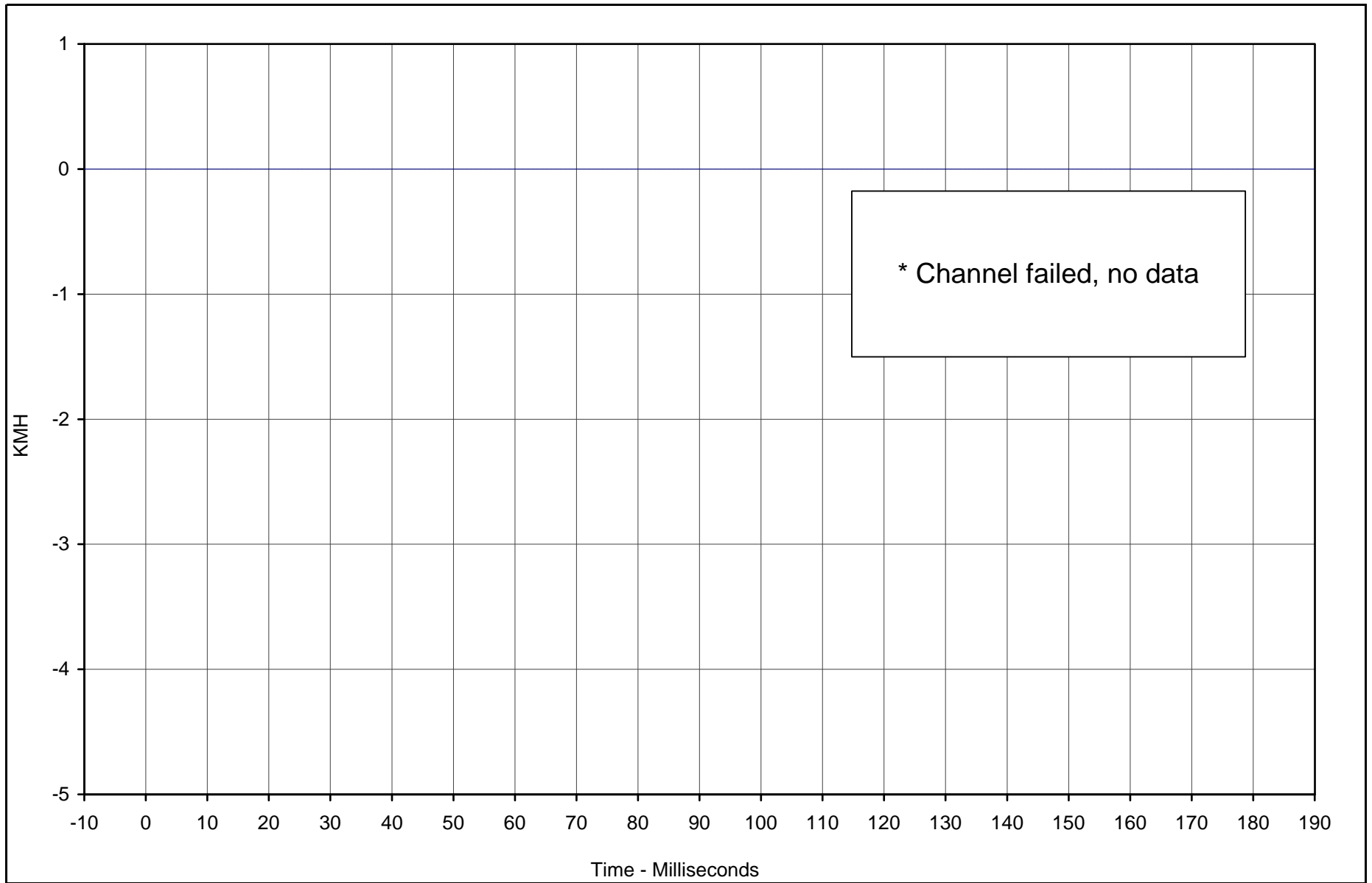

* Channel failed, no data

Curve Description	CURNO	Type	Units	Max	Time	Min	Time	SAE Class
Vehicle CG X Velocity	068	IN1	KMH	0.0	0.0	0.0	0.0	180



Test Vehicle: 2003 Toyota 4 Runner SR5 4WD SUV

Test Date: 2/27/03

Test Program: 55/28 km/h Side Impact NCAP

NHTSA No.: M35107

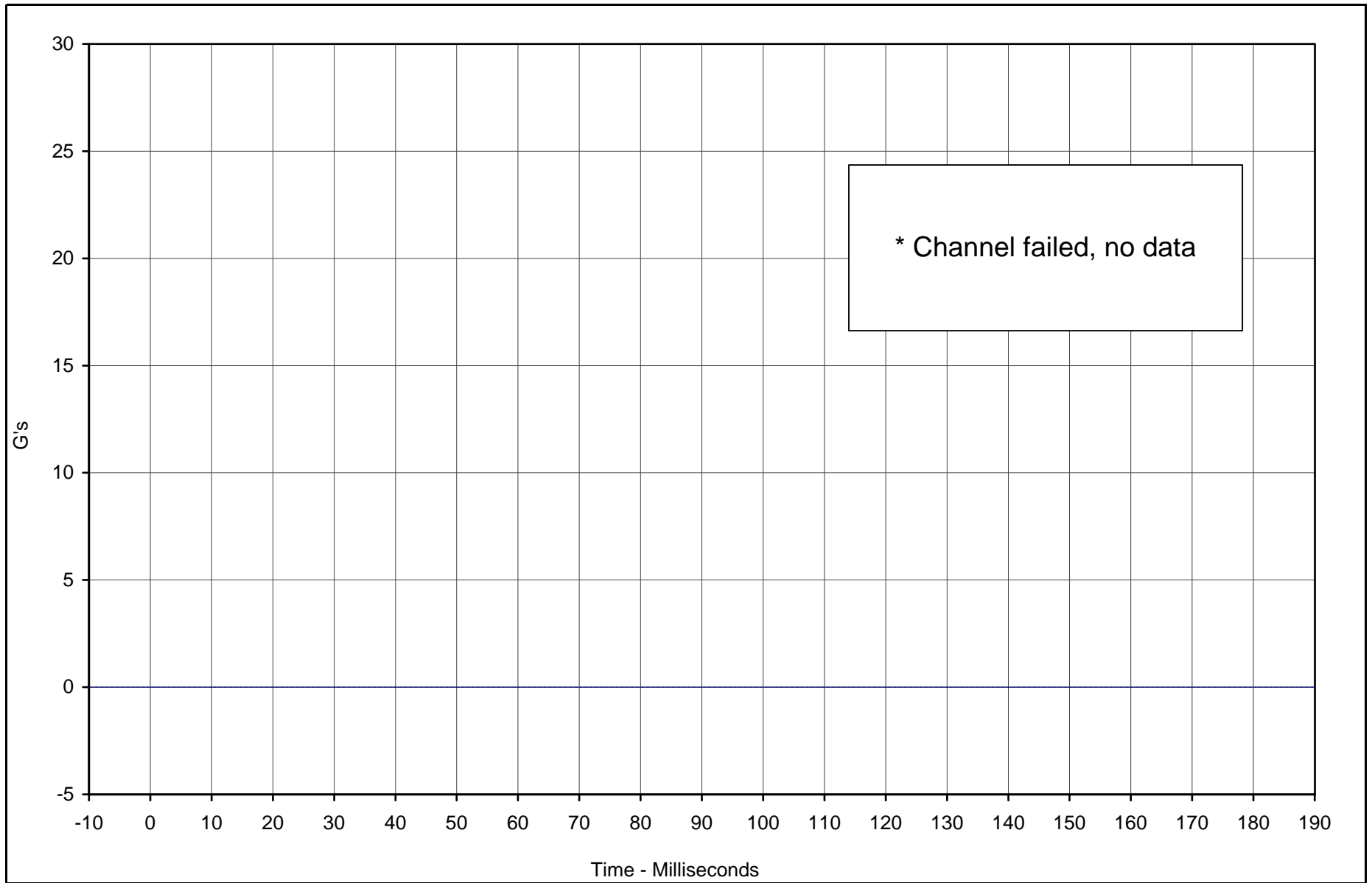

* Channel failed, no data

Curve Description	CURNO	Type	Units	Max	Time	Min	Time	SAE Class
Vehicle CG Y	069	FIL	G's	0.0	0.0	0.0	0.0	60



Test Vehicle: 2003 Toyota 4 Runner SR5 4WD SUV

Test Date: 2/27/03

Test Program: 55/28 km/h Side Impact NCAP

NHTSA No.: M35107

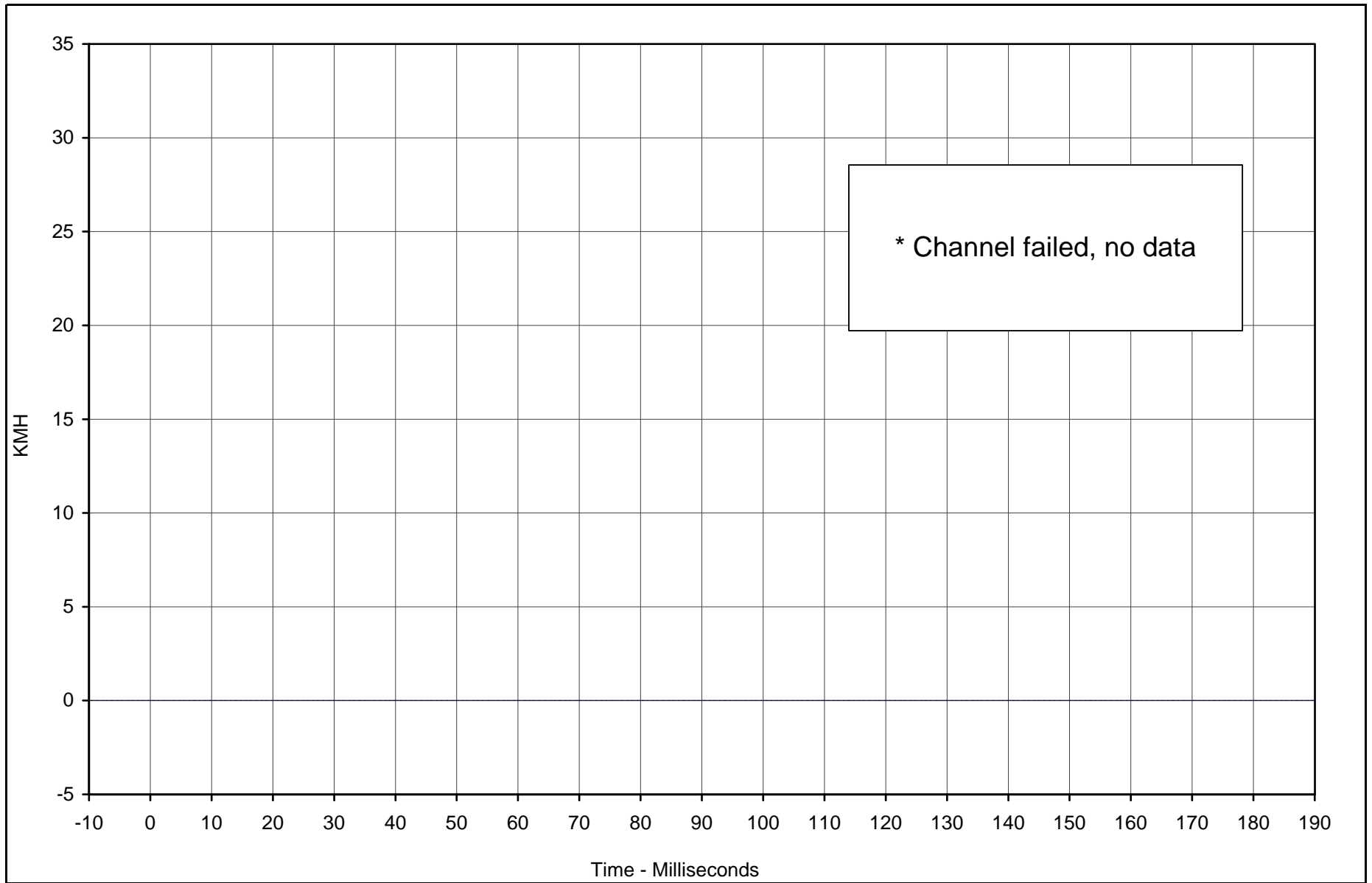

* Channel failed, no data

Curve Description	CURNO	Type	Units	Max	Time	Min	Time	SAE Class
Vehicle CG Y Velocity	069	IN1	KMH	0.0	0.0	0.0	0.0	180



Test Vehicle: 2003 Toyota 4 Runner SR5 4WD SUV

Test Date: 2/27/03

Test Program: 55/28 km/h Side Impact NCAP

NHTSA No.: M35107

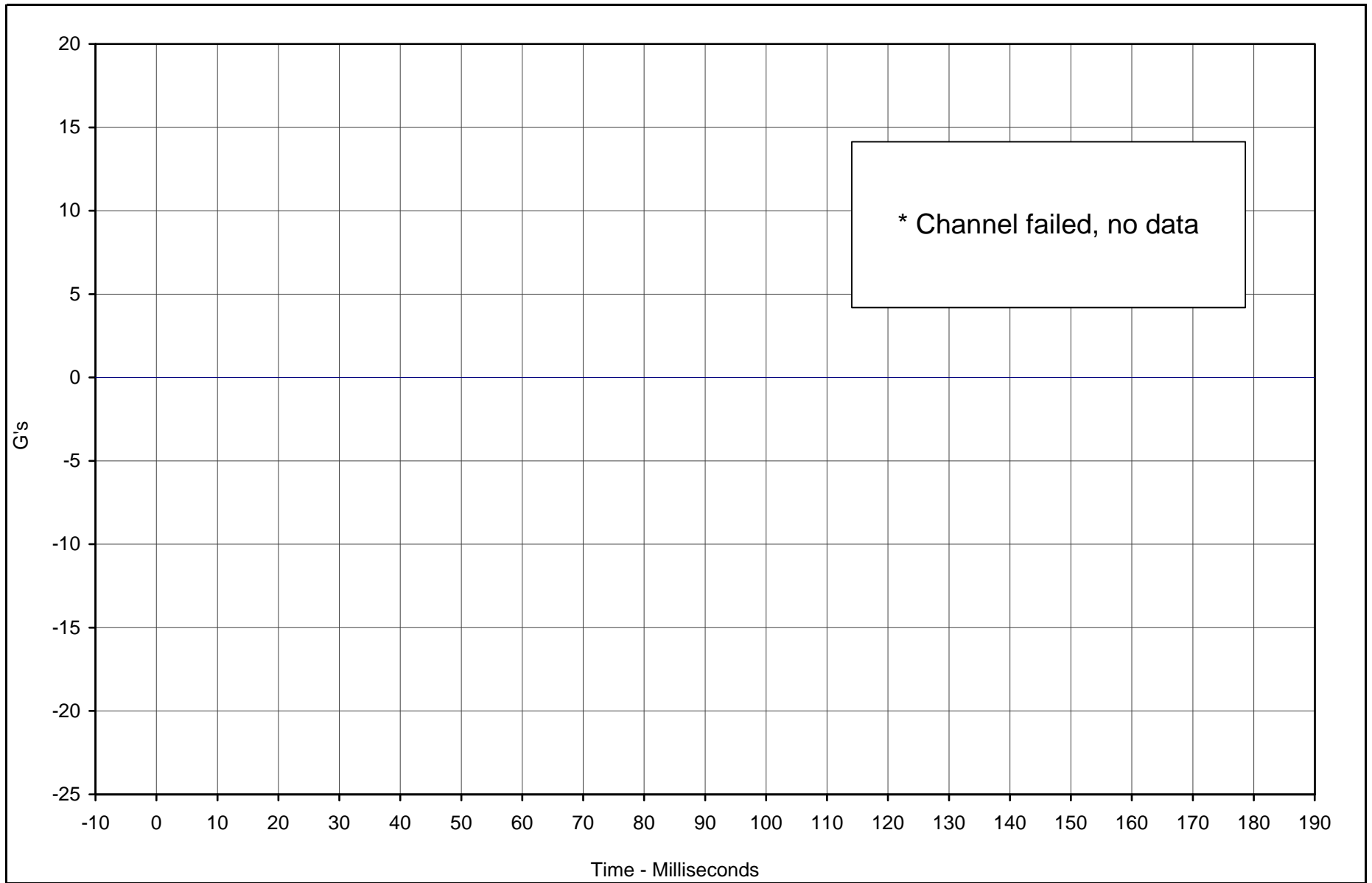

* Channel failed, no data

Curve Description	CURNO	Type	Units	Max	Time	Min	Time	SAE Class
Vehicle CG Z	070	FIL	G's	0.0	0.0	0.0	0.0	60



Test Vehicle: 2003 Toyota 4 Runner SR5 4WD SUV

Test Date: 2/27/03

Test Program: 55/28 km/h Side Impact NCAP

NHTSA No.: M35107

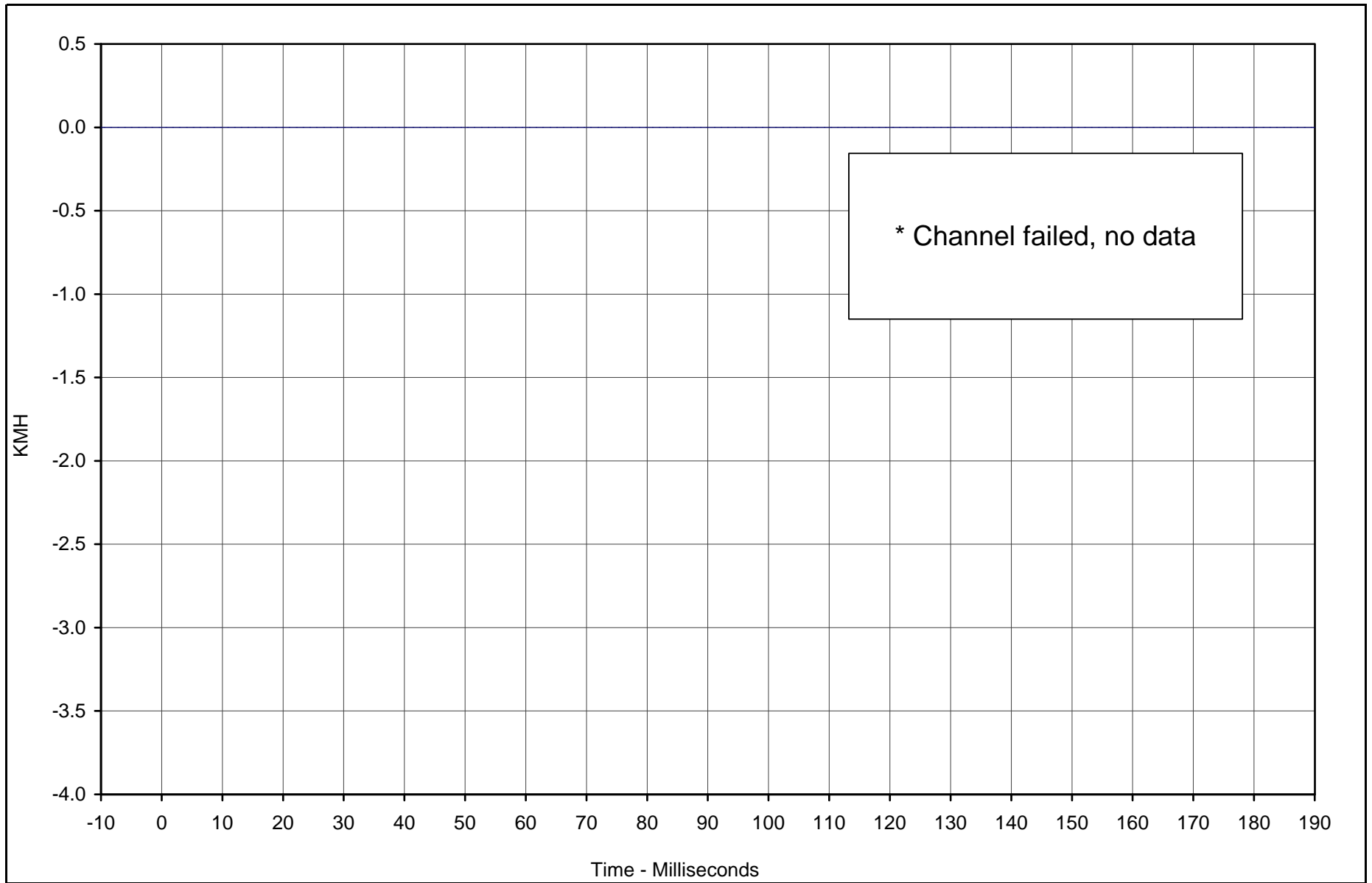

* Channel failed, no data

Curve Description	CURNO	Type	Units	Max	Time	Min	Time	SAE Class
Vehicle CG Z Velocity	070	IN1	KMH	0.0	0.0	0.0	0.0	180



Test Vehicle: 2003 Toyota 4 Runner SR5 4WD SUV

Test Date: 2/27/03

Test Program: 55/28 km/h Side Impact NCAP

NHTSA No.: M35107

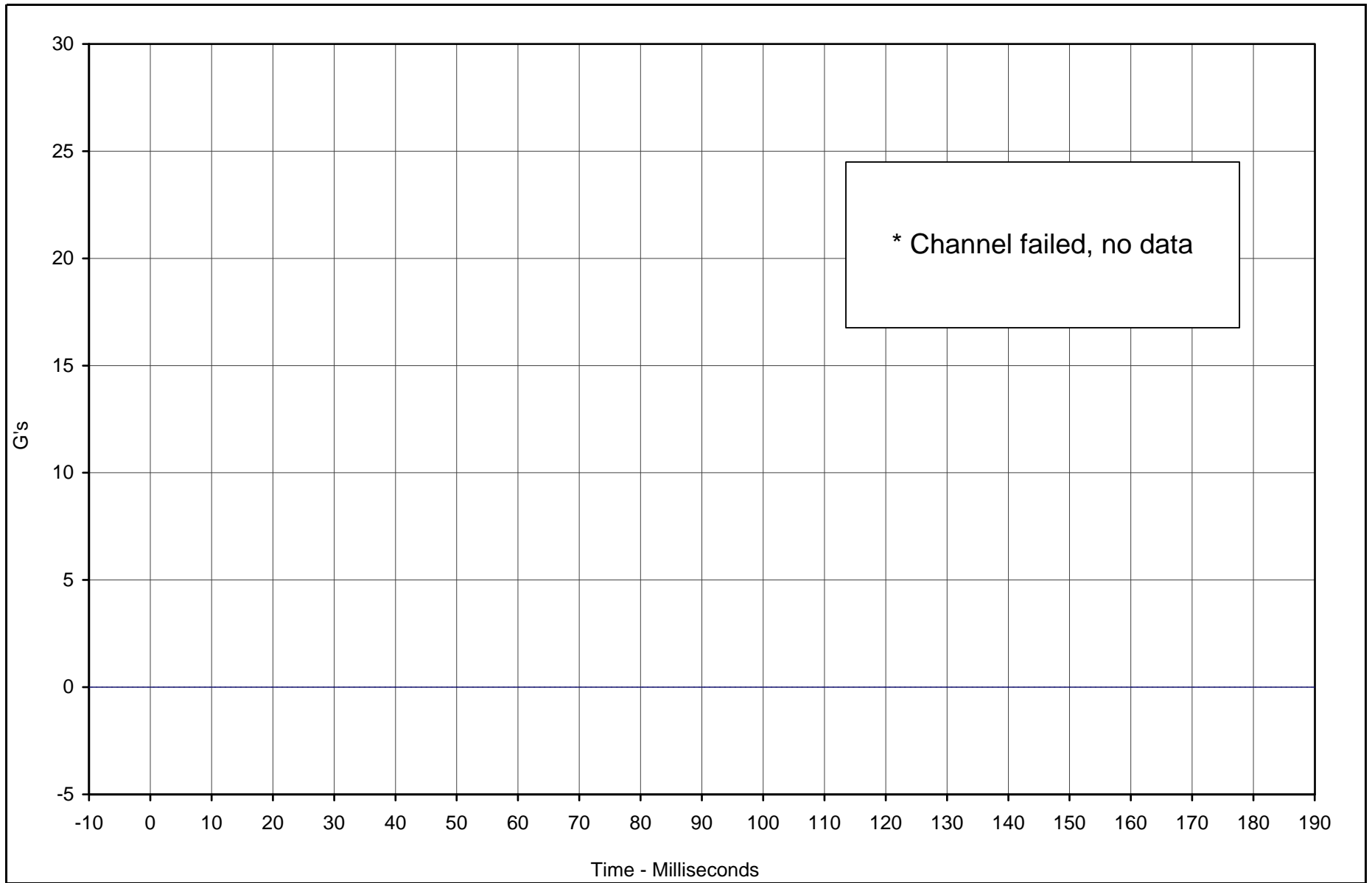

* Channel failed, no data

Curve Description	CURNO	Type	Units	Max	Time	Min	Time	SAE Class
Vehicle CG Resultant	068	RES	G's	0.0	0.0	0.0	0.0	60



Test Vehicle: 2003 Toyota 4 Runner SR5 4WD SUV

Test Date: 2/27/03

Test Program: 55/28 km/h Side Impact NCAP

NHTSA No.: M35107

B-137

TR-P23003-05-NC

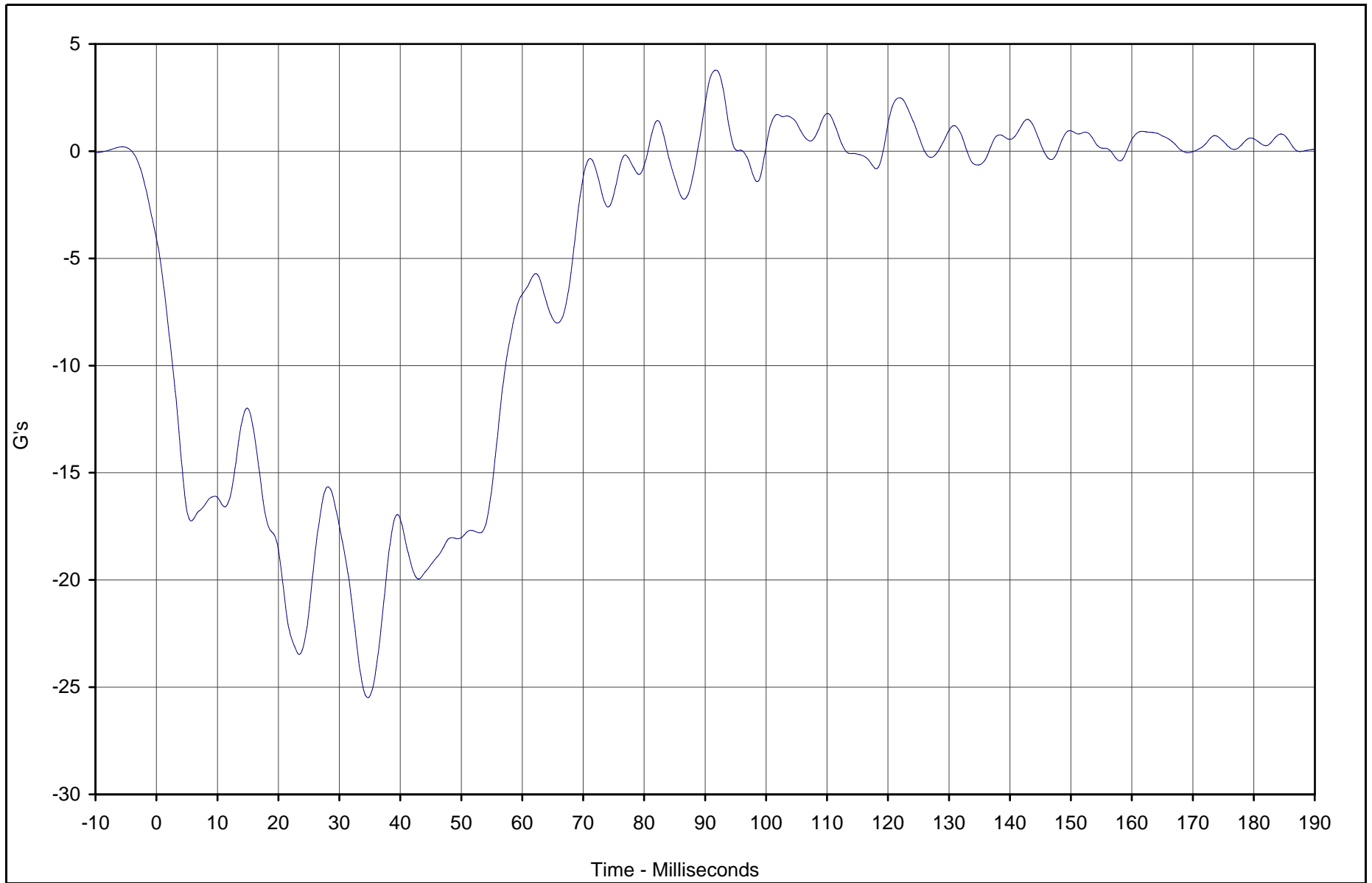

Curve Description	CURNO	Type	Units	Max	Time	Min	Time	SAE Class
MDB CG X	071	FIL	G's	3.8	91.8	-25.5	34.7	60



Test Vehicle: 2003 Toyota 4 Runner SR5 4WD SUV

Test Date: 2/27/03

Test Program: 55/28 km/h Side Impact NCAP

NHTSA No.: M35107

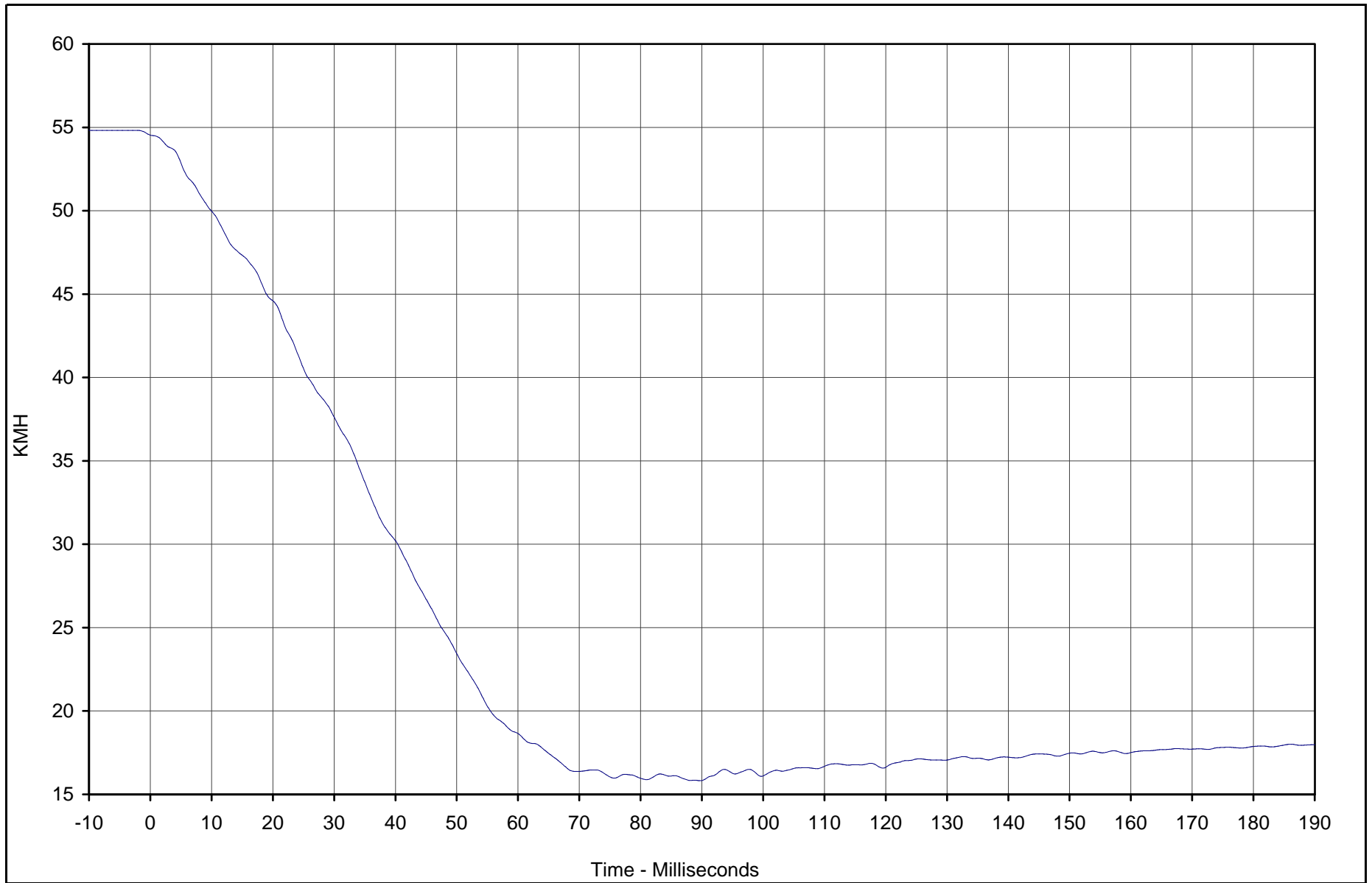

Curve Description	CURNO	Type	Units	Max	Time	Min	Time	SAE Class
MDB CG X Velocity	071	IN1	KMH	54.5	0.0	15.8	89.7	180



Test Vehicle: 2003 Toyota 4 Runner SR5 4WD SUV

Test Date: 2/27/03

Test Program: 55/28 km/h Side Impact NCAP

NHTSA No.: M35107

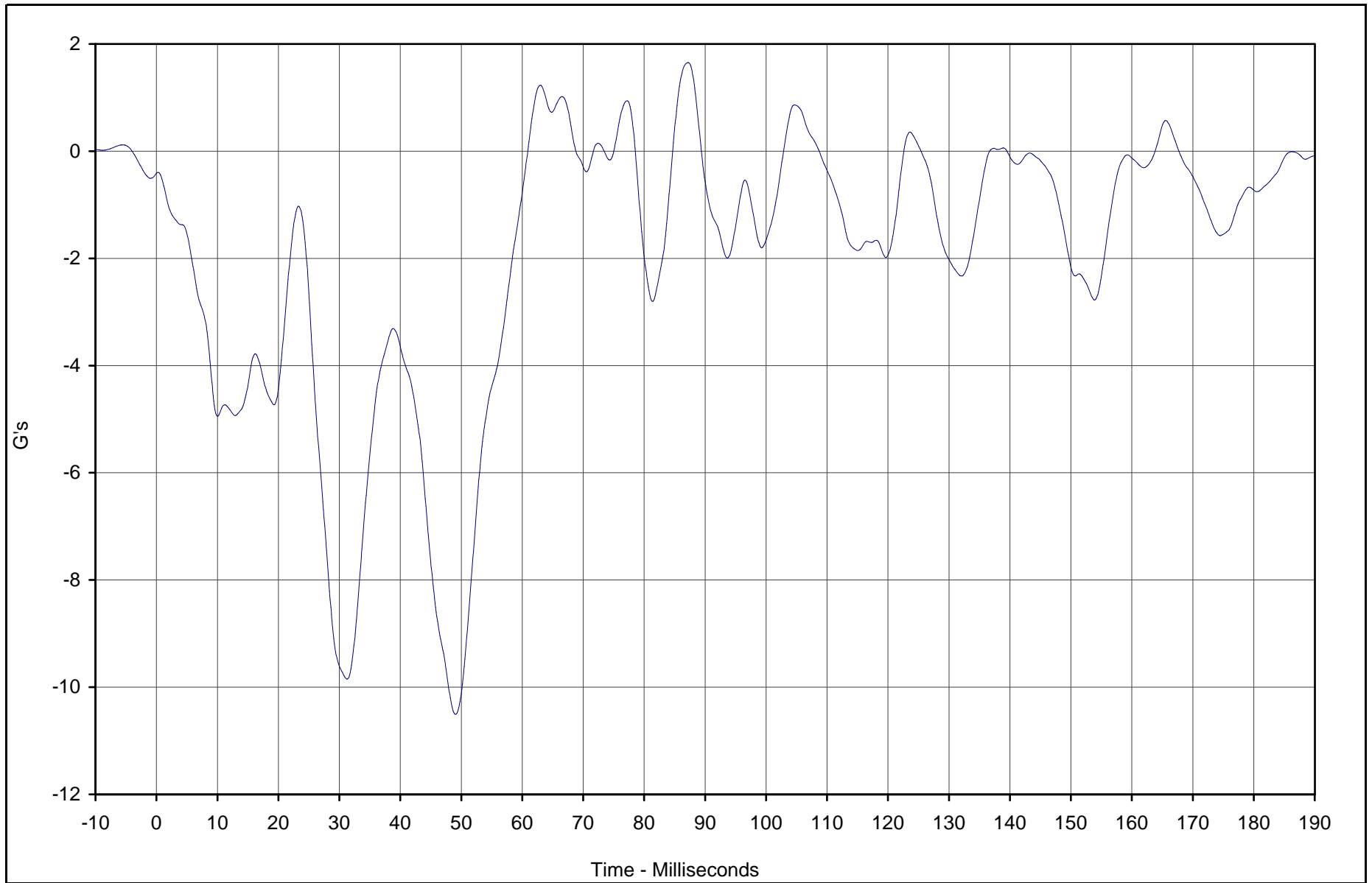

Curve Description	CURNO	Type	Units	Max	Time	Min	Time	SAE Class
MDB CG Y	072	FIL	G's	1.7	87.2	-10.5	49.1	60



Test Vehicle: 2003 Toyota 4 Runner SR5 4WD SUV

Test Date: 2/27/03

Test Program: 55/28 km/h Side Impact NCAP

NHTSA No.: M35107

B-140

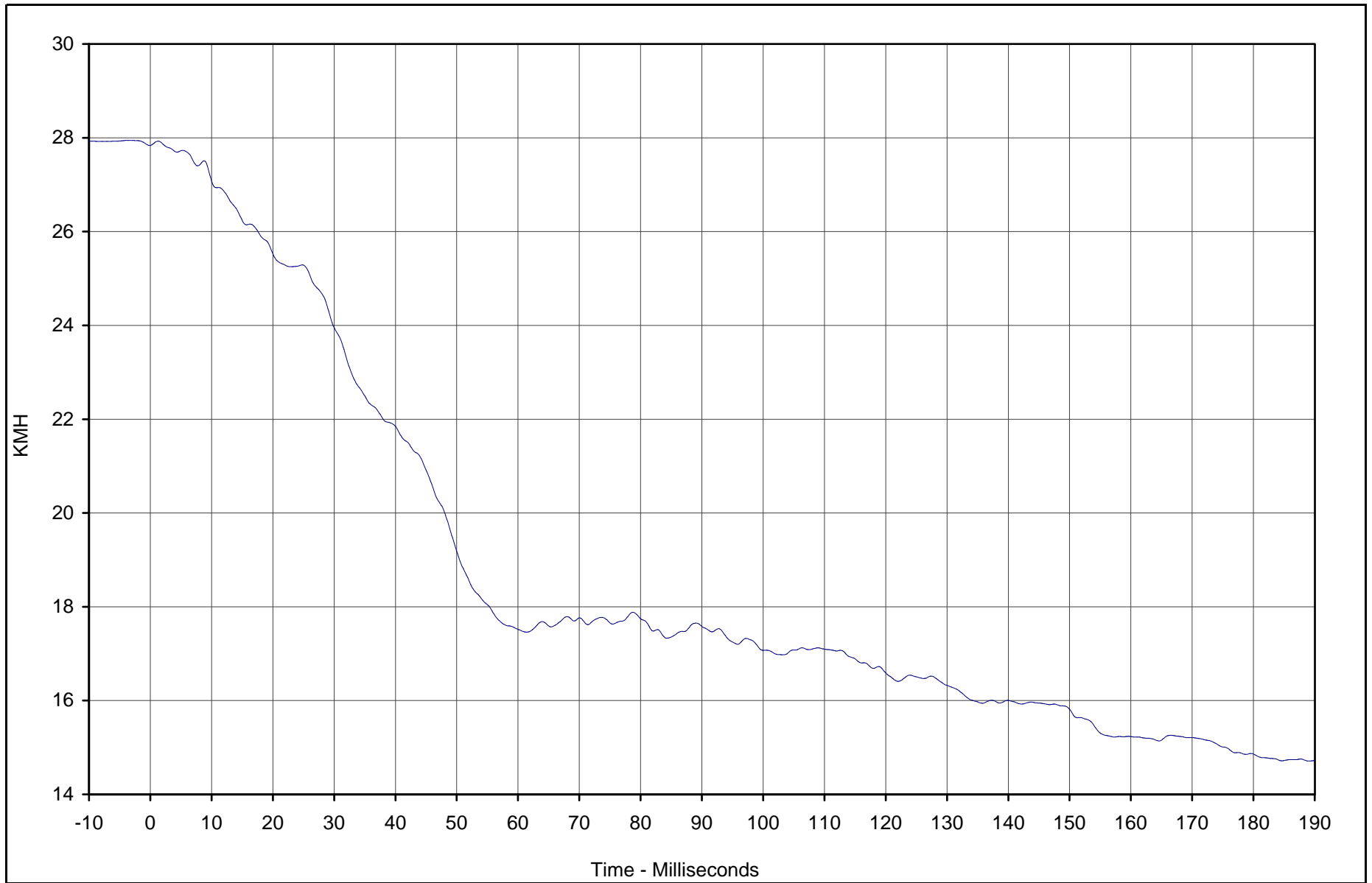

Curve Description	CURNO	Type	Units	Max	Time	Min	Time	SAE Class
MDB CG Y Velocity	072	IN1	KMH	27.9	1.3	14.7	189.1	180



Test Vehicle: 2003 Toyota 4 Runner SR5 4WD SUV

Test Date: 2/27/03

Test Program: 55/28 km/h Side Impact NCAP

NHTSA No.: M35107

TR-P23003-05-NC

B-141

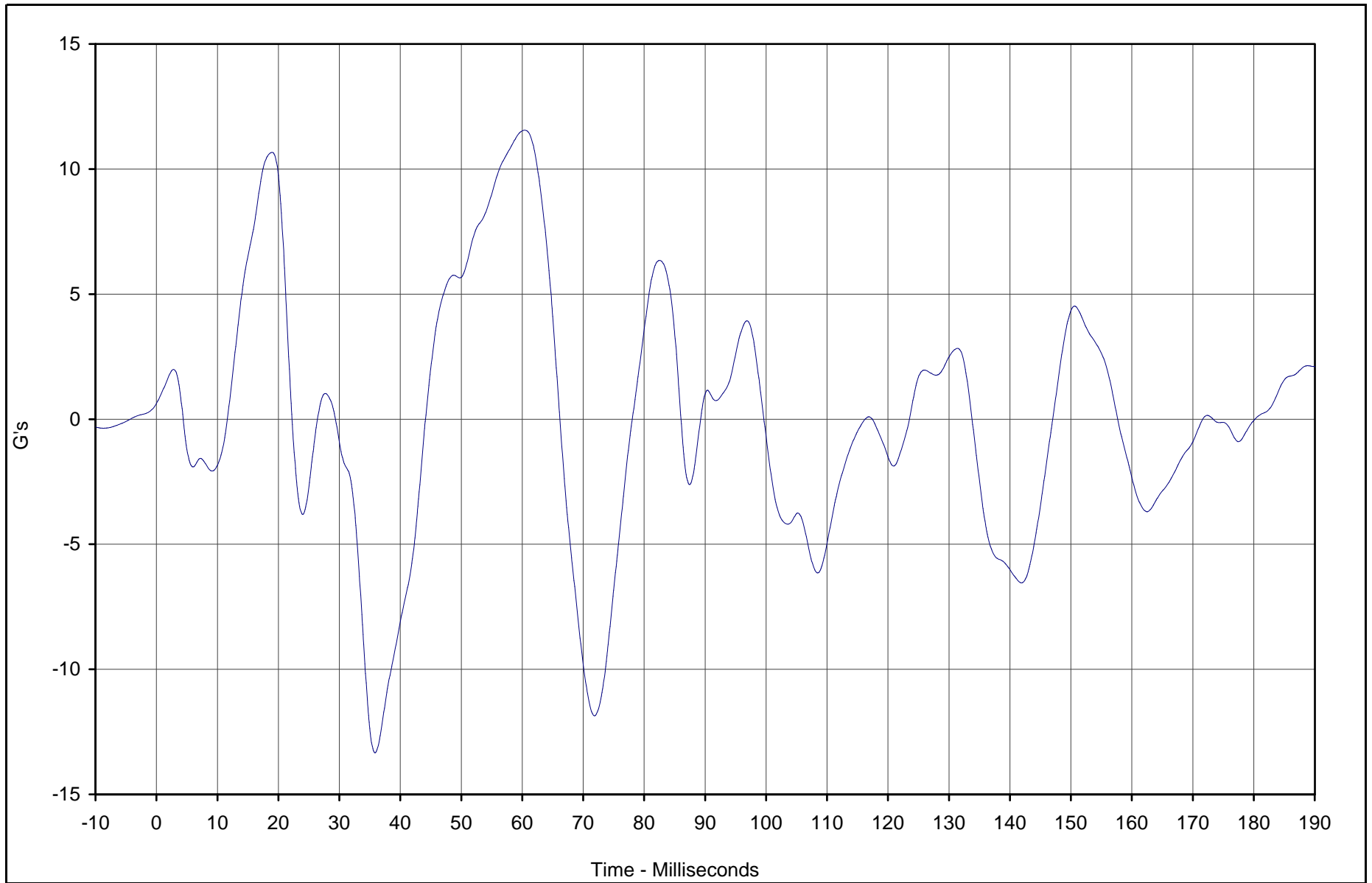

Curve Description	CURNO	Type	Units	Max	Time	Min	Time	SAE Class
MDB CG Z	073	FIL	G's	11.6	60.4	-13.3	35.9	60



Test Vehicle: 2003 Toyota 4 Runner SR5 4WD SUV

Test Date: 2/27/03

Test Program: 55/28 km/h Side Impact NCAP

NHTSA No.: M35107

TR-P23003-05-NC

B-142

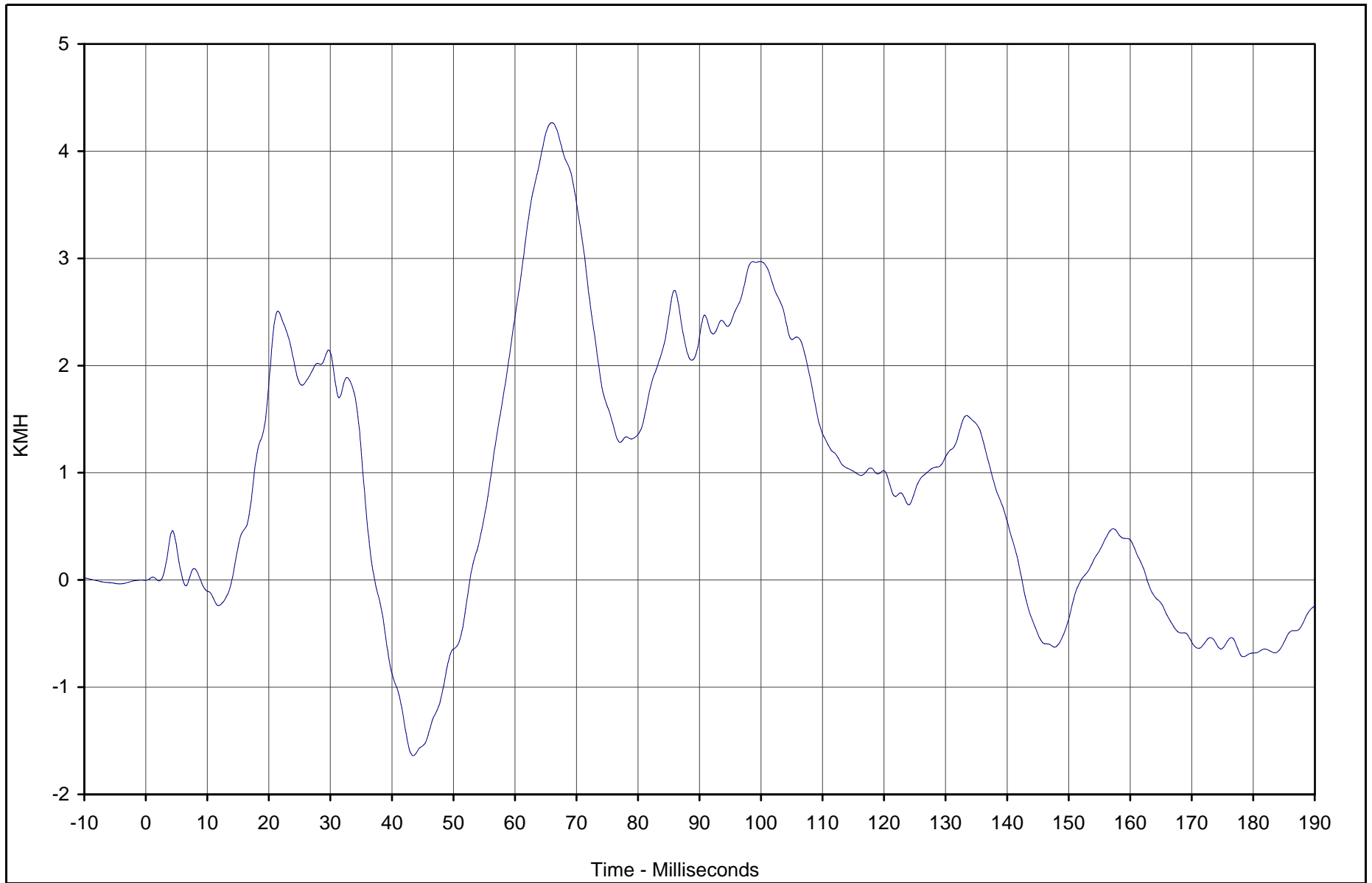

Curve Description	CURNO	Type	Units	Max	Time	Min	Time	SAE Class
MDB CG Z Velocity	073	IN1	KMH	4.3	66.0	-1.6	43.5	180



Test Vehicle: 2003 Toyota 4 Runner SR5 4WD SUV

Test Date: 2/27/03

Test Program: 55/28 km/h Side Impact NCAP

NHTSA No.: M35107

TR-P23003-05-NC

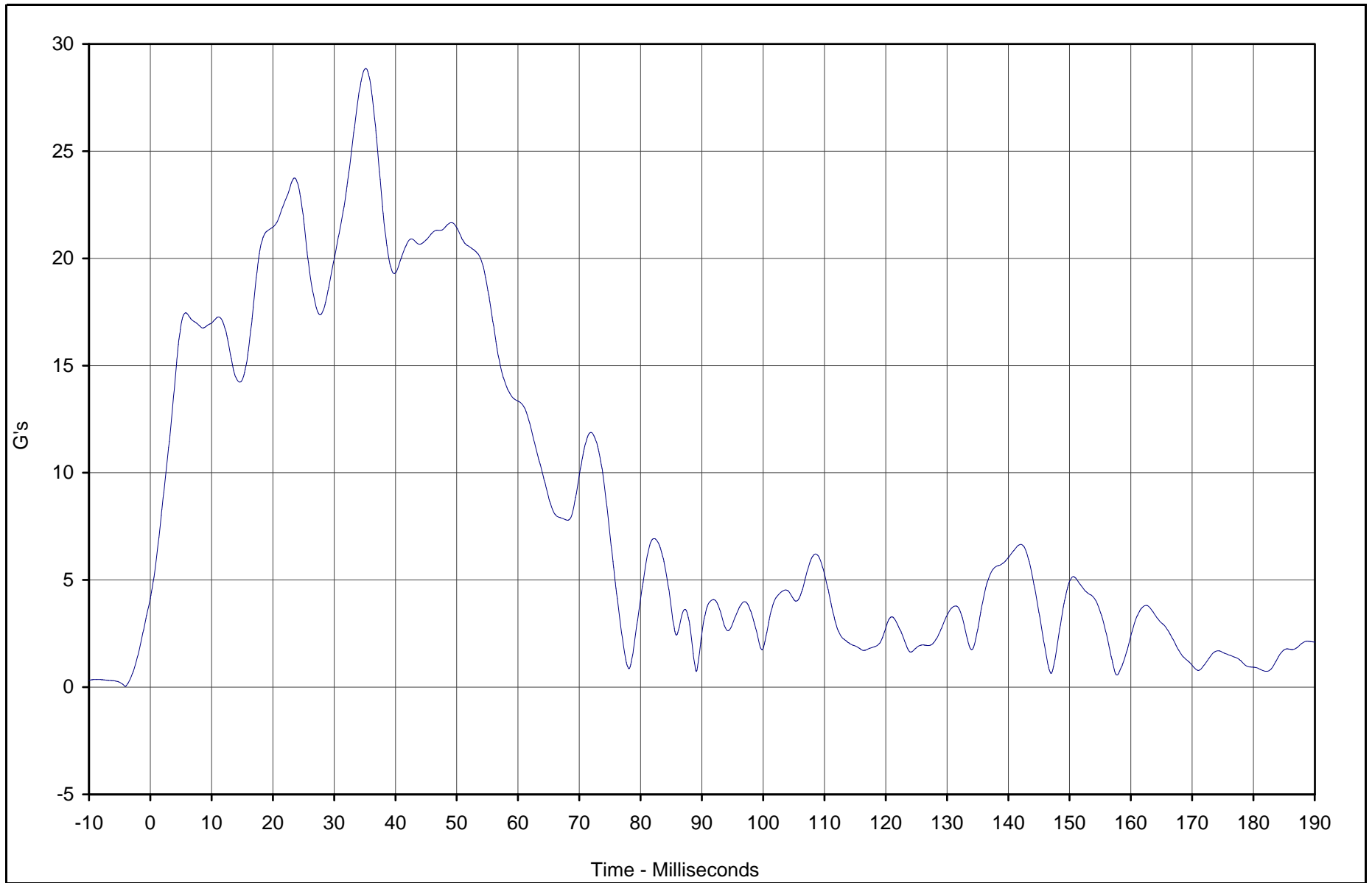

Curve Description	CURNO	Type	Units	Max	Time	Min	Time	SAE Class
CG Resultant	071	RES	G's	28.9	35.2	0.6	157.7	60



Test Vehicle: 2003 Toyota 4 Runner SR5 4WD SUV

Test Date: 2/27/03

Test Program: 55/28 km/h Side Impact NCAP

NHTSA No.: M35107

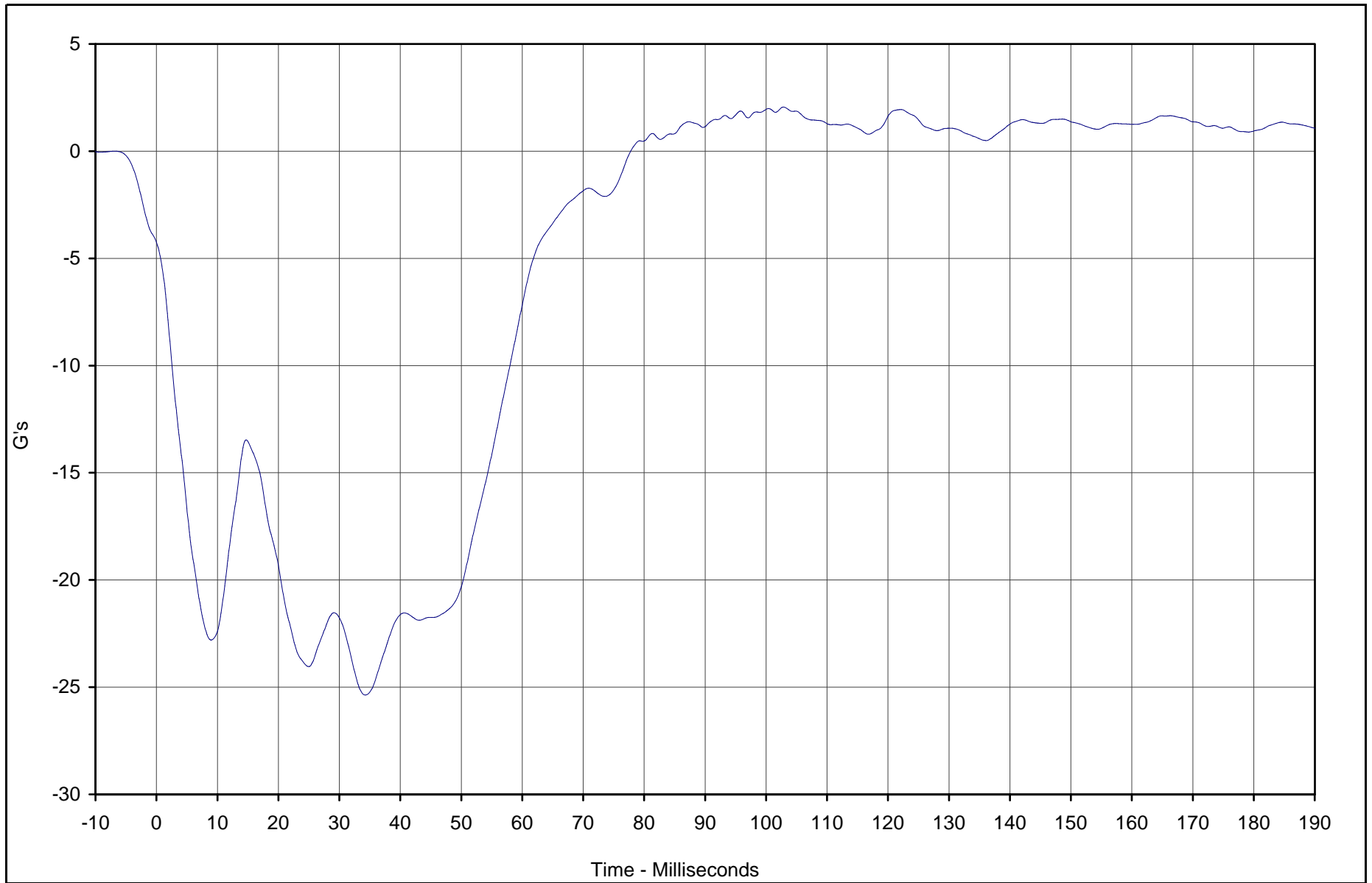

Curve Description	CURNO	Type	Units	Max	Time	Min	Time	SAE Class
MDB Rear X	074	FIL	G's	2.1	102.9	-25.4	34.3	60



Test Vehicle: 2003 Toyota 4 Runner SR5 4WD SUV

Test Date: 2/27/03

Test Program: 55/28 km/h Side Impact NCAP

NHTSA No.: M35107

B-145

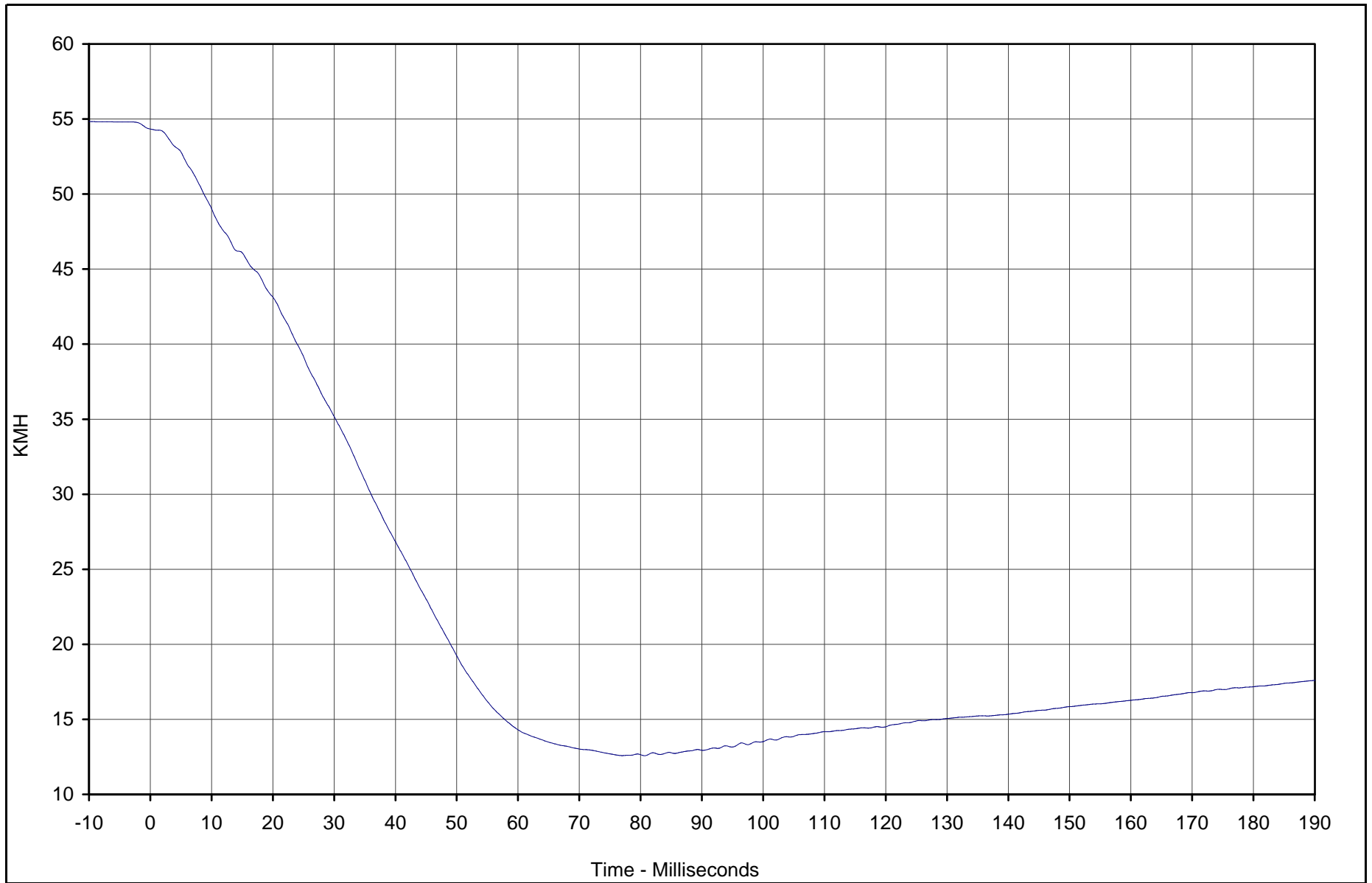

TR-P23003-05-NC

Curve Description	CURNO	Type	Units	Max	Time	Min	Time	SAE Class
MDB Rear X Velocity	074	IN1	KMH	54.3	0.0	12.6	80.6	180



Test Vehicle: 2003 Toyota 4 Runner SR5 4WD SUV

Test Date: 2/27/03

Test Program: 55/28 km/h Side Impact NCAP

NHTSA No.: M35107

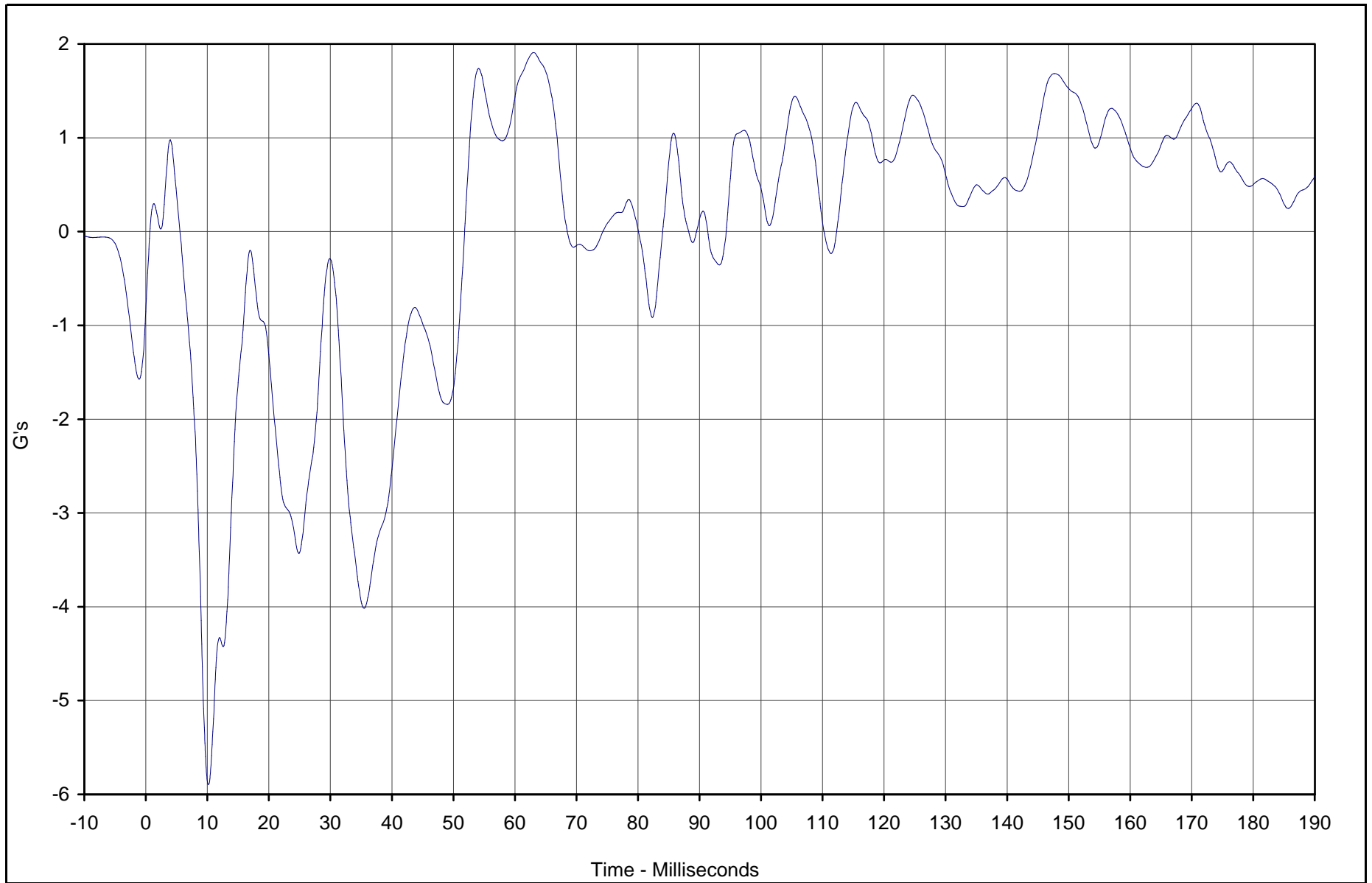

Curve Description	CURNO	Type	Units	Max	Time	Min	Time	SAE Class
MDB Rear Y	075	FIL	G's	1.9	63.1	-5.9	10.2	60



Test Vehicle: 2003 Toyota 4 Runner SR5 4WD SUV

Test Date: 2/27/03

Test Program: 55/28 km/h Side Impact NCAP

NHTSA No.: M35107

B-147

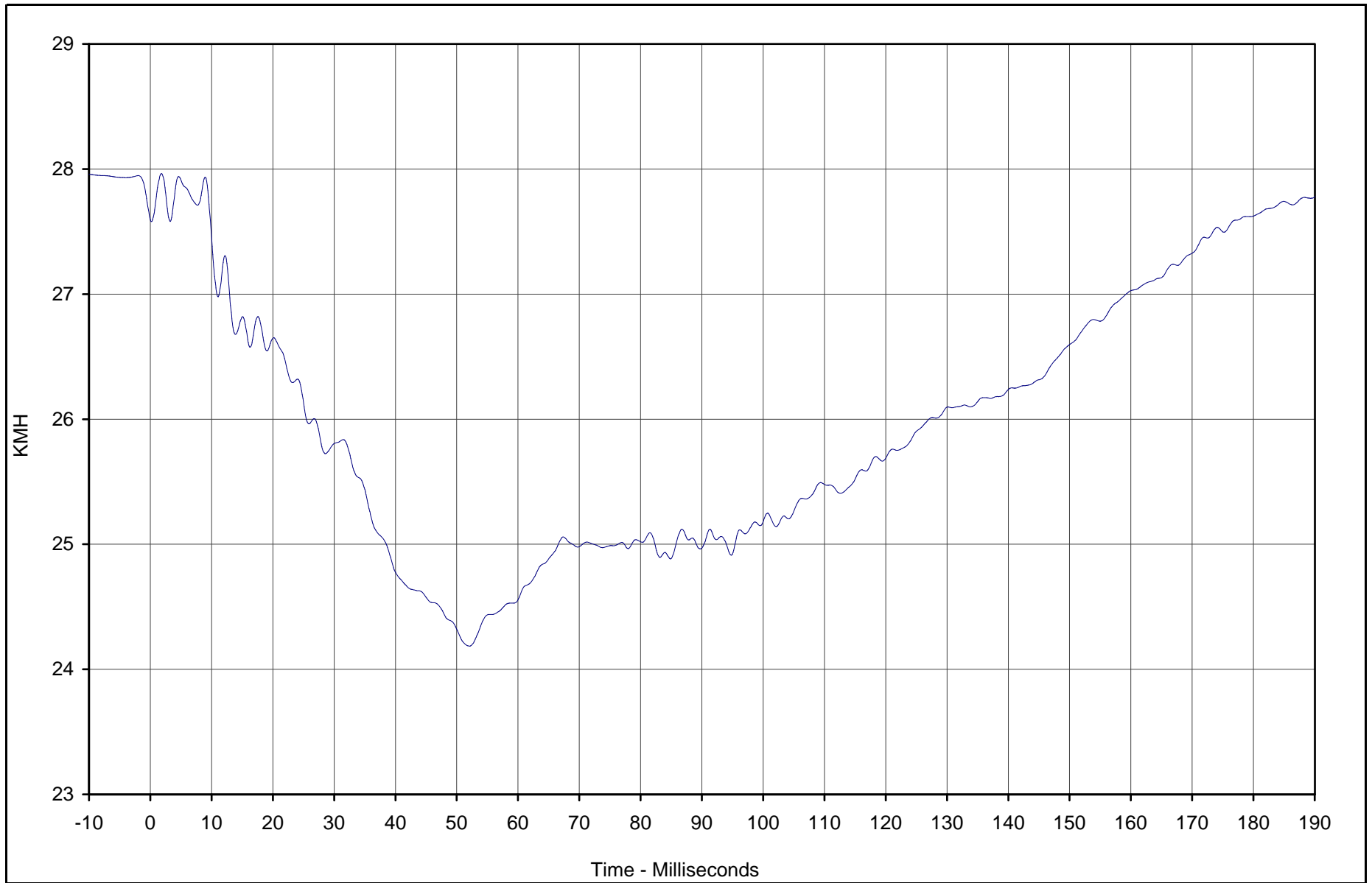

Curve Description	CURNO	Type	Units	Max	Time	Min	Time	SAE Class
MDB Rear Y Velocity	075	IN1	KMH	28.0	1.8	24.2	52.1	180



Test Vehicle: 2003 Toyota 4 Runner SR5 4WD SUV

Test Date: 2/27/03

Test Program: 55/28 km/h Side Impact NCAP

NHTSA No.: M35107

TR-P23003-05-NC

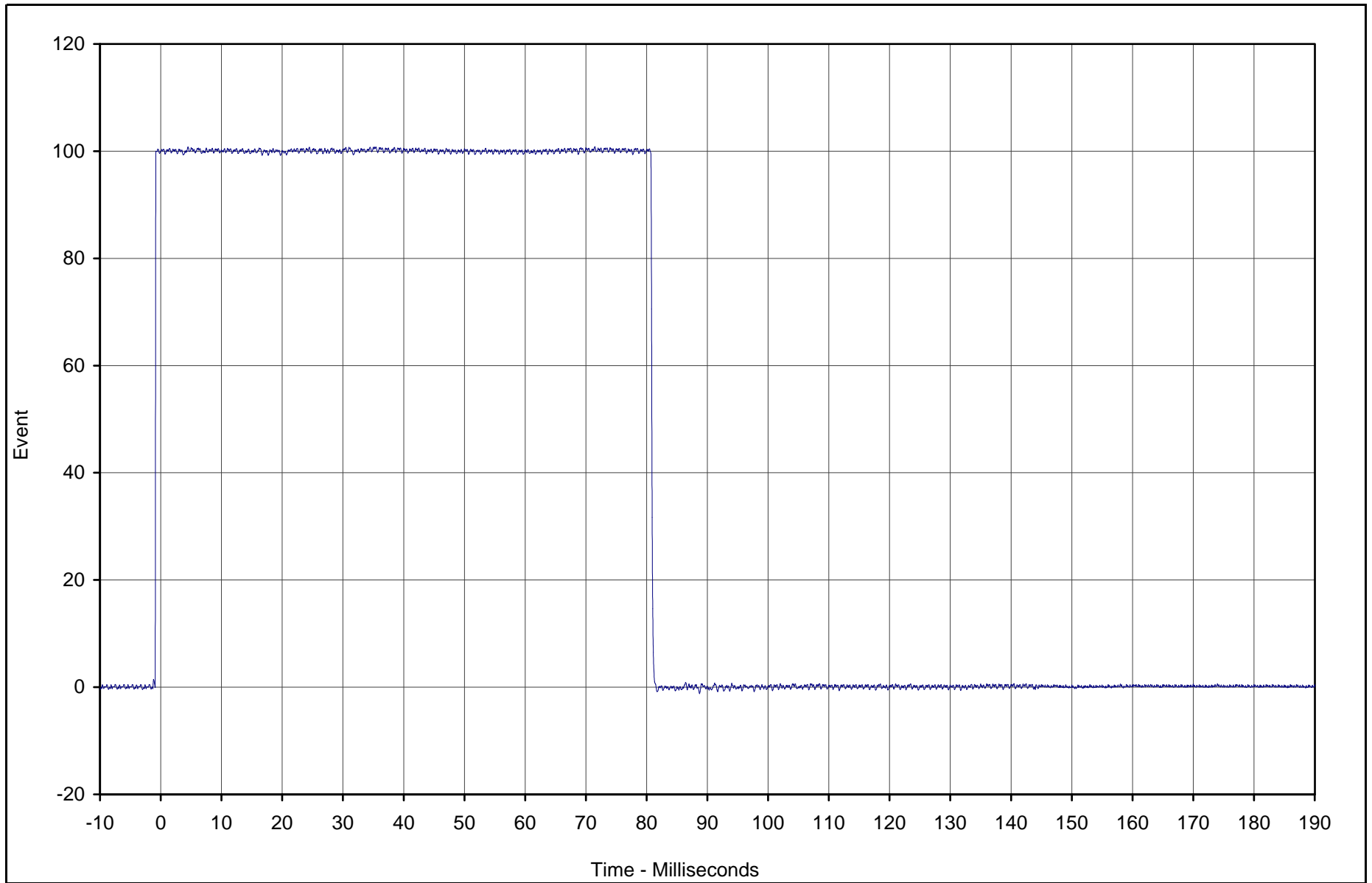

Curve Description	CURNO	Type	Units	Max	Time	Cross %	Time	SAE Class
MDB Right Bumper Contact	076	FIL	Event	100.8	71.5	50.0	-0.8	1000



Test Vehicle: 2003 Toyota 4 Runner SR5 4WD SUV

Test Date: 2/27/03

Test Program: 55/28 km/h Side Impact NCAP

NHTSA No.: M35107

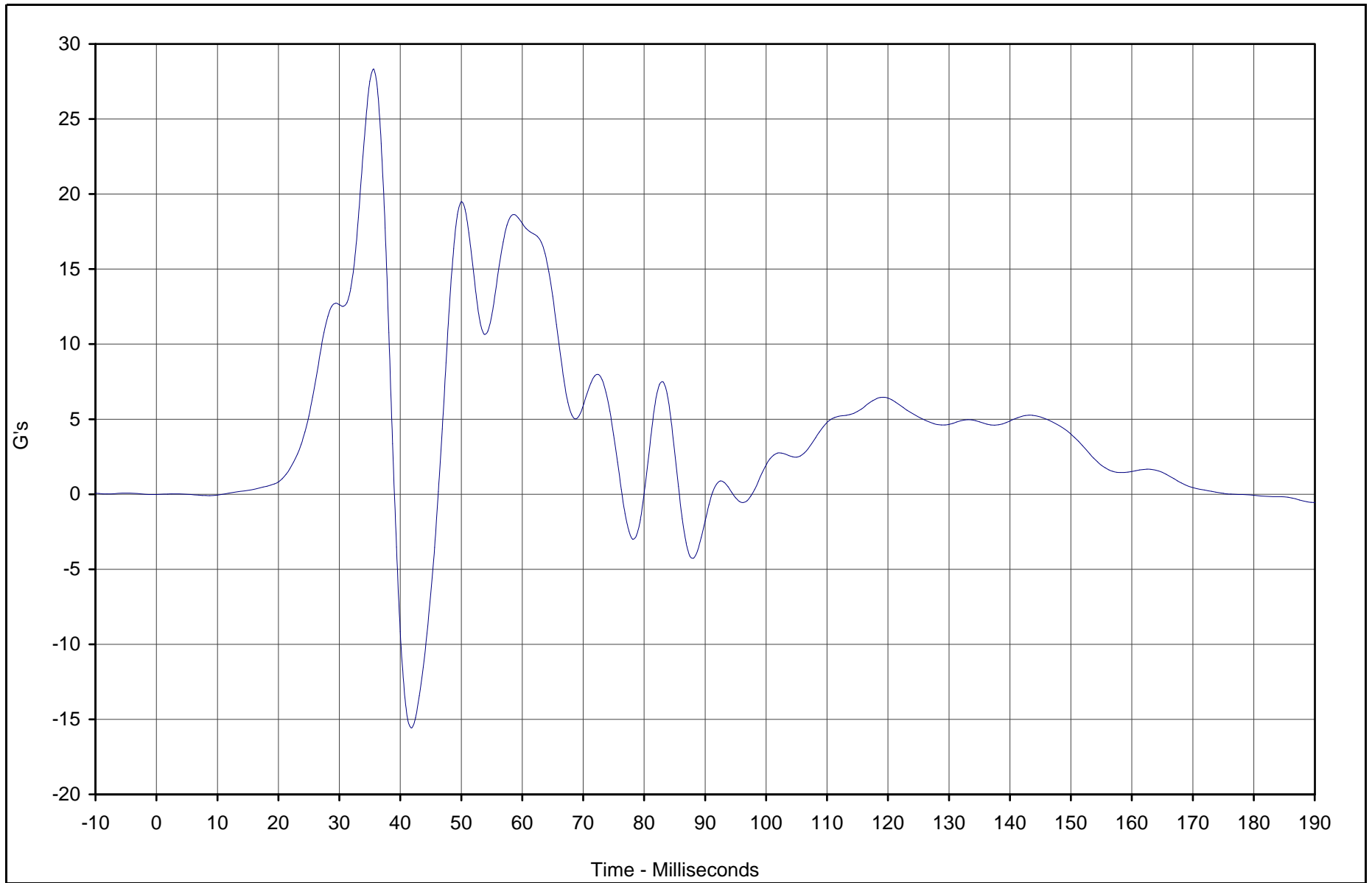

Curve Description	CURNO	Type	Units	Max	Time	Min	Time	SAE Class
Driver Upper Rib Primary Y	013	FIR	G's	28.3	35.6	-15.6	41.9	FIR100



Test Vehicle: 2003 Toyota 4 Runner SR5 4WD SUV

Test Date: 2/27/03

Test Program: 55/28 km/h Side Impact NCAP

NHTSA No.: M35107

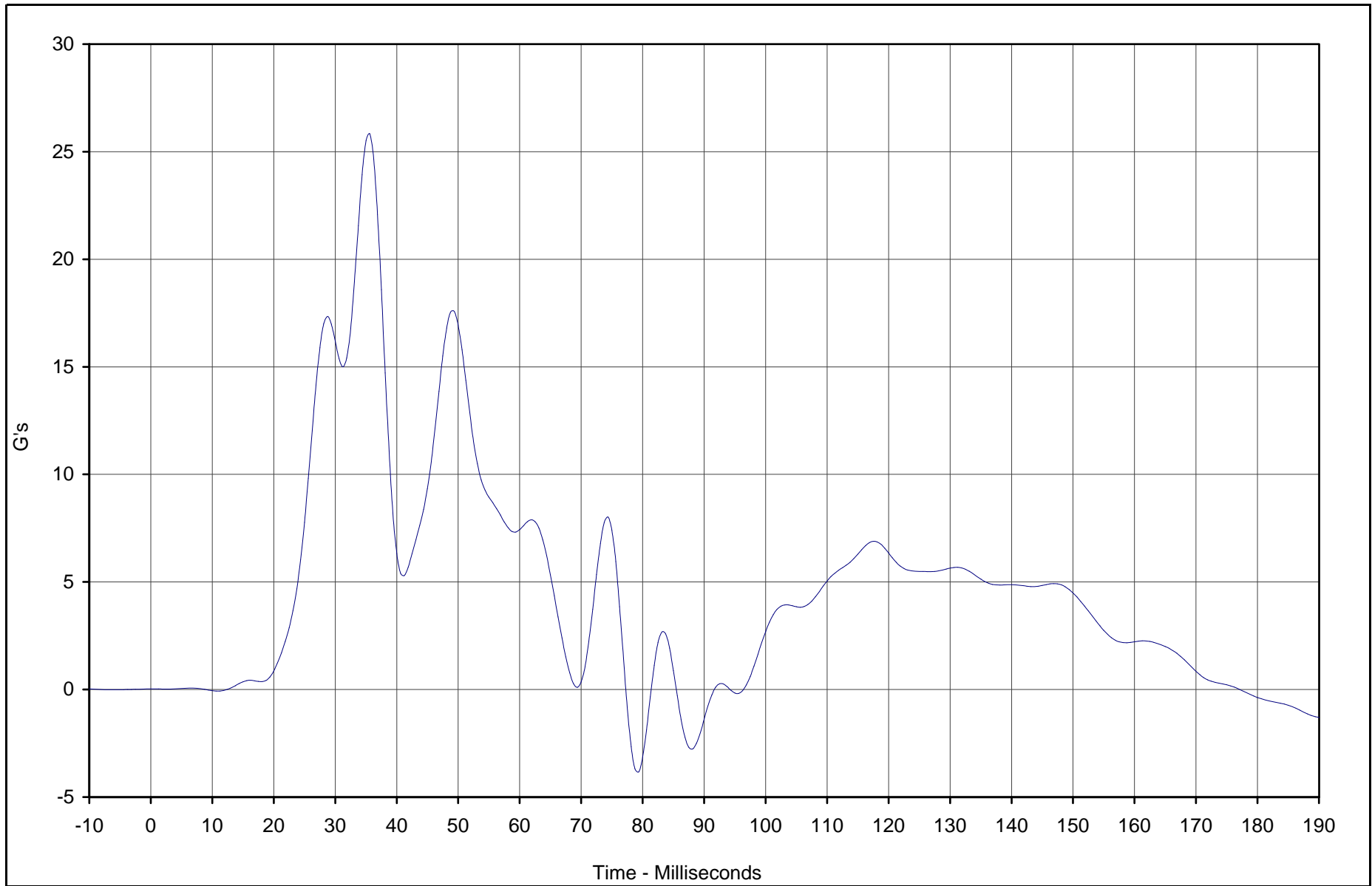

Curve Description	CURNO	Type	Units	Max	Time	Min	Time	SAE Class
Driver Lower Rib Primary Y	014	FIR	G's	25.8	35.6	-3.8	79.4	FIR100



Test Vehicle: 2003 Toyota 4 Runner SR5 4WD SUV

Test Date: 2/27/03

Test Program: 55/28 km/h Side Impact NCAP

NHTSA No.: M35107

B-151

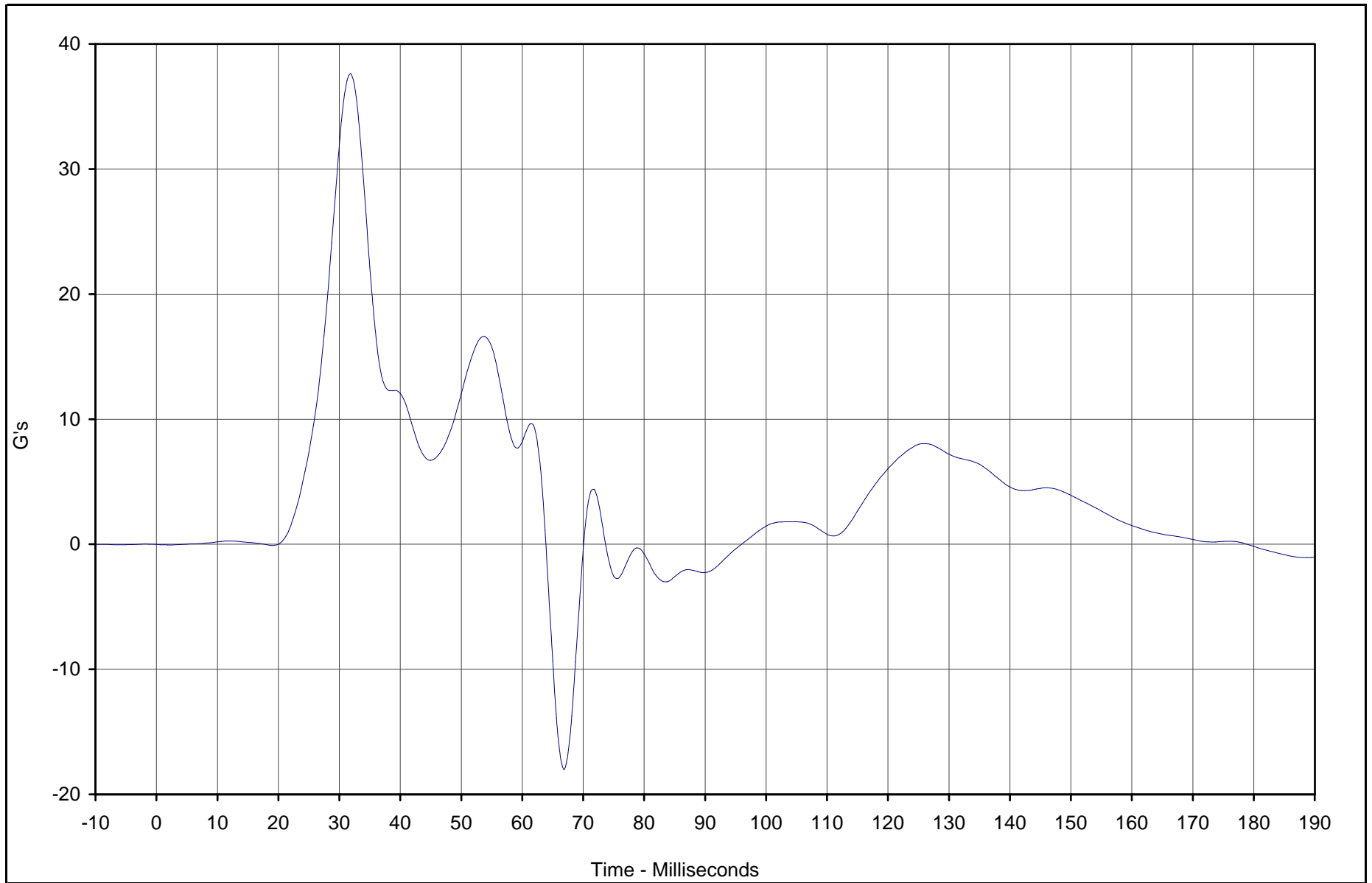

TR-P23003-05-NC

Curve Description	CURNO	Type	Units	Max	Time	Min	Time	SAE Class
Driver Lower Spine Primary Y	015	FIR	G's	37.6	31.9	-18.0	66.9	FIR100



Test Vehicle: 2003 Toyota 4 Runner SR5 4WD SUV

Test Date: 2/27/03

Test Program: 55/28 km/h Side Impact NCAP

NHTSA No.: M35107

B-152

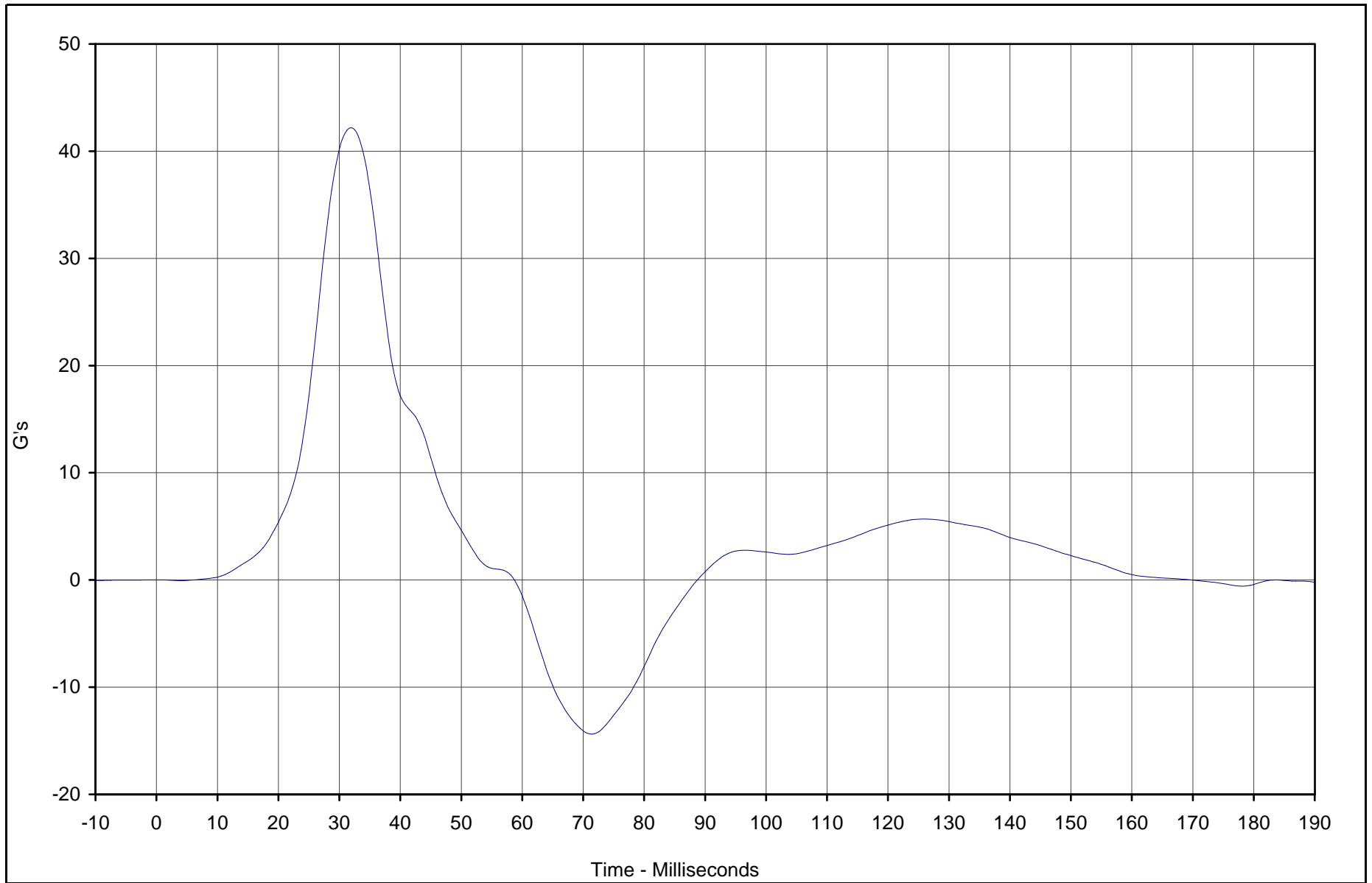

TR-P23003-05-NC

Curve Description	CURNO	Type	Units	Max	Time	Min	Time	SAE Class
Driver Pelvis Primary Y	016	FIR	G's	42.2	31.9	-14.4	71.3	FIR100



Test Vehicle: 2003 Toyota 4 Runner SR5 4WD SUV

Test Date: 2/27/03

Test Program: 55/28 km/h Side Impact NCAP

NHTSA No.: M35107

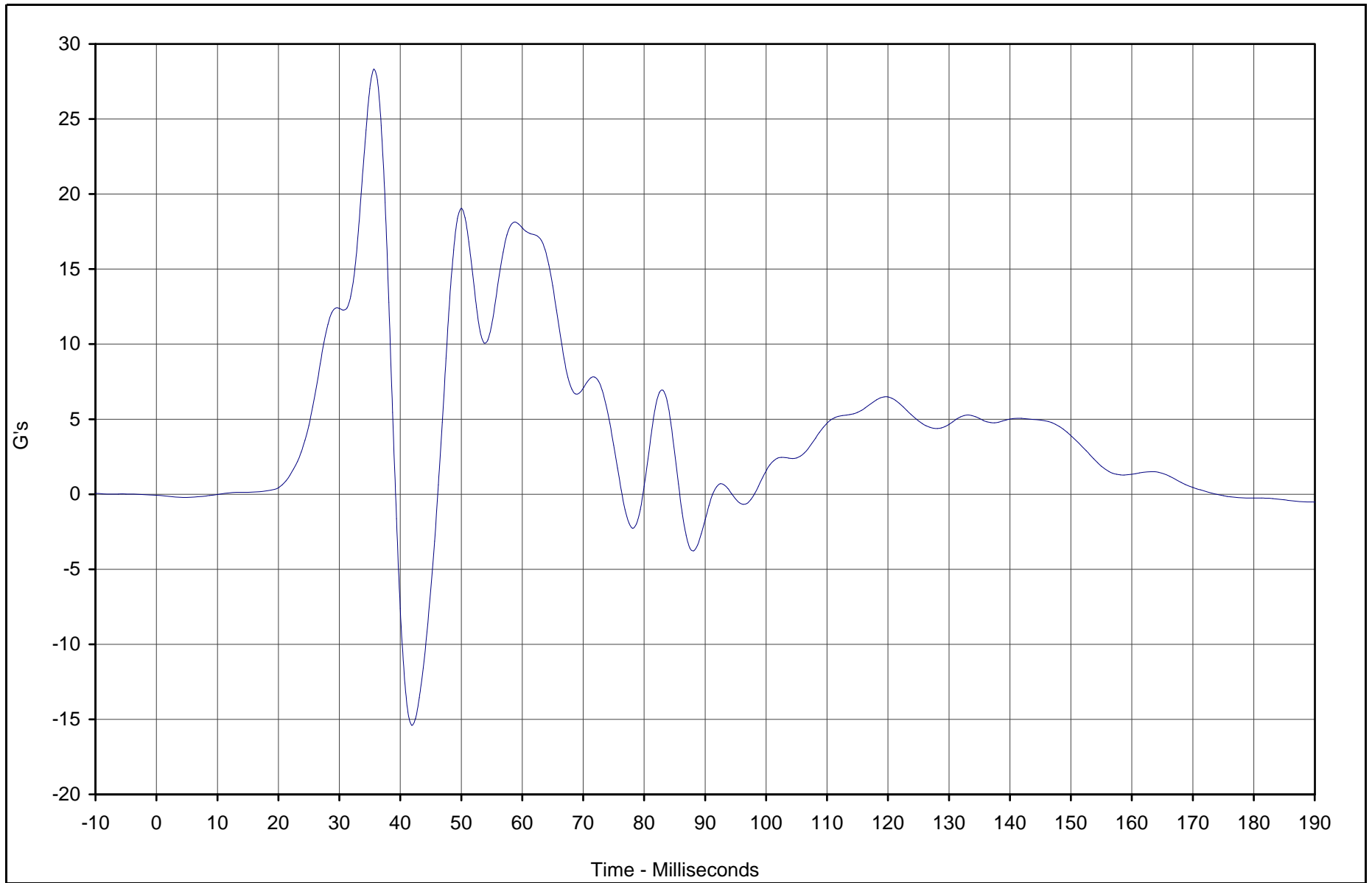

Curve Description	CURNO	Type	Units	Max	Time	Min	Time	SAE Class
Driver Upper Rib Redundant Y	017	FIR	G's	28.3	35.6	-15.4	41.9	FIR100



Test Vehicle: 2003 Toyota 4 Runner SR5 4WD SUV

Test Date: 2/27/03

Test Program: 55/28 km/h Side Impact NCAP

NHTSA No.: M35107

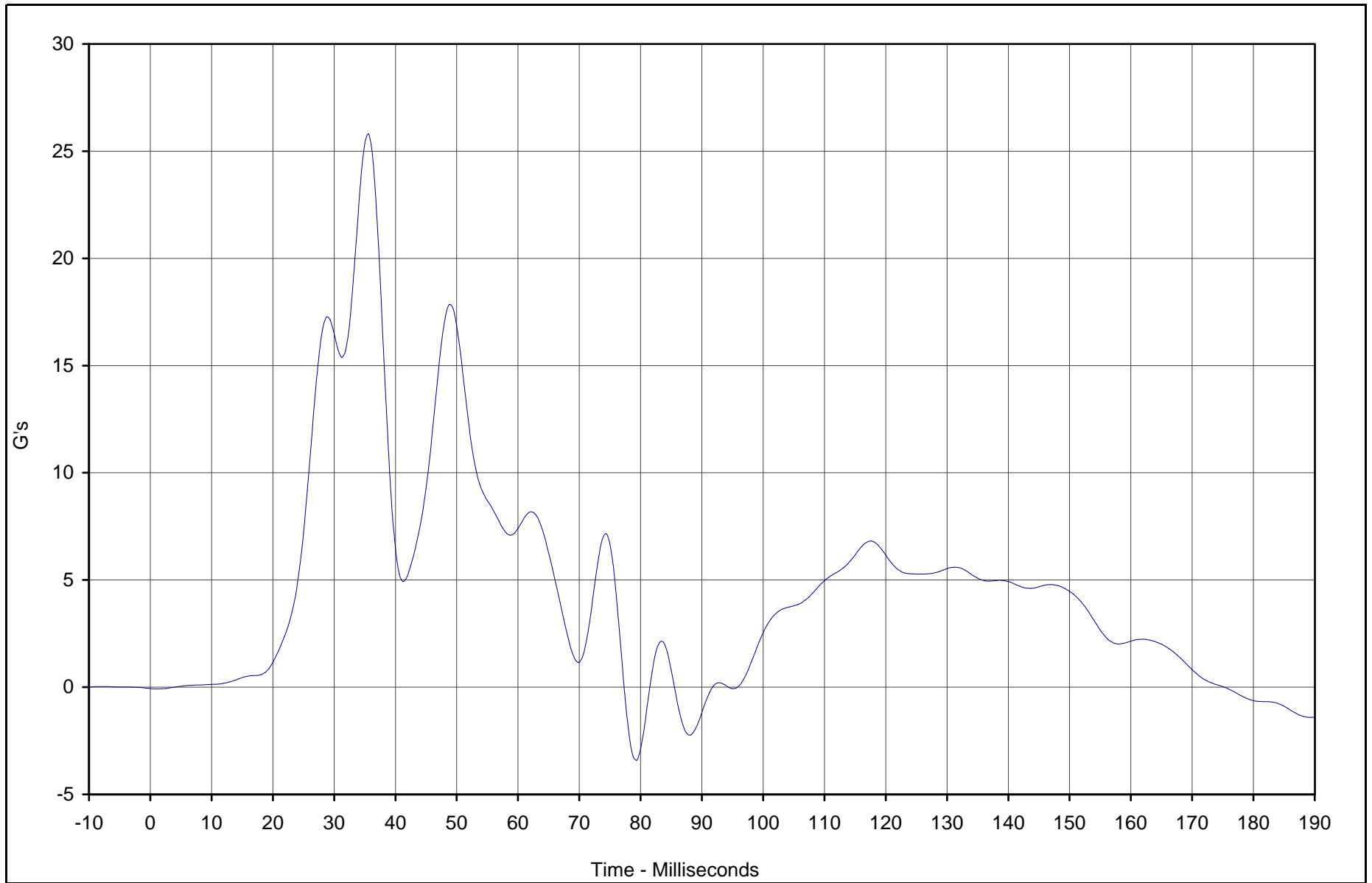

Curve Description	CURNO	Type	Units	Max	Time	Min	Time	SAE Class
Driver Lower Rib Redundant Y	018	FIR	G's	25.8	35.6	-3.4	79.4	FIR100



Test Vehicle: 2003 Toyota 4 Runner SR5 4WD SUV
 Test Program: 55/28 km/h Side Impact NCAP

Test Date: 2/27/03
 NHTSA No.: M35107

B-155

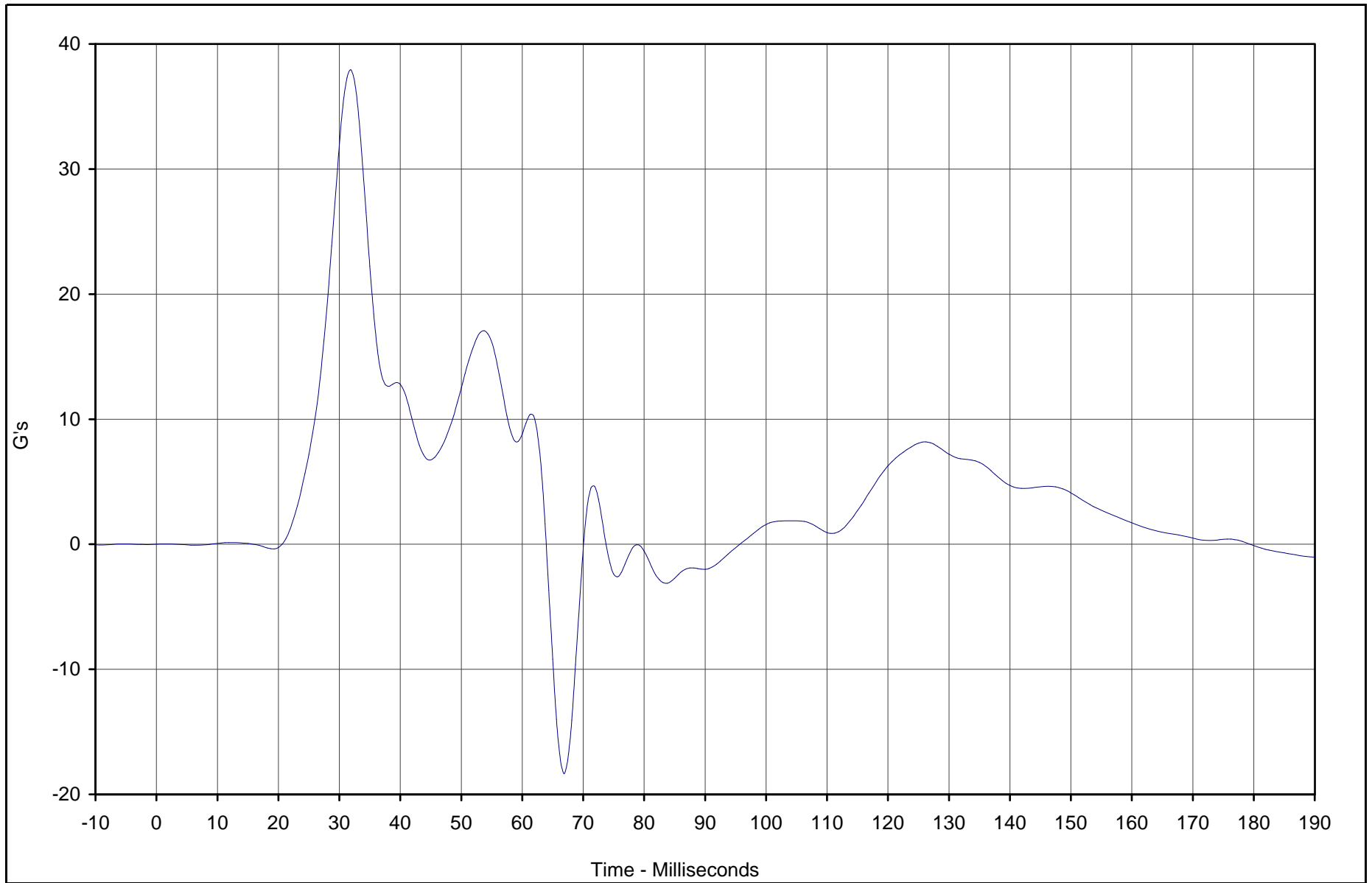

Curve Description	CURNO	Type	Units	Max	Time	Min	Time	SAE Class
Driver Lower Spine Redundant Y	019	FIR	G's	37.9	31.9	-18.3	66.9	FIR100



Test Vehicle: 2003 Toyota 4 Runner SR5 4WD SUV

Test Date: 2/27/03

Test Program: 55/28 km/h Side Impact NCAP

NHTSA No.: M35107

TR-P23003-05-NC

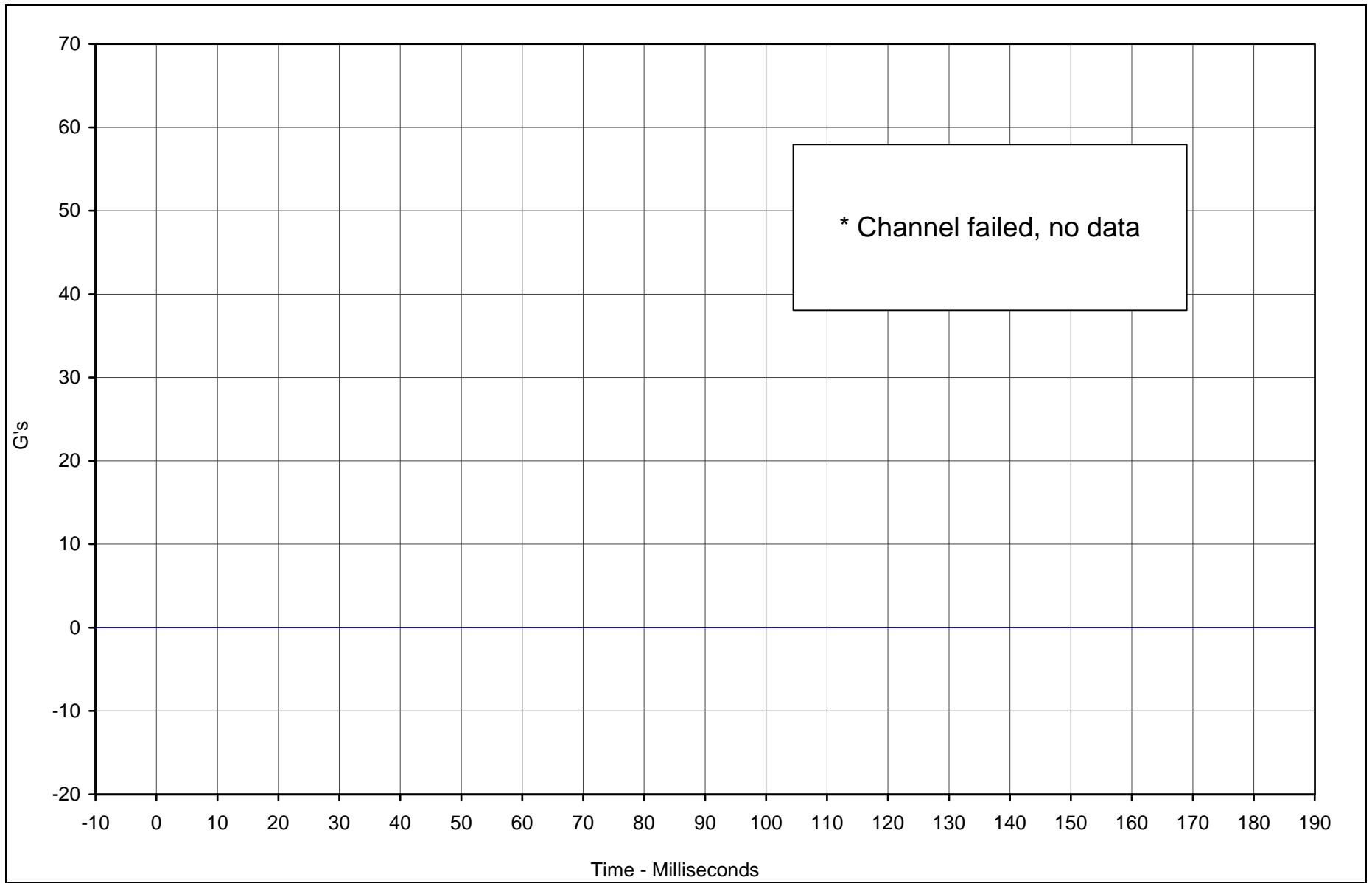

* Channel failed, no data

Curve Description	CURNO	Type	Units	Max	Time	Min	Time	SAE Class
Driver Pelvis Redundant Y	020	FIR	G's	0.0	0.0	0.0	0.0	FIR100



Test Vehicle: 2003 Toyota 4 Runner SR5 4WD SUV

Test Date: 2/27/03

Test Program: 55/28 km/h Side Impact NCAP

NHTSA No.: M35107

B-157

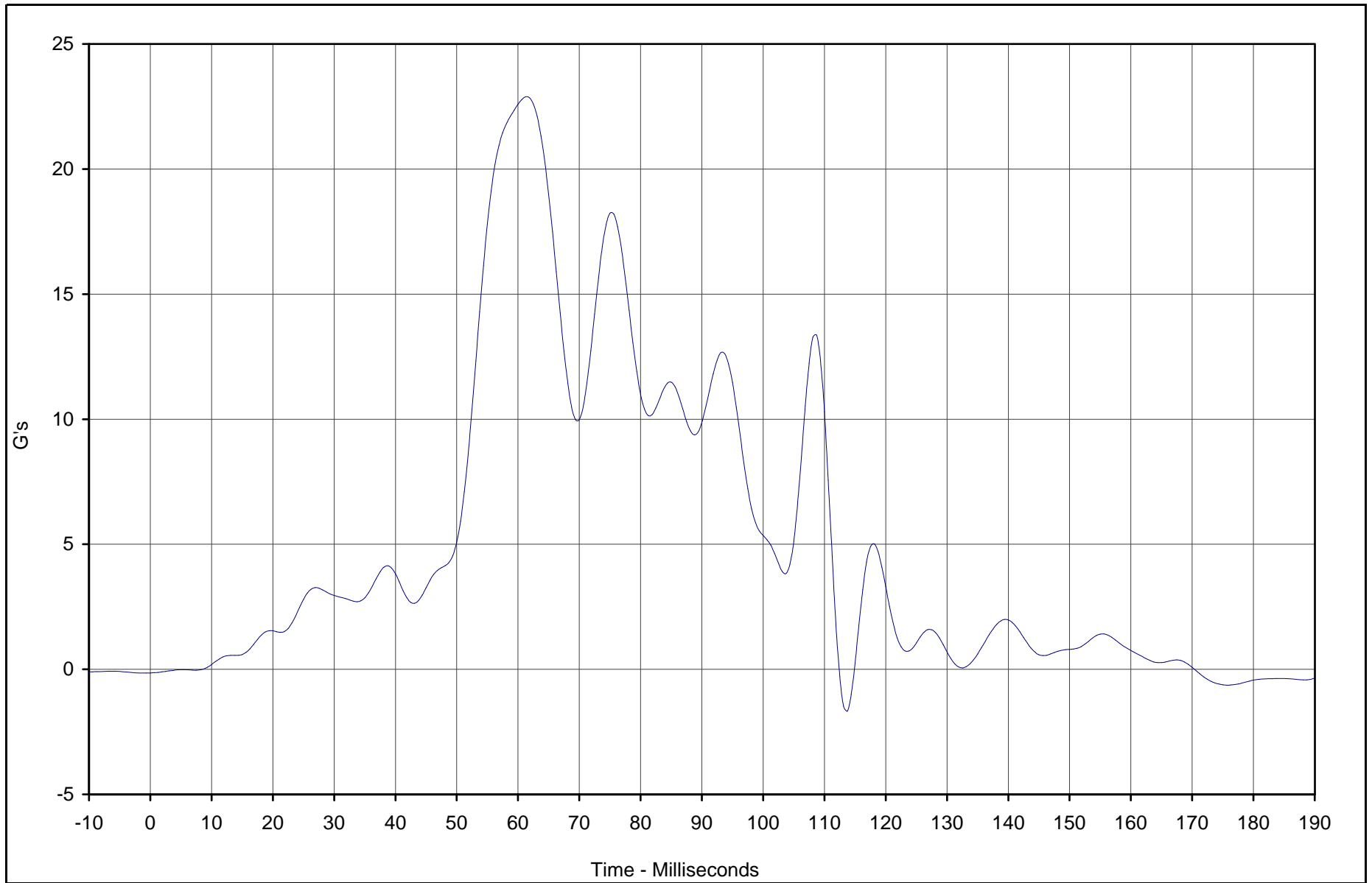

Curve Description	CURNO	Type	Units	Max	Time	Min	Time	SAE Class
Pass. Upper Rib Primary Y	035	FIR	G's	22.9	61.3	-1.7	113.8	FIR100



Test Vehicle: 2003 Toyota 4 Runner SR5 4WD SUV

Test Date: 2/27/03

Test Program: 55/28 km/h Side Impact NCAP

NHTSA No.: M35107

TR-P23003-05-NC

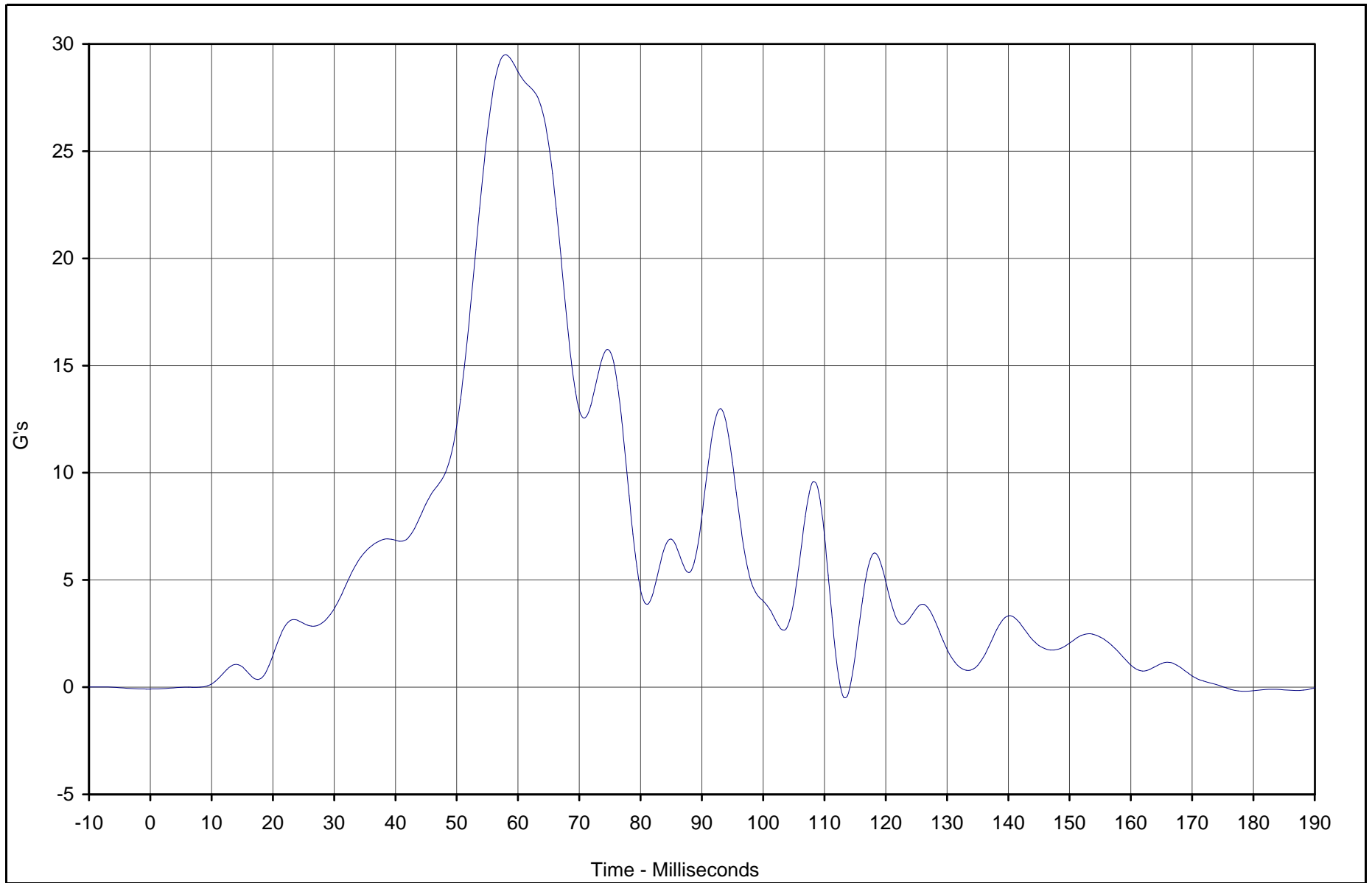

Curve Description	CURNO	Type	Units	Max	Time	Min	Time	SAE Class
Pass. Lower Rib Primary Y	036	FIR	G's	29.5	58.1	-0.5	113.1	FIR100



Test Vehicle: 2003 Toyota 4 Runner SR5 4WD SUV

Test Date: 2/27/03

Test Program: 55/28 km/h Side Impact NCAP

NHTSA No.: M35107

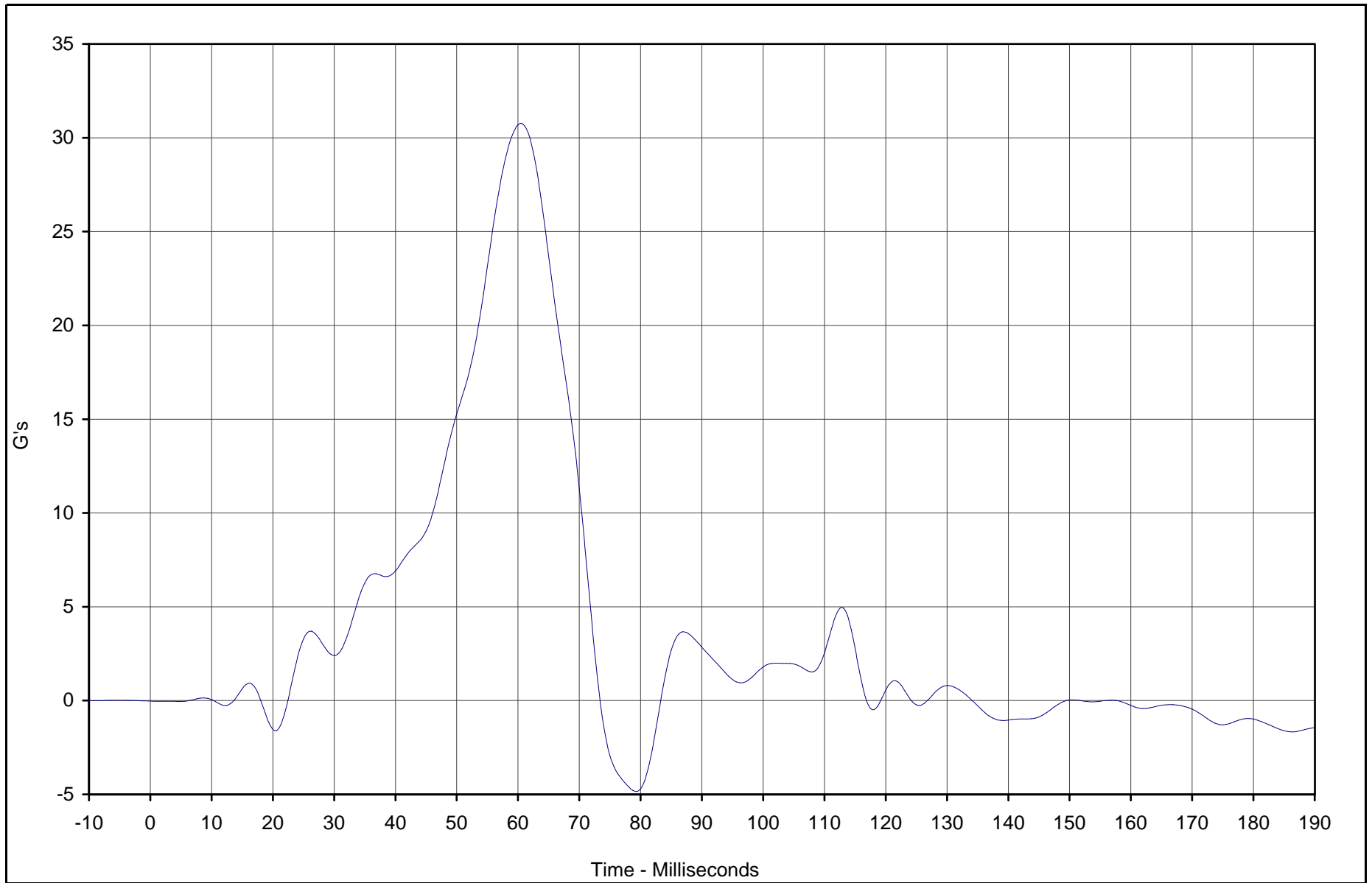

Curve Description	CURNO	Type	Units	Max	Time	Min	Time	SAE Class
Pass. Lower Spine Primary Y	037	FIR	G's	30.8	60.6	-4.8	79.4	FIR100



Test Vehicle: 2003 Toyota 4 Runner SR5 4WD SUV

Test Date: 2/27/03

Test Program: 55/28 km/h Side Impact NCAP

NHTSA No.: M35107

B-160

TR-P23003-05-NC

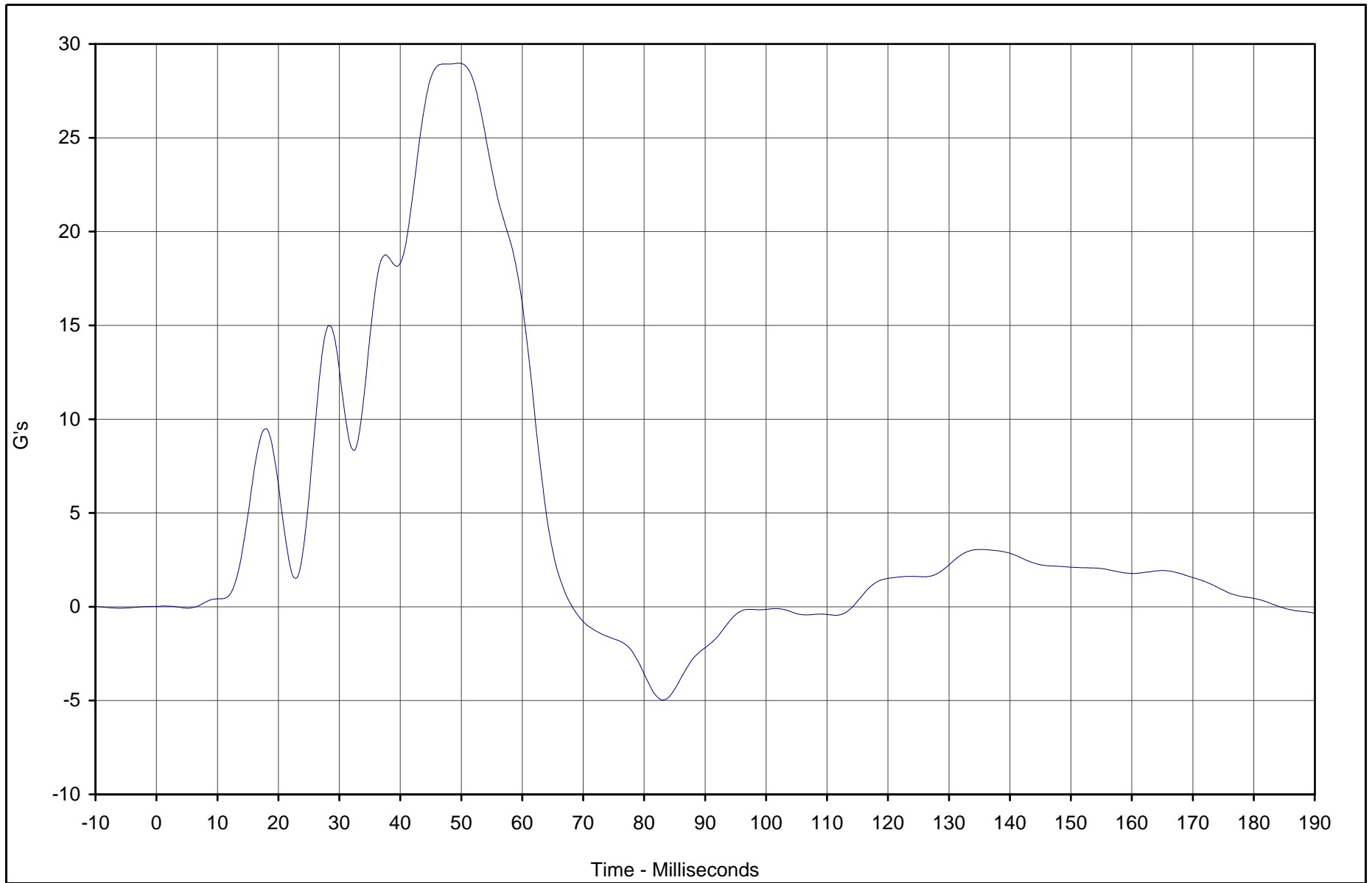

Curve Description	CURNO	Type	Units	Max	Time	Min	Time	SAE Class
Pass. Pelvis Primary Y	038	FIR	G's	29.0	49.4	-5.0	83.1	FIR100



Test Vehicle: 2003 Toyota 4 Runner SR5 4WD SUV

Test Date: 2/27/03

Test Program: 55/28 km/h Side Impact NCAP

NHTSA No.: M35107

B-161

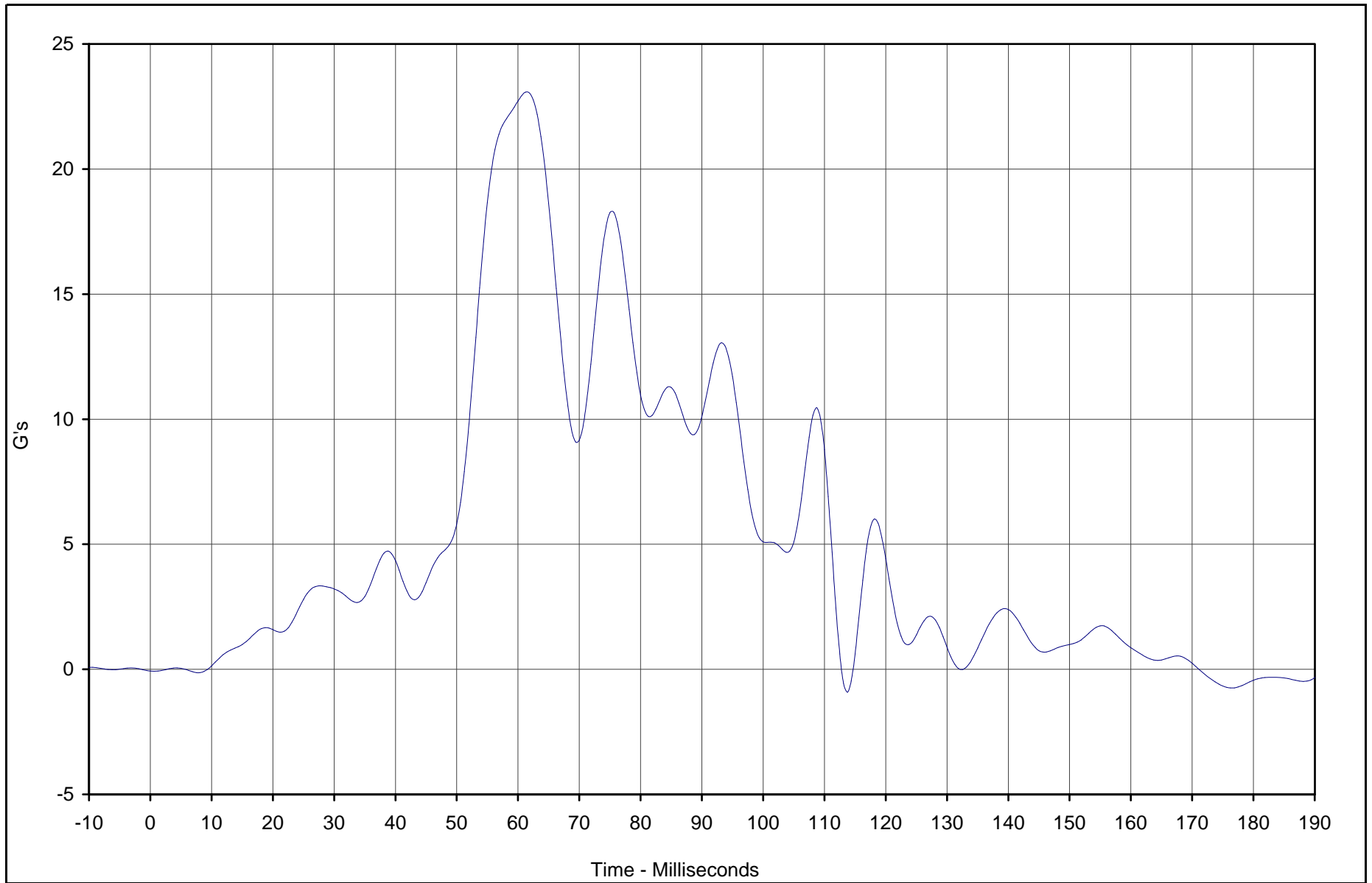

Curve Description	CURNO	Type	Units	Max	Time	Min	Time	SAE Class
Pass. Upper Rib Redundant Y	039	FIR	G's	23.1	61.3	-0.9	113.8	FIR100



Test Vehicle: 2003 Toyota 4 Runner SR5 4WD SUV

Test Date: 2/27/03

Test Program: 55/28 km/h Side Impact NCAP

NHTSA No.: M35107

TR-P23003-05-NC

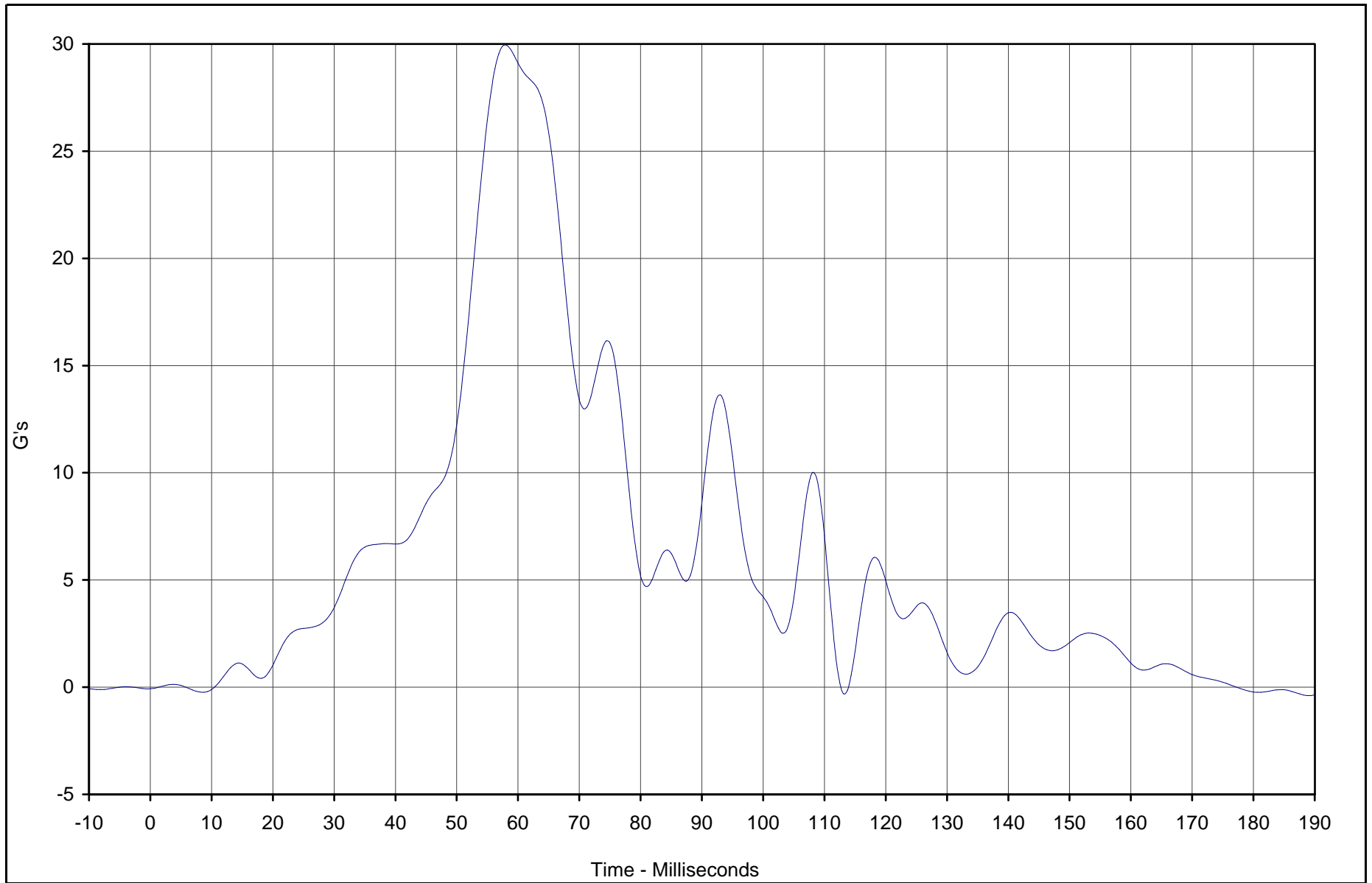

Curve Description	CURNO	Type	Units	Max	Time	Min	Time	SAE Class
Pass. Lower Rib Redundant Y	040	FIR	G's	29.9	58.1	-0.4	189.4	FIR100



Test Vehicle: 2003 Toyota 4 Runner SR5 4WD SUV

Test Date: 2/27/03

Test Program: 55/28 km/h Side Impact NCAP

NHTSA No.: M35107

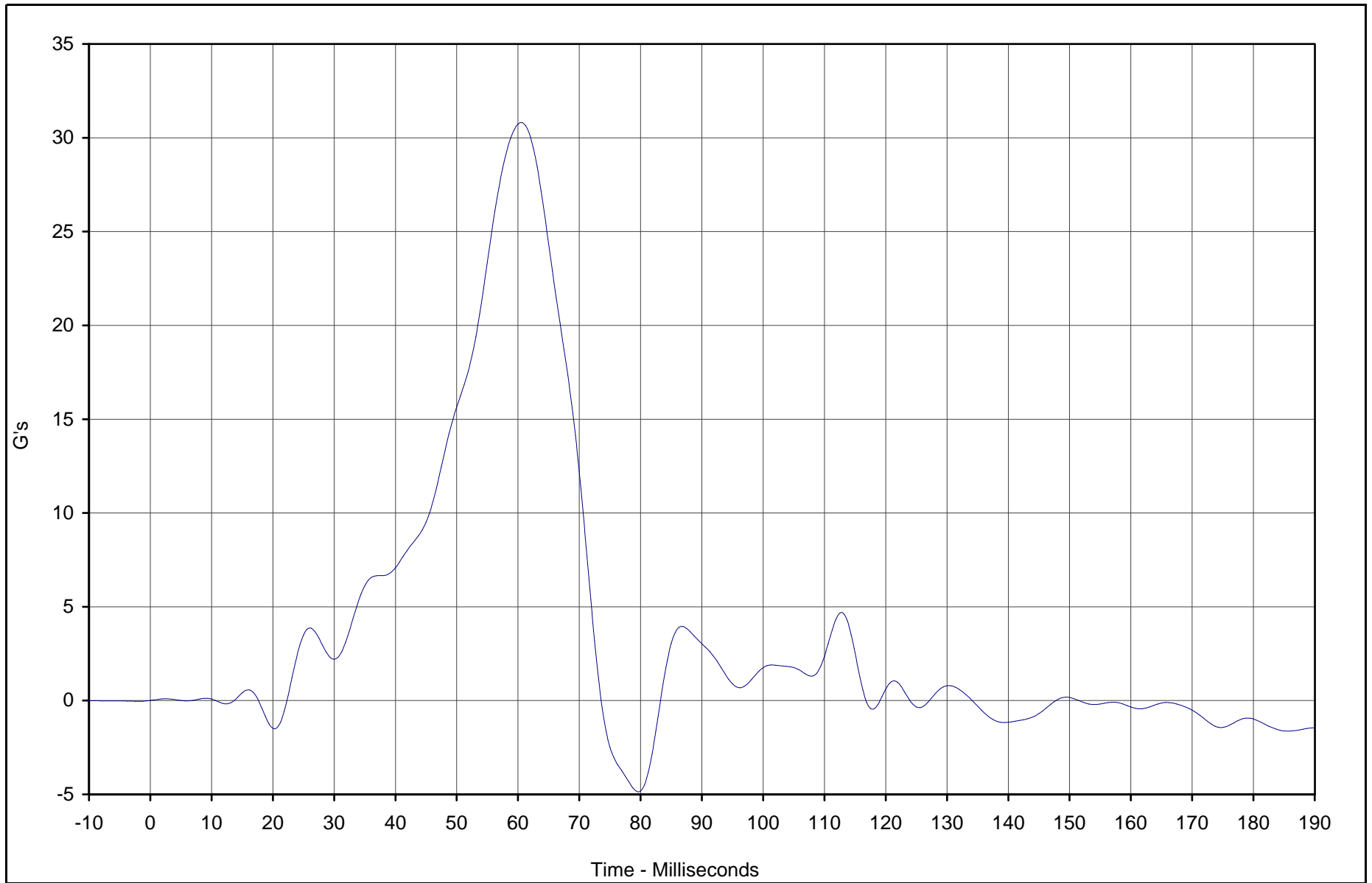

Curve Description	CURNO	Type	Units	Max	Time	Min	Time	SAE Class
Pass. Lower Spine Redundant Y	041	FIR	G's	30.8	60.6	-4.8	79.4	FIR100



Test Vehicle: 2003 Toyota 4 Runner SR5 4WD SUV
 Test Program: 55/28 km/h Side Impact NCAP

Test Date: 2/27/03
 NHTSA No.: M35107

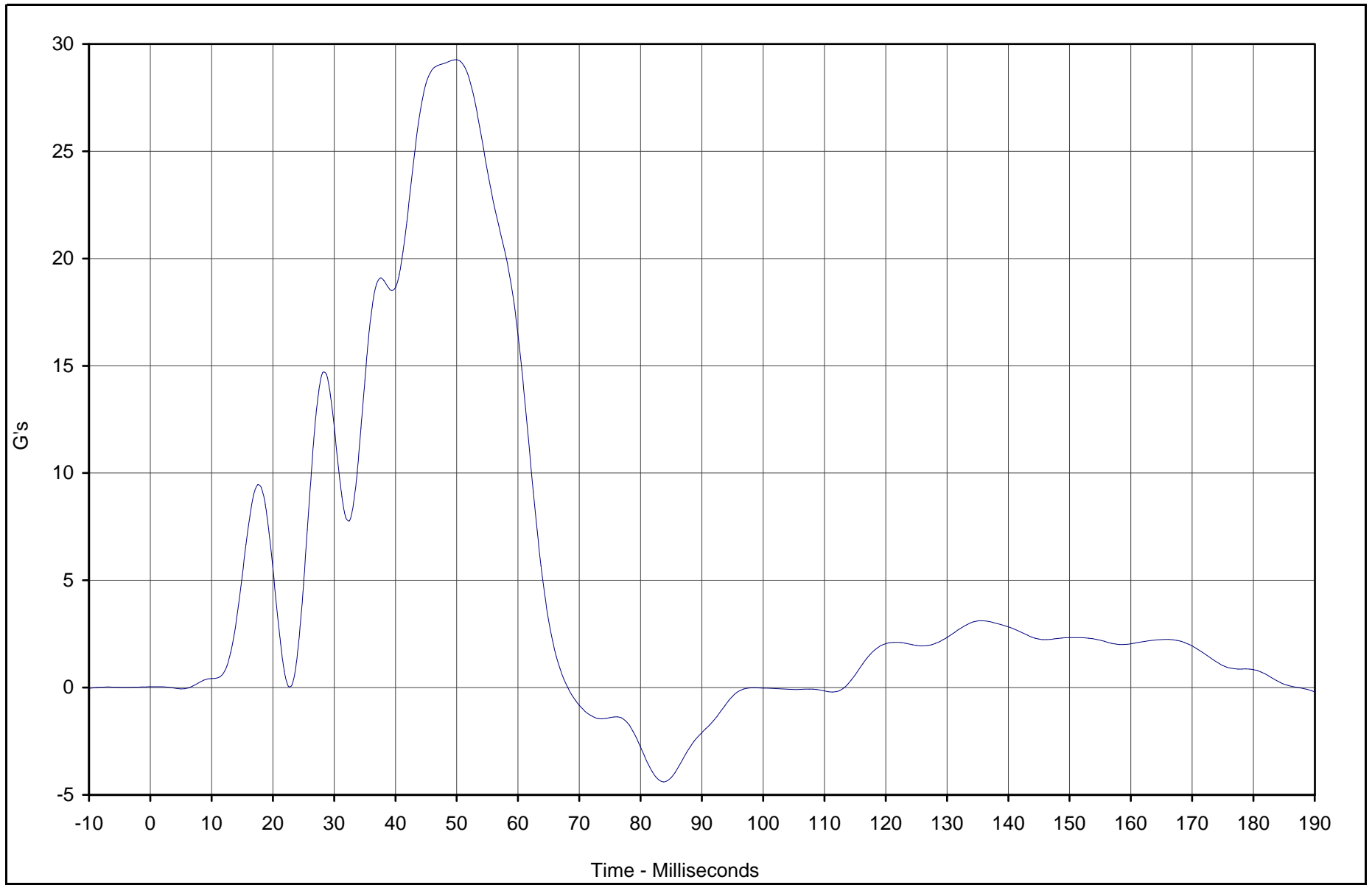

Curve Description	CURNO	Type	Units	Max	Time	Min	Time	SAE Class
Pass. Pelvis Redundant Y	042	FIR	G's	29.3	50.0	-4.4	83.8	FIR100



Test Vehicle: 2003 Toyota 4 Runner SR5 4WD SUV

Test Date: 2/27/03

Test Program: 55/28 km/h Side Impact NCAP

NHTSA No.: M35107

APPENDIX C
SID/HIII CONFIGURATION AND PERFORMANCE VERIFICATION DATA

APPENDIX C
PRE-TEST SID / HIII CONFIGURATION AND PERFORMANCE VERIFICATION DATA



Calibration Data Sheet Side Impact Hybrid Dummy (SID/HIII) External Measurements

ATD Serial No.: 274

Tested Parameter	Units	Specification	Result	Pass/Fail
Laboratory Temperature	°C	18.9 to 25.6	21.1	Pass
Laboratory Relative Humidity	%	10 to 70	30	Pass
SH- Seated Height	mm	889 to 909	890	Pass
HP- Hip Point Height	mm	99 (reference)	99	Pass
RH- Rib Height	mm	502 to 520	515	Pass
KH- Knee Pivot From Back Line	mm	511 to 526	520	Pass
KV- Knee Pivot From Floor	mm	490 to 505	495	Pass
HW- Hip Width	mm	356 to 391	375	Pass
Overall Test Results				Pass

C-1

TR-P23003-05-NC

Laboratory Technician

February 22, 2003

Test Date



Calibration Data Sheet Side Impact Hybrid Dummy (SID/HIII) Thorax Lateral Impact

ATD Serial No.: 274

Test I.D.: TH03A

Tested Parameter	Units	Specification	Result	Pass/Fail
Laboratory Temperature	°C	18.9 to 25.6	21.1	Pass
Laboratory Relative Humidity	%	10 to 70	30	Pass
Probe Velocity	m/s	4.21 to 4.33	4.24	Pass
Upper Rib Acceleration	G's	37.0 to 46.0	44.4	Pass
Lower Rib Acceleration	G's	37.0 to 46.0	42.1	Pass
Thoracic Spine Acceleration	G's	15.0 to 22.0	20.9	Pass
Overall Test Results				Pass

C-2

TR-P23003-05-NC

Laboratory Technician

February 21, 2003

Test Date

C-3

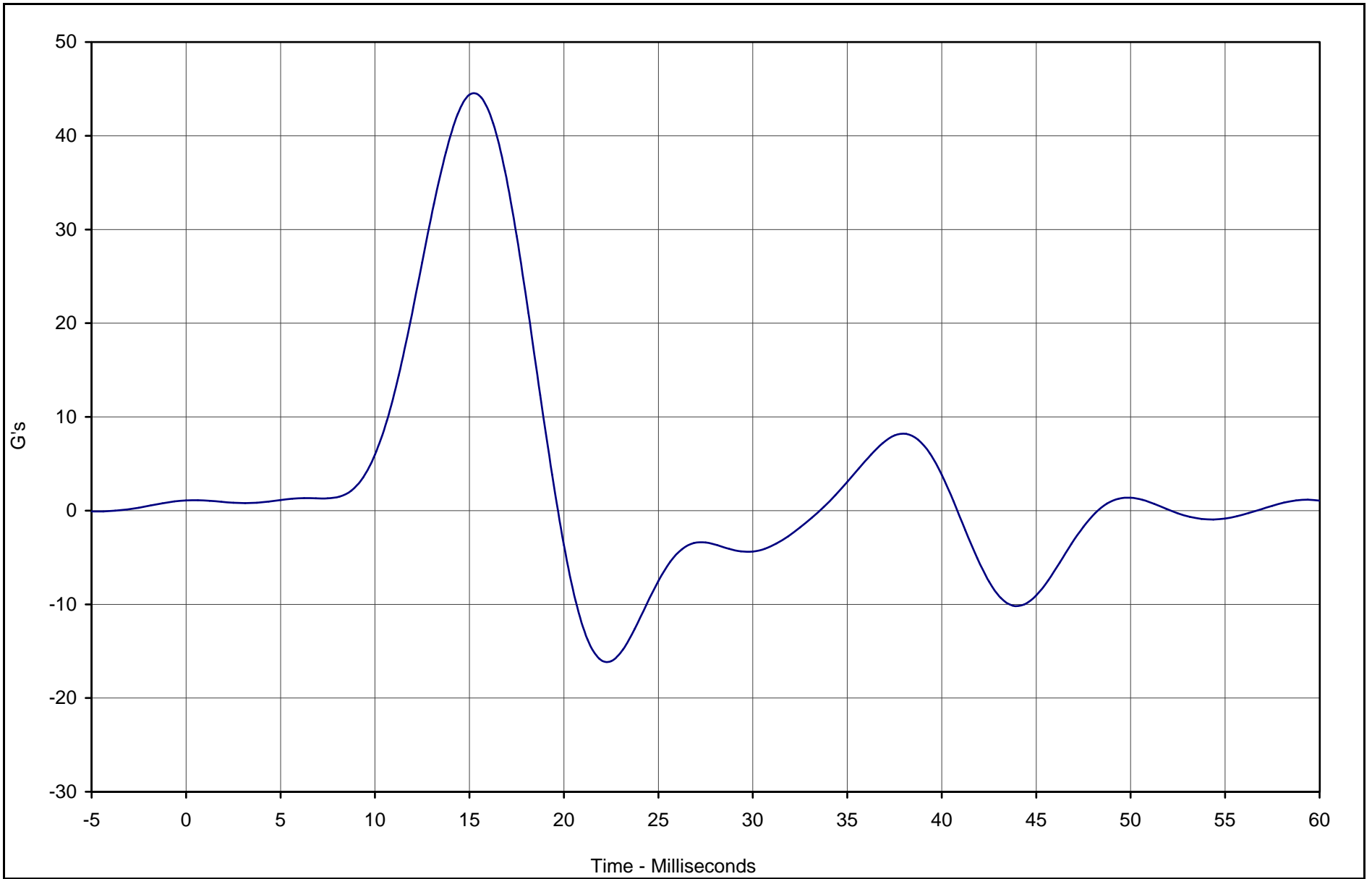

TR-P23003-05-NC

Curve Description	CURNO	Type	Units	Max	Time	Min	Time	SAE Class
Upper Rib Y Acceleration	001	FIL	G's	44.4	15.0	-16.1	22.5	FIR100



Test Vehicle: SID / HIII Thorax Lateral Impact

SID Serial No.: 274

Test Date: 2/21/03

Test I.D.: TH03A

C-4

TR-P23003-05-NC

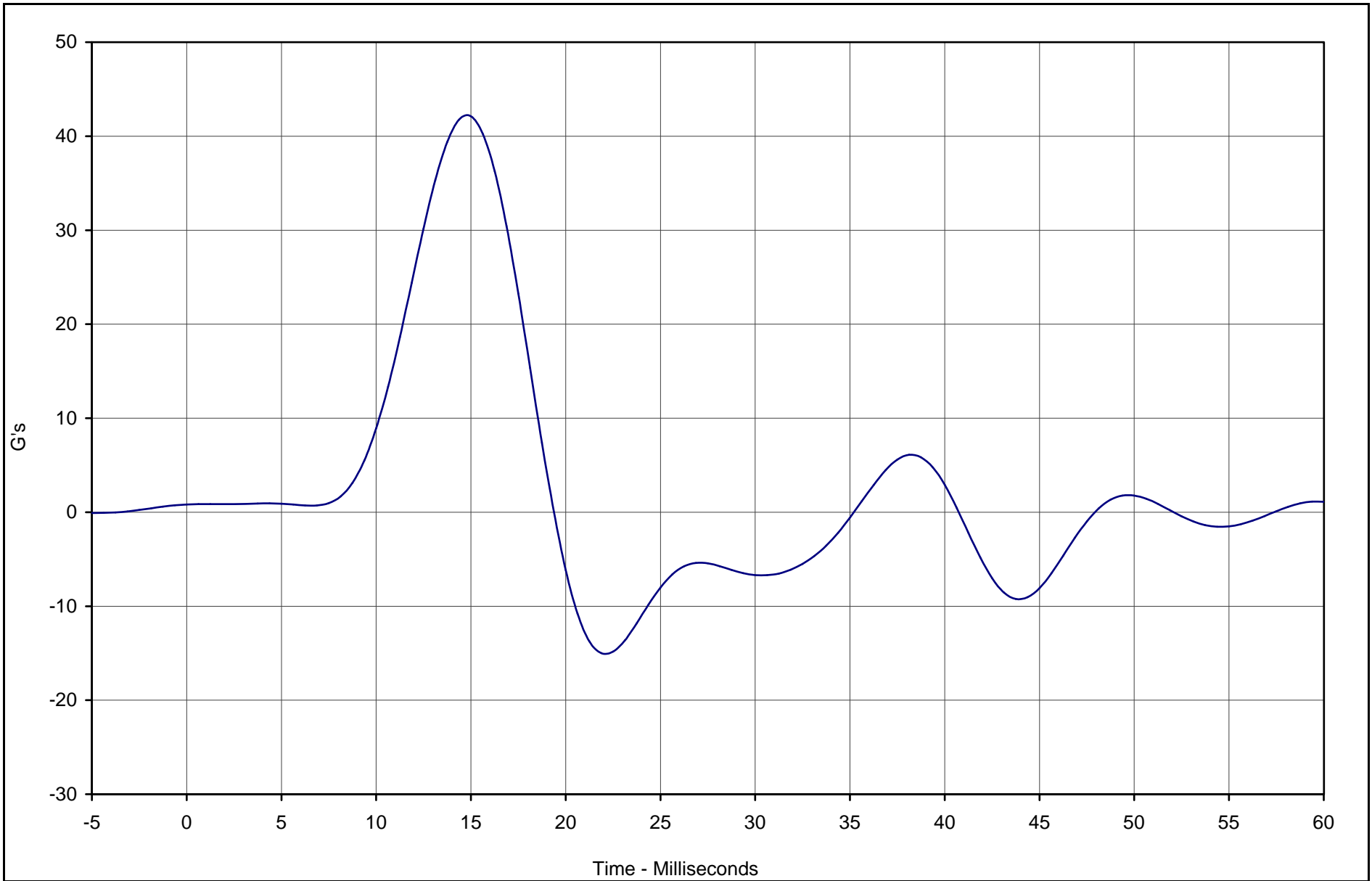

Curve Description	CURNO	Type	Units	Max	Time	Min	Time	SAE Class
Lower Rib Y Acceleration	002	FIL	G's	42.1	15.0	-15.0	21.9	FIR100



Test Vehicle: SID / HIII Thorax Lateral Impact

SID Serial No.: 274

Test Date: 2/21/03

Test I.D.: TH03A

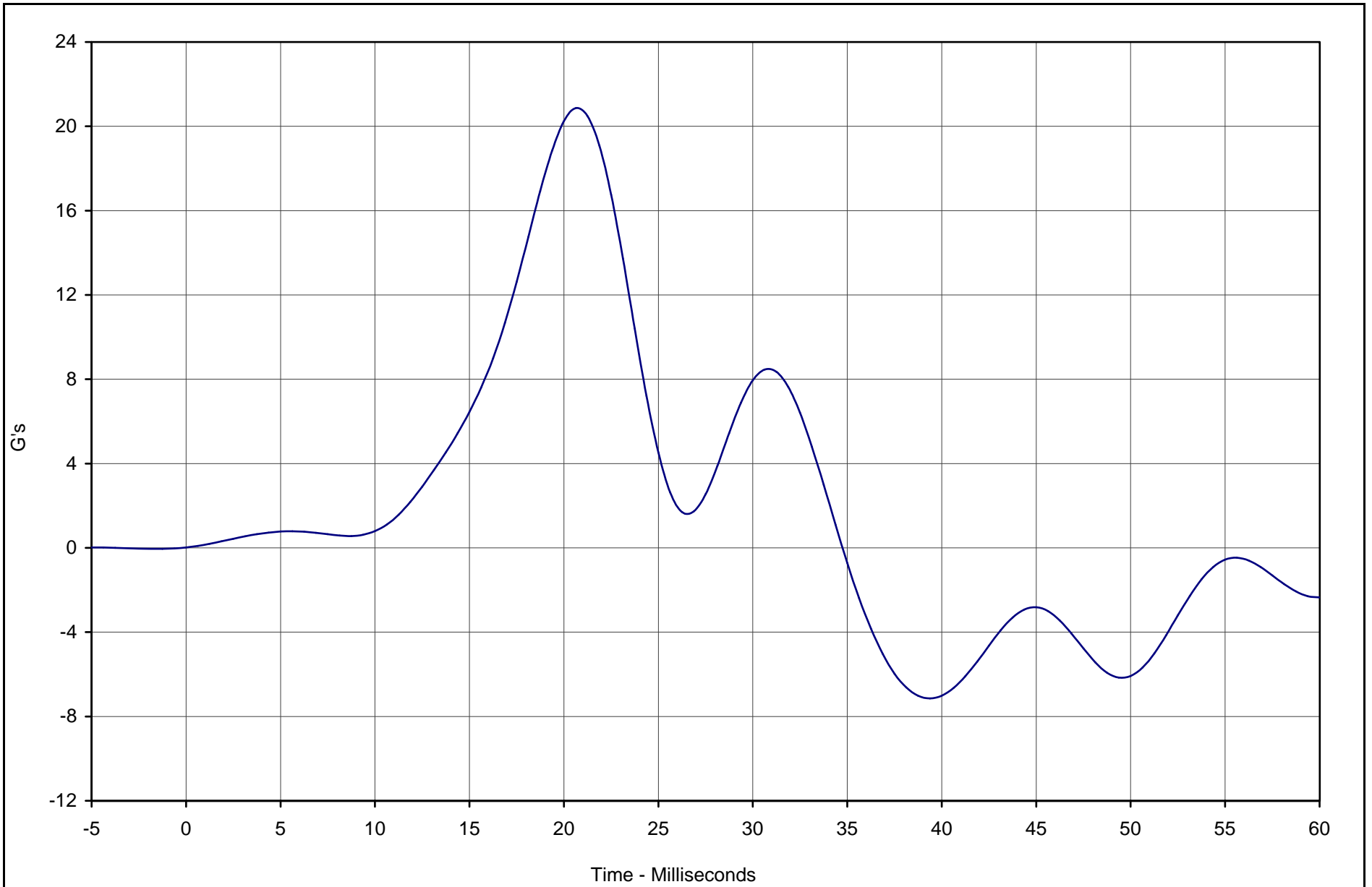

Curve Description	CURNO	Type	Units	Max	Time	Min	Time	SAE Class
Lower Spine Y Acceleration	003	FIL	G's	20.9	20.6	-7.1	39.4	FIR100



Test Vehicle: SID / HIII Thorax Lateral Impact

SID Serial No.: 274

Test Date: 2/21/03

Test I.D.: TH03A



Calibration Data Sheet Side Impact Hybrid Dummy (SID/HIII) Pelvis Lateral Impact

ATD Serial No.: 274

Test I.D.: PI03A

Tested Parameter	Units	Specification	Result	Pass/Fail
Laboratory Temperature	°C	18.9 to 25.6	21.1	Pass
Laboratory Relative Humidity	%	10 to 70	30	Pass
Probe Velocity	m/s	4.21 to 4.33	4.28	Pass
Peak Pelvis Acceleration	G's	40.0 to 60.0	49.5	Pass
Acceleration Time Above 20 G's	Msec.	3.0 to 7.0	6.3	Pass
Overall Test Results				Pass

C-6

TR-P23003-05-NC

Laboratory Technician

March 21, 2003

Test Date

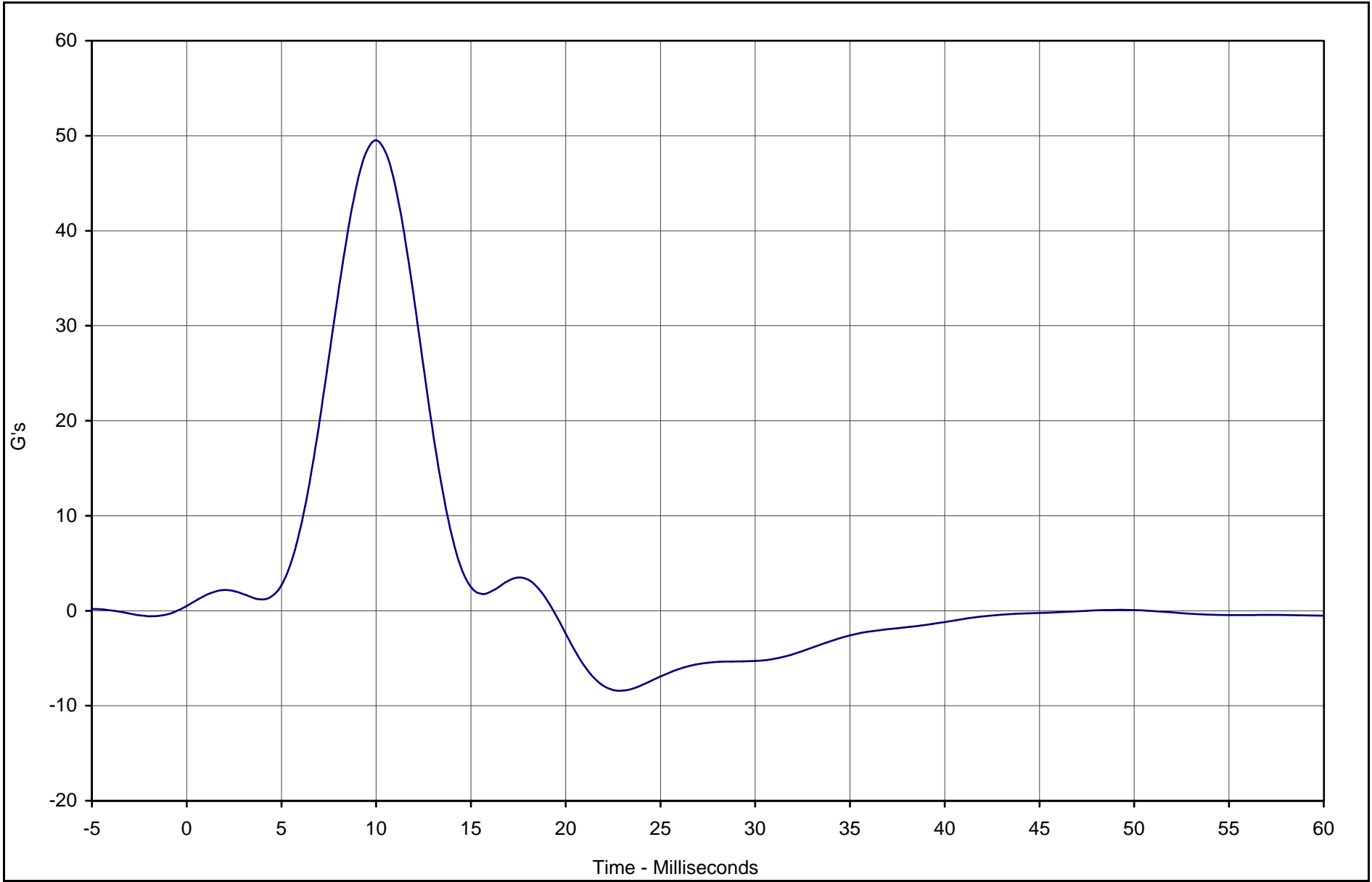

Curve Description	CURNO	Type	Units	Max	Time	Min	Time	SAE Class
Pelvis Y Acceleration	001	FIL	G's	49.53471	10	-8.389118	23.125	FIR100



Test Vehicle: Side Impact Dummy (SID) Pelvis Lateral Impact

SID Serial No.: 274

Test Date: 37701

Test I.D.: PI03A



Calibration Data Sheet Side Impact Hybrid Dummy (SID/HIII) Head Drop Lateral Impact Test

ATD Serial No.: 274

Test I.D.: HD01A

Tested Parameter	Units	Specification	Result	Pass/Fail
Laboratory Temperature	°C	18.9 to 25.6	21.1	Pass
Laboratory Relative Humidity	%	10 to 70	30	Pass
Peak Resultant Acceleration	G's	120.0 to 150.0	124.1	Pass
Peak Longitudinal Acceleration	G's	≤15.0	4.9	Pass
Is Acceleration Unimodal?	Yes/No	Yes	Yes	Pass
Oscillations After Main Pulse	%	<10	4.7	Pass
Overall Test Results				Pass

C-8

TR-P23003-05-NC

Laboratory Technician

March 21, 2003

Test Date

C-9

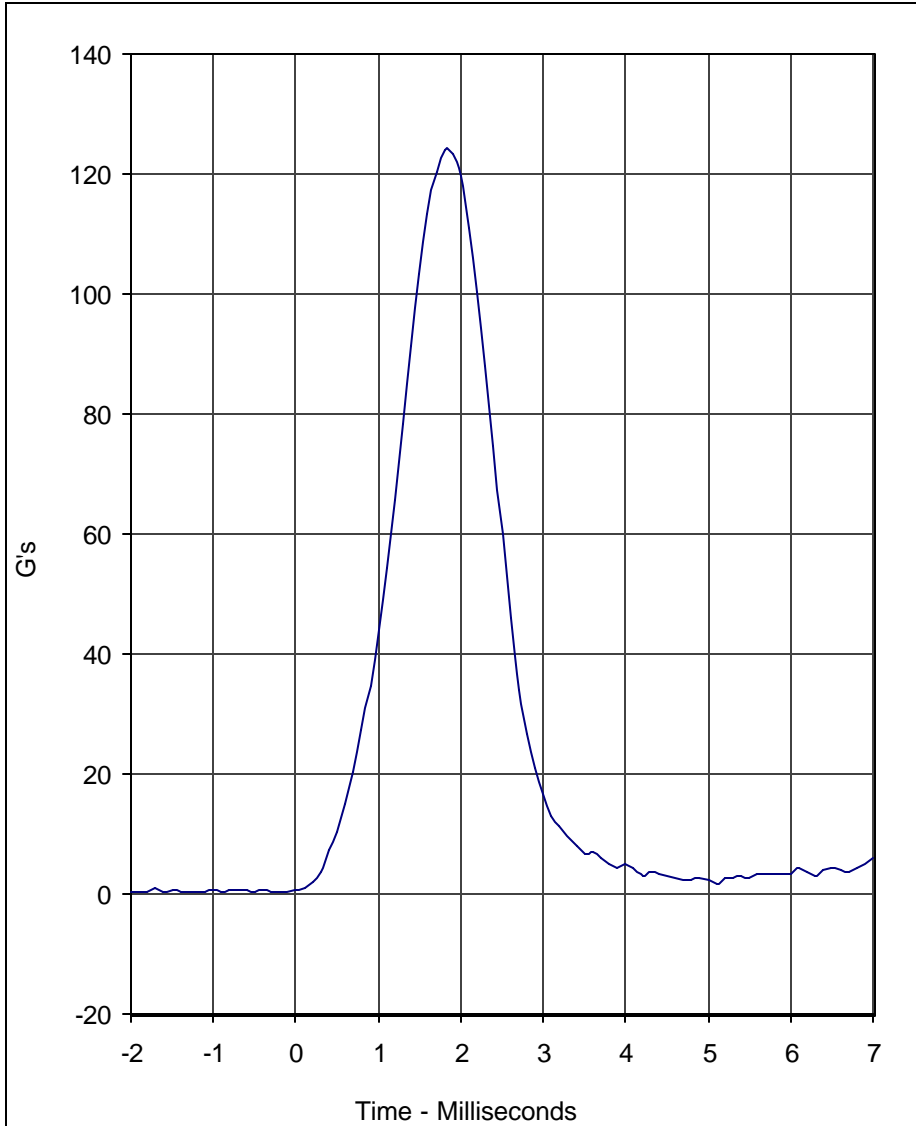

Curve Description	CURNO	Type
Head Resultant	001	RES

Units	Max	Time	Min	Time	SAE Class
G's	124.1	1.8	0.2	-0.3	1000

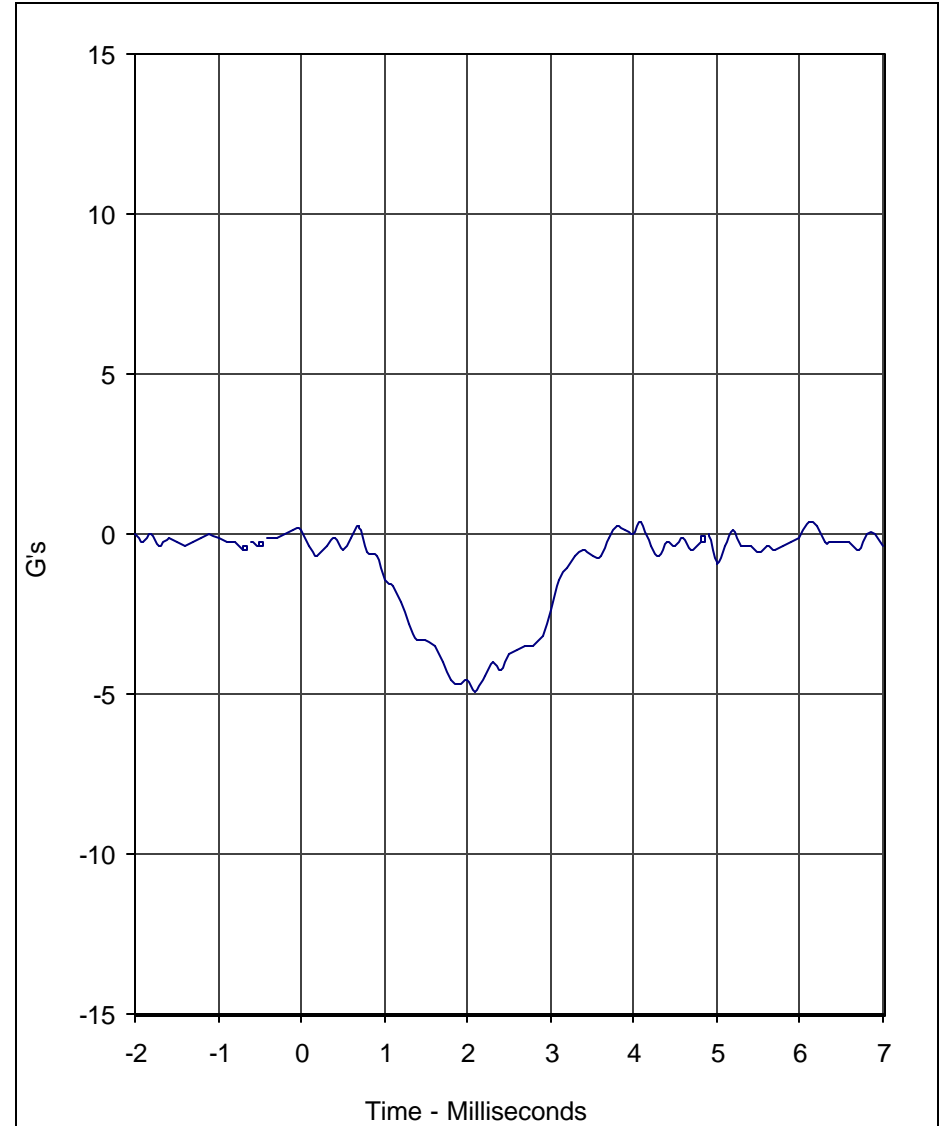

Curve Description	CURNO	Type
Head Y	002	FIL

Units	Max	Time	Min	Time	SAE Class
G's	0.4	4.1	-4.9	2.1	1000

Test Program: SID / HIII Head Drop Lateral Impact Test
 Test Date: 3/21/03

A.T.D. Serial No.: 274
 Test I.D.: HD01A



TR-P23003-05-NC



Calibration Data Sheet Side Impact Hybrid Dummy (SID/HIII) Neck Pendulum Lateral Test

ATD Serial No.: 274

Test I.D.: NB04A

Tested Parameter		Units	Specification	Result	Pass/Fail
Laboratory Temperature		°C	20.6 to 22.2	21.1	Pass
Laboratory Relative Humidity		%	10 to 70	30	Pass
Pendulum Velocity		m/s	6.89 to 7.13	7.11	Pass
Pendulum Deceleration	10	Msec.	1.96 to 2.55	2.18	Pass
	20	Msec.	4.12 to 5.10	4.46	Pass
	30	Msec.	5.73 to 7.01	6.43	Pass
	40 to 70	Msec.	6.27 to 7.64	6.69	Pass
Maximum "D" Plane Rotation		Degrees	66.0 to 82.0	69.8	Pass
Maximum "D" Plane Rotation Time After Peak Moment		Msec.	2.0 to 15.0	14.8	Pass
"D" Plane Rotation Decay Time From Peak Angle to Zero Angle		Msec.	58.0 to 67.0	63.2	Pass
Calculated Moment About Occipital Condyle		N•m	73.0 to 88.0	75.5	Pass
Moment About Occipital Condyle Decay, Time From Positive Peak Value To 0 N•m		Msec.	49.0 to 64.0	50.4	Pass
Overall Test Results					Pass

Laboratory Technician

February 22, 2003

Test Date

C-10

TR-P23003-05-NC

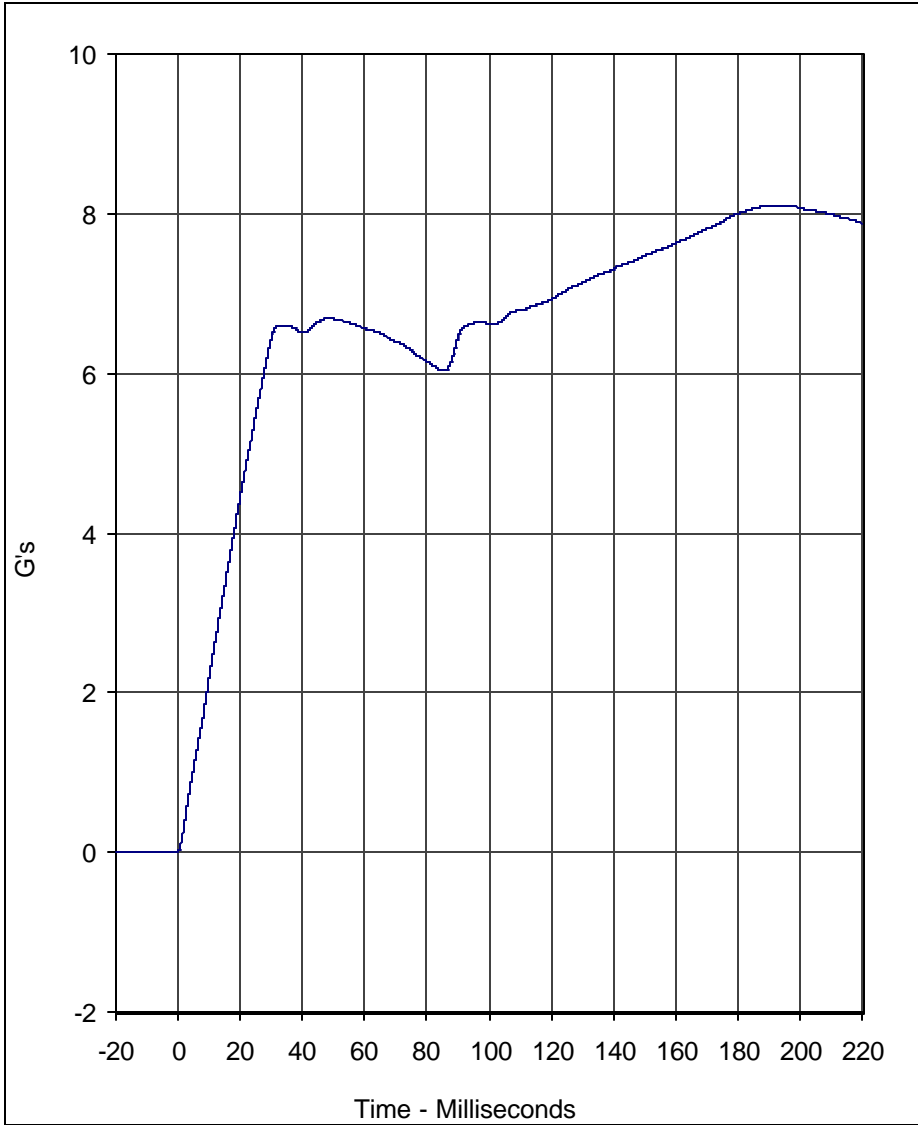

Curve Description	CURNO	Type
Pendulum Velocity	001	FIL

Units	Max	Time	Min	Time	SAE Class
G's	8.1	194.4	0.0	-0.7	180

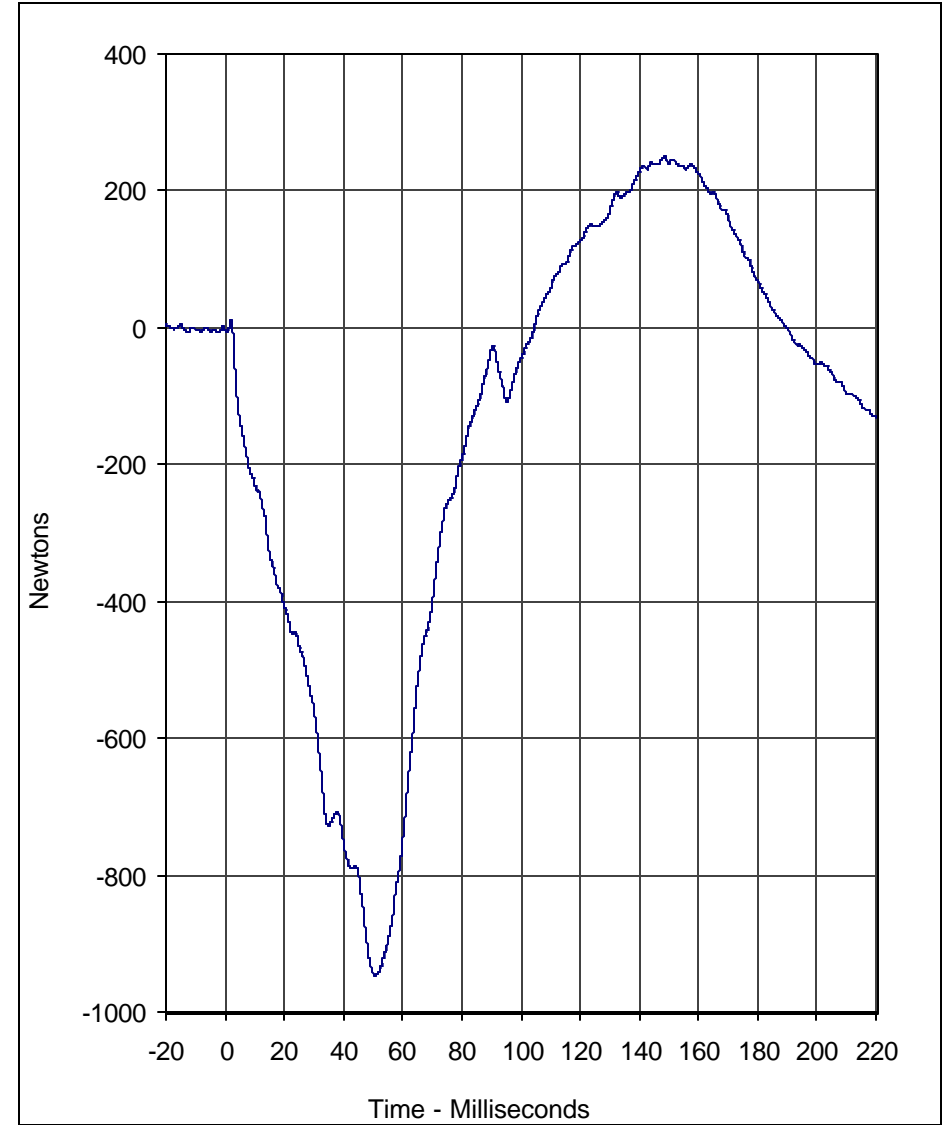

Curve Description	CURNO	Type
Neck Force Y	002	FIL

Units	Max	Time	Min	Time	SAE Class
Newtons	250.3	148.4	-946.9	50.7	180

Test Program: SID / HIII Neck Pendulum Lateral Test
 Test Date: 2/22/03

A.T.D. Serial No.: 274
 Test I.D.: NB04A



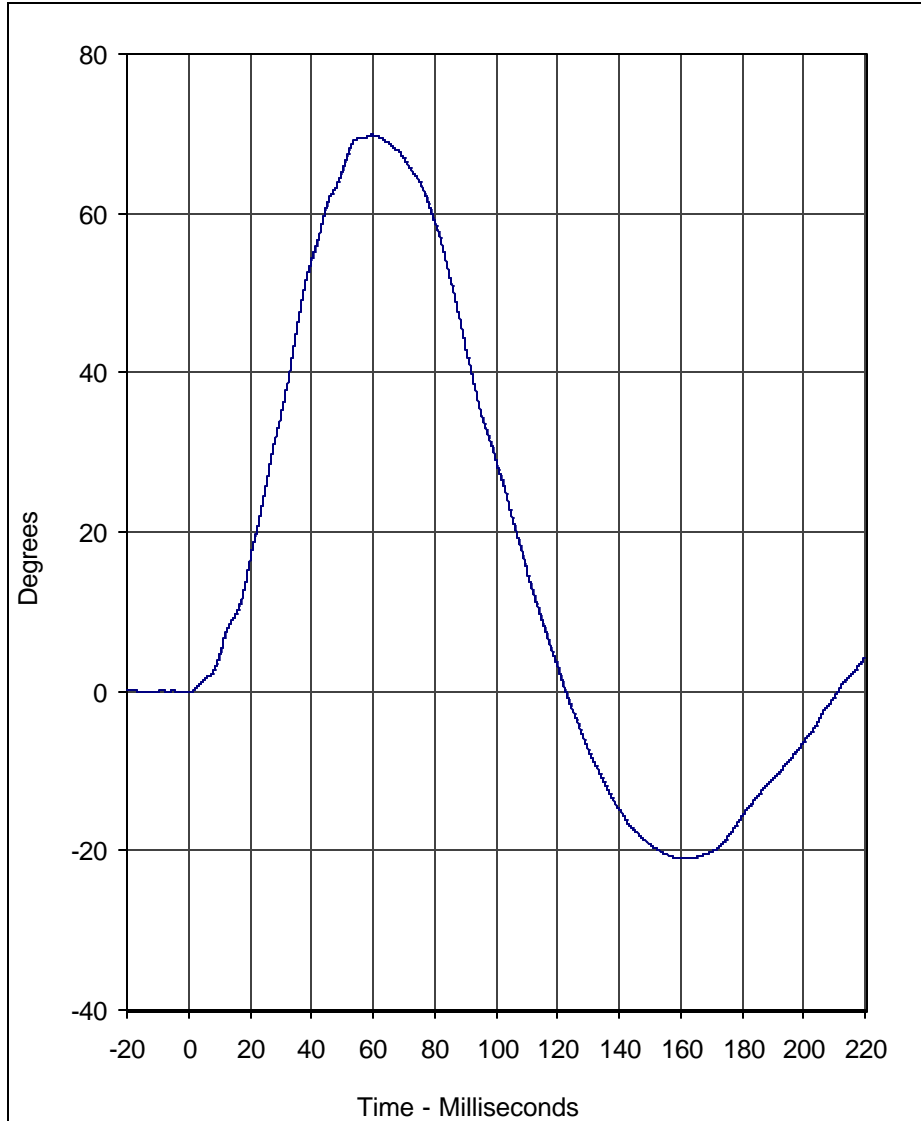

Curve Description	CURNO	Type
"D" Plane Rotation	003	FIL

Units	Max	Time	Min	Time	SAE Class
Degrees	69.8	59.5	-21.0	160.1	180

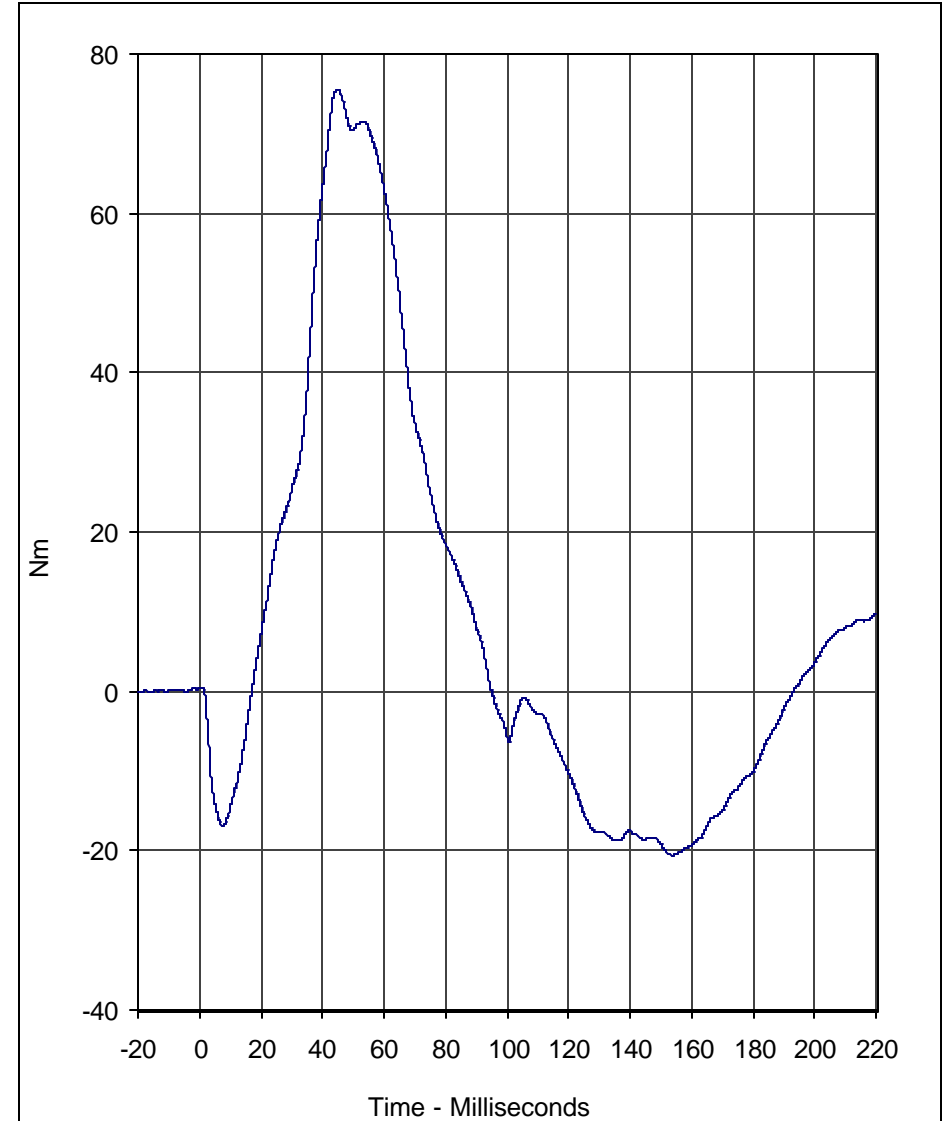

Curve Description	CURNO	Type
Moment About Occipital Condyle	004	FIL

Units	Max	Time	Min	Time	SAE Class
Nm	75.5	44.7	-20.6	153.7	180

Test Program: SID / HIII Neck Pendulum Lateral Test
 Test Date: 2/22/03

A.T.D. Serial No.: 274
 Test I.D.: NB04A





Calibration Data Sheet Side Impact Hybrid Dummy (SID/HIII) External Measurements

ATD Serial No.: 275

Tested Parameter	Units	Specification	Result	Pass/Fail
Laboratory Temperature	°C	18.9 to 25.6	21.1	Pass
Laboratory Relative Humidity	%	10 to 70	30	Pass
SH- Seated Height	mm	889 to 909	900	Pass
HP- Hip Point Height	mm	99 (reference)	99	Pass
RH- Rib Height	mm	502 to 520	505	Pass
KH- Knee Pivot From Back Line	mm	511 to 526	525	Pass
KV- Knee Pivot From Floor	mm	490 to 505	500	Pass
HW- Hip Width	mm	356 to 391	385	Pass
Overall Test Results				Pass

C-13

TR-P23003-05-NC

Laboratory Technician

February 22, 2003

Test Date



Calibration Data Sheet Side Impact Hybrid Dummy (SID/HIII) Thorax Lateral Impact

ATD Serial No.: 275

Test I.D.: TH03B

Tested Parameter	Units	Specification	Result	Pass/Fail
Laboratory Temperature	°C	18.9 to 25.6	21.1	Pass
Laboratory Relative Humidity	%	10 to 70	30	Pass
Probe Velocity	m/s	4.21 to 4.33	4.24	Pass
Upper Rib Acceleration	G's	37.0 to 46.0	45.4	Pass
Lower Rib Acceleration	G's	37.0 to 46.0	42.4	Pass
Thoracic Spine Acceleration	G's	15.0 to 22.0	22.0	Pass
Overall Test Results				Pass

C-14

TR-P23003-05-NC

Laboratory Technician

February 21, 2003

Test Date

C-15

TR-P23003-05-NC

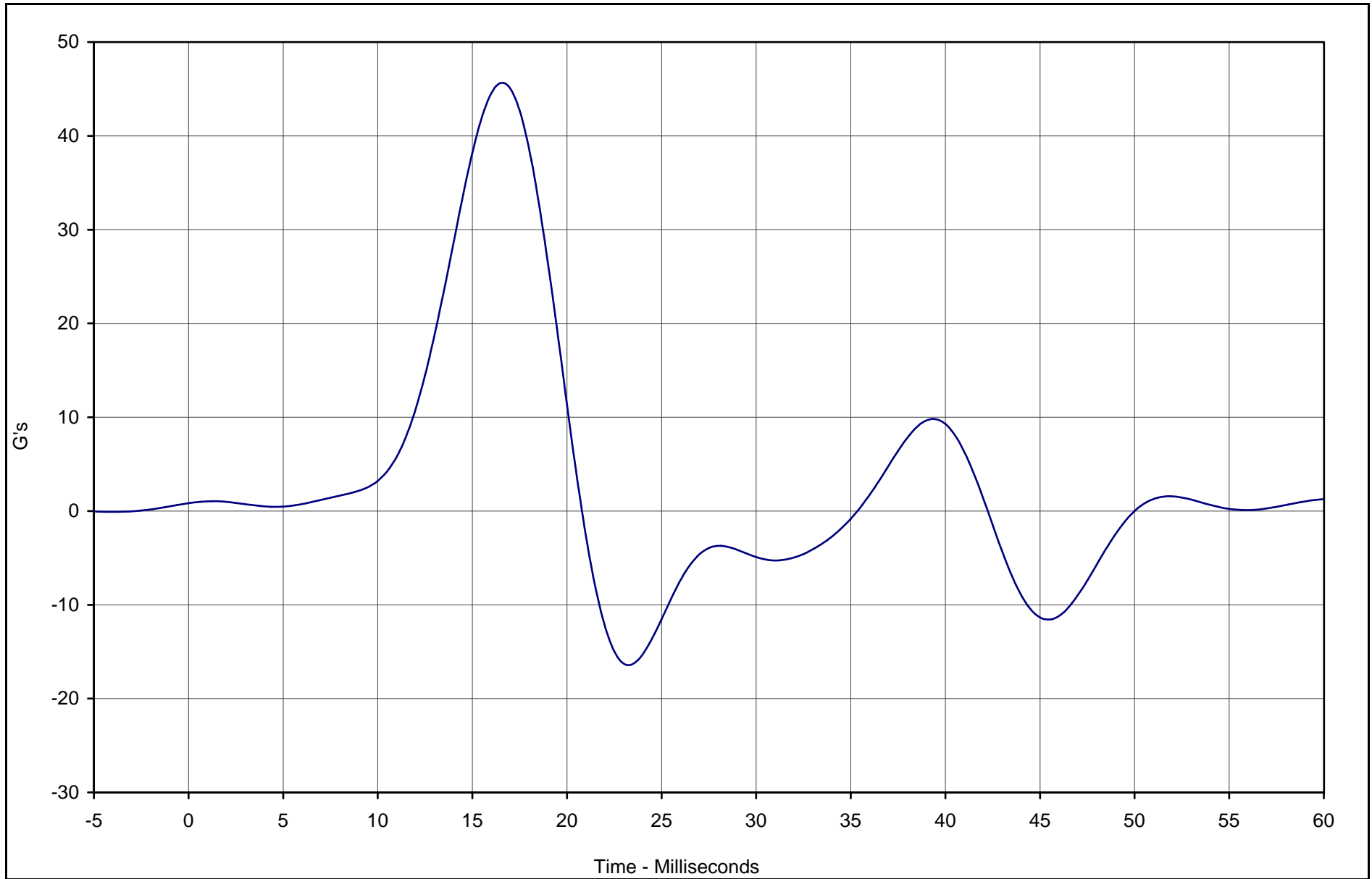

Curve Description	CURNO	Type	Units	Max	Time	Min	Time	SAE Class
Upper Rib Y Acceleration	001	FIL	G's	45.4	16.9	-16.4	23.1	FIR100



Test Vehicle: SID / HIII Thorax Lateral Impact

SID Serial No.: 275

Test Date: 2/21/03

Test I.D.: TH03B

C-16

TR-P23003-05-NC

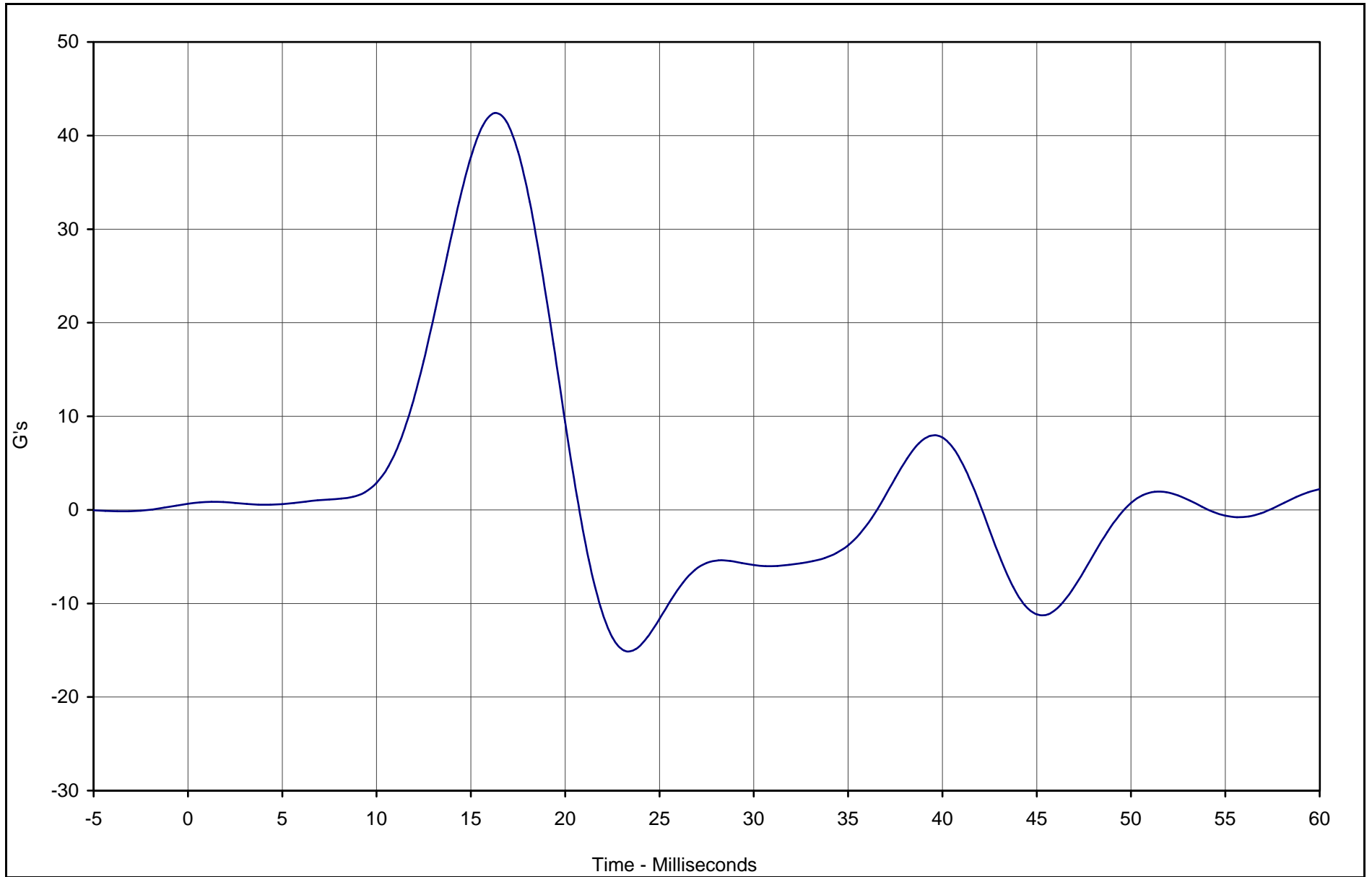

Curve Description	CURNO	Type	Units	Max	Time	Min	Time	SAE Class
Lower Rib Y Acceleration	002	FIL	G's	42.4	16.3	-15.0	23.1	FIR100



Test Vehicle: SID / HIII Thorax Lateral Impact

SID Serial No.: 275

Test Date: 2/21/03

Test I.D.: TH03B

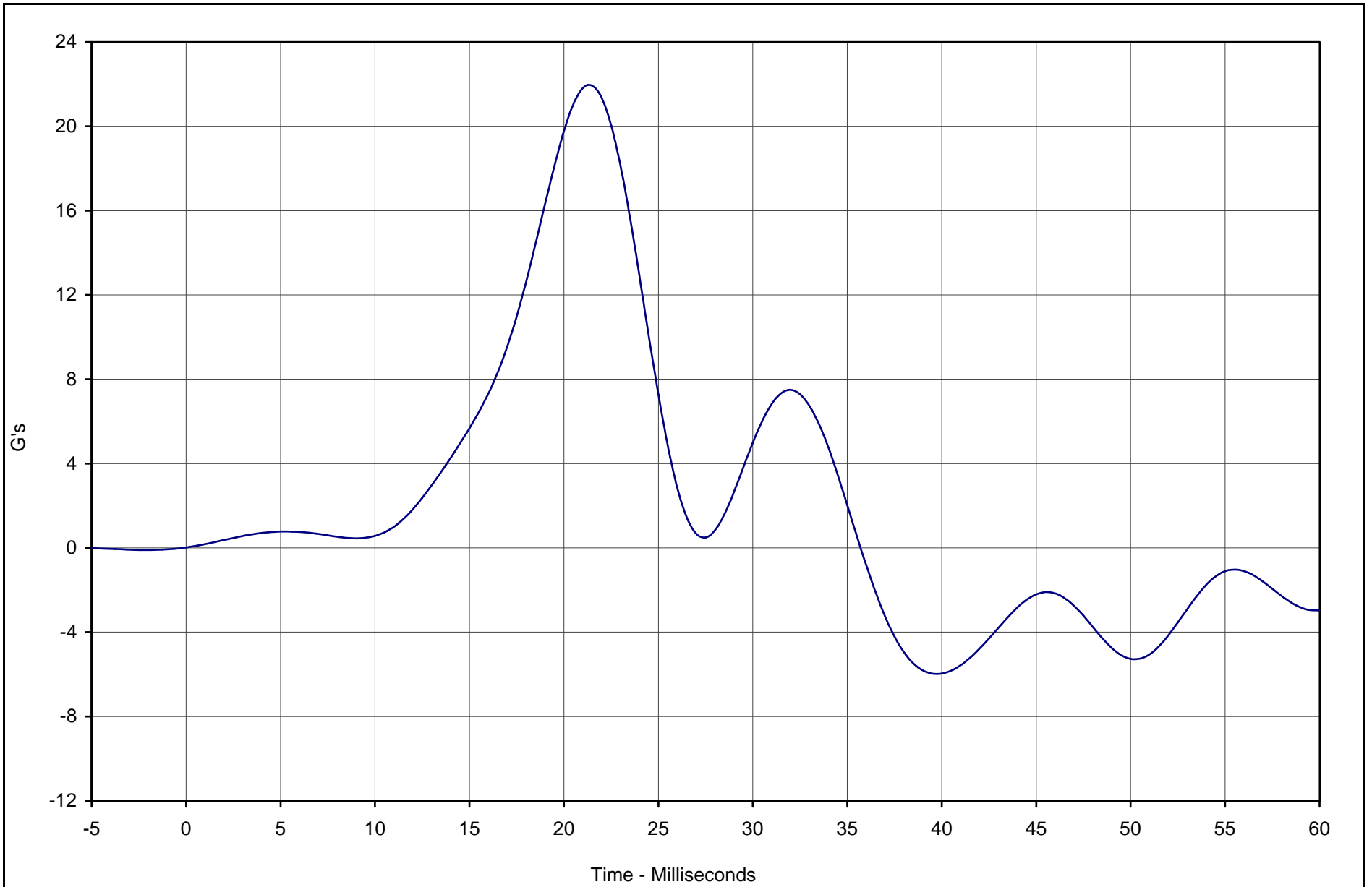

Curve Description	CURNO	Type	Units	Max	Time	Min	Time	SAE Class
Lower Spine Y Acceleration	003	FIL	G's	22.0	21.3	-6.0	40.0	FIR100



Test Vehicle: SID / HIII Thorax Lateral Impact

SID Serial No.: 275

Test Date: 2/21/03

Test I.D.: TH03B



Calibration Data Sheet Side Impact Hybrid Dummy (SID/HIII) Pelvis Lateral Impact

ATD Serial No.: 275

Test I.D.: PI03B

Tested Parameter	Units	Specification	Result	Pass/Fail
Laboratory Temperature	°C	18.9 to 25.6	21.1	Pass
Laboratory Relative Humidity	%	10 to 70	30	Pass
Probe Velocity	m/s	4.21 to 4.33	4.28	Pass
Peak Pelvis Acceleration	G's	40.0 to 60.0	41.9	Pass
Acceleration Time Above 20 G's	Msec.	3.0 to 7.0	6.9	Pass
Overall Test Results				Pass

C-18

TR-P23003-05-NC

Laboratory Technician

March 21, 2003

Test Date

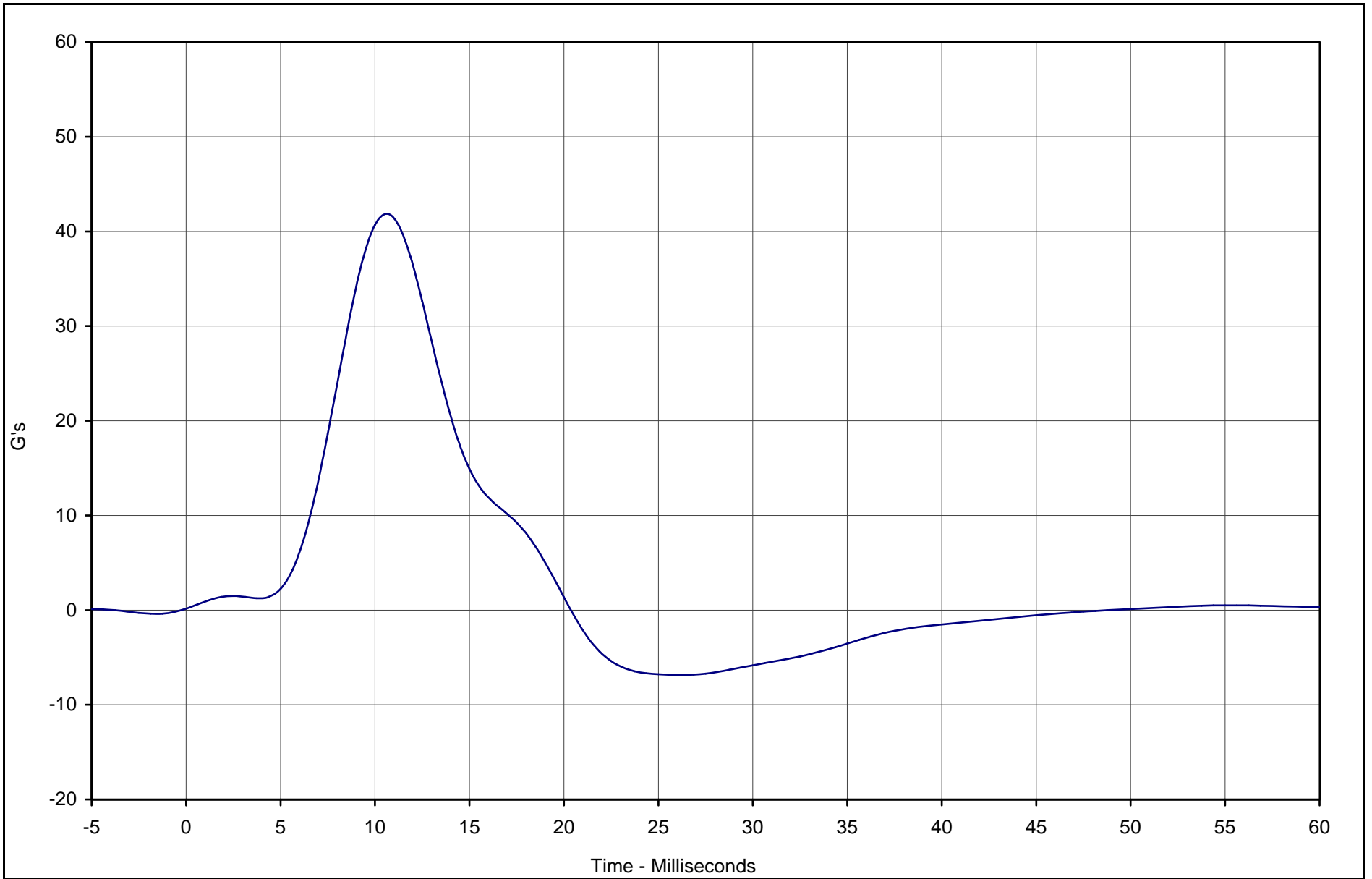

Curve Description	CURNO	Type	Units	Max	Time	Min	Time	SAE Class
Pelvis Y Acceleration	001	FIL	G's	41.86577	10.625	-6.858183	26.25	FIR100



Test Vehicle: Side Impact Dummy (SID) Pelvis Lateral Impact

SID Serial No.: 275

Test Date: 37701

Test I.D.: PI03B



Calibration Data Sheet Side Impact Hybrid Dummy (SID/HIII) Head Drop Lateral Impact Test

ATD Serial No.: 275

Test I.D.: HD01B

Tested Parameter	Units	Specification	Result	Pass/Fail
Laboratory Temperature	°C	18.9 to 25.6	21.1	Pass
Laboratory Relative Humidity	%	10 to 70	30	Pass
Peak Resultant Acceleration	G's	120.0 to 150.0	131.8	Pass
Peak Longitudinal Acceleration	G's	≤15.0	3.3	Pass
Is Acceleration Unimodal?	Yes/No	Yes	Yes	Pass
Oscillations After Main Pulse	%	<10	4.0	Pass
Overall Test Results				Pass

C-20

TR-P23003-05-NC

Laboratory Technician

March 21, 2003

Test Date

C-21

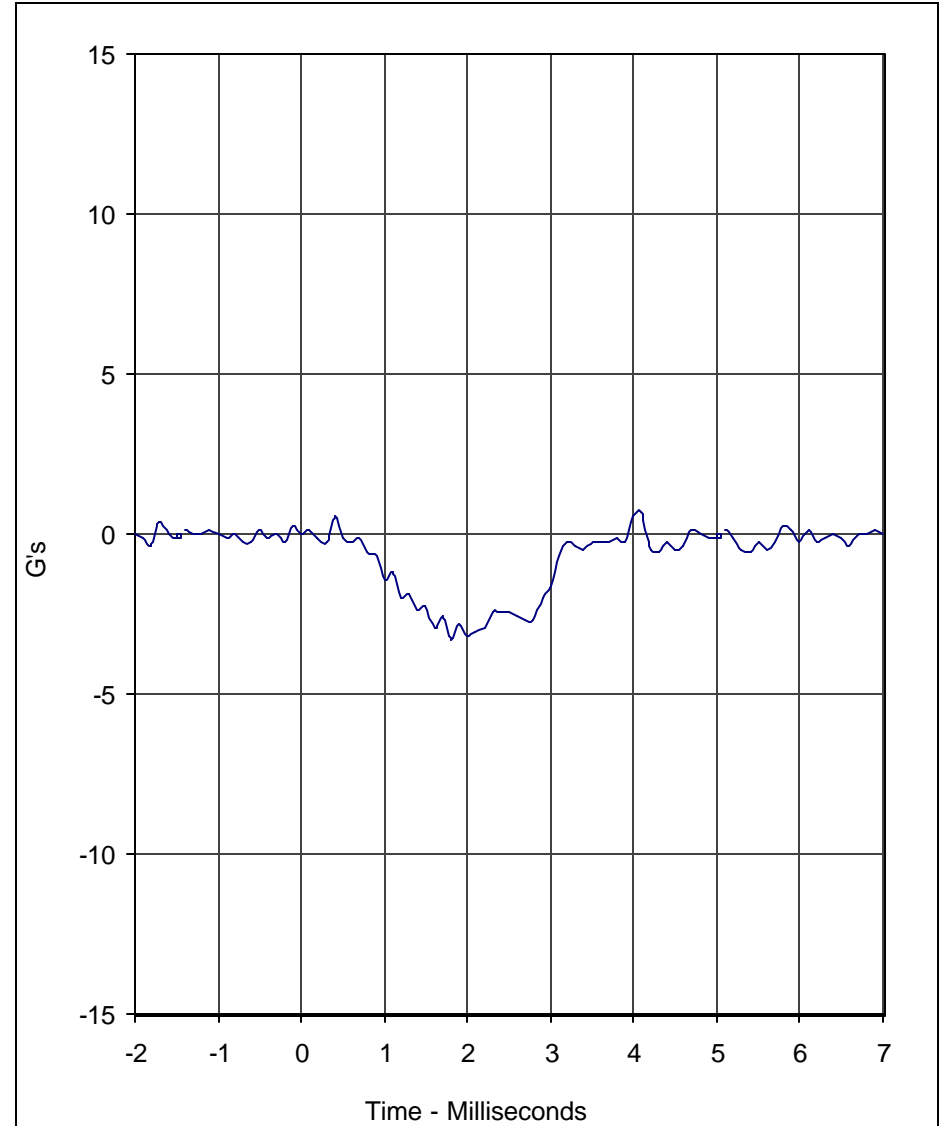
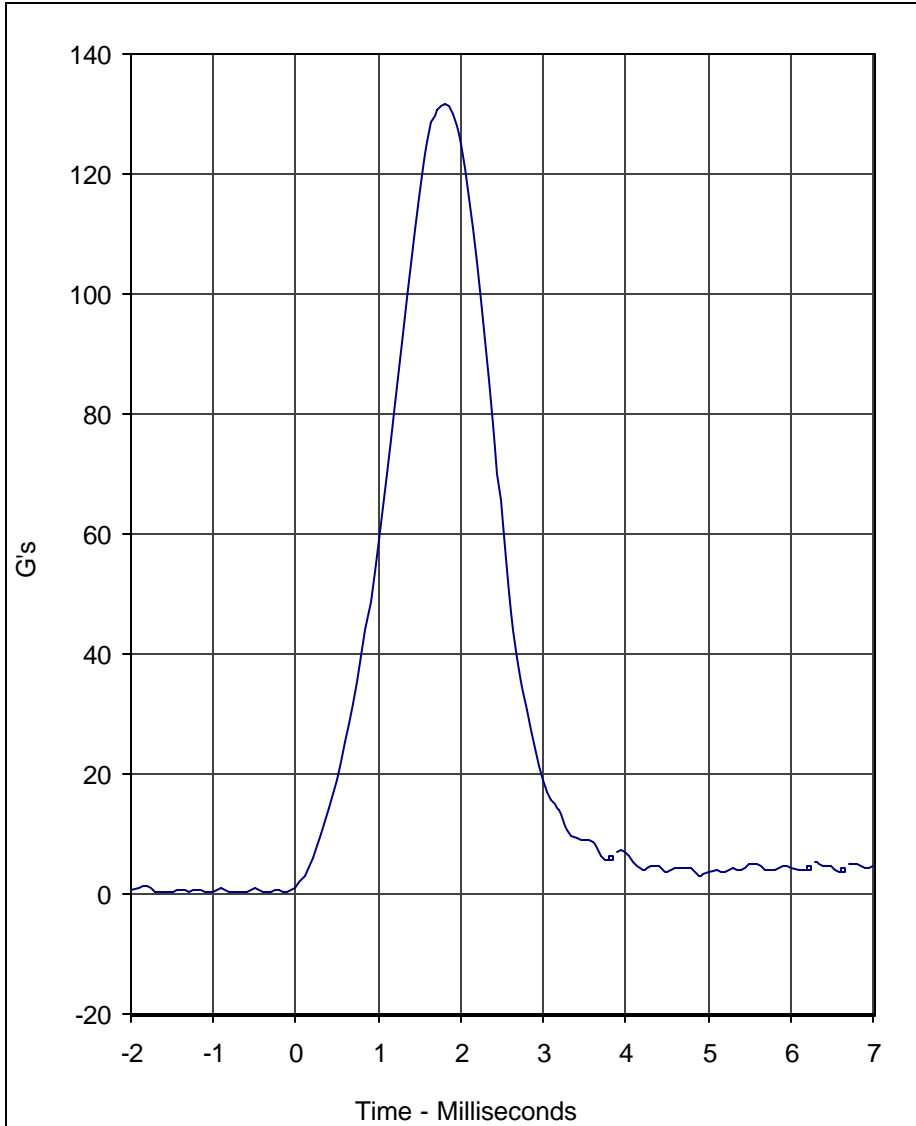

Curve Description	CURNO	Type
Head Resultant	001	RES

Curve Description	CURNO	Type
Head Y	002	FIL

Units	Max	Time	Min	Time	SAE Class
G's	131.8	1.8	0.3	-1.1	1000

Units	Max	Time	Min	Time	SAE Class
G's	0.7	4.1	-3.3	1.8	1000

Test Program: SID / HIII Head Drop Lateral Impact Test
 Test Date: 3/21/03

A.T.D. Serial No.: 275
 Test I.D.: HD01B



TR-P23003-05-NC



Calibration Data Sheet Side Impact Hybrid Dummy (SID/HIII) Neck Pendulum Lateral Test

ATD Serial No.: 275

Test I.D.: NB05G

Tested Parameter		Units	Specification	Result	Pass/Fail
Laboratory Temperature		°C	20.6 to 22.2	21.1	Pass
Laboratory Relative Humidity		%	10 to 70	30	Pass
Pendulum Velocity		m/s	6.89 to 7.13	7.01	Pass
Pendulum Deceleration	10	Msec.	1.96 to 2.55	2.46	Pass
	20	Msec.	4.12 to 5.10	4.98	Pass
	30	Msec.	5.73 to 7.01	6.82	Pass
	40 to 70	Msec.	6.27 to 7.64	6.87	Pass
Maximum "D" Plane Rotation		Degrees	66.0 to 82.0	73.5	Pass
Maximum "D" Plane Rotation Time After Peak Moment		Msec.	2.0 to 15.0	13.3	Pass
"D" Plane Rotation Decay Time From Peak Angle to Zero Angle		Msec.	58.0 to 67.0	62.4	Pass
Calculated Moment About Occipital Condyle		N•m	73.0 to 88.0	76.9	Pass
Moment About Occipital Condyle Decay, Time From Positive Peak Value To 0 N•m		Msec.	49.0 to 64.0	49.1	Pass
Overall Test Results					Pass

Laboratory Technician

February 22, 2003

Test Date

C-22

TR-P23003-05-NC

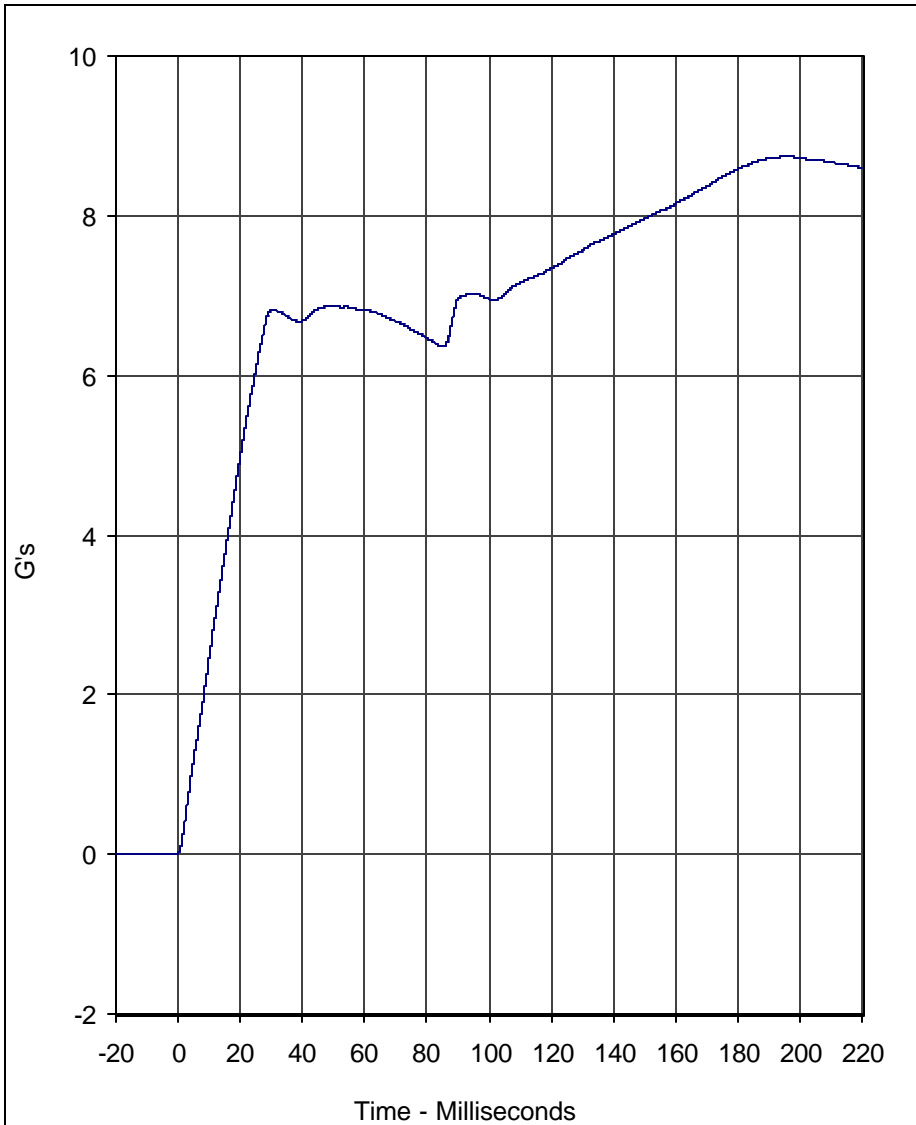

Curve Description	CURNO	Type
Pendulum Velocity	001	FIL

Units	Max	Time	Min	Time	SAE Class
G's	8.7	196.0	0.0	-0.5	180

Test Program: SID / HIII Neck Pendulum Lateral Test
 Test Date: 2/22/03

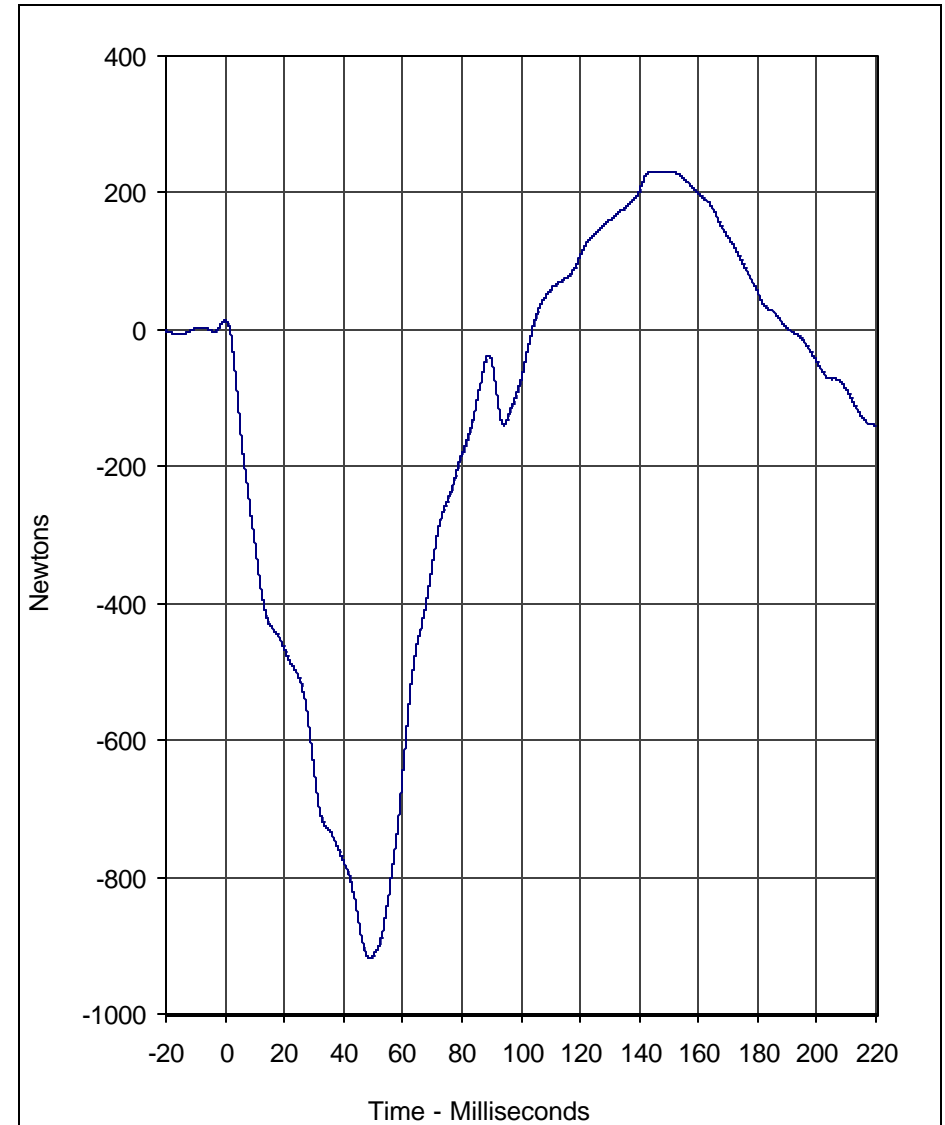

Curve Description	CURNO	Type
Neck Force Y	002	FIL

Units	Max	Time	Min	Time	SAE Class
Newtons	231.8	144.3	-917.5	48.9	60

A.T.D. Serial No.: 275
 Test I.D.: NB05G



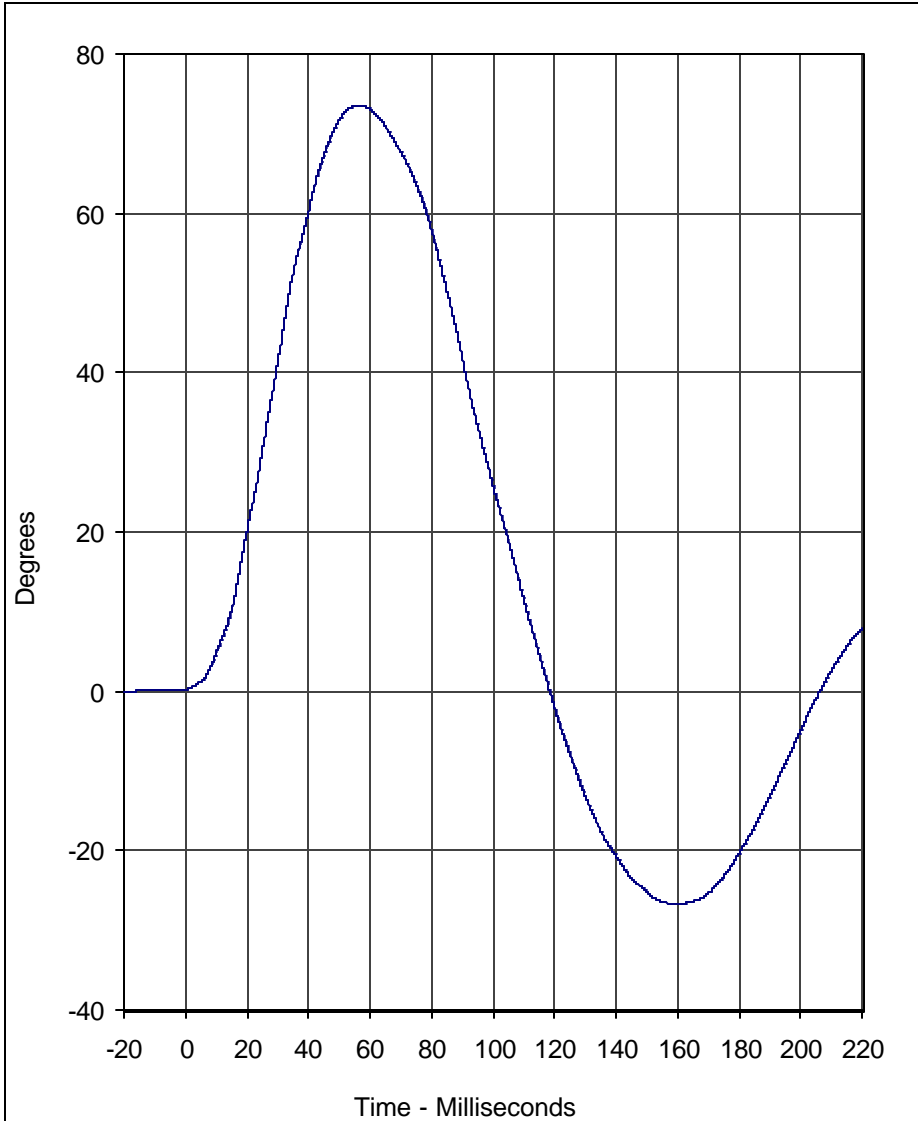

Curve Description	CURNO	Type
"D" Plane Rotation	003	FIL

Units	Max	Time	Min	Time	SAE Class
Degrees	73.5	56.2	-26.7	159.4	60

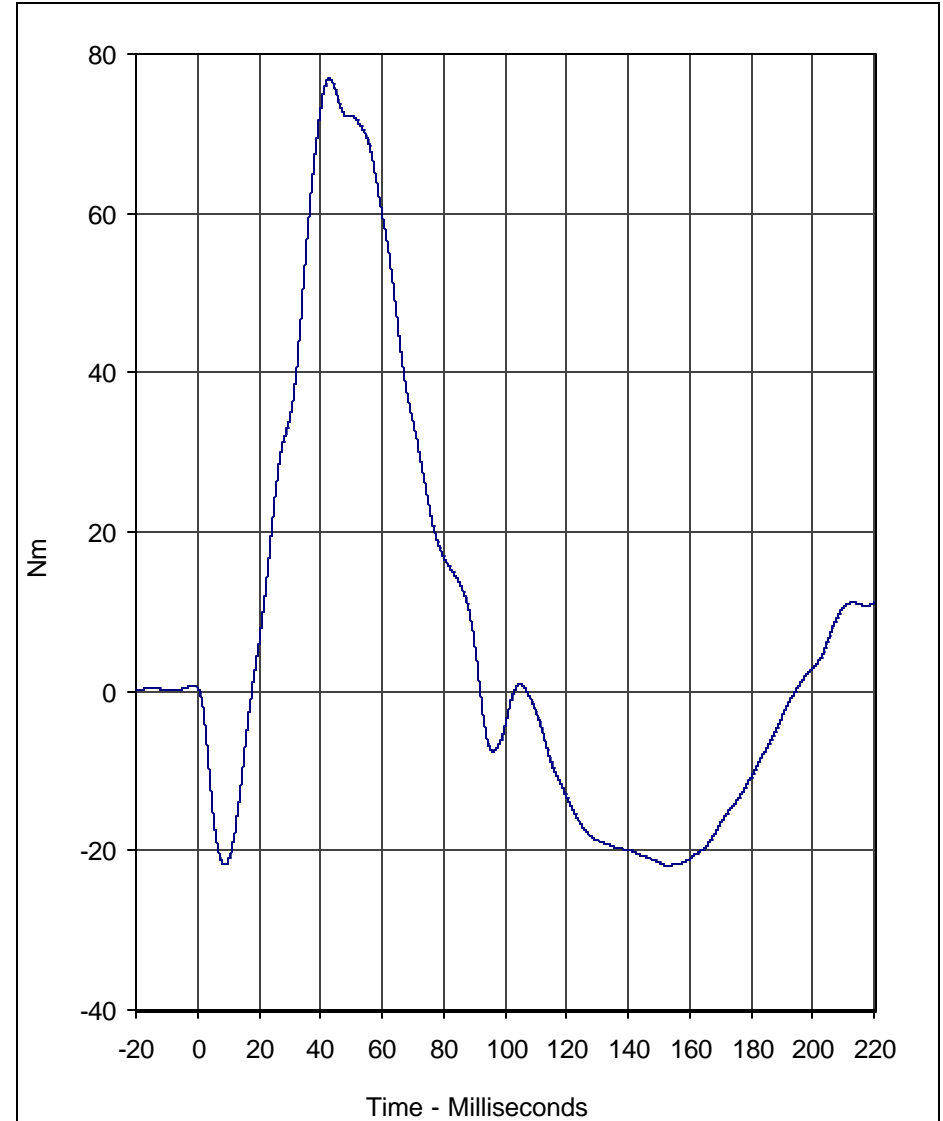

Curve Description	CURNO	Type
Moment About Occipital Condyle	004	FIL

Units	Max	Time	Min	Time	SAE Class
Nm	76.9	42.9	-21.9	153.0	60

Test Program: SID / HIII Neck Pendulum Lateral Test
 Test Date: 2/22/03

A.T.D. Serial No.: 275
 Test I.D.: NB05G



APPENDIX C
POST-TEST SID / HIII CONFIGURATION AND PERFORMANCE VERIFICATION DATA



Calibration Data Sheet Side Impact Hybrid Dummy (SID/HIII) External Measurements

ATD Serial No.: 274

Tested Parameter	Units	Specification	Result	Pass/Fail
Laboratory Temperature	°C	18.9 to 25.6	21.1	Pass
Laboratory Relative Humidity	%	10 to 70	30	Pass
SH- Seated Height	mm	889 to 909	905	Pass
HP- Hip Point Height	mm	99 (reference)	99	Pass
RH- Rib Height	mm	502 to 520	520	Pass
KH- Knee Pivot From Back Line	mm	511 to 526	515	Pass
KV- Knee Pivot From Floor	mm	490 to 505	495	Pass
HW- Hip Width	mm	356 to 391	385	Pass
Overall Test Results				Pass

C-25

TR-P23003-05-NC

Laboratory Technician

March 8, 2003
Test Date



Calibration Data Sheet

Side Impact Hybrid Dummy (SID/HIII)

Thorax Lateral Impact

ATD Serial No.: 274

Test I.D.: TH03C

Tested Parameter	Units	Specification	Result	Pass/Fail
Laboratory Temperature	°C	18.9 to 25.6	21.1	Pass
Laboratory Relative Humidity	%	10 to 70	30	Pass
Probe Velocity	m/s	4.21 to 4.33	4.30	Pass
Upper Rib Acceleration	G's	37.0 to 46.0	44.8	Pass
Lower Rib Acceleration	G's	37.0 to 46.0	43.6	Pass
Thoracic Spine Acceleration	G's	15.0 to 22.0	19.5	Pass
Overall Test Results				Pass

C-26

TR-P23003-05-NC

Laboratory Technician

March 7, 2003

Test Date

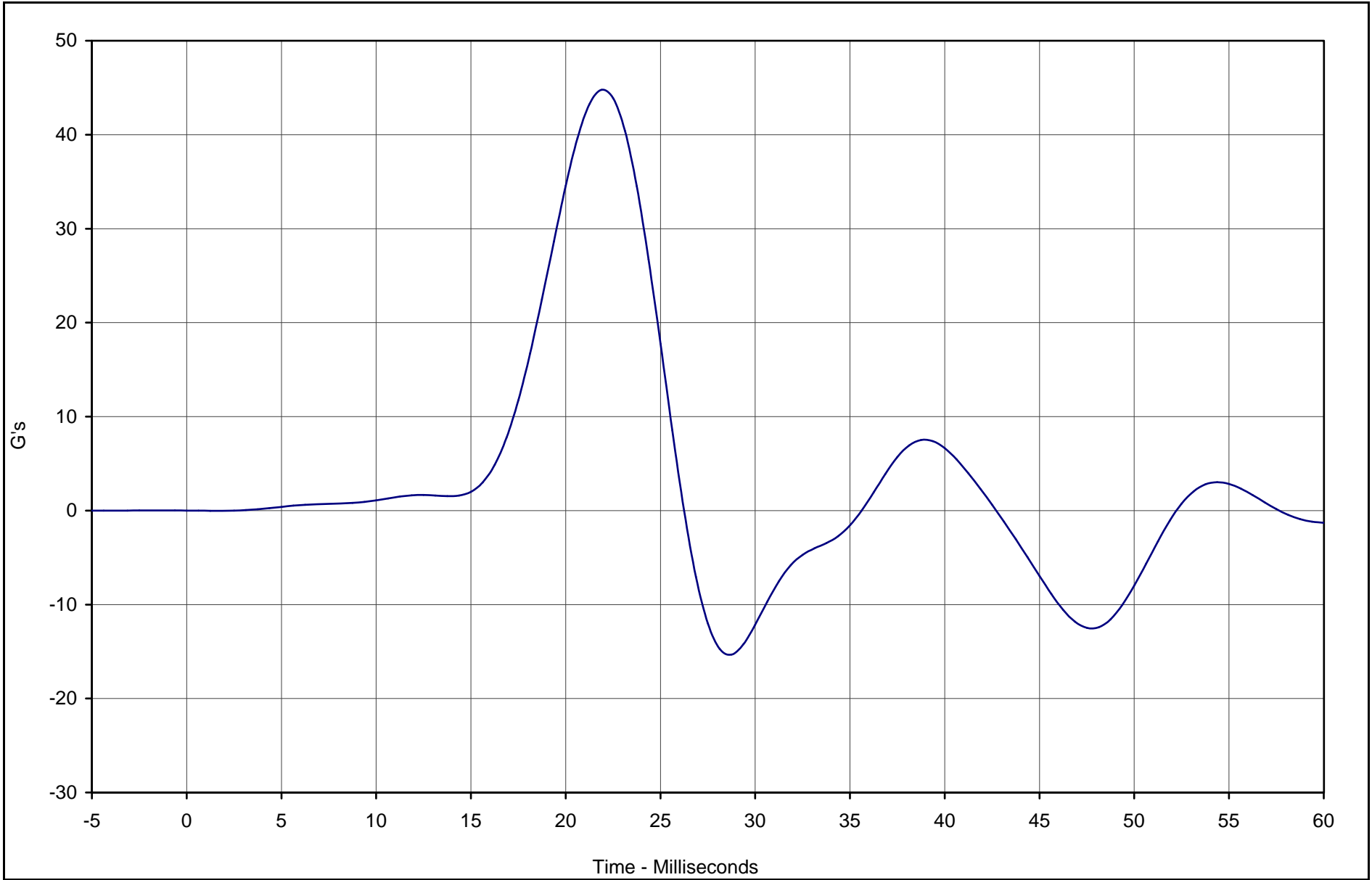

Curve Description	CURNO	Type	Units	Max	Time	Min	Time	SAE Class
Upper Rib Y Acceleration	001	FIL	G's	44.8	21.9	-15.3	28.8	FIR100



Test Vehicle: SID / HIII Thorax Lateral Impact

SID Serial No.: 274

Test Date: 3/7/03

Test I.D.: TH03C

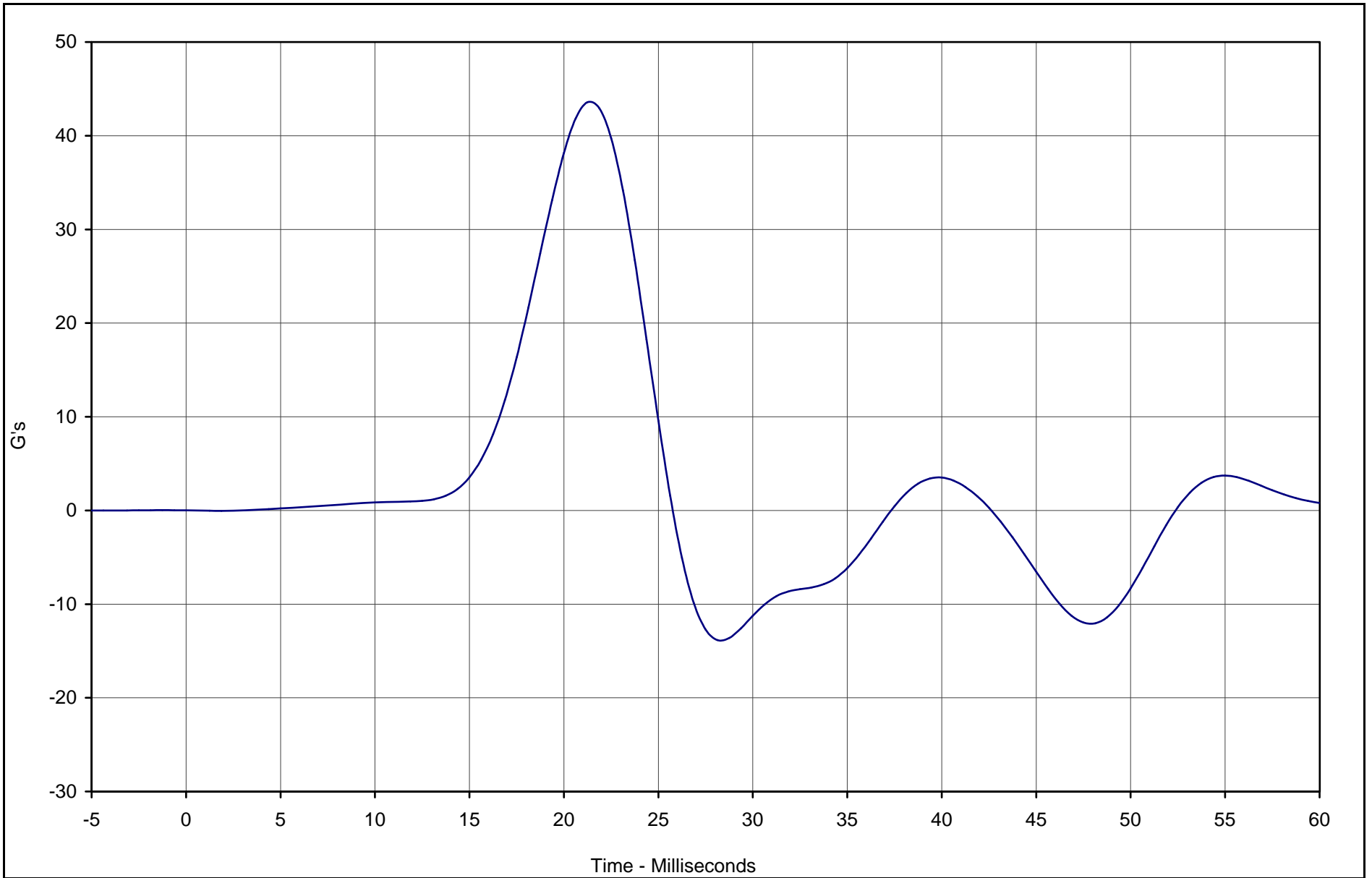

Curve Description	CURNO	Type	Units	Max	Time	Min	Time	SAE Class
Lower Rib Y Acceleration	002	FIL	G's	43.6	21.3	-13.8	28.1	FIR100



Test Vehicle: SID / HIII Thorax Lateral Impact

SID Serial No.: 274

Test Date: 3/7/03

Test I.D.: TH03C

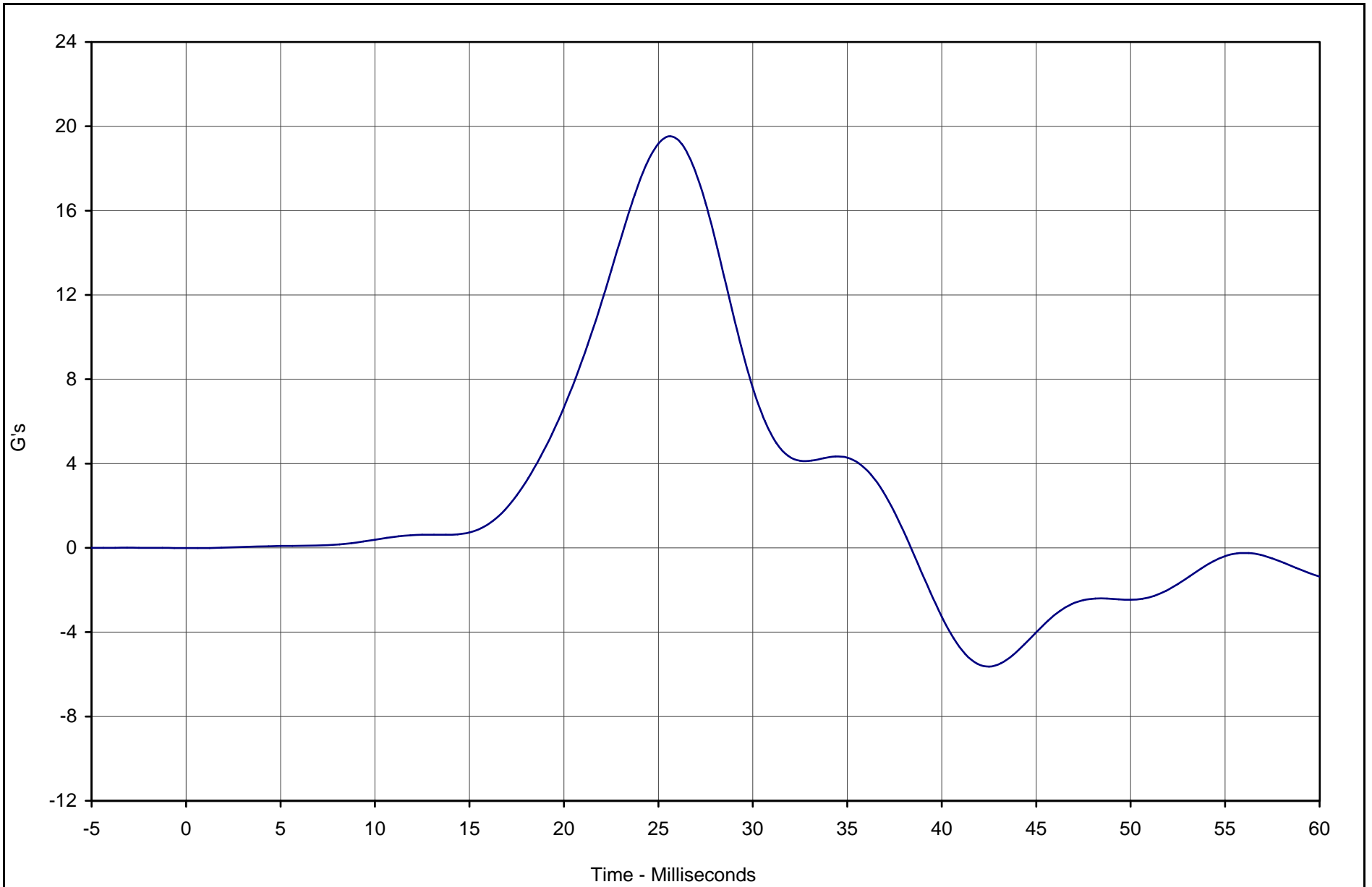

Curve Description	CURNO	Type	Units	Max	Time	Min	Time	SAE Class
Lower Spine Y Acceleration	003	FIL	G's	19.5	25.6	-5.6	42.5	FIR100



Test Vehicle: SID / HIII Thorax Lateral Impact

SID Serial No.: 274

Test Date: 3/7/03

Test I.D.: TH03C



Calibration Data Sheet

Side Impact Hybrid Dummy (SID/HIII)

Pelvis Lateral Impact

ATD Serial No.: 274

Test I.D.: PI03C

Tested Parameter	Units	Specification	Result	Pass/Fail
Laboratory Temperature	°C	18.9 to 25.6	21.1	Pass
Laboratory Relative Humidity	%	10 to 70	30	Pass
Probe Velocity	m/s	4.21 to 4.33	4.26	Pass
Peak Pelvis Acceleration	G's	40.0 to 60.0	45.4	Pass
Acceleration Time Above 20 G's	Msec.	3.0 to 7.0	6.3	Pass
Overall Test Results				Pass

C-30

TR-P23003-05-NC

Laboratory Technician

March 7, 2003

Test Date

C-31

TR-P23003-05-NC

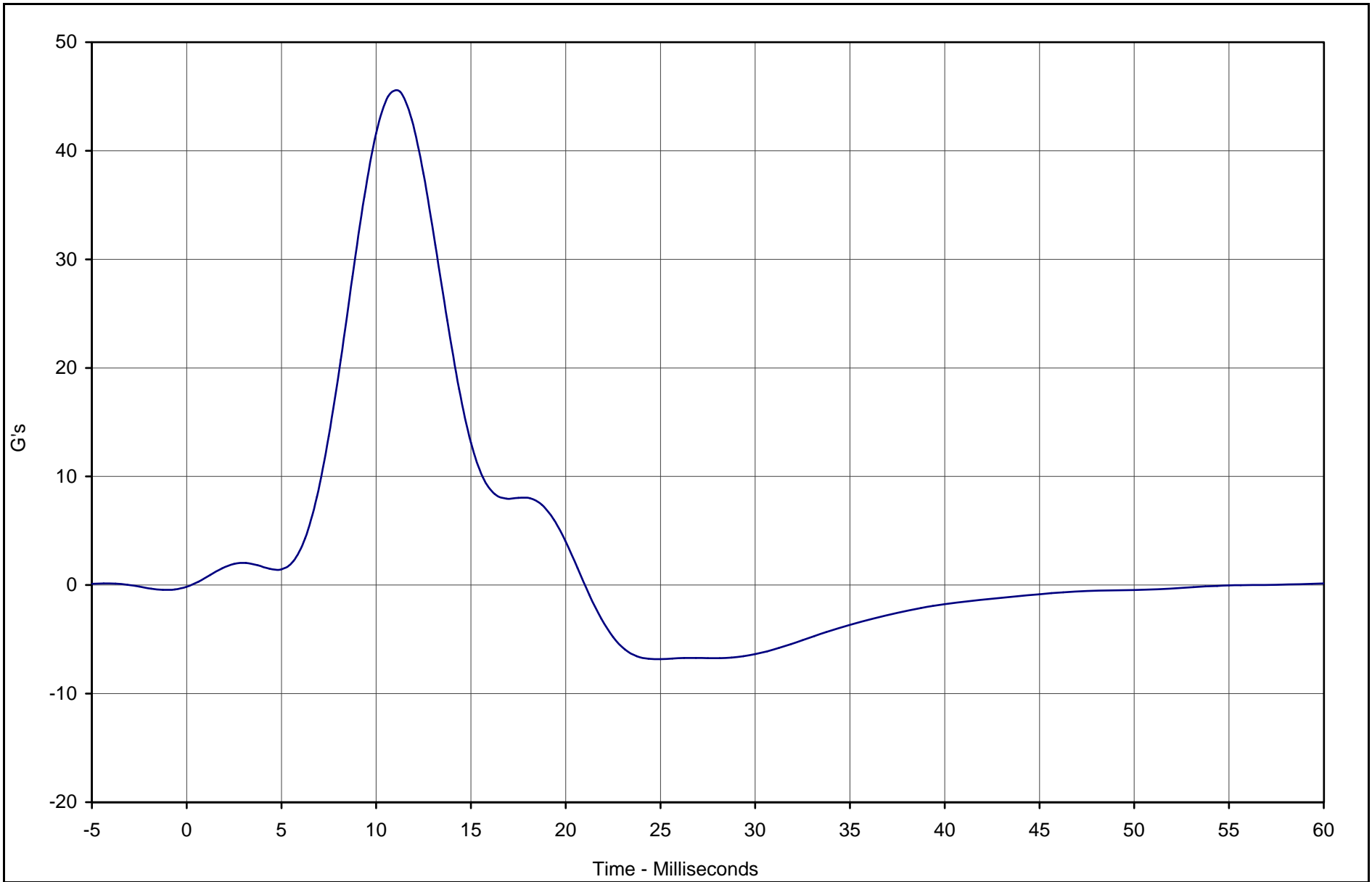

Curve Description	CURNO	Type	Units	Max	Time	Min	Time	SAE Class
Pelvis Y Acceleration	001	FIL	G's	45.4	11.3	-8.5	0.0	FIR100



Test Vehicle: Side Impact Dummy (SID) Pelvis Lateral Impact

SID Serial No.: 274

Test Date: 3/7/03

Test I.D.: PI03C



Calibration Data Sheet Side Impact Hybrid Dummy (SID/HIII) Head Drop Lateral Impact Test

ATD Serial No.: 274

Test I.D.: HD01C

Tested Parameter	Units	Specification	Result	Pass/Fail
Laboratory Temperature	°C	18.9 to 25.6	21.1	Pass
Laboratory Relative Humidity	%	10 to 70	30	Pass
Peak Resultant Acceleration	G's	120.0 to 150.0	140.4	Pass
Peak Longitudinal Acceleration	G's	≤15.0	8.9	Pass
Is Acceleration Unimodal?	Yes/No	Yes	Yes	Pass
Oscillations After Main Pulse	%	<10	4.2	Pass
Overall Test Results				Pass

C-32

TR-P23003-05-NC

Laboratory Technician

March 7, 2003

Test Date

C-33

TR-P23003-05-NC

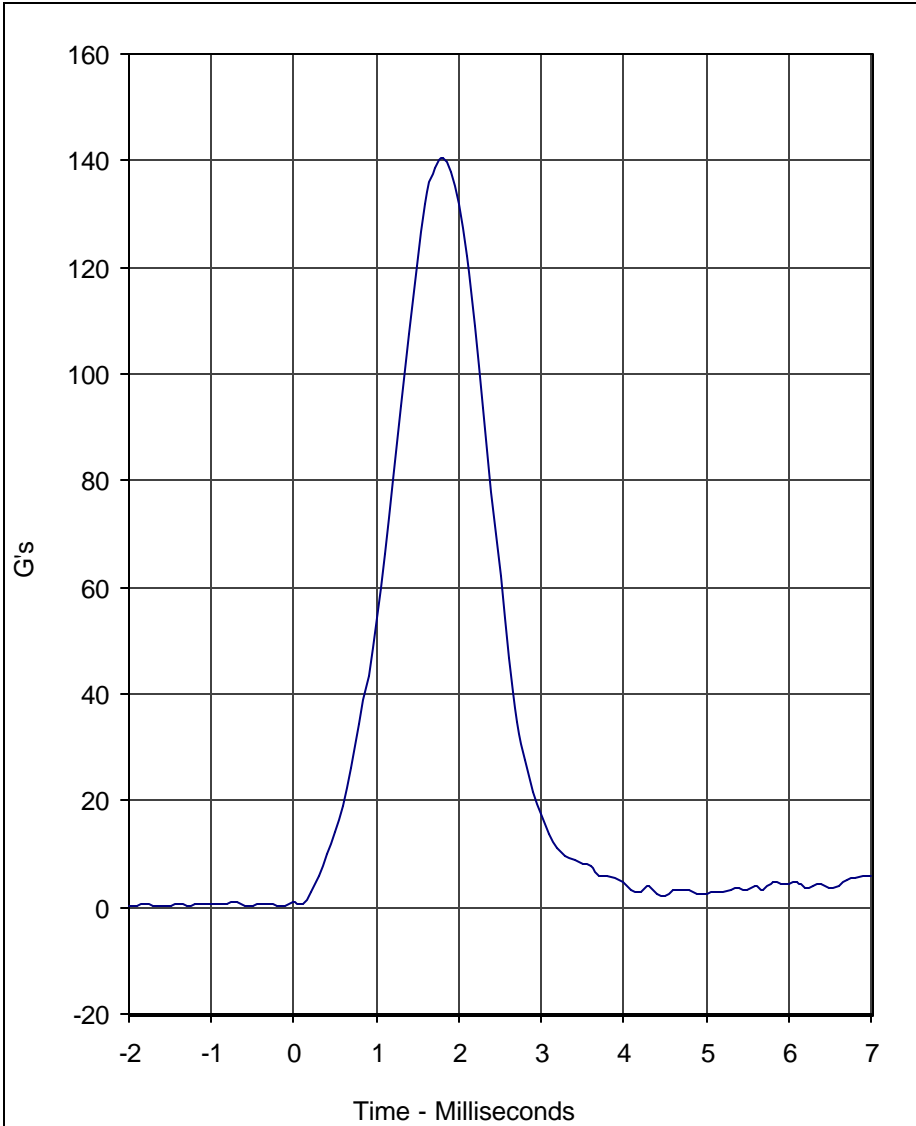

Curve Description	CURNO	Type
Head Resultant	001	RES

Units	Max	Time	Min	Time	SAE Class
G's	140.4	1.8	0.2	-1.6	1000

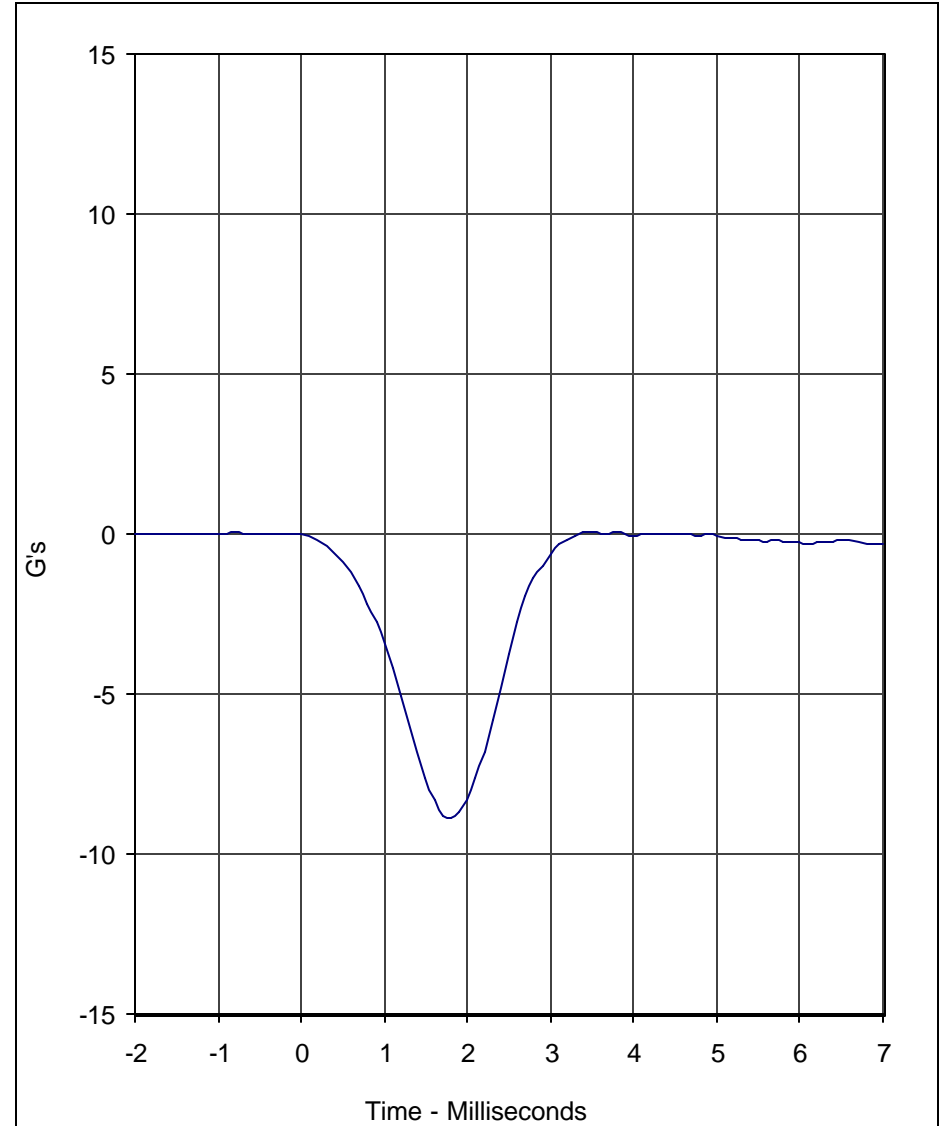

Curve Description	CURNO	Type
Head Y	002	FIL

Units	Max	Time	Min	Time	SAE Class
G's	0.1	3.5	-8.9	1.8	1000

Test Program: SID / HIII Head Drop Lateral Impact Test
 Test Date: 3/7/03

A.T.D. Serial No.: 274
 Test I.D.: HD01C





Calibration Data Sheet Side Impact Hybrid Dummy (SID/HIII) Neck Pendulum Lateral Test

ATD Serial No.: 274

Test I.D.: NB09A

Tested Parameter		Units	Specification	Result	Pass/Fail
Laboratory Temperature		°C	20.6 to 22.2	21.1	Pass
Laboratory Relative Humidity		%	10 to 70	30	Pass
Pendulum Velocity		m/s	6.89 to 7.13	7.10	Pass
Pendulum Deceleration	10	Msec.	1.96 to 2.55	2.25	Pass
	20	Msec.	4.12 to 5.10	4.60	Pass
	30	Msec.	5.73 to 7.01	6.63	Pass
	40 to 70	Msec.	6.27 to 7.64	6.90	Pass
Maximum "D" Plane Rotation		Degrees	66.0 to 82.0	71.1	Pass
Maximum "D" Plane Rotation Time After Peak Moment		Msec.	2.0 to 15.0	6.7	Pass
"D" Plane Rotation Decay Time From Peak Angle to Zero Angle		Msec.	58.0 to 67.0	63.0	Pass
Calculated Moment About Occipital Condyle		N•m	73.0 to 88.0	87.5	Pass
Moment About Occipital Condyle Decay, Time From Positive Peak Value To 0 N•m		Msec.	49.0 to 64.0	51.6	Pass
Overall Test Results					Pass

Laboratory Technician

March 8, 2003

Test Date

C-34

TR-P23003-05-NC

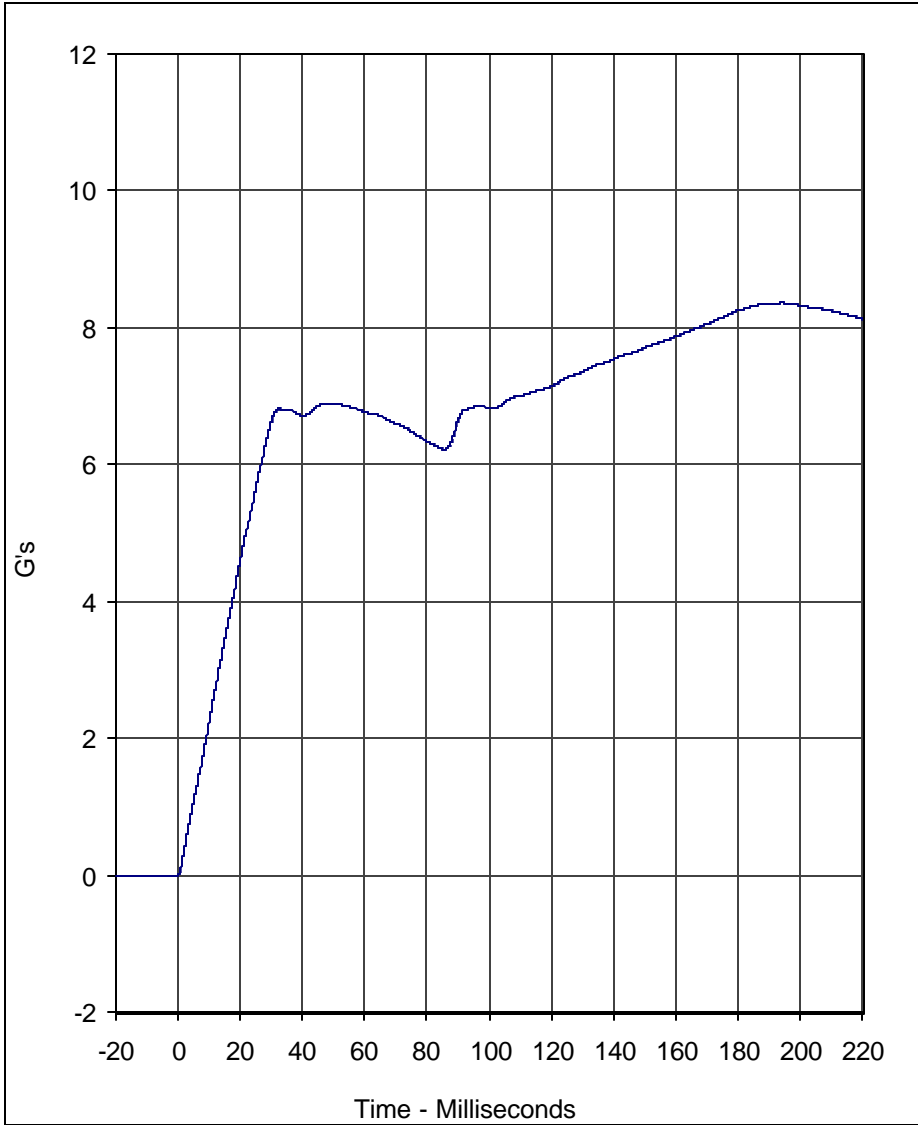

Curve Description	CURNO	Type
Pendulum Velocity	001	FIL

Units	Max	Time	Min	Time	SAE Class
G's	8.4	194.4	0.0	-0.7	180

Test Program: SID / HIII Neck Pendulum Lateral Test
 Test Date: 3/8/03

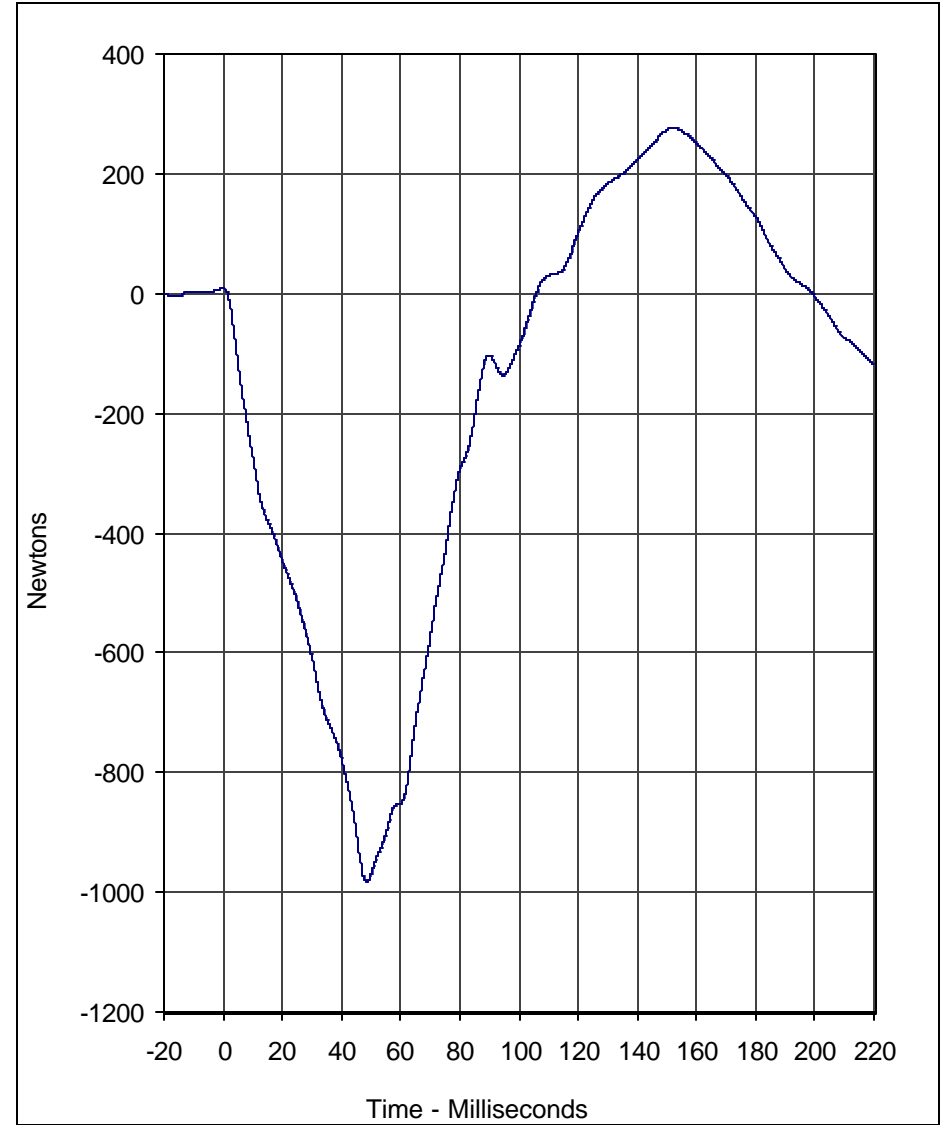

Curve Description	CURNO	Type
Neck Force Y	002	FIL

Units	Max	Time	Min	Time	SAE Class
Newtons	275.8	152.1	-983.1	48.5	60

A.T.D. Serial No.: 274
 Test I.D.: NB09A



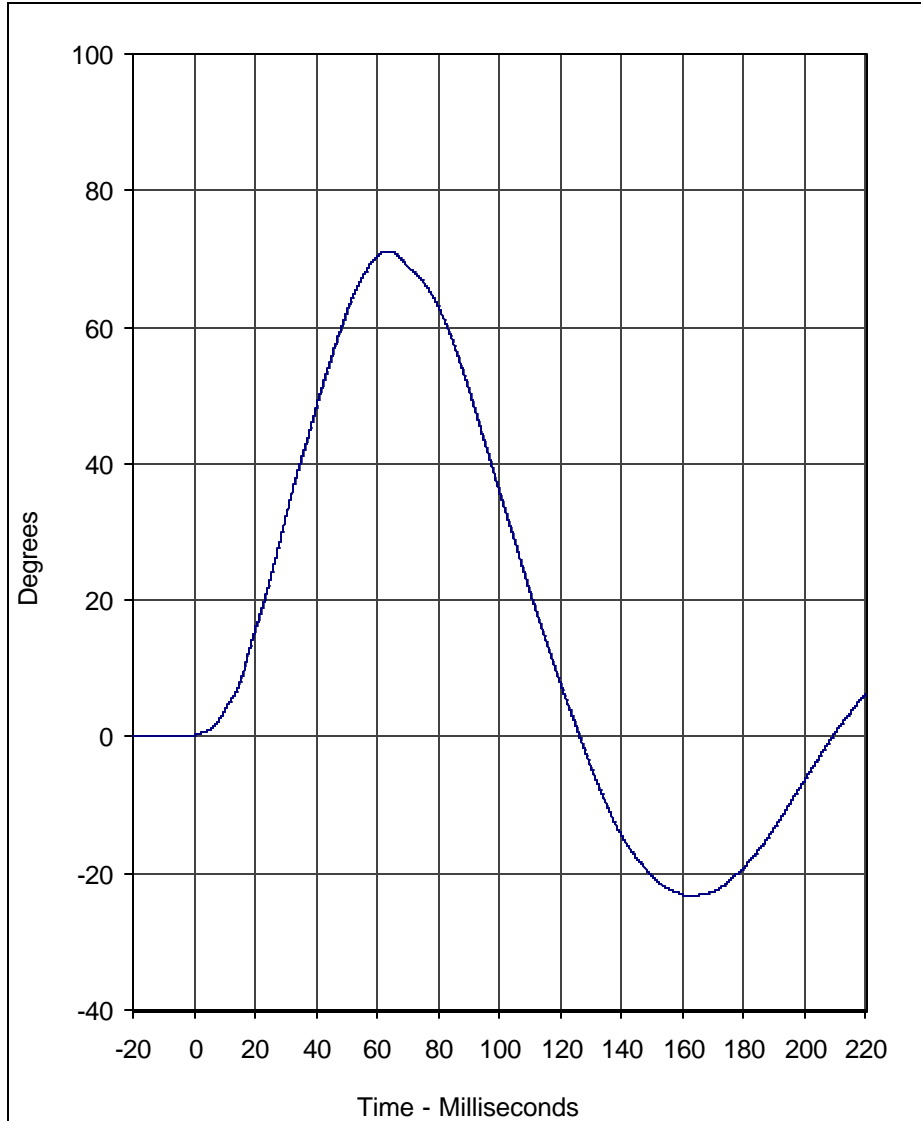

Curve Description	CURNO	Type
"D" Plane Rotation	003	FIL

Units	Max	Time	Min	Time	SAE Class
Degrees	71.1	63.5	-23.3	162.9	60

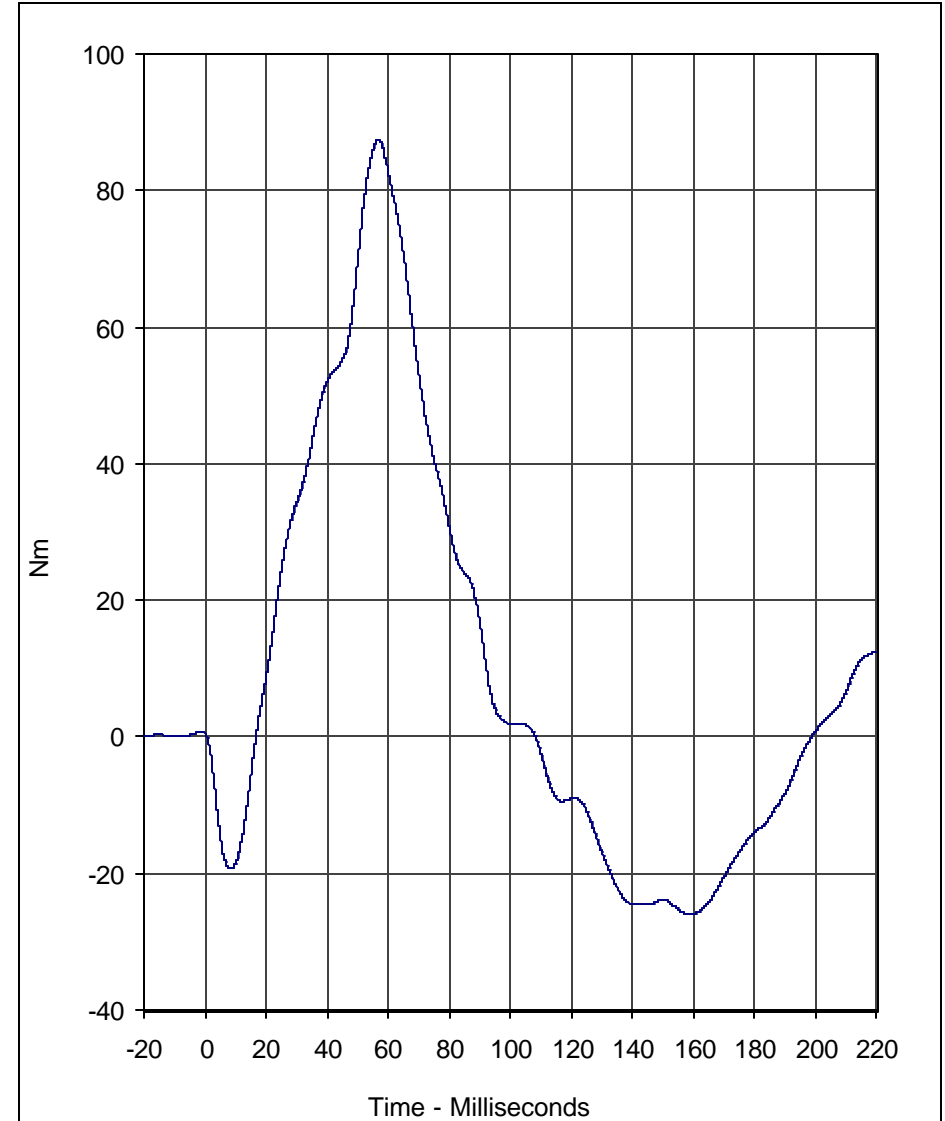

Curve Description	CURNO	Type
Moment About Occipital Condyle	004	FIL

Units	Max	Time	Min	Time	SAE Class
Nm	87.5	56.8	-25.9	158.9	60

Test Program: SID / HIII Neck Pendulum Lateral Test
 Test Date: 3/8/03

A.T.D. Serial No.: 274
 Test I.D.: NB09A





Calibration Data Sheet Side Impact Hybrid Dummy (SID/HIII) External Measurements

ATD Serial No.: 275

Tested Parameter	Units	Specification	Result	Pass/Fail
Laboratory Temperature	°C	18.9 to 25.6	21.1	Pass
Laboratory Relative Humidity	%	10 to 70	30	Pass
SH- Seated Height	mm	889 to 909	895	Pass
HP- Hip Point Height	mm	99 (reference)	99	Pass
RH- Rib Height	mm	502 to 520	510	Pass
KH- Knee Pivot From Back Line	mm	511 to 526	515	Pass
KV- Knee Pivot From Floor	mm	490 to 505	495	Pass
HW- Hip Width	mm	356 to 391	390	Pass
Overall Test Results				Pass

C-37

TR-P23003-05-NC

Laboratory Technician

March 8, 2003
Test Date



Calibration Data Sheet

Side Impact Hybrid Dummy (SID/HIII)

Thorax Lateral Impact

ATD Serial No.: 275

Test I.D.: TH03D

Tested Parameter	Units	Specification	Result	Pass/Fail
Laboratory Temperature	°C	18.9 to 25.6	21.1	Pass
Laboratory Relative Humidity	%	10 to 70	30	Pass
Probe Velocity	m/s	4.21 to 4.33	4.30	Pass
Upper Rib Acceleration	G's	37.0 to 46.0	42.4	Pass
Lower Rib Acceleration	G's	37.0 to 46.0	45.7	Pass
Thoracic Spine Acceleration	G's	15.0 to 22.0	20.4	Pass
Overall Test Results				Pass

C-38

TR-P23003-05-NC

Laboratory Technician

March 7, 2003

Test Date

C-39

TR-P23003-05-NC

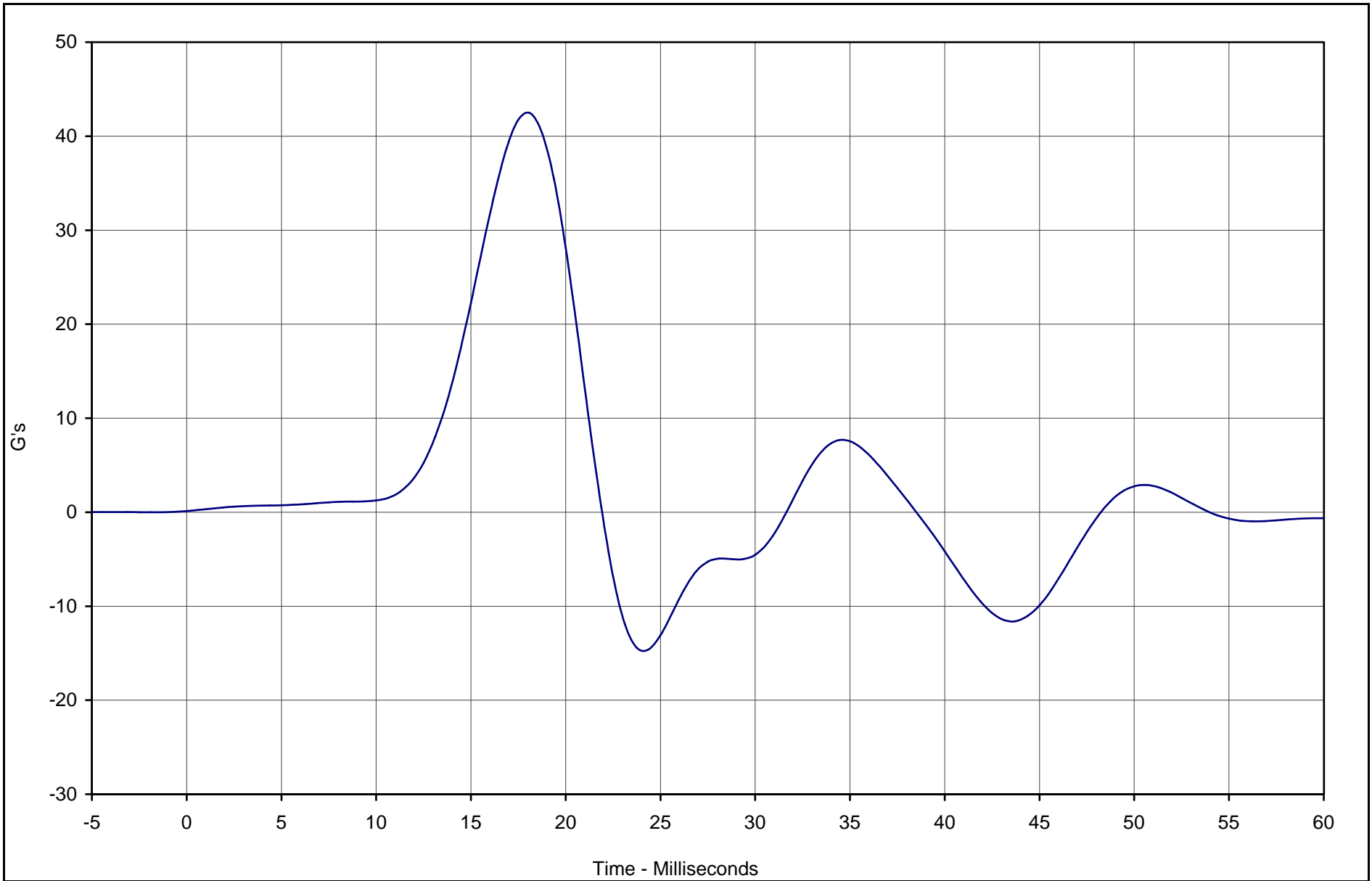

Curve Description	CURNO	Type	Units	Max	Time	Min	Time	SAE Class
Upper Rib Y Acceleration	001	FIL	G's	42.4	18.1	-14.6	24.4	FIR100



Test Vehicle: SID / HIII Thorax Lateral Impact

SID Serial No.: 275

Test Date: 3/7/03

Test I.D.: TH03D

C-40

TR-P23003-05-NC

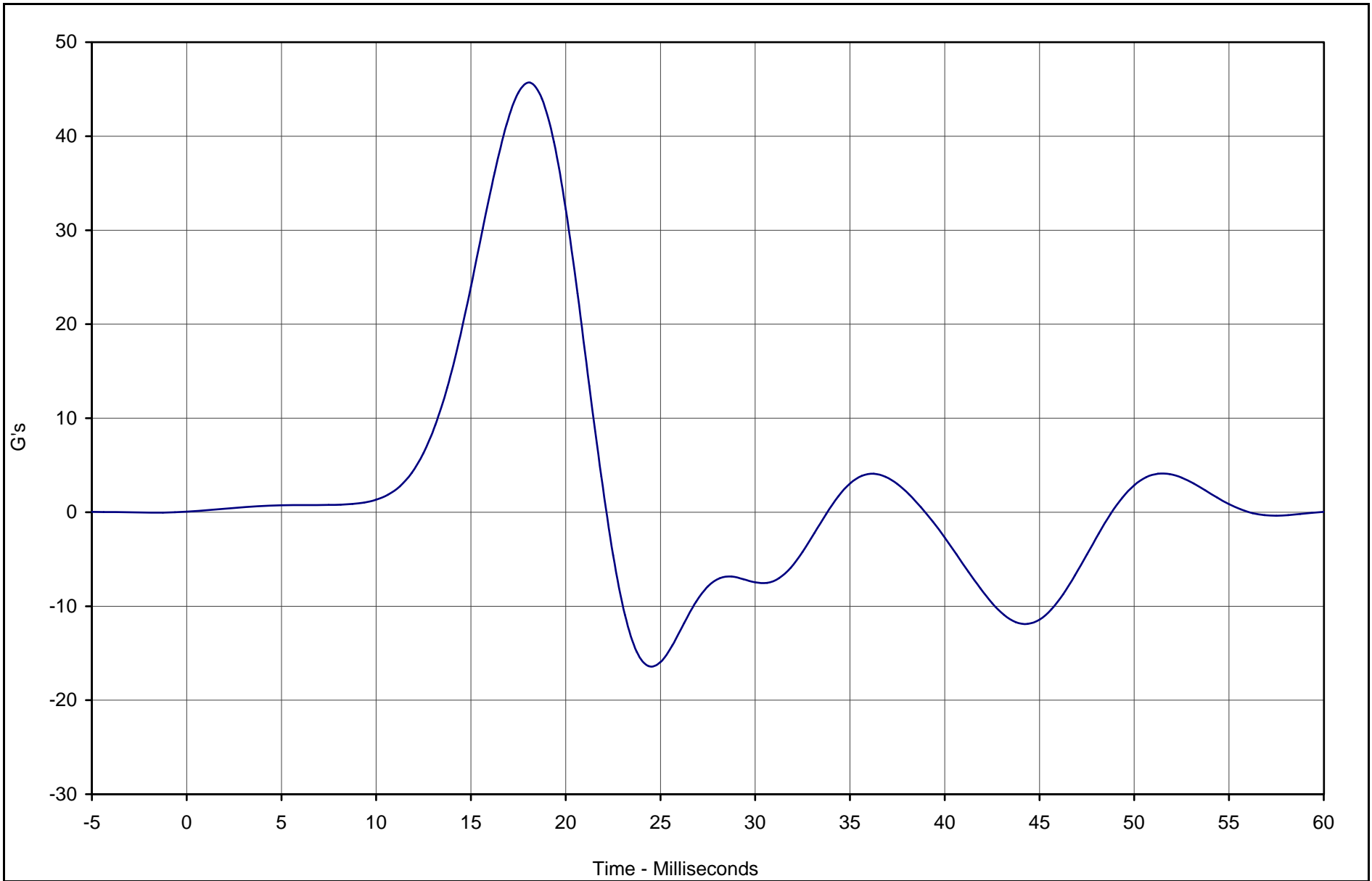

Curve Description	CURNO	Type	Units	Max	Time	Min	Time	SAE Class
Lower Rib Y Acceleration	002	FIL	G's	45.7	18.1	-16.4	24.4	FIR100



Test Vehicle: SID / HIII Thorax Lateral Impact

SID Serial No.: 275

Test Date: 3/7/03

Test I.D.: TH03D

C-41

TR-P23003-05-NC

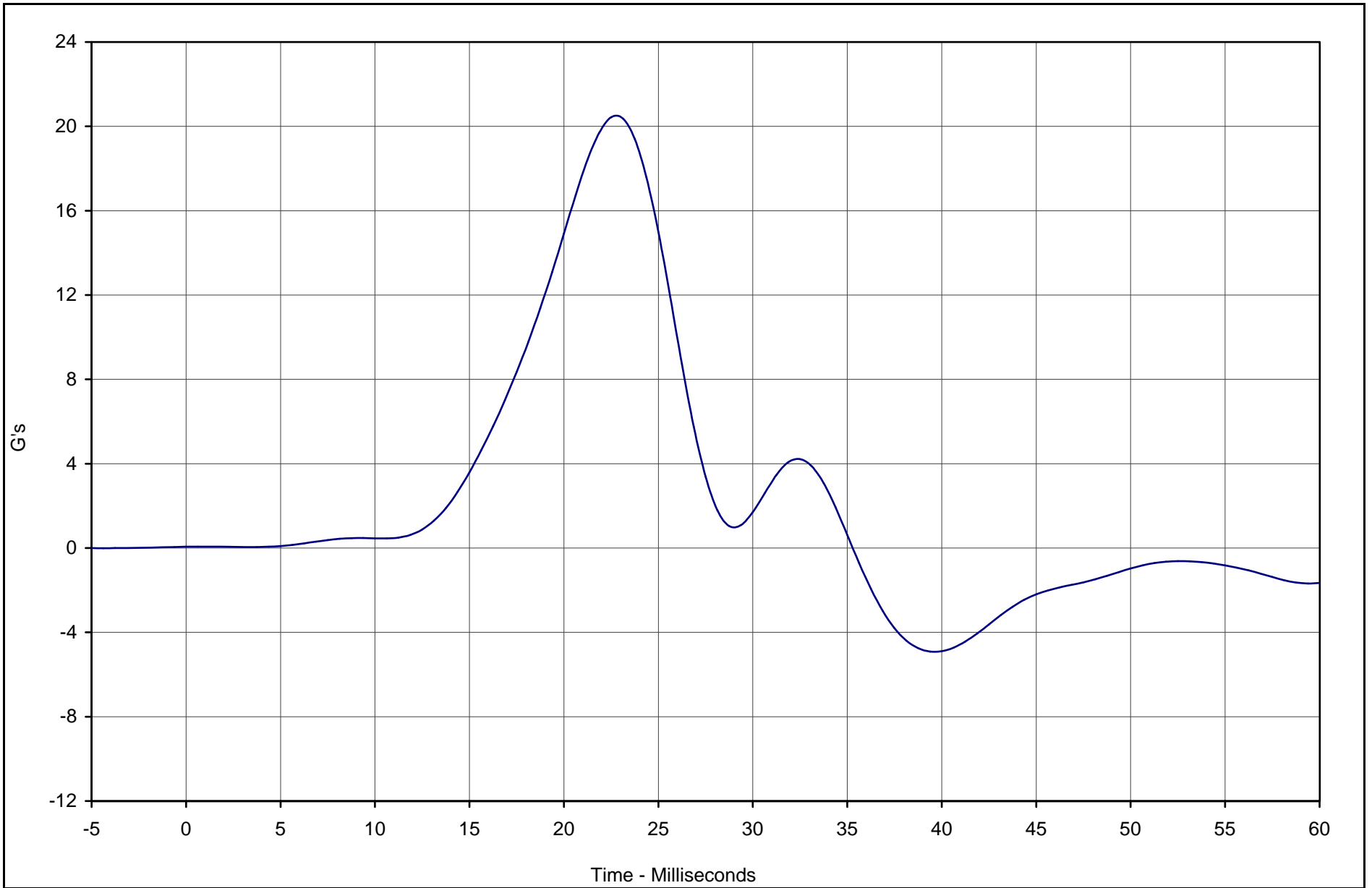

Curve Description	CURNO	Type	Units	Max	Time	Min	Time	SAE Class
Lower Spine Y Acceleration	003	FIL	G's	20.4	22.5	-4.9	39.4	FIR100



Test Vehicle: SID / HIII Thorax Lateral Impact

SID Serial No.: 275

Test Date: 3/7/03

Test I.D.: TH03D



Calibration Data Sheet Side Impact Hybrid Dummy (SID/HIII) Pelvis Lateral Impact

ATD Serial No.: 275

Test I.D.: PI03D

Tested Parameter	Units	Specification	Result	Pass/Fail
Laboratory Temperature	°C	18.9 to 25.6	21.1	Pass
Laboratory Relative Humidity	%	10 to 70	30	Pass
Probe Velocity	m/s	4.21 to 4.33	4.29	Pass
Peak Pelvis Acceleration	G's	40.0 to 60.0	42.2	Pass
Acceleration Time Above 20 G's	Msec.	3.0 to 7.0	6.9	Pass
Overall Test Results				Pass

C-42

TR-P23003-05-NC

Laboratory Technician

March 7, 2003

Test Date

C-43

TR-P23003-05-NC

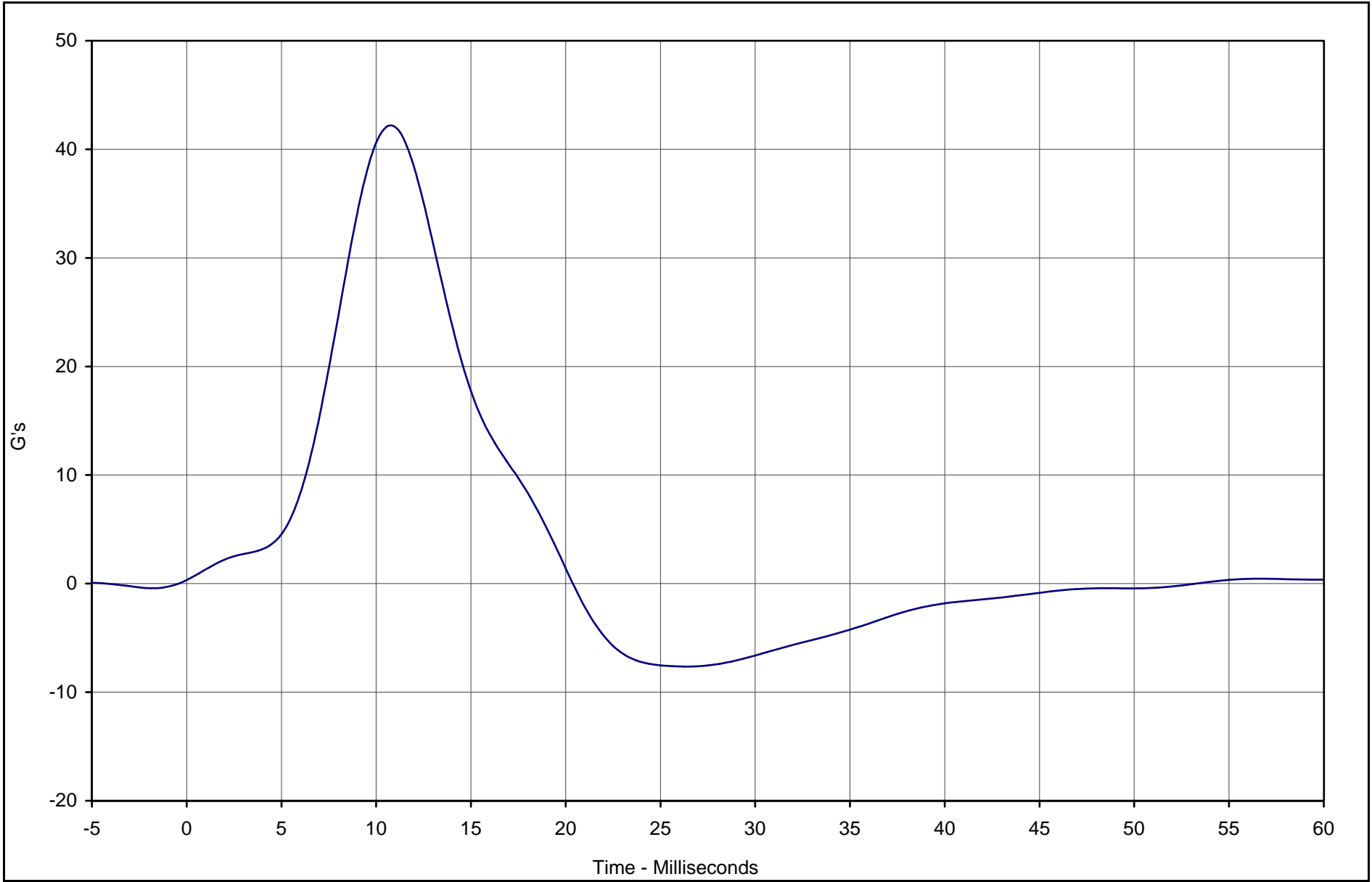

Curve Description	CURNO	Type	Units	Max	Time	Min	Time	SAE Class
Pelvis Y Acceleration	001	FIL	G's	42.2	10.6	-7.6	26.3	FIR100



Test Vehicle: Side Impact Dummy (SID) Pelvis Lateral Impact

SID Serial No.: 275

Test Date: 3/7/03

Test I.D.: PI03D



Calibration Data Sheet Side Impact Hybrid Dummy (SID/HIII) Head Drop Lateral Impact Test

ATD Serial No.: 275

Test I.D.: HD01D

Tested Parameter	Units	Specification	Result	Pass/Fail
Laboratory Temperature	°C	18.9 to 25.6	21.1	Pass
Laboratory Relative Humidity	%	10 to 70	30	Pass
Peak Resultant Acceleration	G's	120.0 to 150.0	137.2	Pass
Peak Longitudinal Acceleration	G's	≤15.0	3.5	Pass
Is Acceleration Unimodal?	Yes/No	Yes	Yes	Pass
Oscillations After Main Pulse	%	<10	3.9	Pass
Overall Test Results				Pass

C-44

TR-P23003-05-NC

Laboratory Technician

March 7, 2003

Test Date

C-45

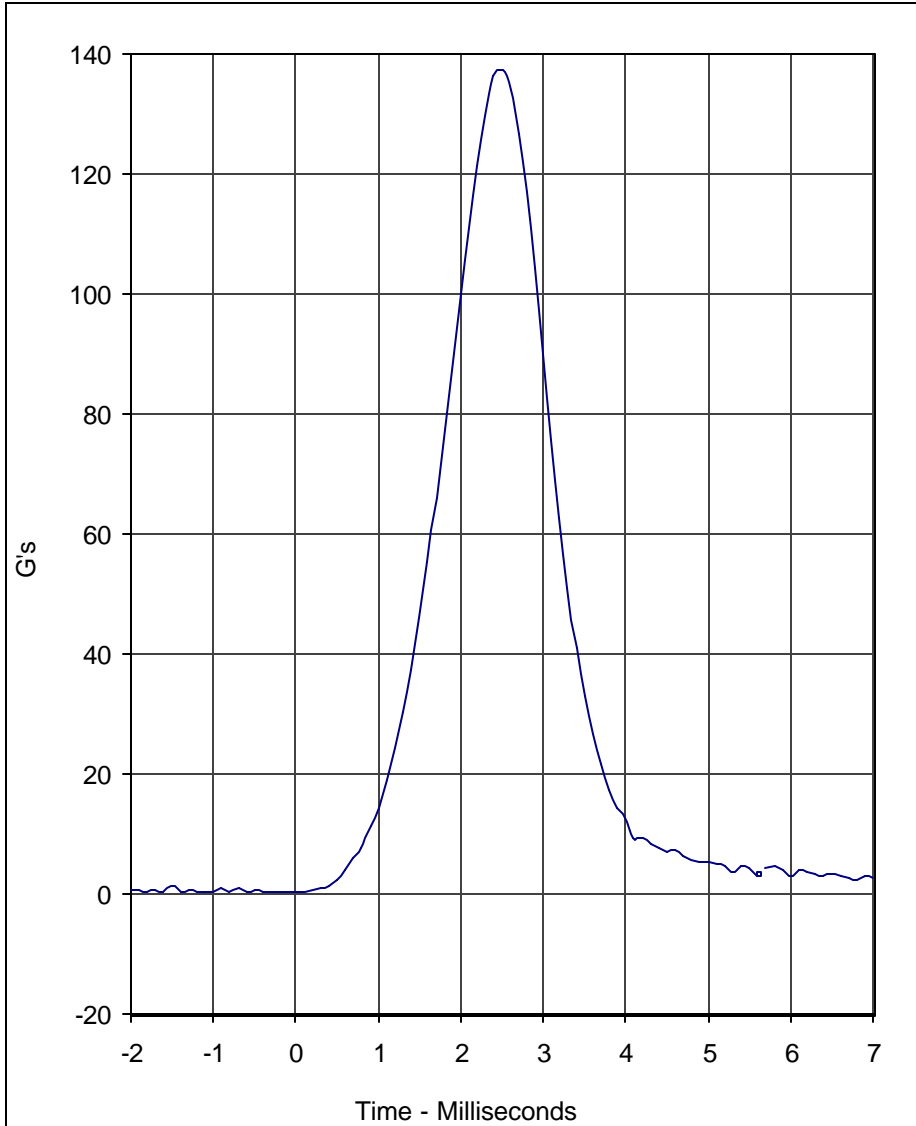

Curve Description	CURNO	Type
Head Resultant	001	RES

Units	Max	Time	Min	Time	SAE Class
G's	137.2	2.5	0.2	-0.4	1000

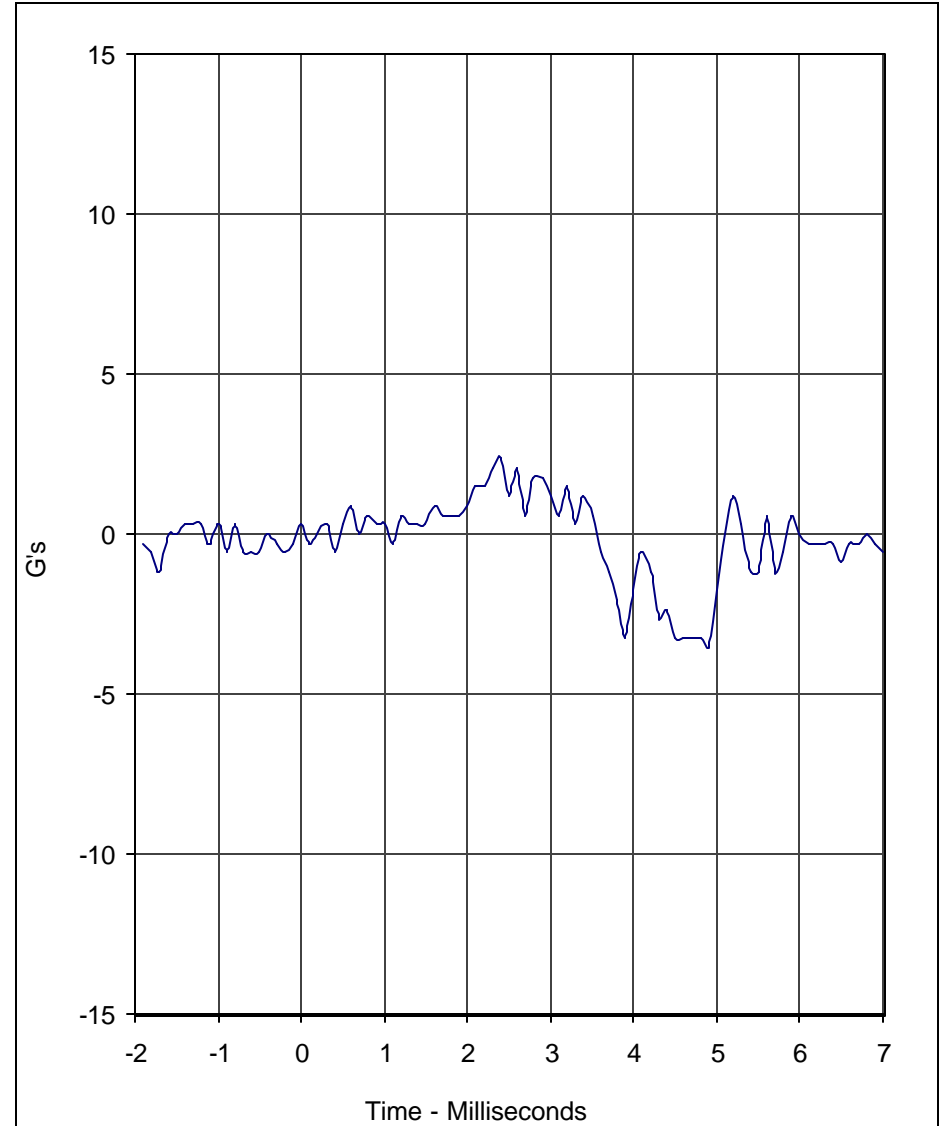

Curve Description	CURNO	Type
Head Y	002	FIL

Units	Max	Time	Min	Time	SAE Class
G's	2.4	2.4	-3.5	4.9	1000

Test Program: SID / HIII Head Drop Lateral Impact Test
 Test Date: 3/7/03

A.T.D. Serial No.: 275
 Test I.D.: HD01D



TR-P23003-05-NC



Calibration Data Sheet Side Impact Hybrid Dummy (SID/HIII) Neck Pendulum Lateral Test

ATD Serial No.: 275

Test I.D.: NB11D

Tested Parameter		Units	Specification	Result	Pass/Fail
Laboratory Temperature		°C	20.6 to 22.2	21.1	Pass
Laboratory Relative Humidity		%	10 to 70	30	Pass
Pendulum Velocity		m/s	6.89 to 7.13	7.03	Pass
Pendulum Deceleration	10	Msec.	1.96 to 2.55	2.32	Pass
	20	Msec.	4.12 to 5.10	4.81	Pass
	30	Msec.	5.73 to 7.01	6.68	Pass
	40 to 70	Msec.	6.27 to 7.64	7.56	Pass
Maximum "D" Plane Rotation		Degrees	66.0 to 82.0	70.6	Pass
Maximum "D" Plane Rotation Time After Peak Moment		Msec.	2.0 to 15.0	14.8	Pass
"D" Plane Rotation Decay Time From Peak Angle to Zero Angle		Msec.	58.0 to 67.0	63.2	Pass
Calculated Moment About Occipital Condyle		N•m	73.0 to 88.0	76.3	Pass
Moment About Occipital Condyle Decay, Time From Positive Peak Value To 0 N•m		Msec.	49.0 to 64.0	50.4	Pass
Overall Test Results					Pass

Laboratory Technician

March 8, 2003

Test Date

C-46

TR-P23003-05-NC

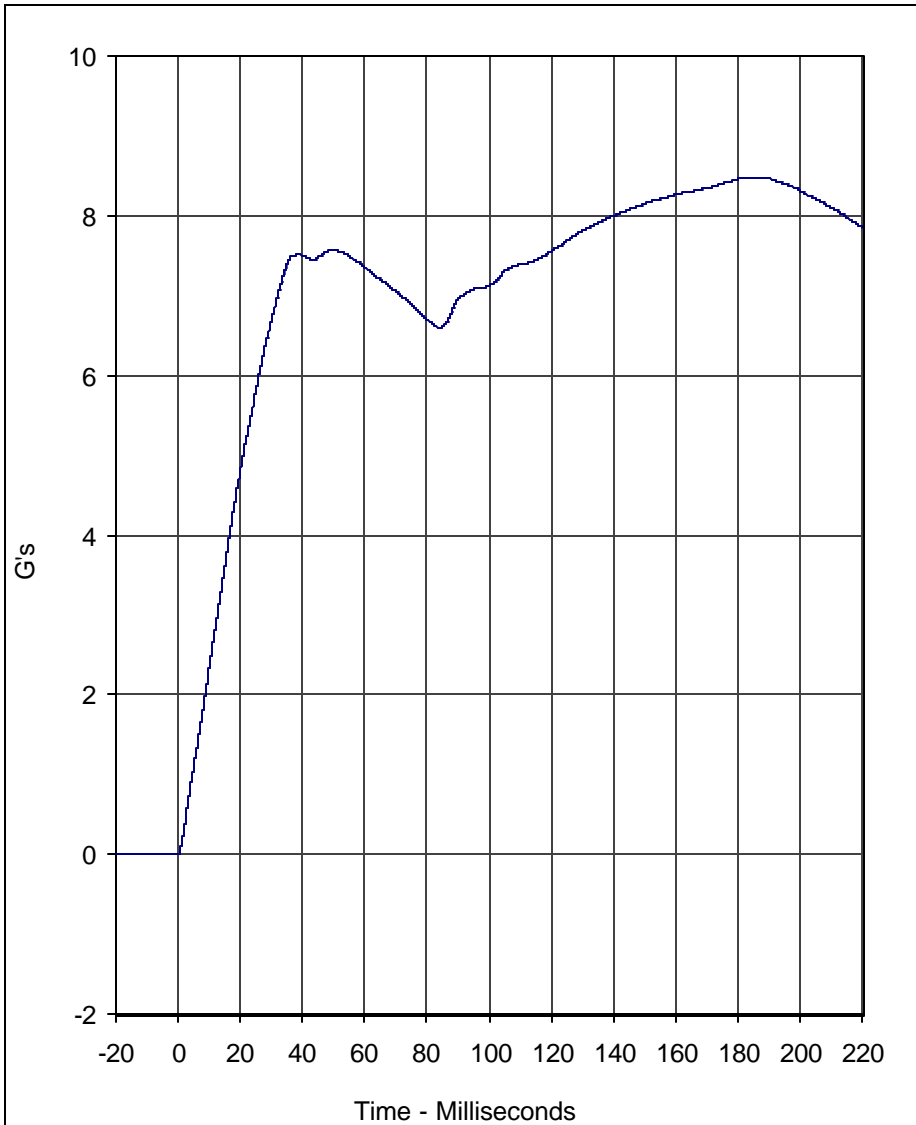

Curve Description	CURNO	Type
Pendulum Velocity	001	FIL

Units	Max	Time	Min	Time	SAE Class
G's	8.5	183.2	0.0	-20.0	180

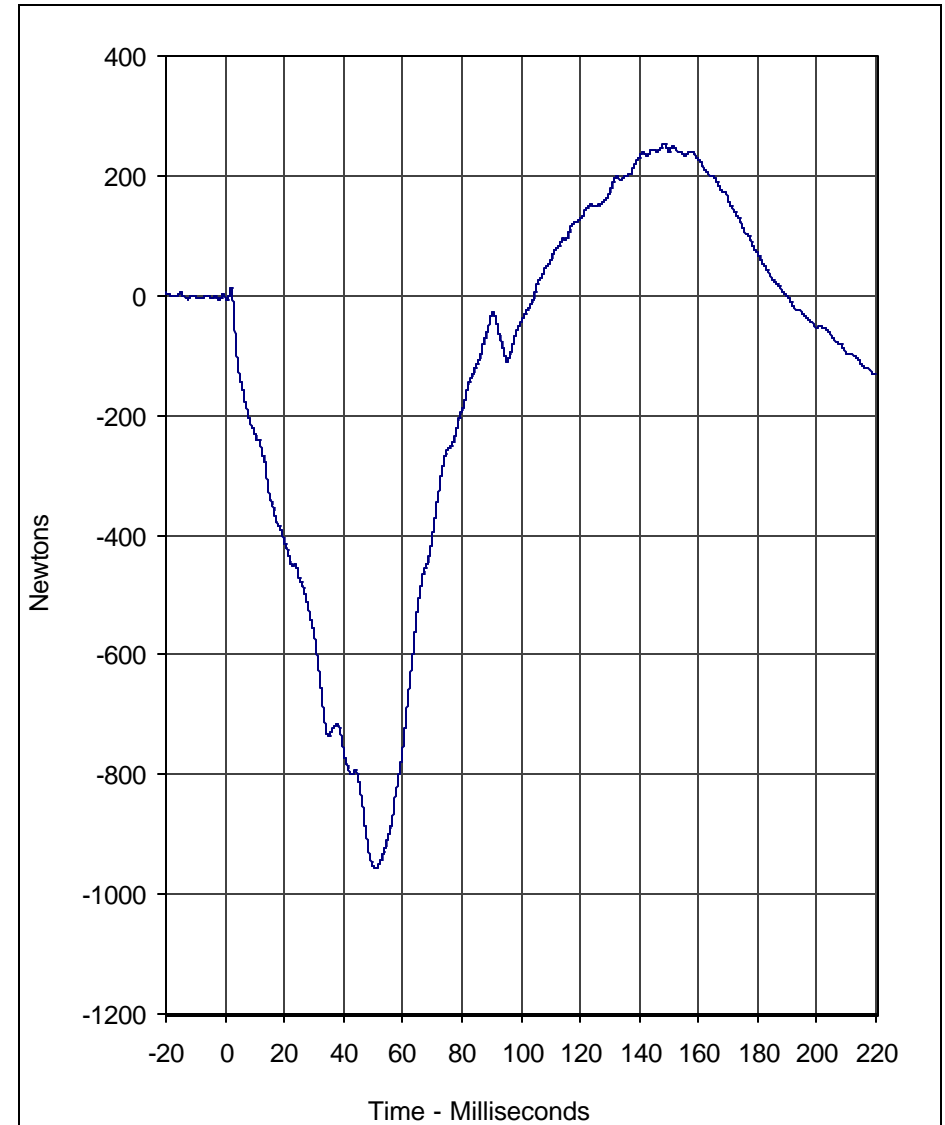

Curve Description	CURNO	Type
Neck Force Y	002	FIL

Units	Max	Time	Min	Time	SAE Class
Newtons	252.9	148.4	-956.8	50.7	180

Test Program: SID / HIII Neck Pendulum Lateral Test
 Test Date: 3/8/03

A.T.D. Serial No.: 275
 Test I.D.: NB11D



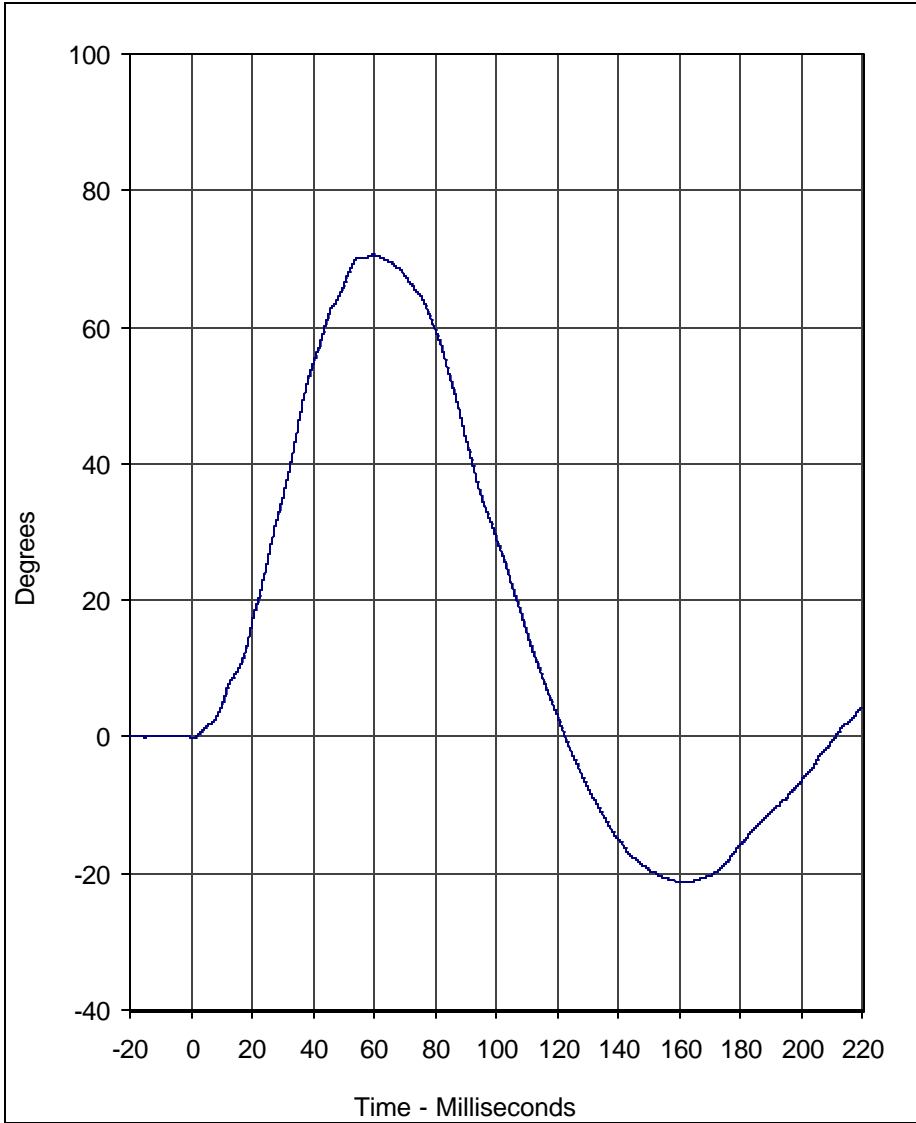

Curve Description	CURNO	Type
"D" Plane Rotation	003	FIL

Units	Max	Time	Min	Time	SAE Class
Degrees	70.6	59.5	-21.2	160.1	180

Test Program: SID / HIII Neck Pendulum Lateral Test
 Test Date: 3/8/03

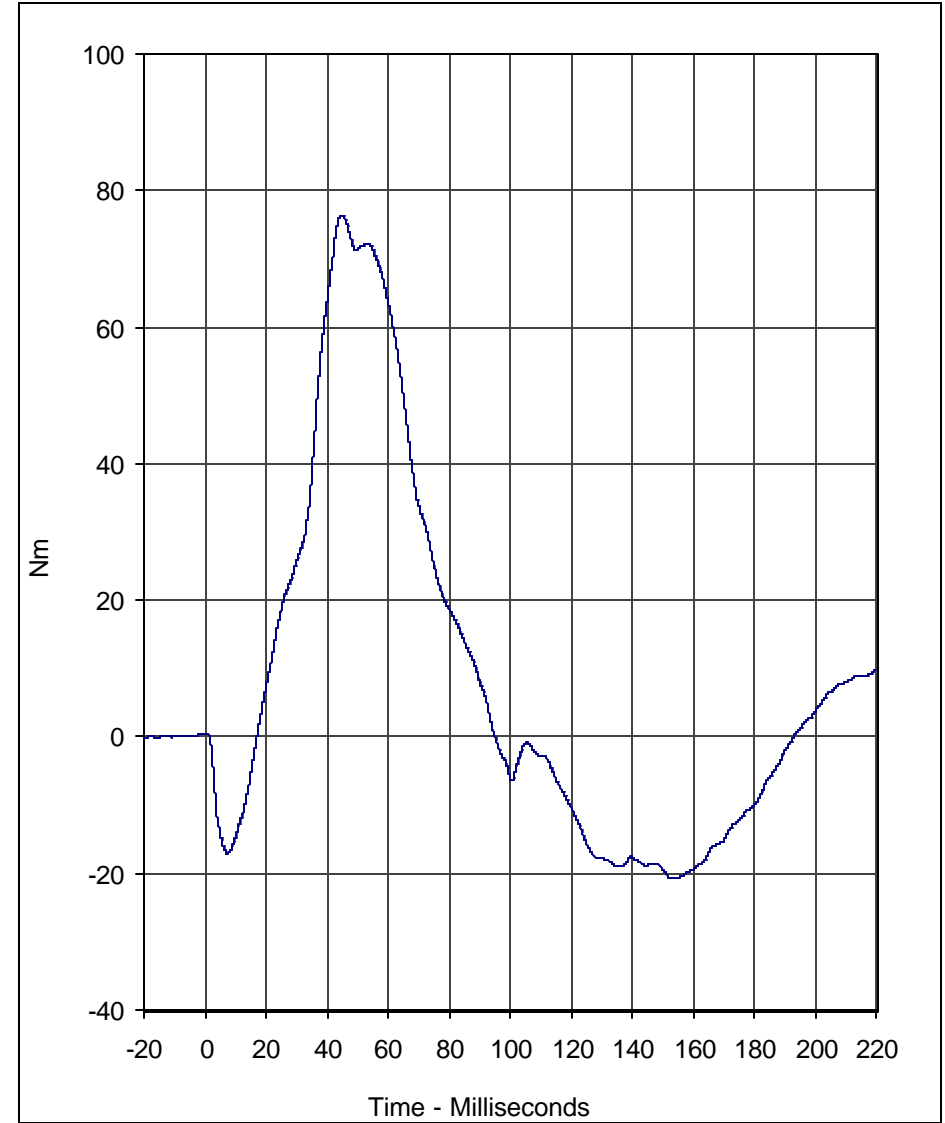

Curve Description	CURNO	Type
Moment About Occipital Condyle	004	FIL

Units	Max	Time	Min	Time	SAE Class
Nm	76.3	44.7	-20.8	153.7	180

A.T.D. Serial No.: 275
 Test I.D.: NB11D



APPENDIX D
TEST EQUIPMENT LIST AND CALIBRATION INFORMATION

**55/28 km/h Side Impact NCAP
Instrumentation Data Channel Assignments
Driver SID/HIII Serial Number 274
2/27/03
2003 Toyota 4 Runner SR5 4WD SUV**

CH.	LOCATION	AXIS	IDENT. NO.	DESCRIPTION	MFR	MODEL	UNITS
1	Head CG	X	KEAC086	Accel.,1/2 bridge	Endevco	7264-2000X	G
2	Head CG	Y	KEAC087	Accel.,1/2 bridge	Endevco	7264-2000Y	G
3	Head CG	Z	KEAC088	Accel.,1/2 bridge	Endevco	7264-2000Z	G
4	Head CG, Redundant	X	KEAC060	Accel.,1/2 bridge	Endevco	7264-2000	G
5	Head CG, Redundant	Y	KEAC061	Accel.,1/2 bridge	Endevco	7264-2000	G
6	Head CG, Redundant	Z	KEAC062	Accel.,1/2 bridge	Endevco	7264-2000	G
7	Neck Force	X	GPUN01FX	Load cell, six axis neck	R. A. Denton	1716A	N
8	Neck Force	Y	GPUN01FY	Load cell, six axis neck	R. A. Denton	1716A	N
9	Neck Force	Z	GPUN01FZ	Load cell, six axis neck	R. A. Denton	1716A	N
10	Neck Moment	X	GPUN01MX	Load cell, six axis neck	R. A. Denton	1716A	Nm
11	Neck Moment	Y	GPUN01MY	Load cell, six axis neck	R. A. Denton	1716A	Nm
12	Neck Moment	Z	GPUN01MZ	Load cell, six axis neck	R. A. Denton	1716A	Nm
13	Upper Rib Primary	Y	KEAC070	Accel.,1/2 bridge	Endevco	7264-2000X	G
14	Lower Rib, Primary	Y	KEAC071	Accel.,1/2 bridge	Endevco	7264-2000Y	G
15	Lower Spine, Primary	Y	KEAC072	Accel.,1/2 bridge	Endevco	7264-2000Z	G
16	Pelvis, Primary	Y	KEAC090	Accel.,Full bridge	Endevco	7264-2000X	G
17	Upper Rib Redundant	Y	KEAC076	Accel.,1/2 bridge	Endevco	7264-2000X	G
18	Lower Rib, Redundant	Y	KEAC077	Accel.,1/2 bridge	Endevco	7264-2000Y	G
19	Lower Spine, Redundant	Y	KEAC078	Accel.,1/2 bridge	Endevco	7264-2000Z	G
20	Pelvis, Redundant	Y	KEAC089	Accel.,1/2 bridge	Endevco	7264-2000X	G
21	Thorax Contact	N/A	T0	Contact Switch	Tapeswitch	8 oz. Yellow	%
22	Pelvis Contact	N/A	T0	Contact Switch	Tapeswitch	8 oz. Yellow	%

**55/28 km/h Side Impact NCAP
Instrumentation Data Channel Assignments
Passenger SID/HIII Serial Number 275
2/27/03
2003 Toyota 4 Runner SR5 4WD SUV**

CH.	LOCATION	AXIS	IDENT. NO.	DESCRIPTION	MFR	MODEL	UNITS
23	Head CG	X	KEAC069	Accel.,1/2 bridge	Endevco	7264-2000X	G
24	Head CG	Y	KEAC080	Accel.,1/2 bridge	Endevco	7264-2000Y	G
25	Head CG	Z	KEAC082	Accel.,1/2 bridge	Endevco	7264-2000Z	G
26	Head CG, Redundant	X	KEAC083	Accel.,1/2 bridge	Endevco	7264-2000X	G
27	Head CG, Redundant	Y	KEAC084	Accel.,1/2 bridge	Endevco	7264-2000Y	G
28	Head CG, Redundant	Z	KEAC085	Accel.,1/2 bridge	Endevco	7264-2000Z	G
29	Neck Force	X	GPUN01FX	Load cell, six axis neck	R. A. Denton	1716A	N
30	Neck Force	Y	GPUN01FY	Load cell, six axis neck	R. A. Denton	1716A	N
31	Neck Force	Z	GPUN01FZ	Load cell, six axis neck	R. A. Denton	1716A	N
32	Neck Moment	X	GPUN01MX	Load cell, six axis neck	R. A. Denton	1716A	Nm
33	Neck Moment	Y	GPUN01MY	Load cell, six axis neck	R. A. Denton	1716A	Nm
34	Neck Moment	Z	GPUN01MZ	Load cell, six axis neck	R. A. Denton	1716A	Nm
35	Upper Rib Primary	Y	KEAC066	Accel.,1/2 bridge	Endevco	7264-2000X	G
36	Lower Rib, Primary	Y	KEAC067	Accel.,1/2 bridge	Endevco	7264-2000Y	G
37	Lower Spine, Primary	Y	KEAC068	Accel.,1/2 bridge	Endevco	7264-2000Z	G
38	Pelvis, Primary	Y	KEAC079	Accel.,1/2 bridge	Endevco	7264-2000X	G
39	Upper Rib Redundant	Y	KEAC073	Accel.,1/2 bridge	Endevco	7264-2000X	G
40	Lower Rib, Redundant	Y	KEAC074	Accel.,1/2 bridge	Endevco	7264-2000Y	G
41	Lower Spine, Redundant	Y	KEAC075	Accel.,1/2 bridge	Endevco	7264-2000Z	G
42	Pelvis, Redundant	Y	KEAC081	Accel.,1/2 bridge	Endevco	7264-2000X	G
43	Thorax Contact	Y	T0	Contact Switch	Tapeswitch	8 oz. Yellow	%
44	Pelvis Contact	Y	T0	Contact Switch	Tapeswitch	8 oz. Yellow	%

**55/28 km/h Side Impact NCAP
Instrumentation Data Channel Assignments
Vehicle Accelerometers**

2/27/03

2003 Toyota 4 Runner SR5 4WD SUV

CH.	LOCATION	AXIS	IDENT. NO.	DESCRIPTION	MFR	MODEL	UNITS
45	Right at Sill Front Seat	X	KETX2A	Accel., Triax	I.C. Sensor	3031-200	G
46	Right at Sill Front Seat	Y	KETX2B	Accel., Triax	I.C. Sensor	3031-200	G
47	Right at Sill Front Seat	Z	KETX2C	Accel., Triax	I.C. Sensor	3031-200	G
48	Right at Sill Rear Seat	X	KETX3A	Accel., Triax	I.C. Sensor	3031-500	G
49	Right at Sill Rear Seat	Y	KETX3B	Accel., Triax	I.C. Sensor	3031-500	G
50	Right at Sill Rear Seat	Z	KETX3C	Accel., Triax	I.C. Sensor	3031-500	G
51	Rear Floorpan Above Axle	X	KETX4A	Accel., Triax	I.C. Sensor	3031-500	G
52	Rear Floorpan Above Axle	Y	KETX4B	Accel., Triax	I.C. Sensor	3031-500	G
53	Rear Floorpan Above Axle	Z	KETX4C	Accel., Triax	I.C. Sensor	3031-500	G
54	Left Sill at Rear Door	Y	KEVA012	Accel., Vehicle block	I.C. Sensor	3031-500	G
55	Left Sill at Front Door	Y	KEVA001	Accel., Vehicle block	I.C. Sensor	3031-500	G
56	Left Front Door Centerline	Y	ICST004X	Accel., Triax	I.C. Sensor	3031-500	G
57	Rear Occupant Compartment	Y	KEVA006	Accel., Vehicle block	I.C. Sensor	3031-200	G
58	Left Front Door Mid-Rear	Y	ICST004Y	Accel., Triax	I.C. Sensor	3031-500	G
59	Left Front Door Upper Centerline	Y	ICST004Z	Accel., Triax	I.C. Sensor	3031-500	G
60	Rear Door Mid-Rear	Y	ICST005X	Accel., Triax	I.C. Sensor	3031-500	G
61	Rear Door Upper Centerline	Y	ICST005Y	Accel., Triax	I.C. Sensor	3031-500	G
62	B-Post Lower	Y	KEBX2A	Accel., Biax	I.C. Sensor	3031-500	G
63	B-Post Middle	Y	KEBX2B	Accel., Biax	I.C. Sensor	3031-500	G
64	A-Post Lower	Y	KEBX1A	Accel., Biax	I.C. Sensor	3031-200	G
65	A-Post Middle	Y	KEBX1B	Accel., Biax	I.C. Sensor	3031-500	G
66	Front Seat Track	Y	KEIC008Y	Single	I.C. Sensor	3031-500	G
67	Rear Seat Structure	Y	N/A	N/A	N/A	N/A	N/A
68	Vehicle CG	X	KETX2A	Accel., Triax	I.C. Sensor	3031-200	G
69	Vehicle CG	Y	KETX2B	Accel., Triax	I.C. Sensor	3031-200	G
70	Vehicle CG	Z	KETX2C	Accel., Triax	I.C. Sensor	3031-200	G

**55/28 km/h Side Impact NCAP
Instrumentation Data Channel Assignments
Moving Deformable Barrier
2/27/03
2003 Toyota 4 Runner SR5 4WD SUV**

CH.	LOCATION	AXIS	IDENT. NO.	DESCRIPTION	MFR	MODEL	UNITS
71	MDB CG	X	ICST001X	Accel., Triax	I.C. Sensor	3031-500	G
72	MDB CG	Y	ICST001Y	Accel., Triax	I.C. Sensor	3031-500	G
73	MDB CG	Z	ICST001Z	Accel., Triax	I.C. Sensor	3031-500	G
74	MDB Rear Centerline	X	ICST002X	Accel., Triax	I.C. Sensor	3031-50	G
75	MDB Rear Centerline	Y	ICST002Y	Accel., Triax	I.C. Sensor	3031-50	G
76	Right Bumper Contact	N/A	T0	Contact Switch	Tapeswitch	40 oz. Grey	%