

REPORT NUMBER: NCAPCHILD-MGA-2003-003

**NEW CAR ASSESSMENT PROGRAM
FRONTAL BARRIER IMPACT TEST**

**Evenflo Vanguard 5
Evenflo Titan**

NHTSA NUMBER: M30100

**PREPARED BY:
MGA RESEARCH CORPORATION
5000 WARREN ROAD
BURLINGTON, WI 53105**



Test Date: January 8, 2003

Report Date: January 20, 2003

FINAL REPORT

**PREPARED FOR:
U.S. DEPARTMENT OF TRANSPORTATION
NATIONAL HIGHWAY TRAFFIC SAFETY ADMINISTRATION
RULEMAKING
OFFICE OF CRASHWORTHINESS STANDARDS
400 SEVENTH STREET, SW, ROOM 5313
WASHINGTON, D.C. 20590**

This final test report was prepared for the U.S. Department of Transportation, National Highway Traffic Safety Administration, in response to Contract Number DTNH22-01-D-12005.

This publication is distributed by the U.S. Department of Transportation, National Highway Traffic Safety Administration, in the interest of information exchange. The opinions, findings and conclusions expressed in this publication are those of the author(s) and not necessarily those of the Department of Transportation or the National Highway Traffic Safety Administration. The United States Government assumes no liability for its contents or use thereof. If trade or manufacturers' names or products are mentioned it is only because they are considered essential to the object of the publication and should not be construed as an endorsement. The United States Government does not endorse products or manufacturers.

Prepared by: David Winkelbauer Date: 1/20/03
David Winkelbauer, Facility Director

Reviewed by: Gary Strassburg Date: 1/20/03
Gary Strassburg, Project Engineer

FINAL REPORT ACCEPTED BY:

Manager, New Car Assessment Program

Date of Acceptance

COTR, NCAP Frontal Impact Program

Date of Acceptance

Technical Report Documentation Page

1. Report No. NCAPCHILD-MGA-2003-003		2. Government Accession No.		3. Recipient's Catalog No.																									
4. Title and Subtitle Final Report of New Car Assessment Program Testing of Evenflo Vanguard 5 and Evenflo Titan Child Restraint Systems NHTSA No.: M30100				5. Report Date January 20, 2003																									
				6. Performing Organization Code MGA																									
7. Author(s) David Winkelbauer, Project Engineer				8. Performing Organization Report No. NCAPCHILD-MGA-2003-003																									
9. Performing Organization Name and Address MGA Research Corporation 5000 Warren Road Burlington, WI 53105				10. Work Unit No.																									
				11. Contract or Grant No. DTNH22-01-D-12005																									
12. Sponsoring Agency Name and Address U.S. Department of Transportation National Highway Traffic Safety Administration Rulemaking, Office of Crashworthiness Standards 400 Seventh Street, SW, Room 5313 Washington, D.C. 20590				13. Type of Report and Period Covered Final Report 1/8/03 to 1/20/03																									
				14. Sponsoring Agency Code NVS-111																									
15. Supplementary Notes																													
16. Abstract The subject CRS Evenflo Vanguard 5 and Evenflo Titan were tested in conjunction with a Frontal NCAP test in support of research in accordance with the specifications of the Office of Crashworthiness Standards Test Procedure for the determination of CRS crashworthiness. This test was conducted at MGA Research Corporation in Burlington, Wisconsin on January 8, 2003 in conjunction with Frontal NCAP.																													
<table border="1"> <thead> <tr> <th>Measurement Description</th> <th>Units</th> <th colspan="2">Threshold / Pos. 3 ATD</th> <th colspan="2">Threshold / Pos. 4 ATD</th> </tr> </thead> <tbody> <tr> <td>Head Injury Criteria (HIC36)</td> <td>N/A</td> <td>N/A</td> <td>502</td> <td>N/A</td> <td>542</td> </tr> <tr> <td>Head Injury Criteria (HIC15)</td> <td>N/A</td> <td>570</td> <td>245</td> <td>390</td> <td>258</td> </tr> <tr> <td>Max. Thorax Accel. (3msec Clip)</td> <td>G's</td> <td>55</td> <td>32</td> <td>50</td> <td>35</td> </tr> </tbody> </table>						Measurement Description	Units	Threshold / Pos. 3 ATD		Threshold / Pos. 4 ATD		Head Injury Criteria (HIC36)	N/A	N/A	502	N/A	542	Head Injury Criteria (HIC15)	N/A	570	245	390	258	Max. Thorax Accel. (3msec Clip)	G's	55	32	50	35
Measurement Description	Units	Threshold / Pos. 3 ATD		Threshold / Pos. 4 ATD																									
Head Injury Criteria (HIC36)	N/A	N/A	502	N/A	542																								
Head Injury Criteria (HIC15)	N/A	570	245	390	258																								
Max. Thorax Accel. (3msec Clip)	G's	55	32	50	35																								
17. Key Words 56.3 km/h NCAP Frontal Barrier Impact Test New Car Assessment Program (NCAP) Evenflo Vanguard 5 Evenflo Titan NHTSA No: M30100				18. Distribution Statement Copies of this report are available from: National Highway Traffic Safety Admin., Technical Ref. Division, Room 5108 (NAD-52) 400 Seventh Street, S.W. Washington, D.C. 20590																									
19. Security Classif. (of this report) Unclassified		20. Security Classif. (of this page) Unclassified		21. No. of Pages 100	22. Price																								

Form DOT F1700.7 (8-72)

TABLE OF CONTENTS

<u>Section</u>		<u>Page No</u>
1	Purpose and Summary of Test	1
2	Data Sheets	2
<u>Data Sheet No.</u>		
1	Crash Test Summary	2
2	CRS Parameter Data	3
3	Child Dummy Positioning in Vehicle	4
4	Child Dummy Injury Criteria Values	5
5	CRS Performance Data	8
6	CRS Camera Data	9
<u>Appendix</u>		
A	Photographs	A
B	Child Dummy Response Data Traces	B
C	Child Dummy Calibration Information	C
D	Test Equipment List and Calibration Information	D

SECTION 1

PURPOSE AND SUMMARY OF TEST

PURPOSE

The purpose of this test was to obtain CRS performance data in a frontal impact NCAP condition.

This 56.5 kph frontal barrier impact test is part of the Vehicle Barrier Impact Testing Program sponsored by the National Highway Traffic Safety Administration (NHTSA) under contract number DTNH22-01-D-12005.

SUMMARY

Both child dummies were instrumented with head, chest, and pelvic triaxial accelerometers. In addition, rear head z acceleration, and upper and lower six axis neck force and moment sensors were utilized.

The right rear (Position 3) child dummy (S/N 42) and left rear (Position 4) child dummy (S/N 40) were calibrated before this test. Child dummy certification information is found in Appendix C.

The right rear child dummy's HIC was 502; maximum chest deceleration over 3 msec was 31.8 g's. The left rear child dummy's HIC was 542; maximum chest deceleration over 3 msec was 35.0 g's. Position 3 used the vehicle LATCH and top tether for attachment. Position 4 used the vehicle lap and shoulder belt and top tether for attachment.

**SECTION 2
DATA SHEET NO. 1
CRASH TEST SUMMARY**

TEST DUMMY INFORMATION

Description	Position 3 CRS	Position 4 CRS
Dummy Type / Serial No.	HIII 3 Year Old / 42	HIII 3 Year Old / 40
Number of Data Channels	23	23
Restraint System	Evenflo Vanguard 5	Evenflo Titan

CAMERA COVERAGE

High Speed	16
Real Time	1
Total	17

POST TEST DOOR OPENING

Description	Front	Rear
Left Side Doors	Door remained closed and latched; Door opened with tools	Door remained closed and latched; Door opened with tools
Right Side Doors	Door remained closed and latched; Door opened without tools	Door remained closed and latched; Door opened without tools
Hatch/Other Door	None	None

POST TEST SEAT DATA

Location	Seat Movement (mm)	Seat Back Failure
P1 (Left Front)	3	None
P2 (Right Front)	0	None
P3 (Right Rear)	0	None
P4 (Left Rear)	0	None

VISIBLE DUMMY CONTACT POINTS

Description	Position 3 CRS (S/N 42)	Position 4 CRS (S/N 40)
Head Contact	Right rear headrest	Overhead Shield
Upper Torso Contact	None	None
Lower Torso Contact	None	None
Left Foot Contact	Seat back	Seat back
Right Foot Contact	Seat back	Seat back

SECTION 2... (continued)

**DATA SHEET NO. 2
CRS PARAMETER DATA**

Child Restraint System (Position 3)	Evenflo Vanguard 5
Child Restraint System (Position 4)	Evenflo Titan
NHTSA No.	M30100

TARGET TEST WEIGHT CALCULATION

Measured Parameter	Units	Value
Total Delivered Weight (UVW)	kg	2667.6
Weight of 2 P572E ATDs	kg	156.0
Rated Cargo/Luggage Weight (RCLW)	kg	99.3
Calculated Vehicle Target Weight (TVTW)	kg	2922.9

TEST VEHICLE WEIGHTS

	Units	As Tested (ATW) (Axle)		
		Front	Rear	Total
Left	kg	783.4	711.7	
Right	kg	703.1	718.5	
Ratio	%	51.0	49.0	
Totals	kg	1486.5	1430.2	2916.7

As tested weight of vehicle includes two ATDs, two 3 year olds with CRS, cargo, equipment and instrumentation.

SECTION 2... (continued)

DATA SHEET NO. 3
CHILD DUMMY POSITIONING IN VEHICLE

Child Restraint System (Position 3)	Evenflo Vanguard 5
Child Restraint System (Position 4)	Evenflo Titan
NHTSA No.	M30100

Dummy Measurements for CRS Passengers

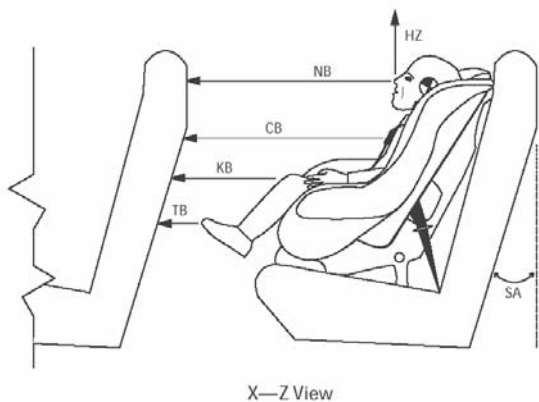

X—Z View

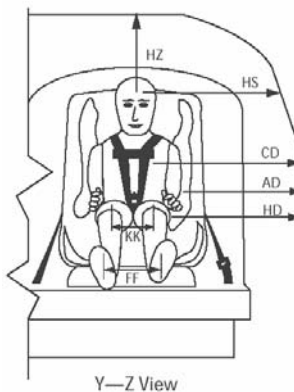

Y—Z View

X—Z View

HZ	-	Head to Roof
HS	-	Head to Side Window
CD	-	Chest to Door
AD	-	Arm to Door
HD	-	H-Point to Door
KK	-	Knee to Knee
FF	-	Foot to Foot
NB	-	Nose to Front Seat Back
CB	-	Chest to Front Seat Back
KB	-	Knee to Front Seat Back
TB	-	Toe to Front Seat Back
SA	-	Seat Back Angle

Measurement	Pre-Test (mm)		Post-Test (mm)	
	P3 CRS (42)	P4 CRS (40)	P3 CRS (42)	P4 CRS (40)
SA (deg)	23.7	23.7	23.7	23.7
HS	424	430	408	433
CD	391	382	372	382
AD	249	238	232	230
HD	314	282	294	270
HZ	396	382	382	380
NB	667	624	642	640
CB	670	610	642	635
KK	135	148	128	155
FF	135	148	85	189
KB - LEFT	379	354	375	320
KB - RIGHT	380	358	370	325
TB - LEFT	92	68	86	80
TB - RIGHT	89	62	95	69

All dimensions in mm (unless noted)

P3 – Right Rear Passenger

P4 – Left Rear Passenger

SECTION 2... (continued)

**DATA SHEET NO. 4
CHILD DUMMY INJURY CRITERIA VALUES**

Child Restraint System (Position 3)	Evenflo Vanguard 5
Child Restraint System (Position 4)	Evenflo Titan
NHTSA No.	M30100

HEAD PEAK ACCELERATIONS

Location	Axis	Units	Position 3				Position 4			
			Max	Time	Min	Time	Max	Time	Min	Time
Head CG	X	G's	41.1	199	-29.8	95	1.0	40	-34.0	122
Head CG	Y	G's	1.3	200	-5.5	112	2.9	72	-6.3	88
Head CG	Z	G's	40.7	102	-10.7	49	44.7	87	-8.4	49
Resultant	N/A	G's	49.5	199			51.7	97		
Rear	Z	G's	55.3	96	-19.1	51	59.6	92	-14.5	50

UPPER NECK PEAK FORCES AND MOMENTS

Location	Axis	Units	Position 3				Position 4			
			Max	Time	Min	Time	Max	Time	Min	Time
Neck Force	X	N	14	177	-657	95	12	20	-857	119
Neck Force	Y	N	6	52	-122	117	138	131	-49	65
Neck Force	Z	N	1635	98	-276	49	1370	103	-282	49
Resultant	N/A	N	1757	98			1568	101		
Neck Moment	X	N•m	1.7	193	-10.5	96	1.1	183	-10.4	99
Neck Moment	Y	N•m	5.4	168	-9.4	105	3.9	159	-6.2	112
Neck Moment	Z	N•m	4.2	115	-1.0	188	2.3	116	-1.2	59
Resultant	N/A	N•m	13.4	101			11.3	99		

LOWER NECK PEAK FORCES AND MOMENTS

Location	Axis	Units	Position 3				Position 4			
			Max	Time	Min	Time	Max	Time	Min	Time
Neck Force	X	N	109	200	-672	101	146	200	-584	104
Neck Force	Y	N	114	84	-81	128	96	72	-47	15
Neck Force	Z	N	807	101	-465	50	700	92	-323	49
Resultant	N/A	N	1050	101			830	102		
Neck Moment	X	N•m	2.2	76	-23.0	117	3.7	74	-21.3	114
Neck Moment	Y	N•m	100.2	95	-8.5	200	94.1	98	-10.6	200
Neck Moment	Z	N•m	0.5	27	-14.5	96	1.6	136	-10.9	95
Resultant	N/A	N•m	102.1	95			96.3	98		

SECTION 2... (continued)

**DATA SHEET NO. 4... (continued)
CHILD DUMMY INJURY CRITERIA VALUES**

Child Restraint System (Position 3)	Evenflo Vanguard 5
Child Restraint System (Position 4)	Evenflo Titan
NHTSA No.	M30100

CHEST PRIMARY PEAK ACCELERATIONS

Location	Axis	Units	Position 3				Position 4			
			Max	Time	Min	Time	Max	Time	Min	Time
Chest CG	X	G's	4.1	153	-28.2	114	3.4	153	-35.8	96
Chest CG	Y	G's	0.8	200	-5.4	93	1.1	116	7.1	94
Chest CG	Z	G's	7.5	200	-22.5	80	6.9	91	-19.0	71
Resultant	N/A	G's	32.4	81			36.4	96		

TETHER FORCE

Location	Axis	Units	Position 3				Position 4			
			Max	Time	Min	Time	Max	Time	Min	Time
Tether Force	N/A	N	486	99			615	94		

PELVIC PEAK ACCELERATIONS

Location	Axis	Units	Position 3				Position 4			
			Max	Time	Min	Time	Max	Time	Min	Time
Pelvis	X	G's	7.3	167	-33.6	74	10.1	132	-51.9	77
Pelvis	Y	G's	2.8	105	-3.6	74	6.7	93	-14.1	102
Pelvis	Z	G's	21.5	83	-5.4	200	1.9	87	-22.4	76
Resultant	N/A	G's	39.0	74			56.3	76		

SECTION 2... (continued)
DATA SHEET NO. 4... (continued)
CHILD DUMMY INJURY CRITERIA VALUES

Child Restraint System (Position 3)	Evenflo Vanguard 5
Child Restraint System (Position 4)	Evenflo Titan
NHTSA No.	M30100

HEAD INJURY CRITERIA (HIC36)

Location	HIC	T ¹ (msec)	T ² (msec)	Average Acceleration (G's)
Position 3 - Right	502	85.5	121.5	45.5
Position 4 – Left	542	81.7	117.7	46.9

HIC is as defined in FMVSS 208. The maximum time interval from t1 to t2 is 36 milliseconds.

HEAD INJURY CRITERIA (HIC15)

Location	HIC	T ¹ (msec)	T ² (msec)	Average Acceleration (G's)
Position 3 - Right	245	93.1	108.1	48.4
Position 4 – Left	258	91.6	106.6	49.5

HIC is as defined in FMVSS 208. The maximum time interval from t1 to t2 is 15 milliseconds.

CLIP SUMMARY

Location	CLIP	T ¹ (msec)	T ² (msec)
Position 3 - Right	32	79.4	82.4
Position 4 – Left	35	96.7	99.7

The maximum chest resultant acceleration is defined as the maximum acceleration which exceeds 0.003 seconds in duration.

POSITION 3 NECK INJURY SUMMARIES

Nij V10	Nij
Ntf	0.49
Nte	0.97
Ncf	0.0
Nce	0.26

POSITION 4 NECK INJURY SUMMARIES

Nij V10	Nij
Ntf	0.17
Nte	0.76
Ncf	0.03
Nce	0.19

SECTION 2... (continued)

**DATA SHEET NO. 5
CRS PERFORMANCE DATA**

Child Restraint System (Position 3)	Evenflo Vanguard 5
Child Restraint System (Position 4)	Evenflo Titan
NHTSA No.	M30100

POSITION 3 CRS POST-TEST INSPECTION

Location	Damage	Remarks
Upper Tether Strap	None	
Upper Tether Buckle	None	
Upper Tether Hook	None	
Vehicle Upper Tether Anchor	None	
Lower Anchor Strap	None	
Lower Anchor Buckle	None	
Lower Anchor Hooks	None	
Vehicle Lower CRS Anchors	None	
Five Point Harness Connections	None	
Cracks on CRS	None	
Fabric Tears on CRS	None	
Vehicle Seat Structure	None	
Vehicle Seat Fabric Tears	None	
Child Dummy	None	

POSITION 4 CRS POST-TEST INSPECTION

Location	Damage	Remarks
Upper Tether Strap	None	
Upper Tether Buckle	None	
Upper Tether Hook	None	
Vehicle Upper Tether Anchor	None	
Lower Anchor Strap	None	
Lower Anchor Buckle	None	
Lower Anchor Hooks	None	
Vehicle Lower CRS Anchors	None	
Five Point Harness Connections	None	
Cracks on CRS	Yes	At vehicle seat belt locations
Fabric Tears on CRS	None	
Vehicle Seat Structure	None	
Vehicle Seat Fabric Tears	None	
Child Dummy	None	

SECTION 2... (continued)

DATA SHEET NO. 6
CRS CAMERA DATA

Child Restraint System (Position 3)	Evenflo Vanguard 5
Child Restraint System (Position 4)	Evenflo Titan
NHTSA No.	M30100

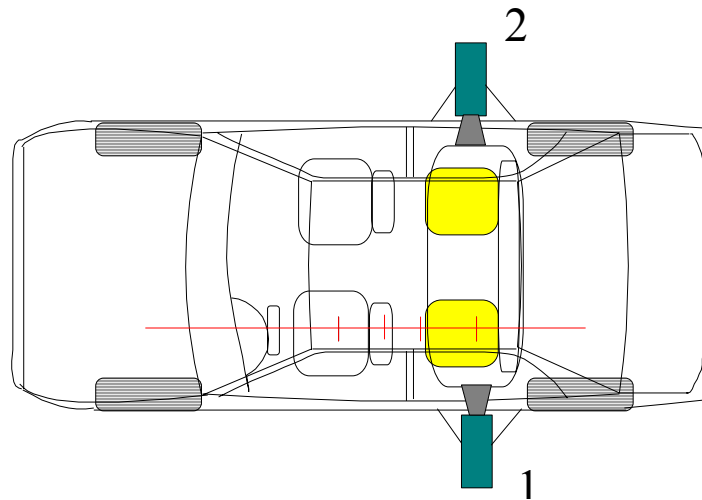

No.	Camera View	Location (mm) *			Angle (deg)	Lens (mm)	Speed (fps)
		X	Y	Z			
1	Left Side CRS Lateral View					13	513
2	Right Side CRS Lateral View					13	503

*COORDINATES:

- +X = film plane rearward of barrier
- +Y = film plane to right of monorail centerline
- +Z = film plane above ground level

APPENDIX A
PHOTOGRAPHS

TABLE OF PHOTOGRAPHS

Photo No. 1.	Close-up View of Position 3 CRS Label	A-1
Photo No. 2.	Pre-Test Frontal View of Position 3 CRS	A-2
Photo No. 3.	Post-Test Front View of Position 3 CRS	A-3
Photo No. 4.	Pre-Test Rear View of Position 3 CRS	A-4
Photo No. 5.	Post-Test Rear View of Position 3 CRS	A-5
Photo No. 6.	Pre-Test Left Side View of Position 3 CRS	A-6
Photo No. 7.	Post-Test Left Side View of Position 3 CRS	A-7
Photo No. 8.	Pre-Test Right Side View of Position 3 CRS	A-8
Photo No. 9.	Post-Test Right Side View of Position 3 CRS	A-9
Photo No. 10.	Close-up View of Position 4 CRS Label	A-10
Photo No. 11.	Pre-Test Frontal View of Position 4 CRS	A-11
Photo No. 12.	Post-Test Front View of Position 4 CRS	A-12
Photo No. 13.	Pre-Test Rear View of Position 4 CRS	A-13
Photo No. 14.	Post-Test Rear View of Position 4 CRS	A-14
Photo No. 15.	Pre-Test Left Side View of Position 4 CRS	A-15
Photo No. 16.	Post-Test Left Side View of Position 4 CRS	A-16
Photo No. 17.	Pre-Test Right Side View of Position 4 CRS	A-17
Photo No. 18.	Post-Test Right Side View of Position 4 CRS	A-18
Photo No. 19.	Pre-Test Position 3 Right Side View	A-19
Photo No. 20.	Post-Test Position 3 Right Side View	A-20
Photo No. 21.	Pre-Test Position 3 Right $\frac{3}{4}$ Side View	A-21
Photo No. 22.	Post-Test Position 3 Right $\frac{3}{4}$ Side View	A-22
Photo No. 23.	Pre-Test Position 4 Left Side View	A-23
Photo No. 24.	Post-Test Position 4 Left Side View	A-24
Photo No. 25.	Pre-Test Position 4 Left $\frac{3}{4}$ Side View	A-25
Photo No. 26.	Post-Test Position 4 Left $\frac{3}{4}$ Side View	A-26
Photo No. 27.	Post-Test Position 3 Feet Contact	A-27
Photo No. 28.	Post-Test Position 4 Feet Contact	A-28
Photo No. 29.	Post-Test Position 3 Head Contact (headrest)	A-29
Photo No. 30.	Post-Test Position 4 Head Contact (overhead shield)	A-30
Photo No. 31.	Post-Test Position 4 CRS Seat Damage	A-31
Photo No. 32.	Post-Test Position 4 CRS Seat Damage	A-32
Photo No. 33.	Post-Test Position 4 CRS Seat Damage	A-33

Manufactured in 22NOV02

Model # 3691261 P1

Close-up View of Position 3 CRS Label

A-2.



Pre-Test Frontal View of Position 3 CRS

A-3.



Post-Test Front View of Position 3 CRS

A-4.



Pre-Test Rear View of Position 3 CRS

A-5.



Post-Test Rear View of Position 3 CRS

A-6.



Pre-Test Left Side View of Position 3 CRS

A-7.



Post-Test Left Side View of Position 3 CRS

A-8.



Pre-Test Right Side View of Position 3 CRS

A-9.



Post-Test Right Side View of Position 3 CRS



Close-up View of Position 4 CRS Label

A-11.



Pre-Test Frontal View of Position 4 CRS

A-12.



Post-Test Front View of Position 4 CRS

A-13.



Pre-Test Rear View of Position 4 CRS

A-14.



Post-Test Rear View of Position 4 CRS

A-15.



Pre-Test Left Side View of Position 4 CRS

A-16.



Post-Test Left Side View of Position 4 CRS

A-17.



Pre-Test Right Side View of Position 4 CRS

A-18.



Post-Test Right Side View of Position 4 CRS



Pre-Test Position 3 Right Side View

A-20.



Post-Test Position 3 Right Side View

A-21.



Pre-Test Position 3 Right ¾ Side View

A-22.



Post-Test Position 3 Right ¾ Side View



Pre-Test Position 4 Left Side View

A-24.



Post-Test Position 4 Left Side View

A-25.

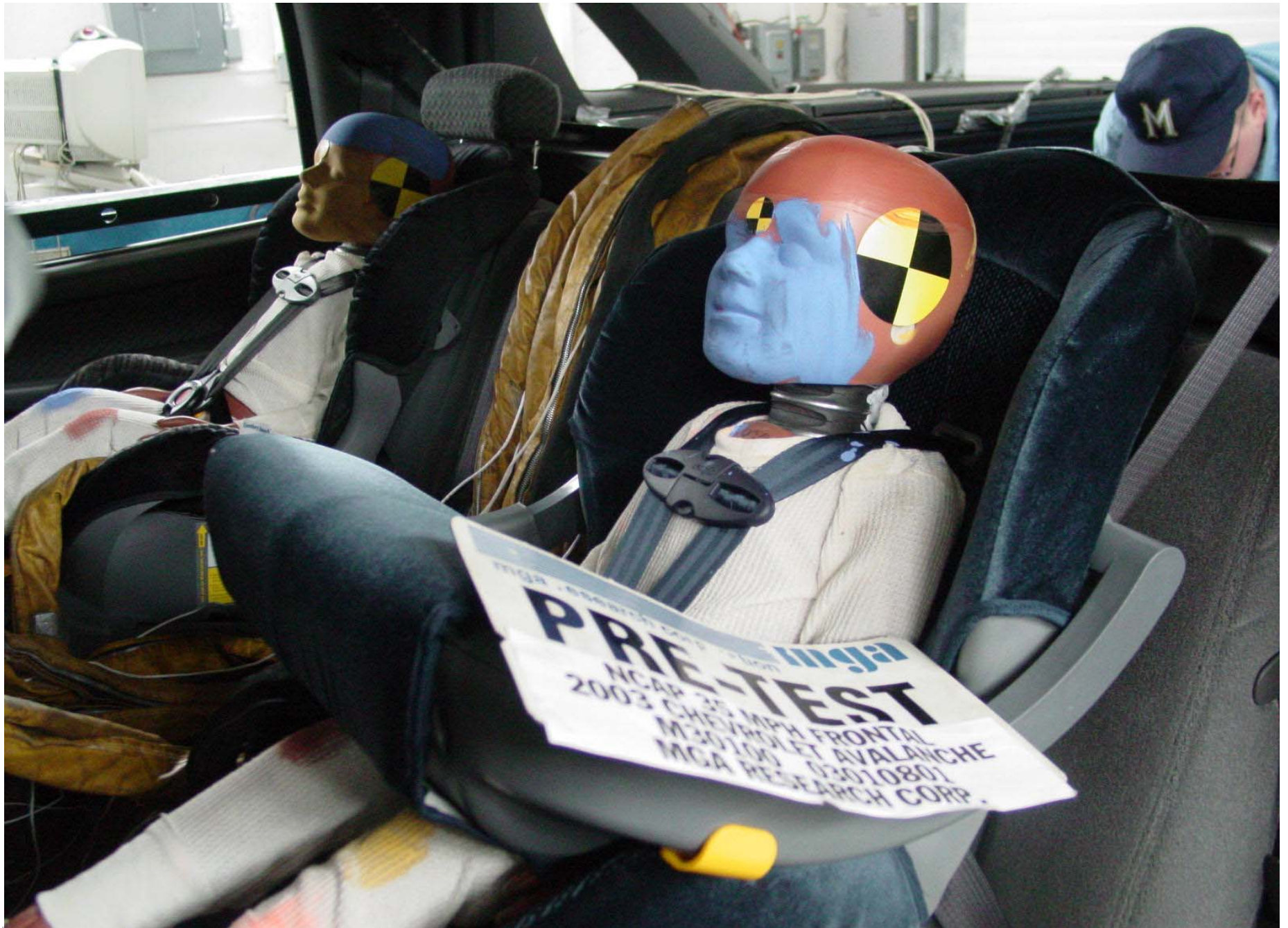

Pre-Test Position 4 Left ¾ Side View



Post-Test Position 4 Left ¾ Side View



Post-Test Position 3 Feet Contact



Post-Test Position 4 Feet Contact



Post-Test Position 3 Head Contact (headrest)



Post-Test Position 4 Head Contact (overhead shield)

A-31.



Post-Test Position 4 CRS Seat Damage

A-32.



Post-Test Position 4 CRS Seat Damage

A-33.



Post-Test Position 4 CRS Seat Damage

APPENDIX B
CHILD DUMMY RESPONSE DATA TRACES

TABLE OF DATA PLOTS

Figure No. 1.	LRP Child Head X Acceleration vs. Time	B-1
Figure No. 2.	LRP Child Head Y Acceleration vs. Time	B-1
Figure No. 3.	LRP Child Head Z Acceleration vs. Time	B-1
Figure No. 4.	LRP Child Head Resultant Acceleration vs. Time	B-1
Figure No. 5.	LRP Child Head X Velocity vs. Time	B-2
Figure No. 6.	LRP Child Head Y Velocity vs. Time	B-2
Figure No. 7.	LRP Child Head Z Velocity vs. Time	B-2
Figure No. 8.	LRP Child Upper Neck Force X vs. Time	B-3
Figure No. 9.	LRP Child Upper Neck Force Y vs. Time	B-3
Figure No. 10.	LRP Child Upper Neck Force Z vs. Time	B-3
Figure No. 11.	LRP Child Upper Neck Force Resultant vs. Time	B-3
Figure No. 12.	LRP Child Upper Neck Moment X vs. Time	B-4
Figure No. 13.	LRP Child Upper Neck Moment Y vs. Time	B-4
Figure No. 14.	LRP Child Upper Neck Moment Z vs. Time	B-4
Figure No. 15.	LRP Child Upper Neck Moment Resultant vs. Time	B-4
Figure No. 16.	LRP Child Lower Neck Force X vs. Time	B-5
Figure No. 17.	LRP Child Lower Neck Force Y vs. Time	B-5
Figure No. 18.	LRP Child Lower Neck Force Z vs. Time	B-5
Figure No. 19.	LRP Child Lower Neck Force Resultant vs. Time	B-5
Figure No. 20.	LRP Child Lower Neck Moment X vs. Time	B-6
Figure No. 21.	LRP Child Lower Neck Moment Y vs. Time	B-6
Figure No. 22.	LRP Child Lower Neck Moment Z vs. Time	B-6
Figure No. 23.	LRP Child Lower Neck Moment Resultant vs. Time	B-6
Figure No. 24.	LRP Child Chest X Acceleration vs. Time	B-7
Figure No. 25.	LRP Child Chest Y Acceleration vs. Time	B-7
Figure No. 26.	LRP Child Chest Z Acceleration vs. Time	B-7
Figure No. 27.	LRP Child Chest Resultant Acceleration vs. Time	B-7
Figure No. 28.	LRP Child Chest X Velocity vs. Time	B-8
Figure No. 29.	LRP Child Chest Y Velocity vs. Time	B-8
Figure No. 30.	LRP Child Chest Z Velocity vs. Time	B-8

Figure No. 31.	LRP Child Chest Displacement vs. Time	B-8
Figure No. 32.	LRP Child Pelvis X Acceleration vs. Time	B-9
Figure No. 33.	LRP Child Pelvis Y Acceleration vs. Time	B-9
Figure No. 34.	LRP Child Pelvis Z Acceleration vs. Time	B-9
Figure No. 35.	LRP Child Pelvis Resultant Acceleration vs. Time	B-9
Figure No. 36.	LRP Child Pelvis X Velocity vs. Time	B-10
Figure No. 37.	LRP Child Pelvis Y Velocity vs. Time	B-10
Figure No. 38.	LRP Child Pelvis Z Velocity vs. Time	B-10
Figure No. 39.	LRP Tether Force vs. Time	B-11
Figure No. 40.	LRP Child Head Z – Rear Acceleration vs. Time	B-11
Figure No. 41.	LRP Child Head Z – Rear Velocity vs. Time	B-11
Figure No. 42.	RRP Child Head X Acceleration vs. Time	B-12
Figure No. 43.	RRP Child Head Y Acceleration vs. Time	B-12
Figure No. 44.	RRP Child Head Z Acceleration vs. Time	B-12
Figure No. 45.	RRP Child Head Resultant Acceleration vs. Time	B-12
Figure No. 46.	RRP Child Head X Velocity vs. Time	B-13
Figure No. 47.	RRP Child Head Y Velocity vs. Time	B-13
Figure No. 48.	RRP Child Head Z Velocity vs. Time	B-13
Figure No. 49.	RRP Child Upper Neck Force X vs. Time	B-14
Figure No. 50.	RRP Child Upper Neck Force Y vs. Time	B-14
Figure No. 51.	RRP Child Upper Neck Force Z vs. Time	B-14
Figure No. 52.	RRP Child Upper Neck Force Resultant vs. Time	B-14
Figure No. 53.	RRP Child Upper Neck Moment X vs. Time	B-15
Figure No. 54.	RRP Child Upper Neck Moment Y vs. Time	B-15
Figure No. 55.	RRP Child Upper Neck Moment Z vs. Time	B-15
Figure No. 56.	RRP Child Upper Neck Moment Resultant vs. Time	B-15
Figure No. 57.	RRP Child Lower Neck Force X vs. Time	B-16
Figure No. 58.	RRP Child Lower Neck Force Y vs. Time	B-16
Figure No. 59.	RRP Child Lower Neck Force Z vs. Time	B-16
Figure No. 60.	RRP Child Lower Neck Force Resultant vs. Time	B-16
Figure No. 61.	RRP Child Lower Neck Moment X vs. Time	B-17

Figure No. 62.	RRP Child Lower Neck Moment Y vs. Time	B-17
Figure No. 63.	RRP Child Lower Neck Moment Z vs. Time	B-17
Figure No. 64.	RRP Child Lower Neck Moment Resultant vs. Time	B-17
Figure No. 65.	RRP Child Chest X Acceleration vs. Time	B-18
Figure No. 66.	RRP Child Chest Y Acceleration vs. Time	B-18
Figure No. 67.	RRP Child Chest Z Acceleration vs. Time	B-18
Figure No. 68.	RRP Child Chest Resultant Acceleration vs. Time	B-18
Figure No. 69.	RRP Child Chest X Velocity vs. Time	B-19
Figure No. 70.	RRP Child Chest Y Velocity vs. Time	B-19
Figure No. 71.	RRP Child Chest Z Velocity vs. Time	B-19
Figure No. 72.	RRP Child Chest Displacement vs. Time	B-19
Figure No. 73.	RRP Child Pelvis X Acceleration vs. Time	B-20
Figure No. 74.	RRP Child Pelvis Y Acceleration vs. Time	B-20
Figure No. 75.	RRP Child Pelvis Z Acceleration vs. Time	B-20
Figure No. 76.	RRP Child Pelvis Resultant Acceleration vs. Time	B-20
Figure No. 77.	RRP Child Pelvis X Velocity vs. Time	B-21
Figure No. 78.	RRP Child Pelvis Y Velocity vs. Time	B-21
Figure No. 79.	RRP Child Pelvis Z Velocity vs. Time	B-21
Figure No. 80.	RRP Tether Force vs. Time	B-22
Figure No. 81.	RRP Child Head Z – Rear Acceleration vs. Time	B-22
Figure No. 82.	RRP Child Head Z – Rear Velocity vs. Time	B-22

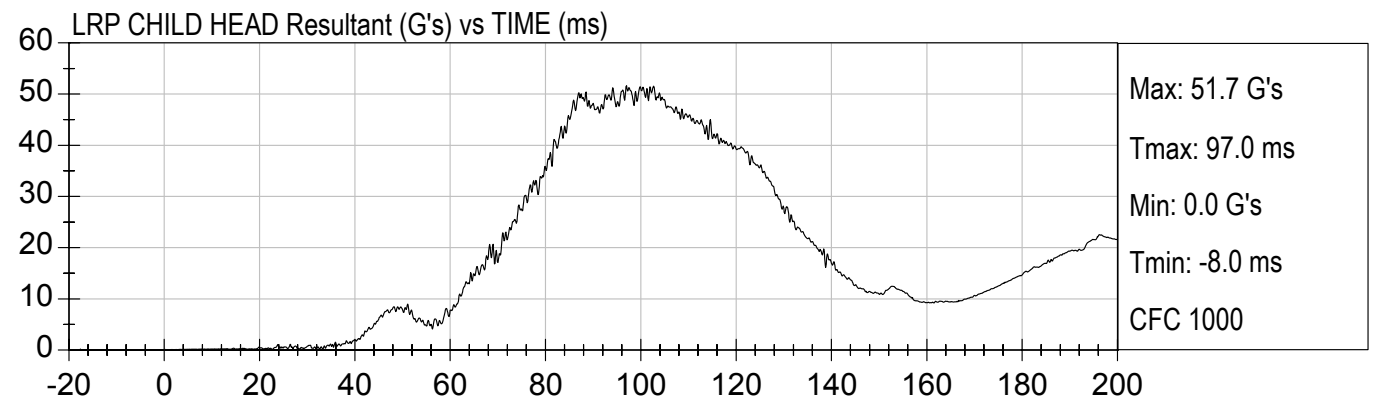
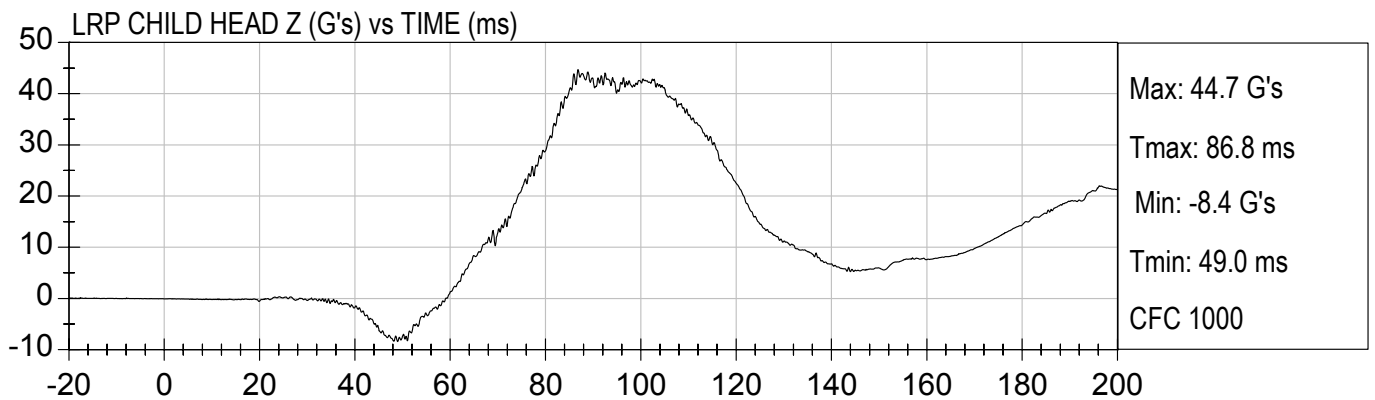
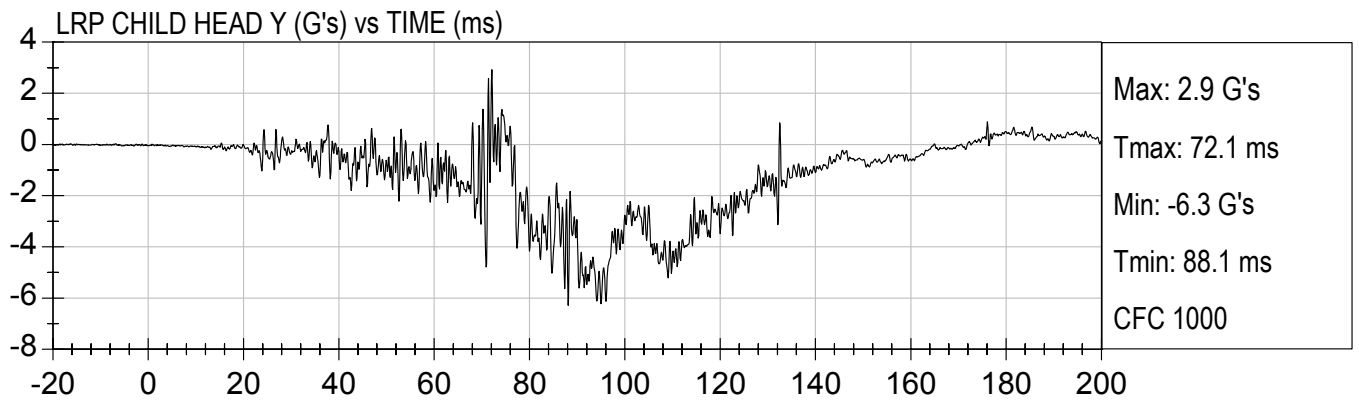
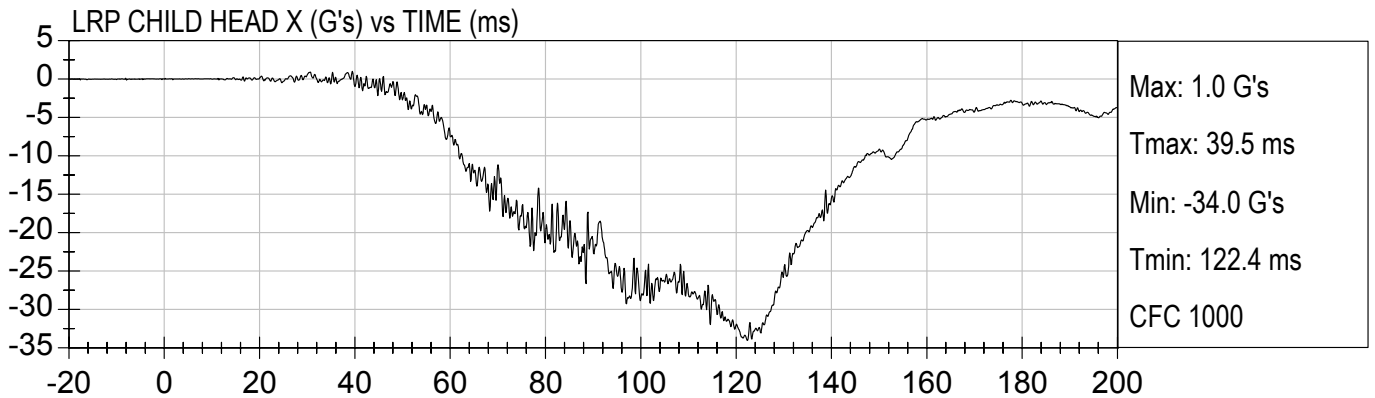

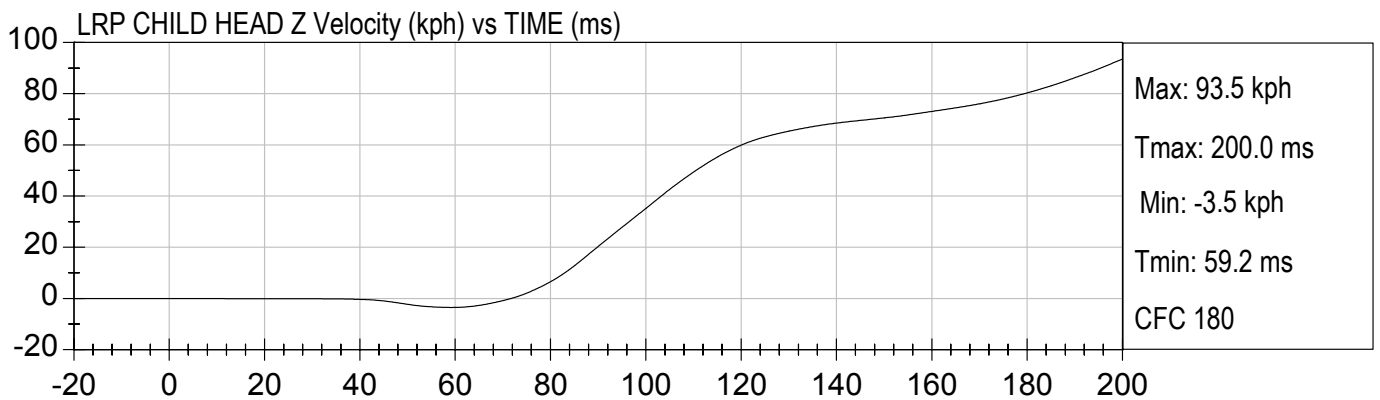
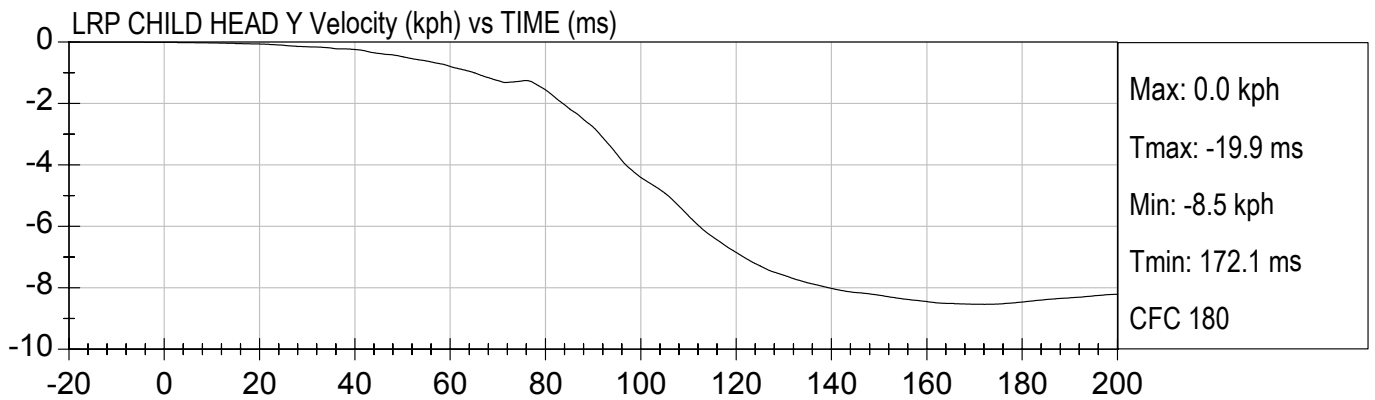
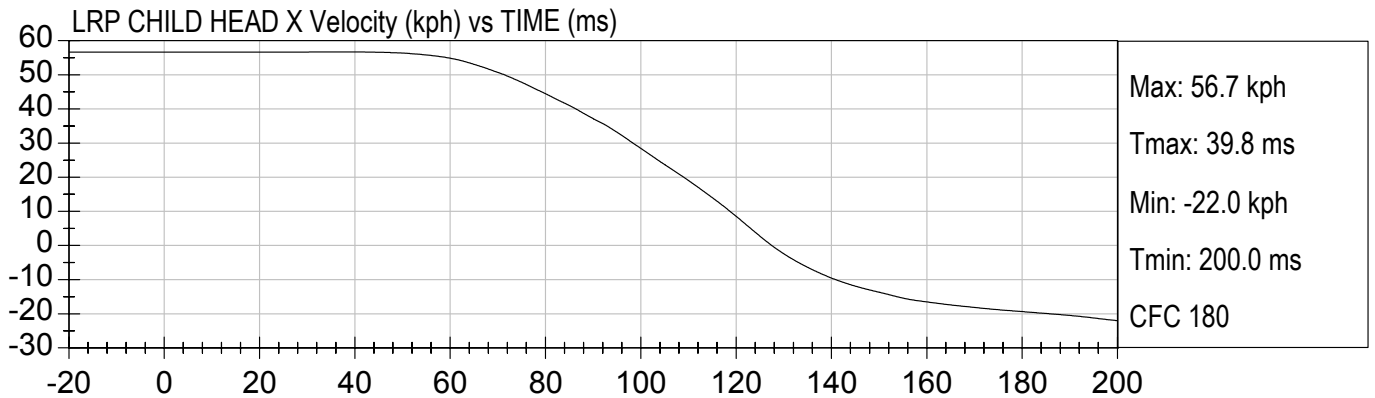

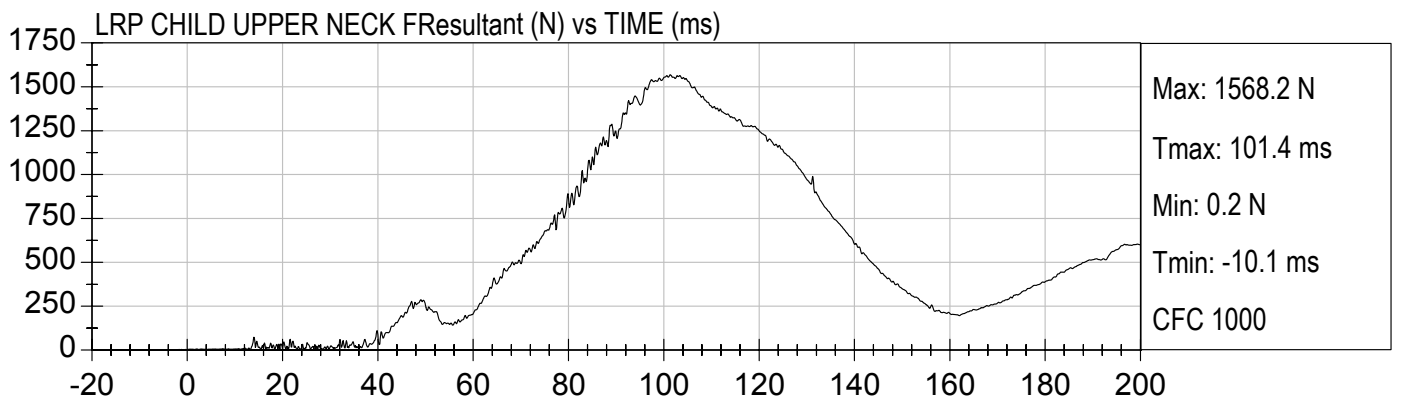
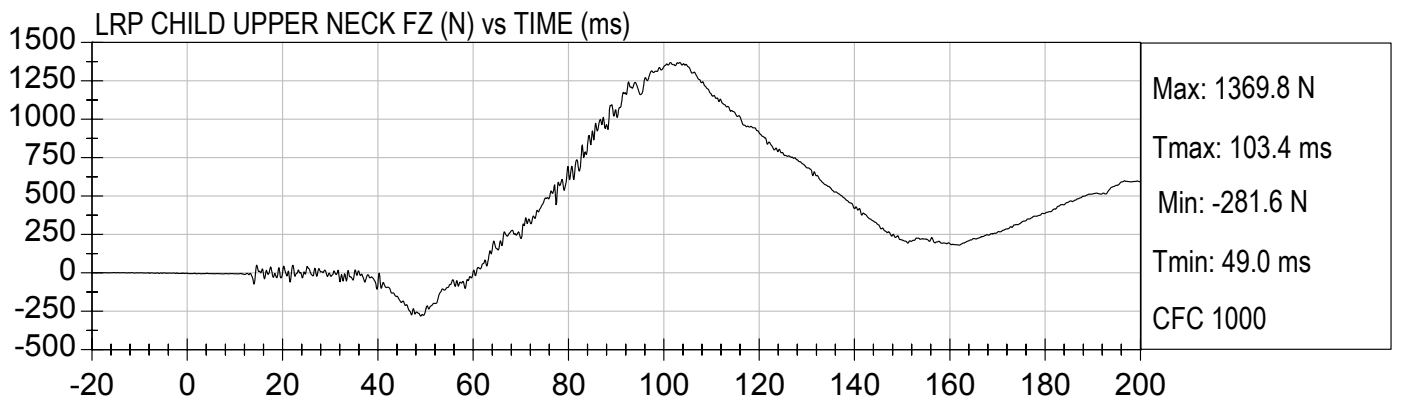
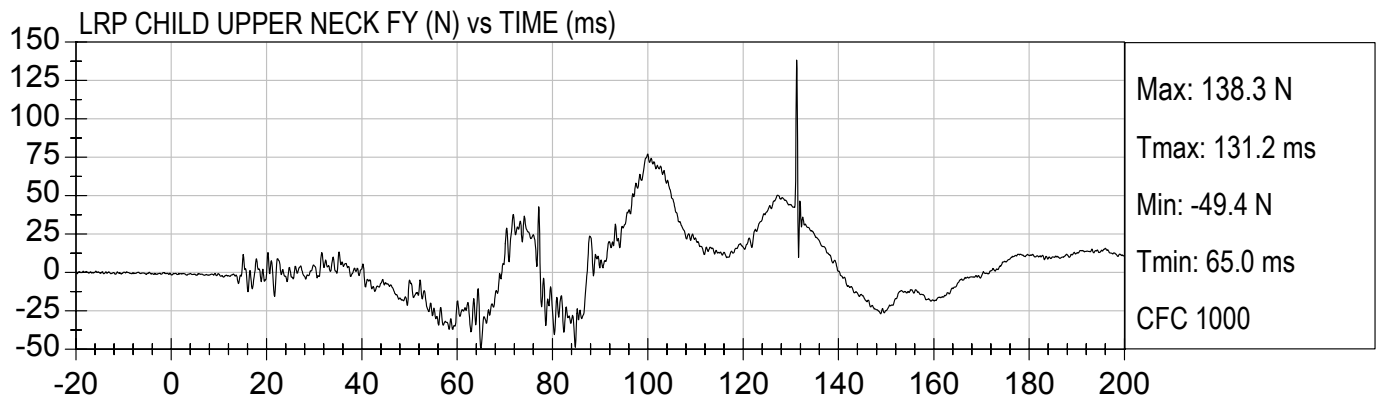
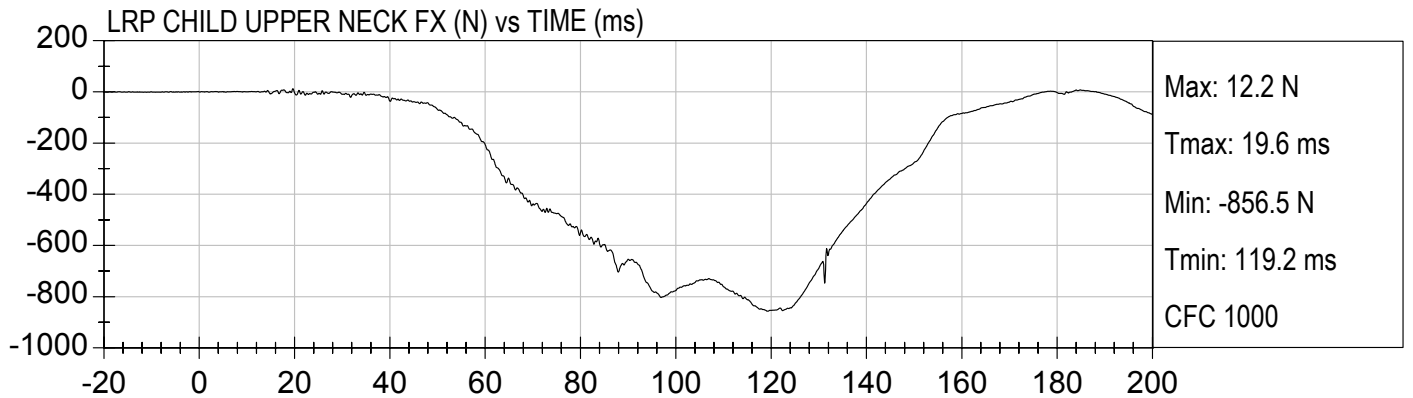

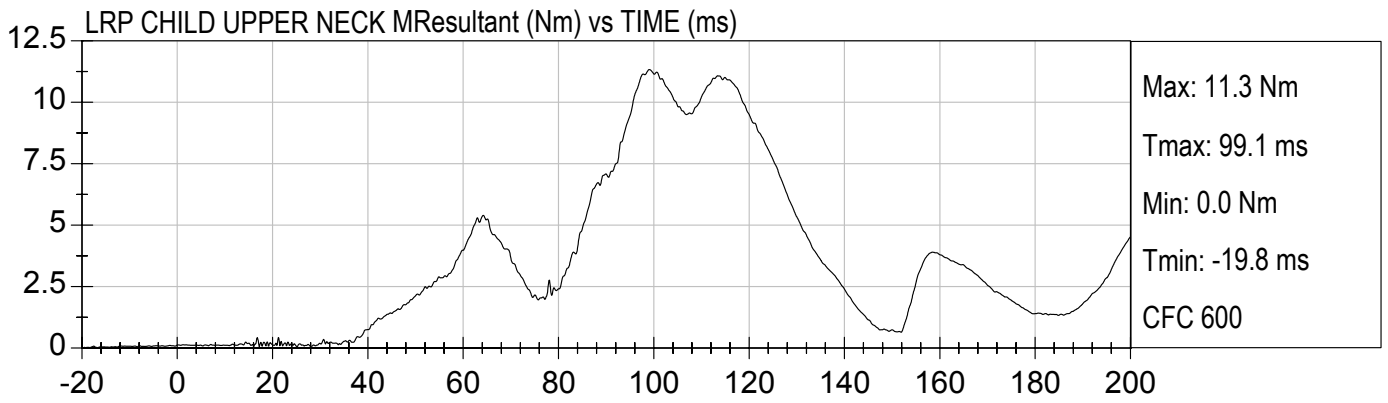
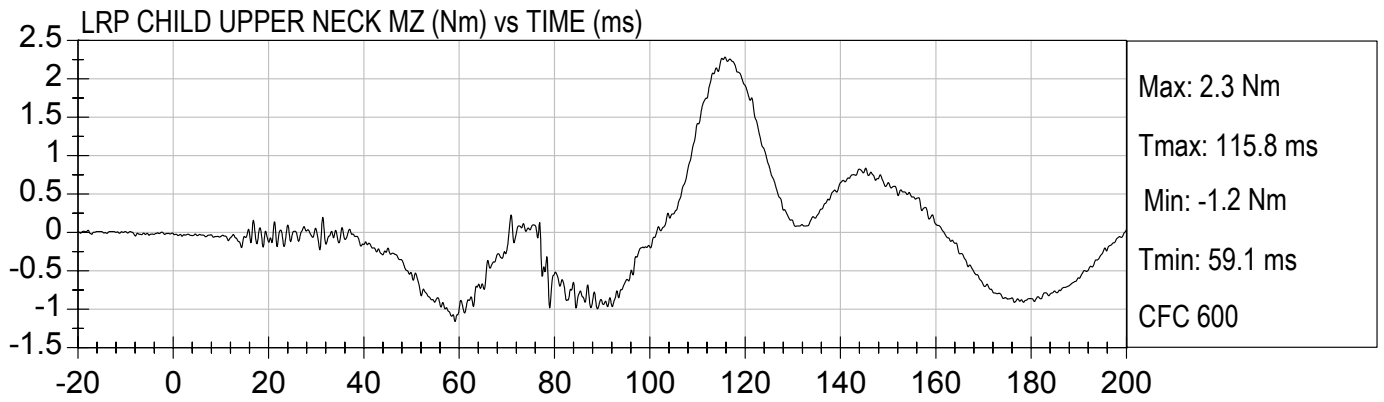
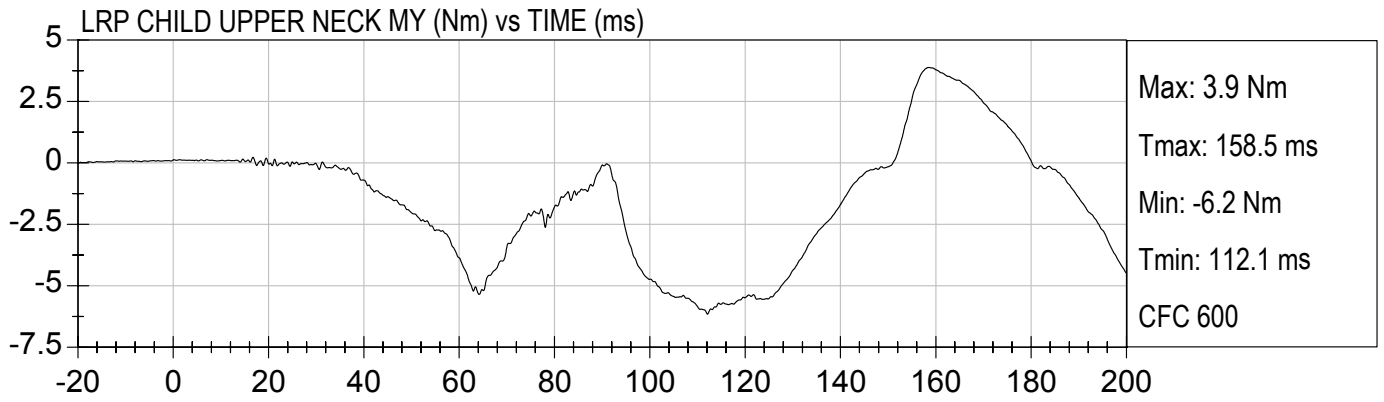
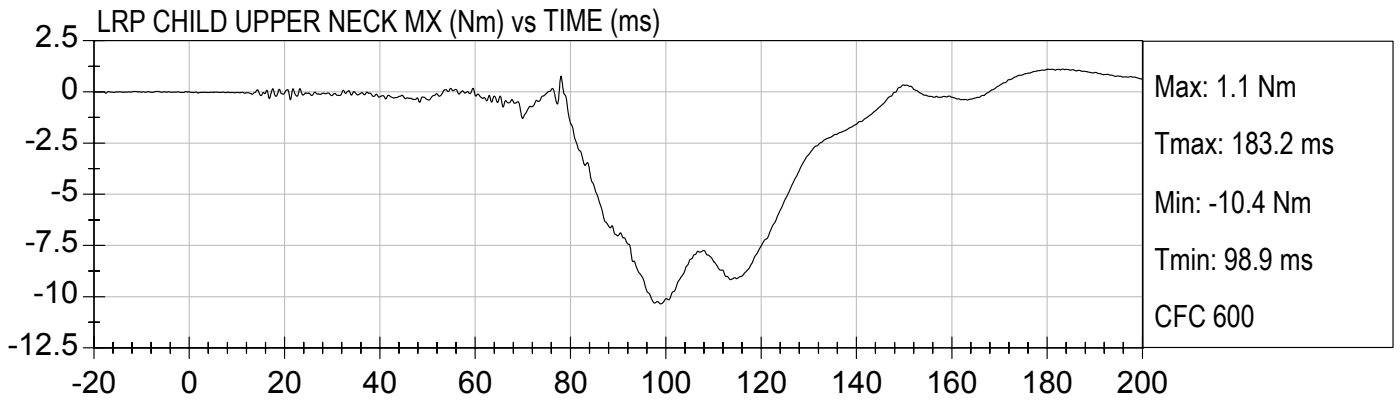

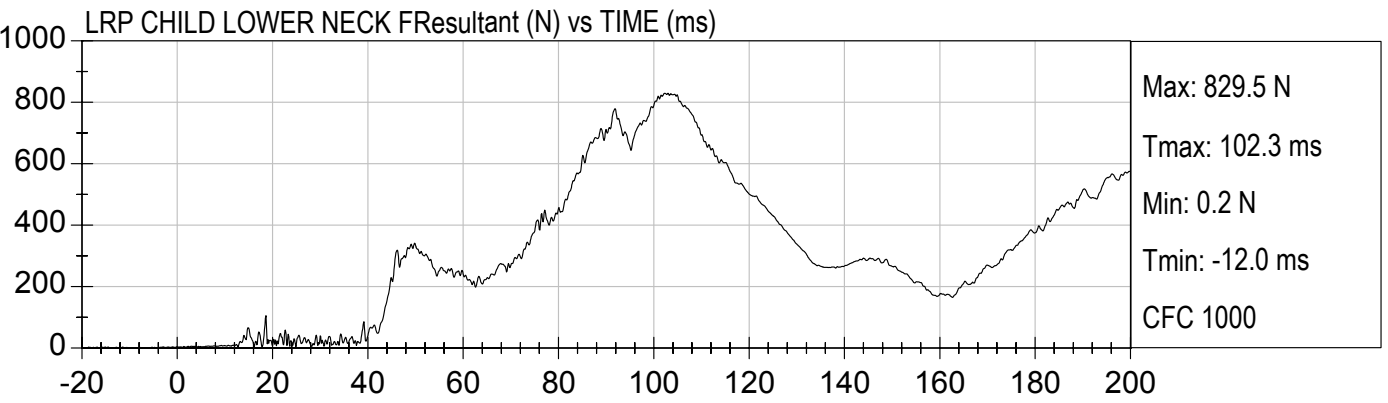
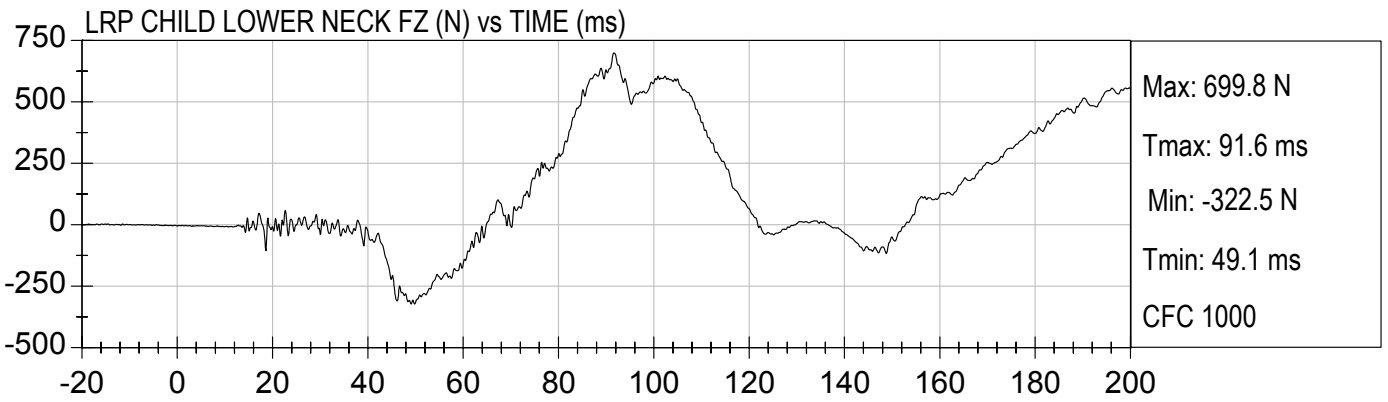
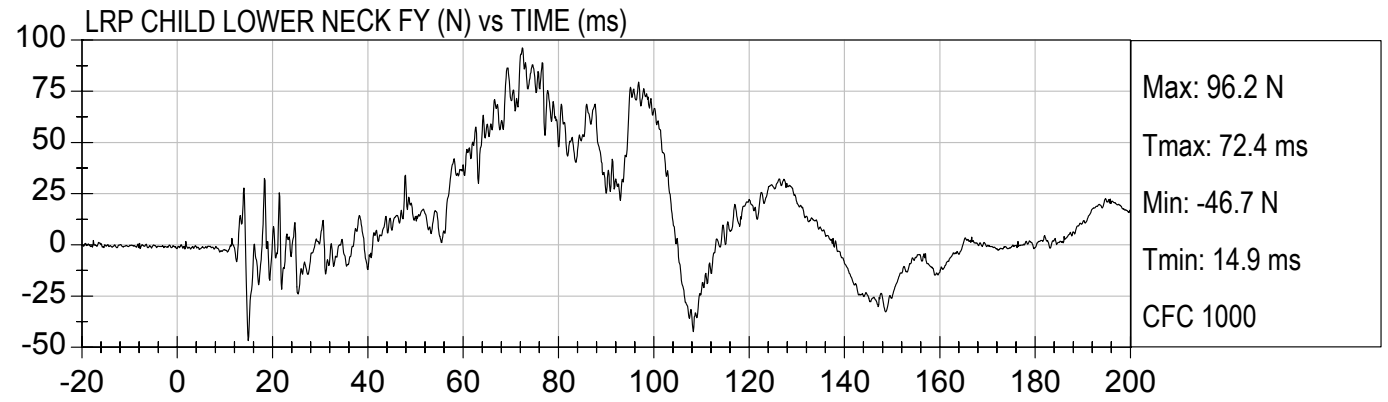
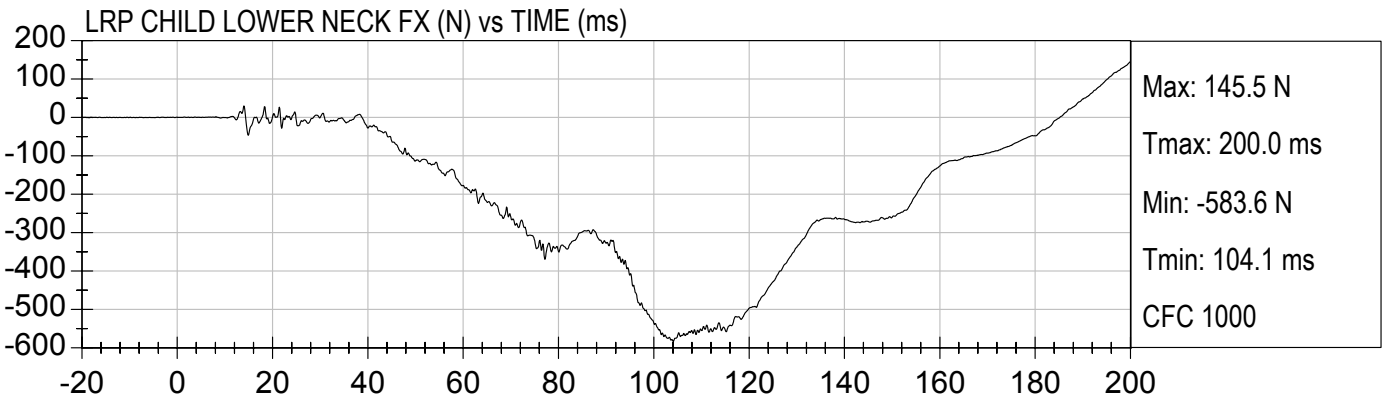

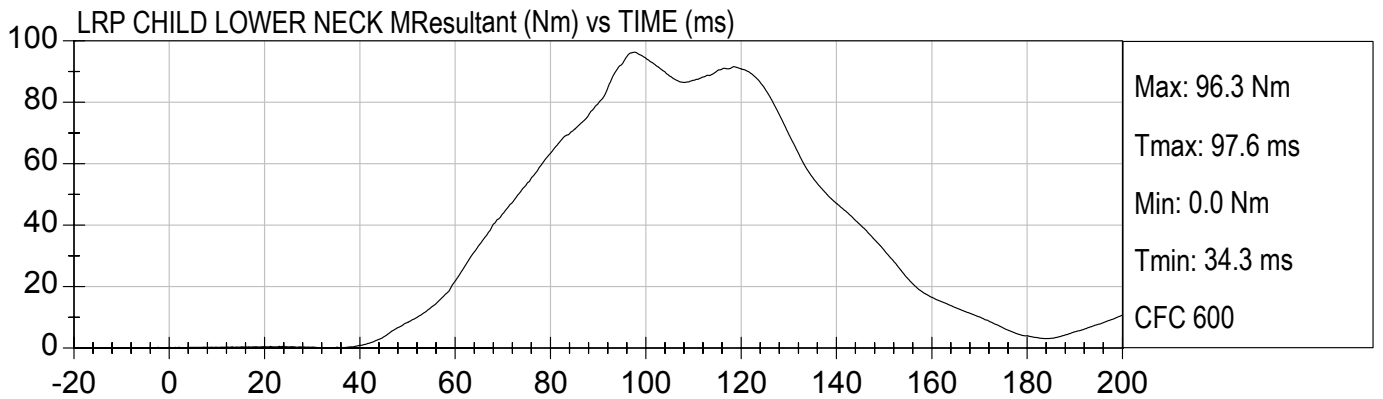
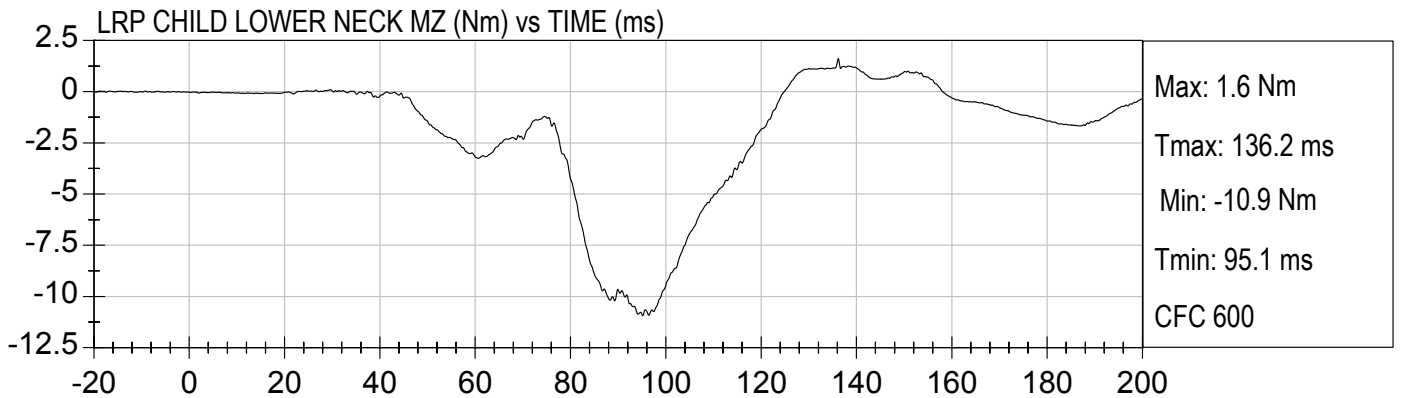
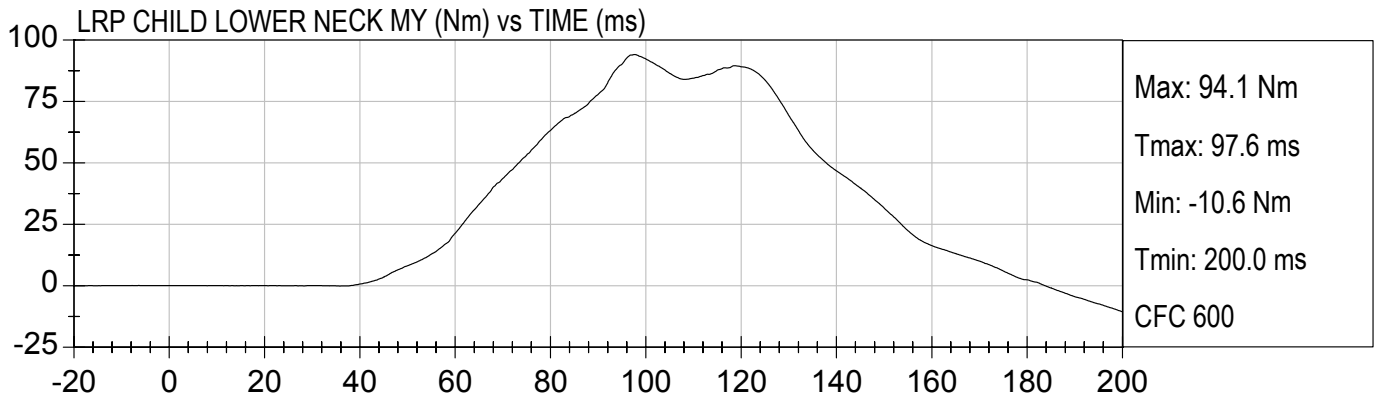
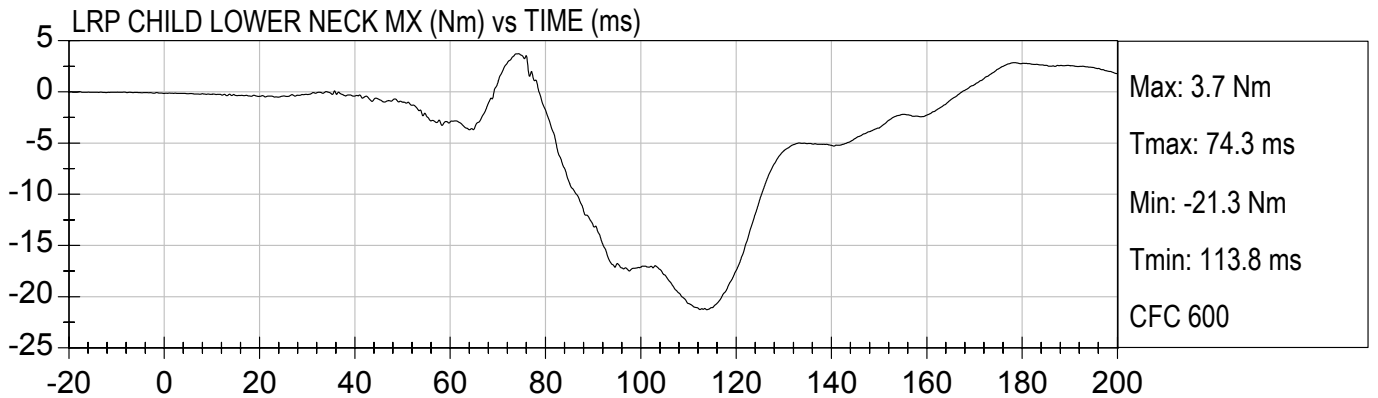

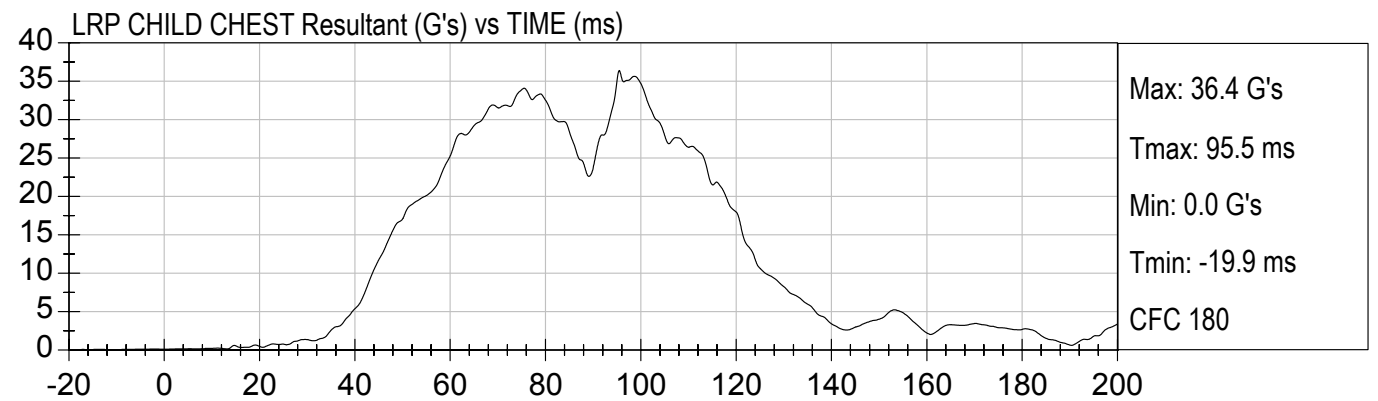
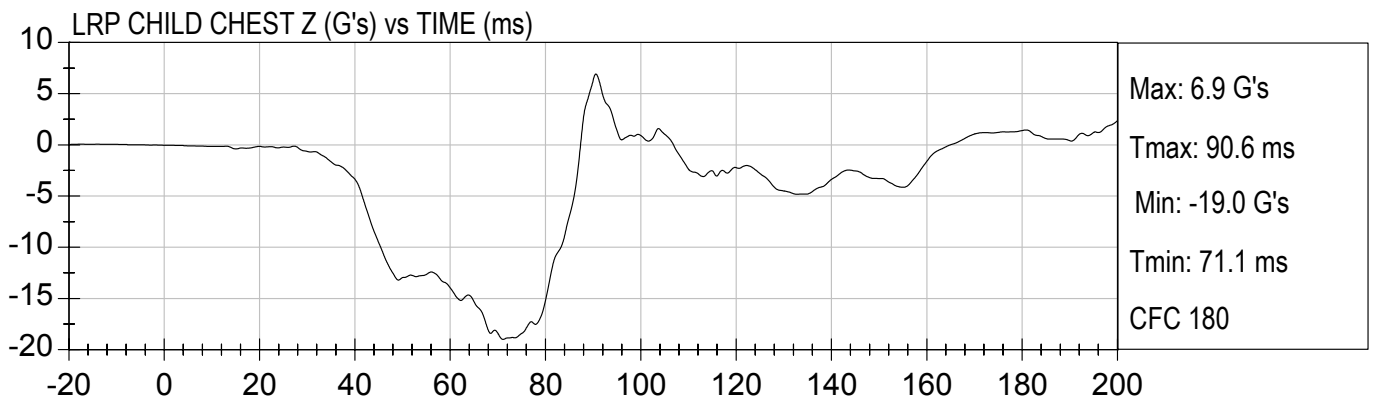
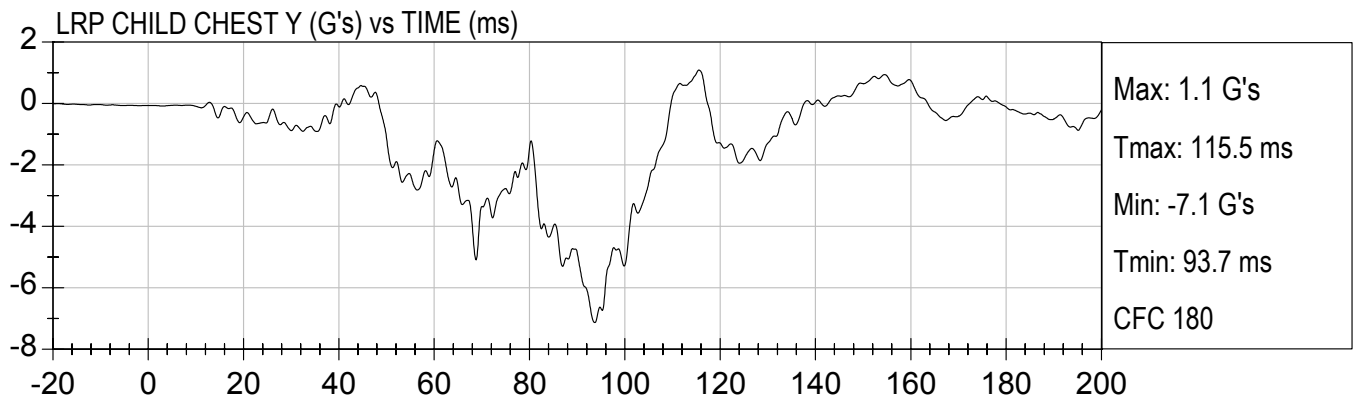
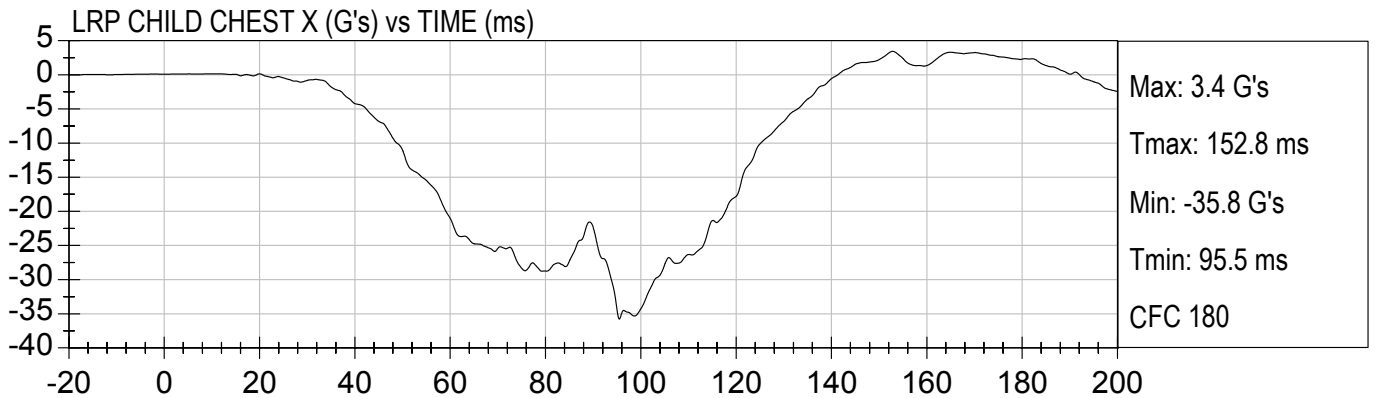

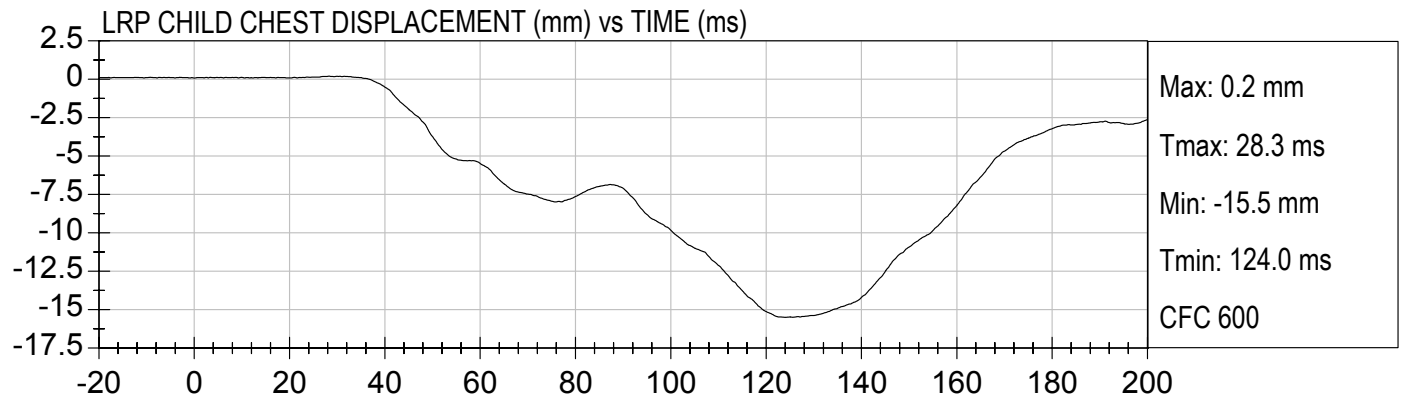
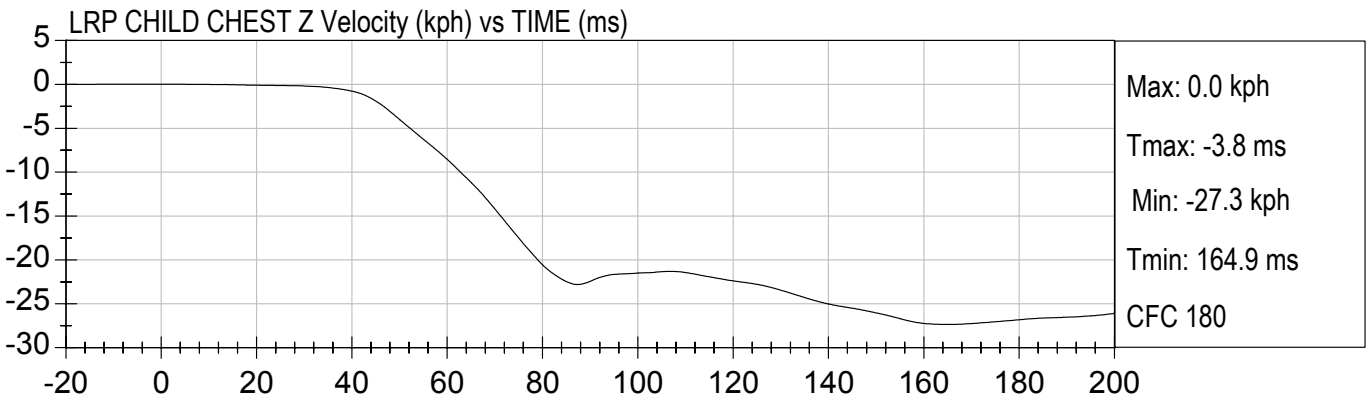
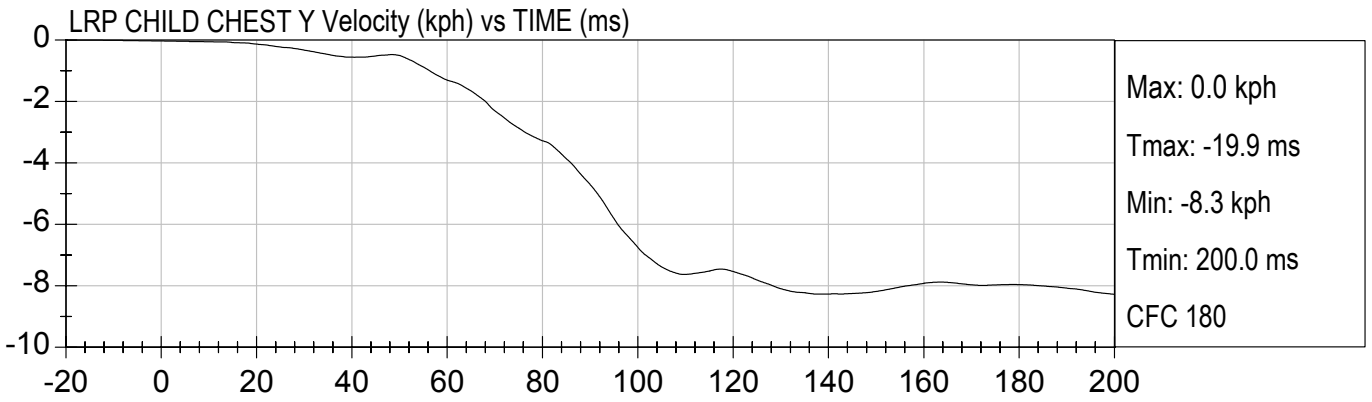
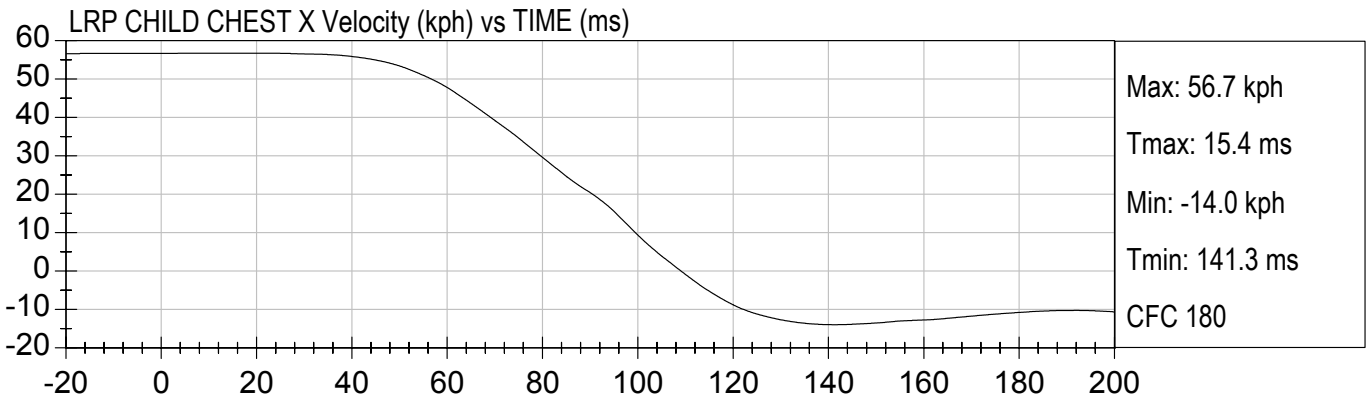

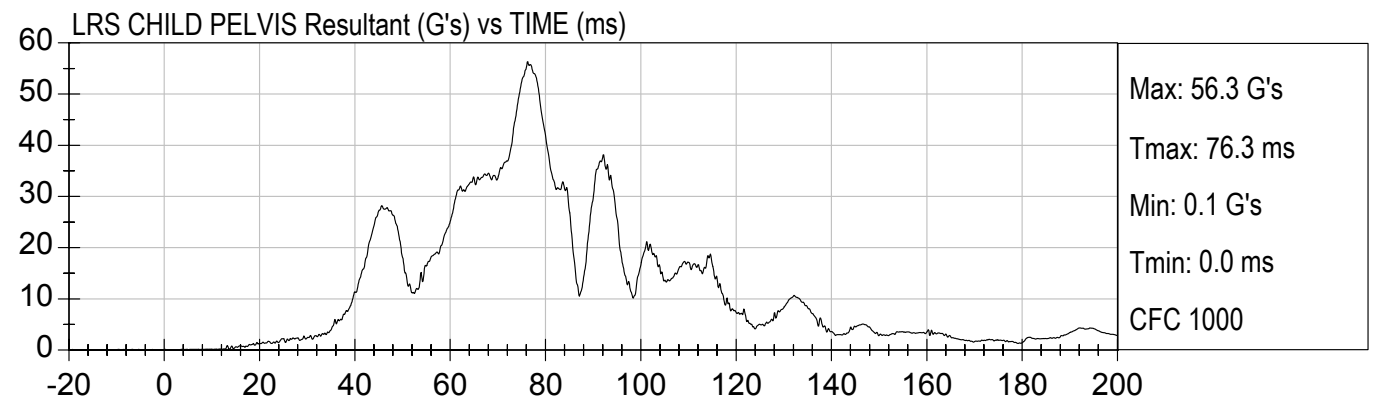
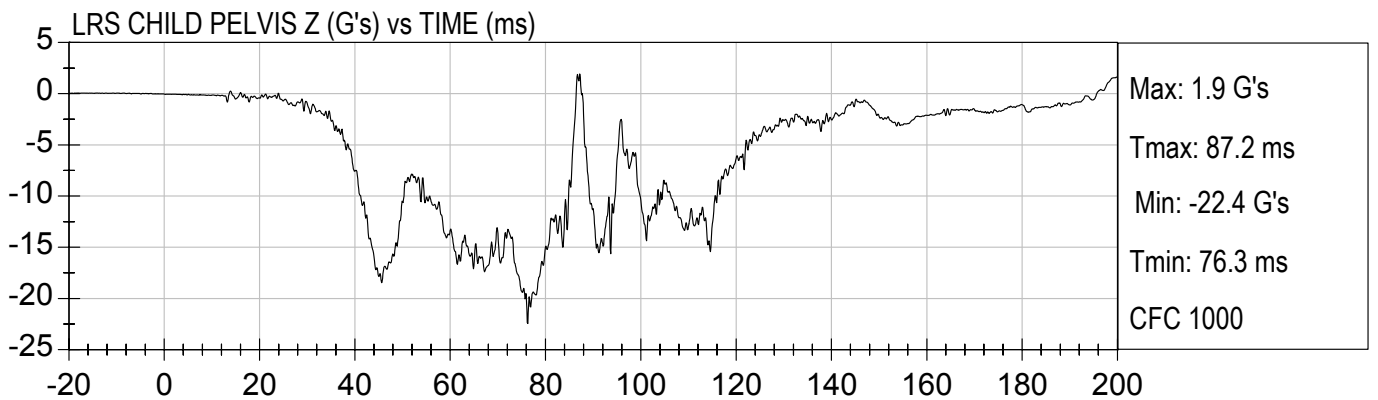
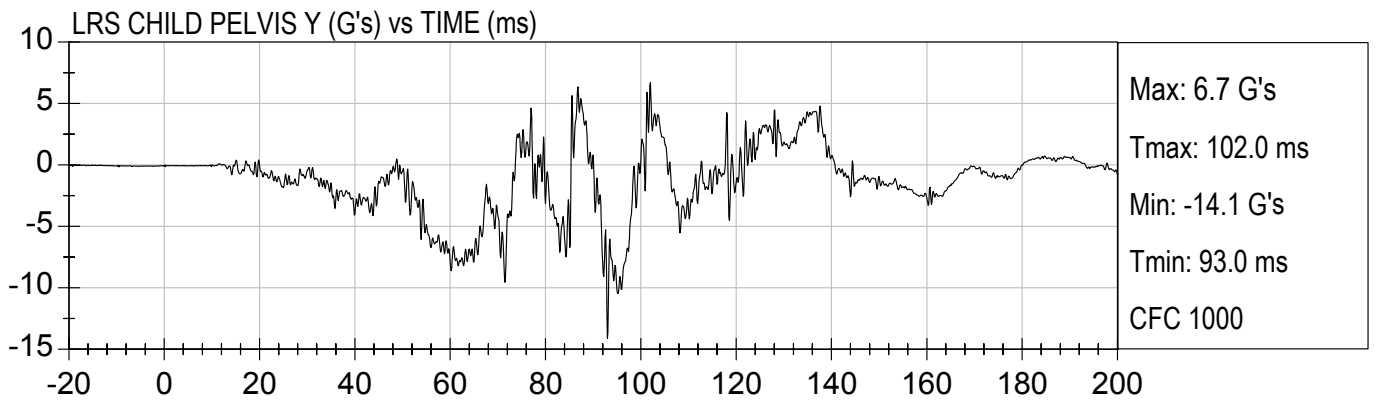
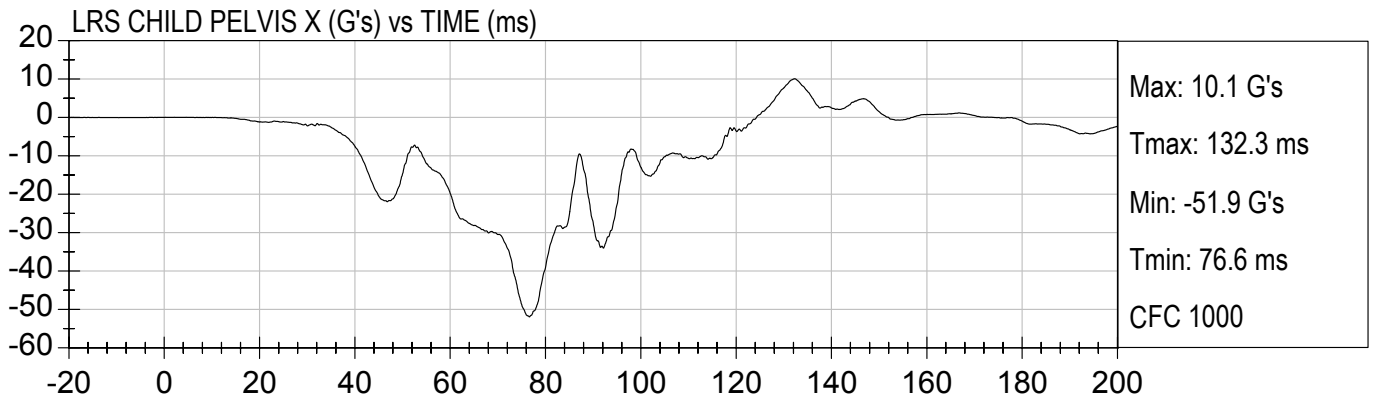

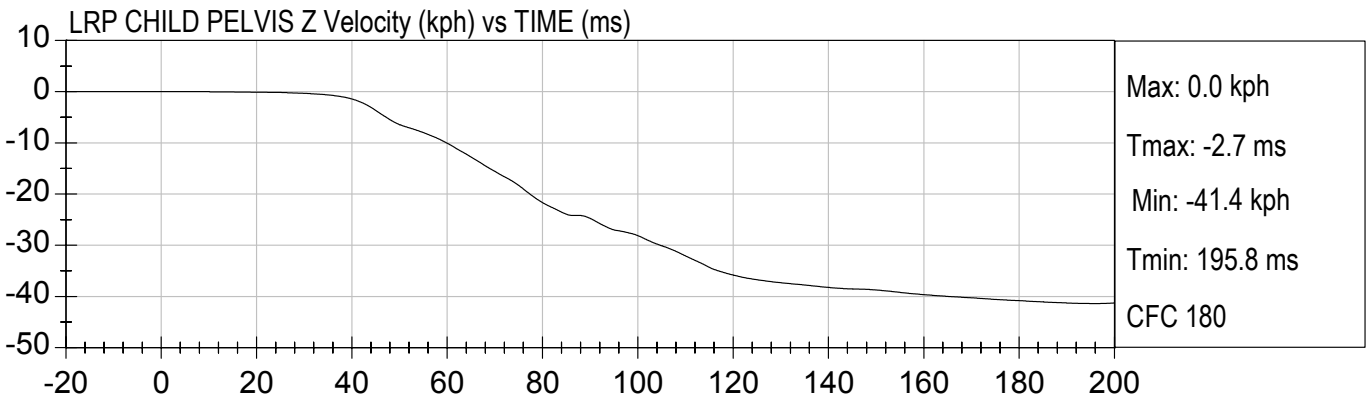
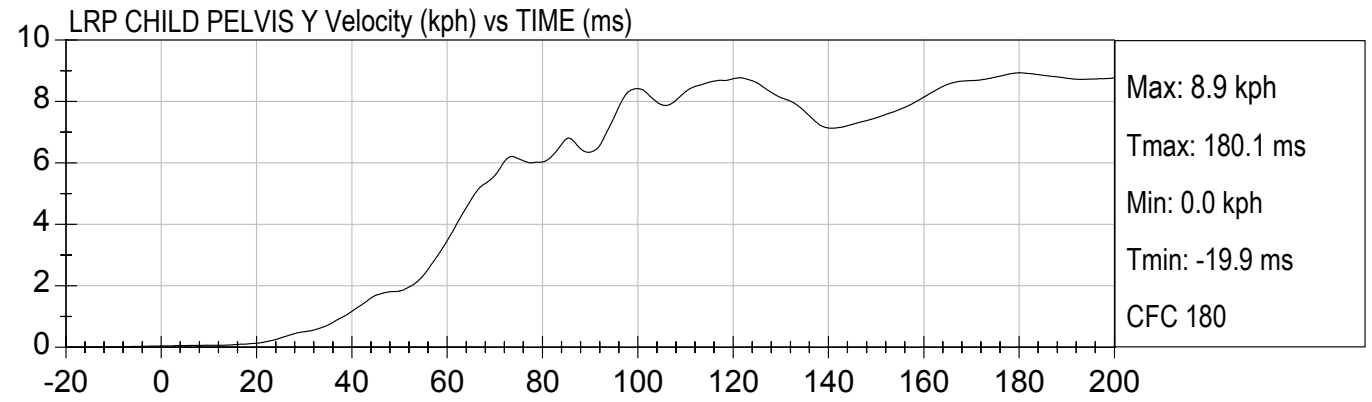
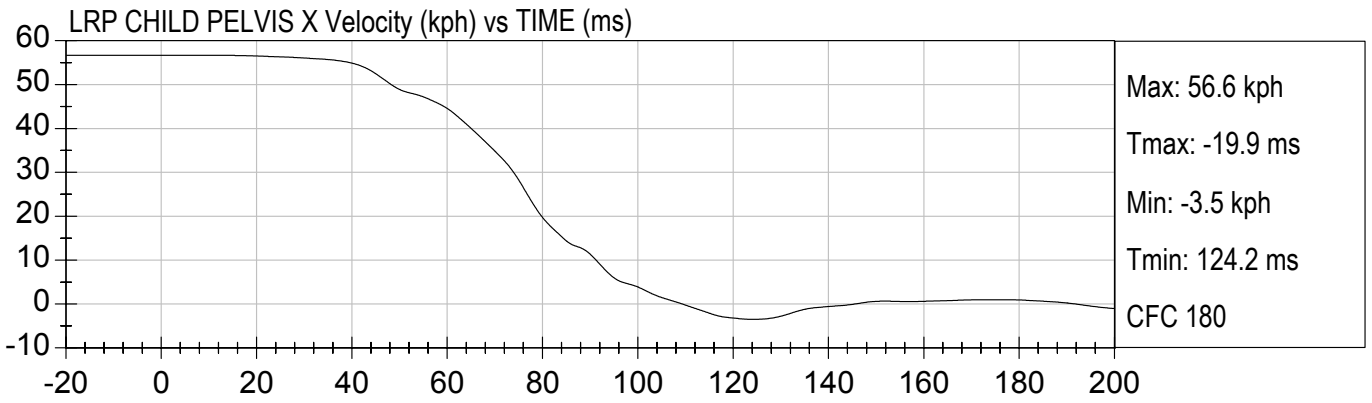

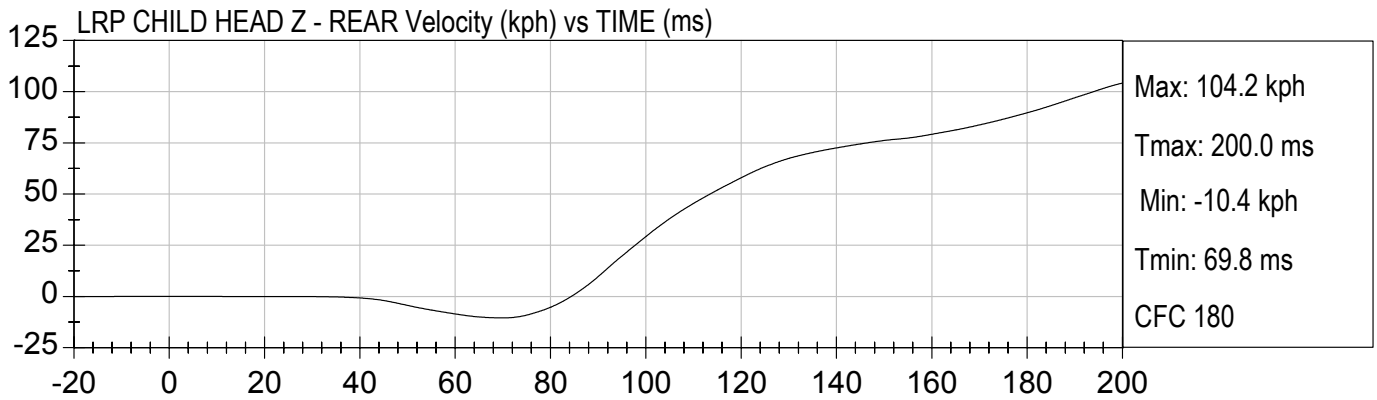
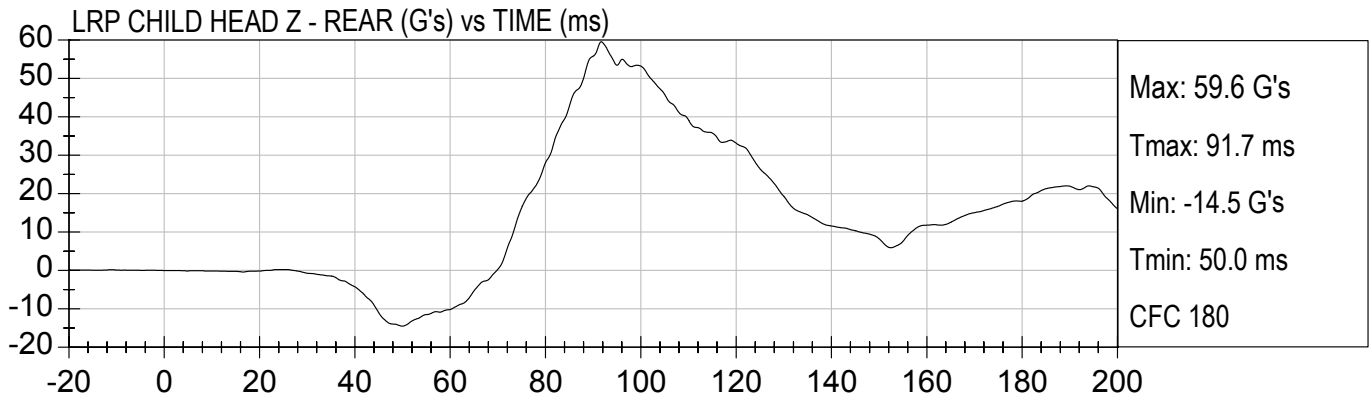
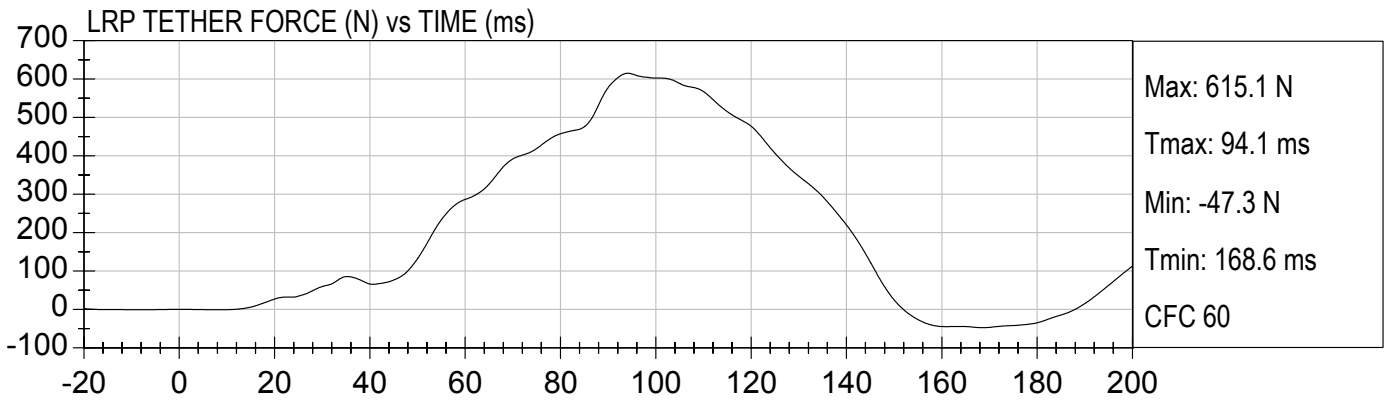

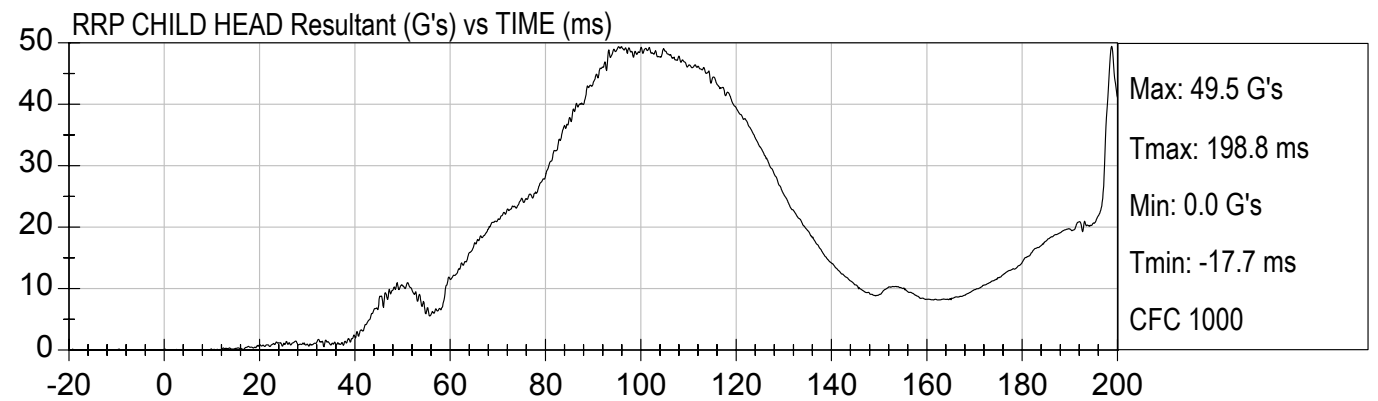
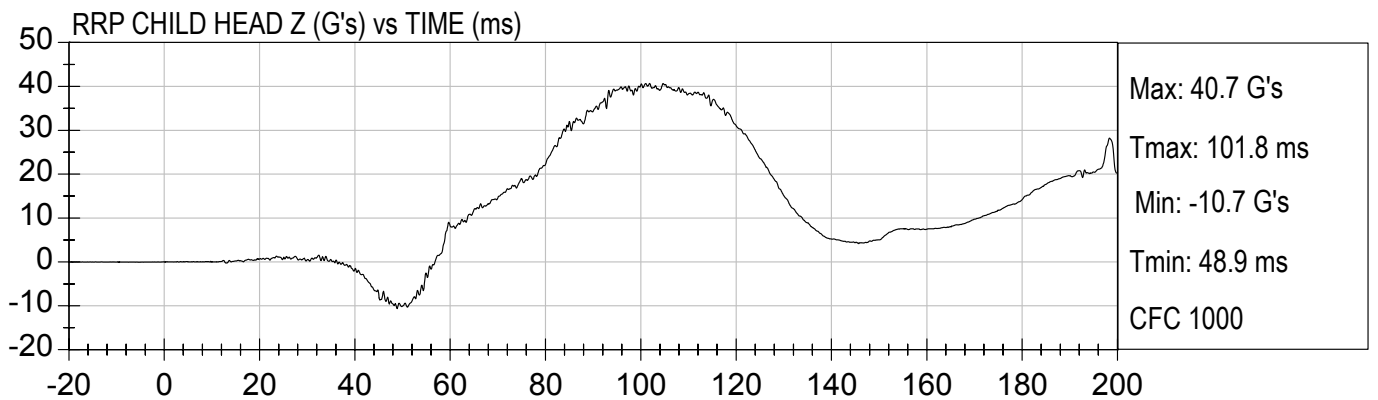
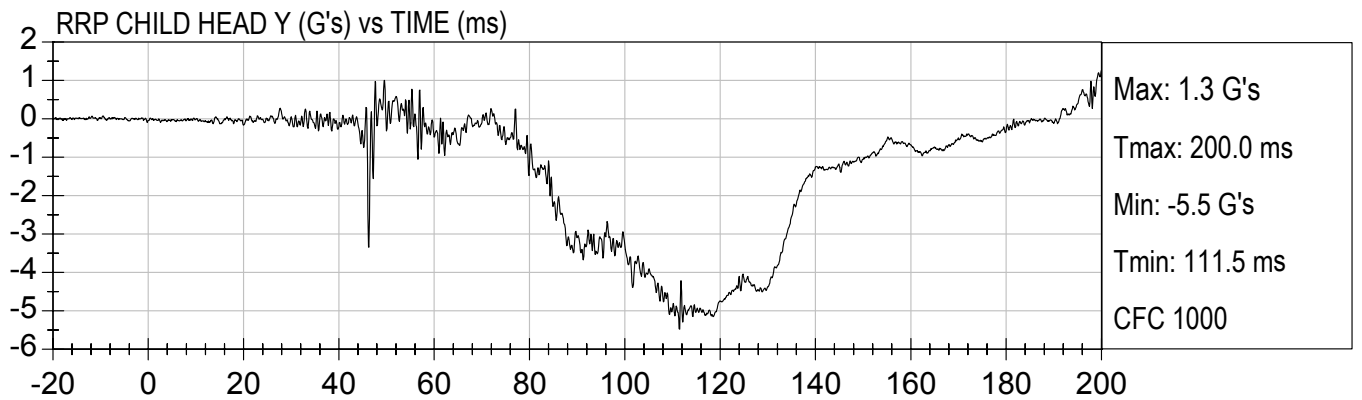
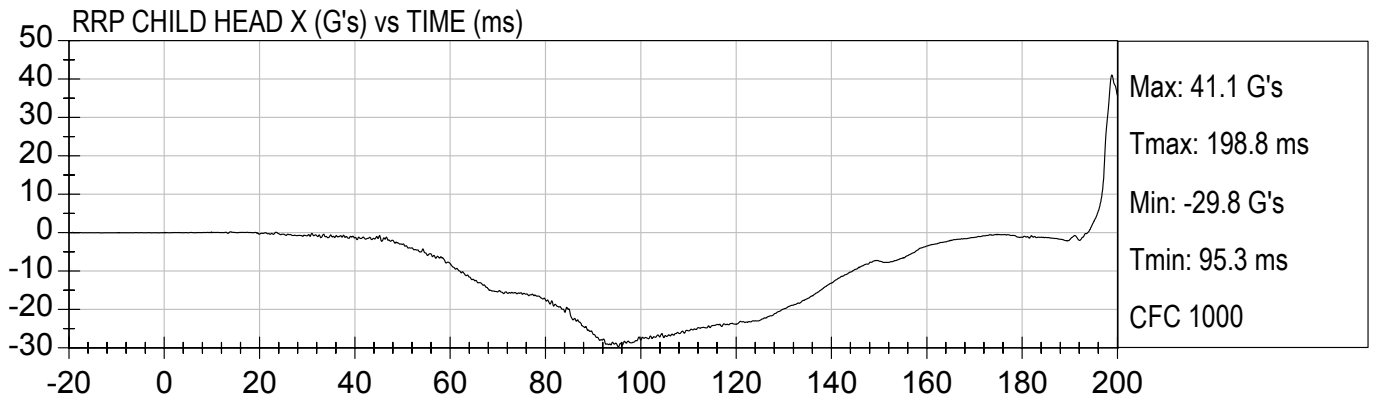

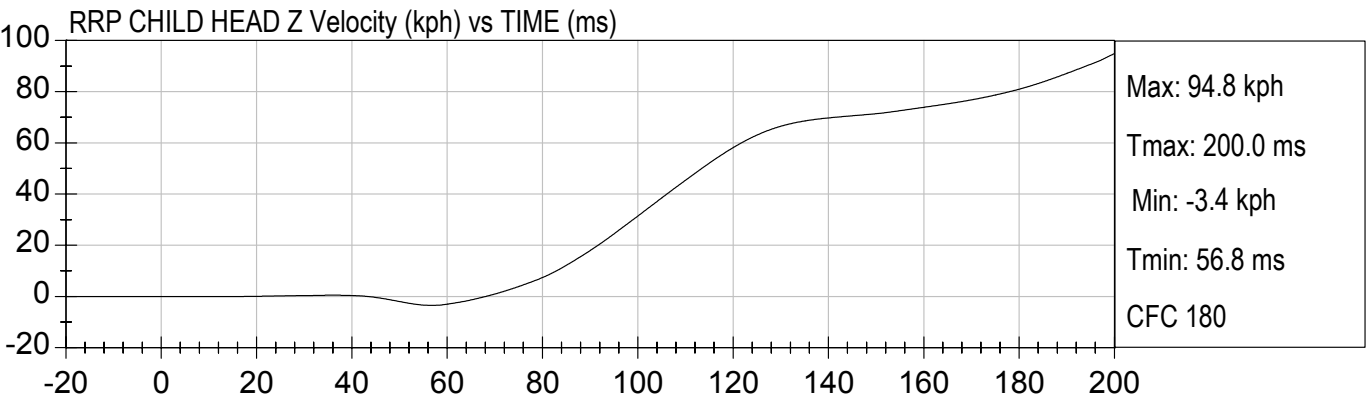
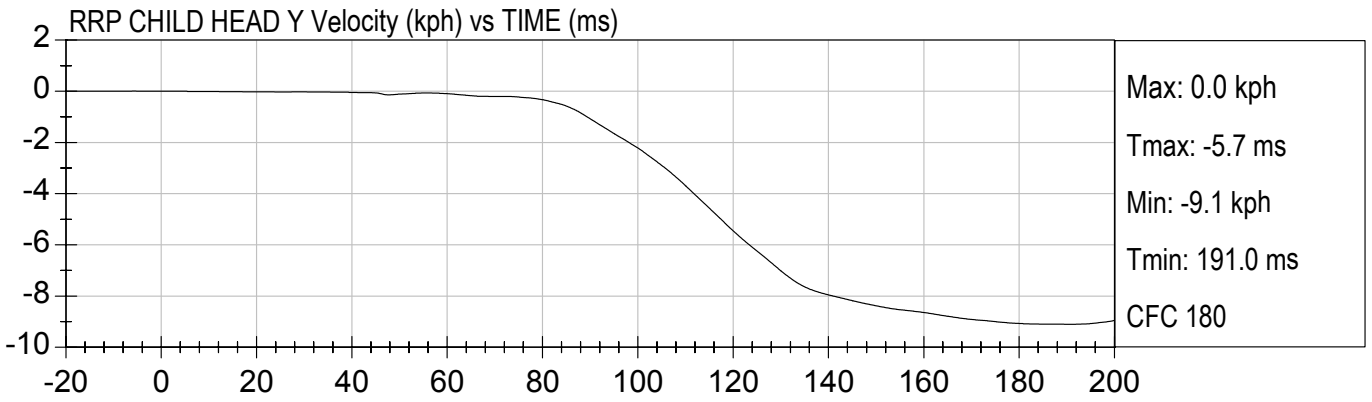
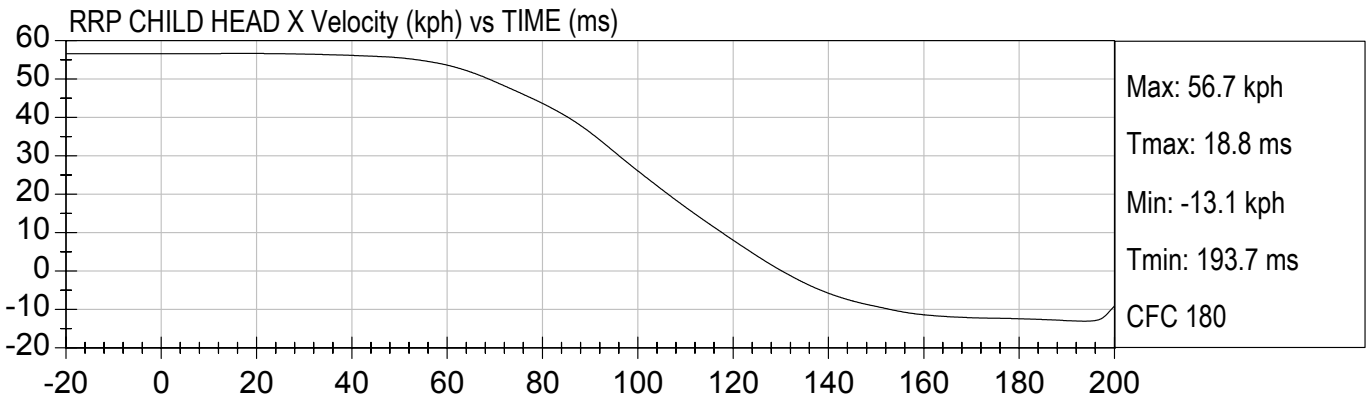

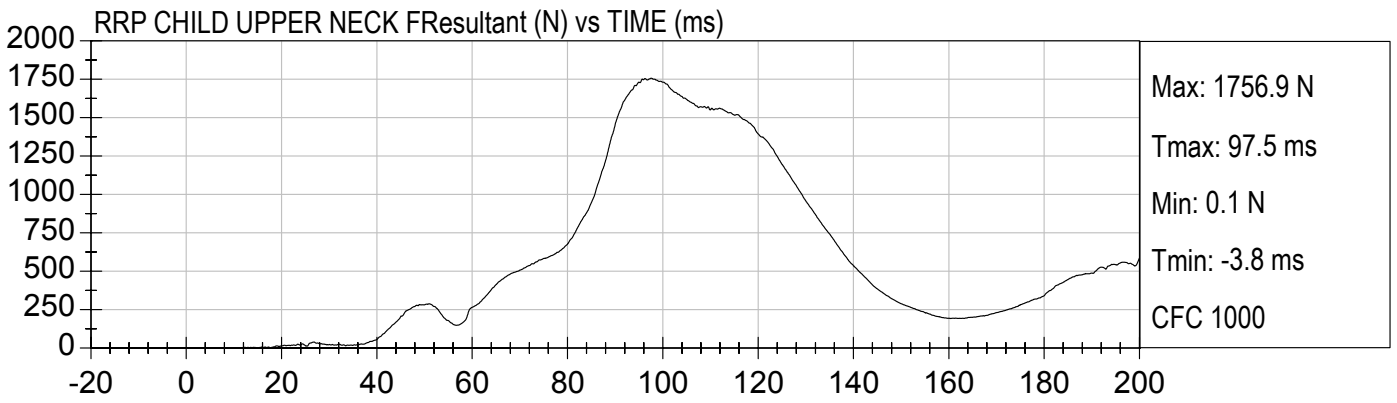
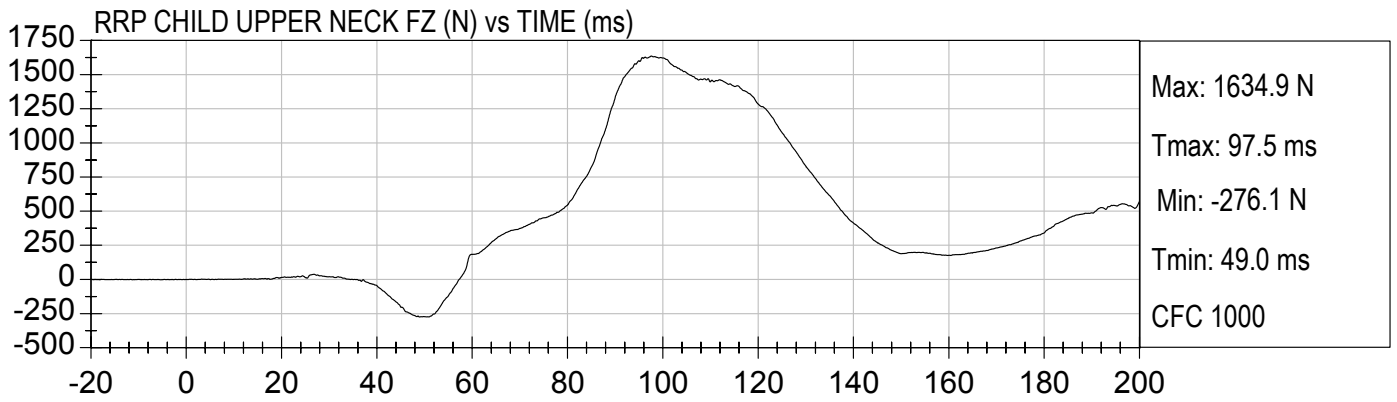
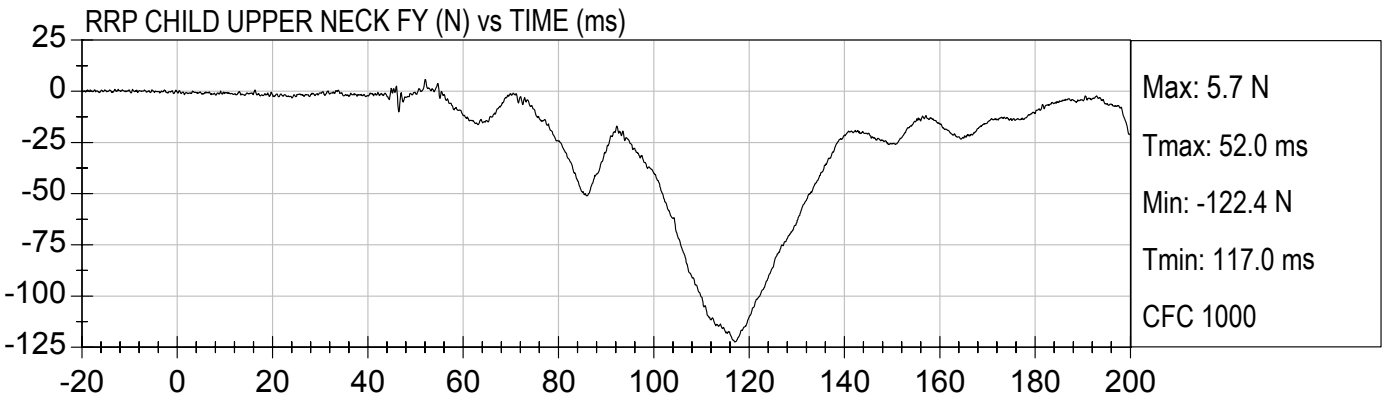
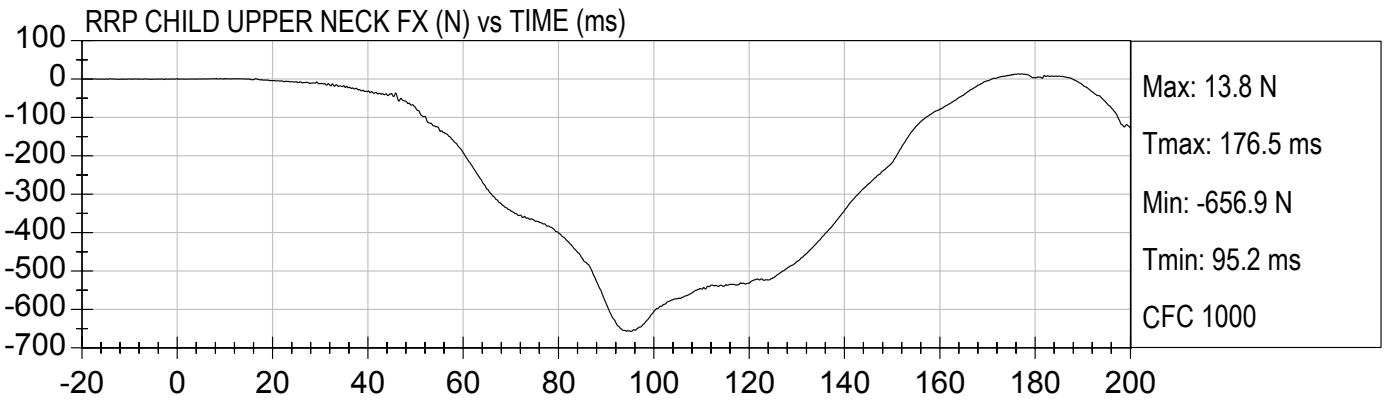

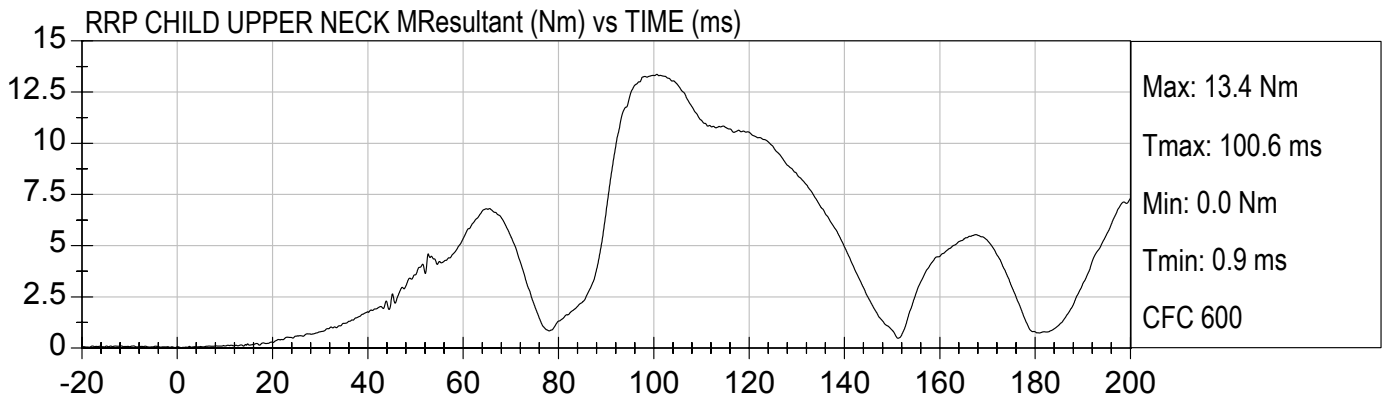
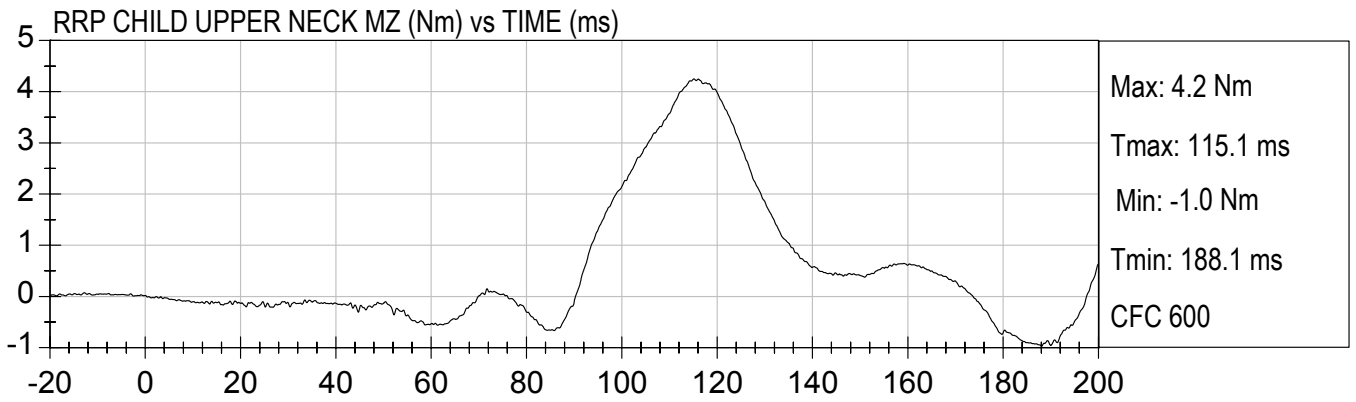
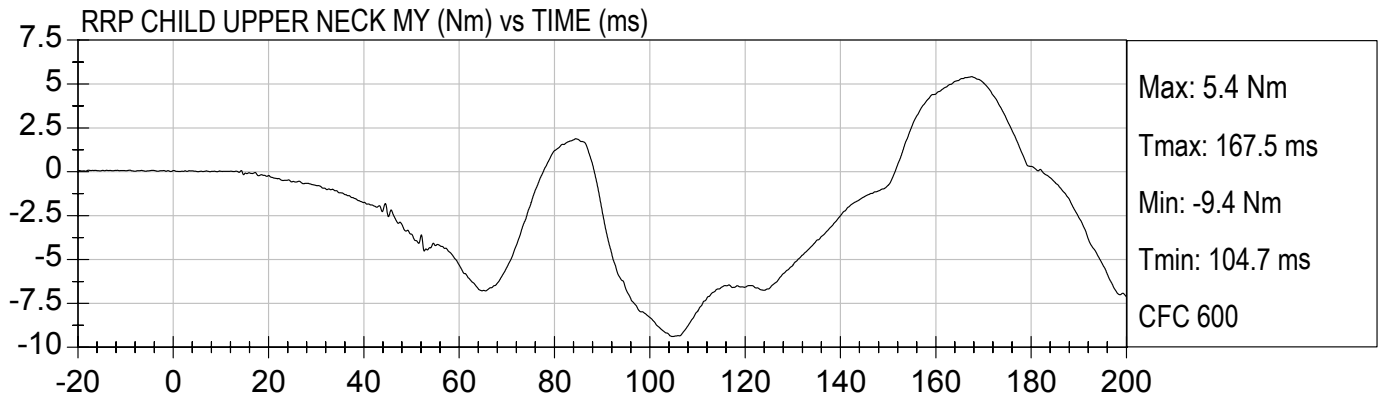
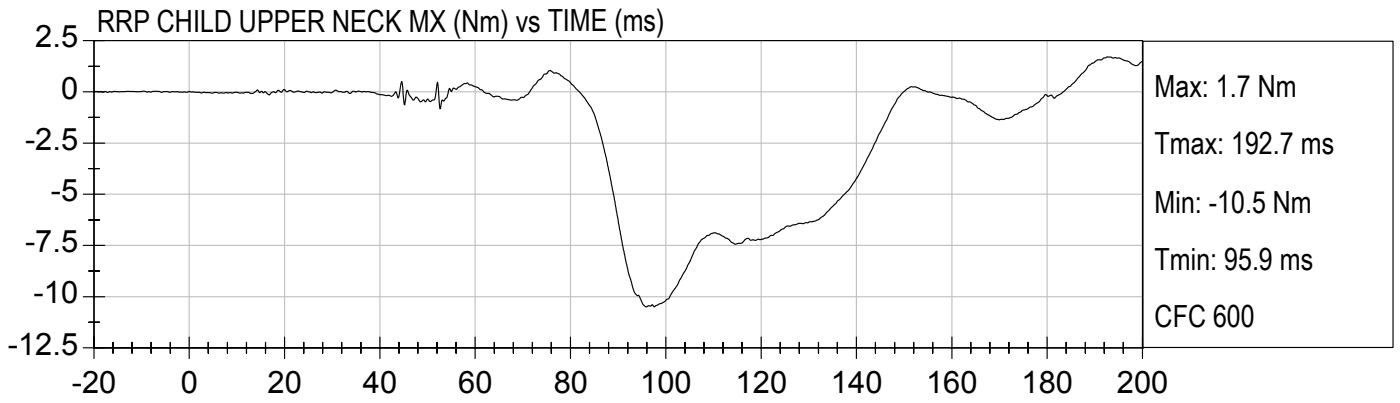

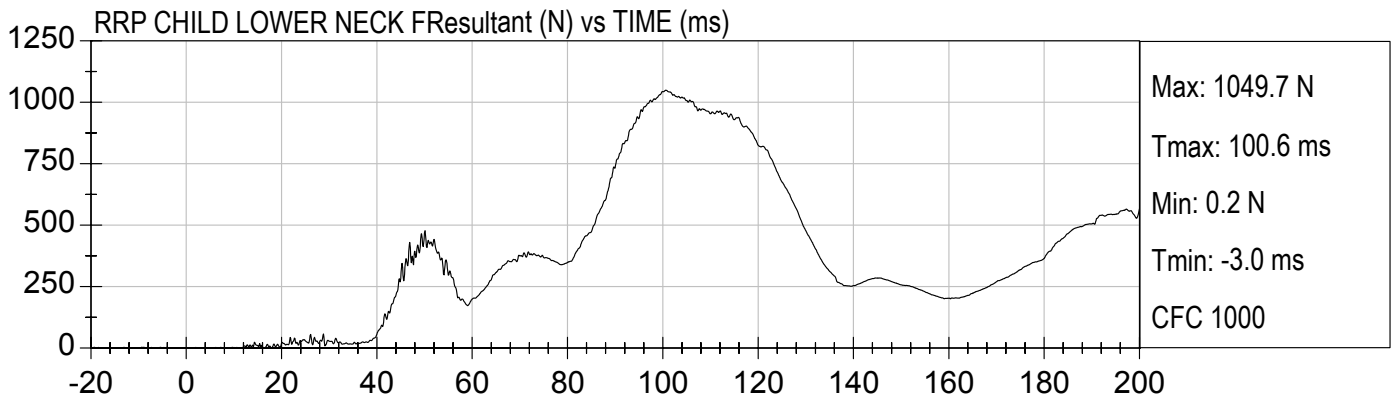
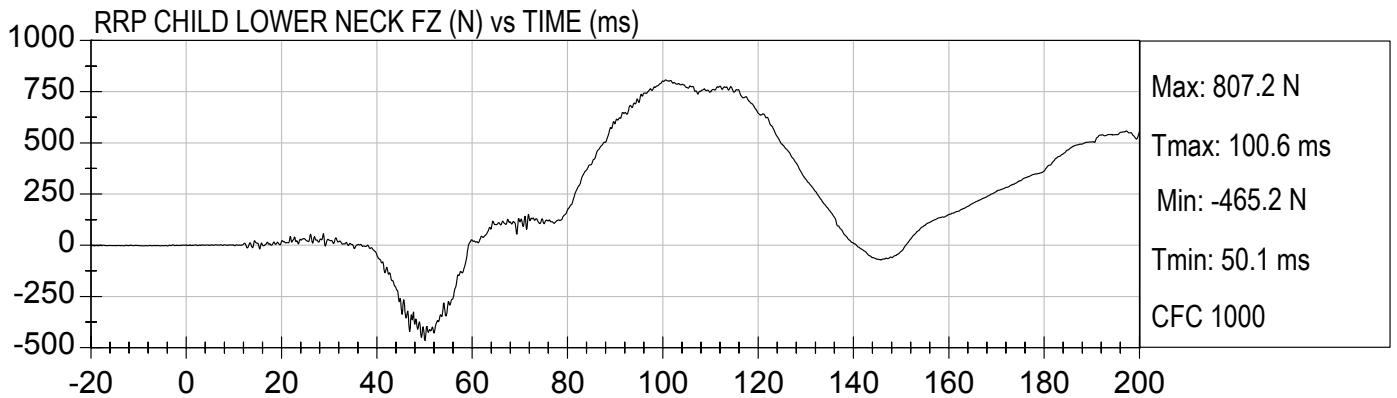
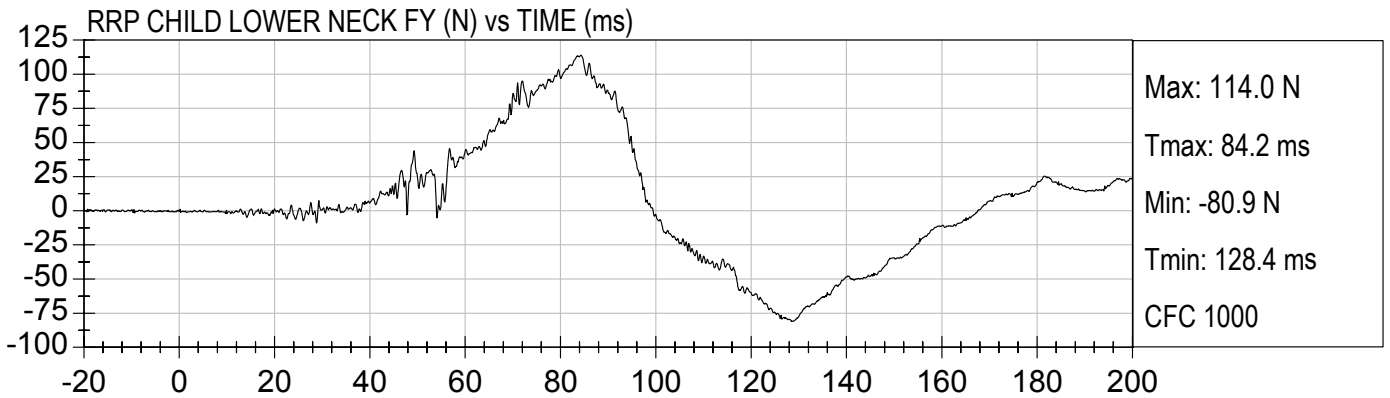
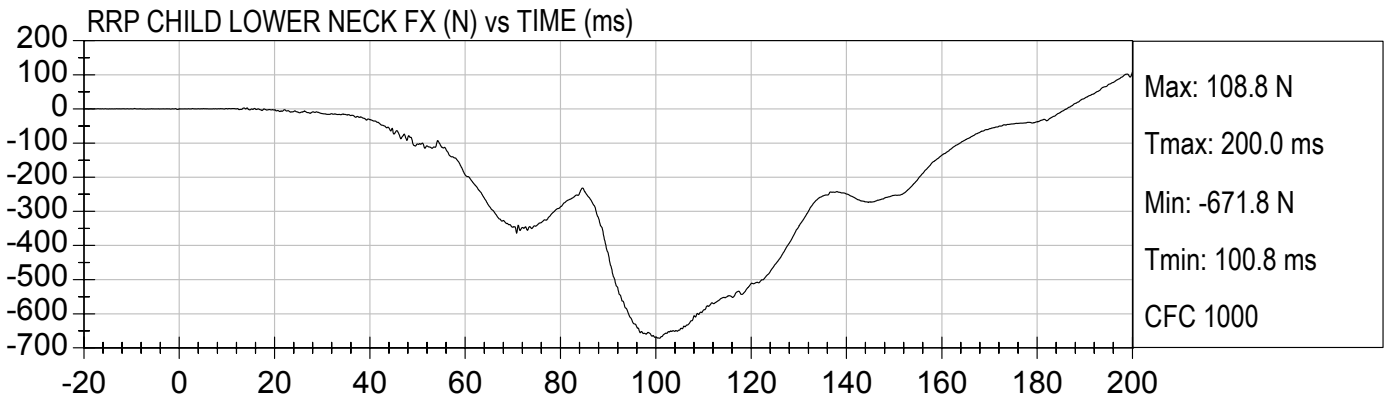

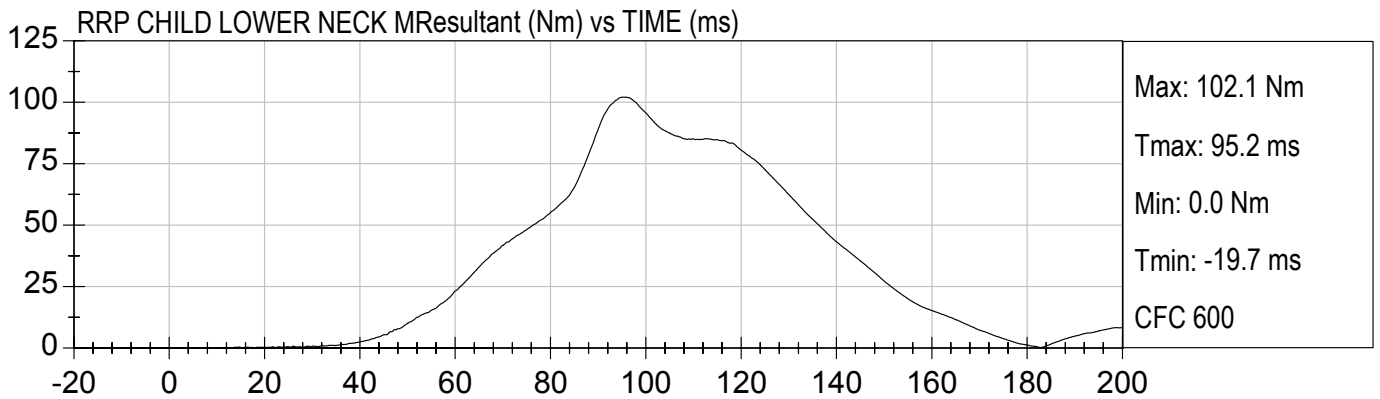
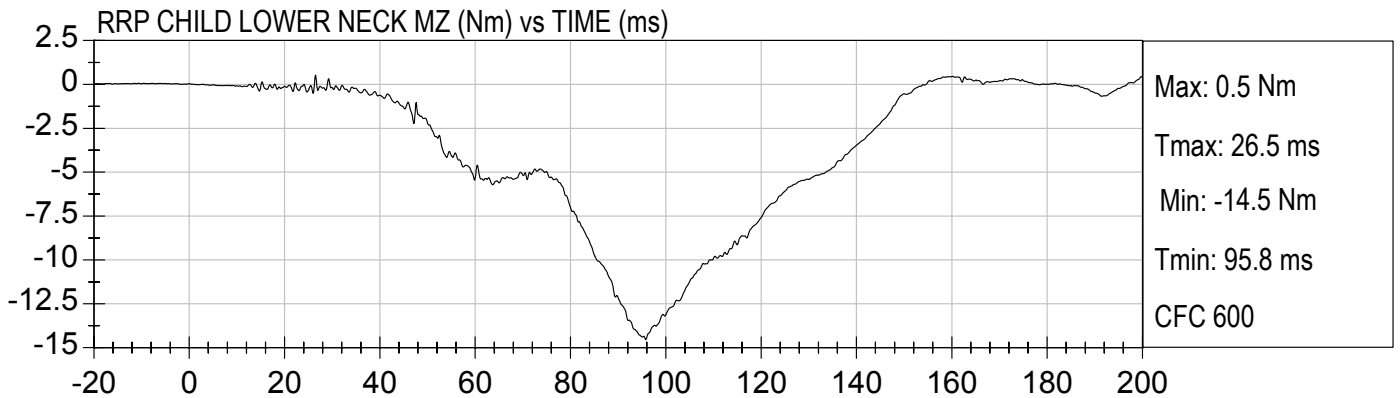
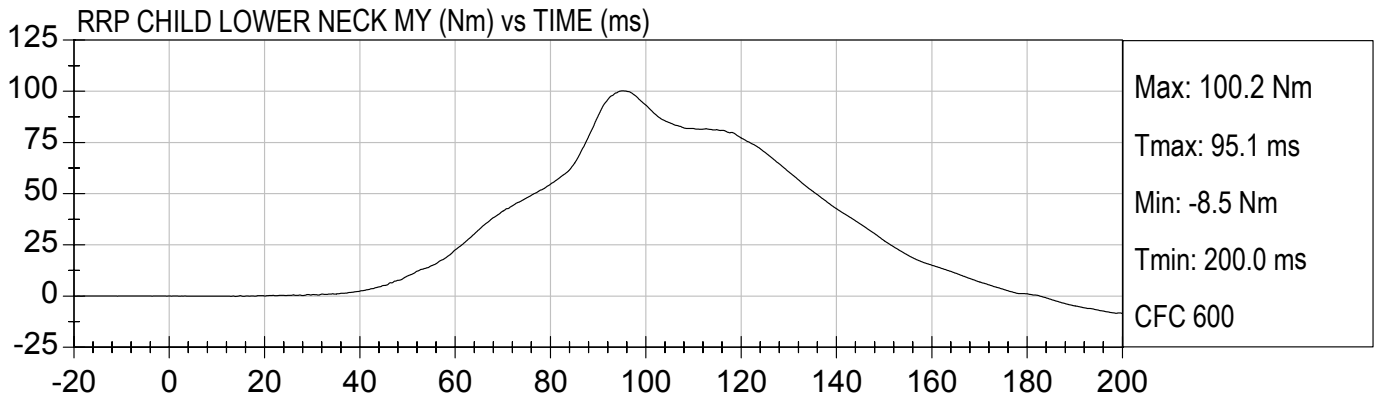
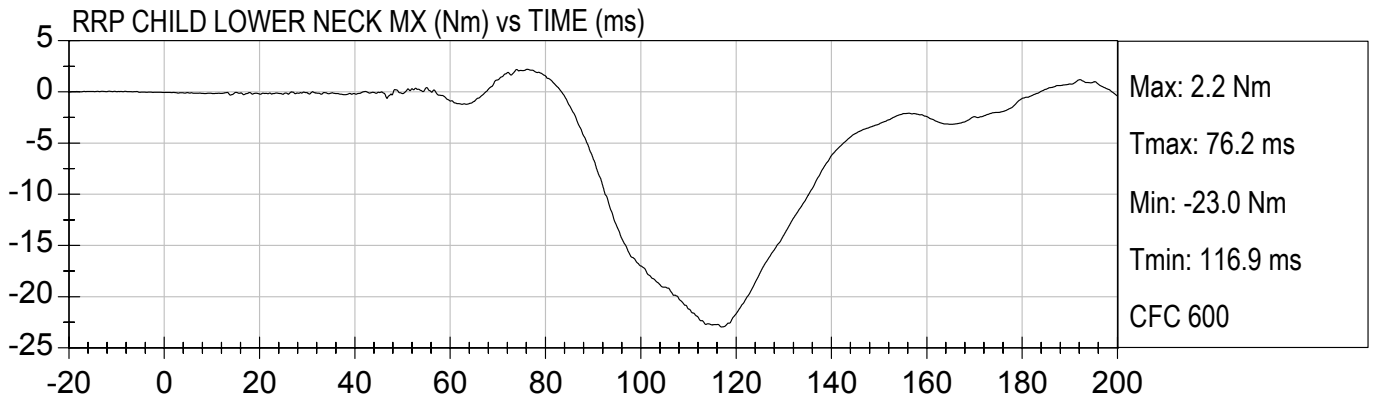

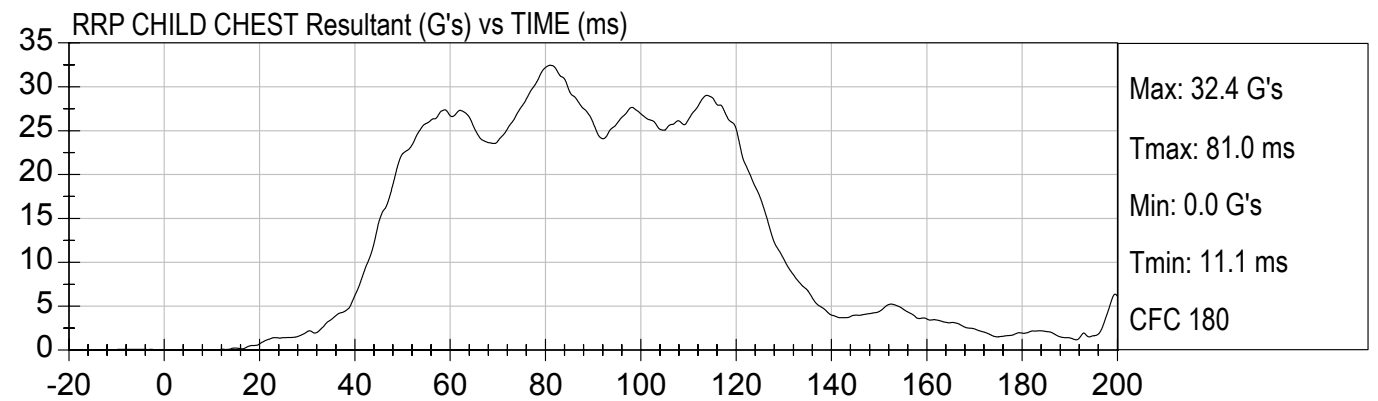
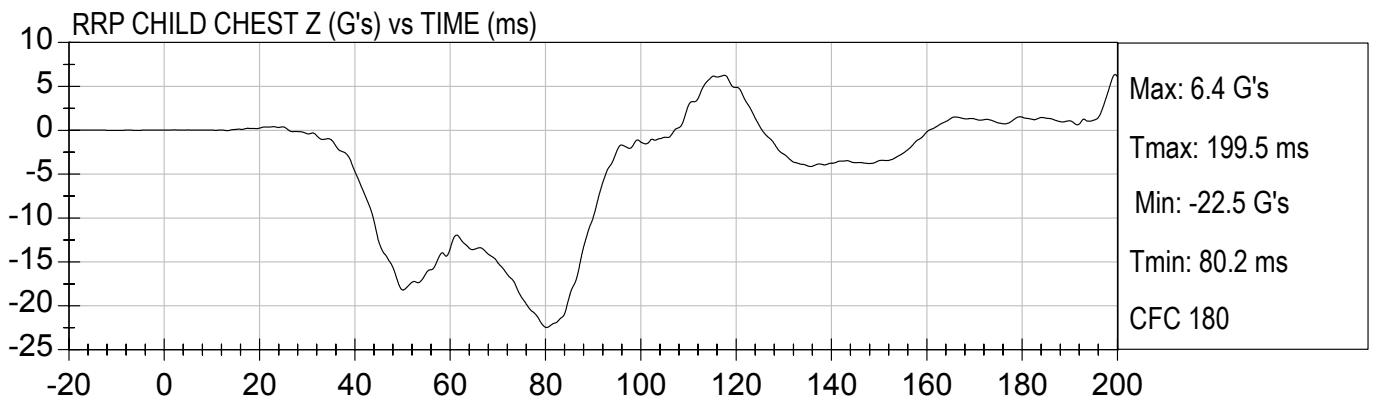
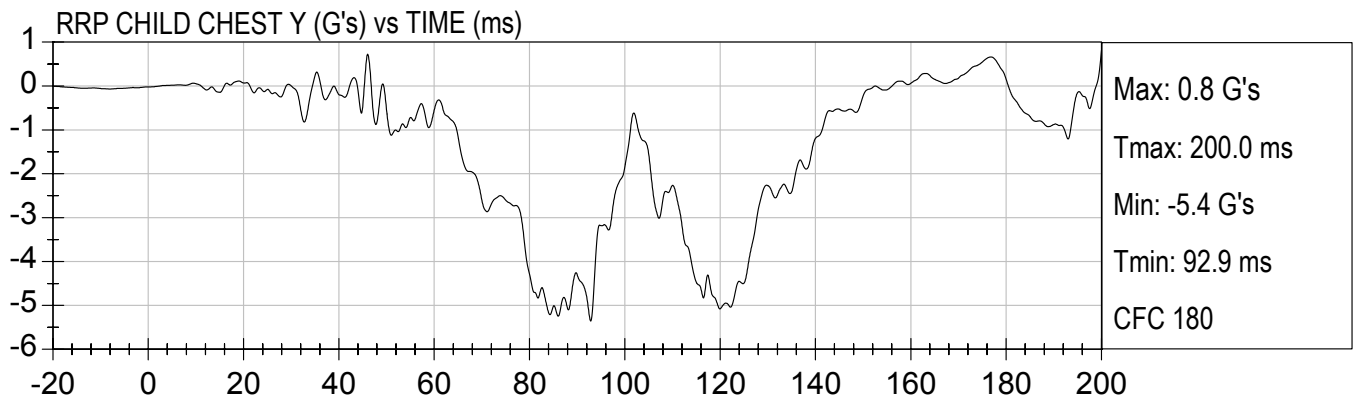
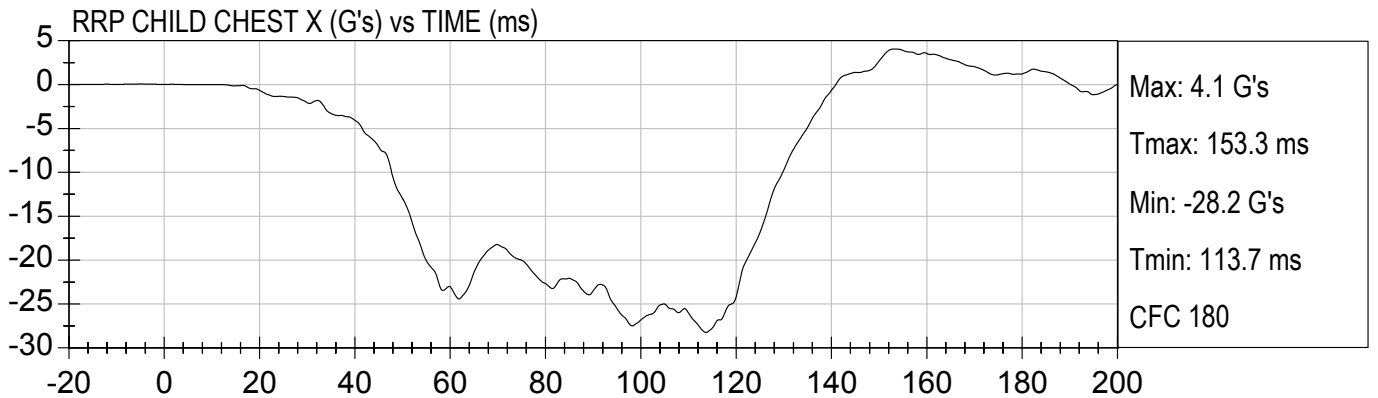

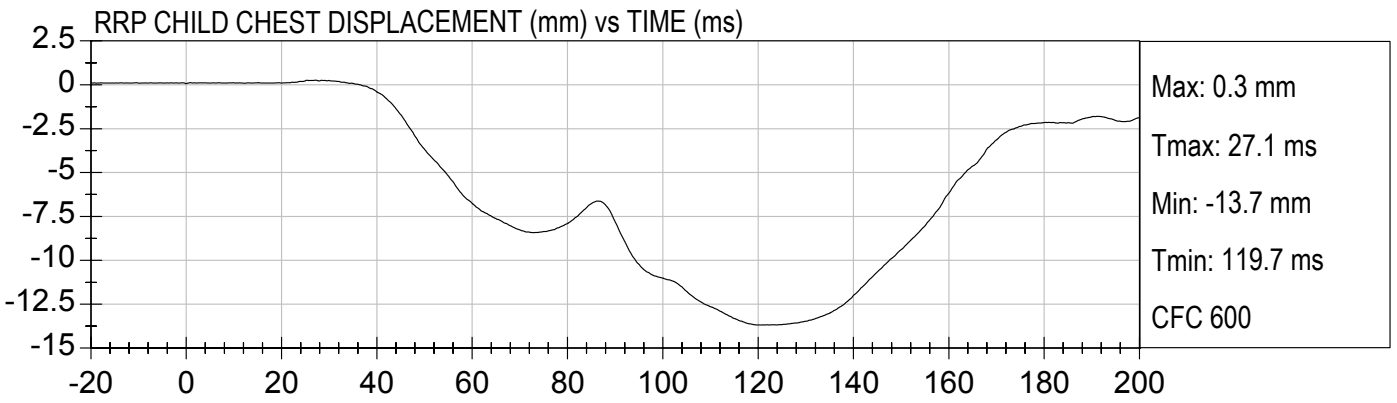
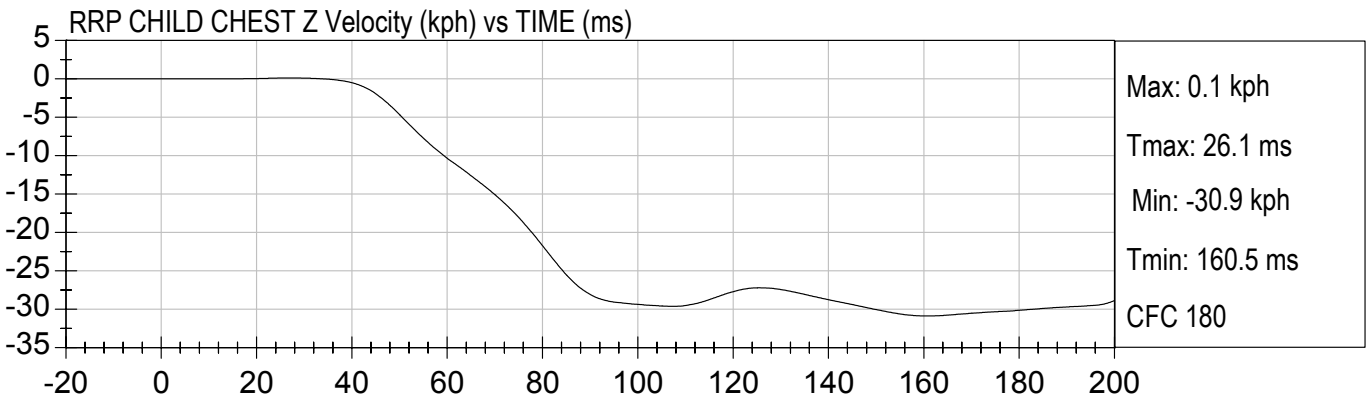
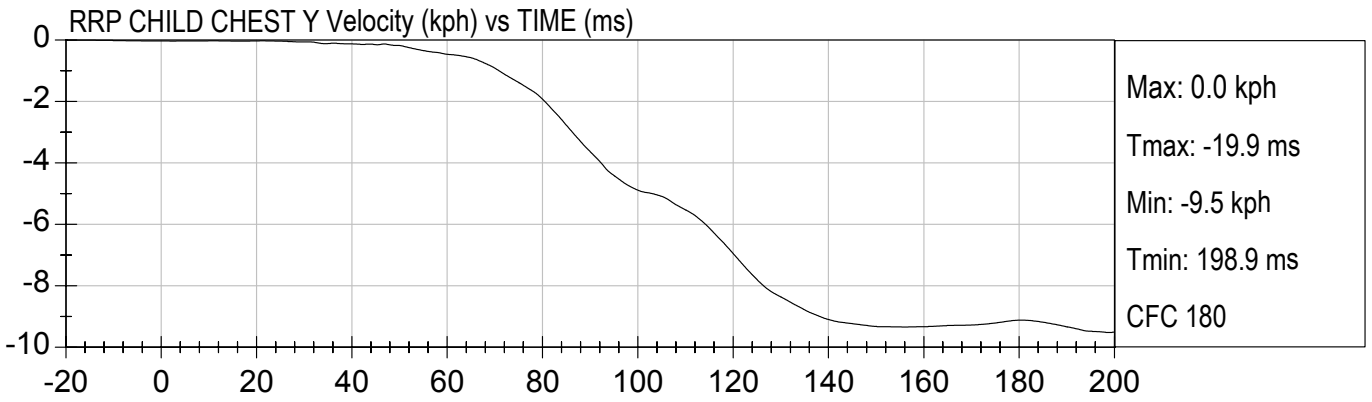
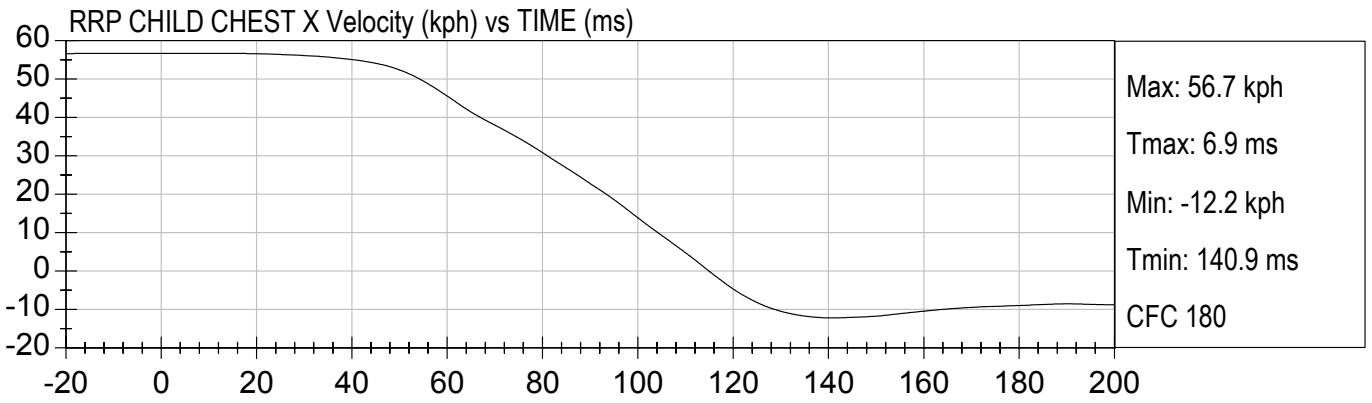

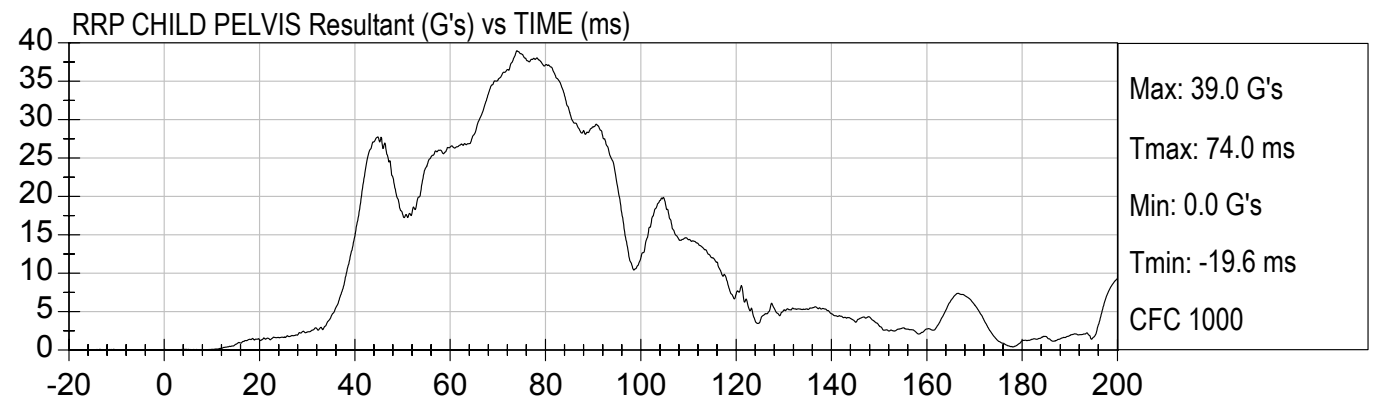
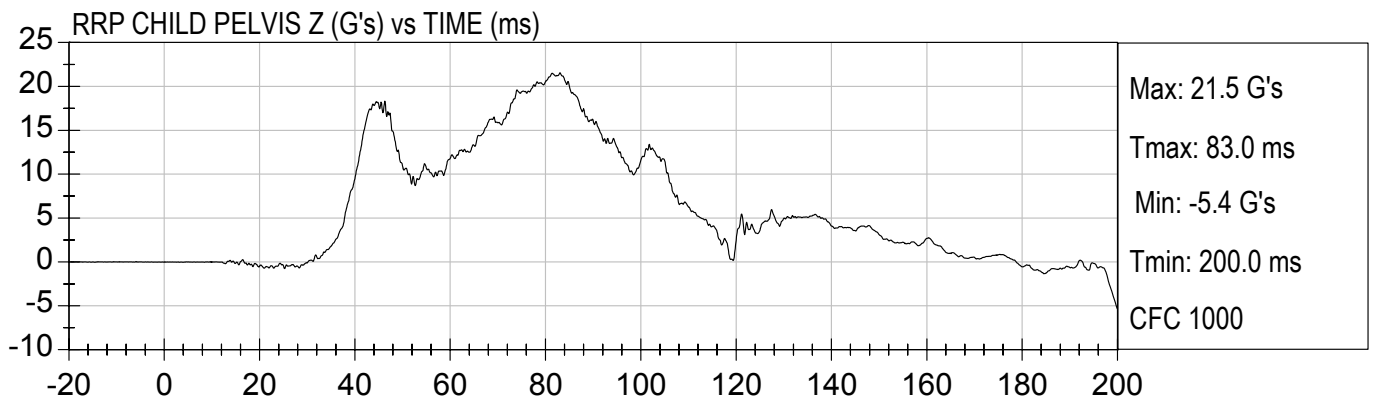
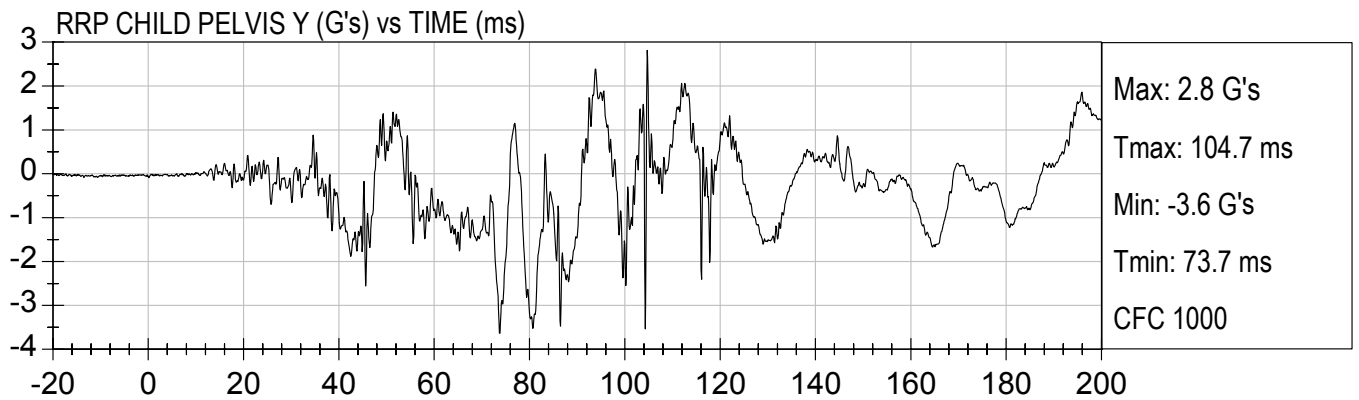
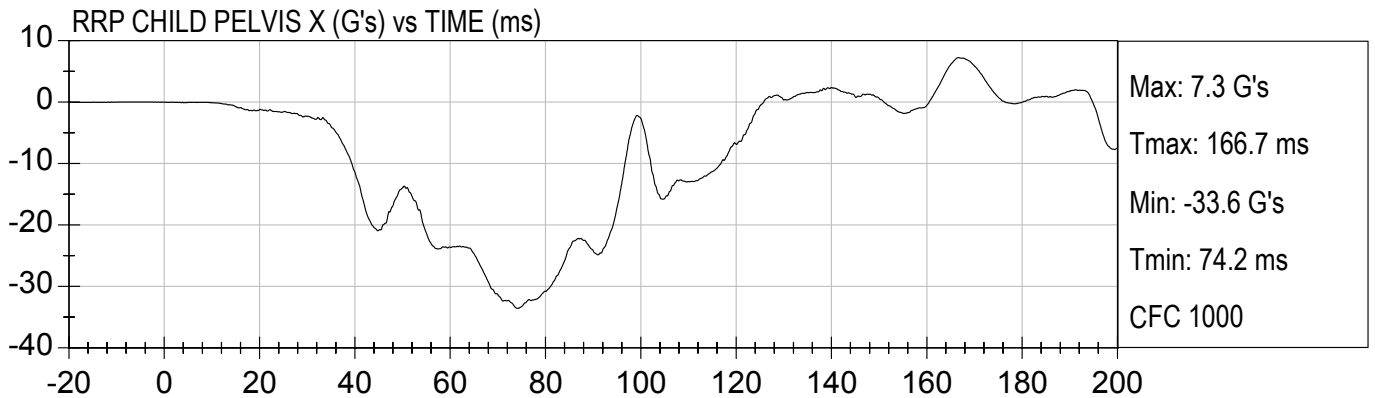

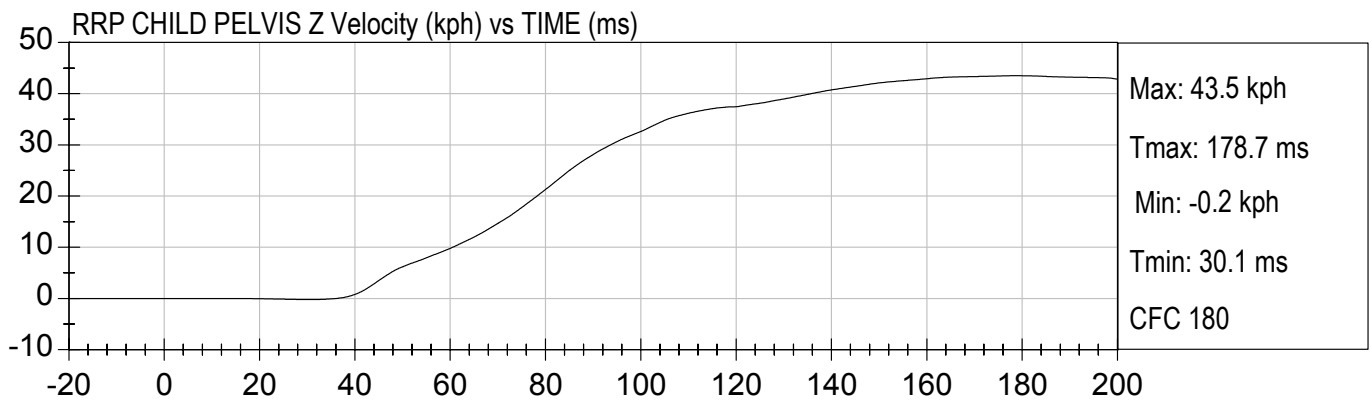
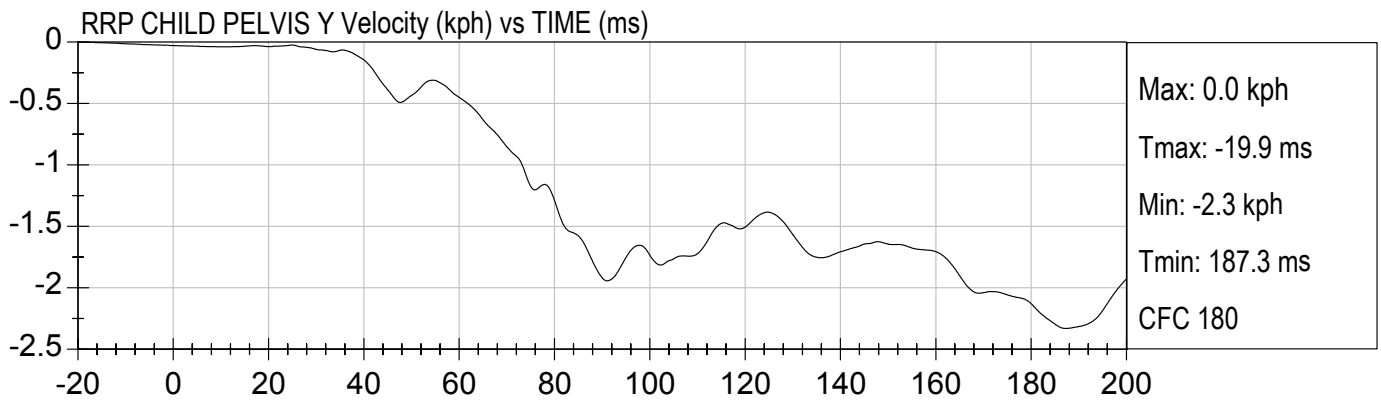
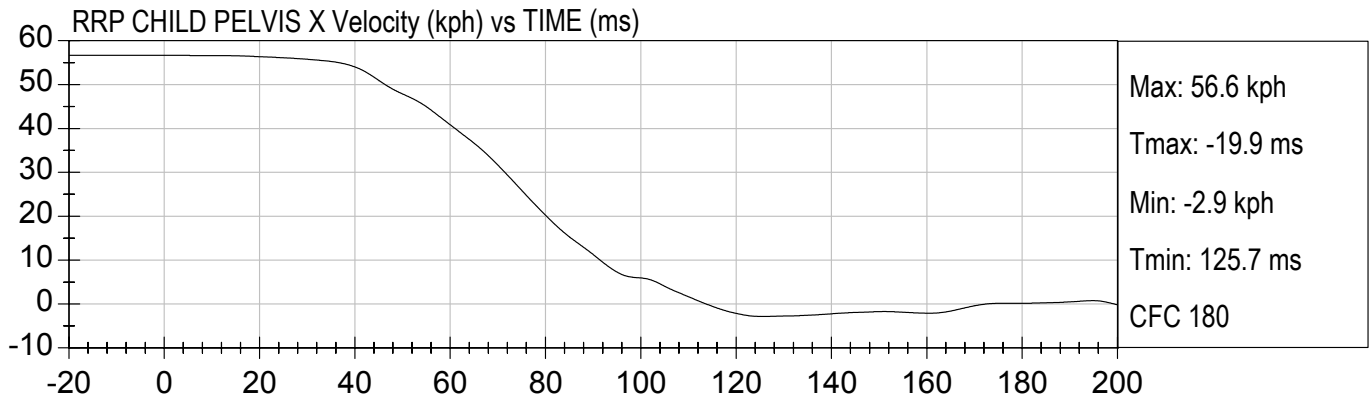

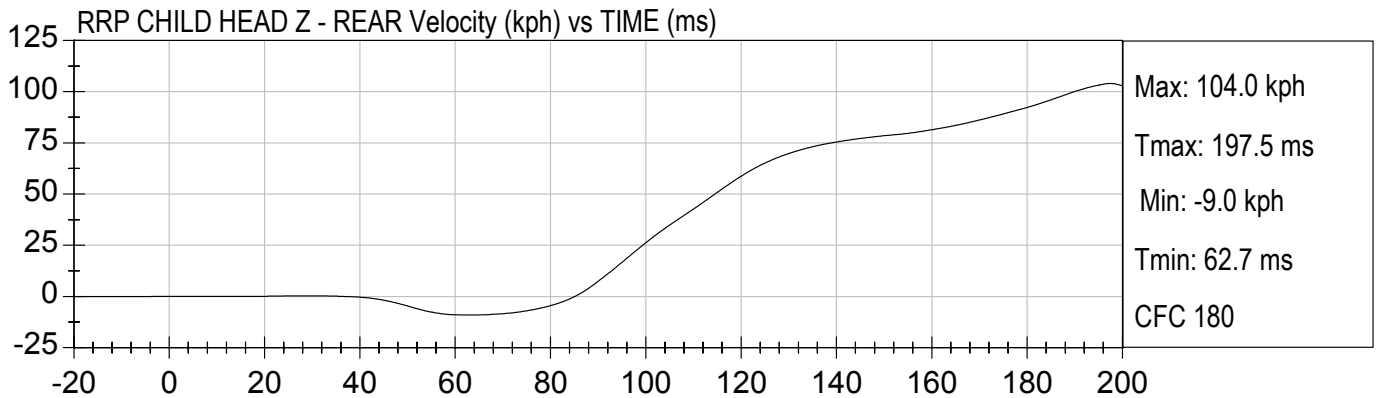
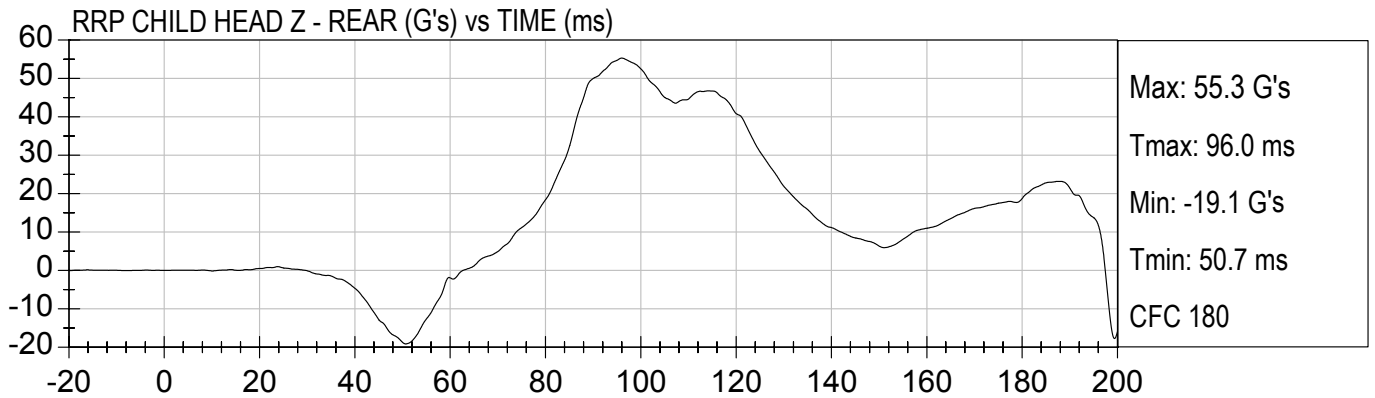
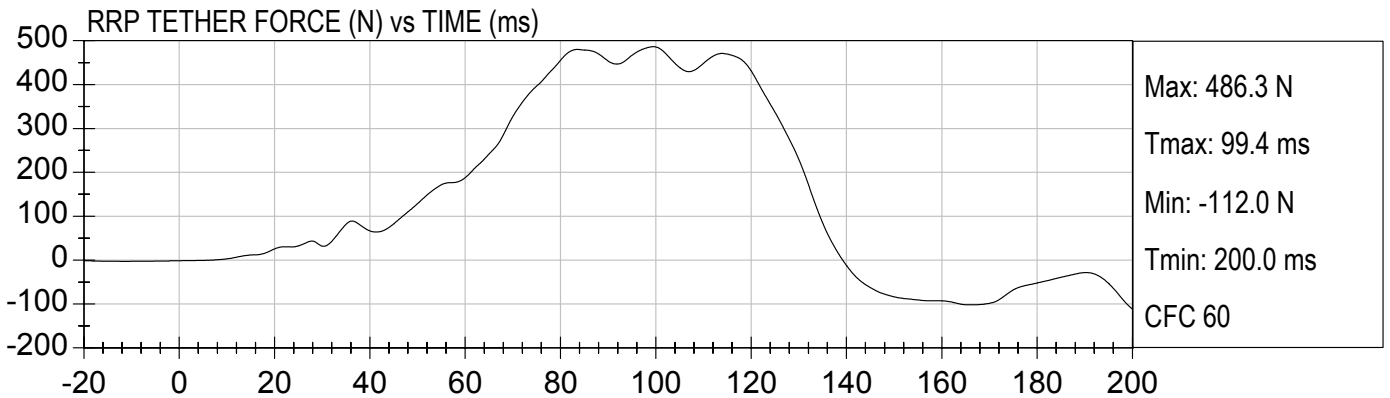

APPENDIX C
CHILD DUMMY CALIBRATION INFORMATION

Hybrid III Calibration Data Sheet
3 Year Old
Head Drop Calibration

ATD Serial No: 040

Test I.D.: D021451

Tested Parameter	Units	Specification	Result	Pass/Fail
Laboratory Temperature	deg C	18.9 to 25.5	21.6	Pass
Laboratory Relative Humidity	%	10 to 70	29	Pass
Peak Resultant Acceleration	G's	250.0 to 280.0	267.1	Pass
Peak Lateral Acceleration	G's	<= +/- 15.0	-5.2	Pass
Is Acceleration Unimodal?	Yes/No	< 10% Peak	Yes	Pass
Overall Test Results				Pass

 Laboratory Technician

 11/13/2002
 Test Date

 Approved By



Test Description: Head Drop

Test Date: 11/13/2002

Component: D021451

Speed: 0 ft/s, 0.00 m/s

HEAD RESULTANT (G's) vs TIME (ms)

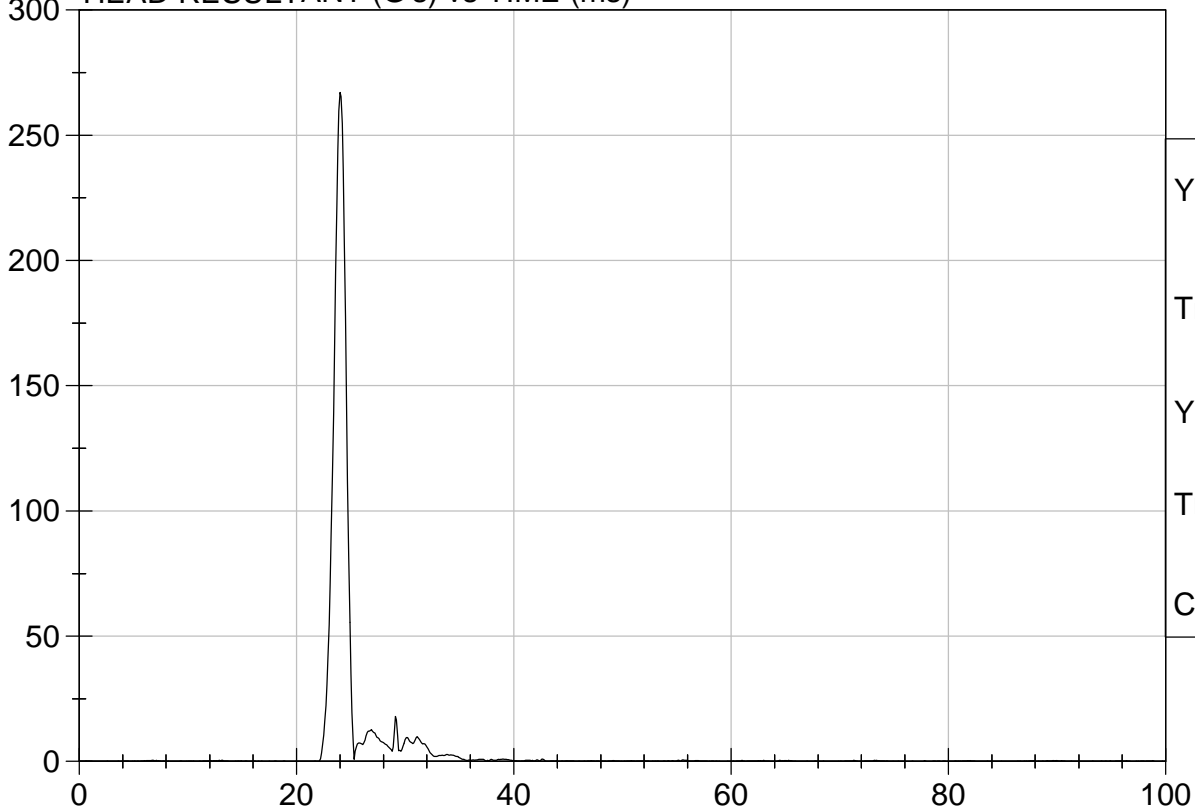

YMax: 267.1 G
Tmax: 24.0 ms
YMin: 0.0 G
Tmin: 0.2 ms
CFC 1000

HEAD Y (G's) vs TIME (ms)

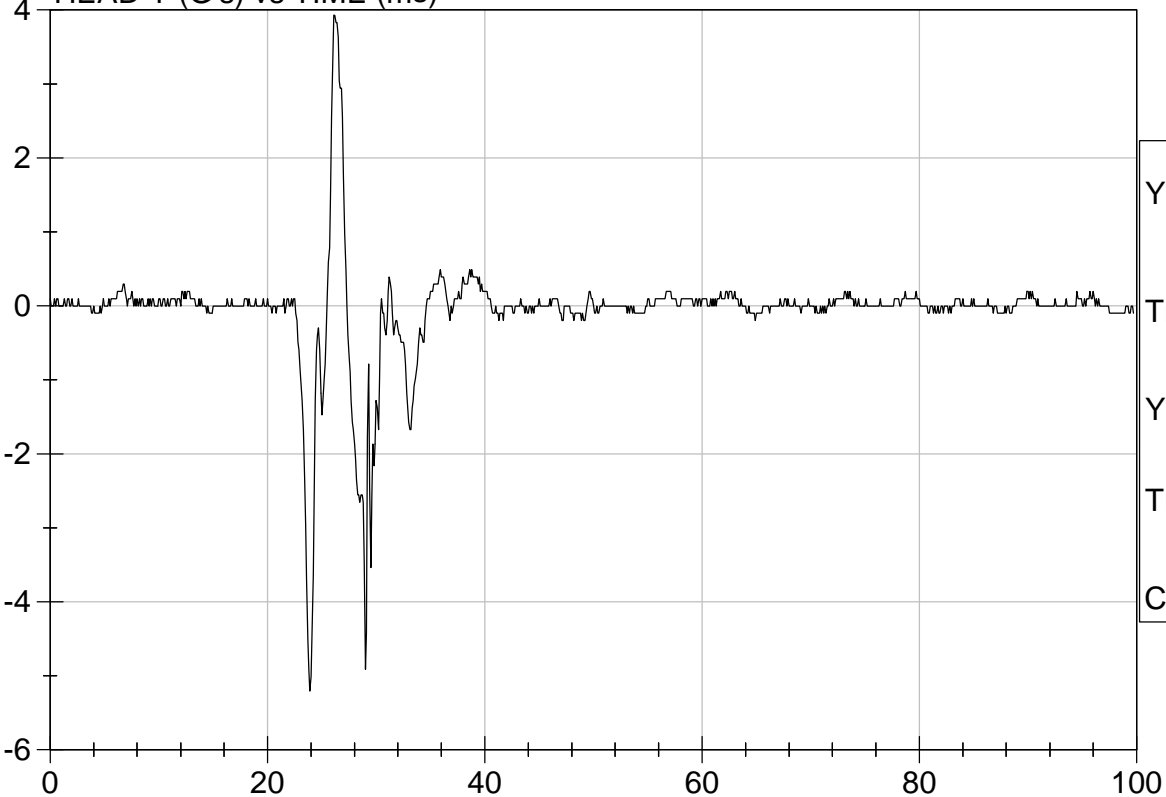

YMax: 3.9 G
Tmax: 26.1 ms
YMin: -5.2 G
Tmin: 23.9 ms
CFC 1000

Hybrid III Calibration Data Sheet
3 Year Old
Neck Flexion Test

ATD Serial No: 040

Test I.D: D021452

Tested Parameter		Units	Specification	Result	Pass/Fail
Laboratory Temperature		deg C	20.6 to 22.2	21.6	Pass
Laboratory Relative Humidity		%	10 to 70	29	Pass
Pendulum Speed		m/s	5.4 to 5.6	5.49	Pass
Pendulum Deceleration	10 msec	m/s	2.0 - 2.7	2.2	Pass
	15 msec	m/s	3.0 - 4.0	3.2	Pass
	20 msec	m/s	4.0 - 5.1	4.4	Pass
D Plane Rotation		deg	70 - 82	78.0	Pass
Peak Moment within Deflection Corridor		deg	42.0 - 53.0	46.1	Pass
Positive Moment - Time Curve Decay to 10 Nm		msec	60.0 - 80.0	71.9	Pass
Overall Test Results					Pass

Laboratory Technician

11/13/2002

Test Date

Approved By



Test Description: Neck Flexion

Test Date: 11/13/2002

Component: D021452

Speed: 18.02 ft/sec, 5.49 m/sec

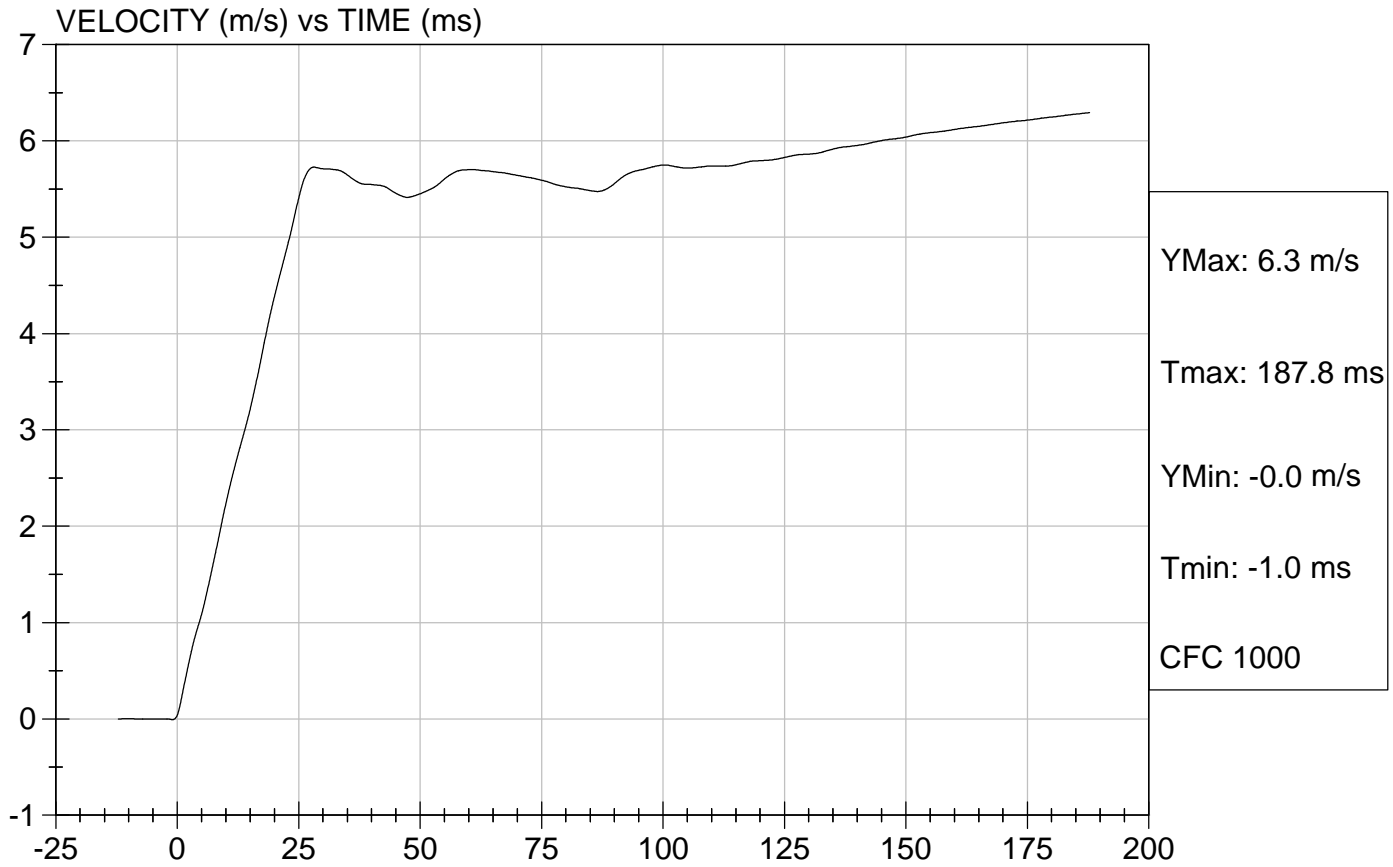



Test Description: Neck Flexion

Test Date: 11/13/2002

Component: D021452

Speed: 18.02 ft/s, 5.49 m/s

NECK ROTATION (Deg) vs TIME (ms)

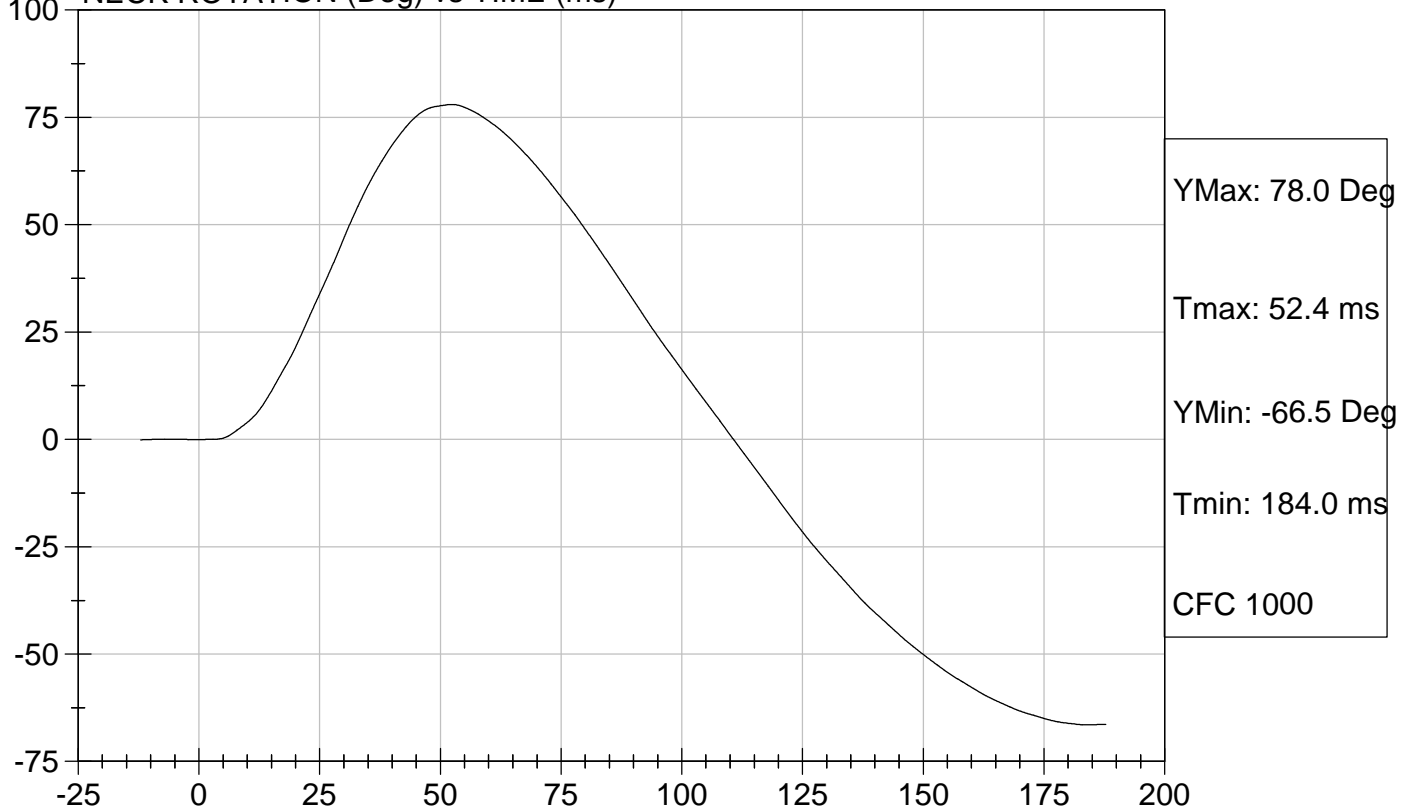

NECK MOMENT Y (Nm) vs TIME (ms)

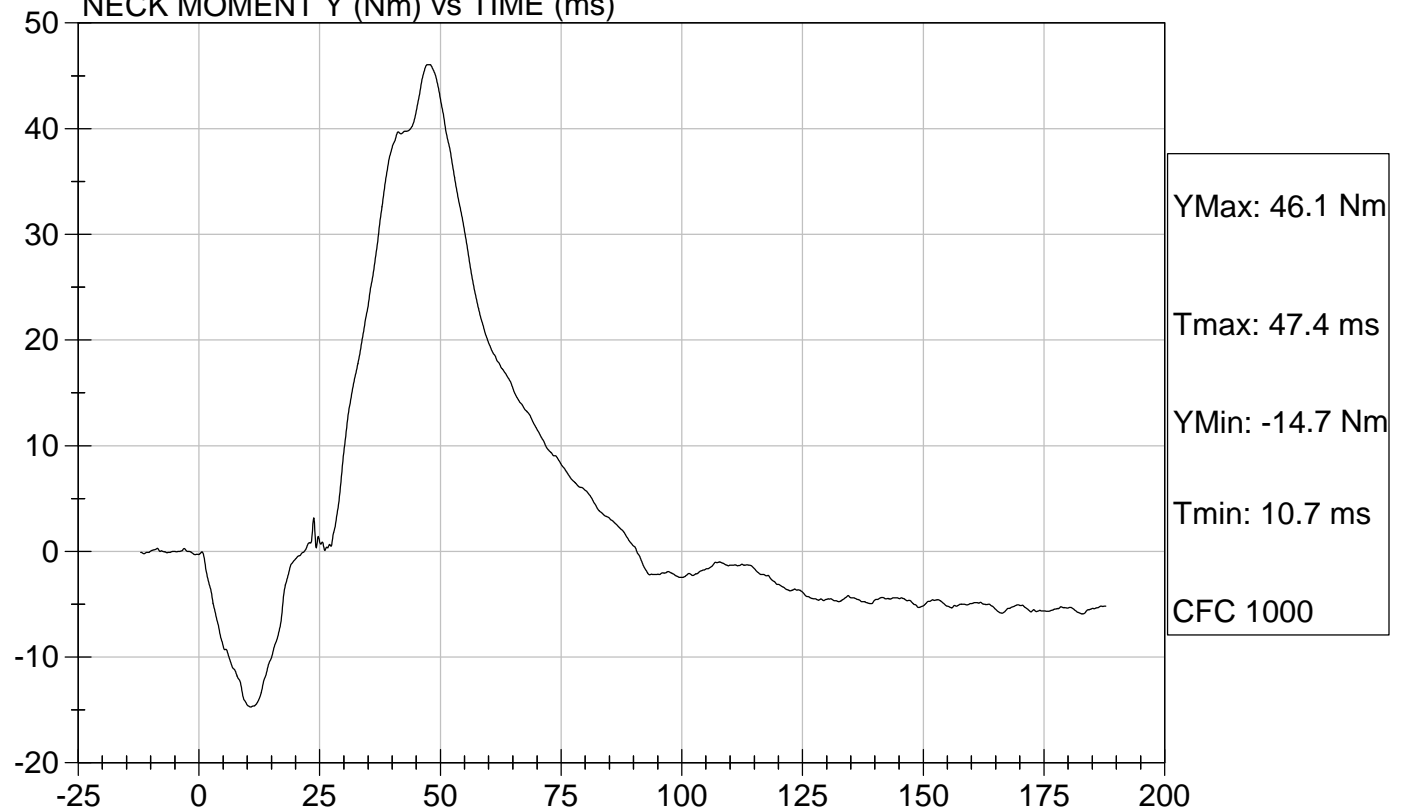

Hybrid III Calibration Data Sheet
3 Year Old
Neck Extension Test

ATD Serial No: 040

Test I.D: D021453

Tested Parameter		Units	Specification	Result	Pass/Fail
Laboratory Temperature		deg C	20.6 to 22.2	21.5	Pass
Laboratory Relative Humidity		%	10 to 70	31	Pass
Pendulum Speed		m/s	3.55 to 3.75	3.67	Pass
Pendulum Deceleration	6 msec	m/s	1.0 - 1.4	1.3	Pass
	10 msec	m/s	1.9 - 2.5	2.2	Pass
	14 msec	m/s	2.8 - 3.5	3.0	Pass
D Plane Rotation		deg	83 - 93	90.2	Pass
Peak Moment within Deflection Corridor		deg	-53.3 - -43.7	-48.0	Pass
Negative Moment - Time Curve Decay to -10 Nm		msec	60.0 - 80.0	67.1	Pass
Overall Test Results					Pass

 Laboratory Technician

11/14/2002

 Test Date

 Approved By



Test Description: Neck Extension Test Date: 11/14/2002

Component: D021453

Speed: 12.03 ft/sec, 3.67 m/sec

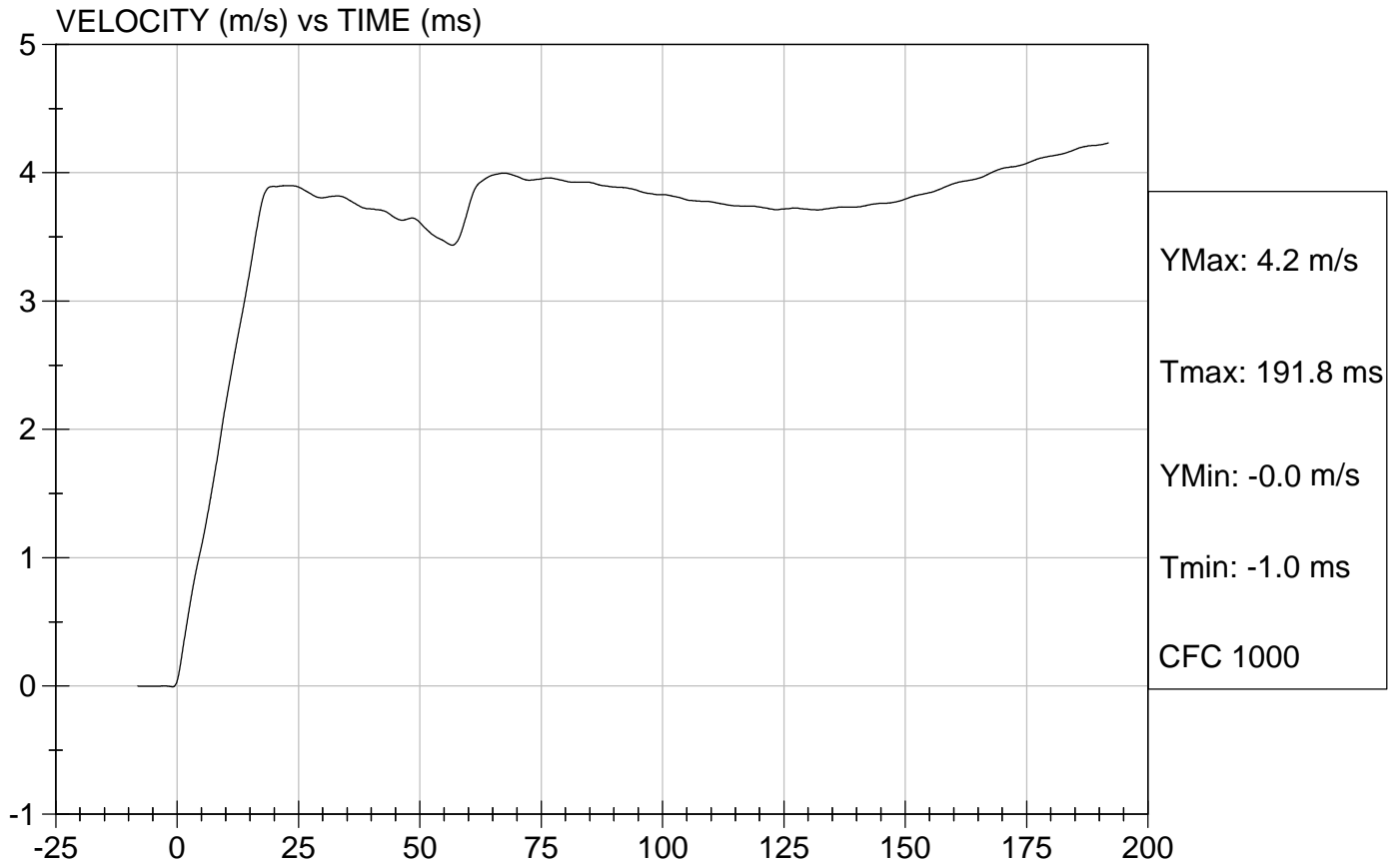



Test Description: Neck Extension

Test Date: 11/14/2002

Component: D021453

Speed: 12.03 ft/s, 3.67 m/s

NECK ROTATION (Deg) vs TIME (ms)

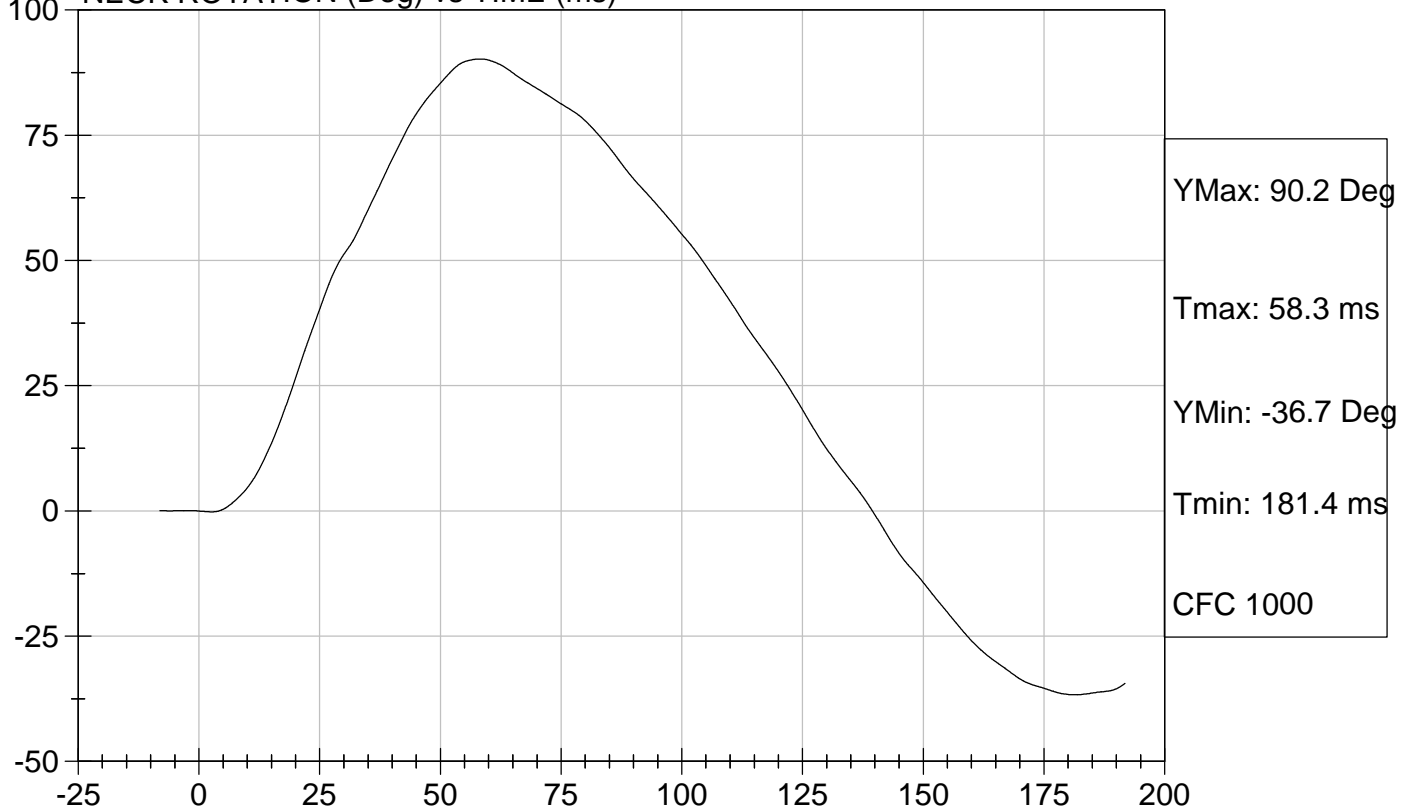

NECK MOMENT Y (Nm) vs TIME (ms)

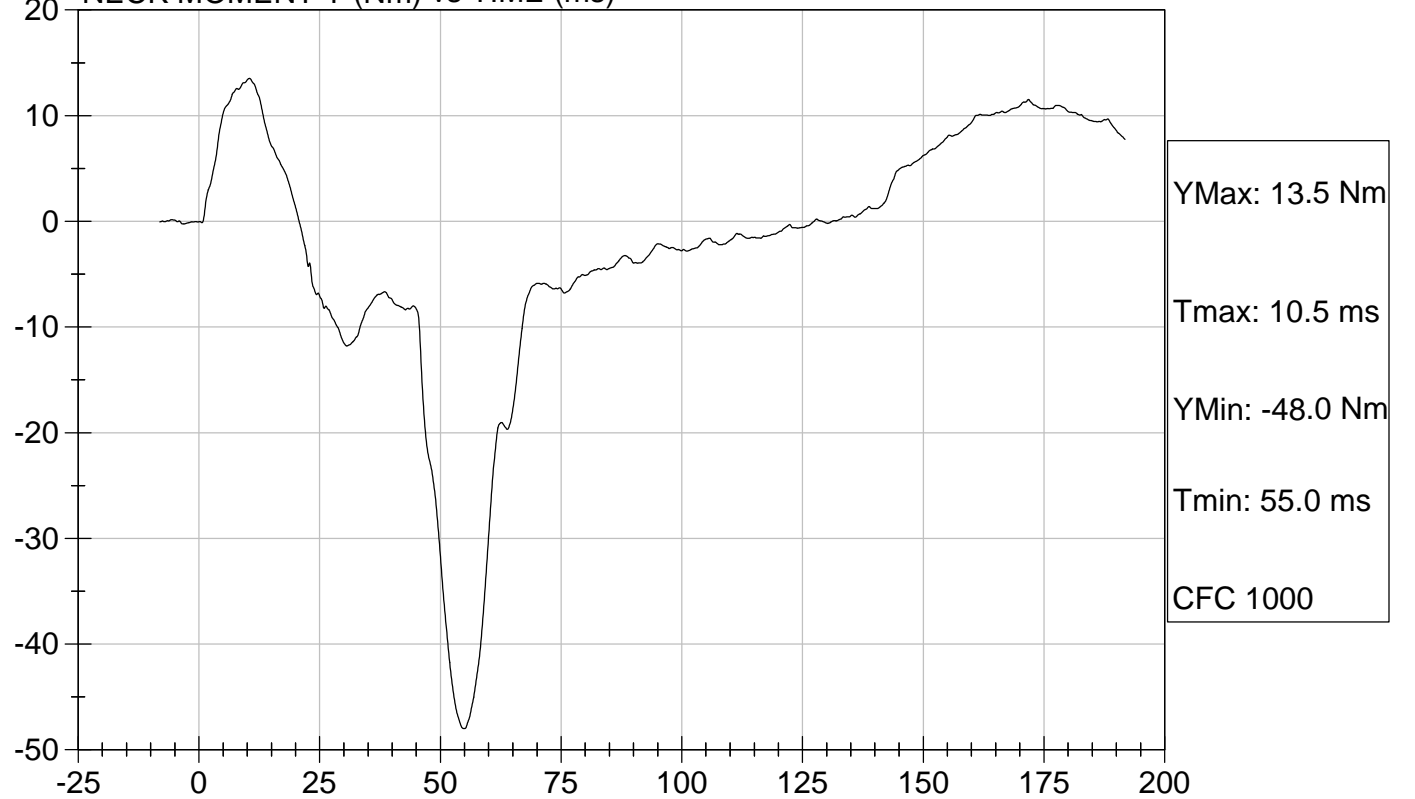

Hybrid III Calibration Data Sheet
3 Year Old
Thorax Impact Test

ATD Serial No: 040

Test I.D.: D021454

Tested Parameter	Units	Specification	Result	Pass/Fail
Laboratory Temperature	deg C	20.6 to 22.2	21.5	Pass
Laboratory Relative Humidity	%	10 to 70	31	Pass
Probe Velocity	m/s	5.9 to 6.1	5.96	Pass
Peak Deflection	mm	32 - 38	33	Pass
Peak Resistive Force w/in Deflection Corridor	kN	0.68 - 0.81	0.69	Pass
Internal Hysteresis	%	65 to 85	71	Pass
Max Force 12.5 mm - 32 mm Deflection	kN	Max 0.86	0.84	Pass
Overall Test Results				Pass

 Laboratory Technician

 11/19/2002
 Test Date

 Approved By



Test Description: Thorax Impact

Test Date: 11/19/2002

Component: D021454

Speed: 19.55 ft/sec, 5.96 m/sec

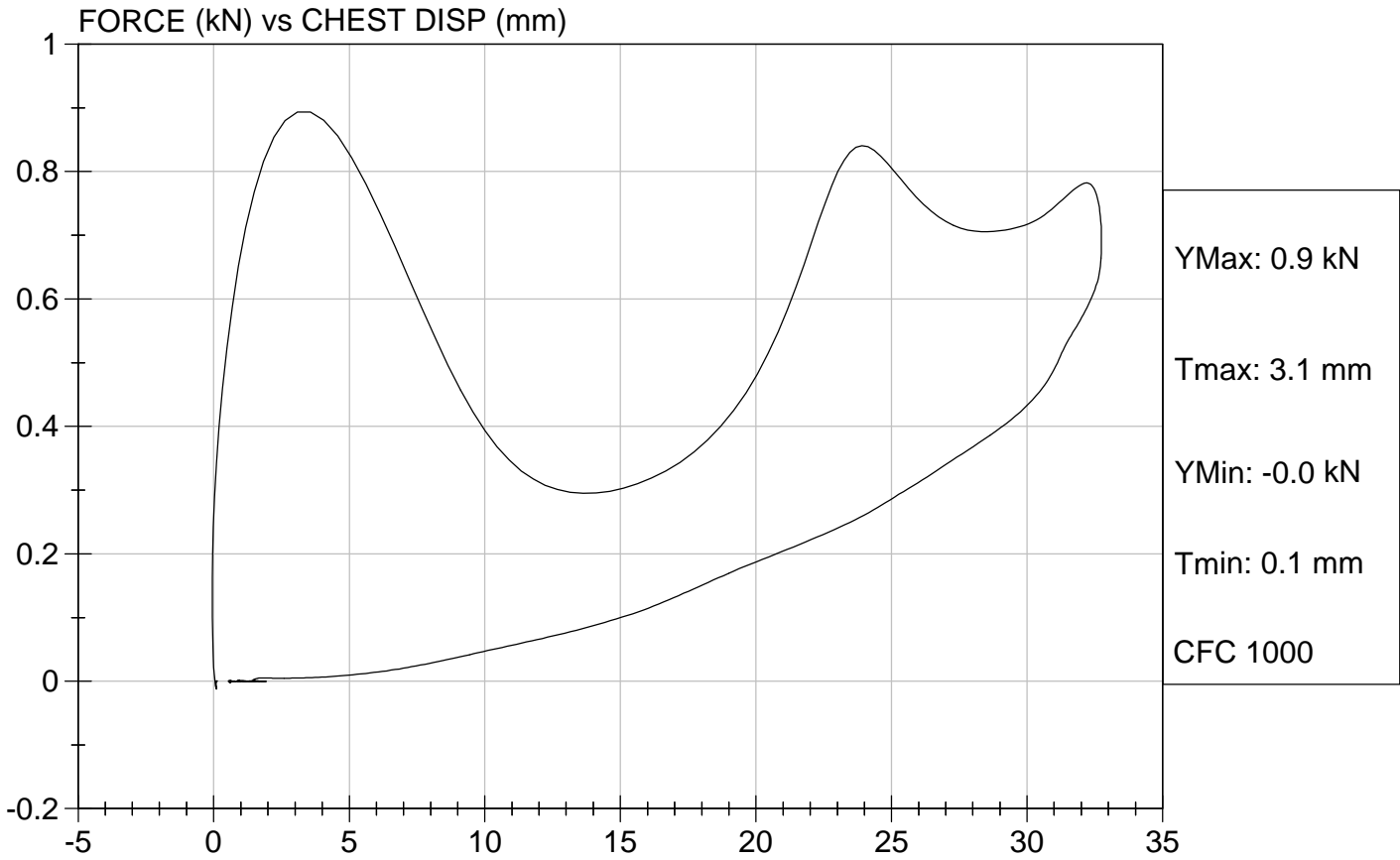

Hybrid III Calibration Data Sheet
3 Year Old
Torso Lumbar Flexion

ATD Serial No: 040

Test I.D.: D021455

Tested Parameter	Units	Specification	Result	Pass/Fail
Laboratory Temperature	deg C	18.9 to 25.6	21.8	Pass
Laboratory Relative Humidity	%	10 to 70	28	Pass
Force At 45 deg.	N	130 - 180	142	Pass
Initial Angle	deg	0 - 15	7	Pass
Return Angle	deg	0 - 10	5	Pass
Overall Test Results				Pass

 Laboratory Technician

 11/19/02
 Test Date

 Approved By

Hybrid III Calibration Data Sheet
3 Year Old
Head Drop Calibration

ATD Serial No: 042

Test I.D.: D021461

Tested Parameter	Units	Specification	Result	Pass/Fail
Laboratory Temperature	deg C	18.9 to 25.5	22.1	Pass
Laboratory Relative Humidity	%	10 to 70	29	Pass
Peak Resultant Acceleration	G's	250.0 to 280.0	258.3	Pass
Peak Lateral Acceleration	G's	<= +/- 15.0	9.9	Pass
Is Acceleration Unimodal?	Yes/No	< 10% Peak	Yes	Pass
Overall Test Results				Pass

 Laboratory Technician

 11/13/2002
 Test Date

 Approved By



Test Description: Head Drop

Test Date: 11/13/2002

Component: D021461

Speed: 0 ft/s, 0.00 m/s

HEAD RESULTANT (G's) vs TIME (ms)

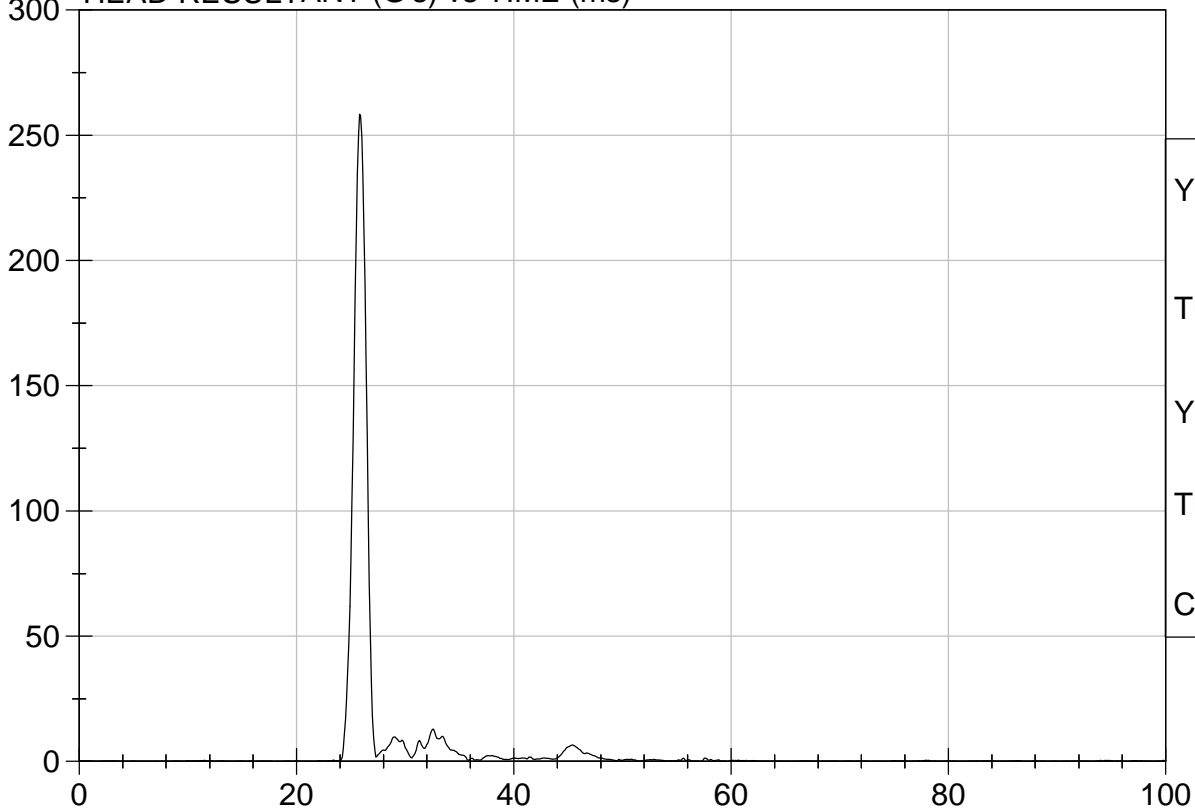

YMax: 258.3 G

Tmax: 25.8 ms

YMin: 0.1 G

Tmin: 1.1 ms

CFC 1000

HEAD Y (G's) vs TIME (ms)

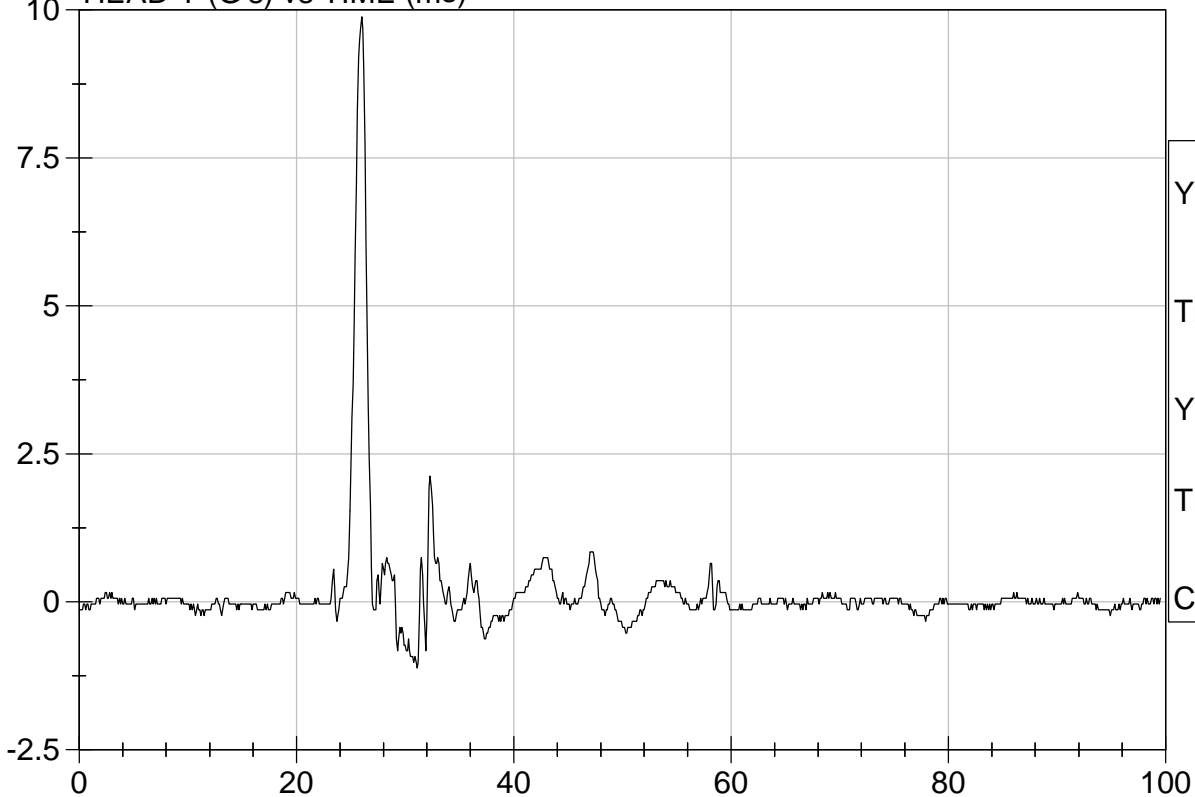

YMax: 9.9 G

Tmax: 26.0 ms

YMin: -1.1 G

Tmin: 31.1 ms

CFC 1000

Hybrid III Calibration Data Sheet
3 Year Old
Neck Flexion Test

ATD Serial No: 042

Test I.D: D021462

Tested Parameter		Units	Specification	Result	Pass/Fail
Laboratory Temperature		deg C	20.6 to 22.2	21.6	Pass
Laboratory Relative Humidity		%	10 to 70	31	Pass
Pendulum Speed		m/s	5.4 to 5.6	5.53	Pass
Pendulum Deceleration	10 msec	m/s	2.0 - 2.7	2.3	Pass
	15 msec	m/s	3.0 - 4.0	3.4	Pass
	20 msec	m/s	4.0 - 5.1	4.5	Pass
D Plane Rotation		deg	70 - 82	81.0	Pass
Peak Moment within Deflection Corridor		deg	42.0 - 53.0	45.1	Pass
Positive Moment - Time Curve Decay to 10 Nm		msec	60.0 - 80.0	72.0	Pass
Overall Test Results					Pass

 Laboratory Technician

11/14/2002

 Test Date

 Approved By



Test Description: Neck Flexion

Test Date: 11/14/2002

Component: D021462

Speed: 18.15 ft/sec, 5.53 m/sec

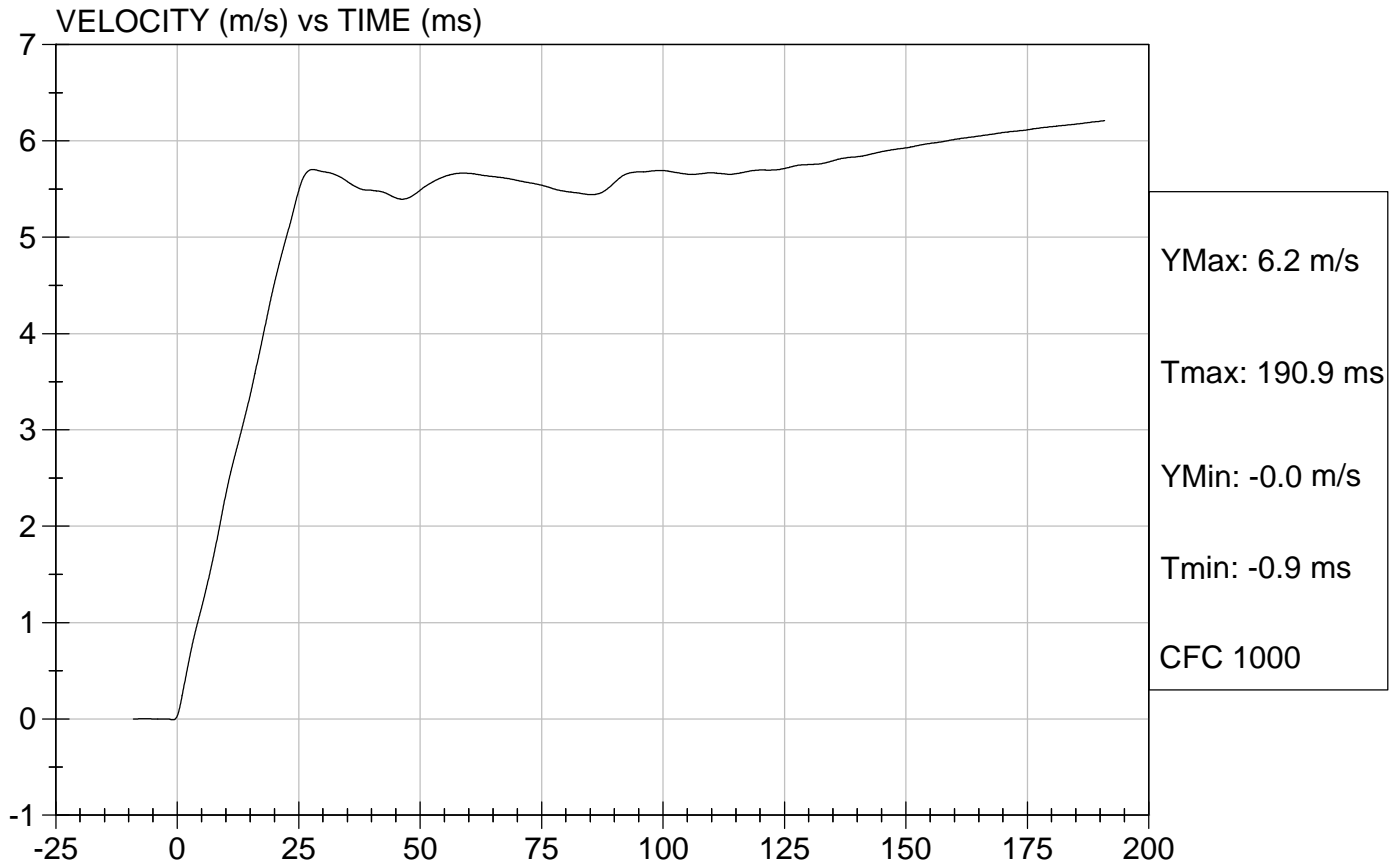



Test Description: Neck Flexion

Test Date: 11/14/2002

Component: D021462

Speed: 18.15 ft/s, 5.53 m/s

NECK ROTATION (Deg) vs TIME (ms)

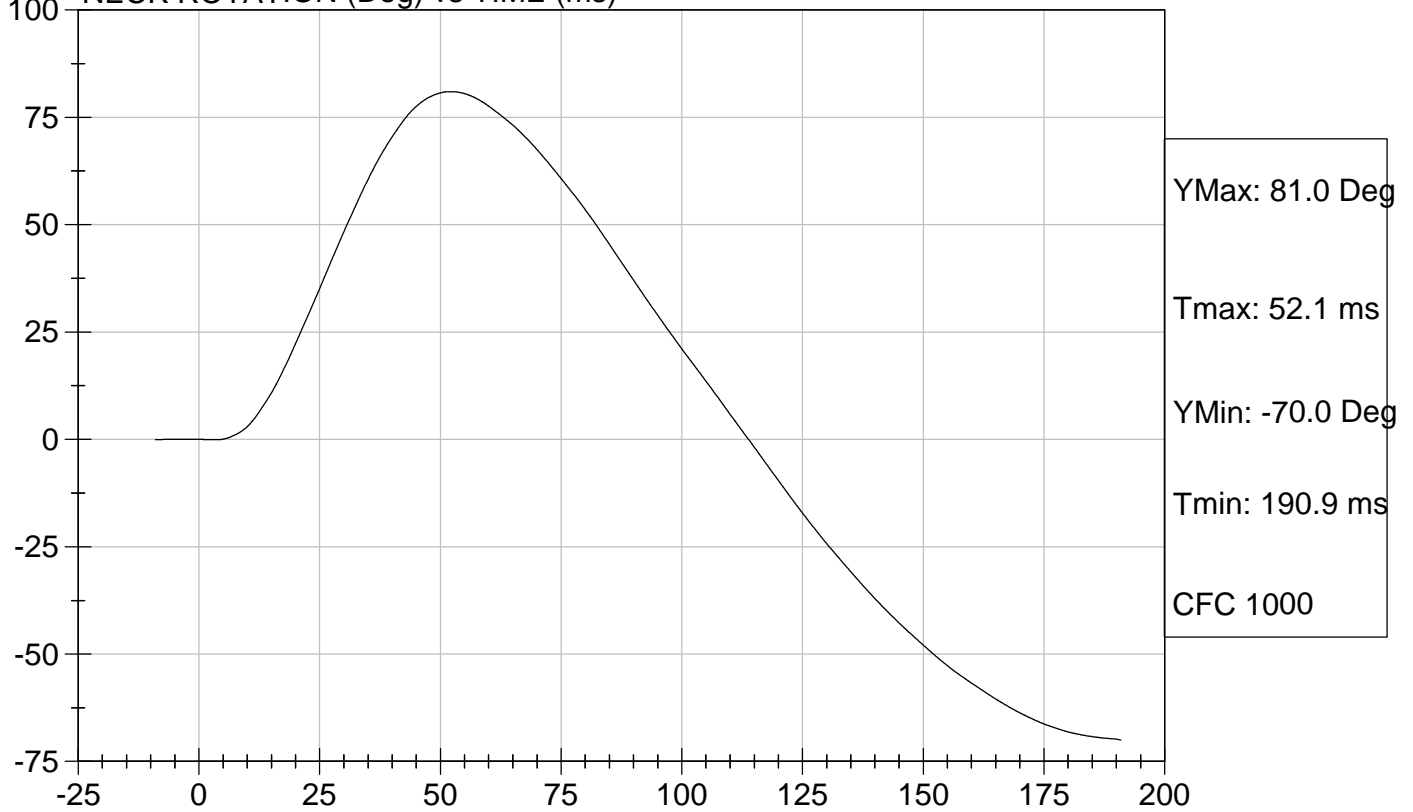

NECK MOMENT Y (Nm) vs TIME (ms)

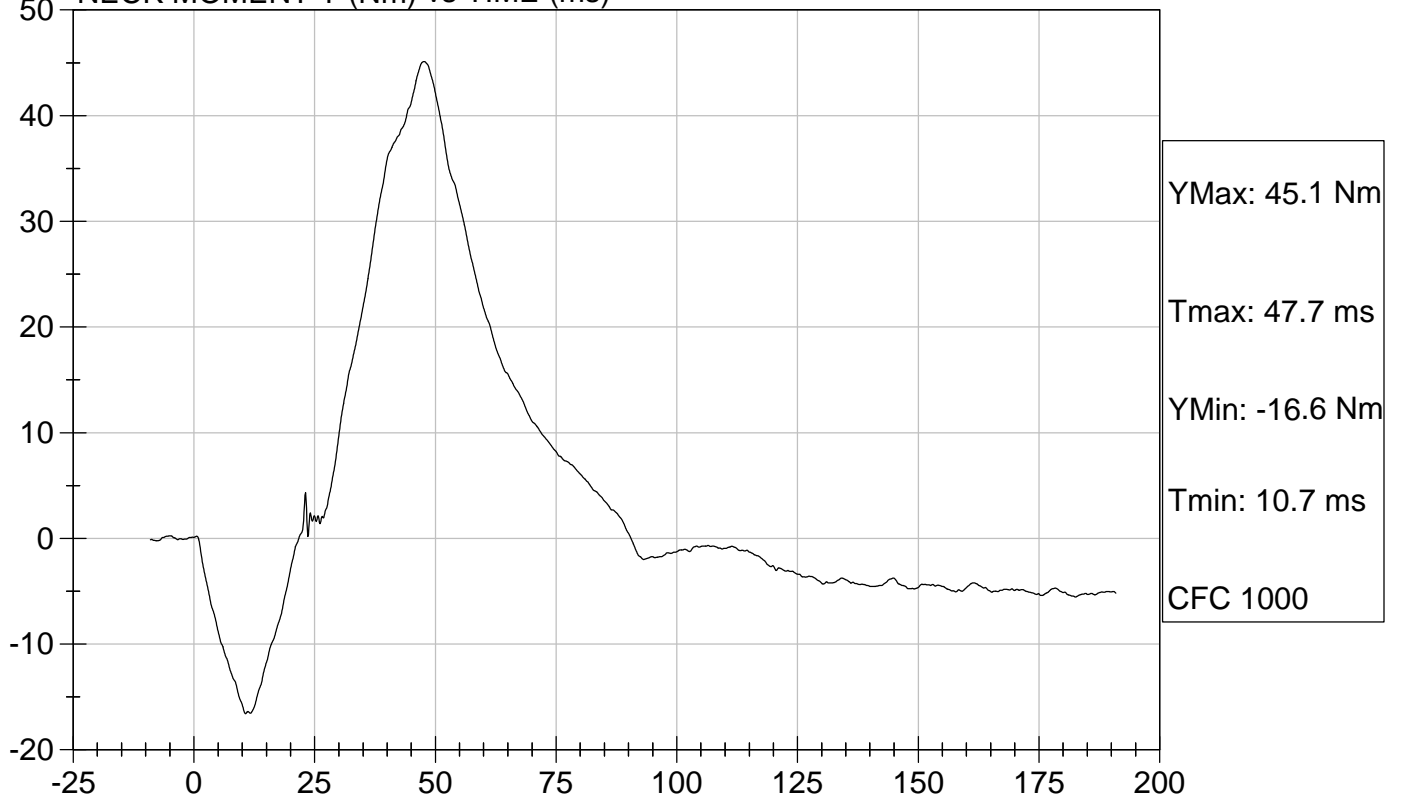

Hybrid III Calibration Data Sheet
3 Year Old
Neck Extension Test

ATD Serial No: 042

Test I.D: D021463

Tested Parameter		Units	Specification	Result	Pass/Fail
Laboratory Temperature		deg C	20.6 to 22.2	21.5	Pass
Laboratory Relative Humidity		%	10 to 70	31	Pass
Pendulum Speed		m/s	3.55 to 3.75	3.73	Pass
Pendulum Deceleration	6 msec	m/s	1.0 - 1.4	1.3	Pass
	10 msec	m/s	1.9 - 2.5	2.2	Pass
	14 msec	m/s	2.8 - 3.5	3.0	Pass
D Plane Rotation		deg	83 - 93	85.8	Pass
Peak Moment within Deflection Corridor		deg	-53.3 - -43.7	-44.5	Pass
Negative Moment - Time Curve Decay to -10 Nm		msec	60.0 - 80.0	69.9	Pass
Overall Test Results					Pass

Laboratory Technician

11/14/2002

Test Date

Approved By



Test Description: Neck Extension Test Date: 11/14/2002

Component: D021463

Speed: 12.23 ft/sec, 3.73 m/sec

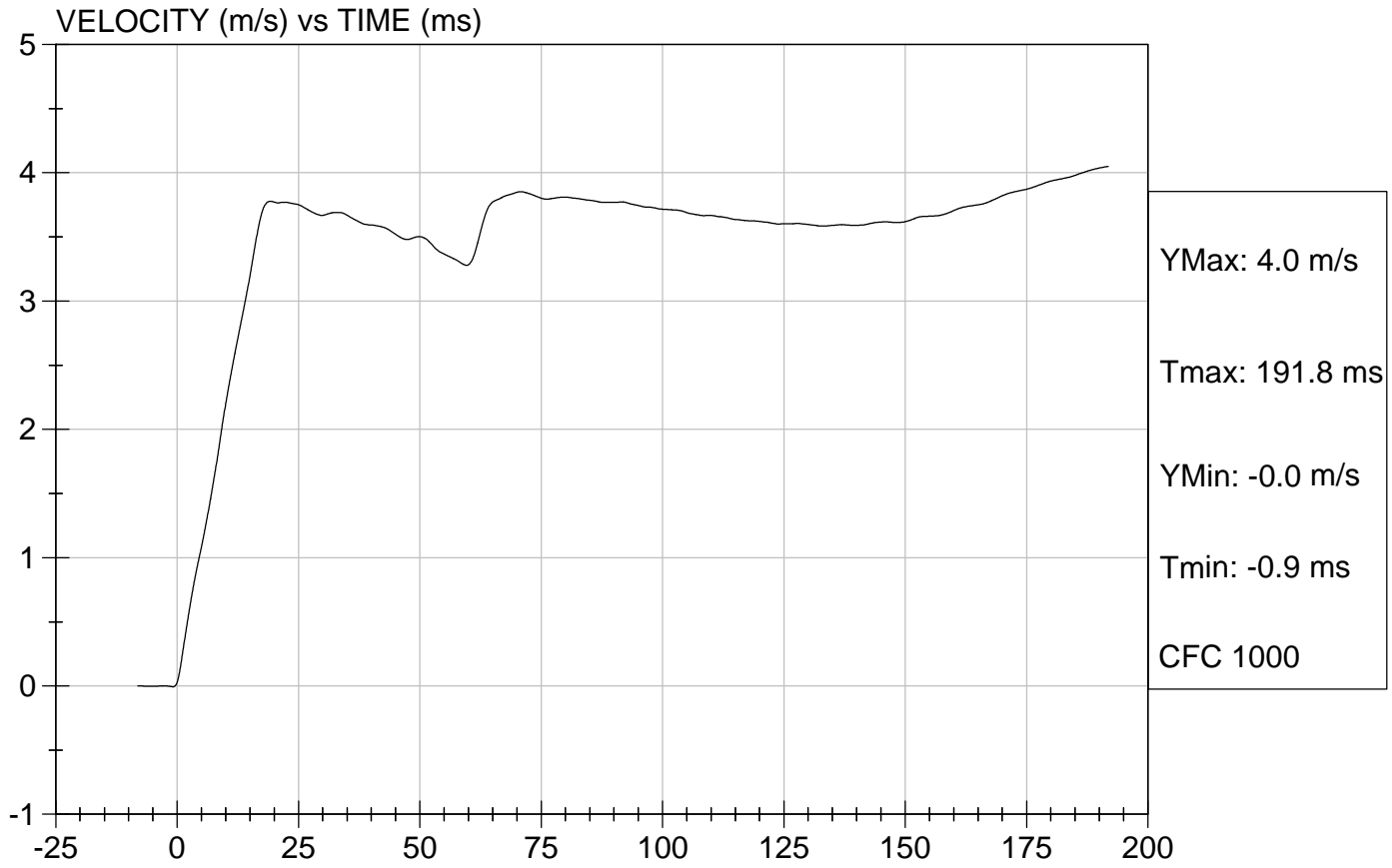



Test Description: Neck Extension

Test Date: 11/14/2002

Component: D021463

Speed: 12.23 ft/s, 3.73 m/s

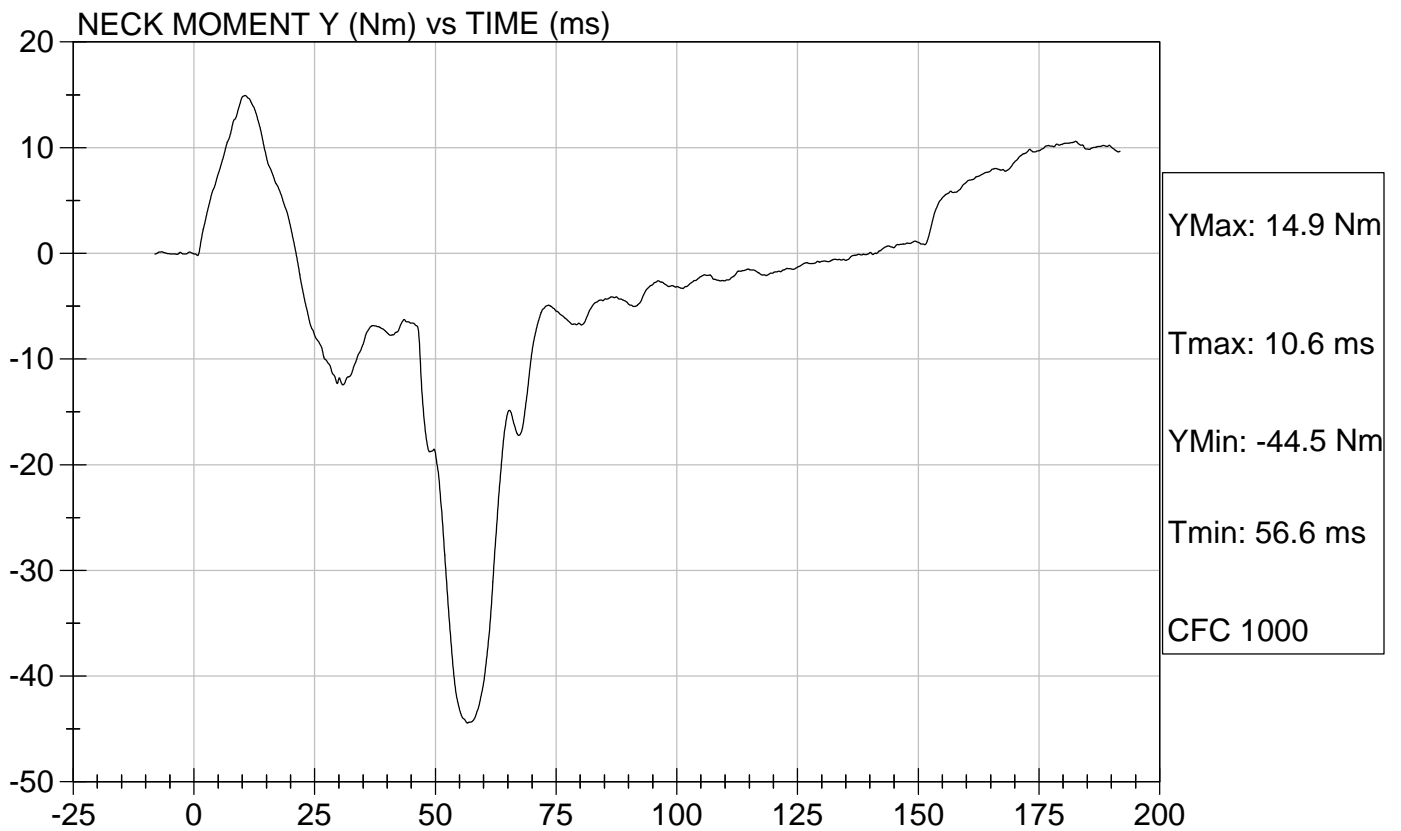
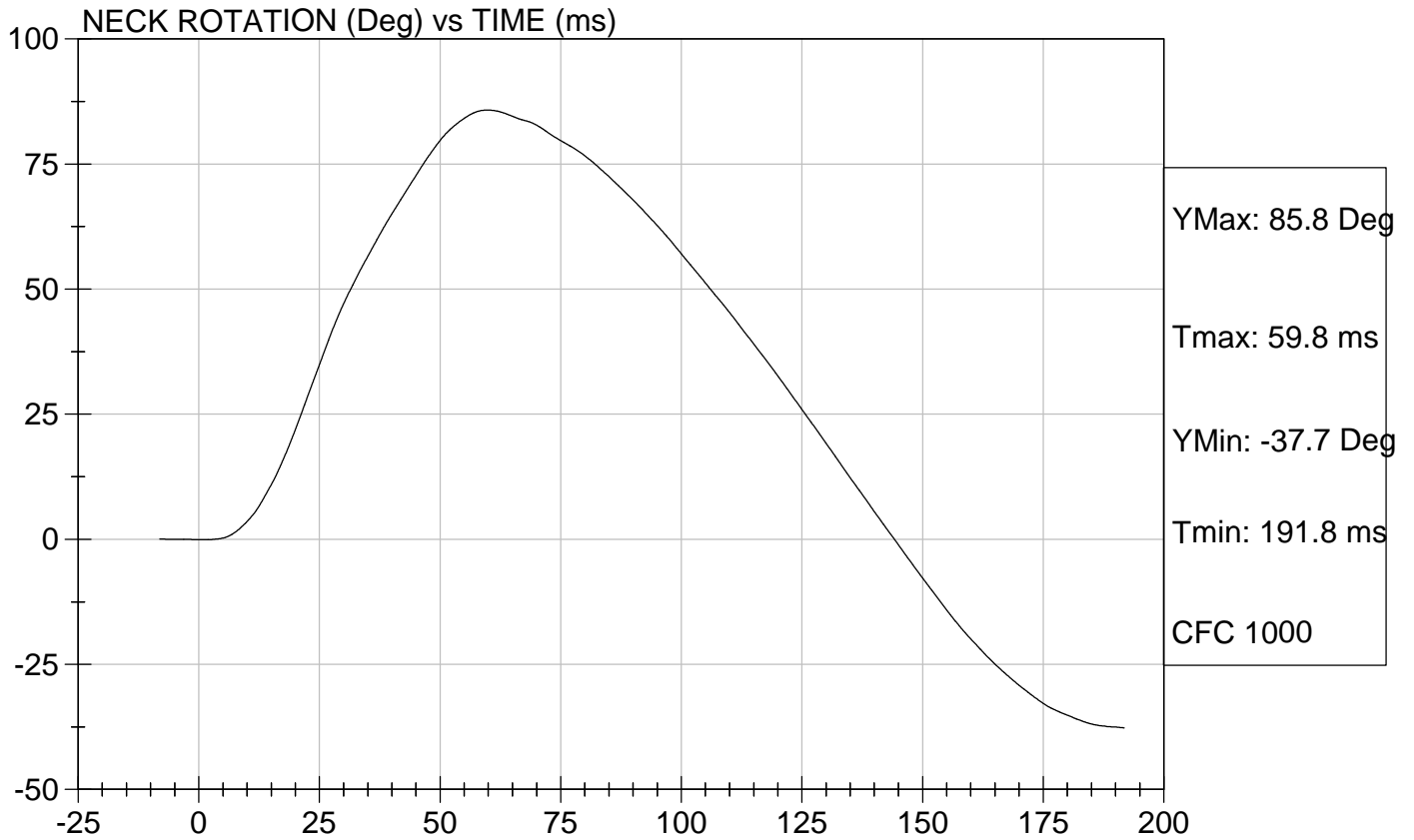

Hybrid III Calibration Data Sheet
3 Year Old
Thorax Impact Test

ATD Serial No: 042

Test I.D.: D021464

Tested Parameter	Units	Specification	Result	Pass/Fail
Laboratory Temperature	deg C	20.6 to 22.2	20.8	Pass
Laboratory Relative Humidity	%	10 to 70	26	Pass
Probe Velocity	m/s	5.9 to 6.1	6.00	Pass
Peak Deflection	mm	32 - 38	33	Pass
Peak Resistive Force w/in Deflection Corridor	kN	0.68 - 0.81	0.72	Pass
Internal Hysteresis	%	65 to 85	72	Pass
Max Force 12.5 mm - 32 mm Deflection	kN	Max 0.86	0.80	Pass
Overall Test Results				Pass

 Laboratory Technician

 11/15/2002
 Test Date

 Approved By



Test Description: Thorax Impact

Test Date: 11/15/2002

Component: D021464

Speed: 19.67 ft/sec, 6.00 m/sec

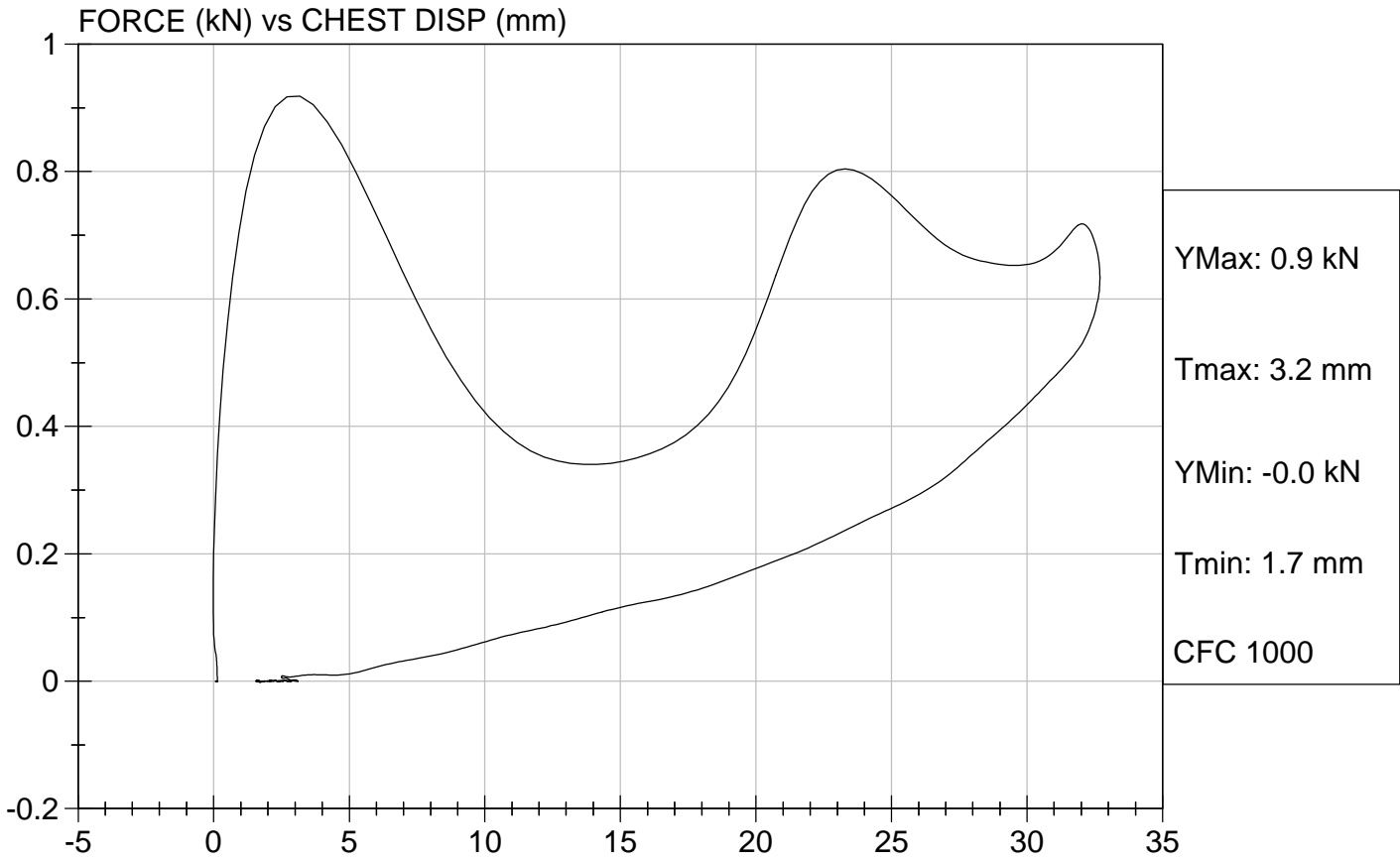

Hybrid III Calibration Data Sheet
3 Year Old
Torso Lumbar Flexion

ATD Serial No: 042

Test I.D.: D021465

Tested Parameter	Units	Specification	Result	Pass/Fail
Laboratory Temperature	deg C	18.9 to 25.6	21.8	Pass
Laboratory Relative Humidity	%	10 to 70	28	Pass
Force At 45 deg.	N	130 - 180	157	Pass
Initial Angle	deg	0 - 15	8	Pass
Return Angle	deg	0 - 10	6	Pass
Overall Test Results				Pass

 Laboratory Technician

 11/19/02
 Test Date

 Approved By

APPENDIX D

TEST EQUIPMENT LIST AND CALIBRATION INFORMATION

INSTRUMENTS FOR LRP CHILD DUMMY S/N: 40

	SERIAL NO.	MANUFACTURER	CALIBRATION DATE
Head X	AAMD5	Endevco	11/16/02
Head Y	J27509	Endevco	11/13/02
Head Z	J20014	Endevco	11/16/02
Head Z - Rear	AC9F9	Endevco	11/16/02
Upper Neck Load Cell	86	Denton	10/4/02
Lower Neck Load Cell	210	Denton	10/4/02
Chest X	AC9P8	Endevco	11/13/02
Chest Y	J23996	Endevco	11/16/02
Chest Z	H12-F08	Entran	11/16/02
Chest Deflection Gauge	40	Servo	11/15/02
Pelvis X	BG37J	Endevco	11/16/02
Pelvis Y	J35560	Endevco	11/16/02
Pelvis Z	DE15J	Endevco	11/16/02
Tether Force	105	FTSS	11/25/02

INSTRUMENTS FOR RRP CHILD DUMMY S/N: 42

	SERIAL NO.	MANUFACTURER	CALIBRATION DATE
Head X	H10-F10	Entran	11/13/02
Head Y	H10-F12	Entran	11/13/02
Head Z	AJ4L1	Endevco	11/13/02
Upper Neck Load Cell	121	FTSS	10/4/02
Lower Neck Load Cell	120	FTSS	10/4/02
Chest X	J19547	Endevco	11/13/02
Chest Y	CC92H	Endevco	11/13/02
Chest Z	J26976	Endevco	11/13/02
Chest Deflection Gauge	42	Servo	11/15/02
Pelvis X	BE95J	Endevco	11/13/02
Pelvis Y	DE54J	Endevco	11/13/02
Pelvis Z	H12-F30	Entran	11/13/02